

TIMBER FRAMING

JOURNAL OF THE TIMBER FRAMERS GUILD

Number 69, September 2003



Tour Charpentier de France

TIMBER FRAMING

JOURNAL OF THE TIMBER FRAMERS GUILD
NUMBER 69 SEPTEMBER 2003

CONTENTS

LETTERS	2
Paul Oatman, Peter Sinclair, Joel McCarty	
HISTORIC AMERICAN ROOF TRUSSES	4
I. SCISSOR TRUSSES	
Jan Lewandoski	
HISTORIC SCISSOR TRUSS ANALYSIS	15
Ed Levin	
OUR OWN TOUR DE FRANCE	18
Will Beemer	
LIFTING APPARATUS CALCULATIONS	29
Grigg Mullen	

On the cover, view of a well-preserved street in Rouen, a town visited by several Guild members following a guided tour of timber-framed buildings in northeastern France. Note trussed wall framing over broad shop windows, slate siding on buildings at the center of the view and the exuberant multiplicity of bracing patterns. The building visible at the far end of the street appears to have had its roof raised. Will Beemer's report on the tour, page 18. Photo by Chris Madigan.

Copyright © 2003
Timber Framers Guild, PO Box 60, Becket, MA 01223
www.tfguild.org
888-453-0879

Editorial Correspondence

PO Box 275, Newbury, VT 05051
802-866-5684 journal@tfguild.org

Editor Kenneth Rower

Contributing Editors

Guild Affairs Will Beemer, Joel McCarty
History Jack A. Sobon
Timber Frame Design Ed Levin

Published Quarterly. Subscription \$25 annually
or by membership in the Timber Framers Guild.
ISSN 1061-9860

TIMBER FRAMING, Journal of the Timber Framers Guild, reports on the work of the Guild and its members, and appears quarterly, in March, June, September and December. The journal is written by its readers and pays for interesting articles by experienced and novice writers alike.



1 9 8 5



LETTERS

More Words, Please

A GLOSSARY of timber frame terms is indeed needed and you have published the first draft (TF 68). Although you refer to a couple of notable sources for your definitions, you bypassed the most notable reference in the English language, the *Oxford English Dictionary*, a work 70 years in the making, first published in 1928 with five supplements and newly published in the year 2000. (However, in my research on *drawboring* [see TF 67], I was able to predate the *OED*, which cites J. Smith's reference of 1812; I quote Moxon from 1703. I have not told the *OED* of this find as I am still searching for earlier sources.) All words should be given with their first usage. For some reason this was done with only one term, *tusk tenon*.

Some errors do exist in your first draft. A timber frame is not a braced frame. *Braced frame* does not appear in the *OED*, yet it does appear in the 1923 *Audels Carpenters and Builders Guide* with an illustration of braced framing, the main difference being that a braced frame employs a common joist system on all floor levels devoid of summer beams and floor timbers. A *full frame* is the term given in *Audels* for timber framing. Also, a *binding joist* need not travel transversely and its primary function is to carry *bridging joists*, which also can travel in any direction.

I'm in the process of researching summers and breast summers along with gins and girders, dormants and sleepers, and I will have an essay in the next couple of months. On a final note, what the hell is a *tongue and fork*? I find no reference to this anywhere.

PAUL OATMAN

24500 Robin Hood Drive
Pioneer, California 95666
209-295-5100

I READ your glossary of terms (TF 68) and would like to add a few (I notice you don't use John Fitchen, John Stevens, Greg Huber or yours truly as references): Raising Hole, Column, H-Bent Post, Hood Beam, Hearth Beam, Trimmer Beams, Outrigger (for Pentice), Carrier Beam, Lap Dovetail, Verdiepingh, Dekbalk, Diminished Haunch, Major-Minor Rafter Systems, Ridge Beams, Sleeper, Barrack Pole, Corbel Brace, Upper Purlin, Removable Center Pole for Wagon Door, Threshing Floor, Mow Poles, Flitch, Shingle and Thatch.

Strut and *column* are John Fitchen terms for Dutch barn parts. *Trimmers* are parts of the framing for a Dutch jambless fireplace hood. Trimmers are used also in the cellar and joined to the hearth beam. They contain the masonry of the hearth and support the floor boards. *Lap dovetail* is a commonly used term in the Hudson

The Best of Times

I HAVE been going to and fro across the earth this summer, and so I recommend you take along your Membership Directory. So far this summer I have reveled in the hospitality of the Coopers, the Buckwalters, the Gakers and the extended Collins family way out there in Illinois. In turn, more than a handful of better and lesser known Guild members have found themselves on the pull-out in the Alstead office. The Quakers used to send off their mobile members with something called a Traveling Minute, a paper testifying to their good standing in the Meeting, opening the door to all manner of potlucks. We have our directory. Canadian member Neville Bodsworth gleefully reports that the only way he was able to enter newly secure America this time was by pointing to his very own name in the Guild Membership Directory: incontrovertible proof of his good character!

Stick to the two-lanes and the mundane good that comes from reading local newspapers, flirting with slow-food waitresses and asking for directions even when you don't need them. I have written elsewhere regarding the pleasures of the communities we find ourselves part of. Most of the folks we brush up against are connected by accidents of proximity. Our Guild *gestalt* adheres by virtue of common purpose. Whether it is the purpose of community service, of becoming a more accomplished timber framer or simply a brief respite from what passes for normal life out there, what we have to offer each other is remarkable. We have proven adept at creating communities whose stories and accomplishments may outlast us all. (On the other hand, in one case, the destroyed Rindge Pavilion, we have already outlasted the thing we built.) These communities are temporary (and occasionally intemperate!) in their creation, but permanent in spirit. Memory, says Magliozzi, is the only paradise from which man cannot be driven.

I am between events, having just returned from a remarkable week with various Guild members, the five resolute Heartwood apprentices and an extraordinary collection of more than 150 Mohawked, multiply pierced, tattooed, charming and determined high school students (and alums) at The Mountain School in Vershire, Vermont. It was the best of times. We will never be the same. It all worked so well that I kept waiting for the other shoe to fall. I fully expected someone to sprint across the site shouting "We can't find Bent Five!" or to discover that half of the rafters were an inch short. (You might wonder how I came to think along those particular lines.) In the end, disaster was not averted; it just never turned up. There were two "special" braces, which we tried very hard to reverse during the raising, but those young student eyes were too sharp for that. All of this was accomplished practically underwater (we were driven from the frame at least once each day by rain and storm), in the midst of a festival of accomplishment (including the Barn-O-Meter in the dining hall, which measured progress over the past year). Most of the timber, and most of the excellent food, came from the school's pastoral organic farming operation, which we were there to augment by means of this 56x56 barn. In the end, it all came down to singing, speeches, tears and a barn dance. Thus Robert Frost, in "Two Tramps in Mud Time":

*But yield who will to their separation,
My object in living is to unite
My avocation and my vocation
As my two eyes make one in sight.
Only where love and need are one,
And the work is play for mortal stakes,
Is the deed ever really done
For Heaven and the future's sakes.*

—JOEL MCCARTY

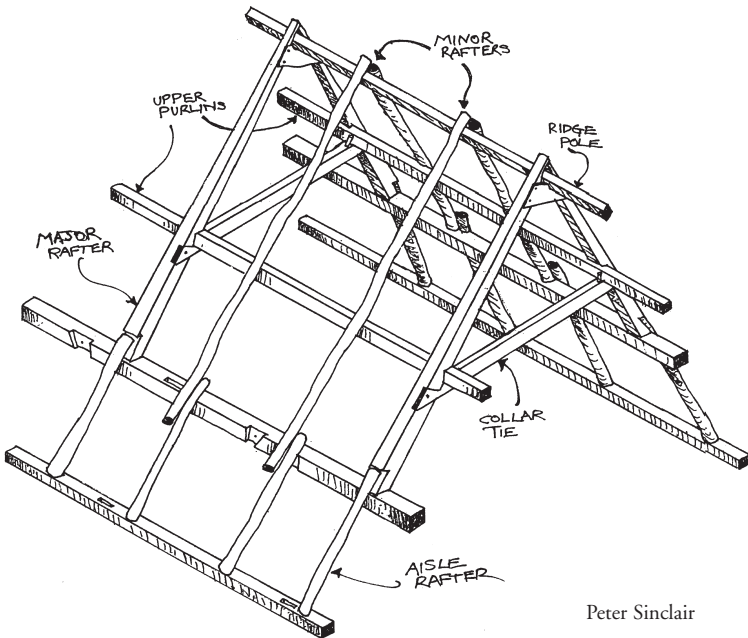

Peter Sinclair

Major-Minor rafter roof system in a New World Dutch barn.

Valley. *Diminished haunch* is used here to describe the angled shoulder seen on the layout face of a scribe rule frame. Perhaps it should be called a *diminished shoulder*. A simple drawing would help here. *Principal rafters* and *principal purlins* are parts of English rafter systems. I think that principal rafters [properly defined] are triangulated with a tie beam as in the English and German traditions. The Dutch tend to depend on collar ties. I believe that the contribution of New World Dutch timber framing to the development of American timber framing is overlooked; people interested in the latter subject tend to have a New England view. The definition of *verdiepingh* is simply "story," but we who have adopted it have confined it to mean the column length above the anchorbeam. We should properly say, *verdiepingh above the beam*. *Bent* is a Dutch word that indicates the concept might have origins in Holland.

The term *major-minor* has been used for quite some time to describe this New World Dutch rafter system. It differs from the English in that there is no [base] tie beam that triangulates the rafters. A four-sided ridge beam, known as the *noekhout* in Holland, is part of this system. The upper purlin is supported by collars on the major rafters and in turn supports the minor rafters. I think it is a system associated with thatch, like the major-minor rafter system of the hay barrack.

The major rafters are not necessarily placed on a bent as is normal for English principal rafters. A characteristic of much Dutch framing is the placement of rafters on a spacing independent of the posts and columns. I like the major-minor rafter definition because it describes a tradition that is not English. Its roots and Old World terminology can best be seen in the book *Historische houtconstructies in Nederland*, by G. Berends, 1996 [reviewed in TF 43].

PETER SINCLAIR

Hudson Valley Vernacular Architecture
West Hurley, NY 12491-0202,

hvvernar@netstep.net

June 20, 2003

Editor's Note. The glossary of timber framing terms published in the last issue of the journal is a work in progress, intended to be revised and enlarged at each new appearance. Its purpose is not to defeat error but to record usage and, where possible, to provide clarification. Peter Sinclair's offering of terms used by students of the New World Dutch barn is welcome. As Paul Oatman has discovered, the OED does not necessarily include specialist terms that may be limited to a certain trade, and certainly takes no responsibility for the shop-talk of American timber framers.

HISTORIC AMERICAN ROOF TRUSSES

I. Scissor Trusses

THIS article is first in a series to discuss and illustrate the form, function and joinery of American timber-framed roof trusses of the past, showing typical examples with variations. The series was developed from original research under a grant from the National Park Service and the National Center for Preservation Technology and Training. Its contents are solely the responsibility of the authors and do not represent the official position of the NPS or the NCPTT. Further articles to appear in TIMBER FRAMING will treat Kingpost Trusses and Queenpost Trusses.

She. . . devoured a Trusse of Sallet. (Thomas Tickell, 1712)

The Wooden Trusses, or rather Arches under its Roof. . . .
(C. Labelye in a description of Westminster Bridge, 1751)

A truss is a framed structure with a system of members so arranged and secured to one another that the stresses transmitted from one member to another are either axial tension or compression. (H. Parker, *Simplified Design of Structural Wood*, 1988)

IN THE English language, the word *truss* has been used since at least the 14th century to refer to a group of objects, usually agricultural products, bound firmly together. By the mid-18th century, the word is in use to describe both built-up beams and roof frames that would, by virtue of ingenious joinery and arrangement of members, span greater distances and support heavier loads than would traditional English late-medieval roof systems. These improved roof frame designs, based largely upon Italian examples found in books by Palladio and others, had been sporadically used in England since the 16th century. By the mid-19th century, the modern principles of truss behavior were articulated and, following the work of Squire Whipple, Herman Haupt and others (see Bibliography), subject to quantitative analysis.

Most vernacular wooden roof trusses constructed during the several hundred years when these principles were evolving were designed and built by framers using their experience, structural intuition and familiarity with the materials, on occasion with the assistance of a drawing in one of the many contemporary builders' guides, which often illustrated trusses for different spans. Some of the trusses, even comparatively early ones, conform tightly to strict notions of axial loading and equilibrium of forces. Others, from all periods, depart from what a modern engineer would call true truss form and reflect either the need to position members eccentrically to make room for their timber joinery or an idiosyncratic understanding of the form. The historical availability of very large dimension timber, and certain properties of timber such as its great resistance in shear perpendicular to the grain, have allowed many departures from true truss form to function successfully for hundreds of years.

Anywhere in the eastern US, the best framing in town is likely to be concealed in the attics of churches and public buildings, in the form of timber trusses commonly spanning 36 to 72 ft. in the

clear. Before 1850, the great majority of American roof trusses fit into four categories—kingpost, queenpost, scissor and raised bottom chord—and regional variations on them such as the Germanic *Liegenderstuhl* (see TF 52) in eastern Pennsylvania. The trusses were undoubtedly built by the more ambitious professional framers in a locality, whose names in most cases have been forgotten. Their material was local timber—the preferred and the available species—and it's evident from the checking and movement in the truss members as well as commentary from the period that the timber was used green. "Observe that it is best to truss girders when they are fresh sawn out," wrote Peter Nicholson in the 1837 edition (the 12th) of *The Carpenter's New Guide*. Earlier, in *The New Practical Builder* (1825), Nicholson had written:

The usual EXTERNAL FORM of a roof has two surfaces, which generally rise from opposite walls, with the same inclination. . . . To FRAME TIMBERS, so that their external surfaces shall keep this position, is the business of *trussing*; and the ingenuity of the carpenter is displayed in making the strongest roof with a given quantity of timbers. . . . No direct rule can be given for the disposition and position of supporting timbers: the best way to judge of this is, such a disposition as will make the connecting timbers as short as possible, and the angles as direct as possible. Oblique or acute angles occasion very great strains at the joints, and should therefore be avoided. One grand principle to be obtained, in every frame or roof, is, to resolve the whole frame into the least number of triangles, which must be considered as the elements of framing. Quadrilateral figures must be avoided, if possible; and this may be done by introducing a diagonal, which will resolve it into two triangles; for, without this, a four-sided figure will be moveable round its angles. Sometimes it may be necessary to resolve a quadrangular piece of framing into *four* triangles, by means of two diagonal pieces, particularly when this figure occurs in the middle of a roof.

While constructed of large wooden members, many historic trusses use original iron straps or bolts at joints where substantial tension occurs. Trussed roof systems are common; perhaps as many as 10,000 still exist in the US from before 1850. After 1850, many trusses are found fitted with more iron in the form of king or queen rods and iron shoes at the feet of principal rafters. If we extend our survey period to 1925, after which roof trusses become replaced by all-steel trusses or factory-made wood trusses with steel connectors, their number may be 20,000.

Whatever their number, historic roof trusses are little studied. Church and meetinghouse attics are dark, filled with bat droppings and noxious thermal insulation materials; they normally lack floors and they are difficult of access. But searchers who persevere are amply rewarded by the magnificence of the structure they find. Notable work was done by J. Frederick Kelly in his two-volume

Early Connecticut Meetinghouses (1948), which contains drawings of the truss forms found in 84 pre-1830 meetinghouses. David Yeomans' book *The Trussed Roof* (1992) deals primarily with English sources for American trusses but also includes New World examples, as do his articles "A Preliminary Study of 'English' Roofs in Colonial America" and "British and American Solutions to a Roofing Problem." The late Lee Nelson also devoted valuable attention to roof truss joinery in the Delaware Valley and elsewhere.

It is common today to refer to the upper and lower major elements of trusses as *top* and *bottom chords*, and to be understood. But the published builders' authorities in 18th- and 19th-century America used a more familiar terminology. Generally, in the works of Benjamin, Nicholson, Treadgold and Bell, roof frames are said to have *principal rafters* and *tie beams* rather than top and bottom chords. In the extensive papers of John Johnson, a framer of both bridges and churches in Burlington, Vermont, from the 1790s to 1840, and later the Surveyor General of the state, church trusses have beams below and rafters above. In our discussion of scissor trusses, reference to the tie beam or lower chord is complicated by the two-part nature of what in other trusses is a single member. The terms *scissor chord* and *scissor tie* will be used interchangeably to refer to one part of this distinctive assembly and, in the plural form, to refer to the complete assembly.

THE SCISSOR TRUSS. Distinct from other major truss types, the scissor has a two-member tie beam, or bottom chord, with each member bearing on a wall and restraining the principal rafter (or upper chord), then rising at an angle to cross the other rising tie and terminate near the midpoint of the opposite principal rafter. Frequently a kingpost and sometimes struts are incorporated into the truss as well. Occasionally the tie beams cross but do not reach the opposing rafters, terminating in space or in the side of a vertical strut instead. Scissor trusses were commonly used in roof framing to accommodate interior vaulting, domes and coves, or whenever the center of the ceiling beneath was designed to rise higher than the wall plates of the building. The lack of any horizontal tie beam separates the scissor truss formally from various raised bottom chord trusses that may have scissors braces or ascending bottom chord-like members. It is also distinctive because the rising members are positively joined at their crossing.

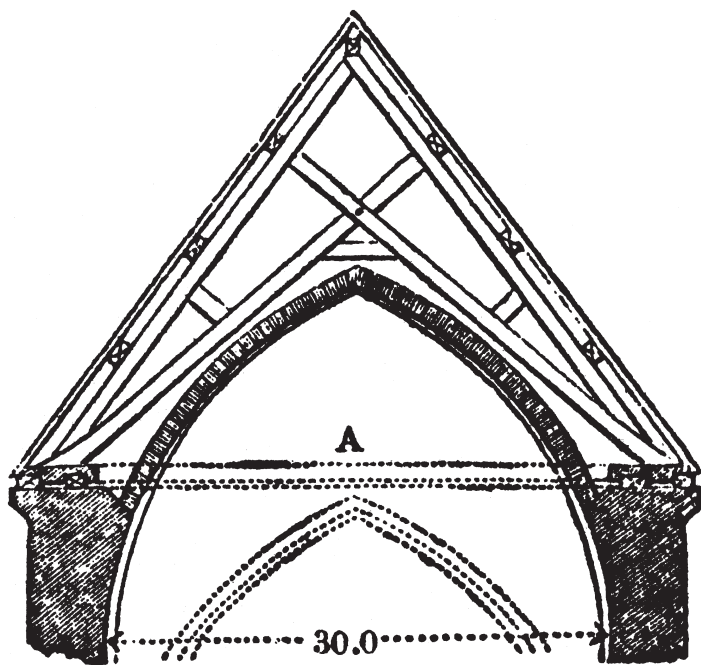

Fig. 701b.

FIG 1. GWILT'S ILLUSTRATION OF AN EARLY FORM OF SCISSOR TRUSS.



FIG. 2. SCISSOR-BRACED ROOF CROSS-FRAME, NORTHEAST TRANSEPT, LINCOLN CATHEDRAL, CA. 1200.

A great many medieval roofs were of scissor truss form. If the scissor members did not provide bearing to the principal rafters, or if they were not continuous, such roofs were, properly termed, *scissor braced*. Joseph Gwilt's 1867 *Encyclopedia of Architecture* provides a drawing of a roof frame identifiable to us as a scissor truss without kingpost, and calls it a northern French method of roofing over vaulting (Fig.1). Hewett illustrates a number of scissor-braced roofs (Fig. 2). In both sources the indicated timber sections (or scantlings) are small, typically 5x5. Scissor trusses of similar form, though with larger timber, show up again during the Gothic revival in America during the mid-19th century. A good example is in the 1876 Congregational church in Barton, Vermont, discussed below. The steep pitches and relatively narrow spans of medieval Gothic roofs avoided many of the problems of bending and pushing walls apart that heavy timber trusses are designed to solve in relatively low-pitched, wide-span structures.

Throughout most of the 18th and 19th centuries, Neoclassical designs dominated church construction in the eastern US, encouraging flatter roof pitches, commonly as low as 6:12, over wider spans of 32 to 70 ft., unsupported by aisle posts. Sometimes trusses were asked to support steeple loads and suspended galleries as well. Shallow vaults, domes and coved ceilings were in style, and scissor trusses were built to accommodate them. These trusses sustained higher bending and tensile forces than the steeply pitched Gothic forms. Consequently, strengthening members were added, different joinery incorporated and scantling sizes increased. In Kelly's 1948 study of pre-1830 Connecticut churches, some ten out of 84 roof systems were varieties of scissor trusses, and all included kingposts as well as subsidiary posts variously called queenposts, princeposts or struts.

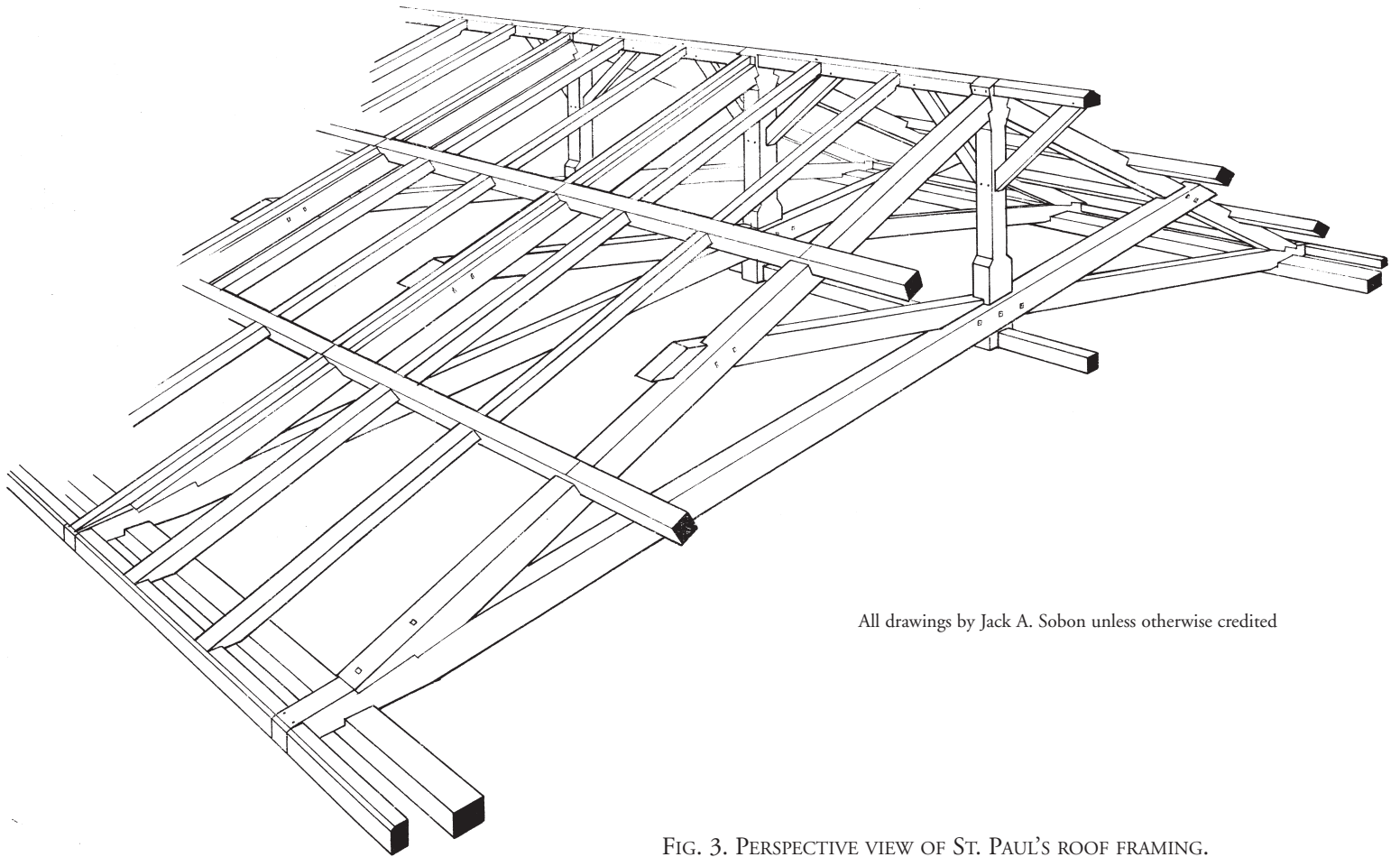

All drawings by Jack A. Sobon unless otherwise credited

FIG. 3. PERSPECTIVE VIEW OF ST. PAUL'S ROOF FRAMING.

ST. PAUL'S EPISCOPAL CHURCH (1822), Windsor, Vermont. With a span of 50 ft. and a roof pitch of 6:12, St. Paul's is a successful example of an American-style scissor truss used in a Neoclassical rather than a Gothic design. The scissor chords foot their principal rafters and join opposing principal rafters near the latter's midpoints, the whole assisted only by a single kingpost. The scantling sizes are large: the scissor ties are 7x13, the principal rafters 9x11 and the kingposts 9x12. The joinery is sophisticated and exacting, in that a great many bearing shoulders are produced and then well fastened with T-headed wrought bolts

recessed into the faces of the timber. The timber is all high-quality old-growth white pine except for the braces of mixed oak. The layout, like that of virtually all historic trusses, is scribed, but with no evidence of the use of the 24-in. mark system of fitting (see TF 24:9).

The role of the kingpost in this scissor truss is fourfold:

1. With the flat pitch of the roof and low rise of the vault, the scissor beams are long and subject to sagging because of ceiling- and self-weight, and possibly subject to compressive buckling. The kingpost, trapped and supported at the top by the principal rafters,

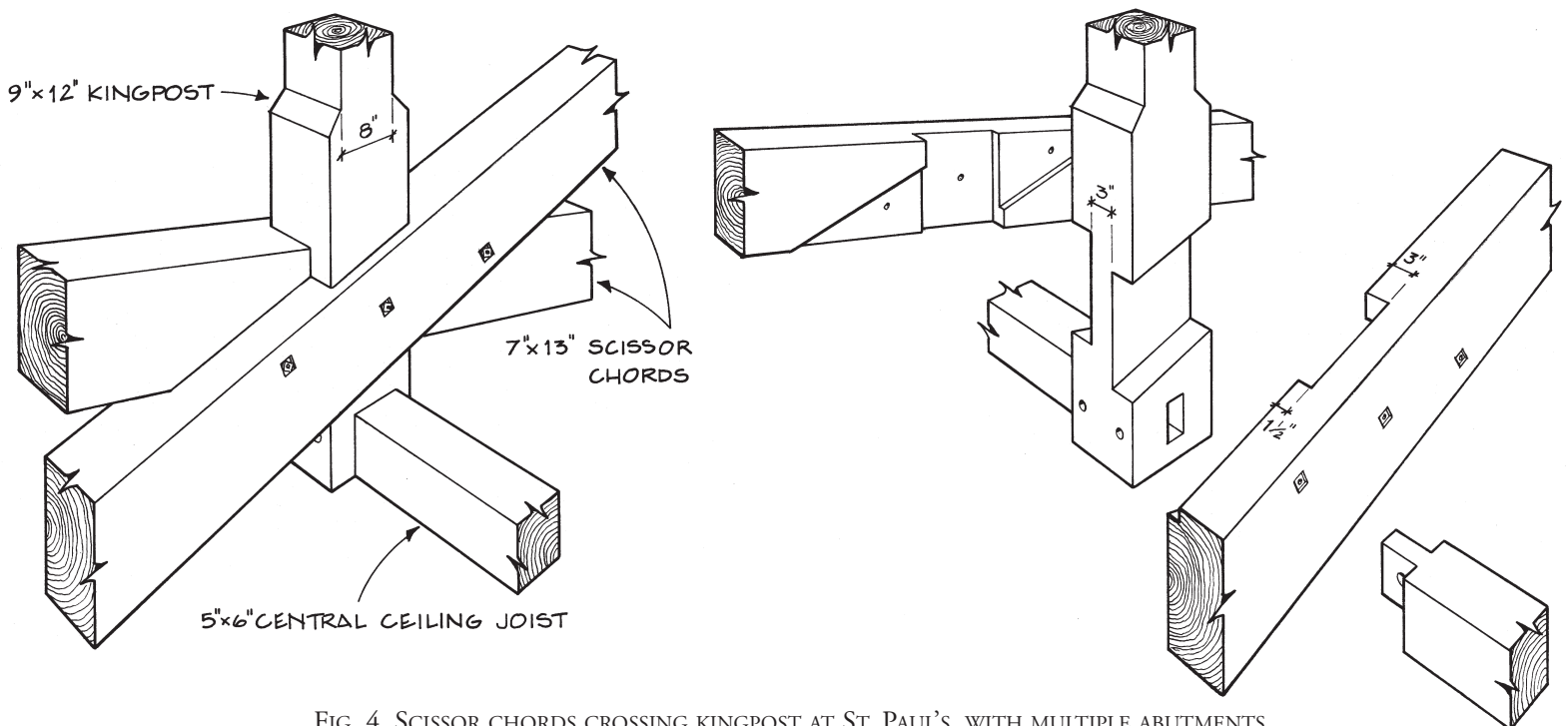

FIG. 4. SCISSOR CHORDS CROSSING KINGPOST AT ST. PAUL'S, WITH MULTIPLE ABUTMENTS.

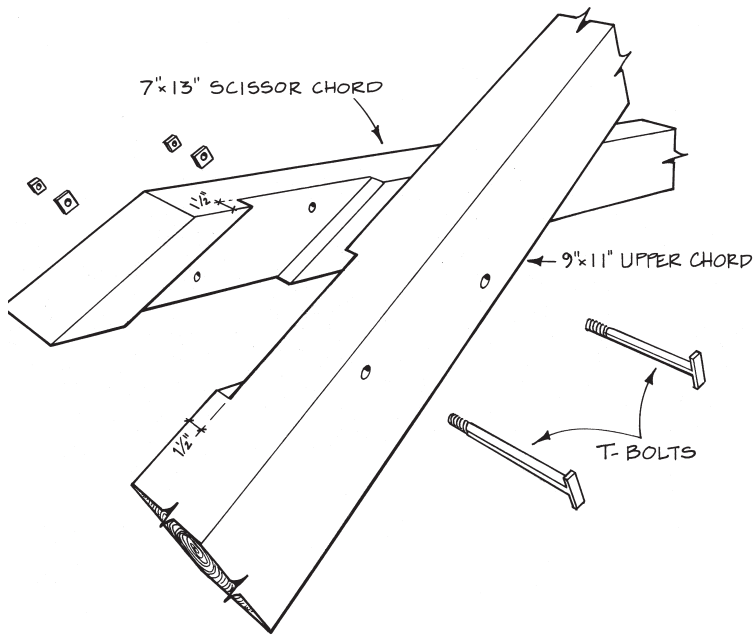

FIG. 5. CONNECTION AT UPPER END OF SCISSOR CHORD, ST. PAUL'S.

is in tension, holding up both scissor chords where it intersects them near their midpoint.

2. Since the combined scissor chords can be seen as a divided, angled tie beam or bottom chord, the joint where they cross each other is responsible for bearing the tensile loads in that tie. The addition of the kingpost at that joint provides both additional room for joinery and more bearing shoulders. At St. Paul's, the kingpost allows 12 sets of bearing shoulders to be developed around it (Fig. 4), as opposed to only four if the bottom chord members merely clasped each other in passing. It also contributes its own triangulated stiffness. In fact, the framers of St. Paul's were so eager to use the extra material the kingpost made available for joinery that they fabricated a non-planar truss—it will not lie flat on a deck—by bending the scissor beams outward slightly (or perhaps by using a natural bend) where the three members meet, in order to clasp and shoulder adequately but still leave plenty of wood in each member.

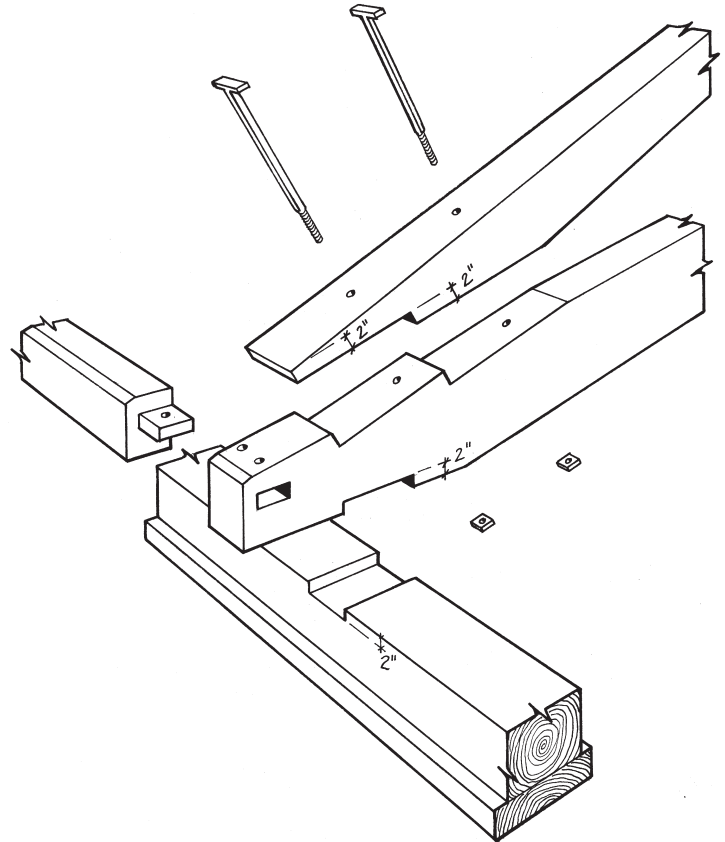

FIG. 7. EXPLODED VIEW OF PRINCIPAL RAFTER BEARING ON SCISSOR CHORD AND SCISSOR CHORD BEARING ON PLATE AT ST. PAUL'S.

The joint at the opposing rafter also may contribute to resisting tension in a lower scissor chord, but in most observed cases the joint is shallow, providing short relish on the pins (if they are there at all), and suggesting that the framer only expected compression at this joint. Asher Benjamin in *The Elements of Architecture* (1843) is specific on this point, describing the portion of a scissor beam between the rafter foot and the kingpost as being in tension, and the segment from kingpost to rafter as being in compression. The behavior of the members may well be more complex and depend upon loading conditions such as wind, snow, steeple loads and suspended galleries. Stress reversals may occur. At St. Paul's, between the upper end of the scissor beam and the principal rafter (or upper chord), the framers fabricated a semi-engaged, double-bolted and shouldered lap joint with a small amount of end relish (Fig. 5). Their intention may have been to gain additional resistance to tension in the scissor chord, or this joint may have been necessitated by the notable displacement from the truss plane of the scissor members at the kingpost, and the subsequent difficulty of bending the scissor members back into the plane of the rafters over a short distance.

3. The kingpost provides the basis for longitudinal bracing of the roof system, achieved by braces rising from the kingposts to a five-sided ridge.

4. Finally, the kingpost in St. Paul's carries a longitudinal wooden member tenoned into its bottom end that supports the center of the lath system for the plaster ceiling below. (In stone vaulting this element is called a ridge rib.)

The bearing of the principal rafter on the scissor chord is a double-shouldered notch normal to the rafter, affixed with two T-bolts (Figs. 6 and 7). The outermost shoulder has bearing right at the outer edge of the wall plate. Beyond this outermost shoulder, 13 in.

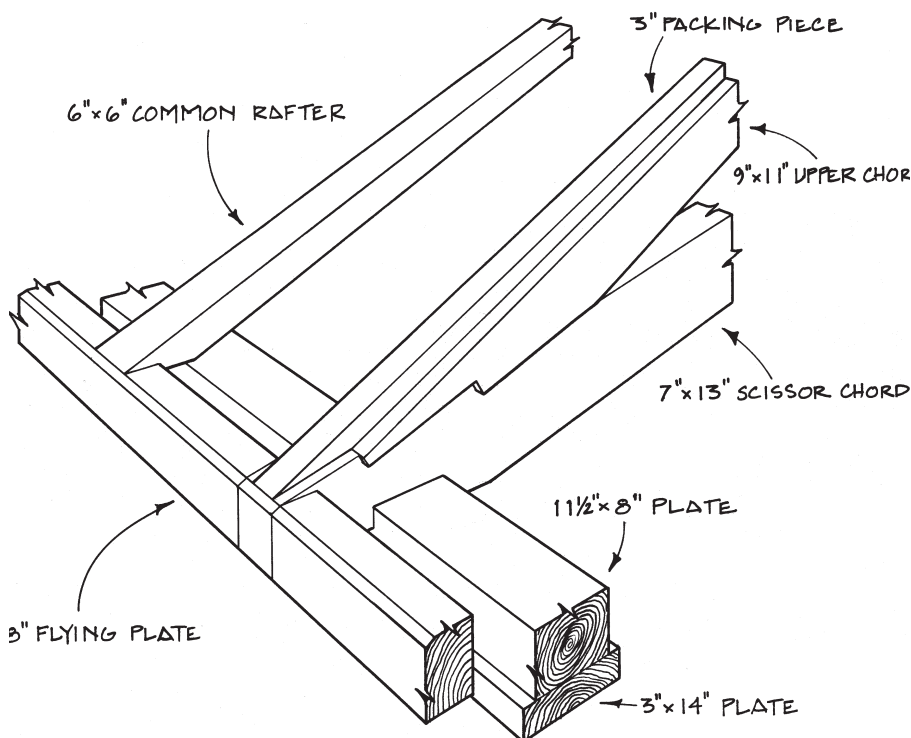

FIG. 6. ST. PAUL'S TRUSS FRAMING VIEWED AT WALL PLATE.



Ken Rower

St. Paul's Episcopal Church, Windsor, Vermont, 1822.

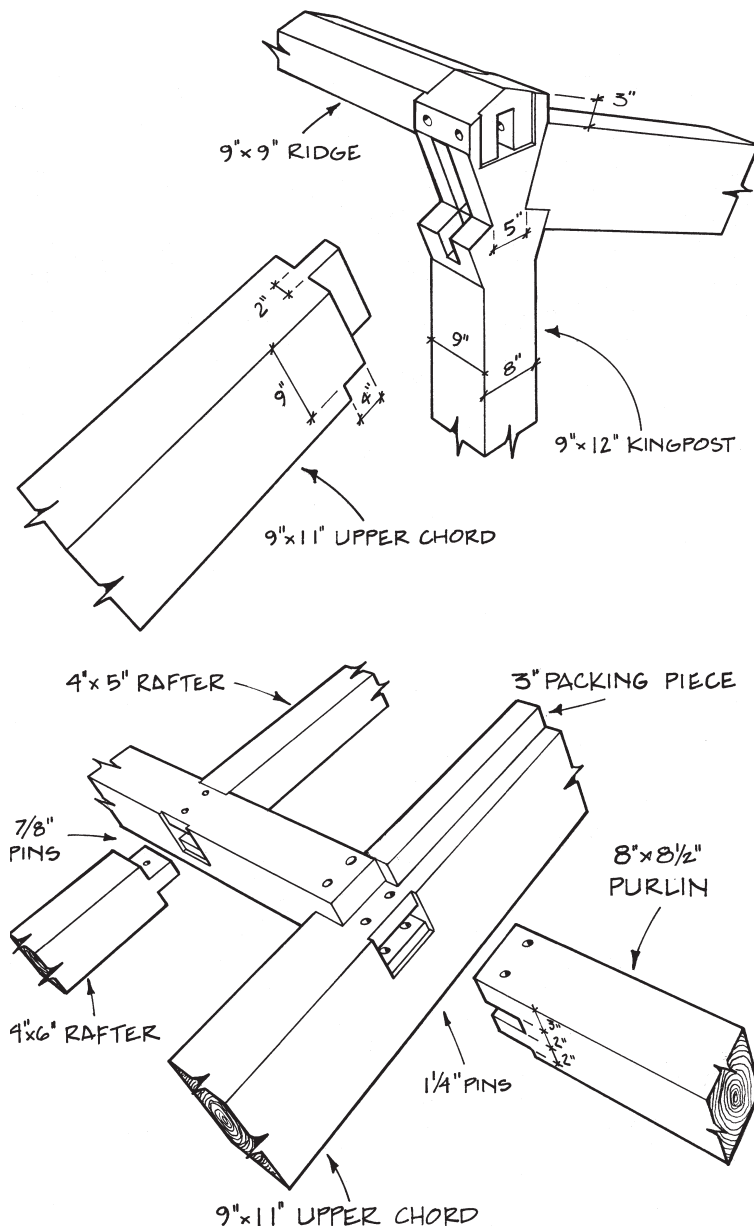

FIG. 8. KINGPOST AND PURLIN CONNECTION DETAILS, ST. PAUL'S.

of relish form an eave overhang, including a flying plate tenoned and pinned. Substantial relish beyond the bearing shoulder serves two purposes: one is the provision of adequate end distance for the joint, and the second, particularly important in cold and snowy parts of the country, is the location of joinery well inward from the eaves, which are very subject to leakage and deterioration from ice damming. Lowering the top of the principal rafter 3 in. below the top of the common rafter and purlin plane accomplishes this inward movement, and also favorably allows the purlins to bear partly on top of the principal rafter (Fig. 8).

Each scissor chord is notched over the 11½ x 8 wall plate, itself notched 2 in. deep to receive the chord. This plate sits upon a 3x14 plank covering most of the top of the brick wall. It is impossible to determine in its assembled condition how well this lower plate is affixed to the brickwork, but it is clear that the upper plate is meant to float atop the lower, attached with only a few nails. This is probably designed to accommodate the tendency of a scissor, or any truss with a raised or discontinuous bottom chord, to spread apart some distance when first erected.

The first interior scissor truss at St. Paul's stands under the rear of the telescoping framing that carries a two-stage belfry and cupola. The designer or framer was aware of the deflection these loads were likely to cause in any truss so located, particularly a scissor truss. Intermediate posts were thus erected off the top of the vestibule wall that crosses under the middle of the belfry frame, and braced girts and steeply angled braces were framed from these vestibule posts into the rear belfry posts over the truss, so as to transfer most of this rear steeple load forward and to the ground through the vestibule wall, with apparent success.

The St. Paul trusses stand 9 ft. 6 in. on center, linked longitudinally by a 9x9 five-sided ridge and its oak braces mortised into each kingpost head, the ridge rib mortised into each kingpost extension at the center of the vault and, finally, by the 8x8½ purlins (Figs. 3 and 8). There are three rows of purlins including the eaves purlin (or flying plate), and three sets of common rafters. Reflecting their load, the upper common rafters are 4x5 in section, the middle commons are 4x6 in section and the lower are 6x6, while their lengths are nearly identical. Such refined reflection of load in timber sizing is more typically a trait of older scribe rule framing (before 1800)—which, often following the natural lines of the material, used non-uniform sections, tapered rafters, flared posts, and the like—than of 19th-century industrialized framing, which tended toward repetitive member sections, modularity, uniformity of section along a length and a very simplified lumber list, in spite of an increasing ability by builders to analyze frame loads quantitatively.

St. Paul's of Windsor, seen in the photo above at left, was designed by Alexander Parris, and the roof was possibly framed by Solomon Willard, with whom Parris is known to have worked in Boston. Parris is associated with Asher Benjamin and Ammi Young as the best-known designer-builders of the transitional period from the Federal style to the Greek Revival style in New England. Elements of both styles appear in the photograph. It is not known whether the roof truss was designed by Parris or Willard or by a skilled local framer, but Parris did apprentice from 1799-1801 with a housewright, and it was common at the time for architects (or at least those who owned books) to design the framed truss if one was called for by the nature of the building.

THE FIRST PARISH FEDERATED CHURCH (1826) in South Berwick, Maine, shown in the photo on the facing page, is 47 ft. wide by 68 ft. long; its scissor trusses (Fig. 9) span 45 ft. in the clear over the audience room. (This last term, found in Kelly, will be more inclusive for our purposes than the modern "sanctuary" or the Gothic "nave.") The trusses include

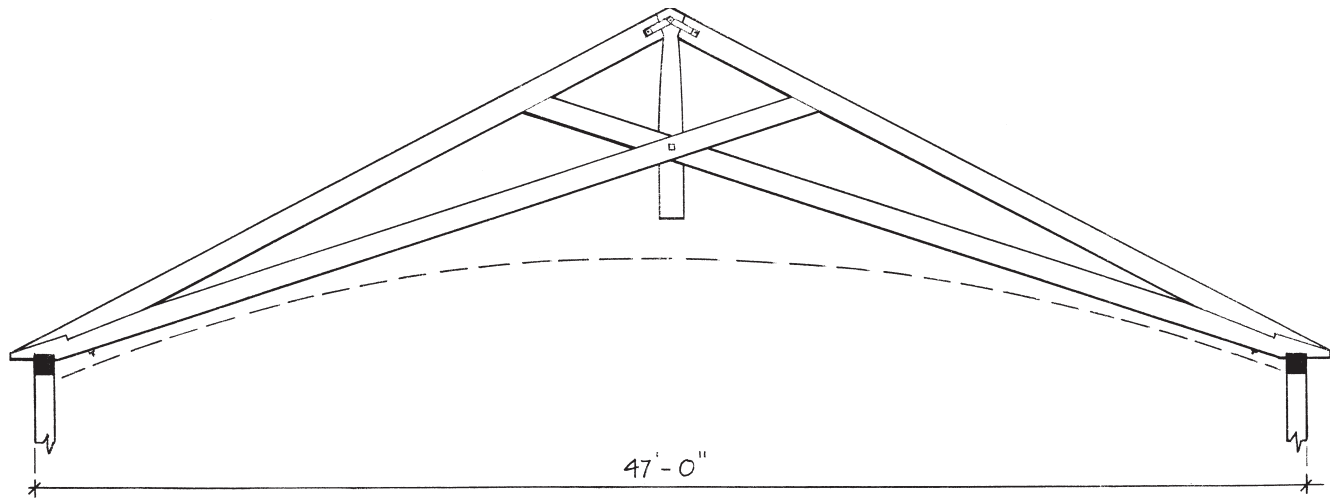

FIGURE 9. ELEVATION OF SCISSOR TRUSS AT FIRST PARISH FEDERATED.



Ken Rower

First Parish Federated Church, South Berwick, Maine, 1826.

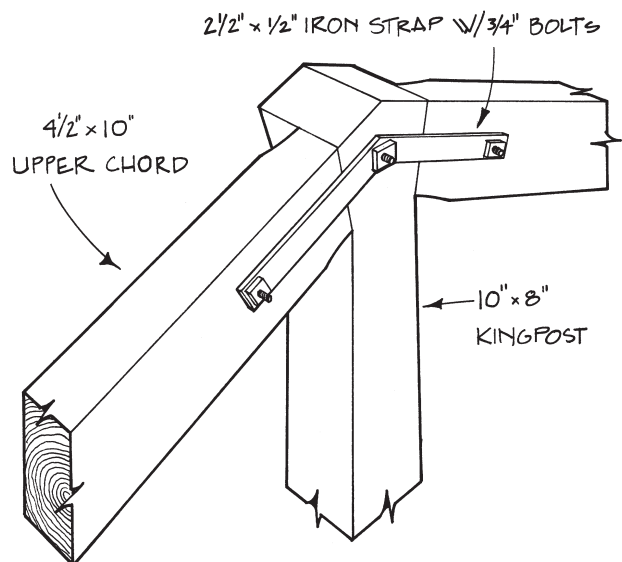

FIGURE 10. STRAPPED KINGPOST JOINT, FIRST PARISH FEDERATED.

kingposts and are closely spaced, 2 ft. 11 in. on center, producing a remarkable count of 19 trusses. Close spacing reduces scantling sizes and eliminates the need for purlins or common rafters (see “The Close Spacing of Trusses” in TF 67). The timber is all softwood, a mixture of Eastern white pine and Eastern hemlock; the roof pitch is 6.3:12. The $4\frac{1}{2} \times 10$ rafter and scissor chord material is hewn three sides and sawn one side, indicating that baulks were hewn approximately 10×10 and then sawn down the middle to make two timbers. An iron strap with three bolts spans the face of the mortise and tenon joints between the kingpost and the principal rafters (Fig. 10), probably an attempt to compensate for the less-than-right-angle bearing of the rafters at the kingpost head.

Many historic trusses in this country depart farther yet from normality to the rafter axis at the kingpost joint, without any resulting displacement at the joint. (A good example is the kingpost truss at the 1760 Christ Church in Shrewsbury, N.J.) This stability may be due to the rafter’s hard end grain compressing into the kingpost’s softer side grain at the joint and so developing adequate friction, along with a little help from the stub tenon—although relish between the end of the rafter mortise and the top of the kingpost is generally so short that it alone could bear little load.

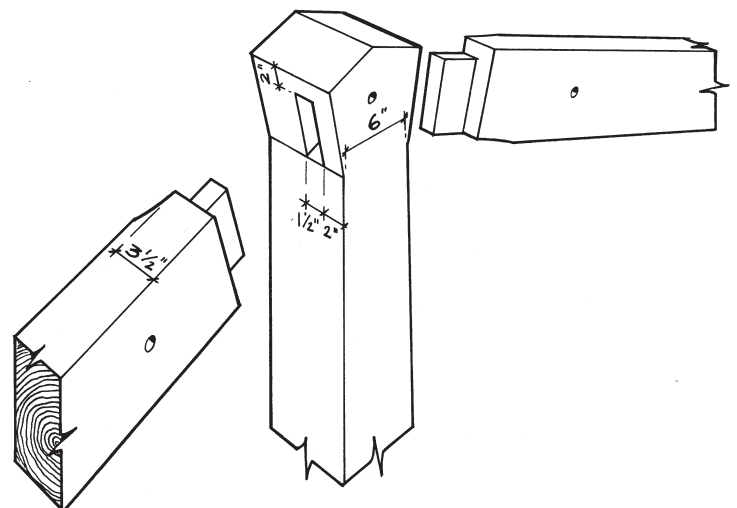

FIGURE 11. AT FIRST PARISH, PRINCIPAL RAFTERS ARE HELD TO FRONT FACE OF KINGPOST RATHER THAN CENTERED, AND INNER TENON SHOULDERS ARE HEWN AWAY.

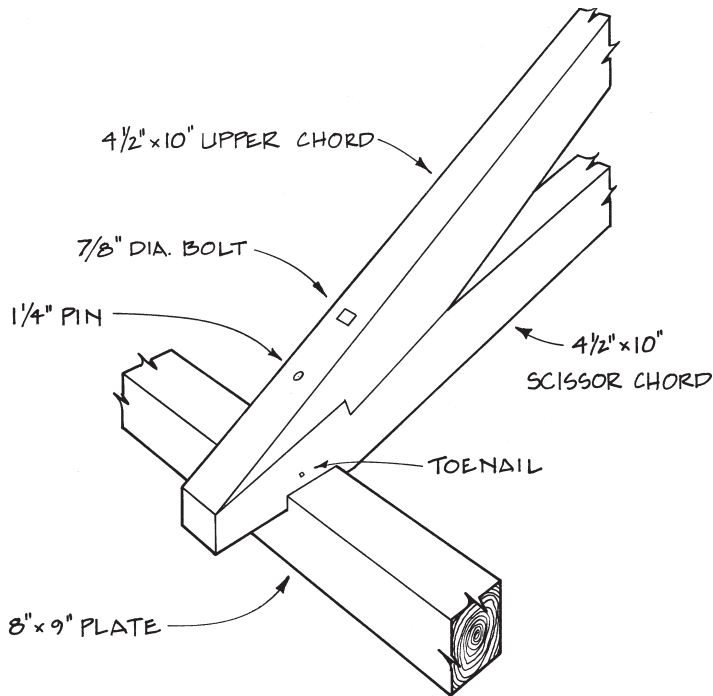

FIGURE 12. RAFTER FOOT AND SCISSOR CHORD TERMINATION AT PLATE, FIRST PARISH FEDERATED.

At First Parish Federated, $4\frac{1}{2} \times 9\frac{1}{2}$ scissor tie beams sit upon the wall plate and $4\frac{1}{2} \times 9\frac{1}{2}$ principal rafters bear upon them with a single shoulder, normal to the rafter, assisted by a $1\frac{1}{4}$ -in. pin and a $\frac{7}{8}$ -in. bolt (Fig. 12). The scissor ties cross and clasp each other at the kingpost and then continue on to join via barefaced tenons the bottom surfaces of the opposing principal rafters, above the latter's midpoint (Fig. 15). The mortise and tenon joint at the rafter is unpinned, designed only to work in compression, but, when examined, it was slightly withdrawn on most trusses, indicating that, if compression occurs, it is sporadic.

The 8-in.-thick kingposts are shaped with a form of entasis: at 10 in. wide for the lower two-fifths of their length, they curve in gracefully to 6 in. at the neck below the rafters, then return to 10 in. wide across the flared head. The scissor ties half-lap into each

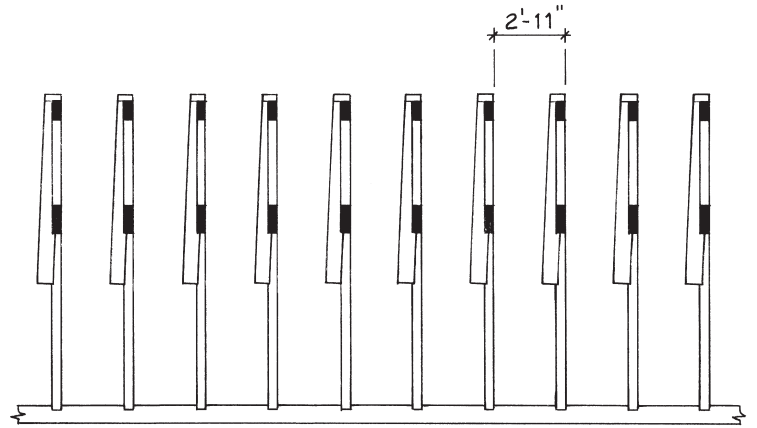

FIGURE 14. KINGPOSTS AT FIRST PARISH ARE FORCED OUT OF PLUMB BY CROSSING OF SCISSOR CHORDS.

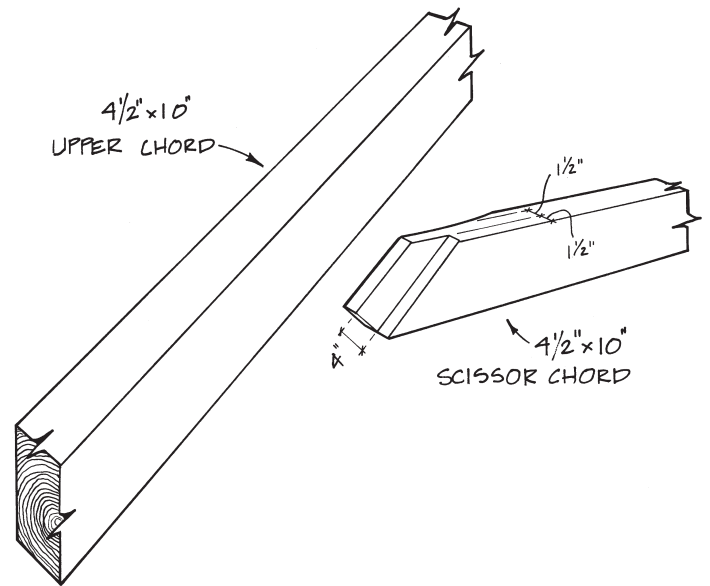

FIGURE 15. EXPLODED VIEW OF SCISSOR CHORD TO UPPER CHORD (PRINCIPAL RAFTER) CONNECTION, FIRST PARISH FEDERATED.

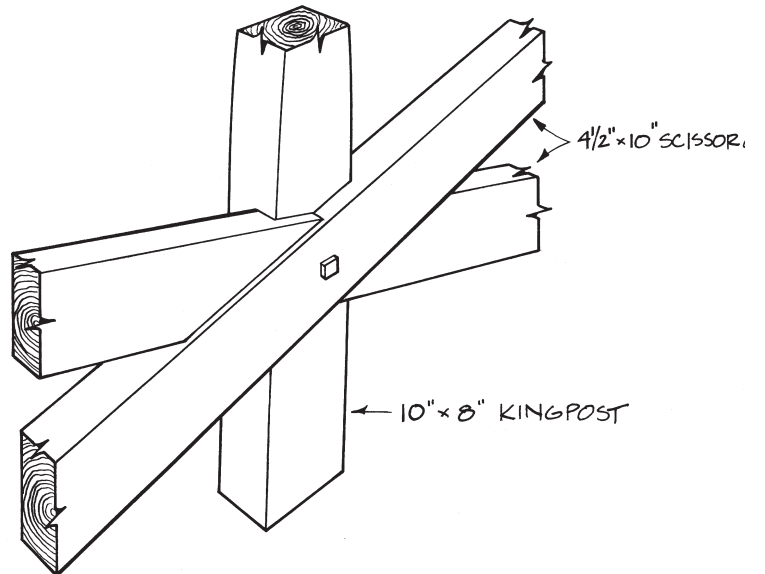
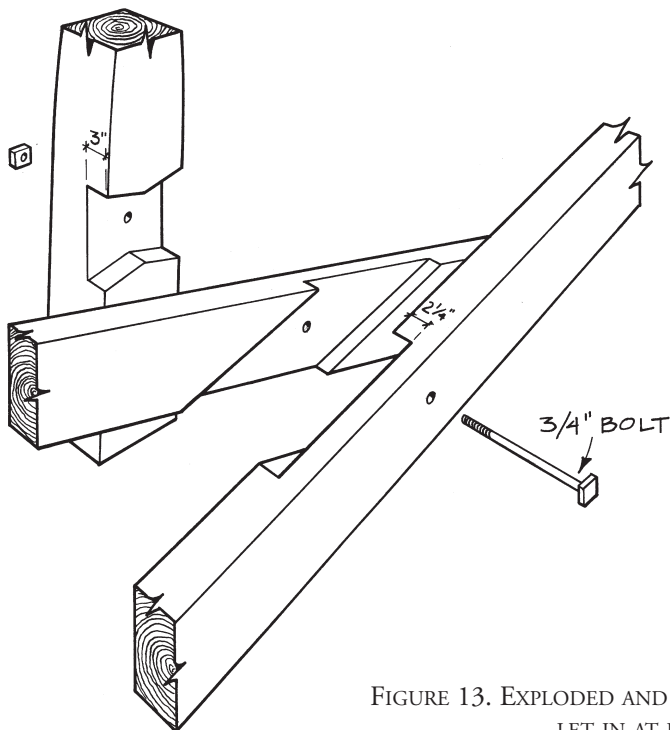

FIGURE 13. EXPLODED AND ASSEMBLED VIEWS OF SCISSOR CHORDS CROSSING AND LET IN AT KINGPOST, FIRST PARISH FEDERATED.

other at their crossing and bear on a kingpost shoulder there, but (unlike the truss at St. Paul's) do not clasp the kingpost, although the three members are all transixed by a $\frac{3}{4}$ -in. bolt (Fig. 13). The geometry of this arrangement is such that the kingposts do not hang plumb but slope a few degrees to the rear of the rafter-tie beam vertical plane (Fig. 14). Again we have a non-planar truss (but at St. Paul's the rafters depart from plumb rather than the kingposts). Additional eccentricities at the South Berwick church are the greater thickness of the kingpost compared to the principal rafters, the setting of the principal rafters to the front face of the kingposts (presumably to minimize the distortion in the truss) rather than to the customary center (Fig. 11), and the adzed reduction of the rear shoulder of the principal rafter at this joint. The resulting barefaced tenon has substantially less compressive bearing than a two-shouldered tenon.

The trusses are seated in a trench on the 8x9 wall plate. The scissor chord does not notch over the plate, but is affixed to it by a $\frac{1}{4}$ -in. hardwood pin and two small toenails (Figs. 12 and 16). This arrangement suggests that the trusses were erected and allowed to find an equilibrium within themselves while spreading a bit, unrestrained by any notch. Once the trusses settled, the toenails likely stabilized them while the $\frac{1}{4}$ -in. hole for the pin was bored. St. Paul's of Windsor also has provision for some spreading of the scissor truss—always preferable, of course, to the trusses pushing the walls out of plumb.

The only visible signs of a layout system at Berwick are Roman numerals on each kingpost, slightly above the scissor crossing, suggestive of the scribe method that persisted in bridge and roof truss framing long after it had been abandoned for other sorts of frames.

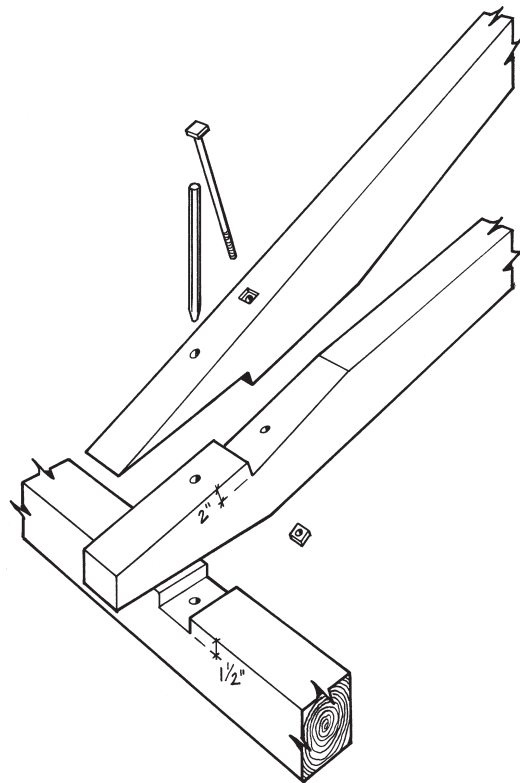
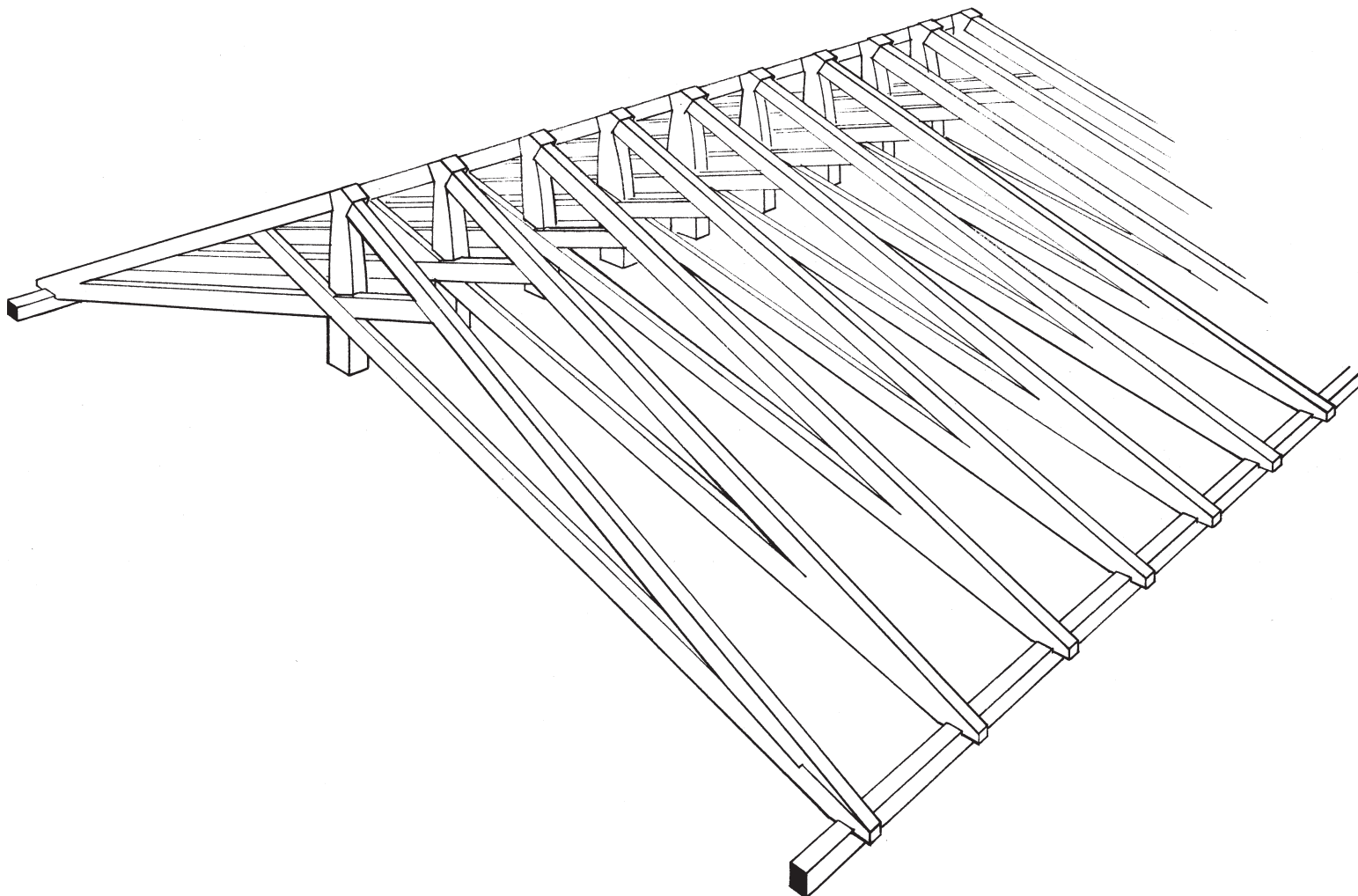

FIGURE 16. EXPLODED VIEW OF RAFTER AND SCISSOR TIE AT PLATE, FIRST PARISH FEDERATED. TRUSS WAS FREE TO SETTLE AND SPREAD BEFORE BEING PINNED TO PLATE.



Perspective view of closely spaced trusses at First Parish Federated.

THE BARTON CONGREGATIONAL CHURCH (1876), Barton, Vermont. The scissor trusses in this northern Vermont church more closely approximate medieval Gothic scissor roof frames than do the earlier, Neoclassical-designed examples in Windsor and South Berwick. The Barton church, shown at right, has Gothic features such as asymmetrical front towers, a Gothic pinnacle at the apex of the front gable and, most important, a 12:12 roof pitch. (However, most of the door, window and exterior finish detailing is Italianate.) The main body of the church measures 42 ft. 8 in. wide by 68 ft. long, and the interior of the audience room is ceiled with a three-sided vault spanned by four decoratively cased trusses. These polychrome ceiling trusses have a raised bottom chord, queenposts of a sort and straight arch-bracing members rising from brackets attached to the wall posts. The apparent principal rafters of these visible decorative trusses, rising at a 6:12 pitch, are actually the bottom chords of the scissor trusses that support the high roof of the church, and they emerge in the attic uncased, to cross each other and rise to join the principal roof rafters. The cased arch braces may also conceal a structural wall brace rising to these ties, but the remainder of the truss visible from below is non-structural.

There are four trusses in the attic, on 14-ft. centers, with principal rafters 7x11 rising at a 12:12 pitch. These bear upon the 7x11 scissor chords with a double-shouldered joint transfixed by two 1/16-in. bolts (Fig. 18). The outer 2-in. vertical shoulder is developed over a very short horizontal distance, 6 in., and is thus vulnerable to horizontal shear failure. However, examination of the joints shows only massive compression from this large and heavy roof. The junction of the principal rafters and tie beams begins inboard of the wall plate, but the outer bearing shoulder ends up right over it. The joined truss members continue beyond the plate into the cornice where they dead-end in space, not forming the basis of any cornice framing. All the timber is very high quality Eastern spruce.

The principal rafters are simply mitered at their apex and support a 1 1/4-in.-dia. king rod that drops between them to support the scissor ties at their crossing several feet below. The scissor ties are tenoned into the principal rafters and affixed with two 7/8-in.-dia. turned white ash pins. Because of the high vaulting inside, the scissor ties intersect the principal rafters far above their midpoint,



Ken Rower

Barton Congregational Church, Barton, Vermont, 1876. Italianate finish and trim enclose a decorated Gothic interior, below. The cased rafters at the ceiling enclose the scissor chords of the roof truss.

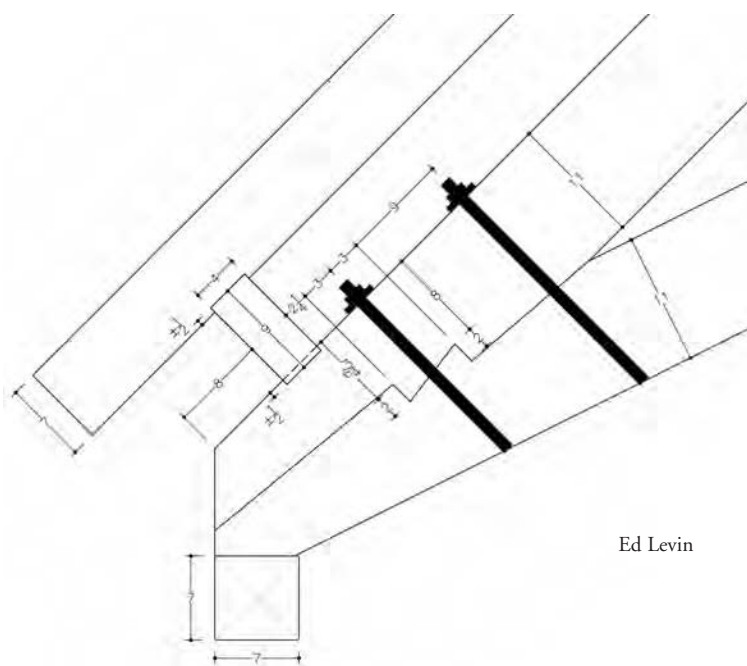
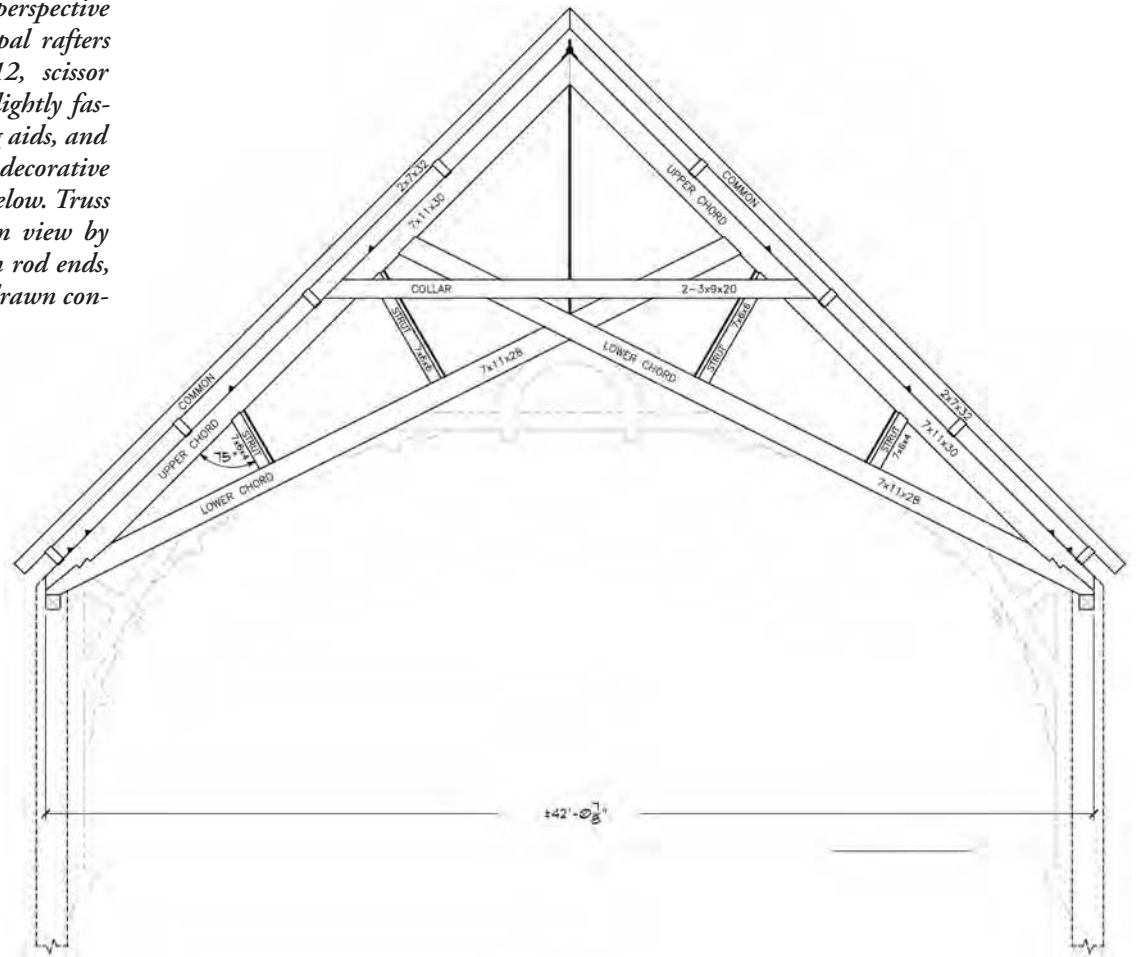

FIGURE 18. DOUBLE-SHOULDERED, DOUBLE-BOLTED JOINT BETWEEN PRINCIPAL RAFTER AND SCISSOR CHORD, BARTON CONGREGATIONAL. TERMINATION SHOWN AT PLATE IS CONJECTURAL.



Jan Lewandoski

Scissor truss elevation and interior perspective view, Barton Congregational. Principal rafters (upper chords) are pitched at 12:12, scissor (lower) chords at 6:12. The collars, lightly fastened, appear to have served as raising aids, and were left in place. Light lines indicate decorative framing visible from audience room below. Truss terminations at plate, concealed from view by purlins in the attic, and lower tension rod ends, concealed by interior finish, are here drawn conjecturally.



Ed Levin

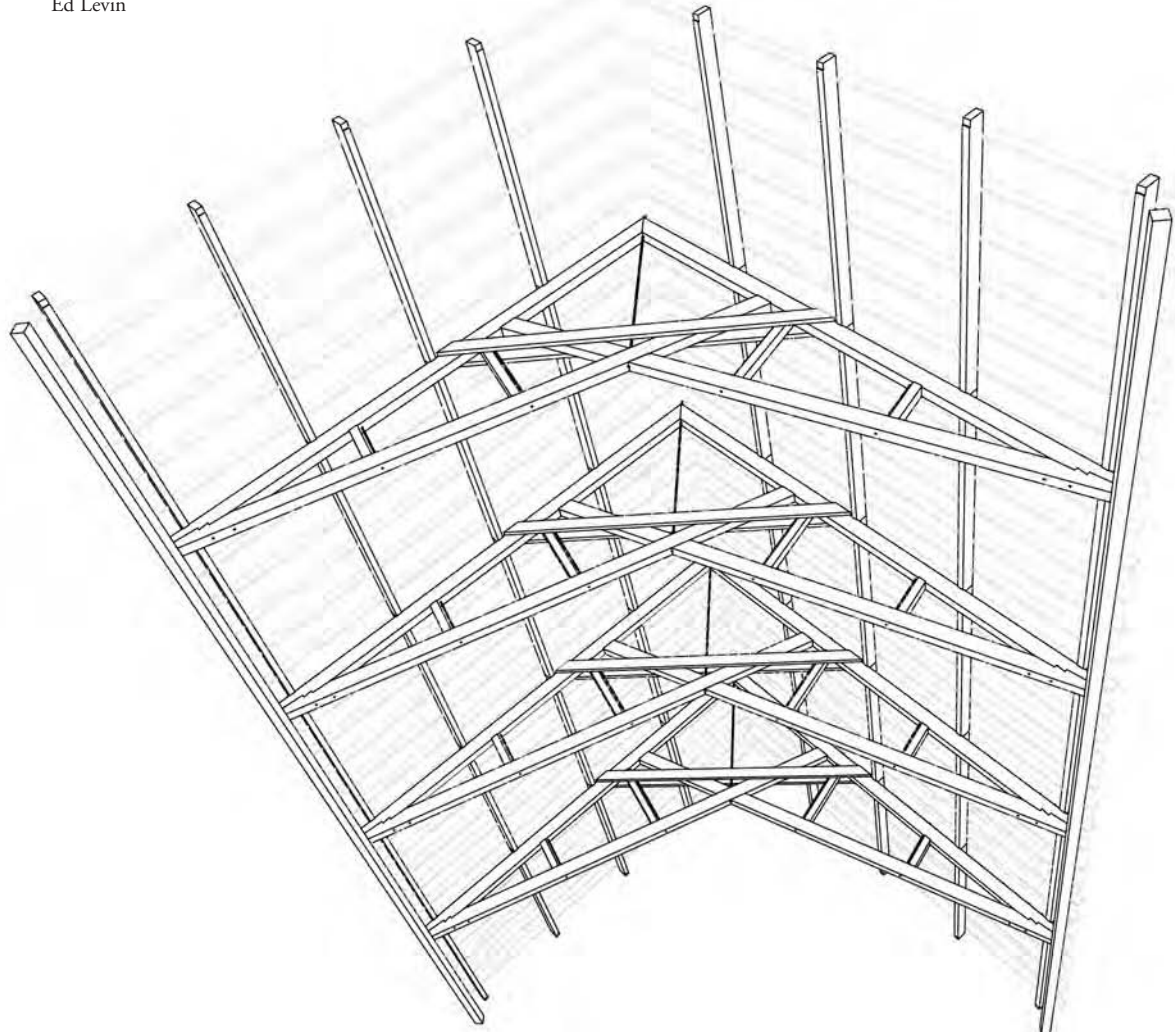



Jan Lewandoski

Researchers E. Levin and K. Rower (as Diogenes) in the attic of the Barton Congregational Church. Spruce scissor chord rises to meet principal rafter just above Levin's left hand. Untenoned strut combined with iron rod visible at lower left. Pair of 3x9 planks flanking strut and scissor chord appear to have been raising aids.

leaving long lengths of unsupported rafter below this point. To help reduce bending in these long spans, struts paralleled by 1-in.-dia. iron rods rise from the top surface of the scissor ties to the bottom surface of the principal rafters at two other points. These struts are let into gains but are not tenoned into the truss members. While the upper ends of the scissor ties are compressed heavily into their mortise shoulders in the principal rafters, the top ends of the struts show greater or lesser openings (one being quite detached), suggesting that tension outward, or sagging of the scissor ties, has produced greater displacement in the truss than any compressive weight of the roof. (It would be instructive, however, to examine this truss under heavy wind loading to see if the rafters compress on the lower struts. Snow loading may not be a problem because of the steep pitch.)

At their crossing, the scissor tie beams half-lap and clasp one another in the plane of the truss. The kingrod, which allows a truly planar truss, helps the bottom chords resist bending, especially where the chords are reduced by joinery; but, unlike Windsor's kingpost, it cannot increase stiffness by adding shoulders or triangulations. Examination of the crossing joint shows that the ties are

uniformly compressing one another's top shoulders, leaving a $\frac{3}{8}$ -in. opening at the bottom, which reflects either compression above or shrinkage, or both. This condition of the joint is consistent with some spreading in tension under load.

The four trusses and the untrussed gables at Barton carry four lines of bolted 4x9 purlins, with 2x7 rafters on 30-in. centers set above them. Shallow trenches in the lower edges of both rafters and purlins locate them on their supports. Viewed from the outside, the roof plane is flat and regular, without telltale bumps or openings of the cornice at truss locations, indicating a uniform, successful functioning of the roof system in spite of the long span between trusses. There is exterior evidence of slight outward buckling of the wall posts, suggesting that the cased arch bracing that rises to the scissor ties in the audience room of the church is structural and is transmitting roof loads to the wall posts, which might be too small to easily resist them.

The tendency of timber framers to imitate medieval roof systems originally designed to be restrained by massive masonry constructions, and to build them instead over relatively light timber-walled structures, began at least with the Gothic revival and continues today. In recognition of the resulting problems, 19th-century English Gothic style wooden churches sometimes included brick-founded wooden buttresses added to the exterior of every wall post. At St. Andrew's (1869) in St. Johnsbury, Vermont, which has such an arrangement, a large floor beam continues from within the church out onto the buttress base to receive a mortised timber brace at its outer end that rises at a steep angle to help the wall post support horizontal loads. The connection is made at two-thirds of wall height. St. Luke's (1870) in Chester, Vermont, has wooden buttresses, but they are empty inside. The aisled, untrussed roof system needed restraint by tie rods in the late 20th century.

—JAN LEWANDOSKI

Jan Lewandoski of Restoration and Traditional Building in Stannard, Vermont (janlrt@sover.net), has examined hundreds of church attics and steeples. As co-investigators for the historic truss series, Ed Levin, Ken Rower and Jack Sobon contributed research to this article.

Bibliography

- Bell, W. *The Art and Science of Carpentry Made Easy*, Phila., 1891.
 Benjamin, Asher. *The Elements of Architecture*, Boston, 1843.
 — *The Architect or Practical House Carpenter*, Boston, 1839.
 — *The American Builder's Companion*, Boston, 1827.
 Gwilt, Joseph. *The Encyclopedia of Architecture*, London, 1867.
 Haupt, Herman. *General Theory of Bridge Construction*, N.Y., 1856.
 Hewett, Cecil. *English Historic Carpentry*, Chichester, Phillimore & Co., 1980; reprinted by Linden Publishing, Fresno, Calif., 1997.
 Johnson, John. *Papers 1795-1842*, University of Vermont Special Collections, Burlington, Vermont.
 Kelly, J.F. *Early Connecticut Meetinghouses*, N.Y., Columbia University Press, 1948.
 Lewandoski, Jan. "The Close Spacing of Trusses," *Timber Framing* 67, March 2003.
 Nelson, Lee. "Early Wooden Truss Connections vs. Wood Shrinkage," *APT Bulletin*, vol. XXVII, no. 1-2, 1996.
 Nicholson, Peter. *The Carpenter's New Guide*, Philadelphia, 1837.
 — *The New Practical Builder*, Philadelphia, 1825.
 Palladio, Andrea, *The Four Books of Architecture*, London, 1738.
 Treadgold, Thomas. *Elementary Principles of Carpentry*, Phila., 1837.
 Whipple, Squire. *An Elementary and Practical Treatise on Bridge Building*, Albany, Van Nostrand, 1873.
 Yeomans, David. *The Trussed Roof*, Aldershot, Scolar Press, 1992.
 — "A Preliminary Study of 'English' Roofs in Colonial America," *APT Bulletin*, vol. XIII, no. 4.
 — "British and American Solutions to a Roofing Problem," *Journal of the Society of Architectural Historians*, vol. L, no. 3, 1991.

Historic Scissor Truss Analysis

Some writers have given designs for . . . having the tie-beam omitted for the accommodation of an arch in the ceiling. This and all similar designs are seriously objectionable and should always be avoided; as the small height gained by the omission of the tie-beam can never compensate for the powerful lateral strains, which are exerted by the oblique position of the supports, tending to separate the walls. (R. G. Hatfield, *The American House-Carpenter*, New York, 1857.)

[The figure] exhibits an example of a roof with tie-beams so framed as to admit of finishing a curved ceiling. This practice of thus dispensing with a horizontal or single tie-beam should be used with great caution, as the work is always liable to settle. (Thomas W. Silloway, *Text-Book of Modern Carpentry*, Boston, 1858.)

AUTHORS of mid-19th-century builder's guides were not alone in holding the scissor truss in low esteem, helping to account for the relative scarcity of the truss type, and the dim regard for scissor trusses that persists to the present day. However, a close look at four proven examples of the truss type, described in summary form in the table below, may go a long way to belie the general opinion.

Truss Vital Statistics

Name	Date	Span	Truss Spacing	Pitch	Timbers	Iron Rods
St. Paul's Episcopal	1822	50'	9'-6"	6:12	5	0
First Parish Federated	1826	47'	3'	6.3:12	5	0
Trinity United Methodist	1858	62'	16'	9:12	12	12
Barton Congregational	1876	42'	14'	12:12	8	5

We inspected St. Paul's Episcopal in Windsor, Vermont; First Parish Federated in South Berwick, Maine; and Barton Congregational in Barton, Vermont. Information on Trinity United Methodist, in New Bedford, Massachusetts, was provided by David Fischetti of DCF Engineering in Cary, North Carolina.

The four roofs divide naturally by age, style and form. The churches in Windsor and South Berwick both date from the 1820s, and both are in Neoclassical style, featuring low-pitched roofs supported by elegantly simple trusses almost identical in form. The trusses comprise five timbers each: two upper chords (principal rafters), two lower chords (scissors) plus kingpost. In both buildings the framing is essentially medieval in character, with heavy timber members connected with traditional timber joinery, augmented by through bolts (plus an iron strap across the peak joint in South Berwick). Truss layout is based on traditional geometry rather than any evolved sense of statics. This geometric genesis is particularly apparent at St. Paul's, where scissors join rafters at midspan (6:12 rafter pitch, 2:12 scissor pitch), and purlins and ridge split the span into six even divisions.

In contrast to these classical antecedents, the frames in New Bedford and Barton are mid- and late-century Gothic Revival structures with steeper roofs, and a proliferation and elaboration of truss parts. Pure geometry has clearly ceded its driving role to analytical logic in the determination of truss layout. The number of elements in the truss has doubled and trebled, with the majority of pieces segregated by function (compression-only, tension-only), and iron rods substituting for timbers as tension members. There

is also a change in timber species. In the earlier trusses, Eastern white pine and hemlock serve as major members (with oak braces at Windsor), but at Barton structurally superior Eastern spruce is used throughout, and at New Bedford even stronger long-leaf Southern yellow pine (presumably imported by sea).

The Barton trusses have double 3x9 collars sandwiching the upper ends of the scissors and upper struts, but the 3x9s are only lightly nailed and seem to have served principally to stiffen the truss in plane and to restrain lodged struts during raising. The Barton struts are not tenoned or pinned but sit in simple shallow housings in the chords. Each strut is paired with a 1-in.-dia. steel rod just upslope, thus the struts act as compression-only members, the rods in tension only. In the Finite Element Analysis model described below, the coupled rods and struts are represented by single elements, and the collars are omitted.

TO sort out the workings of scissor trusses, and compare and contrast performance of the structures under review here, I built Finite Element Analysis (FEA) models of the individual trusses and examined their behavior under load as predicted by the computer models. *Minimum Design Loads for Buildings and Other Structures* (ASCE Standard 7-98) and the *National Design Specification for Wood Construction* (NDS-1997) provided load conditions and design values.

Each truss was freighted with appropriate dead load plus live load, based on 65 psf ground snow load and 90 mph wind. While this may have been a bit heavy on the snow and light on the wind for New Bedford (and vice versa for Barton), the numbers are not too far out of line with official specs, and served to level the field for meaningful comparison among the four structures.

Each truss was then subjected to 15 separate load cases. *Balanced gravity load* was the sum of timber self-weight, roof dead load, suspended ceiling dead load plus uniform snow load. *Unbalanced load* factored in the three dead load cases, plus upwind wind pressure, downwind suction, 0.3 times windward side snow load and 1.5 times leeward side snow load. To account for the transitory nature of wind and snow loads and for the probability of multiple loads combining at full strength, load combination and duration factors were applied to the balanced and unbalanced load cases. To test for possible stress reversals in parts of the truss, I also looked at dead load plus wind at up to twice normal strength, and at dead load plus wind uplift.

I drew conclusions from the frame models principally on qualitative output. Were given members in tension or compression? Was there significant bending? Deflection? Could certain load combinations be associated across the board with particular patterns of resultant behavior? Quantitative output can be used to compare behavior truss to truss, or as an indicator of order of magnitude of resultant loads and stresses. But there is no guarantee of close correlation between FEA resultants and real-world forces and stresses.

The principal advantage of the scissor truss is the inclined profile of its lower chords, which easily accommodates vaulted ceilings. The tradeoff is the acknowledged tendency for the eaves of scissor trusses to spread outward and the roof to settle (as cautioned in the epigraphs from Mssrs. Hatfield and Silloway). But how much spread and settlement can one expect?

Compare St. Paul's to a standard kingpost truss with continuous tie beam and equivalent span, pitch and load. Under dead or uni-

form live load, horizontal deflections at the eave are four times greater in the scissor truss, while vertical displacements are two and a half times higher. In quantitative terms, the 50-ft. span, 6:12 pitch kingpost truss can be expected to spread $\frac{1}{16}$ in. under dead load, $\frac{3}{16}$ in. under uniform dead plus live load, with attendant vertical deflections of $\frac{3}{16}$ in. and $\frac{1}{2}$ in. respectively. Under the same loads, the St. Paul's scissor truss spreads $\frac{9}{16}$ in. and $1\frac{5}{16}$ in. and sags $\frac{3}{4}$ in. and $2\frac{1}{16}$ in.

These numbers reflect elastic behavior of standing trusses under load, modeled using tabulated NDS elastic moduli for timbers and assigned joint stiffnesses based on available research literature. The point of the latter is that timber frame joints do not behave like pinned connections—they have give above and beyond the elasticity of the members being joined, and some accounting must be made for the joint flexibility to obtain realistic results.

And what about the initial settlement that occurs when a truss is first raised and the joints come home under load? Even the most carefully cut joinery is not perfectly snug. And, since long-span church roof trusses operate at the upper end of allowable stresses and loads for heavy timber, one might expect significant initial settlement. (For example, it's not unusual for timber bridge trusses to lose several inches of camber upon initial erection.) The only reliable indicator of initial settlement is prior experience, but we can put together an educated guess. By assigning a certain amount of slippage to each joint in the truss and then stretching and squeezing the frame in accordance with the expected tension and compression loading, we arrive at a theoretical deflected elevation representing the net effect of the expected settlement.

Once again using St. Paul's as our guinea pig, and assuming $\frac{1}{8}$ in. travel per joint, we find $1\frac{1}{8}$ in. spread at the eaves and (depending where you measure) $1\frac{3}{4}$ in. to 2 in. subsidence at midspan. Increase individual joint travel to $\frac{1}{4}$ in. and (not surprising) you double this accumulated X and Y movement. In comparison, given $\frac{1}{8}$ -in. quantum slippage in the equivalent kingpost truss (see above), we can expect a gain of half an inch horizontally and a corresponding drop in height of about 1 to $1\frac{3}{8}$ in.

With both initial settlement and ongoing deflection under load, truss behavior is governed by connections rather than members, as you might expect in a truss, by definition a structure in which axial loads predominate over bending. In addition to initial settlement and deflection under load, shrinkage of green timber also causes trusses to sag. For instance, as the width of a kingpost diminishes, the abutting rafters squeeze in and down at the peak. Similar effects are felt at other major intersections. The resulting subsidence was well known to 19th-century carpenters, and it was standard practice to compensate by pre-cambering the truss. Indeed, established formulas were used to calculate incremental increases in member length to overcome shrinkage for given spans, truss types and timber dimensions.

Idiosyncrasies. One peculiarity of our two Neoclassical scissor trusses is that they were not built in plane. In Windsor, the scissor chords bend around the kingposts, deflecting out of plane around $1\frac{1}{2}$ -in. a third of the way along their 39-ft. length. Evidence indicates that the scissors did not have to be forced to assume this curve. Examining the stock used, it seems clear that paired scissors for a given truss were converted from a single tree. Accumulated tension towards the bark side caused the cloven halves to bow away from the heart, and the builders took advantage of the resulting curves. Under load, the predominating tension in the lower chords wants to straighten them out, but since they oppose one another on either side of the kingpost, any distorting tendency is damped out.

The asymmetry in South Berwick takes a different form. Here the chords all run true to plane (subject to minor variations in timber section) while the kingpost is tilted out of plumb, lying flush with the rafters at the peak, but skewing out of plane $1\frac{1}{2}$ -in. at the

scissor crossing 5 ft. below. No forced curves here (hardly possible in a short 8x10). In the FEA model, this apparent eccentricity imparts a twist to the truss under load, pulling the crossing and kingpost foot side-ways, resulting in significant horizontal deflection and bending stress in scissors and rafters. But the problem vanishes under closer inspection: absent the kingpost, all parts of the truss lie symmetrically along the centerline, and there is no inherent tendency to torque out of plane under load. Reinserting the central column does nothing to alter this action, the only eccentricity being that the lines of force in the kingpost do not run parallel to the grain of the piece. It seems that, at least when analyzing traditional timber framing, there is some danger in leveling a charge of eccentricity simply because centroids of intersecting members are disjunct. And, in any case, at First Parish the close spacing of the trusses and their frequent attachment to the roof and ceiling diaphragms above and below would arrest any sideways distortion.

At Barton, the decorative casework framed into the lower chords below the ceiling plane (photo page 20) may play a role. Making conjectural allowance for this in the Barton frame model, we find it seems to offer a considerable assist to the roof above, reducing force, stress and deflection in the truss. However, this contribution comes at a cost, since the load is channeled down the interior bracket at the eave, pushing out against the sidewall. Indeed, when sighting up the exterior walls at the truss locations, a modest bulge appears at the appropriate distance below the eave.

Comparison of the FEA results reveal more similarities than differences among the trusses, notwithstanding the noted characteristic variances that distinguish Windsor and Berwick from New Bedford and Barton. In all four structures, the balanced gravity load case governs (i.e., produces the most stringent test of truss members and connections). The resultant axial load pattern is similar in all four trusses: principal rafters (upper chords) in compression, kingposts in tension and scissors (lower chords) in tension below their crossing and in compression above it. This distribution of force and stress persists in almost all loadings. The only condition that provokes any stress reversal is dead plus wind load in the absence of snow. In that situation, the upper end of the downwind scissor goes into tension, but it takes wind in excess of 100 mph to do the job, and even then the stress reversal is fairly mild (tension loads $\leq 1,000$ pounds). Crank the wind speed up to 130 mph and the leeward scissor-to-rafter joint is still only looking at a ton or two of tension load.

This analysis also puts to rest concerns about uplift, since maximum wind uplift force is in every case less than opposing dead load. Lateral load due to wind poses a more difficult problem. Because of the inherent tendency of scissor trusses to push outward on supporting sidewalls, their builders often provided minimal lateral connection between truss and wall. To complicate matters for the researcher, this joinery often remains a mystery sandwiched inaccessibly in the eaves between ceiling and roof. So the best evidence of the adequacy of the arrangement may simply be the persistence of the union between roof and walls.

Given the minimalist layout of the Windsor and Berwick trusses, one feels tempted to simplify them even further by eliminating the kingposts. Don't submit to this urge! Remove the kingpost from any of the scissor truss models under consideration here and disaster ensues: the scissor crossing plummets downward, and bending stresses and deflections go off the charts. To cite a favorite example, absent the kingpost in Windsor and maximum bending stress jumps from 858 psi to 5335 psi, eave spread widens from $1\frac{11}{32}$ in. to 6 in. and midspan deflection grows from 2 in. to an astonishing 16 in.! Kingpost excision results in similar radical inflation in bending and deflection in the other three trusses (although the effects are somewhat less severe in New Bedford and Barton with their optimized truss layouts). Meanwhile, truant kingposts

actually provoke slight reductions in axial forces in truss members since more load is taken up in bending. But the lesson remains brutally clear: no scissor trusses without kingposts (or kingrods).

Predicted values of axial, shear and bending stress remain within allowable ranges in all four structures (I did not check combined bending and axial loading). Since loads are often applied eccentrically and members are continuous across joints, bending stress is not negligible, as one might expect in an ideal truss. As suggested earlier, connections rather than members are the controlling factor, so it's surprising that it isn't tension stress that governs, but rather bearing and shear.

In fact, a key to the viability of scissor trusses lies in their ingenious avoidance of tension joinery at timber ends. From early examples like Windsor and Berwick, it's clear that each scissor truss must pass four crucial joinery tests: at the roof peak and foot, and at the scissor crossing and scissor-to-rafter intersection. The kingrods in Barton develop 40,000 lbs. in tension, mandating total washer area of 130 sq. in. bearing against the upper rafter surfaces. (Similar conditions obtain in New Bedford.) Actual washer area in Barton is in the 40-60 sq. in. range, implying cross-grain pressure on the spruce rafters two to three times greater than the tabulated 400 psi. So either actual kingrod tension is significantly less than the FEA prediction or the timber can bear side-grain pressure well in excess of the allowable, or both. It's worth noting in passing that the builders in Barton and New Bedford asked and got a lot from their materials throughout—the kingrods in both cases undergo tension stress in excess of tabulated values for mild steel.

SINCE our four scissor truss peak joints are no different from those in an ordinary kingpost truss, we will ignore them here and examine the three remaining connections peculiar to scissor construction, focusing on Windsor and Barton as exemplars, respectively, of early and late scissor truss construction. In the exposition below, the following design values were used to assess stress levels: 1000 psi for bearing parallel to the grain (F_g), 400 psi for compression perpendicular to the grain ($F_{c\perp}$) and a maximum of 130 psi for shear parallel to the grain (F_v).

Scissor-to-Rafter Joint. As indicated earlier, the scissor chords shift from tension to compression above their crossing. Along with the sign reversal, the magnitude of the axial load also drops, with compressive forces in the upper scissors from a fifth to a third the values of the lower tensile loads. Predicted compression ranges from a low of 4000 pounds in Berwick up to 15,000 pounds in Windsor, and in each case ample size of the members and abundant joint area offers sufficient bearing surface to resolve these forces within allowable stress limits.

The Crossing. Three force vectors are resolved at this connection: compression loads from the opposing scissors pushing in and down, and tension load from the kingpost pulling up. Forces in the scissors at the crossing are essentially unchanged from those at their upper ends where they join the rafters and, as above, the scissor-to-kingpost-to-scissor crossing provides plenty of joinery surface. The big hit is the contribution of the kingposts and kingrods, with forces of 40,000 pounds in kingrods at Barton and New Bedford (see discussion above) and 14,500 and 21,000 pounds respectively in the 8x10 and 9x12 kingposts in Berwick and Windsor. Kingpost tension imparts bearing stress to the scissor side-grain. At First Parish, this works out to 10 percent above the allowable value, at St. Paul's, a comfortable 29 percent below the limit. The other limiting factor is shear in the kingpost abutments that support the scissor chords. At Berwick, there is an abundance of relish, over 200 sq. in. In Windsor, we seem to have close to the absolute minimum required, around 165 sq. in.

The Foot Joint. By framing the rafter over and into the scissor chord, what would otherwise be an impossible tension connection

is ingeniously transformed into a compression joint. Since all accumulated force in the scissor truss must flow through this joint, load magnitudes here are the highest in the system, and it's not surprising that this is the locus of greatest divergence between the expectations of the historic builders and modern engineering standards.

Again the issues are bearing and shear. Looking first at the former, for the three churches where we have data, the joinery is similar: the rafter is footed on the scissor, secured by one (Berwick) or two 2-in.-deep abutments (Barton and Windsor) abetted by two bolts (Berwick, one bolt and one 1¼-in. pin). Typically, available side grain bearing area is ample, at minimum 500 percent above what's needed. Not so end grain bearing. Allotting 3000 pounds per bolt or pin (a generous allowance by NDS specs) the timber joinery is left to carry considerable load: 14,200 pounds in Berwick, 37,500 at Barton and a daunting 42,300 pounds for St. Paul's. This works out to respective bearing stresses of 1580 psi, 1340 psi and 1510 psi on the abutments. Taking into account bearing at angles to the grain of the members (the angle between the incoming rafter and scissor), allowable bearing stress values range from a low of 870 psi in Barton to 885 psi in Windsor and a high of 959 psi in Berwick, putting bearing in Barton at 154 percent of capacity, Berwick at 165 percent and Windsor topping the list at 171 percent.

Let's look next at long-grain shear stress in the material backing up the abutments in the scissors. Given its lower shear load, First Parish squeaks by under the allowable at 124 psi (95 percent of capacity). In Windsor we're looking at 195 psi (150 percent) and in Barton at 211 psi (162 percent).

Have we found the Achilles heel of historic scissor trusses? I think a few words in mitigation are in order. First, a reminder that, on almost all prior counts, the trusses have stood up to scrutiny. In vetting the preceding analysis, several questions come to mind. Let's start with bolt capacity: NDS specs notwithstanding, it seems possible, even likely, that the bolts and pins securing scissor foot joints carry significantly more load than tabulated values allot to them. Second, there is the issue of the loads themselves. Given timber weight plus conservative mandates for snow and roof and ceiling dead load, our trusses are modeled as carrying 80 lbs. of load per sq. ft. of tributary area. If we could weigh the roofs, I suspect that we'd find them tipping the scales somewhere in the 40-50 psf range, perhaps 60-70 psf in the heaviest snow years. ASCE 7-98 provisions call for the trusses to bear an additional 10 percent of snow and 15 percent of wind load due to audience room capacities in excess of 300 people, plus a 20 percent snow surcharge given their unheated attics (Importance Factor, $I=1.1$ for snow, $I=1.15$ for wind; Thermal Factor, $C_t = 1.2$). And, despite the height and exposed position of the church roofs, no concomitant provision is made for lessening snow load via exposure factor (C_e).

A one-third reduction in load would bring even the beleaguered foot joints into compliance with code. Taking into account the ameliorating factors, the reader must decide whether this is a reasonable proposition. Some modest load discount does not seem out of line. One must also consider the possibility that the clear, fine-grained, old-growth timber in the trusses can cope with stress well in excess of modern limitations. I came to the subject a skeptic of historic scissor trusses, but my sceptical inquiries have revealed only their ingenuity and the wisdom of their builders. The most persuasive argument remains the trusses themselves. They stand unbowed, largely unchanged from their natal state, ready to face future centuries of heat, cold, snow and wind.

—ED LEVIN

Research and advice for this article were contributed by Jan Lewandoski, Ken Rower and Jack Sobon. Axial and bending diagrams for the four trusses are available from the author (elewin@valley.net).

Our own Tour de France

WOULD, *could*, France and its timber framing be that much different from neighboring Germany or England, which I had visited recently on other Guild tours? With the formation of the European Union and change of currency to the Euro, I expected that Europe would have become more homogenous. Yet, even flying in to Paris, I could notice a difference. Paris had only *one* skyscraper; the rest of the city lay below in a diorama of grey metal roofs, yellow stone buildings and radiating streets punctuated by landmarks we had seen dozens of times in pictures. The farms were much more numerous than in Germany and, while the French fields to the west of Paris shared the same characteristic hedgerow patterns as England, they seemed much bigger. The tiny villages ended abruptly at the edge of the farmland (no sprawl here), and the obvious importance of agriculture in a civilization famed for its food and wine also reflected a fierce independence. No way were the French going to be dependent upon outsiders to provide their sustenance.

The few French carpenters I had met over the years also showed this independent streak. They jealously guarded their hard-earned knowledge, passed on by tradition since before the Middle Ages and gained only by an arduous apprenticeship of up to seven years. In the Guild's recent efforts to reach out internationally, France seemed the most difficult bastion to scale.

Skilled tradesmen who have successfully completed their apprenticeships are called *compagnons*. A few have come over to the US and generously decided to open up a bit and share their knowledge with Guild members. At the Guild's Millersville Conference in 1989, *compagnon* Frédéric Brillant showed up unannounced and caused an ever-larger crowd of onlookers to scratch their heads as he demonstrated (even after dark) the French version of scribing. In 1991 he led a team to reconstruct the extensive roof of the old Cabildo in New Orleans (see TF 21 and 23). This was the first large-scale practical application of the French scribe system accessible to Guild members, and a rare opportunity for Frédéric as well. The Guild later held two French scribe workshops, one in 1994 with Marc Guilhemjouan in Penetanguishene, Ontario (viewable on the video "Timber Frame Gazebo," available through the Guild), and another in 1995 with Paul Russell (who had studied in France) in Syracuse, New York. Occasionally I met *compagnons* at Benson Woodworking in New Hampshire as they came through the US working and gaining experience; one such was Boris Noël, who would be our tour guide on this trip.

Through these exchanges, stories around the campfire (or the glow of a Gauloise cigarette, as the case might be) and fleeting glimpses of notebooks and drawings, it became clear to me that the French have a carpentry tradition unlike any other in the world. Besides being unbroken for centuries, and ensconced in a proud and admired fraternity, it also thrives on traditional tools and techniques. While other European carpenters seem to have embraced technology to the fullest (and the best-built houses I've seen are in Germany), the French relish making their own hand tools and carrying everything they need on their backs. Well, *in* the back of a tiny truck, perhaps. But we rarely saw a computer in a classroom at the trade schools.

Given the breadth of building knowledge these *compagnons* show, including engineering and familiarity with the other trades, we decided to organize a tour to their home ground. This would complete the quartet of trips to timber framing Meccas, with Guild members now able to go to Japan, England, Germany or

France on framing tours organized by Guild members. I'm sure there will be more tours to come, perhaps to new places with new timber framing discoveries. But I can't wait to get back to France.

MOST of us—we were 18 all together—rendezvoused at the tiny Hotel St. André des Arts, a 19th-century timber-framed building right in the middle of the Latin Quarter, the liveliest part of Paris. I wanted to make a beeline for the Librairie du Compagnonnage, a bookstore (the French for library is *bibliothèque*) in the rue de Brosse, right next door to the *compagnon* house we would visit on Monday. Michele patiently kept up with me as we crossed the Seine and rushed past the soaring buttresses and gargoyles of Notre Dame. The bookstore had hundreds of titles covering various trades and their history, but I concentrated on the *charpente* section. Unable to read French very well, I looked for books with big pictures and few words, and locked onto a classic: Louis Mazerolle's *Traité Théorique et Pratique de Charpente*. This exceptionally large book contains beautiful drawings tracing the development of roof and stairs and the three-legged bench that serves as a model for many *compagnon* masterpieces, as well as descriptions of hand tools and joinery. I had to check both my credit card balance and the dimensions of my suitcase, but I could not resist buying the book. The Librairie has a catalog available online, by fax or by mail (see *Resources* at the end of this article).

My book passion satisfied for the moment, we could now "relax" a bit and take advantage of our central location and Paris's excellent transit system *le Métro* to see as much as possible before our tour officially started. We followed a typical tourist trail to the artist colony on the steep hills of Montmartre and the remarkable alabaster Basilique du Sacré Coeur at the top, then took a walk past the Moulin Rouge all the way down to the Arc de Triomphe, along the Champs Elysées, through the Place de la Concorde and past the Louvre. We ended up at a small restaurant back across the river called Aux Charpentiers (10, rue Mabillon, 6th *arrondissement*), which displayed carpentry masterpieces and photographs on the walls and had a *compagnon* museum next door.

Boris Noël and I met early Monday morning to pick up two rental vans. Leaving the van depot and heading back to the hotel to pick up the others, I dodged buses and motorcycle couriers (one a day is killed in Paris) while traversing streets I would have sworn were too narrow for two vehicles to pass. But the van and I survived, and now I figure I can drive anywhere.

Our first stop was a short hop from the hotel, at the Paris house of the Compagnons du Devoir. Here we met with some of the principal players of the organization and learned the sequence of education. I had had a preview by reading an excellent recent book on the subject, *The Artisans and Guilds of France*, by François Icher. It was a surprise to learn that there are actually three different organizations. The one we are most familiar with is the Association Ouvrière des Compagnons du Devoir du Tour de France, known also by its simpler name Compagnons du Devoir, and which includes most carpenters. There is also the Union Compagnonnique des Compagnons du Tour de France des Devoirs Unis, and the Fédération Compagnonnique des Métiers du Bâtiment. All trace their origins, rites and allegiances back to three legendary pre-Christian characters: Solomon, Father Soubise, and Master Jacques. After completing Solomon's temple, followers of these three continued their craft traditions, eventually in France

under the strict auspices and control of the Church. During the Middle Ages, apprentices and journeymen in the guilds had to work under a master to become masters themselves. One could not leave the master and start his own business without the master's permission. This was a system bound to cause problems eventually; by the 17th century, the journeymen began to band together and lead strikes. Some stayed with the Church, or directly competed, which led to sometimes-violent strife and a division into the three groups we see today. Ultimately the journeymen won and were given the freedom to pursue their trade independently after completing their education, which had kept intact other traditions passed down through the ages.

Today, a young student (at about age 14) interested in following this path will visit one of the *compagnon* houses for an interview. The houses serve as dormitories, libraries, archives, classrooms, shops and dining rooms for dozens of *compagnons* who are either studying or working in the area. There are principal houses in major cities throughout France, dozens of smaller houses in minor towns, and ten or so in other countries, all serving thousands of *compagnons* in training. A *mère*, in charge of the housekeeping and meals, and a *responsable*, in charge of the academic and social programs, supervise each major house.

If the young man's grades pass muster (no women are as yet admitted to *compagnonnage*, although the organizations are discussing admitting women in the future), he is then invited to his first year as an *apprenti* (also known as a "rabbit"). Here he gets exposure to the other trades before he has to decide on one for good. School at the house, interspersed with work at companies in the area, lasts for three years. At the end of this time, the student, now become an *aspirant*, is given a logbook and a list of skills he must learn before he can complete his training. He may obtain these skills through traveling (his *Tour de France*) and working a minimum of six months and a maximum of one year at any one shop, staying at a *compagnon* house in the area. With his logbook complete, he may then return to a house for a year to complete a masterpiece and become a master. This system of houses throughout the country, with an open door to any *compagnon* passing through for one night or many, contributes much to the success of the program in France.

Students pay \$500 per month for room and board while staying in a house long-term, but the rest of the program is funded by a portion of French corporate taxes called apprenticeship taxes and designated for education. Companies are required to pay the tax, which is significant, but they can determine where their tax dollars will go. The *compagnon* organization lobbies appropriate companies aggressively to support their programs, which of course can eventually supply the companies with skilled hands. For their own part, *compagnons* pay about \$100 in annual dues, and some contribute further by teaching.

The Compagnons du Devoir have 8500 young workers in training, including 5300 apprentices (initial training two years), placed in 37 houses throughout France; these young workers alternate between six weeks working at a local company and two weeks in courses at the training center. Further along are 1300 trainees (spending the period between their apprenticeship and their *Tour de France*) and 2000 *aspirants* and *compagnons* perfecting their skills on the *Tour de France*. Some 300 leave France to work abroad annually. (Such traveling is considered part of the *Tour*.) All together, these workers represent 23 trades in the Compagnons du Devoir.

We visited three *compagnon* houses on our tour. We saw well-maintained libraries, exuberant camaraderie, comfortably designed offices, classrooms and dining rooms, with tradition rampant, and in every lobby numerous examples of the masterpieces graduating *compagnons* must complete.



Photos Will Beemer

Carved wooden balcony, a compagnon masterpiece built in 1521, at L'Eglise de l'assomption at Villemaur-sur-Vanne, east of Paris. Below, the double-brace style commonly used in northern France to support broad overhangs, here seen at Troyes. Brace patterns know no limits.



Mid-afternoon we traveled east a few hours to the tiny village of Villemaur-sur-Vanne and visited the 16th-century Assumption Church. The bell tower and cruciform roof were easily accessible timber frames, but took second fiddle to the ornate carved façade on the choir loft. We arrived in Troyes, checked into the Hotel Relais Saint Jean, tucked in a narrow street just off the old town square, and walked to dinner at a restaurant Boris's company (Valentin, a group of about 25 workers) had renovated. Walking the streets of Troyes the next day, we learned more about their work, admiring residential and commercial projects throughout the old city. We saw the traditional marking system used to identify timbers and well as accurately reproduced surfaces, and many *lucarnes* (overleaf), with cantilevered timbered soffits carved with symbolic motifs and attractive double bracing systems for the overhangs. The contrasting pastel colors on the timbers and infill formed a distinctive pattern among the restored houses of Troyes. But it was disconcerting to look at a house we thought was well preserved or repaired, only to find it was a new house built from re-claimed timber. It was hard to tell what we were looking at. Undeniably beautiful and accurate, but hard to grasp chronologically. There is a problem in walking down a street and not being able to tell which are the historic buildings and which the clever reproductions.



Substantial dormer at Troyes, so heavily framed perhaps to support loads brought up on the pulley just visible at the center of the overhang. Lead flashing shields the thick edge of the tile siding.



Display of measuring tools at the Maison de l'outil in Troyes. Notice the jambe de force, or leg of strength, rising between the showcases and stoutly connected to the principal rafter by a triple-tenoned link.



Roof framing at Ste. Madeleine, Troyes, 12th century.

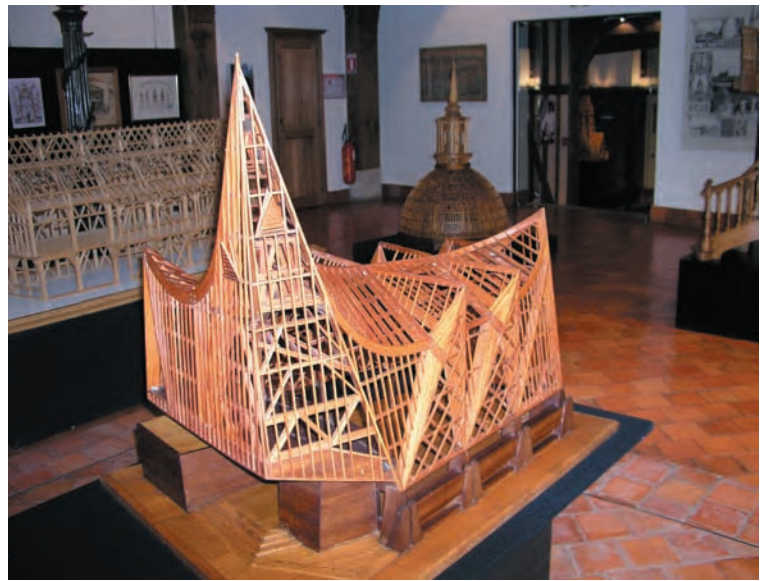

Masterpieces on display at the Maison d l'outil. Despite its sweeping modern curves, the ambitious effort front and center bears more than a little relation to traditional French church architecture. Below, Tim Whitehouse (front), Michele Beemer and Chris Madigan admiring a student's work at the compagnon house in Troyes.

We climbed to the top of the Church of Ste. Madeleine, the oldest church in Troyes (mid-12th century), with its Renaissance bell tower, Gothic nave and magnificently flamboyant stone-carved chancel screen. As we looked out over the rooftops, we saw many cats jumping from roof to roof below. Sure enough, on the way back to the hotel we passed through the rue des Chats, so narrow that the houses flanking the alley actually touched at their peaks.

At the Maison de l'Outil, *the* tool museum in France, run by the Compagnons du Devoir, we saw a collection of over 20,000 tools for working wood, iron, stone and leather, including 8,000 hand-made examples from the 18th and 19th centuries (below). The beautiful Renaissance-style building in the rue de la Trinité dates to 1556 and was originally a rich merchant's house. The town council donated it to the *compagnons* in 1969 so that young apprentices would find themselves faced with their own history, and to awaken in them the desire to explore their cultural heritage including masterpieces made by their forbears (example below). Except for the Bibliothèque Forney in Paris, the library here constitutes the most important technical library in France. It has more than 32,000 reference books for craftsmen, including the 35 volumes of *L'Encyclopédie* of Diderot and d'Alembert (1751-1780) as well as a 1572 edition of the treatise *De Architectura* (10 volumes)





Hipped roof of the 16th-century market hall (restored) at Piney, in the Champagne region. At right above, detail of necked tying joint, in which the tie beam is bridled over the post top and a twin tenon projects up from the latter to enter the underside of the plate.

by Vitruvius, the first-century Roman architect rediscovered in the Renaissance. In the bookshop we could purchase many of the same titles available from the Librairie du Compagnonnage in Paris.

After we toured Troyes for a few hours on our own (four-fifths of the central area is built of wood), we drove to the outskirts of town to visit the local house of the *compagnons*. This modern structure, with detached dormitory, is uniquely suited to craft training: ground-floor workshops surround a central courtyard while second-floor classrooms overlook the shops and an annex with kitchen, dining room, conference rooms and offices. At dinner, the manifestations of fraternal community life were apparent in the boisterousness of the students. Later, rather than give a formal presentation of what our work was about, we naturally broke off into smaller groups of six to ten to look at each others' accomplishments. It left us in awe to look at the work of some of these teenagers, and for their part they were surprised to see the level of timber framing practiced in the US, given their experience of exported American culture. We left the students with a number of mementos, including TFG patches and pins, and autographed books by American timber framing luminaries. But the most treasured souvenirs there and elsewhere on the tour were the traditional French doughnut-shaped plumb bobs cast in lead and brought along by Tim Whitehouse and inscribed with the TFG and Compagnons du Devoir initials, the date and the word *Amitiés* (friendship). Tim in turn left France with his own collection of plumb bobs people bestowed on him after rummaging through their toolboxes.

We used our hotel in Troyes as a base for a few days to make convenient day trips to the countryside. While traveling the Aube River and the Champagne region, we stopped in the tiny town of Piney to visit the restored 16th-century open market hall. Boris's company Valentin had used old timber to keep it going for another 500 years. Its massive hipped roof of curved principal rafters, principal purlins and common rafters demonstrated the adaptability of the scribe system. Dragon beams at the corners supported the hip rafters at their feet.

Here at Piney we saw a necked tying joint at the top of all the posts identical to that shown in *Historic American Timber Joinery*. We saw other remarkable similarities to American joinery and, after we described the principles of square rule layout, Boris said it was a common practice in France as well, at least in a version (akin

to mapping) that recognizes variations in timber when cutting joinery, but remains quite distinct from scribing. We interpreted Boris's remarks to mean that the French lay out the joinery using square rule (mortises and tenons a certain distance off a reference face) but scribe the lengths (which means there would be no reductions or housings). Indeed, we never saw a square housing that I recall, only diminished housings for bearing. While we may be enamored of the French scribe method, the French themselves apparently use it only for a small fraction of their work, and only when there is no other way. Some carpenters we met have never used it since leaving school.

At Longsols, a village of 300 people, we visited the recently restored 15th-century church of Saint-Julien and Saint-Blaise. The Champagne region has a unique heritage of half-timbered churches, less famous but no less surprising than the wooden churches of Norway. In Champagne, carpenters originally worked in timbers of oak, poplar and chestnut; inside the churches, beams are often decorated with monster faces, to remind one that hell is always open, ready to swallow the sinner. We were honored with a Champagne reception at the *hôtel de ville* (town hall) by Mme. Mergey, the mayor, and we had the feeling we were the biggest thing to happen in town for a long time. She and her entourage



Church of St. Julien and St. Blaise, Longsols, originally 15th century, recently restored. The framed gable end overhang with carved double brackets and arch braces shows the possibilities of the framer's art before structure and decoration were disconnected by the Renaissance. Interior shown overleaf.



St. Julien et St. Blaise, Longsols, 15th century, restored. Some of these old timbers are newly placed.

were proud of their tiny church and pleased that we took such an interest in it. We complimented her on the quality and the beauty of the *réhabilitation*.

After lunch in Montiéramey, we stopped in Boris's hometown of Montreuil-sur-Barse to visit his family and neighboring new houses made by the Valentin firm with old timbers. We began to notice the occasional use of new painted timbers among old unfinished ones. For example, ridges and hips might be a bright pink against the whitewashed roof boards and weathered old timber. It seemed a rather bold technique.



Newly framed structure, Montreuil, using old and new timbers, the latter painted for yet more contrast. Note legs of strength to carry roof loads down from collars to tie beams, thus dissipating much rafter action.

Continuing through farm fields and forests, we paused at a washhouse at a country crossroads. A small stream entered one end of a timber-framed building and ran down an open courtyard in the center. The stream could be dammed at the lower end, causing the 6-ft.-wide by 3-ft.-deep channel to fill for washing. This simple public convenience, cared for and open to anyone, spotlessly clean and empty in the middle of the day, could only be compared to a fine lap pool on a private estate in the US.



Five-story derelict 19th-century water-powered mill, Bar-sur-Seine. Heavily framed, originally infilled and stuccoed and with a Mansard slate roof; it awaits an angel or a recycler. Detail below.



In Bar-sur-Seine we saw a massive 19th-century timber-framed water-powered sawmill and factory, later a hotel, partly open to the weather after a failed restoration attempt, waiting for new owners to finish the job. Just down the street, we came upon one of the most remarkable buildings on the tour, a 16th-century timber-framed house with fully carved front. As we moved east, closer to Germany, we could see growing evidence of the prosperity of the region at that period, with dwellings beautifully carved and painted inside and out.

Our last stop before heading back to Troyes was a visit to the Champagne fields. We drove to the top of a hill to look down at the rolling vineyards, then on to Celles-sur-Ources for a visit to the Champagne house Laurent. Monsieur Laurent gave us a cellar tour and tasting before showing us his new house under construction. Again we saw brightly colored timber (green and pink) combined with the old weathered look.



Conspicuous 16th-century house at Bar-sur-Seine, with remarkable carved frame, framed gable-end overhang, brick and stucco infill. There seems to be a municipal problem at the corner.



New house underway at Celles-sur-Ources in the Champagne region.

WE MADE an early departure the next morning for the four-hour drive to Strasbourg. This most beautiful of cities, hard by the German border, has changed nationalities many times over the centuries and still retains German street names and a strong affinity for various forms of *würst* and *sauerkraut* (a big change from our previous menus). With our guide for the next few days, *compagnon* Pierre Thomassin, we took a street-

car through the bustling city to the old town and got our first glimpse of the rose-colored cathedral and its intricately carved stone façade. At the Place Broglie we boarded a canal boat for a tour through the locks and rivers surrounding the city, paid for by the Boston-Strasbourg Committee (Boston is Strasbourg's sister city in the US). We were told of the old cranes that used to unload barges along the canals, and we couldn't help thinking that building one similar to the Norwell Crane (see TF 64) might be a great cooperative project between the TFG and the Compagnons du Devoir. Timbered buildings and stone bridges drifted past our gaze, the unity broken only by the ultra-modern headquarters of the European Union.

After lunch at the ancient customs house, we headed for a tour of the roofs of the Strasbourg Cathedral, literally the high point of the trip for me. The original cathedral, started in the 9th century, fell victim to the looting and fires that plagued many churches in the Dark Ages. The accepted starting date for the present cathedral is 1176. At this time, stone vaulting replaced highly flammable timber roofs.

The 13th century is considered the apex of cathedral-building in Europe, and the masons and carpenters of Strasbourg were not to be outdone. Every cathedral at this time elaborated on the theme of the Last Judgement, but here the treatment was unique. The master mason created the famous Doomsday Pillar, an elaborately carved octagonal column serving as the median support of the north transept, but one of the greatest attractions for me (that day too surrounded by visitors to be photographed) was the 30-ft.-tall stone-cased astronomical clock from 1550. It included a planarium showing the current position of the heavenly bodies and a solar perpetual calendar whose position was marked by a shaft of light through a hole in the wall of the cathedral. The clock itself contained an elaborate mechanism that drove chariots and cherubs, prophets and soldiers, Apostles and a figure of Death, not to mention lions and other creatures, all to mark the passage of every quarter hour. On top of it all, the likeness of the master mason who built the case, Hans Uhlberger, peeked over the edge.



An early meter stick, fixed to the wall at Strasbourg Cathedral.

Our behind-the-scenes tour up the narrow spiral staircases to the roof was a special treat. Near a side entrance we saw the masons' benchmarks incised into the base courses of the roseate sandstone, including a line representing the length of a standard block, as well as an iron bar fixed to the wall said to be the length of the master's forearm and used as a common unit of measurement. As we gazed up the soaring façade, we could see that each



On the north tower of the cathedral, Diane and Chris Feddersohn (at right) and Russell Ley survey the roofs of Strasbourg, below.



block had a small raising hole in it where one side of the grapples took hold for the trip up the wall. Each block also had a small rune carved into it as the signature of the stonecutter. There must have been hundreds of them.

Climbing to the spire offered continuously changing views of flying buttresses, crouching gargoyles and a sea of roofs and dormers below. At the highest point, we were above the bells but still below the main spire, yet the parapet walkway allowed us to completely circle the towers on the outside (photos above). Inside, the main roofs of the transepts and nave were framed with *Liegendestuhl* trusses (see TF 52) over the stone vaults. This fram-



Softwood *Liegendestuhl* (lying chair) trusses and heavy longitudinal X-bracing support the framing of the weather roof of Strasbourg Cathedral. Such German-style framing prevails in Alsace.



Small traditional Alsace house, half timbered, with tiled, jerkin-head gable roof and pentices over the gable windows, at the Ecomusée d'Alsace in Ungersheim.

ing was an obvious German influence that we would see repeatedly throughout Alsace. Trap doors in the attic floor allowed us to look down 120 ft. into the nave, but a real surprise was to open a door in the end wall to look directly across 30 ft. of void to the great rose window in the west façade.

We finally had to descend from our aerie to make our dinner engagement at the Strasbourg *compagnon* house. This appeared to be the largest of the houses we would visit, located at the edge of the historical “la petite France” quarter of the city, where we had another chance to visit with students in their drawing studio (photo on back cover) and admire their enthusiasm and dedication. Masterpieces and posters extolling the virtues of their training provided added inspiration.

Our last full day on the tour included a trip down to Ungersheim and the Ecomusée d'Alsace, an open-air museum of traditional Alsatian houses. Their style is unique in France: tall, half-timbered with snub-nosed gables, gingerbread trim, colorful ornamentation, double balconies and tiled, timber-framed awnings over the windows on the gables. We saw a concentration of dozens of such houses, brought in from 12 regions of Alsace. Their most striking



The Carpenters' Wall at the Ecomusée d'Alsace, a work of modern art.



Storks are regular tenants on the buildings at the Ecomusée.

feature—vibrant color, originating as oxide dyes used in the native textile industry—we saw throughout the nearby countryside and in Strasbourg as well. Houses were whitewashed or painted in cerulean blues, browns, yellows or terracotta red, their oak timbers often darkened with walnut oil. Sometimes the timbers were outlined with colored margins in the *torchis* (the wattle and daub infill between the timbers). The half-timbering (or *colombage*) was especially ornate under the windows, with numerous slanted timbers



Parti-colored wattle-and-daubed barns at the Ecomusée d'Alsace, with outlined timbers. Note typical jerkin-head roof, with truncated ridge to allow a short hip that gives some protection to the gable end.



New Alsatian house in Ochfelden built in traditional style but using straw-clay brick infill and straw batt insulation, demoed below by a delighted Dave Carlon.

accenting the verticals and horizontals. Multistory houses here were often platform framed in the German fashion, like stacking boxes, each frame separate from the one below. Topping off almost every building at the Ecomusée, often at both ends of the ridge, were stork nests, many complete with baby storks. Perhaps most curious of all was the 20-ft. wall, an artistic installation in homage to carpenters and their work.

Though it was not part of the collection at the Ecomusée, we did later visit an evidently eco-conscious house at Ochfelden, a new structure nearing completion built in traditional Alsatian style but using straw insulation (manufactured in batts) and straw-clay bricks for infill.





Vintner's establishment at Châtenois, built by framer Jocelyn Berger, with carved figurative detail.

As for traditional Alsatian framing methods, Boris proclaimed that old buildings in Alsace, including the oldest part of the roof of the Strasbourg Cathedral and its bell tower, used square rule layout. "It's a German way of building," he explained. "You pay more attention to the quality of the timber-cutting, and then you use square rule. This system was already in place during the 13th century. Scribe rule is a Latin way of building and a totally different approach."

After a stop at the Haute Königsburg castle high above the Alsace plain, we traveled the wine road to Châtenois. Here we visited a winery fronted by a typically ornate new Alsatian house-cum-tasting room, built by the only female timber framer we met on the tour, Jocelyn Berger, who also happens to be married to a *compagnon*. She warned us that she would soon be riding a Harley across the US to visit timber framing shops.

AFTER bidding adieu to our guide Pierre, we returned to Paris and met for a final dinner together before heading our separate ways. A few of us then conducted a brief self-guided tour in Normandy and met in Rouen with François Calame, an architect and ethnologist with the Ministry of Culture, who organized recent workshops inviting carpenters from Lithuania, Finland, Norway, Poland, Turkey, England, Romania, Sweden, Belgium and France to explore their traditions and methods by building together, under the auspices of Wooden Culture in Europe (www.woodenculture.org). François gave us a whirlwind tour of the oldest buildings in Rouen, among them a charnel house (now an art school) that received bodies during the Black Plague. Students languidly hung out of window openings carved with death's heads and crossbones in blackened timbers; the word *Goth* sprang to mind. Half-timbered buildings were everywhere, along with examples of a regional technique to cover exterior timber surfaces in slates (see front cover). In our exploration of the carved frames of France, we often found self-portraits of the craftsmen who built them, sometimes smiling, at other times in an attitude or gesture reflecting a deteriorating relationship with the client.

We moved out to the coast at Honfleur, a picturesque port where the Seine empties into the English Channel, and toured the unique wooden Church of Ste. Catherine, which has parallel double barrel-vaulted naves. (The congregation found they needed



At top, in Rouen, a charnel house in the era of the Black Death, now put to use as an art school. Above, shopfronts with trussed breast beams over the openings. The braces are termed "décharges couplées."



The builder of the house is portrayed on the right. The masked, taloned creature supporting the building is not identified. The plaque commemorates a particularly bloody battle from which Richard Sans Peur, Duke of Normandy, emerged victorious.

more room and could afford it after building the first nave.) The seafood and coastal atmosphere provided a refreshing change from the farmland we had been touring. Nevertheless, we headed inland a few miles to Pont l'Évêque, source of the famous cheese, to visit A. Desperrois and Sons, a *compagnon* shop recommended to us by Boris and François. His was actually the first fully functioning timber frame shop we had visited outside of the schools. Now we saw computers and CAD systems in the office, but a healthy pile of reclaimed timber still supplied the needs of the shop. Monsieur Desperrois confided that, although his training was to draw by hand and to make and use hand tools (and that this is the best way to learn), computers and power tools become necessary in the competitive world of the building business. Most of the work continues to be restoration, or new construction with old timbers. In the shop we saw frames being laid out by the traditional French scribe method of transferring lines up via plumb bob from the full-size floor drawing to the assemblies of timbers, and we glimpsed a 14-year-old "rabbit" unloading a forklift under the guidance of an older *compagnon*. This first year *apprenti* would later evolve into a "fox" and then a "dog" by the time he graduated and became a fin-



General Store in Beaumont-en-Auge, Normandy, offering groceries, wines, hardware, tobacco and newspapers.



François Calame, who guided a post-tour rour in Rouen, discussing colombage, the French system of half-timbering.



The workshop at Desperrois et fils. A rolling bridge crane and chain and circular saws make heavy work somewhat lighter. Most timber used is reclaimed, both for repair and new work.

ished journeyman years later. The early induction into the world of work in a real shop setting is just as important as the academic training received at the *compagnon* houses.

Michele and I boarded the train in Lisieux for the trip back to the airport at Roissy, leaving a mere trio of our original 18 tourists to explore the countryside for a few more days. Here they would seek out some of the most astounding architectural treasures of the local Pays d'Auge—manor houses tucked into the woodlands and lush meadows of Normandy. Most of these houses are not open to the public, but we thought the trio would get lucky, as we all were on our Tour de France.

—WILL BEEMER
Tedd Benson, Dave Carlon, Diane Feddersohn and Boris Noël contributed observations to this article.

RESOURCES

Librairie du Compagnonnage, 2, rue de Brosse, 75004 Paris, www.compagnons-du-devoir.com. Telephone 01 4887 8814, fax 01 4804 8549 (omit the initial zero when calling or faxing from abroad). Catalog available. The bookstore will mail order to the States (although postage could be expensive), and most of the staff speaks and reads English.

Maison de l'Outil et de la Pensée Ouvrière, 7, rue de la Trinité, 10000 Troyes, www.maison-de-l-outil.com. Telephone 03 2573 2826. E-mail: maison.de.l.outil@wanadoo.fr.

Ecomusée d'Alsace, Ungersheim, www.ecomusee-alsace.com.

Musée du Compagnonnage, Cloître Saint-Julien, 8, rue Nationale, 37000 Tours. Telephone 02 4761 0793.

Bibliothèque Forney, 1, rue du Figuier, 75004 Paris. Telephone 01 4278 1460.

(The last two venues were not on the tour.)

BOOKS

The Artisans and Guilds of France, by François Icher, 2000, Harry N. Abrams. ISBN 0-8109-4390-5. The history and organization of the *compagnon* system.

The French Farmhouse: Its History, Construction and Regional Styles, by Elsie Burch Donald, 1995, Abbeville Press. ISBN 0-7892-0037-6. French farmhouses and timber framing.

Manor Houses in Normandy, by Régis Faucon and Yves Lescroart, 1997, Könemann. ISBN 3-89508-703-3. Beautiful pictures. (Books are available through www.summerbeambooks.com.)

QUALITY TOOLS FOR

TIMBERFRAMERS



Makita® Chain Mortiser

Save countless hours cutting mortises by using Makita's chain mortiser. This machine cuts extremely fast, accurately, and can pivot to three cutting positions without resetting. Chain mortiser comes complete with $\frac{23}{32}$ -in. chain, sharpening holder assembly, wrench, and chain oil. An unbelievable machine!

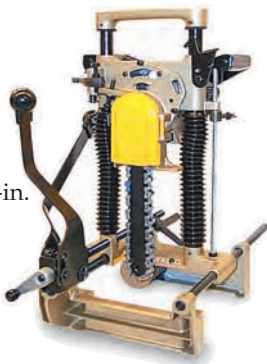

Makita® 16 $\frac{5}{16}$ -in. Circular Saw

Standard Equipment 32-tooth Carbide Blade! 16 $\frac{5}{16}$ -in. blade cuts 6 $\frac{3}{16}$ at 90° and 4 $\frac{3}{4}$ at 45°. HD 2,200-rpm motor with electric brake gives you plenty of power to cut the big stuff. Has precision gearing with ball and needle bearings for smooth and efficient power transmission. Includes combination blade, rip fence, and two wrenches. Top quality product!



The Commander

For over two centuries the maker's family has provided timber framer's and carpenter's mallets for persuading immovable objects. We've all heard "...get a bigger hammer" and this is what it means. Head is made from extremely dense hardwood and the handle is made out of Japanese White Oak, noted for its strength and longevity. Head is metal banded to reduce splitting. Head measures 5 x 5 x 9 $\frac{3}{4}$ and weighs approx. 120 oz. Handle measures 36 in. Seen at log and timberframe construction sites all over.

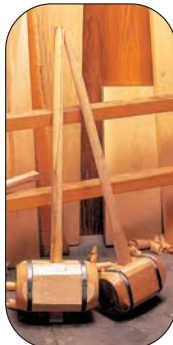

Free Catalog

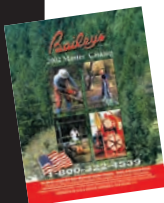

Call for a FREE 116 page full color 2002 Master Catalog mention source code QX4Z

Bailey's Est. 1975

The World's Largest Mail Order Woodsman Supplies Company - Selling at Discounted Prices

www.baileys-online.com

1-800-322-4539

www.timberwolftools.com

1-800-869-4169



TIMBERWOLF TOOLS

BIG TIMBER POWER TOOLS



PROTOOL CMP 150 Chain Mortiser

*Speed * Power * Precision*

German Engineered Quality

8-1/16, 9-5/8 & 13-3/4 In. Planers
13-3/16, 14-15/16 & 16-1/2 In. Circular Saws

11-1/2 In. Portable Band Saws

Drill Guides, Beam Saws, Slot Cutters and More...

Exclusive Distributor

PROTOOL®
Power Tools For Professionals

Lifting Apparatus Calculations

IT'S all very nice to know about rope, knots and rigging, but it's even better to be able to do something useful with them. Of the several types of lifting apparatus, shear legs are the most stable, but the least adaptable in use. A gin pole is more adaptable, but requires more guys to ensure stability. Finally, a derrick is the most adaptable assembly, but requires the most complicated construction. Safe design of the three different lifting systems comes down to these basic considerations:

The poles have to be strong enough to carry the compressive loads.

The guys have to be strong enough to handle the tension within the safe working capacity of the line.

There must be sufficient guys to stabilize the apparatus and prevent movement in the wrong direction if something should fail.

The lifting tackle must have adequate safe lifting capacity.

Finally, guy anchors must have sufficient capacity to resist the guy loads, and the poles must be prevented from sinking into the ground. (Calculations to meet these requirements form a subject unto itself, to be taken up in a future article.)

Before you can check for safe design, you have to know the loads in the various parts of the system.

SHEAR LEGS. Shear legs are made by lashing or bolting together two legs crossed at the top, with the hoisting tackle suspended from the intersection. A heavy back guy running from the intersection to a ground anchor and a similar but lighter front guy complete the assembly. The spread of the poles at the base stabilizes the shear legs in the plane perpendicular to the guys.

Compression in the poles and tension in the heavy back guy does the work of holding the tackle in the air as a load is lifted. The lighter front guy prevents the assembly from falling backward should the back guy be overtightened or a load be released too quickly. Adjusting the length of the guys can move the top of the shear forward or back. This allows the load to be positioned forward or backward, but not side to side.

Rigging Shears. When shear legs are erected, the spread of the legs should be equal to about one-half the height of the shears. The procedure: Lay two timbers together on the ground in line with the guys, with the butt ends pointing toward the back guy and close to the point of erection. Place a large block under the tops of the legs just below the point of lashing and insert a small spacer block between the tops at the same point. The separation between the legs at this point should be equal to one-third the diameter of one leg to make handling of the lashing easier.

With sufficient 1-in. rope for 14 turns around both legs, make a clove hitch (see TF 68, "Ropes and Knots") around one leg and take eight turns around both legs above the clove hitch. Wrap the turns tightly so that the lashing is smooth and without kinks. Finish by taking two frapping turns (see upper left corner of Fig. 1) around the lashing between the legs and securing the end of the rope to the other leg just below the lashing. For handling heavy

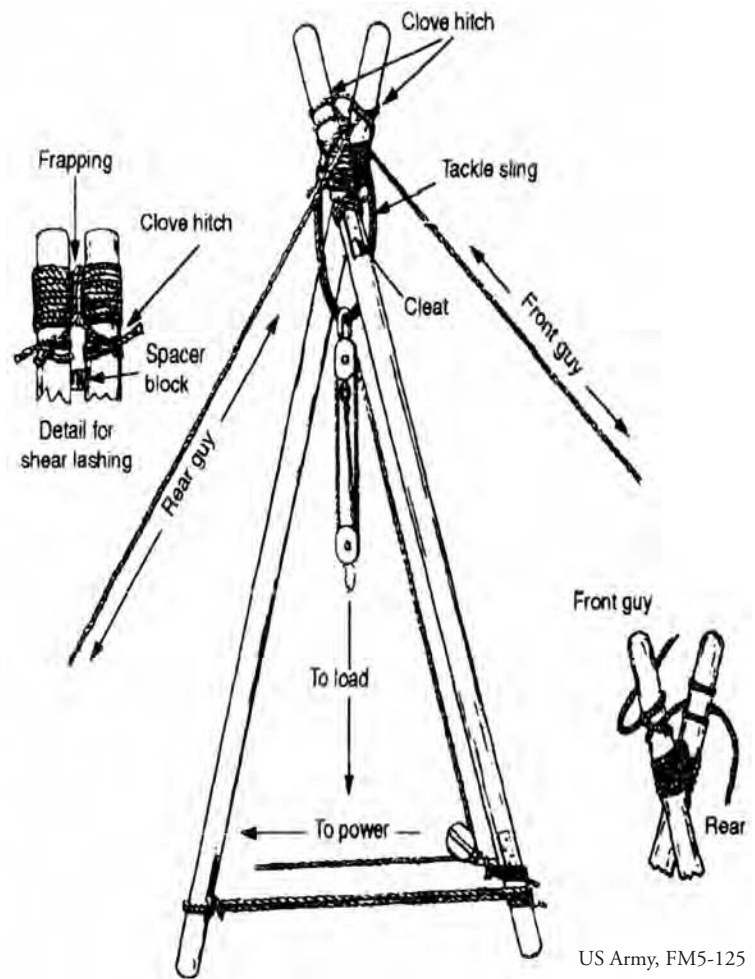

FIG. 1. SHEAR LEGS, RIGGED.

US Army, FM5-125

loads, increase the number of lashing turns. To prevent the poles from slipping in the lashing, a cleat should be spiked to each pole just below the lashing. Or a hole can be drilled through each pole and a steel pin inserted.

Of course, it's much simpler to attach lifting tackle, guys and any safety lines to the shear legs before they're up in the air. Take a minute and consider what rigging might be useful once the shear legs are standing.

To begin, place a sling of appropriate strength around the top of the shear legs. The sling should be choked around the poles and positioned so that the loose end comes across the top of the lashing and hangs between the legs. If the sling hangs to one side or comes around the outside of one leg, the shear legs will twist when a load is lifted. This can cause a premature and dramatic failure.

Reeve a set of blocks and place the hook of the upper block through the sling. Secure the sling in the hook by mousing. Fasten the lower snatch block to one of the legs near the butt so that it will be in a convenient position when the shears have been raised but will be out of the way during erection. Rig another tackle in the back guy near its anchorage if you intend to use the shears on heavy lifts. Using clove hitches, secure the two guys to the top of the shears above the lashing, attaching to the legs opposite their anchorages. A clove hitch is the preferred knot for this application as it is stronger than a loop made with a bowline. Once all the rigging is in place, the shear legs can be erected.

The descriptions of constructing, rigging, and raising shear legs, gin poles and derricks are substantially taken from the public-domain US Army Field Manual FM 5-125, Rigging Techniques, Procedures, and Applications, modified somewhat to fit with timber framing practices. The sections on load calculations for each device and the sections on safe design were developed by the author.

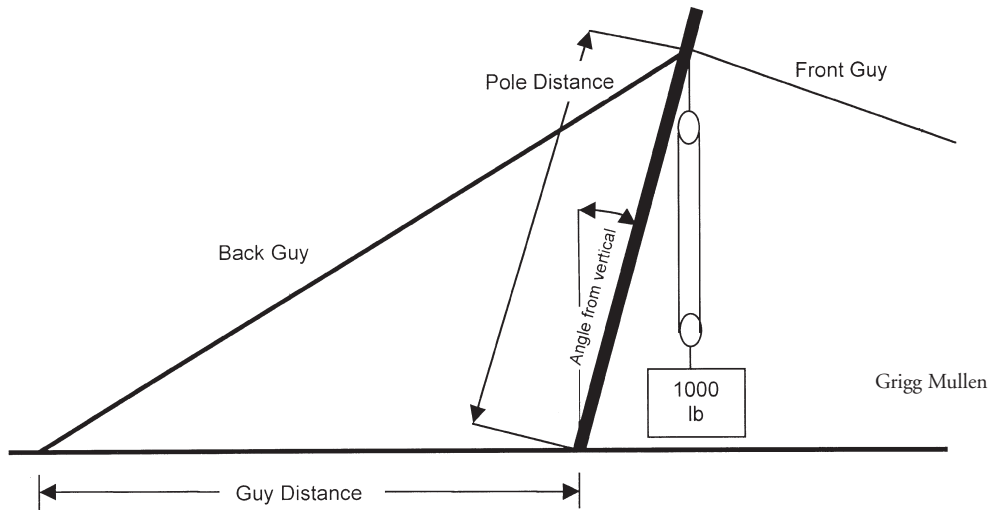

FIG. 2. SHEAR LEGS DIMENSIONS.

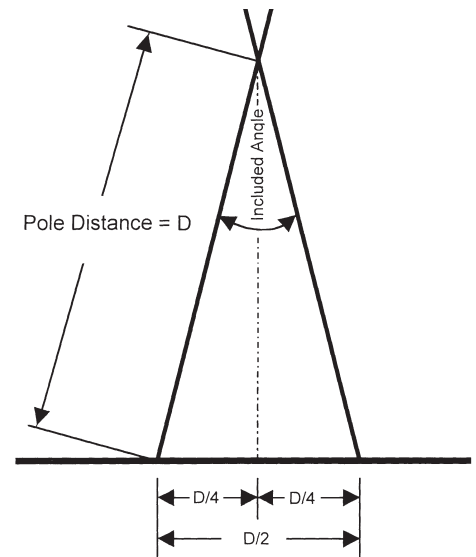

FIG. 3. SHEAR LEGS INCLUDED ANGLE.

Load Calculations for Shear Legs. To be sure the various parts of the system are properly sized, we must know the loads in the system. The following information allows us to calculate the compression in each of the shear legs and the tension in the back guy, and thus pole and guy size. The calculations are the same for a set of shear legs, a gin pole or a derrick.

Using regular engineering, the calculation of compression in the shear legs and tension in the back guy is a fairly ugly matter. However, the graphs that follow make it possible to calculate the loads using several dimensions of the shear legs assembly (Fig. 2):

Pole Distance is the distance from the ground to the attachment point for the guys and tackle if the pole is standing vertical. In the case of a single pole, it would be simply the length along the pole from the butt to the attachment point. The splayed shear legs complicate things slightly.

Guy Distance is the horizontal distance along the ground from the butt of the pole to the guy anchor.

Angle from Vertical is the angle of forward lean in the shear legs.

Ratio is *Guy Distance* divided by *Pole Distance*.

For an example, let's plug in the following values:

Guy Distance = 30 ft.

Pole Distance = 20 ft.

Angle from Vertical = 15 degrees

Spread between legs at base = 10 ft.

Ratio = (Guy Distance)/(Pole Distance) = (30 ft.)/(20 ft.)=1.5

Determining the Guy Tension. Start at the 15-degree point on the horizontal axis of the graph. Go up to the curved line for a ratio of 1.5. Then go horizontally over to the vertical axis. Read off the load in the guy as a percentage of the total load. The guy load as a percent of total load is 37 percent, and the load is thus 370 lbs.

Determining the Compression in the Shear Legs. Start at the 15-degree point on the horizontal axis of the graph. Go up to the curved line for a ratio of 1.5. Then go horizontally over to the vertical axis. Read off the total compression in both shear legs as a percentage of the total load.

Compression in Shear Legs

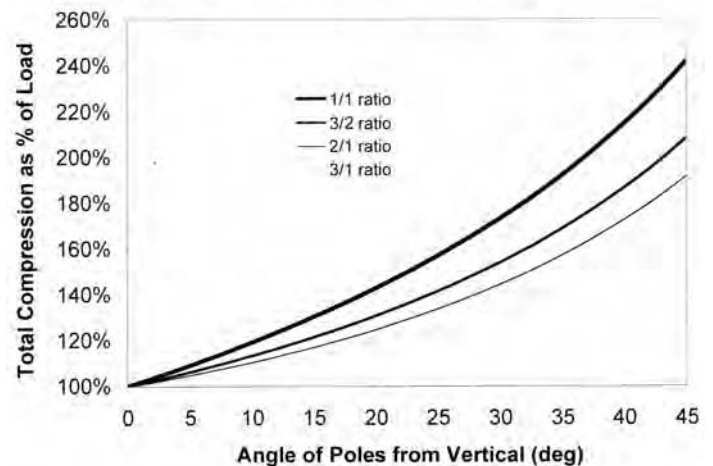

Total compression as a percent of total load is 122 percent and thus total compression is 1220 lbs.

But you're not done yet! The 1220 lbs. is the total compression carried by both shear legs. If the two poles making up the shear legs were standing parallel, then the load in each leg would be half the total compression. But the legs stand at an angle to each other, so the answer takes a bit more work.

A method used for determining sling loads based on included angle works well for this problem. If the legs are splayed to half the leg length as described earlier in the text, the included angle shown in Fig. 3 can be found using trigonometry. Since the sine value of an angle can be calculated in a right triangle by dividing the side of the triangle opposite the angle by the hypotenuse of the triangle, then, for half the angle,

$$\text{Sine} = D/4 \div D = 0.25.$$

From trigonometric tables, or by using the inverse function on a suitable calculator, we find that 0.25 is the sine of 14.4 degrees. The included angle between the shear legs is then 28.8 degrees. Using 30 degrees is close enough, and slightly conservative.

Tension in Guy

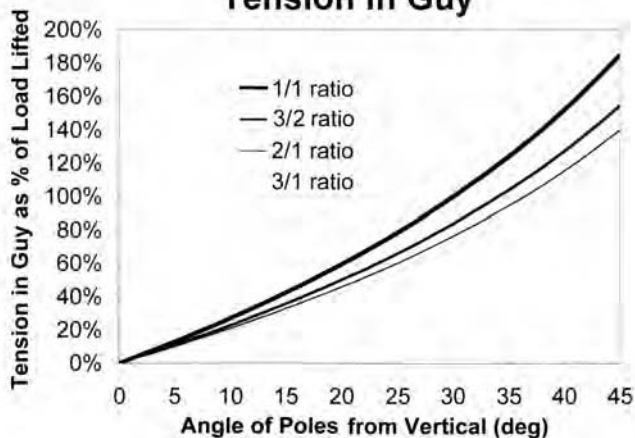

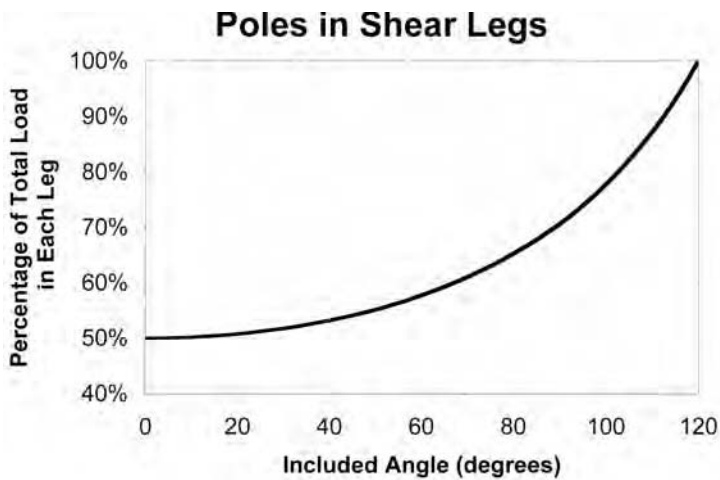

Using the chart above for percentage of load versus included angle, start at the 30-degree point on the horizontal axis of the graph. Go up to the curved line. Then go horizontally over to the vertical axis. Read off the load in each pole as a percentage of the total load. The total load is the total compression carried by the two poles in the shear legs. Pole load as a percent of total compression load is 52 percent and thus equals $.52 \times 1220$ lbs. or 634 lbs.

GIN POLES. A gin pole comprises a single upright pole guyed at the top to maintain a vertical or nearly vertical position and equipped with suitable hoisting tackle. The gin pole is used widely in erection work because of the ease with which it can be rigged, moved and operated. It is suitable for raising loads of medium weight where only a vertical lift is required.

The gin pole may also be used to drag loads horizontally toward the base of the pole when preparing for a vertical lift. It should not be inclined more than 45 degrees from the vertical.

The gin pole offers a bit more freedom in positioning the lift than a set of shear legs. The pole is secured by both a set of fore and

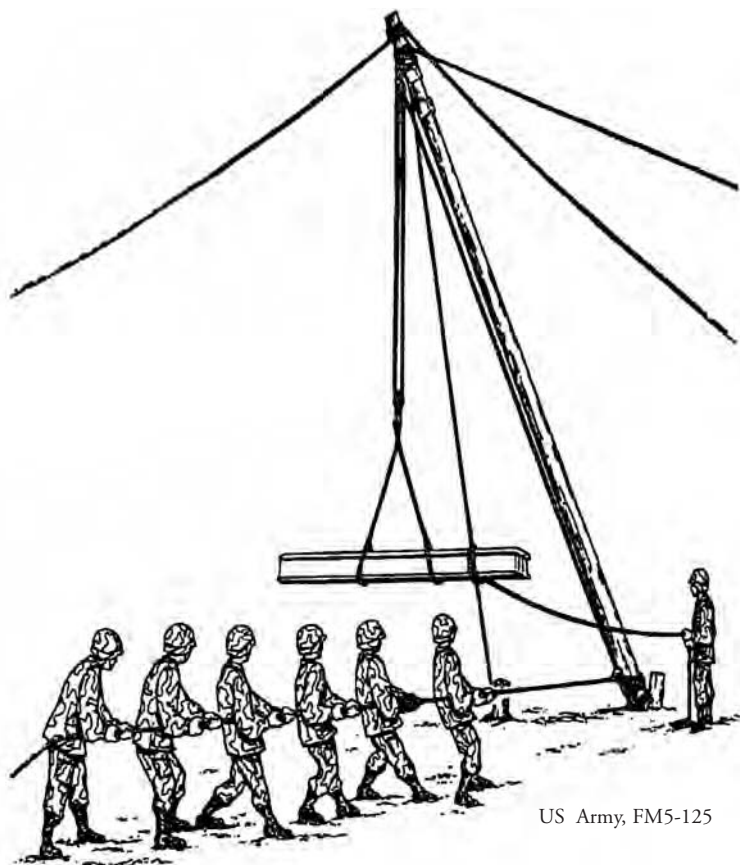

FIG. 4. A GIN POLE IN USE.

aft guys and a set of side guys. By adjusting the four guys, it is possible to move the tip of the pole both forward and back and side to side. Any positioning should be done before the lift, and then the lift performed vertically. *Note well that if the pole is to be moved side to side, the side guys must have the same capacity as the back guy.*

Rigging and Raising a Gin Pole. This procedure follows much the same process as setting shear legs: attach all the rigging, set the base of the pole and then raise it into position. The major difference is that there are four guy lines to control during the raising. Unlike shear legs, the gin pole is not stable in one plane. All four guys must constantly be tightened and adjusted to keep the pole in position during its raising. The spread at the base of shear legs keeps them from flopping sideways. The side guys on the gin pole perform the same function.

Load Calculations for a Gin Pole. The load calculations for a gin pole are almost exactly the same as those for the shear legs. The only difference is that the total compression load is being carried by one pole instead of being split between two poles. When lifting the same load, a single gin pole must then be a heavier pole than either leg of a pair of shear legs.

DERRICKS. A derrick is a vertical gin pole or mast combined with a second, movable pole called a boom. The major advantage of a derrick is that the load can easily be moved in and out and side to side as well as up or down. The general arrangement of a derrick is shown in Fig. 5.

The boom tackle lifts the load. The mast tackle is used to position the load in or out from the mast, and the entire boom can be pushed sideways to position the load from side to side.

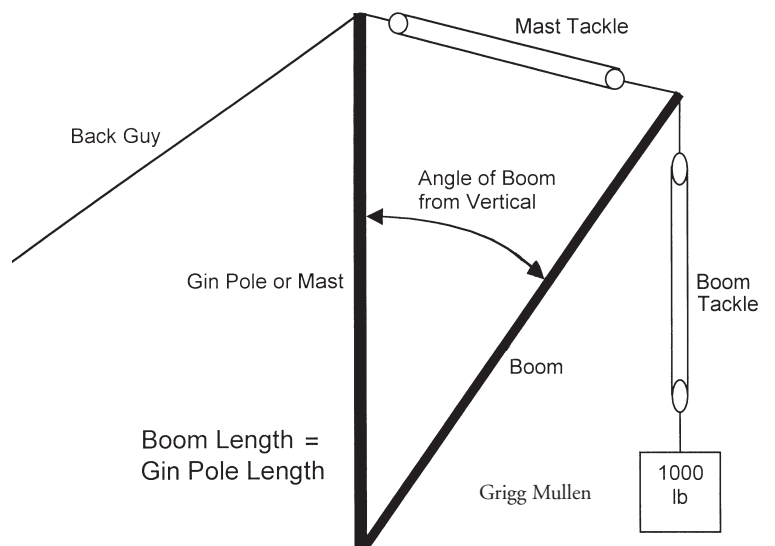

FIG. 5. SCHEME OF A DERRICK WITH LOAD. SIDE GUYS NOT SHOWN.

Rigging Boom Derricks. Initially, rigging a derrick is almost the same as rigging a gin pole. The gin pole is raised and secured, then the boom is added to the system. However, the addition of the boom does increase the loading on the guys. And the ability to swing the load sideways also means that the back guy or either of the side guys could carry the entire guy load. The guys need to be sized accordingly.

The major consideration in attaching the boom is to ensure that the end of the boom remains resting at all times against the bottom of the gin pole. The bottom of the boom can be forked to nestle against the pole, and then constrained by a loose lashing between the two poles.

Once the gin pole is in position, place the boom in position against the bottom of the gin pole. Rigging the end of the boom is

the same as rigging the top of the gin pole with the addition of a second sling to attach the mast tackle to the boom. Once the rigging is in place, attach the tackle from the gin pole to the end of the boom and lift the boom into position.

Boom Derrick Load Calculations. For a sample calculation, let's use the following dimensions in the derrick drawing at the start of this section:

- Guy distance = 60 ft.
- Pole distance (length from base to guy) = 30 ft.
- Boom length from base to tackle attachment = 30 ft.
- Angle of the boom from vertical = 20 degrees
- Ratio = Guy Distance ÷ Pole Distance = 60 ft. ÷ 30 ft. = 2.0

Derrick Guy Tension

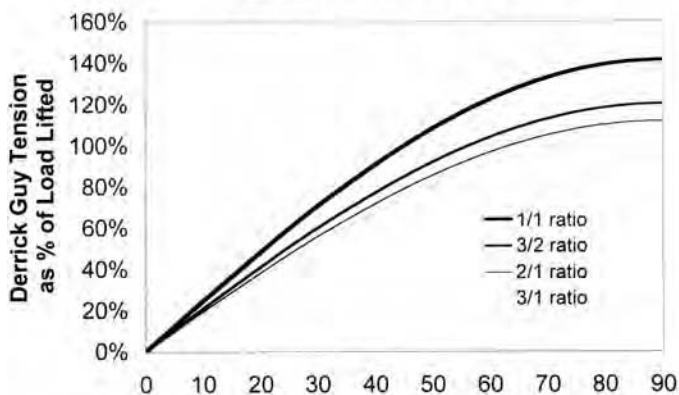

Mast Tackle

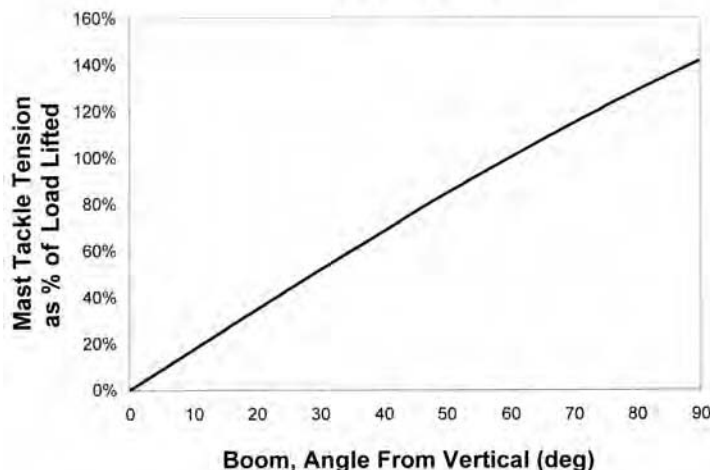

To determine the derrick guy tension, start at the 20-degree point on the horizontal axis of the graph. Go up to the curved line for a ratio of 2.0. Then go horizontally over to the vertical axis. Read off the load in the derrick guy as a percentage of the total load. Guy load as a percent of total load is 39 percent and thus equals 390 lbs. for our total load of 1000 lbs.

Bear in mind, however, that the boom is movable by intent. The limiting case of the guy tension would be reached as the boom approached horizontal. For the guy:pole distance ratio of 2:1 in this example, the maximum guy tension would be 110 percent of the load being lifted, or 1100 lbs. in our illustration. And, again, all of the guys would have to be sized to resist this load.

The process for determining the tension in the mast tackle is the same. But, since the boom is designed to move, the tackle has to be sized to resist the maximum load. Using trig again, with the gin pole and boom of equal lengths, the maximum tension in the mast tackle (the boom at horizontal, the tackle at 45 degrees) is $\sqrt{2}$ times the load to be lifted.

Maximum mast tackle load = $(\sqrt{2}) 1000 \text{ lbs.} = 1414 \text{ lbs.}$

Easier to remember than $\sqrt{2}$ or 1.414 would be a rule of thumb to size the mast tackle for 150 percent of the load to be lifted. That would also provide a bit of additional safety.

Determining Compression in the Derrick Gin Pole and Boom. To determine the compression in the derrick gin pole, start at the 20-degree point on the horizontal axis of the graph. Go up to the curved line for a ratio of 2.0. Then go horizontally over to the vertical axis. Read off the pole compression as a percentage of the total load. Compression as a percent of total load is 25 percent and thus equals .25 x 1000 lbs. or 250 lbs.

Again, the load on the system changes with the position of the boom. The gin pole must be sized to resist the maximum possible load. Reading the graph, the maximum compression in the gin pole for a 2:1 guy ratio is 150 percent of the load to be lifted, or 1.5 x 1000 lbs. = 1500 lbs.

Derrick Gin Pole Compression

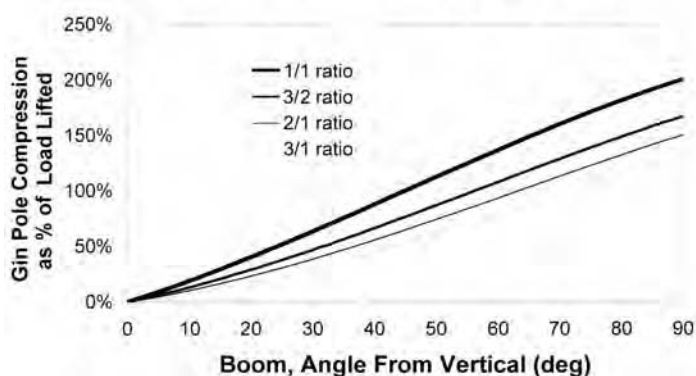

Compression in the Boom. There is no graph for compression in the boom because that force remains constant for the amount of load to be lifted. When the boom is vertical, the load acts directly downward on the boom, causing a compression equal to the load. As the boom swings downward, the mast tackle begins to pick up some of the load. But the tackle is angled in relation to the boom, so a portion of the mast tackle load acts along the boom, inducing some compression. When the boom length is equal to the mast length, the decrease in direct compression from the load is exactly offset by an increase in compression from the mast tackle.

SAFE DESIGN. For a lifting system to be safe, all of its components must be safe. The important items to consider are the strength of the poles, the bearing capacity of the soil under the pole butt, the capacity of the ropes and tackle and guys and, finally, the capacity of the guy anchors.

The following are appropriate factors of safety for the various parts of the system:

Wood poles: Use the allowable stresses in the *National Design Specification for Wood Construction* (NDS-1997).

Ropes and tackle: Use 5 to 1 as a minimum.

Ground anchors and pole bases: Use 2.5 to 1.

Strength of Poles. The poles carry the tension in the lifting or mast tackle into the ground as compressive load. The poles are the only compression pieces in the system; everything else works in tension.

There are two ways that a pole can fail. Either the wood can crush from being overloaded (not likely), or the leg can buckle like a bow. The buckling tendency depends on the overall length of the pole, its diameter and how the ends are constrained. A long, skin-

ny flagpole buckles at a lower load than a short, wide column captured top and bottom in a floor system.

Checking Pole Size for Safety. The worst-case example in the various systems is the mast in the derrick. The 30-ft. pole carries a compressive load of 1500 lbs. As a first check, we'll use an oak pole with a 6-in. tip diameter.

For No. 1 mixed oak, the NDS gives an allowable compressive stress parallel to the grain of 775 psi. Two failure methods need to be checked: compression and buckling.

Checking first for failure in compression, the actual compressive stress in the pole has to be below the allowable 775 psi.

$$\text{Stress} = \text{Load} \div \text{Area}$$

$$\text{Load} = 1500 \text{ lbs.}$$

$$\text{Sectional area of a pole} = \pi r^2$$

$$\text{Minimum section of a 6-in.-dia.-tip pole} = 28.3 \text{ sq.in.}$$

$$\text{Stress} = 1500 \text{ lbs.} \div 28.3 \text{ sq. in.} = 81.3 \text{ psi}$$

$$81.3 \text{ psi} < 775 \text{ psi}$$

But compressive failure of the poles is not going to be the prime failure mode. A much bigger concern is buckling of the poles. The longer and skinnier a pole is, the more it's likely to fail in buckling. The way to quantify "long and skinny" is through a number called the slenderness ratio:

$$\text{Slenderness ratio} = \text{length} \div \text{diameter} = l/d$$

$$\text{Length} = \text{length of the pole (true for our cases with poles restrained at each end)}$$

$$\text{Diameter} = \text{the minimum diameter of the pole}$$

The higher the slenderness ratio, the less load a pole can carry before buckling. Reducing the allowable compressive stress in the pole to account for the slenderness ratio ensures an adequate factor of safety. The following chart is used to determine the allowable stress in the pole to prevent buckling. The chart is conservative as it is based on low-strength wood (No. 2 white pine). Better quality wood would allow for higher loads in the poles.

For our sample 30-ft. mast with 6-in. tip, the capacity in compression is simply checked: if $l = 30 \text{ ft.}$ or 360 in. and $d = 6 \text{ in.}$ (minimum dimension), our slenderness ratio is then

$$l/d = 360 \text{ in} \div 6 \text{ in} = 60.$$

Note that if the mast were a 6x8 timber instead of a pole, d would be the minimum dimension of the timber, or again 6 in., despite the greater section of the rectangular timber.

To determine the allowable compression in the gin pole, start at the $l/d = 60$ point on the horizontal axis of the graph. Go up to the curved line. Then go horizontally over to the vertical axis. Read off

the allowable compressive stress in the pole for buckling as a percentage of allowable compressive stress parallel to the grain.

Allowable compressive stress against buckling as percent of total load is found to be 11 percent. Allowable compressive stress against buckling is then 11 percent x 775 psi or 85 psi.

We had previously computed the actual compressive stress in the 6-in.-dia. pole as 81.3 psi, less than the allowable stress of 85 psi. A higher margin of safety would be preferable. It is common practice to limit the slenderness ratio to a value less than 50. For our case,

$$l/d \text{ desired} = 50$$

$$l = 360 \text{ in.}$$

$$d = l/50 = (360 \text{ in})/50 = 7.2 \text{ in.}$$

So the safe conclusion is to use an 8-in.-dia. pole, which would produce a slenderness ratio of $360/8$, or 45. Rechecking allowable stress in buckling for $l/d = 45$, allowable compressive stress against buckling as a percent of total load = 18 percent, and allowable compressive stress against buckling is then $.18 \times 775 \text{ psi}$ or 140 psi.

$$\text{Sectional area of an 8-in.-dia. pole} = 50.3 \text{ sq. in.}$$

$$\text{Actual compressive stress} = 1500 \text{ lbs.} \div 50.3 \text{ sq. in.} = 29.8 \text{ psi}$$

$$29.8 \text{ psi} < 140 \text{ psi} = \text{Safe.}$$

Notice how a small increase in pole size makes a major difference in the safety factor against buckling.

CAPACITY of the ropes and tackle and guys. The ropes, tackle and guys must also be sized to carry the expected loads. The common minimum safety factor in rope for block and tackle and guys is 5:1. For a critical application such as an elevator, the minimum factor of safety is 10:1.

Guy Ropes. For the derrick, at our Ratio of 2.0 (p.32), the maximum tension in the guy rope to lift the 1000-lbs. load would be 1118 lbs. Multiplying by the safety factor of 5, we arrive at a minimum required breaking strength of 5600 lbs. for the guy rope.

From the chart of rope strengths (see TF 68, "Ropes and Knots"), we know that breaking strength of 1-in. 3-strand Manila rope is 8100 lb and of 1/2-in. Dacron (polyester) double-braid is 8200 lbs. Either would work as a guy rope.

Rope used in block and tackle. With a rope load of, say, 245 lbs. and the safety factor of 5, the minimum required breaking strength for the rope is then 1225 lbs. From our chart in TF68, the breaking strength of 1/2-in. three-strand Manila is 2380 lbs., more than we need, but anything smaller than 1/2-in. rope would be hard on the hands of the folks pulling on the rope.

Capacity of blocks. Often the safe working capacity of a block is less than the total capacity of the number of strands of rope that can be threaded through the block. For example, a commonly available three-sheave wood-shell block for 1-in. fiber rope has a safe working capacity of 4800 lbs. But the safe capacity of the six strands of 1-in. Manila rope (one on either side of each sheave) that can be reeved through this block is 9700 lbs. *Note that the only way to determine the safe capacity of a block is to refer to the manufacturer's literature.*

Calculating for safe rigging, if it seems a lot of work, is really a simple process of solving individually for each part of the system and then putting all the parts back together. Don't get spooked, just start with the load to be lifted and work forward from there.

—GRIGG MULLEN

Grigg Mullen teaches engineering at the Virginia Military Institute in Lexington. This article is third in a series on timber frame rigging. Previous articles appeared in TF 67 ("Raising Calculations and Prep") and TF 68 ("Ropes and Knots"). A final article on ground anchors and soil considerations will appear in a future issue.



Supplying timbers for over 20 years

Custom Cut Timbers

Clears / STK / #1 Structural

Douglas fir • Western Red Cedar • AYC
random or specified lengths • other grades available

We will quote any timber inquiry,
no matter how unusual.

Cowichan Lumber Ltd.

North Vancouver, BC, Canada
800-918-9119

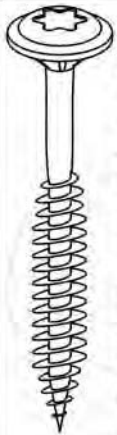

The "Star Drive" Construction / Lag Screw

The Construction / Lag Screw is a vastly improved alternative to the common lag screw. The uses for this screw are virtually unlimited. These screws are heat treated and hardened making them stronger and more durable than ordinary lag screws, have a built on round washer with smooth edges for a professional finish, a sharp notched point for exact quick starting and less walking, are lubricated and have deep cutting threads for quick easy driving. This unique design usually eliminates the need for pre-drilling and provides a neat finished appearance.

Gold Zinc Coated Hardened Steel: High Quality Steel C1022 Heat Treated And Hardened From 2 1/2" to 12" Lengths

Drive Without Pre-drilling: Star Recess Provides Twice The Torque Of Phillips Or Square Drives - Star Drive™ Reduces Worker Fatigue

Round Washer Head: 5/8" & 1 1/16" Diameter Heads And 5 Cutting Nibs

Deep, Wide, Sharp Threads: With Optimized Thread Depth To Thread Spacing

Sharp Point: Sharp Notched Point Reduces Splitting And Drive Torque Requirements



SCREW PRODUCTS INC.

"THE ULTIMATE WOOD SCREW"

223 SW 160th St • Seattle, WA 98166 • Phone: 206.242.8880 • Toll Free: 877.844.8880
Fax: 206.766.8880 • www.screw-products.com • info@screw-products.com

DOUGLAS FIR TIMBERS up to 24x30 50'



Reliance

SPECIALTY
BUILDING PRODUCTS

Toll free 800 697 4705
Fax 509 262 0250
sales@reliancesbp.com
www.reliancesbp.com

SOMETIMES BEING DEAD CAN BE A GOOD THING

Custom Timber Packages from

FOREST SALVAGED STANDING DEAD DOUGLAS-FIR & LARCH

SUPERIOR STABILITY

LONG LENGTHS / LARGE SIZES

ENVIRONMENTALLY FRIENDLY

COMPETITIVE PRICING

QUICK QUOTE TURN AROUND • SHORT LEAD TIMES
HIGH QUALITY TIMBERS • PERSONAL SERVICE

CLARK'S FORK TIMBER

New York Office

Phone (315) 986-8119 • Fax (315) 986-2622

South Carolina Office

Phone (864) 898-1655 • Fax (864) 898-1675

www.clarksforktimber.com

RECLAIMED / SALVAGED INDUSTRIAL TIMBERS ARE
ALSO AVAILABLE FROM OUR SISTER COMPANY,
RESOURCE SOLUTIONS.



Kiln-Dried Timber!

SunDried™ Resolves
The Green Dilemma

SunDried™ can dry most hardwoods and softwoods, including Northern Red Oak, Douglas Fir and Eastern White Pine.

SunDried™ Wood Technologies has refined a unique radio frequency/vacuum technology that uniformly kiln-dries whole timbers, bringing the percentage of the wood's moisture content down to single digits. SunDried™ timber is as dry at its heart as it is on the surface.

With SunDried™ Timbers you get:

- Dimensional Stability
- Optimal Structural Integrity
- No Additional Checking
- Peace of Mind

(304) 965-7700
sundriedwood.com

Fax (304) 965-7795
P.O. Box 130
Elkview, WV 25071

Foard
P A N E L

The Timber Framers' Panel Company

www.FoardPanel.com

P.O. Box 185, West Chesterfield, NH 03466
603-256-8800, info@foardpanel.com

"APPRECIATE" YOUR INVESTMENT

ENCLOSE your timber frame with America's premier structural insulating panels. Our polyurethane panels' in-molded wire chases, cam-locking system and T&G joints allow for the quickest of installations. Available in R-values of R-28, R-35 or R-43. Murus EPS panels are offered in R-16, R-23, R30, R-38 or R-45.

Polyurethane or EPS, consider Murus for all your SIP needs!



murus

STRUCTURAL INSULATING PANELS

PO Box 220
Mansfield, PA 16933
570-549-2100
Fax 570-549-2101
www.murus.com
murus@epix.net

TIMBERS

- Cypress •
- Southern Yellow Pine •
- Oak •

Paul Whitehurst
Tarboro, North Carolina

phone 252-641-0591 fax 252-752-1494



Your Post & Beam Source

Pine • Oak
Hemlock

Post & beam timbers and lumber in over 12 patterns

Grade stamping and dressed timbers available

PLUS our building supply store can supply you with everything else you need!

W. D. COWLS, INC.
134 Montague Road, P.O. Box 9677
North Amherst, MA 01059
413-549-1403 • Fax 413-549-0000

info@cowls.com • www.cowls.com

Hundegger USA



Ask us about the updated
K2 Joinery Machine
and the new
PBA Panel Machine

Call or e-mail us for a free video

(435) 654-3028 OR (801) 361-4030

INFO@HUNDEGGERUSA.COM • WWW.HUNDEGGERUSA.COM



OUR QUALITY

... limited only by
your imagination!

EVERGREEN SPECIALTIES LTD.

FOR SALE

DRY LARCH the conifer that thinks it's a hardwood
NATURE'S RECYCLED TIMBER
SELECTIVELY LOGGED STANDING DRY TREES
DIRECT FROM THE FOREST TO YOU
DRY BANDSAWN JOISTS, POSTS & BEAMS

Harder and Stronger than Douglas Fir
Dense grain: up to 20 rings/in.
Used for timber construction
PHOTOS via e-mail on request

Contact Bruce Lindsay
Toll free 877-988-8574
FAX 604-988-8576
Timber Supplier since 1989

When compromise is not an option, call us.



Dreaming Creek

Timber Frame Homes, Inc.
Powhatan, VA 23139 804-598-4328
Fax 804-598-3748
www.dreamingcreek.com
sales@dreamingcreek.com

QUALITY TIMBERS

OAK AND SOUTHERN YELLOW PINE
LENGTHS UP TO 45 FT.
FAST DELIVERY ON STOCK SIZES

**World's finest timber,
expertly sawn
for appearance.**

Douglas Fir Red Cedar
Sitka Spruce Yellow Cedar

Any size. Any grade. Any specification.
Kiln Drying. S4S. Delivered prices.

**Pacific
Timber
Supply Ltd.**



2999 Beach Drive, Victoria, BC
Canada V8R 6L1
Tel: (250) 380-9688
Fax: (250) 380-6388
Email: info@PacificTimber.com



Port Orford cedar, Curry County, Oregon

*Trees selectively harvested.
Timbers sawn to your specifications.*

EAST FORK LUMBER CO., INC.
P.O. Box 275 • Myrtle Point, Oregon 97458
Tel. 541-572-5732 • Fax 541-572-2727 • eflc@uci.net

A Precise Production Tool at a Competitive Cost

A 100 Year Tradition Continues. Quality-Made in Germany



- Chain Mortisers
- Carpenter's Chainsaws
- Slotting Mortisers

SAUER - 6" Chain Mortiser
1 1/2" or 2" Chain & Bar
Support Frame Included

Call now! (416) 675-2366
TimberTools.com

Hull Forest Products, Inc.

Sustainable forestry, quality products

- Kiln-dried flooring:
red oak, white oak, and hickory
- Eastern white pine paneling and flooring
12-20 in. wide
- Post and beam timbers up to 26 ft. long



Proud manufacturers of
NHLA quality lumber

101 Hampton Rd. • Pomfret Center, CT 06259

tel 800-353-3331 • fax 860-974-2963 • www.hullforest.com

Contact Craig H. Capwell, capwell@hullforest.com

QUALITY OAK TIMBERS

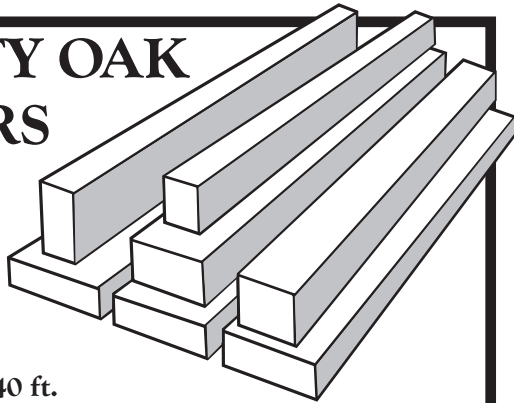

- Accurate,
custom
4-sided
planing
up to 9 x 15 x 40 ft.

- Also 2x6 and 1x6 T&G
White Pine in stock

Call for
timber price list,
419-281-3553

Hochstetler Milling, Ltd.
552 St. Rt. 95
Loudonville, OH 44842

FRASERWOOD INDUSTRIES

KILN DRIED TIMBERS

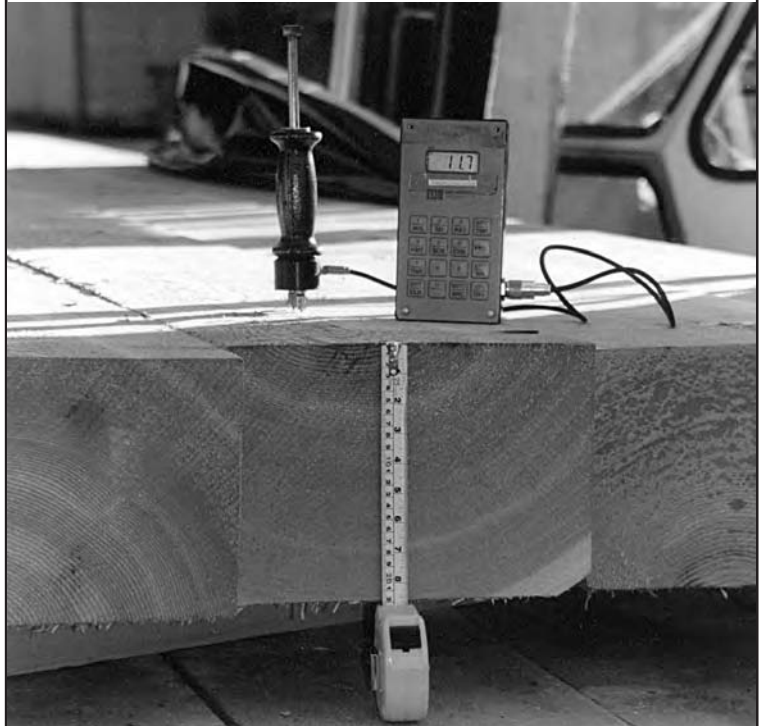

**“Your timbers offer the
reality of which we have
dreamed for many years.”**

Ben Brungraber, PhD, PE, Operations Director,
Benson Woodworking Co.

Fraserwood Industries' radio
frequency/vacuum kiln with its unique
restraining system can dry timber of all
dimensions and up to 40 ft. long
to 12% MC with minimal degrade.

FRASERWOOD INDUSTRIES
Please call Peter Dickson at (604) 892-7562.
For more information, visit our web page at
www.fraserwoodindustries.com.



©Heidi Marty Photography

Timber frame pavilion by
Centennial Timber Frames

- A leading company in the structural design of
timberframe & log structures
- Services range from Design Review to
Full Construction Document Packages
- Licensed in 46 states & Canada
- Supporter, TFG & ILBA



STRUCTURAL

BEAUDETTE
CONSULTING
ENGINEERS, INC.

131 WEST MAIN
MISSOULA, MT 59802

TEL: (406) 721-7315

FAX: (406) 542-8955

www.bceweb.com

**performs
in every
season**



- Urethane or EPS cores
- 4 x 8 to 8 x 24
- Full CAD/CAM pre-cut services
- Panels for timber frames and hybrids
- Delivery anywhere in North America
- A crane truck for ease of unloading if your site is within 300 miles of our plant

 **winterpanel**

74 Glen Orne Drive, Brattleboro, VT 05301
802-254-3435 Fax: 802-254-4999

winterpanel.com

Foam Laminates of Vermont

*Supplying quality stressskin panels for
Timber Frame structures since 1982*

- Superior Quality
- Built to your Specifications
- Curtainwall and Structural
- Professional Installation Available
- Friendly, Knowledgeable Service
- Specializing in Timber Frame Enclosures

PO Box 102 Hinesburg, VT 05461
802-453-4438 Phone 802-453-2339 Fax
E-mail foamlam@sover.net
www.foamlaminates.com

LANDARK

WOOD FINISH

All natural, citrus base, penetrating finish
timbers • logs • v-groove • cabinets • doors • floors

Advantages:

- No chemical additives**, driers, or petroleum products
- User friendly**, biodegradable, non-ozone depleting
- Reduces further checking**, even in green oak
- Renewable resources** used for all ingredients

Available in:

- Liquid finish** (wicks deeply into checks)
- Soft wax** (nonstaining end-grain sealer)
- Aniline dye wiping stain** (one step, soft wax base)
- Exterior finish** (weathers to silver-gray)

Mike and Nita Baugh
215 Townes Rd, Augusta, SC 29860

803-279-4116
fax 803-278-6996

**Subscribe
Now!**

through the pages of *Timber Frame Homes*, the premier magazine showcasing these classic, yet contemporary homes.



Yes! Send me a one-year subscription to **Timber Frame Homes** – 4 issues plus a bonus summer issue for just **\$14.97!**

525

- Check enclosed payable to **Home Buyer Publications, Inc.** (mail to *Timber Frame Homes*, 80 S. Early St., Alexandria, VA 22304)
- Please bill me Call 800-294-7006 or visit www.timberframehomes.com

Name _____

Address _____

City _____

State/Zip _____

Offer valid in U.S. only. Canadian subscriptions, \$19.97 (Prepaid U.S. funds). Foreign subscriptions, \$26.97 (Prepaid U.S. funds).

INSULSPAN™

No. 1 Brand Leader in Structural Insulated Panels

**Your complete building system solution,
preferred by timber framers everywhere.**



Sold and serviced nationwide, Insulspan leads the industry in the development, manufacturing and performance of structural insulated panels.

1.800.PANEL.10

INSULSPAN™

STRUCTURAL INSULATED PANEL SYSTEM

www.insulspan.com



Masters of our craft

mafell

The widest range of specialized machines for timber framing

- Extreme planing widths pose no problems for MAFELL's ZH 320 E lightweight beam planer.

ZH 320 E

Carpentry planer

Quality made in Germany



Please call us!
We can provide leaflets with detailed information and all technical data.

MAFELL North America Inc.
1975 Wehrle Drive, Suite 120 · Williamsville, N.Y. 14221
Phone: (716) 626-9303 · FAX (716) 626-9304
e-mail: mafell@msn.com · Internet: www.mafell.com

GRUPPE DREI WS 1.2000

For color ad rates
(not expensive)

CALL

Joel McCarty
603-835-2077
joel@tfguild.org



EnerGreen
Building Systems Ltd

Manufacturers of Structural Insulated Panels

It's a Wrap!



Tested & Engineered
3-D CAD, customized drawings
Full Service - Design to Installation
Engineered structural components also available
Prompt service to Western States, Alaska and Canada
Precision pre-cutting + lumber installation = job site ready



3294 262 Street, Aldergrove, BC, Canada V4W 2X2
604-856-0600 Fax: 604-856-0608

www.energreenbsl.com

PUBLISHED BY
THE TIMBER FRAMERS GUILD
PO BOX 60, BECKET, MA 01223

NON-PROFIT ORG.
U.S. POSTAGE
PAID
EAST BARRE, VT
PERMIT NO. 2

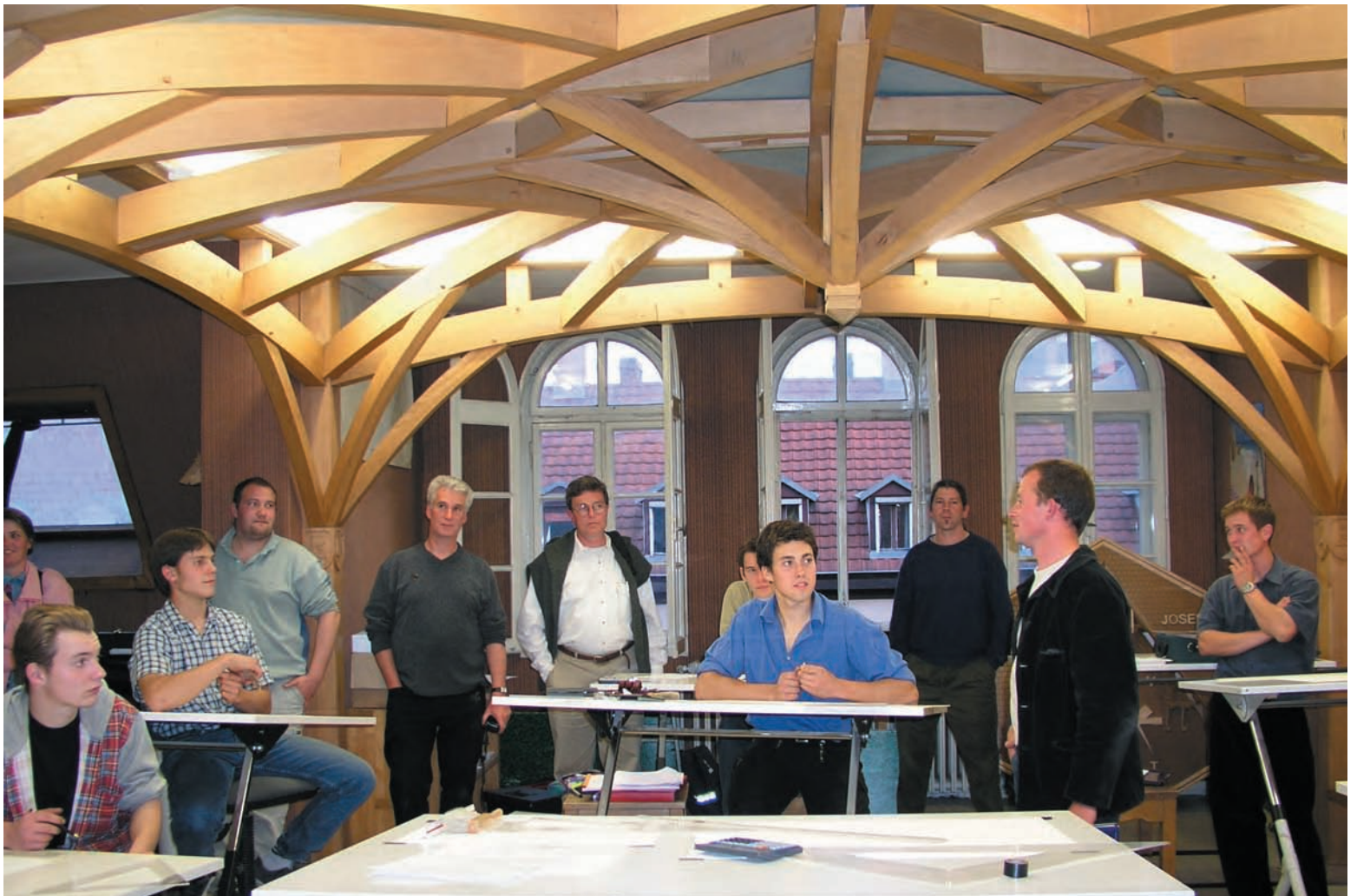

Will Beemer

Above, the TFG tour group visits the drawing studio at the Compagnon du Devoir house in Strasbourg. Boris Noël, who led the group for much of the tour, stands second from right. Under the framed canopy at the back, from right, Tim Whitehouse, Denis Marcom, Chris Madigan.