COMMUNITY GARDEN GUIDE SEASON EXTENSION

SEED STARTING

Vegetable gardening in the Great Lakes States requires a little more effort than in more temperate areas. It is often necessary to start many vegetable plants indoors to allow adequate time for the plants to bear fruit. The first stage of successful gardening begins with the proper starting of vegetable bedding plants. Sturdy, well cared for bedding plants will be more disease resistant, more productive, and produce better quality fruit. Likewise, seeds not started indoors require proper handling and care if a reasonable level of success is to be achieved.

BEDDING PLANT PRODUCTION

Proper timing for seeding of plants that will be transplanted as bedding plants into the garden is critical. Bedding plants must be large enough at planting time to allow them adequate time to produce the desired vegetable crop. Some plant seeds require treatments called scarification or stratification before planting. Scarification of seed involves scratching the seed coat to aid in germination. In some cases, seed can be scarified by placing the seed in a jar of gravel or sand and shaking it to scratch the seed coat. Stratification of seed requires giving the seed a cold treatment by placing it in a freezer for a period of time. If this is the case, additional pre-seeding time needs to be planned into the plant propagation calendar. These measures are generally not required when seed is purchased. It may become an issue if seed is saved.

FROST FREE DATE

The first step growing vegetable bedding plants successfully is to determine the last “frost free date” for your area. This information is generally available at University Extension Service Offices and local garden supply stores. Some seed catalogs will also provide that information, but it tends to be general in nature.

GROWING MEDIUM

Growing medium for starting plants can consist of commercially available potting soil or compost produced on-site. Potting soil is widely available in garden stores and through garden supply catalogs. Compost is considered the best medium for starting plants, as it contains trace nutrients and discourages many plant diseases. For seed starting, it is recommended that a fine textured growing medium be used for fine seed sized plants. The fine textured medium should

not contain any fertilizer amendments. After plants have developed two true leaves, they should be transplanted into a larger pot that has been filled with a coarser textured medium. Large seed size plants can be started in coarser medium and need not be re-potted. If compost is used, it will be necessary to screen the material to the proper texture needed for the different plant propagation stages.

PLUG FLATS AND PLANTING CELLS

Plug flats are formed plastic sheets that contain small cells used for seed starting. After germination, seedlings are generally transplanted into larger plant cells. A good all-purpose size of plug tray contains 200 cells per tray. Planting cells come in a variety of sizes. It is important to select the size of plant cell for the particular type of plant you are growing. A table of recommended plant cell sizes for selected vegetable plants can be found at the end of this garden guide. Plant cell trays, used to hold plug flats and plants cells come in a standard size of 11 by 21 1/4 inches. Plastic planting cells come in numerous sizes and configurations. The configuration; whether a single, 4-pack, or 6-pack planting cell; is of less importance than the appropriate size of cell for the plant being grown in it.

SANITATION

Proper sanitation is essential to ensure positive results when growing bedding plants. Newly purchased plant cells do not require any special attention and may be used for planting as is. Planting cells may be reused if proper precautions are taken. Used cells will often harbor disease organisms that can kill seedlings. Damping Off Disease is the disease that kills seedlings most commonly. Proper sanitation will prevent most occurrences of this disease. Used flats and cells should be sterilized by soaking in a 10 percent solution of household bleach and water. Soak trays for 1 to 2 hours, rinse thoroughly, and plant.

GERMINATION

For the best results when germinating seeds, the use of a propagation mat is recommended. Plant seeds in moist growing medium at the recommended depth. Cover seeds with approximately 1/8 inch of granular purlite. The purlite tends to keep the planted surface drier, reducing the chance of damping off. Purlite is also very light, allowing sprouting seeds to easily emerge. Water planted seed, being careful not to dislodge the purlite and seeds. Loosely cover the seeded flat with plastic to retain moisture. Place the flats on the propagation mat and set the temperature control to the recommended germination temperature. Placing a thermometer on top of the trays provides a useful way to monitor temperatures. Check the flats daily. The application of heat from a propagation mat tends to dry plug cells out rapidly. Periodically moisten seed flats as needed, being careful not to over water. As soon as seedlings emerge, remove the plastic covering



Propagation mat and controller.

and place the flat under propagation lights. Place the seedlings as close as possible to the lights without allowing the vegetation to contact the light bulb. Keeping the plants close to the light source keeps the plants from becoming “leggy” and spindly. Lower the plants as they grow, keeping them just below the lights.

Many seed catalogs and seed packets contain information on germination temperatures. Germination temperatures of several easily grown plants are listed below.

| <i>Germination Temperatures of Selected Vegetable Plants</i> | | | |
|--|----------------|---------------|---------------------|
| Broccoli 77° F | Eggplant 85° F | Onion 70° F | Summer Squash 80° F |
| Cabbage 86° F | Herbs 65° F | Pepper 85° F | Tomato 85° F |
| Cucumber 86° F | Melon 90° F | Pumpkin 85° F | Winter Squash 80° F |

TRANSPLANTING

Small seeded plants such as peppers, tomatoes, cabbage, etc. may be started by seeding into 200 cell plug flats. The advantage is that a large number of plants can be started and placed on a propagation mat for germination. Plants started in these small cells must be transplanted into larger cells as soon as the first true leaves develop. Larger seeded plants such as squash, melons, cucumber, etc. should be started in the cells that they will be grown in until transplanting.

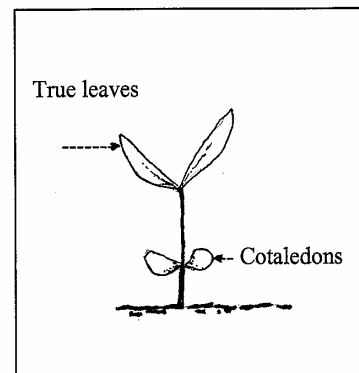

Bedding plant at two leaf stage.

When transplanting a seedling into a larger cell, carefully work the seedling from the plug tray with a small knife or similar tool. Be careful not to dislodge the growing medium or damage the plant stem. Pre-fill the plant cells with a coarser growing medium. Hollow an area in the growing medium to accept the seedling. Place the root mass near the bottom of the plant cell and carefully pack the medium around the seedling. Water the plants well and place under the grow lights for the next growth stage.

LIGHTS

Florescent grow-lights are recommended for plant propagation as they provide the proper light spectrum required for plant growth. Grow-lights are fairly expensive. To economize on costs, it is possible to install one grow-light and one conventional florescent light in each light fixture.

A timer should be placed on the propagation rack lights. Generally, 12 hours of “daylight” per 24 hour time period is adequate for good plant growth.



Home made propagation racks. Each rack will hold 24 standard plant propagation trays.



Quality tomato plant seedlings. Note the stocky stature and good leaf development.

HARDENING OFF

Hardening off plants refers to acclimatizing them to the outdoor environment. Plants grown indoors have not been exposed to wind, direct sunlight, or fluctuations in temperature. Plants grown indoors cannot be placed directly in the sunlight. Doing so will cause the foliage to sunburn and either kill the plant or reduce the plant’s ability to thrive. To harden plants off, it is necessary to move the plants outdoors and protect them from direct sunlight and strong breezes.

To harden plants off, move the plants outdoors, protect them from direct sunlight and strong breezes; keeping them in partial shade in the late afternoon. Cover the plants with spunbond polyester row cover material. After a couple of days, move the plants into direct sunlight but keep them covered with row cover material. After about 5 days, remove the row cover and allow gentle breezes to “work” the plants. Be sure to keep the bedding plants well watered, as they will tend to dry out more quickly in an outdoor environment. After about a week, the plants should be ready to plant in the garden.

RECOMMENDED PLANTS TO START AS BEDDING PLANTS

| CROP [s] small seed [l] large seed (planting cell size) | WEEKS BEFORE TRANSPLANTING | SEED PLANTING DEPTH (Inches) | TRANSPLANT SPACING | |
|--|----------------------------------|---------------------------------------|-----------------------|----------------|
| | | | WITHIN ROW | BETWEEN ROW |
| Broccoli [s] (1) | 4-6 | 1/4-1/2 | 8-10" | 18-24" |
| Cabbage [s] (1) | 4-6 | 1/4-1/2 | 18-24" | 30" |
| Cucumber [l] (2) | 4-5 | 1/2 | 2' | 5-6' |
| Eggplant [s] (2) | 8 | 1/4 | 18" | 18-24" |
| Herbs [s] (1) | 4 | 1/4 | 4-6" | 12-18" |
| Lettuce [s] (2) | 4-5 | 1/4 | 12" | 12" |
| Melon [l] (3) | 4-5 | 1/4 | 2-3' | 6' |
| Onion [s] (*) | 8 | 1/4 | 4" | 12" |
| Pepper [s] (2) | 8 | 1/4 | 12-18" | 2-3' |
| Pumpkin [l] (3) | 2-4 | 1 | 5-6' | 5-6' |
| Summer Squash [l] (3) | 2-4 | 3/4-1 | 18" | 2-3' |
| Tomato [s] (3) | 8 | 1/4 | 18"-24" | 3' |
| Watermelon [l] (3) | 4-5 | 1/2-3/4 | 3-4' | 3-4' |
| Winter Squash [l] (3) | 2-4 | 1 | 3-4' | 4-5' |

Recommended Planting Cell Sizes

- (1) - 1 1/2" x 1 1/2"
- (2) - 2" x 2"
- (3) - 4" x 4"

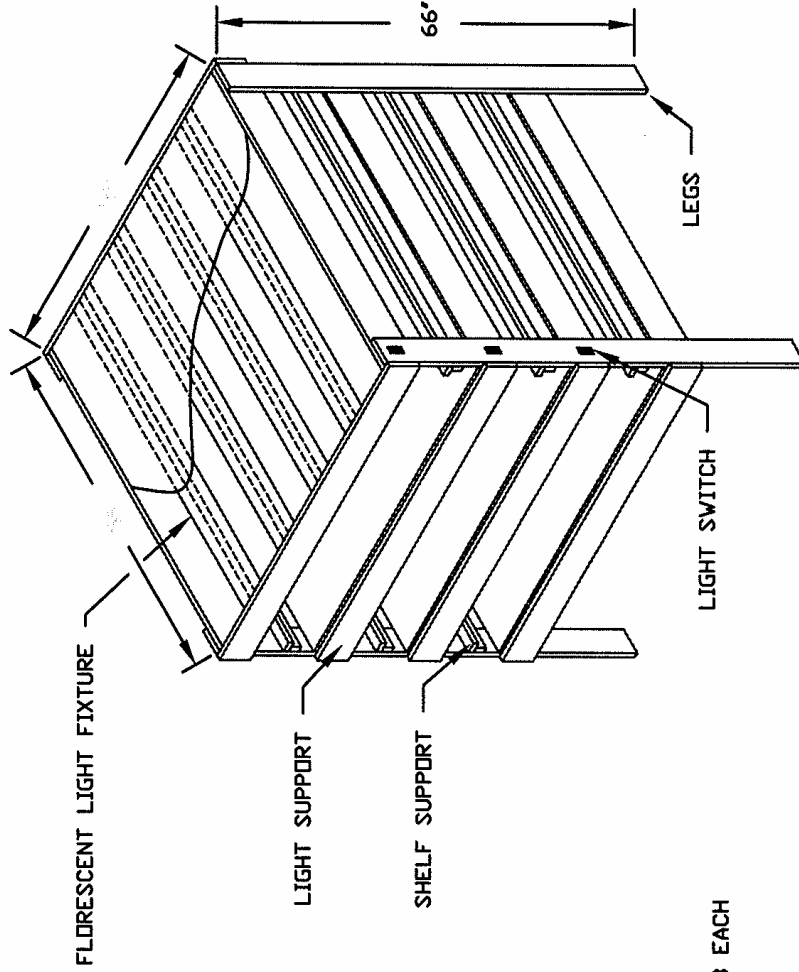

BILL OF MATERIALS

- SIDE SUPPORTS - LIGHT
2"X 4"X 10' - 5 EACH
- SHELF SUPPORT
1"X 4"X 10' - 2 EACH
- LEGS
2"X4"X 8' - 4 EACH
- END SUPPORT BOARD - LIGHT
2"X 4"X 8' - 5 EACH
- LIGHT SUPPORT CLEAT
1"X 4"X 10' - 3 EACH
- 1/2"X 4"X 8' PLYWOOD - 4 EACH
- TOP SHELF - 1 EACH
48" X 54"
- INTERNAL SHELF - 3 EACH
44 7/8" X 54"
- 4 FOOT FLORESCENT LIGHT FIXTURES - 12 EACH
- 4 FOOT FLORESCENT GROW LIGHTS - 24 EACH
- 125 VOLT SINGLE POLE LIGHT SWITCH - 3 EACH
- 4 INCH OCTAGONAL METAL SWITCH BOX - 3 EACH
- 4 INCH OCTAGONAL METAL SWITCH BOX COVER - 3 EACH
- 14-2 ROMEX NM WIRE - 50 FEET
- 1/2 INCH WIRE STAPLES - 10 EACH
- 14 GAUGE WIRE NUTS - 1 BAG
- WIRE/BOX CLIPS - 8 EACH
- 14-3 ELECTRIC WIRE - 10 FEET
- 14-3 ELECTRIC PLUG - 1 EACH
- ELECTRICAL TAPE - 1 ROLL
- 8 X 2 1/2 TORX OR PHILLIPS SCREWS - 5 POUNDS
- 8 X 3/4 PAN HEAD SHEET METAL SCREWS - 1 POUND
- TORX OR PHILLIPS HEAD DRILL BIT - 1 EACH

PLANT PROPAGATION RACK

| | |
|-----------|----------|
| OWNER | |
| COUNTY | LCC, WI. |
| Designed: | Checked: |
| SHEET | DF |

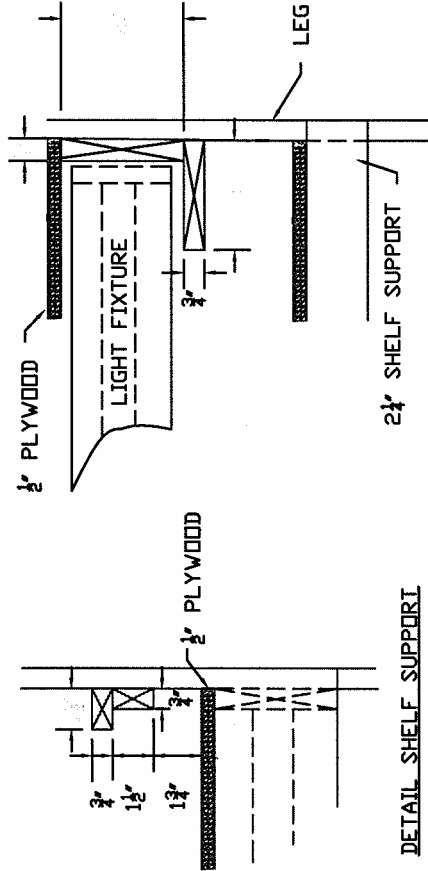
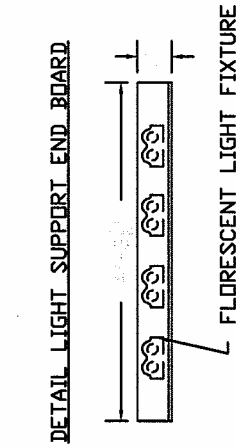
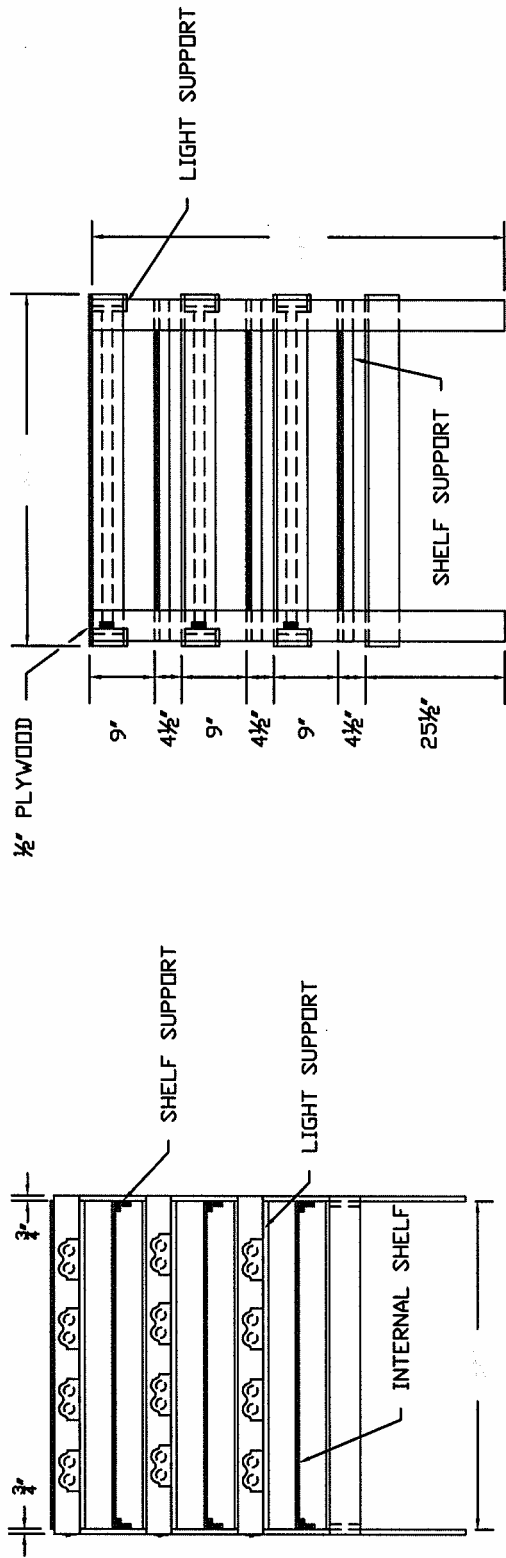

PLANT PROPAGATION RACK
 DETAIL SHEET

| | |
|----------|----------|
| OWNER | _____ |
| COUNTY | LCC, WI. |
| Designed | Checked |
| SHEET | OF |

Approved: _____
 Checked: _____
 Drawn: _____
 Date: _____

**PROPAGATION RACK
 WIRING DIAGRAM**
 Page 1 of 1

NRCS
 National Resource Conservation Service
 United States Department of Agriculture

02-22 02/20/00

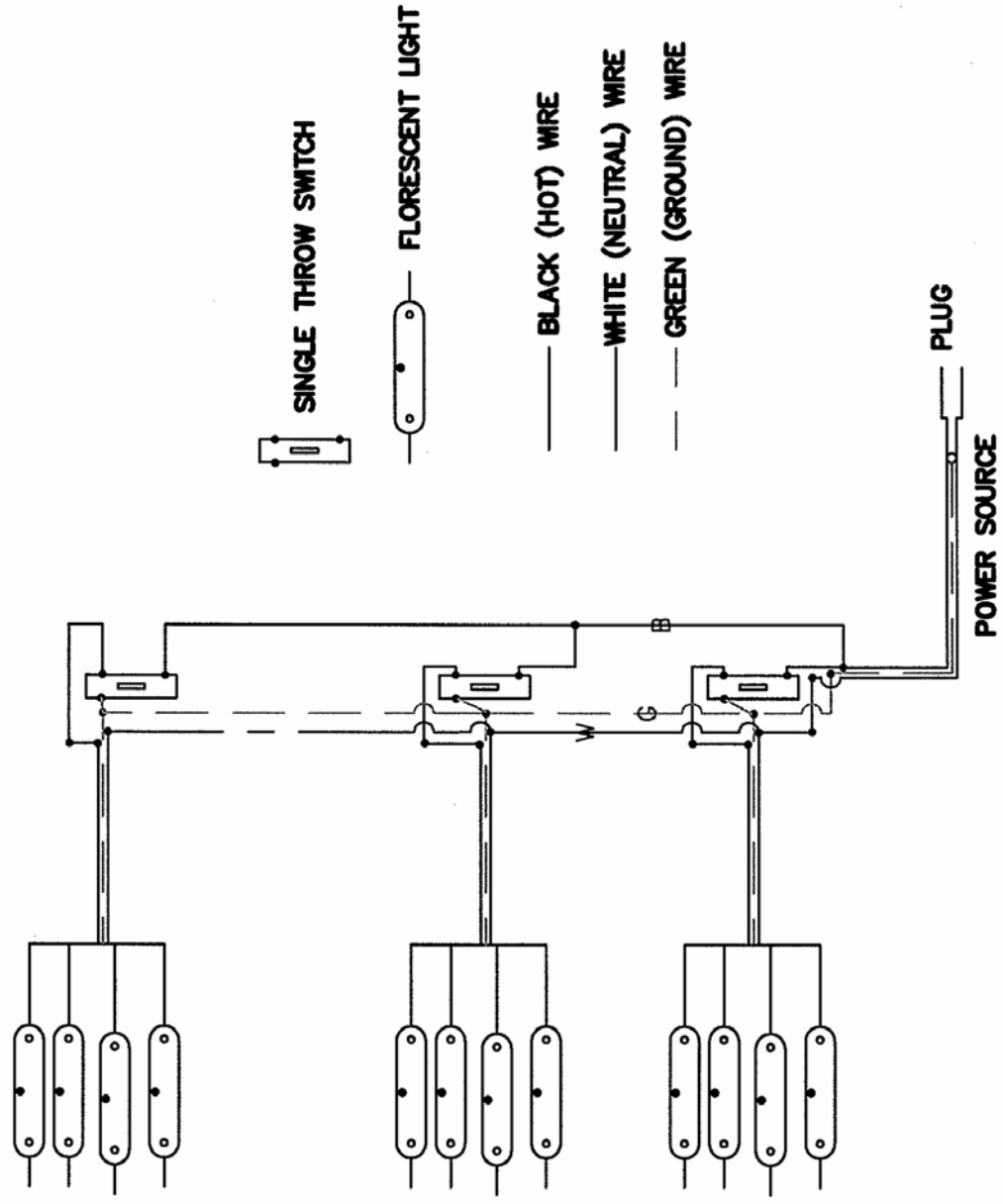

SINGLE THROW SWITCH

FLORESCENT LIGHT

BLACK (HOT) WIRE
WHITE (NEUTRAL) WIRE
GREEN (GROUND) WIRE

SOURCES

Propagation racks of various sizes are available from commercial sources including greenhouse supply, gardening supply, and seed companies. The propagation rack pictured in this guide is about the most economical alternative if large quantities of bedding plants are to be started and if there are space limitations.

CONTRIBUTORS

Thomas Cogger, Tribal Liaison, NRCS, Ashland, WI.

David Burgdorf, Plant Materials Specialist, NRCS, East Lansing, MI.

Wisconsin State Plant Materials Committee.

Rose Lake Plant Materials Center, NRCS, East Lansing, MI.

Glenn Lamberg, American Indian Liaison, NRCS, Fremont, MI.

Rick Knysz, CAD Instructor, Newaygo County Career-Tech Center, Fremont, MI.

Paul Johnson, Civil Engineering Technician, NRCS, Ashland, WI.

CONTACT INFORMATION

- Rose Lake Plant Materials Center, NRCS, 7472 Stoll Road, East Lansing, MI 48823-9420; telephone (517) 641-6300.
- David Burgdorf, Plant Materials Specialist, NRCS, East Lansing, MI at: dave.burgdorf@mi.usda.gov
- John Leif, Plant Materials Center Manager, NRCS, East Lansing, MI at: john.leif@mi.usda.gov

The U.S. Department of Agriculture (USDA) prohibits discrimination in all its programs and activities on the basis of race, color, national origin, sex, religion, age, disability, political beliefs, sexual orientation, and marital or family status. (Not all prohibited bases apply to all programs.) Persons with disabilities who require alternative means for communication of program information (Braille, large print, audiotape, etc.) should contact USDA's TARGET Center at (202) 720-2600 (voice and TDD). To file a complaint of discrimination write USDA, Director, Office of Civil Rights, Room 326-W, Whitten Building, 14th and Independence Avenue, SW, Washington, DC 20250-9410 or call (202) 720-5964 (voice or TDD). USDA is an equal opportunity provider and employer.