

**FOREST INVENTORY AND ANALYSIS
NATIONAL CORE FIELD GUIDE**

VOLUME I: FIELD DATA COLLECTION PROCEDURES FOR PHASE 2 PLOTS

Version 3.1



**NORTHERN RESEARCH STATION
FOREST SERVICE
U.S. DEPARTMENT OF AGRICULTURE
OCTOBER 2006**

“Anyone who establishes a permanent plot should recognize that he or she hereby assumes responsibility for furnishing workers with a complete picture of conditions on the plot at the time of its establishment. Not only must each plot be properly marked and all measures are in near perfect order, but all notes and records must be complete. Otherwise, the plots may fail to yield the desired results and those who in later years become responsible for their care and for the analysis of the data, may be led to serious mistakes.”

[U.S. Department of Agriculture, Forest Service 1935.]

NRS Note to User: Version 3.1 is a by-product of the merger of the North Central and Northeast FIA units effective October 1, 2006. Data elements and procedures from the previous regional guides may no longer be applicable. Version 3.1 is based on the *National Core Field Guide, Version 3.0*. All data elements are national unless indicated as follows:

- National data elements that end in “+N” (e.g., x.x+N) have added values/codes*. Any additional regional text for a national data element is hi-lighted or shown as a “NRS Note.”
- All regional data elements end in “N” (e.g., x.xN). The text for a regional data element is not hi-lighted.
- All state specific regional data elements end in “N-XX” (e.g., x.xN-ME). The text for state data element is not hi-lighted.
- National data elements or procedures with light gray text are not applicable in the North.

* It should be noted that all national data elements with added regional values/codes must be collapsed back to existing national standards by the Information Group unless supported by *NIMS*.

Text in hi-lighted boxes indicates procedural or data elements changes from 3.0 to 3.1 for either former North Central or Northeast crews, or other special instructions that apply to data collection or data processing.

Red italicized highlighted text reflects a correction/clarification that has been made since 08/18/2006 -- 1st print release.

Please direct questions or comments about this document to:

Kathryn M. Tillman
Forest Inventory and Analysis Unit
USDA Forest Service
11 Campus Blvd., Ste. 200
Newtown Square, PA 19073

(610)557-4053
kmtillman@fs.fed.us

INTRODUCTION.....	7
FIELD GUIDE LAYOUT	8
UNITS OF MEASURE.....	9
0.0 GENERAL DESCRIPTION	9
0.1 PLOT SETUP.....	11
0.2 PLOT INTEGRITY.....	12
0.3N PLOT DATA SECURITY	13
0.4N WILDERNESS AREAS	13
1.0 PLOT LEVEL DATA	17
1.0.1N CYCLE [CYCL]	17
1.0.2N SUB-CYCLE [SUBC]	17
1.1 STATE [ST].....	17
1.1.1N UNIT [UNIT]	17
1.2 COUNTY [CNTY].....	18
1.3 PLOT NUMBER [PLT#].....	18
1.4 PLOT STATUS [STAT].....	18
1.5 PLOT NONSAMPLED REASON [REAS]	18
1.6 SUBPLOTS EXAMINED [EXAM].....	19
1.7+N SAMPLE KIND [SK].....	20
1.7.1N PHASE	21
1.8 PREVIOUS PLOT NUMBER.....	21
1.9+N FIELD GUIDE VERSION.....	21
1.10 CURRENT and PREVIOUS DATE.....	21
1.10.1+N YEAR [YEAR].....	21
1.10.2 MONTH [MONT].....	22
1.10.3 DAY [DAY].....	22
1.10.4N PREVIOUS YEAR	22
1.10.5N PREVIOUS MONTH	22
1.11 DECLINATION (CORE OPTIONAL)	22
1.12 HORIZONTAL DISTANCE TO IMPROVED ROAD [RDIS].....	22
1.13 WATER ON PLOT [WTYP].....	23
1.14 QA STATUS [QAST].....	23
1.15 CREW TYPE [CRTY].....	24
1.15.1N CRUISER [CRUI]	24
1.15.2N TALLIER [TALL]	24
1.15.3N ONE OR TWO PERSON PLOT [CRSZ]	24
1.15.4N PLOT SEASON [SEAS]	25
1.16 GPS Coordinates	25
1.16.1 GPS Unit Settings, Datum, and COORDINATE SYSTEM	25
1.16.2 Collecting Readings	25
1.16.3 GPS UNIT [UNIT]	26
1.16.4 GPS SERIAL NUMBER [GPS#]	26
1.16.5 GPS DATUM.....	26
1.16.6 COORDINATE SYSTEM.....	26
1.16.7 Latitude	27
1.16.8 Longitude	28
1.16.9 UTM ZONE	29
1.16.10 EASTING (X) UTM.....	29
1.16.11 NORTHING (Y) UTM	29
1.16.12 Correction for "Offset" Location.....	29
1.16.13 AZIMUTH TO PLOT CENTER [AZM]	29
1.16.14 DISTANCE TO PLOT CENTER [DIST]	29
1.16.15+N GPS ELEVATION [ELEV].....	29
1.16.16 GPS ERROR [ERRS]	30
1.16.16.1N GPS PDOP [PDOP]	30
1.16.17 NUMBER OF READINGS [READ]	31
1.16.18 GPS FILENAME (CORE OPTIONAL).....	31
1.17 MACROPLOT BREAKPOINT DIAMETER (CORE OPTIONAL)	31
1.18 PLOT-LEVEL NOTES	31

2.0	CONDITION CLASS	33
2.1	DETERMINATION OF CONDITION CLASS.....	33
2.1.1	Step 1: Delineate the plot area by CONDITION CLASS STATUS	33
2.1.2	Step 2: Further subdivide Accessible Forest Land by 6 delineation variables.....	33
2.2	CONDITION CLASS STATUS DEFINITIONS.....	33
2.3	CONDITION CLASS ATTRIBUTES.....	37
2.4	DELINEATING CONDITION CLASSES DIFFERING IN CONDITION CLASS STATUS:	37
2.4.1	CONDITION CLASS NUMBER [CON#].....	42
2.4.2	CONDITION CLASS STATUS [CDST].....	42
2.4.3	CONDITION NONSAMPLED REASON [REAS].....	42
2.5	DELINEATING CONDITION CLASSES WITHIN ACCESSIBLE FOREST LAND:.....	43
2.5.1	RESERVED STATUS [RESV].....	46
2.5.2	OWNER GROUP [OWNG].....	47
2.5.3+N	FOREST TYPE [FTYP].....	47
2.5.4	STAND SIZE CLASS [STSZ].....	47
2.5.5	REGENERATION STATUS [SORI].....	49
2.5.6	TREE DENSITY [DENS].....	49
	ANCILLARY (NON-DELINEATING) VARIABLES.....	50
2.5.7	OWNER CLASS [OWNC].....	50
2.5.8	PRIVATE OWNER INDUSTRIAL STATUS [INDU].....	51
2.5.9	ARTIFICIAL REGENERATION SPECIES [SOSP].....	51
2.5.10	STAND AGE [SAGE].....	51
2.5.11	DISTURBANCE 1 [DIS1].....	52
2.5.12	DISTURBANCE YEAR 1 [DYR1].....	53
2.5.13	DISTURBANCE 2 [DIS2].....	54
2.5.14	DISTURBANCE YEAR 2 [DYR2].....	54
2.5.15	DISTURBANCE 3 [DIS3].....	54
2.5.16	DISTURBANCE YEAR 3 [DYR3].....	54
2.5.17	TREATMENT 1 [TRE1].....	54
2.5.18	TREATMENT YEAR 1 [TYR1].....	55
2.5.19	TREATMENT 2 [TRE2].....	55
2.5.20	TREATMENT YEAR 2 [TYR2].....	55
2.5.21	TREATMENT 3 [TRE3].....	55
2.5.22	TREATMENT YEAR 3 [TYR3].....	55
2.5.22.1N	STAND HISTORY [HIST].....	55
2.5.22.2N-ME	STAND STRUCTURE [MEST].....	56
2.5.23	PHYSIOGRAPHIC CLASS [PHYS].....	56
2.5.23.1N	PRODUCTIVITY STATUS [PROD].....	57
2.5.24+N	PRESENT NONFOREST LAND USE [NFLU].....	58
2.5.24.1N	NONFOREST TREES [NFTR].....	61
3.0	SUBPLOT INFORMATION	63
3.1	SUBPLOT NUMBER.....	63
3.2	SUBPLOT STATUS [STAT].....	63
3.3	SUBPLOT NONSAMPLED REASON [REAS].....	64
3.4	SUBPLOT CENTER CONDITION [SCEN].....	64
3.5	MICROPLOT CENTER CONDITION [MCEN].....	65
3.6	SUBPLOT SLOPE [SLOP].....	65
3.7	SUBPLOT ASPECT [ASP].....	65
3.8	SNOW/WATER DEPTH [SWD].....	66
3.8.1N-ME	CROWN CLOSURE [MECC].....	66
3.9	SUBPLOT CONDITION LIST (CORE OPTIONAL).....	66
4.0	BOUNDARY REFERENCES	67
4.1	REFERENCE PROCEDURE.....	67
4.2	BOUNDARY DATA.....	69
4.2.1	SUBPLOT NUMBER.....	69
4.2.2	PLOT TYPE [TYPE].....	69
4.2.3	BOUNDARY CHANGE [CHNG].....	69
4.2.4	CONTRASTING CONDITION [CCON].....	70
4.2.5	LEFT AZIMUTH [LAZM].....	70
4.2.6	CORNER AZIMUTH [CAZM].....	70

4.2.7	CORNER DISTANCE [CDIS].....	70
4.2.8	RIGHT AZIMUTH [RAZM]	70
4.2.9N	PERCENT AREA [%ARE]	71
5.0	TREE AND SAPLING DATA.....	73
5.1	SUBPLOT NUMBER	74
5.2	TREE RECORD NUMBER [TR#].....	75
5.3	CONDITION CLASS NUMBER [CON#].....	75
5.4	AZIMUTH [AZM]	76
5.5	HORIZONTAL DISTANCE [DIST].....	76
5.6	PREVIOUS TREE STATUS [PAST]	79
5.7	PRESENT TREE STATUS [TRST].....	79
5.7.1	RECONCILE [RECO]	80
5.7.2	STANDING DEAD [DEAD]	81
5.7.3	MORTALITY (CORE OPTIONAL).....	84
5.8	SPECIES [SPP]	84
5.9	DIAMETER [DBH].....	85
5.9.1	PREVIOUS DIAMETER AT BREAST HEIGHT [DBHO].....	86
5.9.2	DIAMETER AT BREAST HEIGHT (DBH)	86
5.9.3	PREVIOUS DIAMETER AT ROOT COLLAR.....	92
5.9.4	DIAMETER AT ROOT COLLAR (DRC)	92
5.9.4.1	DRC STEM DIAMETER.....	94
5.9.4.2	DRC STEM STATUS	94
5.10	PAST NUMBER OF STEMS	95
5.11	CURRENT NUMBER OF STEMS	95
5.12	DIAMETER CHECK [DCHE].....	95
5.12.1N	TREE CLASS [TCC]	96
5.12.2N	TREE GRADE [TRGD]	99
5.12.3N	SAWLOG LENGTH [SAW]	101
5.12.4N	% ROUGH BOARD-FOOT CULL [BRGH].....	101
5.12.5N	% ROTTEN/MISSING BOARD-FOOT CULL [BROT].....	102
5.12.6N	BOLE LENGTH [BOLE].....	103
5.25	% ROUGH CUBIC-FOOT CULL (CORE OPTIONAL) [CRGH].....	103
5.13	% ROTTEN/MISSING CUBIC-FOOT CULL [ROTT].....	104
5.14	TOTAL LENGTH [THGT]	104
5.15	ACTUAL LENGTH [ACTU]	105
5.16	LENGTH METHOD [METH].....	105
5.17	CROWN CLASS [CCC]	105
5.18	UNCOMPACTED LIVE CROWN RATIO (P2 – CORE OPTIONAL / P3 – CORE).....	106
5.19	COMPACTED CROWN RATIO [CRC]	107
5.20	Tree Damage	110
5.20.1	DAMAGE LOCATION 1 (CORE OPTIONAL).....	110
5.20.2	DAMAGE TYPE 1 (CORE OPTIONAL)	110
5.20.3	DAMAGE SEVERITY 1 (CORE OPTIONAL)	110
5.20.4	DAMAGE LOCATION 2 (CORE OPTIONAL).....	110
5.20.5	DAMAGE TYPE 2 (CORE OPTIONAL)	110
5.20.6	DAMAGE SEVERITY 2 (CORE OPTIONAL)	110
5.20.7N	DAMAGE AGENTS STANDARD [1DAM, 2DAM].....	110
5.21	CAUSE OF DEATH [CAUS]	111
5.22	MORTALITY YEAR (CORE OPTIONAL)	111
5.23	DECAY CLASS [DECA].....	111
5.24	LENGTH TO DIAMETER MEASUREMENT POINT (CORE OPTIONAL) [DIAH].....	112
5.26	MISTLETOE CLASS (CORE OPTIONAL)	113
5.27	TREE NOTES	113
5.28N-MN	BALSAM FIR BOUGHS	113
5.28.1N-MN	BOUGHS AVAILABLE [BAVA].....	113
5.28.2N-MN	BOUGHS HARVESTED [BHAR]	113
5.28.3N-MN	BOUGHS HARVESTING GUIDELINES [GUID].....	113
5.29N-ME	MAINE'S 5 TH MICROPLOT SAPLING DATA	113
5.30N-OH	OHIO SK8 "PRISM" POINT TREE DATA.....	113
5.31N	FOREST TO NONFOREST VARIABLES	113

6.0	SEEDLING DATA.....	115
6.1	SUBPLOT NUMBER.....	115
6.2	SPECIES [SPP].....	115
6.3	CONDITION CLASS NUMBER [CON#].....	115
6.4	SEEDLING COUNT [SED#].....	115
7.0	SITE TREE INFORMATION.....	117
7.1	SITE TREE SELECTION.....	117
7.2	SITE TREE DATA VARIABLES.....	117
7.2.0N	TREE RECORD NUMBER [TR#].....	117
7.2.1	CONDITION CLASS LIST [CONL].....	117
7.2.2	SPECIES [SPP].....	118
7.2.3	DIAMETER [DBH].....	119
7.2.4	SITE TREE LENGTH [HGHT].....	119
7.2.5	TREE AGE AT DIAMETER [AGE].....	119
7.2.6	SITE TREE NOTES.....	119
7.2.7+N	SUBPLOT NUMBER (CORE OPTIONAL) [SUB#].....	119
7.2.8+N	AZIMUTH (CORE OPTIONAL) [AZM].....	120
7.2.9+N	HORIZONTAL DISTANCE (CORE OPTIONAL) [DIST].....	120

NATIONAL APPENDICES.....	121
Appendix 1N. State, Unit, County, Parish or Borough FIPS codes.....	123
Appendix 2+N. FIA Forest Type Codes.....	135
Appendix 4N. Site Tree Selection Criteria and Species List.....	153
Appendix 5N. Determination of Stocking Values for Land Use Classification.....	155
Appendix 6N. Glossary.....	169
Appendix 7. Tolerance / MQO / Value / Units Table.....	175
Appendix 8. Tree Coding Guide for RECONCILE.....	181

REGIONAL APPENDICES.....	185
Appendix A. Plot Establishment and/or Relocation Procedures.....	187
Appendix B. Ownership Data Collection Procedures.....	203
Appendix C. Additional Northern Data Collection Procedures.....	211
Appendix D. State / Species Specific Data Collection Variables and Procedures.....	226
Appendix E. Tables and Charts.....	248
Appendix F. Tree Class Illustrations.....	268
Appendix G. GPS User's Guide.....	279
Appendix H. Tally Item Guides, Sheets and Prompts.....	285

REGIONAL SUPPLEMENTS

If required by the user, these additional supplemental instructions will be made available.

Invasive Plants Protocols
LandMark CE Installation
Allegro CE Owner's Manual
Site Index Curves for the West
Regional Change Document from 3.0 to 3.1 (East and West editions)

VOLUME II: FIELD DATA COLLECTION PROCEDURES FOR PHASE 3 INDICATORS

If required by the user, these additional sections are included in the field guide. These page numbers are not associated with the main portion of this field guide. The page number format for these sections will be the section number plus the page number (e.g., 9 - 1).

9.0	OZONE BIOINDICATOR PLANTS (EAST)
10.0	LICHEN COMMUNITIES
11.0	SOIL MEASUREMENTS AND SAMPLING
12.0	CROWNS: MEASUREMENTS AND SAMPLING
13.0	VEGETATION DIVERSITY AND STRUCTURE
14.0	DOWN WOODY MATERIALS AND FUELS

**FOREST INVENTORY AND ANALYSIS
NATIONAL CORE FIELD GUIDE**

VOLUME I: FIELD DATA COLLECTION PROCEDURES FOR PHASE 2 PLOTS

Version 3.1

Version History:

- 1.1: March 1999 (first version implemented, Maine, 1999)
- 1.2: August 1999
- 1.3: September 1999 (revised from Bangor, ME Data Acquisition Band meeting, Aug 1999)
- 1.4: February 2000 (revised from Charleston, SC Data Acquisition Band meeting, Dec 1999)
- 1.5: January 2001 (revised from Portland, OR Data Acquisition Band meeting, Sept 2000)
- 1.6: March 2002 (revised from Tucson, AZ Joint Band meeting, Jan 2002)
- 1.7: February 2003 (revised from Charleston, SC Joint Band Meeting, Feb 2003)
- 2.0: April 2003 (revised from Atlantic City, NJ, Data Acquisition Band Meeting, Mar 2003)
October 2003 (revised from Anchorage, AK, Data Acquisition Band Meeting, Aug. 2003)
January 2004 (revised from Data Acquisition Band conference calls with FIA Management Team Approval)
August 2004 (revised from Asheville, NC, Data Acquisition Band Meeting, Aug. 2004)
- 3.0: October 2005 (revised from change management process, change proposals approved by FIA Management Team, from Asheville, NC, Data Acquisition Meeting, Aug. 2004, and from Las Vegas, NV, Data Acquisition Meeting, Mar. 2005)
- 3.1: October 2006 (Version 3.0 revised for new Northern region, July 2006)

Mention of trade names or commercial products does not constitute endorsement or recommendation for use.

INTRODUCTION

This document describes the standards, codes, methods, and definitions for Forest Inventory and Analysis (FIA) field data items. The objective is to describe CORE FIA field procedures that are consistent and uniform across all FIA units. **This CORE is the framework for regional FIA programs; individual programs may add regional variables, but may not change the CORE requirements.** Unless otherwise noted, the items in this field guide are considered CORE, that is, the information will be collected by all FIA Units as specified. Items or codes specified as CORE OPTIONAL are not required by individual units; however, if the item is collected or coded, it will be done as specified in this field guide. It is expected that on average all items in Volume I can be measured by a two-person field crew in less than one day, including travel time to and from the plot.

The FIA program is in transition, changing in response to legislation and new customer demands. One of these demands is for increased consistency, which this field guide begins to address. Another change was the merger of the FIA program with the field plot component of the Forest Health Monitoring (FHM) program's Detection Monitoring. A systematic grid was established that includes some, but not all former FIA plots. This grid contains the Phase 2 plots, the annual survey plots that are designed for measurement on a rotation such that a portion of the plots are measured each year. The rotation length varies by region. The former FHM Detection Monitoring field plots are the Phase 3 plots, a subset of the Phase 2 plots. The same basic plot and sampling designs are used on all the plots.

The focus of Volume I is on data that are collected in the field on all Phase 2 plots in the FIA sample. The methods in Volume I are also used on Phase 3 plots except when specifically noted

otherwise in the methods text. Volume II of the series describes an additional, expanded suite of data collected on the Phase 3 subset of plots. Volume II contains methods for the following indicators: ozone bioindicator plants; lichen communities; soils (physical and chemical characteristics); crown condition; vegetation diversity and structure; and down woody material. Volume III of the series (in preparation) will document the office procedures including data elements measured in the office, data from other sources that are merged into the FIA database, and CORE compilation and analysis algorithms. When complete, the three-volume set will describe the CORE FIA program field data, all of which are measured consistently across the country.

FIELD GUIDE LAYOUT

Each section of the field guide corresponds to one of the following sections:

- 0 General Description
- 1 Plot
- 2 Condition
- 3 Subplot
- 4 Boundary
- 5 Tree Measurements
- 6 Seedling
- 7 Site Tree
- + National Appendices 1 – 8
- + Regional Appendices A – J

Each section begins with a general overview of the data elements collected at that level and background necessary to prepare field crews for data collection. Descriptions of data elements follow in this format:

DATA ELEMENT NAME [North PDR prompt]
<Brief variable description>

When collected: <when data element is recorded>

Field width: <X digits>

Tolerance: <range of measurement that is acceptable>

MQO: <measurement quality objective>

Values: <legal values for coded variables>

Data elements, descriptions of when to collect the data elements, field width, tolerances, MQO's, and values, apply to both Phase 2 plots (formerly called FIA plots) and Phase 3 plots (formerly called FHM Detection Monitoring plots) unless specifically noted. Field width designates the number of columns (or spaces) needed to properly record the data element.

NRS Note: Some regional data items are described in the field guide but do not require any data entry. These variables are "hidden" variables that are required for regional programming and/or logic checks on collected data items. Data items that require a field entry have an associated PDR prompt. Some of these items may be auto-filled (i.e., downloaded values).

Tolerances may be stated in +/- terms or number of classes for ordered categorical data elements (e.g., +/- 2 classes); in absolute terms for some continuous variables (e.g., +/- 0.2 inches); or in terms of percent of the value of the data element (e.g., +/- 10 percent of the value). For some data elements, no errors are tolerated (e.g., PLOT NUMBER).

NRS Note: Some CORE variable tolerances have been tightened to comply with regional requirements.

MCO's state the percentage of time when the collected data are required to be within tolerance. Percentage of time within tolerance is generally expressed as "at least X percent of the time," meaning that crews are expected to be within tolerance at least X percent of the time.

PLOT NOTES will be available on every PDR screen for ease in recording notes.

UNITS OF MEASURE

The field guide will use ENGLISH units as the measurement system.

Plot Dimensions:

Macroplot:

Radius = 58.9 feet
Area = 10,899 square feet or 0.25 acre (ac) or 1/4 acre

Subplot:

Radius = 24.0 feet
Area = 1,809.56 square feet or approximately 0.04 acre or approximately 1/24 acre

Microplot:

Radius = 6.8 feet
Area = 145.27 square feet or approximately 0.003 acre or approximately 1/300 acre

Annular plot:

Radius = from 24.0 feet to 58.9 feet
Area = 9088.4 square feet or approximately 0.21 acre or 5/24 acre

The distance between subplot centers is 120.0 feet horizontal.
The minimum area needed to qualify as accessible forest land is 1.0 acre.
The minimum width to qualify as accessible forest land is 120.0 ft

Tree Limiting Dimensions:

breast height	4.5 ft
stump height	1.0 ft
merchantable top	4.0 in DOB
merchantable top for woodland	1.5 in DOB
minimum conifer seedling length	0.5 ft
minimum hardwood seedling length	1.0 ft
seedling/sapling DBH/DRC break	1.0 in DOB
sapling/tree DBH/DRC break	5.0 in DOB

0.0 GENERAL DESCRIPTION

The CORE field plot consists of four subplots approximately 1/24 acre in size with a radius of 24.0 feet. The center subplot is subplot 1. Subplots 2, 3, and 4 are located 120.0 feet horizontal (+/- 7 feet) at azimuths of 360, 120, and 240 degrees, respectively, from the center of subplot 1 (see Figure 1). Throughout this field guide, the use of the word 'plot' refers to the entire set of four subplots. 'Plot center' is defined as the center of subplot 1. As a CORE OPTION, the field plot

may also include macroplots that are $\frac{1}{4}$ acre in size with a radius of 58.9 feet; each macroplot center coincides with the subplot's center. Macroplots are numbered in the same way as subplots.

If the macroplots are not installed, the subplots are used to collect data on trees with a diameter (at breast height, DBH, or at root collar, DRC) of 5.0 inches or greater. If the macroplots are installed, then subplots are used to collect data on trees from a diameter 5.0 inches to the breakpoint diameter and the macroplot is used to collect data on trees with diameter greater than the breakpoint diameter.

NRS Note: Macroplots are not installed in the North and all reference to a macroplot in Section 1.0 to 7.0 has been removed for this regional guide.

Each subplot contains a microplot of approximately $\frac{1}{300}$ acre in size with a radius of 6.8 feet. The center of the microplot is offset 90 degrees and 12.0 feet horizontal (+/- 1 foot) from each subplot center. Microplots are numbered in the same way as subplots. Microplots are used to select and collect data on saplings (DBH/DRC of 1.0 inch through 4.9 inches) and seedlings [DBH/DRC less than 1.0 inch in diameter and greater than 0.5 foot in length (conifers) or greater than 1.0 foot in length (hardwoods)].

As a CORE OPTION for a Phase 2 plot that is not part of the Phase 3 subset, data for one or more of the Phase 3 indicators may be collected on the plot. If a region exercises the option to collect one or more Phase 3 indicator(s) on a Phase 2 only plot, the entire suite of measurements for the particular indicator(s) described in the appropriate chapter must be collected for the data for that indicator to be core optional.

Each unit may choose which Phase 3 indicators to collect as core optional on a Phase 2 plot that is not a Phase 3 plot. They may choose no indicators, all indicators or a subset. If they choose to collect data for a Phase 3 indicator, all the procedures for the indicator must be followed for that indicator to be considered core optional (data in National NIMS). If a subset of measurements for an indicator are collected, that is considered a regional enhancement and the data will be in the regional database.

Macroplots may be used to provide a better sample of rare population elements, such as very large trees.

The annular plot may be used for destructive sampling; for example soil samples. Also the term annular plot will be used for instructions in the field guide, for example, instructions on numbering trees when the macroplots are installed.

NRS Note: Annular plots are not installed in the North and all reference to an annular plot in Section 1.0 to 7.0 has been removed for this regional guide.

Data are collected on field plots at the following levels:

Plot	Data that describe the entire cluster of four subplots.
Subplot	Data that describe a single subplot of a cluster.
Condition Class	A discrete combination of landscape attributes that describe the environment on all or part of the plot. These attributes include CONDITION CLASS STATUS, RESERVED STATUS, OWNER GROUP, FOREST TYPE, STAND SIZE CLASS, REGENERATION STATUS, and TREE DENSITY.

Boundary	An approximate description of the demarcation line between two condition classes that occur on a single subplot, microplot, or macroplot. There is no boundary recorded when the demarcation occurs beyond the fixed radius plots.
Tree	Data describing saplings with a diameter 1.0 inch through 4.9 inches, and trees with diameter greater than or equal to 5.0 inches
Seedling	Data describing trees with a diameter less than 1.0 inch and greater than or equal to 0.5 foot in length (conifers) or greater than or equal to 1.0 foot in length (hardwoods).
Site Tree	Data describing site index trees.

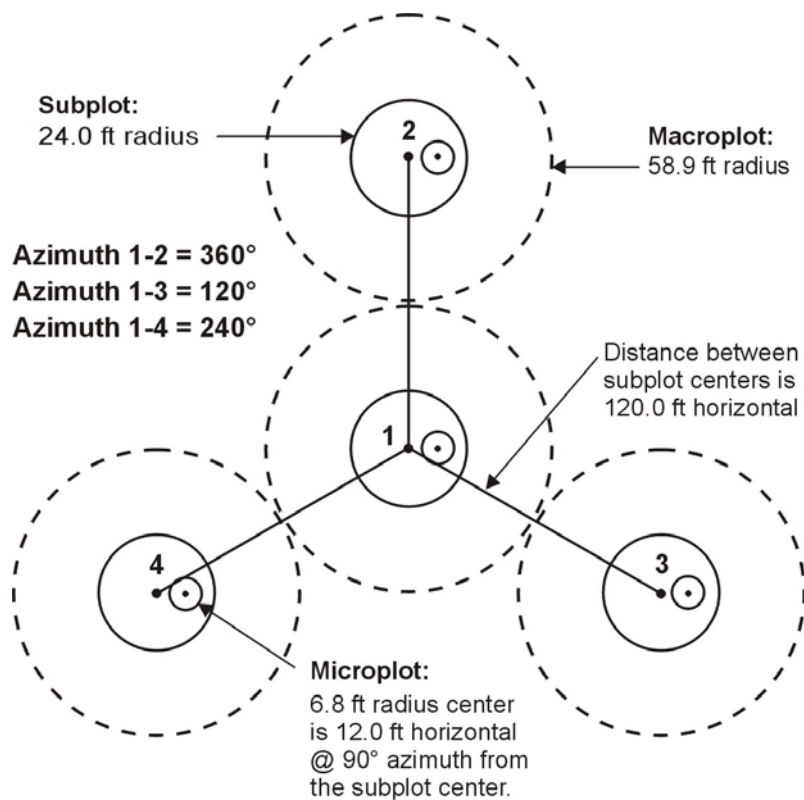

Figure 1. FIA Phase 2 plot diagram. See individual Phase 3 chapters for Phase 3 plot figures.

0.1 PLOT SETUP

Plots will be established according to the regional guidelines of each FIA unit. (See Regional Appendix A for plot establishment and/or relocation procedures.) When the crew cannot occupy the plot center because safety hazards exist, or the plot center is inaccessible or out of the sample, the crew should check the other subplots. If any subplot centers can be occupied and are in the sample, the subplots that can be occupied should be established and sampled following normal procedures. When a subplot center or microplot center cannot be occupied, no

data will be collected from that subplot or microplot; instead, the entire subplot or microplot should be classified according to the condition preventing occupancy.

The following table provided can assist in locating subplot 2-4 from a subplot other than subplot 1.

Subplot From	Numbers To	Azimuth <i>degrees</i>	Backsight	Distance <i>feet</i>
2	3	150	330	207.8
2	4	210	030	207.8
3	4	270	090	207.8

If a subplot was installed incorrectly at the previous visit, the current crew should remeasure the subplot in its present location and contact the field supervisor. In cases where individual subplots are lost (cannot be relocated), use the following procedures:

- assign the appropriate present CONDITION CLASS STATUS Code(s) to the new subplot (usually CONDITION CLASS STATUS = 1 or 2)
- assign PRESENT TREE STATUS = 0 and RECONCILE = 7 to all downloaded trees (i.e., incorrectly tallied at the previous survey)
- assign PRESENT TREE STATUS = 1 or 2 and RECONCILE codes 3 or 4 (i.e., missed live or missed dead) to all trees on the new subplot.
- assign the next TREE RECORD NUMBER for all new trees.

NRS PDR Note: If two remeasurement subplot data are reversed within the data recorder (i.e., subplot 3 data is entered as subplot 4, and 4 is 3), the current crew does not correct the data in the field. Collect the data the way it was collected last cycle (i.e., tree data assigned to the wrong subplot). The regional office must be notified with an explanation of the problem and the subplot tree data will be corrected at the regional office.

The historical data set will also require correction in the database by the Information Group so the new data set will match the historical data set.

0.2 PLOT INTEGRITY

Each FIA unit is responsible for minimizing damage to current or prospective sample trees and for specifying how these trees are monumented for remeasurement. The following field procedures are permitted:

- Scribing and nailing tags on witness trees so that subplot centers can be relocated.
- Boring trees for age on subplots and macroplots to determine tree age, site index, stand age, or for other reasons. Not applicable in the North.
- Nailing and tagging trees on microplots, subplots, and macroplots so that these trees can be identified and relocated efficiently and positively at times of remeasurement.
- Nailing, scribing, or painting microplot, subplot, and macroplot trees so that the point of diameter measurement can be accurately relocated and remeasured.

All other potentially damaging procedures that may erode subplot integrity are prohibited. The following practices are specifically prohibited:

- Boring and scribing some specific tree species that are known to be negatively affected (i.e., the initiation of infection or callusing).

- Boring trees for age on subplots to determine tree age, site index, stand age, or for other reasons.
- Chopping vines from tally trees. When possible, vines should be pried off trunks to enable accurate measurement. If this is not possible, alternative tools (calipers, Biltmore sticks) should be used.

NRS Note: The use of alternative tools is not applicable.

- Toppling of dead trees or saplings.

0.3N PLOT DATA SECURITY

All collected data are considered SENSITIVE MATERIAL and are private! NRS-FIA must safeguard all the data to best of our ability. Do not give out any information about specific plots or landowners unless authorization has been given from St. Paul or Newtown Square. Plot information can be given to the owner of the property, but guidelines need to be followed.

All plot locations from GPS coordinates, photo images and maps and PLOT NUMBER requests are directed through St. Paul or Newtown Square. It is a federal offence to intentionally release this data.

Landowners are allowed access to plot data collected on their property. If they request information, it is okay to give them a photocopy of the plot record, photo image and maps; but the PLOT NUMBER and the associated starting point and plot center GPS coordinates from all plot records are blacked-out. If the landowner specifically requests the GPS coordinates, forward the request to Newtown Square.

NRS-FIA has partnerships with other public agencies and other organizations. Many times, we are allowed to share information with these different partners. Prior to releasing any plot information verify with St. Paul or Newtown Square that the requestor has entered into a Memorandum of Understanding (MOU) with the Forest Service. This MOU serves to outline the conditions under which the Forest Service will release plot locations to partners who are actively engaged in implementing or forwarding the Forest Service mission through work or research, and the protections imposed to insure continued privacy and confidentiality of the personal information released.

It is everyone's responsibility to keep our data safe and secure in order to ensure access to our plots in the future. NRS-FIA must maintain a working relationship with our partners and the private landowners and security is one way to achieve that goal.

[Preceding text paraphrased from the NCFG, Version 3.0 and NEFIA's Plot Coordinate MOU.]

0.4N WILDERNESS AREAS

An Intra-Agency Agreement O5-SU-FIA01 is in effect until October 1, 2009 for WILDERNESS AND WILD AND SCENIC RIVERS (WWSR). This IA provides special provisions for conducting FIA inventories in Wilderness areas on the National Forest System. The special provisions from this document have been noted in this field guide where it concerns plot establishment, diameter measurements, stand age and site index. Other provisions from the IA are as follows:

- At least one week prior to commencement of field operations, FIA will furnish the designated WWSR Wilderness Manager with the following information:
 - a. Names of key personnel involved and their titles.

- b. Number of personnel per party.
 - c. Dates and locations of field work within Wilderness boundaries.
 - d. Cellular telephone numbers used by all inventory crews in lieu of radio frequencies and call names and numbers.
- This agreement does not authorize any entry upon, or activities within, any lands not under the jurisdiction of the WWSR Wilderness Manager, including private in holdings within National Forest boundaries. Such activities must be coordinated and authorized prior to entry, through the respective agency or owner.
 - Field personnel must carry an approved research permit at all times when engaged in data collection activities in Wilderness. This permit shall only apply to the timeframe and content of the approved project plan of work.

Measuring and recording methods in Wilderness areas must be sensitive to the generally undisturbed character of these areas and leave as few signs of disturbance as possible. It is important to be able to relocate plots, subplots, and trees measured during the inventory. In Wilderness areas, less visible markings are always appropriate. Detailed, concise sketches and notes will make subsequent relocation easier.

- Identifying tags/nails - Marking tags/nails should be used minimally, painted an approved color, and face away from obvious trails and roads. Tags and nails may only be used at the base of the reference tree. All other tally trees are marked with a nail only at the base.
- Flagging - Any flagging used to facilitate entry and exit from the plot area will be removed upon completion of the plot measurements.
- Painting/Scribing - This practice will not be used to monument the plot, identify witness trees, or to mark breast height.

Specimen Collection

- No personal flora or fauna collection is permitted on Wilderness lands. Collections are for scientific or educational purposes only, dedicated to public benefit, and may not be used for personal or commercial profit. All collections for scientific purposes must be approved by the WWSR Wilderness Manager.
- No archeological or vertebrate paleontological materials may be collected. Upon location of any historical or archeological remains field work will cease and the site shall be reported immediately to the local WWSR Wilderness Manager. No disturbance of such a site is permitted.

Site Condition

- All refuse associated with field operations shall be removed from Wilderness lands and the site of any data collection or encampment shall be returned to the condition in which it was found, except as authorized by the project work plan.
- Soil disturbance is prohibited, except as specifically authorized in the mutually agreed upon project work plan.
- Temporary markers, such as flagging, may not remain in place for more than one week when study teams are not present on a site. Paint, or similar semi-permanent markers, may not be applied to rocks, plants, or other natural surfaces.

Wildlife Interaction

- Harassment, hazing, or other disturbance of wildlife is prohibited.
- Problem encounters with wildlife, including any experienced or observed incidents of wildlife obtaining food or garbage from humans, shall be reported promptly to the WWSR Wilderness Manager. All food and garbage will be stored in a sealed containers approved by the local WWSR Wilderness Manager. Field personnel will make all reasonable efforts to prevent wildlife from obtaining food or garbage from humans.

National Parks have similar requirements. Permits are required for any research work completed within the park. FIA has a national agreement to use tags and nails. Do not paint or scribe in a National Park.

1.0 PLOT LEVEL DATA

All variables listed in Section 1.0 are collected on plots with at least one accessible forested condition (PLOT STATUS = 1) and all NONFOREST/NONSAMPLED plots (PLOT STATUS = 2 or PLOT STATUS = 3). In general, plot level data apply to the entire plot and they are recorded from the center of subplot 1. A plot is considered nonforest if no part of it is currently located in forest land (CONDITION CLASS STATUS = 1). A plot is nonsampled if the entire plot is not sampled for one of the reasons listed in PLOT NONSAMPLED REASON.

If a forest plot has been converted to nonforest or becomes a nonsampled plot, the previous data are reconciled and an attempt is made to visit the plot during the next inventory. If a nonforest plot becomes forest or access is gained to a previously nonsampled plot, a new forest ground plot is installed. All nonforest and nonsampled plots are visited if there is any reasonable chance that they might include some forest land condition class.

Trees on previously forest land plots will be reconciled during data processing. There is a distinction between plots that have been clearcut, and plots that have been converted to another land use. A clearcut plot is considered to be forest land until it is actively converted to another land use. Additional information concerning land use classifications is contained in Section 2.3.

1.0.1N CYCLE [CYCL]

This variable represents the number of times a state has been inventoried (includes periodic and annual). In the annual inventory, a cycle is the completion of all sub-cycles.

When collected: All plots

Field width: 2 digits

Tolerance: N/A

MQO: N/A

Values: Downloaded value and preprinted on plot location sheet

1.0.2N SUB-CYCLE [SUBC]

This variable identifies the sub-panels that are being inventoried. In the annual forest inventory, a sub-cycle is the completion of 14 sub-panels (five year cycle length) or 10 sub-panels (seven year cycle length) in a year.

When collected: All plots

Field width: 1 digit

Tolerance: N/A

MQO: N/A

Values: Downloaded value and preprinted on plot location sheet

1.1 STATE [ST]

Record the unique FIPS (Federal Information Processing Standard) code identifying the State where the plot center is located.

When collected: All plots

Field width: 2 digits

Tolerance: No errors

MQO: At least 99% of the time

Values: See Appendix 1 (Downloaded value and preprinted on plot location sheet)

1.1.1N UNIT [UNIT]

Record the unique code identifying the inventory unit where the plot center is located.

When collected: All plots

Field width: 1 digit

Tolerance: No errors
MQO: At least 99% of the time
Values: See Appendix 1 (Downloaded value and preprinted on plot location sheet)

1.2 COUNTY [**CNTY**]

Record the unique FIPS (Federal Information Processing Standard) code identifying the county, parish, or borough (or unit in AK) where the plot center is located.

When collected: All plots
Field width: 3 digits
Tolerance: No errors
MQO: At least 99% of the time
Values: See Appendix 1 (Downloaded value and preprinted on plot location sheet)

1.3 PLOT NUMBER [**PLT#**]

Record the identification number, unique within a county, parish, or borough (survey unit in AK), for each plot. If SAMPLE KIND = 3, the plot number will be assigned by the National Information Management System (NIMS).

NRS Note: A new plot number will be determined by the Field Data Manager (FDM).

When collected: All plots
Field width: 5 digits
Tolerance: No errors
MQO: At least 99% of the time
Values: 00001 to 99999 (Downloaded value and preprinted on plot location sheet)

1.4 PLOT STATUS [**STAT**]

Record the code that describes the sampling status of the plot. In cases where a plot is inaccessible, but obviously contains no forest land, record PLOT STATUS = 2. In cases where a plot is access-denied or hazardous land use and has the possibility of forest, record PLOT STATUS = 3.

When collected: All plots
Field width: 1 digit
Tolerance: No errors
MQO: At least 99% of the time
Values:
1 Sampled – at least one accessible forest land condition present on plot
2 Sampled – no accessible forest land condition present on plot
3 Nonsampled

1.5 PLOT NONSAMPLED REASON [**REAS**]

For entire plots that cannot be sampled, record one of the following reasons.

When collected: When PLOT STATUS = 3
Field width: 2 digits
Tolerance: No errors
MQO: At least 99% of the time
Values:
01 Outside U.S. boundary – Entire plot is outside of the U.S. border.

- 02 Denied access – Access to the entire plot is denied by the legal owner, or by the owner of the only reasonable route to the plot. Because a denied-access plot can become accessible in the future, it remains in the sample and is re-examined at the next occasion to determine if access is available. A plot note is required specifying who (may or may not be the plot's landowner if crossing multiple properties) and why, if an explanation is given.
- 03 Hazardous – Entire plot cannot be accessed because of a hazard or danger, for example cliffs, quarries, strip mines, illegal substance plantations, high water, etc. Although most hazards will not change over time, a hazardous plot remains in the sample and is re-examined at the next occasion to determine if the hazard is still present.
- 05 Lost data – Plot data file was discovered to be corrupt after a panel was completed and submitted for processing. This code is applied at the time of processing after notification to the units. This code is for office use only.
- 06 Lost plot – Entire plot cannot be found. Whenever this code is assigned, a replacement plot is required. The plot that is lost is assigned SAMPLE KIND = 2 and NONSAMPLED REASON = 6. The replacement plot is assigned SAMPLE KIND = 3.
- 07 Wrong location – Previous plot can be found, but its placement is beyond the tolerance limits for plot location. Whenever this code is assigned, a replacement plot is required. The plot being relocated is assigned SAMPLE KIND = 2 and NONSAMPLED REASON = 7. Its replacement plot is assigned SAMPLE KIND = 3. This code is not applicable in the North.
- 08 Skipped visit – Entire plot skipped. Used for plots that are not completed prior to the time a panel is finished and submitted for processing. This code is for office use only.
- 09 Dropped intensified plot - Intensified plot dropped due to a change in grid density. This code used only by units engaged in intensification. This code is for office use only.
- 10 Other – Entire plot not sampled due to a reason other than one of the specific reasons already listed. A field note is required to describe the situation.

1.6 SUBPLOTS EXAMINED [EXAM]

Record the number of subplots examined.

NRS Note: If PLOT STATUS is 2 or 3 and this status is determined in the office, it is coded as 1. Any PLOT STATUS 2 or 3 that is verified on site (i.e., field visit) is coded as 4. Previously forested plots that are now nonforest requires a site visit to assign the PRESENT TREE STATUS and other required variables for trees that are now in a nonforest condition. Code 4 indicates that all on-site field variables including GPS data, "Plot Establishment or Relocation" variables are completed.

Each state has a maximum of 25 nonforest QA/QC plots that require a field visit to confirm if the P1 photo interpretation was properly determined at the regional office. These plots cannot be coded as 1. These plots require on-site field verification. (See Regional Appendix A for additional information.)

When collected: When PLOT STATUS = 2 or 3

Field width: 1 digit

Tolerance: No errors

MQO: At least 90% of the time

Values:

- 1 Only subplot 1 center condition examined and all other subplots assumed (inferred) to be the same – determined in office from photos, maps, etc.
- 4 All four subplots fully described (no assumptions/inferences) – on site field verification. Subplot center does not need to be occupied.

1.7+N SAMPLE KIND [SK]

Record the code that describes the kind of plot being installed.

NRS (East) Note: When a plot is being established over an old Northeast *periodic* inventory plot, the regional SAMPLE KIND will be 5, 6 or 8. In most cases these older plots will be 1/5-acre fixed radius plots, 1/5-acre fixed with four variable radius points, or variable radius plots (i.e., 10-point). When these plots are remeasured, the plot center of subplot 1 will be established over the old *periodic* inventory plot center. (See Regional Appendix C and/or D for special instructions for eastern crews.)

When collected: All plots

Field width: 1 digit

Tolerance: No errors

MQO: At least 99% of the time

Values: (Downloaded value and preprinted on plot location sheet)

- 1 Initial plot establishment (P2 or P3) - the initial establishment and sampling of a national design plot (FIA Field Guide versions 1.1 and higher). In the former Northeast, this may include old periodic plots converted to P3. SAMPLE KIND 1 is assigned under the following circumstances:
 - Initial activation of a panel or subpanel
 - Reactivation of a panel or subpanel that was previously dropped
 - Resampling of established plots that were not sampled at the previous visit (PLOT STATUS = 3 and PLOT NONSAMPLED REASON = 02 or 03 from the previous annual inventory cycle).
- 2 Remeasurement (P2 or P3) – remeasurement of a national design plot that was sampled at the previous annual inventory cycle.
- 3 Replacement plot (P2 or P3) - a replacement plot for a previously established plot. Assign SAMPLE KIND = 3 if a plot is re-installed at a location other than the original location (i.e., plots that have been lost, moved, or otherwise replaced). Note that replacement plots require a separate plot file for the replaced plot. Replaced plots are assigned SAMPLE KIND = 2, PLOT STATUS = 3, and the appropriate NONSAMPLED REASON code. The plot number for the new (replacement) plot is assigned by NIMS. In the North contact the regional office for a new plot number.
- 5 Remeasurement of a NE or former FHM plot – remeasurement of a previously established 4-subplot fixed radius plot. Tree data remeasured at subplot 1 – 4. All microplots are being established for the first time unless the plot was formerly FHM which requires microplot data remeasurement.

- 6 Remeasurement of a NE plot – remeasurement of a previously established fixed radius plot. Tree data remeasured at subplot 1 only. Subplots 2 – 4 are being established for the first time. All microplots are being established for the first time.
- 7 This former NE code is no longer in use.
- 8 Remeasurement of a NE plot (OH only) – remeasurement of a previously established variable radius plot (i.e., 10-point). Tree data remeasured at five old prism points. Subplots 1 – 4 are being established for the first time. All microplots are being established for the first time.

1.7.1N PHASE

This variable indicates the type of plot that is being completed. Phase 2 represents all plots from the base grid. Phase 3 plots area a subset of Phase 2. Phase 3 plots were previously identified and known as FHM plots.

When collected: All plots

Field width: 1 digit

Tolerance: N/A

MQO: N/A

Values: 2 or 3 (downloaded “hidden” value and preprinted on plot location sheet only)

1.8 PREVIOUS PLOT NUMBER

Record the identification number for the plot that is being replaced.

NRS Note: This previous plot number associated with the replacement plot is applied at the regional office by the Information Group.

When collected: When SAMPLE KIND = 3

Field width: 5 digits

Tolerance: No errors

MQO: At least 99% of the time

Values: 00001 to 99999

1.9+N FIELD GUIDE VERSION

Record the version number of the National Core Field Guide that was used to collect the data on this plot. FIELD GUIDE VERSION will be used to match collected data to the proper version of the field guide.

NRS Note: The field guide version will be applied by the regional office after the data has been electronically submitted from the field.

When collected: All plots

Field width: 2 digits (x.y)

Tolerance: No errors

MQO: At least 99% of the time

Values: 3.1

1.10 CURRENT and PREVIOUS DATE

Record the year, month, and day that the current plot visit was completed. Previous plot year and month for all remeasurement plots are downloaded/hidden variables used for logic checks in condition and tree data.

1.10.1+N YEAR [YEAR]

Record the year that the plot was completed.

When collected: All plots
Field width: 4 digits
Tolerance: No errors
MQO: At least 99% of the time
Values: \geq 2006

1.10.2 MONTH [MONT]

Record the month that the plot was completed.

When collected: All plots
Field width: 2 digits
Tolerance: No errors
MQO: At least 99% of the time
Values:

January	01	May	05	September	09
February	02	June	06	October	10
March	03	July	07	November	11
April	04	August	08	December	12

1.10.3 DAY [DAY]

Record the day of the month that the plot was completed.

When collected: All plots
Field width: 2 digits
Tolerance: No errors
MQO: At least 99% of the time
Values: 01 to 31

1.10.4N PREVIOUS YEAR

The year that the plot was previously completed is used as a logic check for recorded condition and tree data.

When collected: All plots
Field width: 4 digits
Tolerance: N/A
MQO: N/A
Values: Downloaded "hidden" value and preprinted on plot location sheet

1.10.5N PREVIOUS MONTH

The month that the plot was previously completed is used as a logic check for recorded condition and tree data.

When collected: All plots
Field width: 2 digits
Tolerance: N/A
MQO: N/A
Values: Downloaded "hidden" value and preprinted on plot location sheet

1.11 DECLINATION (CORE OPTIONAL)

This variable is not collected in the North.

1.12 HORIZONTAL DISTANCE TO IMPROVED ROAD [RDIS]

Record the straight-line distance from plot center (subplot 1) to the nearest improved road. An improved road is a road of any width that is maintained as evidenced by pavement, gravel, grading, ditching, and/or other improvements.

NRS Note: A private drive or access road within accessible forest land is considered a road if it meets the qualifications stated above. Improved roads should not have advanced rutting, old washouts, old fallen trees, vegetation, etc. that inhibits regular vehicular travel.

When collected: All plots with at least one accessible forest land condition class (PLOT STATUS = 1)

Field width: 1 digit

Tolerance: No errors

MQO: At least 90% of the time

Values:

- | | |
|---|----------------------|
| 1 | 100 ft or less |
| 2 | 101 to 300 ft |
| 3 | 301 to 500 ft |
| 4 | 501 to 1000 ft |
| 5 | 1001 ft to 1/2 mile |
| 6 | 1/2 to 1 mile |
| 7 | 1 to 3 miles |
| 8 | 3 to 5 miles |
| 9 | Greater than 5 miles |

1.13 WATER ON PLOT [WTYP]

Record the water source that has the greatest impact on the area within the accessible forest land portion of any of the four subplots. The coding hierarchy is listed in order from large permanent water to temporary water **that does not qualify as a separate condition**. This variable can be used for recreation, wildlife, hydrology, and timber availability studies.

When collected: All plots with at least one accessible forest land condition class (PLOT STATUS = 1)

Field width: 1 digit

Tolerance: No errors

MQO: At least 90% of the time

Values:

- | | |
|---|---|
| 0 | None – no water sources within the accessible forest land CONDITON CLASS |
| 1 | Permanent streams or ponds too small to qualify as noncensus water |
| 2 | Permanent water in the form of deep swamps, bogs, marshes with or without standing trees present and less than 1.0 ac in size, or with standing trees |
| 3 | Ditch/canal – human-made channels used as a means of moving water, such as irrigation or drainage which are too small to qualify as noncensus water |
| 4 | Temporary streams |
| 5 | Flood zones – evidence of flooding when bodies of water exceed their natural banks |
| 9 | Other temporary water – specify in PLOT NOTES |

NRS Note: Permanent water **with trees** (i.e., a forested bog or swamp) and a forested flood zone do not have an acreage limitation. [Clarification 10/05/2006.]

1.14 QA STATUS [QAST]

Record the code to indicate the type of plot data collected, using the following codes:

When collected: All plots

Field width: 1 digit

Tolerance: No errors

MQO: At least 99% of the time

Values:

- | | |
|---|--------------------------|
| 1 | Standard production plot |
| 2 | Cold check |

- 3 Reference plot (off grid)
- 4 Training/practice plot (off grid)
- 5 Botched plot file (disregard during data processing)
- 6 Blind check
- 7 Hot check (production plot)

1.15 CREW TYPE [CRTY]

Record the code to specify what type of crew is measuring the plot.

When collected: All plots

Field width: 1 digit

Tolerance: No errors

MQO: At least 99% of the time

Values:

- 1 Standard field crew
- 2 QA crew (any QA crew member present collecting data)

NRS Note (coding change for former NE crews): The former 3-digit data collector identification coding system has been expanded to 4-digits. A data collector identified with a number less than 5000 are former North Central data collectors (e.g., former NC data collector 0064 is still 0064). A number 5000 or greater are former Northeast data collectors (e.g., former NE data collector 008 is now 5008).

1.15.1N CRUISER [CRUI]

Record the identification number of the person that cruised the plot. If the plot is completed as a one person plot (solo data collection), enter your assigned number for both CRUISER and TALLIER.

When collected: All plots

Field width: 4 digits

Tolerance: No errors

MQO: At least 99% of the time

Values: > 0000

1.15.2N TALLIER [TALL]

Record the identification number of the person that tallied the plot. If the plot is completed as a one person plot (solo data collection), enter your assigned data collection for both CRUISER and TALLIER.

When collected: All plots

Field width: 4 digits

Tolerance: No errors

MQO: At least 99% of the time

Values: > 0000

1.15.3N ONE OR TWO PERSON PLOT [CRSZ]

Enter a code which indicates that the plot could be completed with one person crew or it should be completed with a two person crew.

When collected: All plots

Field width: 1

Tolerance: N/A

MQO: N/A

Values:

- 1 Could be completed by a one person crew
- 2 Should be completed by a two person crew

1.15.4N PLOT SEASON [SEAS]

Enter the code reflecting the best time of year to access and complete this plot. If there are no hindrances (e.g., water, vegetation, remoteness) for completing this plot at anytime of year, enter code 3. **Do not base your assessment on whether or not the plot is chosen for P3, PA regeneration or invasive tally. [Clarification 10/10/2006.]**

When collected: All plots

Field width: 1

Tolerance: N/A

MQO: N/A

Values:

- 1 Winter
- 2 Summer
- 3 Anytime

1.16 GPS Coordinates

Use a global positioning system (GPS) unit to determine the plot coordinates and elevation of all field-visited plot locations.

1.16.1 GPS Unit Settings, Datum, and COORDINATE SYSTEM

Consult the GPS unit operating manual or other regional instructions to ensure that the GPS unit internal settings, including Datum and Coordinate system, are correctly configured.

Each FIA unit will determine the Datum to be used in that region. Most will use the NAD 27 Datum (also known as NAS-C or NA 27 CONUS/CLK66), but coordinates collected using any appropriate datum can be converted back to a national standard (NAD 83) for reporting purposes.

Each FIA unit will also determine which coordinate system to use. Regions using a Geographic system will collect coordinates in Degrees, Minutes, and Seconds of Latitude and Longitude; the regions using the UTM coordinate system will collect UTM Easting, Northing, and Zone.

1.16.2 Collecting Readings

Collect at least 180 GPS readings at the plot center. These may be collected in a file for post-processing or may be averaged by the GPS unit. Each individual position should have an error of less than 70 feet if possible (the error of all the averaged readings is far less).

Soon after arriving at plot center, use the GPS unit to attempt to collect coordinates. If suitable positions (180 readings at error less than or equal to 70 feet) cannot be obtained, try again before leaving the plot center.

If it is still not possible to get suitable coordinates from plot center, attempt to obtain them from a location within 200 feet of plot center. Obtain the azimuth and horizontal distance from the "offset" location to plot center. If a PLGR unit or **LANDMARK CE software** is used, use the Rng-Calc function in the PLGR or **offset function in LANDMARK** to compute the coordinates of the plot center. If another type of GPS unit is used, record the azimuth and horizontal distance as described in Sections 1.15.12 and 1.15.13.

Coordinates may be collected further away than 200 feet from the plot center if a laser measuring device is used to determine the horizontal distance from the "offset" location to plot center. Again, if a PLGR unit or **LANDMARK CE software** is used, use the Rng-Calc function in the PLGR or **offset function in LANDMARK** to compute the coordinates of the plot center. If another type of GPS unit is used, record the azimuth and horizontal distance as described in Sections 1.16.12 and 1.16.13.

In all cases try to obtain at least 180 positions before recording the coordinates.

1.16.3 GPS UNIT [UNIT]

Record the kind of GPS unit used to collect coordinates. If suitable coordinates cannot be obtained, record 0.

NRS Note: If GPS coordinates cannot be taken for any reason, enter code 0 and regional SP coordinates are required. (See Regional Appendix A for required PDR SP variables.) The remaining GPS variables for PC are not recorded.

When collected: All field visited plots

Field width: 1 digit

Tolerance: No errors

MQO: At least 99% of the time

Values:

- 0 GPS coordinates not collected
- 1 Rockwell Precision Lightweight GPS Receiver (PLGR)
- 2 Other brand capable of field-averaging including LANDMARK CE
- 3 Other brands capable of producing files that can be post-processed
- 4 Other brands not capable of field-averaging or post-processing

1.16.4 GPS SERIAL NUMBER [GPS#]

Record the last six digits of the serial number on the GPS unit used.

When collected: When GPS UNIT > 0

Field width: 6 digits

Tolerance: No errors

MQO: At least 99% of the time

Values: 000001 to 999999

1.16.5 GPS DATUM

Record the acronym indicating the map datum that the GPS coordinates are collected in (i.e., the map datum selected on the GPS unit to display the coordinates).

NRS Note: All GPS coordinates will be collected using NAD83. NAD27 that was applied in the former Northeast for 2.0 or earlier versions of the field guide is not longer used. All NAD27 coordinates written on 2.0 or earlier tally sheets have been converted to NAD83. These converted coordinates are preprinted on the current plot location tally sheet.

NAD83 will be applied by the regional office after the data has been electronically submitted from the field.

When collected: When GPS UNIT >0

Field width: 5 characters (cccn)

Tolerance: No errors

MQO: At least 99% of the time

Values:

NAD27	North American Datum of 1927
NAD83	North American Datum of 1983
WGS84	World Geodetic System of 1984

1.16.6 COORDINATE SYSTEM

Record a code indicating the type of coordinate system used to obtain readings.

NRS Note: The geographic coordinate system value 1 will be applied by the regional office after the data has been electronically submitted from the field.

When collected: When GPS UNIT > 0

Field width: 1 digit

Tolerance: No errors

MQO: At least 99% of the time

Values:

- 1 Geographic coordinate system
- 2 UTM coordinate system

NRS Note (procedural change for former NC crews): The former procedure of collecting latitude and longitude as degrees and decimal minutes is no longer applicable. Coordinates will now be collected as degrees, minutes and seconds for latitude and longitude at both SP and PC.

1.16.7 Latitude

Record the latitude of the plot center to the nearest hundredth second, as determined by GPS.

NRS Note: Latitude is also collected for all new starting points (SP) where a course to plot is being established for the first time or a starting point is changed from the previous cycle. A starting point should be changed if the old location is no longer adequate for plot relocation. E.g., due to a new road, there is now a better access point to the plot. A new SP is installed along the new road that reduces the chaining distance to the plot. This SP data are recorded on the plot location sheet and the data recorder. See Regional Appendix A for required PDR SP variables.

On a remeasurement annual plot (SK 2), latitude at PC is remeasured even if the previous value is satisfactory for plot relocation.

NOTE: The following can be customized at the region level (e.g., decimal minutes to the nearest thousandth) as long as the final results recorded are within the specified tolerance to the nearest hundredth of a second or +/- 1.01 ft.

NRS Note (procedural change for NC and NE): The following six national variables associated with latitude and longitude degrees, minutes and seconds will be recoded as two variables in the regional PDR program and the plot record. Record the following format for degrees, minutes and seconds for both latitude and longitude as displayed in *LANDMARK CE*:

LAT N = xx° xx' xx.xx"
LONG W = xxx° xx' xx.xx"

1.16.7.1 LATITUDE DEGREES

Record the latitude degrees of the plot center as determined by GPS.

When collected: When COORDINATE SYSTEM = 1

Field width: 3 digits (1st digit is + or -, last 2 digits are numeric)

Tolerance: No errors

MQO: At least 99% of the time

Values:

1.16.7.2 LATITUDE MINUTES

Record the latitude minutes of the plot center as determined by GPS.

When collected: When COORDINATE SYSTEM = 1

Field width: 2 digits

Tolerance: No errors

MQO: At least 99% of the time
Values: 1 – 59

1.16.7.3 LATITUDE SECONDS

Record the latitude decimal seconds of the plot center to the nearest hundredth place as determined by GPS.

When collected: When COORDINATE SYSTEM = 1
Field width: 4 digits
Tolerance: +/- 140 ft
MQO: At least 99% of the time
Values: 0.00 - 59.99

1.16.8 Longitude

Record the longitude of the plot center, to the nearest hundredth second, as determined by GPS.

NRS Note: Longitude is also collected for all new starting points where a course to plot is being established for the first time or a starting point is changed from the previous cycle. This data is recorded on the plot location sheet and the data recorder. See Regional Appendix A for required PDR SP variables.

On a remeasurement annual plot (SK 2), longitude at PC is remeasured even if the previous value is satisfactory for plot relocation.

NOTE: The following can be customized at the region level (e.g., decimal minutes to the nearest thousandth) as long as the final results recorded are within the specified tolerance to the nearest hundredth of a second or +/- 1.01 ft.

1.16.8.1 LONGITUDE DEGREES

Record the longitude degrees of the plot center as determined by GPS.

When collected: When COORDINATE SYSTEM = 1
Field width: 4 digits (1st digit is + or -, last 3 digits are numeric)
Tolerance: No errors
MQO: At least 99% of the time
Values:

1.16.8.2 LONGITUDE MINUTES

Record the longitude minutes of the plot center as determined by GPS.

When collected: When COORDINATE SYSTEM = 1
Field width: 2 digits
Tolerance: No errors
MQO: At least 99% of the time
Values: 1 – 59

1.16.8.3 LONGITUDE SECONDS

Record the longitude decimal seconds of the plot center to the nearest hundredth place as determined by GPS.

When collected: When COORDINATE SYSTEM = 1
Field width: 4 digits
Tolerance: +/- 140 ft
MQO: At least 99% of the time
Values: 0.00 – 59.99

1.16.9 UTM ZONE

This variable is not applicable in the North.

1.16.10 EASTING (X) UTM

This variable is not applicable in the North.

1.16.11 NORTHING (Y) UTM

This variable is not applicable in the North.

NRS Note: The following variables pertaining to the correction for "offset" are used only if the recorded latitude and longitude coordinates **do not** relate to the plot center and require post correction at the regional office. In the North, most GPS units have program software utilities to calculate plot center coordinates if azimuth and distance are known to plot center.

1.16.12 Correction for "Offset" Location

As described in Section 1.14.2, coordinates may be collected at a location other than the plot center (an "offset" location). If a PLGR **unit or LANDMARK CE software** is used all offset coordinates will be "corrected" back using the Rng/Calc function **or offset function**. If a GPS unit other than a PLGR **or LANDMARK CE software** is used, then record items 1.16.13 and 1.16.14.

1.16.13 AZIMUTH TO PLOT CENTER [**AZM**]

Record the azimuth from the location where coordinates were collected to actual plot center. If coordinates are collected at plot center, record 000.

When collected: When GPS UNIT = 2, 3 or 4

Field width: 3 digits

Tolerance: +/- 3 degrees

MQO: At least 99% of the time

Values: 000 when coordinates **are** collected at plot center; 001 to 360 when coordinates **are not** collected at plot center

1.16.14 DISTANCE TO PLOT CENTER [**DIST**]

Record the horizontal distance in feet from the location where coordinates were collected to the actual plot center. If coordinates are collected at plot center, record 000. As described in Section 1.16.2, if a laser range finder is used to determine DISTANCE TO PLOT CENTER, offset locations may be up to 999 feet from the plot center. If a range finder is not used, the offset location must be within 200 feet.

When collected: When GPS UNIT = 2, 3 or 4

Field width: 3 digits

Tolerance: +/- 6 ft

MQO: At least 99% of the time

Values: 000 when coordinates **are** collected at plot center; 001 to 200 when a Laser range finder **is not** used to determine distance; 001 to 999 when a Laser range finder **is** used to determine distance

1.16.15+N GPS ELEVATION [**ELEV**]

Record the elevation above mean sea level of the plot center, in feet, as determined by GPS.

NRS Note: If GPS coordinates are collected at different location other than PC, record the regional code of 99999 for GPS ELEVATION. If a negative elevation is determined by GPS, enter the elevation as mean sea level (i.e., 00000) **due to the limitation of the regional PDR program to accept negative values. [Clarification 10/05/2006.]**

When collected: When GPS UNIT = 1, 2 or 4

Field width: 6 digits (1st digit is + or -, last 5 digits are numeric)

Tolerance:

MQO: At least 99% of the time
 Values: -00100 to +20000, 99999

State	Highest Point	Elevation	Lowest Point	Elevation
Connecticut	Mt. Frissel – S slope	2,380	Long Island Sound	Sea level
Delaware	Ebright Azimuth	448	Atlantic Ocean	Sea level
D.C.	Tenleytown at Reno Reservoir	410	Potomac River	1
Illinois	Charles Mound	1,235	Mississippi River	279
Indiana	Hoosier Hill Point	1,257	Ohio River	320
Iowa	Hawkeye Point	1,670	Mississippi River	480
Kansas	Sunflower	4,039	Verdigris River	679
Maine	Mt. Katahdin	5,267	Atlantic Ocean	Sea level
Maryland	Backbone Mt.	3,360	Atlantic Ocean	Sea level
Massachusetts	Mt. Greylock	3,487	Atlantic Ocean	Sea level
Michigan	Mt. Arvon	1,979	Lake Erie	572
Minnesota	Eagle Mt.	2,301	Lake Superior	600
Missouri	Taum Sauk Mt.	1,772	St. Francis River	230
Nebraska	Panorama Point	5,424	Missouri River	840
New Hampshire	Mt. Washington	6,288	Atlantic Ocean	Sea level
New Jersey	High Point	1,803	Atlantic Ocean	Sea level
New York	Mt. Marcy	5,344	Atlantic Ocean	Sea level
North Dakota	White Butte	3,506	Red River	750
Ohio	Campbell Hill	1,549	Ohio River	455
Pennsylvania	Mt. Davis	3,213	Delaware River	Sea level
Rhode Island	Jerimoth Hill	812	Atlantic Ocean	Sea level
South Dakota	Harney Peak	7,242	Big Stone Lake	966
Vermont	Mt. Mansfield	4,393	Lake Champlain	95
West Virginia	Spruce Knob	4,861	Potomac River	240
Wisconsin	Timms Hill	1,951	Lake Michigan	579

1.16.16 GPS ERROR [ERRS]

Record the EHE error as shown on the GPS unit to the nearest foot. As described in Section 1.16.2, make every effort to collect readings only when the error less than or equal to 70 feet. However, if after trying several different times during the day, at several different locations, this is not possible, record readings with an error of up to 999 feet.

When collected: When GPS UNIT =1 or 2

Field width: 3 digits

Tolerance: No errors

MQO: At least 99% of the time

Values: 000 to 070 if possible; 071 to 999 if an error of less than 70 cannot be obtained

NRS Note (new variable for former NC crews): This variable is applicable when *LANDMARK CE* is utilized.

1.16.16.1N GPS PDOP [PDOP]

Record the Position Dilution of Precision (PDOP) value as shown on the *LANDMARK CE* software to the nearest tenth. When averaging, the software requires a minimum amount of precision to determine whether or not to ignore a positional measurement. The recorded PDOP measures the overall accuracy of measurements.

Note: If the GPS UNIT does not display this value, enter 0.0.

When collected: When GPS UNIT = 2
Field width: 2 digits (x.y)
Tolerance: No errors
MQO: At least 99% of the time
Values: 0.0, 0.1 to 8.0

1.16.17 NUMBER OF READINGS **[READ]**

Record a 3-digit code indicating how many readings were averaged by the GPS unit to calculate the plot coordinates. Collect at least 180 readings if possible.

When collected: When GPS UNIT = 1 or 2
Field width: 3 digits
Tolerance: No errors
MQO: At least 99% of the time
Values: 001 to 999

1.16.18 GPS FILENAME (CORE OPTIONAL)

This variable is not applicable in the North.

1.17 MACROPLOT BREAKPOINT DIAMETER (CORE OPTIONAL)

This variable is not applicable in the North.

1.18 PLOT-LEVEL NOTES

Use these fields to record notes pertaining to the entire plot. If the notes apply only to a specific subplot or other specific aspect of the plot, then make that clear in the notes. Others may find this information helpful when checking or processing the plot data, or even when re-establishing the plot during the next inventory cycle. **The value of good notes cannot be overemphasized.**

When collected: All plots
Field width: Unlimited alphanumeric character field
Tolerance: N/A
MQO: N/A
Values: English language words, phrases and numbers

2.0 CONDITION CLASS

The Forest Inventory and Analysis (FIA) plot is cluster of four subplots in a fixed pattern. Subplots are never reconfigured or moved in order to confine them to a single condition class; a plot may straddle more than one condition class. Every plot samples at least one condition class: the condition class present at plot center (the center of subplot 1).

2.1 DETERMINATION OF CONDITION CLASS

2.1.1 Step 1: Delineate the plot area by CONDITION CLASS STATUS

The first attribute considered when defining a condition class is CONDITION CLASS STATUS. The area sampled by a plot is assigned to condition classes based upon the following differences in CONDITION CLASS STATUS:

1. Accessible forest land
2. Nonforest land
3. Noncensus water
4. Census water
5. Nonsampled

Accessible forest land defines the population of interest for FIA purposes. This is the area where most of the data collection is conducted.

At time of re-inventory, one additional attribute, PRESENT NONFOREST LAND USE, is used to define new condition classes if the sampled area on a plot has changed from accessible forest land to nonforest land (NOTE: see Section 2.5.24). This allows tracking of land use changes without requiring mapping of all nonforest condition classes on all plots.

2.1.2 Step 2: Further subdivide Accessible Forest Land by 6 delineation variables

Any condition class sampled as accessible forest land may be further subdivided, in order of listed priority, into smaller condition classes if distinct, contrasting condition classes are present because of variation in any of the following attributes within the sampled area:

1. RESERVED STATUS
2. OWNER GROUP
3. FOREST TYPE
4. STAND SIZE CLASS
5. REGENERATION STATUS
6. TREE DENSITY

No other attribute shall be the basis for recognizing contrasting accessible forest land condition classes. For each condition class recognized, several "ancillary attributes" that help describe the condition will be collected, but will not be used for delineation purposes (see Sections 2.5.7 to 2.5.23).

2.2 CONDITION CLASS STATUS DEFINITIONS

1. Accessible Forest Land

Land that is within the population of interest, is accessible, is on a subplot that can be occupied at subplot center, can safely be visited, and meets at least one of the two following criteria:

- (a) the condition is at least 10-percent stocked by trees (Appendix 3) of any size or has been at least 10-percent stocked in the past. Additionally, the condition is not subject to nonforest

use(s) that prevent normal tree regeneration and succession such as regular mowing, intensive grazing, or recreation activities.

NRS Note: For pasture or range where there is mowing (i.e., brush hogging to control regeneration of trees and shrubs; not for recreation or yard maintenance) or intensive grazing, stocking must be at least 10% by trees ≥ 1.0 inch DBH. If this factor is met for stocking, the plot is given CONDITION CLASS STATUS 1 and the plot is installed.

or

- (b) in several western woodland species (Appendix 3) where stocking cannot be determined, and the condition has at least 5 percent crown cover by trees of any size, or has had at least 5 percent cover in the past. Additionally, the condition is not subject to nonforest use that prevents normal regeneration and succession such as regular mowing, chaining, or recreation activities.

NRS Note: The preceding text is not applicable in the states of KS, NE, ND and SD where Rocky Mountain Juniper (*Juniperis scopulorum*) may be encountered. This is the only woodland species recognized in the North and is generally found in the western half of these states. This species is represented in Appendix 5 stocking tables and the standard procedures for determining stocking are applied.

To qualify as forest land, the prospective condition must be at least 1.0 acre in size and 120.0 feet wide measured stem-to-stem from the outer-most edge. Forested strips must be 120.0 feet wide for a continuous length of at least 363.0 feet in order to meet the acre threshold. Forested strips that do not meet these requirements are classified as part of the adjacent nonforest land.

Transition zones and forest/nonforest encroachment – When an accessible forest land condition encroaches into a nonforest condition, the border between forest and nonforest is often a gradual change in tree cover or stocking with no clear and abrupt boundary. In addition, it may be difficult to determine exactly where the forested area meets the minimum stocking criteria and where it does not. For these cases, determine where the land clearly meets the 10 percent minimum forest land stocking, and where it clearly is less than required stocking; divide the zone between these points in half, and determine the side of the zone on which the subplot center is located. Classify the condition class of the subplot based on this line (Figure 2).

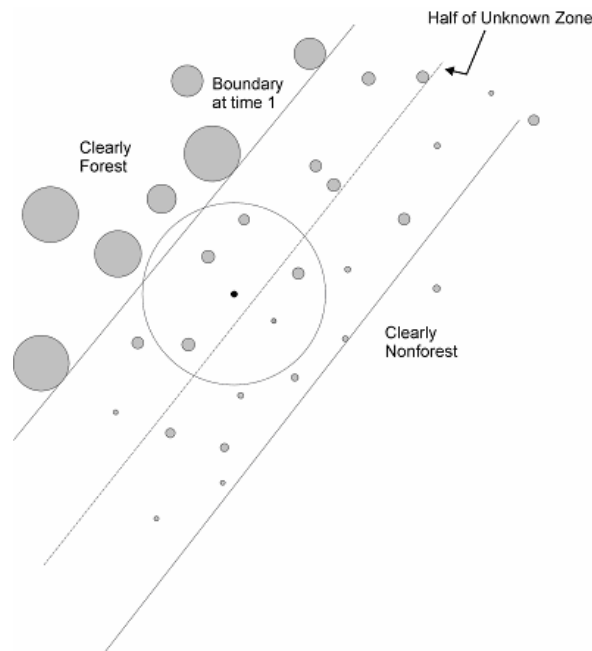

Figure 2. Example of classifying the condition class of the subplot in a transition zone with forest/nonforest encroachment.

For example, at measurement time 1, a clear and distinct boundary existed between the forest and nonforest condition classes. At time 2, however, there now exists a zone of regeneration or small diameter trees between the previous forest condition and where the nonforest clearly remains. If the zone of encroachment is clearly stocked where it meets the nonforest, classify the entire zone as forest. If the zone is clearly nonforest up to the original stand, call it all nonforest. If the encroachment or transition zone is not clearly stocked where it meets the nonforest, determine where it is clearly stocked (forest) and where it is clearly not stocked (nonforest); divide this zone in half, and classify the entire subplot based on which side of the line the subplot center falls.

Treated strips – Occasionally, crews will come across plantations of trees, in which rows of trees alternate with strips of vegetation that have been bulldozed, mowed, tilled, treated with herbicide, or crushed. Because these strip treatments are conducted to optimize growth or to release the stand, the areas are considered forest land, and the treatment is considered a timber stand improvement operation. Do not confuse these practices with similar treatments on nonforest lands such as yards or rights-of-way. Contact with the landowner may help determine the intent of a treatment.

Indistinct boundary due to the condition minimum-width definition – Do not subdivide subplots where a condition class may change due only to the forest vs. nonforest minimum width (120.0 feet) definition. Although the point where the definition changes from forest to nonforest creates an invisible “line” between conditions, **this definitional boundary is not distinct and obvious**. See Figures 3 and 4. Where the point of the definition change occurs on the subplot, determine only if the subplot center is on the forest or nonforest side of that approximate boundary, and classify the entire subplot based on the condition of the subplot center. If the boundary crosses through the center of the subplot, classify the subplot as the condition it most resembles. If the boundary occurs between subplots, classify each subplot based on its relation to the definitional boundary.

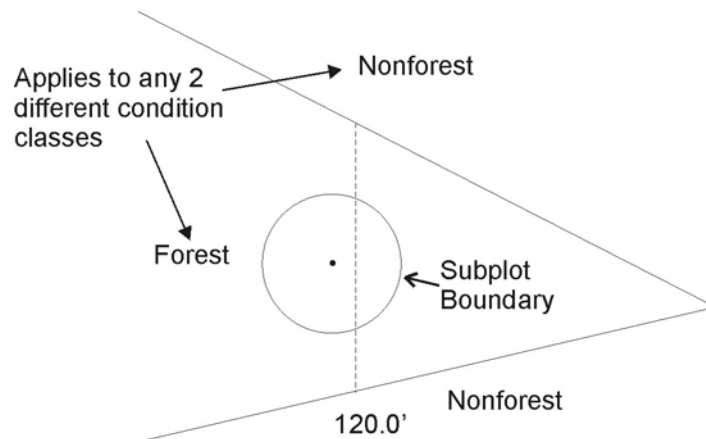

Figure 3. Forest condition narrows within a nonforest condition. Examine the location of the subplot center in reference to the approximate line where the forest narrows to 120.0 ft wide. In this example, the entire subplot is classified as forest.

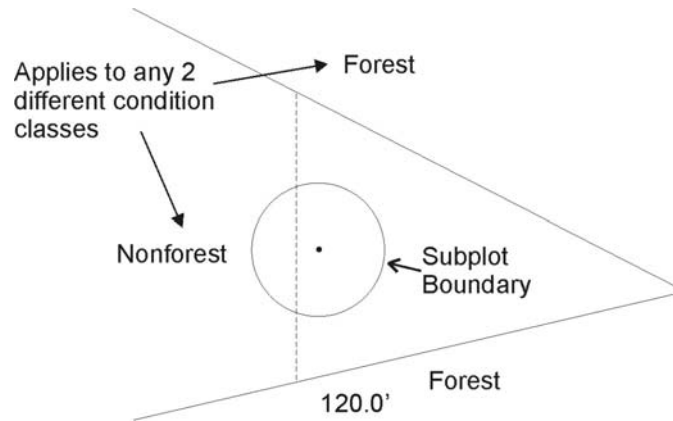

Figure 4. Nonforest condition narrows within a forest condition. Examine the location of the subplot center in reference to the approximate line where the nonforest narrows to 120.0 ft wide. In this example, the entire subplot is classified as forest.

2. **Nonforest Land**
Nonforest land is any land within the sample that does not meet the definition of accessible forest land or any of the CONDITION CLASS STATUS values defined in #'s 3 and 4 in Section 2.2. To qualify, the area must be at least 1.0 acre in size and 120.0 feet wide; five exceptions are discussed at the beginning of Section 2.4. Do not consider evidence of "possible" or future development or conversion. A nonforest land condition will remain in the sample and will be examined at the next plot visit to see if it has become forest land.
3. **Noncensus Water**
Lakes, reservoirs, ponds, and similar bodies of water 1.0 acre to 4.5 acres in size. Rivers, streams, canals, etc., 30.0 feet to 200 feet wide.
4. **Census Water**
Lakes, reservoirs, ponds, and similar bodies of water 4.5 acres in size and larger; and rivers, streams, canals, etc., more than 200 feet wide (1990 U.S. Census definition).
5. **Nonsampled**
See section 2.4.3 CONDITION NONSAMPLED REASON for descriptions of land that qualifies as nonsampled.

2.3 CONDITION CLASS ATTRIBUTES

A CONDITION CLASS NUMBER and a classification for CONDITION CLASS STATUS are required for every condition class sampled on a plot. For each condition class classified as accessible forest land, a classification is required for each of the following attributes:

2.5.1	RESERVED STATUS	}	Attributes where a change causes a separate condition class
2.5.2	OWNER GROUP		
2.5.3	FOREST TYPE		
2.5.4	STAND SIZE CLASS		
2.5.5	REGENERATION STAT		
2.5.6	TREE DENSITY		
2.5.7	OWNER CLASS	}	Ancillary - changes do not delineate a new condition class
2.5.8	PRIVATE OWNER INDUSTRIAL STATUS		
2.5.9	ARTIFICIAL REGENERATION SPECIES		
2.5.10	STAND AGE		
2.5.11	DISTURBANCE (up to 3 coded)		
2.5.12	DISTURBANCE YEAR (1 per disturbance)		
2.5.17	TREATMENT (up to 3 coded)		
2.5.18	TREATMENT YEAR (1 per treatment)		
2.5.22.1N	STAND HISTORY		
2.5.23	PHYSIOGRAPHIC CLASS		
2.5.23.1N	PRODUCTIVITY STATUS		
2.5.24+N	PRESENT NONFOREST LAND USE (for area converted from accessible forest land condition class to nonforest land since last inventory; in the North, all plots with nonforest condition class).		
2.5.24.1N	NONFOREST TREES		

When classifying CONDITION CLASS STATUS, OWNER GROUP, RESERVED STATUS, and PRESENT NONFOREST LAND USE, base the classification on what is present within the area defined by the fixed radius plot (subplot or microplot). When classifying all other condition class variables, base the classification on the macroplot.

2.4 DELINEATING CONDITION CLASSES DIFFERING IN CONDITION CLASS STATUS:

The first step in delineating condition classes is to recognize differences in CONDITION CLASS STATUS. The most common difference is adjacent accessible forest land and nonforest land. Adjacent accessible forest land and nonforest land condition classes are recognized only if each of the two prospective condition classes is at least 1.0 acre in size, and each is at least 120.0 feet in width. These size and width minimums apply to both accessible forest land and nonforest land.

Within an accessible forest land condition class, unimproved roads, rock outcrops, and natural nonforest openings less than 1.0 acre in size and less than 120.0 feet in width are considered forest land and are not delineated and classified as a separate nonforest condition class.

Within a nonforest land condition class, forested areas or linear strips of trees less than 1.0 acre in size and less than 120.0 feet in width are considered part of the nonforest condition class and are noted as inclusions.

NRS Note (procedural change for former NE and NC crews): The procedures described and illustrated in Figures 6N, 6.1N and 6.2N are new or modified from previous regional guides. In the EAST, this change will result in forest strips that were once inclusions of nonforest land to be treated as forest land. In the WEST, forest strips less than 30 feet in width are now treated as inclusions.

Five exceptions to these size and width requirements apply:

1. Developed nonforest condition: human-caused nonforest land condition classes such as homes or cabins that are less than 1.0 acre in size and 120.0 feet in width and are surrounded by forest land. There are three kinds of developed nonforest conditions that do not have to meet area or width requirements (Figures 5 and 6).
 - a) Improved roads: paved roads, gravel roads, or improved dirt roads regularly maintained for long-term continuing use. Unimproved traces and roads created for skidding logs are not considered improved roads.
 - b) Maintained rights-of-way: corridors created for railroads, power lines, gas lines, and canals that are periodically treated to limit the establishment and growth of trees and shrubs.
 - c) Developments: structures and the maintained area next to a structure, all less than 1.0 acre in size and surrounded by forest land. Examples of developments are houses or trailers on very small lots, communication installations in a small cleared area within forest land, and barns and sheds.

NRS Note: Improved roads, R.O.W. and noncensus water that are less than 120.0 feet in width do not necessarily break up a forest condition that are between “switchbacks” as shown in Figure 5. Other regional variations of the “switchback” rule can be found in Regional Appendix C. In other situations as shown in Figure 6N, where there is an improved R.O.W, development or noncensus water, a strip of forest land may have minimum width of 30.0 feet and minimum length of 120.0 feet as long as there is “qualifying” accessible forest land that lies across from the nonforest strip. See Figure 6N. Since the forest strip cannot be delineated as its own condition, the condition variables are determined from the “qualifying” accessible forest land.

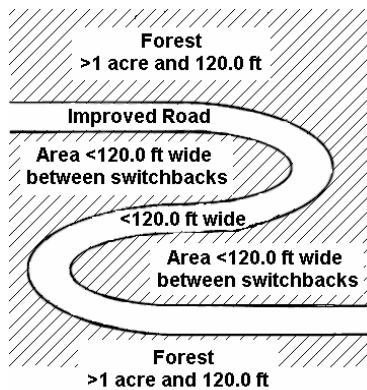

Figure 5. Example of a switchback road.

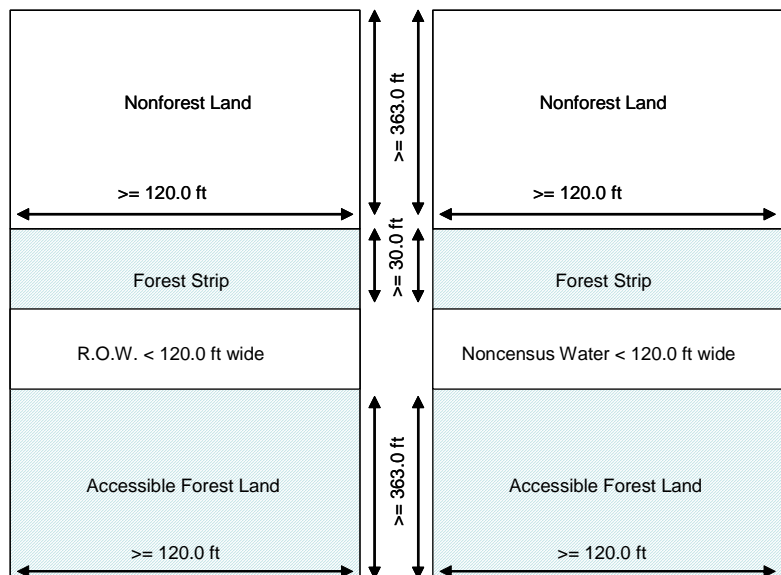

Figure 6N. Example of nonforest and forest strips when the nonforest strip is developed (i.e., R.O.W or structures) or noncensus water. If the nonforest strip is not noncensus water or one of the developed conditions listed under exception 1, see Figure 7b+N.

NRS Note: The next two illustrations show a procedure to combine two forest strips in order to achieve the minimum width and acreage for accessible forestland. This is in contrast to Figure 6N which shows accessible forest land (i.e., 1 acre and 120.0 ft) adjacent to the nonforest "developed" strip or noncensus water. In both figures below, the width of the nonforest condition is not used to measure overall width since these represent a separate CONDITION CLASS STATUS. As in Figure 6N, a forest strip must be at least 30.0 feet in width. Strips less than 30.0 feet in width are treated as inclusions of the adjacent nonforest condition.

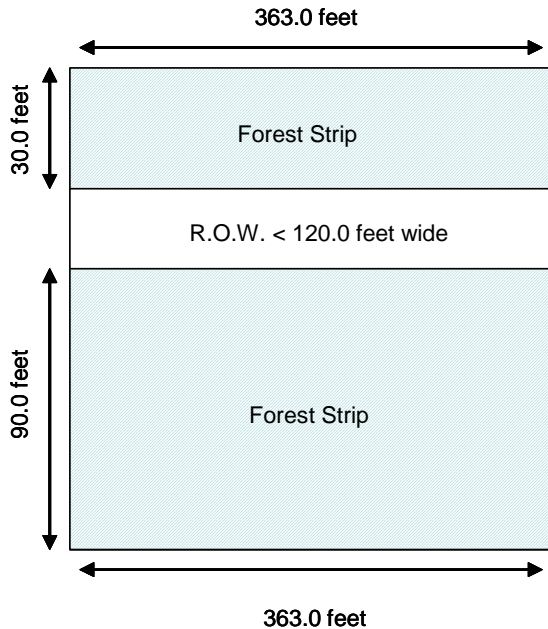

Figure 6.1N. Two forest strips exist on either side of a R.O.W. The R.O.W. is it's own condition, however, a developed condition can be jumped if less than 120.0 ft in width. The width of the R.O.W. cannot be used to measure the overall width of the forest. If the combined forest strips measure to be at least 120 ft in width and 363 ft in length, then the combined strips can be defined as accessible forest land.

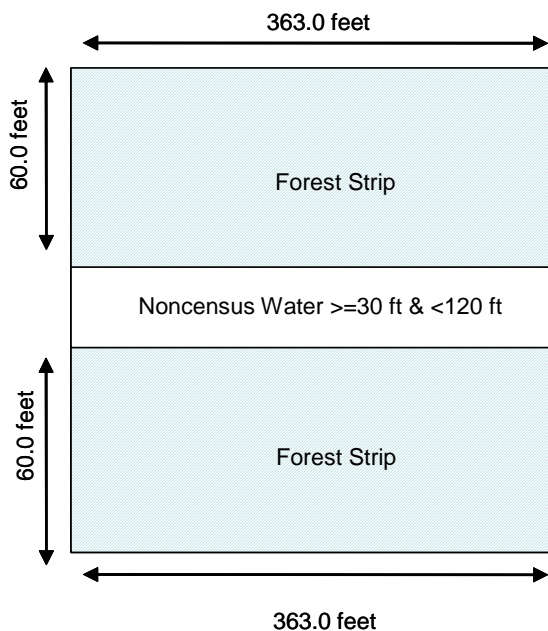

Figure 6.2N. Two forest strips exist on either side of noncensus water. The noncensus water is it's own condition, however, noncensus water can be jumped if less than 120.0 ft in width. The width of the noncensus water cannot be used to measure the overall width of the forest. If the combined forest strips measure to be at least 120 ft in width and 363 ft in length, then the combined strips can be defined as accessible forest land.

2. Distinct, alternating strips of forest and nonforest land: this situation occurs when a plot or subplot samples a condition class that is less than 1.0 acre in size and less than 120.0 feet in width. The condition class is one of a series of parallel strips of forest and nonforest land in which none of the strips meet the minimum width requirement. This exception applies only to nonforest conditions that are not listed under #1, e.g., improved roads, maintained rights-of-way, and developments.
 - a) For many small intermingled strips, determine the total area that the alternating strips occupy, and classify according to the CONDITION CLASS STATUS (forest land or nonforest land) that occupies the greater area. If the area of alternating strips is so large or indistinct as to make a total area determination impractical, then classify the sample as forest land. See Figure 7Na.

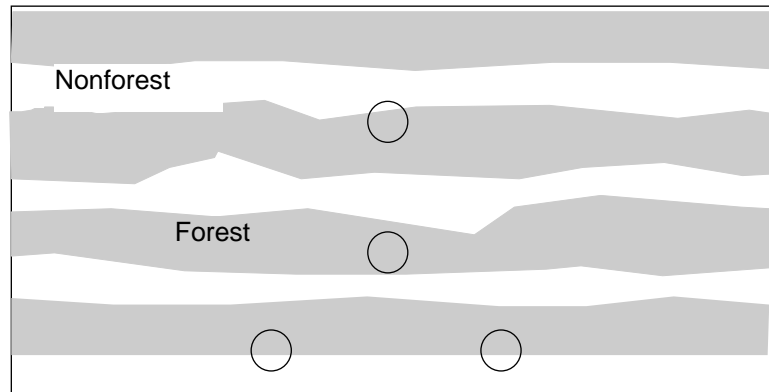

Figure 7aN. Entire plot area consists of strips of forest and nonforest land. None of the strips meets the 120 ft minimum width to qualify as a separate land use and the nonforest strips are not developed nonforest conditions. In this example, the entire area is classified as forest since the sum of the areas occupied by the forest land use exceeds the sum of the nonforested area in this example.

- b) For two alternating strips of forest and nonforest between two qualifying areas of nonforest land and forest land, see Figure 7b+N. Figure 7b+N delineates the boundary between the forest and nonforest condition classes for four different examples. The plot center defines the plot condition for all strips covered by the arrow. Any subplot that falls in the alternating strips uses the rule. Any subplot that falls in assigned nonforest / forest is assigned that type. If either strip of land is less than 30.0 feet wide, then the strip is treated as inclusion of the surrounding or adjacent condition. Note: The nonforest strip in Figure 7b+N is not “developed” as described in Exception 1 and shown in Figure 6N. See Regional Appendix C for more regional Figure 7b+N illustrations.

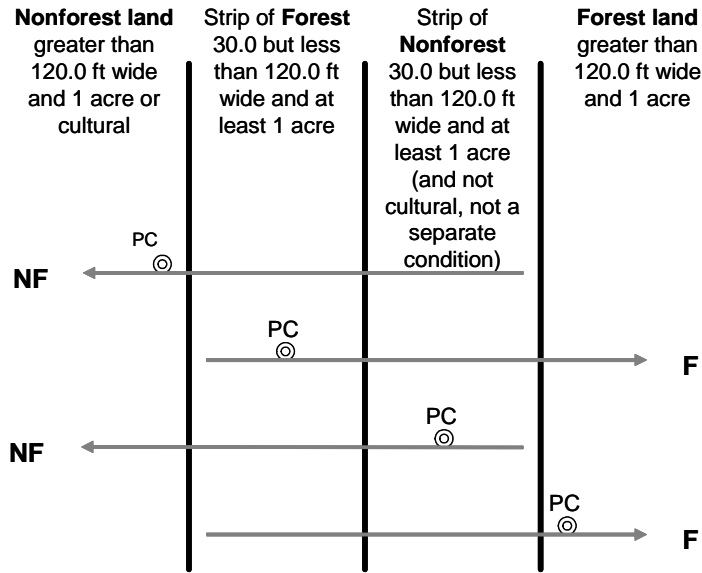

Figure 7b+N. Example of alternating strips of forested and nonforested conditions (that *is neither a developed feature as indicated in "Exception 1" nor linear noncensus water*). PC is the plot center (center of subplot 1) and the strips are treated as either F or NF based on this location. *[Clarification 10/04/2006.]*

- The 120.0-foot minimum width for delineation does not apply when a corner angle is 90 degrees or greater (Figure 8).

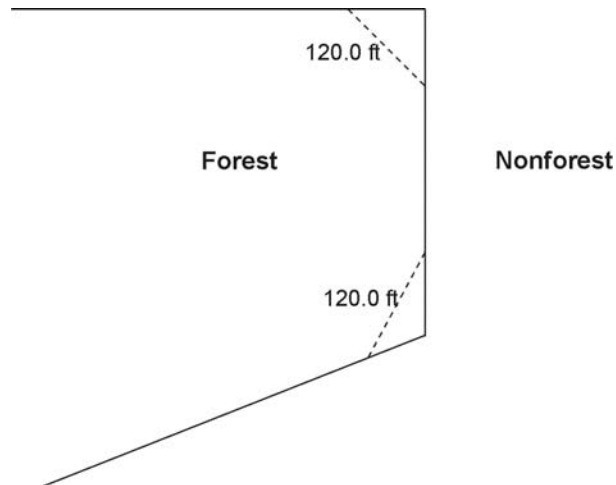

Figure 8. Illustration of the 90 degree corner rule. The dotted lines do not create nonforest conditions.

- Linear water features: natural water features that are linear in shape such as streams and rivers. A linear water feature must meet the definition for Census or noncensus water to be nonforest area. Therefore, a linear water feature must be at least 30.0 feet wide and

cover at least 1.0 acre. The width of a linear water feature is measured across its channel between points on either side up to which water prevents the establishment and survival of trees. To determine whether a linear water feature qualifies as nonforest, rely on all available information on hand such as aerial photos, topographic maps, past survey land calls, and ocular estimates at the current survey visit. Linear water features that do not meet the definition for Census or noncensus water should be classified as forest land only if bounded by forest land on both shores. Crews are NOT expected to measure the length of a linear water feature to determine if it meets the 1.0 acre requirement; use professional judgment and common sense on any linear water feature.

5. Nonsampled conditions within accessible forest land are delineated, regardless of size, as a separate condition.

NRS Note (procedural change for former NC crews): The practice of tracking conditions from previous cycles is no longer a field procedure. All plots are numbered sequentially beginning with condition class 1 from subplot 1's PC at each inventory visit. The responsibility of tracking area changes caused by condition changes between cycles is completed at the regional office by the Information Group.

2.4.1 CONDITION CLASS NUMBER [CON#]

On a plot, assign and record a number for each condition class. The condition class at plot center (the center of subplot 1) is designated condition class 1. Other condition classes are assigned numbers sequentially at the time each condition class is delineated.

NRS Note: On remeasurement plots, conditions are renumbered to reflect current conditions (i.e., condition class 1 always represents subplot 1's plot center).

When collected: All condition classes
Field width: 1 digit
Tolerance: No errors
MQO: At least 99% of the time
Values: 1 to 9

2.4.2 CONDITION CLASS STATUS [CDST]

Record the code that describes the sampling status of the condition class. The instructions in Sections 2.3 and 2.4 apply when delineating condition classes that differ by CONDITION CLASS STATUS.

When collected: All condition classes
Field width: 1 digit
Tolerance: No errors
MQO: At least 99% of the time
Values:

- 1 Accessible forest land
- 2 Nonforest land
- 3 Noncensus water
- 4 Census water
- 5 Nonsampled

2.4.3 CONDITION NONSAMPLED REASON [REAS]

For portions of plots that cannot be sampled (CONDITION CLASS STATUS = 5), record one of the following reasons.

When collected: When CONDITION CLASS STATUS = 5
Field width: 2 digits

Tolerance: No errors

MQO: At least 99% of the time

Values:

- 01 Outside U.S. boundary – Assign this code to condition classes beyond the U.S. border.
- 02 Denied access area – Any area within the sampled area of a plot to which access is denied by the legal owner, or to which an owner of the only reasonable route to the plot denies access. There are no minimum area or width requirements for a condition class delineated by denied access. Because a denied-access condition can become accessible in the future, it remains in the sample and is re-examined at the next occasion to determine if access is available. In some regions denied access plots may be replaced; check with the field supervisor regarding regional protocols for plot replacement.
- 03 Hazardous situation – Any area within the sampled area on plot that cannot be accessed because of a hazard or danger, for example cliffs, quarries, strip mines, illegal substance plantations, temporary high water, etc. Although the hazard is not likely to change over time, a hazardous condition remains in the sample and is re-examined at the next occasion to determine if the hazard is still present. There are no minimum size or width requirements for a condition class delineated by a hazardous condition. In some regions hazardous plots may be replaced; check with the field supervisor regarding regional protocols for plot replacement.
- 10 Other – This code is used whenever a plot or condition class is not sampled due to a reason other than one of the specific reasons listed. A field note is required to describe the situation.

2.5 DELINEATING CONDITION CLASSES WITHIN ACCESSIBLE FOREST LAND:

Accessible forest land is subdivided into condition classes that are based on differences in RESERVED STATUS, OWNER GROUP, FOREST TYPE, STAND SIZE CLASS, REGENERATION STATUS, and TREE DENSITY. Section 2.1 applies when delineating contrasting forest condition classes. Specific criteria apply for each of the six attributes and are documented by attribute in 2.5.1 to 2.5.6. “Stands” are defined by plurality of stocking for all live trees that are not overtopped.

Additionally, each separate forest condition class recognized within accessible forest land must be at least 1.0 acre in size and at least 120.0 feet in width. If prospective contrasting forest land condition classes do not each meet these minimum size and width requirements, the most similar prospective conditions should be combined until these minimums are attained.

No other attribute shall be the basis for recognizing contrasting condition classes within accessible forest land. For each condition class recognized, many “ancillary attributes” that help describe the condition will be collected, but will not be used for delineation purposes (see Sections 2.5.7 to 2.5.23).

NRS Note (procedural change for former NE crews): The procedure of subdividing accessible forest land by NE’s *Regional Land Use 20 – 52* is no longer applicable. These forest land codes are no longer applied in the field. Only the national delineation variables of RESERVED STATUS, OWNER GROUP, FOREST TYPE, STAND SIZE CLASS, REGENERATION STATUS and TREE DENSITY can subdivide accessible forest land.

General instructions for delineating condition classes within accessible forest lands:

1. Distinct boundary within a subplot or microplot – Separate condition classes ARE recognized if, within a subplot, two (or more) distinctly different condition classes are present and delineated by a distinct, abrupt boundary. The boundary is referenced; see Section 4.0.
2. Indistinct boundary within a subplot – Separate condition classes are NOT recognized if the prospective condition classes abut along an indistinct transition zone, rather than on an abrupt, obvious boundary. Only one condition is recognized, and the subplot is classified entirely as the condition it most resembles.

Example: The four subplots all sample only accessible forest land. Subplots 1, 3, and 4 sample what is clearly a stand of large diameter trees. Subplot 2 falls in the middle of a stand size transition zone. In the zone, the large diameter stand phases into a sapling stand.

Subplot 2 must not be divided into two condition classes on the basis of stand size. Instead, it is treated entirely as part of the large diameter condition class or is assigned entirely to a new condition class that is classified as a seedling-sapling stand. The latter occurs only if the crew thinks the entire subplot is more like a stand of seedlings-saplings than a stand of large diameter trees; then the boundary between the large and small diameter stands is assumed to occur between and not on the subplots.

3. A boundary or transition zone between fixed radii plots that sample distinctly different condition classes – Separate condition classes are recognized and recorded when a valid attribute obviously differs between two fixed radius plots, but a distinct boundary or indistinct transition zone exists outside the sampled (fixed-radius) area of the subplots. In such cases, a boundary, if present, is not referenced.

Example: The northernmost subplot (2) samples entirely accessible forest land. The other three subplots, 1, 3, and 4, fall clearly in a nonforest meadow. Between subplot 1 and 2 is a transition zone; the number of trees present goes from none to what clearly represents at least 10-percent tree stocking. Two condition classes are sampled: accessible forest land sampled on subplot 2, and nonforest land sampled on the other subplots.

4. Riparian forest area – A riparian forest area is defined as a forest area between 30.0 and 120.0 feet wide, and 1.0 acre or more in size, cumulative, and adjacent to but not necessarily present on both sides of a naturally occurring or artificially created body of water or watercourse with continuous or intermittent flow. Riparian forest areas may be associated with but not limited to streams, rivers, lakes, sloughs, seeps, springs, marsh, bogs, beaver ponds, sink holes, cypress domes and ponds, man-made ditches and canals. A riparian forest area must be associated “within forest” and contain at least one distinct and obvious change in a condition class delineation attribute from its adjacent accessible forest land condition class. Figures 9-14 provide examples of when to delineate riparian forest area as a separate condition class. In these figures, forest type “A” qualifies as its own condition (≥ 120 . feet and ≥ 1 acre). The riparian area represented by forest type “B” qualifies as its own condition if the area is between 30.0 and 120.0 feet and is ≥ 1 acre. In addition, see Figure 14.1N Riparian Flowchart.

Note: When the width of forest adjacent to a stream is between 120.0 feet and 150.0 feet and the width of the riparian forest is at least 30.0 feet wide, the rules for identifying the non-riparian forest (at least 30.0 feet but less than 120.0 feet) need to be modified. The non-riparian forest can be between 30.0 feet and 120.0 feet and mapped as a separate

condition as long as it meets the criteria for delineating a separate condition class, otherwise it will be an inclusion in the riparian forest condition class.

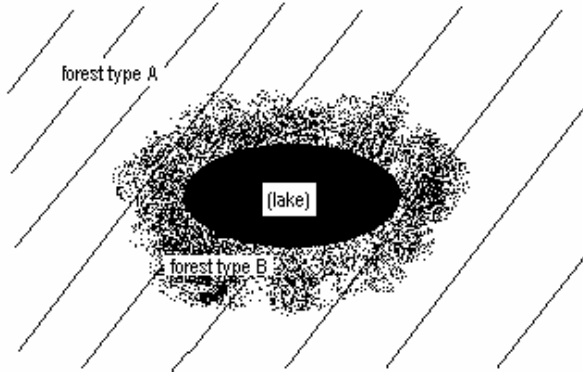

Figure 9. Forest type B is a separate condition class (riparian) if the band of it is between 30.0 feet and 120.0 feet wide, and is ≥ 1.0 acre in size.

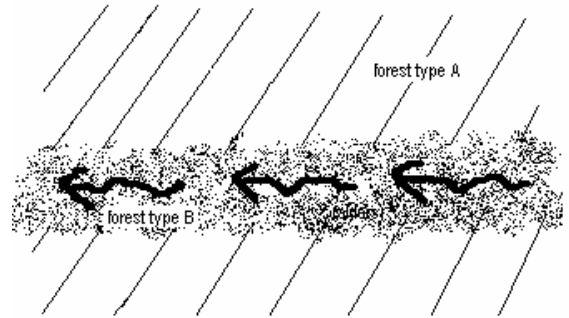

Figure 10. Forest type B is a separate condition class (riparian) if the band of it is between 30.0 feet and 120.0 feet wide, and is ≥ 1.0 acre in size.

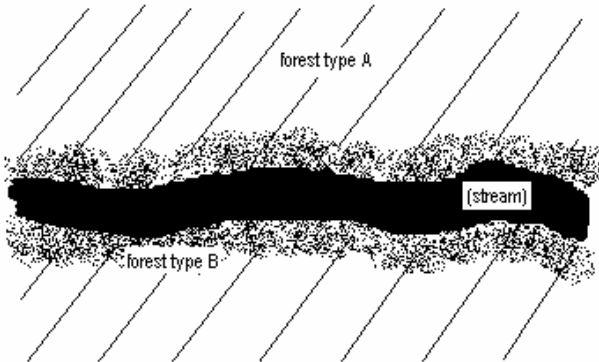

Figure 11. If the stream is < 30.0 feet wide, forest type B is a separate condition class (riparian) if the sum of the two widths of the bands falls between 30.0 feet and 120.0 feet wide, and is ≥ 1.0 acre in size.

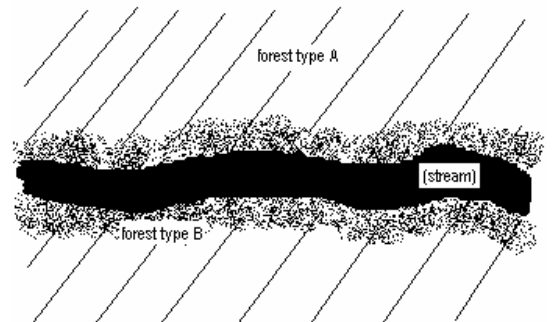

Figure 12. If the stream is > 30.0 feet wide, forest type B is a separate condition class (riparian) if either of the two widths of the bands falls between 30.0 feet and 120.0 feet wide and is ≥ 1.0 acre in size.

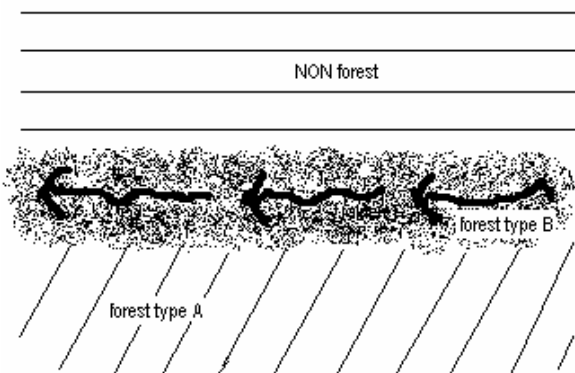

Figure 13. Forest type B is a separate condition class (riparian) if the band of it is between 30.0 feet and 120.0 feet wide, and is ≥ 1.0 acre in size.

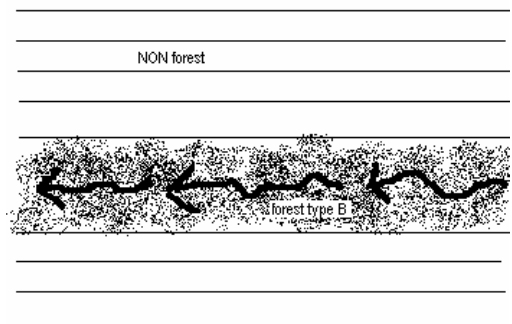

Figure 14. In a non-forested area, a band of forest type B that is < 120.0 feet wide is NOT considered a riparian area. It is not a separate condition class at all.

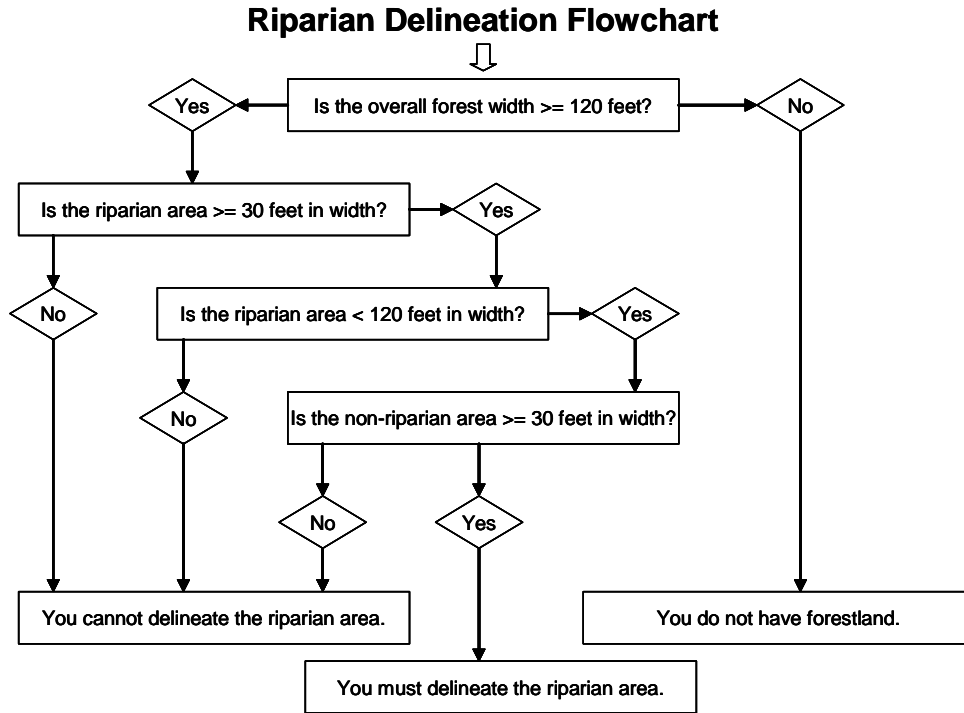

Figure 14.1N.

2.5.1 RESERVED STATUS [RESV]

Record the code that identifies the reserved designation for the condition. Reserved land is withdrawn by law(s) prohibiting the management of land for the production of wood products (not merely controlling or prohibiting wood-harvesting methods). Such authority is vested in a public agency or department, and supersedes rights of ownership. The prohibition against management for wood products cannot be changed through decision of the land manager (management agency) or through a change in land management personnel, but rather is permanent in nature.

NRS Note: RESERVED STATUS is code as 0 for all private land (OWNER GROUP = 40) regardless of conservation easements that may restrict harvesting. All public land requires documentation in the PLOT NOTES of RESERVED STATUS. This designation removes the associated forest into noncommercial forest land. See Regional Appendix C for additional instructions about documentation procedures for reserved public land.

When collected: CORE: All accessible forestland condition classes (CONDITION CLAS STATUS = 1); CORE OPTIONAL: Non-forest condition classes (CONDITION CLASS STATUS >1)

Field width: 1 digit

Tolerance: No errors

MQO: At least 99% of the time

Values:

- 0 Not reserved
- 1 Reserved

2.5.2 OWNER GROUP [OWNG]

Record the OWNER GROUP code identifying the ownership (or the managing Agency for public lands) of the land in the condition class. Conditions will be delineated based on changes in OWNER GROUP only; separate conditions due to changes in OWNER GROUP are recognized only where differences can be clearly identified on the ground when visiting the plot.

NRS Note: When OWNER GROUP = 40 at subplot 1's plot center, owner name and address data are required. See Regional Appendix B for ownerships data collection procedures and required regional owner variables.

When collected: CORE: All accessible forest land condition classes (CONDITION CLASS STATUS = 1); CORE OPTIONAL: Non-forest condition classes (CONDITION CLASS STATUS > 1)

Field width: 2 digits

Tolerance: No errors

MQO: At least 99% of the time

Values:

10	Forest Service
20	Other Federal
30	State and Local Government
40	Private

2.5.3+N FOREST TYPE [FTYP]

Record the code corresponding to the FOREST TYPE (from Appendix 2) that best describes the species with the plurality of stocking for all live trees in the condition class that are not overtopped.

NRS Note: When determining forest type, first try to match the trees present with the "named" type. If this does not match the stand, match the stand with the trees listed as associates under each type even if the named type species are not in present in the stand.

If STAND SIZE CLASS is nonstocked, then FOREST TYPE is determined by the following hierarchy:

- For SAMPLE KIND = 2 plots, record the FOREST TYPE of the condition at the previous inventory.
- For all other plots:
 1. Evaluate any seedlings available to determine the FOREST TYPE.
 2. If no seedlings exist, use adjacent stands and your best professional judgment to determine FOREST TYPE.

When collected: All accessible forest land condition classes (CONDITION CLASS STATUS = 1)

Field width: 3 digits

Tolerance: No errors in group or type

MQO: At least 99% of the time in group; at least 95% of the time in type. No MQO when STAND SIZE CLASS = 0.

Values: See Appendix 2

The instructions in Sections 2.1 and 2.4 apply when delineating, within accessible forest land, contrasting conditions based on differences in FOREST TYPE.

2.5.4 STAND SIZE CLASS [STSZ]

Record the code that best describes the predominant size class of all live trees in the condition class.

When collected: All accessible forest land condition classes (CONDITION CLASS STATUS = 1)

Field width: 1 digit

Tolerance: No errors

MQO: At least 99% of the time

Values:

- 0 Nonstocked
Meeting the definition of accessible forest land, and one of the following applies:
 - (a) less than 10 percent stocked by trees of any size, and not classified as cover trees (see code 6), or
 - (b) for several western woodland species where stocking standards are not available, less than 5 percent **crown cover** of trees of any size.
- 1 \leq 4.9 inches (seedlings / saplings)
At least 10 percent stocking (or 5 percent crown cover if stocking standards are not available) in trees of any size; and at least 2/3 of the crown cover is in trees less than 5.0 inches DBH/DRC.
- 2 5.0 – 8.9 inches (softwoods) / 5.0 – 10.9 inches (hardwoods)
At least 10 percent stocking (or 5 percent crown cover if stocking standards are not available) in trees of any size; and at least 1/3 of the crown cover is in trees greater than 5.0 inches DBH/DRC **and** the plurality of the crown cover is in softwoods between 5.0 – 8.9 inches diameter and/or hardwoods between 5.0 – 10.9 inches DBH, and/or western woodland trees 5.0 – 8.9 inches DRC.
- 3 9.0 – 19.9 inches (softwoods) / 11.0 – 19.9 inches (hardwoods)
At least 10 percent stocking (or 5 percent crown cover if stocking standards are not available) in trees of any size; and at least 1/3 of the crown cover is in trees greater than 5.0 inches DBH/DRC **and** the plurality of the crown cover is in softwoods between 9.0 – 19.9 inches diameter and/or hardwoods between 11.0 – 19.9 inches DBH, and for western woodland trees 9.0 – 19.9 inches DRC.
- 4 20.0 – 39.9 inches
At least 10 percent stocking (or 5 percent crown cover if stocking standards are not available) in trees of any size; and at least 1/3 of the crown cover is in trees greater than 5.0 inches DBH/DRC **and** the plurality of the crown cover is in trees between 20.0 – 39.9 inches DBH.
- 5 40.0 + inches
At least 10 percent stocking (or 5 percent crown cover if stocking standards are not available) in trees of any size; and at least 1/3 of the crown cover is in trees greater than 5.0 inches DBH/DRC **and** the plurality of the crown cover is in trees \geq 40.0 inches DBH.
- 6 Cover trees (trees not on species list, used for plots classified as nonforest)
Less than 10 percent stocking by trees of any size, and greater than 5 percent **crown cover** of species that comprise cover trees.

The instructions in Sections 2.1 and 2.4 apply when delineating, on accessible forest land, contrasting conditions based on differences in STAND SIZE CLASS.

Within the sampled area on microplot or subplot, recognize only very obvious contrasting stands of different mean diameter with an abrupt boundary. Example: an obvious abrupt boundary exists within the sampled (fixed-radius) area of a subplot and demarcates a STAND SIZE CLASS

change. Use tree stocking of all live trees that are not overtopped to differentiate between stand-size classes; for most western woodland forest types (e.g., pinyon, juniper, gambel oak) where stocking standards are not readily available, use percent tree cover to represent stocking.

Use crown cover as the surrogate for stocking to determine STAND SIZE CLASS. View the plot from the top down and examine crown cover. The stand must have at least 5 percent of the crown cover in STAND SIZE CLASSES of 1, 2, 3, 4, or 5 or any combination of these STAND SIZE CLASSES; otherwise the STAND SIZE CLASS is 0. If 2/3 of the crown cover is STAND SIZE CLASS = 1, classify the condition as STAND SIZE CLASS = 1. If less than 2/3 of the crown cover is STAND SIZE CLASS = 1, classify the condition as STAND SIZE CLASS = 2, 3, 4, or 5, based on which of these STAND SIZE CLASSES has the most crown cover.

2.5.5 REGENERATION STATUS [**SORI**]

Record the code that best describes the artificial regeneration that occurred in the condition.

When collected: All accessible forest land condition classes (CONDITION CLASS STATUS = 1)

Field width: 1 digit

Tolerance: No errors

MQO: At least 99% of the time

Values:

- | | |
|---|---|
| 0 | Natural – present stand shows no clear evidence of artificial regeneration.
Includes unplanted, recently cut lands |
| 1 | Artificial – present stand shows clear evidence of artificial regeneration |

The instructions in section 2.1 and 2.4 apply when delineating, within accessible forest land, contrasting conditions based on differences in REGENERATION STATUS.

For a forest land condition to be delineated and/or classified as artificially regenerated, the condition must show distinct evidence of planting or seeding. If it is difficult to determine whether or not a stand has been planted or seeded, then use code 0. If no distinct boundary exists within the sampled (fixed-radius) area on any subplot, then do not recognize separate conditions. In many regions of the West, trees are not planted in rows, and planted stands do not differ in physical appearance from natural conditions. In these cases, there is no need to differentiate conditions based on stand origin.

NOTE: Plot records or verbal evidence from landowner is acceptable for determining regeneration status.

2.5.6 TREE DENSITY [**DENS**]

Record a code to indicate the relative tree density classification. Base the classification on the number of stems/unit area, basal area, tree cover, or stocking of all live trees in the condition that are not overtopped, compared to any previously defined condition class TREE DENSITY.

The instructions in Sections 2.1 and 2.4 apply when delineating, within accessible forest land, contrasting conditions based on differences in TREE DENSITY.

Codes 2 and higher are used ONLY when all other attributes used to delineate separate condition classes are homogenous, i.e., when a change in density is the ONLY difference within what would otherwise be treated as only one forest condition. Otherwise, code 1 for all condition classes. Codes 2 and higher are usually, but not always, used to demarcate areas that differ from an adjacent area due to forest disturbance, e.g., a partial harvest or heavy, but not total tree mortality due to a ground fire. Delineation by density should only be done when the less-dense condition is 50 percent or less as dense as the more dense condition.

Do not distinguish between low-stocked stands or stands of sparse and patchy forest.

When collected: All accessible forest land condition classes (CONDITION CLASS STATUS = 1)

Field width: 1 digit

Tolerance: No errors

MQO: At least 99% of the time

Values:

- 1 Initial density class
- 2 Density class 2 - density different than 1
- 3 Density class 3 - density different than 1 and 2

In order to qualify as a separate condition based on density, there MUST be a distinct, easily observed change in the density of an area's tree cover or basal area.

Examples of valid contrasting conditions defined by differences in tree density are:

- the eastern half of an otherwise homogeneous, 20-acre stand has many trees killed by a bark beetle outbreak,
- one portion of a stand is partially cut over (with 40 square feet basal area per acre) while the other portion is undisturbed (with 100 square feet basal area per acre).

NOTE: In these examples, RESERVED STATUS, OWNER GROUP, FOREST TYPE, STAND SIZE CLASS, and REGENERATION STATUS are the same.

ANCILLARY (NON-DELINEATING) VARIABLES

2.5.7 OWNER CLASS [OWNC]

Record the OWNER CLASS code that best corresponds to the ownership (or the managing Agency for public lands) of the land in the condition class. Conditions will **NOT** be delineated based on changes in owner class. If multiple owner classes within a group occur on a single condition class, record the owner class closest to the plot center.

When collected: CORE: All accessible forest land condition classes (CONDITION CLASS STATUS = 1); CORE OPTIONAL: Non-forest condition classes (CONDITION CLASS STATUS > 1)

Field width: 2 digits

Tolerance: No errors

MQO: At least 99% of the time

Values:

Owner Classes within Forest Service Lands (Owner Group 10):

- 11 National Forest
- 12 National Grassland
- 13 Other Forest Service

Owner Classes within Other Federal Lands (Owner Group 20)

- 21 National Park Service
- 22 Bureau of Land Management
- 23 Fish and Wildlife Service
- 24 Departments of Defense/Energy
- 25 Other Federal

Owner Classes within State and Local Government lands (Owner Group 30)

- 31 State

- 32 Local (County, Municipality, etc.)
- 33 Other Non Federal Public

Owner Classes within Private lands (Owner Group 40)

- 41 Corporate (including private educational institutions)
- 42 Non Governmental Conservation / Natural Resources Organization
- examples: Nature Conservancy, National Trust for Private Lands, Pacific Forest Trust, Boy Scouts of America, etc.
- 43 Unincorporated Partnerships / Associations / Clubs – examples: Hunting Clubs that **own, not lease** property, recreation associations, 4H, etc.
- 44 Native American (Indian) – within reservation boundaries
- 45 Individual

2.5.8 PRIVATE OWNER INDUSTRIAL STATUS [INDU]

Record the code identifying the status of the owner with regard to being considered industrial as determined by whether or not they own and operate a primary wood processing plant. A primary wood processing plant is any commercial operation which originates the primary processing of wood on a regular and continuing basis. Examples include: pulp or paper mill, sawmill, panel board mill, post or pole mill, etc. Cabinet shops, “mom & pop” home-operated businesses, etc., should not be considered as industrial plants. If any doubt exists with the determination by the field crew about the owner’s industrial status due to name, commercial plant size, type plant, etc., choose code 0.

Note: FIA unit or State headquarters may have to maintain a list of recognized industrial owners within a State for crews to use when making these determinations.

When collected: CORE: All accessible forest land condition classes (CONDITION CLASS STATUS = 1) when the owner group is private (OWNER GROUP 40); CORE OPTIONAL: Non-forest condition classes (CONDITION CLASS STATUS > 1) when the owner group is private (OWNER GROUP 40)

Field width: 1 digit

Tolerance: No errors

MQO: At least 99% of the time

Values:

- 0 Land **is not** owned by industrial owner with a wood processing plant
- 1 Land **is** owned by industrial owner with wood processing plant

2.5.9 ARTIFICIAL REGENERATION SPECIES [SOSP]

Record the species code of the predominant tree species for which evidence exists of artificial regeneration in the stand. This attribute is ancillary; that is, contrasting condition classes are never delineated based on variation in this attribute.

When collected: All accessible forest land condition classes (CONDITION CLASS STATUS = 1) with evidence of artificial regeneration (REGENERATION STATUS = 1)

Field width: 4 digits

Tolerance: No errors

MQO: At least 99% of the time

Values: See Appendix 3

2.5.10 STAND AGE [SAGE]

Record the average total age, to the nearest year, of the trees (plurality of all live trees not overtopped) in the predominant STAND SIZE CLASS of the condition, determined using local procedures. Record 000 for non-stocked stands.

An estimate of STAND AGE is required for every forest land condition class defined on a plot. Stand age is usually highly correlated with stand size and should reflect the average age of all trees that are not overtopped. Unlike the procedure for site tree age (TREE AGE AT DIAMETER), estimates of STAND AGE should estimate the time of tree establishment (e.g., not age at the point of diameter measurement). Note: For planted stands, estimate age based on the year the stand was planted (e.g., do not add in the age of the planting stock).

To estimate STAND AGE, select two or three dominant or codominant trees from the overstory. If the overstory covers a wide range of tree sizes and species, try to select the trees accordingly, but it is not necessary to core additional trees in such stands. The variance associated with mean stand age increases with stand heterogeneity, and additional cores are not likely to improve the estimate. Core each tree at the point of diameter measurement and count the rings between the outside edge and the core to the pith. Add in the number of years that passed from germination until the tree reached the point of core extraction to determine the total age of the tree. Unless more specific information is provided at training or by the unit, add 5 years to all eastern species, 5 years to western hardwoods, and 10 years to western softwoods. Assign a weight to each core by visually estimating the percentage of total overstory trees it represents. Make sure the weights from all cores add up to 1.0, compute the weighted average age, and record. For example, if three trees aged 34, 62, and 59 years represent 25 percent, 60 percent, and 15 percent of the overstory, respectively, the weighted stand age should be:

$$(34 \times 0.25) + (62 \times 0.60) + (59 \times 0.15) = 55 \text{ years.}$$

In some cases, it may be possible to avoid coring trees to determine age. If a stand has not been seriously disturbed since the previous **annual** survey, simply add the number of years since the previous **annual** inventory to the previous STAND AGE. In other situations, cores collected from site trees can be used to estimate STAND AGE.

NRS (East) Note: Previous *periodic* inventory records should not be used to determine STAND AGE due to a difference in *periodic* and annual collection procedures.

If a condition class is nonstocked, assign a STAND AGE of 000.

If all of the trees in a condition class are of a species which, by regional standards, cannot be bored for age (e.g., mountain mahogany, tupelo) record 998. This code should be used in these cases only.

If tree cores are not counted in the field, but are collected and sent to the office for the counting of rings, record 999. Note on the core the % of stand that type of core represents so that STAND AGE can be calculated later. **Not applicable in the North.**

**Boring or drilling on plots located in Wilderness areas on National Forests will be done on representative non-tally trees and only when absolutely necessary to estimate site, age, or growth. (This will generally be the case during initial establishment of permanent plots.)
[INTRA-AGENCY AGREEMENT 05-SU-FIA01]**

When collected: All accessible forest land condition classes (CONDITION CLASS STATUS = 1)
Field width: 3 digits
Tolerance: +/- 10%
MQO: At least 95% of the time
Values: 000 to 997, 998, 999 **(999 is not applicable in the North)**

2.5.11 DISTURBANCE 1 [DIS1]

Record the code corresponding to the presence of the following disturbances. Disturbance can connote positive or negative effects. The area affected by any natural or human-caused disturbance must be at least 1.0 acre in size. Record up to three different disturbances per

condition class from most important to least important as best as can be determined. This attribute is ancillary; that is, contrasting conditions are never delineated based on variation in this attribute.

For initial forest plot establishment (initial grid activation or newly forested plots), the disturbance must be within the last 5 years. For remeasured (periodic or annual) plots recognize only those disturbances that have occurred since the previous annual inventory year.

The following disturbance codes require "significant threshold" damage, which implies mortality and/or damage to 25 percent of all trees in a stand or 50 percent of an individual species' count. Additionally, some disturbances affect forests but initially may not affect tree growth or health (e.g., grazing, browsing, flooding, etc.). In these cases, a disturbance should be coded when at least 25 percent of the soil surface or understory vegetation has been affected.

When collected: All accessible forest land condition classes (CONDITION CLASS STATUS = 1)
Field width: 2 digits
Tolerance: No errors
MQO: At least 99% of the time
Values:

<u>Code</u>	<u>Definition</u>
00	None - no observable disturbance
10	Insect damage
11	insect damage to understory vegetation
12	insect damage to trees, including seedlings and saplings
20	Disease damage
21	disease damage to understory vegetation
22	disease damage to trees, including seedlings and saplings
30	Fire (from crown and ground fire, either prescribed or natural)
31	ground fire
32	crown fire
40	Animal damage
41	beaver (includes flooding caused by beaver)
42	porcupine
43	deer/ungulate
44	bear (CORE OPTIONAL)
45	rabbit (CORE OPTIONAL)
46	domestic animal/livestock (includes grazing):
50	Weather damage
51	ice
52	wind (includes hurricane, tornado)
53	flooding (weather induced such as a catastrophic event like a hurricane or other major rain event. Periodic flooding that occurs as part of the natural forest ecosystem should not be coded.)
54	drought
55	earth movement/avalanches
60	Vegetation (suppression, competition, vines):
70	Unknown/not sure/other (include in NOTES)
80	Human-caused damage – any significant threshold of human-caused damage not described in the DISTURBANCE codes listed or in the TREATMENT codes listed. Must include a plot-level note to describe further.

2.5.12 DISTURBANCE YEAR 1 [DYR1]

Record the year in which DISTURBANCE 1 occurred. If the disturbance occurs continuously over a period of time, record 9999.

When collected: When DISTURBANCE 1 > 00
 Field width: 4 digits
 Tolerance: +/- 1 year for measurement cycles of 5 years; +/- 2 years for measurement cycles of > 5 years
 MQO: At least 99% of the time
 Values: Since the previous plot visit, or the past 5 years for plots visited for the first time

- 2.5.13 **DISTURBANCE 2 [DIS2]**
 If a stand has experienced more than one disturbance, record the second disturbance here. See DISTURBANCE 1 for coding instructions.
- 2.5.14 **DISTURBANCE YEAR 2 [DYR2]**
 Record the year in which DISTURBANCE 2 occurred. See DISTURBANCE YEAR 1 for coding instructions.
- 2.5.15 **DISTURBANCE 3 [DIS3]**
 If a stand has experienced more than two disturbances, record the third disturbance here. See DISTURBANCE 1 for coding instructions.
- 2.5.16 **DISTURBANCE YEAR 3 [DYR3]**
 Record the year in which DISTURBANCE 3 occurred. See DISTURBANCE YEAR 1 for coding instructions.
- 2.5.17 **TREATMENT 1 [TRE1]**
 Forestry treatments are a form of disturbance. These human disturbances are recorded separately here for ease of coding and analysis. The term treatment further implies that a silvicultural application has been prescribed. This does not include occasional stumps of unknown origin or sparse removals for firewood, Christmas trees, or other miscellaneous purposes. The area affected by any treatment must be at least 1.0 acre in size. Record up to three different treatments per condition class from most important to least important as best as can be determined. This attribute is ancillary; that is, contrasting conditions are never delineated based on variation in this attribute.

For initial forest plot establishment (initial grid activation or newly forested plots), the treatment must be within the last 5 years. For remeasured (periodic or annual) plots recognize only those treatments that have occurred since the previous annual inventory year.

When collected: All accessible forest land condition classes (CONDITION CLASS STATUS = 1)
 Field width: 2 digits
 Tolerance: No errors
 MQO: At least 99% of the time
 Values:

<u>Code</u>	<u>Definition</u>
00	<u>None</u> - No observable treatment.
10	<u>Cutting</u> - The removal of one or more trees from a stand due to a silvicultural operation that affects 1 acre or more. (See regional variable 2.5.22.1N – <u>STAND HISTORY.</u>)
20	<u>Site preparation</u> - Clearing, slash burning, chopping, disking, bedding, or other practices clearly intended to prepare a site for either natural or artificial regeneration.

- 30 Artificial regeneration - Following a disturbance or treatment (usually cutting), a new stand where at least 50% of the live trees present resulted from planting or direct seeding.
- 40 Natural regeneration - Following a disturbance or treatment (usually cutting), a new stand where at least 50% of the live trees present (of any size) were established through the growth of existing trees and/or natural seeding or sprouting.
- 50 Other silvicultural treatment - The use of fertilizers, herbicides, girdling, pruning, **noncommercial thinning**, or other activities (not covered by codes 10-40) designed to improve the commercial value of the residual stand, or chaining, which is a practice used on western woodlands to encourage wildlife forage.

2.5.18 TREATMENT YEAR 1 [TYR1]

Record the year in which TREATMENT 1 occurred.

When collected: When TREATMENT 1 > 00

Field width: 4 digits

Tolerance: +/- 1 year for measurement cycles of 5 years; +/- 2 years for measurement cycles of > 5 years

MQO: At least 99% of the time

Values: Since the previous plot visit, or the past 5 years for plots visited for the first time

2.5.19 TREATMENT 2 [TRE2]

If a stand has experienced more than one treatment, record the second treatment here. See TREATMENT 1 for coding instructions; code 00 if none.

2.5.20 TREATMENT YEAR 2 [TYR2]

Record the year in which TREATMENT 2 occurred. See TREATMENT YEAR 1 for coding instructions.

2.5.21 TREATMENT 3 [TRE3]

If a stand has experienced more than two treatments, record the third treatment here. See TREATMENT 1 for coding instructions; code 00 if none.

2.5.22 TREATMENT YEAR 3 [TYR3]

Record the year in which TREATMENT 3 occurred. See TREATMENT YEAR 1 for coding instructions.

NRS Note (new variable for former NC crews): This variable is applied when TREATMENT = 10.

2.5.22.1N **STAND HISTORY [HIST]**

Record the code that best describes the cutting TREATMENT.

When collected: TREATMENT = 10

Field width: 1 digit

Tolerance: No errors

MQO: At least 99% of the time

Values:

- 1 Clear-cut: the removal of all merchantable trees from an area. This practice often leaves a large number of unsalable trees.

- 2 Partial cut: the removal of scattered individual trees or very small groups of trees. Selection, diameter limit cutting, seed tree, shelterwood cuts, and commercial thinning should also be included.
- 3 Strip cut: the removal of alternating strips of trees. A common example is to cut strips the width of a feller/buncher and leave similar strips uncut.

2.5.22.2N-ME STAND STRUCTURE [MEST]

See Regional Appendix D for state and/or species specific variable data collection procedures and codes.

2.5.23 PHYSIOGRAPHIC CLASS [PHYS]

Record the code that best describes the PHYSIOGRAPHIC CLASS of the condition within the plot area; land form, topographic position, and soil generally determine physiographic class.

When collected: All accessible forest land condition classes (CONDITION CLASS STATUS = 1)

Field width: 2 digits

Tolerance: No errors

MQO: At least 80% of the time

Values:

- Xeric** Sites that are normally low or deficient in moisture available to support vigorous tree growth. These areas may receive adequate precipitation, but experience a rapid loss of available moisture due to runoff, percolation, evaporation, etc.
- 11 Dry Tops - Ridge tops with thin rock outcrops and considerable exposure to sun and wind.
- 12 Dry Slopes - Slopes with thin rock outcrops and considerable exposure to sun and wind. Includes most steep slopes with a southern or western exposure.
- 13 Deep Sands - Sites with a deep, sandy surface subject to rapid loss of moisture following precipitation. Typical examples include sand hills, sites along the beach and shores of lakes and streams, and many deserts.
- 19 Other Xeric - All dry physiographic sites not already described.
- Mesic** Sites that have moderate but adequate moisture available to support vigorous tree growth except for periods of extended drought. These sites may be subjected to occasional flooding during periods of heavy or extended precipitation.
- 21 Flatwoods - Flat or fairly level sites outside flood plains. Excludes deep sands and wet, swampy sites.
- 22 Rolling Uplands - Hills and gently rolling, undulating terrain and associated small streams. Excludes deep sands, all hydric sites, and streams with associated flood plains.
- 23 Moist Slopes and Coves - Moist slopes and coves with relatively deep, fertile soils. Often these sites have a northern or eastern exposure and are partially shielded from wind and sun. Includes moist mountain tops and saddles.
- 24 Narrow Flood plains/Bottomlands - Flood plains and bottomlands less than 1/4-mile in width along rivers and streams. These sites are normally well drained but are

subjected to occasional flooding during periods of heavy or extended precipitation. Includes associated levees, benches, and terraces within a 1/4 mile limit. Excludes swamps, sloughs, and bogs.

25 Broad Flood plains/Bottomlands - Flood plains and bottomlands 1/4 mile or wider in width along rivers and streams. These sites are normally well drained but are subjected to occasional flooding during periods of heavy or extended precipitation. Includes associated levees, benches, and terraces. Excludes swamps, sloughs, and bogs with year-round water problems.

29 Other Mesic - All moderately moist physiographic sites not already described.

Hydric Sites that generally have a year-round abundance or over-abundance of moisture. Hydric sites are very wet sites where excess water seriously limits both growth and species occurrence.

31 Swamps / Bogs - Low, wet, flat forested areas usually quite extensive that are flooded for long periods of time except during periods of extreme drought. Excludes cypress ponds and small drains.

32 Small Drains - Narrow, stream-like, wet strands of forest land often without a well-defined stream channel. These areas are poorly drained or flooded throughout most of the year and drain the adjacent higher ground.

33 Bays and wet pocosins - Low, wet, boggy sites characterized by peaty or organic soils. May be somewhat dry during periods of extended drought. Examples include ~~sites in the Lake States with lowland swamp conifers~~ or the Carolina bays in the southeast US. (See National Appendix 6+N – GLOSSARY for definitions of bays and pocosins.)

34 Beaver ponds

35 Cypress ponds

39 Other hydric - All other hydric physiographic sites.

2.5.23.1N PRODUCTIVITY STATUS [PROD]

Record the code that indicates the productivity of the forest condition. A forest land productivity table with limited species can be found in Regional Appendix E as an aid for determining productivity. In addition site index can be used as an indicator of productivity in the WEST by using provided western site index curves. (Note: These site index curves are available as regional supplement to this field guide.) If the site index meets the minimum value indicated below for that species, the forest is considered productive.

Species	Name	Minimum SI Value
0066	Rocky Mountain juniper	25
0068	eastern red cedar	25
0071	tamarack	20
0095	black spruce	20
0122	Ponderosa pine	21
0241	northern white cedar	15
	Other available species	35

[Correction 10/05/2006.]

When collected: CONDITION CLASS STATUS = 1

Field width: 1 digit

Tolerance: No errors

MQO: At least 99% of the time

Values:

- 0 Unproductive – Forest land incapable of producing 20 cubic feet per acre per year because of adverse site conditions. Adverse conditions include sterile soils, dry climate, poor drainage, high elevation, steepness, and rockiness. Vegetation, if present, is widely spaced and scrubby, or tree growth cannot be established. These conditions can be due to forces of nature or human-caused disturbances.
- 1 Productive – Forest land capable of producing in excess of 20 cubic feet per acre per year. Productive forest land may be nonstocked provided that neither any natural condition, nor any activity by humans, prevents or inhibits the establishment of tree seedlings.

NRS Note (coding change for former NC and NE crews): The codes and definitions associated with the *NC Land Use* variable are no longer applicable. Forest land use codes associated with *NC Land Use* are no longer applied in the field. Both NC and NE's previous nonforest land use classifications have been collapsed into an existing national nonforest code or an added regional nonforest code that is associated with the national variable PRESENT NONFOREST LAND USE. The indication of "with" or "without" trees is now indicated by a new variable – NONFOREST TREES.

2.5.24+N PRESENT NONFOREST LAND USE [NFLU]

Record this attribute when area sampled and classified at last inventory as accessible forest land is now nonforest land. The area that has changed is a new, separate condition class. It should not be considered part of any nonforest land condition class(es) sampled during the previous inventory that may still be present. Instructions in Sections 2.1 and 2.4 apply. When classifying these cases, select the classification that, within sampled area, indicates what the majority of this changed area is now if more than one nonforest classes are present. **[Correction 10/05/2006.]**

NRS Note: The Northern region will record this attribute on all plots with nonforest land.

(CORE OPTIONAL) - Record the PRESENT NONFOREST LAND USE for all nonforest conditions (CONDITION CLASS STATUS = 2), regardless of past condition.

NRS Note: When CONDITION CLASS STATUS = 2, PRESENT NONFOREST LAND USE is required. However, the delineation of multiple nonforest land uses is not required. When CONDITION CLASS STATUS = 2, the first nonforest land use delineated on a subplot in numeric order is recorded for the entire plot. Additional nonforest land uses are not delineated.

When collected: CORE: SAMPLE KIND = 2, previous CONDITION CLASS STATUS = 1, current CONDITION CLASS STATUS = 2; CORE OPTIONAL: current CONDITION CLASS STATUS = 2

Field width: 2 digits

Tolerance: No errors

MQO: At least 99% of the time

Values:

- 10 Agricultural land - Land managed for crops, pasture, or other agricultural use. The area must be at least 1.0 acre in size and 120.0 feet wide with the exception of the regional land use windbreak/shelterbelt. A windbreak or shelterbelt can be less than 120.0 feet wide and less than 1 acre. If a windbreak or shelterbelt qualifies and

meets the definition of accessible forest land, then it is not considered nonforest.

Use the 10 code only for cases not better described by one of the following:

- 11 Cropland
 - 12 Pasture (improved through cultural practices)
 - 13 Idle farmland
 - 14 Orchard/Nursery
 - 15 Christmas tree plantation
 - 16 Maintained wildlife opening (NRS code)
 - 17 Windbreak/Shelterbelt (NRS code)
- 20 Rangeland - Land primarily composed of grasses, forbs, or shrubs. This includes lands vegetated naturally or artificially to provide a plant cover managed like native vegetation and does not meet the definition of pasture. The area must be at least 1.0 acre in size and 120.0 feet wide.
- 30 Developed - Land used primarily by humans for purposes other than forestry or agriculture. Use the 30 code only for land not better described by one of the following:
- 31 Cultural: business (industrial/commercial), residential, and other places of intense human activity.
 - 32 Rights-of-way: improved roads, railway, power lines, maintained canal
 - 33 Recreation: parks, skiing, golf courses
 - 34 Mining and wasteland (NRS code)
- 40 Other - Land parcels greater than 1.0 acre in size and greater than 120.0 feet wide, that do not fall into one of the uses described above. Examples include undeveloped beaches, barren land (rock, sand), noncensus-water, marshes, bogs, permanent ice, and snow (i.e., glaciers). Use the 40 code only for cases not better describe by one of the following:
- 41 Nonvegetated (DAB proposed LU)
 - 42 Wetland (NRS code)
 - 43 Beach (NRS code)
 - 44 DAB future LU
 - 45 Chaparral (DAB proposed LU0)

The following are the national and regional nonforest land use sub-codes. The following are regional definitions developed for both national and regional sub-codes. Use these codes in conjunction with CONDITION CLASS STATUS 2.

11 – CROPLAND

Land utilized for agricultural crops including silage and feed grains; and bare farm fields resulting from cultivation or harvest.

12 – IMPROVED / MAINTAINED PASTURE

Land maintained and used and for grazing with stocking less than 10 percent in live trees (established seedlings or larger trees), except that occasional large trees with the obvious function of providing shade for livestock, and small single trees or clusters of hawthorn or eastern red cedar should be ignored when determining stocking. Evidence of maintenance, besides the degree of grazing, includes condition of fencing, presence of stock ponds or water tanks. Land also periodically brush hogged indicated by seedlings 3 to 4 feet in height and basal scars present on trees.

13 – IDLE FARMLAND

Former cropland or pasture that has not been tended within the last 2 years and that has less than 10 percent stocking with live trees, (established seedlings or larger trees) regardless of species. A field that is between crop rotations should not be called idle, however, cropland.

14 – ORCHARD/NURSERY

Land utilized for orchards and nursery stock.

15 – CHRISTMAS TREE PLANTATION

Active Christmas tree plantation must show signs of annual shearing. Record tree species used in the plantation in the PLOT NOTES.

16 – MAINTAINED WILDLIFE OPENING (NRS code)

Land maintained as a permanent opening of primarily herbaceous vegetation within woodland areas to provide food and cover benefits for early successional wildlife species. [Source: USDA NRCS]

17 – WINDBREAK/SHELTERBELT (NRS code)

Windbreaks or shelterbelts are plantings of single or multiple rows of trees or shrubs that are established for environmental purposes. Windbreaks or shelterbelts are generally established to protect or shelter nearby leeward areas from troublesome winds. Such plantings are used to reduce wind erosion, protect growing plants (crops and forage), manage snow, and improve irrigation efficiency. Windbreaks also protect structures and livestock, provide wildlife habitat, improve aesthetics, and provide tree or shrub products. Also, when used as a living screen, windbreaks control views and lessen noise. [Source: USDA NRCS, Windbreak/Shelterbelt Conservation Practice Job Sheet 380, April 1997]

31 – CULTURAL

Cultural includes multiple family housing – More than one family household per structure, for example, condominiums, townhouses, row houses and apartment buildings. Single family housing – One family or person per structure. Industrial/commercial – Supply yards, parking lots, shopping centers, factories, etc.

32 – RIGHTS-OF-WAY

Highways, railroads, airports, pipelines, gas/oil wells, or power lines. The following are not considered a R.O.W.

- A canal that qualifies as census or noncensus water is coded as CONDITION CLASS STATUS 3 or 4.
- A driveway adjacent or within a residential area is not considered a R.O.W *unless it's bounded by accessible forest land. [Clarification 10/05/2006.]*
- A farm lane adjacent or within cropland, pasture, idle farmland and other agriculture is not considered a R.O.W.

A rail trail that is part of the "rail banking" program is classified as a R.O.W. The rail banking program, created by a congressional amendment in 1983 [to the 1968 National Trails System Act], allows the temporary, though often long-term, use of a disused rail corridor as a public trail while maintaining the option of reactivating the corridor for rail use. If a rail trail can be documented as being part of this program, then a rail trail is a R.O.W. If not, it is treated as an inclusion of the adjacent land use.

33 – RECREATION

Parks, campgrounds, playing fields, athletic, sports tracks, etc.

34 – MINING AND WASTELAND (NRS code)

Surface mining, gravel pits, dumps, landfills or reclaimed mining areas. Note: Reclaimed mining areas are not always nonforest. Some trees such as black locust readily adapt to reclaimed areas. If the stocking requirement is met, the land is considered forest land. The field crew will make the decision of whether the land is productive or unproductive. Reclaimed mine areas should remain in this land use until either stocking is met for accessible forest land or another nonforest land use applies.

42 – WETLAND (NRS code)

Areas subjected to periodic tidal flooding or other areas where water is present for extended periods during the growing season and for longer periods during the non-growing season. Water usually comes from rainfall, snowmelt, a rising water table, groundwater seepage, or incoming tides. Water may be present on the surface of wetlands for varying periods, as in flooded or ponded wetlands, or it may simply keep the underlying soils saturated near the surface with no surface water present. Wetlands include bogs, marshes, salt marshes, swamps, meadows and fens. [Source: Tiner]

- Bogs are not always nonforest. Some tree species such as black spruce can adapt to bog conditions. If the stocking requirement is met, the land is considered forest land. The decision as to whether the land is productive or unproductive will be made by the field crews.
- Swamps are not always nonforest. Some tree species readily adapt to the swamp conditions. If the stocking requirement is met, the land is considered forest land. The decision of whether the land is productive or unproductive will be made by the field crews.

43 – BEACH (NRS code)

Sandy or pebbly shore associated with an ocean or lake.

2.5.24.1N NONFOREST TREES [NFTR]

Record the presence or absence of trees ≥ 5.0 in DBH that are within the nonforest condition represented in the "plot triangle." The plot triangle is formed by the three outer subplots and represents approximately .84 acres. The plot triangle correlates with the regional office photo interpretation that assesses whether or not a plot is sent to the field for data collection. For example, a plot that is determined to be a nonforest PLOT STATUS (as shown in Figure 14.2N "A") is not sent to the field. However, any plot that the interpreter questions the PLOT STATUS (e.g., partial forest land, reversion, or an outer subplot is within 66 feet of forest land) is sent to the field for verification of status. (Note: These questionable status plots are not part of the nonforest QA/QC plot sample. The nonforest QA/QC plot sample includes only those plots that the interpreter assigned a PLOT STATUS = 2.)

To assess the presence or absence of trees, consider only those trees represented within the plot triangle that is in a nonforest condition. See Figure 14.2N "A or B". If the nonforest plot or subplot can be occupied without a substantial time investment (i.e., easy access including owner contact and traversing), then ground observation is used. If the nonforest plot or subplot cannot be occupied, then aerial photo interpretation and/or ground observation is allowed.

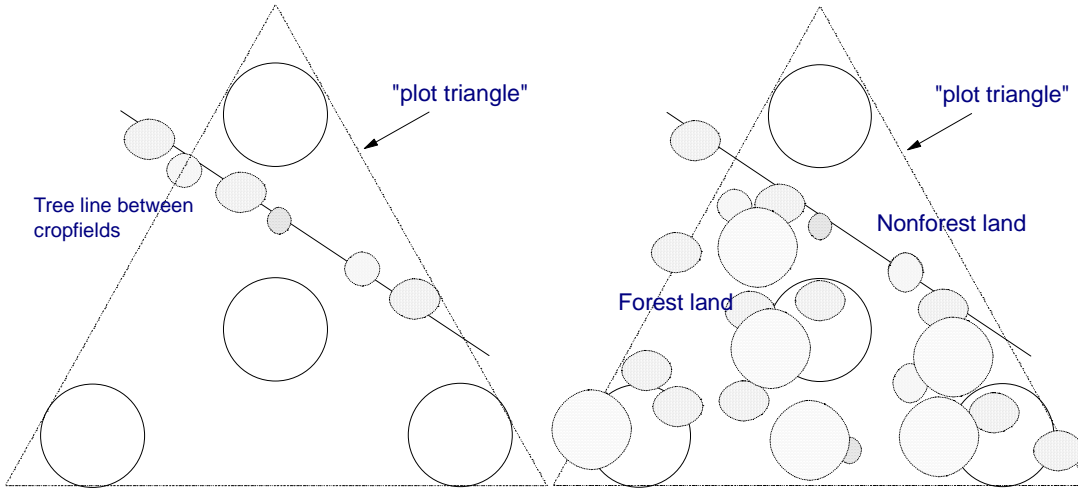

Figure A. Entire plot is classified as nonforest land with trees.

Figure B. Subplots 1, 3 and 4 classified as forest land. Subplot 2 classified as nonforest land without trees.

Figure 14.2N

When collected: CONDITION CLASS STATUS = 2

Field width: 1 digit

Tolerance: No errors

MQO: At least 99% of the time

Values:

- 1 Nonforest land **without** trees ≥ 5.0 in DBH
- 2 Nonforest land **with** trees ≥ 5.0 in DBH

3.0 SUBPLOT INFORMATION

Each subplot is described by a series of area parameters relating to topographic features and existing cover type. These data also relate to the microplot, since the microplot is contained within the subplot perimeter.

Subplots 2, 3 and 4 are located 120.0 feet horizontal (+/- 7 feet tolerance for initial establishment) at azimuths of 360, 120 and 240 degrees, respectively, from the center of subplot 1. The center of the microplot is offset 90 degrees and 12.0 feet horizontal (+/- 1 foot tolerance for initial establishment) from each subplot center. If a subplot or microplot was installed incorrectly at the previous cycle, remeasure the subplot or microplot in its present location, make a notation in the plot record, and contact a field supervisor. [Preceding paragraph paraphrased from Section 0.1 PLOT SETUP.]

NRS Note: A subplot with forest land may be difficult to occupy for accurate tree data measurements due to inaccessibility of the subplot center (e.g., seasonal high water, busy road way, etc.). In the case of water, some inaccessibility can be minimized by accessing a plot during low tide, the dry season, or after winter freezing. Crews should do their best to safely occupy the subplot center. If necessary, a crew should return to a plot with additional gear so a subplot can be safely occupied. However, if a subplot cannot be done safely, the entire subplot should be classified as **CONDITION CLASS STATUS = 5** and **NONSAMPLED REASON = 03**. Crews should also be aware that each state has a sample of plots that are completed during the summer window. This sample includes P3 plots, plots selected for invasive plants tally, and plots selected for the Pennsylvania Regeneration study. For these plots, do your best to occupy the plot and collect the data. Anytime a subplot cannot be occupied, a **PLOT NOTE** is required explaining conditions that prevented occupancy.

NRS Note: Subplots and microplots are monumented by either a metal pin or wooden dowel. Only a single marker is required at the subplot or microplot centers. The current crew should replace a marker if it has deteriorated. The replaced marker should be removed from the plot site. If the old marker is not found, write a **PLOT NOTE** indicating that a new marker has been set by triangulating from existing tally trees or reference trees. Crews should be careful that edge trees (subplot or microplot) that were correctly determined to be "out or in" by the previous crew are not now "in or out" when replacing a marker.

3.1 SUBPLOT NUMBER

Record the code corresponding to the number of the subplot.

NRS PDR Note: This variable is determined by the subplot selection in the PDR program.

When Collected: All subplots
Field width: 1 digit
Tolerance: No errors
MQO: At least 99% of the time
Values:

- 1 Center subplot
- 2 North subplot
- 3 Southeast subplot
- 4 Southwest subplot

3.2 SUBPLOT STATUS [STAT]

Indicate whether or not this subplot currently has at least one accessible forested condition class.

When collected: All subplots
Field width: 1 digit

Tolerance: No errors

MQO: At least 99% of the time

Values:

- 1 Sampled – at least one accessible forest land condition present on subplot
- 2 Sampled – no accessible forest land condition present on subplot
- 3 Nonsampled

3.3 SUBPLOT NONSAMPLED REASON [REAS]

For entire subplots that cannot be sampled, record one of the following reasons.

When collected: When SUBPLOT STATUS = 3

Field width: 2 digits

Tolerance: No errors

MQO: At least 99% of the time

Values:

- 01 Outside U.S. boundary – Assign this code to condition classes beyond the U.S. border.
- 02 Denied access area – Any area within the sampled area of a plot to which access is denied by the legal owner, or to which an owner of the only reasonable route to the plot denies access. There are no minimum area or width requirements for a condition class delineated by denied access. Because a denied-access condition can become accessible in the future, it remains in the sample and is re-examined at the next occasion to determine if access is available. In some regions denied access plots may be replaced; check with the field supervisor regarding regional protocols for plot replacement.
- 03 Hazardous situation – Any area within the sampled area on plot that cannot be accessed because of a hazard or danger, for example cliffs, quarries, strip mines, illegal substance plantations, temporary high water, etc. Although the hazard is not likely to change over time, a hazardous condition remains in the sample and is re-examined at the next occasion to determine if the hazard is still present. There are no minimum size or width requirements for a condition class delineated by a hazardous condition. In some regions hazardous plots may be replaced; check with the field supervisor regarding regional protocols for plot replacement.
- 04 Time limitation – This code applies to full subplots that cannot be sampled due to a time restriction. This code is reserved for areas with limited access, and in situations where it is imperative for the crew to leave before the plot can be completed (e.g., scheduled helicopter rendezvous) **and it is impossible for the crew to return to complete the data collection**. Use of this code requires notification to the field supervisor. This code should not be used for an entire plot (use code 8 (skipped visit) when an entire plot is skipped; see Section 1.5).
- 05 Lost data – The plot data file was discovered to be corrupt after a panel was completed and submitted for processing. This code is assigned to entire plots or full subplots that could not be processed, and is applied at the time of processing after notification to the region. Note: This code is for office use only.
- 10 Other – This code is used whenever a plot or condition class is not sampled due to a reason other than one of the specific reasons already listed. A field note is required to describe the situation.

3.4 SUBPLOT CENTER CONDITION [SCEN]

Record the CONDITION CLASS NUMBER of the condition class at the subplot center.

When collected: All subplots
Field width: 1 digit
Tolerance: No errors
MQO: At least 99% of the time
Values: 1 to 9

3.5 **MICROPLOT CENTER CONDITION [MCEN]**

Record the CONDITION CLASS NUMBER of the condition class at the microplot center.

When collected: All microplots where subplot center is CONDITION CLASS STATUS = 1, 2, 3
Field width: 1 digit
Tolerance: No errors
MQO: At least 99% of the time
Values: 1 to 9

3.6 **SUBPLOT SLOPE [SLOP]**

Record the angle of slope across the subplot to the nearest 1 percent. SUBPLOT SLOPE is determined by sighting the clinometer along a line parallel to the average incline (or decline) of each subplot. This angle is measured along the shortest pathway down slope before the drainage direction changes. To measure SUBPLOT SLOPE, Observer 1 should stand at the uphill edge of the subplot and sight Observer 2, who stands at the downhill edge of the subplot. Sight Observer 2 at the same height as the eye-level of Observer 1. Read the slope directly from the percent scale of the clinometer:

- If slope changes gradually across the subplot, record an average slope.
- If slope changes across the subplot, but the slope is predominantly of one direction, code the predominant slope percentage rather than the average.
- If the subplot **center** falls directly on or straddles a canyon bottom or narrow ridge top, code the average slope of the side hill(s).
- If the subplot falls on a canyon bottom or on a narrow ridge top, but most of the area lies on one side hill, code the slope of the side hill where most of the area lies.

NRS Note: If slope is less than 5 percent on the subplot, slope = 000. If subplot is partially forested, the slope is determined across the entire subplot. [Clarification 10/05/2006.]

When collected: All subplots with at least one accessible forest land condition present on subplot (SUBPLOT STATUS = 1)
Field width: 3 digits
Tolerance: +/- 10%
MQO: At least 90% of the time
Values: 000, **005** to 155

3.7 **SUBPLOT ASPECT [ASP]**

Record the aspect across the subplot, to the nearest 1 degree. SUBPLOT ASPECT is determined along the direction of slope for land surfaces with at least 5 percent slope in a generally uniform direction. SUBPLOT ASPECT is measured with a hand compass along the same direction used to determine slope.

- If aspect changes gradually across the subplot, record an average aspect.
- If aspect changes across the subplot, but the aspect is predominately of one direction, code the predominate direction rather than the average.
- If the subplot **center** falls **directly** on or straddles a canyon bottom or narrow ridge top, code the aspect of the ridge line or canyon bottom.
- If the subplot falls on a canyon bottom or on a narrow ridge top, but most of the area lies on one side hill, code the aspect of the side hill.

**NRS Note: If subplot is partially forested, the aspect is determined across the entire subplot.
[Clarification 10/05/2006.]**

When collected: All subplots with at least one accessible forest land condition present on subplot
(SUBPLOT STATUS = 1)

Field width: 3 digits

Tolerance: +/- 10 degrees

MQO: At least 90% of the time

Values:

000	no aspect, slope < 5 percent
001	1 degree
002	2 degrees
.	.
.	.
360	360 degrees, due north

3.8 SNOW/WATER DEPTH [SWD]

Record to the nearest 0.1 foot the average approximate depth of water or snow covering the subplot at the time of data collection. This variable is used to indicate subplots where some variables (e.g., seedling count, total lengths) may be measured with less certainty due to conditions at the time of measurement.

NRS Note: If snow amounts are excessive on the microplot, the seedling tally as describe in 6.0 SEEDLING DATA is restricted to seedlings visible above the snow. Do not excavate snow from the microplot to achieve a better measurement. This practice may compromise the integrity of the microplot by exposing seedlings and other vegetation to animal browsing; and by exposing seedlings to extreme temperatures that may lead to mortality.

When collected: All subplots with at least one accessible forest land condition present on subplot
(SUBPLOT STATUS = 1)

Field width: 2 digits (x.y)

Tolerance: +/- 0.5 ft

MQO: At the time of measurement (no MQO after initial date of visit)

Values: 0.0 to 9.9

3.8.1N-ME CROWN CLOSURE [MECC]

See Regional Appendix D for state and/or species specific variable data collection procedures and codes.

3.9 SUBPLOT CONDITION LIST (CORE OPTIONAL)

This variable is not collected in the North.

4.0 BOUNDARY REFERENCES

Boundary reference data are used to compute the area for the condition classes sampled on a plot and to remeasure plots. Record all boundaries between condition classes that occur within the sampled (fixed-radius) area on subplots and microplots. Boundaries outside sampled (fixed-radius) areas are not referenced.

In addition to using the recording procedures described herein, sketch maps of condition class boundaries onto the pre-printed plot diagrams on paper field tally sheets.

NRS Note: If PLOT STATUS = 1, then delineation is required between CONDITION CLASSES 1, 2, 3, 4 and/or 5. If PLOT STATUS = 2, then delineation is required between CONDITION CLASSES 2, 3, 4 and/or 5.

However, delineation of multiple nonforest land uses as described within CONDITION CLASS 2 is not required. When CONDITION CLASS STATUS = 2, the first nonforest land use delineated on a subplot in numeric order is recorded for the entire plot. Additional nonforest land uses are not delineated. Use the pre-printed plot diagram to illustrate the other nonforest land uses not recorded. The plot diagram is useful for plot relocation during the next cycle.

4.1 REFERENCE PROCEDURE

Reference, within the sampled area on each microplot and subplot, the approximate boundary of each condition class that differs from the condition classes at a subplot center. Trees selected on these fixed-radius plots are assigned to the actual condition in which they lie regardless of the recorded approximate boundary delineated.

NRS Note: Not all boundaries are straight lines. The straight lines determined by the boundary referencing procedure should not be used to assign a tree's condition number. [Clarification 10/05/2006.]

Boundary referencing is done by recording azimuths and distances from subplot center to the reference points and/or from microplot center to the reference points (Figures 15 and 16). Each boundary is marked by a maximum of three points - two where the boundary intersects the subplot circumference or microplot circumference, and one "corner" point between the two end points, if necessary. Only the corner point requires a distance, since the distance from the center to the circumference is always equal to the fixed plot radius.

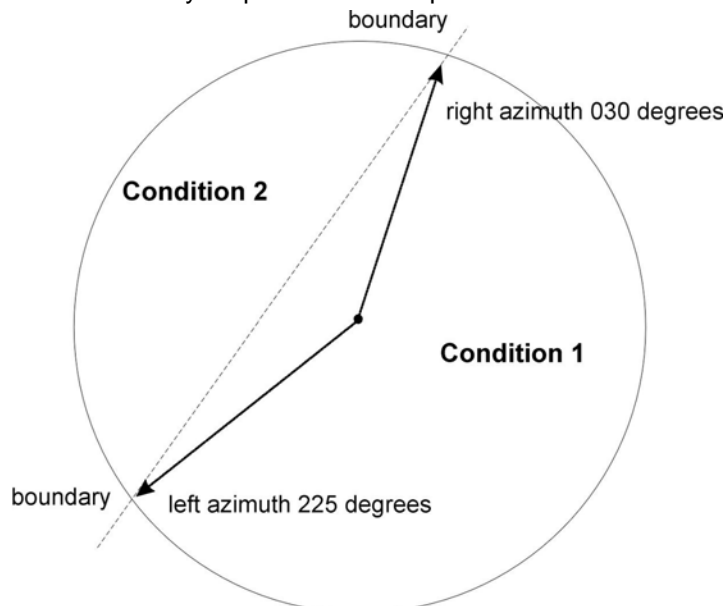

Figure 15. How to measure a straight boundary on a microplot or subplot.

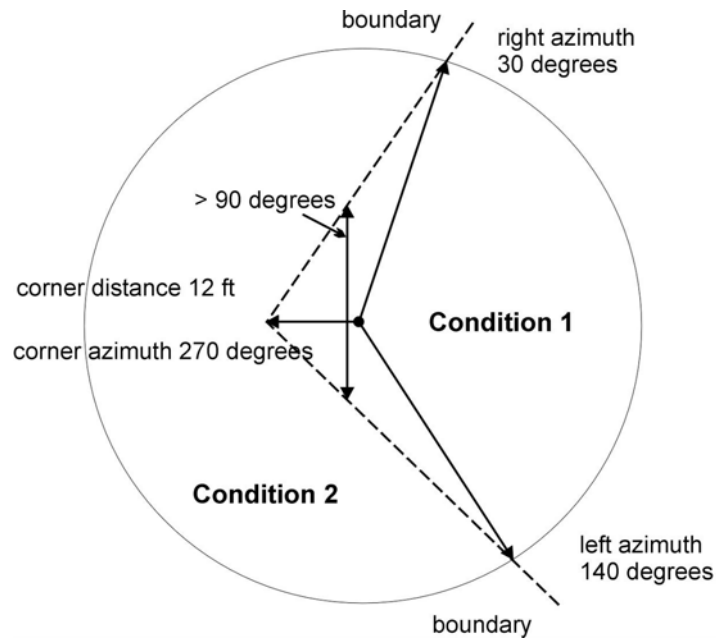

Figure 16. How to measure a boundary with a corner on a subplot.

Microplot boundaries are referenced to the microplot center. Note that the larger the plot, the greater likelihood of a need for a boundary corner to record boundaries that are not straight lines.

Refer to Sections 2.1 and 2.4 for general condition class delineation guidelines. The following additional rules apply when referencing a boundary within a subplot or microplot:

1. When a boundary between accessible forest land and nonforest land or between two contrasting accessible forest land condition classes is clearly marked, use that feature to define the boundary. Examples of clear demarcation are a fence line, plowed field edge, sharp ridge line, and water's edge along a stream course, ditch, or canal.
2. When a boundary between forest land and nonforest land is not clearly marked by an obvious feature, the boundary should follow the nonforest side of the stems of the trees at the forest edge.
3. When a boundary between two contrasting forest land condition classes is not clearly marked, map along the stems of the contrasting condition. When the boundary between two contrasting forest land condition classes is separated by a narrow linear inclusion (creek, fire line, narrow meadow, unimproved road), establish the boundary at the far edge, relative to subplot center, of the inclusion.
4. When a plot is remeasured, the crew will examine the boundaries referenced at last inventory. If no change has occurred, the current crew will retain the boundary data that were recorded at last inventory. If a boundary has changed, or a new boundary is present, or the previous crew made an obvious error, record new or updated boundary data. Delete boundaries that are no longer distinct.

5. Although individual MQOs are specified for the azimuths and distances, in practice a crew will be considered 'correct' when the difference in areas as mapped by the original crew and by the QA crew is less than 10 percent of the subplot or microplot area. This allows for slight variations in azimuths or distances due to the approximate nature of mapping procedures. (See NRS Note for BOUNDARY CHANGE.)

4.2 BOUNDARY DATA

Record the appropriate values for each boundary mapped on the subplot or microplot as follows:

4.2.1 SUBPLOT NUMBER

Record the code corresponding to the number of the subplot.

NRS PDR Note: This variable is determined by the subplot selection in the PDR program.

When collected: All boundaries

Field width: 1 digit

Tolerance: No errors

MQO: At least 99% of the time

Values:

- | | |
|---|-------------------|
| 1 | Center subplot |
| 2 | North subplot |
| 3 | Southeast subplot |
| 4 | Southwest subplot |

4.2.2 PLOT TYPE [TYPE]

Record the code to specify whether the boundary data are for a subplot or microplot.

When collected: All boundaries

Field width: 1 digit

Tolerance: No errors

MQO: At least 99% of the time

Values:

- | | |
|---|--------------------|
| 1 | Subplot boundary |
| 2 | Microplot boundary |

4.2.3 BOUNDARY CHANGE [CHNG]

Remeasurement (SAMPLE KIND = 2 and 5) locations only. Record the appropriate code to indicate the relationship between previously recorded and current boundary information.

NRS Note: On remeasurement plots, if the current azimuths are within 10 degrees of the previous azimuths and no physical change has taken place, record the previous crew's boundary data. BOUNDARY CHANGE = 0.

When collected: SAMPLE KIND = 2 and 5, All boundaries

Field width: 1 digit

Tolerance: No errors

MQO: At least 99% of the time

Values:

- | | |
|---|---|
| 0 | No change - boundary is the same as indicated on plot map and/or data collected by a previous crew. |
| 1 | New boundary or boundary data has been changed to reflect an actual on-the-ground physical change resulting in a difference from the boundaries recorded. |

- 2 Boundary has been changed to correct an error from previous crew.
- 3 Boundary has been changed to reflect a change in variable definition.

4.2.4 **CONTRASTING CONDITION [CCON]**

Record the CONDITION CLASS NUMBER of the condition class that contrasts with the condition class located at the subplot center (for boundaries on the subplot) or at the microplot center (for boundaries on the microplot), e.g., the condition class present on the other side of the boundary line. See section 3.0 for subplot data.

When collected: All boundaries
Field width: 1 digit
Tolerance: No errors
MQO: At least 99% of the time
Values: 1 to 9

4.2.5 **LEFT AZIMUTH [LAZM]**

Record the azimuth from the subplot or microplot center to the farthest left point (facing the contrasting condition) where the boundary intersects the subplot or microplot circumference.

When collected: All boundaries
Field width: 3 digits
Tolerance: +/- 10 degrees
MQO: At least 90% of the time
Values: 001 to 360

4.2.6 **CORNER AZIMUTH [CAZM]**

Record the azimuth from the subplot or microplot center to a corner or curve in a boundary. If a boundary is best described by a straight line between the two circumference points, then record 000 for CORNER AZIMUTH (000=none).

When collected: All boundaries
Field width: 3 digits
Tolerance: +/- 10 degrees
MQO: At least 90% of the time
Values: 000 to 360

4.2.7 **CORNER DISTANCE [CDIS]**

Record the horizontal distance, to the nearest 1 foot, from the subplot or microplot center to a boundary corner point.

When collected: All boundaries when CORNER AZIMUTH > 000
Field width: 2 digits
Tolerance: +/- 1 ft
MQO: At least 90% of the time
Values:
 microplot 01 to 07 ft (actual limiting distance is 6.8 ft)
 subplot 01 to 24 ft

4.2.8 **RIGHT AZIMUTH [RAZM]**

Record the azimuth from subplot or microplot center to the farthest right point (facing the contrasting condition) where the boundary intersects the subplot or microplot circumference.

When collected: All boundaries
Field width: 3 digits
Tolerance: +/- 10 degrees

MQO: At least 90% of the time
Values: 001 to 360

4.2.9N PERCENT AREA [%ARE]

The percent area represents the portion of the plot in the CONTRASTING CONDITION.

NRS PDR Note: This variable is a calculated by the PDR program.

When collected: All boundaries
Field width: 3 digits
Tolerance: N/A
MQO: N/A
Values: 001 to 100

5.0 TREE AND SAPLING DATA

Trees at least 5.0 inches in diameter are sampled within the subplot. 'Tally trees' are defined as all live and standing dead trees in accessible forest land condition classes encountered on the subplot the first time a subplot is established, and all trees that grow into a subplot thereafter. These data yield information on tree volume, growth, mortality, and removals; wildlife habitats; forest structure and composition; biomass; and carbon sequestration.

Trees with a diameter at least 1.0 inch but less than 5.0 inches, termed saplings, are sampled within the microplot. 'Tally saplings' are defined as all live saplings in accessible forest land condition classes encountered the first time a microplot is established, and all saplings that grow into each microplot thereafter are included until they grow to 5.0 inches or larger, at which time they are tallied on the 24.0-foot subplot and referenced (new AZIMUTH and HORIZONTAL DISTANCE taken) to the subplot center. Saplings are often generically termed trees within the national and regional variable text. Refer to "When Collected" to see if a variable pertains to a sapling as well as tree.

For multi-stemmed western woodland species, a cumulative DRC is used to compute diameter as described in Sections 5.9 and 5.9.4.

NRS Note: DRC procedures are applied only on Rocky Mountain Juniper (*Juniperis scopulorum*) – species code 0066 – in the states of KS, NE, ND and SD. This species is generally found in the western half of these states.

Trees are alive if they have any living parts (leaves, buds, cambium) at or above the point of diameter measurement, either diameter at breast height (DBH) or diameter at root collar (DRC). Trees that have been temporarily defoliated are still alive. If the stem is broken and still attached below DBH, the stem is tallied as a live tree. The severity of the break (i.e., more or less than 50% attached) on a live stem is not considered. Therefore as long as the stem is attached and the tree is live at DBH, it is tallied. See Figure 16.1N.

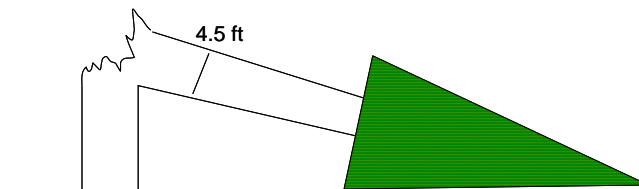

Figure 16.1N. Example of a live tree with a broken stem below 4.5 feet.

Once tallied, dead trees over 5.0 inches in diameter are tracked until they no longer qualify as standing dead. **Working around dead trees is a safety hazard - crews should exercise extreme caution! Trees that are deemed unsafe to measure should be estimated.**

To qualify as a standing dead tally tree, dead trees must be at least 5.0 inches in diameter, have a bole which has an unbroken ACTUAL LENGTH of at least 4.5 feet, and lean less than 45 degrees from vertical as measured from the base of the tree to 4.5 feet.

Portions of boles on dead trees that are separated greater than 50 percent (either above or below 4.5 feet), are considered severed and are included in Down Woody Material (DWM) if they otherwise meet DWM tally criteria.

For western woodland species (Appendix 3) with multiple stems, a tree is considered down if more than 2/3 of the volume is no longer attached or upright; do not consider cut and removed volume. For western woodland species with single stems to qualify as a standing dead tally tree, dead trees must be at least 5.0 inches in diameter, be at least 1.0 foot in unbroken ACTUAL LENGTH, and lean less than 45 degrees from vertical.

Live and dead standing tally trees, and partially separated boles of dead tally trees, do not have to be self-supported. They may be supported by other trees, branches, or their crown.

Trees that have been cut above DBH qualify as tally trees, provided they meet the size requirement.

NRS Note: Trees that have been cut above DBH qualify as removals. This includes trees with high stumps and trees that have been cut with wood remaining at DBH (i.e., barber-chair). High stumps are usually a result of winter harvesting due to excessive snow total amounts. In addition, high stumps on trees with natural butt-swell (where it is normal to cut above 4.5 ft.) do not qualify as standing dead trees.

The following apply at remeasurement:

- If at the previous visit a forked tree was recorded as two separate trees but should have been recorded as one tree, delete one tree (apply PRESENT TREE STATUS = 0, RECONCILE = 7) and correct the diameter for the remaining tree (apply PRESENT TREE STATUS = 1, DIAMETER CHECK = 2). Record and explanation in TREE NOTES.
- If at the previous visit a forked tree was recorded as one tree but should have been recorded as two separate trees, correct the diameter for the remeasured tree to represent one tree (apply PRESENT TREE STATUS = 1, DIAMETER CHECK = 2), and add the other fork as a new tree (apply PRESENT TREE STATUS = 1, RECONCILE = 3 or 4). Record an explanation in TREE NOTES.

NRS Note: If a subplot was installed incorrectly at the previous visit, the current crew should remeasure the subplot in its present location. In cases where individual forested subplots are lost (cannot be relocated and is not a land use change), apply the following procedures:

- Assign PRESENT TREE STATUS = 0 and RECONCILE = 7 to all downloaded trees (i.e., incorrectly tallied at the previous survey)
- Assign PRESENT TREE STATUS = 1 or 2 AND RECONCILE codes 3 or 4 (i.e., missed live or missed dead) to all trees on the new installed subplot with the next new TREE RECORD NUMBER for that subplot.

Begin tallying trees at an azimuth of 001 degrees from subplot center and continue clockwise around the subplot. Repeat this sequence for trees on the microplot.

5.1 SUBPLOT NUMBER

Record the subplot number where the tree occurs.

NRS PDR Note: This variable is determined by the subplot selection in the PDR program.

When Collected: All live tally trees ≥ 1.0 in DBH/DRC and standing dead tally trees ≥ 5.0 in DBH/DRC

Field width: 1 digit

Tolerance: No errors

MQO: At least 99% of the time

Values:

- | | |
|---|-------------------|
| 1 | Center subplot |
| 2 | North subplot |
| 3 | Southeast subplot |
| 4 | Southwest subplot |

5.2 TREE RECORD NUMBER [TR#]

Record a code to uniquely and permanently identify each tree on a given subplot. The TREE RECORD NUMBERS must be unique within a subplot – being unique is more important than being sequential. In general, work clockwise from azimuth 001 to 360, and work outwards from subplot center to subplot perimeter. On remeasured plots, use the previously assigned tree number. Saplings tallied on microplots will retain their initially assigned tree number if they grow to tree size. Missed trees will be assigned the next available tree number. DO NOT renumber all plot trees in order to assign a more “correct” tree number to a missed tree. Numbers assigned to trees that are subsequently found to be extra will be dropped and not reused.

If TREE RECORD NUMBERS are not assigned in the field, record 000.

NRS PDR Note: A new TREE RECORD NUMBER is assigned in the field. The next available tree number is on the printed plot sheets and is also an option on the PDR program. If a remeasurement tree is missing from the electronic data file, enter the data using the assigned tree number from the previous cycle’s printed tree data and enter all associated previous history data.

Note: If this is a Phase 3 plot, match the trees on this point to the hard copy list provided. Record the three-digit FHM tree number assigned to each standing tree.

When Collected: All live tally trees ≥ 1.0 in DBH/DRC and standing dead tally trees ≥ 5.0 in DBH/DRC

Field width: 3 digits

Tolerance: No errors

MQO: At least 99% of the time

Values: 000 or 001 to 999

5.3 CONDITION CLASS NUMBER [CON#]

Record the CONDITION CLASS NUMBER in which each tree is located. Often, a referenced boundary is approximate and may or may not represent the actual “on the ground” boundary. Trees selected for tally are assigned to the actual condition in which they lie regardless of the recorded approximate boundary (Figure 17).

NRS Note: Trees and saplings are tallied only on accessible forest land. Trees and saplings that were previously measured on forest land and now fall in a nonforest condition require minimal tree data collection. See 5.31N FOREST TO NONFOREST VARIABLES for a listing of these variables.

When Collected: All trees

Field width: 1 digit

Tolerance: No errors

MQO: At least 99% of the time

Values: 1 to 9

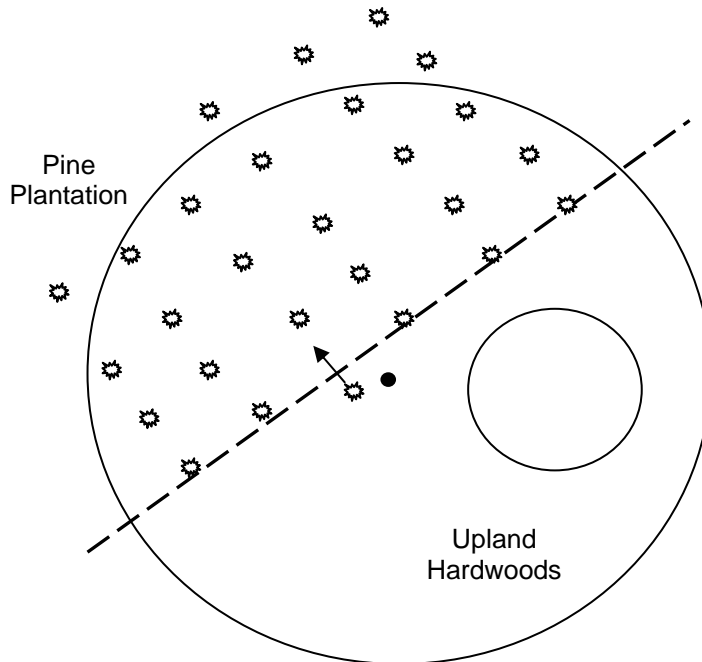

Figure 17. Ragged CONDITION CLASS boundary and tree condition class designation.

5.4 **AZIMUTH [AZM]**

Record the AZIMUTH from the subplot center (for trees greater than or equal to 5.0 inches DBH/DRC) or the microplot center (for trees greater than or equal to 1.0 inch and less than 5.0 inches DBH/DRC), sight the center of the base of each tree with a compass. Sight to the geographic center for multi-stemmed western woodland species (Appendix 3). The geographic center is a point of equal distance between all tallied stems for a given woodland tree. Record AZIMUTH to the nearest degree. Use 360 for north.

NRS PDR Note: Do not repeat azimuths on a subplot or microplot. If warranted, separate trees by one degree. In addition, change only those azimuths that exceed the current ten degree tolerance unless the previous recorded azimuth causes current on the ground confusion like trees located in a clump. It makes sense to change these azimuths even if the previous azimuths are within tolerance.

When Collected: All live tally trees ≥ 1.0 in DBH/DRC and standing dead tally trees ≥ 5.0 in DBH/DRC

Field width: 3 digits

Tolerance: +/- 10 degrees

MQO: At least 90% of the time

Values: 001 to 360

NRS Note (procedural change for former NC crews): The procedures utilized by NC for measuring horizontal distance to "down and windthrown" trees is no longer applicable. New regional procedures for down and windthrown trees are described and illustrated.

5.5 **HORIZONTAL DISTANCE [DIST]**

Record the measured HORIZONTAL DISTANCE, to the nearest 0.1 foot, from the subplot center (for trees greater than or equal to 5.0 inches DBH/DRC) or microplot center (for trees greater than

or equal to 1.0 inch and less than 5.0 inches DBH/DRC) to the pith of the tree at the base. For all multi-stemmed western woodland trees (woodland species indicated in Appendix 3), the HORIZONTAL DISTANCE is measured from subplot or microplot center to the "geographic center" of the tree. The geographic center is a point of equal distance between all tallied stems for a given woodland tree.

Here are additional regional instructions to determine horizontal distance measurement for trees that lean, windthrown, or on steep terrain.

- A leaning tree is determined to be "in" or "out" of a plot radius by measuring the horizontal distance from plot center, to the center of the tree at the base. The direction that the tree leans is of no consequence.
- For a down and windthrown tree measure the horizontal distance to the spot where the center of the tree would have been if the tree was still standing (i.e., measure the distance to the center of the stump, or ground cavity). See illustration below.

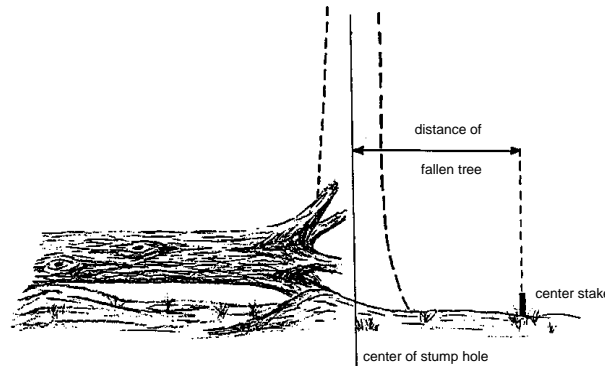

- A tree on steep terrain, occasionally, cannot be accurately measured by taking a direct horizontal distance. When this happens, the slope distance (measured parallel to the ground) and the percent slope (measured with a clinometer and this too is parallel to the ground) from subplot center to the tree will be needed to calculate the horizontal distance. See Figure 17.1N. The formula for calculating the horizontal distance is as follows:

$$\frac{\text{measure slope distance to tree}}{100 \text{ ft slope distance}} = \frac{\text{horizontal distance to tree}}{100 \text{ ft horizontal distance}}$$

For example, a tree has a slope distance of 25.9 ft and the slope is 48 %. Using the Slope Correction table in the Regional Appendix E, you find that the correction for 100 ft with 48 % slope is 10.9 ft.

All that's left is to solve the equation:

$$\frac{25.9 \text{ ft}}{110.9 \text{ ft}} = \frac{\text{horizontal distance to tree}}{100 \text{ ft}}$$

Solve for the horizontal distance, HD = 23.4 ft.

NRS PDR Note: If the *FIA PDR Application* is available, there is a function utility that allows you to determine horizontal distance. For this utility enter the measured slope distance and the percent slope and the utility calculates a horizontal distance.

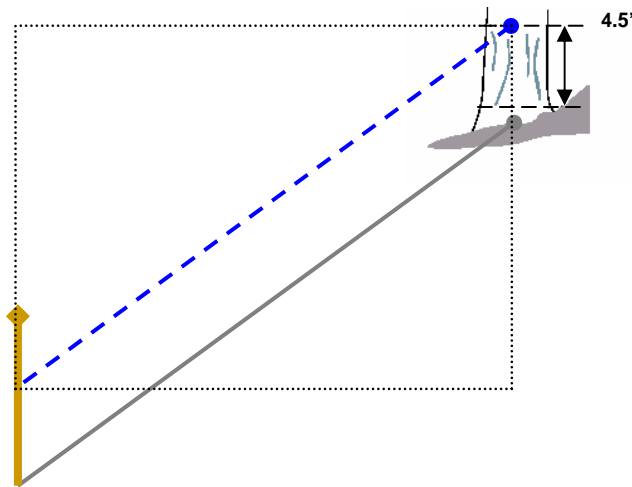

Figure 17.1N: A slope distance (dashed line) is measured parallel to the ground from the subplot center to the center of the tree and percent slope is measured along this dashed line (slope distance).

There is an alternative method to measure the slope distance and percent slope as shown in Figure 17.2N. Either measurement method will yield a horizontal distance when applied to the formula on the previous page or entered into the horizontal distance utility in the *FIA PDR Application*.

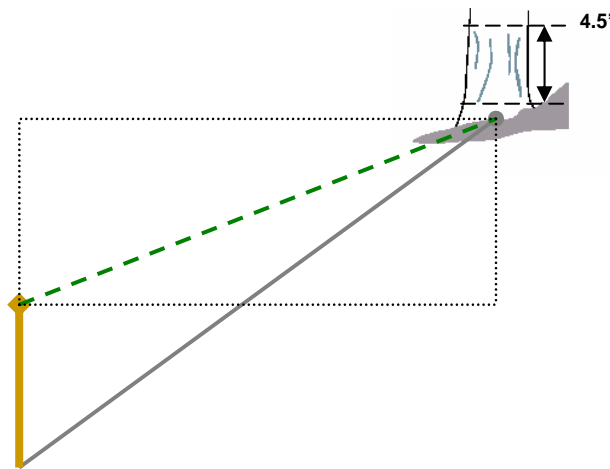

Figure 17.2N: A slope distance (dashed line) is measured from the subplot center to the center of the tree and percent slope is measured along the dashed line (slope distance.)

NRS Note: If a previous tree is located on the "outer" edge of a subplot (i.e., 23.8 to 24.2 ft), then apply the following rules. If the current crew determines a previously tallied tree is now at < 24.2 ft, the tree will remain IN. Similarly if the current crew determines that a previously non-tallied tree is ≥ 23.8 ft, the tree will remain OUT unless it is considered ingrowth. This also applies to saplings on the microplot's "outer" ring (i.e., 6.6 to 7.0 ft). On the microplot, a previously tallied sapling is now at ≤ 7.0 ft, the sapling will remain IN. If a previously non-tallied sapling is at ≥ 6.6 ft, the sapling will remain OUT unless it is considered ingrowth. This allowance is due to the difficulty of determining pith location and other factors like slope and subplot and/or microplot

center relocation. When the old pin or dowel is not found, the current crew should make sure that all “edge” trees or saplings that were in or out on the previous occasion, are still in or out unless ingrowth.

Edges trees that are just off the subplot or microplot may be marked with a small “X” and with a small dab of paint at the base to indicate where pith center was determined. This practice will assist the next crew in remeasurement.

NRS PDR Note: Change the previous recorded distance if it does not meet the indicated regional tolerance for trees. Example, if the previous distance was recorded as 15.2 and the current distance is now 16.0, the previous value is satisfactory. There is no need to change this value unless the previous distance causes current on the ground confusion like trees located in a clump. In these situations it makes sense to change this distance even if the previous distance is within tolerance.

When Collected: All live tally trees ≥ 1.0 in DBH/DRC and standing dead tally trees ≥ 5.0 in DBH/DRC

Field width: 3 digits (xx.y)

Tolerance: Microplot: +/- 0.2 ft; Microplot woodland species: +/- 0.4 ft; Subplot: +/- 1.0 ft from 00.1 to 23.0 ft and Subplot: +/- 0.2 ft from 23.1 to 24.0 ft; Subplot woodland species: +/- 2.0 ft

MQO: At least 90% of the time

Values: Microplot: 00.1 to 06.8; Subplot: 00.1 to 24.0

5.6 PREVIOUS TREE STATUS [PAST]

If not downloaded from the previous inventory, record PREVIOUS TREE STATUS for each remeasured tally tree. This code is used to track the status of sample trees over time. This information is needed to correctly assign volume information to the proper component of volume change.

NRS (East) Note: PREVIOUS TREE STATUS is applicable on all previously tallied trees if SK = 5-P3 (all subplots and microplots) or 5 (all subplots). If SK = 6, then subplot 1 only. Note: Microplots are being established for the first time on SK 5 and 6.

When collected: On remeasurement plots (SAMPLE KIND = 2, 5 or 6), all previously tallied trees ≥ 1.0 in DBH

Field width: 1 digit

Tolerance: No errors

MQO: At least 95% of the time

Values:

- 1 Live Tree – alive at the previous inventory
- 2 Dead tree – standing dead tree at the previous inventory

5.7 PRESENT TREE STATUS [TRST]

Record a current PRESENT TREE STATUS for each tallied tree; this code is used to track the status of sample trees over time: as they first appear, as ingrowth, as they survive, and when they die or are removed. This information is needed to correctly assign volume information to the proper component of volume change.

NRS Note: A remeasured tree that is now in a “nonforest” condition is assigned the appropriate PRESENT TREE STATUS. For example, a tree that was previously live in accessible forest land and is still present and live in a residential area is coded as 1. If the tree has died (includes trees that have been removed and not utilized), it is coded as 2. If the tree has been removed and utilized, it is coded as 3. If the PRESENT TREE STATUS cannot be determined for a tree now in a “nonforest” condition (i.e., crew is unable to occupy the subplot), apply code 2 or 3. When applying code 2 or 3, apply known local utilization practices or best professional judgment for a tree that is now located in a nonforest condition.

NRS Note: When occupying accessible forest land, a remeasured tree that has a temporary hazardous situation (e.g., hornet's nest, seasonal high water, etc.) isolating the tree on the subplot or microplot, should not be given a PRESENT TREE STATUS = 0. These trees should be given PRESENT TREE STATUS = 1 or 2 and the crew is allowed to estimate the measured variables. When estimating measured variables, view similar trees on plot and be conservative. For a new tree, these same rules apply. A tree that occupies a permanent hazardous situation requires that the subplot area be delineated as nonsampled (CONDITION CLASS STATUS 5).

When Collected: All new live tally trees ≥ 1.0 in DBH/DRC; All new **standing** dead tally trees ≥ 5.0 in; On remeasurement plots, all previously tallied trees

Field width: 1 digit

Tolerance: No errors

MQO: At least 95% of the time

Values:

- 0 No status -- tree is not presently in the sample (remeasurement plots only). Tree was incorrectly tallied at the previous inventory, currently is not tallied due to definition or procedural change, or is not tallied due to natural causes, **or is not tallied because of inaccessibility (i.e., hazardous or denied)**. Requires RECONCILE code = 5 – 9.
- 1 Live tree – any live tree (new, remeasured or ingrowth)
- 2 Dead tree -- any dead tree (new, remeasured, or ingrowth), regardless of cause of death. Includes all previously standing dead trees that no longer qualify as standing dead, as well as trees killed by silvicultural or land clearing activity, and are assumed not to have been utilized.
- 3 Removed - a tree that has been cut and removed by direct human activity related to harvesting, silviculture or land clearing (remeasurement plots only). The tree is assumed to have been utilized.

Note: On remeasured plots, crews must collect new AZIMUTH and HORIZONTAL DISTANCE information from the subplot center for microplot saplings that grow to become subplot trees. For live subplot trees that shrink to become live saplings on the microplot, crews must collect new AZIMUTH and HORIZONTAL DISTANCE information from the microplot center.

5.7.1 RECONCILE [RECO]

For remeasurement locations only, record a RECONCILE code for any new tally tree that was not tallied in the previous inventory, and for all no status remeasurement trees (PRESENT TREE STATUS = 0). This code is used to identify the reason a new tree appeared in the inventory, and identify the reason a remeasurement tree no longer qualifies as a tally tree. This information is needed to correctly assign volume information to the proper component of volume change.

NRS (East) Note: RECONCILE is applicable on all previously tallied trees if SK = 5-P3 (all subplots and microplots) or 5 (all subplots). If SK = 6, then subplot 1 only. Note: Microplots are being established for the first time on SK 5 and 6 and do not require a RECONCILE code.

When Collected: On SAMPLE KIND = 2, **5 or 6**; all new live tally trees ≥ 1.0 in DBH/DRC (PRESENT TREE STATUS = 1 and no PREVIOUS TREE STATUS), all new **standing** dead tally trees ≥ 5.0 in (PRESENT TREE STATUS = 2 and no PREVIOUS TREE STATUS), **all previously tallied trees when** PRESENT TREE STATUS = 0

Field width: 1 digit

Tolerance: No errors

MQO: At least 95% of the time

Values:

Codes 1 - 4 are valid for new trees (**PRESENT TREE STATUS = 1 or 2**) on the plot:

- 1 Ingrowth or reversions – either a new tally tree not qualifying as through growth or a new tree on land that was formerly nonforest and now qualifies as forest land (reversion or encroachment).
- 2 Through growth – new tally tree 5.0 inches DBH/DRC and larger, within the microplot, which was not missed at the previous inventory (i.e., grew from seedling to pole size between inventory cycles). Code is valid on SK2 or SK5-P3 only.
- 3 Missed live – a live tree missed at previous inventory and that is live or dead now.
- 4 Missed dead – a dead tree missed at previous inventory that is dead now.

Codes 5 - 9 are valid for remeasured trees (**PRESENT TREE STATUS = 0**) that no longer qualify as tally:

- 5 Shrank – live tree that shrank below threshold diameter on microplot/subplot
- 6 Missing (moved) – tree was correctly tallied in previous inventory, but has now moved beyond the radius of the plot due to natural causes (i.e., small earth movement, hurricane). Tree must be either live before and still alive now or dead before and dead now. If tree was live before and now dead, this is a mortality tree and should have PRESENT TREE STATUS = 2 (not 0).
- 7 Cruiser error – erroneously tallied at previous inventory
- 8 Procedural change – tree was tallied at the previous inventory, but is no longer tallied due to a definition or procedural change
- 9 Tree was sampled before, but now the area where the tree was located is nonsampled. All trees on the nonsampled area have RECONCILE = 9.

Code 5 is used to indicate live trees that shrink below the diameter threshold on the microplot/subplot. For example, if a live remeasurement tree shrinks below the 5.0 inch DBH/DRC, then record the following combination of codes: PREVIOUS TREE STATUS = 1, PRESENT TREE STATUS = 0, RECONCILE = 5. If a live measured tree shrinks below the 5.0 inch threshold on the subplot and is currently greater than or equal to 1.0 inch on the microplot, then record PREVIOUS TREE STATUS = 1, PRESENT TREE STATUS = 1. Record all required items for a tally sapling. Use the tree coding guide in Appendix 8 to determine the national coding method for remeasurement trees.

5.7.2 STANDING DEAD [DEAD]

Record the code that describes whether the tree qualifies as standing dead or not. To qualify as a standing dead tally tree, dead trees must be at least 5.0 inches in diameter, have a bole which has an unbroken ACTUAL LENGTH of at least 4.5 feet, and lean less than 45 degrees from vertical as measured from the base of the tree to 4.5 feet. **For standing dead trees that are curved or bent, apply the same rules (i.e., from the base of the tree to 4.5 feet.)** See Figures 18-20 for examples.

“Unbroken” is defined as at least 50 percent attached to the original source of growth. The degree of lean on dead trees with partially separated (i.e., 1 to 50 percent) boles is measured from the base of the tree to the **top of** ACTUAL LENGTH **at 4.5 feet.**

Portions of boles on dead trees that are separated greater than 50 percent (either above or below 4.5 feet), are considered severed and are included in Down Woody Material (DWM) if they otherwise meet DWM tally criteria.

For western woodland species (Appendix 3) with multiple stems, a tree is considered down if more than 2/3 of the volume is no longer attached or upright; do not consider cut and removed volume. For western woodland species with single stems to qualify as a standing dead tally tree, dead trees must be at least 5.0 inches in diameter, be at least 1.0 foot in unbroken ACTUAL LENGTH, and lean less than 45 degrees from vertical.

Live and dead standing tally trees, and partially separated boles of dead tally trees, do not have to be self-supported. They may be supported by other trees, branches, or their crown.

NRS (East) Note: STANDING DEAD is applicable on all previously tallied trees if SK = 5-P3 (all subplots) or 5 (all subplots). If SK = 6, then subplot 1 only.

When collected: SAMPLE KIND = 2, **5 or 6**: All dead tally trees (PRESENT TREE STATUS = 2)

Field width: 1 digit

Tolerance: No errors

MQO: At least 99% of the time

Values:

- 0 No – tree does not qualify as standing dead (includes a previously tallied tree that is still standing but with a current diameter < 5.0 in DBH)
- 1 Yes – tree does qualify as standing dead

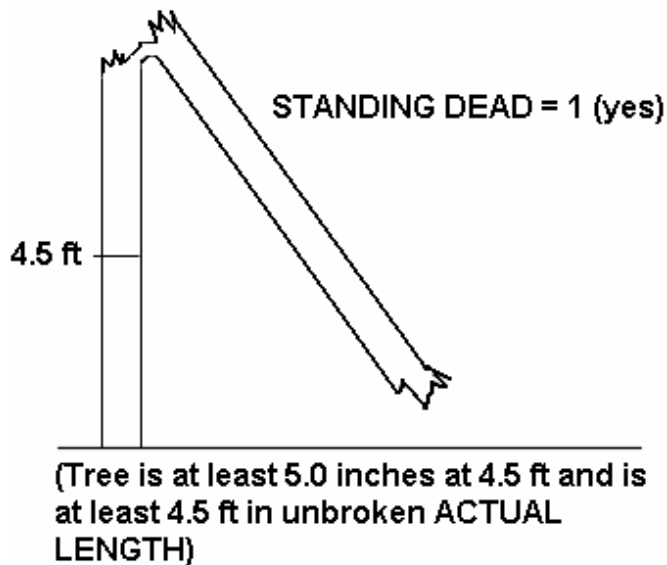

Figure 18. Example of an unbroken bole to 4.5 feet.

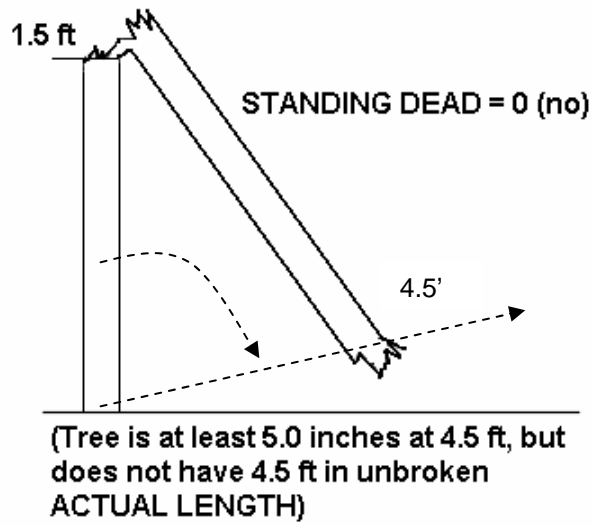

Figure 19+N. Example of an unbroken length of < 1.5 feet.

Note: The break at 1.5 ft is at least 50% attached. The lean angle is determined at 4.5 ft.

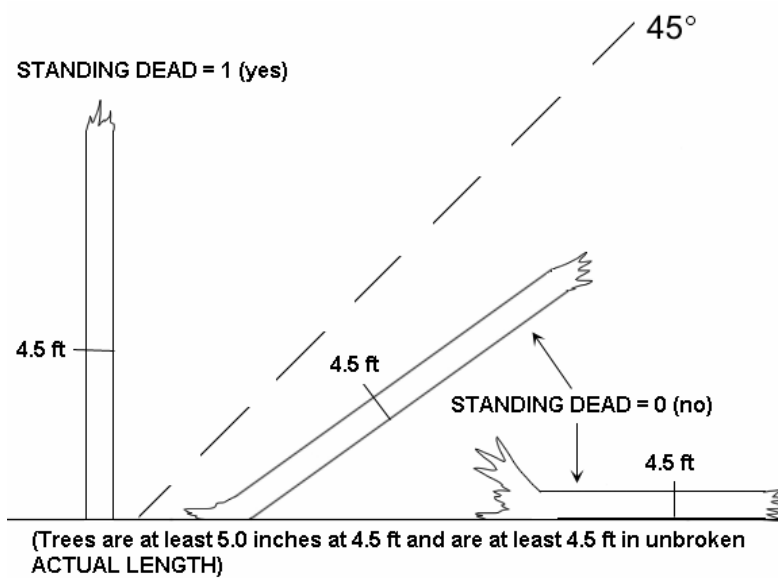

Figure 20. Other examples of dead trees.

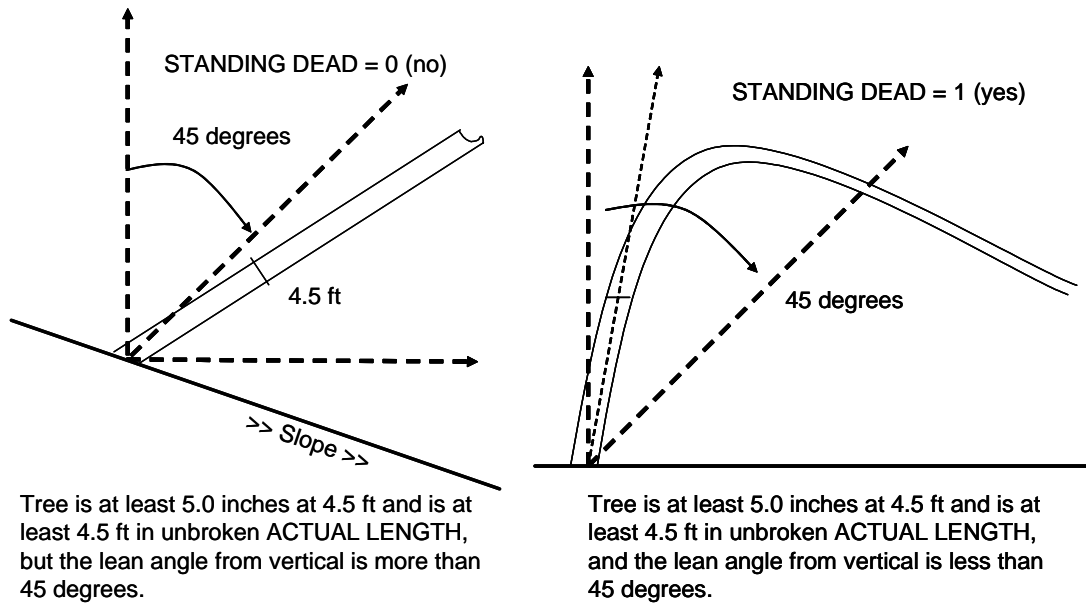

Figure 20.1N. Example of dead tree on slope. Figure 20.2N. Example of dead bent or curved tree.

5.7.3 MORTALITY (CORE OPTIONAL)

This variable is not collected in the North.

5.8 SPECIES [SPP]

Record the appropriate SPECIES code from the list in Appendix 3. If you encounter a species not listed in Appendix 3 and are not sure if it should be tallied as a tree, consult your Field Supervisor. If the species cannot be determined in the field, tally the tree, but bring branch samples, foliage, cones, flowers, bark, etc. to your supervisor for identification. If possible, collect samples outside the subplots from similar specimens and make a note to correct the SPECIES code later. Use code 0299 for unknown dead conifer, 0998 for unknown dead hardwood when the genus or species codes cannot be used, and 0999 for other or unknown live tree. The generic **genus** code should only be used when you are sure the species is on the species list, but you cannot differentiate among acceptable species. This is often the case with standing dead trees on newly established plots. In this case use the sample collections procedures described earlier in this paragraph. The species code list in Appendix 3 includes all tree species tallied in the Continental U.S. and Alaska. Species designated East/West are commonly found in those regions, although species designated for one region may occasionally be found in another. Species marked as Woodland designate species where DRC is measured instead of DBH. Species that have an "X" in the Core column are tallied in all regions. All other species on the list are "core optional".

NRS Note: All serviceberry (*Amelanchier* spp.) and hawthorn (*Crategegus* spp.) are tallied. These two species can be coded using the generic genus code (0356 and 0500), if the species cannot be determined. If a hybrid species is found, naturally or planted, code the species with the most dominant characteristic from Appendix 3. If the neither of the hybrid species are listed, then assign code 0999 and write a tree NOTE.

When Collected: All live tally trees ≥ 1.0 in DBH/DRC and standing dead tally trees ≥ 5.0 in DBH/DRC

Field width: 4 digits

Tolerance: No errors

MQO: At least 99% of the time for genus, at least 95% of the time for species

Values: See Appendix 3

5.9 DIAMETER [DBH]

Diameters are measured at either breast height (DBH) or at the root collar (DRC). Species requiring DRC, referred to as woodland species, are denoted with a "w" in Appendix 3. Trees with diameters between 1.0- and 4.9-inches are measured on the 6.8-foot radius microplot, those with diameters of 5.0-inches and larger are measured on the 24-foot radius subplots.

In order to accurately remeasure diameter (DBH or DRC) at the same point on the tree bole at successive visits, regions have the option of measuring and recording the distance from the ground to the point of diameter measurement, or marking the point of measurement with a scribe, crayon, paint, or aluminum nail. When marking trees for the first time, measure the diameter after the mark is in place. Use caution to avoid damaging trees with scribes and nails. Do not scribe or nail trees less than 3.0-inches in diameter, or species vulnerable to introduction of pathogens (e.g., aspen) or thin barked trees. Do not penetrate the cambium when using a bark scribe. A scribe that penetrates the cambium has been found to cause damage and swelling that affects not only the health of tree but compromises growth calculations. Any tree that has been scribed in the past, do not scribe again. Apply paint to the mark created by the scribe.

The diameter mark is located approximately one inch below where the diameter is taken and it faces the subplot center or microplot center. If using a bark scribe or paint marker, the mark should be approximately two inches long or as appropriate for a sapling. Check for irregularities before making diameter marks (see "Special DBH Situations" rule 4).

The use of scribes and paint are prohibited on plots located in Wilderness areas on National Forests. Tally trees will not be painted or scribed. **Mark each tally tree 5.0" DBH and larger with only a nail at ground level** either facing subplot center or on the uphill side of the tree if there is a slope. If the sample tree is in view of a known path or trail, place the nail away from the path or trail and make a PLOT NOTE. **A reference tree to the subplot center utilizes both a nail and tag.** If only saplings are on the subplot, mark a couple of them with nails at ground level and note which are so marked in the PLOT NOTES. **Nails should not be used on thin barked trees.** If diameter is not taken at DBH, **the LENGTH TO DIAMETER MEASUREMENT POINT is recorded.** Cutting vines and moss will not be done. In cases where vines or moss preclude the use of diameter tapes for estimation of diameter, calipers or other estimation procedures may be used. [INTRA-AGENCY AGREEMENT 05-SU-FIA01] **[Clarification 10/05/2006.]**

Remeasurement trees:

When remeasuring the diameter of a tree tallied at a previous survey, always take the measurement at the location monumented by the previous crew unless it is not physically possible (e.g., tree buried by mudslide), there is an abnormality at the previous DIAMETER measurement point, or the previous location is more than 12 inches beyond where the diameter should be measured according to current protocols (either because protocols have changed or the previous crew made a mistake). Assign a DIAMETER CHECK code of 2 whenever the point of measurement is moved.

When Collected: All live tally trees ≥ 1.0 in DBH/DRC and standing dead tally trees ≥ 5.0 in DBH/DRC

Field width: 4 digits (xxx.y)

Tolerance: +/- 0.1 in per 20.0 in increment of measured diameter on all live trees and dead trees with DECAY CLASS = 1, 2; +/- 1.0 in per 20.0 in increment of measured diameter on dead trees with DECAY CLASS = 3, 4, 5; For woodland species: +/- 0.2 in per stem

MQO: At least 95% of the time. For example: a tree with a diameter of 41.0 in would have a tolerance of plus or minus 0.3 in. (Note: the MQO for point of measurement is +/- 0.2 in when the tree is first measured and within 1 ft of the location established by the previous crew when the tree is remeasured.)

Values: 001.0 to 999.9

5.9.1 PREVIOUS DIAMETER AT BREAST HEIGHT [DBHO]

This is the DBH assigned at the previous survey. It has been downloaded from the previous inventory. Any change made to this field signifies an error at the time of the previous inventory. DIAMETER CHECK should be set to 2 and an explanation is required in the notes if previous DBH is changed.

5.9.2 DIAMETER AT BREAST HEIGHT (DBH)

Unless one of the following special situations is encountered, measure DBH at 4.5 feet above the ground line on the uphill side of the tree. Round each measurement down to the last 0.1 inch. For example, a reading of 3.68 inches is recorded as 3.6 inches.

Special DBH situations:

1. Forked tree: In order to qualify as a fork, the stem in question must be at least 1/3 the diameter of the main stem and must branch out from the main stem at an angle of 45 degrees or less. Forks originate at the point on the bole where the piths intersect. Forked trees are handled differently depending on whether the fork originates below 1.0 foot, between 1.0 and 4.5 feet, or above 4.5 feet.

NRS Note: A dead or missing stem is treated the same as a live stem on forked trees.

- Trees forked below 1.0 foot. Trees forked in this region are treated as distinctly separate trees (Figure 21). Distances and azimuths are measured individually to the center of each stem where it splits from the stump (Figure 24 A-C). DBH is measured for each stem at 4.5 feet above the ground. When stems originate from pith intersections below 1 foot, it is possible for some stems to be within the limiting distance of the microplot or subplot, and others to be beyond the limiting distance. If stems originating from forks that occur below 1.0 foot fork again between 1.0 and 4.5 feet (Figure 24-E), the rules in the next paragraph apply.

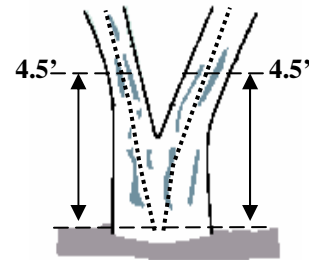

Figure 21. Forked below 1.0 ft.

- Trees forked between 1.0 foot and 4.5 feet. Trees forked in this region are also counted as separate trees (Figure 22), but only one distance and azimuth (to the central stump) is used for all (Figure 24 D-F). Although a single azimuth and distance applies to all, multiple stems should be recorded as they occur in clockwise order (from front to back when one stem is directly in front of another). The DBH of each fork is measured at a point 3.5 feet above the pith intersection. When forks originate from pith intersections between 1.0 and 4.5 feet, the limiting distance is the same for all forks--they are either all on, or all off the plot.

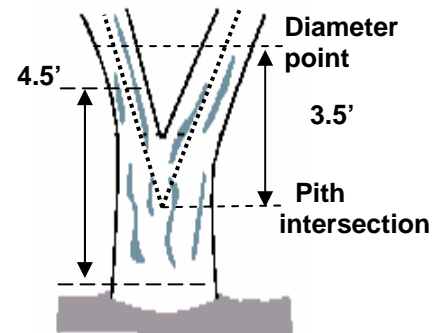

Figure 22. Forked between 1.0-4.5 ft.

Multiple forks are possible if they all originate from approximately the same point on the main stem. In such cases, measure DBH on all stems at 3.5 feet above the common pith intersection (Figure 24-F).

NRS Note: Diameter measurement due to a fork is to be taken 3.5 feet above the pith separation or at a “reasonable” reach for remeasurement. Place a diameter mark that can be consistently reached and remeasured by the next crew. If a diameter marked has already been placed, review the diameter procedures for “remeasurement trees” described in 5.9 DIAMETER.

Once a stem is tallied as a fork that originated from a pith intersection between 1.0 and 4.5 feet, do not recognize any additional forks that may occur on that stem. Measure the diameter of such stems just below the base of stem separation as shown in Figure 24-E (i.e., do not move the point of diameter the entire 3.5 feet above the first fork).

NRS Note: If there is not 3.5 feet present above the pith separation, measure the diameter at the point of the break.

- Trees forked at or above 4.5 feet. Trees forked in this region count as one single tree (Figure 23). If a fork occurs at or immediately above 4.5 feet, measure diameter below the fork just beneath any swelling that would inflate DBH.

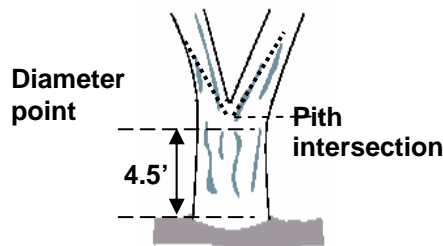

Figure 23. One tree.

2. Stump Sprouts. Stump sprouts originate between ground level and 4.5 feet on the boles of trees that have died or been cut. Stump sprouts are handled the same as forked trees, with the exception that stump sprouts are not required to be 1/3 the diameter of the dead bole. Stump sprouts originating below 1.0 foot are measured at 4.5 feet from ground line. Stump sprouts originating between 1.0 foot and 4.5 feet are measured at 3.5 feet above their point of occurrence. As with forks, rules for measuring distance and azimuth depend on whether the sprouts originate above or below 1.0 foot. For multi-stemmed woodland species, treat all new sprouts as part of the same new tree.

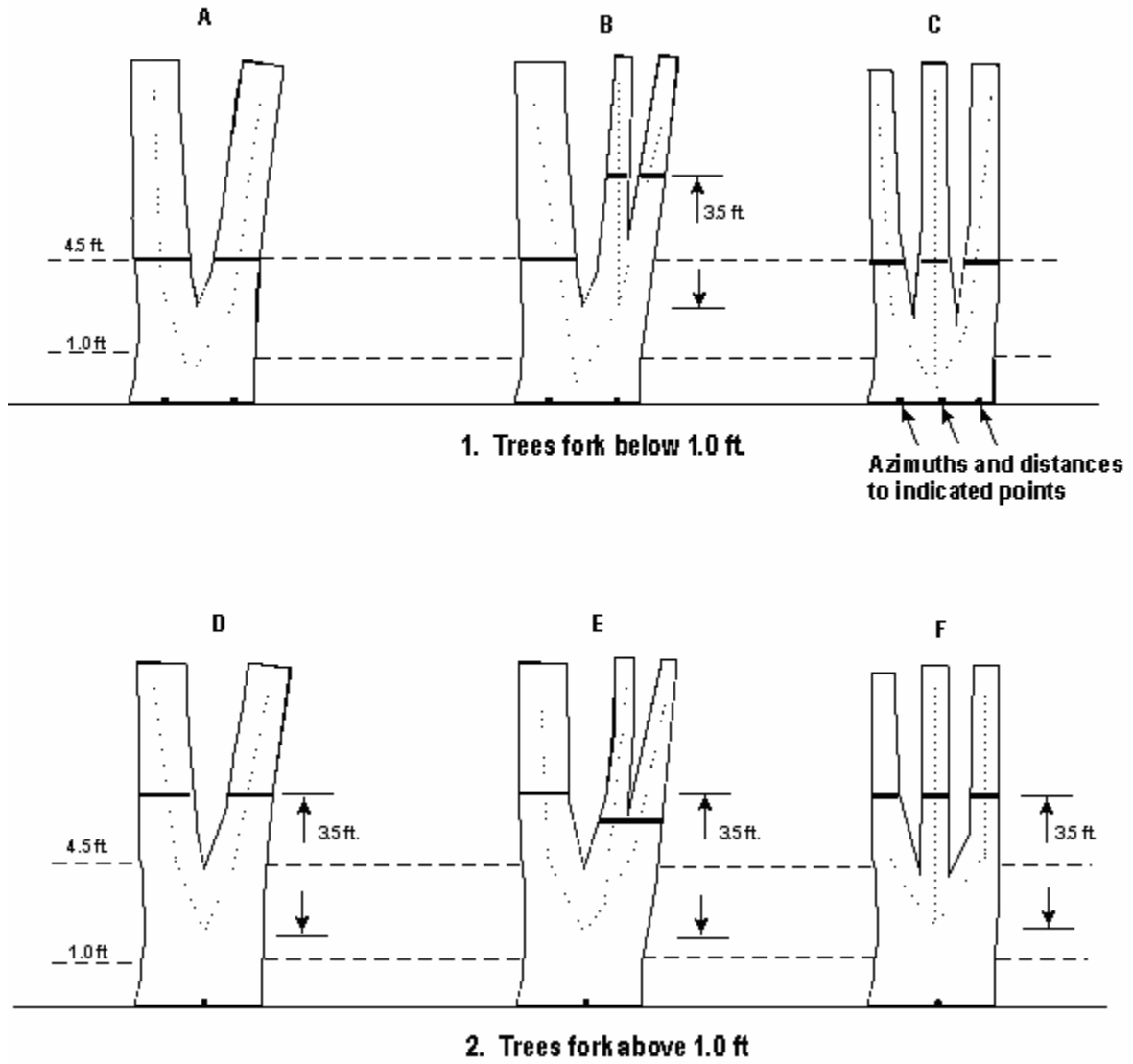

Figure 24. Summary of where to measure DBH, distance, and azimuth on forked trees.

NRS PDR Note: Azimuths are not repeated in the regional *FIA PDR Application*. The functionality of the program requires at least one degree difference between tally trees.

3. Tree with butt-swell or bottleneck: Measure these trees 1.5 feet above the end of the swell or bottleneck if the swell or bottleneck extends 3.0 feet or more above the ground (Figure 25).

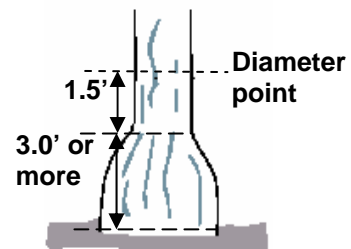

Figure 25. Bottleneck tree.

4. Tree with irregularities at DBH: On trees with swellings (Figure 26), bumps, depressions, and branches (Figure 27) at DBH, diameter will be measured immediately above the irregularity at the place it ceases to affect normal stem form.

NRS Note: If the normal diameter point is out of reach due to the irregularity, it is acceptable to measure the diameter below 4.5 feet. Indicate the diameter height with variable 5.24, LENGTH TO DIAMETER MEASUREMENT POINT.

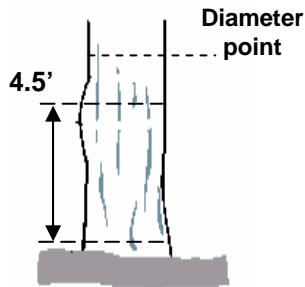

Figure 26. Tree with swelling.

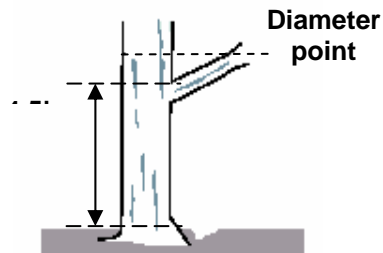

Figure 27. Tree with branch.

5. Tree on slope: Measure diameter at 4.5 feet from the ground along the bole on the uphill side of the tree (Figure 28).

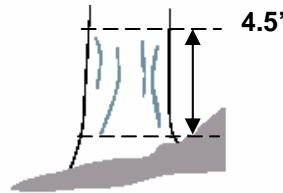

Figure 28. Tree on a slope.

6. Leaning tree: Measure diameter at 4.5 feet from the ground along the bole. The 4.5-foot distance is measured along the underside face of the bole (Figure 29).

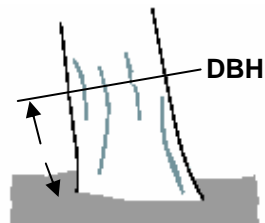

Figure 29. Leaning tree.

7. Turpentine tree: On trees with turpentine face extending above 4.5 feet, estimate the diameter at 10.0 feet above the ground and multiply by 1.1 to estimate DBH outside bark.
8. Independent trees that grow together: If two or more independent stems have grown together at or above the point of DBH, continue to treat them as separate trees. Estimate the diameter of each, set the "DIAMETER CHECK" code to 1, and explain the situation in the notes.
9. Missing wood or bark. Do not reconstruct the DBH of a tree that is missing wood or bark or at the point of measurement. Record the diameter, to the nearest 0.1 inch, of the wood and bark that is still attached to the tree (Figure 30). If a tree has a localized abnormality (gouge, depression, etc.) at the point of DBH, apply the procedure described for trees with irregularities at DBH (Figure 26 and 27).

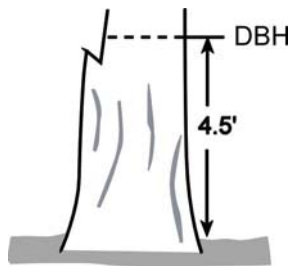

Figure 30. Tree with part of stem missing.

10. Live windthrown tree: Measure from the top of the root collar along the length to 4.5 feet (Figure 31).

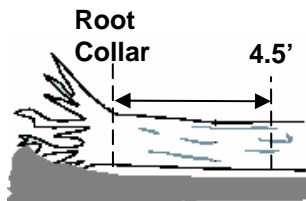
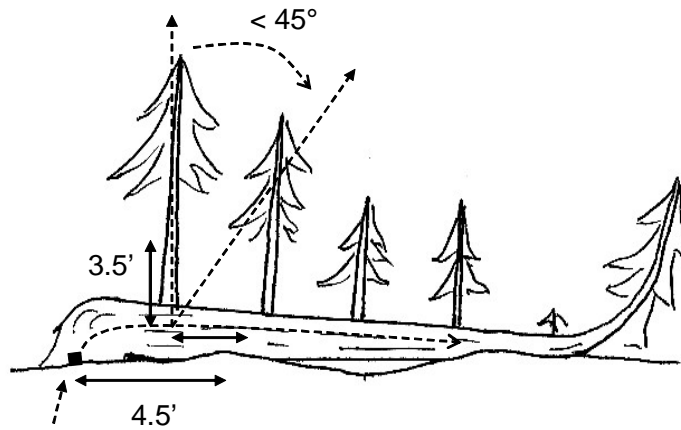

Figure 31. Tree on the ground.

11. Down live tree with tree-form branches growing vertical from main bole. When a down live tree, touching the ground, has vertical (less than 45 degrees from vertical) tree-like branches coming off the main bole, first determine whether or not the pith of the main bole (averaged along the first log of the tree) is above or below the duff layer.
 - If the **general** pith **line** of the main bole is above the duff layer, use the same forking rules specified for a forked tree, and take all measurements accordingly (Figure 32+N).
 - a. If the pith intersection of the main down bole and vertical tree-like branch occurs below 4.5 feet from the stump along the main bole, treat that branch as a

separate tree, and measure DBH 3.5 feet above the pith intersection for both the main bole and the tree-like branch.

- b. If the intersection between the main down bole and the tree-like branch occurs beyond the 4.5 feet point from the stump along the main bole, treat that branch as part of the main down bole.



HDist & Az taken at this point for both measured stems.

Figure 32+N. Down tree above duff. In this example, 2 stems are measured. The stem along the ground and 1st tree-like branch.

- If the **general** pith **line** of main tree bole is below the duff layer, ignore the main bole, and treat each tree-like branch as a separate tree; take DBH and length measurements from the ground, not necessarily from the top of the down bole (Figure 33). However, if the top of the main tree bole curves out of the ground towards a vertical angle, treat that portion of that top as an individual tree originating where the pith leaves the duff layer.

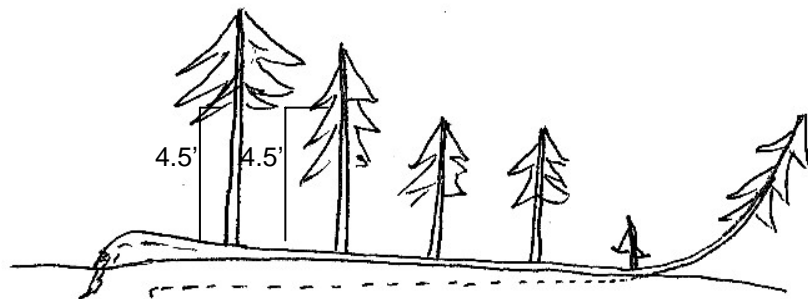

Figure 33. Down tree below duff.

12. Tree with curved bole (pistol butt tree): Measure along the bole on the uphill side (upper surface) of the tree (Figure 34).

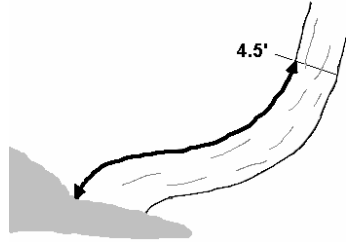

Figure 34. Tree with curved bole (pistol butt tree).

13. Tree growing on objects: When trees are growing on objects, such as rocks or logs, measure at 4.5 feet above the root crown rather than above the forest floor. (Figure 34.1N). [Source: FSH2409.12-2000] Trees that reside in water much of the year can also produce "prop-like" roots, measure diameter in a similar method at 4.5 feet above the root crown.

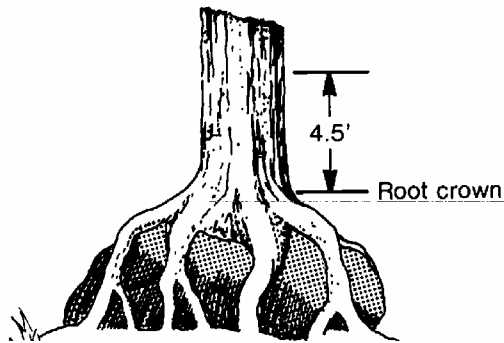

Figure 34.1N. Trees growing on objects (e.g., rocks, logs).

5.9.3 PREVIOUS DIAMETER AT ROOT COLLAR

This is the DRC assigned at the previous survey. It has been downloaded from the previous inventory. Any change made to this field signifies a misclassification at the time of the previous inventory. "DIAMETER CHECK" should be set to 2 and an explanation is required in the notes if previous DRC is changed.

5.9.4 DIAMETER AT ROOT COLLAR (DRC)

For species requiring diameter at the root collar (refer to Appendix 3), measure the diameter at the ground line or at the stem root collar, whichever is higher. For these trees, treat clumps of stems having a unified crown and common root stock as a single tree; examples include mesquite, juniper, and mountain mahogany. Treat stems of woodland species such as Gambel oak and bigtooth maple as individual trees if they originate below the ground. For woodland trees, record DRC STEM DIAMETER and DRC STEM STATUS (described below). Then compute and record the DRC value from the individual stem diameter information.

NRS Note: The DRC procedure is applied only on Rocky Mountain Juniper (*Juniperis scopulorum*) – species code 0066 – in the states of KS, NE, ND and SD. This species is generally found in the western half of these states. DBH procedures described in section 5.9.2 are not applicable to species code 0066.

Measuring woodland stem diameters: Before measuring DRC, remove the loose material on the ground (e.g., litter) but not mineral soil. Measure just above any swells present, and in a location so that the diameter measurements are a good representation of the volume in the stems (especially when trees are extremely deformed at the base). Stems must be at least 1 foot in length and at least 1.0 inch in diameter 1 foot up from the stem diameter measurement point to qualify for measurement. Whenever DRC is impossible or extremely difficult to measure with a diameter tape (e.g., due to thorns, extreme number of limbs), stems may be estimated and recorded to the nearest 1.0-inch class. Additional instructions for DRC measurements are illustrated in Figure 35. For each qualifying stem of the woodland tree, measure and record DRC STEM DIAMETER (5.9.4.1) and indicate the DRC STEM STATUS (5.9.4.2)

NRS Note: If one measurement of DRC at the root collar can be accomplished, then take one measurement as shown in Figure 35, example 3. Mark the DRC measurement point. If growth habits and/or soil level make one measurement impossible as shown in Figure 35, example 6, then mark and measure the qualifying stems.

Computing and Recording DRC: For all tally trees requiring DRC, with at least one stem 1 foot in length and at least 1.0 inch in diameter 1 foot up from the stem diameter measurement point, DRC is computed as the square root of the sum of the squared stem diameters. For a single-stemmed DRC tree, the computed DRC is equal to the single diameter measured.

Use the following formula to compute DRC:

$$\text{DRC} = \text{SQRT} [\text{SUM} (\text{stem diameter}^2)]$$

Round the result to the nearest 0.1 inch. For example, a multi-stemmed woodland tree with stems of 12.2, 13.2, 3.8, and 22.1 would be calculated as:

$$\begin{aligned} \text{DRC} &= \text{SQRT} (12.2^2 + 13.2^2 + 3.8^2 + 22.1^2) \\ &= \text{SQRT} (825.93) \\ &= 28.74 \\ &= 28.7 \end{aligned}$$

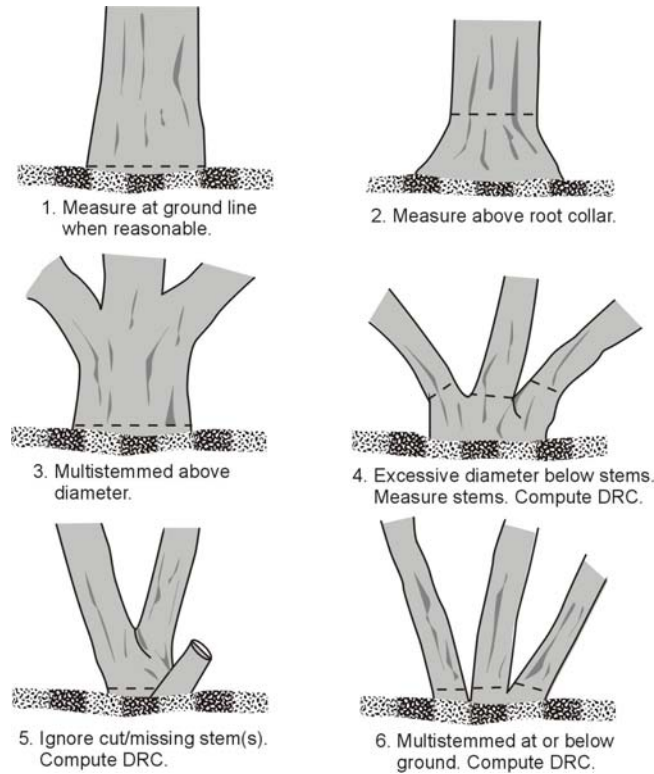

Figure 35. How to measure DRC in a variety of situations.

NRS PDR Note: When species code 0066 is entered, the *FIA PDR Application* will open a utility that allows the entry of the next two variables – DRC STEM DIAMETER and DRC STEM STATUS. The utility allows the entry of multiple stems and upon completion of these entries; it calculates a value for 5.9 – DIAMETER.

5.9.4.1 DRC STEM DIAMETER

Record the diameter of each individual qualifying stem on the woodland tree.

When collected: All stems on woodland tree species that are at least 1 ft in length and at least 1.0 in in diameter 1 ft up from the stem diameter measurement point

Field width: 4 digits (xxx.y)

Tolerance: +/- 0.2 in per stem

MQO: At least 95% of the time

Values: 001.0 to 999.9

5.9.4.2 DRC STEM STATUS

Record the status of each individual stem on the woodland tally tree.

When collected: All stems on woodland tree species that are at least 1 ft in length and at least 1.0 in in diameter 1 ft up from the stem diameter measurement point

Field width: 1 digit

Tolerance: No errors

MQO: At least 95% of the time

Values:

- 1 live stem
- 2 dead stem

5.10 PAST NUMBER OF STEMS

If the PAST NUMBER OF STEMS does not equal the CURRENT NUMBER OF STEMS, **do not** change the preprinted value. Make a note in TREE NOTES suggesting the possible reason for the difference.

When collected: Value is preprinted for SAMPLE KIND = 2 locations

Field width: 2 digits

Tolerance: No errors

MQO: At least 90% of the time

Values: 1 to 99

5.11 CURRENT NUMBER OF STEMS

Record the total number of stems that were measured for DRC (e.g., record 1 stem as 01; record 12 stems as 12). Count only the number of qualifying stems used to calculate DRC. Qualifying stems are those that are at least 1.0 foot in length and at least 1.0 inch in diameter, 1 foot up from the measurement point.

When collected: For tallied **woodland** species with at least one stem 1.0 in in diameter or larger; includes woodland species tallied on the microplot

Field width: 2 digits

Tolerance: No errors

MQO: At least 90% of the time

Values: 1 to 99

5.12 DIAMETER CHECK [**DCHE**]

Record this code to identify any irregularities in diameter measurement positions (e.g., abnormal swellings, diseases, damage, new measurement positions, etc.) that may affect use of this tree in diameter growth/change analyses.

When Collected: All live tally trees ≥ 1.0 in DBH/DRC and standing dead tally trees ≥ 5.0 in DBH/DRC

Field width: 1 digit

Tolerance: No errors

MQO: At least 99% of the time

Values:

- 0 Diameter measured accurately
- 1 Diameter estimated
- 2 Diameter measured at different location than previous measurement (remeasurement trees only)

Note: If both codes 1 and 2 apply, use code 2.

NRS Note (procedural change for former NE crews and code changes for both NC and NE):

In the former Northeast, the following variable TREE CLASS was a summation of other regional variables. The recording of TREE CLASS is now completed prior to collecting other regional variables and will determine which regional variables relating to sawtimber and poletimber require collection.

The TREE CLASS codes and definitions have also been revised from previous NC and NE regional guides. The previously used 2-digit coding system applied by NC is no longer valid. Other changes include the elimination of the short-log cull, the classification of down dead trees, and the requirement of assigning tree class to saplings. Also metal except for aluminum is now considered as rotten/missing cull.

5.12.1N TREE CLASS [TCC]

This code represents a classification of the overall quality of a tree that is ≥ 5.0 inches DBH. It classifies the quality of a live sawtimber tree based on the present condition. It also forecasts the potential quality of a live poletimber tree when it becomes sawtimber size. For standing dead trees, it will identify those trees that could be salvaged for wood fiber (i.e., chips) if a salvage operation was imminent.

Prior to assigning a tree class, it is necessary to determine sawlog length and the amount of board-foot cull present within the sawlog length. When evaluating the sawlog length for tree class, the sawlog length is measured between a 1 foot stump and a 9.0-in top DOB for hardwoods or a 7.0-in top DOB for softwoods. For trees that fork only use one stem when determining sawlog length (i.e., follow the stem yielding the most merchantable volume). See % ROUGH BOARD-FOOT CULL and % ROTTEN BOARD-FOOT CULL for the criterion that determines cull within the sawlog length.

When estimating the potential sawlog length for live poletimber size trees, apply the following "Two-inch Rule". Take the current DBH minus two-inches on a poletimber size tree. This diameter is used to determine the potential DOB of the future sawlog length when the tree becomes sawtimber-size. For example, a tree with an 8.0-in DBH today, applies a 6.0 top DOB on today's bole to project the potential sawlog length when the tree reaches sawtimber size. (The "Two-inch Rule" assumes that a tree's diameter increases uniformly along its bole.)

When Collected: All trees ≥ 5.0 in DBH/DRC when PRESENT TREE STATUS = 1 or PRESENT TREE STATUS = 2 and STANDING DEAD = 1

Field width: 1 digit

Tolerance: No errors

MQO: At least 90% of the time

Values:

- 2 Growing Stock – A live sawtimber-size tree with one-third or more of the gross board-foot volume in the entire sawlog length meeting grade, soundness, and size requirements; or the potential to do so for poletimber-size trees. It must contain one merchantable 12-foot log or two non-contiguous merchantable 8-foot logs, now (sawtimber) or prospectively (poletimber).
- 3 Rough Cull – A live tree that does not contain at least one 12-foot sawlog or two non-contiguous 8-foot logs now (sawtimber) or prospectively (poletimber), primarily because of roughness or poor form within the sawlog length. Or sawtimber and prospectively poletimber with two-thirds or more of its gross board-foot volume that does not meet size, soundness, and grade requirements; and 50% or more of the assigned total board-foot cull within the sawlog length is rough cull.
- 4 Rotten Cull – A live tree that does not contain at least one 12-foot sawlog or two non-contiguous 8-foot logs now (sawtimber) or prospectively (poletimber) and/or do not meet grade specifications for percent sound primarily because of rot within the sawlog length. Or sawtimber and prospectively poletimber with two-thirds or more of its gross board-foot volume that does not meet size, soundness, and grade requirements; and 50% or more of the assigned total board-foot cull within the sawlog length is rotten cull.
- 5 Salvable Dead – A standing dead tree with at least one-third merchantable sound volume. ROTTEN/MISSING CUBIC-FOOT CULL does not exceed 67%. Note: ROUGH CUBIC-FOOT CULL is not a criterion for determining salvable dead.
- 6 Nonsalvable Dead – A standing dead tree that does not qualify as salvable.

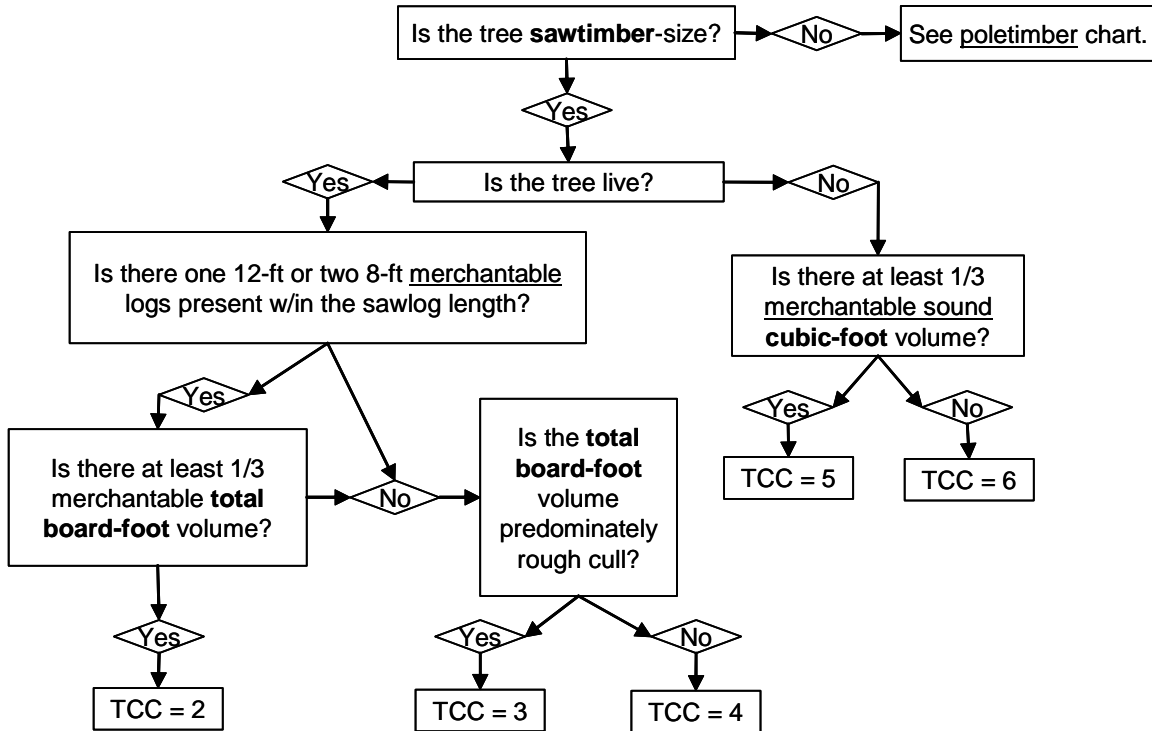

Figure 35.1N. TREE CLASS flowchart for sawtimber-size trees – ≥ 9.0 -in for softwoods or ≥ 11.0 -in DBH for hardwoods.

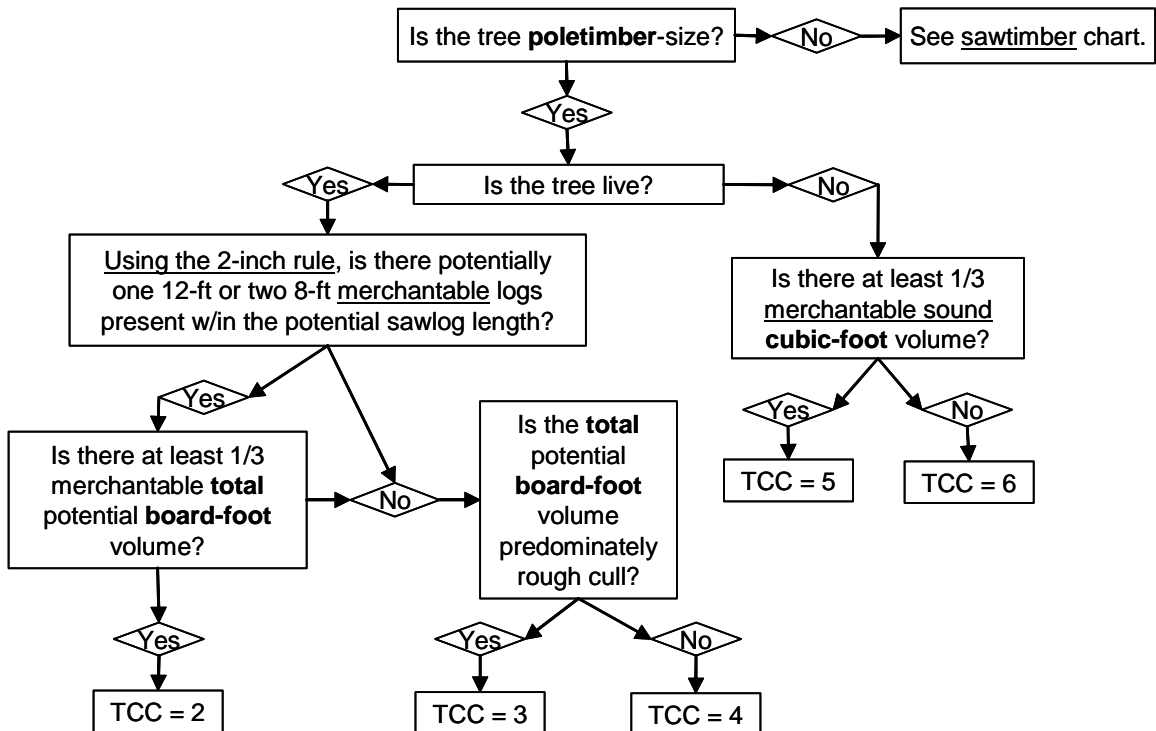

Figure 35.2N. TREE CLASS flowchart for poletimber-size trees – ≥ 5.0 -in DBH all trees.

Step 1: When determining TREE CLASS, the entire sawlog length (1 foot stump to a 9.0-in top DOB hardwoods or 7.0-in top DOB softwoods) must be visually divided into 8 foot or longer log lengths. The length of 8 foot or longer logs is determined by the presence of “stoppers” within the entire sawlog length. The following is a list of “stoppers” to be applied:

- Fork – A fork must be at least 1/3 the diameter of the main stem and branch out from the main stem at 45 degrees or less. For trees that fork only use one stem when determining the remaining sawlog length (i.e., follow the stem yielding the most merchantable volume).
- Excessive sweep or crook – To determine if the sweep or crook exceeds the maximum allowed; refer to the sweep or crook deduction tables in Regional Appendix E.
- Rot or missing wood – A cross-section that is 50% or more affected by rot or missing wood. All conks and fungal wedges are stoppers, except *Phellinus Tremulae* on aspen.
- Cankers – A canker that is at least 50% or more of the circumference at the point of occurrence. Note: One face or side represents 40% of the circumference. A canker is measured at the widest distance between the outside of the canker swelling.
- Metal – All metal except aluminum research tags and nails.

Note: “Rough stoppers” include forks, excessive sweep and crook as described above. “Rot stoppers” include rot/missing wood, cankers and metal as described above. Depending on the type of stopper, the board-foot cull associated below a stopper is either rough board-foot cull or rotten/missing board-foot cull.

Step 2: Assume that all live trees will reach sawtimber-size. Assume all poletimber-size trees will become sawtimber. Use the “two-inch rule” for poletimber-size trees to estimate the future top DOB for either a hardwood or a softwood. Do not attempt to predict mortality. The goal of the tree classification system is basically a check of the straightness and soundness of the sawlog length or the potential sawlog length for poletimber-size trees. A small diameter poletimber-size tree should be allowed more leeway due to the possibilities of growing out of deformities. Noncommercial species should be treated the same as commercial species.

Live Trees

- a. Start at a 1 ft stump and continue up the stem until the first stopper is encountered. Note: If the tree forks between 1 ft and 4.5 ft, start at the pith intersection (see Figure 22).
- b. Measure the distance between the starting point and the stopper.
- c. If the length is less than 8 ft, the entire length is either rough or rotten board-foot cull. If a rot stopper is encountered, the associated volume below the stopper is assessed as rotten/missing board-foot cull. If a rough stopper is encountered, the associated volume below the stopper is assessed as rough board-foot cull.
- d. If the length is 8 ft or more, the 8 ft or longer length must meet minimum grading specification for that species. If grading specifications are not met, the portion of the 8 ft or longer length that does not meet grade is assessed as board-foot cull. E.g., 20 ft is measured between a starting point and a stopper. The 20 ft length can be divided into an 8 ft and 12 ft logs. The 12 ft log meets grade and is not culled, but the 8 foot log does not meet grade and is culled. Note: It is very rare for a hardwood or pine not to meet

minimum grading requirements. However, "other softwoods" have a stricter grading requirement and often upper logs do not meet grade.

- e. The first stopper becomes the next starting point. Again measure up the tree until the next stopper is encountered. Continue this process until a 9.0 in top DOB for hardwoods or a 7.0 in top DOB for softwoods is reached.
- f. If one 12 ft or two noncontiguous 8 ft merchantable logs are not present, the tree is classified as either rough or rotten cull. If the majority of the total board-foot cull in the entire sawlog length is assessed as rough cull, TREE CLASS = 3. If the majority of total board-foot cull in the entire sawlog length is assessed as rotten/missing cull, TREE CLASS = 4.
- g. If one 12 ft or two noncontiguous 8 ft merchantable logs are present, the entire sawlog length is next assessed for total board-foot cull including any rot or missing wood that is assessed to be less than 50% at the cross-section (i.e., sector cull). If the tree has one-third or more merchantable volume (i.e., 67% or less total board-foot cull), TREE CLASS = 2. If total board-foot cull is greater than 67%, TREE CLASS = 3 or 4.

Standing Dead Trees

- a. If the tree is dead (sawtimber or poletimber), determine whether or not the ROTTEN/MISSING CUBIC-FOOT CULL in the entire bole length is greater than 67%. If yes, TREE CLASS = 6. If no, TREE CLASS = 5.

ROTT = 01 - 67%, TREE CLASS = 5.

ROTT = 68 - 99%, TREE CLASS = 6.

SEE TREE CLASS ILLUSTRATIONS IN REGIONAL APPENDIX F.

NRS Note (procedural change for former NE crews and code definition changes for both NC and NE): In the former Northeast, the following variable TREE GRADE was previously assigned to all live or dead sawtimber size trees. The recording of TREE GRADE is now limited to sawtimber trees classified as growing stock, TREE CLASS = 2.

The TREE GRADE tables have also been revised from previous NE and NC regional guides. Only a 12 ft grading section is now required in the butt 16 ft for all species to meet the minimum TREE GRADE of 1, 2, 3 or 4. Grade 5 now indicates a growing stock tree that has at least one merchantable upper 12 ft log or two merchantable noncontiguous 8 ft logs.

5.12.2N TREE GRADE [TRGD]

Record a tree grade for all sawtimber size trees classified as growing stock. At least a 12 foot grading section is required in the butt 16 feet for all species. Growing stock that does not have a merchantable grade in the butt section will be assigned grade 5.

When Collected: TREE CLASS = 2 when DBH \geq 9.0 in for softwoods or \geq 11.0 in DBH for hardwoods

Field width: 1 digit

Tolerance: No errors

MQO: At least 90% of the time

Values: See Regional Appendix E for complete grading specifications for each species group

Hardwoods – Use the specifications for Hardwood Tree Grades (1, 2 or 3) or the Tie and Timber Grade (4) for all hardwood trees. Grade 5 is recorded for a hardwood that does not have a 12-foot sawlog in the butt 16-foot grading section. Note: When determining the grade of upper logs, 8-foot sawlogs need to meet all the minimum grading factors except for length for hardwood tree grades 3 or 4.

Eastern white pine – Use the Eastern White Pine Tree Grades (1, 2, 3 or 4) for eastern white pine only. Grade 5 is recorded for a white pine that does not have a 12-foot sawlog in the butt 16-foot grading section. Note: When determining the grade of upper logs, 8-foot sawlogs need to meet all the minimum grading factors except for length for white pine tree grade 4.

Other pines – Use the Pine Tree Grades (1, 2 or 3) for all pines except eastern white pine. There is no grade 4 for the Pine Tree Grades. Grade 5 is recorded for a pine that does not have a 12-foot sawlog in the butt 16-foot grading section. Note: When determining the grade of upper logs, 8-foot sawlogs need to meet all the minimum grading factors except for length for pine tree grade 3.

Other softwoods– Use the Other Softwoods Tree Grade (1) for spruce, fir, hemlock, larch (tamarack), cedar and cypress. Grade 5 is recorded for a softwood that does not have a 12-foot sawlog in the butt 16-foot grading section. Note: When determining the grade of upper logs, 8-foot sawlogs need to meet all the minimum grading factors except for length for other softwood grade 1.

For tree grading purposes, determine the amount of cull in the 12, 14 or 16 foot graded section. Use this cull percentage only to assign a final tree grade. Do not record this amount of cull as the % ROUGH and/or ROTTEN BOARD-FOOT CULL for the entire tree. % ROUGH and/or ROTTEN BOARD-FOOT CULL is the cull assigned to the entire SAWLOG LENGTH and not the graded section.

The grading section is determined by the position of “stoppers” as defined in TREE CLASS within the butt 16 feet. E.g., if a stopper is positioned at 9 feet, then a 12 foot grading section cannot be obtained within the butt 16 feet. These trees are graded as 5.

Any section containing rot or metal stopper except aluminum DBH tags and nails is unsound cull. Rot does not necessarily render a grade 5 unless it is positioned so it is impossible to get a grading section that meets the minimum merchantable tree grade associated with the species. Metal does not necessarily render a grade 5 unless the metal is positioned so it is impossible to obtain a 12 foot section free of metal in the 16 foot grading section.

Note: Aluminum DBH tags and nails that have been placed for research are ignored and are not treated as cull and does not affect grade.

NRS Note (procedural change for former NE crews): In the former Northeast, the following variable SAWLOG LENGTH was assigned to all live or dead sawtimber size trees. The recording of SAWLOG LENGTH is now limited to sawtimber-size trees classified as growing stock or salvable dead, TREE CLASS = 2 or 5.

NE previously stopped a sawlog length prior to reaching a 9.0 in top DOB for hardwoods or 7.0 in top DOB for softwoods. These rules are no longer valid. All lengths now terminate at the minimum top DOB associated with that species regardless of merchantability. In addition for trees that fork, follow the fork that may yield the most merchantable volume. This may or may not be the largest diameter stem.

5.12.3N SAWLOG LENGTH [SAW]

Record sawlog length to the last whole foot of all sawtimber-sized trees that are TREE CLASS = 2 or 5. The measurement begins from a 1 foot stump to a minimum top sawlog diameter: 9.0 inch DOB (diameter outside bark) for hardwoods and 7.0 inch DOB for softwoods.

- For trees that fork only use one stem when determining sawlog length (i.e., follow the stem yielding the most merchantable volume).
- And/or to the point of the break on a broken stem. If the stem is broken but attached, record any additional length to the minimum top DOB for hardwoods or softwoods.

When Collected: NRS-EAST: All TREE CLASS 2 or 5 \geq 11.0 in DBH hardwoods or \geq 9.0 in DBH softwoods

Field Width: 2 digits

Tolerance: +/- 4 feet for trees \leq 40 feet, or +/- 10% of true length for trees > 40 feet

MQO: At least 90% of the time

Values: 12 to 99

NRS Note (procedural change for former NE crews): In the former Northeast, the following variables relating to board-foot cull were assigned to all live or dead sawtimber size trees. The recording of board-foot cull is now limited to sawtimber trees classified as growing stock or salvable dead, TREE CLASS = 2 or 5. In addition, board-foot cull will now be coded as percent rough and/or rotten. The former board-foot soundness variable is no longer being utilized.

5.12.4N % ROUGH BOARD-FOOT CULL [BRGH]

Rough board-foot cull is the volume within the recorded SAWLOG LENGTH that cannot be used to produce boards, because of forks, sweep, crook, large limbs and other sound defects. The total board-foot cull also includes the entire volume of sections that do not meet the minimum size, length and grade requirements. Estimate the percent rough cull volume by using the appropriate board-foot volume cull estimating aid table for either hardwoods or softwoods found in Regional Appendix E. Record the actual percentage of rough board-foot cull.

To determine the amount of rough board-foot cull, it is necessary to visually divide the recorded SAWLOG LENGTH into sections that are 8 feet or longer. The amount of rough cull to be recorded is the total volume of the sawlog length that does not qualify as logs. These are:

- Fork – A fork must be at least 1/3 the diameter of the main stem and branch out from the main stem at 45 degrees or less.
- 1/3 diameter limb – A limb 1/3 or more of the main stem diameter at the point of occurrence. Or all limbs \geq 2 inches within a 1 foot section that when totaled equals 1/3 or more of the diameter of the bole.
- Excessive sweep or crook – To determine if the sweep or crook exceeds the maximum allowed; refer to the sweep or crook deduction tables in Regional Appendix E.
- Sections less than 8 feet in length below a rough “stopper.”
- Sections 8 feet in length or longer that do not meet minimum grading specifications.

Logs in the upper portion of the tree, determining the grade is difficult. For hardwoods, simply make sure the log appears to meet the requirements for a grade 4 (no internal rot). If it is clear that an upper log has internal rot, then it must be examined further to determine if it can at least meet the requirements for a grade 3. For white pines, simply make sure the upper logs meet the requirements for grade 4. For other pines, simply make sure the upper logs meet the

requirements for a grade 3. And for the other softwoods, the upper logs must meet the requirements for grade 1. If any of the upper logs do not meet the minimum grade requirements, then this portion of the tree is cull.

Note: Grade requirements for the upper logs are based on log grades and not tree grades. Log grades allow for the scaling diameter (diameter inside bark) to be 8 inches for hardwoods and 6 inches for softwoods. A minimum allowable length is 8 feet. Since log grade rules are no longer instructed in the north, tree grade specifications are applied except for the scaling diameter and minimum lengths.

When Collected: NRS-EAST: All TREE CLASS 2 or 5 \geq 11.0 in DBH hardwoods or \geq 9.0 in DBH softwoods
Field Width: 2 digits
Tolerance: +/- 10%
MQO: At least 90% of the time
Values: 00 to 67

5.12.5N % ROTTEN/MISSING BOARD-FOOT CULL [BROT]

Rotten and missing board-foot cull is the volume with the recorded SAWLOG LENGTH that cannot be used to produce boards, because of rot and other unsound defects within sawlogs. ("Missing" is wood absent from a log or part of a log that otherwise would usually be regarded as naturally complete. It may be caused by advanced decay, fire, or the operation of a machine or tool. It also includes sections that contain metal other than aluminum research tags and nails.) Cull is determined by visual evidence on the tree and not by sounding. Record the actual percentage of rotten board-foot cull.

Rotten and missing board-foot cull includes sections that contain rot or missing wood as determined by sector cull. Estimate percent rotten cull volume by using the appropriate board-foot volume cull estimating aid tables for hardwoods or softwoods found in Regional Appendix E.

- Rot or missing wood (including conks and fungal wedges) – any presence.
- Cankers – any degree of severity.
- Metal (except aluminum research nails and tags) – Cull at least a 1 foot cross-section above and below the metal at the point of occurrence.
- Lengths less than 8 feet below a "rot stopper" as described in TREE CLASS.

When Collected: NRS-EAST: All TREE CLASS 2 or 5 \geq 11.0 in DBH hardwoods or \geq 9.0 in DBH softwoods
Field Width: 2 digits
Tolerance: +/- 10%
MQO: At least 90% of the time
Values: 00 to 67

NRS Note: % ROUGH BF CULL + % ROTTEN/MISSING BF CULL cannot be greater than 67%. If the actual amount of the combined board-foot cull is greater than 67%, then TREE CLASS is not 2 or 5; and board-foot cull is not required.

NRS Note (procedural change for former NE crews): NE previously stopped a bole length prior to reaching a 4.0 in top DOB for all species. These rules are no longer valid. All lengths now terminate at the minimum top DOB of 4.0 inches regardless of merchantability. In addition for trees that fork, follow the fork that may yield the most merchantable volume. This may or may not be the largest diameter stem.

5.12.6N BOLE LENGTH [BOLE]

Record a bole length to the last whole foot of all live and standing dead trees. The measurement begins from a 1 foot stump to a minimum top bole diameter of 4.0 inches DOB for both hardwoods and softwoods.

- For trees that fork only use one stem when determining bole length (i.e., follow the stem yielding the most merchantable volume).
- And/or to the point of the break on a broken stem. If the stem is broken but attached, record any additional length to the minimum 4.0 in top DOB.

When Collected: NRS-EAST: All live trees ≥ 5.0 in DBH and all standing dead tally trees ≥ 5.0 in DBH when TREE CLASS 5

Field Width: 2 digits

Tolerance: +/- 4 feet for trees ≤ 40 feet, or +/- 10% of true length for trees > 40 feet

MQO: At least 90% of the time

Values: 04 to 99

NRS Note (procedural change for former NE crews): In the former Northeast, the following variables relating to cubic-foot cull will now be coded as percent rough and rotten. The former cubic-foot soundness variable is no longer being utilized.

5.25 % ROUGH CUBIC-FOOT CULL (CORE OPTIONAL) [CRGH]

NRS Note: The variable number is correct as it relates to the national field guide.

For each live tally tree 5.0 inches DBH/DRC and larger, record the total percentage of cubic-foot volume that is cull due to sound dead material or tree form. Record to the nearest 1 percent. When estimating volume loss (tree cull), only consider the cull on the merchantable bole/portion of the tree, from a 1-foot stump to a 4-inch top (i.e., REGIONAL BOLE LENGTH) using the appropriate cubic-foot volume cull aid found in Regional Appendix E

For western woodland species, the merchantable portion is between the point of DRC measurement to a 1.5-inch DOB top, and rough cull includes only sound dead.

Refer to local defect guidelines as an aid in determining cull volume for various damages such as crook, fork, sweep, pistol butt, etc. ~~Small trees (5-9 inches for softwoods and 5-11 inches for hardwoods) that have poor form and are not expected to ever produce merchantable material should be coded 99% rough cull.~~ NRS assesses the amount of actual cull present.

Starting at a 1 foot stump, visually divide the bole length into 4 foot or longer sections. The amount of rough cull to be recorded is the total volume of the bole length that that does not qualify as potential cubic-foot volume. These are sections containing:

- Fork – A fork must be at least 1/3 the diameter of the main stem and branch out from the main stem at 45 degrees or less.
- 1/3 diameter limb – A limb 1/3 or more of the main stem diameter at the point of occurrence. Or all limbs ≥ 2 inches within a 1 foot section that when totaled equal 1/3 or more of the diameter of the bole.
- Excessive sweep and crook – Sweep and crook is usually not a factor in 4 ft lengths
- Sections less than 4 feet in length below a “rough stopper” as described by TREE CLASS.

When Collected: CORE OPTIONAL: All live tally trees ≥ 5.0 in DBH/DRC; NRS-EAST: All live trees ≥ 5.0 in DBH and all standing dead tally trees ≥ 5.0 in DBH when TREE CLASS 5

Field width: 2 digits

Tolerance: +/- 10%

MQO: At least 90% of the time

Values: 00 to 99

5.13 % ROTTEN/MISSING CUBIC-FOOT CULL [ROTT]

Record the percent rotten or missing cubic-foot cull for all live tally trees greater than or equal to 5.0 inches DBH/DRC (CORE) and all standing dead tally trees greater than or equal to 5.0 inches DBH/DRC (CORE OPTIONAL).

Record the percentage of rotten and missing cubic-foot volume, to the nearest 1 percent.

("Missing" is wood absent from a log or part of a log that otherwise would usually be regarded as naturally complete. It may be caused by advanced decay, fire, or the operation of a machine or tool. It also includes sections that contain metal other than aluminum research tags and nails.)

When estimating volume loss (tree cull), only consider the cull on the merchantable bole/portion of the tree, from a 1-foot stump to a 4-inch top (i.e., REGIONAL BOLE LENGTH). Do not include any cull estimate above ACTUAL LENGTH. For western woodland species, the merchantable portion is between the point of DRC measurement to a 1.5-inch DOB top.

NRS Note: Rotten and missing cubic-foot cull includes sections that contain rot or missing wood or as determined by sector cull. Estimate percent rotten cull volume by using the appropriate cubic-foot volume cull estimating aid tables for all species found in Regional Appendix E.

Rotten and missing volume loss is often difficult to estimate. Refer to supplemental disease and insect pests field guides and local defect guidelines as an aid in identifying damaging agents and their impact on volume loss. Use your best judgment and be alert to such defect indicators as the following:

- Cankers or fruiting bodies – any presence.
- Swollen or punky knots.
- Dull, hollow sound of bole (use regional standards).
- Large dead limbs, especially those with frayed ends.
- Sawdust around the base of the tree.
- Metal (except aluminum research nails and tags) – Cull at least a 1 foot cross-section above and below the metal at the point of occurrence.
- If live, sections less than 4 feet in length below a "rot stopper" as described by TREE CLASS

When Collected: CORE (NRS-WEST): All live tally trees ≥ 5.0 in DBH/DRC; CORE OPTIONAL: All live and standing dead tally trees ≥ 5.0 in DBH/DRC; NRS-EAST: All live tally trees ≥ 5.0 in DBH and all standing dead trees ≥ 5.0 in DBH when TREE CLASS = 5

Field width: 2 digits

Tolerance: +/- 10 %

MQO: At least 90% of the time

Values: 00 to 99

NRS Note: % CF ROUGH CULL + % CF ROTTEN/MISSING CULL cannot exceed 100%.

5.14 TOTAL LENGTH [THGT]

Record the TOTAL LENGTH of the tree, to the nearest 1.0 foot from ground level to the top of the tree. For trees growing on a slope, measure length on the uphill side of the tree. If the tree has a missing top (top is broken and completely detached from the tree), estimate what the total length

would be if there were no missing top. Forked trees should be treated the same as unforked trees.

When Collected: Phase 2 CORE - All live tally trees ≥ 5.0 in DBH/DRC; Phase 2 CORE OPTIONAL - All live tally trees ≥ 1.0 in DBH/DRC and all standing dead tally trees ≥ 5.0 in DBH/DRC; Phase 3 CORE - All live tally trees ≥ 1.0 in DBH/DRC

Field width: 3 digits

Tolerance: +/- 10 % of true length

MQO: At least 90% of the time

Values: 005 to 400

5.15 ACTUAL LENGTH [ACTU]

For trees with missing tops (top on live trees is completely detached; top on dead trees is greater than 50 percent detached from the tree). If the break is along the stem length, the actual length terminates where there is 50% of the stem remaining. If the top is intact including dead tops on live trees, this item may be omitted. Record the ACTUAL LENGTH of the tree to the nearest 1.0 foot from ground level to the break. Use the length to the break for ACTUAL LENGTH until a new leader qualifies as the new top for TOTAL LENGTH; until that occurs; continue to record ACTUAL LENGTH to the break. Trees with previously broken tops are considered recovered (i.e., ACTUAL LENGTH = TOTAL LENGTH) when a new leader (dead or alive) is 1/3 the diameter of the broken top at the point where the top was broken (not where the new leader originates from the trunk). Forked trees should be treated the same as unforked trees.

When Collected: Phase 2 CORE - All live and standing dead tally trees (with broken or missing tops) ≥ 5.0 in DBH/DRC; Phase 2 CORE OPTIONAL - All live tally trees (with broken or missing tops) 1.0 – 4.9 in DBH/DRC; Phase 3 CORE - All live tally trees (with broken or missing tops) ≥ 1.0 in DBH/DRC; NRS-ME – See Regional Appendix D

Field width: 3 digits

Tolerance: +/- 10 % of true length

MQO: At least 90% of the time

Values: 005 to 400

5.16 LENGTH METHOD [METH]

Record the code that indicates the method used to determine tree lengths.

When Collected: Phase 2 CORE - All live tally trees ≥ 5.0 in DBH/DRC; Phase 2 CORE OPTIONAL - All live tally trees ≥ 1.0 in DBH/DRC and all standing dead tally trees ≥ 5.0 in DBH/DRC; Phase 3 CORE - All live tally trees ≥ 1.0 in DBH/DRC; NRS-ME – See Regional Appendix D

Field width: 1 digit

Tolerance: No errors

MQO: At least 99% of the time

Values:

- | | |
|---|--|
| 1 | Total and actual lengths are field measured with a measurement instrument (e.g., clinometer, relascope, tape, laser) |
| 2 | Total length is visually estimated, actual length is measured with an instrument |
| 3 | Total and actual lengths are visually estimated |

5.17 CROWN CLASS [CCC]

Rate tree crowns in relation to the sunlight received and proximity to neighboring trees (Figure 36). Base the assessment on the position of the crown at the time of observation. Example: a formerly overtopped tree which is now dominant due to tree removal is classified as dominant.

When Collected: All live tally trees ≥ 1.0 in DBH/DRC

Field width: 1 digit

Tolerance: No errors

MQO: At least 85% of the time

Values:

- 1 Open Grown – trees with crowns that received full light from above and from all sides throughout most of its life, particularly during its early developmental period.
- 2 Dominant – trees with crown extending above the general level of the crown canopy and receiving full light from above and partly from the sides. These trees are taller than the average trees in the stand and their crowns are well developed, but they could be somewhat crowded on the sides. Also, trees whose crowns have received full light from above and from all sides during early development and most of their life. Their crown form or shape appears to be free of influence from neighboring trees.
- 3 Co-dominant – trees with crowns at the general level of the crown canopy. Crowns receive full light from above but little direct sunlight penetrates their sides. Usually they have medium-sized crowns and are somewhat crowded from the sides. In stagnated stands, co-dominant trees have small-sized crowns and are crowded on the sides.
- 4 Intermediate – trees that are shorter than dominants and co-dominant, but their crowns extend into the canopy of co-dominant and dominant trees. They receive little direct light from above and none from the sides. As a result, intermediate trees usually have small crowns and are very crowded from the sides.
- 5 Overtopped – trees with crowns entirely below the general level of the crown canopy that receive no direct sunlight either from above or the sides.

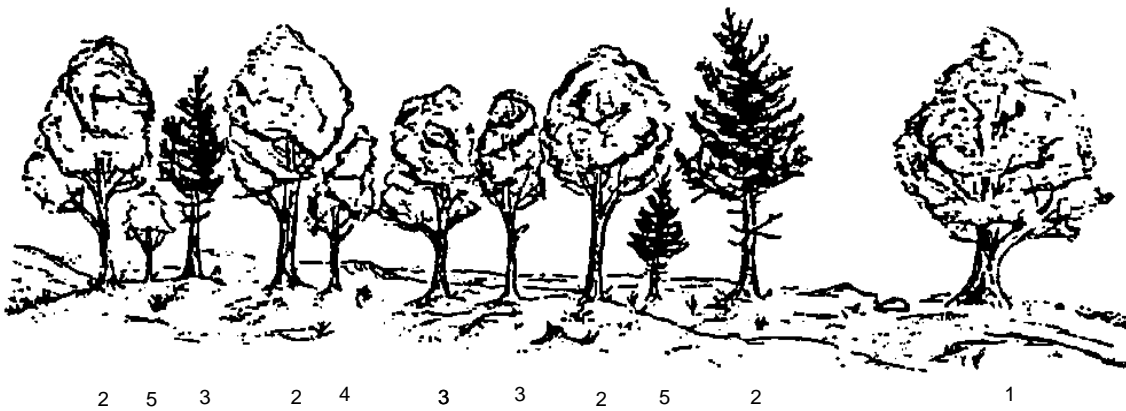

Figure 36. Examples of CROWN CLASS code definitions (numbers are the CROWN CLASS codes).

5.18 UNCOMPACTED LIVE CROWN RATIO (P2 – CORE OPTIONAL / P3 – CORE)
 Variable not collected for PHASE 2 in the North. See VOLUME II: FIELD DATA COLLECTION PROCEDURES FOR PHASE 3 INDICATORS – 12.0 CROWNS: MEASUREMENTS AND SAMPLING

5.19 COMPACTED CROWN RATIO [CRC]

Record the COMPACTED CROWN RATIO for each live tally tree, 1.0 inch and larger, to the nearest one percent. COMPACTED CROWN RATIO is that portion of the tree supporting live foliage (or in the case of extreme defoliation should be supporting live foliage) and is expressed as a percentage of the actual tree length. To determine COMPACTED CROWN RATIO, ocularly transfer lower live branches to fill in large holes in the upper portion of the tree until a full, even crown is visualized.

Do not over-compact trees beyond their typical full crown situation. For example, if tree branches tend to average 2 feet between whorls, do not compact crowns any tighter than the 2-foot spacing (Figure 39). Figure 40 shows an example of COMPACTED CROWN RATIO on a leaning tree.

Open-crown conifer (e.g., ponderosa pine or white pine) –

Uncompacted:

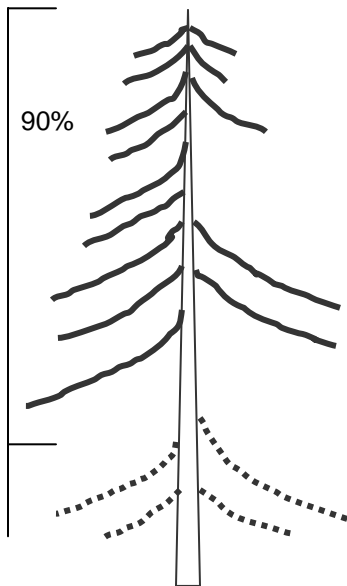

Compacted:

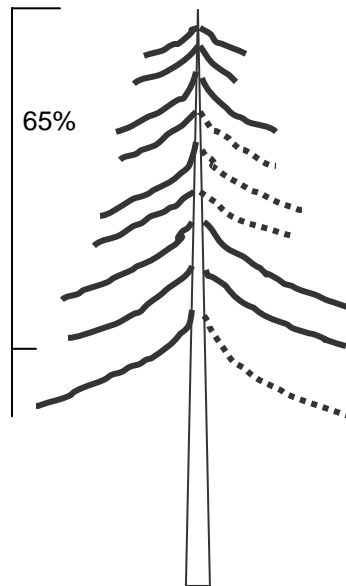
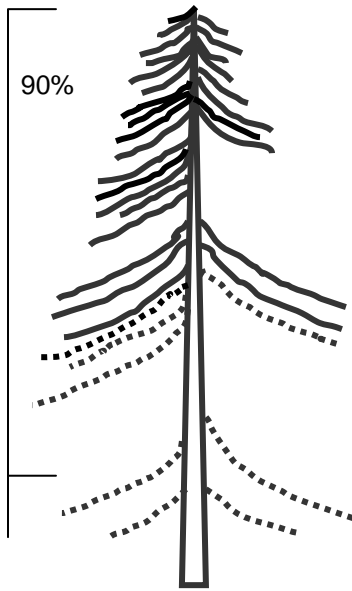

Figure 39a. Examples of and comparison between COMPACTED CROWN RATIO and UNCOMPACTED LIVE CROWN RATIO of open-crown conifers.

Dense-crown conifer (e.g., subalpine fir or balsam fir) –

Uncompacted:



Compacted:

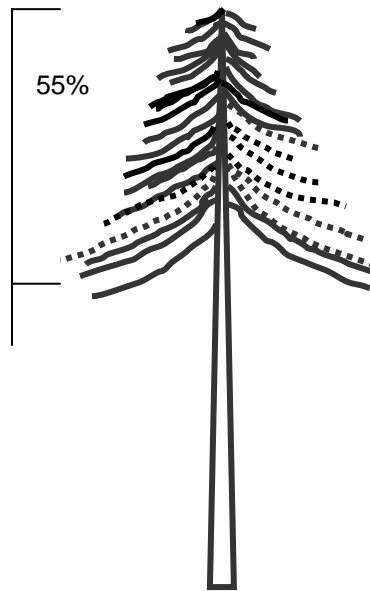

Figure 39b. Examples of and comparison between COMPACTED CROWN RATIO and UNCOMPACTED LIVE CROWN RATIO of dense-crown conifers.

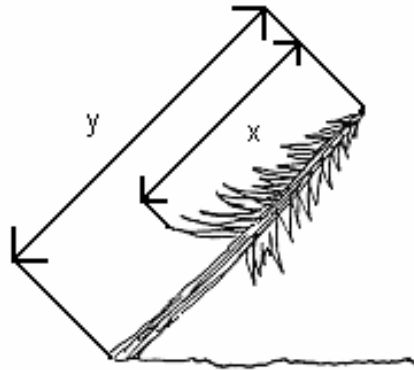
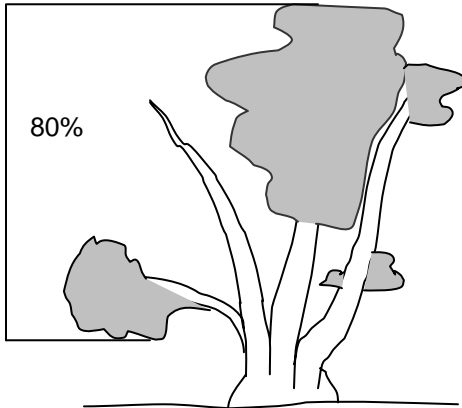

Figure 40. COMPACTED CROWN RATIO on a leaning tree.
CROWN RATIO = (x/y)100.

For multi-stemmed western woodland species, ocularly transfer lower live foliage to fill large holes on all stems and form an even crown across the tree (Figure 41).

When Collected: All live tally trees ≥ 1.0 in DBH/DRC
Field width: 2 digits
Tolerance: +/- 10 %
MQO: At least 80% of the time
Values: 00 to 99

Uncompacted:



Uncompacted:

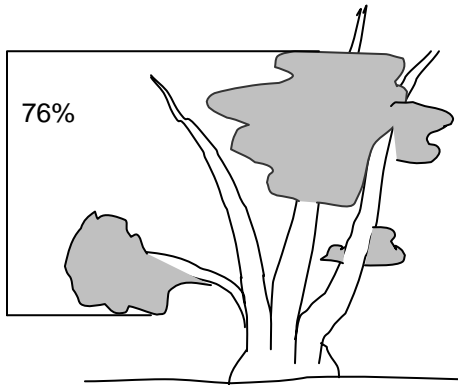

Uncompacted:

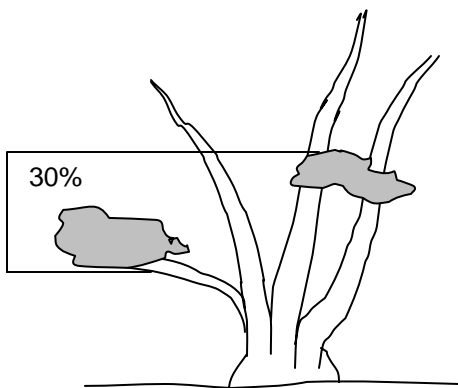

Compacted:

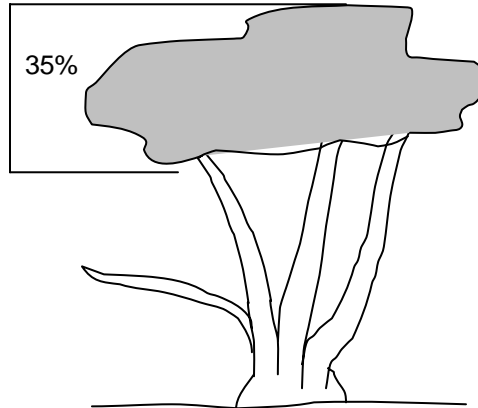

Compacted:

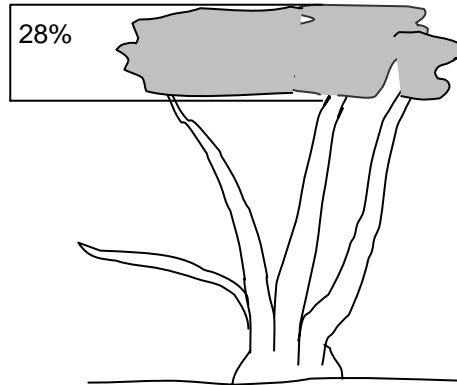

Compacted:

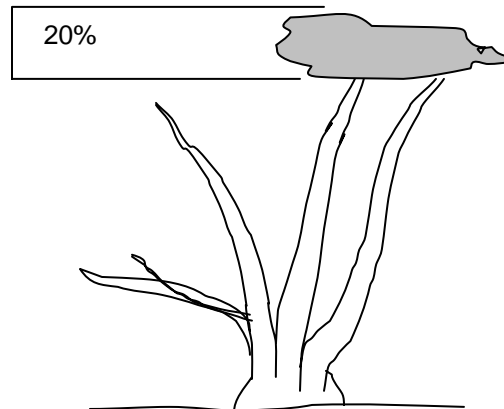

Figure 41. Examples of and comparison between COMPACTED CROWN RATIO and UNCOMPACTED LIVE CROWN RATIO of western woodland species.

5.20 Tree Damage

The CORE OPTIONAL National "Tree Damage" variables will not be collected in the North.

5.20.1 DAMAGE LOCATION 1 (CORE OPTIONAL)

5.20.2 DAMAGE TYPE 1 (CORE OPTIONAL)

5.20.3 DAMAGE SEVERITY 1 (CORE OPTIONAL)

5.20.4 DAMAGE LOCATION 2 (CORE OPTIONAL)

5.20.5 DAMAGE TYPE 2 (CORE OPTIONAL)

5.20.6 DAMAGE SEVERITY 2 (CORE OPTIONAL)

NRS Note (coding change for former NC crews): The damage agent codes for weather and fire have been changed from the previously listed codes in NCFG v3.0. These two codes now correlate to the national CAUSE OF DEATH coding scheme.

5.20.7N DAMAGE AGENTS STANDARD [1DAM, 2DAM]

From the list provided record up to two damage agents observed on a tree. These damages may indicate either serious damage or merely a presence of an agent. If more than two damage agents are observed, base decisions on the relative abundance of the agent. Record the generic damage code (shown in bold) unless a more specific agent is listed. Note: Not all damage agents are listed for the region.

When Collected: All live trees ≥ 5.0 in DBH/DRC

Field width: 3 digits

Tolerance: No errors

MQO: At least 80% of the time

Values:

<u>CODE</u>	<u>DAMAGE</u>	<u>HOST SPECIES</u>	<u>SEVERITY</u>
000	Healthy (no damage)	All	
100	Insect defoliators	All	> 20% affected
113	Gypsy moth	Hardwood	Any occurrence
130	Shoot and branch insects	All	Any occurrence on leader; > 20% branches affected
140	Branch gall insects	All	> 20% affected
150	Bole borers	All	Any occurrence on bole
170	Bark beetles	Conifer	> 20% crown dead/dying
190	Root / root collar insects	Conifer	Entire crown off-color/dead
200	Foliage disease	All	> 20% affected
210	Shoot blights	All	Any occurrence on leader; > 20% shoots affected
220	Mistletoe	0071, 0094, 0095, 0105	Any occurrence
240	Bole rusts	Pine	Any occurrence on bole
250	Bole cankers	Hardwood	Any occurrence on bole
251	<i>Eutypella</i> canker	Maple	Any occurrence on bole
252	<i>Hypoxylon</i> canker	0743, 0746	Any occurrence on bole
254	<i>Nectria</i> canker	Hardwood	Any occurrence on bole
257	Butternut canker	0601	Any occurrence on bole
260	Stem decay (heart rot)	All	Any occurrence on bole
271	Ash yellows	Ash	Any occurrence

<u>CODE</u>	<u>DAMAGE</u>	<u>HOST SPECIES</u>	<u>SEVERITY</u>
281	Dutch elm disease	Elm	Any occurrence
282	Oak wilt	Oak	Any occurrence
290	Root / butt rot	All	Any occurrence
291	<i>Annosus</i> root rot	Conifer	Any occurrence
292	<i>Armillaria</i> root rot	All	> 20% dieback
300	Fire	All	> 20% crown affected; any to leader; any to bole cambium
400	Animal damage	All	> 20% crown affected; any to leader; any to bole cambium
500	Weather	All	> 20% crown affected; any to leader; any to bole cambium
800	Logging / TSI / Other human	All	> 20% crown affected; any to leader; any to bole cambium
860	Chemical	All	> 20% crown affected

[Correction 10/05/2006.]

5.21 CAUSE OF DEATH [CAUS]

Record a cause of death (COD) for all trees that have died or been cut since the previous survey. If cause of death cannot be reliably estimated, record unknown/not sure/other.

NRS Note: A remeasure tree that has died and is now in a nonforest condition is assigned the appropriate COD. For example, a tree that was previously live in accessible forest land and died due to disease in a residential area is coded as 20.

NRS (East) Note: CAUSE OF DEATH is applicable on all previously tallied trees if SK = 5-P3 (all subplots and microplots) or 5 (all subplots). If SK = 6, then subplot 1 only.

When Collected: CORE: SAMPLE KIND = 2, 5 or 6 plots: all PREVIOUS TREE STATUS = 1 and PRESENT TREE STATUS = 2 or 3; or PRESENT TREE STATUS = 2 and RECONCILE = 1, 2, or 3; CORE OPTIONAL: SAMPLE KIND = 1 plots; all MORTALITY = 1

Field width: 2 digits

Tolerance: No errors

MQO: At least 80% of the time

Values:

- 10 Insect
- 20 Disease
- 30 Fire
- 40 Animal
- 50 Weather
- 60 Vegetation (suppression, competition, vines/kudzu)
- 70 Unknown/not sure/other - includes death from human activity not related to silvicultural or landclearing activity (accidental, random, etc.). TREE NOTES required.
- 80 Silvicultural or landclearing activity (death caused by harvesting or other silvicultural activity, including girdling, chaining, etc., or to landclearing activity)

5.22 MORTALITY YEAR (CORE OPTIONAL)

This variable is not collected in the North.

5.23 DECAY CLASS [DECA]

Record for each standing dead tally tree, 5.0 inches in diameter and larger, the code indicating the tree's stage of decay.

When Collected: All standing dead tally trees \geq 5.0 in DBH/DRC

Field width: 1 digit
 Tolerance: +/- 1 class
 MQO: At least 90% of the time
 Values: Use the following table for guidelines:

Decay class stage (code)	Limbs and branches	Top	% Bark Remaining	Sapwood presence and condition*	Heartwood condition*
1	All present	Pointed	100	Intact; sound, incipient decay, hard, original color	Sound, hard, original color
2	Few limbs, no fine branches	May be broken	Variable	Sloughing; advanced decay, fibrous, firm to soft, light brown	Sound at base, incipient decay in outer edge of upper bole, hard, light to reddish brown
3	Limb stubs only	Broken	Variable	Sloughing; fibrous, soft, light to reddish brown	Incipient decay at base, advanced decay throughout upper bole, fibrous, hard to firm, reddish brown
4	Few or no stubs	Broken	Variable	Sloughing; cubical, soft, reddish to dark brown	Advanced decay at base, sloughing from upper bole, fibrous to cubical, soft, dark reddish brown
5	None	Broken	Less than 20	Gone	Sloughing, cubical, soft, dark brown, OR fibrous, very soft, dark reddish brown, encased in hardened shell

*Characteristics are for Douglas-fir. Dead trees of other species may vary somewhat. Use this only as a guide.

5.24 LENGTH TO DIAMETER MEASUREMENT POINT (CORE OPTIONAL) [DIAH]

Record this item when tree diameter measurement locations are not monumented. For those trees measured directly at 4.5 feet above the ground, leave this item blank. If the diameter is not measured at 4.5 feet, record the actual length from the ground, to the nearest 0.1 foot, at which the diameter was measured for each tally tree, 1.0 inch DBH and larger. Leave this item blank for western woodland species measured for diameter at root collar.

When Collected: CORE OPTIONAL: All live and dead tally trees (except western woodland species) ≥ 1.0 in DBH

Field width: 3 digits

Tolerance: +/- 0.2 ft

MQO: At least 90% of the time

Values: 00.1 – 15.0

5.26 MISTLETOE CLASS (CORE OPTIONAL)

This variable is not applicable in the North.

5.27 TREE NOTES

Record notes pertaining to an individual tree as called for to explain or describe another variable.

NRS PDR Note: The regional *FIA PDR Application* allows for the entry of a tree note. Up to 80 characters can be entered per tree.

When collected: All trees

Field width: Alphanumeric character field

Tolerance: N/A

MQO: N/A

Values: English language words, phrases and numbers

5.28N-MN BALSAM FIR BOUGHS

See Regional Appendix D for state and/or species specific variable data collection procedures and codes.

5.28.1N-MN BOUGHS AVAILABLE [BAVA]

5.28.2N-MN BOUGHS HARVESTED [BHAR]

[Correction 10/05/2006.]

5.28.3N-MN BOUGHS HARVESTING GUIDELINES [GUID]

5.29N-ME MAINE'S 5TH MICROPLOT SAPLING DATA

See Regional Appendix D for state and/or species specific variable data collection procedures and codes.

5.30N-OH OHIO SK8 "PRISM" POINT TREE DATA

See Regional Appendix D for state and/or species specific variable data collection procedures and codes.

5.31N FOREST TO NONFOREST VARIABLES

Tree and/or saplings previously tallied on accessible forest land and are now located in a nonforest condition require the following variables.

<u>Number</u>	<u>Data Element Name</u>	<u>PDR Prompt</u>
5.2	TREE RECORD NUMBER	TR#
5.3	CONDITION CLASS NUMBER	CON#
5.4	AZIMUTH	AZM
5.5	HORIZONTAL DISTANCE	DIST
5.6	PREVIOUS TREE STATUS	PAST
5.7	PRESENT TREE STATUS	STAT
5.7.1	RECONCILE	RECO
5.7.2	STANDING DEAD	DEAD
5.8	SPECIES	SPP
5.21	CAUSE OF DEATH	CAUS

Note: A RECONCILE code is required if PRESENT TREE STATUS = 0. A STANDING DEAD code is required if PRESENT TREE STATUS = 2.

Ingrowth trees are not tallied. Missed trees from the last cycle are not to be reconciled, since the collection of this data is subjective due to the condition change. Erroneously tallied trees from the last cycle can be reconciled if it is determined that a cruiser error or a procedural change has taken place since the last cycle.

NRS PDR Note: To prevent trees from mistakenly being coded on a non-forest condition, each tree will receive the following critical PDR message: "You have a tree on a non-forest condition. This is only valid if condition went from forest to non-forest."

When collected: All trees when previous CONDITION CLASS STATUS = 1 and current CONDITION CLASS STATUS = 2, 3, 4 or 5

6.0 SEEDLING DATA

Stocking and regeneration information are obtained by counting live seedlings within the 6.8-foot radius microplot located 90 degrees and 12.0 feet from each subplot center within each of the four subplots. Conifer seedlings must be at least 6.0 inches in length and less than 1.0 inch at DBH/DRC in order to qualify for tallying. Hardwood seedlings must be at least 12.0 inches in length and less than 1.0 inch at DBH/DRC in order to qualify for tallying. For western woodland species, each stem on a single tree must be less than 1.0 inch in DRC. Seedlings are counted in groups by species and condition class, up to five individuals per species. Counts beyond five estimated. Only count seedlings occurring in accessible forest land condition classes.

NRS Note: A seedling is measured to the tip of the terminal bud. If the minimum length requirement is met for either a hardwood or softwood, the seedling is tallied.

6.1 SUBPLOT NUMBER

Use the procedures outlined in Section 3.1.

When Collected: All counts of seedlings

6.2 SPECIES [SPP]

Use the procedures outlined in Section 5.8.

When Collected: All counts of seedlings

Field width: 4 digits

Tolerance: No errors for genus, no errors for species

MQO: At least 90% of the time for genus, at least 85% of the time for species

Values: See Appendix 3

6.3 CONDITION CLASS NUMBER [CON#]

Use the procedures outlined in Section 2.0.

When Collected: All counts of seedlings

6.4 SEEDLING COUNT [SED#]

On each microplot, record the number of live tally tree seedlings, by species and condition class. Count up to five individuals by species: estimate the total count if there are more than five individuals of any given species in any given condition class. When seedlings are distributed evenly on a microplot, a suggested method of estimating is to count the number of seedlings on one quarter of the microplot and multiply by four (given that there is only one condition class on the microplot). Repeat for each species. Conifer seedlings must be at least 6.0 inches in length and less than 1.0 inch at DBH to qualify for counting. Hardwood seedlings must be at least 12.0 inches in length and less than 1.0 inch at DBH in order to qualify for counting.

For western woodland species, each stem on a single tree must be less than 1.0 inch at DRC.

NRS (West) Note: This applies to Rocky Mountain juniper (0066) in the states of KS, NE, ND and SD.

Multiple "suckers" that originate from the same location, and stump sprouts are considered one seedling. Do not tally or count "layers" (undetached branches partially or completely covered by soil, usually at the base) as seedlings. Do not tally any seedlings that sprout from a live tally tree.

NRS Note: If snow amounts are excessive on the microplot, the seedling tally is restricted to seedlings visible above the snow. Do not excavate snow from the microplot to achieve a better measurement. This practice may compromise the integrity of the microplot by exposing seedlings and other vegetation to animal browsing; and by exposing seedlings to extreme temperatures that may lead to mortality.

When Collected: Each accessible forest land condition class on each microplot
Field width: 3 digits
Tolerance: No errors for 5 or less per species; +/- 20% over a count of 5
MQO: At least 90% of the time
Values: 001 through 999

6.5N-ME SHRUB AND VINE DATA FOR THE MAINE INVENTORY

See Regional Appendix D for state and/or species specific variable data collection procedures and codes.

6.5.1N-ME SUBPLOT NUMBER

6.5.2N-ME SHRUB AND VINE SPECIES [SPP]

6.5.3N-ME CONDITION CLASS NUMBER [CON#]

6.5.4N-ME SHRUB COUNT [SHRU]

7.0 SITE TREE INFORMATION

Site trees are a measure of site productivity expressed by the height to age relationship of dominant and co-dominant trees. If suitable site trees are available, site tree data are required for every accessible forest land condition class defined on a plot. An individual site tree may be used for more than one condition class where differences in condition classes are not the result of differences in site productivity. For example, when different condition classes are caused solely due to differences in reserved status, owner class, and/or disturbance-related differences in density (e.g., heavily thinned vs. unthinned), a site tree may be used for more than one condition class. When in doubt, do not use a site tree for more than one condition class.

7.1 SITE TREE SELECTION

Select at least one site tree for each accessible forest land condition class where no previous site tree data exist. The absence of site tree data may occur because:

- This is the first visit to the site
- On the previous visit no suitable site tree could be found for the condition
- On the previous visit the selected site tree(s) did not yield suitable site information.
- Since the last visit there has been a change in condition class that renders the previous data incompatible with the current conditions

NRS PDR Note: On a remeasurement plot, site index data collected on the last occasion will be downloaded to the PDR. The data must be reviewed. If the site index data are no longer valid (i.e., does not meet current site tree selection criteria or is no longer suitable for the condition), the data are deleted and new site index data are required. If no data are downloaded, site index data are required for the forested condition. All new plots with accessible forest land or plots that have changed from nonforest to forest require site index data.

If a site tree is needed; select a tree from a species common to the condition class being sampled, based on the criteria listed in Appendix 4. Select trees off the subplot where possible. Use only trees that have remained in a dominant or co-dominant crown position throughout their entire life span. If possible, trees should be 5.0 inches in diameter, or larger, and at least 20 years old. Trees that are visibly damaged, trees with ring patterns that exhibit signs of suppression, and trees with rotten cores should be rejected. If there are no acceptable site trees or site trees are not collected, record the reason in the plot notes and leave this section blank.

NRS Note: A tree cored for stand age may or may not be suitable site tree. If the tree cored for stand age meets the site tree selection criteria, then this tree can be used for both stand age and site index.

7.2 SITE TREE DATA VARIABLES

7.2.0N TREE RECORD NUMBER [TR#]

Record a code to uniquely and permanently identify each site index tree. On remeasured plots, use the previously assigned site index tree number. These trees will keep their original number as long as they meet the criteria for site trees. If a new tree is selected, use the "next available tree number" function on the *FIA PDR Application* to assign a number. [Correction 10/04/2006.]

When Collected: All site trees
Field width: 3 digits
Tolerance: No errors
MQO: At least 99% of the time
Values: 001 to 999

7.2.1 CONDITION CLASS LIST [CONL]

List all CONDITION CLASSES that the site index data from this tree represent.

When Collected: All site trees
 Field width: 5 digits
 Tolerance: No errors
 MQO: At least 99% of the time
 Values: 1 to 9 or 10000 to 98765

7.2.2 SPECIES [SPP]

Use the same procedures described in Section 5.8 (Appendix 4 lists preferred site tree species by region).

NRS Note: The species table below has been modified for the Northern region. Species indicated with an "E" are acceptable to core in the eastern states. Species indicated with a "W" are acceptable to core in the western states.

When Collected: All site trees
 Values:

Code	Common Name	NRS	
		E	W
0012	balsam fir	E	W
0043	Atlantic white-cedar	E	
0068	eastern redcedar	E	W
0070	larch (introduced)	E	
0071	tamarack (native)	E	W
0094	white spruce	E	W
0095	black spruce	E	W
0097	red spruce	E	
0105	jack pine	E	W
0110	shortleaf pine	E	W
0122	Ponderosa pine		W
0125	red pine	E	W
0128	pond pine	E	
0129	eastern white pine	E	W
0130	Scotch pine	E	W
0131	loblolly pine	E	
0132	Virginia pine	E	
0241	northern white cedar	E	W
0261	eastern hemlock	E	W
0316	red maple	E	W
0317	silver maple	E	W
0318	sugar maple	E	W
0371	yellow birch	E	W
0375	paper birch	E	W
0402	bitternut hickory	E	W
0407	shagbark hickory	E	W
0462	hackberry		W
0531	American beech	E	W
0541	white ash	E	W
0543	black ash	E	W
0544	green ash	E	W
0602	black walnut		W
0611	sweetgum	E	W
0621	yellow-poplar	E	W
0742	eastern cottonwood	E	W
0743	bigtooth aspen	E	W
0746	quaking aspen	E	W
0762	black cherry		W

Code	Common Name	NRS	
		E	W
0802	white oak	E	W
0806	scarlet oak	E	W
0812	southern red oak	E	
0813	cherrybark oak	E	
0817	shingle oak	E	W
0827	water oak	E	
0830	pin oak	E	W
0832	chestnut oak	E	
0833	northern red oak	E	W
0835	post oak	E	W
0837	black oak	E	W
0901	black locust	E	W
0951	American basswood	E	W
0972	American elm	E	W

7.2.3 **DIAMETER [DBH]**

Use the same procedures described in Section 5.9.

When Collected: All site trees

7.2.4 **SITE TREE LENGTH [HGHT]**

With a clinometer or other approved instrument, measure the total length of the site tree from the ground to the top of the tree. Record to the nearest 1.0 foot. **SITE TREE LENGTH** must be measured; no estimates are permitted on site trees.

When Collected: All site trees

Field width: 3 digits

Tolerance: +/- 10% of true length

MQO: At least 90% of the time

Values: 005 to 999

7.2.5 **TREE AGE AT DIAMETER [AGE]**

Record the tree age as determined by an increment sample. Bore the tree at the point of diameter measurement (DBH) with an increment borer. Count the rings between the outside edge of the core and the pith. Do not add years to get total age.

When Collected: All site trees

Field width: 3 digits

Tolerance: +/- 5 years

MQO: At least 95% of the time

Values: 001 to 999

7.2.6 **SITE TREE NOTES**

Record notes pertaining to an individual site tree.

When collected: All site trees as necessary

Field width: alphanumeric character field

MQO: N/A

Values: English language words, phrases and numbers

7.2.7+N **SUBPLOT NUMBER (CORE OPTIONAL) [SUB#]**

Record the subplot number to which the site tree is referenced.

When Collected: All site trees

Field width: 1 digit

Tolerance: No errors

MQO: At least 99% of the time

Values:

- 1 Center subplot
- 2 North subplot
- 3 Southeast subplot
- 4 Southwest subplot
- 9 Previous site tree not referenced

NRS PDR Note: If "9" is downloaded into the PDR, this indicates that there is no available site tree subplot number data. This will be common for all previous eastern states where site index reference data were not required. SUBPLOT NUMBER is now a required variable for all new site trees.

7.2.8+N AZIMUTH (CORE OPTIONAL) [AZM]

Record the AZIMUTH from the subplot center; sight the center of the base of each tree with a compass. Record the AZIMUTH to the nearest degree. Use 360 for north.

When Collected: All site trees

Field width: 3 digits

Tolerance: +/- 10 degrees

MQO: At least 90% of the time

Values: 001 to 360, 999

NRS PDR Note: If "999" is downloaded into the PDR, this indicates that there is no available site tree azimuth data. This will be common for all previous eastern states where site index reference data were not required. AZIMUTH is now a required variable for all new site trees.

7.2.9+N HORIZONTAL DISTANCE (CORE OPTIONAL) [DIST]

Record the measured HORIZONTAL DISTANCE, to the nearest 0.1 foot, from the subplot center to the pith of the tree at the base.

NRS Note: A suitable site tree must not be further than 200 ft from any subplot center. [Clarification 10/05/2006.]

When Collected: All site trees

Field width: 4 digits (xxx.y)

Tolerance: +/- 5 ft

MQO: At least 90% of the time

Values: 0001 to 2000, 9999

NRS PDR Note: If "9999" is downloaded into the PDR, this indicates that there is no available site tree horizontal distance data. This will be common for all previous eastern states where site index reference data were not required. HORIZONTAL DISTANCE is now a required variable for all new site trees.

NATIONAL APPENDICES

1. State, **Unit** and County, Parish or Borough FIPS Codes
 - State and County, Parish or Borough codes are the standard federal 2- and 3-digit codes for States and Counties, Parishes, or Boroughs, respectively.
2. FIA Forest Type Codes

These are the codes that correspond to the National FIA forest typing algorithm. Definitions for the types will be included in a future draft. Units may choose to also add local forest type groupings.
3. FIA Tree Species Codes
 - This list includes all species deemed to be tally trees with western woodland trees measured for DRC indicated.
4. Site Tree Selection Criteria and Species List
5. Determination of Stocking Values for Land Use Classification
6. Glossary
7. Tolerance / MQO / Value / Units Table
8. Tree Coding Guide for RECONCILE

Appendix 1N. State, Unit, County, Parish or Borough FIPS codes

States are sorted by county.

<u>State</u>	<u>Unit</u>	<u>County</u>	<u>Unit</u>	<u>County cont'd.</u>
09 CT	1	001	Fairfield	1 009 New Haven
	1	003	Hartford	1 011 New London
	1	005	Litchfield	1 013 Tolland
	1	007	Middlesex	1 015 Windham
10 DE	1	001	Kent	
	1	003	New Castle	
	1	005	Sussex	
11 DC	1	001	District of Columbia	
17 IL	3	001	Adams	3 103 Lee
	1	003	Alexander	3 105 Livingston
	2	005	Bond	3 107 Logan
	3	007	Boone	3 109 McDonough
	3	009	Brown	3 111 McHenry
	3	011	Bureau	3 113 McLean
	2	013	Calhoun	3 115 Macon
	3	015	Carroll	2 117 Macoupin
	3	017	Cass	2 119 Madison
	3	019	Champaign	2 121 Marion
	3	021	Christian	3 123 Marshall
	2	023	Clark	3 125 Mason
	2	025	Clay	1 127 Massac
	2	027	Clinton	3 129 Menard
	3	029	Coles	3 131 Mercer
	3	031	Cook	2 133 Monroe
	2	033	Crawford	2 135 Montgomery
	2	035	Cumberland	3 137 Morgan
	3	037	DeKalb	3 139 Moultrie
	3	039	De Witt	3 141 Ogle
	3	041	Douglas	3 143 Peoria
	3	043	DuPage	1 145 Perry
	3	045	Edgar	3 147 Piatt
	2	047	Edwards	3 149 Pike
	2	049	Effingham	1 151 Pope
	2	051	Fayette	1 153 Pulaski
	3	053	Ford	3 155 Putnam
	1	055	Franklin	1 157 Randolph
	3	057	Foulton	2 159 Richland
	1	059	Gallatin	3 161 Rock Island
	2	061	Greene	2 163 St. Clair
	3	063	Grundy	1 165 Saline
1	065	Hamilton	3 167 Sangamon	
3	067	Hancock	3 169 Schuyler	
1	069	Hardin	3 171 Scott	
3	071	Henderson	2 173 Shelby	
3	073	Henry	3 175 Stark	
3	075	Iroquois	3 177 Stephenson	
1	077	Jackson	3 179 Tazewell	
2	079	Jasper	1 181 Union	
2	081	Jefferson	3 183 Vermilion	
2	083	Jersey	2 185 Wabash	
3	085	JoDaviess	3 187 Warren	

1	087	Johnson	2	189	Washington
3	089	Kane	2	191	Wayne
3	091	Kankakee	1	193	White
3	093	Kendall	3	195	Whiteside
3	095	Knox	3	197	Will
3	097	Lake	1	199	Williamson
3	099	La Salle	3	201	Winnebago
2	101	Lawrence	3	203	Woodford

18	IN	4	001	Adams	2	093	Lawrence
		4	003	Allen	4	095	Madison
		4	005	Bartholome	4	097	Marion
		4	007	Benton	4	099	Marshall
		4	009	Blackford	1	101	Martin
		4	011	Boone	4	103	Miami
		2	013	Brown	2	105	Monroe
		4	015	Carroll	4	107	Montgomery
		4	017	Cass	2	109	Morgan
		2	019	Clark	4	111	Newton
		1	021	Clay	4	113	Noble
		4	023	Clinton	3	115	Ohio
		2	025	Crawford	2	117	Orange
		1	027	Daviess	2	119	Owen
		3	029	Dearborn	1	121	Parke
		4	031	Decatur	2	123	Perry
		4	033	De Kalb	1	125	Pike
		4	035	Delaware	4	127	Porter
		2	037	Dubois	1	129	Posey
		4	039	Elkhart	4	131	Pulaski
		3	041	Fayette	1	133	Putnam
		2	043	Floyd	4	135	Randolph
		4	045	Fountain	3	137	Ripley
		3	047	Franklin	4	139	Rush
		4	049	Fulton	4	141	St. Joseph
		1	051	Gibson	2	143	Scott
		4	053	Grant	4	145	Shelby
		1	055	Greene	2	147	Spencer
		4	057	Hamilton	4	149	Starke
		4	059	Hancock	4	151	Steuben
		2	061	Harrison	1	153	Sullivan
		4	063	Hendricks	3	155	Switzerland
		4	065	Henry	4	157	Tippicanoe
		4	067	Howard	4	159	Tipton
		4	069	Huntington	3	161	Union
		2	071	Jackson	1	163	Vanderburg
		4	073	Jasper	1	165	Vermillion
		4	075	Jay	1	167	Vigo
		3	077	Jefferson	4	169	Wabash
		3	079	Jennings	4	171	Warren
		4	081	Johnson	2	173	Warrick
		1	083	Knox	2	175	Washington
		4	085	Kosciusko	4	177	Wayne
		4	087	Lagrange	4	179	Wells
		4	089	Lake	4	181	White
		4	091	La Porte	4	183	Whitley

19	IA	3	001	Adair	2	101	Jefferson
		3	003	Adams	1	103	Johnson
		1	005	Allamakee	1	105	Jones
		2	007	Appanoose	2	107	Keokuk
		3	009	Audubon	4	109	Kossuth
		1	011	Benton	2	111	Lee

1	013	Black Hawk	1	113	Linn
2	015	Boone	2	115	Louisa
1	017	Bremer	2	117	Lucas
1	019	Buchanan	4	119	Lyon
4	021	Buena Vist	2	121	Madison
1	023	Butler	2	123	Mahaska
4	025	Calhoun	2	125	Marion
3	027	Carroll	2	127	Marshall
3	029	Cass	3	129	Mills
1	031	Cedar	1	131	Mitchell
4	033	Cerro Gord	3	133	Monona
4	035	Cherokee	2	135	Monroe
1	037	Chickasaw	3	137	Montgomery
2	039	Clarke	2	139	Muscatine
4	041	Clay	4	141	O'Brien
1	043	Clayton	4	143	Osceola
1	045	Clinton	3	145	Page
3	047	Crawford	4	147	Palo Alto
2	049	Dallas	4	149	Plymouth
2	051	Davis	4	151	Pocahontas
2	053	Decatur	2	153	Polk
1	055	Delaware	3	155	Pottawatta
2	057	DesMoines	2	157	Poweshiek
4	059	Dickinson	3	159	Ringgold
1	061	Dubuque	4	161	Sac
4	063	Emmet	1	163	Scott
1	065	Fayette	3	165	Shelby
1	067	Floyd	4	167	Sioux
4	069	Franklin	2	169	Story
3	071	Fremont	1	171	Tama
3	073	Greene	3	173	Taylor
1	075	Grundy	3	175	Union
2	077	Guthrie	2	177	Van Buren
2	079	Hamilton	2	179	Wapello
4	081	Hancock	2	181	Warren
2	083	Hardin	2	183	Washington
3	085	Harrison	2	185	Wayne
2	087	Henry	2	187	Webster
1	089	Howard	4	189	Winnebago
4	091	Humboldt	1	191	Winneshiek
4	093	Ida	3	193	Woodbury
2	095	Iowa	4	195	Worth
1	097	Jackson	4	197	Wright
2	099	Jasper			

20	KS	2	001	Allen	2	107	Linn
		2	003	Anderson	3	109	Logan
		1	005	Atchison	2	111	Lyon
		3	007	Barber	3	113	McPherson
		3	009	Barton	2	115	Marion
		2	011	Bourbon	1	117	Marshall
		1	013	Brown	3	119	Meade
		2	015	Butler	1	121	Miami
		2	017	Chase	3	123	Mitchell
		2	019	Chautauqua	2	125	Montgomery
		2	021	Cherokee	2	127	Morris
		3	023	Cheyenne	3	129	Morton
		3	025	Clark	1	131	Nemaha
		1	027	Clay	2	133	Neosho
		3	029	Cloud	3	135	Ness
		2	031	Coffey	3	137	Norton
		3	033	Comanche	1	139	Osage
		2	035	Cowley	3	141	Osborne

2	037	Crawford	3	143	Ottawa
3	039	Decatur	3	145	Pawnee
1	041	Dickinson	3	147	Phillips
1	043	Doniphan	1	149	Pottawatomie
1	045	Douglas	3	151	Pratt
3	047	Edwards	3	153	Rawlins
2	049	Elk	3	155	Reno
3	051	Ellis	3	157	Republic
3	053	Ellsworth	3	159	Rice
3	055	Finney	1	161	Riley
3	057	Ford	3	163	Rooks
1	059	Franklin	3	165	Rush
1	061	Geary	3	167	Russell
3	063	Gove	3	169	Saline
3	065	Graham	3	171	Scott
3	067	Grant	3	173	Sedgwick
3	069	Gray	3	175	Seward
3	071	Greeley	1	177	Shawnee
2	073	Greenwood	3	179	Sheridan
3	075	Hamilton	3	181	Sherman
3	077	Harper	3	183	Smith
3	079	Harvey	3	185	Stafford
3	081	Haskell	3	187	Stanton
3	083	Hodgeman	3	189	Stevens
1	085	Jackson	3	191	Sumner
1	087	Jefferson	3	193	Thomas
3	089	Jewell	3	195	Trego
1	091	Johnson	1	197	Wabaunsee
3	093	Kearny	3	199	Wallace
3	095	Kingman	1	201	Washington
3	097	Kiowa	3	203	Wichita
2	099	Labette	2	205	Wilson
3	101	Lane	2	207	Woodson
1	103	Leavenworth	1	209	Wyandotte
3	105	Lincoln			

23	ME	8	001	Androscoggin	9	017	Oxford
		2	003	Aroostook	3	019	Penobscot
		8	005	Cumberland	5	021	Piscataquis
		9	007	Franklin	8	023	Sagadahoc
		4	009	Hancock	7	025	Somerset
		6	011	Kennebec	6	027	Waldo
		6	013	Knox	1	029	Washington
		6	015	Lincoln	8	031	York

24	MD	5	001	Allegany	2	027	Howard
		2	003	Anne Arundel	2	029	Kent
		2	005	Baltimore	2	031	Montgomery
		3	009	Calvert	2	033	Prince George's
		2	011	Caroline	2	035	Queen Anne's
		2	013	Carroll	3	037	St. Mary's
		2	015	Cecil	4	039	Somerset
		3	017	Charles	2	041	Talbot
		4	019	Dorchester	2	043	Washington
		2	021	Frederick	4	045	Wicomico
		5	023	Garrett	4	047	Worcester
		2	025	Harford			

25	MA	1	001	Barnstable	1	015	Hampshire
		1	003	Berkshire	1	017	Middlesex
		1	005	Bristol	1	019	Nantucket

1	007	Dukes	1	021	Norfolk
1	009	Essex	1	023	Plymouth
1	011	Franklin	1	025	Suffolk
1	013	Hampden	1	027	Worcester

26	MI	3	001	Alcona	3	085	Lake
		1	003	Alger	4	087	Lapeer
		4	005	Allegan	3	089	Leelanau
		3	007	Alpena	4	091	Lenawee
		3	009	Antrim	4	093	Livingston
		3	011	Arenac	1	095	Luce
		2	013	Baraga	1	097	Mackinac
		4	015	Barry	4	099	Macomb
		3	017	Bay	3	101	Manistee
		3	019	Benzie	2	103	Marquette
		4	021	Berrien	3	105	Mason
		4	023	Branch	3	107	Mecosta
		4	025	Calhoun	1	109	Menominee
		4	027	Cass	3	111	Midland
		3	029	Charlevoix	3	113	Missaukee
		3	031	Cheboygan	4	115	Monroe
		1	033	Chippewa	4	117	Montcalm
		3	035	Clare	3	119	Montmorenc
		4	037	Clinton	4	121	Muskegon
		3	039	Crawford	3	123	Newaygo
		1	041	Delta	4	125	Oakland
		2	043	Dickinson	3	127	Oceana
		4	045	Eaton	3	129	Ogemaw
		3	047	Emmet	2	131	Ontonagon
		4	049	Genesee	3	133	Osceola
		3	051	Gladwin	3	135	Oscoda
		2	053	Gogebic	3	137	Otsego
		3	055	Grand Traverse	4	139	Ottawa
		4	057	Gratiot	3	141	Presque Isle
		4	059	Hillsdale	3	143	Roscommon
		2	061	Houghton	4	145	Saginaw
		4	063	Huron	4	147	St. Clair
		4	065	Ingham	4	149	St. Joseph
		4	067	Ionia	4	151	Sanilac
		3	069	Iosco	1	153	Schoolcraft
		2	071	Iron	4	155	Shiawassee
		3	073	Isabella	4	157	Tuscola
		4	075	Jackson	4	159	Van Buren
		4	077	Kalamazoo	4	161	Washtenaw
		3	079	Kalkaska	4	163	Wayne
		4	081	Kent	3	165	Wexford
		2	083	Keweenaw			

27	MN	2	001	Aitkin	4	089	Marshall
		3	003	Anoka	4	091	Martin
		2	005	Becker	4	093	Meeker
		2	007	Beltrami	3	095	Mille Lacs
		3	009	Benton	3	097	Morrison
		4	011	Big Stone	4	099	Mower
		4	013	Blue Earth	4	101	Murray
		4	015	Brown	4	103	Nicollet
		1	017	Carlton	4	105	Nobles
		3	019	Carver	4	107	Norman
		2	021	Cass	3	109	Olmsted
		4	023	Chippewa	3	111	Otter Tail
		3	025	Chisago	4	113	Pennington
		4	027	Clay	3	115	Pine

2	029	Clearwater	4	117	Pipestone
1	031	Cook	4	119	Polk
4	033	Cottonwood	4	121	Pope
2	035	Crow Wing	3	123	Ramsey
3	037	Dakota	4	125	Red Lake
4	039	Dodge	4	127	Redwood
3	041	Douglas	4	129	Renville
4	043	Faribault	3	131	Rice
3	045	Fillmore	4	133	Rock
4	047	Freeborn	2	135	Roseau
3	049	Goodhue	1	137	St. Louis
4	051	Grant	3	139	Scott
3	053	Hennepin	3	141	Sherburne
3	055	Houston	4	143	Sibley
2	057	Hubbard	3	145	Stearns
3	059	Isanti	4	147	Steele
2	061	Itasca	4	149	Stevens
4	063	Jackson	4	151	Swift
3	065	Kanabec	3	153	Todd
4	067	Kandiyohi	4	155	Traverse
4	069	Kittson	3	157	Wabasha
1	071	Koochiching	2	159	Wadena
4	073	Lac qui Parle	4	161	Waseca
1	075	Lake	3	163	Washington
2	077	Lake of the Woods	4	165	Watonwan
3	079	Le Sueur	4	167	Wilkin
4	081	Lincoln	3	169	Winona
4	083	Lyon	3	171	Wright
4	085	McLeod	4	173	Yellow Medicine
2	087	Mahnomen			

29	MO	4	001	Adair	4	117	Livingston
		4	003	Andrew	2	119	McDonald
		4	005	Atchison	4	121	Macon
		4	007	Audrain	1	123	Madison
		2	009	Barry	3	125	Maries
		4	011	Barton	4	127	Marion
		4	013	Bates	4	129	Mercer
		3	015	Benton	3	131	Miller
		1	017	Bollinger	5	133	Mississippi
		5	019	Boone	5	135	Moniteau
		4	021	Buchanan	4	137	Monroe
		1	023	Butler	5	139	Montgomery
		4	025	Caldwell	3	141	Morgan
		5	027	Callaway	5	143	New Madrid
		3	029	Camden	2	145	Newton
		5	031	Cape Girar	4	147	Nodaway
		4	033	Carroll	1	149	Oregon
		1	035	Carter	5	151	Osage
		4	037	Cass	2	153	Ozark
		3	039	Cedar	5	155	Pemiscot
		4	041	Chariton	5	157	Perry
		2	043	Christian	4	159	Pettis
		4	045	Clark	3	161	Phelps
		4	047	Clay	4	163	Pike
		4	049	Clinton	4	165	Platte
		5	051	Cole	3	167	Polk
		4	053	Cooper	3	169	Pulaski
		1	055	Crawford	4	171	Putnam
		4	057	Dade	4	173	Ralls
		3	059	Dallas	4	175	Randolph
		4	061	Daviess	4	177	Ray
		4	063	DeKalb	1	179	Reynolds

1	065	Dent	1	181	Ripley
2	067	Douglas	5	183	St. Charle
5	069	Dunklin	3	185	St. Clair
5	071	Franklin	5	186	Ste. Genev
5	073	Gasconade	1	187	St. Francois
4	075	Gentry	5	189	St. Louis
4	077	Greene	4	195	Saline
4	079	Grundy	4	197	Schuyler
4	081	Harrison	4	199	Scotland
4	083	Henry	5	201	Scott
3	085	Hickory	1	203	Shannon
4	087	Holt	4	205	Shelby
5	089	Howard	5	207	Stoddard
2	091	Howell	2	209	Stone
1	093	Iron	4	211	Sullivan
4	095	Jackson	2	213	Taney
4	097	Jasper	2	215	Texas
5	099	Jefferson	4	217	Vernon
4	101	Johnson	5	219	Warren
4	103	Knox	1	221	Washington
3	105	Laclede	1	223	Wayne
4	107	Lafayette	2	225	Webster
4	109	Lawrence	4	227	Worth
4	111	Lewis	2	229	Wright
4	113	Lincoln	5	510	St. Louis
4	115	Linn			

31	NE	1	001	Adams	1	095	Jefferson
		2	003	Antelope	1	097	Johnson
		2	005	Arthur	1	099	Kearney
		2	007	Banner	2	101	Keith
		2	009	Blaine	2	103	Keya Paha
		1	011	Boone	2	105	Kimball
		2	013	Box Butte	2	107	Knox
		2	015	Boyd	1	109	Lancaster
		2	017	Brown	2	111	Lincoln
		1	019	Buffalo	2	113	Logan
		1	021	Burt	2	115	Loup
		1	023	Butler	1	117	Madison
		1	025	Cass	2	119	McPherson
		1	027	Cedar	1	121	Merrick
		2	029	Chase	2	123	Morrill
		2	031	Cherry	1	125	Nance
		2	033	Cheyenne	1	127	Nemaha
		1	035	Clay	1	129	Nuckolls
		1	037	Colfax	1	131	Otoe
		1	039	Cuming	1	133	Pawnee
		1	041	Custer	2	135	Perkins
		1	043	Dakota	1	137	Phelps
		2	045	Dawes	1	139	Pierce
		1	047	Dawson	1	141	Platte
		2	049	Deuel	1	143	Polk
		1	051	Dixon	1	145	Red Willow
		1	053	Dodge	1	147	Richardson
		1	055	Douglas	2	149	Rock
		2	057	Dundy	1	151	Saline
		1	059	Fillmore	1	153	Sarpy
		1	061	Franklin	1	155	Saunders
		1	063	Frontier	2	157	Scotts Bluff
		1	065	Furnas	1	159	Seward
		1	067	Gage	2	161	Sheridan
		2	069	Garden	1	163	Sherman
		2	071	Garfield	2	165	Sioux

1	073	Gosper	1	167	Stanton
2	075	Grant	1	169	Thayer
1	077	Greeley	2	171	Thomas
1	079	Hall	1	173	Thurston
1	081	Hamilton	1	175	Valley
1	083	Harlan	1	177	Washington
2	085	Hayes	1	179	Wayne
1	087	Hitchcock	1	181	Webster
2	089	Holt	2	183	Wheeler
2	091	Hooker	1	185	York
1	093	Howard			

33	NH	3	001	Belknap	3	011	Hillsborough
		2	003	Carroll	3	013	Merrimack
		3	005	Cheshire	3	015	Rockingham
		2	007	Coos	3	017	Strafford
		2	009	Grafton	3	019	Sullivan

34	NJ	1	001	Atlantic	1	023	Middlesex
		1	003	Bergen	1	025	Monmouth
		1	005	Burlington	1	027	Morris
		1	007	Camden	1	029	Ocean
		1	009	Cape May	1	031	Passaic
		1	011	Cumberland	1	033	Salem
		1	013	Essex	1	035	Somerset
		1	015	Gloucester	1	037	Sussex
		1	017	Hudson	1	039	Union
		1	019	Hunterdon	1	041	Warren
		1	021	Mercer			

36	NY	7	001	Albany	2	063	Niagara
		5	003	Allegany	3	065	Onieda
		8	005	Bronx	2	067	Onondaga
		6	007	Broome	2	069	Ontario
		5	009	Cattaraugus	8	071	Orange
		2	011	Cayuga	2	073	Orleans
		5	013	Chautauqua	2	075	Oswego
		6	015	Chemung	6	077	Otsego
		6	017	Chenango	8	079	Putnam
		1	019	Clinton	8	081	Queens
		7	021	Columbia	7	083	Rensselaer
		6	023	Cortland	8	085	Richmond
		6	025	Delaware	8	087	Rockland
		8	027	Dutchess	1	089	St. Lawrence
		2	029	Erie	7	091	Saratoga
		4	031	Essex	7	093	Schenectady
		1	033	Franklin	8	095	Schoharie
		3	035	Fulton	6	097	Schuyler
		2	037	Genesee	2	099	Seneca
		8	039	Greene	5	101	Steuben
		4	041	Hamilton	8	103	Suffolk
		3	043	Herkimer	8	105	Sullivan
		1	045	Jefferson	6	107	Tioga
		8	047	Kings	6	109	Tompkins
		3	049	Lewis	8	111	Ulster
		2	051	Livingston	4	113	Warren
		2	053	Madison	7	115	Washington
		2	055	Monroe	2	117	Wayne
		7	057	Montgomery	8	119	Westchester
		8	059	Nassau	2	121	Wyoming
		8	061	New York	2	123	Yates

38	ND	1	001	Adams	1	055	McLean
		1	003	Barnes	1	057	Mercer
		1	005	Benson	1	059	Morton
		1	007	Billings	1	061	Mountrail
		1	009	Bottineau	1	063	Nelson
		1	011	Bowman	1	065	Oliver
		1	013	Burke	1	067	Pembina
		1	015	Burleigh	1	069	Pierce
		1	017	Cass	1	071	Ramsey
		1	019	Cavalier	1	073	Ransom
		1	021	Dickey	1	075	Renville
		1	023	Divide	1	077	Richland
		1	025	Dunn	1	079	Rolette
		1	027	Eddy	1	081	Sargent
		1	029	Emmons	1	083	Sheridan
		1	031	Foster	1	085	Sioux
		1	033	Golden Valley	1	087	Slope
		1	035	Grand Fork	1	089	Stark
		1	037	Grant	1	091	Steele
		1	039	Griggs	1	093	Stutsman
		1	041	Hettinger	1	095	Towner
		1	043	Kidder	1	097	Traill
		1	045	LaMoure	1	099	Walsh
		1	047	Logan	1	101	Ward
		1	049	McHenry	1	103	Wells
		1	051	McIntosh	1	105	Williams
		1	053	McKenzie			

39	OH	1	001	Adams	5	089	Licking
		6	003	Allen	6	091	Logan
		4	005	Ashland	4	093	Lorain
		4	007	Ashtabula	6	095	Lucas
		2	009	Athens	5	097	Madison
		6	011	Auglaize	4	099	Mahoning
		3	013	Belmont	6	101	Marion
		1	015	Brown	4	103	Medina
		5	017	Butler	2	105	Meigs
		3	019	Carroll	6	107	Mercer
		6	021	Champaign	5	109	Miami
		5	023	Clark	3	111	Monroe
		1	025	Clermont	5	113	Montgomery
		5	027	Clinton	2	115	Morgan
		4	029	Columbiana	6	117	Morrow
		3	031	Coshocton	3	119	Muskingum
		6	033	Crawford	3	121	Noble
		4	035	Cuyahoga	6	123	Ottawa
		5	037	Darke	6	125	Paulding
		6	039	Defiance	2	127	Perry
		6	041	Delaware	5	129	Pickaway
		4	043	Erie	1	131	Pike
		5	045	Fairfield	4	133	Portage
		5	047	Fayette	5	135	Preble
		5	049	Franklin	6	137	Putnam
		6	051	Fulton	4	139	Richland
		1	053	Gallia	1	141	Ross
		4	055	Geauga	6	143	Sandusky
		5	057	Greene	1	145	Scioto
		3	059	Guernsey	6	147	Seneca
		5	061	Hamilton	6	149	Shelby
		6	063	Hancock	4	151	Stark
		6	065	Hardin	4	153	Summit

3	067	Harrison	4	155	Trumbull
6	069	Henry	3	157	Tuscarawas
1	071	Highland	6	159	Union
2	073	Hocking	6	161	Van Wert
3	075	Holmes	2	163	Vinton
4	077	Huron	5	165	Warren
1	079	Jackson	2	167	Washington
3	081	Jefferson	4	169	Wayne
6	083	Knox	6	171	Williams
4	085	Lake	6	173	Wood
1	087	Lawrence	6	175	Wyandot

42	PA	9	001	Adams	0	067	Juniata
		5	003	Allegheny	8	069	Lackawanna
		5	005	Armstrong	9	071	Lancaster
		5	007	Beaver	5	073	Lawrence
		7	009	Bedford	9	075	Lebanon
		9	011	Berks	9	077	Lehigh
		7	013	Blair	8	079	Luzerne
		8	015	Bradford	6	081	Lycoming
		9	017	Bucks	6	083	Mc Kean
		5	019	Butler	5	085	Mercer
		7	021	Cambria	0	087	Mifflin
		6	023	Cameron	8	089	Monroe
		8	025	Carbon	9	091	Montgomery
		6	027	Centre	8	093	Montour
		9	029	Chester	9	095	Northampton
		6	031	Clarion	8	097	Northumberland
		6	033	Clearfield	0	099	Perry
		6	035	Clinton	9	101	Philadelphia
		8	037	Columbia	8	103	Pike
		5	039	Crawford	6	105	Potter
		9	041	Cumberland	8	107	Schuylkill
		0	043	Dauphin	0	109	Snyder
		9	045	Delaware	7	111	Somerset
		6	047	Elk	6	113	Sullivan
		5	049	Erie	8	115	Susquehanna
		7	051	Fayette	6	117	Tioga
		6	053	Forest	0	119	Union
		0	055	Franklin	6	121	Venango
		0	057	Fulton	6	123	Warren
		5	059	Greene	5	125	Washington
		0	061	Huntingdon	8	127	Wayne
		5	063	Indiana	5	129	Westmoreland
		6	065	Jefferson	8	131	Wyoming
					9	133	York

44	RI	1	001	Bristol	1	007	Providence
		1	003	Kent	1	009	Washington
		1	005	Newport			

46	SD	1	003	Aurora	1	069	Hyde
		1	005	Beadle	1	071	Jackson
		1	007	Bennett	1	073	Jerauld
		1	009	Bon Homme	1	075	Jones
		1	011	Brookings	1	077	Kingsbury
		1	013	Brown	1	079	Lake
		1	015	Brule	2	081	Lawrence
		1	017	Buffalo	1	083	Lincoln
		2	019	Butte	1	085	Lyman
		1	021	Campbell	1	087	McCook

1	023	Charles Mi	1	089	McPherson
1	025	Clark	1	091	Marshall
1	027	Clay	2	093	Meade
1	029	Codington	1	095	Mellette
1	031	Corson	1	097	Miner
2	033	Custer	1	099	Minnehaha
1	035	Davison	1	101	Moody
1	037	Day	2	103	Pennington
1	039	Deuel	1	105	Perkins
1	041	Dewey	1	107	Potter
1	043	Douglas	1	109	Roberts
1	045	Edmunds	1	111	Sanborn
2	047	Fall River	2	113	Shannon
1	049	Faulk	1	115	Spink
1	051	Grant	1	117	Stanley
1	053	Gregory	1	119	Sully
1	055	Haakon	1	121	Todd
1	057	Hamlin	1	123	Tripp
1	059	Hand	1	125	Turner
1	061	Hanson	1	127	Union
2	063	Harding	1	129	Walworth
1	065	Hughes	1	135	Yankton
1	067	Hutchinson	1	137	Ziebach

50	VT	3	001	Addison	2	015	Lamoille
		3	003	Bennington	2	017	Orange
		2	005	Caledonia	2	019	Orleans
		3	007	Chittenden	3	021	Rutland
		2	009	Essex	2	023	Washington
		2	011	Franklin	3	025	Windham
		2	013	Grand Isle	3	027	Windsor

54	WV	2	001	Barbour	2	057	Mineral
		2	003	Berkeley	3	059	Mingo
		3	005	Boone	4	061	Monongalia
		2	007	Braxton	3	063	Monroe
		4	009	Brooke	2	065	Morgan
		4	011	Cabell	3	067	Nicholas
		4	013	Calhoun	4	069	Ohio
		3	015	Clay	2	071	Pendleton
		4	017	Doddridge	4	073	Pleasants
		3	019	Fayette	2	075	Pocahontas
		4	021	Gilmer	2	077	Preston
		2	023	Grant	4	079	Putnam
		3	025	Greenbrier	3	081	Raleigh
		2	027	Hampshire	2	083	Randolph
		4	029	Hancock	4	085	Ritchie
		2	031	Hardy	4	087	Roane
		2	033	Harrison	3	089	Summers
		4	035	Jackson	2	091	Taylor
		2	037	Jefferson	2	093	Tucker
		3	039	Kanawha	4	095	Tyler
		2	041	Lewis	2	097	Upshur
		4	043	Lincoln	4	099	Wayne
		3	045	Logan	2	101	Webster
		3	047	McDowell	4	103	Wetzel
		4	049	Marion	4	105	Wirt
		4	051	Marshall	4	107	Wood
		4	053	Mason	3	109	Wyoming
		3	055	Mercer			

55	WI	3	001	Adams	3	073	Marathon
		2	003	Ashland	1	075	Marinette
		2	005	Barron	3	077	Marquette
		2	007	Bayfield	1	078	Menominee
		5	009	Brown	5	079	Milwaukee
		4	011	Buffalo	3	081	Monroe
		2	013	Burnett	1	083	Oconto
		5	015	Calumet	1	085	Oneida
		3	017	Chippewa	5	087	Outagamie
		3	019	Clark	5	089	Ozaukee
		5	021	Columbia	4	091	Pepin
		4	023	Crawford	4	093	Pierce
		5	025	Dane	2	095	Polk
		5	027	Dodge	3	097	Portage
		5	029	Door	2	099	Price
		2	031	Douglas	5	101	Racine
		4	033	Dunn	4	103	Richland
		3	035	Eau Claire	5	105	Rock
		1	037	Florence	2	107	Rusk
		5	039	Fond du La	4	109	St. Croix
		1	041	Forest	4	111	Sauk
		4	043	Grant	2	113	Sawyer
		5	045	Green	1	115	Shawano
		5	047	Green Lake	5	117	Sheboygan
		4	049	Iowa	2	119	Taylor
		2	051	Iron	4	121	Trempealeau
		3	053	Jackson	4	123	Vernon
		5	055	Jefferson	1	125	Vilas
		3	057	Juneau	5	127	Walworth
		5	059	Kenosha	2	129	Washburn
		5	061	Kewaunee	5	131	Washington
		4	063	La Crosse	5	133	Waukesha
		4	065	Lafayette	3	135	Waupaca
		1	067	Langlade	3	137	Waushara
		1	069	Lincoln	5	139	Winnebago
		5	071	Manitowoc	3	141	Wood

NRS (East) Note: In PA there are special county codes for all plots on the national forest. "400" has been added to the county code (e.g., 483). If you complete a national forest plot that does not have this special designation, do not change the code in the field. This coding change is done by the Information Group only.

In WV there is a similar county notation for plots on the national forest. "200" has been added to the county code (e.g., 271). However, not all plots on the national forest have this designation. This special identification is no longer used in WV and therefore plots on the national forest may have the 200+ designation or retain the normal county code. Whatever the county code is for a national forest plot, do not change this code in the field. Leave the code as is.

Appendix 2+N. FIA Forest Type Codes

NRS Note: The following list includes all forest types in the Continental U.S. – modified for the North. East/West designation indicates types that are commonly found in those regions (East includes NRS and SRS and West includes PNW and IW), but may occasionally be found in another.

East	West	Code	Species Type
White / Red / Jack Pine Group			
E		101	Jack pine
E		102	Red pine
E		103	Eastern white pine
E		104	Eastern white pine / Eastern hemlock
E		105	Eastern hemlock
Spruce / Fir Group			
E		121	Balsam fir
E		122	White spruce
E		123	Red spruce
E		124	Red spruce / balsam fir
E	W	125	Black spruce
E		126	Tamarack
E		127	Northern white-cedar
Loblolly / Shortleaf Pine Group			
E		161	Loblolly pine
E		162	Shortleaf pine
E		163	Virginia pine
E		165	Table Mountain pine
E		166	Pond pine
E		167	Pitch pine
Pinyon / Juniper Group			
E		181	Eastern redcedar
E	W	182	Rocky Mountain juniper
Douglas-fir Group			
E	W	201	Douglas-fir
Ponderosa Pine Group			
E	W	221	Ponderosa pine
Lodgepole Pine Group			
	W	281	Lodgepole pine
Exotic Softwoods Group			
E		381	Scotch pine
E	W	383	Other exotic softwoods
E		384	Norway spruce
E		385	Introduced larch
Oak / Pine Group			
E		401	Eastern white pine / N. red oak / white ash
E		402	Eastern redcedar / hardwood
E		404	Shortleaf pine / oak

East	West	Code	Species Type
E		405	Virginia pine / southern red oak
E		406	Loblolly pine / hardwood
E		409	Other pine / hardwood
Oak / Hickory Group			
E		501	Post oak / blackjack oak
E		502	Chestnut oak
E		503	White oak / red oak / hickory
E		504	White oak
E		505	Northern red oak
E		506	Yellow-poplar / white oak / N. red oak
E		507	Sassafras / persimmon
E		508	Sweetgum / yellow-poplar
E		509	Bur oak
E		510	Scarlet oak
E		511	Yellow-poplar
E		512	Black walnut
E		513	Black locust
E		515	Chestnut oak / black oak / scarlet oak
E		519	Red maple / oak
E		520	Mixed upland hardwoods
Oak / Gum / Cypress Group			
E		601	Swamp chestnut oak / cherrybark oak
E		602	Sweetgum / Nuttall oak / willow oak
E		605	Overcup oak / water hickory
E		606	Atlantic white-cedar
E		607	Baldcypress / water tupelo
E		608	Sweetbay / swamp tupelo / red maple
Elm / Ash / Cottonwood Group			
E		701	Black ash / American elm / red maple
E		702	River birch / sycamore
E	W	703	Cottonwood
E	W	704	Willow
E		705	Sycamore / pecan / American elm
E		706	Sugarberry / hackberry / elm / green ash
E		707	Silver maple / American elm
E		708	Red maple / lowland
E	W	709	Cottonwood / willow
Maple / Beech / Birch Group			
E		801	Sugar maple / beech / yellow birch
E		802	Black cherry
E		803	Cherry / ash / yellow-poplar
E		805	Hard maple / basswood
E		807	Elm / ash / honey locust
E		809	Red maple / upland
Aspen / Birch Group			
E	W	901	Aspen
E	W	902	Paper birch
E		903	Gray birch
E	W	904	Balsam poplar

East	West	Code	Species Type
			Exotic Hardwoods Group
E		991	Paulownia
E	W	995	Other exotic hardwoods

For non-stocked stands, see section 2.5.3 for procedures to determine FOREST TYPE.

Eastern Forest Type Descriptions

WHITE/RED/JACK PINE GROUP

101 Jack pine: Associates – red pine, northern pin oak, quaking and bigtooth aspen, paper birch, black spruce, and white spruce. Sites--generally driest, most porous sands but also on more moist, sandy soils near swamps and on rocky hills and ledges.

102 Red pine: Associates – white, jack, or pitch pine; northern pin oak; white oak; red maple; paper birch; quaking and bigtooth aspen, chestnut oak, northern red oak, and hemlock. Sites--spotty distribution in Northeast and sandy and gravelly locations or dry sandy loam soils; often in plantations.

103 Eastern white pine: Associates – pitch pine, gray birch, aspen, red maple, pin cherry, white oak, paper birch, sweet birch, yellow birch, black cherry, white ash, northern red oak, sugar maple, basswood, hemlock, northern white-cedar, yellow-poplar, white oak, chestnut oak, scarlet oak, and shortleaf pine. Sites--wide variety, but best development on well drained sands and sandy loams.

104 Eastern white pine/ Eastern hemlock: Associates – beech, sugar maple, basswood, red maple, yellow birch, black cherry, white ash, paper birch, sweet birch, northern red oak, white oak, chestnut oak, yellow-poplar, and cucumbertree. Sites--wide variety but favors cool locations, moist ravines, and north slopes.

105 Eastern hemlock: Associates – beech, sugar maple, yellow birch, basswood, red maple, black cherry, white ash, white pine, paper birch, sweet birch, northern red oak, and white oak. Sites--cool locations, moist ravines, and north slopes.

SPRUCE/FIR GROUP

121 Balsam fir: Associates – black, white, or red spruce; paper or yellow birch; quaking or bigtooth aspen, beech; red maple; hemlock; tamarack; black ash; or northern white-cedar. Sites--upland sites on low lying moist flats and in swamps.

122 White spruce: Associates – black spruce, balsam fir, quaking aspen, paper birch, jack pine, red spruce, sugar maple, beech, and yellow birch. Sites--moist, sandy loam or alluvial soils--found on many different sites but especially typical of stream banks, lake shores, and adjacent slopes.

123 Red spruce: Associates – vary widely and may include red maple, yellow birch, eastern hemlock, eastern white pine, white spruce, northern white-cedar, paper birch, pin cherry, gray birch, mountain ash, beech, striped maple, sugar maple, northern red oak, red pine, and aspen. Sites--include moderately well drained to poorly drained flats and thin-slopes and on varying acidic soils in abandoned fields and pastures. This code should be used where red spruce comprises a plurality or majority of the stand's stocking but where balsam fir is either nonexistent or has very little stocking. Otherwise the plot would be coded 124, red spruce/balsam fir.

124 Red spruce/balsam fir: Associates – red maple, paper birch, white pine, hemlock, white spruce, and northern white-cedar. Sites--moderately drained to poorly drained flats or on thin-soiled upper slopes.

125 Black spruce: Associates – white spruce, balsam fir, jack pine, quaking aspen, paper birch, tamarack, northern white-cedar, black ash, or red maple. Sites--acid peat swamps but also on moist flats and uplands.

126 Tamarack (eastern larch): Associates – northern white cedar, red maple, black ash, and quaking aspen. Sites--wet swamps.

127 Northern white-cedar: Associates – tamarack, yellow birch, paperbirch, black ash, red maple, white pine, and hemlock. Sites--slow drainage (not stagnant bogs) areas that are not strongly acid.

LOBLOLLY/SHORTLEAF PINE GROUP

161 Loblolly pine: Associates – sweetgum, southern red oak, post oak, blackjack oak, blackgum, yellow-poplar, and pond pine. Sites--in Delaware and Maryland both on upland soils with abundant moisture but good drainage and on poorly drained depressions.

162 Shortleaf pine: Associates – white oak, southern red oak, scarlet oak, black oak, hickory, post oak, blackjack oak, blackgum, red maple, pitch pine, and Virginia pine. Sites--low, well drained ridges to rocky, dry, south slopes and the better drained spur ridges on north slopes and also on old fields.

163 Virginia pine: Associates – shortleaf pine, white oak, chestnut oak, southern red oak, black oak, sweetgum, red maple, blackgum, and pitch pine. Sites--dry sites, often abandoned fields.

165 Table Mountain pine: Associates – chestnut oak, scarlet oak, pitch pine, pine, and black oak. Sites--poor, dry, often rocky slopes.

166 Pond pine: Associates – loblolly pine, sweetgum, baldcypress, and Atlantic white-cedar. Sites--rare, but found in southern New Jersey, Delaware, and Maryland in low, poorly drained acres, swamps, and marshes.

167 Pitch pine: Associates – chestnut oak, scarlet oak, table-mountain pine, black oak, and blackgum. Sites--relatively infertile ridges, dry flats, and slopes.

PINYON / JUNIPER GROUP

181 Eastern redcedar: Associates – gray birch, red maple, sweetbirch, Virginia Pine, shortleaf pine, oak. Sites--usually dry uplands and abandoned fields on limestone outcrops and other shallow soils but can grow well on good sites.

PONDEROSA PINE GROUP

221 Ponderosa pine

DOUGLAS-FIR GROUP

201 Douglas-fir: Sites – unmanaged or abandoned Christmas tree plantations in the North.

EXOTIC SOFTWOODS GROUP

381 Scotch pine: plantation type, not naturally occurring.

383 Other exotic softwoods

384 Norway spruce: plantation type, not naturally occurring

385 Introduced larch: plantation type, usually Japanese larch, European larch, or a hybrid of the two (Dunkeld larch) - not naturally occurring. Sites--well-drained uplands; heavy plantation in New York.

OAK/PINE GROUP

401 Eastern white pine/northern red oak/white ash: Associates – red maple, basswood, yellow birch, bigtooth aspen, sugar maple, beech, paper birch, black cherry, hemlock, and sweet birch. Sites--deep, fertile, well-drained soil.

402 Eastern redcedar/hardwood: Associates – oak, hickory, walnut, ash, black locust, dogwood, blackgum, hackberry, winged elm, shortleaf pine, and Virginia pine. Sites--usually dry uplands and abandoned fields.

404 Shortleaf pine/oak: Associates - (oaks generally include white, scarlet, blackjack, black, post, and southern red) hickory, blackgum, sweetgum, Virginia pine, and pitch pine. Sites--generally in dry, low ridges, flats, and south slopes.

405 Virginia pine/southern red oak: Associates – black oak, scarlet oak, white oak, post oak, blackjack oak, shortleaf pine, blackgum, hickory, pitch pine, table-mountain pine, chestnut oak. Sites--dry slopes and ridges.

406 Loblolly pine/hardwood: Associates – wide variety of moist and wet site hardwoods including blackgum, sweetgum, yellow-poplar, red maple, white and green ash, and American elm; on drier sites associates include southern and northern red oak, white oak, post oak, scarlet oak, persimmon, and hickory. Sites--usually moist to very moist though not wet all year but also on drier sites.

409 Other pine/hardwood: catchall type for other unnamed pine-hardwood combinations that meet the stocking requirement for oak-pine. These are stands where hardwoods (usually oaks) comprise the plurality of stocking with at least a 25 to 49 percent pine or eastern redcedar component.

OAK/HICKORY GROUP

501 Post oak/blackjack oak: Associates – black oak, hickory, southern red oak, white oak, scarlet oak, shingle oak, live oak, shortleaf pine, Virginia pine, blackgum, sourwood, red maple, winged elm, hackberry, chinkapin oak, shumard oak, dogwood, and eastern redcedar. Sites--dry uplands and ridges.

502 Chestnut oak: Associates – scarlet oak, white oak, black oak, post oak, pitch pine, blackgum, sweetgum, red maple, red oak, shortleaf pine, Virginia pine. Sites--rocky outcrops with thin soil, ridge tops.

503 White oak/red oak/hickory: Associates – scarlet oak, bur oak, pinoak, white ash, sugar maple, red maple, walnut, basswood, black locust, beech, sweetgum, blackgum, yellow-poplar, and dogwood. Sites--wide variety of well drained upland soils.

504 White oak: Associates – black oak, northern red oak, bur oak, hickory, white ash, yellow-poplar. Sites--scattered patches on upland, loamy soils but on drier sites than type 503.

505 Northern red oak: Associates – black oak, scarlet oak, chestnut oak, and yellow-poplar. Sites--spotty distribution on ridge crests and north slopes in mountains but also found on rolling land, slopes, and benches on loamy soil.

506 Yellow-poplar/white oak/northern red oak: Associates – black oak, hemlock, blackgum, and hickory. Sites--northern slopes, coves, and moist flats.

507 Sassafras/persimmon: Associates – elm, eastern redcedar, hickory, ash, sugar maple, yellow-poplar, and oaks. Sites--abandoned farmlands and old fields.

508 Sweetgum/yellow-poplar: Associates – red maple, white ash, green ash, and other moist site hardwoods. Sites--generally occupies moist, lower slopes.

509 Bur oak: Associates—northern pin oak, black oak, chinkapin oak, and eastern redcedar in northern and dry upland sites; shagbark hickory, black walnut, eastern cottonwood, white ash, American elm, swamp white oak, honey locust, and American basswood in southern and lowland

sites. Sites – drier uplands to moist bottomlands with the drier uplands more common in the northern part of the range and the moist bottomlands more common in the southern part of the range.

510 Scarlet oak: Associates – black oak, southern red oak, chestnut oak, white oak, post oak, hickory, pitch pine, blackgum, sweetgum, black locust, sourwood, dogwood, shortleaf pine, and Virginia pine. Sites--dry ridges, south- or west-facing slopes and flats but often moister situations probably as a result of logging or fire.

511 Yellow-poplar: Associates – black locust, red maple, sweet birch, cucumbertree, and other moist-site hardwoods (except sweetgum, see type 508) and white oak and northern red oak (see type 506). Sites--lower slopes, northerly slopes, moist coves, flats, and old fields.

512: Black walnut: Associates – yellow-poplar, white ash, black cherry, basswood, beech, sugar maple, oaks, and hickory. Sites--coves and well-drained bottoms.

513 Black locust: Associates – many species of hardwoods and hardpines may occur with it in mixture, either having been planted or from natural seeding. Sites--may occur on any well-drained soil but best on dry sites, often in old fields.

515 Chestnut oak/black oak/scarlet oak: Associates—northern and southern red oaks, post oak, white oak, sourwood, shagbark hickory, pignut hickory, yellow-poplar, blackgum, sweetgum, red maple, eastern white pine, pitch pine, Table Mountain pine, shortleaf pine, and Virginia pine. Sites—dry upland sites on thin-soiled rocky outcrops on dry ridges and slopes.

519 Red maple/oak: Associates – the type is dominated by red maple and some of the wide variety of central hardwood associates include upland oak, hickory, yellow-poplar, black locust, sassafras as well as some central softwoods like Virginia and shortleaf pines. Sites -- uplands.

520 Mixed upland hardwoods: Associates – Any mixture of hardwoods of species typical of the upland central hardwood region, should include at least some oak. Sites--wide variety of upland sites.

OAK/GUM/CYPRESS GROUP

601 Swamp chestnut oak/cherrybark oak: Associates – white ash, hickory, white oak, shumard oak, blackgum, sweetgum, southern red oak, post oak, American elm, winged elm, yellow-poplar, and beech. Sites--within alluvial flood plains of major rivers on all ridges in the terraces and on the best fine sandy loam soils on the highest first bottom ridges.

602 Sweetgum/Nuttall oak/willow oak: Associates – green ash, American elm, pecan, cottonwood, red maple, honeylocust, and persimmon. Sites--very wet.

605 Overcup oak/water hickory: Associates – willow oak, American elm, green ash, hackberry, persimmon, and red maple. Sites--in South within alluvial flood plains in low, poorly drained flats with clay soils; also in sloughs and lowest backwater basins and low ridges with heavy soils that are subject to late spring inundation.

606 Atlantic white-cedar: Associates – North includes gray birch, pitch pine, hemlock, blackgum, and red maple. South includes pond pine, baldcypress, and red maple. Sites--usually confined to sandy-bottomed, peaty, interior, and river swamps, wet depressions, and stream banks.

607 Baldcypress/water tupelo: Associates – willow, red maple, American elm, persimmon, overcup oak, and sweetgum. Sites--very low, poorly drained flats, deep sloughs, and swamps wet most all the year.

608 Sweetbay/swamp tupelo/red maple: Associates – blackgum, loblolly and pond pines, American elm, and other moist-site hardwoods. Sites--very moist but seldom wet all year--shallow ponds, muck swamps, along smaller creeks in Coastal Plain (rare in Northeast).

ELM/ASH/COTTONWOOD GROUP

701 Black ash/American elm/red maple: Associates – silver maple, swamp white oak, sycamore, pin oak, blackgum, white ash, and cottonwood. Sites--moist to wet areas, swamps, gullies, and poorly drained flats.

702 River birch/sycamore: Associates – red maple, black willow, and other moist-site hardwoods. Sites--moist soils at edges of creeks and rivers.

703 Cottonwood: Associates – willow, white ash, green ash, and sycamore. Sites--streambanks where bare, moist soil is available.

704 Willow: Associates – cottonwood, green ash, sycamore, pecan, American elm, red maple, and boxelder. Sites--streambanks where bare, moist soil is available.

705 Sycamore/pecan/American elm: Associates – boxelder, green ash, hackberry, silver maple, cottonwood, willow, sweetgum, and river birch. Sites--bottomlands, alluvial flood plains of major rivers.

706 Sugarberry/hackberry/elm/green ash: Associates – pecan, blackgum, persimmon, honeylocust, red maple, hackberry, and boxelder. Sites--low ridges and flats in flood plains.

707 Silver maple/American elm: Associates – sweetgum, pin oak, swamp white oak, eastern cottonwood, sycamore, green ash, and other moist-site hardwoods (depending on region). Sites – well-drained, moist sites along river bottoms and floodplains, and beside lakes and larger streams.

708 Red maple/lowland: Associates – white ash, green ash, sycamore, American elm, red maple and boxelder. Sites – moist to wet areas, swamps, gullies, and poorly drained flats.

709 Cottonwood/willow: Associates – white ash, green ash sycamore, American elm, red maple and boxelder. Sites – stream banks where bare, moist soil is available.

MAPLE/BEECH/BIRCH GROUP

801 Sugar maple/beech/yellow birch: Associates – basswood, red maple, hemlock, northern red oak, white ash, white pine, black cherry, sweet birch, American elm, rock elm, and eastern hophornbeam. Sites--fertile, moist, well-drained sites.

802 Black cherry: Associates – sugar maple, northern red oak, red maple, white ash, basswood, sweet birch, butternut, American elm, and hemlock. Sites--fertile, moist, well-drained sites.

803 Cherry/ash/yellow-poplar: Associates – sugar maple, American beech, northern red oak, white oak, blackgum, hickory, cucumbertree, and yellow birch. Sites -- fertile, moist, well-drained sites.

805 Hard maple/basswood: Associates – white ash, northern red oak, eastern hophornbeam, American elm, red maple, eastern white pine, eastern hemlock. Sugar maple and basswood occur in different proportions but together comprise the majority of the stocking. Sites -- fertile, moist, well-drained sites.

807 Elm/ash/honeylocust: Associates – locust, silver maple, boxelder, elm, red maple, green ash predominate. Found in East Central United States. Sites – bottom land.

809 Red maple/upland: Associates – the type is dominated by red maple and some of the wide variety of northern hardwood associates include sugar maple, beech, birch, aspen, as well as some northern softwoods like white pine, red pine, and hemlock; this type is often man-made and may be the result of repeated cuttings. Sites -- uplands. (See Type 519 under oak/hickory group)

ASPEN/BIRCH GROUP

901 Aspen: Associates – paper birch, pin cherry, bur oak, green ash, American elm, balsam poplar, and boxelder. Sites--all kinds of soils except very driest sands and wettest swamps; found on burns, clearcuts, and abandoned land.

902 Paper birch: Associates – aspen, white pine, yellow birch, hemlock, red maple, northern red oak, and basswood. Sites--wide range of upland site, common on burns or clearcuts.

903 Gray birch: Associates – primarily red maple, but including aspen, pin cherry, black cherry, birches (yellow, sweet and paper), white pine, white ash, sugar maple, northern red and white oak. Sites – poor soils that are commonly found on abandoned farms, severe burns, and mining or logged areas. [Source: *Forest Cover Types of the U.S and Canada, 1980*]

904 Balsam poplar: Associates – balsam fir, white spruce, black spruce, tamarack, aspen, and paper birch. Sites – uplands and flood plains.

EXOTIC HARDWOODS GROUP

991 Paulownia:

995 Other exotic hardwoods:

For non-stocked stands, see sections 2.5.3 for procedures to determine FOREST TYPE.

Appendix 3N. FIA Tree Species Codes

This list includes all tree species tallied in the Continental U.S. – modified for the North. Species designated East/West are commonly found in those regions (East includes NRS and SRS and West includes PNW and IW), although species designated for one region may occasionally be found in another. Woodland species designate species where DRC is measured instead of DBH. Species that have an “X” in the Core column are tallied in all regions. All other species on the list are “core optional”. The North tallies all Core and “core optional” species.

NRS Note: Not all tree species are listed in this table that may occur in the North. If not listed, invasive tree species are tallied using species code 0999. The use of code 0999 requires a tree NOTE with the species identified. Dead trees are coded in the following order of identification hierarchy: Species code, Genus code, 0299 or 0998, or 0999.

Core	East	West	WdInd	FIA	PLANTS00	Common Name	Genus	Species
	E	W		0010	ABIES	Fir spp.	Abies	spp.
X	E	W		0012	ABBA	balsam fir	Abies	balsamea
X		W		0015	ABCO	white fir	Abies	concolor
X	E			0016	ABFR	Fraser fir	Abies	fraseri
	E	W		0040	CHAMA4	cedar spp.	Chamaecyparis	spp.
X	E			0043	CHTH2	Atlantic white-cedar	Chamaecyparis	thyoides
	E	W		0057	JUNIP	redcedar, juniper spp.	Juniperus	spp.
X	E			0061	JUAS	Ashe juniper	Juniperus	ashei
X	E	W	w	0066	JUSC2	Rocky Mountain juniper	Juniperus	scopulorum
X	E			0068	JUVI	eastern redcedar	Juniperus	virginiana
	E	W		0070	LARIX	larch spp.	Larix	spp.
X	E	W		0071	LALA	tamarack (native)	Larix	laricina
	E	W		0090	PICEA	spruce spp.	Picea	spp.
X	E			0091	PIAB	Norway spruce	Picea	abies
X	E	W		0094	PIGL	white spruce	Picea	glauca
X	E	W		0095	PIMA	black spruce	Picea	mariana
X	E	W		0096	PIPU	blue spruce	Picea	pungens
X	E			0097	PIRU	red spruce	Picea	rubens
	E	W		0100	PINUS	pine spp.	Pinus	spp.
X	E			0105	PIBA2	jack pine	Pinus	banksiana
X		W		0108	PICO	lodgepole pine	Pinus	contorta
X	E			0110	PIEC2	shortleaf pine	Pinus	echinata
X		W		0113	PIFL2	limber pine	Pinus	flexilis
X	E	W		0122	PIPO	ponderosa pine	Pinus	ponderosa
X	E			0123	PIPU5	Table Mountain pine	Pinus	pungens
X	E			0125	PIRE	red pine	Pinus	resinosa
X	E			0126	PIRI	pitch pine	Pinus	rigida

Core	East	West	WdInd	FIA	PLANTS00	Common Name	Genus	Species
X	E			0128	PISE	pond pine	Pinus	serotina
X	E			0129	PIST	eastern white pine	Pinus	strobus
X	E			0130	PISY	Scotch pine	Pinus	sylvestris
X	E			0131	PITA	loblolly pine	Pinus	taeda
X	E			0132	PIV2	Virginia pine	Pinus	virginiana
X	E			0136	PINI	Austrian pine	Pinus	nigra
		W		0200	PSEUD7	Douglas-fir spp.	Pseudotsuga	spp.
X		W		0202	PSME	Douglas-fir	Pseudotsuga	menziesii
	E			0220	TAXOD	cypress spp.	Taxodium	spp.
X	E			0221	TADI2	baldcypress	Taxodium	distichum
X	E			0222	TAAS	pondcypress	Taxodium	ascendens
	E	W		0230	TAXUS	yew spp.	Taxus	spp.
	E	W		0240	THUJA	Thuja spp.	Thuja	spp.
X	E			0241	THOC2	northern white-cedar	Thuja	occidentalis
	E	W		0260	TSUGA	hemlock spp.	Tsuga	spp.
X	E			0261	TSCA	eastern hemlock	Tsuga	canadensis
X	E	W		0299	2TE	unknown dead conifer	Tree	evergreen
	E	W		0310	ACER	maple spp.	Acer	spp.
X	E	W		0313	ACNE2	boxelder	Acer	negundo
X	E			0314	ACNI5	black maple	Acer	nigrum
X	E			0315	ACPE	striped maple	Acer	pensylvanicum
X	E			0316	ACRU	red maple	Acer	rubrum
X	E			0317	ACSA2	silver maple	Acer	saccharinum
X	E			0318	ACSA3	sugar maple	Acer	saccharum
	E			0319	ACSP2	mountain maple	Acer	spicatum
	E			0320	ACPL	Norway maple	Acer	platanoides
		W	w	0321	ACGL	Rocky Mountain maple	Acer	glabrum
	E	W		0330	AESCU	buckeye, horsechestnut spp.	Aesculus	spp.
X	E			0331	AEGL	Ohio buckeye	Aesculus	glabra
X	E			0332	AEFL	yellow buckeye	Aesculus	flava
	E			0336	AEPA	red buckeye	Aesculus	pavia
X	E			0341	AIAL	ailanthus	Ailanthus	altissima
X	E	W		0345	ALJU	mimosa/silktree	Albizia	julibrissin
		W		0350	ALNUS	alder spp.	Alnus	spp.
X	E			0355	ALGL2	European alder	Alnus	glutinosa
	E	W		0356	AMELA	serviceberry spp.	Amelanchier	spp.

Core	East	West	WdInd	FIA	PLANTS00	Common Name	Genus	Species
	E	W		0357	AMAR3	common serviceberry	Amelanchier	arborea
	E	W		0358	AMSA	roundleaf serviceberry	Amelanchier	sanguinea
X	E			0367	ASTR	pawpaw	Asimina	triloba
	E	W		0370	BETUL	birch spp.	Betula	spp.
X	E			0371	BEAL2	yellow birch	Betula	alleghaniensis
X	E			0372	BELE	sweet birch	Betula	lenta
X	E			0373	BENI	river birch	Betula	nigra
X	E			0374	BEOC2	water birch	Betula	occidentalis
X	E	W		0375	BEPA	paper birch	Betula	papyrifera
X	E			0379	BEPO	gray birch	Betula	populifolia
X	E			0391	CACA18	American hornbeam, musclewood	Carpinus	caroliniana
	E			0400	CARYA	hickory spp.	Carya	spp.
X	E			0401	CAAQ2	water hickory	Carya	aquatica
X	E			0402	CACO15	bitternut hickory	Carya	cordiformis
X	E			0403	CAGL8	pignut hickory	Carya	glabra
X	E			0404	CAIL2	pecan	Carya	illinoensis
X	E			0405	CALA21	shellbark hickory	Carya	laciniosa
X	E			0407	CAOV2	shagbark hickory	Carya	ovata
X	E			0408	CATE9	black hickory	Carya	texana
X	E			0409	CAAL27	mockernut hickory	Carya	alba
X	E			0410	CAPA24	sand hickory	Carya	pallida
X	E			0412	CAOV3	red hickory	Carya	ovalis
	E	W		0420	CASTA	chestnut spp.	Castanea	spp.
	E			0421	CADE12	American chestnut	Castanea	dentata
X	E			0422	CAPU9	Allegheny chinkapin	Castanea	pumila
	E			0423	CAPUO	Ozark chinkapin	Castanea	pumila var. ozarkensis
X	E	W		0424	CAMO83	Chinese chestnut	Castanea	mollissima
	E			0450	CATAL	catalpa spp.	Catalpa	spp.
X	E			0451	CABI8	southern catalpa	Catalpa	bignonioides
X	E			0452	CASP8	northern catalpa	Catalpa	speciosa
	E	W		0460	CELT1	hackberry spp.	Celtis	spp.
X	E	W		0461	CELA	sugarberry	Celtis	laevigata
X	E	W		0462	CEOC	hackberry	Celtis	occidentalis
	E	W		0463	CELAR	netleaf hackberry	Celtis	laevigata var. reticulata

Core	East	West	WdInd	FIA	PLANTS00	Common Name	Genus	Species
X	E			0471	CECA4	eastern redbud	Cercis	canadensis
X	E			0481	CLKE	yellowwood	Cladrastis	kentukea
	E	W		0490	CORNU	dogwood spp.	Cornus	spp.
X	E			0491	COFL2	flowering dogwood	Cornus	florida
	E			0500	CRATA	hawthorn spp.	Crataegus	spp.
	E			0501	CRCR2	cockspur hawthorn	Crataegus	crus-galli
	E			0502	CRMO2	downy hawthorn	Crataegus	mollis
	E			0503	CRBR3	Brainerd hawthorn	Crataegus	brainerdii
	E			0504	CRCA	pear hawthorn	Crataegus	calpodendron
	E			0505	CRCH	fireberry hawthorn	Crataegus	chrysocarpa
	E			0506	CRDI	broadleaf hawthorn	Crataegus	dilatata
	E			0507	CRFL	fanleaf hawthorn	Crataegus	flabellata
	E			0508	CRMO3	oneseed hawthorn	Crataegus	monogyna
	E			0509	CRPE	scarlet hawthorn	Crataegus	pedicellata
	E			5091	CRPH	Washington hawthorn	Crataegus	phaenopyrum
	E			5092	CRSU5	fleshy hawthorn	Crataegus	succulenta
	E			5093	CRUN	dwarf hawthorn	Crataegus	uniflora
	E			0520	DIOSP	persimmon spp.	Diospyros	spp.
X	E			0521	DIVI5	common persimmon	Diospyros	virginiana
X	E			0531	FAGR	American beech	Fagus	grandifolia
	E	W		0540	FRAXI	ash spp.	Fraxinus	spp.
X	E			0541	FRAM2	white ash	Fraxinus	americana
X	E			0543	FRNI	black ash	Fraxinus	nigra
X	E			0544	FRPE	green ash	Fraxinus	pennsylvanica
X	E			0545	FRPR	pumpkin ash	Fraxinus	profunda
X	E			0546	FRQU	blue ash	Fraxinus	quadrangulata
	E			0550	GLEDI	locust spp.	Gleditsia	spp.
X	E			0551	GLAQ	waterlocust	Gleditsia	aquatica
X	E			0552	GLTR	honeylocust	Gleditsia	triacanthos
X	E	W		0561	GIBI2	Ginkgo, maidenhair tree	Ginkgo	biloba
X	E			0571	GYDI	Kentucky coffeetree	Gymnocladus	dioicus
	E			0580	HALES	silverbell spp.	Halesia	spp.
X	E			0591	ILOP	American holly	Ilex	opaca
	E	W		0600	JUGLA	walnut spp.	Juglans	spp.
X	E			0601	JUCI	butternut	Juglans	cinerea
X	E	W		0602	JUNI	black walnut	Juglans	nigra

Core	East	West	WdInd	FIA	PLANTS00	Common Name	Genus	Species
	E	W		0605	JUMI	Texas walnut	Juglans	microcarpa
X	E			0611	LIST2	sweetgum	Liquidambar	styraciflua
X	E			0621	LITU	yellow-poplar	Liriodendron	tulipifera
X	E			0641	MAPO	Osage-orange	Maclura	pomifera
	E			0650	MAGNO	magnolia spp.	Magnolia	spp.
X	E			0651	MAAC	cucumbertree	Magnolia	acuminata
X	E			0652	MAGR4	southern magnolia	Magnolia	grandiflora
X	E			0653	MAVI2	sweetbay	Magnolia	virginiana
X	E			0654	MAMA2	bigleaf magnolia	Magnolia	macrophylla
X	E			0655	MAFR	mountain magnolia, Fraser magnolia	Magnolia	fraseri
X	E			0658	MATR	umbrella magnolia	Magnolia	tripetala
	E	W		0660	MALUS	apple spp.	Malus	spp.
X	E			0662	MAAN3	southern crabapple	Malus	angustifolia
X	E			0663	MACO5	sweet crabapple	Malus	coronaria
X	E			0664	MAIO	prairie crabapple	Malus	ioensis
	E			0680	MORUS	mulberry spp.	Morus	spp.
X	E			0681	MOAL	white mulberry	Morus	alba
X	E			0682	MORU2	red mulberry	Morus	rubra
X	E			0684	MONI	black mulberry	Morus	nigra
	E			0690	NYSSA	tupelo spp.	Nyssa	spp.
X	E			0691	NYAQ2	water tupelo	Nyssa	aquatica
X	E			0693	NYSY	blackgum	Nyssa	sylvatica
X	E			0694	NYBI	swamp tupelo	Nyssa	biflora
X	E			0701	OSVI	eastern hophornbeam	Ostrya	virginiana
X	E			0711	OXAR	sourwood	Oxydendrum	arboreum
X	E			0712	PATO2	paulownia, empress-tree	Paulownia	tomentosa
	E	W		0720	PERSE	bay spp.	Persea	spp.
X	E			0722	PLAQ	water-elm, planertree	Planera	aquatica
	E	W		0729	PLATA	sycamore spp.	Platanus	spp.
X	E			0731	PLOC	American sycamore	Platanus	occidentalis
	E	W		0740	POPUL	cottonwood and poplar spp.	Populus	spp.
X	E	W		0741	POBA2	balsam poplar	Populus	balsamifera
X	E			0742	PODE3	eastern cottonwood	Populus	deltoides
X	E			0743	POGR4	bigtooth aspen	Populus	grandidentata
X	E			0744	POHE4	swamp cottonwood	Populus	heterophylla

Core	East	West	WdInd	FIA	PLANTS00	Common Name	Genus	Species
X	E	W		0745	PODEM	plains cottonwood	Populus	deltooides ssp. monilifera
X	E	W		0746	POTR5	quaking aspen	Populus	tremuloides
X		W		0747	POBAT	black cottonwood	Populus	balsamifera ssp. trichocarpa
X		W		0749	POAN3	narrowleaf cottonwood	Populus	angustifolia
X	E			0752	POAL7	silver poplar	Populus	alba
X	E			0753	PONI	Lombardy poplar	Populus	nigra
	E	W		0760	PRUNU	cherry and plum spp.	Prunus	spp.
	E	W		0761	PRPE2	pin cherry	Prunus	pensylvanica
X	E			0762	PRSE2	black cherry	Prunus	serotina
	E	W		0763	PRVI	common chokecherry	Prunus	virginiana
	E			0764	PRPE3	peach	Prunus	persica
X	E			0765	PRNI	Canada plum	Prunus	nigra
X	E			0766	PRAM	American plum	Prunus	americana
	E			0769	PRAL5	Allegheny plum	Prunus	alleghaniensis
	E	W		0770	PRAN3	Chickasaw plum	Prunus	angustifolia
X	E			0771	PRAV	sweet cherry (domesticated)	Prunus	avium
	E			0772	PRCE	sour cherry (domesticated)	Prunus	cerasus
	E			0773	PRDO	European plum (domesticated)	Prunus	domestica
	E			0774	PRMA	Mahaleb plum (domesticated)	Prunus	mahaleb
	E	W		0800	QUERC	oak – deciduous spp.	Quercus	spp.
X	E			0802	QUAL	white oak	Quercus	alba
X	E			0804	QUBI	swamp white oak	Quercus	bicolor
X	E			0806	QUCO2	scarlet oak	Quercus	coccinea
X	E			0809	QUEL	northern pin oak	Quercus	ellipsoidalis
X	E			0812	QUFA	southern red oak	Quercus	falcata
X	E			0813	QUPA5	cherrybark oak	Quercus	pagoda
X	E			0816	QUIL	scrub oak	Quercus	ilicifolia
X	E			0817	QUIM	shingle oak	Quercus	imbricaria
X	E			0820	QULA3	laurel oak	Quercus	laurifolia
X	E			0822	QULY	overcup oak	Quercus	lyrata
X	E			0823	QUMA2	bur oak	Quercus	macrocarpa
X	E			0824	QUMA3	blackjack oak	Quercus	marilandica

Core	East	West	WdInd	FIA	PLANTS00	Common Name	Genus	Species
X	E			0825	QUMI	swamp chestnut oak	Quercus	michauxii
X	E			0826	QUMU	chinkapin oak	Quercus	muehlenbergii
X	E			0827	QUNI	water oak	Quercus	nigra
X	E			0828	QUBU2	Nuttall oak	Quercus	buckleyi
X	E			0830	QUPA2	pin oak	Quercus	palustris
X	E			0831	QUPH	willow oak	Quercus	phellos
X	E			0832	QUPR2	chestnut oak	Quercus	prinus
X	E			0833	QURU	northern red oak	Quercus	rubra
X	E			0834	QUSH	Shumard's oak	Quercus	shumardii
X	E			0835	QUST	post oak	Quercus	stellata
X	E			0837	QUVE	black oak	Quercus	velutina
X	E			0840	QUMA6	dwarf post oak	Quercus	margaretiae
	E			0845	QUPR	dwarf chinkapin oak	Quercus	prinoides
X	E	W		0901	ROPS	black locust	Robinia	pseudoacacia
	E	W		0919	SASAD	western soapberry	Sapindus	saponaria var. drummondii
	E	W		0920	SALIX	willow spp.	Salix	spp.
	E	W		0921	SAAM2	peachleaf willow	Salix	amygdaloides
	E	W		0922	SANI	black willow	Salix	nigra
	E	W		0923	SABE2	Bebb willow	Salix	bebbiana
X	E			0925	SACA5	coastal plain willow	Salix	caroliniana
X	E			0926	SAPY	balsam willow	Salix	pyrifolia
	E	W		0927	SAAL2	white willow	Salix	alba
X	E			0929	SASE10	weeping willow	Salix	sepulcralis
X	E			0931	SAAL5	sassafras	Sassafras	albidum
	E			0934	SORBU	mountain ash spp.	Sorbus	spp.
	E			0935	SOAM3	American mountain ash	Sorbus	americana
X	E			0936	SOAU	European mountain ash	Sorbus	aucuparia
X	E			0937	SODE3	northern mountain ash	Sorbus	decora
	E			0950	TILIA	basswood spp.	Tilia	spp.
X	E			0951	TIAM	American basswood	Tilia	americana
	E			0952	TIAMH	white basswood	Tilia	americana var. heterophylla
	E			0953	TIAMC	Carolina basswood	Tilia	americana var. caroliniana
	E			0970	ULMUS	elm spp.	Ulmus	spp.
X	E			0971	ULAL	winged elm	Ulmus	alata

Core	East	West	WdInd	FIA	PLANTS00	Common Name	Genus	Species
X	E			0972	ULAM	American elm	Ulmus	americana
X	E			0973	ULCR	cedar elm	Ulmus	crassifolia
X	E			0974	ULPU	Siberian elm	Ulmus	pumila
X	E			0975	ULRU	slippery elm	Ulmus	rubra
X	E			0976	ULSE	September elm	Ulmus	serotina
X	E			0977	ULTH	rock elm	Ulmus	thomasii
	E	W		0991	TAMAR2	saltcedar	Tamarix	spp.
X	E			0993	MEAZ	chinaberry	Melia	azedarach
X	E			0996	COOB2	smoketree	Cotinus	obovatus
	E	W		0997	ELAN	Russian-olive	Elaeagnus	angustifolia
X	E	W		0998	2TB	unknown dead hardwood	Tree	broadleaf
X	E	W		0999	2TREE	other, or unknown live tree	Tree	unknown

Appendix 4N. Site Tree Selection Criteria and Species List

A. Eastern U.S. Site-Tree Selection Criteria modified for the North

Ideally, site trees in the eastern U.S. should be between 20-70 years old. If preferred trees cannot be found in this age range, expand the age range to 15-120 years. Reject trees outside the 15-120 year age range, trees that exhibit signs of damage, trees with ring patterns that show signs of suppression, trees less than 5.0 inches DBH, trees with abnormalities at DBH, and trees with rotten cores. A list of preferred site-tree species is provided. Site trees should be selected in the following order of preference:

- 1st Choice: representative of the stand, on the list for your region.
- 2nd Choice: representative of the stand, on the list for an adjoining eastern region.
- 3rd Choice: not representative of the stand, on the list for your region.
- 4th Choice: not representative of the stand, on the list for an adjoining eastern region.

NRS Note: The species table below has been modified for the Northern region. Species indicated with an "E" are acceptable to core in the eastern states. Species indicated with a "W" are acceptable to core in the western states.

Code	Common Name	NRS	
0012	balsam fir	E	W
0043	Atlantic white-cedar	E	
0068	eastern redcedar	E	W
0070	larch (introduced)	E	
0071	tamarack (native)	E	W
0094	white spruce	E	W
0095	black spruce	E	W
0097	red spruce	E	
0105	jack pine	E	W
0110	shortleaf pine	E	W
0122	Ponderosa pine		W
0125	red pine	E	W
0128	pond pine	E	
0129	eastern white pine	E	W
0130	Scotch pine	E	W
0131	loblolly pine	E	
0132	Virginia pine	E	
0241	northern white cedar	E	W
0261	eastern hemlock	E	W
0316	red maple	E	W
0317	silver maple	E	W
0318	sugar maple	E	W
0371	yellow birch	E	W
0375	paper birch	E	W
0402	bitternut hickory	E	W
0407	shagbark hickory	E	W
0462	hackberry		W
0531	American beech	E	W
0541	white ash	E	W
0543	black ash	E	W
0544	green ash	E	W

Code	Common Name	NRS	
0602	black walnut		W
0611	sweetgum	E	W
0621	yellow-poplar	E	W
0742	eastern cottonwood	E	W
0743	bigtooth aspen	E	W
0746	quaking aspen	E	W
0762	black cherry		W
0802	white oak	E	W
0806	scarlet oak	E	W
0812	southern red oak	E	
0813	cherrybark oak	E	
0817	shingle oak	E	W
0827	water oak	E	
0830	pin oak	E	W
0832	chestnut oak	E	
0833	northern red oak	E	W
0835	post oak	E	W
0837	black oak	E	W
0901	black locust	E	W
0951	American basswood	E	W
0972	American elm	E	W

Appendix 5N. Determination of Stocking Values for Land Use Classification

Stocking values are required to determine if a CONDITION CLASS STATUS = 1 (accessible forest land) exists on a plot. This will determine which data items must be recorded for the condition. When the CONDITION CLASS STATUS is in question (usually a nonforest area that is in the process of reverting to forest land or a marginal site that can only support a low number of trees), the crew must determine if there is sufficient stocking to classify the condition as forest. A minimum stocking value of 10 percent is required for accessible forest land (unless the condition was previously forested, such as a recent clear cut).

The following tables show the stocking values to assign to trees or the number of trees per acre to determine if a plot meets the minimum stocking to be considered forest land. In the determination of stocking for this purpose, the field crew should consider the condition over its entire area, not just the trees and seedlings that would be tallied on the subplots and microplots, especially when the plot straddles conditions. Also, for stocking purposes, consider a clump of trees (e.g., stump sprouts) less than 5 inches DBH to be a single tree.

The number of trees per acre needed to obtain minimum stocking depends on the DBH of the largest tree on the plot in the condition being evaluated, and the species and DBH of each of the tally trees. If the condition occurs on all four subplots and the trees are distributed fairly evenly over the entire condition area, the following steps can be used to determine if the condition has the minimum number of trees per acre for forest land.

Observe all of the **live trees on the plot (i.e., all 4 subplots and/or temporary subplots)** and classify the condition, based on the tree with the largest DBH, into one of the following groups; the largest tree observed has a DBH of 5 inches or greater, 4.0-4.9 inches, 3.0-3.9 inches, 2.0-2.9 inches, 1.0-1.9 inches or less than 1.0 inch DBH. **In the North, use the *Stocking Values* table to determine if the condition meets minimum stocking, use table 5a plus 5b.**

When using a *Stocking Values* table, begin a tally of each subplot and microplot and sum the stocking values for each tree tallied based upon its species and size class. **If a species is not listed, use the unknown code 0999 value.** When the stocking values for the tallied trees equals or exceeds 10, the condition meets the minimum stocking requirement for forest land.

For example, a condition that was formerly nonforest is no longer being maintained as nonforest and has begun to revert. A check of all four subplots and microplots confirms that the largest tree there is in the 3.0 – 3.9 inches DBH class. The tally of microplot 1 is one red maple (species code = 316) seedling. The sum of the stocking value (table 5a) to this point is 2.4 and the tally continues on microplot 2.

Subplot Number	Plot Type	Species	Size Class	Number Tallied	Stocking Value
1	2	316	< 1.0	1	2.4
Total					2.4

The tally at microplot 2 is two red maple seedlings. The stocking value for the two seedlings is 4.8. The cumulative stocking value to this point is 7.2. Since the minimum value of 10 percent stocking has not been reached, the tally continues to subplot 3.

Subplot Number	Plot Type	Species	Size Class	Number Talled	Stocking Value
1	2	316	< 1.0	1	2.4
2	2	316	< 1.0	2	4.8
Total					7.2

At microplot 3 one sugar maple (species code = 318) sapling in the 1.0 – 1.9-inch DBH class is tallied. The cumulative stocking value is now 13.1 and the condition meets the minimum stocking to be considered forest land.

Subplot Number	Plot Type	Species	Size Class	Number Talled	Stocking Value
1	2	316	< 1.0	1	2.4
2	2	316	< 1.0	2	4.8
3	2	318	1.0 – 1.9	1	5.9
Total					13.1

When trees of more than one diameter class are present, their contribution towards meeting the minimum must be combined. For example:

In a lodgepole pine stand (species code = 108), the largest tree in the condition is 5.0+ inches DBH. If at least 20 trees that are 5.0-6.9 inches DBH are found on the four subplots, the minimum stocking of 10 percent (table 5b: 5th row, 1st column) is met. In the same condition only 5 tally trees in the 13.0-14.9-inch DBH class are needed to meet minimum stocking of 10 percent. If the tally were three 5.0-6.9-inch trees and two 13.0-14.9-inch DBH class trees (total stocking of $3 \times 0.5 + 2 \times 2.2 = 5.9$), the combined stocking would not meet the minimum 10 percent ($5.9 < 10$) and the condition would be classified nonforest.

Other things observed on the plot will influence the determination of condition class status. In the last lodgepole pine example, evidence of a recent disturbance that reduced the stocking (cutting, fire, etc.) should be considered. Also, a very uneven distribution of the trees across the condition can greatly change the observed number of trees per acre on plots installed across the condition.

If the condition does not cover all four subplots entirely, trees per acre must be expanded using an expansion factor. The expansion factor is equal to $400/\text{sum of the percent of subplot area (\%ARE)}$ for the condition. The trees per acre value of every diameter class are multiplied by this expansion factor.

If the trees are not uniformly distributed throughout the condition or the condition occurs on only a small portion of the plot (half the plot or less), use your best judgment in assigning status. You may place several additional temporary subplots in the condition in order to get a larger sample to base stocking on. When additional temporary subplots or judgment is used to assign land use, a note should be made on the plot sheet. Use the following procedure to establish these temporary subplots in a condition:

- A. Consider locations 120.0 feet horizontal distance from the highest numbered subplot in the condition. First consider the location 0° azimuth from the subplot center. If this location is unsuitable, consider in order locations at azimuth 120°, and 240°. When a suitable location

has been found, establish the temporary subplot. Temporary subplots should be entirely within the condition (locations should not be within 24.0 feet of a mapped boundary).

- B. If Step A fails to yield a suitable subplot location, repeat Step A at each of the next highest-numbered regular subplots in the condition.
- C. If Steps A and B have been exhausted and a suitable temporary subplot still has not been found, repeat Step A at each temporary subplot in turn, beginning with the first temporary subplot that was established.

If more than one temporary subplot is to be established, repeat Steps A and B to establish the second lowest-numbered temporary subplot next, and continue in order until you have enough temporary subplots established in the condition to get a good, representative estimate of stocking. The general rule for establishing temporary subplots is:

- Install the lowest temporary subplot off the highest established subplot, until all the established subplots have been exhausted.
- Then establish the lowest temporary subplot yet to be established off the lowest one already established (lowest off highest, then lowest off lowest).

If there is a transition zone between two conditions use your best judgment to be sure that trees tallied in the transition zone do not have too much weight in the assignment of a land use.

How to Install Stocking Subplots << Additional Regional Instructions

If it is unclear if a particular condition will meet the minimum stocking levels required for **CONDITION CLASS STATUS 1** (accessible forest land), the following procedures are used to determine the stocking level.

1. To determine if minimum stocking is reached, the crew samples all live trees on each of the four 1/24 acre subplots (tree tally), and the four 1/300 acre reproduction plots (seedling and sapling tally) located 90 degrees and 12.0 feet from the subplot centers. The sample may consist of any combination of regular subplots and/or temporary subplots, provided all subplots fall entirely in the questionable condition.
2. The crew installs temporary subplots as necessary to yield four 1/24 acre sample areas. Use the Stocking Plot Reference Diagram showing the temporary subplot layout relative to the actual plot location. (See Figure A5.1N, A5.2N and A5.3N for illustrated examples.)
 - a. Begin by locating the temporary subplots off the "highest" numbered regular subplot that falls in the questionable condition (e.g., 4 is the highest numbered regular subplot, next 3 and then 2). The temporary subplots are located in the following order: 1) 120.0 feet at 360 degrees, 2) 120.0 feet and 120 degrees, then 3) 120.0 feet at 240 degrees.
 - b. If this fails to yield 4 subplots that fall entirely within the questionable condition, install the remaining temporary subplots off the next highest numbered regular subplot that falls in the questionable condition.
 - c. If this fails to produce a suitable location, rotate the temporary subplot off the other temporary subplots in the order they were installed until 4 subplots have been located in the questionable condition. (See Figure A5.3N for illustrated example.)
3. If any time, the tally indicates that minimum stocking levels have been met, do not install the remaining temporary subplots. Note: Crew may need to install all 4 subplots and/or temporary subplots to identify the largest tree on the plot so that the correct stocking values can be obtained from the tables.

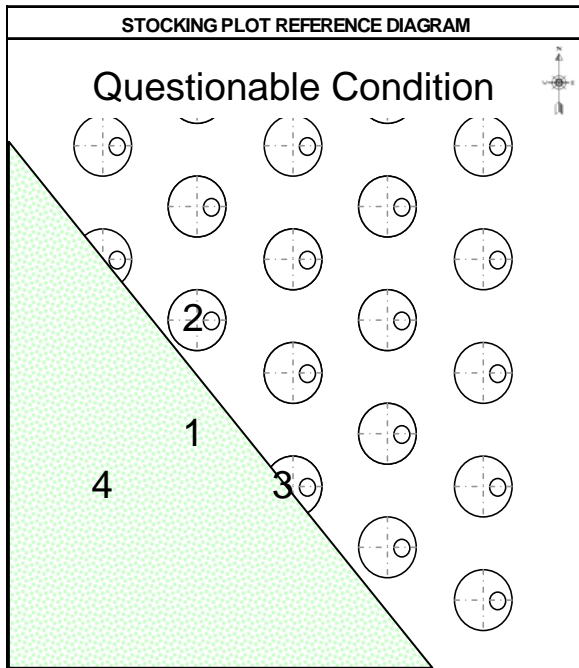

Figure A5.1N. In this illustration a plot straddles a forest and a questionable condition. Subplots 1 and 4 are entirely in forest. Subplot 3 straddles the conditions and subplot 2 falls entirely in the questionable condition. Since subplot 3 is the “highest” numbered normal subplot in the questionable condition, temporary subplots are first installed from this subplot. See Figure A5.2.

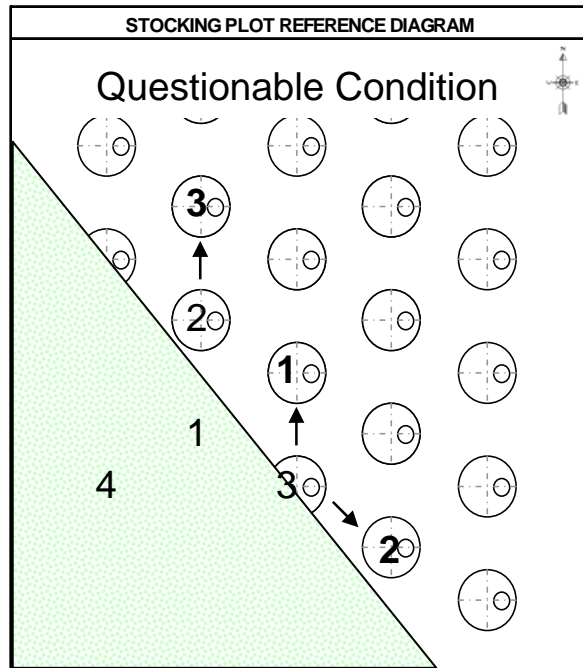

Figure A5.2N. The illustration shows the temporary subplot installation sequence from the original subplot 3. The 1st temporary subplot is installed at 360 degrees and the 2nd temporary subplot is installed at 120 degrees. The 3rd temporary subplot is installed from original subplot 2. Since original subplot 2 falls in the questionable condition, this subplot and the 3 temporary subplots are used to determine stocking.

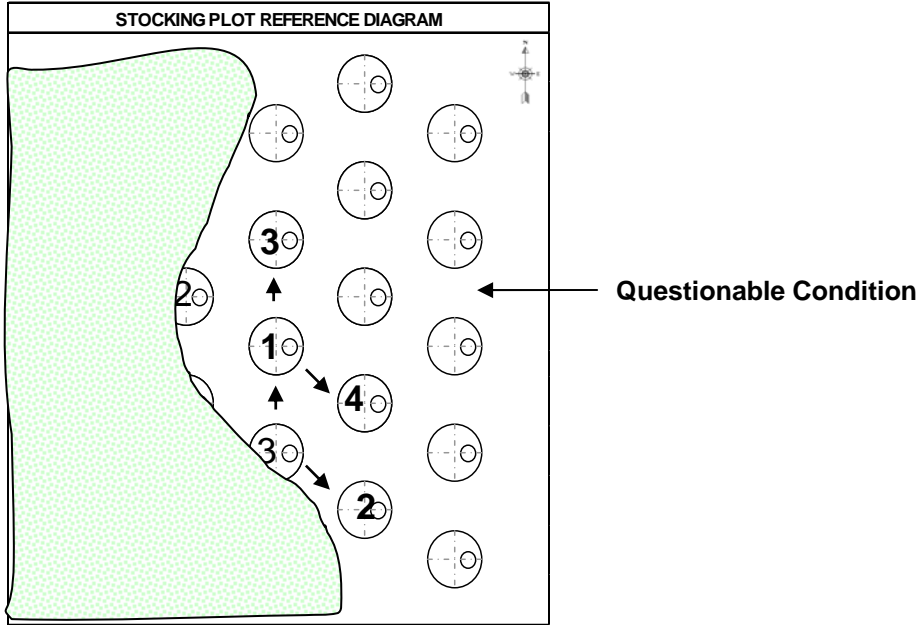

Figure A5.3N. This illustration shows how to install temporary subplots from temporary subplots. Original subplot 3 is the highest numbered normal subplot in the questionable condition. From subplot 3, 2 temporary subplots can be installed at 360 and 120 degrees. The next highest normal subplot in the questionable condition is 2, but no temporary subplots can be installed from this subplot. Temporary subplot 3 and 4 are installed from the 1st temporary subplot installed.

NRS Note: On the following page, the use of a regional Stocking Check Worksheet is described and illustrated. The use of the worksheet and the Stocking Plot Reference Diagram documents the procedures used to verify whether or not a questionable condition met minimum stocking for accessible forest land. This worksheet and diagram is attached to any plot where stocking is checked.

STOCKING CHECK WORKSHEET						
DBH of the largest tally tree on the plot = 03.2						
Column used from Table 5a + 5b: 3.0-3.9						
SUBPLOT NUMBER	PLOT TYPE	SPECIES	DBH	NUMBER TALLIED BY DBH SIZE CLASS	STOCKING VALUE	CUMULATIVE TOTAL
x	x	xxxx	xxx	x	xx.x	xx.x
1'	2	0611	032	1	7.6	7.6
2'	2	0068	001	1	2.3	9.9
3'	2	0316	001	3	2.4	17.1

Figure A5.4. Determine the largest tree on the 4 subplots and/or temporary subplots used for stocking. This diameter determines the stocking value column used from Table 5a or 5b. Find the species and go across the table to the appropriate diameter column and record this value. The “largest diameter tree” is the first stocking value entered in the stocking check worksheet. In this example the largest tree on the 4 subplots was on temporary subplot 1’s microplot. Additional tally on the temporary subplots were required to finish the stocking check.

STOCKING CHECK WORKSHEET						
DBH of the largest tally tree on the plot = 07.1						
Column used from Table 5a + 5b: 5.0+						
SUBPLOT NUMBER	PLOT TYPE	SPECIES	DBH	NUMBER TALLIED BY DBH SIZE CLASS	STOCKING VALUE	CUMULATIVE TOTAL
x	x	xxxx	xxx	x	xx.x	xx.x
1'	1	0129	071	1	1.2	1.2
2'	2	0068	001	3	1.6	6.0
3'	2	0316	001	3	1.6	10.8

Figure A5.5. This example of using the stocking worksheet uses the same species and count from the Figure A5.4. However, a different column is used because now the largest tree is 7.1 inches on the plot and not 3.2.

Table 5a. Stocking values for all tallied trees on the four subplots and microplots **modified for the North's species list.**

	DBH of the largest tally tree in the condition																				
	5.0+						4.0-4.9					3.0-3.9				2.0-2.9			1.0-1.9		Seed-ling
	DBH of tally tree						DBH of tally tree					DBH of tally tree				DBH of tally tree			DBH of tally tree		
Species	5.0-6.9	4.0-4.9	3.0-3.9	2.0-2.9	1.0-1.9	Seed-ling	4.0-4.9	3.0-3.9	2.0-2.9	1.0-1.9	Seed-ling	3.0-3.9	2.0-2.9	1.0-1.9	Seed-ling	2.0-2.9	1.0-1.9	Seed-ling	1.0-1.9	Seed-ling	Seed-ling
10, 12, 16, 70, 71, 90, 91, 94, 96, 97	0.7	6.9	5.2	4.0	2.6	1.2	7.9	6.2	4.6	3.0	1.4	7.6	5.7	3.7	1.8	7.4	4.9	2.3	7.2	3.5	7.0
57, 61, 95	0.7	6.2	4.7	3.6	2.3	1.1	7.1	5.6	4.2	2.7	1.3	6.9	5.1	3.3	1.6	6.7	4.4	2.1	6.5	3.2	6.3
68, 105, 123, 126, 130, 132, 230, 299	1.0	9.1	6.9	5.3	3.4	1.6	10.4	8.3	6.1	4.0	1.9	10.1	7.5	4.9	2.3	9.9	6.5	3.1	9.6	4.7	9.3
108	0.5	5.0	3.7	2.9	1.9	0.8	5.7	4.5	3.3	2.2	1.0	5.5	4.1	2.7	1.3	5.4	3.5	1.7	5.2	2.5	5.1
110	0.8	7.3	5.5	4.3	2.7	1.2	8.3	6.6	4.9	3.2	1.5	8.1	6.0	3.9	1.9	7.9	5.2	2.5	7.6	3.7	7.4
66, 100, 113, 122, 321, 800, 823, 826	0.5	5.0	3.8	2.9	1.9	0.9	5.7	4.6	3.4	2.2	1.0	5.6	4.1	2.7	1.3	5.4	3.6	1.7	5.3	2.6	5.1
125, 136	0.7	6.8	5.1	4.0	2.6	1.2	7.7	6.1	4.6	3.0	1.4	7.5	5.6	3.7	1.7	7.3	4.8	2.3	7.1	3.5	6.9
128	1.1	10.2	7.7	5.9	3.8	1.7	11.6	9.2	6.8	4.5	2.1	11.3	8.4	5.5	2.6	11.0	7.2	3.5	10.7	5.2	10.4
129	0.8	7.5	5.7	4.4	2.8	1.3	8.6	6.8	5.1	3.3	1.5	8.4	6.2	4.1	1.9	8.1	5.3	2.6	7.9	3.8	7.7
131	0.9	8.3	6.3	4.8	3.1	1.4	9.4	7.5	5.6	3.6	1.7	9.2	6.8	4.5	2.1	8.9	5.9	2.8	8.7	4.2	8.4
15, 200, 202	0.7	6.8	5.1	4.0	2.6	1.2	7.7	6.2	4.6	3.0	1.4	7.5	5.6	3.7	1.7	7.3	4.8	2.3	7.1	3.5	6.9
43, 241	0.7	6.1	4.6	3.6	2.3	1.0	6.9	5.5	4.1	2.7	1.2	6.8	5.0	3.3	1.6	6.6	4.3	2.1	6.4	3.1	6.2
240, 260, 261	0.8	7.7	5.8	4.5	2.9	1.3	8.7	7.0	5.2	3.4	1.6	8.5	6.3	4.1	2.0	8.3	5.4	2.6	8.0	3.9	7.8
40	0.5	4.8	3.6	2.8	1.8	0.8	5.4	4.3	3.2	2.1	1.0	5.3	3.9	2.6	1.2	5.1	3.4	1.6	5.0	2.4	4.8

Table 5a. Stocking values for all tallied trees on the four subplots and microplots **modified for the North's species list.**

Species	DBH of the largest tally tree in the condition																				
	5.0+						4.0-4.9					3.0-3.9				2.0-2.9			1.0-1.9		Seed-ling
	DBH of tally tree						DBH of tally tree					DBH of tally tree				DBH of tally tree			DBH of tally tree		
	5.0-6.9	4.0-4.9	3.0-3.9	2.0-2.9	1.0-1.9	Seed-ling	4.0-4.9	3.0-3.9	2.0-2.9	1.0-1.9	Seed-ling	3.0-3.9	2.0-2.9	1.0-1.9	Seed-ling	2.0-2.9	1.0-1.9	Seed-ling	1.0-1.9	Seed-ling	Seed-ling
310, 316, 317, 319, 320, 341, 356, 357, 358, 367, 391, 420, 421, 424, 471, 481, 490, 491, 550, 551, 561, 571, 580, 583, 591, 653, 680, 681, 682, 684, 701, 711, 760, 761, 763, 764, 765, 766, 769, 770, 771, 772, 773, 774, 919, 920, 921, 922, 923, 925, 926, 927, 929, 934, 935, 936, 937, 991, 996, 997, 998, 999	1.0	9.6	7.2	5.6	3.6	1.6	10.9	8.7	6.4	4.2	2.0	10.6	7.9	5.2	2.4	10.3	6.8	3.3	10.0	4.9	9.8
350, 355	1.3	11.7	8.8	6.8	4.4	2.0	13.3	10.6	7.9	5.1	2.4	13.0	9.6	6.3	3.0	12.6	8.3	4.0	12.3	5.9	11.9
314, 315, 318, 330, 331, 332, 336, 370, 371, 372, 450, 451, 452, 531, 552, 712	1.2	10.9	8.2	6.3	4.1	1.8	12.4	9.8	7.3	4.8	2.2	12.1	9.0	5.9	2.8	11.7	7.7	3.7	11.4	5.5	11.1
373, 374, 375, 379	1.1	10.5	7.9	6.1	4.0	1.8	12.0	9.5	7.1	4.6	2.1	11.6	8.7	5.7	2.7	11.3	7.4	3.6	11.0	5.3	10.7

Table 5a. Stocking values for all tallied trees on the four subplots and microplots **modified for the North's species list.**

Species	DBH of the largest tally tree in the condition																				
	5.0+						4.0-4.9					3.0-3.9				2.0-2.9			1.0-1.9		Seed-ling
	DBH of tally tree						DBH of tally tree					DBH of tally tree				DBH of tally tree			DBH of tally tree		
	5.0-6.9	4.0-4.9	3.0-3.9	2.0-2.9	1.0-1.9	Seed-ling	4.0-4.9	3.0-3.9	2.0-2.9	1.0-1.9	Seed-ling	3.0-3.9	2.0-2.9	1.0-1.9	Seed-ling	2.0-2.9	1.0-1.9	Seed-ling	1.0-1.9	Seed-ling	Seed-ling
400, 401, 402, 403, 404, 405, 407, 408, 409, 410, 412, 422, 423, 500, 501, 502, 503, 504, 505, 506, 507, 508, 509, 520, 521, 641, 660, 662, 663, 664, 802, 804, 806, 808, 809, 812, 813, 816, 817, 820, 822, 824, 825, 827, 828, 830, 831, 832, 833, 834, 835, 837, 840, 845, 901, 931, 5091, 5092, 5093	1.2	11.6	8.8	6.8	4.4	2.0	13.2	10.5	7.8	5.1	2.4	12.9	9.6	6.3	3.0	12.5	8.2	3.9	12.2	5.9	11.8
600, 601, 602, 605	1.4	12.7	9.6	7.4	4.8	2.2	14.5	11.5	8.5	5.6	2.6	14.1	10.5	6.9	3.2	13.7	9.0	4.3	13.3	6.5	12.9
220, 221, 222, 611, 690, 691, 693, 694	0.7	6.8	5.2	4.0	2.6	1.2	7.8	6.2	4.6	3.0	1.4	7.6	5.6	3.7	1.7	7.4	4.9	2.3	7.2	3.5	7.0
741, 743, 746	1.2	10.9	8.3	6.4	4.1	1.9	12.5	9.9	7.3	4.8	2.2	12.1	9.0	5.9	2.8	11.8	7.8	3.7	11.5	5.6	11.1
540, 541, 543, 545, 546, 621, 650, 651, 652, 654, 655, 658, 720, 722, 762, 993	1.0	9.3	7.0	5.4	3.5	1.6	10.6	8.4	6.3	4.1	1.9	10.3	7.7	5.0	2.4	10.0	6.6	3.2	9.8	4.7	9.5

Table 5a. Stocking values for all tallied trees on the four subplots and microplots **modified for the North's species list.**

	DBH of the largest tally tree in the condition																				
	5.0+						4.0-4.9					3.0-3.9				2.0-2.9			1.0-1.9		Seed-ling
	DBH of tally tree						DBH of tally tree					DBH of tally tree				DBH of tally tree			DBH of tally tree		
Species	5.0-6.9	4.0-4.9	3.0-3.9	2.0-2.9	1.0-1.9	Seed-ling	4.0-4.9	3.0-3.9	2.0-2.9	1.0-1.9	Seed-ling	3.0-3.9	2.0-2.9	1.0-1.9	Seed-ling	2.0-2.9	1.0-1.9	Seed-ling	1.0-1.9	Seed-ling	Seed-ling
950, 951, 952, 953	1.0	9.2	7.0	5.4	3.5	1.6	10.5	8.4	6.2	4.0	1.9	10.2	7.6	5.0	2.3	10.0	6.5	3.1	9.7	4.7	9.4
313, 345, 460, 461, 462, 463, 544, 729, 731, 740, 742, 744, 745, 747, 749, 752, 753, 970, 971, 972, 973, 974, 975, 976, 977	1.2	10.8	8.1	6.3	4.1	1.8	12.3	9.8	7.2	4.7	2.2	12.0	8.9	5.8	2.7	11.6	7.6	3.7	11.3	5.5	11.0

Table 5b. Stocking values for all trees tallied on the subplot only modified for the North's species list.													
Species	5.0-6.9	7.0-8.9	9.0-10.9	11.0-12.9	13.0-14.9	15.0-16.9	17.0-18.9	19.0-20.9	21.0-22.9	23.0-24.9	25.0-26.9	27.0-28.9	29.0+
10, 12, 16, 70, 71, 90, 91, 94, 96, 97	0.7	1.1	1.6	2.1	2.6	3.2	3.8	4.4	5.1	5.8	6.5	7.2	8.0
57, 61, 95	0.7	0.9	1.1	1.4	1.6	1.9	2.1	2.4	2.6	2.9	3.1	3.4	3.6
68, 105, 123, 126, 130, 132, 230, 299	1.0	1.5	2.2	3.0	3.8	4.7	5.6	6.6	7.7	8.9	10.1	11.4	12.7
108	0.5	0.9	1.3	1.7	2.2	2.8	3.4	4.1	4.8	5.6	6.4	7.3	8.2
110	0.8	1.3	2.0	2.7	3.6	4.6	5.7	6.9	8.2	9.6	11.1	12.7	14.4
66 , 100, 113, 122, 321, 800, 823, 826	0.5	1.0	1.5	2.2	2.9	3.8	4.9	6.0	7.3	8.6	10.1	11.8	13.5
125, 136	0.7	1.2	1.7	2.3	3.0	3.7	4.6	5.4	6.4	7.4	8.4	9.5	10.7
128	1.1	1.8	2.6	3.5	4.5	5.6	6.8	8.2	9.6	11.1	12.7	14.3	16.1
129	0.8	1.2	1.7	2.3	2.9	3.6	4.2	5.0	5.7	6.6	7.4	8.3	9.2
131	0.9	1.5	2.1	2.9	3.8	4.8	5.9	7.1	8.3	9.7	11.1	12.6	14.2
15, 200, 202	0.7	1.1	1.6	2.1	2.7	3.3	4.0	4.7	5.4	6.2	7.0	7.8	8.7
43, 241	0.7	1.1	1.6	2.3	3.0	3.8	4.7	5.7	6.8	7.9	9.2	10.5	11.8
240, 260, 261	0.8	1.5	2.4	3.6	4.9	6.5	8.4	10.4	12.8	15.3	18.2	21.2	24.6
40	0.5	0.8	1.2	1.6	2.1	2.6	3.2	3.8	4.5	5.2	5.9	6.7	7.5
310, 316, 317, 319, 320, 341, 356, 357, 358, 367, 391, 420, 421, 424, 471, 481, 490, 491, 550, 551, 561, 571, 580, 583, 591, 653, 680, 681, 682, 684, 701, 711, 760, 761, 763, 764, 765, 766, 769, 770, 771, 772, 773, 774, 919, 920, 921, 922, 923, 925, 926, 927, 929, 934, 935, 936, 937, 991, 996, 997, 998 , 999	1.0	1.6	2.2	3.0	3.8	4.6	5.5	6.5	7.5	8.6	9.7	10.9	12.1
350, 355	1.3	1.9	2.6	3.3	4.1	5.0	5.9	6.8	7.8	8.9	9.9	11.0	12.1
314, 315, 318, 330, 331, 332, 336, 370, 371, 372, 450, 451, 452, 531, 552, 712	1.2	2.0	3.0	4.2	5.6	7.2	9.0	11.0	13.1	15.4	17.8	20.5	23.3
373, 374, 375, 379	1.1	1.9	3.0	4.2	5.6	7.2	9.0	11.0	13.1	15.5	18.0	20.7	23.6

Table 5b. Stocking values for all trees tallied on the subplot only modified for the North's species list.													
Species	5.0-6.9	7.0-8.9	9.0-10.9	11.0-12.9	13.0-14.9	15.0-16.9	17.0-18.9	19.0-20.9	21.0-22.9	23.0-24.9	25.0-26.9	27.0-28.9	29.0+
400, 401, 402, 403, 404, 405, 407, 408, 409, 410, 412, 422, 423, 500, 501, 502, 503, 504, 505, 506, 507, 508, 509, 520, 521, 641, 660, 662, 663, 664, 802, 804, 806, 808, 809, 812, 813, 816, 817, 820, 822, 824, 825, 827, 828, 830, 831, 832, 833, 834, 835, 837, 840, 845, 901, 931, 5091, 5092, 5093	1.2	2.0	2.9	3.9	5.0	6.2	7.5	8.9	10.4	11.9	13.6	15.3	17.2
600, 601, 602, 605	1.4	2.1	2.9	3.9	4.9	5.9	7.1	8.3	9.6	10.9	12.3	13.7	15.2
220, 221, 222, 611, 690, 691, 693, 694	0.7	1.3	1.9	2.7	3.6	4.6	5.7	7.0	8.3	9.8	11.4	13.1	14.9
741, 743, 746	1.2	1.8	2.5	3.2	4.0	4.9	5.8	6.8	7.8	8.9	10.0	11.1	12.3
540, 541, 543, 545, 546, 621, 650, 651, 652, 654, 655, 658, 720, 722, 762, 993	1.0	1.4	1.8	2.2	2.6	3.0	3.5	3.9	4.3	4.8	5.2	5.7	6.2
950, 951, 952, 953	1.0	1.8	2.8	4.0	5.5	7.2	9.1	11.3	13.7	16.3	19.1	22.2	25.5
313, 345, 460, 461, 462, 463, 544, 729, 731, 740, 742, 744, 745, 747, 749, 752, 753, 970, 971, 972, 973, 974, 975, 976, 977	1.2	2.0	3.0	4.2	5.6	7.2	8.9	10.9	13.0	15.2	17.7	20.3	23.1

ST	UNIT	CNTY	PLOT #
XX	X	XXX	XXXX

STOCKING CHECK WORKSHEET						
DBH of the largest tally tree on the plot =						
Column used from Table 5a + 5b:						
SUBPLOT NUMBER	PLOT TYPE	SPECIES	DBH	NUMBER TALLIED BY DBH SIZE CLASS	STOCKING VALUE	CUMULATIVE TOTAL
x	x	xxxx	xx.x	x	xx.x	xx.x
		0				
		0				
		0				
		0				
		0				

STOCKING CHECK WORKSHEET						
DBH of the largest tally tree on the plot =						
Column used from Table 5a + 5b:						
SUBPLOT NUMBER	PLOT TYPE	SPECIES	DBH	NUMBER TALLIED BY DBH SIZE CLASS	STOCKING VALUE	CUMULATIVE TOTAL
x	x	xxxx	xx.x	x	xx.x	xx.x
		0				
		0				
		0				
		0				
		0				

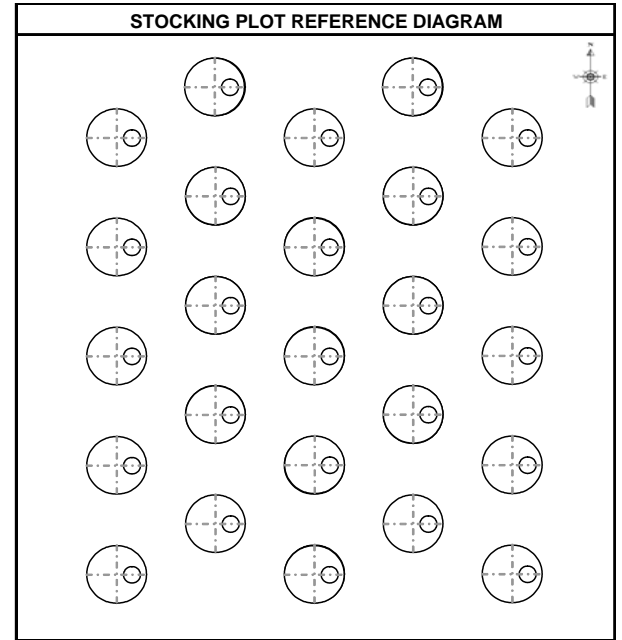

STOCKING PLOT NOTES:

Appendix 6N. Glossary

Accessible Forest Land – Land that is within sampled area (the population of interest), is accessible and can safely be visited, and meets at least one of the two following criteria:

- (a) the condition is at least 10-percent stocked by trees (appendix 3) of any size or has been at least 10-percent stocked in the past. Additionally, the condition is not subject to nonforest use(s) that prevent normal tree regeneration and succession such as regular mowing, grazing, or recreation activities, or
- b) in several western woodland types where stocking cannot be determined, and the condition has at least 5 percent crown cover by trees of any size, or has had at least 5 percent cover in the past. Additionally, the condition is not subject to nonforest use that prevent normal regeneration and succession such as regular mowing, grazing, or recreation activities.

ACTUAL LENGTH – For trees with broken or missing tops. The actual length of the tree is recorded to the nearest 1.0 foot from ground level to the highest remaining portion of the tree still present and attached to the bole. If the top is intact, this item may be omitted. Forked trees should be treated the same as unforked trees.

Agricultural Land – Land managed for crops, pasture, or other agricultural use. Evidence includes geometric field and road patterns, fencing, and the traces produced by livestock or mechanized equipment. The area must be at least 1.0 acre in size and 120.0 feet wide at the point of occurrence.

Annular plot – a circular ring with a beginning radius of 24.0 feet from subplot center and an ending radius of 58.9 feet.

ARTIFICIAL REGENERATION SPECIES – Indicates the predominant species that is planted or seeded in an artificially regenerated condition.

Bay forests – These forests are restricted to coastal depressions or floodplains where saturated conditions prevail. Surface flooding is common, but usually not persistent. They occur exclusively in the Coastal Plain Physiographic province, and range from Maryland to southeast Texas.

Blind check – a re-installation done by a qualified inspection crew without production crew data on hand; a full re-installation of the plot for the purpose of obtaining a measure of data quality. The two data sets are maintained separately. Discrepancies between the two sets of data are not reconciled. Blind checks are done on production plots only.

Bogs – Peatlands usually lacking an overlaying layer of mineral soils. They occur primarily in formerly glaciated areas of the northeastern U.S., the north-central states, and Canada and often develop in deep glaciated lakes. Bogs are characterized by evergreen trees and shrubs and are often covered with sphagnum moss.

Bole – The main stem of a tree, extending from one foot above the ground to the point on the tree where DOB reaches 4 inches

Boundary – The intersection of two or more conditions on a subplot or microplot. Each boundary is described by recording the azimuth and horizontal distance from the subplot or microplot center to the left and right points of where the boundary intersects the perimeter of the subplot or microplot. An azimuth and distance to a corner point may also be described, if one exists. If multiple boundaries exist at a subplot, they are recorded in the order of their occurrence on the subplot, starting from north and proceeding around the compass.

Carolina bays – Elliptical depressions of the southeastern Coastal Plain which are consistently oriented in a northwest-southeast direction and many of which contain shrub bog communities. They occur predominately in the coastal areas of South Carolina and in southeastern North Carolina.

Census Water – Rivers and streams that are more than 200 feet wide and bodies of water that are greater than 4.5 acres in size.

Certification plot – a plot installed by a certification candidate. It may be a training plot or a production plot. The candidate working alone installs the plot.

Clear-cut – The cutting of all merchantable trees from an area. Often leaves a large number of unsalable trees.

Cold check – an inspection done either as part of the training process, or as part of the ongoing QC program. Normally the installation crew is not present at the time of inspection. The inspector has the completed data in-hand at the time of inspection. The inspection can include the whole plot or a subset of the plot. Discrepancies between the two sets of data may be reconciled. Cold checks are done on production plots only.

CONDITION CLASS – The combination of discrete landscape and forest attributes that identify and define different strata on the plot. Examples of such attributes include condition class status, forest type, stand origin, stand size, owner group, reserve status and stand density.

Conservation easement – A conservation easement is a restriction placed on a piece of property to protect its associated resources. The easement is either voluntarily donated or sold by the landowner and constitutes a legally binding agreement that limits certain types of uses or prevents development from taking place on the land in perpetuity while the land remains in private hands. A conservation easement is legally binding, whether the property is sold or passed on to heirs. [Source: nature.org]

Cropland – Land under cultivation within the past 24 months, including orchards and land in soil improving crops, but excluding land cultivated in developing improved pasture.

CROWN CLASS – A classification of trees based on dominance in relation to adjacent trees within the stand as indicated by crown development and the amount of sunlight received from above and sides.

Cull – Portions of a tree that are unusable for industrial wood products because of rot, form, or other defect.

Diameter at Breast Height (DBH) – The diameter of the bole of a tree at breast height (4.5 feet above the ground), measured outside of the bark.

Diameter at Root Collar (DRC) – The diameter of a tree measured at the ground line or stem root collar, measured outside of the bark.

Diameter Outside Bark (DOB) – A diameter that may be taken at various points on a tree, or log, outside of the bark. Diameter Outside Bark is often estimated.

Federal Information Processing Standard (FIPS) – A unique code identifying U.S. States and counties (or units in Alaska).

Fens – A type of peatland which resemble bogs. However, fens support marsh-like vegetation including sedges and wildflowers. The main differences between fens and bogs are in flora, hydrology and water chemistry. Fens, like bogs, tend to occur in glaciated areas of the northern United States. [Source: www.aquatic.uoguelph.ca and EPA 843-F-01-002b]

Forest Industry Land – Land owned by companies or individuals that operate wood-using plants.

Forest Trees – Plants having a well-developed, woody stem and usually more than 12 feet in height at maturity.

FOREST TYPE – A classification of forest land based upon the trees or tree communities that constitute the majority of stocking on the site.

GPS – Global Positioning System. Information from this system is collected and used to determine the latitude and longitude of each plot.

Hardwoods – Dicotyledonous trees, usually broad-leaved and deciduous.

Hot check – an inspection normally done as part of the training process. The inspector is present on the plot with the trainee and provides immediate feedback regarding data quality. Data errors are corrected. Hot checks can be done on training plots or production plots.

Idle Farmland -- Former cropland or pasture that has not been tended within the last 2 years and that has less than 10 percent stocking with live trees.

Improved Pasture -- Land that is currently maintained and used for grazing. Evidence of maintenance, besides the degree of grazing, includes condition of fencing, presence of stock ponds, periodic brush removal, seeding, irrigation, or mowing.

Inclusion – An area that would generally would be recognized as a separate condition, except that it is not large enough to qualify. For example, a ½ acre pond within a forested stand.

Industrial Wood – All roundwood products, except firewood.

Inspection crew – a crew of qualified QC/QA individuals whose primary responsibility is the training, certification and inspection of production crews.

Land Area – As defined by the Bureau of the Census: The area of dry land and land temporarily or partially covered by water such as marshes, swamps, and river flood plains (omitting tidal flats below mean tide); streams, sloughs, estuaries and canals less than 200 feet in width, and ponds less than 4.5 acres in area.

Legal Description – A legal description is used to describe the location of land in legal documents. The Land Ordinance of 1785 devised a system base lines and meridian lines using to survey the western lands outside the initial 13 colonies. Base lines run east/west and meridian lines run north/south. Along these lines the land was divided into 6 square mile blocks, called "Townships". Each Township is given an identifying number, according to where it falls. The east/west numbers are identified by the term "Range" and the north/south numbers are identified by the term "Township". Each township is divided into 36 square-mile parcels of 640 acres, called "Sections". Every section is numbered from 1 to 36, depending upon its position within the township. A section can be further divided into halves, quarters, etc. [Source: <http://www.csuchico.edu/lbib/maps/townships.html>]

Macroplot – A circular, fixed area plot with a radius of 58.9 feet. Macroplots may be used for sampling relatively rare events.

Maintained Road – Any road, hard topped or other surfaces, that is plowed or graded periodically and capable of use by a large vehicle. Rights-of-way that are cut or treated to limit herbaceous growth are included in this area.

Marsh – Low, wet areas characterized by heavy growth of weeds and grasses and an absence of trees. Marshes are separated into freshwater and saltwater types. Freshwater marshes are primarily inland, while salt marshes line the coasts of North America. [Source: www.aquatic.uoguelph.ca]

Meadows – Wet meadows are herb-dominated areas saturated for long periods during the growing season, but are seldom flooded. Some sedge meadows may have standing surface water and look more marsh-like in appearance. Wet meadows are often associated with agricultural lands, especially pastures. Wet meadows commonly occur in poorly drained areas such as shallow lake basins, low-lying depressions, and the land between shallow marshes and upland areas. Precipitation serves as their primary water supply, so they are often dry in the summer. [Source: *Tiner and EPA 843-F-01-002b*]

Measurement Quality Objective (MQO) – Describes the acceptable tolerance for each data element. MQOs consist of two parts: a statement of the tolerance and a percentage of time when the collected data are required to be within tolerance.

Merchantable Top – The point on the bole of trees above which merchantable material cannot be produced. Merchantable top is 1.5 inches for western woodland species and 4.0 inches for all other species.

Microplot – A circular, fixed-radius plot with a radius of 6.8 feet that is used to sample trees less than 5.0 inches at DBH, as well as other vegetation.

National Forest Land – Federal lands which have been legally designated as National Forests or purchase units, and other lands under the administration of the Forest Service, including experimental areas and Bankhead-Jones Title III lands.

Native American (Indian) Land – Tribal lands held in fee, or trust, by the Federal government but administered for Indian tribal groups and Indian trust allotments. This land is considered “Private Lands”, Owner Group 40.

Non-census Water – Bodies of water from 1 to 4.5 acres in size and water courses from 30 feet to 200 feet in width.

Nonforest Land -- Land that does not support, or has never supported, forests, and lands formerly forested where use for timber management is precluded by development for other uses. Includes areas used for crops, improved pasture, residential areas, city parks, improved roads of any width and adjoining rights-of-way, power line clearings of any width, and noncensus water. If intermingled in forest areas, unimproved roads and nonforest strips must be more than 120.0 feet wide, and clearings, etc., more than one acre in size, to qualify as nonforest land.

Nonstockable – Areas of forest land that are not capable of supporting trees because of the presence of rock, water, etc.

Other Federal Lands – Federal land other than National Forests. These include lands administered by the USDI Bureau of Land Management, USDI National Park Service, USDI Fish and Wildlife Service, Department of Defense, Department of Energy, Army Corps of Engineers, and military bases.

OWNER CLASS -- A variable that classifies land into fine categories of ownership.

OWNER GROUP – A variable that classifies land into broad categories of ownership; Forest Service, Other Federal Agency, State and Local Government, and Private. Differing categories of Owner Group on a plot require different conditions.

Phase 1 (P1) – FIA activities done as part of remote-sensing and/or aerial photography.

Phase 2 (P2) – FIA activities done on the network of ground plots formerly known as FIA plots.

Phase 3 (P3) – FIA activities done on a subset of Phase 2 plots formerly known as Forest Health Monitoring plots. Additional ecological indicator information is collected from Phase 3 plots.

Plot – A cluster of four subplots that samples approximately 1/6 acre. The subplots are established so that subplot 1 is centered within the sample and the centers of subplots 2, 3, and 4 are located 120.0 feet from the center of subplot 1 at azimuths of 360, 120, and 240 degrees, respectively. Each subplot has an associated microplot and macroplot.

Pocosins – The word pocosin comes from the Algonquin Native American word for "swamp on a hill". These evergreen shrub and tree dominated landscapes are found on the Atlantic Coastal Plain from Virginia to northern Florida, though most are found in North Carolina. Usually, there is no standing water present in pocosins, but a shallow water table leaves the soil saturated for much of the year. They range

in size from less than an acre to several thousand acres located between and isolated from old or existing stream systems in most instances. [Source: www.epa.gov/owow/wetlands/types/]

PRIVATE OWNER INDUSTRIAL STATUS – Indicates whether Private land owners own and operate a wood processing plant.

Production crew – a crew containing at least one certified individual. The crew is involved in routine installation of plots.

Production plot – a plot that belongs to the 6000-acre grid database. It may also be used for training purposes.

REGENERATION STATUS – A stand descriptor that indicates whether a stand has been naturally or artificially regenerated.

Reserved Land – Land that is withdrawn from timber utilization by a public agency or by law.

RESERVE STATUS – An indication of whether the land in a condition has been reserved.

Saplings – Live trees 1.0 to 4.9 inches DBH.

Seedlings – Live trees less than 1.0 DBH that are at least one foot tall.

Softwoods – Coniferous trees, usually evergreen having needles or scale-like leaves.

STAND AGE – A stand descriptor that indicates the average age of the live trees not overtopped in the predominant stand size-class of a condition.

STAND DENSITY – A stand descriptor that indicates the relative tree density of a condition class. The classification is based on the number of stems/unit area, basal area, tree cover, or stocking of all live trees in the condition which are not overtopped, compared to any previously defined condition class tree density.

STAND SIZE – A stand descriptor that indicates which size-class of trees that are not overtopped constitutes the majority of stocking in the stand.

State, County and Municipal Lands – Lands owned by states, counties, and local public agencies or municipalities, or lands leased to these government units for 50 years or more.

Stocking – The relative degree of occupancy land by trees, measured as basal area or the number of trees in a stand by size or age and spacing, compared to the basal area or number of trees required to fully utilize the growth potential of the land; that is, the stocking standard.

Subplot – A circular, fixed-area plot with a radius of 24.0 feet. Each subplot represents ¼ of the fixed plot sample unit.

Swamps – Wet areas dominated by woody shrubs and trees, some with hardwoods such as red maple and ashes and others with softwoods like cedar and spruce. Willows, alders, shrubby dogwoods, and buttonbush dominate shrub swamps. Some shrub swamps are permanent, while others slowly transform to forested swamps.

TOTAL LENGTH – The total length of the tree, recorded to the nearest 1.0 foot from ground level to the tip of the apical meristem. For trees growing on a slope, measure on the uphill side of the tree. If the tree has a broken or missing top, the total length is estimated to what the length would be if there were no missing or broken top. Forked trees should be treated the same as unforked trees

Training plot – a plot established for training or certification purposes only. It does NOT belong to the 6000-acre grid database.

Transition Zone – An area where a distinct boundary between two or more different conditions cannot be determined.

Wetlands – Areas subject to periodic tidal flooding or other areas where water is present for extended periods during the growing season and for longer periods during the non-growing season. Water usually comes from rainfall, snowmelt, a rising water table, groundwater seepage, or incoming tides. Water may be present on the surface of wetlands for varying periods, as in flooded or ponded wetlands, or it may simply keep the underlying soils saturated near the surface with no surface water present. [Source: *Tiner*]

Appendix 7. Tolerance / MQO / Value / Units Table

Core optional variables are in italics. n/a is not applicable.

NRS Note: This table does not include regional variables or reflect tightened tolerances for some national CORE variables.

Variable Name	Tolerance	MQO	Values	Units
General Description				
New Subplot Location	+/- 7 feet	at least 95% of the time	n/a	feet
New Microplot Location	+/- 1 foot	at least 95% of the time	n/a	feet
Plot Level Data				
STATE	No errors	at least 99% of the time	Appendix 1	n/a
COUNTY	No errors	at least 99% of the time	Appendix 1	n/a
PLOT NUMBER	No errors	at least 99% of the time	00001 to 99999	n/a
PLOT STATUS	No errors	at least 99% of the time	1 to 3	n/a
PLOT NONSAMPLED REASON	No errors	at least 99% of the time	01 to 03 and 05 to 10	n/a
SUBPLOTS EXAMINED	No errors	at least 90% of the time	1, 4	n/a
SAMPLE KIND	No errors	at least 99% of the time	1 to 3	n/a
PREVIOUS PLOT NUMBER	No errors	at least 99% of the time	00001 to 99999	n/a
FIELD GUIDE VERSION	No errors	at least 99% of the time	3.0	n/a
YEAR	No errors	at least 99% of the time	> 2003	year
MONTH	No errors	at least 99% of the time	Jan – Dec (01 – 12)	month
DAY	No errors	at least 99% of the time	01 to 31	day
<i>DECLINATION</i>	<i>No errors</i>	<i>at least 99% of the time</i>	<i>-359.0 to 359.0</i>	<i>degrees</i>
HORIZONTAL DISTANCE TO IMPROVED ROAD	No errors	at least 90% of the time	1 to 9	n/a
WATER ON PLOT	No errors	at least 90% of the time	0 to 5, 9	n/a
QA STATUS	No errors	at least 99% of the time	1 to 7	n/a
CREW TYPE	No errors	at least 99% of the time	1, 2	n/a
GPS UNIT	No errors	at least 99% of the time	0 to 4	n/a
GPS SERIAL NUMBER	No errors	at least 99% of the time	000001 to 999999	n/a
GPS DATUM	No errors	at least 99% of the time	NAD27, NAD83, WGS84	n/a
COORDINATE SYSTEM	No errors	at least 99% of the time	1, 2	n/a
LATITUDE DEGREES	No errors	at least 99% of the time		degrees
LATITUDE MINUTES	No errors	at least 99% of the time	1 – 59	minutes
LATITUDE SECONDS	+/- 140 ft	at least 99% of the time	0.00 – 59.99	seconds
LONGITUDE DEGREES	No errors	at least 99% of the time		degrees
LONGITUDE MINUTES	No errors	at least 99% of the time	1 – 59	minutes
LONGITUDE SECONDS	+/- 140 ft	at least 99% of the time	0.00 – 59.99	seconds
UTM ZONE	No errors	at least 99% of the time	03-19Q and 03-19W	n/a
EASTING (X) UTM	+/- 140 ft	at least 99% of the time		
NORTHING (Y) UTM	+/- 140 ft	at least 99% of the time		
AZIMUTH TO PLOT CENTER	+/- 3 degrees	at least 99% of the time	000 at plot center 001 to 360 not at plot center	degrees
DISTANCE TO PLOT CENTER	+/- 6 ft	at least 99% of the time	000 at plot center 001 to 200 if a Laser range finder not used 001 to 999 if a Laser range finder is used	feet
GPS ELEVATION		at least 99% of the time	-00100 to 20000	feet
GPS ERROR	No errors	at least 99% of the time	000 to 070 if possible 071 to 999 if an error < 70 cannot be obtained	feet

Variable Name	Tolerance	MQO	Values	Units
NUMBER OF READINGS	No errors	at least 99% of the time	001 to 999	n/a
GPS FILENAME	No errors	at least 99% of the time	Letters and numbers	n/a
MACROPLOT BREAKPOINT DIAMETER	No errors	at least 99% of the time	21, 24, and 30	inches
PLOT-LEVEL NOTES	n/a	n/a	English, alpha-numeric	n/a
Condition Class Information				
CONDITION CLASS NUMBER	No errors	at least 99% of the time	1 to 9	n/a
CONDITION CLASS STATUS	No errors	at least 99% of the time	1 to 5	n/a
CONDITION NONSAMPLED REASON	No errors	at least 99% of the time	01, 02, 03, 10	n/a
RESERVED STATUS	No errors	at least 99% of the time	0, 1	n/a
OWNER GROUP	No errors	at least 99% of the time	10, 20, 30, 40	n/a
FOREST TYPE	No errors	at least 99% of the time in group at least 95% of the time in type no MQO when STAND SIZE CLASS = 0	Appendix 2	n/a
STAND SIZE CLASS	No errors	at least 99% of the time	0 to 6	class
REGENERATION STATUS	No errors	at least 99% of the time	0, 1	n/a
TREE DENSITY	No errors	at least 99% of the time	1 to 3	n/a
OWNER CLASS	No errors	at least 99% of the time	11-13; 21-25; 31-33; 41-45	class
PRIVATE OWNER INDUSTRIAL STATUS	No errors	at least 99% of the time	0, 1	n/a
ARTIFICIAL REGENERATION SPECIES	No errors	at least 99% of the time	Appendix 3	n/a
STAND AGE	+/- 10%	at least 95% of the time	000 to 997, 998, 999	year
DISTURBANCE 1	No errors	at least 99% of the time	00; 10-12; 20-22; 30-32; 40-46; 50-55; 60; 70; 80	n/a
DISTURBANCE YEAR 1	+/- 1 year for 5-year measure. cycles +/- 2 years for > 5-year measure. cycles	at least 99% of the time	Since the previous plot visit, or the past 5 years for plots visited for the first time; 9999 if disturbance occurs continuously over time	year
DISTURBANCE 2	No errors	at least 99% of the time	00; 10-12; 20-22; 30-32; 40-46; 50-55; 60; 70; 80	n/a
DISTURBANCE YEAR 2	+/- 1 year for 5-year measure. cycles +/- 2 years for > 5-year measure. cycles	at least 99% of the time	Since the previous plot visit, or the past 5 years for plots visited for the first time; 9999 if disturbance occurs continuously over time	year
DISTURBANCE 3	No errors	at least 99% of the time	00; 10-12; 20-22; 30-32; 40-46; 50-55; 60; 70; 80	n/a

Variable Name	Tolerance	MQO	Values	Units
DISTURBANCE YEAR 3	+/- 1 year for 5-year measure. cycles +/- 2 years for > 5-year measure. cycles	at least 99% of the time	Since the previous plot visit, or the past 5 years for plots visited for the first time; 9999 if disturbance occurs continuously over time	year
TREATMENT 1	No errors	at least 99% of the time	00, 10, 20, 30, 40, 50	n/a
TREATMENT YEAR 1	+/- 1 year for 5-year measure. cycles +/- 2 years for >5-year measure. cycles	at least 99% of the time	Since the previous plot visit, or the past 5 years for plots visited for the first time	year
TREATMENT 2	No errors	at least 99% of the time	00, 10, 20, 30, 40, 50	n/a
TREATMENT YEAR 2	+/- 1 year for 5-year measure. cycles +/- 2 years for >5-year measure. cycles	at least 99% of the time	Since the previous plot visit, or the past 5 years for plots visited for the first time	year
TREATMENT 3	No errors	at least 99% of the time	00, 10, 20, 30, 40, 50	n/a
TREATMENT YEAR 3	+/- 1 year for 5-year measure. cycles +/- 2 years for >5-year measure. cycles	at least 99% of the time	Since the previous plot visit, or the past 5 years for plots visited for the first time	year
PHYSIOGRAPHIC CLASS	No errors	at least 80% of the time	xeric: 11, 12, 13, 19 mesic: 21, 22, 23, 24, 25, 29 hydric: 31, 32, 33, 34, 35, 39	n/a
PRESENT NONFOREST LAND USE	No errors	at least 99% of the time	10-15; 20; 30-33; 40	n/a
Subplot Information				
SUBPLOT NUMBER	No errors	at least 99% of the time	1 to 4	n/a
SUBPLOT/MACROPLOT STATUS	No errors	at least 99% of the time	1 to 3	n/a
SUBPLOT NONSAMPLED REASON	No errors	at least 99% of the time	01 to 05, 10	n/a
SUBPLOT CENTER CONDITION	No errors	at least 99% of the time	1 to 9	n/a
MICROPLOT CENTER CONDITION	No errors	at least 99% of the time	1 to 9	n/a
SUBPLOT SLOPE	+/- 10 %	at least 90% of the time	000 to 155	percent
SUBPLOT ASPECT	+/- 10 degrees	at least 90% of the time	000 to 360	degrees
SNOW/WATER DEPTH	+/- 0.5 ft	at the time of measurement	0.0 to 9.9	feet
SUBPLOT/MACROPLOT CONDITION LIST	No errors	at least 99% of the time	1000 to 9876	n/a
Boundary Data				
SUBPLOT NUMBER	No errors	at least 99% of the time	1 to 4	n/a
PLOT TYPE	No errors	at least 99% of the time	1 to 3	n/a
BOUNDARY CHANGE	No errors	at least 99% of the time	0 to 3	n/a
CONTRASTING CONDITION	No errors	at least 99% of the time	1 to 9	n/a
LEFT AZIMUTH	+/- 10 degrees	at least 90% of the time	001 to 360	degrees

Variable Name	Tolerance	MQO	Values	Units
CORNER AZIMUTH	+/- 10 degrees	at least 90% of the time	000 to 360	degrees
CORNER DISTANCE	+/- 1 ft	at least 90% of the time	microplot: 01 to 07 (6.8 ft actual limiting distance) subplot: 01 to 24 macroplot: 01 to 59 (58.9 ft actual limiting distance)	feet
RIGHT AZIMUTH	+/- 10 degrees	at least 90% of the time	001 to 360	degrees
Tree and Sapling Data				
SUBPLOT NUMBER	No errors	at least 99% of the time	1 to 4	n/a
TREE RECORD NUMBER	No errors	at least 99% of the time	000, 001 to 999	n/a
CONDITION CLASS NUMBER	No errors	at least 99% of the time	1 to 9	n/a
AZIMUTH	+/- 10 degrees	at least 90% of the time	001 to 360	degrees
HORIZONTAL DISTANCE	microplot: +/- 0.2 ft microplot woodland species: +/- 0.4 ft subplot: +/- 1.0 ft subplot woodland species: +/- 2.0 ft annular plot: +/- 3.0 ft annular plot woodland species: +/- 6.0 ft	at least 90% of the time	microplot: 00.1 to 06.8 subplot: 00.1 to 24.0 annular plot: 24.1 to 58.9	feet
PREVIOUS TREE STATUS	No errors	at least 95% of the time	1, 2	n/a
PRESENT TREE STATUS	No errors	at least 95% of the time	0 to 3	n/a
RECONCILE	No errors	at least 95% of the time	1 to 4: valid for new trees on the plot 5 to 9: valid for remeasured trees that no longer qualify as tally	n/a
STANDING DEAD	No errors	At least 99% of the time	0, 1	n/a
MORTALITY	No errors	at least 85% of the time	0, 1	n/a
SPECIES	No errors	at least 99% of the time for genus at least 95% of the time for species	Appendix 3	n/a
DIAMETER	+/- 0.1 inch per 20.0 inch increment of measured diameter on all live trees and dead trees with DECAY CLASS = 1, 2 +/-1.0 inch per 20.0 inch increment of measured diameter on dead trees with DECAY CLASS = 3, 4, 5 For woodland species: +/- 0.2 inch per stem	at least 95% of the time	001.0 to 999.9	inches
DRC STEM DIAMETER	+/- 0.2 inch per stem	at least 95% of the time	001.0 to 999.9	inch
DRC STEM STATUS	No errors	at least 95% of the time	1, 2	n/a

Variable Name	Tolerance	MQO	Values	Units
PAST NUMBER OF STEMS	No errors	at least 90% of the time	1 to 99	n/a
CURRENT NUMBER OF STEMS	No errors	at least 90% of the time	1 to 99	n/a
DIAMETER CHECK	No errors	at least 99% of the time	0 to 2	n/a
ROTTEN / MISSING CULL	+/- 10%	at least 90% of the time	00 to 99	percent
TOTAL LENGTH	+/- 10% of true length	at least 90% of the time	005 to 400	feet
ACTUAL LENGTH	+/- 10% of true length	at least 90% of the time	005 to 400	feet
LENGTH METHOD	No errors	at least 99% of the time	1 to 3	n/a
CROWN CLASS	No errors	at least 85% of the time	1 to 5	n/a
UNCOMPACTED LIVE CROWN RATIO	+/- 10%	at least 90% of the time	00 to 99	percent
COMPACTED CROWN RATIO	+/- 10%	at least 80% of the time	00 to 99	percent
<i>DAMAGE LOCATION 1</i>	<i>+/- 1 location class</i>	<i>at least 80% of the time</i>	<i>0 to 9</i>	<i>class</i>
<i>DAMAGE TYPE 1</i>	<i>No errors</i>	<i>at least 80% of the time</i>	<i>1-5; 11-13; 20-25; 31</i>	<i>n/a</i>
<i>DAMAGE SEVERITY 1</i>	<i>+/- 1 valid class unless otherwise defined by the DAMAGE TYPE</i>	<i>at least 80% of the time</i>	<i>Defined for each DAMAGE TYPE</i>	<i>class</i>
<i>DAMAGE LOCATION 2</i>	<i>+/- 1 location class</i>	<i>at least 80% of the time</i>	<i>0 to 9</i>	<i>class</i>
<i>DAMAGE TYPE 2</i>	<i>No errors</i>	<i>at least 80% of the time</i>	<i>1-5; 11-13; 20-25; 31</i>	<i>n/a</i>
<i>DAMAGE SEVERITY 2</i>	<i>+/- 1 valid class unless otherwise defined by the DAMAGE TYPE</i>	<i>at least 80% of the time</i>	<i>Defined for each DAMAGE TYPE</i>	<i>class</i>
CAUSE OF DEATH	No errors	at least 80% of the time	10 to 80	n/a
MORTALITY YEAR	+/- 1 year for 5-year measure. cycles +/- 2 years for > 5-year measure. cycles	at least 70% of the time	1995 or higher	year
DECAY CLASS	+/- 1 class	at least 90% of the time	1 to 5	class
LENGTH TO DIAMETER MEASUREMENT POINT	+/- 0.2 ft	at least 90% of the time	00.1 to 15.0	feet
ROUGH CULL	+/- 10 %	at least 90% of the time	00 to 99	percent
MISTLETOE CLASS	+/- 1 class	at least 90% of the time	0 to 6	class
TREE NOTES	n/a	n/a	English, alpha-numeric	n/a
Seedling Data				
SUBPLOT NUMBER	No errors	at least 99% of the time	1 to 4	n/a
SPECIES	No errors	at least 90% of the time for genus at least 85% of the time for species	Appendix 3	n/a
CONDITION CLASS NUMBER	No errors	at least 99% of the time	1-9	n/a
SEEDLING COUNT	No errors for 5 or less per species +/- 20% over a count of 5	at least 90% of the time	001-999	number
Site Tree Information				
CONDITION CLASS LIST	No errors	at least 99% of the time	1 to 9 or 10000 to 98765	n/a

Variable Name	Tolerance	MQO	Values	Units
SPECIES	No errors	at least 99% of the time for genus at least 95% of the time for species	Appendix 3	n/a
DIAMETER	+/- 0.1 inch per 20 inches of diameter on trees with a measured diameter	at least 95% of the time	001.0 to 999.9	inches
SITE TREE LENGTH	+/- 10% of true length	at least 90% of the time	005 to 999	feet
TREE AGE AT DIAMETER	+/- 5 years	at least 95% of the time	001 to 999	year
SITE TREE NOTES	n/a	n/a	English, alpha-numeric	n/a
<i>SUBPLOT NUMBER</i>	<i>No errors</i>	<i>at least 99% of the time</i>	<i>1 to 4</i>	<i>n/a</i>
<i>AZIMUTH</i>	<i>+/- 10 degrees</i>	<i>at least 90% of the time</i>	<i>001 to 360</i>	<i>degrees</i>
<i>HORIZONTAL DISTANCE</i>	<i>+/-5 ft</i>	<i>at least 90% of the time</i>	<i>000.1 to 200.0</i>	<i>feet</i>

Appendix 8. Tree Coding Guide for RECONCILE

Previous Measurement	Present Measurement	PREVIOUS TREE STATUS	PRESENT TREE STATUS	RECONCILE	STANDING DEAD	CAUSE OF DEATH
SAMPLE KIND 1 or 3						
	Live 1.0-4.9 DBH/DRC		1			
	Dead 5.0+ DBH/DRC		2			
SAMPLE KIND 2 (Remeasure)						
Live 5.0+ DBH/DRC	Live 5.0+ DBH/DRC	1	1			
Live 1.0-4.9 DBH/DRC on microplot	Live 5.0+ DBH	1	1			
Live 1.0-4.9 DBH/DRC on microplot	Live 1.0-4.9 DBH/DRC on microplot	1	1			
Live 5.0+ DBH/DRC	Live but shrank < 5.0 and on microplot	1	1			
Live 1 inch +	Live but land no longer qualifies as forest	1	1			
Live 5.0+ DBH/DRC	Standing dead 5.0+	1	2		1	10-80
Live 5.0+ DBH/DRC	Down dead 5.0+ or standing dead < 5.0	1	2		0	10-80
Live 1.0-4.9 DBH/DRC on microplot	Dead 1.0-4.9 DBH/DRC	1	2		0	10-80
Live 1.0-4.9 DBH/DRC on microplot	Dead 5.0+ (standing or down)	1	2		0 or 1	10-80
Live 1.0+ DBH/DRC	Cruiser unable to locate tree due to a weather (including geologic, such as landslide) or fire event & assume tree is down dead or you can see tree and it is dead and off the plot	1	2		0	30 or 50
Live 1.0+ DBH/DRC	Cut and left in the woods	1	2		0	80
Live 1 inch +	Dead and land no longer qualifies as forest (land clearing or conversion to nonforest land use)	1	2		0 or 1	10-80
Live 1.0+ DBH/DRC	Tree removed (cut and hauled away)	1	3			80
Live 1 inch +	Gone (cut and removed?) and land no longer qualifies as forest	1	3			80

Previous Measurement	Present Measurement	PREVIOUS TREE STATUS	PRESENT TREE STATUS	RECONCILE	STANDING DEAD	CAUSE OF DEATH
Dead 5.0+ DBH/DRC	Dead standing 5.0+ DBH/DRC	2	2		1	
Dead 5.0+ DBH/DRC	Dead down 5.0+	2	2		0	
Dead 5.0+ DBH/DRC	Standing dead DBH/DRC < 5.0	2	2		0	
Dead 5.0+ DBH/DRC	Cruiser is unable to locate tree due to a weather (including geologic) or fire event & assume it is down dead	2	2		0	
Dead 5.0+ DBH/DRC	Tree removed (cut and hauled away)	2	3			
Live 5.0+ DBH/DRC	Tree shrank <5.0 and NOT on microplot	1	0	5		
Live 1.0-4.9 DBH/DRC	Tree shrank <1.0	1	0	5		
Live 1.0-4.9 DBH/DRC	Live 1.0-4.9 DBH/DRC, shouldn't have been tallied—beyond 6.8—cruiser error	1	0	7		
Live 5.0+ DBH/DRC	Live 5.0+ DBH/DRC, shouldn't have been tallied – beyond 24.0—cruiser error	1	0	7		
Live 1.0+ DBH/DRC	No longer a tally species	1	0	8		
Live 1.0+ DBH/DRC	Tree moved off plot due to a geologic (i.e., slight earth movement) or weather event (i.e., hurricane) and you can still see it (Live before, live now)	1	0	6		
Live 1.0+ DBH/DRC	Nonsampled area now	1	0	9		
Dead 5.0+ DBH/DRC	No longer a tally species	2	0	8		
Dead 5.0 DBH/DRC	Tree moved off plot due to a geologic (i.e., small earth movement) or weather event (i.e., hurricane) and you can still see the tree	2	0	6		
Dead 5.0 inch +	Nonsampled area now	2	0	9		
Missed live	Live 1.0+ DBH/DRC	-	1	3		
< 5.0 live	5.0+ DBH/DRC live (not on the microplot)	-	1	1		
< 1.0 live	1.0-4.9 DBH/DRC live	-	1	1		

Previous Measurement	Present Measurement	PREVIOUS TREE STATUS	PRESENT TREE STATUS	RECONCILE	STANDING DEAD	CAUSE OF DEATH
< 1.0 live	5.0+ DBH/DRC live (on the microplot) (Through growth)	-	1	2		
Nonsampled area before	Live 1.0+	-	1	3		
Nonforest before	Forest now, Live 1.0+	-	1	1		
Missed dead	Dead 5.0+ DBH/DRC	-	2	4	1	
Missed live	Dead 5.0+ DBH/DRC	-	2	3	1	10-80
< 5.0 live	5.0+ DBH/DRC dead (very rare)	-	2	1	0 or 1	10-80
Nonsampled area before	Standing dead 5.0+	-	2	3 or 4		
Nonforest before	Forest now, standing dead 5.0+	-	2	1		

REGIONAL APPENDICES

- A Plot Establishment and/or Relocation Procedures (*SP variables*)
- B Ownership Data Collection Procedures (*private ownership variables*)
- C Additional Northern Data Collection Procedures (*NE periodic to annual plots, previous plot designs, "switchback" rule, etc.*)
- D State / Species Specific Data Collection Variables & Procedures (*ME Variables, MN Balsam Fir Boughs, OH SK8 Variables, PA Regeneration Study*)
- E Tables and Charts (*tree grades, cull tables, etc.*)
- F Tree Class Illustrations
- G GPS User's Guide
- H Tally Item Guides, Tally Sheets and PDR Prompts

Appendix A. Plot Establishment and/or Relocation Procedures

Note (procedural change for former NE crews): The text that follows is primarily the procedures that were included with *NCFG v3.0*. Many of the plot establishment and relocation procedures between NC and NE are the same with a few exceptions and these are primarily related to the type of image sent to the field from this or previous cycles. If you have any questions as to what needs to be done on this cycle, please contact your supervisor. This aspect of the data collection will continue to evolve with technology and other procedures that are determined to be more efficient for the region.

The multi-page NE plot record sheets for ownership, course-to-plot, GPS, notes, sketch maps and plot diagrams will no longer be utilized. A one page multifunctional tally sheet will now be utilized that includes all of these items and more! This one page sheet allows for easier FAX transmission of plot sample location data.

This appendix describes how new sample plots are established and how remeasure sample plots are relocated. Most remeasure plots that are revisited during this cycle have previous starting point (SP) and course to sample location. On these plots, this previous information should be used and followed unless there has been considerable change to the area; or there is a more efficient way to access plot center. The course to sample location is updated at the time of each visit by the new crew to insure that the plot can be relocated. It is critical that all plots can be relocated without the aid of GPS by using standard compass and chaining procedures.

“Surveying in forest land as compared with work done in towns and on farms is carried out under unfavorable circumstances. In the first place, timber and brush growth offer an obstruction to sighting; second, the work is often done far from a well supplied base; third, the limits of cost allowed are often the lowest practicable. These conditions have a strong effect upon the methods employed, and they also affect the choice of outfit. Equipment for such work should not usually be expensive, it should be as compact and portable as possible, and it should not be so delicate or so complicated as to be likely to get seriously out of order and so hold up a job.” – *Austin Carey, Woodsman’s Manual, Fourth Edition, 1932.*

Note: Prior to plot establishment, land owner permission (verbal or written) must be obtained for all plots that require access. See Regional Appendix B for additional information.

LOCATING A PLOT USING THE IMAGE

There is a mix of new and re-measurement plots sent to the field for measurement. The imagery used to aid in establishing sample plots can vary from state to state. Generally, when aerial photography is being used, it will most often be products from the National Aerial Photography Program (NAPP) or the National Agricultural Imagery Program (NAIP). NAPP products are usually 10” by 10” contact prints with a nominal scale of 1:40,000. They may be color infrared, or black and white. NAIP products are printed on to 8.5 x 11-in photo paper and have a nominal scale of 1:18,000. These may be true color or color infrared. The main difference between the photography is that NAPP images are taken during leaf-off and NAIP is taken during leaf-on. Crews may find it difficult to detect roads and other features that occur within forest land when using NAIP.

East/West Note: NAIP is the primary imagery being utilized for both east and west crews. The image will indicate the nominal scale.

The steps of locating the plot center include the following:

Review old course to sample location when available

- Use and re-record old course to plot information if still valid
 - Re-monument the STARTING POINT (SP)
 - Record a BASELINE on the new image
 - Record SP information (species, DBH, etc)
 - Collect GPS at the SP and record

- Record and traverse the “Course to Sample Location”

Establish new course to plot information if old information is not available or useable

- Monument the STARTING POINT
- Select and record a BASELINE on the image
- Select and record SP description
- Collect GPS at the SP and record
- Determine “Course to Sample Location”
 - distance and azimuth computation
 - chaining
 - location correction
- Record and traverse the “Course to Sample Location”

LOCATING A PLOT USING GPS COORDINATES

When establishing a plot for the first time use the provided GPS coordinates. These coordinates are listed on the printed plot sheet provided to the crew. The true location of the plot is the ‘X’ (or dot) on the image. If the ground location determined by the GPS is markedly different than the ‘X’ on the image (i.e., two chains plus or a different land use), then the ground location will need to be adjusted to the location of the ‘X’.

Level of hierarchy for plot location:

1. Pinprick on an aerial photo image from last cycle
2. Pinprick on a DOQ from last cycle
3. ‘X’ on a DOQ
4. GPS coordinates from last crew (assuming an error was not made when collecting)
5. GPS coordinates on the plot sheet

Navigating from SP to PLOT CENTER (PC) using GPS coordinates.

1. Enter provided PC coordinates from plot sheet into GPS unit
2. Establish a SP, collect and record coordinates
3. Navigate to within 100 – 120 feet of the PC coordinates entered
4. Let the GPS unit average again at this point and read the distance and azimuth to PC
5. Chain the remaining distance and azimuth to PC and establish the plot

BASELINE

A BASELINE (or reference line) is established on a photo image so that it is oriented with the ground as to compass direction.

Locate the BASELINE by finding two features on the ground that is easily recognized on the new photo or image. The two features should be at least 10 chains apart for scale 1:20,000 and 20 chains apart for scale 1:40,000 to help minimize error. Select such features as straight road sections, drainage ditches, or two distinct trees. Avoid using railroads or major power lines since they influence the compass reading.

Pinprick both features on the photo and circle the pinpricks on the back of the photo. Draw a line between these pinpricks on the back of the photo with an arrow at one end of the line to indicate the azimuth direction.

Measure the azimuth between the two features with a compass to the nearest half-degree and record it on the back of the photograph.

STARTING POINT

A starting point (SP) is established for the purpose of locating a sample plot. **It should be as near as possible to the sample location, yet not on the same acre as the sample plot.** An SP must be at least 140 feet from PC. When utilizing the *FIA PDR Application* utility “Locate Subplot,” the utility that

allows you to traverse directly to subplots 2 – 4, requires that an “off plot” location like SP be at least 140 feet from the destination subplot.

When selecting the SP, make sure it is easily located on the ground and on the photograph and not likely to die or be cut by next survey. Select a prominent tree located at the edge of a field or clearing, at a bend in a stream, or any landmark easy to find on the next survey. A SP tree must provide the next crew a point from which to physically and efficiently chain to PC from during all seasons and water levels (**i.e., without the aid of a GPS**). It will help re-locate the plot center at the time the plot is re-measured.

Using both the new and/or old photograph(s) and/or provided image, locate the SP. Note: For the remainder of this appendix, photo will refer to any image format.

Pinprick the SP on the photo that has the sample location pinpricked. Label and circle the pinprick "SP" on the back of the photo.

For remeasurement plots, re-establish the original SP if it is available to reuse and still meets the requirements mentioned.

If the SP pinprick is missing from the old photo, refer to "SP Description" on the old plot sheet and determine the SP location according to the azimuth and distance to plot center (PC). Any openings on the photo (such as clearings, roads, woods trails, lakes, and streams) are good locations where the SP might logically be located. Also check the sketch of the area on the original plot sheet.

If the old SP is suitable, the cruiser re-scribes (not in reserved areas), repaints (not in reserved areas), and re-measures DBH. The tallier checks the "Course to Sample Location" on the plot sheet to see if it seems reasonable. The tallier then transfers the original course to sample location, SP description, and the re-measured DBH to the new plot sheet, and in the data recorder. On the new photo, pinprick the SP and record the course to sample location on the back of the photo.

Note: *Starting point information does not require recollection unless there has been major change (e.g., old SP has been cut due to a new housing development) that may hinder plot relocation during the next cycle. [Clarification 10/05/2006.]*

STARTING POINT TREE MONUMENTATION (East v. West)

East Procedures: In the field, mark the SP with two parallel diagonal scribe or paint marks, each about 4 inches long and 4 inches apart, at 5-1/2 ft above ground, and near the ground, below an imaginary 1 ft high stump. The lower marks are referred to as “stump scribes.” Place the stump scribes on the downhill side of the tree whenever possible. This is done in case the SP is cut. The stump mark in most cases can still be viewed after a tree is cut. The SP marks should face the direction of approach so that future crews may readily find them.

Note (procedural change for former NE crews): The practice of establishing two SP witness trees is no longer required unless conditions warrant.

If a bark scribe is used, **DO NOT CUT INTO THE CAMBIUM**. It is important that scribe marks be made carefully so that they do not expose or penetrate the cambium of the tree. Cutting into the cambium can compromise the health of a tree. Scribes should only be made in the outer bark layer of thick-barked trees. Use paint on thin-barked trees.

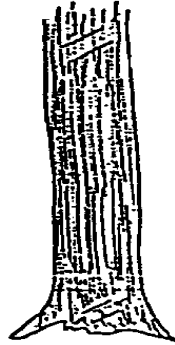

Figure RA1a. Illustration of SP marks in the east. Note: Bark scribes and/or paint have been utilized in previous cycles.

West Procedures: Mark the SP with paint facing the direction of normal approach. Paint "SP" (in letters four-inches tall) at 5-1/2 ft above ground. Paint three-inches tall "SP" below an imaginary 1 ft high stump. Place on the downhill side of the tree whenever possible. Again this is done in case the SP is cut.

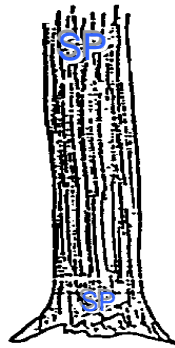

Figure RA1b. Illustration of SP marks in the west.

Never paint or scribe trees located on a landowner's yard without permission from landowner.

Note: For either procedure, use discretion in painting or scribing trees on private lands and in other well-traveled areas like public trails. Make a note when the applied marking deviates from normal procedures on the plot sheet. In reserved areas paint and scribes are not used unless the manager of the reserved area indicates otherwise. Instead, nail a tag marked with "SP" to the base of the tree. Please make a note on the plot sheet if reserved areas are marked differently than with a nail and tag at the base.

Note: Black Hills National Forest plots in South Dakota receive a tag at the base and at DBH.

If the reserved area is a National Park or National Wilderness Area, we have a National agreement to use tags and nails. An excerpt for the National Forest Wilderness areas agreement is shown below.

The use of scribes and paint are prohibited on plots located in Wilderness areas on National Forests. Starting point trees will not be painted or scribed. Instead, nail a tag marked with "SP" to the base of the tree facing the direction of normal approach. If the starting point is in the view of a known path, trail or other public area, place the tag away from the public area. In addition describe the starting point on the plot record and include reference landmarks. If old scribe marks are present, do not re-scribe. Apply tags as instructed. [INTRA-AGENCY AGREEMENT 05-SU-FIA01]

Describe the SP on the plot sheet under "Starting Point Description." Include the landmarks you used to locate SP. Specify details of the SP such as:

- Species, DBH, and the face on which the tree is painted.
- Any nearby road, fence, pasture, etc. and the tree's location in relation to that feature.
- Any noticeable characteristic of the SP tree, such as a fork at 10 feet, multiple stems, deer stand, etc.

- Take a GPS reading at SP tree and record on the plot sheet and in the data recorder.

COURSE TO SAMPLE LOCATION

AZIMUTH AND DISTANCE COMPUTATION

On the back of the photograph, connect the pinpricks for the SP and plot center (PC) with a straight line. Extend this line to intersect the BASELINE. Lines should extend well beyond the intersection to allow reading the back-sight off the 360° protractor to check the accuracy of the angle being measured.

If the BASELINE and the line to the sample location do not intersect on the photograph, draw a straight line or additional REFERENCE LINE that will intersect the BASELINE and the "Course to Sample Location" line (i.e., course to plot). Indicate the directions of the sample location line and the BASELINE by putting an arrow at the end of each line. Measure the angle between these lines, starting from the BASELINE.

Be sure to use an inverted 360° protractor or flip a standard 360° protractor over. Align the 360° protractor over the azimuth of the BASELINE to get the azimuth of the sample location line. The azimuth is read directly off the protractor once the azimuth of the BASELINE is correctly aligned on the inverted protractor. This is because east-west azimuths are reversed 180° when working on the back of the photo. Repeat this procedure if a REFERENCE LINE is needed to intersect the course to sample location. To minimize error, check the back-sights of both BASELINE and "Course to Sample Location" lines. Back-sight is the surveying method taken backwards or 180° in the opposite direction. Ex: If your baseline was 20° then the back-sight would be 200. If the SP to PC was 90 then the back-sight (or PC to SP) would be 270. If the protractor is precisely aligned then the two lines (baseline and SP to PC line) will be lined up accurately with each of their back-sights being 180° in the opposite direction. This is a check to see if the protractor is precisely aligned.

Important Note: East-west azimuths are reversed when working on back of photo with standard protractor. Inverted protectors are available.

Refer to Figure RA2. Measure the distance on the photo from the SP to the PC, to the nearest quarter chain, with a photo scale. (Photo scales, corresponding to the aerial photography, are supplied.) Hold the photo up to the light and carefully measure, from the center of one pinprick to the center of the other. (Sometimes it helps to use your stereoscope as a magnifier.) Record both distance (in feet) and direction on the back of the photo, on the plot sheet under "Course to Sample Location", and in the data recorder.

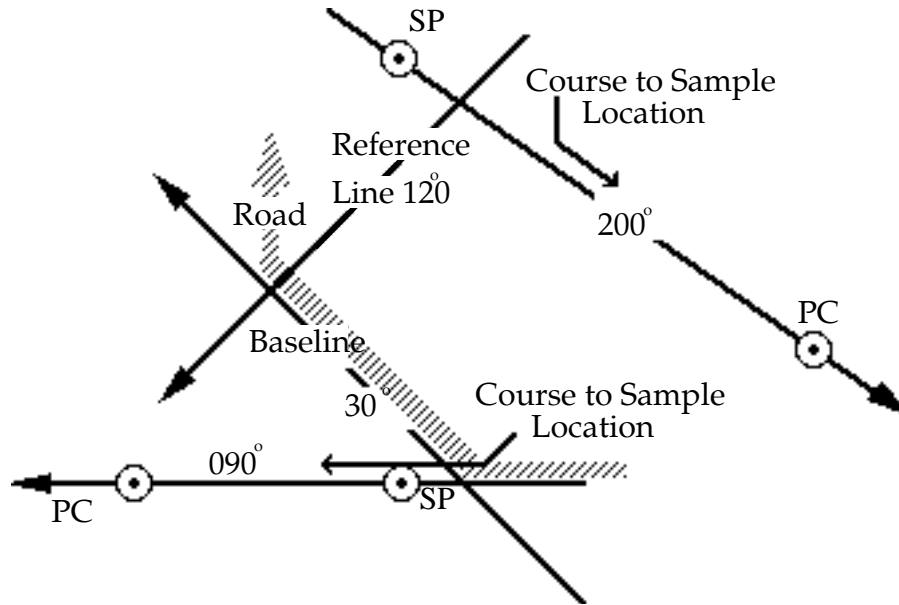

Figure RA2. Back of photo documentation that includes azimuths for baseline, reference line and course to sample location. Documentation also includes the identification of SP and PC.

CHAINING

Using compass and tape run a course on the computed azimuth. Distance correction for slope is necessary when slope exceeds 10%. Using the *Suunto* clinometer, slope correction can be quickly determined and added after the line is run out. In Regional Appendix E a slope correction table is available to determine the correct adjustment that is added to the line along the slope. For example, to chain a horizontal distance of 66.0 feet on a 25% slope, chain 68.0 feet (66.0 + 2.0) on the slope. Once the computed course has been run, place a permanent stake at the end of the computed course.

Important: Make sure that photograph location agrees with ground location.

LOCATION CORRECTION FOR PLOTS ESTABLISHED BY PINPRICK

If the ground location is clearly not the point pinpricked on the photograph (more than 2 chains error), and the correct location can be determined on the ground, place a second pin at the correct location. Note the azimuth and distance from the initial pin to the relocated pin and record these items under "Course to Sample Location" on the plot header sheet and remove the first pin. The initial pin is referred to as a "Turning Point." The second pin becomes the location of the plot.

This is only done when on a new plot and it is obvious that the location arrived at with the chaining azimuth and distance does not agree with the location on the photo or image provided.

If using a remeasurement plot's original course to plot information, chain the computed azimuth and distance along the approach line and mark the location. If the original PC is found here continue to relocate other subplots and establish any new subplot or microplot locations as needed.

USING ORIGINAL SP AND COURSE TO SAMPLE LOCATION

If the original PC is not found at the end of the chaining, search the area for evidence of the old plot. Items to look for are paint on the tree bases (vertical line) and at breast height (horizontal line). In the west, look for 10-inch wire pins and bits of flagging at each subplot, and witness trees (painted with an "X"). In the east, look for a dowel at subplot center and subplot 1 witness trees (i.e., marked with two parallel lines above DBH and below a 1 foot stump line).

After finding PC, establish a Turning Point (TP) if the distance between PC and the end of the approach line exceeds 3% of the chaining distance.

Occasionally, while chaining in, you may pass near or over PC. To minimize the length of a turning point, or perhaps eliminate the need for a turning point, reduce the chaining distance by backtracking along the line of approach.

In the event that, after chaining the prescribed distance, no evidence of the old plot can be found, the following alternatives for locating PC are available.

- Using the original SP, look for landmarks to discern if the plot is in the area. Look especially for mistaken openings, trails, etc.
- Search an area of five chains around the end of the approach line(s).
- Return to the SP, check the photo work, and try re-chaining.
- Check the photo work to see if the original crew chained in the opposite direction.
- Pick a new SP, establish a new approach line, and chain in from there.

An easy way to establish a new SP, when needed, is to inspect the vicinity of the original SP for a suitable replacement. The following three options are available once you've found a replacement (Figures RA3a, RA3b and RA3c). Note that Figure RA2 shows the plot sketch east-west azimuths would need to be reversed if drawn on the back of the photo.

Figure RA3a.

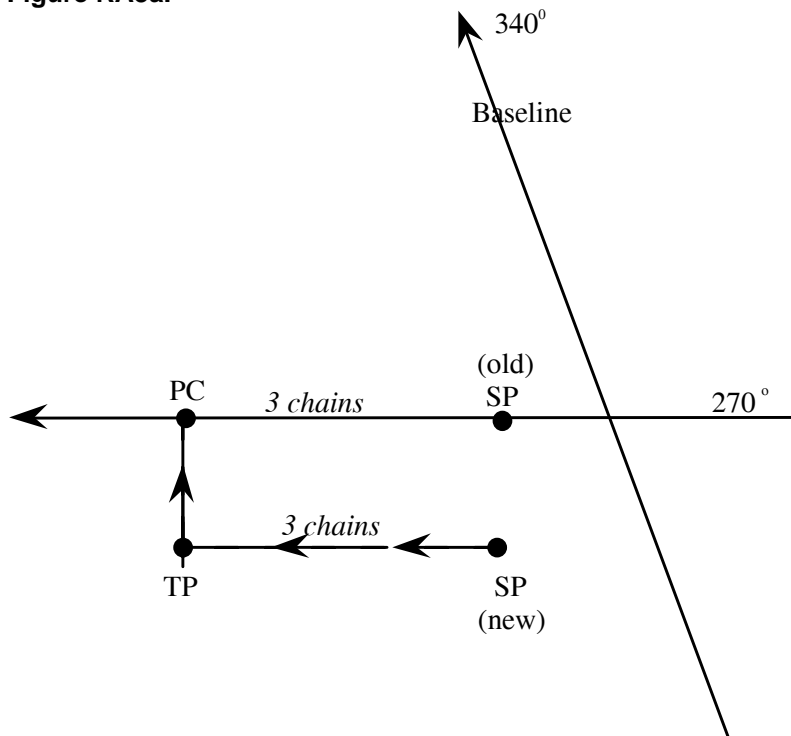

If the new SP is close by, pick the tree on the photo and use the original course to sample location. Leave a marker at your destination and look for plot center. It should be approximately the same distance and azimuth that the old SP is from the new SP. Once PC is found, make a Turning Point (TP) from your marker to PC.

Figure RA3b.

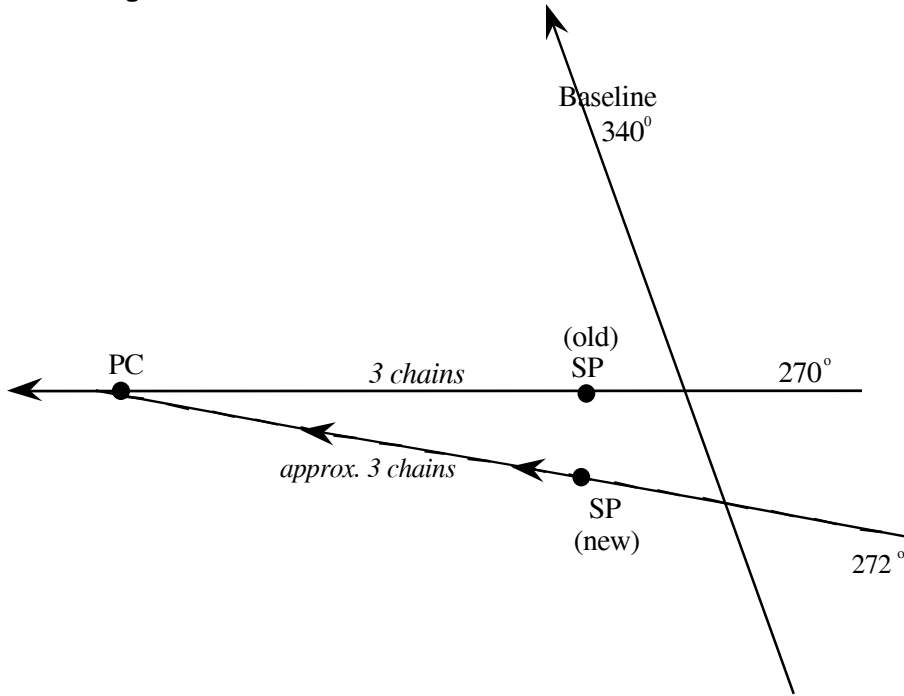

Depending on how far the new SP is from the old SP, you may try adding or subtracting a degree or two (whichever is appropriate) and follow this azimuth into the plot. Adding a few feet onto the old distance may be helpful. Use a marker to show where you ended your chaining. Scan the area for the plot center and then make the necessary Turning Point to plot center.

Figure RA3c.

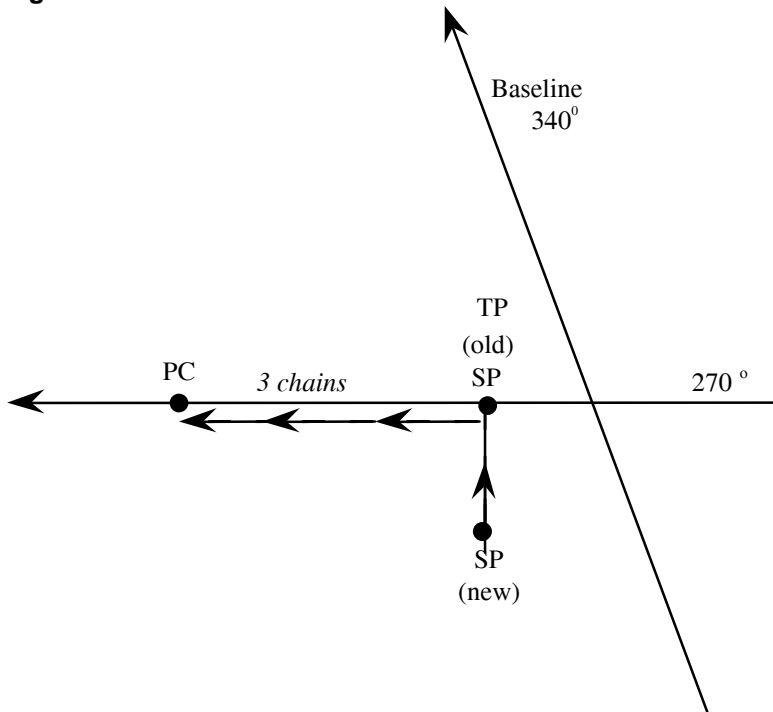

Measure the distance and azimuth from the new SP to the original SP. Record this information in "Course to Sample Location". Record the old course to sample location to the right of this new course. At this time, a new SP has been established and the original SP is used as a Turning Point in the course to sample location. Note: This is the least desirable choice, for it may result in having two turning points--one at the beginning and one at the end.

After finding some evidence of the old plot, look for trees marked at the base and at DBH with paint. When several of these trees are found in close proximity, examine the original plot data and try to match these trees to trees on one of the original subplots.

Match by comparing current tree species, azimuths, distances, and DBH to the data for trees on the tree record sheet. Once it is determined which subplot the trees are on, use triangulation to find the subplot

center and mark it with a piece of galvanized or aluminum wire bent into a loop with a piece of blue flagging tied through it. (The east marks the subplot center with a dowel.) If this is not the plot center, move to the plot center by knowing which subplot you are on and chaining the distance and azimuth to the correct location to plot center.

After finding the old pin at Plot Center, inspect the condition of the old pin or dowel. If the old pin or dowel requires replacement, remove the old pin or dowel and place a new marker at the same location. Note: The use of multiple markers at plot center is not required. Multiple markers can degrade the accuracy of horizontal distance measurements to individual tally trees. If the old pin or dowel cannot be found, triangulate to accurately re-establish the plot center in the original location.

It is very important to locate each individual subplot that you are required to re-measure as accurately as possible. Finding each subplot is a challenge—most of the flagging disintegrates and the wires rust and look just like twigs or roots. The best method is to run out 120 feet (add slope if greater than 10%) from the subplot 1 at the proper azimuth, mark the spot, and search by running your hands through the area.

If several tally trees identifiable, use the triangulation method to relocate the subplot. If this is not possible, due to lack of trees or other circumstances, locate adjacent subplots and use these to triangulate to the missing subplot. This procedure should provide the general location of the missing subplot and reduce the search area.

CHAINING TO OTHER THAN PC

In chaining to PC, you may encounter some condition that makes it impossible or impractical to physically reach PC and put in a marker. PC may be in water, the center of a barn, or on a busy highway. Other subplots on the plot may be in a forest condition and the plot must be installed. In this case, chain to any one of the outer subplots and establish it first. This can be done by using the *FIA PDR Application* utility "Locate Subplot" to compute the direct distance and azimuth to take from the SP to any subplot center and chaining directly to a given subplot. This method is best when you can see you will have trouble reaching PC before you start chaining.

Note: This program utility works only if you are farther than 140 ft away from PC.

A "Turning Point" can also be used at any point when chaining to reach another subplot center. At any point while chaining, establish a Turning Point, chain the distance and azimuth from PC to the subplot you wish to chain to, and then continue on your original course. For example, the course from the SP to PC is 200°, 700 ft. After chaining 600 ft you can see that PC will be in a river and it would be best to chain to subplot 2. At 600 ft, establish a Turning Point and go 360°, 120 ft (the distance and azimuth from PC to subplot 2). Establish another Turning Point and complete the original course (200° for the remaining 100 ft) to reach subplot 2.

The following example illustrates the previously describe method of using a "Turning Point" to locate subplots 2 - 4 when subplot 1 is inaccessible. In the example beginning on the next page, the stream is noncensus water that is too deep to access or cross. The crew establishing the plot does not know that the subplot is inaccessible until they encounter the stream while chaining from SP to PC.

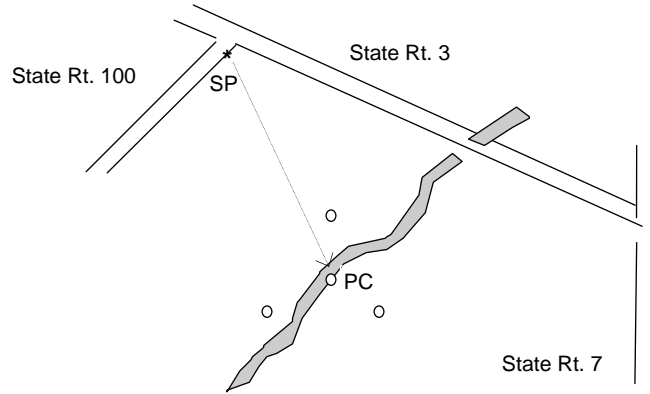

Originally, the course to plot was 534 ft at 150°. The crew chains 500 ft to the edge of the stream and they realize that they cannot occupy subplot 1.

To establish subplot 2 without occupying subplot 1, the crew should establish a turning point (TP1) at the 400 ft station of the course to sample location and proceed due north for 120 ft. Here a second turning point (TP2) is established and the crew should proceed 134 ft at the original course to sample location azimuth of 150°. This is the proper location of subplot 2. Note that TP1 could be established at any subplot along the original traverse as long as the distance from TP2 to subplot 2 is adjusted as well.

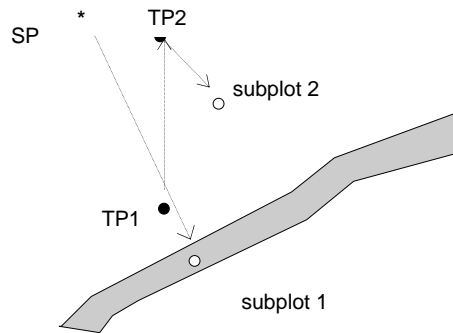

After completing the tally at subplot 2, subplots 3 and 4 now need to be established. Since the creek divides subplot 3 from the rest of the plot, and the stream cannot be safely crossed, subplot 3 will have to be accessed from the opposite side of the creek.

As for subplot 4, it can be accessed directly from subplot 2. The distance and azimuth from subplot 2 to subplot 4 is 207.8 ft at 210°. (See the table in Section 0.1 showing how to locate outer subplots from a subplot other than subplot 1.)

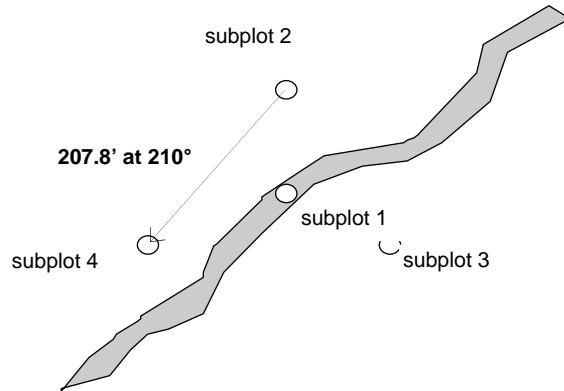

Finally to complete subplot 3, the crew will need to access this subplot from the other side of the stream. A second SP and course to sample location is established using the aerial photography. (Note: If this procedure is followed for a new plot, you must first accurately pinprick the PC ground location and orient the photo.) Example below: SP #2 to PC is 400 ft at 220°.

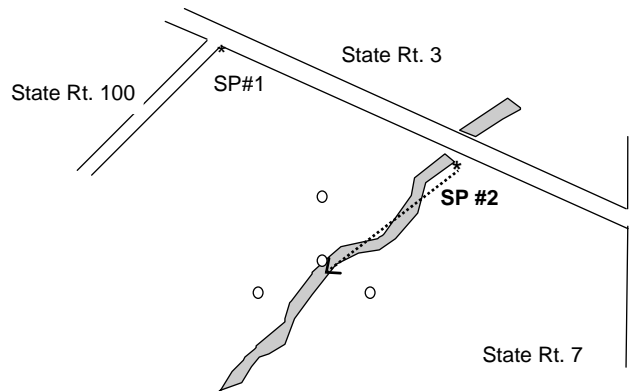

However, we cannot occupy P.C. and the goal in establishing a second SP and course to sample location is to establish subplot 3. This can be accomplished by proceeding 120° for 120 ft from SP #2 to a turning point. This turning point represents the relative location of subplot 3 to subplot 1. From the turning point, proceed on the calculated course to sample location of 400 ft for 220° to locate subplot 3. This procedure uses the same techniques as used to locate subplot 2 from the original course to sample location.

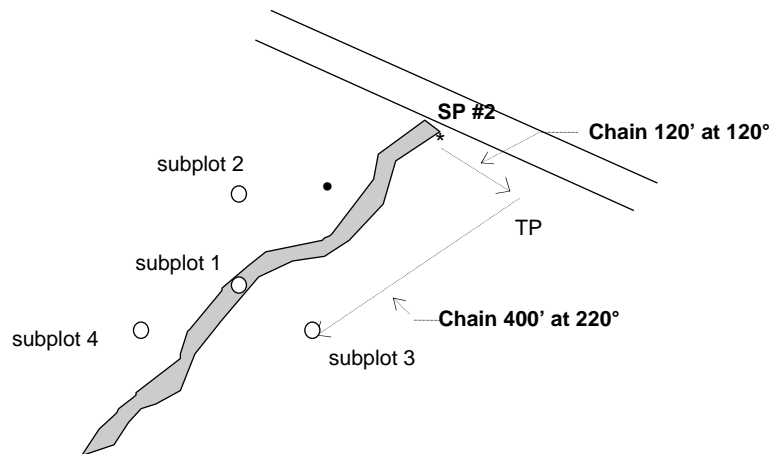

This is just one example to illustrate locating subplots without occupying subplot 1. Another method that can be utilized is using the GPS unit. In the above illustration, the coordinates at subplot 3 can be determined from the subplot 1 coordinates. Coordinates are then collected at SP #2. A course to plot can then be determined from these two sets of coordinates. However, caution must be used when establishing subplot 3 in this method. All GPS coordinates involve error. Therefore, prior to any data collection at subplot 3, the crew should verify, the best they can, that they are the proper distance and azimuth from the other subplots.

Crews should implement a method that is most efficient given various conditions that exist on the photo and plot area.

Whenever subplots are established without occupying subplot 1, a detailed description of the methods used must be written in the PLOT NOTES. Photos with more than one SP and course to sample location must be properly labeled. Also whenever subplot 1 is not physically occupied, the crew should reference one of the subplots (2-4) with reference trees and collect GPS coordinates at this point. These coordinates are recorded in the PLOT NOTES only since they do not reflect PC at subplot 1.

DISTURBED OR LOST PLOT

If re-measurement plot cannot be located, the crew must bring this plot to the attention of the crew leader, QA personnel or field supervisor. Due to the importance of remeasurement data, a second attempt by a veteran field crew, crew leader, QA personnel or the field supervisor will be made. If on the second attempt the plot cannot be relocated, the plot is re-established using one of the following guidelines.

DISTURBED

When there has been a major disturbance (such as the area has been clearcut and bulldozed) and it is obvious that the plot cannot be relocated, establish the plot as near as possible to the old PC.

- This plot does not get a new PLOT NUMBER.
- Account for previous trees before entering any new tree data.

NOT DISTURBED (LOST PLOT)

For a remeasurement plot where there has been no major disturbance to the plot area, the initial crew must do their best to find the previous plot location. If the first crew fails to locate the plot, a second veteran crew, crew leader, QA personnel or field supervisor should attempt to find it. If both efforts fail, then a replacement plot is placed in at the location of the X' on the image or the corresponding GPS coordinate.

- PLOT STATUS of 3 is assigned to the lost location data file.
- A plot file will be completed with the original number of the lost plot.
- A second plot file will be created with the new PLOT NUMBER for the plot sampled.
- Both data files and plot sheets will be returned to the regional office.

PLOT IN THE WRONG LOCATION

If a re-measurement plot was established in the wrong location (i.e., not in the same location as the photo pinprick), re-establish the plot in that wrong location. If the error is more than 2 chains or if it needs clarification for next crew, re-pinprick the new photo where the plot is actually located.

Note: Occasionally the error will be less than 2 chains; but due a physical feature on the ground or photo, the pinprick requires correction. Example, the pinprick is on the north side of the road, but the plot is on the south side of the road. In this case please re-pinprick the new photo.

In the "Notes" section of the plot sheet, indicate that you moved the pin prick to agree with the original location the plot was installed. Record the distance and azimuth (using a photo scale) from the original pinprick on the new photo to where the plot is actually located. Bring such plots to the attention of the crew leader or state supervisor. It is assumed that the plot is located in the correct location unless physical evidence of the plot is found in the wrong place (i.e., pins/dowels, paint or flagging).

PREVIOUSLY DENIED ACCESS PLOTS

If a plot was Denied Access (DA) during the last cycle, it will be sent out in the new cycle to see if access will be granted this time around.

- Contact the current land owner to ask for permission
- Code as DA if owner denies once again
- If permission is granted, reference the previous Sample Kind (SK) on last cycle's plot sheet
 - If it was a SK 1, then it was a new plot last during the last cycle and it has never been installed. Install the plot as a new plot, but SK = 2 for this cycle.
 - If it was a plot that has been previously installed in the past (i.e., 2 cycles ago), locate the plot based on the plot location data from the last successful visit. Treat as a new plot (i.e., do not reconcile data from 2 cycles ago), but SK = 2 for this cycle.
 - If it was a plot that has been previously installed in the past, but the plot data from the last successful visit is not available or inadequate for relocation; establish the plot at the 'X' on the photo or provided GPS coordinate. Treat as new plot, but SK = 2 for this cycle.

LOCATION DIFFERENT THAN REMEASUREMENT PLOT LOCATION

If the new DOQ or NAIP location and/or the coordinates do not match up with the previous DOQ or NAIP and/or coordinates, the previous information is considered correct. Be sure to place the plot in the same location that the previous crew placed the plot. Example, if the previous crew placed the plot completely in a non-forest condition but the new DOQ or NAIP places a point in a forested condition, assume the previous crew was correct. Locate the previous location using the SP to PC "Course to Sample Location" or the subplot "Reference Tree" information.

NON-FOREST QA/QC PLOTS

Each state in the west and some states in the east have a maximum of 25 non-forest QA/QC plots that need to be visited each year. These plots are selected to verify if the P1 photo interpretation was completed properly. These plots require a ground visit to confirm if they are truly non-forest or if they are actually forested on the ground. Any type of field crew can complete these plots. The crewleader or supervisor will need to provide the download data for these plots. QA STATUS = 6 on these plots.

Navigate to the vicinity of the plot and visually determine the status of the plot. If it is clearly a non-forest condition, there is no need to occupy plot center. The photo work will need to be completed to establish course to sample location (do not calculate this information between a SP and a digitized PI coordinate). A SP coordinate is required like any other plot that is field visited. If a digitized PI coordinate is provided, calculate new PC coordinates by using the SP coordinates and the "Course to Sample Location" information unless PC is occupied. If PC is occupied, collect the GPS coordinates at PC. If a true GIS PI coordinate is provided (i.e., these are plots that have never been established and the GIS PI coordinate represent the true ground location without any associated error), it is not necessary to calculate PC coordinates unless PC is occupied. If PC is occupied, collect the GPS coordinates at PC.

If the status of the plot is questionable, it is necessary to check for stocking on the plot. If stocking is met, the plot will need to be measured under the same guidelines as a regular P2 plot and the complete data will be loaded into the database. If stocking is checked, (whether the plot is stocked or not) photo work will need to be completed, the PC coordinates need to be entered, and reference trees need to be collected to ensure the next crew will be able to locate the exact location for stocking purposes in the future.

- If PLOT STATUS is determined to be nonforest, complete as PLOT STATUS = 2
- If PLOT STATUS is determined to be with forest land, complete as PLOT STATUS = 1

OTHER SAMPLE PLOT LOCATION RECORD DATA

SKETCH MAP OF PLOT LOCATION

A “Starting Point Map” must be drawn for all plots. Sketch maps should provide enough information so that a plot can be relocated without the use of the aerial photos or GPS coordinates. Details (bridges, rivers, trails, etc.) and mileage to an easily located intersection or reference point must be included. Inspectors check the quality of a sketch map by attempting to locate a plot with the sketch map. A plot that cannot be located due to a poor sketch will be considered unsatisfactory. Neatness and clarity are desired. Artwork is not necessary and is not required. A good sketch map should take no more than five to ten minutes to complete.

It must include:

- References to the nearest town or major secondary road
- Names and/or numbers (if available) for all roads shown on the sketch along with house or box numbers, when appropriate
- Intersections and other easily identified landmarks.
- Use common symbols to represent features like fences, railroads, etc.
- Include North arrow with a not to scale reference (N.T.S)
- Location of SP and PC identified.
- Record distances between road intersections from an originating intersection or town to SP. Distances are recorded in miles, tenth’s of mile, chains, or feet.

PLOT DIAGRAM

Use this space to show the location of contrasting condition classes, and any unique features on or near the plot that may be helpful in relocating the plot at the next inventory. It is important that condition class boundaries be sketched in accurately to avoid problems on the next cycle when these boundaries will be remeasured.

SUBPLOT REFERENCE TREES

Subplot reference trees are used whenever there is a concern that the next crew may have a problem locating a subplot. Make complete notes of everything that you do so that it will be clear to the next crew. In some cases an object other than a tree can be used as a suitable reference marker.

Subplot center is referenced for the following situations:

- SUBPLOT STATUS = 1, subplot center is forested and no live trees \geq 5.0 in DBH tallied on subplot or live saplings \geq 3.0 in DBH tallied on the microplot.
- SUBPLOT STATUS = 1, subplot center is nonforest and no live trees \geq 5.0 in DBH tallied on subplot or live saplings \geq 3.0 in DBH tallied on the microplot.
- SUBPLOT STATUS = 2, subplot center is within 60 feet of a forest edge.
- A plot that requires a stocking check to determine condition must be referenced.

Reference trees should be **within 60 feet of the subplot center and** marked above DBH and at the base with paint or scribe marks facing the subplot center. There is no preferred reference mark. E.g., if using paint, an appropriate mark may be the associated subplot number. This mark makes it easier for the next cycle’s crew to identify the subplot. If using a scribe, an appropriate mark may be an “X” or a triple-scribe mark “\”. Whichever mark is used, indicate the mark type on the plot sheet’s “Reference Tree” grid along with the other reference information as shown in the example. **[Clarification 10/05/2006.]**

Sub#	Spp	DBH	Dist	Azm	Mark
1	0931	060	265	003	///

In reserved areas do not use paint (or scribes) unless permission is granted. If permission is denied, a nail and tag is used with a reference mark at the base of the reference tree only. National Parks or National Wilderness areas require a nail and tag be used for a reference tree.

NOTES

Record any additional information regarding ownership, plot and/or subplot relocation.

“Notes should be full and exact so as to furnish for the benefit of later comers a complete record of the work done. In the case of resurveys they should be particularly clear as to the old marks found, so that the evidence which governed in the resurvey may be a matter of record. This rule holds especially in regard to starting points and corners...Notes should be so plainly and clearly written that any fairly intelligent man can understand them. They should be honest as well, not concealing actual errors...Errors are normal and to be expected. They grow out of imperfections in method that are imposed on the survey or by limitations in the matter of expense. Errors are not to be confused with mistakes or blunders.” – *Austin Carey, Woodsman’s Manual, Fourth Edition, 1932.*

STARTING POINT VARIABLES

GPS STARTING POINT

Record the latitude and longitude of the “SP” on the plot sheet and data recorder using the same procedures for collecting PC coordinates. See Regional Appendix H – GPS User’s Guide.

Note (procedural change for former NC and NE crews): The following six regional variables associated with latitude and longitude degrees, minutes and seconds will be recoded as two variables in the regional PDR program and the plot record. Record the following format for degrees, minutes and seconds for both latitude and longitude as displayed in *LANDMARK CE*:

LAT N = xx° xx' xx.xx"
LONG W = xxx° xx' xx.xx"

SP LATITUDE DEGREES

Record the latitude degrees of the SP as determined by GPS.

When collected: When COORDINATE SYSTEM = 1
Field width: 3 digits (1st digit is + or -, last 2 digits are numeric)
Tolerance: No errors
MQO: At least 99% of the time
Values:

SP LATITUDE MINUTES

Record the latitude minutes of the SP as determined by GPS.

When collected: When COORDINATE SYSTEM = 1
Field width: 2 digits
Tolerance: No errors
MQO: At least 99% of the time
Values: 1 – 59

SP LATITUDE SECONDS

Record the latitude decimal seconds of the SP to the nearest hundredth place as determined by GPS.

When collected: When COORDINATE SYSTEM = 1
Field width: 4 digits
Tolerance: +/- 140 ft

MQO: At least 99% of the time
Values: 0.00 - 59.99

SP LONGITUDE DEGREES

Record the longitude degrees of the SP as determined by GPS.

When collected: When COORDINATE SYSTEM = 1
Field width: 4 digits (1st digit is + or -, last 3 digits are numeric)
Tolerance: No errors
MQO: At least 99% of the time
Values:

SP LONGITUDE MINUTES

Record the longitude minutes of the SP as determined by GPS.

When collected: When COORDINATE SYSTEM = 1
Field width: 2 digits
Tolerance: No errors
MQO: At least 99% of the time
Values: 1 – 59

SP LONGITUDE SECONDS

Record the longitude decimal seconds of the SP to the nearest hundredth place as determined by GPS.

When collected: When COORDINATE SYSTEM = 1
Field width: 4 digits
Tolerance: +/- 140 ft
MQO: At least 99% of the time
Values: 0.00 – 59.99

AZIMUTH TO PC [AZM1]

Record compass direction from the SP tree to the PC.

When collected: All plots visited in the field
Field width: 3 digits
Tolerance: None
MQO: 99% of the time
Values: 1-360

DISTANCE TO PC [DIS1]

Record the horizontal distance from the SP tree to the PC to the nearest foot.

When collected: All plots visited in the field
Field width: 4 digits
Tolerance: +/- 33 feet (1/2 chain)
MQO: 99% of the time
Values: 1 - 9999

Repeat the above two items if needed for tuning points to PC.

AZIMUTH TO PC [AZM2]
DISTANCE TO PC [DIS2]
AZIMUTH TO PC [AZM3]
DISTANCE TO PC [DIS3]
AZIMUTH TO PC [AZM4]
DISTANCE TO PC [DIS4]

Appendix B. Ownership Data Collection Procedures

OWNERSHIP INFORMATION

Ownership data are usually the first variables completed by a field crew. The process begins with a trip to the local tax office to review plat maps, examine aerial photos and interview the tax collector in an attempt to determine who owns the plot location. (Some counties and townships now have landowner parcel information available on the internet and at no fee. These sites have viewable parcel maps with owner name and address links based on the parcel number.) If ownership is obtained from a courthouse or town office write the parcel number underneath the owner information section on the plot sheet, this will make it easier to obtain the owner data at the start of the next cycle.

Although ownership information is only required for plots that are forested at PC, it is often a good idea to collect ownership information on all of the plots in the county, or town, while you are at the court house or township office. This is especially true in states or regions where there is a relatively small amount of nonforest land. The time spent gathering this extra information during your first visit will usually be a fraction of the time spent on a return visit after you discover that a previously nonforest plot has reverted to forest land.

Permission, verbal or written, must be obtained for all plots that require access. This is a requirement of federal legislation in *The Farm Bill*.

The following are a list of steps that describe how to go about obtaining permission once the landowner has been identified at the courthouse or town office

1. If the telephone number is determined, call the landowner to get permission. Plan ahead so that this is completed before you head to a county. Write on the plot sheet who granted permission and on what date along with any restrictions to access that the owner might have, such as to leave the gate open or be sure to call on the day of the visit.

Retrieve an owner's telephone number via the internet or by calling directory assistance (area code + 555-1212); or try one of the following websites.

- www.superpages.com : Go to People Pages tab. This website is good for looking up people's names. Ex: If you type the first name of William, it will also find the Bill's and Will's too.
- www.whitepages.com : "Look up by Address" is a very helpful tool. This enables you to find landowners telephone numbers if they have a business at that address listed or if lady remarries and changes her last name. It also finds neighbors that live on the same road.
- www.people.yahoo.com
- www.michigan.gov/dnr - go to Forests, Land & Water tab >> center of the page to Michigan forests >> then to Commercial Forest Program. This will list landowners by legal description if they are in the CFL Program. This land is open to hunting and fishing.

Also for more unusual last names (so not Smith), you can look on the internet for other folks with the same last name that live in the area, and try giving them a call and hope they are a relative. Identify yourself and briefly describe the program, next explain that you are unable to find the landowner to get permission and was hoping that they were a relative and would know how to get a hold of them.

2. If a telephone number cannot be determined, drive by the owners place (if it is near the plot). If no one is home at the owner's house leave a note and a phone number to contact you. **If the owner does not live near the plot, stop at a house near the plot and try to get a telephone number from them.**
3. If you **(1)** cannot find a phone number and you leave a note at their house and don't hear back from the owner; **OR** if you **(2)** can't find the phone number and the owner does not live near the plot; **OR** if **(3)** a landowner does not return your telephone calls; **OR** if **(4)** you have already tried a "near by" neighbor's house to get some contact information which did not help; then send the landowner a certified letter (certified so you know if they received the letter). Only send a letter *after* you have attempted the 4 options above. Keep records of your attempts on the plot sheet. It is up to the person that is assigned the plot to send the letter and to monitor the plot status right through sending the electronic data – not necessarily the crewleader. Your name should be on the letter, the registered mail green card, and the return envelope. The crewleader will send out these letters once a week.

This letter should contain:

- Access consent reply slip
- Self-Addressed-Stamped-Envelope
- Landowner Information Sheet
- "Your State in a Nutshell" sheet, if available
- The FIA brochures along with the landowner insert
- Your business card.
- Don't forget to sign your landowner letter and make sure the date other relevant information on the letter and reply-slip are correct.

Post cards will be sent to each office. Be sure to fill in the appropriate information on the post card.

4. Once you send a letter the plot is yours to track for permission. It is your responsibility to track it once it is sent and to handle it once it comes back.
5. If you do not hear back from the landowner within **30** days of the delivery date on the green registered mail card that you get back in the mail, send the owner a FIA contact post card which will state that you have sent them information more than 30 days ago and have still not heard from them. The post card will state that this is the last contact they will have from us and to please reply within 2 weeks. Keep notes on the plot sheet of these dates and include all postal forms with the plot.
6. If you do not hear back from the owner within **30** days of sending the **post card** out call the plot denied. A plot is ruled denied after all the steps above have been exhausted.
7. If the owner **does** call back after these 60 days have passed and the plot is already processed as denied call your supervisor, who will address the issue in the database so that the plot can be done by the crew. Once a panel is completed and the next panel is started, the PLOT STATUS is not changed.
8. If your letter comes back from the post office as "**undeliverable**" or "**return to sender**" call the courthouse and double check on the ownership for the parcel. If the wrong address was obtained in the first place, begin the contact process again. If the same address is identified by the courthouse, called the plot denied and explain in the notes section.

9. If your letter comes back as “**not claimed**” or “**refused**” start the whole letter process over from the start, just this time do not send the letter certified – send it normal mail. If you do not hear back from the owner after 30 days send the post card, if you do not hear back from the post card after 30 days call it denied.
10. When a plot is denied the plot sheet must document the landowner contact attempts. Write in the notes section who was contacted and who denied it along with the dates of contact. If given, state why the landowner denied access. Attach a copy of all letters received back to the plot

It is important to plan ahead and the preceding steps should provide an efficient, consistent means to gather permission across the region. If you are assigned a small county without much public land, all contacts should be made prior to traveling. When one owner has multiple plots on their land, send one letter to cover all of the plots. An example of this would be some of the many large hunting clubs in Northern Lower MI. In some cases their plots might cross over county boundaries. Organize these plots based on ownership – not based on county. Be sure to let the owner know that they may have more plots on their land next year as well.

There may be other problems related to accessing a plot. Advance notice may be required to obtain keys, special permits, etc., prior to property access. Supervisors will provide assistance and instructions for these and other situations.

Note: Publicly owned lands like national parks and wilderness areas require permits for access and data collection. Some state publicly owned land also requires permits. Crews working in New York must have a permit to access all state owned lands. Contact your field supervisor for assistance in obtaining these permits.

PRIVATE OWNER VARIABLES

Landowner variables are recorded on the plot sheet and in the PDR program. The plot sheet will indicate the owner regardless of OWNER GROUP. The PDR program owner data are recorded only when subplot 1's center condition is forested and the OWNER GROUP = 40. If subplot 1's PC is nonforest, ownership information is not entered even if there is forest land on the plot.

Note: This electronic owner data are used to generate the *National Woodland Ownership Survey* sample and therefore subplot 1's PC status is the sampling criteria for this survey.

Upon accessing the plot verify the following with the landowner.

- Courthouse ownership information is not always up to date. Adjust as necessary on the plot sheet and in the PDR program when making contacts in the field.
- Public Land Survey System (PLSS) legal descriptions printed on the plot sheets are not always correct. If a change is necessary, mark it on the plot sheet and note the change to allow the database to be adjusted. Note: The following eastern states do not use this form of legal description: DE, CT, MA, MD, ME, NH, NJ, NY, PA, RI, VT and WV. OH and all states west use this legal description format of township, range, section and subdivision.
- If the person contacted is not the person listed as the owner, be sure to note who granted you access. This will assist the QA crews and the crews for next cycle.
- List date contacted and any restrictions that the landowner has placed on access. If the plot is accessed at a later date, the crew will be aware of the landowner's requests.

NRS Note (procedural change for former NC crews): Electronic owner data is now only recorded when subplot 1's center condition is forest land and OWNER GROUP = 40. Previously, the first forested condition encountered with private ownership was entered. This procedure is no longer valid.

NRS PDR Note: See table at the end of this appendix for example data entry for OWNER FIRST NAME & OWNER LAST NAME.

OWNER FIRST NAME [FIRST NAME]

Enter the first name of the owner.

When collected: OWNER GROUP = 40 and SUBPLOT 1 CENTER CONDITION = CONDITION CLASS STATUS 1

Field width: 40 characters

Tolerance: No errors

MQO: 99% of the time

Values:

OWNER LAST NAME [LAST NAME]

Enter the last name of the owner.

When collected: OWNER GROUP = 40 and SUBPLOT 1 CENTER CONDITION = CONDITION CLASS STATUS 1

Field width: 40 characters

Tolerance: No errors

MQO: 99% of the time

Values:

OWNER STREET [STREET]

Record the street address for the owner.

When Collected: OWNER GROUP = 40 and SUBPLOT 1 CENTER CONDITION = CONDITION CLASS STATUS 1

Field width: 40 characters

Tolerance: No errors

MQO: 99% of the time

Values:

OWNER CITY [CITY]

Record city name for the owner.

When Collected: OWNER GROUP = 40 and SUBPLOT 1 CENTER CONDITION = CONDITION CLASS STATUS 1

Field width: 40 characters

Tolerance: No errors

MQO: 99% of the time

Values:

OWNER STATE [STATE]

Record two digit State name for the owner.

When Collected: OWNER GROUP = 40 and SUBPLOT 1 CENTER CONDITION = CONDITION CLASS STATUS 1

Field width: 2 digits

Tolerance: No errors

MQO: 99% of the time

Values: all two character state codes

OWNER ZIP [ZIP]

Record city zip code for the owner.

When Collected: OWNER GROUP = 40 and SUBPLOT 1 CENTER CONDITION = CONDITION CLASS STATUS 1

Field width: 15 characters

Tolerance: No errors

MQO: 99% of the time

Values:

PHONE [PHONE]

Record phone number of the landowner. Record using dashes between area code and the next 3 digits (exchange) and between the exchange and the number (i.e.: nnn-xxx-nnnn).

When Collected: OWNER GROUP = 40 and SUBPLOT 1 CENTER CONDITION = CONDITION CLASS STATUS 1

Field width: 10 digits

Tolerance: None

MQO: When available

Values: nnn-xxx-nnnn

OWNER REQUESTS INFORMATION [SEND INFO ST. PAUL]

If the landowner requests more information on the forest inventory data that the field crew can not provide, this data item should be set to 'Y'. This item has a default setting of 'N' so if there is a request from the landowner that St. Paul or Newtown Square must fulfill, this should be changed to 'Y'.

If the landowner request information, indicate on the plot sheet exactly what information the landowner is requesting. Discuss the minimal level of measurement on their specific piece of property. Inform them of our website (most of data is now available online) and offer to give them pamphlets and publications on FIA. If they request a copy of the data from the plot on their property, feel free to provide that data, but be sure sensitive data is not disclosed (see Section 0.3N – PLOT DATA SECURITY). If they request future publications, the regional office can fulfill that request, but the landowner should be advised that it could be several years before a publication is sent.

When collected: All plots

Field width: 1 digit

Tolerance:

MQO:

Values:

Y Yes

N No

Ownership Data Collection and Various Cases
Note: Enter ownership information for OWNER GROUP = 40
Note: Enter up to 40 characters for each scrolling field
Note: Do not use any punctuation except commas as described below and hyphens in hyphenated last names.
Note: Typical rule for estates, trusts, etc., will be to include in the FirstName field in parenthesis after the first name. See examples below.

Situation	Solution	E.g., Courthouse Listing of Owner (s)	E.g., FirstName Input	E.g., LastName Input
Trust / Trustee	Enter the Trust name only	Wilfred Gray (Trust)	Wilfred (Trust)	Gray
		James Jackson Trustee for the Jimmy Trust	Jimmy (Trust)	Jackson
Estate	Enter in LastName with the following format 'Estate of FirstName LastName'	Estate of Allen Anderson	Allen (Estate)	Anderson
		Henry Davidson (Estate)	Henry (Estate)	Davison
Hyphenated Name	Enter the full hyphenated last names under LastName with the hyphen	Cynthia Durst-McKay	Cynthia	Durst-McKay
Apostrophe	Enter name w/o the apostrophe leaving no spaces; do no capitalize the letter after the apostrophe	Kathy O'Neil	Kathy	Oneil
Dual caps in Last Name	Enter the name as on word with intermediate capitalization	Tammy McAllister	Tammy	Mcallister
Two First Names	Enter the two first names under FirstName	Sally Ann Hansen	Sally Ann	Hansen
Middle Initial	Include as part of the FirstName w/o period	Jackie C. Christopherson	Jackie C	Christoperson

Situation	Solution	E.g., Courthouse Listing of Owner (s)	E.g., FirstName Input	E.g., LastName Input
Prefixes	Include as part of FirstName in the format 'first suffix' w/o comma or period	Dr. Christopher Steele	Christopher Dr	Steele
Suffixes	Include as part of FirstName in the format 'first suffix' w/o comma or period	Michael Haynes the Third	Michael III	Haynes
		Ralph Jones, Jr.	Ralph Jr	Jones
Two owners – same last name	Enter first names in FirstName; Enter last name in LastNames	Jack & Patricia Frost	Jack & Patricia	Frost
		Steve Paulson Jr. and Steve Paulson Sr.	Paulson, Steve Jr	Paulson, Steve Sr
		Dr. and Mrs. Karl Kubas	Karl Dr Mrs	Kubas
Two owners – different last name	Enter one owner under FirstName ' lastname, firstname'; and the other owner under LastName 'lastname, firstname	George Nelson, Gregory T. Harris	Harris, Gregory T	Nelson, George
		Jesse Jackson II and Jesse Jackson III	Jackson, Jesse II	Jackson, Jesse III
More than two owners	Enter on the first name listed	Liz Hanna, Dennis Hanna, Dacia Meneguzzo	Liz	Hanna
		Stephan Gonzalez, et. Al.	Stephan	Gonzalez
		Steve Paulson Jr. (Etux)	Steve Jr	Paulson
		Dr. and Mrs. Karl Kubas & Jackie Jones	Karl Dr	Kubas
		Michael Bates I, Michael Bates II, and Michael Bates III	Michael I	Bates

Situation	Solution	E.g., Courthouse Listing of Owner (s)	E.g., FirstName Input	E.g., LastName Input
Cannot find owner information	Enter 'Cannot find' in LastName	Unsure		Cannot find
		Could not locate owner		Cannot find
Miscellaneous examples		West Suburban Bank Trust #2272	Trust #2272	West Suburban Bank
		O.J. Tretter Trust #1	O J (Trust #10	Tretter
	Business contact name optional	Big 3 Precision – Dale R. Morrison		Big 3 Precision – Dale R
		William Owers Revocable Living Trust	William (Revocable Living Trust)	Owers
		Enip'S Inc.		Enips Inc
		C & Lyahr 1989 Family Trust	(1989 Family Trust)	C & Lyahr
		Rex Chappelear Family Trust	Rex (Family Trust)	Chappelear
		E. Lechien – Compound Land Trust	E (Compound Land Trust)	Lechien
		Walter Land Trust	(Land Trust)	Walter

Appendix C. Additional Northern Data Collection Procedures

This appendix covers items that are not explained in the main text of Sections 0 through 7.

ALTERNATES (East only)

During the initial establishment of the Annual Inventory Cycle, occasionally it will not be possible to establish a previously established periodic plot (SK 5, 6 or 8) due to inadequate previous plot records from the periodic inventory. When this happens, promptly notify Newtown Square. If an alternate is warranted, another plot is sent and all office and field copies of the plot listings are updated to show the change. The sample kind for these alternate plots will be either SK 1, 5, 6 or 8 depending on the state. Once an alternate is selected, the original plot is no longer in the sample and requires only a notation as to why an alternate was requested on the plot record and no other data entry is required. These alternate plots are not SK 3 Replacement plots.

East/ West Note: An SK 3 Replacement plot is authorized when an SK 2 plot cannot be established due to inadequate previous plot records from the previous annual cycle. The SK 2 plot being replaced requires minimal data entry as required for a PLOT STATUS 3 and NONSAMPLED REASON = 06.

CENSUS WATER

Apply one of the following rules and in the PLOT NOTES specifically identify the river, lake, or other body of water:

- If all or any portion of a remeasured plot is determined to be census water due to some change (physical or definitional) since the previous inventory, the plot is installed and delineated.
- If a new plot's center (PC at subplot 1) falls on land and portions of the plot falls in census water, the plot is installed and delineated.
- If a new plot's center (PC at subplot 1) falls in census water and portions of the plot falls on land, the plot is installed and delineated.
- **(East Only) If a new plot falls entirely in census water (i.e., all four subplots), an alternate is required.** Why? The hex center, not the plot, determines whether a field plot is warranted for data collection. If the hex center is on land, then at least some portion of the plot must also fall on land based on the east's current field plot selection protocols. Therefore, a plot sent to the field has a hex center associated with land and not census water. Note: The west applies different field plot selection protocols. The differences are under review and will be modified as warranted by the Biometric & Geospatial Sciences Group.

RESERVED LAND

All public land (federal, state or local) requires documentation in the PLOT NOTES of RESERVED STATUS. The designation of reserved removes the associated forest into noncommercial forest land. Example:

- RESERVED STATUS = 1, Allegheny National Forest – Hickory Creek Wilderness Area
Source – J. Smith, ANF
- RESEVED STATUS = 0, Bald Eagle State Forest
Source – S. Jones, PA Bureau of Forestry

State supervisors may be able to provide a list of public lands that qualify as reserved. The web based source Wilderness.net lists wilderness areas that may be found on Forest Service, Fish

and Wildlife Service, National Park Service and the Bureau of Land Management. A public entity may also have GIS layers showing public land protected by law.

NRS Note (procedural change for former NC crews): The requirement of collecting current DBH and TREE CLASS for trees in a nonforest condition is no longer required. Also the practice of accounting for missed or erroneously tallied trees now in a nonforest condition is no longer applicable.

LANDUSE CHANGE FROM FOREST TO NONFOREST

If the current condition of previous tally trees converts from forest to nonforest between cycles, the following data is required on trees now in a nonforest condition.

Site Index data is downloaded, so if the entire plot is now nonforest, it will need to be deleted to avoid errors relating to SI. If a portion of the plot is forested, make sure only forest conditions are in the condition class list.

Tree and Sapling requirements for previously tallied trees now on nonforest condition:

- TREE RECORD NUMBER – Download
- PRESENT TREE STATUS
- PREVIOUS TREE STATUS – Download
- RECONCILE, if PRESENT TREE STATUS = 0
- HORIZONTAL DISTANCCE – Download
- PREVIOUS DBH – Download
- SPECIES – Download
- AZIMUTH – Download
- CONDITION CLASS NUMBER
- STANDING DEAD, if PRESENT TREE STATUS = 2
- CAUSE OF DEATH

Ingrowth trees are not tallied. **Missed** trees from the last cycle are not to be reconciled, since the collection of this data is subjective due to the condition change. **Erroneously tallied** trees from the last cycle can be reconciled if it is determined that a cruiser error or a procedural change has taken place since the last cycle.

NRS PDR Note: To prevent trees from mistakenly being coded on a non-forest condition, each tree will receive the following critical PDR message: “You have a tree on a non-forest condition. This is only valid if condition went from forest to non-forest.”

RECONCILING THE PREVIOUS TALLY

During this inventory on SK 6, the trees that fall on subplot 1 are the only trees that will be reconciled to the previous inventory. On SK 2 and 5, the trees that fall on all 4 subplots will be reconciled to the previous inventory. Only trees 5 inches DBH and greater within the 24.0 ft subplot radius will be tallied, or reconciled, as part of the regular tally procedure. All trees that are further than 24.0 ft away from subplot center will be ignored. On SK 2 or 5-P3 (former FHM plots in the east), the saplings that fall on all 4 microplots will be reconciled to the previous annual inventory.

On remeasure plots that were previously classified as nonforest, if PC at subplot 1 is still nonforest, record any forest boundaries within the 24.0 ft subplot radius. Only trees 5.0 inches DBH and greater on forested subplots will be tallied. As well as trees 1.0 inch DBH or greater on forested microplots will be tallied. Give all trees RECONCILE 3 or 4.

National Appendix 8 shows tree coding for many situations. Refer to this appendix for proper coding. If you are still unsure on how to code a tree, contact your supervisor.

The following examples are common, simple situations. A correct reconciliation may be time demanding and complex. However, this is a critical part of the inventory. Training will be provided. Crews are to direct any questions to supervisors as soon as possible.

Examples:

1. The first tree to be tallied at subplot 1 is now an ingrowth, dead ingrowth, or previously missed tree. Assign the first available tree number and record the appropriate current data. If there were 35 trees on this subplot the last time, assign this tree number 036. Tree 036 will receive PRESENT TREE STATUS = 1 or 2 and RECONCILE = 3 or 4.

The next tree tallied was tree number 001 at the last inventory. Since trees are no longer being renumbered each inventory, previous tally tree number 001 is current tree number 001.

2. The first tree on the old plot record was a 24.0-inch DBH sugar maple, followed by an 8.0-inch DBH beech. The beech is present and is the first live tree starting from an azimuth of 001. There is no evidence of the sugar maple. Check the area to the plot radius limit to see if there is a stump of the maple. Perhaps there is -- perhaps not. In this case, tree is dead and down. The maple was, and still is, tree number 001 AND receives PRESENT TREE STATUS = 2 and STANDING DEAD = 0. The beech tree is tree number 002 and is still present and receives PRESENT TREE STATUS = 1.

Note (East Only): On SK 6, 24.0 feet was not a critical distance during the last periodic inventory because the plot radius extended to 52.7 feet. The current SK 6 electronic history file will display only those trees ≤ 24.0 feet on the last occasion. Current crews will need to decide whether trees at the critical distance should remain in or out of this cycle's tally. In addition, previous tally trees that had a recorded horizontal distance > 24.0 feet may have an actual horizontal distance ≤ 24.0 feet. These trees will need to be added to electronic data. Previous data for these trees are available from the previous cycle's tree data sheet.

Example:

1. Tree 006 has a previously recorded distance of 23.7 feet. The crew during this cycle determines that the actual distance is 24.3 feet. This tree is removed from the data by using PRESENT TREE STATUS = 0 and RECONCILE = 7.
2. Tree 023 has a previously recorded distance of 24.3. The crew during this cycle determines that the actual distance is 23.4 feet. This is not a missed tree. The tree must be added to the current tally with the previous history data. TREE RECORD NUMBER = 023 along with the appropriate history variables of PREVIOUS TREE STATUS and PREVIOUS DBH.

I

INFORMATION FOR THE NEW YORK INVENTORY FOR SAMPLE KIND 6

During the last periodic New York inventory the majority of the plots established were a 10-point design. After the 10-point reconciliation was completed, a 1/5-acre overlay was completed at point 1. (See Figure 4)

Figure 4: 10-point prism plot with 1/5 acre overlay (52.7 ft radius). Each point is located at 70 feet from another point at 360, 120, 240 or 300 degrees.

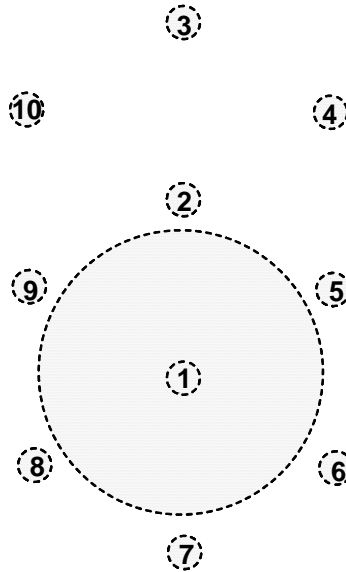

On the last occasion only minimal tree data was collected on the overlay. These variables were the following:

- TREE RECORD NUMBER
- SPECIES
- HORIZONTAL DISTANCE
- AZIMUTH
- DBH
- TREE CONDITION CLASS
- TREE CLASS
- MERCHANTABILITY CLASS
- NOTES

On this occasion only the trees from the 1/5-acre overlay are reconciled at subplot 1. Crews will be supplied with a history data of the previous tally trees to be reconciled from the 1/5-acre overlay within subplot 1. All plot variables are collected. Additional tally from the old 10-point design will be ignored. However, this information will be attached to the plot record and may aid you in relocating the plot. (See Figure 5)

Figure 5: 10-point plot with 1/5 overlay (52.7 ft radius) and current 4-subplot overlay. This plot represents current SK 6 (Note: v3.0 this was SK 7. SK 7 for v3.1 has been collapsed into SK 6.)

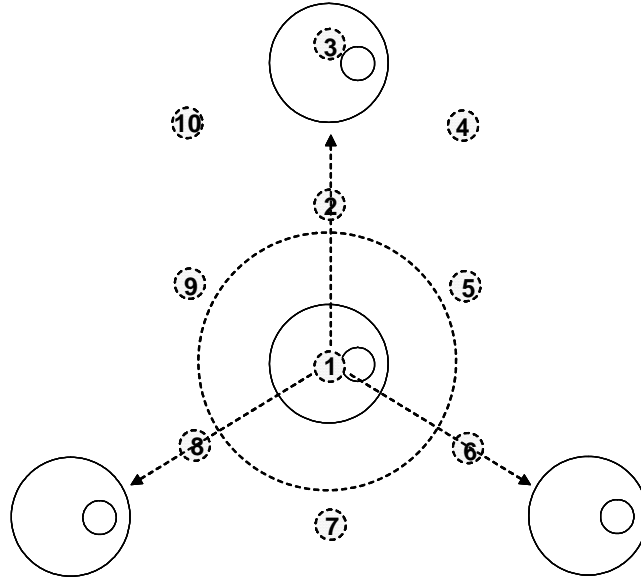

OTHER OLD NE PERIODIC PLOT DESIGNS – Additional figures 6 through 8 are to aid in relocating remeasure plots. Pins, dowels and scribes can still be found for these old plot designs since many of the point locations overlap the 4-subplot plot design as shown in these figures.

Figure 6: Old 1/5 acre (52.7 ft radius) with prism points and new 4 subplot overlay. The prism points were at the cardinal points located 98.4 feet from PC. This plot represents SK 6. (Note that Figure 5 is also SK 6.)

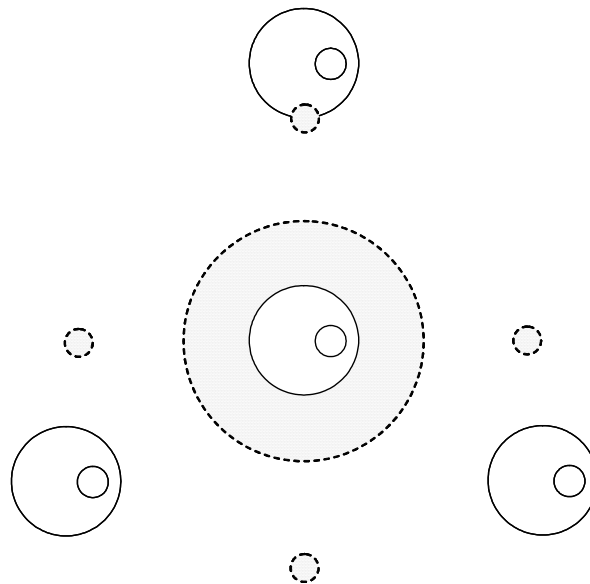

Figure 7: Old 1/5 acre (52.7 ft radius) and new 4 subplot overlay. This plot represents current SK 6 (Note: v3.0 this was SK 7. SK 7 for v3.1 has been collapsed into SK 6.)

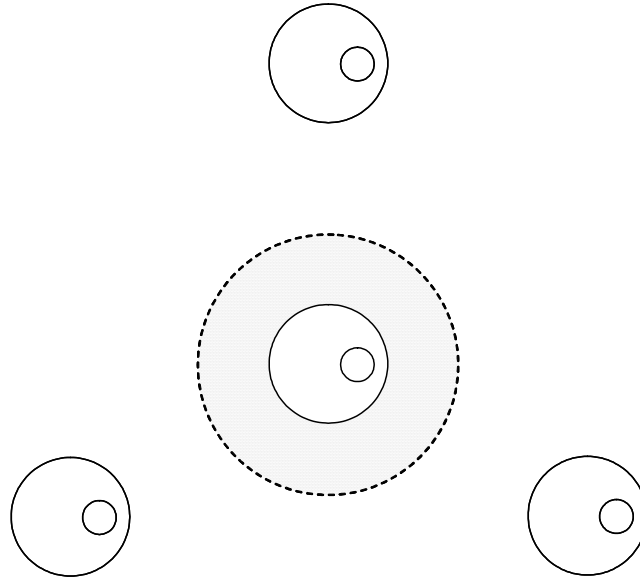
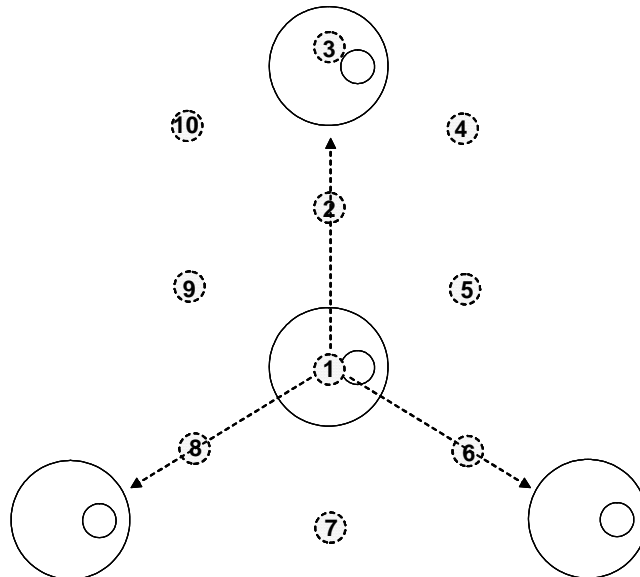

Figure 8: Old 10-point prism plot and new 4 subplot overlay. This plot represents current SK 8.



OLD NC VARIABLE RADIUS PERIODIC PLOT

The old variable radius plot consisted of 10 prism points from the last periodic inventory. The layout of these points is shown in Figure 9. 101's PC is the same as subplot center number 1 of the current P2 plot design. All of the old points consisted of a variable radius (37.5 BAF) plot to sample trees 5.0 inches and larger and a fixed radius micro plot (6.8 ft. radius) to sample trees less than 5.0 inches. Monumentation remains for this old 10 point cluster so don't be confused by the paint, pins, or tree tags that may be present.

Figure 9. Old variable radius plot layout.

From subplot center	70' to subplot center	Azimuth
101	102	0°
102	103	0°
103	104	120°
104	105	180°
105	106	180°
106	107	240°
107	108	300°
108	109	0°
109	110	0°

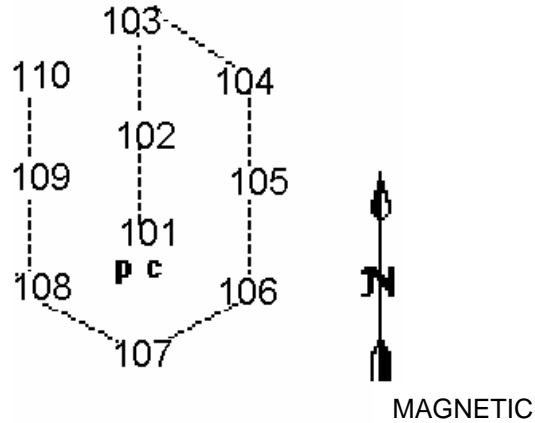

PREVIOUS LAND USE CODES FOR REFERENCE ONLY – DO NOT APPLY THESE CODES

The following is a listing of the former North Central and Northeast land use codes from regional guide's version 3.0. **These codes are not valid for version 3.1, but are for reference only.**

<u>NORTHEAST FIELD GUIDE, VERSION 3.0</u>	
CONDITION CLASS STATUS = 1	CONDITION CLASS STATUS = 2
<u>Commercial Forest Land</u>	<u>Nonforest Land</u>
20 Timberland	61 Cropland
30 Other forest land	63 Pasture
52 Urban forest land	65 Idle farmland
	67 Other agriculture
<u>Noncommercial Forest Land</u>	69 Wetlands
31 Unproductive other forest land	73 Rights-of-way
32 <u>Reserved</u> other forest land	75 Mining and waste land
33 Unproductive <u>reserved</u> other forest land	77 Developed recreation
40 Unproductive forest land	79 Industrial and commercial land
41 Unproductive <u>reserved</u> forest land	81 Residential
50 <u>Reserved</u> forest land	85 Other nonforest
	87 Christmas tree plantations or farms

<u>NORTH CENTRAL FIELD GUIDE, VERSION 3.0</u>	
<u>Code</u>	<u>NC Land Use</u>
20	Timberland
21	Pastured Timberland
22	Plantations
40	Unproductive forest land
41	Reserved forest land-unproductive
45	Reserved forest land-productive
57	Wide windbreaks (> 120')
59	Wooded pasture
46	Christmas tree plantations
50	Reserved nonforest with trees
51	Cropland with trees
52	Improved pasture w/ trees
53	Wooded strip (natural)
54	Idle farmland with trees
55	Marsh with trees
56	Narrow windbreaks (< 120')
58	Shelterbelt
71	Urban forest land
72	Urban and other with trees
61	Cropland
62	Improved pasture
64	Idle farmland
65	Marsh
66	Other farmland
67	Urban and other areas
68	Rights-of-way
69	Nonforest (reserved)
79	In another country
80	Noncensus water
89	Noncensus water (reserved)
90	Census water
96	Inaccessible
99	Denied access

TWO ALTERNATING STRIPS – Figure 7b+N, Section 2.4

On the following pages are 4 examples on how to apply "Exception Rule 7b" for two alternating strips of forest and nonforest between two qualifying areas of nonforest land and forest land (From Section 2.4). The nonforest strip for Figure 7b+N is not developed or noncensus water and both the forest strip and the nonforest strip are at least 30 ft and less than 120 ft wide and 1 acre in size. If either strip does not meet these dimensions, then the strip is treated as an inclusion of the adjacent land use. Note: Not all plot scenarios are shown.

From Figure 7b+N, Section 2.4



Example 1

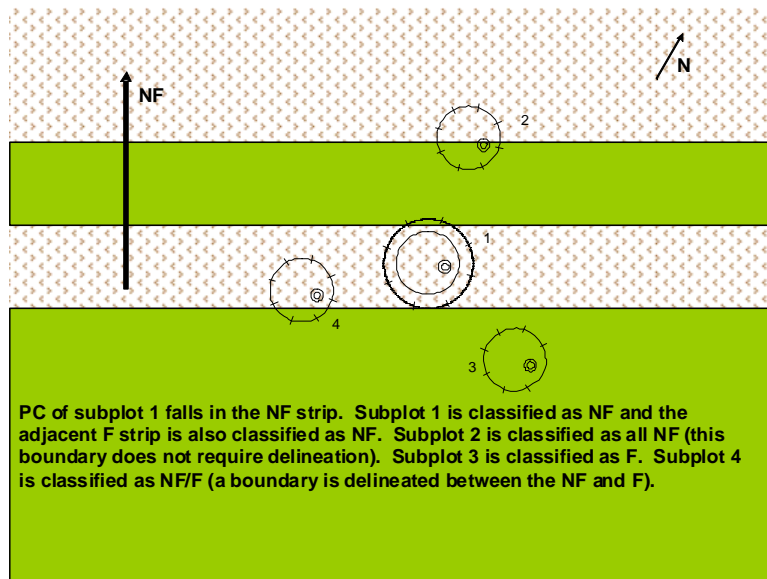

Example 2

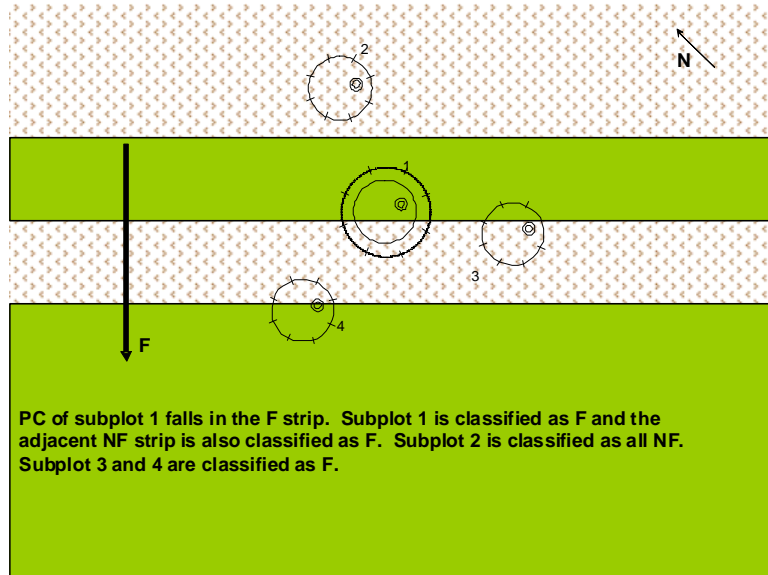

Example 3

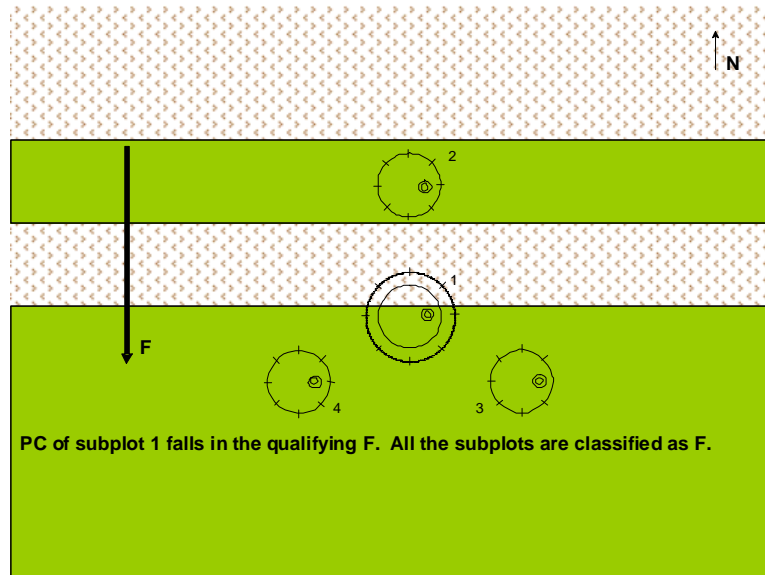

Example 4

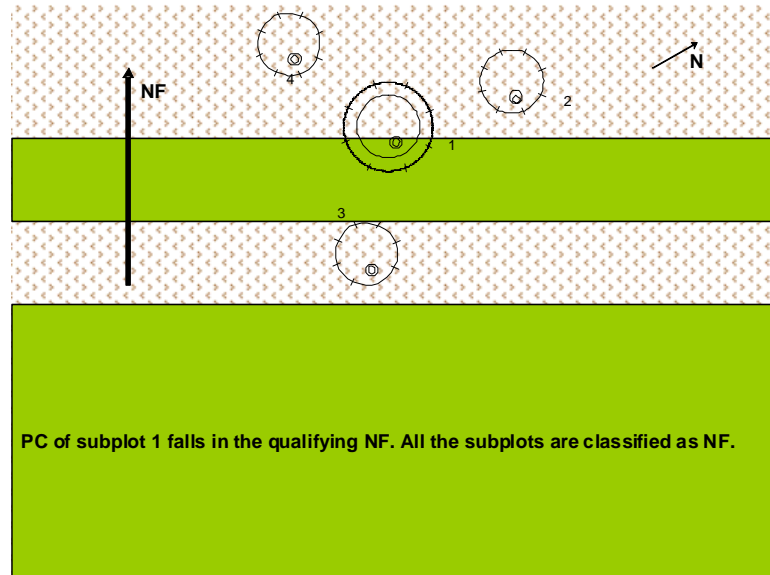

“SWITCHBACK” RULE – Figure 5, Section 2.4

The following illustrations show examples of how to apply the “switchback” rule from Section 2.4, Figure 5 in the North. Switchbacks are not common in the northern region, but other situations that resemble switchbacks can be found like crisscrossing roads or oxbows formed by waterways that exist in large tracts of forest. The “switchback” rule if properly applied reduces forest fragmentation caused by R.O.W., other “developed” conditions and noncensus linear water features that are less than 120.0 feet wide that exist within accessible forest land.

The key to understanding the “switchback” rule is that the questionable subplot must BE within a parcel of forest that qualifies as accessible forest land and there must be one opposing parcel on the opposite side of the nonforest strip that also qualifies as accessible forest land.

NRS Note: If there ever is any doubt as to whether or not a parcel qualifies as forest land, it is better to err on the side of forest land and contact your supervisor to discuss the unique plot situation.

In this illustration the plot falls in a parcel of forest represented by sub-parcels Q1 through Q4. Each sub-parcel meets the minimum specifications for accessible forest land that is 120.0 ft wide and at least 1 acre. Applying the “switchback” rule, subplot 1 can be classified as accessible forest land. Note that “120.0 feet and less than 90 degree” rule (see Section 2.2, Figure 2) does not apply to subplot 1 since the sub-parcels Q2, Q3 and Q4 are accessible forestland. At subplot 4, the nonforest condition created by the R.O.W. is recorded and delineated.

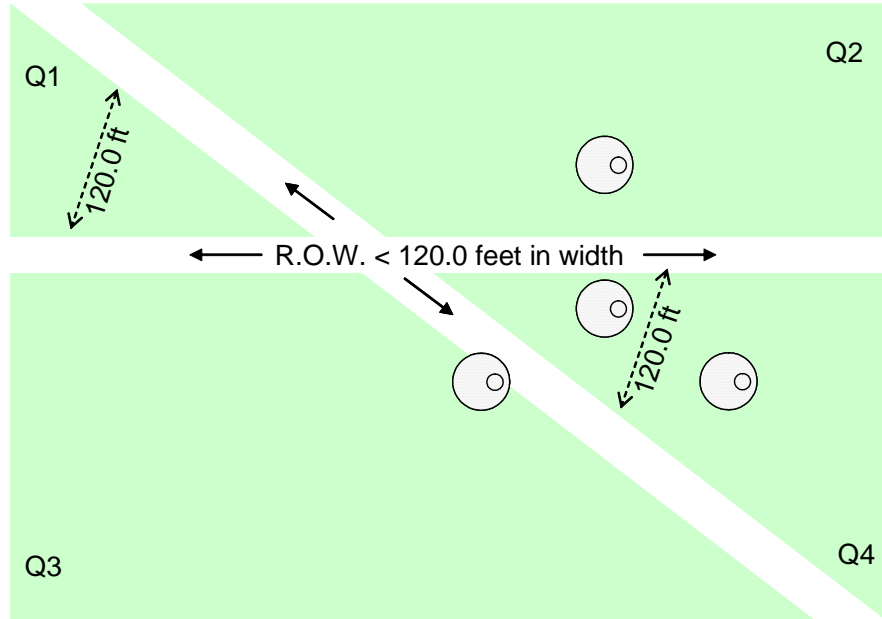

In this next illustration the plot falls in a parcel of forest represented by sub-parcels Q1, Q3 and Q4. Q2 is nonforest. Sub-parcels Q1, Q3 and Q4 meet the minimum specifications for accessible forest land. Sub-parcel Q2 qualifies as nonforest land. Applying the “switchback” rule, subplot 1 can still be classified as accessible forest land. Note that “120.0 feet and less than 90 degree” rule does not apply to subplot 1 since the sub-parcel Q3 and Q4 are accessible forestland. Subplot 2 is classified as nonforest. At subplot 4, the R.O.W. is delineated as nonforest.

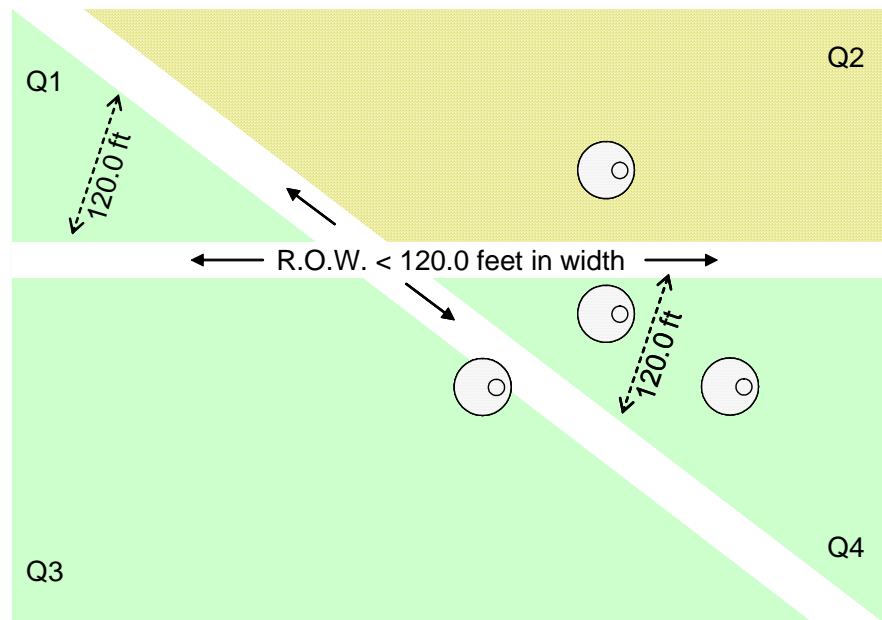

In this illustration the plot falls in a parcel of forest represented by sub-parcel Q1 and Q3. Q2 and Q4 are nonforest. Sub-parcels Q1 and Q3 meet the minimum specifications for accessible forest land. Sub-parcel Q2 and Q4 qualifies as nonforest land. Subplots 1 through 3 are classified as nonforest. Subplot 4 is classified as forest and the R.O.W. is delineated as nonforest.

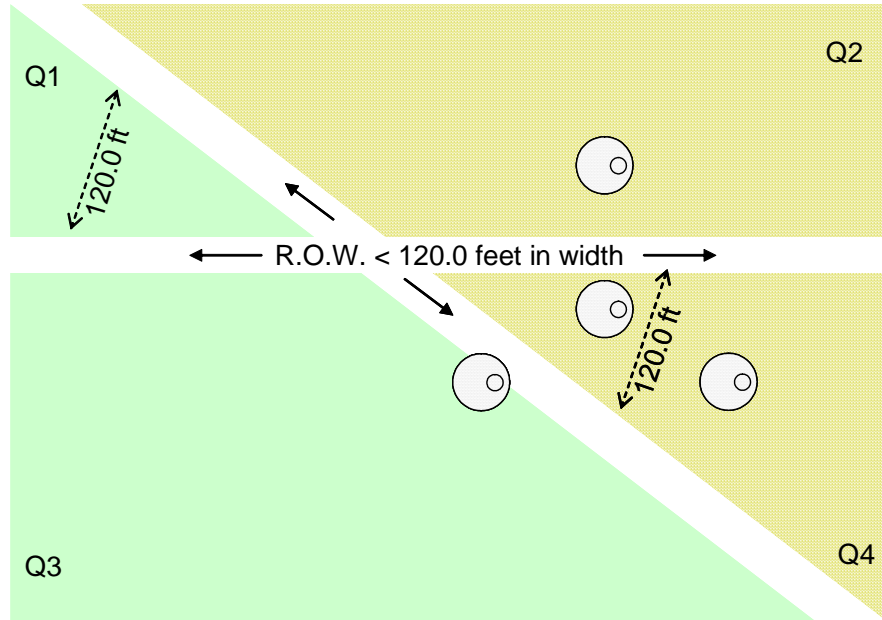

In this final illustration the plot falls in a parcel of forest represented by sub-parcel Q1 and Q4. Q2 and Q3 are nonforest. Sub-parcels Q1 and Q4 meet the minimum specifications for accessible forest land. Note that "120.0 feet and less than 90 degree" rule now applies to subplot 1 since the sub-parcel Q2 and Q3 are nonforest. Subplot 1, 2 and 4 are classified as nonforest. At subplot 4 the entire plot is classified as a single nonforest land use since delineation is not required between nonforest land uses. Subplot 3 is classified as forest.

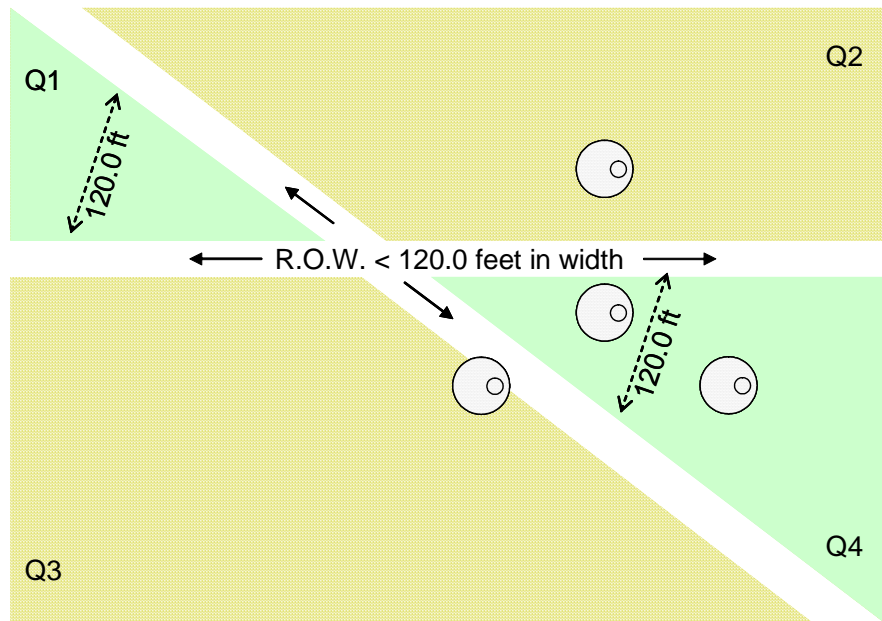

Appendix D. State / Species Specific Data Collection Variables and Procedures

STATE = 23

2.5.22.2N-ME STAND STRUCTURE [MEST]

Record the code describing the basic stand structure of the trees in the condition. This attribute is ancillary, that is, contrasting conditions are never delineated based on variation in this attribute.

When collected: STATE = 23 and CONDITION CLASS STATUS = 1

Field width: 1 digit

Tolerance: No errors

MQO: At least 99% of the time

Values:

- 1 Single-storied: stands characterized by an even canopy of uniform height with close competition between trees. The smaller trees are usually members of the stand that were stressed or overtopped and have fallen behind their associates. Regeneration and/or tall relics from a previous stand may be present. Most of the trees in the condition are within the height class of the average stand height.
- 2 Two-storied: stands composed of two relatively even but distinct canopy layers, such as a mature overstory with an understory sapling layer, possibly from seed tree and shelterwood operations, or an overstory of tall conifers with an understory of low hardwoods. Neither canopy is necessarily continuous or closed, but both canopy levels tend to be uniformly distributed across the stand. Each canopy level must cover at least 25 percent of the condition.
- 3 Multi-storied: stands generally containing trees from every size group on a continuum from seedlings to mature trees and are characterized by a broken or uneven canopy layer. Usually the largest number of trees is in the smaller diameter classes. Consider any stand with three or more structural layers as multi-storied if each of the three or more layers covers at least 25 percent of the condition.
- 4 Mosaic: stands contain at least two distinct size classes each of which covers at least 25 percent of the condition; however, these classes are not uniformly distributed but are grouped in small repeating aggregations, or occur in stringers less than 120.0 ft. (36.6 m.) wide, throughout the stand. Each size class aggregation is too small to be recognized and mapped as an individual stand; the aggregations may or may not be single-storied
- 5 Nonstocked: Less than 10-percent tree stocking present.

NRS Note to ME data collectors: The following variables will be collected through the end of this CYCLE.

3.8.1N-ME CROWN CLOSURE [MECC]

Estimate the percent of the subplot that is covered by live trees directly overhead and record the appropriate code. If foliage is not present due to seasonal variation or temporary defoliation, visualize the amount of live crown that would normally be present.

When collected: STATE = 23 and SUBPLOT STATUS = 1

Field width: 1 digit
Tolerance: +/- 1 class
MQO: At least 90% of the time
Values:

0	0 to 25%
1	26 to 50%
2	51 to 75%
3	> 75%

NRS Note to ME data collectors: Maine collects ACTUAL LENGTH and LENGTH METHOD on all live saplings located on MICROPLOTS 1 – 4. Maine also collects shrub and vine data on MICROPLOTS 1 – 4.

5.29N+ME MAINE'S 5TH MICROPLOT SAPLING DATA

Additional live sapling data is collected in Maine. The 5th microplot is located at 270 degrees and 12.0 feet from the center subplot. Minimal data are collected on these saplings and will not be remeasured on the next occasion. The required sapling data are SUBPLOT NUMBER (recorded as 5), TREE RECORD NUMBER, SPECIES, DBH, CONDITION CLASS NUMBER, and ACTUAL LENGTH. Note: This data set is not reconciled between annual cycles.

5.15+ME ACTUAL LENGTH [ACTU]

For trees with missing tops (top on live trees is completely detached; top on dead trees is greater than 50 percent detached from the tree). If the top is intact **including dead tops on live trees**, this item may be omitted. Record the ACTUAL LENGTH of the tree to the nearest 1.0 foot from ground level to the break. Use the length to the break for ACTUAL LENGTH until a new leader qualifies as the new top for TOTAL LENGTH; until that occurs; continue to record ACTUAL LENGTH to the break. Trees with previously broken tops are considered recovered (i.e., ACTUAL LENGTH = TOTAL LENGTH) when a new leader (dead or alive) is 1/3 the diameter of the broken top at the point where the top was broken (not where the new leader originates from the trunk). Forked trees should be treated the same as unforked trees.

When Collected: STATE = 23 – All live tally trees \geq 1.0 in DBH

Field width: 3 digits
Tolerance: +/- 10 % of true length
MQO: At least 90% of the time
Values: 005 to 400

5.16+N-ME LENGTH METHOD [METH]

Record the code that indicates the method used to determine tree lengths.

When Collected: STATE = 23 – All live tally trees \geq 1.0 in DBH

Field width: 1 digit
Tolerance: No errors
MQO: At least 99% of the time
Values:

- 1 Total and actual lengths are field measured with a measurement instrument (e.g., clinometer, relascope, tape, laser)
- 2 Total length is visually estimated, actual length is measured with an instrument
- 3 Total and actual lengths are visually estimated

6.5N-ME SHRUB AND VINE DATA FOR THE MAINE INVENTORY

Additional vegetation information is obtained by counting live shrubs, dwarf shrubs and vines within the 3.7 foot radius microplot located 90 degrees and 12.0 feet from each subplot center within each of the four subplots. Only count live shrubs, dwarf shrubs and vines occurring in accessible forest land.

6.5.1N-ME SUBPLOT NUMBER

Use the procedures outlined in Section 3.1.

NRS PDR Note: This variable is determined by the subplot selection in the PDR program.

When Collected: STATE = 23 and CONDITION CLASS STATUS =1 for all counts of live shrubs, dwarf shrubs and vines

6.5.2N-ME SHRUB AND VINE SPECIES [SPP]

Record the appropriate SPECIES code from the list in Appendix F. If you encounter a species not listed in Appendix F and are not sure if it should be tallied, consult your supervisor. If the species cannot be determined in the field, tally the shrub or vine, but bring branch samples, foliage, cones, flowers, bark, etc. to your supervisor for identification. If possible collect samples outside the subplots from similar specimens and make a note to correct the SPECIES code later. Use the UNKNOWN or generic SPECIES code only when you encounter a shrub or vine where you know the species but the species is not on the species list.

When Collected: STATE = 23 and CONDITION CLASS STATUS = 1 for all counts of live shrubs, dwarf shrubs and vines

Field width: 4 digits (9xxx)

Tolerance: No errors for genus, no error for species

MQO: At least 90% of the time for genus, at least 85% of the time for species

Values: See page **228-230 [Correction 10/04/2006.]**

6.5.3N-ME CONDITION CLASS NUMBER [CON#]

Use the procedures outlined in Section 2.0.

When Collected: STATE = 23 and CONDITION CLASS STATUS = 1 for all counts of live shrubs, dwarf shrubs and vines

6.5.4N-ME SHRUB COUNT [SHRU]

On each 3.7 foot radius microplot, record the number of live deciduous and evergreen shrubs by SPECIES and CONDITION CLASS NUMBER. Count up to 5 individuals by species; estimate the total count if more than 5 individuals but less than 50 of any given species in any given condition class. If the estimated count exceeds 49, then record 50. Shrubs must be at least 12.0 inches in length in order to qualify for counting.

Dwarf shrubs and vines are tallied by occurrence and condition class. Individual counts of specimens are not required for these life forms.

When Collected: SPP = deciduous shrub code or evergreen shrub code

Field width: 2 digits

Tolerance: No errors for 5 or less per species; +/- 20% over a count of 5

MQO: At least 90% of the time

Values: 01 to 50

SHRUB AND VINE SPECIES CODES FOR MAINE

DECIDUOUS SHRUBS

Code	PLANTS00	Common name	Genus	Species
9350	ALNUS	Alder spp.	Alnus	spp.
9352	ALINR	speckled alder	A.	incana ssp. rugosa (rugosa)
9353	ARSP2	Hercules club	Aralia	spinosa
9365	PHOTI	chokeberry spp.	Photinia (Aronia)	spp.
9366	RHODO	azalea spp.	Rhododendron (Azalea)	spp.
9368	BERBE	barberry spp.	Berberis	spp.
9381	CEOC2	buttonbush	Cephalanthus	occidentalis
9458	CEAM	New Jersey tea	Ceanothus	americanus
9465	CLAL3	sweet pepperbush	Clethra	alnifolia
9475	CHVI3	fringetree	Chionanthus	virginicus
9485	COPE80	sweetfern	Comptonia	peregrina
9492	COAL2	alternate-leaved dogwood	Cornus	alternifolia
9493	COAM2	silky dogwood	C.	amomum (obliqua)
9494	CORU	round-leaved dogwood	C.	rugosa (circinata)
9496	CORA6	gray-stemmed/panicled dogwood	C.	racemosa (paniculata)
9497	COSES	red-osier dogwood	C.	sericea ssp. sericea (stolonifera)
9501	COAM3	American hazelnut	Corylus	americana
9502	COCO6	beaked hazelnut	C.	cornuta (rostrata)
9525	DIPA9	leatherwood	Dirca	palustris
9535	ELAEA	autumn olive or Russian olive	Elaeagnus	spp.
9549	GAYLU	huckleberry spp.	Gaylussacia	spp.
9585	HAVI4	witch-hazel	Hamamelis	virginiana
9592	ILMO	large-leaf holly	Ilex	montana (monticola)
9593	ILVE	winterberry holly	Ilex	verticillata
9604	LEUCO5	fetter-bush spp.	Leucothoe	spp.
9609	LIBE3	common spicebush	Lindera	benzoin
9635	LONIC	bush honeysuckle spp.	Lonicera	spp.
9637	LYONI	male-berry, staggerbush spp.	Lyonia	spp.
9643	MYGA	sweet gale	Myrica	gale
9644	MOPE6	bayberry	Morella (Myrica)	pensylvanica
9685	NEMU2	mountain-holly	Nemopanthus	mucronatus
9725	PHOP	ninebark	Physocarpus	opulifolius
9845	RHAMN	buckthorn spp.	Rhamnus	spp.
9856	RHODO	azalea (deciduous) spp.	Rhododendron (Azalea)	spp.
9864	RHCO	winged sumac	Rhus	copallinum
9865	RHGL	smooth sumac	R.	glabra
9866	RHHI2	staghorn sumac	R.	hirta (typhina)
9868	TOVE	poison sumac	Toxicodendron (Rhus)	vernix
9870	RIBES	currant, gooseberry spp.	Ribes	spp.
9905	ROSA5	Rose spp.	Rosa	spp.
9915	RUBUS	briar, bramble, dewberry spp.	Rubus	spp.
9925	SANIC4	American elderberry	Sambucus	nigra ssp. canadensis (canadensis)

Code	PLANTS00	Common name	Genus	Species
9926	SARA2	red-berried elderberry	S.	racemosa
9929	SALIX	shrub willows spp. (all other willows not indicated in tree codes)	Salix	spp.
9937	SPIRA	spirea spp.	Spiraea	spp.
9982	STTR	American bladdernut	Staphylea	trifolia
9983	VACCI	Blueberry spp.	Vaccinium	spp.
9985	VIBUR	Viburnum spp.	Viburnum	spp.
9986	VIAC	maple-leaved viburnum	V.	acerifolium
9987	VILA11	hobblebush viburnum	V.	lantanoideis (alnifolium)
9988	VINUC	wild raisin, withe-rod	V.	nudum var. cassinoides (cassinoides)
9989	VIDE	arrowwood	V.	dentatum
9990	VILE	nannyberry	V.	lentago
9991	VIPR	blackhaw	V.	prunifolium
9992	VIOPA2	highbush cranberry	V.	opulus var. americanum (trilobum)
9994	ZAAM	common prickly-ash	Zanthoxylum	americanum
9997	2SD	unknown or not listed		

If species is not listed, use generic genus code.

EVERGREEN SHRUBS

Code	PLANTS00	Common Name	Genus	Species
9045	CHCA2	leatherleaf	Chamaedaphne	calyculata
9061	JUCO6	common juniper	Juniperus	communis
9232	TACA7	Canada yew	Taxus	canadensis
9357	ANPOG	bog rosemary	Andromeda	polifolia var. glaucophylla (glaucophylla)
9605	KAAN	sheep laurel	Kalmia	angustifolia
9606	KALA	mountain laurel	K.	latifolia
9607	KAPO	swamp laurel	K.	polifolia
9608	LEGR	Labrador tea	Ledum	groenlandicum
9642	MOCE2	wax myrtle	Morella (Myrica)	cerifera
9855	RHODO	rhododendron spp.	Rhododendron	spp.
9945	SYTI	sweetleaf	Symplocos	tinctoria
9998	2SE	unknown or not listed		

If species is not listed, use generic genus code.

DWARF SHRUBS

Code	PLANTS00	Common Name	Genus	Species
9363	ARUV	bearberry	Arctostaphylos	uva-ursi
9364	ARAL2	alpine bearberry	Arctostaphylos	alpinus
9441	CHMA3	striped pipsissewa	Chimaphila	maculata
9442	CHUM	pipsissewa	Chimaphila	unbellata ssp. cisatlantica
9498	COCA13	bunchberry	Cornus	canadensis

9547	GAHI2	creeping snowberry	Gaultheria (Chiogenes)	hispidula
9548	GAPR2	teaberry	Gaultheria	procumbens
9603	DILA	diapensia	Diapensia	lapponica
9615	LIBO3	twinflower	Linnaea	borealis ssp. americana
9618	LOPR	alpine azalea	Loiseleuria	procumbens
9675	MIRE	partridgeberry	Mitchella	repens
9677	SITR3	three-toothed cinquefoil	Sibbaldiopsis (Potentilla)	tridentata
9981	VACCI	cranberry spp.	Vaccinium	spp.
9996	2SUBS	unknown or not listed		

If species is not listed, use generic genus code.

VINES

Code	PLANTS00	Common Name	Genus	Species
9451	AMBR2	hog peanut	Amphicarpaea	bracteata
9454	APAM	ground-nut	Apios	americana
9455	CESC	American bittersweet	Celastrus	scandens
9477	CLEMA	clematis sp.	Clematis	spp.
9636	LONIC	vine honeysuckle	Lonicera	spp.
9715	PAQU2	Virginia creeper	Parthenocissus	quinquefolia
9867	TORAR	poison ivy	Toxicodendron (Rhus)	radicans ssp. radicans (radicans)
9934	SMILA2	Greenbrier spp.	Smilax	spp.
9993	VITIS	Grape spp.	Vitis	spp.
9995	2V	unknown or not listed		

If species is not listed, use generic genus code.

STATE = 27 and SPECIES = 0012

NRS Note to MN data collectors: The following variable set will be collected through the end of this CYCLE.

5.28N-MN BALSAM FIR BOUGHS

There is an increasing interest in the collection of balsam boughs for the manufacture of evergreen products. The information collected will be available to assess the health and sustainability of the balsam bough resource in the region.

5.28.1N-MN BOUGHS AVAILABLE [BAVA]

Record the code for all live balsam fir (0012) ≥ 1.0 in DBH that describes if harvestable boughs are present. The tree must meet the following criteria to be coded as having boughs available:

- Branches in the bottom 7.5 feet of the tree
- At least one branch no larger in diameter than a pencil where clipped
- At least 18 inches in length and at least 75% live needles throughout

When collected: STATE = 27 and SPECIES = 0012 and DBH ≥ 1.0 in

Field width: 1 digit

Tolerance: No errors

MQO: N/A

Values:

- | | |
|---|---------------------|
| 0 | No boughs available |
| 1 | Boughs available |

5.28.2N-MN BOUGHS HARVESTED [BHAR]

Record the code for all live balsam fir (0012) ≥ 1.0 in DBH that describes whether boughs have been harvested or not. **[Correction 10/05/2006.]**

When collected: STATE = 27 and SPECIES = 0012 and DBH ≥ 1.0 in

Field width: 1 digit

Tolerance: No errors

MQO: N/A

Values:

- | | |
|---|--------------------------------|
| 0 | Boughs have not been harvested |
| 1 | Boughs have been harvested |

5.28.3N-MN BOUGHS HARVESTING GUIDELINES [GUID]

Record the code for all live balsam fir (0012) ≥ 1.0 in DBH that has bough harvesting, and whether Standard Balsam Bough Harvesting Guidelines have been applied. The guidelines are listed below:

- Branches cut were no larger in diameter than a pencil
- Part of the cut branches were left for growth and regeneration
- On smaller trees at least 50% of the trees limbs were left in the upper portion of the tree

When collected: BOUGHS HARVESTED = 1

Field width: 1 digit

Tolerance: No errors

MQO: N/A

Values:

- 0 Guidelines not applied
- 1 Guidelines applied

STATE = 39

5.30N+OH OHIO SK8 "PRISM" POINT TREE DATA

During the last periodic Ohio inventory the majority of the plots established were a 10-point design. 37.5 BAF prisms were used to sample the trees on each of the ten points. For the new inventory, the national 4-subplot design will overlay this 10-point design. **In order to establish a growth, removal and mortality estimates; a partial remeasurement on five of the ten points will be completed during the first cycle of the Annual Forest Inventory.** The previous "prism" points to be reconciled are 1, 2, 6, 7 and 8. (See Figure 1)

Figure 1: 10-point with 4-subplot overlay

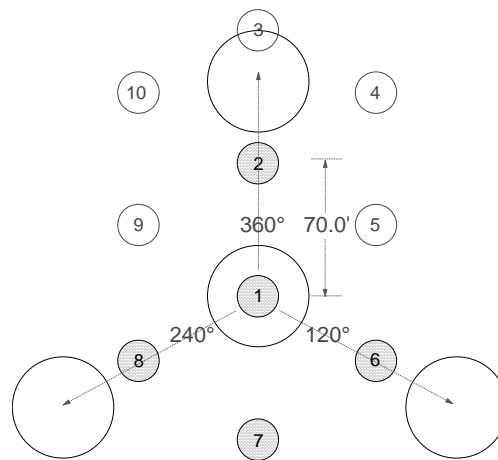

On the plot record and data recorder "prism" points 1, 2, 6, 7 and 8 will be renumbered as 5, 6, 7, 8 and 9. The national 24 ft fixed radius subplots will continue to be numbered 1 through 4. (See Figure 2)

Figure 2: New numbers for prism points

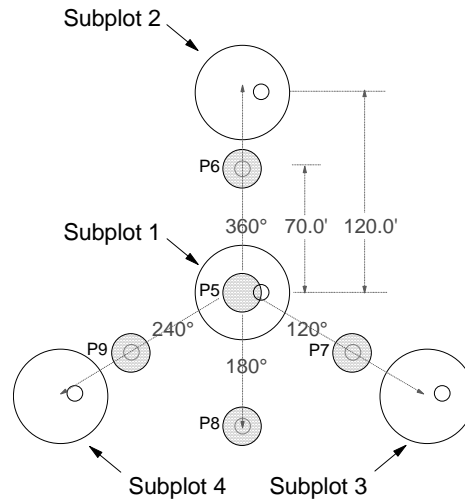

The following tree variables will be collected on the “prism” points for remeasurement and ingrowth:

- SUBPLOT NUMBER (record as 5, 6, 7, 8 and 9)
- TREE RECORD NUMBER [TR#]
- SPECIES [SPP]
- DBH [DBH]
- TREE CLASS [TCC]
- NOTES

Ingrowth (trees ≥ 5.0 -in DBH) will be measured on a microplot (6.8 ft radius) located at point center (PC). Even though point 5 is concentric with subplot 1, it will be necessary to complete a separate tally for these ingrowth trees. The tree variables on the “ingrowth” microplots will be the same as the “prism” points less the previous information.

Note: Even though you are not recording tree grade, lengths and culls, these variables need consideration prior to assigning tree class.

Crews will be supplied with a printout of the previous tally trees to be reconciled from these points. Since these were prism tallies, it is important to realize that **“prism” trees may be located 70 ft or more from PC depending on the DBH and percent slope.** E.g., A tree with a 40.0-in DBH, no slope, has a limiting “horizontal” distance of 56.8 ft.; same tree, 60% slope, has a limiting “slope” distance of 66.2 ft. Since the tally was dependent on the limiting distance, large diameter trees could occur on multiple points. **To reconcile “prism” points, the horizontal distance is measured from PC to the center of the tree at DBH.**

On the last occasion crews tallied the points in order from one to ten. Each point was located 70.0 ft and 360°, 120°, 240°, or 300° from the last point. In addition all ten points were located in the same condition. The condition was defined at plot center of point 1. Points that fell in contrasting conditions were rotated from the highest non-rotated point.

For example, point 1 through 10 fell in forest land except for point 7 (P8). The first location to establish this rotated point would be 70 ft at 360° from point 10, then at 240°, and finally at 300°. (If point 10 did not yield a location, then the same procedure was

followed at point 9 at 240°, etc. This procedure was continued until the point could be established in the same condition as point 1.) The point was then renumbered as point 17 (P8) to indicate the rotation, and the new point location was documented on the plot diagram. (See Figure 3)

Figure 3: "Old" point rotation procedure

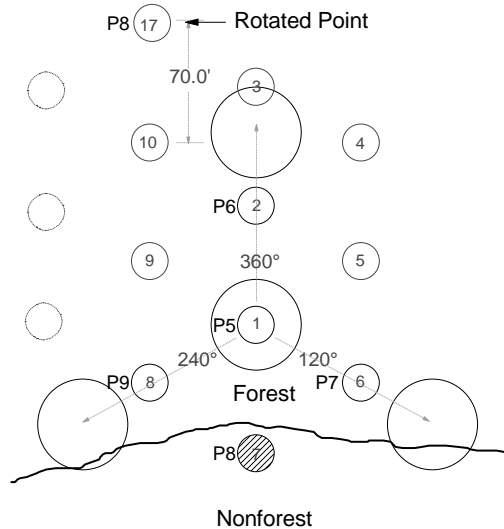

On this occasion complete the "regular" tally at subplot 1, and then complete the "partial" tally of point 5. The previous trees from "prism" point 5 within the 24 ft radius of PC at subplot 1 will require a second tally to complete the reconciliation. It is important that all "like" tree variables match between subplot 1 and point 5. The remainder of the subplots and "prism" points should be completed as field conditions warrant. I.e., a crew may find it more efficient to complete subplot 2 before completing "prism" point 6 or vice versa.

Plots where PC was nonforest on the last occasion and is still nonforest at PC, nothing needs to be done with the prism points. Install the current 4 subplot design.

Plots where PC was nonforest on the last occasion and is now forest at PC, then all 5 prism points requires a tally of the 6.8 ft microplot. The next available tree number for the prism point is used for the ingrowth (this should be 001 in most cases). Installation of the current 4 subplot design is also completed.

Since on the last occasion PC determined the land use for the entire plot, any prism point that fell outside a nonforest land use would have been rotated to match the same land use at PC. For nonforest plots these rotated prism points were never established. To locate these rotated prism points today, use the old 10-point plot design and make a determination where these rotated points would have been placed based on any markings on the old plot record, old photography and current ground conditions. This will not be easy and could be time consuming depending on the situation. If it is impossible to determine where the rotated points are to be located due to indistinct boundaries, use the standard prism point locations and proceed with the tally.

For example, on the last occasion PC fell in a R.O.W. The entire plot was called nonforest (land use 73). Even though the prism points were not established, 2 out of the 10 prism points fell in forest land and would have been rotated into the nonforest land use. These points would have been 17 and 18 rotated from point 10. (See Figure 3a)

Figure 3a: PC was nonforest on the last occasion with "rotated" point locations

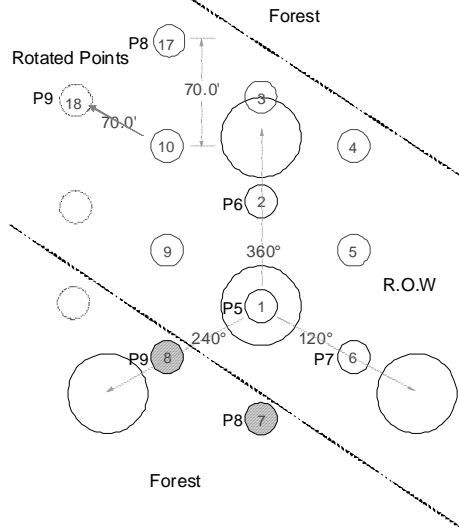

Today, the R.O.W is no longer maintained and has reverted back to forest. Therefore, prism points renumbered as P5, P6, P7, P8 and P9 must be visited. P5, P6 and P7 are still at the standard location of the 10-point plot design, but P8 and P9 are not. These 2 points are at the rotated position as illustrated in Figure 3a and 3b.

Figure 3b: PC was nonforest on the last occasion and is now forest due to land use change.

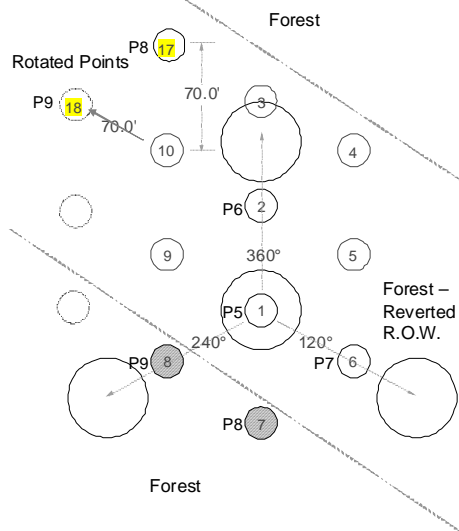

STATE = 42

Pennsylvania's Regeneration Study

Field Instructions for Pennsylvania's Regeneration Study (PRS)

42.0 Overview

The regeneration assessment is being conducted in Pennsylvania at the request of the State's forestry community. There is concern that regeneration is lacking in many stands and with over half of the State's forests in a financially mature condition, this is a critically important issue. The regeneration data will provide answers to questions about advance regeneration, post-disturbance regeneration, and future forest composition. The data will be used to quantify regeneration adequacy statewide, provide estimates of numbers of seedlings per acre, and for research into regeneration dynamics. Regeneration plots are selected prior to the field season and are visited during the leaf-on season from June through September.

The figure on the next page summarizes measurements needed for the regeneration assessment. Data are collected at three levels: the entire sample plot, the subplot, and the microplot. **The associated vegetation and regeneration tallies should be completed for all accessible forest land conditions that are encountered.**

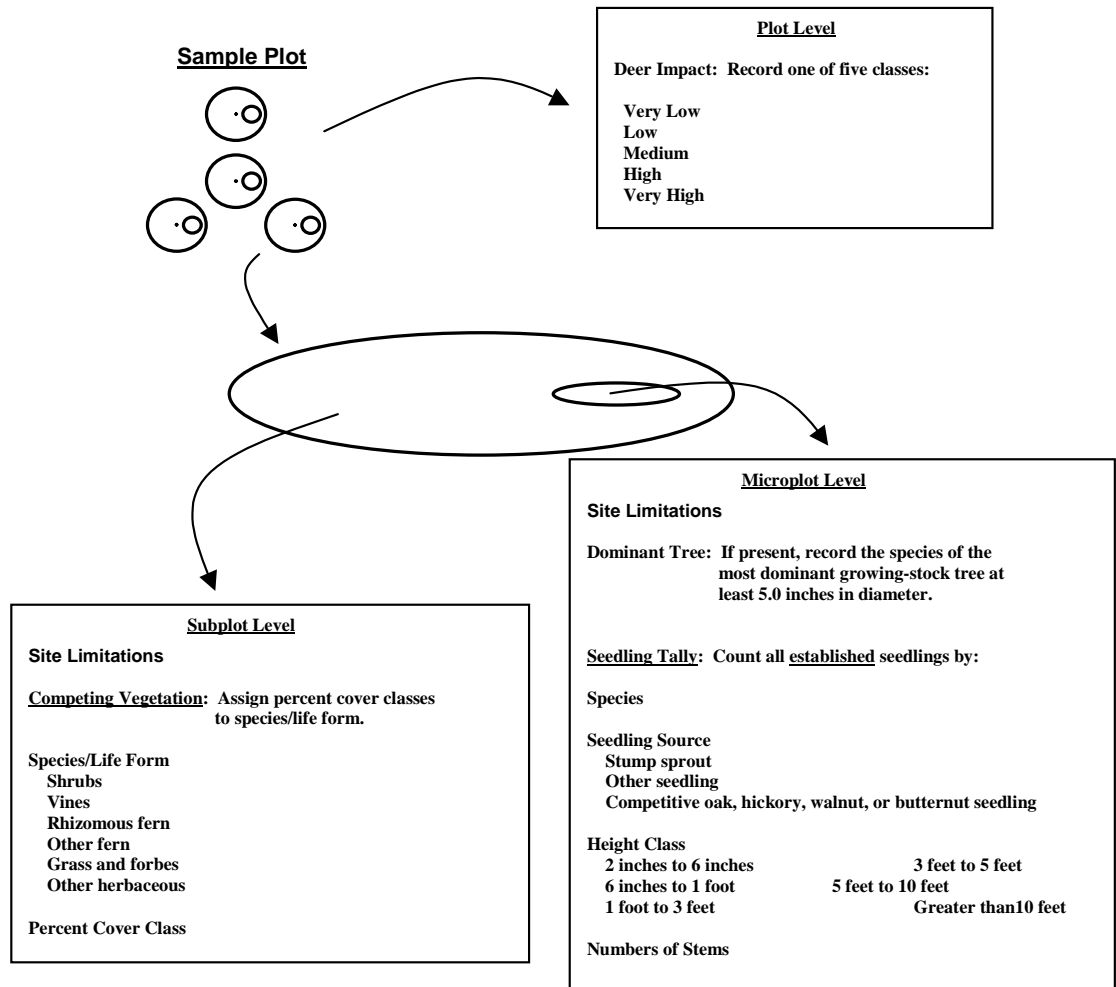

42.1.0 Plot Data

42.1.1 State, Unit, County and Plot Number
 Refer to Section 1 of this field guide.

42.1.2 CURRENT MONTH/DAY/YEAR
 Refer to Section 1 of this field guide.

42.1.3 DEER IMPACT [IMP]

Estimate the amount of browsing pressure that deer are exerting on regeneration. Deer impact is a function of deer population and the amount of available food sources within one-square mile surrounding the plot.

Code	Definition
1	Very Low - Plot is inside a well-maintained deer enclosure.
2	Low - No browsing observed, vigorous seedlings present (no deer enclosure present).
3	Medium - Browsing evidence observed but not common, seedlings present.
4	High - Browsing evidence common <u>OR</u> seedlings are rare.

5	Very High - Browsing evidence omnipresent <u>OR</u> forest floor bare, severe browse line.
----------	---

Degree of deer browsing can be a difficult variable to quantify due to preferences that deer have for various food sources and the elusive nature of deer populations. Although not a complete list of species in Pennsylvania, the following deer preference list may be useful for assigning deer impact:

Species	Browse Preference	Tolerance of Browsing
Black Cherry	L	L
Fern	L	H
Grass & Sedge	L-M	H
Striped Maple	L-M	H
American Beech	M	H
Birches	H	M
Oak	H	M-H
Hickory	H	M-H
Ash	H	M
Rubus spp.	H	M-H
Pin Cherry	H	L
Red Maple	H	L
Sugar Maple	H	L
Yellow-poplar	H	L
Cucumbertree	H	L
Eastern Hemlock	H	L

In addition, a handout showing the Pennsylvania Game Commission's estimates of deer density by county will be provided. Deer densities in excess of 20 deer per square mile of forest are generally considered to inhibit the development of tree seedlings.

42.2.0 Subplot Data

Complete the subplot data for all forested conditions.

42.2.1 SUBPLOT NUMBER

Record the code corresponding to the subplot number.

42.2.2 CONDITION CLASS NUMBER [CON#]

Record the corresponding condition class number.

42.2.3 SUBPLOT SITE LIMITATIONS [SLIM]

Record site limitation codes 2 and 3 if they occur on at least 30 percent of the subplot or condition area, else record as code 1.

Code	Definitions
1	No site limitations
2	Rocky surface with little or no soil
3	Water-saturated soil (during the growing season)

42.2.4 COMPETING VEGETATION [CVEG]

Assign percent cover classes to species/life forms within the subplot. The sum of the percent cover classes may exceed 100 percent. For subplots with more than one condition, only record percent cover for the portion of the subplot in the condition. For example, if 50 percent of the

subplot is in a condition and is entirely covered with *Rubus* spp., record 99 for percent cover class (100 percent cover).

42.2.5 SPECIES/LIFE FORM [SPLF]

Code	Definition
	Deciduous Shrubs (See listing following these instructions.)
	Evergreen Shrubs (See listing following these instructions.)
	Vines (See listing following these instructions.)
0001	Rhizomous Fern, including Bracken, Hay-scented, and New York
0002	Other Fern
0003	Grass
0004	Other Herbaceous

42.2.6 PERCENT COVER CLASS [PCOV]

Assign a cover class to each species or life form.

Code	Definition	Code	Definition
01	1 to 9 percent	50	50 to 59 percent
10	10 to 19 percent	60	60 to 69 percent
20	20 to 29 percent	70	70 to 79 percent
30	30 to 39 percent	80	80 to 89 percent
40	40 to 49 percent	90	90 to 100 percent

As an aid in determining percent cover, consider that one-percent cover of the 24-foot radius subplot is equivalent to a square 4.2 feet on each side or a circle with a radius of 2.4 feet. Ten percent cover is equivalent to a square 13.4 feet on each side or a circle with a radius of 7.6 feet.

42.3.0 Microplot Data

Complete the microplot data for microplots within accessible forest land.

42.3.1 MICROPLOT NUMBER

Record the code corresponding to the microplot number (same as subplot number).

42.3.2 MICROPLOT CENTER CONDITION CLASS [MCEN]

Record the corresponding condition class number.

42.3.3 MICROPLOT SITE LIMITATIONS [MLIM]

Record the following site limitation if it dominates the area of the microplot or condition:

Code	Definition
1	No site limitation
2	Rocky surface with little or no soil
3	Water-saturated soil (during the growing season)
4	Thick duff layer (in excess of two-inches thick)

42.3.4 DOMINANT TREE [DOMT]

Record the presence/absence of at least one growing-stock tree 5.0-inches or larger in diameter at breast height on the microplot or condition by recording species code. If there are no such trees, record as "000." If more than one such tree is present, record the species code of the tree with the largest diameter.

42.3.5 Tree and Seedling Data

Tally all established seedlings (< 1.0-inch DBH) for stems rooted within the microplot by species, seedling source, and height class.

Count all seedlings at least 2-inches tall with at least two normal-sized leaves that do not still bear cotyledons.

For most species encountered, the tug test should be used to determine if seedlings are established. Seedlings that slip out of the ground with a slight tug do generally not have sufficient root systems to survive through the growing season and are not established.

- Small oak, hickory, walnut, and butternut seedlings (less than 1-foot tall) should be at least 6-inches tall or have a root-collar diameter (RCD) of at least 0.20 inches.
- Pine seedlings should have at least two whorls or be at least 6-inches tall.

42.3.5.1 SPECIES [SPP]

Record valid tree species code (see Appendix 3).

42.3.5.2 SEEDLING SOURCE [SRCE]

Discriminate between stump sprouts and other seedlings. Tally clumps of stump sprouts as one seedling and tally only the tallest, most dominant sprout for each stump. Tally sprouts on stumps that originate from cutting or mortality only. Stumps must be at least 2 inches in diameter to qualify as having sprouts.

A special code (3) is used for oak, hickory, walnut, and butternut that are classified as "competitive." Research indicates that competitive seedlings are highly likely to become dominant or codominant stems in the next stand. To be classified as competitive, stems must have an RCD > 0.75 inches. In situations with relatively high tally, it should only be necessary to check a few RCD's.

Code	Definition
1	Stump sprout
2	Other seedling
3	Competitive oak, hickory, walnut, or butternut seedling

42.3.5.3 HEIGHT CLASS [HGTC]

Each seedling is assigned a height class.

Code	Definition	Code	Definition
1	2 inches to 6 inches	4	3 feet to 5 feet
2	6 inches to 1 foot	5	5 feet to 10 feet
3	1 foot to 3 feet	6	Greater than 10 feet

42.3.5.4 NUMBERS OF STEMS [SED#]

Record the number of tree seedlings in each category described by species, seedling source, and height class. The first five seedlings of each species must be counted precisely. Counts above five may be estimated. In the case of beech root suckers, count all individuals unless they arise from a single root node, in which case they should be counted as a single stem.

42.2.5 SPECIES/LIFE FORM – SHRUB AND VINE SPECIES CODES FOR ITEM

DECIDUOUS SHRUBS

Code	PLANTS00	Common name	Genus	Species
9350	ALNUS	Alder spp.	Alnus	spp.
9352	ALINR	speckled alder	A.	incana ssp. rugosa (rugosa)
9353	ARSP2	Hercules club	Aralia	spinosa
9365	PHOTI	chokeberry spp.	Photinia (Aronia)	spp.
9366	RHODO	azalea spp.	Rhododendron (Azalea)	spp.
9368	BERBE	barberry spp.	Berberis	spp.
9381	CEOC2	buttonbush	Cephalanthus	occidentalis
9458	CEAM	New Jersey tea	Ceanothus	americanus
9465	CLAL3	sweet pepperbush	Clethra	alnifolia
9475	CHVI3	fringetree	Chionanthus	virginicus
9485	COPE80	sweetfern	Comptonia	peregrina
9492	COAL2	alternate-leaved dogwood	Cornus	alternifolia
9493	COAM2	silky dogwood	C.	amomum (obliqua)
9494	CORU	round-leaved dogwood	C.	rugosa (circinata)
9496	CORA6	gray-stemmed/panicled dogwood	C.	racemosa (paniculata)
9497	COSES	red-osier dogwood	C.	sericea ssp. sericea (stolonifera)
9501	COAM3	American hazelnut	Corylus	americana
9502	COCO6	beaked hazelnut	C.	cornuta (rostrata)
9525	DIPA9	leatherwood	Dirca	palustris
9535	ELAEA	autumn olive or Russian olive	Elaeagnus	spp.
9549	GAYLU	huckleberry spp.	Gaylussacia	spp.
9585	HAVI4	witch-hazel	Hamamelis	virginiana
9592	ILMO	large-leaf holly	Ilex	montana (monticola)
9593	ILVE	winterberry holly	Ilex	verticillata
9604	LEUCO5	fetter-bush spp.	Leucothoe	spp.
9609	LIBE3	common spicebush	Lindera	benzoin
9635	LONIC	bush honeysuckle spp.	Lonicera	spp.
9637	LYONI	male-berry, staggerbush spp.	Lyonia	spp.
9643	MYGA	sweet gale	Myrica	gale
9644	MOPE6	bayberry	Morella (Myrica)	pennsylvanica
9685	NEMU2	mountain-holly	Nemopanthus	mucronatus
9725	PHOP	ninebark	Physocarpus	opulifolius
9845	RHAMN	buckthorn spp.	Rhamnus	spp.
9856	RHODO	azalea (deciduous) spp.	Rhododendron (Azalea)	spp.
9864	RHCO	winged sumac	Rhus	copallinum
9865	RHGL	smooth sumac	R.	glabra
9866	RHHI2	staghorn sumac	R.	hirta (typhina)
9868	TOVE	poison sumac	Toxicodendron (Rhus)	vernix
9870	RIBES	currant, gooseberry spp.	Ribes	spp.
9905	ROSA5	Rose spp.	Rosa	spp.
9915	RUBUS	briar, bramble, dewberry spp.	Rubus	spp.
9925	SANIC4	American elderberry	Sambucus	nigra ssp. canadensis (canadensis)

Code	PLANTS00	Common name	Genus	Species
9926	SARA2	red-berried elderberry	S.	racemosa
9929	SALIX	shrub willows spp. (all other willows not indicated in tree codes)	Salix	spp.
9937	SPIRA	spirea spp.	Spiraea	spp.
9982	STTR	American bladdernut	Staphylea	trifolia
9983	VACCI	Blueberry spp.	Vaccinium	spp.
9985	VIBUR	Viburnum spp.	Viburnum	spp.
9986	VIAC	maple-leaved viburnum	V.	acerifolium
9987	VILA11	hobblebush viburnum	V.	lantanoides (alnifolium)
9988	VINUC	wild raisin, withe-rod	V.	nudum var. cassinoides (cassinoides)
9989	VIDE	arrowwood	V.	dentatum
9990	VILE	nannyberry	V.	lentago
9991	VIPR	blackhaw	V.	prunifolium
9992	VIOPA2	highbush cranberry	V.	opulus var. americanum (trilobum)
9994	ZAAM	common prickly-ash	Zanthoxylum	americanum
9997	2SD	unknown or not listed		

If species is not listed, use generic genus code.

EVERGREEN SHRUBS

Code	PLANTS00	Common Name	Genus	Species
9045	CHCA2	leatherleaf	Chamaedaphne	calyculata
9061	JUCO6	common juniper	Juniperus	communis
9232	TACA7	Canada yew	Taxus	canadensis
9357	ANPOG	bog rosemary	Andromeda	polifolia var. glaucophylla (glaucophylla)
9605	KAAN	sheep laurel	Kalmia	angustifolia
9606	KALA	mountain laurel	K.	latifolia
9607	KAPO	swamp laurel	K.	polifolia
9608	LEGR	Labrador tea	Ledum	groenlandicum
9642	MOCE2	wax myrtle	Morella (Myrica)	cerifera
9855	RHODO	rhododendron spp.	Rhododendron	spp.
9945	SYTI	sweetleaf	Symplocos	tinctoria
9998	2SE	unknown or not listed		

If species is not listed, use generic genus code.

DWARF SHRUBS

Code	PLANTS00	Common Name	Genus	Species
9363	ARUV	bearberry	Arctostaphylos	uva-ursi
9364	ARAL2	alpine bearberry	Arctostaphylos	alpinus
9441	CHMA3	striped pipsissewa	Chimaphila	maculata
9442	CHUM	pipsissewa	Chimaphila	unbellata ssp. cisatlantica
9498	COCA13	bunchberry	Cornus	canadensis

9547	GAHI2	creeping snowberry	Gaultheria (Chiogenes)	hispidula
9548	GAPR2	teaberry	Gaultheria	procumbens
9603	DILA	diapensia	Diapensia	lapponica
9615	LIBO3	twinflower	Linnaea	borealis ssp. americana
9618	LOPR	alpine azalea	Loiseleuria	procumbens
9675	MIRE	partridgeberry	Mitchella	repens
9677	SITR3	three-toothed cinquefoil	Sibbaldiopsis (Potentilla)	tridentata
9981	VACCI	cranberry spp.	Vaccinium	spp.
9996	2SUBS	unknown or not listed		

If species is not listed, use generic genus code.

VINES

Code	PLANTS00	Common Name	Genus	Species
9451	AMBR2	hog peanut	Amphicarpaea	bracteata
9454	APAM	ground-nut	Apios	americana
9455	CESC	American bittersweet	Celastrus	scandens
9477	CLEMA	clematis sp.	Clematis	spp.
9636	LONIC	vine honeysuckle	Lonicera	spp.
9715	PAQU2	Virginia creeper	Parthenocissus	quinquefolia
9867	TORAR	poison ivy	Toxicodendron (Rhus)	radicans ssp. radicans (radicans)
9934	SMILA2	Greenbrier spp.	Smilax	spp.
9993	VITIS	Grape spp.	Vitis	spp.
9995	2V	unknown or not listed		

If species is not listed, use generic genus code.

Appendix E. Tables and Charts

This appendix includes tree grading tables, hardwood tree grade defects, cull estimation tables, and other aids for data collection.

HARDWOOD TREE GRADES			
GRADING FACTORS	GRADE 1	GRADE 2	GRADE 3
Length of grading zone (ft)	Butt 16	Butt 16	Butt 16
Length of grading section ^a (ft)	Best 12	Best 12	Best 12
Minimum DBH (in)	16 ^b	13	11
Minimum DIB at the top of the grading section (in)	13 ^b 16 20	11 ^c 12	8
Clear cuttings on 3rd best face ^d minimum length (ft)	7 5 3	3 3	2
number on face (max)	2	2 3	unlimited
yield in face length (min)*	5/6	4/6	3/6
Cull deduction, including crook and sweep but excluding shake, maximum w/in grading section (%)	9	9 ^e	50

- ^a Whenever a 14- or 16-ft section of the butt log is better than the best 12-ft section, the grade of the longer section will become the grade of the tree. This longer section, when used, is the basis for determining the grading factors, such as diameter and cull deduction.
- ^b In basswood and ash, DIB at the top of the grading section may be 12-in and DBH may be 15-in.
- ^c Grade 2 trees can be 10-in DIB at the top of the grading section if otherwise meeting surface requirements for small grade 1's.
- ^d A clear cutting is a portion of a face free of defects, extending the width of the face. A face is one-fourth of the surface of the grading section as divided lengthwise.
- ^e 15% crook and sweep, or 40% total cull deduction are permitted in grade 2 if size and surface of grading section qualify as grade 1. If rot shortens the required clear cuttings to the extent of dropping the butt log to grade 2, do not drop the tree's grade to 3 unless the cull deduction for rot is greater than 40%.

*Minimum Yield in Face Length			
Face Length	Grade 1 Min. Yield	Grade 2 Min. Yield	Grade 3 Min. Yield
12-ft	10-ft	8-ft	6-ft
14-ft	11.7-ft	9.3-ft	7-ft
16-ft	13.3-ft	10.7-ft	8-ft

Source: U.S.D.A. Forest Service Research Paper NE-333, 1976.

NRS Note (procedural change for former NC crews): NRS will not apply the "form class 78" rule as noted in the source document. This rule allows the minimum DBH to be less than is indicated in the above table. The rule is not applied because form class 78 does not apply to all hardwood species across the region.

A hardwood that does not have a 12-foot sawlog in the butt 16-foot grading section is recorded as grade 5. Note: When determining the grade of upper logs, 8-foot sawlogs need to meet all the minimum grading factors except for length for hardwood tree grades 3 or 4.

LOG SURFACE ABNORMALITIES THAT ARE HARDWOOD TREE GRADING DEFECTS

Bark distortions – Many log surface abnormalities appear to be only breaks in the normal bark pattern. Overgrown knots, mechanical wounds, holes of all types, ingrown bark, and bird peck are typical defects under bark distortions which can be definitely established from bark appearance. They are all grading defects. A slight bark distortion consisting of a simple horizontal break across the normal bark pattern is not a grading defect.

Bulge – A general enlargement of a section of the log and a sign of internal rot.

Bump – Bumps usually indicate overgrown knots or other defects. Surface swells (less than 1" rise in 12" of length) can be disregarded as a grading defect.

Burls – A sound, hard, woody protuberance on the log with no protruding limbs, etc.

Butt scar – Damage at the base of the tree. Scars of recent origin are usually associated with a limited amount of rotten or stained wood. Severe rot is usually associated with older scars. If the scar extends into the log beyond the slab section, the area involved is a grading defect.

Bird peck – There must be four bird pecks within a square foot to affect the tree grade and be considered a defect. First, determine the tree grade without the bird pecks. If the tree grade is determined to be 1 or 2, then down grade the tree by one grade. If the tree graded out to be a 3 or 4 without the bird pecks, then ignore them as defects and record the initial tree grade.

Canker – A definite, relatively localized lesion, primarily of bark and wood.

Conk – It is the fruiting body of a wood rotting fungus located on the bole of the tree and is an indication of serious internal rot.

Epicormic branches and dormant bud clusters – Epicormic branches are found at point on the stem. Dormant bud clusters may develop on the stem any time during the life of a tree.

Holes – All holes are grading defects.

Knots – Cut or broken-off limbs or sprout branches, green or dead, protruding, flush or depressed but with exposed sound or rotten wood.

Metal – Logs suspected of or known to contain metal should either be long butted or rejected. All metal (except aluminum research tags and nails) is considered an unsound grading defect.

Rot – Wood which has decayed to the point where it is useless.

Seams – Seams are cracks or splits running with the grain for part of or full length of the log. They are generally caused by wind, lightning or frost and extend from the bark to the center of the log. They may be open or completely healed. They are very damaging and especially so when they run spirally around the log.

- No clear cuttings can be taken on a log face that includes a full-length straight seam or a spiral seam. However, one straight seam can be placed on the edge of one face and ignored. This fixes the location of all other defects.
- A deep seam entering a face but not running full length may be overlaid with a clear cutting for one-third of its length, starting at the inner end. Note: This is difficult to determine on a standing tree. See Figure RA_E1.

- When a deep seam is entirely within a log, clear cuttings can be laid over from each end for a distance equal to one-fourth its full length. Note: This is difficult to determine on a standing tree. See Figure RA_E2.

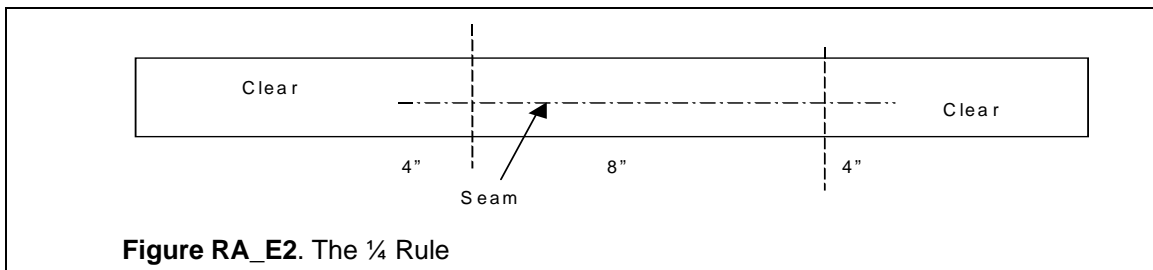
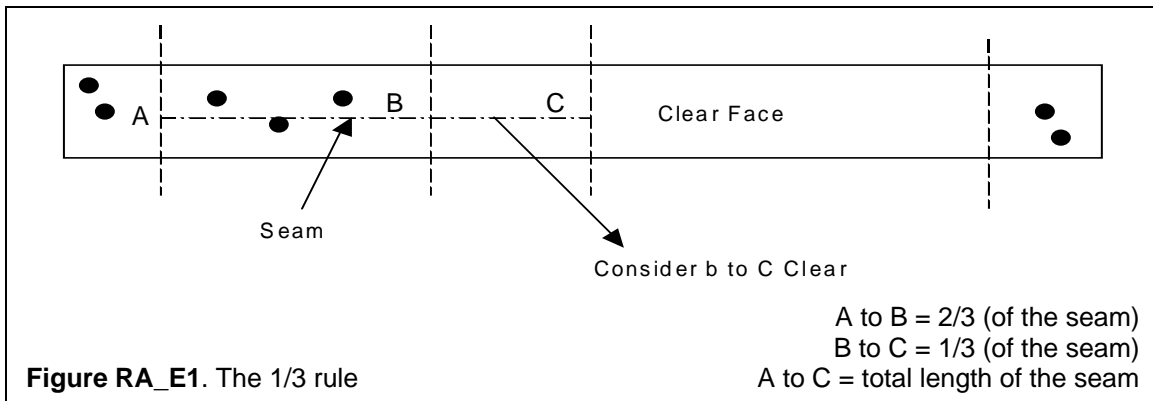

Wounds – Wounds or injuries that expose sapwood and/or heartwood are defects. The following are a few guidelines for wounds:

- Old wounds are commonly associated with stain, decay, and/or insects and the affected area becomes a defect.
- New “fresh” wounds (less than 1 year old) are disregarded as long as deterioration is not visible.
- If new or old wounds look superficial, disregard them.

Source: Official Grading Rules for Northern Hardwood and Softwood Logs and Tie Cuts
 (Effective Sept. 1, 1998).

HARDWOOD CONSTRUCTION GRADE 4	
GRADING FACTORS	SPECIFICATIONS
Position in tree	Butts and uppers
Scaling diameter (in)	8-in DIB and larger
Length, w/o trim (ft)	12-ft and longer
Clear cuttings	No requirements (not graded on cutting basis)
Maximum sweep allowance	One-fourth DIB of small end for half logs, and one-half DIB for logs 16-ft long
Sound surface defects -	
Single knots	Any number, if none has an average collar ^a diameter that is more than one-third of the log diameter at the point of occurrence.
Whorled knots	Any number, provided the sum of the collar diameters does not exceed one-third the log diameter at the point of occurrence.
Knots	Any number not exceeding knot specifications, if they do not extend more than 3-in into the contained tie or timber.
Unsound surface defects ^b	Any number and size, if they do not extend into contained tie or timber. If they extend into contained tie or timber, they shall not exceed size, number, and depth of limits for sound defects.

^a Knot collar is the average of the vertical and horizontal diameters of the limb, or knot swelling, as measured flush with the surface of the log.

^b Interior defects are not visible in standing trees. They are considered in grading cut logs. No interior defects are permitted except one shake not more than one-third the width of the contained tie or timber, and one split not more than 5-in long.

Note: The hi-lighted text indicates NRS modification from the original hardwood construction log grade (U.S.D.A. Forest Service General Technical Report NE-1, 1973).

NRS Note (procedural change for former NC crews): The above table is similar to specifications from the NCFG v3.0. Minimum length has been changed from 8 ft to 12 ft when grading the butt 16 ft.

A hardwood that does not have a 12-foot sawlog in the butt 16-foot grading section is recorded as grade 5. Note: When determining the grade of upper logs, 8-foot sawlogs need to meet all the minimum grading factors except for length for hardwood tree grades 3 or 4.

EASTERN WHITE PINE TREE GRADES				
GRADING FACTORS	GRADE 1	GRADE 2	GRADE 3	GRADE 4
Minimum DBH (in)	9	9	9	9
Length of grading zone (ft)	Butt 16	Butt 16	Butt 16	Butt 16
Length of grading section (ft)	Best 12	Best 12	Best 12	Best 12
Maximum weevil injury in butt 16 ft (number)	None	None	2 Injuries	No limit
Minimum face requirements on grading section	Two full length or four 50% length good faces ¹ . (In addition, knots on balance of faces shall not exceed size limitations for Grade 2 sections.)	NO GOOD FACES REQUIRED. Maximum diameter of knots on 3 best faces: SOUND RED KNOTS not to exceed 1/6 of scaling diameter or 3-in maximum ² . DEAD OR BLACK KNOTS , including over-grown knots, not to exceed 1/12 scaling diameter and 1-1/2-in maximum.	NO GOOD FACES REQUIRED. Maximum diameter of knots on 3 best faces: SOUND RED KNOTS not to exceed 1/3 of scaling diameter of 5-in maximum ² . DEAD OR BLACK KNOTS , including over-grown knots, not to exceed 1/6 scaling diameter and 2-1/2-in maximum.	Includes all trees not qualifying for Grade 3 or better and judged to have at least 1/3 of their gross volume in sound wood suitable for manufacture into standard lumber.
Maximum sweep or crook in grading section (%)	20	30	40	No limit
Maximum total scaling deduction in grading section (%)	50	50	50	No limit

After the tentative grade of the section is established from face examination, the section will be **reduced one grade** whenever the following defects are evident⁴:

CONKS, PUNK KNOTS AND PINE BORER DAMAGE ON THE SURFACE OF THE SECTION

Degrade one grade if present on one face.
 Degrade two grades if present on two faces.
 Degrade three grades if present on three to four faces.

If the final grade of the grading section is 1, 2 or 3, examine the tree for weevil injuries in the merchantable stem **above** 16-ft. If the total apparent weevil damage exceeds 3, degrade the tree grade one below the section grade³. Otherwise the tree grade is the same as the final section grade.

¹ Trees under 16-in DBH require four full length good faces.
² Scaling diameter is estimated at the top of the grading section.
³ No tree will be designated below Grade 4 unless net tree scale is less than one-third of gross tree scale.

Note: The hi-lighted text indicates NRS modification from the original EWP Tree Grade Table (U.S.D.A. Forest Service Research Paper NE-214, 1971). **[Correction 10/12/2006.]**

NRS Note (procedural change for former NC and NE crews): For NC, the application of white pine log grade specification is no longer applicable from *NCGF v3.0*. The above tree grade table will be applied to all white pines. For NE, the length of the grading section is now 12 ft within the 1st 16 ft.

A white pine that does not have a 12-foot sawlog in the butt 16-foot grading section is recorded as grade 5. Note: When determining the grade of upper logs, 8-foot sawlogs need to meet all the minimum grading factors except for length for white pine tree grade 4.

WHITE PINE COLLAR DIAMETER LIMITS FOR WHITE PINE TREE GRADING

WHITE PINE COLLAR DIAMETER LIMITS FOR RED AND BLACK KNOTS				
SCALING DIAMETER (D.J.B. inches)	GRADE 1 AND 2		GRADE 3	
	BLACK KNOTS 1/12 th	RED KNOTS 1/6 th	BLACK KNOTS 1/6 th	RED KNOTS 1/3 rd
7	7/12"	1 - 1/6"	1 - 1/6"	2 - 1/3"
8	2/3"	1 - 1/3"	1 - 1/3"	2 - 2/3"
9	3/4"	1 - 1/2"	1 - 1/2"	3"
10	5/6"	1 - 2/3"	1 - 2/3"	3 - 1/3"
11	11/12"	1 - 5/6"	1 - 5/6"	3 - 2/3"
12	1"	2"	2"	4"
13	1 - 1/12"	2 - 1/6"	2 - 1/6"	4 - 1/3"
14	1 - 1/6"	2 - 1/3"	2 - 1/3"	4 - 2/3"
15	1 - 1/4"	2 - 1/2"	2 - 1/2" MAX	5" MAX
16	1 - 1/3"	2 - 2/3"		
17	1 - 5/12"	2 - 5/6"		
18	1 - 1/2" MAX	3" MAX		

Red knots – Visible branches, stubs or sockets that are from living branches or branches that have recently died. They are inter-grown with the surrounding wood and contain no rot.

Dead or black knots – Visible branches, stubs or sockets that do not conform to the definition of red knots.

Overgrown knots – Identified by a distinctive circular/elliptical pattern in the bark and are treated the same as dead knots.

Average diameter of red and black knots on white pine – Measured at the point where the limb would normally be trimmed from the main stem. For red knots measure only the heartwood portion of the knot. For black knots measure the whole limb.

PINE TREE GRADES (All pines except White Pine.)			
FACE LENGTH	GRADE 1	GRADE 2	GRADE 3
Best 12 or longer within the butt 16 ft grading section	3 or 4 clear faces	1 or 2 clear faces	No clear faces

After the tentative grade is established, the tree will be **reduced one grade** for each of the following:

- Sweep** - Degrade any tentative Grade 1 or 2 tree one grade if sweep in the lower 12-ft of the grading section amounts to 3 or more inches and equals or exceeds one-fourth the DBH.
- Heart rot** - Degrade any tentative Grade 1 or 2 tree one grade if conks, punk knots, or other evidence of advanced heart rot is found anywhere on the tree stem.
- Note** - No tree can be degraded below Grade 3, provided the total scaling deductions for sweep and/or rot do not exceed two-thirds the gross scale of the tree. Trees with total scaling deductions in excess of two-thirds are classified as cull.

A face is one-fourth the circumference of the grading section and extends the full length of the grading section. Clear faces are those free from knots measuring more than 1/2-in in diameter, overgrown knots of any size, and holes more than 1/4-in in diameter. Faces may be rotated, if necessary, to obtain the maximum number of clear faces on the grading section.

Note: The hi-lighted text indicates NRS modification from the original Southern Pine Tree Grades (U.S.D.A. Forest Service Research Paper SE-40, 1968).

NRS Note (procedural change for former NC and NE crews): The jack and red pine log grade table are no longer applicable from *NCGF v3.0*. The above tree grade table will be applied to all pines except white pine. For NE, the length of the grading section is now 12 ft within the 1st 16 ft.

A pine that does not have a 12-foot sawlog in the butt 16-foot grading section is recorded as grade 5. Note: When determining the grade of upper logs, 8-foot sawlogs need to meet all the minimum grading factors except for length for pine tree grade 3.

OTHER SOFTWOODS					
Minimum Merchantability Specifications for Grade 1					
Grade the best 12 ft within the 1st 16 ft.¹					
Grade	DIB at the top of the grading section	Length (2-ft multiples w/o trim)	Total Deduction	Sweep Permitted	Other Requirements*
1	6" - 12"	12' - 16'	50%	25%	Sound knots not over 2" in diameter are permitted.
	13" +	12' - 16'	50%	25%	Sound knots not over 3" in diameter are permitted.
¹ When ever a 14-ft or 16-ft section of the butt log is better than the best 12-ft section, the grade of the longer section will become the grade of the tree. This longer section, when used, is the basis for determining the grading factors, such as DIB and sweep.					
* One branch or sound knot that exceeds the diameter limitations is permitted to meet Grade 1 specifications. This is a Northern allowance. Sound knots are measured at the point where the limb would normally be trimmed from the main stem.					

Note: The hi-lighted text indicates NRS modification from the original specifications from the Northeast Field Guide, Version 3.0. The above specifications are based on a log grade. Tree grades have never been developed for these other softwood species that include spruce, fir, hemlock, larch (tamarack), cypress and cedar.

NRS Note (procedural change for former NC crews): The softwood log grade specification is no longer applicable from *NCGF v3.0*. The above tree grade table will be applied to softwoods except pines.

“Other” softwood that does not have a 12-foot sawlog in the butt 16-foot grading section is recorded as grade 5. Note: When determining the grade of upper logs, 8-foot sawlogs need to meet all the minimum grading factors except for length for other softwood grade 1.

NRS Note (procedural change for former NC crews): The following “percent” cull tables will be utilized to determine percent board-foot or percent cubic-foot cull for both rough cull and rotten/missing cull. The use of the “short log” board-foot volume table or the “two-variable” cubic-foot lookup volume table are no included in the field guide.

The following table is applied to determine the percent of **hardwood board-foot cull within the sawlog length** (or potential sawlog for a poletimber-size tree) that starts from a 1 foot stump to 9- in top DOB. These tables can be used to determine “sector” cull of a 4-ft section. Any 4-ft section can be reduced by quarters, thirds or one-half. E.g., a 32 ft hardwood sawlog has a fork within the 6th section. The fork accounts for one-half of the volume for that section, and therefore represents 6% board-foot cull.

PERCENT OF BOARD-FOOT CULL OF HARDWOOD SAWTIMBER
 [BY 4-FT SECTIONS & LOCATION IN THE TREE]

LOG (FT)	1ST	2ND	3RD	4TH	5TH	6TH	7TH	8TH	9TH	10TH	11TH	12TH	13TH	14TH	15TH	16TH
1 (16)	29	26	24	21												
1-1/2 (24)	19	18	16	16	16	15										
2 (32)	15	14	13	13	12	12	11	10								
2-1/2 (40)	12	12	11	11	10	10	9	9	8	8						
3 (48)	12	10	10	9	9	9	8	7	7	7	6	5				
3-1/2 (56)	10	10	9	9	9	8	8	7	7	6	5	5	4	3		
4 (64)	9	9	9	8	8	7	7	7	6	6	5	5	4	4	3	3

The following table is applied to determine the percent of **softwood board-foot cull within the sawlog length** (or potential sawlog for a poletimber-size tree) that starts from a 1 foot stump to 7- in top DOB. These tables can be used to determine “sector” cull of a 4-ft section. Any 4-ft section can be reduced by quarters, thirds or one-half. E.g., a 32 ft softwood sawlog has a fork within the 6th section. The fork accounts for one-half of the volume for that section, and therefore represents 5% board-foot cull.

PERCENT OF BOARD-FOOT CULL OF SOFTWOOD SAWTIMBER
 [BY 4-FT SECTIONS & LOCATION IN THE TREE]

LOG (FT)	1ST	2ND	3RD	4TH	5TH	6TH	7TH	8TH	9TH	10TH	11TH	12TH	13TH	14TH	15TH	16TH
1 (16)	33	27	21	19												
1-1/2 (24)	26	20	16	15	12	11										
2 (32)	21	17	14	12	10	9	9	8								
2-1/2 (40)	19	15	12	10	9	8	7	7	7	6						
3 (48)	16	13	11	10	8	7	7	6	6	6	5	5				
3-1/2 (56)	13	12	10	9	7	7	6	6	6	5	5	5	5	4		
4 (64)	10	9	9	8	7	7	6	6	6	5	5	5	5	4	4	4

The following table is applied to determine the percent of **cubic-foot cull within the bole length** that starts at a 1 foot stump to a 4-in top DOB for all species. These tables can be used to determine "sector" cull of a 4-ft section. Any 4-ft section can be reduced by quarters, thirds, or one-half. E.g., a 32 ft bole length has a fork within the 6th section. The fork accounts for one-half of the volume for that section, and therefore represents 4% cubic-foot cull.

PERCENT OF CUBIC-FOOT CULL VOLUME FOR ALL TREES

[BY 4-FT SECTIONS & LOCATION IN THE TREE]

FEET	1ST	2ND	3RD	4TH	5TH	6TH	7TH	8TH	9TH	10TH	11TH	12TH	13TH	14TH	15TH	16TH	17TH	18TH
LENGTH	8	57	43															
	12	42	32	26														
	16	30	26	23	21													
	20	26	23	21	19	11												
	24	24	21	18	17	10	10											
	28	21	19	17	16	10	9	8										
	32	20	18	16	14	10	8	7	7									
	36	19	16	14	13	9	8	8	7	6								
	40	17	15	13	12	9	8	7	7	6	6							
	44	16	14	12	11	9	7	7	7	6	6	5						
	48	15	13	12	10	8	7	7	6	6	6	5	5					
	52	14	12	11	9	8	7	6	6	6	6	5	5	5				
	56	13	11	10	9	8	6	6	6	6	6	5	5	5	4			
	60	12	11	10	9	7	6	6	6	6	5	5	5	5	4	4		
	64	11	10	9	9	7	6	6	6	5	5	5	5	5	4	4	4	
	68	10	10	9	8	6	6	6	5	5	5	5	5	4	4	4	4	4
72	10	9	8	8	6	6	6	5	5	5	4	4	4	4	4	4	4	

METHODS OF DETERMINING SCALING DEDUCTION (Examples based on an 8-foot log with 20-inch scaling diameter)	
<p>If <u>section</u> of bole is affected, deduct percent of log length affected.</p> <p>Example: $\frac{2}{8} = 25$ percent cull</p>	
<p>If <u>sector</u> is affected, multiply percent of circle times percent of length.</p> <p>Example: $\frac{60^\circ}{360^\circ} \times \frac{3}{8} = 6\%$ cull</p>	
<p>For a <u>crook</u>, multiply proportion of diameter displaced times proportion of log length affected by crook.*</p> <p>Example: $\frac{10}{20} \times \frac{2}{8} = 12\%$ b.f. cull</p>	
<p>For a <u>sweep</u>, determine sweep departure and subtract 1" for 8' logs or 2" for 16' logs. Divide by log diameter.</p> <p>Example: $\frac{8-1}{20} = 35\%$ b.f. cull**</p>	
<p>For <u>interior cull</u>, square out interior cull as a percent of total volume of the section. For bd. ft. cull, add 1" to width and to thickness; for cu. ft. cull, use actual dimensions of rot. For bd. ft. cull divide width and thickness by the scaling diameter (ave. d.i.b., small end) minus 1; for cu. ft. cull, divide by scaling diameter. Multiply fractions by percent of log affected.</p> <p>Example: $\frac{8 \times 10}{(20-1)^2} \times \frac{2}{8} = 6\%$ cubic-foot cull</p>	

* No reduction of cubic-foot volume will be made.

** If a straight line between A and B falls outside the bark, the affected section is over 50% cull in board feet.

In the table below, excessive sweep is indicated by the "boxed" values or where values are blank. The values in this table are actual board-feet and not a percentage.

SWEEP DEDUCTION IN BOARD FEET

Sweep departure (inches)	Sweep length (feet)	Scaling diameter of section with sweep (inches)													
		6	7	8	9	10	12	14	16	18	20	22	24	26	28
2	6	1	1	2	2	3	3	4	5	6	6	7	8	9	9
	8	1	1	2	2	3	4	5	5	6	7	8	8	9	10
	10	1	1	2	2	3	4	4	5	6	7	7	8	9	10
	12	1	1	2	2	2	3	4	4	5	5	6	6	7	8
	14	1	1	1	1	1	2	2	2	3	3	3	4	4	5
3	6	0	0	0	0	0	0	0	0	0	0	0	0	0	0
	8	2	3	3	4	5	6	7	9	10	11	13	14	15	17
	10	2	4	5	6	6	8	10	12	13	15	17	19	20	22
	12	3	4	5	6	7	9	11	12	14	16	18	19	21	23
	14	3	4	5	6	7	9	10	12	14	16	17	19	21	23
4	6	3	4	5	6	7	8	11	13	15	17	18	20	22	24
	8	4	5	6	7	9	11	14	16	18	21	23	25	28	30
	10	5	6	8	9	10	13	16	19	21	24	27	29	32	35
	12	5	7	8	10	12	14	18	20	23	26	29	32	35	38
	14	6	8	9	11	12	16	19	22	25	28	31	35	38	41
5	6	6	8	10	11	13	16	19	23	26	29	32	35	39	42
	8	5	7	8	10	12	15	18	21	24	27	31	34	37	40
	10	6	8	10	12	15	18	21	25	29	33	36	40	44	48
	12	8	10	12	12	16	20	25	29	33	37	41	45	50	54
	14	9	11	13	16	18	22	27	32	36	41	45	50	54	59
6	6	10	12	15	17	20	24	29	34	39	44	48	53	58	63
	8	8	9	11	14	17	20	24	27	30	33	36	39	42	46
	10	11	12	14	18	22	26	30	34	38	42	46	50	56	60
	12	10	13	15	18	23	27	32	36	41	46	51	56	64	69
	14	11	15	18	20	23	29	36	41	47	53	59	65	71	77
7	6	13	16	20	23	26	32	39	45	52	58	64	71	77	83
	8	11	13	16	18	21	24	28	32	36	39	43	47	51	56
	10	15	17	22	27	31	36	41	46	51	56	62	67	73	78
	12	19	21	27	33	39	44	50	56	62	67	73	78	84	89
	14	22	25	32	39	45	52	58	65	71	78	84	91	98	104
8	6	25	29	36	44	51	58	66	73	81	88	96	104	112	
	8	24	28	33	40	49	57	64	72	80	88	96	104	112	
	10	19	24	28	33	40	49	57	64	72	80	88	96	104	
	12	25	31	37	42	48	54	59	65	70	76	81	87	92	
	14	25	32	39	46	52	59	66	72	79	86	92	99	106	
9	6	30	37	46	53	61	69	76	84	92	100	108	116	124	
	8	34	39	43	52	61	69	78	87	96	105	113	122	131	
	10	34	39	43	52	61	69	78	87	96	105	113	122	131	
	12	34	39	43	52	61	69	78	87	96	105	113	122	131	
	14	34	39	43	52	61	69	78	87	96	105	113	122	131	

In the table below, excessive crook is indicated by the “boxed” values or where values are blank. The values in this table are actual board-feet and not a percentage.

CROOK DEDUCTION IN BOARD FEET

Crook departure (inches)	Crook length (feet)	Scaling diameter of section with crook (inches)													
		6	7	8	9	10	12	14	16	18	20	22	24	26	28
1	1	0	0	0	0	0	0	1	1	1	1	1	1	1	1
	2	0	0	0	1	1	1	1	1	1	2	2	2	2	2
	3	1	1	1	1	1	1	2	2	2	3	3	3	3	4
	4	1	1	1	1	2	2	3	3	4	4	5	5	6	6
	5	1	1	1	1	2	2	3	3	4	4	5	5	6	6
	6	1	1	2	2	2	3	3	4	5	5	6	6	7	8
2	1	0	0	0	1	1	1	1	1	1	2	2	2	2	3
	2	1	1	1	1	1	2	2	2	3	3	4	4	4	5
	3	1	1	2	2	2	3	3	4	4	5	6	6	7	7
	4	1	1	2	2	3	3	4	5	6	7	8	8	9	10
	5	1	2	2	3	3	4	5	6	8	8	10	10	11	13
	6	2	2	3	4	4	5	7	8	9	10	12	13	14	15
3	1	0	0	1	1	1	1	2	2	2	3	3	3	3	4
	2	1	1	2	2	2	2	3	4	4	5	6	6	7	7
	3	1	2	2	3	3	4	5	6	7	8	9	9	10	11
	4	2	2	3	3	4	5	6	8	9	10	11	12	13	15
	5	2	3	4	4	5	6	8	10	11	13	14	16	17	19
	6	2	3	4	5	6	8	10	12	14	15	17	19	20	23
4	1	1	1	1	1	2	2	2	3	3	4	4	4	5	
	2	1	2	2	3	3	4	5	6	7	8	8	9	10	
	3	1	2	3	4	4	5	7	8	9	10	11	12	13	
	4	2	3	4	5	7	9	10	12	13	15	17	18	20	
	5	3	3	5	6	7	9	11	13	15	17	19	21	22	
	6	3	5	6	7	8	11	13	15	18	20	23	25	27	
5	1			1	2	2	3	3	4	4	5	5	6	6	
	2			2	3	4	4	5	6	7	8	9	10	11	
	3			4	4	5	7	8	10	11	12	14	16	17	
	4			5	6	6	9	11	13	15	17	19	21	22	
	5			6	7	8	11	13	16	19	21	24	26	28	
	6			8	9	10	13	16	19	23	26	29	32	34	
6	1				2	2	2	3	4	4	5	6	7	8	
	2				3	4	5	6	7	9	10	11	13	15	
	3				5	6	8	10	12	13	15	17	20	22	
	4				7	8	10	13	15	18	20	23	25	30	
	5				9	10	13	16	19	23	25	29	32	34	
	6				11	13	16	20	23	27	31	34	38	41	
8	1					3	5	5	6	7	8	8	9	10	
	2					7	9	10	12	13	15	17	18	20	
	3					10	13	16	18	20	23	25	27	30	
	4					14	17	20	24	27	30	33	36	40	
	5					17	22	26	30	34	38	42	45	50	
	6					21	26	31	36	41	46	51	54	60	
10	1							6	7	8	10	10	11	12	
	2							12	14	16	19	21	23	25	
	3							19	22	25	28	31	34	37	
	4							26	29	34	37	41	45	49	
	5							32	37	42	47	52	57	62	
	6							39	45	51	57	63	69	75	

GROSENBAUGH'S RULE 3 & 4 FOR SWEEP AND CROOK DEDUCTION

In determining sweep the number subtracted from actual sweep depends on the log length as follow: 8 thru 10 ft is -1 in, 11 thru 13 ft is -1 ½ in, and 14 thru 16 ft is -2 in.

Rule 3 from Grosenbaugh	Rule 4 from Grosenbaugh
% Sweep = (total sweep – 2(16' log)) / DIB	% Crook = (deflection / DIB) x (length of crook / log length)
% Sweep = (total sweep – 1 (8' log)) / DIB	

The following table allows for quick assessment of whether a log is merchantable without using the formula. E.g., an 8 ft log with a scaling diameter of 12-in and 6-in departure is 42% merchantable. If the departure for the same log is \geq 9-in, then the 8 ft log \geq 67% and therefore the entire 8 ft log is not merchantable due to sweep and is culled.

Table 5.—Sweep deduction from gross scale by length and diameter (in percent; based on rule 3)

Absolute sweep in inches		Scaling diameter, average small end inside bark, in inches											
8-9-10 foot logs	14-15-16 foot logs	8	10	12	14	16	18	20	22	24	26	28	30
—	3	12	10	8	7	6	6	5	5	4	4	4	3
3	4	25	20	17	14	12	11	10	9	8	8	7	7
4	5	38	30	25	21	19	17	15	14	12	12	11	10
5	6	50	40	33	29	25	22	20	18	17	15	14	13
6	7	62	50	42	36	31	28	25	23	21	19	18	17
7	8	—	60	50	43	38	33	30	27	25	23	21	20
8	9	—	—	58	50	44	39	35	32	29	27	25	23
9	10	—	—	67	57	50	44	40	36	33	31	29	27
10	11	—	—	—	64	56	50	45	41	38	35	32	30
11	12	—	—	—	—	62	56	50	45	42	38	36	33
12	13	—	—	—	—	—	61	55	50	46	42	39	37
13	14	—	—	—	—	—	—	60	54	50	46	43	40
14	15	—	—	—	—	—	—	65	59	54	50	46	43
15	16	—	—	—	—	—	—	—	64	58	54	50	47
16	17	—	—	—	—	—	—	—	—	62	58	54	50
17	18	—	—	—	—	—	—	—	—	—	62	57	53
18	19	—	—	—	—	—	—	—	—	—	65	61	57
19	20	—	—	—	—	—	—	—	—	—	—	64	60
20	21	—	—	—	—	—	—	—	—	—	—	—	63
21	22	—	—	—	—	—	—	—	—	—	—	—	67
11-12-13 foot logs													
	3	19	15	12	11	9	8	8	7	6	6	5	5
	4	31	25	21	18	16	14	12	11	10	10	9	8
	5	44	35	29	25	22	19	18	16	15	13	12	12
	6	56	45	38	32	28	25	22	20	19	17	16	15
	7	—	55	46	39	34	31	28	25	23	21	20	18
	8	—	65	54	46	41	36	32	30	27	25	23	22
	9	—	—	62	54	47	42	38	34	31	29	27	25
	10	—	—	—	61	53	47	42	39	35	33	30	28
	11	—	—	—	—	59	53	48	43	40	37	34	32
	12	—	—	—	—	66	58	52	48	44	40	38	35
	13	—	—	—	—	—	64	58	52	48	44	41	38
	14	—	—	—	—	—	—	62	57	52	48	45	42
	15	—	—	—	—	—	—	—	61	56	52	48	45
	16	—	—	—	—	—	—	—	66	60	56	52	48
	17	—	—	—	—	—	—	—	—	65	60	55	52
	18	—	—	—	—	—	—	—	—	—	63	59	55
	19	—	—	—	—	—	—	—	—	—	67	62	58
	20	—	—	—	—	—	—	—	—	—	—	66	62
	21	—	—	—	—	—	—	—	—	—	—	—	65

Note: For odd lengths and half inches of sweep, deductions can be interpolated from the figures given.

Source: Grosenbaugh, L. R. 1952. SHORTCUTS FOR CRUISERS AND SCALERS. Occasional Paper 126, Southern Forest Experiment Station, USDA Forest Service

**TO DETERMINE THE LENGTH OF A SIDE WHEN THE INTERIOR ANGLE IS KNOWN
(SOLVING FOR RIGHT TRIANGLES)**

Many times it will be easier to measure along the edge of a potential contrasting condition than across. The following steps and table can be used to determine when the width across an interior corner angle becomes 120 ft wide.

1. Determine interior angle of corner.
2. Refer to table below to find limiting distance along edge of condition.

Interior Angle of Corner	Limiting Distance (FT)	Interior Angle of Corner	Limiting Distance (FT)
88	86.4	58	123.8
86	88.0	56	127.8
84	89.7	54	132.2
82	91.5	52	136.9
80	93.3	50	142.0
78	95.3	48	147.5
76	97.5	46	153.6
74	99.7	44	160.2
72	102.1	42	167.4
70	104.6	40	175.4
68	107.3	38	184.3
66	110.2	36	194.2
64	113.2	34	205.2
62	116.5	32	217.7
60	120.0	30	231.8

The following formula was used to create the preceding table.

$$\text{Limiting Distance} = 60 / \text{SIN}(\text{Interior Angle} \times .5)$$

See Figure RA_E3 on next page.

EXAMPLE

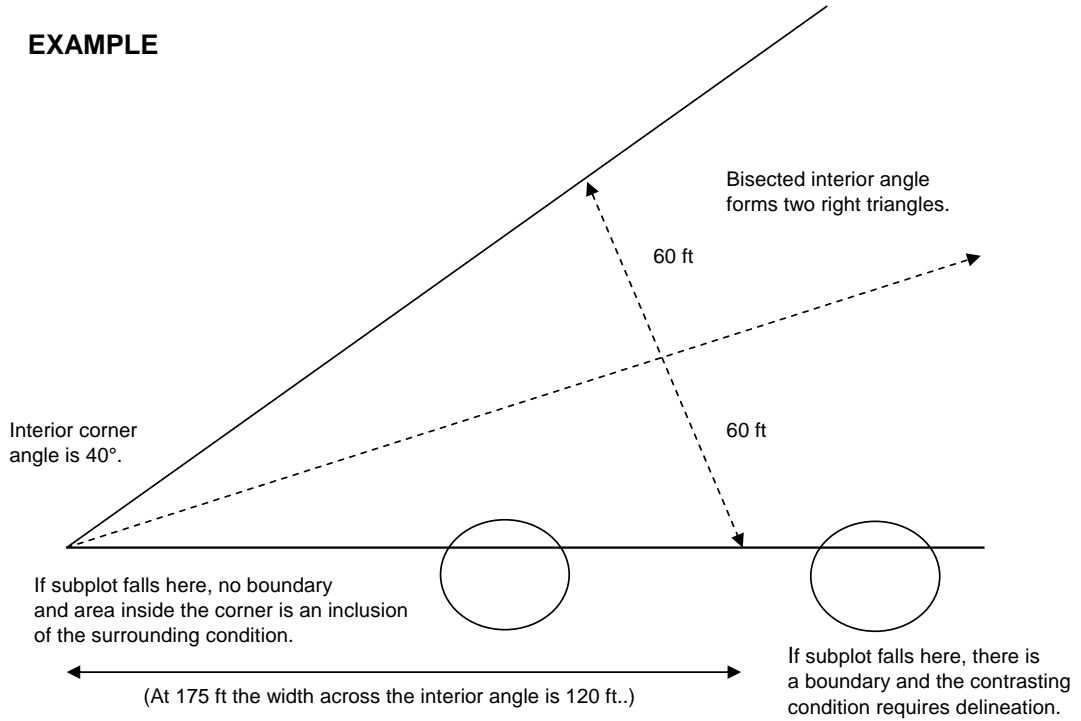

Figure RA_E3.

FOREST LAND PRODUCTIVITY GUIDE

The table below may be used by eastern field crews to assist in the determination of unproductive forest land; that is, land on which the potential productivity is less than 20 cubic feet of industrial wood per acre, per year.

From an increment boring, determine the age class of a tree that is located on the site in question. For example, a 27 year old black spruce in the 20 year age class must be at least 8 feet tall if the site is to be considered as being productive. Sample trees must be representative of the site. The factors of drainage, soils, elevation, and exposure must also be considered.

Total height in feet at upper limit of the unproductive site class

AGE CLASS	BLACK SPRUCE HEIGHT	BLACK ASH HEIGHT	RED MAPLE HEIGHT	CHESTNUT OAK HEIGHT
20	8	12	10	12
30	13	21	17	21
40	19	29	24	29
50	25	34	32	34
60	30	39	37	39
70	33	45	43	45
80	39	50	49	50
90	41	53	53	52
100	43	57	57	56
110	47	60	60	57
120	50	60	61	58
130	51	61	61	59
140	52	62	62	60
150	53	63	62	--
160	--	64	63	--
170	--	65	63	--
180	--	65	63	--

Boring or drilling on plots located in Wilderness areas on National Forests will be done on representative non-tally trees and only when absolutely necessary to estimate site, age, or growth. (This will generally be the case during initial establishment of permanent plots.) [INTRA-AGENCY AGREEMENT 05-SU-FIA01]

Slope Correction in feet
(Distance is measured on slope)

Percent	Feet				
	50'	60'	66'	70'	99'
10	.25	.3	.3	.3	.5
15	.5	.6	.7	.8	1.1
20	1.0	1.2	1.3	1.4	2.0
25	1.5	1.7	2.0	2.2	3.0
30	2.2	2.6	2.9	3.1	4.4
35	3.0	3.6	3.9	4.2	5.9
40	3.9	4.6	5.1	5.4	7.6
45	4.8	5.8	6.4	6.8	9.6
50	5.9	7.1	7.8	8.3	11.7
55	7.1	8.5	9.3	9.9	14.0
60	8.3	10.0	11.0	11.6	16.5
65	9.6	11.6	12.7	13.5	19.1
70	11.0	13.2	14.6	15.5	21.9
75	12.5	15.0	16.5	17.5	24.7
80	14.0	16.8	18.5	19.7	27.8
85	15.6	18.7	20.6	21.9	30.9
90	17.3	20.7	22.8	24.2	34.2
95	18.9	22.8	25.0	26.6	37.6
100	20.7	24.9	27.3	29.0	41.0

Additional percent slope and distances are available in the next table.

SLOPE CORRECTION TABLE									
% SLOPE	Chaining Distances								
	120.0	100.0	98.4	60.0	52.7	49.0	37.2	34.6	24.0
1 - 3	0.0	0.0	0.0	0.0	0.0	0.0	0.0	0.0	0.0
4	0.1	0.1	0.1	0.0	0.0	0.0	0.0	0.0	0.0
6	0.2	0.2	0.2	0.1	0.1	0.1	0.1	0.1	0.0
8	0.4	0.3	0.3	0.2	0.2	0.2	0.1	0.1	0.1
10	0.6	0.5	0.5	0.3	0.3	0.2	0.2	0.2	0.1
12	0.9	0.7	0.7	0.4	0.4	0.4	0.3	0.2	0.2
14	1.2	1.0	1.0	0.6	0.5	0.5	0.4	0.3	0.2
16	1.5	1.3	1.2	0.8	0.7	0.6	0.5	0.4	0.3
18	1.9	1.6	1.6	1.0	0.8	0.8	0.6	0.6	0.4
20	2.4	2.0	1.9	1.2	1.0	1.0	0.7	0.7	0.5
22	2.9	2.4	2.4	1.4	1.3	1.2	0.9	0.8	0.6
24	3.4	2.8	2.8	1.7	1.5	1.4	1.1	1.0	0.7
26	4.0	3.3	3.3	2.0	1.7	1.6	1.2	1.1	0.8
28	4.6	3.8	3.8	2.3	2.0	1.9	1.4	1.3	0.9
30	5.3	4.4	4.3	2.6	2.3	2.2	1.6	1.5	1.1
32	6.0	5.0	4.9	3.0	2.6	2.5	1.9	1.7	1.2
34	6.7	5.6	5.5	3.4	3.0	2.8	2.1	1.9	1.3
36	7.5	6.3	6.2	3.8	3.3	3.1	2.3	2.2	1.5
38	8.4	7.0	6.9	4.2	3.7	3.4	2.6	2.4	1.7
40	9.2	7.7	7.6	4.6	4.1	3.8	2.9	2.7	1.8
42	10.2	8.5	8.3	5.1	4.5	4.1	3.1	2.9	2.0
44	11.1	9.3	9.1	5.6	4.9	4.5	3.4	3.2	2.2
46	12.1	10.1	9.9	6.0	5.3	4.9	3.7	3.5	2.4
48	13.1	10.9	10.7	6.6	5.8	5.4	4.1	3.8	2.6
50	14.2	11.8	11.6	7.1	6.2	5.8	4.4	4.1	2.8
52	15.3	12.7	12.5	7.6	6.7	6.2	4.7	4.4	3.1
54	16.4	13.7	13.4	8.2	7.2	6.7	5.1	4.7	3.3
56	17.5	14.6	14.4	8.8	7.7	7.2	5.4	5.1	3.5
58	18.7	15.6	15.4	9.4	8.2	7.6	5.8	5.4	3.7
60	19.9	16.6	16.4	10.0	8.8	8.1	6.2	5.8	4.0
62	21.2	17.7	17.4	10.6	9.3	8.7	6.6	6.1	4.2
64	22.5	18.7	18.4	11.2	9.9	9.2	7.0	6.5	4.5
66	23.8	19.8	19.5	11.9	10.4	9.7	7.4	6.9	4.8
68	25.1	20.9	20.6	12.6	11.0	10.3	7.8	7.2	5.0
70	26.5	22.1	21.7	13.2	11.6	10.8	8.2	7.6	5.3
72	27.9	23.2	22.8	13.9	12.2	11.4	8.6	8.0	5.6
74	29.3	24.4	24.0	14.6	12.9	12.0	9.1	8.4	5.9
76	30.7	25.6	25.2	15.4	13.5	12.5	9.5	8.9	6.1
78	32.2	26.8	26.4	16.1	14.1	13.1	10.0	9.3	6.4
80	33.7	28.1	27.6	16.8	14.8	13.7	10.4	9.7	6.7
82	35.2	29.3	28.9	17.6	15.5	14.4	10.9	10.1	7.0
84	36.7	30.6	30.1	18.4	16.1	15.0	11.4	10.6	7.3
86	38.3	31.9	31.4	19.1	16.8	15.6	11.7	11.0	7.7
88	39.8	33.2	32.7	19.9	17.5	16.3	12.4	11.5	8.0
90	41.4	34.5	34.0	20.7	18.2	16.9	12.8	12.0	8.3
92	43.1	35.9	35.3	21.5	18.9	17.6	13.3	12.4	8.6
94	44.7	37.2	36.6	22.3	19.6	18.2	13.9	12.9	8.9
96	46.3	38.6	38.0	23.2	20.4	18.9	14.4	13.4	9.3
98	48.0	40.0	39.4	24.0	21.1	19.6	14.9	13.8	9.6
100	49.7	41.4	40.8	24.9	21.8	20.3	15.4	14.3	9.9

Appendix F. Tree Class Illustrations

The following illustrations are examples of how to determine TREE CLASS using the "PERCENT BOARD-FOOT CULL" tables for hardwoods and softwoods located in Regional Appendix E.

For the determination of excessive crook and sweep, use the CROOK DEDUCTION IN BOARD FEET or SWEEP DEDUCTION IN BOARD FEET tables located in Regional Appendix E. Note: GROSENBAUGH'S RULE 3 & 4 FOR SWEEP AND CROOK DEDUCTION can also be applied.

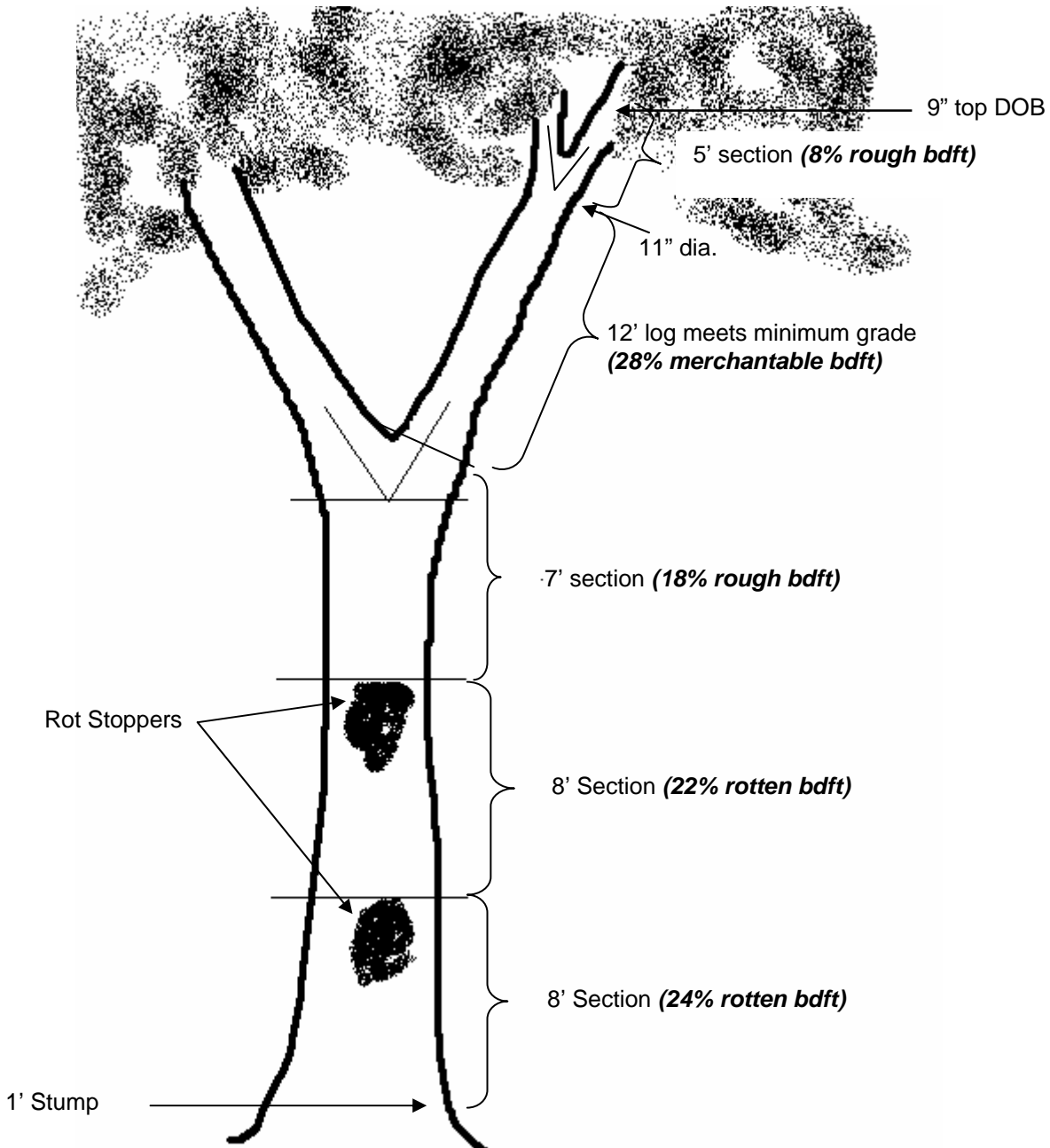

HARDWOOD – Tree Class = 4

Total sawlog length = 40 ft

Board foot volume lost due to rot in the bottom section of the tree = 46% bdf

Rough Cull = 26 % bdf

Merchantable Section = 28% bdf

Since there is only 28% merchantable volume, and the majority of the volume is lost due to rot, TREE CLASS = 4

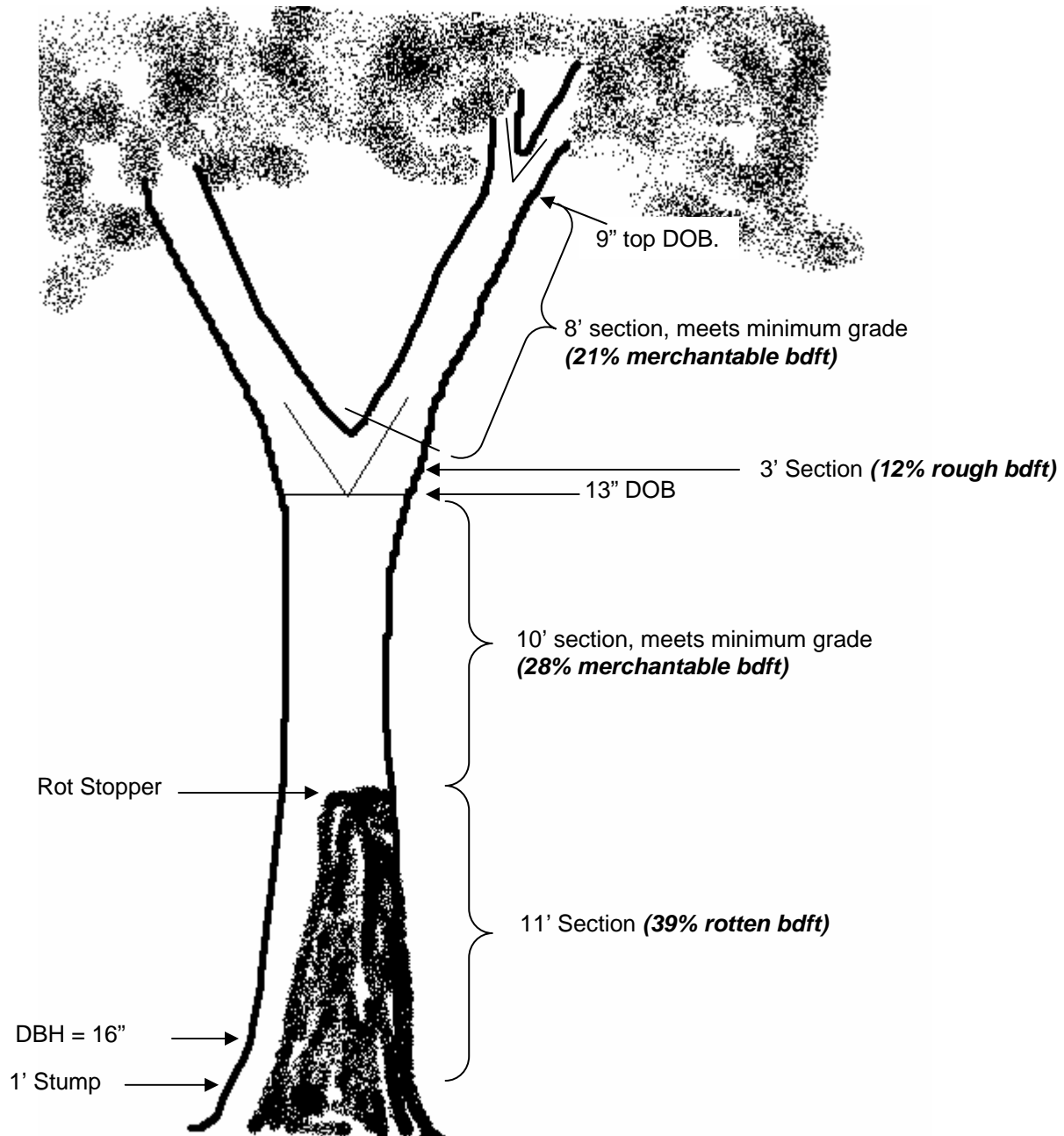

HARDWOOD -- Tree Class = 2

Total sawlog length = 32 ft

Rotten cull = 39% bdf

Rough cull = 12% bdf

Total cull = 51% bdf

Merchantable volume = 49% bdf (28% bdf for the bottom section + 21% bdf for the top section).

Since 49% of the total volume is merchantable (i.e., greater than 1/3 of total volume.), and there are two merchantable 8' logs, TREE CLASS = 2

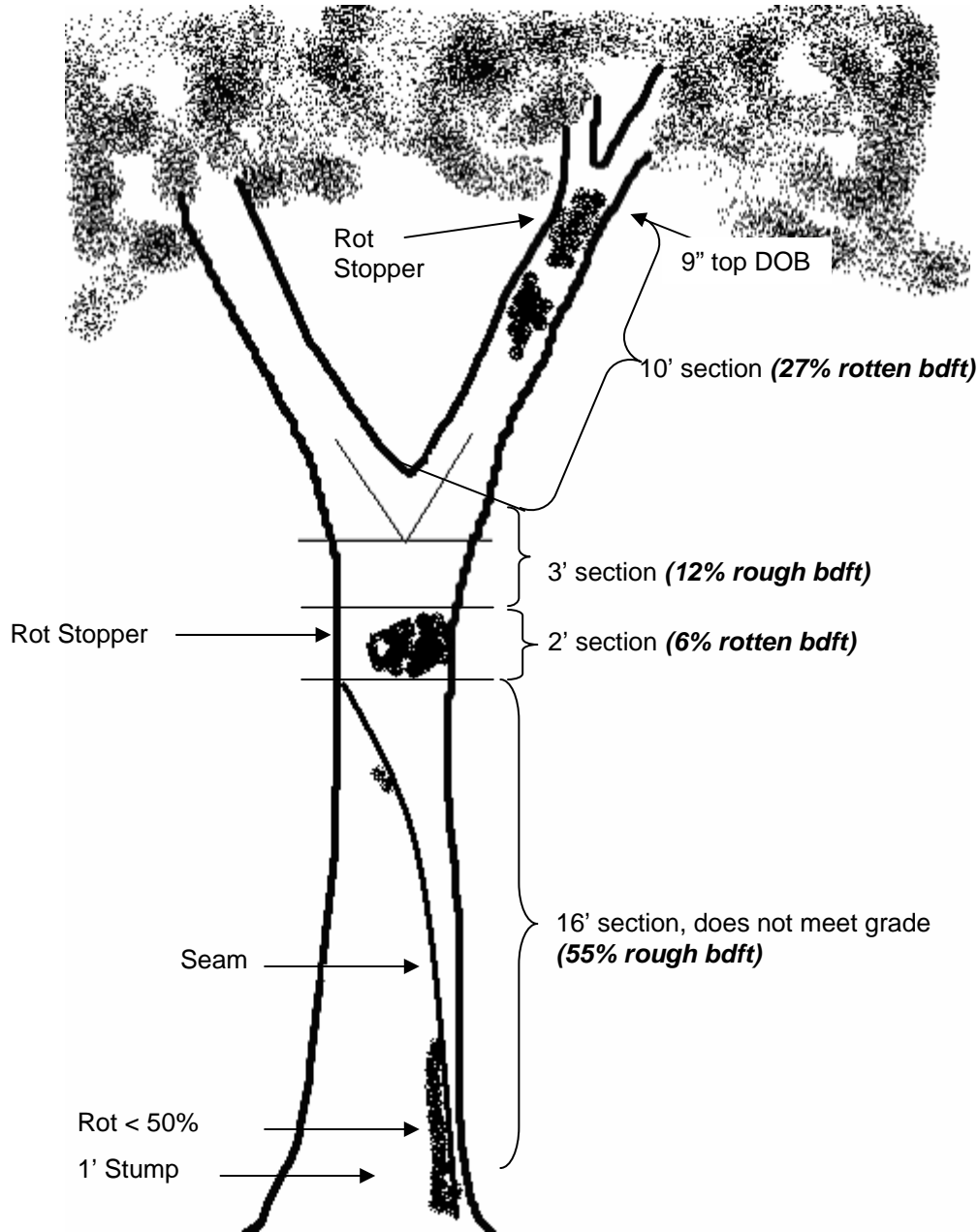

HARDWOOD – Tree Class = 3

Total sawlog length = 31 ft

Rotten cull = 33% bdf

Rough Cull = 67% bdf

Merchantable volume = 0%

Since the proportion of sound cull is greater than 50% of the total volume, TREE CLASS = 3

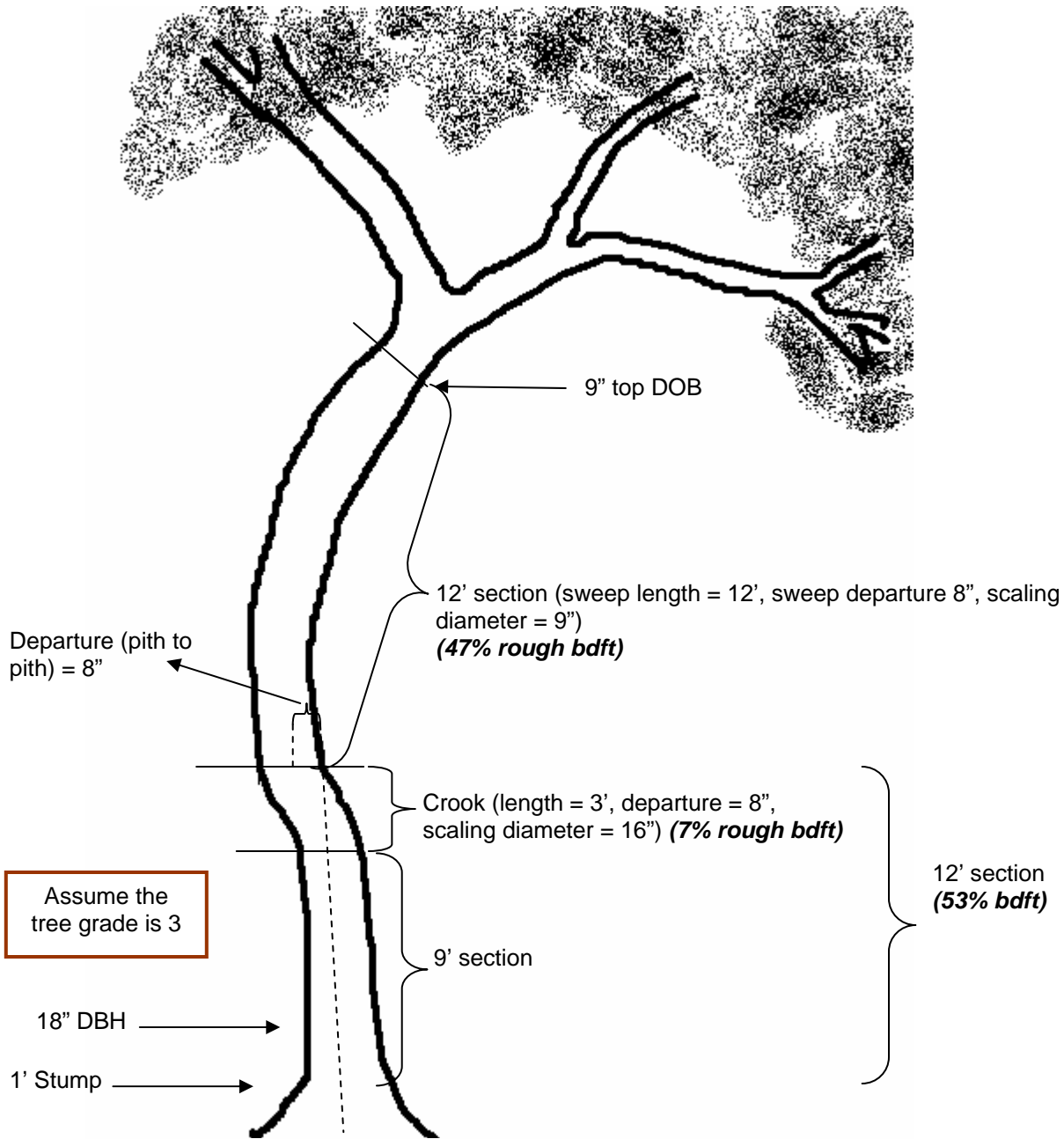

HARDWOOD – Tree Class = 2
 Total sawlog length = 24 ft
 Is the crook a stopper? When determining if a crook is a stopper use the “Crook Deduction in Board Feet” table or the formulas in Regional Appendix E. Using the table, a 16 bdft value is the deduction. Since this value is not in the “blank” or “boxed” area of the table, the crook is not excessive and therefore not a stopper. The 12' log meets grade.
 Is the sweep a stopper? When determining if sweep is a stopper use the “Sweep Deduction in Board Feet” table in Regional Appendix E. Using the table, the deduction value is indicated in a “blank” area of the table, the sweep is excessive and the entire section is rough cull.
 Merchantable volume = 46% (53% - 7% rough cull deduction due to the crook within the 12' section)
 Rough cull = 54% (7% due to the crook + 47% bdft loss due to excessive sweep)
 Since there is one merchantable 12' log and less than 2/3 of the total volume is lost to cull, TREE CLASS = 2

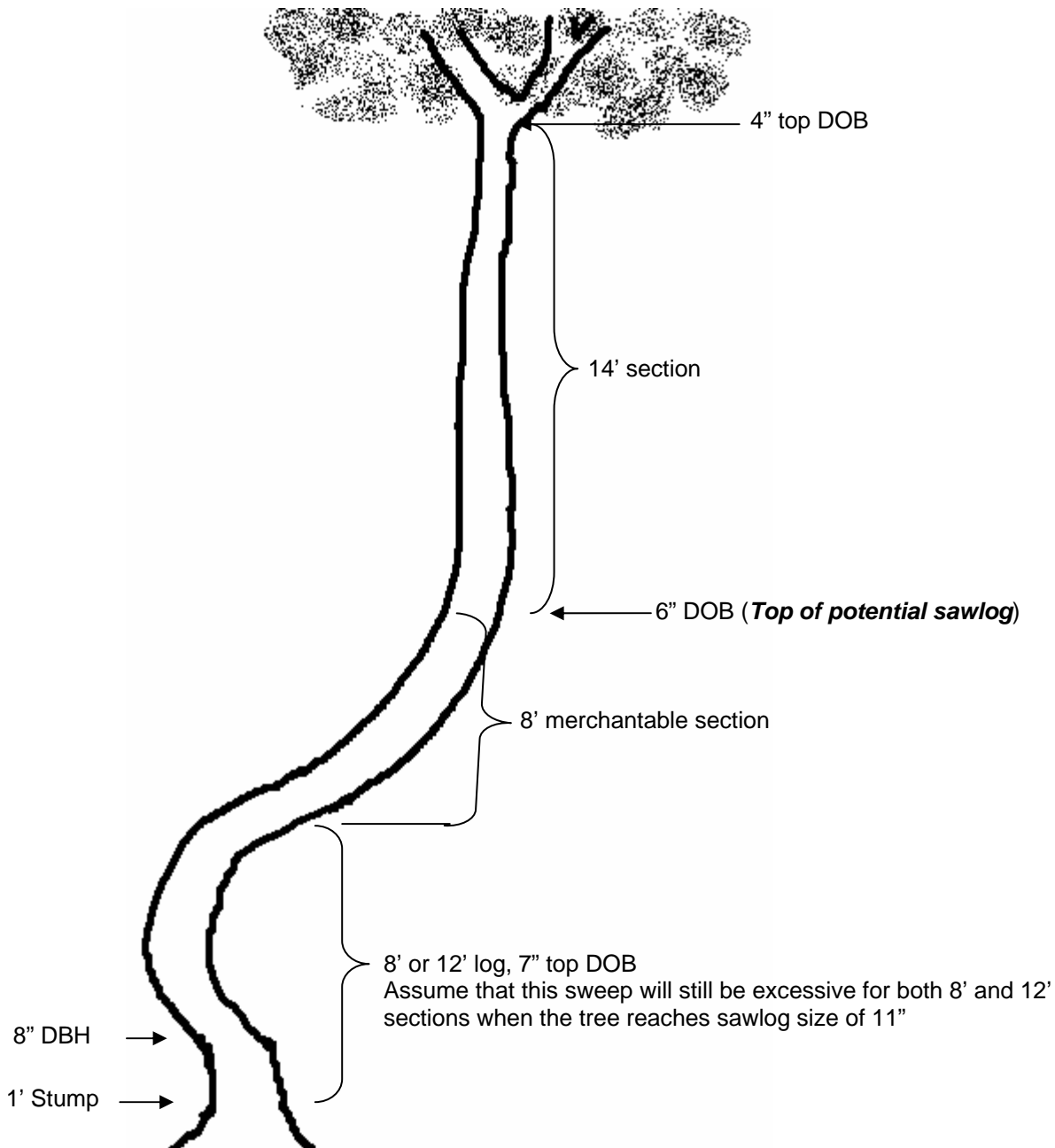

HARDWOOD - Tree Class = 3 (projecting pole/timber-size tree)

Potential sawlog length = 20 ft

Using the 2" rule, the top of the potential saw log is 6". The upper 14' log is therefore ignored for predicting TREE CLASS on pole timber.

Since there is only 1 merchantable 8' potential sawlog, TREE CLASS = 3.

NOTE: If this tree were sawlog size (11" DBH or greater, 9" or greater for softwood), TREE CLASS would still = 3.

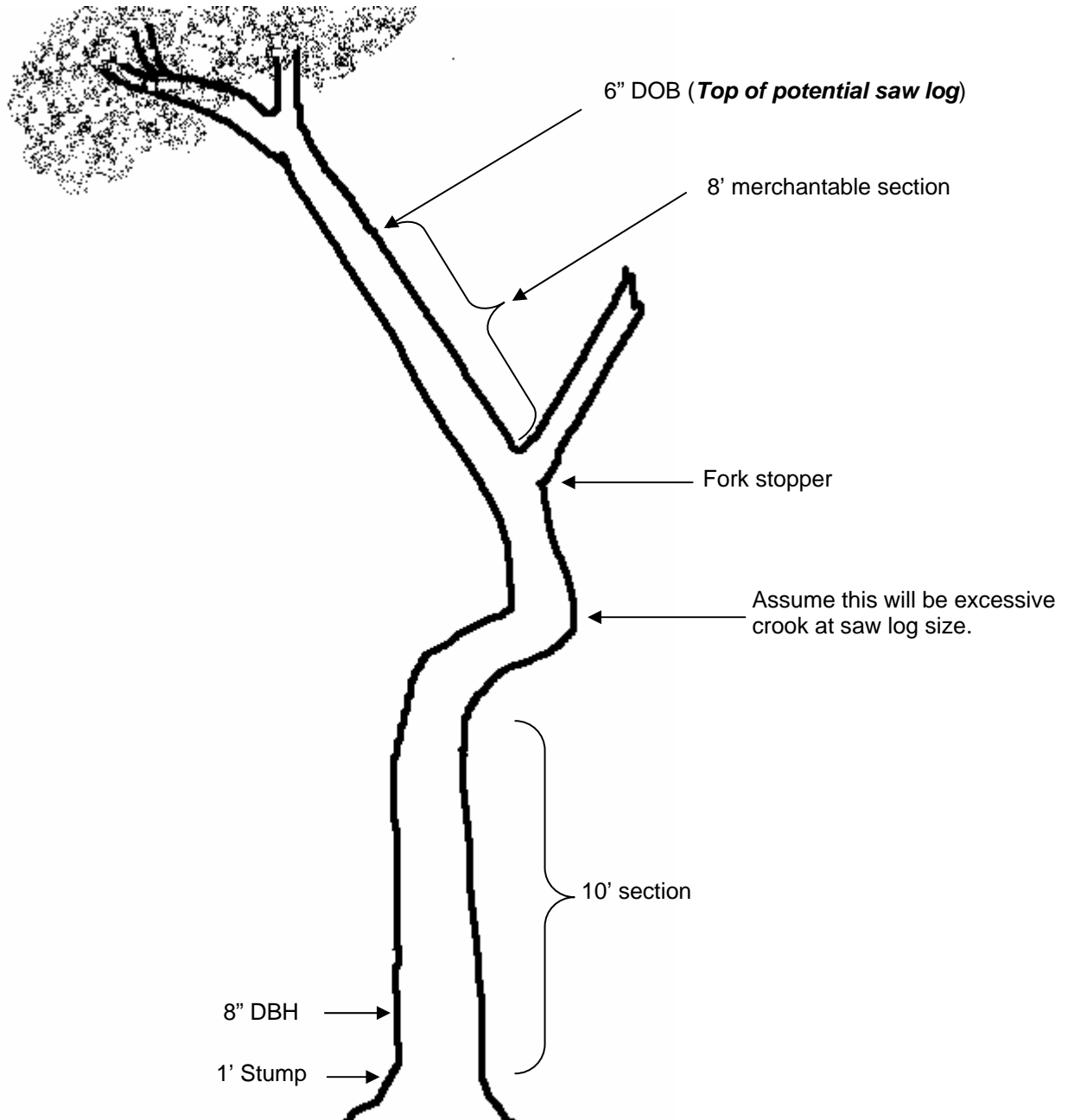

HARDWOOD – Tree Class = 2 (projecting poletimber-size tree)

Using the 2" rule, the top of the potential saw log is 6". There are two 8' or longer merchantable sections between the stump and the potential sawlog top. Assume that less than 2/3 of the total merchantable volume will be lost to sound cull or rot stoppers when the tree reaches saw log size, therefore TREE CLASS = 2.

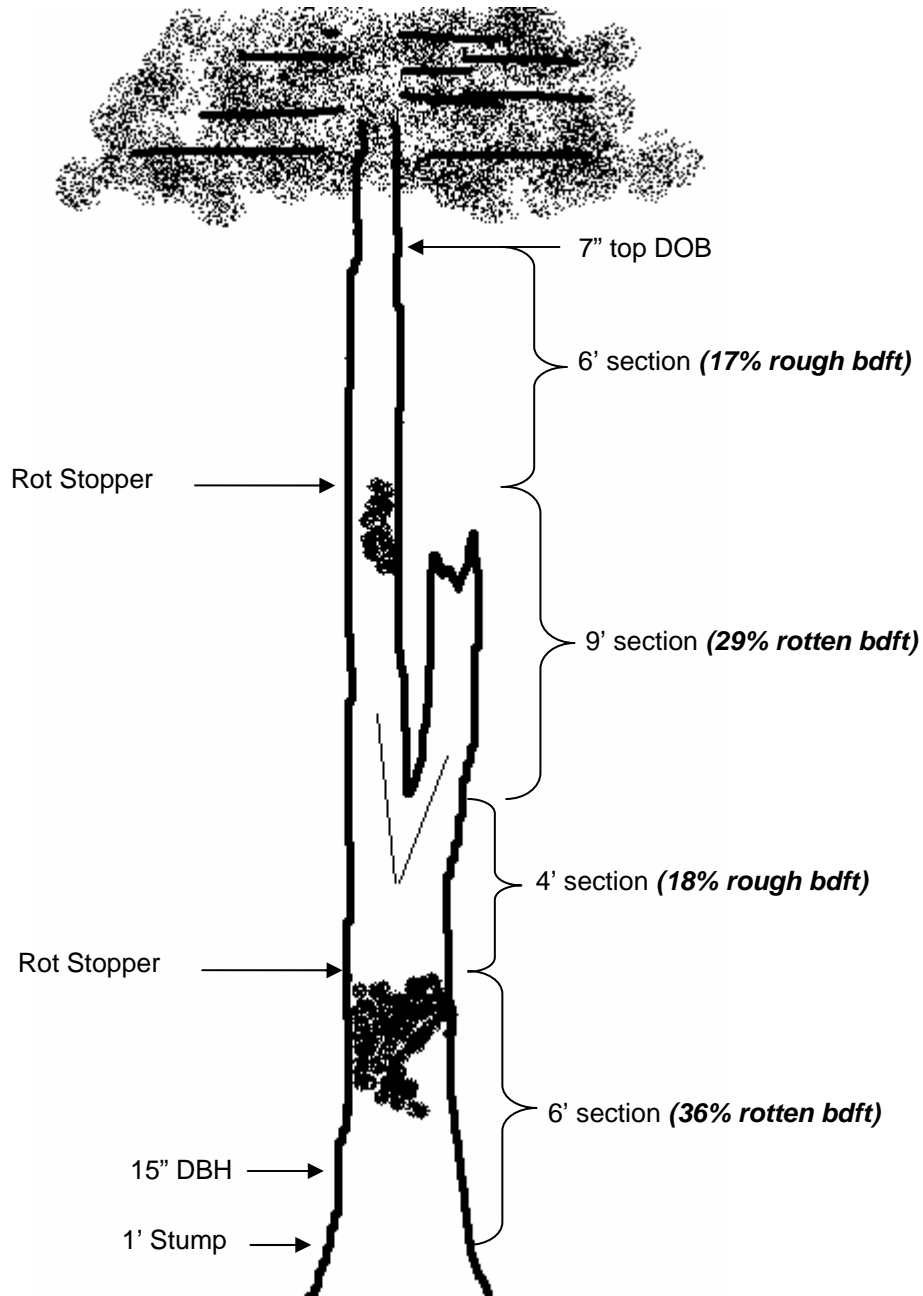

SOFTWOOD – Tree Class = 4

Total sawlog length = 25 ft

Rotten cull = 65% bdf

Rough cull = 35% bdf

Merchantable volume = 0%

Since the proportion of unsound cull is greater than 50% of the total board-foot cull, TREE CLASS = 4

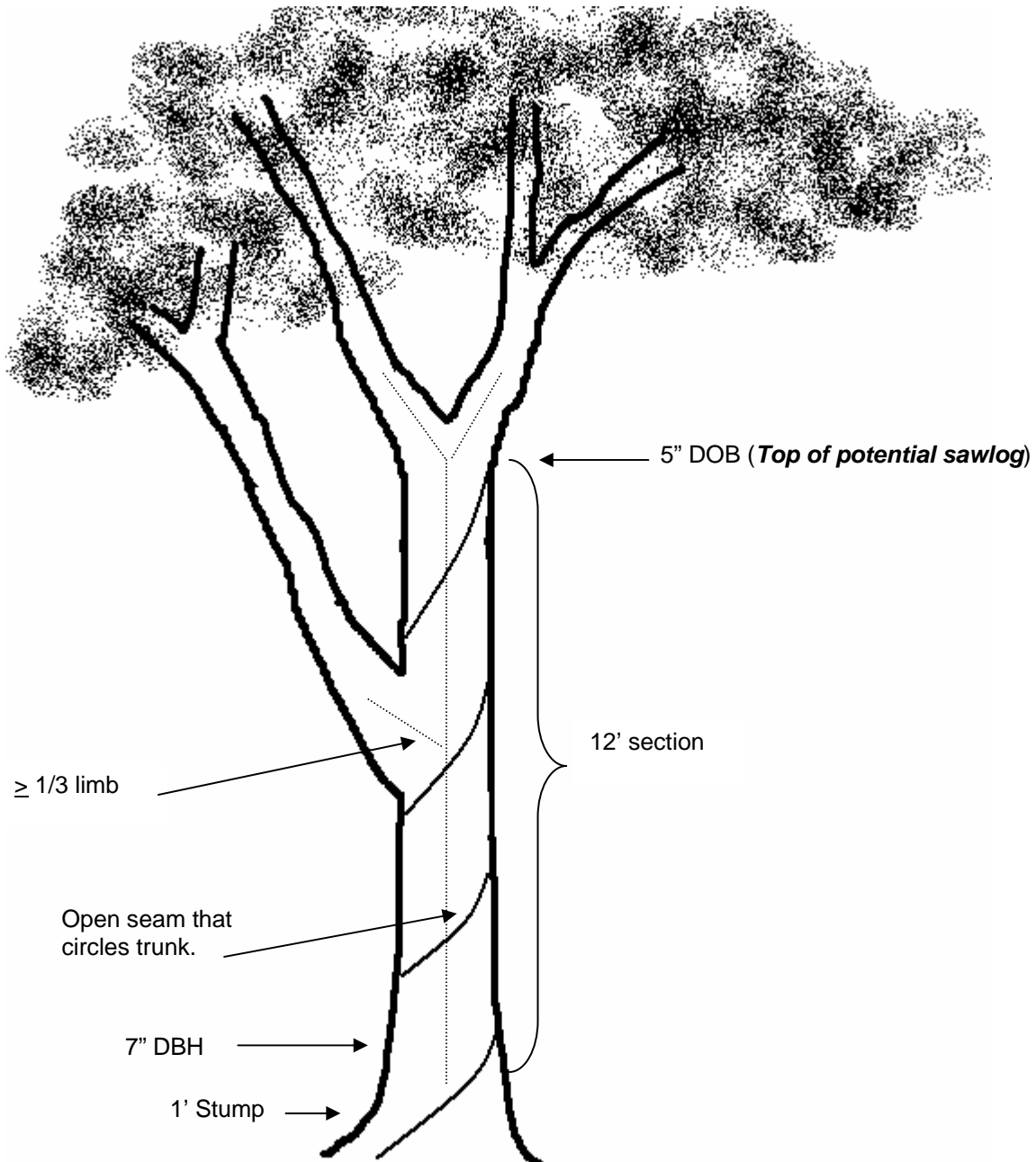

HARDWOOD – Tree Class = 4 (projecting poletimber-size tree)

Total potential sawlog = 12 ft

This tree is less than 11" and therefore does not require a tree grade. However, it must be evaluated to determine if it will meet minimum required tree grade when it reaches saw log size (11").

Assume that both the seam and the $\geq 1/3$ limb diameter limb will be on the tree when it reaches 11". The tree has a potential 12' grading section. Both the limb (sound cull) and the seam (unsound cull) prevent the tree from meeting a potential grade 4. The tree will not qualify as a grade 3 either because the potential board-foot cull will exceed 50% (the rotten cull due to the seam as well as the rough cull associated with the limb). Since that is the only potential sawlog in the projected sawlog length, TREE CLASS = 4. The rotten cull is the majority of the total potential board-foot cull.

NOTE: If $\frac{1}{2}$ the potential board-foot cull of the tree is lost due to rough cull, then TREE CLASS = 3.

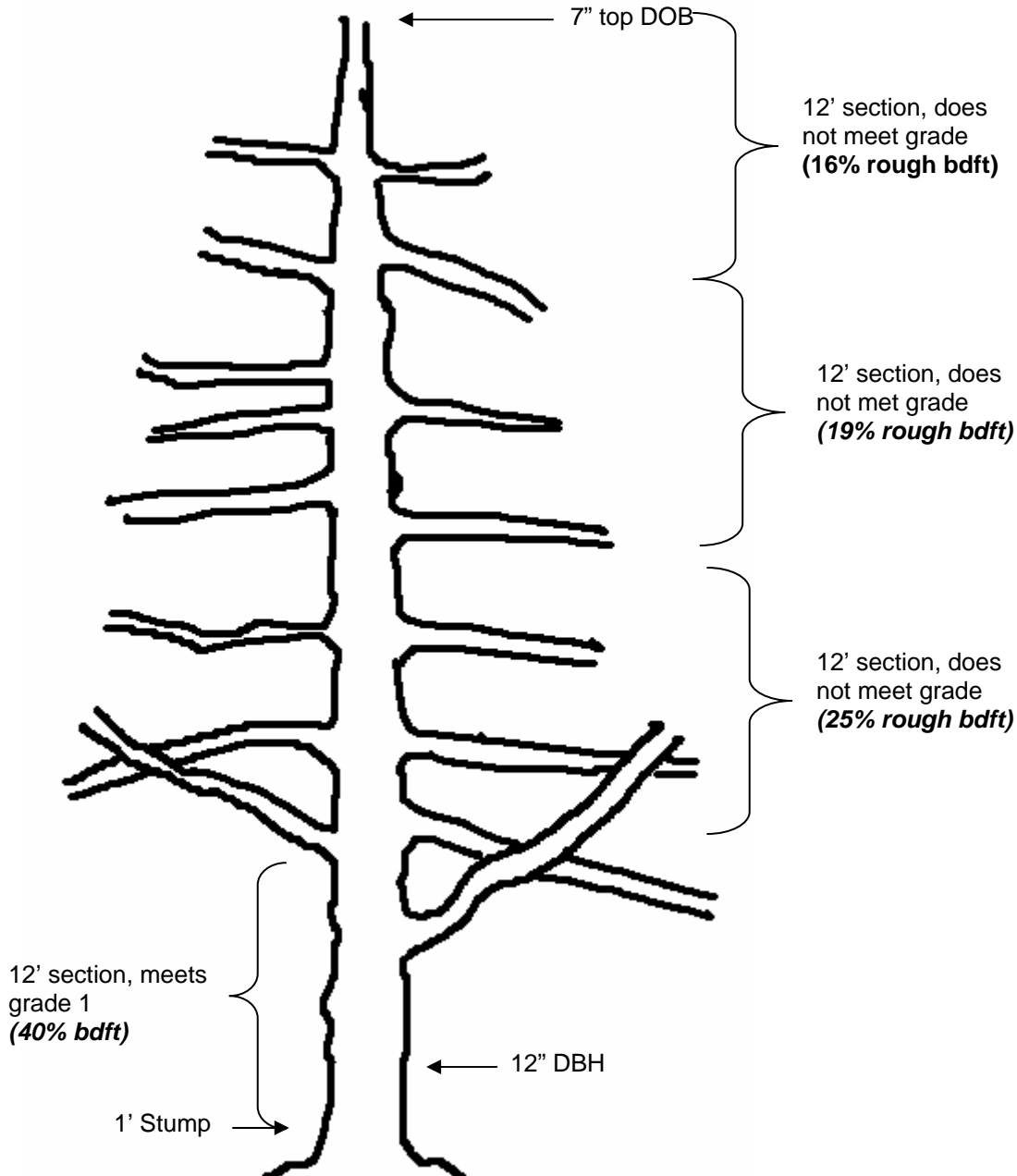

OTHER SOFTWOOD (not White, Red or Jack Pine) - Tree Class = 2

Total sawlog length = 48 ft
 Merchantable volume = 40% bdf
 Rough cull = 60% bdf

Using the other softwoods tree grade table, a sawlog with a minimum DIB between 6" and 12" cannot have 2" or greater knots. These are considered defects in other softwoods. Therefore, everything above the 12' section is rough cull due to the knot size. Note: One branch or knot exceeding the maximum diameter allowed is permitted for grade 1 within any of the sawlogs.

Since the tree has at least one 12' merchantable sawlog and the total board-full cull does not exceed 67%, TREE CLASS = 2

Appendix G. GPS User's Guide

LandMark CE NRS-FIA Users Guide

LandMark CE is ready for use after it has been installed from the CD on the Allegro using ActiveSync and the Bluetooth GPS receiver bonded to that Allegro.

To begin using LandMark CE on the Allegro, click the LandMark desktop icon once and press Enter. The screen below will appear.

NOTE: Depending on the Bluetooth driver, you may need to press the blue key, then F10 to open Bluetooth communication.

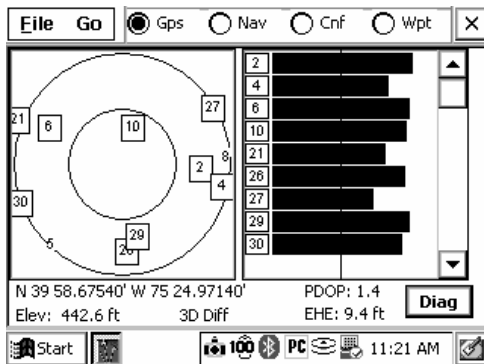

Screen Selection

LandMark CE has four operational screens that are accessed on the top bar. These are the current GPS location screen (Gps), the Navigation Screen (Nav), the Configuration Screen (Cnf), and the Waypoint Screen (Wpt).

Gps Screen

The Gps screen (shown above) displays the current GPS position and other relevant information. In the upper left is a *Skyplot*, which is a graphical representation of the satellite positions directly overhead. The outer circle represents the horizon and the inner circle is 60° above the horizon. The satellites are displayed by their unique satellite number. Satellites used to compute the current GPS position are shown in a square. When an EMTAC GPS receiver is used, WAAS satellites are tracked but not displayed in the *Skyplot*. To the right of the *Skyplot* is the *satellite signal strength* graph. The vertical bar represents 50% of maximum power. Below the *Skyplot* are the current coordinates, elevation, GPS Quality (2D, 3D, 2D Diff, 3D Diff, No Fix, No Comm. Act.), the PDOP, and the EHE. The *Diag* box shows individual satellite details and NMEA string data.

Nav Screen

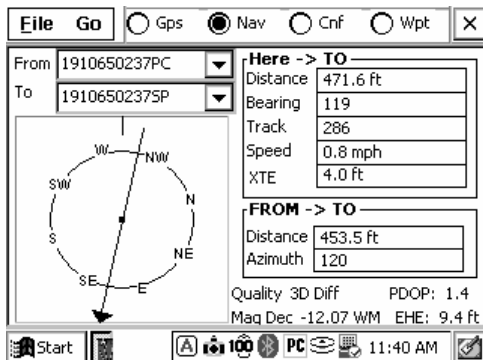

The Nav screen allows users to calculate distances and azimuth between points and navigate to a location. The upper left portion of the screen contains *two drop down lists* of saved waypoints or the current "Here" position.

The *From* and *To* lists are used to select waypoints from which the calculations will be performed. Below the waypoint drop down lists is the *compass*.

The *compass* rotates to show the direction of travel once you start moving. The arrow always points toward the *To* location.

The *compass* body rotates to show the current direction of travel. The *Here* → *To* section shows calculated values based on the current GPS location and the destination (*To*) location.

The *From* → *To* section displays the calculations based on the *From* location to the *To* location. Use this section when calculating course-to-plot distance and azimuth between a saved SP waypoint and a saved PC waypoint.

Displayed at the bottom of the *Nav* screen are the GPS Quality, heading setting, PDOP and EHE values.

Cnf Screens

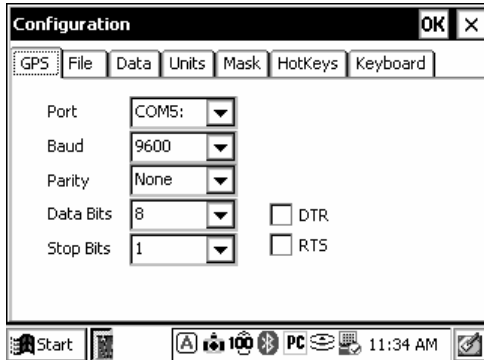

The Cnf screen allows customization of critical LandMark CE settings.

The first screen to appear is the *GPS* screen. The only option that needs changed here is the Com Port. It must match the Bluetooth Com Port setting when the GPS receiver was bonded to the Allegro. It may vary from unit to unit. **When the Com Port is changed, LandMark CE must be shut down and restarted.**

The other defaults that never need changed are: Baud=9600, Parity=None, Data Bits=8, Stop Bits=1. DTR and RTS do not need selected when using an EMTAC GPS receiver.

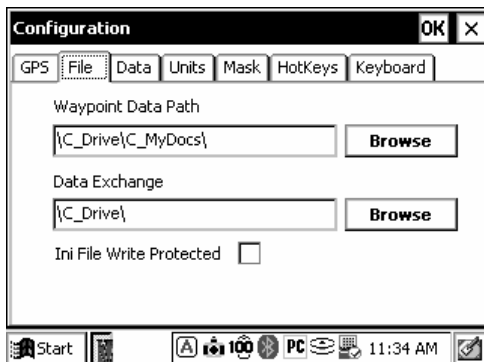

The *File* tab displays where waypoints and data are stored on the Allegro.

When the *Ini File Write Protected* box is checked, the critical GPS settings have been locked and cannot be changed by the user. This is a security measure to insure the GPS data is collected with the highest accuracy and confidence.

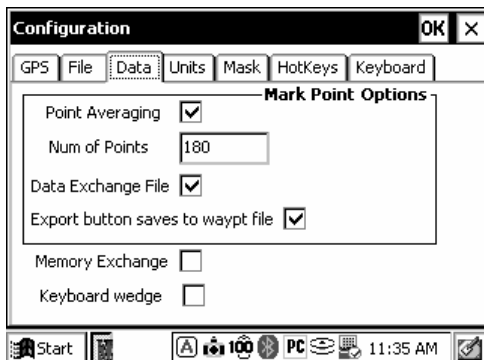

The *Data* tab defines how the waypoints are collected and how they are stored.

FIA will record data that is the average of 180 individual fixes.

The *Data Exchange File*, *Export*, *Memory Exchange* and *Keyboard wedge* functions will be implemented at a future date.

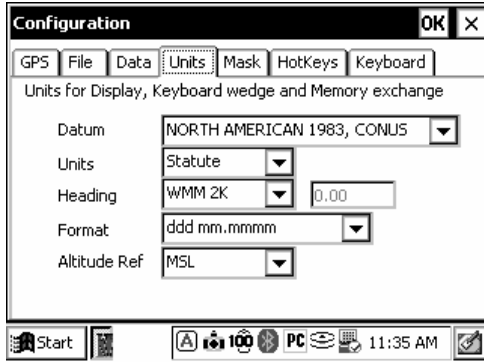

The *Units* tab is used to format the GPS data.

The critical settings that FIA uses for Datum, Units, Heading, Format, and Altitude Ref. are displayed on the graphic to the left.

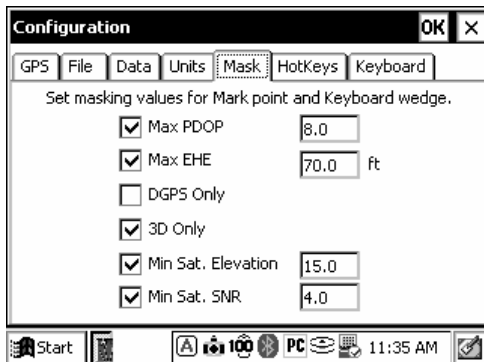

The *Masks* tab is used to set GPS signal masking parameters when marking waypoints. Only the GPS signals that meet the specified criteria will be used in the waypoint averaging solution.

The critical settings that FIA uses for *Max PDOP*, *Max EHE*, *DGPS*, *3D Only*, *Min. Sat. Elevation*, and *Min. Sat. SNR* are displayed on the graphic to the left.

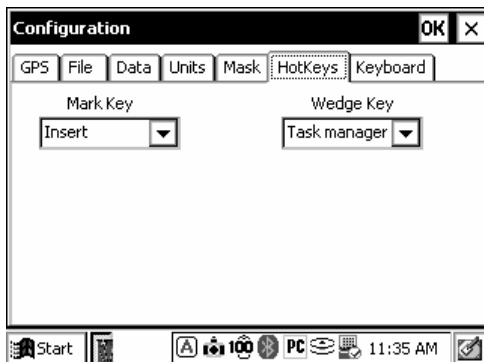

The *HotKeys* tab is used to assign an automatic function to a specific button on the Allegro.

Currently, FIA only uses the Insert key on the Allegro to jump to the Mark Waypoint screen. **The Insert Key (Ins) Allegro on the can be pressed at anytime LandMark CE is running and it will jump to the collect waypoint screen.**

The *Keyboard* tab is not used.

Wpt Screens

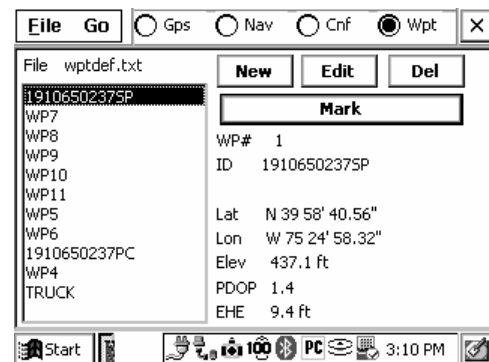

The *Wpt* screen is used to display, edit, manage and collect GPS waypoints.

On the left side of the screen are the saved waypoints. A default filename can be used (as shown) or a unique name such as plot number, SP, PC, etc. To select a waypoint, click on it.

The *New* button opens a screen where coordinates can be entered.

The *Edit* button opens a saved waypoint. Here you can change a waypoint name or apply a coordinate *Offset*.

The *Del* button is used to delete a previously select waypoint from the list. Waypoints can only be deleted one at a time.

The *Mark* button is used to open the *Mark Waypoint* screen to start the averaging waypoint function.

Below the *Mark* button are the GPS details of the selected waypoint.

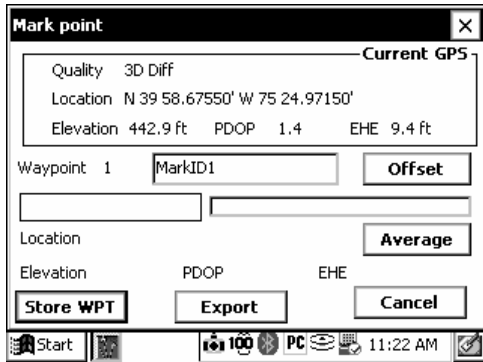

To average waypoints, press the Insert key (Ins) on the Allegro keypad or click the Mark button in the *Wpt* screen.

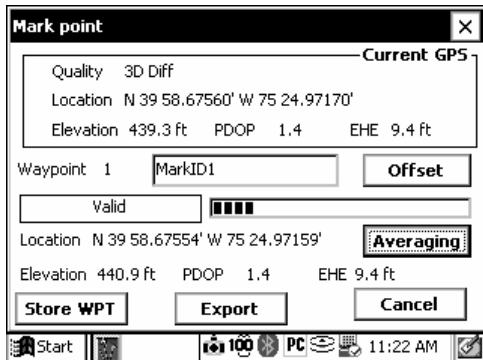

The top box displays the current, single fix GPS data.

Below the Current GPS is the default waypoint name (editable) and a button to apply an Offset (distance, direction, slope) to the averaged coordinates.

Next is a box that displays whether or not the current GPS fix will be valid, based on the GPS masks set up in the *Cnf* screen.

A *Progress Bar* appears when averaging to show the solution progress based on the number of fixes indicated in the *Cnf/Data* screen. Below the status bar is the running average section displaying the coordinates, elevation, PDOP and EHE.

To begin averaging, click the *Average* button. It will change and display the word "Averaging". The status bar will progress as valid fixes are used in the solution. When complete, the word "Averaging" will change back to "Average". During averaging, hold the GPS receiver stationary over the point until the process is complete.

The information to be recorded on the tally sheet is located in the running average section of the screen or you can click *Store WPT* and view the data in the *Wpt* screen.

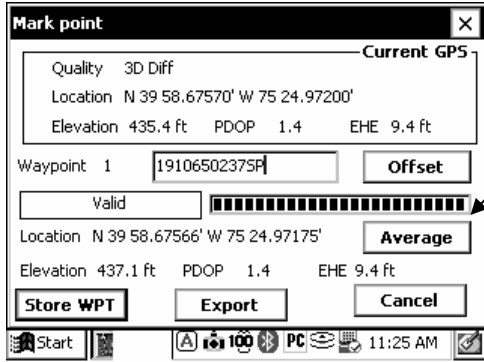

This screen shows that the Averaging process is complete.

The *Progress Bar* is completely fill in and the Average box has changed from "Averaging" back to "Average".

Computing An Offset

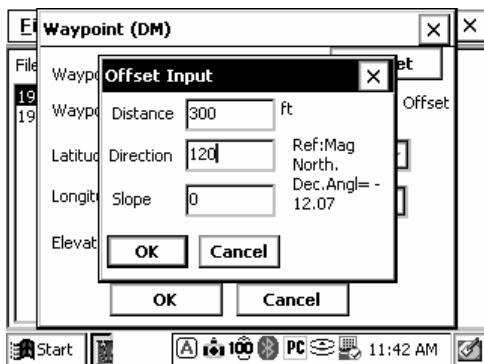

To compute the coordinates of an offset location (i.e. PC cannot be occupied), save your current location as a "180 fix" averaged waypoint. In the Wpt Screen, highlight the previously saved waypoint. Press Edit and then the Offset button. When the Offset Input screen appears, enter the distance, compass direction and slope to the unknown point. Press OK and the Waypoint screen will appear with the calculated offset position shown in a lighter font.

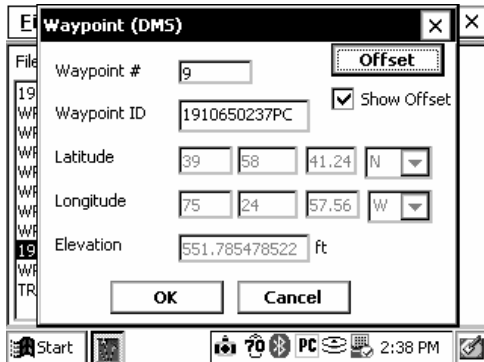

You can toggle between the original and offset coordinates by tapping the Show Offset box. To completely remove the offset calculation, press the Offset button and type "0" for distance, direction and slope.

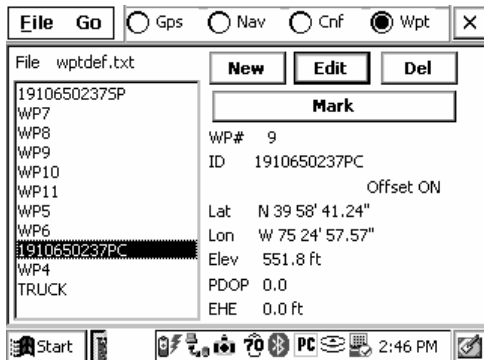

If the offset is not removed, the offset calculation will continued to be displayed on the Wpt screen.

LandMark CE / EMTAC GPS FAQs

- Q. *My Allegro will not connect with the Laptop when using the cradle and USB to load LandMark CE?*
- A. The COM Port on the Allegro may be set to COM 1 for data transfer. LandMark CE can only be loaded through ActiveSync using the USB Port and cradle. See the first page of the instructions in *the LandMark CE Installation Guide*.
- Q. *I just installed LandMark CE on the Allegro, but the EMTAC isn't communicating with the Allegro?*
- A. The EMTAC GPS receiver must be turned on before LandMark CE is started. After LandMark CE is installed on the Allegro, the COM Port in LandMark CE must be changed to match the Com Port setting indicated during the Bluetooth GPS bonding process. Make sure both the EMTAC blue and green lights are flashing.
- Q. *My EMTAC was communicating fine with LandMark CE and then it just stopped and displayed "No Comm. Act."?*
- A. There has been some type of interruption in the Bluetooth signal between the EMTAC and Allegro. On the Allegro, press the blue button and the F10 key to reconnect. Make sure both EMTAC blue and green lights are flashing.
- Q. *The blue or green lights on my EMTAC quit working?*
- A. Switch the EMTAC unit on and off until both lights are on.
- Q. *LandMark CE doesn't always display that I am getting a "3D Diff" fix?*
- A. The EMTAC GPS receiver is capable of picking up two geostationary FAA satellites (WAAS) that broadcast real-time, differential GPS corrections. The two WAAS satellites are positioned near the equator over the Atlantic and Pacific Oceans. Based on your Latitude and view of the sky, the EMTAC may be able to "see" these satellites. GPS fixes that are differentially corrected are more accurate than a "3D Only" fix. The WAAS satellites are not displayed on the Skyplot when using the EMTAC.
- Q. *I can't change the critical settings in the Cnf screens?*
- A. The critical settings are locked to prevent the field user from changing them.
- Q. *I pressed the Insert key (Ins) on the Allegro, but LandMark CE won't start Averaging?*
- A. The Ins key switches to the *Mark Screen*, but you must click the box that shows "Average" to begin Averaging.
- Q. *How do I calculate the coordinates of PC when using an offset from another location?*
- A. After averaging 180 fixes at the offset location on the *Mark Screen*, click Store WPT. Go to the *Wpt Screen* and select the waypoint from the list that will get the Offset. Click the Edit button. Click the Offset button and enter the distance, direction and slope (+ or -) to PC. Click OK. The *Show Offset* box is checked and the Offset information is displayed in grayed-out font. When done recording the Offset, click the *Offset* button and set the distance, direction and slope back to "0". Click OK. If you do not reset the Offset back to "0", the Offset will still be applied for that waypoint in the *Wpt screen*. The words "Offset ON" will be displayed when viewing the waypoint details.
- Q. *How do I minimize LandMark CE when it is open?*
- A. Tap the LandMark CE icon on the bottom taskbar. You may need to make the taskbar visible first.

Appendix H. Tally Item Guides, Sheets and Prompts

TALLY ITEM GUIDES

	<i>Data Element</i>	<i>PDR Prompt</i>	<i>Data Required</i>		
Plot Data	Cycle	CYCL	X	X	X
	Sub-cycle	SUBC	X	X	X
	State	ST	X	X	X
	Unit	UNIT	X	X	X
	Plot Number	PLT#	X	X	X
	Plot Status	STAT	1	2	3
	Plot Nonsampled Reason	REAS			X
	Subplot Examined	EXAM		X	X
	Sample Kind	SK	X	X	X
	Current Year	YEAR	X	X	X
	Current Month	MONT	X	X	X
	Current Day	DAY	X	X	X
	Water on Plot	WTYP	X		
	QA Status	QAST	X	X	X
	Crew Type	CRTY	X	X	X
	Cruiser	CRUI	X	X	X
	Tallier	TALL	X	X	X
	One or Two Person Crew	CRSZ	X		
	Plot Season	SEAS	X		

X Data required

	<i>Date Element</i>	<i>PDR Prompt</i>	<i>Data Required</i>	
GPS Data	Unit Type	UNIT	0	2
	GPS Serial Number	GPS#		X
	Latitude	LAT		X
	Longitude	LONG		X
	Azimuth to Plot Center	AZM		X
	Horizontal Distance to Plot Center	DIST		X
	GPS Elevation	ELEV		X
	GPS Error	ERRS		X
	GPS PDOP	PDOP		X
	Number of Readings	READ		X

X Data required

	<i>Data Element</i>	<i>PDR Prompt</i>	<i>DR</i>
Site Tree Data	Condition Class List	CONL	X
	Species	SPP	X
	Diameter	DBH	X
	Site Tree Length	HGHT	X
	Tree Age at Diameter	AGE	X
	Subplot Number	SUB#	X
	Azimuth	AZM	X
	Horizontal Distance	DIST	X

X Data required for all newly defined conditions that do not have previous SI data.

	Data Element	PDR Prompt	Data Required				
Condition Data	Condition Class Number	CON#	X	X	X	X	X
	Condition Class Status	STAT	1	2	3	4	5
	Condition Nonsampled Reason	REAS					X
	Reserved Status	RESV	X				
	Owner Group	OWNG	X				
	Forest Type	FTYP	X				
	Stand Size	STSZ	X				
	Artificial Regeneration Status	SORI	X				
	Tree Density	DENS	X				
	Owner Class	OWNC	X				
	Industrial Owner Status	INDU	X				
	Artificial Regeneration Species	SOSP	Y				
	Stand Age	SAGE	X				
	Disturbance 1, 2 and 3	DIS123	X				
	Disturbance Year 1, 2 and 3	DYR123	X				
	Treatment 1, 2 and 3	TRE123	X				
	Treatment Year 1, 2 and 3	TYR123	X				
	Stand History	HIST	X				
	Physiographic Class	PHYS	X				
	Productivity	PROD	X				
	Present Nonforest Land Use	NFLU			X		
	Nonforest Trees	NFTR			X		
Stand Structure	MEST		ME				

X Data required
 ME ME only

	Data Element	PDR Prompt	Data Required		
			1	2	3
Subplot Data	Subplot Status	STAT	1	2	3
	Subplot Nonsampled Reason	REAS			X
	Subplot Center Condition	SCEN	X	X	
	Microplot Center Condition	MCEN	X	X	
	Subplot Slope	SLOP	X		
	Subplot Aspect	ASP	X		
	Snow / Water Depth	SWD	X		
Crown Closure	MECC		ME		

	Data Element	PDR Prompt	Data Required	
			Y	Y
Boundary Data	Plot Type	TYPE	Y	Y
	Boundary Change	CHNG*	Y	Y
	Contrasting Condition	CCON	Y	Y
	Left Azimuth	LAZM	Y	Y
	Corner Azimuth	CAZM	Y	Y
	Corner Distance	CDIS	Y	Y
	Right Azimuth	RAZM	Y	Y
Percent Area	%ARE	Y	Y	

X Data required
 Y Data required if multiple conditions occur on subplot
 ME ME only
 * Remeasurement plot only

		Sub 1 - 4 (Trees >= 5.0")													
		PAST >>	Null	Null	1	2	1	2	NT	1	2	NT	1	2	
		TRST >>	1	2	0	1	1	2		2		3			
Tree Data	Data Element	PDR Prompt	Data Required												
	Tree Number	TR#	X	X		D	D	D	D	X	D	D	X	D	D
	Condition Number	COND#	X	X	X	X	X	X	X	X	X	X	X	X	X
	Azimuth	AZM	X	X	D	D	D	D	X	D	D	X	D	D	
	Horizontal Distance	DIST	X	X	D	D	D	D	X	D	D	X	D	D	
	Previous Tree Status	PAST			X	X	X	X		X	X		X	X	
	Present Tree Status	TRST	X	X	X	X	X	X	X	X	X	X	X	X	
	Reconcile	RECO			X	X			X			X			
	Standing Dead	DEAD						X		X	X				
	Species	SPP	X	X	D	D	D	D	X	D	D	X	D	D	
	Previous Diameter at Breast Height	DBHO			D	D	D	D		D	D		D	D	
	Diameter at Breast Height	DBH	X	X			X	X	X	X	X	X			
	Diameter Check	DCHE					X	X	X	X	X	X			
	Tree Class	TCC	X	X			X	X	X	X	X	X			
	Tree Grade	TRGD	G				G		G						
	Saw Length	SAW	S ^e	S ^e			S ^e	S ^e	S ^e	S ^e	S ^e	S ^e			
	Board-foot Rough Cull	BRGH	S ^e	S ^e			S ^e	S ^e	S ^e	S ^e	S ^e	S ^e			
	Board-foot Rotten Cull	BROT	S ^e	S ^e			S ^e	S ^e	S ^e	S ^e	S ^e	S ^e			
	Bole Length	BOLE	B ^e	B ^e			B ^e	B ^e	B ^e	B ^e	B ^e	B ^e			
	Cubic-foot Rough Cull	CRGH	B ^e	B ^e			B ^e	B ^e	B ^e	B ^e	B ^e	B ^e			
	Cubic-foot Rotten Cull	ROTT	L/B ^e	L/B ^e			L/B ^e	L/B ^e	L/B ^e	L/B ^e	L/B ^e	L/B ^e			
	Total Length	THGT	L				L		L						
	Actual Length	ACTU	X	X			X	X	X	X	X	X			
	Length Method	METH	L				L		L						
	Crown Class	CCC	L				L		L						
Compact Crown Ratio	CRC	L				L		L							
P3 Crown Variables	P3CRN	P				P	P	P							
Damage Agents Standard 1 and 2	DAM1,2	X				X		X							
Cause of Death	CAUS		X				X		X		X	X	X		
Decay Class	DEC		X				X		X	X	X				
Length to Diameter Measurement Point	DIAH	X	X			X	X	X	X	X	X				
Boughs Available	BAVA	F				F	F	F							
Boughs Harvested	BHAR	F				F	F	F							
Boughs Harvesting Guidelines	GUID	F				F	F	F							

Null Subplot previously not installed.

NT Tree not tallied last cycle

D Downloaded

X Data required

G If TCC = 2 and sawtimber size

S^e If TCC = 2 or 5 and sawtimber size, eastern crews only

B^e If TCC = 2, 3, 4 or 5, eastern crews only

L/B^e Live tees, western crews only / If TCC = 2, 3, 4 or 5, eastern crews only

L Live trees only

F If species = 0012, MN only

P P3 only

Tree variables for remeasured trees now on on nonforest land (PAST = 1 or 2 and TRST = 0, 1, 2 or 3).

		Micro 1 - 4 (Trees >= 1.0" to < 5.0")						
		PAST >>	1	1	NT	1	1	
		TRST >>	1	0	1	2	3	
Sapling Data	Data Element	PDR Prompt	Data Required					
	Tree Number	TR#	X	D	D	X	D	D
	Condition Class Number	COND#	X	X	X	X	X	X
	Azimuth	AZM	X	D	D	X	D	D
	Horizontal Distance	DIST	X	D	D	X	D	D
	Previous Tree Status	PAST		D	D		D	D
	Present Tree Status	TRST	X	X	X	X	X	X
	Reconcile	RECO		X		X		
	Species	SPP	X	D	D	X	D	D
	Previous Diameter at Breast Height	DBHO		D	D			D
	Diameter at Breast Height	DBH	X		X	X		
	Diameter Check	DCHE			X	X		
	Total Length	THGT	P		P	P		
	Actual Length	ACTU	P/ME		P/ME	P/ME		
	Length Method	METH	P/ME		P/ME	P/ME		
	Crown Class	CCC	X		X	X		
	Compact Crown Ratio	CRC	X		X	X		
	P3 Crown Variables	P3CRN	P		P	P		
	Cause of Death	CAUS					X	X
	Length to Diameter Measurement Point	DIAH	X		X	X		
Boughs Available	BAVA	F		F	F			
Boughs Harvested	BHAR	F		F	F			
Boughs Harvesting Guidelines	GUID	F		F	F			

Null Microplot previously not installed

NT Tree not tallied last cycle

D Downloaded

X Data required

F If species = 0012, MN only

P P3 only

ME ME only

Tree variables for remeasured saplings now on on nonforest land (PAST = 1 and TRST = 0, 1, 2 or 3).

[Above table corrected 10/05/2006. Corrections are not highlighted.]

			Tree	Sap
P3 Crown Variables	Data Element	PDR Prompt	Data Required	
	Uncompacted Crown Ratio	UCRC	X	X
	Crown Light Exposure	CRLE	X	X
	Crown Position	CRPO	X	X
	Crown Vigor Class	CRVC		X
	Crown Density	CRDN	X	
	Crown Dieback	CRDB	X	
	Transparency	CRTR	X	

X Data required on all live P3 trees and saplings.

Seed	Data Element	PDR Prompt	DR
	Species	SPP	X
	Condition Class Number	CON#	X
	Seedling Count	SED#	X

X Data required if microplot has accessible forest land

State/Unit/County/Plot:

Township Range Section Subdivision Cycle Subcycle Intensity Past Date Date

Sample Kind Previous Field-Plot? P3 Plot Cruiser Name & # Tallier Name & #

Starting Point Description: _____

Course to Sample Location
 Direction: _____
 Distance _____
 to subplot: _____

Starting Point Map (include N arrow on map) : SP Latitude: _____ SP Longitude: _____

Notes (plot, site tree) :

Parcel:

N

Reference Trees:					
Sub#	Spp	DBH	Dist	Azm	Mark

Owner name: _____
 Address/phone: _____

Comment: _____

Contact name/date: _____ Type of contact: Personal ___ Phone ___ Other ___

2nd Annual Inventory Plotsheets Version 2.0 8/22/2005

State/Unit/County/Plot:

Water Type X (WTYP) Road Distance X (RDIS) QA Status X (QAST) Crew Type X (CTYP)

	Date	Initials
Office edit		
Field edit		

Lat/Long Record:

PC Latitude DD MM.MMM(N:)	PC Longitude DDD MM.MMM (W:)	Elevation XXXXX (ELEV)	GPS Unit X-XXXXXX	Error XXX (ERR)	Readings XXX (RDNG)
------------------------------	---------------------------------	---------------------------	----------------------	--------------------	------------------------

Plot Location:

PI Latitude o	PI Longitude o
GPS Latitude o	GPS Longitude o

Condition Records:

Condition #	NC Land Use	Condition Status	Reserve Status	Physiographic	Regeneration Status	Artificial Regeneration Species	Cond N-Sampled Reason	Forest Type	Stand Size	Stand Age	Tree Density	Owner Group	Owner Class	NC Owner Acres	Industrial Status	Nonf Land Use	Disturbance 1	Disturbance Yr 1	Disturbance 2	Disturbance Yr 2	Disturbance 3	Disturbance Yr 3	Treatment 1	Treatment Yr 1	Treatment 2	Treatment Yr 2	Treatment 3	Treatment Yr 3	
CON#	NCLU	STAT	RESV	PHYS	SORI	SOSP	REAS	FTYP	STSZ	SAGE	DENS	OWN	OWNC	NCPA	INDU	CLU	DIS1	DYR1	DIS2	DYR2	DIS3	DYR3	TRE1	TYR1	TRE2	TYR2	TRE3	TYR3	
X	XX	X	X	XX	X	XXXX	XX	XXX	X	XXX	X	XX	XX	X	X	XX	XX	XXXX	XX	XXXX	XX	XXXX	XX	XXXX	XX	XXXX	XX	XXXX	

Subplot Records:

Subplot #	Subplot/Annual Plot Status	Subplot Ctr Cond	Microplot Ctr Cond	Percent Slope	Aspect	Snow/Water Depth	Subplot N-sampled Reason
STAT	SCEN	MCEN	SLOP	ASP	SWD	REAS	
XXX	X	X	X	XXX	XXX	XX	XX
1							
2							
3							
4							

Boundary Records:

Subplot #	Contrasting Cond	Plot Type	Left Azimuth	Right Azimuth	Corner Azimuth	Corner Distance	Boundary Change
CCON	TYPE	LAZM	RAZM	CAZM	CDIS	CHNG	
XXX	X	X	XXX	XXX	XXX	XXX	X

Site Tree Records:

Tree #	DBH	Species	Length	Tree Age	Subplot#	Distance	Azimuth	Condition Class List	Next Available Site Tree #
TR#	DBH	SPP	HGHT	AGE	SUB#	DIST	AZM	CONL	
XX	XXXX	XXX	XXX	XXX	XXX	XXX	XXX	XXXXX	XXX

State/Unit/County/Plot:

Straddler: ___ P3 Hex: _____ P3#: ___

PI Land Use: _____

Next Consecutive Tree Number :	
Subplot#	Tree#
1	1
2	1
3	1
4	1

Tree Records:

Subplot #	Tree #	Species	Distance	Azimuth	DBH	Status

Subplot #	Tree #	Species	Distance	Azimuth	DBH	Status
-----------	--------	---------	----------	---------	-----	--------

Plot Level Notes:

Tree Level Notes:

Subplot	Tree #	Notes
---------	--------	-------

Subplot	Tree #	Notes
---------	--------	-------

State/Unit/County/Plot: [REDACTED] **Menominee County** Page 1 of 7

Township	Range	Section	Subdivision	Cycle	Subcycle	Intensity	Past Date	Date (MM/DD/YYYY)
				7	1	2	March, 2001	
Sample Kind	NC Sample Kind	P3 Plot	Cruiser Name & #			Tallier Name & #		
2	6	N						

Starting Point Description:
24.1 DBH YELLOW BIRCH PAINTED ON NW FACE
≈ 1 ch. E of Marsh + ≈ 1 ch. SE of BEAVER DAM

Course to Sample Location
 Direction: 297°
 Distance: 3 ch (198')
 to subplot: PC

Starting Point Map (Include N arrow on map): SP Latitude: 0 SP Longitude: 0

KEY	Miles
W to X	= 0.45
X to Y	= 0.25
Y to Z	= 0.3
W to Z	= 70 FEET

Notes (plot, site tree):

GATE Open @ time of visit

Field: Marsh and stream completely dry at time of visit

SP to P+3 Center = 297° for 77 ft

Office: Finger of Marsh cuts into P+3 but < 120 ft wide

COND #1
 STAT #1
 Sugar Maple w/ Balsam

Sub#.	Spp	DBH	Dist	Azm	Mark

Reference Trees:

Owner name: Bob Smith

Address/phone: _____

Comment: 715-555-5555

Type of contact: Personal _____ Phone Other _____

Contact name: Bob Smith on 7/20/05 (Nice guy., Opened Gates for us.)

2nd Annual Inventory Plotsheet c:\plotsheets\programslow-reports\pscrw8.rpt Version 1.2 Created on 8/11/2004

PDR Module Hot Keys

BkSp - Delete Entered Text

A or D - Top of Record
B or J - Middle of Record

Tab Left - Previous Record
Tab Right - Next Record

F - First Record
L - Last Record
G - Goto Record

C - Help

H - Home

I - Select Subplot
O - Previous Subplot
U - Next Subplot

S - Save Plot

M - Get Slope Correction

N - Tree Note | Plot Note

W - Edit Current Record
X - Edit Current Menu

Z - Copy trees from pt 101 to pt 1

F1 - Next Menu
F2 - Previous Menu
F3 - Main Menu
F4 - Next Tree Number
F5 - Functions

To turn the touchscreen off press the blue button then press the BkSp button.

To turn the touchscreen on press the blue button then press the BkSp button.

PDR PROMPT INDEX

%ARE	71	4.2.9N	DIS2	54	2.5.13	RESV	46	2.5.1
1DAM, 2DAM	110	5.20.7N	DIS2	202	Appendix A	ROTT	104	5.13
ACTU	105	5.15	DIS3	54	2.5.15	SAGE	51	2.5.10
AGE	119	7.2.5	DIS3	202	Appendix A	SAW	101	5.12.3N
ASP	65	3.7	DIS4	202	Appendix A	SCEN	64	3.4
AZM	29	1.16.13	DIST	29	1.16.14	SEAS	25	1.15.4N
AZM	76	5.4	DIST	76	5.5	SED#	115	6.4
AZM	120	7.2.8+N	DIST	120	7.2.9+N	SEND INFO	207	Appendix B
						ST. PAUL		
AZM1	202	Appendix A	DYR1	53	2.5.12	SHRU	227	6.5.4N-ME
AZM2	202	Appendix A	DYR2	54	2.5.14	SK	20	1.7+N
AZM3	202	Appendix A	DYR3	54	2.5.16	SLOP	65	3.6
AZM4	202	Appendix A	ELEV	29	1.16.15+N	SORI	49	2.5.5
BAVA	231	5.28.1N-MN	ERRS	30	1.16.16	SOSP	51	2.5.9
BHAR	231	5.28.2N-MN	EXAM	19	1.6	SPP	84	5.8
BOLE	103	5.12.6N	FIRST NAME	206	Appendix B	SPP	115	6.2
BRGH	101	5.12.4N	FTYP	47	2.5.3+N	SPP	118	7.2.2
BROT	102	5.12.5N	GPS#	26	1.16.4	SPP	227	6.5.2N-ME
CAUS	111	5.21	GUID	231	5.28.3N-MN	ST	17	1.1
CAZM	70	4.2.6	HGHT	119	7.2.4	STAT	18	1.4
CCC	106	5.17	HIST	55	2.5.22.1N	STAT	63	3.2
CCON	70	4.2.4	INDU	51	2.5.8	STATE	206	Appendix B
CDIS	70	4.2.7	LAST NAME	206	Appendix B	STREET	206	Appendix B
CDST	42	2.4.2	LAZM	70	4.2.5	STSZ	47	2.5.4
CHNG	69	4.2.3	MCEN	65	3.5	SUB#	119	7.2.7+N
CITY	206	Appendix B	MECC	225	3.8.1N-ME	SUBC	17	1.0.2N
CNTY	18	1.2	MEST	225	2.5.22.2N-ME	SWD	66	3.8
CON#	42	2.4.1	METH	105	5.16	TALL	24	1.15.2N
CON#	75	5.3	MONT	22	1.10.2	TCC	96	5.12.1N
CON#	115	6.3	N (SP LAT)	201	Appendix A	THGT	105	5.14
CON#	227	6.5.3N-ME	N (PC LAT)	27	1.16.7	TR#	75	5.2
CONL	117	7.2.1	NFLU	58	2.5.24+N	TR#	117	7.2.0N
CRC	107	5.19	NFTR	61	2.5.24.1N	TRE1	54	2.5.17
CRGH	103	5.25	OWNC	50	2.5.7	TRE2	55	2.5.19
CRSZ	24	1.15.3N	OWNG	47	2.5.2	TRE3	55	2.5.21
CRTY	24	1.15	PAST	79	5.6	TRGD	99	5.12.2N
CRUI	24	1.15.1N	PDOP	30	1.16.16.1N	TRST	79	5.7
CYCL	17	1.0.1N	PHONE	207	Appendix B	TYPE	69	4.2.2
DAY	22	1.10.3	PHYS	56	2.5.23	TYR1	55	2.5.18
DBH	85	5.9	PLT#	18	1.3	TYR2	55	2.5.20
DBH	119	7.2.3	PROD	57	2.5.23.1N	TYR3	55	2.5.22
DBHO	86	5.9.1	QAST	23	1.14	UNIT	17	1.1.1N
DCHE	95	5.12	RAZM	70	4.2.8	UNIT	26	1.16.3
DEAD	81	5.7.2	RDIS	22	1.12	W (SP LON)	201	Appendix A
DECA	111	5.23	READ	31	1.16.17	W (PC LON)	28	1.16.8
DENS	49	2.5.6	REAS	18	1.5	WTYP	23	1.13
DIAH	112	5.24	REAS	42	2.4.3	YEAR	21	1.10.1+N
DIS1	52	2.5.11	REAS	64	3.3	ZIP	207	Appendix B
DIS1	202	Appendix A	RECO	80	5.7.1			

[Correction 10/05/2006. Corrections are not highlighted.]