REX User's Guide

**Arthur V. Hays, Lance M. Optican, Barry J. Richmond,
John W. McClurkin**

**Laboratory of Sensorimotor Research
National Eye Institute
National Institutes of Health**

| | |
|---|----|
| Rex At a Glance... 1 | |
| Data Acquisition | 1 |
| Data File Format | 1 |
| Laboratory Control | 1 |
| Displays | 1 |
| User Interface | 1 |
| PC to PC Communication. | 2 |
| Multi-Unit Sorters. | 2 |
| Rex Structure and Operating System Environment | 2 |
| Availability | 2 |
| A Unix-Based Multiple-Process System for Real-Time Data Acquisition and Control 3 | |
| Introduction. | 3 |
| Rex Structure | 3 |
| Previous Design Approach | 3 |
| New Approach. | 4 |
| Rex Processes | 4 |
| Data | 4 |
| ProcSwitch | 4 |
| Scribe. | 5 |
| Int | 5 |
| Running Line Display | 5 |
| Window Display | 5 |
| Raster Display | 5 |
| Laboratory Control | 6 |
| State Concepts. | 6 |
| State Set Specification Language | 7 |
| Runtime Considerations | 7 |
| Shared Data Structures | 7 |
| Event Buffer | 7 |
| Analog Buffer | 8 |
| Menu System. | 8 |
| Data File Formats | 8 |
| Rex Header Block | 8 |
| E-file Format | 9 |
| A-file Format. | 9 |
| Data File Consistency | 9 |
| Data File Portability | 9 |
| Discussion. | 10 |
| References. | 10 |
| SPOT: State Process Translator for REX 11 | |
| Introduction. | 11 |

| | |
|--|-----------|
| Process Control | 11 |
| Spot Language Specification | 11 |
| Spot file sections | 11 |
| Include files | 12 |
| User defined actions | 12 |
| User defined menus | 13 |
| User defined functions | 18 |
| Real time variables | 19 |
| Comments | 19 |
| State set declaration | 19 |
| States | 20 |
| Escapes | 21 |
| Error Handling: Abort List | 22 |
| General Considerations | 22 |
| Example | 23 |
| REX Actions Library 35 | |
| State Set Controls | 36 |
| reset_s | 36 |
| set_times Pset_times | 37 |
| getClockTime, PgetClockTime | 38 |
| Data Window Controls | 39 |
| awind | 39 |
| pre_post, Ppre_post | 40 |
| uw_set | 41 |
| Digital Output Controls | 42 |
| dio_on, dio_off, dio_onoff, dio_out, Pdio_on, Pdio_off, Pdio_onoff, Pdio_out | 42 |
| Digital to Analog Controls | 43 |
| da_cntrl, da_cntrl_1, da_cntrl_2 Pda_cntrl, Pda_cntrl_1, Pda_cntrl_2 | 43 |
| da_set, da_set_1, da_set_2, Pda_set, Pda_set_1, Pda_set_2 | 45 |
| da_mode Pda_mode | 47 |
| da_offset Pda_offset | 48 |
| da_cursor Pda_cursor | 49 |
| Ramp Controls | 50 |
| ra_new Pra_new | 50 |
| ra_compute_time Pra_compute_time | 52 |
| ramptd Pramptd | 53 |
| ra_tostart, Pra_tostart | 54 |
| ra_start Pra_start | 55 |
| ra_stop Pra_stop | 56 |
| ra_phistart Pra_phistart | 57 |
| ra_phiend Pra_phiend | 58 |
| Memory Array Controls | 59 |

| | |
|--|----|
| ma_cntrl Pma_cntrl | 59 |
| ma_reset Pma_reset. | 60 |
| ma_start Pma_start | 61 |
| ma_stop Pma_stop. | 62 |
| Running Line Controls | 63 |
| rl_setbar | 63 |
| rl_addbar | 64 |
| rl_setspike | 65 |
| sd_mark | 66 |
| Saccade Detector Controls | 67 |
| sd_set. | 67 |
| Eye Window Controls. | 68 |
| wd_cntrl. | 68 |
| wd_pos | 69 |
| wd_siz | 70 |
| wd_src_pos, wd_src_check. | 71 |
| Obsolete Actions. | 73 |
| rl_trig. | 73 |
| rl_erase | 73 |
| rl_stop | 73 |
| wd_disp | 73 |
| wd_cursor | 73 |
| wd_center | 73 |
| When Things Don't Work 75 | |
| When and what to recompile. | 75 |
| No return value specified from actions. | 75 |
| Where is the moving display?. | 75 |
| Paradigm not behaving or operating properly times, arguments to actions incorrect, menu variables mysteriously changed, nothing corresponds to initialized values.75 | |
| Roots take longer and longer to read... | 75 |
| Data Keeping Windows | 75 |
| A state named init | 76 |
| Menu variable names cannot have embedded spaces; symptom- can write a root, but then not read it back in | 76 |
| Debugging Aids | 76 |
| Endless abort loop. | 76 |
| Arguments to actions are not passed correctly | 76 |
| REX Graphical User Interface 79 | |
| Introduction. | 79 |
| Process Switching Tool bar | 80 |
| Files. | 80 |

| | |
|--|-----|
| Displays | 81 |
| Cntrl-B. | 82 |
| Data | 82 |
| Int Process Tool bar | 82 |
| Controls Menu. | 82 |
| States Menu | 84 |
| User Menus | 85 |
| Eye Win. | 86 |
| Analog Sig. | 88 |
| Sac Detect | 90 |
| Bits | 90 |
| Control Panel. | 91 |
| Data Displays | 94 |
| Window Display | 94 |
| Running Line Display | 96 |
| Raster Display | 98 |
| REX Version Release Notes 105 | |
| REX 7.2, 1 Mar. 2001 | 105 |
| REX 7.1, 5 Feb. 2001 | 105 |
| REX 5.4, 1 Jan. 95 | 105 |
| REX 5.0, 8 April 94 | 105 |
| REX 4.3c, 4 April 1994 | 106 |
| REX 4.3, 24 Nov. 93. | 106 |
| REX 4.2, 9 Nov. 93. | 108 |
| REX 4.1b, 18 Nov. 92. | 108 |
| REX 4.1, Oct. 92. | 108 |
| REX 4.0, Step 92 | 109 |
| Current bugs: | 109 |
| REX 3.11, Jul. 88 | 109 |
| REX 3.10, Jun. 87. | 110 |
| The following enhancements were made to REX: | 110 |
| REX 3.5, 27 May 86. | 111 |
| REX 3.4, 30 Nov. 84. | 112 |
| REX 3.3, 30 Oct. 84 | 112 |
| Bugs fixed in this version: | 112 |
| Bugs reported in this version: | 112 |
| REX 3.2 | 112 |
| Current bugs of Release 3.2: | 112 |
| REX Internal Calibrations 115 | |
| REX Internal Calibrations | 115 |
| A/D Full Scale Range Calibrations. | 116 |

| | |
|--|-----|
| Configuring PC Systems for Running REX 117 | |
| REX Software Configuration | 117 |
| REX Hardware Configuration | 117 |
| PC | 117 |
| Real-time Interface Cards | 118 |
| D/A Cards | 118 |
| Digital I/O | 119 |
| Counter/Timer Card | 119 |
| Device Addresses, Vectors, Jumpers | 119 |
| EISA Configuration for HP Vectra (obvious settings not listed) | 122 |
| Analogics DAS-12/50 | 122 |
| Computer Boards CIO-DDA06, CIO-DAC08, CIO-DAC16 | 122 |
| Industrial Computer Source PCDIO | 122 |
| | 123 |
| Digital I/O Rack Panels and Circuits | 123 |
| Appendix A: Example Orders | 131 |
| Following are copies of the orders we used at NIH: | 131 |
| For QNX: | 133 |
| Noise tests of: Adac 5508SHR, National ATMIO16-X | 134 |
| Appendix B: REX License Agreement | 135 |
| GLVEX User's Manual 137 | |
| OVERVIEW | 137 |
| What's New | 137 |
| Additions | 137 |
| Subtractions | 138 |
| Starting GLvex | 139 |
| Coordinate System | 140 |
| Video Fields | 140 |
| Animation | 140 |
| Stimuli | 141 |
| Calibration pattern | 142 |
| Flow fields | 142 |
| Objects | 143 |
| Communications | 143 |
| Communications with Rex | 143 |
| Synchronizing parallel I/O communications | 144 |
| Ethernet communications | 144 |
| Synchronizing ethernet communications | 146 |
| Synchronizing stimuli | 146 |
| Parallel I/O Communication errors | 147 |
| KEYBOARD COMMANDS | 148 |

| | |
|---|------------|
| Keyboard commands not terminated by a <return> | 148 |
| <i>PAGE UP</i> 148 | |
| <i>PAGE DOWN</i> 149 | |
| <i>UP ARROW</i> 149 | |
| <i>DOWN ARROW</i> 149 | |
| <i>LEFT ARROW</i> 149 | |
| <i>RIGHT ARROW</i> 149 | |
| Keyboard commands terminated by a <return> | 149 |
| " <i>b</i> "; Set screen background color 149 | |
| " <i>c</i> "; Absolute clipping rectangle, Clear 149 | |
| " <i>D</i> "; Debug flag 150 | |
| " <i>d</i> "; Rex scaling 150 | |
| " <i>e</i> "; Set erase method 150 | |
| " <i>F</i> "; Fixation point properties 151 | |
| " <i>f</i> "; Switch fixation point, set video frame rate 151 | |
| " <i>H h</i> "; Help message 152 | |
| " <i>k</i> "; Start / stop okn stimulus 152 | |
| " <i>L</i> "; Look up table color 152 | |
| " <i>l</i> "; Foreground and background luminance 152 | |
| " <i>M</i> "; Start a movie clip 153 | |
| " <i>m</i> "; Link two objects on mouse 153 | |
| " <i>O</i> "; Flow fields 154 | |
| " <i>o</i> "; Foreground and background colors 156 | |
| " <i>P</i> "; Copy pattern 157 | |
| " <i>p</i> "; Draw pattern 157 | |
| " <i>q</i> "; Quit 159 | |
| " <i>r</i> "; Absolute ramps 159 | |
| " <i>S</i> "; Switch all objects 160 | |
| " <i>s</i> "; Switch, set active object, set sync 161 | |
| " <i>t</i> "; Timing commands 161 | |
| " <i>W</i> "; Video sync size 161 | |
| " <i>w</i> "; Set window size 161 | |
| " <i>X</i> "; Video Sync X and Y coordinates 162 | |
| " <i>x</i> "; Absolute X and Y coordinates 162 | |
| " <i>Z</i> "; Set the size of all objects. 162 | |
| " <i>z</i> "; Set the size of active object 162 | |
| REX ACTIONS | 163 |
| Actions That Duplicate Command Line Arguments. | 164 |
| <i>PvexEraseMethod</i> 164 | |
| <i>PvexVideoSync</i> 165 | |
| <i>PvexDigitalSync</i> 166 | |
| <i>PvexSetRexScale</i> 167 | |
| Actions That Set Luminance and Color | 168 |
| <i>PvexSetBackLum</i> 168 | |
| <i>PvexSetFixColors</i> 169 | |
| <i>PvexSetStimLuminances</i> 170 | |
| <i>PvexSetStimColors</i> 171 | |
| <i>PvexSetGrayScale</i> 172 | |
| <i>PvexSetObjectGrayScale</i> 173 | |
| <i>PvexSetLutEntryClr</i> 174 | |
| <i>PvexSetObjectLutEntryClr</i> 175 | |
| Actions That Switch Stimuli | 176 |
| <i>PvexAllOff</i> 176 | |
| <i>PvexSwitchFix</i> 177 | |
| <i>PvexDimFix</i> 178 | |
| <i>PvexPreloadStim, PvexSwapBuffers</i> 179 | |
| <i>PvexSwitchStim</i> 180 | |
| <i>PvexSetStimSwitch</i> 181 | |
| <i>PvexTimeStim</i> 182 | |
| <i>PvexSequenceStim</i> 183 | |
| Actions That Position Stimuli | 184 |

| | |
|--|-----|
| <i>PvexSetFixLocation</i> | 184 |
| <i>PvexStimLocation, PvexStimFromFixPoint</i> | 185 |
| <i>PvexShiftLocation</i> | 186 |
| <i>PvexReportLocation</i> | 187 |
| <i>PvexMessage</i> | 188 |
| <i>PvexSetActiveObject</i> | 189 |
| Actions That Draw Stimuli | 190 |
| <i>PvexClipRectSet, PvexClipRectFromFixPoint</i> | 190 |
| <i>PvexClearClipRect</i> | 191 |
| <i>PvexDrawWalsh</i> | 192 |
| <i>PvexDrawHaar</i> | 193 |
| <i>PvexDrawRandom</i> | 194 |
| <i>PvexDrawAnnulus</i> | 195 |
| <i>PvexDrawBar</i> | 196 |
| <i>PvexDrawFlowField</i> | 197 |
| <i>PvexMaskFlowField</i> | 198 |
| <i>PvexDrawUserPattern</i> | 199 |
| <i>PvexDrawRgbUserPattern</i> | 201 |
| <i>PvexDrawTiffImage</i> | 203 |
| <i>PvexDrawOknGrating</i> | 204 |
| <i>PvexLoadPatterns</i> | 205 |
| <i>PvexCopyObject</i> | 207 |
| Actions That Control Ramps | 208 |
| <i>PvexNewRamp, PvexNewRampFromFixPoint</i> | 208 |
| <i>PvexLoadRamp</i> | 209 |
| <i>PvexToRampStart</i> | 210 |
| <i>PvexStartRamp</i> | 211 |
| <i>PvexResetRamps</i> | 212 |
| Actions That Control OKN Stimuli | 213 |
| <i>PvexStartOkn</i> | 213 |
| <i>PvexStopOkn</i> | 214 |
| Actions That Control Flow Fields | 215 |
| <i>PvexNewFlow</i> | 215 |
| <i>PvexMakeFlowMovie</i> | 216 |
| <i>PvexToFlowMovieStart</i> | 217 |
| <i>PvexStartFlow</i> | 218 |
| <i>PvexTimeFlow</i> | 219 |
| <i>PvexShowFlowMovie</i> | 220 |
| <i>PvexStartFlowRamp</i> | 221 |
| <i>PvexStopFlowRamp</i> | 222 |
| Actions That Control Object Movies | 223 |
| <i>PvexShowMovieClip</i> | 223 |
| <i>PvexStopMovie</i> | 224 |
| Actions That Set Arbitrary Trigger Points | 225 |
| <i>PvexSetTriggers</i> | 225 |
| REX COMMANDS | 226 |
| SET_ERASE_METHOD | 227 |
| ENABLE_REX_VIDEO_SYNC | 228 |
| DISABLE_REX_VIDEO_SYNC | 229 |
| ENABLE_REX_DIGITAL_SYNC | 230 |
| DISABLE_REX_VIDEO_SYNC | 231 |
| SET_REX_SCALE | 232 |
| SET_BACK_LUM | 233 |
| SET_FP_ON_CLR | 234 |
| SET_FP_DIM_CLR | 235 |
| SET_STIM_LUMINANCES | 236 |

| | |
|--------------------------------|-----|
| SET_STIM_COLORS | 237 |
| SET_GRAY_SCALE | 238 |
| SET_OBJECT_GRAY_SCALE | 239 |
| SET_LUT_ENTRY_CLR | 240 |
| SET_OBJECT_LUT_ENTRY_CLR | 241 |
| ALL_OFF | 242 |
| SWITCH_FIX_POINT | 243 |
| DIM_FIX_POINT | 244 |
| PRELOAD_STIM | 245 |
| SWAP_BUFFERS | 246 |
| SWITCH_STIM | 247 |
| SET_STIM_SWITCH | 248 |
| TIME_STIM | 249 |
| SEQUENCE_STIM | 250 |
| SET_FP_LOCATION | 251 |
| STIM_LOCATION | 252 |
| STIM_FROM_FIX_POINT | 253 |
| SHIFT_LOCATION | 254 |
| REPORT_LOCATION | 255 |
| SET_ACTIVE_OBJECT | 257 |
| SET_FP_SIZE | 258 |
| CLIP_RECT_SET | 259 |
| CLIP_RECT_SET_FROM_FP | 260 |
| FULL_CLIP_RECT | 261 |
| DRAW_WALSH_PATTERN | 262 |
| DRAW_HAAR_PATTERN | 263 |
| DRAW_RANDOM_PATTERN | 264 |
| DRAW_ANNULUS | 265 |
| DRAW_BAR | 266 |
| DRAW_FLOW_PATTERN | 267 |
| MASK_FLOW | 268 |
| DRAW_USER_PATTERN | 269 |
| DRAW_RGB_USER_PATTERN | 271 |
| DRAW_TIFF_IMAGE | 273 |
| DRAW_OKN_PATTERN | 274 |
| LOAD_PATTERN | 275 |
| COPY_OBJECT | 276 |
| NEW_RAMP | 277 |
| NEW_RAMP_FROM_FP | 278 |
| LOAD_RAMP | 279 |
| LOAD_PIXEL_RAMP | 280 |
| TO_RAMP_START | 281 |
| START_RAMP | 282 |

| | |
|--|------------|
| RESET_RAMPS | 283 |
| NEW_FLOW | 284 |
| START_FLOW. | 285 |
| TIME_FLOW | 286 |
| MAKE_FLOW_MOVIE. | 287 |
| TO_FLOW_MOVIE_START | 288 |
| SHOW_FLOW_MOVIE. | 289 |
| START_FLOW_RAMP | 290 |
| STOP_FLOW_RAMP | 291 |
| START_OKN | 292 |
| SHOW_MOVE_CLIP. | 293 |
| STOP_MOVIE | 294 |
| SET_TRIGGERS | 295 |
| ERRORS AND WARNINGS. | 297 |
| Memory Management Errors | 298 |
| Object memory errors | 299 |
| VEX-REX Parallel I/O Communication Errors | 300 |
| Argument Errors | 302 |
| Memory Management Warnings. | 303 |
| Pattern Specification Warnings. | 304 |
| Flow Field Transforms | 305 |
| Contrast Specification | 306 |
| Color, Luminance Specification Warnings. | 307 |
| Sample Spot File Demonstrating Socket Communication | 308 |

Rex At a Glance...

Data Acquisition

Rex continually acquires samples from the a/d converter and stores the data to a circular memory buffer. This data is stored to disk when a window is opened. Data is stored until the window is closed. Each window has an associated pre-time and post-time. These times specify additional data that will be saved before the window is opened and after the window is closed. Data stored to disk can originate either from an a/d converter or from global memory variables.

- a/d sample rate (acquire rate) and disk store rate can be different- e.g. a signal can be sampled at 1000Hz and stored to disk at 250Hz.
- All rates (acquire rate and store rate) can be independently set on a per signal basis; all signals are not required to be acquired or stored at the same rate.
- Maximum a/d sample rate (acquire rate) per channel: 2000Hz.
- Overall throughput to disk has been tested to at least 16k samples/sec on a 486/33 with SCSI disk.
- Each signal can be identified with an ascii string that is available to analysis programs.

Data File Format

Rex produces only two types of files: the E-file and the A-file. The E-file contains short fixed records that identify epochs or times of occurrence. The A-file is composed of variable length data records. The E-file indexes the A-file. Both files include additional information (such as sequence numbers and magic numbers) that can be used to verify file integrity.

Laboratory Control

Rex includes a state-set interpreter and language, Spot, for laboratory control. Applications are programmed using Spot and associated C functions (termed actions) that are called from the state-sets. Users can also write custom actions in C. The state-set interpreter supports multiple, independent state chains. Timing resolution for the interpreter is 1msec.

Rex supports industry standard 'Opto 22' type I/O modules for interfacing with devices in the laboratory. These modules can interface with DC and AC voltages and provide optical isolation between the computer and the laboratory.

Displays

Rex includes three displays. The running-line display is an oscilloscope simulation. The window display is an X-Y display suitable for showing eye position and eye position windows. The raster display shows on-line rasters and spike density functions. This display is completely user customizable in terms of number of rasters, histograms displayed, size, position, triggers, etc.

User Interface

Users interact with Rex via a graphical interface consisting of pull-down menus, dialogs, and toggle buttons. Variables and parameters in Rex are contained in structures. The contents of all structures can be saved in ascii to a file (termed a root file).

PC to PC Communication

Rex provides two methods for PC to PC communication. The first system, pcmsg, is suitable for real-time. 'pcmsg' requires two interface boards that include the Intel 8255 parallel interface chip (commonly found on digital I/O boards). 'pcmsg' is designed so that the two boards can be cabled together directly, pin for pin, without any external glue logic. 'pcmsg' provides an eight bit communications channel between the PCs. This channel is full-duplex- information can travel in both ways simultaneously. The handshaking protocol is designed to be independent of timing differences between the PCs. The programming interface presents a messaging model- messages are packaged and sent between the machines. Messages include checksum. The second method of communication is to use Ethernet with TCP/IP sockets.

Multi-Unit Sorters

Rex communicates with the Mex multi-unit sorter program via parallel interface using one 8255 parallel chip. Rex will also communicate with the Spectrum Scientific MNAP system using counter-timer boards. Each board will accept up to 20 units from the MNAP system. In order to accept more units, the Rex PC must have available slots for more counter timer boards.

Rex Structure and Operating System Environment

Rex is composed of multiple cooperating processes. For example, keyboard commands, writing to disk, raster display, data acquisition are all handled by different processes. This architecture, originally designed to run on Unix, is not easily ported to DOS. Therefore the QNX real-time operating system was chosen to support Rex on the PC. QNX provides a Unix foundation in a real-time context with fast interrupt response and disk I/O.

Availability

Rex is available free of charge via executing a short license agreement (the purpose of this agreement is to preserve the government's rights to Rex and restrict re-distribution). The Rex manual and a copy of the agreement can be obtained via anonymous ftp from [lsr.nei.nih.gov](ftp://lsr.nei.nih.gov).

A Unix-Based Multiple-Process System for Real-Time Data Acquisition and Control

A.V. Hays, Jr. B.J. Richmond L.M. Optican J.W. McClurkin
National Eye Institute, National Institute of Mental Health, 9000 Rockville Pike, Bethesda, MD., 20892

Introduction

Rex (*Real-time EXperimentation*) is a real-time system that utilizes a multiple process structure to divide its functions among various cooperating processes. A running Rex system includes the *procSwitch* process to control process interaction, the *scribe* process to write data on disk, an *int* process to respond to interrupts from clocks, analog-to-digital converters, etc., a *running line* process that functions as a digital oscilloscope, an *window* process to display analog data in an X-Y coordinate system, and a *raster* process to generate on-line displays of unit activity. A Rex system is not limited to these processes and may include others. This modular architecture is flexible and easy to maintain. Various applications may use the same *procSwitch* and *scribe* processes but different *int*, *running line*, *window* or *raster* processes. The boundaries imposed by distributing Rex among multiple processes afford some protection against code becoming excessively intertwined and difficult to modify. Rex is written in C, a structured high level language.

Laboratory control is accomplished with a state-based interpreter in the *int* process. A state set description language is translated into tables which drive the interpreter. Rex stores sampled analog data in rotating buffers in a common memory area shared by all processes. Inter process communication messages are also passed through this area. Rex produces only two types of data files. One stores information characterized by epochs and contains long integer times of occurrence, the other stores variable length records such as analog data or experimental parameters. The epoch file indexes the data file. Both files contain additional information inserted by *scribe* that can be used to verify their integrity or aid in their reconstruction in case of partial loss or corruption.

The original version of Rex ran on the pdp11 using a V6/V7 Unix kernel that was modified to support real-time applications. The PC version of Rex currently runs with the Photon Window Manager on the QNX operating system, a POSIX compliant real-time system.

Rex Structure

Rex is designed for an environment composed of multiple laboratories, each equipped with PCs. These computers are devoted entirely to the on-line tasks in each laboratory. In addition larger machines may exist for off-line tasks such as data analysis, data archiving, program development, etc.

Previous Design Approach

In a previous approach to developing software for this environment a single large program performed all the functions of data acquisition, control, and display generation. To conserve space the machines ran under a small operating system with real-time capability, RT-11. Coding was done in assembly language for efficiency and access to hardware registers. As more laboratories with different needs used this program, it became larger and more complex. Modularity broke down as different programmers modified it. This single program was difficult to debug, maintain, and modify. Capabilities not needed in one experiment were removed when memory space was critical, and other capabilities

were added. A feature of one version was often difficult to transfer to another because of buried differences.

Debugging problems were more difficult since the operating system did not run the program under the protection of memory management. Stacks could overflow without being caught and the operating system itself could be corrupted.

New Approach

The multiple-process structure of Rex solves many of these problems. With inexpensive solid state memories the laboratory computers can be configured with enough memory to run a larger and more sophisticated operating system such as Unix. A process in Unix consists of a program memory image, register values, status of open files, etc. Unix is a timesharing system and schedules run time among processes that reside in memory or are swapped out to secondary storage. Processes are executed under the full protection of memory management; stack faults are caught, a process has access only to its own address space, and execution of sensitive instructions such as *halt* or *reset* is prohibited. Each process interacts with other processes only through inter process communication protocols.

The major functions of Rex exist as individual Unix processes. The boundaries thus imposed enforce some degree of modularity in Rex. Of course any process can still be poorly constructed internally. However, there is a “firewall” between it and the rest of the system. Its interactions are better defined than if it were a section or overlay in a single large program, sharing the same address space and registers.

The multiple-process structure facilitates maintenance and the development of new functions. Rex systems may run different processes for various applications yet still include the same processes for functions such as keyboard handling and file writing. When changes are made to processes each Rex system needs only to run the new versions to be updated. When debugging, each process has its own address space and can be traced separately. Multiple processes also provide a way for large systems to effectively utilize the full memory capacity of machines such as the pdp11, which have a larger physical memory space than virtual address space. For example, the pdp11/73 has a memory capacity of 4MB and a virtual address space of 64KB text, 64KB data.

Rex is written in C, a structured high level language. C has separate compilation, provides full access to hardware, and is very efficient. C is easily interfaced to assembly language.

Rex Processes

A typical Rex system is composed of five or more processes. The most common processes are described below.

Data

The data process is a null process that declares the common in core data area and launches the procSwitch process. It is executed before other Rex processes and remains in memory at all times. Since the data process is the first process executed it is named Rex.

ProcSwitch

The procSwitch process supervises the launching of all other processes and the opening and closing of files. ProcSwitch displays a small tool bar containing pull-down menus and toggle buttons that provide user input. ProcSwitch maintains a table of all currently established Rex processes and their status.

Scribe

The scribe process writes and maintains data files on disk. When a Rex process desires that data be saved on disk it sends a message to scribe telling it what the data is and where it is located. It is scribe's responsibility to write the data into the proper file in the correct format. For example, the int process might sample data from an analog-to-digital converter and store it in a rotating buffer. When a high water mark is reached it sends a message to scribe to write the data to disk.

Int

Every experiment is unique, and hence some part of Rex must be easily adaptable to the investigator's needs. This is accomplished in Rex by devoting one process, int, to the experiment-specific code. The experiments currently running under Rex investigate the neurophysiology of the visual and eye movement systems. Stimuli are presented to subjects according to a behavioral paradigm. Analog signals are digitized and events (such as pressing a bar or the firing of cells in the brain) are recorded by the computer. Since the control of the experiment and the collection of the data are dependent on the behavior of the subject in these applications, a great deal of digital signal processing must be done in real-time by Rex (e.g., the onset of a rapid eye movement is detected by a digital filter).

In its present configuration Rex is interrupt driven from the real-time clock, which normally interrupts at a one kilohertz rate. (Other applications may have higher sampling rates when less processing is required.) The int process is divided into two parts, an upper-level one that handles the communication with the other Rex processes and the operator, and a lower-level one that responds to the interrupts. The upper-level part displays a tool bar containing pull-down menus and toggle buttons to handle user input. When a new int process is launched, its tool bar appears adjacent to the procSwitch tool bar. The lower-level subroutine is divided into functionally discrete sections, making it simple to modify. Rex provides a method for users to easily create new int processes (see next section). During an experiment many int processes may be executed by Rex; the experimental paradigm can be changed quickly by switching to a different int process.

Running Line Display

The running line display process provides the functions of a digital oscilloscope. It can display analog data, neuronal units, and a timing bar. The time base of the display varies from 30 Hz to 1000 Hz. It has free running and triggered modes. In triggered mode, it has repeat and one-shot modes. Rex supports multiple running displays.

Window Display

The window display process provides an X-Y display of analog data. It has immediate and storage modes. In storage mode, the screen refresh rate can be set to any interval between 16 and 1024 msec, or the screen refresh can be triggered. In triggered storage mode, users can vary the number of draws between refresh cycles. Rex supports multiple window displays.

Raster Display

The raster display provides T-Y plots of unit data. The data are grouped according to experimental condition for each plot. Unit data can be displayed as spike rasters or as spike density functions. The raster display can have multiple pages, each containing up to 64 plots. Data from up to 10 different units can be displayed in each plot. Rex supports multiple raster displays.

Laboratory Control

To achieve useful control in the laboratory, timing and sequencing of events in real-time must occur precisely and efficiently. State notation is a powerful tool for accomplishing this control. The advantage of state notation is that it is simple and easy to learn, yet able to implement even the most complex control sequences. The process of reducing a control problem to state notation often helps clarify the problem and identify logical errors. Rex incorporates a state set processor for laboratory control. This processor is a part of the int process; it is executed on interrupt from the clock, currently every millisecond.

State Concepts

State notation as implemented in Rex includes the following elements. A state is the current condition or stage of a control sequence. A state consists of the specification of a function to occur when the state is entered (actions) and the conditions that must be met for transition to occur to another state (escapes). Escapes to other states can happen in the following ways:

- *Countdown of a timer to zero.*
- *Bit pattern set in a flag word.*
- *Bit pattern not set in a flag word.*
- *True return from a function call.*
- *Variable equal to a constant.*
- *Variable less than a constant.*
- *Variable greater than a constant.*

Each state contains a long integer (32 bits) to specify the time for escapes on timer countdown (an integer random factor can also be specified). Upon entering a state this long time is loaded into a counter which is then decremented each interrupt. States may contain multiple escapes of mixed types. Each escape is evaluated in turn at interrupt time; transition occurs on the first escape found true.

The Rex state processor is small and designed for fast execution. It uses a linked list to efficiently test escapes. State actions are not performed directly, but are accomplished by calls to functions. The action is therefore the address of a function that is called by the state processor when the state is entered. Up to ten arguments can be passed to the function. The arguments can be constants of type long or pointers to global variables. Many standard actions are available in a system library, or users may write their own. An example of a commonly used action is `dio_on(BIT)`. This action sets a bit (specified by the device id BIT) in the digital output interface word without disturbing other bits already set.

A provision is made to store a record of state transitions and the time of the transition on disk. This is done by specifying an integer event code contained either in the state or returned by an action. When a state transition occurs this code is entered into the event buffer. If the action for that state returns an event code it overrides the one stored in the state and is entered instead. A state in Rex, therefore, is composed of:

- Event code.
- Action (function address) and up to ten long integer or global variable pointer arguments.
- Long time to initialize timer for timed escapes.
- Integer random factor for time.
- Escapes.

State Set Specification Language

A user specifies state sets by writing in a language called *Spot* (State Processor Translator). The Spot compiler translates the language into the tables that drive the state processor. The Spot compiler is implemented with the compiler writing tools of Unix: Lex and Yacc. Spot source files are divided into two sections. The first section contains C source code and is passed through Spot untouched to the C compiler. Functions for actions are placed in this section. The second section is the state set specification.

The Spot source file is the primary user interface to the Rex system. Contained in the file is the complete laboratory control specification for an experiment including the source for any specialized actions not found in the system library. Usually, when modifying or creating new Rex applications, the user will only have to be concerned with this one file. To further simplify the user interface the generation of the Rex int process (as well as all Rex processes) is under the control of *make*, a Unix utility. After the user edits the Spot source file he simply types the command *make sf=spotname* where *spotname* is the name of the Spot source file. This utility then performs all necessary compilations (including Spot), library searching, and loading, and yields a new int process.

Runtime Considerations

At runtime the state set processor begins execution when the real-time clock is started. Some of the variables contained in a state can be changed at runtime. A special pull-down menu, accessed from the int tool bar, exists to do this. The changeable variables are arguments to actions, times, and the event code.

Shared Data Structures

The data process sets up a data space that is shared by all of the processes. A process adjusts its memory map to reference the shared space. This space contains the data buffers and the inter process communication area.

When an interrupt occurs, the int process may collect data. This data need not be saved on the disk, but must be available for on-line display by other processes. Int keeps this data in two buffers in the shared space. Data that can be described as an epoch (e.g., a single-unit's action potential, or when the subject presses a bar) are stored in the event buffer. Any data that can not be described as an epoch (e.g., eye position or target position) are stored in the analog buffer. The internal structures of the event and analog buffers are different, and when the data are saved on the disk, two separate files are used (see below).

Event Buffer

All event data can be identified by only two numbers: an event code and a time of occurrence. The int process records epochs by entering them into a circular event buffer. If events are being saved, scribe writes the data to the disk whenever a high water mark is reached. The circular buffer is large enough to make many events available to the running line, window, and raster display processes. During a neurophysiological experiment, the most common event is the single-unit action potential, or spike. These can occur with average firing rates as low as 1 per second, or as high as 1000 per second. It is essential that some representation of them be available on-line. The raster display process provides an on-line version of the standard unit raster, built out of the incore event buffer.

Analog Buffer

During the experiments run with Rex many analog signals must be sampled and saved. Collection of analog data is greatly complicated by several factors. For example, the time from which to begin saving may precede the actual time when recognition of the need to save occurs, e.g., one may wish to save eye position from 100 msec. before the beginning of an eye movement. Also, the number of samples collected during the run may be greater than the storage capacity of the disk. The approach taken in Rex is to collect the data continuously in rotating buffers, and only store data according to requests in the state set.

A very large buffer is used to hold the analog samples, and when the buffer is full, the load pointer wraps around to the beginning of the buffer. The user controls the saving of this data on the disk with actions in the state set. These actions control the opening, closing and canceling of a data keeping window. Scribe keeps all data collected from the time the window is opened until the window closes, no matter how many times the buffer wraps around (within the limits of the computer's capacity). If a high water mark is hit, scribe writes out a partial data record marked with a continuation flag.

The user also specifies the number of samples to be kept before the window is opened, and the number of samples to be kept after the window is closed. The user need only be concerned with opening and closing the data keeping window. The Rex system performs the bookkeeping necessary to store the data on disk. In addition, every time an analog record is written out an event is generated that indexes the analog record (see below).

Menu System

Rex provides a menu system that allows variables to be accessed and changed at run time. Variables have different types including char, string, octal, decimal, etc. A function can be created to be called when a menu or menu variable is accessed. This function may be called before access, after access, or both. This function can affect how the variable is accessed. For example, the function might prohibit a variable from being changed if the new value is not legal, or perform necessary initialization when a variable is set to a new value.

Data File Formats

Rex data is stored in two files. The E-file contains data which can be described as epochs. The A-file contains all other data, including information about the experimental run that created the data. The E-file also indexes the A-file. Both files contain redundant information so that a complete loss of either file does not preclude access to the other file, and that partial losses from one file can be bridged over. The E-file has a fixed record length structure, while the A-file has a variable record length structure. Both files begin with a one block header. The Unix system dynamically allocates file space; pre-determination of file length is unnecessary.

Rex Header Block

A 512 byte header block is written for both files when they are created. The first word of the header block is a size, in bytes. In the E-file this is the size of the fixed record length, in the A-file it is the size of a fixed-length header associated with each variable length record. The next item in the header block is the file name used to create the files. Then follows the version number for the Rex system that created the file. These two items are stored as null-terminated ASCII strings, making them readable without a special program. The rest of the header block is available for other information.

E-file Format

After the header block, the E-file consists of an arbitrary number of records, each four words long. The structure of each record is identical. The first word is a sequence number added by the scribe process. The second word is the event code for this record. If the code is a positive number, it corresponds to an event that occurred at a time which is stored in the next two words as a long integer. (Time is kept as clock ticks, and the clock rate is kept in a standard header stored in the A-file.) If the code is negative, the record is an index to a variable length record in the A-file; the next two words form a long integer that is the offset in bytes from the beginning of the A-file to the record header.

A-file Format

After the header block the A-file consists of an arbitrary number of variable length records. Every record is written in the same format: a ten word analog header followed by an arbitrary length data field. The structure of the analog header is the same for every record. The first two words are a long integer magic number. The third word is an unsigned ordinal sequence number assigned by the scribe process. The fourth word is the event code for this record (the same as the event code in the E-file record which indexes this A-file record). The next two words form a long integer containing the time of occurrence of the epoch associated with this record. The following two words form a long integer available to the user. The next word is an integer used to mark continuation records. The last word is the length (in bytes) of the following data field.

Since Rex collects data in rotating buffers, it is possible to store arbitrarily long streams of data. For practical reasons this stream is broken up into short data records that are stored on the disk. When the data buffer pointer exceeds a high water mark, the scribe process writes a partial data record into the A-file. Subsequent pieces of the data stream are then written as continuation records. Each continuation record has the same format as all other A-file records, except for non-zero continuation words in the headers.

Data File Consistency

The Rex file formats incorporate redundant information to allow the consistency of files to be checked, and some effort to be made at restoring damaged files. Since data is often transferred from disk to disk, or from disk to tape and back again, it is necessary to check that blocks have not been lost or scrambled. Both files are consistent if their sequence numbers are correct and if the analog records in the A-file are correctly indexed by the E-file. If the E-file becomes corrupted, it is easily re synchronized by searching for a block boundary, since the event record size evenly divides the physical block size. If the A-file becomes corrupted, it may be re synchronized by searching for the magic number. This number (1210832817L) is four bytes long, chosen to be unique by word or byte search, and outside the range of 12 bit analog-to-digital converters. The amount of data missing can be determined from the gap in the sequence numbers. A utility program exists (\f3srdd\f1) which checks the data files and verifies their consistency.

Data File Portability

Problems may arise when data files are moved to other computers. In general, data is not portable across machine architectures. Differences may involve word size (e.g. 16 bits on pdp11, 32 bits on VAX), byte ordering within words, and bit ordering (whether least significant bit is to left or right). Because of alignment differences a structure used in a C program to access a data file on one machine may not access the same fields properly on another machine.

One solution to this problem is to add to analysis programs multiple ways of accessing data files and multiple formats for each machine. A much simpler solution, however, is to instead change the data file for each machine. This permits a uniform access method and single data file structure for all architectures. With this solution porting analysis programs to new machines does not require new data formats or changes to access methods. A utility program exists to convert the Rex data files to a new format. The identification of the current format of the data file is stored in the data file header block. Information is not lost during conversion- given the current format a data file can be again converted to any other format.

Discussion

The prototype version of Rex was completed in March of 1981, and ran on the pdp11 processor. The PC port of Rex was completed in Spring of 1992. Rex comprises about 8000 lines of C code (comments not included).

Rex takes advantage of many Unix features to provide a real-time laboratory system that is easy to use. The Spot language and the make utility allow the user to easily create new Rex modules to meet his experimental needs. Hence the investigator has more time to spend on the design of the experiment and the analysis of the data.

References

Unix is a trademark of the Bell Telephone Laboratories. RT-11, pdp11, and DEC are trademarks of Digital Equipment Corporation. QNX is a trademark of Quantum Software Systems, Ltd., 175 Terrence Matthews Crescent, Kanata, Ontario K2M 1W8, (613) 591-0931.

Ritchie, D.M. and Thompson, K., "The Unix Timesharing System," Bell System Technical Journal, Vol. 57 (1978), pp. 1905-1929.

Kernighan, B.W. and Ritchie, D.M., The C Programming Language, Prentice-Hall, New Jersey, 1978. Snapper, A.G. and Inglis, G.B., "SKED Software System, Manual 3 Rev. D," State Systems, Inc., Kalamazoo, MI.

Lesk, M.E. and Schmidt, E., "Lex - A Lexical Analyzer Generator," Unix Programmer's Manual, Seventh Edition (1979), Bell Telephone Laboratories, New Jersey. Johnson, S.C.,

"Yacc: Yet Another Compiler-Compiler," *ibid.* Feldman, S.I., "Make - A program for Maintaining Computer Programs," *ibid.*

SPOT: State Process Translator for REX

Barry J. Richmond Arthur V. Hays Lance M. Optican John W. McClurkin

Introduction

The REX real-time laboratory control and data acquisition system has been designed so control paradigms for specific experiments can be flexibly implemented. During implementation the user's attention is largely directed to features that are unique for the experiment being designed. This end is realized through implementation of a translator for a state-set based control specification language, Spot (State Processor Translator). The Spot translator produces tables that are compiled by the C compiler. These tables contain specifications that define states; associated with each state are conditions, escapes, that govern transitions to other states. When a new state is entered a user written subroutine (termed an action) can be called if its name is included in the specification of the new state. Virtually no restrictions are placed upon the action. It may touch hardware, do calculations and set flags for later use, process lists of stimuli, etc. The Spot translator makes the chain of states extremely easy to specify and edit. Multiple, independent state chains are permitted and executed in parallel.

Process Control

REX process control is implemented using a logical structure which depends upon states, actions, and escapes. This system is table driven, executed by an interpreter that runs every millisecond. The tables are difficult to construct by hand, so a translatable language, Spot, has been implemented to make the creation of the tables transparent to the user.

Control routines are always in a current state. When an appropriate condition, recognized in either hardware or software, occurs, a transition or escape to another state takes place. When a new state is entered after an escape has occurred two useful things happen. First, a function called an action, may be called. Actions are usually written in the C language, and must be compatible with C calling conventions. The action may be passed up to sixteen arguments. These arguments can be either long integers or pointers to variables. Second, an event code composed of an integer number and a long integer time-of-occurrence can be placed into the event buffer. The user selects the event code. Standard event codes generally come from some #include file, while specific codes for the particular experiment may be placed directly in the paradigm specification. If the user wishes, a code may be returned by the action which will be placed in the event buffer instead. For example, if the action was setting some variables from a table, it might return a code that indicates which table entry was selected.

A state also contains the variables time (a long integer), and random (a short integer). When a state is entered, a countdown timer is initialized to the time variable (if it is non-negative) plus a portion of the random variable. The random variable is divided into quarters, with 0, 1/4, 1/2, 3/4, or the whole added to the timer. *Note if the time variable is negative, the countdown timer is not re-initialized when the state is entered.*

Spot Language Specification

Spot file sections

The Spot translator takes as input a specification file (termed a spot file) with suffix ".d". Each Spot specification file is divided into two sections separated by the delimiter "%%". The first section is

composed of include files, actions and other pre-initialized subroutines, user defined menus, user defined functions, and user defined real time variables. Actions may also be placed in user libraries; however, placing actions specific to individual paradigms in the paradigm's Spot file is usually much more convenient. Between the first and second sections a "%%" delimiter is placed. The second section contains the Spot state set specification for the paradigm. The state set chains of the paradigm are declared here. The Spot translator produces a C source file, with the suffix ".d.c" appended to the Spot file name.

Include files

The following headers are included automatically in the C source produced by Spot.

```
#include <stdio.h>
#include <sys/types.h>
#include "../hdr/sys.h"
#include "../hdr/cnf.h"
#include "../hdr/proc.h"
#include "../hdr/buf.h"
#include "../hdr/menu.h"
#include "../hdr/state.h"
#include "../hdr/ecode.h"
#include "../hdr/device.h"
#include "../hdr/cdsp.h"
#include "../hdr/idsp.h"
#include "../hdr/int.h"
```

Since these headers are automatically added by Spot they should not be included again in the ".d" Spot file.

User defined actions

Rex includes a library of actions that can be called from states, but this library will probably not be sufficient to build a complete experimental paradigm. In particular, if users want to present a number of conditions in a random sequence they will need to write an action that selects the experimental condition for each trial. For example:

```
#include "memSac.h" /* table of conditions */

/* global variables */
int mfTargX = 0;
int mfTargY = 0;
int antiTargX = 0;
int antiTargY = 0;
int trialCounter = -1;
int totalTrials = 0;
int currstim;
int blockcount = 0;

int pick_targ_location()
{
    static int ptrlst[2 * NUM_STIM] = { 0 };
    static int rs_shift = 10;
    int targx;
    int targy;
```

```

/* build list of conditions */
if(--trialCounter <= 0) {
    trialCounter = NUM_STIM;
    for(i = 0; i < trialCounter; i++) ptrlst[i] = i;
    shuffle(trialCounter, rs_shift, ptrlst);
    blockcount++;
}
currstim = ptrlst[trialCounter - 1];
totalTrials++;
memSacTrialList[currstim].total++;

/* set the time of the target-fixation point gap state */
set_times("gap", memSacList[currstim].delay, -1);

/* set the location of the target window */
switch(memSacList[currstim].direction) {
case 1:      /* target in movement field */
    targx = mfTargX;
    targy = mfTargY;
    break;
case -1:    /* target opposite movement field */
    targx = antiTargX;
    targy = antiTargY;
    break;
}

/* action to set eye window position */
wd_pos(WIND1, targx, targy);

/* return code to enter into E file */
return(memSacList[currstim].ecode);
}

```

Beginning with Rex 7.2, actions can have up to 10 arguments. The arguments can be either type long constants, or pointers to global variables.

User defined menus

You may build menus to allow modification of variables at run time. The menus are accessed from a dialog launched from the *int* process tool bar. Prior to version 7.0, Rex allowed user menus to access submenus. Submenus are no longer supported because they are no longer needed.

Default Menu. Spot will build one menu automatically. This menu is named *state_vars*. All that is needed for this menu is a list of variables to display. The list of variables is defined in an array of structures of type *VLIST* and must be named *state_vl*. For example:

```

VLIST state_vl[] = {
{"clear_all_da", &clear_all, NP, clearVaf, ME_AFT, ME_DEC},
{"do_two_ramps", &do_two_ramps, NP, NP, 0, ME_DEC},
{"ramp0_xda", &r0_xda, NP, NP, 0, ME_DEC},
{"ramp0_yda", &r0_yda, NP, NP, 0, ME_DEC},
{"ramp1_xda", &r1_xda, NP, NP, 0, ME_DEC},
{"ramp1_yda", &r1_yda, NP, NP, 0, ME_DEC},
{"fix_xwind", &fxwd, NP, NP, 0, ME_DEC},

```



```

{"fix_ywind", &fywd, NP, NP, 0, ME_DEC},
{"fix_oxwind", &foxwd, NP, NP, 0, ME_DEC},
{"fix_oywind", &foywd, NP, NP, 0, ME_DEC},
{"user_msg", &tst_user, NP, NP, 0, ME_DEC},
{"single_trace", &tst_single, NP, singleVaf, ME_AFT, ME_DEC},
{NS},
};

```

Table 1: VLIST Structure

| Member name | Example |
|------------------|--------------|
| char *vl_name | clear_all_da |
| void *vl_add | &clear_all |
| void *vl_basep | NP |
| int (*vl_accf)() | clearVaf |
| char vl_flag | ME_AFT |
| char vl_type | ME_DEC |

The VLIST structure has the following format:

Vl_name is the character string that will identify the variable in the menu. This character string may not have any imbedded spaces.

Vl_add is the address of the variable itself. This variable must be a global.

Vl_basep is an amount that may be added to the variable pointer. For simple global variables, *vl_basep* should be NP (null pointer). If *vl_add* is a pointer to the first element of an array, *vl_basep* might be the offset into the array for this variable.

Vl_accf() is the address of a function to be called when the variable is changed. Variable access functions are useful for checking the range of a variable or doing some type of initialization. If you do not need a variable access function, the *vl_accf()* member of the structure should be NP.

Vl_flag is a flag variable that consist of the or'ed combination of any of the following bits: ME_BEf, ME_AFT, ME_LB, ME_ILB, ME_GB, ME_IGB. The ME_BEf bit indicates that the variable access function *vl_accf()* should be called before changing the value of the menu variable. The ME_AFT bit indicates that the variable access function should be called after changing the value of the menu variable. The

ME_LB bit indicates that the value of *vl_basep* should be added directly to *vl_add*. The ME_ILB bit indicates that *vl_basep* is the address of the value that should be added to *vl_add*. The ME_GB bit indicates that the menu contains a global pointer (*me_basep*) that must be added to *vl_add*. The ME_IGB bit indicates that the menu global pointer is the address of the value that must be added to *vl_add*.

Vl_type is a flag that indicates the variable type. Valid types are ME_ACHAR, ME_OCT, ME_DEC, ME_HEX, ME_LOCT, ME_LDEC, ME_LHEX, and ME_STR. *Me_achar* indicates that the variable is a single ascii character. *Me_oct* indicates that the variable is on octal value. *Me_dec* indicates that the variable is a decimal value. *Me_hex* indicates that the variable is a hexadecimal value. *Me_loct* indicates that the variable is a long octal value. *Me_ldec* indicates that the variable is a long decimal value. *Me_lhex* indicates that the variable is a long hexadecimal value. *Me_str* indicates that the variable is a string.

The last entry in any VLIST structure array must be *NS*, on a line by itself. *NS* stands for "null string", and marks the end of the variable list. **Note, failure to end the VLIST definition with an NS line will cause REX to crash when it attempts to display the menu.**

If you only use the default state_vars menu, then you must also define a help message. The name of the help message must be "*hm_sv_vl*". For example:

```

char hm_sv_vl[] = "\
do_two_ramps-\n\
0: one ramp active\n\

```

1: two ramps active";

If you don't want to define a help message, then the help message must be defined using a null string. For example:

```
char hm_sv_vl[] = "";
```

MENU structure. The reason that submenus are no longer needed is that you are not limited to using just the default menu. You may define as many menus as you wish. The menus will be displayed in a pull down list. This makes accessing menus easier than using chains of submenus.

The list of menus to display is defined in an array of structures of type *MENU* and must be named *umenus*. For example:

```
MENU umenus[] = {
{"state_vars", &state_vl, NP, NP, 0, NP, hm_sv_vl},
{"separator", NP},
{"ramp_list", &ramp_vl, NP, ral_maf, ME_BEF, ral_agf, hm_ramp},
{"separator", NP},
{"eye_winds", &eyewnds_vl, NP, ral_maf, ME_BEF, ral_agf, hm_eyewnds},
{"eye_offsets", &eyeoffs_vl, NP, ral_maf, ME_BEF, ral_agf, hm_eyeoffs},
{NS},
};
```

Table 2: MENU structure

| Member Name | Example |
|--------------------|-----------|
| char * me_name | ramp_list |
| VLIST *me_vlp | &ramp_vl |
| unsigned me_basep | NP |
| int (*me_accf)() | ral_maf |
| int me_flag | ME_BEF |
| int (*me_rtagen)() | ral_afg |
| char *me_help | hm_ramp |

The MENU structure has the following format:

Me_name is the character string that will be displayed in the pull down menu list. This character string may not have any imbedded spaces.

Me_vlp is a pointer to the array of VLIST structures that define the variables to be accessed from this menu.

Me_basep is a value that may be added to the address of each variable in this menu's VLIST structures array.

Me_accf() is the address of the menu access function. This function can be used to set the *me_basep* in cases where the menu displays elements of an array of structures.

Me_flag is a flag variable that consists of the or'ed combination of any of the following bits: ME_BEF, ME_AFT. The ME_BEF bit indicates that the menu access function should be called before accessing the menu variables. The ME_AFT bit indicates that the menu access function should be called after accessing the menu variables.

Me_rtagen() is the address of a the root argument generation function. If the menu requires arguments, for example if it

accesses the members of an array of structures, this function will generate the array indices when writing root files.

Me_help is a pointer to this menu's help message.

Rex 7.0 and later allow special menu entries marked by the *me_name* "separator". The *me_vlp* member of these entries must be null (NP). The remaining MENU structure members may be left undefined. If you do define the remaining members of a *separator* MENU structure, they must be defined to be 0. Rex will put a separator line in the user menus pull down menu where ever there is a *separator* entry.

As with the arrays of VLIST structures, the last entry in the *umenus* array must be NS. **Failure to end the umenus definition with an NS line will cause Rex to crash when it attempts to display the user menus pull down menu.**

Rex will display the menus in the order they are listed in the *umenus* array. This allows you to group menus as you like, separating logical groups of menus with *separator* entries.

More menu examples. The following code snippets illustrate how to use menus to access members of a structure and how to access members of an array of structures. This example shows the menu access for a single instance of a structure.

```
typedef struct {
    int len;
    int ang;
    int vel;
    int xoff;
    int yoff;
    int type;
    int ecode;
} RMP_PAR;

RMP_PAR ramp;

VLIST ramp_vl[] = {
{"length", &((RMP_PAR *)NP)->len, NP, NP, ME_GB, ME_DEC},
{"angle", &((RMP_PAR *)NP)->ang, NP, NP, ME_GB, ME_DEC},
{"velocity", &((RMP_PAR *)NP)->vel, NP, NP, ME_GB, ME_DEC},
{"xoff", &((RMP_PAR *)NP)->xoff, NP, NP, ME_GB, ME_DEC},
{"yoff", &((RMP_PAR *)NP)->yoff, NP, NP, ME_GB, ME_DEC},
{"type", &((RMP_PAR *)NP)->type, NP, NP, ME_GB, ME_DEC},
{"ecode", &((RMP_PAR *)NP)->ecode, NP, NP, ME_GB, ME_DEC},
{NS},
};
char hm_ramp_vl[] = "";

MENU umenus[] = {
{"ramp_par", &ramp_vl, &ramp, NP, 0, NP, hm_ramp_vl},
{NS},
};
```

In this example the phrase `&((RMP_PAR *)NP)->len` in the *ramp_vl* definition indicates that this variable address is the address of the *len* member of a structure of type *RMP_PAR*. The *ME_BG* notation indicates that a menu global base pointer must be added to this variable address. In the *umenus* definition, the menu global base pointer *me_basep* is given the value of *&ramp*, the instance of the *RMP_PAR* structure being accessed by this menu. This example assumes that *ramp* is a globally defined variable.

The next example shows a snippet of code for a menu that access members of an array of structures.

```
typedef struct {
    int len;
    int ang;
    int vel;
    int xoff;
    int yoff;
```

```

    int type;
    int ecode;
} RMP_PAR;

RMP_PAR rampList[16];

int r_agf(int call_cnt, MENU *mp, char *astr)
{
    if(call_cnt >= 16) *astr= '\0';
    else itoa_RL(call_cnt, 'd', astr, &astr[P_ISLEN]);
    return(0);
}

int r_maf(int flag, MENU *mp, char *astr, ME_RECUR *rp)
{
    int rampnum;

    if(*astr == '\0') rampnum = 0;
    else rampnum = atoi(astr);

    if((rampnum < 0) || (rampnum >= 16)) return(-1);
    mp->me_basep = (unsigned)&rampList[rampnum];
    return(0);
}

VLIST ramp_vl[] = {
{"length", &((RMP_PAR *)NP)->len, NP, NP, ME_GB, ME_DEC},
{"angle", &((RMP_PAR *)NP)->ang, NP, NP, ME_GB, ME_DEC},
{"velocity", &((RMP_PAR *)NP)->vel, NP, NP, ME_GB, ME_DEC},
{"xoff", &((RMP_PAR *)NP)->xoff, NP, NP, ME_GB, ME_DEC},
{"yoff", &((RMP_PAR *)NP)->yoff, NP, NP, ME_GB, ME_DEC},
{"type", &((RMP_PAR *)NP)->type, NP, NP, ME_GB, ME_DEC},
{"ecode", &((RMP_PAR *)NP)->ecode, NP, NP, ME_GB, ME_DEC},
{NS},
};
char hm_ramp_vl[] = "";

MENU umenus[] = {
{"rampList", &ramp_vl, NP, r_maf, ME_BEf, r_agf, hm_ramp_vl},
{NS},
};

```

This examples shows two functions, the root argument generation function *r_agf* and the menu access function *r_maf* that are needed for menu access to arrays of structures. The purpose of the root argument generation function is to convert an integer array index value into an ascii string to be written into a root file. In the argument list for *r_agf*, *call_cnt* is the element of the array, *mp* is a pointer to the menu struct (in this case *&umenus[0]*), and *astr* is a pointer to a string variable that holds the ascii representation of the index.

The purpose of the menu access function is to convert an ascii string into an integer array index and set a pointer to the appropriate array element. In the argument list for *r_maf*, *mp* is a pointer to the menu struct (in this case *&umenus[0]*) and *astr* is a pointer to the string to be converted to an integer index. The arguments *flag* and *rp* are required by the function protocol but are not used in this example.

In the *umenus* definition, the value of *me_basep* is set to null (NP) because *me_basep* is computed by the access function.

User defined functions

In Rex, actions are just functions, but they are functions that are called by the state processor and are only called once when the processor enters a state. Thus, they will only be called when the Rex clock is running. Rex 7.0 also provides a mechanism for calling functions independently of the state processor. This mechanism is to list the functions in an array of structures of type `USER_FUNC`. The name of the `USER_FUNC` array must be *ufuncs*. The functions themselves are ordinary C functions. They should be of type *int* or *void*. The functions may have up to sixteen arguments and the arguments may be of type *int*, *float*, or *char **. The functions are called by entering values for their arguments in the user functions dialog that can be displayed from a pull down menu in the *int* process tool bar. User defined functions must be defined, then listed in the *ufuncs* array. For example:

```
void f_rampReset(void)
{
    ( body of function );
    return;
}

void f_rampOffset(int Xoff, int Yoff)
{
    ( body of function );
    return;
}

USER_FUNC ufuncs[] = {
    {"reset", &f_rampReset, "void"},
    {"offset", &f_rampOffset, "%d %d"},
    {NS},
};
```

Table 3: USER_FUNC Structure

| Member name | Example |
|----------------|--------------|
| char n_name[] | "offset" |
| int (*n_ptr)() | f_rampOffset |
| char format[] | "%d %d" |

The `USER_FUNC` structure has the format: *N_name* is a character string that identifies the function in the dialog. This string may have imbedded spaces.

N_ptr() is the name of the function that will be called. To get the function called, you enter values for the arguments in the dialog's text widget, then enter a carriage return.

Format is a character string consisting of tokens that are used to convert the text you enter in the widget to the values that are passed to the function. The tokens are separated by a space.

The meaning of the tokens is the same as in a C `printf` statement, i.e. "`%d`" indicates conversion to an integer value, "`%f`" indicates

conversion to a floating point value, etc. Currently, Rex supports conversion to integer, floating point and character strings, i.e. "`%d %f` and `%s`". You must enter one token for each argument in your function. This allows Rex to do some error checking. If your function doesn't take any arguments, they you should set the format string to "`void`". If you want to write functions that take a variable number of arguments, leave the *format* character string blank. This will cause Rex to parse what you enter in the function's widget into two character strings. The first will be all of the characters up to the first space.

The second will be the rest of the string. Rex will call your function with pointers to these two character strings. In this case, you must define your function to take two *char ** arguments, i.e.

```
void function(char *str1, char *str2)
```

You will need to add code to your function to parse the two character strings to extract the arguments.

As with the arrays of *VLIST* and *MENU* structures, the last entry in the *ufuncs* array must be NS. ***Failure to end the ufuncs definition with an NS line will cause Rex to crash when it attempts to display the user functions dialog.***

Real time variables

Prior to Rex 7.0, values of variables could only be displayed by bringing up a menu or by typing a command such as *type trials*. Once displayed the values were not updated. If you had variables that tracked the subject's performance such as percent correct or number of trials completed, you had to repeatedly bring up the menu or type the command to see the new values for these variables. Rex 7.0 provides a mechanism to continuously display the values of variables. This mechanism is to list the variables in an array of structures of type RTVAR. The name of the RTVAR array must be *rtvars*. For example:

```
RTVAR rtvars[] = {  
  {"number of trials", &nTrials},  
  {"trials remaining", &trialsRemaining},  
  {"blocks completed", &nBlocks},  
  {"total trials", &totalTrials},  
  {"number correct", &correctTrials},  
  {"number wrong", &errorTrials},  
  {"percent correct", &percentCorrect},  
  {NS},  
};
```

Table 4: RTVAR Structure

| Member Name | Example |
|---------------|--------------------|
| char *rt_name | "number of trials" |
| int *rt_var | &nTrials |

The RTVAR structure has the following format: *Rt_name* is a character string that identifies the variable in the dialog. This name may have imbedded spaces. *Rt_var* is the address of the variable to be displayed. Real time variables must be of type *int*. You can display up to 64 variables in the dialog.

Rex updates the display with the values of the variables every second for as long as the dialog is displayed.

As with the arrays of *VLIST*, *MENU*, and *USER_FUNC* structures, the last entry in the *rtvars* array must be NS.

Failure to end the rtvars definition with an NS line will cause Rex to crash when it attempts to display the real time variables dialog.

Comments

Comments are allowed anywhere, and unlike comments in the C compiler, they may be nested. They are stripped out of the output file.

State set declaration

The beginning of the state set declaration is marked by the delimiter "%%%". Following the "%%%" delimiter, each paradigm must start with the keyword *ident* or *id*, followed by the paradigm number

(which is displayed on the screen at run-time). This is not optional and Spot will give an error if it is not included. Optionally, the keyword *restart* followed by the name of an initialization subroutine may follow.

%%

id 300

restart rinitf

(declaration of state set chains)

A Spot file may have multiple independent chains of states which are executed asynchronously. Each of the asynchronous chains must start with a name followed by an open curly brace. The entire chain must then be terminated by a close curly brace. After the opening curly brace the next statement must be *status* or *stat*, followed by ON or OFF to indicate whether the chain is on or off at start or restart time. For example:

```
chainA {  
status ON  
    (state declarations...)  
}
```

States

Each state begins with its name followed by a colon, e.g. *fpon:*. The initial state in each chain must be indicated by preceding it with the keyword *begin*. An example of the first state in a chain:

```
begin fpon:  
    code FPONCD  
    rl +30  
    time 2000  
    rand 1000  
    to stimon
```

An example of a subsequent state in a chain:

```
stimon:  
    code STIMCD  
    do dio_on(LED2)  
    rl 50  
    time 500  
    to stimoff
```

If there is an event code to be put into the event buffer when the state is entered, it must be next. The event code is specified using keyword *code*, for example *code 1101* or *code FPONCD*. Beginning with Rex7.2, you can specify the event code with a pointer to a global variable as well as with a constant value. This allows you to drop trial specific event codes without having to call an action. For example:

```
code &trialCode
```

Actions, running line levels, and times follow in any order with the following restriction: time and random must be adjoining in either order.

Running line. The running line is used both to indicate state transitions in the running line display and to trigger the running line and eye window displays. The running line level is displayed on the REX moving display as a continuous line at different positions on the screen. Its keyword specifier is *rl*. Running line levels are absolute when not preceded by a + or -, and relative when they are preceded by a + or -.

Actions. Actions are C-callable subroutines. One action is allowed per state, and is called immediately when the state is entered. *Note that the initial state of a chain cannot contain an action.* An action is identified by the keyword *do*. Beginning with Rex7.2, actions may have up to ten arguments. The arguments may be either long integers or pointers to global variables. **NOTE! If you write your own actions, you must declare any arguments as longs or pointers so that they will be accessed properly by the C compiler.** Action arguments can be examined and changed through the REX menu system at run time.

All actions must return an integer value. If the return value is non-zero, it is assumed to be an ecode and is loaded into the event buffer. *Note that only one ecode per state can be loaded into the event buffer.* An ecode returned by an action has priority over an ecode declared as part of the state using the *code* keyword, and will be entered instead.

Escapes

Escapes have the following format -

to nextstate [on time]

to nextstate on +,-,CONSTANT \ & int_variable_name_or_address

to nextstate on [+,-]CONSTANT > int_variable_name_or_address

to nextstate on [+,-]CONSTANT < int_variable_name_or_address

to nextstate on [+,-]CONSTANT = int_variable_name_or_address

to nextstate on [+,-]CONSTANT ? int_variable_name_or_address

to nextstate on [+,-]CONSTANT % function_name_or_address

The keyword that indicates an escape is *to*. The next word is the name of a state to go to on transition. Conditions for transition are specified after the keyword *on*. A state may contain up to ten escapes. Each escape is tested in sequence. A transition occurs upon the first escape that tests true. After an escape tests true, transition occurs immediately- the remaining escapes in the state are not evaluated.

The tests for transition in an escape all have the same form: a constant (CONSTANT) is evaluated against a memory location (*int_variable_name_or_address*), or the integer return from a function call (*function_name_or_address*). The field *int_variable_name_or_address* can be either the name of a variable, or the address of a variable. Spot distinguishes between these two cases as follows. If the name is a numeric constant, or the first letter is upper case, it is assumed to be the *address* of a variable. Otherwise, it is assumed to be the *name* of a variable. Likewise, the field *function_name_or_address* can either be the name of a function, or the address of a function. The same rules are applied as for variables to distinguish between the two. Examples:

to nexstate on +01 & goo /* goo is name of variable */

to nexstate on +01 & 0x20 /* 0x20 is memory address */

#define FLAG 0x20

to nexstate on +01 & FLAG /* FLAG is memory address */

The PC architecture, as opposed to the pdp11, has separate memory and I/O address spaces. One is forced to use I/O instructions to access I/O ports. The field **int_variable_name_or_address** is *always* in the memory address space. There is no way to access the I/O address space in an escape test.

Transition on Timer Countdown to Zero: 'time'. This escape condition results in a transition when the timer ticks down to zero. The last two words "*on time*" are assumed, and are optional.

Transition On Bit Test: '&'. This escape condition performs a bitwise and between the CONSTANT and the integer variable. If the CONSTANT is preceded by a +, transition occurs if the result of the test is true. If the CONSTANT is preceded by a -, transition occurs if the result of the test if false. This test,

then, will result in a transition for the + case when any of the bits set in the CONSTANT are also set in the variable. For the - case transition results only when all of the bits set in the CONSTANT are also not set in the variable. Note that the + or - sign is required in this condition.

Transition on Comparison Test: '>', '<', '='. This escape condition performs a comparison between the CONSTANT and the integer variable. If the CONSTANT is greater than (>), less than (<), or equal to (=) the integer variable, transition occurs. The sign is optional. If it is not present, the CONSTANT is assumed to be positive.

Transition on Query: '??'. This escape condition first performs a comparison between the CONSTANT and the integer variable, then decrements the integer variable. If the integer variable is less than or equal to the CONSTANT, transition occurs.

Transition on Return Value of Function: '%'. This escape condition first calls the function whose name or address is specified by *function_name_or_address*. The integer return value from this function is then compared to CONSTANT. If they are equal, transition occurs.

Error Handling: Abort List

When an error or special condition occurs during state set processing it is often necessary for certain actions to be executed to effect a reinitialization or resetting to known conditions (for example, turning off stimuli, returning mirrors to center, etc.). A special action exists to facilitate this named *reset_s(arg)*. The state names containing the actions that should be executed on error are listed after the keyword *abort list:*. When the action *reset_s(arg)* is called, the actions specified in the abort list will be executed in sequence. If *arg* is -1 (the usual case) the abort list of all chains will be executed. If *arg* is a positive number, the abort list of only that chain will be executed.

Note the following distinctions between the *abort list* keyword and the *restart* keyword. After the *abort list* keyword one places the name of states. The actions of these states are called whenever the *reset_s()* action is executed, or during a *reset statelist* command. Note, however, ecodes will not be entered into the event buffer from actions called in this manner from the abort list.

After the *restart* keyword one places a single C function name (not a state name). This function may in turn call actions, or other C functions. The function specified after the *restart* keyword will be executed the first time the clock is begun, and afterwards whenever a *reset statelist* command is issued.

When the *reset statelist* command is issued, the state processor does the following:

- Calls *reset_s(-1)* which results in the *abort list* actions being executed.
- Executes the function specified after the *restart* keyword.
- Re initializes the state list chains to the first state.
- Enters into the event buffer an ecode composed of the paradigm number specified after the 'id' keyword or'ed with the INIT_MASK.

General Considerations

Numbers preceded by a zero are passed on to the C compiler as they are, so they will be treated as octal. White space is free, so use it liberally to make your code clear to the users and yourself.

Error checking by Spot is miniscule. If a syntax error is detected the line number at which it is recognized will be reported, and Spot will terminate. Line numbers reported by Spot refer to lines in the ".d" Spot file. Errors might also be reported later by the C compiler when the C source file generated by Spot, the ".d.c" file, is compiled. In this case the error line numbers will refer to the ".d.c" file.

Corrections must be made, however, to the input to Spot, the ".d" file, and not to the intermediate ".d.c"

file. The user is responsible for seeing that escapes actually go to existing states. The C compiler might catch this error, but it is not guaranteed.

A few debugging aids exist at run-time. The running line display is often useful for debugging since its level is determined by values specified in the state declarations. Clicking on the debug button in the int process tool bar brings up a dialog displaying buttons for all the states, grouped by chain. As each state is entered, the color of its button is toggled between yellow and blue, and the time the state was entered is printed on the button.

Debugging messages can be printed by using the routines `dprintf()`, `dputchar()`, `dputs()` and `rxerr()`. If one of these routines is called from the interrupt level, or when the variable `doutput_inmem` in the control-param menu is non-zero, the results are not printed on the console. They are instead stored in a rotating buffer in memory. This buffer can be printed by issuing the command `int print_debug`. The variable `doutput_rotate` determines whether the memory buffer rotates when filled: if non-zero the buffer rotates, if zero the buffer freezes when filled and does not accept further input. The buffer is initialized with a '\$' as the first character. If the variable `doutput_tofile` is non-zero, the contents of the buffer are also printed to a file in `/tmp` when the `int print_debug` command is issued. For more information about these debugging routines, see the comments in the source files `"sys/rlib/dprintf.c"` and `"sys/rlib/dputs.c"`.

Example

An example of a complete spot file with multiple chains of states follows:

```
/*
 * Rex ramp test paradigm.
 *
 */
#include <stdlib.h>
#include "../hdr/ramp.h"
#include "ldev_tst.h"
#include "lcode_tst.h"

#define RAMP0 0 /* ramps and windows used in paradigm */
#define RAMP1 1
#define WIND0 0
#define WIND1 1
#define EYEALL ((WD0_XY << (WIND0 * 2)) | (WD0_XY << (WIND1 * 2)))
#define EYEH_SIG 0 /* signal numbers for eyes */
#define EYEV_SIG 1
#define OEYEH_SIG 2
#define OEYEV_SIG 3

typedef struct {
    int len;
    int ang;
    int vel;
    int xoff;
    int yoff;
    int xwind;
    int ywind;
    int oxwind;
    int oywind;
    int eyehoff;
    int eyevoff;
```

```

    int oeyehoff;
    int oeyevoff;
    int type;
    int ecode;
} RA_LIST;

#define E_D0 2000 /* ramp direction series */
#define E_D45 2001
#define E_D90 2002
#define E_D135 2003
#define E_D180 2004
#define E_D225 2005
#define E_D270 2006
#define E_D315 2007

/*
 * Direction series for tracking.
 */
RA_LIST list0[] = {
    200, 315, 5, 0, 0, 50, 50, 40, 40, 40, 40, 0, 0, RA_CENPT, E_D315,
    200, 90, 10, 0, 0, 50, 50, 40, 40, 20, 20, 0, 0, RA_CENPT, E_D90,
    200, 225, 15, 0, 0, 50, 50, 40, 40, 10, 10, 0, 0, RA_CENPT, E_D225,
    200, 0, 20, 0, 0, 50, 50, 40, 40, 30, 30, 0, 0, RA_CENPT, E_D0,
    200, 180, 25, 0, 0, 50, 50, 40, 40, 40, 40, 0, 0, RA_CENPT, E_D180,
    200, 45, 30, 0, 0, 50, 50, 40, 40, 20, 20, 0, 0, RA_CENPT, E_D45,
    200, 270, 35, 0, 0, 50, 50, 40, 40, 10, 10, 0, 0, RA_CENPT, E_D270,
    200, 135, 40, 0, 0, 50, 50, 40, 40, 30, 30, 0, 0, RA_CENPT, E_D135,
    200, 0, 5, 0, 0, 50, 50, 40, 40, 20, 40, 0, 0, RA_CENPT, E_D0,
    200, 315, 10, 0, 0, 50, 50, 40, 40, 0, 0, 40, 40, RA_CENPT, E_D315,
    200, 45, 15, 0, 0, 50, 50, 40, 40, 0, 0, 20, 20, RA_CENPT, E_D45,
    200, 225, 20, 0, 0, 50, 50, 40, 40, 0, 0, 10, 10, RA_CENPT, E_D225,
    200, 90, 25, 0, 0, 50, 50, 40, 40, 0, 0, 30, 30, RA_CENPT, E_D90,
    200, 180, 30, 0, 0, 50, 50, 40, 40, 0, 0, 40, 40, RA_CENPT, E_D180,
    200, 135, 35, 0, 0, 50, 50, 40, 40, 0, 0, 20, 20, RA_CENPT, E_D135,
    200, 270, 40, 0, 0, 50, 50, 40, 40, 0, 0, 10, 10, RA_CENPT, E_D270,
    -1, -1, -1,-1,-1, -1, -1, -1, -1,-1,-1, -1, -1, 0, -1,
};

RA_LIST *rlp = &list0[0];
int rxwind = 0, rywind = 0;
int roxwind = 0, roywind = 0;
int fxwd = 100, fywd = 100;
int foxwd = 50, foywd = 50;
int do_two_ramps = 1;
int r0_xda = 0, r0_yda = 1, r1_xda = 2, r1_yda = 3;
int clear_all= 0;
int tst_single= 0; single_step= 0;
RL rl_sav;

int nTrials;
int trialsRemaining = 16;
int nBlocks = 0;
int correctTrials = 0;
int errorTrials = 0;

```

```

int totalTrials = 0;
int percentCorrect = 0;

int
nexttramp(long flag)
{
    if(flag || (rlp->len == -1)) {
        rlp= &list0[0];
        nBlocks++;
        nTrials = 0;
        trialsRemaining = 16;
    }
    else {
        nTrials++;
        totalTrials++;
        trialsRemaining--;
    }

    ra_new(RAMP0, rlp->len, rlp->ang, rlp->vel, rlp->xoff, rlp->yoff,
        rlp->ecode, rlp->type);
    if(do_two_ramps) {
        ra_new(RAMP1, rlp->len, ((rlp->ang + 180) % 360),
            rlp->vel, rlp->xoff, rlp->yoff, rlp->ecode, rlp->type);
    }
    rxwind= rlp->xwind;
    rywind= rlp->ywind;
    roxwind= rlp->oxwind;
    roywind= rlp->oywind;

    off_eye(rlp->eyehoff, rlp->eyevoff);
    off_oe(rlp->oeyehoff, rlp->oeyevoff);

    rlp++;

    return(rlp->ecode);
}

int
rampstart(long LED)
{
    ra_start(RAMP0, 1, LED);
    if(do_two_ramps) ra_start(RAMP1, 1, LED);
    return(0);
}

int
rampstop(void)
{
    ra_stop(RAMP0);
    if(do_two_ramps) ra_stop(RAMP1);
    clear_all_da();
    return(0);
}

```

```

int
ramptset(long rnum, long preset, long rand)
{
    RA_RAMP_TIME ra_time;

    ra_time= ra_compute_time(rnum, preset, rand);
    if(ra_time.ra_ramp_time_preset != -1) {
        set_times("timeramp", (long)ra_time.ra_ramp_time_preset, (long)ra_time.ra_ramp_time_random);
        ramp[rnum].ra_rampflag |= RA_TIMESTART;
    }
    return(0);
}

```

```

int
set_wsiz(long flag)
{
    if(flag) {
        wd_siz(WIND0, rxwind, rywind);
        wd_siz(WIND1, roxwind, roywind);
    } else {
        wd_siz(WIND0, fxwd, fywd);
        wd_siz(WIND1, foxwd, foywd);
    }
    return(0);
}

```

```

int correctTrial()
{
    score(YES);
    correctTrials++;
    if(totalTrials) percentCorrect = 100 * correctTrials / totalTrials;
    return(0);
}

```

```

int errorTrial()
{
    score(NO);
    errorTrials++;
    if(totalTrials) percentCorrect = 100 * correctTrials / totalTrials;
    return(0);
}

```

```

void
rinitf(void)
{
    /*
     * Initializations.
     */
    da_cntrl_2(r0_xda, DA_RAMP_X, RAMP0, r0_yda, DA_RAMP_Y, RAMP0);    /* first ramp */
    da_cntrl_2(r1_xda, DA_RAMP_X, RAMP1, r1_yda, DA_RAMP_Y, RAMP1);    /* second ramp */
    da_cursor(r0_xda, r0_yda, CU_DA_ONE);    /* da cursors */
    da_cursor(r1_xda, r1_yda, CU_DA_TWO);
    clear_all_da();
    wd_disp(D_W_ALLCUR & ~D_W_JOY);    /* all cursors but joystick */
}

```

```

wd_src_pos(WIND0, WD_DA, r0_xda, WD_DA, r0_yda);
wd_src_pos(WIND1, WD_DA, r1_xda, WD_DA, r1_yda);
wd_src_check(WIND0, WD_SIGNAL, EYEH_SIG, WD_SIGNAL, EYEV_SIG);
wd_src_check(WIND1, WD_SIGNAL, OEYEH_SIG, WD_SIGNAL, OEYEV_SIG);
wd_siz(WIND0, fxwd, fywd);
wd_siz(WIND1, foxwd, foywd);
wd_pos(WIND0, 0, 0);
wd_pos(WIND1, 0, 0);
wd_cntrl(WIND0, WD_ON);
wd_cntrl(WIND1, WD_ON);
rlp= &list0[0];
wd_test(1);          /* put windows in test mode */
ustatus("REX test paradigm");
}

int
clear_all_da(void)
{
    da_set_2(r0_xda, 0, r0_yda, 0);
    da_set_2(r1_xda, 0, r1_yda, 0);
    return(0);
}

int marknum= 1;
int
newmark()
{
    RL_CHAN *rcp;

    if(marknum > 4) marknum= 1;
    sd_mark(marknum-1, marknum);
    marknum++;

    return(0);
}

int tst_user= 0;
int strcount= 0;

int
newstring()
{
    if(!tst_user) return(0);
    if(strcount == 0) {
        ustatus("Change 1");
        strcount= 1;
    } else {
        ustatus("Back to test...");
        strcount= 0;
    }
    return(0);
}

#pragma off (unreferenced)

```

```

int
do_clear_vaf(int flag, MENU *mp, char *astr, VLIST *vlp, int *tvadd)
{
#pragma on (unreferenced)
    clear_all_da();
    return(0);
}

static int rl_valid= 0;
#pragma off (unreferenced)
int
setup_single_vaf(int flag, MENU *mp, char *astr, VLIST *vlp, int *tvadd)
{
#pragma on (unreferenced)

    if(tst_single) {
        /*
         * Setup single trace mode. Save current rl struct.
         */
        rl_sav= i_b->rl;
        rl_valid= 1;
        i_b->d_flags |= D_RL_SINGLE;
        single_step= 0;
    }
    else {
        /*
         * Return to continuous mode.
         */
        if(rl_valid) i_b->rl= rl_sav;
        i_b->d_flags &= ~D_RL_SINGLE;
    }
    return(0);
}

/*
 * Declaration of statelist menu.
 */
VLIST state_vl[] = {
{"clear_all_da",    &clear_all, NP, do_clear_vaf, ME_AFT, ME_DEC},
{"do_two_ramps",   &do_two_ramps, NP, NP, 0, ME_DEC},
{"ramp0_xda",      &r0_xda, NP, NP, 0, ME_DEC},
{"ramp0_yda",      &r0_yda, NP, NP, 0, ME_DEC},
{"ramp1_xda",      &r1_xda, NP, NP, 0, ME_DEC},
{"ramp1_yda",      &r1_yda, NP, NP, 0, ME_DEC},
{"fix_xwind",      &fxwd, NP, NP, 0, ME_DEC},
{"fix_ywind",      &fywd, NP, NP, 0, ME_DEC},
{"fix_oxwind",     &foxwd, NP, NP, 0, ME_DEC},
{"fix_oywind",     &foywd, NP, NP, 0, ME_DEC},
{"test_user_msg",  &tst_user, NP, NP, 0, ME_DEC},
{"test_single_trace", &tst_single, NP, setup_single_vaf, ME_AFT, ME_DEC},
{NS},
};

char hm_sv_vl[]= "\

```

```

do_two_ramps-\n\
0: one ramp active\n\
1: two ramps active";

int ral_agf(int call_cnt, MENU *mp, char *astr)
{
    if(call_cnt >= 16) {
        /*
         * Done. Return null to terminate writing of root for
         * this menu.
         */
        *astr= '\0';
    }
    else itoa_RL(call_cnt, 'd', astr, &astr[P_ISLEN]);
    return(0);
}

int ral_maf(int flag, MENU *mp, char *astr, ME_RECUR *rp)
{
    RA_LIST *rlp;
    int rampnum;

    if(*astr == '\0') rampnum = 0;
    else rampnum = atoi(astr);

    if((rampnum < 0) || (rampnum >= 16)) return(-1);
    rlp = &list0[rampnum];
    mp->me_basep = (unsign)rlp;
    return(0);
}

/*
 * Declaration of ramp list menu
 */
VLIST ramp_vl[] = {
{"length", &((RA_LIST *)NP)->len, NP, NP, ME_GB, ME_DEC},
{"angle", &((RA_LIST *)NP)->ang, NP, NP, ME_GB, ME_DEC},
{"velocity", &((RA_LIST *)NP)->vel, NP, NP, ME_GB, ME_DEC},
{"xoff", &((RA_LIST *)NP)->xoff, NP, NP, ME_GB, ME_DEC},
{"yoff", &((RA_LIST *)NP)->yoff, NP, NP, ME_GB, ME_DEC},
{"type", &((RA_LIST *)NP)->type, NP, NP, ME_GB, ME_DEC},
{"ecode", &((RA_LIST *)NP)->ecode, NP, NP, ME_GB, ME_DEC},
NS,
};
char hm_ramp_vl[] = "";

/*
 * Declaration of eye windows menu
 */
VLIST eyewnds_vl[] = {
{"xwind", &((RA_LIST *)NP)->xwind, NP, NP, ME_GB, ME_DEC},
{"ywind", &((RA_LIST *)NP)->ywind, NP, NP, ME_GB, ME_DEC},
{"oxwind", &((RA_LIST *)NP)->oxwind, NP, NP, ME_GB, ME_DEC},
{"oywind", &((RA_LIST *)NP)->oywind, NP, NP, ME_GB, ME_DEC},
};

```



```

NS,
};
char hm_eyewnds_vl[] = "";

/*
 * Declaration of offsets menu
 */
VLIST eyeoffs_vl[] = {
{"eyehoff", &((RA_LIST *)NP)->eyehoff, NP, NP, ME_GB, ME_DEC},
{"eyevoff", &((RA_LIST *)NP)->eyevoff, NP, NP, ME_GB, ME_DEC},
{"oeyehoff", &((RA_LIST *)NP)->oeyehoff, NP, NP, ME_GB, ME_DEC},
{"oeyevoff", &((RA_LIST *)NP)->oeyevoff, NP, NP, ME_GB, ME_DEC},
NS,
};
char hm_eyeoffs_vl[] = "";
/*
 * User-supplied menu table.
 */
MENU umenus[] = {
{"state_vars", &state_vl, NP, NP, 0, NP, hm_sv_vl},
{"separator", NP},
{"ramp_list", &ramp_vl, NP, ral_maf, ME_BEF, ral_agf, hm_ramp_vl},
{"separator", NP},
{"eye_winds", &eyewnds_vl, NP, ral_maf, ME_BEF, ral_agf, hm_eyewnds_vl},
{"eye_offsets", &eyeoffs_vl, NP, ral_maf, ME_BEF, ral_agf, hm_eyeoffs_vl},
NS,
};

/* Declaration of ramp reset function */
void f_rampReset(void)
{
    int i;

    i = 0;
    while(list0[i].len > 0) {
        list0[i].len = 200;
        list0[i].xoff = 0;
        list0[i].yoff = 0;
        i++;
    }

    list0[0].ang = 315;
    list0[1].ang = 90;
    list0[2].ang = 225;
    list0[3].ang = 0;
    list0[4].ang = 180;
    list0[5].ang = 45;
    list0[6].ang = 270;
    list0[7].ang = 135;
    list0[8].ang = 0;
    list0[9].ang = 315;
    list0[10].ang = 45;
    list0[11].ang = 225;
}

```

```

    list0[12].ang = 90;
    list0[13].ang = 180;
    list0[14].ang = 135;
    list0[15].ang = 270;
    return;
}

/* Declaration of ramp length function */
void f_rampLength(int length)
{
    int i;

    for(i = 0; i < 16; i++) list0[i].len = length;
    return;
}

/* Declaration of ramp angle function */
void f_rampAngle(int angle)
{
    int i;

    for(i = 0; i < 16; i++) list0[i].ang += angle;

    return;
}

/* Declaration of ramp offset function */
void f_rampOffset(int Xoff, int Yoff)
{
    int i;

    for(i = 0; i < 16; i++) {
        list0[i].xoff = Xoff;
        list0[i].yoff = Yoff;
    }
    return;
}

/*
 * User-supplied function table.
 */
USER_FUNC ufuncs[] = {
{"reset", &f_rampReset, "void"},
{"length", &f_rampLength, "%d"},
{"angle", &f_rampAngle, "%d"},
{"offset", &f_rampOffset, "%d %d"},
{NS},
};

/*
 * User-supplied real-time variable table
 */
RTVAR rtvars[] = {
{"number of trials", &nTrials},

```

```

{"trials remaining", &trialsRemaining},
{"blocks completed", &nBlocks},
{"total trials", &totalTrials},
{"number correct", &correctTrials},
{"number wrong", &errorTrials},
{"percent correct", &percentCorrect},
{NS},
};

```

```
%%
```

```
id 700
```

```
restart rinitf
```

```
main_set {
```

```
status ON
```

```
begin first:
```

```
code STARTCD
```

```
time 1500
```

```
to pause1
```

```
pause1:
```

```
to pause2 on +PSTOP & softswitch
```

```
to go on -PSTOP & softswitch
```

```
pause2:
```

```
code PAUSECD
```

```
to go on -PSTOP & softswitch
```

```
go:
```

```
code ENABLECD
```

```
rI 0
```

```
to selramp
```

```
selramp:
```

```
do nextramp(0) /* select next ramp */
```

```
to stramp
```

```
stramp:
```

```
/*
```

```
* Start the next ramp. Pass name of device on mirror
```

```
* so that it can be turned off at end of ramp (if it
```

```
* has not already been turned off explicitly by an action.
```

```
*/
```

```
do rampstart(LED1)
```

```
rI 15
```

```
to openw
```

```
openw:
```

```
do awind(OPEN_W)
```

```
to fpon on +RA_STARTED & ramp[RAMP0].ra_rampflag
```

```
fpon:
```

```
code FPONCD
```

```
do dio_on(LED1)
```

```
rI 5
```

```
time 250
```

```
to eyeon
```

```
eyeon:
```

```
rI 40
```

```
time 250
```

```
to error on +EYEALL & eyeflag /* start checking for eye */
```

```
to stimon
```

```

stimon:
  code STIMCD
  do dio_on(BACKLT)
  to error on +EYEALL & eyeflag
  to wdchange
wdchange:
  do set_wsiz(1)    /* flag true for ramp sizes */
  rl 50
  to setpres
setpres:
  /*
  * Compute time until ramp is completed.  Args to
  * ramptset action are a preset and random.
  */
  do ramptset(RAMP0, 80, 20)
  to error on +EYEALL & eyeflag
  to fpoff on +RA_TIMEDONE & ramp[RAMP0].ra_rampflag
fpoff:
  code FPOFFCD
  do dio_off(LED1)
  rl 35
  to stoff
stoff:
  code STOFFCD
  do dio_off(BACKLT)
  to closew
closew:
  do awind(CLOSE_W)
  to wdback
wdback:
  do set_wsiz(0)    /* flag false for fixation sizes */
  to rewon
rewon:
  do dio_on(BEEP)
  time 35
  to rewoff
rewoff:
  do dio_off(BEEP)
  to stopramp
stopramp:
  do rampstop(1)    /* stop ramp; move to 0,0 */
  rl 20
  to correct
correct:
  do correctTrial()
  to first
error:          /* abort trial */
  do awind(CANCEL_W)
  to reset
reset:
  code ERR1CD
  do reset_s(-1)
  to wrong
wrong:

```

```

    do errorTrial()
    to first
  abort list:
    fpoff stoff rewoff stopramp wdback closew
}

/*
 * Ramp timing state set. Works together with ra_compute_time() action.
 */
rampt_set {
  status ON
  begin ramptw:
    to timeramp on +RA_TIMESTART & ramp[RAMP0].ra_rampflag
  timeramp:
    /*
     * The escape time for this state is computed by ramptset()
     * action each time it is called.
     */
    to ramptw on -RA_TIMESTART & ramp[RAMP0].ra_rampflag
    to ramptd
  ramptd:
    code RTDONECD
    do ramptd(RAMP0) /* this action will set RA_TIMEDONE bit */
    to ramptw
}

/*
 * Marks test set.
 */
marks_set {
  status ON
  begin mfirst:
    to msecond
  msecond:
    do newmark()
    time 3000
    to mthird
  mthird:
    do newstring()
    to mfirst
}

```

REX Actions Library

Actions are C-callable subroutines executed by the state-set processor. Each state can contain one action. The action is executed when the state is entered. In rex versions 7.1 and earlier, an action can be called with up to six arguments. These arguments are long integers. If the action is listed in a state, the arguments must be constants. In rex versions 7.2 and later, an action can be called with up to ten arguments. In the standard versions of the actions (i.e. ra_new) the arguments must be long integers. In the "P" versions of the actions (i.e. Pra_new) all arguments are pointers to variables.

State-set description files, or Spot files, usually contain source for some actions that are specific to the particular paradigm. Spot files also call other actions that are general in nature and common to many paradigms. These commonly used actions are stored in a system library, and are automatically searched whenever a new paradigm is linked. The following pages document the actions that are provided in the system actions library.

State Set Controls

reset_s

call the abort list

SYNOPSIS. reset_s(long flag)

flag: constant

ADDITIONAL HEADERS REQUIRED. None

DESCRIPTION. reset_s causes the abort list to be executed. If flag is negative, abort lists of all chains are executed. If flag is zero or positive, the abort list of only the current chain is executed.

Note: do not place a state that calls this action in the abort list. You will create an endless loop.

RETURN VALUE. Returns 0

EXAMPLE. reset_s(-1)

Abort lists of all state chains are executed.

FILE. /rex/act/scntrl.c

set_times Pset_times

set a state's time and random entries

SYNOPSIS. `set_times(char *name, long time, long rand)`

`Pset_times(char *name, long *time, long *rand)`

name: name of the state

time: value of the time entry

random: value of the rand entry

ADDITIONAL HEADERS REQUIRED. None

DESCRIPTION. `set_times` allows users to dynamically set the time and rand entries of a state. If either the time or rand arguments are -1, the corresponding value is not changed.

RETURN VALUE. Returns 0

EXAMPLE. `set_times("timeramp", thisTime, thisRand)`

Sets the time entry of the state timeramp to the value contained in the variable `thisTime`, and sets the rand entry of the state timeramp to the value contained in the variable `thisRand`. The values of `thisTime` and `thisRand` can be changed on a trial-by-trial basis.

FILE. `/rex/act/stateTime.c`

getClockTime, PgetClockTime

get the current rex clock time. Only the pointer version (PgetClockTime) of the function is an action

SYNOPSIS. getClockTime(), PgetClockTime(long *time)

ADDITIONAL HEADERS REQUIRED. None

DESCRIPTION. getClockTime allows users to get the rex clock time.

RETURN VALUE. getClockTime() returns a long value that is the current rex clock time. PgetClockTime(long *time) loads the rex clock time into the variable pointed to by its argument and returns 0.

EXAMPLE. *long time;*

```
time = getClockTime()
```

Gets the current rex clock time. **Note: This function is not an action.** It can be called from an action to get the current clock time. This can be useful for computing reaction times during an experiment.

```
PgetClockTime(&time)
```

Returns the current rex clock time in the variable "time". The variable must be of type long.

Note: This function can be an action or it can be called from an action.

FILE. /rex/act/stateTime.c

Data Window Controls

Rex stores event and analog data in internal, rotating buffers. The data window controls determine how data is written from these internal buffers to files on disk.

awind

control analog data storage window

SYNOPSIS. `awind(long ctlflag)`

`ctlflag`: See below

ADDITIONAL HEADERS REQUIRED. None

DESCRIPTION. `awind` controls the analog storage window. *ctlflag* may be one of the following:

`OPEN_W`: open analog window.

`CLOSE_W`: close analog window.

`CANCEL_W`: cancel currently open analog window.

RETURN VALUE. Returns the following event codes:

`WOPENCD`: If request is to open window.

`WCLOSECD`: If request is to close window.

`WCANCELCD`: If request is to cancel window

`WERRCD`: If `ctlflag` is an illegal value.

Note that these codes are returned based on the value of `ctlflag` and DO NOT signify that the window command was successfully executed. For example if an open request is made during the `w_post` time after the previous window has been closed, the window will not be opened, however the `WOPENCD` event code is entered into the event buffer signifying that the request was issued.

EXAMPLE. `awind(OPEN_W)`

This command will open the analog window from the current time minus the `w_pre` time.

SEE ALSO. `pre_post()`, `uw_set()`

FILE. `/rex/act/awind.c`

pre_post, Ppre_post

set pre-time and post-time of analog window

SYNOPSIS. `pre_post(long pre_time, long post_time) Ppre_post(long *pre_time, long *post_time)`
pre_time, post_time: times in units of msec. *pre_time, *post_time are pointers to long variables containing the pre and post times.

ADDITIONAL HEADERS REQUIRED. None

DESCRIPTION. pre_post sets times associated with the manipulation of the analog window. The pre-time is the time previous to the window open request that analog data saving is begun. The post-time is the time after the window close request that analog data continues to be saved. If a window open request comes shortly after the previous close request it may be possible that the previous post-time and current pre-time will cause window overlap. In this case the full contents of both windows is still saved and there will be duplication of stored data on disk. This guarantees that data records will always be the full size requested.

Note well a possible trouble area: if an open request is given during the post-time the request is ignored. Only one window can be processed at a time; open requests are not stacked.

Please also note that pre-times and post-times are guaranteed to be at least as long as specified. Most likely, however, the actual pre-time and post-time will be somewhat longer than the times specified. This is due to the way REX manipulates and stores data from the in-memory circular buffers. Default values are 100 msec for both pre-time and post-time.

RETURN VALUE. Returns 0

EXAMPLE. `pre_post(100, 100), Ppre_post(&preTime, &postTime)`

Set the pre-time and post-time to at least 100 msec. Set the pre-time and post-time to at least the values contained in the variables preTime and postTime.

SEE ALSO. awind(), uw_set()

FILE. /rex/act/awind.c

uw_set

control latched unit data storage window

SYNOPSIS. `uw_set(long ctlflag)`

ctlflag: See below

ADDITIONAL HEADERS REQUIRED. None

DESCRIPTION. `uw_set` controls the latched unit storage window. *ctlflag* may be one of the following:

1: open the unit window.

0: close the analog window.

By default, *ctlflag* is 1. This command will have no effect if `LATCHED_UNITS` is not defined in `cnf.h`.

RETURN VALUE. Returns the following event codes:

`UWOPENCD`: If request is to open window.

`UWCLOSECD`: If request is to close window.

EXAMPLE. `uw_set(1)`

This command will open the latched unit window from the current time.

SEE ALSO. `awind()`, `pre_post()`

FILE. `/rex/act/uw_set.c`

Digital Output Controls

dio_on, dio_off, dio_onoff, dio_out, Pdio_on, Pdio_off, Pdio_onoff, Pdio_out

control digital outputs

SYNOPSIS. `dio_on(DIO_ID id), dio_off(DIO_ID id), dio_onoff(DIO_ID id_on, DIO_ID id_off),
dio_out(DIO_ID id, long value)`

DIO_ID: Device id specifying device, port, and bit(s) to turn on or off (see below)

`Pdio_on(DIO_ID *id), Pdio_off(DIO_ID *id), Pdio_onoff(DIO_ID *id_on, DIO_ID *id_off),
Pdio_out(DIO_ID *id, long *value);`

DIO_ID * address of the device id specifying device, port and bits to turn on or off (see below)

ADDITIONAL HEADERS REQUIRED. None

DESCRIPTION. `dio_on, dio_off, dio_onoff` and `dio_out` control digital output devices. The output device, port, and bit(s) to turn on or off are specified by the DIO_ID. This id is defined by using the macro `Dio_id()`. For example, suppose an LED is connected to bit 3 on port 2 of the Industrial Computer Source PCDIO board. One would define a DIO_ID as follows:

```
#define LED1 Dio_id(PCDIO_DIO, 2, 0x4)
```

One could then turn this LED on by using the `dio_on` action:

```
dio_on(LED1);
```

To use the pointer version of this action, define a DIO_ID and assign it to a variable as follows:

```
#define LED1 Dio_id(PCDIO_DIO, 2, 0x4)
```

```
long led;
```

```
led = LED1;
```

```
Pdio_on(&led);
```

The `dio_off` and `Pdio_off` actions turn the specified bits off. The `dio_onoff` and `Pdio_onoff` actions take two id arguments- the first id is turned on, the second is turned off. The actions `dio_on`, `Pdio_on`, `dio_off`, `Pdio_off`, `dio_onoff`, and `Pdio_onoff` keep a software state of the digital output port. Setting or clearing bits does not affect the state of other bits previously set in the same port. The actions `dio_out` and `Pdio_out` do NOT keep a software state. The contents of value are directly copied to the port; all the bits in the port will be changed to match value.

Definitions for DIO_IDs are kept in the header `/rex/hdr/cnf.h`, and in various local headers in `/rex/ssset`. This system enhances portability of Spot files among different laboratories. To use a Spot file in a laboratory where devices are connected to different interfaces or bits, one only has to change the DIO_ID definitions, not the Spot files. For further information see the header file `/rex/hdr/device.h`.

RETURN VALUE. Returns 0

EXAMPLE. `dio_on(LED1)`

This example turns on LED1.

```
dio_off(LED1)
```

This example turns off LED1.

```
dio_onoff(LED2, LED1)
```

This example turns on LED2, and turns off LED1.

SEE ALSO. `/rex/hdr/device.h, /rex/hdr/cnf.h`

FILE. `/rex/act/dout.c, /rex/int/dio.c`

Digital to Analog Controls

da_cntrl, da_cntrl_1, da_cntrl_2 Pda_cntrl, Pda_cntrl_1, Pda_cntrl_2

control d/a converter

SYNOPSIS. da_cntrl_1(long da, long s, long snum)

Pda_cntrl_1(long *da, long *s, long *snum);

da_cntrl_2(long da0, long s0, long snum0, long da1, long s1, long snum1)

Pda_cntrl_2(long *da0, long *s0, long *snum0, long *da1, long *s1, long *snum2)

da, da0, da1: d/a converter number

s, s0, s1: source connected to d/a converter output

snum, snum0, snum1: source number specifier

Note: following function cannot be called as an action:

da_cntrl(int cnt, DA_CNTRL_ARG (*ap[])) /* not an action! */

typedef struct {

int da_cntrl_num;

int da_cntrl_src;

int da_cntrl_src_num;

} DA_CNTRL_ARG;

da_cntrl_num: d/a converter number

da_cntrl_src: source connected to d/a converter output

da_src_num: source number specifier

Note: the pointer version of this function can be called as an action:

Pda_cntrl(int *cnt, DA_CNTRL_ARG (*ap[]))

ADDITIONAL HEADERS REQUIRED. None

DESCRIPTION. The da_cntrl_1, Pda_cntrl_1, da_cntrl_2, and Pda_cntrl_2 actions control the operation of the d/a converter. da_cntrl_1 and Pda_cntrl_1 can be called to control a single converter. da_cntrl_2 and Pda_cntrl_2 can be called to control two different converters. In the case of the da_cntrl_2 and Pda_cntrl_2 actions, the operation of both converters will be changed as close together in time as possible with no interrupts permitted between the first and second converter.

The da_cntrl_1, da_cntrl_2 actions take the following arguments:

danum: d/a converter number

src: source to which the d/a converter is connected. This source supplies the output of the d/a. The source can be any of the following:

DA_STBY: d/a is in standby mode and is not connected to a source. When in this mode the output of the d/a can still be changed, however, by calling the da_set_1, da_set_2 actions.

DA_RAMP_X: source is the X component of the internal ramp generator. src_num specifies the ramp generator number.

DA_RAMP_Y: source is the Y component of the internal ramp generator. src_num specifies the ramp generator number.

DA_JOY_X: source is the X component of the joystick. src_num is ignored.

DA_JOY_Y: source is the Y component of the joystick. src_num is ignored.

DA_WIND_X: source is the X component of the position of the eye window. *src_num* specifies the window number.

DA_WIND_Y: source is the Y component of the position of the eye window. *src_num* specifies the window number.

DA_SIGNAL: source is a signal. *src_num* specifies the signal number.

DA_MEM: source is an internal memory array. *src_num* specifies the internal memory array number.

src_num: source number specifier, if needed.

The pointer versions of these actions take pointers to variables as arguments

By default, all d/a converters are initialized to DA_STBY mode unless changed by calling this action.

The function *da_cntrl* can be used to control the operation of more than two d/a converters. The operation of the d/a's will be changed as close together in time as possible, with no intervening interrupts allowed. *da_cntrl* is not an action, however, and it cannot be called as an action from a state because its arguments are not of type long. However, it can be called from user-written C-code subroutines in the Spot file. This function takes the following arguments:

cnt: number of DA_CNTRL_ARG structs passed as arguments

DA_CNTRL_ARG: pointer to array of structs containing d/a converter number, source, and source number specifier.

The function *Pda_cntrl* is an action because its arguments are pointers to variables.

Note that there would normally be no reason to use the *da_cntrl* function instead of the *da_cntrl_1* and *da_cntrl_2* actions unless one wanted to control more than two d/a's as simultaneously as possible. The *da_cntrl_1* and *da_cntrl_2* actions are wrapper functions that repackage the arguments and call *da_cntrl*.

RETURN VALUE. Returns 0

EXAMPLES. *da_cntrl_2(0, DA_RAMP_X, 0, 1, DA_RAMP_Y, 0).*

Connect d/a number 0 to the X component of ramp generator 0, and d/a number 1 to the Y component of ramp generator 0.

```
da_cntrl_1(4, DA_SIGNAL, 0)
```

Connect d/a number 4 to signal number 0.

```
DA_CNTRL_ARG da_arg_struct[] = {
```

```
{0, DA_RAMP_X, 0},
```

```
{1, DA_RAMP_Y, 0},
```

```
{2, DA_RAMP_X, 1},
```

```
{3, DA_RAMP_Y, 1}};
```

```
da_cntrl(4, &da_arg_struct)
```

Connect d/a numbers 0 and 1 to ramp generator 0, and connect d/a numbers 2 and 3 to ramp generator 1.

SEE ALSO. *da_cursor()*, *da_mode()*, *da_offset()*, *da_set_1,2()*

FILE. */rex/act/da_cntrl.c*

da_set, da_set_1, da_set_2, Pda_set, Pda_set_1, Pda_set_2

output value to d/a converter

SYNOPSIS. da_set_1(long num, long val) da_set_2(long num0, long val0, long danum1, long value1)

Pda_set_1(long *num, long *val) da_set_2(long *num0, long *val0, long *num1, long *value1)

num: d/a converter number

val: output value

Note: following function cannot be called as an action:

```
da_set(int cnt, DA_SET_ARG (*ap)[]) /* not an action! */
```

```
typedef struct {  
int da_set_num;  
int da_set_val;  
} DA_SET_ARG;
```

da_set_num: d/a converter number

da_set_val: output value

Note: the pointer version of this function can be called as an action

```
Pda_set(int *cnt, DA_SET_ARG (*ap)[])
```

ADDITIONAL HEADERS REQUIRED. None

DESCRIPTION. The da_set_1 and da_set_2 actions cause the specified value to be output to the d/a converter. da_set_1 can be called to output to a single converter. da_set_2 can be called to output two values to two different converters. In the case of the da_set_2 action, both converters will be updated as close together in time as possible with no interrupts permitted between the first and second converter.

The function da_set can be used to update more than two d/a converters. The d/a's will be updated as close together in time as possible, with no intervening interrupts allowed. da_set is not an action, however, and it cannot be called as an action from a state because its arguments are not of type long. However, it can be called from user-written C-code subroutines in the Spot file. This function takes the following arguments:

cnt: number of DA_SET_ARG structs passed as arguments

DA_SET_ARG: pointer to array of structs containing d/a converter number and output value.

Note that there would normally be no reason to use the da_set function instead of the da_set_1 and da_set_2 actions unless one wanted to update more than two d/a's as simultaneously as possible. The da_set_1 and da_set_2 actions are wrapper functions that repackage the arguments and call da_set.

RETURN VALUE. Returns 0

EXAMPLE. da_set_1(0, 100)

Output value 100 to d/a converter number 0.

```
da_set_2(0, 100, 1, 100)
```

Output value 100 to d/a's 0 and 1 as close together in time as possible.

```
DA_SET_ARG da_arg_struct[] = {  
{0, 100},  
{1, 100},  
{2, 100},  
{3, 100}};  
da_set(4, &da_arg_struct)
```

Output value 100 to first four d/a's as close together in time as possible. Cannot be called as an action!

SEE ALSO. da_cntrl_1,2(), da_cursor(), da_mode(), da_offset()

FILE. /rex/act/da_set.c

da_mode Pda_mode

set d/a converter offset output mode

SYNOPSIS. `da_mode(long danum, long mode) Pda_mode(long *danum, long *mode)`

danum: d/a converter number

mode: offset output mode

ADDITIONAL HEADERS REQUIRED. None

DESCRIPTION. The `da_mode` action determines whether an offset will be applied to the output of the d/a converter. mode can be the following:

DA_DIRECT: no offset is applied to d/a output

DA_OFFSET_CONN: offset is applied to d/a output for all connected sources (all sources except DA_STBY)

DA_OFFSET_STBY: offset is applied to d/a output when source is DA_STBY

Note that DA_OFFSET_CONN and DA_OFFSET_STBY can be specified together or each individually. The applied offset is provided by the `da_offset` action. Offset mode is useful to accomplish stabilization.

By default, all d/a converters are initialized to DA_DIRECT mode unless changed by calling this action.

RETURN VALUE. Returns 0

EXAMPLE. `da_mode(0, DA_OFFSET_CONN)`

Set d/a converter 0 to apply offset to each output value when source is anything other than DA_STBY (e.g. when the source is the signal for eyeh).

`da_mode(0, DA_OFFSET_CONN | DA_OFFSET_STBY)`

Set d/a converter 0 to apply offset to each output value for all connected sources and also when source is DA_STBY.

SEE ALSO. `da_cntrl_1,2()`, `da_cursor()`, `da_offset()`, `da_set_1,2()`

FILE. `/rex/act/da_mode.c`

da_offset Pda_offset

specify offset for d/a converter

SYNOPSIS. da_offset(long danum, long offset) Pda_offset(long *danum, long *offset)

danum: d/a converter number

offset: offset value

ADDITIONAL HEADERS REQUIRED. None

DESCRIPTION. The da_offset action specifies an offset for a d/a converter. This offset will not be applied, however, unless the d/a is set to one of the offset modes (see da_mode() action). The Pda_offset action takes pointers to values as arguments.

By default, the offset of all d/a converters is initialized to 0 unless changed by calling this action.

RETURN VALUE. Returns 0

EXAMPLE. *da_offset(0, 100)*

Set offset for d/a converter number 0 to 100. Note that this offset will not be applied unless the d/a converter is set to one of the offset modes (see da_mode() action).

SEE ALSO. da_cntrl_1,2(), da_cursor(), da_mode(), da_set_1,2()

FILE. /rex/act/da_offset.c

da_cursor Pda_cursor

specify d/a numbers for the two d/a window display cursors.

SYNOPSIS. *da_cursor*(long x_danum, long y_danum, long cursor)

Pda_cursor(long *x_danum, long *y_danum, long *cursor)

x_danum: d/a converter number for x position of cursor

y_danum: d/a converter number for y position of cursor

cursor: d/a cursor

ADDITIONAL HEADERS REQUIRED. None

DESCRIPTION. The REX window display incorporates two cursors for d/a converters (excessive cpu time would be required to support more than two d/a cursors). These cursors are represented by an octagon symbol and a cross sign symbol. The *da_cursor* action is used to specify the d/a converter numbers corresponding to each of these two cursors. Arguments are:

x_danum: d/a number for x component of cursor position

y_danum: d/a number for y component of cursor position

cursor specifies one of the two available cursors:

CU_DA_ONE: cursor shaped like an octagon

CU_DA_TWO: cursor shaped like an X

By default, the CU_DA_ONE cursor is connected to d/a converters 0 and 1, and the CU_DA_TWO cursor is connected to d/a converters 2 and 3.

RETURN VALUE. Returns 0

EXAMPLE. *da_cursor*(4, 5, CU_DA_ONE)

Set the octagon cursor X position to d/a number 4, and the Y position to d/a number 5.

SEE ALSO. *da_cntrl_1,2()*, *da_mode()*, *da_offset()*, *da_set_1,2()*

FILE. /rex/act/da_cursor.c

Ramp Controls

Rex can generate up to 10 linear arrays of values called ramps. These arrays can be used to control the d/a converters.

ra_new Pra_new

specify new ramp

SYNOPSIS. ra_new(int rnum, int len, int angle, int vel, int xoff, int yoff, int ecode, int type)

Pra_new(int *rnum, int *len, int *angle, int *vel, int *xoff, int *yoff, int *ecode, int *type)

The ra_new routine can not be specified as an action in a state due to size of argument list. Must be called from a C-subroutine in the Spot file. However, the Pra_new routine can be specified as an action in a state.

rnum: ramp number

len: tenths of degree

angle: degrees

vel: degrees per second

xoff, yoff: tenths of degree

ecode, type: See below

ADDITIONAL HEADERS REQUIRED. None

DESCRIPTION. ra_new specifies and computes parameters for a new ramp from the given arguments. Ramps are specified in a combination of polar and rectangular coordinates as follows:

len: one half total length of ramp in tenths of degree.

angle: polar angle of ramp, assuming 0 degrees is motion from monkey right to left in horizontal plane. Higher angles proceed in clockwise direction, 90 degrees is motion from monkey view bottom to top in vertical plane.

vel: Velocity of ramp in degrees/sec. Range: 1 to 1000 degs/sec.

xoff, yoff: x and y offset of Cartesian reference point of ramp in tenths of degree. Even though the ramp is primarily specified in polar coordinates, its reference point may have a Cartesian offset. See type below for explanation of the reference point.

ecode: currently not used.

type: flag used to specify type of ramp.

The ramp has a reference point that can be given a Cartesian offset. This reference point can be considered to be the beginning, middle, or end of the ramp by setting the proper bit in type. For example, if a ramp were specified with a length of 10 degrees and the reference point in the middle, the ramp would begin 10 degrees before the reference point and continue to 10 degrees after the reference point (length is one half total length). If, however, the reference point were the beginning the ramp would start at the reference point and continue for 20 degrees.

type must have one (and only one) of the following bits set:

RA_CENPT (02): reference point is the middle or center of ramp.

RA_BEGINPT (04): reference point is the beginning of ramp.

RA_ENDPT (010): reference point is the end of ramp.

In addition to the above flag bits, another bit causes the mirrors to begin motion at a point before the actual start of the ramp. This initial distance is calculated to provide 25 msec of acceleration time for the mirrors to reach a stable velocity before reaching the starting point of the ramp. Therefore if a stimulus is illuminated at the starting point of the ramp the mirrors will already be at constant velocity.

RA_NO25MS (01): If set, do not add acceleration distance to beginning of ramp.

Note well that `ra_new()` or `Pra_new()` must be called before every ramp, even if the parameters of the ramp haven't changed from the previous ramp. For example, if the same ramp is to be output over and over, `ra_new()` or `Pra_new()` must be called between each one.

Variables controlling the ramp may be accessed from user-written C code if needed. However, these variables should not be written or changed- only read. The header `rex/hdr/ramp.h` defines the `ramp[]` structure. Some variables of interest:

ramp[rnum].ra_timeleft: time left on ramp
ramp[rnum].ra_rampflag: state of ramp generator
ramp[rnum].ra_x.ra_pos: current X position of ramp
ramp[rnum].ra_y.ra_pos: current Y position of ramp

The `ra_compute_time` and `ramptd` functions can be used to vary the length of ramps in a random fashion:

RETURN VALUE. Returns 0

EXAMPLE. `ra_new(0, 100, 90, 10, 0, 0, 0, RA_BEGINPT / RA_NO25MS)`

Specifies new ramp number 0 which begins at offset 0,0 and moves vertically from bottom to top for 20 degrees. There is no 25 msec acceleration time.

SEE ALSO. •`ra_phistart()`, `ra_phiend()`, `ra_start()`, `ra_stop()`, `ra_tostart()`

NOTES. The ramp is the only built-in waveform generator in REX. To drive the d/a's with other types of waveforms (e.g. sinusoids) the waveform is pre-computed and stored in a memory buffer. This buffer can then be used to drive the d/a directly by specifying the `DA_MEM` source (see `da_cntrl_1,2`).

FILE. `/rex/act/ramp_act.c`

ra_compute_time Pra_compute_time

Compute the time remaining before current ramp completes based on specified preset and random percentages

SYNOPSIS. `ra_compute_time(long rnum, long presetper, long randper)`

`Pra_compute_time(long *rnum, long *presetper, long *randper, RA_RAMP_TIME *ra_time)`

This function computes the time remaining before the ramp completes based on the specified preset and random percentages. The *ra_compute_time* version of this function can not be specified as an action because it returns a structure of type RA_RAMP_TIME rather than an int. It must be called from an action. The *Pra_compute_time* version of this function can be specified as an action because it returns the RA_RAMP_TIME structure in the fourth argument.

```
typedef struct {  
    long ra_ramp_time_preset;  
    long ra_ramp_time_random;  
} RA_RAMP_TIME;
```

rnum: ramp number

presetper: preset percentage

randper: random percentage

RETURN VALUE. The `ra_compute_time` function returns a structure of type RA_RAMP_TIME. The `Pra_compute_time` action returns 0

EXAMPLE. `ra_time = ra_compute_time(rnum, preset, rand).`

`Pra_compute_time(&rnum, &preset, &rand, &ra_time)`

SEE ALSO. •`ra_phistart()`, `ra_phiend()`, `ra_start()`, `ra_stop()`, `ra_tostart()`

FILE. `/rex/act/ramp_act.c`

ramptd Pramptd

This function sets the RA_TIMEDONE flag for the current ramp. This function is an action, and is used in conjunction with ra_compute_time or Pra_compute_time

SYNOPSIS. ramptd(long rnum) Pramptd(long *rnum)

The ra_compute_time function computes the time remaining until the ramp completes based on the specified percentages. Suppose one wanted to stop a ramp after 70% of the duration plus an added random 10%. The ra_compute_time function would be called with arguments of 70 for presetper and 10 for randper. The function would return an instance of the RA_RAMP_TIME struct with the computed preset and random times. These values are then inserted into the time and random fields of a state (this state is usually in a separate chain from the main paradigm). When this state transitions the action ramptd is called to set the RA_TIMEDONE bit to terminate the ramp. An example of the use of these functions is in the test paradigm /rex/sset/tstramp.d.

RETURN VALUE. Returns 0

EXAMPLE. *ramptd(RAMP0) Sets the RA_TIMEDONE bit in ramp 0*

SEE ALSO. •ra_phistart(), ra_phiend(), ra_start(), ra_stop(), ra_tostart()

FILE. /rex/act/ramp_act.c

ra_tostart, Pra_tostart

move mirrors to starting position of ramp

SYNOPSIS. ra_tostart(long rnum) Pra_tostart(long *rnum)

rnum: ramp number

ADDITIONAL HEADERS REQUIRED. None

DESCRIPTION. ra_tostart moves the mirrors to the starting position of the specified ramp. This action is not necessary in general since ra_start moves the mirrors to the starting position as part of initiating a ramp. However for some paradigms such as fixation- ramp away, it is necessary to hold the mirrors at the starting position for some time before the ramp begins.

Note that if the 25 msec acceleration time is enabled, the mirrors will move to a position before the specified start of the ramp.

RETURN VALUE. Returns 0

EXAMPLE. ra_tostart(0)

This action moves the mirrors to the starting position of ramp number 0.

SEE ALSO. ra_new(), ra_phistart(), ra_phiend(), ra_start(), ra_stop()

FILE. /rex/act/ramp_act.c

ra_start Pra_start

start ramp

SYNOPSIS. ra_start(long rnum, long ctlflag, DIO_ID device)

Pra_start(long *rnum long *ctlflag, DIO_ID *device)

rnum: ramp number

ctlflag: constant

device: device specification recognized by dio_off()

ADDITIONAL HEADERS REQUIRED. None

DESCRIPTION. ra_start initiates the ramp. Following arguments may be specified:

rnum: ramp number

ctlflag: if non-zero, there will be a 40 msec pause after moving the mirrors to the starting point of the ramp before starting the ramp. This allows the mirrors to settle after the jump to the starting position. Note that this settling time is independent of the 25 msec acceleration time- one does not affect the other; either, none, or both can be specified.

device: If non-zero, this argument is taken to be the device of the illumination stimulus on the mirrors. When the ramp completes, it is turned off.

A bit is set in ramp[rnum].ra_rampflag when the ramp actually begins (the mirrors are directly over the starting position). This takes into account settling pauses or the 25 msec acceleration time if enabled. Therefore this bit can be tested to determine when an illumination stimulus should be turned on (octal value of bit shown in parenthesis):

RA_STARTED (01): when this bit becomes set in ramp[rnum].ra_rampflag the mirrors are over the starting position of the ramp.

RETURN VALUE. Returns 0

EXAMPLE. ra_start(0, 1, LED1)

Start ramp number 0 with settling pause; turn off LED1 automatically when ramp completes.

SEE ALSO. ra_new(), ra_phistart(), ra_phiend(), ra_stop(), ra_tostart()

FILE. /rex/act/ramp_act.c

ra_stop Pra_stop

stop ramp

SYNOPSIS. ra_stop(long rnum) Pra_stop(long *rnum)

rnum: ramp number

ADDITIONAL HEADERS REQUIRED. None

DESCRIPTION. ra_stop terminates the specified ramp.

RETURN VALUE. This action may return the following values:

RDONECD: If ramp had not completed but was currently running when ra_stop was executed.

0: If ramp had completed when ra_stop was executed.

EXAMPLE. ra_stop(0)

Stop ramp number 0 if currently running.

SEE ALSO. ra_new(), ra_phistart(), ra_phiend(), ra_start(), ra_tostart()

FILE. /rex/act/ramp_act.c

ra_phistart Pra_phistart

start phi blinking on ramp

SYNOPSIS. ra_phistart(long rnum), Pra_phistart(long *rnum)

rnum: ramp number

ADDITIONAL HEADERS REQUIRED. None

DESCRIPTION. ra_phistart switches the ramp device (ramp[rnum].ra_device) to the phi device (ramp[rnum].ra_phidevice), and starts phi blinking. The variables ramp[rnum].ra_phidevice, ramp[rnum].ra_pontime, and ramp[rnum].ra_pofftime must have been previously initialized.

RETURN VALUE. Returns 0

EXAMPLE. ra_phistart(0)

Start phi blinking on ramp number 0.

SEE ALSO. ra_new(), ra_phiend(), ra_start(), ra_tostart()

FILE. /rex/act/ramp_act.c

ra_phiend Pra_phiend

end phi blinking on ramp

SYNOPSIS. ra_phiend(long rnum) Pra_phiend(long *rnum)
rnum: ramp number

ADDITIONAL HEADERS REQUIRED. None

DESCRIPTION. ra_phiend Ends phi blinking. The variables ramp[rnum].ra_phidevice
ramp[rnum].ra_pontime and ramp[rnum].ra_pofftime must have been previously initialized.

RETURN VALUE. Returns 0

EXAMPLE. ra_phiend(0)
End phi blinking on ramp number 0.

SEE ALSO. ra_new(), ra_phistart(), ra_start(), ra_tostart()

FILE. /rex/act/ramp_act.c

Memory Array Controls

Rex allows users to define up to 16 arrays of arbitrary values that can be used to control the d/a converters. This allows greater flexibility than the simple linear arrays provided by the ramp generator

ma_cntrl Pma_cntrl

Control memory array resources

SYNOPSIS. `ma_cntrl(int num, int *map, int count, int rate, int repeat)`

`Pma_cntrl(int *num, int *map, int *count, int *rate, int *repeat)`

num: number of the memory array

map: pointer to memory array data

count: number of points in memory array data

rate: number of milliseconds to wait before sending next element

repeat: number of times to repeat memory array

ADDITIONAL HEADERS REQUIRED. none.

DESCRIPTION. `ma_cntrl` registers a user defined array with the *int* process. Once registered, the contents of the memory array may be output to a d/a converter by linking the array to the port using the *da_cntrl* commands above.

To use *ma_cntrl*, you first allocate space for the array, then assign values to the array elements. You then call *ma_cntrl* to register the parameters of the array with *int*. After initializing the array resources, *ma_cntrl* calls *ma_reset* to set initial parameters.

RETURN VALUE. Returns 0.

EXAMPLE:

```
int array[500];
int scale = 800;
int rate = 5;
int repeat = 1;
double ang_inc;
ang_inc = (2 * M_PI) / 500;
for(i = 0; i < 500; i++) array[i] = sin(i * ang_inc) * scale;
ma_cntrl(0, array, 500, rate, repeat);
```

This example establishes an array of 500, initializes the elements of the array with a sinusoid, and registers the array with *int*.

SEE ALSO. `ma_start()`, `ma_stop()`, `ma_reset()`

FILE. `/rex/act/ma_set.c`

ma_reset Pma_reset

reset previously registered memory array resources to their initial state.

SYNOPSIS: `ma_reset(int num) Pma_reset(int *num)`

num: number of the memory array

ADDITIONAL HEADERS REQUIRED. None.

DESCRIPTION: If you wish to output a memory array on a number of trials, you do not need to define and register for each trial. Rather, you may define and register the array once, then merely call *ma_reset* before each trial to reset the array resources to their initial states. This is particularly useful if computation of the array values is fairly time-consuming.

RETURN VALUE. None

EXAMPLE. `ma_reset(0);`

This command resets the resources of a previously registered array so that it can be played out again.

SEE ALSO. `ma_cntrl()`, `ma_start()`, `ma_stop()`

FILE. `/rex/act/ma_set.c`

ma_start Pma_start

start outputting a memory array to the d/a converters.

SYNOPSIS. `ma_start(int num); Pma_start(int *num)`

num: memory array number

ADDITIONAL HEADERS REQUIRED. None.

DESCRIPTION. `ma_start` initiates output of the memory array. The argument specifies that array to initiate. You must define and register the array before calling `ma_start`. Also, before calling `ma_start`, you must make sure that the array resources are in their initial states by calling `ma_cntrl` or `ma_reset`.

Once Rex begins to play the memory array, it sets the MA_RUN bit in `ma[num].ma_status`. After Rex has play the array requisite number of repeats, it clears the MA_RUN bit in `ma[num].ma_status`. This allows you to define escapes on the beginning and end of the memory array output.

RETURN VALUE. returns 0

EXAMPLE. `ma_start(0)`

This command starts playing memory array 0

SEE ALSO. `ma_cntrl()` `ma_reset()` `ma_stop()`

FILE. `/rex/act/ma_set.c`

ma_stop Pma_stop

stop memory array

SYNOPSIS. ma_stop(int num) Pma_stop(int *num)

num: number of memory array to stop

ADDITIONAL HEADERS REQUIRED. None

DESCRIPTION. ma_stop stops a previously started memory array. The argument specifies that array to stop. After Rex stops the array, it clears the MA_RUN bit in ma[num].ma_status. This allows you to define escapes on the beginning and end of the memory array output.

RETURN VALUE. returns 0

EXAMPLE. ma_stop(0)

This command stops playing memory array 0

SEE ALSO. ma_cntrl() ma_reset() ma_start()

FILE. /rex/act/ma_set.c

Running Line Controls

rl_setbar

set bar value on running line display

SYNOPSIS. `rl_setbar(long value)`

value: bar value

ADDITIONAL HEADERS REQUIRED. None

DESCRIPTION. `rl_setbar` sets the value of the bar line on the running line display

RETURN VALUE. Returns 0

EXAMPLE. `rl_setbar(10)`

Set the bar line value to 10.

SEE ALSO. `rl_setbar()`, `rl_addbar()`, `rl_trig()`, `rl_stop()`, `rl_erase()`, `sd_mark()`

FILE. `/rex/act/rl_set.c`

rl_addbar

add to the current bar value on running line display

SYNOPSIS. `rl_addbar(long value)`

value amount to add to current bar value

ADDITIONAL HEADERS REQUIRED. None

DESCRIPTION. `rl_addbar` adds a value to the current value of the bar line on the running line display.

RETURN VALUE. Returns 0

EXAMPLE. `rl_addbar(-10)`

Subtract 10 from the current value of the bar line.

SEE ALSO. `rl_setbar()`, `rl_addbar()`, `rl_trig()`, `rl_stop()`, `rl_erase()`, `sd_mark()`

FILE. `/rex/act/rl_set.c`

rl_setspike

put a spike dot on running line display

SYNOPSIS. `rl_setspike(long spike_num)`

spike_num: spike number

ADDITIONAL HEADERS REQUIRED. None

DESCRIPTION. `rl_setspike` puts a dot on the running line display signifying the occurrence of the designated spike.

RETURN VALUE. Returns 0

EXAMPLE. `rl_setspike(0)`

Put a dot on the running line display for spike number 0.

SEE ALSO. `rl_setbar()`, `rl_addbar()`, `rl_trig()`, `rl_stop()`, `rl_erase()`, `sd_mark()`

FILE. `/rex/act/rl_set.c`

sd_mark

put a mark on a signal channel running line trace

SYNOPSIS. *sd_mark*(long channel, long mark)

ADDITIONAL HEADERS REQUIRED. None

DESCRIPTION. *sd_mark* puts a mark on a running line signal channel trace. This is used by the saccade detector to mark the beginning and end of saccades, but is also available to the user to place marks. Each mark is composed of a varying number of dots situated vertically. The maximum number of marks is defined by `RL_MARKMAX` in the file `idsp.h`.

RETURN VALUE. Returns 0

EXAMPLE. *sd_mark(0, 3)*

Place mark number 3 on the running line trace for channel 0.

SEE ALSO. *rl_setbar()*, *rl_addbar()*, *rl_trig()*, *rl_stop()*, *rl_erase()*, *sd_mark()*

FILE. `/rex/act/sd_set.c`

Saccade Detector Controls

sd_set

saccade detector control

SYNOPSIS. *sd_set*(long ctlflag)

ctlflag: octal constant

ADDITIONAL HEADERS REQUIRED. None

DESCRIPTION. *sd_set* controls the saccade detector. If *ctlflag* is non-zero, the saccade detector is turned on. If *ctlflag* is zero, it is turned off.

The variable *sacflags* can be tested for the following values:

SF_HOR (01): if this bit is set detector is following saccade on horizontal component; if not set following saccade on vertical component.

SF_ONSET (010): saccade start seen

SF_GOOD (020): saccade accepted

The global variables *h_sacinit* and *v_sacinit* contain the initial position of a possible saccade. The global variables *h_sacend* and *v_sacend* contain the final position of the most recently accepted saccade. The global variables *h_sacsize* and *v_sacsize* contain the size of the most recently accepted saccade.

RETURN VALUE. Returns 0

EXAMPLE. *sd_set(1)*

Saccade detector is turned on.

FILE. /rex/act/sd_set.c

Eye Window Controls

wd_cntrl

turn window on/off

SYNOPSIS **wd_cntrl(long wdnun, long flag).** wdnun: window number
flag: control flag

ADDITIONAL HEADERS REQUIRED. None

DESCRIPTION. The `wd_cntrl` action turns the specified eye window on/off. `flag` can be the following:

WD_OFF: turn window off

WD_ON: turn window on

Turning an eye window on causes Rex to set corresponding bits in the global variable `eyeflag` depending on whether the eye is inside or outside the window. Separate tests are made for vertical and horizontal position. Turning an eye window off prevents Rex from testing eye position against that window.

RETURN VALUE. Returns 0

EXAMPLE. `wd_cntrl(0, WD_ON)`

Turn window number 0 on.

SEE ALSO. `wd_center()`, `wd_src_check,pos()`, `wd_cursor()`, `wd_disp()`, `wd_pos()`, `wd_siz()`

FILE. `/rex/act/wd_set.c`

wd_pos

set eye window position

SYNOPSIS. `wd_pos(long wdnnum, long xpos, long ypos)`

wdnum: window number

xpos, ypos: x and y position of window in tenths of degree

ADDITIONAL HEADERS REQUIRED. None

DESCRIPTION. `wd_pos` specifies the position of the designated window.

RETURN VALUE. Returns 0

EXAMPLE. `wd_pos(0, 100, 200)`

Set window number 0 to position +10, +20 degrees.

SEE ALSO. `wd_center()`, `wd_src_check,pos()`, `wd_cntrl()`, `wd_cursor()`, `wd_disp()`, `wd_siz()`

FILE. `/rex/act/wd_set.c`

wd_siz

set eye window size

SYNOPSIS. *wd_siz*(long wdnum, long xsiz, long ysiz)

wdnum: window number

xsiz, ysiz: size in tenths of degree of distance from center of window to side, i.e. one half window size.

ADDITIONAL HEADERS REQUIRED. None

DESCRIPTION. *wd_siz* specifies the size of a window. The sizes can be different values for horizontal and vertical. Size is specified as length from center of window to one side.

RETURN VALUE. Returns 0

EXAMPLE. *wd_siz(0, 100, 200)*

Set window number 0 size to 20 degrees across horizontal, and 40 degrees vertical.

SEE ALSO. *wd_center()*, *wd_src_check,pos()*, *wd_cntrl()*, *wd_cursor()*, *wd_disp()*, *wd_pos()*

FILE. /rex/act/wd_set.c

wd_src_pos, wd_src_check

specify source for window position and source for window to check

SYNOPSIS. *wd_src_pos*(long wdnnum, long x_src, long x_src_num, long y_src, long y_src_num)

wd_src_check(long wdnnum, long x_src, long x_src_num, long y_src, long y_src_num)

wdnum: window number

x_src: x source

x_src_num: x source number specifier

y_src: y source

y_src_num: y source number specifier

ADDITIONAL HEADERS REQUIRED. None

DESCRIPTION. REX provides a two-dimensional window capability. A window is characterized by an x and y size, an x and y position, and an x and y source to check. A set of flags is maintained in the global variable *eyeflag*. These flags can be tested from the Spot file to determine if a source is within the bounds of a window.

The *wd_src_pos* and *wd_src_check* actions specify the x and y components of the source that governs the window position and the source for the window to check. Possible sources valid for both actions are:

WD_DIRPOS: The source is a direct position specified by the *wd_pos* action. *src_num* is ignored.

WD_RAMP_X: source is the X component of the internal ramp generator. *src_num* specifies the ramp generator number.

WD_RAMP_Y: source is the Y component of the internal ramp generator. *src_num* specifies the ramp generator number.

WD_JOY_X: source is the X component of the joystick. *src_num* is ignored.

WD_JOY_Y: source is the Y component of the joystick. *src_num* is ignored.

WD_DA: source is the current output of the d/a converter. *src_num* specifies the d/a converter number.

WD_SIGNAL: source is a signal. *src_num* specifies the signal number.

WD_MEM: source is an internal memory array. *src_num* specifies the internal memory array number.

RETURN VALUE. Returns 0

EXAMPLE. *wd_src_check(0, WD_SIGNAL, 0, WD_SIGNAL, 1)*

If the horizontal eye is signal 0, and the vertical eye is signal 1, this action will set the source for window number 0 to check to eye position. The following examples then specify various sources for the x, y position of the window.

wd_src_pos(0, WD_DIRPOS, 0, WD_DIRPOS, 0)

The position of window 0 is controlled by the *wd_pos* action.

wd_src_pos(0, WD_RAMP_X, 0, WD_RAMP_Y, 0)

The position of window 0 is controlled by ramp generator number 0.

wd_src_pos(0, WD_DA, 0, WD_DA, 1)

The x position of window 0 is controlled by d/a 0, the y position is controlled by d/a 1.

wd_src_pos(0, WD_JOY_X, 0, WD_JOY_Y, 0)

The position of window number 0 is controlled by the joystick.

SEE ALSO. `wd_center()`, `wd_cntrl()`, `wd_cursor()`, `wd_disp()`, `wd_pos()`, `wd_siz()`

FILE. `/rex/act/wd_set.c`

Obsolete Actions

Beginning with Rex 7.1, you can have multiple running line and eye window displays. The properties of each display can be set independently of the others. This new functionality makes several actions relating to these displays obsolete. These actions are maintained in the actions library so that old spot files will compile, however, these actions have no effect. They simply return a 0.

rl_trig

The running line displays are now triggered by the running line level. Each display can be set to run in either triggered or continuous mode. The trigger level of each display can be set independently.

rl_erase

The running line displays can only be erased by iconifying the display window.

rl_stop

Because there may be multiple running line displays, they can not be stopped from the Spot file.

wd_disp

The display options for each window display are set using toggle buttons in the bottom part of the display window.

wd_cursor

Each window display can show all eight eye windows. Each eye window is represented by a rectangle. The choice of which eye windows to display is made using toggle buttons in the bottom part of the display window.

wd_center

The cursor that is the center of the screen can be set in each window display independently.

When Things Don't Work

Arthur V. Hays Revised 10 September 92

When and what to recompile.

There are two levels of making REX. The first is when modifications have been made ONLY to the spot file (the .d file) of a paradigm, or to the source of the int process. In this case only the int process needs to be recompiled. This is done by changing directory to "rex/sset" and typing the command "make sf=whatever". The second level is when changes have been made to the source of other parts of the REX system. In this case, the entire REX system may need to be recompiled. To do this, change directory to "rex/sset" and type command "make complete".

No return value specified from actions.

An action must always specify a return value- either 0 or an ecode to be loaded into the Efile.

Where is the moving display?

Symptom: the clock is begun, the status says the clock is on, but there is no moving display.
Possible remedy: make sure the running line stop switch is not on.

Paradigm not behaving or operating properly times, arguments to actions incorrect, menu variables mysteriously changed, nothing corresponds to initialized values.

The REX root file mechanism is very powerful, but must be used carefully. If changes are made to a paradigm BUT the root for the old version is read than any new default initializations may be lost. This can easily happen, for many times a paradigm is actually run by invoking a root file that in turn reads another initialization root file. For example, a state may be changed in the spot file so that it now calls an action where previously it did not. When the old root file is read all arguments to the action will be set to zero, for the state previously did not call an action. This occurs because the state, even though its function has been modified, still has the same name- states are accessed by name when roots are read. Likewise defaults of menu variables may be lost if an old root is read.

Problems caused by reading old roots can be very subtle. If mysterious problems are encountered the safest course is to manually begin the new process to ensure that no roots are read. If symptoms are different when process is run a new root can be written out and compared to old root to determine differences.

Roots take longer and longer to read...

Remember that when a new root is written and a root file of the same name currently exists, the new root is APPENDED to the existing root file. Thus a root file may get longer and longer but still work properly, for the end of the root file will have the current values.

Data Keeping Windows

Data is saved in REX by opening and closing "windows". Windows have an associated pre time and post time. The pre time is the time in msec before the window is opened that data keeping will

actually start. The post time is the time after the window is closed that data will continue to be kept. If a previous window overlaps a subsequent window (e.g. the previous window's post time overlaps the subsequent window's pre time) then the data in the overlapped section is stored twice on the disk- both windows are completely written even though parts overlap. Note, however, that only one window can be active at a time. If a previous window has been closed BUT is still being written during the post time, a subsequent window CANNOT be opened until the post time has expired. The open request is ignored if given during the post time of a previous window (however, an open window ecode IS loaded into the Efile). Also, no error indication will occur. Therefore, one must be sure that a previous window's post time has elapsed before giving a subsequent open window request. For situations where timings are close a flag can be tested in the state set to determine exactly when the post time has expired and the previous window is completed.

A state named init

The spot compiler prepends "s" to the name of all states. If a state is named "init" it will become "sinit". This name conflicts with another symbol in an obscure way- no error is reported, however the paradigm will crash. Therefore, do not name a state "init".

Menu variable names cannot have embedded spaces; symptom- can write a root, but then not read it back in

Menu variable names cannot have embedded spaces. Spaces are parsed as argument delimiters. To simulate a space, use an underscore. If a menu variable name does have an embedded space, everything will seem to work fine until a root is read. The part of the variable name after the space will be interpreted as the value for the variable. The space serves to delimit the name of the variable from its value.

Debugging Aids

Some debugging aids exist. These will allow printing of debugging messages. See the section in the Spot manual titled "General Considerations" for more info on these aids.

Endless abort loop

Don't place a state that contains the action `reset_s()` in the abort list. You will create an endless loop. The action `reset_s()` causes the abort list to be executed.

Arguments to actions are not passed correctly

Arguments to actions are always long integers. Therefore, the arguments to actions must be declared as long integers. For example, the following action has three arguments and is correctly written:

```
do_something(long a, long b, long c)
{
    int arg3;
    arg3 = c;      /* conversion to int done automatically
                  by C compiler */
}
```

However, the next action shown below will not work because the C compiler is not informed that the arguments are longs. The C compiler will assume they are ints, and not pick them up properly:

```
do_something(a, b, c)
{
    int arg3;
    arg3 = c;    /* this will not put the correct value
                  for 'c' in 'arg3' */
}
```

Paradigms written for the pdp11 version of REX must be changed so that all action arguments are declared as longs.

REX Graphical User Interface

John W. McClurkin, Ph.D.
Laboratory of Sensorimotor Research
National Eye Institute
National Institutes of Health

Introduction

Beginning with release 7.0, we have fully ported Rex to QNX's Photon window system. Use of the window system allowed us to not only present better displays of data, but to also provide a graphical user interface. The reasons for doing this are as follows:

- *Better self documentation.* Older versions of Rex used a command-line interface in which the experimenter interacted with the program through a series of screen menus and a set of commands (verbs and nouns). Efficient use of this interface required experimenters to memorize the keystrokes needed to bring up the menus and the rather terse verb-noun combinations needed to execute commands (i.e. "k B" to beginning saving event and analog data). With the graphical user interface, all menus are available from menu buttons, and all commands are executed by clicking on buttons that are displayed in the interface.
- *Better data displays.* The data displays of older versions of Rex were limited to VGA (640X480) resolution. This limited the resolution of the data that could be displayed. Older versions of Rex had three types of data display; an X-Y display of analog data (the eye window display), an oscilloscope-like display of analog and unit data (the running line display), and a histogram-raster display of unit data (the raster display). The X-Y and oscilloscope displays could be superimposed, but the raster display was separate. To view raster data, the other displays had to be disabled. Because of the resolution of the display, a maximum of 16 rasters or histograms could be displayed, a serious limitation in conducting experiments with many conditions. With the Photon window system we are able to use resolutions of up to 1280X1024. Also, the Photon window manager maintains 9 virtual desktops, allowing various data displays to be spread out while retaining ease of access. By placing each display in its own window, we are able to provide multiple X-Y, oscilloscope, and raster displays. Because of the higher resolution, raster displays can have up to 64 plots. By using spike density functions instead of histograms, summary and trial by trial data can be superimposed. Because we can provide multiple copies of each type of display, experimenters can have both triggered and free-running oscilloscope displays, high and low gain X-Y displays, and multiple sets of rasters.
- *Better performance tracking.* Experimenters frequently need to monitor the progress of an experiment or subject's performance. This is done by continuously updating variables such as percent correct, number of trials per block, or number of trials completed, etc. In older versions of Rex, to view such variables, experimenters had to place them in menus and then display the menus using keyboard commands. These menus could not be updated while being displayed, so to see new values, experimenters had to dismiss, then re-display the menu. With the graphical user interface, we are able to construct dialogs that display and automatically update any variables the experimenter needs.

The new features of Rex have rendered some old features obsolete. The following is a list of changes in the behavior of Rex:

- *Root files.* With Rex 7.0, only the int process uses the old Rex root files. Because experimenters can bring up multiple eye window and running line displays, we have disabled the running line and eye window entries in the root file. We plan to provide an alternate root system for these displays. Because of the increased functionality and the possibility of having multiple raster displays, the raster display root is now separate from the main root file.
- *Verbs and nouns.* Because the verb-noun syntax of Rex commands has been replaced by button clicks, the root file system no longer supports verb-noun strings.

Process Switching Tool bar

When you start Rex, you are greeted by a short tool bar as shown here. Use the controls in this tool bar to launch all other Rex applications.

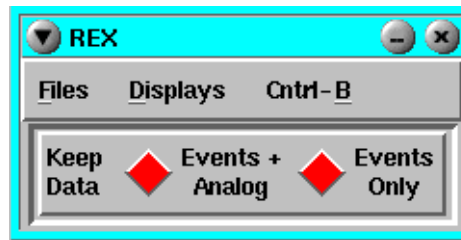

Files

Clicking on the *Files* button will display a menu with the following items:

- Processes
- Root Files
- Open Data File
- Close Data File

Selecting the *Process*, *Root Files*, or *Open Data File* items will bring up a file browser dialog similar to that shown here, except for the action buttons at the bottom.

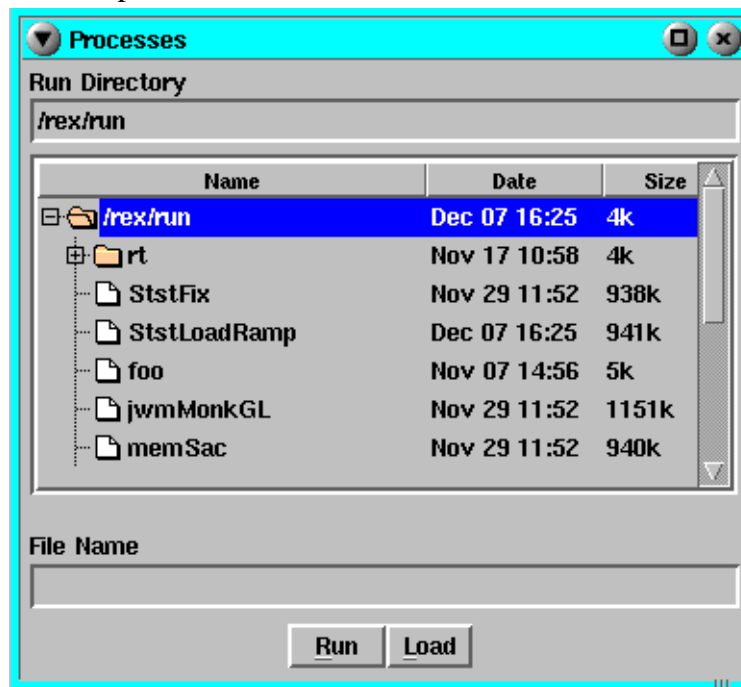

The file selection tool displays the contents of the directory specified in the *Directory* text field. Changing the entry in the *Directory* text field or clicking on a directory folder in the file list display causes the directory to be copied to the *File Name* text field. However, if you just open a directory by clicking on the + sign to the right of the folder, the directory name is not copied to the *File Name* text field. Sorry, that just the way this Photon widget works. If you select a file by clicking on its name in the file list display, the name is appended to the string in the *File Name* text field. Alternately, you can specify a file by typing its name in the *File Name* text field. You then do something with the file by clicking on one of the action buttons at the bottom of the dialog.

With the *Process* dialog, clicking on the *Run* action button will load the int process you selected, put it in the run state, and display an int process tool bar (shown below) just to the right of the process switching tool bar. This is equivalent to executing the command “r p name” in older versions of Rex. Clicking on the *Load* action button will load the int process you selected, but put it in a stopped state and iconify its tool bar. This is equivalent to executing the command “l p name” in older versions of Rex. If you already have an int process running and you click the *Run* action button with a new int process name, Rex will stop the current running int process and iconify its tool bar, load the new int process, put it in the run state and display its tool bar. This is equivalent to executing the command “c p name” in older versions of Rex when you want to change to a new int process.

With the *Root Files* dialog, clicking the *Read* action button will read in the root file you selected. Note, with Rex 7.0 and later, you must have an int process in the run state before reading in a root file. Clicking on the *All*, *Sys + User*, *System*, *User*, or *States* action buttons will write out a root file with the name entered in the *File Name* text field. A root file created with the *All* button will contain the current values of all menu items and all states. A root file created with the *Sys + User* button will contain the current values of all menu items, but no states. A root file created with the *System* button will contain only the current values of the system menus. A root file created with the *User* button will contain only the current values of the user menus. A root file created with the *States* button will contain only the current values of the process states.

With the *Open Data File* dialog, the file list is shown as a convenience to indicate what data files you already have. Rex will not reopen an existing data file, so even if you select a file from the list, you will have to modify its name in the *File Name* text widget before clicking on the *Open* action button. You can also open a data file by entering its name in the *File Name* text field and hitting the return key. On opening the new data file, Rex will automatically close the dialog and will display the data file name in the tool bar window frame next to the label *REX*.

Rex does not display a dialog when you select the *Close Data File* item from the *Files* menu. It just closes the data file and removes the file name from the tool bar window frame.

Displays

Clicking on the *Displays* button when the window is active will display a menu with the following items:

- Window Display
- Raster Display
- Running Line Display

The Window Display is an X-Y plot which displays the positions of the eye signals and eye windows. The Raster Display shows unit activity as both spike rasters and spike density functions. The Running Line display is an oscilloscope display that shows analog and unit data. Prior to Rex 7.0 you could have only one copy of each display although the eye window display and the running line display could be superimposed. With Rex 7.0 and later, you can have multiple copies of each display active

simultaneously. The only limitation is that you can have only 32 processes loaded at one time. Each type of display counts as one process. The Rex data displays are described in detail below.

Cntrl-B

The Cntrl-B button provides the function for Rex 7.0 that entering cntrl-b provided for earlier versions of Rex. Clicking this button stops data collection, closes the data file, and kills the current running process. Rex will also present a dialog asking whether you want to exit rex.

Data

The process switching tool bar has a panel labeled *Keep Data* that contains two toggle buttons, *Events + Analog* and *Events Only*. These buttons turn data saving on and off. Rex saves data in two files, an *A* file and an *E* file. The *E* file contains the times of event codes and neuron spike activity. The *A* file contains analog data. Most likely, you will want to save both event and analog data, but, if you are not interested in eye movements, you can conserve disk space by saving *Events Only*.

You can save data only if Rex's millisecond clock is running, and you can start Rex's millisecond clock only if you have an int process running. So why are the data file and data saving functions in the process switching tool bar instead of in the int process tool bar? Though most people don't do it, Rex can save data from multiple int processes into the same data file. (The purpose of the ID code in the spot files is to keep the data from different int processes separated in the data file.) Placing the data file and data saving functions in the process switching tool bar makes them independent of int processes.

Int Process Tool bar

When you compile a spot file, you create an int (or interrupt) process. This process controls the specifics of your experiment. When you select an int process to run, Rex displays a tool bar to the right of the process switching tool bar. The base name of the spot file used to create the int process is displayed in the tool bar window frame (in this case, *tstramp*). The buttons in the menu bar allow you to bring up dialogs that display the various system and user menus. The buttons in the control panel below the menu bar implement basic experiment controls.

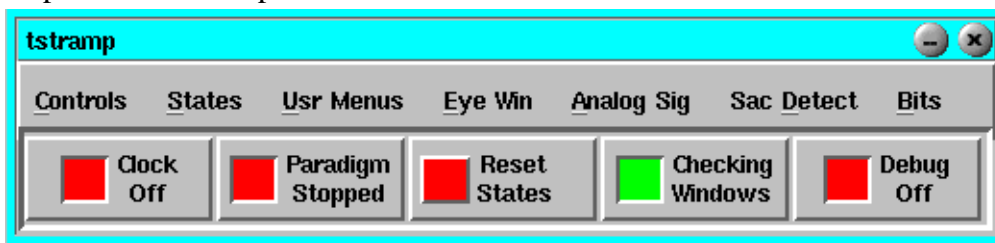

Controls Menu

Clicking on the *Controls* menu button will display a menu with the following items:

- Process Controls
- Ramp Controls
- Ramps Summary
- D to A Controls
- D to A Summary
- Mem Array Controls
- Mem Array Summary

- Smi Controls

Selecting one of the *Controls* items will bring up a dialog box that has a collection of widgets that allow you to change values. Selecting one of the *Summary* items will bring up a dialog box that displays the current values but is not editable. The *Ramp Controls* dialog is shown below. The default values for variables, or values set by the spot file are displayed in the *Actual* panel to the right. The override controls are displayed in the *Override* panels to the left. To change parameters, select the ramp number from the list at the left. Click the *Dialog* button, changing the indicator from red to green and the label to “Dialog Enabled”. This will enable the *Menu Override* widgets for this ramp. Enter the values you want in the appropriate numerical boxes. The values will not take effect until you click on the blue *Menu Override* buttons to the left of the numerical boxes. When set, the *Menu Override* buttons will

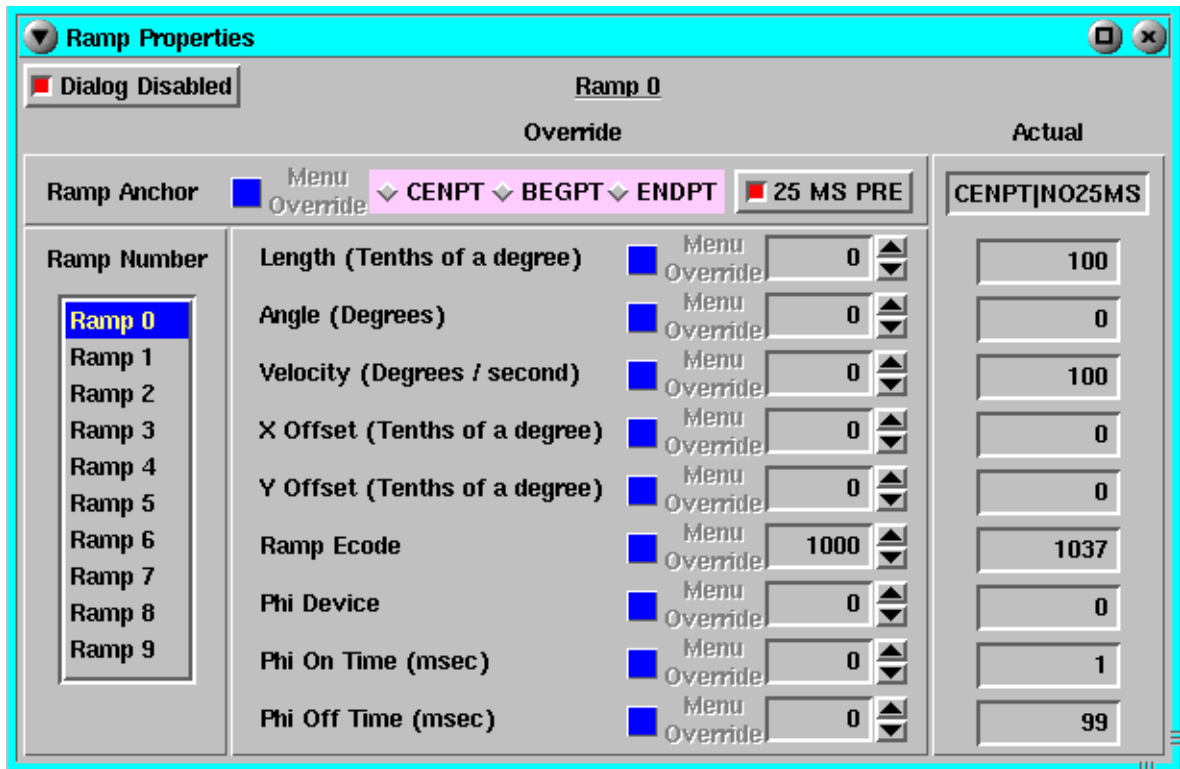

display a large, yellow check mark. If you un-check a *Menu Override* button, the override is removed but the value of the parameter will not change until your spot file changes it. The other control dialogs have a similar format.

The *Ramp Summary* dialog is shown as an example of summary dialogs. The other summaries have a similar format.

| Ramp | Anchor | Length | Angle | Velocity | X Off | Y Off | Ecode | Phi Dev | Phi On | Phi Off |
|------|--------------|--------|-------|----------|-------|-------|-------|---------|--------|---------|
| 0 | CENPT NO25MS | 100 | 0 | 100 | 0 | 0 | 1037 | 0 | 1 | 99 |
| 1 | CENPT NO25MS | 100 | 0 | 100 | 0 | 0 | 1037 | 0 | 1 | 99 |
| 2 | CENPT NO25MS | 100 | 0 | 100 | 0 | 0 | 1037 | 0 | 1 | 99 |
| 3 | CENPT NO25MS | 100 | 0 | 100 | 0 | 0 | 1037 | 0 | 1 | 99 |
| 4 | CENPT NO25MS | 100 | 0 | 100 | 0 | 0 | 1037 | 0 | 1 | 99 |
| 5 | CENPT NO25MS | 100 | 0 | 100 | 0 | 0 | 1037 | 0 | 1 | 99 |
| 6 | CENPT NO25MS | 100 | 0 | 100 | 0 | 0 | 1037 | 0 | 1 | 99 |

States Menu

Clicking on the *States* menu button will display a menu with the following items:

- Show All States
- Show Timed States

Selecting either of these menu items will display a dialog that allows you to set parameters in your state set definitions. The difference between the two items is that the *Show All States* dialog presents all of the states in your paradigm, whereas the *Show Timed States* dialog presents only those states which have a *time* or *rand* value.

The states in your paradigm are listed in the *State List* tree. The states in each chain are listed in their own branch of the tree. Individual chains can be opened or closed by clicking on the + or - symbol

to the left of the chain name. To view or change the parameters of a particular state, click on its name in the *State List* tree.

The top panel of the dialog contains widgets that allow you to change the preset and random times for this state and to set the running line level for this state. The *Abs* and *Rel* buttons indicate whether the running line level in this state was set to an absolute (rl 10) or relative value (rl +10). If both the *Abs* and *Rel* buttons are de-selected, then no running line level was specified for this state. If you enter a running line level and click the *Abs* button, the running line will be *set* to the level you entered in the numerical widget. If you click the *Rel* button, the running line will be *changed by* the amount you entered in the numerical widget.

The middle panel of the dialog contains widgets that allow you to change the arguments of the action called in this state. Use the *Dec* and *Hex* toggle buttons to view the argument as a decimal or hexadecimal value. Use the scroll bar at the right to display the entire list of arguments.

The bottom panel of the dialog contains buttons that list the escapes for this state. Currently, the buttons are not functional, we may add the ability to change the parameters of an escape or to add new escapes at run time. Use the scroll bar at the right to display the entire list of escapes.

User Menu

Clicking on the *User Menus* menu button will display a menu with the following items:

- Menu > (a pull right menu)
- Functions
- Real-time Variables

Menu >. Selecting the *Menu >* pull right menu will display a list of the menus you defined in your spot file. This list is generated from the *umenus* array. Selecting a menu will display a dialog containing the variables in that menu. Use the scroll bar at right, or resize the dialog window to see more of the menu items. To change values, you can either enter the values into the individual text fields, or enter a series of index-value pairs in the *Batch Arguments* text field. For example, entering “1 180 3 100” in the *Batch Arguments* text field would set angle to 180 and xoff to 100. Rex will display an error dialog and abort if you enter an index that is out of range or don’t enter the value member of the index-value pair.

Note: in either case you must type a carriage return (Enter) for the value or values to be changed.

In this example, the menu items are members of an array of structures named *ramp_list*. The

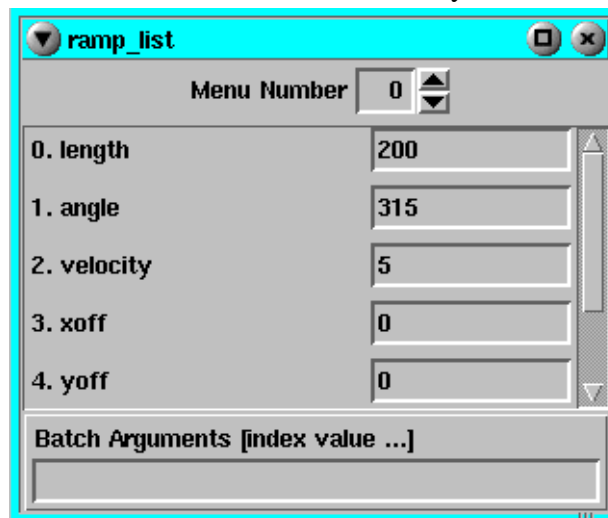

Menu Number shows the index number of the array element whose values are displayed in the middle

panel of the dialog. When you change the *Menu Number*, Rex will call the menu access function that you defined for this menu to get pointers to the new elements. If the menu displays items that are not members of an array of structures (Rex determines this by whether or not you defined a menu access function), the *Menu Number* label and widget are inactive (grayed out).

Functions. Selecting the *Functions* item from *User Menus* will display a dialog that lists your user-defined functions. This dialog is generated from the *ufuncs* array in your spot file. Use the scroll bar on the right or resize the dialog window if necessary to view all of the functions. To call a function, just enter its arguments in the *Function Arguments* text field and type a carriage return. Rex will parse text

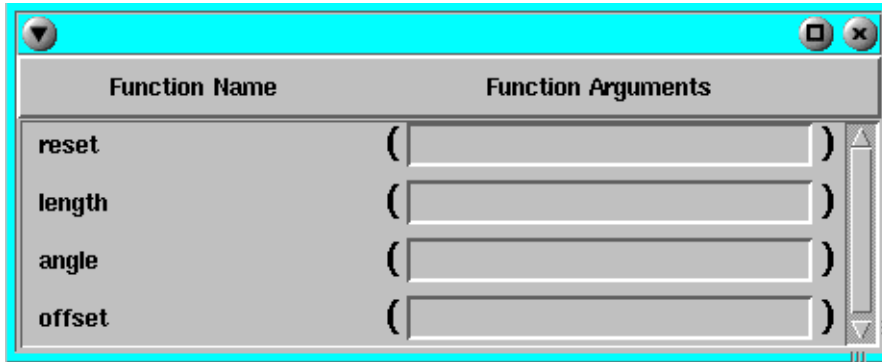

you entered according to the format string you provided in the *ufuncs* array and call the function. If the number of arguments you enter don't match the number of tokens in the format string, Rex will post an error dialog and abort the call. If you didn't provide a format string, Rex will assign all of the characters up the first space to one character array and all of the rest of the characters to a second character array and call your function with two *char ** arguments. In this case, it is up to your function to parse the arguments.

Real-time Variables. Selecting the *Real-time Variables* item from *User Menus* will display a dialog that lists the variables in your *rtvars* array. These variables must be globals, and they must be of type *int*. The

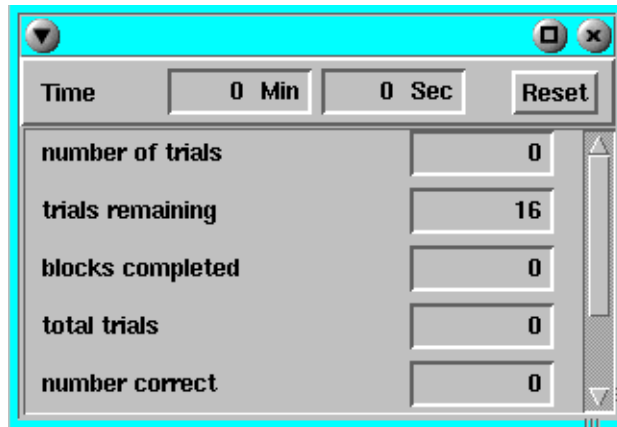

fields in *Real-time Variables* dialog are not editable. They are for display only. The dialog updates the values of the variables every second as long as the dialog is open. The *Time* field show the number of minutes and seconds that the Rex clock has been running since the dialog was opened. The *Reset* button will set the *Time* values and the values of all of the variables to 0.

Eye Win

Clicking on the *Eye Win* menu button will display a menu with the following items:

- Eye Window Controls
- Eye Offset Controls
- Eye Window Summary

Eye Window Controls. Selecting the *Eye Window Controls* item from the *Eye Win* menu will display a dialog that allows you to change the parameters of the electronic windows that Rex uses to monitor eye position. The frequency with which Rex compares a signal to the eye window is governed by the *Eye Win Check Rate*. The fields in the *Actual* panel show the current state of the window. To override values, select the window you want to modify from the list at the left. Enable the dialog for that window by clicking the *Dialog* button so that the indicator turns green and the text reads “Dialog Enabled”. If neither the *On* or *Off* toggles in the *Window* panel are set, then the window is under control of the spot file. Clicking the *On* toggle will force Rex to compare signals with the window. Clicking the *Off* toggle will prevent Rex from comparing signals with the window. To override position, size or source numbers, enter the values you want in the numerical fields, then click the blue *Menu Override* buttons. The buttons will display a yellow check mark when the override is in effect. If none of the *Position* or *Check* toggles are selected, these parameters are controlled by your spot file. To override the spot file click the appropriate button. To disable the override, unselect the button. When you disable an override, control of that parameter is returned to your spot file, but the parameter itself will not change until you call the appropriate action.

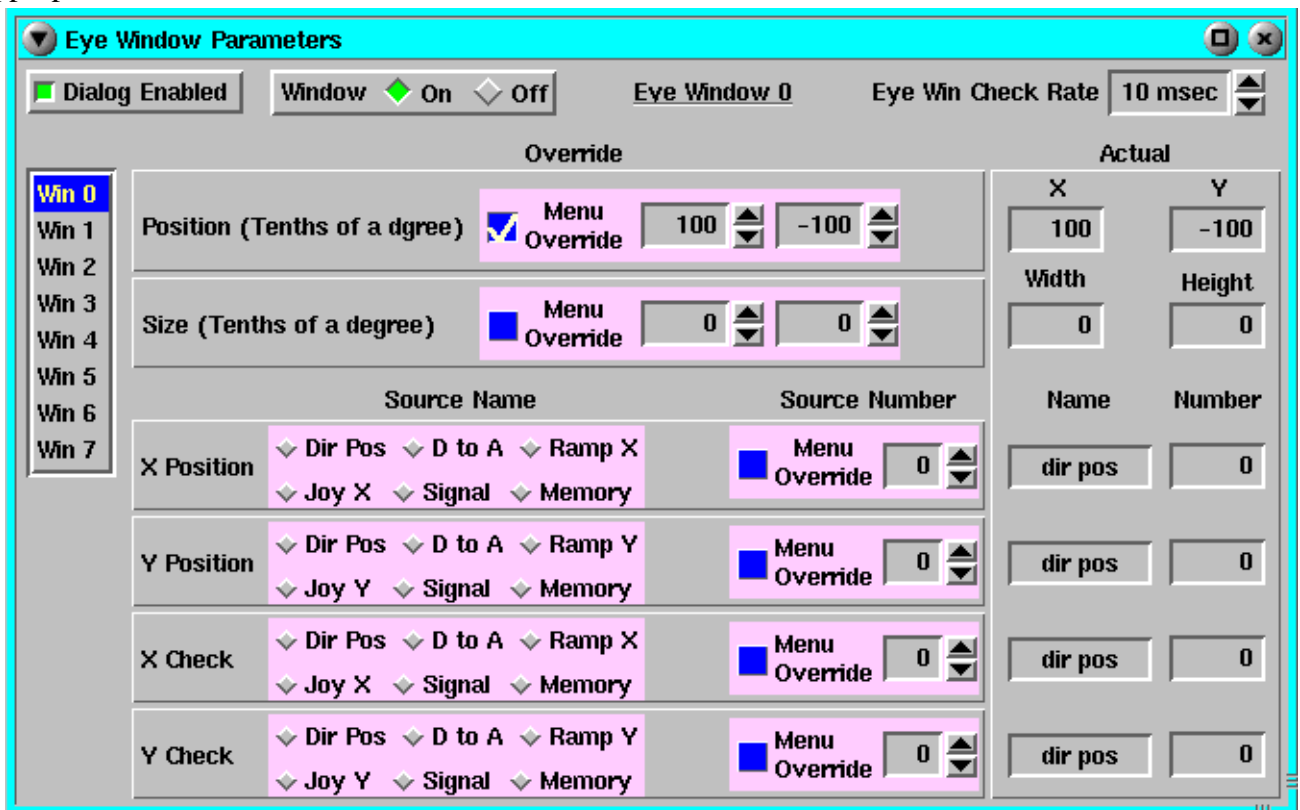

Eye Offset Controls. When monitoring the positions of both of a subject’s eyes, it is often the case that the two eyes do not seem to be looking at the same point, even when the subject is fixating a small point. This offset may be an artifact introduced by the eye monitoring system rather than a true reflection of the subject’s direction of gaze. To overcome this artifact, Rex allows an offset to be applied to either eye

signal. Selecting the *Eye Offset Controls* item from the *Eye Win* menu will display a dialog that allows you the change the offset parameters.

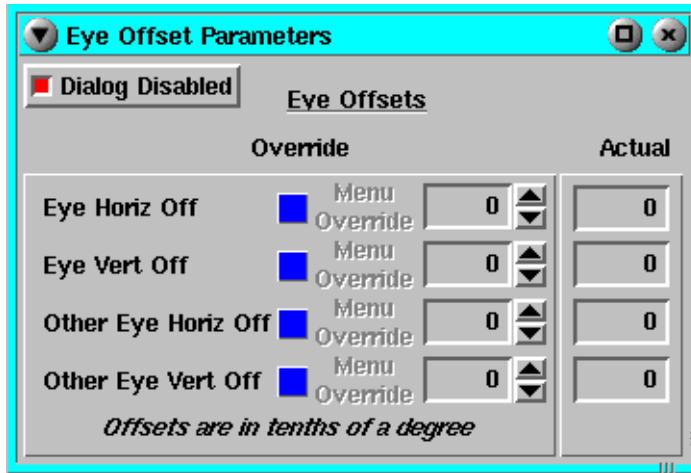

Eye Window Summary. Selecting the *Eye Window Summary* item from the *Eye Win* menu will display a summary of the parameters of all of the eye windows you have defined.

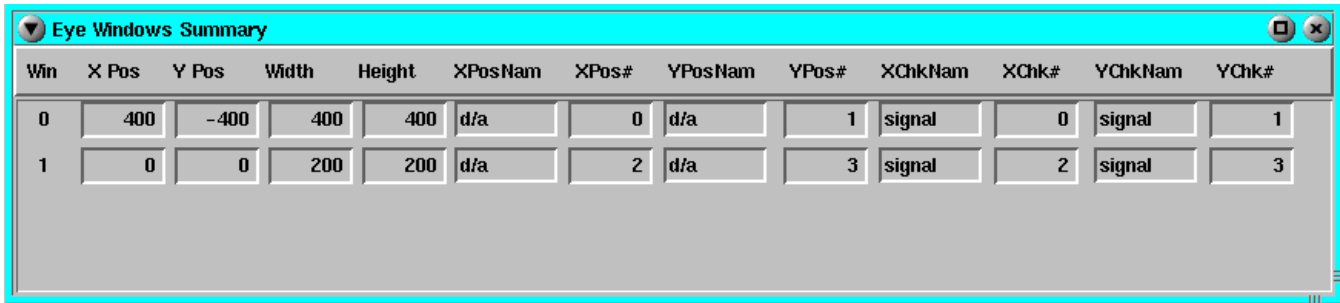

Analog Sig

Clicking on the *Analog Sig* menu button will display a menu with the following items:

- Analog Signal Controls
- Analog Signal Summary

Analog Signal Controls. Selecting the *Analog Signal Controls* item from the *Analog Sig* menu will display a dialog that allows you to control the parameters of the analog signals saved by Rex. Select the

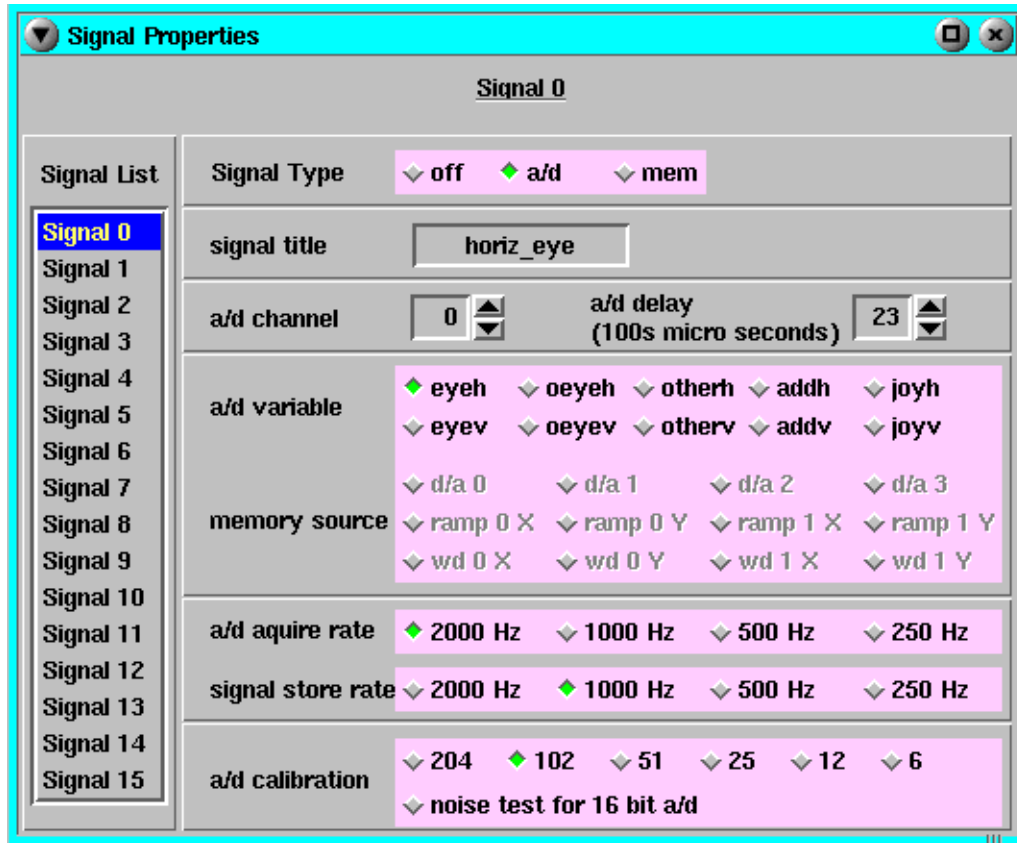

signal you want to modify from the *Signal List* at the left. Rex can store either the input from the A/D converters or a memory location as an analog signal. Set the signal type by clicking on either the *a/d* or *mem* buttons in the *Signal Type* panel. Selecting the *off* button will disable that signal. The dialog will disable or enable the *a/d variable* set of buttons or the *memory source* set of buttons depending on which of the *Signal Type* buttons you select. For A/D signals, the dialog provides options for setting the *a/d channel*, the *a/d delay* and the *a/d acquire rate*. If you have a low frequency signal, you can reduce the size of the analog files in your experiments by selecting one of the lower *signal store rates*.

Analog Signal Summary. Selecting the *Analog Signal Summary* item from the *Analog Sig* menu will display a summary of all of the signals that are on.

The screenshot shows the 'Signals Summary' dialog box with a table of signal parameters:

| Sig | Type | Channel | A Rate | S Rate | Cal | Gain | Delay | Name | Title |
|-----|------|---------|--------|--------|-----|------|-------|-------|------------|
| 0 | mem | -1 | 250 | 250 | -1 | -1 | 0 | - | - |
| 1 | a/d | 1 | 2000 | 1000 | 102 | 1 | 23 | eyev | vert_eye |
| 2 | a/d | 2 | 2000 | 1000 | 102 | 1 | 23 | oeyeh | other_eyeh |
| 3 | a/d | 3 | 2000 | 1000 | 102 | 1 | 23 | oeyev | other_eyev |
| 4 | a/d | 4 | 2000 | 1000 | 102 | 1 | 23 | addh | add_h |
| 5 | a/d | 5 | 2000 | 1000 | 102 | 1 | 23 | addv | add_v |
| 6 | a/d | 6 | 2000 | 250 | 102 | 1 | 23 | invh | horiz_inv |

Sac Detect

Clicking on the *Sac Detect* menu button will display a dialog that allows you to set up the parameters for Rex's saccade detector. If neither the *On* or *Off* buttons are selected, then the saccade

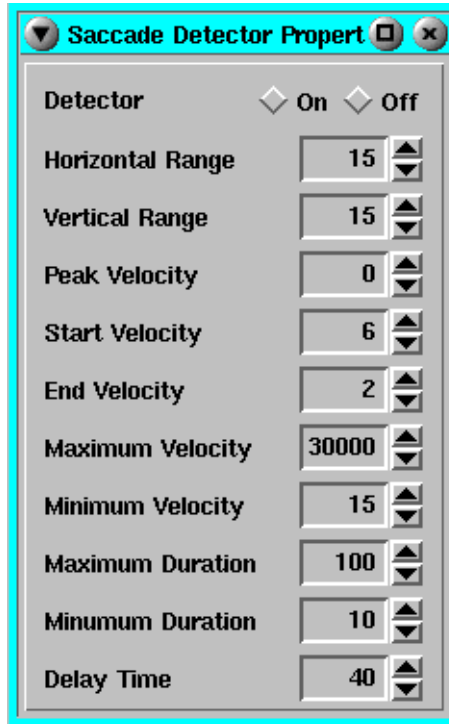

detector is under the control of your spot file.

Bits

Clicking on the *Bits* menu button will display a dialog that allows you to set or clear various bits in the digital I/O. In this dialog the panels correspond to the Grayhill output panels. Numbered toggles

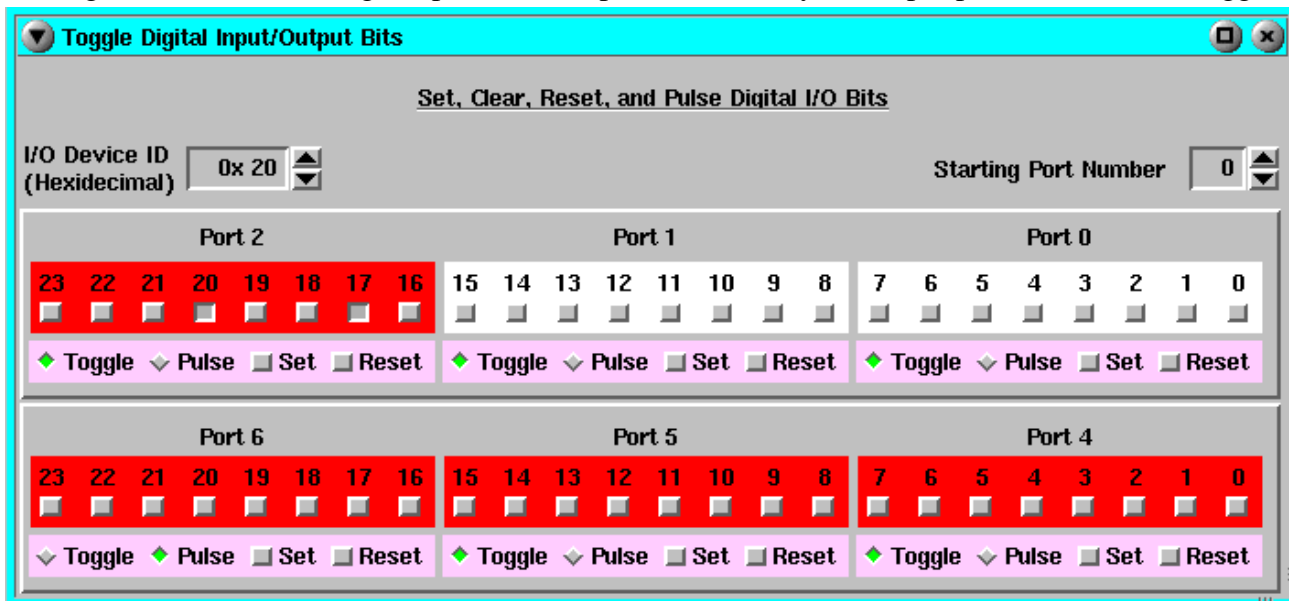

represent the individual bits in a port. Sets of toggles with white backgrounds represent bits in ports configured for input. Sets of toggles with red backgrounds represent bits in ports configured for output.

The sets of toggles below each port labeled *Toggle*, *Pulse*, *Set*, and *Reset* configure the different modes of the dialog. The dialog only displays panels corresponding to two Grayhill panels. If you have more than two Grayhill panels, you can display panels corresponding to those higher ports by incrementing the *Starting Port Number* value.

The actual value sent to each port is determined by the mode toggles. If the *Toggle* mode is selected, an output bit will be set as soon as the corresponding toggle is set and will remain set for as long as the toggle remains set. If the *Pulse* mode is selected, only one output bit can be set at a time. The bit's toggle will be set only as long as you press the left mouse button. Releasing the mouse button unsets the toggle and unsets the output bit. If you unset all of the mode toggles, then the port is in *Set* mode. You can set or unset any of the bit toggles, but nothing will be sent to the output port until you click on the *Set* mode toggle. The bits in the output port will remain set until you click on the *Reset* mode toggle.

Control Panel.

Below the menu bar in the int process tool bar is a panel containing 5 buttons.

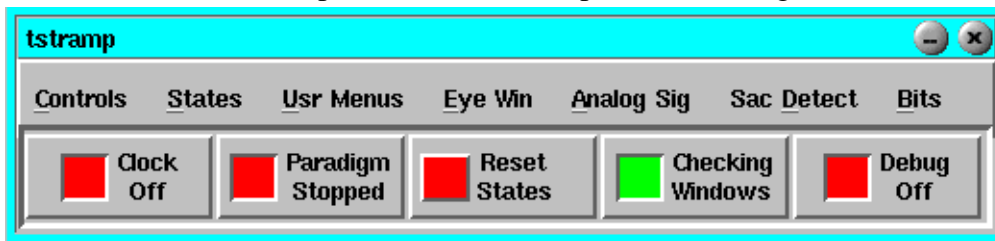

Clock. The *Clock* button starts and stops Rex's millisecond clock. To start or stop the clock, click on the button. When the clock is running, the indicator is green and the button label reads "Clock On". When the clock is stopped, the indicator is red and the label reads "Clock Off". This button implements the *begin clock* and *end clock* commands.

Paradigm. The *Paradigm* button sets the value of the *softswitch* variable. When *softswitch* is on, the indicator is green and the label reads "Paradigm Running". When *softswitch* is off, the indicator is red and the label reads "Paradigm Stopped". This button implements the *ps so* command. To make your paradigm use this information you need to have escapes such as "**to state on +PSTOP & softswitch**" and "**to state on -PSTOP & softswitch**" instead of "**to state on +PSTOP & drinput**".

Reset States. The *Reset States* button implements the "r s" or reset states command. When you click on the button, the indicator turns green and a "reset states" command is issued. The indicator turns red as soon as you release the mouse button.

Windows. The *Windows* button controls whether or not Rex checks analog signals against the electronic eye windows. When Rex is checking signals, the indicator is green and the label reads "Checking Windows". In this state, Rex will set or clear bits in the *eyeflag* variable depending on whether a given signal is inside or outside of the electronic window. To force Rex to ignore the windows, click on the button. The indicator will turn red and the label will read "Ignoring Windows". In this state Rex will report that all signals are always inside their windows.

Debug. Older versions of Rex provided a mechanism for debugging spot files. If you set the *debug_states* variable in the *control_param* menu to 1, as the state processor entered each state, it would print the name of the state. With Rex 7.0, this debugging information is provided in a dialog. Click on the Debug button to display the dialog. When debugging is enabled, the button's indicator turns green and

label reads “Debug On”. When debugging is disabled, the button’s indicator turns red and the label reads “Debug Off”. The dialog contains a button for each state. The state buttons are grouped together by chains. If the name of the state is preceded by a “T”, the state’s *time* variable is non-zero. As the state processor enters each state, it toggles the color of state’s button between yellow and blue. It also prints the time that it entered the state in the button. If you toggle the *Reset States* button, the color of all buttons is set to blue. You can freeze the dialog by toggling the *Debug* button to off. This makes it very easy to see which states your paradigm enters and when. It also makes it easy to see where your

paradigm gets stuck. If you click on a state button, Rex will display a dialog, similar to the *States Menu*

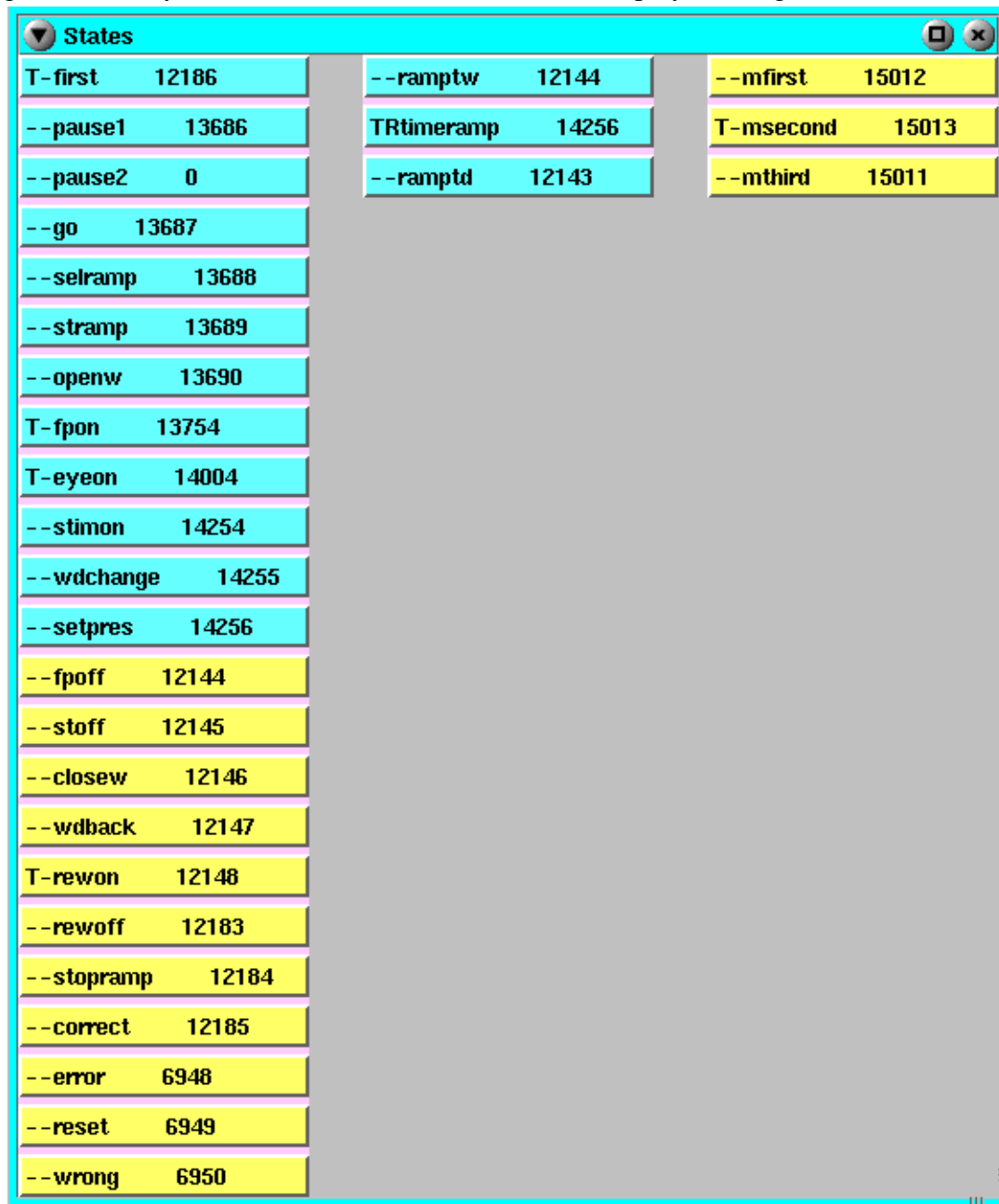

The screenshot shows a window titled "States" with a list of states and their corresponding addresses. The states are arranged in three columns. The first column contains states like T-first, --pause1, --pause2, --go, --selramp, --stramp, --openw, T-fpon, T-eyeon, --stimon, --wdchange, --setpres, --fpoff, --stoff, --closew, --wdback, T-rewon, --rewoff, --stopramp, --correct, --error, --reset, and --wrong. The second column contains states like --ramptw, TRtimeramp, and --ramptd. The third column contains states like --mfirst, T-msecond, and --mthird. Each state is followed by its address.

| State | Address | State | Address | State | Address |
|------------|---------|------------|---------|-----------|---------|
| T-first | 12186 | --ramptw | 12144 | --mfirst | 15012 |
| --pause1 | 13686 | TRtimeramp | 14256 | T-msecond | 15013 |
| --pause2 | 0 | --ramptd | 12143 | --mthird | 15011 |
| --go | 13687 | | | | |
| --selramp | 13688 | | | | |
| --stramp | 13689 | | | | |
| --openw | 13690 | | | | |
| T-fpon | 13754 | | | | |
| T-eyeon | 14004 | | | | |
| --stimon | 14254 | | | | |
| --wdchange | 14255 | | | | |
| --setpres | 14256 | | | | |
| --fpoff | 12144 | | | | |
| --stoff | 12145 | | | | |
| --closew | 12146 | | | | |
| --wdback | 12147 | | | | |
| T-rewon | 12148 | | | | |
| --rewoff | 12183 | | | | |
| --stopramp | 12184 | | | | |
| --correct | 12185 | | | | |
| --error | 6948 | | | | |
| --reset | 6949 | | | | |
| --wrong | 6950 | | | | |

that allows you to modify parameters of the state.

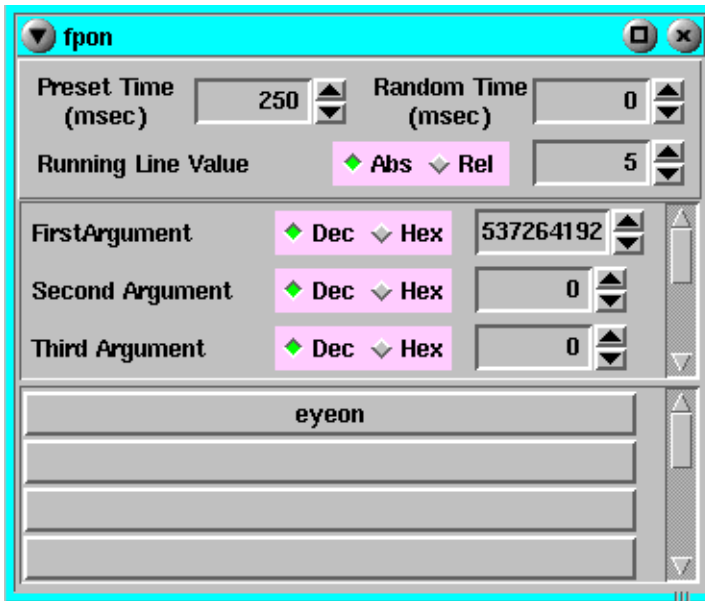

Data Displays

Rex provides three types of data display. The *Window* display shows cursors representing six analog signals and eight eye window positions in X-Y coordinates. The *Running Line* display shows eight channels of analog signals, unit activity, and *running line* level over time. The *Raster* display shows rasters and spike density functions of unit activity.

Window Display

You launch the window display by selecting the *Window Display* item from the *Displays* menu in the *Process Switching* tool bar. In this display, eye offsets are displayed in the numerical fields at the top of the display panel. The scales at the left and bottom of the display show the spatial extent of the display in degrees. The horizontal and vertical extents are always the same, so if you resize the display to a rectangular shape, square eye windows will appear rectangular. The toggle buttons in the bottom

panel control which signals are displayed. The color of the toggle when set corresponds to the color of its cursor in the display.

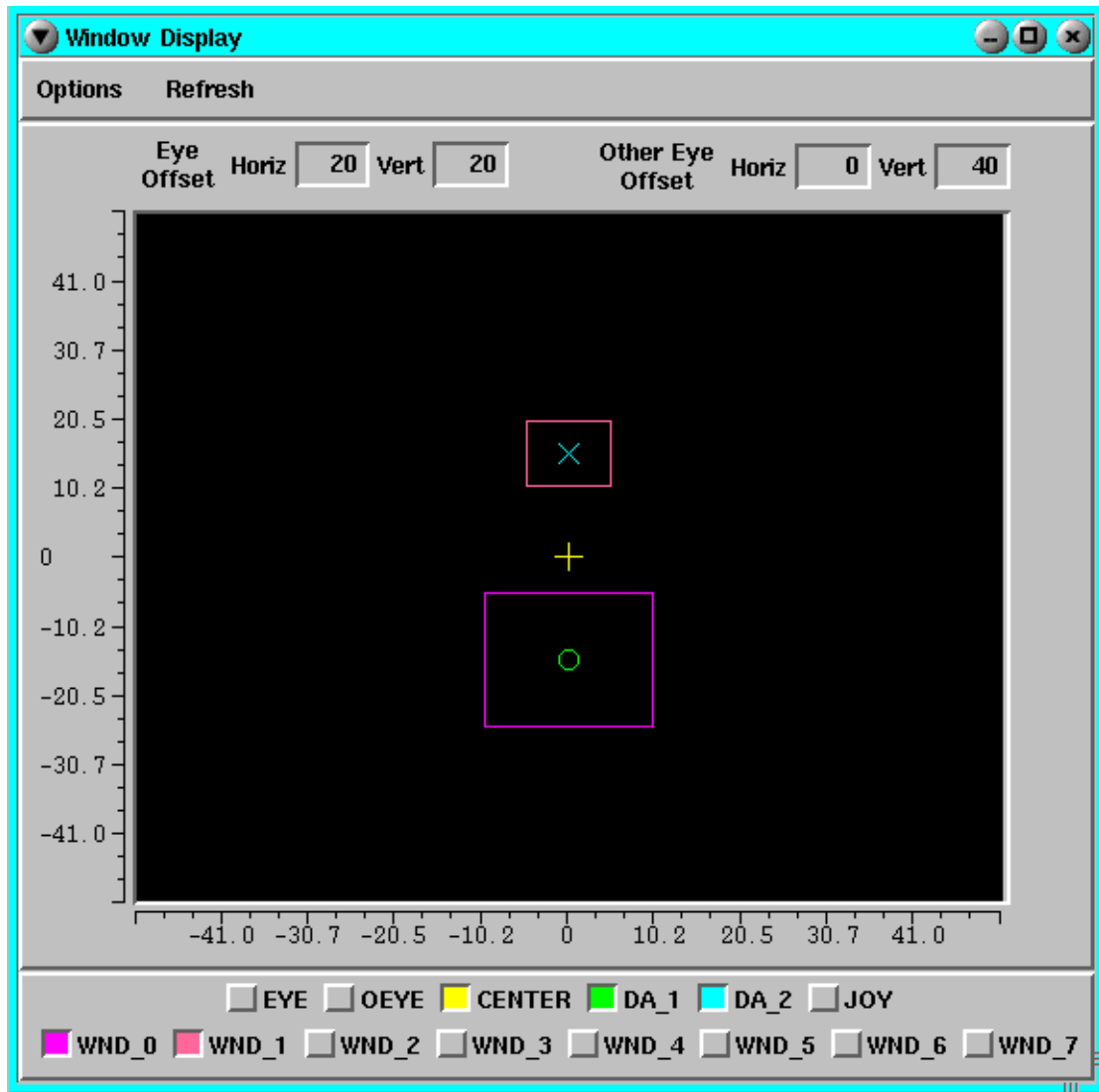

Window display options. Clicking the *Options* button in the menu bar will display a dialog that allows you to set various parameters of the display. The *Window Scale* toggle buttons control the overall extent

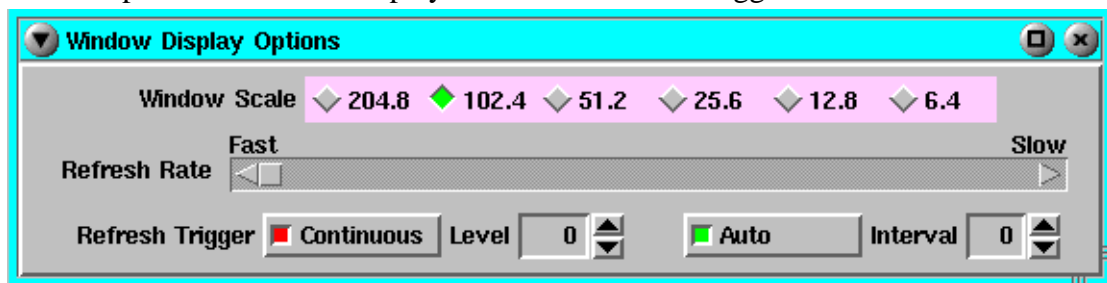

of the display in degrees. Higher numbers represent lower gain. The *Refresh Rate* slider controls how often the display is refreshed when the *Refresh Trigger* is continuous. At the fastest refresh rate, the display is erased prior to every draw (16 milliseconds). At slower refresh rates, a number of draws occur before the display is refreshed. This causes moving cursors to leave trails.

The display can be put in triggered mode by clicking on the *Refresh Trigger* toggle. In this mode, the indicator is green and the label reads “Triggered”. You set the trigger level with the *Level* numerical field. In triggered mode, data are drawn only when the running line level in the paradigm equals the level you set in the *Level* field. When the display is refreshed is governed by the states of the *Auto* toggle and *Interval* field. In auto refresh mode, the toggle indicator is green and the label reads “Auto”. In manual refresh mode, the toggle indicator is red and the label reads “Manual”. If the display is in auto refresh mode and the *Interval* is 0, then the display will be refreshed just prior to each trigger. If the *Interval* is greater than 0, then the display will draw over several triggers before refreshing. If the refresh mode is manual, then the display will be refreshed when ever you press the *Refresh* button on the menu bar.

Storage mode example. Lets suppose you would like to see the track of a subject’s saccade. In the state in your spot file that you give the prompt to make the saccade, set the running line level to a unique value, say 50. Then, in the state that your paradigm reaches when the subject completes the saccade, change the running line level to something else, say 49. In the *Window Display Options* dialog, set the *Refresh Trigger* toggle to Triggered mode and set the *Level* to 50. Now the display will draw data only during the saccade and without refreshing, so that the display will show the entire track of the saccade. If the refresh mode is *Auto* and the *Interval* is 0, then the display will be refreshed prior to each saccade. If the *Interval* is 5, then the display will draw 5 saccades before being refreshing, so you will see the tracks of 5 saccades. If the refresh mode is *Manual*, the display will keep drawing saccades, one on top of the next until you click the *Refresh* button in the menu bar.

Running Line Display

You launch the running line display by selecting the *Running Line* item from the *Displays* menu in the *Process Switching* tool bar. The toggle buttons in the bottom panel control which channels are displayed. The color of the toggle when set corresponds to the color of its trace in the display. The title of the toggle shows the signal carried in that channel. The *rline* toggle determines whether the *running line* level is displayed. The *units* toggle determines whether unit activity is displayed. The width of the display and the display rate determine the length of the epoch of data displayed. If you increase the width of the window or reduce the display rate, you will see a longer period of data. The *Running Line* display can operate in either *continuous* or *triggered* modes. By default, the display is in continuous mode. To put the display in *triggered mode*, click on the button labeled “Continuous”. Its indicator will change color to green and its label will change to “Triggered”. In triggered mode, the display sweep will start when the running line level reaches the trigger level and continue to the end of the display. Set the trigger level in the *Level* numerical field. The trigger is a level trigger, not an edge trigger. In triggered mode, the display has *repeat* and *one shot* modes. Be default, the display in repeat mode. In this mode, a new sweep will start after the previous sweep completes each time the running line level reaches the trigger level. To put the display in *one shot mode*, click on the button labeled “Repeat”. Its indicator will change color to green and its label will change to “One Shot”. In triggered, one shot mode, the display sweep will start when the running line level reaches the trigger level and continue to the end of the

display and then stop. To enable another sweep, click on the *Reset* button in the menu bar. When the

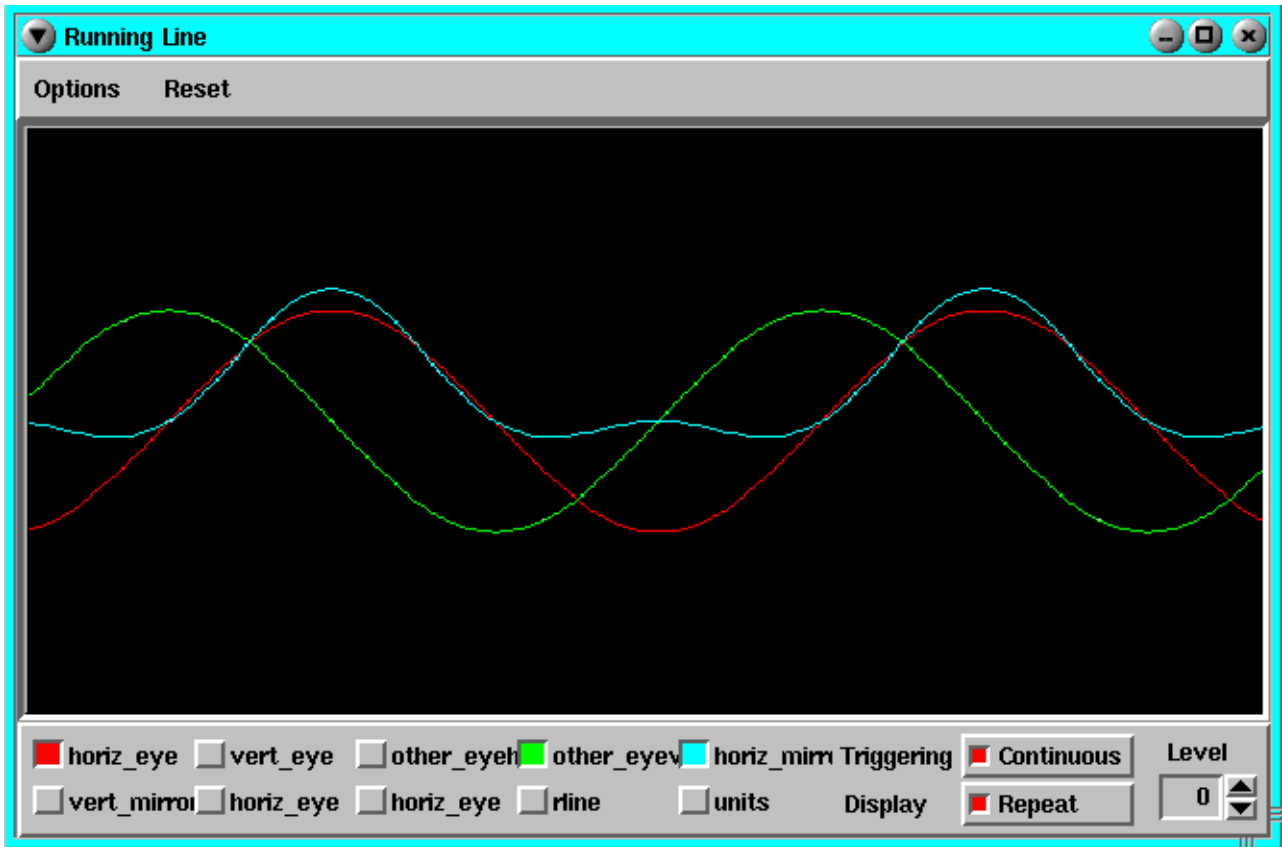

display is in continuous mode, the *Repeat/One Shot* button has no effect.

Running line display options. Clicking the *Options* button in the menu bar will display a dialog that allows you to set various parameters of the display. The *Gain* toggle buttons set the overall vertical scale

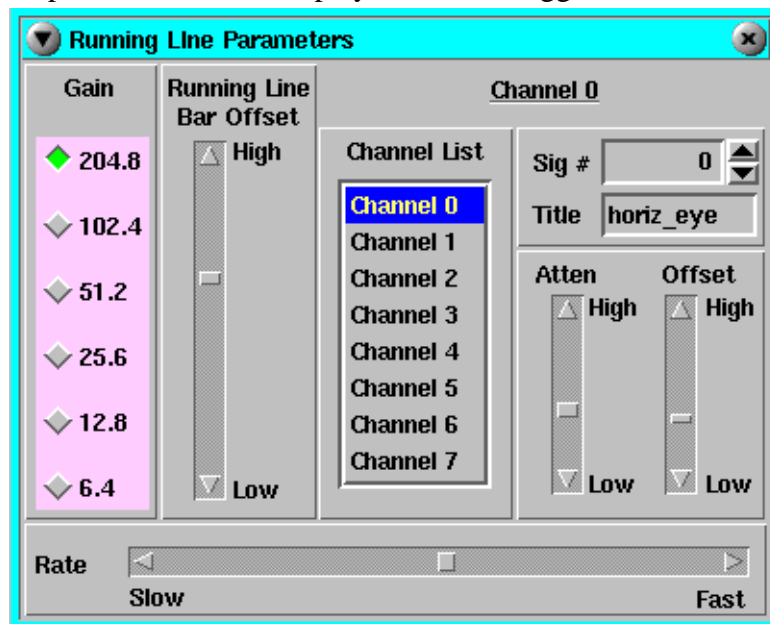

of the display in degrees. Higher numbers represent lower gain. The *rate* slider sets the time base of the display. The *Running Line Bar Offset* slider sets the base location of the running line trace in the display.

To set the parameters of the eight analog channels, select a channel from the *Channel List*. The signal number is shown in the *Sig #* numerical field. You can set this to any of the signals you have defined. The *Title* field displays the signal's title. This is not an editable field. You can reduce the gain of the signal with the *Atten* slider. High attenuation represents low gain. The *Offset* slider sets the base location of the channel's signal.

Raster Display

You launch the raster display by selecting the *Raster Display* item from the *Displays* menu in the *Process Switching* tool bar. The raster display can show up to 64 plots per page. The number of pages is

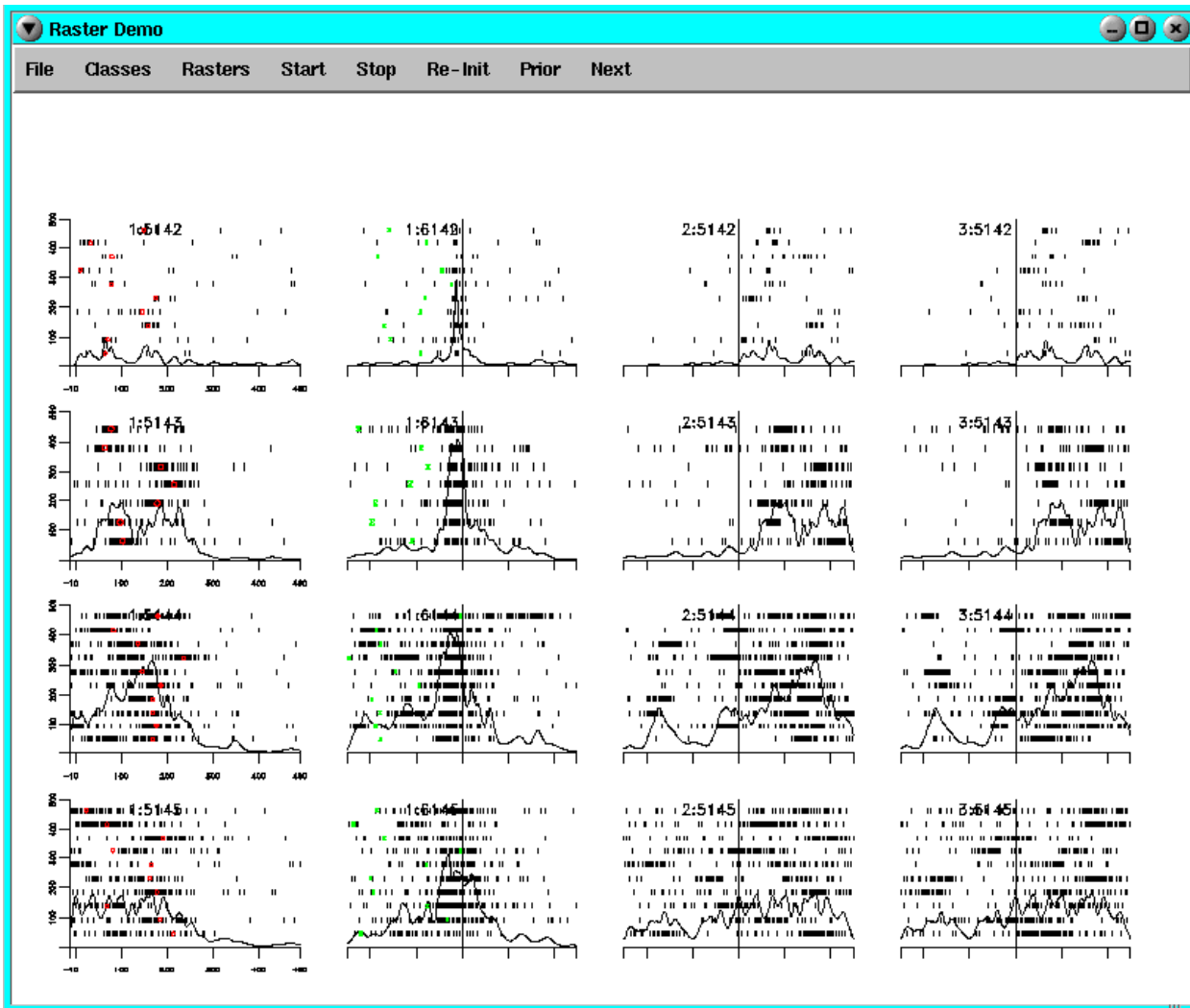

limited only by your RAM and virtual memory. The plots can show combined rasters and spike density functions (shown) or rasters or spike density functions alone. Each plot can show the data from up to 10 neurons. The plot can also show the time of occurrence of one other event in the trial (the red and green marks in the plots on the left above).

Configuration. To use the raster display you must first tell Rex how you want to organize your data and how you want to lay out each raster page.

Data organization. To tell Rex how to organize your data, click on the *Classes* button in the menu bar and select the *Build Select Specs* item from the menu. here. This brings up the *Ecode Selection Set*

dialog. The top panel contains two numerical fields for entering the *start code* and the *pre time*. The

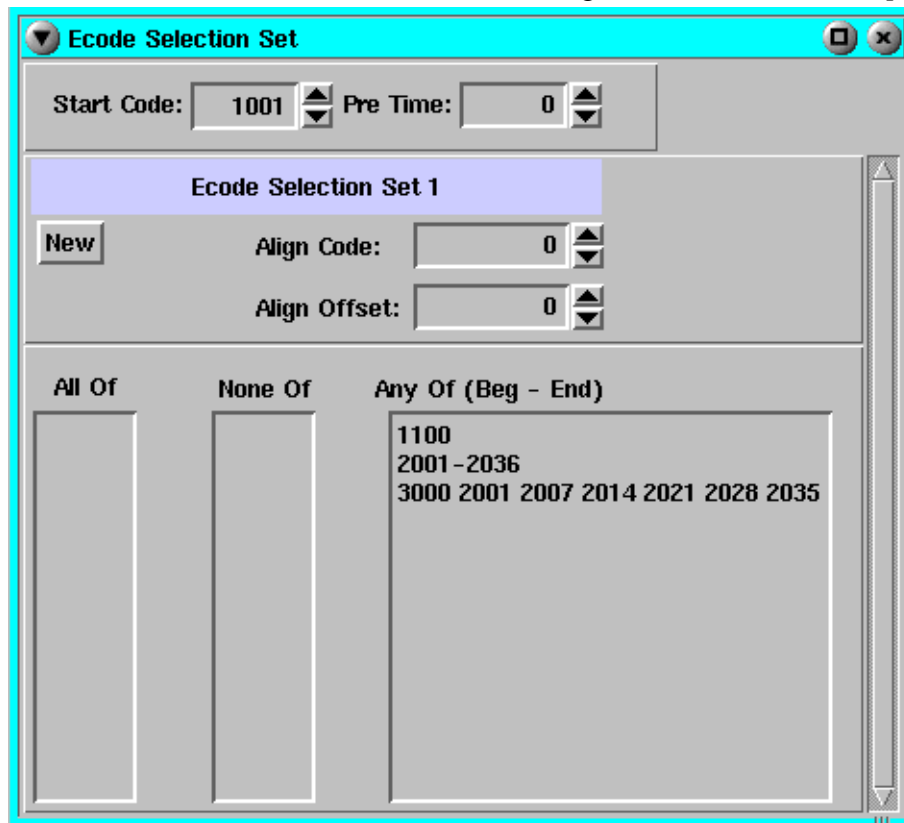

default value for the *start code* is 1001. You don't need to change this unless you use a different trial start code. Enter the amount of analog pre time that you use in the *pre time* numerical field.

There are three text fields in the bottom panel labeled *All Of*, *None Of*, and *Any Of (Beg - End)*. The *All Of* column is for listing the ecodes that each trial must contain to be accepted for plotting in the raster display. Enter each of these "correct" ecodes, followed by a *<return>*. You can enter as many ecodes as you want. Remember to end each entry with a carriage return. If you want to delete an entry, you must remember to use a *<return>* after deleting the entry.

An alternative to making a list of ecodes that each trial must contain is to make a list of ecodes that each trial must not contain to be accepted for plotting. You list these "error" ecodes in the *None Of* column. As with the *All Of* column press *<return>* after entering each ecode. It is not necessary to use both the *All of* and the *None Of* lists. In fact it is not necessary to use either the *All Of* or the *None Of* columns. If you leave both of these columns blank, Rex will plot all of the trials in your data file looking for *Any Of* ecodes.

The *Any Of* ecodes tell Rex how to organize your data for plotting. Rex searches each trial that passes the *All Of* or *None Of* tests for the ecodes in the *Any Of* list. Rex will group all trials that contain the same *Any Of* ecode will together. If a trial contains several *Any Of* ecodes, Rex will place it into multiple groups.

You can plot your data by individual stimulus conditions, or you can create super sets of conditions. To specify individual stimulus conditions, enter a single ecode or a range of ecodes on a line in the *Any Of* list. You specify ecode ranges by listing the first and last ecodes of the range on the line separated by a dash. For example, the second line in the illustration above causes Rex to create a class for each ecode from 2001 to 2036, inclusively. To specify a super set of conditions, enter a number to identify the super set, followed by a list of the ecodes you want included in the set. For example, the

third line in the illustration above, causes Rex to create the super set 3000, consisting of trials containing the ecodes 2001, 2007, 2014 2021, 2028, and 2035. Rex will align the data from the 6 types of trials on the time of the ecode in the list, or on the time of the *Align Code* (see below).

NOTE WELL: The super set code (3000) must be a number that you do not use as an ecode in your spot file. Further, each of the ecodes in the list must occur only once in the trial. If the super set code is an ecode that you use to identify a stimulus condition, then you will not be able to plot that condition by itself. Also, trials that include the super set code as an ecode may not be aligned properly in the data plot. If a trial contains more than one of the ecodes in the list, it will be included more than once in the plot, each time with a different alignment.

To compare data from different trials, you must align the data on events in the trials. Rex can use three methods to align data. The default method is to align the data using the time of the *Any Of* ecodes in the trials. If you want to align data on an ecode that is not in the *Any Of* list, enter the ecode on the *Align Code* line in the middle panel of the ecode selection window. Each trial in the set must contain this ecode. If a trial doesn't contain the *align code*, the data from that trial will be aligned on the time of the *Any Of* ecode. If you want to align the data at a given time before or after an alignment ecode or analog record mark, enter the time in milliseconds on the *Align Offset* line. If you enter a negative number, Rex will align the data the specified number of milliseconds before the alignment mark. If you enter a positive number, Rex will align the data the specified number of milliseconds after the alignment mark.

You can define multiple ecode selection sets. To define a new set, click on the New button in the middle panel of the dialog. The label will change to reflect the new selection set number and the scroll bar at the right will shorten, reflecting the addition of a selection set. You can use the scroll bar to view your selection sets.

When you create a new selection set, all of the parameters of the previous set are copied to the new set so you don't have to enter everything. For example, you might have one set of *Any Of* codes to group your data, but you might want to align it in several different ways. Define the first set of selection criteria, click *New*, then just change the *Align Code* in second set. Or you might want to view the data from correct and incorrect trials separately. Define the first set of selection criteria and use a reward code in the *All Of* list, click *New*, then delete the reward code from the *All Of* list and enter it in the *None Of* list.

Rex will use two parameters to group your data, the number of the selection set and the ecodes in the *Any Of* list.

Page Layout. To define how Rex is to lay out the raster plots, click on the *Rasters* button in the menu bar and select the *Build Raster Specs* item. This dialog is divided into thirds. The top part of the dialog contains fields to define page-wide parameters of your plots. The middle part of the dialog contains a set of buttons that allow you to select individual plots. The bottom of the dialog contains fields to enter the parameters for individual plots.

To set up you raster specification, first, decide how many rows and columns of plots you want per page and enter these values in the *Rows* and *Columns* numerical fields. The appropriate number of buttons in the button panel will become active. Enter the text of a page label if you like. Below the label text field is a set of buttons that allow you to select the font for the label. The choices correspond to normal, bold, and italic. You specify the size of the label in the *Size* numerical field. The size is in hundredths of an inch. The *Left* and *Bottom* fields allow to specify the position of the page title on the page. These values are in fractions of a page. Specifying a *Left* position of 0.10 causes the page title to begin one tenth of the page width from the left edge. Specifying a *Bottom* position of 0.90 causes the page title to begin one tenths of the page height up from the bottom edge.

To specify a plot, click on the appropriate cell in the cell panel. The button will turn yellow and the current selection set and ecode will be displayed. You specify the data to be plotted using widgets in the bottom left panel of the dialog. You specify the scaling of the data using the widgets in the bottom right panel of the dialog.

Enter the selection set number and the ecode of the data for this plot in the *Set* and *Ecode* numerical fields. Use the *Sigma* numerical field to specify the width of the Gaussian kernel used to build spike density functions. The larger the value for *Sigma*, the smoother the spike density function. If you enter a negative value for *Sigma*, Rex will use an adaptive kernel in building spike density functions. By default, Rex plots both spike rasters and spike density functions in each plot. To disable either type of plot, deselect the *Raster* or *Density* toggle button. You can display up to 10 units per plot. Rex draws each unit in a different color. List the units you want to display in the *Units* text field. After each unit's number, enter a *<return>*. You can display the time of occurrence of one other ecode in each plot. For example, a plot might contain data aligned on the time of occurrence of a saccade target. You can display the time of occurrence of the saccade by having your paradigm drop and ecode when the saccade

starts and entering that ecode in the *Mark Ecode* numerical field. Enter the symbol you want Rex to use

in plotting this ecode in the *Mark Symbol* field. The default symbol is an *hourglass*. Other symbols are *circle*, *diamond*, *square*, or any alpha-numeric symbol. Set the size of the symbol in the *Mark Size* field. The size is in hundredths of an inch. If you enter a mark size of 0, Rex will automatically size the symbols to match the number of raster lines in the plot.

At the bottom of the input panel you can define a label for the plot. If you enter “default” for the *Plot Label*, Rex will use the values of *Set* and *Ecode* to build a plot label. For example if the *Set* is 1 and the *Ecode* is 2000, the default plot label would be “1:2000”. Choose the font type by clicking on one of

the three *Font* buttons. The size of the font is in hundredths of an inch. Set the position of the label using the *Left* and *Bottom* fields. These values are fractions of the plot width and height.

To set the scaling factors for the plot, first enter a *Start* value. This is the time in milliseconds from the alignment code that you want to start plotting data. Enter the duration in milliseconds of the plot in the *Display for* field. You set the vertical scaling of the plot using the *Max Rate* field. This value is in spikes per second. The *Tic Interval* field allows you to set the distance between tick marks on the X axis. If you want a Y axis, click on the *Y Axis?* button. If you want an alignment line, click on the *Alignment Line?* button. The differences between the Y axis and the alignment line are that the Y axis is always drawn at the left edge of the plot whereas the alignment line is drawn where ever time is 0, and the Y axis has tick marks, numbering, and a label whereas the alignment line is just a vertical line. If you want Rex to number the axes, click on the *Number Axes?* button. Choose the format of the numbers selecting either the *Int* or *Float* toggle buttons. Choose the font of the numbers from the *Font* group toggle buttons and enter the size of the numbers in the *Size* field. If you want labels on the X or Y axes, enter the text in the *X Label* and *Y Label* fields. Set the font of the labels by selecting one of the *Font* group toggles. Set the size of the labels in the *Size* field.

When you select successive plots, the parameters of the previous plot are copied to the new plot. Therefore you don't have to set all of the parameters for each plot. You just have to change the parameters that differ.

If you want another page of plots, click on the *New* button at the top of the dialog. The dialog title will change to reflect the page number and the scroll bar at the right will get shorter. When you define a new page, all of the parameters from the previous page are copied to the new page. Therefore all you have to do is click each cell button and change just the parameters that are different for this page. You can review each page using the scroll bar.

After you have defined the data organization and page layouts, you can save the parameters in a root file. Click on the *File* button in the menu bar and select the *Write Root* item from the menu. This will bring up a file browser dialog that displays the contents of the root directory and provides a field to enter the root file name. To use a previously defined raster display, read in a raster root file by selecting the *Read Root* item from the *File* menu.

Displaying Rasters. To display raster data, start the Rex clock by clicking the *Clock* button in the int process tool bar and start the paradigm switching the PSTOP switch or clicking on the *Paradigm* button in the tool bar. Next click the *Start* button in the raster display menu bar. The raster display will collect data for two trials and then begin plotting rasters. If you defined multiple pages of rasters you can display the different pages by clicking the *Prior* and *Next* buttons in the raster display menu bar. To pause the raster display, click the *Stop* button in the menu bar. The display will ignore all data until you click the *Start* button again. If you click the *Re-Init* button in the menu bar, the display will stop and erase all of the current data. When you click *Start*, the display will begin displaying new rasters.

Saving Rasters. If you want to save a set of rasters, click the *Stop* button to stop the display, then select the *Save Rasters* item from the *File* menu. This will bring up a file browser dialog that lets you enter the name of the raster file. Rex will save the current page as a *tig* file. If you have multiple pages of rasters, you need to click the *Prior* and *Next* buttons to display each page, select a file name for that page, then save the file. The *tig* files can be printed on a postscript printer or can be converted to postscript by the *ptig* program.

REX Version Release Notes

Arthur V. Hays

REX 7.2, 1 Mar. 2001

This release allows actions to have pointers as arguments as well as long integers. This allows actions defined in states to have variable arguments, and it allows actions to return values that can be used in the spot file. The rex actions library includes versions of each action that take pointers as arguments, facilitating the declaration of actions in states. The rex actions library also includes a set of 60 actions for controlling the GLvex stimulus display program. These actions cut down the amount of code you have to write and reduce the potential for error when using GLvex. This release also allows the *code* declaration in a state to have a pointer as well as a constant. That is, this release allows the declaration *code &code* in a state as well as the declarations *code 1100* or *code FPONCD*.

REX 7.1, 5 Feb. 2001

This release is built using the Photon window system to provide a graphical user interface. This new interface provides multiple eye window, running line and raster displays. The eye window display has a storage mode that allows you to see the full path of eye movements. The raster display allows multiple pages with up to 64 plots per page. The command line menu and verb-noun interfaces have been replaced with graphical dialogs.

REX 5.4, 1 Jan. 95

This release includes work done on the REX window displays. A new display combining both the window and running line (the 'both' display) is available. Also, color is implemented in the displays. The raster display has been changed to fully occupy a 640 by 480 VGA resolution screen. The running line display can now be customized and split into different vertical sections. The traces can be triggered from the Spot file, and a new mode has been added that prevents erasing of the previous trace to simulate a storage scope. An example of this type of running line control is in the 'tstramp' Spot file.

A software switch has been added for the PSTOP, RLSTOP, etc bits. These bits used to have to be controlled by external switches. To use the software switch, change the paradigm to look for PSTOP in the variable 'softswitch' instead of 'drinput'. Then the noun 'softswitch' can be used from the keyboard to set and clear bits such as PSTOP.

Some minor changes to Spot were made. The first state of a chain cannot contain an action. Also, up to 10 escapes are now supported. This version also contains interface code to the MEX multi-unit analyzer.

A bug exists in the running line code. By default, 8 running line channels are initialized. They are set to display various signal numbers- 0-3, 8 and 9. If one changes the default signal list so that any of these signals are no longer valid, then the running line display will complain. The solution is to change the running line menus so that they don't reference a non-active signal.

REX 5.0, 8 April 94

This release includes new programming interfaces for controlling the d/a converters, signal windows, and ramps. The interfaces have been made more general, and REX now supports multiple d/a

converters, signal windows (8 by default), and ramps (10 by default) simultaneously. These changes require paradigm modifications to include new actions. Please see the sample paradigm at the end of the Spot manual.

This release only runs under QNX 4.2, the 32-bit version of QNX. However REX is still compiled to run 16 bit, except for spot. spot has been modified to permit a max of six arguments to actions.

Some new variables have been added to the control_param menu. Please see the description of this menu in Chapter 6. Also, two new verbs were added to the tty noun: map tty and unmap tty. These verbs permit the VGA screen to be returned to text mode while REX is running. One could then use 'telnet' or an editor in the background without affecting REX.

The d/a converters can now be driven by pre-computed waveforms stored in memory. The ramp is still generated at run time as before, but other waveforms can now be used by pre-computing them and storing them into memory buffers. This feature will be more usable when REX is ported to 32-bit mode and the length of memory buffers is not restricted.

PLEASE NOTE!!!

With this release, one must change the unit latch circuit! Please see the new circuit in Chapter 9 of the REX manual. If you don't make the change, your unit data will be corrupted.

REX 4.3c, 4 April 1994

This is a version of REX 4.3b ported from QNX 4.0.1 to QNX 4.2. You must use the latest update of 4.2 available from QNX's BBS system. It may run on the version from your diskettes, but I don't guarantee it. Note that QNX is on the net now (qnx.com), however they don't have anonymous ftp up yet. So you must download updates from the BBS or call them for diskettes.

When you install your QNX 4.2 kernel, specify that you want the 32 bit version. However, REX is still running in 16 bit mode except for 'spot'.

This version has some advantages- menus print out without missing characters, reading roots is very fast. Note that the way the screen is switched from text to graph mode is different under 4.2. If you used to use the program 'greset' located in rex/sys/matrox, it will no longer work properly and should not be used.

The file 'config.tar' contains my configuration files. You will need to make a new kernel to run Rex. The file 'boot/go' is a shell file to make the new kernel and install it. This must be done after downloading any updates as well. This new kernel build file assumes that your a/d is on interrupt number 5. If not, edit 'boot/build/aha32.1' and change the flag to 'Proc' for the interrupt level of your a/d.

PLEASE NOTE!!!

With this release, one must change the unit latch circuit! Please see the new circuit in Chapter 9 of the REX manual. If you don't make the change, your unit data will be corrupted.

REX 4.3, 24 Nov. 93

Release 4.3 adds a new field to the sample header that specifies the delay of the anti-aliasing filter on the a/d inputs.

A subsystem for PC to PC communication has been added. This subsystem implements an 8-bit wide full-duplex point-to-point link between the REX PC and other PCs. Each link requires a dedicated 24-bit parallel I/O chip (the Intel 8255). The link is designed so that the interface boards containing the 8255 chip can be cabled together directly, pin for pin, without external glue logic or cable re-mapping. The link protocol is designed to be independent of timing differences between the PCs. The

programming interface presents a messaging model to the user. Messages include checksums. Please see `rex/hdr/pcmsg.h` and `rex/int/pcmsg.c` for further info about this subsystem.

REX 4.3 conversion: a temporary fix to the rextools has been made that knows about the upgraded data files in version 4.3 of REX. It is installed on irisf. (Since this is a temporary fix, there is an extra printout to stderr that announces whether your files are in "old" or "new" format.) If you have any data files that were collected under the version of 4.2 that included the delay variable, those files will not work correctly. they are really 4.3 version data files.

I made a perl script to convert A- and E-files from 4.2 to 4.3 **ONLY FOR THOSE FILES!** If you run it on good 4.2 files, you will ruin them! So, if and only if your 4.2 files fail to go through `grdd`, `brdd`, or `trdd`, fix them by running the file "rex4_3patcher" on irisf. If you just type "rex4_3patcher", it will give a usage message (of course!). Report problems to me. Lance 11/24

1-4.2, FIX). A bug was found in the PC to PC messaging code that resulted in receive checksum errors being reported on Type 1 messages when both Type 1 and Type 2 messages were being used. To fix this bug, add a single line of code to `/rex/int/pcmsg.c`:

```
/*
 * Compare checksums.
 */
switch(p->pcm_msg_type) {
case PCM_TYPE0:
    rxerr("pcm_msg_process(): TYPE0 has cksum");
    goto rx_reset;
case PCM_TYPE1:
#ifdef PCM_DEBUG
    puts("rx_type1_ck ");
#endif
    p->pcm_rx_calcksum &= 0xff;
    p->pcm_rx_cksum &= 0xff; /* ADD THIS LINE HERE */
    /* fall through */
case PCM_TYPE2:
```

2-4.3, FIX). The code that saves the contents of the digital input word is currently *after* the code that looks to check for units. This means that the times for units are offset by 1msec. To fix this problem, look in `int/int.c` and make sure that the section titled "Digital input processing" is just *before* instead of *after* the section titled "Collect units data". If this is not the case, edit `int.c` and move it. Thanks to Barry Richmond for finding this.

3-4.3, FIX). A problem has existed with the variable `ras_wakeup_ecode` in the `'dsplay'` menu. When a root was read back in, this variable would often be set to 0. The fix for this is to add a single line of code to `/rex/sys/rlib/access.c`:

```
/*
 * of odd num of args, however, *pp must be checked for NP
 * both before and after incrementing in for() statement below.
 */
for(pp= pbuf; *pp != NP; pp= (*pp == NP ? pp : pp+1)) {
    far_ptr= 0; /* ADD THIS LINE HERE */
    vlp= mp->me_vlp;
    if(isdigit(*pbuf[0])) line= atoi(*pp++);
    else line= sindex(*pp++, &vlp->vl_name, sizeof(VLIST));
```

Then, you must recompile *all* of rex by running a `'make complete'`.

3-4.3, FIX). A bug in PC-REX affects the setting of variables read in from root files. If the variable is out of range, it may be changed to something else. For example, the reset_s(-1) action that is used in the spot file to cause the abort list to be executed requires a '-1' argument. When this argument is read in from a root file, it is changed. Then, the actions in the abort list are no longer called.

I will be fixing this bug this week. Until then, a temp fix would be to edit your root and change the argument for the reset_s action from 0xffffffff to -1. The menu system will accept -1, but not 0xffffffff. A good way to tell what is affected is to run rex and then run your process without calling in a root. Write a root, and then read it back in right away. Then write a second root. The first and second roots should be identical on a 'diff' except for the line containing the date. If there are differences then they are caused by this bug.

4-4.3, FIX). A bug in the menu system sometimes resulted in errors in inputting null-value type variables.

REX 4.2, 9 Nov. 93

Release 4.2 incorporates a new A-file format and signal specification menus. It is now possible to specify sampling rates for each a/d channel independently from a menu. Global memory variables can also be stored to the A-file. The new A-file format is incompatible with the old, however.

REX 4.1b, 18 Nov. 92

Release 4.1b is a minor release which fixes some bugs in the d/a converter code. It also adds the code for resetting the unit latch. A new command, \f3bit, has been added. This permits output bits on the default digital I/O device to be turned on/off easily from the keyboard for testing purposes. The header "/rex/hdr/lab.h" has been folded into "/rex/hdr/cnf.h". Support for a joystick was added to the action wd_ctl and mr_set. Joystick support currently is enabled by a define in "/rex/hdr/cnf.h".

A new system of naming major and minor releases has been established. Major releases will be designated by numerics, e.g. version 4.2. Minor releases will be designated by lower case letters, e.g. version 4.2c. Current version levels are displayed by the command type proc.

The default address for the d/a card has been changed from 0x210 to 0x180. This is because some of the ICS d/a card addresses can only be set modulo 0x20, not 0x10. If you originally installed your d/a card at 0x210 you will either need to change it to 0x180, or modify "/rex/hdr/cnf.h" to reflect the old address.

All non-system ecodes have been removed from "/rex/hdr/ecode.h". This is most of the codes greater than 1000. Please place paradigm-specific ecodes in headers in "/rex/sset", and include these headers in your Spot file. The intent is to keep most of the user-specific code in the sset directory.

REX 4.1, Oct. 92

Release 4.1 adds the programming interface for digital I/O devices. This addition necessitated changing the arguments to actions from ints to long ints. Because of this change, existing actions need to be modified so that their arguments are explicitly declared as longs. This is a minor change, but \f3ALL existing user-written actions must be modified to run properly. See section 11 of Chapter 4, "When Things Don't Work", for a more detailed information and examples.

Changes were also made to the menu handler code for accessing state variables. Arguments to actions are now printed in hex and base 10. A hex number can be entered from the keyboard by

prefacing it with "0x". In general the PC world thinks in hex (as opposed to octal for pdp11s). A knowledge of the hex digits will be very useful for the PC version of REX.

Some modifications have been made to Spot. An escape test has been added that will call a function and transition to the next state based on the return value of the function. The Spot document has been updated, and the section on escape tests has been expanded. The need for three sections in Spot files disappeared in REX 3.10, however they were kept for compatibility. In this release, Spot has been modified so that it only accepts files that have two sections- a C code section, and a Spot language section. To modify existing Spot files, simply move the entire third section (after the double percent) into the first section. Then delete the last double percent that marked the beginning of the third section.

The "/rex/lhdr" directory has been deleted. All header files that pertain to the general REX source are now in "/rex/hdr". Header files that pertain to each individual laboratory (such as files that declare local ecodes, or local device ids) are now kept in "/rex/sset". See the chapter "Installing REX" for an overview of important configuration headers and their locations.

REX 4.0, Step 92

Release 4.0 is the first release of the PC version of REX. This version is a port of REX 3.11. REX 4.0 runs on the QNX operating system. Incore space for the event buffer and analog buffer were increased, given the PC's larger address space. QNX currently runs in 16 bit protected mode. When a later release supports 32 bit mode the only limit on the buffers will be memory size.

The C compiler under QNX is ANSI C. ANSI C is more stringent in error checking than the compiler on the pdp11. Existing paradigms will generate many errors the first time they are compiled, and will have to be converted to ANSI C.

Current bugs:

1-4.0). Output to dumb tty has gaps when clock is on. This is because QNX does not restart output to slow ttys after interruption by a signal (the pdp11 version of Unix did this). Note that input from the keyboard is not affected. One can stop the clock to see intact printout on the screen. While the clock is on, one must know the line number of the variable being changed. This problem is not easily solved, and requires porting a public domain version of the standard I/O library.

2-4.0). When REX is exited, an error message is printed concerning "null pointer assignment detected". This is benign.

REX 3.11, Jul. 88

Release 3.11 adds support for two eyes, and changes to the window display. The primary eye channel is now displayed on the window display as an 'X', the other eye channel is displayed as an 'O'. The two channels are simply called the 'eye' and 'other eye'. There are two windows as well, which can be different sizes.

Offsets can now be applied to the eye channel signals. These offsets are in effect for all on-line operations on the eye signals such as the window check, saccade detection, displays, etc. The offsets are not applied to the values stored in the A-file, however. The offset mechanism is useful when sampling two eyes at various depths. The applied offset is changed to compensate for varying angles between the eyes, thus keeping the displays and window check accurate.

The following actions have been added: wd_osiz(), wd_pos(), wd_ctl(), off_eye(), and off_oeeye(). The action wd_set() has been removed. The following menus have been added or changed:

wind/mir has been split into windows and mirror. Menu offsets_eye has been added. Menus control-param and dsplay have been changed.

A number of default display configurations have also been added to the raster display. Displays from 1 to 16 rasters are now available.

REX 3.10, Jun. 87

Release 3.10 has been converted to run under the new real-time 11/73 kernel that utilizes 22 bit addressing. A number of advantages result:

1.) All REX processes are now compiled split I/D. This yields much more room for paradigms and more complicated raster displays.

2.) The Unix kernel utilizes full 22 bit addressing. Multiple loaded paradigms now reside in memory, instead of being swapped out. This makes changing processes almost instantaneous. A bug was present in the old kernel that caused intermittent system crashes, most often when changing processes or escaping to the shell. This condition no longer arises, given the much larger memory available. One should no longer need to follow such precautionary steps as ending the clock, or explicitly stopping or killing the current process before executing a change process command. One can also escape to the shell at any time, even with the clock on, without fear of a crash.

3.) The interrupt part of REX now runs in the 11/73's supervisor mode, instead of kernel mode as before. Such errors in the interrupt routine as segmentation violations, stack overflows, etc. used to cause a crash when run in kernel mode. These errors are now caught and recovered from. In addition, the restriction that all variables used in the lower level of the interrupt routine be initialized is no longer needed. In fact, there is now no difference between the first and third sections of the Spot file. Variables and code can be placed in either section, and variables do not have to be initialized in either section. Therefore there is no longer any need to run the shell file 'prt_bs' in the run directory to check paradigms for uninitialized variables.

4.) There is now only one kernel for both REX and using the Ethernet. One does not have to reboot another kernel to use the Ethernet.

The following enhancements were made to REX:

1.) Support for more than 80 states was added. The statelist menu now can be advanced to the next page of states by typing '>' to the prompt after the menu is entered. The previous page is accessed by '<'. Alternatively, the nth page can be directly accessed by typing 'set statelist n' where 'n' is the desired page. For example 's s 1' enters the first page. The upper limit on states is probably between 150 and 200, depending on how much other code is in the Spot file.

2.) Information concerning errors which occur in the interrupt routine and are caught and recovered by the kernel is stored in the error file. In addition, when an error occurs the clock is stopped and all files closed.

Conversion of paradigms to REX 3.10 requires one change in the Spot file. A help message string for the 'state_vars' menu must now be defined in the spot file. (The help message is the information that appears on the right side of the screen when some menus are accessed.) If a help message for the 'state_vars' menu is not desired, it must at least be defined as a null string. The following example of a 'state_vars' declaration at the end of a Spot file also includes a definition for a help message to be printed on the right side of the screen:

```
%%  
/*
```

```
* Declaration of statelist menu.
```

```

*/
extern int tstate, tloop;
VLIST state_vl[] = {
    "tstate",          &tstate, NP, NP, 0, ME_DEC,
    "tloop",          &tloop, NP, NP, 0, ME_DEC,
    NS,
};
/*
* Help message.
*/
char hm_sv_vl[] = "\
tstate:\n\
0: norm, no error\n\
1: pri < 6, panic halt\n\
2: signal stack\n\
3: sup stack\n\
4: kernel stack\n\
5: sys call\n\
6: seg violation";

```

If a help message is not desired, the following definition **MUST** appear to avoid an error message when compiling:

```

/*
* Null help message.
*/
char hm_sv_vl[] = "";

```

The I/O page in the lower level of the interrupt routine is now mapped with memory management register 6 instead of 7. All device addresses defined in the header "device.h" have been changed to reflect this (see macro 'd_(addr)' declared at beginning of "device.h"). If you have added new devices to REX, redefine their addresses using this macro just as the addresses in "device.h" are defined.

The part of the matrox library that writes text strings on the screen has been replaced with a more efficient version written by Lance Optican. The text part of the raster displays draws much faster.

REX 3.5, 27 May 86

Release 3.5 integrates in support for ADAC devices written by Bill Newsome and Grant Tech. devices written by Jack Nelson. In addition the following bugs were discovered and/or fixed:

1-3.5, FIX). Bug existed in computation of awtime in write to disk section of int.c. This is the time of the beginning of an analog record, or the time of the beginning of a continuation record. Problem only appeared if SAMP_P_ACQ and MS_P_INT defined in lhdr/samp.h were not equal. Fix occurs in two places where awtime is computed. This bug found independently by Jack Nelson and Reuben Gellman.

2-3.5, FIX). Bug in incrementing pointer 'ladr_3' in a/d handlers in int.c for versions that store more than two channels at a time in a buffer. The old sequence was to use ladr_3 to store first sample and auto increment. Then the second sample was stored. At this point value bufinc_4 was added to ladr_3 to step it to next buffer. However, it would now be pointing one ahead of the proper location because it had previously been auto incremented. This would result in the horizontal and vertical buffers being one sample out of sync with each other. Fixed by adding (bufinc_4 - 1) instead of bufinc_4 alone. Thanks to Jack Nelson for finding this.

REX 3.4, 30 Nov. 84

Release 3.4 contains support for the Unibus Data Translation a/d converter. No old bugs fixed or new ones reported.

REX 3.3, 30 Oct. 84

Release 3.3 includes changes to makefiles and bug fixes of Release 3.2. The makefiles were changed so that paradigms could be recompiled from a local subset of the int source that is likely to be different per investigator while sharing a single copy of the majority of the REX source. This is useful when multiple users share a single machine, and when integrating new releases REX (since code that is specific per user is kept separately from the shared source).

Bugs fixed in this version:

1-3.2, FIX). Afile, Efile overflow errors now reported.

2-3.2, FIX). String compare function bug resolved by changing improper uses of match() to strcmp().

6-3.2, FIX). Control B problem resolved by not calling dumpe() under certain conditions from dumperr() in scribe (dumpe() was flooding screen with output because of errors due to Efile pointers not being valid since clock had never been started). Now dumperr() will not call dumpe() unless, in addition to other constraints, Efile keeping is also enabled.

Bugs reported in this version:

7-3.3). When a command is given to read a rootfile that doesn't exist an error is reported. However, system status is not returned to full quiescent state- rootflag still shows that a rootfile is being read. If at this time another process is run, it will see the rootflag and try to read the non-existent root, giving another error message.

REX 3.2

Release 3.2 is the first general release of Version 3 REX. It was debugged during Summer '84 running experiments conducted by Bob Wurtz and Bill Newsome on Bob's 11/34 system.

Current bugs of Release 3.2:

1-3.2). Afile, Efile overflow when no more space remains on disk not reported with an error.

2-3.2). Bug in string compare function used in distinguishing process names. A process name that is a subset of another process name is compared as equal.

3-3.2). The JHU/Unix kernel sometimes swaps out all swappable processes and then hangs up- it cannot swap anyone back in. This bug appears primarily when running new REX interrupt processes or changing the current interrupt process. One can verify this bug by typing "(control) t" when the keyboard stops responding. All non-locked processes (data, scribe, and int are normally locked) will be swapped out (identified by a '-' by the process id).

An interim fix has been put into comm to help mitigate the effect of this bug. During some of the process control operations comm locks itself in memory to guarantee it will not be locked out on the swap device. This works most of the time.

4-3.2). The window on the window display will sometimes flicker briefly at its last position when being changed to a new position. For example, if the window is at 0,0, then is turned off and moved to 200,200 and turned on again, it might briefly appear at 0,0 before appearing at 200,200. This bug is do to a section of the window display being re-interrupted during processing. ONLY the display is wrong, the actual window checking function is always accurate.

5-3.2). srdd will not parse '1c=num', '2c=num' arguments unless a preceding flag is present.

6-3.2). Control B will produce erratic results if done if clock has never been begun.

REX Internal Calibrations

REX Internal Calibrations

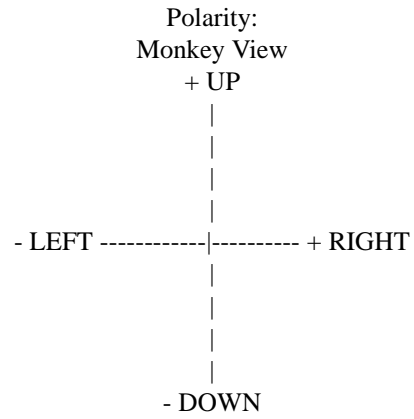

A/D Full Scale Range Calibrations

Full scale range for A/D input is selected by 'eye-calib-num' in control menu. Note that Rex performs most internal operations on the A/D signals at a resolution of 40 steps/degree, 2's complement representation.

'cal' = 'eye-calib-num' in control menu.

'shift' = internal shift factor used for conversions

FS = Full Scale

ST= a/d Steps

Table 1:

| 10 Bit A/D | cal | shift | 12 Bit A/D | cal | shift |
|-------------------------|-----|-------|-------------------------|-----|-------|
| 102.4 deg FS, 10 ST/deg | 5 | -2 | 102.4 deg FS, 40 ST/deg | 0 | 0 |
| 51.2 deg FS, 20 ST/deg | 6 | -1 | 51.2 deg FS, 80 ST/deg | 1 | 1 |
| 25.6 deg FS, 40 ST/deg | 7 | 0 | 25.6 deg FS, 160 ST/deg | 2 | 2 |
| 12.8 deg FS, 80 ST/deg | 8 | 1 | 12.8 deg FS, 320 ST/deg | 3 | 3 |
| 6.4 deg FS, 160 ST/deg | 9 | 2 | 6.4 deg FS, 640 ST/deg | 4 | 4 |

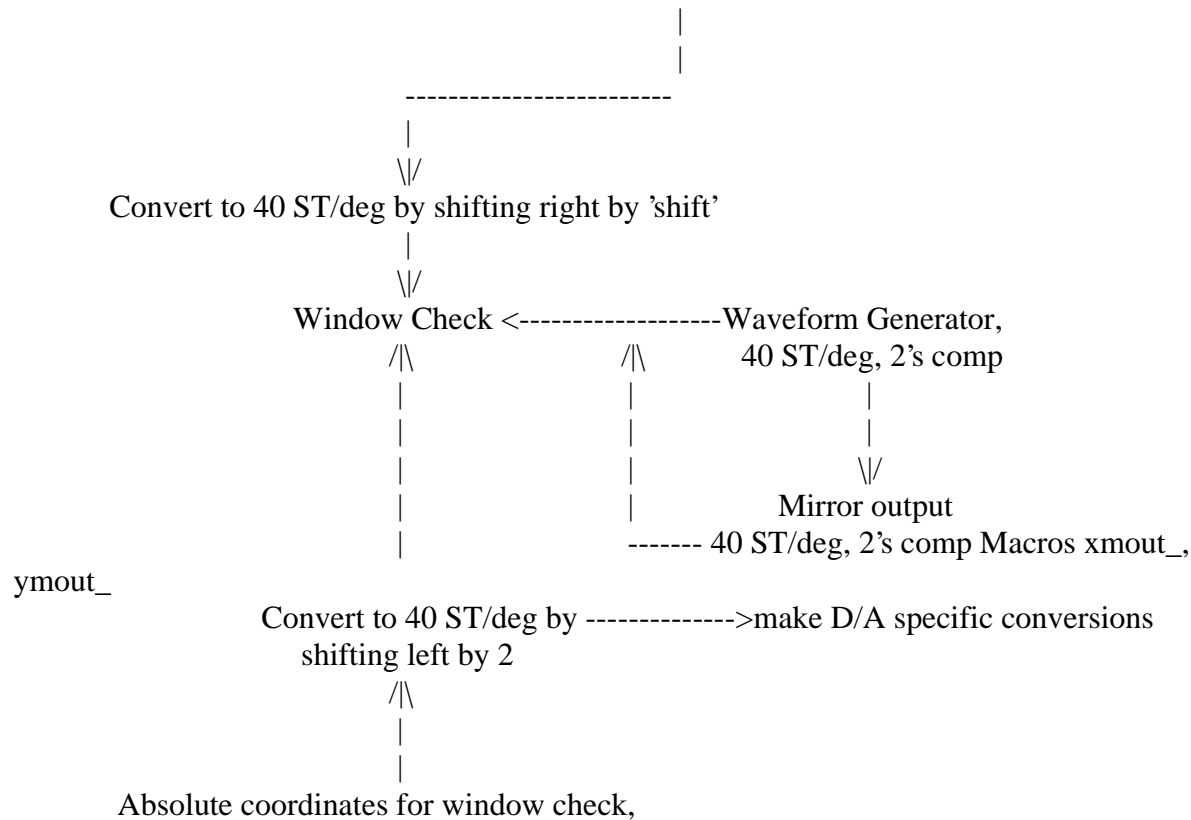

Configuring PC Systems for Running REX

Arthur V. Hays
Revised 7 Apr. 94

REX Software Configuration

REX for the PC runs on the QNX operating system. QNX is a distributed real-time operating system that is POSIX compliant. We chose the QNX operating system because it provides an application programming interface that closely parallels the Unix environment that REX runs under on the pdpd11. It is also a 32 bit protected mode operating system that has real-time support. QNX provides real-time features such as attaching to interrupts and fast service times and context switches. It has proven very reliable and robust. Through POSIX compatibility, Unix programs are easily ported. The C compiler used under QNX is Watcom C.

REX does not run on DOS. DOS programs, however, can be run under QNX by using an additional product called RUNDOS. This is a DOS emulator. This emulator is quite good, and will run Windows 3.1 in \f2standard\f1 mode! QNX is a product of QNX Software in Canada. We usually place our orders with Florida Datamation. QNX Software also sells a TCP/IP option for QNX. This permits communication via ethernet to other machines. NFS and X-windows are also available.

The disk can be partitioned so that DOS and QNX have separate segments. One can then boot either DOS or QNX. Under QNX, one can read/write the DOS segment. Under DOS, however, one cannot see the QNX segment.

REX Hardware Configuration

PC

The preferred PC for REX is a 486/33 or faster machine, with EISA or PCI bus. The machine should have 4 or 5 available ISA slots for real-time devices. These slots would be allocated as follows: a/d card, d/a card, digital i/o card, and one or two free. I recommend only buying a system that is known to run QNX (one can call QNX and ask whether they know if QNX runs on a machine under consideration). This recommendation is due to the fact that the QNX operating system runs in protected mode. It exercises the hardware more vigorously than DOS. Note that devices that require DOS drivers \f3will not work\f1 under QNX. Sometimes a device will emulate another (e.g. a SCSI controller will emulate an Adaptec) when used with a supplied driver. This driver, however, is written for DOS. DOS drivers cannot be used under QNX. This is a very important point to remember when considering purchasing devices to run under QNX. If the device depends on any supplied software written for DOS, it will not work under QNX.

REX will run in only 4MB, but I recommend 16MB. The disk should be at least 400MB. This is to contain both a QNX partition and a DOS partition. The disk should be a SCSI disk (see below). QNX supports the Adaptec controllers very well. Other SCSI controllers may be supported under QNX, but call QNX before ordering to verify. REX currently uses only VGA 640-480 resolution. Any VGA adapter will work. However, in the future REX may use X Windows. In this case, greater resolution and screen size would be desirable. Call QNX for a list of the currently supported adapters. A 17 inch or greater screen would also be needed.

REX also currently requires a dumb tty that can emulate the VT100. Please note that VT100 emulation IS REQUIRED. REX wont work with anything else. This tty is connected to serial port 2 and runs the REX menu interface. The VGA screen then takes the place of the old Matrox display.

Will REX run on less expensive PC configurations? Perhaps, but I haven't tested it. I would imagine that an ISA bus would be fine, however it is difficult to use more than 14MB of memory on an ISA bus machine. The only EISA card we are currently using is the Adaptec 1740/1742. It is also available for ISA as the Adaptec 1540/1542. In the future the PCI bus will be more popular, and the Adaptec and the graphics card may both be supported by QNX on this bus. The disk type is very important. The SCSI controller works by DMA. Other types, such as IDE and ESDI, do not use DMA and require CPU cycles to move data. This can lock out the CPU and interfere with real-time processing.

QNX supports the Western Digital/SMC 8013 ethernet card very well. I have not been able to get the 3Com cards to work. I suggest purchasing the 8013.

Real-time Interface Cards

A/D Cards Two a/d cards are recommended for PC-REX. One is an inexpensive 12 bit low-end card, the other a 16 bit card. The low cost unit is the Analogics DAS-12/50, \$500. It will sample 8 channels at 1KHz with 12 bit resolution. It cannot be used to sample any faster.

I also evaluated 16 bit a/d converters. I tested the ADAC 5508SHR, the Analogics LSDAS16, and the National Instruments ATMIO16-X. The disappointing fact is that one doesn't really get 16 bits with the current generation of products. When the input is grounded, the output of the converter ranges over 4-5 counts. A 16 bit converter has 4 more bits than a 12 bit, and this equals 16 additional counts. Therefore, one gets only about 2/3 of this extra resolution (5 counts of noise/16 possible counts). Statistically the situation is better, given some processing or averaging. The standard deviation is only .5 - .7 counts. Whether you should use a 16 bit converter depends on your application. If you are looking at slow velocities, processing the signal (such as software differentiation), etc. the extra resolution may be very helpful.

I quantitatively tested the ADAC and National Instruments (I did not like the way the Analogics did software calibration, and sent it back before I did these latest tests). The National card was cleaner (see results below). It is more expensive (\$2k vs. \$1.3k), however it has a lot more features including 16 bit dacs, full auto calibration, dual dma, extensive on-board buffering, a channel-gain list, double the conversion rate, etc.

My a/d recommendations therefore are the Analogics DAS-12/50 for an entry level 12 bit converter at 50KHz throughput (\$500), and the National Instruments ATMIO16-X for 16 bit at 100KHz throughput (\$2000). I don't have a higher throughput (100-500KHz) 12 bit converter programmed into REX, but would suggest one of the National Instruments cards. Note if you think you may have need in the future for anything more than just 8 channels at 1KHz you should buy the ATMIO16-X.

Some other cards are known to work under REX, and are listed in the "/rex/hdr/cnf.h" file. Included are the DT2821, which works fine and has excellent performance (but is costly). Note that the DT2801 cannot work under REX- it cannot generate an interrupt. If you have this widely used card, you may be able to trade it up to a DT2821. The Analogics and National Instruments cards are preferred for new purchases.

D/A Cards

REX supports d/a cards with programmed I/O transfers. REX typically can update d/as once per msec. The recommended cards can be purchased with from 6 to 16 converters/card.

Digital I/O

For digital I/O, IO module systems are used. These systems are composed of 'racks' (a 'rack' in this terminology is a pc board, not a floor standing cabinet) and 'bricks' that plug into the racks. The bricks contain solid state relays or dry contact relays. You use one brick per bit. The racks are driven by a single digital I/O card in the PC.

Note that you might not need all the different types of modules ordered here at NIH. Some of these modules I wanted to have on hand in case of special applications. If you have TTL-level inputs, an input module is not even needed. TTL-level inputs can be wired directly into the digital I/O card. However, when using the module the LED indicator on the rack will be used. Note that DC input modules are not standardized across all vendors (such as Grayhill, Potter & Brumfield, Opto 22, Gordos, Crydom). Each company's DC input module has different timing specs and input impedances. These specs are important when interfacing TTL or LSTTL gates. The Grayhill module has a high input impedance (1.8k) and can be driven easily by a TTL (sinks 16ma) or 74 series LSTTL (sinks 8ma) gate. However, its switching times are somewhat slow: 250usec on/400usec off. I am currently looking at some other modules that have lower input impedances but faster switching times (50usec on/100 usec off). See circuit diagrams at end of this document for more info.

You will probably certainly need the DC output module and dry-contact relay module. If you want to switch AC loads by this system you should also get an AC output module.

Counter/Timer Card

For unit input, we may use a counter/timer card. However, it is currently not programmed into REX and we are just using the digital inputs for units. The counter/timer should permit unit resolutions of 10 usec (vs. current 1-2 msec). You should not buy this card at present since it is not being used.

Device Addresses, Vectors, Jumpers

The following is a list of the addresses, vectors, and DMA assignments we use at NIH. Note that these can be changed. The files "/rex/hdr/cnf.h", "/rex/hdr/device.h", and "/rex/int/cnf.c" contain the configuration information.

Table 1: Vectra Configuration for QNX and REX

| Interrupts | | |
|------------|---------------------------|--|
| 0 | System Timer | |
| 1 | Keyboard | |
| 2 | Cascaded interrupts 8-15: | |
| | 8 | CMOS Real-time clock (not used by QNX) |
| | 9 | Unused |
| | 10 | COM3 (VT100 serial port) |
| | 11 | Adaptec 1740 |

Table 1: Vectra Configuration for QNX and REX

| Interrupts | | |
|------------|---|----------------------------|
| | 12 | Vectra internal mouse port |
| | 13 | Coprocessor |
| | 14 | IDE disk (if enabled) |
| | 15 | Unused |
| 3 | SMC 8013 and/or Archive 1/4" tape adapter | |
| 4 | COM1 (modem) | |
| 5 | a/d converter | |
| 6 | Floppy | |
| 7 | LPT1 | |

Interrupt priorities are established by QNX at boot time by assigning one of the levels to be the highest. The priority then decreases from the assigned level for each succeeding interrupt number. Note that interrupt 2 is really the cascaded input from interrupts 8-15. QNX, by default, assigns interrupt 3 to be highest. This results in a priority order from highest to lowest of: 3, 4, 5, 6, 7, 0, 1, 8, 9, 10, 11, 12, 13, 14, 15. For REX, a new QNX kernel build must be built specifying the flag "-i 5" to Proc (by editing the build file in /boot/build). This changes the assignment of the highest priority interrupt to level 5 and results in a priority order of: 5, 6, 7, 8, 9, 10, 11, 12, 13, 14, 15, 0, 1, 2, 3, 4. The idea is to make the A/D interrupt the highest.

If your A/D cannot be set to level 5, place it somewhere else. Be careful to keep its priority the highest. Also note that COM4 on a Vectra cannot be used with an ATI Graphics Ultra. The 8514/A part of the ATI card uses I/O addresses at 2e8.

Note that REX requires a dumb tty that can emulate a VT100. At NIH, I connect this tty to COM3. I use COM1 for a modem. This tty can be connected to any port, however. If you change it from COM3, you must edit "/etc/config/sysinit.1" to make sure a 'login' is started on the terminal.

Table 2: DMA Channels

| 8 bit channels | | 16 bit channels | |
|----------------|-------------------|-----------------|--------------------------|
| 0 | Unused | 4 | Unused |
| 1 | Unused | 5 | Adaptec 1740 |
| 2 | Floppy | 6 | A/D |
| 3 | Archive 1/4" tape | 7 | A/d (when using dual DMA |

Table 3: Addresses

| I/O Port Addresses (in Hex) | | Memory Address (in Hex) | | |
|-----------------------------|-------------------|-------------------------|------|------------------------------|
| Address | What | Address | Size | What |
| 170-178 | IDE disk | a0000-affff | 64k | ATI video board |
| 180-19f | d/a board | b0000-b7fff | 32k | Unused |
| 200-207 | Archive 1/4" tape | b8000-bffff | 32k | ATI text |
| 23c-23f | Mouse | c0000-c7fff | 32k | ATI BIOS (shadowed to e0000) |
| 240-25f | a/d board | c8000-cbfff | 16k | Unused |
| 280-294 | Digital I/O | cc000-cffff | 16k | SMC 8013 |
| 2e0-?? | ATI 8514/A | d0000-d3fff | 16k | Adaptec 1740 |
| 300-31f | SMC 8013 | d4000-dffff | 48k | Unused |
| 330-333 | Adaptec 1740 | | | |
| 378-37f | LPT1 | | | |
| 3f1-3f7 | Floppy | | | |
| 3e8-3ef | COM3 | | | |
| 3f8-3ff | COM1 | | | |

EISA Configuration for HP Vectra (obvious settings not listed)

- System board Cache memory: enabled Enhanced video performance: copy BIOS to RAM at E0000 AFTER init
- Mouse and serial port board Serial port: COM3 (used for VT100)
- Serial port and parallel port board Serial port: COM1 (used for modem) Parallel port: LPT1
- Adaptec 1740 Note: you should have received a floppy from Adaptec with your 1740. It has the EISA .cfg file needed for configuration. Interface mode: Use standard mode, with interrupt level 11 I/O Port: 330h. DMA: 5. Host adapter BIOS: D0000H. Host ID: 7. SCSI reset: enable. SCSI configuration: standard mode, parity on, sync negation on, disconnection on.
- Vectra memory board Reserved memory: 384k (0 KB remapped)

Analogics DAS-12/50

The Analogics board should be jumpered for address 0x240. Other jumper options are for differential inputs and full scale range. The vector and DMA are set by software. The DAS-12/50 has a 26 pin High Density 'D' connector. This type of connector is somewhat unusual. It is a high density version of the regular 'D' style, and has one more pin- 26 instead of 25. One can order the connector from Digikey. The other option is to buy the Analogics screw terminal box (\$200). This box may also have an area to put RC anti-aliasing filters.

Computer Boards CIO-DDA06, CIO-DAC08, CIO-DAC16

These boards should be jumpered for address 0x180. I also jumper the boards to include a wait state. The simultaneous update jumper should be on 'UPDATE XX' for individual updates. These boards have a 37 pin 'D' connector. The '2M37DSM' termination board from Industrial Computer Source provides screw terminal connections for this connector. This board can also be ordered from Newark. The manufacturer is Augat/RDI.

Industrial Computer Source PCDIO

This board should be jumpered for address 0x280. See Figure 1 for other jumpers configuration information.

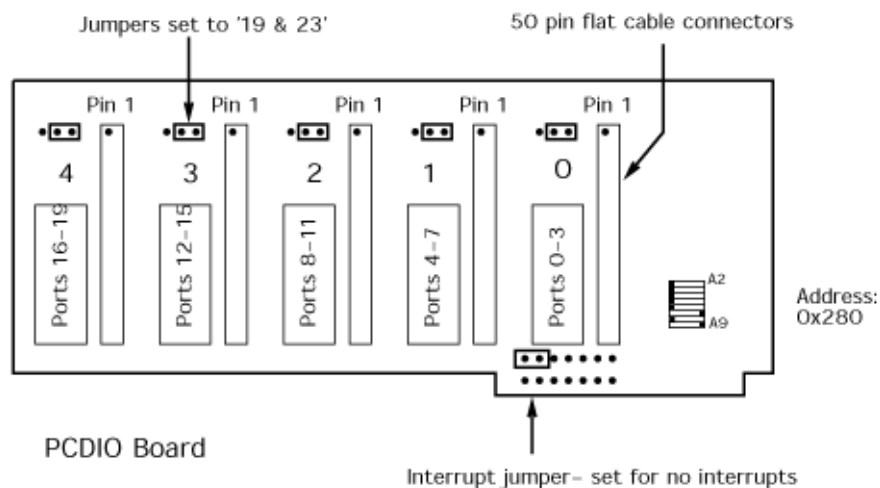
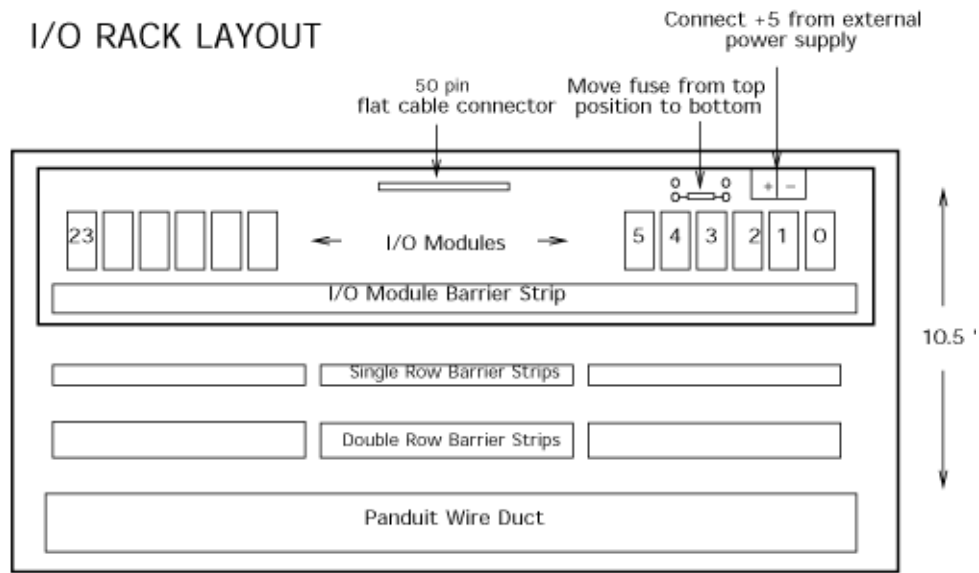

Figure 1: PCDIO Configuration

Digital I/O Rack Panels and Circuits

Digital I/O is accomplished using I/O rack systems. These systems are composed of a PC board (termed a 'rack'), and potted modules which plug into the PC board. There are four general types of modules: DC input, DC output, AC input, AC output (AC modules will switch 110v). The Industrial Computer Source digital I/O board will drive up to five racks, each rack holding 24 modules. The racks are mounted on standard BUD aluminum panels. See Figure 2.



Notes:

1. Mount single and double row barrier strips on 3/4" spacers.
2. All positions on single row barrier strip are connected to +5v.
3. Do not use computer's power supply to power I/O rack. You must have an external +5v. supply. Connect this supply to connectors in upper right hand corner of board. Then move fuse from top position to bottom position (it just pulls out of pin sockets).
4. Barrier strips have 14 positions.

Figure 2: I/O Rack Layout

Also mounted on the BUD panel are two rows of terminal barrier strips. The single-row strip is wired to +5v. The double-row strip is not connected to power or ground. These strips provide space to wire resistors and pots.

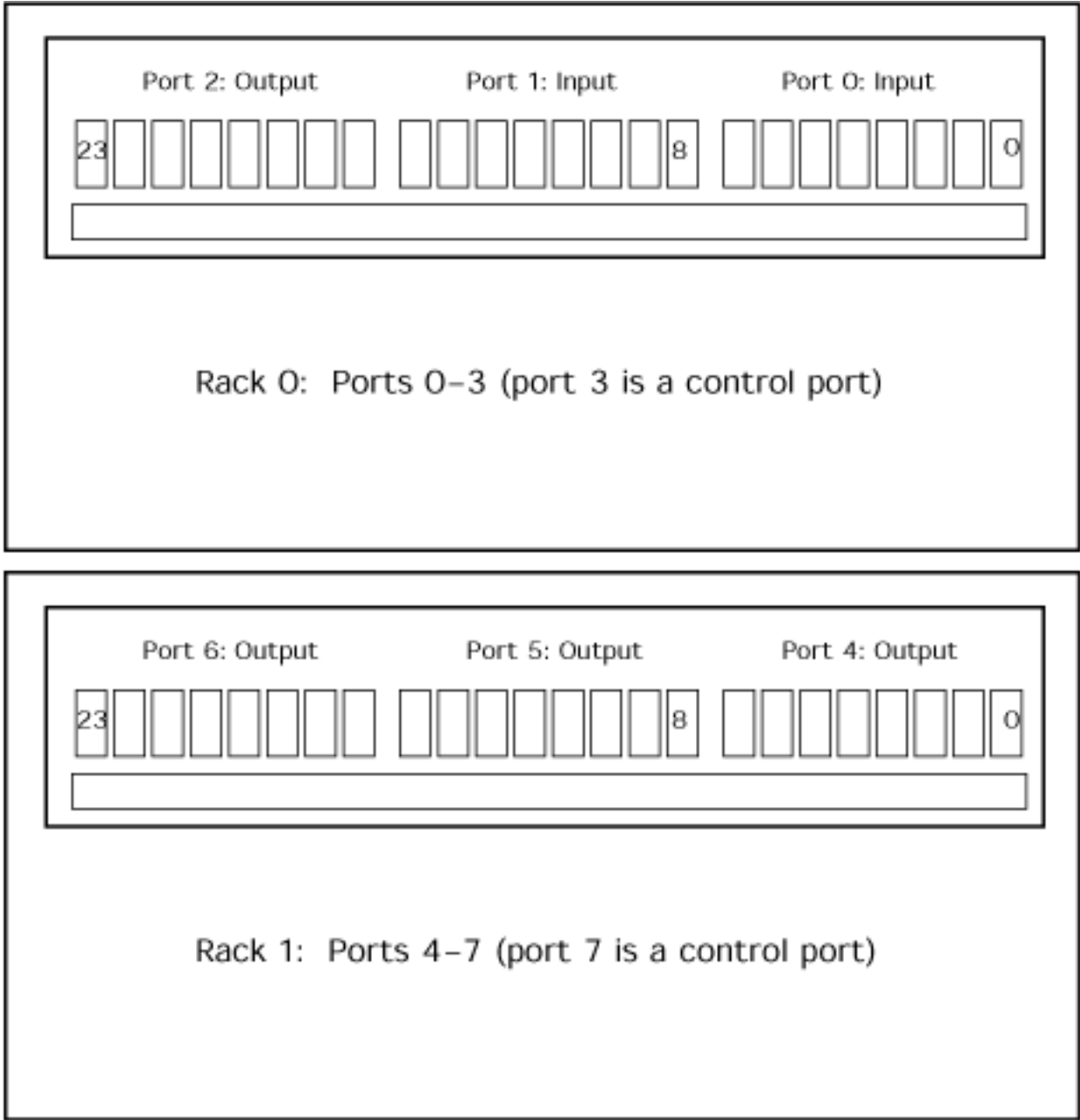

Note: Every fourth port on an 8255 programmable peripheral interface chip is a control port. Do not use this port to address I/O modules.

Figure 3: Port Layout

Each eight modules form a group called a 'port'. A typical REX system requires a minimum of 16 input modules, and 32 output modules. See Figure 3.

Each I/O module incorporates an opto-isolator. Following are suggested wiring diagrams for various input circuits. Figure 4 shows a switch input. REX requires at least two switch inputs- one to start/stop the paradigm, the other to freeze the running line display.

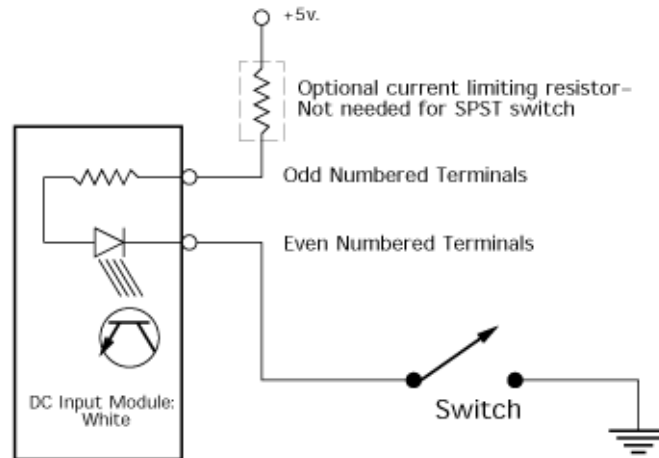

Figure 4: Switch Input Circuit

Logic outputs can also drive the I/O module inputs. Figure 5 shows an input driven by a TTL or LSTTL gate. Note that an input module is not required. An 18 ga. wire can be inserted in the bottom two pins in place of an I/O module. However, the LED will not function without the I/O module.

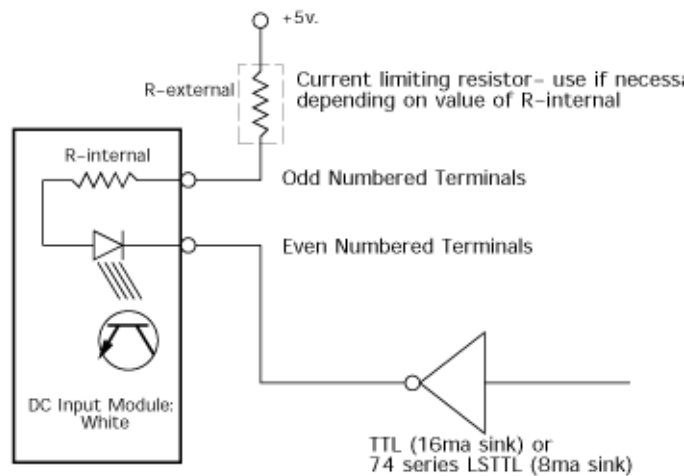

Figure 5: TTL Input Circuit

In the future, REX may collect unit input either through a timer card or a multi-unit analyzer. Until that time, a latch is required to catch the unit pulse. This is constructed with a 7474 D-type latch. See figure 6. Note that the reset pulse is not passed through a red output brick. This is because the red brick will not pass a pulse smaller than 12usec in width. This would require a timing loop in REX that would be processor-speed dependent. To avoid this timing problem, the red brick is bypassed. A jumper is inserted instead of the brick. This jumper connects the reset pulse directly to the digital I/O card.

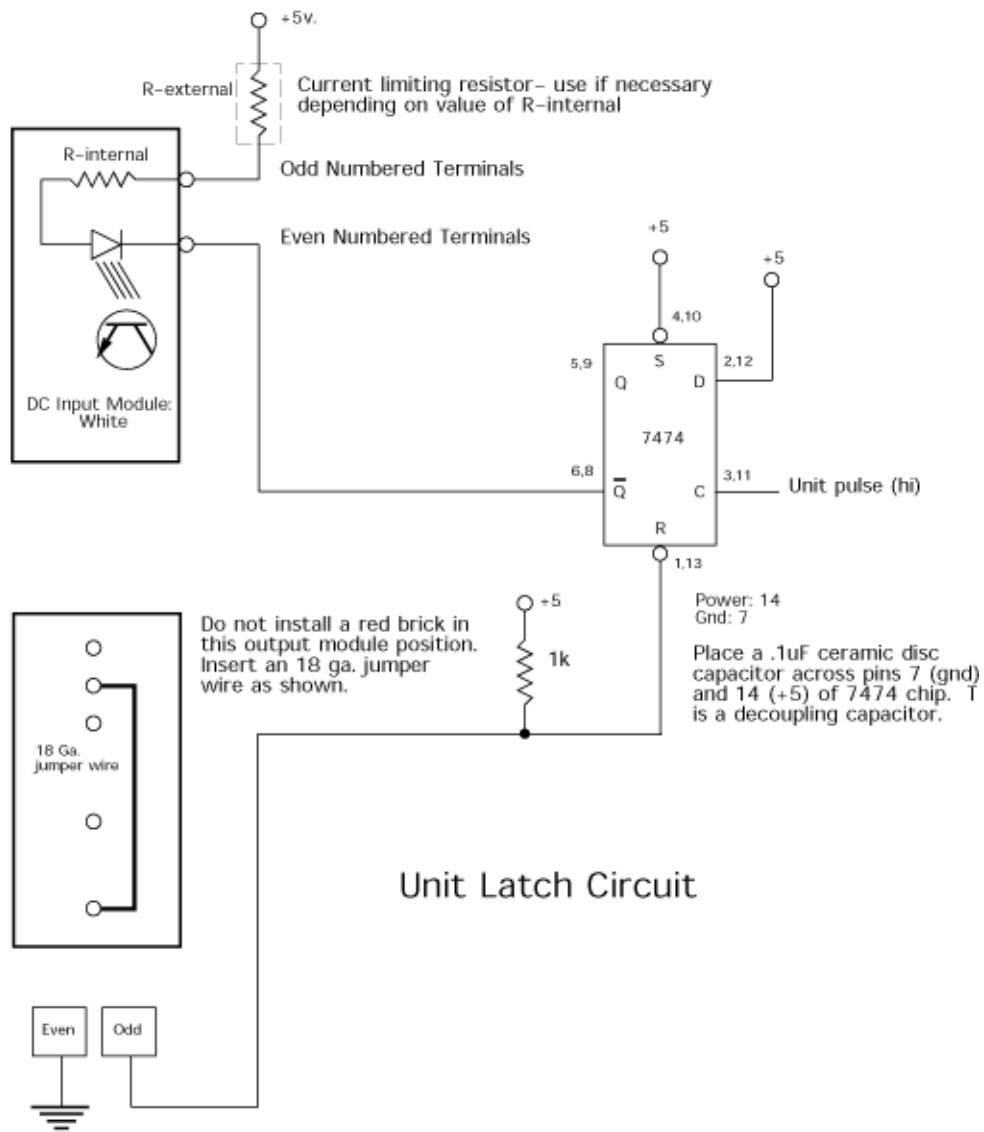
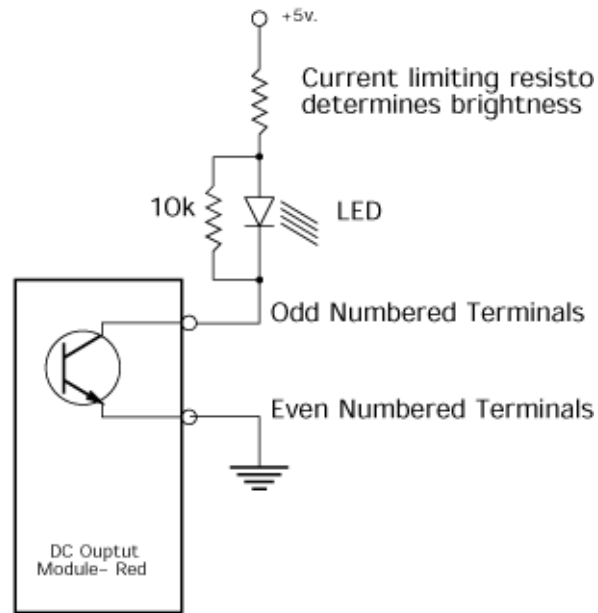

Figure 6: Unit Latch Circuit

The following circuits show various ways to drive LEDs. Figure 7 shows a single LED with a fixed current limiting resistor. This resistor could also be replaced with a pot to vary the brightness. Note the 10k shunt resistor. A DC output module has a small amount of leakage current in the off state, typically 10-30 micro amps. This current, though small, is still sufficient to illuminate an LED in a dark

room. The resistor shunts this current around the LED, preventing the LED from becoming forward biased when the I/O module is off.



10k resistor in parallel with LED is required to shunt leakage current from I/O module.

Figure 7: Single LED

Figure 8 shows an LED which can be dimmed. This circuit requires two I/O modules, and two pots.

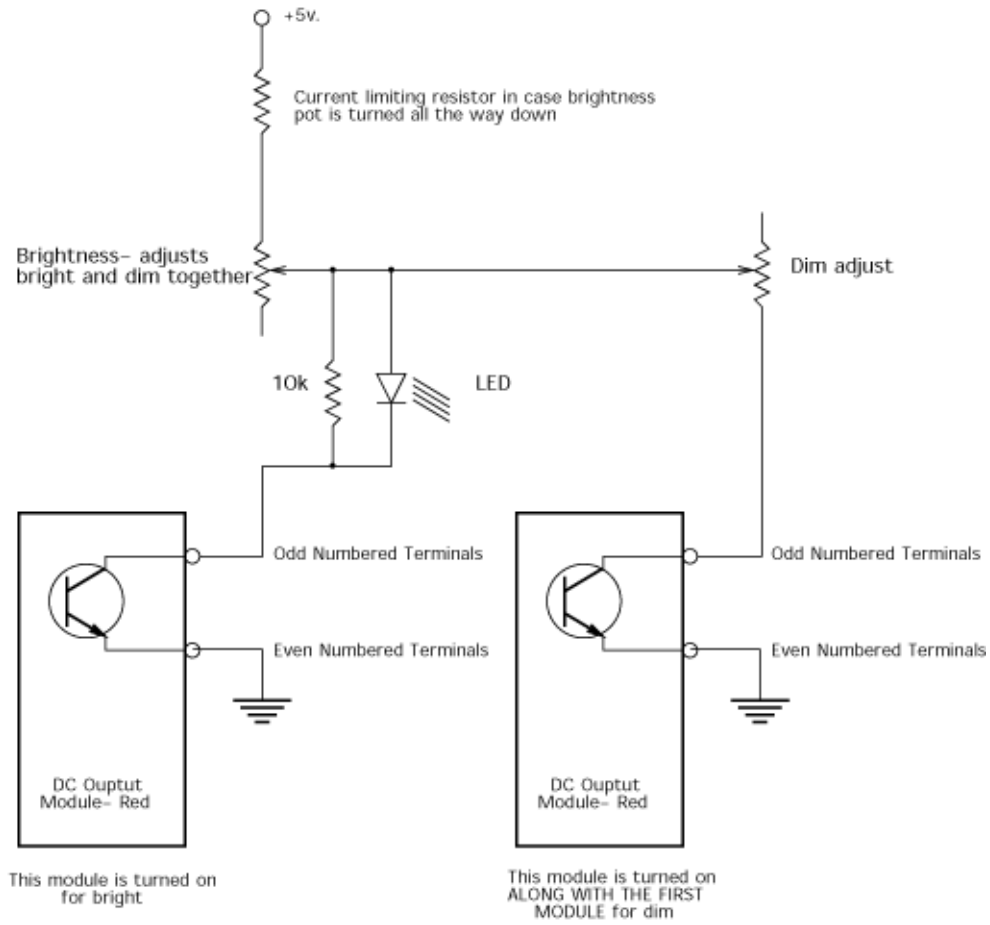

10k resistor in parallel with LED is required to shunt leakage current from I/O module.

Figure 8: Dimmable LED

The last two figures show how to physically connect the above circuits on the I/O rack panel. Figure 9 shows the connection diagrams for a single LED, either variable brightness or fixed brightness.

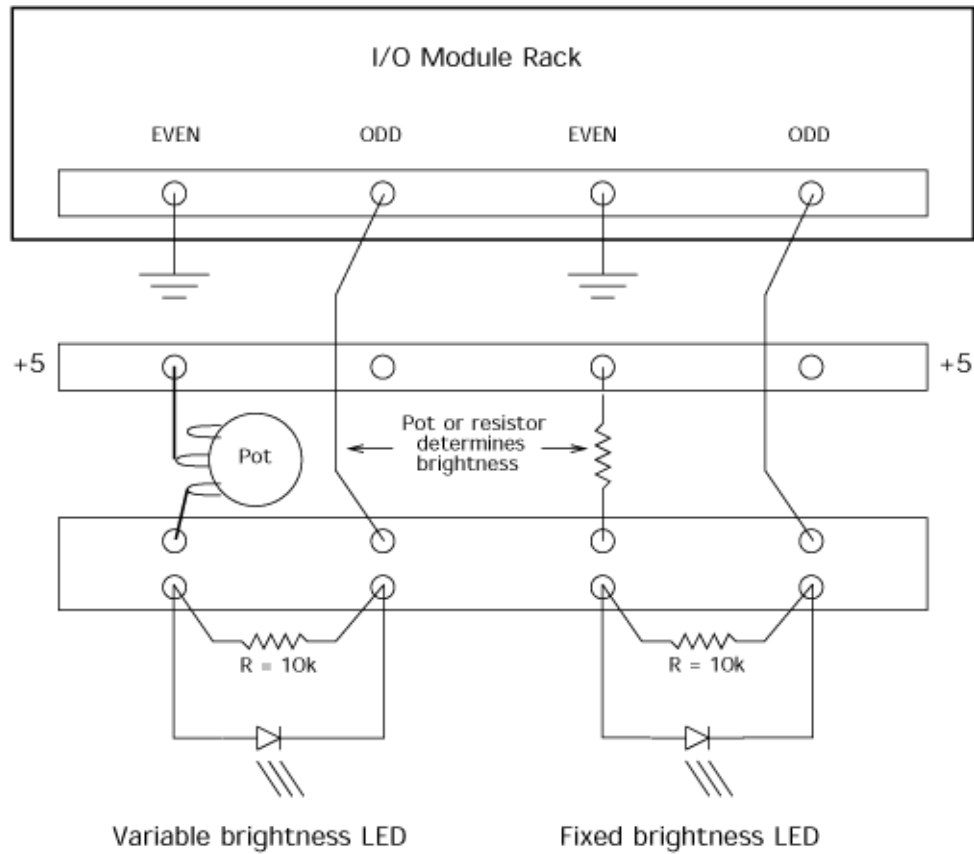

Note: solder 18 ga. solid wire to pot.
The stiffness of this wire will hold pot in place.

10k resistor in parallel with LED is required to shunt leakage current from I/O module.

Figure 9: Single LED Connections

Figure 10 shows the connection diagram for a dimmable LED.

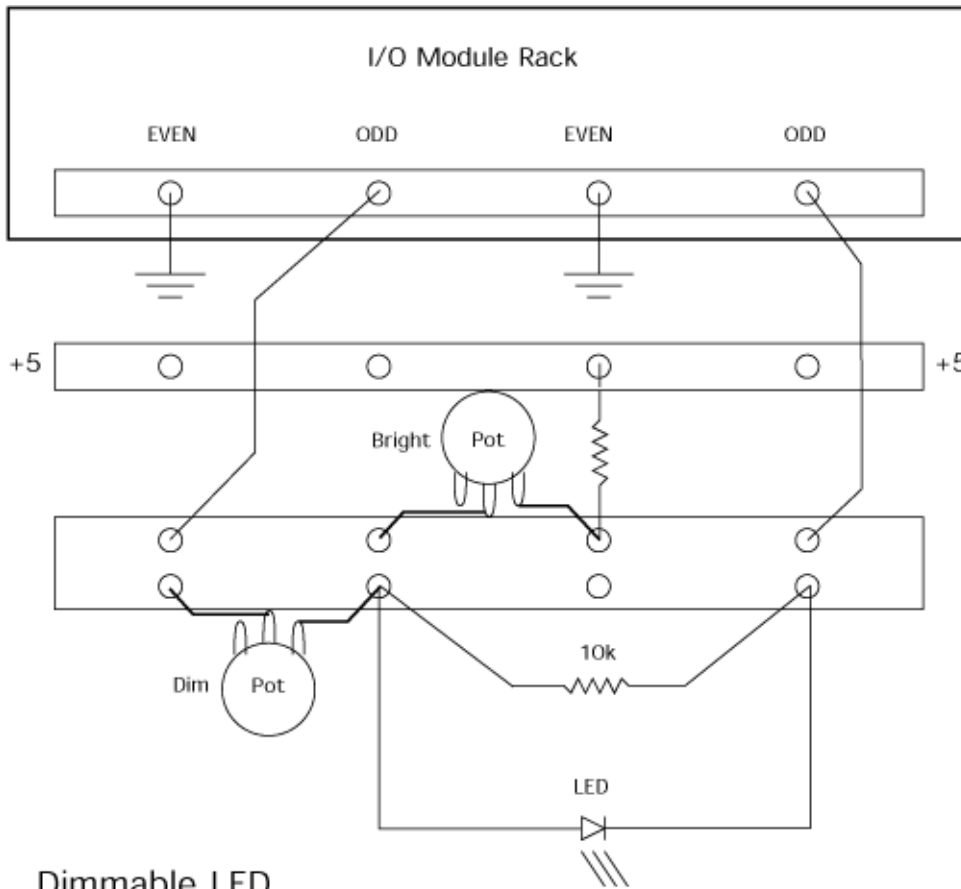

Dimmable LED

Note: solder 18 ga. solid wire to pot.
The stiffness of this wire will hold pot in place.

10k resistor in parallel with LED is required to shunt leakage current from I/O module.

Figure 10: Dimmable LED Connections

The a/d input requires low pass filtering to prevent aliasing. At NIH, we use a custom built box that has an instrumentation amplifier and a six pole Frequency Devices active Bessel filter. At the very minimum, a single pole RC filter should be used. Figure 11 shows the circuit for an RC filter for a differential input with a corner frequency of 241Hz.

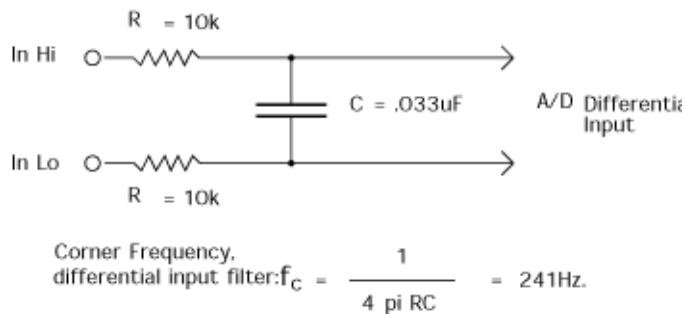

Figure 11: Single Pole RC Filter

Appendix A: Example Orders

Following are copies of the orders we used at NIH:

Industrial Computer Source
10180 Scripps Ranch Blvd.
San Diego, CA 92131-1298
(800) 523-2320
FAX: (619) 271-9666
Attn.: Mark Thurman

Table 4:

| Item | Order Number | Description | Qty | Price ea. |
|------|--------------|-------------------------------|-----|-----------|
| 1 | DCC20/A | 20 Channel Counter/Timer card | 1 | \$395 |
| 2 | PCDIO120-P | Digital I/O card | 1 | \$350 |
| 3 | 2M37DSM | 37 pin termination board | 1 | \$29 |

NOTE: Don't order the counter/timer card at this time. It is not currently used, and may never be

Computer Boards, Inc.
44 Wood Ave.
Mansfield, MA 02048
(508) 261-1123
FAX: (508) 261-1094

Table 5:

| Item | Order Number | Description | Qty | Price ea. |
|------|--------------|---------------------|-----|-----------|
| 1 | CIO-DDA06 | 6 channel D/A card | 1 | \$349 |
| 2 | CIO-DAC08 | 8 channel D/A card | 1 | \$549 |
| 3 | CIO-DAC16 | 16 channel D/A card | 1 | \$899 |

NOTE!!! Don't order all 3! Choose which one you need, based on how many d/a's you want.
(Analogics may have another representative for your area. Call (508) 977-3000 to ask.)

Rep-tron, Inc.
 6925-D Oakland Mills Road
 Columbia, MD 21045
 Attn.: Darrell Covell
 (410) 995-6322
 FAX: (410) 995-6325

Table 6:

| Item | Order Number | Description | Qty | Price ea. |
|------|--------------|----------------------------|-----|-----------|
| 1 | DAS-12/50 | 50KHz 12 bit a/d converter | 1 | \$449 |
| 2 | ACAB-22 | 2 meter cable | 1 | \$90 |

NOTE!!! This is the 12 bit a/d. Order only one a/d- either this one or the 16 bit one. National Instruments

15851-A Crabbs Branch Way
 Rockville, MD 20855
 Attn.: Linda Provencher
 (301) 258-0125

Item Order Number Description

Qty Price ea.

Table 7:

| Item | Order Number | Description | Qty | Price ea. |
|------|--------------|----------------------|-----|-----------|
| 1 | AT-MIO16-X | 16 bit A/D converter | 8 | \$2000 |

NOTE!!! This is the 16 bit a/d. Order only one a/d- either this one or the 12 bit one.

MS Electronics
 8031 Cessna Ave.
 Gaithersburg, MD 20879
 (301) 921-0200
 FAX (301) 921-4996
 Attn.: John Heyden

Item Order Number

Description

QtyPrice ea.

Table 8:

| Item | Order Number | Description | Qty |
|------|-----------------------|--|-----|
| 1 | Grayhill 70RCK24-HL | 24 Module I/O rack | 2 |
| 2 | Grayhill 70-ODC5 | DC output module | 30 |
| 3 | Grayhill 70-IDC5 | DC input module | 8 |
| 4 | Grayhill 70-OAC5 | AC output module | 4 |
| 5 | Grayhill 70-OAC5A5 | AC output module, NC | 2 |
| 6 | Grayhill 70-IAC5 | AC input module | 2 |
| 7 | Grayhill 70-ODC5A | DC output module, 200V | 2 |
| 8 | Opto 22 ODC5R | Dry contact output module, normally open | 8 |
| 9 | Opto 22 Input Switch | Standard size input test switch | 2 |
| 10 | Opto 22 Output Switch | Standard size output test switch | 2 |
| 11 | Gordos ODC5ML | FET DC output module | 2 |
| 12 | Bud PA-1106 MG | 10.5" Rack panel, metallic grey | 2 |
| 13 | Panduit E1x2LG6 | Wiring duct, 6' length | 1 |
| 14 | Panduit WR2-C20 | Wire Retainer, 100/pckg. | 1 |
| 15 | Beau 71114-7233/14-50 | Terminal block | 10 |
| 16 | Beau 77014-50 | Terminal block | 10 |

NOTE: Each rack handles 24 bits (output or input). Adjust quantities accordingly. Quantities below are good estimate for one lab. For digital inputs that are logic levels you don't need a DC input module. The I/O rack must be mounted on the Bud panel so it can be screwed into a 19" rack cabinet. You will need 50 pin flat cables to connect the rack to the card in the pc.

For QNX:

NOTE!!!! As of Oct. 92, QNX Software has a promotion for University users. You can buy QNX for an enormous savings. Contact QNX Software DIRECTLY at (613) 591-0931.

Florida Datamation
 4720 NW Boca Roton Blvd.
 Suite 101-D
 Boca Roton, FL 33431
 (800) 642-5938
 Attn.: David Schimmel

Order the latest release of QNX, Watcom C, TCP/IP.

Noise tests of: Adac 5508SHR, National ATMIO16-X

Sampling rate: all 8 channels scanned each msec. For ADAC, pacer clock is 33.3KHz, for National 20KHz. Data below is for channel 1. Every other point was saved, so effective sample rate for data below is 500Hz. Channel inputs 5-7 were open.

In front of A/D input is a Burr-Brown instrumentation amp with gain of 2, and a Freq. Devices 6-pole Bessel filter with corner freq of 181Hz. A/D inputs were set to differential, -10, +10 volts, gain of 1.

Data was taken with input grounded (labeled 'gnd'), and connected to one of our lab devices (labeled 'coil'). This device was generating a DC level.

Histograms of output, giving sample value and number of counts for that value:

adac_coil_h 8 total bins, mean:.1596, sd: 1.0796

-3: cnt: 32

-2: cnt: 593

-1: cnt: 4043

0: cnt: 4618

1: cnt: 4390

2: cnt: 1505

3: cnt: 120

4: cnt: 2

adac_gnd_h 6 total bins, mean: 1.1754, sd:.7511

-1: cnt: 182

0: cnt: 2318

1: cnt: 8209

2: cnt: 4589

3: cnt: 418

4: cnt: 5

nix_coil_h 6 total bins, mean: -9.5482, sd:.9468

-12: cnt: 89

-11: cnt: 2634

-10: cnt: 4818

-9: cnt: 5897

-8: cnt: 1766

-7: cnt: 99

nix_gnd_h 5 total bins, mean: -178.9268, sd:.5319

-181: cnt: 11

-180: cnt: 1590

-179: cnt: 10993

-178: cnt: 2686

-177: cnt: 23

Appendix B: REX License Agreement

REX for the PC is distributed under a license agreement. This has been implemented to preserve the LSR's rights to negotiate with any companies that may want to commercialize PC-REX. The intent is **NOT** to restrict its distribution in any way to researchers.

The source to REX is kept on machine lsr.nei.nih.gov under /usr/ftp/rex. The distribution includes the REX source and the manual. The REX source is encrypted. The manual is not encrypted. In order to get the REX source, you must fax the completed license form below. You will then be contacted and given the decryption password. You can pick up the encrypted file via anonymous ftp. Please fill out license form and return via FAX to (301) 402-0511. My voice number is (301) 496-7143.

Statement of Terms and Conditions for Release of

The PC-REX Software System

The Federal Government of the United States of America is hereinafter "THE GOVERNMENT". The Laboratory of Sensorimotor Research, hereinafter "LSR", an agency of THE GOVERNMENT, is the originator of the PC-REX package.

The PC-REX Package is a collection of computer programs, data files, and associated documentation, which may be provided in either or both electronic and printed form, hereinafter referred to as "PC-REX".

(enter name of corporation or private individual requesting PC-REX),
having an office at:

is hereinafter referred to as "RECIPIENT".

1. PC-REX is an unpublished work that is not generally available to the public, except through the terms of this limited distribution. THE GOVERNMENT grants recipient a personal, non-exclusive, non-transferable license and right to use PC-REX. No right is granted for any use of PC-REX by any third party.
2. RECIPIENT will be responsible for assuring that PC-REX will not be released or sold to any other party without the prior written approval of LSR.
3. RECIPIENT guarantees that PC-REX, and any modified versions thereof, will not be published for profit or in any manner offered for sale to THE GOVERNMENT. If PC-REX is modified or enhanced using funds from THE GOVERNMENT, THE GOVERNMENT owns the results, whether PC-REX is the basis of or incidental to a contract. PC-REX may be used in contracts with THE GOVERNMENT but no development charge may be made as part of its use.
4. PC-REX is provided "as is", without warranty. Neither THE GOVERNMENT or LSR is liable or responsible for maintenance, updating, or correcting any errors in any materials provided. In no event shall THE GOVERNMENT or LSR be liable for any loss or for any indirect, special, punitive, exemplary, incidental, or consequential damages arising from use, possession, or performance of PC-REX.
5. RECIPIENT will own full rights to any data files, databases or images created using PC-REX.

By signing here, RECIPIENT signifies agreement to these terms and conditions of the PC-REX distribution as detailed above.

RECIPIENT's Signature

RECIPIENT's Printed Name

Title

Corporation

Mailing Address

City, State, Zip Code, Country

Phone #

FAX #

Date

E-mail

GLVEX User's Manual

John W. McClurkin, Ph.D.
Laboratory of Sensorimotor Research
National Eye Institute
National Institutes of Health

OVERVIEW

GLvex is a WindowsNT-based program which displays a variety of visual stimuli on a video monitor. Although it can be used as a stand-alone program, it was primarily designed to interface with the Rex real-time data acquisition and control package. GLvex requires a PC running Windows NT V4.0 or higher with at least 64 megabyte of RAM, a graphics card that supports OpenGL version 1.1 and a mouse. For communication with the machine running Rex, you will need either an ethernet card or an Industrial Computer Source PCDIO 24 ISA parallel digital I/O card. If you are using the parallel I/O card, the port address of the card must be set to 0x280. I have tested GLvex with an STB Velocity 128 AGP graphics card, an Intergraph Intense Pro 3D PCI graphics card, an Elsa Gloria XL graphics card, an Omnicomp 3DAEMON TWIN PCI graphics card, and with SGI's 320 and 540 workstations. While GLvex will run on OEM graphics cards as long as they support OpenGL, animation performance is not as good as higher end boards such as the Intergraph and the Omnicomp. The best performance is with the SGI workstations. To use the parallel I/O card under windows NT V4.0 you must install Industrial Computer's PeekPoke drivers. These are included in the file icspp.zip in the distribution. To install, unzip the file and follow the installation instructions.

What's New

Additions

Vex 3.1 has the capability to display two- and three-dimensional flow fields. The points in the flow fields are updated in real time so there is no limitation on the length of time that flow field stimuli can be presented.

Vex 3.6 adds the capability to vary the life spans of the checks in flow fields, and the capability to vary the coherence of the movement of the checks in the flow fields. Vex 3.6 has the capability to respond to queries from Rex about the locations of display objects, and allows Rex to set the active object.

Vex 3.8 eliminates the need to switch overlapping objects on or off in a last-on, first-off sequence.

Vex 4.0 changes the COPY_OBJECT command to allow the copied object to be stretched horizontally or vertically. Also, the luminance or color of the copied object can now be set independently of the source object. Vex 4.0 also adds a new command; DRAW_RECTANGLE_RANDOM_PATTERN. DRAW_RECTANGLE_RANDOM_PATTERN differs from DRAW_RANDOM_PATTERN in that the vertical and horizontal resolution of the pattern can be specified independently.

Vex 4.1 cleans up some bugs and improves the keyboard interface.

Vex 4.2 allows two objects to be moved in synchrony with the mouse.

Vex 4.3 adds movies to the list of objects to display. The movies can be either flow fields or sequences of objects. The frames of the flow field movies are stored in extended memory using a simple

extended memory manager. For this reason, Vex 4.3 **MUST** be run under Dos 6.2 or higher. If you want to run under Windows 95, you must use the pif file provided. This pif file causes Windows 95 to reboot into dos only mode. Vex 4.3 will not run in the default Windows 95 Dos shell. Vex 4.3 also will not run under Windows NT. Vex 4.3 also adds a ramp that erases the object that is being moved. This allows small objects to be placed on a ramp and moved without needing clipping rectangles or erasing annuli to eliminate the trail left by the object as it moves. However, the maximum size of the object that can be placed on an erase-ramp is smaller than that which can be placed on a standard ramp.

Vex 4.4 does away with the simple extended memory manager, using instead the Pharlap 286 Dos extender. This allows Vex 4.4 to run under the Windows 95 version of Dos. To do this, you must reboot the computer into Dos mode, or use the pif file provided. You cannot use a Dos shell under Windows 95 or Windows NT. Vex 4.4 provides a flag to allow users state whether objects may overlap or not. Setting this flag improves drawing performance when objects don't overlap. Vex 4.4 also allows ramps and flow fields to be run at the same time. The user can set a flow field running over a number of trials as a conditioning stimulus while running ramps on a per-trial basis. Vex 4.4 also allows users to load patterns from Rex.

Vex 4.5 adds circular motion to the ramp generator. Also ramps can oscillate or run continuously.

GLvex is a port of Vex 4.5 to OpenGL and the Windows NT operating system. I did this to eliminate the dependence on any particular graphics card, and to eliminate the need for the Pharlap 286 Dos Extender. GLvex is a 32-bit application. We have found that, in some LCD Projectors, the video fields are not phase locked to the vertical sync pulse. This means that the display cannot be synchronized to the data by software alone. GLvex adds a video syncing object flashes when synchronization is necessary. You can place this object anywhere on the screen. This video sync can be disabled. Included with this manual is the schematic for a photo diode trigger that we use in the LSR. GLvex adds automatic correction for tangent error. For calibration, users now input the distance from the subject's eyes to the screen and the width of the initial calibration pattern, both in millimeters, instead of the number of Rex units per pixel. GLvex adds the ability load ramps from Rex. This allows users to have ramps that vary in velocity (i.e., accelerating or decelerating ramps). GLvex enables users to choose the object erase method. The default, `WHOLE_SCREEN`, is to simply clear the screen. This method is slower, particularly on low-end graphics boards, but allows users to move flow fields with the mouse while the flow field is running. This may be useful for mapping movement-sensitive neurons. The user may choose `EACH_OBJECT`, which erases individual objects or checks. This method achieves the fastest performance. GLvex runs in `RGBA` mode rather than color lookup table mode. To maintain backwards compatibility, GLvex maintains its own 256 byte color lookup tables, one for each object. Users may specify user objects using either `RGB` values or color lookup table values. There is no limit to the number of objects you can have in GLvex, other than system memory.

Subtractions

The following Rex commands have been eliminated from vex 3.1: `JOYSTICK_LOCATION`, `PATTERN_CHECK_SIZE`, `DRAW_POLYGON`, and `REX_DRIVE_RAMP`. The command `SHIFT_LOCATION` can be substituted for the commands `JOYSTICK_LOCATION` or `REX_DRIVE_RAMP`. The size of checks in stimulus patterns must be specified when the pattern is specified, so the command `PATTERN_CHECK_SIZE` is redundant. The command `DRAW_POLYGON` was never implemented in earlier versions of GLvex, so it has been deleted. This command may be implemented in a later version of GLvex.

Starting GLvex

You start GLvex from a WinNT console window. GLvex has several command line arguments. To get a list of arguments, type GLvex -h. You will get the following help message.

GLvex command line arguments:
-r name: name of the rex machine
[-p n]: number of port on which to connect socket [default 9999]
[-n n.n.n.n]: IP address of the ethernet card to use (default NULL)
-o n: set number of objects
-Hz n: set video vertical refresh rate
-v [0/1]: {disable/enable} rex video sync
-d [0/1]: [disable/enable] rex digital sync
-e [0/1]: [each object/whole screen] erase
-Sx n: X coordinate of the video sync object
-Sy n: Y coordinate of the video sync object
-Sw n: width of the video sync object in pixels
-Sh n: height of the video sync object in pixels
-s n: distance between viewer and screen [mm]
-w n: width of calibration pattern [mm]
You must enter values for both -s and -w to set scaling
Press any key to exit

Note, the argument identifier (-Hz, etc.) must be separated from the parameter by a space. The default video refresh rate is 60 Hz. By default, both the video sync and digital sync are enabled (have values of 1). By default, the erase method is whole screen (has a value of 1). By default, the video sync object is located in the upper left corner of the screen and is 64 X 64 pixels in size. Therefore you do not need to enter values for these arguments unless you need something different. Since the distance between the viewer and the screen and the width of the calibration pattern will probably be the same for all of your experiments, you can start GLvex without entering values for screen distance and pattern width, make the measurements, then add those values to the command line arguments the next time you start. With the exception of the number of objects argument, all of the other arguments can also be set with keyboard commands or with rex commands. If you do not enter a value for the number of objects, you will get the following prompt.

Enter number of objects

GLvex will then wait until you enter a value.

To make entering these command line arguments easier, you can create a shortcut to GLvex and enter the arguments on the command line of the shortcut. Then all you need to do is double-click the shortcut symbol to launch GLvex with the desired arguments. Click the right mouse button on the desktop and select New-Shortcut. In the Create Shortcut window, select Browse and traverse the drives and folders to where you installed GLvex.exe. Select GLvex.exe and click open. Enter the command line arguments you want in the Command line: window after the program name. Click Next and enter a name for the short cut. Click Finish. Now, whenever you launch GLvex from this shortcut, the command line arguments you entered will be applied.

Included in the distribution is an icon for GLvex -- GLvex.ico. To set the icon for the short cut, click on the short cut with the right mouse button, select the Shortcut tab, click on Change Icon, select the Browse button, enter the GLvex directory in the path, and select the GLvex icon.

To make debugging easier, set the window size of the console or shortcut to 80 columns and 25 lines, but set the screen buffer size to 80 columns and 200 to 300 lines. This way, you can set the debug flag, run you paradigm for a trial or two, then use the scroll bar on the console window to scan the debugging output.

Normally, GLvex runs as a full screen application. This means that the window decorations (border, title bar) are not shown. If you set the WinNT task bar option to Auto hide, then there will be no windows decorations at all. This also means that the console from which you started GLvex will be covered. GLvex does have a pseudo-console that appears in the upper-left corner of the screen to echo keyboard commands and display help messages, but this is not sufficient for debugging output. Therefore, you can set the window size to be smaller than the screen resolution so you can see debugging output in the WinNT console window. Once you have reduced the window size, you cannot go back to full screen mode, even if you try to set the window size to the screen resolution. The window decorations will always be visible. To go back to full screen mode, you will need to quit and restart GLvex.

Coordinate System

The screen coordinate system used by GLvex is the same as that used by rex. That is, the center of the screen has a coordinate of 0x, 0y. Negative x values are in the left half of the screen, and negative y values are in the lower half of the screen. The basic unit of position in rex is one tenth of a degree. Therefore, in GLvex, a rex unit is defined as one tenth of a degree of visual angle. All position and window commands to GLvex will be in rex units if you set the scale factors properly. However, if you set the screen distance value to 0, then all position commands to GLvex will be in raw pixels.

Video Fields

In raster displays, drawing begins in the upper left corner of the screen, and continues left-to-right, top-to-bottom, until the bottom right corner of the screen. With the graphics board running at 60Hz, this process is repeated 60 times a second. To set the display rate and spatial resolution, click on the Windows NT desktop with the right mouse button to bring up the Display Properties panel. Select the refresh frequency and desktop area you want. GLvex is able to determine the desktop area, but not the refresh frequency. Therefore, you will need to enter the refresh frequency using the keyboard command described below. In GLvex a video field is defined as the time it takes draw the screen once. At 60Hz, a video field is 16.67 milliseconds. All stimuli in GLvex must be presented for some integer number of video fields. Because modern video cards allow a range of vertical refresh rates, I have included a keyboard command in GLvex to set the vertical refresh rate. You will need to set this to get accurate flow field speeds and ramp movement speeds.

Animation

GLvex allows several types of animation. You can have flow fields in which checks move in a two- or three-dimensional space, You can place stimuli on ramps such that the stimulus moves across the screen. You can define square wave gratings in which the bars drift horizontally or vertically. You can set up sequences of stimuli to be displayed as a movie. In computing the animation sequences, GLvex assumes that all drawing will be completed in one vertical refresh cycle of the video system. However, if your animation involves a lot of drawing, the graphics hardware may not be able to draw everything in one vertical refresh cycle. When this occurs, your animation will be much slower than you specified. For example, the drawing requires between 1 and 2 vertical refresh cycles, your animation will run at half the speed you specified. Further, if the drawing requires exactly 1 vertical refresh cycle, the movement will likely be jerky.

GLvex has no way of knowing how much time the drawing is taking so it has no way of adjusting the animation to deliver the speed you specified. Therefore, you should manually time your

animation sequences. You do not need precision timing to do this because the speed drops so much as the drawing timing increases; first to half speed, then to third speed, then to quarter speed, etc. It is possible to test this by setting up an animation sequence to take, say two seconds, and then counting "one mississippi, two mississippi" as the sequence runs. One way or another, you should test the speed of your animations. If you find that your animation runs slower than you specified, you should increase the specified speed to compensate.

How much drawing can be done in each vertical refresh cycle depends on the graphics hardware. Generally, the more expensive the hardware, the more it can draw in each vertical refresh cycle. Of the machines I have tested, I have found that the SGI 320 workstation provide the best animation performance for the price of Windows NT workstations. If you need higher animation performance, Dell, Hewlett Packard, and IBM among others offer high end graphics workstations using Intergraph graphics that may be better. Further, though I haven't done it yet, it would not be difficult to port GLvex to unix and X windows so that it could be run on high end unix graphics workstations such as the SGI Octane series.

Stimuli

Most GLvex static stimuli are sets of square checks that are laid out in a rectangular matrix to form the desired pattern. The resolution of a pattern refers to the number of rows and columns of the check matrix. Pattern checks are not the same as video pixels. A video pixel is the smallest element that the graphics board can draw on the screen, and depends on the hardware configuration. A pattern check is the smallest element of a pattern, and is a logical concept. Each pattern check can be several video pixels high and wide. The exceptions to this are bar, annulus, and circle stimuli, and TIFF images.

Flow field stimuli are lists of points distributed at random in a two- or three-dimensional space. The resolution parameter of static patterns has no meaning for flow fields, so the size of the flow field stimulus is limited only by the size of the display screen.

Types of stimuli. GLvex will display the following types of stimuli:

- Walsh patterns with a resolution of 16 checks X 16 checks.
- Haar patterns with a resolution of 16 checks X 16 checks.
- User defined patterns with a resolution of up to 255 checks X 255 checks. User defined patterns need not be square.
- Random check patterns with a resolution of up to 255 checks X 255 checks. Random check patterns need not be square.
- Circular spots and annuli..
- Oriented bar stimuli.
- RGBA Tiff images.
- A calibration pattern with a resolution of 40 checks X 40 checks.
- Two- and three-dimensional flow fields.
- Movies.
- Square gratings to be used as optokinetic nystagmus stimuli.

Stimuli can be grouped into two classes: two tone stimuli and continuous tone stimuli. Two tone stimuli are those that have one set of checks that are one color or luminance and a second set of checks that are a second color or luminance. These two colors or luminances are termed foreground colors and background colors. Two tone stimuli may be monochromatic, that is consist of "white" and "black" checks, or they may be poly chromatic, consisting of red and green checks or yellow and blue checks, etc. In monochromatic stimuli, the foreground and background checks can each have any of 256 shades

of gray. In poly chromatic stimuli, the foreground and background checks can each have any of 16,777,216 colors. Walsh patterns, Haar patterns, random check patterns, circles, flow fields okn gratings and annuli are all two toned stimuli. User defined patterns may be two toned. Examples of how to define a two toned user pattern are given below.

Continuous tone stimuli may have up to 256 different gray levels or any number of colors simultaneously. The calibration pattern is a continuous tone pattern, and users may define continuous tone patterns. Examples of how to define a continuous toned user pattern are given below.

Calibration pattern

When you first start GLvex, it will display a calibration pattern on the screen. This calibration pattern is 40 checks high and 40 checks wide. The pattern is a hollow white square that is bisected by horizontal, vertical, and diagonal white bars. The horizontal and vertical bars contain sets of 16 gray shades. The center of the pattern has a black spot that indicates the 0, 0 coordinate of the display. The width of the square in video pixels is printed across the pattern. This pattern can be used to determine whether your monitor has any barrel or pincushion distortion, and whether the horizontal and vertical scales are the same. The gray shades give you a standard that you can use to tweak the contrast and brightness controls of your monitor to give you the best dynamic range. This pattern is also essential for setting the Rex calibration. To set Rex calibration, you will need to measure the distance from the viewer to the screen in millimeters, and the width of the calibration pattern in millimeters. GLvex will use these values to calculate the number of video pixels per rex unit (1/10 of a degree) and to correct for tangent error.

Flow fields

Flow fields are drawn in rectangular objects which can be of any size up the to the limits of the screen. Additionally, a rectangular portion of the flow field can be masked out. This mask can be located anywhere in the object. Multiple flow fields may be displayed simultaneously. For three-dimensional flow fields, the movement of the points are specified by 6 parameters: movement along the X and Y axes (sheer), movement along the Z axis (vergence), rotation about the Z axis (roll), rotation about the Y axis (yaw), and rotation about the X axis (pitch). For two-dimensional flow fields, the parameters which produce movement in depth (vergence, yaw, and pitch) must be set to 0 or the program will hang.

The movement of points in the flow fields in the X-Y plane are specified in rex units (tenths of a degree of visual angle). The movement of points in depth are in the linear equivalents of rex units. That is; if your display subtends 1 degree of visual angle per centimeter, then movement of 10 degrees/second along the Z axis would be equivalent to movement of 10 centimeters/second.

To use flow field stimuli, you must first define the flow field pattern. After defining the pattern you may define an occluding mask if you wish. The last step is to define the movement parameters of the flow field. Only after fully defining the flow field may you start the flow fields. Failure to follow this sequence will result in error messages or may cause the GLvex computer to crash.

Starting and stopping the movement of the flow fields is independent of switching the objects on or off. After a flow field movement has started, the object in which it is drawn may be turned off and then on again to produce a blink stimulus. While the object is off, the positions of the points in the flow field will be continuously update according to the transformation matrix so that when the object is turned back on, the points will be in the positions that they would have been in had they not been turned off. Also, an object containing a flow field pattern may be switched on and off without putting the flow field in motion, allowing you use flow field patterns as static stimuli.

When you stop the movement of groups of flow fields, you should stop all the flow fields that are running. If you start flow fields moving in 4 objects, and then stop the flow fields in two of the objects, the checks in the stopped flow fields will jitter back and forth as long as the flow fields in the remaining two objects continue in motion.

Objects

GLvex draws all stimuli in logical objects. The objects may be switched on or off for static displays, or they may be placed on ramps for moving displays. Presenting stimuli using GLvex is somewhat like presenting pictures using an overhead projector. Using an overhead can be broken into three steps, you first draw a picture or write some text on a sheet of acetate, you then place the acetate on the projector platen and slide it into the correct position, and finally you turn the overhead projector on. All three of these steps are independent. That is, the projector does not have to be turned on to draw a picture on a sheet of acetate or to position the acetate. A GLvex object is analogous to a sheet of acetate, GLvex drawing operations are analogous to drawing on the acetate, GLvex positioning operations are analogous to sliding the acetate around on the projector platen, and GLvex switching operations are analogous to switching the projector on or off. Moving an object on a GLvex ramp is analogous to sliding the acetate around on the projector platen while the projector is on.

The three steps in displaying a stimulus in GLvex take different amounts of time, just as they do in using overhead projectors. Drawing a stimulus in an object can take a fair amount of time depending on the complexity of the stimulus (several seconds for a large random check pattern). Positioning an object on the screen is fairly fast, but switching an object on or off is the fastest operation. By making the three steps in presenting stimuli independent, GLvex allows you to group the time consuming steps of drawing and positioning into one action to be called at the beginning of the trial, thus falling in the inter-trial interval.

One of the properties of GLvex objects is priority. Object 1 has the highest priority, and objects with higher numbers have lower priorities. The fixation point has the highest priority of all. High priority objects always occlude lower priority objects. This is different from previous versions of vex where object 1 had the lowest priority and higher number objects had higher priorities.

TIP: If you want to move one object around on the screen while other objects are on, performance will be best if you move the highest priority object.

Communications

Users may communicate with GLvex directly through the keyboard, from rex, or with the mouse. Objects can be moved on the screen or flashed on and off using the mouse. To move the active object, move the mouse while holding down the right mouse button. Pressing the left mouse button will turn the active off. This is different from previous versions of vex where pressing the left mouse button caused the object to reverse contrast. Pressing the left mouse button will turn off all types of objects, not just two-toned objects as was the case with previous versions of vex. You can change the active object using the "s" command described below. Sometimes, the object will not go to the edges of the screen. In this case, re-specify the active object using the "s". command. The keyboard and rex protocols are described below.

Communications with Rex

GLvex can use either of two protocols to communicate with Rex. The first method is to use a parallel I/O card and the subroutines in pcmsg. This communication algorithm is fully handshaked and

has no timing dependencies. The code on either the TX_PC (transmitting) side or the RX_PC (receiving) side can be interrupted indefinitely at any point and the algorithm will still function properly when execution is resumed. The algorithm would be simpler if the handshaking lines were latched. However, the 8255 chip on the PIO board was not designed to talk directly to another 8255. It does not permit an efficient algorithm without external glue logic to latch the handshake lines. If the receiving PC encounters an error the ERROR line is set. The transmitting PC then aborts the transfer and returns an error to the caller. Error conditions are therefore passed from the receiving end back to the transmitting end. Errors are not sent from the transmitting end to the receiving end. However, the transmitting end reports an error to the caller if message receiving is not enabled on the receiving end.

Synchronizing parallel I/O communications

To ensure that messages between rex and GLvex are not garbled when you are using the pcm_{sg} communication protocol, actions in your paradigm that communicate with GLvex should be called only when the transmission line is clear, and your paradigm should be ready to handle signals returned from GLvex. At the present time this synchronization must be done explicitly. The best way to ensure proper synchronization is to embed actions that communicate with GLvex in a set of three states as follows:

Example GLvex parallel I/O communication state set:

```

.
.          /* other states in your paradigm */
.
to vstwts /* vstwts means vex state wait to send */

vstwts:
to vexst on 0 % tst_tx_rdy /* test if transmission is ready */
vexst:          /* a state that sends a message to vex */
do vex_call() /* do action which sends a message to vex */
to vexack on 0 % tst_rx_new/* escape when vex signal is received */

vexack:
code ECODE /* to indicate the start of a display change */
do pcm_ack(0)/* do action which acknowledges signal from vex */
time 100
rand 100
to othst /* othst means other states */

othst:
.
.          /* other states in your paradigm */
.

```

The escapes *tst_tx_rdy* and *tst_rx_new* are functions defined in *vex_com.c* that test whether the transmission line is ready and whether a new message has been received, respectively. Beginning with Rex 7.2 the GLvex escape functions are defined in the *vexActions.c* located in */rex/act*. In this example, note that in the states *vstwts* and *vexst*, the rex variables *time* and *rand* are not given values. These variables should not be given values in states that test the transmission lines. In particular, you should not write paradigms that exit from states before the communication conditions have been met. This can cause problems. You may find that not giving the time variable a value causes your paradigm to hang. This is a bug in your spot file which you should try to fix rather than ignore.

Ethernet communications

The second method is to use an ethernet card and the subroutines in *pcsSockets*. To use this method, you must use the sockets version of Rex and you should have the QNX TCP/IP Developer's toolkit installed on your computer. Ethernet communications are more easily implemented in your spot

files and have a broader bandwidth than do parallel I/O communications. However, ethernet communications are subject to network fluctuations, especially if you connect the GLvex and Rex machines using a network with a lot of other machines. Depending on your situation, you may be better off using a 3 or 4 port mini-hub to isolate your experimental machines from the rest of the network. Also, ethernet communications do not guarantee millisecond precision in synchronizing communications between the GLvex and rex machines, so the use of the video sync object is more important.

To use ethernet communications, connect your GLvex and rex machines to your network, then try to ping each machine from the other using their names.

For example: From the rex machine execute: ping vex_machine_name. From the GLvex machine execute: ping rex_machine_name. Don't use the IP addresses because the ethernet communications protocol implemented in rex only uses names, not IP addresses. Your systems must pass this test or the ethernet communications won't work.

To use ethernet communications you must set the flags that will compile the sockets code. Edit the /rex/hdr/cnf.h file and make sure that it contains the line:

```
#define PCS_SOCKET /* PC to PC messaging code with sockets */
```

The /rex/int directory should contain the files pcsSocket.c and pcsSocket.o.

Once you have your rex and GLvex machines communicating you can turn to your spot files. In each spot file you must define a restart function. The beginning of the first chain of states should look something like:

```
%%
id 100
restart rinitf
main_set {
status ON
begin first:
    .
    .
    .
```

In this example, rinitf is the name of the restart function. You can call it anything you want. This function is called whenever you start a paradigm using the r p command, reset the states using the r s menu command, or return to a paradigm using the c p command. The restart function should look something like:

```
rinitf(void) {
    char *port = GLVEX_PORT_STR; /* defined in ../hdr/pcsSocket.h to be "9999" */
    char *host = "lsl-sgia"; /* name of the GLvex name as defined in /etc/hosts */
    char *subnet = 0; /* unless you have several ethernet cards in your machine */
    pcsSetPeerAddr(host, port); /* set the name of the GLvex machine */
    pcsAllocPassivSocket(subnet, port); /* open a udp socket to the GLvex machine */
    wd_disp(D_W_EYE_X);
    .
    .
    .
    /* other functions in rinitf */
    .
}
```

When you launch GLvex, you should set the name of your rex machine on the command line using the -r flag described above:

```
GLvex.exe -r lsl-labvex -o 5... (other arguments)
```

This argument tells GLvex to accept commands only from the machine lsl-labvex.

Synchronizing ethernet communications

The ethernet communications protocol between rex and GLvex are not as complicated as the parallel I/O protocol. You need not test to see if the transmission line is clear and you do not need to acknowledge responses from GLvex. Therefore, the set of states described for the parallel I/O communications protocol can be reduced to the following:

Example GLvex ethernet communication state set:

```

      .
      .          /* other states in your paradigm */
      .
to vexst          /* escape to the vex state */
vexst:           /* a state that sends a message to vex */
do vex_call()    /* do action which sends a message to vex */
to nextst on 0 % tst_rx_new/* escape when GLvex signal received */

nextst:
code ECODE      /* to indicate the start of a display change */
time 100
rand 100
to othst        /* othst means other states */

othst:
      .
      .          /* other states in your paradigm */
      .
```

Note: The only escapes you should use from states that call these actions are when the function `tst_rx_new` returns 0 or when a photo cell is triggered by the video sync object.

Synchronizing stimuli

GLvex sends a signal at the beginning of the first video field when the display needed to be synchronized to the data collection (i.e., when a stimulus was turned on or a ramp started). Your spot file can drop an ecode when Rex receives the signal to allow you to align data across trials. This digital form of synchronization may not be possible for some digital displays. In some LCD and DLP projectors, the video display is not phase locked to the vertical sync pulse. (It's true, just don't ask me why). Therefore, GLvex includes a video synchronizing signal. This signal is a small black square. By default, it is located in the upper left corner of the screen, but you can place it anywhere you wish. This square will flash white for one video field when synchronization is needed. You can tape a photo diode over the square and use its signal to align data. Included in this documentation is a schematic for a trigger system that we use in the LSR. The video sync object will be displayed only when you send commands from rex that require timing. It will not be displayed for batchable commands from rex, or for keyboard commands. By default, both digital and video sync signals are enabled, but you can disable either or both by command line arguments, keyboard commands, or rex commands.

There is a practical difference between the digital and video synchronization signals. Each digital synchronization signal must be acknowledged. If your spot file doesn't wait for the digital sync signal using the `tst_rx_new` function and doesn't acknowledge the signal with the `pcm_ack` function, communications between GLvex and rex will get screwed up and your paradigm will hang. The video synchronization signals do not need to be acknowledged. In the LSR, we feed the output of the photo diode into a latch that goes high when the video sync flashes white and stays high until reset by the rex paradigm. Further flashes have no effect. Therefore, to use only the video sync signals you are interested in, you can send a reset command to the digital I/O port (`dio_on()`) just before you are expecting a critical sync signal. This will clear any previously latched signals.

Parallel I/O Communication errors

This section is repeated in the ERRORS AND WARNINGS section.

It is possible for communications between the rex and GLvex PC's to get out of sync when you are using the pcmmsg protocol. If this happens, your paradigm will hang, or the stimulus display will become erratic. In either event, stop the rex paradigm by setting the PSTOP switch to on, hit the <return> key on the GLvex PC to halt any messages to rex, type "r s" on the rex PC to restart the state list, and finally, set the PSTOP switch to off to resume the paradigm. If your paradigm still does not run, check to see if the GLvex PC is hung by typing "<return>". Vex should print a help message. If not, reboot the GLvex PC using the cntrl-alt delete sequence. If GLvex is not hung, kill and reload the offending rex process. In the worst case, you will have to quit rex and reboot the GLvex PC.

There are four general ways that rex to GLvex communications can get out of sync.

- First, if you end the rex clock to stop a paradigm, or you reset the state list after rex has sent a command to GLvex but before GLvex has sent its response signal, you may de synchronize the communications. To avoid this, ALWAYS stop paradigms using the PSTOP switch before ending the rex clock or using the r s command. This should guarantee that all communications have been resolved. At this point, you can end the clock, begin the clock, reset the state list, or open and close files.
- Second, including states that call actions which communicate with GLvex in the rex abort list. Rex will attempt to execute these actions without testing the transmission bits or acknowledging signals from GLvex. This will cause problems. Monkey (subject) errors must be handled explicitly in the following manner:

Example state loop:

```
.
.          /* other states in your paradigm */
.
to vstwts

vstwts:
to vexst on 0 % tst_tx_rdy /* test if transmission is ready */

vexst:
do vex_time() /* vex command that will take a while */
to error on +WDO_XY & eyeflag
to vexack on 0 % tst_rx_new/* escape when signal is received */

vexack:
code ECODE
do pcm_ack(0)          /* acknowledge signal from vex */
time 100
rand 100
to othst

othst:
.
.          /* other states in your paradigm */
.

error:
code ERR1CD
do reset_s(-1) /* but don't include vex states in abort list */
to alloff on 0 % tst_tx_rdy

alloff:
do off_all() /* turn off all stimuli and fixation point */
to offack on 0 % tst_rx_new
```

```

offack:
           do pcm_ack(0)
           time 5000           /* time out */
           to disabl

abort:
           offrew
           clwind

```

Third, the monkey can make an error that causes an escape from a state such as vexst in the example above that is expecting a signal from GLvex just as GLvex is about to send the signal. In the above example, if the actions to handle monkey errors do not send the abort command off_all() before GLvex sends the signal at the end of the vex_time() action, you may have an extra, unacknowledged signal from GLvex. This situation should occur infrequently.

Fourth, you are careless in testing the transmit and receive bits in your paradigm or you do not acknowledge signals from GLvex. Study the example spot file at the end of this document carefully. In particular, don't hide the pcm_ack(0) action in other actions to save on the number of states in your paradigm. While this is legal, it will make your paradigms harder to debug. This type of error will cause frequent hang-ups but may not occur on every trial. In particular, be suspicious if your paradigm runs properly only if some states need to have the time variable set to some minimum value.

KEYBOARD COMMANDS

Unless otherwise indicated, keyboard commands are case sensitive. That is the command beginning with the letter x is different the command beginning with the letter X. Most of the keyboard commands affect a single object. A keyboard command is used to select which object is active. Once an object has been made active, it remains active until changed. All subsequent keyboard commands such as drawing, switching, moving, or sizing will affect only that object. There are two forms of keyboard commands; single stroke commands which are not terminated by a <return>, and single or multi-stroke commands which are terminated with a <return>.

Keyboard commands not terminated by a <return>

These keys may be tapped once for a single execution of the command, or they may be pressed and held for repeated execution of the command. Vex will not be able to keep up with repeat execution, so the action will continue for a while after you have released the key. Also, you will get input buffer overflow errors if you hold the key down too long.

PAGE UP

For Walsh, Haar, user, and TIFF stimuli, this key decreases the stimulus number by one. For example, if Walsh pattern 2 is drawn in the active object, pressing the "PAGE UP" key will draw Walsh pattern 1 in the active object. Similarly, if the user pattern defined in file "P102" is drawn in the active object, pressing the "PAGE UP" key will draw the user pattern defined in file "p101" in the active object. If the TIFF pattern defined in file "I102.tif" is drawn in the active object, pressing the "PAGE UP" key will draw the TIFF pattern defined in the file "I101.tif". For bar stimuli, this key changes the orientation of the bar by -10 degrees. For annulus and circle stimuli, this key reduces the outer radius by 1. For random check stimuli, this key reduces the percentage of white checks by 1. For flow field stimuli, this key changes the xy angle of motion by -10 degrees.

PAGE DOWN

This key is the opposite of PAGE UP. For Walsh, Haar, user, and TIFF stimuli, this key increases the stimulus number by one. For bar stimuli, this key changes the orientation of the bar by 10 degrees. For annulus and circle stimuli, this key increases the outer radius by 1. For random check stimuli, this key increases the percentage of white checks by 1. For flow field stimuli, this key changes the xy angle of motion by 10 degrees. You can type these two keys while the flow field is running and the checks will change direction immediately. If you have defined a number of user patterns or TIFF images in files with consecutive numbers (p100, p101, p102, p103, I100.tif, I101.tif, I102.tif, etc.), you can display each pattern in sequence with these keys.

UP ARROW

Moves the active object up one video pixel.

DOWN ARROW

Moves the active object down one video pixel.

LEFT ARROW

Moves the active object left one video pixel.

RIGHT ARROW

Moves the active object right one video pixel.

Keyboard commands terminated by a *<return>*

"b"; Set screen background color

This command sets the screen background color or luminance. This command is not case sensitive. If you type "*b<return>*", you will get a help message similar to the following:

b [r g b]: set Background color to rgb
b [n]: set Background luminance level to n
Current background = 128 128 128

The letters *r g b* in brackets stand for the values of red, green, and blue to use for the screen background. The values for *r*, *g*, and *b* each can range from 0 to 255. The letter *n* in brackets stands for the gray level to use for the screen background. These values can range from 0 to 255.

Example commands:

b 128 0 0

This command sets the screen background to a medium red.

b 128

This command sets the screen background to a medium gray.

"c"; Absolute clipping rectangle, Clear

These commands set the clipping rectangle of the active object, and clear the screen. If you type "*c<return>*", you will get a help message similar to the following:

clear: clear the screen
cfull: set Clipping rectangle to FULL screen
cr [x y w h]: set Clipping rectangle to location x, y, width w, height h

The letter *w* in brackets stands for the width of the clipping rectangle in rex units (tenths of a degree). The letter *h* in brackets stands for the height of the clipping rectangle in rex units. The letter *x* in brackets stands for the X coordinate of the center of the clipping rectangle in rex units. The letter *y* in

brackets stands for the Y coordinate of the center of the clipping rectangle in rex units. The word full in brackets stands for setting the clipping rectangle to the full screen.

Example commands:

cr -10 -10 150 100

This command places the center of the clipping rectangle 1 degree below and to the left of the center of the screen, and makes the clipping rectangle for the active object 15 degrees wide and 10 degrees tall.

cfull

This command makes the clipping rectangle for the active object span the entire screen.

clear

This command completely clears the screen, and sets all object switches to OFF. This command is useful for cleaning up garbage left by improperly sequenced switch or move commands.

"D"; Debug flag

This command sets the debug condition. If you type "*D*<return>", you will get a help message similar to the following:

D [0/1]: set Debug state to 0 = NO, 1 = YES

Example commands:

D 1

This command will turn the rex debugging flag on. When the debugging flag is on, GLvex will print to the console window every command and parameter that it receives from rex, and it will print each signal that it sends to rex. To use this command effectively, you should use the w command (see below) to reduce the size of the GLvex display window so you can see the console window. Also, if you set the console window screen buffer size to 200 to 300 lines, you will be able to run your paradigm for several trials, then be able to use the scroll bar on the console window to view the debugging output.

"d"; Rex scaling

This command sets up the rex scaling factor. If you type "*d*<return>", you will get a help message similar to the following:

d [d w]: set screen distance, pattern width in millimeters

The letter *d* in brackets stands for the distance from the viewer to the screen. The letter *w* in brackets stands for the width of the initial calibration pattern. Both values must be in millimeters.

Example command:

d 572 900

This command sets the screen distance to 572 millimeters and the pattern width to 900 millimeters.

"e"; Set erase method

GLvex allows two methods of erasing stimuli; clearing the entire screen or erasing each individual object with rectangles the color of the screen background. By default, the erase method is set to clearing the entire screen. Erasing each object is much faster than clearing the entire screen, especially on low-end graphics boards. However, using the entire screen method allows you to move and switch a running flow field with the mouse. This could be useful in mapping the receptive fields of movement sensitive neurons such as those found in area MT of the Macaque. If you type "*e*<return>", you will get a help message similar to the following:

e [0/1]: set erase method to 0 = each object 1 = whole screen

The letters *0/1* in brackets stand for the erase method.

Example command:

e 1

This command sets the erase method to clear the entire screen.

"F"; Fixation point properties

Commands beginning with "F" set the properties of the fixation point. If you type "*F*<return>", you will get a help message similar to the following:

Fc [n]: set Fixation luminanCe to n
Fc [r g b]: set Fixation Color to r g b
Fm [n]: set Fixation diM level to n
Fm [r g b]: set Fixation diM color to r g b
Fx [n m]: move Fixation point to nX mY
Fz [n]: set Fixation point size to n pixels

In the two "*Fc*" commands, the letter *n* in brackets stands for the on luminance of the fixation point, and the letters *r g b* in brackets stand for the on color of the fixation point. Similarly, in the two "*Fm*" commands, the letter *n* in brackets stands for the dim luminance of the fixation point, and the letters *r g b* in brackets stand for the dim color of the fixation point. In both the *Fc* and *Fm* commands, the values for *n* and for *r*, *g*, and *b* can range from 0 to 255. In the "*Fx*" command, the letters *n m* in brackets stand for the *X* and *Y* coordinates of the fixation point location. In the "*Fz*" command, the letter *n* stands for the size of the fixation point in video pixels.

Example commands:

Fc 64

This command will make the fixation point dark gray when it is turned on.

Fm 128 0 0

This command will make the fixation point turn medium red when it is dimmed.

Fx 200 200

This command moves the fixation point into the upper right part of the screen.

Fz 4

This command makes the fixation point 4 video pixels high and 4 video pixels wide.

"f"; Switch fixation point, set video frame rate

These commands switch and dim the fixation point and tell GLvex the vertical refresh rate of your monitor. If you type "*f*<return>", you will get the following help message:

fpon: turn Fixation point on
fpoFF: turn Fixation point off
fpdim: dim the Fixation point
fr [n]: set frame rate to n Hz

Example commands:

fpdim

This command dims the fixation point.

fr 100

This command tells GLvex that the frame rate of your monitor is 100 Hz. GLvex uses the frame rate to calculate how big to make each step of a ramp or how far to move each check in a flow field on each screen refresh. Note: Low-end graphics boards may not be able to produce smooth animation such as ramps or flow fields at high frame rates. You may get a better looking display by setting the frame rate lower than you are actually using.

"H h"; Help message

This command prints out the following help message:

Single key stroke commands are:

h: print this message

arrow keys: move active object

[Page Up]/[Page down]: decrement/increment stimulus number

Commands requiring arguments start with the letters:

b, c, D, d, e, F, f, L, l, M, m, O

o, P, p, q, r, S, s, t, w x, Z, z

Type the first letter of the command for a help message and current values

This command is not case sensitive.

"k"; Start / stop okn stimulus

This command starts or stops an OKN drifting square wave grating. if you type "*k*<return>", you will get a help message similar to the following:

kb [o]: start OKN movement in object *o*

ke: stop OKN movement

The letter *o* in brackets stands for the number of the object containing the OKN grating.

Examples command:

kb 2

This command starts an OKN grating in object 2 drifting.

ke

This command stops all OKN drifting gratings

"L"; Look up table color

This command sets the color of a color lookup table entry for the active object. In GLvex, each object has its own color lookup table. If you type "*L*<return>", you will get a help message similar to the following:

L [n]: get current values for lookup table entry *n*

L [n r]: set color lookup table entry *n* to color *r r r*

L [n r g b]: set color lookup table entry *n* to colors *r g b*

The letter *n* in brackets stands for the number of the color lookup table. It can range from 0 to 255. The letters *r g b* in brackets stand for the values of red, green, and blue to place in the color lookup table entry. They also can range from 0 to 255.

Example command:

L 4 255 0 255

This command sets places a magenta color in the active object's lookup entry 4.

"I"; Foreground and background luminance

This command sets the luminances of the foreground and background checks of two tone stimuli in the active object. If you type "*l*<return>", you will get a help message similar to the following:

I [n m]: set Luminances of foreground/background checks of active object to *n/m*

Current luminances of active object are 255, 0

The letter *n* in brackets stands for the luminance of the foreground checks, and the letter *m* in brackets stands for the luminance of the background checks. These values can range from 0 to 255

Example commands:

I 255 0

This command sets the foreground and background pixels of the active object to 255 and 0, respectively. This command will have no effect if the active object has a continuous tone stimulus.

"M"; Start a movie clip

Commands beginning with "M" start movie clips. If you type "*M*<return>", you will get a help message similar to the following:

Start a movie clip

Mo [f l i c]: start an Object movie

Mf [o n f l]: start flow field movie

Ms: stop movies

You can get an explanation of the parameters in the "Mo" command by typing *Mo*<return> to get a help message similar to the following:

f = first object in movie

l = number of objects in the movie

i = number of video fields per movie frame

c = number of movie cycles

The value for *l* cannot exceed the number of objects you created when you started Vex.

You can get an explanation of the parameters in the "Mf" command by typing *Mf*<return> to get a help message similar to the following:

o = the first object with a flow field movie

n = the number of objects with movies

f = first frame of the movie

l = last frame of movie

The value for *l* cannot exceed the number of frames defined for the movie (see below). You can show a movie for shorter periods if you want.

Example commands:

Mf 1 2 100 300

This command will start movies at frame 100 of flow fields that were previously defined for objects 1 and 2 and will display them for 300 frames.

Mo 2 20 5 5

This command will show an object movie using objects 2 through 20. Each object will be displayed for 5 video and the movie will repeat 5 times.

"m"; Link two objects on mouse

This command links or unlinks two objects to be moved with the mouse. The purpose of this command is to allow mapping of binocular receptive fields. If you type "*m*<return>", you will get a help message similar to the following:

m [m s]: mouse acts on two objects [Master & Slave]

m [m]: mouse acts on Master only [default]

The letter *m* in brackets stands for the number of the master object, and the letter *s* in brackets stands for the number of the slave object. Even if you link two objects with this command, the arrow keys will move only the slave object, and the *x* command will move only the master object. Changing the active object with the *s* command or entering a single parameter in the *m* command will break the master-slave bond.

Example command:

m 1 2

This command links object 2 to object 1 for action by the mouse.

"O"; Flow fields

The commands beginning with "O" allow you to set up and run flow fields. If you type "O<return>", you will get the following help message:

```
Compute Optic flow field for active object
Op [w h n f p s]: set flow field Pattern
Om [w h x y]: set flow field Mask
Ot [x z v r p y s c]: set Translation of flow field
Ov [o l]: make a flow field moVie
Os [o n]: Set the first field of a flow field movie
OB [o1 o2]: Begin flow fields in objects o1 through o2
Ob begin flow field in active object
Oe end flow fields
Or [r o c]:begin flow field in active object and Ramp r with Object o cycle [0 1 2]
```

In the "Op" command, the letters in brackets stand for the parameters of the flow field. You can get an explanation of the parameters by typing "Op<return>" to get a help message similar to the following:

```
w = width of flow field
h = height of flow field
n = distance to near plane
f = distance to far plane
p = tenths percent coverage [<= 255]
s = check size
Current values for object 0:
    width = 640
    height = 480
    near = 500
    far = 2000
    tenths percent = 50
```

The values for the near and far planes determine whether the flow field is two- or three-dimensional. If the values for the near and far planes are equal, the flow field will be two-dimensional. If the values for the near plane are less than the far plane, the flow field will be three-dimensional. For three-dimensional flow fields, if the value for the near plane is much smaller than the values for the height or width, you will get wide-angle distortion during yaw or pitch movements. If the value for the near plane is much larger than the values for the height or width, you will get telephoto distortion during yaw or pitch movements.

Example commands:

```
Op 640 480 1 1 50 4
```

This command will set up a two-dimensional flow field 640 rex units wide, 480 rex units high with 5% of its area covered by checks and the checks will be 4 pixels square.

```
Op 1000 700 1000 3000 10 4
```

This command will set up a three-dimensional flow field 1000 rex units wide and 700 rex units high with 1% of its area covered by checks and the checks will be 4 pixels square. The near plane will be 1000 rex units from the viewer, and the far plane will be 3000 rex units from the viewer. If the visual display subtends 1 centimeter/degree of visual angle, then the near plane will be 1 meter from the viewer and the far plane will be 3 meters from the viewer.

In the "Om" command, the letters in brackets stand for the dimensions and location of an occluding mask over the flow field. You can get an explanation of the parameters by typing "Om<return>" to get a help message similar to the following:

```
w = width of mask
h = height of mask
```

x = x coordinate of mask in object
y = y coordinate of mask in object
Current values for object 0
width = 100
height = 100
x = -100
y = 0

Example commands:

Om 200 200 -100 0

This command will create an occluding mask in a flow field that is 200 rex units wide and high, and centered 100 rex units to the left of the center of the object.

In the "Ot" command, the letters in brackets stand for the parameters defining the way in which the checks in the flow field will move. You can get an explanation of the parameters by typing "Ot<return>" to get a help message similar to the following:

x = angle of 2-D translation in degrees [0 to 360]
z = angle of 3-D translation in degrees [-90 to 90]
v = translation velocity in degrees / sec
r = rate of rotation in degrees / sec
p = rate of pitch in degrees / sec
w = rate of yaw in degrees / sec
s = life span of checks in fields
c = percent of checks coherent
Current values for object 0

angle = 45
depth = 0
velocity = 20
rotation = 0
pitch = 0
yaw = 0
span = 0
coherence = 100

The *x* parameter is an angle that specifies the direction of movement in the X-Y plane. A value of 0 represents movement to the right, and a value of 90 represents movement upwards. The *z* parameter is an angle that specifies the direction of movement in depth. A value of 90 represents movement away from the viewer, a value of 0 represents no movement in depth, and a value of -90 represents movement toward the viewer. The *v* parameter represents the translational velocity of the checks in the direction specified by the compound X-Y-Z angle. The X- and Y- velocity components are multiplied by the cosine of the *z* parameter, so specifying *z* values of 90 or -90 will produce pure vergence movement no matter how you set the *a* parameter. The *s* parameter defines the life span of checks in the flow field in numbers of video fields. For a flickering display, this parameter must have a value of 3 or greater. Setting this parameter to 0 will produce a continuous flow field. The *c* parameter defines the percentage of checks in the flow field that move as specified. All other checks will move in random directions at random speeds.

Example command:

Ot 90 45 10 0 0 0 10 100

This command will produce translation at 10 degrees/sec (100 rex units / sec) upward and away from the viewer. Each check will be displayed for 10 video fields, and then turned off and moved to a new location. All checks will move in the specified direction.

Ot 0 90 10 20 0 0 0 50

This command will produce a counter-clockwise rotation of 20 degrees/sec coupled with translation away from the viewer at 10 degrees/sec. The checks will remain on as long as the movement continues. Half of the checks will move in the specified manner, and half will move in random directions.

In the "Ov" command, the letters in brackets stand for the number of the object in which to make the movie and the length of the movie in frames. You can get an explanation of the parameters by typing "Ov<return>" to get a help message similar to the following:

o = object with flow movie

l = number of frames in movie

The number of frames defines the maximum length of the movie, but you can show it for shorter periods if you want. Before creating a movie in any object, you must define a flow field pattern for that object and you must define the way in which the checks in the flow field will move. You may also define an occluding mask.

Example commands:

Ov 1 300

This command will create a flow field movie in object 1 that can be run for up to 300 frames.

In the Os command, the letters in brackets stand for the object containing the flow field movie and the starting frame of the movie. You can get an explanation of the parameters by typing "Os<return>" to get the following help message:

o = object for movie

s = starting frame of the movie

Example command:

Os 2 50

This command will set the flow field in object 2 to movie frame 50.

In the OB command, the letters o1 and o2 in brackets stand for the lowest and highest priority objects in which you want to have moving flow fields. The Ob command starts the flow field in the active object. The Oe command, stops the flow fields in all objects.

Example command:

OB 1 4

This command will start flow fields moving in objects 1 through 4.

You can get an explanation of the parameters in the "Or" command by typing "Or<return>" to get the following help message:

r = number of ramp to run with flow field

o = number of object to put on ramp

c = type of ramp cycle

c = 0: ramp runs once

c = 1: oscillation - ramp goes back and forth

c = 2: loop - ramp runs over and over

Example command:

Or 1 5 0

This command will start the flow field in the active object and start ramp number 1 with object number 5. The ramp will run once.

"o"; Foreground and background colors

This command sets the colors of the foreground and background checks of two tone stimuli in the active object. If you type "o<return>", you will get a help message similar to the following:

of [r g b]: set cOlor of object foreground to r, g, b

ob [r g b]: set cOlor of object background to r, g, b

Current values:

object 1 forgrnd rgb = 255 255 255; backgrnd rgb = 0 0 0
object 2 forgrnd rgb = 255 0 0; backgrnd rgb = 0 255 0

The letters *r g b* in brackets stand for the values of red, green, and blue to use for the object foreground or background. These values can range from 0 to 255

Example commands:

of 255 0 0

ob 0 255 0

These two commands will make the active object have a red foreground and a green background. This command will have no effect if the active object has a continuous tone stimulus.

"P"; Copy pattern

This command copies the pattern in one object to a second object. If you type "*P*<return>", you will get the following help message:

P [s d]: coPy pattern from Source object to Destination object

**P [s d x y]: coPy pattern from Source object to Destination object
and scale width by X% and height by Y%**

The letter *s* in brackets stands for the number of the source object, and the letter *d* in brackets stands for the number of the destination object. In the second example of the command, the letter *x* in brackets stands for the percentage to scale the width of the copied object and the letter *y* in brackets stands for the percentage to scale the height of the copied object. To increase the size of the copied object, use *x* and *y* values greater than 100. To decrease the size of the copied object, use *x* and *y* values less than 100.

Example command:

P 1 2

This command will copy the stimulus pattern in object 1 to object 2. The main purpose of this command is to allow you to draw exact copies of random check or flow field patterns in several objects, but it will copy any pattern. The reason that this command is needed is that if you execute the draw random pattern function separately for each object, the patterns would have the same statistical properties but the positions of the "white" and "black" checks would be different.

"p"; Draw pattern

These commands draw patterns in the active object. Currently, GLvex will draw patterns based on one of 8 functions: Walsh functions, Haar functions, User defined templates, User defined RGB templates, Random functions, Annuli, Bars, and Tiff images. To draw a filled circle, specify an annulus with an inner radius of 0. If you type "*p*<return>", you will get a help message similar to the following:

pa [o i c]: draw Annulus with outer radius o, inner radius i, contrast c

pb [a w h c]: draw a bar with angle a, width w, height h, contrast c

ph [n c s]: draw Haar pattern n with contrast c size s

pk [a s w h t]: draw translation OKN stimulus angle a speed s w X h size bar width t

pr [p r c s]: draw Random pattern with p% white, r X c checks, size s

pt [n]: draw a TIFF image from the file In.tif

pu [n c s]: draw User pattern from the file

Pn with contrast c size s

pu [n s]: draw user RGB pattern from the file Pn size s

pw [n c s]: draw Walsh pattern n with contrast c size s

Current patterns:

object 1 function w pattern = 1 contrast = 1

object 2 function u pattern = 101 contrast = -1

object 3 function c radius = 40 contrast = 1

object 4 function r resolution = 120 percent white = 10

The letter immediately following *p* stands for the function of the pattern. The letter *n* in brackets following the *pw*, *ph*, *pt* and *pu* commands stands for the pattern number. The letter *s* in brackets following the *ph*, *pr*, *pu*, and *pw* commands stands for the size of the pattern checks. The letter *c* in brackets following the *pw*, *ph*, *pu*, and *pa* commands stands for the contrast (normal or reverse) of the pattern. The contrast value can be either 1 for normal contrast or -1 for reverse contrast. The letter *p* in brackets following the *pr* command stands for the percentage of white checks in the random pattern. The letters in brackets following the *pr* command stands for the number of rows and the letter *c* in brackets following the *pr* command stands for the number of columns in the random check pattern. The letter *o* in brackets following *pa* stands for the outer radius of the annulus, and the letter *i* in brackets following *pa* stands for the inner radius of the annulus. If the value for *i* is 0 then the pattern will be a filled circle. The letter *a* in brackets following the *pk* command stands for the direction of drift. This value must be 0, 90, 180, or 270. The letter *s* in brackets following the *pk* command stands for the speed of drift in degrees/second. The letter *w* in brackets following the *pk* command stands for the width of the grating in tenths of a degree. The letter *h* in brackets following the *pk* command stands for the height of the grating in tenths of a degree. The letter *t* in brackets following the *pk* command stands for the thickness of the bars in the grating in tenths of a degree.

Example commands:

pw 119 1

This command will draw a "normal" contrast version of Walsh pattern 119 (an 8 X 8 checkerboard) in the active object.

pu 101 -1

This command will use the template found in the file p101 to draw a "reverse" contrast version of the user-defined pattern.

pa 40 20 1

This command will draw a "normal" contrast annulus with an outer radius of 40 and an inner radius of 20 in the active object.

Valid pattern numbers for *w* and *h* functions range from 0 to 255. Valid pattern numbers for *u* and *t* functions range from 0 to 65536. This means that files containing user-defined templates can only have names ranging from P0 to P65536. Files containing TIFF images can only have names ranging from I0.tif to I65536.tif.

To make user-defined patterns, you must provide GLvex with a template of the pattern you want. The template can be a set of numbers indicating the color lookup table entries to use for each check, or a set of 3 numbers indicating the R, G, and B values to use for each check. This template is defined in an ascii file which must be placed in the directory from which you run GLvex. The format of the lookup table template file is:

```

r c
n ... n
...
...
...
n ... n

```

The letters *r* and *c* indicate the number of rows and columns in the pattern. The maximum number of rows or columns is 255. The pattern may be rectangular, i.e., you do not need to have the same number of rows and columns. The letters *n* indicate the values for the individual checks in the pattern. If *n* equals 1, the object's foreground color will be used in that check. If *n* equals -1, the object's background color will be used in that check. If *n* equals 0, the screen's background color will be used in that check. If *n* equals 2 - 255, color lookup table entries 2 - 255 will be used in that check.

The format of the RGB template file is:

```
r c 3
r g b.....r g b
.....
.....
.....
r g b.....r g b
```

The letters *r* and *c* indicate the number of rows and columns in the pattern, and the number 3 indicates that there are 3 values for each check. You must use a 3 in this location and no other number. The maximum number of rows or columns is 255. The pattern may be rectangular, i.e., you do not need to have the same number of rows and columns. The letters *r g b* indicate the red, green, and blue values for the individual checks in the pattern. The *r*, *g*, and *b* values must be separated by at least 1 space but the triplets may be separated by more than 1 space for readability.

Example of a file for a user defined pattern with 3 rows and 8 cols. This file defines a horizontal "white" bar flanked by two "black" bars. The name of the file might be "P1".

```
3 8
-1 -1 -1 -1 -1 -1 -1 -1
 1  1  1  1  1  1  1  1
-1 -1 -1 -1 -1 -1 -1 -1
```

Example of a file for a user defined RGB pattern with 3 rows and 8 cols. This file defines a horizontal "red" bar flanked by two "green" bars. The name of the file might be "P2000".

```
3 8 3
0 255 0 0 255 0 0 255 0 0 255 0 0 255 0 0 255 0 0 255 0
255 0 0 255 0 0 255 0 0 255 0 0 255 0 0 255 0 0 255 0 0
0 255 0 0 255 0 0 255 0 0 255 0 0 255 0 0 255 0 0 255 0
```

Example of a file for a user defined pattern with 8 rows and 8 cols. This pattern will have 8 vertical strips of different gray levels if you set up a gray scale ranging from 128 to 184. The name of the file might be "P100".

```
8 8
128 136 144 152 160 168 176 184
128 136 144 152 160 168 176 184
128 136 144 152 160 168 176 184
128 136 144 152 160 168 176 184
128 136 144 152 160 168 176 184
128 136 144 152 160 168 176 184
128 136 144 152 160 168 176 184
128 136 144 152 160 168 176 184
```

"q"; Quit

This commands quits GLvex. These commands are not case sensitive. If you type "q<return>", you will get the following help message:

```
qv: quit Vex
```

"r"; Absolute ramps

The command *rc* computes the absolute location of ramps, and the command *rs* starts ramps. If you type "r<return>", you will get the following help message:

```
rc [n len ang vel xoff yoff type action]: Compute a ramp
rs [r o c]: Start Ramp r with Object o continuation c [0 1 2]
rstop: stop all ramps reset: reset ramps
```

In the "rc" command, the letters in brackets stand for the parameters of the ramp. You can get an explanation of the parameters by typing "rc<return>" to get a help message similar to the following:

n = number of ramp to compute **len = half of the linear length [tenths of a degree]**
len = radius of circular ramp [tenths of a degree]
ang = slope of linear ramp in degrees
ang = starting point of circular ramp
vel = velocity of ramp in degrees / sec
xoff, yoff = location of ramp reference point
type = type and reference point of ramp
 type = 2: linear ramp centered on the reference point
 type = 4: linear ramp beginning at the reference point
 type = 8: linear ramp ending at the reference point
 type = 16: Clock-wise circular ramp centered on reference point
 type = 32: Counter clock-wise circular ramp centered on reference point
action = object switch after end of ramp
 action = 1: leave object on after end of ramp
 action = 0: turn object off after end of ramp

Example commands:

```
rc 1 200 45 20 100 -100 2 0
```

This command will compute ramp 1 with a length of 40 degrees, a direction of 45 degrees, a speed of 20 degrees / second, and a mid-point that is 10 degrees to the right and 10 degrees below the center of the screen. The object will be switch off after the end of the ramp

```
rc 1 200 45 20 100 -100 16 1
```

This command will compute a circular ramp with a radius of 40 degrees, a starting location 45 degrees from the center, a surface speed of 20 degrees / second, and a mid-point that is 10 degrees to the right and 10 degrees below the center of the screen. The object will be left on after the end of the ramp

In the "rs" command, the letters in brackets stand for the number of the ramp to run and the object to put on it. You can get an explanation of the parameters by typing "rs<return>" to get a help message similar to the following:

r = number of ramp to run
o = object to put on the ramp
c = type of ramp cycle
 c = 0: ramp runs once
 c = 1: oscillation - ramp goes back and forth
 c = 2: loop - ramp runs over and over

Each ramp must have been previously computed with the rc command.

Example commands:

```
rs 1 1 0
```

This command will place object 1 on ramp 1 and start ramp 1 moving. The ramp will run once. You can start two ramps simultaneously with the command:

```
rs 1 1 0 2 2 0
```

This command will place object 1 on ramp 1, object 2 on ramp 2 and start both ramps moving. Both ramps will run once.

"S"; Switch all objects

These commands switch all objects on or off. If you type "S<return>", you will get the following help message:

Ston: Switch all objects on
Stoff: Switch all objects off

"s"; Switch, set active object, set sync

These commands switch the active object on or off, enable or disable the sync signals and change the active object. If you type "*s*<return>", you will get a help message similar to the following:

s [n]: make object n active [release slave]
ston: Switch active object on
stoff: Switch active object off
syncVon: Switch video sync on
syncVoff: Switch video sync off
syncDon: Switch digital sync on
syndDoff: Switch digital sync off
Object number 1 is now active

The letter *n* in brackets stands for the object to be made active. It must be a valid object number.

Example command:

s 2

This command makes object 2 active, and breaks any master-slave linkages created with the *m* command.

"t"; Timing commands

These commands affect the timing of the stimuli. If you type "*t*<return>", you will get the following help message:

t [n]: turn active object on for n fields
t [o1 m n o2 p]: object 1 for m fields, n gap, object 2 for p fields

Example command:

t 45

This command will display the active object for 45 video fields.

t 1 30 30 2 30

This command will display object 1 for 30 fields, wait 30 fields, then display object 2 for 30 fields.

"W"; Video sync size

By default, the size of the video sync object is 64 pixels wide and 64 pixels high. However, for low resolution screens such as 640 X 480, this may be too large. This command sets the size of the video sync object. If you type "*W*<return>", you will get the following help message.

Ws [w h]: set video sync size to width w, height h

The letter *w* in brackets stands for the width of the video sync square in pixels The letter *h* in brackets stands for the height of the video sync square in pixels

Example command:

Ws 32 32

This command will set the size of the video sync square to 32 pixels wide and 32 pixels high.

"w"; Set window size

Normally, GLvex runs in a full screen window. However, there are times when you might want to reduce the size of the window. For example, to see the console window during debugging. If you type "*w*<return>", you will get the following help message:

ws [w h]: set Window size to width w, height h

The letter *w* in brackets stands for the width of the GLvex window. The letter *h* in brackets stands for the height of the GLvex window.

Example commands:

ws 800 600

This command will set the size of the window that GLvex runs in to 800 pixels wide and 600 pixels high. **NOTE: Once you have changed the size of the GLvex window you cannot go back to a full screen window.** To go back to full screen mode, you will need to restart GLvex.

"X"; Video Sync X and Y coordinates

By default, GLvex places the video sync object in the upper left corner of the screen. This command allows you place the object anywhere you like. if you type "X<return>" you will get the following help message:

X [n m]: set video sync location to nX mY

The letter *n* in brackets stands for the X coordinate of the sync object. The letter *m* in brackets stands for the Y coordinate of the sync object.

Example command:

X 0 240

This command places the sync object at the left edge of the screen, 240 pixels from the bottom.

"x"; Absolute X and Y coordinates

This command moves the active object to an absolute position on the screen. If you type "x<return>", you will get a help message similar to the following:

X [n m]: move active object to nX mY location on screen

Current locations:

object 1 x = 100, y = 100

object 2 x = -100, y = 100

The letter *n* in brackets stands for the horizontal position and the letter *m* in brackets stands for the vertical position of the object in rex units. The center of the screen is location "0 0". Negative X values will place the object in the left half of the screen, and negative Y values will place the object in the bottom half of the screen.

Example command:

x -50 -50

This command will position the active object 5 degrees below and to the left of the screen center.

"Z"; Set the size of all objects.

This command sets the sizes of the pattern checks in all objects. If you type "Z<return>", you will get a help message similar to the following:

Z [n]: set size of pattern checks in all objects to n pixels

The letter *n* in brackets stands for the height and width of each pattern check in video pixels.

Example command:

Z 4

This command will set the pattern check size of all objects to 4 video pixels by 4 video pixels.

"z"; Set the size of active object

This command sets the size of the pattern checks in the active object. If you type "z<return>", you will get a help message similar to the following:

z [n]: set size of pattern checks in active object to n pixels

The letter *n* in brackets stands for the height and width of each pattern check in video pixels.

Example command:

z 2

This command will set the pattern check size of the active object to 2 video pixels by 2 video pixels.

REX ACTIONS

Rex 7.2 introduces a new control protocol. You can now send commands to GLvex using a set of actions. All of the actions take points to global variables as arguments. The reason for this change is to provide an interface that is more simple and robust. The earlier command protocol required you to load values into a *char* buffer, then call a function to send the buffer to Rex. You had to break *int* and *float* variables into byte arrays by hand. Getting the order of the bytes wrong resulted in nonsensical displays. Also, filling out the buffer required a lot of coding which was both tedious and error prone. With the actions control protocol, you assign values to global array elements, then call the action with the arrays as arguments. The action takes care of assembling the buffer for GLvex. One disadvantage of the actions control protocol is that all of the new vex actions are non-batchable. That is, only one vex action can be called per state. You cannot write an action that calls a series of vex actions. If you try, only the last action will be executed. This means that your paradigms will have more states. However, you will have to write fewer actions so your spot files will be shorter.

All spot files using Rex actions must include the header file "GLcommand.h" and either the header file "pcsSocket.h" or the header file "pcmsg.h", depending on whether you are using the ethernet or parallel I/O communication protocol.

All of these actions return a value of 0. However, GLvex will return various digital signals after completing the required action. If the video sync is enabled, GLvex will flash the sync object white on the first video field in which the action is completed for those actions requiring precise timing. ***Note: The only escapes you should use from states that call these actions are when the function `tst_rx_new` returns 0 or when a photo cell is triggered by the video sync object.***

With Rex 7.2, you can continue to use the older Rex commands described below, and you can write some actions that use the Rex commands while defining other states that use the Rex actions. If you have an earlier version of Rex, you must use the Rex commands describe below.

Actions That Duplicate Command Line Arguments

PvexEraseMethod

set the erase method to be either whole screen or individual objects.

SYNOPSIS. PvexEraseMethod(int *method)

method: erase method, can be WHOLE_SCREEN or EACH_OBJECT

DESCRIPTION. PvexEraseMethod allows you to set whether GLvex turns off stimuli by clearing the whole screen or by erasing individual stimuli. If method equals WHOLE_SCREEN, the whole screen will be erased. If method is EACH_OBJECT, then GLvex will erase objects by drawing a rectangle the color of the background over them. If method is WHOLE_SCREEN, then GLvex will erase objects by clearing the entire screen. The EACH_OBJECT method is faster, but the WHOLE_SCREEN method is more robust. The default method is EACH_OBJECT. Once the erase method is set, it will remain in effect until changed, so you only need to call this command once. This variable can be set using the -e command line argument to GLvex. The WHOLE_SCREEN and EACH_OBJECT constants are defined in GLcommand.h

RETURN VALUE. Glvex will return the signal BATCH_DONE (241) after completing this action

EXAMPLE.

```
int method = WHOLE_SCREEN;

%%
state:
    do PvexEraseMethod(&method)
    to nextstate on 0 % tst_rx_new
```

FILE. /rex/act/vexActions.c

PvexVideoSync

switch the video sync signal.

SYNOPSIS. PvexVideoSync(int *sync)

sync: switch determining whether GLvex will use a video syncing signal, can be 0 or 1

DESCRIPTION. PvexVideoSync allows you to turn on or off GLvex's video syncing object. When the video sync is enabled, GLvex will draw a small black square in the upper left corner of the screen. This square will flash white for 1 video field when synchronization is needed. The video sync is enabled by default. Once the video sync is enabled, it will remain enabled until disabled, so you only need to call this action once. This variable can be set using the -v command line argument to GLvex.

RETURN VALUE. Glvex will return the signal BATCH_DONE (241) after completing this action

EXAMPLE.

```
int sync = 1;
```

```
%%
```

```
state:
```

```
do pvexVideoSync(&sync)  
to nextstate on 0 % tst_rx_new
```

FILE. /rex/act/vexActions.c

PvexDigitalSync

switch the digital sync signal.

SYNOPSIS. PvexDigitalSync(int *sync)

sync: switch determining whether GLvex will use a digital syncing signal, can be 0 or 1

DESCRIPTION. PvexDigitalSync allows you to turn on or off GLvex's digital syncing signal. When the digital sync is enabled, GLvex will return a signal via ethernet or pcmmsg at the beginning of the first video field where synchronization is needed. The digital sync is enabled by default. Once the digital sync is enabled, it will remain enabled until disabled, so you only need to call this action once. This variable can be set using the -d command line argument to GLvex.

RETURN VALUE. Glvex will return the signal BATCH_DONE (241) after completing this action

EXAMPLE.

```
int sync = 1;
```

```
%%
```

```
state:
```

```
do pvexDigitalSync(&sync)  
to nextstate on 0 % tst_rx_new
```

FILE. /rex/act/vexActions.c

PvexSetRexScale

set the scale factors to allow tangent correction in the placement of objects on the screen

SYNOPSIS. `PvexSetRexScale(int *distance, int *width)`

distance: distance from the subject to the screen in millimeters

width: width of the initial calibration pattern in millimeters.

DESCRIPTION. `PvexSetRexScale` allows you to set the parameters necessary for `GLvex` to compute locations on the viewing screen in degrees of visual angle. Once the scale is set, it will remain in effect until reset, so you only need to call this action once. The distance variable can be set using the `-s` command line argument to `GLvex`, and the width variable can be set using the `-w` command line argument to `GLvex`.

RETURN VALUE. `GLvex` will return the signal `BATCH_DONE` (241) after completing this action

EXAMPLE.

```
int width = 290;
```

```
int distance = 573;
```

```
%%
```

```
state:
```

```
    do PvexSetRexScale(&distance, &width)
```

```
    to nextstate on 0 % tst_rx_new
```

FILE. `/rex/act/vexActions.c`

Actions That Set Luminance and Color

PvexSetBackLum

set the luminance or color of the screen background

SYNOPSIS. PvexSetBackLum(int *r, int *g, int *b)

r: intensity of red in the background, can be 0 to 255

g: intensity of green in the background, can be 0 to 255

b: intensity of blue in the background, can be 0 to 255

DESCRIPTION. This is action sets the luminance or color of the screen background. It requires three parameters, the values for the red, green, and blue guns.

RETURN VALUE. Glvex will return the signal BATCH_DONE (241) after completing this action

EXAMPLE:

```
/* set background to medium gray */
```

```
int red = 127;
```

```
int green = 127;
```

```
int blue = 127;
```

```
%%
```

```
state:
```

```
do PvexSetBackLum(&red, &green, &blue)
```

```
to nextstate on 0 % tst_rx_new
```

FILE. /rex/act/vexActions.c

PvexSetFixColors

sets the colors of the fixation point when it is switched on or dimmed

SYNOPSIS. PvexSetFixColors(int *or, int *og, int *ob, int *dr, int *dg, int *db)

or: intensity of red in fixation point when switched on, can be 0 to 255

og: intensity of green in fixation point when switched on, can be 0 to 255

ob: intensity of blue in fixation point when switched on, can be 0 to 255

dr: intensity of red in fixation point when dimmed, can be 0 to 255

dg: intensity of green in fixation point when dimmed, can be 0 to 255

db: intensity of blue in fixation point when dimmed, can be 0 to 255

DESCRIPTION. This function allows you to specify what the color or luminance of the fixation point will be when it is switched on and when it is dimmed.

RETURN VALUE. Glvex will return the signal BATCH_DONE (241) after completing this action

EXAMPLE.

```
int onRed = 255;
```

```
int onGreen = 0;
```

```
int onBlue = 0;
```

```
int dimRed = 0;
```

```
int dimGreen = 255;
```

```
int dimBlue = 0;
```

```
%%
```

```
state:
```

```
do PvexSetFixColors(&onRed, &onGreen, &onBlue, &dimRed, &dimGreen, &dimBlue)
to nextstate on 0 % tst_rx_new
```

FILE. /rex/act/vexActions.c

PvexSetStimLuminances

sets the foreground and background luminances of one- and two-tone stimuli

SYNOPSIS. PvexSetStimLuminances(int *nObjects, int *objList, int *fgList, int *bgList)

nObjects: number of objects to set

objList: array of object numbers to set

fgList: array of foreground luminances, can be 0 to 255

bgList: array of background luminances, can be 0 to 255

DESCRIPTION. This function allows you to specify the gray levels of the foreground and background checks of a number of objects.

RETURN VALUE. Glvex will return the signal BATCH_DONE (241) after completing this action

EXAMPLE.

```
int num;
int objects[255];
int fore[255];
int back[255];

int setup()
{
    int i;
    num = 15;
    for(i = 0; i < num; i++) {
        objects[i] = i * 2;
        fore[i] = 255;
        back[i] = 0;
    }
    return(0);
}

%%
prev:
    do setup()
    to state:

state:
    do PvexSetStimLuminances(&num, objects, fore, back)
    to nextstate on 0 % tst_rx_new
```

FILE. /rex/act/vexActions.c

PvexSetStimColors

sets the foreground and background colors of one- and two-tone stimuli

SYNOPSIS. PvexSetStimColors(int *nObjects, int *objList, int *fgrList, int *fggList, *fgbList, int *bgrList, int *bggList, int *bgbList)

nObjects: number of objects to set

objList: array of object numbers to set

fgrList, fggList, fgbList: arrays of foreground red, green and blue values, can be 0 to 255

bgrList, bggList, bgbList: arrays of background red, green and blue values, can be 0 to 255

DESCRIPTION. This function allows you to specify the colors of the foreground and background checks of a number of objects

RETURN VALUE. Glvex will return the signal BATCH_DONE (241) after completing this action

EXAMPLE.

```
int num;
int objects[255];
int foreRed[255], foreGreen[255], foreBlue[255];
int backRed[255], backGreen[255], backBlue[255];

int setup()
{
    int i;
    num = 15;
    for(i = 0; i < num; i++) {
        objects[i] = i * 2;
        foreRed[i] = 255 - (i * 15);
        foreGreen[i] = 0 + (i * 15);
        foreBlue[i] = 127;
        backRed[i] = 127;
        backGreen[i] = 0 + (i * 15);
        backBlue[i] = 255 - (i * 15);
    }
    return(0);
}

%%
prev:
    do action
    to state;

state:
    do PvexSetStimColors(&num, objects, foreRed, foreGreen, foreBlue,
                        backRed, backGreen, backBlue)
    to nextstate on 0 % tst_rx_new
```

FILE. /rex/act/vexActions.c

PvexSetColorMask

sets the red, green, blue and alpha masks

SYNOPSIS. `PvexSetColorMask(int *nObjects, int *objList, int *redList, int *greenList, *blueList, int *alphaList)`

`nObjects`: number of objects to set

`objList`: array of object numbers to set

`redList`: array of values for the red mask, can be either 0 or 255

`greenList`: array of values for the green mask, can be either 0 or 255

`blueList`: array of values for the blue mask, can be either 0 or 255

`alphaList`: array of values for the alpha mask, can be either 0 or 255

DESCRIPTION. This function allows you to specify which color planes will be used to draw objects. A mask value of 0 for a plane disables drawing in that plane. A mask value of 255 for a plane enables drawing in that plane. By default all planes are enabled. If all masks are enabled, colors for each object are specified by the `PvexSetStimColors` function above and high priority objects will occlude lower priority objects where they intersect. If any of the masks are disabled, colors for each object are specified by the masks that are enabled and objects are blended where they intersect.

RETURN VALUE. `Glvex` will return the signal `BATCH_DONE` (241) after completing this action

EXAMPLE.

```
int num;  
int objects;  
int redMask, greenMask, blueMask, alphaMask;
```

```
int setup()
```

```
{  
    int i;  
    num = 1;  
    objects = 2;  
    redMask = 0;  
    greenMask = 255;  
    blueMask = 0;  
    alphaMask = 0;  
    return(0);  
}
```

```
%%
```

```
prev:
```

```
do action  
to state;
```

```
state:
```

```
do PvexSetColorMask(&num, &objects, &redMask, &greenMask, &blueMask,  
                    &alphaMask);  
to nextstate on 0 % tst_rx_new
```

This example enables only the green mask for object number 2. With this mask, object 2 will be drawn only in shades of green, regardless of its foreground or background colors. Also, all objects will be blended where they intersect.

FILE. `/rex/act/vexActions.c`

PvexSetGrayScale

sets up a gray scale for all objects in each object's color lookup table

SYNOPSIS. PvexSetGrayScale(int *start, int *length)

start: index into color lookup table to start gray scale, can be 0 to 255

length: number of gray levels in gray scale, can be 1 to 255

DESCRIPTION. This action sets up a gray scale in all objects' color lookup tables. The sum of the start and length parameters cannot exceed 255. The luminance range of the gray scale is always 0 to 255. The size of the steps between luminances is determined by the length of the gray scale. This command is used to initialize a gray scale for continuous tone stimuli.

RETURN VALUE. Glvex will return the signal BATCH_DONE (241) after completing this action

EXAMPLE.

```
int start = 64;
```

```
int length = 128;
```

```
%%
```

```
state:
```

```
do PvexSetGrayScale(&start, &length)
```

```
to nextstate on 0 % tst_rx_new
```

FILES. /rex/act/vexActions.c

PvexSetObjectGrayScale

sets up a gray scale for each specified object in that object's color lookup table

SYNOPSIS. PvexSetObjectGrayScale(int *nObjects, int *objList, int *startList, int *lengthList)

nObjects: number of objects to set

objList: list of the object numbers to set

startList: index into each object's color lookup table to start its gray scale, can be 0 to 255

lengthList: number of gray levels in each object's gray scale, can be 1 to 255

DESCRIPTION. This action sets up a gray scale in the object's color lookup tables. The sum of the start and length parameters cannot exceed 255. The luminance range of the gray scale is always 0 to 255. The size of the steps between luminances is determined by the length of the gray scale. This command is used to initialize a gray scale for continuous tone stimuli.

RETURN VALUE. Glvex will return the signal BATCH_DONE (241) after completing this action

EXAMPLE.

```
int num;
int objList[15];
int startList[15];
int lengthList[15];

int setup()
{
    int i;
    for(i = 0; i < 15; i++) {
        objList[i] = i + 3;
        startList[i] = 32 + (i * 2);
        lengthList[i] = 64;
    }
    return(0);
}

%%
prev:
    do setup()
    to state

state:
    do PvexSetObjectGrayScale(&num, objList, startList, lengthList)
    to nextstate on 0 % tst_rx_new
```

FILES.

/rex/act/vexActions.c

PvexSetLutEntryClr

sets the color of the specified entry in each object's color look up table

SYNOPSIS. PvexSetLutEntryClr(int *nEntries, int *entryList, int *rList, int *gList, int *bList)

nEntries: number of entries to set, can be 1 to 255

entryList: array of look up table indices to set, can be 0 to 255

rList: array of red values, can be 0 to 255

gList: array of green values, can be 0 to 255

bList: array of blue values, can be 0 to 255

DESCRIPTION. This action allows you to set the red, green, and blue values of a number of entries in the color lookup tables of all objects. Each object has a color look up table of 255 entries.

RETURN VALUE. Glvex will return the signal BATCH_DONE (241) after completing this action

EXAMPLE.

```
int num;
int list[32];
int red[32];
int green[32];
int blue[32];

int setup()
{
    int i;
    for(i = 0; i < 32; i++) {
        list[i] = i + 32;
        red[i] = i * 8;
        green[i] = i * 4;
        blue[i] = 127;
    }
    return(0);
}

%%
prev:
    do setup()
    to state

state:
    do PvexSetLutEntryClr(&num, list, red, green, blue)
    to nextstate on 0 % tst_rx_new
```

FILE. /rex/act/vexActions.c

PvexSetObjectLutEntryClr

sets the color of the specified entry in the specified object's color look up table

SYNOPSIS. PvexSetObjectLutEntryClr(int *nObjects, int *objectList, int *nEntries, int *entryList,
int *rList, int *gList, int *bList)

nObjects: number of objects to set

objList: list of object numbers to set

nEntries: number of entries to set, can be 1 to 255

entryList: array of look up table indices to set, can be 0 to 255

rList: array of red values, can be 0 to 255

gList: array of green values, can be 0 to 255

bList: array of blue values, can be 0 to 255

DESCRIPTION. This action allows you to set the red, green, and blue values of a number of entries in the color lookup tables of a number of objects. Each object has a color look up table of 255 entries. The sizes of the entryList, rList, gList, and bList arrays must be at least as large as the product of the number of objects and the number of entries.

RETURN VALUE. Glvex will return the signal BATCH_DONE (241) after completing this action

EXAMPLE.

```
int nObjects, nEntries;
int objList[32], entryList[1024], red[1024], green[1024], blue[1024];

int setup()
{
    int i;
    int j;
    nObjects = 32;
    nEntries = 32;
    for(i = 0; i < nObjects; i++) {
        objList[i] = i;
        for(j = 0; j < nEntries; j++) {
            entryList[j] = i;
            red[j] = i * 8;
            green[j] = i * 4;
            blue[j] = 127;
        }
    }
    return(0);
}

%%
prev:
    do action
    to state

state:
    do PvexSetObjectLutEntryClr(&nObjects, objList, &nEntries, entryList, red, green, blue)
    to nextstate on 0 % tst_rx_new
```

FILE. /rex/act/vexActions.c

Actions That Switch Stimuli

PvexAllOff

switch off all objects and the fixation point

SYNOPSIS. PvexAllOff(void);

DESCRIPTION. This action switches all objects and the fixation point off. Its purpose is to quickly and simply clear the screen

RETURN VALUE. If the digital sync is enabled, Glvex will return the signal ABORT_TRIAL (255) at the beginning of the first clear video field. In this case, you should escape to the next state when the tst_rx_new function returns 0, indicating receipt of a signal from GLvex. If the video sync is enabled, the sync square will flash white for the first field in which all objects are off.

EXAMPLE.

%%

state:

```
do PvexAllOff()
to nextstate on 0 % tst_rx_new/* if digital sync */
to nextstate on +PHOTO_CELL & drinput/* if video sync*/
```

FILE. /rex/vexActions.c

PvexSwitchFix

switches the fixation point on or off

SYNOPSIS. PvexSwitchFix(int *switch)

switch: whether the fixation point turns on or off, can be OBJ_OFF or OBJ_ON

DESCRIPTION. This action allows you to switch the fixation point on or off. if the value of switch is OBJ_OFF, the fixation point will be switched off. If the value is OBJ_ON, the fixation point will be switched on.

RETURN VALUE. If the digital sync is enabled, Glvex will return the signal FIX_ON (254) or FIX_OFF (253) at the beginning of the first video field in which the fixation point is switched. If the video sync is enabled, the sync square will flash white for the first field in which the fixation point is switched.

EXAMPLE.

```
int switch = OBJ_ON;
```

```
%%
```

```
state:
```

```
    do PvexSwitchFix(&switch)
```

```
    to nextstate on 0 % tst_rx_new/* if digital sync */
```

```
    to nextstate on +PHOTO_CELL & drinput/* if video sync*/
```

FILE. /rex/act/vexActions.c

PvexDimFix

dim the fixation point

SYNOPSIS. PvexDimFix(void);

DESCRIPTION. This action allows you to dim the fixation point object to the color or luminance previously defined.

RETURN VALUE. If the digital sync is enabled, Glvex will return the signal FIX_DIM (252) at the beginning of the first video field in which the fixation point is dimmed. If the video sync is enabled, the sync square will flash white for the first field in which the fixation point is dimmed.

EXAMPLE.

```
%%
```

```
state:
```

```
do PvexDimFix()
```

```
to nextstate on 0 % tst_rx_new/* if digital sync */
```

```
to nextstate on +PHOTO_CELL & drinput/* if video sync*/
```

FILE. /rex/act/vexActions.c

PvexPreloadStim, PvexSwapBuffers

load a set of objects into the drawing page but don't display them yet

SYNOPSIS. PvexPreloadStim(int *nObjects, int *objList, int *swtchList)

nObjects: number of objects to load

objList: array of object numbers

switchList: array of switch values, can be OBJ_OFF or OBJ_ON

PvexSwapBuffers(void)

DESCRIPTION. Normally, GLvex switches objects on or off by placing them in its draw buffer, then doing a buffer swap to display the objects. If you have a lot of objects or large objects, it may take GLvex several video frames to get the draw buffer set up. These two actions allow you to have GLvex place the objects into its draw buffer when time is not critical, then to swap the buffers when a short latency is needed.

RETURN VALUE. Glvex will return the signal LIST_ON (249) if the first object in the list is to be switched on or LIST_OFF (248) if the first object in the list is to be switch off after completing the PvexPreloadStim action. If the digital sync is enabled, GLvex will return the signal BUFFER_SWAP (232) at the beginning of the first video field after the buffer swap. If the video sync is enabled, the sync object will flash white in the first video field after the buffer swap.

EXAMPLE.

```
int num, objArray[15], swtchArray[15];
```

```
int setup()
```

```
{
    int i;
    num = 15;
    for(i = 0; i < num; i++) {
        objArray[i] = i + 1;
        swtchArray[i] = OBJ_ON;
    }
    return(0);
}
```

```
%%
```

```
prev:
```

```
do setup()
to state
```

```
state:
```

```
do PvexPreloadStim(&num, objArray, swtchArray)
to nextstate on 0 % tst_rx_new
```

```
.
.
.
```

```
onState:
```

```
do PvexSwapBuffers()
to newstate on 0 % tst_rx_new/* if digital sync */
to nextstate on +PHOTO_CELL & drinput/* if video sync*/
```

FILE. /rex/act/vexActions.c

PvexSwitchStim

switches a number of objects on or off

SYNOPSIS. `PvexSwitchStim(int *nObjects, int *objList, int *swtchList)`

`nObjects`: number of objects to switch

`objList`: array of object numbers

`swtchList`: array of switch values, can be `OBJ_OFF` or `OBJ_ON`

DESCRIPTION. This action allows you to switch a number of objects on or off. You can switch some of the objects on and some off simultaneously

RETURN VALUE. If the digital sync is enabled, `GLvex` will return the signal `LIST_ON` (249) if the first object's switch is on or `LIST_OFF` (248) if the first object's switch is off in the first video field in which the switch is executed. If the video sync is enabled, the sync object will flash white in the first video field in which the switch is executed.

EXAMPLE.

```
int num;
int objArray[16];
int swtchArray[16];

int setup()
{
    int i;
    num = 16;
    for(i = 0; i < num; i++) {
        objArray[i] = i + 1;
        if(i % 2) swtchArray[i] = OBJ_ON;
        else swtchArray[i] = OBJ_OFF;
    }
    return(0);
}

%%
prev:
    do setup()
    to state

state:
    do PvexSwitchStim(&num, objArray, swtchArray)
    to nextstate on 0 % tst_rx_new/* if digital sync */
    to nextstate on +PHOTO_CELL & drinput/* if video sync */
```

FILE. `/rex/act/vexActions.c`

PvexSetStimSwitch

sets the switches a number of objects to on or off

SYNOPSIS. PvexSwitchStim(int *nObjects, int *objList, int *swtchList)

nObjects: number of objects to switch

objList: array of object numbers

swtchList: array of switch values, can be OBJ_OFF or OBJ_ON

DESCRIPTION. This action allows you to set the switches of a number of objects to on or off. You can set some of the switches on and some off simultaneously. This action does not actually switch the objects. The objects will be switched by the next action that changes the display. The purpose of this action is to switch objects on or off while a ramp, flow field, or movie is running. For example, you would use this command if you wanted to blink a pursuit target off and on while it is moving.

RETURN VALUE. If the digital sync is enabled, GLvex will return the signal FLOW_RAMP_CHANGE (234) if you call this action while a ramp is running in the first video field in which the switch is executed. If the video sync is enabled, the sync object will flash white in the first video field in which the switch is executed. If you call this action when no ramp, flow field or movie is running, GLvex will return the signal BATCH_DONE (241) after completing the action.

EXAMPLE.

```
int num;
int objArray[16];
int swtchArray[16];

int setup()
{
    int i;
    num = 16;
    for(i = 0; i < num; i++) {
        objArray[i] = i + 1;
        if(i % 2) swtchArray[i] = OBJ_ON;
        else swtchArray[i] = OBJ_OFF;
    }
    return(0);
}

%%
prev:
    do setup()
    to state

state:
    do PvexSwitchStim(&num, objArray, swtchArray)
    to nextstate on 0 % tst_rx_new/* if digital sync */
    to nextstate on +PHOTO_CELL & drinput/* if video sync */
```

FILE. /rex/act/vexActions.c

PvexTimeStim

presents a number of objects for a fixed interval

SYNOPSIS. `PvexTimeStim(int *nObjects, int *objList, int *nFields)`

`nObjects`: number of objects to time

`objList`: array of object numbers

`nFields`: number of video fields to display objects, can be 1 to 255

DESCRIPTION. This action allows you to present a number of objects for a precise interval. The interval will be more precise than that you can achieve if you use Rex's clock.

RETURN VALUE. If the digital sync is enabled, GLvex will return the signal `TIME_ON` (248) at the beginning of the first video field in which the objects are on, and the signal `TIME_OFF` (247) at the beginning of the first video field in which the objects are off. If the video sync is enabled, the video sync object will flash white in the first video field in which the objects are on and again in the first video field in which the objects are off.

EXAMPLE.

```
int num
int objects[4];
int fields;

int setup()
{
    int i
    num = 4;
    fields = 8;
    for(i = 0; i < num; i++) objects[i] = i + 10;
    return(0);
}

%%
prev:
    do setup()
    to state

state:
    do PvexTimeStim(&num, objects, &fields)
    to nextstate on 0 % tst_rx_new/* if the digital sync is enabled */
    to nextstate on +PHOTO_CELL & drinput/* if the video sync is enabled */
```

FILE. /rex/act/vexActions.c

PvexSequenceStim

presents a group of objects for a fixed interval, waits, presents a second group of objects for a fixed interval.

SYNOPSIS. PvexSequenceStim(int *nFrstObj, int *firstList, int *firstFields, int *gapFields,
int *nScndObj, int *secondList, int *secondFields)

nFrstObj: number of objects in the first group. firstList: array of object numbers in the first group. firstFields: number of video fields to present first group of objects. gapFields: number of video fields to wait before presenting second group of objects (may be 0). nScndObj: number of objects in the second group. secondList: array of object numbers in the second group. secondFields: number of video fields to present second group of objects

DESCRIPTION. This action allows you to present one group of objects for a specified number of video fields, followed by a second group of objects for another specified number of video fields. The maximum number of fields is 255.

RETURN VALUE. If the digital sync is enabled, GLvex will return three or four signals from this command, depending on whether there is a gap between presentations of the two lists of objects. FIRST_ON (245) is sent when the first list of objects is turned on, FIRST_OFF (244) is sent at the beginning of the gap, if any. SECOND_ON (243) is sent when the second list of objects is turned on. SECOND_OFF (242) is sent when the second list of objects is turned off. If the video sync is enabled, the rex video sync square will flash white when the first list of objects is turned on, at the beginning of the gap, if any, when the second list of objects is turned on, and when the second list of objects is off.

EXAMPLE.

```
int i, n1, frst[5], frstFlds, gap, n2, scnd[5], scndFlds;
int setup()
{
    n1 = n2 = 5;
    frstFlds = 2; scndFlds = 30; gap = 0;
    for(i = 0; i < 5; i++) {
        frst[i] = i + 1;
        scnd[i] = i + 10;
    }
    return(0);
}

%%
prev:
    do setup()
    to state

state:
    do PvexSequenceStim(&n1, frst, &frstFlds, &gap, &n2, scnd, &scndFlds)
    to first on 0 % tst_rx_new/* if digital sync is enabled */
    to first on +PHOTO_CELL & drinput/* if video sync is enabled */

first:
    to second on 0 % tst_rx_new/* if digital sync is enabled */
    to second on +PHOTO_CELL & drinput /* if video sync is enabled */

second:
    to nextstate
```

FILE. /rex/act/vexActions.c

Actions That Position Stimuli

PvexSetFixLocation

sets the location of the fixation point object

SYNOPSIS. PvexSetFixLocation(float *x, float *y)

x: the x coordinate of the fixation point in 10ths of a degree

y: the y coordinate of the fixation point in 10ths of a degree

DESCRIPTION. This action sets the location of the fixation point object

RETURN VALUE. Glvex will return the signal BATCH_DONE (241) after completing this action

EXAMPLE.

```
float fpx = 0.0;  
float fpy = 0.0;
```

```
%%
```

```
state:
```

```
do PvexSetFixLocation(&fpx, &fpy)  
to nextstate on 0 % tst_rx_new
```

FILE. /rex/act/vexActions.c

PvexStimLocation, PvexStimFromFixPoint

set the locations of a number of objects

SYNOPSIS. PvexStimLocation(int *nObjects, int *objList, float *xList, float *yList)

PvexStimFromFixPoint(int *nObjects, int *objList, float *xList, float *yList)

nObjects: number of objects to position

objList: array of object numbers

xList: array of the x coordinates of the objects in 10ths of a degree

yList: array of the y coordinates of the objects in 10ths of a degree

DESCRIPTION. These actions set the locations of a number of objects. PvexStimLocation sets the locations in absolute screen coordinates. PvexStimFromFixPoint sets the locations relative to the location of the fixation point

RETURN VALUE. Glvex will return the signal BATCH_DONE (241) after completing this action

EXAMPLE.

```
int num;
int objectArray[4];
float xArray[] = { 100.00, 100.00, -100.00, -100.00 };
float yArray[] = { 100.00, -100.00, -100.00, 100.00 };

int setup()
{
    int i;
    num = 4;
    for(i = 0; i < num; i++) {
        objectArray[i] = i + 1;
    }
    return(0);
}

%%
prev:
    do setup()
    to state

state:
    do PvexStimLocation(&num, objectArray, xArray, yArray);
    to nextstate on 0 % tst_rx_new
```

FILE. /rex/act/vexActions.c

PvexShiftLocation

sets the location of a number of objects and signals when the shift is complete

SYNOPSIS. `PvexShiftLocation(int *nObjects, int *objList, float *xList, float *yList)`

`nObjects`: number of objects to position

`objList`: array of object numbers

`xList`: array of the x coordinates of the objects in 10ths of a degree

`yList`: array of the y coordinates of the objects in 10ths of a degree

DESCRIPTION. This action sets the locations of a number of objects and signals the beginning of the first video field in which the object positions have changed. This action is useful if you want to move a GLvex object with a Rex ramp, or if you want to move objects with a joystick connected to one of Rex's A/D ports.

RETURN VALUE. If the digital sync is enabled, GLvex will return the signal SHIFTED (240) at the beginning of the first video field in which the objects are shifted. The rex video sync square will not flash for this command.

EXAMPLE.

```
int num;
int objectArray[4];
float xArray[] = { 100.00, 100.00, -100.00, -100.00 };
float yArray[] = { 100.00, -100.00, -100.00, 100.00 };

int setup()
{
    int i;
    num = 4;
    for(i = 0; i < num; i++) {
        objectArray[i] = i + 1;
    }
    return(0);
}

%%
prev:
    do setup()
    to state

state:
    do PvexShiftLocation(&num, objectArray, xArray, yArray);
    to nextstate on 0 % tst_rx_new
```

FILE. /rex/act/vexActions.c

PvexReportLocation

asks GLvex to report the location of the indicated object

SYNOPSIS. PvexReportLocation(int *object)

object: number of the object whose location you want

DESCRIPTION. This action, together with PvexMessage described below, allow you to query GLvex as to the location of objects. The purpose of these two actions is to allow you to have Rex eye windows follow objects that are moving on GLvex ramps. It is particularly important that the only escape you should use in a state that calls this action is when the function *tst_rx_new* returns 0.

RETURN VALUE. GLvex will return the signal OBJECT_LOCATION (233) plus the X and Y coordinates of the selected object. Use the action PvexMessage to get the X and Y coordinates

EXAMPLE.

```
int vexMessage;
int vexX, vexY;
int trgsiz;
int obj = 1;

int targ_wnd(void)
{
    wd_pos(WIND1, vexX, vexY);
    wd_siz(WIND1, trgsiz, trgsiz);
    wd_cntrl(WIND1, WD_ON);
    return(0);
}

%%
state:
    do PvexReportLocation(&obj);
    to tstmsg on 0 % tst_rx_new/* no other escapes */

tstmsg:
    do PvexMessage(&vexMessage, &vexX, &vexY)
    to tarwnd on OBJECT_LOCATION = vexMessage
    to otherstate /* do something else if the signal returned is not OBJECT_LOCATION */

tarwnd:
    do targ_wnd
    to nextstate
```

FILE. /rex/act/vexActions.c

PvexMessage

returns the signal number and possibly the location of an object

SYNOPSIS. `PvexMessage(int *code, int *x, int *y)`

code: the signal returned by GLvex

x: the x coordinate of the object specified in a call to PvexReportLocation in 10ths of a degree

y: the y coordinate of the object specified in a call to PvexReportLocation in 10ths of a degree

DESCRIPTION. This action retrieves any of the signals returned by GLvex and places them in the variable *code*. If the signal was OBJECT_LOCATION (233), then this action places the X coordinate of the object in the variable *x* and the Y coordinate of the object in the variable *y*. NOTE: This action should only be called from a state which is entered because GLvex returned a signal

RETURN VALUE. returns 0

EXAMPLE.

```
int code;
```

```
int x, y;
```

```
%%
```

```
laststate:
```

```
/* do some action that sends commands to GLvex */
```

```
to state on 0 % tst_rx_new
```

```
state:
```

```
do PvexMessage(&code, &x, &y)
```

```
to codestate on FLOW_RAMP_CHANGE = code
```

```
to endstate on FLOW_RAMP_STOP = code
```

```
to tarwnd on OBJECT_LOCATION = code
```

```
codestate:
```

```
endstate:
```

```
tarwnd:
```

FILE. /rex/act/vexActions.c

PvexSetActiveObject

sets GLvex's active object

SYNOPSIS. PvexSetActiveObject(int *object)

object: number of the object to make active

DESCRIPTION. This action has the same effect as the *s* keyboard command.

RETURN VALUE. Glvex will return the signal BATCH_DONE (241) after completing this action

EXAMPLE.

```
int active = 2;
```

```
%%
```

```
state:
```

```
    PvexSetActiveObject(&active)  
    to nextstate on 0 % tst_rx_new
```

FILE. /rex/act/vexActions.c

Actions That Draw Stimuli

PvexClipRectSet, PvexClipRectFromFixPoint

sets a clipping rectangle to limit the extent that an object is visible

SYNOPSIS. PvexClipRectSet(int *nObjs, int *oList, int *wList, int *hList, int *xList, int *yList)

PvexClipRectFromFixPoint(int *nObs, int *oList, int *wList, int *hList, int *xList, int *yList)

nObjs: number of objects for which clipping rectangles are needed

oList: array of object numbers

wList: array of clipping rectangle widths in 10ths of a degree

hList: array of clipping rectangle heights in 10ths of a degree

xList: array of the X coordinates of the clipping rectangles in 10ths of a degree

yList: array of the Y coordinates of the clipping rectangles in 10ths of a degree

DESCRIPTION. These actions set clipping rectangles for a number of objects. The clipping rectangle of each object is independent of the clipping rectangles of other objects. You can use clipping rectangles to achieve optic flow by moving a large object behind a smaller clipping rectangle. Another use is to display small parts of a complex image. PvexClipRectSet sets the location of the clipping rectangles in absolute screen coordinates. PvexClipRectFromFixPoint sets the location of the clipping rectangles relative to the fixation point

RETURN VALUE. Glvex will return the signal BATCH_DONE (241) after completing this action

EXAMPLE.

```
int num, objArray[4], widthArray[4], heightArray[4], xArray[4], yArray[4];
```

```
int setup()
```

```
{
```

```
    int i;
```

```
    num = 4;
```

```
    for(i = 0; i < num; i++) {
```

```
        objArray[i] = i + 1;
```

```
        widthArray[i] = 50;
```

```
        heightArray[i] = 50;
```

```
        if(i < 2) xArray[i] = 50;
```

```
        else xArray[i] = -50;
```

```
        if(i % 3) yArray[i] = -50;
```

```
        else yArray[i] = 50;
```

```
    }
```

```
    return(0);
```

```
}
```

```
%%
```

```
state:
```

```
do PvexClipRectSet(&num, objArray, widthArray, heightArray, xArray, yArray)
```

```
to nextstate on 0 % tst_rx_new
```

FILE. /rex/act/vexActions.c

PvexClearClipRect

remove the clipping rectangles from a number of objects

SYNOPSIS. `PvexClearClipRect(int *nObjects, int *objList)`

`nObjects`: number of objects to clear

`objList`: array of object numbers

DESCRIPTION. This action clears the clipping rectangles that were set by the previous actions.

RETURN VALUE. GLvex will return the signal BATCH_DONE (241) when it completes this action

EXAMPLE.

```
int num
int objArray[4];

int setup()
{
    int i
    num = 4;
    for(i = 0; i < num; i++) objArray[i] = i + 1;
    return(0);
}

%%
prev:
    do setup()
    to state

state:
    do PvexClearClipRect(&num, objArray);
    to nextstate on 0 % tst_rx_new
```

FILE. /rex/act/vexActions.c

PvexDrawWalsh

draws patterns based on Walsh functions in a number of objects

SYNOPSIS. PvexDrawWalsh(int *nObjects, int *objList, int *patList, int *sizList, int *cntrstList)

nObjects: number of objects to draw in

objList: array of object numbers

patList: array of Walsh function numbers on which to base patterns; can be 0 to 255

sizList: array of sizes of the pattern checks in screen pixels; can be 1 to 255

cntrstList: array of the contrasts of the patterns in each object; can be 1 or -1.

DESCRIPTION. This action draws patterns based on Walsh functions in objects. Walsh patterns are 16 rows by 16 columns. The individual checks in the patterns can be either "white" or "black", depending on the Walsh function number. White checks are drawn in the object's foreground color, black checks are drawn in the object's background color. The size parameter sets the sizes of the individual checks. That means that the smallest Walsh pattern can be 16 pixels high and 16 pixel wide. Specifying a contrast of -1 yields a contrast reversed version of a pattern specified with a contrast of 1.

RETURN VALUE. GLvex will return the signal BATCH_DONE (241) when it completes this action

EXAMPLE.

```
int num
int objects[16];
int walsh[16] = { 0, 17, 34, 51, 68, 85, 102, 119, 136, 153, 170, 187, 204, 221, 238, 255 };
int size[16];
int contrast[16];
```

```
int setup()
{
    int i;
    num = 16;
    for(i = 0; i < num; i++) {
        object[i] = 1 + 1;
        size[i] = 4;
        contrast[i] = 1;
    }
    return(0);
}

%%
prev:
    do setup
    to state

state:
    do PvexDrawWalsh(&num, objects, walsh, size, contrast)
    to nextstate on 0 % tst_rx_new
```

FILE. /rex/act/vexActions.c

PvexDrawHaar

draws patterns based on Haar functions in a number of objects

SYNOPSIS. `PvexDrawHaar(int *nObjects, int *objList, int *patList, int *sizList, int *cntrstList)`

`nObjects`: number of objects to draw in

`objList`: array of object numbers

`patList`: array of Haar function numbers on which to base patterns; can be 0 to 255

`sizList`: array of sizes of the pattern checks in screen pixels; can be 1 to 255

`cntrstList`: array of the contrasts of the patterns in each object; can be 1 or -1.

DESCRIPTION. This action draws patterns based on Haar functions in objects. Haar patterns are 16 rows by 16 columns. The individual checks in the patterns can be either "white", "black", or "transparent", depending on the Haar function number. White checks are drawn in the object's foreground color, black checks are drawn in the object's background color, transparent checks are drawn in the screen's background color. The size parameter sets the sizes of the individual checks. That means that the smallest Haar pattern can be 16 pixels high and 16 pixel wide. Specifying a contrast of -1 yields a contrast reversed version of a pattern specified with a contrast of 1.

RETURN VALUE. `GLvex` will return the signal `BATCH_DONE` (241) when it completes this action

EXAMPLE.

```
int num
int objects[16];
int haar[16] = { 0, 17, 34, 51, 68, 85, 102, 119, 136, 153, 170, 187, 204, 221, 238, 255 };
int size[16];
int contrast[16];

int setup()
{
    int i;
    num = 16;
    for(i = 0; i < num; i++) {
        object[i] = 1 + 1;
        size[i] = 4;
        contrast[i] = 1;
    }
    return(0);
}

%%
prev:
    do setup()
    to state

state:
    do PvexDrawHaar(&num, objects, walsh, size, contrast)
    to nextstate on 0 % tst_rx_new
```

FILE. `/rex/act/vexActions.c`

PvexDrawRandom

draws patterns of random checks in a number of objects

SYNOPSIS. PvexDrawRandom(int *nObj, int *oList, int *cList, int *rList, int *sList, int *pList)

nObj: number of objects to draw in

oList: array of object numbers

cList: array of the numbers of columns in the random patterns: can be 1 to 255

rList: array of the numbers of rows in the random patterns; can be 1 to 255

sList: array of the sizes of the individual checks in the patterns in screen pixels; can be 1 to 255

pList: array of the percentage of white checks in the pattern; can be 1 to 99

DESCRIPTION. This action draws random check patterns in objects. The checks are either "white" or "black". White checks are drawn in the object's foreground color, black checks are drawn in the object's background color. The patterns may be square or rectangular. To have equal numbers of white and black checks, the pList parameter should be 50. If the pList parameter is less than 50, there will be fewer white than black checks. If the pList parameter is more than 50, there will be more white than black checks

RETURN VALUE. GLvex will return the signal BATCH_DONE (241) when it completes this action

EXAMPLE.

```
int num;  
int objects[4];  
int rows[4];  
int cols[4];  
int size[4];  
int pwhite[4];
```

```
int setup()  
{  
    int i;  
    num = 4;  
    for(i = 0; i < num; i++) {  
        objects[i] = i + 1;  
        rows[i] = 50;  
        cols[i] = 75;  
        size[i] = 4;  
        pwhite[i] = 50;  
    }  
    return(0);  
}  
  
%%  
prev:  
    do setup()  
    to state  
  
state:  
    do PvexDrawRandom(&num, objects, cols, rows, size, pwhite)  
    to nexstate on 0 % tst_rx_new
```

FILE. /rex/act/vexActions.c

PvexDrawAnnulus

draws circular stimuli in objects

SYNOPSIS. PvexDrawAnnulus(int *nObjects, int *objList, int *outerList, int *innerList, int *cntrstList)

nObjects: number of objects to draw in

objList: array of object numbers

outerList: array of the outer radii of the annuli in 10ths of a degree; may be 2 to 255

innlerList: array of the inner radii of the annuli in 10ths of a degree; may be 0 to 255

cntrstList: array of the contrasts of the annuli; may be 1 or -1

DESCRIPTION. This action draws circular and annular stimuli in objects. The inner an outer radii are in 10ths of a degree of visual angle. If the inner radius is 0, GLvex will draw a filled circle. If the contrast is 1, the annulus will be drawn in the object's foreground color. If the contrast is -1, the annulus will be drawn in the object's background color. The center of the annulus is transparent. To get a center-surround annulus requires two objects.

RETURN VALUE. GLvex will return the signal BATCH_DONE (241) when it completes this action

EXAMPLE.

```
/*
 * use two objects to create an annulus with a black center and a white surround
 * the two objects must be given the same location coordinates
 */
int num = 2;
int objects[2] = { 1, 2 }
int outer[2] = { 10, 5 };
int inner[2] = { 5, 0 };
int contrast[2] = { 1, -1 };

%%
state:
    doPvexDrawAnnulus(&num, objects, outer, inner, contrast)
    to nextstate on 0 % tst_rx_new
```

FILE. /rex/act/vexActions.c

PvexDrawBar

draws rectangular stimuli in objects

SYNOPSIS. PvexDrawBar(int *nObjs, int *oList, int *anglList, int *widList, int *lenList, int *cntrList)

nObjs: number of objects to draw in

oList: array of object numbers;

anglList: array of the orientations of the bars in degrees; can be 0 to 180

widList: array of the widths of the bars in 10ths of a degree; can be 1 to 255

lenList: array of the lengths of the bars in 10ths of a degree; can be 1 to 255

cntrList: array of the contrasts of the bars in 10ths of a degree; can be 1 or -1

DESCRIPTION. This action draws rectangular stimuli in objects. The width and length parameters are in 10ths of a degree of visual angle. If the contrast is 1, the bar will be drawn in the object's foreground color. If the contrast is -1, the bar will be drawn in the object's background color.

RETURN VALUE. GLvex will return the signal BATCH_DONE (241) when it completes this action

EXAMPLE.

```
int num;
int objects[8];
int angles[8];
int widths[8];
int lengths[8];
int contrasts[8];
```

```
int setup()
{
```

```
    int i;
    num = 8;
    for(i = 0; i < num; i++) {
        objects[i] = i + 1;
        angles[i] = i * 22;
        widths[i] = 2;
        lengths[i] = 10;
        contrasts[i] = 1;
    }
```

```
    return(0);
```

```
}
```

```
%%
```

```
prev:
```

```
    do setup()
    to state
```

```
state:
```

```
    do PvexDrawBar(&num, objects, angles, widths, lengths, contrasts)
    to nextstate on 0 % tst_rx_new
```

FILE. /rex/act/vexActions.c

PvexDrawFlowField

sets initial check locations in flow field patterns with rectangular boundaries

SYNOPSIS. PvexDrawFlowField(int *nObjects, int *objList, int *widthList, int *heightList,
int *nearList, int *farList, int *covList, int *sizList)

nObjects: number of objects in which to draw flow fields

objList: array of object numbers

widthList: array of flow field widths in 10ths of a degree

heightList: array of flow field heights in 10ths of a degree

nearList: array of near clipping planes in 10ths of a degree

farList: array of far clipping planes in 10ths of a degree

covList: array of 10ths of a percent of field covered by checks; can be 1 to 255

sizList: array of check sizes

DESCRIPTION. This action specifies the initial positions of the checks in flow field stimuli in a number of objects. The near and far parameters are the distances to the near and far clipping planes of the flow field. If the near and far parameters are the same, you will get a two dimensional flow field. If the near parameter is smaller than the far parameter, you will get a three dimensional flow field. Three dimensional flow fields are required for yaw, pitch, and zoom movements (see PvexNewFlow).

RETURN VALUE. GLvex will return the signal BATCH_DONE (241) when it completes this action

EXAMPLE.

```
int num = 1;
```

```
int object = 2;
```

```
int width = 100;
```

```
int height = 100;
```

```
int near = 500;
```

```
int far = 1500;
```

```
int coverage = 25;
```

```
int size = 4;
```

```
%%
```

```
state:
```

```
do PvexDrawFlowField(&num, &object, &width, &height, &near, &far, &coverage, &size)  
to nextstate on 0 % tst_rx_new
```

FILE. /rex/act/vexActions.c

PvexDrawEllipticalFlowField

sets initial check locations in flow field patterns with elliptical boundaries

SYNOPSIS. PvexDrawElliptical FlowField(int *nObjects, int *objList, int *radList, int *widthList, int *heightList, int *nearList, int *farList, int *covList, int *sizList)

nObjects: number of objects in which to draw flow fields

objList: array of object numbers

radList: array of flow field radii in 10ths of a degree

widthList: array of flow field widths in percentages of the radius

heightList: array of flow field heights in percentages of the radius

nearList: array of near clipping planes in 10ths of a degree

farList: array of far clipping planes in 10ths of a degree

covList: array of 10ths of a percent of field covered by checks; can be 1 to 255

sizList: array of check sizes

DESCRIPTION. This action specifies the initial positions of the checks in flow field stimuli in a number of objects. The flow field drawn by this action will have a circular or elliptical boundary. If the width and height values are 100, the flow field will have a circular boundary with a radius equal to the radius value. If either the width or the height value is not 100, the boundary will be stretched or shrunk in that dimension, producing an elliptical boundary. The near and far parameters are the distances to the near and far clipping planes of the flow field. If the near and far parameters are the same, you will get a two dimensional flow field. If the near parameter is smaller than the far parameter, you will get a three dimensional flow field. Three dimensional flow fields are required for yaw, pitch, and zoom movements (see PvexNewFlow).

RETURN VALUE. GLvex will return the signal BATCH_DONE (241) when it completes this action

EXAMPLE.

```
int num = 1;  
int object = 2;  
int radius = 150;  
int width = 100;  
int height = 100;  
int near = 500;  
int far = 1500;  
int coverage = 25;  
int size = 4;
```

```
%%
```

```
state:
```

```
do PvexDrawEllipticalFlowField(&num, &object, &radius, &width, &height,  
                                &near, &far, &coverage, &size)
```

```
to nextstate on 0 % tst_rx_new
```

FILE. /rex/act/vexActions.c

PvexMaskFlowField

masks part of a flow field

SYNOPSIS. PvexMaskFlowField(int *nObjects, int *oList, int *wList, int *hList, int *xList, int *yList)

nObjects: number of objects to mask

oList: array of object numbers

wList: array of mask widths in 10ths of a degree

hList: array of mask heights in 10ths of a degree

xList: array of x coordinates of mask centers in 10ths of a degree

yList: array of y coordinates of mask centers in 10ths of a degree

DESCRIPTION. This action allows you mask part of a flow field stimulus. The x and y parameters are position relative to the center of the flow field object. *Note: you must first draw a flow field in an object before setting the flow field mask for that object.*

RETURN VALUE. GLvex will return the signal BATCH_DONE (241) when it completes this action

EXAMPLE.

```
int num = 1;
```

```
int object = 2;
```

```
int width = 10;
```

```
int height = 10;
```

```
int x = 0;
```

```
int y = 0;
```

```
%%
```

```
state:
```

```
do PvexMaskFlowField(&num, &object, &width, &height, &x, &y)
```

```
to nextstate on 0 % tst_rx_new
```

FILE. /rex/act/vexActions.c

PvexDrawUserPattern

draws a pattern defined in user's template file

SYNOPSIS. PvexDrawUserPattern(int *nObjects, int *objList, int *pList, int *sList, int *cList)

nObjects: number of objects in which to draw

objList: array of object numbers

pList: array of pattern numbers

sList: array of pattern check sizes in screen pixels

cList: array of pattern contrasts, can be 1, 0, -1, or between 2 and 255

DESCRIPTION. This action allows you to define a pattern in a template file. The name of the template file must be "Pnumber" where number is the number of the pattern. For example the file P10 holds the template for pattern number 10. The format of the template file is:

```
r c
n n n ... n n n
n n n ... n n n
n n n ... n n n
...
...
...
n n n ... n n n
n n n ... n n n
n n n ... n n n
```

The letters *r* and *c* indicate the number of rows and columns in the pattern. The maximum number of rows or columns is 255. The pattern may be rectangular, i.e., you do not need to have the same number of rows and columns. The letter *n* indicate the values for the individual checks in the pattern. If *n* equals 1, the object's foreground color will be used in that check. If *n* equals -1, the object's background color will be used in that check. If *n* equals 0, the screen's background color will be used in that check. If *n* equals 2 - 255, lookup table entries will be use in that check.

Example of a file for a user defined pattern with 8 rows and 8 cols. This file defines a "white" and a "black" bar centered in a gray region. The name of the file might be "P1".

```
8 8
0 0 0 1 -1 0 0 0
0 0 0 1 -1 0 0 0
0 0 0 1 -1 0 0 0
0 0 0 1 -1 0 0 0
0 0 0 1 -1 0 0 0
0 0 0 1 -1 0 0 0
0 0 0 1 -1 0 0 0
0 0 0 1 -1 0 0 0
```

Example of a file for a user defined pattern with 8 rows and 2 cols. This file also defines a "white" and a "black" bar, but does not have the gray region. The name of the file might be "P2".

```
8 2
1 -1
1 -1
1 -1
1 -1
1 -1
1 -1
1 -1
1 -1
```

RETURN VALUE. GLvex will return the signal BATCH_DONE (241) when it completes this action

EXAMPLE.

```
int num;
int objects[5];
int patterns[5];
int sizes[5];
int contrasts[5];

int setup()
{
    int i;
    num = 5;
    for(i = 0; i < num; i++) {
        objects[i] = i + 1;
        patterns[i] = i + 10;
        sizes[i] = 4;
        contrasts[i] = 1;
    }
    return(0);
}

%%
prev:
    do setup()
    to state:

state:
    do PvexDrawUserPattern(&num, objects, patterns, sizes, contrasts)
    to nextstate on 0 % tst_rx_new
```

FILE. /rex/act/vexActions.c

PvexDrawRgbUserPattern

draws an rgb pattern defined in user's template file

SYNOPSIS. PvexDrawRgbUserPattern(int *nObjects, int *objList, int *pList, int *sList, int *cList)

nObjects: number of objects in which to draw

objList: array of object numbers

pList: array of pattern numbers

sList: array of pattern check sizes in screen pixels

cList: array of contrasts for the patterns, can be 1 or -1

DESCRIPTION. This action allows you to define an RGB pattern in a template file. The name of the template file must be "Pnumber" where number is the number of the pattern. For example the file P10 holds the template for pattern number 10. The format of the template file is:

```
r c 3
r g b r g b r g b ... r g b r g b r g b
r g b r g b r g b ... r g b r g b r g b
r g b r g b r g b ... r g b r g b r g b
...
...
...
r g b r g b r g b ... r g b r g b r g b
r g b r g b r g b ... r g b r g b r g b
r g b r g b r g b ... r g b r g b r g b
```

The letters *r* and *c* indicate the number of rows and columns in the pattern. The number 3 indicates that each pixel is defined by 3 values, *r g* and *b*. This number can only be 3. The maximum number of rows or columns is 255. The pattern may be rectangular, i.e., you do not need to have the same number of rows and columns. The letters *r g b* indicate the values for red, green, and blue for the individual checks in the pattern.

Example of a file for a user defined pattern with 8 rows and 8 cols. This file defines a "red" and a "green" bar centered in a blue region. The name of the file might be "P1000".

```
8 8 3
0 0 255 0 0 255 0 0 255 255 0 0 0 255 0 0 0 255 0 0 0 255 0 0 255 0 0 255
0 0 255 0 0 255 0 0 255 255 0 0 0 255 0 0 0 255 0 0 0 255 0 0 255 0 0 255
0 0 255 0 0 255 0 0 255 255 0 0 0 255 0 0 0 255 0 0 0 255 0 0 255 0 0 255
0 0 255 0 0 255 0 0 255 255 0 0 0 255 0 0 0 255 0 0 0 255 0 0 255 0 0 255
0 0 255 0 0 255 0 0 255 255 0 0 0 255 0 0 0 255 0 0 0 255 0 0 255 0 0 255
0 0 255 0 0 255 0 0 255 255 0 0 0 255 0 0 0 255 0 0 0 255 0 0 255 0 0 255
0 0 255 0 0 255 0 0 255 255 0 0 0 255 0 0 0 255 0 0 0 255 0 0 255 0 0 255
0 0 255 0 0 255 0 0 255 255 0 0 0 255 0 0 0 255 0 0 0 255 0 0 255 0 0 255
```

Example of a file for a user defined pattern with 8 rows and 2 cols. This file also defines a "red" and a "green" bar, but does not have the blue region. The name of the file might be "P2000".

```
8 2 3
255 0 0 0 255 0
255 0 0 0 255 0
255 0 0 0 255 0
255 0 0 0 255 0
255 0 0 0 255 0
255 0 0 0 255 0
255 0 0 0 255 0
255 0 0 0 255 0
```

RETURN VALUE. GLvex will return the signal BATCH_DONE (241) when it completes this action

EXAMPLE.

```
int num;
int objects[5];
int patterns[5];
int sizes[5];
int contrasts[5];

int setup()
{
    int i;
    num = 5;
    for(i = 0; i < num; i++) {
        objects[i] = i + 1;
        patterns[i] = i + 10;
        sizes[i] = 4;
        contrasts[i] = 1;
    }
    return(0);
}

%%
prev:
    do setup()
    to state:

state:
    do PvexDrawRgbUserPattern(&num, objects, patterns, sizes, contrasts)
    to nextstate on 0 % tst_rx_new
```

FILE. /rex/act/vexActions.c

PvexDrawTiffImage

draws a tiff image in an object

SYNOPSIS. PvexDrawTiffImage(int *nObjects, int *objList, int *patList)

nObjects: number of objects in which to draw images

objList: array of object numbers

patList: array of pattern numbers

DESCRIPTION. This action allows you to draw a TIFF image in an object. The image is taken from a file named "Inumber.tif" where "number" is the image number you are going to use for that image. For example, I100.tif is a valid tiff image file name. I chose to have file names start with "I" because they contain images, not patterns. The reason for requiring the ".tif" extension is so that other windows programs can recognize the file as a TIFF file. Though TIFF image files may contain multiple images, currently GLvex will only draw the first image in the file. Further, GLvex does not support image compression. The images in the TIFF files should be in RGBA format.

RETURN VALUE. GLvex will return the signal BATCH_DONE (241) when it completes this action

EXAMPLE.

```
int num;
int objects[16];
int patterns[16];

int setup()
{
    int i;
    num = 16;
    for(i = 0; i < 16; i++) {
        objects[i] = i + 1;
        patterns[i] = i + 100;
    }
    return(0);
}

%%
prev:
    do setup()
    to state

state:
    do PvexDrawTiffImage(&num, objects, patterns)
    to nextstate on 0 % tst_rx_new
```

FILE. /rex/act/vexActions.c

PvexDrawOknGrating

draws an opto-kinetic stimulus grating in a number of objects

SYNOPSIS. `PvexDrawOknGrating(int *nObjects, int *objList, int *dirList, int *speedList, int *widList, int *heightList, int *barwidList)`

`nObjects`: number of objects in which to draw

`objList`: array of object numbers

`dirList`: array of grating drift directions, can be 0, 90, 180, or 270

`speedList`: array of drift rates in degrees / sec

`widList`: array of grating widths in 10ths of a degree

`heightList`: array of grating heights in 10ths of a degree

`barwidList`: array of grating bar widths in 10ths of a degree

DESCRIPTION. This action draws one dimensional square wave gratings in objects to be used as opto-kinetic stimuli. The gratings may be horizontal or vertical, the direction of drift may be left, right, up, or down.

RETURN VALUE. GLvex will return the signal BATCH_DONE (241) when it completes this action.

EXAMPLE.

```
int num;
int object, direction, speed, width, height, barwidth;

int setup()
{
    num = 1
    object = 1;
    direction = 180;
    speed = 10;
    width = 100;
    height = 100;
    barwidth = 10;

    return(0);
}

%%
prev:
    do setup()
    to state

state:
    do PvexDrawOknGrating(&num, &object, &direction, &speed, &width, &height,
                          &barwidth)
    to nextstat on 0 % tst_rx_new
```

FILE. /rex/act/vexActions.c

PvexLoadPatterns

loads patterns defined in Rex into GLvex

SYNOPSIS. PvexLoadPatterns(int *nObjects, int *objList, int *stimList, int *sizList, int *rowList, int *colList, int *checkList)

nObjects: number of objects in which to draw

objList: array of object numbers

stimList: array of stimulus numbers, dummy variable needed by GLvex

sizList: array of check sizes in screen pixels

rowList: array of numbers of rows of checks in pattern

colList: array of numbers of cols of checks in pattern

checkList: array of color lookup table indices for checks in pattern, can be 0 to 255

DESCRIPTION. This action is similar to PvexDrawUserPattern but you define the template in Rex rather than in a file. The purpose of this action is to allow you to change the check values randomly, enabling you to add visual noise that changes from trial to trial to a pattern. The color or luminance of each check is determined by the value of the color lookup table element referenced by that check's value. You will need to set up gray scales or color lookup tables for each object. The size of the checkList array must be at least as large as the sum of the products of the row values and the column values.

RETURN VALUE. GLvex will return the signal BATCH_DONE (241) when it completes this action.

EXAMPLE.

```
int num;
int objArray[50];
int stimArray[50];
int sizArray[50];
int rows[50];
int cols[50];
int checks[5000];

int setup()
{
    int i, j, k, l;
    int nRows, nCols;
    nRows = nCols = 10;
    num = 50;
    l = 0;
    for(i = 0; i < num; i++) {
        objArray[i] = i + 1;
        stimArray[i] = i + 1;
        sizArray[i] = 4;
        for(j = 0; j < nRows; j++) {
            for(k = 0; k < nCols; k++) {
                checks[l++] = getRand();
            }
        }
    }
    return(0);
}

%%
prev:
    do setup()
    to state:

state:
    do PvexLoadPatterns(&num, objArray, stimArray, sizArray, rows, cols, checks)
    to nextstate on 0 % tst_rx_new
```

FILE. /rex/act/vexActions.c

PvexCopyObject

copies the pattern in one object to another object

SYNOPSIS. PvexCopyObject(int *source, int *destination, int *xscale, int *yscale)

source: number of the source object

destination: number of the destination object

xscale: percentage to scale copy width, 100 means no scaling

yscale: percentage to scale copy height, 100 means no scaling

DESCRIPTION. This action allows you make duplicates of random check and flow field patterns. The copied patterns can be stretched or shrunk in either width or height. The scaling is not cumulative. That is, if you copy a pattern from object 1 to object 2 with 125% scaling, then copy object 2 to object 3, also with 125% scaling, object 3 will be 125% larger than object 1, not 125% larger than object 2.

RETURN VALUE. GLvex will return the signal BATCH_DONE (241) when it completes this action.

EXAMPLE.

```
int num = 1;
int source = 1;
int dest = 2;
int rows = 50;
int cols = 50;
int size = 4;
int pwhite = 50;
int xScale = 150;
int yScale = 100;
```

```
        return(0);
}

%%
state:
    do PvexDrawRandom(&num, &source, &cols, &rows, &size, &pwhite)
    to copystate on 0 % tst_rx_new
copystate:
    do PvexCopyObject(&source, &dest, &xScale, &yScale)
    to nextstate on 0 % tst_rx_new
```

FILE. /rex/act/vexActions.c

Actions That Control Ramps

PvexNewRamp, PvexNewRampFromFixPoint

computes parameters for a number of ramps

SYNOPSIS. PvexNewRamp(int *nRamps, int *rampList, int *lenList, int *dirList, int *velList,
int *xList, int *yList, int *typeList, int *actList)

nRamps: number of ramps to compute

rampList: array of ramp numbers, ramp numbers must be sequential

lenList: array of lengths in 10ths of a degree, length is half the length of the ramp

dirList: array of ramp directions in degrees

velList: array ramp velocities in degrees per second

xList: array of the X coordinates of ramp locations in 10ths of a degree

yList: array of the Y coordinates of ramp locations in 10ths of a degree

typeList: array of types of the ramps

actList: array of actions at ramp end, can be ON_AFTER_RAMP or OFF_AFTER_RAMP

DESCRIPTION. This action allows you specify the parameters of a number of ramps. The typeList parameters define the reference points of the ramps. RA_CENPT (02): reference point is the center of the ramp. RA_BEGINPT (04): reference point is beginning of the ramp. RA_ENDPT(08): reference point is end of the ramp. RA_CLKWISE(16) ramp is a clockwise circular ramp and the reference point is the center of the circle. RA_CCLKWISE(32): ramp is a counter clockwise circular ramp and the reference point is the center of the circle. The reference point for PvexNewRamp is relative to the center of the screen. The reference point for PvexNewRampFromFixPoint is relative to the fixation point. The actList parameter determines whether the object on the ramp will be left on or turned off when the ramp stops.

Once specified, GLvex can move objects according to the specifications. If you are defining new ramps, the ramp numbers must be sequential. If you are redefining old ramps, the ramp numbers need not be sequential. Once defined, a ramp remains defined until changed. That is, unlike the Rex action *ra_new*, you do not have to call this action on every trial. Call it once to define some ramps, then reuse them as often as you like.

RETURN VALUE. GLvex will return the signal BATCH_DONE (241) when it completes this action.

EXAMPLE:

```
int num = 1;
int ramp = 1;
int length = 200;           /* half the length of the ramp in Rex units */
int direction = 15;        /* direction of travel in degrees */
int speed = 20;           /* speed of 20 degrees / sec */
int rx = 100;             /* X coordinate of reference point */
int ry = -10;            /* Y coordinate of reference point */
int type = RA_CENPT;      /* rx and ry define middle of ramp */
int act = ON_AFTER_RAMP;  /* leave object on when ramp stops */

%%
state:
    do PvexNewRamp(&num, &ramp, &length, &direction, &speed, &rx, &ry, &type, &act)
    to nextstate on 0 % tst_rx_new
```

FILE. /rex/act/vexActions.c

PvexLoadRamp

defines ramps from coordinates passed from Rex

SYNOPSIS. PvexLoadRamp(int *nRmp, int *rmpList, int *actList, int *stpList, float *xLst, float *yLst)

nRmp: number of ramps

rmpList: array of ramp numbers

actList: array of actions at ramp end, can be ON_AFTER_RAMP or OFF_AFTER_RAMP

stpList: array of the number of steps of each ramp

xLst: array of the X coordinates of each step of each ramp

yLst: array of the Y coordinates of each step of each ramp

DESCRIPTION. This action allows you to specify arbitrary movements for objects.

RETURN VALUE. GLvex will return the signal BATCH_DONE (241) when it completes this action.

EXAMPLE:

```
float Xarray[1024], Yarray[1024];
int num = 2;
int ramps[2] = { 1, 2 };
int steps[2] = { 256, 768 };
int act[2] = { ON_AFTER_RAMP, ON_AFTER_RAMP};

int setup() /* define two horizontal ramps that increase speed */
{
    int i, j, k, end;
    float x, y;
    k = 0;
    for(i = 0; i < num; i++) {
        if(i == 0) end = 256;
        else end = 768;
        x = ((float)end / 2);
        y = 0.0;
        for(j = 0; j < end; j++) {
            Xarray[k] = x;
            Yarray[k] = y;
            if(j < (end / 2)) x += 1.0;
            else x += 2.0;
        }
    }
    return(0);
}

%%
prev:
    do setup
    to state

state:
    do PvexLoadRamp(&num, ramps, act, steps, Xarray, Yarray)
    to nextstate on 0 % tst_rx_new
```

FILE. /rex/act/vexActions.c

PvexToRampStart

places objects at the beginnings of their ramps

SYNOPSIS. `PvexToRampStart(int *nObjects, int *objList, int *rampList)`

`nObjects`: number of objects

`objList`: array of object numbers

`rampList`: array of ramp numbers

DESCRIPTION. This action positions a number of objects at the beginnings of the ramps that will govern their movement. The objects carried by the ramps can contain any kind of image or pattern. You must use the actions described above to define the ramps before calling this action.

RETURN VALUE. `GLvex` will return the signal `BATCH_DONE` (241) when it completes this action.

EXAMPLE. `int num;`

```
int objList[5];
```

```
int rampList[5];
```

```
int setup()
```

```
{
```

```
    int i;
```

```
    num = 5;
```

```
    for(i = 0; i < num; i++) {
```

```
        objList[i] = i + 1;
```

```
        rampList[i] = i + 1;
```

```
    }
```

```
    return(0);
```

```
}
```

```
%%
```

```
prev:
```

```
    do setup()
```

```
    to state
```

```
state:
```

```
    do PvexToRampStart(&num, objList, rampList)
```

```
    to nextstate on 0 % tst_rx_new
```

FILE. `/rex/act/vexActions.c`

PvexStartRamp

starts a number of ramps moving

SYNOPSIS. `PvexStartRamp(int *nRamps, int *rmpList, int *objList, int *cycleList)`

`nRamps`: number of ramps to start

`rmpList`: array of ramp numbers

`objList`: array of object numbers to place on ramps

`cycleList`: array of ramp cycle types

DESCRIPTION. This action starts ramps moving. You must use the actions described above to define the ramps before calling this action. The cycle types can be `RA_ONCE` (0) which causes the ramp to run once, `RA_OSCIL` (1) which causes the ramp to go back and forth, and `RA_LOOP` (2) which causes the ramp to run over and over.

RETURN VALUE. If the digital sync is enabled, `GLvex` will return the signal `FLOW_RAMP_START` (236) when the ramps start moving, the signal `FLOW_RAMP_STOP` (235) when the ramps stop moving, and the signal `FLOW_RAMP_CHANGE` (234) at each step specified by the *PvexSetTriggers* action (see below). If the video sync is enabled, the sync object will flash white when the ramps start, when the ramps stop, and at each step specified by the *PvexSetTriggers* action.

EXAMPLE.

```
int num = 5;
int ramps[5], objects[5], cycles[5];

int setup()
{
    int i;
    for(i = 0; i < num; i++) {
        ramps[i] = i + 1;
        objects[i] = i + 1;
        cycles[i] = RA_ONCE;
    }
    return(0);
}

%%
prev:
    do setup
    to state

state;
    do PvexStartRamp(&num, ramps, objects, cycles)
    to run on 0 % tst_rx_new

run:
    to stop on 0 % tst_rx_new

stop:
    to nextstate
```

FILE. `/rex/act/vexActions.c`

PvexResetRamps

resets RA_ONCE ramps to their starting positions

SYNOPSIS. PvexResetRamps(void)

DESCRIPTION. You may have experimental conditions in which you have some ramps running in one of the continuous modes (RA_OSCIL or RA_LOOP) and others running in RA_ONCE mode. You may also have experimental conditions in which you have a flow field stimulus running continuously in conjunction with a ramp running in RA_ONCE mode. In either of these cases, you can restart the RA_ONCE ramps without affecting the continuously running ramps or the flow field by calling this action.

RETURN VALUE. If the digital sync is enabled, GLvex will return the signal FLOW_RAMP_CHANGE (234) when the ramps restart. If the video sync is enabled, the sync object will flash white when the ramps restart.

EXAMPLE.

```
%%  
state:  
    do PvexResetRamps()  
    to nextstate on 0 % tst_rx_new
```

FILE. /rex/act/vexActions.c

Actions That Control OKN Stimuli

PvexStartOkn

starts a number OKN gratings drifting

SYNOPSIS. PvexStartOkn(int *nObjects, int *objList)

nObjects: number of objects to start

objList: array of object numbers

DESCRIPTION. This action starts OKN gratings drifting. You must have defined the OKN gratings prior to calling this action.

RETURN VALUE. If the digital sync is enabled, GLvex will return the signal FLOW_RAMP_START (236) when the gratings start. If the video sync is enabled, the sync object will flash white when the gratings start

EXAMPLE.

```
int num;
int object, direction, speed, width, height, barwidth;

int setup()
{
    num = 1
    object = 1;
    direction = 180;
    speed = 10;
    width = 100;
    height = 100;
    barwidth = 10;

    return(0);
}

%%
prev:
    do setup()
    to state

state:
    do PvexDrawOknGrating(&num, &object, &direction, &speed, &width, &height,
                          &barwidth)
    to nextstate on 0 % tst_rx_new

nextstate:
    do PvexStartOkn(&num, &object)
    to next on 0 % tst_rx_new
```

FILE. /rex/act/vexActions.c

PvexStopOkn

stops all OKN gratings

SYNOPSIS. PvexStopOkn(void)

DESCRIPTION. This action stops all OKN gratings that are drifting. You must have previously defined OKN stimuli and called PvexStartOkn before calling this action.

RETURN VALUE. If the digital sync is enabled, GLvex will return the signal FLOW_RAMP_STOP (235) when the gratings stop. If the video sync is enabled, the sync object will flash white when the gratings stop

EXAMPLE. **int num;**

int object, direction, speed, width, height, barwidth;

int setup()

```
{  
    num = 1  
    object = 1;  
    direction = 180;  
    speed = 10;  
    width = 100;  
    height = 100;  
    barwidth = 10;
```

```
    return(0);
```

```
}
```

%%

prev:

```
do setup()  
to state
```

state:

```
do PvexDrawOknGrating(&num, &object, &direction, &speed, &width, &height,  
                      &barwidth)  
to startstate on 0 % tst_rx_new
```

startstate:

```
do PvexStartOkn(&num, &object)  
to runstate on 0 % tst_rx_new
```

runstate:

```
time 1000  
to stopstate
```

stopstate:

```
do PvexStopOkn()  
to nextstate on 0 % tst_rx_new
```

FILE. /rex/act/vexActions.c

Actions That Control Flow Fields

PvexNewFlow

sets the translation matrices of a number of flow field objects

SYNOPSIS. PvexNewFlow(int *nObjects, int *objList, int *xyList, int *zList, int *velList, int *rollList, int *pitchList, int *yawList, int *spanList, int *coherList)

nObjects: number of flow field objects

objList: array of object numbers

xyList: array of flow directions in the X-Y plane

zList: array of flow directions along the Z axis (only valid for 3-D flow fields)

velList: array of linear velocities

rollList: array of angular velocities around the Z axis

pitchList: array of angular velocities around the X axis (only valid for 3-D flow fields)

yawList: array of angular velocities around the Y axis (only valid for 3-D flow fields)

spanList: array of check life spans (in video fields)

coherList: array of percentages of coherent checks

DESCRIPTION. This action sets the direction of movement of the checks in a flow field. Checks can move in a linear direction or in a rotational direction. Linear and rotational movement can be combined. If the checks are given a non-zero life span, they will move as directed by the translation matrix for the given number of video fields, then they will turn off. This gives a scintillating appearance to the flow field. The percentage of coherent checks governs the number of checks that will move in the direction specified by the translation matrix. Non-coherent checks will move in random directions.

RETURN VALUE. GLvex will return the signal BATCH_DONE (241) when it completes this action.

EXAMPLE.

```
int num = 4;
int objects[4] = { 1, 2, 3, 4 };
int xy[4] = { 0, 90, 180, 270 };
int z[4] = { 0, 45, -45, 90 };
int vel[4] = { 10, 15, 20, 25 };
int roll[4] = { 0, 0, 0, 0 };
int pitch[4] = { 0, 0, 0, 0 };
int yaw[4] = { 0, 0, 0, 0 };
int span[4] = { 0, 5, 0, 5 };
int coher[4] = { 100, 75, 50, 25 };

%%
state:
    do PvexNewFlow(&num, objects, xy, z, vel, roll, pitch, yaw, span, coher)
    to nextstate on 0 % tst_rx_new
```

FILE. /rex/act/vexActions.c

PvexShiftFlow

changes the translation matrices of a number of flow field objects while the checks are moving

SYNOPSIS. PvexShiftFlow(int *nObjects, int *objList, int *xyList, int *zList, int *velList, int *rollList,
int *pitchList, int *yawList, int *spanList, int *coherList)

nObjects: number of flow field objects

objList: array of object numbers

xyList: array of flow directions in the X-Y plane

zList: array of flow directions along the Z axis (only valid for 3-D flow fields)

velList: array of linear velocities

rollList: array of angular velocities around the Z axis

pitchList: array of angular velocities around the X axis (only valid for 3-D flow fields)

yawList: array of angular velocities around the Y axis (only valid for 3-D flow fields)

spanList: array of check life spans (in video fields)

coherList: array of percentages of coherent checks

DESCRIPTION. This action changes the direction of movement of the checks in a flow field while the checks are moving. Checks can move in a linear direction or in a rotational direction. Linear and rotational movement can be combined. If the checks are given a non-zero life span, they will move as directed by the translation matrix for the given number of video fields, then they will turn off. This gives a scintillating appearance to the flow field. The percentage of coherent checks governs the number of checks that will move in the direction specified by the translation matrix. Non-coherent checks will move in random directions.

RETURN VALUE. If the digital sync is enabled, GLvex will return the signal **FLOW_RAMP_CHANGE** (234) at the beginning of the first video field in which the checks change direction. If the video sync is enabled, the sync object will flash white at the beginning of the first video field in which the checks change direction.

EXAMPLE.

```
int num = 4;
int objects[4] = { 1, 2, 3, 4 };
int xy[4] = { 0, 90, 180, 270 };
int z[4] = { 0, 45, -45, 90 };
int vel[4] = { 10, 15, 20, 25 };
int roll[4] = { 0, 0, 0, 0 };
int pitch[4] = { 0, 0, 0, 0 };
int yaw[4] = { 0, 0, 0, 0 };
int span[4] = { 0, 5, 0, 5 };
int coher[4] = { 100, 75, 50, 25 };

%%
state:
    do PvexNewFlow(&num, objects, xy, z, vel, roll, pitch, yaw, span, coher)
    to nextstate on 0 % tst_rx_new
```

FILE. /rex/act/vexActions.c

PvexMakeFlowMovie

makes a series of flow field frames

SYNOPSIS. `PvexMakeFlowMovie(int *nObjects, int *nFrames, int *objList)`

`nObjects`: number of flow field objects

`nFrames`: number of frames in all movies

`objList`: array of flow field object numbers

DESCRIPTION. This action allows you to pre-compute the movement of checks in a flow field for later display. This action is useful if you want to display exactly the same sequence of check movements on successive trials. You must call *PvexDrawFlowField* and *PvexNewFlow* to define flow field stimuli and setup the translation matrices before calling this action.

RETURN VALUE. GLvex will return the signal BATCH_DONE (241) when it completes this action.

EXAMPLE.

```
int num = 4;
int nFrames = 100;
int objects[4] = { 2, 3, 4, 5 };
int widths[4] = { 100, 100, 100, 100 };
int heights = { 100, 100, 100, 100 };
int nears[4] = { 500, 500, 500, 500 };
int fars[4] = { 1500, 1500, 1500, 1500 };
int coverages[4] = { 25, 25, 25, 25 };
int sizes[4] = { 4, 4, 4, 4 };
int xy[4] = { 0, 90, 180, 270 };
int z[4] = { 0, 45, -45, 90 };
int vel[4] = { 10, 15, 20, 25 };
int roll[4] = { 0, 0, 0, 0 };
int pitch[4] = { 0, 0, 0, 0 };
int yaw[4] = { 0, 0, 0, 0 };
int span[4] = { 0, 5, 0, 5 };
int coher[4] = { 100, 75, 50, 25 };

%%
state:
    do PvexDrawFlowField(&num, objects, widths, heights, nears, fars, coverages, sizes)
    to trans on 0 % tst_rx_new

trans:
    do PvexNewFlow(&num, objects, xy, z, vel, roll, pitch, yaw, span, coher)
    to movie on 0 % tst_rx_new

movie:
    do PvexMakeFlowMovie(&num, &nFrames, objects)
    to nextstate on 0 % tst_rx_new
```

FILE. /rex/act/vexActions.c

PvexToFlowMovieStart

shows the starting frame of a flow field movie.

SYNOPSIS. `PvexToFlowMovieStart(int *nObjects, int *startFrame, int *objList)`

`nObjects`: number of flow field objects

`startFrame`: the number of the movie frame to use as the start

`objList`: array of flow field object numbers

DESCRIPTION. This action allows you to show the starting frame of a flow field movie before starting the movie. Thus, when you show a flow field movie, you do not need to start on the first frame. You must call *PvexDrawFlow*, *PvexNewFlow*, and *PvexMakeFlowMovie* to define the flow field and the translation matrices and make the movie before calling this action.

RETURN VALUE. GLvex will return the signal BATCH_DONE (241) when it completes this action.

EXAMPLE.

```
int num = 4;
int nFrames = 100;
int startFrame = 25;
int objects[4] = { 2, 3, 4, 5 };
int widths[4] = { 100, 100, 100, 100 };
int heights = { 100, 100, 100, 100 };
int nears[4] = { 500, 500, 500, 500 };
int fars[4] = { 1500, 1500, 1500, 1500 };
int coverages[4] = { 25, 25, 25, 25 };
int sizes[4] = { 4, 4, 4, 4 };
int xy[4] = { 0, 90, 180, 270 };
int z[4] = { 0, 45, -45, 90 };
int vel[4] = { 10, 15, 20, 25 };
int roll[4] = { 0, 0, 0, 0 };
int pitch[4] = { 0, 0, 0, 0 };
int yaw[4] = { 0, 0, 0, 0 };
int span[4] = { 0, 5, 0, 5 };
int coher[4] = { 100, 75, 50, 25 };

%%
state:
    do PvexDrawFlowField(&num, objects, widths, heights, nears, fars, coverages, sizes)
    to trans on 0 % tst_rx_new

trans:
    do PvexNewFlow(&num, objects, xy, z, vel, roll, pitch, yaw, span, coher)
    to movie on 0 % tst_rx_new

movie:
    do PvexMakeFlowMovie(&num, &nFrames, objects)
    to moviestart on 0 % tst_rx_new

moviestart:
    do PvexToFlowMovieStart(&num, &startFrame, objects)
    to nextframe on 0 % tst_rx_new
```

FILE. /rex/act/vexActions.c

PvexStartFlow

starts the flow fields in a number of objects

SYNOPSIS. `PvexStartFlow(int *nObjects, int *objList)`

`nObjects`: number of flow field objects

`objList`: array of flow field object numbers

DESCRIPTION. This actions starts the checks in the specified flow field objects moving according to the objects' translation matrices. You must have called the *PvexDrawFlowField* and *PvexNewFlow* actions before calling this action.

RETURN VALUE. If the digital sync is enabled, GLvex will return the signal `FLOW_RAMP_START` (236) when the checks begin to move. If the video sync is enabled, the sync object will flash white when the checks begin to move.

EXAMPLE.

```
int num = 4;
```

```
int objects[4] = { 1, 2, 3, 4 };
```

```
%%
```

```
state:
```

```
    do PvexStartFlow(&num, objects)
```

```
    to nextstate on 0 % tst_rx_new
```

FILE. /rex/act/vexActions.c

PvexTimeFlow

runs the flow fields in a number of objects for a given number of video fields

SYNOPSIS. `PvexTimeFlow(int *nObjects, int *fields, int *objList)`

`nObjects`: number of flow field objects

`fields`: number of video fields to show flow field

`objList`: array of flow field object numbers

DESCRIPTION. This actions starts the checks in the specified flow field objects moving according to the objects' translation matrices and moves them for the given number of video fields. You must have called the *PvexDrawFlowField* and *PvexNewFlow* actions before calling this action.

RETURN VALUE. If the digital sync is enabled, GLvex will return the signal `FLOW_RAMP_START` (236) when the checks begin to move, and the signal `FLOW_RAMP_STOP` (235) when the checks stop moving. If the video sync is enabled, the sync object will flash white when the checks begin to move, and again when the checks stop moving.

EXAMPLE.

```
int num = 4;
int frames = 60;
int objects[4] = { 1, 2, 3, 4 };

%%
state:
    do PvexTimeFlow(&num, &frames, objects)
    to run on 0 % tst_rx_new

run:
    to nexstate on 0 % tst_rx_new
```

FILE. /rex/act/vexActions.c

PvexShowFlowMovie

shows a number of flow field movie

SYNOPSIS. `PvexShowFlowMovie(int *nObjects, int *startFrame, int *lastFrame, int *objList)`

`nObjects`: number of flow field objects

`startFrame`: number of the frame on which to start the movie

`lastFrame`: number of the last frame to display

`objList`: array of flow field object numbers

DESCRIPTION. This action shows flow field movies. The length of the movie is `lastFrame - startFrame`. The movies in all objects must start and end on the same frame number. You must call *PvexDrawFlow*, *PvexNewFlow*, and *PvexMakeFlowMovie* before calling this action.

RETURN VALUE. If the digital sync is enabled, GLvex will return the signal `FLOW_RAMP_START` (236) when the checks begin to move, and the signal `FLOW_RAMP_STOP` (235) when the checks stop moving. If the video sync is enabled, the sync object will flash white when the checks begin to move, and again when the checks stop moving.

EXAMPLE.

```
int num = 4;
```

```
int start = 10;
```

```
last = 50;
```

```
int objects[4] = { 1, 2, 3, 4 };
```

```
%%
```

```
state:
```

```
do PvexShowFlowMovie(&num, &start, &last, objects)
```

```
to run on 0 % tst_rx_new
```

```
run:
```

```
to nextstate on 0 % tst_rx_new
```

FILE. /rex/act/vexActions.c

PvexStartFlowRamp

starts flow fields and ramps together

SYNOPSIS. PvexStartFlowRamp(int *nFlows, int *flwList, int *nRamps, int *rmpList, int *objList)

nFlows: number of flow field objects

flwList: array of flow field object numbers

nRamps: number of ramps

rmpList: array of ramp numbers

objList: array of object numbers to be carried on the ramps

DESCRIPTION. This action allows you to start a number of flow fields and a number of ramps simultaneously. This allows you to study the effects of pursuit with a moving background. You must define all of the flow fields, translation matrices, and ramps before calling this action.

RETURN VALUE. If the digital sync is enabled, GLvex will return the signal FLOW_RAMP_START (236) when the checks and ramps begin to move. If the video sync is enabled, the sync object will flash white when the checks and ramps begin to move.

EXAMPLE.

```
int nFlows = 2;
int flows[2] = { 1, 2 };
int nRamps = 2;
int ramps[2] = { 1, 2 };
int objects[2] = { 3, 4 };
```

```
%%
```

```
state:
```

```
do PvexStartFlowRamp(&nFlows, flows, &nRamps, ramps, objects)
to nextstate on 0 % tst_rx_new
```

FILE. /rex/act/vexActions.c

PvexStopFlowRamp

stops all ramps and flow fields

SYNOPSIS. PvexStopFlowRamp(void)

DESCRIPTION. This actions stops all of the flow fields and ramps that you have running

RETURN VALUE. If the digital sync is enabled, GLvex will return the signal FLOW_RAMP_STOP (235) after all movement has stopped. If the video sync is enabled, the sync object will flash white after all movement has stopped.

EXAMPLE.

```
%%
```

```
state:
```

```
    do PvexStopFlowRamp()
    nextstate on 0 % tst_rx_new
```

FILE. /rex/act/vexActions.c

Actions That Control Object Movies

PvexShowMovieClip

displays a sequence of objects

SYNOPSIS. PvexShowMovieClip(int *nClips, int *objList, int *nFrames, int *interval, int *cycles)

nClips: number of clips to show simultaneously

objList: array of the numbers of the first object in each movie clip

nFrames: number of objects in each movie

interval: number of video fields to display each frame of all clips

cycles: number of times to show the clips

DESCRIPTION. This action allows you to present an arbitrary number of objects in sequence. Several groups of objects may be presented simultaneously. If all of the objects in each group have the same position, the effect is that of showing a movie. You may also distribute the positions of the objects. Each object is displayed for the same amount of time. If you want more than one group of objects, each group must consist of the same number of objects.

RETURN VALUE. If the digital sync is enabled, GLvex will return the signal MOVIE_START (239) when the first object in each clip is shown, and the signal MOVIE_STOP(238) after the last object in each clip is shown. If the video sync is enabled, the sync object will flash white when the first object in each clip is shown, and again after the last object in each clip is shown.

EXAMPLE.

```
int num = 2;
```

```
int objects[2] = { 1, 51 };
```

```
int nFrames = 50;
```

```
int interval = 5;
```

```
int cycles = 2;
```

```
%%
```

```
state:
```

```
do PvexShowMovieClip(&num, objects, &nFrames, &interval, &cycles)
```

```
to runstate on 0 % tst_rx_new
```

```
runstate:
```

```
to stopstate on 0 % tst_rx_new
```

FILE. /rex/act/vexActions.c

PvexStopMovie

stops all flow field movies and movie clips

SYNOPSIS. PvexStopMovie(void)

DESCRIPTION. This action allows you to halt flow field movies and movie clips in the event that an error has occurred.

RETURN VALUE. If the digital sync is enabled, GLvex will return the signal FLOW_RAMP_STOP (235) if you have been showing a flow field movie or the signal MOVIE_STOP if you have been showing a movie clip after all movement has stopped. If the video sync is enabled, the sync object will flash white after all movement has stopped.

EXAMPLE.

```
%%
```

```
state:
```

```
    do PvexStopMovie()  
    to nextstate on 0 % tst_rx_new
```

FILE. /rex/act/vexActions.c

Actions That Set Arbitrary Trigger Points

PvexSetTriggers

sets a list of steps at which to send a trigger

SYNOPSIS. `PvexSetTriggers(int *nTrigs, int *rmpList, int *trigList, int *frameList)`

`nTrigs`: number of trigger lists

`rmpList`: array of the numbers of the ramps or movie clips in which to place triggers

`trigList`: array of the number of triggers in each trigger list

`frameList`: array of the step numbers of each ramp or frame numbers of each movie clip to trigger

DESCRIPTION. When you define ramps using *PvexLoadRamp* or setup movie clips using *PvexShowMovieClip*, you may want to introduce discontinuities into the display. For example, you may want the object on a ramp to change speed or direction, or you may want one of the objects in a movie clip to have a different property, color, luminance, size, etc. To have GLvex tell you when it displays the discontinuity, you need to tell it the ramp step number or movie frame of the discontinuity. This action allows you to do that. You may set a maximum of 10 trigger points in each ramp or movie clip.

RETURN VALUE. GLvex will return the signal `BATCH_DONE` (241) after completing this action.

During the display, if the digital sync is enabled, GLvex will return the signal

`FLOW_RAMP_CHANGE` (234) at each ramp step specified in the call or the signal `MOVIE_CHANGE` (237) at each frame specified in the call. If the video sync is enabled, the sync object will flash white at each trigger point.

EXAMPLE.

```
int num = 2;
int ramps[2] = { 1, 2 };
int triggers[2] = { 4, 8 };
int frames[12] = { 10, 20, 30, 40, 20, 40, 80, 100, 120, 140, 160, 180 };
```

```
%%
```

```
state:
```

```
do PvexSetTriggers(&num, ramps, triggers, frames)
to nextstate on 0 % tst_rx_new
```

FILE. `/rex/act/vexActions.c`

REX COMMANDS

To facilitate communication, a number of actions and functions have been defined in a file named `GLvex_com.c`. This file should be `"#included"` at the top of any spot file that communicates with `GLvex`. In addition, I have used `#defines` to give provide names for the `GLvex` command values. These `#defines` are listed in a file named `GLcommand.h` which is `#included` in `GLvex_com.c`. Both the `GLvex_com.c` and the `GLcommand.h` files should be placed in the `/rex/sset` directory.

A number of the `GLvex` commands are batchable; that is, several commands with their parameters can be loaded into `vexbuff[]` for a single transmission to `GLvex`. These commands are batchable because `GLvex` will return one signal (`BATCH_DONE`) after executing all commands in `vexbuff[]`. Other commands should not be batched because `GLvex` returns a signal after completing each of these commands. Loading several non-batchable commands into `vexbuff[]` at one time may cause communication problems between `GLvex` and `Rex`, or may cause the time stamps in the `rex E-file` to be inaccurate. You may either load a single non-batchable command and its parameters into `vexbuff[]`, or load one non-batchable command into `vexbuff[]` at the end of a series of batchable commands. In either case, `GLvex` will return the signal of the non-batchable command.

`Rex` spot files control the behavior of `GLvex` by calling actions which first load command values and parameters into the `vexbuff[]` command buffer, and then call the `to_vex()` function. Both `vexbuff[]` and `to_vex()` are defined in `GLvex_com.c`. The following list describes the commands that can be executed from a `rex` spot file together with example actions. In this list, each section header consists of the `#defined` name of the command. **Note: The only escapes you should use from states that call these commands are when the function `tst_rx_new` returns 0 or when a photo cell is triggered by the video sync object.**

All of the actions that can be done using the keyboard commands described above can also be done from `rex` using the proper sequences of the commands described below.

SET_ERASE_METHOD

This is a batchable command that sets which erase method will be used. This command requires 1 parameter, which must be `EACH_OBJECT` (0) or `WHOLE_SCREEN` (1). If the parameter is `EACH_OBJECT`, then `\v3GLvex` will erase objects by drawing a rectangle the color of the background over them. If the parameter is `WHOLE_SCREEN`, then `GLvex` will erase objects by clearing the entire screen. The `EACH_OBJECT` method is faster, but the `WHOLE_SCREEN` method is more robust. The default method is `EACH_OBJECT`. Once the erase method is set, it will remain in effect until changed, so you only need to call this command once.

Example action:

```
setup()
{
    unsigned short index;
    index = 0;
        .
        .                               /* other batchable commands */
        .
    vexbuf[index++] = SET_ERASE_METHOD;
    vexbuf[index++] = WHOLE_SCREEN; /* #defined in GLcommand.h */
        .
        .                               /* other batchable commands */
        .
    to_vex(index);
    return(0);
}
```

`GLvex` will return the signal `BATCH_DONE` (241) after completing all commands in the list regardless of whether digital synchronization is enabled or not.

ENABLE_REX_VIDEO_SYNC

This is a batchable command that enables the video sync for synchronizing the display with rex. It does not require any parameters. When the video sync is enabled, GLvex will draw a small black square in the upper left corner of the screen. This square will flash white for 1 video field when synchronization is needed. The video sync is enabled by default. Once the video sync is enabled, it will remain enabled until disabled, so you only need to call this command once.

Example action:

```
setup()  
{  
    unsigned short index;  
    index = 0;  
        .  
        . /* other batchable commands */  
        .  
    vexbuf[index++] = ENABLE_REX_VIDEO_SYNC;  
        .  
        . /* other batchable commands */  
        .  
    to_vex(index);  
    return(0);  
}
```

GLvex will return the signal BATCH_DONE (241) after completing all commands in the list regardless of whether digital synchronization is enabled or not.

DISABLE_REX_VIDEO_SYNC

This is a batchable command that disables the video sync for synchronizing the display with rex. It does not require any parameters. The video sync is enabled by default. Once the video sync is disabled, it will remain disabled until enabled, so you only need to call this command once.

Example action:

```
setup()
{
    unsigned short index;
    index = 0;
        .
        .                               /* other batchable commands */
        .
    vexbuf[index++] = DISABLE_REX_VIDEO_SYNC;
        .
        .                               /* other batchable commands */
        .
    to_vex(index);
    return(0);
}
```

GLvex will return the signal BATCH_DONE (241) after completing all commands in the list regardless of whether digital synchronization is enabled or not.

ENABLE_REX_DIGITAL_SYNC

This is a batchable command that enables the digital sync for synchronizing the display with rex. It does not require any parameters. When the digital sync is enabled, GLvex will return a signal via pcmsg at the beginning of the first video field where synchronization is needed. The digital sync is enabled by default. Once the digital sync is enabled, it will remain enabled until disabled, so you only need to call this command once.

Example action:

```
setup()  
{  
    unsigned short index;  
    index = 0;  
        .  
        . /* other batchable commands */  
        .  
    vexbuf[index++] = ENABLE_REX_DIGITAL_SYNC;  
        .  
        . /* other batchable commands */  
        .  
    to_vex(index);  
    return(0);  
}
```

GLvex will return the signal BATCH_DONE (241) after completing all commands in the list regardless of whether digital synchronization is enabled or not.

DISABLE_REX_VIDEO_SYNC

This is a batchable command that disables the digital sync for synchronizing the display with rex. It does not require any parameters. The digital sync is enabled by default. Once the digital sync is disabled, it will remain disabled until enabled, so you only need to call this command once.

Example action:

```
setup()  
{  
    unsigned short index;  
    index = 0;  
        .  
        .                               /* other batchable commands */  
        .  
    vexbuf[index++] = DISABLE_REX_DIGITAL_SYNC;  
        .  
        .                               /* other batchable commands */  
        .  
    to_vex(index);  
    return(0);  
}
```

GLvex will return the signal BATCH_DONE (241) after completing all commands in the list regardless of whether digital synchronization is enabled or not.

SET_REX_SCALE

This is a batchable command that sets the scaling factors. This command requires four parameters. The first two parameters are the hi- and lo- bytes of the distance between the viewer and the screen in millimeters. The last two parameters are the hi- and lo- bytes of the with of the calibration pattern in millimeters.

Example action:

```
short screenDistance = 572; /* distance between viewer and screen */
short patternWidth = 900; /* width of initial calibration pattern */
set_scale(void)
{
    unsigned short index;
    index = 0;
        .
        .
        .
    vexbuf[index++] = SET_REX_SCALE;
    vexbuf[index++] = hibyte(screenDistance);
    vexbuf[index++] = lobyte(screenDistance);
    vexbuf[index++] = hibyte(patternWidth);
    vexbuf[index++] = lobyte(patternWidth);
        .
        .
        .
    to_vex(index);
    return(0);
}
```

GLvex will return the signal BATCH_DONE (241) after completing all commands in the list regardless of whether digital synchronization is enabled or not. The hibyte() and lobyte() functions are defined in GLvex_com.c.

SET_BACK_LUM

This is a batchable command that sets the luminance or color of the screen background. It requires three parameters, the values for the red, green, and blue guns. These parameters can range from 0 to 255.

Example action:

```
/*
 * This action will set the background to a specified color
 */
bgrnd_clr(long r, long g, long b)
{
    unsigned short index;
    index = 0;
    vexbuf[index++] = SET_BACK_LUM;
    vexbuf[index++] = r;
    vexbuf[index++] = g;
    vexbuf[index++] = b;
    .
    .
    .
    to_vex(index);
    return(0);
}
```

GLvex will return the signal BATCH_DONE (241) after completing all commands in the list regardless of whether digital synchronization is enabled or not.

SET_FP_ON_CLR

This is a batchable command that sets what the color or luminance of the fixation point will be when it is switch on. It requires three parameters, the values for the red, green, and blue guns. These parameters can range from 0 to 255.

Example action:

```
/*
 * This action will set the fixation point to a specified gray luminance.
 */
int lum;                /* value may be set in Rex state variables menu */
fpon_lum(void)
{
    unsigned short index;
    index = 0;
    vexbuf[index++] = SET_FP_ON_CLR;
    vexbuf[index++] = lum;
    vexbuf[index++] = lum;
    vexbuf[index++] = lum;
    .
    .
    .
    to_vex(index);
    return(0);
}
```

GLvex will return the signal BATCH_DONE (241) after completing all commands in the list regardless of whether digital synchronization is enabled or not.

SET_FP_DIM_CLR

This is a batchable command that sets what the color or luminance of the fixation point will be when it is dimmed. It requires three parameters, the values for the red, green, and blue guns. These parameters can range from 0 to 255.

Example action:

```
/*
 * This action will set the fixation point dim level to a specified color
 */
fpdim_clr(long r, long g, long b)
{
    unsigned short index;
    index = 0;
    vexbuf[index++] = SET_FP_DIM_CLR;
    vexbuf[index++] = r;
    vexbuf[index++] = g;
    vexbuf[index++] = b;
    .
    .
    .
    to_vex(index);
    return(0);
}
```

GLvex will return the signal BATCH_DONE (241) after completing all commands in the list regardless of whether digital synchronization is enabled or not.

SET_STIM_LUMINANCES

This is a batchable command that sets the foreground and background luminances of one- and two-tone stimuli. The first parameter is the number of objects to set. Each object requires three parameters, the object number, the luminance of the foreground pixels, and the luminance of the background pixels. The luminance values can range from 0 to 255.

Example action:

```
/*
 * This action will set the luminances of three objects to the same level
 */
short fgl = 255;
short bgl = 0;
short num_stim = 3;
short list[] = { 2, 3, 4 };
stim_lum(void)
{
    unsigned short index; short i;
    index = 0;
    vexbuf[index++] = SET_STIM_LUMINANCES;
    vexbuf[index++] = num_stim; /* number of objects */
    for(i = 0; i < num_stim; i++) {
        vexbuf[index++] = list[i]; /* object number */
        vexbuf[index++] = fgl;      /* foreground luminance */
        vexbuf[index++] = bgl;      /* background luminance */
    }
    .
    .
    .
    to_vex(index);
    return(0);
}
```

GLvex will return the signal BATCH_DONE (241) after completing all commands in the list regardless of whether digital synchronization is enabled or not.

SET_STIM_COLORS

This is a batchable command that sets the foreground and background colors of one- and two-tone stimuli. The first parameter is the number of objects to set. Each object requires seven parameters, the object number, the levels of red, green, and blue for the foreground pixels, and the levels of red, green and blue for the background pixels. The levels of each color can range from 0 to 255.

Example action:

```
/*
 * This action will set the foreground and background colors
 * of an object.
 */
short fgr = 255;
short fgg = 128;
short fgb = 0;
short bgr = 0;
short bgg = 0;
short bgb = 255;
stim_clr(void)
{
    unsigned short index;
    index = 0;
    vexbuf[index++] = SET_STIM_COLORS;
    vexbuf[index++] = 1;           /* number of objects */
    vexbuf[index++] = 2;           /* object number */
    vexbuf[index++] = fgr;         /* foreground red */
    vexbuf[index++] = fgg;         /* foreground green */
    vexbuf[index++] = fgb;         /* foreground blue */
    vexbuf[index++] = bgr;         /* background red */
    vexbuf[index++] = bgg;         /* background green */
    vexbuf[index++] = bgb;         /* background blue */
    .
    .
    .
    to_vex(index);
    return(0);
}
```

GLvex will return the signal BATCH_DONE (241) after completing all commands in the list regardless of whether digital synchronization is enabled or not.

SET_COLOR_MASK

This is a batchable command that controls the writing of color channels in objects. If any color channels are disabled, then objects will not occlude each other when they intersect. Rather, the objects will be blended. The first parameter is the number of objects to set. Each object requires five parameters, the object number, the flag for red channel, the flag for green channel, the flag for blue channel, and the flag for the alpha channel. The flags must be either 0 to disable writing a channel or 255 to enable writing a channel. By default, all channels are enabled.

Example action:

```
/*
 * This action enables writing in the red channel only for object 1 and in the green channel
 * only for object 2.
 */
colorMask(void)
{
    unsigned short index;
    index = 0;
    vexbuf[index++] = SET_COLOR_MASK;
    vexbuf[index++] = 2;          /* number of objects to set */
    vexbuf[index++] = 1;         /* first object number */
    vexbuf[index++] = 255;       /* flag for the red channel */
    vexbuf[index++] = 0;         /* flag for the green channel */
    vexbuf[index++] = 0;         /* flag for the blue channel */
    vexbuf[index++] = 0;         /* flag for the alpha channel */
    vexbuf[index++] = 2;         /* second object number */
    vexbuf[index++] = 0;         /* flag for the red channel */
    vexbuf[index++] = 255;       /* flag for the green channel */
    vexbuf[index++] = 0;         /* flag for the blue channel */
    vexbuf[index++] = 0;         /* flag for the alpha channel */
    .
    .
    .
    to_vex(index);
    return(0);
}
```

GLvex will return the signal BATCH_DONE (241) after completing all commands in the list regardless of whether digital synchronization is enabled or not.

SET_GRAY_SCALE

This is a batchable command that sets up a gray scale in all objects' color lookup tables. It requires two parameters. The first parameter is the index of the lookup table where the gray scale will start. The value of this parameter can range from 0 to 255. The second parameter is the number of bytes in the gray scale. The value of this parameter can range from 1 to 255. The sum of the start and length parameters cannot exceed 255. The luminance range of the gray scale is always 0 to 255. The size of the steps between luminances is determined by the length of the gray scale. This command is used to initialize a gray scale for continuous tone stimuli.

Example action:

```
/*
 * This action sets up a 128 byte gray scale starting at
 * lookup table index 64.
 */
gray(void)
{
    unsigned short index;
    index = 0;
    vexbuf[index++] = SET_GRAY_SCALE;
    vexbuf[index++] = 64;          /* start of gray scale */
    vexbuf[index++] = 128;       /* length of gray scale */
    .
    .
    .
    to_vex(index);
    return(0);
}
```

GLvex will return the signal BATCH_DONE (241) after completing all commands in the list regardless of whether digital synchronization is enabled or not.

SET_OBJECT_GRAY_SCALE

This is a batchable command that sets up a gray scale in the specified object's color lookup table. The first parameter is the number of objects to set. Each object requires three parameters. The first parameter is the object number. The second parameter is the index of the lookup table where the gray scale will start. The value of this parameter can range from 0 to 255. The third parameter is the number of bytes in the gray scale. The value of this parameter can range from 1 to 255. The sum of the start and length parameters cannot exceed 255. The luminance range of the gray scale is always 0 to 255. The size of the steps between luminances is determined by the length of the gray scale. This command is used to initialize a gray scale for continuous tone stimuli.

Example action:

```
/*
 * This action sets up a 128 byte gray scale starting at
 * lookup table index 64 in objects 5 and 10.
 */
list[] = {5, 10};
gray(void)
{
    unsigned short index;
    int i;
    index = 0;
    vexbuf[index++] = SET_OBJECT_GRAY_SCALE;
    vexbuf[index++] = 2;          /* number of objects to set */
    for(i = 0; i < 2; i++) {
        vexbuf[index++] = list[i];    /* list of object numbers */
        vexbuf[index++] = 64;        /* start of gray scale */
        vexbuf[index++] = 128;      /* length of gray scale */
    }
    .
    .
    .
    to_vex(index);
    return(0);
}
```

GLvex will return the signal BATCH_DONE (241) after completing all commands in the list regardless of whether digital synchronization is enabled or not.

SET_LUT_ENTRY_CLR

This is a batchable command that sets the colors in a variable number of color lookup table entries for all objects. The first parameter is the number of lookup table entries to set. Each lookup table entry requires four parameters, the table index and the values for the red, green, and blue guns for that index. These parameters can range from 0 to 255;

Example action:

```
/*
 * This action loads counter phase red and green ramps into the lookup
 * table from index 64 to 127.
 */
rg_ramp()
{
    unsigned short index;
    int i;
    int red, green, blue;
    red = 255;
    green = 0;
    blue = 0;
    index = 0;
    vexbuf[index++] = SET_LUT_ENTR_CLR;
    vexbuf[index++] = 64; /* number of table entries to set */
    for(i = 0; i < 64; i++) {
        vexbuf[index++] = i + 64; /* table index */
        vexbuf[index++] = red; /* red value */
        vexbuf[index++] = green; /* green value */
        vexbuf[index++] = blue; /* blue value */
        red -= 4; /* decrement red */
        green += 4; /* increment green */
    }
    .
    .
    .
    to_vex(index);
    return(0);
}
```

GLvex will return the signal BATCH_DONE (241) after completing all commands in the list regardless of whether digital synchronization is enabled or not.

SET_OBJECT_LUT_ENTRY_CLR

This is a batchable command that sets the colors in a variable number of color lookup table entries for the specified object. The first parameter is the number of objects to set. Each object has two parameters, the object number, and the number of entries to set. Each lookup table entry requires four parameters, the table index and the values for the red, green, and blue guns for that index. These parameters can range from 0 to 255;

Example action:

```
/*
 * This action loads counter phase red and green ramps into the lookup
 * table from index 64 to 127 in objects 2 and 3.
 */
list[] = {2, 3};
rg_ramp()
{
    unsigned short index;
    int i, j;
    int red, green, blue;
    red = 255;
    green = 0;
    blue = 0;
    index = 0;
    vexbuf[index++] = SET_OBJECT_LUT_ENTR_CLR;
    vexbuf[index++] = 2; /* number of objects to set */
    for(i = 0; i < 2; i++) {
        vexbuf[index++] = list[i]; /* object number */
        vexbuf[index++] = 64; /* number of table entries to set for this object */
        for(j = 0; j < 64; j++) {
            vexbuf[index++] = j + 64; /* table index */
            vexbuf[index++] = red; /* red value */
            vexbuf[index++] = green; /* green value */
            vexbuf[index++] = blue; /* blue value */
            red -= 4; /* decrement red */
            green += 4; /* increment green */
        }
    }
    .
    .
    . /* other batchable commands */
    to_vex(index);
    return(0);
}
```

GLvex will return the signal BATCH_DONE (241) after completing all commands in the list regardless of whether digital synchronization is enabled or not.

ALL_OFF

This is a non-batchable command that turns off the fixation point and all stimuli by clearing both drawing pages, and stops all ramps and flow fields. It does not require any parameters.

Example action:

```
off_all(void)  
{  
    unsigned short index;  
    index = 0;  
    vexbuf[index++] = ALL_OFF;  
    to_vex(index);  
    return(0);  
}
```

If the digital sync is enabled, GLvex will return the signal ABORT_TRIAL (255) at the beginning of the first clear video field. Otherwise GLvex will not return any signal after this command. If the video sync is enabled, the rex video sync square will flash white for the first field in which the objects are off. If you use the ALL_OFF function to abort ramps or flow fields, the normal ramp and flow field completion signals will not be sent. The off_all() action shown above is defined in GLvex_com.c.

SWITCH_FIX_POINT

This is a non-batchable command that switches the fixation point on or off. It requires one parameter, the switch value. The switch values are 0 for OFF and 1 for ON.

Example actions:

```
/*
 * This action will switch the fixation point on.
 */
on_fix(void)
{
    unsigned short index;
    index = 0;
    vexbuf[index++] = SWITCH_FIX_POINT;
    vexbuf[index++] = OBJ_ON; /* GLcommand.h: #define OBJ_ON 1 */
    to_vex(index);
    return(0);
}
```

If the digital sync is enabled, GLvex will return the signal FIX_ON (254) at the beginning of the video field in which the fixation point is switched on. Otherwise GLvex will not return any signal after this command. If the video sync is enabled, the rex video sync square will flash white for the first field in which the fixation point is switch on.

```
/*
 * This action will switch the fixation point off.
 */
off_fix(void)
{
    unsigned short index;
    index = 0;
    vexbuf[index++] = SWITCH_FIX_POINT;
    vexbuf[index++] = OBJ_OFF; /* GLcommand.h: #define OBJ_OFF 0 */
    to_vex(index);
    return(0);
}
```

If the digital sync is enabled, GLvex will return the signal FIX_OFF (253) at the beginning of the video field in which the fixation point is switched off. Otherwise GLvex will not return any signal after this command. If enabled, the rex video trigger will flash white for the first field in which the fixation point is switch off. The on_fix() and off_fix() actions shown above are defined in GLvex_com.c.

DIM_FIX_POINT

This is a non-batchable command that dims to fixation point to a preset level. It does not require any parameters.

Example action:

```
dim_fix(void)  
{  
    unsigned short index;  
    index = 0;  
    vexbuf[index++] = DIM_FIX_POINT;  
    to_vex(index);  
    return(0);  
}
```

If the digital sync is enabled, GLvex will return the signal FIX_DIM (252) at the beginning of the video field in which the fixation is dimmed. Otherwise GLvex will not return any signal after this command. If enabled, the rex video trigger will flash white for the first field in which the fixation point is switch dimmed. The dim_fix() action shown above is defined in GLvex_com.c.

SWAP_BUFFERS

This is a non-batchable command that swaps the display and drawing buffers. It requires no arguments.

Example action:

```
/*  
 * This action will swap the display and draw buffers  
 */  
swap_buffers()  
{  
    unsigned short index;  
    index = 0;  
    vexbuf[index++] = SWAP_BUFFERS;  
    to_vex(index);  
    return(0);  
}
```

If the digital sync is enabled, GLvex will return the signal BUFFER_SWAP (232). The signal is sent at the beginning of the video field in which the buffers are swapped. Otherwise GLvex will not return any signal after this command. If enabled, the rex video trigger will turn white on the first field after the buffers are swapped.

SWITCH_STIM

This is a non-batchable command that switches a variable number of objects on or off. The first parameter is the number of objects to switch. Each object requires two parameters, the object number and the switch value. The switch values are 0 for OFF and 1 for ON.

Example actions:

```
/*
 * This action will switch object 3 on and object 4 off, simultaneously.
 */
sw_stim()
{
    unsigned short index;
    index = 0;
    vexbuf[index++] = SWITCH_STIM;
    vexbuf[index++] = 2;          /* number of objects to switch */
    vexbuf[index++] = 3;          /* first object number */
    vexbuf[index++] = OBJ_ON;     /* GLvex_com.c: #define OBJ_ON 1 */
    vexbuf[index++] = 4;          /* second object number */
    vexbuf[index++] = OBJ_OFF;    /* GLvex_com.c: #define OBJ_OFF 0 */
    to_vex(index);
    return(0);
}
```

If the digital sync is enabled, GLvex will return the signal STIMULUS_ON (251) if the first object switch is "on", or the signal STIMULUS_OFF (240) if the first object switch is "off". The signal is sent at the beginning of the video field in which the objects are switched. Otherwise GLvex will not return any signal after this command. If enabled, the rex video trigger will flash white for the first field in which the objects are switched.

SET_STIM_SWITCH

This is a batchable command that sets the switches of a variable number of objects, but does not implement the switch. Switch implementation will be done by the next non-batchable command that is executed. The first parameter is the number of object switches to set. Each object requires two parameters, the object number and the switch value. Switch values can be ON (1) or OFF (0). The purpose of this command is to turn an object on in the field in which the ramp carrying it begins to move. You can also turn an object on at some time after its ramp begins to move. This allows you some independence between switching objects and starting ramps, but still allows synchronization.

Example action:

```
/*
 * This action sets the switches of objects 1, 2, & 3 to ON
 */
set_switch()
{
    unsigned short index;
    index = 0;
    /* surround switch */
    vexbuf[index++] = SET_STIM_SWITCH;
    vexbuf[index++] = 3;          /* number of objects to switch */
    vexbuf[index++] = 1;          /* object number */
    vexbuf[index++] = OBJ_ON;     /* switch value */
    /* center switch */
    vexbuf[index++] = 2;          /* object number */
    vexbuf[index++] = OBJ_ON;     /* switch value */
    /* square switch */
    vexbuf[index++] = 3;          /* object number */
    vexbuf[index++] = OBJ_ON;     /* switch value */
    .
    .
    .
    to_vex(index);
    return(0);
}
```

GLvex will return the signal BATCH_DONE (241) after completing all commands in the list regardless of whether digital synchronization is enabled or not.

TIME_STIM

This is a non-batchable command that presents a variable number of objects for a given number of video fields. The first parameter is the number of objects to present. Each object requires one parameter, the object number. The last parameter is the number of fields to present the objects. The number of fields can range from 1 to 255.

Example action:

```
/*
 * This action will present objects 3 and 4 simultaneously for 60 fields.
 */
short fields = 60; /* value may be set in Rex state variables menu */
st_time(void)
{
    unsigned short index;
    index = 0;
    vexbuf[index++] = TIME_STIM;
    vexbuf[index++] = 2;          /* number of objects to present */
    vexbuf[index++] = 3;          /* first object number */
    vexbuf[index++] = 4;          /* second object number */
    vexbuf[index++] = fields;     /* number of video fields */
    to_vex(index);
    return(0);
}
```

If the digital sync is enabled, GLvex will return two signals from this command. The signal TIME_ON (247) is sent at the beginning of the video field in which the objects are turned on, and the signal TIME_OFF (246) is sent at the beginning of the video field in which the objects are turned off. Otherwise GLvex will not return any signal after this command. If the video sync is enabled, the rex video sync square will flash white for the first field in which the objects are switched on and again in the first field in which the objects are switched off.

SEQUENCE_STIM

This is a non-batchable command that presents one list of objects for a given number of video fields, switches them off, waits for a given number of video fields, and then presents a second list of objects for a given number of video fields. The first parameter is the number of objects in the first list. Each of these objects requires one parameter, the object number. The next two parameters are the number of fields to present the first list, and the number of fields to wait between lists. The value for the number of fields to wait between lists can be 0. The next parameter is the number objects in the second list. Each of these objects requires one parameter, the object number. The last parameter is the number of fields to present the second list.

Example action:

```
/*
 * This action will present object 1 for 60 fields, wait 10 fields,
 * and then present objects 3, 4, and 5 for 120 fields.
 */
short fld1 = 60;
short fld2 = 10;
short fld3 = 120;
short n_in_frst = 1;
short frst_lst[] = { 1 };
short n_in_scnd = 3;
short scnd_lst[] = { 3, 4, 5 };
sequence(void) {
    unsigned short index;
    short i;
    index = 0;
    vexbuf[index++] = SEQUENCE_STIM;
    vexbuf[index++] = n_in_frst; /* number of objects in first list */
    for(i = 0; i < n_in_frst) {
        vexbuf[index++] = frst_lst[i];/* object number */
    }
    vexbuf[index++] = fld1; /* number of fields to present first list */
    vexbuf[index++] = fld2; /* number of fields in gap (can be 0) */
    vexbuf[index++] = n_in_scnd; /* number of objects in second list */
    for(i = 0; i < n_in_scnd; i++) {
        vexbuf[index++] = scnd_lst[i];/* object number */
    }
    vexbuf[index++] = fld3; /* number of fields to present second list */
    to_vex(index);
}
```

If the digital sync is enabled, GLvex will return three or four signals from this command, depending on whether there is a gap between presentations of the two lists of objects. The signal FIRST_ON (245) is sent at the beginning of the video field in which the first list of objects is turned on. The signal FIRST_OFF (244) is sent at the beginning of the first video field of the gap, if any. The signal SECOND_ON (243) is sent at the beginning of the video field in which the second list of objects is turned on. The signal SECOND_OFF (242) is sent at the beginning of the video field in which the second list of objects is turned off. Otherwise GLvex will not return any signal after this command. If the video sync is enabled, the rex video sync square will flash white for the first field in which the first list of objects is turned on, for the first field of the gap, if any, for the first field in which the second list of objects is turned on, and for the first field in which the second list of objects is off.

SET_FP_LOCATION

This is a batchable command that sets the position of the fixation point on the screen. The X and Y coordinates must be floating point values. It requires eight parameters, the first four of which are the four bytes of the X coordinate of the fixation point location, and the second four of which are the four bytes of the Y coordinate of the fixation point location. The X and Y coordinates are in REX units, i.e., tenths of a degree. REX and GLvex have the same screen coordinate system, i.e., 0,0 is the center of the screen, negative X values are to the monkey's left, and negative Y values are down.

Example action:

```
float fpx = 0.0;           /* value may be set in Rex state variables menu */
float fpy = 0.0;           /* value may be set in Rex state variables menu */
fix_pos(void)
{
    unsigned short index;
    short i;
    char *flbuf;
    index = 0;
    vexbuf[index++] = SET_FP_LOCATION;
    flbuf = float2byte(fpx);      /* convert floating point X value to chars */
    for(i = 0; i < 4; i++) vexbuf[index++] = flbuf[i];
    flbuf = float2byte(fpy);      /* convert floating point Y value to chars */
    for(i = 0; i < 4; i++) vexbuf[index++] = flbuf[i];
    .
    .
    .
    to_vex(index);
    return(0);
}
```

GLvex will return the signal BATCH_DONE (241) after completing all commands in the list regardless of whether digital synchronization is enabled or not. The float2byte() function is defined in GLvex_com.c.

STIM_LOCATION

This is a batchable command that sets the position of an object on the screen. The X and Y coordinates of the object locations must be floating point values. The first parameter is the number of objects to locate. Each object requires nine parameters. The first parameter is the object number. The next four parameters are the four bytes of the X coordinate of the object location. The last four parameters are the four bytes of the Y coordinate of the object location. The X and Y coordinates are in REX units, i.e., tenths of a degree. REX and GLvex have the same screen coordinate system, i.e., 0,0 is the center of the screen, negative X values are to the monkey's left, and negative Y values are down.

Example action:

```
/*
 * This action will position two objects,
 * one in the upper left quadrant, and
 * one in the lower left quadrant. */
float stx[] = { -100.0, 100.0 };
float sty[] = { -100.0, -100.0 };
short ob[] = { 1, 2 };
stm_pos(void)
{
    unsigned short index;
    short i, j;
    char *flbuf;
    index = 0;
    vexbuf[index++] = STIM_LOCATION;
    vexbuf[index++] = 2;          /* number of objects to position */
    for(i = 0; i < 2; i++) {
        vexbuf[index++] = ob[i];    /* object number */
        flbuf = float2byte(stx[i]);
        for(j = 0; j < 4; j++) vexbuf[index++] = flbuf[j];
        flbuf = float2byte(sty[i]);
        for(j = 0; j < 4; j++) vexbuf[index++] = flbuf[j];
    }
    .
    .
    .
    to_vex(index);
    return(0);
}
```

GLvex will return the signal BATCH_DONE (241) after completing all commands in the list regardless of whether digital synchronization is enabled or not. The float2byte() function is defined in GLvex_com.c.

STIM_FROM_FIX_POINT

This is a batchable command that determines the position of an object relative to the fixation point. The first parameter is the number of objects to locate. Each object requires nine parameters. The first parameter is the object number. The next four parameters are the four bytes of the X coordinate of the object location relative to the fixation point. The last four parameters are the four bytes of the Y coordinate of the object location relative to the fixation point. The X and Y coordinates are in REX units, i.e., tenths of a degree. For this command, object coordinate 0,0 is the fixation point location, which may not be the same as the center of the screen. Negative X values are to the monkey's left of the fixation point, and negative Y values are below the fixation point.

Example action:

```
/*
 * This action will position an object below and to the right
 * of the fixation point.
 */
float rlx = 100;
float rly = -100;
rel_pos(void)
{
    unsigned short index;
    int i;
    char *flbuf;
    index = 0;
    vexbuf[index++] = STIM_FROM_FIX_POINT;
    vexbuf[index++] = 1;          /* number of objects to position */
    vexbuf[index++] = 2;        /* first object number */
    flbuf = float2byte(rlx);
    for(i = 0; i < 4; i++) vexbuf[index++] = flbuf[i];
    flbuf = float2byte(rly);
    for(i = 0; i < 4; i++) vexbuf[index++] = flbuf[i];
    .
    .
    .
    to_vex(index);
    return(0);
}
```

GLvex will return the signal BATCH_DONE (241) after completing all commands in the list regardless of whether digital synchronization is enabled or not. The float2byte() function is defined in GLvex_com.c.

SHIFT_LOCATION

This is a non-batchable command that sets the position of an object on the screen. The X and Y coordinates must be floating point values. The first parameter is the number of objects to locate. Each object requires nine parameters. The first parameter is the object number. The next four parameters are the four bytes of the X coordinate of the object location. The last four parameters are the four bytes of the Y coordinate of the object location. The X and Y coordinates are in REX units, i.e., tenths of a degree. REX and GLvex have the same screen coordinate system, i.e., 0,0 is the center of the screen, negative X values are to the monkey's left, and negative Y values are down. This command is identical to STIM_LOCATION except that it returns a signal at the beginning of the first video field in which the objects are shifted. The purpose of this command is to allow Rex ramps to control GLvex objects.

Example action:

```
/*
 * This action will shift two objects
 */
float stx[] = { -100, 100 };
float sty[] = { -100, -100 };
short ob1 = 1;
short ob2 = 2;
stm_pos(void)
{
    unsigned short index;
    int i;
    char *flbuf;
    index = 0;
    vexbuf[index++] = SHIFT_LOCATION;
    vexbuf[index++] = 2;          /* number of objects to position */
    vexbuf[index++] = ob1;       /* first object number */
    flbuf = float2byte(stx[0]);
    for(i = 0; i < 4; i++) vexbuf[index++] = flbuf[i];
    flbuf = float2byte(sty[0]);
    for(i = 0; i < 4; i++) vexbuf[index++] = flbuf[i];
    vexbuf[index++] = ob2;       /* first object number */
    flbuf = float2byte(stx[1]);
    for(i = 0; i < 4; i++) vexbuf[index++] = flbuf[i];
    flbuf = float2byte(sty[1]);
    for(i = 0; i < 4; i++) vexbuf[index++] = flbuf[i];
    to_vex(index);
return(0);
}
```

If the digital sync is enabled, GLvex will return the signal SHIFTED (240) at the beginning of the first video field in which the objects are shifted. The rex video sync square will not flash for this command. The float2byte() function is defined in GLvex_com.c.

REPORT_LOCATION

This is a non-batchable command that reports the screen location of a specified object. This command has a single parameter, the number of the object whose location is desired. The purpose of this command is to allow rex to find the location of a GLvex object to use for positioning an eye movement window.

Example set of actions:

```
/*
 * Action that gets object location from VEX
 */
short act = 1;
object_location()
{
    short index
    index = 0;
    vexbuf[index++] = REPORT_LOCATION;
    vexbuf[index++] = act;
    to_vex(index);
    return(0);
}

/*
 * Action that moves target window to GLvex
 * object location
 */
targ_wnd(void)
{
    unsigned char *msg;
    unsigned char code;
    msg = vex_message();/* get the last message from vex */
    if(msg) { /* if msg is not null */
        code = vex_code(msg);/* get the return code from the message */
        if(code == OBJECT_LOCATION) {
            vex_location(msg);/* unpack coordinates into vx and vy */
            wd_pos(WIND1, vx, vy);
            wd_siz(WIND1, tarsiz, tarsiz);
            wd_cntrl(WIND1, WD_ON);
        }
    }
    return(0);
}
```

One way to use this command is to set up a second state chain.

Example state chain:

```
/*
 * Object location query state set
 */
where_set{
status ON
begin      start:
                to halt
```

```

halt:          to qrywts on -PSTOP & drinput
qrywts:       to query on 0 % tst_tx_rdy
query:        do object_location()
              to qryack on 0 % tst_rx_new
qryack:       do pcm_ack(0)
              to stgwnd
stgwnd:       do targ_wnd()
              time 200
              to halt

```

```

}
```

GLvex will return two floating point values representing the X and Y coordinates of the selected object packed into an array of 8 bytes regardless of whether digital synchronization is enabled or not. The rex video sync square will not flash for this command. The vex_message() subroutine retrieves the last message from GLvex. The vex_code(char *) subroutine gets the code value from the msg argument. The vex_location(char *) subroutine unpacks the coordinates from the byte array msg and loads them into the long variables vx and vy. Vex_message, vex_code(char *), vex_location(char *), vx, and vy are all defined in GLvex_com.c.

SET_ACTIVE_OBJECT

This is a batchable command that changes the active object. Subsequent keyboard commands or movements of the mouse will affect the object specified by this command. The REPORT_LOCATION command will report the location of this object. This command has a single parameter, the number of the object to make active.

Example action:

```
/*
 * Action that sets the active object in VEX
 */
short act = 1;
set_active()
{
    short index;
    index = 0;
    vexbuf[index++] = SET_ACTIVE_OBJECT;
    vexbuf[index++] = act;
        .
        .
        .
    to_vex(index);
    return(0);
}
```

GLvex will return the signal BATCH_DONE (241) after completing all commands in the list regardless of whether digital synchronization is enabled or not.

SET_FP_SIZE

This is a batchable command that sets the size of the fixation point. It requires one parameter, which sets the radius of the fixation point in video pixels.

Example action:

```
/*
 * This action sends the four GLvex commands that determine
 * the properties and location of the fixation point as a single
 * batch command.
 */
short fpsiz = 4; /* value may be set in Rex state variables menu */
short fplum = 128; /* value may be set in Rex state variables menu */
short fpdim = 96; /* value may be set in Rex state variables menu */
float fpx = 0.0; /* value may be set in Rex state variables menu */
float fpy = 0.0; /* value may be set in Rex state variables menu */
set_fp()
{
    unsigned short index;
    int i;
    char *flbuf;
    index = 0;
    vexbuf[index++] = SET_FP_SIZE;
    vexbuf[index++] = fpsiz;
    vexbuf[index++] = SET_FP_ON_CLR;
    vexbuf[index++] = fplum;
    vexbuf[index++] = fplum;
    vexbuf[index++] = fplum;
    vexbuf[index++] = SET_FP_DIM_CLR;
    vexbuf[index++] = fpdim;
    vexbuf[index++] = fpdim;
    vexbuf[index++] = fpdim;
    vexbuf[index++] = SET_FP_LOCATION;
    flbuf = float2byte(fpx); /* convert a float to a string of 4 bytes */
    for(i = 0; i < 4; i++) vexbuf[index++] = flbuf[i];
    flbuf = float2byte(fpy);
    for(i = 0; i < 4; i++) vexbuf[index++] = flbuf[i];
    to_vex(index);
    return(0);
}
```

GLvex will return the signal BATCH_DONE (241) after completing all commands in the list regardless of whether digital synchronization is enabled or not. The float2byte() function is defined in GLvex_com.c.

CLIP_RECT_SET

This is a batchable command sets an object's clipping rectangle. The first parameter is the number of objects to set. Each object requires nine parameters, the object number, the hi- and lo- bytes of the X coordinate of the center of the clipping rectangle, the hi- and lo- bytes of the Y coordinate of the center of the clipping rectangle, the hi- and lo- bytes of the width of the clipping rectangle, and, the hi- and lo- bytes of the height of the clipping rectangle. All four of the clipping rectangle parameters are in REX units, i.e., tenths of a degree. You must use clipping rectangles if you want to place random patterns on ramps to display translational flow fields.

Example action:

```
/*
 * This action will set clipping rectangles in two objects.
 */
int rfx = -100;          /* X coordinate of receptive field */
int rfy = -30;          /* Y coordinate of receptive field */
int clipx[] = { 300, 100 }; /* width of surround texture aperture */
int clipy[] = { 300, 100 }; /* height of surround texture aperture */
int ob[] = { 1, 2 };
set_obj(void)
{
    unsigned short index;
    short i;
    /* surround clipping rectangle */
    vexbuf[index++] = CLIP_RECT_SET;
    vexbuf[index++] = 2;          /* number of apertures */
    for(i = 0; i < 2; i++) {
        vexbuf[index++] = 1;      /* surround object number */
        vexbuf[index++] = hbyte(rfx); /* high byte of center x */
        vexbuf[index++] = lbyte(rfx); /* low byte of center x */
        vexbuf[index++] = hbyte(rfy); /* high byte of center y */
        vexbuf[index++] = lbyte(rfy); /* low byte of center y */
        vexbuf[index++] = hbyte(clipx[i]); /* high byte of width */
        vexbuf[index++] = lbyte(clipx[i]); /* low byte of width */
        vexbuf[index++] = hbyte(clipy[i]); /* high byte of height */
        vexbuf[index++] = lbyte(clipy[i]); /* low byte of height */
    }
    .
    .
    .
    to_vex(index);
    return(0);
}
```

GLvex will return the signal BATCH_DONE (241) after completing all commands in the list regardless of whether digital synchronization is enabled or not. The hbyte() and lbyte() functions are defined in GLvex_com.c.

CLIP_RECT_SET_FROM_FP

This is a batchable command sets an object's clipping rectangle, relative to the fixation point. The first parameter is the number of objects to set. Each object requires nine parameters, the object number, the hi- and lo- bytes of the horizontal distance of the center of the clipping rectangle from the fixation point, the hi- and lo- bytes of the vertical distance of the center of the clipping rectangle from the fixation point, the hi- and lo- bytes of the width of the clipping rectangle, and the hi- and lo- bytes of the height of the clipping rectangle. All four of the clipping rectangle parameters are in REX units, i.e., tenths of a degree. You must use clipping rectangles if you want to place random patterns on ramps to display translational flow fields.

Example action:

```
/*
 * This action will clipping rectangles in two objects.
 */
int rfx = -100;          /* X coordinate of receptive field */
int rfy = -30;          /* Y coordinate of receptive field */
int clipx[] = { 300, 100 }; /* width of surround texture aperture */
int clipy[] = { 300, 100 }; /* height of surround texture aperture */
int ob[] = { 1, 1 };
set_obj(void)
{
    unsigned short index;
    short i;
    /* surround clipping rectangle */
    vexbuf[index++] = CLIP_RECT_SET_FROM_FP;
    vexbuf[index++] = 2; /* number of apertures */
    for(i = 0; i < 2; i++) {
        vexbuf[index++] = ob[i]; /* surround object number */
        vexbuf[index++] = hbyte(rfx); /* high byte of center x */
        vexbuf[index++] = lbyte(rfx); /* low byte of center x */
        vexbuf[index++] = hbyte(rfy); /* high byte of center y */
        vexbuf[index++] = lbyte(rfy); /* low byte of center y */
        vexbuf[index++] = hbyte(clipx[i]); /* high byte of width */
        vexbuf[index++] = lbyte(clipx[i]); /* low byte of width */
        vexbuf[index++] = hbyte(clipy[i]); /* high byte of height */
        vexbuf[index++] = lbyte(clipy[i]); /* low byte of height */
    }
    .
    .
    .
    to_vex(index);
    return(0);
}
```

GLvex will return the signal BATCH_DONE (241) after completing all commands in the list regardless of whether digital synchronization is enabled or not. The hbyte() and lbyte() functions are defined in GLvex_com.c.

FULL_CLIP_RECT

This is a batchable command that resets the clipping rectangles of objects to the full screen. The first parameter is the number of objects. Each object has one parameter, the object number.

Example action:

```
/*
 * This action restores the clipping rectangles of 4 objects to full screen.
 */
restore_clip(void)
{
    unsigned short index;
    short i;
    index = 0;
    vexbuf[index++] = FULL_CLIP_RECT;
    vexbuf[index++] = 4;                /* number of objects */
    for(i = 0; i < 4; i++) {
        vexbuf[index++] = i + 1; /* object number */
    }
    .
    .
    .
    to_vex(index);
    return(0);
}
```

GLvex will return the signal BATCH_DONE (241) after completing all commands in the list regardless of whether digital synchronization is enabled or not.

DRAW_WALSH_PATTERN

This is a batchable command that draws a Walsh pattern in an object. The first parameter is the number of objects to draw in. Each object requires four parameters, the object number, the pattern number, the pattern check size, and the contrast. The pattern numbers can range from 0 to 255. The contrast can be either 1 for normal contrast patterns, or -1 for reverse contrast patterns.

Example action:

```
/*
 * This action draws Walsh patterns in three objects.
 */
short patterns[] = { 7, 18, 21, 24, 43, 63 };
short ptrlst[6] = { 0 };
short ob[] = { 3, 5, 2 };
short size = 4;
draw_walsh()
{
    unsigned short index;
    short i, j;
    static int rs_shift = 10;
    static int trlcnt = 6;
    for(i = 0; i < trlcnt; i++) ptrlst[i] = i;
    shuffle(trlcnt, rs_shift, ptrlst);
    index = 0;
    vexbuf[index++] = DRAW_WALSH_PATTERN;
    vexbuf[index++] = 3; /* number of objects */
    for(i = 0; i < 3; i++) {
        j = ptrlst[i];
        vexbuf[index++] = ob[i]; /* object number */
        vexbuf[index++] = patterns[j]; /* pattern number */
        vexbuf[index++] = size; /* pattern check size */
        vexbuf[index++] = 1; /* positive contrast */
    }
    .
    .
    .
    to_vex(index);
    return(0);
}
```

GLvex will return the signal BATCH_DONE (241) after completing all commands in the list regardless of whether digital synchronization is enabled or not.

DRAW_HAAR_PATTERN

This is a batchable command that draws a Haar pattern in an object. The first parameter is the number of objects to draw in. Each object requires four parameters, the object number, the pattern number, the pattern check size, and the contrast. The pattern numbers can range from 0 to 255. The contrast can be either 1 for normal contrast patterns, or -1 for reverse contrast patterns.

Example action:

```
/*
 * This action draws Walsh patterns in three objects.
 */
short patterns[] = { 7, 18, 21, 24, 43, 63 };
short ptrlst[6] = { 0 };
short ob[] = { 3, 5, 2 };
short size = 4;
draw_haar()
{
    unsigned short index;
    short i, j;
    static int rs_shift = 10;
    static int trlcnt = 6;
    for(i = 0; i < trlcnt; i++) ptrlst[i] = i;
    shuffle(trlcnt, rs_shift, ptrlst);
    index = 0;
    vexbuf[index++] = DRAW_HAAR_PATTERN;
    vexbuf[index++] = 3; /* number of objects */
    for(i = 0; i < 3; i++) {
        j = ptrlst[i];
        vexbuf[index++] = ob[i]; /* object number */
        vexbuf[index++] = patterns[j]; /* pattern number */
        vexbuf[index++] = size; /* pattern check size */
        vexbuf[index++] = 1; /* positive contrast */
    }
    .
    .
    .
    to_vex(index);
    return(0);
}
```

GLvex will return the signal BATCH_DONE (241) after completing all commands in the list regardless of whether digital synchronization is enabled or not.

DRAW_RANDOM_PATTERN

This is a batchable command that draws a rectangular, random, two-dimensional matrix of "white" and "black" checks in an object. The first parameter is the number of objects to draw in. Each object requires five parameters, the object number, the horizontal resolution of the random pattern, the vertical resolution of the random pattern, the pattern check size, and the percentage of checks to make "white". The horizontal and vertical resolution determines the number of rows and columns in the matrix, and can range from 2 to 180. The white check percentage can range from 1 to 99. The random number generator is given a new seed number on each call, so each call will produce a different pattern of checks.

Example action:

```
/*
 * This action draws two different random patterns with the same resolution
 * and percentage of white checks in two objects.
 */
short horizontal = 60;    /* 60 columns */
short vertical = 120;    /* 120 rows 7200 checks */
short pwhite = 20; /* 1440 of 7200 checks to be "white" */
short ob[] = { 1, 2 };
short size = 4;          /* pattern check size */
draw_random()
{
    unsigned short index;
    short i;
    index = 0;
    vexbuf[index++] = DRAW_RANDOM_PATTERN;
    vexbuf[index++] = 2;          /* number of objects */
    for(i = 0; i < 2; i++) {
        vexbuf[index++] = ob[i];    /* object number */
        vexbuf[index++] = horizontal; /* horizontal resolution */
        vexbuf[index++] = vertical; /* vertical resolution */
        vexbuf[index++] = size;    /* pattern check size */
        vexbuf[index++] = pwhite; /* percentage of white checks */
    }
    .
    .
    .
    to_vex(index);
    return(0);
}
```

GLvex will return the signal BATCH_DONE (241) after completing all commands in the list regardless of whether digital synchronization is enabled or not.

DRAW_ANNULUS

This is a batchable command that draws an annulus in an object. The first parameter is the number of objects to draw in. Each object requires four parameters, the object number, the outer radius of the annulus, the inner radius of the annulus, and the contrast. If the inner radius is 0, then GLvex will draw a filled circle. The contrast can be either 1 for normal contrast annuli, or -1 for reverse contrast annuli.

Example action:

```
/*
 * This action draws an annulus in an object.
 */
short outer = 45;
short inner = 10;
short obi = 1;
short size = 4;
draw_annulus()
{
    unsigned short index;
    index = 0;
    vexbuf[index++] = DRAW_ANNULUS;
    vexbuf[index++] = 1;          /* number of objects */
    vexbuf[index++] = obi;       /* object number */
    vexbuf[index++] = outer; /* outer radius */
    vexbuf[index++] = inner; /* inner radius (can be 0) */
    vexbuf[index++] = 1;        /* positive contrast */
    .
    .
    .
    to_vex(index);
    return(0);
}
```

GLvex will return the signal BATCH_DONE (241) after completing all commands in the list regardless of whether digital synchronization is enabled or not.

DRAW_BIG_ANNULUS

This is a batchable command that draws an annulus in an object. It differs from the previous command in that the values for the inner and outer radii are integers rather than unsigned chars. Thus, larger annuli may be drawn. The first parameter is the number of objects to draw in. Each object requires six parameters, the object number, the high byte of the outer radius of the annulus, the low byte of the outer radius of the annulus, the high byte of the inner radius of the annulus, the low byte of the inner radius of the annulus, and the contrast. If the inner radius is 0, then GLvex will draw a filled circle. The contrast can be either 1 for normal contrast annuli, or -1 for reverse contrast annuli.

Example action:

```
/*
 * This action draws an annulus in an object.
 */
short outer = 45;
short inner = 10;
short obi = 1;
short size = 4;
draw_annulus()
{
    unsigned short index;
    index = 0;
    vexbuf[index++] = DRAW_ANNULUS;
    vexbuf[index++] = 1;          /* number of objects */
    vexbuf[index++] = obi;       /* object number */
    vexbuf[index++] = hibyte(outer); /* high byte of outer radius */
    vexbuf[index++] = lobyte(outer); /* low byte of outer radius */
    vexbuf[index++] = hibyte(inner); /* high byte of inner radius (can be 0) */
    vexbuf[index++] = lobyte(inner); /* low byte of inner radius (can be 0) */
    vexbuf[index++] = 1;        /* positive contrast */
    .
    .
    .
    to_vex(index);
    return(0);
}
```

GLvex will return the signal BATCH_DONE (241) after completing all commands in the list regardless of whether digital synchronization is enabled or not. The hibyte() and lobyte() functions are defined in GLvex_com.c.

DRAW_BAR

This is a batchable command that draws a bar in an object. The first parameter is the number of objects to draw in. Each object requires 5 parameters, the object number, the orientation of the bar, the width of the bar, length of the bar, and the contrast of the bar. The contrast can be either 1 for a normal contrast bar, or -1 for a reverse contrast bar. A normal contrast bar is drawn in the object's foreground color, and a reverse contrast bar is drawn in the object's background color.

Example action:

```
/*
 * This action draws an oriented bar in an object.
 */
short angle = 15;
short width = 5;
short length = 200;
short contrast = 1;
draw_bar()
{
    unsigned short index;
    index = 0;
    vexbuf[index++] = DRAW_BAR;
    vexbuf[index++] = 1;          /* number of objects */
    vexbuf[index++] = 5;          /* this object number */
    vexbuf[index++] = angle;      /* orientation of the bar (0 - 180 degrees)*/
    vexbuf[index++] = width;      /* width of the bar in rex units */
    vexbuf[index++] = length;     /* length of the bar in rex units */
    vexbuf[index++] = contrast;   /* a normal contrast bar */
    .
    .
    .
    to_vex(index);
    return(0);
}
```

GLvex will return the signal BATCH_DONE (241) after completing all commands in the list regardless of whether digital synchronization is enabled or not.

DRAW_FLOW_PATTERN

This is a batchable command that specifies the initial positions of checks for a flow field. The first parameter is the number of objects in which to draw flow fields. Each object requires 11 parameters; the object number, the hi- and lo- bytes of the width of the flow field, the hi- and lo- bytes of the height of the flow field, the hi- and lo- bytes of the distance to the near plane, the hi- and lo- bytes of the distance to the far plane, the coverage of the flow field, and the check size. The width and height, are in rex units, i.e., tenths of a degree of visual angle. You specify the distances to the near and far planes in rex units, but these parameters are converted internally from degrees of visual angle to the equivalent linear distance. If the far value is greater than the near value, the flow field will be three-dimensional, otherwise the flow field will be two-dimensional. The coverage of the flow field is the percentage of the area of the flow field you want covered by checks expresses in tenths of a percent.

Example action:

```
/* This action sets up three-dimensional flow fields in 2 objects */
short wide[] = { 640, 200 };
short tall[] = { 480, 200 };
short ob[] = { 2, 3 };
short near = 640;          /* near value is less than */
short far = 2000;         /* far value for 3-D flow field */
short cov = 50;           /* 5% of flow field area will be covered by checks*/
short size = 4;
draw_flow()
{
    unsigned short index;
    short i;
    index = 0;
    vexbuf[index++] = DRAW_FLOW_PATTERN;
    vexbuf[index++] = 2;                                     /* number of objects */
    for(i = 0; i < 2; i++) {
        vexbuf[index++] = ob[i];          /* object number */
        vexbuf[index++] = hbyte(wide[i]); /* high byte of flow field width */
        vexbuf[index++] = lbyte(wide[i]); /* low byte of flow field width */
        vexbuf[index++] = hbyte(tall[i]); /* high byte of flow field height*/
        vexbuf[index++] = lbyte(tall[i]); /* low byte of flow field height */
        vexbuf[index++] = hbyte(near);    /* high byte of near plane distance */
        vexbuf[index++] = lbyte(near);    /* low byte of near plane distance */
        vexbuf[index++] = hbyte(far);     /* high byte of far plane distance */
        vexbuf[index++] = lbyte(far);     /* low byte of far plane distance */
        vexbuf[index++] = cov;            /* tenths percent coverage */
        vexbuf[index++] = size;           /* check size */
    }
    .
    .
    .
    to_vex(index);
    return(0);
}
```

GLvex will return the signal BATCH_DONE (241) after completing all commands in the list regardless of whether digital synchronization is enabled or not. The hbyte() and lbyte() functions are defined in GLvex_com.c.

DRAW_ELLIPTICAL_FLOW_PATTERN

This is a batchable command that specifies the initial positions of checks for a flow field. The checks will be in an elliptical pattern. The first parameter is the number of objects in which to draw flow fields. Each object requires 12 parameters; the object number, the hi- and lo- bytes of the radius of the pattern the hi- and lo- bytes of the width of the flow field, the hi- and lo- bytes of the height of the flow field, the hi- and lo- bytes of the distance to the near plane, the hi- and lo- bytes of the distance to the far plane, the coverage of the flow field, and the check size. The radius is in rex units and the width and height are percentages of the radius. To get a circular pattern, make the width and height 100.

Example action:

```
/** This action sets up three-dimensional flow fields in 2 objects */
short wide[] = { 640, 200 };
short tall[] = { 480, 200 };
short ob[] = { 2, 3 };
short near = 640;          /* near value is less than */
short far = 2000;         /* far value for 3-D flow field */
short cov = 50;          /* 5% of flow field area will be covered by checks*/
short size = 4;
draw_flow()
{
    unsigned short index;
    short i;
    index = 0;
    vexbuf[index++] = DRAW_ELLIPTICAL_FLOW_PATTERN;
    vexbuf[index++] = 2;          /* number of objects */
    for(i = 0; i < 2; i++) {
        vexbuf[index++] = ob[i];    /* object number */
        vexbuf[index++] = hbyte(wide[i]); /* high byte of flow field width */
        vexbuf[index++] = lbyte(wide[i]); /* low byte of flow field width */
        vexbuf[index++] = hbyte(tall[i]); /* high byte of flow field height */
        vexbuf[index++] = lbyte(tall[i]); /* low byte of flow field height */
        vexbuf[index++] = hbyte(near); /* high byte of near plane distance */
        vexbuf[index++] = lbyte(near); /* low byte of near plane distance */
        vexbuf[index++] = hbyte(far); /* high byte of far plane distance */
        vexbuf[index++] = lbyte(far); /* low byte of far plane distance */
        vexbuf[index++] = cov;      /* tenths percent coverage */
        vexbuf[index++] = size;     /* check size */
    }
    .
    .
    .
    to_vex(index);
    return(0);
}
```

GLvex will return the signal BATCH_DONE (241) after completing all commands in the list regardless of whether digital synchronization is enabled or not. The hbyte() and lbyte() functions are defined in GLvex_com.c.

MASK_FLOW

This is a batchable command that defines an area within a flow field where checks will not be drawn. The first parameter is the number of objects in which to mask flow fields. Each object requires 13 parameters. The first parameter is the object number. The next four parameters are the hi- and lo-bytes of the width of the mask and the hi- and lo- bytes of the height of the mask. The next four parameters are the four bytes of the X coordinate of the mask in the flow field. The last four parameters are the four bytes of the Y coordinate of the mask in the flow field. The width, height, X-, and Y-coordinates are all in rex units, i.e., tenth of a degree of visual angle. The X-, and Y-coordinates are relative to the center of the object. Negative X values are in the left half of the object, and negative Y values are in the lower half of the object. A flow field pattern must be specified for an object before a flow field mask can be specified for the object. The width and height of the mask should not exceed the width and height of the flow field.

Example action:

```
/*
 * This action sets up a mask in a flow field pattern in 1 object
 */
short wide = 200;
short tall = 200;
short obi = 2;
short x = -20.0;
short y = 20.0;
mask_flow()
{
    unsigned short index;
    int i;
    index = 0;
    vexbuf[index++] = MASK_FLOW;
    vexbuf[index++] = 1; /* number of objects */
    vexbuf[index++] = obi; /* object number */
    vexbuf[index++] = hbyte(wide); /* high byte of mask width */
    vexbuf[index++] = lobyte(wide); /* low byte of mask width */
    vexbuf[index++] = hbyte(tall); /* high byte of mask height */
    vexbuf[index++] = lobyte(tall); /* low byte of mask height */
    flbuf = float2byte(x);
    for(j = 0; j < 4; j++) vexbuf[index++] = flbuf[j];
    flbuf = float2byte(y);
    for(j = 0; j < 4; j++) vexbuf[index++] = flbuf[j];
    .
    .
    . /* other batchable commands */
    to_vex(index);
    return(0);
}
```

GLvex will return the signal BATCH_DONE (241) after completing all commands in the list regardless of whether digital synchronization is enabled or not. The hbyte() and lobyte() functions are defined in GLvex_com.c.

DRAW_USER_PATTERN

This is a batchable command that draws a user defined pattern in an object. The pattern is defined in a file named "Pnumber" where "number" is the pattern number you are going to use for that pattern. The first parameter is the number of objects to draw in. Each object requires five parameters, the object number, the high byte of the pattern number, the low byte of the pattern number, the pattern check size, and the contrast. The pattern numbers can range from 0 to 65536. The contrast can be either 1 for normal contrast patterns, or -1 for reverse contrast patterns.

The format of the pattern template is:

```
r c
n n n ... n n n
n n n ... n n n
n n n ... n n n
...
...
...
n n n ... n n n
n n n ... n n n
n n n ... n n n
```

The letters r and c indicate the number of rows and columns in the pattern. The maximum number of rows or columns is 255. The pattern may be rectangular, i.e., you do not need to have the same number of rows and columns. The letter n indicate the values for the individual checks in the pattern. If n equals 1, the object's foreground color will be used in that check. If n equals -1, the object's background color will be used in that check. If n equals 0, the screen's background color will be used in that check. If n equals 2 - 255, lookup table entries will be use in that check.

Example of a file for a user defined pattern with 8 rows and 8 cols. This file defines a "white" and a "black" bar centered in a gray region. The name of the file might be "p1".

```
8 8
0 0 0 1 -1 0 0 0
0 0 0 1 -1 0 0 0
0 0 0 1 -1 0 0 0
0 0 0 1 -1 0 0 0
0 0 0 1 -1 0 0 0
0 0 0 1 -1 0 0 0
0 0 0 1 -1 0 0 0
0 0 0 1 -1 0 0 0
```

Example of a file for a user defined pattern with 8 rows and 2 cols. This file also defines a "white" and a "black" bar, but does not have the gray region. The name of the file might be "p2".

```
8 2
1 -1
1 -1
1 -1
1 -1
1 -1
1 -1
1 -1
1 -1
```

Example action:

```
/*
 * This action draws user defined patterns in three objects.\
 */
short patterns[] = { 1, 2, 3, 4, 5, 6 };
short ptrlst[6] = { 0 };
short ob[] = { 3, 5, 2 };
short size = 4;
draw_user()
{
    unsigned short index;
    short i, j;
    static int rs_shift = 10;
    static int trlcnt = 6;
    for(i = 0; i < trlcnt; i++) ptrlst[i] = i;
    shuffle(trlcnt, rs_shift, ptrlst);
    index = 0;
    vexbuf[index++] = DRAW_USER_PATTERN;
    vexbuf[index++] = 3;                /* number of objects */
    for(i = 0; i < 3; i++) {
        j = ptrlst[i];
        vexbuf[index++] = ob[i];        /* object number */
        vexbuf[index++] = hbyte(patterns[j]); /* high byte of pattern number */
        vexbuf[index++] = lobyte(patterns[j]); /* low of pattern number */
        vexbuf[index++] = size;        /* pattern check size */
        vexbuf[index++] = 1;          /* positive contrast */
    }
    .
    .
    .
    to_vex(index);
    return(0);
}
```

GLvex will return the signal BATCH_DONE (241) after completing all commands in the list regardless of whether digital synchronization is enabled or not.

DRAW_RGB_USER_PATTERN

This is a batchable command that draws a user defined RGB pattern in an object. The pattern is defined in a file named "Pnumber" where "number" is the pattern number you are going to use for that pattern. The first parameter is the number of objects to draw in. Each object requires four parameters, the object number, the high byte of the pattern number, the low byte of the pattern number, and the pattern check size. The pattern numbers can range from 0 to 65536.

The format of the pattern template is:

```
r c 3
r g b r g b r g b ... r g b r g b r g b
r g b r g b r g b ... r g b r g b r g b
r g b r g b r g b ... r g b r g b r g b
...
...
...
r g b r g b r g b ... r g b r g b r g b
r g b r g b r g b ... r g b r g b r g b
r g b r g b r g b ... r g b r g b r g b
```

The letters r and c indicate the number of rows and columns in the pattern. The number 3 indicates that each pixel is defined by 3 values, r g and b. This number can only be 3. The maximum number of rows or columns is 255. The pattern may be rectangular, i.e., you do not need to have the same number of rows and columns. The letters r g b indicate the values for red, green, and blue for the individual checks in the pattern.

Example of a file for a user defined pattern with 8 rows and 8 cols. This file defines a "red" and a "green" bar centered in a blue region. The name of the file might be "P1000".

```
8 8 3
0 0 255 0 0 255 0 0 255 255 0 0 0 255 0 0 0 255 0 0 0 255 0 0 255 0 0 255
0 0 255 0 0 255 0 0 255 255 0 0 0 255 0 0 0 255 0 0 0 255 0 0 255 0 0 255
0 0 255 0 0 255 0 0 255 255 0 0 0 255 0 0 0 255 0 0 0 255 0 0 255 0 0 255
0 0 255 0 0 255 0 0 255 255 0 0 0 255 0 0 0 255 0 0 0 255 0 0 255 0 0 255
0 0 255 0 0 255 0 0 255 255 0 0 0 255 0 0 0 255 0 0 0 255 0 0 255 0 0 255
0 0 255 0 0 255 0 0 255 255 0 0 0 255 0 0 0 255 0 0 0 255 0 0 255 0 0 255
0 0 255 0 0 255 0 0 255 255 0 0 0 255 0 0 0 255 0 0 0 255 0 0 255 0 0 255
0 0 255 0 0 255 0 0 255 255 0 0 0 255 0 0 0 255 0 0 0 255 0 0 255 0 0 255
```

Example of a file for a user defined pattern with 8 rows and 2 cols. This file also defines a "red" and a "green" bar, but does not have the blue region. The name of the file might be "P2000".

```
8 2 3
255 0 0 0 255 0
255 0 0 0 255 0
255 0 0 0 255 0
255 0 0 0 255 0
255 0 0 0 255 0
255 0 0 0 255 0
255 0 0 0 255 0
255 0 0 0 255 0
```

Example action:

```
/*
* This action draws user defined patterns in three objects.
```



```

*/
short patterns[] = { 1001, 1002, 1003, 1004, 1005, 1006 };
short ptrlst[6] = { 0 };
short ob[] = { 3, 5, 2 };
short size = 4;
draw_rgb_user()
{
    unsigned short index;
    short i, j;
    static int rs_shift = 10;
    static int trlcnt = 6;
    for(i = 0; i < trlcnt; i++) ptrlst[i] = i;
    shuffle(trlcnt, rs_shift, ptrlst);
    index = 0;
    vexbuf[index++] = DRAW_RGB_USER_PATTERN;
    vexbuf[index++] = 3; /* number of objects */
    for(i = 0; i < 3; i++) {
        j = ptrlst[i];
        vexbuf[index++] = ob[i]; /* object number */
        vexbuf[index++] = hbyte(patterns[j]); /* high byte of pattern number */
        vexbuf[index++] = lobyte(patterns[j]); /* low of pattern number */
        vexbuf[index++] = size; /* pattern check size */
        vexbuf[index++] = 1; /* positive contrast */
    }
    . /* other batchable commands */
    .
    to_vex(index);
    return(0);
}

```

GLvex will return the signal BATCH_DONE (241) after completing all commands in the list regardless of whether digital synchronization is enabled or not.

DRAW_TIFF_IMAGE

This is a batchable command that draws a TIFF image in an object. The image is taken from a file named "Inumber.tif" where "number" is the image number you are going to use for that image. I chose to have file names start with "I" because they contain images, not patterns. The reason for requiring the ".tif" extension is so that other windows programs can recognize the file as a TIFF file. Though TIFF image files may contain multiple images, currently GLvex will only draw the first image in the file. Further, GLvex does not support image compression. The images in the TIFF files should be in RGBA format.

The first parameter is the number of objects to draw in. Each object requires three parameters, the object number, the high byte of the image number, and the low byte of the image number. The image numbers can range from 0 to 65536.

Example action:

```
/*
 * This action draws a TIFF image in three objects.
 */
short patterns[] = { 1001, 1002, 1003, 1004, 1005, 1006 };
short ptrlst[6] = { 0 };
short ob[] = { 3, 5, 2 };
draw_tiff()
{
    unsigned short index;
    short i, j;
    static int rs_shift = 10;
    static int trlcnt = 6;
    for(i = 0; i < trlcnt; i++) ptrlst[i] = i;
    shuffle(trlcnt, rs_shift, ptrlst);
    index = 0;
    vexbuf[index++] = DRAW_TIFF_IMAGE;
    vexbuf[index++] = 3;                                     /* number of objects */
    for(i = 0; i < 3; i++) {
        j = ptrlst[i];
        vexbuf[index++] = ob[i];                             /* object number */
        vexbuf[index++] = hbyte(patterns[j]); /* high byte of pattern number */
        vexbuf[index++] = lobyte(patterns[j]); /* low of pattern number */
    }
    .
    .                                                         /* other batchable commands */
    .
    to_vex(index);
    return(0);
}
```

GLvex will return the signal BATCH_DONE (241) after completing all commands in the list regardless of whether digital synchronization is enabled or not.

DRAW_OKN_PATTERN

This is a batchable command that creates either a horizontal or a vertical square wave pattern that can be used as an optokinetic nystagmus stimulus. The first parameter is the number of objects to draw in. Each object requires 11 parameters, the object number, the hi- and lo-bytes of the direction of movement, the hi- and lo-bytes of the speed of movement, the hi- and lo-bytes of the width of the pattern, the hi- and lo-bytes of the height of the pattern, and the hi- and lo-bytes of the width of the bars. The direction of movement can only be 0 degrees, 90 degrees, 180 degrees, and 270 degrees. The height and width of the pattern and the width of the bars are in rex units, i.e., tenths of a degree of visual angle. The speed of movement is in degrees / second.

Example action:

```
/* This action sets up an OKN stimulus in object 2 */
draw_okn()
{
    unsigned short index;
    short direction;
    short speed;
    short width;
    short height;
    short thick;
    direction = 90;           /* upwards movement */
    speed = 10;             /* ten degrees/second */
    width = 300;           /* pattern is 30 degrees wide */
    height = 250;         /* pattern is 25 degrees high */
    thick = 10;           /* bars are 1 degree wide (and 30 degrees long) */
    index = 0;
    vexbuf[index++] = DRAW_OKN_PATTERN;
    vexbuf[index++] = 1;     /* number of objects to draw OKN stimuli in */
    vexbuf[index++] = 2;     /* object number */
    vexbuf[index++] = hbyte(direction); /* high byte of the direction of movement */
    vexbuf[index++] = lbyte(direction); /* low byte of the direction of movement */
    vexbuf[index++] = hbyte(speed); /* high byte of the speed of movement */
    vexbuf[index++] = lbyte(speed); /* low byte of the speed of movement */
    vexbuf[index++] = hbyte(width); /* high byte of the width of stimulus */
    vexbuf[index++] = lbyte(width); /* low byte of the width of stimulus */
    vexbuf[index++] = hbyte(height); /* high byte of the height of stimulus */
    vexbuf[index++] = lbyte(height); /* low byte of the height of stimulus */
    vexbuf[index++] = hbyte(thick); /* high byte of the thickness of the bars */
    vexbuf[index++] = lbyte(thick); /* low byte of the thickness of the bars */
    .
    .
    .
    to_vex(index);
    return(0);
}
```

If you turn object 2 on after calling this action, you will see a stationary, horizontal square wave grating. You must use the START_OKN command described below to start the bars moving. GLvex will return the signal BATCH_DONE (241) after completing all commands in the list regardless of whether digital synchronization is enabled or not. The hbyte() and lbyte() functions are defined in GLvex_com.c.

LOAD_PATTERN

This is a batchable command that loads a user pattern from Rex. The first parameter is the number of the object into which to load the pattern. The second parameter is the stimulus number. The third parameter is the size of the checks in the pattern. The fourth parameter is the number of rows in the pattern. The fifth parameter is the number of columns in the pattern. The remaining parameters are the values to be loaded into the individual checks in the pattern, from upper left to lower right. The number of check values you supply must equal the number of rows multiplied by the number of columns.

Example actions:

```
#define MVLENGTH 20
#define IMAGE_TOTAL 2 * MVLENGTH
#define MAX_LOOKUP_NUMBER 100
struct grid_struct {
    int obj;
    int colorch;
};
static struct grid_struct grid[IMAGE_TOTAL][MAX_LOOKUP_NUMBER];
int rand_noise()
{
    int flag1;
    if(rand() < (RAND_MAX/2)) flag1 = -1;
    else flag1 = 1;
    return(flag1 * ((double)rand() / ((double)RAND_MAX + 1)) * range);
}
grid_val()
{
    int rand_perc, i, j;
    int chksz = 10; int fbd = 50; unsigned short index = 0;
    for (i = 0; i < IMAGE_TOTAL; i++) {
        for(j = 0; j < 100; j++) {
            rand_perc = ((float)rand_noise() * fbd) / 100.0;
            grid[i][j].colorch = rand_perc;
        }
        vexbuf[index++] = LOAD_PATTERN;
        vexbuf[index++] = i + 1; /* object number */
        vexbuf[index++] = i + 1; /* stimulus number */
        vexbuf[index++] = chksz; /* check size */
        vexbuf[index++] = 10; /* number of rows in stimulus */
        vexbuf[index++] = 10; /* number of columns in stimulus */
        for(j = 0; j < 100; j++) { /* the 100 values for the stimulus */
            vexbuf[index++] = grid[i][j].colorch;
        }
    }
    .
    .
    .
    to_vex(index);
    return(0);
}
```

GLvex will return the signal BATCH_DONE (241) after completing all commands in the list regardless of whether digital synchronization is enabled or not.

COPY_OBJECT

This is a batchable command that copies the stimulus in one object into a second object. It requires 6 parameters, the number of the source object, the number of the destination object, the hi- and lo- bytes of the percentage of horizontal scaling of the copied object, and the hi and lo- bytes of the percentage of the vertical scaling of the copied object. The purpose of this command is to draw identical random check patterns or identical flow field patterns in multiple objects, however it will copy any pattern from one object to another with the exception of TIFF images. NOTE: If you want to create a series of copies, each of a different size, then start with the same source object each time. For example, if you want to scale the pattern in object 1 by 125% and by 150%, you should copy object 1 to object 2 with 125% scaling and then copy object 1 to object 3 with 150% scaling. If you copy object 1 to object 2 with 125% scaling, then copy object 2 to object 3 with 125% scaling, object 3 will be 125% of the size of object 1, not object 2. (i.e. object 3 will be the same size as object 2, not 25% larger).

Example action:

```
/* draw random pattern in one object, copy into second object and shrink width by 10% */
short vres = 100; short hres = 200; short size = 5; short prcnt = 20;
short ob1 = 1; short ob2 = 2;
short xs = 90; short ys = 100; /* copy will be 90% as wide as and same height as source */
binoc(void)
{
    unsigned short index;
    index = 0;
    /* draw random pattern in one object */
    vexbuf[index++] = DRAW_RANDOM_PATTERN;
    vexbuf[index++] = 1; /* number of objects */
    vexbuf[index++] = obi; /* object number */
    vexbuf[index++] = hres; /* horizontal pattern resolution */
    vexbuf[index++] = vres; /* vertical pattern resolution */
    vexbuf[index++] = size; /* size of pattern checks */
    vexbuf[index++] = prcnt; /* percentage of white checks */
    /* copy and shrink random pattern from object 1 to object 2 */
    vexbuf[index++] = COPY_OBJECT;
    vexbuf[index++] = ob1; /* source object number */
    vexbuf[index++] = ob2; /* destination object number */
    vexbuf[index++] = hbyte(xs); /* high byte of horizontal scaling */
    vexbuf[index++] = lobyte(xs); /* low byte of horizontal scaling */
    vexbuf[index++] = hbyte(ys); /* high byte of vertical scaling */
    vexbuf[index++] = lobyte(ys); /* low byte of vertical scaling */
    .
    .
    /* other batchable commands */
    .
    to_vex(index);
    return(0);
}
```

GLvex will return the signal BATCH_DONE (241) after completing all commands in the list regardless of whether digital synchronization is enabled or not. The hbyte() and lobyte() functions are defined in GLvex_com.c.

NEW_RAMP

This is a batchable command that defines a new ramp or redefines an old ramp. The first parameter is the number of ramps to define. Each ramp requires 13 parameters; the ramp number, the hi- and lo- bytes of the length, the hi- and lo- bytes of the angle, the hi- and lo- bytes of the velocity, the hi- and lo- bytes of the X reference point, the hi- and lo- bytes of the Y reference point, the ramp type, and the end action. Length is half the total length in tenths of a degree. Angle is the polar angle of the ramp with 0 degrees defining motion from the monkey's left to right. Velocity is in degrees/second. Reference point is a cartesian point in tenths of a degree. For circular ramps, the length is the radius of the circle, and angle is the starting point of the object on the rim of the circle. Spot files that use ramps must include the /rex/hdr/ramp.h header file.

Type defines the reference point of the ramp. RA_CENPT (02): reference point is the center of the ramp. RA_BEGINPT (04): reference point is the beginning of the ramp. RA_ENDPT (08): reference point is the end of the ramp. RA_CLKWISE (16): computes a clockwise circular ramp centered on reference point RA_CCLKWISE (32): computes a counter-clockwise circular ramp centered on reference point.

Action defines what happens to the object on the ramp after the ramp stops. OFF_AFTER_RAMP (0): object turns off after the end of the ramp. ON_AFTER_RAMP (1): object stays on after the end of the ramp.

Example action:

```
/* This action defines a ramp. */
short length = 200; short direction = 15; short speed = 20; short rfx = 100; short rfy = -10;
make_ramp(void)
{
    unsigned short index;
    index = 0;
    vexbuf[index++] = NEW_RAMP;
    vexbuf[index++] = 1; /* number of ramps */
    vexbuf[index++] = 1; /* ramp number */
    vexbuf[index++] = hibyte(length); /* high byte of ramp length */
    vexbuf[index++] = lobyte(length); /* low byte of ramp length */
    vexbuf[index++] = hibyte(direction); /* high byte of ramp direction */
    vexbuf[index++] = lobyte(direction); /* low byte of ramp direction */
    vexbuf[index++] = hibyte(speed); /* high byte of ramp speed */
    vexbuf[index++] = lobyte(speed); /* low byte of ramp speed */
    vexbuf[index++] = hibyte(rfx); /* high byte of X offset */
    vexbuf[index++] = lobyte(rfx); /* low byte of X offset */
    vexbuf[index++] = hibyte(rfy); /* high byte of Y offset */
    vexbuf[index++] = lobyte(rfy); /* low byte of Y offset */
    vexbuf[index++] = RA_CENPT; /* reference is center of ramp */
    vexbuf[index++] = ON_AFTER_RAMP; /* object stays on after end of ramp */
    .
    .
    . /* other batchable commands */
    to_vex(index);
    return(0);
}
```

GLvex will return the signal BATCH_DONE (241) after completing all commands in the list regardless of whether digital synchronization is enabled or not. The hibyte() and lobyte() functions are defined in GLvex_com.c.

NEW_RAMP_FROM_FP

This is a batchable command that defines a new ramp or redefines an old ramp, relative to the fixation point. The first parameter is the number of ramps to define. Each ramp requires 13 parameters; the ramp number, the hi- and lo- bytes of the length, the hi- and lo- bytes of the angle, the hi- and lo- bytes of the velocity, the hi- and lo- bytes of the horizontal distance from the fixation point, the hi- and lo- bytes of the vertical distance from the fixation point, the ramp type, and the end action. Length is half the total length in tenths of a degree. Angle is the polar angle of the ramp with 0 degrees defining motion from the monkey's left to right. Velocity is in degrees/second. Offset is a cartesian point in tenths of a degree. Spot files that use ramps must include the /rex/hdr/ramp.h header file.

Type defines the reference point of the ramp. RA_CENPT (02): reference point is the center of the ramp. RA_BEGINPT (04): reference point is the beginning of the ramp. RA_ENDPT (08): reference point is the end of the ramp. RA_CLKWISE (16): computes a clockwise circular ramp. RA_CCLKWISE (32): computes a counter-clockwise circular ramp.

Action defines what happens to the object on the ramp after the ramp stops.

OFF_AFTER_RAMP (0): object turns off after the end of the ramp. ON_AFTER_RAMP (1): object stays on after the end of the ramp

Example action:

```
/* This action defines a ramp.*/
short length = 200; short direction = 15; short speed = 20; short rfx = 100; short rfy = -20;
make_ramp(void)
{
    unsigned short index;
    index = 0;
    vexbuf[index++] = NEW_RAMP_FROM_FP;
    vexbuf[index++] = 1; /* number of ramps */
    vexbuf[index++] = 1; /* ramp number */
    vexbuf[index++] = hbyte(length); /* high byte of ramp length */
    vexbuf[index++] = lbyte(length); /* low byte of ramp length */
    vexbuf[index++] = hbyte(direction); /* high byte of ramp direction */
    vexbuf[index++] = lbyte(direction); /* low byte of ramp direction */
    vexbuf[index++] = hbyte(speed); /* high byte of ramp speed */
    vexbuf[index++] = lbyte(speed); /* low byte of ramp speed */
    vexbuf[index++] = hbyte(rfx); /* high byte of horiz distance from FP */
    vexbuf[index++] = lbyte(rfx); /* low byte of horiz distance from FP */
    vexbuf[index++] = hbyte(rfy); /* high byte of vertical distance from FP */
    vexbuf[index++] = lbyte(rfy); /* low byte of vertical distance from FP */
    vexbuf[index++] = RA_CENPT; /* reference is center of ramp */
    vexbuf[index++] = OFF_AFTER_RAMP; /* object turns off after end of ramp */
    .
    .
    .
    to_vex(index);
    return(0);
}
```

GLvex will return the signal BATCH_DONE (241) after completing all commands in the list regardless of whether digital synchronization is enabled or not. The hbyte() and lbyte() functions are defined in GLvex_com.c.

LOAD_RAMP

This is a batchable command that loads a user defined ramp from Rex. The command is for users who want ramps that are not linear or circular. The first parameter is the number of ramps to load. Each ramp requires four parameters, the number of the ramp, the end action, high byte of the number of steps in the ramp, and the low byte of the number of steps in the ramp. Each step requires eight parameters, the four bytes of the X coordinate of the step, and the four bytes of the Y coordinate of the step. The step coordinates are in Rex units. Spot files that define user loaded ramps do not need to include the /rex/hdr/ramp.h header file.

End action defines what happens to the object on the ramp after the ramp stops.

OFF_AFTER_RAMP (0): object turns off after the end of the ramp. ON_AFTER_RAMP (1): object stays on after the end of the ramp.

Example action:

```
/* This action loads a ramp computed in Rex to GLvex */
struct ramp {
    float x;
    float y;
}
struct ramp thisRamp[300];
loadRamp()
{
    unsigned short index;
    int i, j, steps;
    char *flbuf;
    /******
    * You would put code to load the ramp steps here
    *****/
    steps = 300;
    index = 0;
    vexbuf[index++] = LOAD_RAMP;
    vexbuf[index++] = 1; /* number of ramps to load */
    vexbuf[index++] = 1; /* this ramp number */
    vexbuf[index++] = ON_AFTER_RAMP; /* object stays on after end of ramp */
    vexbuf[index++] = hbyte(steps); /* hi byte of number of ramp steps */
    vexbuf[index++] = lbyte(steps); /* lo byte of number of ramp steps */
    for(i = 0; i < steps; i++) {
        flbuf = float2byte(thisRamp[i].x);
        for(j = 0; j < 4; j++) vexbuf[index++] = flbuf[j];
        flbuf = float2byte(thisRamp[i].y);
        for(j = 0; j < 4; j++) vexbuf[index++] = flbuf[j];
    }
    .
    .
    /* other batchable commands */
    .
    .
    to_vex(index);
    return(0);
}
```

GLvex will return the signal BATCH_DONE (241) after completing all commands in the list regardless of whether digital synchronization is enabled or not. The hbyte() and lbyte() functions are defined in GLvex_com.c. The float2byte() function is defined in GLvex_com.c.

LOAD_PIXEL_RAMP

This is a batchable command that loads a user defined ramp from Rex. The command is for users who want ramps that are not linear or circular. The first parameter is the number of ramps to load. Each ramp requires four parameters, the number of the ramp, the end action, high byte of the number of steps in the ramp, and the low byte of the number of steps in the ramp. Each step requires eight parameters, the four bytes of the X coordinate of the step, and the four bytes of the Y coordinate of the step. This command is the same as LOAD_RAMP except that the step coordinates are in screen pixels rather than in Rex units. Spot files that define user loaded ramps do not need to include the /rex/hdr/ramp.h header file.

End action defines what happens to the object on the ramp after the ramp stops.

OFF_AFTER_RAMP (0): object turns off after the end of the ramp. ON_AFTER_RAMP (1): object stays on after the end of the ramp.

Example action:

```
/* This action loads a ramp computed in Rex to GLvex */
struct ramp {
    float x;
    float y;
}
struct ramp thisRamp[300];
loadRamp()
{
    unsigned short index;
    int i, j, steps;
    char *flbuf;
    /******
    * You would put code to load the ramp steps here
    *****/
    steps = 300;
    index = 0;
    vexbuf[index++] = LOAD_RAMP;
    vexbuf[index++] = 1; /* number of ramps to load */
    vexbuf[index++] = 1; /* this ramp number */
    vexbuf[index++] = ON_AFTER_RAMP; /* object stays on after end of ramp */
    vexbuf[index++] = hibyte(steps); /* hi byte of number of ramp steps */
    vexbuf[index++] = lobyte(steps); /* lo byte of number of ramp steps */
    for(i = 0; i < steps; i++) {
        flbuf = float2byte(thisRamp[i].x);
        for(j = 0; j < 4; j++) vexbuf[index++] = flbuf[j];
        flbuf = float2byte(thisRamp[i].y);
        for(j = 0; j < 4; j++) vexbuf[index++] = flbuf[j];
    }
    .
    .
    . /* other batchable commands */
    to_vex(index);
    return(0);
}
```

GLvex will return the signal BATCH_DONE (241) after completing all commands in the list regardless of whether digital synchronization is enabled or not. The hibyte() and lobyte() functions are defined in GLvex_com.c. The float2byte() function is defined in GLvex_com.c.

TO_RAMP_START

This is a batchable command that moves objects to the beginnings of the ramps that will carry them. Ramps must be defined before calling TO_RAMP_START. The first parameter is the number of objects to position. Each object has two parameters, the number of the object and the number of the ramp that will carry it. This command is necessary if you want to display a stationary object at the beginning of a ramp before starting the ramp.

Example action:

```
/*
 * This action will move an object that was turned on in a different
 * part of the screen to the beginning of a ramp.
 */
jump_and_run(void)
{
    unsigned short index;
    index = 0;
    vexbuf[index++] = TO_RAMP_START;
    vexbuf[index++] = 1;          /* number of objects to position */
    vexbuf[index++] = 3;          /* object number */
    vexbuf[index++] = 2;          /* ramp number */
    .
    .
    .
    to_vex(index);
    return(0);
}
```

GLvex will return the signal BATCH_DONE (241) after completing all commands in the list regardless of whether digital synchronization is enabled or not.

START_RAMP

This is a non-batchable command that places objects on ramps and starts the ramps moving. The first parameter is the number of ramps to start. Each ramp requires three parameters, the number of the ramp, the number of the object to place on that ramp, and the type of cycle. There are three types of ramp cycle

RA_ONCE (0): ramp runs once.

RA_OSCIL (1): ramp goes back and forth until stopped.

RA_LOOP (2): ramp runs over and over until stopped.

Ramps of differing speeds, lengths, or cycle may be started together. Switching the object and moving the object are independent actions. Each object must be positioned at the beginning of the ramp and then turned on, or must have its switch set to "ON" to be displayed. If the object placed on a ramp is switched off, the ramp will run but nothing will be displayed.

Example action:

```
/*
 * This action starts two ramps.
 */
short rmp[] = { 1, 2 };
short obi[] = { 1, 2 };
get_going(void)
{
    unsigned short index;
    short i;
    index = 0;
    vexbuf[index++] = START_RAMP;
    vexbuf[index++] = 2;      /* number of ramps to start */
    for(i = 0; i < 2; i++) {
        vexbuf[index++] = rmp[i];    /* ramp number */
        vexbuf[index++] = obi[i];    /* object number to put on ramp */
        vexbuf[index++] = RA_ONCE; /* run each ramp once */
    }
    to_vex(index);
    return(0);
}
```

If the digital sync is enabled, GLvex will return the signal FLOW_RAMP_START (236) at the beginning of the video field in which the ramp starts moving, and the signal FLOW_RAMP_STOP (235) at the beginning of the first video field after the ramp stops moving. Also GLvex will return the signal FLOW_RAMP_CHANGE (234) at each step specified in the SET_TRIGGERS command (see below). If the digital sync is not enabled, GLvex will not return any digital signal in this command. If the video sync is enabled, the rex video sync square will flash white for the first field in which the ramps are running, and for the first field after the ramps have stopped. Also, the rex video sync square will flash white for one field at each step specified in the SET_TRIGGERS command (see below).

RESET_RAMPS

This is a non-batchable commands that resets ramps that were set to run only once. This is ramps with a cycle type of RA_ONCE. The purpose of this command is to allow users to restart an RA_ONCE ramp that is running in conjunction with a flow field or with RA_LOOP or RA_OSCIL ramps. It requires no parameters. This command can be used in conjunction with the SET_STIM_SWITCH command (see above) to change which objects will be displayed when the ramps restart.

Example action:

```
reset_ramp()
{
    unsigned short index;
    index = 0;
    vexbuf(index++) = SET_STIM_SWITCH; /* set stimulus switches */
    vexbuf(index++) = 2;                /* number of objects to set */
    for(i = 0; i < 2; i++) {
        vexbuf(index++) = i + 5; /* object numbers 5 and 6 */
        if(!i) vexbuf(index++) = OBJ_ON; /* set object 5 switch on */
        else vexbuf(index++) = OBJ_OFF; /* and object 6 switch off */
    }
    vexbuf[index++] = RESET_RAMPS;
    to_vex(index);
    return(0);
}
```

If the digital sync is enabled, GLvex will return the signal FLOW_RAMP_CHANGE (234) at the beginning of the first video field in which the ramp is reset. Otherwise GLvex will not return any signal after this command. If the video sync is enabled, the rex video sync square will flash white for the first field in which the ramp is reset.

NEW_FLOW

This is a batchable command that defines the translation matrix for flow fields. The first parameter is the number of objects. Each object requires 15 parameters; the object number, the hi- and lo- bytes of the angle of movement in 2-D, the hi- and lo- bytes of the angle of movement in 3-D, the hi- and lo- bytes of the velocity, the hi- and lo- bytes of the rotation about the Z-axis (roll), the hi- and lo- bytes of the rotation about the X-axis (pitch), the hi- and lo- bytes of the rotation about the Y-axis (yaw), the life span of the checks, and the percentage of coherent checks. If the value for life span is 0, then the checks will be displayed constantly. If the value for life span is greater than 3, then each check will be displayed for the specified number of fields as it moves, then moved to a new location and be redrawn again for the specified number of fields. This gives the flow field a scintillating appearance. If the value for coherence is less than 100, then some of the checks will move in quasi-random directions.

Example action:

```
/* Set up a sliding, expanding flow field in one object and a contracting field in a second object. */
short xy[] = { 180, 0 }; short z[] = { -45, 90 }; short ob[] = { 1, 2 };
short vel = 10;           /* velocity of checks in degrees / sec */
short span = 10;         /* number of video field each check is displayed */
short coher = 50;        /* percentage of checks that move in the specified direction */
make_transform()
{
    short index, i, roll, pitch, yaw;
    index = 0;
    roll = pitch = yaw = 0;
    vexbuf[index++] = NEW_FLOW;
    vexbuf[index++] = 2;           /* number of objects */
    for(i = 0; i < 2; i++) {
        vexbuf[index++] = ob[i]; /* object number */
        vexbuf[index++] = hbyte(xy[i]); /* high byte of translation in 2-D */
        vexbuf[index++] = lobyte(xy[i]); /* low byte of translation in 2-D */
        vexbuf[index++] = hbyte(z[i]); /* high byte of translation in depth */
        vexbuf[index++] = lobyte(z[i]); /* low byte of translation in depth */
        vexbuf[index++] = hbyte(vel); /* high byte of translation in depth */
        vexbuf[index++] = lobyte(vel); /* low byte of translation in depth */
        vexbuf[index++] = hbyte(roll); /* high byte of roll rate */
        vexbuf[index++] = lobyte(roll); /* low byte of roll rate */
        vexbuf[index++] = hbyte(pitch); /* high byte of pitch rate */
        vexbuf[index++] = lobyte(pitch); /* low byte of pitch rate */
        vexbuf[index++] = hbyte(yaw); /* high byte of yaw rate */
        vexbuf[index++] = lobyte(yaw); /* low byte of yaw rate */
        vexbuf[index++] = span;           /* life span of checks */
        vexbuf[index++] = coher;         /* coherence of checks */
    }
    .
    .
    .           /* other batchable commands */
    to_vex(index);
    return(0);
}
```

GLvex will return the signal BATCH_DONE (241) after completing all commands in the list regardless of whether digital synchronization is enabled or not. The hbyte() and lobyte() functions are defined in GLvex_com.c.

SHIFT_FLOW

This is a non batchable command that defines the translation matrix for flow fields while the flow fields are moving. The parameters are the same as those of the NEW_FLOW command.

Example action:

```
/* Set up a sliding, expanding flow field in one object and a contracting field in a second object. */
short xy[] = { 180, 0 }; short z[] = { -45, 90 }; short ob[] = { 1, 2 };
short vel = 10;          /* velocity of checks in degrees / sec */
short span = 10;        /* number of video field each check is displayed */
short coher = 50;       /* percentage of checks that move in the specified direction */
make_transform()
{
    short index, i, roll, pitch, yaw;
    index = 0;
    roll = pitch = yaw = 0;
    vexbuf[index++] = NEW_FLOW;
    vexbuf[index++] = 2;          /* number of objects */
    for(i = 0; i < 2; i++) {
        vexbuf[index++] = ob[i]; /* object number */
        vexbuf[index++] = hbyte(xy[i]); /* high byte of translation in 2-D */
        vexbuf[index++] = lbyte(xy[i]); /* low byte of translation in 2-D */
        vexbuf[index++] = hbyte(z[i]); /* high byte of translation in depth */
        vexbuf[index++] = lbyte(z[i]); /* low byte of translation in depth */
        vexbuf[index++] = hbyte(vel); /* high byte of translation in depth */
        vexbuf[index++] = lbyte(vel); /* low byte of translation in depth */
        vexbuf[index++] = hbyte(roll); /* high byte of roll rate */
        vexbuf[index++] = lbyte(roll); /* low byte of roll rate */
        vexbuf[index++] = hbyte(pitch); /* high byte of pitch rate */
        vexbuf[index++] = lbyte(pitch); /* low byte of pitch rate */
        vexbuf[index++] = hbyte(yaw); /* high byte of yaw rate */
        vexbuf[index++] = lbyte(yaw); /* low byte of yaw rate */
        vexbuf[index++] = span;          /* life span of checks */
        vexbuf[index++] = coher;        /* coherence of checks */
    }
    .
    .
    .
    to_vex(index);
    return(0);
}
```

If the digital sync is enabled, GLvex will return the signal FLOW_RAMP_CHANGE (234) at the beginning of the video field in which the flow fields change movement. Otherwise GLvex will not return any signal after this command. If the video sync enabled, the rex video sync square will flash white for the first field in which the flow fields change movement. The hbyte() and lbyte() functions are defined in GLvex_com.c.

START_FLOW

This is a non-batchable command that starts the flow fields in a variable number of objects. The first parameter is the number of objects to turn on. Each object requires one parameters, the object number.

Example actions:

```
/*
 * This action will switch on the flow fields in objects 3 and 5, simultaneously.
 */
sw_flow()
{
    unsigned short index;
    index = 0;
    vexbuf[index++] = START_FLOW;
    vexbuf[index++] = 2;          /* number of objects to switch */
    vexbuf[index++] = 3;          /* first object number */
    vexbuf[index++] = 5;          /* second object number */
    to_vex(index);
    return(0);
}
```

If the digital sync is enabled, GLvex will return the signal FLOW_RAMP_START (232) at the beginning of the video field in which the flow fields start. Otherwise GLvex will not return any signal after this command. If the video sync enabled, the rex video sync square will flash white for the first field in which the flow fields start.

TIME_FLOW

This is a non-batchable command that presents flow fields in a variable number of objects for a given number of video fields. The first parameter is the number of objects to present. Each object requires one parameter, the object number. The last parameter is the number of video fields to present the flow fields. The number of fields can range from 1 to 255.

Example action:

```
/*
 * This action will present flow fields in objects 3 and 4 simultaneously for 60 fields.
 */
short fields = 60; /* value may be set in Rex state variables menu */
flow_time(void)
{
    unsigned short index;
    index = 0;
    vexbuf[index++] = TIME_FLOW;
    vexbuf[index++] = 2;          /* number of objects to present */
    vexbuf[index++] = 3;          /* first object number */
    vexbuf[index++] = 4;          /* second object number */
    vexbuf[index++] = fields;     /* number of video fields */
    to_vex(index);
    return(0);
}
```

If the digital sync is enabled, GLvex will return two signals from this command. The signal FLOW_RAMP_START (232) is sent at the beginning of the video field in which the flow fields are turned on, and the signal FLOW_RAMP_STOP (231) is sent at the beginning of the first video field after the flow fields stop. Otherwise GLvex will not return any signal after this command. If the video sync is enabled, the rex video sync square will flash white for the first field in which the flow fields start, and again for the first field in which the flow fields stop.

MAKE_FLOW_MOVIE

This a batchable command that creates the successive frames of flow field movies and places them in memory for subsequent playback. The first parameter is number of objects that will contain the movies. The second parameter is the number of frames in the movies. One parameter is required for each of the movie objects, the object number. Before using this command, you must call DRAW_FLOW_PATTERN and NEW_FLOW for each of the objects that hold flow movies.

Example action:

```
/*
 * This action defines flow field movies 500 frames long
 * based on flow fields defined for objects 2 and 3.
 */
short mobi = 1;
short fobi[] = { 2, 3 };
short wide = 600;
short tall = 400;
short near = 600;
short far = 1500;
short cov = 20; /* 50% of flow field area will be covered by checks*/
short size = 4; /* size of the flow field checks */
short xy[] = { 180, 270 }; /* xy direction of the flow fields */
short z = -45; /* z (depth) angle of the flow field */
short vel = 100; /* velocity of checks in 1/10ths degree / sec */
short span = 0; /* life span of the checks (continuous) */
short coher = 100; /* coherence of motion */
short nframes = 500; /* number of frames */
flow_movie()
{
    short index, i, roll, pitch, yaw;
    /* DRAW_FLOW_PATTERN and NEW_FLOW have already been
     * called for objects 2 and 3 */
    index = 0;
    vexbuf[index++] = MAKE_FLOW_MOVIE; /* define the flow movie */
    vexbuf[index++] = 2 /* number of objects containing movies */
    vexbuf[index++] = nframes; /* number of frames in the movies */
    for(i = 0; i < 2; i++) {
        vexbuf[index++] = fobi[i]; /* object number */
    }
    .
    .
    . /* other batchable commands */
    to_vex(index);
    return(0);
}
```

GLvex will return the signal BATCH_DONE (241) after completing all commands in the list regardless of whether digital synchronization is enabled or not. The hbyte() and lbyte() functions are defined in GLvex_com.c.

TO_FLOW_MOVIE_START

This is a batchable that sets the flow fields in flow field objects to the starting frame of a flow field movie. The first parameter is the number of objects to set up. You must build a flow field movie for each of these objects before using this command (see above). The second parameter is the starting frame of the movie. All objects must start on the same frame. For each object, only one parameter is needed, the object number.

Example action:

```
set_movie()
{
    short index;
    index = 0;
    vexbuf[index++] = TO_FLOW_MOVIE_START;
    vexbuf[index++] = 2;          /* number of objects to set up */
    vexbuf[index++] = 50;        /* frame at which the flow move will start */
    vexbuf[index++] = 1;        /* first object with flow field movie */
    vexbuf[index++] = 2;        /* second object with flow field movie */
    .
    .
    .
    to_vex(index);
    return(0);
}
```

GLvex will return the signal BATCH_DONE (241) after completing all commands in the list regardless of whether digital synchronization is enabled or not.

SHOW_FLOW_MOVIE

This is a non-batchable command that displays flow field movies. The first parameter is the number of movies to show. The second parameter is the starting frame of the movies. The third parameter is the last frame to show. Each movie requires one parameter, the number of the object containing the movie. Each movie must start on the same frame and end on the same frame. The movies must have been defined prior to calling this function. The number of frames to show can be less than the number of frames defined.

Example action:

```
/*
 * this action displays a single flow field movie of 60 frames
 * beginning with frame 30 and ending with frame 90
 */
int obi = 1;
int start = 30;
int end = 90;
start_movie()
{
    short index;
    index = 0;
    vexbuf[index++] = SHOW_FLOW_MOVIE;
    vexbuf[index++] = 1;          /* number of flow movies */
    vexbuf[index++] = start;     /* first frame of the movie */
    vexbuf[index++] = end;      /* last frame of the movie */
    vexbuf[index++] = obi;      /* number of the object containing the movie */
    to_vex(index);
    return(0);
}
```

If the digital sync is enabled, GLvex will return two signals from this command. The signal MOVIE_START (239) is sent at the beginning of the video field in which the ramp starts moving, and the signal MOVIE_STOP (238) is sent at the beginning of the first video field after the ramp stops moving. Otherwise GLvex will not return any signal after this command. If the video sync is enabled, the rex video sync square will flash white for the first field in which the movie starts, and again for the first field in which the movie stops.

START_FLOW_RAMP

This is a non-batchable command that runs ramps and flow fields simultaneously. The first parameter is the number of flow fields to run. Each flow field requires one parameter, the object in which the flow field was drawn. After listing the flow field objects, the next parameter is the number of ramps to run. Each ramp requires two parameters, the number of the ramp to run and the number of the object to put on the ramp. This display works best if the objects on the ramps have a higher priority (i.e., lower numbers) than the objects containing flow fields. Before using this command, you must call DRAW_FLOW_PATTERN and NEW_FLOW for each of the objects that will hold flow fields, and you must call NEW_RAMP for each of the ramps you use.

Example action:

```
/*This action runs a flow field and a ramp */
flow_ramp(void)
{
    unsigned short index; short i;
    index = 0;
    vexbuf(index++) = START_FLOW_RAMP;
    vexbuf(index++) = 2;          /* number of flow fields to start */
    for(i = 0; i < 2; i++) vexbuf(index++) = i + 5; /* flow field object numbers 5 and 6 */
    vexbuf(index++) = 2;          /* number of ramps to start */
    for(i = 0; i < 2; i++) {
        vexbuf(index++) = i + 1; /* run ramps 1 and 2 */
        vexbuf(index++) = i + 3; /* put objects 3 and 4 on the ramps */
    }
    to_vex(index);
    return(0);
}
```

If the digital sync is enabled, GLvex will return the signal FLOW_RAMP_START at the beginning of the first video field in which the flow fields and ramps start moving. If the video sync is enabled, the rex video sync square will flash white for the field in which the flow fields and ramps start. The display will continue until the RA_ONCE ramps have completed. During this period, GLvex will run all of the ramps, but will display only those objects that you have switched ON. If the digital sync is enabled, GLvex will then return the signal FLOW_RAMP_CHANGE at the beginning of the first video field after the ramp objects have turned stopped. If the video sync is enabled, the rex video square will flash white for the field in which the ramps stop. At this point the flow fields will still be running. You have a couple of choices now. You can stop the flow fields and get out of this loop entirely by switching off the flow fields using the STOP_FLOW_RAMP command (see below). If you do this, GLvex will send the signal FLOW_RAMP_STOP at the beginning of the video field after the flow field stops moving if the digital sync is enabled. If the video sync is enabled, the rex video sync square will flash white for the field in which the flow fields stop moving. Alternately, you can send the command RESET_RAMPS (see below). GLvex will place the ramp objects at the beginnings of their respective ramps, start all ramps running again, and send the signal FLOW_RAMP_CHANGE at the beginning of the first video field in which the ramps start moving if the digital sync is enabled. If the video sync is enabled, the rex video sync square will flash white for the field in which the ramps start again. You can leave the flow fields running across multiple trials while using the RESET_RAMPS command to restart the ramps at the beginning of each trial. In this way, you can use the flow fields as an adapting stimulus.

STOP_FLOW_RAMP

This is a non-batchable command that stops all ramps, flow fields, and OKN gratings. It requires no parameters.

Example action:

```
stop()  
{  
    unsigned short index;  
    index = 0;  
    vexbuf[index++] = STOP_FLOW_RAMP;  
    to_vex(index);  
    return(0);  
}
```

If the digital sync is enabled, GLvex will return the signal FLOW_RAMP_STOP (235) at the beginning of the first video field after the ramps stop. Otherwise GLvex will not return any signal after this command. If the video sync is enabled, the rex video sync square will flash white for the first field after the ramps have stopped.

START_OKN

This is a non-batchable command that starts the bars moving in square-wave, OKN gratings. The first parameter is the number of objects to start. Each object requires one parameter, the object number. You must define an OKN grating in an object before calling this function.

Example action:

```
startOkn()
{
    unsigned short index;
    int i;
    index = 0;
    vexbuf[index++] = START_OKN;
    vexbuf[index++] = 2;           /* start OKN movement in two objects */
    for(i = 0; i < 2; i++) {
        vexbuf[index++] = i + 2;   /* objects 2 and 3 have OKN gratings */
    }
    to_vex(index);
    return(0);
}
```

If the digital sync is enabled, GLvex will return the signal FLOW_RAMP_START (236) at the beginning of the first video field in which the bars are moving. Otherwise GLvex will not return any signal after this command. If the video sync is enabled, the rex video sync square will flash white for the first field in which the bars are moving.

SHOW_MOVE_CLIP

This is a non-batchable command that displays sequences of objects for a given number of video fields each. It is assumed that you have loaded the appropriate patterns in the objects and positioned them on the screen before calling this function. The first parameter is the number of clips to show. All clips will be shown simultaneously. Each clip requires one parameter, the number of the first object in the clip. Each of the clips must have the same number of objects and the objects must be sequential. After entering the starting objects for each clip, this command requires three more parameters. These are the total number of frames in the movie, the number of video fields to display each frame, and the number of times to cycle through the movie. If you set the number of cycles to 0, the movie will run in a continuous loop until you stop it with the STOP_MOVIE command (see below).

Example action:

```
/*
 * this action displays two movie clips of 20 frames each.
 * each frame is shown for 2 video fields and the movie
 * loops 5 times */
clp1 = 1;
clp2 = 21;
nframes = 20;
interval = 2;
cycles = 5;
start_movie()
{
    short index;
    index = 0;
    vexbuf[index++] = SHOW_MOVE_CLIP;
    vexbuf[index++] = 2;           /* number of movie clips */
    vexbuf[index++] = clp1;       /* number of the first object in clip 1 */
    vexbuf[index++] = clp2;       /* number of the first object in clip 2 */
    vexbuf[index++] = nframes;    /* number of frames each in clip */
    vexbuf[index++] = interval;   /* video fields to show each frame */
    vexbuf[index++] = cycles;     /* number of times to loop through movie */
    to_vex(index);
    return(0);
}
```

If the digital sync is enabled, GLvex will return the signal MOVIE_START (226) at the beginning of the video field in which movie starts, and the signal MOVIE_STOP (225) at the beginning of the first video field after the movie stops. Also GLvex will return the signal MOVIE_CHANGE (237) at each frame specified in the SET_TRIGGERS command (see below). If the digital sync is not enabled, GLvex will not return any digital signal in this command. If the video sync is enabled, the rex video sync square will flash white for the first field of the movie, and for the first field after the movie stops. Also, the rex video sync square will flash white for one field at each frame specified in the SET_TRIGGERS command (see below).

STOP_MOVIE

This is a non-batchable command that stops flow field and object movies. It does not require any parameters. This command allows you to stop an object movie that is in a continuous loop or to stop object or flow field movies before their designated number of cycles or frames have completed.

Example action:

```
/*
 * this action stops all running movies
 */
stop_movie()
{
    short index;
    index = 0;
    vexbuf[index++] = STOP_MOVIE;
    to_vex(index);
    return(0);
}
```

If the digital sync is enabled, GLvex will return MOVIE_STOP (233) at the beginning of the first video field after the movie has stopped. Otherwise GLvex will not return any signal after this command. If the video sync is enabled, the rex video sync square will flash white for the first field after the movie stops. This command has no effect and GLvex will not return any signals if the command is issued outside the context of the SHOW_FLOW_MOVIE or SHOW_MOVIE_CLIP commands.

SET_TRIGGERS

This is a batchable command that allows you to tell GLvex that you want a trigger to be sent when a ramp reaches a specified step or an object movie reaches a specified frame. You can specify up to 10 triggers for each ramp or object movie. The first parameter is the number of trigger sets to define. Each trigger set requires two parameters, the ramp number or object movie number from which you want triggers, and the number of triggers in you want in that ramp or object movie. Each trigger requires two parameters, the hi- and lo- bytes of the ramp step or movie frame where you want the trigger.

Example action:

```
/*
 * This action sets up two user defined ramps, then specifies that
 * triggers be sent when the objects on the ramps change direction
 */
struct ramp {
    float x;
    float y;
}
struct ramp rampOne[300];
struct ramp rampTwo[200];
loadRamp()
{
    unsigned short index;
    short i, j, stepsOne, stepsTwo;
    short breakOne, breakTwo;
    rampOne[0].x = -150.0;      /* starting location of the first ramp */
    rampOne[0].y = -150.0;
    for(i = 1; i < 150; i++) { /* ramp goes to the right */
        thisRamp[i].x = thisRamp[i - 1].x + 2.0;
        thisRamp[i].y = thisRamp[i - 1].y;
    }
    for(; i < 300; i++) {      /* ramp goes up */
        thisRamp[i].x = thisRamp[i - 1].x;
        thisRamp[i].y = thisRamp[i - 1].y + 2.0;
    }
    rampTwo[0].x = -100.0;     /* starting location of second ramp */
    rampTwo[0].y = -100.0;
    for(i = 1; i < 100; i++) { /* ramp goes up and to the right */
        thisRamp[i].x = thisRamp[i - 1].x + 2.0;
        thisRamp[i].y = thisRamp[i - 1].y + 2.0;
    }
    for(; i < 200; i++) {     /* ramp goes down and to the right */
        thisRamp[i].x = thisRamp[i - 1].x + 2.0;
        thisRamp[i].y = thisRamp[i - 1].y - 2.0;
    }
    stepsOne = 300;
    stepsTwo = 200;
    breakOne = 150;
    breakTwo = 100;
    index = 0;
    vexbuf[index++] = LOAD_RAMP;
    vexbuf[index++] = 2;      /* number of ramps to load */
    vexbuf[index++] = 1;     /* first ramp number */
}
```

```

vexbuf[index++] = OBJ_ON;           /* object stays on after end of ramp */
vexbuf[index++] = hbyte(stepsOne);  /* hi byte of steps in first ramp */
vexbuf[index++] = lbyte(stepsOne);  /* lo byte of steps in first ramp */
for(i = 0; i < stepsOne; i++) {
    flbuf = float2byte(rampOne[i].x);
    for(j = 0; j < 4; j++) vexbuf[index++] = flbuf[j];
    flbuf = float2byte(rampOne[i].y);
    for(j = 0; j < 4; j++) vexbuf[index++] = flbuf[j];
}
vexbuf[index++] = 2;                 /* second ramp number */
vexbuf[index++] = OBJ_ON;           /* object stays on after end of ramp */
vexbuf[index++] = hbyte(stepsTwo); /* hi byte of the number of steps in second ramp */
vexbuf[index++] = lbyte(stepsTwo); /* lo byte of the number of steps in second ramp */
for(i = 0; i < stepsTwo; i++) {
    flbuf = float2byte(rampTwo[i].x);
    for(j = 0; j < 4; j++) vexbuf[index++] = flbuf[j];
    flbuf = float2byte(rampTwo[i].y);
    for(j = 0; j < 4; j++) vexbuf[index++] = flbuf[j];
}
vexbuf[index++] = SET_TRIGGERS;
vexbuf[index++] = 2;                 /* number of trigger sets */
vexbuf[index++] = 1;                 /* first ramp from which the triggers will come */
vexbuf[index++] = 1;                 /* number of triggers in this set */
vexbuf[index++] = hbyte(breakOne); /* hi byte of the step number on which to trigger */
vexbuf[index++] = lbyte(breakOne); /* lo byte of the step number on which to trigger */
vexbuf[index++] = 2;                 /* second ramp from which the triggers will come */
vexbuf[index++] = 1;                 /* number of triggers in this set */
vexbuf[index++] = hbyte(breakTwo); /* hi byte of the step number on which to trigger */
vexbuf[index++] = lbyte(breakTwo); /* lo byte of the step number on which to trigger */
.
.
.
to_vex(index);
return(0);
}

```

GLvex will return the signal BATCH_DONE (241) after completing all commands in the list regardless of whether digital synchronization is enabled or not. The hbyte() and lbyte() functions are defined in GLvex_com.c.

ERRORS AND WARNINGS

There are a number of conditions that will result in errors or warnings. Errors are fatal and require that you exit GLvex and fix the problem. Warnings are not fatal and GLvex will continue execution, but you may not be able to access all of the functions, or get the result you were expecting.

Memory Management Errors

During the initialization phase and when computing ramps and flow fields, GLvex dynamically allocates the memory it needs on the host computer. Failure to allocate memory for objects is fatal and will cause GLvex to quit. Failure to allocate memory for ramps or flow fields is not fatal, but, if you attempt to run a ramp or flow field that could not be allocated, you will get unpredictable results.

Object memory errors

GLvex allocates space for the object structures, stimulus templates, and flow field buffers in the host computer memory. If there is not sufficient host memory for the requested number of objects you will get an error message similar to the following:

Unable to allocate memory for 25 objects
Exit and invoke GLvex requesting fewer objects
Press any key to exit

VEX-REX Parallel I/O Communication Errors

It is possible for the parallel I/O communications between the rex and GLvex PC's to get out of sync. If this happens, your paradigm will hang, or the stimulus display will become erratic. In either event, stop the rex paradigm by setting the PSTOP switch to on, hit the <return> key on the GLvex PC to halt any messages to rex, type r s on the rex PC to restart the state list, and finally, set the PSTOP switch to off to resume the paradigm. If your paradigm still does not run, check to see if the GLvex PC is hung by typing "<return>". GLvex should print a help message. If not, quit GLvex. If GLvex is not hung, kill and reload the offending rex process. In the worst case, you will have to quit rex and GLvex.

There are four general ways that rex to GLvex communications can get out of sync.

First, if you end the rex clock to stop a paradigm, or you reset the state list after rex has sent a command to GLvex but before GLvex has sent its response signal, you may de synchronize the communications. To avoid this, ALWAYS stop paradigms using the PSTOP switch. This should guarantee that all communications have been resolved. At this point, you can end the clock, begin the clock, reset the state list, or open or close files.

Second, including states that call actions which communicate with GLvex in the rex abort list. Rex will attempt to execute these actions without testing the transmission bits or acknowledging signals from GLvex. This will cause problems. Monkey (subject) errors must be handled explicitly in the following manner:

Example state loop:

```
.
.          /* other states in your paradigm */
.
to vstwts

vstwts
to vexst on 0 % tst_tx_rdy /* test if transmission is ready */

vexst:
do vex_time()          /* vex command that will take a while */
to error on +WD0_XY & eyeflag
to vexack on 0 % tst_rx_new/* escape when signal is received */

vexack:
code ECODE
do pcm_ack(0)          /* acknowledge signal from vex */
time 100
rand 100
to othst

othst
.
.          /* other states in your paradigm */
.

error:
code ERR1CD
do reset_s(-1) /* but don't include vex states in abort list */
to alloff on 0 % tst_tx_rdy

alloff:
do off_all() /* action that turns off all stimuli and fixation point */
to offack on 0 % tst_rx_new

offack:
do pcm_ack(0)
time 5000              /* time out */
to disabl

abort:
offrew                /* no vex communications in these */
clwind                /* two states */
```

Third, the monkey can make an error that causes an escape from a state such as vexst in the example above that is expecting a signal from GLvex just as GLvex is about to send the signal. In the above example, if the actions to handle monkey errors do not send the abort command off_all() before GLvex sends the signal at the end of the vex_time() action, you may have an extra, unacknowledged signal from GLvex. This situation should occur infrequently.

Fourth, you are careless in testing the transmit and receive bits in your paradigm or you do not acknowledge signals from GLvex. Study the example spot file at the end of this document carefully. In particular, don't hide the pcm_ack(0) action in other actions to save on the number of states in your paradigm. While this is legal, it will make your paradigms harder to debug. This type of error will cause frequent hang-ups but may not occur on every trial. In particular, be suspicious if your paradigm runs properly only if some states need to have the time variable set to some minimum value.

Argument Errors

In sending a command to GLvex, you load a buffer with a number that represents the command, followed by more numbers that represent the parameters for the command. GLvex parses this buffer by assuming that the first value represents a command. GLvex treats a number of the following values as arguments for that command. How many of the following values are treated as values depends on the command number. Any given number can be treated as a command or as an argument, depending on its context. If you do not load the buffer correctly, GLvex will not be able to parse the buffer correctly. This results in unpredictable behavior. If you are not getting the result you expect, shrink the main window with the "w s" command, then turn on debugging with the "D 1" command. If you get the message:

rexIn: Command # is an invalid command

rexIn: Aborting input loop

you probably have not loaded the correct number of arguments into the buffer. If the values that GLvex prints out are vastly different from what you think they should be, you probably have not loaded the bytes of integer or floating point values in the correct order.

Memory Management Warnings

When you compute a new ramp, GLvex dynamically allocates space for the X and Y buffers that hold the sequence of object positions defined by the ramp. If you run out of host memory, GLvex will print the following a warning similar to the following:

compute_ramp: Warning, unable to malloc space for ramp 10

Execution will continue, but the ramp will not be computed. If you attempt to start the ramp, you will get unpredictable results. If you have this problem, try recomputing an old ramp. If, in recomputing an old ramp, you get a warning similar to,

compute_ramp: Warning, unable to realloc space for ramp 10

you will probably have to quit GLvex to free up memory. I don't know how many ramps can be defined simultaneously. It will depend on the lengths and speeds of the ramps. The shorter and faster the ramp, the more that can be defined simultaneously.

When you compute a new flow field, GLvex dynamically allocates a floating point buffer to hold the 3-D homogeneous coordinates of the points in the flow field, and two integer buffers to hold the 2-D projects of the points in the flow field. If you run out of host memory, GLvex will print warnings similar to the following:

make_flow: Warning, unable to malloc space for object 10 hvec

make_flow: Warning, unable to malloc space for object 10 pvec[0]

make_flow: Warning, unable to malloc space for object 10 pvec[1]

When you recompute an old flow field, GLvex dynamically reallocates the 3-D homogeneous coordinates buffer and the two 2-D projection buffers. If you run out of host memory, GLvex will print warnings similar to the following:

make_flow: Warning, unable to realloc space for object 10 hvec

make_flow: Warning, unable to realloc space for object 10 pvec[0]

make_flow: Warning, unable to realloc space for object 10 pvec[1]

Execution will continue, but the flow field will not be computed. The object's stimulus type will be set to NULL so that you won't be able to create masks, movement transforms, or to start the flow fields. This is done to avoid unpredictable results. To correct this problem, you will probably have to quit GLvex to free up memory. When you restart GLvex, try defining smaller or less densely covered flow fields.

Pattern Specification Warnings

If you attempt to specify a pattern number greater than 255 (say 256), you will get the following message:

**256 is an invalid number to specify pattern
Pattern number must be between 0 and 255**

A pattern will be drawn but only the low byte of the number will be used, so you will get an unexpected result.

If you attempt to draw a random check pattern with a resolution greater than 255 (say 300), you will get the following message:

**random check resolution 300 is too high
setting resolution to 255**

A random check pattern will be drawn with a resolution of 255.

If you attempt to draw a flow field with more than 10% coverage (say 15%), you will get a message similar to the following:

**make_flow: tenth percent coverage 150 is too high
setting coverage to 100 tenths percent**

A flow field will be drawn with 10% coverage.

If you attempt to create a flow field mask that is larger than the flow field, you will get the following message:

make_flow_mask: Warning, mask is larger than view field

No mask will be drawn in the flow field.

In specifying a user pattern (say P101), if you don't have a file with the proper name in the working directory (in this case P101), you will get a message similar to the following:

Error: make_user could not open file P101

If you attempt to define a user pattern with more than 255 rows or columns (say 260 X 300), you will get a message similar to the following:

make_user: rows = 190 cols = 70

make_user: Error, number of rows or columns must not be greater than 180

In these two cases, GLvex will not draw any pattern, and the stimulus in the object will be unchanged.

Flow Field Transforms

GLvex supports both two- and three- dimensional flow fields. If you are using 2-D flow fields, the three transform parameters which produce movement in depth (vergence, yaw, pitch) must be set to 0. If you try to compute a transform that produces movement in depth for a 2-D flow field, you will get the following message:

compute_transform: Warning, no depth movement allowed in 2-D flow fields.

Setting trans.v, trans.w, trans.p to 0

The transform will be computed, but with the depth parameters set to 0. If you requested a transform with nothing but movement in depth, then the flow field will not move when turned on.

Contrast Specification

In specifying patterns from the keyboard, you must specify the contrast of the pattern, normal or reverse, even if it is a continuous tone pattern. Failure to specify the contrast will result in the pattern being drawn with unpredictable luminances. However, GLvex will not print any warnings.

Color, Luminance Specification Warnings.

All color and luminance values can range only between 0 and 255. If you try to specify a color or luminance value outside this range you will get a warning similar to the following:

red value 256 out of range

If you enter an illegal value from the keyboard, no change will be made. If you enter an illegal value from rex, the object you are changing may take on an unpredictable color or luminance.

Sample Spot File Demonstrating Socket Communication

```
#include "../hdr/ramp.h"
#include "localEcodes.h"
#include "memSac.h"
#include "GLvex_com.c"
#include "shuffle.c"
#define WIND0 0
#define WIND1 1
#define RAMP_DONE 1
#define RAMP_ON 2
#define TARG_SWITCH 4
#define LOCATE 8

/* begin user action block */
int rampFlag = 0;
int vexMessage = 0;
int mfTargX = 0;
int mfTargY = 0;
int rLength = 150;
int rSpeed = 5;
int trialCounter = -1;
int blockcount = 0; /* number of blocks of trials */
int totalTrials = 0;
int correctTrials = 0;
int errorTrials = 0;
int percentCorrect = 0;
int currstim;
int targsiz = 100;

int pick_ramp_direction()
{
    static int ptrlst[2 * NUM_STIM] = { 0 };
    static int rs_shift = 10;
    int rDir;
    int index;
    int i;
    char *flbuf;

    if(--trialCounter <= 0) {
        trialCounter = NUM_STIM;
        for(i = 0; i < trialCounter; i++) ptrlst[i] = i;

        /* shuffle ptrlst to randomize stimulus conditions */
        shuffle(trialCounter, rs_shift, ptrlst);
        blockcount++;
    }

    currstim = ptrlst[trialCounter - 1]; /* index to this condition */
    totalTrials++;
    memSacTrialList[currstim].total++;

    /* set the time of the target-fixation point gap */
    set_times("rampon", memSacList[currstim].delay, -1);
}
```

```

/* set the location of the target window */
switch(memSacList[currstim].direction) {
case 1:
    rDir = 0;
    break;
case -1:
    rDir = 180;
    break;
}

/* define the ramp */
index = 0;
vexbuf[index++] = NEW_RAMP;
vexbuf[index++] = 1; /* number of ramps */
vexbuf[index++] = 1; /* ramp number */
vexbuf[index++] = hibyte(rLength); /* high byte of ramp length */
vexbuf[index++] = lobyte(rLength); /* low byte of ramp length */
vexbuf[index++] = hibyte(rDir); /* high byte of ramp direction */
vexbuf[index++] = lobyte(rDir); /* low byte of ramp direction */
vexbuf[index++] = hibyte(rSpeed); /* high byte of ramp speed */
vexbuf[index++] = lobyte(rSpeed); /* low byte of ramp speed */
vexbuf[index++] = hibyte(0); /* high byte of X offset */
vexbuf[index++] = lobyte(0); /* low byte of X offset */
vexbuf[index++] = hibyte(0); /* high byte of Y offset */
vexbuf[index++] = lobyte(0); /* low byte of Y offset */
vexbuf[index++] = RA_CENPT; /* reference is center of ramp */
vexbuf[index++] = OBJ_OFF; /* object switches off at end of ramp */

/* set the location of the saccade target */
vexbuf[index++] = STIM_LOCATION;
vexbuf[index++] = 1; /* number of objects */
vexbuf[index++] = 2; /* object number */
flbuf = float2byte(mfTargX);
for(i = 0; i < 4; i++) vexbuf[index++] = flbuf[i];
flbuf = float2byte(mfTargY);
for(i = 0; i < 4; i++) vexbuf[index++] = flbuf[i];
to_vex(index);
wd_pos(WIND1, mfTargX, mfTargY);
return(memSacList[currstim].ecode);
}

int to_ramp_start()
{
    int index;

    index = 0;
    vexbuf[index++] = TO_RAMP_START;
    vexbuf[index++] = 1; /* number of objects */
    vexbuf[index++] = 1; /* object number */
    vexbuf[index++] = 1; /* ramp number */
    to_vex(index);
    return(0);
}

```

```

int wndxctr = 0;
int wndyctr = 0;
int wndsiz = 5;
ctr_wnd()
{
    wd_pos(WIND0, wndxctr, wndyctr);
    wd_siz(WIND0, wndsiz, wndsiz);
    wd_siz(WIND1, targsiz, targsiz);
    return (0);
}

int pursuitOn()
{
    int index;

    index = 0;
    vexbuf[index++] = SWITCH_STIM;
    vexbuf[index++] = 1; /* number of objects */
    vexbuf[index++] = 1; /* object number */
    vexbuf[index++] = OBJ_ON; /* turn object on */
    to_vex(index);
    return(0);
}

int start_ramp()
{
    int index;

    index = 0;
    vexbuf[index++] = START_RAMP;
    vexbuf[index++] = 1; /* number of ramps to start */
    vexbuf[index++] = 1; /* ramp number */
    vexbuf[index++] = 1; /* number of object on ramp */
    vexbuf[index++] = RA_ONCE; /* run ramp once */
    to_vex(index);
    return(0);
}

int object_location()
{
    short index;

    index = 0;
    vexbuf[index++] = REPORT_LOCATION; /* tells REX where VEX target is */
    vexbuf[index++] = 1; /* object number */
    to_vex(index);

    return(0);
}

int vex_gate(long flag)
{
    if(flag) rampFlag = RAMP_ON;
}

```



```

        else rampFlag = RAMP_DONE;
        return(0);
    }

int resetSwitch()
{
    vexMessage &= ~TARG_SWITCH;
    return(0);
}

/*
 * Subroutine that tests the return message from vex
 */
int tstVexMsg()
{
    unsigned char *msg;
    unsigned char code;

    msg = vex_message(); /* retrieve message from GLvex */
    if(msg) { /* if message is not null */
        code = vex_code(msg); /* returned code */
        if(code == FLOW_RAMP_STOP) rampFlag = RAMP_DONE;
        else if(code == FLOW_RAMP_CHANGE) {
            vexMessage = TARG_SWITCH;
        }
        else if(code == OBJECT_LOCATION) {
            vexMessage = LOCATE;
            vex_location(msg); /* unpack x and y values to globals vx, vy
*/
        }
        else vexMessage = 0;
    }

    return(0);
}

int targ_wnd(void)
{
    wd_pos(WIND0, vx, vy); /* set position from globals vx, vy */
    wd_siz(WIND0, wndsiz, wndsiz); /* set window size */
    wd_cntrl(WIND0, WD_ON); /* turn window on */

    return(0);
}

int flash_on()
{
    int index;

    index = 0;
    vexbuf[index++] = SET_STIM_SWITCH;
    vexbuf[index++] = 1; /* number of objects */
    vexbuf[index++] = 2; /* object number */
    vexbuf[index++] = OBJ_ON; /* turn object on */
}

```

```

        to_vex(index);
        return(0);
    }

int flash_off()
{
    int index;

    index = 0;
    vexbuf[index++] = SET_STIM_SWITCH;
    vexbuf[index++] = 1;           /* number of objects */
    vexbuf[index++] = 2;           /* object number */
    vexbuf[index++] = OBJ_OFF; /* turn object on */
    to_vex(index);
    return(0);
}

int goodTrial()
{
    correctTrials++;
    memSacTrialList[currstim].good++;

    if(totalTrials) percentCorrect = (correctTrials * 100) / totalTrials;
    if(memSacTrialList[currstim].total) {
        memSacTrialList[currstim].percent =
            (memSacTrialList[currstim].good * 100) /
            memSacTrialList[currstim].total;
    }
    return(0);
}

int badTrial()
{
    errorTrials++;
    memSacTrialList[currstim].bad++;

    if(totalTrials) percentCorrect = (correctTrials * 100) / totalTrials;
    if(memSacTrialList[currstim].total) {
        memSacTrialList[currstim].percent =
            (memSacTrialList[currstim].good * 100) /
            memSacTrialList[currstim].total;
    }
    return(0);
}

rinitf()
{
    char *port = GLVEX_PORT_STR;
    char *host = "Isr-sgia";
    char *subnet = 0;

    pcsSetPeerAddr(host, port);
    pcsAllocPassiveSocket(subnet, port);
}

```

```

    wd_disp(D_W_EYE_X);
    wd_src_pos(WIND0, WD_DIRPOS, 0, WD_DIRPOS, 0);
    wd_src_check(WIND0, WD_SIGNAL, 0, WD_SIGNAL, 1);
    wd_src_pos(WIND1, WD_DIRPOS, 0, WD_DIRPOS, 0);
    wd_src_check(WIND1, WD_SIGNAL, 0, WD_SIGNAL, 1);
    wd_center(CU_CENTER);
    wd_cntrl(WIND0, WD_ON);
    wd_cntrl(WIND1, WD_ON);
    return (0);
}

VLIST state_vl[] = {
    "fixWndSiz", &wndsiz,    NP,        NP,        0,        ME_DEC,
    "fix_x_ctr", &wndxctr,   NP,        NP,        0,        ME_DEC,
    "fix_y_ctr", &wndyctr,   NP,        NP,        0,        ME_DEC,
    "targWndsiz", &targsiz,   NP,        NP,        0,        ME_DEC,
    NS,
};
char hm_sv_vl[] = "";

MENU umenus[] = {
    "state_vars", &state_vl,  NP,        NP,        0,        NP,hm_sv_vl,
    NS,
};

void f_setTargs(int xpos, int ypos)
{
    mfTargX = xpos;
    mfTargY = ypos;
    return;
}

USER_FUNC ufuncs[] = {
    {"setTargets", &f_setTargs, "%d %d"},
    {""},
};

RTVAR rtvars[] = {
    {"blocks completed", &blockcount},
    {"trials completed", &totalTrials},
    {"block trials left", &trialCounter},
    {"tot correct trls", &correctTrials},
    {"tot error trls", &errorTrials},
    {"tot prcnt right", &percentCorrect},
    {"25 prcnt right", &memSacTrialList[0].percent},
    {"50 prcnt right", &memSacTrialList[1].percent},
    {"100 prcnt right", &memSacTrialList[2].percent},
    {"200 prcnt right", &memSacTrialList[3].percent},
    {"400 prcnt right", &memSacTrialList[4].percent},
    {"800 prcnt right", &memSacTrialList[5].percent},
    {"1600 prcnt right", &memSacTrialList[6].percent},
    {"25 prcnt right", &memSacTrialList[7].percent},
    {"50 prcnt right", &memSacTrialList[8].percent},
    {"100 prcnt right", &memSacTrialList[9].percent},
};

```

```

        {"200 prcnt right", &memSacTrialList[10].percent},
        {"400 prcnt right", &memSacTrialList[11].percent},
        {"800 prcnt right", &memSacTrialList[12].percent},
        {"1600 prcnt right", &memSacTrialList[13].percent},
        {"", 0},
};

%%
id 300
restart rinitf
main {
stat ON
begin
    first:
        to disabl

    disabl:
        to enable on -PSTOP & softswitch /* paradigm enabled? */

    enable:
        code ENABLECD
        rl 0
        to pcktarg

    pcktarg:
        do pick_ramp_direction()
        to fpncmd on 0 % tst_rx_new

    fpncmd:
        do on_fix()
        to awnopn on 0 % tst_rx_new

    awnopn:
        code FPONCD
        do awind(OPEN_W)
        rl 10
        to waitfix

    waitfix:
        do ctr_wnd()
        time 1000
        to fixtim on -WD0_XY & eyeflag
        to error

    fixtim:
        time 400
        rand 400
        rl 20
        to error on +WD0_XY & eyeflag
        to setrmp

    setrmp:
        do to_ramp_start()
        to tgncmd on 0 % tst_rx_new

    tgncmd:
        do pursuitOn()
        to fpfcmd on 0 % tst_rx_new

    fpfcmd:
        do off_fix()
        rl 30
        to strtramp on 0 % tst_rx_new

    strtramp:
        do start_ramp()

```

```

rampon:          to rampon on 0 % tst_rx_new
                 do vex_gate(1)
                 rl 40
                 to flshoncmd
                 to waitsac on +RAMP_DONE & rampFlag

flshoncmd:      do flash_on()
                 to timeflsh on +TARG_SWITCH & vexMessage
                 to waitsac on +RAMP_DONE & rampFlag

timeflsh:       code TARGONCD
                 do resetSwitch()
                 rl 50
                 time 100
                 to waitsac on +RAMP_DONE & rampFlag
                 to floffcnd

floffcnd:       do flash_off()
                 to ramprun on +TARG_SWITCH & vexMessage
                 to waitsac on +RAMP_DONE & rampFlag

ramprun:        code TARGOFFCD
                 do resetSwitch()
                 rl 40
                 to waitsac on +RAMP_DONE & rampFlag

waitsac:         code FPOFFCD
                 time 100
                 rl 60
                 to waittarg on +WD0_XY & eyeflag
                 to error

waittarg:        code SACSTARTCD
                 time 100
                 to correct on -WD1_XY & eyeflag
                 to error

correct:         code REWCD
                 do goodTrial()
                 to rewon

rewon:           do dio_on(REW)
                 rl 35
                 time 50
                 to rewoff

rewoff:          do dio_off(REW)
                 to last

error:           code ERRCD
                 do badTrial()
                 time 1000
                 rl 25

```

```

        to last
last:
        do awind(CLOSE_W)
        rl 15
        to first
abort:
        rewoff
        last
}

/*
 * move eye win to follow ramp object
 */
move_win {
status ON
begin    mfirst:
        to halt
        halt:
        to qrywts on -PSTOP & softswitch
        qrywts:
        to qryvex on +RAMP_ON & rampFlag
        qryvex:
        do object_location()
        to tstmsg on 0 % tst_rx_new
        tstmsg:
        do tstVexMsg()
        to stgwnd on +LOCATE & vexMessage
        to wait
        stgwnd:
        do targ_wnd()
        to tstmsg on 0 % tst_rx_new
        to wait
        wait:
        time 50
        to tstmsg on 0 % tst_rx_new
        to halt on +RAMP_DONE & rampFlag
        to qryvex
}

```