

WILD ABOUT HEALTHY VISION

Activity Book for Ages 9-12

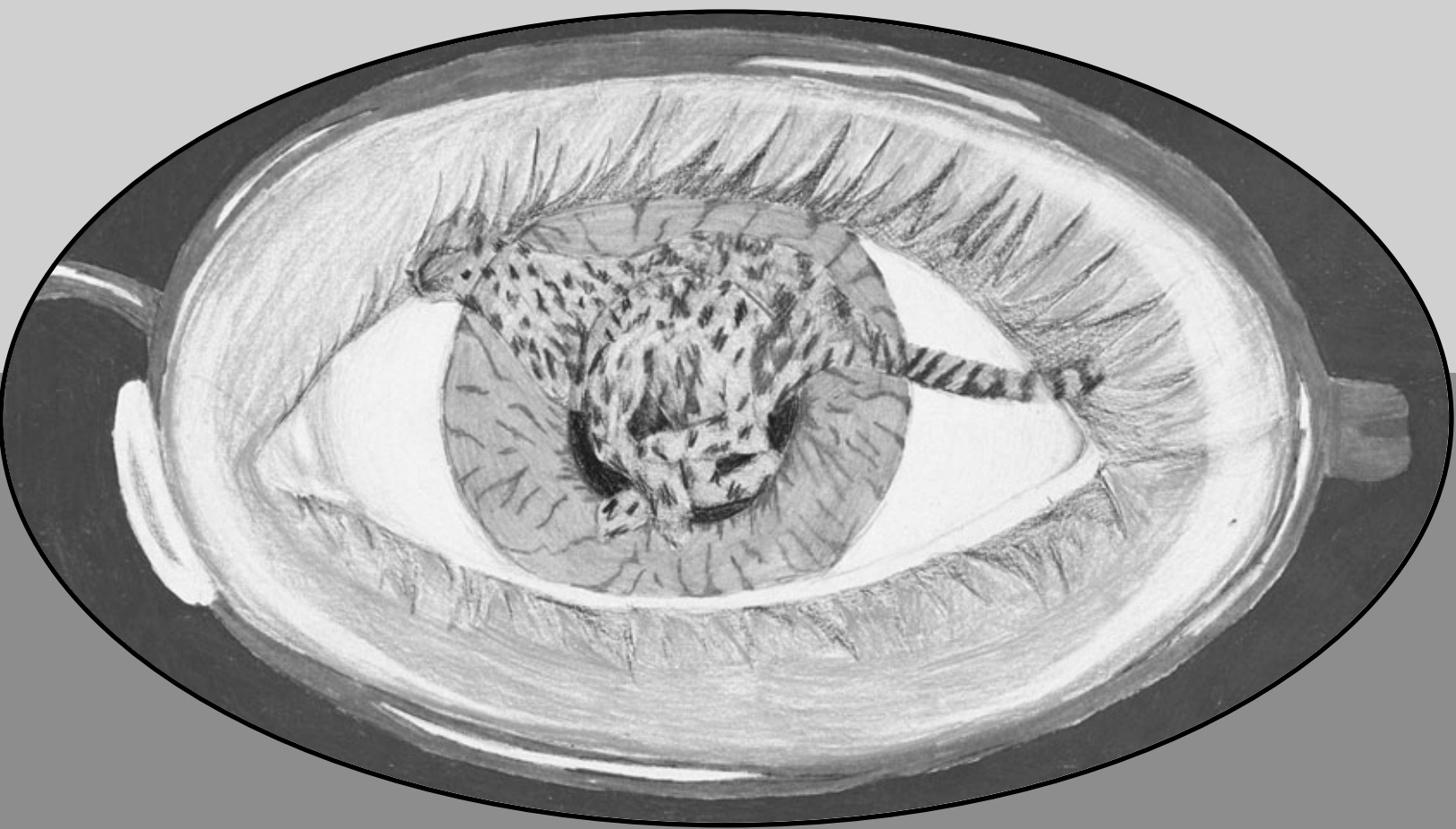

Cover art by Michael, age 11, San Francisco, CA.



U.S. DEPARTMENT OF HEALTH AND HUMAN SERVICES
National Institutes of Health
National Eye Institute



VISION JOURNAL



Hi! We are Erica, Maria, Michael, and Robert, the “Eye Team.” We’re going to give you some “insight” into the importance of protecting your eyes.

We keep a journal of our favorite things to look at. What do you like to look at? Finish the sentences below.

When I get up in the morning, I’m glad I can see because _____

When I look out my window, I’m glad I can see because _____

When I go to school, I’m glad I can see because _____

My favorite things to see in my town are _____
because _____

In the _____ I’m glad I can see because _____
(your favorite season)

The colors that I like best are _____ because _____

In the night sky I like to see _____ because _____



INSIDE THE EYE

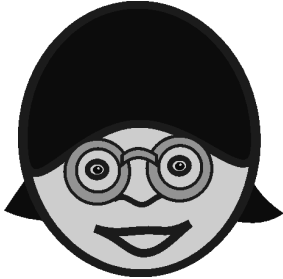

The eye has many parts that work together to help you see. Read about it and be amazed!

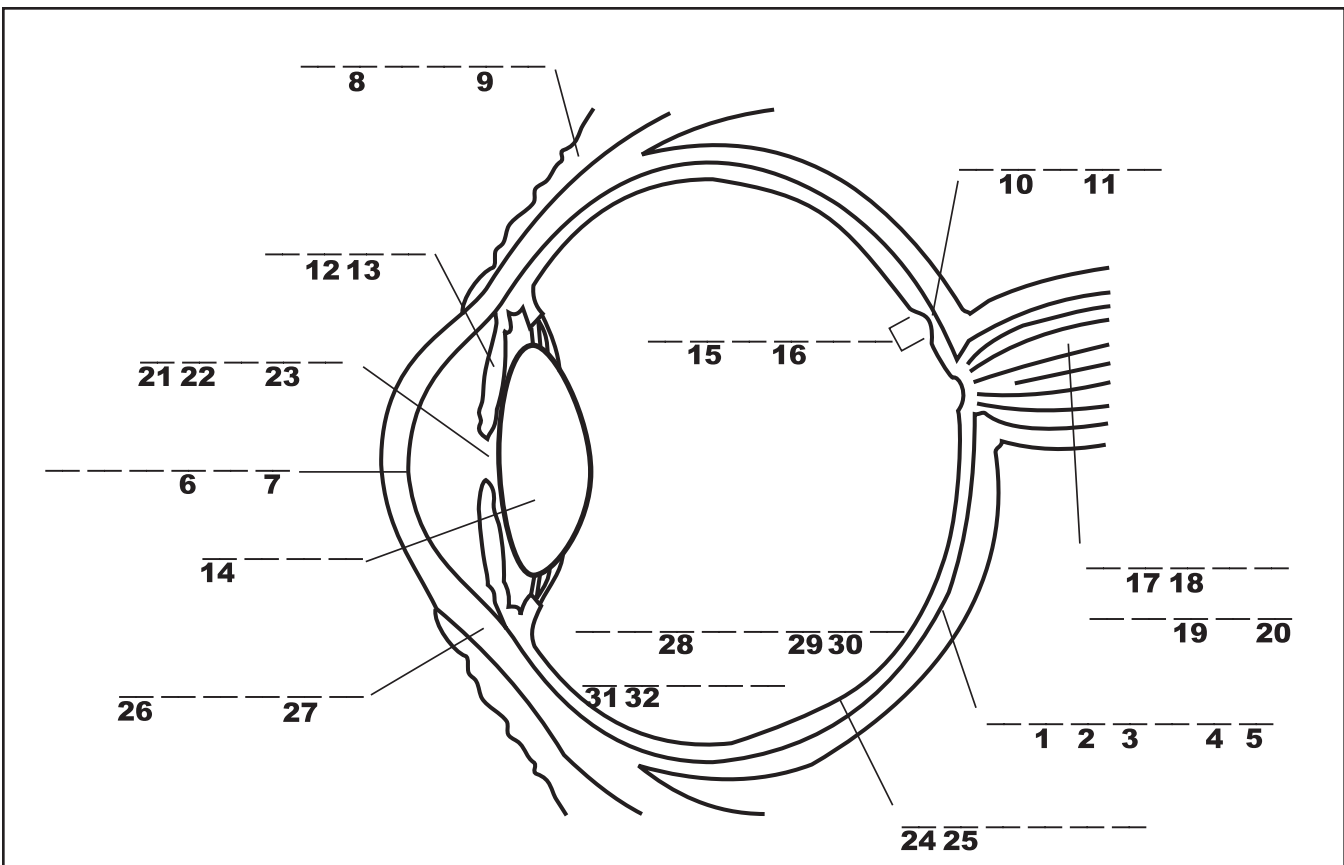

Directions: Label each eye part. On the next page are the definitions for the parts of the eye.
Hint: The label spaces will help you find the right word; some of the spaces have numbers underneath. Look at the puzzle at the bottom of the next page. Above each number write the letter in the matching label space. Then, complete the puzzle to learn something interesting about how you see with your eyes.



Choroid (KOR oyd) A layer of blood vessels that feeds the retina.

Cornea (KOR nee uh) The clear outer part of the eye's focusing system located at the front of the eye.

Eyelid (I lid) The skin-covered structure that protects the front of the eye; limits light entering the eye; spreads tears over the cornea.

Fovea (FOH vee uh) The center of the macula; gives the sharpest vision.

Iris (I ris) The colored part of the eye; regulates the amount of light entering the eye.

Lens (lenz) The clear part of the eye behind the iris that helps to focus light on the retina; allows the eye to focus on both far and near objects.

Macula (MAK yoo luh) The small, sensitive area of the retina that gives central vision; contains the fovea.

Optic nerve (OP tic nrv) The bundle of more than 1 million nerve fibers that carry visual messages from the retina to the brain.

Pupil (PU pl) The opening at the center of the iris. The iris adjusts the size of the pupil and controls the amount of light that can enter the eye.

Retina (RE tin uh) The light-sensitive tissue lining the back of the eyeball; sends electrical impulses to the brain.

Sclera (SKLEH ruh) The tough white outer coat of the eye.

Vitreous humor (VIT ree us HU mr) The clear gel filling the inside of the eye.

I spy with my little eye. How? Figure out the puzzle to find out.

___ ___ ___ ___ e t ___ n ___ ___ ees the w ___ r ___ ___ ___ s ___ d ___ d ___ wn.
 28 1 11 12 4 15 26 2 14 5 30 21 13 25 29

___ ___ ___ ___ b ___ ___ in t ___ ___ ___ s it ___ ___ g ___ ___ s ___ d ___ ___ ___ .
 8 10 32 3 24 7 22 19 6 27 23 31 18 9 20 16 17

Answer to the puzzle: The retina sees the world upside down. Your brain turns it right side up.



YOUR EYES AND THE PINHOLE CAMERA

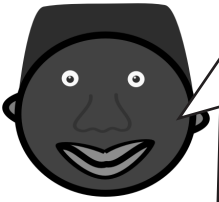

Two things have to happen in order to see. First, an image forms on a sensitive surface. Then, something interprets that image.

An eye works like a camera. Eyes and cameras have three things in common:

- a lens that focuses light
- an opening that controls how much light gets in
- a sensitive surface that records the image the light is carrying

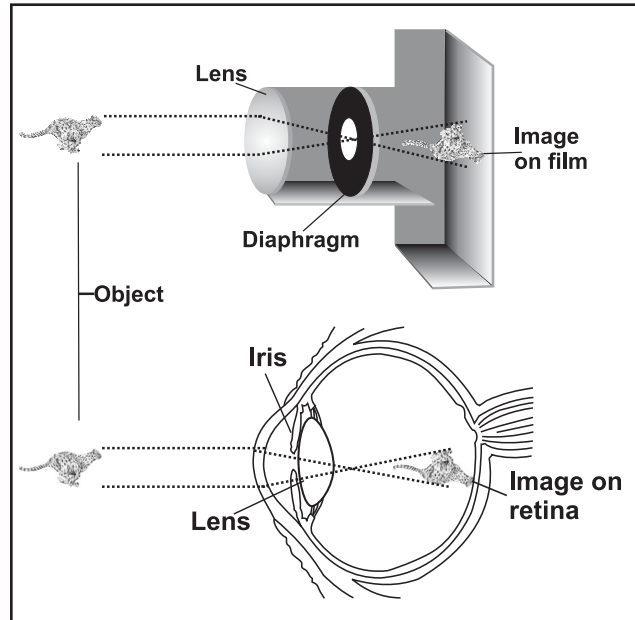

Try this exercise to learn how your eye uses light to record an image.

Light hits and bounces off objects in straight lines in all directions. Use a ruler and a pencil and draw straight lines of light

- bouncing off the cheetah
- entering the aperture or opening of the box
- striking the retina or film of the box.

Notice this: All the light entering the box is mixed up. If your eye or camera had an opening that big, you'd record a very strange image of the cheetah!

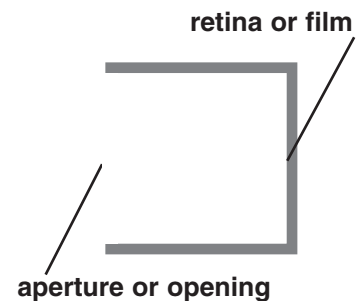
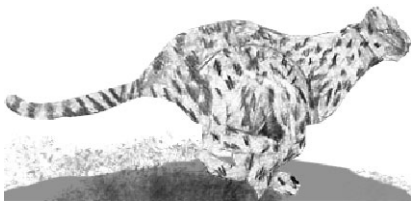



Now, use the ruler and pencil and draw straight lines of light bouncing off the top and bottom of the cheetah, through the aperture or opening, and striking the back of the box.

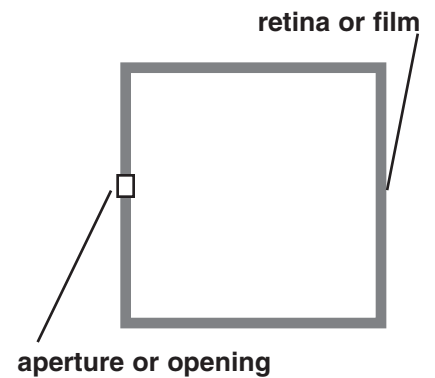
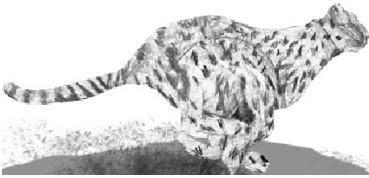

1. Do you still have all the light mixing in a disorganized way on the back of the box?
No, you don't because you have fewer lines of light!
2. What about the image? Is it right side up or upside down?
Actually, if you follow your lines carefully you should see that it is upside down!

Your retina sends the recorded image to the brain. The brain interprets the image, turns it right side up and gives it meaning. The camera interprets the image when you develop the film.



Making a Pinhole Camera

There are more interesting comparisons between cameras and eyes. You can see things close up and far away because the lens of your eye changes shape to adjust the focus. Cameras with an adjustable focal length can do the same thing, but cameras with a fixed focal length cannot. Try creating your own camera to see how light travels!

Materials

An empty box
Tracing paper
Tape
A pin
Scissors
Black paint
Dark towel
Thick brown paper

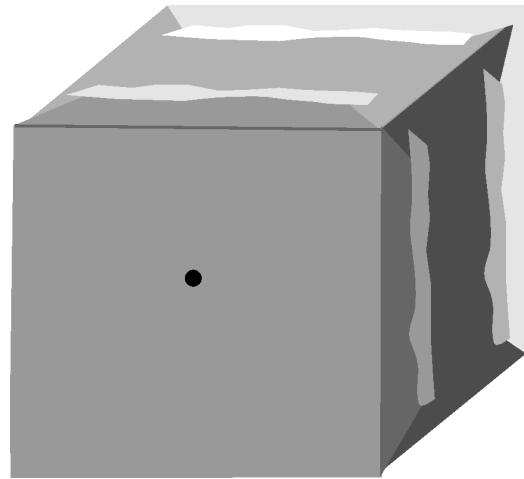

Procedure

1. Cut the ends of the box.
2. Paint the inside of the box black.
3. Tape the piece of tracing paper over one end of the box.
4. Tape the piece of brown paper over the other end.
5. With the pin, make a small round hole in the middle of the brown paper.
6. Use the dark towel to cover your head and the tracing paper end of the box.
7. Aim the camera at a window and look at the tracing paper from about six inches away.



SEEING IN 3-D

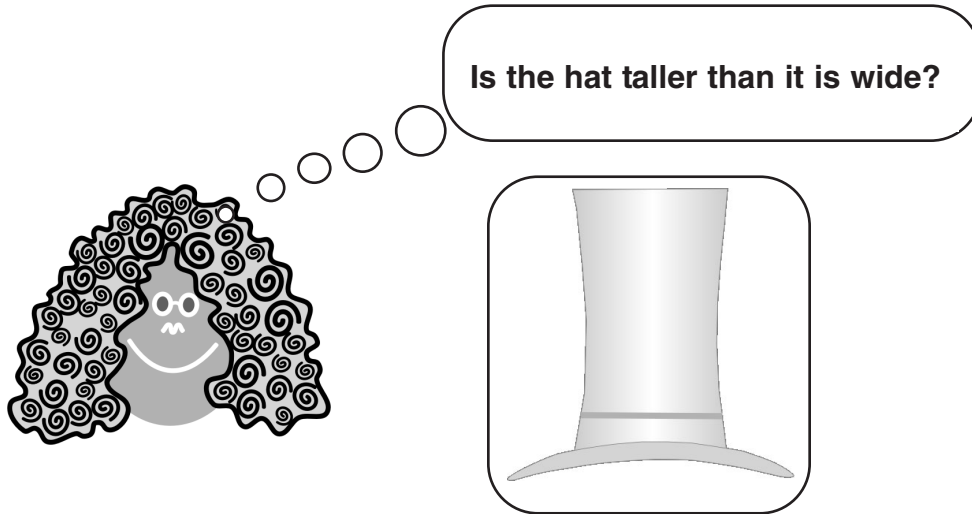

Look in a mirror. Your eyes are side by side so you can see in a three-dimensional world. This ability is called stereo vision. Both eyes look at the same object, but each eye has a slightly different viewpoint that records a slightly different image. Play **Jumping Bug** to check out the two different views of your right and left eye.

JUMPING BUG

1. Lay this book down on a flat surface. Look down at the bug from above. Center your nose over the bug.
2. Close one eye. Put your thumb between the book and your nose. Your thumb should hide the bug completely.
3. Now, open the closed eye at the same time you close the other. What happens? Does the bug “jump”? Yes? You must have pretty good stereo vision!

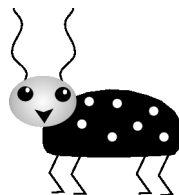



BOTH EYES ON

For good stereo vision, your eyes must work as a team. Your eyes can get clues about depth, shading, lighting, and position. It is most helpful when objects move away from or toward you.

Test your stereo vision with **Both Eyes On**. Remember, in order to see in 3-D, your eyes must work together. **Both Eyes On** can tell you whether your eyes are “on” at the same time. Remove glasses or contacts; this activity may work better without them.

1. Lay this book down on a flat surface. Look at Robert from above.
2. Your nose should be centered over Robert.
3. Focus on Robert.
4. Put your thumb in front of your nose. If both eyes are working together you will see Robert in a frame of thumbs.
5. Switch your focus to your thumb. Now, you have two Roberts framing your thumb!





OPTICAL ILLUSIONS

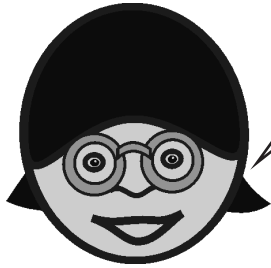

The optical illusions below try to trick your stereo vision. Now that you've learned about stereo vision, see if you can figure out the tricks.

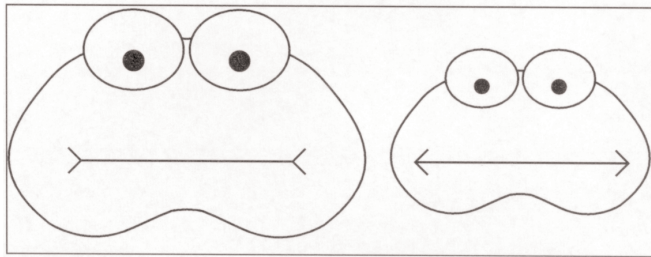

Which frog has a bigger mouth?
Measure to be sure.

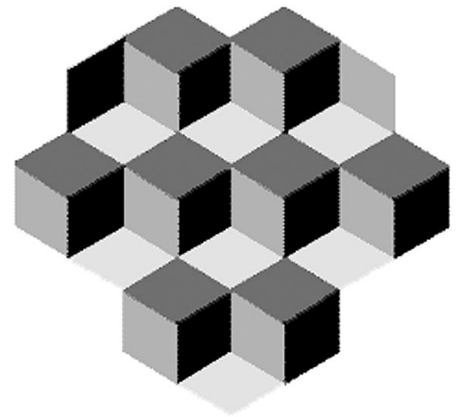

How many cubes can you find—7 or 8?

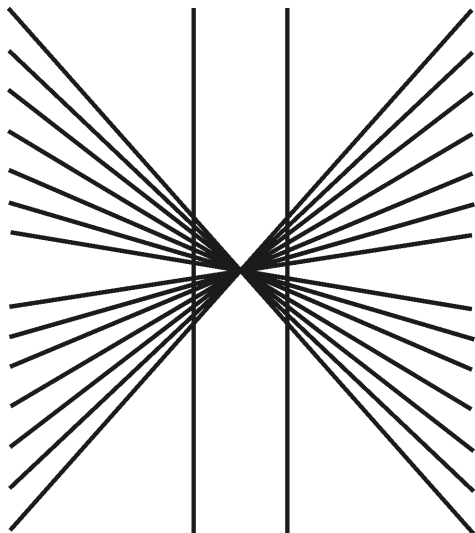

Are the up-and-down lines straight or bent? Use a ruler to check.

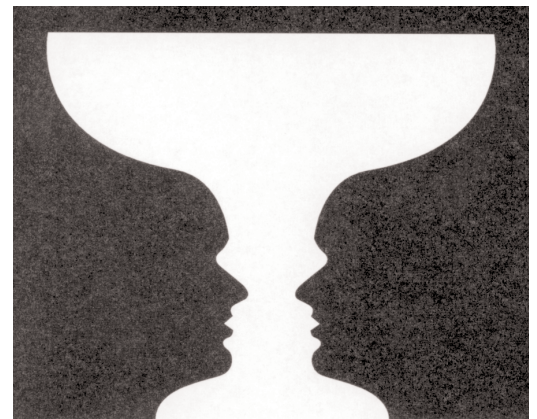

Do you see a vase or do you see two faces looking at each other?
Can you see both?



FOUR SERIOUS EYE DISEASES



More than 14 million people in the United States have low vision. Low vision means that even with regular glasses, contact lenses, medicine, or surgery, people find everyday tasks difficult to do. Reading the mail, shopping, cooking, seeing the TV, and writing can seem challenging to people with low vision.

For any vision problems, visit either an ophthalmologist (off-thuh-MAH-luh-gist) or an optometrist (op-TAH-muh-trist).

Look at the information about four serious eye diseases on this page. Then survey the eye health of your family or friends. Use your information to plan a campaign to raise awareness of the need for regular and early eye exams.



Simulation of normal vision



Simulation of age-related macular degeneration



Simulation of cataracts



Simulation of diabetic retinopathy



Simulation of glaucoma

AGE-RELATED MACULAR DEGENERATION (AMD) is the leading cause of blindness in older people. AMD affects a tiny area in the middle of the retina called the macula. AMD can destroy the central vision. Central vision is needed for reading and driving, among other common tasks. Scientists are learning the causes and treatment of AMD.

CATARACTS form when the lens of the eye grows cloudy. The cloudy lens can be replaced with a plastic lens in a very safe and successful surgery.

DIABETIC RETINOPATHY damages the blood vessels in the eye. It is a leading cause of blindness in adults, but treatments that use lasers or surgery can prevent serious vision loss.



GLAUCOMA is called the “sneak thief of sight” because it does not give any warning signs of loss of vision. This blinding disease damages the optic nerve. Glaucoma can be treated with medication, lasers, or surgery.

Other Eye Problems

MYOPIA, also called nearsightedness, means that a person sees nearby objects more clearly than objects that are far away. It occurs when the eyeball is too long or the cornea is too rounded so that light is focused in front of the retina instead of directly on it.

AMBLYOPIA (am-blee-OH-pee-uh) is often called “lazy eye.” **STRABISMUS** (struh-BIZ-mus) may be called “crossed eyes.” If amblyopia and strabismus are treated early, they can be corrected.

Protecting Your Family’s Eyes

Survey the members of your family (including everyone in your extended family) and friends. Ask the questions below to help you gather information.

- Does anyone in the family wear glasses? YES / NO (circle one) If YES, why?

- When was the last time anyone in the family visited an ophthalmologist or optometrist for an eye exam? _____

- Does your family visit an ophthalmologist or optometrist regularly or only when there seems to be a problem?

What is the overall “picture” of eye health in your family?

Using the information on these two pages and your survey, create a campaign for your family and friends to raise awareness of eye disease and ways to guard against it.

Make your campaign:

- easy for people to understand quickly
- stand out enough to catch attention.

Campaign ideas:

- create posters
- write e-mails
- organize a dinner table discussion
- put on a skit in your living room.

Have fun!



EYE SAFETY

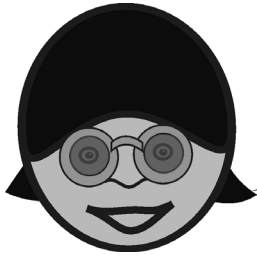

**Hey! Your eyes are important.
Protect them!**

Eye Safety Tips

Eye injury is just as serious as eye disease. Read the tips below to learn more about how to protect your eyes from injury.



- Remove trash from lawns to get rid of anything that could be thrown into your eyes while mowing.
- Wear safety goggles while mowing or using fertilizers or chemicals.
- Use guards on all power equipment to cut down on flying trash.
- Avoid toys with sharp or rigid points, shafts, spikes, rods, and dangerous edges.

- Avoid flying toys and toys that launch things into the air.
- Keep BB guns away from others and use them only under adult supervision.

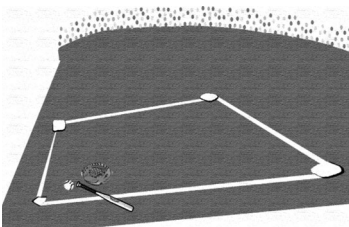
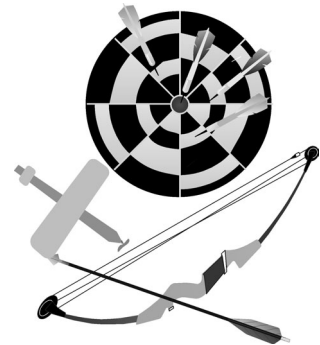

- **Play baseball?** Wear a sports eye guard and face guard attached to your helmet.
- **Play basketball or soccer?** Wear sports eye guards.
- **Play football?** Wear a face mask and sports eye guards.
- **Play hockey?** Wear a face mask and sports eye guards.

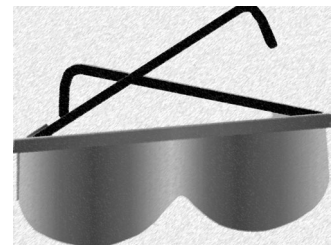

- **Don't play with fireworks.**



Of course, the eye has its own “safety” devices. For example:

- Boney eye sockets protect eyes from getting hit.
- Eyebrows keep some light out of your eyes.
- Eyelids and eyelashes close to keep particles, like dust, out of your eyes.
- Tears keep the eyes moist and wash away particles that get into your eyes.

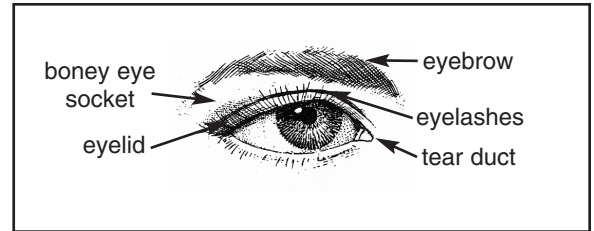

First Aid Tips

1. If particles, like sand or dust, get into your eye, don't rub! Wash your eye out with water.
2. If your eye gets hit with a ball or a rock or a fist, put cold cloths on it for 15 minutes. This should make the swelling go down and relieve the pain. Go to a doctor!
3. If an object like a stick or pencil gets stuck in your eye, do not pull it out. This is very serious! Put a loose bandage on your eye. Don't put any pressure on the object. Go to a doctor immediately.
4. If a chemical from a class experiment or a cleaning fluid or battery acid splashes in your eye, wash your eye out with water for at least 10 minutes. Go to a doctor immediately.



Directions: Spread the word about eye safety.

1. Interview your friends and family.
 - Ask them to list their usual activities. Do they clean in the kitchen? Mow the lawn? Play a sport?
 - Ask them if they know what dangers they face with each activity and what to do in case something happens.
2. Examine your survey and decide what your family members need to know to take care of their eyes.
3. Create simple eye safety reminders. Make note cards, a checklist, or large, colorful posters, depending on how much information you want to give.
4. Post your reminders in places where they will do the most good. For example, if your big sister mows the lawn, post the lawn-mowing reminder near her equipment.

Challenge:

Talk with your teachers at school to discover eye safety problems in their classrooms. Then, find a friend or friends to work with you to create reminders to post in the classroom to help your classmates protect their eyes. Make sure you show everything to your teacher before you post your reminders.



MIXED-UP EYES GAME



Hope we can remember all the eye words for this game!

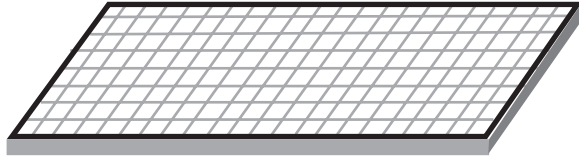

A	A	C	E	E	G	I	L	L	M	O	P	R	S	T	V
A	A	C	E	E	G	I	L	L	M	O	P	R	S	T	W
A	B	C	E	E	H	I	L	L	N	O	P	R	S	T	Y
A	B	C	E	E	H	I	L	L	N	O	P	R	S	U	Y
A	B	D	E	F	H	I	L	L	N	O	P	R	S	U	Y
A	C	D	E	F	H	I	L	L	N	O	P	R	S	U	Y
A	C	D	E	F	H	I	L	L	N	O	R	S	T	U	Y
A	C	D	E	F	H	I	L	L	N	O	R	S	T	U	Y
A	C	D	E	G	H	I	L	L	N	O	R	S	T	U	Y
A	C	D	E	G	H	I	L	L	N	O	R	S	T	U	Y
A	C	D	E	G	H	I	L	L	N	O	R	S	T	U	Y
A	C	D	E	G	I	J	L	L	N	O	R	S	T	U	Y
A	C	D	E	G	I	J	L	L	M	N	O	P	R	S	Y
A	C	E	E	G	I	J	L	L	M	O	P	R	S	T	V
A	C	E	E	G	I	L	L	L	M	O	P	R	S	T	V
A	C	E	E	G	I	L	L	L	M	O	P	R	S	T	V
A	C	E	E	G	I	L	L	L	M	O	P	R	S	T	V
A	C	E	E	G	I	L	L	L	M	O	P	R	S	T	V

