

C. A. 112  
114B

24526

DRAFT

OPERATIONAL PROTOCOL FOR THE ELASTOL AND DEMOUSIFIER FIELD TRIAL

Prepared by

Environmental Emergencies Technology Division (EETD), Environment Canada

and

Seakem Oceanography

August 24, 1987 (Version 3)

## TABLE OF CONTENTS

	<u>Page</u>
List of Figures	iv
List of Appendices	iii
1.0 Summary	1
1.1 Objectives	3
1.2 Overall Schedule	4
2.0 General Information	5
2.1 Site	5
2.2 Coordination	5
2.3 Operating Restraints	5
2.4 Accomodation	5
2.5 Timing	8
3.0 Experimental Design	9
3.1 Experimental Overview	9
3.2 Detailed Procedure for Selecting the Layout Track	9
3.3 Procedure for Laying Slicks	9
3.4 Order of Slicks	13
3.5 Procedure for Laying Slicks - The MARY HICHENS Movements	13
3.6 Procedure for Sampling Slicks - The MARY HICHENS Movements	14
3.7 Procedure for Innotech Remote Sensing Aircraft	14
3.8 Procedure for Laying Slicks - Deck Crew	18
3.9 Procedure for Treating Slicks - Sample Crew	18
3.10 Procedure for Sample Slick - Sample A	21
3.11 Procedure for Analyzing Slicks - On-board Analysis	24
3.12 Procedure for Deploying Oceanographic Equipment and Taking Readings	25
3.13 Procedure for Deploying Oil Recovery Sampling Boat	26
3.14 Procedure for Taking Meteorological Readings	27

TABLE OF CONTENTS (.../continued)

	<u>Page</u>
3.15 Procedure for Deploying Spill Tracking Equipment and Taking Readings	28
3.16 Procedure for Spill Countermeasures	29
3.17 Contingency Plans	30
3.18 ARGOS buoy schedule	31
3.19 Detailed Oil Delivery	32
3.20 Procedure for Test of Shipborne Radar to Track Surface Slicks	32
4.0 Equipment	33
5.0 Arrival/Lodging/Departure/Shipping	35
6.0 Detailed Schedule	36
7.0 Procedure for Test Run - September 8	43
7.1 General	43
7.2 Detailed Procedure	43
8.0 Individual Tasking	44
8.1 Overall Assignments	44
8.2 Ed Tennyson	44
8.3 Merv Fingas	44
8.4 Roger Percy	46
8.5 Cam Mackenzie	46
8.6 Ed Tedeschi	47
8.7 Bob Gershey	47
8.8 Bruce Batstone	48

## APPENDICES

	<u>Page</u>
8.9 Mark Bobra	48
8.10 ODOCA-I, R. Percy	49
8.11 Larry Hannon	49
8.12 Bernie Wood	49
9.0 Communication	50
10.0 Safety	51
Appendices	
Appendix 1. Drawings of the MARY HICHENS	52
Appendix 2. Conversion and Weight Conversions	58
Appendix 3. Maps	60
Appendix 4. Information on the FALCON	68
Appendix 5. Detailed Analytical Procedures for Elasticity	72
Appendix 6. Detailed Analytical Procedures for Water Content	74
Appendix 7. Oceanography Equipment Brochures	76

## LIST OF FIGURES

	<u>Page</u>
Figure 1. Map of Area	6
Figure 2. Map of Area	7
Figure 3. Selection of Slick Laying Track	10
Figure 4. Plumbing for Spill Laying	11
Figure 5. Slick Treatment and Numbers	12
Figure 6. Main Ship Deployment During Slick Laying	16
Figure 7. Main Ship Deployment During Sampling	17
Figure 8. Diagram of Dispenser Apparatus	19
Figure 9. Suggested Treatment Pattern	20
Figure 10. Devices to Sample Slick	22
Figure 11. Diagram of Practise Run	41a
Figure 12. Overall Organization	45

# ELASTOL AND DEMOUSIFIER FIELD TESTING PROJECT

## 1.0 SUMMARY

### Overall

Environment Canada and the U.S. Minerals Management Service have entered into an agreement to test Elastol both in the laboratory and in the field. A general program has been set up to evaluate Elastol. Protocol describes field testing of Elastol and demousifier.

Elastol is a simple polymer which, when added to oil, renders it visco-elastic and thus, the oil adheres to recovery surfaces. The product also causes thickening of oil slicks and might also allow burning of oil at sea. Little testing has been done on Elastol although it has successfully been used in a number of cleanups in basins and holding ponds. The demousifier that will be used is a product blended by EETD. The product worked very well in laboratory and tank tests and will be tested at sea to verify its practicality in real situations.

### Environmental Toxicity of Elastol and Demousifier

The C&P laboratory tested both Elastol and the demousifier and found no toxicity measurable below 10,000 mg/L using the test protocol described for dispersants. This test is basically a 96-hour LC<sub>50</sub> to Rainbow Trout.

Shell has tested their demousifier and report also no measurable toxicity.

GTA has tested their own product, Elastol, under those conditions specified by the EPA for inclusion into the U.S. National Contingency Plan list.

Their results are as follows:

<u>Material Tested</u>	<u>Species</u>	<u>LC50 (ppm)</u>	
Elastol	<u>Fundulus heteroclitus</u>	50,000	96-hr
	<u>Artemia salina</u>	100,000	48-hr
No. 2 Fuel Oil	<u>Fundulus heteroclitus</u>	4,400	96-hr
	<u>Artemia salina</u>	175	48-hr
Elastol and No. 2 Fuel Oil (1:10)	<u>Fundulus heteroclitus</u>	3,900	96-hr
	<u>Artemia salina</u>	340	48-hr

A special toxicity test was conducted at the C&P Halifax laboratory with the two oil field chemicals "Elastol" and "Brand S Demulsifier" to determine if any synergism resulted from the mixture of these products with the C&P standard test oil, Alberta Sweet Mix Blend.

Three tanks were prepared, each with 40 litres of sea water, 30 ppt salinity. To each of these tanks 10 three-spined stickleback were added and then 400 mLs of the test oil resulting in a nominal concentration of 10,000 ppm and a slick thickness of 4.67 mm. The gelling agent "Elastol" was added to one tank at a ratio of 1:500, gelling agent to oil. To another tank the "Brand S Demulsifier" was added at a ratio of 1:1000, demulsifier to oil. The third tank was a control of oil only. Each of the tanks were thoroughly agitated at the beginning of the 96-hour test and aerated at the rate of 200 mL/min for the duration. The test was conducted at 15°C with pH and dissolved oxygen monitored initially and at 96 hours. These values were within acceptable levels over the duration of the test.

The results at the termination of the 96-hour test period gave no mortality in any of the mixtures indicating no synergistic effects between either of the treating agents and the test oil.

All test data show that the two products have very low toxicity and may in fact inhibit the oil toxicity by preventing dispersion.

#### Lab Testing

An extensive program of testing has been completed at Environment Canada's River Road Laboratory in Ottawa. Elastol has shown great promise for field use.

#### Tank Testing of Elastol

The second phase of the study was a test of the degradation of elasticity with waves and time. Preliminary testing has shown that degradation does not occur and that small portions of Elastol can dramatically increase elasticity. The Esso test tank in Calgary, Alberta was used for these tests.

#### Field Tests

Field tests are planned for September 8-12 offshore Nova Scotia. The location will be halfway between Sable Island and Halifax (44° 15'N, 61° 50'W). The tests will simulate real spill situations and be a full-scale test of operational capabilities. Tests will include only those parameters that cannot be measured in tank or near-shore situations. The plan will be to lay a series of slicks with various treatments and monitor them over a four-day period both from ship and remote sensing aircraft. Surface samples will be taken at approximate logarithmic intervals. Surface samples will be analyzed for the usual parameters, density, viscosity, etc., but additionally, in the case of the Elastol - for elasticity, and in the case of the demulsifier - for water content. At the end of the trial it may be possible to burn the slicks if the Elastol causes the slick thicknesses observed in the lab.

The time of the test (early September) was chosen to provide ideal water conditions (8 to 10°C) and low fog probability. The location (East Coast Canada) was chosen as the West Coast would be unlikely to have sufficiently calm sea conditions during this time.

A test matrix for the spills (of 5 barrels minimum) is as follows:

	<u>Elastol</u>	<u>Demousifier</u>
	Alberta Sweet Mixed Blend	Emulsifying Oil (Bunker C and ASMB)
1.	Control	Control
2.	Premixed at 3000 ppm	Premixed at 1000 ppm
3.	Treated at 1000 ppm	Treated at 250 ppm
4.	Treated at 3000 ppm	Treated at 1000 ppm
5.	Treated at 9000 ppm	Treated after Emulsification at 4000 ppm

The oil will be pumped from a spill tank through a 2½" floating line. A two-way valve (one leg hooked to seawater) in front of the pump will allow for rapid oil removal from the lines - eliminating the long trail-off often obtained at such sea trials.

The Canadian Coast Guard ship MARY HICHENS will be used as the main vessel. She will carry 2 Rossboroughs (used for sampling vessels) and oil recovery equipment. She has accommodation for at least 9 supernumeraries.

The slick will be monitored by Innotech using the Falcon jet aircraft and instrumentation formerly flown by CCRS. A possibility exists that ESRI will monitor the slick with a king air and the Esso simple remote sensing system.

### 1.1 Objectives

The objectives of the field trial, in order of priority are:

1. To determine the field effectiveness of Elastol and Demousifier as spill treating agents,
2. To assess the overall usefulness and practicality of these treating agents in the open-ocean environment, and
3. To assess the fate and behaviour of oil slicks treated with these two agents.



## 1.2 Overall Schedule

September 7, Day 1 14:00 - briefing of Mary Hichens' Commanding Officer  
21:00 - briefing at Port Hawkesbury

September 8, Day 0 08:00 - Commence load equipment on Mary Hichens  
14:00-16:00 - dry run in Canso Strait  
17:00 - depart for trial site

September 9, Day 1 09:00-13:15 - put out slicks and take first samples  
15:00-18:00 - take second sample

September 10, Day 2 07:00-10:00 - take sample of previous day's slicks  
10:30-14:00 - put out slicks and take first samples  
16:00-19:00 - take second sample

September 11, Day 3 07:30-10:30 - take sample of Day 1 slicks and countermeasures  
10:30-12:00 - extra time for countermeasures  
14:00-17:00 - sample Day 2 slicks and countermeasures  
17:00-18:00 - extra time for countermeasures  
18:00 - depart for home base (Mulgrave)

September 12, Day 4 07:00 - MARY HICHENS at port  
09:00 - last remote sensing overflight

## 2.0 GENERAL INFORMATION

### 2.1 Site

The site chosen is 44° 15' N, 61° 50' W and is a point halfway between Sable Island and Halifax. Figures 1 and 2 provide additional information on the sites.

The site was chosen as being the least ecological sensitive site within about a 100-mile range of the coast. The water depth is about 172 metres (m) and the site is about 60 kilometres (km) from the nearest shoreline. Mulgrave is about 150 km or 120 knots from the site.

### 2.2 Coordination

The overall responsibility of the trial plan rests with Merv Fingas of EETD. Seakem Oceanography, Bob Gershey and Bill Batstone, have been retained to provide detailed coordination of the trial, logistics at the trial, provide some equipment, collect some data, and prepare a full report on the experiment. During the actual field trial, Merv Fingas and Ed Tennyson will jointly direct and coordinate activities. Routine ship-keeping, etc. will, of course, reside with the master of the vessel. Communication to sample boats will be performed via hand-held radio and, with the Falcon, via 126.7 on the VHF band.

### 2.3 Operating Constraints

The following weather/sea state logistic conditions will force rescheduling of the trial on a day-by-day basis or delay to a latter portion of the day:

- i) unacceptable flying conditions
- ii) sea states greater than that in which small boats cannot operate safely (greater than Beaufort 3 or 4)
- iii) urgent tasks for the MARY HICHENS
- iv) serious mechanical difficulties

### 2.4 Accomodations

The MARY HICHENS has bunk accomodations in the helm for 9 persons and can take an additional 3 persons if they provide their own sleeping bags and air/foam mattresses. Provisions have been made to provide meal service to all persons.

The following spaces are reserved for main-room accomodation:

1. Ed Tennyson, U.S. MMS
2. Merv Fingas, EETD
3. Cam Mackenzie, ESSO
4. Ed Tedeschi, GTA
5. Roger Percy, C&P
6. Bob Gershey, Seakem
7. Bruce Batstone, Seakem
8. Mark Bobra, Consultchem
9. Larry Hannon, U.S.M.M.S.
10. Bernie Wood, CCG.

**FIGURE 1 - MAP OF AREA**

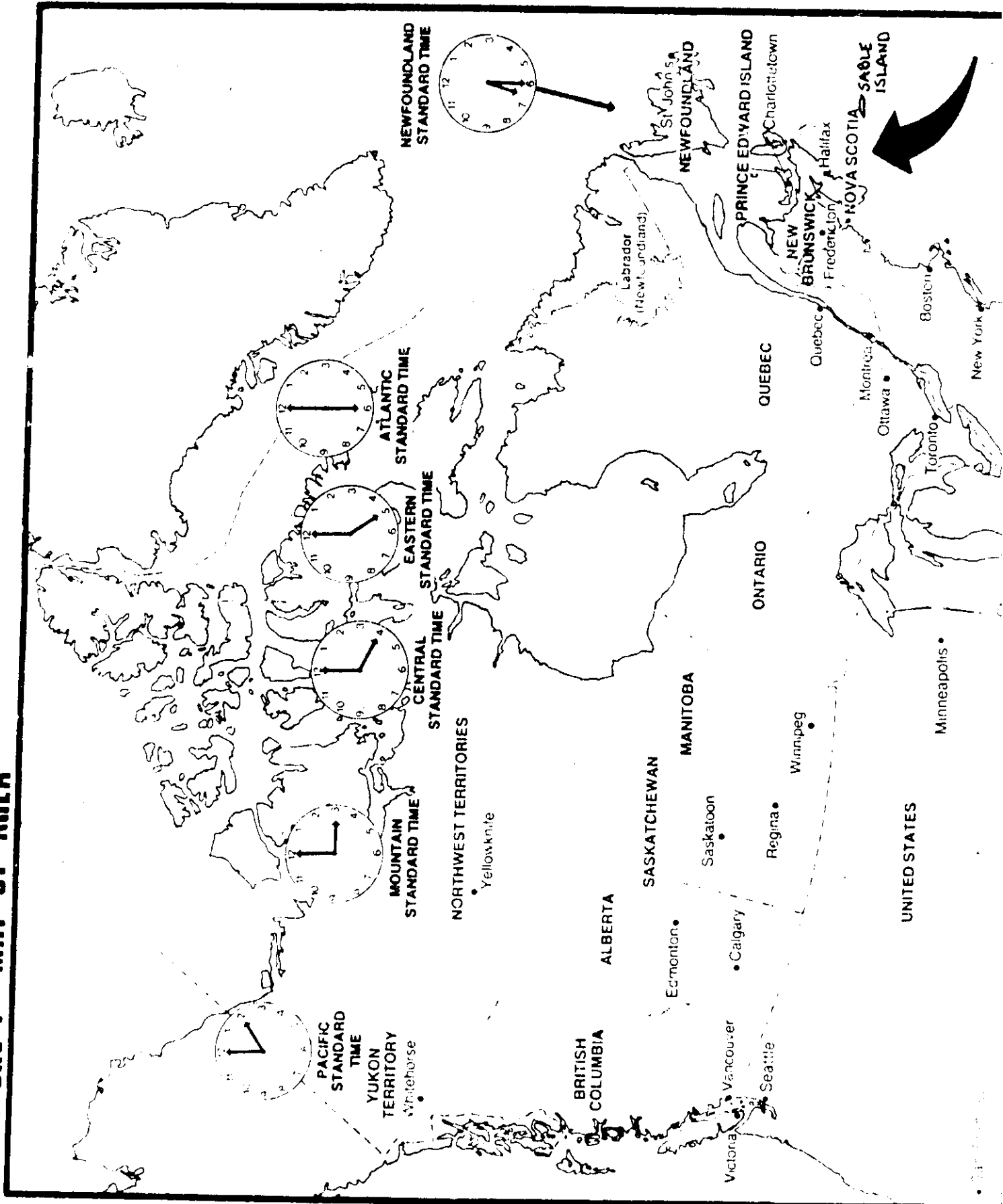



44° 15' N 61° 50' W



SCALE 1:2,000,000

0 15 30 miles



Sable Island

VARMOUTH SHELBURNE

LUNENBURG

DIGBY

TRICORD

ANTICOST

STICOU

COLESTER

LANSDOWN

CUMBER

JOHN

ANTICOST

TRICORD

## 2.5 Timing

The sea trial is scheduled to begin on September 9. Loading will begin on September 8 and a dry run will also be conducted on the same day to ensure that everyone becomes familiar with his duties and equipment, and also to ensure that the equipment is functional. Participants should arrive in Mulgrave by September 7 and can stay overnight at commercial accommodations in Port Hawkesbury. Departure for the actual sea trial should take place at 17:00 on September 8. Three full days are required to complete the trial according to plan. Should a postponement be required for weather or other reasons, all items will be moved down accordingly. This can be done to a maximum of one-and-a-half days before the MARY HICHENS is required to resume her normal duties.

### 3.0 EXPERIMENTAL DESIGN

#### 3.1 Experimental Overview

The experimental design is similar for both the Elastol and demousifier trials. Five slicks are laid in each trial to yield a total of 10 slicks. One slick in each set will be an untreated control. One slick will be pretreated with a medium dosage of the agent. Three will be treated at sea with high, medium and low doses of the agent. In the case of the demousifier trial, one of the slicks will not be treated until the 6-hour sample time to assess the effect of demousifier on slicks already emulsified.

Samples will be taken at approximately 1, 6, 22, and 32 or 49 hours. The slick which will be laid secondly will only be sampled at 32 hours rather than 49 to allow the vessel to return on the evening of the third day.

Each slick is sampled and the sample analyzed onboard the MARY HICHENS for elasticity (in the case of the Elastol trial) or for water content (in the case of the demousifier trial). Other measurements will be done onshore to stored samples.

Remote sensing (IR/UV scanning) will be a prime data acquisition method and can proceed in most weather conditions.

The minimum means to achieve the objectives include laying the slicks, treating them, performing some remote sensing, and obtaining some samples.

Ancillary experiments such as Argos buoy evaluation and testing of the U.S. Coast Guard towed fluorometer may be incorporated into the tests.

#### 3.2 Detailed Procedure for Selecting the Layout Track

Upper wind directions are often different than surface winds and typically are 30° to the right of surface winds. To enable the slicks to be laid in such a manner that they can be flown over both up and down wind by the remote sensing aircraft, the direction of the upper winds should first be determined by calling the weather office for upper wind direction. This is then compared to the surface wind direction to ensure that these are not the same, and thus, that the slicks will not converge on the water surface. This is illustrated in Figure 3.

#### 3.3 General Procedure for Laying Slicks

The piping arrangement is shown in Figure 4. Spill tanks marked at 1 m<sup>3</sup> or 5 barrels (175 gallons) are filled with the test oil from the two bulk (5000 gallon) storage tanks. Upon signal from the spill commander (Merv Fingas), the spill tank is discharged via a 2½" pump, and 2½" line behind the ship. The 2½" line has floats on it and a paravane to prevent it from flapping. As soon as the tank is empty, a 2-way valve from the pump is flipped to allow seawater to be pumped through the line, thus removing the oil and preventing a long trailing slick as the ship pulls away. During discharge, the ship will proceed at approx. 0.5 knots perpendicular to the upper wind direction.

Two discharge tanks are available to ensure backup and also to allow one tank to be filled from bulk tanks while the other is hooked up to the discharge system. Quick connects should be used to ensure that hook-ups can be made rapidly.

# FIGURE 3 - SELECTION OF THE SLICK LAYING TRACK

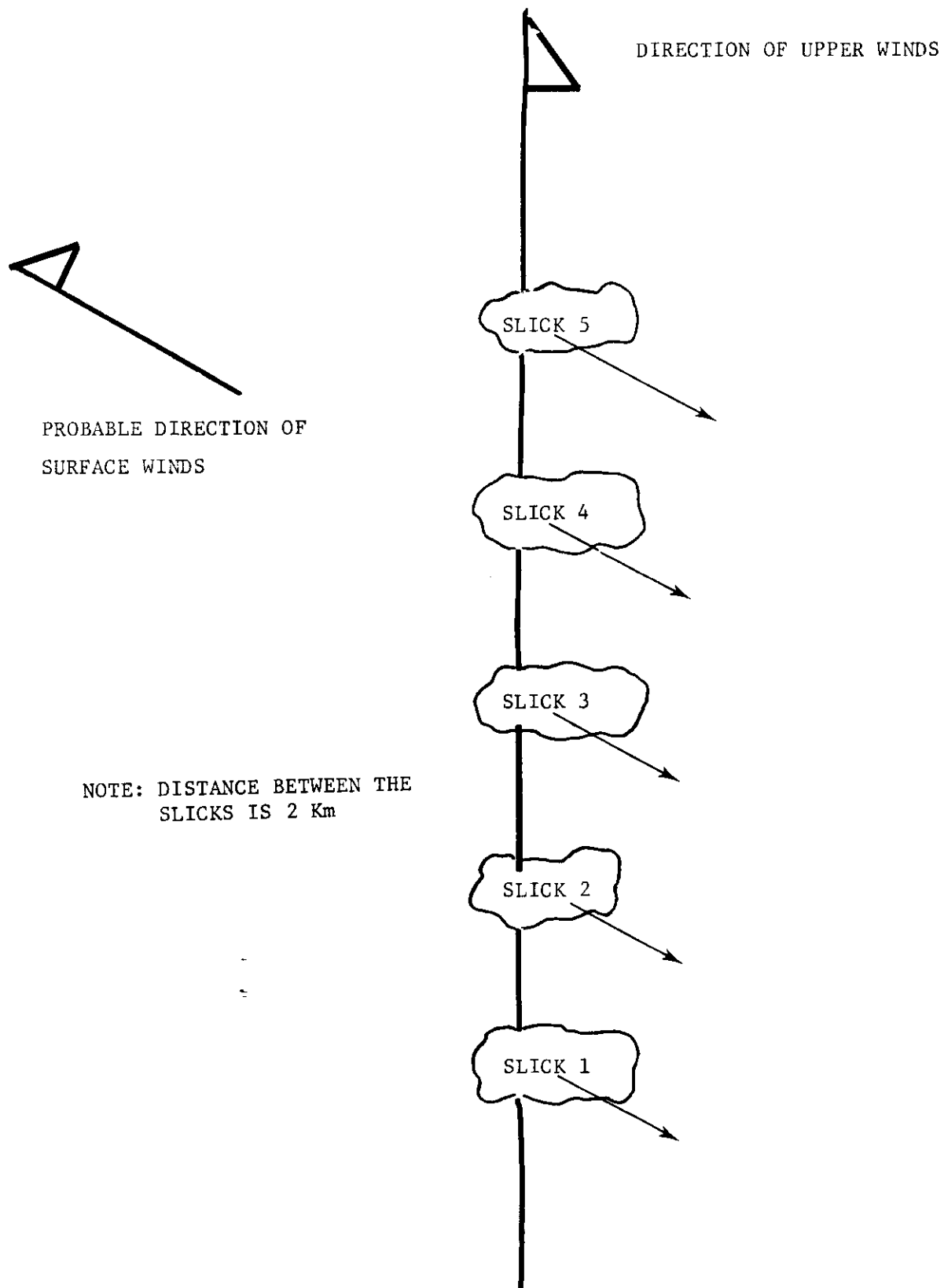

# FIGURE 4 - PLUMBING FOR SPILL LAYING

(To be finalized with commanding officer)

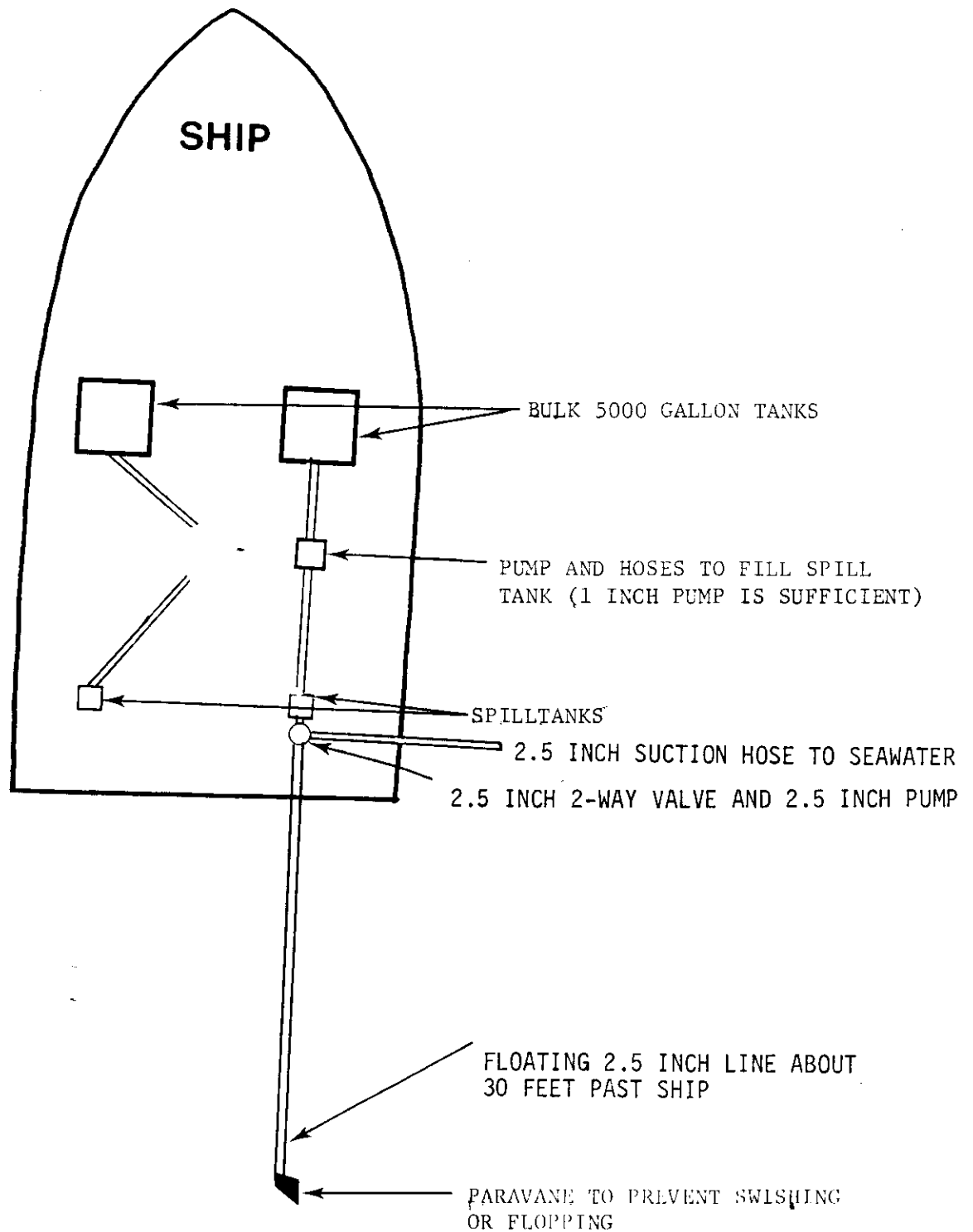



# FIGURE 5 -- SLICK TREATMENT AND NUMBERS

↑  
DIRECTION OF UPPER  
WINDS AND  
SLICK LAYING PROCEEDURE

ELASTOL

SLICK 10  
PRETREATED 3000ppm

SLICK 9  
9000ppm

SLICK 8  
CONTROL

SLICK 7  
1000ppm

SLICK 6  
3000ppm

DEMOUSSIFIER

SLICK 5  
PRETREATED 1000ppm

SLICK 4  
TREATED AT 6 HOUR SAMPLE  
TIME- 4000ppm

SLICK 3  
CONTROL

SLICK 2  
250ppm

SLICK 1  
1000ppm

For pre-treated slicks, the agent is added to the spill tank just as it begins to fill with the oil from the bulk tank. This will ensure that the agent is well-mixed in the tank. This should not be done longer than about 10 minutes before discharge for the Elastol treatment, as the Elastol will stick to the tank or make the oil very viscous.

### 3.4 Order of Slicks

The slick laying will begin from the starting point and proceed upwind. This will ensure that the slicks do not converge. The treatment for the slicks is chosen so that the control is centred and also so that sampling/treating time is minimal.

### 3.5 Procedure for Laying Slicks - The MARY HICHENS Movement

Figure 6 provides a summary scheme of this procedure. The procedure can be summarized as follows:

1. Slick is laid and crew to treat and sample dropped off.
2. Next slick is laid, another crew to treat and sample this slick is dropped off.
3. An untreated slick is laid, and the ship returns to the first slick to pick up the sample crew.
4. Ship proceeds to next slick point.

The detailed procedure is as follows:

1. Start. Vessel moves to position to lay slick number 1, this is done and the sample crew number 1 is deployed.
2. Vessel proceeds to position number 2 (2 km toward the upper wind direction). At  $\frac{1}{2}$  hour past start time slick number 2 is laid, and during the relative low vessel speed, sample crew number 2 is deployed.
3. The vessel then proceeds to lay slick number 3 (4 km from start, 2 km toward the upper wind direction from last slick). This is a control slick with no treatment applied and, thus, a sample/treatment crew is not needed here for about another hour. The third slick is laid at about the 1-hour point.
4. The MARY HICHENS depart for slick number 1 and picks up sample crew number 1, and then on to slick number 2 to pick up sample crew number 2.
5. The sample crew number 1 is taken to the control slick (slick number 3) and put down.
6. The MARY HICHENS proceeds to position number 4 to lay slick number 4. Sample crew number 2 is left.
7. The MARY HICHENS proceeds to pick up sample crew number 1 from slick number 3. The rendezvous time is about 1 hour after the departure time.
8. This done, the vessel proceeds to position number 5 to lay the last slick (slick number 5) of the series. Sample crew number 1 is left to treat the oil and to take the 1-hour sample.

9. The vessel proceeds to slick number 4 to pick up sample crew number 2.
10. At the 4-hour mark, the MARY HICHENS picks up sample crew number 1 at slick number 5.
11. The round of slick laying and sampling is complete.

### 3.6 Procedure for Sampling Slicks - The MARY HICHENS Movements

The procedure is outlined in Figure 7 and is somewhat analogous to the slick laying procedure:

1. Ship (MARY HICHENS) begins at slick number 1, deploys sample crew number 1.
2. Ship proceeds to slick number 2, deploys sample crew number 2.
3. Ship proceeds to pick up sample crew number 1 at slick number 1, and sample crew number 2 at slick number 2. Each leg of the trip is expected to take 20 minutes throughout the entire sampling procedure.
4. Ship proceeds to slick number 3 and deploys sample crew number 1.
5. Ship proceeds to slick number 4 and deploys sample crew number 2.
6. Ship returns to slick number 3 to pick up sample crew number 1, then on to slick number 4 to pick up sample crew number 2.
7. Ship proceeds to slick number 5 to deploy sample crew number 1 and waits for this crew in the vicinity of the slick.
8. Upon recovery of sample crew number 1, sampling is complete. Time since start is about 160 minutes.

### 3.7 Procedures for Innotech Remote Sensing Aircraft

Telephone communication will be established on each morning of the field trial to ensure that schedules are as planned and that weather permits operation according to plan. Communication while in air will be via VHF channel 146.7.

#### Flight Schedule

<u>Day</u>	<u>Sept</u>	<u>Sortie</u>	<u>Sensor Hours</u>	<u>Time (E.D.T.)</u>	<u>Target</u>
1	9	1	1 3/4	11:15-13:00	first set of slicks
		2	3/4	16:00-16:45	first set of slicks
2	10	3	2	13:00-15:00	both sets of slicks
		4	3/4	16:00-16:45	both sets of slicks
3	11	5	1	09:00-10:00	both sets of slicks
4	12	6	3/4	09:00-09:45	both remnants of slicks possible last run on way home if look poor, move up to day 3

As noted earlier in the protocol, an attempt will be made to align all slicks along the upper wind axis. Should this prove to be successful, much time on making passes will be saved.

# FIGURE 6 -- MAIN SHIP DEPLOYMENT DURING SLICK LAYING

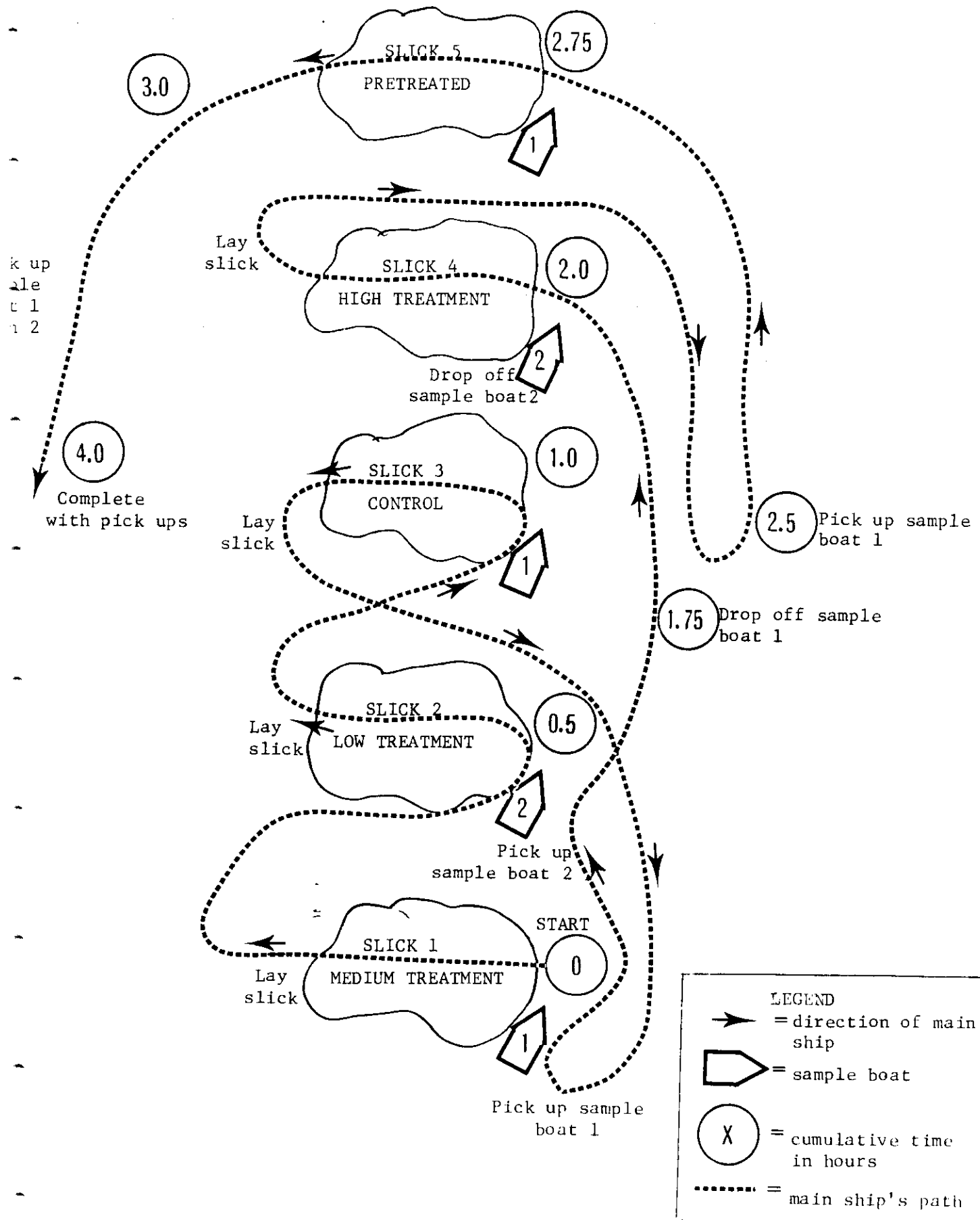

# URE 7 -- PATH OF THE MARY HICHENS FOR SAMPLING PURPOSES

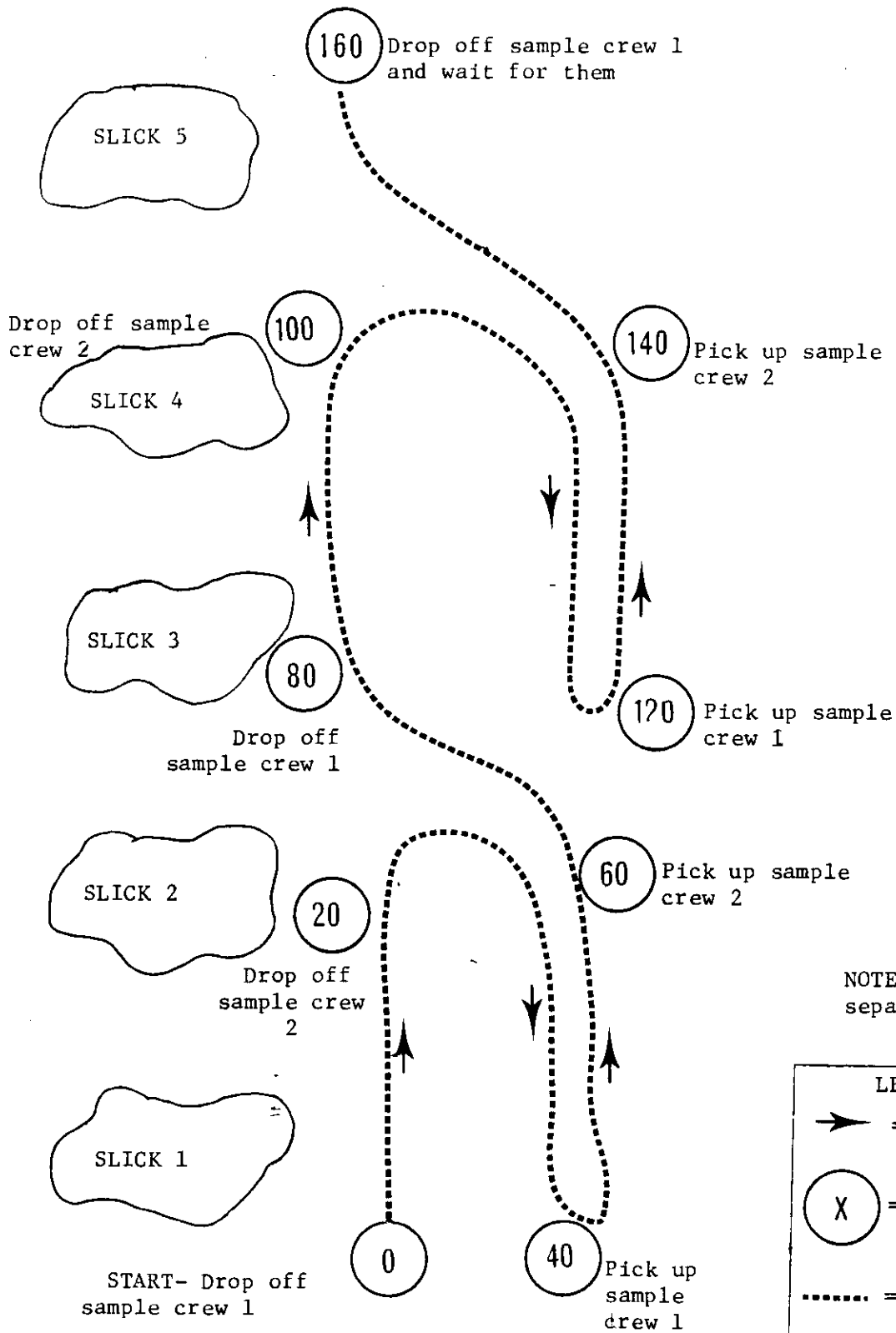

The last sortie noted for Day 4 could be moved up to the end of Day 3 if it appears that little oil will be left or weather will be unfavourable on Day 4.

### 3.8 Procedures for Laying Slicks - Deck Crew

The plumbing layout for laying slicks was illustrated in Figure 4. The procedure is to fill the spill tank to the prescribed mark for 175 gallons (0.8 metres) or 5 barrels which is the dump quantity in any case. Upon start command the 2½" pump is started to pump the oil out the 2½" floating line. As soon as the tank is empty, a 2-way valve is used to switch the pump draw to sea water. This will clear the line of oil and avoid the long trailing slick normally observed at sea trials.

For the pretreated slicks the product is added to the tank before it is filled. In the case of the Elastol, this is done only a few minutes before the spill takes place as Elastol sets up significantly in 10 minutes and we do not wish to pump highly elasticized oil.

At this time it is not known whether or not the floating hose will have to be pulled back on the ship for transiting to the next site.

### 3.9 Procedure for Treating Slicks - Sampling Crew

Before leaving the MARY HICHENS, personnel in the sample boat should ensure that they have 2 air bottles and 2 sets of treatment agents for each slick so that if difficulties are encountered, alternate means are there. Application crews will note that the regulators for the demousifier and Elastol are different. The regulators for the demousifier are set at 20 psi and for Elastol at 40 psi. The applicators themselves are also different. An extra device is available for each product.

The apparatus for dispensing Elastol and demousifier are illustrated in Figure 8. The treatments are pre-weighed and packaged in separate bottles so they can be emptied into the funnels of the applicators, air line hooked up, tank opened, and spray begun. Always spray down wind. A suggested treatment pattern is shown in Figure 9.

Each device sprays about 15 feet and the pistol should be aimed slightly downward to prevent loss of product. The devices have been built to apply the product at a correct dosage when the boat goes about 1 knot and the slick is 100 microns or relatively thick which it will be when it is treated. If a little agent should remain after doing the thick slick, re-do some portion of it. Applying a lot of agent to the sheen will simply waste it. Excess agent is best put on the thick leading edge of the slick.

**FIGURE 8 -- DIAGRAM OF DISPENSER APPARATUS**

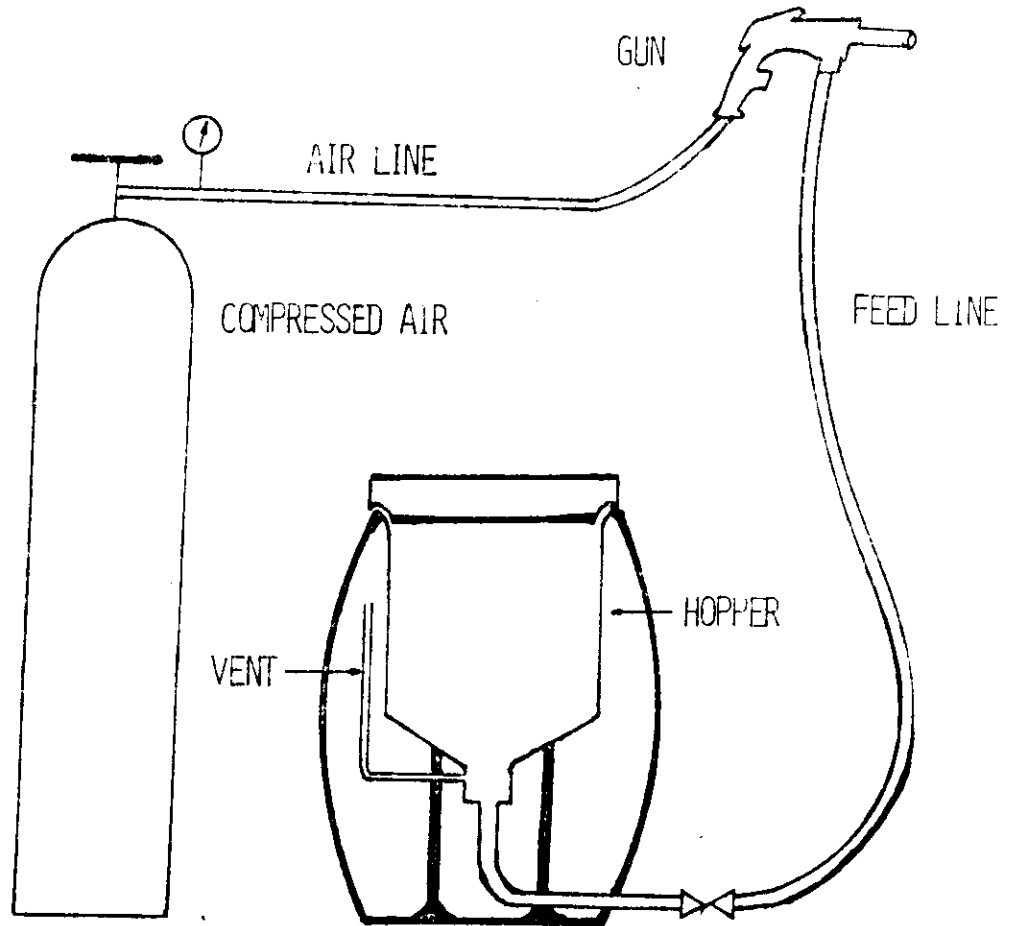

# FIGURE 9 -- SUGGESTED TREATMENT PATTERN

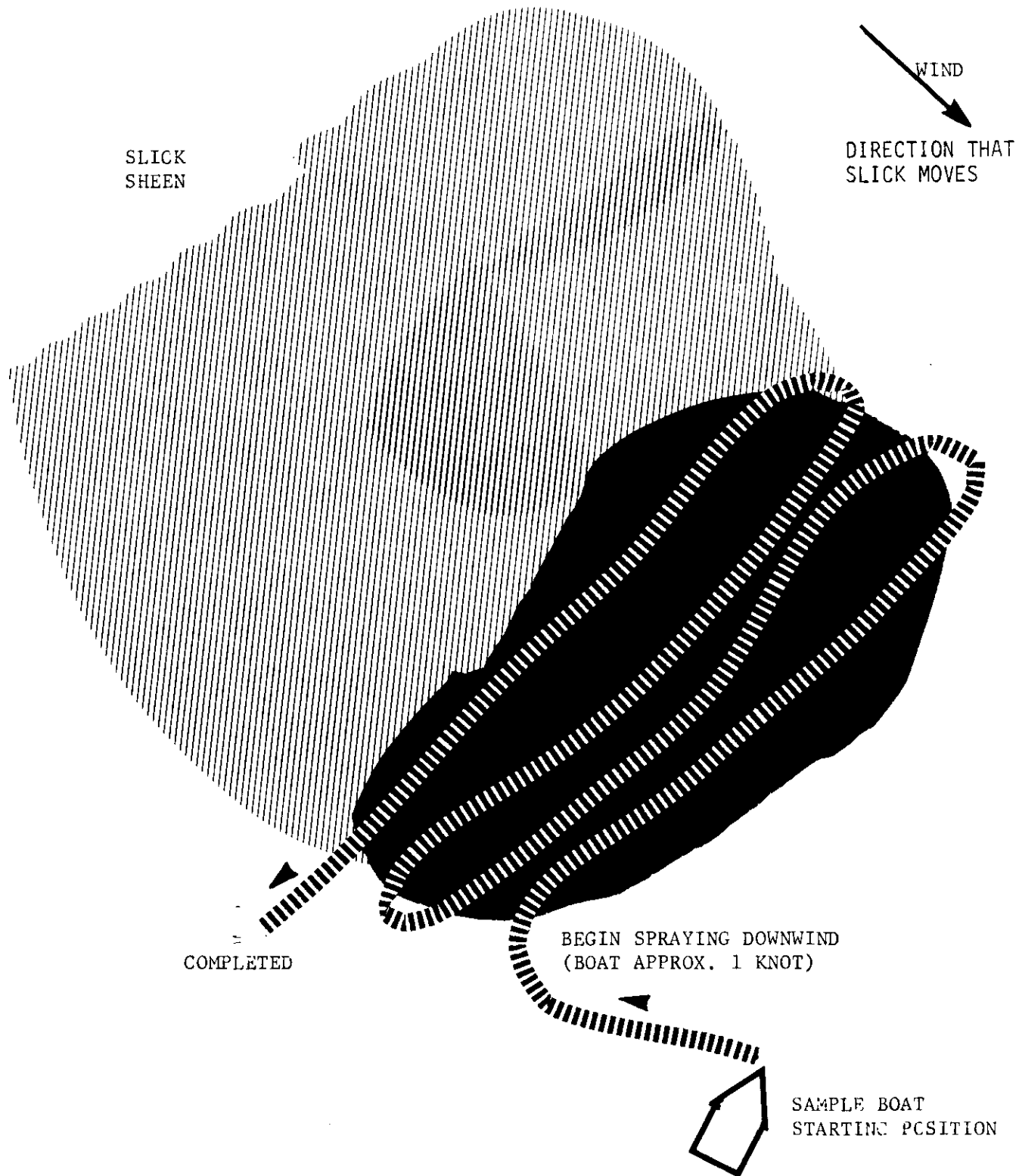



### 3.10 Procedure for Sampling Slicks - Sampling Crew

The devices to collect a slick sample are illustrated in Figure 10. Device B will primarily be used to collect samples.

The basic rules for collecting samples are:

1. Always collect typical samples, never exceptional ones. If an exceptional situation is seen, collect and bottle separately.
2. Sample quantity for this trial is very important - a minimum of 20 mL of oil is needed for the tests and 50 mL is the desired amount. It is difficult to collect this much oil only.
3. Try to get three dips of oil from different places to get a more representative sample.
4. Pre-label all bottles before trial begins and ensure these are correct before filling with new sample.

# FIGURE 10 - DEVICES TO SAMPLE SLICK

**a**

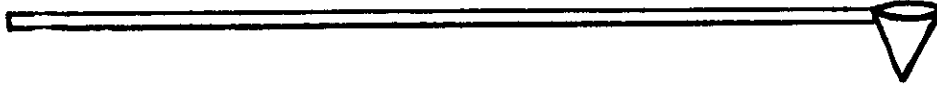

Cup attached to pole for very thick slicks.

**b**

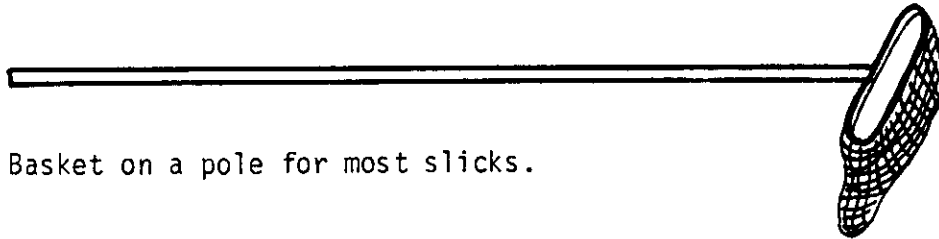

Basket on a pole for most slicks.

**c**

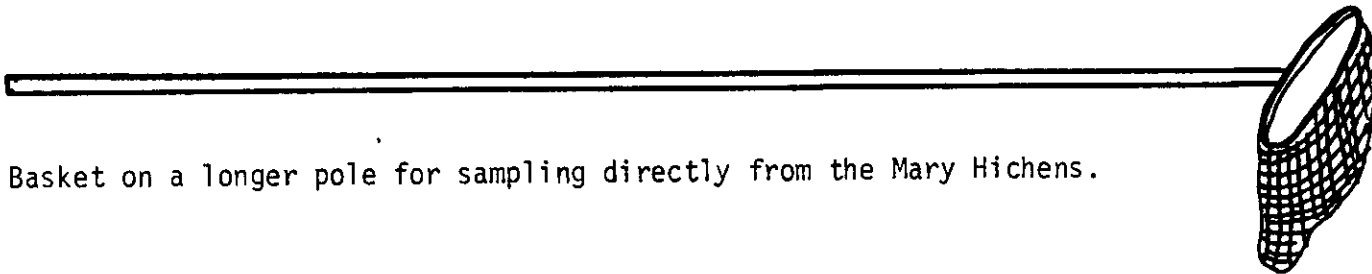

Basket on a longer pole for sampling directly from the Mary Hichens.

(additional procedural notes will be developed)

### 3.11 Procedure for Analyzing Samples

Samples when brought aboard are taken directly and immediately to Mark Bobra. He will separate the oil from debris and netting material, bottle a few mL for latter analysis and then take 20-50 mL for immediate analysis. This will be done immediately as both water content and elasticity change with time. Time that sample is analyzed is as crucial as time sample is taken. After a particular analysis is done, the bucket is cleaned, ready for taking another sample.

### 3.12 Procedure for Deploying Oceanographic Equipment and Taking Readings

The wave climate will be monitored using a Datawell waverider buoy which houses a surface-following accelerometer, transmitter and O.D.A.S. strobe light. The buoy will be tethered to the sea floor near the test site by a recoverable mooring system. The receiving station will be installed on board the Mary Hichens prior to departing Mulgrave. The receiver is capable of picking up the buoy signal over a 30 km range.

All wave data will be logged digitally by a Compaq portable computer communicating with the receiver via an RS232 port. Custom software will generate real-time output of wave height and period during the trials and record all data to floppy disk.

The receiving hardware, cabling and antenna will be installed and tested by B. Batstone on Sept. 7. The mooring and wave buoy will be deployed 10-15 km downwind of the first spill site. This should permit clear reception of the data signal throughout the trials. The mooring will be recovered just prior to returning to Mulgrave following the tests. Seakem personnel will demobilize the equipment in port.

### 3.13 Procedure for Deploying Oil Recovery Sampling Boat

Procedures will be developed with the commanding officer of the Mary Hichens.

### 3.14 Procedure for Taking Meteorological Readings

Over the relatively short duration of these sea trials and in light of the application of the meteorological data, synoptic MANMAR observations will be sufficient for monitoring atmospheric parameters. However, MANMAR observations will be taken hourly during the sea trial. MANMAR observations are performed routinely by Coast Guard vessels while at sea and as a result, this task need not impinge on the limited manpower available. The Mary Hichens is designated as an Auxiliary Observation Vessel by AES. MANMAR log books, sea temperature buckets, stevenson screens, barometers and anemometers all are currently available on the Mary Hichens. Additional equipment is available from the Port Meteorological Officer at AES Bedford, N.S. if necessary.

The use of an automated weather station will be reserved as an option means of monitoring, but the data required probably does not justify the expense of installing and using this sort of system on a non-stationary platform.

### 3.15 Procedure for Deploying Spill Tracking Equipment and Taking Readings

Buoys are numbered 1 to 12. It would be expedient to place number 1 in slick number 1 and so on.

Buoys should be turned on at the switch on the base before casting them into the slick. The buoys should have been checked beforehand to ensure that they are transmitting. The buoy should be cast from the stern to a position near the oil discharge shortly after oil discharge begins. This will ensure that the buoy starts its drift in the thick portion of the slick.

Tracking of the buoys should be done periodically to ensure that they are not leaving the slicks very dramatically. If they are, procedures should be begun to recover them during slack times. Since the slicks must be found next day by this means, it would be wise to reposition the buoys just before dark if this becomes necessary. If the buoys are obviously not following the slicks, the remote sensing flights will be needed to locate slicks for sampling purposes and to re-position buoys for locating slicks on a short term basis.

The spill tracker should be ready to provide directional indication for MARY HICHENS when sampling runs begin.



### 3.16 Procedure for Spill Countermeasures

On September 11, after the sampling run on Day 2 slicks, a decision will be made on what is sufficient oil remaining intact on any slick or whether it is thick enough to burn. If the decision is positive, the MARY HICHENS will proceed to the candidate slick and pass the thick portion from an upwind course. An ignitor will be cast into the thick portion and the MARY HICHENS will proceed to a safe location to observe the burn. This will be repeated until all slicks are burned or until it is decided that such action is futile.

If burning does not work, a crew headed by Ed Tedeschi will take the Morris skimmer, power pack, boom, recovery drum and proceed in the sea truck to corral and recover the remaining oil. This is done for all 10 slicks if weather permits.

## Contingency Plans

The following are the general procedures to follow in the event of the problems shown:

<u>Problem</u>	<u>Solution</u>
Whatever reason, trial must be ended by one day.	- If the second day slicks are not already laid, do so in afternoon of first day, sampling runs are done in evening.
Weather conditions do not permit work on first day, Sept. 9.	- Modify schedule as above to lay two sets of slicks on one day and sample run in the evening.
A particular sample run cannot be done.	- Move it to another time or omit it.
Weather is fine for Day 1 but recast badly for Day 2.	- Proceed to spill both sets on Day 1 and do sample run 2 in the evening.
Weather/sea conditions do not permit operation on the water with boats.	- Perform treatment and sampling directly from the MARY HICHENS, equipment has been provided to do this.
End of the experiment is done and weather moves in unexpectedly.	- Depart for Mulgrave and cancel remainder of experiment.
MARY HICHENS is called away for rescue mission.	- Delay or abandon trial.

### 3.18 ARGOS DRIFTER SCHEDULE

- 2 September - Argos drifters received at MMS storage, Bays-Dulles.
- 3 September - Argos drifters turned on and Argos network interrogated (Landover, MD), via IBM PC or compatible, to verify all eight drifters are being properly received both by MMS and the Coast Guard R&D Center.
- 4 September - Argos drifters all packaged and loaded on Mr. Hannon's personal vehicle. Happy BIRTHDAY Mr. Hannon !!!!!!!!!!!
- 6 September - Argos drifters passed through Customs in Halifax. Mr. Hannon spends the night in Halifax.
- 7 September - Argos drifter turned on at Seakem Oceanography LTD (Bedford Institute, Dartmouth) and Argos network interrogated (Bedford Institute), via IBM PC or compatible, to verify all eight drifters are being properly received both by MMS and the U.S. Coast Guard R&D Center. Mr. Hannon drives to Hawkesbury, Wandelyn Inn in time for 9:00 p.m. briefing with Merving Fingas, Environment Canada.
- 8 September - Argos drifters are loaded on board Mary Hichens. Mr. Hannon helps load ship as necessary.
- 9 September - Four Argos drifters tested and deployed from Mary Hichens after laying control slick (slick #3). The deployment will be accomplished by Mr. Hannon from a basket at the end of the Mary Hichens crane, 30 feet out over the side, to prevent any possibility of the drifters becoming fouled in the ship's propeller. Mr. Hannon assists as necessary.
- 10 September - Four Argos drifters tested and deployed from Mary Hichens after laying control slick (slick #8). Deployment same as 9 September. Mr. Hannon assists as necessary.
- 11 - 12 Sept. - Mr. Hannon assists operations as necessary.

- ° Standard meteorological observations will be taken at hourly intervals by the Canadian Coast Guard aboard the Mary Hichens during the spill trails.
- ° Canadian Aircraft Remote Sensing Data will be taken twice daily for the first two days of the spill trails and once for the final two days. This is a total of 7 hours sensor data, which is a very large data set. The Canadians will provide slick maps, properly annotated, for each pass over the oil spill area.
- ° The U.S. Coast Guard R&D Center will monitor the Argos network for the two test runs and for the spill trails. They will provide corrected position data for the eight drifters during the experiment.

- ° Other data which will be made available to MMS:
  - ° Wave-rider Data (wave height and direction)
  - ° Orion tracker buoys - deployed one in each of ten slicks (Position of the slick taken from the Mary Hichens at specific intervals)
  - ° Chemical analysis of the oil slicks at specific intervals

### 3.19 Detailed Procedures for Oil Delivery

R. Goodman is making the arrangements for the initiation of the process. The oil has already been loaded in a tanker truck. \_\_\_\_\_ is the transporter. The truck will arrive in Halifax on \_\_\_\_\_ and be delivered directly to Seakem. Seakem will arrange for the drop of the bunker in the appropriate compartment.

The tanker will be taken to Mulgrave on September 7, for unloading into bulk tanks on the MARY HICHENS, September 8, at about 10:00 a.m.

The contact at the ESSO Halifax refinery is \_\_\_\_\_ for delivering Bunker C.

### 3.20 Detailed Procedures for Test of Ship-bourne Radar to Detect Surface Oil Slicks

After a sampling run, the ship is brought to a position so that slicks would appear in the radar view. The experimenter (Merv or Ed, with the commanding officer's approval) will turn up the gain and assess whether or not this appears to be giving a view of the slick. If the slick does appear gain is recorded, a polaroid shot of the radar display taken and the experiment continued. This will enable gain to be taken as a variable for clarity of slick presentation. This may not function and the effort will be abandoned as soon as this becomes apparent. The radar may also have a switch to turn off the sea clutter generator. If this is the case, a separate run will be done to measure the slicks with the clutter generator off at various gain settings. The experiment should not last longer than 15 minutes. A polaroid camera with a wide-angle lens is required.

#### 4.0 EQUIPMENT

<u>Equipment</u>	<u>Responsibility</u>	<u>Backup</u>	<u>Notes</u>
<u>Spill Laying</u>			
2½" hose + float + paravane	CCG	extra hose	
2½" 2-way valve	CCG	-	
two 5000 gallon tanks	CCG	-	
hose + pumps for spill	CCG	extra pump	
tank fill			
2½" pump	CCG	extra pump	
two spill tanks	Seakem	-	
<u>Logistics/Countermeasures</u>			
two Rossboroughs	CCG	-	
sea truck	CCG	-	
Vikoma skimmer	CCG	-	
Morris skimmer	CCG	-	
18" boom	CCG	-	
recovery drums (8)	CCG	-	
power packs, hoses, etc.	CCG	-	
sorbent for vessel cleaning	CCG	-	
<u>Spill Tracking</u>			
receivers	Esso	extra receiver	
15 buoys	Esso	5 extra	
binoculars	Esso		for visual confirmation
<u>Command</u>			
tape recorder	Merv Fingas	-	
camera	Merv Fingas	-	
binoculars	Merv Fingas	-	
note book	Merv Fingas	-	
<u>Application</u>			
3 demousifier appliers	Merv Fingas	1 extra	
3 Elastol appliers	Merv Fingas	1 extra	
8 air cylinders - small	Merv Fingas	-	
8 large cylinders	Seakem	-	
premeasured Elastol	Merv Fingas	½ extra	
premeasured demousifier	Merv Fingas	½ extra	
cylinder refill system	Merv Fingas	-	

<u>Equipment</u>	<u>Responsibility</u>	<u>Backup</u>	<u>Notes</u>
<u>Sampling</u>			
3 cup samples	Merv Fingas	1 extra	
3 nets	Merv Fingas	1 extra	
2 large boat samples	Merv Fingas	1 extra	
80 sample bottles	Seakem	½ extra	
10 pairs of gloves	Seakem	½ extra	
40 small sample bottles	Seakem	-	
bottle labels, etc.	Seakem	-	
<u>On-board Analysis</u>			
elasticity device	Mark Bobra	viscometer	
2 spectronic 20's	Mark Bobra	1 extra	
viscometer	Mark Bobra	-	
solvents	Mark Bobra	½ extra	
glassware, cuvettes, gloves, etc.	Mark Bobra	½ extra	
<u>Test Medium</u>			
oil	Ron Goodman	30% extra	
75 barrels ASMB			
75 barrels ASMB and Bunker C mixed			
tank truck	Ron Goodman/ Merv Fingas	-	
dye for practise test	Merv Fingas	-	
practise medium	Merv Fingas		
<u>Other</u>			
video camera	Merv Fingas	below	
extra video camera	Roger Percy	-	
video tape	Merv Fingas	about 5	
high quality still camera	probably Merv Fingas	-	
extra film	Merv Fingas	about 10	
extra sea sickness medicine	Seakem?	-	
floater suits	Merv Fingas	3 extra	
portable radios	CCG	need 4 for small boats, 1 for rear deck	
Hard hats	CCG, EPS Seakem	about 2 each	

## 5.0 Arrival/Logistics

Experimenters should arrive at Port Hawkesbury on Monday, September 7. A briefing will be held at 9:00 p.m. in the room of Merv Fingas at the Wandelyn Inn.

A block of rooms have been renewed at the Wandelyn Inn in Hawkesbury for the night of September 7. Call to make your own bookings out of this block. The booking has been made under the name of "Elastol experiment". The phone number is (902) 625-0320.

The best means to get to Mulgrave is by car from Halifax. Mulgrave is directly opposite Hawkesbury with the Strait of Canso in between. Follow signs to the causeway, then follow the main street (highway) through Hawkesbury and you will see the Wandelyn Inn. To get to the Coast Guard base, go to the Nova Scotia side, follow the signs to Mulgrave and the base will come up on your left shortly after you enter the small village of Mulgrave.

Those pre-shipping equipment can do so to the following address:

Ray Carpenter  
Emergency Service Centre  
Canadian Coast Guard Base  
P.O. Box 69  
Mulgrave, Nova Scotia

Ray's phone number is (902) 747-3430.

Mark all items as "Elastol Experiment"

6.0 DETAILED SCHEDULE

<u>Day</u>	<u>Time</u>	<u>Event</u>	<u>MARY HICHENS</u>	<u>Slick Crew</u>	<u>Sample Boat 1</u>	<u>Sample Boat 2</u>	<u>Command</u>	<u>Falcon</u>
<u>Sept 7</u>	14:00	briefing	Commanding Officer	-	-	-	-	-
	21:00	briefing	-	crews arrive at Port Hawkesbury			-	-
<u>Sept 8</u>	08:00	start loading	all load equipment on MARY HICHENS				-	-
	14:00	practise run	leaves mooring	loads tanks	gets ready	gets ready	-	-
	14:20	practise slick 1	at slick 1	lay slick 1	onto water	-	-	-
	14:50	practise slick 2	at slick 2	lay slick 2	-	onto water	-	-
	15:20	-	to slick 1	-	pick up	-	-	-
	15:40	-	to slick 2	-	-	pick up	-	-
	16:00	debriefing	to dock	scientific crew debriefing			-	-
	17:00	departure	depart for spill site	-	-	-	-	-
<u>Sept 9</u>	08:00	decision	-	-	-	-	contact re go/no go set direction	contact
	08:30	-	to slick position 1	get ready	get ready	get ready	-	-
	09:00	spill #1	at #1	release #1	on water	-	-	-
	09:30	spill #2	at #2	release #2	-	on water	-	-
	10:00	spill #3	at #3	release #3	-	-	-	-
	10:20	pick up sample crew 1	at #1	-	pick up	-	-	-



<u>Day</u>	<u>Time</u>	<u>Event</u>	<u>MARY HICHENS</u>	<u>Slick Crew</u>	<u>Sample Boat 1</u>	<u>Sample Boat 2</u>	<u>Command</u>	<u>Falcon</u>	
<u>Sept 9</u>	10:30	pick up sample crew 2	at #2	-	-	pick up	-	-	
	11:00	spill #4	at #4	release #4	-	on slick 4	-	-	
	11:15	RS start	-	-	-	-	-	sensors on	
	11:30	pick up sample crew 1	at #3	-	pick up	-	-	-	
	11:45	spill #5	at #5	release pretreated	on slick 5	-	-	sensors on	
	12:15	pick up	at #4	-	-	pick up	-	sensors on	
	12:45	pick up sample #1	at #5	-	pick up	-	-	-	
	13:00	complete slick laying and first samples					-	-	sensors off
	14:45	crews ready for sampling			-	-	-	-	
	15:00	sample #1	at #1	-	onto #1	-	-	-	
	15:20	sample #2	at #2	-	-	onto #2	-	-	
	15:40	pick up crew 1	at #1	-	pick up	-	-	-	
	16:00	pick up crew 2	at #2	-	-	pick up	-	sensors on	
	16:20	sample 3	at #3	-	onto #3	-	-	-	
	16:40	sample 4	at #4	-	-	onto #4	-	sensors off	
	16:45	-	-	-	-	-	-	-	
	17:00	pick up	at #3	-	pick up	-	-	-	

<u>Day</u>	<u>Time</u>	<u>Event</u>	<u>MARY HICHENS</u>	<u>Slick Crew</u>	<u>Sample Boat 1</u>	<u>Sample Boat 2</u>	<u>Command</u>	<u>Falcon</u>
<u>Sept 9</u>	17:20	pick up crew 2	at #4	-	-	pick up	-	-
	17:40	sample 5	at #5	-	onto 5	-	-	-
	18:00	pick up crew 1	at #5	-	pick up	-	-	-
<u>Sept 10</u>	06:00	decision	-	locate slick	-	-	contact re go/no go	contact
	06:30	-	to #1	sampling crews ready	-	-	-	-
	07:00	sample 1	at #1	-	onto 1	-	-	-
	07:20	sample 2	at #2	-	-	onto 2	-	-
	07:40	pick up crew 1	at #1	-	pick up	-	-	-
	08:00	pick up crew 2	at #2	-	-	pick up	-	-
	08:20	sample 3	at #3	-	onto #3	-	-	-
	08:40	sample 4	at #4	-	-	onto #4	-	-
	09:00	pick up crew 1	at #3	-	pick up	-	-	-
	09:20	pick up crew 2	at #4	-	-	pick up	-	-
	09:40	sample	at #5	-	onto #5	-	-	-
	10:00	pick up crew 1	-	-	pick up	-	-	-

Sample round at 22 hours complete.  
 Crews ready for 2nd slick laying.  
 MARY HICHENS proceeds to second set of slicks or #6

10:30	spill #6	at #6	spill #6	onto #6	-	-	-	-
11:00	spill #7	at #7	spill #7	-	onto #7	-	-	-
11:30	spill #8	at #8	spill #8	-	-	-	-	-
11:50	pick up crew 1	at #6	-	pick up	-	-	-	-

<u>Day</u>	<u>Time</u>	<u>Event</u>	<u>MARY HICHENS</u>	<u>Slick Crew</u>	<u>Sample Boat 1</u>	<u>Sample Boat 2</u>	<u>Command</u>	<u>Falcon</u>
<u>Sept 10</u>	12:00	pick up	at #7	-	-	pick up	-	-
	12:15	sample #8	at #8	-	onto #8	-	-	-
	12:30	spill #9	at #9	spill #9	-	onto #9	-	-
	13:00	pick up crew 1	at #8	-	pick up	-	-	sensors on
	13:15	spill #10	at #10	-	onto #10	-	-	-
	13:45	pick up crew 2	at #9	-	-	pick up	-	-
	14:00	pick up crew 1	at #10	-	pick up	-	-	-
		Laying slick finished.						
	15:00	remote sensing off	-	-	-	-	-	sensors off
	15:45	-	to slick #18 or #6	crews ready for second sample on Day 2 slicks	-	-	-	-
	16:00	sample #6	to #6	-	onto #6	-	-	-
	16:20	sample #7	at #7	-	-	onto #7	-	-
	16:40	pick up crew 1	at #6	-	pick up	-	-	-
	17:00	pick up crew 2	at #7	-	-	pick up	-	sensors on
	17:20	sample #8	at #8	-	onto #8	-	-	-
	17:40	sample #9	at #9	-	-	onto #9	-	sensors off
	18:00	pick up crew 1	at #8	-	pick up	-	-	-
	18:20	pick up crew 2	at #9	-	-	pick up	-	-

<u>Day</u>	<u>Time</u>	<u>Event</u>	<u>MARY HICHENS</u>	<u>Slick Crew</u>	<u>Sample Boat 1</u>	<u>Sample Boat 2</u>	<u>Command</u>	<u>Falcon</u>
<u>Sept 10</u>	18:40	sample #10	at #10	-	onto #10	-	-	-
	19:00	pick up crew 1	at #5	-	pick up	-	-	-
		Slick sampling round complete.						
<u>Sept 11</u>	06:30	decision	-	-	-	-	go/no go decision	contact
	07:15	to first day slicks #1a	-	-	-	-	-	-
		Sampling crew ready; decision on countermeasures try, if go burning tried after sample crew pick up, if go on physical countermeasures.						
	07:30	sample #1a	at #1a	*	onto #1a	-	-	-
	07:50	sample #2	at #2	*	-	onto #2	-	-
	08:10	pick up crew 1	at #1	-	pick up	-	-	-
	08:30	pick up crew 2	at #2	-	-	pick up	-	-
	08:50	sample #3	at #3	*	onto #3	-	-	-
	09:00	-	-	-	-	-	-	sensors on
	09:10	sample #4	at #4	*	-	onto #4	-	-
	09:30	pick up crew 1	at #3	-	pick up	-	-	-
	09:50	pick up crew 2	at #4	-	-	pick up	-	-
	10:00	-	-	-	-	-	-	sensors off

\* countermeasures?

<u>Day</u>	<u>Time</u>	<u>Event</u>	<u>MARY HICHENS</u>	<u>Slick Crew</u>	<u>Sample Boat 1</u>	<u>Sample Boat 2</u>	<u>Command</u>	<u>Falcon</u>
<u>Sept 11</u>	10:10	sample #5	at #5	*	onto #5	-	-	-
	10:30	pick up crew 1	at #5	-	pick up	-	-	-
	10:30	Time allotted to perform countermeasures on first day slicks.						
	12:00							
	13:30	Crews ready to sample and perform countermeasures on second day slick if possible.						
	14:00	sample #6	at #18 or #6	*	onto #6	-	-	-
	14:20	sample #7	at #7	*	-	onto #7	-	-
	14:40	pick up crew 1	at #6	-	pick up	-	-	-
	15:00	pick up crew 2	at #7	-	-	pick up	-	-
	15:20	sample #8	at #8	*	onto #8	-	-	-
	15:40	sample #9	at #9	*	-	onto #9	-	-
	16:00	pick up crew 1	at #8	-	pick up	-	-	-
	16:20	pick up crew 2	at #9	-	-	pick up	-	-
	16:40	sample #10	at #10	*	onto #10	-	-	-
	17:00	pick up crew 1	at #10	-	pick up	-	-	-
	17:00	Additional time to clean up slick from Day 2.						
	18:00	Return to home base, MARY HICHENS departs.						

\* countermeasures

# FIGURE 11 - DIAGRAM OF PRACTISE RUN

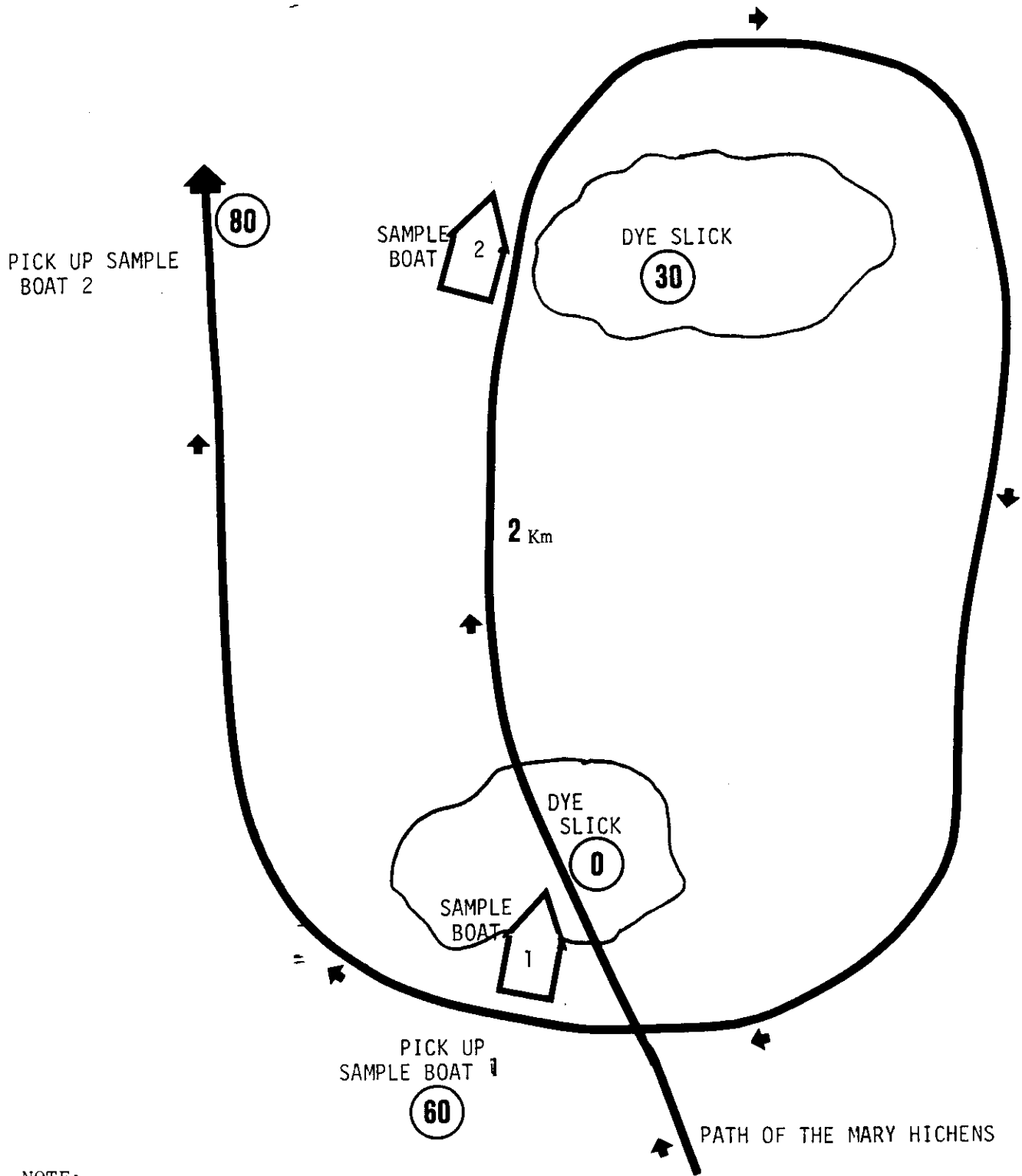

NOTE:

(X) is cumulative time in minutes

<u>Day</u>	<u>Time</u>	<u>Event</u>	<u>MARY HICHENS</u>	<u>Slick Crew</u>	<u>Sample Boat 1</u>	<u>Sample Boat 2</u>	<u>Command</u>	<u>Falcon</u>
<u>Sept 12</u>	07:00	Arrive	Mulgrave,	crews	demobilize.			
	09:00							sensors on
	09:45							sensors off
	09:45							depart for Ottawa

## 7.0 PROCEDURE FOR THE PRACTISE RUN, SEPTEMBER 8, 1987

### 7.1 General

A practise run will be conducted on the afternoon of the first day aboard ship, Tuesday, September 8. The objectives of the practise are to ensure that all persons are familiar with their duties, that equipment functions, that equipment required is there, and that the plan basically works.

The plan is outlined in Figure 11. Two slicks (water and a bit of harmless dye) are laid and sample crews placed at each slick. The crews practise application with surrogate treating agent using the demousifier units. The treating agent is a few mL of dyed naphtha. The sample crews practise with the sample gear as well. After about an hour, they are picked up again. Immediately after the second crew is picked up and gear stored, a debriefing will be held to review the practise and correct any deficiencies. The MARY HICHENS can proceed to tie up, lost gear is taken aboard, and any other items necessary as to correct noted deficiencies.

### 7.2 Detailed Schedule and Procedure

1. At 14:00 hours, the MARY HICHENS leaves dock, proceeds to a point halfway in the Strait of Canso.
2. The slick laying crew has filled both spill tanks to the required mark with sea water and put a small amount of dye (food coloring or rhodamine B) into the tank.
3. At 14:20, the MARY HICHENS will be in position for the first slick. Crew lays dyed water slick and sample crew number 1 enters the water.
4. The MARY HICHENS leaves for sample position number 2, 2 km down channel.
5. Sample crew number 1 applies their practise treating agent. Does some practise sampling.
6. The MARY HICHENS is on station at slick number 2 at 14:50. Slick number 2 is laid. Sample crew number 2 is deployed.
7. Sample crew number 2 practises treating the slick with the surrogate fluid and practise sampling.
8. The MARY HICHENS proceeds to slick position number 1 and picks up sample crew number 1 at 15:20, then on to pick up sample crew number 2 at 15:40.
9. The MARY HICHENS proceeds to the dock and will tie up until departure at 17:00.
10. A debriefing meeting is held at 16:00 to review the practise and correct any deficiencies.
11. From 16:00 to 17:00 last minute loading details and corrections are made.
12. Ship departs for trial area at 17:00.



## 8.0 INDIVIDUAL TASKINGS

### 8.1 Overall

The organization chart is shown in Figure 12. In summary, there are 5 work stations; bridge where M. Fingas and E. Tennyson will coordinate the exercise, two sample boats, the rear deck of the MARY HICHENS used for recovery of small boats.

### 8.2 Spill Coordinator B - Ed Tennyson - (703) 648-7752

Work Station: Bridge

Alternate: Roger Percy

Tasks:

- go/no go decisions to all
- communicate to sample boats and remote sensing aircraft
- record times and events
- fill in for Merv Fingas if not available

Pretrial: - coordinate U.S. agencies' participation

Approximate Schedule:

Sept. 7 (pm)	- on station in Mulgrave/Port Hawkesbury
Sept. 8 (am)	- assist with loading
(pm)	- assist in practise run
Sept. 9-11	- trial coordination
Sept. 12	- finished, depart

### 8.3 Spill Coordinator - Merv Fingas - (613) 998-9622

Work Station: Bridge

Alternate(s): Ed Tennyson, Roger Percy

Tasks:

- go/no go decision to all
- communicate to sample boats and remote sensing aircraft
- record times and events
- chair post-mortems and briefing meetings

Pretrial:

- experimental plan
- supplying application and analytical gear

Approximate Schedule:

Sept. 7	- arrive in Mulgrave, check goods, pre-analyze oil
Sept. 8 (am)	- organize loading
(pm)	- coordinate spill trial practise run
Sept. 9-11	- coordinate trial
Sept. 12	- organize unloading

# FIGURE 12 - OVERALL ORGANIZATION

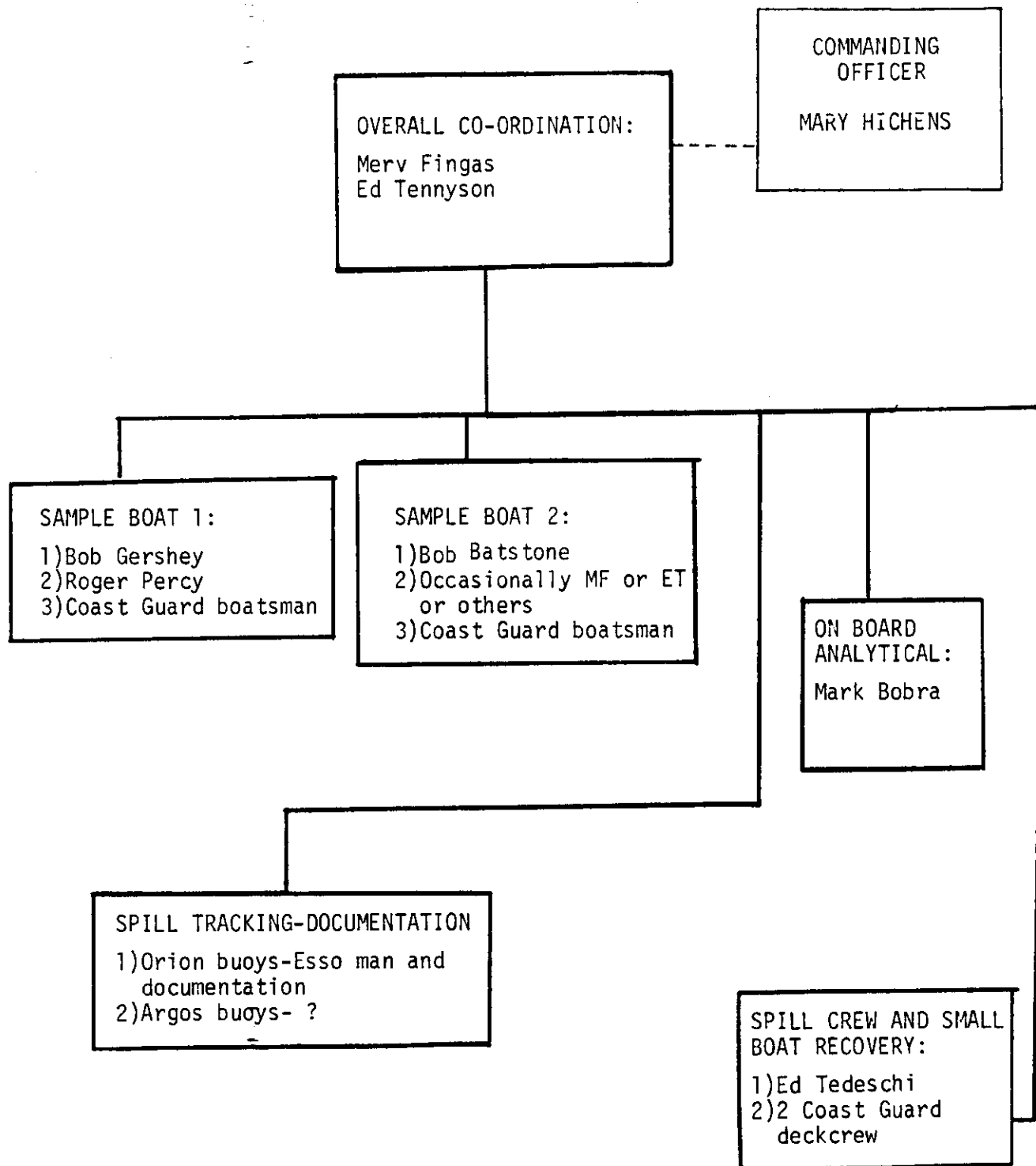

8.4 Sample Boat Documenter - Roger Percy - (902) 426-2576

Work Station: Sample Boat 1

Pre-trial Alternate: Randy Simmons

Alternate: Larry Hannon

Tasks:

- helps sample boat take samples and apply Elastol/demousifier
- take still and video photographs of application, sampling and general slick appearance
- documents countermeasures attempts

Pretrial:

- help coordinate and write plans
- coordinate ocean dumping permit
- Coast Guard liaison

Approximate Schedule:

Sept. 7 (pm)	- arrive Port Hawkesbury
Sept. 8 (am)	- help load MARY HICHENS
(pm)	- practise run
Sept. 9-10 (am)	- sample/laying runs
(pm)	- sampling runs
Sept. 11 (am)	- sampling runs
(pm)	- countermeasures
Sept. 12	- finished

8.5 Spill Tracking/Documentation - Cam Mackenzie (416) 968-4429

Work Station: MARY HICHENS, rear deck

Pre-trial Alternate: ?

Alternate: Ed Tedeschi

Tasks:

- turns on and throws out a tracking buoy for each slick
- checks the operability of trackers occasionally and notes the position of buoy in slick when possible
- takes video of each entire discharge; takes occasional video of other rear deck activities
- takes still photographs of the above
- assists in recovery of sample boat crews

Pretrial:

- brings tracking buoys and tracking receivers
- tests these beforehand
- coordinate acquisition of oil

Approximate Schedule:

Sept. 7 (am)	- arrive in Port Hawkesbury
Sept. 8 (am)	- helps load MARY HICHENS
(pm)	- practise run, also puts out buoys
Sept. 9-10	- puts out and tracks buoys, documents with video and stills
Sept. 11	- tracks buoys, helps in buoy recovery

8.6 Spill Laying/Countermeasures - Ed Tedeschi - (703) 631-6655

Work Station: MARY HICHENS, rear deck  
- during countermeasures, on sea truck

Pre-trial Alternate: Jerry Tripp

Alternate: Larry Hannon

Tasks:

- organizes, coordinates, supervises, etc. the laying of all the slicks, filling of spill tanks, etc.
- assists and coordinates the recovery of the sampling crews
- during recovery, coordinates the use of Morris and Vikoma skimmers and booms on the sea truck

Pretrial: - supplies enough Elastol for the trial

Approximate Schedule:

Sept. 7	(pm)	- arrive Port Hawkesbury
Sept. 8	(am)	- help load MARY HICHENS
	(pm)	- practise run
Sept. 9-10	(am)	- slick laying
	(pm)	- sample boat recovery
Sept. 11	(am)	- sample boat recovery
	(pm)	- countermeasures
Sept. 12		- finished

8.7 Sampler/Applicator/Consultant - Bob Gershey - (902) 463-0932

Work Station: sample boat number 1

Pre-trial Alternate: Bruce Batstone

Alternate: Bruce Batstone

Tasks:

- in sample boat number 1, applies treating agent and takes samples
- coordinate trial small aspects
- take laboratory samples with him for later analysis
- take collected data for report preparation

Pretrial:

- plan and help coordinate planning
- arrange for spill tanks, air cylinders and other equipment
- review and add to spill plan

Approximate Schedule:

Sept. 7	(am)	- arrive in Mulgrave
	(pm)	- help check out supplies
Sept. 8	(am)	- help load MARY HICHENS
	(pm)	- practise run
Sept. 9-10		- sampling and application
Sept. 11	(am)	- sampling
	(pm)	- documentation
Sept. 12		- take data, sample, equipment disposition

8.8 Sample/Applicator - Bruce Batstone - (902) 463-0932

Work Station: sample boat number 2

Pre-trial Alternate:

Alternate: Bob Gershey

Tasks: - in sample boat number 2, applies treating agent and takes samples  
- assists Gershey when not in sample boat number 2

Pretrial: - helps prepare plan  
- arranges for some of the equipment

Approximate Schedule:

Sept. 7 (am)	- arrive Mulgrave
(pm)	- help check out supplies
Sept. 8 (am)	- help load MARY HICHENS
(pm)	- practise run
Sept. 9-10	- sampling and application
Sept. 11 (am)	- sampling
(pm)	- documentation
Sept. 12	- assists with demobilization

8.9 On-board Analysis - Mark Bobra - (613) 998-9622

Work Station: temporary laboratory in hospital area

Pre-trial Alternate: Peter Kawamura

Alternate: Merv Fingas

Tasks: - analyzes Elastol-treated series for elasticity and viscosity  
- analyzes demousifier-treated series for water content and viscosity  
- prepares samples for laboratory analysis

Pretrial: - prepares analysis equipment needed

Approximate Schedule:

Sept. 7 (am)	- arrive Mulgrave
(pm)	- helps Merv with oil pre-analysis
Sept. 8 (am)	- help load MARY HICHENS
(pm)	- does mock run to check out equipment
Sept. 9-11	- on-board analysis
Sept. 12	- demobilize

8.10 Ocean Dumping Control Inspector - Roger Percy (902) 426-2576

Work Station: not specified

Pre-trial Alternate: ?

Alternate: ?

Tasks: - does his duties according to ODCA procedure

Pretrial: -

Approximate Schedule: Sept. 7 (pm) - arrive  
Sept. 8-12 - ODCA activities

8.11 Argos Buoy Experimenter - Larry Hannon

Work Station: rear deck of MARY HICHENS

Pre-trial Alternate: Bob Labelle

Alternate: CAM Mackenzie

Tasks: - puts out Argos-trackable buoy in slicks during the first trial  
- try to visually (binoculars) follow these over the first period to assess their initial direction

Pretrial: - arranges to get Argos buoys to Canada

Approximate Schedule: Sept. 7 (pm) - arrives  
Sept. 8 (am) - help load MARY HICHENS  
(pm) - observes practise trial  
Sept. 9-11 - deploys and watches buoy  
Sept. 12 - finished

8.12 Countermeasures Specialist - Bernie Wood

Work Station: all possible

Pre-trial Alternate: none

Alternate: E. Tedeschi

Tasks: - assists in laying slicks  
- works with E. Tedeschi  
- arranges and plans countermeasures

Pretrial: - none

Approximate Schedule: Sept. 7 (pm) - arrive Hawkesbury  
Sept. 8 (am) - helps load MARY HICHENS  
(pm) - practice  
Sept. 9-12 - assists or alternates in duties as necessary on spill laying and countermeasures crew.

## 9.0 COMMUNICATION

Sample boat to command will be done on frequency 81a or 19. Rear deck portable radio will also be on the same frequency.

The Falcon will communicate to the bridge on VHF 146.7 or 121.5. Communication to the crew before hand to confirm the trial schedule will be done by radio-telephone.

## 10.0 SAFETY

Rules of conduct of the MARY HICHENS will be adhered to. A briefing on these will be provided on September 8.

All experimenters will wear floater suits if they are on the rear deck or in the sample boats. Hard hats may also be required on the rear deck.



APPENDIX 1:

THE MARY HICHENS



# CCGS MARY HICHENS

## PRINCIPAL PARTICULARS

LENGTH OVERALL	64.70m
LENGTH B.P.	56.40m
BREADTH MOULDED	13.80m
DEPTH HELPER DECK	6.90m
DEPTH MAIN DECK	4.75m
DRAFT (W.L.)	5.91m

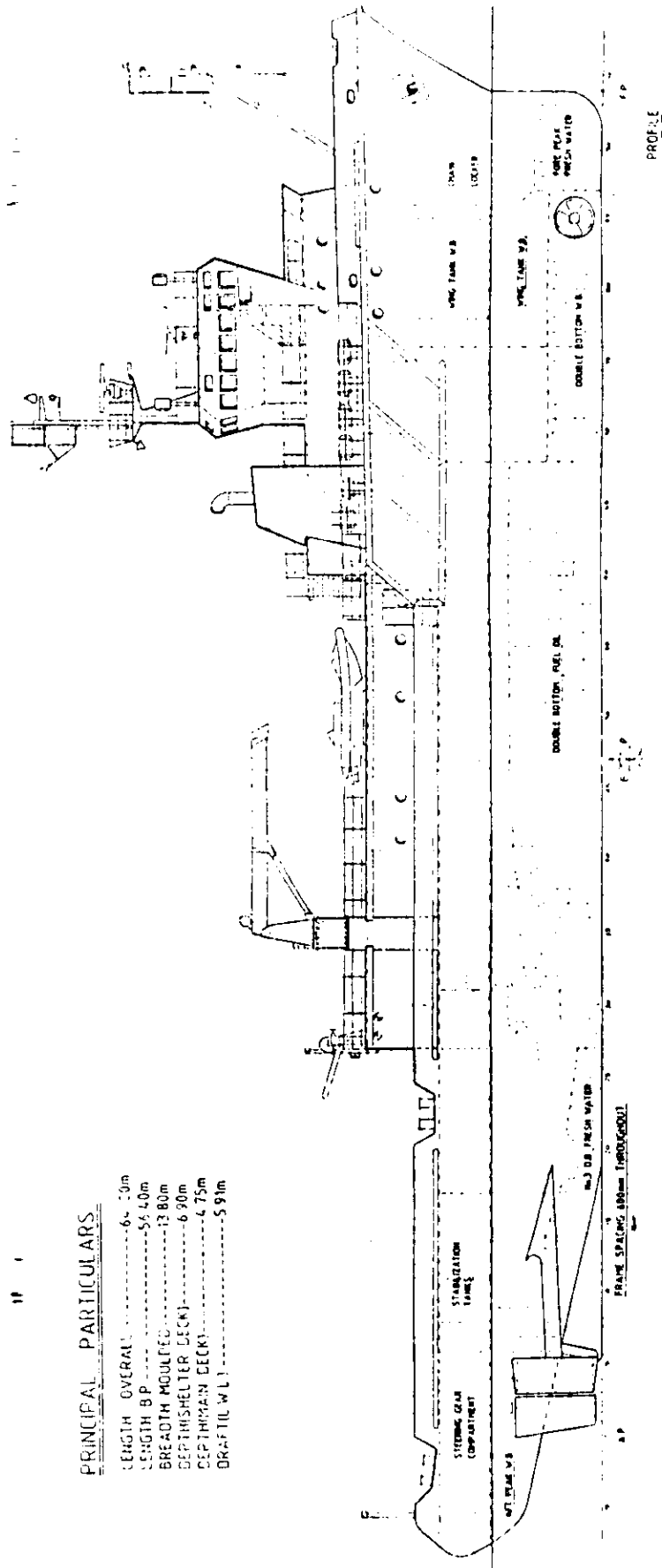



# CCGS MARY HICHENS

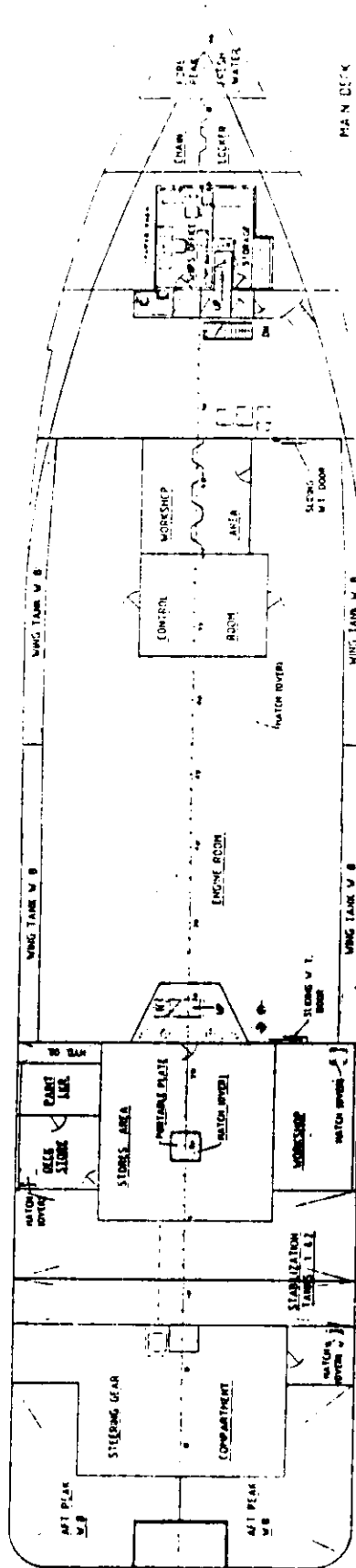



APPENDIX 2:

CONVERSION AND WEIGHT CHARTS

FOR TREATMENT AMOUNTS

Spilled Oil Amount - 5 barrels  
- 175 gallons  
- 796 Litres

Treatments:

<u>WEIGHT</u>		<u>RATIO</u>
500 PPM	-	1:2000
250 PPM	-	1:4000
1000 PPM	-	1:1000
1500 PPM	-	1:667
2000 PPM	-	1:500
3000 PPM	-	1:333
4000 PPM	-	1:250

To Treat Oil To:

Use Agent in Litres (kilogram (I))

250 PPM	0.199	(0.17)
500 PPM	0.398	(0.33)
1000 PPM	0.796	(0.67)
1500 PPM	1.194	(1.0)
3000 PPM	2.388	(2.0)
4000 PPM	3.184	(2.7)
9000 PPM	7.164	(6.0)

(I) at oil density of 0.84 for ASMB



APPENDIX 3:

MAPS

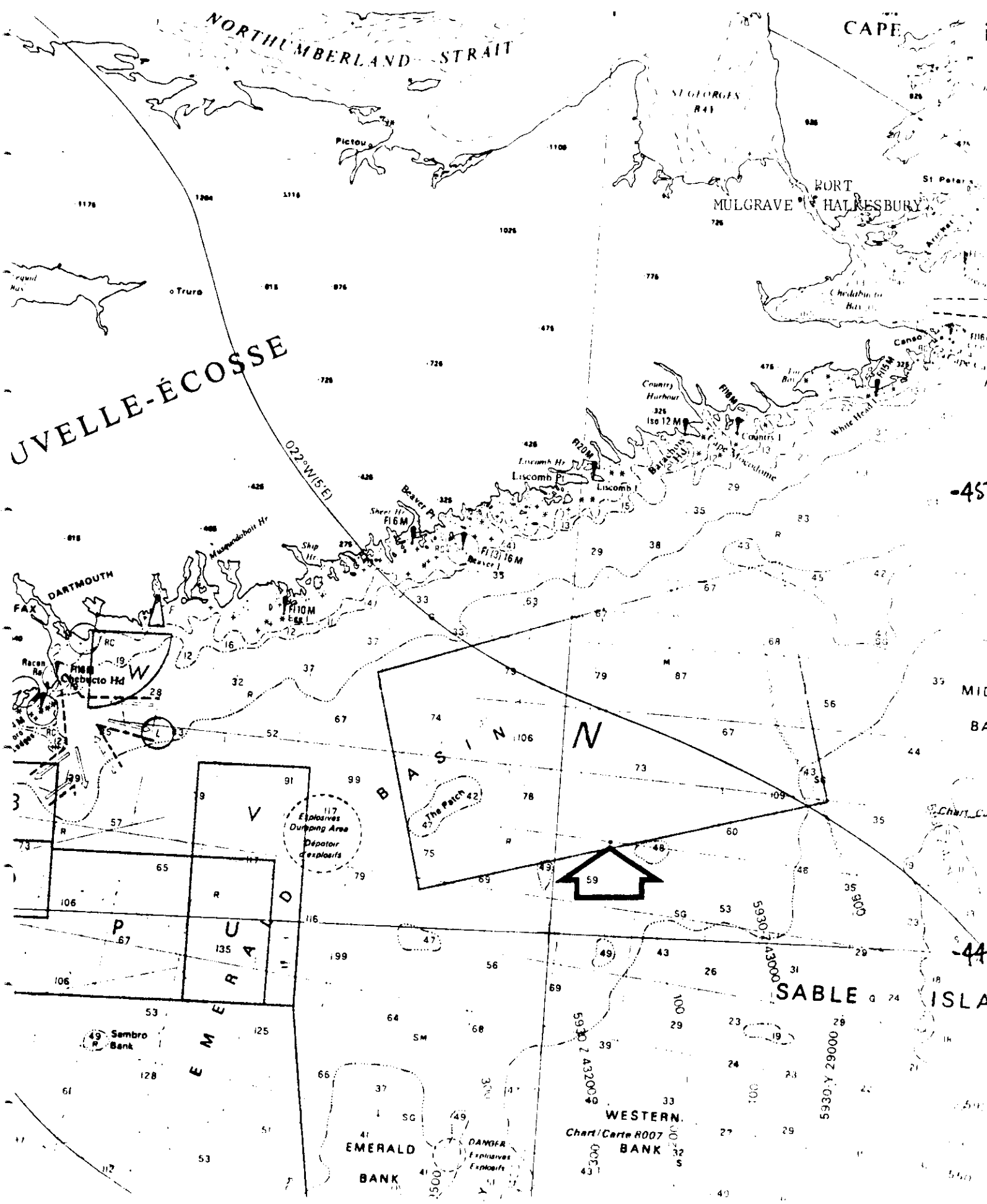

GENERAL MAP OF AREA

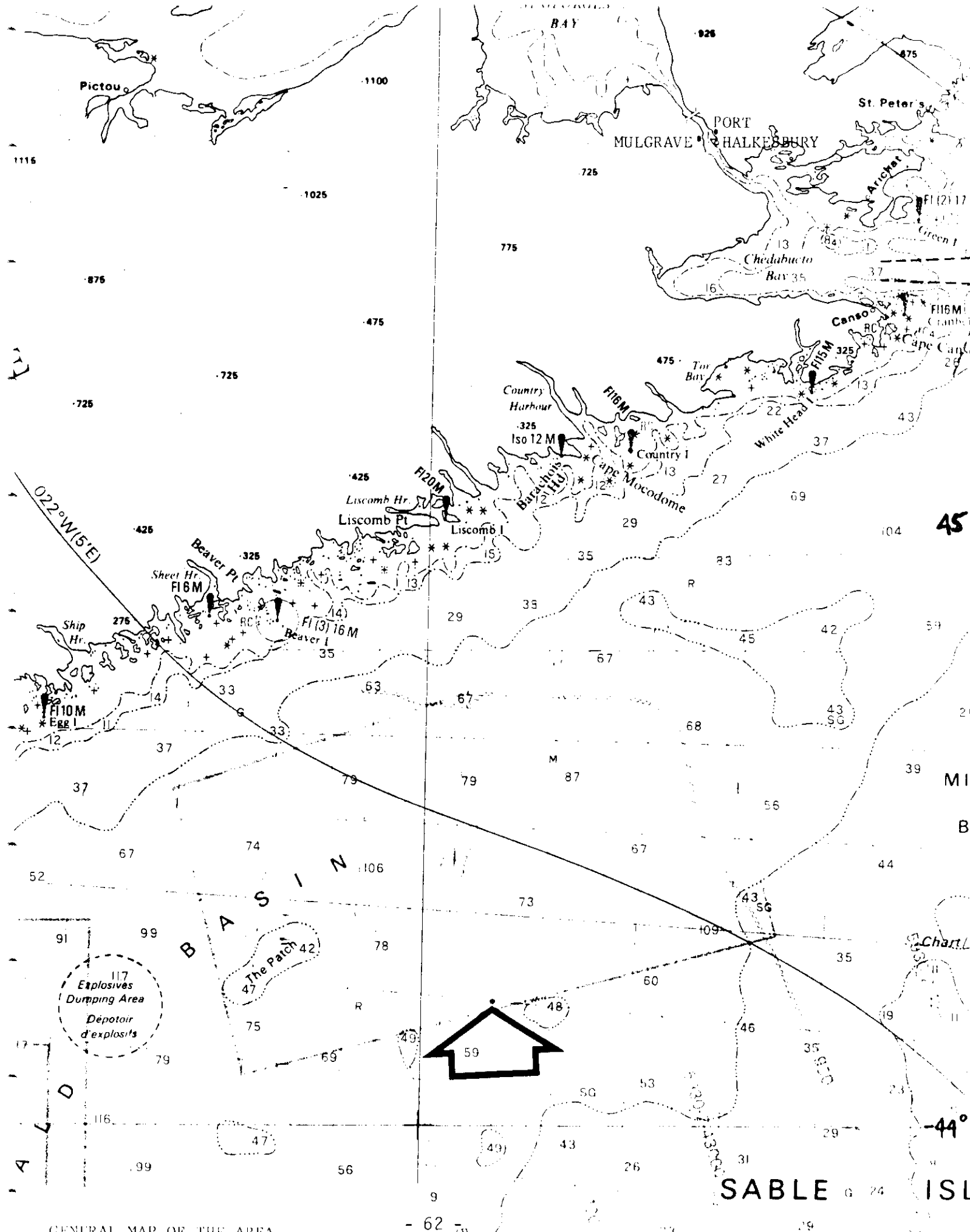

GENERAL MAP OF THE AREA

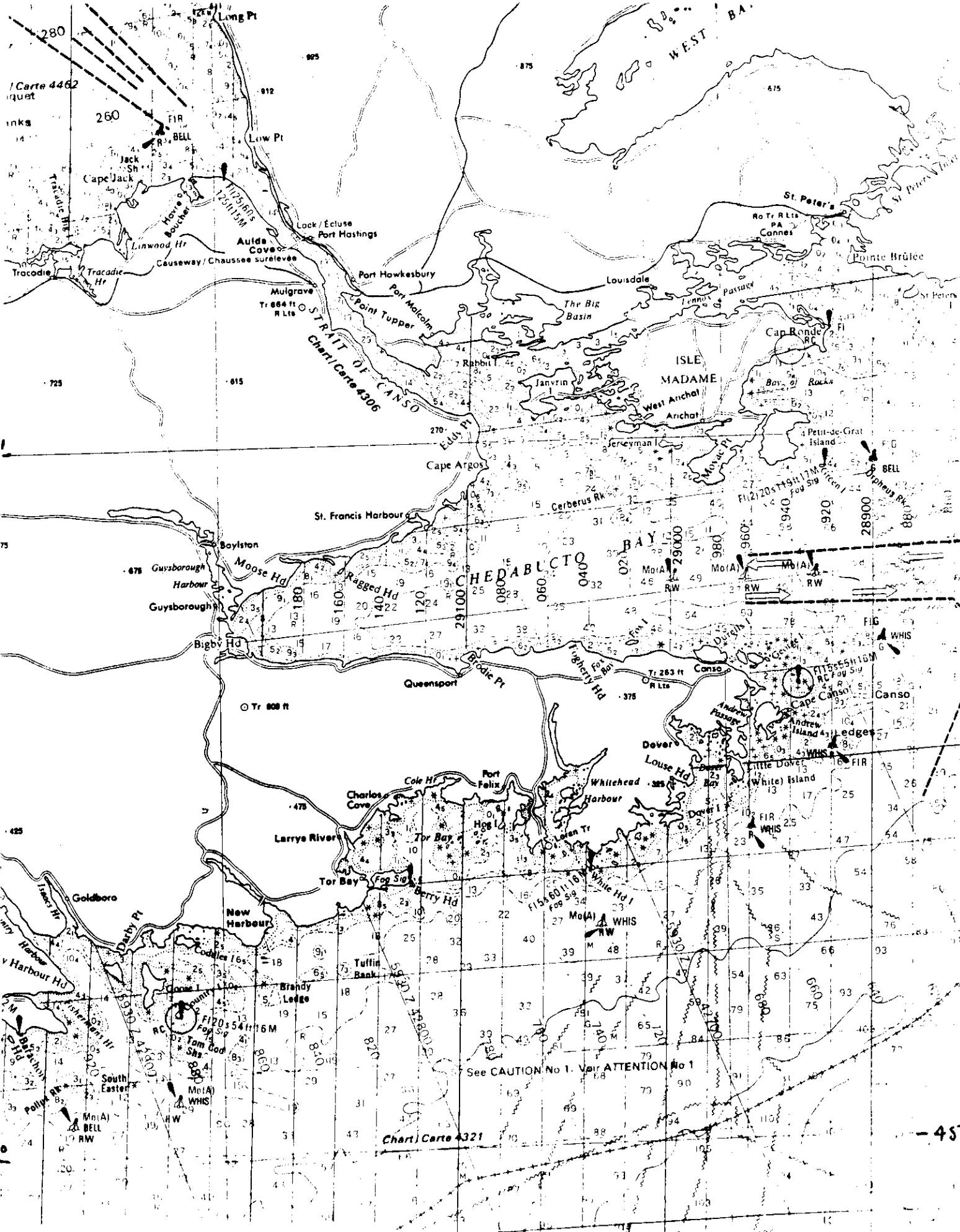

MULGRAVE AND SURROUNDING AREA



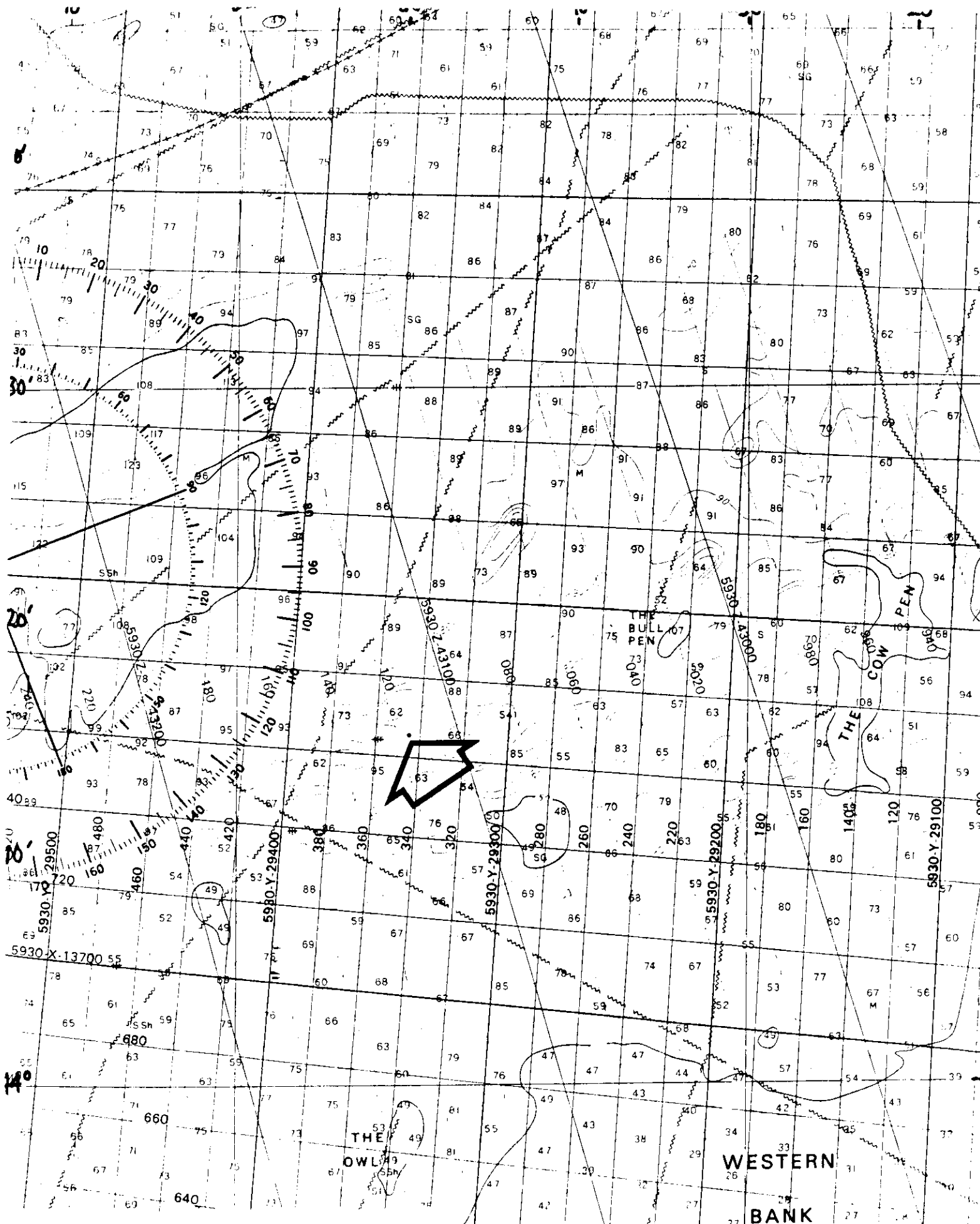

DETAILED MAP OF AREA

10' 20' 30' 40' 50' 60'

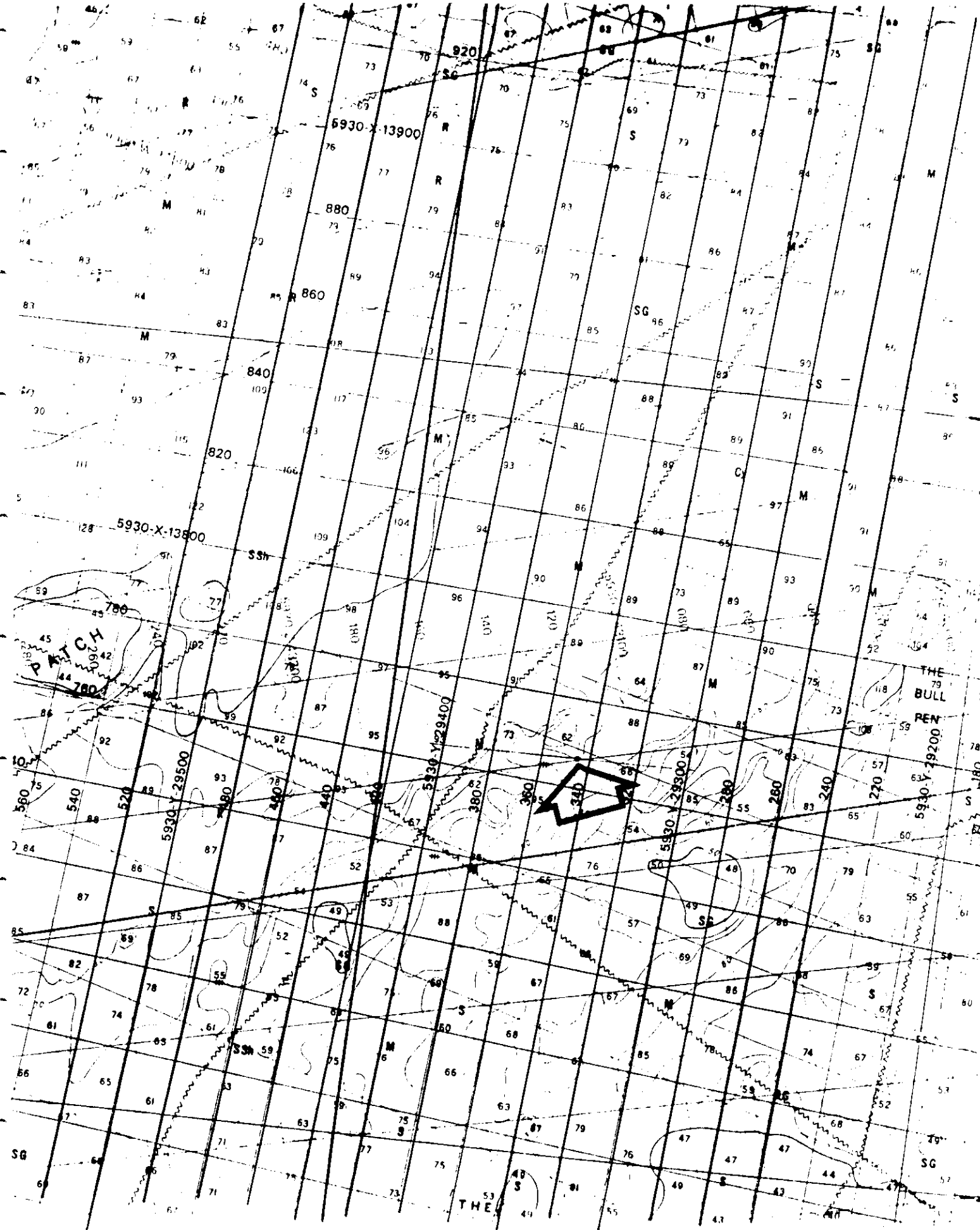

-30

S 2

44

DETAILED MAP OF AREA

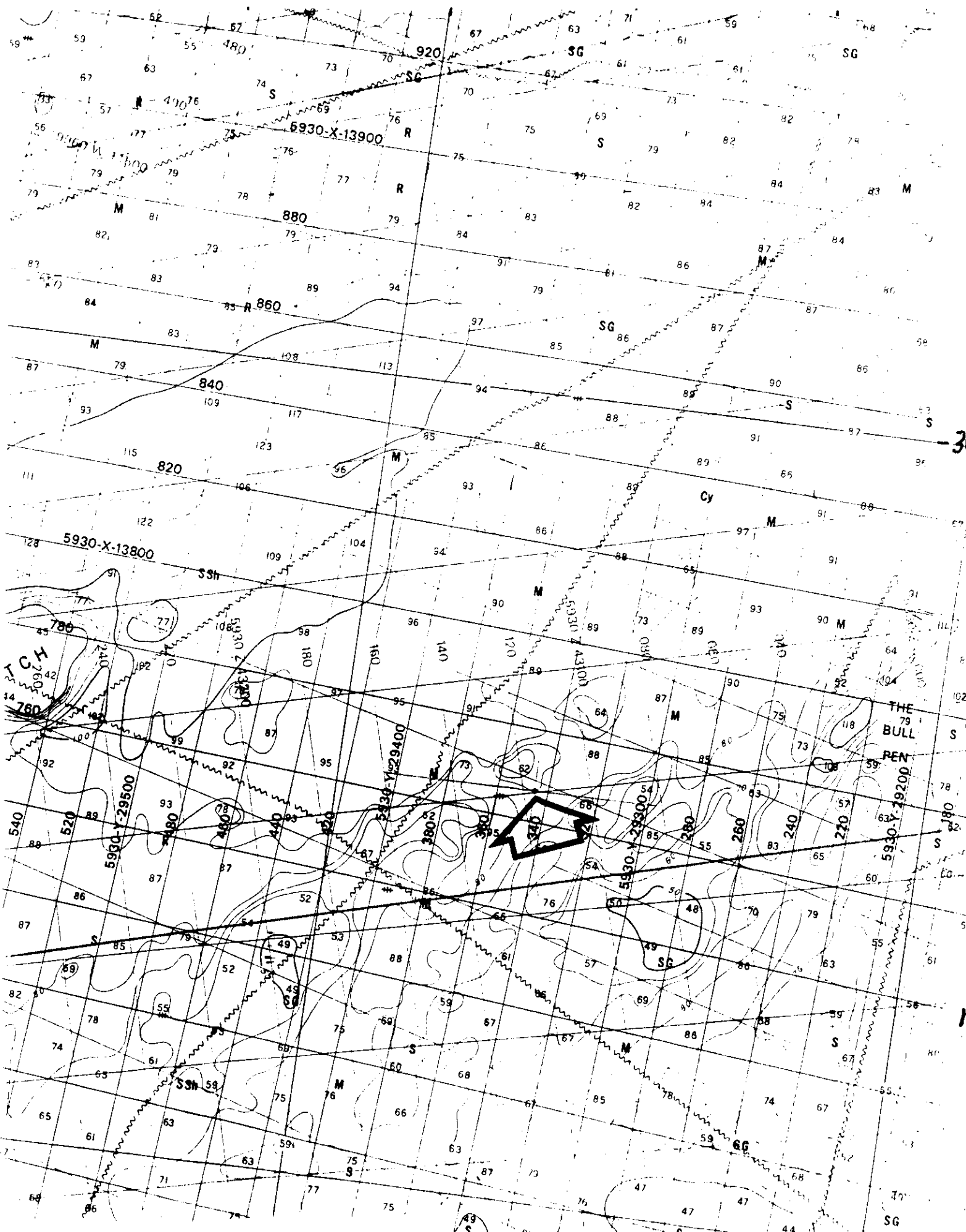

DETAILED MAP OF AREA



APPENDIX 4:

INFORMATION ON THE FALCON

## Cost recovery

Costs for services provided have always been held to a minimum in order to introduce remote sensing techniques to the Canadian scientific community. Beginning in 1973, a line-kilometre charge has been applied in the External Project category. In keeping with Treasury Board directives, the charge has been increased gradually to reflect more closely the data acquisition costs.

Operation of the aircraft for Cooperative and Lease Projects is not funded by CCRS and so all incremental costs associated with the additional flying required in these categories are charged to the user.

Consumables, processing and reproduction of the final imagery are charged at CCRS cost in both the External and Cooperative Project categories. Details of current cost and invoicing procedures are contained in a technical supplement.

FALCON-20

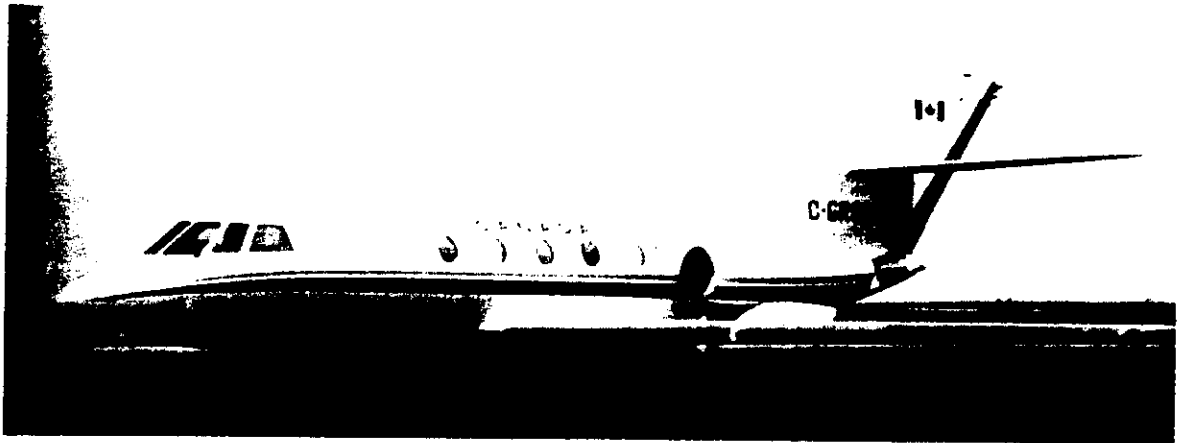

CONVAIR-580

## FALCON-20

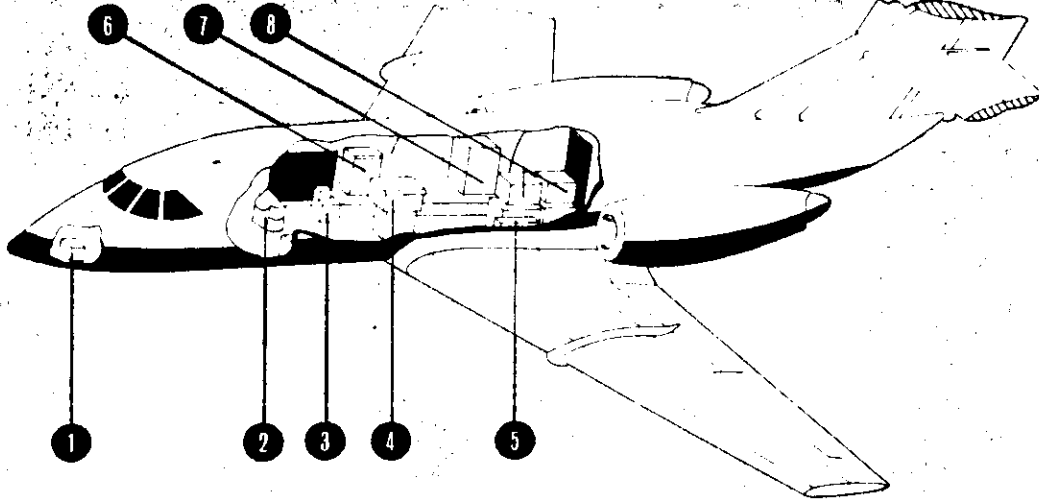

Cutaway view of the Falcon-20 aircraft showing systems used in a typical visible infrared remote sensing project. The pushbroom imager (MEIS) or the multispectral scanner (MSS) is the principal sensor on all projects flown with this aircraft.

- |   |  |
|---|--|
| 1. Multispectral Scanner (MSS-Daedalus 1260)                              | 6. MEIS Console and Real-time Display for MSS and MEIS |
| 2. Metric Camera (RC-10)  | 7. MSS Console   |
| 3. Pushbroom Visible Imager (MEIS II)                                     | 8. High-Density Digital Tape Recorder                  |
| 4. Mission Manager's Console (camera controls and navigation data logger) | 9. Navigation Data Logger Tape Recorder                |
| 5. Inertial Navigation System   |  |

Cutaway view of CV-580 showing location of sensor systems used during typical microwave remote sensing projects. The synthetic aperture radar (SAR) is the principal sensor on most projects flown in this aircraft.

- |   |  |
|---|--|
| 1. High-Density Digital Tape Recorders for SAR and Scatterometer Data | 10. Inertial Navigation Unit                           |
| 2. C- and Ku-band Scatterometers                                      | 11. Global Navigation System Antenna                   |
| 3. Navigation Rack  | 12. SAR Antennas                                       |
| 4. SAR Real-Time Processor  | 13. Metric Camera (RC-10)                              |
| 5. SAR Electronics  | 14. Ku-band Scatterometer Antenna                      |
| 6. SAR X-band Transmitter   | 15. Downward-looking Low Light Level Television Camera |
| 7. SAR X-band and C-band Receiver                                     | 16. Navigation Data Logger (MAID)                      |
| 8. SAR C-band Transmitter   | 17. C-band Scatterometer Antenna                       |
| 9. Microwave Radiometer   |  |

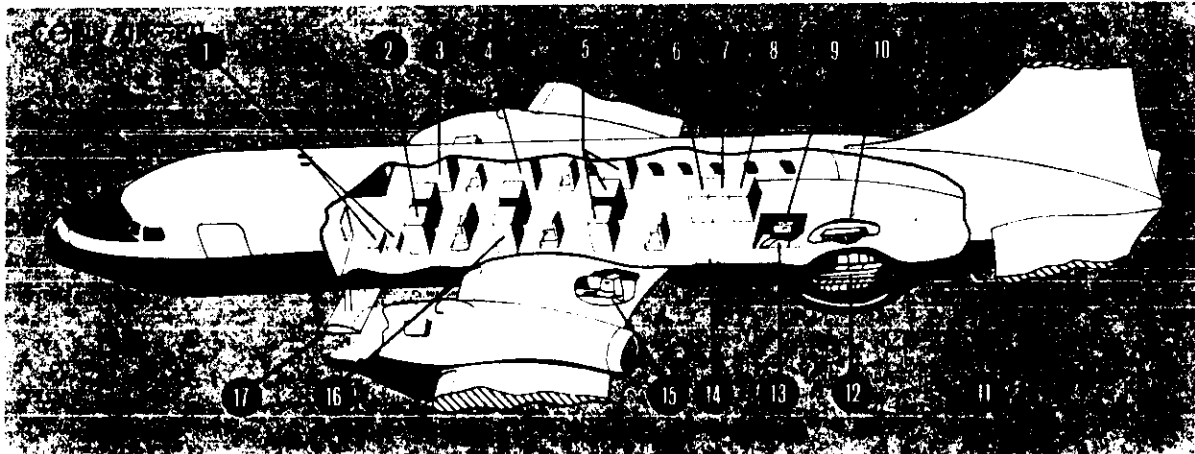

## Airborne Operations

The Canada Centre for Remote Sensing operates, in cooperation with industry, a fleet of three aircraft equipped with sophisticated optical, radar and laser sensors. The aircraft are fitted with special navigation and data management systems to record and annotate the output of several sensors.

The fleet includes a Falcon Fan-Jet, which can operate at altitudes of 12 000 m; a long-range, radar-equipped Convair 580; and a DC-3, which is used for low-level operations and for testing new sensors. All aircraft are flown and operated by Innotech Aviation of Montreal. Sensor operators and technicians are provided through a subcontract by Intera Technologies Limited of Calgary.

Aircraft are used for the acquisition of airborne data requested by users and for the development and demonstration of new sensors. User requests may be either research or operational in nature. Research proposals with good potential for future operational use are flown under a plan that assists the development of new applications by reducing the user's cost. In contrast, operational users cover all incremental costs associated with their project through a preestablished leasing arrangement.

Depending on the nature of the sensors used, the data obtained can appear in electronic or photographic form. Data from electronic sensors are recorded on magnetic tape and processed at CCRS. Master tapes are archived at CCRS and copies are provided as computer-compatible tapes or in hard-copy form. Films from photographic cameras are processed by the National Air Photo Library Reproduction Centre. Master negatives are placed in the National Air Photo Library; copies of the data can be acquired through that agency.

The number and type of sensors carried by the aircraft may vary according to the requirements of the mission to be flown and the capability of the aircraft.

A complete description of the aircraft, sensors, flight operations and procedures for flight requests is available from the Airborne Operations Section of CCRS.

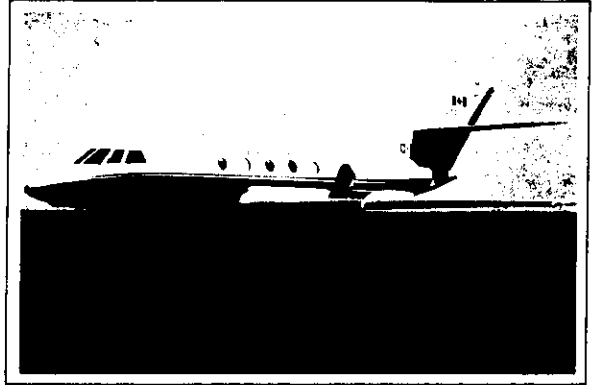

Falcon Fan-Jet.



Convair 580.

APPENDIX 5:  
DETAILED ANALYTICAL PROCEEDURE  
FOR ELASTOL

### Procedure for Die Swell (ELASTICITY) Measurement

Pour 20 to 50 ml of oil into the clean, dry stainless steel syringe. The sample should contain a minimum quantity of free water and no foreign matter which could block the needle. Place the plunger in the syringe and mount the assembled syringe onto the pumping mechanism. With the microscope and camera focused at the tip of the needle, start the pump motor.

Allow one third to one half of the oil to dispense from the syringe in order to establish a steady flow and then take photographs.

APPENDIX 6:  
DETAILED ANALYTICAL PROCEEDURE  
FOR WATER CONTENT

APPENDIX 7:

OCEANOGRAPHY EQUIPMENT BROCHURES



## WEATHER STATION

### Aanderaa Weather Station

This station is designed for automatic operation at remote locations using internal battery power supply, either on land or on moored buoys. It is a fully self contained station that can operate for up to six months with hourly sampling of data.

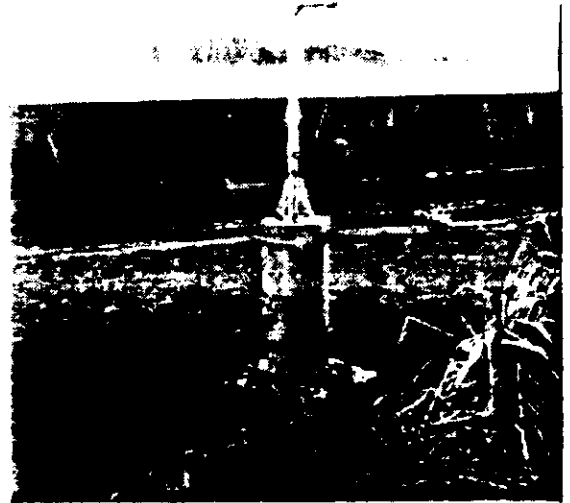

## WAVERIDER AND ACCESSORIES

### Datawell Waverider/F1

The Datawell Waverider/F1 is a surface following accelerometer buoy, which transmits data to a shore station up to 30 km away. The 0.9 m buoys have battery capacity for 18 month deployments.

See also Datawell WAREP Mark II-F for the receiver, and Sea Data Model 1236 data logger for one type of data logger.

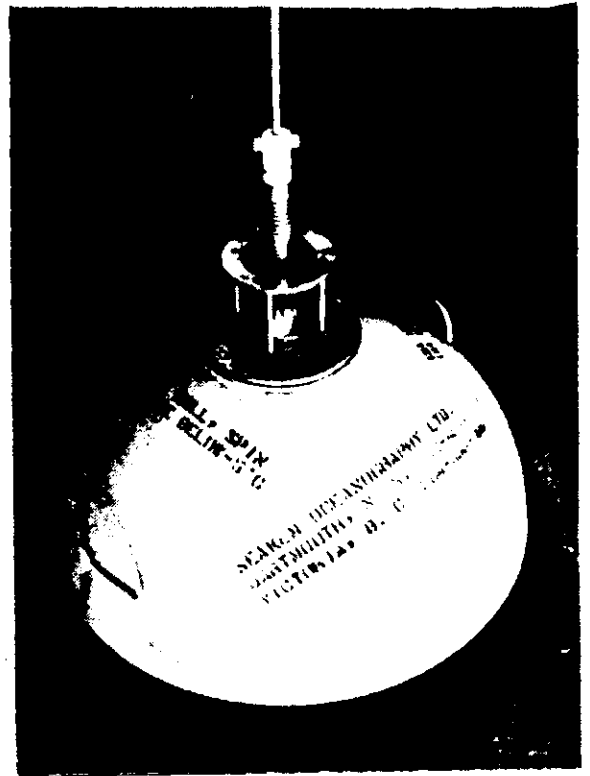

### Datawell WAREP Mark II-F

The Datawell WAREP Mark II-F is a receiver designed to receive data transmitted by the Datawell waverider buoy. The frequency received is crystal selectable, so a WAREP can be altered to receive from any buoy. Note that the WAREP does not log the data it receives.

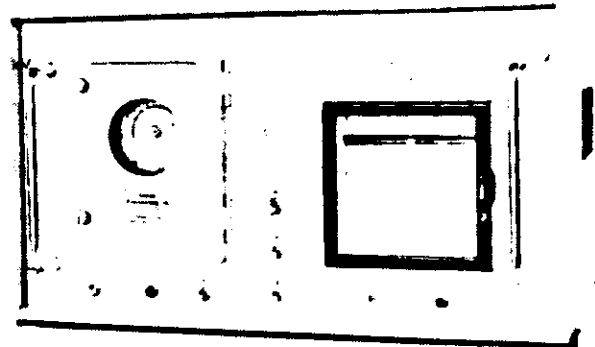

### Datawell Diwar Receiver/Real Time

The Diwar receiver is designed to receive signals from Datawell Waverider buoys and convert the signal into a Serial Data string to be output through an RS232 line to a computer. It also has an analog voltage output as with the WAREP receiver. It is presently configured to be used with an IBM compatible computer for real time wave data analysis/display and output.

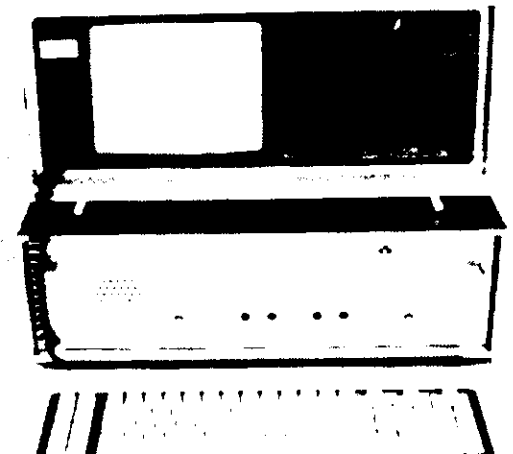

ORION ELECTRONICS LIMITED



OIL SPILL TRACKING

Saulnierville  
Nova Scotia  
Canada  
B0W 2Z0  
Tele. (902) 769-3059  
Telex: 019-38506

The heart of the system, the oil spill tracker, is a small buoy used for tracking oil spills and conducting circulation flow studies. Virtually all of the oil companies drilling offshore Canada now have oil spill tracking packages on site.

Developed by Orion Electronics Limited and the Canadian Department of Environment, the buoy has a drift characteristic similar to an oil spill. Batteries, transmitter, off/on switch, antenna and ballast are enclosed in a plastic dome and stabilizer.

The transmitter is activated by a waterproof switch on the exterior of the buoy. Once deployed, the buoy will drift with a spill and can be tracked from a ship, helicopter, or aircraft. Users include coast guards, environmental protection services, oil companies, oceanographers, port authorities and companies involved in oil spill prevention clean-up and control.

The Tracker Buoy features low cost, ruggedness and light weight, expendability, long shelf life, built in batteries, and deployable from ship/helicopter.

It's advantages are reduced search time and costs, and spill tracking in all visibilities.

Complete packages for instant use or long storage. Buoys, receivers, antennas can be operating on chartered boat or helicopter within minutes.

For tankers, deck-mount units are available complete with buoys.

## Tracker Buoy

Size:

approximately 27 cm diameter, 16 cm high

Weight:

5 Kgm.

Transmitter:

Frequency-VHF, Power-50 or 100mW, Range: Depending on height of antenna up to 16Km from ship, minimum 48Km. from aircraft or helicopter (50mW beacon).

Activation:

Waterproof toggle switch. LED indicates battery state.

Operating life:

weeks or more.

Shelf life:

Years.

Colour:

Fluorescent orange.

## Monitoring Receiver

Panel Connectors: External power, headphones, auxiliary (for remote meter), and antenna.

Controls: Audio Gain (loudspeaker built in), "Tone" - squelch - normal switch, and 10 channel switch.

## ELECTRICAL

Frequency Range: 100-300MHz (various models) Sensitivity: 127dBm or better (0.1uV) IF Bandwidth: 9.5KHz Adjacent Channel Rejection: 70db typical at  $\pm 25$ KHz Image Rejection: one 70db Size: 25x30x13cm (10x12x5") Weight: 2.8Kgm. (7lbs) without batteries.

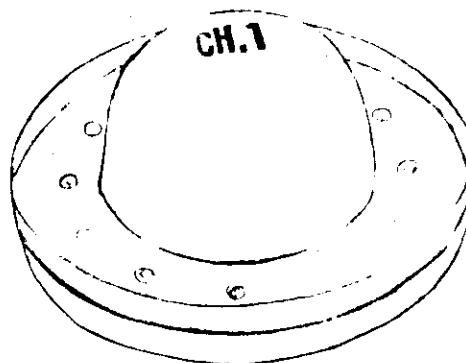

ON TRACK AT ALL TIMES

### Reducing Uncertainty

1. Deployed when the spill occurs the buoys keep transmitting many weeks - let you find the spill at night, in fog, or in heavy weather. They determine drift rate and direction.

2. Offshore spills often occur at night or in bad weather. In the heat of repair work or saving the ship, the initial spill can be lost - until it turns up on the beach! By carrying and deploying buoys each tanker operator keeps some small control over the situation, and that control, however tenuous, can be immensely valuable. It can be used from tankers, oil rigs, shore connections, or deployed from aircraft.

3. Operators who have used this equipment in real situations say that the security, confidence, and time-saving that comes from being able to go directly to the slick at any time without complex navigation, guesses, or computers is invaluable. That confidence reduces tension and increases productivity.

### Reducing Costs

1. Protection  
Most clean-up contractors have

been in the uncomfortable position of booming beach A whilst the oil is quietly coming ashore on beach B. Avoid that by deploying buoys. The cost of a buoy is minimal compared with the possible consequence of not using it.

### 2. Dispersion

Boats and aircraft spraying dispersant often have real problems preventing under or overspray - especially if a slick is drifting. If ORION equipment is used, they can always find their position relative to a drifting slick-reducing operating time and making the dispersant more effective - Cut down vessel time and dispersant use.

### 3. Reduce Search Time

In offshore spills millions of dollars are spent on aircraft search time, even in good weather. Reduce it up to 50% by using Orion buoys. Extends the operating envelope of aircraft (no low flying searches in bad weather!) and improves safety.

### 4. Increase Efficiency

In remote locations chartered vessels often don't have good navigation gear. Use of Orion packages can really speed up operations and operator efficiency.

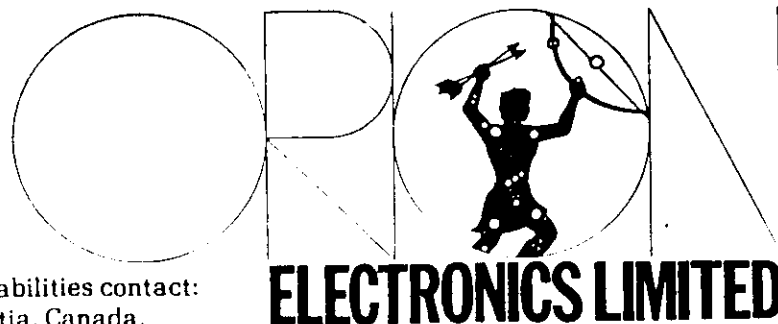

For further information on our equipment and capabilities contact:  
Orion Electronics Limited, Saulnierville, Nova Scotia, Canada,  
POW 2Z0 Phone (902) 769-3059 Telex 019-38506

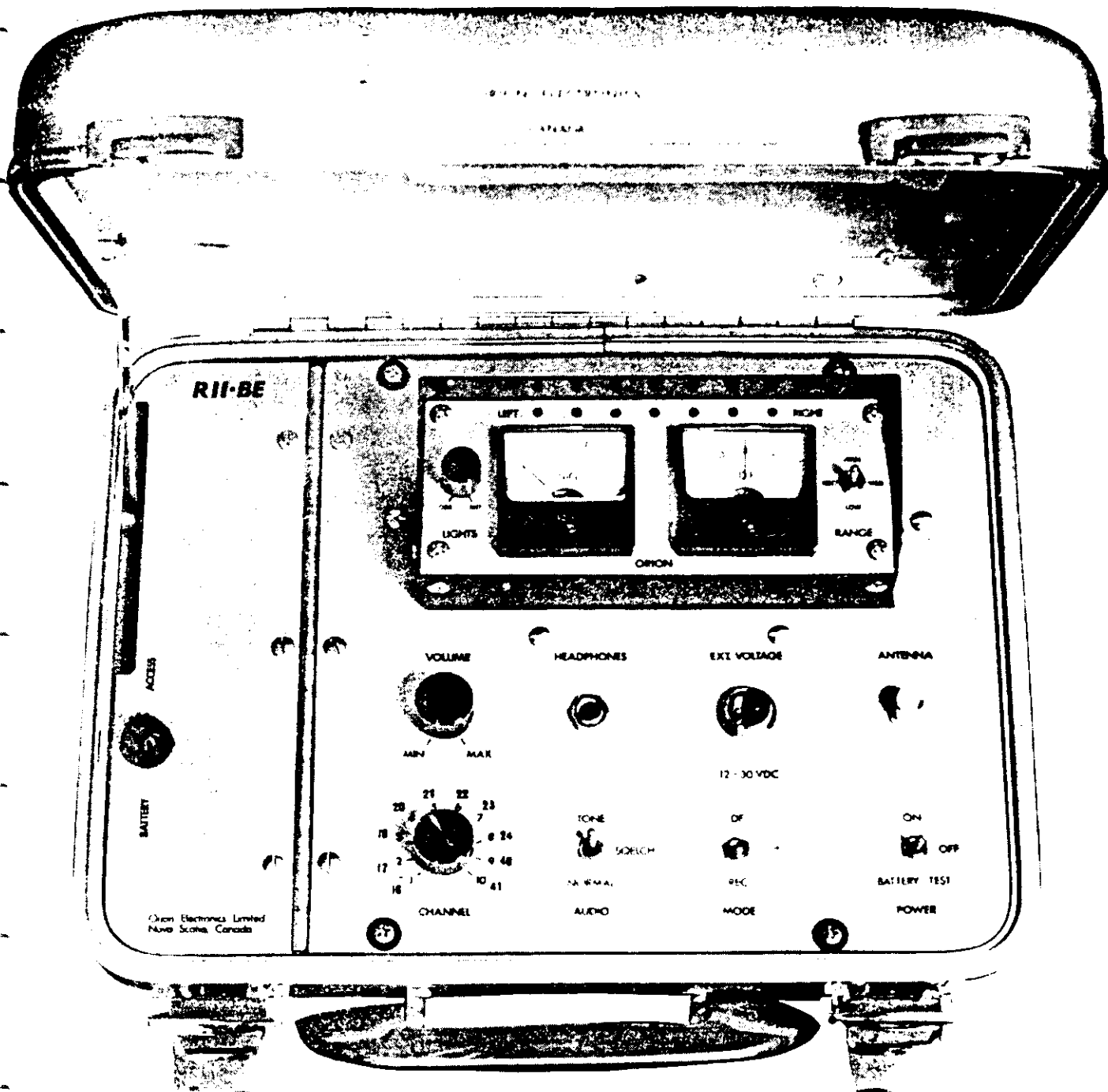

The R-11B is a portable receiver built to the highest standard of craftsmanship which utilizes the best of components for maximum reliability under severe conditions.

State of the art circuit design makes this electronically perhaps the world's best VHF homing receiver - capable of homing on signals as small as  $10^{-7}$  volt with excellent interference rejection. Bear-

### HOMING RECEIVER

ings can, therefore, be obtained on lower power transmitters at longer distance.

The Homing Receiver features internal battery or external power, battery access through hinged front panel compartment, battery test switch to check batteries or external

power source, two large analog meters for signal strength and direction to give good readings on pulsed signals. R-11BE has plug in remote unit for use in vehicles, aircraft, etc. The "Tone" switch gives audio beep which increases in pitch as the transmitter gets closer. It has a rugged vibration and shock resistant "Briefcase type" case with gasket closure.

# AANDERAA INSTRUMENTS

FANAVEIEN 13  
P.O. BOX 160  
5061 BERGEN, NORWAY  
TEL.: (06) 13 25 00  
TELEX 40049

DATA COLLECTING INSTRUMENTS FOR LAND, SEA AND AIR

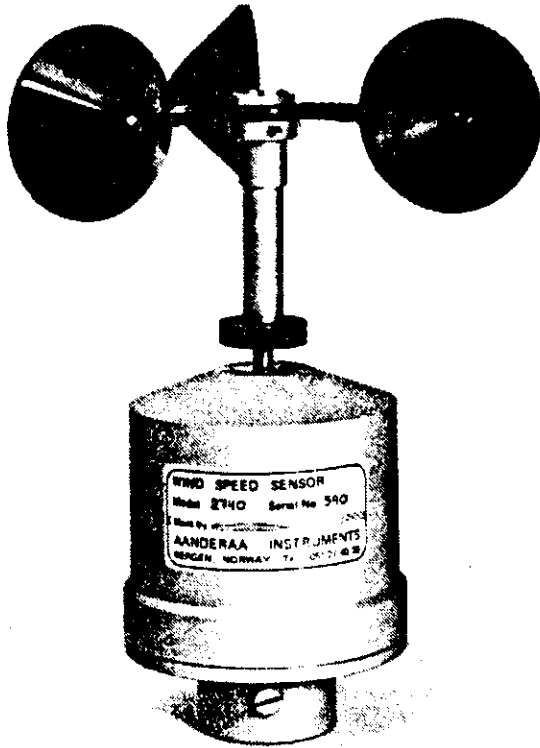

## WIND SPEED SENSOR 2740

(Average and Maximum Speed)

*This sensor will measure the average and maximum wind speed during the sampling interval. It is designed for use with Aanderaa datalogging systems.*

The Wind Speed Sensor 2740 consists of a three cup rotor on top of an aluminium housing that is designed for easy mounting on a 25 mm vertical tube. The rotor bearings consist of two stainless steel ball bearings, protected by a surrounding skirt. The lower end of the skirt is furnished with a magnet. The magnet's rotation is sensed by a reed contact located inside the housing.

The sensor employs a new principle, whereby the arithmetic mean of the wind is always obtained regardless of the length of the sampling interval, provided it is greater than 8 seconds and does not exceed 3 hours. The maximum wind speed is the highest speed that has occurred over a 2 second period at any time during the sampling interval.

When a reading is to be taken, the arrival of -6 Volts from the datalogger resets the electronic counters, and the shift

registers are subsequently advanced by the bridge voltage pulses, which enable the data to enter the datalogger in digital form.

Both average and maximum wind speed will have the same conversion factor for calculation of speed in meters per second. The factor is independent of sampling interval used.

The counter requires a continuous voltage supply to operate. This voltage supply is obtained from the datalogger's main battery (9 Volts). Current consumption is in the range of 100 - 365 microamperes from this battery, dependant upon wind speed. The higher the wind speed, the greater the current consumption will be.

Do not fasten this sensor to structures other than of aluminium or plastic, to avoid galvanic corrosion.

# SPECIFICATIONS

# WIND SPEED SENSOR 2740

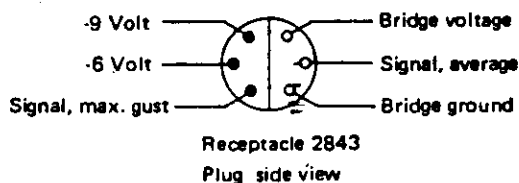
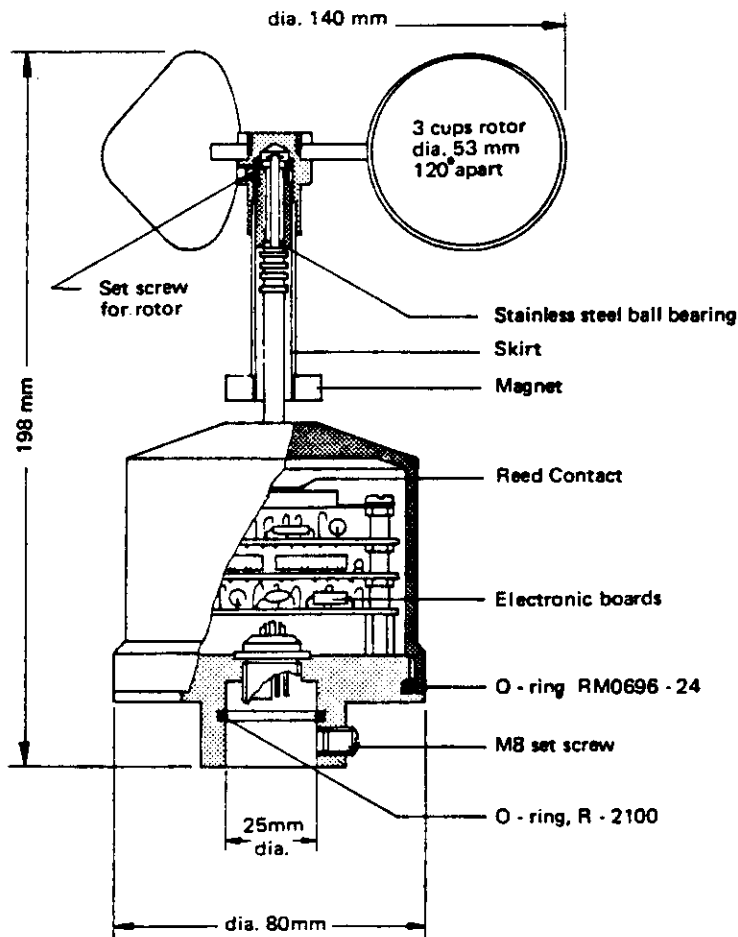

<b>Threshold speed:</b>	30-50 cm/sec.
<b>Range:</b>	up to 60 m/sec.
<b>Accuracy:</b>	±2% or ±20 cm/sec. whichever is greater.
<b>Calibration factor:</b>	1.194 m wind way for each revolution. Two counts each rotor revolution.
<b>Operating temperature:</b>	-40 to +50°C.
<b>Electrical connection:</b>	Receptacle 2843 mating Aanderaa water tight plug 2828 (or Lemo plug F2306).
<b>Material Housing:</b>	Alumimium 6061T6, anodized 20µ.
<b>Weight:</b>	0.5 kilograms.
<b>Packing:</b>	Playwood case 360 x 280 x 105 mm.
<b>Gross weight:</b>	4.1 kilograms, (add 0.7 kg. for Sensor cable 2842).

*Sensor Cable 2842 (10 meter cable with water tight plugs), is available for connecting this sensor to the connector board of the Aanderaa Datalogging System. Price NOK 385.- Other lengths, or seperate plugs and cables, available on request.*

## CALIBRATION

The calibration of this sensor is given by the formula:

$$\text{Wind speed m/sec.} = 0,0746 \cdot N \quad (N = \text{datalogger reading}).$$



# AANDERAA INSTRUMENTS

560 ALPHA ST., VICTORIA  
BRITISH COLUMBIA  
CANADA V8Z 1B2  
TELEPHONE (604) 386-7783  
TELEX 046-7390

DATA COLLECTING INSTRUMENTS FOR LAND, SEA AND AIR

---

---

---

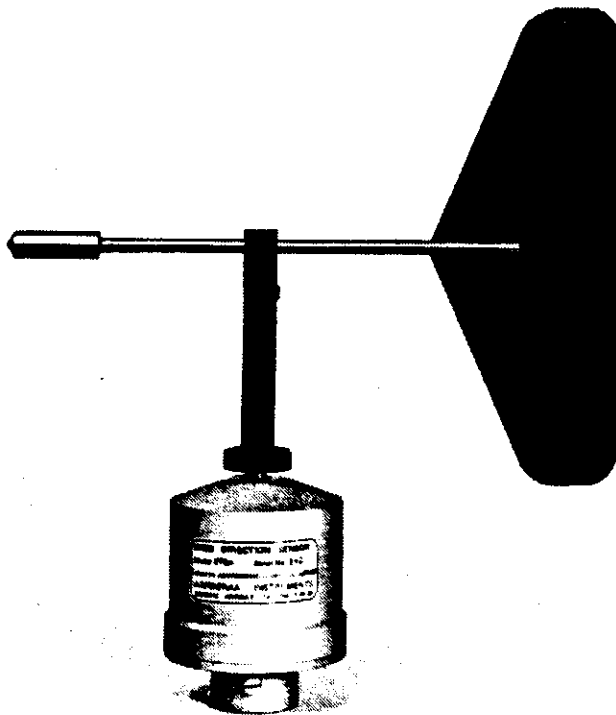

## WIND DIRECTION SENSOR 2750

A sensor to measure wind direction, designed for use with Aanderaa *Datalogger DL-2*.

This wind direction sensor consists of a light wind vane which can turn on a vertical pivot, mounted on top of an aluminium housing that is designed for easy mounting on a 25 mm vertical tube. The vane is coupled magnetically to a following device with electrical read-out (Compass 1248) inside the housing.

When direction is to be read, the following device is clamped by applying current to a clamping coil inside it. In this way, the wind direction is given as a potentiometer setting. A set of resistors are connected to the compass to make the signal compatible with the datalogger.

For the purpose of damping the vane movements, the space between the pivot and the surrounding PVC skirt is filled with silicone oil. The oil damping will permit the vane to line up even with very light wind.

The housing is furnished with a mark that must be orientated towards north for true reading. When properly orientated, this sensor will cause the datalogger to read 0 for wind coming from north, and 256, 512 and 768 for wind coming from east, south and west respectively.

Do not fasten this sensor to structures other than of aluminium or plastic, to avoid galvanic corrosion.

# SPECIFICATIONS

# WIND DIRECTION SENSOR 2750

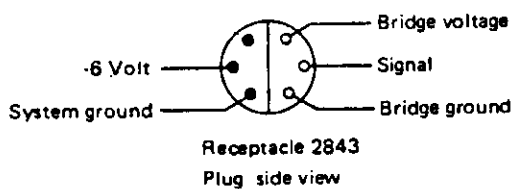
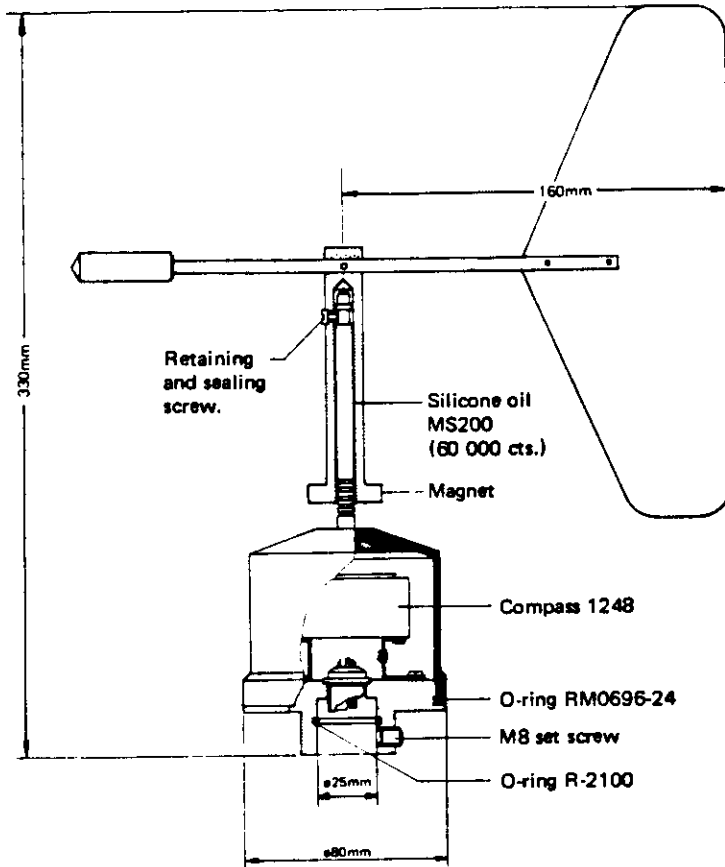

Sensor Cable 2842 (10 meter cable with water tight plugs), is available for connecting this sensor to the connector board of the Aanderaa Datalogging System. Price NOK. 385,-. Other lengths, or separate plugs and cables, available on request.

- Threshold speed:** Less than 30 cm/sec.
- Accuracy:** Better than  $\pm 5^\circ$ .
- Operating temperature:**  $-40$  to  $+50^\circ\text{C}$ .
- Electrical connection:** Receptacle 2843 mating Aanderaa water tight plug 2828 (or Lemo plug F306)
- Mounting:** On Aanderaa Sensor Arm 2710 or on vertical tube with OD. 25 mm.
- Material Housing:** Aluminium 6061T6, anodized  $20\mu$
- Weight:** 0.6 kilograms.
- Packing:** Plywood case 360 x 280 x 105 mm.
- Gross weight:** 4.2 kilograms, (add 0.7 kg. for Sensor cable 2842).

### Electronic circuit:

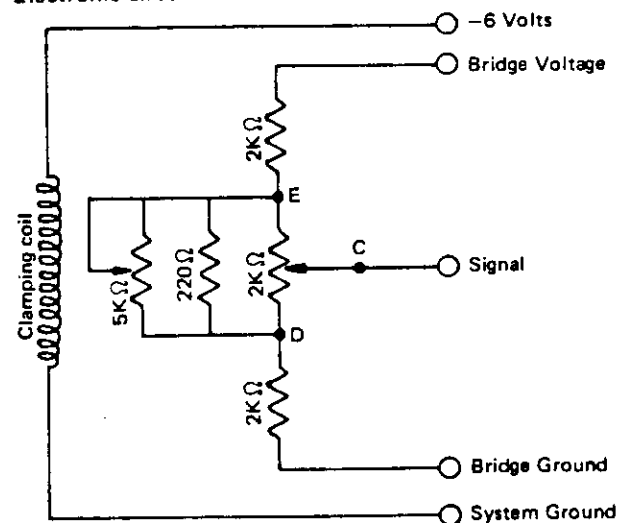

### CALIBRATION

Provided the orientation mark on this sensor is oriented toward north, the standard calibration formula:

Direction, degrees =  $1,5 + 0,349 \cdot N$  is valid. (N = datalogger reading).

# AANDERAA INSTRUMENTS

FANAVEIEN 13  
P.O. BOX 160  
5051 BERGEN, NORWAY  
TEL. BERGEN 13 25 00  
TELEX 40049

DATA COLLECTING INSTRUMENTS FOR LAND, SEA AND AIR

## AIR PRESSURE SENSOR 2810

*A barometric pressure sensor for Aanderaa Automatic Weather Station and other applications.*

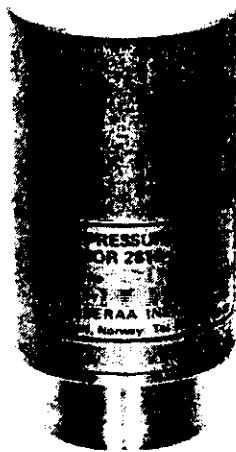

The monolithic technology used for modern electronic devices, may also be used for making small pressure sensors. Sensors made by this method have very small hysteresis and very low ageing.

Since the size of such sensing elements can be very small, it is possible to operate the sensing element at constant temperature. In this way, changes in the ambient temperature will not affect the reading of the sensor.

The Air Pressure Sensor 2810 employs a small silicon chip of 4x4 mm as sensing element. In the central area of this chip, there is a thin membrane that is subjected to the atmospheric pressure on one side and to a vacuum on the other. The membrane is furnished with 4 diffused resistors that form a Wheatstone bridge, whose output signal is proportional to the atmospheric pressure. In this way, the chip can act as an absolute pressure sensing device.

The chip has 4 heating resistors and one temperature sensing resistor diffused onto it. These resistors, together with an external control circuit, allow the chip to be held at a constant temperature of 47 °C during measurement.

The 2810 sensor consists of a base unit and a 2-inch cover, which is screwed onto the base and sealed with an O-ring. The atmospheric pressure is admitted through 6 holes in the base unit and led to the chip by a small tube.

The sensor shows outstanding performance, as it has practically no hysteresis, no temperature effect and no ageing. It is also insensitive to mechanical acceleration. It can be operated in any position and it can be submerged in water without any harm being done to it.

The current consumption for heating of the silicon chip varies with the ambient temperature. At 47 °C the heating current is zero and it increases linearly with decreasing temperature to a maximum of 35 mA at -30 °C. When a reading is wanted, a control voltage of -6 V is switched on. The sensor will then be heated to the correct temperature within 5 seconds, after which a reading is taken. The heating current is normally switched off between readings.

**SPECIFICATIONS**

**AIR PRESSURE SENSOR 2810**

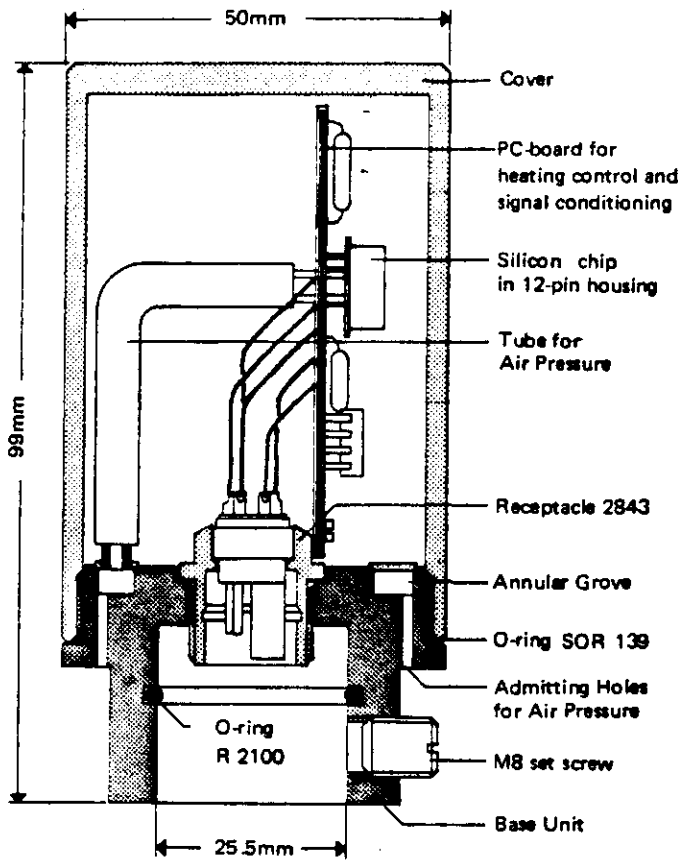

- Measuring range: 920 – 1080mb.
- Accuracy: ±0,2mb.
- Resolution: 0.2mb
- Operation temperature range: -30° to +47°C
- Output impedance: 45Ω
- Sensor output: Aanderaa halfbridge.
- Supply Voltage: -6 Volt
- Heating current: (47 – T) 0.38 mA  
T is ambient temperature in degrees C.
- Electrical connection: Aanderaa water tight plug 2828.  
(or Lemo plug F2306.)
- Material and finish: Aluminum 6061 T anodized 20μ
- Weight: 200 g.
- Packing: Card board box 300 x 200 x 210 mm.
- Gross weight: 600 g.

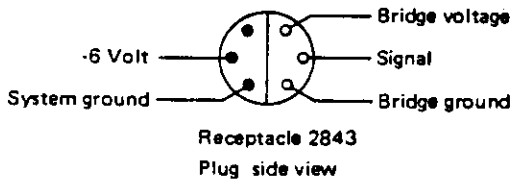

*Sensor Cable 2842 (10 meter cable with water tight plugs), is available for connecting this sensor to the connector board of the Aanderaa Datalogging System. Price NOK 350,-. Other lengths, or separate plugs and cables, available on request.*

**CALIBRATION** of Sensor Serial No. ....

Readings at ..... mb .....

Readings at ..... mb .....

Readings at ..... mb .....

Readings at ..... mb .....

Readings at ..... mb .....

Readings at ..... mb .....

Readings at ..... mb .....

Readings at ..... mb .....

Readings at ..... mb .....

Readings at ..... mb .....

This gives the following coefficients in the formula:

Pressure (mb) = A + B · N

A = .....

B = .....

Date ..... Sign. ....

# AANDERAA INSTRUMENTS

FANAVEIEN 13 B  
P.O. BOX 160  
5051 BERGEN, NORWAY  
TEL.: 05/13 25 00  
TELEX 40049

DATA COLLECTING INSTRUMENTS FOR LAND, SEA AND AIR

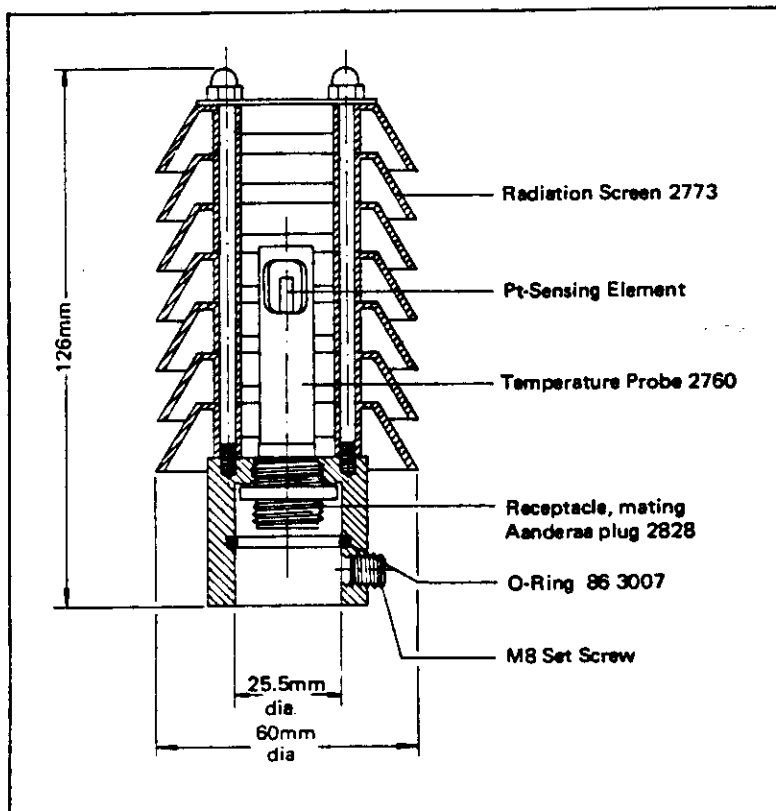

**AIR TEMPERATURE SENSOR 2775**  
*A platinum air temperature sensor designed for the Aanderaa Automatic Weather Station, Sensor Plug-In Board 3010 or Datalogger DL-2.*

*Air Temperature Sensor 2775 consists of a temperature probe fitted inside a radiation screen. The sensor can be plugged directly onto the Aanderaa Automatic Weather Station, or it can be used separately with an interconnecting cable. The sensor is based upon the ohmic half-bridge principle and employs a 500  $\Omega$  film type platinum resistor as the sensing element. This temperature sensor exists in two versions. One with the temperature range  $-44$  to  $+49$   $^{\circ}\text{C}$ , designated 2775 and one with the range  $-8$  to  $+41$   $^{\circ}\text{C}$ , designated 2775A.*

The radiation screen will protect the temperature probe from sun radiation when the surrounding air masses velocity is 0.5 m/sec. or higher.

This sensor can be used with a connecting cable up to 300 meter length. If such long cables are used the cable resistance has to be taken into consideration and corrected for. (See reverse side.)

**SPECIFICATIONS**

**AIR TEMPERATURE SENSOR 2775/2775A**

Electric Circuit:

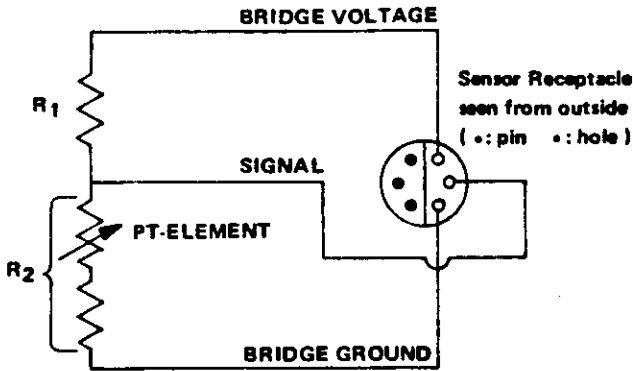

	<b>2775</b>	<b>2775A</b>
Resistor, R <sub>1</sub> :	1000Ω	530Ω
Resistor, R <sub>2</sub> :	500 Ω+Pt 500Ω	Pt 500Ω
Measuring Range:	-44 to +49°C	-8 to +41°C
Accuracy:	±0,1°C	±0,05°C
Time Constant:	Less than 2,5 sec.	
Sensor Output:	Aanderaa halfbridge	
Electrical Connection:	6-pin receptacle mating Aanderaa water tight plug 2828 (or Lemo plug F2306).	
Material and finish,		
Temperature Probe:	Aluminium anodized 20μ	
Radiation Screen:	White nylon.	
Weight:	125 g.	

General formula for Datalogger reading when half-bridge sensor is used:

$$\text{Reading } N = \left( \frac{R_2}{R_1 + R_2} - \frac{21}{44} \right) 22 \cdot 1023$$

*Sensor Cable 2842 (10 meter cable with watertight plugs), is available for connecting this sensor to the Aanderaa Datalogging Systems. Price NOK 480.-. Other lengths, or separate plugs and cables, available on request.*

**CALIBRATION**

SENSOR TYPE..... SERIAL NO.....

Temp. °C			
Reading, N			

These calibration points, gives the following coefficients in the double coefficients formula. Temp., °C = (A+a)+(B+b)N+cN<sup>2</sup>

Coefficients	2775	2775A
a	1,552	1,250
b	-0,009473	-0,005564
c	0,000009614	0,000004719
A		
B		

Date..... Sign.....

*If a sensor cable longer than 50 meters is used, the reading N must be corrected, due to the cable resistance. Add a correction factor for each 10 m of cable as follows: (N-512) · 0,0014 for the 2775 sensor or (N-512) · 0,0028 for the 2775A sensor.*

# AANDERAA INSTRUMENTS

560 ALPHA ST., VICTORIA  
BRITISH COLUMBIA  
CANADA V8Z 1B2  
TELEPHONE (604) 388-7783  
TELEX 048-7390

DATA COLLECTING INSTRUMENTS FOR LAND, SEA AND AIR



## RELATIVE HUMIDITY SENSOR 2820

*A sensor for measuring Relative Humidity. Specially designed to fit Aanderaa Automatic Weather Station.*

Relative humidity is one of the basic parameters in meteorology, and a RH sensor will normally be included in a weather station. Sensor 2820 is designed to fit Aanderaa Automatic Weather Station, but can be used as a separate unit as well.

The 2820 sensor consists of a RH probe with a receptacle for a water tight plug and a radiation screen to protect it against sun radiation and rain.

Sensor 2820 utilizes a bundle of hygroscopic hair and a silicone beam which detects the variations in length of the hair as humidity changes. The hair bundle is tensioned by a spring which transfers the deflection to the beam. Two resistors diffused onto each side of the beam are parts of a temperature controlled half-bridge. In this way, the variation in length of the hair is converted to an electrical signal.

A human hair has limitations as a humidity sensor, as it may change calibration if subjected to air of less than 15 % RH or more than 95 % RH.

The hair in the 2820 has been subjected to a salt impregnation process, which greatly improves the hygroscopic properties of the hair. The 2820 sensor can therefore be used at all humidities without change in calibration.

It should be noted that the time constant of the sensor, which is in the order of a few minutes for relative humidity between 30 and 100 %, will be much longer when the humidity is low, and especially if temperature is low. Therefore, the 2820 sensor is not suited for measurements of rapid changes in relative humidity.

For indoor measurements, or other applications where radiation protection is not required, the RH probe (designated 2822) is available as a separate unit.

**SPECIFICATIONS**

**RELATIVE HUMIDITY SENSOR 2820**

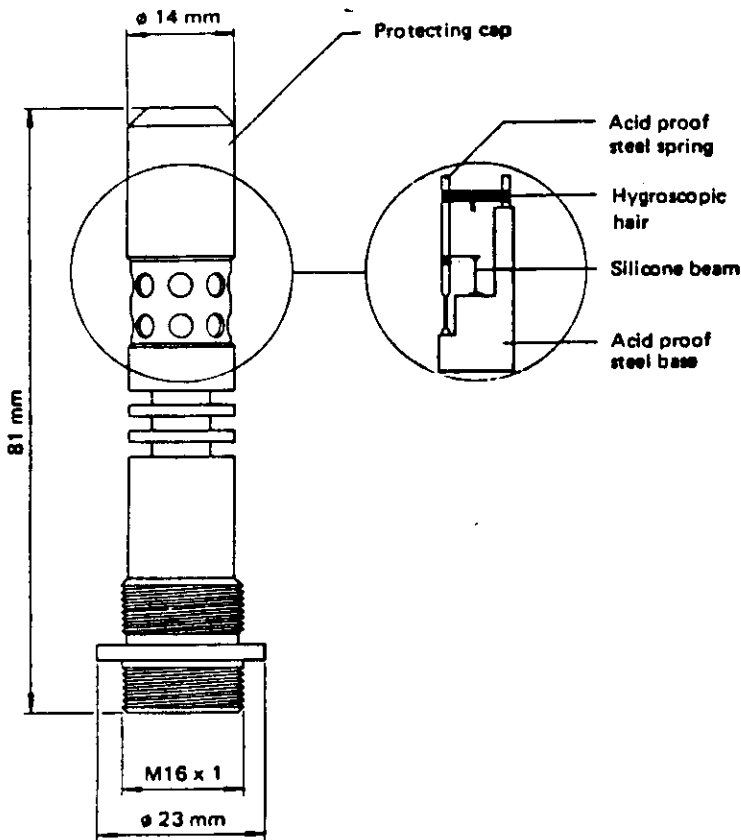

**RH probe 2822**

**Range:** 5 to 100 % RH.  
**Accuracy:** ±3 % RH.  
**Resolution:** 0.3 % RH.  
**Output impedance:** 500 Ω.  
**Sensor output:** Aanderaa halfbridge.  
**Operating temperature:** -30 to +50 °C.  
**Electrical connection:** Aanderaa water tight plug 2828. (Or Lemo plug F2306)  
**Material and finish, Probe:** Aluminium 6061T anodized 20 μm. White nylon.  
**Radiation screen:**  
**Overall dimensions, radiation screen:** 60 mm diameter. 127.5 mm height.  
**Net weight:** 160 g.  
**Gross weight:** 600 g.  
**Package:** Card board box 300 x 200 x 210 mm.

**Calibration (20 °C):** Serial no: .....  
 Reading N = ..... at ..... % RH.  
 Reading N = ..... at ..... % RH.  
 Reading N = ..... at ..... % RH.  
 Reading N = ..... at ..... % RH.  
 Reading N = ..... at ..... % RH.

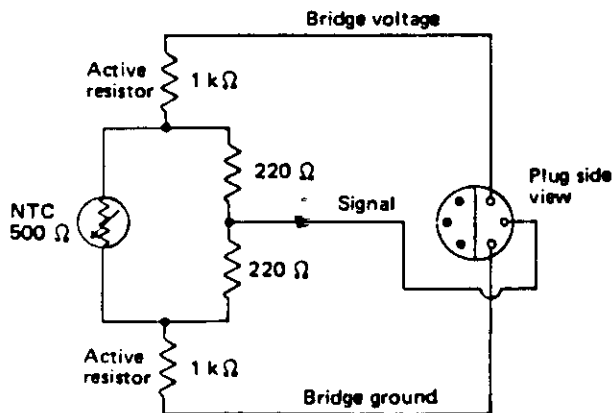

This gives the following coefficients in the formula:  
 Humidity = A + B · N + C · N<sup>2</sup> + D · N<sup>3</sup> [ % RH ]  
 A = ..... C = .....  
 B = ..... D = .....

Date ..... / ..... 19 .....  
 Sign .....



# AANDERAA INSTRUMENTS

FANAVEIEN 13  
P.O. BOX 180  
5051 BERGEN, NORWAY  
TEL.: (05) 27 40 30  
TELEX 40049

DATA COLLECTING INSTRUMENTS FOR LAND, SEA AND AIR

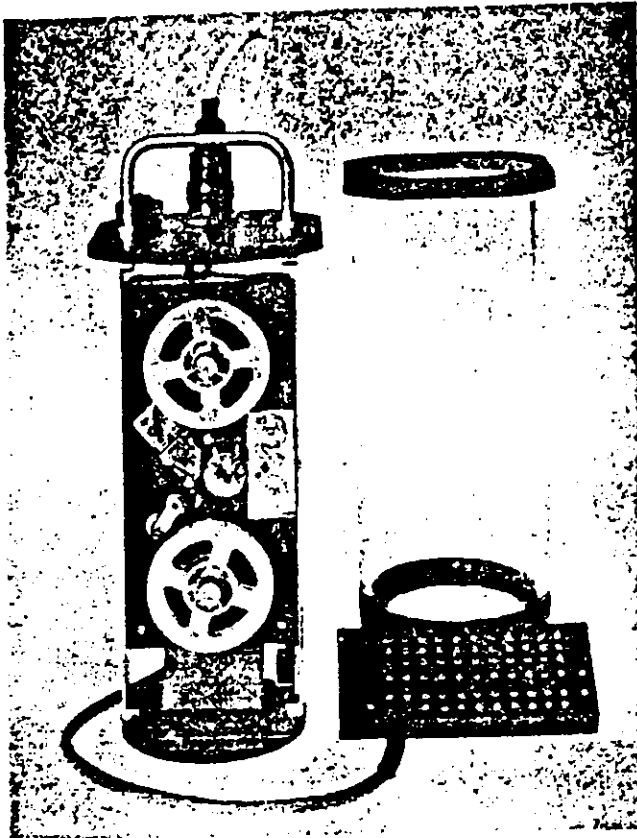

Picture shows datalogger removed from housing, and Connector Board 2371B. This connector permits easy connection of sensing element wires.

This weatherproof, battery operated and fully self contained datalogger has been developed to record data in places where no electricity supply is available.

Analog signals from 12 different channels, are converted to digital data and stored on 1/4 inch reel to reel magnetic tape. The first channel is reserved for the instrument's reference number and the remaining 11 for the measured data. The capacity of a full tape reel (600 ft.), is equal to 6 months of recording at one hour intervals.

Sensors of the standard Aanderaa three - wire half bridge type will plug directly to the connector board of this datalogger. Sensors with voltage or digital output can be

## 12-CHANNEL DATALOGGER DL-1

*A self contained datalogger for recording environmental data at sea or on land.*

Price FOB Bergen:

Datalogger DL-1  
(including Connector Board 2371B)

used when connected via signal conditioning units. These units are moulded into epoxy and plug onto the connector board. *See overleaf*

The datalogger is normally triggered at preset intervals by a built in quartz clock, but external triggering is also possible. Parallel with recording of data the same signals are routed to the connector board output jacks for remote reading.

Aanderaa Instruments offers various equipment for reading tape from this datalogger. Such equipment permits direct plots of recorded data, conversion to 1/2 inch magnetic tape, or direct computer infeed of data. A mail service providing these services is also available.

# SPECIFICATIONS

## MEASURING SYSTEM:

Self balancing bridge with sequential measuring of twelve channels, recorded on magnetic tape. Each channel is represented as a ten bit binary word. The first channel gives a fixed reference reading, acting as a control and identification of the instrument.

Bridge Voltage: -6 volts, pulsed  
 Scanning Range: 1/22 of bridge voltage, symmetrical around bridge midpoint.  
 Measuring Speed: 4 seconds, each channel.

## SENSING ELEMENTS:

Halfbridges: 3-wire halfbridge sensors plug directly to connector board. Preferred resistance each arm, 2000 ohms.

Sensors with voltage output: The following converters are available (connect directly to connector board).

mV-Converter 2190: range 0 to  $\pm 136$ mV  
 mV-Converter 2190B: range 0 to + 272mV  
 mV-Converter 2190C: range 0 to - 272mV  
 mV-Converter 2190D: range 0 to + 5000mV  
 mV-Converter 2190E: range 0 to - 5000mV  
 Digital Sensors: Pulse Counter 2271 is available for counting pulses 0 - 1023. Based on contact closure.

## RECORDING SYSTEM:

Type: Reel to reel 1/4 inch magnetic tape.  
 Coding: 10 bit binary words (short and long pulses) in serial form.  
 Storage Capacity: 5000 samplings using 600 feet of magnetic tape on 3 inch reels.

## CLOCK:

Type: Quartz Crystal Clock 2574  
 Accuracy: Better than  $\pm 2$  sec/day within 0°C to 20°C.  
 Sampling Intervals: 0.5, 1, 2, 5, 10, 15, 20, 30, 60 and 180 minutes, selectable by interval selecting switch.

External Triggering: A six volts positive pulse to output terminal on connector board will activate the instrument.

## REMOTE READING (telemetry):

- 5 volts binary pulses, available on connector board output terminals.

## POWER:

Battery 2291: 9 volts 5Ah., alkaline type (6 Mallory MN 1400).  
 Size: 63 x 50 x 80mm.

## OPERATING TEMPERATURE:

- 4 to 40 degrees C.

## MATERIALS:

Top End Plate: PVC plastic and nickel plated bronze.  
 Housing: Acryl (PMMA)  
 Connector Board: Epoxy (Araldite D)

## WEIGHT:

Net weight: 4 kg.  
 Gross weight: 9 kg.

## DIMENSIONS:

Height including handle: 380mm  
 Size of endplate: 140 x 140mm

## PACKING:

Plywood instrument case, 19 x 22 x 60 cm.

## WARRANTY:

One year against faulty materials and workmanship.

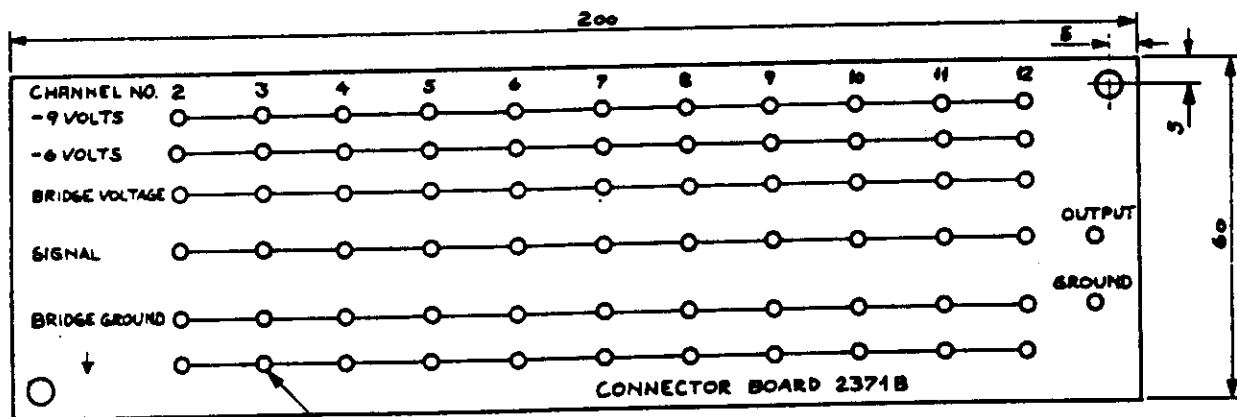

SIX RECEPTACLES FOR 2mm PLUGS EACH CHANNEL

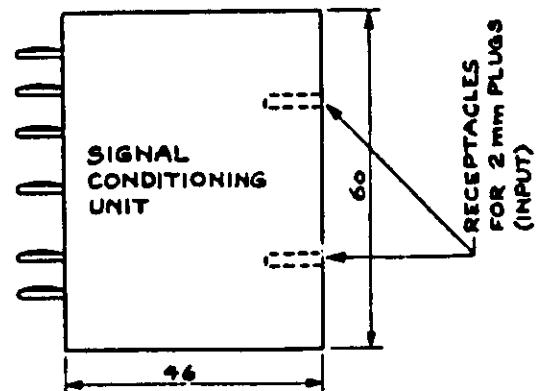

## Distributors:

Canada: Aanderaa Instruments Ltd., 560 Alpha St., Victoria, B.C. V8Z 1B2, Tel. (604) 386-7783, Telex 049-7390  
 Tel. (617) 933-8120 Telex 94-0555