

PART



# **Hot-Mix Asphalt Laydown and Compaction**



# 13 Mix Delivery

The purpose of the haul vehicle is to transport the asphalt mixture from the asphalt plant to the paver. This must be done without delay and with minimal change in the characteristics of the mix during the delivery process, and without segregation. Three primary types of trucks are usually employed to transport HMA—end-dump, bottom- or belly-dump, and live-bottom. The loading of the three types of trucks, either directly from the pugmill at a batch plant or from the surge silo at a batch or drum-mix plant, is reviewed in Section 11, with emphasis on techniques for preventing segregation. This section focuses on the unloading of the mix at the paving site from each type of truck; use of a material transfer vehicle is also briefly discussed. A review of hauling procedures is then presented.

## UNLOADING OF MIX

### End-Dump Trucks

An end-dump truck delivers the HMA directly from the truck bed into the hopper of the paver. The mix is unloaded by raising the truck bed and allowing the mix to slide down the bed into the hopper. When the bed is raised, it should not come into contact with the hopper and should not be carried by or ride on any portion of the paver. For smaller-capacity end-dump trucks, contact with the paver is normally not a problem. Such contact can be a problem, however, when large tractor-semitrailer units are used as haul vehicles, particularly when the truck bed is extended to its highest point. When a portion of the weight of the truck is being carried by the paver, the screed tow points of the laydown machine may be changed, which in turn will affect the smoothness of the finished mat. A typical end-dump truck is shown in Figure 13-1.

An end-dump truck can also be used to deliver the mix to a windrow on the roadway in front of the paver. The windrow can be formed in one of two ways. First, a spreader box or windrow sizer can be used. In this case, the mix is deposited into the box and is uniformly metered out onto the roadway as the truck moves for-

ward, typically pulling the windrow box behind it. The amount of HMA placed in the windrow is determined by the setting of the discharge opening in the box. This procedure provides the most accurate means of keeping a constant supply of mix in front of the paver. The mix is then picked up from the roadway surface by a windrow elevator attached to the front of the paving machine.

A second means of creating a windrow using an end-dump truck is to use a windrow blender device, which is usually attached to a small front-end loader. In this case, the mix is dumped onto the existing pavement surface across the full width of the truck bed. The amount of HMA discharged from the truck is controlled by both the width of the opening of the truck bed tailgate, which is chained to prevent full opening, and the forward speed of the truck. The mix is folded into a windrow by the blending unit as that device is pushed forward by the loader. As a result of the tumbling action that occurs as the mix is being shaped into the windrow, some remixing of the material occurs, and segregation may be reduced or eliminated. The size of the windrow is controlled by the height of the discharge opening at the back of the blender. Because of the length of the wings on the windrow blender, mix can be carried for some distance if the truck deposits too much mix at some point on the existing pavement surface.

### Bottom- or Belly-Dump Trucks

A bottom- or belly-dump truck delivers its load onto the roadway in front of the paver. The mix is deposited from underneath the truck bed into a windrow, as seen in Figure 13-2. For this method of mix delivery, it is important that the correct amount of material be placed down the length of the windrow to match the paving width and depth being placed without allowing the hopper to run out of mix or become overloaded. Continuous operation of the paver, which must be equipped with a pickup machine (windrow elevator) (see Figure 13-3), can be accomplished only if a continuous and consistent supply of mix is available. It is more difficult, however, to maintain a consistent amount of mix in the paver hopper for leveling courses of HMA, which are necessarily





**FIGURE 13-1** Typical end-dump truck.

of variable thickness, than for courses whose thickness is more constant.

Control of the amount of HMA discharged from a bottom-dump truck is based on the width of the gate opening under the truck and the speed of the truck. The amount of mix deposited at any time is therefore highly dependent on the skill of the person controlling the discharge gates and on the truck driver's attention to operating the truck at the required speed. Manual control of the discharge requires constant attention to ensure that neither too little nor too much mix is fed into the paver hopper (the hopper should be filled to a level above the top of the flow gates or tunnel openings at all times). The amount of mix needed in the windrow depends on the width and thickness of the layer being placed. Thus a different gate opening on the truck bed is needed according to variations in project conditions and truck speed.

The amount of mix available to be picked up by the windrow elevator on the front of the paver should be



**FIGURE 13-2** Typical bottom- or belly-dump truck.



**FIGURE 13-3** Material pickup machine.

consistent. Should the amount of mix being delivered to the paver become out of balance with the quantity of mix needed by the paver, an adjustment must be made in the discharge operation of the bottom-dump truck. If the problem is noticed before the paver is under- or overloaded, the amount of mix deposited on the roadway can easily be altered by changing the width of the gate opening on the truck or by adjusting the forward travel speed of the truck during discharge.

Should the paver run out of mix in the hopper, additional HMA should be placed in the hopper without the paver moving forward. Depending on the equipment available to the contractor at the paving site, such as a small loader, doing so may be very difficult. In some cases, the paver operator may have to raise the paver screed and then move the paver forward to pick up mix. When enough mix is in the hopper, the paver must be backed up, the screed set back down, more mix placed in the windrow in front of the paver, and paving started once again. Needless to say, this is not good paving practice and does not usually result in placement of a smooth mat.

Should the hopper become overloaded with mix, some of the material in the windrow in front of the paver must be removed so that the paver can move forward without additional mix being picked up. Once the mix in the hopper has reached the desired level, the paver must again start picking up additional mix from the windrow.

The ability of the paver to place a smooth mat will be affected by the uniformity of the volume of mix being fed to it. Because of the difficulty in adjusting the quantity of mix needed by the paver when the hopper is either under- or overloaded, it is important that the size of the windrow of mix produced by the bottom-dump truck be as consistent as possible. Keeping the

size of the windrow constant is easier than correcting the problem of too little or too much mix in the paver hopper.

One method to better control the amount of material in the paver hopper is to form a windrow that is a little short of that needed by the paver. An additional bottom-dump truck is then kept just in front of the laydown machine, traveling over the windrow placed by the earlier truck or trucks, to supplement the amount of mix in the windrow as needed. This type of operation overcomes the potential problem of under- or overfilling the paver hopper and greatly speeds up the paving process.

### Live-Bottom Trucks

A live-bottom truck (also known as a flow-boy or horizontal-discharge truck) employs a conveyor belt or slat conveyor in the bottom of the truck bed to discharge the mix without the need to raise the bed. This type of truck usually deposits the mix directly into the hopper of the paver, as does an end-dump truck, but it can also deliver the mix to the existing pavement surface for pickup by a windrow elevator on the paver, as does a bottom-dump truck. Further, the live-bottom truck moves the HMA in a mass, which minimizes segregation as compared with end-dump trucks. Because the bed of this type of truck is not raised, there is no potential problem with the bed pressing on the paver hopper. A typical live-bottom truck is shown in Figure 13-4.

### Material Transfer Vehicle

An additional method used to deliver mix to the paver is a material transfer vehicle (MTV) (see Figure 13-5). An MTV is basically a surge bin on wheels that can hold up to 32 000 kg (35 tons) of mix, depending on the



FIGURE 13-4 Typical live-bottom truck.



FIGURE 13-5 Material transfer vehicle.

size of the unit. HMA is deposited from an end-dump or live-bottom truck into the hopper on the front of the vehicle, which may be equipped with a remixing auger or augers. The purpose of the auger system is to reblend the coarse and fine particles of the HMA and reduce any segregation and temperature variation that may have occurred in the mix as a result of the operation of the surge or storage silo or truck-loading procedures (see Section 11). The mix is carried from the hopper through the augers and then to a conveyor, which delivers the mix into a vertical extension or insert in the hopper.

The MTV should allow the paver to operate almost continuously, without stopping between truckloads of mix, as long as a continuous supply of mix is available from the asphalt plant. Therefore, the paver operator can keep the head of material in front of the screed constant by supplying a continuous amount of mix back to the screed and obtain a smoother mat. Use of an MTV also eliminates the problems of the haul truck bumping the paver and the truck driver holding the brakes on the truck when being pushed by the paver. As noted, however, the MTV is essentially a mobile surge bin; when it runs out of material, the paver must stop, and a continuous paving operation is not possible. Keeping a constant stream of trucks in front of the paver or MTV is therefore necessary if a continuous paving operation is to be achieved. If a gap occurs, the MTV should be stopped without being completely emptied when waiting for trucks, so that a consistent minimum amount of mix is retained on the augers to mix with the new, possibly segregated, material delivered from the next haul truck. In addition, the paver should be stopped with the hopper half full so that the amount of HMA in front of the paver screed remains constant and the proper smoothness of the mat is achieved. Indeed, the head of



material in front of the paver screed is the most important factor in obtaining a smooth-riding pavement layer (see Section 16).

The MTV can be operated directly in front of the paver or off to one side. Because of the weight of this piece of equipment when full of mix, it is necessary to determine ahead of time that the pavement over which this machinery will be operated can support the loaded weight without being overstressed and damaged. Several smaller, simpler MTVs have been developed by various equipment manufacturers. Because of the limited surge capacity of most of these smaller devices, however, it is more likely that the paving operation will have to stop because of the MTV running out of material.

## HAULING PROCEDURES

### Cleaning of the Bed and Application of Release Agent

The bed of the haul truck, whether an end-dump, bottom-dump, or live-bottom truck, should be free of all deleterious materials before mix is placed in it. Any debris in the bed from previous use of the truck should be removed. The bed should be reasonably smooth and free of any major indentations or depressions where the truck bed release agent and HMA could accumulate.

Once the bed is clean, it should be coated with a release agent to prevent the HMA from sticking to the bed. Nonpetroleum-based materials, such as limewater or one of a variety of commercial products, should be used for this purpose. The release agent should be sprayed uniformly over the sides and bottom of the truck bed and should be used in the minimum quantity necessary to cover most of the surface area of the bed without runoff. Any excess agent should be drained from the bed before the truck is loaded with mix.

Diesel fuel should not be used as a release agent for the truck bed (see Figure 13-6). If an excessive amount of diesel fuel is used and accumulates in depressions in the bed of the truck, it can cause changes in the properties of the binder material with which it comes in contact. If an area of the finished HMA mat contains excessive diesel fuel, a soft spot and maybe a pothole will result (see Figure 13-7). In addition, use of diesel fuel can contribute to environmental problems as the fuel evaporates or if it soaks into the ground. Thus, although often convenient and economical, diesel fuel should not be used as the release agent in the bed of a haul truck.



**FIGURE 13-6 Diesel fuel is an unacceptable release agent.**

### Insulation

If warranted by environmental conditions, the sides and bottom of the truck bed should be insulated. The insulation should be tight against the body of the bed, and there should be no gaps between the side of the truck and the insulation through which wind could enter. The insulation material should be protected on its outside face with plywood or a similar cover. Missing or torn insulation should be replaced.

Some coarse-graded mixes, such as friction courses, stone-matrix asphalt, and coarse-graded Superpave, tend to cool more quickly than fine-graded mixes, and mixes containing polymer tend to stiffen more quickly as they cool. A well-insulated truck will help minimize any temperature loss.



**FIGURE 13-7 Pothole caused by overlaying of spilled diesel fuel.**

## Use of Tarpaulins

Every haul truck should be equipped with a tarpaulin that can be used as needed to protect the HMA in case of inclement weather. The tarp should be made of a water-repellent material, be of sufficient weight and strength to resist tearing, and be in good condition with no holes or tears. Most important, the tarp should be large enough to cover the top of the load and extend down over the sides and the tailgate of the truck at least 0.3 m (1 ft) all around the truck bed to ensure that the mix is protected adequately from wind and rain. The tarp should also have enough tie-down points so that it will be properly secured and will not flap in the wind during delivery of the mix from the plant to the paver.

Some trucks are equipped with tarps that run from the front to the back of the truck in a rail atop the sideboards of the truck. The rail keeps the tarp stretched across the top of the load of mix and covers the mix without the tarp having to extend over the sides of the truck bed. As long as the tarp is tight, this arrangement can provide adequate cover for the mix. For safety reasons, it is desirable to use tarps that can be extended by mechanical means over the length of the bed of the truck without the driver having to climb up the sides of the vehicle.

A tarp that does not completely cover the load during transport may be worse than having no tarp at all on the load. Research has shown that unless the tarp extends over the sides of the truck, airflow under the tarp will increase the rate of cooling of the mix. In addition, any water that falls on the tarp during rainy weather will run into the truck bed instead of off the side of the vehicle. Indeed, even when the tarp covers the bed, if there is any water on the tarp when the truck is ready to discharge mix into the paver hopper, the water should first be removed by raising the bed of the truck and letting the water run off before the truck backs into the hopper. This water removal operation should not be done on the pavement in front of the lay-down machine.

Tarps are not normally necessary in warm weather and for relatively short haul distances between the plant and the paver. If a tarp is used, however, it should be removed from the top of the bed before the truck is unloaded into the laydown machine. Doing so allows the mix to be inspected visually for defective material, such as uncoated aggregate or excessive asphalt content, before being discharged into the paver.

## Crusting of the Mix

There is no set limit on how far a load of HMA can be transported. Many variables affect the maximum haul distance, but the key factors are the workability of the mix while it is passing through the paver and the ability to compact the mix once it has been placed by the paver. Both of these factors are highly dependent on the temperature of the mix.

HMA in a mass, such as when the mix is confined in a truck bed, will maintain a reasonable temperature for as long as 2 or 3 hours. The rate of cooling of the mix depends on such variables as its temperature at the time of production, the ambient air temperature, and the efficiency of any insulation used on the sides and bottom of the truck. When hauled long distances without being covered by a tarp, HMA will cool and develop a crust on the top. The crust serves as an insulating layer for the rest of the mix in the truck bed and reduces the rate of cooling for the remainder of the material. Thus within limits, crust formation can be beneficial. However, the crust must be completely broken down before reaching the paver, or tears and pulls in the finished mat surface will occur.

If the load of mix is properly tarped, the amount of crust buildup will be minimized because the wind will have significantly less effect on the rate of cooling of the mix. The slight crust thickness that does form during transport will usually be broken up completely as the mix is discharged from the haul vehicle into the paver, carried by the slat conveyors back to the augers, and passed under the paver screed. As long as chunks of asphalt mix do not affect the quality of the mat behind the paver, the crust that forms on top of the mix during delivery will not be detrimental to the long-term performance of the mix. If chunks of mix can be seen behind the screed, however, changes need to be made in the mix production temperature, the amount of insulation on the truck bed, the covering of the load with the tarp, the paving schedule (waiting for warmer ambient temperatures), or any combination of these factors. It has also been shown that using an MTV results in some remixing, which helps break down any chunks that may exist.

## Rain

Judgment is required when rain occurs at the paving site and mix is still in the trucks waiting to be unloaded. One alternative is to stop paving and return any mix in the trucks to the plant to be recycled at a later date. If the rain is relatively light and appears likely to continue for some



time, and if the pavement surface has been tacked and does not contain puddled water, the trucks can be unloaded as quickly as possible and the rollers brought up directly behind the paver to compact the mix before it cools completely. If the existing pavement surface contains puddles of water, however, placement of the HMA should not be continued.

Some specifications permit the contractor to place mix that is “in transit” on the roadway even during a rainstorm. Although most of the HMA placed during rain performs adequately over time, it is better practice to refrain from placing the mix if the rain is heavy and the pavement surface is very wet or standing water exists on the surface. With the advent of pavement recycling, the material not placed can easily be recycled later. The only cost involved is that of hauling the mix back to the plant and reprocessing it through the plant. Any mix that is placed during rain will cool very quickly as a result of the rapid heat transfer from the mix to the wet underlying pavement surface and the cooling of the mix by the rain itself. It is thus very difficult to obtain proper density in the mix because of its low temperature. A lack of compaction, and therefore a high air void content in the mix, leads to poor pavement performance.

If the rain appears to be of short duration—a passing shower—the mix can be held in the haul truck instead of being dumped into the paver hopper. It should then be laid after the shower has passed and the pavement surface is free of puddles. Again, because of the mass of mix in the truck bed, the mix will lose temperature slowly if the load is properly tarped—no water can get into the bed. Once the rain has stopped and any puddles of water have been swept from the roadway surface, the mix can be unloaded from the waiting trucks into the paver and laid down. As long as chunks of mix do not appear behind the screed and the rollers can properly densify the mix, little harm is done by holding the mix in the haul trucks for even 2 or 3 hours, depending on environmental conditions.

### Bumping of the Paver

When an end-dump or live-bottom truck is used to deliver mix to the paver, the truck driver should back the truck up to the laydown machine but stop just short of touching the paver. Once the truck has come to a halt and the driver has released the brakes on the vehicle, the paver operator should start the machine moving forward, picking up the stopped truck. The key to this process is that the paver picks up the truck instead of the truck backing into and bumping the paver. Use of this procedure will reduce the incidence of screed marks and roughness in the mat. Given the smoothness specifications now

being implemented in most states, it is imperative that the truck-unloading operation not add to the problem. Upon being told why it is important not to bump the paver, most truck drivers will use the correct unloading techniques.

### Unloading

If an end-dump truck is used and if the mix being delivered to the paver has a tendency to segregate, the bed of the truck should be raised a short distance to break the load to the rear and allow the mix in the bed to shift and slide back against the tailgate before it is opened. This practice will cause any segregated coarse aggregate material to be incorporated back into the mass of mix rather than being delivered first into the paver hopper. Once the tailgate is opened, this procedure will also allow the mix to be discharged from the truck in a mass and to flood the hopper of the paver, further reducing the possibility of segregation behind the paver screed. In addition, raising the bed before the truck backs into the paver reduces the time required to unload the truck and makes the truck exchange more efficient.

The same procedure should be employed, if possible, when a live-bottom truck is used to transport the mix. On some such trucks, it may be possible to start the belt or slat conveyor for a few seconds before the end gate on the truck is opened. Doing so will create a mass of material that can be delivered to the hopper, instead of allowing any coarse aggregate particles that have rolled to the end gate to exit into the hopper first.

For bottom-dump trucks, the gates on the bottom of the truck bed should be opened wide to allow a mass of mix to be discharged, instead of only some of the mix dribbling out if the gates are partially opened. The size of the windrow should then be controlled by the forward speed of the haul truck. If only a small amount of mix is needed in the windrow, the gates can be chained so they do not fully open, thus limiting the amount of HMA deposited on the roadway and creating the correct-size windrow. These procedures all require coordination between the paver crew and the truck driver.

### SUMMARY

The following key factors should be considered when monitoring truck loading, hauling, and unloading operations:

- The truck bed should be free of all contaminants. The bed should be lightly and uniformly coated with a





nonpetroleum release agent; diesel fuel should not be used for this purpose.

- If insulation around the truck bed is required, it should be tight to the sides and bottom of the truck.

- The truck should be equipped with a tarpaulin that is in good condition, without tears and holes. The tarp should be large enough to cover the bed and wrap over its sides and end. The tarp should have enough fasteners so that it can be tied down completely and will not flap in the wind. If side rails are used to hold the tarp in place, the tarp should be stretched tightly over the load of mix.

- End-dump and live-bottom discharge trucks should stop short of the paver and allow that machine to pick up the truck on the move, instead of bumping into the stopped paver.

- The bed on an end-dump truck should be raised a short distance and the mix in the truck allowed to break

and slide against the tailgate before the tailgate is opened to discharge mix into the paver hopper. The belt or slat conveyor on a live-bottom truck should be started a few seconds before the end gate is opened, if possible, to discharge a mass of asphalt mix into the hopper instead of just a dribble of coarse aggregate particles.

- The load carried in a bottom-dump truck should be deposited uniformly on the roadway in front of the paver so that the amount of mix picked up by the windrow elevator enables the paver operator to maintain a uniform head of material in front of the paver screed. Alternatively, the windrow should purposely be built slightly short of mix and one truck kept in front of the paver, acting as a mobile surge bin to provide any additional mix needed by the paver.

- End-dump trucks should not be allowed to contact or transfer any weight to the paver hopper.



# 14 Surface Preparation

The performance of HMA under traffic is directly related to the condition of the surface on which the pavement layers are placed. For a full-depth asphalt pavement, if the condition of the subgrade soil is poor (particularly if it is wet and rutted under the haul trucks), the ultimate life of the roadway may be significantly reduced. For HMA layers placed on top of a new, untreated granular base course, that base material should be stable, the surface should be dry, and the base should not be distorted by the trucks carrying mix to the paver. For mix laid on top of existing asphalt layers, that surface should be properly prepared—potholes filled, cracks sealed, and the surface cleaned. A tack coat should also be used to ensure a bond between the existing pavement surface and the new asphalt overlay.

## BASE PREPARATION FOR NEW HMA PAVEMENTS

### Subgrade Soil

If the asphalt pavement is to be placed directly on the subgrade soil, that subgrade material should meet all applicable requirements for moisture content, density, structural support, and smoothness. After the subgrade soil has been determined to be ready for paving and before paving is allowed to commence, the subgrade should be checked to ensure that it will be able to support the weight of the haul traffic. The subgrade must provide a firm foundation before the asphalt paving begins. If distortion of the subgrade soil occurs during the paving operation, placement of the mix should be stopped until the condition of the soil can be corrected.

There is generally no need to place a prime coat of asphalt emulsion or cutback asphalt on the subgrade soil. This is especially true when the soil is a silty clay or clay material because the prime coat material cannot be absorbed into that subgrade material. The use of a prime coat on sandy subgrade soils is also questionable. If the sandy material displaces excessively under the wheels of the haul trucks, it should be stabilized with some type of binder material before paving to achieve the required load-bearing properties. In such cases, the application of

a prime coat will generally not be enough to hold the sandy soil in place during paving operations. A prime coat should not be used as a substitute for proper preparation of the subgrade soil.

### Granular Base Course

If the asphalt layer is to be constructed directly on a new or existing untreated granular base layer, that base material should meet all the requirements for moisture content, density, structural strength, and smoothness. Proof rolling should be done, however, on top of the granular base material, and the amount of deflection of the base and the amount of indentation of the truck wheels in the granular base course material should be noted. If the base material is stable and dry and does not deflect and indent significantly under the wheels of a loaded tandem-axle truck, placement of the prime coat or the new asphalt mix should be permitted to start. If the condition of the granular material is not satisfactory, the base course should be reworked or stabilized until it is in the proper condition for overlaying.

The prime coat acts as a temporary waterproofing layer that protects the base course and prevents it from absorbing excess moisture during rain before paving. It also allows the base course to be used for light traffic, binds together any dust on the surface of the granular base layer, promotes the bond between the base-course material and the new HMA overlay, and prevents slippage of thin overlying pavement layers. However, the purpose of a prime coat is to protect the underlying materials from wet weather. If the underlying materials can be covered prior to the rainfall, then a prime coat is not needed. When a prime coat is used, the prime coat material should be applied to the base course with a pressure distributor at least 48 hours before paving is to begin. Typically, a cutback asphalt (MC-30 or MC-70) is used as the prime coat material, if available. An inverted asphalt emulsion (emulsion containing limited amounts of cutter stock material) also has been applied successfully. The application rate should vary with the openness (porosity) of the base course material. Typical application rates range from  $0.65 \text{ l/m}^2$  ( $0.15 \text{ gal/yd}^2$ ) or less for a very tight surface to  $1.8 \text{ l/m}^2$  ( $0.40 \text{ gal/yd}^2$ ) for an open



surface. No more prime coat material should be applied than can be absorbed completely by the granular base course in 24 hours. If all of the prime coat material is not completely absorbed, the excess should be blotted with sand or removed.

## PREPARATION OF EXISTING SURFACES FOR HMA OVERLAYS

### HMA over HMA

The degree of preparation needed for an existing asphalt pavement depends on the condition of that surface. At a minimum, failed areas should be removed and replaced; potholes properly patched; cracks cleaned out and sealed; and ruts filled in or, preferably, removed by cold milling.

### *Pavement Replacement and Patching*

It is generally inadvisable to attempt to bridge failed areas with new overlay material unless a very thick overlay is to be constructed. Removal and replacement should be carried out on all existing pavement areas where severe load-related distress has occurred. All HMA and granular base materials that have failed should be excavated or cold milled and then either recycled or wasted. Subgrade distortion should be repaired by undercutting and replacement with suitable backfill material. Proper subsurface drainage should be installed as necessary. New granular base course material, stabilized base course layers, or HMA mix should be placed in order to bring the strength of the pavement structure in each failed area to the same level as the surrounding good pavement layers. If HMA is used to patch a large area, it should be placed with a paver and compacted with one or more large rollers (see Figure 14-1).



**FIGURE 14-1** Patches placed with paving machine.

Localized failed areas should be patched properly. Each should be cut back to sound pavement and squared up, with the sides as vertical as possible, the loose material and water in the hole removed, a tack coat applied to the sides and bottom of the hole, the mix placed in the hole, and the new material adequately compacted, preferably with a roller (see Figures 14-2 and 14-3). If the pothole is deeper than 100 mm (4 in.), the mix should be placed in more than one layer and each layer compacted properly.

### *Crack Filling*

Badly cracked pavement sections, especially those with pattern cracking (e.g., map or alligator), must be patched or replaced. The benefits of filling other cracks in the existing surface depend, in part, on the width of the cracks. If the cracks are narrow [less than 10 mm ( $\frac{3}{8}$  in.) in width], it is doubtful that the crack-sealing material will actually enter the crack instead of pooling on the pavement surface. Such cracks can be widened, if desired, with a mechanical router before sealing is attempted. If wider cracks are present, they should be blown out with air and cleaned of debris. The crack-sealing material should be inserted when the cracks are clean and dry. The level of the crack-filling material should be slightly lower than that of the surrounding pavement surface and should not spill over the top of the crack, where it could create a bump in the new pavement layer during the rolling process (see Figure 14-4).

Depending on the cause of the cracking, the amount of reflective cracking that occurs in an overlay can sometimes be reduced by the use of a surface treatment (seal coat) on the existing pavement. If that pavement structure contains a great number of cracks, consideration should be given to applying a surface treatment instead of filling



**FIGURE 14-2** Removal of existing pavement prior to patching.



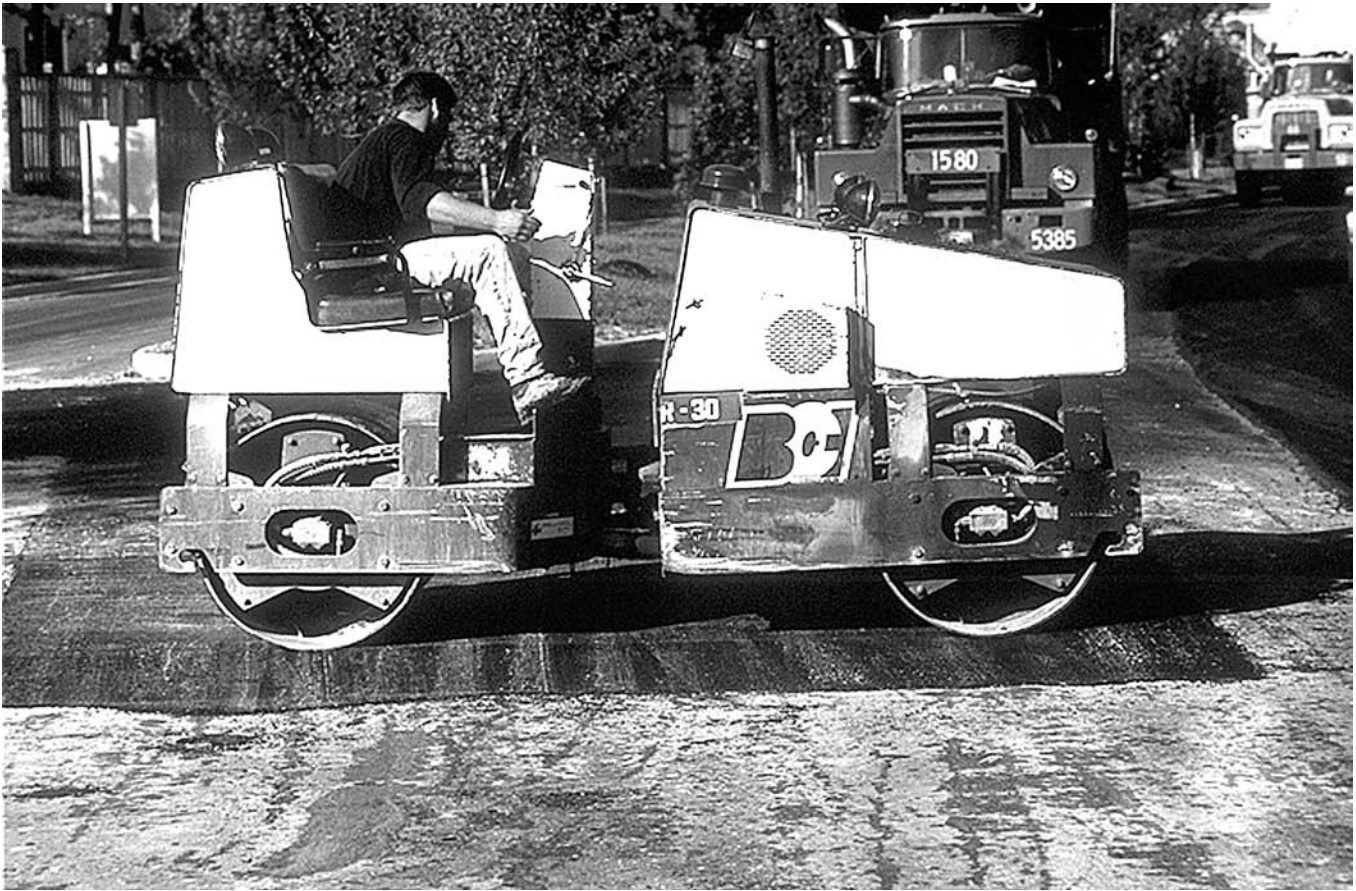

**FIGURE 14-3** Compaction of patch.

individual cracks. The cracks should be cleaned, if feasible, by being blown out with air. The surface treatment should be applied when the pavement surface is clean and dry and should consist of a single application of asphalt binder material (asphalt cement, cutback asphalt, or asphalt emulsion) and cover aggregate. Alternatively, a

slurry seal consisting of an asphalt emulsion, fine aggregate, and water may be used.

### *Leveling Courses*

Common practice in the past has been to place a leveling course on the existing pavement surface to improve the rideability of the pavement structure. This leveling course, sometimes called a wedge and level course or a scratch course, is designed to fill in the low spots on the pavement surface. This leveling action is accomplished using the floating screed on the paver, with more HMA being placed in the low spots than on the high spots in the existing pavement surface. The areas with thicker mix, however, typically compact more than areas with thinner mix. This problem, termed differential compaction, requires that multiple courses be constructed over a pavement surface that is badly out of shape before a smooth surface can be obtained. As the mix passes from under the paver screed, it is in loose condition. Compaction by the rollers reduces the thickness of the newly placed layer. The rule of thumb is that conventional mixes will compact approximately 6 mm per 25 mm ( $\frac{1}{4}$  in. per 1 in.)



**FIGURE 14-4** Bump caused by use of excessive crack sealant.



of compacted thickness. Thus to achieve a compacted course 25 mm (1 in.) thick, about 31 mm (1¼ in.) of mix would have to be placed by the paver. Similarly, approximately 95 mm (3¾ in.) of mix would need to pass from under the paver screed to construct a layer with a compacted thickness of 75 mm (3 in.).

When a leveling course is placed, the HMA laid in the low areas (in the wheelpaths if the pavement is rutted) will be thicker than the mix placed over the high points in the surface (between the wheelpaths). The thicker mix will compact more under the rollers, particularly if a pneumatic tire roller is used, than will the mix that is thinner. Thus, low spots will still exist in the wheelpaths where the mix has been compacted to a different degree (and thus a different air void content) than the mix between the wheelpaths. Because of the problem of differential compaction, multiple layers of mix are usually needed to completely eliminate the roughness in the existing pavement surface. A rule of thumb is that one layer after compaction will remove approximately 80 percent of a low spot. Two layers, each being compacted separately, will remove approximately 95 percent of a low spot.

### Milling

Milling, also called cold planing, can be used to remove the high points in the existing surface in lieu of placing a leveling course (filling in the low spots). Milling can be accomplished in any width necessary, from 150 mm (6 in.) to more than 4 m (13 ft). Figure 14-5 illustrates a typical milling machine. If equipped with automatic grade and slope controls similar to those used on an asphalt paver, the milling machine is capable of producing a level surface in one pass over the existing surface. The RAP produced by the milling process can be hauled



FIGURE 14-5 Typical milling machine.

back to the asphalt plant for future recycling. In addition, if the milled surface is properly cleaned, its texture can enhance the bond between the new and old layers and may reduce the possibility of slippage of the overlay over the existing surface.

A pavement surface that has been milled is typically very dusty and dirty. Once the pavement has dried, multiple sweepings with a mechanical broom are usually needed to remove all of the residual grit from the milled surface. In some cases, it may be necessary to dampen the milled surface before sweeping or to air blow or flush the milled surface with water to remove dust and very fine material completely. Any dust and dirt left on the milled surface will greatly affect the bond between that course and the new asphalt overlay. Because of the increased surface of the milled pavement (from the grooves left by the cutting teeth on the milling machine), an additional quantity of tack coat material may be required to ensure an adequate bond between the old and new layers (see Figure 14-6). That increased quantity is a function of the type, number, condition, and spacing of the teeth on the cutting mandrel of the milling machine but is typically in the range of 20 to 30 percent more than for an unmilled surface.

### HMA over Portland Cement Concrete

When HMA is placed over a portland cement concrete (PCC) pavement, the PCC surface should likewise be properly prepared. Any severely distressed areas in the concrete slabs should be cut out, removed, and replaced with either PCC or HMA using full-depth slab repair techniques. Corrective work should also be completed on the underlying subbase or subgrade material, if necessary. Any severely spalled areas at joints should be repaired using partial-depth slab replacement methods.



FIGURE 14-6 Tack coat on milled surface.



PCC should be used for partial-depth repairs. Rocking slabs should be stabilized. Depending on the condition of the PCC pavement, procedures such as crack and seat, break and seat, or rubblizing of the existing pavement can be used before the overlay is placed, particularly if the slabs are rocking under traffic loading. Consideration can also be given to the use of a crack-relief layer between the existing PCC pavement and the new overlay.

For joints that are poorly sealed, the old seal material should be removed and the joints cleaned. When dry, the joints should be resealed with appropriate joint-sealing material. Care should be taken not to overfill the joints, particularly in cool weather when they are open wide. In all cases, as with crack sealant, the final level of the joint-sealing material should be below the top of the surrounding pavement surface. Once the patching and re-sealing have been accomplished, the surface of the PCC pavement should be cleaned completely using mechanical brooms and air blowing or water flushing, or both, where needed.

### Tack Coat

The purpose of a tack coat is to ensure a bond between the existing pavement surface and the new asphalt overlay. The tack coat should not be used in lieu of cleaning the existing surface—removing accumulated dust and dirt by mechanical brooming or by flushing with air or water. If a good bond is not formed between the existing surface and the new overlay, slippage may occur. The new overlay may be shoved in a longitudinal direction by traffic, particularly at locations where the traffic accelerates or where vehicle brakes are applied. Thus the pavement surface must be clean before the tack coat is applied.

The tack coat material—which is normally asphalt emulsion but can also be asphalt cement or cut-back asphalt—should be applied by a pressure distributor, as shown in Figure 14-7. All nozzles on the distributor should be fully open and functioning and should be turned at the same angle to the spray bar, approximately 30°. In addition, the spray bar should be at the proper height above the pavement surface to provide for a double or triple lap of the liquid asphalt material. The result will be the proper amount of overlap between the nozzles and a uniform application of the tack coat to the road surface. The tack coat material should be heated to the proper temperature so that it is fluid enough to be sprayed uniformly from the nozzles instead of coming out in strings.



FIGURE 14-7 Distributor applying tack coat.

### *Application Rate Versus Residual Rate*

Uniformity of application and a proper application rate are key to achieving a successful tack coat. Figure 14-8 illustrates a tack coat application that is uneven as a result of improper equipment operation, with too much tack coat in some areas and not enough in others. If the correct amount of tack coat is sprayed on the surface, some of the existing surface will still be visible through the tack coat; not all of the existing pavement surface will be covered. Use of a diluted asphalt emulsion tack coat (slow-setting asphalt emulsion diluted 1:1 with water) will result in complete coverage and a very thin residual asphalt film on the pavement surface. Proper tack coat application will leave a residual asphalt cement content of approximately 0.18 to 0.27 l/m<sup>2</sup> (0.04 to 0.06 gal/yd<sup>2</sup>) on the roadway. The amount of residual tack coat needed will depend on the condition of the pavement surface. An open-textured surface requires more tack coat than a surface that is tight



FIGURE 14-8 Improperly adjusted distributor.

or dense, and a dry, aged surface requires more tack coat than a surface that is “fat” or flushed. In addition, more tack coat may be needed on a milled surface because of the increased surface area, as discussed earlier; a residual rate of as much as  $0.36 \text{ l/m}^2$  ( $0.08 \text{ gal/yd}^2$ ) of asphalt cement may be needed to ensure a proper bond.

It is essential to differentiate between the residual tack coat rate (the amount of asphalt cement remaining on the pavement surface after the water has evaporated) and the application rate (the amount of emulsion sprayed from the distributor). Most asphalt emulsions contain 60 to 65 percent residual asphalt cement and 35 to 40 percent water, plus a small amount of emulsifying agent. For ease of calculation, it can be assumed that an asphalt emulsion is approximately two-thirds asphalt cement and one-third water. The amount of asphalt cement left on the pavement surface after the water has evaporated from the emulsion is the most important factor in obtaining a bond between the existing pavement surface and the new overlay. To determine the application rate for the tack coat material, start with the amount of residual asphalt cement required on the pavement surface and work backward.

As an example, suppose that the present pavement surface is relatively tight and dense. It is determined that the residual amount of asphalt cement on the pavement surface needs to be  $0.18 \text{ l/m}^2$  ( $0.04 \text{ gal/yd}^2$ ). If an undiluted SS-1 asphalt emulsion is used for the tack coat, the application rate for that material should be approximately  $0.27 \text{ l/m}^2$  ( $0.06 \text{ gal/yd}^2$ ), calculated as  $(0.18) \div (\frac{2}{3}) = 0.27 \text{ l/m}^2$  [ $(0.04) \div (\frac{2}{3}) = 0.06 \text{ gal/yd}^2$ ]. If the SS-1 asphalt emulsion has been diluted with equal parts water, the application rate needed to obtain the same amount of residual asphalt on the pavement surface will be different. Using a 1:1 dilution rate, the application rate for a residual amount of  $0.18 \text{ l/m}^2$  ( $0.04 \text{ gal/yd}^2$ ) will be  $0.54 \text{ l/m}^2$  ( $0.12 \text{ gal/yd}^2$ ). Thus with the use of a 1:1 diluted emulsion, twice as much emulsion must be applied to the pavement surface from the distributor to have the same amount of residual asphalt when all of the water has evaporated.

If the amount of water in an asphalt emulsion is not taken into account when determining the application rate from the distributor, the correct degree of adhesion may not be achieved. Too little tack coat will not provide sufficient bond between the old and new pavement layers. On the other hand, too much tack coat may contribute to slippage of the overlay on the existing pavement surface and bleeding of the tack coat material through a thin overlay.

If asphalt cement instead of an asphalt emulsion is used as the tack coat material, the residual amount of asphalt on the pavement surface should be the same as the applied amount. Thus if  $0.18 \text{ l/m}^2$  ( $0.04 \text{ gal/yd}^2$ ) of residual binder material is desired, the application rate from the distributor should also be  $0.18 \text{ l/m}^2$  ( $0.04 \text{ gal/yd}^2$ ).

### *Breaking and Setting Time*

When an asphalt emulsion is applied as a tack coat, it is brown in color because it contains both asphalt cement and water. After a very short period of time, the emulsion will break—change color from brown to black—and the water will begin to evaporate. The rate of evaporation will depend on the type and grade of the emulsion used, the application rate, the temperature of the existing pavement surface, and environmental conditions. Once all the water is gone, the emulsion is said to have “set.” The rate of set depends on the same conditions that control the rate of break of the emulsion. Under most circumstances, an emulsion will set in 1 to 2 hours.

There is some controversy about whether HMA can be placed on top of an asphalt emulsion before the emulsion is set—while some water is still retained on the pavement surface. There is even more controversy about whether HMA can be placed on top of an asphalt emulsion before it has broken—while the asphalt cement and water are still combined. In the past, it was generally believed that the emulsion should be completely set before new mix is laid on top of the tack coat material. Experience has shown, however, that new HMA can usually be placed on top of an unset tack coat and even over an unbroken tack coat emulsion with no detrimental effect on pavement performance; the bond will still be formed. Indeed, in Europe the emulsion tack coat is often applied to the pavement surface underneath the paver—from a spray bar located just behind the paver drive tires or tracks and just before the head of HMA in front of the paver screed. With this tack coat application point, the emulsion will be unbroken when the mix is laid on top of it, but the emulsion will break immediately upon contact with the new HMA. The water,  $0.36 \text{ l/m}^2$  ( $0.08 \text{ gal/yd}^2$ ), typically will evaporate and escape as steam through the loose hot mix. There is not enough water to lower the mat temperature significantly.

While it is believed that the asphalt emulsion can be properly paved over before being fully set, and even before being broken, it is also important that the tack coat material remain on the pavement surface to create the bond between the layers. If the tack coat material is not



set and a significant amount of haul truck traffic runs over the unset material, much of the tack coat may be picked up by the truck tires and tracked down the roadway. Thus either the tack coat should be allowed to set before haul truck traffic is permitted to run over it, or the amount of truck traffic should be minimized.

If asphalt cement is used as the tack coat material, it will cool to ambient temperature very quickly. Further, because there is no carrier material (water) to evaporate, paving may immediately follow the asphalt cement tack coat application.

If the overlay is to be constructed under traffic, the tack coat is normally placed only a short distance in front of the paver—within the lane closure and far enough ahead for the tack to set properly before the HMA is laid on top of it. Traffic is kept off of the tack coat at all times. If the roadway being paved is closed to traffic, the tack coat can be placed as much as 24 hours ahead of the laydown operation. Doing so will ensure that the tack coat is completely set before the mix is placed on top of it. Under unusual circumstances, if traffic must travel over the tack coat before the overlay is placed, a light layer of sand can be spread on top of the tack coat to prevent its pickup by traffic. The application rate of the sand should be in the range of 2.2 to 4.4 kg/m<sup>2</sup> (4 to 8 lb/yd<sup>2</sup>), depending on the application rate of the tack coat material and the gradation of the sand. Excess sand should be broomed from the pavement surface before the overlay is placed to ensure a proper bond between the overlay and the existing surface.

If equipment problems (plant or paver breakdowns) prevent tack coat material that has been applied from the distributor from being paved over before traffic must use the roadway, it is suggested that posted speed limits on that section of roadway be significantly reduced until the overlay operation can take place. It is not good practice to place the tack coat one day, permit traffic to run over the tack coat for a period of time, and then place the overlay at a later date. Depending on the amount of residual asphalt cement on the pavement surface and environmental conditions, the level of friction available for traffic at the pavement surface may be greatly reduced by the presence of the tack coat material. The excess tack will also be thrown on vehicles, creating a major public relations problem. In addition to lowering the posted speed limits, it may be advisable to apply sand to the tacked surface as discussed above.

The application of tack coat material is essential when an overlay is being constructed on an old existing pavement surface—either HMA, PCC, or surface treatment. A tack coat often is not needed, however, when a layer of new mix is being placed over another layer of

asphalt pavement that has been laid within a few days, as long as the underlying new layer has not become dirty under traffic or from windblown dust. If a tack coat is used on a recently placed HMA layer, the residual asphalt content should be minimal—in the range of 0.09 l/m<sup>2</sup> (0.02 gal/yd<sup>2</sup>), or half of what is needed for most old, tight, existing surfaces. Thus the application rate for an undiluted SS-1 emulsion should be only approximately 0.14 l/m<sup>2</sup> (0.03 gal/yd<sup>2</sup>). Additional tack coat material is not necessary since the material will not be absorbed into the new underlying pavement surface.

## SUMMARY

The following key factors should be considered when monitoring surface preparation operations:

- A prime coat is generally not needed on subgrade soil. There is a difference of opinion on the benefits of using a prime coat on a granular base course, but in many cases a prime coat can be eliminated without detrimental effect on the performance of the pavement structure.

- Before paving an existing surface, any failures in the surface must be removed and replaced or repaired by patching unless a very thick overlay is constructed.

- If there are cracks in an existing asphalt pavement surface, they generally should be sealed individually, or some type of surface treatment should be applied to the whole roadway area. Joints in PCC pavement that are poorly sealed should be routed out and sealed. Rocking PCC slabs should be stabilized.

- A rough, uneven asphalt surface should be leveled with asphalt mix (using a paver to place the mix) to fill in the low spots in the surface or should be cold milled with a milling machine to remove the high spots.

- Once the needed repairs have been completed, the pavement surface should be cleaned of all dust, dirt, and other debris. This should be accomplished using multiple passes of a mechanical broom. If brooming does not remove all accumulated dirt, flushing with air or water may be required.

- The application of a tack coat must be accomplished before an overlay is constructed on an existing asphalt or PCC surface. The distributor used should be checked to ensure that all the nozzles are open and set at the correct angle and that the spray bar is at the proper height above the pavement surface.

- The application rate for the tack coat should be based on the desired residual amount of asphalt cement on the road surface, which should be between 0.18 and 0.27 l/m<sup>2</sup> (0.04 and 0.06 gal/yd<sup>2</sup>) for normal surfaces.





The application rate should also be based on the actual amount of asphalt cement in the emulsion—whether the emulsion is diluted or not before it is applied. An undiluted SS-1 emulsion should be applied from the distributor at a rate of 0.27 l/m<sup>2</sup> (0.06 gal/yd<sup>2</sup>) to obtain 0.18 l/m<sup>2</sup> (0.04 gal/yd<sup>2</sup>) of residual asphalt on the pavement surface.

■ Milled pavements may need a greater amount of residual tack coat. Too little tack coat will not provide the needed bond between the old and new layers. On the other hand, too much tack coat may promote slippage of the new overlay on the old pavement or bleeding of the tack material through a thin overlay.

■ HMA usually can be placed on top of an emulsion tack coat before it has completely set, and even before it has broken—changed color from brown to black. The tack coat should not be picked up and tracked by the haul trucks, however.

■ Tack coat should not be left exposed to traffic. If doing so is necessary, proper precautions, such as reducing the posted speed limit on the roadway and sanding the surface, should be taken.

■ A tack coat is normally not needed between layers of new HMA. If used, the amount of residual asphalt on the roadway surface should be approximately half that appropriate for an old, tight, existing pavement surface.



# 15 Mix Placement

The primary purpose of the paver is to place the HMA to the desired width, grade, cross slope, and thickness and to produce a uniform mat texture. The paver should also be able to place the HMA in a manner that results in improved rideability and smoothness of the roadway.

There are two types of pavers—track (crawler) and rubber-tire—which are basically the same and perform similar functions in a paving operation. The track paver, whose tracks may be all steel, steel equipped with rubber pads, or an endless rubber track, offers a high degree of flotation and traction when traveling across weak underlying pavement structures by providing an increased area over which to spread the weight of the paver. This type of paver is therefore typically used when paving on a soft or yielding base. A rubber-tire paver is generally used when placing HMA over well-compacted granular base course layers or over existing HMA or PCC pavements. In addition, if the paver is to be moved regularly under its own power between paving locations, a rubber-tire paver or track paver with an endless rubber track is generally used because the travel speed of these vehicles is much greater than that of the other types of track pavers.

The paver consists of two primary parts—the tractor unit and the screed unit. The tractor unit provides the motive power to the paver and pushes the haul truck in front of the paver during the unloading process if the mix is being delivered directly from the truck into the paver hopper (see Section 13). The tractor unit also transfers the asphalt mixture from the receiving hopper on the front of the machine to the augers at the back of the paver. The screed unit is attached to the tractor unit at only one point on each side of the paver and “floats” on the HMA. The screed provides the initial texture and compaction to the HMA as it passes out from under the unit. Figure 15-1 is a schematic showing the tractor and screed units.

## TRACTOR UNIT

The tractor unit fulfills all of the functions necessary to receive the asphalt mix directly from the haul trucks or to pick the mix up from a windrow, carry it through the

machine back to the augers, and then distribute it across the width of the screed. The tractor unit, equipped with either rubber tires or tracks, is powered by its own engine and provides the propulsion energy required to move the machine forward, pushing the haul vehicle ahead of it if necessary. It has the following major components: the truck push rollers, and a material feed system consisting of a mix-receiving hopper, slat conveyors, material flow gates (usually), and a pair of augers. The tractor unit also provides the motive power for the screed by pulling it behind the tractor.

## Push Rollers

The push rollers, located on the front of the paver hopper, are used to maintain contact with the tires of the haul truck and to push that truck ahead of the paver. The rollers must be clean and free to rotate in order to allow smooth forward travel of the paver. If the push rollers are not cleaned periodically and do not rotate freely, the truck tires will slide on the rollers and increase the load on the paver. Moreover, if one roller rotates freely and the other does not, the paver may be more difficult to steer.

Many pavers are equipped with a truck hitch that is located underneath or incorporated into the push rollers on the front of the paver. The purpose of the hitch is to keep the truck in contact with the paver and thereby prevent the truck driver from pulling away from the paver and inadvertently dumping mix on the pavement in front of the paver. The hitch, controlled by the paver operator, has arms, with rollers attached, extending forward. The rollers are retracted into the truck tire rim and against the tire itself, preventing the truck from losing contact with the paver during the unloading process. Once the truck bed has been emptied of mix, the truck hitch is withdrawn, and the truck is able to pull away from the paver.

## Material Feed System

The material feed system on the tractor unit plays a very important part in producing a consistent, high-quality mat behind the laydown machine. In this section the



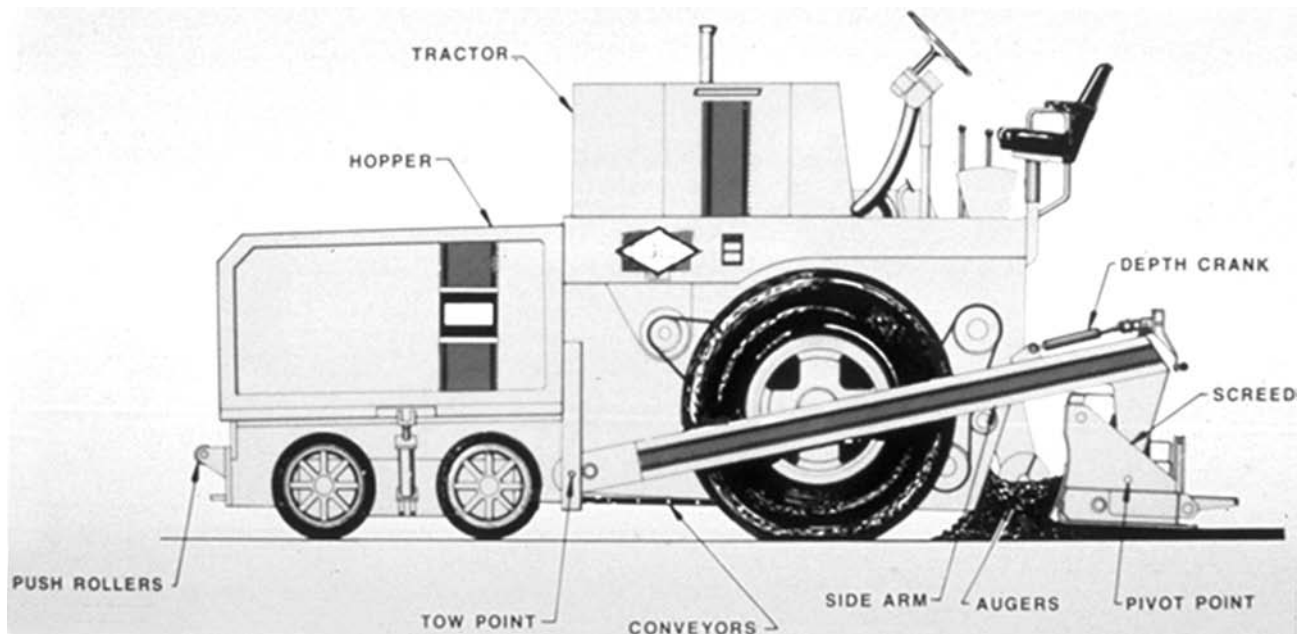

**FIGURE 15-1** Schematic of HMA paver.

components of the material feed system and its basic operation are reviewed.

### *Material Feed System Components*

As noted, the material feed system typically consists of a paver hopper, slat conveyors, material flow gates, and a pair of augers.

**Paver Hopper** The paver hopper, shown in Figure 15-2, is used as a temporary storage area for the asphalt mix delivered from the haul vehicle, the windrow elevator, or the material transfer vehicle (MTV). The hopper capacity compensates for the fluctuating material demands encountered when paving over irregular grades



**FIGURE 15-2** Loaded HMA paver hopper.

and thus helps maintain a constant paving speed. When mix is delivered with a haul vehicle, the hopper must be wide enough to allow the body of the haul vehicle to fit within it. In addition, particularly for smaller pavers, the hopper must be low enough to permit the truck bed to be raised without the bed placing weight on the front of the hopper.

The front of the hopper is designed to minimize the spillage of mix out of the hopper during operation or while dumping the hopper wings. Overflow guards or flashing further reduces spillage out of the hopper during raising or dumping of the paver wings. The condition of these guards should be checked regularly since they are often damaged by haul truck beds as HMA is unloaded. In addition, for certain types and sizes of haul trucks, the shape of the guards may need to be changed to prevent spillage of the mix onto the existing pavement surface.

If a windrow elevator (see Figure 15-3) is used to feed mix to the paver, the hopper should have enough volume so that the paver can temporarily store the HMA if the demand for mix at the screed varies, such as when placing a leveling course. In addition, since the amount of mix in the windrow itself may vary, the hopper must be large enough to hold fluctuating amounts of mix delivered to it without overflowing or allowing the screed to run out of material. The blades on the slat conveyor of the windrow elevator must be set at the right level to pick up as much of the mix that has been placed on the existing pavement as possible. Essentially no mix should be left in the windrow, except perhaps a minimal



**FIGURE 15-3** Windrow elevator.

amount in the low spots on the pavement surface when a leveling course is being placed. Any thin layer of material remaining will cool quickly and may result in difficulties in compacting the HMA. In addition, longitudinal streaks may occur in the mat behind the paver at the same location as the outside edges of the windrow.

The amount of mix in the paver hopper should always be kept at a level above the top of the flow gates or tunnel openings at the back of the hopper. Doing so permits the paver operator to keep the conveyors on the paver full and thus maintain a constant head of HMA in front of the paver screed, providing for a smooth mat behind the screed. This practice is particularly important between truckloads of mix in order to reduce segregation problems.

As shown in Figure 15-4, the sides, or wings, of the hopper are movable. Any mix left to stand for a long period of time in the corners of the hopper will cool and may appear as chunks of material in back of the screed



**FIGURE 15-4** HMA paver with wings lifted.

when it passes through the paver. Thus the mix is periodically moved from the sides of the hopper into the middle of the hopper by folding the wings (sides) and depositing the mix on top of the area of the conveyors.

Many paver operators dump (fold) the wings of the paver after each truckload of mix has been emptied into the hopper. This is not good practice and should generally be avoided. Moreover, to prevent spillage of the mix out of the front of the hopper when the wings are folded, the operator often pulls down the amount of mix left in the hopper by continuing to run the slat conveyors to feed mix back to the augers after the truck has pulled away from the paver. This practice may result in the slat conveyor running nearly empty and can lead to increased mat problems if segregated mix is deposited on the conveyor slats, either from the paver wings or from the haul truck, and is carried back to the augers and screed. Thus it is not good practice to dump the paver wings after each truckload of mix has been delivered or to deposit the mix held in the wings into the empty paver hopper, because either procedure can significantly decrease the quality and smoothness of the finished mat.

To minimize segregation, the paver operator should fold the wings as infrequently as possible—only often enough to keep the material sufficiently hot for proper placement and compaction. The frequency with which the wings are dumped depends on the rate of delivery of the mix to the paver, the temperature of the mix, and environmental conditions. The wings should be emptied before the mix that collects in the corners of the hopper has cooled to the point where chunks are formed that cannot be broken up as that mix moves through the paver to the augers and under the screed. On colder and windier days, the hopper wings must be dumped more frequently than on warmer and calmer days.

When it is necessary to dump the wings, the sides of the hopper should be slowly raised as soon as the haul truck has been emptied and has pulled away from the paver. A steady forward paving speed of the laydown machine should be maintained as the hopper sides continue to rise. The wings should be fully elevated before the amount of mix remaining in the hopper is lower than the top of the flow gates or the openings at the back of the hopper. (The slat conveyors should never be visible at the time the wings are raised—or at any other time during the paving operation.) The paver should be stopped before the tunnel openings or flow gates are visible, and the sides of the hopper then lowered. This procedure minimizes the segregation problem that often occurs when the sides of the hopper are emptied, while still

cleaning the cooler mix out of the corners of the hopper. As discussed later, keeping the hopper relatively full between truckloads of mix maintains a constant head of asphalt mix in front of the paver screed and also reduces any segregation that might be present in the mix. In addition, the wings should not be “banged” repeatedly as they are emptied.

To prevent the HMA from collecting in the corners of the paver hopper and thus avoid having to dump the hopper wings to remove the cold material, a fillet can be placed in each corner of the hopper. A triangular piece of sheet steel can be bolted to the sides of the hopper, reaching from the top back corner to the floor of the hopper just outside the flow gate opening, and also to the lower front corner of the hopper. This fillet prevents mix from being carried in the corners of the hopper and eliminates the need to empty the hopper wings. The fillet can be sized and located so that it is still possible to completely fit the apron of an end-dump truck bed into the paver hopper and empty the truck without the truck bed coming in contact with the hopper.

It is also possible simply not to empty the wings of the paver at all during the paving day. If the HMA is allowed to collect in each wing, it will cool and build up a natural angle of repose. This cold HMA will then prevent new mix from the haul trucks, windrow elevator, or MTV from collecting in the wings. At the end of the day, the cold material can be removed from each wing area by raising and shaking the sides of the hopper. The two big chunks of mix can then be transported back to the asphalt plant for recycling. Although this method does prevent mix from collecting in the hopper wings following the initial buildup, it is better practice to install a fillet in each wing to eliminate both the collection and need for disposal of HMA in the wing area.

**Slat Conveyors** At the bottom of the paver hopper there is typically a set of slat conveyors consisting of heavy chains and flight bars (see Figure 15-5). The slat conveyors are a continuous system, with the slats being rotated back to the bottom of the hopper underneath the paver itself. These devices are used to carry the asphalt mix from the hopper through the tunnels on the paver and back to the augers. The slat conveyor on one side of the paver operates independently from that on the other side. On most newer pavers, the conveyor system operates independently of the speed of the paver, and on some pavers, the speed of the conveyors is also independent of the speed of the augers. Thus the amount of mix being carried back through the paver on one side may differ from that being delivered on the other side, and the paver



**FIGURE 15-5** Slat conveyors at bottom of paver hopper.

operator can feed more or less material to either side of the paver to pave ramps, mailbox turnouts, and tapers.

On some pavers, the slat conveyor system has been replaced by a screw conveyor system. The purpose of this latter system is to remix the HMA in the paver hopper and reduce segregation behind the screed. Two parallel screw conveyors—one with left-hand pitch and one with right-hand pitch—run longitudinally down the length of the paver, one on each side of the machine, pulling the mix from the paver hopper and discharging it to the transverse augers in front of the screed. The screw conveyors are equipped with mixing paddles to blend the mix from side to side as it is moved along by the conveyor. For this system to function properly, however, there must be enough mix retained in the paver hopper between truckloads of mix—the level of mix remaining in the hopper should be above the level of the flow gates or tunnel openings at the back of the hopper—so that there is material to blend together. If the screw conveyors are visible between truckloads of mix, this system will not properly address the potential segregation problem.

To carry the mix farther back to the augers when the mix is delivered by the slat conveyors, some pavers are equipped with an extended floor plate at the rear end of the conveyor system. This plate is used to deposit the mix closer to the augers instead of letting it fall quickly to the underlying pavement surface when it comes off of the conveyors. This system is used to eliminate longitudinal segregation at the auger gearbox.

**Flow Gates** At the back of the paver hopper on most pavers is a set of flow gates. These gates, one over each of the two slat conveyors, are used to regulate the amount of mix that can be delivered by each conveyor



to the corresponding auger on the paver. Flow gates are found on pavers on which the speed of the slat conveyor system and that of the auger on each side of the machine are interlocked, so that the speed of the auger increases when that of the slat conveyor is increased. The gates can be moved vertically, either manually or mechanically (electrically). Depending on the vertical setting of the gates, more or less mix is permitted to enter each paver tunnel. The location of the flow gates is shown in Figures 15-6 and 15-7.

The flow gates should be adjusted to provide a uniform head of material (at a level at or just above the center of the auger shaft) in front of the screed for each particular mat width, mat thickness, and paving speed. If the demand for mix is different on each side of the machine (different paving width or mat thickness), the elevation of the flow gates should differ on each side of the hopper accordingly. On some pavers, a sensor is located behind the flow gates to monitor the amount of mix passing into the tunnel and alert the operator of a low- or a no-material flow condition.

Flow gates are not used with pavers on which the conveyor and the auger on each side of the machine are driven separately. On such machines, the speed of each conveyor can be adjusted independently of the speed of the corresponding auger. If more mix is required on one side of the machine than on the other, the speed of the conveyor on that side is increased by the paver operator or by the automatic flow control system to deliver more HMA back to the augers, thus keeping the head of material in front of the screed consistent.

**Augers** The mix carried to the back of the tractor unit by the slat conveyors is deposited in front of the augers (see Figures 15-8 and 15-9). Like the two slat conveyors, the augers on each side of the paver are

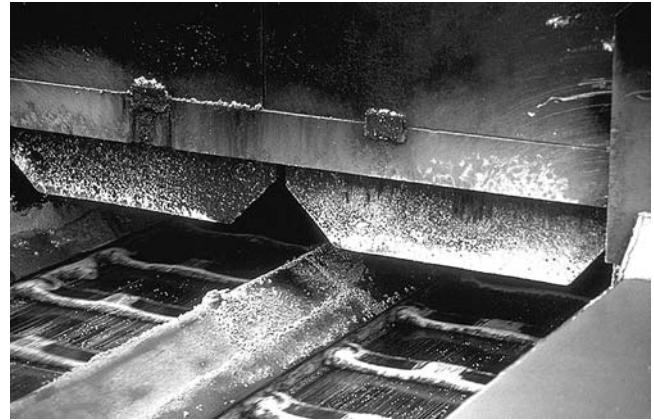

**FIGURE 15-7** Flow gates at back of paver hopper.

operated independently of one another. The auger on one side of the paver, however, is usually run in conjunction with the slat conveyor on that same side of the paver (unless a paver with independent conveyor and auger drive motors—and no flow gates—is used). In addition, the paver operator has the option of running the left or right conveyor and auger system in either manual or automatic mode. In automatic mode, a feed control sensor on that side of the machine controls the level of material at the outside edge of the auger. It is extremely important that the augers carry a consistent amount of mix across the front of the screed so that the head of material in front of the screed remains as constant as possible.

The mix placed in the auger chamber from the slat conveyors is distributed across the width of the paver screed by the movement of the two independent augers. At the junction of the two augers in the center of the

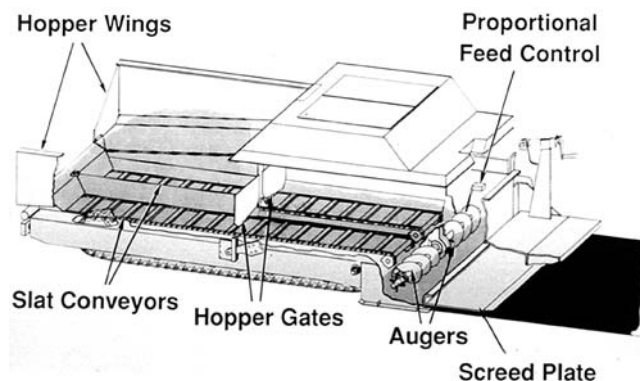

**FIGURE 15-6** Material flow through paver.



**FIGURE 15-8** Paver auger.

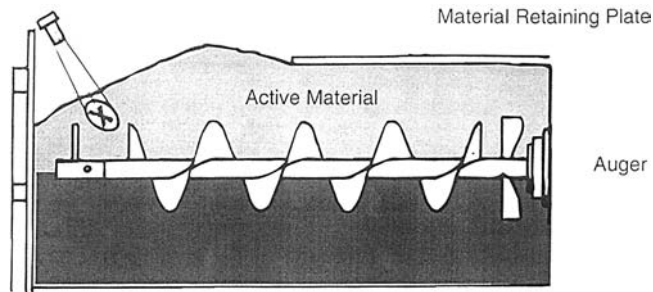

**FIGURE 15-9** Schematic of paver auger.

paver, adjacent to each side of the auger gearbox, there typically is a different-shaped auger (reverse auger) or a paddle used to tuck mix under the gearbox and ensure that the mix placement at this location is the same as that across the rest of the width of the mix being laid. A paver equipped with a pair of reverse paddles is shown in Figure 15-10.

If sufficient mix is not placed under the center of the screed because of a lack of mix being tucked under the gearbox, a longitudinal streak may be seen behind the paver at the center of the screed. It is sometimes thought that such a streak is a form of segregation because the surface texture of the mat at that location is more open than that of the adjacent mix and is generally darker in color. This, however, is not really a segregation problem. Rather, the rougher texture and darker color are generally caused by a lack of mix placed under the gearbox and thus passing under the screed at that point. Indeed, if carefully measured, the elevation of the mix in the streak will be slightly below that of the surrounding mix—the streak is a low spot in the mat surface. If a gearbox streak is visible at the center of the main paver screed, installation of a reverse auger or paddle system on the paver should be considered if such a system is

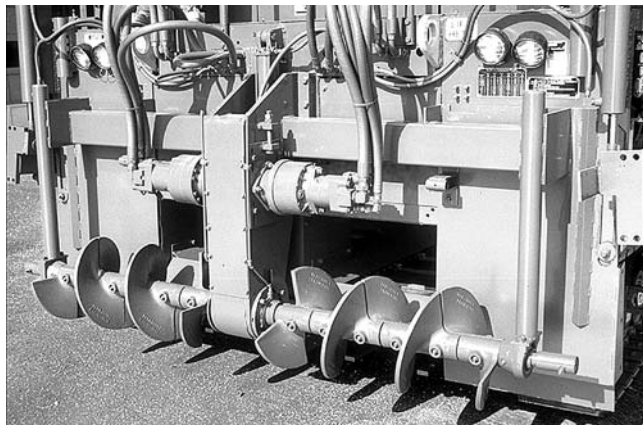

**FIGURE 15-10** Paver auger with gearhousing at midpoint equipped with reverse paddles.

not already present. If the reverse augers or paddles are present, adjustments should be made to tuck more mix under the gearbox; worn augers or paddles should be replaced if necessary.

Newer pavers are equipped with variable-height augers—the elevation of the auger can be changed. The height of the auger is normally set in accordance with the paving depth. As a general rule, the augers should be set as low as possible to minimize the amount of mix carried in the auger chamber. The elevation of the bottom of the auger, however, should never be even with or lower than the top of the mix being laid, as this may result in differences in mat texture.

### *Operation of Material Feed System*

The amount of mix carried in the auger chamber should be as constant as possible. The proper depth of material on the augers is at the center of the auger shaft, as seen in Figure 15-11. The level of material carried in front of the screed should not be so low as to expose the lower portion of the screw conveyor flights. Further, the level of mix delivered to the screed should never be so high as to cover the upper portion of the auger, as shown in the figure.

If the feed system is set and operating properly, the slat conveyors and augers on each side of the paver will rarely shut off; they will operate in a slow continuous manner. This continuous action of the conveyors and augers is accomplished by setting the proper position for the hopper flow gates (if any) and determining the correct speed setting for the slat or screw conveyors and for the augers. *The key to placement of a smooth pavement layer is use of the material feed system to maintain a constant head (level) of material in front of the screed, primarily by keeping the slat conveyors and augers running as close to 100 percent of the time as possible.* Intermittent operation of the slat conveyor and auger systems may cause roughness in the mat, as well as both auger shadows and ripples in the mat behind the screed, as discussed elsewhere in this section.

There are two types of material feed control systems conventionally used on paving machines—constant speed and variable or proportional speed. Many newer pavers have an automatic feed system based on sonic control.

**Constant Speed** As noted earlier, the slat conveyor and auger on one side of the paver act independently from the slat conveyor and auger on the other side of the paver. On older pavers, the speed of the slat conveyors



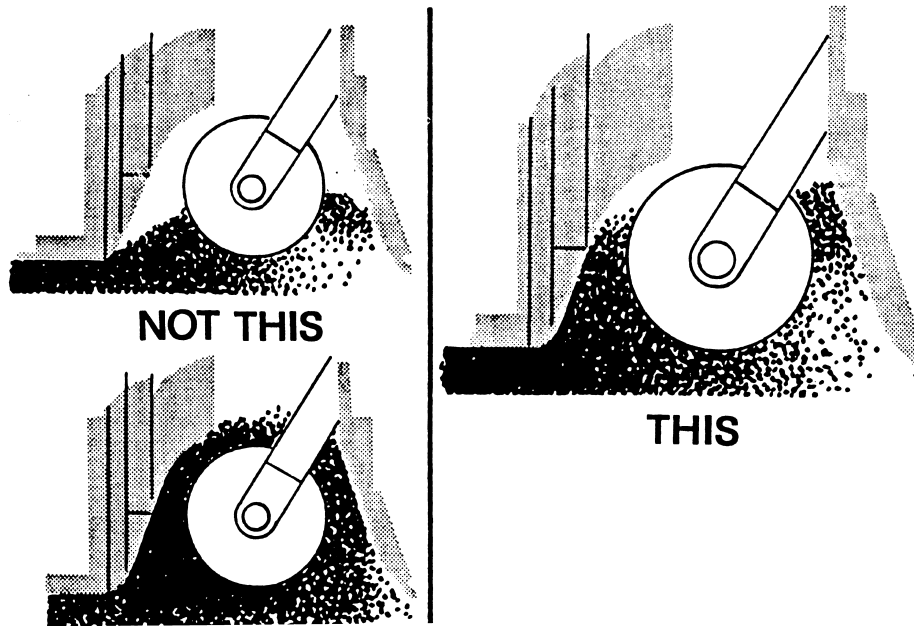

**FIGURE 15-11** Correct and incorrect mix levels in paver auger chamber.

and augers is constant in manual mode. The paver operator can control the amount of mix being carried back to the screed only by adjusting the height of the flow gates.

If the gates are set too high, the material feed system will provide too much asphalt mix to the augers whenever the slat conveyors and augers are running. The result will be a significant increase in the head of material in front of the screed and increased pressure on the screed. This increased pressure will in turn change the angle of attack of the screed and increase the thickness of the mat being placed, and the angle of attack of the screed will be increased slightly as the screed rotates around its pivot point. On the other hand, if the gates are set too low, the material feed system will not be able to deliver enough material to the augers, thus reducing the head of mix in front of the screed and the force pushing on the screed. The result will be a reduction in the thickness of the mat being placed as the screed rotates around its pivot point and a decrease in the angle of attack of the screed.

As noted, with these older systems, the only way the operator can control the head of material in front of the screed is by proper setting of the flow gates at the back of the paver hopper. The flow gates and feeder on-off switches must be set at a position that allows the slat conveyors and augers on each side of the machine to run as close to 100 percent of the time as possible. For most paving operations, if the flow gates are properly set for

the paver speed, paving width, and mat thickness, the conveyor and auger systems will typically run about 80 to 90 percent of the time under manual control.

A flow control sensor or paddle can be placed on each side of the paver near the outer ends of the augers. This sensor monitors the amount of mix being carried in front of the screed and activates the corresponding slat conveyor and auger when mix is needed. This flow control system is really a limit switch in which a mechanical wand or paddle floats on top of the mix and rotates the limit switch shaft as the level of mix in front of the screed changes. When too much mix is sensed in front of the screed, the limit switch shuts off the mix delivery system. When mix is needed, the paddle rotates downward on top of the lesser quantity of mix in front of the screed, and the conveyor-auger system starts up. Even with use of a flow control sensor, however, the amount of mix delivered to the screed is actually controlled only by the position (elevation) of the flow gate on the back of the paver hopper. The height of each flow gate is set to keep the head of HMA in front of the screed constant—near the center of the auger shaft—and the delivery system running as close to full time as possible. This is very difficult to accomplish, especially if the paver is being used to level an existing pavement surface and the demand for mix is variable.

Changes in the head of material may result from the off-on-off-on operation of a constant-speed feed control system. These changes may in turn cause surface shad-



ows and ripples in the surface of the mix. This problem can be avoided through use of a variable-speed or sonic automatic feed control system.

**Variable (Proportional) Speed** Some pavers are designed so that in manual mode, the paver operator can select one of several speeds for the slat conveyors, each essentially a percentage of the maximum conveyor speed. Once the conveyor speed has been selected, the speed of the auger is set proportionately. The operator is responsible for controlling the speed of the slat conveyors and augers to keep a constant level of asphalt mix in front of the paver screed. The flow of material to the screed is still essentially regulated by the height of the hopper flow gates, however, and by the starting and stopping of the slat conveyor and auger on each side of the paver. With this manual system, changes in demand for mix are met by changing the speed of the feed system.

A flow or feed control sensor can also be used with this system to monitor the amount of HMA in the auger chamber in front of the screed. As the level of HMA in front of the screed rises and falls, the speed of the feed system increases or decreases to maintain a constant level and uniform flow of mix across the width of the screed.

For the automatic feed control system to function properly, the feed sensor paddle or wand should be located as close to the outside ends of the augers as possible. If rigid paver screed extensions are used, the control arm should be mounted beyond the ends of the augers, just inside the end gate on the paver screed. If a hydraulically extendable screed is used, the location of the feed sensor control arm should be such that the amount of mix carried in front of the extensions is minimized. In most cases, this means the sensor should be mounted on the end gate of the paver screed and the sensor paddle or wand hung only a short distance in front of the end of the extendable screed.

For rear-mounted hydraulic screed extensions, discussed later in this section, it is important to minimize the amount of mix carried in front of the screed on the extension. A flow control sensor system should be employed to severely limit the amount of HMA carried in front of the screed extension. That sensor should be mounted on the end gate of the screed just in front of the leading edge of the screed.

**Sonic Control** Newer pavers are often equipped with an automatic feed system that uses ultrasound to monitor the amount of mix being carried on the augers. This system basically operates on the same basis as a variable-speed limit switch system by measuring the

amount of mix in front of the screed and controlling the speed of the slat conveyors and auger system to maintain a constant head of material at the screed. The sonic feed system uses reflected sound waves to sense the level of mix. The system sends out pulses several times per second. A timing circuit is started when the pulse is sent out and is stopped when the first echo is received back. The length of time between when the pulse is sent out and the echo is received is used to calculate the distance to the material being sensed—the head of material in the auger chamber. The controller then varies the speed of the conveyors and augers on each side of the machine proportionally to maintain a constant level of mix across the front of the screed.

## SCREED UNIT

The screed unit, which is towed by the tractor unit, establishes the thickness of the asphalt layer and provides the initial texture to the new surface. In addition, through its weight and vibratory action, the screed imparts some level of density to the material being placed. Figure 15-12 shows the paver screed and tow arms.

The concept of the free-floating paver screed was developed in the early 1930s. That concept allows the paver screed, which is attached to the tractor unit at only one point on each side of the machine, to average out changes in grade or elevation experienced by the wheelbase (rubber tires or crawler tracks) of the tractor unit. The floating-screed concept is employed on all modern asphalt pavers in use today.

## Tow (Pull) Points

The screed unit is attached to the tractor unit at only one point on each side of the paver. This point, shown in Figure 15-12, is called the tow (or pull) point. The tow points are really pin-type connections that allow the leveling arms (also called side arms or pull arms) of the screed to rotate or pivot around those points. This pin connection reduces the transmission of movement between the tractor and screed units.

The concept of the tow points and the free-floating screed allows the tractor unit to provide the wheelbase for the screed unit. The screed then pivots around the tow points, which are located in the center of the length of the wheelbase on the tractor unit and respond to the average grade being spanned by the tractor wheelbase. When paving over irregular grades, the tractor can pivot much like a see-saw without changing the line of pull for the screed.



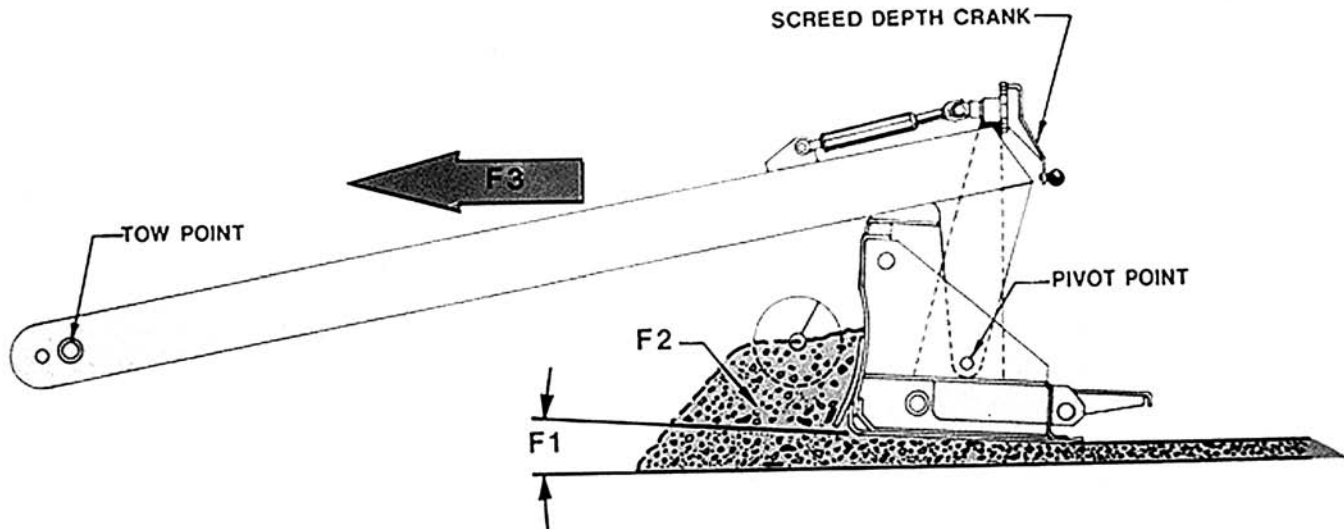

FIGURE 15-12 Action of paver screed and tow arms.

For the floating-screed principle to work properly under manual control, it is important that the tow points on both sides of the tractor be at the same level above the ground. (Automatic screed control is addressed in Section 16.) The position of the tow points can be altered by raising or lowering the rods on which the tow points are mounted. For most asphalt mixtures, the tow points are positioned near the center of the rod. For some asphalt mixtures, however, such as those that are very stiff or very tender, it may be advantageous to raise or lower the elevation of the tow points to improve the texture of the mat being placed. (If the paver is being operated under automatic grade and slope control, as discussed in the following section, the elevation of the tow points is typically centered when paving begins. The location then changes as paving proceeds to maintain the proper angle of attack of the screed.)

When some pavers are operated under manual control and the tow points are too high, the front of the screed is tilted down to maintain the proper angle of attack for the desired mat thickness. This can result in premature wear on the strike-off and the leading edge of the screed, a reduction in the smoothness of the mat, and a decrease in the degree of compaction imparted to the mix. When the tow points are too low, on the other hand, the front of the screed is tilted up to maintain the correct thickness of the asphalt mix being placed. Additional wear can then occur on the trailing edge of the screed.

For a paver not equipped with automatic screed controls, there is typically an 8:1 ratio between the movement of the tow points and the change in the angle of attack of the front edge of the paver screed. Thus if the tow

points are moved upward 25 mm (1 in.), the angle of attack of the screed will be increased by 3 mm ( $\frac{1}{8}$  in.). As discussed in detail below, the paver must move forward approximately five lengths of the leveling arms before the screed moves up to the new level of the tow points and the forces on the screed are again in equilibrium.

The combination of the screed pivot points at the ends of the leveling arms attached to the tractor and the thickness control device at the screed makes it possible to adjust the angle of attack of the screed unit. The angle of attack is illustrated in Figure 15-13. Because of the way the screed is attached to the tractor, the screed acts in a manner similar to that of a water skier being pulled by a speedboat. As the motorboat goes faster, the water skier comes farther out of the water, and the angle of attack of the water skis decreases. Similarly, as the paver goes faster, the angle of attack of the screed decreases, and the mat being placed by the paver is thinner. If the skier is traveling over a calm water surface, the angle of attack of the skis will remain constant. If the skier attempts to cross the wake of the boat, however, the angle of attack of the

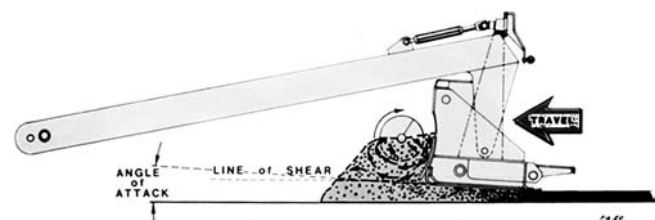

FIGURE 15-13 Angle of attack for paver screed.

skis will increase as the skis climb up over the wave. Similarly, if the head of material in front of the paver screed increases, the angle of attack of the screed will increase as the screed reacts to the increase in force on it. The result will be a thicker mat being placed by the paver.

Manual screed control is discussed in detail later in this section. First, however, forces acting on the screed and the effects of starting and stopping the paver are reviewed.

### Forces Acting on the Screed

Two primary forces constantly act on the paver screed as the paver places the mix. The first is the towing force of the tractor, which varies as the speed of the paver increases and decreases. The second is the head of material pushing against the screed. As the amount of asphalt material in the auger chamber that pushes against the screed changes, the net force acting on the screed also changes. As the forces acting on the screed change, the screed must come to a new angle of attack to compensate for the change in force acting on it. In addition, the line of pull—the angle at which the tractor pulls the screed forward—will influence the attack angle of the screed.

The forces on the screed must be in equilibrium (the sum of all forces equal to zero) for the screed to remain at a constant angle of attack as it is towed by the tractor unit. When a change in any one force occurs, the screed will rise or fall, and the thickness of the mat being placed will change accordingly. A change in the angle of attack of the screed will also result. The screed will react to the change in the force against it until it reaches a new equilibrium elevation where the forces are in balance.

### Paver Speed

Because the speed of the paver has a major effect on the angle of attack of the paver screed, it is good paving practice to keep the speed as consistent as possible during lay-down operations. Under manual material flow control and screed control, if the other forces on the screed remain constant, an increase in the paver speed results in a decrease in the thickness of the asphalt layer being placed. This occurs at the faster paver speed because the angle of attack of the screed has changed. As the speed is increased, the angle of attack of the screed decreases, and the thickness of the mat placed also decreases until an equilibrium condition is again reached. Similarly, a decrease in the speed of the paver causes an increase in the thickness of the mat. The screed then climbs to a new elevation until its equilibrium is reestablished.

The above occurs, however, only as long as no other changes are made in the system—if the level of the tow points and the amount of mix in the auger chamber remain constant. It should be noted, however, that as the paver speed is increased or decreased, the rate of feed of HMA through the paver must also be changed to maintain a constant head of material in the auger chamber. As the paver speed increases, if no additional mix is delivered by the slat conveyors to the augers to compensate for the change in demand for mix, less mix is available to pass under the screed, and the thickness of the layer is further reduced.

If the paver operator manually changes the amount of mix fed back to the augers or if the feed control sensors accomplish the same function automatically, the angle of attack of the screed remains constant because of the effect of the head of material in front of the screed. As discussed above, however, the thickness of the mat placed still changes because of the change in paver speed. To maintain a constant mat thickness with a change in paver speed, therefore, a manual change must be made in the setting of the thickness control screws (depth cranks) located at the paver screed. For an increase in paver speed, the depth crank must be turned so that the screed rotates around its pivot point, and the angle of attack is increased manually to compensate for the decrease in angle of attack that naturally occurs when the speed is increased. Similarly, for a decrease in paver speed, the depth crank must be turned in the opposite direction so that the angle of attack of the screed is manually decreased to compensate for the automatic increase in the angle of attack that occurs when the speed of the paver is decreased. The amount of manual change needed in the setting of the thickness control screws, up or down, depends on the amount of change in the speed of the paver, faster or slower, respectively.

Those not familiar with the forces acting on the paver screed often assume that the thickness of the mat being placed increases as the speed of the paver increases (for a constant head of material maintained in front of the screed). This assumption is incorrect, as explained above. In fact, the opposite is true. Thus to fully understand the effect of a change in the speed of the paver on the angle of attack of the screed, one must remember that for the forces on the screed to be in equilibrium, each change in force must be accompanied by an equal, but opposite, change in force.

It is highly desirable to keep the speed of the paver constant in order to maintain a constant angle of attack of the screed and thus a constant thickness of the mat being placed. The speed of the paver should thus be matched to



the production rate of the asphalt plant and to the thickness and width of the mat being placed. The maximum paver speed can be determined for different combinations of plant production rates and mat thicknesses.

As an example, for a mat that is 3.7 m (12 ft) wide, the paver should be operated at a speed of only 4.6 m (15 ft) per minute in order to place all of the mix provided by a plant producing HMA at a rate of approximately 91 tonnes (100 tons) per hour at a compacted layer thickness of 25 mm (1 in.). Similarly, for a plant production rate of 454 tonnes (500 tons) per hour, for the same mat width of 3.7 m (12 ft) and for a compacted layer thickness of 50 mm (2 in.), the maximum paver speed should be approximately 11.5 m (38 ft) per minute.

As noted earlier, to achieve the smoothest possible mat behind the paver screed, it is essential to keep the paver moving at a constant speed at all times. There is no sense in running the paver faster than necessary to place all of the delivered mix and then stopping to wait for the next haul truck to arrive at the paving site. The subject of slowing the paver down or stopping it between truckloads of mix is discussed further below.

### *Head of Material*

If the volume of mix in the auger chamber is increased, the force on the screed also increases, causing the screed to rotate around its pivot point and thus rise. This action then causes the angle of attack of the screed to increase until a new equilibrium position is reached, resulting in placement of a thicker mat. If the amount of material being carried on the augers is decreased, the thickness of the mat is reduced, all other factors being equal, as the angle of attack of the screed decreases. Thus one of the primary factors affecting the consistency of the thickness of the layer being constructed is the consistency of the head of material (amount of HMA) in front of the paver screed.

The head of material in the auger chamber is directly affected by the operation of the slat conveyors and augers on each side of the paver. When the slat conveyors and augers are operating, the mix is pulled from the paver hopper, through the tunnel, and is distributed across the front of the screed by the augers. As long as this flow of material is relatively constant, the head of material pushing against the screed remains relatively constant as well, and the mat being placed has a smooth and consistent texture.

If the head of material is allowed to vary, however, the screed moves up and down in relation to and reac-

tion to the forces acting on it. As the amount of mix being carried by the augers is decreased because the slat conveyor and auger systems are shut off, the screed moves downward, thus reducing the thickness of the mat behind the screed. As the slat conveyor and auger systems come on, more mix is carried back to the augers and across the front of the screed. This increases the force on the screed and causes it to rise to a new elevation, resulting in a thicker mat. Thus, the position or elevation of the flow gates is very important in regulating the amount of mix in front of the screed.

The head of material is affected each time the slat conveyors and augers are turned off and on. This is true particularly if the position of the flow gates is not properly set initially. For this reason, as suggested earlier, the use of a variable-speed or sonic automatic feed control system is important because these types of devices keep the slat conveyors and augers running as much of the time as possible, provided the flow gates are properly set. This in turn keeps the head of material relatively constant and allows the screed to place a mat of consistent thickness. A constant head of material against the paver screed also significantly reduces the occurrence of ripples and auger shadows.

If the paver is not equipped with flow gates, the speed of the conveyors and augers must be controlled so that the head of material is kept constant. For either type of system, however, with or without flow gates on the paver, a consistent head of material in front of the screed is associated with a consistently smooth mat behind the paver.

Another factor that affects the uniformity of the head of material in front of the screed is the temperature of the mix. If a cold load of material is deposited in the paver hopper and carried back to the screed by the slat conveyors and the augers, the colder, stiffer mix increases the force acting on the screed and causes the screed to rise, increasing the thickness of the layer placed. If, on the other hand, a hot load of mix is delivered to the paver, the decrease in viscosity of the binder material reduces the stiffness of the HMA and reduces the force of the mix on the screed when the mix is deposited in front of it. This situation causes the screed to fall and reduces the layer thickness.

### *Line of Pull*

The line of pull refers to the angle at which the screed is pulled forward. A smoother pavement surface is generally placed when the towing force is applied relatively

parallel to the grade over which the tractor unit is running. Thus the elevation of the tow points should be set in relation to the thickness of the mat being constructed. As a general rule, thin lifts of HMA require a lower initial tow point setting, while thick lifts of mix require a higher initial setting. Setting the initial tow point height to match the thickness of the material being placed results in the towing forces applied to the screed being relatively parallel to the grade. Unwanted influences that might cause texture and smoothness problems are not applied to the screed.

For a relatively thin mat, if the tow point setting is extremely high, the towing forces are applied at an upward angle that increases the lift forces acting on the screed. To maintain a given thickness of material, the angle of attack of the screed must then be decreased to compensate for the increased lift. In this condition, the screed runs at a slightly nose-down angle of attack. Only the front portion of the screed is then compacting and finishing the HMA being placed; the result is poor mat texture and extreme wear on the front portion of the bottom of the screed plate. In addition, when the paver stops, the screed has more of a tendency to rock or teeter as the tractor relaxes the tension on the screed. This may increase the amount of settling of the screed and introduce bumps into the mat.

For a relatively thick mat, if the tow point setting is extremely low, the towing forces are applied at a downward angle that decreases the lift forces applied to the screed. To maintain a given thickness of HMA, the angle of attack of the screed must then be increased to compensate for the decreased lift. In this condition, the screed runs at a slightly nose-up angle of attack, with only the rear portion of the screed compacting and finishing the mix being placed. This causes poor mat texture and extreme wear on the rear portion of the bottom of the screed plate. Increased control of the forces applied to the screed is thus gained by setting the tow points in relation to the thickness of the mat being placed.

## Effects of Stopping and Starting the Paver

### Short Stops

If the paver can be operated continuously at a constant speed without stopping, the smoothness of the mix placed should be excellent, as long as the screed operator does not continually change the angle of attack of the screed by turning the thickness control cranks and the head of material in front of the screed remains constant.

If bottom-dump trucks are used to deliver the mix from the plant to the laydown machine, there is a chance that the paving operation can be continuous if there is a long enough windrow of mix out ahead of the paver. If the next truck does not arrive at the paving site before the end of the windrow is reached, however, the paver will obviously have to stop and wait until more HMA is windrowed by the truck and is available to be picked up by the windrow elevator on the paver.

If an MTV is used to deliver mix from the haul vehicles to the paver hopper, there is also a chance that the paving operation can be continuous as long as the haul trucks arrive at the MTV before it runs out of mix. Since the MTV is essentially a surge bin on wheels, as discussed in Section 13, the amount of mix it can carry is limited, even taking into account the additional mix in the extended hopper on the paver. If the next haul truck does not arrive in time to keep the MTV and the paver hopper from becoming empty, the paving operation must come to a halt.

If end-dump or live-bottom trucks are used to deliver the mix to the hopper on the paver, there is little chance that a continuous paving operation can be accomplished unless the paving speed is very slow. Since the speed of the paver affects the angle of attack of the screed, and therefore the smoothness of the mat being placed, maintaining a constant speed without stopping is a desirable but unrealistic goal. For the paver to be able to keep moving forward at the selected paving speed while the truck exchange process was being completed, the following things would have to occur very efficiently if end-dump trucks were being used: the bed of the empty truck would have to be lowered, that truck would have to pull out away from the paver, the next truck would have to back up to the paver, the bed of that truck would have to be raised (if not done ahead of time, as it should be in order to move the mix back against the tailgate of the truck; see Section 13), and the tailgate would have to be opened and mix delivered into the paver hopper. All of this would have to happen before the amount of mix in the paver hopper had been reduced to a level below the top of the hopper flow gates so that the head of material in front of the screed would not be affected. On real paving projects, this level of efficiency is not normally obtained consistently.

Typically, the paver operator starts to slow the paver down once the haul truck is empty, the windrow runs out, or the MTV is almost empty. The operator usually hopes that the next truck will arrive before the paver is out of mix. Sometimes that occurs, but often it does not,



and the paver is stopped. As the paver is gradually slowed down, however, the angle of attack of the screed changes (increases), and the thickness of the mat increases slightly. If the hopper is emptied of mix, the head of material in front of the screed is reduced, the angle of attack of the screed is decreased, and the thickness of the mat is also decreased—a gradual dip is built into the pavement surface.

Once new mix has been delivered into the empty paver hopper, either from the haul vehicle, from the windrow elevator, or from the MTV, the paver operator usually starts the slat conveyors on the paver and pulls a slug of mix back to the augers. The head of mix in the auger chamber builds up, and the paver is quickly brought back to paving speed by the operator. The high head of material causes the screed to rise and the mix thickness to increase. Because the paver reaches paving speed quickly, the paver speed has little effect on the angle of attack of the screed, given the delayed reaction time of the screed. The net effect of the high head of material and the quick increase in paver speed is a thicker pavement section—a bump is built into the pavement surface.

If the mix in the haul truck is segregated, and if that segregated mix is delivered into the empty paver hopper from both the end of one truckload and the beginning of the next truckload, the segregated coarse aggregate particles will be carried back to the augers and dumped on the pavement surface immediately in front of the low spot just constructed by the screed. If this occurs, truckload-to-truckload segregation (see Section 13) will be both felt (as a gradual dip and then a bump in the pavement surface) and seen.

If the paver needs to be stopped because additional mix is temporarily not available, it should be stopped as quickly and smoothly as possible, and before the level of mix in the hopper is drawn down below the top of the flow gates or the tunnel openings. This will keep the head of material in front of the screed constant at the same time that the effect of the change in the paver speed on the angle of attack of the screed is minimized because of the rapid speed change.

When more HMA arrives, it should be placed into the “half-full” paver hopper from the haul truck, windrow elevator, or MTV. The paver operator should then return the laydown machine to the desired paving speed as quickly as possible, again minimizing the effect of the change in paver speed on the angle of attack of the screed. Since the head of material has been kept constant, a smooth mat will be constructed—no dip, no bump, and no segregation. It has been found that the “rapid stop, rapid start” procedure for stopping the

paver provides for good mat smoothness and consistent mat thickness.

### *Longer Stops*

If there is going to be a long delay before the arrival of the next haul vehicle, consideration should be given to constructing a transverse joint, as discussed in Section 17. The acceptable length of a delay so that it is still possible to place and compact the mix to obtain the required level of smoothness and density will depend on a number of factors, including the environmental conditions (air temperature, surface temperature, and wind velocity) at the paving site, the temperature of the mix in the paver hopper, and the uncompacted thickness of the mat beneath the screed.

If it is decided not to construct a transverse joint but to put the paving operation on temporary hold until the next haul truck arrives, the paver should be stopped with the hopper as full as possible—above the level of mix that is typically kept in the hopper (above the top of the flow gates or tunnel openings) during short stops. Keeping the hopper full will reduce the rate of cooling of the mix during the waiting time because the mix will remain in a mass. In addition, the paver should not be moved forward during the waiting period, but should remain in one position until the new mix is available.

There is a tendency for the paver operator to sit in one spot for a while, move the paver forward a short distance, and then wait again. If the next truck does not arrive shortly, the operator often repeats this process until the paver hopper is empty. This practice is incorrect and can lead to the construction of a significant length of poor-quality pavement.

While the paver is sitting in one spot, the mix in the paver hopper will cool. The rate of cooling will be reduced if the amount of mix in the hopper is kept constant; as suggested above, the greater the mass of mix, the slower will be the rate of temperature loss. If the paver is moved forward periodically and the amount of mix in the hopper is decreased as some of the mix is laid by the paver, the rate of cooling of the remaining mix will increase. Depending on when the next haul truck arrives and how many moves the paver makes, the level of mix left in the paver hopper may become very low and the material quite cold.

Further, while the paver is stopped, a certain amount of mix will be retained in the auger chamber—the head of material in front of the screed. Since a portion of this HMA is in contact with the underlying pavement surface, cooling of this material will take place. In addi-



tion, the HMA that is actually under the paver screed and in contact with the existing surface will cool—even more rapidly than the mix in the auger chamber—because of the thinner layer and lesser volume of the uncompacted mix under the screed. Further, there will be some distance of mix behind the paver screed that cannot be reached by the rollers. Typically this length is about 1 m (3 ft) and is related to the amount of overhang of the walkway on the back of the screed and the curvature of the roller drum or tires. For most pavers, the total length of mix from the front of the auger chamber to the front edge of the roller drum that will cool quickly and be uncompacted will range from 2 to 3 m (6 to 9 ft). If the paver remains in one spot while waiting for the next truck to arrive, that distance of mix will usually have a lower level of density than the rest of the mat since the compactive effort of the rollers cannot be applied in this area, and the mix will be cooler when the paver finally moves forward.

Even more low-density mix will be placed if the paver moves forward periodically while awaiting the arrival of more mix. Each time the paver moves and stops, another distance of mix in contact with the existing pavement surface between the augers and the rollers will cool quickly, and proper density will probably not be achieved. In addition, as the hopper is periodically emptied, not only will the remaining mix lose temperature more rapidly, but the head of material in front of the screed will be reduced, and a low spot or dip will be built into the pavement surface. Good paving practice therefore dictates that the paver remain in one position, with the hopper as full as possible and the head of material constant, until additional mix arrives.

## Manual Screed Control

In this section, procedures involved in manual screed control are reviewed. Automatic screed control and the ways in which it differs from manual control are covered in Section 16.

### *Thickness Control Cranks*

As noted earlier, the screed is attached to the leveling or tow arms on each side of the paver through pivot points. The thickness control mechanism, usually either a crank or a handle, allows the screed to be moved or rotated around the pivot points. The key to the leveling action of the screed is its ability, by rotating around the pivot points and being attached to the tractor unit only at the tow points, to establish an equilibrium position based on the forces applied to it. As the mix passes under the

screed plate, the screed floats on the mix, establishing the mat thickness and the texture of the material, as well as providing the initial compaction of the HMA.

For a constant position of the tow points (the tractor unit running on a level surface and without automatic screed controls), altering the setting of the thickness control devices changes the angle of attack of the screed and the forces acting on the screed. This in turn causes the screed to move up or down to a new elevation as the paver moves forward, thus altering the thickness of the mat being placed. The reaction of the screed to changes in the position of the thickness control settings, however, is not instantaneous. Rather, there is a lag in the reaction that allows the screed to average out variations in the input forces acting on it.

### *Yield*

There is a tendency for the screed operator to continually turn the thickness control cranks in order to control the amount of mix being placed. This is particularly true of paving projects on which the yield—the amount of mix available to be laid (set up in the plans) over a given area—is tightly controlled. Frequently the screed operator will check the mat thickness using a rod or ruler (depth gauge) at a given point. On the basis of that single reading, the operator often will then adjust the setting of the thickness control cranks, changing the angle of attack of the screed and thus the thickness of the mat. When a subsequent check is done a short time later and the depth measured does not match the required uncompacted thickness, another change is made in the setting of the thickness control cranks and the angle of attack, so that the thickness of the mat is altered once again. This approach of using individual measurements to set the screed does not accomplish the desired goal of obtaining a smooth mat, nor does it typically accomplish the goal of correctly controlling the amount of mix placed along a given length of pavement.

Because of the delayed reaction time of the screed, discussed further below, there is a significant lag between the time the thickness control cranks are turned and the time the screed attains the new equilibrium point at the new thickness level. A single mat depth measurement should not be used to justify a change in the angle of attack of the screed. Indeed, even two or three measurements should not be averaged to determine whether a change in the setting of the thickness control cranks is needed. If the uncompacted thickness of the mat is to be checked using a depth gauge, the mat thickness behind the screed should be measured at least five times at 2-m



(6-ft) intervals longitudinally. The thickness control cranks should then be turned only if the average measured thickness is more than 6 mm ( $\frac{1}{4}$  in.) less or more than the desired uncompacted thickness of the mat.

A better way to check yield, if it must be measured periodically, is to determine the distance that the amount of mix in 10 truckloads of HMA should cover, based on the width and uncompacted thickness being laid. This distance is then compared with the length the paver has actually placed using the same number of tonnes (tons) of mix. If the distance covered is significantly less than it should have been, the setting of the thickness control cranks should be changed to slightly decrease the angle of attack of the screed, decreasing the amount of mix placed and therefore increasing the distance a given amount of material will cover. If the distance covered is significantly greater than it should have been, the thickness control cranks should be turned a small amount in the opposite direction to thicken the mat.

### Screed Reaction Time

Figure 15-14 shows the reaction time of the screed when a change is made in its angle of attack, either at the screed or at the tow points. After the tow points have been raised, it takes approximately five times the length of the leveling or tow arms on the paver screed for the screed to complete 99 percent of the change, up or down, to the desired new elevation. This means that if the length of the leveling arms is 3 m (10 ft), the paver must move forward at least 15 m (50 ft) before the required input to the thickness control device is completely carried out by the paver screed. The same applies if the angle of attack of the screed is changed by turning the thickness control cranks on the back of the paver at the screed itself.

**Changing the Screed Pivot Point** As an example, assume that it is desired to increase the thickness of the mat being placed from 25 mm (1 in.) to 37 mm ( $1\frac{1}{2}$  in.). An input is made to the thickness control crank by turning it to change the angle of attack of the screed. The movement of the thickness control mechanism causes the screed to move around the pivot points and increases the angle of attack.

As shown in Figure 15-14, approximately 63 percent of the thickness change in the mat is accomplished after the paver has moved forward a distance equal to one leveling arm length, or 3 m (10 ft) in this example. As the paver moves forward another 3 m (10 ft), about 87 percent of the desired thickness change is completed. Approximately 95 percent of the thickness change is accomplished by the time a distance of 9 m (30 ft) has been traveled—three leveling arm lengths of 3 m (10 ft) each. Only when the paver has moved down the roadway a distance equal to at least five leveling arm lengths, however, is some 99+ percent of the thickness change completed.

The above example applies also to a reduction in the thickness control settings at the screed. A screed operator desiring to reduce the depth of the asphalt layer turns the thickness control crank in the opposite direction and causes the screed to rotate around the pivot points. As the paver moves forward, the decreased angle of attack of the screed causes it to move downward, thereby reducing the amount of mix being fed under the screed. The screed continues its downward movement until the forces acting on it are again in equilibrium. If the pavement layer depth were being changed from 37 mm ( $1\frac{1}{2}$  in.) to 25 mm (1 in.), the paver would still have to move more than five lengths of the leveling arm before 99+ percent of the thickness change would be completed.

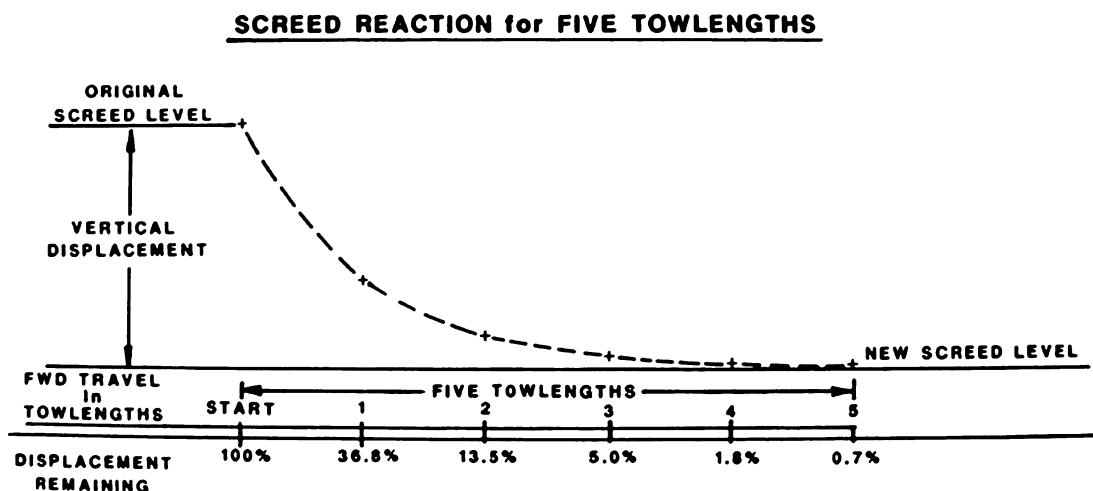

FIGURE 15-14 Screed reaction time.



The reaction time of the screed is the same regardless of the amount of change input to the thickness control cranks. Thus whether the cranks are turned enough times to increase the thickness from 25 mm (1 in.) to 50 mm (2 in.) or more times to increase the thickness from 25 mm (1 in.) to 75 mm (3 in.), at least five times the length of the tow arm will be required for the change to be completed. The reaction time is also the same if the thickness is decreased, from any level to any other thickness, regardless of the actual amount of the thickness change.

When a paver is being operated manually, it is essential for the screed operator to be aware of this lag in the reaction time of the screed. As noted, the paver must move forward at least one leveling arm length before 63 percent of the thickness change is completed. If a second change in the setting of the thickness control crank is made before the first change has been accomplished, the first change will never be completed, and it will still take an additional five times the length of the leveling arm for the second thickness change to be carried out. For this reason, continual changes in the setting of the thickness control devices are likely to be highly detrimental to the development of a smooth mat.

**Changing the Tow Point Elevation** The above discussion applies to a change in the location of the tow points of the screed leveling arm where it is attached to the tractor unit. If the tow points are displaced, the change in their elevation translates to a change in the angle of attack of the paver screed. The paver must still move forward for a distance of approximately five times the length of the leveling arm on the machine for the screed to react to the change in the location of the tow points and move up or down to the new elevation.

As a roadway is being paved without the use of automatic grade and slope controls, the tractor unit moves upward and downward in response to the grade of the underlying pavement. The vertical movement of the tractor translates into vertical movement of the tow points on the sides of the paver. Each time the tractor goes over a hump or into a dip in the existing pavement surface, the elevation of the tow points changes. This in turn alters the angle of attack of the screed, causing the amount of material flowing under the screed to be decreased or increased. The fact that it takes five times the length of the leveling arm before the screed reacts completely to a change in the location of the tow points allows the screed to reduce the thickness of the asphalt mix being placed over the high places in the existing surface and to place more mix in the low spots on the present roadway. It is this averaging or leveling action

that forms the basis for the floating-screed principle discussed earlier.

The use of automatic paver controls, discussed in the next section, allows the paver to construct a smoother pavement by keeping the location of the screed tow points constant, relative to a predetermined reference, as the tractor unit moves up and down vertically in response to small changes in the grade of the underlying pavement surface. By maintaining the tow points at a constant relationship to the predetermined reference while the tractor moves vertically, the force on the screed remains constant, and the angle of attack of the screed is consistent in comparison with the reference. This allows the screed to carry out the leveling action needed over a longer reference length in order to reduce the roughness of the existing surface through the application of the new asphalt layer.

### *Screed Strike-Offs*

The screed on some pavers is equipped with a device on its front edge called a strike-off (or sometimes a pre-strike-off). The purpose of this device is to control the amount of HMA allowed to pass under the nose of the screed, thereby affecting the screed's angle of attack. The strike-off is also used to reduce the wear on the leading edge of the screed. The proper positioning of the strike-off assembly is illustrated in Figure 15-15.

When the strike-off is attached to the front of the screed, its position becomes important relative to the ability of the screed to handle the asphalt mix properly. If the strike-off is set too high, as shown in the figure, extra material is fed under the screed, causing the screed to rise. The resulting increase in the mat thickness must be overcome by manually reducing the angle of attack of the screed, using the thickness control cranks. This in turn causes the screed to pivot around its pivot points and ride with a slight nose-down-lower angle of attack. Rapid wear of the screed nose plate results. Moreover, only the front portion of the screed is compacting and finishing material being placed, and this often leads to inconsistent mat texture. In addition, the screed settles when the paver is stopped between truckloads of mix because the screed's weight is carried only on its front.

On the other hand, when the strike-off is set too low, the thickness of the lift is reduced because not enough HMA is allowed to pass under the screed. To maintain the proper mat thickness, the angle of attack of the screed must be altered, causing the screed to ride on its tail in a slight nose-up attitude. This increases the wear on the back edge of the screed and reduces the compactive effort applied by the screed. It also causes the screed to settle whenever the paver is stopped because



### Main Screed Strike-Off

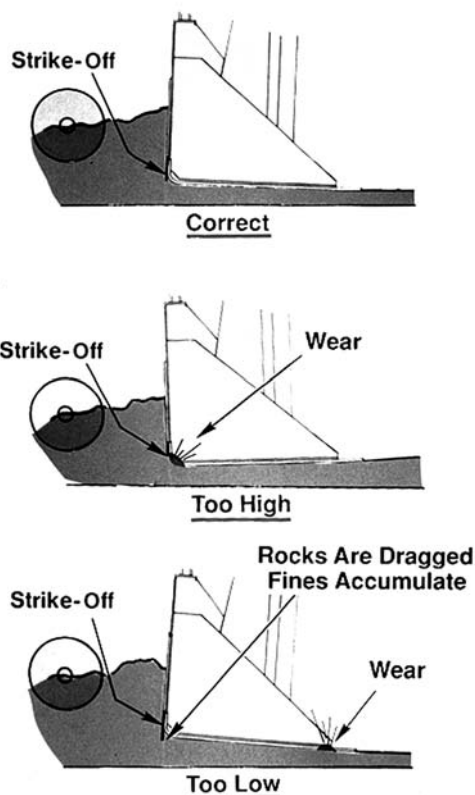

**FIGURE 15-15** Proper positioning of strike-off assembly.

of the concentration of the screed's weight on a smaller surface area. The exact location of the strike-off depends on the make and model of paver being used and on the depth of the layer being placed by the paver. For relatively thin layers of pavement [25 mm (1 in.) thick or less], the strike-off is usually placed lower than when thicker lifts of mix are being placed. Similarly, for thick lifts of asphalt pavement [greater than 50 mm (2 in.)], the strike-off assembly is usually raised slightly above the normal position. In general, the strike-off is located in the range of 5 to 13 mm ( $\frac{3}{16}$  to  $\frac{1}{2}$  in.) above the bottom plane of the main screed plate. No compaction of the mix occurs under the strike-off.

#### Screed Heaters

The screed is equipped with two or more heaters or burners, depending on the age and model of the paver. The purpose of the heaters is to preheat the plate on the bottom of the screed to the temperature of the HMA being laid. The screed should be heated before paving operations begin and at any time the screed has been raised out of the mix for an extended period. The screed must be at

nearly the same temperature as the asphalt material passing under it to ensure that the mix does not stick to the screed plate and tear, imparting a rough texture to the mat. A properly heated screed provides for a more uniform mat surface texture and a more consistent mat thickness.

To preheat the screed, the burners are normally operated for a period of 10 to 20 minutes before the lay-down operation begins. Care should be taken to avoid overheating, which can cause permanent warping of the screed plate. Electric screed heaters are now sometimes used and tend to provide more uniform heating of the screed. Usually within 10 minutes after paving has begun, the temperature of the screed plate has increased to the point at which it can generally be maintained by the temperature of the mix passing under it. Thus the burners are not needed and are shut off. A major misconception is that the heaters can be used to heat up cold material as it passes under the screed. This is simply not true: at the very best, only the very top surface of the mix is warmed up slightly, while the bottom of the screed may be superheated to the point of warping. For the same reasons, the screed heaters should not be used in an attempt to increase the temperature of the mix sitting under the screed for a period of time while awaiting the arrival of the next haul truck.

In cool weather—during start-up when the plant is cold, the haul truck beds are cold, and the paver metal is cold—it is sometimes advantageous to start paving with the second or third truckload of mix delivered to the paver, rather than the first load produced and delivered. This second or third load of mix is typically higher in temperature than the first load and will therefore serve to heat the paver more and reduce the amount of tearing that might occur under the screed. Placing the second or third truckload of mix first can provide for a more uniform surface texture when paving must be accomplished in lower ambient temperatures.

#### Screed Crown Control

The screed can be angled at its center to provide for positive or negative crown. The amount of crown that can be introduced into the screed varies with the width of the screed and with the make and model of the equipment. The crown is typically adjusted using a turnbuckle device to flex the bottom of the screed and impart the desired degree of crown. When rigid extensions are used in conjunction with the screed, the crown being placed in the pavement by the paver can usually be altered as well at any of the points where the extensions are joined. If a hydraulically extendable screed is being used with the paver, the crown can be introduced not only in the cen-

ter of the screed, but also at the points between the screed and the hydraulic extensions.

Most of the paver manufacturers recommend that the screed be warped slightly, from front to back in its center, to facilitate the passage of mix under the screed and to obtain a more uniform texture on the asphalt mat. This process involves setting the lead crown on the screed slightly above the tail crown on the screed. In general, there should be more lead than tail crown, but the amount of difference depends on the make of paver and the type of screed. Normally the lead crown setting is 1 to 5 mm ( $\frac{1}{32}$  to  $\frac{3}{16}$  in.) greater than the tail crown setting, with 3 mm ( $\frac{1}{8}$  in.) being the average difference between the crown settings.

For hydraulically extendable screeds, discussed below, some paver manufacturers do not recommend setting any amount of lead crown into the front edge of the screed. Because of differences in the recommendations for different makes and models of pavers, it is suggested that the manufacturer's operation manual be consulted before the crown is set into the screed.

### Screed Vibrators

The amount of compaction imparted to the asphalt mix by the screed is a function of many variables. The properties of the mix itself are important—its stiffness, its temperature, and the amount of asphalt cement and moisture it contains all affect the ability of the screed to densify the mix. The degree of compaction achieved is also affected by the amount of bearing pressure applied to the mix by the screed, as well as the thickness of the HMA passing under the screed.

Two factors within the screed itself also contribute to the degree of compaction achieved: the frequency of vibration (number of vibrations per minute) and the amplitude (amount of force) imparted by the screed. The frequency of vibration is controlled by the rotary speed of the vibrator shaft and is adjusted by turning a control valve located on the screed. Increasing the revolutions per minute of the shaft will increase the frequency of the vibration and thus the compactive effort. In general, the vibrators should be used at the highest frequency setting to obtain the maximum compactive effort from the screed.

The applied amplitude is determined by the location of the eccentric weights on the shaft. The position of the eccentric weights can be altered to increase or decrease the amount of compactive effort applied to the mix by the screed, as illustrated in Figure 15-16. Typically, the amplitude setting selected is related to the thickness of

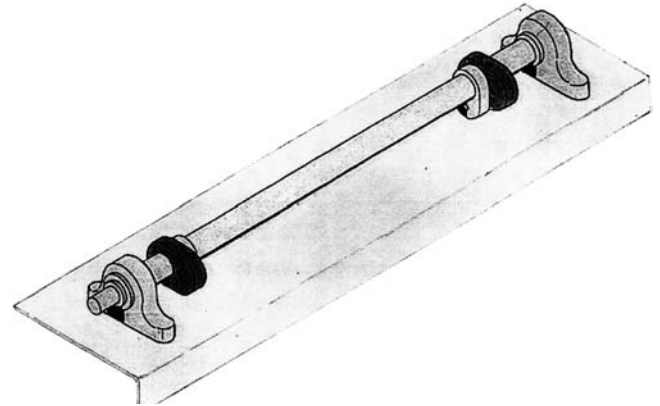

FIGURE 15-16 Screed vibration shaft with weights.

the mat being placed—lower amplitude for thinner lifts and higher amplitude for thicker lifts.

The density achieved by the paver screed is also a function of the speed of the paver. As the paver moves faster, the screed dwells for less time over any particular point in the new mat, and thus the amount of compactive effort applied by the screed decreases. It can be expected that approximately 75 to 85 percent of the theoretical maximum density of the HMA will be obtained when the mix passes out from under the paver screed.

On some paving projects, the screed is not used in the vibratory mode—the vibration is shut off. This is often done so that members of the paving crew can walk across or ride on the screed in relative comfort; it is difficult to ride on the screed all day if it is vibrating. To derive the benefits of the screed in obtaining the density of the mat, however, the screed should be operated in the vibratory mode, and the crew members should find another means of traveling along the length of the paving site.

### Screed Extensions, Cut-Off Shoes, and End Plates

**Rigid Extensions** When the basic width of the screed [2.4 m (8 ft) for small pavers and 3.0 m (10 ft) for larger machines] needs to be changed to accommodate increased paving widths, rigid screed extensions can be used, as illustrated in Figure 15-17. These extensions come in several widths, usually 150 mm (6 in.), 0.3 m (1 ft), 0.6 m (2 ft), and 0.9 m (3 ft). To keep the paver in balance, the width of the rigid extensions added to the paver screed should be approximately equal on both sides of the machine, if possible.

It is important that the screed extensions be attached securely to the screed. Further, it is essential



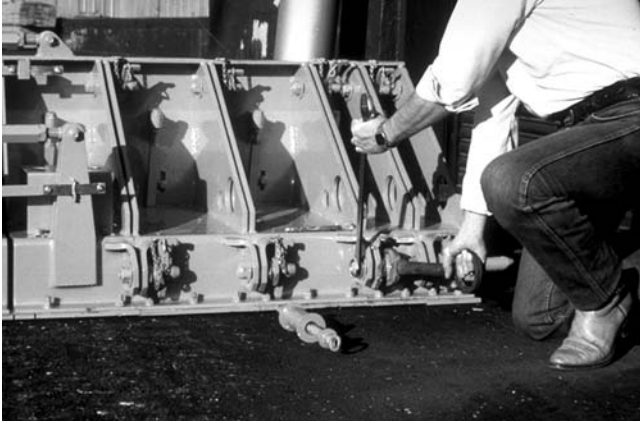

FIGURE 15-17 Rigid screed extension.

that the extensions be set at the same elevation and angle as the screed to prevent the presence of a transition line or ridge at the intersection of the screed and the extensions or between the different extensions. Alignment of the front edge of an extension is typically controlled independently of the alignment of the rear edge.

Whenever a rigid extension is used on the screed, auger extensions and the accompanying auger tunnel extensions should also be used. The length of all the auger and tunnel extensions should in general be the same as that of the screed extensions to allow room between the end of the auger and the end plate of the screed. Typically, the distance between the end of an auger extension and the end plate should be about 450 mm (18 in.). Further, whenever rigid screed extensions are employed on a paver with a strike-off, a strike-off assembly must also be added to the extensions and set at the same elevation as the strike-off on the screed.

**Strike-Off Extensions** Strike-off extensions are often used to increase the paving width on projects that do not require an actual screed extension with heat and vibratory compaction capability. Such strike-off extensions are used for driveway and mailbox turnouts and for some types of intersection paving where variable widths are frequently encountered. Typically, this type of extension is merely a vertical blade that cuts off the mix as it passes under the strike-off unit (see Figure 15-18). In some cases, a very short section of horizontal plate is attached to the strike-off assembly.

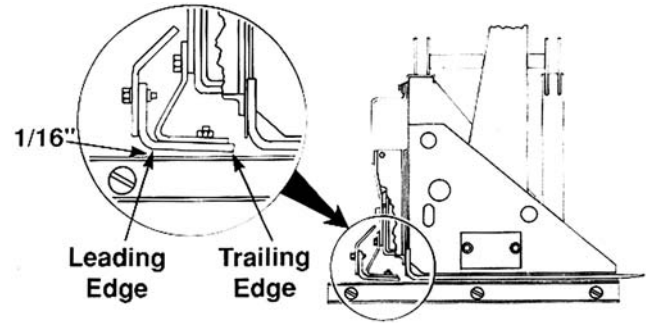

FIGURE 15-18 Strike-off extension.

When correctly installed and adjusted, strike-off extensions can be extended and retracted without influencing the mat directly behind the screed. When these strike-off extensions are extended, the HMA placed by the extensions must be thicker than the mix that passes under the screed because the mix laid by the extensions is not compacted as is that under the screed. The difference in the two thicknesses should be adjusted, depending on the properties of the mix being placed, so that after compaction by the rollers, no difference remains in the compacted thickness of the two portions of the mat. In addition, the mix laid by the strike-off extension will typically have a significantly rougher texture than the mix laid by the screed, as shown in Figure 15-19. Sometimes this difference in texture will remain visible even after the mix has been compacted.

It is suggested that strike-off extensions not be used for mainline paving so that the surface texture and compaction of the entire traveled width will be consistent. Thus for a typical lane 3.7 m (12 ft) wide, the screed should be extended either with rigid extensions or with a hydraulically extendable screed.

**End Plates and Cutoff Shoes** An end plate (or end gate or edger plate) is attached to the end of the screed to restrict the outward movement of the mix around the end of the screed, as shown in Figure 15-20. The vertical alignment of the end gate is adjustable so that mix can be bled out from under the gate if necessary. In typical operating mode, however, the end plate is positioned tight to the surface being paved to retain the mix and control the width of material being placed.

Cutoff shoes can be used, if necessary, to reduce the width of mix placed so it is less than the screed width.

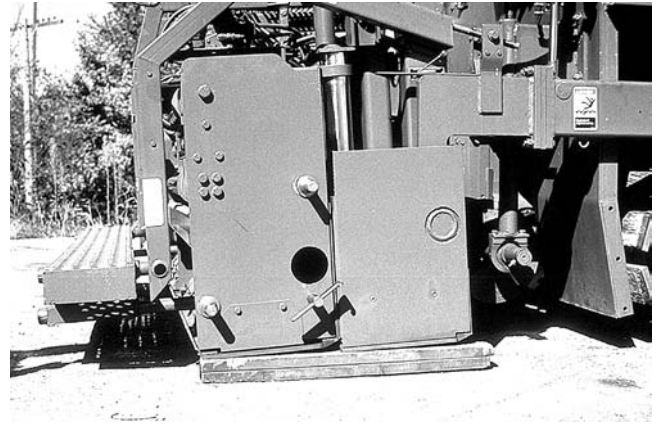

**FIGURE 15-19** Difference in texture under strike-off extension.

Standard cutoff shoes are attached to the paver end gate. Typically, the cutoff shoes come in widths of 0.3 m (1 ft) or 0.6 m (2 ft) and are adjustable in increments of 37 mm (1½ in.) or 75 mm (3 in.), depending on the paver manufacturer.

**Hydraulically Extendable Screeds** Most paver manufacturers have developed hydraulically extendable screeds that trail the main screed on the paver. One make of pavers, however, is equipped with an extendable screed that places the extendable portion of the screed in front of the main screed. An example of an extendable screed is shown in Figure 15-21.

For all hydraulically extendable screeds, it is important that the height and the angle of attack of the extendable screeds (on each side of the main screed) be properly set. If the extensions on the extendable portion of the



**FIGURE 15-20** End plate on paver.

screed are not properly aligned with the main screed, a longitudinal mark or ridge will occur in the surface of the mix at the junction between the two screeds, indicating a difference in thickness. This mark can easily be eliminated by adjusting the elevation of the extendable screed in relation to that of the main screed. In addition to the longitudinal mark, a mismatch in elevation between the two screeds can result in a difference in surface texture, as well as a difference in the degree of compaction obtained. For front-mounted extensions, the extendable screed is usually set at a height slightly below the main screed. For rear-mounted extensions, the height of the extendable portion of the screed is normally set at the same height as the main screed, but the extensions usually have a slightly more positive attack angle as compared with the main screed. In general, however, the forces that act on the extendable screeds and the main screed are similar.



**FIGURE 15-21** Hydraulically extendable screed.



Further, if a strike-off assembly is used on the main screed, similar strike-off devices should be used on the extendable screed sections.

If a front-mounted hydraulically extendable screed is to be used at a fixed extended width for a period of time, the paver should be equipped with auger extensions equal to the width of the extended screed and ending approximately 450 mm (18 in.) from the end plate. Use of these auger extensions will enhance the distribution of the asphalt mix across the width being paved and help maintain a constant head of material pushing on the entire width of the screed. Auger tunnel extensions should also be added to the paver.

For pavers equipped with a rear-mounted hydraulically extendable screed, auger extensions often are not employed even when the screed will be used at a fixed extended width for a period of time. If auger extensions are used on such pavers, an excess of mix may build up in front of the screed extensions, as shown in Figure 15-22. This condition may result in several problems with the mat behind the screed, such as nonuniform texture and variable mat thickness, and therefore should not be allowed to occur. With rear-mounted extensions, the HMA material will naturally flow out to the end of the screed without assistance from auger extensions. In addition, without auger extensions, less mix will typically be carried in front of the extendable section of the screed. For rear-mounted extensions, the material feed sensors must be mounted on the end gate of the screed to limit the amount of mix carried in front of the extendable portion of the screed.

If a hydraulically extendable screed—especially a front-mounted extension—is to be employed where the width being paved changes frequently, some paver man-



**FIGURE 15-22** Buildup of excess mix in front of extended screed.

ufacturers recommend that the machinery be equipped with kickout paddles or augers at the end of the main auger. This device helps push the mix out to the end of the extendable screed and keeps the head of material in front of the screed as constant as possible. Other pavers are equipped with augers that extend automatically as the screed is extended. For either type of paver, the material feed sensors should be mounted on the end gate of the screed to ensure that an adequate amount of material is delivered to the outside edge of the screed.

## SUMMARY

The following key factors should be considered in monitoring mix placement operations:

- If the mix is being delivered by a haul truck that dumps it directly into the paver hopper, the truck should stop just short of the paver. The paver should be moving forward when it comes in contact with the truck—the paver should pick up the truck instead of the truck backing into the paver. When raised, the bed of the haul truck should not rest on any portion of the paver.

- Before the tailgate on the haul truck is opened to deliver mix to the paver hopper, the truck bed should be raised slowly until the mix in the bed moves against the tailgate. This procedure allows the mix to move in a mass into the paver hopper when the tailgate is opened and reduces the amount of segregation behind the screed. If the tailgate-opening lever cannot be reached when the truck bed is raised, it should be modified to allow for operation from ground level when the bed is raised.

- If a windrow elevator is used to gather mix from a windrow on the roadway and deliver it to the paver hopper, the slat conveyors should pick up essentially all of the mix that is in the windrow, leaving none on the existing surface. For the placement of a leveling course, it may be necessary to leave some minimum amount of mix on the pavement surface under the windrow elevator because of the unevenness of the existing pavement surface.

- The windrow should be sized so that the amount of mix in the paver hopper is always above the top of the flow gates or the tunnel openings.

- When a paver must be stopped to wait for trucks, it should be stopped as quickly and smoothly as possible. Enough mix should remain in the paver hopper to be at least at the level of the top of the flow gates or tunnel openings. In no case should the hopper be emptied to the point that the slat conveyors at the bottom of the hopper are visible. The slat conveyors also should never

be visible when a windrow elevator or MTV is used to deliver mix to the paver hopper. The amount of mix in the hopper should be consistent so that the head of material in front of the paver screed remains constant.

- When the paver is stopped to allow the next truckload of mix to move into position, the wings on the paver may be folded, but only when necessary to prevent buildup of cold mix in the hopper corners. The wings should not be banged repeatedly as they are emptied. The wings should be dumped into a relatively full paver hopper: the amount of HMA in the hopper should be above the top of the flow gates or tunnel openings when the wings are emptied. Dumping the wings into a relatively full hopper may result in some mix spilling out of the front of the hopper; overflow guards should be used to contain as much mix as possible.

- Once a new truckload of mix has begun to be emptied into the hopper, the paver should be brought up to paving speed as quickly as feasible and operated at a constant speed in accordance with the amount of mix being delivered from the plant. This practice will keep the head of material in front of the screed as constant as possible.

- The paver should not be operated at a slower-than-normal speed while the truck exchange is being completed. If the paver continues to move forward while one truck is leaving and the next is moving into delivery position, the amount of mix in the hopper will be drawn down, possibly to the point that the hopper is emptied. This procedure will cause the amount of mix at the augers to be reduced, in turn causing the angle of attack of the screed and thus the thickness of the mat to decrease. Reducing the speed of the paver from normal paving speed to crawl speed between truckloads will also change the forces acting on the screed, further altering the thickness of the asphalt layer. In addition,

when the newly delivered mix is emptied into the hopper and pulled back to the augers by the slat conveyors, the large mass of mix (head of material) against the screed will cause the screed to rise, increasing the thickness of the mat. Thus slowing the paver down between truckloads of mix while emptying the hopper should be avoided because it causes significant changes in the forces acting on the screed and accompanying changes in the thickness of the layer being constructed.

- The flow gates on each side of the machine on the back of the paver hopper should be set at a height that permits the slat conveyors and corresponding augers to operate as close to 100 percent of the time as possible. The key to a smooth layer of mix is maintaining a constant head of material in front of the screed. The key to a constant head of material is a constant paver speed and continuous operation of the paver augers.

- If the paver is equipped with automatic flow control devices, that equipment should be set at a location near the end plate in order to maintain a constant head of mix in front of the screed by keeping the auger running continuously. The location of the device is important to preventing too much or too little mix from being carried at the outside edge of the screed.

- If the paver screed is being operated under manual control, the screed operator should not change the angle of attack of the screed by turning the thickness control cranks except to increase or decrease the thickness of the layer being placed. Once the controls have been turned, it takes at least five times the length of the tow arm on the paver before the screed completes the input change in thickness. If the paver is being operated under automatic grade and slope control, the screed operator should not attempt to change the angle of attack of the screed by turning the thickness control cranks at all.



# 16 Automatic Screed Control

As discussed in Section 15, the screed unit on the paver is attached to the tractor unit at only one point on each side of the paver, called the tow (or pull) point. As the tractor follows the existing grade with its rubber tires or crawler tracks, the length of the paver wheelbase becomes the reference for the screed. Because of the reaction time required for the screed, the screed will respond more slowly to changes in grade than will the tractor. Thus under manual screed control (covered in Section 15), the screed will average out deviations in the roughness of the underlying pavement layer, placing more mix over the low points and less mix over the high points in the existing pavement.

Automatic screed controls are used to keep the elevation of the tow points on the paver at a predetermined elevation relative to the reference (either a preset string-line or a long mobile ski). Deviations in the pavement surface are averaged out over the length of the reference. As the tractor unit moves up and down over the existing grade, the elevation of the tow points moves over a smaller range than would be the case if the relatively short wheelbase of the tractor provided the reference. Keeping the elevation of the tow points constant in direct relationship to the reference permits the screed to maintain a more consistent angle of attack, which in turn provides for a smoother mat behind the screed. It should be noted, however, that many factors affect the smoothness of the mix placed by the paver. The use of automatic screed controls by itself does not ensure that the mat constructed will be smooth. Proper attention to the operation of the paver, as discussed in Section 15, is extremely important to obtaining a smooth-riding pavement layer.

## MANUAL VERSUS AUTOMATIC SCREED CONTROL

If the paver always moved over a level grade, the forces on the screed would be constant as long as the paver was moving at a constant speed and there was a consistent head of material in front of the screed. The towing force on the screed would be stable and the head of material in

front of the screed consistent as long as the feed control system was set to operate as much of the time (close to 100 percent) as possible. Under these conditions, a very smooth asphalt mat could be obtained from behind the paver without the screed operator ever changing the setting of the thickness control cranks on the back of the screed. Indeed, once the angle of attack of the screed had been set when the paver started up in the morning, no changes to the setting of the thickness control cranks would ever be needed.

In the real world, however, the tractor unit operates over a variable grade. As the elevation of the existing surface moves up and down, the wheelbase of the tractor unit follows that grade (see Section 15). This vertical movement of the tractor as it moves forward causes the elevation of the tow points on the tractor to change in direct relation to the movement of the tractor unit. As the location of the tow points is thus altered, the angle of attack of the screed changes.

If the elevation of the tow points is raised, the screed will be rotated upward relative to the change in elevation of the tow points. As the paver moves forward a distance equal to at least five times the length of the leveling or tow arms on the machine, the screed will float up to the new elevation, and the asphalt mat placed will be thicker. If the tractor unit moves into a dip in the existing pavement surface, the elevation of the tow points will be lowered, reducing the angle of attack of the screed. If no other changes are made in the forces acting on the screed, the screed will move downward as the paver travels forward, lessening the thickness of the layer being placed.

The self-leveling action of the screed takes place continuously as the tractor unit travels over the roadway. The thickness of the mat being laid is determined by the reaction of the screed to the location of the tow points, the speed of the tractor, and the head of material in the auger chamber. The entire operation occurs without the thickness control cranks on the screed ever being changed. The floating-screed principle permits the paver to reduce the thickness of the mix placed on high points in the existing pavement surface and to increase the depth of the material deposited on low points.





If the thickness control cranks or handles are turned by the screed operator, the screed will react (change its angle of attack) by rotating around the hinge or pivot points where it is attached to the leveling arms and thus to the tow points of the screed. As the paver moves forward, the screed will float up to or down to the new elevation. As with a change in elevation of the tow points on the leveling arms, the paver must travel forward a distance of at least five lengths of the leveling arms before the change in the depth of the mat is fully realized.

On many projects, particularly those involving the resurfacing of an existing pavement, the screed operator is forced by the job specifications to maintain a certain yield of asphalt mix per square yard or per station. It is not uncommon to see a screed operator continually checking the thickness of the mat being placed by the paver and adjusting the setting of the thickness control cranks to increase or decrease the amount of mix being placed. These changes in the setting of the thickness control system are made without regard to the simultaneous changes to the screed as the elevation of the tow points changes while the tractor unit moves forward over the variable grade.

Two inputs, then, are being provided to the self-leveling system at the same time. The first is the vertical movement of the tow points of the screed in reaction to changes in the movement of the paver wheelbase. The second is the screed operator's manual changing of the thickness control cranks, illustrated in Figure 16-1. These two inputs may be in the same direction, or they may be in opposite directions, even canceling each other out.

Under manual screed operation, the ability of the screed operator to produce a consistently smooth asphalt layer is dependent on a number of factors. The first is the frequency at which the operator adjusts the setting of the thickness control cranks: the more the screed operator changes the angle of attack of the screed, the more un-

even the resulting pavement will be. The second factor is the roughness of the existing pavement surface: the more the screed operator tries to assist the self-leveling action of the screed, the rougher the resulting pavement surface will be. Third is the need to meet a certain maximum yield specification. It is difficult, particularly for thin courses, to produce a smooth pavement layer while staying within a certain volume of material usage. This is particularly true if a minimum overlay thickness is specified along with the yield criteria. This problem is discussed in detail later in this section. The fourth factor is related to the screed operator's need to match the elevation of the longitudinal joint in the adjacent lane. As paving speeds have increased because of higher plant production rates, it has become more difficult to manually maintain the level of the new mat relative to the adjacent mat.

When it is desired to produce a constant cross slope across the width of the lane being paved, automatic grade and slope controls can be used to control the elevation of the tow points of the screed on both sides of the paver at the same time. This is very difficult to do manually, even with two experienced screed operators. A grade control can be used on both sides of the machine; more commonly, a grade control is used on one side of the paver and a slope control on the other.

The primary purpose of automatic screed controls is to produce an asphalt pavement layer that is smoother than the paver can accomplish by itself using only the wheelbase of the tractor unit and the free-floating screed, and smoother than a screed operator can achieve by continually changing the setting of the thickness control cranks. As noted, automatic screed controls function by maintaining the elevation of the screed tow points in relation to a reference other than that of the wheelbase of the paver itself. That reference is typically longer than the wheelbase of the tractor unit. Figure 16-2 illustrates a screed and attached ski.

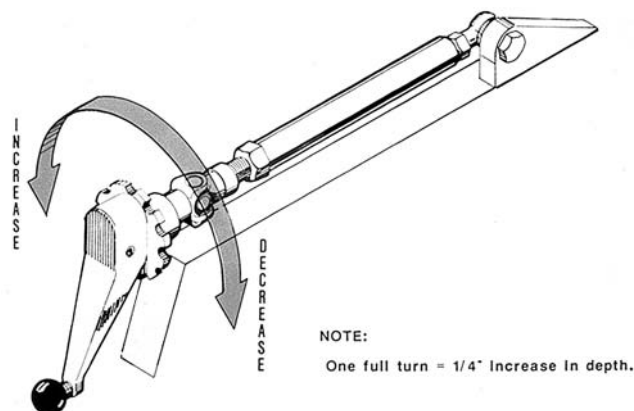
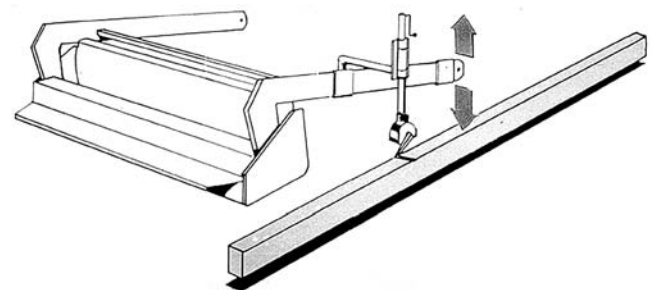

FIGURE 16-1 Thickness control crank.



GRADE SENSOR MOUNTING POSITION #1—SIDE ARM MOUNT

FIGURE 16-2 Screed and attached ski.



The elevation of the tow points is kept constant in relation to a given grade reference. The automatic system does not permit the relative position of the tow points to change even though the tractor unit is moving up and down vertically in response to the roughness of the surface over which it is traveling. By maintaining the tow points at a constant elevation, the angle of attack of the screed is also maintained at a constant setting. This allows the screed to ride at a consistent angle, permitting it to do an even better job of reducing the quantity of mix placed over the high spots in the existing pavement surface and increasing the amount of mix laid in the low spots.

Before the automatic screed control is engaged and before paving starts, the screed should be “nulled” (i.e., angle of attack set at a flat or zero angle position). Once the paver is moving, the proper angle of attack should then be set for the thickness being placed, and the control engaged. If automatic controls are being used on the paver, the screed operator should not try to change the angle of attack of the screed manually by turning the thickness control cranks. If such an attempt is made while the machine is moving, the automatic grade and slope controls will attempt to compensate for the manual input by changing the elevation of the tow points. Manual input will be needed only if the tow point actuator (hydraulic ram) has reached the limit of its travel—if the tow point ram is at its upper or lower limit. In this case, the paver should be stopped and the tow arm reset at the centerpoint of its length of travel. The screed should be nulled, the paver restarted, and the proper angle of attack input to the screed before paving continues.

Note that when a superelevated curve that requires a change from the existing cross slope is being paved, it is necessary to run the grade sensor on one side of the paver automatically and the slope sensor on the other side of the paver manually. This practice allows changes to be made in the amount of superelevation and provides the required degree of cross slope.

## GRADE CONTROL

### Types of Grade References

Grade sensors are used to monitor the elevation of the existing pavement surface in a longitudinal direction. Three basic types of grade references can be used to maintain the elevation of the screed tow points: (a) erected stringline, (b) mobile reference or ski, and (c) joint matching shoe. On some paving projects with proper sight distance, such as an airport runway or large vehicle test pad, a laser system can also be used.

Each type of grade reference can be used alone on either side of the paver; each can also be used on both sides of the paver at the same time. The same type of grade reference can be used on both sides of the machine, or a different type can be mounted on each side. For example, a preset stringline can be used on one side and a mobile reference on the other. This use of double grade references makes it possible to average out the variations in the profile of the existing pavement surface on both sides of the lane being paved. However, use of double grade references generally will not produce a uniform cross slope for the new asphalt layer unless a preset stringline is used on both sides of the laydown machine. An effective approach is to combine the use of grade and slope controls. When a grade reference is used in conjunction with a slope control device, the grade sensor is typically positioned on the centerline side of the paver, with the slope control determining the depth of the mat on the outside edge of the pavement.

The grade sensor or wand is in contact with the reference in all but sonic systems. As the grade of the reference changes, the wand senses that change and sends an electrical signal to the control panel on the paver. A signal is then sent, in turn, to the tow points on either side of the paver, and their elevation is changed relative to the change sensed by the grade sensor.

If a sonic or noncontact system is used, a sound pulse is sent out from a transducer toward the reference—stringline, mobile reference, or existing pavement surface. When the sound pulse hits the reference, a portion of that pulse is reflected back to the transducer, which also acts as a receiver. The time required for the sound to travel to the reference and back is measured, and the distance is calculated on the basis of the speed of sound. Thus the elevation of the tow points is controlled without the sensor actually coming in contact with the reference itself. On one sonic system, a “working window” is used to prevent the system from making a major change in the elevation of the tow points when a false signal is received. This window is plus or minus 61 mm (2.4 in.) from the elevation of the reference. If the distance measured by the sonic system is greater than the window range, the control of the grade sensor is switched to manual, and no changes are sent to the tow points.

### Erected Stringline

The use of an erected stringline, shown in Figure 16-3, provides for placement of the smoothest possible asphalt mat behind the paver screed. The stringline can be made of wire or nylon cord. This method of supply-





**FIGURE 16-3 Stringline for grade control.**

ing elevation input provides the most consistent reference for the paver tow points, enabling a predetermined grade to be matched very accurately if the controls are used properly.

In application, the use of an erected stringline has a number of drawbacks that may offset the increased smoothness obtained. First, the elevation of the erected stringline must be set by a surveying crew. The accuracy of the elevation of the line and the resulting pavement smoothness are directly dependent on the care taken during erection. If the grade set by the surveyors is incorrect in any way, the paver screed will duplicate that error in the pavement surface. On horizontal curves, it is very difficult to use an erected stringline to control the grade of the new pavement layer. Since the string cannot be set in a curve, a series of chords must be used to simulate the radius of the curve. This in turn requires the positioning of a large number of support posts and rods, usually at intervals of 1.5 to 6.0 m (5 to 20 ft), around the curve.

The stringline must also be very taut when it is set. Typically, the string is supported at intervals of 8 m (25 ft) on metal posts and rods. The string or wire is first anchored at one end of its length and then pulled tight and anchored at the other end. It is extremely important that there be no dips or sags between the support rods. If the string is not stretched tightly, the sensor wand on the paver, which can run either atop or below the stringline, will react to the sags in the line and duplicate those sags in the new pavement surface. Even when high-strength line is used, it is not always possible to keep the line tight enough to prevent small sags from occurring.

It should be noted that any sags in the stringline will not be duplicated at the exact same longitudinal location in the pavement surface because of the delay in the reaction time of the screed once an input has been made to the

elevation of the tow points (see Section 15). As the grade sensor travels over the dip in the stringline, the elevation of the tow points changes. The paver must travel a distance equal to five times the length of the tow arm, however, before the change in the mat thickness is fully completed. Thus any sag in the stringline will be manifested in the pavement surface, but at some length down the roadway from the position of the sag in the stringline.

Another disadvantage of the erected stringline is that the haul trucks and all paving personnel must keep away from the line and not disturb it in any way. Once the line has been set at the proper elevation, it must remain untouched both before and after passing of the paver sensor over the line. Any change in the elevation of the line will result in a change in the input to the grade sensor and movement of the tow points on the paver leveling arms.

With a properly set and maintained stringline, the mat placed by a paver equipped with automatic screed controls can be very smooth and at the correct elevation, primarily because of the extended length of the reference being used as compared with the more limited length of a mobile reference. However, unless smoothness or compliance with a predetermined grade reference is extremely important, as with an airport runway where a consistent longitudinal and transverse profile is required, it is questionable whether the added expense of erecting and maintaining a stringline is cost-effective for the typical HMA paving job. Thus for the vast majority of highway paving projects, an erected stringline is not used.

### *Mobile Reference*

The various paver manufacturers use different types of mobile reference devices to extend the relative wheelbase for the automatic screed control system. The operation of these reference systems, however, is essentially the same. The purpose of the mobile reference is to average the deviations in the existing pavement surface out over a distance that is greater than the wheelbase of the tractor unit itself.

One version of a mobile reference employs a rigid tubular grade reference (pipe) that is 6.1, 9.1, or 12.2 m (20, 30, or 40 ft) in length, as seen in Figure 16-4. For this version, the pipe or tube rides directly on the existing pavement surface. A spring-loaded wire is typically stretched along the ski on top of the pipe. The grade sensor that inputs the electrical signal to the paver tow points rides on top of the wire. As the ends of the pipe move up and down over the existing grade, the stretched wire on the ski is used to average out the differences in elevation that occur under the mobile reference.





**FIGURE 16-4** Paver with mobile reference employing rigid pipe.

The primary problem with the use of a rigid pipe or any rigid reference is the fact that if a singular high point is present in the pavement under the reference, the front end of the pipe will ride up over the hump until the midpoint on the length of the pipe is reached. At that time, the pipe will break over, and its front end will tip downward, like a seesaw. That change in slope will continue until the back end of the reference is off of the high point. The bump duplicated in the mat behind the paver may be more pronounced than it would have been if a floating-beam reference had been used.

A floating-beam mobile reference consists of a series of feet or shoes attached to the bottom of a beam, as shown in Figure 16-5. One or more of the feet can pass over a singular high or low point in the existing pavement surface without altering the slope of the entire beam. The feet are spring loaded so they can be deflected by a large stone on the pavement surface, for example, without pushing the whole beam upward. The grade sensor usually rides directly on the beam at its midpoint. As with the other types of mobile references, this floating-beam system averages out the variation of the existing grade over a 9.1- or 12.2-m (30- or 40-ft) distance.

Another type of floating-beam mobile reference system is illustrated in Figure 16-6. The beam is normally 9.1 or 12.2 m (30 or 40 ft) in length. Instead of multiple feet spread out along the length of the beam, however, a series of shoes is placed at each end of the beam. These shoes are allowed to rotate and can be individually displaced by isolated disruptions in the existing pavement surface without changing the elevation of the entire beam. Thus the beam can average the grade of the surface over the length of the reference without being influenced by the presence of a single high point or dip.



**FIGURE 16-5** Floating-beam mobile reference.

On mobile reference systems other than the floating-beam type, the grade sensor should be located in the center of the length of the beam to ensure that the input to the paver tow points will be made equally over the length of the reference. If the grade sensor is not located in the center of the length of the mobile reference, the ski will not average out the changes in elevation in the existing pavement surface uniformly. As suggested earlier, the ski can be thought of as a seesaw, and the location of the grade sensor can be regarded as similar to the seesaw's pivot point. If the sensor is offset (closer to one end of the ski than the other), a change in elevation at the longer end of the reference will be magnified and result in a greater input change to the elevation of the tow points. Conversely, a change in elevation on the shorter end of the ski will result in a lesser change in the location of the screed tow points. Thus, except for unusual circumstances, the grade sensor should be located in the center of the length of the ski.



**FIGURE 16-6** Floating-beam mobile reference with shoes at ends of beam.

Of the mobile reference devices described above, the floating-beam type with multiple feet or shoes typically results in a smoother pavement because of its ability to ignore isolated deviations in grade (a rock on the roadway, for example). Moreover, the longer the grade reference used, within reason, the better the paver will average out variations in the elevation of the existing pavement surface. A mobile reference will not, however, ensure that the mix being placed is at the proper elevation. The elevation is controlled by the elevation of the underlying pavement surface and the thickness of the mat being laid.

One paver manufacturer has produced a mobile reference ski that is 16.8 m (55 ft) in length from front to back, termed an over-the-screed reference (see Figure 16-7). On this device, part of the reference beam is located in front of the screed. This portion of the reference is basically a floating-beam system, equipped with a series of spring-loaded shoes, that senses the grade of the existing pavement surface. To the rear of the screed, riding on a series of spring-loaded wheels or large shoes, is another floating beam that is used to reference the grade

of the newly placed asphalt mix. A set of intermediate bridge beams that extends up and over the screed is used to join the two parts of the floating beam. The grade sensor rides on one of the intermediate bridge beams and transmits the average grade of the front and back beams to the paver tow points to control their elevation.

Another version of the over-the-screed reference is available. On this device, the front ski consists of a floating beam in front of the screed that rides on the existing pavement surface. Another floating beam rides on the newly placed mat behind the screed. Instead of the bridge beams connecting the two beams, however, a stringline or wire is used. The grade wand rides on the stringline and senses the average change in grade between the front and back reference beams.

Because of its greater length relative to the other types of reference, the over-the-screed reference provides for a smoother mat. In addition to the greater length of the reference, however, the fact that the rear ski rides on the new mix is also important for smoothness. Since the new mat should be significantly smoother than the existing pavement surface, the average variation sensed by the grade wand is limited, resulting in fewer changes to the elevation of the tow points as the paver moves down the roadway. This device may not be practical, however, in hilly terrain or on pavement that has a large number of vertical curves.

### *Joint-Matching Shoe*

The joint-matching shoe, shown in Figures 16-8 and 16-9, consists of a short shoe or ski [approximately 0.3 m (1 ft) long] that is used to reference the grade of an adjacent pavement lane. This type of mobile reference is used only when the grade being sensed is relatively smooth. The shoe rotates around its own pivot point and when displaced supplies an electrical input signal to the paver tow points. The shoe should be checked to ensure that it is free to rotate properly.

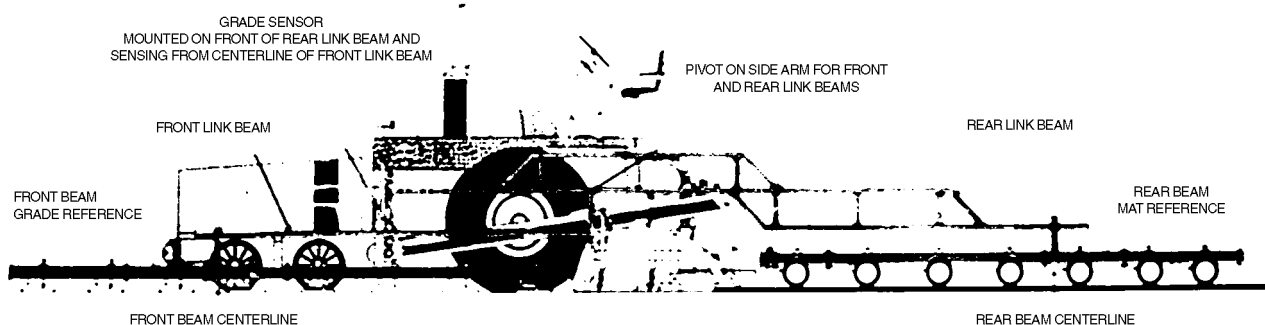

**FIGURE 16-7** Over-the-screed reference.



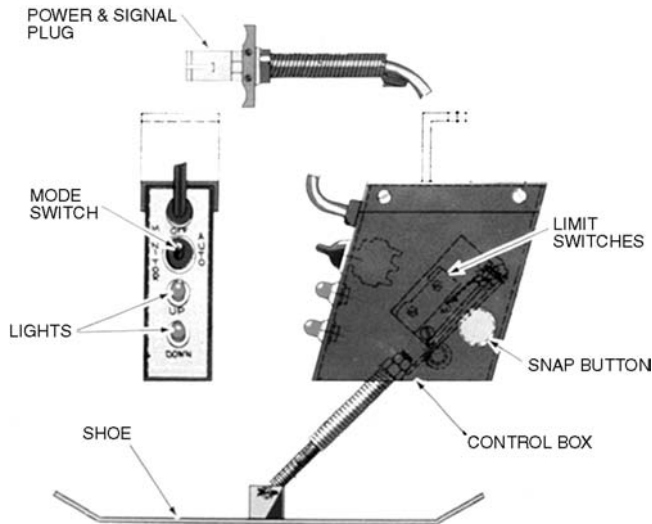

**FIGURE 16-8** Shoe for matching joints.

Because of its short length, the joint-matching shoe will not significantly reduce major variations in the pavement surface. Indeed, the purpose of the shoe is to duplicate the grade of the adjacent surface. This grade-control device should be used with caution because pebbles, rocks, and other obstructions over which the shoe may ride will result in grade changes being input to the screed tow points. Further, because of the delay in the reaction of the screed once the tow point elevation has been changed (see Section 15), the input from the pavement surface over which the joint-matching shoe is passing will not be duplicated at the same longitudinal location in the new pavement surface. The joint-matching shoe thus does not truly match the joint. However, if the shoe is placed at the tow point, the screed is about 1 baseline length behind the shoe, and 63 percent of any thick-

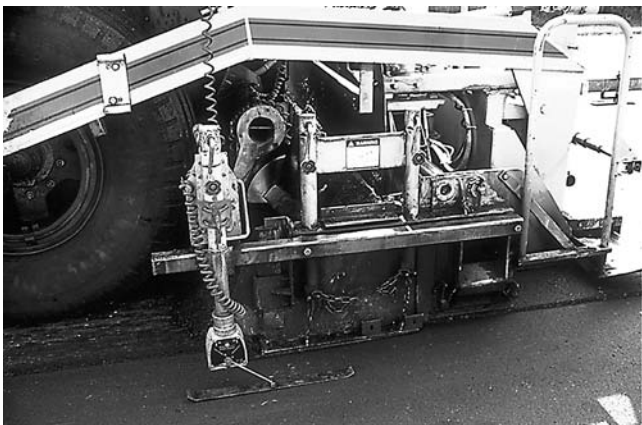

**FIGURE 16-9** Operation of joint-matching shoe.

ness change will occur when the screed arrives at the point where the shoe called for the change.

When placing the second lane of a base course or a binder course layer, it may be better to use a longer mobile reference [a ski 9.1 m (30 ft) long] instead of a joint-matching shoe. The mobile reference will provide better input for constructing a smooth pavement surface than will the joint-matching shoe. For a surface course layer, however, the joint-matching shoe may be used to ensure that the elevation of the mix on both sides of the longitudinal joint is the same, although the use of a longer mobile reference is still better paving practice.

### Lasers

Laser technology has been used successfully on a number of paving projects. For locations where the sight distance is adequate and the pavement being placed has a constant slope, a laser system can be employed to control the elevation of the tow points on the paver. A transmitter sends a laser signal to a receiver unit on the lay-down machine. This signal controls the grade of the mat by regulating the tow point location in relation to the laser beam. When used properly, the laser grade control system is capable of providing a very smooth mat behind the paver. To keep the tow points from moving randomly if a haul truck or other object passes through the laser beam, a delay is built into the control system so that the beam can be interrupted briefly without changing the position of the tow points.

### Location of Grade Reference

The various paver manufacturers make different recommendations regarding placement of the grade-control sensors. In the past, it was often suggested that the sensor be mounted adjacent to the tow point on the side(s) of the paver on which the grade control was being used. Because of the delayed reaction time of the screed, however, it has been found that a better place to mount the grade sensor is either part of the way up the leveling arm of the screed or near the screed. The grade sensor is sometimes hung at the tow point when used in conjunction with a joint-matching shoe, but it is suggested that, even with the latter type of reference, a better place to locate the sensor is on the leveling arm, one-third to two-thirds of the way between the tow point and the screed.

The tow arm or side mounting position typically is recommended when long vertical deviations in the present pavement surface need to be corrected. When

the sensor is located on the leveling arm, less time is required to react to changes in grade, and the angle of attack of the screed is altered quickly. On some occasions, particularly for wide paving, it is best to mount the grade sensor near or on the paver screed. To function properly, the sensor must be located in front of the pivot or hinge point of the screed.

The location of the grade sensor makes a difference in the reaction of the tow points and the screed to the grade being sensed. There is no set rule, however, for the proper location in which to place the grade sensor. It is recommended, therefore, that the paver manufacturer's suggested placement be used. If no location is suggested, it is recommended that the sensor be hung on the leveling arm, at a point one-third to two-thirds the length of the arm between the tow point and the screed.

The operation of the grade-control sensor should be checked regularly. The sensor wand should be lifted a very short distance, less than 3 mm ( $\frac{1}{8}$  in.), when the machine is stopped and the movement of the tow points is observed. Manually moving the sensor should result in a corresponding movement of the tow points. If the wand is raised or lowered and the actuator or ram does not move, either the system is turned off, or the sensitivity of the sensor is set too wide. In the latter case, the dead-band range or the sensitivity setting is too great.

When the paver is moving, the up and down lights on the grade sensor should blink to indicate that a signal is being sent to the tow point actuator. If the grade sensor uses a meter instead of lights, the reading on the meter should change when the sensor wand is moved, as well as when the paver is placing mix on the roadway. In addition, the elevation of the tow points should change occasionally, depending on the roughness of the existing pavement surface, so that the angle of attack of the screed will remain constant as the tractor unit follows the underlying pavement grade. The change in elevation of the tow points, however, should be smooth. The tow points should not be moving up and down rapidly or constantly as the paver travels forward.

## SLOPE CONTROL

As noted earlier, paving that is done with automatic screed controls is usually accomplished with a combination of grade control on one side of the paver and slope control to determine the grade on the other side of the machine. The slope control operates through a slope sensor that is located on a cross-beam between the two side arms of the screed. One side of the screed is con-

trolled by the grade sensor, while the other is controlled by the slope controller. In almost every case, the inside or centerline edge of the mat is controlled by grade and the outside edge by slope, because it is much more difficult to subsequently match the centerline joint if slope control is used on that side of the paver.

When slope control is used, the thickness of the mat on the side of the machine that is controlled by the slope sensor may be variable in depth, depending on the condition of the existing pavement surface. The desired degree of cross slope is dialed in to the slope controller, shown in Figure 16-10. This cross slope is then regulated by a pendulum device that is part of the slope-control system. Without regard to the grade of the existing pavement, the slope controller maintains a constant cross slope regardless of the resulting thickness of the asphalt layer placed. If there is a high point in the present pavement surface, the slope controller causes the screed to place less material over that location; if there is a low point in the existing pavement, the slope controller causes the screed to deposit more mix in that location. It is good practice to check the slope of the lane routinely with a carpenter level or other method (Figure 16-11).



FIGURE 16-10 Slope-control device.





**FIGURE 16-11** Checking slope of mat surface behind paver.

For a wide pavement, such as an airport runway, it is good practice to check the elevation of the outside edge of the mix being placed after two passes of the paver in the longitudinal direction. If the slope is not set properly or the slope sensor setting is changed accidentally, the error may be compounded in the slope setting all the way across the pavement. The result may be a very thick or very thin layer of mix on the edge of the runway. Use of one or more stringlines across a wide pavement can help provide the proper cross slope.

### **YIELD, MINIMUM THICKNESS, AND SCREED CONTROLS**

The paving specifications for HMA overlay projects are written in a variety of ways. The specifications may call for a minimum thickness of mix to be placed. In such cases, it is usually necessary that the paver place a mat thickness that is greater than the minimum depth required in the contract for the minimum thickness specification to be met at all points in the pavement layer. The amount of extra thickness depends on the roughness of the existing pavement: the more uneven the surface being paved, the greater will be the volume of mix needed to ensure compliance with the minimum thickness requirement.

To illustrate, if the existing pavement is relatively even and a minimum HMA overlay thickness of 25 mm (1 in.) is required, the paver thickness-control system must be set to place an average depth of uncompacted HMA of approximately 38 mm (1½ in.). This means the angle of attack of the screed must be such that the average thickness placed will ensure the minimum depth of mix over all the high spots in the pavement surface.

A second type of specification calls for placement of a given amount of mix, in terms of kilograms of mix per square meter (pounds of mix per square yard), over the pavement surface area. In this case, the thickness requirement is an average, not a minimum, depth. If the specifications for a project call for placement of 60 kg of mix per m<sup>2</sup> (approximately 110 lb per yd<sup>2</sup>) or approximately 25 mm (1 in.) of compacted thickness for an HMA mixture, the paver screed need not be set at as great an angle in order to place the mix to an average compacted depth of 25 mm (1 in.), as compared with a minimum specification thickness of 25 mm (1 in.).

The paver screed, if left to operate without human intervention on the thickness-control cranks and running either with or without automatic controls, will typically overyield mix. This means the paver will require more material than would otherwise be expected in order to react to variations in the grade of the existing pavement and to place less mix on the high spots and more on the low spots. To meet the yield requirement, therefore, it is usually necessary to reduce somewhat the thickness of the mat being placed, and this means that any minimum thickness requirement will not be met.

Conversely, if the paver is allowed to operate on its own, the machine will be able to place a smooth mat, but the amount of mix required will typically be greater than plan quantity. In this case, an extra quantity of mix must be available beyond that calculated from the length, width, and thickness of the paving project area. Such an operation will thus not be practical for a project with a yield specification.

An additional problem with a yield specification is the longitudinal distance used to determine the yield value. In some cases, yield is checked after every truckload of mix. This frequency of checking often leads to continual changes in the thickness-control cranks on the paver. Yield should be checked only periodically—for example, the tons of mix placed over a distance of 300 m (1,000 ft). Another option is to check the yield no more than once per hour of paving.

A third type of specification requires a certain degree of smoothness for the finished pavement surface. Many such specifications exist. Most are related to the amount of deviation permitted from a straightedge of a given length, or a certain maximum number of millimeters (inches) of roughness per unit of length, typically a kilometer (mile) or some fraction thereof. Although it is normally possible to meet such smoothness requirements through the use of automatic screed controls, ultimate success in doing so will depend on the amount of mix available to be placed, the condition of the existing pavement, and the number of layers of mix to be laid. The



amount of mix necessary to meet a smoothness requirement will usually be greater than the amount needed to meet a given yield requirement. For most existing pavement surfaces, it is not reasonable to expect to achieve a smooth overlay if only one resurfacing course is placed. Indeed, if the existing pavement surface is quite rough, it may be difficult to meet a smoothness requirement even after two new layers of mix have been constructed. Smoothness specifications should therefore be related to the condition of the present pavement surface unless the existing surface is milled or the overlay consists of at least two layers.

A significant problem arises when it is necessary to meet some specified yield requirement and a minimum thickness or smoothness requirement simultaneously. Because of the principle of the floating screed (see Section 15), it generally is not possible to meet both of these requirements at the same time on the same project, depending on the smoothness of the pavement being overlaid. This is particularly true for thin overlays. The governing criterion (yield, minimum thickness, or smoothness) should be determined at the time the job is designed and should be stated in the contract documents. That same criterion should also be discussed and agreed upon between contractor and agency representatives before paving begins (during the preconstruction meeting).

## SUMMARY

The following factors should be considered in monitoring automatic screed control operations:

- The screed operator should not attempt to make manual changes in the angle of attack of the screed by turning the thickness-control cranks, because the automatic controls will attempt to change the elevation of the tow points to compensate for the manual input to the screed.

- The grade sensor should be checked to ensure that it is working properly. If the wand (which rides on the stringline or mobile reference beam) is raised 3 mm ( $\frac{1}{8}$  in.), there should be a corresponding movement of the actuator or ram at the tow points on the paver. If the wand is raised (or lowered) and the actuator does not move, either the system is not turned on or the sensitivity of the sensor is set too wide—with too great a dead-band or sensitivity setting.

- When the sensor is set on the grade reference and the paver is moving forward, the up and down lights on the sensor should blink occasionally or the constantly

blinking lights should change in intensity occasionally, both top and bottom, to indicate that a signal is being sent from the sensor to the tow point cylinder. On grade sensors that use a meter, the meter should indicate a change in reading as the paver travels down the roadway. Further, the movement of the tow point actuator should be smooth, without constant or rapid up and down movement.

- If a stringline or wire is used as the grade reference, the line should be very taut; there should be no sags in the line, particularly between the vertical support locations. Tautness can be checked by sighting down the line. The grade sensor wand should ride easily over the stringline and not be displaced in a vertical direction when it passes over a support arm. Every effort should be made to keep all personnel and equipment from coming in contact with the stringline and disturbing it, either longitudinally or vertically.

- If a mobile reference is used for grade control, the sensor should ride on the reference at the midpoint of the reference length. This placement allows the input to the paver to be made equally over the length of the mobile reference. If the mobile reference is equipped with multiple feet or shoes, each device should be checked to ensure that it is clean and free to move or rotate around its own hinge or spring point. The length of the mobile reference should be as long as practical to provide for the greatest averaging out of variations in the elevation of the existing roadway surface. The length of the reference should be longer than the wheelbase of the tractor unit.

- If a joint-matching shoe is used for grade control, it should be checked to ensure that it is free to move or rotate around its own hinge or spring point.

- If the automatic control system includes grade control on one side of the paver and slope control on the other, the layer being placed should be checked regularly to ensure that the proper elevation is being built into the pavement layer by the paver. This regular checking is particularly important on very wide pavements, such as an airport runway.

- On most paving projects, the grade-control sensor should be hung on the leveling (tow) arm of the paver, typically between one-third and two-thirds of the distance between the tow point and the screed. On some projects, the sensor can be placed just in front of the screed, but it should never be placed behind the pivot point of the screed. The sensor, except when used in conjunction with a joint-matching shoe, should generally not be located at the tow point.



## 17

# Joint Construction

During the construction of HMA pavements, two types of joints are encountered. The first is a transverse joint, which is constructed whenever the paving operation is interrupted for a period of time—anywhere from 15 minutes to several weeks or more. The second is a longitudinal joint, which is built when a lane of HMA is constructed adjacent to a previously placed lane of mix. The techniques for constructing each type of joint are discussed in this section.

## TRANSVERSE JOINTS

### Suspension of Paving

The way a transverse joint is constructed depends primarily on whether traffic will be traveling over the asphalt mix before the paving is restarted. If traffic will not be passing over the end of the pavement, a vertical butt joint can be constructed; otherwise, a tapered joint must be built. In either case, the operation of the paver is essentially the same, but the construction of the joint itself is different.

It is important that the paver be run in normal fashion right up to the point at which the transverse joint is constructed. This means the head of material in front of the screed should remain as consistent as possible up to and at the location of the joint, so that the forces acting on the screed will be constant, and a consistent angle of attack will be maintained for the screed. The result will be a uniform mat thickness at the joint—the same thickness as that of the previously placed mix.

It is common but incorrect practice to empty out the paver hopper when a transverse joint is to be built. The paver operator runs the hopper out of mix, and the transverse joint is constructed at the point where the empty paver has stopped. As the hopper is emptied, however, the amount of mix carried on the augers is reduced until it is minimal. This process reduces the head of material in front of the paver screed, causing the screed angle to fall. The thickness of the mat then gradually decreases as the joint location is approached. The transverse joint is thus built at a low point in the new pavement surface, resulting in a dip that will be felt by traffic.

It is much better practice to locate the transverse joint at a point where the head of material in front of the screed is normal. This type of operation, however, requires more work on the part of the paving crew. If the joint is made where the pavement thickness (head of material) is constant, the paver screed is simply raised up at the point where the joint is to be built. Doing so leaves a great deal of mix on the roadway—the amount of mix that was in front of the screed. Except for the amount of mix needed to construct a taper, this material will have to be removed and then wasted or returned to the asphalt plant to be used as RAP. In addition, it will be necessary to dispose of the amount of mix remaining in the paver hopper. The advantage of this practice, however, is a smooth transition across the joint instead of a dip.

### Butt Joints

For a butt joint (Figure 17-1), a vertical face is constructed by hand across the width being paved. This operation consists of raking, shoveling, and then removing the mix that is located downstream of the selected joint location. The mix thus removed is discarded or returned to the plant to be recycled. The mix that is in place upstream of the joint is not touched in any manner.

Compaction of the mix on the upstream side of the joint is accomplished in normal fashion. It is necessary, however, for the rollers to compact the mix immediately adjacent to the joint. For this to be done properly, runoff boards must be placed next to the joint. The thickness of the boards should be approximately equal to the compacted thickness of the layer being placed. In addition, the boards must be wide and long enough to support the full size of a roller. The compaction equipment passes over the mix at the joint and onto the boards before the rolling direction is reversed. This practice ensures that the transverse joint receives the same degree of compaction as the rest of the mix in the pavement layer.

If runoff boards are not used, the front wheel of the compaction equipment is normally run up to the transverse joint, stopping just short of the joint. The roller di-