



# **Installation Reference Guide**

## **Labor Requirements and Tools and Equipment**

### *Fighting the Fires of Hate: America and the Nazi Book Burnings*

#### **Estimated labor requirements for unpacking**

At least two workers to unload truck. It should take approximately an hour to unload.

#### **Estimated labor requirements for installation:**

Two workers will be needed to install the exhibition, four are recommended. It is estimated that it will take no more than one day to install the exhibition.

#### **Estimated labor requirements for de-installation**

Two workers, preferably the same workers who installed the exhibition, will be needed to de-install the exhibition. It is estimated that de-installation will take two to three hours.

#### **Estimated labor requirements for packing:**

At least two workers are needed to load truck. It should take approximately one hour to load the truck.

#### **Equipment needed for unloading and loading truck**

All crates containing the exhibition structures are a suitcase style with wheels for easy transport. Dollies may be required for the 6 Audio/Visual crates, and the truck should be equipped with one.

#### **Tools to be provided by the host venue for installation**

**Table and chairs** – to set up 4 tabletop computer systems with touch screen interactive computer program in section 3 of the exhibition, *Authors and Their Books*. Configuration is to the discretion of the host institution.

**Step ladder** – 4' or 6' height to connect header panels.

**Surge protectors** – to be attached to all audio visual elements as a precaution, particularly on the 4 free-standing kiosks.

Extension **cords** and **power strips** may be required depending on the placement of the audio visual elements. We also recommend the use of OSHA approved cord molding or duct tape to secure and protect the electrical cords that may need to run across the exhibition space.

## Crate List

### *Fighting the Fires of Hate: America and the Nazi Book Burnings*

#### 6 Audio/Visual crates # 1 – 6

- 4 large (70.5" x 34" x 12", approximately 215 pounds each)
- 2 small (24" x 24" x 24", approximately 70 pounds each)

CRATE #	CONTENTS
crate 1	AV kiosk for section 2 – <i>Students in the Nazi Revolution</i>
crate 2	AV kiosk for section 4 – <i>Immediate American Responses</i>
crate 3	AV kiosk for section 5 – <i>America at War</i>
crate 4	AV kiosk for section 6 – <i>Recurring Symbol</i>
crate 5	2 tabletop computer systems for section 3 – <i>Authors and Their Books</i> 4 sets of headphones
crate 6	2 tabletop computer systems for section 3 – <i>Authors and Their Books</i> 4 sets of headphones

#### 20 suitcase style crates #7 – 26

- 13 standard size (32" x 43" x 12", approximately 115 pounds each)
- 7 accessory size \* (16.5" x 29.5" x 10", approximately 45 pounds each)

CRATE #	CONTENTS
Crate 7	panels 1-3, a-c
Crate 8	panels 4-8, b-c
*Crate 9	panels 4-8, a condition report notebook installation manual brochure holders
Crate 10	panels 9-13, b-c
*Crate 11	panels 9-13, a
Crate 12	panels 14-19, b-c
*Crate 13	panels 14-19, a
Crate 14	panels 20-24, b-c
*Crate 15	panels 20-24, a
Crate 16	panels 25-28, a-c
Crate 17	panels 29-32, a-c
Crate 18	panels 33-36, a-c
Crate 19	panels 37-41, b-c
*Crate 20	panels 37-41, a
Crate 21	panels 42-47, b-c
*Crate 22	panels 42-47, a
Crate 23	panels 48-51, a-c
Crate 24	panels 52-55, a-c
Crate 25	panels 56-60, b-c
*Crate 26	panels 56-60, a

**OPEN THIS CRATE FIRST**

## Unpacking and Installation instructions

### *Fighting the Fires of Hate: America and the Nazi Book Burnings*

#### Suitcase style crates

These crates contain all of the exhibition panel structures.

Each set of accorded panel systems is a set of 3, 4, 5 or 6 folds. Each fully assembled fold has three inset pieces. The lower two pieces are parts **B** and **C**, and they do not disassemble – only fold down for storage. The third piece, part **A**, is separate from these, and must be attached on top as an individual piece (see drawings below). All panels are numbered sequentially to match the desired flow of the exhibition content.

The crates do not need to be opened in any specific order, but we recommend placing the crates in the general area of the room where that portion of the exhibition will be displayed before opening and unpacking each crate. The introductory section (timeline) should be at the beginning of the exhibition, and the title kiosk can be placed wherever seems most appropriate to the space.

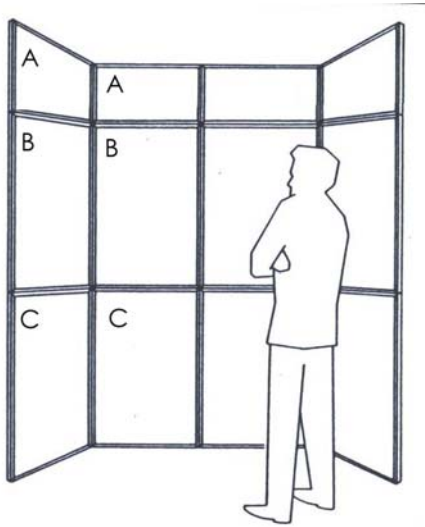

fully assembled and installed panel system

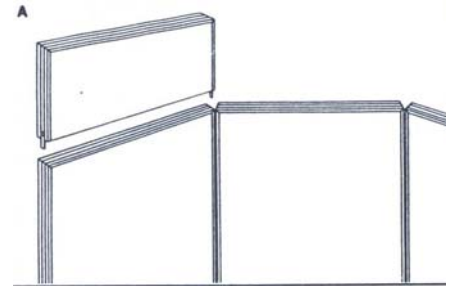

## Deinstallation and Packing

### *Fighting the Fires of Hate: America and the Nazi Book Burnings*

1. Unlock and fold down all panel systems.

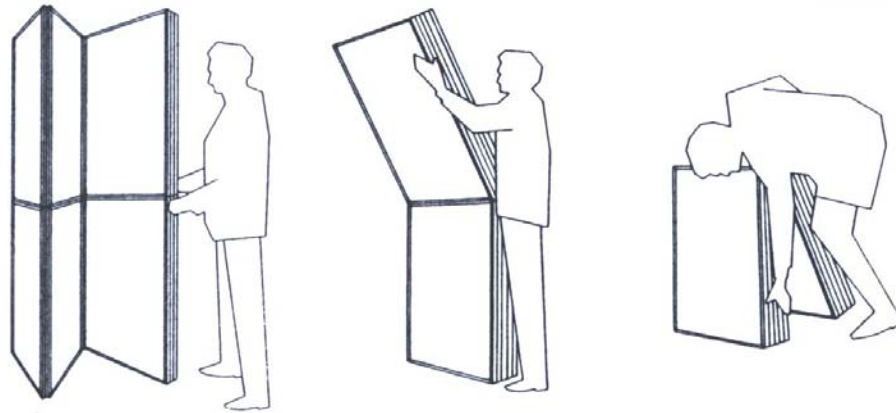

2. Reattach Velcro strap, and return them to their crates as labeled. Make sure a piece of cardboard remains between each layer.

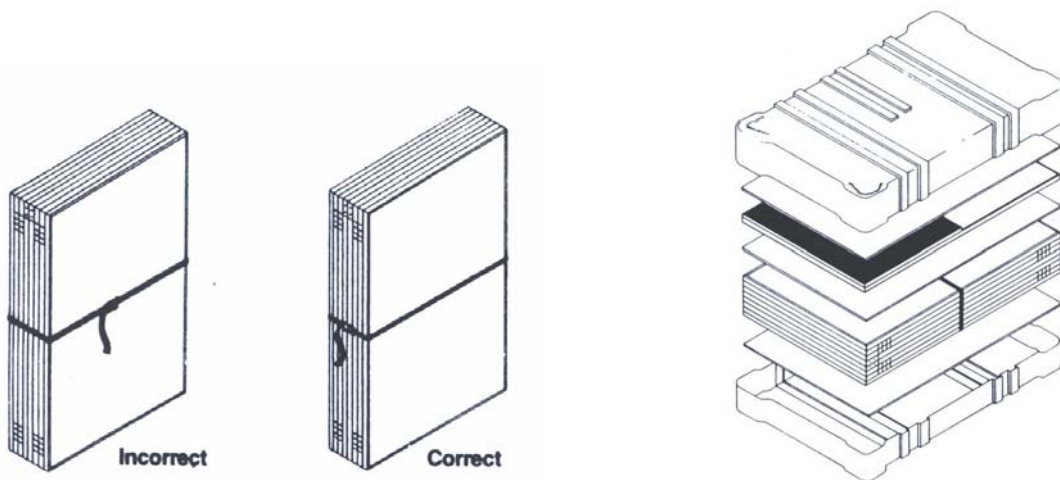

3. Secure strapping on outside of crates.
4. Return each AV kiosk to their crates as labeled.

## **Routine Maintenance**

### *Fighting the Fires of Hate: America and the Nazi Book Burnings*

This exhibition was designed to be care-free. However, the surfaces may require cleaning. All exhibition components, including the structures themselves, AV kiosks, and computer monitors can be cleaned with a normal glass cleaner. Do not apply cleaner directly onto the screen, but rather apply cleaner to paper towel or cloth and then use to clean the glass. Be cautious of getting the electronics themselves damp.

If any serious damage occurs, please do not attempt to make any repairs yourself. **Please report any damage or malfunction immediately to USHMM Traveling Exhibitions, 202.314.0325**, so a replacement panel can be ordered, or a technician can be sent.

USHMM will provide service to AV kiosks periodically throughout the exhibition's tour to dust internally.