

TIMBER FRAMING

JOURNAL OF THE TIMBER FRAMERS GUILD

Number 74, December 2004



D-I-Y Down Under

TIMBER FRAMING

JOURNAL OF THE TIMBER FRAMERS GUILD
NUMBER 74 DECEMBER 2004

CONTENTS

TOPICS Rick Collins	2
HISTORIC AMERICAN ROOF TRUSSES IV. COMPOSITE AND RAISED BOTTOM CHORD TRUSSES Jan Lewandoski	4
COMPOSITE AND RAISED BOTTOM CHORD TRUSS ENGINEERING Ed Levin	20
D-I-Y DOWN UNDER II Rob Hadden	22

On the cover, end view and interior detail of newly made barn with guest quarters in Castlemaine, Victoria, Australia. The owner-builder, an artist and self-taught mason and timber framer, chainmilled most of the timber from salvage logs of many species and gathered and laid all the stones in the masonry foundation. Inspired by English design largely from the Welsh Marches, though not exclusively so, the frame was cut by English scribe rule and raised piece by piece using gin pole, shear legs and tackle. Pegs are cleft and shaved. Photos by Mandy Murphy. Story page 22.

Copyright © 2004
Timber Framers Guild, PO Box 60, Becket, MA 01223
www.tfguild.org
888-453-0879

Editorial Correspondence

PO Box 275, Newbury, VT 05051
802-866-5684 journal@tfguild.org

Editor Kenneth Rower

Contributing Editors

Guild Affairs Will Beemer, Joel McCarty
History Jack A. Sobon
Timber Frame Design Ed Levin

Published Quarterly. Subscription \$25 annually (apply to any address above) or by membership in the Guild.
ISSN 1061-9860

TIMBER FRAMING, Journal of the Timber Framers Guild, reports on the work of the Guild and its members, and appears quarterly, in March, June, September and December. The journal is written by its readers and pays for interesting articles by experienced and novice writers alike.



1 9 8 5

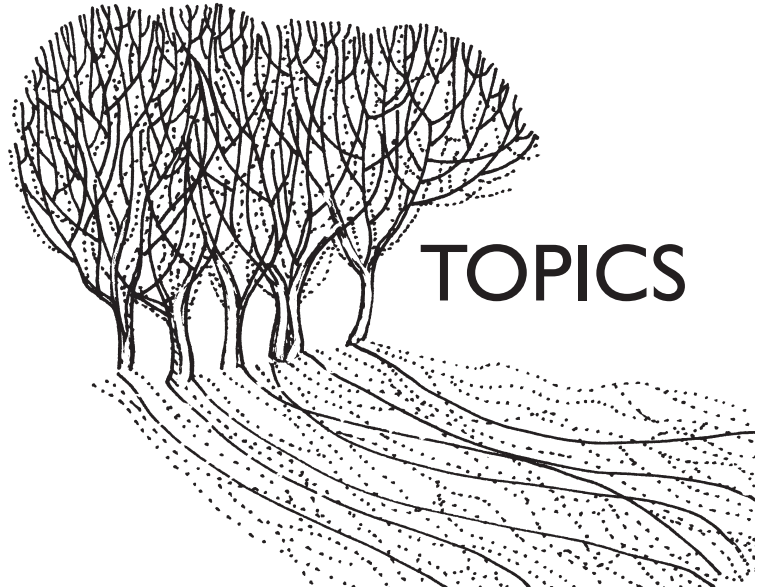

Respectful Restoration

THE Illinois Yearly Friends Meeting House in McNabb, Ill., was raised in 1874 by English-descended Quakers moving west, and has since withstood tornadoes, termites, lightning and other mortal threats. When the original Quaker settlers moved to central Illinois earlier in the 19th century, they built their small community on some of the most fertile land in North America. Their first meetinghouse rose in 1831. The 1874 structure is the third to stand in the settlement.

The building sits on a limestone foundation, probably quarried from the nearby Illinois River valley, and typical of the period in descending only 20 in. below grade. Despite its shallowness, the 16-in.-broad wall remains in good condition. Settlers in the Midwest built shallow foundations until the early part of the 20th century, surprising in view of the harsh winter season. A lack of stone in easily accessible locations was surely a key factor and, in a new building environment, many settlers were probably unfamiliar with the deep deposits of glacial till concealed beneath the prairie soil. Fortunately for the Meeting House, its surrounding soil is well drained, minimizing frost heaves, and its timber frame construction is capable of absorbing minor shifts without structural degradation.

By the 1860s, there was a wood shortage in Illinois. Almost 15 million acres of prime hardwood forest had been cut. After the Civil War, railways were built, which opened up resources in Wisconsin, Michigan and Minnesota. Houses, barns, churches, bridges and other structures in Illinois were built using white and red pine from states to the north. Many of the pine buildings have deteriorated over time because of poor maintenance or have been lost to tornadoes.

By the end of the 19th century, the lumber barons had moved down to Missouri, logging out all but a few acres of the shortleaf (hard) pine that once grew throughout the Ozarks. The Friends Meeting House is built with shortleaf pine, probably some of the first to be imported into Illinois. Like many buildings in the Midwest built of such pine, it has been able to withstand the elements for the last 130 years with little maintenance. The higher resin content in the hard pine might make the timber resistant to decay, and its greater strength helps withstand high winds and tornadoes, especially important for the Meeting House, which stands in an area of frequent tornadoes.



Joel McCarty

Iron rods support scarfed tie beam. Edge-halved scarf in floor girder. Notch carries joist. Quaker meetinghouse was built for two sexes.

The Meeting House roof is supported by well-executed 48-ft. clearspan trusses with a 9:12 roof pitch. Each truss comprises 6x8 rafters 27 ft. long, 6x6 raking struts, scarfed 8x10 bottom chord members (27 ft. each) and a 7x12 oak kingpost. Iron fastenings are all hand forged; 1-in.-dia. tension rods flank the kingpost to help support the two-piece lower chord, and 1-in. bolts fasten the rafter tails to the lower chord. Another 1-in. bolt clamps the lower chord to the kingpost, passing up through the connection to a buried nut in the kingpost. The bottom chord extends out over the walls to carry soffit and fascia.

The interior is sheathed with solid tongue-and-groove boarding covered with horsehair plaster. Bents are 12 ft. on center; 2x6 framing on 16-in. centers fills in between the posts. The walls are 20 ft. tall. Except for descending curtain partitions to separate the building when desired into men's and women's sides, the interior is open. The exterior is simple, but the trim is well placed and the walls are sided with 6-in. clear quartersawn pine bevel siding applied directly to the studs. The windows, appropriately for the wall height, are 10 ft. tall, with double-hung 6-over-4-light sashes.

Early in 2002, a committee from the Meeting House asked us to do an inspection and assess whether the building could be restored. We determined initially that termites had infested the northern third of the building, and the bridled scarf joints in the bottom chords of the attic trusses had separated 3/4 in. to 1 1/4 in. as well. The building had also begun to settle in the northeast corner because of drainage problems with a downspout. We presented the committee with a bid and began discussing in detail how the restoration would be performed. After consultation with an architectural firm and an engineering firm, a plan was developed to restore the building. Two years passed while these details were hammered out and the Illinois Yearly Meeting raised the necessary funds from its membership.

The members of the Meeting were concerned about sustainability of resources and the local economy. For that reason we chose local white oak to replace the existing hard pine. Architects and historical committees are often concerned that replacement material match that of the original building. The IYM members believed (and I agreed) that this requirement can sometimes occlude the point of a restoration. We ought to take a national look at the impact of harvesting and shipping from distant locations. In many places throughout our country, we should reduce our consumption of outside resources and stimulate the local economy. The use of local resources should be paramount when a restoration is considered.

When we restore buildings, our firm's intent is to preserve and promote the original intent of the builders of the day. This intent may be subject to the taste of a client, who may pick a different

stylistic period to represent. After all, there are plenty of simulated historic buildings that rely on illusory façades. In this case, the members of the Meeting chose to keep the building as nearly like the original as possible. As a restoration company that specializes in the structural components, we aimed to repeat the original methods and joinery used to produce the building.

Our scope of work, after two years of meetings and negotiations, was to lift the building and install new sills under the 72-ft. north eaves wall, to repair the separating tie beams, to replace floor joists and to rebuild the foundation. Termites had had their way with the sills and girders. Some settling had occurred as well in the floating foundation, in part because of infrequently maintained downspouts.

We dealt first with the attic-truss bottom-chord separations, by rigging with cables and turnbuckles to prevent further spreading. After several weeks of tightening the rigging we were able to draw the building together about 3/8 in. We felt this would be enough to stabilize matters, and that any further action would damage the large plaster ceiling below. The most recent plaster job had certainly been completed after the bulk of the spreading had occurred in the bottom chord members.

We removed the flooring by slicing the existing subfloor and finish floor into sections that could later be relaid, using epoxy to seal the cut seams. The original men's side of the building had fir flooring installed over an original single floor of hard pine. The women's side had linoleum over the original hard pine. The flooring came up well and quickly in sections approximately 32 in. wide and 12 ft. long, cut along existing joints in the boards.

To remove and replace the sill beam on the north wall, we lifted the entire building at once. The old sill was removed, the new one installed and the masons went to work on the limestone foundation. New girders, cut at the shop using the same joinery as the original, slid into place. We dropped in the joists and closed the floor back up. Since the building had a history of termites, we installed both an EPDM (petroleum rubber) membrane and 1/8-in. high-density plastic under all sills and girders and extending a minimum of 4 in. past the foundation wall. All new timbers and all accessible old timbers we sprayed with Timbor borate treatment.

The original structure was so rigid and well put together that all was accomplished without a crack in the plaster walls and ceilings. Our intent was to get the building ready for the next 100 years. We feel we accomplished that goal. Barring natural disaster, the Illinois Yearly Meeting House could continue to serve its Meeting for centuries to come.

—RICK COLLINS
Rick Collins (r.collins@trilliumdell.com) directs Trillium Dell Timberworks in Knoxville, Illinois.

HISTORIC AMERICAN ROOF TRUSSES

IV. Composite and Raised Bottom Chord Trusses

THIS article is fourth in a series to discuss and illustrate the form, function and joinery of American timber-framed roof trusses of the past, showing typical examples with variations. The series was developed from original research under a grant from the National Park Service and the National Center for Preservation Technology and Training. Its contents are solely the responsibility of the authors and do not represent the official position of the NPS or the NCPTT. Previous articles in the series have treated Scissor Trusses (TF 69), Queenpost Trusses (TF 71) and Kingpost Trusses (TF 72).

Truss: A combination of timber framing, so arranged, that if suspended at two given points, and charged with one or more weights in certain others, no timber would press transversely upon another except by strains exerting equal and opposite forces. —Jos. Gwilt, The Encyclopedia of Architecture, London, 1867, p. 1272.

The Grubenmann bridges are the culmination of a centuries-old tradition of the art of building with wood and devising and erecting structures of notable span on craft principles. In the following century the modern engineering approach took over and favoured the construction of structures in which the stresses caused by external forces could be calculated mathematically. By contrast the Grubenmann brothers apparently dimensioned their structures only by empirical methods; their bridges were characterized by a redundancy of structural elements and what is called static indeterminacy (or hyperstaticity) . . . not one structure but a combination of different structures that reinforce each other . . . they are a synthesis of craft tradition with the fruits of continuous experiment. —Massimo Laffranchi and Paolo De Giorgi, "Some Remarks on the Grubenmann's Wooden Bridge Structures," in Angelo Maggi and Nicola Novone, eds., John Soane and the Wooden Bridges of Switzerland, p. 115.

THE four timber frame roof systems discussed in this article all break the rule given in the first epigraph. They fail to correspond strictly to modern engineering standards for truss behavior, particularly those concerned with clearly defined load paths and determinacy. Nonetheless, all have had long service lives, from 175 to 235 years, and still stand today, although some have been damaged by inherent flaws and the traumas of existence.

The oldest roof, at the all-timber-framed Christ Episcopal Church, Shrewsbury, N.J. (1769-74), uses raised bottom chord trusses designed by the Philadelphia architect Robert Smith (1722-1777). Alarming but not catastrophic failures were identified in the trusses in the early 1990s after a century of bearing the extraordi-

nary weight of slate roofing and for an indeterminate time suffering sill and foundation problems that caused some trusses to load eccentrically. A remarkably heavy fall of wet snow revealed the failures and led to remediation.

The roof of St. John's Episcopal Church, Portsmouth, N.H. (1807), a neoclassical brick structure designed by Alexander Parris, is also framed with raised bottom chord trusses, but with the added complication of gallery post extensions that clasp the large rising (or oblique) ties as they climb toward the raised bottom chord and support the principal rafters near the point where the raised bottom chord tenons into them. The overall condition of this large roof is good with the exception of tension failures where expected at junctions between raised bottom chord and principal rafter.

The stone-built Central Moravian Church in Bethlehem, Pa. (1803), much the largest of our examples, has kingpost and queenpost roof trusses framed intimately together in each roof frame in a composite design. Conceivably the elements of the composite design interfere with each other, but in practice they appear to function largely independently and with great success across the 65-ft. span.

Finally, the Sutton Baptist Church at Sutton, Vt. (1832), presents a vernacular framer's idiosyncratic mixing of queen- and kingpost elements at the rear steeple truss, where queenpost braces use and support the steeple posts as queens, but deflection in the bottom chord is picked up by a tenon at the bottom of a sort of kingpost unsupported by any principal rafters. Instead, this kingpost is hung from above by a small tenon, assisted lower down by an offset and discontinuous straining beam and the short braces rising to it. Again, this unlikely frame is performing well across a 44-ft. span.

WHEN does a roof frame become a nonconforming truss? Probably when the intention is to span a greater distance than practical by individual members, and by a particular arrangement of members and joinery disregarding whether all resultant loadings are axial or equal and opposed. Thus, any pair of rafters with a collar beam located below their midpoints might be called a raised bottom chord truss; the collar becomes the tie beam or lower chord of the truss. This assemblage of three members works only for very short spans or steeply pitched roofs, such as Gothic or Gothic Revival structures. But classically inspired structures of the 18th and 19th centuries favored lower pitches, often close to 7:12. In raised tie beam roofs with lower pitches, the bending of the rafters and their tendency to spread the walls, as well as the increasing tension loads at the tie beam-to-rafter connection, caused a rethinking of the frame, challenging the limits of traditional wooden timber and requiring iron straps and additional wooden structural members. Joseph Hammond, discussing 18th-century church designs in Pennsylvania and New

Jersey, traced the evolution of the low-pitch, long-span raised bottom chord truss from Christopher Wren's design for St. Paul's Cathedral in London (1706) through the various editions of Francis Price's *The British Carpenter* (first published 1733), to the Philadelphia area churches of Robert Smith, including St. Paul's Episcopal (1760-61) with its span of 65 ft. (Hammond, 16). A similar design, though with less iron reinforcement, shows up hundreds of miles to the northwest at the Cazenovia, N.Y., First Presbyterian Church by 1805.

Truss assemblies composed of two truss forms are not historically unusual. Numerous 18th- and 19th-century church roofs and wooden bridges employ queenpost trusses with a kingpost or kingrod captured in the middle panel, and with struts rising from the queenposts to stiffen the straining beam where the kingrod descends from it. Indeed, this same composite truss shows up much earlier in Palladio's 16th-century bridge designs and again in *The British Carpenter*, where in some cases a kingpost truss is superimposed above the queenpost truss with the kingpost suspending the straining beam, incidentally providing a peak for the roof. In numerous surviving bridge trusses of this composite design, all the elements, whether tension or compression, appear to be loaded, and we can conclude they are contributing to the overall functioning of the truss (Figs. 1 and 2).

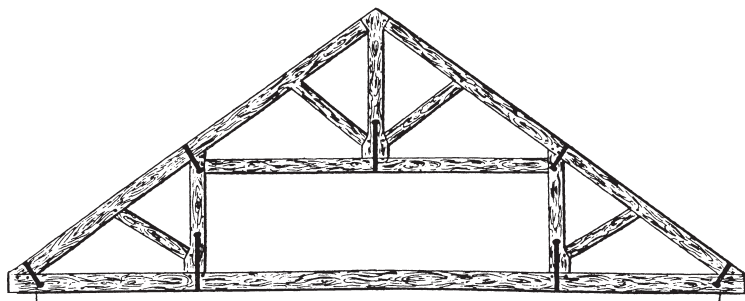

Fig. 1. Kingpost truss superimposed above queenpost truss, from Plate I of Francis Price, *The British Carpenter*, 1733.

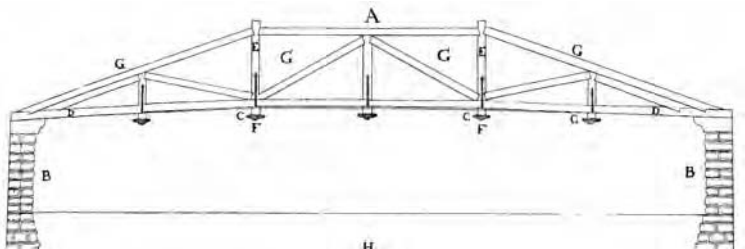

Fig. 2. Queenpost truss with kingpost captured in middle panel, shown in Palladio's *Four Books* (1570), from a 1738 London edition.

In long-span bridge framing, it is common for a timber or plank arch to be superimposed or integrally framed into (typically) a multiple kingpost truss, as in the Burr Arch designs or the great Long Truss variant at North Blenheim, N.Y., but the only example I know of arch trussing in a church roof is the polygonal arch constructed in 1752 in the Reformed Church at Grub, Switzerland, and that truss runs longitudinally in the church, interacting with a series of transverse roof frames (Maggi and Navone, 124).

However, some trusses do have superfluous members that under service conditions remain unloaded or even loose, and from these we can infer on the part of the designer an unclear understanding of load paths and truss behavior. The powerful truss at

the Central Moravian Church is one of these, where field examination discloses that the struts rising from kingpost feet to queenpost heads and from queenpost feet to the central joggle of the kingpost are randomly tight and loose, suggesting that each of the interpenetrated truss types is managing to work alone or in parallel with the other.

English and Continental sources show us numerous roof frames that either don't qualify as trusses at all, for example queenpost systems that depend entirely upon a stout cambered tie beam for stability, or kingpost systems equipped with numerous braces that look useful when the frame is lying on the ground but become loose as soon as the truss is stood up bearing only its own weight. Some of these apparently superfluous members may earn their keep when the roof is loaded eccentrically by heavy snow or high wind, much as the crossing braces in the central panels of bridge trusses take turns being loaded when a moving vehicle shifts the center of the bridge slightly and causes a reversal of stresses around the midpoint.

The examination of church attics of notable span in eastern North America (qualified by the small percentage it is possible to see in one lifetime) generally reveals trusses so rationalized that we suspect the builders were very experienced and endowed with good structural instincts, or they were in possession of builders' guides that included sound truss designs. Exceptions exist. Puny raking struts or ties rising from tie beam to rafter in such roofs as at the Strafford, Vt., Town House (1799) or at the Windham, Vt., Congregational Church (1801), discussed in Part III of this series (see TF 72), are archaic holdovers that play no role or only a tiny one in the functioning of these otherwise completely realized trusses. Another puzzling example is the kingpost truss roof of the 1829 Newbury, Vt., Methodist Church, where 9x9 vertical members parallel the kingpost at the quarter points of the span, unsupported by struts or bracing, seemingly awaiting (nonexistent) gallery posts below to help them prop the midspan of the rafters. Without the gallery posts, these unsupported posts at Newbury serve merely to load and deflect the bottom chord at a point 10 ft. distant from the kingpost tension joint (Fig. 3).



Ken Rower

Fig. 3. Naïve truss at Newbury, Vermont, Methodist Church, 1829. Apparent queenpost merely adds unwanted load to truss chord.

All of the four roof trusses discussed below have members or joinery that lead contemporary observers to shake their heads and wonder why such framing choices were made, and how such non-conforming trusses actually work. By examining these trusses for what is loose or open, broken or heavily compressed, by entering thin rulers into supposed bearing surfaces of joints, by striking braces and struts with mallets to hear how they ring, we can hope to find out where the forces run.

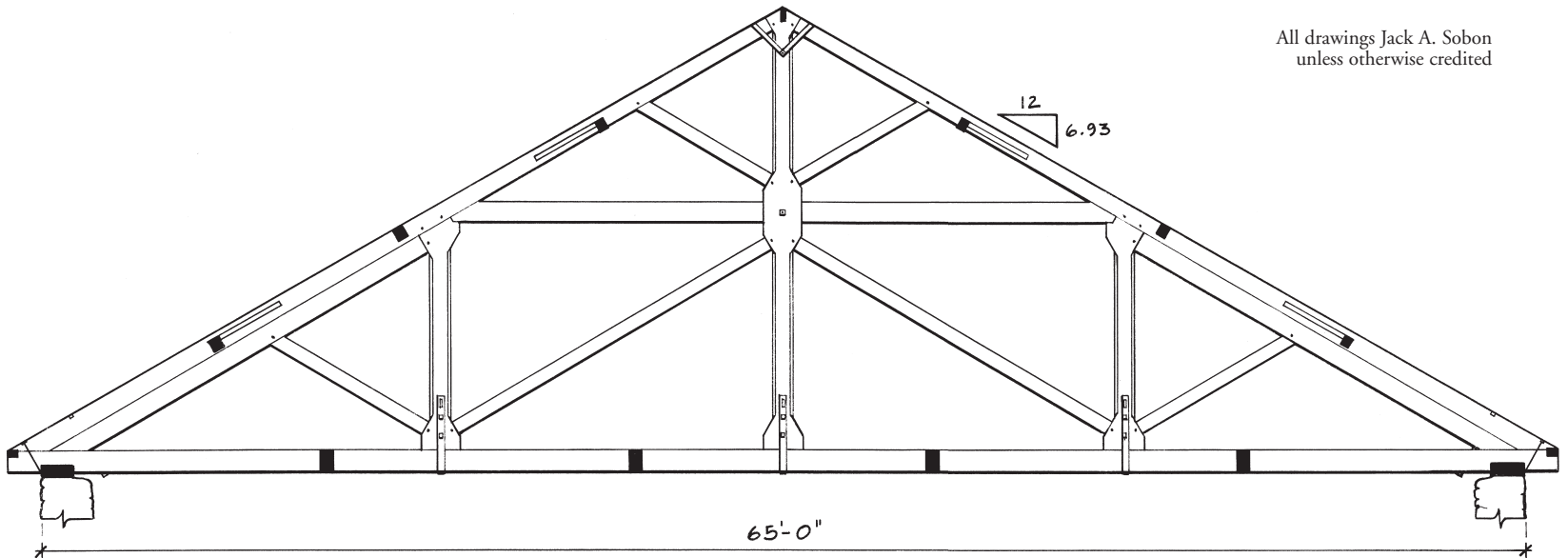

Fig. 4. Composite truss at Central Moravian Church, Bethlehem, Pa. (1803-1806). Kingpost and queenpost elements interact.

CENTRAL MORAVIAN CHURCH, Bethlehem, Pa. (1803-1806). This immense church is crowned by a most commodious attic, spacious and well floored, permitting researchers to walk about upright (an unusual liberty) among ten 65-ft.-span trusses spaced a nominal 10 ft. on center. In the middle of the building, rather than at one end, the sleepers for the braces and posts of the sturdy cupola spread themselves across the bottom chords of six trusses. The entire ensemble of roof framing bears on 17x6 timber plates over mortared and parged rubble stone walls, typically 27 in. thick.

The Central Moravian trusses are gigantic and appear capable of their long span, both on first impression and after examination of the members and joinery for evidence of excessive strain. The form is a combined kingpost and queenpost, not merely overlaid on each other but with certain structural members interacting (Fig. 4). The kingpost in each of the trusses is a 20-ft. 7x20 oak timber, joggled at three locations: at the foot, where (in four out of ten cases) it carries struts; at the peak, where it flares in excess of 90 degrees to provide extra-normal bearing for the principal rafters; and at roughly its mid-height, where, halved and bolted, it crosses the 7x11 straining beam of the queenpost truss. The mid-height joggles also carry rising struts to the principal rafters, and receive rising braces from the joggles at the feet of the queenposts (Figs. 5 and 6).

Looking at this composite truss on paper, we can imagine that the straining beam is acting as the bottom chord of a superimposed kingpost truss forming the peak of the roof, and that the lower portion of the kingpost is acting as part of a subsidiary truss captured within the queenpost truss. But direct examination of the joinery shows this not to be true. On all the trusses, the majority of struts that rise from queenpost foot to kingpost joggle are unloaded to the touch. Even at the four trusses around the tower that have struts rising from the kingpost bottom joggle to the queenpost heads (possibly with the intent of turning the queenposts into princeposts), as well as from queenpost bottom to kingpost joggle, loading and looseness are random. Meanwhile, the struts that rise from the mid-kingpost joggle to the principal rafters are loaded and, in the one case of possibly useful interaction, the halved crossing between the kingpost and the straining beam is jammed shut but compressed neither top nor bottom, suggesting that the kingpost is helping the slender 7-in. straining beam resist compressive buckling over its 28-ft. length. (An attempt to combat buckling in overlong compression members is sometimes the rationale for otherwise noncontributing counterbracing in bridge truss panels.)

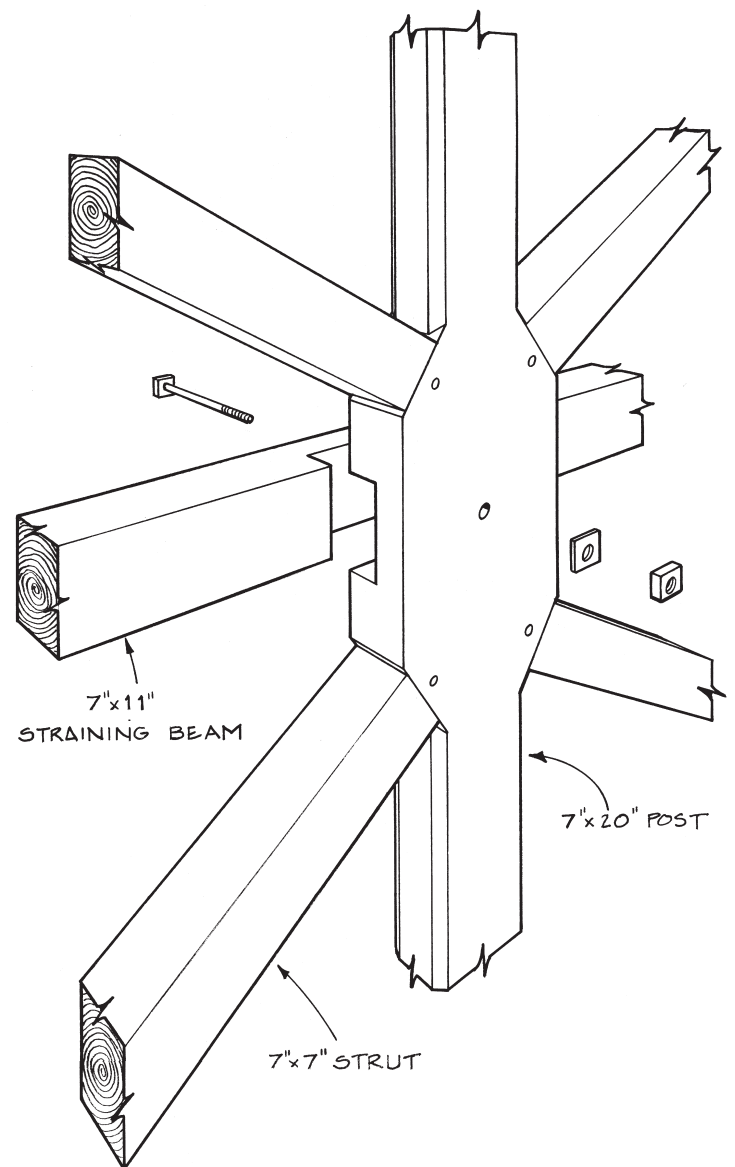

Fig. 5. Central Moravian 7x20 oak kingpost, accommodating struts in four directions and the halved crossing of a straining beam.

The Central Moravian truss contains huge amounts of timber joined in complex and exacting ways. While its kingpost form is typical (with the exception of the extra mid-height joggle and its intersections with the queenpost elements), the queenpost framing

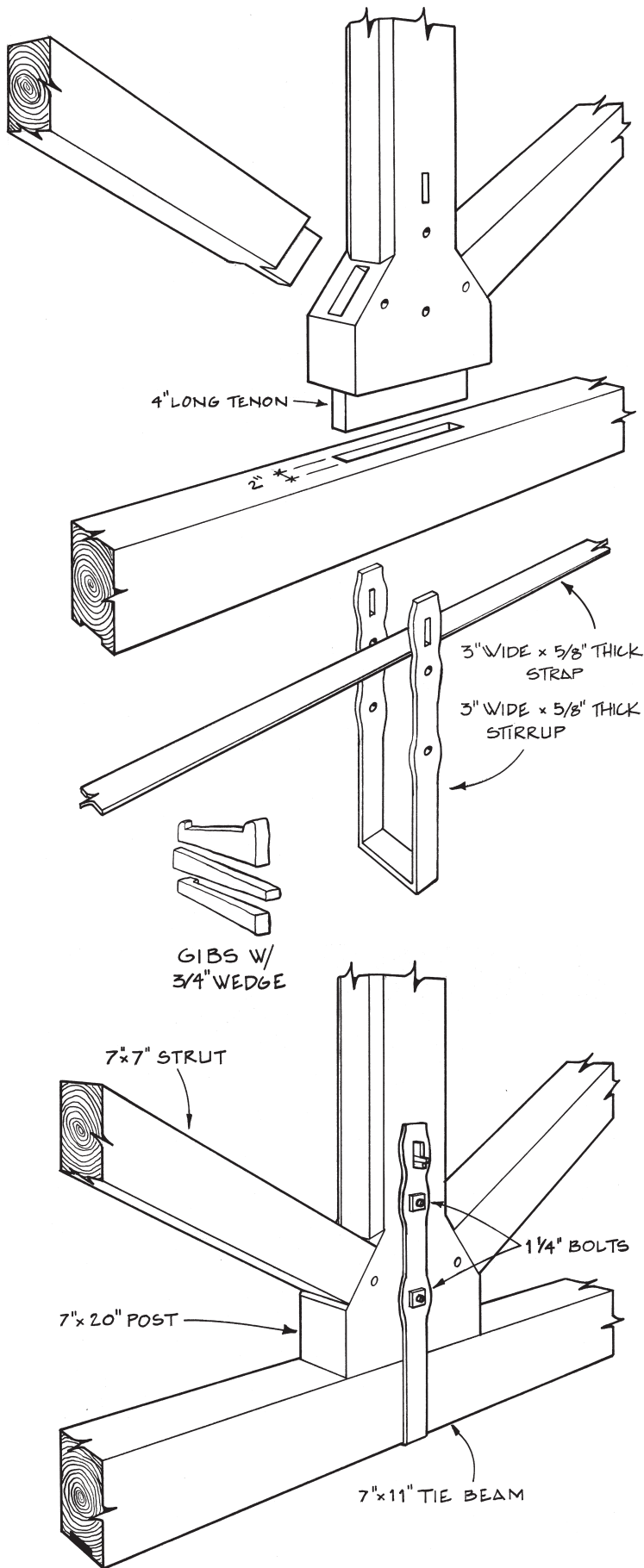

Fig. 6. Exploded and assembled views of Central Moravian post foot. Wedged and bolted straps reinforce critical joint and entire lower chord.

displays an unusual relationship between the posts and the straining beam. The 20-in.-wide flared head of the queenpost receives an independent 7x10 queenpost brace that rises from a mortise in the tie beam snug under the principal rafter. This brace tenons into the

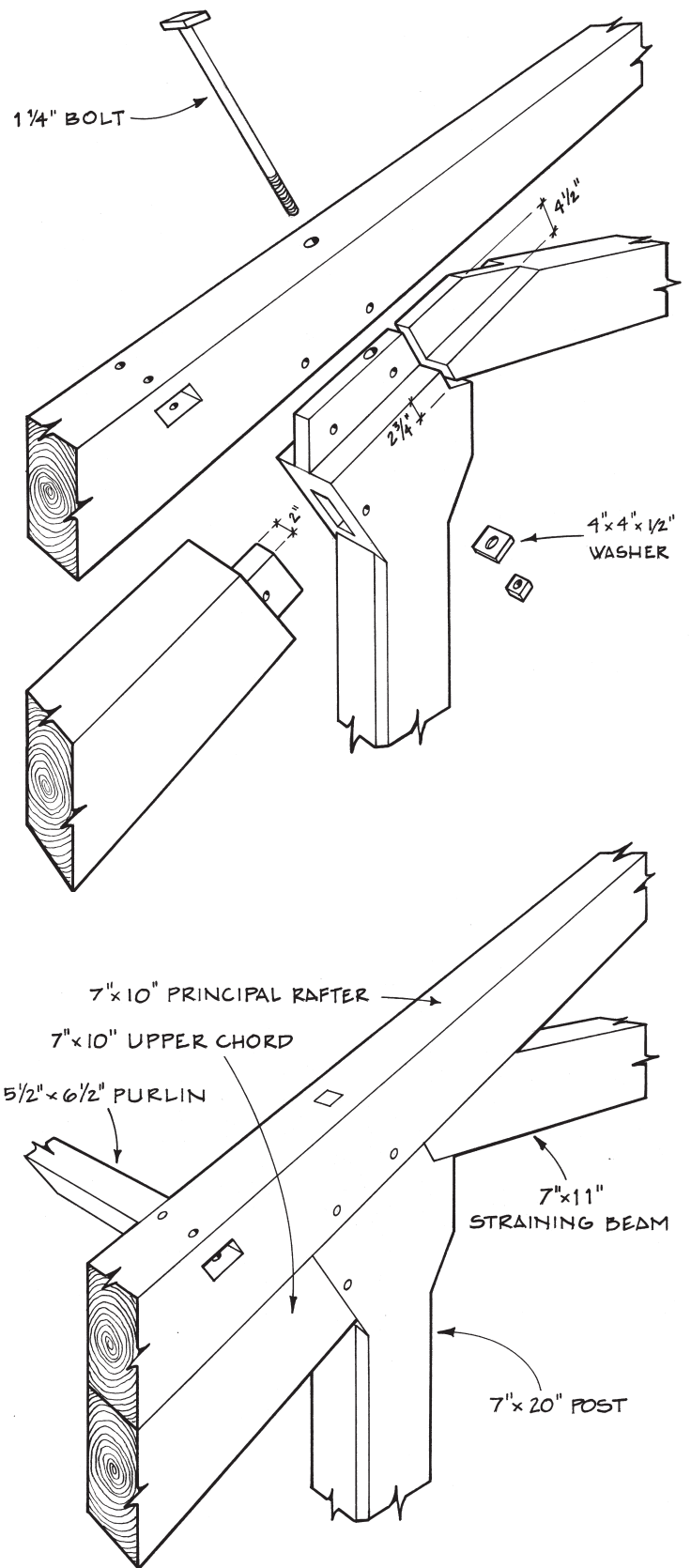

Fig. 7. Exploded and assembled views of queenpost head, showing elements of queenpost truss captured by principal rafter of kingpost truss.

flared shoulder of the queenpost. The 7x11 straining beam, surprisingly, shoulders for less than 3 in. on the upper portion of the queenpost and tenons into the principal rafter over most of its cross-section. The queenpost also tenons into the principal rafter and is pinned. In most cases, its flared head is also pierced by a bolt running axially through the mortise and tenon joint and helping to bind the entire ensemble together. Without this bolt there is some danger of the straining beam slipping upward and lifting the principal rafter off the queenpost under loading (Fig. 7).



Ken Rower

Fig. 8. Some queenpost heads at Central Moravian, obstructed by struts, cannot be bolted to the principal rafters and are stapled instead.

While the wooden truss forms were handled in a somewhat unusual and perhaps archaic way, the builders were not shy about incorporating metal. In addition to the bolting we have noted, the king- and queenposts, merely stub-tenoned where they enter the bottom chord, rely on carefully fastened U-straps that join the members to carry the major share of joint tension (Fig. 6 previous page). At the other end of the kingpost, a forked iron yoke helps restrain the principal rafters to the kingpost head, a measure hardly necessary considering the extra-normal bearing (Fig. 10).

The most remarkable and unusual use of iron in the truss is a substantial iron tension tie that runs on the underside of each bottom chord, hooking into stirrups at each end that rise and capture the principal rafters where they bear on the bottom chord, and likely designed to compensate for the relatively small 7x11 section of the 65-ft. bottom chord. These ties, 5/8-in.-thick x 3-in.-wide iron straps, are made up of three 20-ft. sections joined by 1 1/4-in. through bolts and two L-shaped end sections that hook into the stirrups. Each tension tie is periodically through-bolted to the bottom chord and captured by U-straps at the posts (Figs. 12-13.)

The timber at Central Moravian is all hewn. The bottom chord, principal rafters, queenpost main braces and straining beam are white pine and all other truss members are oak. The layout is scribe rule with straight chisel marks for joinery and gouge marks next to them indicating the truss number.

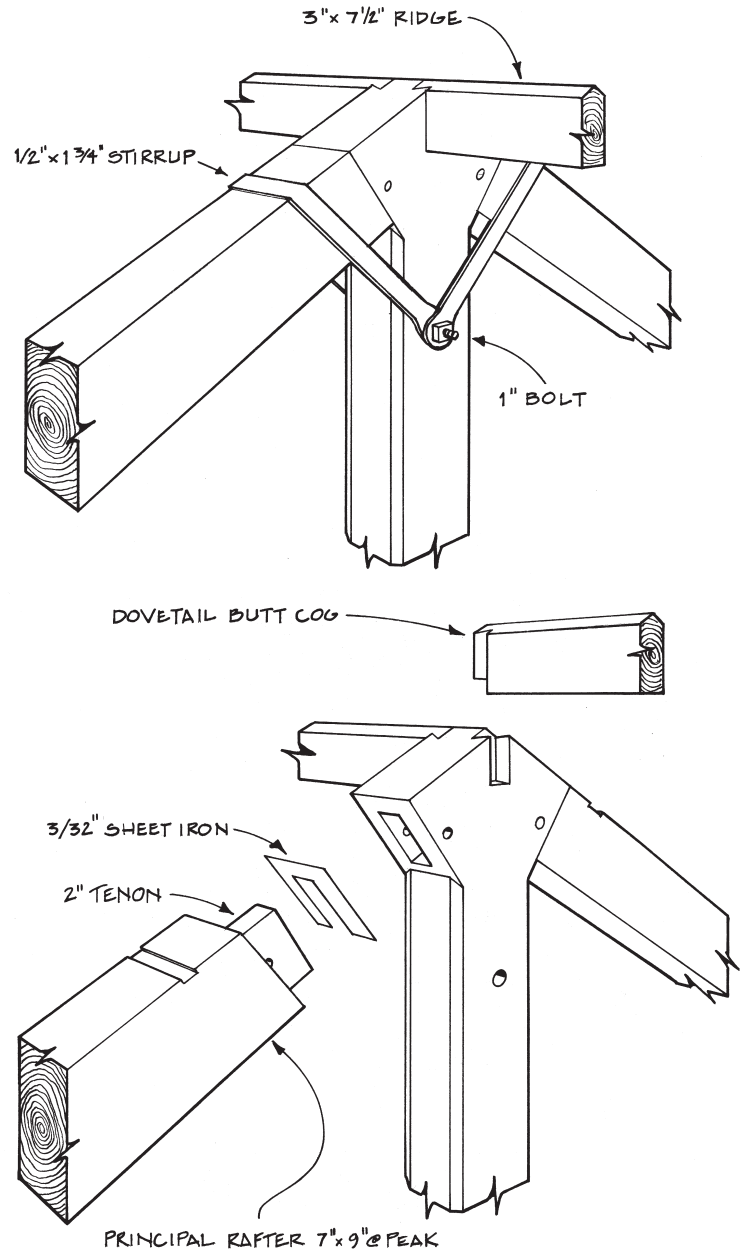

Fig. 10. Kingpost head, exploded and assembled views, at Central Moravian Church. Sheet iron may be meant to protect joint from deforming. Post is oak; principal rafter is pine. Iron strap at top represents more belt-and-suspenders engineering.



Fig. 9. Rubble stone walls at Central Moravian are parge-d. Substantial cupola is placed centrally, supported ultimately by six trusses.



Fig. 11. Coved ceiling is formed entirely below the attic floor. Spacious, classically decorated interior is well maintained.

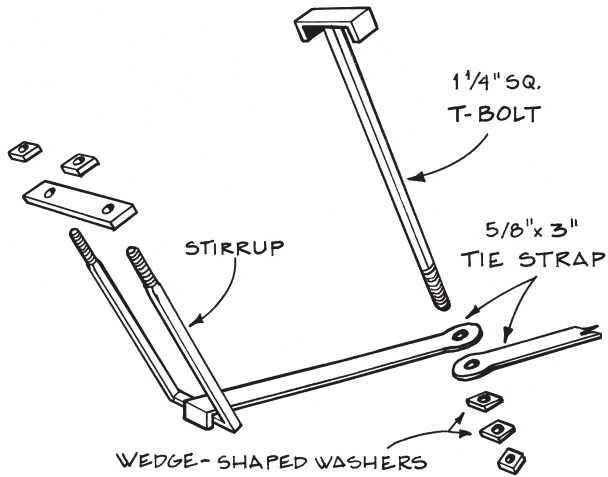

Fig. 12. Exploded view of Central Moravian hardware fastening principal rafter (or upper chord of kingpost system) to lower chord, meanwhile restraining upper chord of queenpost system and attaching to 5/8-in. x 3-in. iron tie strap running under entire lower chord. The strap is segmented and periodically bolted to the lower chord through eyes at the segment ends, with wedge-shaped washers provided to obtain perfect bearing for the nut on the angled surface.

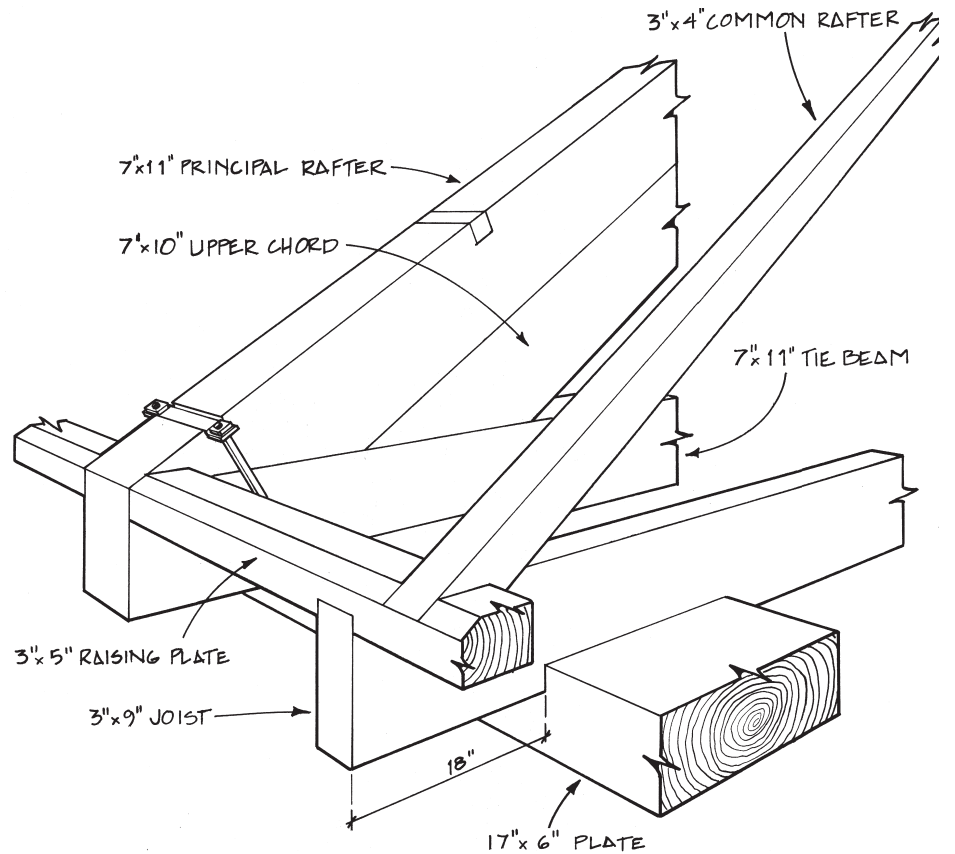

Fig. 13. Views of truss chord end conditions at Central Moravian. Above, assembled view showing principal rafter (or kingpost truss upper chord), queenpost upper chord, tie beam (or lower chord common to both truss systems), together with common rafter, common rafter plate and common joist. Below, exploded views without hardware.

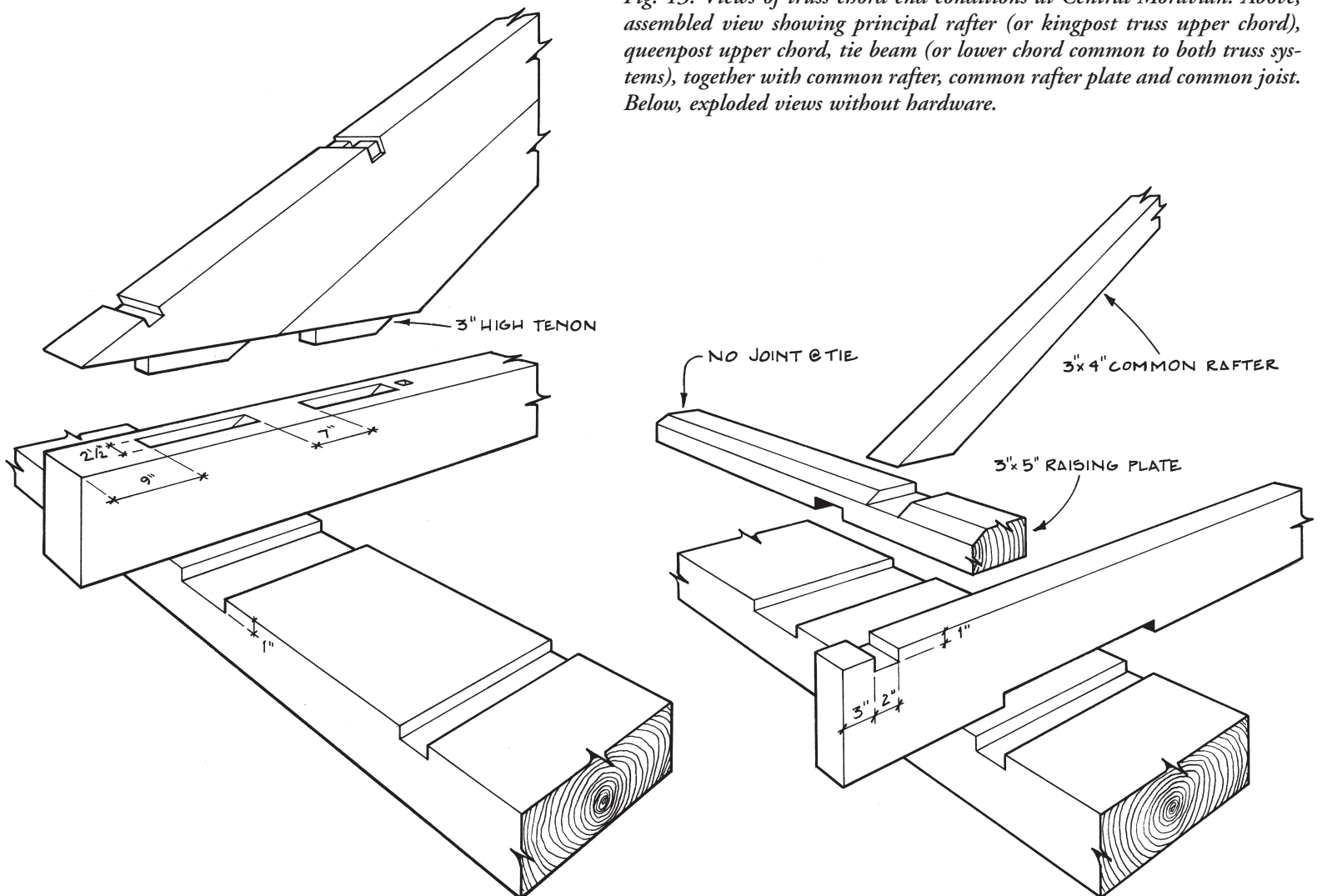
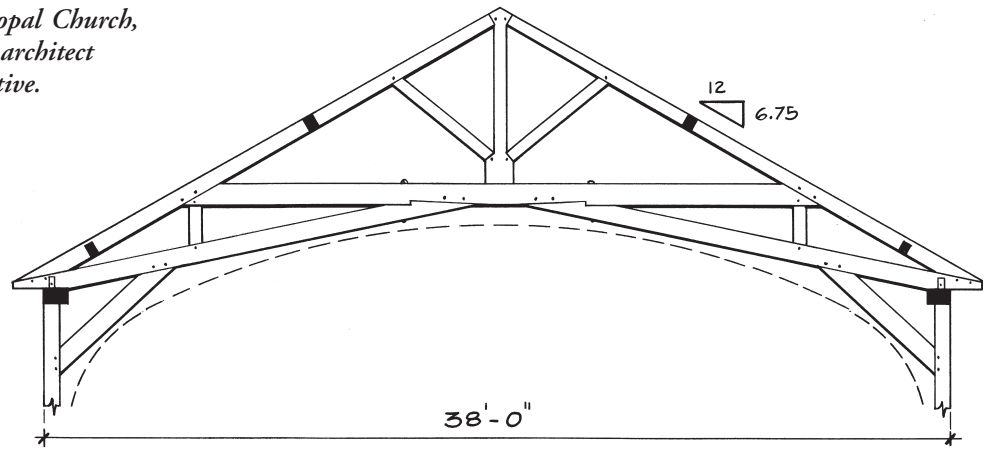

Fig. 14. Raised bottom chord truss at Christ Episcopal Church, Shrewsbury, N.J. (1769), designed by Philadelphia architect Robert Smith (1722-1777). Short struts are distinctive.



CHRIST EPISCOPAL CHURCH, Shrewsbury, N. J. (1769). Three others of colonial architect Robert Smith's documented church commissions also employed such a raised bottom chord truss to support the roof (see TF 73). At St. Peter's Episcopal (1771) in nearby Freehold is another almost identical surviving truss that probably can be attributed to Smith. The truss design appears in Price's *The British Carpenter* by 1733, and Christopher Wren used it as early as 1706. A great many medieval roof frames employed the collared rafter pair with braces rising from rafter to collar, but the change that turns it into a sort of truss is the introduction of oblique ties that bear on the wall and attempt to restrain the load of the rafters in the fashion of a typical truss bottom chord. These ties rise and join the raised tie beam near its midpoint, where an attempt is made to produce a strong tension joint through the use of long mortise and tenon joints with multiple pegs, often reinforced by iron straps (Fig. 14).

A further recognition of the high tensile forces developed by this nonconforming truss, particularly when used in a low-pitch roof (Shrewsbury is slightly under 7:12), is implied by the appearance of iron straps at a great many of the joints in every printed illustration of the form. The 1786 *Rules for Measuring and Valuing House-Carpenters Work* promulgated by The Carpenters' Company of Philadelphia depicts the truss with extensive iron work on Plate VI, and describes it using the curious term "hammerbeam" for the oblique rising ties, a term also used by Smith and Price. The same truss design appears in Nicholson's *New Carpenters Guide* (Plate 45) as late as 1837, and in Thomas Tredgold's *Elementary Principles of Carpentry* (Plate 9) in that same year. Tredgold, while praising Price's work in general, criticizes this truss, particularly for the high strains developed by the oblique disposition of the "beams" (Price's "hammerbeams" or my "oblique ties"), and points out defects such as the excessive number of joints and the "certainty of the considerable change of figure from flexure" (Tredgold, 93).

Among modern commentators, David Yeomans, author of *The Trussed Roof*, also finds "hammerbeam" for the oblique tie not the customary use for the term, and relates that "in spite of the apparent weakness of the raised tie beam arrangement, in England it remained the standard solution to the high vaulted ceiling throughout the 18th century" (Yeomans, 130). The late Cecil Hewett, in *English Cathedral and Monastic Carpentry*, refers to the truss over the west portico of St. Paul's as "a king-post with raking strut design . . . mounted upon collars with which the other components form built camber beams" (Hewett, 69).

The eight trusses (excluding end walls) at Shrewsbury span 38 ft. and are spaced between 5 ft. 10 in. and 8 ft. 7 in. apart, reflecting window positions in the supporting timber-framed walls. Combined with the diagonal bracing rising from wall post to oblique tie, the trusses collectively provide the rough form for a vaulted ceiling, the usual reason for employing the raised bottom

chord. The scribe-ruled timber frame is composed of mixed white and red oak timber, most members hewn but some braces and common rafters vertically sawn, and fastened with both 7/8-in. and 1 1/4-in. pins. The timber-framed walls of this church are not solid-sheathed but carry spaced let-in nailers to which long white cedar shakes are affixed, in the manner of several other 18th-century New Jersey churches I have examined. Shrewsbury is the only one of Smith's churches to employ the raised bottom chord truss unaccompanied by the mass of a masonry wall.

In the Shrewsbury truss, principal rafters taper from 6x9 at the butt to 5x5 at the peak and rise from long mortises in the upper surface of the oblique ties. The principal rafters tenon into a shortened kingpost, the head of which is flared variably but always with bearing at less than 90 degrees. The kingpost is as much as 5x11 at its head and typically 5 1/2x13 at its foot, where a 2-in. tenon roughly 6 in. by 13 in. penetrates the raised tie beam and supports it on two 1 1/4-in. pins. Mortised struts rise from kingpost to rafter (Figs. 15 and 18).

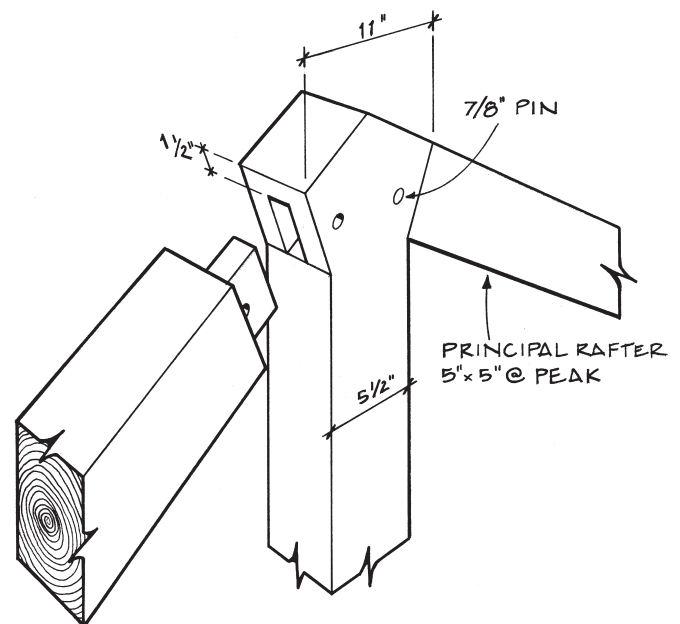

Fig. 15. Detail at Christ Episcopal kingpost head.

The 6x9 raised bottom chord through tenons into the principal rafters about 7 ft. above the wall plate, fixed there by two pins without the help of the ironwork common at this same joint in other churches. The crucial tension joint between the oblique tie and the raised bottom chord depends mostly on an elongated double-pinned mortise-and-tenon joint and an additional shoulder acting in shear. These are assisted by a single 7/8-in. bolt, driven



Christ Episcopal Church

Fig. 16. Christ Episcopal Church, Shrewsbury, N.J., 1769, photographed ca. 1870. Stained glass had been installed in the original window openings in 1867, but otherwise the building remained essentially unchanged. Wall shingles were white cedar.

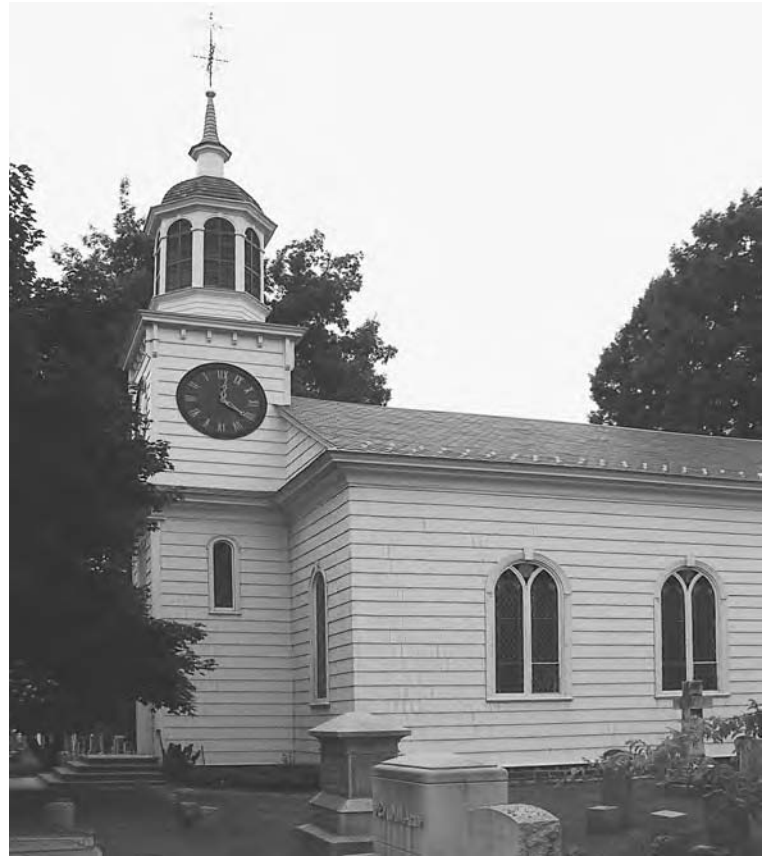

Ken Rower

Fig. 17. Christ Episcopal Church in 2004, clock tower added in 1874. The cupola was transferred, apparently intact, and the twin entrances surmounted by windows done away with in favor of new first-floor windows flanking the entry tower. Wall shingles remain white cedar.

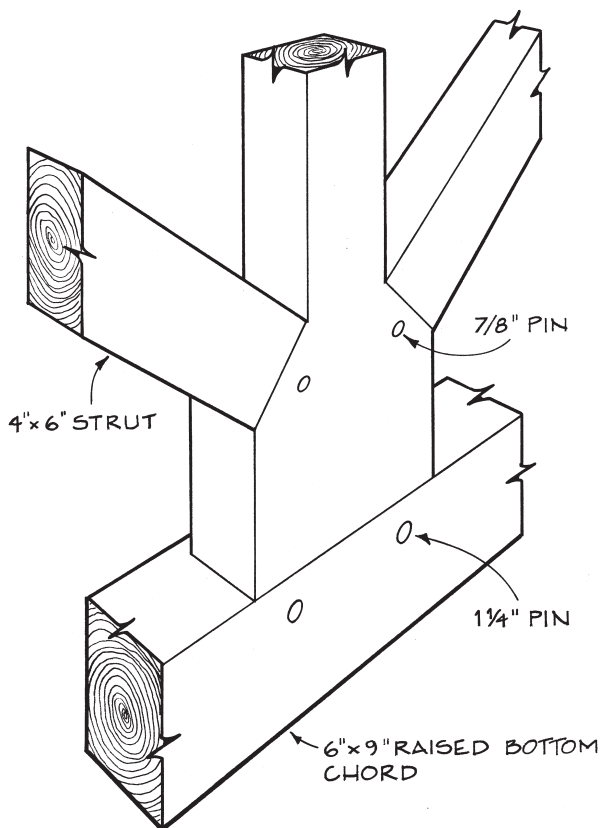
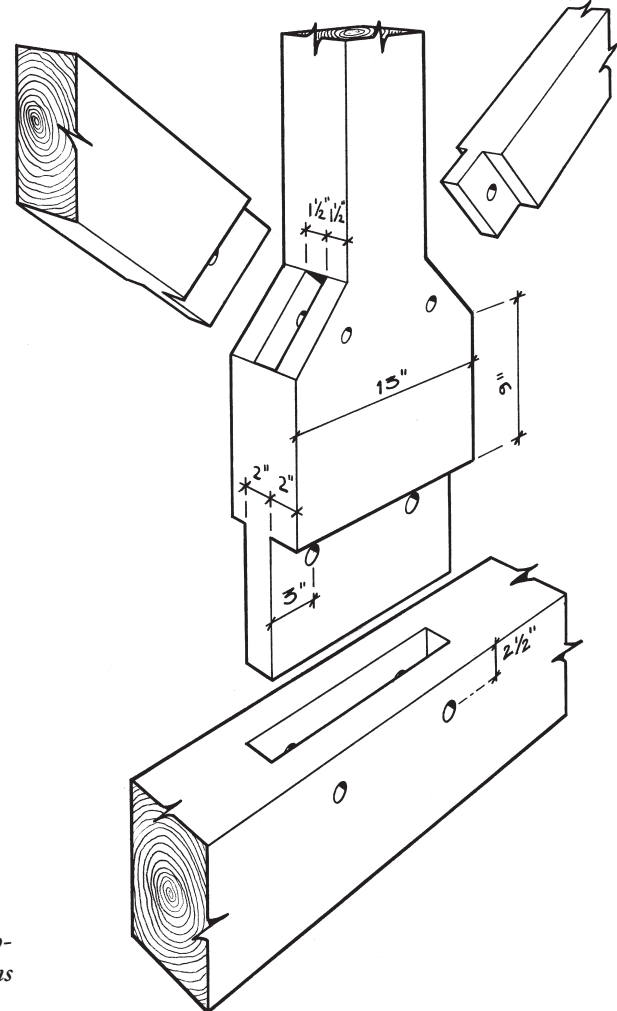

Fig. 18. Exploded and assembled views of the Christ Episcopal kingpost-to-raised bottom chord connection. Through tenon is fastened by two stout pins but is otherwise unassisted by dovetail or iron strap.



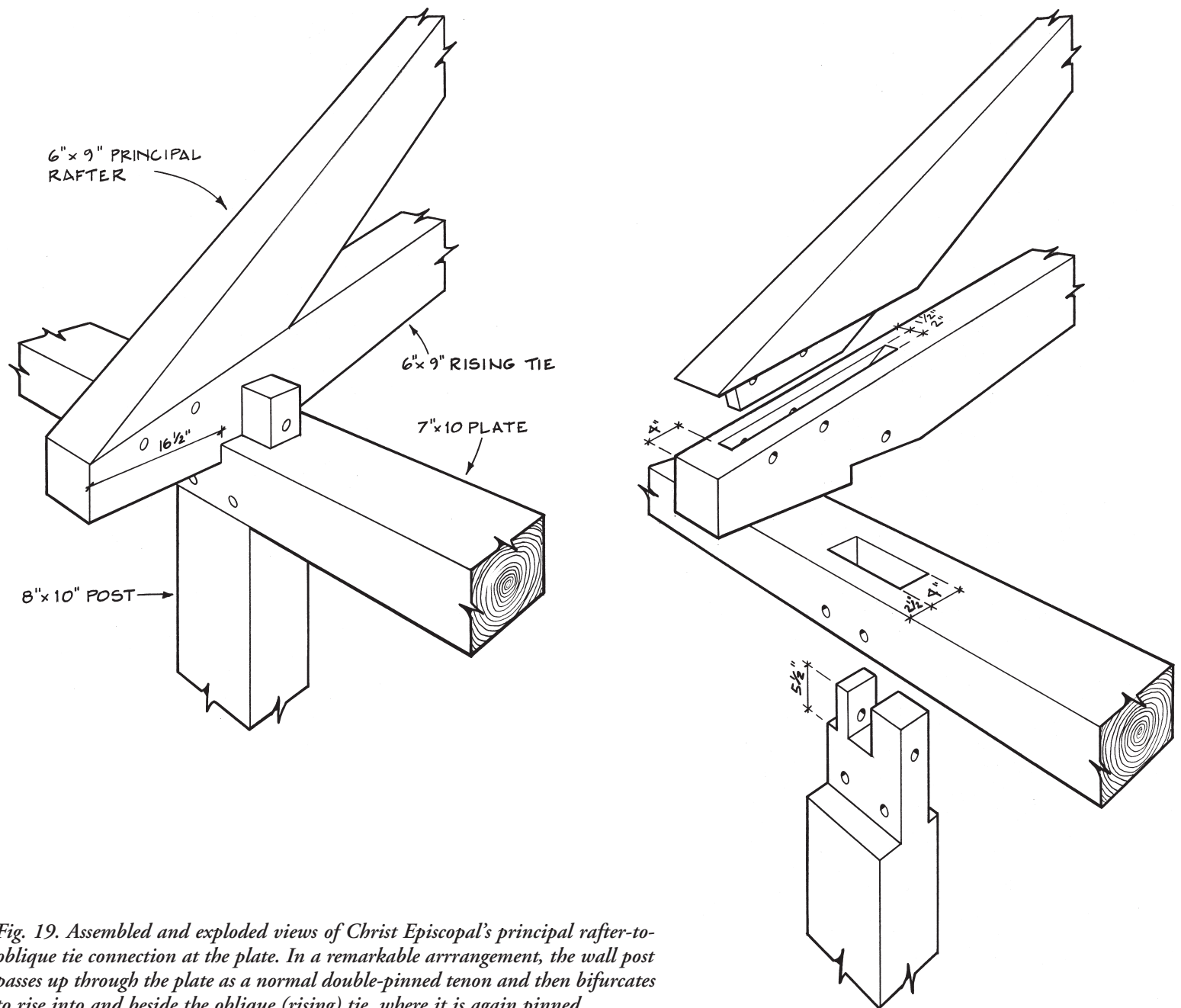

Fig. 19. Assembled and exploded views of Christ Episcopal's principal rafter-to-oblique tie connection at the plate. In a remarkable arrangement, the wall post passes up through the plate as a normal double-pinned tenon and then bifurcates to rise into and beside the oblique (rising) tie, where it is again pinned.

from the bottom of the tie and clinched around a short section of wooden pin on top of the chord (Figs. 19-21).

Most designs for this joint, including the 1786 Philadelphia rule book plate and the Freehold drawing (Hammond, 21), feature bolts and a steel yoke that links the oblique ties, the raised chord and the kingpost, in recognition of the trouble likely to occur here where tension is not carried in a straight line.

The term "raised bottom chord" probably should not refer merely to the horizontal member in this system. The functional bottom chord—that is, the principal wall-to-wall tension member—really comprises the two oblique ties and a middle section of the raised chord, giving an arched three-piece bottom chord. The task of keeping this arched chord from stretching and flattening falls to its joinery, which is difficult to make adequate in wood, and to the kingpost that suspends the middle section of the chord.

The most unusual joinery in the Shrewsbury church connects the wall post to both the plate and the truss itself at the foot of the oblique tie. The 8x10 wall post reduces itself to a 4-in. by 10-in. tenon passing entirely through the plate and, once emerged, dividing itself into two tenons, one tenon standing alongside the oblique tie that bears here and the other penetrating the oblique tie in a blind mortise (Fig. 19).

A 7/8-in. pin then transfixes the tie and both tenons. This connection is the only one at the plate (the oblique tie of the truss shoulders only on the outside of the plate), but it appears unstressed and intact, suggesting that truss failures have spread the entire wall at points or that the multiple members of the truss have responded within the span to vertical movements in the frame such as sill or foundation problems, which are known to have occurred below the points of truss damage. The wooden trusses at Shrewsbury are currently (and probably permanently) assisted by paired longitudinal steel bridge trusses assembled within them that extend from gable end to gable end of the building. These engineered steel trusses were designed to pick up and reinforce numerous failed joints and members discovered in the 1990s.

A notable but unexpected point of failure in the Shrewsbury trusses occurred where a short vertical strut joins the bottom of a raised chord, quite near its rafter junction, to the top of the oblique tie near its midspan, within 1 ft. of the bearing of the large double-pinned brace rising from the wall post to the bottom of the oblique tie. At first glance this strut would appear to provide an improved load path from rafter and collar to a point lower on the wall post (Fig. 22). But an oblique tie broke at exactly this point on the west side of one of the trusses. It appears that the truss can fail at this

Fig. 20. Exploded and assembled views of raised chord-to-oblique tie connection at Christ Episcopal. While no iron strap is applied, the bolt keeps the bearing surfaces firmly together. The oblique (or rising) tie is pulled against the pins and shoulder of the raised tie by the thrust of the principal rafter at the end of the system as seen in Fig. 19.

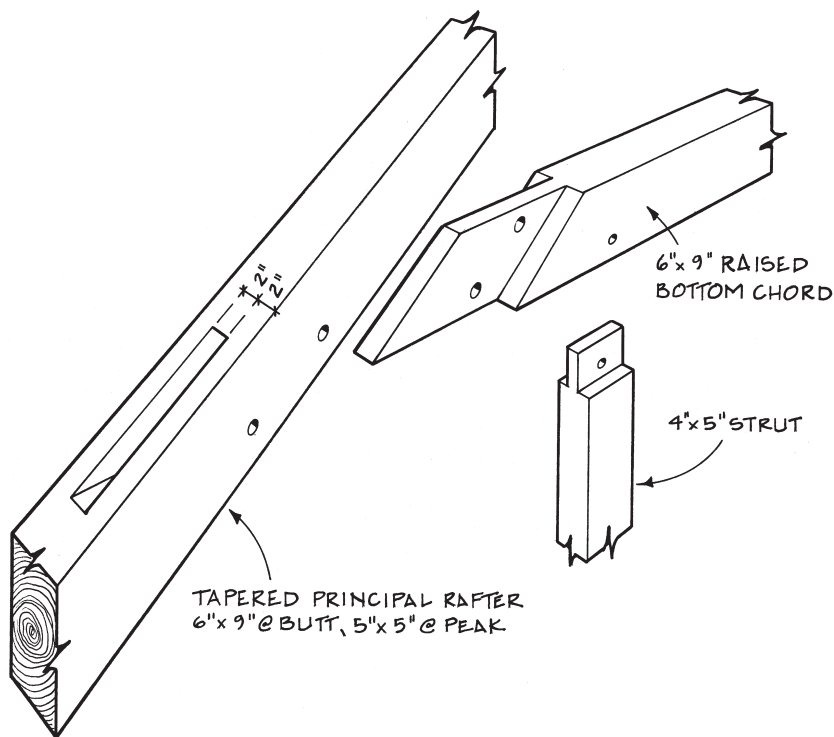
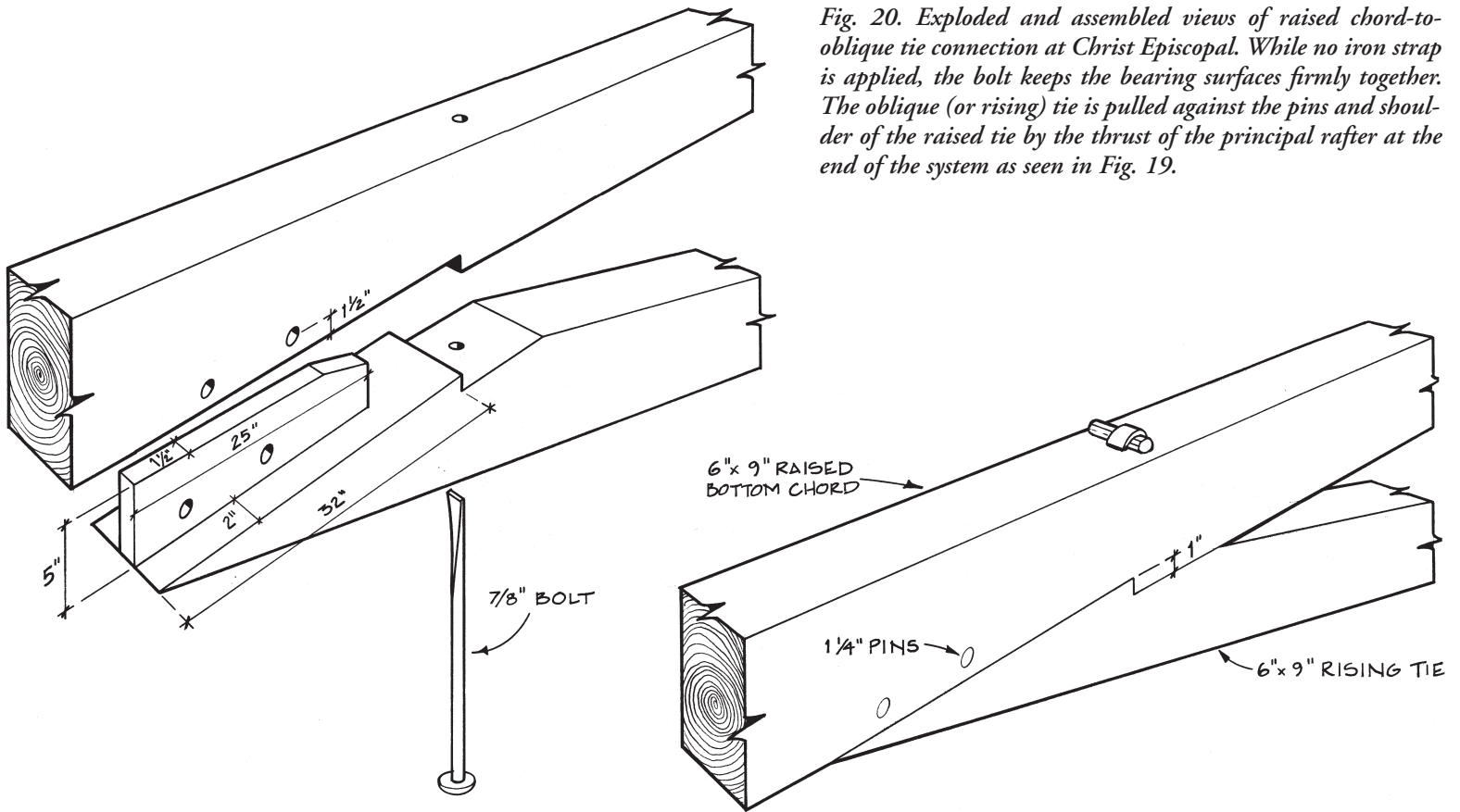

Fig. 21. Principal rafter-to-raised bottom chord joint at Christ Episcopal. Through mortise is especially laborious to cut and implies an assumption of considerable tension in the connection. Tenon relish behind pins is extended greatly, allowing pins to be set well away from interface of joint for maximum mortise strength in withdrawal.

point if the bearing wall at its opposite end drops because of sill or foundation problems. Should that happen, the short strut could force itself into the oblique tie and the force then go through the oblique tie and into the diagonal brace (bending the wall post), or it could deflect and break the oblique tie, already weakened by its two closely spaced mortises for brace and strut.



Ken Rower

Fig. 22. Principal rafter at Shrewsbury descending past connection with raised chord to meet oblique tie over plate. Brace rises from post to oblique tie, and vertical strut connects latter and raised chord. Some back-primed shingles visible at wall.

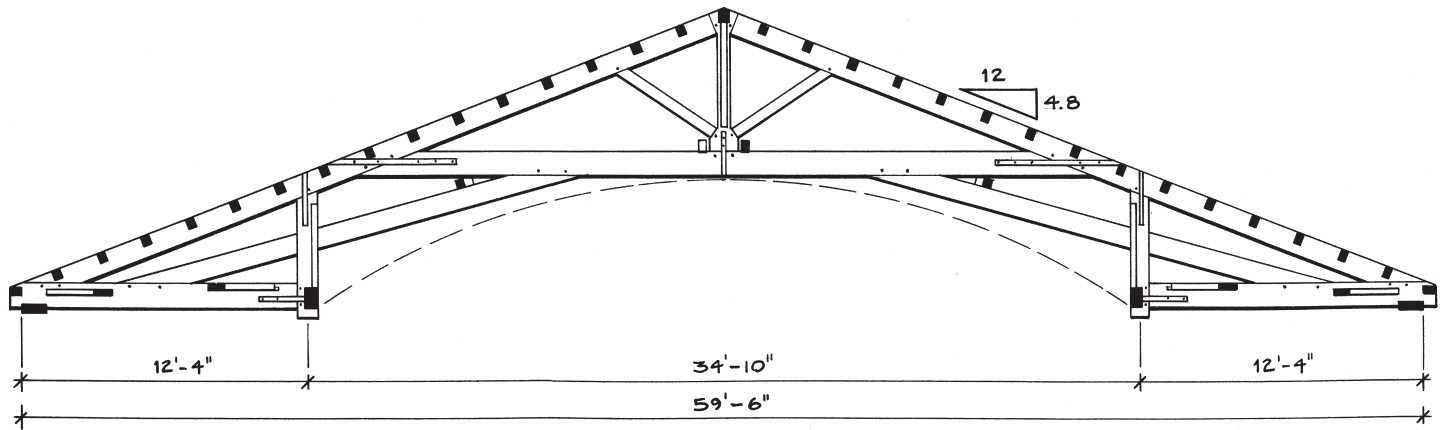

Fig. 23. Raised bottom chord truss at St. John's Church, Portsmouth, N.H. (1807), an exceptional form within an exceptional truss form.

ST. JOHN'S CHURCH, Portsmouth, N.H. (1807). St. John's was designed by the 26-year-old Alexander Parris of Portland, Maine, who went on to design many other churches, among them St. Paul's Episcopal in Windsor, Vermont (1822), whose attic trusses are scissor-form (see TF 69). One of the first New Hampshire churches built of brick, St. John's reflects Asher Benjamin's and William Pain's published works in the design of some exterior

features (Candee, 86). The roof, over galleries flanking a vaulted nave, is framed with a sort of raised bottom chord truss. Some specifications of this truss, such as the large dimensions of the timber and the continuation of the rising ties almost to the outside wall, imply a clear span. But the extension of gallery posts into the plane of the truss, where they intersect in a deliberate fashion with several members, renders its functioning complicated (Fig. 23).

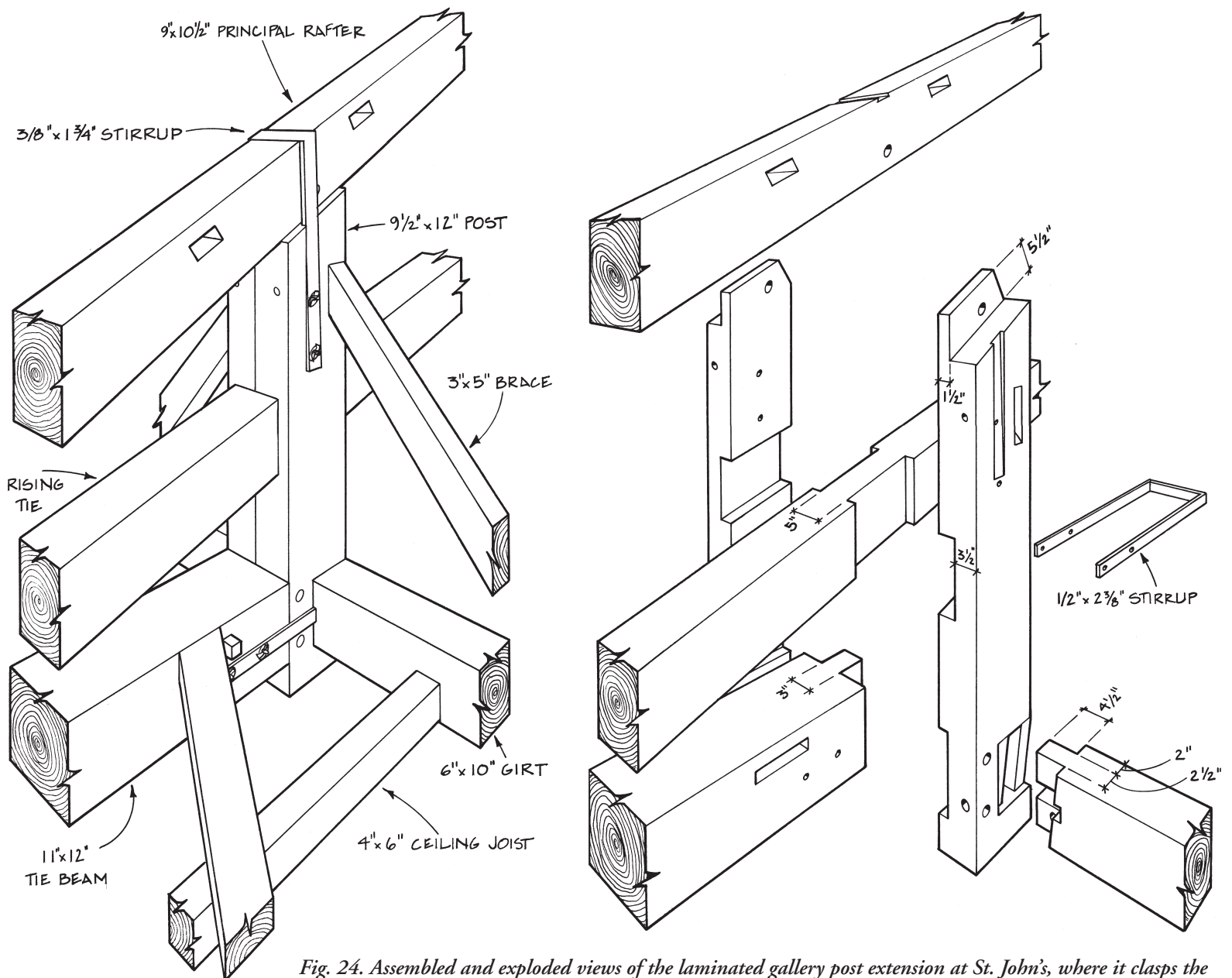

Fig. 24. Assembled and exploded views of the laminated gallery post extension at St. John's, where it clasps the oblique (rising) tie, while the principal rafter passes over and the gallery tie is strapped and pinned on.

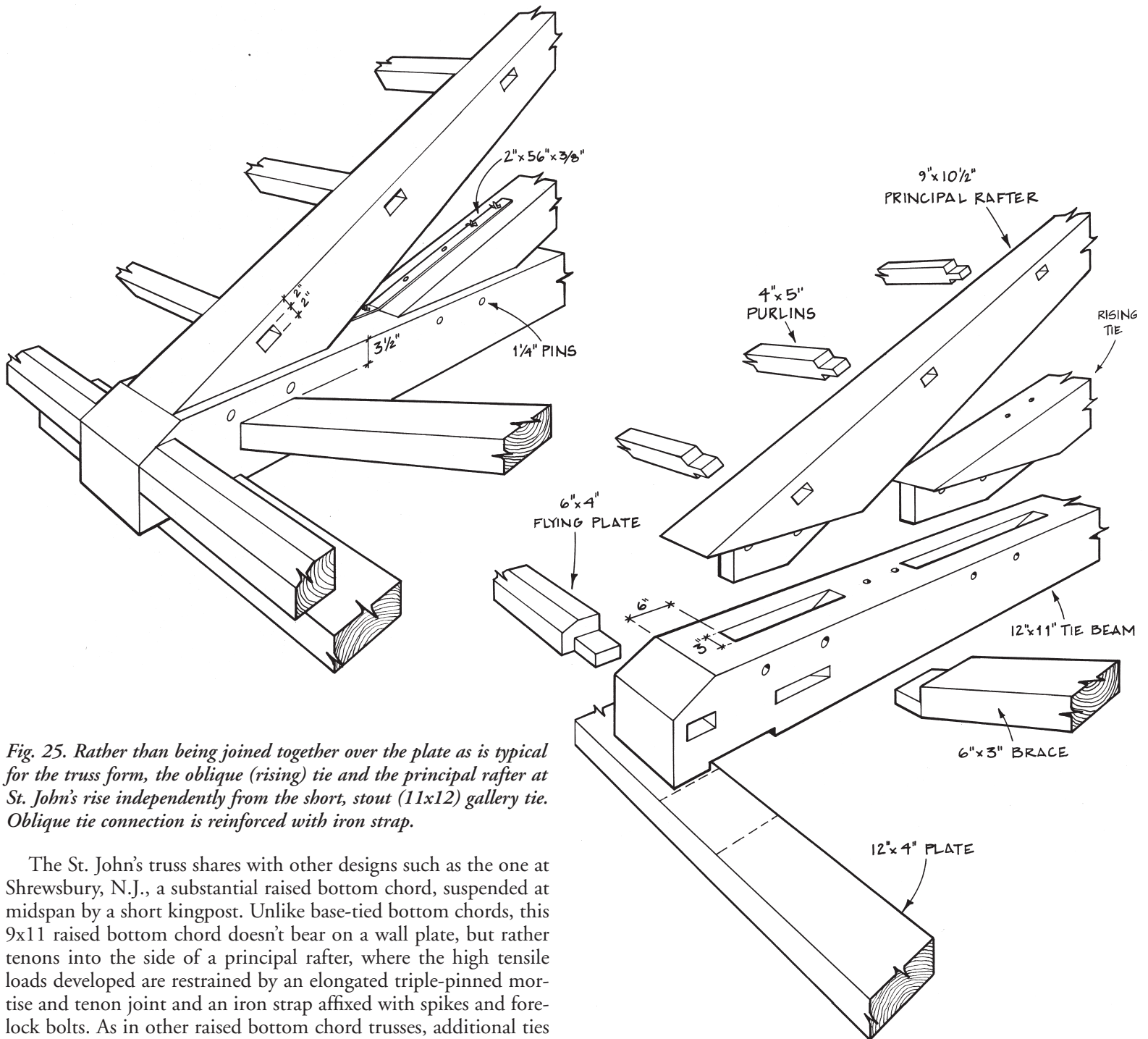

Fig. 25. Rather than being joined together over the plate as is typical for the truss form, the oblique (rising) tie and the principal rafter at St. John's rise independently from the short, stout (11x12) gallery tie. Oblique tie connection is reinforced with iron strap.

The St. John's truss shares with other designs such as the one at Shrewsbury, N.J., a substantial raised bottom chord, suspended at midspan by a short kingpost. Unlike base-tied bottom chords, this 9x11 raised bottom chord doesn't bear on a wall plate, but rather tenons into the side of a principal rafter, where the high tensile loads developed are restrained by an elongated triple-pinned mortise and tenon joint and an iron strap affixed with spikes and forelock bolts. As in other raised bottom chord trusses, additional ties rise obliquely to this bottom chord, where they are double-pinned and bolted.

The first anomaly at St. John's is that these oblique ties do not rise from the wall plates, where the ties themselves could bear the outward thrust of the principal rafters. Instead, both the oblique ties and the principal rafters rise from gallery tie beams, stout 11x12 members that lap over the wall plates and at the other end tenon into the gallery post extensions 12 ft. 4 in. inboard (Fig. 25).

A second difference is the unusual gallery post extensions themselves, sawn half-columns that clasp the obliquely rising ties, with both members reduced and shouldered at the passage, and then continue on to tenon into the principal rafter approximately 20 in. downslope from its junction with the raised bottom chord. These extensions sit directly over the turned and carved gallery columns exposed in the audience room below (Fig. 24 facing page).

Many New England churches of the time have gallery posts that extend upward to support a purlin in the roof system or to become queenposts in a truss above the ceiling. This truss in turn may have a kingpost truss superimposed on its straining beam, or gallery posts might extend to support the upper kingpost truss slightly inboard of

its lower chord's tenoned junction with the principal rafters (Kelly, I, 303 and II, 86). In addition, the raised kingpost is supported by inner main braces that descend to the lower chord and bear over the gallery posts. In such cases, because of their support, the tie beam's function as a bottom chord ends at the gallery posts.

The problem at St. John's is that the gallery post extensions prop the principal rafters near midspan but do not directly or even closely support the raised bottom chord and its joints with the principal rafter. Perhaps consequent from this anomaly are the only failures we observed at St. John's: two separated junctions between raised bottom chords and principal rafters, one noteworthy and one resulting in complete destruction of the chord tenon at this pinned and strapped joint (Fig. 29 overleaf).

The unfortunate positioning of the gallery post-chord-rafter junction may not have been the framer's original intention. An upside-down chalk drawing on the side of one of the oblique ties provides an elevation of the truss, obviously drawn before erection and probably before assembly. In the drawing, the gallery post joins the chord and rafter at a discrete node.



Ken Rower

Figs. 26 and 27. St. John's Church, Portsmouth, N.H., 1807, rich in crisp neoclassical detail. The cornice and pediment base are made of molded brick. Below, tapered and carved gallery posts directly support short posts of truss hidden in attic. Researchers in background.

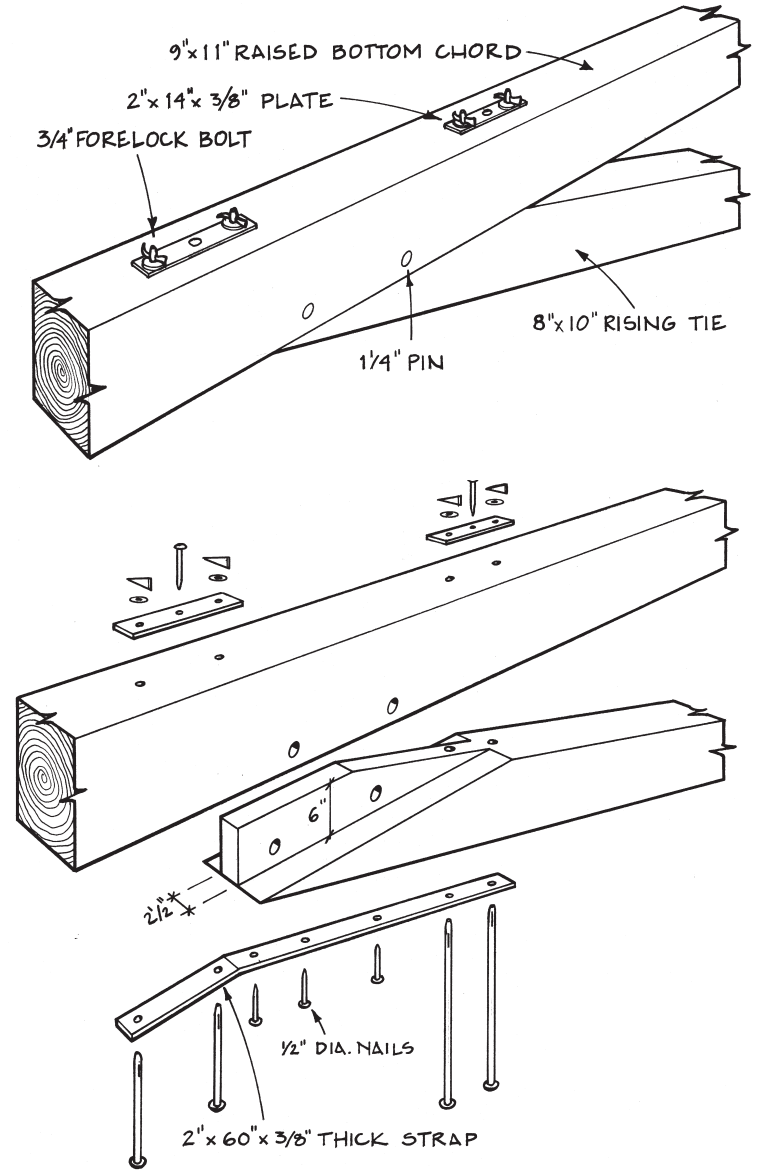

Fig. 28. Exploded and assembled views of joint between raised bottom chord and oblique (rising) tie at St. John's. Iron reinforcement is elaborately fastened with draw-wedged forelock bolts.

In a typical raised bottom chord truss, the oblique ties combine with the middle portion of the raised bottom chord to form the true, arched, lower chord of the truss. At St. John's, the functional interruption of the oblique tie by the clasping gallery post, and the fact that the oblique tie does not restrain the principal rafter in any



Dan Boyle

Fig. 29. Tenon destruction in raised chord withdrawn from principal rafter in St. John's truss. Strap may conceal shear failure in chord.

direct fashion, changes our view of its work. Inward of its joint with the post, the oblique tie works as a brace (usually in compression but perhaps in tension under unbalanced roof loads) propping the raised bottom chord. Outward of the gallery post, the oblique tie works as a brace stiffening the post extension against the several forces it is opposing. A survey of Asher Benjamin and William Pain imprints before 1806 shows the problem of aisled churches with vaulted naves dealt with somewhat differently. Both authors illustrate the raised bottom chord truss in aisled buildings, but the oblique ties are omitted and replaced by steep braces rising from gallery post extension to bottom chord, or else the raised bottom chord itself is turned into a straining beam with the gallery extensions serving as queenposts (Benjamin 1797, pl. 27, 2; Pain 1792, pl. 5, 7; Pain 1791, pl. 135).

Yeomans reproduces two drawings for roof trusses, in the 18th-century London church St. John's of Smith Square, that bear interesting similarities to St. John's of Portsmouth (Yeomans, 80). The English examples have flat-ceilinged aisles with vaulted naves and raised bottom chord kingpost trusses high in the ceiling. In one drawing, braces rise from the aisle post extensions to strut the principal rafters several feet short of the raised chord-rafter junction. In the other drawing, an oblique tie rises from the short tie beam over the aisle, as in Portsmouth, passes through or alongside a gallery post extension, crosses the raised bottom chord and terminates at joggles on the short kingpost, transforming itself from a tie into a

compressed main brace. Without being able to attribute direct influence on the design of St. John's Portsmouth, we have from such sources an idea of concepts current at the time in prestigious and large-scale framing.

The kingposts and braces at St. John's Portsmouth are oak, but the remaining large and long timber is white pine. The oak pins are $\frac{7}{8}$ and $1\frac{1}{4}$ inch according to use. The framing is scribe ruled and, most unusual, much of the joinery is centered rather than set closer to one face. The roof pitch is relatively low, approximately 5:12, and the five interior trusses are spaced typically 12 ft. 6 in. apart. The overall condition of the truss system is very good.

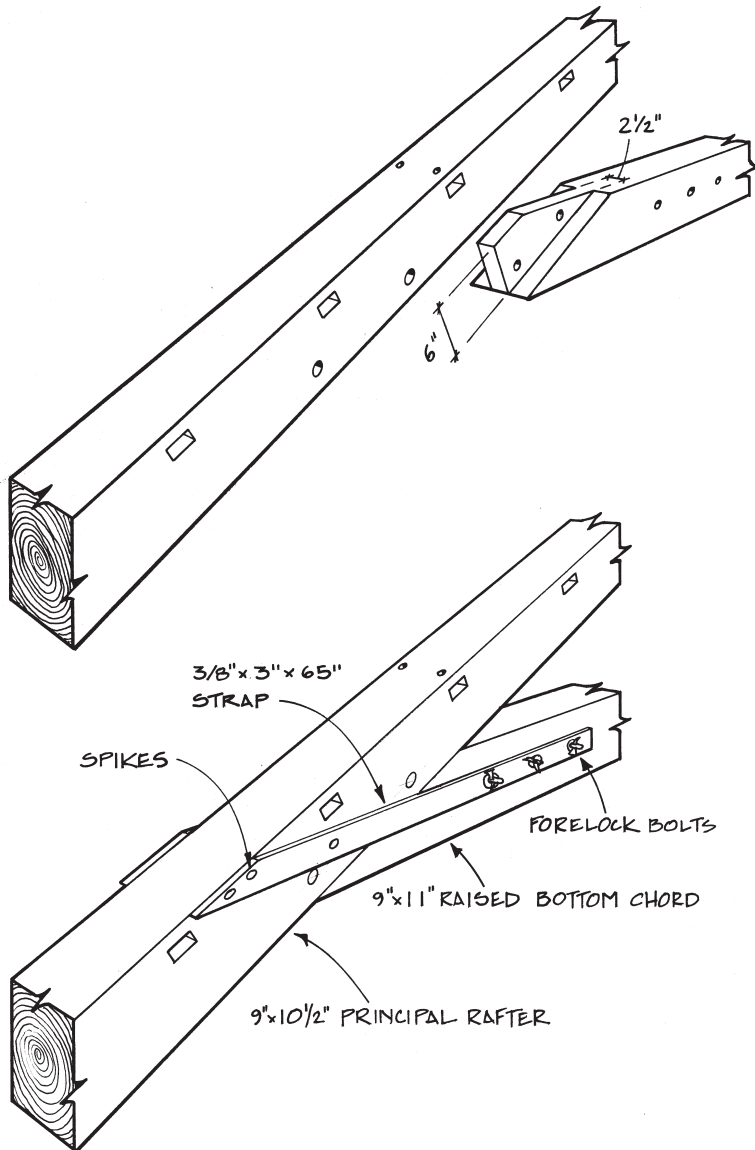

Fig. 30. Exploded and assembled views of side-strapped joint between principal rafter and raised bottom chord at St. John's. Stout bolts in chord are not matched by spikes in rafter, perhaps because of mortise.

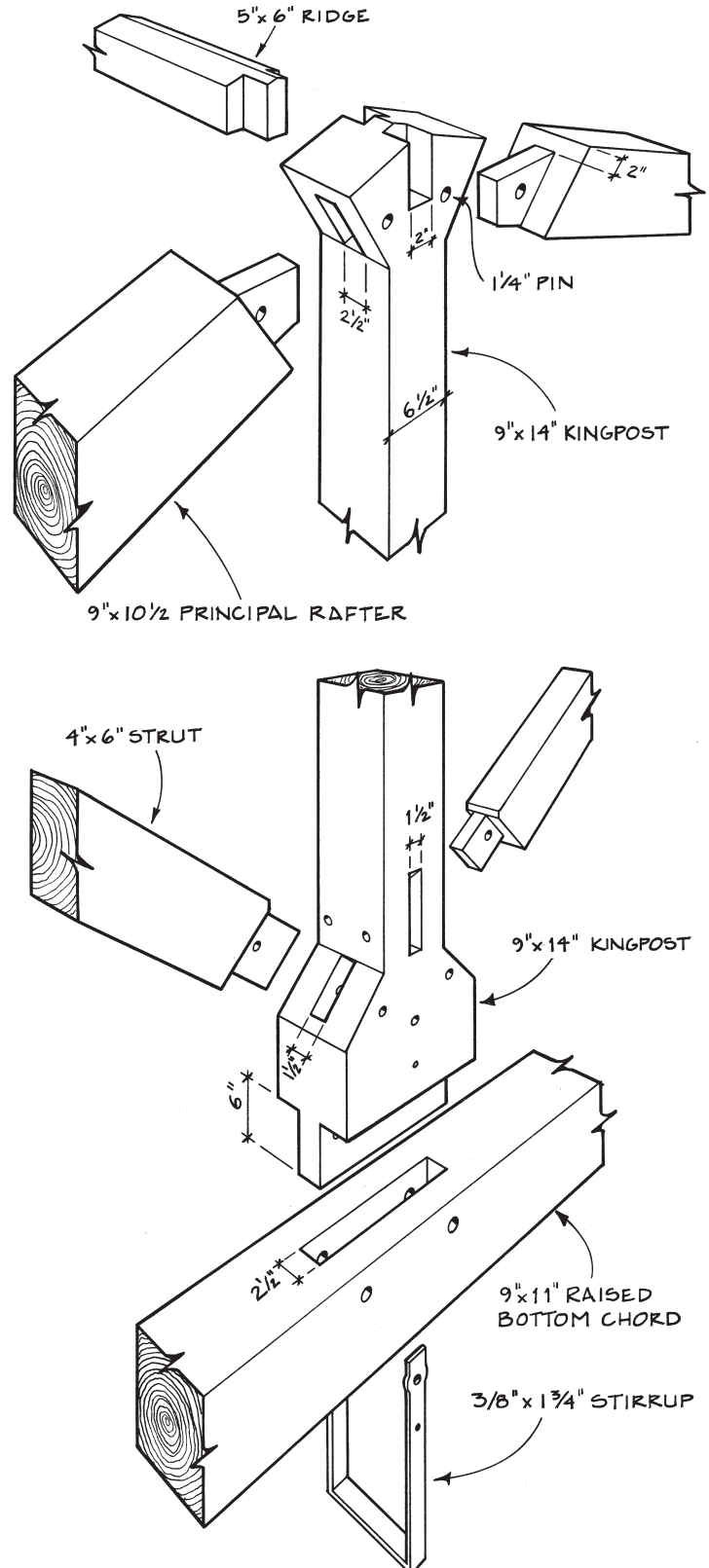
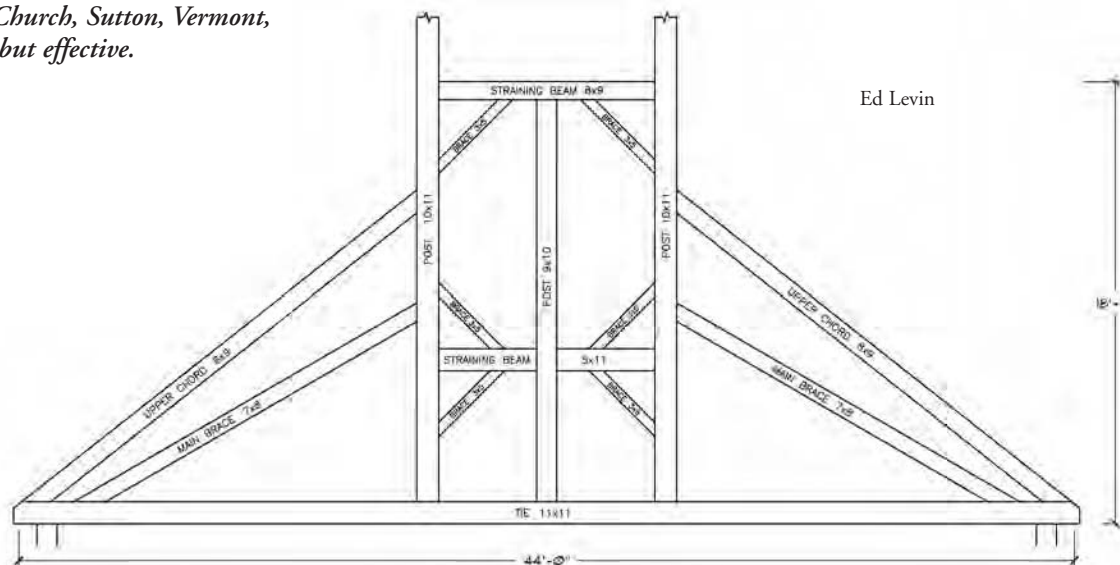

Fig. 31. Exploded views of St. John's kingpost head and foot joints.

Fig. 32. Tower truss at Sutton Baptist Church, Sutton, Vermont, 1832. Construction is unconventional but effective.



SUTTON BAPTIST CHURCH, Sutton, Vermont (1832). Located in a remote town in northeastern Vermont, the Sutton Church's audience room is much altered, but its roof frame is in original and near-perfect condition. Conventional timber-framed kingpost trusses span the 44-ft. width of the building, but of particular interest to us is the truss at the rear of the steeple. While it is common for a kingpost roof system to include in this location a queenpost truss that efficiently incorporates the rear tower posts as queens and reflects the greater load imposed by the steeple, the Sutton truss is in fact a composite that includes king- and queenpost elements, neither fully realized into a truss, but the ensemble ultimately successful. (Sometimes the term composite refers to the mixing of wood and metal members in a truss; we use it here to mean two truss forms in one.)

The bottom chord of the composite truss is a single 11x11 stick 44 ft. long of old-growth spruce. Rising from the bottom chord equidistant from midspan are two 10x11 rear steeple posts that share with the front steeple posts the load of approximately 50 vertical ft. of tower, belfry and spire. Queenpost 7x8 main braces rise from a point about 2 ft. inboard of the bearing of the bottom chord on the exterior wall to a point 8 ft. up on the tower-queenposts. The 8x9 principal rafters of the church, supporting the roof covering, also rise, but at a steeper angle, to tenon into the tower-queenposts 13 ft. above the bottom chord (Fig. 32).

The makings of a double-raftered queenpost truss are here, but there are discordant elements. Neither of the main brace pairs is opposed directly by a straining beam; the lower main braces support the posts about 2 ft. above the mortise and tenon joints of a 5x11 horizontal girt that crosses, interrupted, to the other tower-queenpost. This 5x11 timber has substantial bracing rising and descending to it from the tower-queens, stiffening the whole adequately to act as an offset straining beam. The upper main braces, truncated principal rafters, bear on the tower post about 4 ft. below the next candidate for a straining beam, but 3x5 rising braces stiffen the offset connection and nearly provide an in-line attachment of rafter to girt.

Why the framer chose to offset his main braces and straining beams is not clear, but neither was he unknowing, for his choices all worked: there is no visible bending in the posts or sagging of the tower. Further demonstration of either idiosyncrasy or sophisticated creativity are the short (3½-in.) tenons of the queenposts at the bottom chord. They alone cannot suspend the chord in tension but, because of the nonconforming truss form, the queenposts don't bear on the chord either.

The midspan of the bottom chord is supported by a triple-pinned (1½-in. pins) through tenon at the bottom of a sort of

kingpost, an 18-ft. 10x11 timber tenoned at its top into the straining beam-equivalent of the upper tower assembly, but with a short (4-in.) tenon and two pins incapable of bearing significant load. No principal rafters or braces shoulder into this kingpost. The majority of its support comes from the two-piece lower straining beam that tenons into each side of the kingpost with vertical tenons 2½ in. by 11 in. This discontinuous straining beam is kept from sagging by 3x5 braces rising from low on the posts to a point about 1 ft. away from where the halves of the beam engage the kingpost. This unlikely assembly is constructed entirely of old-growth spruce, the lightness of which relative to its strength may contribute to its successful performance.

What were the intended load paths in the indeterminate Sutton truss and what are the actual paths? The framer clearly intended the kingpost, the only vertical member with substantial tension joinery, to support the bottom chord in tension via the through tenon engaging the chord with three 1½-in. pins. The framer also likely expected the discontinuous straining beam and its braces to support the kingpost on its stiff 11-in.-tall tenons. Whether planned for or not, the 3½-in. double-pinned tenons at queenpost foot and kingpost head also contribute some capacity.

Probing the various joints of a truss with a thin metal blade, to determine which shoulders are bearing, can yield surprising results. At Sutton, all the joints between verticals and bottom chord are tight, indicating more than adequate tension capacity. The joint at the top of the kingpost is open about ⅜ in., suggesting that the tensile load carried by the kingpost would exceed the capacity of that pinned mortise and tenon unassisted. At the discontinuous straining beam below, where one would predict compressive loading on the tops of the two inner tenons and on both of the lower diagonal braces, one straining beam tenon and its brace are heavily loaded as expected, but the opposing member and its brace appeared to be bearing no kingpost load. (Note that both halves of the straining beam are loaded axially as part of the tower queenpost truss.)

The unequal loading on the two parts of the beam may result from some eccentricity in the plumbness of the completed frame or, more likely, it may be an artifact of the original framing work, with one half-straining beam and brace set slightly higher than the other. The taller assembly, with the help of the connection at the top of the post, might itself provide enough bearing on its tenon to support the entire kingpost load.

Probing and tapping also reveal a new and unexpected source of support for the kingpost that probably came into play shortly after the Sutton truss was erected: the diagonal braces of a longitudinal connecting girt between the kingpost of the tower truss and the

lower portion of the kingpost on the next interior truss. The mechanics are straightforward and arise from an endemic problem of a great many early New England churches. The front of Sutton's steeple, heavy, tall and exposed to wind loading, bears on a continuously framed gable wall of the church, while the rear (the two queenposts and their superimposed load), rests on the first interior truss, a clear-span the width of the church. No matter how powerful the truss, some deflection will occur here from transverse shrinkage of vertical members, end-grain compression of main braces and even the small percentage of longitudinal shrinkage that adds up significantly in very long main braces. Since the front of the steeple is fully supported to the ground and will not deflect, the sagging of the truss at the rear produces a rearward rotation of the steeple, further increasing the load on the interior truss, finally producing that appearance of backward lean and even a slight kink in the roof so often seen on early churches.

The tower truss kingpost at Sutton now bears back heavily on its longitudinal brace and connector, and the thrust is carried through the connector and its lower diagonal brace to the foot of the next interior kingpost. The latter is through-tenoned to a tie beam carrying joists and a finished ceiling and thus quite capable of resisting the partly horizontal thrust. The longitudinal braces that rise toward the tower truss kingpost are very heavily compressed on their bearing shoulders, whereas the braces rising away are loose in their mortises.

—JAN LEWANDOSKI

Jan Lewandoski of Restoration and Traditional Building in Stannard, Vt. (janlrt@sover.net), has examined hundreds of trusses and steeples. Co-investigators for the truss series Ed Levin, Ken Rower and Jack Sobon contributed research and advice for this article. Marcus Brandt, of Bethlehem, Pa., contributed significant research and support to the investigation of the Central Moravian Church in Bethlehem. Joseph Hammond provided help at Christ Episcopal Church in Shrewsbury, N.J., and Dan Boyle at St. John's Church, Portsmouth, N.H.

Bibliography

- Benjamin, Asher, *The American Builders Companion*, Sixth ed., 1827. Dover reprint, New York, 1969.
- , *The Country Builders Assistant*, Dickman, Greenfield, Mass., 1797 and 1800.
- Candee, Richard, *Building Portsmouth*, Portsmouth Advocates, 1996.
- Carpenters Company of Philadelphia, *Rules for Measuring and Valuing House-Carpenters Work 1786*. The Pyne Press reprint, Princeton, 1971.
- Gwilt, Joseph, *The Encyclopedia of Architecture*, Longmans, Green, London, 1867.
- Hammond, Joseph, "The 18th-Century Church Designs of Robert Smith," *Timber Framing* 73, 2004.
- Hewett, Cecil, *English Cathedral and Monastic Carpentry*, Phillimore, Chichester, 1985.
- Kelly, J.F., *Early Connecticut Meetinghouses*, Columbia University Press, New York, 1948.
- Langley, Batty, *The City and Country Builder's and Workman's Treasury of Designs*, London, 1740.
- Pain, William, *The Practical House Carpenter*, J. Taylor, London, 1791 and 1815.
- , *The Practical Builder*, Norman, Boston, 1792.
- Palladio, Andrea, *The Four Books of Architecture*, Isaac Ware, London, 1738. Dover reprint, New York, 1965.
- Price, Francis, *The British Carpenter*, London, 1733.
- Maggi, Angelo and Nicola Navone, eds., *John Soane and the Wooden Bridges of Switzerland*, Accademia di architettura, Mendrisio, Università della Svizzera italiana, 2003.
- Tredgold, Thomas, *Elementary Principles of Carpentry*, Carey and Hart, Philadelphia, 1837.
- Yeomans, David, *The Trussed Roof*, Scolar Press, Aldershot, 1992.



Jan Lewandoski

Figs. 33 and 34. Kingpost in tower truss at Sutton Baptist Church is supported by pins at the top and by the tenons of the braced beams seen near bottom of photo and also seen passing from left to right in the photo below. Below, the kingpost is linked and braced back to the bottom of the next kingpost truss via the lowest beam seen on the right.



Composite and Raised Bottom Chord Truss Engineering

From the beginning of this series, roof live load applied to all truss frame models has been based on 65 psf ground snow load. This figure made sense in interior northern New England but, in the cases of Portsmouth, N.H., and especially Bethlehem, Pa., and Shrewsbury, N.J., it represents an unrealistically high load. Therefore I have reduced roof live load at Portsmouth to 75 percent of the prior standard and, on the Pennsylvania and New Jersey trusses, to half.—EL

SUTTON BAPTIST CHURCH. The tower truss at the Sutton, Vt., church is an anomaly. One can only guess at the expectations of the builder but, clearly, load path disposition can be changed by adjusting stiffness of the critical joints at the kingpost head and queenpost feet (without any alteration to timber layout). It may be that our man was something of an intuitive genius who understood the cardinal rule that load goes to stiffness and tuned up his truss accordingly. To test this theory, we built a finite element analysis (FEA) model of the Sutton tower truss, adjusting the relative stiffness of individual joints in an attempt to approximate real world conditions. In the diagram on the facing page, the over-the-top bending load of Sutton's principal rafters is likely an artifact resulting from uncertain disposition of the roof load (Fig. 1).

Examination of the Sutton joinery clarifies both the builder's intentions and their result. Triple 1½-in. pins securing a through tenon at the kingpost foot make a persuasive case that the preferred carrying mechanism for the center of the tie was through tension in the kingpost base, to be picked up by the left and right lower straining beams, thence via compression in the lower braces down to the queenposts, up the posts, then down and out via the main braces to the tie (Fig. 2).

Close inspection indicates that some healthy portion of the load is indeed tracing this path, at least on one side of the building where braces and straining beam come up solidly against their respective bearings (on the opposite side a ¼-in. gap remains). But it turns out that the tower truss is also supported by longitudinal braces under the ridge line running down and back to the kingpost of the next truss inboard over the audience room. The midline bracing, in conjunction with kingposts, longitudinal girders, attic floor and audience room ceiling all combine to brace the roof frame in the ridgewise direction, and it is this whole system that keeps our mystery tower truss afloat.

CENTRAL MORAVIAN CHURCH, Bethlehem, Pa. The appropriate professional assessment of this truss would seem to be, *WOW!* Our engineering model reflects the character of the magnificent and stately original, easily handling loads over the longest span of any we have encountered with minimal resultant deflection, bending and axial load. This truss meets and exceeds expectations, performing as a kingpost superimposed above a queenpost. It breaks new ground in the thoughtful use of well-wrought iron hardware to supplement timber joinery, appropriate to the scale of the structure and its proportionately larger loads. Only two small parts of the composition can be faulted.

First, contrary to intention, the 7x8 struts that rise from the queenpost feet to join the kingpost just below the straining beam carry no compressive load, and indeed act in mild tension. However, they can easily be eliminated or disregarded without consequence. Second, the setup for bearing at the ends of the straining beam could be improved. Ideally, you look for ample and direct end-to-side grain bearing of straining beam against queenpost. But here most of the available beam section is used up in an oblique connection to the principal rafter, and the 2¾-in. high abutment between beam and post that remains is tilted 30 degrees off the vertical. In theory, the straining beam can be squeezed out of its bearing, but potential problems are mitigated by the mortise and tenon joints at the queenpost, straining beam and rafter, reinforced by a 1¼-in. bolt that (in most cases) binds post and rafter, securing the straining beam against travel out or up. In addition, despite the size and span of the roof, predicted compressive force in the straining beam is a modest 13,000 lbs. (compared to 30- to 40-kip axial loads found in some queenpost trusses examined in TF 71).

ST. JOHN'S CHURCH. We do well to bear in mind the proportions and layout of Central Moravian while pondering the roof structure of St. John's in Portsmouth, N. H. Of all the buildings we have inspected in this series, St. John's is among the most handsome and impressive in all respects. And while the caliber of the architectural design and execution tends to instill confidence in the structure, this particular configuration of the raised chord truss has an Achilles heel in its layout of raised tie, rafter and gallery post extension. That the truss design is flawed is predicted by computer analysis, which shows tension loads of 25,000-30,000 pounds in the raised chords and bending stresses in the rafters up to twice the allowable value, and is confirmed by a signal joint failure in the roof frame (Fig. 29, page 16).

Several factors contribute to the problem. The first thing that strikes the eye at Portsmouth is the very low profile of the truss. This is the lowest roof pitch of any truss in our database. The combination of low slope, long span (59 ft. 6 in. overall, 34 ft. 10 in. clear between gallery posts) and relatively heavy load is not an auspicious one. Double the roof pitch without otherwise altering the configuration and you reduce predicted deflection by 20 percent and cut maximum tension load in half (although bending stress remains essentially unchanged).

But the principal issue is the 2-ft. distance that horizontally separates the tying joint (raised chord to principal rafter) from the vertical support offered by the gallery post extensions. Under load, the central kingpost assembly wants to descend, loading the raised chord in tension and the rafter in bending at the connection between the two. Keeping the gallery post extensions close to the tying joint would lower tension in the system by about 15 percent and, by reducing the moment arm in the rafter, significantly decrease the bending stress, by 40 percent.

This observation brings us to the oblique ties, which rise from interrupted lower tie beams (or gallery ties) to be sandwiched by the two-part gallery post extensions and then join the raised chord midway from the post extension to the bottom of the kingpost (see Fig. 23, page 14). Given their spring points on the gallery ties, atypical of the raised bottom chord truss form, and their midspan connections to the extended gallery posts, we can presume that these oblique or rising ties were intended to support the raised kingpost assembly and counter its downward deflection, thereby managing resultant force and stress. But they do nothing to alleviate the problem. In fact, they seem to exacerbate the situation.

How can this be? First, the geometry of the roof frame, with its low pitch and aspect ratio, forces the oblique ties to approach the raised chord at a very low angle. For the sloped ties to take up load, they must be put in compression. But since they are so nearly

parallel to the horizontal tie, the net effect of down pressure on the oblique ties is to rotate or bend them downward. And the halving joint at the gallery post extensions gives them torquing leverage, further binding up the roof system. Remove the oblique ties from the roof model, and deflection, bending stress and axial tension load are actually *reduced*, by 4 to 8 percent.

CHRISt EPISCOPAL CHURCH. This Shrewsbury, N.J., church presents a greater effective truss span than St. John's (38 ft. vs. 34 ft. 10 in.). Its roof is perched atop 22-ft. wooden sidewalls and the pitch is steeper (7:12 vs. 5:12), thus probably exposing it rather more to wind from the nearby Atlantic Ocean.

Under balanced load, Shrewsbury's deflections fall in the same moderate range as with similar loading at Portsmouth (max. $d_y = \frac{1}{2}$ in.), but bending stress is way down (well within the allowable range for oak), and tension loads top out at 15,400 pounds in the oblique ties and 11,500 pounds in the kingpost. All other parts are loaded in compression, save for the short midspan section of the raised chord between the inner ends of the oblique ties. More to the point, gravity loading yields three tension joints: oblique tie to raised chord, kingpost to raised chord, and the peak joint. At the kingpost foot, tension drops off below the incoming struts to a modest 8200 pounds. And the 15-kip tying load is easily handled by the tie-to-raised chord joint with its arsenal of pins, bolt, tenon and housing, even when measured by the strict standards of *NDS*.

Harking back to Portsmouth, it's worth recalling that the oblique ties at St. John's act in compression (albeit slightly), while those at Shrewsbury, more typical of the raised chord truss form, carry substantial tension because of their direct linkage to the principal rafter feet, identical in function and position to the downslope portion of the rising ties of lower chords in scissor trusses.

With its tall sidewall, the Shrewsbury frame looked fair to be derailed by wind. But the unbalanced loadcase had no effect on post tension, only slightly increased tie tension to 18,000 pounds (still within tolerances) and caused modest inflation in bending stress. Downwind brace pressure on the wall posts did raise a bending spike in the post at the brace joint but without transgressing design values for the 10x8 oak, surprising me. And vertical deflection remained unchanged. Something had to give, however, and it was side sway, with the top of the structure shifting 3 to 4 in. in high wind. Application of load duration and combination factors would bring down this value. Plus, we have taken no account of the diaphragm effect of walls, roof and ceiling, whose stiffening effect likely exceeds that of the timber frame (put another way, "It's the lath and plaster, stupid!").

Attempting to understand a recorded failure at the vertical strut-to-raised chord joint, of which the computer model gave no indication, we threw everything we had at the building: double wind load, double snow load downwind, upwind wall post subsiding several inches (the "major trauma" loadcase). With all the stops pulled out, we did manage to get the downwind raised chord to go into tension (4600 lbs.), which presumably might pull the joint apart, especially given a strategically located defect and a strut mortise near the raised chord end.

All of this does not imply that Shrewsbury and its family of raised chord trusses are in the same structural league with their conventional cousins, the orthodox kings, queens and scissors. But they did present neat solutions to design issues of their day and were adopted by some of the best builders; they are found in some of the best buildings on both sides of the Atlantic from Wren's time onward. For my part, a close encounter with the Shrewsbury truss and its kin may not have prompted the sort of profound conversion that made me a born-again scissor truss convert when we began this series on historic trusses (see TF 69), but it did go far to quell my skepticism.

—ED LEVIN

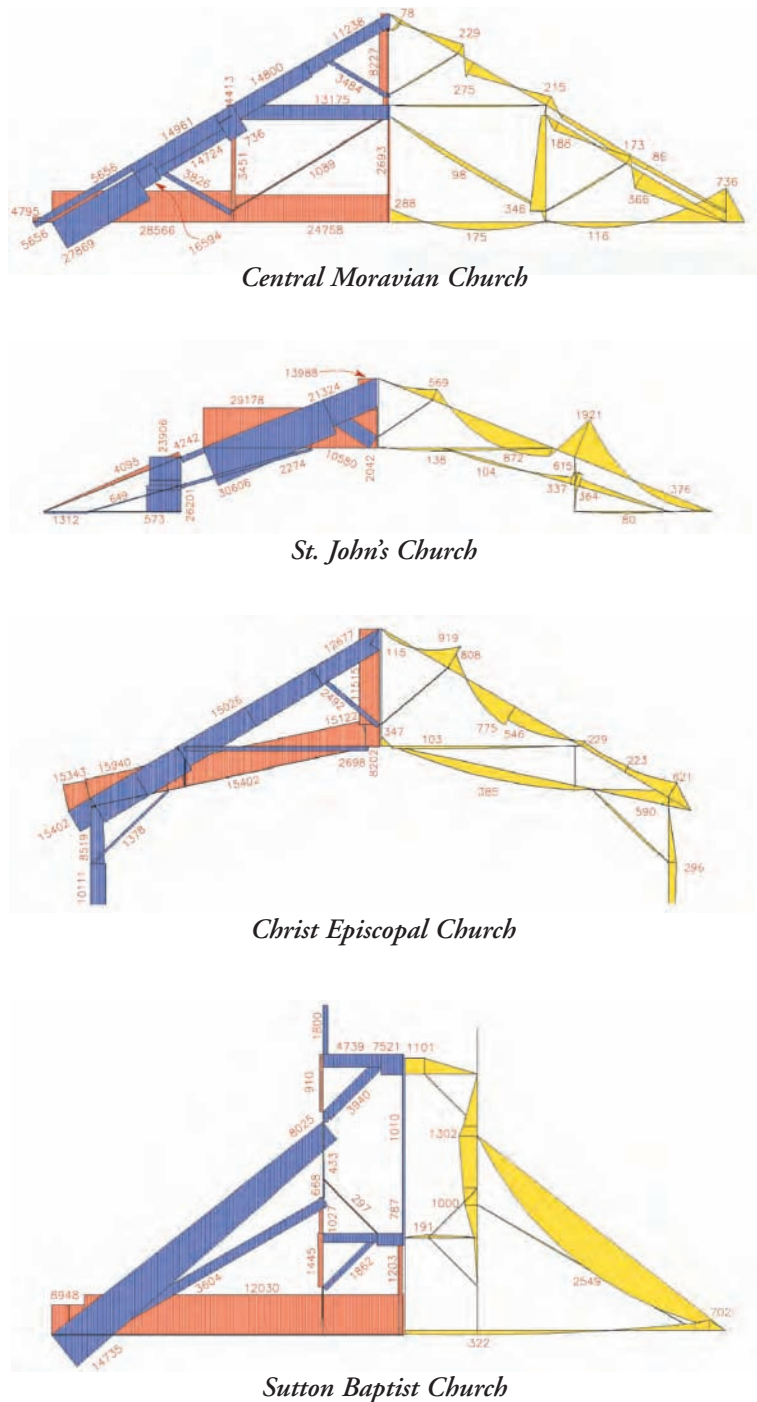
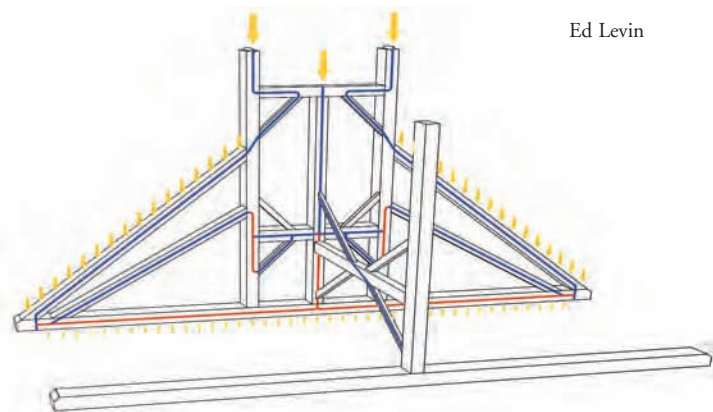

Fig. 1. In the diagrams above (not to scale), axial forces are on the left (blue for compression, red for tension, in lbs.) and bending stresses (yellow, in lbs.) are on the right.



Ed Levin

Fig. 2. Sutton tower truss load path. Blue is compression, red tension and the yellow arrows represent loads. Next truss back takes some load.

D-I-Y Down Under II

IN October 2001, after returning to my home in Castlemaine, Victoria, from the Carpenters' Fellowship Frame 2001 conference and a timber house-spotting tour in England, I was out of work the day I arrived home. The firm I worked for had been taken over, and now my services "were no longer required." Though I had known of the scenario awaiting me upon my return, I was a *very* happy man.

It was the chance of a lifetime to realise my ambition to construct an English barn in Australia and to bid farewell to full-time employment for at least a year. For a very practical and down-to-earth person, I had a strong belief that fate would provide all I needed to construct this building from the immediate environment. Getting a generous severance payout was icing on the cake.

Gathering the timber needed for such a large building had begun some years before with the delivery of a number of very large 100-year-old Lombardy and silver poplars (*Populus nigra* and *P. alba* respectively) cleared from some of our waterways in the interests of reinstating native vegetation. This removal of some of our cultural heritage meant the loss of some beautiful trees but my gain of free timber and a second life of sorts for the wood. The 40-ft. semi-trailer loaded with 30-ft. logs and stretching down the drive was a sight to behold, even if getting the logs off by hand used a lot of grunt.

Next on the list was a fallen hoop pine (*Araucaria cunninghamii*, a native species from Queensland) and a huge 130-year-old stone pine (*Pinus pinea*) windfall, 5 ft. through at the base, from the local botanical gardens. These trees were donated by the local council and transported free of charge instead of becoming landfill.

I had also acquired (this time for \$300 Australian plus delivery costs) a 5-ft.-dia. forked cypress pine (*Cupressus leylandii*), but some of it had rotted and at least a third of the wood proved of no use. As late as this year, I collected more mature cypress pine being removed from the grounds of a 1905 house, as well as Monterey pine (*Pinus radiata*) from another house nearby.

I had built the stone base wall for the barn over the previous year using rock freely available on our property and in sufficient quantity to do both the barn and a forthcoming house that will be our residence. (An earlier house I had built using the same principles, featured in TF 58, will become a bed-and-breakfast.) This process fitted well with my preference for using only local materials. I used lime mortar to build the walls, and it has proved itself superior to cement in all possible ways.

The checkerboard plinth directly under the timber frame is influenced by wall systems seen in Wiltshire in England. There it is quite common to see stone and flint used to construct entire houses. In lieu of flint, I used new, rejected bricks from a local brickworks. Again, a great resource to use—and the materials would have become landfill.

Inspiration for the frame design came from the Midlands of England, particularly places such as Pembridge and the Welsh Marches borderlands, where roughly square panels with a middle rail are used. But the outshot frame and one of the trusses over the last bay are pure Kentish (the Southeast) just to add variety. I deliberately steered clear of elaborate framing in favour of a utilitarian approach, to produce a functional building providing storage and a workshop to construct the house in.

The neighbors observing the logs delivered over two years and spread over five acres were becoming nervous—for good reason, as it happened: it took me three months to mill the timber with a Husqvarna 3120 that is not exactly quiet. A cutting list was first

priority. By numbering and listing the logs, I could then calculate what was available from each one and tick the timbers off the framing plan. The stone pine yielded all the posts, rails, studs and the giant arch braces, which came from huge swept branches. Lovely timber, very dense and heavy, with a fresh-cut smell of sweet fragrant soap. The only problem with this tree was its spiral grain, which caused some rather alarming twisting of planks and even posts. This was a worry when I started, but I determined I would just have to put up with its eccentric behaviour as it dried. In the end, scribing the joints allowed the use of all the timber.

The cypress pine was delightful to cut, the proverbial hot knife through butter, and the timber did not move. It provided all of the 7x8 purlins 15 ft. long, which remained just as cut with no wind at all, and what remained I cut for the 5x15 tapered principal rafters and assorted other truss pieces including curved struts and studs and collars. Tapering the principals, quite a common technique in parts of Wales, I extended to most of the wall bracing. It imparts more animation to the finished design.

The poplar logs yielded the tiebeams 7x14 by 19 ft. long and all the roof wind braces. Immensely heavy when soaking wet, but very light when dried out. Two of the logs in particular contained so much moisture that it oozed from their butt ends for many weeks.

One problem from the start was lack of room to do a full-scale layout directly on the floor in the English tradition (the plinth was in the way). Instead, string lines placed on the outside edge of the plinth provided the external reference lines to use in combination with the inch-and-a-half lines snapped on the timbers. Cross-frames I laid out *in situ* on the plinth and leveled. Most I then scribed using a spirit level held plumb rather than the plumb bob, as transferring layout marks on straight timbers stacked in position is much easier. The slower plumb-bob method came into its own with the violently twisted braces.

Having observed unsightly shrinkage at braces heels after seasoning (as the brace shrinks in width the heel of the shoulder must move off its bearing,) and knowing that a 13-in.-wide green brace is going to shrink big-time, I deliberately added a half inch to the scribed shoulder line to blind-house the centered braces into their receiving timbers. Careful cutting made the joints unobtrusive, and the end result is that no gap has appeared after nearly three years. Getting the right shape for the arch braces called for a radius of about 20 ft. Using pencil and nonstretching soft wire, I drew arcs on my planks to match their natural shallow curves.

The continual shifting of huge and heavy timbers took its toll on me. The heat of our summer was unbearable at times and required continual topping up of my energy reserves.

AS each long top plate run was 75 ft., a number of scarfs were required, which I placed over each of three cross-frame posts and made long enough to be supported by a brace. These joints were stop-splayed and undersquinted with folding wedges and four face pegs. Where the last run of a plate ran over the solid earth wall of the guest quarters (the end bay of the building), offering continuous support, I used a simpler edge-halved and bridled joint. Instead of laying out the scarfs with individual lines, I used a template made from thin plywood. By using the inch-and-a-half reference lines on both sides of a timber, I could locate the template with great accuracy and scribe the shape with a Japanese marking knife. The templates were cut with a knife as well, so there was no kerf and both parts of the template matched precisely. This system worked extremely well and saved a



Toni Lumsden

Author converts stone pine log into four matching posts. Husqvarna 3120 runs in Westford mill, made in Western Australia. Timber conversion took three months.



Inch-and-a-half reference line plainly visible on side of post aligns mortises for rail and brace, plus tenons for plate above and sill below.



Rob Hadden (all others)

Finished frame is 19x75 ft. with an 8-ft. outshot (at left above) about 13 ft. long. Checker-board plinth surmounts sandstone walls 15 in. thick, double-skinned with rubble infill.



Completed layout assembly of Kentish-style truss. Note struck chalk line on layout floor. Iron drift pins are indispensable in scribe rule layout.



Setting the 5-piece scarfed 75-ft. plates. Post jowls are uniquely shaped. In the background, the author's first effort (1994-2000), a masonry building with timber-framed roof.



Bridled scarfs join sills or plates where continuously supported. Elsewhere scarfs are stop-splayed.

lot of laborious marking-out time. I leveled each plate as well as possible after snapping a stringline on one side, then used my level again to transfer the terminal points at both ends across to the other side. Connecting the dots gave a parallel line on the other side of the timber. Placing the templates on parallel lines on each side of the timber then provided a twist-free layout.

A hand-cranked boring machine that I purchased from an industrial antiques dealer in South Australia roughed out the mortises. In the local hardware store, I found an old-stock 1½-in. Marples drill bit to fit the chuck, and the machine didn't look back. It just slowly cut its way through whatever I presented it to, unlike faster-turning power drills that sometimes stop dead in their tracks when the leadscrew on the bit becomes clogged. The boring machine works equally well on our local hardwoods but does require more muscle power.

AFTER nearly six months of cutting and drilling and chopping and trial fitting, the whole frame was finished, complete with tapered braces, and ready for reassembly. This procedure, as all framers know, is the proof of the pudding. I couldn't afford to hire a crane, so I devised a hand-raising with help from my wife, Toni Lumsden. Stout galvanized pipe yielded a tripod with extension legs. It could also be used for shear legs or a gin pole depending on requirements. I was amazed at just how easy it is to raise timbers, no matter how heavy or cumbersome, with a block and tackle and tripod. To raise the heavy tie beams, for instance, I found the exact center of the building and marked it on the floor, then used a plumb bob suspended from the block and tackle to locate a lifting point exactly over this position. I then positioned the tie beam and attached the block and tackle to its center point. Once lifted aloft and aligned to the post tenons, the tie beam slotted straight down into place with a satisfying dull thud as the air was expelled from each mortise. The large braces, pegged previously to the posts, needed only a gentle prod to get into position ready for the tie beam. No anxious moments at all.

Raising the principal rafters and purlins was a different matter altogether. The rafters had to go up tilted at a 45-degree angle and then dangle precariously as I lowered them into position while standing on the top of a ladder with sledgehammer in hand ready to tap them into final position. The curved struts provided useful support. Raised on a pair of shear legs, the purlins went up rotated at 45 degrees to slide over the splines that would connect them together, with the trusses spread a little to accept the purlins into their housings on the rafter faces. I found splining an excellent system to join the purlin runs, one that could be done by measurement once the trusses were up.

I scribe-fitted the lap-jointed windbraces *in situ* and severely tapered their tenons from shoulder to tip to minimise the amount of timber removed from the lap housings in both the purlin and the principal rafter. These braces were affixed with large handmade nails, not pegs, unnecessary in this application. (There is plenty of historical precedent in the UK for this method of attaching wind braces in barns, and indeed nails were routinely used in buildings for various purposes. The late Cecil Hewett's books illustrate this point.) Since the braces were laid on top and it was only their extremities that would do any work, nails were the obvious choice. With no evident tannins in the cypress and poplar, corrosion was of little worry.

The main frame up, I cut all the common rafters (purchased uncharacteristically from a local mill) in assembly-line fashion, then pushed them up into position over the purlins and lowered them into the step-lap rafter seats for pegging. (All pegs in the frame were ¾ in.) Some of the timbers in the trusses were left free edged as they came from the tree. The collar in one truss had a decidedly serpentine shape that made the scribing of the studs

somewhat interesting, to say the least. Frames in England show a lot of this feature, making use of much more bent timber than we ever do today. The shape and grain of timber determine its use in a given frame, optimum strength being one of the most obvious benefits. I often found myself considering where each particular timber would fit best, calculating the most economical and functional use for the material at hand.

I chose traditional wattle and daub as the fabric for the frame. With no insulation requirements for the barn, I could do so without having to worry about building regulations. I made the wattles from offcuts of 3-in. slabs of poplar sawn once into strips and then in two, to give 1½-in. slats, which I then wove around the staves. They alone involved roughly a month's worth of labor. The daub was a mixture of local clay sieved through ¼-in. galvanized mesh and mixed with three parts of sharp, gritty washed river sand. It took forever to hand-daub both sides of the walls and then more weeks for the daub to dry out during a cold winter, but the rough, uneven texture followed by numerous coats of limewash has paid dividends handsomely. Putting a hat on the structure was simply a matter of laying on secondhand sheets of corrugated iron and nailing tight to the common rafters. Most of the iron came from local shops in town that were having their roofs replaced. That old synchronicity was at work again as the goods I needed manifested themselves.

The decision to have guest quarters only came about during construction. What was to have been an open-roofed joinery workshop in the last bay suddenly sprouted a large mud brick chimney, an upper floor with two rooms and a miniscule toilet tucked under stairs narrow and steep enough to put the teeth of any building inspector on edge. I milled leftover log ends into 9x9s and then ripped them on the diagonal to yield triangular treads. These were toenailed to 3x5 stringers. Simple and fast to construct, this medieval style of stair predates all our typical stair construction.

The floor upstairs called for old, wide boards that are just not commercially available in Australia. I was fortunate to have six huge (and donated) Monterey pines, one of which I milled into 1-in. planks. Some of the finished planks were nearly 24 in. wide; most varied upward of 10 in. Placed at random and with patched-in bits to complete the picture, this floor looked simply stunning straight off the mill with no planing or sanding. Old handmade nails (from a reclamation yard) stopped them from wandering and looked the part.

But the most unusual feature of this room was that the northwest corner sloped gently down 7 in. out of horizontal. This distortion merely replicated the sagging of a building over time, but it did nevertheless make for exceptional joinery decisions. The building inspector, upon making his final inspection (before the stairs were put in, I might add), looked somewhat perplexed at the slope of the windows in the wall and just said, "Err . . . Rob, I think your spirit level is broken."

So, has it all been worth it, not only physically, but mentally as well? The answer would have to be a resounding yes! The lessons learnt along the way were invaluable, especially since the house proper is the next project looming on the horizon. Staying motivated day after day, week after week and finally year after year has not been easy, but the rewards are just fantastic when I remember that, even after two and a half years' lost wages, I am still in front financially. It would have cost many times what I might have earned to employ an English carpenter to come over to build what I built. But most of all, this building, like its magical bush setting, is made of wood, stone and mud, and a lot of synchronicity.

—ROB HADDEN

Rob Hadden (marmalade@castlemaine.net) lives about 65 miles from Melbourne. Trained as a fine artist, he last reported on the progress of his empire in TF 58 (December 2000).



Rob Hadden

Early in raising, posts, rails and braces for one cross-frame and one wall are up. Once all are up, long plates, tie beams, truss elements, principal rafters and purlins follow in that order.



Toni Lumsden

The author seated at the boring machine roughing out a mortise. Depth stop is not original equipment.



Toni Lumsden

Setting collar with tripod and tackle. Using a plumb bob dropped from the hook, tripod rigging is centered over building midline for lift of tie beam at its midpoint.



Rob Hadden

*Plates (shown before cutting common rafter steplap seats) are 6x6 Monterey cypress (*C. macrocarpa*), 7x14 tie beams are poplar, 8x7 purlins are cypress pine as are 5x15 principal rafters. Wind braces are lap-jointed to principals and purlins.*



Rob Hadden

Sawn and resawn wattles woven laboriously over the staves in preparation for the clay-and-sand daub infill to be applied from both sides and coated with lime.



Port Orford cedar, Curry County, Oregon

*Trees selectively harvested.
Timbers sawn to your specifications.*

EAST FORK LUMBER CO., INC.
P.O. Box 275 • Myrtle Point, Oregon 97458
Tel. 541-572-5732 • Fax 541-572-2727 • efc@uci.net

Hull Forest Products, Inc.

Sustainable forestry, quality products

- Kiln-dried flooring:
red oak, white oak, and hickory
- Eastern white pine paneling and flooring
12-20 in. wide
- Post and beam timbers up to 26 ft. long



Proud manufacturers of
NHQA quality lumber

101 Hampton Rd. • Pomfret Center, CT 06259
tel 800-353-3331 • fax 860-974-2963 • www.hullforest.com
Contact Craig H. Capwell, capwell@hullforest.com

CUSTOM TIMBER PACKAGES

Southern Yellow Pine

You can have it all - strength, beauty and affordability

Forest Salvaged Standing Dead Douglas-Fir

Sometimes Being Dead can be a Good Thing

Other Species Available

*From White Oak to Reclaimed to Rounds to the unusual,
give us a call, chances are we can get it for you.*

QUICK QUOTE TURN-AROUND • SHORT LEAD TIMES • HIGH QUALITY TIMBERS • PERSONAL SERVICE

CLARK'S FORK TIMBER

New York Office
Phone (585) 243-2795
Fax (585) 243-5036

South Carolina Office
Phone (864) 898-1655
Fax (864) 898-1675

www.clarksforktimber.com

Supplying timbers for over 20 years

Custom Cut Timbers

Clears / STK / #1 Structural

Douglas fir • Western Red Cedar • AYC
random or specified lengths • other grades available

**We will quote any timber inquiry,
no matter how unusual.**

Cowichan Lumber Ltd.

North Vancouver, BC, Canada
800-918-9119

Kiln-Dried Timber!

SunDried Resolved the "Green" Dilemma

SunDried Wood Technologies has refined a unique radio frequency/vacuum technology that uniformly kiln-dries whole timbers, bringing the percentage of the wood's moisture content down to single digits. SunDried timber is as dry at its heart as it is on the surface.

With SunDried Timbers you get:

- Dimensional Stability
- Optimal Structural Integrity
- No Additional Checking
- Peace of Mind

(304) 965-7700
sundriedwood.com
P.O. Box 130, Elkview, WV 25071

SunDried can dry most hardwoods and softwoods, including Northern Red Oak, Douglas Fir and Eastern White Pine



Reliance
SPECIALTY
BUILDING PRODUCTS

DOUGLAS FIR TIMBERS
UP TO 24X30 50'

TIMBERS SELECT FOR APPEARANCE
FOHC NO WANE GRN, STANDING DEAD OR KD S4S OR RGH

QUALITY WOOD PRODUCTS
FROM THE PACIFIC NORTHWEST

WWW.RELIANCESBP.COM
800 697 4705

"APPRECIATE" YOUR INVESTMENT

ENCLOSE your timber frame with America's premier structural insulating panels. Our polyurethane panels' in-molded wire chases, cam-locking system and T&G joints allow for the quickest of installations. Available in R-values of R-28, R-35 or R-43. Murus EPS panels are offered in R-16, R-23, R30, R-38 or R-45.

Polyurethane or EPS, consider Murus for all your SIP needs!



murus

STRUCTURAL INSULATING PANELS

PO Box 220
Mansfield, PA 16933
570-549-2100
Fax 570-549-2101
www.murus.com
murus@epix.net

Foard
PANEL

The Timber Framers' Panel Company

www.FoardPanel.com

P.O. Box 185, West Chesterfield, NH 03466
603-256-8800, info@foardpanel.com



Your
Post &
Beam
Source

Pine • Oak
Hemlock

Post & beam timbers and
lumber in over 12 patterns

Grade stamping and
dressed timbers available

PLUS our building
supply store can supply
you with everything else
you need!

W. D. COWLS, INC.

134 Montague Road, P.O. Box 9677
North Amherst, MA 01059
413-549-1403 • Fax 413-549-0000

info@cowls.com • www.cowls.com

Hundegger USA



Ask us about the updated
K2 Joinery Machine
and the new
PBA Panel Machine

Call or e-mail us for a free video

(435) 654-3028 OR (801) 361-4030

INFO@HUNDEGGERUSA.COM-WWW.HUNDEGGERUSA.COM

QUALITY TOOLS FOR

TIMBERFRAMERS



Makita® Chain Mortiser

Save countless hours cutting mortises by using Makita's chain mortiser. This machine cuts extremely fast, accurately, and can pivot to three cutting positions without resetting. Chain mortiser comes complete with $\frac{23}{32}$ -in. chain, sharpening holder assembly, wrench, and chain oil. An unbelievable machine!

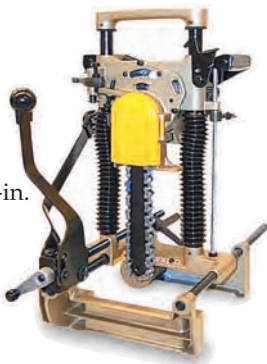

Makita® 16 $\frac{5}{16}$ -in. Circular Saw

Standard Equipment 32-tooth Carbide Blade! 16 $\frac{5}{16}$ -in. blade cuts 6 $\frac{3}{16}$ at 90° and 4 $\frac{3}{4}$ at 45°. HD 2,200-rpm motor with electric brake gives you plenty of power to cut the big stuff. Has precision gearing with ball and needle bearings for smooth and efficient power transmission. Includes combination blade, rip fence, and two wrenches. Top quality product!



The Commander

For over two centuries the maker's family has provided timber framer's and carpenter's mallets for persuading immovable objects. We've all heard "...get a bigger hammer" and this is what it means. Head is made from extremely dense hardwood and the handle is made out of Japanese White Oak, noted for its strength and longevity. Head is metal banded to reduce splitting. Head measures 5 x 5 x 9 $\frac{3}{4}$ and weighs approx. 120 oz. Handle measures 36 in. Seen at log and timberframe construction sites all over.

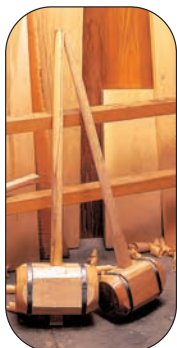

Free Catalog

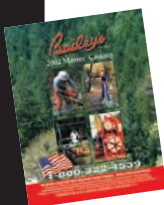

Call for a FREE 116 page full color 2004 Master Catalog mention source code QX4Z

Bailey's Est. 1975

The World's Largest Mail Order Woodsman Supplies Company - Selling at Discounted Prices

www.baileys-online.com

1-800-322-4539

TIMBERWOLF TOOLS

PROTOOL
CMP 150
Chain Mortiser

1-800-869-4169

www.timberwolftools.com

Mortisers, planers, circular saws and more...

Your best source for specialty power tools

mafelli

**Carpenter's Saw
ZS 260 E**



Up to 60°C tilt range on both sides

3.6 hp output

Constant cut display

**Carpenter's Beam Planer
ZH 320 E**



Excellent chip ejection

Unrivalled power development

Practical handle arrangement

**Portable Circular
Carpentry Saw
MKS 185 E**



Maximum cutting depths

Maximum stability with minimum weight

Tiltable to 60°

MAFELL North America Inc.
1975 Wehrle Drive, Suite 120 Williamsville, N.Y. 14221, USA
Phone 1-888-736-3812 Fax 716 626-9304 E-mail: mafell@msn.com

**performs
in every
season**



- Urethane or EPS cores
- 4 x 8 to 8 x 24
- Full CAD/CAM pre-cut services
- Panels for timber frames and hybrids
- Delivery anywhere in North America
- A crane truck for ease of unloading if your site is within 300 miles of our plant



winterpanel

74 Glen Orne Drive, Brattleboro, VT 05301

802-254-3435 Fax: 802-254-4999

winterpanel.com

**Provide added value by offering
EnerGreen SIP wall and roof
systems with your home packages.**

It's a Good Fit.



EnerGreen Structural Insulated Panel Company Inc.
3294 - 262 Street, Aldergrove, BC, Canada V4W 2X2
Tel: 604-856-0600 Fax: 604-856-0608

www.energreesip.com



OUR QUALITY

... limited only by
your imagination!

EVERGREEN SPECIALTIES LTD.

LUMBER - STONE

DOUG FIR, CEDAR, FIR-LARCH
TIMBERS UP TO 36 X 36 X 60
AD, RF KD, FOREST SALVAGE

BIG ROCKS, BOULDERS, PAVERS
GRANITE, MARBLE, STONE, SLATE
SIGNS, STAIRS, FOUNTAINS

Bruce Lindsay
PH 604-988-8574
FAX 604-988-8576

When compromise is not an option, call us.

Timeless Beauty

Timbers, Flooring & Millwork
from Reclaimed Materials

Contact Liz Bieter:
218-727-2145
or email:
liz@duluthtimber.com

Locations:
Duluth, Minnesota
Ukiah, California
Edison, Washington

DULUTH TIMBER COMPANY
LOGGING THE INDUSTRIAL FOREST

PREMIUM WEST COAST TIMBER

ANY SIZE ANY GRADE
ANY SPECIFICATION
S4S KILN DRYING
DELIVERED PRICES

DOUGLAS FIR
RED CEDAR
YELLOW CEDAR



**West Forest
Timber Inc.**

RESORT COMMERCIAL RESIDENTIAL

Alfred Butterfield
2999 Beach Drive, Victoria, BC,
V8R 6L1 Canada
Tel: 250-595-2758
Fax: 250-595-2958
Email: Alf@WestForestTimber.com

FRASERWOOD INDUSTRIES

KILN DRIED TIMBERS

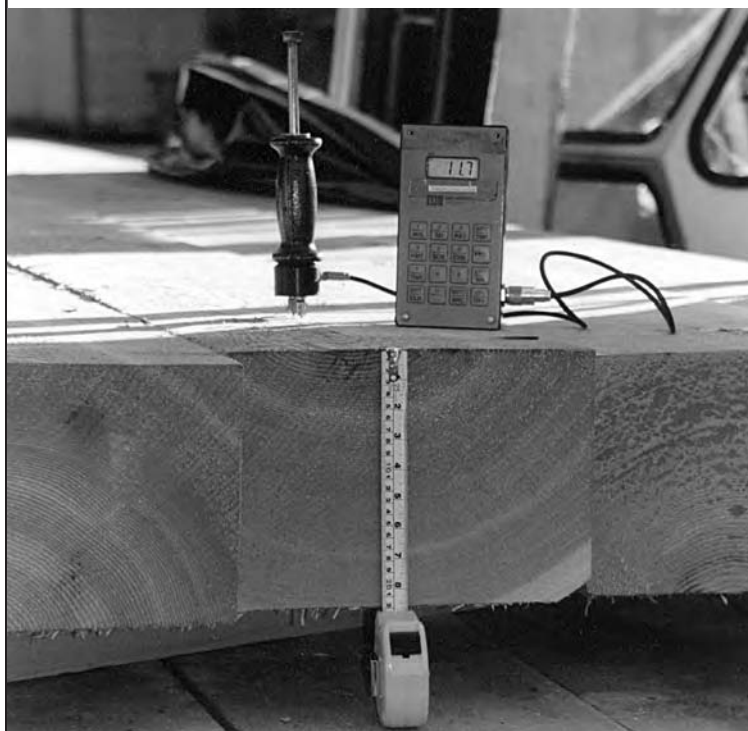

**“Your timbers offer the
reality of which we have
dreamed for many years.”**

Ben Brungraber, PhD, PE, Operations Director,
Benson Woodworking Co.

Fraserwood Industries' radio
frequency/vacuum kiln with its unique
restraining system can dry timber of all
dimensions and up to 40 ft. long
to 12% MC with minimal degrade.

FRASERWOOD INDUSTRIES

Please call Peter Dickson at (604) 892-7562.
For more information, visit our web page at
www.fraserwoodindustries.com.

A Precise Production Tool at a Competitive Cost

A 100 Year Tradition Continues. Quality-Made in Germany

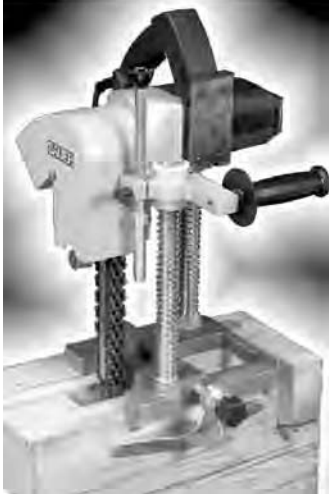

- Chain Mortisers
- Carpenter's Chainsaws
- Slotting Mortisers

SAUER - 6" Chain Mortiser
1 1/2" or 2" Chain & Bar
Support Frame Included

Call now! (416) 675-2366
TimberTools.com

Foam Laminates of Vermont

Supplying quality stressskin panels for
Timber Frame structures since 1982

- Superior Quality
- Built to your Specifications
- Curtainwall and Structural
- Professional Installation Available
- Friendly, Knowledgeable Service
- Specializing in Timber Frame Enclosures

PO Box 102 Hinesburg, VT 05461
802-453-4438 Phone 802-453-2339 Fax
E-mail foamlam@sover.net
www.foamlaminates.com



All natural, citrus base, penetrating finish
timbers • logs • v-groove • cabinets • doors • floors

Advantages:

- No chemical additives,**
driers, or petroleum products
- User friendly,** biodegradable,
non-ozone depleting
- Reduces further checking,**
even in green oak
- Renewable resources**
used for all ingredients

Available in:

- Liquid finish**
(wicks deeply into checks)
- Soft wax**
(nonstaining end-grain sealer)
- Aniline dye wiping stain**
(one step, soft wax base)
- Exterior finish**
(weathers to silver-gray)

Mike and Nita Baugh
215 Townes Rd, Augusta, SC 29860

803-279-4116
fax **803-278-6996**

QUALITY OAK TIMBERS

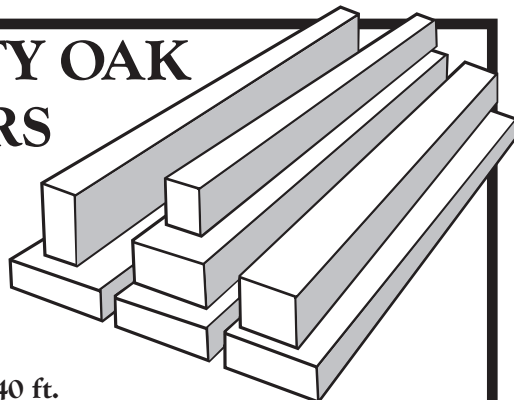

- Accurate,
custom
4-sided
planing
up to 9 x 15 x 40 ft.
- Also 2x6 and 1x6 T&G
White Pine in stock

Call for
timber price list,
419-281-3553

Hochstetler Milling, Ltd.
552 St. Rt. 95
Loudonville, OH 44842

INSULSPAN™

No. 1 Brand Leader in Structural Insulated Panels

Your complete building system solution,
preferred by timber framers everywhere.



Sold and serviced nationwide, Insulspan leads the
industry in the development, manufacturing and
performance of structural insulated panels.

1.800.PANEL.10

INSULSPAN™
STRUCTURAL INSULATED PANEL SYSTEM
www.insulspan.com



PUBLISHED BY
THE TIMBER FRAMERS GUILD
PO BOX 60, BECKET, MA 01223

NON-PROFIT ORG.
U.S. POSTAGE
PAID
EAST BARRE, VT
PERMIT NO. 2



Barbara Cuffley

Above, exterior detail of new barn in Victoria, Australia, built using mostly salvaged materials and sandstone found on the property. Timbers were chainmilled from a variety of unwanted pine, poplar and cypress logs. Underneath the fresh limewash is clay-sand daub applied to poplar wattles. The large empty wall bay gives onto the interior space shown at right. Story page 22.

