

NASA TECHNICAL NOTE



NASA TN D-7720

NASA TN D-7720

**CASE FILE
COPY**

APOLLO EXPERIENCE REPORT - FOOD SYSTEMS

*by Malcolm C. Smith, Jr., Rita M. Rapp,
Clayton S. Huber, Paul C. Rambaut,
and Norman D. Heidelbaugh*

*Lyndon B. Johnson Space Center
Houston, Texas 77058*



NATIONAL AERONAUTICS AND SPACE ADMINISTRATION • WASHINGTON, D. C. • JULY 1974

1. Report No. NASA TN D-7720	2. Government Accession No.	3. Recipient's Catalog No.	
4. Title and Subtitle APOLLO EXPERIENCE REPORT FOOD SYSTEMS		5. Report Date July 1974	
		6. Performing Organization Code	
7. Author(s) Malcolm C. Smith, Jr., JSC; Rita M. Rapp, JSC; Clayton S. Huber, Technology, Inc.; Paul C. Rambaut, JSC; and Norman D. Heidelbaugh, JSC		8. Performing Organization Report No. JSC S-390	
9. Performing Organization Name and Address Lyndon B. Johnson Space Center Houston, Texas 77058		10. Work Unit No. 914-50-95-07-72	
		11. Contract or Grant No.	
12. Sponsoring Agency Name and Address National Aeronautics and Space Administration Washington, D. C. 20546		13. Type of Report and Period Covered Technical Note	
		14. Sponsoring Agency Code	
15. Supplementary Notes The JSC Director waived the use of the International System of Units (SI) for this Technical Note, because, in his judgment, the use of SI units would impair the usefulness of the report or result in excessive cost.			
16. Abstract Development, delivery, and use of food systems in support of the Apollo 7 to 14 missions are discussed in this report. Changes in design criteria for this unique program as mission requirements varied are traced from the baseline system that was established before the completion of the Gemini Program. Problems and progress in subsystem management, material selection, food packaging, development of new food items, menu design, and food-consumption methods under zero-gravity conditions are described. The effectiveness of various approaches in meeting food system objectives of providing flight crews with safe, nutritious, easy to prepare, and highly acceptable foods is considered. Nutritional quality and adequacy in maintaining crew health are discussed in relation to the establishment of nutritional criteria for future missions. Technological advances that have resulted from the design of separate food systems for the command module, the lunar module, the Mobile Quarantine Facility, and the Lunar Receiving Laboratory are presented for application to future manned spacecraft and to unique populations in earthbound situations.			
17. Key Words (Suggested by Author(s)) <ul style="list-style-type: none"> * Caloric Requirements * Electrolytes * Menu Design * Dehydrated Food * Carbohydrates 		18. Distribution Statement STAR Subject Categories: 05 and 31.	
19. Security Classif. (of this report) None		20. Security Classif. (of this page) None	
		21. No. of Pages 74	22. Price \$3.75

APOLLO EXPERIENCE REPORT EDITORIAL COMMITTEE

The material submitted for the Apollo Experience Reports (a series of NASA Technical Notes) was reviewed and approved by a NASA Editorial Review Board at the Lyndon B. Johnson Space Center consisting of the following members: Scott H. Simpkinson (Chairman), Richard R. Baldwin, James R. Bates, William M. Bland, Jr., Aleck C. Bond, Robert P. Burt, Chris C. Critzos, John M. Eggleston, E. M. Fields, Donald T. Gregory, Edward B. Hamblett, Jr., Kenneth F. Hecht, David N. Holman (Editor/Secretary), and Carl R. Huss. The prime reviewer for this report was Donald T. Gregory.

CONTENTS

Section	Page
SUMMARY	1
INTRODUCTION	2
MANAGEMENT EFFORT	3
ORIGINAL FOOD AND PACKAGING DESIGN CONSIDERATIONS	4
Food	4
Packaging	7
Food Safety	9
THE BASELINE APOLLO SYSTEM AND SUBSEQUENT DESIGN CHANGES . . .	11
Baseline System	11
Basic Design Changes	15
Primary-Package Design Changes	17
CONTINGENCY FEEDING SYSTEM	20
FOOD STOWAGE	23
PERSONAL HYGIENE AND ACCESSORY ITEMS	28
FOOD DEVELOPMENT	28
NUTRITION	32
MENU SELECTION	37
MOBILE QUARANTINE FACILITY FOOD SYSTEM	39
LUNAR RECEIVING LABORATORY FOOD SYSTEM	40
THE APOLLO 14 FOOD SYSTEM	41
POTENTIAL SPINOFF APPLICATIONS	48
CONCLUDING REMARKS	49

Section	Page
REFERENCES	52
BIBLIOGRAPHY	54
APPENDIX — VARIOUS APERTURE CONCEPTS FOR THE REHYDRATABLE FOOD PACKAGE	58

TABLES

Table		Page
I	MICROBIOLOGICAL REQUIREMENTS FOR SPACE FOODS	6
II	ENVIRONMENTAL TEST PARAMETERS AND MEASUREMENTS FOR THE PACKAGED-FOOD AND PERSONAL HYGIENE ITEMS	8
III	BASELINE MENU FOR THE BLOCK II COMMAND MODULE, APRIL 1967	12
IV	BASELINE MENU FOR THE LUNAR MODULE, APRIL 1967	12
V	FOOD SYSTEM WEIGHTS AND VOLUMES SUPPLIED FOR SELECTED APOLLO MISSIONS	25
VI	APOLLO PROGRAM BASELINE FOODS, APRIL 1967	30
VII	FOODS QUALIFIED FOR FLIGHT	31
VIII	ANALYTICAL REQUIREMENTS FOR FLIGHT-QUALIFICATION TESTING	32
IX	BODY-WEIGHT CHANGES AND ENERGY INTAKES FOR THE APOLLO 7 TO 14 MISSIONS	34
X	COMPARISON OF AVERAGE DAILY INFLIGHT NUTRIENT INTAKES FOR THE APOLLO 7 TO 14 MISSIONS	35
XI	MEASUREMENT OF CREWMAN BONE DENSITY BEFORE AND AFTER THE APOLLO 7, 8, AND 14 MISSIONS	36
XII	APOLLO 14 COMMANDER'S MENUS FOR DAYS 1 TO 5	42
XIII	APOLLO 14 LUNAR MODULE PILOT'S MENUS FOR DAYS 1 TO 5	42
XIV	APOLLO 14 COMMAND MODULE PILOT'S MENUS FOR DAYS 1 TO 5	43
XV	APOLLO 14 LUNAR MODULE MENU	44
XVI	PANTRY STOWAGE IN THE APOLLO 14 COMMAND MODULE FOR DAYS 6 TO 10	45
XVII	APOLLO 14 MOBILE QUARANTINE FACILITY FOOD	47

FIGURES

Figure		Page
1	Organizational support for the Apollo food system and personal hygiene items	4
2	Eight critical control points for Apollo foods	10
3	Examples of typical bite-size foods	13
4	Examples of typical rehydratable foods	14
5	Typical package for bite-size foods	14
6	Baseline rehydratable-beverage package (top) compared with a current beverage package	14
7	Original Apollo rehydratable-food package (top) compared with modified designs for semisolid foods (center) and beverages (bottom)	18
8	Contingency-feeding-system nylon restrainer pouch with attached pontube and filled (at 3.5 psia) beverage package	20
9	Contingency-feeding-system pontube with rehydration-valve adapter	20
10	Pontube with mouthpiece adapter	21
11	Contingency-feeding-system restrainer assembly	
	(a) Top view	22
	(b) Side view	22
12	Evolution of the contingency-feeding-system valve-adapter pontube (earliest concept at top, intermediate concept at center, and current design at bottom)	22
13	Apollo 8 contingency-feeding system, shown assembled and packaged in nonflammable Kel-F-82 material (top). The valve-adapter pontube is in the center, and the restrainer pouch is at the bottom	23
14	Final contingency-feeding-system restrainer pouch, shown with rehydratable-beverage package installed before closure of the zippers. A valve-adapter pontube is also shown	23
15	Apollo CM food-stowage areas	24

Figure		Page
16	Apollo LM food-stowage area and water-dispenser location, shown in an aft view of the LM	24
17	Fit-check tool installed on an LHEB food-stowage container	24
18	Lower equipment bay food-stowage container	25
19	Rehydratable-food spoon-bowl package with water dispenser inserted in the rehydration valve	27
20	Rehydratable-food spoon-bowl package	27
21	One-piece plastic-film cone aperture	59
22	Sponge-lined (closed-cell sponge) plastic-film cone aperture	59
23	Double-plastic-film cone aperture	60
24	Sponge-lined (open-cell sponge) double-plastic-film cone aperture	60
25	One-piece plastic-film cone aperture (reversing)	60
26	One-piece plastic-film cone aperture for spade adapter	60
27	Compression-spring-loaded poppet-valve aperture	61
28	Conical-spring-loaded poppet-valve aperture	61
29	Leaf-spring-loaded poppet-valve aperture	61
30	Sponge-loaded (closed-cell sponge) poppet-valve aperture	61
31	Conical-spring-loaded plug-valve aperture	62
32	Leaf-spring-loaded plug-valve aperture	62
33	Elastomer-loaded plug-valve aperture	62
34	Elastomer-loaded plug-valve aperture with flexible probe connection	62
35	Rectangular sponge (closed-cell sponge) aperture, axial insertion . . .	63
36	Rectangular sponge (closed-cell sponge) aperture, perpendicular insertion	63

Figure		Page
37	Cylindrical sponge (closed-cell sponge) aperture	63
38	Sponge aperture for needle adapter	63
39	Silastic-bead aperture	64
40	Rigid-diaphragm aperture	
	(a) Aperture closed	64
	(b) Aperture open	64
41	Slit-rubber aperture	
	(a) Aperture closed	64
	(b) Aperture open	64
42	Elastic-diaphragm aperture	
	(a) Aperture closed	65
	(b) Aperture open	65
43	Pierced-diaphragm aperture	
	(a) Aperture structure	65
	(b) Probe inserted	65
44	Flapper-valve aperture	66
45	Combination closure	66

APOLLO EXPERIENCE REPORT

FOOD SYSTEMS

By Malcolm C. Smith, Jr., Rita M. Rapp,
Clayton S. Huber,* Paul C. Rambaut, and
Norman D. Heidelbaugh
Lyndon B. Johnson Space Center

SUMMARY

On each successive flight in the United States manned space-flight program, food system improvements have been introduced; thus, a logical sequence of progressive development has occurred from the earliest concepts to the advanced food system used for the Apollo 14 mission. As a result, a wide variety of foods and dispensing techniques was added to the inventory of efficient and acceptable means for dietary support of man in space in the Apollo Program. Food systems were designed and developed to provide the Apollo flight crewmembers with the nutrients, energy, and electrolytes that are necessary for maintenance of normal metabolism. These foods were adequate to maintain work efficiency and performance under unique environmental and mental stress conditions that are characteristic of the program to successfully land men on the lunar surface and return them safely to Earth.

Experience with the Apollo Program demonstrated that successful development, fabrication, testing, and spacecraft integration of food systems required unique technical management efforts to coordinate and establish priorities between and within biological and engineering considerations. This situation is caused by several factors inherent to foods in general and foods for manned space flight: (1) most foods are dead biological materials that have lost the original capabilities to adapt to environmental changes; (2) food habits and prejudices are highly individualized and deeply ingrained in the tastes of the intended consumers (the astronauts) and the interested nonconsumers (the program, system, and subsystem managers); (3) foods are inadequately defined in biological terms, and this situation is compounded by the need of aerospace system management to have absolute definitions of foods in engineering terms; and (4) criteria and configurations usually are required long before specific knowledge of the final consumer is available. Generally, food systems for manned space flight consist of a group of poorly defined components (foods) that can be infinitely variable and that are designed to satisfy the absolute physical criteria for the spacecraft. The fact that criteria for the adequate support of the physiological and psychological processes of man are poorly defined results in a natural tendency to place a lower priority on the development effort needed to meet the nutritional requirements of the individual crewmember. Large individual

*Technology, Inc.

biological variations were also factors that were found to have a significant negative effect on the ability to predict and establish valid nutritional criteria for Apollo missions.

A review of known and anticipated spacecraft requirements revealed that the baseline food system was adequate and qualified for flight. However, the baseline system was modified and improved before the Apollo 7 launch and with each subsequent mission. The culmination of these modifications is represented in the description of the Apollo 14 food system. The Apollo 14 food system could be viewed as the most successful of those used for the Apollo 7 to 14 missions, but a number of design problems and functional discrepancies remained open and justified continued developmental effort. These open items are readily classified as food packaging and dispensing, development of more conventional food types, and development of improved techniques for direct and indirect measurement of nutritional adequacy.

INTRODUCTION

The selection of unique foods and food-packaging methods for manned space flight has resulted from known or anticipated conditions and characteristics of the flight vehicles, the mission environments, and the requirement for optimal crew performance. Crew performance cannot be compromised by foods that are not absolutely safe nor by daily rations that are not nutritionally complete. Successful food system support of manned space flight requires continual review and modification of food systems that can be designed to adapt to changes in vehicle and equipment requirements, mission profiles and objectives, individual eating habits and preferences, and biochemical individuality of the crewmembers. Implementation of these types of modifications and a necessity for design flexibility were not anticipated when the prime contract was awarded in April 1967. The contract that was awarded was based on fixed designs and on components that were flight qualified during the Gemini Program.

In the two-man Gemini and Voskhod flights, which were scheduled to last as long as 2 weeks, nutritional considerations began to constrain the food system designers. Longer flights subsequently necessitated even more stringent measures to minimize weight and volume. Within an exceedingly small weight and volume envelope, provision had to be made for an adequate ration of energy, protein, fat, minerals, and vitamins. This Gemini food system envelope (1.7 lb/man/day and 110 in³/man/day) also contained all the packaging materials that would protect the foods in environments with different gravity fields, temperatures, pressures, accelerations, and vibratory conditions. Because some part of the water supply in the Gemini spacecraft was to be made available as a product of fuel cell operation, it became highly attractive from a food-acceptance and weight-saving standpoint to employ dehydrated food that could be rehydrated in flight. The use of dehydrated food had the additional appeal of excellent preservation of nutritional value and prolonged stability in the absence of refrigeration. For these reasons, Gemini food consisted principally of dehydrated items. Such foods have undergone extensive nutritional and acceptance evaluations. Flavorful foods and beverages were packaged in efficient moisture and gas barriers formed into flexible packages that also incorporated a folded tube through which the food could be dispensed in zero g. Foods and beverages were rehydrated with water at ambient temperature; in some cases, reconstitution times as long as 30 minutes were required.

The first design efforts for an Apollo food system were initiated by the prime contractor for the Apollo command module (CM) through a subcontract. Before 1965, it was determined to be in the best interest of the Government to provide the food system as Government-furnished equipment, and a cost-plus-fixed-fee contract for the Apollo food system was awarded. Later, that contract was terminated and was awarded to another firm for the Apollo Block I food system. Competition for the Apollo Block II food system was limited to two firms that were exceptionally qualified to deliver the system off the shelf. A contract was awarded in April 1967.

MANAGEMENT EFFORT

The original management effort for the Apollo Block II food system appeared minimal; in fact, the program was geared for management on a part-time basis by two individuals, both of whom had backgrounds and training in biomedical sciences. No provisions were made or anticipated for technical support in engineering, systems management, and biomedical laboratory operations. Also, no administrative support for clerical and secretarial tasks was allocated. The original management plan appeared to be adequate to provide sets of food and personal hygiene items for all Apollo missions because it was based on several assumptions: (1) that the system was flight qualified because of the similarity between the Gemini and the Apollo Block I systems, (2) that no design and development effort was required, (3) that all components had been fabricated and would require only final assembly and inspection to meet launch schedules, and (4) that configuration of the flight articles had been established and documented in the award of a contract. During the early planning for Apollo missions, it was assumed that the Gemini food system would be adequate. The crewmen of Gemini VII had been able to accomplish their 14-day mission without major problems, and design improvements had been implemented throughout the remaining Gemini missions. The inaccuracy of these assumptions was demonstrated by experience with the food systems employed for the Apollo 7, 8, and 9 missions. It became apparent that a system adequate for the types of missions flown in the Gemini Program was not necessarily adequate for the characteristic Apollo missions. The reason for this incompatibility is not clearly defined, but several hypotheses are presented in this report.

A diagram of the management scheme as it evolved to meet the demands for timely support of manned ground-based test vehicles and of the Apollo 7 to 11 missions is shown in figure 1. This management scheme was quite effective in the accurate prediction of problems, the rapid recognition of changes required, and the efficient implementation of solutions and improvements in the Apollo food system. Not shown in the management scheme in figure 1 are the internal relationships at the NASA Lyndon B. Johnson Space Center (JSC) (formerly the Manned Spacecraft Center (MSC)) because, in a schematic, these relationships would not be significantly different from others within NASA. However, it is important to point out that the Subsystem Manager for Apollo Food was given authority that was commensurate with the responsibilities of the position. Without this latitude of authority to act and make decisions concerning changes in the design and configuration of the food system, it is doubtful that the numerous improvements in foods and packaging would have been possible within the allotted time frames and funds available.

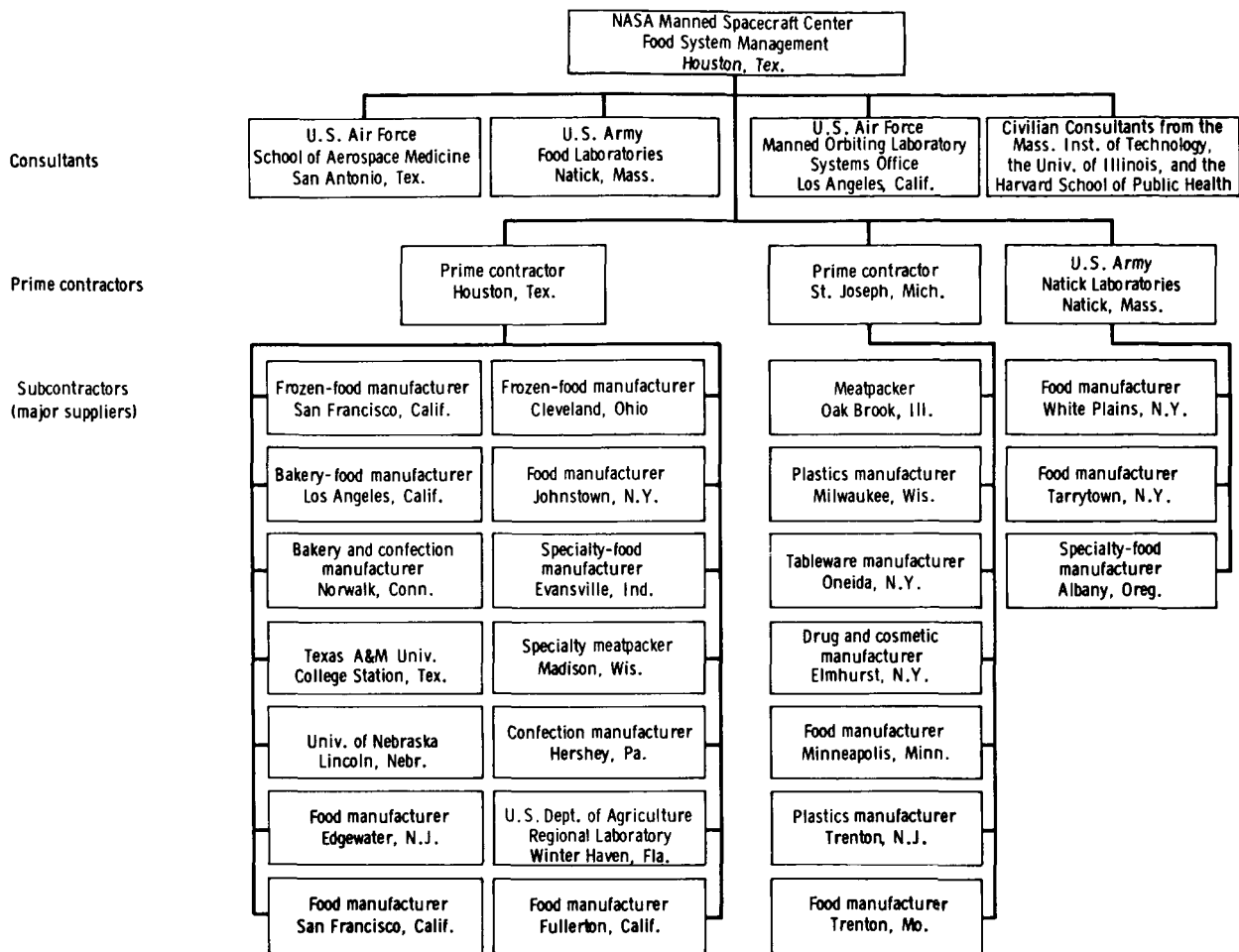

Figure 1. - Organizational support for the Apollo food system and personal hygiene items.

ORIGINAL FOOD AND PACKAGING DESIGN CONSIDERATIONS

Original design criteria for the Apollo food system were evolved from experience in food systems development for military, civilian, and aerospace (Mercury and Gemini) use. The most important design criteria for the original, or baseline, Apollo food system are summarized briefly in the following subsections for foods and for packaging. These criteria were modified to reflect experience gained with each Apollo mission and to meet updated and expanded mission objectives.

Food

Weight. - Maximum allowable food weight for a 14-day mission was 1.7 lb/man/day. This allowance ruled out the use of any food other than that which had been stabilized by dehydration. Dehydration as an effective method of weight reduction and food

preservation was possible because adequate quantities of water would be available as a byproduct of electrical power generation in the command and service module (CSM) fuel cells.

Volume. - Total food-stowage volume was limited to approximately 5000 cubic inches provided by two CSM food-stowage containers, volume L-3 in the left-hand equipment bay (LHEB) and volume B-1 in the lower equipment bay (LEB). For three crewmembers on a 14-day mission, this total allowed an average volume of 119 in³/man/day for food, packaging, and accessories. Dehydrated and compressed foods were required for optimal use of the available stowage volume.

Crew acceptance. - Individual foods were required to receive a score of 6 or better when evaluated for crew acceptance on a 9-point hedonic scale by a trained test panel of food and nutrition experts.¹ A wide variety of food flavors was to be provided to preclude monotony.

Preparation time. - Dehydrated foods that could be rehydrated completely in 15 minutes or less and that required minimal kneading or mixing were to be used. Bite-size foods were to be used as much as possible because these foods are ready to eat without further preparation and have nutrient density better than that of rehydratables.

Food-residue stabilization. - Foods that would be consumed completely, leaving minimal residue in the package to preclude microbiological growth and putrefaction, were desirable. A germicidal agent to be mixed with any residual food was required. This germicide was chosen to be effective in preventing the growth of micro-organisms but to be nontoxic to crewmembers. Methods for resealing and restowing used food packages were required.

Wholesomeness. - Certified, top-quality food raw materials were required along with traceability and historical records. Food handlers were required to be trained in the proper sanitary techniques for food processing and storage. The foods had to be capable of being processed in controlled-access and controlled-environment facilities (class 10 000 cleanrooms or better). The health of the food-handling personnel was to be monitored, and strict standards for cleanliness with maximum permissible numbers and types of micro-organisms in food, packaging material, processing equipment, and work areas were to be imposed. The microbiological requirements for space foods are listed in table I. These original requirements did not include criteria for yeast and molds, anaerobes, or viral particles.

¹Hedonic scales for food acceptance are based on the degree of pleasure or pain to be derived from consumption of a particular food. A score of 9 is a perfect rating for acceptance; ratings of 5 and below indicate increasing degrees of distaste in decreasing order.

TABLE I. - MICROBIOLOGICAL REQUIREMENTS FOR SPACE FOODS

Micro-organism	Test limit
Total aerobes	Not greater than 10 000/g of sample
Total coliforms	Not greater than 10/g of sample
Fecal coliforms	Negative in a 1.0-g sample
Fecal streptococci	Not greater than 20/g of sample
Coagulase-positive staphylococci	Negative in a 5.0-g sample
Salmonellae	Negative in a 10-g sample

Gastrointestinal compatibility. - Foods with minimal indigestible components (such as crude fiber) were selected. Foods that were relatively bland and unseasoned; foods that would not result in generation of noticeable quantities of gastrointestinal gas and flatus; foods that were completely digestible and readily absorbed in the small intestines; and foods that would result in feces of normal consistency, but that would cause minimal frequency and mass of defecations, were selected. Also, foods that either reinoculate the intestinal tract with normal microflora or that provide necessary substrate to maintain the growth and balance of normal intestinal microflora were desirable.

Nutrient content. - Foods were to be processed, formulated, or fortified to maximize nutrient density on a weight and volume basis and to provide energy levels of 2800 kcal/man/day in the CM and 3200 kcal/man/day in the lunar module (LM). The selected foods would provide a daily energy intake made up of 28 percent fat, 54 percent carbohydrate, and 17 percent protein. Other requirements for the selected foods were provision of 100 g/man/day of protein, 1000 mg/man/day of calcium (Ca), 500 mg/man/day of phosphorus (P), 1800 mg/man/day of potassium (K), and other nutrients equal to or exceeding the minimum daily requirements established by the National Academy of Sciences - National Research Council as recommended dietary allowances (ref. 1).

Stability. - Design considerations for stability included physical, chemical, microbiological, and organoleptic qualities after exposure to nominal environmental conditions of ground, storage, delivery, spacecraft launch, Earth and lunar orbit, lunar landing, and return to Earth.

Physical: Packaging was designed to protect the food against physical damage from handling, shipment, stowage, and launch. Dispersion of food particles into the

cabin environment was to be prevented by the use of proper package design, edible food coatings, and compression or molding of the foods during processing to eliminate rough, sharp edges. Foods were selected that, after processing, would withstand external pressures as great as 760 torr at 135° F for 3 hours, 100° F for 6 months, or 70° F for 1 year without the occurrence of irreversible fusion, deformation, or development of off-flavor or off-color characteristics.

Chemical: Foods stable at spacecraft temperature extremes (3 hours at 135° F, 6 months at 100° F, or 1 year at 70° F) were selected. The moisture content of the foods was reduced to retard the formation of indigestible pigments and aminocarbohydrate group complexes at elevated temperatures. Finally, the foods were to be packaged in such a way that oxidation of nutrients was prevented by elimination of oxygen through decreasing the headspace by the use of inert gas. Contamination by environmental water vapor and oxygen was prevented by use of a plastic laminate impermeable to these elements.

Microbiological: The foods were processed in a manner that ensured small populations of pathogenic and food spoilage bacteria, yeasts, and molds and that reduced water content (or water activity) to levels below those required for growth of micro-organisms.

Contingency. - The selected foods were to provide for minimal metabolic maintenance during contingency periods when the crewmen would be required to wear full pressure suits continuously for as long as 115 hours if accidental loss of cabin pressure should occur.

Shape and size. - Foods amenable to irregular stowage-volume configurations were to be selected. Reproducibility to ensure uniform nutrient content and the validity of preflight spacecraft stowage studies was required.

Packaging

The most important design considerations with regard to food packaging are summarized as follows.

Protection. - The food package must prevent physical abrasion and deformation and provide a barrier to adventitious contamination by oxygen, water, inert particles, chemicals, and micro-organisms.

Identification. - The food package must identify contents and crewman and must include preparation instructions and traceability information.

Manufacture. - The food packages must be readily reproducible and be of high quality and reliability.

Weight. - The weight of the food package should be minimized by the use of flexible plastic-film laminates.

Volume. - The volume of the food package should be minimized by vacuum packaging and by the use of flexible plastic-film laminates.

Function. - The functional aspects of food system packaging included the following considerations.

1. Practicability of food system use in zero g (refs. 2 to 10)
2. Segregation of discrete sets of food items with a primary package
3. Unitization of food packages into meals by the use of a meal overwrap
4. Practicability of food retrieval in the desired sequence
5. Provision for food reconstitution by the addition of hot ($140^{\circ} \pm 5^{\circ}$ F) or cold (40° F) water
6. Practicability of managing (restrain, contain, and serve) food during meal periods
7. Provision for consumption of food without the use of eating utensils (Scissors were available for opening the packages.)
8. Provision for the temporary restraint of the package during food preparation
9. Provision for use as waste-stowage containers for food and packaging debris after meals

Materials. - The packaging materials were required to have the following quality prerequisites.

1. Adequacy of material quality to maintain high food grade
2. Chemical inertness of the material in spacecraft environments
3. Provision of a hermetic seal to withstand pressures that vary from 1×10^{-6} to 760 torr

Environmental test parameters for Apollo packaged-food and personal hygiene items are summarized in table II.

TABLE II. - ENVIRONMENTAL TEST PARAMETERS AND MEASUREMENTS FOR THE PACKAGED-FOOD AND PERSONAL HYGIENE ITEMS

Parameter	Value
Temperature, ° F	35 to 135
Pressure, torr	1112 to 1×10^{-6}
Atmosphere, percent oxygen	100 at 21.5, 5.0, and 0.1 psia
Acceleration, g	1.0 to 6.0 in +X axis only
Vibration	Sinusoidal and random in all axes

Food Safety

Most of the foregoing criteria contributed to the ultimate safety of the foods and packaging used, but food safety as a separate and distinct discipline must be addressed during the design, manufacture, and use of aerospace food systems. Manned space flight requires accurate control of the environments in spacecraft to maintain life. Food is an indispensable part of that environment. Complex studies and experiments to determine the physiologic performance of man during space flight reinforce the need for accurate definition and control of variables in space foods. Man's increased susceptibility to infection during physical and psychological stress further augments the need for complete definition and strict control of food supplies.

Highly successful systematic procedures to ensure food safety and wholesomeness were developed for the Apollo Program (refs. 11 to 26). These procedures include the strict selection and control of raw materials, personnel, processing techniques, equipment, storage and manufacturing environments, and final assembly for spacecraft stowage. The success of the space food program demonstrates that variables in man's food supply can be accurately quantitated and regulated to the fidelity required. Procedures and standards developed for space foods serve as benchmarks for industry and public food safety programs.

Safety standards for Apollo space foods were implemented by controls classified into four general categories. These categories are personnel, environment, production controls, and end-item tests and assembly. Each of these categories was further divided into units for day-to-day management and implementation. For example, the personnel controls were composed of criteria to ensure the best available motivation, teamwork, medical examinations and on-the-job health care, clothing control, and on-the-job monitoring by Government and contractor management.

Control of the production environment was accomplished primarily by the use of modified cleanroom techniques. Cleanroom techniques are implemented by production sequence selection, equipment sanitization schedules, airflow and air filtration, temperature and humidity control, differential air pressures, and air/surface sampling. Airborne food contaminants were minimized and controlled by the use of cleanroom equipment and techniques for processing and packaging Apollo foods. An additional benefit in food processing is derived from the motivation and psychological impact instilled in the food-production personnel by the cleanroom operation and environment.

Production procedures for Apollo space foods were stipulated by published and controlled specifications for each food item. All raw materials were selected and specified to optimize food quality and minimize the need for food additives. A typical food specification identified 17 quality control stations in the production flow. Eight of the most critical control points for an Apollo food item are shown in figure 2. Each of these stations had definite "go" and "no go" decision criteria for the contractor and Government inspectors assigned to the task.

End-item testing was divided into acceptance testing, package testing, unintentional-additive analyses, microbiologic testing, storage environment inspection, testing to detect storage deterioration, and nutrient analyses. Acceptance testing consisted of organoleptic evaluation of flavor and appearance by a panel of food experts. Each product was required to rate at least 6 on a 9-point hedonic scale, which has a null point at 5. Foods receiving an average rating of 5 or below were rejected. Package testing was

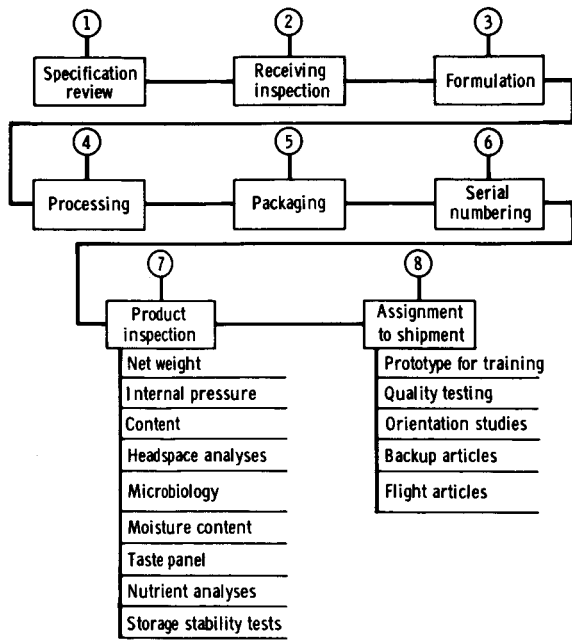

Figure 2.- Eight critical control points for Apollo foods.

lished by the World Health Organization. It must be understood, however, that the levels established by agencies to protect public health are based on safe levels of consumption over an entire lifetime and have very little bearing on levels of consumption during a 10- to 14-day Apollo mission. Despite this disparity, however, the "contaminated" foods were removed from the inventory to better ensure that Apollo foods were not contributing to any future chronic toxicity in American astronauts. The primary significance of these analyses will become apparent as the information is built up in a data bank and used for comparison with space food production lots for future generations of manned space-flight vehicles.

Food-storage environments were routinely checked for specified temperature and humidity levels. These checks are augmented by instorage degradation studies of food samples collected at random for determination of peroxide values, thiobarbituric acid values, accumulation of nonenzymatic browning pigments, pepsin digestibility, and ascorbic acid.

Microbiological quality standards for production of space foods were adapted from the standards successfully used during the Gemini Program. The acute onset and severe consequences of food poisoning and most foodborne diseases were completely accounted for in the specifications for microbiological analysis of foods, packaging, and work surfaces. The microbial limits allowed in these specifications for the Apollo food system are summarized in table I. The original specifications were designed for dehydrated foods and were subsequently expanded in scope to incorporate tests for anaerobic bacilli and for yeast and mold. These additional tests reflected inclusion of normal-moisture foods and more intermediate-moisture foods in the Apollo food systems commencing with the Apollo 8 mission.

performed on each package by physical examination for apparent damage and for leaks and heat-seal integrity when placed in a chamber and held at near-vacuum conditions (29 inches mercury).

Unintentional-additive analyses were performed for arsenic, beryllium, boron, cadmium, lead, mercury, nickel, selenium, thallium, vanadium, and the common chlorinated insecticides. Only two foods (tunafish salad and shrimp cocktail) were found to contain significant quantities of any of these potentially toxic elements and compounds. Tunafish salad contained 0.76 ppm of mercury, and shrimp cocktail contained 0.38 ppm of mercury. Foods from these lots were removed from the inventory of flight food supplies.

The levels of mercury contamination found were well above the accepted safe standards proposed for general populations: 0.01 ppm established by the U. S. Food and Drug Administration and 0.001 ppm estab-

THE BASELINE APOLLO SYSTEM AND SUBSEQUENT DESIGN CHANGES

The baseline configuration of the Apollo food system was very similar to that of the Gemini food system because the Gemini and Apollo Programs were to have been sequential with only a few months time between the last manned Gemini mission and the first manned Apollo mission. However, the first manned Apollo mission was launched almost 2 years after Gemini XII, and the intervening period was used to improve the food system as indicated by reassessment, review, and test programs that were performed. Also, with each succeeding Apollo mission, inflight evaluations and flight crew debriefings revealed additional areas in which improvement through design changes was necessary and feasible. Refinements in selection and processing of foods were constantly probed and tested for potential application to an Apollo mission. Adaptations in foods and packaging were implemented to meet special mission requirements and objectives (e.g., in-suit food systems for lunar surface extravehicular activity, and lunar mission postflight recovery and quarantine). Menu and food adaptations were also implemented to meet individual crewmember needs and preferences. All these changes to the baseline system improved the flexibility and efficiency of the food system without sacrifice in reliability and with considerable improvement in quality.

The culmination of design changes to reflect new technology and to implement improvements is best shown in a description of the Apollo 14 food system. Therefore, the Apollo 14 food system is described separately in a later section of this report.

Baseline System

The baseline Apollo menu was provided for a crew of three for a 14-day mission. The CM menu (table III) was designed on a 4-day cycle that would be repeated starting on the 5th, 9th, and 13th days of a mission; the LM menu (table IV) included meals for 2 days. The baseline menus consisted of beverage powders and of foods that generally were categorized as bite size, rehydratable, or semisolid thermostabilized. The configuration for the baseline Apollo food system was established in 1965 and was designated "Apollo Block I Foods and Personal Hygiene Items."

In the baseline system, the food category designated as semisolid thermostabilized consisted entirely of a chocolate-flavored, nutrient-defined formula food that was packaged in flexible metal tubes. These tubes were designed to be compatible with an inflight contingency situation that would require the wearing of full pressure suits constantly. Microbiological spoilage was prevented in these high-moisture products (40 to 45 percent moisture) by heat processing at temperatures designed to sterilize the product. This type of heat processing of foods is generally referred to as "canning," but that is hardly an accurate description of the process. The process is more accurately described by the term thermostabilization. This slight elaboration on the meaning of the term thermostabilization is included here because, throughout the program, some confusion appeared to exist as to the meaning and use of the word. Also, it should be noted that the term thermostabilized was rarely used to describe foods processed in this manner. Instead, it was found to be easier to use the word "wetpack" to describe foods having normal moisture content and requiring heat processing to prevent food spoilage by microbial growth or by enzymatic autolysis (or both).

TABLE III. - BASELINE MENU FOR THE BLOCK II COMMAND MODULE, APRIL 1967

[Mean daily energy intake per crewmember: 2800 kilocalories]

Meal (a)	Menu for days 1, 5, 9, and 13	Food type (b)	Menu for days 2, 6, 10, and 14	Food type (b)	Menu for days 3, 7, and 11	Food type (b)	Menu for days 4, 8, and 12	Food type (b)
A	Peaches	R	Applesauce	R	Fruit cocktail or corn	R	Ham and applesauce	R
	Bacon squares	B	Sausage patties	R	Bacon squares	B	Peanut cubes	B
	Cinnamon-toasted bread cubes	B	Apricot-cereal cubes	B	Cinnamon-toasted bread cubes	B	Strawberry-cereal cubes	B
	Grapefruit drink (fortified)	D	Cocoa	D	Orange drink	D	Cocoa	D
B	Corn chowder	R	Pea soup	R	Corn chowder	R	Pea soup	R
	Chicken sandwiches	B	Tuna salad	R	Beef pot roast	R	Salmon salad	R
	Coconut cubes	B	Cinnamon-toasted bread cubes	B	Graham-cracker cubes	B	Cheese sandwiches	B
	Sugar-cookie cubes	B	Chocolate cubes	B	Butterscotch pudding	R	Apricot pudding	R
	Cocoa	D	Pineapple-grapefruit drink	D	Grapefruit drink (fortified)	D	Grapefruit drink (fortified)	R
C	Beef and gravy	R	Meat and spaghetti or beef and vegetables	R	Potato soup	R	Shrimp cocktail	R
	Potato salad	R	Cheese sandwiches	B	Chicken salad	R	Chicken and gravy or chicken and vegetables	R
	Brownies	B	Banana pudding	R	Beef sandwiches	B	Cinnamon-toasted bread cubes	B
	Chocolate pudding	R	Pineapple fruitcake	B	Gingerbread	B	Date fruitcake	B
	Orange-grapefruit drink	D	Grapefruit drink (fortified)	D	Cocoa	D	Orange-grapefruit drink	D

^a Approximately 900 kcal/man/day of contingency food will be substituted for standard rehydratable and bite-size foods on the last 5 mission days by deleting puddings, cocoa, cinnamon-toasted bread cubes, and bite-size sandwiches, as appropriate on those days, to make the total daily energy intake approximately 2800 kilocalories.

^b R = rehydratable; B = bite size; D = beverage powder.

TABLE IV. - BASELINE MENU FOR THE LUNAR MODULE, APRIL 1967

[Mean daily energy intake per crewmember: 3200 kilocalories]

Meal	Menu for day 1	Food type (a)	Menu for day 2	Food type (a)
A	Applesauce	R	Bacon squares	B
	Sausage patties	R	Ham and applesauce	R
	Apricot-cereal cubes	B	Cinnamon-toasted bread cubes	B
	Coconut cubes	B	Peanut cubes	B
	Cocoa	D	Grapefruit drink (fortified)	D
B	Pea soup	R	Potato soup	R
	Salmon salad	R	Chicken salad	R
	Cheese sandwiches	B	Butterscotch pudding	R
	Pineapple fruitcake	B	Sugar-cookie cubes	B
	Grapefruit drink (fortified)	D	Pineapple-grapefruit drink	D
C	Beef and gravy	R	Corn chowder	R
	Potato salad	R	Beef sandwiches	B
	Chocolate pudding	R	Cinnamon-toasted bread cubes	B
	Brownies	B	Date fruitcake	B
	Orange-grapefruit drink	D	Cocoa	D

^a R = rehydratable; B = bite size; D = beverage powder.

Each crewman was provided with 15 tubes of the semisolid contingency food, which contained minimal nutrient requirements and provided an energy of 900 kcal/day for 5 days. Command module stowage weight and volume allowances would not accommodate provision of these foods over and above the nominal menus. Therefore, the flight menus had to be designed for replacement of an equivalent quantity of nominal bite-size and rehydratable foods with three tubes of contingency foods per man per day for the last 5 days of a mission.

The bite-size items were dehydrated, compressed, ready-to-eat cubes that consisted of various meats, cheeses, fruits, confections, breads, and cereals. The simplest approach to the fulfillment of the requirements for manned space flight was to use bite-size foods. Special formulations and dehydration procedures, in conjunction with compression, resulted in high-nutrient-density foods that appeared to fulfill or exceed the requirements for all other food systems. Inflight preparation and consumption were simple and only required that the crewmen be able to open the package and eat the foods, which were in a cubed or rectangular form and could be placed comfortably in the mouth. For the best results, the cubes were to be allowed to rehydrate slightly with saliva before they were chewed and swallowed. Control of food crumbling after the primary package was opened in flight was accomplished by careful formulation (use of binders and the control of fat and moisture content); by the use of exact processing procedures; and by the application of edible, protective coatings of suitable formulation (simple gelatin; zein-in-alcohol solution; or an emulsion of sodium caseinate, oil, glycerin, gelatin, and water). The coatings were applied as liquids to each bite-size unit, and the excess moisture or solvent was removed by freeze-drying or air-drying. Examples of bite-size foods are shown in figure 3.

The third major food category, the rehydratables, consisted of precooked, dehydrated foods that required the addition of water for reconstitution before consumption. Most of these foods were processed by freeze dehydration because this method results in a product that is readily reconstituted with water and closely resembles the original food in appearance, flavor, and texture. Rehydratable foods were not as high in nutrient density as were the bite-size foods because the individual servings, although molded to ensure uniform size, were not compressed. The reconstitution process for compressed food generally results in intolerably slow or incomplete rehydration. Also, the primary package required for rehydratable food was considerably larger than the simple pouch that was used for bite-size foods. The larger package was required because of the need for additional space to add water, a tube for expelling liquid or semi-solid food from the package, and a pouch containing a germicidal tablet to stabilize the waste food residue. The penalty in weight and volume was negated by crewmember preference and acceptance of the rehydratable foods because of their relatively familiar flavor, appearance, and texture. Typical rehydratable foods are shown in figure 4.

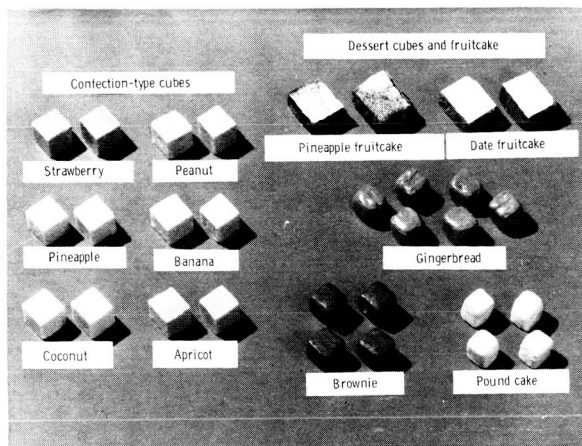

Figure 3. - Examples of typical bite-size foods.

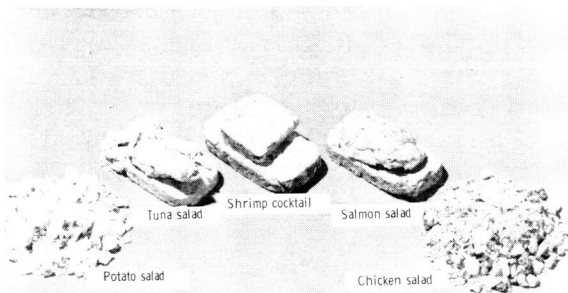

Figure 4.- Examples of typical rehydratable foods.

The primary food packages were designed to satisfy the requirements of each food category. The package material used for the rehydratable and bite-size foods was a four-ply laminate (polyethylene-Mylar-Aclar-polyethylene). However, the configuration and function of the packages were considerably different (figs. 5 and 6).

The package for the bite-size, ready-to-eat foods provided an oxygen and moisture barrier and protection from adventitious contamination and physical abrasion. No special procedures were needed for preparation and consumption in the zero-g conditions in the spacecraft. Rehydratable foods were packaged in a relatively complicated bag with a one-way spring valve for water

insertion at one end. A folded polyethylene tube, which served as a zero-g mouthpiece, was located at the opposite end; this device enabled the crewman to squeeze the rehydrated food into his mouth without danger of accidental dispersion of liquid food in the spacecraft cabin. Each rehydratable package also was provided with a separate compartment for a germicidal tablet (1 gram of 8-hydroxyquinoline sulfate) for stabilization of uneaten food residue.

Foods for the baseline menu had been manufactured approximately 1 year before award of the contract for the Apollo Block II food system. These foods were owned by the Government because they had been produced and received into inventory during the Gemini Program and as a result of the Apollo Block I contract for food and personal hygiene items. After individual foods had been processed, they were hermetically sealed in interim packages (standard steel food cans) that had a nitrogen headspace and



Figure 5.- Typical package for bite-size foods.

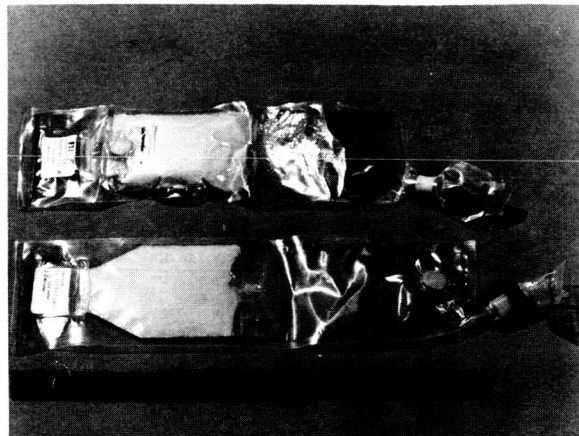

Figure 6.- Baseline rehydratable-beverage package (top) compared with a current beverage package.

were placed in refrigerated storage (40° F). The final installation and vacuum packaging (after a triple flush with nitrogen) of the primary flight packages were not scheduled to begin until 30 days before the specified delivery dates, which coincided with launch and test dates. After completion of the packaging in primary flight packages, foods were arranged efficiently in meal units according to individual crewmember nutrient requirements, mission time lines, and spacecraft stowage-volume configurations. Each group of foods in primary packages that comprised a meal unit was overwrapped, and the overwrapped meal was evacuated to a pressure of 29 inches of mercury after a triple flush with nitrogen. The meal overwrap was a four-ply aluminum foil/plastic laminate that reduced overall volume and provided additional protection against contamination and damage. This meal overwrap also served to unitize and identify each meal and could be used as a container for stowage of waste food and packages after the meal.

Meal overwraps were labeled by mission day, meal, crewman (by color-coded Velcro patch), and serial number. Each meal was attached to the next meal in the menu sequence by a nylon lanyard to ensure ease of sequential retrieval in flight. These diets were designed to provide each crewman with the required energy and nutrients for optimum performance throughout the mission. Daily rations were designed to provide energies of 2800 and 3200 kcal/man/day for crewmen of the CM and LM, respectively. Daily protein, fat, and carbohydrate were 19, 17, and 60 percent, respectively, of the energy provided. Selected foods were fortified with calcium lactate to meet a requirement for 1000 grams of calcium in each daily ration. Personal hygiene and accessory items included in each food system assembly were limited to one toothbrush/man/mission, one wet-skin cleaning towel/man/meal, and one stick of chewing gum/man/meal.

The foregoing description of the baseline Apollo food system is brief, but it should provide the necessary points of reference to comprehend the changes that were implemented as a result of the various programs for system reassessment after the Apollo 1 fire early in 1967. Also, major changes in the food system were initiated as a result of the experience gained from the evaluation of manned ground-based simulation tests of an Apollo command module (2TV-1) and lunar module (LTA-8) and from ground-based functional verification of the U.S. Air Force (USAF) manned orbiting laboratory (MOL) feeding system.

Basic Design Changes

Changes to the baseline food system can be classified most conveniently as (1) those implemented as a direct or indirect result of system reassessment to reduce fire hazards, (2) those implemented to incorporate Apollo 7 experience and MOL food system design and development experience, and (3) those implemented to incorporate Apollo 8 and subsequent flight experience.

Several initial suggestions to reduce the fire hazard in the baseline food system included the potential of supplying nonflammable food packaging. Material specialists in the NASA monitored a survey of nonflammable packaging materials suitable for the Apollo food system. The survey resulted in the acceptance of a recommendation to prevent exposure of combustible foods, primary foods, and primary food packages to the spacecraft environment by replacing the aluminum foil/plastic-laminated film that was used for meal overwraps with a nonflammable material, polytrifluorochloroethylene

copolymer (Kel-F-82). Other recommended changes included were (1) replacement of the adhesive-backed aluminum foil meal-overwrap label with gray tape (TA-44 Polyken tape) approved for spacecraft use; (2) replacement of the nominal nylon cloth lanyard with a Teflon-coated Beta-cloth lanyard; (3) use of Kel-F-82 material, instead of polyethylene film, for flexible partitions in the spacecraft food-stowage containers; and (4) stowage in nonflammable spacecraft-food-container liners made of polyimide material with Teflon-coated Beta-cloth covers.

Other candidate food-packaging materials that were considered in functional verification analyses included Teflon, polyvinylchloride, Kapton Type F, Aclar, and polycarbonate films. Of these materials, only Teflon and Aclar were competitive with the Kel-F-82 material in fulfilling all criteria for food packaging and in reducing the combustion potential. Functional tests using Kel-F-82 and Teflon for the primary food package indicated that the use of heat seals with these materials in the many small, but critical, seams of the package was not reliable. Hence, a waiver was requested and approved to continue the use of the original four-ply plastic-laminate materials for primary food packages because these materials would be protected by the Kel-F-82 meal overwrap at all times other than at mealtimes.

The foregoing changes in materials resulted in several problems. Flaking of the Teflon coating on the Beta-cloth meal-package lanyards presented a potential hazard of inhalation of the resultant aerosol, even in one-g conditions. Beta-cloth lanyards without Teflon coatings were used to solve this problem. The new meal-overwrap material was a primary cause for an increase in food system weight of approximately 0.25 lb/man/day, a total increase of 10.50 pounds or 14 percent of the baseline weight. The most troublesome problem was the increase in stowage volume and the difficulty in stowage of meals overwrapped with the relatively bulky and brittle Kel-F-82 material. Material thickness was found to vary from 4 to 8 mils, with corresponding variations in flex strength. Relatively minor manipulation and abrasion of the meal overwraps frequently resulted in the formation of pinholes and loss of vacuum. The integrity of heat seals was very difficult to establish or maintain until the performance of considerable experimentation resulted in determination of the proper settings of the heat-sealing equipment for pressure, swell time, and temperature. The manufacturer of the overwrap (material) also improved the quality of the product for this unique application. A process change that contributed to improved product strength resulted in an end-item that was primarily amorphous, rather than crystalline, in structure. Because of the protection afforded by the primary food package, the resultant increase in gas permeability was not considered to be a significant disadvantage. The uniform material thickness and improved flex strength resulted in a highly reliable food-package material that was used with increasing frequency as a primary food package for new and improved food items for each succeeding Apollo mission. In addition, the experience gained in overwrap handling and fabrication was of value for purposes of future planning.

The early attempts to work with this relatively unknown material were not fully successful. The initial expense was considerably greater than for the original foil/plastic laminate, and the costly failures nurtured numerous misgivings about the new material. If other alternatives had been available, or even remotely possible, it is doubtful that the use of Kel-F-82 material would have been pursued far enough to realize the success and potential additional applications that are being realized presently.

Primary-Package Design Changes

Packaging for bite-size foods. - The relatively simple package for bite-size foods (fig. 5) functioned well throughout all Apollo flights. The only changes were the decrease in the size of the paper labels and modification of the package size to accommodate either four, six, or eight cubes of food.

Packaging for rehydratable foods. - The package for rehydratable foods served many functions, and the improved current designs are still not optimal. Problems were evident in the germicidal-tablet pouch, heat-seal strength, rehydration valve, zero-g feeder mouthpiece, fabrication methods, package weight and volume, and procedures required for food reconstitution and consumption. In an attempt to increase package reliability and uniformity of quality, to reduce the weight and volume, to standardize parts, to reduce the amount of exposed surface area of combustible materials, and to reduce costs by simplifying and increasing the speed of manufacture, numerous changes were made.

1. The germicidal-tablet pouch was relocated and fabricated as a portion of the basic-package blank cutout. This relocation eliminated a frequent point of package failure caused by the attachment of the germicidal-tablet pouch to the outside of the finished package by a heat-seal process. The time and effort required for fabrication were reduced.
2. The angle of the package shoulder was lowered from 45° to 30° . This change resulted in a more gradual transition from the package-body diameter to the mouthpiece diameter that decreased the pressure stresses at the package shoulder when food was squeezed from the package.
3. The length of the package for semisolid foods was reduced. This change resulted in a weight reduction of 2 grams for each package and of approximately 1 pound for a mission set of food. The exposed combustible surface area was reduced by 7 square inches for each package and by 1470 square inches for a mission set of food.
4. The length of the rehydratable-beverage package (fig. 6) was increased. This change enabled the provision of beverages in 8-ounce servings instead of 6-ounce servings and, thus, increased the amount of beverage available per unit weight and volume of packaging material.
5. A study was initiated to determine the feasibility of reducing the size of the germicidal tablet from 1 to 0.5 gram. Study results later indicated that this change was feasible but not worth the cost of new procurement of germicidal agents and the required documentation changes.
6. Automated package fabrication was instituted. As a result, the production increased from approximately 12 to more than 100 packages/hr. Package uniformity also was improved by using automated production methods.
7. The diameter of the mouthpiece for rehydratable foods was increased from 0.75 inch to 1.25 inches. This change made possible the use of larger pieces of food and, thus, resulted in improved texture and flavor of the rehydratable foods.

The differences in the original rehydratable-food package and the modified designs that were used for the Apollo 8 and subsequent missions are shown in figure 7. However, despite the foregoing design improvements, a few failures occurred during the 2TV-1 test and in the Apollo 7 spacecraft.

Food system support for the 10- and 12-day manned thermovacuum (2TV-1 and 2TV-2) tests of the CSM was accomplished without major problems. The three-man test crews were provided with samples for evaluation purposes. The preferences of each crewmember were considered in designing the menus that were based on a nominal 4-day cycle. Although the decision to reduce flight-menu energy levels from 2800 to 2500 kcal/man/day had been made previously, 2800 kcal/man/day were provided during the ground-based test because additional energy was required to sustain body weight under one-g conditions.

The test was indicative that several problems were inherent in the primary-food package: (1) weakness in the heat-sealed side seams of several rehydratable-food packages, (2) water leakage around the rehydration valve when water was injected into the package and when the test crewmen attempted to eat the rehydrated food, (3) malfunction of the mouthpiece of several rehydratable-food packages, and (4) failure of the heat seal separating the germicidal tablet from the food before food consumption. The problem of weak heat seals was the most significant because uncontrolled dispersion of liquid or dry food particles in a zero-g cabin environment could cause damage to spacecraft equipment or result in inhalation of foreign material by the crewmen.

Similar package failures occurred during a manned test in the MOL simulator at the USAF School of Aerospace Medicine (SAM) at Brooks Air Force Base, Texas. The baseline design for the MOL food system was the same as for the Apollo Program, and the same prime contractor and subcontractors were used. A working group that consisted of representatives from the MOL Systems Office, Los Angeles, California; SAM, San Antonio, Texas; the U.S. Army Food Laboratories, Natick, Massachusetts; and MSC, Houston, Texas, had been unofficially formed to share the design and development tasks of both systems.

A review of the problems showed that the side-seam failures in the rehydratable-food packages were caused by delamination of the package materials. The delamination was traced to a change in the adhesive material that was used by the supplier. Comparison tests showed that the new adhesive material deteriorated and lost strength more quickly than had the original adhesive. Fresh lots of material were procured, and the contract manufacturing specifications that governed the procurement were revised to preclude recurrence of the problem.

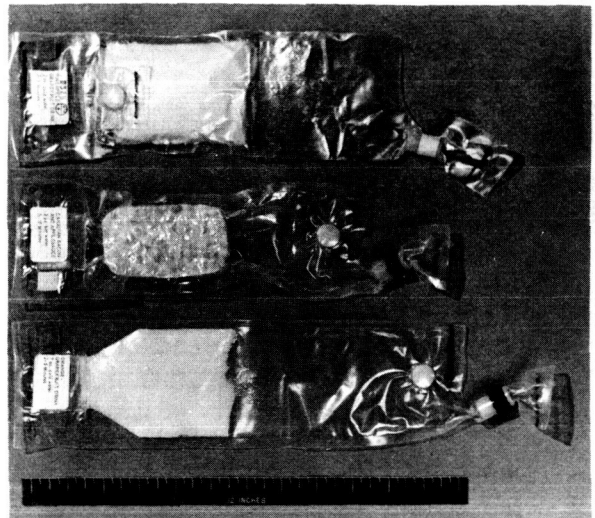

Figure 7. - Original Apollo rehydratable-food package (top) compared with modified designs for semisolid foods (center) and beverages (bottom).

The loss of a heat seal near the germicidal tablet was not attributed to a problem with the material, because the failure appeared to result from inadequate heat, pressure, or dwell time of the heat-seal bar during package fabrication. The failure was a singular occurrence among more than 1000 rehydratable-food packages, and the heat-seal equipment may have had a transient localized failure. However, to prevent a recurrence of this situation, the package-fabrication heat platens were checked and readjusted. Inspection of the integrity of the germicidal-tablet-pouch seals was placed on the list of mandatory 100-percent-inspection points.

Failures in the water valve and mouthpiece during the 2TV-1 test were attributed to poor workmanship and inadequate inspection. Closer supervision of employees, improved fabrication methods, and increased inspection during manufacture were imposed as corrective measures by the contractor. Several batches of test articles were fabricated and tested to verify that the process would be satisfactory. Otherwise, the crewmen were satisfied with the quantity and quality of their food supplies. Post-test analysis of the food set revealed that nearly 90 percent of the available food had been consumed. The 90-percent level of consumption is rather remarkable because approximately 2 to 5 percent of the food is residue that adheres to the walls of the packages.

During the second day of the Apollo 7 mission, further problems with the rehydratable-food packages occurred. The crew reported a rather messy failure of a side seam of a package of chocolate pudding. Subsequently, during the same flight, the crewmen reported finding one mouthpiece that had been sealed shut, a water valve that did not have an accessible opening to allow addition of water, and several other water valves that leaked food or water around the outside of the valve. Postflight analyses were conducted with the assistance of personnel from SAM and from the U.S. Army Natick Laboratories. The cause of the side-seam failures was more elusive this time. An extensive search to determine the source of the problem was required before it was determined that an automated package-fabrication technique should be modified to ensure that heat seals were at least 0.25 inch wide. Verification tests were conducted by SAM personnel, and revised in-process inspection procedures were increased from a 10-percent-sample-test requirement to a 34-percent-sample-test requirement. Contractor and Government inspections of the finished packages were increased to 100 percent.

The working group also developed a more reliable technique for installation of the rehydratable-food-package water valve. This technique included the use of a section of Teflon shrink tubing to form a leakproof friction fit of the water valve to the package. The previous method of hand wrapping nylon thread over the interface was deleted because of susceptibility to human error and the difficulty of checking for discrepancies. Package failures did not recur in any subsequent mission food set. However, the rehydratable-food package is susceptible to failure, and correction of one weak spot or failure point seems to result in a similar failure in another part of the package. Any relaxation in production discipline and quality assurance could be expected to result in a recurrence of package failures.

CONTINGENCY FEEDING SYSTEM

The purpose of the contingency feeding system is to provide nutriment to the crewmen when they are wearing pressurized suits. The nominal Apollo food system was not designed to provide for food consumption while the crewmen are wearing pressurized suits. In case of complete loss of cabin pressure during a mission, the crewmen might be required to wear pressurized suits continuously for as long as 115 hours. Water would be available by passing the probe of the potable-water dispenser through the helmet feedport.

The contingency food system, which had been designed for Apollo Block I, involved a nutrient-defined semisolid food contained in flexible metal tubes that had an attached pontube. Reassessment of the basic system revealed that a crewman could not exert sufficient external pressure on the metal tube to force the semisolid food from the tube, through the pontube, and into his mouth. This problem was attributed to the positive pressure differential (3.5 psia inside the suit) and the viscosity of the semisolid food. The configuration of any food selected for contingency feeding was limited by the size of the helmet feedport, which is 0.34 inch in diameter. In addition, consumption of the basic contingency food each day, as part of the regularly scheduled meals, generally was not acceptable. Stowage weight and volume restrictions made it mandatory that contingency foods be an integral part of the daily menu. Because some missions were scheduled for only 10.6 days duration, it is apparent that 5 days of contingency food comprises almost one-half of the nominal diet. At this level, it is inappropriate to consider the food as being in a contingency category. Also, the sweet chocolate flavor of the food was not acceptable when consumed as a major portion of the diet over a timespan of a week or more.

Prior to selection of a final design (fig. 8), several approaches to contingency feeding were evaluated. The development, designs, and problems associated with each approach are described briefly in this report. Numerous concepts were considered, but only those concepts that were selected for design-verification testing are presented.

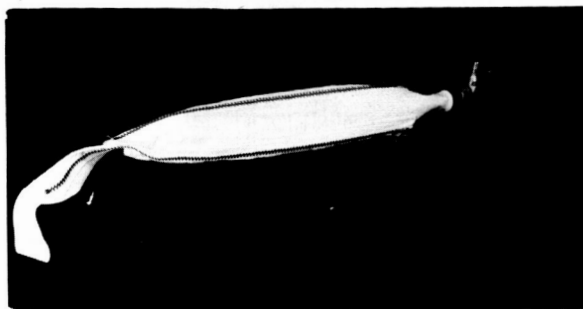

Figure 8.- Contingency-feeding-system nylon restrainer pouch with attached pontube and filled (at 3.5 psia) beverage package.

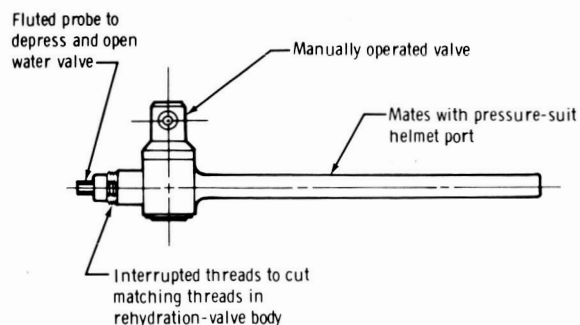

Figure 9.- Contingency-feeding-system pontube with rehydration-valve adapter.

The new design approach was to use the nominal Apollo rehydratable-food packages already included in the nominal food system. Rehydratable-food-package valve adapters and pontubes were designed for attachment to the rehydration valve of the package (fig. 9) and the mouthpiece of the food package (fig. 10). A device (fig. 11) that would restrain the food package and assist in forcing liquid food through the pontube was fabricated and tested. This restrainer-assembly concept incorporated cams and levers to force the food from the package through either type of package adapter pontube into the mouth.

Test evaluation of the food package with pontubes indicated the problem of rupture of the food package. The point of failure was in the heat-sealed side seams. Although the food-package heat seals are tested at 9 psia during package fabrication, sudden surges of internal pressure frequently caused a rupture. Also, prolonged internal over-pressure, as a result of external manipulation used to force liquids through the pontube, resulted in a side-seam failure rate of 29 percent. The metallic food-package-restrainer assembly was unacceptable because the device was awkward to use, was very heavy and bulky, and did not provide adequate support to prevent rupture of the side seams.

The advantage of using the mouthpiece adapter would be that foods having a thicker consistency could be eaten more easily because of the larger orifice at the point of attachment. However, attachment of the mouthpiece adapter to the polyethylene tube on the package caused the tubing to split, and it was difficult to attach and manipulate the adapter with a gloved hand while wearing a full pressure suit. This design concept was discarded.

The contingency feeding system selected was based on the use of a contingency-feeding-system valve adapter and pontube that mate with the beverage-package rehydration valve. The pontube end of the contingency-feeding-system valve adapter passes through the helmet feedport and is accessible to the crewman's mouth. Rupture of the rehydratable-food package is prevented by reinforcement of the side seams on the package with a nylon restrainer pouch. Only fruit-flavored beverage powders are used in the system. Water is added in the nominal manner after the beverage package is safely installed in the nylon restrainer pouch. Application of positive external pressure on the nylon restrainer pouch, which contains the rehydrated beverage, and suction, provided by the crewman, will cause expulsion of the food from the food package, through the valve adapter and pontube, and into the crewman's mouth. A complete assembly (as it would appear after removal from the helmet feedport at an internal pressure of 3.5 psia and with the pontube valve in the closed position) is shown in figure 8.

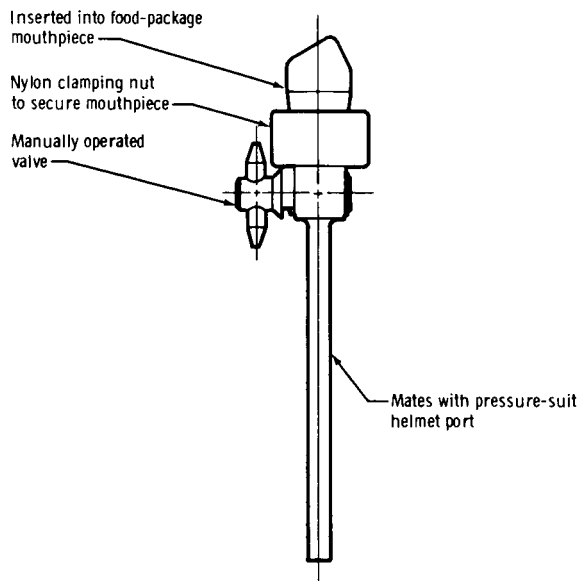
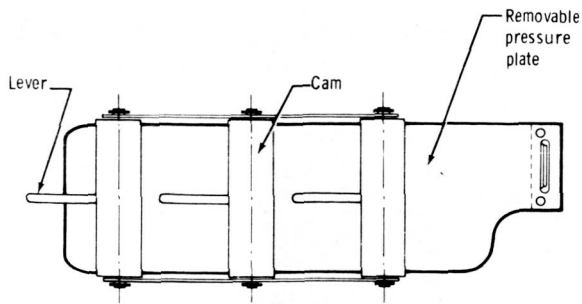
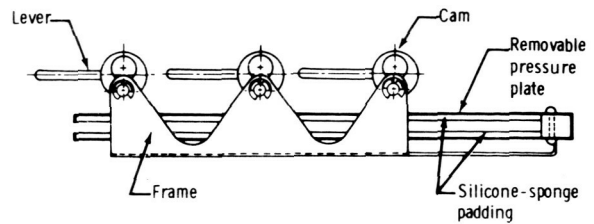

Figure 10. - Pontube with mouthpiece adapter.



(a) Top view.



(b) Side view.

Figure 11. - Contingency-feeding-system restrainer assembly.

The evolution of the valve-adapter pontube that was designed to interface with the rehydration valve of the food package is shown in figure 12. A shutoff valve was incorporated into the valve-adapter pontube to prevent the loss of critical suit pressure if a rupture of the beverage package were to occur. Also, the shutoff valve was incorporated to prevent the loss of liquid from the package after rehydration and to prevent a sudden surge of pressure into the package when the pontube was inserted into the helmet. With the use of a shutoff valve, the pressure inside the package could be gradually equalized with the suit pressure without rupturing the food package when the valve was used with the nylon restrainer pouch. The length of the pontube was increased from 4 to 6 inches to improve accessibility to the crewman's mouth. The one disadvantage of the valve adapter is that the orifice, at the point of attachment, is small; therefore, only low-viscosity fruit beverages were recommended for use.

The nylon restrainer pouch that was included in the Apollo 8 system is shown in figure 13. Although this design prevented rupture of the food package, the crewmen would have been required to insert the food package into the pouch while wearing pressurized gloves, and this was a difficult and time-consuming task.

The last configuration of the food-restrainer pouch as used on Apollo 10 and subsequent missions is shown in figure 14. This design incorporates a double-zipper pouch that enables the crewman to insert the package into a relatively large opening and then restrain it further by closing the second zipper. The only problem encountered during evaluation of the nylon restrainer pouch was a failure in the package between the main section of the package and the germicidal-tablet section. This problem was eliminated by the removal of the

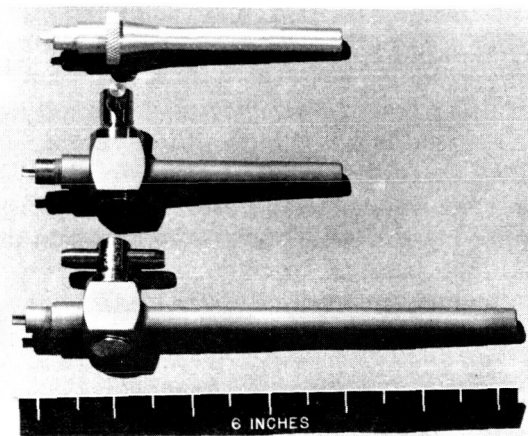

Figure 12. - Evolution of the contingency-feeding-system valve-adapter pontube (earliest concept at top, intermediate concept at center, and current design at bottom).

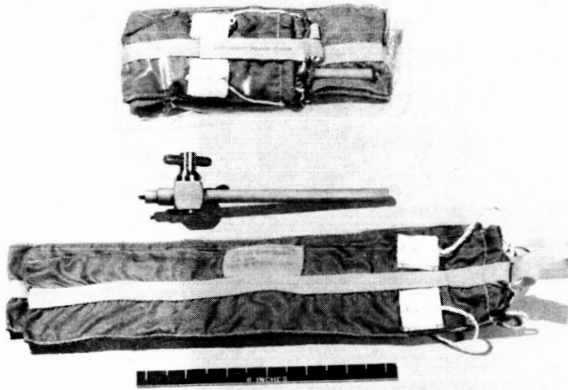

Figure 13.- Apollo 8 contingency feeding system, shown assembled and packaged in nonflammable Kel-F-82 material (top). The valve-adaptor pontube is in the center, and the restrainer pouch is at the bottom.

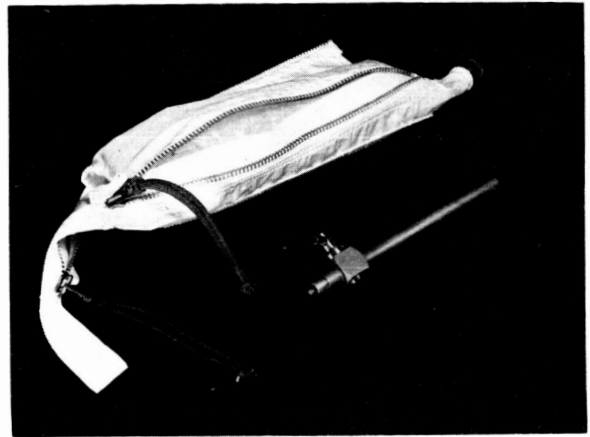

Figure 14.- Final contingency-feeding-system restrainer pouch, shown with rehydratable-beverage package installed before closure of the zippers. A valve-adaptor pontube is also shown.

germicidal tablet from the fruit-beverage package and by the provision of a supply of tablets in an accessory bag, which was stowed separately.

The location of the feedport in the Apollo A7L-style helmet is approximately opposite the left ear; therefore, drinking or eating is an awkward, but not impossible, task. It was anticipated that the crewmen might require the assistance of a fellow crewman when consuming contingency foods.

The contingency feeding system that was used for the Apollo 10 to 14 missions consisted of one valve-adaptor pontube and three nylon food-restrainer pouches. Each restrainer pouch contains a package of beverage powder. Thus, for initial use, the crewman must rehydrate the beverage powder and attach the pontube. After drinking this beverage, the empty package can be replaced with additional beverage packages as many times as the crewman desires or until all beverage powders are consumed. On the Apollo 10 to 14 missions, however, no problems were encountered in maintaining the spacecraft cabin pressure; thus, contingency feeding was not necessary.

FOOD STOWAGE

Spacecraft food-stowage locations, the LEB and the LHEB in the CM and one compartment in the LM, are shown in figures 15 and 16, respectively. The CM stowage containers were manufactured by the prime contractor for the CM and shipped to the food contractor for stowage of the food system. To ensure that stowage of the food system did not result in changes to the external dimensions of the food containers and to ensure the proper interface between the spacecraft and the container, a fit-check tool was provided for use before shipment of the food system to the launch site. The

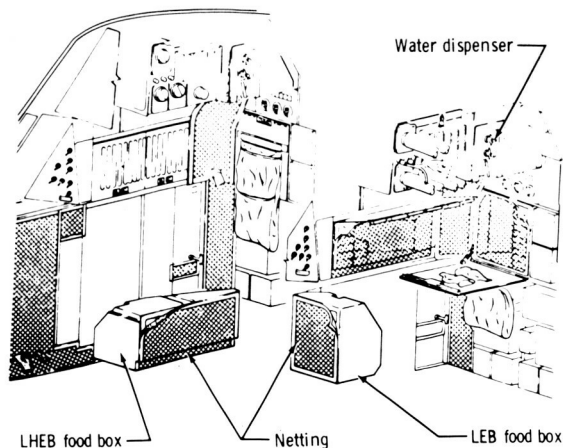

Figure 15.- Apollo CM food-storage areas.

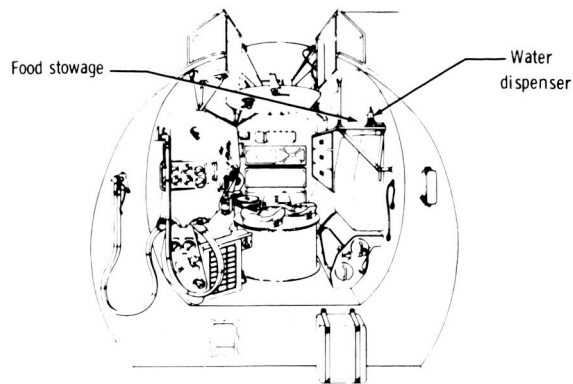

Figure 16.- Apollo LM food-storage area and water-dispenser location, shown in an aft view of the LM.

fit-check tool is shown in figure 17 installed on an LHEB food-storage container. The stowage configuration of the LEB food-storage container (CM compartment B-1) is shown in figure 18 as it appeared for the First Article Configuration Inspection. The crewman locates the first inflight meals by removing the oral hygiene kit (indicated by a tube of toothpaste and bristles of a toothbrush seen on the face of the stowed meals in fig. 18). Then, the crewman follows the lanyard to the meals that are designated for day 1. Meal identification is accomplished by the use of a patch of Velcro that is colored red for the commander (CDR), white for the command module pilot (CMP), and blue for the lunar module pilot (LMP).

Food-storage orientations for the LM were performed according to interface control drawings and specifications. Meals were then shipped to the launch site in mockup LM food containers.

Considerable difficulty was experienced in the coordination between the contractor for the CM and the food contractor. This problem occurred primarily because the dimensions of the food-storage containers were not available until shortly before the 2TV-1 test in May of 1968. The original total volume available in LHEB compartment L-3 and LEB compartment B-1 food-storage containers was 5208 cubic inches. Materials and configuration changes resulted in a reduction of 205 cubic inches, which resulted in a total available volume of 5003 cubic inches. This volume appears to be more than adequate because baseline food and packaging volume requirements averaged

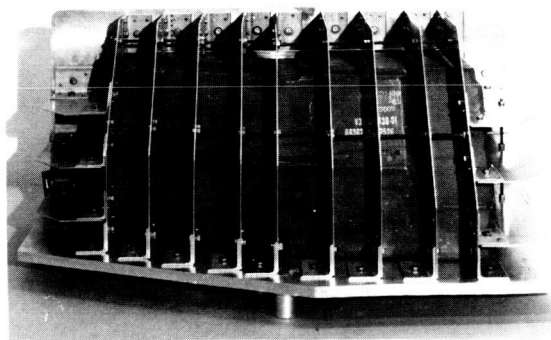

Figure 17.- Fit-check tool installed on an LHEB food-storage container.

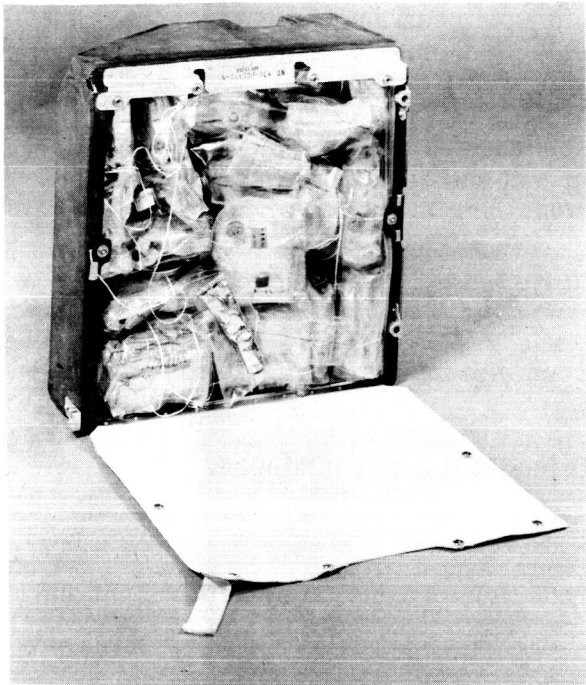

Figure 18. - Lower equipment bay food-stowage container.

115 in³/man/day, for a total requirement of 4830 cubic inches for a 14-day mission. However, the volume that was available was provided in irregular shapes and was not necessarily compatible with food-package and meal shapes. Several changes in the available volume of the spacecraft food containers were necessary because of inconsistent CM wire-bundle dressings behind the containers. This configuration resulted in considerable redesign of meal orientation and stowage.

Despite these irregular shapes and difficulties with firmly defined interfaces, the Apollo Block II system of food stowage was a significant improvement over the systems available for the Gemini and Apollo Block I food systems. For example, the Apollo Block I food-stowage area was subdivided into seven small, irregularly shaped containers that proved to be very inefficient and restrictive for the purposes of food stowage. The food-stowage volume for Gemini missions also was inefficient; however, the most critical factor was that food-stowage containers were not available for

use by the food contractor and meals could not be shipped in the proper configuration to the launch site. Consequently, considerable effort was required to achieve stowage in the Gemini vehicles in the critical period 24 hours before launch.

The weight and volume histories (table V) show an overall growth in these parameters from the low of 115 in³/man/day and 1.8 lb/man/day of food in the baseline system to 188 in³/man/day and 2.48 lb/man/day of food for the Apollo 14 food system. Food acceptance and consumption by the crewmembers also increased considerably during this period, but the relationship of food system weight and volume to crew acceptance is not linear. The increase in all three parameters is primarily attributable to the idealized and unrealistically low weight and volume of the baseline food system and the realistic liberalized allowances for the actual flight systems.

TABLE V. - FOOD SYSTEM WEIGHTS AND VOLUMES SUPPLIED FOR SELECTED APOLLO MISSIONS

Mission	Average weight/ man/day, lb	Average volume/ man/day, in ³
Baseline	1.80	115
Apollo 7	1.92	156
Apollo 11	2.26	178
Apollo 14	2.48	188

The growth in both weight and volume would have been much greater if a number of basic design changes had not been implemented. A number of major factors contributed to the weight increases.

1. Inclusion of conventional foods, thermostabilized and intermediate-moisture type, with normal moisture content (60 to 70 percent and 20 to 30 percent moisture, respectively, compared with dehydrated foods containing less than 7 percent moisture)
2. Use of rigid metal cans as the primary packages for some thermostabilized food
3. Change of meal overwraps from aluminum foil/plastic laminate to nonflammable Kel-F-82 plastic film
4. Addition of partitions to the spacecraft food-stowage containers
5. Addition of the oral hygiene kit

Several major factors contributed to the reduction of the food system weight and volume.

1. Deletion of contingency food in flexible metal tubes
2. Size reduction of the rehydratable-food packages
3. Reduction of the daily energy provisions per man from 2800 to 2500 kilocalories in the CM and from 3200 to 2800 kilocalories in the LM

One of the most significant Apollo food-package improvements that was introduced into the food system was the rehydratable-food spoon-bowl package (figs. 19 and 20). As the name implies, the spoon-bowl package allows for food consumption in a more or less conventional manner by using a spoon to eat from a bowl. The original package for rehydratable foods was characterized by squeezing and sucking food through a plastic mouthpiece into the mouth. The spoon-bowl package acts as a bowl after food rehydration and allows for consumption of liquid foods in weightlessness with the aid of a conventional serving spoon. Conversely, food can be readily consumed in the original squeeze and suction method by removing the rehydration valve after rehydration and mixing and using this orifice as a mouthpiece. In fact, a few crewmembers used this latter option on several occasions in flight.

Limited quantities of the spoon-bowl package were first used on the Apollo 10 flight. This pouch package is shaped with an extension on one side at the bottom of the package for the rehydration valve. Rehydration of foods in the spoon-bowl package is accomplished in the same manner as for the original rehydratable-food package. After the food is mixed with water, the top of the package is cut with scissors along a marked line. The cut flap is held out of the way by mating Velcro patches on the flap and body of the package.

Two parallel plastic zippers are incorporated at the top of the package. The use of two zippers effect a stronger temporary closure, and the lower zipper keeps the top zipper clean during rehydration. The lower zipper also serves as a place where excess

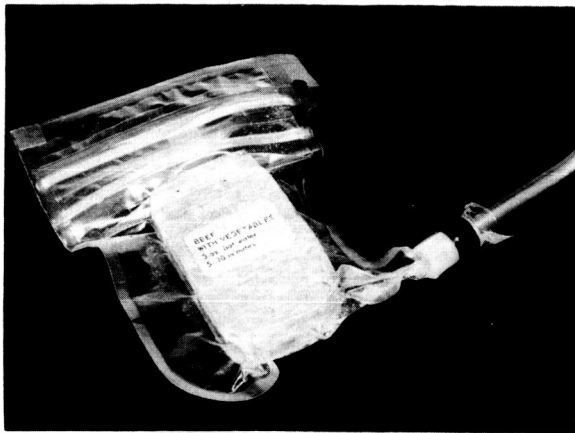

Figure 19. - Rehydratable-food spoon-bowl package with water dispenser inserted in the rehydration valve.

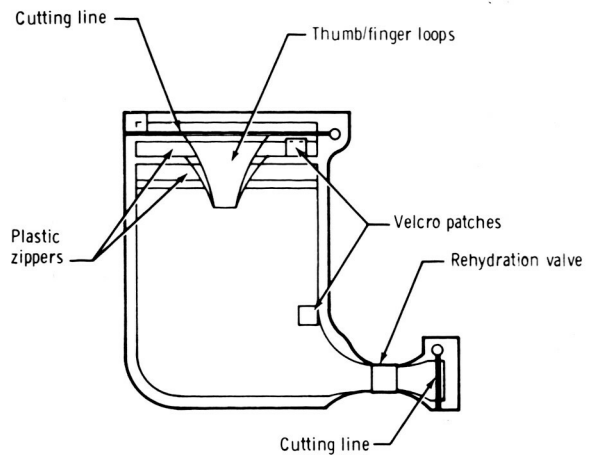

Figure 20. - Rehydratable-food spoon-bowl package.

food can be scraped off the spoon during consumption. Both zippers may be used for temporary reclosure of the package during the mealtime and for final closure after eating, before stowage of the used package with any food residue and a germicidal tablet. On each side of the package, a finger/thumb loop is available for use by the crewman for one-handed opening and closing while using the other hand to spoon out the contents in a rather conventional fashion.

Several approaches for improving the method of adding water to rehydratable foods were investigated during development of the spoon-bowl package, but none offered significant advantages over the basic design. The best of the design modifications considered was based on the use of pliable, self-sealing or self-closing materials that were physically displaced or forced open temporarily by insertion of the water-dispensing probe. These aperture concepts offered simplified manufacture because of the circumvention of a number of the precision parts in the original rehydration valve (such as grooved areas for rubber O-rings and spring-loaded one-way valves). Many of the concepts investigated are included in the appendix of this report. Inclusion of this extensive collection of rehydration-valve or aperture concepts should not be construed to mean that this was the only area of packaging that was thoroughly investigated. Similar studies were conducted for each component of the Apollo food system. Inclusion of these various valve and aperture concepts as an appendix is justified by the fact that the current Apollo and Skylab designs are not optimal and should be improved. This appendix provides a suitable point of departure for improving the design of the food-package rehydration valve in future space food systems.

Many of the detailed design analyses that were performed on Apollo foods and packaging were conducted by the ad hoc Joint NASA-Department of Defense Aerospace Feeding System Working Group. The U.S. Air Force and the U.S. Army provided most of the technical manpower from extensive resources at the School of Aerospace Medicine and the U.S. Army Natick Laboratories.

PERSONAL HYGIENE AND ACCESSORY ITEMS

Changes in personal hygiene and accessory items before the Apollo 7 mission consisted primarily of the inclusion of an oral hygiene kit that contained a roll of dental floss, three toothbrushes, and a tube of ingestible toothpaste. For Apollo 8, new contingency-food-system packages, food-serving spoons, and an extra package of germicidal tablets were provided. Spoons were packaged individually in Kel-F-82 plastic film and were integrated into each subsequent mission food set.

FOOD DEVELOPMENT

As was indicated earlier in this report, the Apollo food system was considered to be fully developed by 1966 and additional research and development were not programmed. Development funds for any flight foods were extremely limited and were designated for the Skylab Program (then the Apollo Applications Program). The unanticipated delay (February 1967 to October 1968) between the first scheduled manned Apollo mission (Apollo 1) and the first actual manned mission (Apollo 7) afforded an opportunity for an investigation of the foods available for the remainder of the Apollo Program. Biomedical personnel from MSC served as test subjects in evaluation of the baseline menu (tables III and IV) by use of the foods as a sole source of sustenance for 5-day periods. The deficiencies that were suspected in the food system were evidenced by subjective reports resulting from these personal experiences. One of the first conclusions was that active crew participation in menu design would be an absolute requirement to ensure success of the inflight food system. Other points of interest that were observed included the fact that a food which was disliked mildly by an individual at the outset might be unbearable when consumed frequently with subsequent meals. The converse was true for other items; for example, a particular food which was disliked mildly when first eaten with a meal might be elevated in preference to "like slightly" at subsequent meals. The composition of meals reflected a preference for individual foods. A favorite item, such as bacon squares, might be anticipated with a response that varied from pleasure to exuberance. Evaluations were performed while maintaining normal work routines, and food preparation was found to be tedious and time consuming. Consumption of food in the manner prescribed for zero g during flight was unnatural and difficult. Food textures and flavors usually were not characteristic of a particular food item; for example, a hard, compressed cube made of toasted breadcrumbs held together by a starch-gelatin matrix and coating does not taste like a conventional slice of toasted bread. As a result of the foregoing evaluations, a review of the Gemini mission data, and ground-based investigations of organoleptic acceptance of aerospace flight-type foods, development efforts were established with an objective of improving the overall food system.

As mentioned previously, funds for development of the food system were not available; however, it is doubtful that the time available for developmental efforts on a contract basis would have been sufficient to be of significant benefit to the early Apollo missions. A NASA contract, which was in effect with the Natick Laboratories, contained requirements for some rather broadly described support services. The support services that were provided concerned menu design, food-preference and flight-qualification screening, writing and maintaining current specifications for food production, supply of

several food formulations (as Government-furnished products) through the MSC to the prime food contractor, and development of experimental foods for the Skylab orbital workshop. This effort was redirected to emphasize improvement of the Apollo Program foods. Personnel at the USAF SAM provided the services of a food technologist on virtually a full-time basis to monitor and perform the developmental efforts at the Natick Laboratories. Also, military personnel assigned to the SAM continued to perform parallel investigations and collaborated on the direction of developmental efforts. Numerous specific projects were undertaken and are listed as follows.

1. Improving the texture of rehydratable foods
2. Increasing the variety of flavors and types of rehydratable and bite-size food items
3. Developing a technique for preservation and packaging of conventional fresh bread
4. Accelerating the development and flight qualification of normal-moisture thermostabilized foods
5. Determining a method for maintaining storage stability of fresh fruit
6. Developing intermediate-moisture foods

The results of the initial efforts were rewarding, and the original list of 47 foods (table VI) was increased to 90 foods that passed flight-qualification tests (table VII). Sixteen foods submitted for test failed and were rejected. In addition to the nominal qualification tests and analyses, selected physical, chemical, and microbiological analyses (table VIII) were performed to establish objective indexes and rates of deterioration. Analyses were performed after 0-, 14-, 30-, and 60-day exposures to simulated spacecraft environments. The interpretation and extrapolation of the analytical data enabled rapid evaluation and a more accurate prediction of the potential for successful flight qualification of new foods that were developed or suggested for subsequent flights.

TABLE VI. - APOLLO PROGRAM BASELINE FOODS, APRIL 1967

Food	Food type (a)	Food	Food type (a)
Beverages		Desserts	
Cocoa	D	Gingerbread	B
Grapefruit drink (fortified)	D	Peanut cubes	B
Orange drink	D	Pineapple fruitcake	B
Orange-grapefruit drink	D	Sugar-cookie cubes	B
Pineapple-grapefruit drink	D	Contingency food	T
Breakfast items		Salads	
Apricot-cereal cubes	R	Chicken	R
Strawberry-cereal cubes	B	Potato	R
Fruits and vegetables		Salmon	R
Applesauce	R	Shrimp cocktail	R
Corn	R	Tuna	R
Fruit cocktail	R	Soups	
Peaches	R	Corn chowder	R
Peas	R	Pea	R
Breads		Potato	R
Cinnamon-toasted bread cubes	B	Meats	
Graham-cracker cubes	B	Bacon squares	B
Desserts		Beef and gravy	R
Apricot pudding	R	Beef pot roast	R
Banana pudding	R	Beef-sandwich bites	B
Brownies	B	Beef and vegetables	R
Butterscotch pudding	R	Cheese-sandwich bites	B
Chocolate cubes	B	Chicken and gravy	R
Chocolate pudding	R	Chicken-sandwich bites	B
Coconut cubes	B	Chicken and vegetables	R
Date fruitcake	B	Ham and applesauce	R
		Sausage patties	R
		Spaghetti and meat sauce	R

^aD = beverage powder; R = rehydratable; B = bite size; T = thermostabilized.

TABLE VII. - FOODS QUALIFIED FOR FLIGHT

Food	Food type (a)	Food	Food type (a)
Beverages		Breads	
Cocoa	D	Cheese-cracker cubes	B
Cherry punch	D	Cinnamon-toasted bread cubes	B
Coffee	D	Toasted bread cubes	B
Fruit punch	D	Desserts	
Grape punch	D	Apricot cubes	B
Grapefruit drink	D	Apricot and cream	B
Grapefruit drink (fortified)	D	Apricot pudding	R
Grapefruit drink (pink)	D	Banana-chocolate pudding	B
Lemon punch	D	Banana rice	R
Lemon-lime punch	D	Banana pudding	R
Milk (whole)	D	Brownies	B
Orange drink	D	Butterscotch pudding	R
Orange drink (fortified)	D	Butterscotch tapioca	B
Orange-grapefruit drink	D	Caramel rice pudding	B
Pineapple juice	D	Chocolate cubes	B
Pineapple-grapefruit drink	D	Chocolate ice cream	B
Raspberry punch	D	Chocolate pudding	R
Strawberry punch	D	Cheesecake	B
Tea with lemon and sugar	D	Coconut cubes	B
Breakfast items		Coffee ice cream	B
Apricot-cereal cubes	B	Custard	B
Creamed wheat cereal	R	Date fruitcake	B
Oatmeal	R	Gingerbread	B
Toasted-oat cereal	R	Maple-walnut tapioca	B
Strawberry-cereal cubes	B	Mocha ice cream	B
Sugar-frosted flakes	R	Nut sundae	B
Fruit and vegetables		Peanut cubes	B
Applesauce	R	Pineapple fruitcake	B
Corn	R	Rum-coconut tapioca	R
Corn chowder	R	Vanilla ice cream	B
Fruit cocktail	R	Meats	
Peaches	R	Alaskan crab	B
Peaches with cottage cheese	R	Beef and gravy	R
English peas	R	Beef and vegetables	R
Soups		Beef barbecue	B
Cream of chicken	R	Beef hash	B
Pea	R	Beef pot roast	R
Potato	R	Beef sandwich	B
Cream of tomato	R	Beef stew	B
Salads		Canadian bacon	B
Chicken	R	Canadian bacon and applesauce	R
Potato	R	Cheese sandwich	B
Salmon	R	Chicken	B
Shrimp cocktail	R	Chicken sandwich	B
Tuna	R	Chicken stew	B
		Chicken with vegetables	R
		Meat and spaghetti	R
		Pork barbecue	R
		Pork sausage	B
		Sausage patties	R
		Stuffed turkey	B

^aD = beverage powder; R = rehydratable; B = bite size; T = thermostabilized.

TABLE VIII. - ANALYTICAL REQUIREMENTS FOR
FLIGHT-QUALIFICATION TESTING

[Types of analyses performed after 0-, 14-, 30-, and 60-day exposures to simulated spacecraft environments]

Test type	Parameters measured
Microbiological	Aerobes Anaerobes Salmonellae Coliforms Enterococci Staphylococci Yeasts and molds
Chemical	Hydrogen ion concentration Moisture Fat Thiobarbituric acid Peroxide value Ascorbic acid Carotene Astacene Nonenzymatic browning Protein
Physical	Frangibility Rehydration rate Organolepticity

NUTRITION

In the determination of the true value of any food system, an assessment of how effectively the foods maintain normal physiological processes is as important as an assessment of the pleasure (hedonics) experienced by the consumer. Physiological assessment was difficult because of the nature of mission objectives that were specified for spacecraft operations and the limited time available for exploration of the lunar surface.

Every manned space flight involved nutrition as an essential component of the life support systems. Space-flight nutrition not only concerns the direct support of the crewmen but also intimately involves the validity and interpretation of a large spectrum of physiological and biochemical measurements obtained during flight.

Apollo food systems were designed to provide the crewmen with the energy, electrolytes, and nutrient balances that are necessary to maintain normal metabolic function, but the systems were not ideally structured to provide for complex evaluation of inflight physiology. The preflight and postflight medical measurements that were made were not expected to enable the detection of subtle changes in nutritional status; however, the data that have been accumulated have resulted in clarification and establishment of trends that can be quantitated later as a result of the complex inflight metabolic medical experiments (series M-070, Nutrition and Musculoskeletal Function experiments) scheduled for the Skylab missions.

Changes that result from nutritional imbalances or deficiencies are slow to manifest themselves in the form of gross physiological symptoms. Even severely deficient energy intake will not always produce remarkable signs for days or even weeks. The incipient danger of such slow manifestations of deficiencies is that correction of the deficiency and return to normal physiological status usually can require even more time than was required to produce the condition. For the relatively short-duration Apollo flights, nutritional measurements must be designed for maximum sensitivity and accuracy to detect the changes that would be much more evident during longer flights. This set of circumstances frequently results in the tendency to overlook the need for measurement and assessment of any medical parameter that is not an acute fulmination or an absolute condition. Therefore, the rationale of providing fuel and electrolytes to maintain the physical ability to perform critical mission tasks is understandable. However, this rationale will not provide data that are necessary for the adequate interpretation of changes in crew health status and for the establishment of accurate criteria for life support on future manned missions.

Preflight and postflight changes in body weight and estimated daily energy intakes for the Apollo 7 to 14 crewmen are presented in table IX; average daily nutrient intakes for these crewmen are listed in table X. The data in these tables are derived from chemical analyses of the food items that were provided for each crewman, an inventory of foods provided for each crewman, and an inventory and evaluation of residual food returned from each flight. Possible inaccuracies in the data occur in the postflight inventory and evaluation because the crewmen occasionally elected to trade foods with one another and failed to make an appropriate entry in the daily flight-menu log. To determine the degree of this type of inaccuracy is difficult, if not impossible, because it is the result of inadvertent omission of a procedure that may seem inconsequential. However, these errors are probably minimal, and the data presented represent the best available assessment of inflight nutrient consumption.

Loss of body weight has been a consistent postflight finding in all Apollo astronauts with the exception of the Apollo 14 CDR and LMP. Most medical opinions ascribe weight losses in Apollo crewmen to losses in total body water. These opinions are based on the fact that Apollo crewmen have regained postflight weight deficits within the first 48 hours after recovery. That logic is incomplete because changes in body composition resulting from changes in proportions of fat and lean tissue are omitted from consideration. The bases for postulating that changes in body weight are caused by loss of lean body mass as well as by loss of total body water are equally as valid but cannot be proved until more sophisticated techniques of anthropometric measurements are employed in future manned space-flight missions. Determination of the type of body-weight loss resulting from protracted periods of null gravity may have profound effects on nutritional criteria and design of foods and food systems for future manned space-flight programs.

TABLE IX. - BODY-WEIGHT CHANGES AND ENERGY INTAKES FOR THE APOLLO 7 TO 14 MISSIONS

Apollo mission	Crewman	Weight, lb				Inflight weight change, lb	Average daily inflight energy intake, kcal
		Average preflight (a)	Launch day	Recovery day	Recovery + 1 day		
7	CDR	193.5	194	189.75	190.50	-4.25	1970
	CMP	153.3	157	147	150.50	-10	2140
	LMP	155.8	156	149.50	153.50	-6.5	1800
8	CDR	168.8	169	160.50	163.25	-8.5	1480
	CMP	169.3	172	164	164.75	-8	1690
	LMP	146.3	142	138	138.50	-4	1340
9	CDR	161.0	159	153.50	156.25	-5.5	1920
	CMP	180.8	178	172.50	181	-5.5	1720
	LMP	163.8	159	153	157.25	-6	1640
10	CDR	175.2	171	168.50	170.75	-2.5	1400
	CMP	169.3	165	159.50	161.25	-5.5	1385
	LMP	175.1	173	163	164.50	-10	1310
11	CDR	173.0	172	164	170	-8	2040
	CMP	166.7	166	159	159	-7	1640
	LMP	172.3	167	166	170	-1	2280
12	CDR	146.8	149.25	145	147	-4.25	1750
	CMP	155.8	155.25	148	152	-7.25	1670
	LMP	154.0	152.50	140	143	-12.5	1690
13	CDR	173.5	177.50	163.50	(b)	-14	1580
	CMP	197.1	197	186	(b)	-11	1540
	LMP	156.2	156	149.50	(b)	-6.5	1520
14	CDR	172.8	168	169	170	+1	2310
	CMP	166.0	165	153	160	-12	1720
	LMP	183.6	176	177	178	+1	2330

^aAverage of weights determined 30, 15, and 5 days before launch.

^bNo measurement taken.

TABLE X. - COMPARISON OF AVERAGE DAILY INFLIGHT NUTRIENT INTAKES
FOR THE APOLLO 7 TO 14 MISSIONS

Apollo mission	Crewman	Chemical analyses of nutrient intake										
		Energy, kcal	Protein, g	Fat, g	Carbo- hydrate, g	Ash, g	Ca, mg	P, mg	Fe, ^a mg	Na, ^b mg	K, mg	Mg, ^c mg
7	CDR	1970	81	72	259	16	644	1060	8	3810	1879	192
	LMP	1800	74	56	268	14	925	841	7	3480	1336	141
	CMP	2140	96	78	280	18	938	1125	9	4000	1958	185
8	CDR	1480	59	39	231	11	427	847	5	3170	1229	113
	LMP	1340	52	33	217	10	366	760	5	2730	986	97
	CMP	1690	80	49	240	15	479	983	7	3980	1571	145
9	CDR	1920	86	60	280	15	562	1146	7	4000	1677	157
	LMP	1640	66	47	252	13	494	892	6	3410	1386	129
	CMP	1720	78	53	240	14	489	1073	6	3770	1708	146
10	CDR	1400	58	34	213	3	836	814	6	2970	1463	107
	LMP	1310	49	30	208	3	854	701	5	2670	1182	96
	CMP	1385	46	30	213	3	808	746	5	2290	1376	104
11	CDR	2040	79	65	290	17	1036	1050	8	2770	1751	138
	LMP	2280	94	73	322	19	1114	1225	9	3220	2061	166
	CMP	1640	71	54	224	14	851	901	7	2060	1441	119
12	CDR	1750	70	50	263	16	1095	1090	9	3580	1835	119
	LMP	1690	57	42	280	15	1291	965	7	3290	1484	108
	CMP	1670	65	49	249	15	1022	1028	8	3240	1685	117
13	CDR	1580	59	50	239	15	870	780	8	3630	2036	107
	LMP	1520	57	49	228	15	786	716	8	3350	1964	102
	CMP	1540	57	47	235	15	871	720	8	3480	1942	98
14	CDR	2310	90	76	309	20	802	1308	11	4870	2485	181
	LMP	2330	81	89	319	20	843	1304	11	4750	2576	192
	CMP	1720	79	61	230	17	809	1109	8	3780	2147	149

^aIron.

^bSodium.

^cMagnesium.

Evaluation of the recorded nutrient intakes indicates that the Apollo 11 LMP recorded the best overall dietary intake. This evaluation of the quality of dietary intake does not necessarily correlate with the changes in body weight and is mentioned only to emphasize the fact that weight loss in flight should not be considered as the only predictor of the adequacy of a particular diet. Food intake for the relatively short duration of the Apollo missions may be most critical for the maintenance of a proper fluid and electrolyte balance. The low levels of food consumption by many crewmen would be expected to reduce their effectiveness to perform if those levels were maintained for periods in excess of 21 to 30 days.

Measurements of changes in bone density as a result of weightlessness were performed on the Apollo 7, 8, and 14 crewmen (table XI). Measurements taken after the Apollo 7 and 8 missions were accomplished by using a radiographic technique pioneered by Dr. P. B. Mack of Texas Woman's University. Bone-density change for the Apollo 14 crewmen was measured by using an improved gamma-ray absorptometric technique that is based on the measurement of photon-beam attenuation by soft and hard body tissues. As anticipated, no changes in bone density were detected. Significant changes in bone density have not been apparent until at least 14 days of exposure to simulated weightlessness (horizontal recumbency and hypokinesia). Similar measurements programmed for later Apollo and Skylab missions will provide additional valuable baseline data and refinement of measurement techniques for use in the Skylab Program medical experiments.

TABLE XI. - MEASUREMENT OF CREWMAN BONE DENSITY BEFORE
AND AFTER THE APOLLO 7, 8, AND 14 MISSIONS

Anatomic site	Changes in bone density, percent		
	CDR	CMP	LMP
Apollo 7 mission (10-day flight), X-ray technique			
Multiple os calcis sections	-4.10	+0.19	+0.85
Multiple hand-phalanx sections	-9.30	+2.04	-6.50
Apollo 8 mission (7-day flight), X-ray technique			
Multiple os calcis sections	-7.08	-6.04	-6.50
Multiple hand-phalanx sections	-2.19	-3.09	-1.00
Apollo 14 mission (10-day flight), photon absorption technique			
Os calcis	+3.3	+5.7	+5.9
Radius	-1.5	-.9	+1.0

On the remaining flights of the Apollo series, extraordinary precautions were taken to ensure that the inflight menus were designed to provide predetermined quantities of such nutrients as phosphorus, potassium, magnesium, sodium, calcium, and nitrogen. Very careful monitoring of water intake was continued. Special nutrient and electrolyte formulations were developed for use on the lunar surface while the crewmen were performing their extravehicular activities. In addition to this rigorous inflight control of nutrient intake, 3-day preflight and postflight nutritional control periods were implemented. In the preflight and postflight periods, foods that approximated the foods and nutrient composition of the inflight rations were provided. These short periods of preflight and postflight nutritional control helped to prevent radical changes in nutrient consumption while the crewmen were adapting from one g to zero g and from zero g to one g. In this way, changes that might otherwise have been brought about by differences in nutritional intake were not incorrectly ascribed to the effects of weightless flight. Analysis of inflight fecal and urine samples provided a better understanding of inflight nutrient efficiency and gastric function.

MENU SELECTION

Literature available on menu design, food habits, food preferences, psychophysiology of eating, appetite, hunger, and related subjects is extensive. Reports, observations, and theories relating to dietary planning for every conceivable type of population have been published. Some of these sources are listed in the bibliography. Examples of the types of populations investigated and reported on include the following.

1. Military - submarine crews, surface vessel crews, long-range ground combat patrols, ballistic missile crews, aircraft alert crews, long-range reconnaissance and bomber crews, medical air evacuation patients, and hospital staffs and patients
2. Civilian - transoceanic airline passengers; coal miners; ethnic groups; minority groups; preschool children; high, low, and middle income groups; and college students
3. Special civilian/military - polar explorers, mountain climbers, athletes, astronauts, and environmental test subjects

Careful selection and elimination of reference materials make it possible to develop and justify almost any point of view and approach to the successful design of menus for a given population. Even if all reports and data published during a specified period of time could be accurately presented, the resulting conclusions and decisions would be highly subjective and probably not pertinent to a new set of circumstances and variables for some future event. The origins and nature of individual food habits and preferences preclude total objectivity in the selection of diets for a group of people.

Many methods were considered for the design of Apollo menus, but experience soon identified two most promising approaches: "individualized menus" for each crewmember and "standardized menus" as recommended for each flight (same menu for each crewmember of any given flight). In turn, each of these approaches was composed of either "formula foods" or "conventional foods."

The formula foods considered were nutrient-defined foods that contained all required dietary allowances plus precise quantities of nutrients specified as a result of medical experiments. Such formula foods could be assembled into either standardized or individualized menus.

In the standardized menu configuration, each crewmember would be provided with an identical formula food using a single acceptable flavor. The quantity of formula to be consumed each day would be identical for each crewmember without allowance for possible differences in physiological or psychological requirements.

In the individualized menu configuration of formula food, various degrees of individualization are possible. To limit the range of possibilities to manageable proportions, it was assumed that this approach is characterized by the following.

1. Nutrient content is identical in each serving or sample, but several different choices of flavors and textures are available for crewmember selection.

2. Daily consumption is established in accordance with individual physiological requirements.

Among the numerous advantages of formula diets for manned space-flight food systems are the following.

1. Accuracy of nutrient intake measurements
2. Uniformity of nutrient consumption
3. Precision of adjustments for correction
4. Decrease in fecal mass and defecation frequency
5. Decrease in gastrointestinal gas and flatus production
6. Ease of measuring and disposing of wastes and residues
7. Stability at 70° F for as long as 24 months
8. Decrease in inflight meal preparation time
9. Reduction in time required for menu design and crew preference testing
10. Elimination of requirement for special inflight preparation equipment
11. Reduction of weight and volume
12. Simplicity of package design
13. Reduction of nutrient and chemical analysis sample size and replication
14. Ease of manufacture
15. Reduction of cost

The formula foods developed to date, however, have a single disadvantage that negates all of these advantages. This disadvantage is manifest in the marginal crew acceptance of the formula diet for periods in excess of a week or two.

It was determined that the best probability for successful design of menus for the Apollo Program would be found in the use of individualized menus composed of conventional foods. To establish a baseline configuration, however, it was necessary to first establish a standardized menu using available Apollo conventional foods.

Conventional foods were selected from an array of Apollo foods consisting of processed natural foods and combinations of natural foods. Standard menus were developed based primarily on average physiological and psychological requirements typical of the astronaut population. This type of menu planning is employed by the Department of Defense to meet the needs of unique military populations. Allowances for individualized menus are made for submarine crews, hospital patients, and others. However, in virtually every instance, the military man is not restricted to eating all meals from a single food service facility — each individual has resources at his disposal to secure food from other sources. These options are never available to the astronaut, and this fact reinforces the requirement to individualize menus to the extent possible.

As flight crew assignments for each Apollo mission were announced, individualized menus were developed using the best information obtainable for the requirements of each individual. The individualized menu gave each crewmember full opportunity to satisfy his food preferences; the only limitation was that the menu selected must be within normal nutritional allowances. It was learned in the Apollo Program that the more a crewmember had opportunity to familiarize himself with the food before flight, the greater was his satisfaction with the food system. Experience with the Apollo food system reinforced the theory that individuals are unique in their food habits, preferences, and requirements.

MOBILE QUARANTINE FACILITY FOOD SYSTEM

The Mobile Quarantine Facility (MQF) was used for ground-based biological isolation of astronauts and support personnel during the initial stages of recovery and transport after the Apollo 11, 12, and 14 lunar landing missions. The MQF food systems (primary and backup) were deployed on the recovery vessels for the Apollo 13 mission but were not used because no lunar landing was made. These foods were returned to the MSC and were later used in support of Project Tektite II missions. A food system was designed to be compatible with the facilities in the MQF and to fulfill postflight quarantine requirements. Requirements for food transfers into the MQF, for garbage transfers out of the MQF, and for rapid meal preparation by untrained personnel in isolation were established and were included in the design of the MQF. Precooked frozen meals were used as the core of the system and were reconstituted by the use of a small microwave oven, which was located inside the MQF. These meals were supplemented with shelf-stable beverages and snacks that were stowed in the MQF before transport to the recovery zone. Production, packaging, handling, and configuration specifications, which were developed to meet the unique requirements of the MQF, were imposed on the contractor who prepared the precooked frozen meals.

During two simulation studies, it was found that exotic gourmet meals were unacceptable because these foods aggravated nausea that was attributed to the relatively rough seas to which the CM is subjected after landing. It was determined that vomiting and even small amount of flatus would be a problem within the confined quarters. It was also determined that a 4-day menu cycle was most acceptable to simulation subjects and that it was most feasible to provide the meals from the foods that were available.

Packaging methods were developed that effectively protected the foods and containers from damage despite the rough handling that occurred during transport of the food system to the aircraft carrier and during the time the food was on board the recovery vessel. Meals for six individuals were packaged in corrugated cartons, complete with the necessary eating utensils. Then, these boxes were enclosed in an insulated shipping container for added protection. Also, the primary meal cartons were used as waste containers for residual food, food trays, and food-packaging material. To prevent putrefaction, residual food was stabilized by the use of 8-hydroxyquinoline sulfate before placement in the primary meal container. To fulfill postflight quarantine requirements, the primary meal carton, which contained residual food and waste material, was placed in double polyethylene bags and hermetically sealed before transfer (through a disinfectant bath) out of the MQF.

During the Apollo 11 recovery phase on board the U.S.S. *Hornet*, the MQF food system was rendered virtually inaccessible. Frozen food storage was located on another deck on the ship and was inaccessible to NASA food support personnel because of U.S. Navy security requirements. Therefore, the MQF food system for subsequent missions was stowed in portable deep-freeze units for transport to and storage on board the recovery ship. These freezers greatly simplified the task of meal transfer because the freezers were stored near the MQF. Dry ice (120 pounds in each freezer) maintained frozen-storage conditions during transit from the MSC to Pearl Harbor, Hawaii. On board the aircraft carrier, the freezers were operated by electrical power and were guarded by U.S. Marine personnel.

Printed menus and instructions inside the MQF for meal preparation aided the crew in meal preparation and coordination. Also, an MSC Food and Nutrition Branch technical representative, who accompanied the food to Hawaii, was on board the recovery ship to serve as the MQF food consultant, and he remained with the crewmen until their return to the MSC. This individual ensured the smooth operation of the MQF feeding system during the hectic activities that are characteristic of the first few days after a space flight.

LUNAR RECEIVING LABORATORY FOOD SYSTEM

A food system was designed to feed flight crews and support personnel in the Lunar Receiving Laboratory (LRL) during the mission quarantine periods after lunar missions. Basically, the system consisted of precooked frozen foods that were supplemented with fresh produce, beverages, and canned items.

The principal requirement for the LRL food system was the provision of meals and preparation equipment that would require a minimum number of galley personnel behind the quarantine barrier. By the use of precooked frozen meals, meal components, and rapid-food-reconstitution equipment (microwave and infrared quartz ovens), the

initially recommended number of six galley personnel that are required in similar conventional food-preparation systems was reduced to one.

A specification in which the requirements were outlined for processing, packaging, and shipping frozen food was prepared and was used to procure frozen foods from qualified commercial sources. All other foods that were used in the LRL operation were Government inspected and purchased on a brand-name basis. Handling procedures were prepared for the acquisition, storage, transfer, preparation, and serving of the food.

An emergency food system that could feed 100 additional persons in the Sample Operations Area of the LRL was also provided in case of a possible break in the quarantine. Freeze-dried foods that were shelf stable at ambient temperatures and that could be prepared readily by each individual were made available for the first 24-hour period. The freeze-dried foods could be supplemented by other convenience foods that could be stored at ambient conditions. Precooked frozen foods, which were similar to the normal LRL foods, could be procured and made available for consumption during the remaining period of an emergency quarantine.

THE APOLLO 14 FOOD SYSTEM

The food system for the Apollo 14 lunar landing mission was the most advanced space-flight food system ever developed at that time. This system provided balanced nutrition for the astronauts during all phases of the mission. Unique constraints were imposed on the food system by the variety of environments and operational conditions that were encountered by the crewmen during this flight. To satisfy all conditions, a wide variety of foods, food-production methods, packages, and food-preparation modes was used that incorporated many of the advances in research and development that have been accomplished in space-flight food systems during the past decade. These advances are indicative of the potential for future improvements.

Before launch, each prime and backup crewmember conscientiously evaluated available flight foods and selected preferred food items. These foods subsequently were assembled into nutritionally balanced menus designed to provide approximately 2105 kcal/man/day of energy and 100 g/man/day of protein. The crewmembers were briefed on spacecraft stowage, food-preparation procedures, and methods of waste disposal. After donning his suit and before departing for the launch pad, each crewman was supplied with a specially prepared frozen sandwich, a package of bacon squares, and a rehydratable beverage. These foods were overwrapped in Kel-F-82 material and placed in a pocket of the space suit for consumption when desired during the first 8 hours after launch. The sandwiches were prepared in the MSC Food and Nutrition Laboratory 72 hours before launch; quality control inspection ensured that the sandwiches met all applicable spacecraft and food system requirements. If, for some reason, microbiological safety standards had been violated, the frozen sandwiches would have been withdrawn and the crewmen would have chosen replacement items from the nominal mission foods.

During flight days 1 to 5, the physical appearance of foods in the CM contrasted sharply with that of conventional foods. The foods provided for each crewmember for days 1 to 5 are listed in tables XII to XIV. New foods included for the Apollo 14 mission

TABLE XII. - APOLLO 14 COMMANDER'S MENUS FOR DAYS 1 TO 5

Meal	Menu for days ^a 1 and ^b 5	Food type (c)	Menu for day 2	Food type (c)	Menu for day 3	Food type (c)	Menu for day 4	Food type (c)
A	Peaches Scrambled eggs Bacon squares (8) Grapefruit drink Coffee, black	RSB RSB IM RD RD	Fruit cocktail Sausage patties Spiced fruit cereal Orange drink Coffee, black	RSB RSB RSB RD RD	Peaches Scrambled eggs Bacon squares (8) Grape drink Coffee, black	T RSB IM RD RD	Mixed fruit Canadian bacon and applesauce Cornflakes Pineapple-grapefruit drink Coffee, black	T RSB RSB RD RD
B	Chicken and rice Applesauce Chocolate bar Orange-grapefruit drink	RSB RSB IM RD	Turkey and gravy Cranberry-orange sauce Pineapple fruitcake (4) Grape punch	T RSB IM RD	Pea soup Bread slices ^d Sandwich spread ^e Butterscotch pudding Grapefruit drink	RSB NS T RSB RD	Chicken and rice soup Meatballs with sauce Lemon pudding Graham-cracker cubes (4) Grape punch	RSB T T D RD
C	Cream of tomato soup Spaghetti and meat sauce Peach ambrosia Cheese-cracker cubes (4) Grape drink	RSB RSB RSB D RD	Cream of chicken soup Frankfurters Banana pudding Brownies (4) Pineapple-grapefruit drink	RSB T RSB IM RD	Lobster bisque Beef stew Beef sandwiches (4) Caramel candy Orange-grapefruit drink	RSB RSB D IM RD	Beef and gravy Chicken and vegetables Chocolate pudding Sugar-cookie cubes (4) Grapefruit drink	T RSB RSB D RD
Total calories		1748		2272		2157		2098

^aDay 1 consisted of meal C only.

^bDay 5 consisted of meal A only.

^cRSB = rehydratable spoon-bowl; IM = intermediate moisture; RD = rehydratable drink; D = dehydrated; T = thermostabilized; NS = natural state.

^dBread: cheese, rye, or white.

^eSandwich spreads: chicken, ham, tuna salad, cheddar cheese, peanut butter, jelly.

TABLE XIII. - APOLLO 14 LUNAR MODULE PILOT'S MENUS FOR DAYS 1 TO 5

Meal	Menu for days ^a 1 and ^b 5	Food type (c)	Menu for day 2	Food type (c)	Menu for day 3	Food type (c)	Menu for day 4	Food type (c)
A	Peaches Scrambled eggs Bacon squares (8) Grapefruit drink Coffee, black	RSB RSB IM RD RD	Fruit cocktail Apricot-cereal cubes (4) Spiced fruit cereal Orange drink Coffee, black	RSB D RSB RD RD	Peaches Scrambled eggs Bacon squares (8) Grape drink Coffee, black	T RSB IM RD RD	Mixed fruit Canadian bacon and applesauce Cornflakes Pineapple-grapefruit drink Coffee, black	T RSB RSB RD RD
B	Beef pot roast Applesauce Jellied fruit candy Orange-grapefruit drink	RSB RSB IM RD	Beef and gravy Cranberry-orange sauce Pineapple fruitcake (4) Grape punch	T RSB IM RD	Pea soup Bread slices ^d (2) Sandwich spread ^e Butterscotch pudding Grapefruit drink	RSB NS T RSB RD	Corn chowder Meatballs with sauce Vanilla pudding Chocolate bar Grape punch	RSB T T IM RD
C	Cream of tomato soup Pork and scalloped potatoes Peach ambrosia Cheese-cracker cubes (4) Grape drink	RSB RSB RSB D RD	Cream of chicken soup Frankfurters Banana pudding Brownies (4) Pineapple-grapefruit drink	RSB T RSB IM RD	Lobster bisque Beef stew Beef sandwiches (4) Apricots Caramel candy Cocoa	RSB RSB D IM IM RD	Beef and gravy Potato soup Chocolate pudding Sugar-cookie cubes (4) Pineapple-grapefruit drink	T RSB RSB D RD
Total calories		1835		2139		2268		2365

^aDay 1 consisted of meal C only.

^bDay 5 consisted of meal A only.

^cRSB = rehydratable spoon-bowl; IM = intermediate moisture; RD = rehydratable drink; D = dehydrated; T = thermostabilized; NS = natural state.

^dBread: cheese, rye, or white.

^eSandwich spreads: chicken, ham, tuna salad, cheddar cheese, peanut butter, jelly.

TABLE XIV. - APOLLO 14 COMMAND MODULE PILOT'S MENUS FOR DAYS 1 TO 5

Meal	Menu for days ^a 1 and ^b 5	Food type (c)	Menu for day 2	Food type (c)	Menu for day 3	Food type (c)	Menu for day 4	Food type (c)
A	Peaches Scrambled eggs Bacon squares (8) Orange drink Cocoa	RSB RSB IM RD RD	Fruit cocktail Cinnamon-toasted bread (4) Pork and scalloped potatoes Orange-grapefruit drink Cocoa	RSB D RSB RD RD	Peaches Scrambled eggs Bacon squares (8) Pineapple-orange drink Cocoa	T RSB IM RD RD	Mixed fruit Canadian bacon and applesauce Cornflakes Orange-grapefruit drink Cocoa	T RSB RSB RD RD
B	Pea soup Chicken salad Turkey bites (4) Orange-grapefruit drink	RSB RSB D RD	Corn chowder Turkey and gravy Cheese sandwiches (4) Pineapple-orange drink	RSB T D RD	Pea soup Bread slices ^d (2) Sandwich spread ^e Creamed chicken bites (6) Orange drink	RSB NS T D RD	Chicken and rice soup Meatballs with sauce Chicken sandwiches (6) Vanilla pudding Pineapple-grapefruit drink	RSB T D T RD
C	Cream of tomato soup Tuna salad Spaghetti and meat sauce Cheese-cracker cubes (4) Orange drink	RSB RSB RSB D RD	Potato soup Meatballs with sauce Chicken and rice Peanut cubes (4) Pineapple-grapefruit drink	RSB T RSB D RD	Lobster bisque Beef stew Potato salad Beef sandwiches (4) Orange-grapefruit drink	RSB RSB RSB D RD	Beef and gravy Shrimp cocktail Chicken stew Sugar-cookie cubes (4) Cocoa	T RSB RSB D RD
Total calories		2006		2128		2013		2138

^aDay 1 consisted of meal C only.

^bDay 5 consisted of meals A, B, and C.

^cRSB = rehydratable spoon-bowl; IM = intermediate moisture; RD = rehydratable drink; D = dehydrated; T = thermostabilized; NS = natural state.

^dBread: cheese, rye, or white.

^eSandwich spreads: chicken, ham, tuna salad, cheddar cheese, peanut butter, jelly.

that had never been consumed in space were lobster bisque and peach ambrosia, both rehydratable; beef jerky in ready-to-eat bite-size pieces; and diced peaches, mixed fruit, and pudding, which were thermostabilized. The thermostabilized items were packaged in 201/208 (2.06 by 2.5 inches) aluminum cans with easy-open, full-panel pull-out lids. The foods available for the CDR and the LMP in the LM are presented in table XV. During the lunar-surface-operation phase, the CMP continued his nominal menu with selection options from the pantry. The foods in pantry stowage for the trans-earth flight are given in table XVI.

During the return flight from the Moon, the Apollo 14 astronauts were free to select any of the foods that were stowed in the pantry (table XVI). Similar configurations were provided for the Apollo 11, 12, and 13 missions. This food selection provided additional information concerning the advantages and problems that are associated with inflight free-choice or cafeteria-type selection of foods. The principal advantage is assumed to be that the crewmember is allowed to select his menu in real time based on appetite and instinctive physiological need. The chief problem is that considerable time can be expended in surveying and locating the various food items to assemble the meal. Information derived from the free-choice food-selection experiences indicates that there are no significant advantages to this approach.

After splashdown and recovery, the Apollo 14 astronauts were confined for approximately 3 days in the MQF during their transport to the MSC LRL in Houston, Texas, by means of the recovery aircraft carrier and a C-141 aircraft. Meals in the MQF consisted primarily of precooked frozen food that required no preparation other than heating in the MQF microwave oven. The Apollo 14 MQF menus are given in table XVII.

During the quarantine period in the LRL, a variety of fresh, frozen, and dry foods and of precooked frozen meals was available for the astronauts and the quarantined LRL

TABLE XV. - APOLLO 14 LUNAR MODULE MENU^a

[2-2/3 man-days (eight meals)]

Meal	Menu for day 1	Food type (b)	Total calories	Menu for day 2	Food type (b)	Total calories
A	None	--	--	Peaches Bacon squares (8) Sugar-coated cornflakes Cocoa Orange-pineapple drink	RSB IM RSB RD RD	668
B	Cream of tomato soup Bread slice Ham salad sandwich spread Caramel candy Pineapple-grapefruit drink Grapefruit drink	RSB NS T IM RD RD	906	Lobster bisque Meatballs with sauce Chocolate bar Pineapple fruitcake (4) Grapefruit drink	RSB T IM IM RD	880
C	Beef and gravy Cheese-cracker cubes (4) Apricots Butterscotch pudding Orange-grapefruit drink Grape punch	T D IM RSB RD RD	875	None	--	--

^aCDR - red Velcro; LMP - blue Velcro.

^bRSB = rehydratable spoon-bowl; IM = intermediate moisture; RD = rehydratable drink; NS = natural state; T = thermostabilized; D = dehydrated.

support staff. The food system was adaptable to variations in the number of persons to be served. Also, the variety of available foods allowed for accommodation and adjustment of the different eating habits, food preferences, and energy requirements of all quarantined personnel. The LRL food program is now being used as the point of departure for the design of the alert-crew food system for the Space Shuttle Program. This program will require strict control of food quality and safety analogous to the controls developed for the Apollo Program.

In general, the comments by the Apollo 14 crewmembers concerning the quality of the inflight foods and the food system were favorable. One crewmember reported a preference for the inflight foods rather than the precooked frozen foods provided in the MQF. Of particular interest were the crewmembers' comments concerning the wide variety of thermostabilized foods packaged in the aluminum cans with full-panel pullout lids. The crewmen reported that the lids were removed carefully and that no accidental dispersion of food occurred.

TABLE XVI. - PANTRY STOWAGE IN THE APOLLO 14

COMMAND MODULE FOR DAYS 6 TO 10

Food	Food type (a)	Quantity	Total
Beverages			
Cocoa	RD	6	
Coffee	RD	16	
Grape drink	RD	2	
Grapefruit drink	RD	6	
Grape punch	RD	2	
Orange-grapefruit drink	RD	6	
Orange juice	RD	20	
Pineapple-grapefruit drink	RD	6	
Pineapple-orange drink	RD	6	70
Breakfast items			
Bacon squares (8)	IMB	12	
Cinnamon-toasted bread cubes (4)	DB	3	
Canadian bacon and applesauce	RSB	3	
Cornflakes	RSB	3	
Fruit cocktail	RSB	3	
Sausage patties	RSB	2	
Scrambled eggs	RSB	6	
Peaches	RSB	3	
Spiced fruit cereal	RSB	3	
Apricots	IM	3	
Peaches	IM	3	44
Cubes/candy			
Brownies (4)	IM	2	
Caramel candy (4)	IM	2	
Chocolate bar	IM	2	
Creamed chicken bites (6)	D	3	
Cheese cracker (4)	D	6	
Cheese sandwiches (4)	D	3	
Beef sandwiches (4)	D	3	
Jellied fruit candy	IM	2	

^aRD = rehydratable drink; IMB = intermediate moisture bite size; DB = dehydrated bite size; RSB = rehydratable spoon-bowl; IM = intermediate moisture; D = dehydrated.

TABLE XVI. - PANTRY STOWAGE IN THE APOLLO 14
 COMMAND MODULE FOR DAYS 6 TO 10 - Continued

Food	Food type (a)	Quantity	Total
Cubes/candy			
Jerky	IM	3	39
Peanut cubes (4)	NS	2	
Pecans (6)	IM	3	
Pineapple fruitcake (4)	IM	2	
Sugar cookies (4)	D	3	
Turkey bites (4)	D	3	
Desserts			
Applesauce	RSB	2	15
Banana pudding	RSB	2	
Butterscotch pudding	RSB	2	
Chocolate pudding	RSB	2	
Cranberry-orange sauce	RSB	3	
Peach ambrosia	RSB	4	
Salads/soups			
Chicken and rice soup	RSB	2	18
Lobster bisque	RSB	3	
Pea soup	RSB	3	
Potato soup	RSB	3	
Shrimp cocktail	RSB	2	
Tomato soup	RSB	3	
Tuna salad	RSB	2	
Sandwich spreads/bread			
Bread (slice)	NS	6	23
Catsup	NS	3	
Cheddar cheese (2 oz.)	NS	3	
Chicken salad (8 oz.)	T	1	
Ham salad (8 oz.)	T	1	
Jelly	NS	3	
Mustard	NS	3	
Peanut butter	NS	3	

^aNS = natural state; IM = intermediate moisture; D = dehydrated; RSB = rehydratable spoon-bowl; T = thermostabilized.

TABLE XVI. - PANTRY STOWAGE IN THE APOLLO 14
COMMAND MODULE FOR DAYS 6 TO 10 - Concluded

Food	Food type (a)	Quantity	Total
Meat items			
Beef pot roast	RSB	3	20
Beef and vegetables	RSB	3	
Beef stew	RSB	3	
Chicken and rice	RSB	2	
Chicken and vegetables	RSB	2	
Chicken stew	RSB	2	
Pork and scalloped potatoes	RSB	2	
Spaghetti with meat sauce	RSB	3	
Thermostabilized food			
Beef and gravy	T	4	12
Frankfurters	T	2	
Meatballs with sauce	T	4	
Turkey and gravy	T	2	

^aT = thermostabilized; RSB = rehydratable spoon-bowl.

TABLE XVII. - APOLLO 14 MOBILE QUARANTINE FACILITY FOOD^a

Meal	Menu for —				
	Day 1	Day 2	Day 3	Day 4	Day 5
Breakfast	Crepes Georgia Cheese omelet Crisp bacon strips Breakfast roll Jelly	Crepes Normandie Link sausage Pancakes Maple sirup	Crepes Diane Cheese omelet Crisp bacon strips Breakfast roll Jelly	Crepes Georgia Plain omelet Breakfast ham Breakfast roll Jelly	Crepes Normandie French toast Crisp bacon strips Maple sirup
Lunch	Roast beef sandwich Corn relish Mixed fruit compote Vanilla ice cream Assorted cookies	Beef stew Dinner roll Plums	Spaghetti with meat sauce Green beans amandine Dinner roll Vanilla ice cream Oatmeal-raisin cookies	Roast beef au jus Duchess potatoes Glazed carrots Dinner roll Fudge brownies	Braised beef tips Tiny whole potatoes with green peas Dinner roll Vanilla ice cream
Dinner	Strip steak Baked potatoes Asparagus spears Dinner roll Apple cobbler	Chicken Kiev White rice Mixed vegetables Dinner roll Fudge cake	Baked ham with pineapple glaze Potatoes au gratin Buttered green peas Dinner roll Cherry cobbler	Short ribs of beef Buttered peas with mushrooms Whole kernel corn Dinner roll Pecan pie	Lobster Newburg White rice French style green beans Dinner roll Almond torte

^aInstant coffee, tea, butter, and sterilized canned whole milk available with each meal.

The CDR and the LMP consumed the foods as outlined in the programed menus, and the body weight of each was maintained throughout the mission. The CMP deviated slightly from the programed menus and reported that the quantity of food supplied for each meal was greater than his appetite needs. A smaller variety of high-preference items would have been more acceptable. The body weight of the CMP at recovery was slightly less than that recorded at launch. The crewmembers reported that undissolved gas was present in the water supply but that the gas caused no significant problem with proper rehydration of food.

POTENTIAL SPINOFF APPLICATIONS

Prediction of potential future applications of new knowledge or technology is fraught with difficulty. It is important, therefore, to record all expertise developed so that future workers can critically review the past in order to glean maximum productivity for any set of accomplishments. The following is a list of advances made during the design, development, and delivery of the Apollo food system that now appear to be most likely candidates for productive spinoff applications for other segments of society.

1. Perfected food dehydration techniques
2. Established optimal food safety standards (tolerance levels for additives, chemical residues, storage conditions, and microbiology)
3. Improved food packaging to facilitate long shelf life
4. Improved diagnostic techniques for detection of changes in bone density
5. Elucidated thermal properties of foods to improve use of power for heating food
6. Improved definition of the nutrient requirements of man
7. Improved understanding of and treatment for bone and muscle diseases by altered nutrition
8. Definitized normal distribution of nutrients in natural food supplies
9. Contributed to knowledge of stability persistence of vitamins and amino acids in stored foods
10. Set nutrient standards for individual food items
11. Improved food cleanroom-production methodology
12. Reduced costs of providing nutrient-balanced foods
13. Enhanced food quality control and inspection procedures

14. Devised foods suitable for consumption from open plates in weightlessness (applicable for eating in cramped, inconvenient conditions; e.g., airplanes)

15. Developed more than 100 new and improved foods (e.g., space food sticks, nutrient-defined drinks, instant rice, nutrient-complete meals in the form of rehydratable powders (instant meals), shelf-stable intermediate-moisture foods (bacon squares, nutritional candy, jelly-filled pastry))

CONCLUDING REMARKS

During the Apollo Program, dramatic progress has been made in the design of the packages for rehydratable solid foods. This progress is exemplified by the Apollo spoon-bowl package. In comparison, little progress has been made in the design of packages for rehydratable liquid foods. The propensity to flow exhibited by bulk liquids in null gravity makes liquid management a distinctly different problem than management of solid and semisolid foods. Continuation of an intensive development program is needed to modify the drink packages to make them more convenient for the crewmembers to handle during preparation and consumption. Testing of some of the new drink packages was scheduled for the Apollo 15 mission.

The intermediate-moisture foods used for the Apollo missions were those for which water activity was controlled to ensure retardation of chemical and microbiological deterioration while maintaining acceptable texture at the time the foods were consumed. These intermediate-moisture foods characteristically are in equilibrium and have water activities of 0.2 to 0.75 on a scale for which water activity is expressed as the ratio of partial pressure of water in the food to the vapor pressure of pure water at the given temperature. The intermediate-moisture foods are highly acceptable, nutritious, safe, and very easy to eat. No preparation for eating the intermediate-moisture foods is required other than removal of the food from the package. Additional intermediate-moisture foods should be developed for future flights. The most popular intermediate-moisture items in the Apollo food system inventory included jellied fruit candy, pecans, peaches, pears, apricots, fruitcakes, bacon squares, nutrient-defined caramel-flavored candy sticks, and nutritionally complete snacks.

An excellent menu variety was provided by including dehydrated ready-to-eat foods for all Apollo missions. In addition, the dehydrated foods, like the intermediate-moisture foods, were convenient to eat during periods in which the number of required mission activities was increased. Historically, the bite-size dehydrated foods are the oldest items in space-flight food systems. These foods and tubes of pureed fruit were the basic types of food used during the Project Mercury space flights. The most acceptable and nutritious of these early food types have been retained for use in contemporary and future space-flight food systems.

Thermostabilized foods are the newest food type to be used in the space program. These foods open the potential for the use of a much wider variety of foods during space flights. Flexible or rigid packages are used. The older package form is the flexible laminate of plastic and aluminum foil that is opened by cutting with scissors at either end and from which food is consumed by using a conventional spoon. This type of

package is now in use for commercial products. A more recent development in thermostabilized-food packaging for manned space flight is the use of rigid aluminum cans with full-panel pullout lids. This type of can was used in space for the first time during the Apollo 10 flight in May 1969. The package proved so successful that its use in the Apollo food system was expanded to include virtually all categories of thermostabilized foods commercially available in aluminum cans fitted with full-panel pullout lids. Although thermostabilized food in this type of package readily fulfills the objectives that space food should be appetizing, safe, nutritious, and convenient to eat, it is costly from a weight and volume standpoint in spacecraft systems that generate or recover water in flight.

The fact that most foods can be consumed in null gravity from open containers by using conventional tableware has been established during the Apollo Program. Expansion of the list of suitable foods on late Apollo flights has provided an extensive selection of foods in a variety of forms that not only will meet the unique requirements of the Skylab and Space Shuttle Programs but also will be highly acceptable to individuals with a variety of food preferences.

A brief insight into some of the problems, solutions, and achievements in the food systems associated with the Apollo Program is presented in this report. The descriptions in this report should contribute to the validation of the hypothesis that food and food system management for manned space flight are complex and unique and cannot be developed successfully through application of simplistic, absolute approaches. The risk involved in following a natural human tendency to design systems that would satisfy known absolute requirements, such as those established for the spacecraft, to the exclusion of the requirements of the consumer should be avoided in future manned-spacecraft food system development.

The Apollo food system has been the most successful and most advanced food system design in the history of the United States manned space-flight program. Accurate solutions to the complex logistical and technical problems were evolved and implemented as a result of the efforts of a large group of people of diverse backgrounds, interests, and skills. The best efforts and abilities of this group were applied to achieve a common goal of designing the various components of the Apollo food system. Although this description sounds like an example of NASA teamwork, it is doubtful that most of the people involved were aware of the full extent of the synchronization of their efforts with the efforts of other persons in similar and diverse areas of expertise. These people, who accepted the tasks that were assigned in either discrete or broad terms, were enthusiastic in their efforts to seek new responsibilities and were willing to commit personal or corporate resources to achieve the goals of manned space flight. Each individual expressed enthusiasm in his own way, and most were caught up in a desire to contribute to a glamorous, adventuresome, and authentic program of space exploration by the United States. Future programs without this kind of enthusiasm and zeal could be more difficult and costly. Such increases in difficulty and cost can only be offset by the implementation of the efficiencies in design and production that evolved as a result of previous space-flight experience.

Food systems that will be designated for future manned space flights will be designed properly only if the experiences gained from previous programs are thoroughly understood. Each mission, vehicle, and crew is different, and all criteria must be reviewed and tested carefully. The success of future food system designs will require

close coordination and understanding of the technological improvements that constantly result from programs in research, operations, and engineering design. Vertical and lateral lines of communication must be open and used in all three areas of endeavor.

Lyndon B. Johnson Space Center
National Aeronautics and Space Administration
Houston, Texas, February 13, 1974
914-50-95-07-72

REFERENCES

1. Anon.: Recommended Dietary Allowances. Seventh ed., Publication 1694, National Academy of Sciences - National Research Council, 1968.
2. Benedikt, Elliot T.: General Behavior of a Liquid in a Zero or Near-Zero Gravity Environment. Weightlessness - Physical Phenomena and Biological Effects. Proceedings of the Symposium on Physical and Biological Phenomena Under Zero-g Conditions, Elliot T. Benedikt, ed., Plenum Press (New York), 1961, pp. 3-32.
3. Neu, J. T.; and Good, Robert J.: Equilibrium Behavior of Fluids in Containers at Zero Gravity. AIAA J., vol. 1, no. 4, Apr. 1963, pp. 814-819.
4. Povitskii, A. S.; and Lyubin, L. Ya.: Emptying and Filling Vessels in Conditions of Weightlessness. Planet. Space Sci., vol. 11, Nov. 1963, pp. 1343-1358.
5. Shuleikin, V. V.: Ground Experiments With Weightless Liquids. Soviet Phys. Dokl., vol. 8, no. 10, Apr. 1964, pp. 985-988.
6. Richards, A.; Streimer, I.; and Wendrow, B.: Foods and Food Systems as Influenced by Zero-Gravity Space Flight. Vol. 5 of Physiological and Performance Determinants in Manned Space Systems, part I, Paul Horowitz, ed., Western Periodicals Co. (North Hollywood, Calif.), 1965, pp. 31-38.
7. Macklin, Martin: Water Handling in the Absence of Gravity. Aerospace Med., vol. 37, no. 10, Oct. 1966, pp. 1040-1045.
8. Vanderveen, John E.; O'Hara, May J.; and Leeber, Donald A.: Consumption of Rehydratable Food in Zero-Gravity Environments Using Conventional Eating Utensils. Aerospace Med., vol. 41, no. 3, Mar. 1970, pp. 306-308.
9. Flentge, R. L.; Grim, A. C.; Doppelt, F. F.; and Vanderveen, J. E.: How Conventional Eating Methods Were Found Feasible for Spacecraft. Food Technol., vol. 25, no. 1, Jan. 1971, pp. 51-54.
10. Rambaut, Paul C.; Bourland, Charles T.; Heidelbaugh, Norman D.; Huber, Clayton S.; and Smith, Malcolm C., Jr.: Some Flow Properties of Foods in Null Gravity. Food Technol., vol. 26, no. 1, Jan. 1972, pp. 58-63.
11. Pelczar, M. J.; et al.: Manual of Microbiological Methods. McGraw-Hill Book Co., Inc. (New York), 1946.
12. Hajna, A. A.; and Damon, S. R.: New Enrichment and Plating Media for the Isolation of Salmonella and Shigella Organisms. Appl. Microbiol., vol. 4, no. 6, Nov. 1956, pp. 341-345.
13. Austin, Philip R.; and Timmerman, Stewart W.: Design and Operation of Clean Rooms. Business News Publishing Co. (Detroit), 1965.

14. Anon. : Clean Room and Work Station Requirements, Controlled Environment. Federal Standard No. 209A, 1966.
15. Cordaro, Joseph T.; Sellers, Walter M.; Ball, Robert J.; and Schmidt, Jerome P. : Study of Man During a 56-Day Exposure to an Oxygen-Helium Atmosphere at 258 mm Hg Total Pressure: Part X - Enteric Microbial Flora. *Aerospace Med.*, vol. 37, no. 6, June 1966, pp. 594-596.
16. Heidelbaugh, Norman D. : Space Flight Feeding Systems: Characteristics, Concepts for Improvement, and Public Health Implications. *J. Am. Vet. Med. Assoc.*, vol. 149, no. 12, Dec. 15, 1966, pp. 1662-1671.
17. Anon. : NASA Standards for Clean Rooms and Work Stations for the Microbiologically Controlled Environment. NASA Handbook 5340.2, 1967.
18. Anon. : Standard Procedures for the Microbiological Examination of Space Hardware. NASA Handbook 5340.1, 1967.
19. Anon. : Contamination Control Handbook. NASA SP-5076, 1969.
20. El-Bisi, Hamed M.; and Powers, Edmund M. : The Microbiological Wholesomeness of Space Foods. Tech. Rept. 70-41-FL, U.S. Army Natick Laboratories, Natick, Mass., 1969.
21. Fox, Donald G. : A Study of the Application of Laminar Flow Ventilation to Operating Rooms. Public Health Monograph 78, U.S. Public Health Service Publication No. 1894, 1969.
22. Darrah, R. M. : Contamination Control in the Food Processing Industry. *Contamination Control*, vol. IX, nos. 7 and 8, 1970, pp. 15-16.
23. Heidelbaugh, Norman D.; and Smith, Malcolm C., Jr. : Potential Applications of Space Food Processing Environment Controls for the Food Industry. Proceedings of the Food Engineering Forum, American Society of Agricultural Engineers, (St. Joseph, Mich.), 1971, pp. 95-105.
24. Heidelbaugh, Norman D.; Smith, Malcolm C., Jr.; Rambaut, Paul C.; Hartung, T. E.; and Huber, Clayton S. : Potential Public Health Applications of Space Food Safety Standards. *J. Am. Vet. Med. Assoc.*, vol. 159, no. 11, Dec. 1, 1971, pp. 1462-1469.
25. Powers, E. M.; Ay, C. C.; Eckfeldt, G. A.; and Rowley, D. B. : Modification of the American Public Health Association Procedure for Counting Yeast and Mold in Cottage Cheese. *Appl. Microbiol.*, vol. 21, no. 1, Jan. 1971, pp. 155-156.
26. Shahidi, Syed A.; and Ferguson, Alphonza R. : New Quantitative, Qualitative, and Confirmatory Media for Rapid Analysis of Food for *Clostridium perfringens*. *Appl. Microbiol.*, vol. 21, no. 3, Mar. 1971, pp. 500-506.

BIBLIOGRAPHY

- Adams, Carsbie C.: Nutrition in Space Flight. Missiles and Rockets, vol. II, no. 11, Nov. 1957, pp. 105-107.
- Bowman, Norman J.: The Food and Atmosphere Control Problem on Space Vessels. Part II - The Use of Algae for Food and Atmosphere Control. J. Brit. Interplanet. Soc., vol. 12, no. 4, July 1953, pp. 159-167.
- Brockmann, M. C.; Henick, A. S.; Kurtz, G. W.; and Tischer, R. G.: Closed Cycle Biological Systems for Space Feeding. Part II - System 3. Food Technol., vol. 12, no. 9, Sept. 1958, pp. 454-458.
- Bychkov, V. P.: Influence of a Diet Consisting of Dehydrated Products on the Functional State of the Human Organism. Environmental Space Sciences, vol. 3, no. 4, July-Aug. 1969, pp. 261-266.
- Bychkov, V. P.: Metabolic Characteristics of Humans Maintained on a Diet of Dehydrated Foods for 120 Days. Environmental Space Sciences, vol. 3, no. 1, Jan.-Feb. 1969, pp. 73-76.
- Chichester, C. O.: Food Technological Problems in Adverse Environments. Federation Proc., vol. 22, Nov.-Dec. 1963, pp. 1447-1450.
- Clamann, Hans G.: Some Metabolic Problems of Space Flight. Federation Proc., vol. 18, no. 4, Dec. 1959, pp. 1249-1255.
- Cooke, Julian P.; and Heidelbaugh, Norman D.: Rapid Decompression and Exposure of Fresh Foods to Near Vacuum Conditions. Rept. SAM-TR-65-321, U.S. Air Force School of Aerospace Medicine, 1966.
- Dymsza, H. A.; Stoewsand, G. S.; Donovan, Patricia; Barrett, F. F.; and Lachance, P. A.: Development of Nutrient-Defined Formula Diets for Space Feeding. Food Technol., vol. 20, no. 10, Oct. 1966, pp. 1349-1352.
- Finkelstein, Beatrice: Feeding Crews in Air Vehicles of the Future. Food Technol., vol. 12, no. 9, Sept. 1958, pp. 445-448.
- Finkelstein, Beatrice: Nutrition Research for the Space Traveler. J. Am. Dietet. Assoc., vol. 36, no. 4, Apr. 1960, pp. 313-317.
- Finkelstein, Beatrice; and McGhee, Bernice: Liquid Diets for Use in High-Altitude, High-Performance Vehicles. WADC Tech. Rept. 59-32, Wright Air Development Center, Wright-Patterson Air Force Base, Ohio, 1959.
- Finkelstein, Beatrice; and Taylor, Albert A.: Food, Nutrition and the Space Traveler. Am. J. Clin. Nutr., vol. 8, no. 6, Nov.-Dec. 1960, pp. 793-800.

- Flentge, Robert L.; and Bustead, Ronald L.: Manufacturing Requirements of Food for Aerospace Feeding. Rept. SAM-TR-70-23, U.S. Air Force School of Aerospace Medicine, 1970.
- Gaume, James G.: Nutrition in Space Operations. Food Technol., vol. 12, no. 9, Sept. 1958, pp. 433-435.
- Hanson, S. W. F.: Some Observations on the Problems of Space Feeding. Food Technol., vol. 12, no. 9, Sept. 1958, pp. 430-432.
- Harper, Alfred E.: Discussion: Proteins in Space Nutrition. Conference on Nutrition in Space and Related Waste Problems. NASA SP-70, 1964, pp. 143-145.
- Heidelbaugh, Norman D.: Influence of the Package on Changes in Stored Heat-Processed Foods. M. S. Thesis, Massachusetts Institute of Technology, 1963.
- Heidelbaugh, Norman D.; and Rosenbusch, Marvin A.: A Method to Manufacture Pelletized Formula Foods in Small Quantities. Rept. SAM-TR-67-75, U.S. Air Force School of Aerospace Medicine, 1967.
- Heidelbaugh, Norman D.; Vanderveen, John E.; and Iger, Howard G.: Development and Evaluation of a Simplified Formula Food for Aerospace Feeding Systems. Aerospace Med., vol. 39, no. 1, Jan. 1968, pp. 38-43.
- Heidelbaugh, Norman D.; Vanderveen, John E.; Klicka, Mary V.; and O'Hara, May J.: Study of Man During a 56-Day Exposure to an Oxygen-Helium Atmosphere at 258 mm Hg Total Pressure: Part VIII - Observations on Feeding Bite-Size Foods. Aerospace Med., vol. 37, no. 6, June 1966, pp. 583-590.
- Hewitt, Eric J.: All-Purpose Matrix for Molded Food Bars. Rept. TR-FD-14, U.S. Army Natick Laboratories, Natick, Mass., 1965.
- Hodgson, James G.; and Tischer, Robert G.: Space Feeding Problems: A Bibliography. Food Technol., vol. 12, no. 9, Sept. 1958, pp. 459-463.
- Hollender, Herbert A.: Development of Food Items to Meet Air Force Requirements for Space Travel. Rept. AMRL-TR-64-38, Aerospace Medical Research Laboratories, Wright-Patterson Air Force Base, Ohio, 1964.
- Hollender, Herbert A.; and Klicka, Mary: Development of Dehydrated and Bite-Size Food Items. Rept. AMRL-TR-65-160, Aerospace Medical Research Laboratories, Wright-Patterson Air Force Base, Ohio, 1965.
- Klicka, Mary V.: Development of Space Foods. J. Am. Dietet. Assoc., vol. 44, no. 5, May 1964, pp. 358-361.
- Klicka, Mary V.; Hollender, H. A.; and Lachance, P. A.: Foods for Astronauts. J. Am. Dietet. Assoc., vol. 51, no. 2, Sept. 1967, pp. 238-245.

- Lachance, Paul A. : Nutrition and Stresses of Short Term Space Flight. Conference on Nutrition in Space and Related Waste Problems. NASA SP-70, 1964, pp. 71-78.
- Lachance, Paul A. ; and Vanderveen, John E. : Problems in Space Foods and Nutrition: Foods for Extended Space Travel and Habitation. Food Technol., vol. 17, no. 5, May 1963, pp. 567-572.
- Mayo, Alfred M. : Some Survival Aspects of Space Travel. J. Aviation Med., vol. 28, no. 5, Oct. 1957, pp. 498-503.
- Michel, Edward L. : Preparation, Handling, and Storage of Foods for Present Space Projects. Conference on Nutrition in Space and Related Waste Problems. NASA SP-70, 1964, pp. 57-63.
- Nanz, Robert A. ; Michel, Edward L. ; and Lachance, Paul A. : Evolution of Space Feeding Concepts During the Mercury and Gemini Space Programs. Food Technol., vol. 21, no. 12, Dec. 1967, pp. 1596-1602.
- Newlin, Harry E. ; and Morris, E. R. : Development of Food Bars Employing Edible Structural Agents. Rept. TR-FD-20, U.S. Army Natick Laboratories, Natick, Mass., 1965.
- O'Hara, May J. ; Chapin, Roy E. ; Heidelbaugh, Norman D. ; and Vanderveen, John E. : Aerospace Feeding: Acceptability of Bite-Size and Dehydrated Foods. J. Am. Dietet. Assoc., vol. 51, no. 2, Sept. 1967, pp. 246-250.
- Sarett, Herbert P. : Use of Formula Diets. Conference on Nutrition in Space and Related Waste Problems. NASA SP-70, 1964, pp. 353-361.
- Schoman, C. M., Jr. : Food Engineering for Atomic Submarines. Food Technol., vol. 13, no. 11, Nov. 1959, pp. 615-620.
- Scrimshaw, Nevin S. ; Johnson, Robert E. ; and Davidson, Charles S. : Panel Discussion. Conference on Nutrition in Space and Related Waste Problems. NASA SP-70, 1964, pp. 367-370.
- Senter, R. J. : Research on the Acceptability of Precooked Dehydrated Foods During Confinement. Rept. AMRL-TDR-63-9, Aerospace Medical Research Laboratories, Wright-Patterson Air Force Base, Ohio, 1963.
- Simons, David G. : Nutrition in Space Flight: Balloon Flight Experience. Food Technol., vol. 12, no. 9, Sept. 1958, pp. 436-441.
- Simons, David G. : Pilot Reactions During "Manhigh II" Balloon Flight. J. Aviation Med., vol. 29, no. 1, Jan. 1958, pp. 1-14.
- Smith, K. J. ; Speckmann, E. W. ; George, Marilyn E. ; Homer, G. M. ; and Dunco, D. Wiltsie : Biochemical and Physiological Evaluation of Human Subjects Wearing Pressure Suits Under Simulated Aerospace Conditions. Rept. AMRL-TR-65-147, Aerospace Medical Research Laboratories, Wright-Patterson Air Force Base, Ohio, 1965.

- Smith, K. J.; Speckmann, E. W.; Lachance, Paul A.; and Dunco, Dorothea W.:
Nutritional Evaluation of a Precooked Dehydrated Diet for Possible Use in Aerospace
Systems. Food Technol., vol. 20, no. 10, Oct. 1966, pp. 1341-1345.
- Smith, Malcolm: The Apollo Food Program. Aerospace Food Technology.
NASA SP-202, 1970, pp. 5-13.
- Smith, Malcolm C., Jr.; Huber, Clayton S.; and Heidelbaugh, Norman D.: Apollo 14
Food System. Aerospace Med., vol. 42, no. 11, Nov. 1971, pp. 1185-1192.
- Speckmann, E. W.; Smith, K. J.; Vanderveen, J. E.; Homer, G. M.; and Dunco,
D. Wiltsie: Nutritional Acceptability of a Dehydrated Diet. Aerospace Med.,
vol. 36, no. 3, Mar. 1965, pp. 256-260.
- Taylor, Albert A.: Present Capabilities and Future Needs for Space Feeding. Food
Technol., vol. 12, no. 9, Sept. 1958, pp. 442-444.
- Vanderveen, John E.; Heidelbaugh, Norman D.; and O'Hara, May J.: Study of Man
During a 56-Day Exposure to an Oxygen-Helium Atmosphere at 258 mm Hg Total
Pressure: Part IX - Nutritional Evaluation of Feeding Bite-Size Foods. Aerospace
Med., vol. 37, no. 6, June 1966, pp. 591-594.
- Vinograd, S. P.: Nutritional Trends in Future Manned Space Flights. Conference on
Nutrition in Space and Related Waste Problems. NASA SP-70, 1964, pp. 17-21.
- Winitz, Milton; Graff, Jack; Gallagher, Neil; Narkin, Anthony; and Seedman,
Daniel A.: Evaluation of Chemical Diets as Nutrition for Man-In-Space. Nature,
vol. 205, no. 4973, Feb. 20, 1965, pp. 741-743.

APPENDIX
VARIOUS APERTURE CONCEPTS FOR THE
REHYDRATABLE FOOD PACKAGE

Some of the aperture concepts investigated for use in the rehydratable-food package are as follows.

1. Cone apertures
 - a. One-piece plastic-film cone (fig. 21)
 - b. Sponge-lined plastic-film cone (fig. 22)
 - c. Double-plastic-film cone (fig. 23)
 - d. Sponge-lined double-plastic-film cone (fig. 24)
 - e. Reversing one-piece plastic-film cone (fig. 25)
 - f. One-piece plastic-film cone for spade adapter (fig. 26)
2. Poppet-valve apertures
 - a. Spring loaded
 - (1) Compression spring (fig. 27)
 - (2) Conical spring (fig. 28)
 - (3) Leaf spring (fig. 29)
 - b. Sponge loaded (fig. 30)
3. Plug-valve apertures
 - a. Spring loaded
 - (1) Conical spring (fig. 31)
 - (2) Leaf spring (fig. 32)
 - b. Elastomer loaded (fig. 33)
 - c. Elastomer loaded, with flexible probe connection (fig. 34)

4. Sponge apertures
 - a. Rectangular, axial insertion (fig. 35)
 - b. Rectangular, perpendicular insertion (fig. 36)
 - c. Cylindrical (fig. 37)
 - d. Sponge for needle adapter (fig. 38)
5. Silastic-bead aperture (fig. 39)
6. Rigid-diaphragm aperture (fig. 40)
7. Slip-rubber aperture (fig. 41)
8. Elastic-diaphragm aperture (fig. 42)
9. Pierced-diaphragm aperture (fig. 43)
10. Flapper-valve aperture (fig. 44)
11. Combination closure (fig. 45)

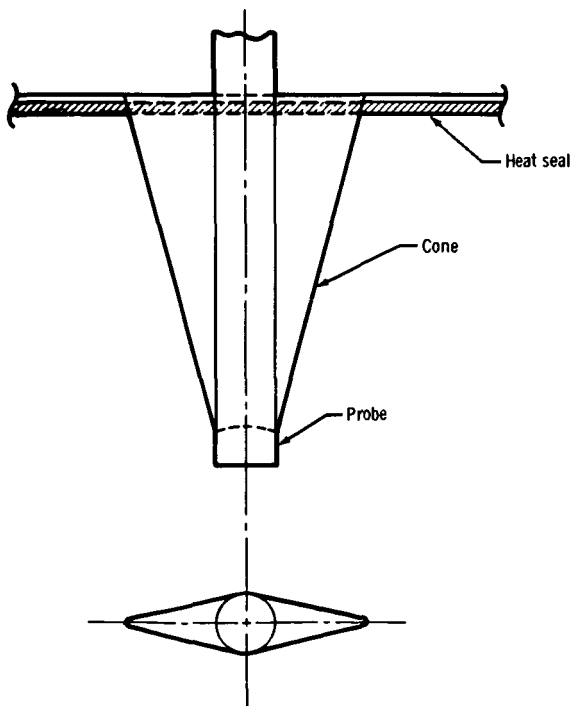

Figure 21. - One-piece plastic-film cone aperture.

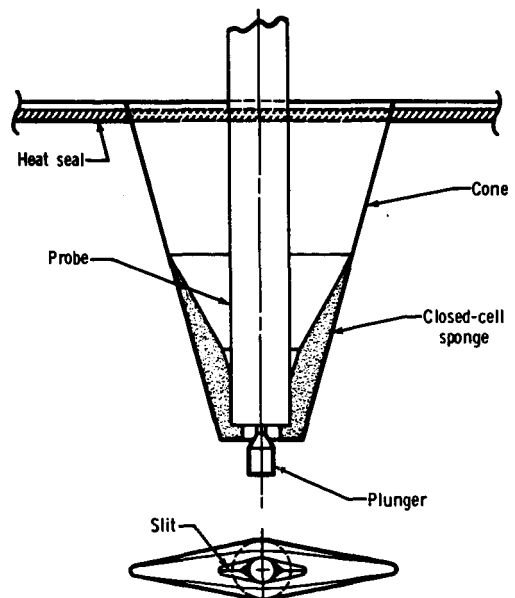

Figure 22. - Sponge-lined (closed-cell sponge) plastic-film cone aperture.

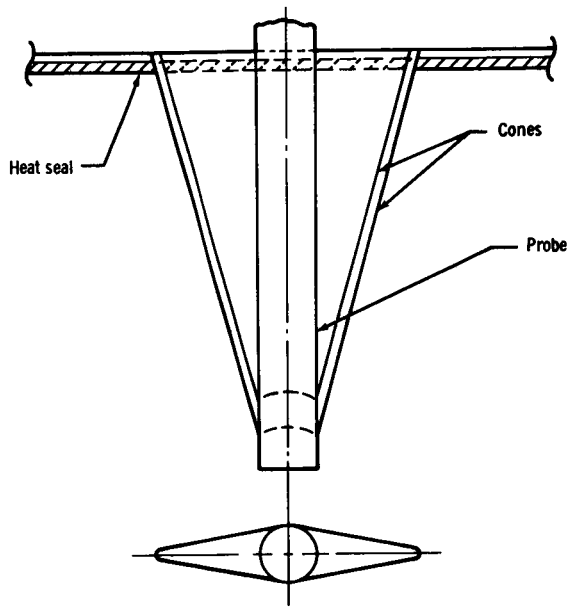

Figure 23.- Double-plastic-film cone aperture.

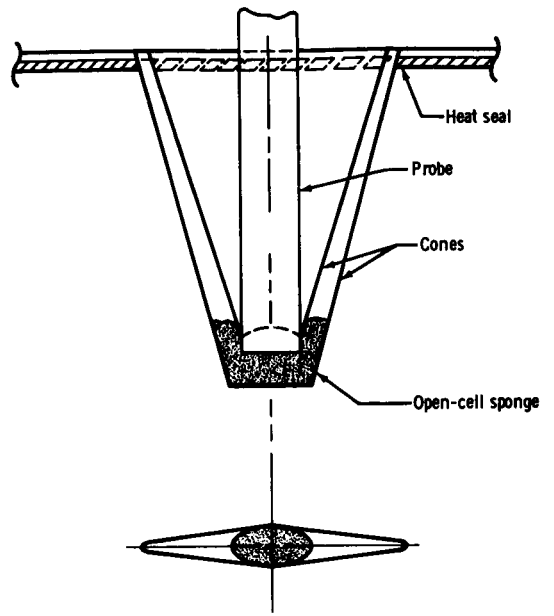

Figure 24.- Sponge-lined (open-cell sponge) double-plastic-film cone aperture.

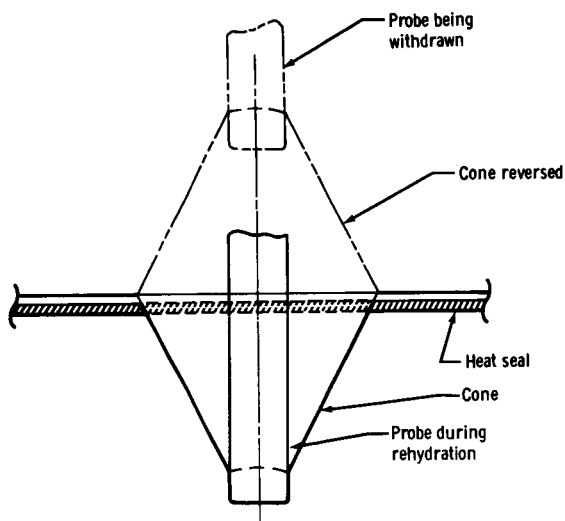

Figure 25.- One-piece plastic-film cone aperture (reversing).

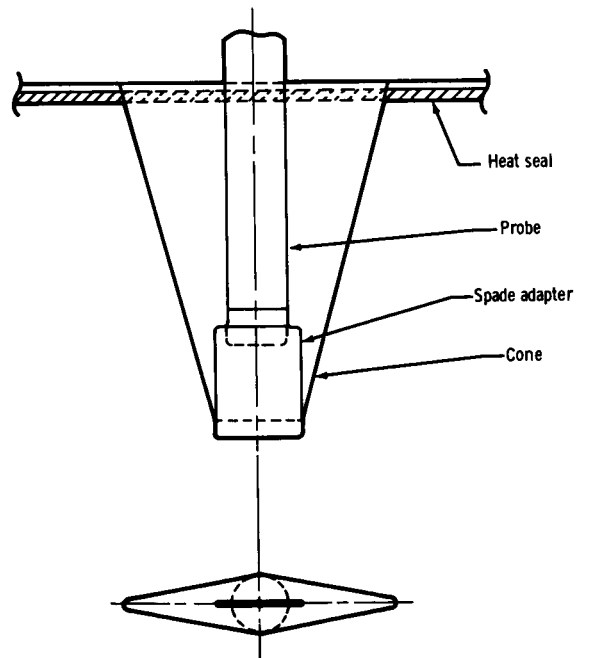

Figure 26.- One-piece plastic-film cone aperture for spade adapter.

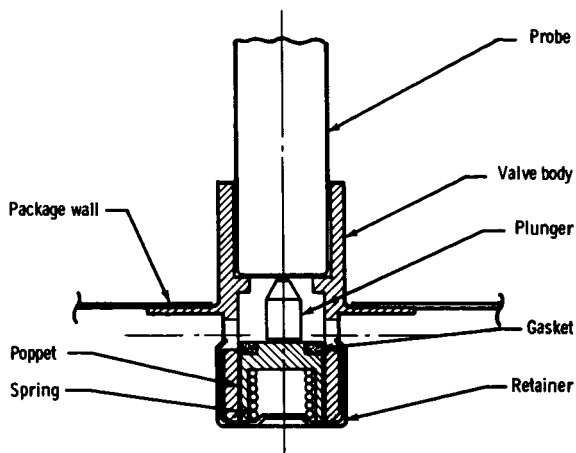

Figure 27. - Compression-spring-loaded poppet-valve aperture.

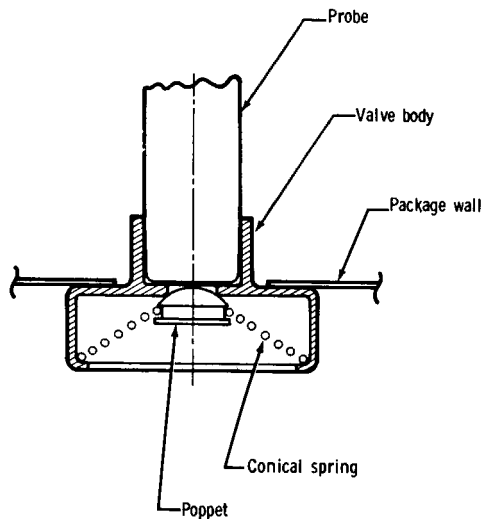

Figure 28. - Conical-spring-loaded poppet-valve aperture.

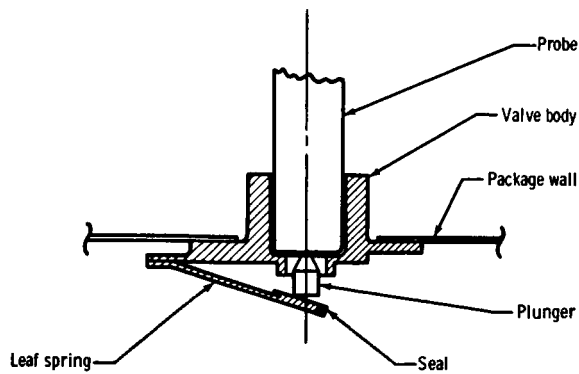

Figure 29. - Leaf-spring-loaded poppet-valve aperture.

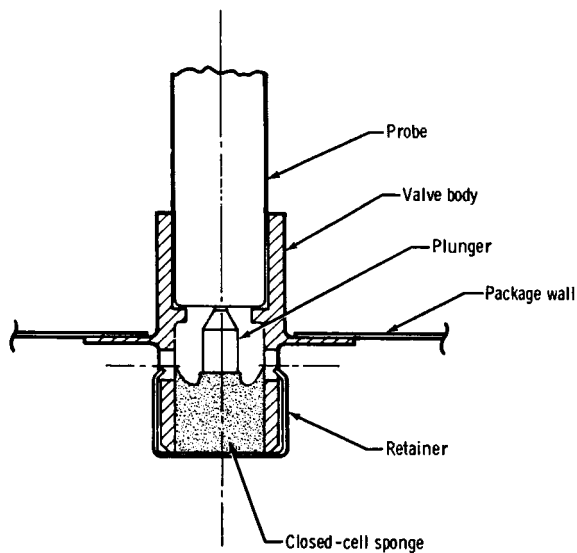

Figure 30. - Sponge-loaded (closed-cell sponge) poppet-valve aperture.

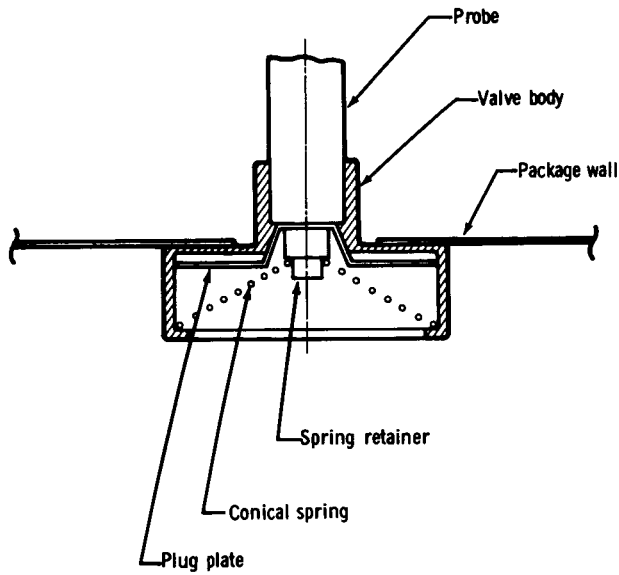

Figure 31. - Conical-spring-loaded plug-valve aperture.

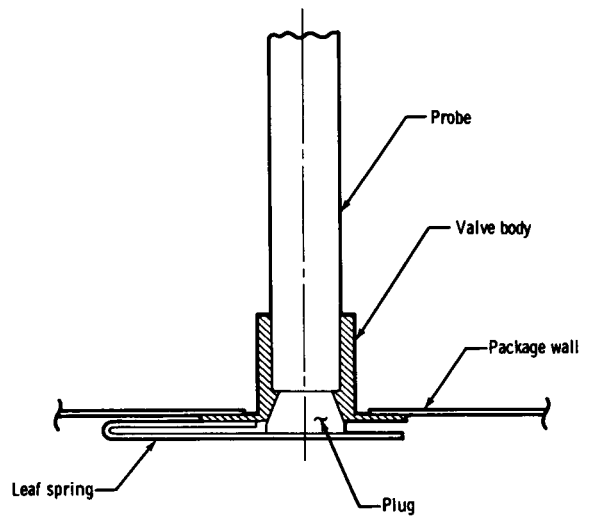

Figure 32. - Leaf-spring-loaded plug-valve aperture.

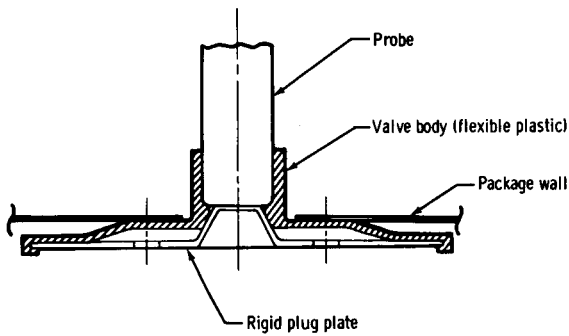

Figure 33. - Elastomer-loaded plug-valve aperture.

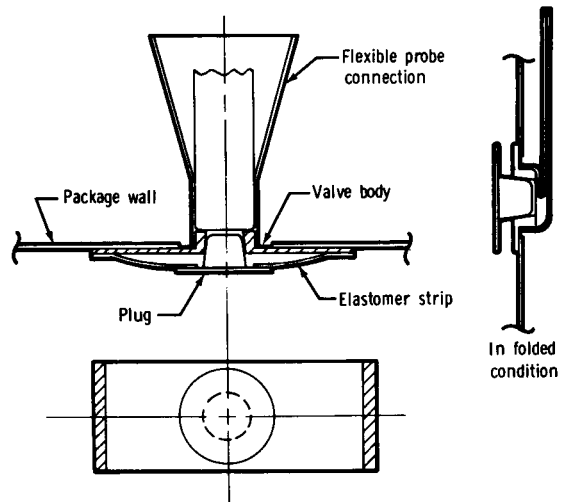

Figure 34. - Elastomer-loaded plug-valve aperture with flexible probe connection.

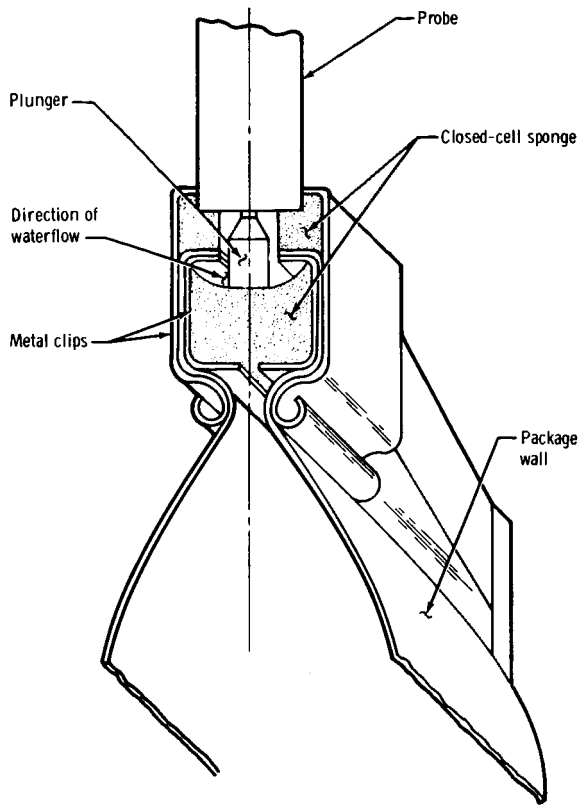

Figure 35.- Rectangular sponge (closed-cell sponge) aperture, axial insertion.

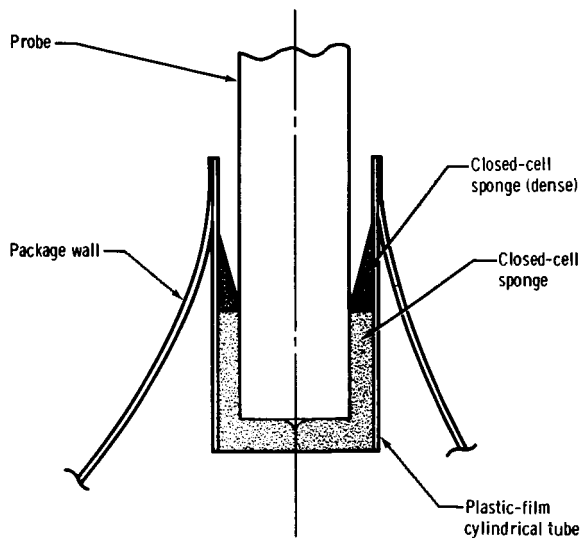

Figure 37.- Cylindrical sponge (closed-cell sponge) aperture.

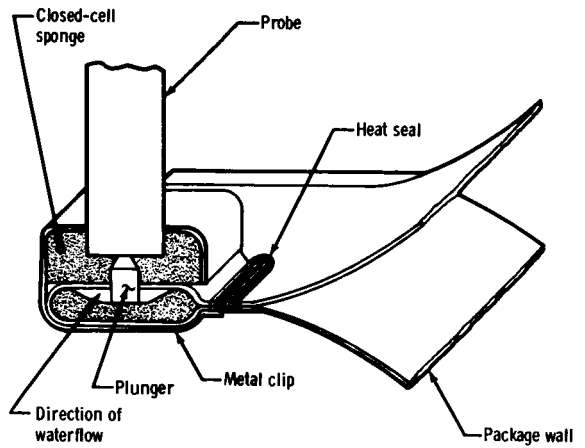

Figure 36.- Rectangular sponge (closed-cell sponge) aperture, perpendicular insertion.

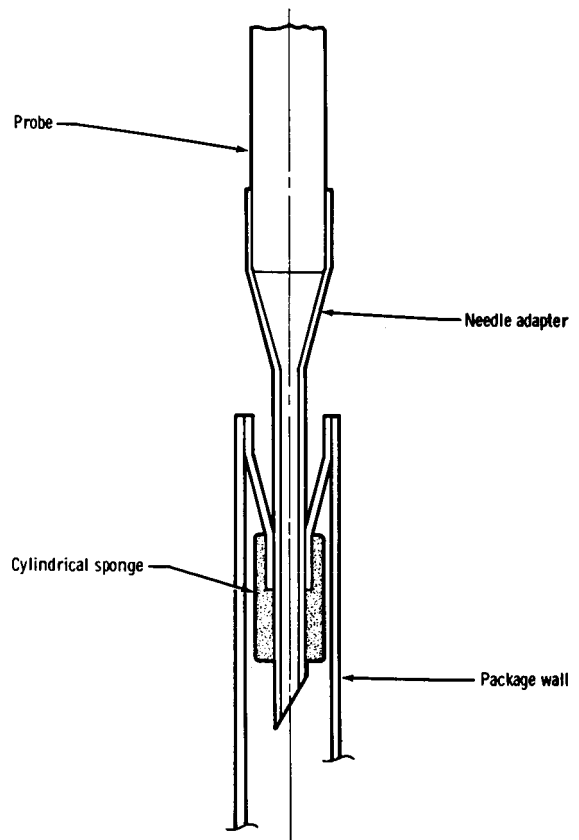

Figure 38.- Sponge aperture for needle adapter.

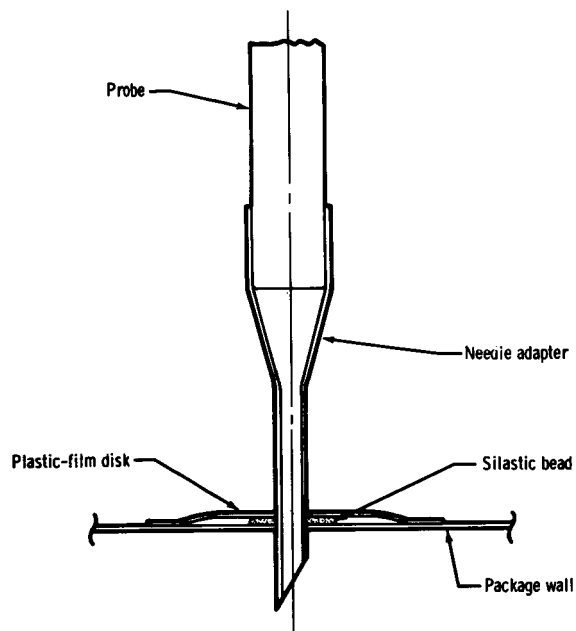
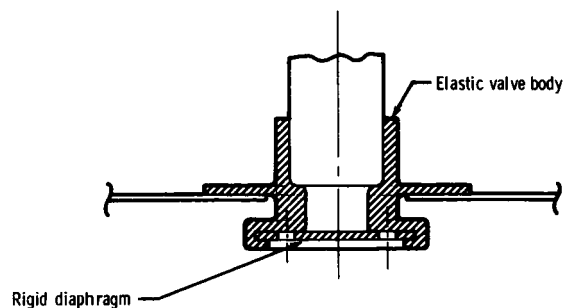
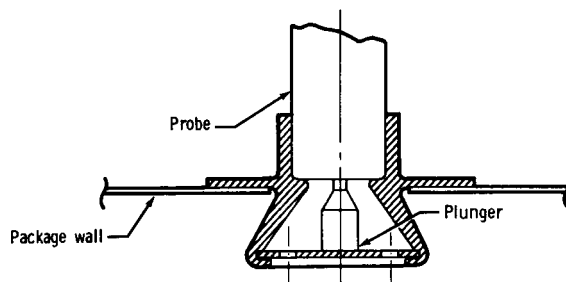

Figure 39. - Silastic-bead aperture.



(a) Aperture closed.



(b) Aperture open.

Figure 40. - Rigid-diaphragm aperture.

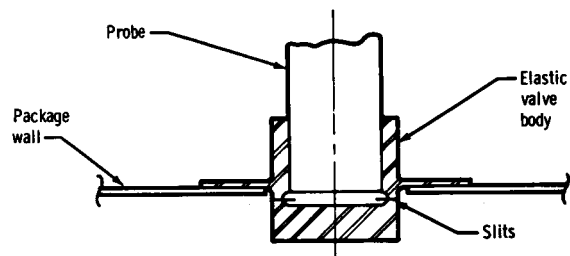

(a) Aperture closed.

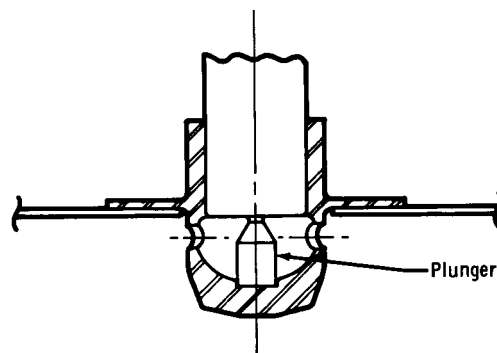

(b) Aperture open.

Figure 41. - Slit-rubber aperture.

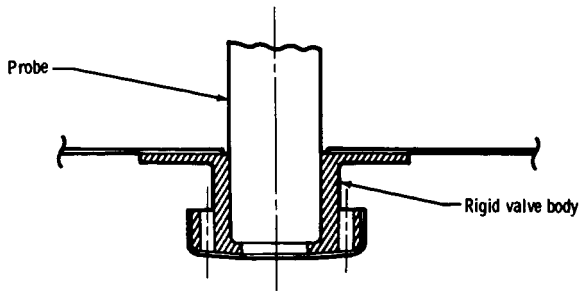

(a) Aperture closed.

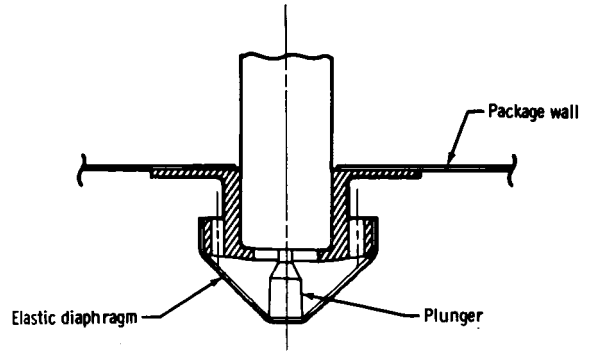

(b) Aperture open.

Figure 42.- Elastic-diaphragm aperture.

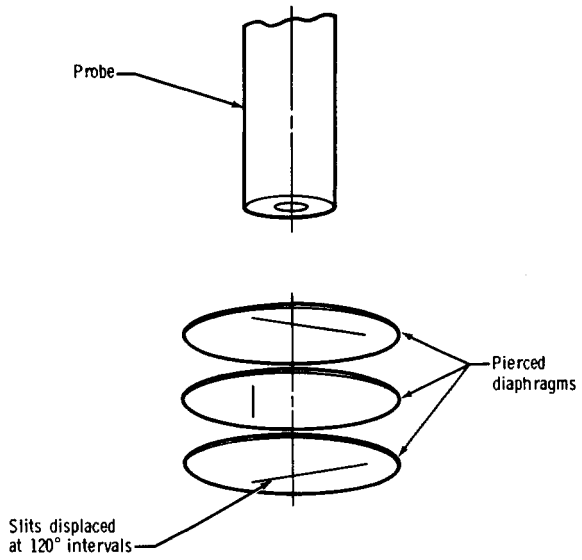

(a) Aperture structure.

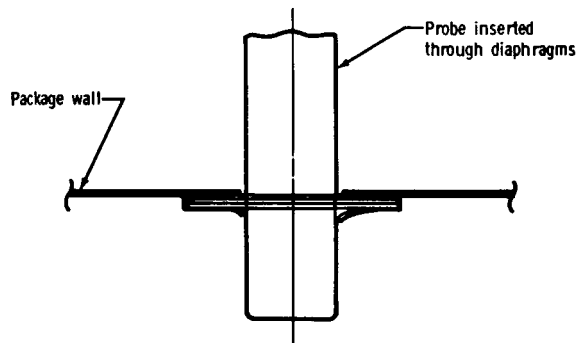

(b) Probe inserted.

Figure 43.- Pierced-diaphragm aperture.

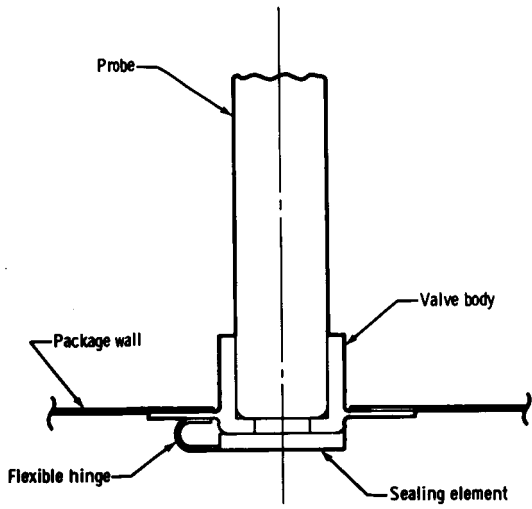

Figure 44.- Flapper-valve aperture.

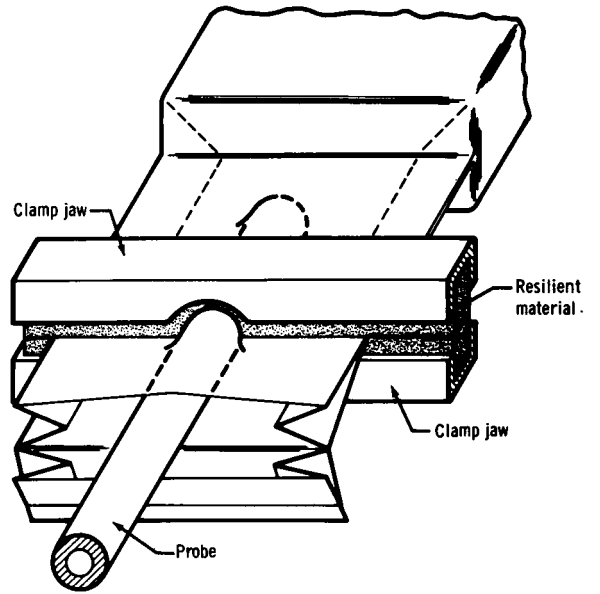

Figure 45.- Combination closure.