



United States Forest
Department Service
of
Agriculture

Washington Office

14th & Independence SW
P.O. Box 96090
Washington, DC 20090-6090

File Code: 1760-1

Date: July 15, 2002

Route To: (5100/1700)

Subject: "Access Guide for Incident Facilities"

To: Regional Foresters

The Forest Service has been working to improve accessibility at fire incident facilities so that all employees who want to be involved are able to support our wildland fire suppression mission. Much can be done to accommodate individuals with disabilities while also improving conditions for all employees.

The enclosed guidebook, Access Guide for Incident Facilities provides a common sense approach to reasonable access at incident facilities. It is recognized that not every incident facility location will lend itself to accessible opportunities, i.e., wilderness spike camps will not be accessible. However, I ask that each incident facility location be evaluated for the potential for accessibility.

The Incident Commander and the Forest Supervisor have the responsibility for providing reasonable access to the temporary living space and work opportunity for all employees, including employees with disabilities. When the need to provide accessibility is identified by an employee, we must provide the necessary accommodations when the location will lend itself to accessible opportunities. We are to ensure the highest level of accessibility at incident facilities while continuing to hold safety as our primary focus for all employees.

Forests are encouraged to assess the incident facility locations that are used repeatedly to determine opportunities for accessibility. Access Guide for Incident Facilities includes a checklist for identifying path of travel, facility location and items for logistics personnel to consider when setting up an incident facility. It also contains an action plan that can be used for flat, urban settings such as schoolyards, fair grounds, etc., that are utilized each summer.

It is our job to support the fire program needs and encourage all employees to actively participate in fire suppression. Many people with disabilities have skills in the areas that are needed including finance, plans, dispatch, demob, GIS, security and training. By providing accessible facilities, all employees who are interested will be able to contribute their valuable skills.

The Access Guide for Incident Facilities provides the planning and organization guidance needed. By integrating these steps into incident command posts, the Forest Service will ensure our ability to utilize our most skilled employees, whether or not that employee has a disability. I strongly endorse this document and ask that all units adopt this process as a standard operating procedure.

/S/ DALE N. BOSWORTH



Caring for the Land and Serving People



Printed on Recycled Paper

United States
Department of
Agriculture

Forest Service

Technology &
Development
Program

5100—Fire Management
June 2002
0251 1801—SDTDC



Access Guide for Incident Facilities

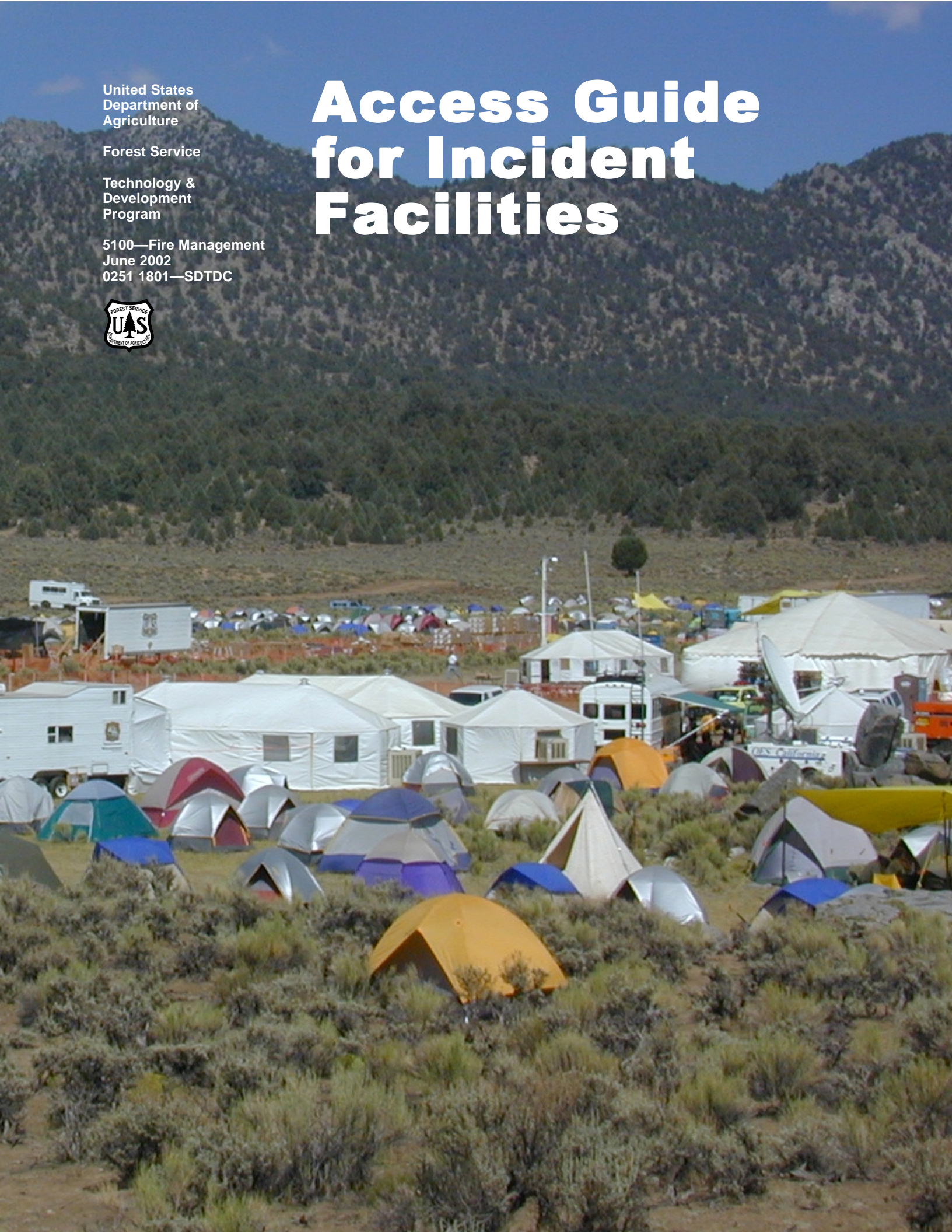

Access Guide for Incident Facilities

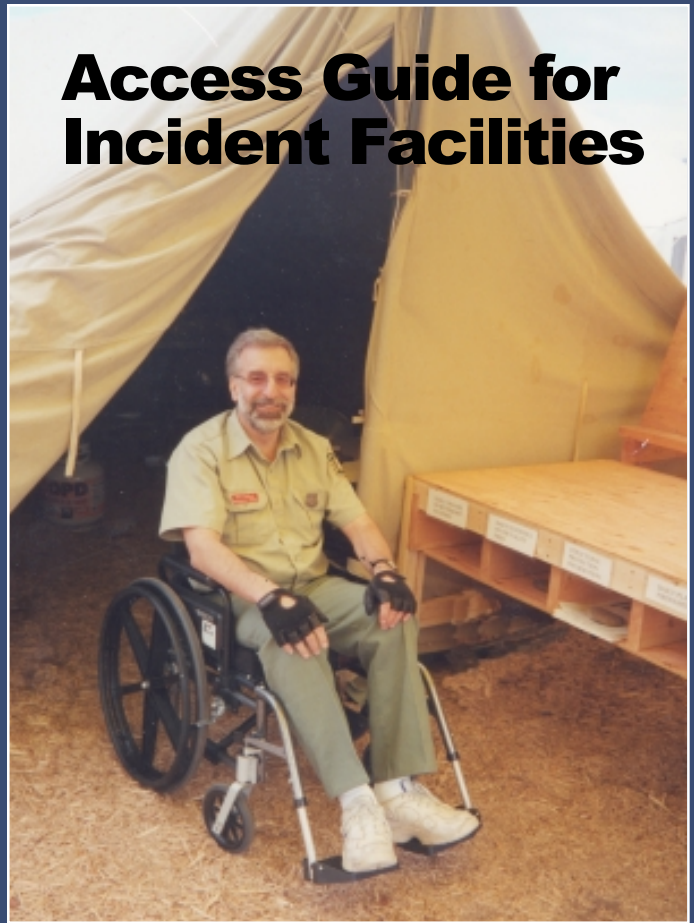

USDA Forest Service
Technology & Development Center
San Dimas, CA

June 2002

Information contained in this document has been developed for the guidance of employees of the Forest Service, USDA, its contractors, and cooperating Federal and state agencies. The Department of Agriculture assumes no responsibility for the interpretation or use of this information by other than its own employees. The use of trade, firm, or corporation names is for the information and convenience of the reader. Such use does not constitute an official evaluation, conclusion, recommendation, endorsement, or approval of any product or service to the exclusion of others that may be suitable.

The U.S. Department of Agriculture (USDA) prohibits discrimination in all its programs and activities on the basis of race, color, national origin, sex, religion, age, disability, political beliefs, sexual orientation, or marital or family status. (Not all prohibited bases apply to all programs.) Persons with disabilities who require alternative means for communication of program information (Braille, large print, audiotape, etc.) should contact USDA's TARGET Center at (202) 720-2600 (voice and TDD).

To file a complaint of discrimination, write USDA, Director, Office of Civil Rights, Room 326-W, Whitten Building, 1400 Independence Avenue SW, Washington, DC 20250-9410, or call (202) 720-5964 (voice and TDD). USDA is an equal opportunity provider and employer.

Acknowledgements 1

Chapter 1—Purpose and Need 3

Chapter 2—Use of the Access Guide for Incident Facilities 5

Chapter 3—Incident Facility Elements 7

Chapter 4—Planning for Emergencies 11

Chapter 5—Accessibility Standards 13

Appendix A—Incident Facility Accessibility Checklist 15

Appendix B—Incident Facility Accessibility Action Plan 17

Request for Comments 21

The following committee developed the *Access Guide for Incident Facilities*:

Norm Carpenter
Sequoia NF, Pacific Southwest Region

Paula Martinez
Los Padres NF, Pacific Southwest Region

Kevin Kennedy
Willamette NF, Pacific Northwest Region

Mark Zavala
San Dimas Technology and Development Center,
Washington Office

Dick Reynolds
Sequoia NF, Pacific Southwest Region

Lynn Boone
Regional Office, Pacific Southwest Region

Dale Dague
San Dimas Technology and Development Center,
Washington Office

Purpose and Need

The purpose of the *Access Guide for Incident Facilities* is to provide the following:

1. Greater opportunities for people of all abilities to work within the incident management organization, and
2. A tool to assist incident personnel to establish safe, accessible, temporary incident facilities throughout the Nation.

In 1968 Congress passed the Architectural Barriers Act requiring that all facilities that are built, bought, rented, or leased by Federal agencies must be accessible to people with disabilities. In 1973 Section 504 of the Rehabilitation Act mandated that people with disabilities were to have equal access to the programs and activities funded by Federal agencies and those entities under contract to Federal agencies. The Americans with Disabilities Act (ADA) of 1990 added State and local government services, public transportation, and public accommodations to those entities required to ensure equal opportunities for persons with disabilities to access facilities and to participate in programs and activities.

The U. S. Department of Agriculture (USDA) Forest Service has been instrumental in developing guidelines that integrate the principles of universal design across a variety of settings. The goal is to accommodate the broadest spectrum of people through design that addresses the needs of both the individual and the environment.

This *Access Guide for Incident Facilities* seeks to address the full range of accommodations for employees and visitors within the incident facility. This document is an important milestone in that process; however, the guidelines presented here are subject to change as new information and technology become available. These guidelines are not standards; rather, they are suggestions to assist in establishing accessible incident facilities.

Use of the Access Guide for Incident Facilities

The *Access Guide for Incident Facilities* was developed to help improve working and living conditions at incident command posts (ICPs) and incident bases. It is a national guide, not mandatory direction. Forest and incident management personnel should use this guide when planning and organizing these facilities to help accommodate persons with disabilities. All of the actions in this guide may not be possible in every situation; however, when the need is identified, it is expected that all feasible steps will be taken to overcome obstacles.

Before selecting an ICP and incident base, incident managers should consider the expected fire size and number of personnel. Site selection should consider location of facilities and ease of movement between them. When site choice is limited and may not meet all the needs of varying disabilities and access or accommodation is unreasonable because of environmental and/or physical factors, it should be documented.

The following chapter, Incident Facility Elements, presents recommendations along with photos and diagrams to help incident personnel develop facilities that are reasonably accessible to everyone. These incident facility elements include: signs, parking, paths of travel, restrooms, workspaces, showers/washbasins, dining area, sleeping areas, and common areas. For each of these key facility elements, the chapter identifies and discusses suggestions for improving access for persons with disabilities. When obtaining accessible resources addressed in this publication, use local vendors—through local purchases or incident buying teams and through Emergency Equipment Rental Agreements (EERA)—because these resources are not available through the national contract or cache system.

Appendix A provides an Incident Facility Accessibility Checklist as a working tool to assist incident managers on the ground. The checklist is a condensed version of the incident facility elements and can be used as a handy field reference to help when actually laying out the ICP and incident base facilities.

Appendix B provides an Incident Facility Accessibility Action Plan to help evaluate ICP and incident base locations that are used repeatedly. It is a useful tool for the host unit to document the barriers encountered in each of the key elements and the steps that may be needed in the future to improve accessibility. When the action plan is completed, it should be included in the final fire package and it should be reviewed with the home unit during the closeout process. An action plan can be useful in post incident reviews and pre-attack planning. Appendix B contains a blank action plan and an example from a past incident.

Incident Facility Elements

The following descriptions of incident facility elements help incident personnel develop facilities that are reasonably accessible to everyone.

Signs

Position signs where every person can see them easily. To assist those who are visually impaired, use sharply contrasting colors for text and background and use large, bold lettering.

Parking

Accessible parking spaces should be designated adjacent to accessible paths of travel. Spaces need to be at least 16 feet wide and signed at a height of 6 feet, see figure 1. After locating workspaces, dining area, showers, and sleeping areas, designate parking spaces that are convenient. Parking areas should be level and not exceed a 2 percent slope in any direction.

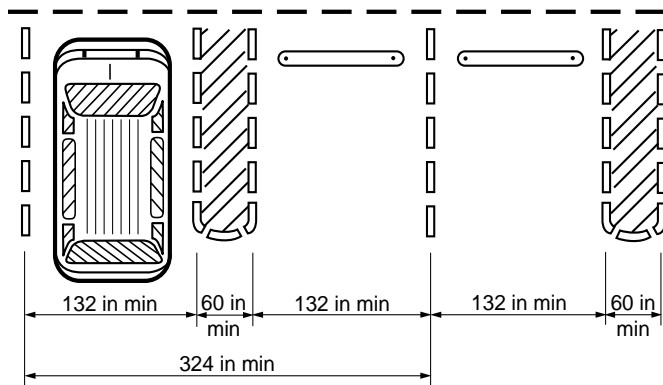

Figure 1—Accessible parking standards.

Paths of Travel

Paths that provide access to facilities and areas of use are among the most critical factors for ensuring accessibility, see figure 2. A sleeping area can be accessible, but if the route to get to it is inaccessible it cannot be used. At least one accessible path should connect all the elements of the site. An accessible path must have a firm, stable surface with good drainage. The following are standards for grade and width of paths:

Path Width	30 to 36 inches (optimum)
Running Grade	5 percent
Maximum Grade	10 percent
Maximum Cross Slope	2 percent
Surface Protrusions	less than 1/2 inch



Figure 2—Paths of travel—a firm and stable surface.

Restrooms (Portable Toilets)

When ordering chemical toilets, ensure that at least one is accessible. A general rule for ordering additional accessible toilets is that 1 in 20 single-user toilets should be accessible, or 1 in 30 toilets depending on facility layout and terrain. Place accessible restrooms along an accessible path of travel and where they are needed most—near parking, workspaces, and sleeping areas, see figure 3.



Figure 3—Accessible toilet.

Workspaces

Workspaces should be at ground level or be accessible by a ramp or a lift. The ground slope must not exceed 2 percent and should be firm and stable.

If tents are used, the doorways must be at least 30 inches wide and without steps or lips. When ordering tents, double doors are preferred over tents that have a single, narrow doorway, see figure 4. It may be possible to remove one of the wall panels from the tent and place a small wedge ramp over the frame at the bottom so that a wheelchair or scooter can enter the work area.



Figure 4—Double door tent.

Workstations must be at least 30 inches wide and 29 to 32 inches high in an area that allows for easy access, see figure 5. It is important to ensure that accessible workstations are integrated with the rest of the staff workstations. Employees are still responsible for requesting reasonable accommodations unique to their disability. Incident managers may be asked to respond to a request and will have to determine whether the request can be accommodated. Small ramps over doorway lips, hardened floor at a sleeping area, a special all-terrain wheelchair for rough surfaces, loud speakers for briefings, and telephone equipment (TTY and large-numbered keypad) are commonly requested.

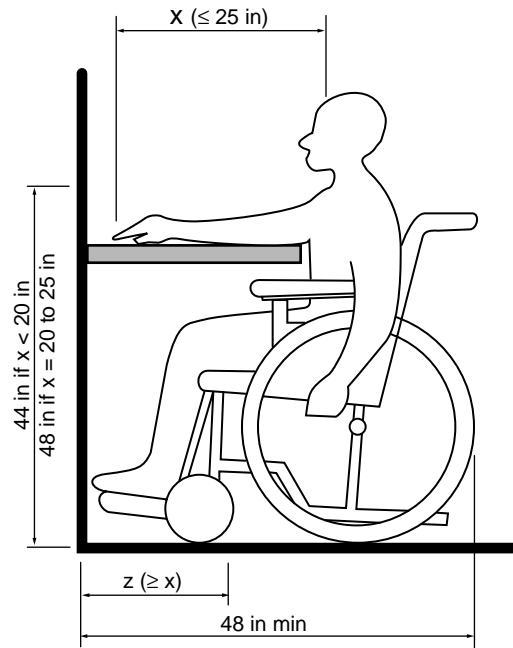

Figure 5—Accessible workstation standards.

Showers/Washbasins

At least one shower should be fully accessible and be located along an accessible path, see figure 6. No less than one washbasin should have knee clearance of 29 inches above the ground. Faucets must be operable by one hand and without tight grasping or pinching. Towels and soap must be readily available and within reach. When accessible shower units are not readily available, special arrangements may be needed for showers outside the incident facility at a location such as a local ranger station, motel, or school.



Figure 6—Accessible shower unit.

Dining Area

An accessible path to the dining area is preferred. If a path of travel cannot be achieved, consider access by vehicle.

The food serving area should be at ground level if possible. It is best to have the food unit leader work with the contractor and have the staff assist with any special needs required. When it is impossible to make the area fully accessible, good customer service can fill the gap.

Eating areas with accessible tables, at least 30 inches wide and 29 to 32 inches high, should be placed close to the opening of the mess tent to avoid congestion in the aisle, see figure 7.



Figure 7—Open and accessible seating area.

Sleeping Areas

When locating sleeping areas, look for ground that is flat and free from potholes and rocks, and that allows space for a minimum 36-inch separation between tents, see figure 8. Like all other areas, the path of travel rule applies. Provide assistance when needed to set up tents and carry gear to the sleeping area.

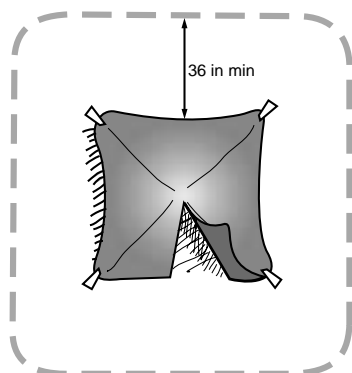

Figure 8—Minimum tent separation distance.

Common Areas

Placement of the common facilities is important. Thoroughly review all aspects of the incident facility layout in common areas, such as banks of telephones, garbage receptacles, check-in areas, demob location, medical unit, time unit, human resource specialist, and briefing and planning areas, see figure 9.

Because it is more difficult to relocate after the fact, good initial planning is essential. It is important to incorporate universal design in planning the entire incident facility.



Figure 9—Incident base, Manter Incident.

Other Considerations (Sight/Hearing/Other Disabilities)

To aid employees with hearing impairments, public address systems located in camp and briefing areas should afford sufficient volume and clarity and loud-speakers should be located strategically. Figure 10 shows the international symbol for an assistive listening device. Presenters during meetings and briefings should be encouraged to speak loudly, enunciate clearly, and be concise.



Figure 10—International symbol for an assistive listening device.

Cooperation and coordination with contractors who provide shower and kitchen equipment are important when service animals are in ICP and incident base facilities, see figure 11.



Figure 11—Service animals may need consideration.

Planning for Emergencies

When planning for an accessible ICP and incident base, it is important to consider the safety of all assigned personnel during emergency situations. During the incident, logistics personnel and others who share responsibility with the command staff and general staff for planning and implementing an evacuation must be aware of any persons needing assistance in the event of an evacuation.

To provide for safety in an emergency, responsible officials should know the type of disability of any employee assigned to their unit. Supervisors share responsibility with all their employees for their individual safety, and by providing input during the development of an evacuation plan, any needs for personnel with disabilities can be planned.

When an incident evacuation plan is prepared, give special attention to the following critical areas when planning for persons with disabilities. **Pre-event Preparation**, should reflect the needs of persons with disabilities and resulting preparations should be communicated to appropriate supervisory personnel. Consider the positioning of vehicles and their readiness for potential evacuation. When establishing **Trigger Points**, address potential special needs for persons with disabilities and allow adequate leadtime for evacuating those persons.

When establishing **Levels of Alert**, consider designating a specific level at which incident personnel needing assistance should evacuate. Make certain the **Alerting Procedure** is capable of reaching all incident personnel, including those persons with sight and hearing limitations, and during nighttime hours. Finally, when establishing the **Evacuation Procedures**, consider potential special vehicle requirements and make sure the gathering point also provides access for persons with disabilities.

Accessibility Standards

Additional information on accessibility standards is available from the following sources:

Access Board
1331 F Street NW, Suite 1000
Washington, DC 20004-1111
Phone: 202-272-0080
Fax: 202-272-0081
TTY: 202-272-0082
www.access-board.gov

- Uniform Federal Accessibility Standard, Federal Standard-795. April 1988. Free.
- Americans with Disabilities Act Accessibility Guidelines, Federal Register-Vol. 56, No. 144. July 1991. Free.
- Forest Service Outdoor Recreation Accessibility Guidelines. Washington Office Web site at www.fs.fed.us/recreation/programs/accessibility .

Incident Facilities Accessibility Checklist

Signs

Y/N

- Are sign colors sharply contrasted?
- Can signs be seen easily by every person?
- Is text large with bold letters?

Parking

Y/N

- Is there at least one parking space on flat terrain (2 percent or less slope) with stable, firm surfacing that is at least 16 feet wide and 20 feet deep?
- Are accessible parking spaces identified and signed?
- Are accessible parking spaces adjacent to accessible paths of travel?

Paths of Travel

Y/N

- Is there at least one accessible path of travel between an accessible parking space and incident facilities?
- Is the path at least 30 to 36 inches wide with 5 percent or less running grade and 2 percent sideslope?
- Is the path surface stable and firm?
- Are surface protrusions less than 1/2 inch?

Restrooms (Portable Toilets)

Y/N

- Is the restroom located on an accessible path of travel?
- Is there at least one accessible unit per 20 to 30 single-user units or one unit at the incident?
- Are restrooms located adjacent to parking, workspaces, and sleeping areas?

Workspaces

Y/N

- Are workspaces located on accessible paths of travel?
- Are workspaces available at ground level?
- If the floor is ground surface, is it firm, stable, and level (2 percent maximum slope)?
- If trailers are used, are there ramped entries?
- If no ramps are available, are there steps with uniform treads and risers, curved nosings, and handrails on both sides?

- Are workstations at least 30 inches wide and 29 to 32 inches high in an area that allows for easy access?
- Are workspace entries at least 30 inches wide with jams less than 1/2 inch deep?

Showers/Washbasins

Y/N

- Are showers and washbasins located on an accessible path of travel?
- Is there at least one shower unit with seating, grab bars, and accessible controls?
- Is there at least one washbasin with at least 29 inches of knee clearance?

Dining Area

Y/N

- Is the food service area along an accessible path of travel?
- Is the serving area at ground level and within reach from a seated position?
- Does at least one table have knee clearance of 29 inches minimum and tabletop height of 32 inches maximum?

Sleeping Areas

Y/N

- Are sleeping areas along accessible routes?
- Is the terrain flat (2 percent slope or less) and the surface firm and stable?
- Is there at least 36 inches of free space around the area designated for a tent?

Incident Facilities Accessibility Action Plan

Incident Name: _____
 Agency: _____
 National Forest/Unit: _____
 Location: _____
 Date of Plan: _____

Name(s), Title(s) and Affiliation of Individuals Who Prepared and/or Assisted with Plan Preparation

Name(s) and Title(s) Of Officials Reviewing Plan

Incident Commander: _____
Name/Date

Logistics Chief: _____
Name/Date

Facilities Unit Leader: _____
Name/Date

Forest Supervisor/Agency Administrator: _____
Name/Date

Brief Description of Site: _____

Elements: Signs

Obstacles to Accessibility: _____

Planned Changes: _____

Parking

Obstacles to Accessibility: _____

Planned Changes: _____

Paths of Travel

Obstacles to Accessibility: _____

Planned Changes: _____

Restrooms (Portable Toilets)

Obstacles to Accessibility: _____

Planned Changes: _____

Workspaces

Obstacles to Accessibility: _____

Planned Changes: _____

Sleeping Areas

Obstacles to Accessibility: _____

Planned Changes: _____

Showers/Washbasins

Obstacles to Accessibility: _____

Planned Changes: _____

Common Areas

Obstacles to Accessibility: _____

Planned Changes: _____

Dining Area

Obstacles to Accessibility: _____

Planned Changes: _____

Other Considerations (Sight/Hearing/Other Disabilities)

Obstacles to Accessibility: _____

Planned Changes: _____

**** COMPLETED ****
Incident Facilities Accessibility Action Plan

Incident Name: Big Fire
 Agency: USDA Forest Service
 National Forest: Smokey National Forest
 Location: Private Cattle Ranch
 Date of Plan: July 27, 2000

Name(s), Title(s) and Affiliation of Individuals Who Prepared and/or Assisted with Plan Preparation

Name(s) and Title(s) Of Officials Reviewing Plan

Incident Commander: _____
Name/Date

Logistics Chief: _____
Name/Date

Facilities Unit Leader: _____
Name/Date

Forest Supervisor/Agency Administrator: _____
Name/Date

Brief Description of Site:

Base camp was located on private cattle ranch land. Grasses, star thistle, and various brush species were common in the open areas; sparse oak and conifers surrounded base camp and became sleeping areas for most personnel.

The terrain was gently rolling with many grades nearly level. Drainages throughout the area left short, steep pitches along some of the travelways. With the exception of the drainages, most pedestrian travelways were less than 5 percent grade.

Although the ground surfaces were irregular and often bumpy, most of the eating areas and ICP were level and smooth, without protrusions. The sleeping areas were scattered over several acres within trees where ground surfaces were covered with duff and fallen branches. Clearing places to sleep was easy.

Elements:

Signs

Obstacles to Accessibility: None. Signs were large and clear.

Planned Changes: None.

Parking

Obstacles to Accessibility: Rough, irregular surfaces; no space assigned for accessible parking.

Planned Changes: Identify and sign a space for accessible parking; smooth a 16 by 20 foot site within easy reach of an accessible toilet and the ICP.

Paths of Travel

Obstacles to Accessibility: Some grades over 5 percent; many covered with wood chips within the high-use areas.

Planned Changes: Provide alternate route under 5 percent to primary use areas; use surface matting rather than wood chips along one route.

Restrooms

Obstacles to Accessibility: None for the two provided (one at ICP parking and one at the medical unit).

Planned Changes: None.

Workspaces

Trailers:

Obstacles to Accessibility: Steps with one rail (doors were 32 inches wide when opened); there was adequate space for wheelchair movement.

Planned Changes: Provide a lift or construct ramps with railings on both sides.

Tents:

Obstacles to Accessibility: Thresholds too high upon entry; most had narrow doors (exceptions were communication and medical tent where double doors were provided).

Planned Changes: Provide ramps over the threshold; use double-door tents wherever possible.

Showers/Washbasins

Showers:

Obstacles to Accessibility: Several steps with railings on both sides; narrow doors.

Planned Changes: Provide hotel accommodations rather than attempt to carry someone with mobility impairments into the facility. Long-term change would be to add a requirement for a single accessible shower unit into the national contract.

Washbasins:

Obstacles to Accessibility: Basins too high; no knee clearance; hardware requires twisting to turn on.

Planned Changes: Provide a separate universally designed basin. Long-term change would be to add a requirement for a single accessible washbasin into the national contract.

Dining Area

Obstacles to Accessibility: For first few days, obtaining food required climbing several steps. Surfacing around area and within eating tents was covered with wood chips. A change in caterers during the incident resulted in relocating the food service, making it accessible at ground level; however, the ground surface was covered with wood chips.

Planned Changes: Provide someone to assist anyone unable to climb the steps; apply surface matting to one seating area. Long-term change would be to add the requirement for ground-level food service into the national contract.

Sleeping Areas

Obstacles to Accessibility: Soft, irregular surfaces covered with duff.

Planned Changes: Provide assistance to smooth out an area, remove duff, and harden surface of the site.

Common Areas

Obstacles to Accessibility: Overhanging tree limbs along paths of travel, which visually impaired individuals would not detect.

Planned Changes: Have camp crews brush and remove all low-hanging tree limbs along paths of travel in camp.

Other Considerations (Sight/Hearing/Other Disabilities)

Obstacles to Accessibility: None.

Planned Changes: None. No one in camp requested reasonable accommodations.

ACCESS GUIDE FOR INCIDENT FACILITIES

Request for Comments

Beneficial comments, such as recommendations, additions, deletions, and any pertinent data that may be used in improving this document may be addressed to USDA Forest Service, San Dimas Technology & Development Center, Attn: Fire Program Leader, 444 East Bonita Avenue, San Dimas, CA 91773-3198.

1. How effective or relevant is this guide? _____

2. What would you change to improve this guide? _____

3. What new or innovative ideas do you have? _____

4. Remarks

Name: _____ Phone: _____

Agency: _____

Address: _____

Fold Here

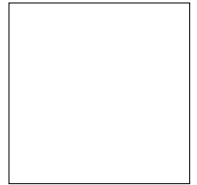

USDA Forest Service
San Dimas Technology & Development Center
Attn: Fire Program Leader
444 East Bonita Avenue
San Dimas, CA 91773-3198

Fold Here