

FAA-E-2772B, August 22, 2006  
SUPERSEDING  
FAA-E-2772A, October 22, 2002  
FAA-E-2772, October 30, 1985



**DEPARTMENT OF TRANSPORTATION**

**FEDERAL AVIATION ADMINISTRATION**

**PERFORMANCE SPECIFICATION**  
**PC BASED**  
**RUNWAY VISUAL RANGE (RVR) SYSTEM**

Navigation Services Lighting Systems Office  
RVR Product Team (AJW-46)

**DISTRIBUTION STATEMENT A. Approved for public release; distribution is unlimited.**

CONTENTS

<u>SECTION</u>	<u>PAGE</u>
1 SCOPE .....	1
1.1 Scope.....	1
1.2 System overview.....	1
2 APPLICABLE DOCUMENTS .....	1
2.1 General.....	1
2.2 Government documents .....	2
2.2.1 Specifications and handbooks.....	2
2.2.1.1 FAA specifications.....	2
2.2.1.2 FAA handbooks .....	2
2.2.2 Other Government documents, drawings, and publications .....	2
2.2.2.1 FAA drawings.....	2
2.2.2.2 Other FAA documents .....	2
2.2.3 Non-FAA Government documents .....	3
2.3 Non-Government documents .....	3
2.4 Order of precedence.....	4
3 REQUIREMENTS.....	4
3.1 System definition .....	4
3.1.1 Functional layouts.....	4
3.1.2 Major components .....	4
3.1.2.1 Data Processing Unit (DPU).....	4
3.1.2.2 Visibility Sensor (VS).....	5
3.1.2.3 Ambient Light Sensor (ALS).....	5
3.1.2.4 Runway Light Intensity Monitor (RLIM).....	5
3.1.2.5 Controller Displays (CD).....	5
3.2 Performance .....	6
3.2.1 RVR product requirements .....	6
3.2.1.1 RVR product definition.....	6
3.2.1.2 RVR product reports .....	6
3.2.1.2.1 Report contents .....	6
3.2.1.2.2 Report update rate.....	6
3.2.1.2.3 Report format .....	6
3.2.1.2.4 Reporting increments.....	6
3.2.1.3 RVR product calculation.....	6
3.2.1.3.1 Data validation .....	7
3.2.1.3.2 Trend data .....	7
3.2.1.3.3 Koschmieder’s Law .....	7
3.2.1.3.4 Allard’s Law .....	7
3.2.1.4 RVR Product accuracy.....	9
3.2.1.5 RVR Product availability.....	9
3.2.2 System requirements.....	9
3.2.2.1 System components .....	9
3.2.2.1.1 Maintainability of electronic equipment.....	9
3.2.2.1.1.1 Reliability.....	10
3.2.2.1.1.2 Maintainability.....	10

CONTENTS

<u>SECTION</u>	<u>PAGE</u>
3.2.2.1.1.3 Self checks .....	10
3.2.2.1.1.4 Periodic maintenance .....	10
3.2.2.1.2 Recoverability .....	11
3.2.2.1.3 Expandability .....	11
3.2.2.1.3.1 Hardware .....	11
3.2.2.1.3.2 Software .....	11
3.2.2.1.3.3 Future capability .....	11
3.2.2.1.4 System certification .....	11
3.2.2.2 Data Processing Unit (DPU) .....	11
3.2.2.2.1 DPU computer hardware .....	12
3.2.2.2.2 DPU operating system software .....	12
3.2.2.2.2.1 System control .....	12
3.2.2.2.2.2 System access and security .....	12
3.2.2.2.2.3 Watchdog timer .....	13
3.2.2.2.2.4 Time source .....	13
3.2.2.2.3 DPU RVR data sets .....	13
3.2.2.2.3.1 Raw data .....	13
3.2.2.2.3.2 Product data .....	13
3.2.2.2.3.3 Maintenance data .....	13
3.2.2.2.3.4 Operational data .....	13
3.2.2.2.3.5 NG RVR data .....	13
3.2.2.2.4 DPU data management .....	13
3.2.2.2.4.1 Data acceptance .....	13
3.2.2.2.4.2 Data processing .....	14
3.2.2.2.4.3 Product dissemination .....	14
3.2.2.2.4.4 Data storage .....	14
3.2.2.2.4.5 Data access .....	14
3.2.2.2.5 DPU archiving .....	14
3.2.2.2.6 DPU interfaces .....	14
3.2.2.2.6.1 Internal (subsystem) interfaces .....	14
3.2.2.2.6.1.1 Primary subsystem interfaces .....	15
3.2.2.2.6.1.2 Alternative subsystem interface capability .....	16
3.2.2.2.6.2 External user interfaces .....	16
3.2.2.2.6.2.1 External display systems .....	17
3.2.2.2.6.2.2 Automated Surface Observing System (ASOS) .....	17
3.2.2.2.6.3 External controlling interfaces .....	17
3.2.2.2.6.3.1 Maintenance Data Terminal (MDT) .....	17
3.2.2.2.6.3.2 Remote Maintenance Monitoring System .....	17
3.2.2.2.6.3.3 External time source .....	18
3.2.2.2.6.3.4 NG RVR interface .....	18
3.2.2.2.7 DPU power .....	19
3.2.2.2.8 DPU installation .....	19
3.2.2.3 Visibility Sensor (VS) .....	19
3.2.2.3.1 VS measurement processing .....	19

## CONTENTS

<u>SECTION</u>	<u>PAGE</u>
3.2.2.3.2 VS measurement range .....	20
3.2.2.3.3 VS calibration .....	20
3.2.2.3.3.1 Calibration device .....	20
3.2.2.3.3.2 Calibration process .....	20
3.2.2.3.4 VS alignment .....	20
3.2.2.3.5 VS accuracy .....	21
3.2.2.3.6 VS interfaces .....	21
3.2.2.3.7 VS power .....	21
3.2.2.3.8 VS installation .....	22
3.2.2.4 Ambient Light Sensor (ALS) .....	22
3.2.2.4.1 ALS measurement processing .....	22
3.2.2.4.2 ALS interfaces .....	23
3.2.2.4.3 ALS power .....	23
3.2.2.4.4 ALS installation .....	23
3.2.2.5 Runway Light Intensity Monitor (RLIM) .....	23
3.2.2.5.1 RLIM measurement processing .....	24
3.2.2.5.2 RLIM interfaces .....	24
3.2.2.5.3 RLIM power .....	24
3.2.2.5.4 RLIM installation .....	25
3.2.2.6 RVR Controller Display (CD) .....	25
3.2.2.6.1 CD readability .....	25
3.2.2.6.2 CD data display and presentation .....	26
3.2.2.6.2.1 Low visibility alarm threshold (LVAT) limits .....	27
3.2.2.6.3 CD control .....	27
3.2.2.6.3.1 Data entry/access .....	27
3.2.2.6.3.2 Keypad intensity .....	27
3.2.2.6.3.3 Controls .....	27
3.2.2.6.3.3.1 Display intensity .....	27
3.2.2.6.3.3.2 Keypad .....	27
3.2.2.6.3.3.3 Touchscreen .....	27
3.2.2.6.3.3.4 Volume .....	27
3.2.2.6.3.3.5 Power .....	28
3.2.2.6.4 CD alarm operation .....	28
3.2.2.6.4.1 Audio alarm operation .....	28
3.2.2.6.4.2 Visual alarm operation .....	28
3.2.2.6.5 CD self-test .....	29
3.2.2.6.6 CD interface .....	29
3.2.2.6.7 CD power .....	30
3.2.2.6.8 CD installation .....	30
3.2.2.6.8.1 Location .....	30
3.2.2.6.8.1.1 Local configuration .....	31
3.2.2.6.8.1.2 Remote configuration .....	31
3.2.2.6.8.2 Hardware size .....	32
3.2.3 Electronic equipment, general requirements .....	32

CONTENTS

<u>SECTION</u>		<u>PAGE</u>
3.2.3.1	Operating environmental conditions.....	33
3.2.3.2	Transportability.....	34
3.2.3.3	Materials, processes and parts.....	34
3.3	System characteristics.....	36
3.3.1	Safety .....	36
3.3.2	Security .....	37
3.3.2.1	Physical security. ....	37
3.3.2.2	Information security.....	37
3.3.3	Human factors.....	37
4	VERIFICATION.....	37
4.1	Verification Requirements Traceability Matrix (VRTM).....	37
4.1.1	Verification methods.....	37
4.1.1.1	Test.....	37
4.1.1.2	Demonstration.....	37
4.1.1.3	Analysis.....	38
4.1.1.4	Inspection.....	38
5	PACKAGING .....	38
6	NOTES.....	38
6.1	Intended use .....	38
6.1.1	Precision approach limits.....	38
6.1.2	RVR system .....	39
6.1.3	RVR system users.....	39
6.2	Acquisition requirements.....	39
6.3	Definitions.....	39
6.4	Abbreviations and acronyms.....	40
6.5	ICAO compliance .....	43

**FIGURES**

<u>FIGURE</u>	<u>PAGE</u>
FIGURE 3-1 RVR System functional block diagram.....	4
FIGURE 3-2 Controller display configurations.....	31

**TABLES**

<u>TABLE</u>	<u>PAGE</u>
TABLE 3-1 Standard runway light settings.....	8
TABLE 3-2 Runway light intensity when edge and centerline settings match .....	8
TABLE 3-3 Runway light intensity when centerline setting is zero (0).....	9
TABLE 3-4 RVR system interface summary .....	15
TABLE 3-5 Characteristics of two-wire interfaces .....	16
TABLE 3-6 DPU/Sensor data interface to the Radio Link.....	16
TABLE 3-7 Runway light currents.....	24
TABLE 3-8 CD data presentation.....	26
TABLE 3-9 Audio alarm conditions.....	28
TABLE 3-10 Displayed alarm conditions .....	29
TABLE 3-11 Channel activation sequence.....	30
TABLE 3-12 General Navigational Aid electronic equipment requirements .....	32
TABLE 3-13 Environmental conditions .....	34
TABLE 3-14 Fungi susceptibility of material .....	36
TABLE 6-1 Precision approach limits and RVR sensor locations.....	38
TABLE 6-2 RVR compliance with ICAO Annex 3 .....	43

**APPENDICES**

<u>APPENDIX</u>	<u>PAGE</u>
APPENDIX A. Verification Requirements Traceability Matrix (VRTM).....	44

## **1 SCOPE**

### **1.1 SCOPE**

This performance specification establishes the performance, design and verification requirements for the forward-scatter meter PC-based Runway Visual Range (RVR) System.

### **1.2 SYSTEM OVERVIEW**

The RVR is an essential system consisting of the hardware and software to calculate an estimate of how far down a runway a pilot can see. The objects viewed may be runway lights or runway markings. The RVR System provides reliable RVR measurements to various users including: local Airport Traffic Control Tower (ATCT) cab and Terminal Radar Approach Control (TRACON) air traffic controllers; Enhanced Traffic Management System (ETMS)/Collaborative Decision Making (CDM) users (airline dispatchers); Automated Surface Observing System (ASOS) and Automated Weather Sensors System (AWSS) users; and Airport Operations Center personnel.

Currently two types of RVR Systems are deployed in the National Airspace System (NAS): Tasker 500 Transmissometer Systems, deployed in the late 1960s; and the new generation-RVR (NGRVR), first deployed in 1994.

The performance requirements established in this specification are for a PC based-RVR System built on the systems requirements and component concepts that have proven successful with the NGRVR. Experience with current operational systems and the apparent availability of commercial systems indicate that forward-scatter meter technology is the current preferred type of visibility sensor for NAS RVR systems, therefore, the PC-based RVR System will also employ this technology. Through the use of modern commercial products and components, the PC-based RVR should exceed reliability, maintainability and availability objectives of this specification.

The PC-based RVR system may be collocated with an existing NG RVR system at airports within the NAS. In such instances, the PC-based RVR system must receive NG RVR system data and integrate it with similar data of the PC-based system for representation of RVR conditions over the relevant RVR airport configuration.

## **2 APPLICABLE DOCUMENTS**

### **2.1 GENERAL**

The documents listed in this section are specified in Sections 3 and 4 of this specification. This section does not include documents cited in other sections of this specification or recommended for additional information or as examples. While every effort has been made to ensure the completeness of this list, document users are cautioned that they must meet all specified requirements in the documents cited in Sections 3 and 4 of this specification, whether or not they are cited specifically herein.

## 2.2 GOVERNMENT DOCUMENTS

### 2.2.1 Specifications and handbooks

The following specifications and handbooks form a part of this document to the extent specified herein. Unless otherwise specified, the issues of these documents are those listed in the issue of the Department of Defense Index of Specifications and Standards (DoDISS) and supplement thereto, cited in the solicitation.

#### 2.2.1.1 FAA specifications

FAA-E-2702A	Low-Impact Resistant Structures.
FAA-G-2100G	Electronic Equipment, General Requirements. <a href="http://www.faa.gov/asd/standards/faq-g-2100g.pdf">http://www.faa.gov/asd/standards/faq-g-2100g.pdf</a>
NAS-MD-793	Remote Maintenance Monitoring System Functional Requirements for the Remote Monitoring Subsystem (RMS).

#### 2.2.1.2 FAA handbooks

FAA Order 6000.15C	General Maintenance Handbook for Airway Facilities.
FAA TI-6560.17	Instructional Book-Runway Visual Range System On-site Requirements.

[Copies of specifications and other applicable FAA documents may be obtained from the Contracting Officer (CO) in the office issuing the invitation-for-bids or request-for-proposals. The request should fully identify material desired, i.e., standard, drawing and specification plus amendment numbers and dates. Requests should cite this specification or the related Screening Information Request (SIR) for the RVR or other use to be made of the requested material. A number of the documents may be obtained at Web site: <http://isddc.dot.gov/>.]

### 2.2.2 Other Government documents, drawings, and publications

The following other Government documents, drawings and publications form a part of this document to the extent specified herein. Unless otherwise specified, the issues are those cited in the solicitation.

#### 2.2.2.1 FAA drawings

FAA- D-6155-21	ALSF-2 (6'-128') & MALSR (40'-128') LIR Structures, Assembly Instructions for LIR Structures MG-20, MG-30, & MG-40.
FAA- D-6282-X	New-Generation Runway Visual Range System.

#### 2.2.2.2 Other FAA documents

DOT/FAA/CT-96/1	Human Factors Design Guide for Acquisition of Commercial Off The Shelf Subsystems, Non-Developmental Items and Developmental Systems.
DOT/FAA/CT-01/08	Human Factors Design Guide Update (Report Number DOT/FAA/CT-96/01: A Revision to Chapter 8-Computer Human Interface Guidelines.
NAS-IC-51035101	Interface Control Document, Maintenance Processor Subsystem (MPS) to Remote Monitoring Subsystem (RMS) Using Simple Asynchronous Interface (SAI).



FAA-NAS-IR-33113106	Interface Requirements Document-PC based Runway Visual Range (RVR) System to Automated Surface Observing System (ASOS)-Draft.
FAA-NAS-IR-32063311	Interface Requirements Document-Facility Global Positioning System (GPS) Time Source to PC Based Runway Visual Range (RVR) System-Draft.
FAA-NAS-IR-33110001	Interface Requirements Document-PC Based Runway Visual Range (RVR) System to RVR CD Subsystem or External User-Draft.

### 2.2.3 Non-FAA Government documents

ASTM G21	Standard Practice for Determining Resistance of Synthetic Polymeric Materials to Fungi.
L-P-516	Plastic Sheet & Plastic Rod, Thermosetting, Cast.
MIL-I-10	Insulating Compound, Electrical, Ceramic Class L.
MIL-I-23264	Insulators, Ceramic, Electrical and Electronic, General Specification for.
MIL-S-22473	Sealing, Locking and Retaining Compounds: (Single-Component).
MIL-S-46163	Sealing, Lubricating, and Wicking Compounds: Thread-Locking, Anaerobic, Single Component.
MIL-STD-810F	Environmental Test Methods and Engineering Guidelines.
MIL-T-22361	Thread Compound; Antiseize, Zinc Dust-Pevolatium.
TT-S-1732	Sealing Compound, Pipe Joint and Thread, Lead Free General Purpose.
NFPA-70	National Electrical Code.
29 CFR 1910	Occupational Safety and Health Standards.
29 CFR 1926	Safety and Health Regulations for Construction.

[Request for copies of: Military documents should be addressed to Defense Automated Printing Service, Building 4/D, 700 Robbins Avenue, Philadelphia, PA 19111-5094. Web site: <http://dodssp.daps.mil/>; American Society for Testing Materials (ASTM), 100 Barr Harbor Drive, West Conshohocken, PA 19428-2959; National Fire Protection Association (NFPA), One Batterymarch Park, PO Box 9101, Quincy, MA 02269-9101.]

### 2.3 NON-GOVERNMENT DOCUMENTS

The following document(s) form a part of this document to the extent specified herein. Unless otherwise specified, the issues of the document, which are Department of Defense (DoD) adopted, are those listed in the issue of the DoDISS cited in the solicitation. Unless otherwise specified, the issues of documents not listed in the DoDISS are the issues of the documents cited in the solicitation.

EIA-STD-232F	Interface Between Data Terminal Equipment and Data Circuit Terminating Equipment Employing Serial Binary Data Interchange.
EIA-STD-485	Standard for Electrical Characteristics of Generators and Receivers for use in Balanced Digital Multipoint Systems.

**2.4 ORDER OF PRECEDENCE**

In the event of conflict between the text in this document and the references cited, the text of this document takes precedence. Nothing in this document, however, supersedes applicable laws and regulation unless a specific exemption has been obtained.

**3 REQUIREMENTS**

Except where specifically noted, the RVR System shall meet the requirements stipulated herein while operating over the full range of the operating environment.

**3.1 SYSTEM DEFINITION**

**3.1.1 Functional layouts**

The RVR System functional block diagram, FIGURE 3-1, provides a functional block diagram of the RVR, its major components and external interfacing items.

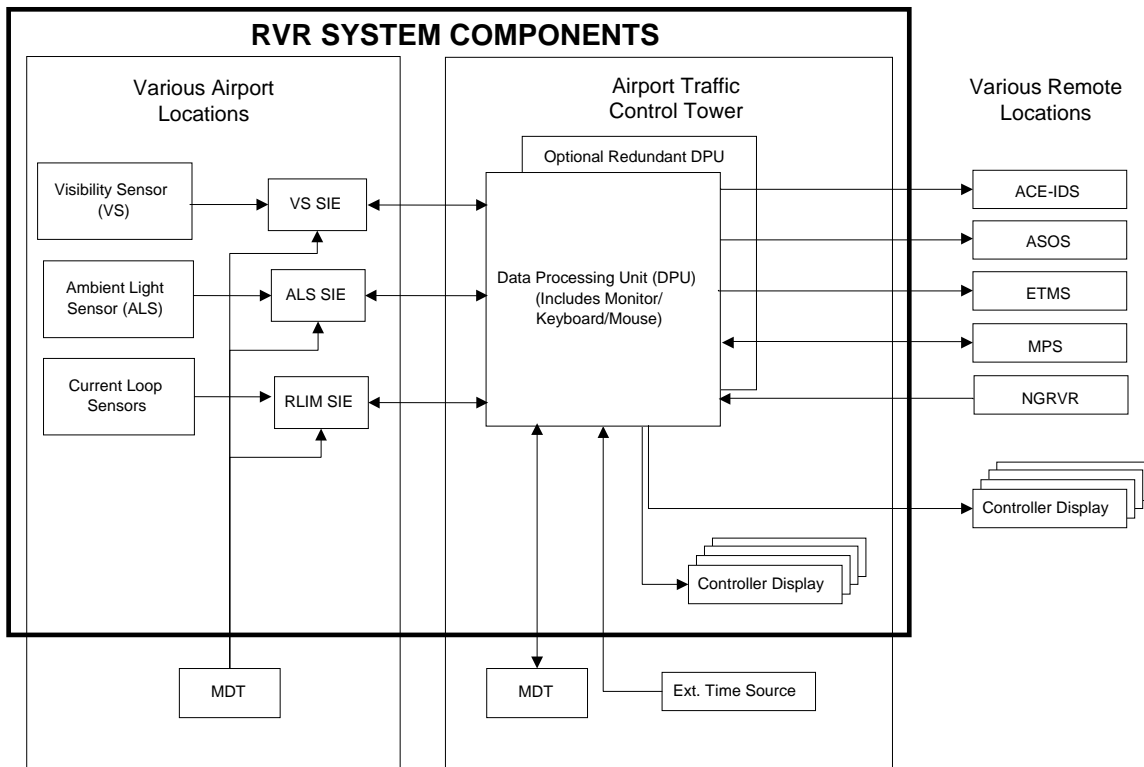

**FIGURE 3-1 RVR System functional block diagram**

**3.1.2 Major components**

**3.1.2.1 Data Processing Unit (DPU)**

The major functions of the DPU are data acceptance, data validation, data processing, product dissemination and data storage. The DPU accepts data inputs, performs various data validation functions, implements RVR algorithms and distributes RVR products. The DPU is also responsible for maintaining real time archiving, system control, system configuration and

maintenance diagnostic and reporting functions. The DPU will have a central processing unit (CPU), operating system software, sensor interfaces, communication interfaces, power supply, monitor, keyboard and a mouse.

The range of capacity, functionality and capability of the DPU is the same regardless of the size or location of the airport. The number of visibility sensors (VS), ambient light sensors (ALS) and runway light intensity monitors (RLIM) connecting to the DPU will vary with each airport's individual requirements. The VS, ALS and RLIM sensors may be located up to 5 nautical miles (nm) from the DPU. The DPU will also accept input from the NG RVR DPU.

### **3.1.2.2 Visibility Sensor (VS)**

The RVR VS is a forward-scatter meter that utilizes the most current sensor technology to measure the clarity of the atmosphere in terms of the visible extinction coefficient. The VS will typically be installed adjacent to a runway at up to three positions along the length of the runway: touchdown (TD), midpoint (MP) and rollout (RO).

Although VS measurements are made at a specific spatial location, their measurements are used to represent the extinction coefficient over large volumes of space. United States installation procedures permit a single sensor to provide RVR data for locations within 2,000 feet of the sensor.

### **3.1.2.3 Ambient Light Sensor (ALS)**

The ALS provides the background light component for the RVR product. Normally two ALSs will be installed in central locations relative to the airfield environment. A single ALS is typically used at airports with only one visibility sensor.

### **3.1.2.4 Runway Light Intensity Monitor (RLIM)**

The RLIM measures runway light settings, which establish the nominal intensities of a High Intensity Runway Lighting (HIRL) System. An RLIM will be capable of monitoring up to eight runway light current loops per runway. RLIMs will be installed within the airport power vault(s).

### **3.1.2.5 Controller Displays (CD)**

Following calculation in the DPU, the content of each RVR product will be easily exportable via standard interface connections to displays such that it is associated with the TD, MP or RO position of a given runway. The DPU will easily interface with several different CDs to include: the RVR Controller Display (see 3.2.2.6), hereafter referred to as "CD"; the existing CD Type FA-10268/6, hereafter referred to as CD Type FA-10268/6; and the existing ASOS Controller Equipment-Information Display System, hereafter referred to as ACE-IDS.

## **3.2 PERFORMANCE**

### **3.2.1 RVR product requirements**

#### **3.2.1.1 RVR product definition**

The RVR product is a calculated estimate of how far down a runway a pilot is expected to see. It is calculated using standardized equations from measurements of three parameters: extinction coefficient, ambient light level and the intensity of the runway lights. The RVR distance values shall be reported in feet.

#### **3.2.1.2 RVR product reports**

##### **3.2.1.2.1 Report contents**

The RVR products reports shall consist of: the runway identification (ID) and sub-ID; the most recently computed RVR product; RVR trends (increasing, decreasing or steady); and the associated intensity settings for the runway lights (edge and centerline).

##### **3.2.1.2.2 Report update rate**

The reported RVR products shall be updated at a minimum rate of once per 15 seconds, or at the rate specified in the applicable Interface Requirements Documents (IRD) identified in 2.2.2.2 and 3.2.2.2.6.

##### **3.2.1.2.3 Report format**

The reported RVR product formats shall be as specified in the applicable Interface Requirements Documents identified in 3.2.2.2.6.2 and 3.2.2.2.6.3.

##### **3.2.1.2.4 Reporting increments**

The RVR System shall report RVR values in: 100-foot increments from zero (0) feet through 800 feet; 200-foot increments from 800 through 3,000 feet; and, 500-foot increments from 3,000 through 6,500 feet.

A value of 6,500 feet shall be used to report RVR above 6,249 feet. An RVR value of zero (0) feet shall indicate runway visual range below 50 feet. The reported RVR shall be rounded off from the calculated value; therefore, the RVR values from 751 feet to 899 feet would be reported as 800 feet.

#### **3.2.1.3 RVR product calculation**

The validity of the VS and ALS measurements shall be checked. Valid values shall be used to calculate 60-second running averages. The RVR product shall be calculated from 60-second running averages of the readings of the VS and the ALS and the last valid reading of the RLIM. The intensities of the runway edge and centerline lights shall be used, as appropriate for the calculated RVR value. Two RVR values shall be calculated: the first for seeing objects using Koschmieder's Law (only VS is used); and the second for seeing lights using Allard's Law (all three sensors are used). The larger calculated value shall be adopted and rounded off according to the reporting increments of 3.2.1.2.4. The RVR product sent to ASOS shall use RLIM light setting step five (5).

**3.2.1.3.1 Data validation**

All sensor data shall be validated to ensure there are no transmission errors or sensor failures. The sensor measurement data shall pass reasonableness checks, including range limits or rate of change limits. If any sensor measurements are found to be invalid, the measurements shall be rejected. Invalid sensor data shall cause an appropriate alarm to be set. Invalid sensor data alarms shall be recorded in the RVR System maintenance data set (see 3.2.2.2.3.3).

**3.2.1.3.2 Trend data**

The RVR trend (increasing, decreasing or steady) shall be determined using a five (5) minute sampling window.

**3.2.1.3.3 Koschmieder's Law**

Koschmieder's Law states:

$$C_t = e^{-\sigma R}$$

Where:        R = RVR  
                    $\sigma$  = atmospheric extinction coefficient  
                    $C_t$  = contrast threshold, which is taken as 0.05

Koschmieder's Law shall give zero RVR whenever the ALS reading is below the night limit of 2 Foot-Lamberts (fL) (6.85 cd/m<sup>2</sup>).

**3.2.1.3.4 Allard's Law**

In metric units, Allard's Law states:

$$E_t = (I/R^2)e^{-\sigma R}$$

Where:         $E_t$  = visual threshold in lux  
                   R = RVR in meters (m)  
                    $\sigma$  = atmospheric extinction coefficient in m<sup>-1</sup>  
                   I = runway light intensity in candelas

The visual threshold  $E_t$  is given by:

$$\text{Log}_{10} E_t = -5.7 + 0.64 \log B$$

Where:        B = background luminance (ambient light) in cd/m<sup>2</sup>.

A lower threshold on  $E_t$  is set at  $6.8 \times 10^{-6}$  lux, which corresponds to the night limit.

The standard runway light settings of a HIRL System, TABLE 3-1, shall be used.

**TABLE 3-1 Standard runway light settings**

Light Setting	Nominal Intensity (I) Candelas (cd)	
	Edge Lights	Centerline Lights
Step 0 (Off)	Zero (0)	Zero (0)
Step 1	15	7.5
Step 2	120	60
Step 3	500	250
Step 4	2,500	1,250
Step 5	10,000	5,000

The nominal intensity of the centerline lights for the same current is half that of the edge lights. Because the centerline lights are located in the runway pavement and are hence more susceptible to contamination than the edge lights, their intensity is degraded by an additional factor of two in calculating the RVR in the following algorithms. Note that for high RVR values the edge lights are more visible because they are brighter than the centerline lights. For low RVR values the centerline lights are more visible than the edge lights because the pilot's vision is within the main beam of the centerline lights but is in the weaker side lobes of the edge lights.

If both the edge light settings and the centerline light settings have values of 1, 2, 3, 4 or 5, then the value to be used for runway light intensity (I) in Allard's Law for certain values of RVR (in feet) shall be in accordance with TABLE 3-2, Runway light intensity when edge and centerline settings match. Note that the centerline light intensity and edge light intensity are taken from the light setting/candela table for the appropriate values of centerline light setting and edge light setting, respectively.

**TABLE 3-2 Runway light intensity when edge and centerline settings match**

No.	Condition	Action
1	$RVR \leq 600$	$I = 50\%$ of Centerline Light Intensity
2	$600 < RVR < 1,000$	Interpolate linearly for "I" between a value of 50% of Centerline Light Intensity at 600 feet and 100% of Edge Light Intensity at 1,000 feet
3	$RVR \geq 1,000$	$I = 100\%$ of Edge Light Intensity

If the edge light setting has a value of 1, 2, 3, 4 or 5 and the centerline light setting has a value of zero (0) then the value to be used for runway light intensity (I) in Allard's Law for certain values of RVR (in feet) shall be in accordance with TABLE 3-3, Runway light intensity when centerline setting is zero (0). Note that if the edge light setting is zero (0), then, regardless of the centerline light setting, a value of zero (0) shall be assigned to the Allard's Law solution.

**TABLE 3-3 Runway light intensity when centerline setting is zero (0)**

No.	Condition	Action
1	RVR < 1,000	Assign a value of zero (0) to the Allard's Law solution
2	RVR ≥ 1,000	I = 100 % of Edge Light Intensity

Note: TABLES 3-2 and 3-3 light setting conditions assume that both edge and centerline lights are configured for a given runway. For those cases where centerline lights are not configured for a given runway (TABLE 3-3) the following action shall be taken: Allard's Law must be computed using a runway light intensity (I) corresponding to the edge light setting for all values of RVR; the RVR System must display a blank space in the associated CD centerline light setting data field; any attempt to configure a runway without edge lights must be treated as erroneous input and rejected by the RVR System.

**3.2.1.4 RVR Product accuracy**

Because of the complexity of Allard’s Law, an overall RVR accuracy is not specified. Rather, the accuracy of each individual sensor is specified (see 3.2.2.3 and 3.2.2.4). Note that the RVR value is much more sensitive to extinction coefficient errors than ambient light or runway light intensity errors.

**3.2.1.5 RVR Product availability**

RVR product availability is more important than strict RVR product accuracy. If the RVR system performance is degraded by environmental factors, such as excessive sensor window contamination, the RVR product shall continue to be output, provided that the reported RVR is not greater than the actual RVR.

**3.2.2 System requirements**

**3.2.2.1 System components**

The RVR System consists of the sensors necessary to produce required RVR products and a windows-based, industrial-grade DPU. The DPU shall contain the necessary hardware and software to meet the requirements of this specification. FIGURE 3-1 illustrates the typical interfaces that the DPU will have to meet the requirements of this specification. The sensor complement for each airport shall include a minimum of one ALS and as many VSs and RLIMs as are needed to provide coverage for the instrumented runways of the airport. The RVR System configuration shall be capable of being configured with two DPUs; two ALSs with sensor interface electronics (SIE); 30 VSs with SIEs; 10 RLIMs consisting of SIEs with 8 current loop sensors each; and 32 CDs on each of the local and remote communications lines.

**3.2.2.1.1 Maintainability of electronic equipment**

The RVR System shall provide for a site and depot concept of maintenance. This concept assumes the use of modular equipment that enables maintenance specialists to correct a majority of equipment failures by replacing the faulty lowest replaceable unit (LRU).

### **3.2.2.1.1.1 Reliability**

A core RVR System, consisting of one DPU, one ALS with SIE and connecting cable, one VS with SIE and connecting cable, two CDs, and one RLIM SIE with four current loop sensors, shall have a Mean-Time-Between-Failure (MTBF) of 5,000 hours, not including communications failures external to the RVR System components.

### **3.2.2.1.1.2 Maintainability**

The RVR System components shall be transportable by one Maintenance Specialist, contain a minimum number of subsystems to meet the RVR System requirements, and be easy to install.

The Mean-Time-To-Repair (MTTR) a single point failure of a core RVR System, consisting of one DPU, one ALS with SIE and connecting cable, one VS with SIE and connecting cable, two CDs, and one RLIM SIE with four current loop sensors, shall be 30 minutes or less exclusive of time required to travel to the affected location.

### **3.2.2.1.1.3 Self checks**

The RVR System shall incorporate self-checks to verify proper operation of all major subsystems. Self-checks shall be used to validate the system measurements and to determine when maintenance is required. Examples of typical functions include power supply voltages, out-of range performance and window contamination signals. Hard alarms shall be generated whenever a parameter is found to be outside acceptable operation limits. A soft alarm shall be generated whenever a parameter is approaching the limit for acceptable operation. The RVR System shall include software that determines whether all RVR processes are operating properly.

The system shall be capable of detecting at least 90 % of all faults. In addition, as a minimum, 90 % of all detected faults shall be isolated to one LRU using automatically initiated diagnostics. Automatically initiated diagnostics shall occur when a hard alarm occurs. Automatically initiated diagnostics shall be designed to identify the faulty LRU. Additional manually initiated diagnostics shall be provided to offer more detailed information on the status of LRUs to aid the maintenance process. All built-in diagnostics shall be capable of initiation from the MPS or a portable MDT. Complete results of the built in diagnostics shall be available to the Maintenance Specialist.

If a failure cannot be isolated to a single LRU, a list of the suspected LRUs shall be generated in order of probability (highest to lowest). Any built-in diagnostics contained in on-line system hardware shall be functionally independent of the rest of the on-line system.

Sensor and DPU self check data, including alarm information, shall be stored in the maintenance data set (3.2.2.2.3.3) for output to the MDT and MPS interfaces, as appropriate.

### **3.2.2.1.1.4 Periodic maintenance**

The RVR System shall be designed such that periodic maintenance of the DPU is not required for the system more often than biweekly. Periodic maintenance on the RVR sensors, at the sensor(s) location, shall not be required more often than once every 90 days. The mean periodic maintenance time (MPMT) shall not exceed 4 hours over a 90 day period for the following system configuration: one DPU, one ALS with SIE and connecting cable, one VS with SIE and



connecting cable, two CDs, and one RLIM SIE with four current loop sensors. The periodic maintenance tasks for the sensors shall require the services of only one person. During the periodic maintenance visits, the calibration and operation of each sensor and the system shall be verified. The procedures and the required frequency of calibration shall be defined by the contractor, keeping in mind that sensor drift outside of the required specification limits constitutes a failure of the system.

The RVR DPU hardware/software configuration shall be designed such that scheduled periodic maintenance is minimized. The RVR System operations shall not be interrupted for routine DPU periodic maintenance.

### **3.2.2.1.2 Recoverability**

All system components of an operationally capable system shall recover automatically from the loss of power, the loss of an interface, loss of critical processes (any RVR System process) and processor lock up.

### **3.2.2.1.3 Expandability**

#### **3.2.2.1.3.1 Hardware**

The RVR System shall be capable of a 50 % growth in the size of the system (additional VSs, ALSs, RLIMs, CPU time, DPU memory, displays and communications ports).

#### **3.2.2.1.3.2 Software**

The RVR System shall be capable of having the software/firmware expanded by up to 50 % of the total lines of code initially implemented.

#### **3.2.2.1.3.3 Future capability**

The RVR System shall be capable of accepting different visibility sensor types, and of upgrading with newer, improved sensors without requiring hardware redesign or major software changes which require use of more than 50 % of addressable memory.

#### **3.2.2.1.4 System certification**

The RVR System shall be certifiable, that is, capable of validating that the system is providing the advertised service to the user in compliance with Chapter 5 of FAA Order 6000.15C.

### **3.2.2.2 Data Processing Unit (DPU)**

The DPU shall use open architecture, standard multitasking Windows-based operating system and object-oriented application software. The computer/server components shall employ current technology that must be sustainable with replacement hardware and software that are both forward and backward compatible.

To assure RVR System availability at critical airports, the option shall be provided for using dual DPUs. Both DPUs shall receive all inputs. The outputs shall be provided by only one DPU (normally the primary DPU). The proper functioning of both DPUs shall be monitored and any failures in either DPU logged to the maintenance files and maintenance interfaces of both. If the primary DPU fails to provide valid RVR products because of a DPU software or hardware failure, RVR functionality shall automatically be switched to the backup DPU.

### **3.2.2.2.1 DPU computer hardware**

The RVR DPU shall contain the necessary processors, memory, disk storage and input/output (I/O) cards/capabilities to, at a minimum, implement the required RVR functionalities. The DPU shall consist of a high-reliability industrial grade server/computer with Redundant Array of Independent Disks (RAID) – two protected redundant hot-swappable hard drive storage and compact disc-rewritable (CD-RW) drive, display, keyboard, mouse and I/O interfaces.

### **3.2.2.2.2 DPU operating system software**

All RVR application software shall be run under a standard Microsoft Windows-based operating system. The application software shall include the functions for system configuration, data validation, system monitoring, diagnostics, communication control and other appropriate routines for execution of the various system functions.

Without making code changes, the DPU shall be locally capable, with restricted access, of configuring: selected system parameters (including configuration, measurements and maintenance parameters) with flexible data formats and locations, including alarms for limits on varying parameters; and output products by specifying parameters to be included, formats, output frequency, output port (or file name and location) and port parameters.

#### **3.2.2.2.2.1 System control**

The RVR system shall be controlled by a single entity at any given time as prioritized in the following list: locally through the DPU's keyboard, mouse and display, locally through the MDT, and remotely through the MPS.

An "on-site operator" is an operator using a local DPU console or a local MDT interface.

If a system control session is initiated using the local DPU console, the local MDT interface shall immediately abort any existing MDT system control sessions and prevent any other MDT system control sessions as long as the local DPU console has an active system control session.

If there is an active system control session on either the local DPU console or a local MDT interface, the MPS interface shall ignore all incoming Equipment Command Messages and Status Command Messages as specified in Section 3.4.3 of NAS-MD-793.

System control shall include the ability to: (a) display the current output of the RVR System including the RVR products and sensor output data; (b) retrieve and display historical RVR data/products from archived files; and (c) allow an on-site operator to initially configure or reconfigure the RVR System airport configuration that includes the ability to independently configure primary and alternate runways, sensor configuration, and system security.

#### **3.2.2.2.2.2 System access and security**

Users shall be able to log into the RVR System on-site using the DPU keyboard and display or MDT. User identification shall be via password. User capabilities shall be limited by general network considerations such as read or write access to specific directories and by specific RVR System functions such as viewing raw data, current products, maintenance data, operational data, archived data, and changing configurations.

**3.2.2.2.2.3 Watchdog timer**

The DPU shall include a Watchdog Timer to detect a processor lock-up and to verify that all RVR System processes are correctly performing their functions. In the event the Watchdog Timer detects a processor failure, it shall initiate a reboot. In the event the Watchdog Timer detects a processor failure in the active DPU of a dual DPU RVR System configuration, a reboot is initiated in the active DPU, and the inactive DPU shall switch to active status. Reboots shall be logged to a daily reboot file. The reason for the reboot shall be logged.

**3.2.2.2.2.4 Time source**

The RVR System shall use an external time source for synchronization of data with other NAS systems as specified in 3.2.2.2.6.3.3. All RVR System functions requiring the use of date and/or time shall utilize the date and time from a DPU system clock synchronized to the external source.

**3.2.2.2.3 DPU RVR data sets****3.2.2.2.3.1 Raw data**

The raw data shall consist of: date time stamp; extinction coefficient; ALS background luminance; associated runway light settings (edge and centerline); current status of sensors, communications and DPU status. Status shall be classified valid or invalid.

**3.2.2.2.3.2 Product data**

The product data shall consist of: date time stamp; runway ID and sub-ID; most recently computed RVR product; and RVR trends (increasing, decreasing, or steady).

**3.2.2.2.3.3 Maintenance data**

The maintenance data shall consist of: date time stamp; hard and soft alarms, warnings and diagnostics; and system failures.

**3.2.2.2.3.4 Operational data**

The operational data shall consist of: date time stamp; current and previous system configurations with user name; and system calibrations.

**3.2.2.2.3.5 NG RVR data**

The NG RVR data shall consist of: date time stamp; VS SIE number, extinction coefficient, window contamination values, sensor temperature, and all maintenance bytes for all configured NG RVR VSs; NG RVR ALS measurement, window contamination value, sensor temperature, and all maintenance bytes; RLIM SIE number, light step measurements for each of the current loop sensors, and all maintenance bytes for all configured NG RVR RLIMs; and the maintenance parameter bytes for the NG RVR Product Processing Unit.

**3.2.2.2.4 DPU data management****3.2.2.2.4.1 Data acceptance**

The DPU shall have the capability to receive RVR sensor data as well as system diagnostics information directly from the RVR sensors. The DPU shall have the capability of receiving all the NG RVR data identified in 3.2.2.2.3.5.

#### **3.2.2.2.4.2 Data processing**

The DPU shall implement the product algorithms. The DPU shall prepare the processed data as RVR products in a digital format.

#### **3.2.2.2.4.3 Product dissemination**

The DPU shall provide RVR products to the interfaces identified in 3.2.2.2.6 as defined by the applicable IRD.

#### **3.2.2.2.4.4 Data storage**

The current product plus raw, maintenance and operational data shall be stored. Every minute the current product and raw and maintenance data shall be archived in three separate daily data files: product data, raw data and maintenance data. Operational data shall be stored quarterly in data files to include the system configuration and calibration data. Data storage shall use an American Standard Code for Information Interchange (ASCII) format to facilitate readability.

#### **3.2.2.2.4.5 Data access**

The stored data shall be accessible to programs running on the DPU and to authorized users, located either locally or at a remote site.

#### **3.2.2.2.5 DPU archiving**

The DPU shall automatically archive RVR product data, raw data, maintenance data, operational data and data received from the NG RVR EU port and have the capacity to store all such data for more than 1.3 years.

The archiving software shall provide the capability for easily extractible and protected retrieval and verification of the stored data by date time stamp to the display and CD-RW drive. The archiving software shall only allow manual deletion of obsolete (older than 1-year) archived data files that have been confirmed as being previously successfully transferred to a CD for permanent archiving.

The accessing, viewing, and downloading of archive data shall be capable without interruption to RVR System operation, including the real time archiving of data.

#### **3.2.2.2.6 DPU interfaces**

##### **3.2.2.2.6.1 Internal (subsystem) interfaces**

TABLE 3-4 provides a summary of the RVR System interfaces. Each RVR sensor type shall be capable of communicating with the DPU across three communication media: copper landline, fiber network or radio link. The primary subsystem interface will utilize copper landlines or fiber-optic network communications utilizing a two-wire modem interface. Alternative means of communications shall be provided on the DPU and sensors to allow data communications across a digital radio link. The following paragraphs identify the requirements for the subsystem interfaces.

**TABLE 3-4 RVR system interface summary**

Interface Name/IRD Number		Quantity of Interfaces	Comments
<b>DPU to:</b>			
VS	TBD*	30	See 3.2.2.2.6.1
ALS	TBD*	2	See 3.2.2.2.6.1
RLIM	TBD*	10	See 3.2.2.2.6.1
NG RVR	FAA Technical Instruction Book 6560.17, Section 3.7 and Table 3-5	1	RS-232 Interface, See 3.2.2.2.6.3.4
Local External Display Systems	NAS-IR-33110001	6	RS-485 Interface (EIA Standard 485)
Remote External Display Systems	NAS-IR-33110001	6	RS-232 Interface
ASOS	NAS-IR-33113106	1	See 3.2.2.2.6.2.2
MPS	NAS-IC-51035101	1	RS-232 Interface, See 3.2.2.2.6.3.2
MDT	TBD*	1	RS-232 Interface
External Time Source	NAS-IR-32063311	1	BNC Coaxial
<b>VS to:</b>			
DPU	TBD*	2	See 3.2.2.2.6.1
MDT	TBD*	1	RS-232 Interface
<b>ALS to:</b>			
DPU	TBD*	2	See 3.2.2.2.6.1
MDT	TBD*	1	RS-232 Interface
<b>RLIM to:</b>			
DPU	TBD*	2	See 3.2.2.2.6.1
MDT	TBD*	1	RS-232 Interface

Note: (\*) denotes interface documents that are part of RVR contract deliverables.

**3.2.2.2.6.1.1 Primary subsystem interfaces**

Many airports within the NAS provide “voice grade” AWG 19, shielded twisted pair landlines or fiber optic networks between the ATCT facility and the RVR sensor locations. The RVR System shall provide integrated modems for data communications between the VS, ALS and RLIM SIEs

and the DPU across these Government-furnished media. The RVR System shall operate across two-wire interfaces with the characteristics described in TABLE 3-5, Characteristics of two-wire interfaces.

**TABLE 3-5 Characteristics of two-wire interfaces**

No.	Characteristic	Type A Best Case	Type B Worst Case
1	Frequency Response		
1.a	1,004 Hz Net Loss	0 dB	22 dB
1.b	404 Hz Net Loss	0 dB	20 dB
1.c	2,750 Hz Net Loss	0 dB	24 dB
1.d	3,000 Hz Net Loss	0 dB	26 dB
2	DC Loop Resistance	N/A	520 Ω
3	Conductor to Conductor Resistance	50 MΩ	20 KΩ
4	Conductor to Ground Resistance	50 MΩ	10 KΩ
5	Signal to Noise	24 dB	24 dB
6	Peak-to-Average Ratio	N/A	66

**3.2.2.2.6.1.2 Alternative subsystem interface capability**

Radio frequency data link communication is required for airports where it is prohibitively expensive to run data wiring between a sensor and the DPU. The radio link will provide an asynchronous RS-232 interface for data communications between the DPU and a sensor. The DPU and VS, ALS and RLIM SIEs shall be configured as Data Transmission Equipment (DTE). The DPU and SIEs for the VS, ALS, and RLIM sensors shall provide the data interface to the radio link as directed in TABLE 3-6, DPU/Sensor data interface to the Radio Link.

**TABLE 3-6 DPU/Sensor data interface to the Radio Link**

No.	Characteristic	Interface
1	Data Rate	Less than or equal to 9,600 baud
2	Data Format	Asynchronous, Half Duplex RS-232
3	Required Interchange Circuits	TD, RD, SG, RTS, CTS, DCD, DSR, DTR (These terms are defined in EIA Standard 232F)

**3.2.2.2.6.2 External user interfaces**

The RVR System shall use open systems interface architecture to support RVR product user interfaces. The external user interfaces are defined as those components interfacing with the

RVR DPU after the internal RVR sensor data is received and processed. The external user interfaces disseminate RVR product data as well as system status and alarm information.

#### **3.2.2.2.6.2.1 External display systems**

The RVR DPU shall interface to the following external display systems via three sets of dual, redundant RS-232 and RS-485 interfaces: the existing CD Type FA-10268/6 and the PC based-RVR CD as specified in 3.2.2.6; the ACE-IDS Control Cabinet or workstation; and the ETMS. The interfaces shall comply with the requirements of FAA-NAS-IR-33110001.

#### **3.2.2.2.6.2.2 Automated Surface Observing System (ASOS)**

In the RVR to ASOS interface, data from up to 20 RVR touchdown sensors shall be sent from the RVR DPU to the ASOS or AWSS processor. Sensor and runway selection shall be configurable. The runway light setting for computation of the reported RVR shall always be step five (5). The RVR System reports a value that is the average of sensor measurements over a period of 1 minute. Detail of this interface can be found in FAA-NAS-IR-33113106.

#### **3.2.2.2.6.3 External controlling interfaces**

##### **3.2.2.2.6.3.1 Maintenance Data Terminal (MDT)**

A MDT is a windows-based laptop computer, loaded with appropriate software to permit it to interface with the DPU and SIE. An MDT port using EIA Standard 232f interface(s) shall be installed on the RVR DPU. The DPU MDT serial port shall enable local access and communication for the purposes of real-time diagnostics, calibration, monitoring and/or control of the VS, ALS and RLIM sensors and the RVR System.

The RVR to MDT interface shall provide, at a minimum, the following functionality or data: help function; immediate response; security through operator sign-on; configurable operator access based on predetermined user needs; terminal timeout; formatted facility data readout showing available parameters, limits and current values of selected parameter(s) along with a log of failures; and selection of a local function MDT or remote MPS function (see 3.2.2.2.6.3.2).

##### **3.2.2.2.6.3.2 Remote Maintenance Monitoring System**

The purpose of the Remote Maintenance Monitoring System is to provide automation support services for the management of the NAS infrastructure.

The RVR System shall implement a Remote Monitoring Subsystem (RMS). RMS system administration and performance shall be in accordance with NAS-MD-793, Section 3.5 and all subsections.

The RMS shall implement functional requirements related to data acquisition, data processing, communication processing, and command processing. RMS data acquisition shall be in accordance with NAS-MD-793, Section 3.1 and all subsections.

RMS data processing shall be in accordance with NAS-MD-793, Sections 3.2 through 3.2.3.2 with the following exceptions. Internal addressing, command codes, and message generation shall follow applicable requirements in NAS-IC-51035101.

RMS communication processing shall be in accordance with NAS-IC-51035101.

RMS command processing shall be in accordance with NAS-MD-793, Sections 3.4 through 3.4.4 with the following exceptions: Command Acceptance and Verification and Command Results Reporting follow applicable requirements in NAS-IC-51035101.

System control via the MPS shall be limited to the following actions: Master reset and Startup/Recovery Equipment Command Messages as defined in NAS-IC-51035101, Section 3.1.2.2.1.11 and RVR system unique Equipment Command Messages. RVR system unique Equipment Command Messages shall include the following functionality: Online/Offline control for each RVR subsystem component; control of alarm (hard alarm) and alert (soft alarm) limits and data quality check limits/parameters, as appropriate; control of RVR system and subsystem component fault diagnostics; and individual RVR subsystem component resets.

The interface between the RVR RMS and the MPS shall be designed in accordance with NAS-IC-51035101 using a dedicated leased line. All communication shall be initiated by the MPS in accordance with NAS-IC-51035101.

The communication link between the MPS and RVR RMS shall be considered inoperable if no MPS poll has been received by the RVR RMS within a configurable time period. The communication link between the MPS and RVR RMS shall also be considered inoperable if the RVR RMS has to send a configurable number of repeated messages to the MPS because of a MPS NAK (not acknowledged) response or timeout. The link shall be considered inoperable until a valid MPS poll is received by the RVR RMS, a message is sent by the RMS to the MPS and the MPS sends an ACK (acknowledged) to the RVR RMS.

Upon re-establishment of the link, the RVR RMS shall send appropriate messages for each Logical Unit to assure that the data available at the MPS reflects the latest configuration and data associated with the RVR system.

### **3.2.2.2.6.3.3 External time source**

An external time source will provide a coded date/time input to the RVR DPU. The DPU shall interface to the external time source and synchronize its internal system clock in accordance with the requirements identified in FAA-NAS-IR-32063311. The purpose of this coded input is to provide clock synchronization with other NAS systems.

### **3.2.2.2.6.3.4 NG RVR interface**

The PC-based RVR system may be collocated with an existing NG RVR system at airports within the NAS. In such instances, the PC-based RVR system shall receive NG RVR system data and integrate it with similar data of the PC-based system for representation of RVR conditions over the relevant RVR airport configuration. The PC-based RVR DPU shall interface with the NGRVR system via the latter's "Engineering User 1" (EU1) port in accordance with the engineering test data details given in FAA Technical Instruction Book 6560.17, Section 3.7 and Table 3-5. The PC-based RVR DPU shall: receive the simplex data stream from the NG RVR DPU; verify that the NG RVR sensors are operating correctly; process the NG RVR ALS measurement in accordance with paragraph 3.2.2.4; recalculate RVR products associated with NG RVR sensors; and format the RVR products for transmission across the external user interfaces described in paragraph 3.2.2.2.6.2. The PC-based RVR DPU shall verify that the NG RVRs VSSs, ALS, and RLIMs are operating properly through analysis of maintenance parameter



bytes provided for each configured NG RVR sensor in the EU1 data stream. The default values for the NG RVR EU-1 port shall be used.

### **3.2.2.2.7 DPU power**

The DPU shall use standard alternating-current (AC) commercial power, single phase, rated at 115 volts (V), ( $\pm 15\%$ ), 60 Hertz (Hz) ( $\pm 3$  Hz). DPU power may be commercial, essential or critical, depending on the particular facility power source availability and definition. All power conditioning systems shall be equipped with input and output fuses and/or circuit breakers and semiconductor protection devices. Battery backup is not required for the DPU.

The DPU shall have an 8-foot long power cable that plugs into a standard 3-prong convenience outlet that provides no more than 10 Amperes (A) (circuit breaker protected).

### **3.2.2.2.8 DPU installation**

The DPU shall be installed in a standard 19" electronics rack, typically located in the equipment room at the ATCT, as shown on FAA Standard Drawings D-6282-3, -7 and -9.

### **3.2.2.3 Visibility Sensor (VS)**

The VS shall utilize forward-scatter meter technology that measures the clarity of the atmosphere and produces a signal proportional to the visible extinction coefficient. It is one of three components used in the determination of the RVR product for a particular location along a runway. The VS has stringent accuracy requirements because its measurement has the greatest influence on the accuracy of the final RVR product. Window contamination results in reporting a higher than actual RVR value and must be controlled or corrected to provide valid VS measurements. In particular, snow clogging of a VS optical window might lead to reported RVR values much higher than actual; such occurrences shall be prevented or detected.

The VS scattering volume shall be representative of the ambient atmosphere. The sensor heads and mounting structure shall not significantly obstruct the free flow of fog or snow into the scatter volume. The sensor heads and mounting structure shall not provide a shadowing effect on the scatter volume. Sources of heat from the sensor shall not significantly warm the scatter volume or region around the VS (and hence affect the fog density in the scatter volume).

#### **3.2.2.3.1 VS measurement processing**

A one-minute running average of the atmospheric extinction coefficient ( $\sigma$ ) shall be calculated. The sensor shall spend at least 75 % of the time measuring the extinction coefficient. No more than 10 % of the data in a particular one-minute average shall come from the previous minute. If less than 75 % of the individual measurements contributing to a one-minute average are valid, the following requirements shall apply: the one-minute average is invalidated and the last valid average coasted until a valid average is obtained or until one minute has elapsed.

To assure a true signal average and to allow signal offsets and sensor noise to be detected, no signal clipping of VS measurement samples shall be allowed. Thus, for example, VS measurement samples at very low extinction coefficients may become negative.

### **3.2.2.3.2 VS measurement range**

To cover the full RVR range of 100 to 6,500 feet, the sensor measurement range shall cover the range of 1.0 to 300 inverse kilometers ( $\text{km}^{-1}$ ) with a resolution of  $0.01 \text{ km}^{-1}$  or 1 % of the measurement, whichever is greater. The VS measurement shall be corrected for atmospheric beam attenuation inside the sensor, which can affect measurements of the highest extinction coefficients.

### **3.2.2.3.3 VS calibration**

The calibration of a VS shall simulate the scattering from fog that is traceable to visibility measurements obtained from one or more reference transmissometers.

#### **3.2.2.3.3.1 Calibration device**

Each calibration device shall generate a scatter signal corresponding to a specific fog extinction coefficient. The scattering devices transfer the calibration of sensor units that have been calibrated against reference transmissometers to the sensors deployed in the field. This transfer process shall be accomplished using a minimum number of steps to avoid accumulation of errors. The calibration device(s) shall be durable and stable enough to assure reliable VS calibration over its lifetime of 20 years.

#### **3.2.2.3.3.2 Calibration process**

Communication with the VS during calibration shall be via the MDT. The RVR System shall report all RVR products associated with a VS as invalid while the calibration/validation process is being conducted on that VS.

The computer/processor in the sensor shall guide the calibration process and provide a progress indication of the calibration process to the maintenance person. The calibration process shall include validation steps that preclude human error in order to avoid serious long-term measurement errors. A progress indicator shall be displayed on the MDT during the VS calibration process. The VS shall not be restored to service until the entire calibration/validation process has been successfully completed.

The VS shall meet the electromagnetic interference (EMI) specifications throughout the calibration process so that significant calibration errors cannot be generated by EMI. After calibration, the VS shall meet the specified accuracy requirements over the entire measurement range of the VS.

#### **3.2.2.3.4 VS alignment**

The VS shall be aligned so that it provides the physical geometry necessary to meet the accuracy specifications below (see 3.2.2.3.5).

The unit-to-unit consistency of forward-scatter meters depends upon the consistency of the scattering geometry from unit to unit. Rough handling may produce significant changes in VS scattering geometry. A method shall be provided to verify the alignment/misalignment of the VS scattering geometry, in its installed location, annually or as required.

The VS sensor head assembly shall be capable of realignment at the depot level when misalignment is detected.

**3.2.2.3.5 VS accuracy**

The following VS accuracy requirements are based on one-minute averages of extinction coefficient.

- a. Under homogeneous atmospheric conditions, scatter meter measurements shall agree with those of a reference transmissometer to within 15 % (standard deviation) for  $\sigma$  (reference)  $> 3 \text{ km}^{-1}$ . The 15 %-standard-deviation requirement is tested at the 90 % confidence level; that is, 90 % of the one-minute-average readings of the scatter meter shall agree to within  $\pm 25$  % with the simultaneous one-minute-average readings of the reference transmissometer(s). Outliers (that is, more than a factor two difference) shall not occur for more than 0.2 % of the measurements.
- b. The fog response of the sensor shall drift by no more than 10 % in 90 days. Note that window contamination correction may be needed to meet this requirement. Window contamination correction shall account for any differences in the effect of dirt and water droplets.
- c. In some cases, snow clogging of the sensors' windows can lead to non-conservative RVR values. Sensor design shall provide valid measurements under virtually all snow conditions. Under conditions where snow clogging adversely affects sensor performance, the sensor shall detect snow clogging and disable its output if a valid measurement cannot be made.
- d. The fog and snow response (relative to the extinction coefficient) of the sensor shall agree to within 10 %.
- e. The unit-to-unit fog response shall vary by no more than  $\pm 7$  % when calibrated by the same scattering device.
- f. The fog response of a sensor shall vary by no more than  $\pm 3$  % when calibrated by different calibration devices.
- g. The sensor offset (clear day response) caused by self-scattering and/or electronic offset shall be less than  $\pm 0.3 \text{ km}^{-1}$ . The zero-light sensor offset (heads blocked) shall be no greater than  $\pm 0.2 \text{ km}^{-1}$ .

**3.2.2.3.6 VS interfaces**

The VS communications interface is defined in 3.2.2.2.6.1.

An MDT port using EIA Standard 232f interface(s) shall be installed on SIE enclosure. The serial port shall enable local access and communication for the purposes of real-time diagnostics, calibration, monitoring and/or control of the sensors and RVR System (3.2.2.2.6.3.1).

**3.2.2.3.7 VS power**

The VS shall use standard AC commercial power, single phase, rated at 115 V, ( $\pm 15$  %), 60 Hz ( $\pm 3$  Hz). The VS shall have a power terminal for connection with a 3-1/C #10 cable as defined in FAA Drawing Number D-6282-7. All power conditioning systems shall be equipped with input and output fuses and/or circuit breakers and semiconductor protection devices.

The VS shall have a battery backup system capable of powering the hardware item, without any interruption to functional operation at  $25^\circ\text{C} \pm 10^\circ\text{C}$ , for a minimum of four hours, without any interruption to functional operation, in the event of a commercial power failure. The battery

power conditioning system shall be capable of simultaneously providing power to the protected equipment while charging its batteries from a 50 % charge condition to a full charge within 12 hours (at 25°C ± 10°C) after return of commercial power.

One, 3-wire grounded and polarized, duplex, (with parallel slots and double sided contacts), outdoor type convenience outlet equipped with a ground fault interrupter, protected by a 20A, 120V rated circuit breaker shall be provided inside the SIE enclosure.

### **3.2.2.3.8 VS installation**

The RVR VS shall be securely mounted on a Government-furnished low impact resistant (LIR) structure, described in FAA-E-2702A, located approximately 35 feet (cable length) from the SIE. The VS assembly shall be mounted at the top of the pole, on the pole cap furnished with the LIR structure, or on the pole itself. No other VS components shall be mounted on the VS pole.

The VSs are installed near the runways for which RVR is estimated. The VS will be mounted approximately 14' above the surface and normally 250 to 400 feet (maximum 1000 feet) from the centerline of the runway to be monitored. The specific LIR structure selected for the RVR VS application is the MG-20 fiberglass pole which is used in conjunction with the MG-20 tilt-down mounting stand. See FAA-D-6282-2, 4, 5, & 6 for typical RVR installation drawings, and FAA-D-6155-21 for typical assembly instructions for the MG-20 LIR structure.

### **3.2.2.4 Ambient Light Sensor (ALS)**

The ALS measures the brightness of the northern sky (for northern hemisphere installations) 6° above the horizon with a 6° field of view. This prevents the sun from directly shining into the lens, which causes immediate overload on the window contamination. A southern hemisphere installation would require the ALS to be pointed 180 degrees directly opposite of true north. The ALS shall include a level to facilitate the correct installation angle. A maximum of two ALSs shall be located on the airfield or at some central location such as the ATCT. If the PC-based RVR system is collocated with a NG RVR system at an airport, the NG RVR system shall provide one of the ALS measurements. If more than one ALS measurement is available, the higher ALS measurement shall be used in calculating RVR.

The ALS shall measure from 0.5 to 10,000 fL, with a resolution of 0.5 fL or 5 % of the measurement, whichever is greater. The accuracy of the ALS measurement at or above 2 fL shall be ± 20 %. Uncorrected ALS window losses shall not exceed 20 % in 90 days. Snow clogging of the ALS will likely result in non-conservative (higher than actual) RVR values and shall be prevented or detected.

#### **3.2.2.4.1 ALS measurement processing**

A one-minute running average of the background luminance (B) shall be calculated. The sensor shall spend at least 75 % of the time measuring the background luminance. No more than 10 % of the data in a particular one-minute average shall come from the previous minute. If less than 75 % of the individual measurements contributing to a one-minute average are valid, the following requirements shall apply: the one-minute average must be invalidated and the last valid average must be coasted until a valid average is obtained or until one minute has elapsed.

To assure a true signal average and to allow signal offsets and sensor noise to be detected, no signal clipping of ALS measurement samples shall be allowed. Thus, for example, sample ALS measurements at very low light levels may be negative.

#### **3.2.2.4.2 ALS interfaces**

The ALS communications interface is defined in 3.2.2.2.6.1.

An MDT port using EIA Standard 232f interface(s) shall be installed on the SIE enclosure. The serial port shall enable local access and communication for the purposes of real-time diagnostics, calibration, monitoring and/or control of the sensors and RVR System (3.2.2.2.6.3.1).

#### **3.2.2.4.3 ALS power**

The ALS shall use standard AC commercial power, single phase, rated at 115 V, ( $\pm 15\%$ ), 60 Hz ( $\pm 3$  Hz). The ALS shall have a power terminal for connection with a 3-1/C #10 cable as defined in FAA-D-6282-7. All power conditioning systems shall be equipped with input and output fuses and/or circuit breakers and semiconductor protection devices.

The ALS shall have a battery backup system capable of powering the hardware item, without any interruption to functional operation at  $25^{\circ}\text{C} \pm 10^{\circ}\text{C}$ , for a minimum of four hours, without any interruption to functional operation, in the event of a commercial power failure. The battery power conditioning system shall be capable of simultaneously providing power to the protected equipment while charging its batteries from a 50 % charge condition to a full charge within 12 hours (at  $25^{\circ}\text{C} \pm 10^{\circ}\text{C}$ ) after return of commercial power.

One, 3-wire grounded and polarized, duplex, (with parallel slots and double sided contacts), outdoor type convenience outlet equipped with a ground fault interrupter, protected by a 20A, 120V rated circuit breaker shall be provided inside the SIE enclosure.

#### **3.2.2.4.4 ALS installation**

The ALS shall be installed as shown on FAA-D-6282-3, -7 and -9.

#### **3.2.2.5 Runway Light Intensity Monitor (RLIM)**

The RLIM SIE is located in the runway lighting power vault. The RLIM determines the runway light setting by measuring the light current. Thus, it gives the actual light setting even if the runway light current regulator fails to correspond to its switch setting. The RLIM, consisting of an SIE and up to 8 current loop sensors, shall accommodate the two types of runway lights used in the United States with maximum currents of 6.6A and 20A, respectively. The RLIM shall determine which light setting is being used by directly measuring the 60 Hz root mean square (rms) lamp current. The current measurement shall be accurate to 6 % of the current or 0.1A, whichever is greater.

Runway light current is associated with the steps outlined in TABLE 3-7, Runway light currents.

**TABLE 3-7 Runway light currents**

<b>Light Setting</b>	<b>6.6 Amperes</b>	<b>20 Amperes</b>
Step 0 (Off)	0 A	0 A
Step 1	2.8 A	8.5A
Step 2	3.4 A	10.3 A
Step 3	4.1 A	12.4 A
Step 4	5.2 A	15.8 A
Step 5	6.6 A	20.0 A

**3.2.2.5.1 RLIM measurement processing**

The RLIM data are not averaged, i.e., each sample is used. If an RLIM data sample is missing, the last valid data sample shall be coasted. RLIM data shall be coasted up to 30 seconds before a failure is declared.

Invalid RLIM measurements shall be treated as a runway light setting of zero (0). Where more than one current regulator is used for a particular set (that is, edge or centerline) of lights, the failure of one RLIM measurement shall lead to a light setting of zero (0) for that set of lights. In other words, if more than one light current regulator is used for the edge/centerline lights and one of the edge/centerline RLIM measurement is invalid, then the edge/centerline light setting shall be set to zero (0). When more than one current regulator is used for a particular set of lights and all the RLIM measurements are valid, then the RLIM measurement with the lowest light setting shall be assigned to that set of lights.

**3.2.2.5.2 RLIM interfaces**

The RLIM communications interface is defined in 3.2.2.2.6.1.

An MDT port using EIA Standard 232f interface(s) shall be installed on the SIE enclosure. The serial port shall enable local access and communication for the purposes of real-time diagnostics, calibration, monitoring and/or control of the sensors and RVR System (3.2.2.2.6.3.1).

**3.2.2.5.3 RLIM power**

The RLIM shall use standard AC commercial power, single phase, rated at 115 V, ( $\pm 15\%$ ), 60 Hz ( $\pm 3$  Hz). The RLIM shall have a power terminal for connection with a 3-1/C #10 cable as defined in FAA-D-6282-7. The RLIM current sensors are passive devices requiring no operating power. All power conditioning systems shall be equipped with input and output fuses and/or circuit breakers and semiconductor protection devices.

The RLIM shall have a battery backup system capable of powering the hardware item, without any interruption to functional operation at  $25^{\circ}\text{C} \pm 10^{\circ}\text{C}$ , for a minimum of four hours in the event of a commercial power failure. The battery power conditioning system shall be capable of simultaneously providing power to the protected equipment while charging its batteries from a

50 % charge condition to a full charge within 12 hours (at 25°C ± 10°C) after return of commercial power.

One, 3-wire grounded and polarized, duplex, (with parallel slots and double sided contacts), outdoor type convenience outlet equipped with a ground fault interrupter, protected by a 20A, 120v rated circuit breaker shall be provided inside the SIE enclosure.

#### **3.2.2.5.4 RLIM installation**

The RLIM and Current Loop Sensor(s) shall be installed similar to the method given on FAA-D-6282-3, -7 and -9.

#### **3.2.2.6 RVR Controller Display (CD)**

The CD shall display RVR products for the specific runway(s) selected by an Air Traffic Controller (hereafter referred to as Controller) using either a keypad or a touch-screen included with the display. The CD shall be readable in both high and low artificial and natural light conditions corresponding to conditions in an ATCT and TRACON. In addition to a means of data entry, the CD shall include an audio alarm and dual communication links to ensure fail-safe data communications from the RVR DPU.

The CD shall be used by the Controller to display RVR products for any runway and simultaneously display RVR products for up to three runways. Each display line shall consist of: the runway ID; the RVR products and trends for the TD, MP, and RO positions; runway edge light step setting; and, centerline light step setting. The CD shall be capable of sounding audio alarms and displaying visual alarms corresponding to each product.

The CD shall receive the incoming serial data stream from the DPU (3.2.2.2) or NGRVR DPU; perform error checks on the data and format and display the product. The CD shall include the means to set Low Visibility Alarm Threshold (LVAT) limits for any of the TD, MP or RO positions of the display. The CD shall issue an alarm consisting of both an audio alarm and a visual indication on the CD whenever an RVR value decreases below a preset alarm limit, or if a failure occurs.

The selected runways and LVAT limits that are set by the Controller shall be stored in non-volatile memory. In case of AC power failure, when the power is restored, the CD shall reinitialize itself and restore all data previously entered by the Controller.

##### **3.2.2.6.1 CD readability**

The display characters' aspect ratio of height to width shall be greater than or equal to 1.0. The CD shall permit viewing in full, direct sunlight from any angle, as installed in an ATCT. The display-viewing surface shall be antiglare. The display shall be readable in light levels ranging from bright sunlight, to artificial light, to near darkness. The display shall be readable at a distance of 10 feet at a horizontal viewing angle of 30° from either side of a vertical plane perpendicular to the display. The display shall be readable at a distance of 10 feet at a vertical viewing angle of 20° from either side of a horizontal plane perpendicular to the display.

**3.2.2.6.2 CD data display and presentation**

The CD shall be capable of displaying the selected runway, the corresponding RVR values and trend, the RVR threshold alarm limits, the edge and centerline runway light setting and status/failure indications.

A Controller shall be able to select a display of RVR products for one to three runways by selecting the runway designation (for example, 14R, 10C, 10R) via the keypad or the touch-screen. It shall be possible to enter a single LVAT for an entire runway or individual LVATs for the TD, MP and RO RVR products for each runway.

The runway designator shall consist of three alphanumeric characters as follows - numeric characters "01" through "36" followed by a blank space or one of the following alphabetic characters: "L", "C" or "R".

Each runway position designator (TD, MP and RO) shall consist of four alphanumeric characters. When a valid RVR product is to be displayed, the first two characters shall represent the RVR product in hundreds of feet and last two characters must be "00". Either a trend arrow indicating "up", "down" or a blank indicating a steady state shall follow each runway position designator.

The runway edge light and centerline light step setting designators shall each consist of one alphanumeric character from "0" to "5" or a blank space.

The CD shall highlight the manually entered data (that is, runway selection and alarm limits) using a special feature such as reverse video or brackets. An LVAT or failure alarm condition shall be indicated by an audio alarm as well as visual alarm consisting of an indicator on the numeric display such as blinking or highlighting. Provisions shall be included to enable the Controller to clear the audio and visual alarms associated with an LVAT or failure alarm. The CD shall use ASCII "blanks" and "F" to indicate the conditions described in TABLE 3-8, CD data presentation.

**TABLE 3-8 CD data presentation**

No.	Scenario	Display
1	Runway position not assigned to a VS (for example, the midpoint position does not have a VS configured).	" " (4 blanks)
2	Centerline Lights not configured.	" " (1 blank)
3	Invalid data or sensor failure. This includes the scenario where a sensor is taken off-line for calibration or other MDT usage.	"FFF " (Runway position) "F" (Edge or Centerline)



#### **3.2.2.6.2.1 Low visibility alarm threshold (LVAT) limits**

LVAT limits shall be operator-assignable for any visibility sensor position on any configured runway. LVAT limits shall be logically assigned to the runway for which the operator enters them such that if the runway display position is moved, the LVAT limits move with it.

Example - If the LVAT limits are assigned to runway 01R in the first CD position and the operator moves runway 01R to CD position two or three, then the LVAT limits move to the new display position.

#### **3.2.2.6.3 CD control**

The CD shall contain the following control functions: AC power; data entry/access; keypad intensity; display intensity; audio alarm volume control; and alarm acknowledge.

##### **3.2.2.6.3.1 Data entry/access**

The CD shall have an alphanumeric keypad or touch-screen data entry/access capability.

##### **3.2.2.6.3.2 Keypad intensity**

If a keypad is used, the keypad intensity and control shall be adjustable so the keypad is clearly visible in near darkness and bright sunlight.

##### **3.2.2.6.3.3 Controls**

###### **3.2.2.6.3.3.1 Display intensity**

The display light intensity control shall be present on the front panel and be adjustable so the display is clearly visible in near darkness and bright sunlight.

###### **3.2.2.6.3.3.2 Keypad**

The keypad, if used, shall satisfy the design criteria for input devices stated in paragraph 8.21.4 of FAA Human Factors Design Guide Update, DOT/FAA/CT-01/08.

Keypad entries shall appear in the appropriate fields in the display. An editing feature shall be included, such as a backspace, to allow entry corrections. The CD shall check for invalid entries, such as an incorrect runway, and indicate any error to the operator. The keypad (if used) shall utilize positive touch-feedback type keys.

###### **3.2.2.6.3.3.3 Touchscreen**

The touchscreen, if used, shall satisfy the design criteria for input devices stated in paragraph 8.21.4 of FAA Human Factors Design Guide Update, DOT/FAA/CT-01/08.

###### **3.2.2.6.3.3.4 Volume**

The volume control for all audio alarms shall be adjustable to a level that satisfies the audio and verbal display criteria cited in paragraph 8.16 of FAA Human Factors Design Guide Update, DOT/FAA/CT-01/08. The audio alarm adjustment shall be a set-up function based on the facility (ATCT or TRACON) ambient noise level. The volume control shall not be located on the face of the display.

**3.2.2.6.3.3.5 Power**

An AC power switch shall be present on the front panel of the CD. The AC power switch shall be marked to indicate when power is on or off. The CD shall utilize a lighted indicator that illuminates when the power switch is turned on. The illumination intensity of the CD power indicator shall be optimized for viewing in near darkness. The power switch shall be either located where the possibility of it being inadvertently activated or deactivated is remote or a protective guard is placed over the switch.

**3.2.2.6.4 CD alarm operation**

Alarms shall be manifested by three beeps and a flashing display. An alarm-acknowledge control shall be used to deactivate all blinking visual alarms and audio alarms simultaneously. If the condition that caused the alarm assumes an acceptable state and then deteriorates beyond a threshold, the alarm(s) shall again become activated.

**3.2.2.6.4.1 Audio alarm operation**

The audio alarm shall be activated in accordance with TABLE 3-9, Audio alarm conditions. Except in the case of a hardware failure peculiar to an individual CD, all audio alarms shall silence after three (3) beeps or when the alarm is acknowledged. The audio alarm tone, frequency, timing and duration shall be as specified in paragraph 8.16 of the FAA Human Factors Design Guide Update, DOT/FAA/CT-01/08.

**TABLE 3-9 Audio alarm conditions**

No.	Alarm Condition	Audio Alarm
1	LVAT Exceeded	Three beeps
2	Edge and Centerline Runway Light Settings do not Match	Delay 15 seconds; then three beeps
3	DPU Failure	Three beeps (after coast time out)
4	Channel Failure	Three beeps (after coast time out)
5	Hardware Failure Peculiar to an Individual CD	Continuous beep
6	Invalid Data Entry	One beep

**3.2.2.6.4.2 Visual alarm operation**

The visual alarm shall operate in accordance with TABLE 3-10, Displayed alarm conditions. All visual alarms shall remain until: acknowledged by the operator; or the condition clears itself; or in the case of a channel failure or CD fault, the condition is corrected by a maintenance action.

**TABLE 3-10 Displayed alarm conditions**

No.	Alarm Condition	Visual Alarm
1	LVAT Exceeded	Affected runway position blinks continuously at a one second rate where the indicator is “on” for 0.5 seconds and “off” for 0.5 seconds.
2	Edge and Centerline Runway Light Settings do not Match	Delay 15 seconds; then affected runway light data field blinks continuously at a one second rate where the indicator is “on” for 0.5 seconds and “off” for 0.5 seconds.
3	DPU Failure	Delay 30 seconds, then display "30 sec DPU Timeout".
4	Channel Failure	Delay 30 seconds, then indicate a channel failure; display the good RVR product set.
5	CD Fault Condition	Display an appropriate message.

**3.2.2.6.5 CD self-test**

The CD shall contain self-test features that will ensure error-free operation of the unit at all times. Upon power-up and once every hour, the CD shall automatically initiate a self-test sequence that ensures proper operation of the processor, memory, and other system components.

A control feature shall be available to allow an operator to manually initiate a self-test. A manually initiated self-test shall enable a comprehensive test of the display portion of the CD and other system components that could not otherwise be permitted during normal operation.

**3.2.2.6.6 CD interface**

Each CD shall contain dual communication interfaces compatible with the DPU (3.2.2.2) and the NGRVR DPU. Each CD shall receive separate identical RVR product sets over each interface. The CD shall use two completely independent data reception circuits. Failure of one communication channel shall not disrupt normal display operations.

The following message errors shall be detected by the CD for both communication channels: Invalid block check code; Invalid Message Field values, Missing start of text; Missing end of text; Missing end of transmission; Parity Error; and Invalid Time Stamp.

The CD shall display the status of both communication channels. In case of a channel failure or a message error, the CD shall "coast" the last RVR product set for 30 seconds. After 30 seconds, if communications have not been restored, the CD shall indicate the channel failure and sound an audible alarm of 3 beeps.

The CD shall switch between the two channels in accordance with the TABLE 3-11, Channel activation sequence. The "\*" in TABLE 3-11 denotes channel data displayed by the CD.

**TABLE 3-11 Channel activation sequence**

No.	Failure	Channel 1	Channel 2
1	Initial State-All Operational	Good*	Good
		↓	↓
2	Channel 1 Failure	Fail	Good*
		↓	↓
3	Channel 1 Repaired	Good	Good*
		↓	↓
4	Channel 2 Failure	Good*	Fail

**3.2.2.6.7 CD power**

The CD shall use standard AC commercial power, single phase, rated at 115 V, ( $\pm 15\%$ ), 60 Hz ( $\pm 3$  Hz). The CD’s power may be commercial, essential or critical, depending on the particular facility. Battery backup is not required for the CD.

The CD shall have an 8-foot long power cable that plugs into a standard 3-prong convenience outlet that provides no more than 10A (circuit breaker protected).

**3.2.2.6.8 CD installation**

**3.2.2.6.8.1 Location**

The CD shall operate in a local configuration in the same facility with the DPU requiring communications over distances of up to 2,000 feet as well as in a remote configuration at sites requiring the use of Government-furnished modems and dedicated lines. All requirements for CD operation shall apply to both local and remote configurations. Refer to FIGURE 3-2 for examples of each configuration.

### Local Configuration

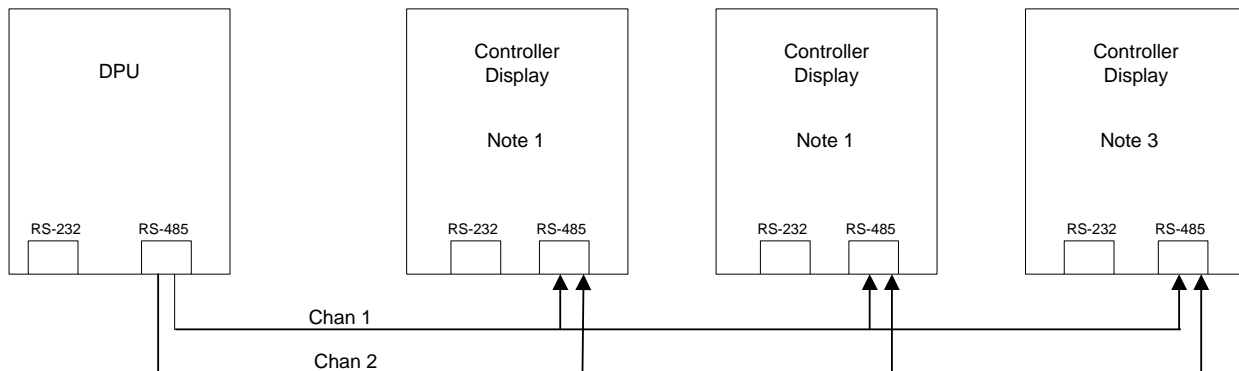

### Remote Configuration

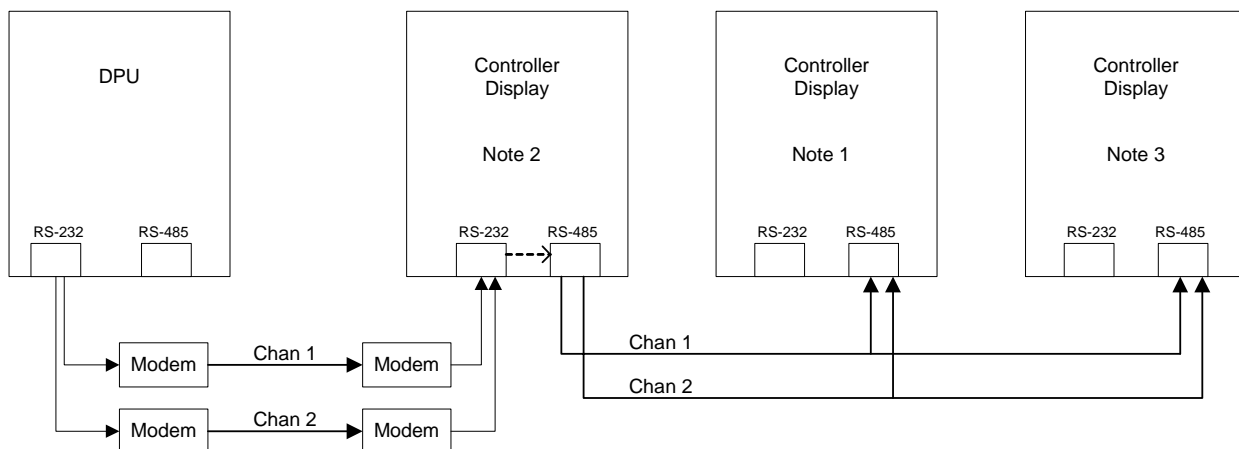

- Note:
1. The CD must be configured for LOCAL operation.
  2. The CD must be configured for REMOTE operation, i.e. the CD must convert RS-232 to RS-485 internally. The internal RS-485 drivers must drive up to 32 additional CDs.
  3. The last CD in the chain must be configured for LOCAL operation and the TERMINATION option must be set. For clarity, only three CDs are illustrated in each configuration.

**FIGURE 3-2 Controller display configurations**

#### 3.2.2.6.8.1.1 Local configuration

In local configuration, up to 32 CDs shall be connected to the DPU using an RS-485 interface for each communication channel.

#### 3.2.2.6.8.1.2 Remote configuration

Using an RS-232 interface, the first remote CD shall be connected to the DPU via Government-furnished modems. The first remote CD shall convert the RS-232 interface to RS-485. A

maximum of 32 additional CDs shall connect to the first remote CD and function as if they were in a local CD configuration. Except for the first CD in a remote chain, any CD that fails shall not affect any other CD in that chain. Each communication channel shall be supplied through a separate Government-furnished modem.

**3.2.2.6.8.2 Hardware size**

The electronics compartment shall not exceed 5.75 inches in height, 8.75 inches in width and 9.0 inches in depth. The faceplate dimensions and hole spacing shall be compliant to with FAA TI-6560.17, Figure 9-11A. If a keypad is used, it shall be integral with the faceplate; that is, the length and width must not extend beyond the faceplate.

**3.2.3 Electronic equipment, general requirements**

The RVR shall meet the general navigational aid equipment requirements of this paragraph and TABLE 3-12, tailored from FAA-G-2100G.

**TABLE 3-12 General Navigational Aid electronic equipment requirements**

<b>Requirement</b>	<b>FAA-G-2100G Paragraph</b>	<b>Applicability Notes</b>
Electrical Power	3.1.1	Applies in total
Mechanical	3.1.2	Applies in total
Software	3.1.3	Applies in total
Operating Environmental Conditions	3.2.1	Applies with additional clarification in 3.2.3.1 and TABLE 3-13 of this specification
Physical Characteristics	3.2.2	Applies in total
Reliability	3.2.3	Applies except where specified in 3.2.2.1.1.1 of this specification
Maintainability	3.2.4	Maintainability requirements in 3.2.2.1.1 of this specification,  Additional maintainability requirements of paragraph 3.2.4 of FAA-G-2100G apply
[Failsafe] External Equipment Interfaces	3.2.5	Applies in total
Electrostatic Discharge	3.2.6	Applies in total
Transportability	3.2.7	Transportability requirements in paragraph 3.2.3.2 of this specification

**TABLE 3-12 General Navigational Aid electronic equipment requirements**

<b>Requirement</b>	<b>FAA-G-2100G Paragraph</b>	<b>Applicability Notes</b>
Materials, Processes and Parts	3.3.1	Applies in total,  Additional materials design constraints are in paragraph 3.2.3.3 of this specification.
Electromagnetic Compatibility (EMI/EMC) and FCC Type Certification	3.3.2	Applies in total
Nameplates and Marking	3.3.3	Applies in total
Interchangeability	3.3.4	Applies in total
Personal Safety and Health	3.3.5	Applies in total
Human [Factors] Engineering	3.3.6	Applies in total
Documentation	3.4	Applies as stated in the Statement of Work
Personnel and Training	3.5	Applies as stated in the Statement of Work
[Quality Assurance] Quality System Requirements	4.1	Applies as stated in the Statement of Work
[Quality assurance] Verification/Compliance to Requirements	4.2	Applies in Total except as modified for 4.2.2.2 and 4.2.2.4 in the Statement of Work.
FCC Type Acceptance and Registration Procedures	4.2.2.2	Applies in total
Preparation for Delivery	5.0	Applies in total

**3.2.3.1 Operating environmental conditions**

The RVR shall meet the requirements of FAA-G-2100G, paragraph 3.2.1 for operating environment conditions with the following clarifications. RVR equipment designed for use in attended facilities (ATCT and TRACON) shall operate in the ambient conditions of Environment I in TABLE 3-13. RVR equipment designed for use in unmanned facilities (equipment shelter) shall operate with the ambient conditions of Environment II listed in TABLE 3-13. Equipment not housed in shelters shall operate in the ambient conditions of Environment III listed in TABLE 3-13.

**TABLE 3-13 Environmental conditions**

Environment <sup>1</sup>	Temperature (°C)	Relative Humidity <sup>3</sup> (%)	Altitude (Feet above sea level)	Wind (mph)	Ice Loading	Rain
I	+10 to +30	10 to 80	0 to 10,000	--	--	--
II	0 to +50	5 to 90	0 to 10,000	--	--	--
III <sup>4</sup>	-50 to +70 <sup>2</sup>	5 to 100	0 to 10,000	0 to 100	Encased in ½” radial thickness clear ice	2”/hour

- Note:
1. I: For equipment installed in an attended facility.  
II: For equipment installed in an unattended facility.  
III: For equipment installed outdoors (antennas, field detectors).
  2. Includes 18°C for solar radiation.
  3. Above 40°C, the relative humidity shall be based upon a dew point of 40°C.
  4. Conformal coating is required.

### 3.2.3.2 Transportability

The RVR System design shall meet the requirements for transportability under commercial shipping conditions as required in category 4,5,7,8,9, 10 and 11 (Transportation) of TABLE 514-I. Vibration environment categories of MIL-STD-810F.

### 3.2.3.3 Materials, processes and parts

The RVR System shall meet the requirements of FAA-G-2100G, paragraph 3.3.1 for materials, processes and parts. Navigational aids are subjected to environmental service conditions that have been found to be detrimental to several types of material not identified in FAA-G-2100G, so the following sub-paragraphs apply further restrictions to the use of such materials in the design of the equipment.

- a. Iron and steel. Iron and steel shall be used only when necessary to comply with strength requirements. Outside equipment enclosures, exposed to Environment III (outside conditions), shall not be made of steel. When approved for use, iron and steel shall be treated to prevent corrosion.
- b. Fibrous Material, Organic. Organic fibrous material shall not be used.
- c. Fungus-inert Materials. Materials used shall be fungus-inert, except within hermetically sealed assembly. TABLE 3-14 Group I lists materials that are inherently fungus-inert, and Group II lists materials that are fungus nutrient in some configurations. Materials from Group I are preferred, but when materials from Group II must be used, they shall be rendered fungus inert by compounding with a permanently effective fungicide or by suitable surface treatment. They shall pass the fungus test specified in ASTM G21, with no visible growth of fungus after 28 days.
- d. Insulating Materials, Electrical. Insulating materials shall be selected based on meeting or exceeding the use requirements of the following: temperature



endurance, moisture absorption and penetration, fungus resistance, dielectric strength, dielectric constant, mechanical strength, dissipation factor, ozone resistance, and flammability. Polyvinyl chloride insulating materials for external cables shall be in accordance with NFPA-70. Ceramics shall conform to MIL-I-10 or equivalent. Ceramic insulators shall conform to MIL-I-23264 or equivalent. Sleeving shall provide adequate dielectric strength and leakage resistance under the designated service conditions. Cast thermosetting plastic used for electrical insulation shall be in accordance with L-P-516 or equivalent. Other electrical materials having moisture absorption of greater than 1 % shall be impregnated with a suitable moisture barrier material.

- e. Lubricants. Lubricants shall be suitable for the purpose intended. Low volatility lubricants shall be used. The lubricant shall be chemically inert with respect to the materials or other lubricants it contacts. Silicone and graphite base lubricants shall not be used.
- f. Rubber (natural). Natural rubber shall not be used.
- g. Wood and Wood Products. Wood and wood products shall not be used inside equipment.
- h. Thread Locking and Retaining Compounds. Thread locking and retaining compounds shall conform to the required operating conditions and MIL-S-22473 or MIL-S-46163 or equivalent and be applied such that the required level of locking or retaining is achieved and maintained. Such compounds shall not impair electrical conductivity, cause or accelerate corrosion or be used where failure would endanger personnel or damage equipment. Such compounds shall be compatible with the material to which they are bonded.
- i. Anti-seize Compounds. Anti-seize compounds shall conform to MIL-T-22361 or TT-S-1732 or equivalent. Graphite base anti-seize compounds shall not be used.

**TABLE 3-14 Fungi susceptibility of material**

<b>GROUP I. Fungus-inert Materials</b>	<b>GROUP II. Not Fungus-inert</b>
Acrylics Acrylonitrile-styrene Acrylonitrile-vinyl-chloride copolymer Ceramics Chlorinated polyether Fluorinated ethylenepropylene copolymer (FEP) Glass Metals Plastic laminates: Silicone-glass fiber Phenolic-nylon fiber Diallylphthalate Polyacrylonitrile Polyamide Polycarbonate Polyester – glass fiber laminates Polyethylene, high density (above 0.940) Polymonochlorotrifluoroethylene Polypropylene Polystyrene Polysulfone Polytetrafluorethylene Polyvinylidene chloride Silicone resin Siloxane-polyolefin polymer Siloxane-polystyrene	ABS (acrylonitrile-butadiene styrene) Acetal Cellulose acetate Epoxy-glass fiber laminates Epoxy-resin Lubricants Melamine-formaldehyde Organic polysulphides Phenor-formaldehyde Polydichlorostyrene Polyethylene, low and medium density (0.940 and below) Polymethyl methacrylate Polyurethane (the ester types are particularly susceptible) Polyrichinoleates Polyvinyl chloride Polyvinyl chloride-acetate Polyvinyl fluoride Rubbers, natural and synthetic Urea-formaldehyde

*Note: under certain conditions, selective microorganisms may attack polyamides.*

**3.3 SYSTEM CHARACTERISTICS**

RVR System shall meet the requirements specified in 3.2 while in accordance with the system characteristics directed by 3.3.

**3.3.1 Safety**

The design and development of electronic equipment shall provide for the safety of personnel during the installation, operation, maintenance, repair and interchange of complete equipment assemblies or component parts. Equipment design for personnel safety shall be equal to or better than the requirements of the Occupational Safety and Health Agency (OSHA) as identified in CFR Title 29, Part 1910 and Part 1926.

### **3.3.2 Security**

#### **3.3.2.1 Physical security.**

The RVR System shall be capable of installation without modification within an airport operations area in the proximity of runways, the ATCT and the TRACON. SIE enclosures near the runways shall be capable of being padlocked.

#### **3.3.2.2 Information security**

The RVR System shall provide a minimum of four (4) access levels.

### **3.3.3 Human factors**

The general and detailed design of the RVR System shall be in accordance with the requirements of Sections 4, 6, 7, 8, 12, 13 and 14 of DOT/FAA/CT-96/1.

Design of the display screens for maintenance and Air Traffic Operations personnel shall be engineered to ensure optimal: usability; efficiency and effectiveness of human performance; and safety.

## **4 VERIFICATION**

This section addresses the system test of the RVR System in support of the FAA Acquisition Management System. System tests are divided between Contractor testing and Government testing. FAA test and evaluation policy and guidelines may be found on the FAA Acquisition System Toolset (FAST) located at <http://fast.faa.gov/>.

### **4.1 VERIFICATION REQUIREMENTS TRACEABILITY MATRIX (VRTM)**

The VRTM, Appendix A, lists all of the requirements that must be met by the RVR System to satisfy the functional and performance requirements in this specification. The VRTM is used to guide the procurement process through a comprehensive mapping of each requirement to one or more tests that will verify the performance of each functionality of the RVR System.

#### **4.1.1 Verification methods**

The following describes the four methods (Test; Demonstration; Analysis; and Inspection) used to measure the RVR System's compliance to the requirements contained in this specification. The four verification methods, listed in decreasing order of complexity, are described in the following paragraphs.

##### **4.1.1.1 Test**

Test is a method of verification wherein performance is measured during or after the controlled application of functional and/or environmental stimuli. Quantitative measurements are analyzed to determine the degree of compliance. The process uses laboratory equipment, procedures, items and services.

##### **4.1.1.2 Demonstration**

Demonstration is a method of verification where qualitative determination of properties is made for an end item, including the use of technical data and documentation. The items being verified are observed, but not quantitatively measured, in a dynamic state.

**4.1.1.3 Analysis**

Analysis is a method of verification that consists of comparing hardware design with known scientific and technical principles, procedures and practices to estimate the capability of the proposed design to meet the mission and system requirements.

**4.1.1.4 Inspection**

Inspection is a method of verification to determine compliance without the use of special laboratory appliances, procedures or services. It consists of a non-destructive static-state examination of the hardware, the technical data and documentation.

**5 PACKAGING**

Packaging requirements shall be as specified in the contract or order.

**6 NOTES**

**6.1 INTENDED USE**

RVR is an estimate of how far down a runway a pilot can see. The objects viewed may be runway lights or runway markings.

**6.1.1 Precision approach limits**

Precision approaches to instrumented runways are permitted only when the RVR value is at or above the minimum value shown in the Precision Approach Limits. These limits are given in TABLE 6-1 along with the required locations for determining RVR. Under low visibility conditions, if the RVR value(s) are not available, then a precision approach may not be allowed.

**TABLE 6-1 Precision approach limits and RVR sensor locations**

<b>Approach Category</b>	<b>Minimum Reported RVR (feet)</b>	<b>Required Locations</b>
Category I	1,800 to 2,400, Depending Upon Approach Lighting Systems	Touchdown
Category II	1,200	Touchdown, Rollout
Category IIIa	700, Centerline Lights Required	Touchdown, Midpoint, Rollout
Category IIIb	200, Centerline Lights Required	Touchdown, Midpoint, Rollout
Category IIIc	0, Centerline Lights Required	Touchdown, Midpoint, Rollout

Runway lighting systems are designed to maximize the value of RVR or pilot visibility. Under conditions when RVR may limit operations, runway lights are more visible than runway markers when set at the highest light levels. At the highest light level and with the minimum natural clarity of the atmosphere at airports, the RVR value typically is never observed to reach the bottom limit of Category IIIb. Thus, the RVR system need not cover Category IIIc.

### 6.1.2 RVR system

An RVR value is specific to a particular runway location. RVR is determined by a system that measures the clarity of the atmosphere in that location and two other parameters: the brightness of the sky against which the runway lights are viewed and the runway light intensity. A single value of ambient light is used for all runways and is taken from the measurement of one of the two required ALSs. The RVR system collects the required measurements, calculates the RVR product using one-minute averages of atmospheric clarity and ambient light and delivers and/or displays the product to users.

### 6.1.3 RVR system users

Currently, the RVR products are displayed for Controllers at the ATCT cab and in the TRACON facility. These Controllers inform pilots of current RVR conditions. RVR values are also delivered to more distant users via ASOS and CDM for use in flight planning. RVR products are also archived for accident/incident investigations.

## 6.2 ACQUISITION REQUIREMENTS

The Government will conduct an operational capabilities test (OCT) of the VS and ALS as a part of the acquisition selection process. Selected requirements from the VRTM that apply to the VS and ALS will be verified in order to determine the suitability of proposed sensors to support the Specification requirements. The test will be conducted at the Otis Weather Test Facility on Cape Cod, MA. The data obtained during the OCT may be used to support portions of Operational Tests conducted after Contract award.

## 6.3 DEFINITIONS

The following definitions apply to the terms and acronyms used in this specification:

Availability	The probability that an item will perform its required function under given conditions at a stated instant of time. Alternatively, ability of an item to perform a required function under given conditions at a stated instant of time.
Diagnostics	Diagnostics refers to the Built-In Test (BIT) and Fault Isolation Test (FIT) features for the determination of subassemblies, boards, parts, etc., that perform below minimum acceptable levels.
Extinction Coefficient	The proportion of luminous flux lost by a collimated beam, emitted by an incandescent source at a colour temperature of 2,700°K, while traveling the length of unit distance in the atmosphere (per meter, $m^{-1}$ ); a measure of the ability of particles or gases to absorb and scatter photons from a beam of light; a number that is proportional to the fraction of photons removed from the sight path per unit length.
Failsafe	The ability of the RVR system to inhibit the output of erroneous data under System and Subsystem failure conditions.

Hard Alarm	An alarm issued when self-check finds a parameter outside the acceptable operation limits.
Mean Time Between Failures (MTBF)	MTBF is equal to the total operating hours of the RVR system divided by the number of system failures.
Reliability	Reliability is the probability that an item will actually perform its intended function for a specified interval under specified conditions.
Runway Visual Range	The range over which the pilot of an aircraft on the centerline of a runway can see the runway surface markings, or the lights delineating the runway, or identifying its centerline.
Soft Alarm	An alarm issued when self-check finds a parameter approaching the acceptable operational limit; in other words, a soft alarm alerts maintenance personnel that a hard alarm might occur in the near future.
Subsystem Failure	An RVR subsystem failure occurs when: (a) there is a communication failure between a sensor and the DPU, (b) any sensor fails or falls out of calibration, or (c) a CD fails. Any communication link failure external to the RVR system is not considered a subsystem or system failure.
System Failure	A system failure occurs when: (a) the system does not output the RVR products, (b) the RVR product output is not correct, or (c) there is a catastrophic failure.

#### 6.4 ABBREVIATIONS AND ACRONYMS

A	Amperes
AC	Alternating Current
ACE-IDS	Automated Surface Observing System Controller Equipment-Information Display System
ALS	Ambient Light Sensor
ASCII	American Standard Code for Information Interchange
ASOS	Automated Surface Observing System
ATCT	Airport Traffic Control Tower
AWSS	Automated Weather Sensors System
B	Background luminance
BIT	Built-in-Test
C	Centigrade

cd	Candelas
CD	Controller Display
CD-RW	Compact Disk-ReWritable
CDM	Collaborative Decision Making
Cm	Centimeter
CO	Contracting Officer
CPU	Central Processing Unit
DC	Direct current
DoDISS	Department of Defense Index of Specifications and Standards
DPU	Data Processing Unit
DTE	Data Transmission Equipment
EMC	Electromagnetic compatibility
EMI	Electromagnetic Interference
ETMS	Enhanced Traffic Management System
EU1	Engineering Unit, Connector 1
F	Fahrenheit
FIT	Fault Isolation Test
fL	Foot-Lambert
HIRL	High Intensity Runway Lighting
Hz	Hertz
I	Light Intensity
ID	Identification
I/O	Input/Output
IRD	Interface Requirements Document
Km	Kilometer
LIR	Low-Impact Resistance
LRU	Lowest Replaceable Unit
LVAT	Low Visibility Alarm Threshold
m	Meter
MDT	Maintenance Data Terminal
MP	Midpoint
MPMT	Mean Periodic Maintenance Time

MPS	Maintenance Processing Subsystem
MTBF	Mean Time Between Failure
NAS	National Airspace System
NGRVR	New Generation Runway Visual Range
nm	Nautical Mile
OCC	Operational Control Center
PAT	Production Acceptance Test
RAID	Redundant Array of Independent Disks
RLIM	Runway Light Intensity Monitor
rms	Root mean square
RMS	Remote Monitoring Subsystem
RO	Rollout
RVR	Runway Visual Range
SAI	Simple Asynchronous Interface
SIE	Sensor interface electronics
SIR	Screening Information Request
SNMP	Simple Network Management Protocol
TBD	To be determined
TD	Touchdown
TDP	Technical Data Package
TIB	Technical Instruction Books
TRACON	Terminal Radar Approach Control
UPS	Uninterruptible Power Source
V	Volt
VS	Visibility Sensor



6.5 ICAO COMPLIANCE

**TABLE 6-2 RVR compliance with ICAO Annex 3**

<b>ICAO Annex 3 Paragraph</b>	<b>Comments</b>
4.7.1	Comply
4.7.2	Comply
4.7.3	Comply
4.7.4	Comply
4.7.5	Comply
4.7.6	Comply
4.7.7	Comply
4.7.8	The RVR always uses actual light settings to calculate local RVR values. ICAO calls for using the appropriate operational light setting for RVR on runways not currently in use. [The FAA uses light setting 5 for the generation of ASOS METAR reports.]
4.7.9	Comply
4.7.10	ICAO calls for rounding down the actual RVR value to the reporting increment. RVR rounds off.
4.7.11	Comply
4.7.12	Comply
4.7.13	ICAO calls for saying above or below for off-scale RVR values. RVR simply reports 6,500 feet or 100 feet.
4.7.14	ICAO gives direction for reports disseminated beyond the airport; specifically, 10-minute averages are mandated. FAA ASOS reports follow this direction but the CDM reports are merely copies of the local reports. Note that this section calls for a 10-minute algorithm for RVR trend and gives other directions.
4.7.15	Comply
4.7.16	Comply
4.7.17	Comply
	RVR guidance (not recommendations) is given in Attachment D and the RVR Manual. The FAA differs in two respects:
	1) The relationship between illuminance threshold and background luminance is different from Attachment D and the manual.
	2) The transition between edge lights and centerline lights uses a simpler and significantly different algorithm than suggested in the RVR Manual.

FAA-E-2772B  
APPENDIX A

**APPENDIX A. Verification Requirements Traceability Matrix (VRTM)**

Requirements			Verification Method	
#	Para. #	Description	Contractor Testing	Remarks
1	3	Except where specifically noted, the RVR System shall <sup>[ps1]</sup> meet the requirements stipulated herein while operating over the full range of the operating environment.	T/A	
2	3.2.1.1	The RVR distance values shall <sup>[ps2]</sup> be reported in feet.	T	
3	3.2.1.2.1	The RVR products reports shall <sup>[ps3]</sup> consist of: the runway identification (ID) and sub-ID; the most recently computed RVR product; RVR trends (increasing, decreasing or steady); and the associated intensity settings for the runway lights (edge and centerline).	T	
4	3.2.1.2.2	The reported RVR products shall <sup>[ps4]</sup> be updated at a minimum rate of once per 15 seconds, or at the rate specified in the applicable Interface Requirements Documents (IRD) identified in 2.2.2.2 and 3.2.2.2.6.	T	
5	3.2.1.2.3	The reported RVR product formats shall <sup>[ps5]</sup> be as specified in the applicable Interface Requirements Documents identified in 3.2.2.2.6.2 and 3.2.2.2.6.3.	T/A	
6	3.2.1.2.4	The RVR System shall <sup>[ps6]</sup> report RVR values in: 100-foot increments from zero (0) feet through 800 feet; 200-foot increments from 800 through 3,000 feet; and, 500-foot increments from 3,000 through 6,500 feet.	T	
7	3.2.1.2.4	A value of 6,500 feet shall <sup>[ps7]</sup> be used to report RVR above 6,249 feet.	T	
8	3.2.1.2.4	An RVR value of zero (0) feet shall <sup>[ps8]</sup> indicate runway visual range below 50 feet.	T	
9	3.2.1.2.4	The reported RVR shall <sup>[ps9]</sup> be rounded off from the calculated value; therefore, the RVR values from 751 feet to 899 feet would be reported as 800 feet.	T	

FAA-E-2772B  
APPENDIX A

Requirements			Verification Method	
#	Para. #	Description	Contractor Testing	Remarks
10	3.2.1.3	The validity of the VS and ALS measurements shall <sup>[ps10]</sup> be checked.	T	
11	3.2.1.3	Valid values shall <sup>[ps11]</sup> be used to calculate 60-second running averages.	T	
12	3.2.1.3	The RVR product shall <sup>[ps12]</sup> be calculated from 60-second running averages of the readings of the VS and the ALS and the last valid reading of the RLIM.	T	
13	3.2.1.3	The intensities of the runway edge and centerline lights shall <sup>[ps13]</sup> be used, as appropriate for the calculated RVR value.	T	
14	3.2.1.3	Two RVR values shall <sup>[ps14]</sup> be calculated: the first for seeing objects using Koschmieder's Law (only VS is used); and the second for seeing lights using Allard's Law (all three sensors are used).	T/A	
15	3.2.1.3	The larger calculated value shall <sup>[ps15]</sup> be adopted and rounded off according to the reporting increments of 3.2.1.2.4.	T/A	
16	3.2.1.3	The RVR product sent to ASOS shall <sup>[ps16]</sup> use RLIM light setting step five (5).	T/A	
17	3.2.1.3.1	All sensor data shall <sup>[ps17]</sup> be validated to ensure there are no transmission errors or sensor failures.	T	
18	3.2.1.3.1	The sensor measurement data shall <sup>[ps18]</sup> pass reasonableness checks, including range limits or rate of change limits.	T	
19	3.2.1.3.1	If any sensor measurements are found to be invalid, the measurements shall <sup>[ps19]</sup> be rejected.	T	
20	3.2.1.3.1	Invalid sensor data shall <sup>[ps20]</sup> cause an appropriate alarm to be set.	T	
21	3.2.1.3.1	Invalid sensor data alarms shall <sup>[ps21]</sup> be recorded in the RVR System maintenance data set (see 3.2.2.2.3.3).	T	
22	3.2.1.3.2	The RVR trend (increasing, decreasing or steady) shall <sup>[ps22]</sup> be determined using a five (5) minute sampling window.	T	

FAA-E-2772B  
APPENDIX A

Requirements			Verification Method	
#	Para. #	Description	Contractor Testing	Remarks
23	3.2.1.3.3	Koschmieder's Law shall <sup>[ps23]</sup> give zero RVR whenever the ALS reading is below the night limit of 2 Foot-Lamberts (fL) (6.85 cd/m <sup>2</sup> ).	T/A	
24	3.2.1.3.4	The Standard runway light settings of a HIRL System, TABLE 3-1, shall <sup>[ps24]</sup> be used.	T	
25	3.2.1.3.4	If both the edge light settings and the centerline light settings have values of 1, 2, 3, 4 or 5, then the value to be used for runway light intensity (I) in Allard's Law for certain values of RVR (in feet) shall <sup>[ps25]</sup> be in accordance with TABLE 3-2, Runway light intensity when edge and centerline settings match.	T/A	
26	3.2.1.3.4	If the edge light setting has a value of 1, 2, 3, 4 or 5 and the centerline light setting has a value of zero (0) then the value to be used for runway light intensity (I) in Allard's Law for certain values of RVR (in feet) shall <sup>[ps26]</sup> be in accordance with TABLE 3-3, Runway light intensity when centerline setting is 0.	T/A	
27	3.2.1.3.4	Note that if the edge light setting is zero (0), then, regardless of the centerline light setting, a value of zero (0) shall <sup>[ps27]</sup> be assigned to the Allard's Law solution.	T	
28	3.2.1.3.4	For those cases where centerline lights are not configured for a given runway (TABLE 3-3) the following action shall <sup>[ps28]</sup> be taken: Allard's Law must be computed using a runway light intensity (I) corresponding to the edge light setting for all values of RVR; the RVR System must display a blank space in the associated CD centerline light setting data field; any attempt to configure a runway without edge lights must be treated as erroneous input and rejected by the RVR System.	T/A	
29	3.2.1.5	If the RVR system performance is degraded by environmental factors, such as excessive sensor window contamination, the RVR product shall <sup>[ps29]</sup> continue to be output, provided that the reported RVR is not greater than the actual RVR.	T	

FAA-E-2772B  
APPENDIX A

Requirements			Verification Method	
#	Para. #	Description	Contractor Testing	Remarks
30	3.2.2.1	The DPU shall <sup>[ps30]</sup> contain the necessary hardware and software to meet the requirements of this specification.	I/A	
31	3.2.2.1	The sensor complement for each airport shall <sup>[ps31]</sup> include a minimum of one ALS and as many VSs and RLIMs as are needed to provide coverage for the instrumented runways of the airport.	I/A	
32	3.2.2.1	The RVR System shall be capable of being configured with two DPUs; two ALSs with sensor interface electronics (SIE); 30 VSs with SIEs; 10 RLIMs consisting of SIEs with 8 current loop sensors each; and 32 CDs on each of the local and remote communications lines.	T/I/A	
33	3.2.2.1.1	The RVR System shall <sup>[ps33]</sup> provide for a site and depot concept of maintenance.	A	
34	3.2.2.1.1.1	A core RVR System, consisting of one DPU, one ALS with SIE and connecting cable, one VS with SIE and connecting cable, two CDs, and one RLIM SIE with four current loop sensors, shall have a Mean-Time-Between-Failure (MTBF) of 5,000 hours, not including communications failures external to the RVR System components.	T/A	
35	3.2.2.1.1.2	The RVR System components shall <sup>[ps35]</sup> be transportable by one Maintenance Specialist, contain a minimum number of subsystems to meet the RVR System requirements and be easy to install.	D	
36	3.2.2.1.1.2	The Mean-Time-To-Repair (MTTR) a single point failure of a core RVR System, consisting of one DPU, one ALS with SIE and connecting cable, one VS with SIE and connecting cable, two CDs, and one RLIM SIE with four current loop sensors, shall be 30 minutes or less exclusive of time required to travel to the affected location.	D/A	
37	3.2.2.1.1.3	The RVR System shall <sup>[ps37]</sup> incorporate self-checks to verify proper operation of all major subsystems.	T	

FAA-E-2772B  
APPENDIX A

Requirements			Verification Method	
#	Para. #	Description	Contractor Testing	Remarks
38	3.2.2.1.1.3	Self-checks shall <sup>[ps38]</sup> be used to validate the system measurements and to determine when maintenance is required.	T	
39	3.2.2.1.1.3	Hard alarms shall <sup>[ps39]</sup> be generated whenever a parameter is found to be outside acceptable operation limits.	T	
40	3.2.2.1.1.3	A soft alarm shall <sup>[ps40]</sup> be generated whenever a parameter is approaching the limit for acceptable operation.	T	
41	3.2.2.1.1.3	The RVR System shall <sup>[ps41]</sup> include software that determines whether all RVR processes are operating properly.	T	
42	3.2.2.1.1.3	The system shall <sup>[ps42]</sup> be capable of detecting at least 90 % of all faults.	T	
43	3.2.2.1.1.3	In addition, as a minimum, 90 % of all detected faults shall <sup>[ps43]</sup> be isolated to one LRU using automatically initiated diagnostics.	T	
44	3.2.2.1.1.3	Automatically initiated diagnostics shall <sup>[ps44]</sup> occur when a hard alarm occurs.	T	
45	3.2.2.1.1.3	Automatically initiated diagnostics shall <sup>[ps45]</sup> be designed to identify the faulty LRU.	T	
46	3.2.2.1.1.3	Additional manually initiated diagnostics shall <sup>[ps46]</sup> be provided to offer more detailed information on the status of LRUs to aid the maintenance process.	T	
47 m1	3.2.2.1.1.3	All built-in diagnostics shall <sup>[ps47]</sup> be capable of initiation from the MPS or a portable MDT.	T	
48	3.2.2.1.1.3	Complete results of the built in diagnostics shall <sup>[ps48]</sup> be available to the Maintenance Specialist.	T	
49	3.2.2.1.1.3	If a failure cannot be isolated to a single LRU, a list of the suspected LRUs shall <sup>[ps49]</sup> be generated in order of probability (highest to lowest).	T	
50 m1	3.2.2.1.1.3	Any built-in diagnostics contained in on-line system hardware shall <sup>[ps50]</sup> be functionally independent of the rest of the on-line system.	A/D	

FAA-E-2772B  
APPENDIX A

Requirements			Verification Method	
#	Para. #	Description	Contractor Testing	Remarks
51 ml	3.2.2.1.1.3	Sensor and DPU self check data, including alarm information, shall <sub>[ps51]</sub> be stored in the maintenance data set (3.2.2.2.3.3) for output to the MDT and MPS interfaces, as appropriate.	T/A	
52	3.2.2.1.1.4	The RVR System shall <sub>[ps52]</sub> be designed such that periodic maintenance of the DPU is not required for the system more often than biweekly.	A	
53 ml	3.2.2.1.1.4	Periodic maintenance on the RVR sensors, at the sensor(s) location, shall <sub>[ps53]</sub> not be required more often than once every 90 days.	A	
54 ml	3.2.2.1.1.4	The mean periodic maintenance time (MPMT) shall not exceed 4 hours over a 90 day period for the following system configuration: one DPU, one ALS with SIE and connecting cable, one VS with SIE and connecting cable, two CDs, and one RLIM SIE with four current loop sensors.	A	
55	3.2.2.1.1.4	The periodic maintenance tasks for the sensors shall <sub>[ps55]</sub> require the services of only one person.	D	
56 ml	3.2.2.1.1.4	During the periodic maintenance visits, the calibration and operation of each sensor and the system shall <sub>[ps56]</sub> be verified.	D	
57	3.2.2.1.1.4	The procedures and the required frequency of calibration shall <sub>[ps57]</sub> be defined by the contractor, keeping in mind that sensor drift outside of the required specification limits constitutes a failure of the system.	A	
58	3.2.2.1.1.4	The RVR DPU hardware/software configuration shall <sub>[ps58]</sub> be designed such that scheduled periodic maintenance is minimized.	A	
59	3.2.2.1.1.4	The RVR System operations shall <sub>[ps59]</sub> not be interrupted for routine DPU periodic maintenance.	T	

FAA-E-2772B  
APPENDIX A

Requirements			Verification Method	
#	Para. #	Description	Contractor Testing	Remarks
60	3.2.2.1.2	All system components of an operationally capable system shall <sup>[ps60]</sup> recover automatically from the loss of power, the loss of an interface, loss of critical processes (any RVR System process), and processor lock up.	T	
61	3.2.2.1.3.1	The RVR System shall <sup>[ps61]</sup> be capable of a 50 % growth in the size of the system (additional VSs, ALSs, RLIMs, CPU time, DPU memory, displays and communications ports).	I/A	
62	3.2.2.1.3.2	The RVR System shall <sup>[ps62]</sup> be capable of having the software/firmware expanded by up to 50 % of the total lines of code initially implemented.	I/A	
63	3.2.2.1.3.3	The RVR System shall <sup>[ps63]</sup> be capable of accepting different visibility sensor types, and of upgrading with newer, improved sensors without requiring hardware redesign or major software changes which require use of more than 50 % of addressable memory.	A/T	
64	3.2.2.1.4	The RVR System shall <sup>[ps64]</sup> be certifiable, that is, capable of validating that the system is providing the advertised service to the user in compliance with Chapter 5 of FAA Order 6000.15C.	T/A	
65	3.2.2.2	The DPU shall <sup>[ps65]</sup> use open architecture, standard multitasking Windows-based operating system and object-oriented application software.	I	
66	3.2.2.2	The computer/server components shall <sup>[ps66]</sup> employ current technology that must be sustainable with replacement hardware and software that are both forward and backward compatible.	I/A	
67	3.2.2.2	To assure RVR System availability at critical airports, the option shall <sup>[ps67]</sup> be provided for using dual DPUs.	T	
68	3.2.2.2	Both DPUs shall <sup>[ps68]</sup> receive all inputs.	T	
69	3.2.2.2	The outputs shall <sup>[ps69]</sup> be provided by only one DPU (normally the primary DPU).	T	



FAA-E-2772B  
APPENDIX A

Requirements			Verification Method	
#	Para. #	Description	Contractor Testing	Remarks
70	3.2.2.2	The proper functioning of both DPUs shall <sup>[ps70]</sup> be monitored and any failures in either DPU logged to the maintenance files and maintenance interfaces of both.	T/A	
71	3.2.2.2	If the primary DPU fails to provide valid RVR products because of a DPU software or hardware failure, RVR functionality shall <sup>[ps71]</sup> automatically be switched to the backup DPU.	T	
72	3.2.2.2.1	The RVR DPU shall <sup>[ps72]</sup> contain the necessary processors, memory, disk storage and input/output (I/O) cards/capabilities to, at a minimum, implement the required RVR functionalities.	I/A	
73	3.2.2.2.1	The DPU shall <sup>[ps73]</sup> consist of a high-reliability industrial grade server/computer with Redundant Array of Independent Disks (RAID) – two protected redundant hot-swappable hard drive storage and compact disc-rewritable CD-RW) drive, display, keyboard, mouse and I/O interfaces.	I/A	
74	3.2.2.2.2	All RVR application software shall <sup>[ps74]</sup> be run under a standard Microsoft Windows-based operating system.	I	
75	3.2.2.2.2	The application software shall <sup>[ps75]</sup> include the functions for system configuration, data validation, system monitoring, diagnostics, communication control and other appropriate routines for execution of the various system functions.	T	
76	3.2.2.2.2	Without making code changes, the DPU shall <sup>[ps76]</sup> be locally capable, with restricted access, of configuring: selected system parameters (including configuration, measurements and maintenance parameters) with flexible data formats and locations, including alarms for limits on varying parameters; and output products by specifying parameters to be included, formats, output frequency, output port (or file name and location) and port parameters.	T/A	

FAA-E-2772B  
APPENDIX A

Requirements			Verification Method	
#	Para. #	Description	Contractor Testing	Remarks
77 m1	3.2.2.2.2.1	The RVR system shall[ps77m1] be controlled by a single entity at any given time as prioritized in the following list: locally through the DPU's keyboard, mouse and display, locally through the MDT, and remotely through the MPS.	T	
77 a	3.2.2.2.2.1	If a system control session is initiated using the local DPU console, the local MDT interface shall[ps77a] immediately abort any existing MDT system control sessions and prevent any other MDT system control sessions as long as the local DPU console has an active system control session.	T	
77 b	3.2.2.2.2.1	If there is an active system control session on either the local DPU console or a local MDT interface, the MPS interface shall[ps77b] ignore all incoming Equipment Command Messages and Status Command Messages as specified in Section 3.4.3 of NAS-MD-793.	T	
78 m1	3.2.2.2.2.1	System control shall[ps78m1] include the ability to: (a) display the current output of the RVR System including the RVR products and sensor output data; (b) retrieve and display historical RVR data/products from archived files; and (c) allow an on-site operator to initially configure or reconfigure the RVR System airport configuration that includes the ability to independently configure primary and alternate runways, sensor configuration, and system security.	T	
79	3.2.2.2.2.2	Users shall[ps79] be able to log into the RVR System on-site using the DPU keyboard and display or MDT.	T	
80	3.2.2.2.2.2	User identification shall[ps80] be via password.	T	
81	3.2.2.2.2.2	User capabilities shall[ps81] be limited by general network considerations such as read or write access to specific directories and by specific RVR System functions such as viewing raw data, current products, maintenance data, operational data, archived data, and changing configurations.	T/A	

FAA-E-2772B  
APPENDIX A

Requirements			Verification Method	
#	Para. #	Description	Contractor Testing	Remarks
82	3.2.2.2.2.3	The DPU shall <sup>[ps82]</sup> include a Watchdog Timer to detect a processor lock-up and to verify that all RVR System processes are correctly performing their functions.	T	
83	3.2.2.2.2.3	In the event the Watchdog Timer detects a processor failure, it shall <sup>[ps83]</sup> initiate a reboot.	T	
84	3.2.2.2.2.3	In the event the Watchdog Timer detects a processor failure in the active DPU of a dual DPU RVR System configuration, a reboot is initiated in the active DPU, and the inactive DPU shall <sup>[ps84]</sup> switch to active status.	T	
85	3.2.2.2.2.3	Reboots shall <sup>[ps85]</sup> be logged to a daily reboot file.	T/A	
86	3.2.2.2.2.3	The reason for the reboot shall <sup>[ps86]</sup> be logged.	T/A	
87	3.2.2.2.2.4	The RVR System shall <sup>[ps87]</sup> use an external time source for synchronization of data with other NAS systems as specified in 3.2.2.2.6.3.3.	T	
88	3.2.2.2.2.4	All RVR System functions requiring the use of date and/or time shall <sup>[ps88]</sup> utilize the date and time from a DPU system clock synchronized to the external source.	T	
89	3.2.2.2.3.1	The raw data shall <sup>[ps89]</sup> consist of: date time stamp; extinction coefficient; ALS background luminance; associated runway light settings (edge and centerline); current status of sensors, communications and DPU status.	T	
90	3.2.2.2.3.1	Status shall <sup>[ps90]</sup> be classified valid or invalid.	T	
91	3.2.2.2.3.2	The product data shall <sup>[ps91]</sup> consist of: date time stamp; runway ID and sub-ID; most recently computed RVR product; and RVR trends (increasing, decreasing, or steady).	T	
92	3.2.2.2.3.3	The maintenance data shall <sup>[ps92]</sup> consist of: date time stamp; hard and soft alarms, warnings and diagnostics; and system failures.	T/A	

FAA-E-2772B  
APPENDIX A

Requirements			Verification Method	
#	Para. #	Description	Contractor Testing	Remarks
93	3.2.2.2.3.4	The operational data shall <sup>[ps93]</sup> consist of: date time stamp; current and previous system configurations with user name; and system calibrations.	T/A	
93 a	3.2.2.2.3.5	The NG RVR data shall <sup>[ps93a]</sup> consist of: date time stamp; VS SIE number, extinction coefficient, window contamination values, sensor temperature, and all maintenance bytes for all configured NG RVR VSs; NG RVR ALS measurement, window contamination value, sensor temperature, and all maintenance bytes; RLIM SIE number, light step measurements for each of the current loop sensors, and all maintenance bytes for all configured NG RVR RLIMs; and the maintenance parameter bytes for the NG RVR Product Processing Unit.	T/A	
94	3.2.2.2.4.1	The DPU shall <sup>[ps94]</sup> have the capability to receive RVR sensor data as well as system diagnostics information directly from the RVR sensors.	T	
94 a	3.2.2.2.4.1	The DPU shall <sup>[ps94a]</sup> have the capability of receiving all the NG RVR data identified in Section 3.2.2.2.3.5.	T	
95	3.2.2.2.4.2	The DPU shall <sup>[ps95]</sup> implement the product algorithms.	T/A	
96	3.2.2.2.4.2	The DPU shall <sup>[ps96]</sup> prepare the processed data as RVR products in a digital format.	T	
97	3.2.2.2.4.3	The DPU shall <sup>[ps97]</sup> provide RVR products to the interfaces identified in 3.2.2.2.6 as defined by the applicable IRD.	T/A	
98	3.2.2.2.4.4	The current product plus raw, maintenance and operational data shall <sup>[ps98]</sup> be stored.	T/A	
99	3.2.2.2.4.4	Every minute the current product and raw and maintenance data shall <sup>[ps99]</sup> be archived in three separate daily data files: product data, raw data and maintenance data.	T/A	
100	3.2.2.2.4.4	Operational data shall <sup>[ps100]</sup> be stored quarterly in data files to include the system configuration and calibration data.	T/A	

FAA-E-2772B  
APPENDIX A

Requirements			Verification Method	
#	Para. #	Description	Contractor Testing	Remarks
101	3.2.2.2.4.4	Data storage shall <sup>[ps101]</sup> use an American Standard Code for Information Interchange (ASCII) format to facilitate readability.	T/A	
102	3.2.2.2.4.5	The stored data shall <sup>[ps102]</sup> be accessible to programs running on the DPU and to authorized users, located either locally or at a remote site.	T/A	
103 m1	3.2.2.2.5	The DPU shall <sup>[ps103]</sup> automatically archive RVR product data, raw data, maintenance data, operational data received from the NG RVR EU port and have the capacity to store data for more than 1.3 years.	T/I/A	
104	3.2.2.2.5	The archiving software shall <sup>[ps104]</sup> provide the capability for easily extractible and protected retrieval and verification of the stored data by date time stamp to the display and CD-RW drive.	T/A	
105	3.2.2.2.5	The archiving software shall <sup>[ps105]</sup> only allow manual deletion of obsolete (older than 1-year) archived data files that have been confirmed as being previously successfully transferred to a CD for permanent archiving.	T/A	
106	3.2.2.2.5	The accessing, viewing, and downloading of archive data shall <sup>[ps106]</sup> be capable without interruption to RVR System operation, including the real time archiving of data.	T	
107	3.2.2.2.6.1	Each RVR sensor type shall <sup>[ps107]</sup> be capable of communicating with the DPU across three communication media: copper landline, fiber network or radio link.	T	
108	3.2.2.2.6.1	Alternative means of communications shall <sup>[ps108]</sup> be provided on the DPU and sensors to allow data communications across a digital radio link.	T	
109	3.2.2.2.6.1.1	The RVR System shall <sup>[ps109]</sup> provide integrated modems for data communications between the VS, ALS and RLIM SIEs and the DPU across these Government-furnished media.	T/I	

FAA-E-2772B  
APPENDIX A

Requirements			Verification Method	
#	Para. #	Description	Contractor Testing	Remarks
110	3.2.2.2.6.1.1	The RVR System shall <sup>[ps110]</sup> operate across two-wire interfaces with the characteristics described in TABLE 3-5, Characteristics of two-wire interfaces.	T/A	
111	3.2.2.2.6.1.2	The DPU and VS, ALS and RLIM SIEs shall <sup>[ps111]</sup> be configured as Data Transmission Equipment (DTE).	T/I/A	
112	3.2.2.2.6.1.2	The DPU and SIEs for the VS, ALS, and RLIM sensors shall <sup>[ps112]</sup> provide the data interface to the radio link as directed in TABLE 3-6, DPU/Sensor data interface to the Radio Link.	T/A	
113	3.2.2.2.6.2	The RVR System shall <sup>[ps113]</sup> use open systems interface architecture to support RVR product user interfaces.	I/A	
114	3.2.2.2.6.2.1	The RVR DPU shall <sup>[ps114]</sup> interface to the following external display systems via three sets of dual, redundant RS-232 and RS-485 interfaces: the existing CD Type FA-10268/6 and the PC based-RVR CD as specified in 3.2.2.6; the ACE-IDS Control Cabinet or workstation; and the ETMS.	T/A	
115	3.2.2.2.6.2.1	The interfaces shall <sup>[ps115]</sup> comply with the requirements of FAA-NAS-IR-33110001.	T/A	
116	3.2.2.2.6.2.2	In the RVR to ASOS interface, data from up to 20 RVR touchdown sensors shall <sup>[ps116]</sup> be sent from the RVR DPU to the ASOS or AWSS processor.	T	
117	3.2.2.2.6.2.2	Sensor and runway selection shall <sup>[ps117]</sup> be configurable.	T	
118	3.2.2.2.6.2.2	The runway light setting for computation of the reported RVR shall <sup>[ps118]</sup> always be step five (5).	T/A	
119	3.2.2.2.6.3.1	An MDT port using EIA Standard 232f interface(s) shall <sup>[ps119]</sup> be installed on the RVR DPU.	I	
120	3.2.2.2.6.3.1	The DPU MDT serial port shall <sup>[ps120]</sup> enable local access and communication for the purposes of real-time diagnostics, calibration, monitoring and/or control of the VS, ALS and RLIM sensors and the RVR System.	T	

FAA-E-2772B  
APPENDIX A

Requirements			Verification Method	
#	Para. #	Description	Contractor Testing	Remarks
121 m1	3.2.2.2.6.3.1	The RVR to MDT interface shall[ps121m1] provide, at a minimum, the following functionality or data: help function; immediate response; security through operator sign-on; configurable operator access based on predetermined user needs; terminal timeout; formatted facility data readout showing available parameters, limits and current values of selected parameter(s) along with a log of failures; and selection of a local function MDT or remote MPS function.	T/A	
122 m1	3.2.2.2.6.3.2	The RVR System shall[ps122m1] implement a Remote Monitoring Subsystem (RMS).	T	
122 a	3.2.2.2.6.3.2	RMS system administration and performance shall[ps122a] be in accordance with NAS-MD-793, Section 3.5 and all subsections.	T	
122 b	3.2.2.2.6.3.2	The RMS shall[ps122b] implement functional requirements related to data acquisition, data processing, communication processing, and command processing.	T	
122 c	3.2.2.2.6.3.2	RMS data acquisition shall[ps122c] be in accordance with NAS-MD-793, Section 3.1 and all subsections.	T	
122 d	3.2.2.2.6.3.2	RMS data processing shall[ps122d] be in accordance with NAS-MD-793, Sections 3.2 through 3.2.3.2 with the following exceptions.	T	
122 e	3.2.2.2.6.3.2	Internal addressing, command codes, and message generation shall[ps122e] follow applicable requirements in NAS-IC-51035101.	T	
122 f	3.2.2.2.6.3.2	RMS communication processing shall[ps122f] be in accordance with NAS-IC-51035101.	T	

FAA-E-2772B  
APPENDIX A

Requirements			Verification Method	
#	Para. #	Description	Contractor Testing	Remarks
122 g	3.2.2.2.6.3.2	RMS command processing shall[ps122g] be in accordance with NAS-MD-793, Sections 3.4 through 3.4.4 with the following exceptions: Command Acceptance and Verification and Command Results Reporting follow applicable requirements in NAS-IC-51035101.	T	
122 h	3.2.2.2.6.3.2	System control via the MPS shall[ps122h] be limited to the following actions: Master reset and Startup/Recovery Equipment Command Messages as defined in NAS-IC-51035101, Section 3.1.2.2.1.11 and RVR system unique Equipment Command Messages.	T	
122 i	3.2.2.2.6.3.2	RVR system unique Equipment Command Messages shall[ps122i] include the following functionality: Online/Offline control for each RVR subsystem component; control of alarm (hard alarm) and alert (soft alarm) limits and data quality check limits/parameters, as appropriate; control of RVR system and subsystem component fault diagnostics; and individual RVR subsystem component resets.	T	
123 m1	3.2.2.2.6.3.2	Reserved.	N/A	
124 m1	3.2.2.2.6.3.2	Reserved.	N/A	
125 m1	3.2.2.2.6.3.2	The interface between the RVR RMS and the MPS shall[ps125m1] be designed in accordance with NAS-IC-51035101 using a dedicated leased line.	T/A	
125 a	3.2.2.2.6.3.2	All communication shall[ps125a] be initiated by the MPS in accordance with NAS-IC-51035101.	T/A	
125 b	3.2.2.2.6.3.2	The communication link between the MPS and RVR RMS shall[ps125b] be considered inoperable if no MPS poll has been received by the RVR RMS within a configurable time period.	T/A	



FAA-E-2772B  
APPENDIX A

Requirements			Verification Method	
#	Para. #	Description	Contractor Testing	Remarks
125 c	3.2.2.2.6.3.2	The communication link between the MPS and RVR RMS shall <sup>[ps125c]</sup> also be considered inoperable if the RVR RMS has to send a configurable number of repeated messages to the MPS because of a MPS NAK response or timeout.	T/A	
125 d	3.2.2.2.6.3.2	The link shall <sup>[ps125d]</sup> be considered inoperable until a valid MPS poll is received by the RVR RMS, a message is sent by the RMS to the MPS and the MPS sends an ACK to the RVR RMS.	T/A	
125 e	3.2.2.2.6.3.2	Upon re-establishment of the link, the RVR RMS shall <sup>[ps125e]</sup> send appropriate messages for each Logical Unit to assure that the data available at the MPS reflects the latest configuration and data associated with the RVR system.	T/A	
126 m1	3.2.2.2.6.3.2	Reserved.	N/A	
127	3.2.2.2.6.3.3	The DPU shall <sup>[ps127]</sup> interface to the external time source and synchronize its internal system clock in accordance with the requirements identified in FAA-NAS-IR-32063311.	T/A	
127 a	3.2.2.2.6.3.3	The PC-based RVR system may be collocated with an existing NG RVR system at airports within the NAS. In such instances, the PC-based RVR system shall <sup>[ps127a]</sup> receive NG RVR system data and integrate it with similar data of the PC-based system for representation of RVR conditions over the relevant RVR airport configuration.	T/A	
127 b	3.2.2.2.6.3.3	The PC-based RVR DPU shall <sup>[ps127b]</sup> interface with the NGRVR system via the latter's "Engineering User 1" (EU1) port in accordance with the engineering test data details given in FAA Technical Instruction Book 6560.17, Section 3.7 and Table 3-5.	T/A	

FAA-E-2772B  
APPENDIX A

Requirements			Verification Method	
#	Para. #	Description	Contractor Testing	Remarks
127 c	3.2.2.2.6.3.3	The PC-based RVR DPU shall <sup>[ps127c]</sup> verify that the NG RVR sensors are operating correctly receive the simplex data stream from the NG RVR DPU; process the NGRVR ALS measurement in accordance with paragraph 3.2.2.4; recalculate RVR products associated with NG RVR sensors; and format the RVR products for transmission across the external user interfaces described in paragraph 3.2.2.2.6.2.	T/A	
127 d	3.2.2.2.6.3.3	The PC-based RVR DPU shall <sup>[ps127d]</sup> verify that the NG RVRs VSs, ALS, and RLIMs are operating properly through analysis of maintenance parameter bytes provided for each configured NG RVR sensor in the EU1 data stream.	T/A	
127 e	3.2.2.2.6.3.3	The default values for the NGRVR EU-1 port shall <sup>[ps127e]</sup> be used	T/A	
128	3.2.2.2.7	The DPU shall <sup>[ps128]</sup> use standard alternating-current (AC) commercial power, single phase, rated at 115 volts (v), ( $\pm 15\%$ ), 60 Hertz (Hz) ( $\pm 3$ Hz).	I/T	
129	3.2.2.2.7	All power conditioning systems shall <sup>[ps129]</sup> be equipped with input and output fuses and/or circuit breakers and semiconductor protection devices.	I	
130	3.2.2.2.7	The DPU shall <sup>[ps130]</sup> have an 8-foot long power cable that plugs into a standard 3-prong convenience outlet that provides no more than 10 Amperes (A) (circuit breaker protected).	I	
131	3.2.2.2.8	The DPU shall <sup>[ps131]</sup> be installed in a standard 19" electronics rack, typically located in the equipment room at the ATCT, as shown on FAA Standard Drawings D-6282-3, -7 and -9.	D/A	
132 m1	3.2.2.3	The VS shall <sup>[ps132]</sup> utilize forward-scatter meter technology that measures the clarity of the atmosphere and produces a signal proportional to the visible extinction coefficient.	I	

FAA-E-2772B  
APPENDIX A

Requirements			Verification Method	
#	Para. #	Description	Contractor Testing	Remarks
133	3.2.2.3	In particular, snow clogging of a VS optical window might lead to reported RVR values much higher than actual; such occurrences shall <sub>[ps133]</sub> be prevented or detected.	T	
134	3.2.2.3	The VS scattering volume shall <sub>[ps134]</sub> be representative of the ambient atmosphere.	T/A	
135	3.2.2.3	The sensor heads and mounting structure shall <sub>[ps135]</sub> not significantly obstruct the free flow of fog or snow into the scatter volume.	T/A	
136	3.2.2.3	The sensor heads and mounting structure shall <sub>[ps136]</sub> not provide a shadowing effect on the scatter volume.	T/A	
137	3.2.2.3	Sources of heat from the sensor shall <sub>[ps137]</sub> not significantly warm the scatter volume or region around the VS (and hence affect the fog density in the scatter volume).	T/A	
138	3.2.2.3.1	A one-minute running average of the atmospheric extinction coefficient ( $\sigma$ ) shall <sub>[ps138]</sub> be calculated.	T	
139 ml	3.2.2.3.1	The sensor shall <sub>[ps139]</sub> spend at least 75 % of the time measuring the extinction coefficient.	A/D	
140	3.2.2.3.1	No more than 10 % of the data in a particular one-minute average shall <sub>[ps140]</sub> come from the previous minute.	T/A	
141	3.2.2.3.1	If less than 75 % of the individual measurements contributing to a one-minute average are valid, the following requirements shall <sub>[ps141]</sub> apply: the one-minute average is invalidated and the last valid average coasted until a valid average is obtained or until one minute has elapsed.	T	
142	3.2.2.3.1	To assure a true signal average and to allow signal offsets and sensor noise to be detected, no signal clipping of VS measurement samples shall <sub>[ps142]</sub> be allowed.	T	

FAA-E-2772B  
APPENDIX A

Requirements			Verification Method	
#	Para. #	Description	Contractor Testing	Remarks
143	3.2.2.3.2	To cover the full RVR range of 100 to 6,500 feet, the sensor measurement range shall <sup>[ps143]</sup> cover the range of 1.0 to 300 inverse kilometers ( $\text{km}^{-1}$ ) with a resolution of $0.01 \text{ km}^{-1}$ or 1 % of the measurement, whichever is greater.	T/A	
144	3.2.2.3.2	The VS measurement shall <sup>[ps144]</sup> be corrected for atmospheric beam attenuation inside the sensor, which can affect measurements of the highest extinction coefficients.	T	
145	3.2.2.3.3	The calibration of a VS shall <sup>[ps145]</sup> simulate the scattering from fog that is traceable to visibility measurements obtained from one or more reference transmissometers.	T/A	
146	3.2.2.3.3.1	Each calibration device shall <sup>[ps146]</sup> generate a scatter signal corresponding to a specific fog extinction coefficient.	T	
147	3.2.2.3.3.1	This transfer process shall <sup>[ps147]</sup> be accomplished using a minimum number of steps to avoid accumulation of errors.	T	
148	3.2.2.3.3.1	The calibration device(s) shall <sup>[ps148]</sup> be durable and stable enough to assure reliable VS calibration over its lifetime of 20 years.	I	
149	3.2.2.3.3.2	Communication with the VS during calibration shall <sup>[ps149]</sup> be via the MDT.	T	
150	3.2.2.3.3.2	The RVR System shall <sup>[ps150]</sup> report all RVR products associated with a VS as invalid while the calibration/validation process is being conducted on that VS.	T	
151	3.2.2.3.3.2	The computer/processor in the sensor shall <sup>[ps151]</sup> guide the calibration process and provide a progress indication of the calibration process to the maintenance person.	D	
152	3.2.2.3.3.2	The calibration process shall <sup>[ps152]</sup> include validation steps that preclude human error in order to avoid serious long-term measurement errors.	D/A	
153	3.2.2.3.3.2	A progress indicator shall <sup>[ps153]</sup> be displayed on the MDT during the VS calibration process.	T/I	

FAA-E-2772B  
APPENDIX A

Requirements			Verification Method	
#	Para. #	Description	Contractor Testing	Remarks
154	3.2.2.3.3.2	The VS shall <sup>[ps154]</sup> not be restored to service until the entire calibration/validation process has been successfully completed.	T	
155	3.2.2.3.3.2	The VS shall <sup>[ps155]</sup> meet the electromagnetic interference (EMI) specifications throughout the calibration process so that significant calibration errors cannot be generated by EMI.	T/A	
156	3.2.2.3.3.2	After calibration, the VS shall <sup>[ps156]</sup> meet the specified accuracy requirements over the entire measurement range of the VS.	T	
157	3.2.2.3.4	The VS shall <sup>[ps157]</sup> be aligned so that it provides the physical geometry necessary to meet the accuracy specifications below (see 3.2.2.3.5).	T	
158	3.2.2.3.4	A method shall <sup>[ps158]</sup> be provided to verify the alignment/misalignment of the VS scattering geometry, in its installed location, annually or as required.	T	
159	3.2.2.3.4	The VS sensor head assembly shall <sup>[ps159]</sup> be capable of realignment at the depot level when misalignment is detected.	D/A	
160	3.2.2.3.5.a	Under homogeneous atmospheric conditions, scatter meter measurements shall <sup>[ps160]</sup> agree with those of a reference transmissometer to within 15 % (standard deviation) for $\sigma$ (reference) > 3 km <sup>-1</sup> .	T	
161	3.2.2.3.5.a	The 15 %-standard-deviation requirement is tested at the 90 % confidence level; that is, 90 % of the one-minute-average readings of the scatter meter shall <sup>[ps161]</sup> agree to within $\pm 25$ % with the simultaneous one-minute-average readings of the reference transmissometer(s).	T	
162	3.2.2.3.5.a	Outliers (that is, more than a factor two difference) shall <sup>[ps162]</sup> not occur for more than 0.2 % of the measurements.	T	
163	3.2.2.3.5.b	The fog response of the sensor shall <sup>[ps163]</sup> drift by no more than 10 % in 90 days.	T	

FAA-E-2772B  
APPENDIX A

Requirements			Verification Method	
#	Para. #	Description	Contractor Testing	Remarks
164	3.2.2.3.5.b	Window contamination correction shall <sup>[ps164]</sup> account for any differences in the effect of dirt and water droplets.	T/A	
165	3.2.2.3.5.c	Sensor design shall <sup>[ps165]</sup> provide valid measurements under virtually all snow conditions.	T/A	
166	3.2.2.3.5.c	Under conditions where snow clogging adversely affects sensor performance, the sensor shall <sup>[ps166]</sup> detect snow clogging and disable its output if a valid measurement cannot be made.	T/A	
167	3.2.2.3.5.d	The fog and snow response (relative to the extinction coefficient) of the sensor shall <sup>[ps167]</sup> agree to within 10 %.	T/A	
168	3.2.2.3.5.e	The unit-to-unit fog response shall <sup>[ps168]</sup> vary by no more than $\pm 7$ % when calibrated by the same scattering device.	T/A	
169	3.2.2.3.5.f	The fog response of a sensor shall <sup>[ps169]</sup> vary by no more than $\pm 3$ % when calibrated by different calibration devices.	T	
170	3.2.2.3.5.g	The sensor offset (clear day response) caused by self-scattering and/or electronic offset shall <sup>[ps170]</sup> be less than $\pm 0.3 \text{ km}^{-1}$ .	T/A	
171	3.2.2.3.5.g	The zero-light sensor offset (heads blocked) shall <sup>[ps171]</sup> be no greater than $\pm 0.2 \text{ km}^{-1}$ .	T/A	
172	3.2.2.3.6	An MDT port using EIA Standard 232f interface(s) shall <sup>[ps172]</sup> be installed on SIE enclosure.	I	
173	3.2.2.3.6	The serial port shall <sup>[ps173]</sup> enable local access and communication for the purposes of real-time diagnostics, calibration, monitoring and/or control of the sensors and RVR System (3.2.2.2.6.3.1).	T/A	
174	3.2.2.3.7	The VS shall <sup>[ps174]</sup> use standard AC commercial power, single phase, rated at 115 V, ( $\pm 15$ %), 60 Hz ( $\pm 3$ Hz).	I/T	
175	3.2.2.3.7	The VS shall <sup>[ps175]</sup> have a power terminal for connection with a 3-1/C #10 cable as defined in FAA Drawing Number D-6282-7.	I/A	
176	3.2.2.3.7	All power conditioning systems shall <sup>[ps176]</sup> be equipped with input and output fuses and/or circuit breakers and semiconductor protection devices.	I	

FAA-E-2772B  
APPENDIX A

Requirements			Verification Method	
#	Para. #	Description	Contractor Testing	Remarks
177	3.2.2.3.7	The VS shall <sup>[ps177]</sup> have a battery backup system capable of powering the hardware item, without any interruption to functional operation at 25°C ± 10°C, for a minimum of four hours, without any interruption to functional operation, in the event of a commercial power failure.	T	
178	3.2.2.3.7	The battery power conditioning system shall <sup>[ps178]</sup> be capable of simultaneously providing power to the protected equipment while charging its batteries from a 50 % charge condition to a full charge within 12 hours (at 25°C ± 10°C) after return of commercial power.	T	
179	3.2.2.3.7	One, 3-wire grounded and polarized, duplex, (with parallel slots and double sided contacts), outdoor type convenience outlet equipped with a ground fault interrupter, protected by a 20A, 120v rated circuit breaker shall <sup>[ps179]</sup> be provided inside the SIE enclosure.	I	
180	3.2.2.3.8	The RVR VS shall <sup>[ps180]</sup> be securely mounted on a Government-furnished low impact resistant (LIR) structure, described in FAA-E-2702A, located approximately 35 feet (cable length) from the SIE.	D/I/A	
181	3.2.2.3.8	The VS assembly shall <sup>[ps181]</sup> be mounted at the top of the pole, on the pole cap furnished with the LIR structure, or on the pole itself.	I	
182	3.2.2.3.8	No other VS components shall <sup>[ps182]</sup> be mounted on the VS pole.	I	
183	3.2.2.4	The ALS shall <sup>[ps183]</sup> include a level to facilitate the correct installation angle.	I	
184	3.2.2.4	A maximum of two ALSs shall <sup>[ps184]</sup> be located on the airfield or at some central location such as the ATCT.	A	
185 m1	3.2.2.4	If the PC-based RVR system is collocated with a NG RVR system at an airport, the NG RVR system <sup>[ps185]</sup> shall provide one of the ALS measurements.	T	

FAA-E-2772B  
APPENDIX A

Requirements			Verification Method	
#	Para. #	Description	Contractor Testing	Remarks
185 a	3.2.2.4	If more than one ALS measurement is available, the higher ALS measurement shall <sup>[ps185a]</sup> be used in calculating RVR.	T	
186	3.2.2.4	The ALS shall <sup>[ps186]</sup> measure from 0.5 to 10,000 fL, with a resolution of 0.5 fL or 5 % of the measurement, whichever is greater.	T/A	
187	3.2.2.4	The accuracy of the ALS measurement at or above 2 fL shall <sup>[ps187]</sup> be $\pm 20$ %.	T	
188	3.2.2.4	Uncorrected ALS window losses shall <sup>[ps188]</sup> not exceed 20 % in 90 days.	T	
189	3.2.2.4	Snow clogging of the ALS will likely result in non-conservative (higher than actual) RVR values and shall <sup>[ps189]</sup> be prevented or detected.	T	
190	3.2.2.4.1	A one-minute running average of the background luminance (B) shall <sup>[ps190]</sup> be calculated.	T	
191	3.2.2.4.1	The sensor shall <sup>[ps191]</sup> spend at least 75 % of the time measuring the background luminance.	T	
192	3.2.2.4.1	No more than 10 % of the data in a particular one-minute average shall <sup>[ps192]</sup> come from the previous minute.	T	
193	3.2.2.4.1	If less than 75 % of the individual measurements contributing to a one-minute average are valid, the following requirements shall <sup>[ps193]</sup> apply: the one-minute average must be invalidated and the last valid average must be coasted until a valid average is obtained or until one minute has elapsed.	T	
194	3.2.2.4.1	To assure a true signal average and to allow signal offsets and sensor noise to be detected, no signal clipping of ALS measurement samples shall <sup>[ps194]</sup> be allowed.	T	
195	3.2.2.4.2	An MDT port using EIA Standard 232f interface(s) shall <sup>[ps195]</sup> be installed on the SIE enclosure.	I	



FAA-E-2772B  
APPENDIX A

Requirements			Verification Method	
#	Para. #	Description	Contractor Testing	Remarks
196	3.2.2.4.2	The serial port shall <sup>[ps196]</sup> enable local access and communication for the purposes of real-time diagnostics, calibration, monitoring and/or control of the sensors and RVR System (3.2.2.2.6.3.1).	T/A	
197	3.2.2.4.3	The ALS shall <sup>[ps197]</sup> use standard AC commercial power, single phase, rated at 115 V, (+ 15 %), 60 Hz ( $\pm$ 3 Hz).	I/T	
198	3.2.2.4.3	The ALS shall <sup>[ps198]</sup> have a power terminal for connection with a 3-1/C #10 cable as defined in FAA-D-6282-7.	I	
199	3.2.2.4.3	All power conditioning systems shall <sup>[ps199]</sup> be equipped with input and output fuses and/or circuit breakers and semiconductor protection devices.	I	
200	3.2.2.4.3	The ALS shall <sup>[ps200]</sup> have a battery backup system capable of powering the hardware item, without any interruption to functional operation at 25°C $\pm$ 10°C, for a minimum of four hours, without any interruption to functional operation, in the event of a commercial power failure.	T	
201	3.2.2.4.3	The battery power conditioning system shall <sup>[ps201]</sup> be capable of simultaneously providing power to the protected equipment while charging its batteries from a 50 % charge condition to a full charge within 12 hours (at 25°C $\pm$ 10°C) after return of commercial power.	T	
202	3.2.2.4.3	One, 3-wire grounded and polarized, duplex, (with parallel slots and double sided contacts), outdoor type convenience outlet equipped with a ground fault interrupter, protected by a 20A, 120v rated circuit breaker shall <sup>[ps202]</sup> be provided inside the SIE enclosure.	I	
203	3.2.2.4.4	The ALS shall <sup>[ps203]</sup> be installed as shown on FAA-D-6282-3, -7 and -9.	D/A	

FAA-E-2772B  
APPENDIX A

Requirements			Verification Method	
#	Para. #	Description	Contractor Testing	Remarks
204	3.2.2.5	The RLIM, consisting of an SIE and up to 8 current loop sensors, shall <sup>[ps204]</sup> accommodate the two types of runway lights used in the United States with maximum currents of 6.6A and 20A, respectively.	T	
205	3.2.2.5	The RLIM shall <sup>[ps205]</sup> determine which light setting is being used by directly measuring the 60 Hz root mean square (rms) lamp current.	T	
206	3.2.2.5	The current measurement shall <sup>[ps206]</sup> be accurate to 6 % of the current or 0.1A, whichever is greater.	T	
207	3.2.2.5.1	If an RLIM data sample is missing, the last valid data sample shall <sup>[ps207]</sup> be coasted.	T	
208	3.2.2.5.1	RLIM data shall <sup>[ps208]</sup> be coasted up to 30 seconds before a failure is declared.	T	
209	3.2.2.5.1	Invalid RLIM measurements shall <sup>[ps209]</sup> be treated as a runway light setting of zero (0).	T	
210	3.2.2.5.1	Where more than one current regulator is used for a particular set (that is, edge or centerline) of lights, the failure of one RLIM measurement shall <sup>[ps210]</sup> lead to a light setting of zero (0) for that set of lights.	T	
211	3.2.2.5.1	In other words, if more than one light current regulator is used for the edge/centerline lights and one of the edge/centerline RLIM measurement is invalid, then the edge/centerline light setting shall <sup>[ps211]</sup> be set to zero (0).	T	
212	3.2.2.5.1	When more than one current regulator is used for a particular set of lights and all the RLIM measurements are valid, then the RLIM measurement with the lowest light setting shall <sup>[ps212]</sup> be assigned to that set of lights.	T	
213	3.2.2.5.2	An MDT port using EIA Standard 232f interface(s) shall <sup>[ps213]</sup> be installed on the SIE enclosure.	I	

FAA-E-2772B  
APPENDIX A

Requirements			Verification Method	
#	Para. #	Description	Contractor Testing	Remarks
214	3.2.2.5.2	The serial port shall <sup>[ps214]</sup> enable local access and communication for the purposes of real-time diagnostics, calibration, monitoring and/or control of the sensors and RVR System (3.2.2.2.6.3.1).	T/A	
215	3.2.2.5.3	The RLIM shall <sup>[ps215]</sup> use standard AC commercial power, single phase, rated at 115 V, (+ 15 %), 60 Hz (+ 3 Hz).	I/T	
216	3.2.2.5.3	The RLIM shall <sup>[ps216]</sup> have a power terminal for connection with a 3-1/C #10 cable as defined in FAA-D-6282-7.	I	
217	3.2.2.5.3	All power conditioning systems shall <sup>[ps217]</sup> be equipped with input and output fuses and/or circuit breakers and semiconductor protection devices.	I	
218	3.2.2.5.3	The RLIM shall <sup>[ps218]</sup> have a battery backup system capable of powering the hardware item, without any interruption to functional operation at 25°C ± 10°C, for a minimum of four hours in the event of a commercial power failure.	T	
219	3.2.2.5.3	The battery power conditioning system shall <sup>[ps219]</sup> be capable of simultaneously providing power to the protected equipment while charging its batteries from a 50 % charge condition to a full charge within 12 hours (at 25°C ± 10°C) after return of commercial power.	T	
220	3.2.2.5.3	One, 3-wire grounded and polarized, duplex, (with parallel slots and double sided contacts), outdoor type convenience outlet equipped with a ground fault interrupter, protected by a 20A, 120v rated circuit breaker shall <sup>[ps220]</sup> be provided inside the SIE enclosure.	I	
221	3.2.2.5.4	The RLIM and Current Loop Sensor(s) shall <sup>[ps221]</sup> be installed similar to the method given on FAA-D-6282-3, -7 and -9.	D/A	
222	3.2.2.6	The CD shall <sup>[ps222]</sup> display RVR products for the specific runway(s) selected by an Air Traffic Controller (hereafter referred to as Controller) using either a keypad or a touch-screen included with the display.	T	

FAA-E-2772B  
APPENDIX A

Requirements			Verification Method	
#	Para. #	Description	Contractor Testing	Remarks
223	3.2.2.6	The CD shall <sup>[ps223]</sup> be readable in both high and low artificial and natural light conditions corresponding to conditions in an ATCT and TRACON.	T	
224	3.2.2.6	In addition to a means of data entry, the CD shall <sup>[ps224]</sup> include an audio alarm and dual communication links to ensure fail-safe data communications from the RVR DPU.	T	
225	3.2.2.6	The CD shall <sup>[ps225]</sup> be used by the Controller to display RVR products for any runway and simultaneously display RVR products for up to three runways.	T	
226	3.2.2.6	Each display line shall <sup>[ps226]</sup> consist of: the runway ID; the RVR products and trends for the TD, MP, and RO positions; runway edge light step setting; and, centerline light step setting.	T	
227	3.2.2.6	The CD shall <sup>[ps227]</sup> be capable of sounding audio alarms and displaying visual alarms corresponding to each product.	T	
228	3.2.2.6	The CD shall receive the incoming serial data stream from the DPU (3.2.2.2) or NGRVR DPU; perform error checks on the data and format and display the product.	T	
229	3.2.2.6	The CD shall <sup>[ps229]</sup> include the means to set Low Visibility Alarm Threshold (LVAT) limits for any of the TD, MP or RO positions of the display.	T	
230	3.2.2.6	The CD shall <sup>[ps230]</sup> issue an alarm consisting of both an audio alarm and a visual indication on the CD whenever an RVR value decreases below a preset alarm limit, or if a failure occurs.	T	
231	3.2.2.6	The selected runways and LVAT limits that are set by the Controller shall <sup>[ps231]</sup> be stored in non-volatile memory.	T	
232	3.2.2.6	In case of AC power failure, when the power is restored, the CD shall <sup>[ps232]</sup> reinitialize itself and restore all data previously entered by the Controller.	T	

FAA-E-2772B  
APPENDIX A

Requirements			Verification Method	
#	Para. #	Description	Contractor Testing	Remarks
233	3.2.2.6.1	The display characters' aspect ratio of height to width shall <sup>[ps233]</sup> be greater than or equal to 1.0.	T	
234	3.2.2.6.1	The CD shall <sup>[ps234]</sup> permit viewing in full, direct sunlight from any angle, as installed in an ATCT.	T	
235	3.2.2.6.1	The display-viewing surface shall <sup>[ps235]</sup> be antiglare.	I/A	
236	3.2.2.6.1	The display shall <sup>[ps236]</sup> be readable in light levels ranging from bright sunlight, to artificial light, to near darkness.	T	
237	3.2.2.6.1	The display shall <sup>[ps237]</sup> be readable at a distance of 10 feet at a horizontal viewing angle of 30° from either side of a vertical plane perpendicular to the display.	T	
238	3.2.2.6.1	The display shall <sup>[ps238]</sup> be readable at a distance of 10 feet at a vertical viewing angle of 20° from either side of a horizontal plane perpendicular to the display.	T	
239	3.2.2.6.2	The CD shall <sup>[ps239]</sup> be capable of displaying the selected runway, the corresponding RVR values and trend, the RVR threshold alarm limits, the edge and centerline runway light setting and status/failure indications.	T	
240	3.2.2.6.2	A Controller shall <sup>[ps240]</sup> be able to select a display of RVR products for one to three runways by selecting the runway designation (for example, 14R, 10C, 10R) via the keypad or the touch-screen.	T	
241	3.2.2.6.2	It shall <sup>[ps241]</sup> be possible to enter a single LVAT for an entire runway or individual LVATs for the TD, MP and RO RVR products for each runway.	T	
242	3.2.2.6.2	The runway designator shall <sup>[ps242]</sup> consist of three alphanumeric characters as follows - numeric characters "01" through "36" followed by a blank space or one of the following alphabetic characters: "L", "C" or "R".	T	
243	3.2.2.6.2	Each runway position designator (TD, MP and RO) shall <sup>[ps243]</sup> consist of four alphanumeric characters.	T	

FAA-E-2772B  
APPENDIX A

Requirements			Verification Method	
#	Para. #	Description	Contractor Testing	Remarks
244	3.2.2.6.2	When a valid RVR product is to be displayed, the first two characters shall <sup>[ps244]</sup> represent the RVR product in hundreds of feet and last two characters must be "00".	T	
245	3.2.2.6.2	Either a trend arrow indicating "up", "down" or a blank indicating a steady state shall <sup>[ps245]</sup> follow each runway position designator.	T	
246	3.2.2.6.2	The runway edge light and centerline light step setting designators shall <sup>[ps246]</sup> each consist of one alphanumeric character from "0" to "5" or a blank space.	T	
247	3.2.2.6.2	The CD shall <sup>[ps247]</sup> highlight the manually entered data (that is, runway selection and alarm limits) using a special feature such as reverse video or brackets.	T	
248	3.2.2.6.2	An LVAT or failure alarm condition shall <sup>[ps248]</sup> be indicated by an audio alarm as well as visual alarm consisting of an indicator on the numeric display such as blinking or highlighting.	T	
249	3.2.2.6.2	Provisions shall <sup>[ps249]</sup> be included to enable the Controller to clear the audio and visual alarms associated with an LVAT or failure alarm.	T	
250	3.2.2.6.2	The CD shall <sup>[ps250]</sup> use ASCII "blanks" and "F" to indicate the conditions described in TABLE 3-8, CD data presentation.	T/A	
251	3.2.2.6.2.1	LVAT limits shall <sup>[ps251]</sup> be operator-assignable for any visibility sensor position on any configured runway.	T	
252	3.2.2.6.2.1	LVAT limits shall <sup>[ps252]</sup> be logically assigned to the runway for which the operator enters them such that if the runway display position is moved, the LVAT limits move with it.	T	
253	3.2.2.6.3	The CD shall <sup>[ps253]</sup> contain the following control functions: AC power; data entry/access; keypad intensity; display intensity; audio alarm volume control; and alarm acknowledge.	I/T	
254	3.2.2.6.3.1	The CD shall <sup>[ps254]</sup> have an alphanumeric keypad or touch-screen data entry/access capability.	T	

FAA-E-2772B  
APPENDIX A

Requirements			Verification Method	
#	Para. #	Description	Contractor Testing	Remarks
255	3.2.2.6.3.2	If a keypad is used, the keypad intensity and control shall <sup>[ps255]</sup> be adjustable so the keypad is clearly visible in near darkness and bright sunlight.	T	
256	3.2.2.6.3.3.1	The display light intensity control shall <sup>[ps256]</sup> be present on the front panel and be adjustable so the display is clearly visible in near darkness and bright sunlight.	I/T	
257	3.2.2.6.3.3.2	The keypad, if used, shall <sup>[ps257]</sup> satisfy the design criteria for input devices stated in paragraph 8.21.4 of FAA Human Factors Design Guide Update, DOT/FAA/CT-01/08.	T/A	
258	3.2.2.6.3.3.2	Keypad entries shall <sup>[ps258]</sup> appear in the appropriate fields in the display.	T	
259	3.2.2.6.3.3.2	An editing feature shall <sup>[ps259]</sup> be included, such as a backspace, to allow entry corrections.	T	
260	3.2.2.6.3.3.2	The CD shall <sup>[ps260]</sup> check for invalid entries, such as an incorrect runway, and indicate any error to the operator.	T	
261	3.2.2.6.3.3.2	The keypad (if used) shall <sup>[ps261]</sup> utilize positive touch-feedback type keys.	I	
262	3.2.2.6.3.3.3	The touchscreen, if used, shall <sup>[ps262]</sup> satisfy the design criteria for input devices stated in paragraph 8.21.4 of FAA Human Factors Design Guide Update, DOT/FAA/CT-01/08.	T/A	
263	3.2.2.6.3.3.4	The volume control for all audio alarms shall <sup>[ps263]</sup> be adjustable to a level that satisfies the audio and verbal display criteria cited in paragraph 8.16 of FAA Human Factors Design Guide Update, DOT/FAA/CT-01/08.	T/A	
264	3.2.2.6.3.3.4	The audio alarm adjustment shall <sup>[ps264]</sup> be a set-up function based on the facility (ATCT or TRACON) ambient noise level.	T	
265	3.2.2.6.3.3.4	The volume control shall <sup>[ps265]</sup> not be located on the face of the display.	I	

FAA-E-2772B  
APPENDIX A

Requirements			Verification Method	
#	Para. #	Description	Contractor Testing	Remarks
266	3.2.2.6.3.3.5	An AC power switch shall <sup>[ps266]</sup> be present on the front panel of the CD.	I	
267	3.2.2.6.3.3.5	The AC power switch shall <sup>[ps267]</sup> be marked to indicate when power is on or off.	I	
268 m1	3.2.2.6.3.3.5	The CD shall <sup>[ps268]</sup> utilize a lighted indicator that illuminates when the power switch is turned on.	I	
269	3.2.2.6.3.3.5	The illumination intensity of the CD power indicator shall <sup>[ps269]</sup> be optimized for viewing in near darkness.	T	
270	3.2.2.6.3.3.5	The power switch shall <sup>[ps270]</sup> be either located where the possibility of it being inadvertently activated or deactivated is remote or a protective guard is placed over the switch.	I	
271	3.2.2.6.4	Alarms shall <sup>[ps271]</sup> be manifested by three beeps and a flashing display.	T	
272	3.2.2.6.4	An alarm-acknowledge control shall <sup>[ps272]</sup> be used to deactivate all blinking visual alarms and audio alarms simultaneously.	T	
273	3.2.2.6.4	If the condition that caused the alarm assumes an acceptable state and then deteriorates beyond a threshold, the alarm(s) shall <sup>[ps273]</sup> again become activated.	T	
274	3.2.2.6.4.1	The audio alarm shall <sup>[ps274]</sup> be activated in accordance with TABLE 3-9, Audio alarm conditions.	T/A	
275	3.2.2.6.4.1	Except in the case of a hardware failure peculiar to an individual CD, all audio alarms shall <sup>[ps275]</sup> silence after three (3) beeps or when the alarm is acknowledged.	T	
276	3.2.2.6.4.1	The audio alarm tone, frequency, timing and duration shall <sup>[ps276]</sup> be as specified in paragraph 8.16 of the FAA Human Factors Design Guide Update, DOT/FAA/CT-01/08.	T/A	
277	3.2.2.6.4.2	The visual alarm shall <sup>[ps277]</sup> operate in accordance with TABLE 3-10, Displayed alarm conditions.	T/A	



FAA-E-2772B  
APPENDIX A

Requirements			Verification Method	
#	Para. #	Description	Contractor Testing	Remarks
278	3.2.2.6.4.2	All visual alarms shall <sup>[ps278]</sup> remain until: acknowledged by the operator; or the condition clears itself; or in the case of a channel failure or CD fault, the condition is corrected by a maintenance action.	T	
279	3.2.2.6.5	The CD shall <sup>[ps279]</sup> contain self-test features that will ensure error-free operation of the unit at all times.	T	
280	3.2.2.6.5	Upon power-up and once every hour, the CD shall <sup>[ps280]</sup> automatically initiate a self-test sequence that ensures proper operation of the processor, memory, and other system components.	T	
281	3.2.2.6.5	A control feature shall <sup>[ps281]</sup> be available to allow an operator to manually initiate a self-test.	T	
282	3.2.2.6.5	A manually initiated self-test shall <sup>[ps282]</sup> enable a comprehensive test of the display portion of the CD and other system components that could not otherwise be permitted during normal operation.	T	
283	3.2.2.6.6	Each CD shall contain dual communication interfaces compatible with the DPU (3.2.2.2) and the NGRVR DPU.	I	
284	3.2.2.6.6	Each CD shall <sup>[ps284]</sup> receive separate identical RVR product sets over each interface.	T	
285	3.2.2.6.6	The CD shall <sup>[ps285]</sup> use two completely independent data reception circuits.	I	
286	3.2.2.6.6	Failure of one communication channel shall <sup>[ps286]</sup> not disrupt normal display operations.	T	
287	3.2.2.6.6	The following message errors shall <sup>[ps287]</sup> be detected by the CD for both communication channels: Invalid block check code; Invalid Message Field values, Missing start of text; Missing end of text; Missing end of transmission; Parity Error; and Invalid Time Stamp.	T	
288	3.2.2.6.6	The CD shall <sup>[ps288]</sup> display the status of both communication channels.	T	

FAA-E-2772B  
APPENDIX A

Requirements			Verification Method	
#	Para. #	Description	Contractor Testing	Remarks
289	3.2.2.6.6	In case of a channel failure or a message error, the CD shall <sup>[ps289]</sup> "coast" the last RVR product set for 30 seconds.	T	
290	3.2.2.6.6	After 30 seconds, if communications have not been restored, the CD shall <sup>[ps290]</sup> indicate the channel failure and sound an audible alarm of 3 beeps.	T	
291	3.2.2.6.6	The CD shall <sup>[ps291]</sup> switch between the two channels in accordance with the TABLE 3-11, Channel activation sequence.	T/A	
292	3.2.2.6.7	The CD shall <sup>[ps292]</sup> use standard AC commercial power, single phase, rated at 115 V, (+ 15 %), 60 Hz (+ 3 Hz).	I/T	
293	3.2.2.6.7	The CD shall <sup>[ps293]</sup> have an 8-foot long power cable that plugs into a standard 3-prong convenience outlet that provides no more than 10A (circuit breaker protected).	I	
294	3.2.2.6.8.1	The CD shall <sup>[ps294]</sup> operate in a local configuration in the same facility with the DPU requiring communications over distances of up to 2,000 feet as well as in a remote configuration at sites requiring the use of Government-furnished modems and dedicated lines.	A/T	
295	3.2.2.6.8.1	All requirements for CD operation shall <sup>[ps295]</sup> apply to both local and remote configurations.	T	
296	3.2.2.6.8.1.1	In local configuration, up to 32 CDs shall <sup>[ps296]</sup> be connected to the DPU using an RS-485 interface for each communication channel.	A/T	
297	3.2.2.6.8.1.2	Using an RS-232 interface, the first remote CD shall <sup>[ps297]</sup> be connected to the DPU via Government-furnished modems.	A/T	
298	3.2.2.6.8.1.2	The first remote CD shall <sup>[ps298]</sup> convert the RS-232 interface to RS-485.	I/A	
299	3.2.2.6.8.1.2	A maximum of 32 additional CDs shall <sup>[ps299]</sup> connect to the first remote CD and function as if they were in a local CD configuration.	A	

FAA-E-2772B  
APPENDIX A

Requirements			Verification Method	
#	Para. #	Description	Contractor Testing	Remarks
300	3.2.2.6.8.1.2	Except for the first CD in a remote chain, any CD that fails shall <sub>[ps300]</sub> not affect any other CD in that chain.	T	
301	3.2.2.6.8.1.2	Each communication channel shall <sub>[ps301]</sub> be supplied through a separate Government-furnished modem.	T	
302	3.2.2.6.8.2	The electronics compartment shall <sub>[ps302]</sub> not exceed 5.75 inches in height, 8.75 inches in width and 9.0 inches in depth.	I	
303	3.2.2.6.8.2	The faceplate dimensions and hole spacing shall <sub>[ps303]</sub> be compliant to with FAA TI-6560.17, Figure 9-11A.	I/A	
304	3.2.2.6.8.2	If a keypad is used, it shall <sub>[ps304]</sub> be integral with the faceplate; that is, the length and width must not extend beyond the faceplate.	I/A	
305	3.2.3	The RVR shall <sub>[ps305]</sub> meet the general navigational aid equipment requirements of this paragraph and TABLE 3-12, tailored from FAA-G-2100G.	T/A	
306	3.2.3.1	The RVR shall <sub>[ps306]</sub> meet the requirements of FAA-G-2100G, paragraph 3.2.1 for operating environment conditions with the following clarifications.	T/A	
307	3.2.3.1	RVR equipment designed for use in attended facilities (ATCT and TRACON) shall <sub>[ps307]</sub> operate in the ambient conditions of Environment I in TABLE 3-13.	T/A	
308	3.2.3.1	RVR equipment designed for use in unmanned facilities (equipment shelter) shall <sub>[ps308]</sub> operate with the ambient conditions of Environment II listed in TABLE 3-13.	T/A	
309 m1	3.2.3.1	Equipment not housed in shelters shall <sub>[ps309]</sub> operate in the ambient conditions of Environment III listed in TABLE 3-13.	T/A	
310	3.2.3.1	Above 40°C, the relative humidity shall <sub>[ps310]</sub> be based upon a dew point of 40°C.	T/A	
311	3.2.3.2	The RVR System design shall <sub>[ps311]</sub> meet the requirements for transportability under commercial shipping conditions as required in category 4,5,7,8,9, 10 and 11 (Transportation) of TABLE 514-I.	I/A	

FAA-E-2772B  
APPENDIX A

Requirements			Verification Method	
#	Para. #	Description	Contractor Testing	Remarks
312	3.2.3.3	The RVR System shall <sup>[ps312]</sup> meet the requirements of FAA-G-2100G, paragraph 3.3.1 for materials, processes and parts.	I/A	
313	3.2.3.3.a	Iron and steel shall <sup>[ps313]</sup> be used only when necessary to comply with strength requirements.	I/A	
314	3.2.3.3.a	Outside equipment enclosures, exposed to Environment III (outside conditions), shall <sup>[ps314]</sup> not be made of steel.	I/A	
315	3.2.3.3.a	When approved for use, iron and steel shall <sup>[ps315]</sup> be treated to prevent corrosion.	I/A	
316	3.2.3.3.b	Organic fibrous material shall <sup>[ps316]</sup> not be used.	I/A	
317	3.2.3.3.c	Materials used shall <sup>[ps317]</sup> be fungus-inert, except within hermetically sealed assembly.	A/T	
318	3.2.3.3.c	Materials from Group I are preferred, but when materials from Group II must be used, they shall <sup>[ps318]</sup> be rendered fungus inert by compounding with a permanently effective fungicide or by suitable surface treatment.	A	
319	3.2.3.3.c	They shall <sup>[ps319]</sup> pass the fungus test specified in ASTM G21, with no visible growth of fungus after 28 days.	A/T	
320	3.2.3.3.d	Insulating materials shall <sup>[ps320]</sup> be selected based on meeting or exceeding the use requirements of the following: temperature endurance, moisture absorption and penetration, fungus resistance, dielectric strength, dielectric constant, mechanical strength, dissipation factor, ozone resistance, and flammability.	A/T	
321	3.2.3.3.d	Polyvinyl chloride insulating materials for external cables shall <sup>[ps321]</sup> be in accordance with NFPA-70.	I/A	
322	3.2.3.3.d	Ceramics shall <sup>[ps322]</sup> conform to MIL-I-10 or equivalent,.	A	
323	3.2.3.3.d	Ceramic insulators shall <sup>[ps323]</sup> conform to MIL-I-23264 or equivalent.	A	
324	3.2.3.3.d	Sleeving shall <sup>[ps324]</sup> provide adequate dielectric strength and leakage resistance under the designated service conditions.	A	

FAA-E-2772B  
APPENDIX A

Requirements			Verification Method	
#	Para. #	Description	Contractor Testing	Remarks
325	3.2.3.3.d	Cast thermosetting plastic used for electrical insulation shall <sup>[ps325]</sup> be in accordance with L-P-516 or equivalent.	A	
326	3.2.3.3.d	Other electrical materials having moisture absorption of greater than 1 % shall <sup>[ps326]</sup> be impregnated with a suitable moisture barrier material.	A	
327	3.2.3.3.e	Lubricants shall <sup>[ps327]</sup> be suitable for the purpose intended.	A	
328	3.2.3.3.e	Low volatility lubricants shall <sup>[ps328]</sup> be used.	A	
329	3.2.3.3.e	The lubricant shall <sup>[ps329]</sup> be chemically inert with respect to the materials or other lubricants it contacts.	A	
330	3.2.3.3.e	Silicone and graphite base lubricants shall <sup>[ps330]</sup> not be used.	A	
331	3.2.3.3.f	Natural rubber shall <sup>[ps331]</sup> not be used.	A/I	
332	3.2.3.3.g	Wood and wood products shall <sup>[ps332]</sup> not be used inside equipment.	A/I	
333	3.2.3.3.h	Thread locking and retaining compounds shall <sup>[ps333]</sup> conform to the required operating conditions and MIL-S-22473 or MIL-S-46163 or equivalent and be applied such that the required level of locking or retaining is achieved and maintained.	A	
334	3.2.3.3.h	Such compounds shall <sup>[ps334]</sup> not impair electrical conductivity, cause or accelerate corrosion or be used where failure would endanger personnel or damage equipment.	A	
335	3.2.3.3.h	Such compounds shall <sup>[ps335]</sup> be compatible with the material to which they are bonded.	A	
336	3.2.3.3.i	Anti-seize compounds shall <sup>[ps336]</sup> conform to MIL-T-22361 or TT-S-1732 or equivalent.	A	
337	3.2.3.3.i	Graphite base anti-seize compounds shall <sup>[ps337]</sup> not be used.	A	
338	3.3	RVR System shall <sup>[ps338]</sup> meet the requirements specified in 3.2 while in accordance with the system characteristics directed by 3.3.	A	

FAA-E-2772B  
APPENDIX A

Requirements			Verification Method	
#	Para. #	Description	Contractor Testing	Remarks
339	3.3.1	The design and development of electronic equipment shall <sup>[ps339]</sup> provide for the safety of personnel during the installation, operation, maintenance, repair and interchange of complete equipment assemblies or component parts.	A	
340	3.3.1	Equipment design for personnel safety shall <sup>[ps340]</sup> be equal to or better than the requirements of the Occupational Safety and Health Agency (OSHA) as identified in CFR Title 29, Part 1910 and Part 1926.	A	
341	3.3.2.1	The RVR System shall <sup>[ps341]</sup> be capable of installation without modification within an airport operations area in the proximity of runways, the ATCT and the TRACON.	A	
342	3.3.2.1	SIE enclosures near the runways shall <sup>[ps342]</sup> be capable of being padlocked.	I	
343 ml	3.3.2.2	Reserved.	N/A	
344	3.3.2.2	The RVR System shall <sup>[ps344]</sup> provide a minimum of four (4) access levels.	T	
345	3.3.3	The general and detailed design of the RVR System shall <sup>[ps345]</sup> be in accordance with the requirements of Sections 4, 6, 7, 8, 12, 13 and 14 of DOT/FAA/CT-96/1.	T/A	
346	3.3.3	Design of the display screens for maintenance and Air Traffic Operations personnel shall <sup>[ps346]</sup> be engineered to ensure optimal: usability; efficiency and effectiveness of human performance; and safety.	A	
347	5	Packaging requirements shall <sup>[ps347]</sup> be as specified in the contract or order.	A	