

DTFA01-96-C-00025  
Modification No. 0111  
~~Modification No. 0051~~  
~~September 21, 1999~~

FAA-E- 2892b  
Change 1  
August 13, 2001  
(including Change 2)



U.S. DEPARTMENT OF TRANSPORTATION  
FEDERAL AVIATION ADMINISTRATION  
SPECIFICATION  
FOR THE  
WIDE AREA AUGMENTATION SYSTEM (WAAS)

## Change History

### LIST OF EFFECTIVE PAGES

USE SPECIFICATION FAA-E-2892B, Change 2, dated August 13, 2001 in its entirety

DESTROY SUPERSEDED SPECIFICATION (FAA-E-2892B, Change 1)

**NOTE:** A vertical line in the outer margins of the pages indicates the portions of the specification effected by the 8/13/01 changes.

**Dates of issue for original and changed pages are:**

Original	July 31, 1995
Change 1	January 16, 1996
Revision B	March 10, 1997
Change 1	September 21, 1999
Change 2	August 13, 2001

<i>Page No.</i>	<i>Spec. Change No.</i>	<i>Change Posted</i>
Cover	02	Editorial
Change History	02	Editorial
iii - v	02	Technical / Editorial
viii	02	Add section
4	02	Delete paragraph
7 - 10	02	Various paragraphs
12 - 14	02	Various paragraphs
30	02	Various paragraphs
2-12 - 2-13	02	Various paragraphs
2-16 - 2-18	02	Various paragraphs

<i>Page No.</i>	<i>Spec. Change No.</i>	<i>Change Posted</i>
2-20 - 2-21	02	Various paragraphs
2-23	02	Various paragraphs
2-27	02	Various paragraphs
2-31	02	Various paragraphs
2-37 - 2-40	02	Various paragraphs
2-41 - 2-44	02	Added paragraphs
2-45 - 2-50	02	Various paragraphs
3-5	02	Various paragraphs
4-6 - 4-7	02	Editorial changes

## **Addendum to the Wide Area Augmentation System (WAAS) Specification**

The WAAS shall be implemented in two phases, Phase 1 and Phase 2/3. For Phase 1 several requirements: (1) have been modified, or (2) will be contained in Phase 1 requirements documents, but will be designed, coded and tested by the end of Phase 2/3. For Phase 2/3, all requirements in FAA-E-2892B shall be met.

The requirements contained in Section 3 of the WAAS specification shall apply to the Phase 1 WAAS, except as noted below:

The following requirements 1-1 and 1-2 shall be contained in all Phase 1 requirements specifications, but shall be designed, coded and tested by the end of Phase 2/3 period of performance:

### **1-1 System Operations and Maintenance (Function 8)**

- 3.1.3.9.2.2.11.3 Component Level Playback
- 3.1.3.9.2.2.11.4 Component Level Observation Data Recording Content
- 3.1.3.9.2.2.11.5 Component Level Navigation Data Recording Content
- 3.1.3.9.2.2.11.6 Component Level Tropospheric Data Recording Content
- 3.1.3.9.3.2.1.3 Fault Isolation Time
- 3.1.3.9.3.2.4 Maintenance Priority Generation
- 3.1.3.9.3.2.10 Record Keeping

### **1-2 Displays**

- 3.1.3.9.2.2.3.1 Displays
- (2) graphical geographic representation of GPS/WAAS coverage,
- (3) graphical geographic representation of the service being provided to the coverage region (precision approach, en route through non-precision approach),

### **1-3 Outputs**

Reference paragraph 3.1.3.9.2.3. The outputs for Phase 1 design, code, and testing shall be:

- a. displays of status;
- b. GPS and WAAS data to archives;
- c. status reporting;
- d. maintenance prioritization data;
- e. system configuration data;
- f. system fault data internally generated by WAAS components or equipment;
- g. WNT/UTC offset; and
- h. GEO satellite testing mode command.

### **1-4 Fault Detection**

The Fault Detection for Phase 1 design, code, and testing shall be:

- 3.1.3.9.3.2.1.1 Fault Detection
- Subfunction 3 fault detection shall be completed within an average time of 60 seconds and a maximum time of 120 seconds.

### **1-5 Status Reporting**

The following requirements shall be contained in all requirements specifications but shall be designed, coded and tested by the end of Phase 2/3 period of performance:

- 3.1.3.9.2.2.6 WAAS Maintenance Alarms
- 3.1.3.9.2.2.7 Alerts
- 3.1.3.9.2.2.8 Alert and Alarm Latency
- 3.1.3.9.2.2.9 Alert and Alarm Acknowledgment

For Phase 1, replace the above paragraphs (3.1.3.9.2.2.6 through 3.1.3.9.2.2.9) with paragraphs 3.1.3.9.2.2.6 through 3.1.3.9.2.2.8 below. These requirements shall be satisfied during Phase 1.

**3.1.3.9.2.2.6 WAAS Status Reporting**

Subfunction 2 shall provide visual and audio indications with time stamp to the WMS personnel and notification to the corrective maintenance subfunction when a WAAS status change occurs. A WAAS status change occurs when one or more LRUs and/or component(s) fails.

**3.1.3.9.2.2.7 WAAS Status Reporting Latency**

Subfunction 2 shall transfer status reporting messages with an average time of 60 seconds and a maximum time of 120 seconds. This time is measured from the generation of the status change to the receipt of the message in the WMS.

**3.1.3.9.2.2.8 Status Reporting Acknowledgment**

Subfunction 2 shall provide the mechanisms for acknowledging status changes. Acknowledgment includes the silencing of audio indications and the preservation of visual indications.

**1-6 Unattended Interior Equipment Design Ranges**

For Phase 1, delete paragraph

- 3.2.6.3.2 Unattended Interior Equipment Design Ranges

**1-7 Performance Requirements**

The Phase 1 WAAS shall meet all of the Phase 2/3 WAAS performance requirements in paragraph 3.2.1, except as noted in Table 1 below. The Phase 1 WAAS provides En Route/Nonprecision Approach (ER/NPA) and Lateral Navigation/Vertical Navigation (LNAV/VNAV) capabilities.

LNAV/VNAV operations are designed to provide instrument approaches with vertical guidance, but with higher minimums than Category I precision approaches. This capability is considered available when a user's horizontal alert limit (HAL) is less than or equal to 0.3 nautical miles and a user's vertical alert limit (VAL) is less than or equal to 50 meters.

**Table 1: GPS/WAAS Signal-in-Space Performance Requirements Exceptions for the Phase 1 WAAS**

Paragraph	Title	Phase 1 WAAS Requirement
3.2.1.2	En Route through Nonprecision Approach Performance Requirements	

Paragraph	Title	Phase 1 WAAS Requirement
3.2.1.2.1	Availability	The availability of the en route through nonprecision approach requirements shall be at least 0.999 at every point within the service volume.
3.2.1.2.4.1	Continuity of Navigation	Given two Geostationary Earth Orbit (GEO) satellite links are available to each user, the continuity of the navigation function shall be at least $(1 - 10^{-5})$ per hour at every location in the service volume.
3.2.1.2.4.2	Continuity of Fault Detection	Given that two GEO satellite links are available to each user, the continuity of the fault detection function shall be at least $(1 - 10^{-5})$ per hour at every location in the service volume, excluding outages of less than 5 minutes.
3.2.1.2.6.1	Full Service	The service volume shall be defined as the volume which meets the 0.999 availability requirement with the FAA-provided Wide area Reference Station (WRS) network and will be at least 35% of the Phase 2/3 full service, and <del>5075%</del> of <del>CONUS</del> (Conterminous United States <del>(CONUS)</del> ).
<b>3.2.1.3</b>	<b><del>Precision Approach Lateral Navigation/Vertical Navigation (LNAV/VNAV) Performance Requirements</del></b>	
3.2.1.3.1	Availability	The availability of the <del>precision approach LNAV/VNAV requirements service</del> shall be at least 0.95 at any point within the service volume with a <del>conservative</del> vertical position error bound of <del>19.250</del> m.
3.2.1.3.3.2	Time-to-Alarm	The WAAS time-to-alarm shall not exceed 6.2 seconds to support <del>precision approach LNAV/VNAV operations</del> .
3.2.1.3.4	Continuity of Function	Given two GEO satellite links are available to each user, the WAAS signal-in-space <del>precision approach</del> continuity of function shall be greater than or equal to $(1 - 5.5 \times 10^{-5})$ per <del>precision approach 150 seconds to support LNAV/VNAV operations</del> .
3.2.1.3.6	Service Volume	The service volume shall be defined as the volume which meets the 0.95 availability requirement with the FAA-provided WRS network and will include the airspace from the surface up to 10,000 feet above the surface for at least <del>5075%</del> of the area within <del>the conterminous 48 states</del> (CONUS).

### 1-8 Signal Processing Requirements

- a. For the Phase 1 WAAS, the requirements in paragraph 3.2.4.2.1.1, Table 3.2-3 shall be as follows:

Table 3.2-3 In-Band Rejection Characteristics Above 5 Degrees

Signal Type	Interference Bandwidth	Total Interference/Minimum Desired Signal Power Ratio (I/S)
-------------	------------------------	---

L1-C/A	$0 < BW \leq 600$ Hz	10 dB
L1-C/A	$600 < BW \leq 1,000$ Hz	15 dB
L1-C/A	$1,000 < BW \leq 10,000$ Hz	$15 + 6\log_{10}(BW/1000)$ dB
L1-C/A	$10,000 < BW \leq 100,000$ Hz	$21 + 3\log_{10}(BW/10000)$ dB
L1-C/A	$100,000$ Hz $< BW$	24 dB
L2-P(Y)	All	24 dB

b. For the Phase 1 WAAS, the requirements in paragraph 3.2.4.2.3 (Special Interference Rejection Capability) are waived.

c. For the Phase 1 WAAS, the GPS/WAAS antenna/receiver shall be designed so as not to preclude the future incorporation of the Special Interference Rejection Capability requirements in paragraph 3.2.4.2.3.

### 1-9 Remote Maintenance Monitoring System (RMMS)

For the Phase 1 WAAS, paragraph 3.1.3.9.5 (Remote Maintenance Monitoring System (RMMS)) is deleted. System status shall be continuously monitored from the Wide-area Master Stations (WMSs).

### 1-10 Precision Approach LNAV/VNAV Service Volume

For Phase 1 “~~PALNAV/VNAV~~ shall be available 0.95 over 750% of CONUS” is interpreted to being over a fixed space. This means that the ~~precision approach~~ LNAV/VNAV service volume is the set A of points  $(\phi, \lambda) = (\text{latitude, longitude})$  in CONUS, where for  $t = \text{time}$ ,

$$\begin{aligned}
 PA(\phi, \lambda, t) &= 1, \text{ if } \del{\text{precision approach}} \text{LNAV/VNAV} \text{ is available at} \\
 &\quad \text{latitude, longitude and time, and} \\
 &= 0, \text{ if } \del{\text{precision approach}} \text{LNAV/VNAV} \text{ is not available at} \\
 &\quad \text{that latitude, longitude and time.}
 \end{aligned}$$

$$\begin{aligned}
 P_{0.95}(\phi, \lambda) &= 1, \text{ if } \del{\text{precision approach}} \text{LNAV/VNAV} \text{ is available at a} \\
 &\quad \text{fixed position, } (\phi, \lambda) \text{ in CONUS, 95\% of the time, and} \\
 &= 0, \text{ otherwise.}
 \end{aligned}$$

Thus,

$$PA = \Pr \left( \frac{\int_{CONUS} P_{0.95}(\phi, \lambda) dA}{\int_{CONUS} dA} \right) \text{ is required to be } \geq 0.75, \text{ where}$$

$$P_{0.95}(\phi, \lambda) = 1, \text{ if } \Pr\left(\frac{\int_{Time} PA(\phi, \lambda, t)dt}{\int_{Time} dt}\right) \geq 0.95,$$
$$= 0, \text{ if } \Pr\left(\frac{\int_{Time} PA(\phi, \lambda, t)dt}{\int_{Time} dt}\right) < 0.95.$$

### 1-11 Avionics Contribution to Pseudorange Error

The Phase 1 avionics contribution to pseudorange error shall be assumed to be zero, i.e.,  
 $\sigma_{air} = 0.0 \text{ m}$ .

### 1-12 Message Type 10 Parameters

For Phase 1, it is permissible to use a fixed value for Message Type 10 function degradation parameters.

WIDE AREA AUGMENTATION SYSTEM (WAAS) SPECIFICATION

Table of Contents

<b>1.0 SCOPE</b> .....	<b>1</b>
1.1 IDENTIFICATION .....	1
1.2 SYSTEM OVERVIEW .....	1
1.3 DOCUMENT OVERVIEW .....	2
<b>2.0 APPLICABLE DOCUMENTS</b> .....	<b>3</b>
2.1 GOVERNMENT DOCUMENTS .....	3
2.1.1 Specifications .....	3
2.1.1.1 FAA .....	3
2.1.1.2 Military .....	3
2.1.2 Standards .....	3
2.1.2.1 FAA Standards .....	3
2.1.2.2 Military Standards .....	3
2.1.2.3 FAA Orders .....	3
2.1.2.4 Other Government Documents .....	54
2.2 NON-GOVERNMENT DOCUMENTS .....	54
<b>3.0 SYSTEM REQUIREMENTS</b> .....	<b>65</b>
3.1 SYSTEM DEFINITION .....	65
3.1.1 WAAS Objectives .....	65
3.1.2 System States and Modes .....	65
3.1.2.1 Continuous Service Mode .....	65
3.1.2.2 Military Emergency Mode .....	65
3.1.3 System Functions .....	65
3.1.3.1 System Functional Relationships .....	75
3.1.3.2 Collect Data (Function 1) .....	76
3.1.3.3 Determine Ionospheric Corrections (Function 2) .....	87
3.1.3.4 Satellite Orbit Determination (Function 3) .....	98
3.1.3.5 Determine Satellite Corrections (Function 4) .....	109
3.1.3.6 Determine Satellite Integrity (Function 5) .....	1240
3.1.3.7 Independent Data Verification (Function 6) .....	1344
3.1.3.8 WAAS Message Broadcast and Ranging (Function 7) .....	1644
3.1.3.9 System Operations and Maintenance (Function 8) .....	1845
3.2 SYSTEM CHARACTERISTICS .....	2723
3.2.1 Signal-in-Space Requirements .....	2723
3.2.1.1 Performance Characteristics Definitions .....	2824
3.2.1.2 En Route Through Nonprecision Approach Performance Requirements .....	3126
3.2.1.3 Precision Approach Performance Requirements .....	3429
3.2.2 Antenna Phase Center Location Requirements .....	3734
3.2.2.1 Antenna Phase Center Location Relative to Local Monument .....	3734
3.2.2.2 Local Monument Location Requirements .....	3734
3.2.3 Processing Requirements .....	3734
3.2.3.1 System Capacity .....	3734
3.2.3.2 Software Development Requirements .....	3734
3.2.3.3 Computer Hardware .....	3834
3.2.4 Signal Processing Requirements .....	3832
3.2.4.1 Sensitivity and Dynamic Range .....	3832
3.2.4.2 RF Interference Rejection .....	3932
3.2.5 Interface Requirements .....	4336
3.2.5.1 External Interface Requirements .....	4336
3.2.5.2 Internal Interface Requirements .....	4337
3.2.6 Ground Based Electronic Equipment Characteristics .....	4337
3.2.6.1 Electrical .....	4437
3.2.6.2 Mechanical .....	4437
3.2.6.3 Interior Equipment Design Ranges .....	4437
3.2.6.4 Exterior Equipment Design Ranges .....	4438



3.2.7	<i>System Quality Factors</i> .....	<del>4438</del>
3.2.7.1	Reliability.....	<del>4438</del>
3.2.7.2	Maintainability.....	<del>4538</del>
3.2.8	<i>WAAS Network Time (WNT)</i> .....	<del>4539</del>
3.2.8.1	WNT/GPS Time Maintenance.....	<del>4539</del>
3.2.8.2	WNT/UTC Time Maintenance.....	<del>4539</del>
3.2.8.3	GEO Satellite Link Clock Stability.....	<del>4539</del>
3.2.9	<i>Fail-Safe, Fail-Soft Operation</i> .....	<del>4639</del>
3.2.10	<i>Personnel Safety</i> .....	<del>4639</del>
3.2.11	<i>Human Engineering</i> .....	<del>4639</del>
3.2.12	<i>System Security</i> .....	<del>4639</del>
<b>4.0</b>	<b>HARDWARE QUALITY ASSURANCE PROVISIONS AND SOFTWARE QUALIFICATION REQUIREMENTS</b> .....	<b><del>4740</del></b>
4.1	TEST PROGRAM.....	<del>4740</del>
4.1.1	<i>WAAS Test Program</i> .....	<del>4740</del>
4.1.1.1	Software Qualification.....	<del>4740</del>
4.1.1.2	Hardware Quality Assurance.....	<del>4740</del>
4.1.1.3	Verification Requirements Traceability Matrix (VRTM).....	<del>4740</del>
4.1.1.4	MTP VRTM.....	<del>4740</del>
4.1.1.5	Types of Testing.....	<del>4740</del>
4.2	GENERAL TESTING REQUIREMENTS.....	<del>4841</del>
4.2.1	<i>Government Witnessing of Testing</i> .....	<del>4841</del>
4.2.2	<i>Quality Assurance Program</i> .....	<del>4841</del>
4.2.2.1	Quality Assurance Program Guidance.....	<del>4841</del>
4.2.2.2	Hardware and Software Quality Control Systems.....	<del>4841</del>
4.2.2.3	Test Conduct.....	<del>4841</del>
4.2.3	<i>Configuration Management</i> .....	<del>4841</del>
4.2.4	<i>Regression Testing</i> .....	<del>4941</del>
4.3	SPECIAL TESTS AND EXAMINATION REQUIREMENTS.....	<del>4941</del>
4.3.1	<i>Use of Simulation</i> .....	<del>4941</del>
4.3.2	<i>Test Samples</i> .....	<del>4941</del>
4.3.3	<i>Interruption of Tests</i> .....	<del>4942</del>
4.3.4	<i>Failure Reporting and Tracking</i> .....	<del>4942</del>
4.3.5	<i>Certification of Test Environment</i> .....	<del>4942</del>
<b>5.0</b>	<b>NOTES</b> .....	<b><del>5043</del></b>
5.1	BACKGROUND INFORMATION.....	<del>5043</del>
5.1.1	<i>Global Positioning System (GPS) System</i> .....	<del>5043</del>
5.1.2	<i>Differential GPS</i> .....	<del>5144</del>
<b>APPENDIX 1:GPS AND GEO SATELLITE OUTAGE RATES AND DURATION</b> .....		<b>1</b>
<b>APPENDIX 2:WIDE AREA AUGMENTATION SYSTEM SIGNAL SPECIFICATION</b> .....		<b>1</b>
<b>1.0</b>	<b>INTRODUCTION</b> .....	<b>1</b>
<b>2.0</b>	<b>SIGNAL CHARACTERISTICS</b> .....	<b>1</b>
2.1	CARRIER FREQUENCY.....	1
2.2	SPURIOUS TRANSMISSIONS.....	1
2.3	MODULATION.....	1
2.4	CARRIER PHASE NOISE.....	1
2.5	SIGNAL SPECTRUM.....	1
2.6	SIGNAL CHARACTERISTICS MODIFIED RELATIVE TO GPS.....	1
2.6.1	<i>Doppler Shift</i> .....	1
2.6.2	<i>Carrier Frequency Stability</i> .....	<del>2</del>
2.6.3	<i>Polarization</i> .....	2
2.6.4	<i>Code/Carrier Frequency Coherence</i> .....	2

2.6.5	User Received Signal Levels.....	2
2.6.6	Correlation Loss.....	3
2.6.7	Maximum Code Phase Deviation.....	3
<b>3.0</b>	<b>WAAS C/A CODES.....</b>	<b>3</b>
3.1	REQUIREMENTS.....	3
3.2	IDENTIFICATION OF WAAS CODES.....	<del>43</del>
3.3	WAAS CODES.....	<del>43</del>
3.4	RECOMMENDED WAAS/GPS CODER IMPLEMENTATION.....	<del>54</del>
<b>4.0</b>	<b>WAAS SIGNAL DATA CONTENTS AND FORMATS.....</b>	<b>76</b>
4.1	INTRODUCTION.....	76
4.2	PRINCIPLES AND ASSUMPTIONS.....	76
4.2.1	Data Rate.....	76
4.2.2	Timing.....	87
4.2.3	Error Corrections.....	98
4.2.4	Tropospheric Models.....	108
4.2.5	Accuracy.....	108
4.2.6	PRN Masks.....	108
4.2.7	Number of Satellites.....	108
4.2.8	Issue of Data.....	108
4.2.9	Acquisition Information.....	108
4.3	FORMAT SUMMARY.....	109
4.3.1	Block Format.....	109
4.3.2	Block Length and Content.....	119
4.3.3	Parity.....	119
4.3.4	Preamble.....	1240
4.4	MESSAGES AND RELATIONSHIPS BETWEEN MESSAGE TYPES.....	1311
4.4.1	Message Type 0.....	1513
4.4.2	PRN Mask Assignments Message Type 1.....	1513
4.4.2.1	PRN Mask Transition.....	1614
4.4.3	Fast Corrections Message Types 2-5.....	1614
4.4.4	Integrity Information Message Type 6.....	1815
4.4.5	Fast Correction Degradation Factor - Message Type 7.....	2017
4.4.6	Estimated RMS Error Message Type 8.....	2218
4.4.7	Long Term Satellite Error Corrections Message Type 25.....	2320
4.4.8	Mixed Fast Correction/GPS Long Term Satellite Error Corrections Messages Type 24.....	2824
4.4.9	Ionospheric Grid Point Mask Message Type 18.....	2825
4.4.10	Ionospheric Delay Corrections Messages Type 26.....	3531
4.4.10.1	Pierce Point Location Determination.....	3632
4.4.10.2	Selection of Ionospheric Grid Points.....	3733
4.4.10.3	Ionospheric Pierce Point Vertical Delay and Model Variance Interpolation.....	3834
4.4.10.4	Computing Slant Ionospheric Delay and Ionospheric Model Variance.....	4136
4.4.11	GEO Navigation Message Type 9.....	4237
4.4.12	GEO Almanacs Message Type 17.....	4439
4.4.13	Null Message Type 63.....	4540
4.4.14	Internal Test Type 62.....	4540
4.4.15	WAAS Network Time/UTC Offset Parameters Message Type 12.....	4540
4.4.16	Degradation Parameters - Message Type 10.....	4641
4.4.17	<del>Clock-Ephemeris Covariance Matrix Message Type 28.....</del>	<del>42</del>
4.5	MODELING THE DEGRADATION OF DATA.....	5145
4.5.1	Fast and Long-Term Correction Degradation.....	5145
4.5.1.1	Fast Correction Degradation.....	5145
4.5.1.2	Range-Rate Correction Degradation.....	5246
4.5.1.3	Long Term Correction Degradation.....	5347
4.5.1.4	Degradation for En Route Through NPA.....	5448
4.5.2	Degradation of Ionospheric Corrections.....	5548
4.6	PRINCIPLE AND RULES FOR THE GENERATION AND USE OF DATA.....	5549

4.7	TIMING.....	<del>5649</del>
<b>5.0</b>	<b>REFERENCES.....</b>	<del>5851</del>
<b>APPENDIX 3: VERIFICATION REQUIREMENTS TRACEABILITY MATRIX (VRTM) .....</b>		<b>1</b>
1.0	DEFINITIONS.....	1
<b>APPENDIX 4: DEFINITIONS AND ACRONYMS.....</b>		<b>1</b>
1.0	DEFINITIONS.....	1
2.0	ACRONYMS.....	<del>76</del>

## WIDE AREA AUGMENTATION SYSTEM (WAAS) SPECIFICATION

### 1.0 Scope

#### 1.1 Identification

This specification establishes the functional and performance requirements for the Wide-Area Augmentation System (WAAS).

#### 1.2 System Overview

The WAAS is a safety-critical system consisting of the equipment and software which augments the Department of Defense (DOD)-provided Global Positioning System (GPS) Standard Positioning Service (SPS). The WAAS provides a signal-in-space (as defined in Appendix 2) to WAAS users to support en route through precision approach navigation. The WAAS users include all aircraft with approved WAAS avionics using the WAAS for any approved phase of flight. The signal in space provides two services: (1) data on GPS and GEO satellites, and (2) a ranging capability. Background information regarding the GPS can be found in Section 5.1 of this specification.

This specification provides functional and performance requirements. It does not direct any particular architecture. However, based on the FAA Satellite Navigation Test Bed, certain architecture elements are considered necessary to meet the requirements of this specification. Figure 1-1 depicts an example WAAS Architecture which includes these minimum necessary elements. The GPS satellites' data are received and processed at widely dispersed sites, referred to as Wide-area Reference Stations (WRSs). These data are forwarded to data processing sites, referred to as Wide-area Master Stations (WMSs), which process the data to determine the integrity, differential corrections, residual errors, and ionospheric information for each monitored satellite and generate Geostationary Earth Orbit (GEO) Satellite navigation parameters. This information is sent to a Ground Earth Station (GES) and uplinked along with the GEO navigation message to GEO satellites. These GEO satellites downlink this data on the GPS Link 1 (L1) frequency with a modulation similar to that used by GPS.

In addition to providing GPS integrity, the WAAS verifies its own integrity and takes any necessary action to ensure that the system meets the WAAS performance requirements. The WAAS also has a system operations and maintenance function that provides information to FAA Airway Facilities (AF) National Airspace System (NAS) personnel.

The WAAS user receiver typically processes: (1) the integrity data to ensure that the satellites being used are providing in-tolerance navigation data, (2) the differential correction and ionospheric information data to improve the accuracy of the user's position solution, and (3) the ranging data from one or more of the GEO satellites for position determination. The WAAS user receivers are not considered part of the WAAS.

The WAAS will have a Functional Verification System (FVS) which will be used for early Development Test and Evaluation (DT&E), refinement of contractor site installation procedures, system level testing, WAAS Operational Testing, and long term support for the WAAS. The FVS will be referred to in the testing requirements in Section 4 and Appendix 3, Verification Requirements Traceability Matrix (VRTM).

# Wide Area Augmentation System Concept

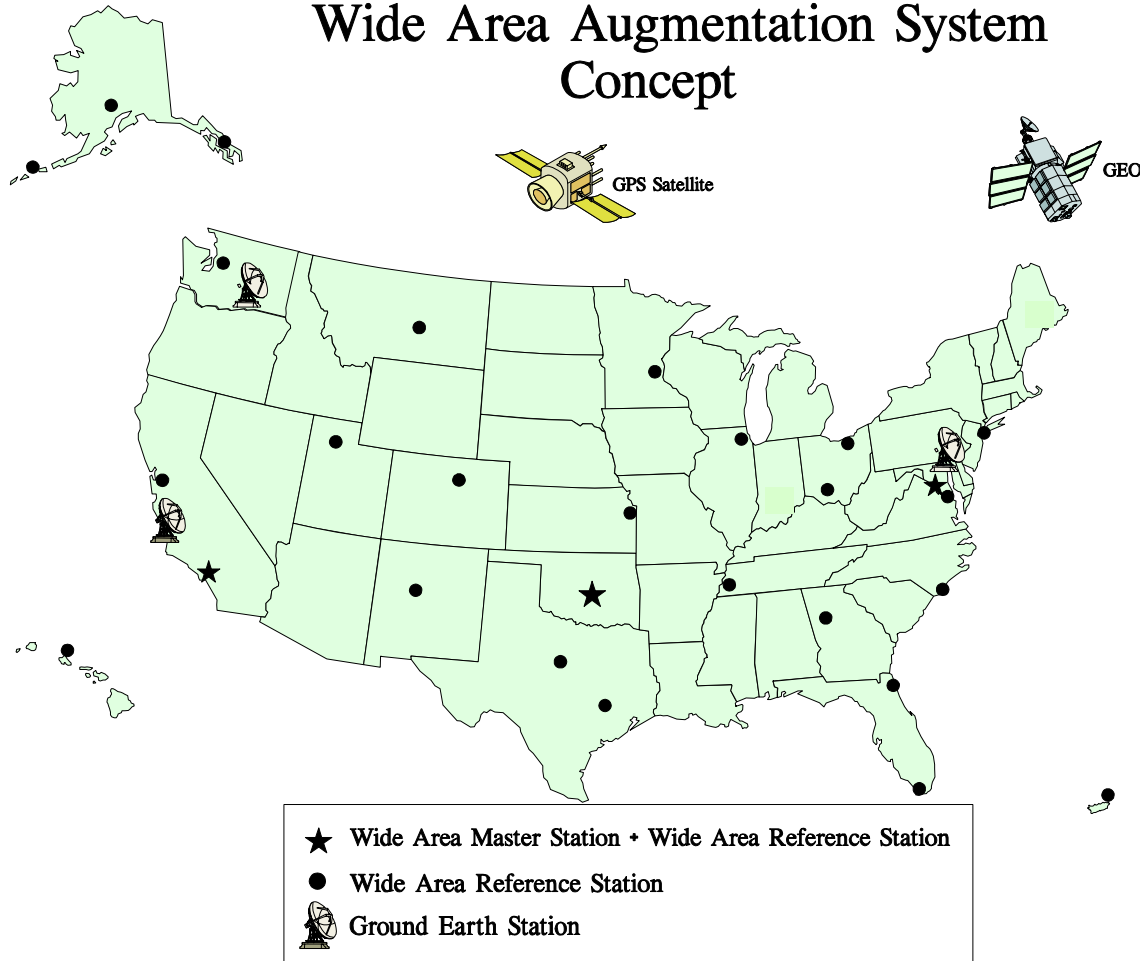

Figure 1-1: Example WAAS Architecture

## 1.3 Document Overview

Section 2 lists the specifications, standards, and orders referred to in this document. Section 3 provides the WAAS functional and performance requirements. Section 4 identifies requirements for testing and verification that the subsystems, sites and system must meet to be compliant with this specification. Section 5 contains notes and background information. In addition, there are four appendices: (1) Appendix 1 provides the GPS and GEO satellite outage rates and durations for performance analyses; (2) Appendix 2 is the WAAS Signal Specification and contains the WAAS message formats; (3) Appendix 3 is the Verification Requirements Traceability Matrix (VRTM); and (4) Appendix 4 provides definitions and acronyms.

## **2.0 Applicable Documents**

The following documents form a part of this specification and are applicable to the extent specified herein. In the event of conflict between documents referenced herein and the contents of this specification, the contents of this specification shall prevail.

### **2.1 Government Documents**

#### **2.1.1 Specifications**

##### **2.1.1.1 FAA**

- a. NAS-SS-1000, National Airspace System (NAS) System Specification, December, 1986
- b. FAA-G-2100F, Electronic Equipment, General Requirements, November, 1993
- c. NAS-MD-793, Remote Maintenance Monitoring System Functional Requirements for the Remote Monitoring Subsystem, Feb 28, 1986
- d. NAS-IR-51035101, Interface Requirements Document Remote Monitoring Subsystem/Maintenance Processor System (RMS/MPS), July 30, 1993

##### **2.1.1.2 Military**

- a. Global Positioning System Standard Positioning Service Signal Specification, dated June 2, 1995
- b. ICD-GPS-200, Revision C, NAVSTAR GPS Space Segment/Navigation User Interfaces, 10 October 1993.

#### **2.1.2 Standards**

##### **2.1.2.1 FAA Standards**

- a. FAA-STD-026, NAS Software Development, August, 1993
- b. FAA-STD-013D, Quality Control Program Requirements, 15 June 1994
- c. FAA-STD-018A, Computer Software Quality Program, Requirements, May 1977
- d. FAA-STD-021A, Configuration Management, August, 1991
- e. FAA-STD-024B, Content and Format Requirements for the Preparation of Test and Evaluation Documentation, August 22, 1994

##### **2.1.2.2 Military Standards**

- a. MIL-STD-973, Configuration Management, Interim Notice 1, 17 April 1992

##### **2.1.2.3 FAA Orders**

- a. FAA Order 6000.15B, General Maintenance Handbook for Airway Facilities, August, 1991
- b. FAA Order 1600.6C, Physical Security Management Program, April 16, 1993
- c. FAA Order 1800.8F, NAS Configuration Management, May, 1991
- d. FAA Order 1810.4B, FAA NAS Test and Evaluation Policy, October, 1992
- e. FAA Order 6000.30B, Policy for Maintenance of the National Airspace System (NAS) through the Year 2000, October, 1991
- f. FAA Order 1600.54B, FAA Automated Information Systems Security Handbook, February, 1989

- g. FAA Technical Standard Order C129, Airborne Supplemental Navigation Equipment Using the Global Positioning System (GPS), December 10, 1992

**2.1.2.4 Other Government Documents**

- a. DOT-VNTSC-RSPA-95-1/DOD-4650.5, Federal Radionavigation Plan 1994.

**2.2 Non-Government Documents**

- a. RTCA/DO-178B, Software Considerations in Airborne Systems and Equipment Certification, December 1, 1992
- b. RTCA/DO-208, Minimum Operational Performance Standards (MOPS) for Airborne Supplemental Navigation Equipment Using Global Positioning System, July 1991
- c. RTCA/DO-229, Minimum Operational Performance Standards (MOPS) for Global Positioning System/Wide Area Augmentation System Airborne Equipment, January 1996
- ~~d. RTCA/DO-229A, Minimum Operational Performance Standards (MOPS) for Global Positioning System/Wide Area Augmentation System Airborne Equipment, June, 1998~~



### **3.0 System Requirements**

This section specifies the functional, performance, interface, and design requirements, and the quality factors and characteristics of the WAAS.

#### **3.1 System Definition**

The WAAS is defined in the sections below which address the objectives of the system, system modes and states, and system functions.

##### **3.1.1 WAAS Objectives**

The objectives of the WAAS are to provide improved: (1) integrity, (2) accuracy, (3) availability, and (4) continuity of service to the Global Positioning System (GPS) Standard Positioning Service (SPS). The ultimate objective is to provide a navigation system for all phases of flight through precision approach.

##### **3.1.2 System States and Modes**

The WAAS shall possess a single state - normal. Periodic maintenance and corrective maintenance do not interrupt the normal state.

###### **3.1.2.1 Continuous Service Mode**

In the normal state, the WAAS shall possess an operational mode of continuous service meeting all of the performance requirements in paragraph 3.2.1.

###### **3.1.2.2 Military Emergency Mode**

In the normal state, the WAAS shall possess a military emergency mode that only meets the performance requirements for en route through non-precision approach services as defined in paragraph 3.2.1.2.

##### **3.1.3 System Functions**

In order to accomplish the four objectives in paragraph 3.1.1 and meet the signal in space performance requirements in paragraph 3.2.1, the WAAS includes eight (8) primary functions. These functions:

- (1) collect data;
- (2) determine ionospheric corrections;
- (3) determine satellite orbits;
- (4) determine satellite corrections;
- (5) determine satellite integrity;
- (6) provide independent data verification;
- (7) provide WAAS message broadcast and ranging; and
- (8) provide system operations and maintenance.

The WAAS functional requirements of this section will be accomplished through a combination of software and firmware development, Non-Development Item (NDI) hardware, and communications. Unless specifically designated as independent, common processing for different functions can be performed by the same equipment. The inputs and outputs are not intended to define any physical interface, but merely to describe the relationships between functions.

### 3.1.3.1 System Functional Relationships

The functional relationships among the WAAS functions are shown in figure 3-1. Each of the eight functions is numbered in the figure and corresponds to the eight functions described under paragraph 3.1.3.

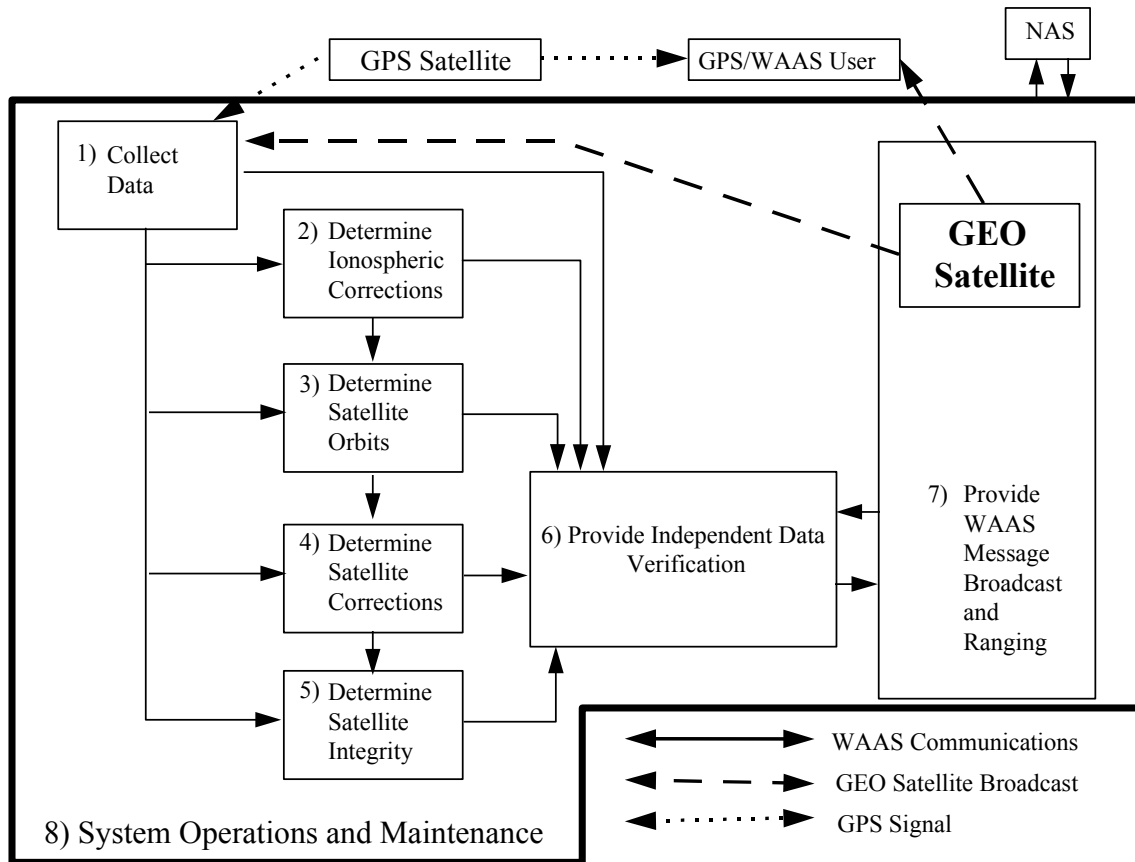

Figure 3-1 WAAS Functional Relationships

### 3.1.3.2 Collect Data (Function 1)

This function receives data from all the satellites that perform the navigation service, including the GPS and GEO satellites, and the tropospheric data required to determine the tropospheric delay. Two independent sets of data will be collected: one for Functions 2-5 and one for Function 6. This function also checks the reasonability of the collected data.

#### 3.1.3.2.1 Inputs

The inputs to Function 1 are:

- a. GPS satellite observables;
- b. GEO satellite observables;
- c. tropospheric observables;
- d. equipment location data; and
- e. equipment calibration data.

### **3.1.3.2.2 Processing**

#### **3.1.3.2.2.1 Collect Raw GPS Observables**

Function 1 shall receive the GPS L1-C/A (Coarse/Acquisition) pseudorange data, the GPS L1/L2 (Link 2) code differential data (without knowledge of the Y-code), and satellite navigation data (as specified in Global Positioning System Standard Positioning Service Signal Specification and the NAVSTAR GPS Interface Control Document, ICD-GPS-200) from all GPS satellites that support the navigation service.

#### **3.1.3.2.2.2 Collect Raw GEO Observables**

Function 1 shall receive GEO L1-C/A pseudorange data and satellite navigation data (as specified in Appendix 2) from all GEO satellites that support the navigation service.

#### **3.1.3.2.2.3 Location of Antenna Phase Center**

Function 1 shall accept and use antenna phase center location data compliant with paragraph 3.2.2.

#### **3.1.3.2.2.4 Data for Tropospheric Corrections**

Function 1 shall collect and use data (accuracies to support the WAAS performance requirements in paragraph 3.2.1 of this specification) so that pseudorange error caused by the troposphere at each of the data collection sites can be minimized.

#### **3.1.3.2.2.5 Receiver Calibration Data**

Function 1 shall accept and use receiver L1/L2 differential pseudorange bias (accuracies to support the WAAS performance requirements in paragraph 3.2.1 of this specification).

#### **3.1.3.2.2.6 Raw Data Reasonability Check**

Function 1 shall screen the collected data for unreasonable values (e.g. outliers or anomalies) and notify Function 8 of any data that fails this test.

#### **3.1.3.2.3 Outputs**

Function 1 outputs shall be:

- a. GPS L1-C/A pseudorange measurements (independent sets);
- b. GPS L1/L2 code differential measurements (independent sets);
- c. GPS satellite navigation data;
- d. GEO L1-C/A code pseudorange data (independent sets);
- e. GEO satellite navigation data;
- f. tropospheric data (independent sets);
- g. antenna phase center locations;
- h. receiver L1/L2 differential pseudorange bias data; and
- i. notification of data that fails the reasonability check.

### **3.1.3.3 Determine Ionospheric Corrections (Function 2)**

In order to determine ionospheric corrections, this function must receive the GPS L1/L2 code differential measurements from Function 1 and determine precise ionospheric delay corrections in terms of vertical delays at geographically defined Ionosphere Grid Points (IGPs).

### 3.1.3.3.1 Inputs

The inputs to Function 2 are:

- a. GPS L1/L2 code differential [datameasurements](#);
- b. receiver L1/L2 differential pseudorange bias;
- c. antenna phase center locations;
- d. GPS satellite navigation data; and
- e. ionospheric grid definition.

### 3.1.3.3.2 Processing

#### 3.1.3.3.2.1 L1 Ionospheric Delay Estimates

Function 2 shall compute vertical delay estimates at each geographically defined Ionosphere Grid Point (IGP) for which data is available, as defined in Appendix 2, paragraph 4.4.10.

#### 3.1.3.3.2.2 Grid Ionospheric Vertical Error (GIVE)

Function 2 shall compute GIVEs for each geographically defined IGP for which data is available.

#### 3.1.3.3.2.3 IGP Selection.

Function 2 shall select specific IGPs to represent the ionosphere as defined in Appendix 2, paragraph 4.4.9, to achieve the required performance while preserving WAAS data link throughput efficiency.

#### 3.1.3.3.2.4 IGP "Not Monitored" Data

Function 2 shall generate data for a "Not Monitored" IGP for any IGP that is in the current mask and not monitored. A "Not Monitored" IGP is defined as an IGP which is included in the current IGP mask but insufficient data is available to calculate a vertical delay estimate.

### 3.1.3.3.3 Outputs

The outputs of Function 2 shall be:

- a. IGP locations;
- b. IGP vertical delay estimates; and
- c. IGP GIVE data.

### 3.1.3.4 Satellite Orbit Determination (Function 3)

This function must receive GPS and GEO satellite data to determine the position, velocity, clock offsets and drifts of the satellites. In addition, this function must generate the GEO satellite ephemeris and almanac data for the GEO satellite ephemeris [messagedata](#).

#### 3.1.3.4.1 Inputs

The inputs to Function 3 are:

- a. GPS L1-C/A pseudorange measurements;
- b. GPS L1/L2 code differential measurements;
- c. GPS satellite navigation data;

- d. GEO L1-C/A code pseudorange data;
- e. GEO satellite navigation data;
- f. tropospheric data;
- g. antenna phase center locations;
- h. receiver L1/L2 differential pseudorange bias;
- i. GEO ionospheric data;
- j. GEO satellite planned maneuvers (manual); and
- k. GPS satellite planned maneuvers (manual).

#### **3.1.3.4.2 Processing**

##### **3.1.3.4.2.1 Minimize Ionosphere and Troposphere Effects**

Function 3 shall reduce the ionosphere and troposphere effects on satellite pseudoranges prior to determining GPS and GEO navigation data such that the required system performance is achieved.

##### **3.1.3.4.2.2 GPS Orbit Determination**

Function 3 shall determine the GPS satellite position and velocity, and time offset and drift with respect to WAAS network time as maintained by Function 8 (Subfunction 2).

##### **3.1.3.4.2.3 GEO Orbit Determination**

Function 3 shall determine the GEO satellite position, velocity, and acceleration and GEO reference time offset and drift with respect to WAAS network time.

##### **3.1.3.4.2.4 GEO Satellite Ephemeris Data**

Function 3 shall compute the GEO satellite ephemeris data identified in Appendix 2, paragraph 4.4.11.

##### **3.1.3.4.2.5 GEO Satellite Almanac Data**

Function 3 shall compute almanacs for all of the GEO satellites including the data identified in Appendix 2, paragraph 4.4.12.

#### **3.1.3.4.3 Outputs**

The outputs of Function 3 shall be:

- a. GPS satellite orbit data;
- b. GEO satellite orbit data;
- c. GEO satellite ephemeris ~~message~~-data; and
- d. GEO satellite almanac data.

#### **3.1.3.5 Determine Satellite Corrections (Function 4)**

In order to determine satellite corrections, this function must receive satellite navigation and orbit data from all of the satellites in view that perform the navigation service, including the GPS and GEO satellites, and determine precise satellite clock and ephemeris error corrections.

##### **3.1.3.5.1 Inputs**

The inputs to Function 4 are:

- a. GPS L1-C/A pseudorange measurements;

- b. GPS L1/L2 code differential measurements;
- c. GPS satellite navigation data;
- d. GEO L1-C/A code pseudorange data;
- e. GEO satellite navigation data;
- f. tropospheric data;
- g. antenna phase center locations;
- h. receiver L1/L2 differential pseudorange bias;
- i. GPS satellite orbit data; and
- j. GEO satellite orbit data.

### **3.1.3.5.2 Processing**

#### **3.1.3.5.2.1 Minimize Ionosphere and Troposphere Effects**

Function 4 shall reduce ionosphere and troposphere effects on satellite pseudoranges prior to determining satellite corrections such that the required system accuracies are achieved.

#### **3.1.3.5.2.2 Satellite Long Term Error Corrections**

Function 4 shall compute satellite long term error corrections for the satellite clock and ephemeris errors as defined in Appendix 2, paragraph 4.4.7.

#### **3.1.3.5.2.3 Satellite Fast Error Corrections**

Function 4 shall compute satellite fast error corrections for the clock errors as defined in Appendix 2, paragraph 4.4.3.

#### **3.1.3.5.2.4 Satellite User Differential Range Error (UDRE)**

Function 4 shall compute UDREs for each satellite, as defined in Appendix 2, paragraph 4.4.3.

#### **3.1.3.5.2.5 Issue of Data**

Upon GPS transmission of a new ephemeris (marked by a new Issue of Data), the WAAS shall continue to use the old GPS ephemeris to determine the long-term (and fast) error corrections for a period of 2 minutes. This delay enables all WAAS users to acquire the new GPS ephemeris information.

#### **3.1.3.5.2.6 Fast Correction Degradation Factor**

Function 4 shall determine Fast Correction Degradation Factor as defined in Appendix 2, paragraph 4.4.5. Note: It is permissible to use a fixed value for Fast Correction Degradation as long as the requirements of all subparagraphs of paragraph 3.2.1 are satisfied.

#### **3.1.3.5.2.7 Estimated RMS Pseudorange Error**

Function 4 shall compute an estimated RMS pseudorange error as defined in Appendix 2, paragraph 4.4.6.

#### **3.1.3.5.2.8 Message Type 10 Degradation Parameters**

Function 4 shall compute degradation parameters as defined in Appendix 2, paragraph 4.4.16. Note: It is permissible to use a fixed value for Message Type 10 Degradation Parameters as long as the requirements of all subparagraphs of paragraph 3.2.1 are met.

### **3.1.3.5.2.9 Clock-Ephemeris Covariance**

Function 4 shall compute the clock-ephemeris covariance matrix as defined in Appendix 2, paragraph 4.4.17.

### **3.1.3.5.3 Outputs**

The outputs of Function 4 shall be:

- a. satellite long term corrections;
- b. satellite fast error corrections;
- c. satellite UDREs;
- d. Fast correction degradation factor;
- e. verified estimated RMS pseudorange error;
- f. Message Type 10 degradation parameters; and
- g. clock-ephemeris covariance matrix.

### **3.1.3.6 Determine Satellite Integrity (Function 5)**

In order to determine satellite and ionospheric correction integrity, this function must receive satellite navigation data from all of the satellites that perform the navigation service, including the GPS and GEO satellites, and provide timely warnings when any satellite or ionospheric correction should not be used for navigation, or if there are any satellites or ionospheric grid points that cannot be monitored for any reason.

#### **3.1.3.6.1 Inputs**

The inputs to Function 5 are:

- a. GPS satellite navigation data;
- b. GEO satellite navigation data;
- c. antenna phase center locations;
- d. satellite long term error corrections;
- e. satellite fast error corrections;
- f. IGP locations;
- g. IGP vertical ionospheric delay estimates;
- h. IGP GIVE data;
- i. Satellite User Differential Range Error (UDRE) data
- j. Message Type 10 degradation parameters
- k. Fast correction degradation factor; and
- l. verified estimated RMS pseudorange error.

#### **3.1.3.6.2 Processing**

##### **3.1.3.6.2.1 Satellite Integrity Determination**

###### **3.1.3.6.2.1.1 Pseudorange "Don't Use" Data**

Function 5 shall generate data for a "Don't Use" message for any satellite whose pseudorange errors are not correctable within the limits of the WAAS message structure.

###### **3.1.3.6.2.1.2 UDRE "Don't Use" Data**

Function 5 shall generate data for a "Don't Use" message for any satellite whose User Differential Range Error exceeds the limits of the WAAS message structure.

#### **3.1.3.6.2.1.3 Ionospheric "Don't Use" Data**

Function 5 shall generate data for a "Don't Use" message for any ionospheric vertical delay correction at an Ionospheric Grid Point (IGP) that exceeds the vertical delay correction limits of the WAAS message structure.

#### **3.1.3.6.2.1.4 GIVE "Don't Use" Data**

Function 5 shall generate data for a "Don't Use" message for any IGP whose Grid Ionospheric Vertical Error (GIVE) exceeds the limits of the WAAS message structure.

#### **3.1.3.6.2.2 Satellite Visibility**

##### **3.1.3.6.2.2.1 Satellite Visibility Determination**

Function 5 shall determine whether all of the satellites that should be in view, based on the GPS and GEO satellite almanac information, are being tracked.

##### **3.1.3.6.2.2.2 "Not Monitored" Data**

Function 5 shall generate data for a "Not Monitored" message for any satellite that is not being monitored by the WAAS.

#### **3.1.3.6.3 Outputs**

The outputs of Function 5 shall be:

- a. data to generate "Don't Use" messages;
- b. data to generate "Not Monitored" messages; and
- c. list of satellites that should be in view, but whose signals are not being received.

#### **3.1.3.7 Independent Data Verification (Function 6)**

In order to accomplish Independent Data Verification, this function must independently verify integrity of all data provided to WAAS users prior to transmission and validate that data while it is active. Verification of data is defined to be a process whereby the data provided to WAAS users is either:

- (1) compared to data derived from independently observed measurements; or
- (2) combined with independently observed measurements and the result is compared to the expected result.

Validation of signal-in-space performance is a process whereby the signal-in-space performance is monitored and determined to be within specification. All data provided to WAAS users includes all information broadcast via a GEO satellite in any of the message formats described in Appendix 2. Data is defined to be active from the time of arrival of the last bit of the WAAS SIS message at a user until the expiration of the user timeout interval (see Appendix 2). Multiple sets of data can be active simultaneously.

Independence is defined as radio frequency (RF) independence from common data collection error sources, such as multipath, and independent hardware for receiving and processing. Data



for all functions may share a common data link between sites, provided the data is partitioned so as to guarantee independence.

### 3.1.3.7.1 Inputs

The inputs to Function 6 are:

- a. independent GPS L1-C/A pseudorange measurements;
- b. independent GPS L1/L2 code differential measurements;
- c. independent GEO L1-C/A code pseudorange data; ~~and~~
- d. independent tropospheric data;
- e. GEO satellite navigation data;
- f. GPS satellite navigation data;
- g. antenna phase center locations;
- h. receiver L1/L2 differential pseudorange bias;
- i. IGP locations;
- j. IGP vertical delay estimates;
- k. IGP GIVE data;
- l. GPS satellite orbit data;
- m. GEO satellite orbit data;
- n. GEO satellite ephemeris ~~message~~ data;
- o. GEO satellite almanac data;
- p. satellite long term corrections;
- q. satellite fast error corrections;
- r. satellite UDREs;
- s. data for "Don't Use" messages;
- t. data for "Not Monitored" messages;
- u. Fast correction degradation factor; ~~and~~
- v. verified estimated RMS pseudorange error; ~~and~~
- w. Message Type 10 degradation parameters.

### 3.1.3.7.2 Processing

There are five subfunctions to be performed within Function 6.

#### 3.1.3.7.2.1 Verification of Ionospheric Corrections (Subfunction 1)

Function 6 shall verify the ionospheric delay corrections and the GIVE data for each IGP location using independent data.

##### 3.1.3.7.2.1.1 Verification Success

Function 6 shall forward all successfully verified ionospheric delay correction data to Function 7.

##### 3.1.3.7.2.1.2 Verification Failure - Accuracy

Function 6 shall set the IGP status to "Not Monitored" and forward this data to Functions 7 and 8 when the L1 ionospheric vertical delay corrections cannot be verified using independent data, but the L1 ionospheric vertical delay corrections as determined by independent sources are within the bounds of the WAAS message structure.

Function 6 shall set the IGP status to “Not Monitored” and forward this data to Functions 7 and 8 when the GIVE cannot be verified using independent data, but the GIVES as determined by independent sources are within the bounds of the WAAS message structure.

### **3.1.3.7.2.2 Verification of Satellite Orbits (Subfunction 2)**

Function 6 shall verify GEO satellite ephemeris and almanac data using independent data.

#### **3.1.3.7.2.2.1 Verification Success**

Function 6 shall forward all successfully verified satellite orbit data to Function 7.

#### **3.1.3.7.2.2.2 Verification Failure**

Function 6 shall set the GEO health status to ~~unhealthy~~ [Ranging Off](#) in the GEO almanac message (Appendix 2, paragraph 4.4.12) and forward this status to Functions 7 and 8.

### **3.1.3.7.2.3 Verification of Satellite Corrections (Subfunction 3)**

Function 6 shall verify the long-term clock and ephemeris corrections, the fast corrections, the Fast correction degradation factors, the Message Type 10 degradation parameters, and the UDRE using independent data.

#### **3.1.3.7.2.3.1 Verification Success**

Function 6 shall forward all successfully verified satellite correction data to Function 7.

#### **3.1.3.7.2.3.2 Verification Failure - Accuracy**

Function 6 shall set the satellite integrity status to “Not Monitored” and forward this data to Functions 7 and 8 when the satellite integrity status cannot be verified using independent data, but both of the pseudorange errors as measured by independent sources are less than 150 m.

Function 6 shall set satellite integrity status to “Not Monitored” and forward this data to Functions 7 and 8 when the UDRE cannot be verified using independent data, but the UDREs as determined by independent sources are within the bounds of the WAAS message structure.

#### **3.1.3.7.2.3.3 Verification Failure – Insufficient Accuracy**

Function 6 shall set the satellite integrity status to “Don’t Use” and forward this data to Functions 7 and 8 when the satellite integrity status cannot be verified using independent data, but at least one of the pseudorange errors as measured by independent sources are greater than 150 m.

Function 6 shall set satellite integrity status to “Don’t Use” and forward this data to Functions 7 and 8 when the UDRE cannot be verified using independent data and at least one of UDREs as determined by independent sources exceed the bounds of the WAAS message structure.

### **3.1.3.7.2.4 Verification of Satellite Integrity (Subfunction 4)**

Function 6 shall verify the "Don't Use" and "Not Monitored" data using independent data.

#### **3.1.3.7.2.4.1 Verification Success**

Function 6 shall forward all successfully verified satellite integrity data to Function 7.

#### **3.1.3.7.2.4.2 Verification Failure**

Function 6 shall set the satellite integrity status to "Don't Use" or "Not Monitored" ("Don't Use" takes precedence) and forward this data to Functions 7 and 8.

#### **3.1.3.7.2.5 Validation of Signal-in-Space Performance (Subfunction 5)**

Function 6 shall continuously monitor the signal-in-space performance parameters of time-to-alarm and accuracy achieved by the WAAS.

##### **3.1.3.7.2.5.1 Validation of Signal-in-Space Performance**

Function 6 shall validate that all active data meets the signal-in-space performance requirements identified in Section 3.2.1.

##### **3.1.3.7.2.5.2 Signal-in-Space Performance Alerts**

Function 6 shall alert Function 7 of any active data which does not meet the signal-in-space performance requirements in Section 3.2.1, or any active data which cannot be validated.

#### **3.1.3.7.3 Outputs**

The outputs of Function 6 shall be:

- a. verified indications for "Don't Use" and "Not Monitored" satellites or IGPs;
- b. verified Satellite fast corrections;
- c. verified Satellite long term clock and ephemeris corrections;
- d. verified IGP locations;
- e. verified IGP vertical delay estimates;
- f. verified IGP GIVE data;
- g. verified GEO satellite ephemeris data;
- h. verified GEO satellite almanac data;
- i. verified Satellite UDREs;
- j. verified Fast correction degradation factor;
- k. verified estimated RMS pseudorange error; and
- l. verified Message Type 10 degradation parameters.

#### **3.1.3.8 WAAS Message Broadcast and Ranging (Function 7)**

In order to provide WAAS message broadcast and ranging, this function must provide a GPS-like ranging source and integrity and correction data to the WAAS users as defined in Appendix 2.

##### **3.1.3.8.1 Inputs**

The inputs to Function 7 are:

- a. verified indications for "Don't Use" and "Not Monitored" satellites or IGPs;
- b. verified satellite fast corrections;
- c. verified satellite long term clock and ephemeris corrections;
- d. verified IGP vertical delay estimates;
- e. verified IGP GIVE data;
- f. verified GEO satellite ephemeris data;
- g. verified GEO satellite almanac data,
- h. verified satellite UDREs;
- i. verified IGP locations;

- j. list of GPS/WAAS satellites;
- k. UTC/WAAS Network Time (WNT) offset;
- l. GEO satellite testing mode command;
- m. Fast correction degradation factor;
- n. verified estimated RMS pseudorange error; ~~and~~
- o. Message Type 10 degradation parameters; ~~and~~
- p. clock-ephemeris covariance matrix.

### **3.1.3.8.2 Processing**

This function shall use GEO satellites to broadcast the WAAS messages to the users and provide ranging sources.

#### **3.1.3.8.2.1 Message Format**

Function 7 shall format the input data into a 500 symbols per second data stream in accordance with the formats in Appendix 2, paragraph 4.0.

#### **3.1.3.8.2.2 Repetition of GPS/WAAS SIS Alarm Messages**

Function 7 shall repeat information sent in response to alarm conditions in the 500 symbols-per-second data stream 3 additional times within the next 3 seconds for a total of 4 consecutive times.

**Note 1:** In order to meet the integrity time-to-alarm in the event that alarm conditions exist on 2 satellites at the same time, the WAAS may need to use Type 6 messages when not all information can be placed in a message of Type 2, 3, 4, 5, or 24. It may minimize the amount of computation required to perform verification and validation functions if this is the only condition under which Type 6 messages are sent.

**Note 2:** Information sent in response to an alarm condition could be any of the following: a revised correction, UDRE, GIVE, or 'Don't Use' message that ensures that post-correction errors are bounded by error bounds (protection levels) as defined in RTCA/DO-229 Appendix J. In order to meet continuity requirements, 'Don't Use' messages may need to be avoided except when required to ensure integrity.

#### **3.1.3.8.2.3 Message Broadcast and Ranging**

Function 7 shall broadcast the WAAS message in accordance with Appendix 2, paragraphs 2.0 and 3.0.

##### **3.1.3.8.2.3.1 Message and Code Combining**

Function 7 shall modulo-2 add the 500 symbols per second data stream to the unique 1.023 MHz 1023 bit Gold Code assigned to each GEO satellite. Modulo-2 add for GPS is described in GPS SPS Signal Specification, paragraph 2.3.3.

##### **3.1.3.8.2.3.2 Signal Modulation**

Function 7 shall modulate the resulting signal to an uplink carrier frequency.

##### **3.1.3.8.2.3.3 Signal Transmission**

Function 7 shall transmit the appropriate data to each GEO satellite. Appropriate data is defined to be data which pertains to the WAAS users within a GEO satellite footprint and data which pertains to a specific GEO satellite.

#### **3.1.3.8.2.3.4 GEO Satellite Reception**

The Function 7 GEO satellite shall receive the uplink signal.

#### **3.1.3.8.2.3.5 GEO Satellite Translation**

The Function 7 GEO satellite shall translate the received uplink signal to the WAAS broadcast carrier frequency of 1575.42 MHz (GPS L1) and transmit it within the satellite footprint in accordance with Appendix 2, paragraph 2.0.

#### **3.1.3.8.2.4 Monitor WAAS Signal Quality**

Function 7 shall monitor the signal quality of each GEO satellite transmission and forward these signal quality parameters to Function 8.

#### **3.1.3.8.3 Outputs**

The outputs of Function 7 shall be:

- a. WAAS messages;
- b. ranging signals; and
- c. WAAS signal quality parameters.

#### **3.1.3.9 System Operations and Maintenance (Function 8)**

In order to accomplish system operations and maintenance, this function must control, monitor, and maintain the WAAS to ensure system functionality and performance in support of the four objectives in paragraph 3.1.1, and the WAAS signal-in-space requirements specified in paragraph 3.2.1. The WAAS shall be capable of operating autonomously, without human intervention. Airway Facilities (AF) NAS operations personnel at the Operations Control Centers (OCCs) or Wide-area Master Stations (WMSs) will monitor the status and performance of the WAAS, and will initiate manual actions such as corrective and periodic maintenance. These AF NAS operations personnel will perform WAAS functions as an adjunct to their other responsibilities. The System Operations and Maintenance function is comprised of four subfunctions:

- (1) system operations and maintenance data collection;
- (2) system monitor and control;
- (3) corrective maintenance; and
- (4) periodic maintenance.

Three terms are used to describe the System Operations and Maintenance function and they are defined as follows:

- a. system - the entire WAAS;
- b. component - individual part of the WAAS, such as a WRS or another part of the WAAS that is in the final architecture; and
- c. equipment - the individual items of equipment within a WAAS component, such as a receiver or a processor.

#### **3.1.3.9.1 System Operations and Maintenance Data Collection (Subfunction 1)**

In order to accomplish the System Operations and Maintenance function, data must be gathered from the WAAS system, components, and equipment.

### **3.1.3.9.1.1 Inputs**

The inputs to Subfunction 1 are:

- a. WAAS component and equipment configuration data;
- b. WAAS component and equipment status data;
- c. WAAS component and equipment performance data;
- d. all outputs from Function 6;
- e. all outputs from Function 1;
- f. WAAS messages and signal quality parameters from Function 7;
- g. ionospheric grid definition;
- h. additional manual inputs (such as, but not limited to, list of GPS/WAAS satellites, information on GPS, state change request); and
- i. Universal Coordinated Time (UTC).

### **3.1.3.9.1.2 Processing**

#### **3.1.3.9.1.2.1 WAAS Component and Equipment Configuration Data**

Subfunction 1 shall receive component and equipment configuration data from each of the WAAS components.

#### **3.1.3.9.1.2.2 WAAS Component and Equipment Status Data**

The status of all WAAS equipment and components shall be provided to Subfunction 1. The type of configuration status data required is design dependent, i.e. is a function of the degree of redundancy in the design of each component, how backup components and equipment are provided for failed components and equipment, etc. Typical status items include: processor configuration status (main, standby, backup), transmitter configuration status (main, standby, backup), receiver configuration status (main, standby, backup), antenna configuration status (main, standby, backup), and any self-generated status reports produced by WAAS equipment and components.

#### **3.1.3.9.1.2.3 WAAS Component and Equipment Performance Data**

Subfunction 1 shall gather performance data on the operation of each WAAS component and equipment within that component. These data include, but are not limited to, the following: CPU utilization, RAM reserves, computer system throughput, and signal strength at GPS receivers.

#### **3.1.3.9.1.2.4 Function 6 Data**

Subfunction 1 shall gather all outputs from Function 6.

#### **3.1.3.9.1.2.5 Function 1 Data**

Subfunction 1 shall gather all outputs from Function 1.

#### **3.1.3.9.1.2.6 WAAS Signal Quality Parameters**

Subfunction 1 shall gather WAAS signal quality parameters from Function 7.

**3.1.3.9.1.2.7 Process Data Update**

Subfunction 1 shall accept the ionospheric grid definition for the purpose of updating internal WAAS process parameters.

**3.1.3.9.1.2.8 Manual Inputs**

Subfunction 1 shall accept all manual inputs, such as, but not limited to, list of GPS/WAAS satellites, information on GPS, and state change request.

**3.1.3.9.1.3 Outputs**

The outputs of System Operations and Maintenance Data Collection shall be:

- a. gathered WAAS Component and Equipment Configuration Data;
- b. gathered WAAS Component and Equipment Status Data;
- c. gathered WAAS Component and Equipment Performance Data;
- d. gathered Function 6 Data;
- e. gathered Function 1 Data;
- f. gathered WAAS Signal Quality Parameters;
- g. ionospheric grid definition;
- h. list of GPS/WAAS satellites ;
- i. gathered additional manual inputs (such as, but not limited to information on GPS, state change request); and
- j. UTC.

**3.1.3.9.2 System Monitor and Control (Subfunction 2)**

In order to accomplish system monitor and control, this subfunction must ensure that the WAAS hardware and software operates within specified tolerances (determined by the particular WAAS implementation, in accordance with FAA Order 6000.15B), monitor configuration of the system and configuration changes, and detect out-of-tolerance conditions. This subfunction includes monitoring of system functional and performance trends to assist in identifying and correcting potential faults before they impact system operations.

### **3.1.3.9.2.1 Inputs**

The inputs to the system monitor and control subfunction are:

- a. gathered WAAS Component and Equipment Configuration Data;
- b. gathered WAAS Component and Equipment Status Data;
- c. gathered WAAS Component and Equipment Performance Data;
- d. gathered Function 6 Data;
- e. gathered WAAS Signal Quality Parameters;
- f. gathered manual inputs;
- g. UTC; and
- h. list of satellites that should be in view but whose signals are not being received.

### **3.1.3.9.2.2 Processing**

#### **3.1.3.9.2.2.1 Continuity of Processing**

System monitor and control shall take place continuously.

#### **3.1.3.9.2.2.2 Operational Configuration Control and Management**

Subfunction 2 shall manage and control the operational configuration of the WAAS to ensure that system functional and performance requirements are being met.

#### **3.1.3.9.2.2.3 Data Presentation**

Subfunction 2 shall generate data and graphical displays of GPS/WAAS configuration and performance information for use by WMS and OCC personnel.

##### **3.1.3.9.2.2.3.1 Displays**

Displays of GPS/WAAS data shall include, as a minimum:

- (1) graphical representation of the status and configuration of all WAAS components and equipment within 2 seconds of arrival at WMS or OCC of status change data (including all alarms, alerts and return-to-normal indications),
- (2) graphical geographic representation of GPS/WAAS coverage,
- (3) graphical geographic representation of the service being provided to the coverage region (precision approach, en route through non-precision approach),
- (4) status of GPS satellites, and
- (5) status of WAAS communications network.

##### **3.1.3.9.2.2.4 Security**

Subfunction 2 shall provide three levels of computer security in the form of user ID's, passwords, and privilege levels to protect the WAAS against unauthorized access in accordance with FAA Order 1600.54B.

##### **3.1.3.9.2.2.5 Degradation Protection**

Subfunction 2 shall protect the WAAS against inadvertent degradation of system performance by authorized personnel.

##### **3.1.3.9.2.2.6 WAAS Maintenance Alarms**

Subfunction 2 shall provide visual and audio alarms with time stamps to the WMS and OCC personnel, and alarm notifications to the corrective maintenance subfunction. A WAAS



Maintenance Alarm is defined to have occurred when any key performance or certifiable parameter of an on-line or off-line and available component or equipment exceeds established operational limits causing loss of service to the user or operator. Indications of imminent component or equipment failure or service interruption require immediate corrective action.

#### **3.1.3.9.2.2.7 Alerts**

Subfunction 2 shall provide visual and audio alerts with time stamps to the WMS and OCC personnel, and alert notifications to the corrective maintenance subfunction. An alert is defined as a notification of an abnormal condition by either an on-line or off-line and available component or equipment that does not cause a loss of service to the user or operator. Indications of component or equipment status outside nominal or desired operational tolerance(s) or predetermined maintenance threshold(s), which may cause component failure or service interruption if appropriate action is not taken, require corrective action.

#### **3.1.3.9.2.2.8 Alert and Alarm Latency**

Subfunction 2 shall transfer alert and alarm messages within an average time of five seconds and a maximum time of eight seconds. This time is measured from the generation of the alert or alarm to the receipt of the message in the WMS and OCC.

#### **3.1.3.9.2.2.9 Alert and Alarm Acknowledgment**

Subfunction 2 shall provide the mechanisms for acknowledging alerts and alarms using no more than 2 keystrokes. Acknowledgment includes the silencing of audio alerts and alarms and preservation of visual indications.

#### **3.1.3.9.2.2.10 System Certification**

Subfunction 2 shall provide sufficient information to allow certification of the WAAS in accordance with the procedures developed under FAA Order 6000.15B.

#### **3.1.3.9.2.2.11 Data Recording, Archiving and Retrieval**

##### **3.1.3.9.2.2.11.1 System Level Recording**

Subfunction 2 shall have a data recording capability to support playback, performance analysis and verification, data analysis, and simulation.

##### **3.1.3.9.2.2.11.2 Component Level Recording Content**

Subfunction 2 shall archive electronically recorded GPS and WAAS received data including GEO broadcast navigation data to meet the data storage, recording, and duration requirements of NAS-SS-1000 Volume I, (paragraph 3.2.1.2.8.3).

##### **3.1.3.9.2.2.11.3 Component Level Playback**

Subfunction 2 shall have the capability to playback the recorded data on a separate and independent subsystem from that used for real-time transmission of data to Function 6.

##### **3.1.3.9.2.2.11.4 Component Level Observation Data Recording Content**

Subfunction 2 shall record, for all tracked satellites and for each WRS location, raw receiver binary data at a minimum rate of 1 Hz sufficient to create the following data from combinations of recorded data:

- (1) L1 carrier phase from GPS and GEO satellites with a resolution of 0.01 cycles;
- (2) L2 carrier phase from GPS satellites (full-wavelength and not squared) with a resolution of 0.01 cycles;
- (3) L1 C/A code pseudorange from GPS and GEO satellites with a resolution of 0.01 m or better; and
- (4) L2 code pseudorange from GPS satellites with a resolution of 0.01 m or better. (The L2 code pseudorange may be satisfied by a cross-correlation mode L2 code delay observation. Other methods such as Z tracking are also acceptable.)

### **3.1.3.9.2.2.11.5 Component Level Navigation Data Recording Content**

Subfunction 2 shall record complete GPS broadcast navigation data for all tracked satellites, whenever the broadcast parameters change, and at least once every hour if broadcast data do not change.

### **3.1.3.9.2.2.11.6 Component Level Tropospheric Data Recording Content**

Subfunction 2 shall record any tropospheric data used to minimize tropospheric effects at a minimum rate of once per minute.

### **3.1.3.9.2.2.11.7 Reserved**

### **3.1.3.9.2.2.12 WAAS Network Time (WNT)**

#### **3.1.3.9.2.2.12.1 WNT Determination**

Subfunction 2 shall derive a WNT standard and maintain it relative to GPS time in accordance with the requirements of paragraph 3.2.8 of this specification.

#### **3.1.3.9.2.2.12.2 WNT/UTC Offset Determination**

Subfunction 2 shall determine the WNT/UTC offset parameters as defined in Appendix 2, paragraph 4.4.15.

#### **3.1.3.9.2.2.13 GEO Satellite Testing**

Subfunction 2 shall have the capability to notify Function 7 to set the GEO satellite to the testing mode, as defined in Appendix 2, Table 2.

### **3.1.3.9.2.3 Outputs**

The outputs of this subfunction shall be:

- a. displays of status, coverage, and service quality;
- b. GPS and WAAS data to archives;
- c. system alarms;
- d. system alerts;
- e. maintenance prioritization data;
- f. system configuration data;
- g. system fault data internally generated by WAAS components or equipment;
- h. WNT/UTC offset; and
- i. GEO satellite testing mode command.

### **3.1.3.9.3 Corrective Maintenance (Subfunction 3)**

In order to accomplish corrective maintenance, this subfunction must verify anomalous conditions detected during nominal system operation, support isolation of faults to the line replaceable unit (LRU), support replacement of defective/faulty LRUs, restore the component or equipment to full capability (including proper levels of redundancy), and perform the required maintenance administration activities.

### **3.1.3.9.3.1 Inputs**

The inputs to the corrective maintenance subfunction are:

- a. maintenance archives;
- b. all Function 6 verification and validation outputs;
- c. external maintenance reports and data;
- d. reconfiguration requests;
- e. equipment verification support requests;
- f. WAAS component and equipment configuration data;
- g. WAAS component and equipment status data;
- h. WAAS configuration change data;
- i. WAAS component and equipment change data; and
- j. alarms, alerts and self-generated data on faults.

### **3.1.3.9.3.2 Processing**

#### **3.1.3.9.3.2.1 Fault Detection and Isolation**

Subfunction 3 shall have the capability to detect and isolate faults.

##### **3.1.3.9.3.2.1.1 Fault Detection**

Subfunction 3 fault detection shall be completed within an average time of 5 seconds and a maximum time of 8 seconds.

##### **3.1.3.9.3.2.1.2 Fault Isolation**

Subfunction 3 fault isolation shall correctly isolate faults to 1 LRU in 90% of all cases and to not more than 4 LRUs in the remaining 10% of all cases.

##### **3.1.3.9.3.2.1.3 Fault Isolation Time**

Subfunction 3 fault isolation shall be completed within a maximum time of 10 minutes.

##### **3.1.3.9.3.2.2 System Configuration Status**

Subfunction 3 shall modify the system configuration to bring backup and stand-by equipment on-line without degrading system performance specified in section 3.2.1.

##### **3.1.3.9.3.2.3 Maintenance During Normal Operation**

Operations in the normal mode shall continue even during periods of corrective maintenance.

##### **3.1.3.9.3.2.4 Maintenance Priority Generation**

Subfunction 3 shall specify the relative order of precedence for open or incomplete maintenance items, including corrective maintenance activities, in the event of multiple system component and equipment failures. This precedence will be established based upon returning the system to nominal operations as effectively as possible.

##### **3.1.3.9.3.2.5 Reserved**

##### **3.1.3.9.3.2.6 Remote Initialization**

Subfunction 3 shall support the remote re-initialization of system components and equipment to reset failures, including restarting hardware such as microcomputers.

#### **3.1.3.9.3.2.7 Remote Reloading of Software and Databases**

Subfunction 3 shall support remote reloading of software and databases without interrupting the normal mode.

#### **3.1.3.9.3.2.8 Off-line Equipment Verification**

Subfunction 3 shall verify system operation in an off-line mode which does not jeopardize system operation after the faulty equipment has been replaced, or the software has been re-initialized or reloaded.

#### **3.1.3.9.3.2.9 Resumption of Operation**

Subfunction 3 shall transfer control of the component to the system monitor and control subfunction after the correction has been verified.

#### **3.1.3.9.3.2.10 Record Keeping**

Subfunction 3 shall support the completion of maintenance administration functions by automatically recording, maintaining and printing log data, system configuration data, alarm and alert data, acknowledgment data, failure data, and other maintenance information, in accordance with FAA Order 6000.15B.

#### **3.1.3.9.3.2.11 Archival of Maintenance Data**

Subfunction 3 shall provide for the archival of maintenance data records.

#### **3.1.3.9.3.2.12 Retrieval of Maintenance Data**

Subfunction 3 shall automatically store, retain, and allow easy access to all maintenance data, configuration management data, administrative data, and maintenance log entries.

#### **3.1.3.9.3.3 Outputs**

The outputs of the Corrective Maintenance subfunction shall be:

- a. fault indications;
- b. failed LRU indications;
- c. reconfiguration commands;
- d. equipment verification support commands;
- e. maintenance data records;
- f. maintenance data archives;
- g. list of corrective maintenance priorities;
- h. initialization commands; and
- i. reloading commands.

#### **3.1.3.9.4 Periodic Maintenance (PM) (Subfunction 4)**

In order to accomplish periodic maintenance, the periodic maintenance requirements must be established and periodic maintenance activities must be managed. Periodic maintenance includes all mandatory activities performed on a routine or scheduled basis to maintain system performance, minimize service interruptions and major system breakdowns, and extend the useful life of the equipment.

#### **3.1.3.9.4.1 Inputs**

The inputs to the periodic maintenance subfunction are:

- a. manufacturer's/vendor's recommended PM schedules;
- b. list of corrective maintenance priorities; and
- c. PM approval.

#### **3.1.3.9.4.2 Processing**

##### **3.1.3.9.4.2.1 Manufacturer's Recommended PM**

Subfunction 4 shall establish the periodic maintenance requirements for each of the WAAS equipment items from manufacturer's or vendor's requirements.

##### **3.1.3.9.4.2.2 Maintenance Coordination**

Subfunction 4 shall receive approval and prioritization of periodic maintenance activities to ensure that these activities do not degrade or threaten system performance.

##### **3.1.3.9.4.2.3 Maintenance During Normal Operations**

Subfunction 4 shall be capable of supporting periodic maintenance activities without compromising system operation or performance.

##### **3.1.3.9.4.2.4 Maintenance Schedule**

Subfunction 4 shall maintain periodic and corrective maintenance schedules in accordance with component and equipment requirements, and display these schedules to help ensure that maintenance activities are completed in a timely and efficient manner (so as to not threaten operation in the normal mode) and that they will be performed only with the knowledge and consent of AF NAS systems operations personnel at the OCCs or WMSs.

##### **3.1.3.9.4.3 Outputs**

The output generated by the Periodic Maintenance subfunction shall be:

- a. maintenance schedule displays; and
- b. maintenance prioritization data.

#### **3.1.3.9.5 Remote Maintenance and Monitoring System (RMMS)**

All Function 8 capabilities shall be remotable so that RMMS requirements can be incorporated into the WAAS in accordance with NAS-MD-793 and the connectivity specified in NAS-IR-51035101, Appendix IV.

### **3.2 System Characteristics**

#### **3.2.1 Signal-in-Space Requirements**

The GPS/WAAS Signal-In-Space (SIS) performance requirements are presented in two parts: those for en route through non-precision approach and those for precision approach. To put the GPS/WAAS SIS performance requirements into perspective with the performance allocation of the other parts of the system, the performance requirements in tables 3.2-1 and 3.2-2 show four categories of performance requirements. Requirements imposed by this specification are in

bold print in the applicable tables. Due to the tradeoffs available in designing the WAAS, some WAAS SIS requirements are imposed by Navigation System requirements. The definitions for the four categories are:

- a. The Total System includes all of the sources that affect the performance parameters during an operation. It includes the performance parameter contributions of the Navigation System and the Flight Technical Error (FTE). The FTE is the accuracy with which the aircraft is controlled as measured by the indicated aircraft position with respect to the indicated command or desired position. The FTE contribution is not shown in the table but it is included in the Total System column.
- b. The Navigation System includes the performance parameters contribution of the GPS/WAAS SIS and the airborne navigation error.
- c. The GPS/WAAS SIS includes the GPS signals, the GEO satellites, and the WAAS ground network.
- d. The column in the table labeled “airborne” includes receiver noise, multipath, and tropospheric effects, and excludes FTE.

The GPS/WAAS SIS performance requirements shall be met under the following conditions: (1) the GPS satellite constellation is operational as defined by the Global Positioning Systems Standard Positioning Service Signal Specification; (2) the user equipment is within the service volume defined by paragraphs 3.2.1.2.6 or 3.2.1.3.6; (3) GPS and GEO satellite outage rates and durations are as provided in Appendix 1; and (4) the Phase 1 avionics contribution to pseudorange error is assumed to be zero.

### **3.2.1.1 Performance Characteristics Definitions**

#### **3.2.1.1.1 Availability**

Availability is defined as the probability that the navigation and fault detection functions are operational and that the GPS/WAAS SIS accuracy, integrity, and continuity of function requirements are met.

#### **3.2.1.1.2 Accuracy**

Accuracy is defined as the degree of conformance between an estimated or measured value at a given time and its true value.

##### **3.2.1.1.2.1 Horizontal Position Accuracy**

The k-th percent horizontal position accuracy is defined to be the value of the k-th percentile of the horizontal radial position error distribution experienced by a standard WAAS receiver at a specific location. The horizontal position accuracy is affected by the GPS/WAAS constellation (geometric effects) and the accuracy of the WAAS pseudorange corrections. Horizontal position accuracy will be specified as 95th percent or 99.999th percent horizontal position accuracy.

##### **3.2.1.1.2.2 Vertical Position Accuracy**

The k-th percent vertical position accuracy is defined to be the value of the k-th percentile of the vertical position error distribution experienced by a standard WAAS receiver at a specific location. The vertical position accuracy is affected by the GPS/WAAS constellation (geometric effects) and the WAAS pseudorange corrections. Vertical position accuracy will be specified as the 95th percent vertical position accuracy.

#### **3.2.1.1.2.3 Pseudorange Accuracy**

The k-th percent pseudorange accuracy is defined to be the value of the k-th percentile of the distribution of the WAAS-corrected pseudorange error which may occur at a specific location over 24 hours. Note that both the clock and ephemeris correction errors and ionospheric model errors contribute to the accuracy performance throughout the service volume. The 95th percent pseudorange accuracy is provided for a standard WAAS receiver, and is used only to define horizontal and vertical position accuracies.

#### **3.2.1.1.2.4 User Differential Range Error (UDRE)**

The UDRE is determined such that the UDRE', defined in paragraph 3.2.1.3.1, bounds the residual (post-correction) pseudorange error attributable to the fast corrections and long-term corrections with a probability of 0.999 at a given location while the data is active. Data is defined to be active from the time of arrival of the last bit of the WAAS SIS message at a user until the expiration of the user timeout interval (see Appendix 2).

#### **3.2.1.1.2.5 User Ionospheric Vertical Error (UIVE)**

The UIVE bounds the residual (post-correction) pseudorange error attributable to the user computed vertical ionospheric delay for a satellite with a probability of 0.999 while the data is active. It is interpolated from Grid Ionospheric Vertical Errors (GIVEs).

#### **3.2.1.1.2.6 Grid Ionospheric Vertical Error (GIVE)**

The GIVE is determined such that any UIVE computed from the GIVEs, bounds the residual (post-correction) error in the user computed vertical ionospheric delay with a probability of 0.999.

#### **3.2.1.1.3 Integrity**

Integrity is defined as the ability of a system to provide timely warnings to users when the system should not be used for navigation. For this specification, there are three components of integrity: Probability of HMI, Time to Alarm, and Alarm Condition. They are defined as follows:

##### **3.2.1.1.3.1 Probability of Hazardously Misleading Information (HMI) for Precision Approach**

For precision approach the probability of HMI for the GPS/WAAS SIS is defined as the probability that one or both of the following conditions is true:

1. The WAAS VPL computed from any active data is less than the actual vertical navigation system error for a period of time greater than or equal to the time-to-alarm, or for a period of time shorter than the time-to-alarm unless followed immediately by the sending of 4 consecutive WAAS broadcast messages that correct the condition.



2. The WAAS HPL computed from any active data is less than the component in any direction of the horizontal navigation system error for a period of time greater than or equal to the time-to-alarm, or for a period of time shorter than the time-to-alarm unless followed immediately by the sending of 4 consecutive WAAS broadcast messages that correct the condition

#### **3.2.1.1.3.2 Probability of HMI for En Route through Non Precision Approach**

For en route through non precision approach the probability of HMI for the GPS/WAAS SIS is defined as the probability that the WAAS horizontal protection level computed from any active data is less than the actual radial horizontal navigation system error for a period of time greater than or equal to the time-to-alarm, or for a period of time shorter than the time-to-alarm unless followed immediately by the sending of 4 consecutive WAAS broadcast messages that correct the condition. The WAAS protection level for en-route through nonprecision approach is defined in RTCA/DO-229 Appendix J.

#### **3.2.1.1.3.3 Time to Alarm**

The WAAS time to alarm is defined as the time starting when an alarm condition occurs to the time that the last bit of the alarm message ("Don't Use" message or a WAAS SIS message that removes the alarm condition) arrives at the user's antenna. Time to detect the alarm condition is included in this requirement.

#### **3.2.1.1.3.4 Alarm Condition**

A WAAS SIS alarm condition is defined to occur when there is any set of satellites for which the user-calculated horizontal and vertical protection level, using any combination of active data, does not bound the actual horizontal and vertical position error.

#### **3.2.1.1.4 Continuity of Function**

Continuity of function is defined as the probability that the navigation accuracy and integrity requirements will be supported by the GPS/WAAS SIS throughout a flight operation or flight hour given that they are supported at the beginning of the flight operation or flight hour and that the flight operation is initiated and predicated on the operation of the function. Satellite outages predicted at least 48 hours in advance of the outage do not contribute to a loss of continuity. Hardware failures and alarm messages that cause operations interruptions impact the continuity of function probability value.

##### **3.2.1.1.4.1 Continuity of Navigation**

The continuity of the navigation function is defined as the probability that the accuracy requirements will be supported by the GPS/WAAS SIS throughout a flight operation or flight hour, given that they were supported at the beginning of the flight operation or flight hour and that the flight operation is initiated and predicated on the operation of the function. Satellite outages predicted at least 48 hours in advance of the outage do not contribute to a loss of continuity.

##### **3.2.1.1.4.2 Continuity of Fault Detection**

The continuity of the fault detection function is defined as the probability that integrity monitoring is supported by the GPS/WAAS SIS, i.e., it supports detection of errors larger than the protection limit with the required probability, within the required time and throughout a

flight operation or flight hour, given that it existed at the beginning of the flight operation or flight hour and that the flight operation is initiated and predicated on the operation of the function. Satellite outages predicted at least 48 hours in advance of the outage do not contribute to a loss of continuity. The integrity monitoring function for en route through nonprecision approach is supported by the GPS/WAAS SIS either through WAAS messages or by providing sufficient ranging sources to support Receiver Autonomous Integrity Monitoring (RAIM) as defined in RTCA/DO-208 as modified by TSO C-129. For precision approach, the integrity monitoring function is supported only by the GPS/WAAS through WAAS messages.

**3.2.1.1.5 Reserved**

**3.2.1.1.6 Service Volume**

The service volume is defined to be those regions which must receive the required level of availability.

**3.2.1.2 En Route Through Nonprecision Approach Performance Requirements**

The GPS/WAAS SIS performance requirements for en route through nonprecision approach phases of flight are summarized in table 3.2-1.

**Table 3.2-1 Performance Requirements  
En Route through Nonprecision Approach (NPA)**

<b>Performance Requirement</b>	<b>Total System</b>	<b>Navigation System</b>	<b>GPS/WAAS Signal-in-Space</b>	<b>Airborne</b>
<b>Availability</b>	0.99999	0.99999	0.99999	Not Specified
<b>Accuracy</b>				
95% Horizontal Position	Not specified	<b>0.054 nmi (100 m)</b>	Not Specified	Not Specified
99.999% Horizontal Position	Not Specified	<b>0.27 nmi (500 m)</b>	Not Specified	Not Specified
95% Vertical Position	N/A	N/A	N/A	N/A
95% Pseudorange	N/A	Not Specified	Not Specified	1.2 m
<b>Integrity</b>				
Probability of HMI	Not Specified	Not Specified	<b>10<sup>-7</sup> / hour</b>	Not Specified
Time-to-Alarm	10 sec	10 sec	<b>8 sec</b>	2 sec
<b>Continuity of Function</b>				
Continuity of Navigation	1- 10 <sup>-5</sup> / hour	1- 10 <sup>-5</sup> / hour	<b>1- 10<sup>-8</sup> / hour</b>	1- 10 <sup>-5</sup> / hour
Continuity of Fault Detection (1)	1-(2 x 10 <sup>-5</sup> ) / hour	1-(2 x 10 <sup>-5</sup> ) / hour	<b>1- 10<sup>-5</sup> / hour</b>	1- 10 <sup>-5</sup> / hour

(1) Excluding outages of less than 5 minutes.

### 3.2.1.2.1 Availability

The availability of the en route through nonprecision approach service, meeting the requirements of paragraphs 3.2.1.2.2 through 3.2.1.2.5, shall be at least 0.99999 at every location within the full service volume.

#### 3.2.1.2.1.1 Unavailability

The integrity requirements in paragraph 3.2.1.2.3.1 shall apply to any information generated by the WAAS during periods of unavailability of en route through nonprecision approach.

### 3.2.1.2.2 Accuracy

#### 3.2.1.2.2.1 95% Horizontal Position Accuracy

The 95% horizontal position accuracy shall not exceed 100 meters at every location over 24 hours within the service volume.

#### 3.2.1.2.2.2 99.999% Horizontal Position Accuracy

The 99.999% horizontal position accuracy shall not exceed 500 meters at every location over 24 hours within the service volume.

### 3.2.1.2.3 Integrity

#### 3.2.1.2.3.1 Probability of Hazardously Misleading Information (HMI)

The probability that any HMI is presented to a user shall not exceed 10<sup>-7</sup> per hour. Note that an invalid UDRE or GIVE might not constitute HMI for en route through nonprecision approach.

**3.2.1.2.3.2 Time to Alarm**

The WAAS time to alarm shall not exceed 8 seconds for the first alarm message for a given alarm condition. However, this requirement is superseded by the more stringent requirement for precision approaches as defined in paragraph 3.2.1.3.3.2.

**3.2.1.2.3.3 Alarm Limit**

A GPS/WAAS SIS alarm shall be generated when the alarm condition defined in paragraph 3.2.1.1.3.4 exists.

**3.2.1.2.4 Continuity of Function**

**3.2.1.2.4.1 Continuity of Navigation**

Given two Geostationary Earth Orbit (GEO) satellite links are available to each user, the continuity of navigation shall be at least  $(1 - 10^{-8})$  per hour at every location and time in the service volume.

**3.2.1.2.4.2 Continuity of Fault Detection**

Given two Geostationary Earth Orbit (GEO) satellite links are available to each user, the continuity of fault detection shall be at least  $(1 - 10^{-5})$  per hour at every location and time in the service volume, excluding outages of less than 5 minutes. Note that while the conditional probability of outages of less than 5 minutes need not be counted against the continuity of fault detection, the availability of the fault detection function itself must still be at least 0.99999 in accordance with the requirement of Paragraph 3.2.1.2.1 and the definition of Paragraph 3.2.1.1.1.

**3.2.1.2.5 Reserved**

**3.2.1.2.6 Service Volume**

**3.2.1.2.6.1 Full Service**

The en route through non precision approach performance requirements of paragraphs 3.2.1.2.1 through 3.2.1.2.5 shall be met from the surface up to 100,000 feet above mean sea level within the region bounded by the line segments defined by consecutive pairs of points in the following list of coordinates and within the northern limits of GEO satellite coverage as defined in paragraph 3.2.4.1.1:

LATITUDE	LONGITUDE
50° N	61° W
50° N	122° W
70° N	140° W
70° N	165° W
68° N	169° W
20° N	164° W
17° N	160° W
17° N	155° W
30° N	120° W
16° N	75° W

16° N            61° W  
50° N            61° W

**3.2.1.2.6.2 Partial Service**

The en route through non precision approach requirements of paragraphs 3.2.1.2.2 and 3.2.1.2.3 shall be met everywhere in the GEO satellite broadcast coverage area within U.S. controlled airspace when the WAAS can monitor the GPS and GEO broadcast satellites. The GEO satellite broadcast coverage area is defined to be areas in which the GEO satellite received signal strength is at least -161 dBW.

**3.2.1.3 Precision Approach Performance Requirements**

The GPS/WAAS SIS performance requirements to support the precision approach phase of flight are summarized in table 3.2-2.

**Table 3.2-2 Performance Requirements Precision Approach**

Performance Requirement	Total System	Navigation System	GPS/WAAS Signal-in-Space	Airborne
<b>Availability</b>	Not Specified	Not Specified	<b>0.999</b>	Not Specified
<b>Accuracy</b>				
95% Horizontal Position	33.5 m	<b>7.6 m</b>	Not Specified	Not Specified
95% Vertical Position	9.8 m	<b>7.6 m</b>	Not Specified	Not Specified
95% Pseudorange	N/A	Not Specified	Not Specified	1.2 m
<b>Integrity</b>				
Probability of HMI	Not Specified	Not Specified	<b>10<sup>-7</sup> / approach</b>	Not Specified
Time-to-Alarm	Not Specified	Not Specified	<b>5.2 sec</b>	Not Specified
<b>Continuity of Function</b>	1- 10 <sup>-4</sup> / approach	1- 10 <sup>-4</sup> / approach	<b>1-(5.5 x 10<sup>-5</sup>)/ approach</b>	1-(4.5 x 10 <sup>-5</sup> )/ approach
Continuity of Navigation	Not Specified	Not Specified	Not Specified	Not Specified
Continuity of Fault Detection	Not Specified	Not Specified	Not Specified	Not Specified

**3.2.1.3.1 Availability**

The availability of the precision approach service shall be at least 0.999 at any point and time within the service volume. Precision approach is defined to be available when the requirements of paragraph 3.2.1.3.2 through 3.2.1.3.5 are met, and when the UDRE and GIVE of some subset of 8 or fewer satellites yield a conservative vertical position error bound of 15.0 meters when used in the following equation:

$$K \sqrt{\sum_{j=1}^n k_{3j}^2 \left( \left( \frac{UDRE'_j}{3.29} \right)^2 + (\sigma_{jair})^2 + \left( \frac{F_j \times UIVE_j}{3.29} \right)^2 \right)} \leq 15.0m,$$

where  $n$  is the number of satellites used in the position solution,  $k_{3j}$  is the partial derivative of the vertical position fixing error with respect to pseudorange error on the  $j$ -th satellite (for a discussion of the  $K$  matrix see GPS SPS Signal Specification, Annex C, Section 4.4),  $\sigma_{air}$  is the standard deviation of the avionics contribution to the pseudorange error,  $F$  is the obliquity factor, defined in Appendix 2, paragraph 4.4.10, and UIVE is calculated from the GIVEs as defined in Appendix 2, paragraph 4.4.10.

UDRE<sub>*i*</sub>' is defined as:

$$UDRE'_i(t) = UDRE_i + 3.29 \times a_i (t - t_0 + t_l)^2 / 2$$

where

$UDRE_i$  = UDRE broadcast for the  $i^{\text{th}}$  satellite (Type 2 - 6)

$a_i$  = fast correction degradation factor for the  $i^{\text{th}}$  satellite (Type 7)

$t$  = current time

$t_0$  = ~~UDRE time of applicability (time of applicability of corresponding fast corrections if IODF<sub>*i*</sub>=3, or time of applicability of Type 6 when IODF<sub>*i*</sub><3) the time the last UDRE data (Type 2-6 or 24) was received that matches the IODF of the fast correction being used. For Message Types 2-5 and 24, this time is the same as the time of applicability of the fast corrections ( $t_{fc}$ ) since they are in the same message. For UDREs broadcast in Type 6 and if the IODF = 3, this time also equals the time of applicability of the fast corrections ( $t_{fc}$ ). For UDREs broadcast in Type 6 and IODF ≠ 3, this time is defined to be the time of transmission of the first bit of the Type 6 message at the GEO.~~

$t_l$  = system latency time (Type 7)

### 3.2.1.3.1.1 Unavailability

The integrity requirements in paragraph 3.2.1.3.3 shall be met during periods of unavailability of precision approach.

### 3.2.1.3.2 Accuracy

#### 3.2.1.3.2.1 Horizontal Position Accuracy

The 95% horizontal position accuracy shall not exceed 7.6 meters at any location in the service volume.

#### 3.2.1.3.2.2 Vertical Position Accuracy

The 95% vertical position accuracy shall not exceed 7.6 meters at any location in the service volume.

### 3.2.1.3.3 Integrity

#### 3.2.1.3.3.1 Probability of Hazardously Misleading Information (HMI)

The probability that HMI is presented to a user during an approach shall not exceed  $10^{-7}$ . The duration of a precision approach is defined to be 150 seconds.

#### 3.2.1.3.3.2 Time to Alarm

The WAAS time to alarm shall not exceed 5.2 seconds for the first alarm message for a given alarm condition.

**3.2.1.3.3.3 Alarm Limit**

A GPS/WAAS SIS alarm shall be generated when the condition defined in paragraph 3.2.1.1.3.4 exists.

**3.2.1.3.4 Continuity of Function**

Given two GEO satellite links are available to each user, the continuity of function shall be at least  $(1 - 5.5 \times 10^{-5})$  per precision approach at every location and time in the service volume. The duration of a precision approach is defined to be 150 seconds.

**3.2.1.3.5 Reserved**

**3.2.1.3.6 Service Volume**

The precision approach performance requirements of paragraphs 3.2.1.3.1 to 3.2.1.3.5 shall be met from the surface up to 10,000 feet above the surface within the airspace of the 48 conterminous states, Hawaii, Puerto Rico, and Alaska (except for the Alaskan peninsula west of longitude 160° W and outside of the limits of the GEO satellite broadcast coverage; the GEO satellite broadcast coverage area is defined to be areas in which the minimum GEO satellite received signal strength is as defined in paragraph 3.2.4.1.1).

### **3.2.2 Antenna Phase Center Location Requirements**

#### **3.2.2.1 Antenna Phase Center Location Relative to Local Monument**

The phase center of each antenna used to receive the GPS and GEO signals shall be located relative to a local monument or a Continuously Operating Reference Station (CORS) with the following accuracies:

- a. Horizontal: 1 cm 95% GPS; and
- b. Vertical: 2 cm 95% GPS.

#### **3.2.2.2 Local Monument Location Requirements**

The local monument used for locating GPS and GEO receive antenna shall be an U. S. Geodetic Survey Federal Base Network Point or equivalent. The requirements are a National Geodetic Survey Quality Code A, or Code B where Code A is impractical, for Horizontal and Ellipsoidal Height and National Geodetic Reference System for Orthometric Height at the following accuracy levels:

- a. Horizontal: 5 cm 95% GPS;
- b. Ellipsoidal Height: 10 cm 95% GPS; and
- c. Orthometric Height: 10 cm NAVD 88.

### **3.2.3 Processing Requirements**

#### **3.2.3.1 System Capacity**

The WAAS shall have a modular design so that expansion can be accomplished by the addition of hardware and software.

##### **3.2.3.1.1 U.S. WAAS**

The U.S. WAAS shall be capable of:

- a. processing input from at least 50 geographically dispersed WRSs that meet the established WRS/WMS interface;
- b. networking of at least six WMSs so that any one of the six can provide the total WAAS service for the service volumes defined in paragraphs 3.2.1.2.6 and 3.2.1.3.6;
- c. switching between WMSs automatically with no interruption in service; and
- d. providing WAAS signal-in-space for at least nine GEO satellites from each WMS at the same time.

##### **3.2.3.1.2 International Expansion**

The U.S. WAAS shall be capable of expanding to accept and process inputs from at least:

- a. 20 international WRSs that meet the established WRS/WMS interface for the U.S. WAAS; and
- b. seven international WMSs that meet the WMS/WMS interface requirements to pass status information. These international WMSs will expand the WAAS service volume to include areas where U.S. WMSs do not have a direct interface with some of the international WRSs (examples: Europe, South America).

#### **3.2.3.2 Software Development Requirements**



Software is defined as computer programs, procedures, rules, and associated documentation and data pertaining to the operation of the WAAS. Software shall be developed in accordance with FAA-STD-026 in conjunction with RTCA/DO-178B.

### **3.2.3.3 Computer Hardware**

#### **3.2.3.3.1 Computer Resource Reserve Capacity**

Processing resource requirements for each element of the WAAS shall be in accordance with FAA-STD-026.

#### **3.2.3.3.2 Computer Memory**

All WAAS memory shall incorporate error sensing, error reporting, and normal status reporting, which will be consistent with meeting the overall system performance requirements in paragraph 3.2.1.

##### **3.2.3.3.2.1 Volatile Memory**

Under worst case loading conditions, no more than 50% of the total addressable, populated memory locations shall be used during execution of any program to hold instructions or data.

##### **3.2.3.3.2.2 Non-Volatile Memory**

Non-volatile memory includes such items as programmable read-only memory, electrically programmable read-only memory, and non-volatile random access memory. Non-volatile memory embedded in any WAAS component or equipment shall be capable of expansion with no effect on form, fit, or interface factors in accordance with 3.2.3.3.2.3.

##### **3.2.3.3.2.3 Memory Increase Capability**

It shall be possible to increase the total amount of each type of memory by 100%.

##### **3.2.3.3.3 Processing Speed**

Each processor, including input/output subsystems, in the WAAS System that executes software in support of system performance requirements shall use no more than 70% of the processor's throughput capability under worst case conditions.

### **3.2.4 Signal Processing Requirements**

#### **3.2.4.1 Sensitivity and Dynamic Range**

##### **3.2.4.1.1 L1-C/A Signal Processing Requirements**

All L1-C/A signal processing requirements to support Function 1 in paragraph 3.1.3.2 shall be met with an input signal (GPS or WAAS) between -161 dBW and -153 dBW (dB relative to 1 watt at the output of a 3dBi linearly polarized antenna) with an elevation angle between 5° and 90° and a sky temperature of 100K.

##### **3.2.4.1.2 L1-P(Y) and L2-P(Y) Signal Processing Requirements**

All GPS L1/L2 signal processing requirements to support Function 1 in paragraph 3.1.3.2 shall be met without knowledge of the Y-Code and with an L1-P(Y) signal between -163 dBW and -155 dBW and an L2-P(Y) signal between -166 dBW and -154 dBW incident on the antenna as

stated above. (Satellites at elevation angles below 5° will not be used without sufficient test data and supporting analysis to justify use of a lower mask angle.)

### 3.2.4.2 RF Interference Rejection

The requirements stated below assume an RF environment in which unintentional interference above the stated rejection levels are absent due to: (1) appropriate antenna site selection, (2) suitable filtering of emissions by offending interference sources, and/or (3) regulatory mandates to curtail offending interference sources.

#### 3.2.4.2.1 In-Band

In-band is defined to include all frequencies between 1217.6 MHz and 1237.6 MHz, for the GPS L2-P(Y) signal and between 1565.42 MHz and 1585.42 MHz for the GPS/WAAS L1-C/A and GPS L1-P(Y) signals. For purposes of verification relative to the paragraphs below, multiple interferers will be at the same elevation angle.

##### 3.2.4.2.1.1 Interferer Above 5 Degrees Elevation

After initial signal acquisition and steady-state operation has commenced, a GPS/WAAS antenna/receiver shall meet all signal processing requirements in the presence of in-band interfering signals that do not exceed the minimum desired signal by more than the following levels (Table 3.2-3) as a function of interfering signal bandwidth (BW) (in Hz):

**Table 3.2-3 In-Band Rejection Characteristics Above 5 Degrees**

Signal Type	Interference Bandwidth	Total Interference/Minimum Desired Signal Power Ratio (I/S)
L1-C/A	$0 < BW \leq 600$ Hz	16 dB
L1-C/A	$600 < BW \leq 1,000$ Hz	21dB
L1-C/A	$1,000 < BW \leq 10,000$ Hz	$21 + 6\log_{10}(BW/1000)$ dB
L1-C/A	$10,000 < BW \leq 100,000$ Hz	$27 + 3\log_{10}(BW/10000)$ dB
L1-C/A	$100,000$ Hz $< BW$	30 dB
L2-P(Y)	All	27 dB

Figure 3.2-1 indicates the respective in-band I/S rejection levels corresponding to Table 3.2-3.

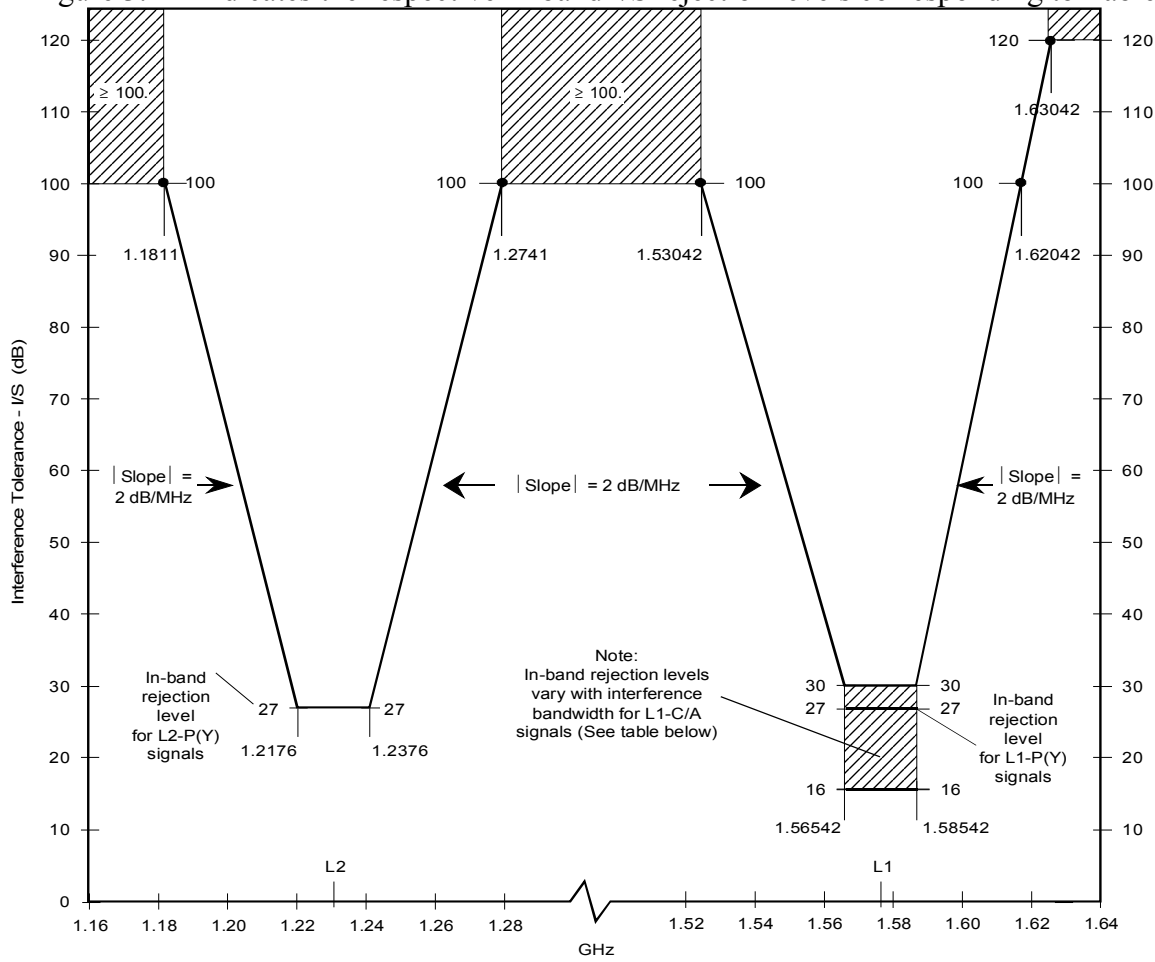

Interference Bandwidth, BW (Hz)	L1-C/A Signal In-band I/S Rejection (dB)
$0 < BW \leq 600$	+16
$600 < BW \leq 1000$	+21
$1000 < BW \leq 10,000$	$21 + 6 \log_{10} (BW/1000)$
$10,000 < BW \leq 100,000$	$27 + 3 \log_{10} (BW/10000)$
$100,000 < BW$	30

Figure 3.2-1: Interference-to-Minimum Desired GPS/WAAS Signal (I/S) Tolerance

3.2.4.2.1.2 Interferer Below 2.5 Degrees Elevation

No in-band interferer or combination of interferers with I/S up to 10 dB above the interfering power ratio in paragraph 3.2.4.2.1.1 (for the appropriate interfering bandwidth) and arriving from an elevation angle of less than or equal to 2.5 degrees shall preclude a GPS/WAAS antenna/receiver from meeting all signal processing requirements.

**3.2.4.2.1.3 Interferer Between 2.5 and 5 Degrees Elevation**

No in-band interferer or combination of interferers arriving from an elevation angle between 2.5 and 5 degrees, and with total I/S less than or equal to a value interpolated between the requirements in paragraphs 3.2.4.2.1.1 and 3.2.4.2.1.2 (for the appropriate interfering bandwidth) shall preclude a GPS/WAAS antenna/receiver from meeting all signal processing requirements.

**3.2.4.2.2 Out-Of-Band**

Out-of-band is defined to include all frequencies less than 1217.6 MHz, all frequencies between 1237.6 MHz and 1565.42 MHz, and all frequencies greater than 1585.42 MHz. For purposes of verification, multiple interferers will be at the same elevation angle.

**3.2.4.2.2.1 CW Interferer Above 5 Degrees Elevation**

After initial signal acquisition and steady-state operation has commenced, a GPS/WAAS antenna/receiver shall meet all signal processing requirements in the presence of out-of-band interfering signals that do not exceed the minimum desired signal power by more than the following levels (Table 3.2-4) as a function of interfering signal frequency:

**Table 3.2-4 Out-of-Band Rejection Characteristics Above 5 Degrees**

Frequency, f (MHz)	Total Interference/Minimum Desired Signal Power Ratio (I/S)
$f \leq 1181.1$	$\geq 100$ dB
$1181.1 < f \leq 1217.6$	$+100 - 2*(f-1181.1)$ dB
$1237.6 < f \leq 1274.1$	$+27 + 2*(f - 1237.6)$ dB
$1274.1 < f \leq 1530.42$	$\geq 100$ dB
$1530.42 < f \leq 1565.42$	$+100 - 2*(f-1530.42)$ dB
$1585.42 < f \leq 1630.42$	$+30 + 2*(f - 1585.42)$ dB
$1630.42 < f$	$\geq 120$ dB

Figure 3.2-1 describes the out-of-band I/S rejection for the GPS/WAAS signals corresponding to Table 3.2-4.

**3.2.4.2.2.2 CW Interferer Below 2.5 Degrees Elevation**

No out-of-band CW interferer or combination of interferers with I/S up to 10 dB above the interfering power ratio in paragraph 3.2.4.2.2.1 for the appropriate interfering frequency and arriving from an elevation angle of less than or equal to 2.5 degrees shall preclude a GPS/WAAS antenna/receiver from meeting all signal processing requirements.

**3.2.4.2.2.3 CW Interferer Between 2.5 and 5 Degrees Elevation**

No out-of-band CW interferer or combination of interferers arriving from an elevation angle between 2.5 and 5 degrees, and with total I/S less than or equal to a value interpolated between the requirements in paragraph 3.2.4.2.2.1 and 3.2.4.2.2.2 (for the appropriate interfering bandwidth) shall preclude a GPS/WAAS antenna/receiver from meeting all signal processing requirements.

**3.2.4.2.3 Special Interference Rejection Capability**

The interference rejection specified in section 3.2.4.2.1 and 3.2.4.2.2 may not be sufficient to ensure that the WAAS meets its performance requirements in the future. The requirements in the paragraphs below specify special interference rejection capability and may be added as a separate item of equipment.

### **3.2.4.2.3.1 Spatial Mitigation**

#### **3.2.4.2.3.1.1 Dynamic Steering**

The GPS/WAAS antenna/receiver shall be capable of dynamically developing and steering at least three antenna pattern nulls of depth at least 30 dB relative to the gain of the antenna/receiver array when there is no interference.

#### **3.2.4.2.3.1.2 Antenna Pattern Nulls**

The antenna pattern nulls shall be able to follow an emitter moving at an angular rate of 0.3 radians per second.

### **3.2.4.2.3.2 Temporal Mitigation**

#### **3.2.4.2.3.2.1 Temporal Filtering**

The GPS/WAAS antenna/receiver shall be able to adaptively reject narrow and broadband interference by temporal filtering.

#### **3.2.4.2.3.2.2 Temporal Rejection**

The temporal rejection shall be capable of adaptive synthesis of at least 30 dB suppression.

#### **3.2.4.2.3.2.3 Temporal Interference Suppression**

The temporal interference suppression capability shall have a minimum of 4096 degrees of freedom and an adaptation time constant of less than 20 ms.

#### **3.2.4.2.3.2.4 Pulse Blanking**

A pulse blanking capability shall be provided.

### **3.2.4.2.3.3 Allowable Degradation**

The use of null steering or temporal filtering techniques shall not degrade the GPS/WAAS SIS performance requirements specified in paragraph 3.2.1.

### **3.2.4.2.4 GEO Uplink Protection**

The WAAS shall protect the GEO uplink from interference and HMI.

#### **3.2.4.2.4.1 Interference Protection**

The WAAS shall ensure that the signal transmitted to the GEO satellite will be protected from interference up to 10 dB above the established normal radiated signal power.

#### **3.2.4.2.4.2 HMI Protection**

The WAAS shall not increase the probability that HMI is broadcast to a user in the presence of unintentional interfering signals up to 10 dB above established normal radiated signal power.

### **3.2.5 Interface Requirements**

#### **3.2.5.1 External Interface Requirements**

The WAAS will have four required external interfaces as listed below:

- a. The GPS to the WAAS
- b. WAAS to the Navigation Service User
- c. WAAS to the National Airspace System (NAS)
- d. NAS to WAAS

##### **3.2.5.1.1 GPS Satellites to the WAAS**

The WAAS shall receive GPS signal data from the GPS Standard Positioning Service (SPS) on the Link 1 (L1) and Link 2 (L2) frequencies in accordance with the Global Positioning System Standard Positioning Service Signal Specification and GPS-ICD-200.

##### **3.2.5.1.2 WAAS to User**

The WAAS shall transmit all of the WAAS messages identified in Appendix 2 to the GPS navigation service users in accordance with the WAAS Signal Specification, Appendix 2.

##### **3.2.5.1.3 WAAS to NAS**

All of the WAAS data required by the NAS, including status and performance data, shall be entered into the NAS from Function 8 through the OCCs.

##### **3.2.5.1.4 NAS to WAAS**

All of the manual entry of data and control shall be entered at the OCC or WMS by Airway Facilities (AF) NAS systems operations personnel.

#### **3.2.5.2 Internal Interface Requirements**

The internal interfaces of the WAAS shall conform to industry or government standard interfaces.

### **3.2.6 Ground Based Electronic Equipment Characteristics**

The ground based electronic equipment shall be Non-Developmental Items (NDI) in accordance with FAA-G-2100F. NDI equipment is defined as any one of the following:

- a. item of supply that is available in the commercial marketplace (COTS);
- b. previously developed item of supply that is in use by a department or agency of the United States, a state or local government, or a foreign Government;
- c. item described above that requires only minor modification to meet the procuring agency's requirements (includes Modified COTS); or
- d. item currently being produced that does not meet the above requirements solely because it is not yet in use, or not available in the commercial marketplace.

The electronic equipment general requirements are tailored in the following subparagraphs. For the purposes of the following paragraphs, the term COTS will refer to all commercial

equipment (paragraphs 3.2.6a, c, and d above); the term NDI refers to non-commercial equipment (paragraph 3.2.6b above).

### **3.2.6.1 Electrical**

The Alternating Current (AC) supply line will be provided by the FAA facility that houses the WAAS component(s). All WAAS equipment shall meet the requirements of FAA-G-2100F, paragraph 3.1.2.2, prior to installing the WAAS component(s). If COTS equipment is chosen, the requirements in FAA-G-2100F, paragraphs 3.1.2.5 through 3.1.2.6.2 and paragraph 3.1.2.8 shall not apply.

### **3.2.6.2 Mechanical**

The WAAS components shall be designed to fit in an FAA-provided facility and meet the applicable mechanical requirements in FAA-G-2100F, paragraph 3.1.3. If COTS equipment is chosen, the requirements in FAA-G-2100F paragraphs 3.1.3.1 through 3.1.3.4.4 do not apply.

### **3.2.6.3 Interior Equipment Design Ranges**

The parts of the WAAS components that will be operated within FAA facilities shall meet the attended interior equipment and unattended interior equipment design ranges.

#### **3.2.6.3.1 Attended Interior Equipment Design Ranges**

The WAAS equipment that will be operated inside of attended FAA facilities, such as WMS operator consoles, shall meet the environmental conditions specified in Environment I in FAA-G-2100F, Table III of paragraph 3.2.1.2.2. If COTS equipment is chosen, the requirements in FAA-G-2100F, paragraphs 3.2.1.4 through 3.2.1.5 do not apply.

#### **3.2.6.3.2 Unattended Interior Equipment Design Ranges**

The WAAS equipment that will be operated inside of unattended FAA facilities, such as WRS equipment, shall meet the environmental conditions specified in Environment II in FAA-G-2100F, Table III of paragraph 3.2.1.2.2. If COTS equipment is chosen, the requirements in FAA-G-2100F, paragraphs 3.2.1.4 through 3.2.1.5 do not apply.

### **3.2.6.4 Exterior Equipment Design Ranges**

The WAAS equipment that will be operated on the outside of FAA facilities, such as antennas, shall meet the environmental conditions specified in Environment III in FAA-G-2100F, Table III of paragraph 3.2.1.2.2. If COTS equipment is chosen, the requirements in FAA-G-2100F, paragraphs 3.2.1.4 through 3.2.1.5 do not apply.

## **3.2.7 System Quality Factors**

### **3.2.7.1 Reliability**

#### **3.2.7.1.1 WAAS Reliability and Redundancy**

The WAAS shall have sufficient reliability and redundancy to meet the overall system performance requirements in paragraph 3.2.1 with no single point of failure.

#### **3.2.7.1.2 Mean Time Between Failure (MTBF)**

Each WAAS component shall have a minimum mean-time-between-failure (MTBF) of 2190 hours.

### **3.2.7.1.3 WAAS Reliability and Availability**

The WAAS design shall satisfy the reliability and availability requirements specified in FAA Order 6000.30B.

### **3.2.7.2 Maintainability**

The maintainability of the WAAS shall be calculated with the following considerations:

#### **3.2.7.2.1 Mean Time To Repair (MTTR)**

Each component in the WAAS shall exhibit a MTTR of not more than 30 minutes, including time required for fault isolation, repair, test, and restoration.

#### **3.2.7.2.2 Initialization Time**

A failure of WAAS operating system software shall have a maximum re-initialization time for each component of 10 minutes.

#### **3.2.7.2.3 Periodic Maintenance Interval**

The minimum interval for periodic maintenance for each component in the WAAS shall not be less than 2,190 hours (quarterly) and be limited to cleaning, inspecting, adjusting and replacing parts in accordance with their service life expectancy or as found necessary during inspection.

#### **3.2.7.2.4 Periodic Maintenance Service Interruptions**

Periodic maintenance shall not require WAAS service interruption or degradation for more than 8 hours per year per component.

#### **3.2.7.2.5 Corrective Maintenance Service Interruptions**

Corrective maintenance shall not interrupt or degrade the performance of any WAAS function.

#### **3.2.7.2.6 Redundant Equipment Switching**

Where redundant equipment is incorporated to provide required availability, switching to the back-up element shall be automatic and be accomplished in time to maintain GPS/WAAS signal-in-space performance.

### **3.2.8 WAAS Network Time (WNT)**

#### **3.2.8.1 WNT/GPS Time Maintenance**

WNT shall be maintained such that the offset from GPS time is less than 50 nanoseconds.

#### **3.2.8.2 WNT/UTC Time Maintenance**

The WNT offset error from UTC (after correction as defined in paragraph 3.1.3.9.2.2.12.2) shall be less than 20 nanoseconds.

#### **3.2.8.3 GEO Satellite Link Clock Stability**

The time domain stability of GEO satellite downlink clocks in the network shall be at least  $2 \times 10^{-13}$  parts over 24 hours.



**3.2.9 Fail-Safe, Fail-Soft Operation**

WAAS equipment shall meet the fail-safe and fail-soft requirements of FAA-G-2100F, paragraphs 3.2.5 and 3.2.6.

**3.2.10 Personnel Safety**

All WAAS LRU, including COTS, shall conform to the applicable personnel safety requirements of FAA-G-2100F, paragraph 3.3.6.

**3.2.11 Human Engineering**

In the selection of hardware and the design of software, all WAAS components shall conform to the applicable human engineering requirements of FAA-G-2100F, paragraph 3.3.7.

**3.2.12 System Security**

All components of the WAAS will be in FAA facilities. The FAA will provide physical security. Where suitable FAA facilities cannot be identified, a security program will be established and shall comply with the physical security requirements of FAA Order 1600.6.

## **4.0 Hardware Quality Assurance Provisions and Software Qualification Requirements**

### **4.1 Test Program**

The WAAS will utilize developed software with NDI hardware. The term quality assurance provisions applies to hardware and non-Computer Software Configuration Item (CSCI) firmware embedded in hardware. The term qualification requirements applies to software designated as a CSCI.

#### **4.1.1 WAAS Test Program**

A WAAS test program, conducted in accordance with FAA Order 1810.4B, "FAA NAS Test and Evaluation Policy", for Developmental Test and Evaluation (DT&E) and Production Acceptance Test and Evaluation (PAT&E) covering both the development and productions phases, shall verify that the requirements of Section 3 of this specification have been met.

##### **4.1.1.1 Software Qualification**

Software qualification requirements shall be defined in accordance with FAA-STD-026 and RTCA/DO-178B.

##### **4.1.1.2 Hardware Quality Assurance**

Hardware quality assurance provisions for NDI hardware shall be defined in accordance with FAA-STD-013D.

##### **4.1.1.3 Verification Requirements Traceability Matrix (VRTM)**

The VRTM in the Master Test Plan (MTP) shall specify the testing requirements.

##### **4.1.1.4 MTP VRTM**

The MTP VRTM shall be based on the VRTM in this specification (Appendix 3), the contract, and subordinate requirements and meet the requirements of FAA-STD-024B.

##### **4.1.1.5 Types of Testing**

Two types of testing will be used to verify that the WAAS has met the requirements of this specification.

##### **4.1.1.5.1 Development Test and Evaluation (DT&E)**

###### **4.1.1.5.1.1 Reliability Testing**

The reliability of the WAAS shall be verified using the analyses methods required by FAA-G-2100F and substantiated by a reliability tracking program where all relevant failures that occur during the test and evaluation program are recorded and the reliability analyses updated to reflect those failures.

###### **4.1.1.5.1.2 Engineering Evaluation and Test Requirements**

The Engineering Evaluation and Test Requirements Program shall include; DT&E at the contractor's facilities, DT&E on a specified group of the Phase 1 WAAS, and delta DT&E testing on the complete Phase 1 WAAS.

###### **4.1.1.5.1.3 Qualification Testing**

Design Qualification Testing (DQT) shall be conducted as part of DT&E testing to establish software qualification and to verify that system performance and functional requirements of Section 3 have been met. Hardware qualification testing is not required for NDI hardware.

#### **4.1.1.5.1.4 Formal Test Verification of Performance**

Formal verification of performance requirements shall be conducted as part of qualification testing to validate the system performance requirements of Section 3.2 by testing and demonstration of the integrity and accuracy requirements, and by demonstration and analysis of the availability and continuity requirements.

#### **4.1.1.5.2 Production Acceptance Test and Evaluation (PAT&E)**

PAT&E consists of: Factory Acceptance Testing (FAT), Site Acceptance Testing (SAT), and Contract Acceptance Inspections (CAI). These tests shall be used to verify the manufacture, installation and checkout of the WAAS components.

### **4.2 General Testing Requirements**

Formal testing is defined to be any testing for which there is a deliverable. The formal test and evaluation program shall meet the following general requirements:

#### **4.2.1 Government Witnessing of Testing**

The government shall have the right to witness and approve all formal testing.

#### **4.2.2 Quality Assurance Program**

##### **4.2.2.1 Quality Assurance Program Guidance**

The quality assurance program shall meet the requirements of FAA-STD-013D, Quality Control Program Requirements, and FAA-STD-018A, Computer Software Quality Program Requirements.

##### **4.2.2.2 Hardware and Software Quality Control Systems**

The quality program shall include a hardware quality control system to monitor all materials and equipment and a software quality control system to monitor all software.

##### **4.2.2.3 Test Conduct**

All formal testing shall be conducted in accordance with the quality assurance program.

#### **4.2.3 Configuration Management**

All formal testing shall be performed under the configuration management requirements of FAA-STD-021, Configuration Management, MIL-STD-973, Notice 1, Configuration Management, and FAA Order 1800.8F, NAS Configuration Management.

#### **4.2.4 Regression Testing**

Regression testing shall be performed as required by individual test plans and the configuration management requirements.

### **4.3 Special Tests and Examination Requirements**

#### **4.3.1 Use of Simulation**

All formal testing shall be performed using the actual WAAS hardware and software except where simulation is required during DT&E testing. Any testing using simulation will be justified in the MTP and confirmed during DT&E on the FVS and during DT&E on the WAAS.

#### **4.3.2 Test Samples**

No hand-picking or pre-screening of hardware shall be allowed unless it is formally a part of the hardware's specification and is also approved by the government.

#### **4.3.3 Interruption of Tests**

Formal tests shall not be interrupted once a test has started except where noted in the approved test procedures.

#### **4.3.4 Failure Reporting and Tracking**

All failures that occur during formal testing shall be documented, tracked, and resolved.

#### **4.3.5 Certification of Test Environment**

All simulations, operating systems, test scripts, configuration management tools, test hardware, analysis tools, Computer Aided Software Engineering (CASE) tools, and any other support software and hardware used to support formal testing shall undergo certification testing and be under formal configuration management. The certification will establish that the support item reliably meets the requirements of its intended function, that it is installed properly, that it is properly documented, and that it is under configuration control.

## 5.0 Notes

### 5.1 Background Information

#### 5.1.1 Global Positioning System (GPS) System

The Global Positioning System (GPS) is a space-based radio positioning and timing system. The system provides, on a worldwide basis, a signal environment that enables users to determine precise, three-dimensional position and velocity, and system time. The GPS was developed, deployed, and is being operated by the U.S. DOD.

The FAA Satellite Navigation Program was created to explore the civil aviation applications of the DOD GPS Program. The GPS constellation as provided by DOD consists of 24 satellites placed in 6 orbital planes with 4 satellites in each plane. The satellites operate in nearly circular orbits with approximately a 12 hour period for each orbit. Operationally, the satellites are positioned so that at least 5 satellites above 5 degrees in elevation are generally in view by a user at any location on the earth's surface. By receiving and processing the signals transmitted from each satellite, a user can determine its location anywhere on the earth in three dimensions.

The Standard Positioning Service (SPS) is a positioning and timing service which is available to all GPS users on a continuous, worldwide basis. The SPS will be provided on the GPS Link 1 (L1) frequency (1575.42 MHz) which contains a Coarse Acquisition (C/A) code and a navigation data message. The SPS will provide, on a daily basis, the capability to obtain horizontal positioning accuracy within 100 meters (95% probability) and 300 meters (99.99% probability), vertical positioning accuracy within 156 meters (95% probability) and 500 meters (99.99% probability), and time transfer accuracy within 340 nanoseconds (95% probability).

The Precise Positioning Service (PPS) is a positioning and timing service which is available to authorized GPS users on a continuous, worldwide basis. The PPS will be provided on the GPS L1 (1575.42 MHz) and L2 (1227.6 MHz) signals which are modulated with a long P-code (or secure Y-code) and the navigation data message. The L1-P(Y) and L2-P(Y) signals can be processed without knowledge of the Y-Code to estimate the ionospheric delay errors on pseudorange measurements derived from GPS SPS signals.

For further details on the GPS system, see references:

- (1) ICD-GPS-200, NAVSTAR GPS Space Segment/Navigation User Interfaces, including changes through IRN-200B-007, July 19, 1993
- (2) GPS SPS Signal Specification
- (3) FAA Order 6880.1, U.S. National Aviation Standard for the GPS SPS, U.S. Department of Transportation, Federal Aviation Administration, August 16, 1993
- (4) DOT-VNTSC-RSPA-92-2/SOS-4650.5, 1992 Federal Radionavigation Plan.

### **5.1.2 Differential GPS**

While the GPS can provide position information to a high degree of accuracy and integrity for most users, special measures must be taken to achieve the levels of availability, accuracy, continuity of service and integrity required to support civil and military aviation operating in the National Airspace System (NAS). One such measure involves the determination of one's position using the satellite signals and then comparing this measurement to a previously determined position relative to the earth's surface. The difference in the two measurements provides a measure of the error of the position determined by using the satellite signals. This error data can be used by a GPS receiver as a correction factor to improve the measurement accuracy. By using this technique with ground reference stations at precisely surveyed locations, GPS can provide the degree of accuracy needed to support precision approach requirements. In addition to the improved accuracy, the ground reference stations can also monitor the signals and provide the proper alert to satisfy the integrity requirements for all phases of flight including precision approach.

**Appendix 1:GPS and GEO Satellite Outage Rates and Duration**

Performance analyses shall take into account GPS and GEO satellite outages. GPS outage rates and durations may be assumed to have two modes with the following rates  $\theta_1$  and  $\theta_2$  and mean durations  $\mu_1^{-1}$  and  $\mu_2^{-1}$ . GPS outage restorations shall be assumed to occur in series and not in parallel. That is, if n GPSs are out of service in outage mode 1, the rate at which restorations occur is  $\mu_1^{-1}$  rather than  $n*\mu_1^{-1}$ . All GPS outages of outage mode 2 shall be assumed to be non-predictable. Of GPS outages of outage mode 1, non-predictable outages shall be assumed to occur at a rate of 0.24 per satellite per year. All other GPS outages of outage mode 1, i.e., 1.41 per year, shall be assumed to be predictable.

	<b>Outage Rate, <math>\theta</math></b>	<b>Mean Duration, <math>\mu^{-1}</math></b>
GPS Outage Mode 1	1.65 per year	12.2 hours
GPS Outage Mode 2	0.16 per year	1.25 months

The outage rates and durations of INMARSAT 3 satellites shall be assumed to be as follows:

	<b>Outage Rate, <math>\theta</math></b>	<b>Mean Duration, <math>\mu^{-1}</math></b>
GEO Outage Mode 1	0.083 per year	19.8 hours
GEO Outage Mode 2	0.014 per year	3 Years

Note 1: All outages of GEOs are assumed to be non-predictable.

Note 2: The contractor is responsible for providing GEO satellite coverage for the broadcast and ranging function to meet the performance requirements in paragraph 3.2.1 of this specification. INMARSAT 3 is used in the above table as an example of GEO satellite outages. The outage rates and durations assumed for other satellites of this type shall take into account both failures of the navigation repeater package and of any satellite elements required for the continued operation of the WAAS broadcast and ranging functions, and shall be substantiated by satellite provided information.

## **Appendix 2: Wide Area Augmentation System Signal Specification**

### **1.0 Introduction**

The Wide Area Augmentation System (WAAS) uses Geostationary satellites (GEOs) to broadcast Global Positioning System (GPS) integrity and correction data to GPS users, and to provide a ranging signal that augments the GPS. This signal specification defines the service to be provided by the WAAS. This document is written to satisfy the following objectives:

- (1) specify the WAAS ranging signal characteristics;
- (2) specify the WAAS integrity data contents and format; and
- (3) specify the WAAS corrections data contents and format.

### **2.0 Signal Characteristics**

The signal broadcast via the WAAS GEOs to the WAAS users is designed to minimize standard GPS receiver hardware modifications. The GPS frequency and GPS-type of modulation, including a Coarse/Acquisition (C/A) PRN code, shall be used. In addition, the code phase timing shall be maintained close to GPS time to provide a ranging capability.

#### **2.1 Carrier Frequency**

The WAAS broadcast shall consist of a single carrier frequency of 1575.42 MHz (GPS L1).

#### **2.2 Spurious Transmissions**

Spurious transmissions shall be at least 40 dB below the unmodulated carrier over all frequencies.

#### **2.3 Modulation**

GPS-type modulation shall be used for the code and the data. Message symbols at a rate of 500 symbols per second (sps) will be added modulo-2 to a 1023-bit PRN code, which shall then be binary phase shift keying (BPSK) modulated onto the carrier at a rate of 1.023 Mcips per second. Code/carrier frequency coherence shall be maintained as described in 2.6.4 of this appendix. The 500 sps shall be synchronized with the 1 kHz C/A code epochs.

#### **2.4 Carrier Phase Noise**

The phase noise spectral density of the unmodulated carrier shall be such that a phase locked loop of 10 Hz one-sided noise bandwidth shall be able to track the carrier to an accuracy of 0.1 radians rms.

#### **2.5 Signal Spectrum**

The broadcast signal shall be at the GPS L1 frequency of 1575.42 MHz. Ninety-nine percent of the broadcast power shall be in a 41 MHz bandwidth centered at the L1 frequency.

#### **2.6 Signal Characteristics Modified Relative to GPS**

##### **2.6.1 Doppler Shift**

The Doppler shift, as perceived by the stationary user, on the signal broadcast by WAAS Geostationary satellites (GEOs) will be less than 40 meters per second ( $\approx 210\text{Hz}$  at L1) in the worst case (at the end of life of the GEOs). The Doppler shift is due to the motion of the GEO.



### 2.6.2 Carrier Frequency Stability

The short-term stability of the carrier frequency (the square root of the Allan Variance) at the input of the user's receiver antenna shall be better than  $5 \times 10^{-11}$  over 1 to 10 seconds, excluding the effects of the ionosphere and Doppler.

### 2.6.3 Polarization

The broadcast signal shall be right-handed circularly polarized. The ellipticity shall be no worse than 2 dB for the angular range of  $\pm 9.1^\circ$  from boresight.

### 2.6.4 Code/Carrier Frequency Coherence

The lack of coherence between the broadcast carrier phase and the code phase shall be limited. The short term (<10 seconds) fractional frequency difference between the code phase rate and the carrier frequency shall be less than  $5 \times 10^{-11}$  (one sigma). That is,

$$\left| \frac{f_{code}}{1.023 \text{ MHz}} - \frac{f_{carrier}}{1575.42 \text{ MHz}} \right| < \frac{\Delta f}{f_0} \quad 1)$$

where  $\Delta f/f_0$  has a one-sigma value of  $5 \times 10^{-11}$ . Over the long term (< 100 seconds), the difference between the change in the broadcast code phase, converted to carrier cycles by multiplying the number of code chips by 1540, and the change in the broadcast carrier phase, in cycles, shall be within one carrier cycle, one sigma. This does not include code/carrier divergence due to ionospheric refraction in the downlink propagation path.

### 2.6.5 User Received Signal Levels

The received radiated power level from a WAAS GEO into a 3 dBi linearly polarized antenna on or near the surface of the earth shall be greater than or equal to -161 dBW at GEO elevation angles greater than 5 degrees. The maximum received signal strength shall be -155 dBW in such an antenna. The expected typical received power versus elevation angle is shown in Figure 1.

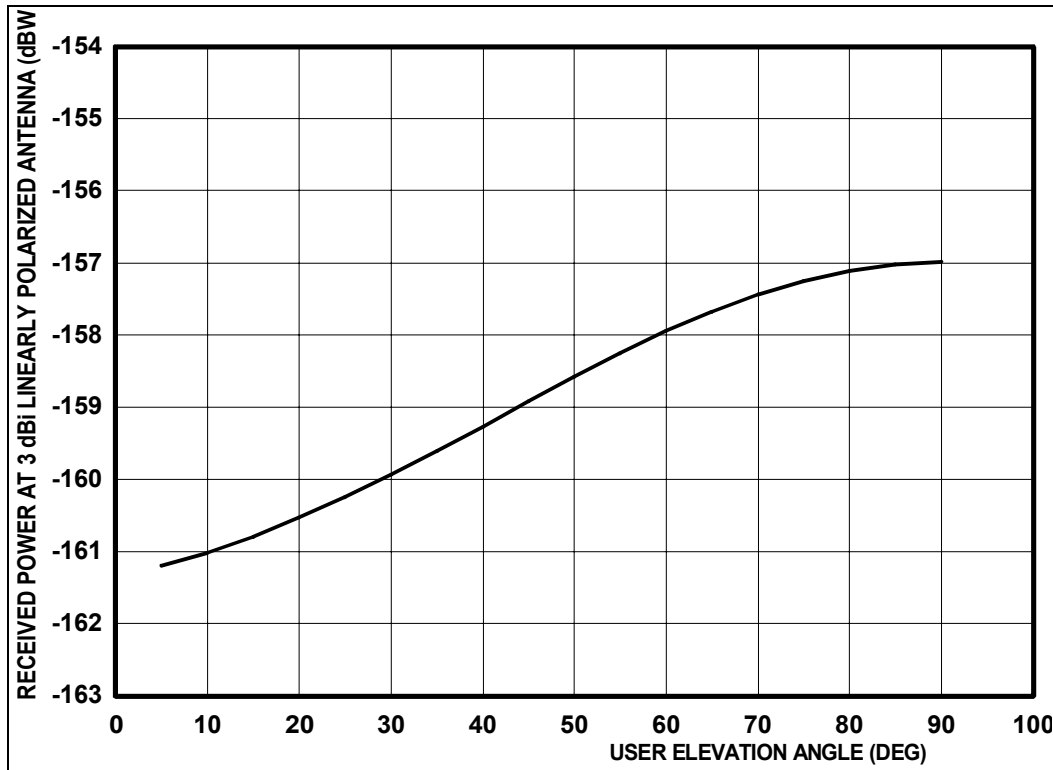

Figure 1. Expected Typical Received Power Levels

### 2.6.6 Correlation Loss

Correlation loss is defined as the ratio of output powers from a perfect correlator for two cases: (1) the actual received WAAS signal correlated against a perfect unfiltered PN reference, or (2) a perfect unfiltered PN signal normalized to the same total power as the WAAS signal in case 1, correlated against a perfect unfiltered PN reference.

The correlation loss resulting from modulation imperfections and filtering inside the WAAS satellite payload shall be less than 1 dB.

### 2.6.7 Maximum Code Phase Deviation

The maximum uncorrected code phase of the broadcast signal shall not deviate from the equivalent WAAS Network Time by more than can be accommodated by the GEO time correction provided in the GEO Navigation Message ( $\pm 2^{-20}$  seconds). The maximum corrected code phase deviation shall be limited in accordance with the overall signal-in-space performance requirements.

## 3.0 WAAS C/A Codes

### 3.1 Requirements

The following is the definition of the C/A codes (herein called the WAAS codes) to be used by WAAS GEOs broadcasting a GPS look-alike signal. The requirements imposed on these selected codes are as follows:

- (1) They must belong to the same family of 1023-bit Gold codes as are the 37 C/A codes reserved by the GPS system and specified in the Global Positioning System Standard Positioning Service Signal Specification [1]. The first 32 are assigned to GPS satellites, while the last 5 (of which two are the same) are reserved for other uses.
- (2) They must not adversely interfere with GPS signals.

### **3.2 Identification of WAAS Codes**

The WAAS codes are identified in three ways:

- (1) PRN number,
- (2) G2 delay in chips,
- (3) initial G2 state.

The definition of either the G2 delay or initial G2 state is required for implementation of the generation of the selected codes. Arbitrary PRN numbers are assigned to the selected codes.

### **3.3 WAAS Codes**

The 19 selected WAAS codes are presented in Table 1. Like the GPS C/A codes, the PRN number is arbitrary, but starting with 120 instead of 1. The actual codes are defined by either the G2 delay or the initial G2 register setting. The ranking of the codes in Table 1 is by the average number of cross-correlation peaks when correlating those codes with the 36 GPS codes with zero Doppler difference. Future GEOs could also have PRN codes associated with the yet to be defined PRNs 139-210.

**Table 1. WAAS Ranging C/A Codes**

PRN	G2 Delay (Chips)	Initial G2 Setting (Octal)*	First 10 WAAS Chips (Octal)*	Geostationary Satellite PRN Allocations
120	145	1106	0671	INMARSAT AOR-E
121	175	1241	0536	Unallocated
122	52	0267	1510	INMARSAT AOR-W
123	21	0232	1545	Unallocated
124	237	1617	0160	Unallocated
125	235	1076	0701	Unallocated
126	886	1764	0013	Inmarsat Reserved
127	657	0717	1060	Unallocated
128	634	1532	0245	Unallocated
129	762	1250	0527	MTSAT-1
130	355	0341	1436	Unallocated
131	1012	0551	1226	INMARSAT IOR
132	176	0520	1257	Unallocated
133	603	1731	0046	Unallocated
134	130	0706	1071	INMARSAT POR
135	359	1216	0561	Unallocated
136	595	0740	1037	Unallocated
137	68	1007	0770	MTSAT-2
138	386	0450	1327	Unallocated

\*In the octal notation for the first 10 chips of the G2 or the WAAS code as shown in these columns, the first digit on the left represents a "0" or "1" for the first chip. The last 3 digits are the octal representation of the remaining 9 chips. (For example, the initial G2 setting for PRN 120 is: 1 001 000 110.) Note that the first 10 WAAS chips are simply the octal inverse of the initial G2 setting.

### 3.4 Recommended WAAS/GPS Coder Implementation

The assigned codes cannot be implemented using the two-tap selection derived for the GPS C/A codes. Thus, the recommended WAAS coder implementation is either a programmable G2 shift register delay with single output (Figure 2), or a programmable initial G2 shift register state with a single output (Figure 3). The reserved GPS C/A codes can also be generated with either of these implementations. Table 2-1 of [1] specifies the G2 shift register delay (called the Code Delay) and the First 10 Chips Octal, which is the octal inverse of the initial G2 shift register state.

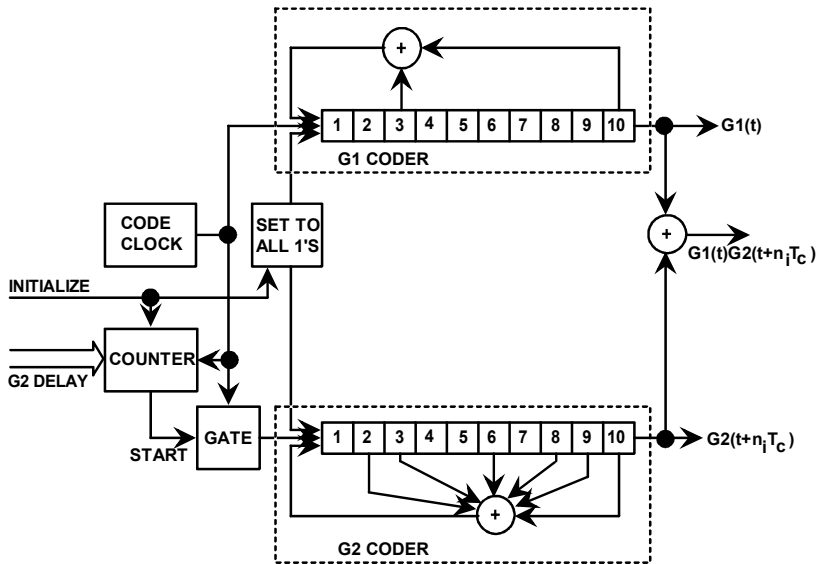

Figure 2. WAAS/GPS Code Implemented With Single G2 Output Plus Programmable G2 Delay

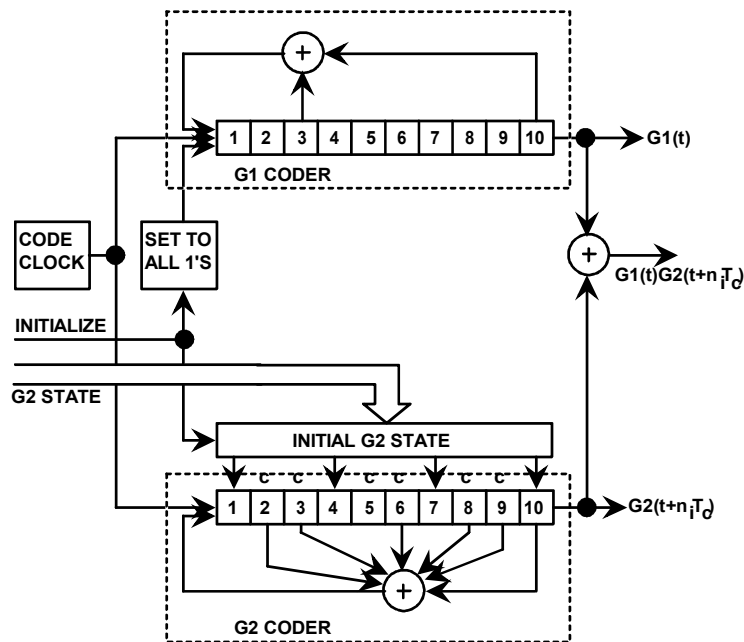

Figure 3. WAAS/GPS Code Implemented With Single G2 Output Plus Programmable G2 State

## 4.0 WAAS Signal Data Contents And Formats

### 4.1 Introduction

A given WAAS GEO shall broadcast either coarse integrity data or both such data and wide area corrections. The coarse integrity data shall provide "Use/Don't Use" information on all satellites in view of the applicable region, including the GEOs. Correction data include estimates of the error after application of the corrections.

The User Differential Range Error (UDRE) bounds the WAAS-corrected pseudorange error due to fast corrections and long-term clock and ephemeris corrections with a probability of 0.999. The parameter,  $\sigma_{UDRE}^2$ , is the variance of a zero-mean Normal distribution which overbounds the user differential range errors which are due to fast corrections and long-term clock and ephemeris corrections, given the current performance of the system. The User Ionospheric Vertical Error (UIVE) is the error in the user-interpolated vertical ionospheric delay for a satellite, while the data is active. It is interpolated from Grid Ionospheric Vertical Errors (GIVES). Appropriately user processed GIVES and UIVE bound the ionospheric delay with a probability of 0.999.

### 4.2 Principles and Assumptions

Certain principles and assumptions are used as a guide in the definition of the format and data contents. First, the signal data bandwidth should have the necessary capacity to broadcast both integrity and corrections data simultaneously for the entire service region. Next, information common to both the integrity and corrections data should not be repeated in order to minimize the required data rate. Note that the delivered level of accuracy can be controlled by adjusting the accuracy of the corrections, but integrity is always provided.

#### 4.2.1 Data Rate

The baseline data rate shall be 250 bits per second. The data shall always be rate 1/2 convolutional encoded with a Forward Error Correction (FEC) code. Therefore, the symbol rate that the GPS receiver must process is 500 symbols per second. The convolutional coding shall be constraint length 7 as standard for Viterbi decoding, with a convolutional encoder logic arrangement as illustrated in Figure 4. The G1 symbol is selected on the output as the first half of a 4 millisecond data bit period. (If soft decision decoding is used, the bit error rate (BER) performance gain of this combination of coding and decoding is 5 dB over uncoded operation.) As an example, algorithms for the implementation of this decoding are described in George C. Clark and J. Bibb Cain, Error-Correction Coding for Digital Communications, Plenum Press, New York, 1981 [2].

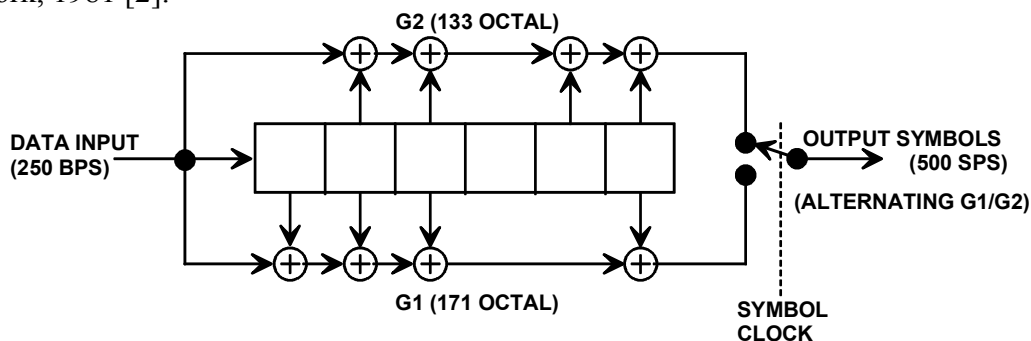

## Figure 4. Convolutional Encoding

### 4.2.2 Timing

WAAS Network Time is defined as that which is maintained, after corrections, to GPS system time, within the overall WAAS performance requirements. Data blocks shall maintain synchronization with the GPS data frames to within the same performance requirements. It is noted that, when using corrections, the user's solution for time will be with respect to the WAAS Network Time, and not with respect to GPS system time. If corrections are not applied, then the solution will be with respect to a composite GPS/WAAS Network Time, and the resulting accuracy will be affected by the difference between the two. WAAS Network Time will be within 50 nanoseconds of GPS system time. Estimates of the time difference between WAAS network time and Universal Coordinated Time (UTC) shall be provided in an appropriate data message (Type 12).

In order to maintain data block synchronization with the GPS data frames, the data input to the convolution encoder of Figure 4 shall be applied 7 bits (14 symbols or 28 milliseconds) early. In this way, the data blocks, although then encoded, are still coherent with one-second epochs of GPS time as transmitted from the GEO. The users' convolutional decoders will also introduce a fixed delay that depends on their respective algorithms (usually 5 constraint lengths, or 35 bits), for which they must compensate to determine system time from the received signal.

These convolutional encoding/decoding delays and their relationships with the start of the data blocks and GPS time are illustrated in Figure 5 for the transponding GEO.

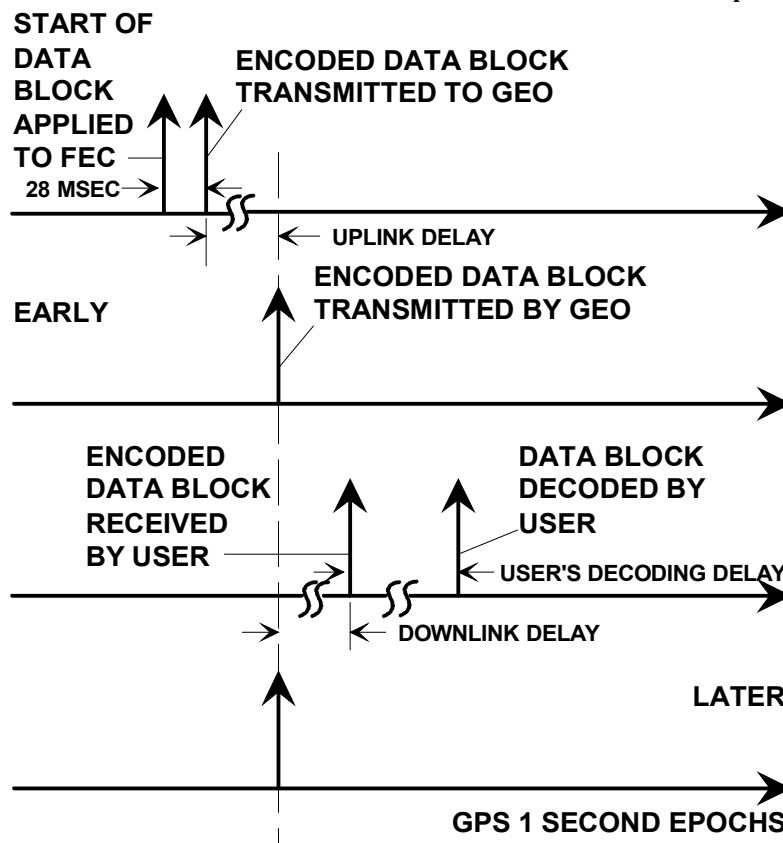

Figure 5. Convolutional Encoding/Decoding Timing Relationships

#### 4.2.3 Error Corrections

There shall be two types of correction data -- fast and slow. The fast corrections are intended to correct for rapidly changing errors such as GPS clock errors, while the slow corrections are for slower changing corrections such as atmospheric and long term satellite clock and ephemeris errors. The fast corrections are common to all users and will be broadcast as such.

For the slower corrections, the users are provided with ephemeris and clock error estimates for each satellite in view (Message Type 24 and 25). Although long term satellite clock errors are common to all regions, they are slow-varying and Issue of Data (IOD) dependent. Therefore, they are best accommodated as part of the slower corrections. Separately, users are provided with a wide-area ionospheric delay model and sufficient real-time data to evaluate the ionospheric delays for each satellite using that model (Message Types 18 and 26). Specific procedures for using the corrections are given with the definition of the relevant messages.

WAAS will ensure that discontinuities in the satellite position after application of long term corrections are minimized so that the range error is typically compensated by the  $\sigma_{UDRE}^2$  when range-rate corrections are calculated (see Section 4.5). In addition, the degradation of accuracy is modeled to account for the possibility that any messages are missed by the user.



#### **4.2.4 Tropospheric Models**

Because tropospheric refraction is a local phenomenon, all users will compute their own tropospheric delay corrections. The WAAS shall remove the tropospheric delay from its corrections and the GEO broadcast messages shall not include any explicit tropospheric corrections.

#### **4.2.5 Accuracy**

Error corrections are formatted to have a resolution of 0.125 meters to satisfy accuracy requirements for the WAAS.

#### **4.2.6 PRN Masks**

*Masks* shall be used to designate which *PRN* belong to which correction *slot*. For example, GPS satellites are assigned the first PRNs (1-37). These masks improve the efficiency of the broadcast by preventing the continual inclusion of PRNs for fast corrections and UDRE indicators.

#### **4.2.7 Number of Satellites**

The WAAS shall provide data for a maximum of 51 satellites.

#### **4.2.8 Issue of Data**

The fast correction data for each satellite supported will be accompanied by a Fast Correction Issue of Data (IODF) to prevent erroneous application of UDRE. The long term satellite correction data for each satellite supported shall be accompanied by Issue of Data (IOD) information to prevent erroneous application of correction data. The WAAS issue of long term satellite correction data shall be identical to the GPS IOD Ephemeris as defined in [1]. Various other issues of data defined below shall also be applied to prevent erroneous use of the PRN and Ionospheric Grid Point (IGP) masks.

#### **4.2.9 Acquisition Information**

Preambles shall be provided in the messages for data acquisition.

### **4.3 Format Summary**

#### **4.3.1 Block Format**

The block format for the 250 bits per second data rate is shown in Figure 6. A block is defined as the complete 250 bits, while a message is defined as the 212 bit data field. The start of the first 8-bit part of every other 24-bit distributed preamble shall be synchronous with the 6-second GPS subframe epoch to within the overall WAAS performance requirements. The block transmission time shall be one second.

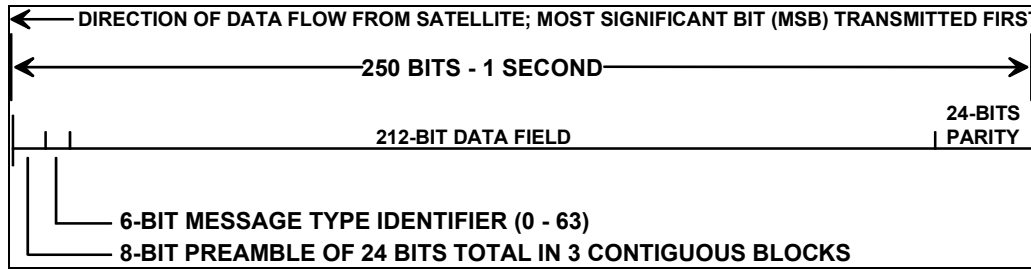

**Figure 6. Data Block Format**

The 8-bit preamble starts at bit 0 of the 250-bit message followed by the 6-bit Message Type at bit 8. The data field then starts at bit 14, followed by the parity field that starts at bit 226. The sequence of the data words is shown in the figures describing the message formats while the number of bits per data word is given in the tables describing message contents. The order of the words in those tables is not related to the sequence of the words in the message.

#### 4.3.2 Block Length and Content

Blocks shall be 250 bits long (one second), consisting of an 8-bit part of a distributed preamble, a 6-bit message type, a 212-bit data field and 24-bits of Cyclic Redundancy Check (CRC) parity. This block length is consistent with the required time-to-alarm, and it provides an efficient parity-to-data ratio. Any message type can occur in any given one-second interval.

#### 4.3.3 Parity

Twenty-four bits of CRC parity shall provide protection against burst as well as random errors with a probability of undetected error  $\leq 2^{-24} = 5.96 \times 10^{-8}$  for all channel bit error probabilities  $\leq 0.5$ . The CRC word is calculated in the forward direction on the entire bit-oriented message, including the block header containing the preamble and message type identifier, and using a seed of 0. The sequence of 24 bits  $(p_1, p_2, \dots, p_{24})$  is generated from the sequence of information bits  $(m_1, m_2, \dots, m_{226})$ . This is done by means of a code that is generated by the polynomial

$$g(X) = \sum_{i=0}^{24} g_i X^i \quad 2)$$

where

$$\begin{aligned} g_i &= 1 \text{ for } i = 0, 1, 3, 4, 5, 6, 7, 10, 11, 14, 17, 18, 23, 24 \\ &= 0 \text{ otherwise} \end{aligned} \quad 3)$$

This code is called CRC-24Q (Q for Qualcomm Corporation) [3]. The generator polynomial of this code is in the following form (using binary polynomial algebra):

$$g(X) = (1 + X)p(X) \quad 4)$$

where  $p(X)$  is the primitive and irreducible polynomial

$$\begin{aligned} p(X) &= X^{23} + X^{17} + X^{13} + X^{12} \\ &\quad + X^{11} + X^9 + X^8 + X^7 + X^5 + X^3 + 1 \end{aligned} \quad 5)$$

When, by the application of binary polynomial algebra, the above  $g(X)$  is divided into

$m(X)X^{24}$ , where the information sequence  $m(X)$  is expressed as

$$m(X) = m_k + m_{k-1}X + m_{k-2}X^2 + \dots + m_1X^{k-1} \quad 6)$$

the result is a quotient and a remainder  $R(X)$  of degree  $< 24$ . The bit sequence formed by this remainder represents the parity check sequence. Parity bit  $p_i$ , for any  $i$  from 1 to 24, is the coefficient of  $X^{24-i}$  in  $R(X)$ .

This code has the following characteristics [4, 5, 6, and 7]:

- (1) it detects all single bit errors per code word.
- (2) it detects all double bit error combinations in a code word because the generator polynomial  $g(X)$  has a factor of at least three terms.
- (3) it detects any odd number of errors because  $g(X)$  contains a factor  $1+X$ .
- (4) it detects any burst error for which the length of the burst is  $\leq 24$  bits.
- (5) it detects most large error bursts with length greater than the parity length  $r = 24$  bits. The fraction of error bursts of length  $b > 24$  that are undetected is:

a)  $2^{-24} = 5.96 \times 10^{-8}$ , if  $b > 25$  bits.

b)  $2^{-23} = 1.19 \times 10^{-7}$ , if  $b = 25$  bits.

The encoding and decoding procedures can be found in [7] (for example). An example message (a Message Type 2) with passed parity is given as follows:

Preamble, Message ID, IODF, IODP:	Binary: 11, followed by Hex: 1824
13 corrections:	Hex: 003 c00 3c2 200 03f 4bc 000 3c0 03c 003 c00 03f fd8
13 UDREIs:	Hex: 0003cb240003f
Parity:	Hex: a0f7dd

#### 4.3.4 Preamble

The distributed preamble shall be a 24-bit unique word, distributed over three successive blocks. These three 8-bit words shall be made up the sequence of bits -- 01010011 10011010 11000110. The start of every other 24-bit preamble shall be synchronous with a 6-second GPS subframe epoch.

With respect to the convolutional encoding, the preamble is within the decoded bit stream. It shall be encoded just like all of the other bits. It is a place marker, and cannot be used for acquisition or encoded bit synchronization prior to convolutional decoding. The user's convolutional decoding algorithm must provide synchronization to the data bits.

#### 4.4 Messages and Relationships Between Message Types

Table 2 presents the set of message types. Unless otherwise stated, data is represented in unsigned binary format.

In order to associate data in different message types, a number of issue of data (IOD) parameters are used. These parameters include:

IOD<sub>k</sub> (GPS IOD Clock - IODC<sub>k</sub>, IOD Ephemeris - IODE<sub>k</sub>): Indicates GPS clock and ephemeris issue of data, where k = satellite

IOD PRN Mask (IODP): Identifies the current PRN mask

IOD Fast Corrections<sub>j</sub> (IODF<sub>j</sub>): Identifies the current fast corrections, where j = fast corrections Message Type (Types 2 - 5)

IOD Ionospheric Grid Point Mask (IODI): Identifies the current Ionospheric Grid Point mask

The relationship among the messages is shown in Figure 7. The GPS IODs (including IODC and IODE) are specific to each satellite, and are updated separately. There is only one active PRN mask and one Ionospheric Grid Point mask. Since fast corrections are always provided in different message types including blocks of 13 satellites, a different IODF is used for each block. Note that the WAAS will ensure that the long-term corrections are sent several times when modified, and the magnitude of the change will be small so that an issue of data is not necessary to connect Type 24 or 25 and Type 2 - 5 messages. In addition, the WAAS shall update long term corrections at a rate high enough to accommodate these small changes, while also accommodating missed messages by the users.

Table 2. Message Types

Type	Contents	Section No.
0	Don't use <del>this GEO for anything (for WAAS testing)</del> <u>for Safety Applications</u>	4.4.1
1	PRN Mask assignments, set up to 51 of 210 bits	4.4.2
2-5	Fast corrections	4.4.3
6	Integrity information	4.4.4
7	Fast Correction Degradation factor	4.4.5
8	Estimated RMS Error message	4.4.6
9	GEO navigation message (X, Y, Z, time, etc.)	4.4.11
10	Degradation Parameters	4.4.16
11	Reserved for future messages	--
12	WAAS Network Time/UTC offset parameters	4.4.15
13-16	Reserved for future messages	--
17	GEO almanacs message	4.4.12
18	Ionospheric grid point masks	4.4.9
19-23	Reserved for future messages	--
24	Mixed fast corrections/long term satellite error corrections	4.4.8
25	Long term satellite error corrections	4.4.7
26	Ionospheric delay corrections	4.4.10
27	Reserved ( <del>WAAS-Service Level</del> Message)	--
<u>28</u>	<u>Clock-Ephemeris Covariance Matrix</u>	<u>4.4.17</u>
<del>2829-61</del>	Reserved for future messages	--
62	Reserved (Internal Test Message)	4.4.14
63	Null Message	4.4.13

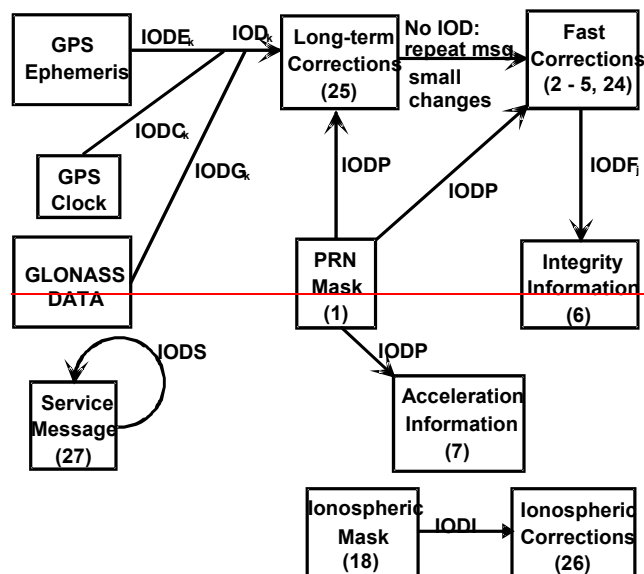

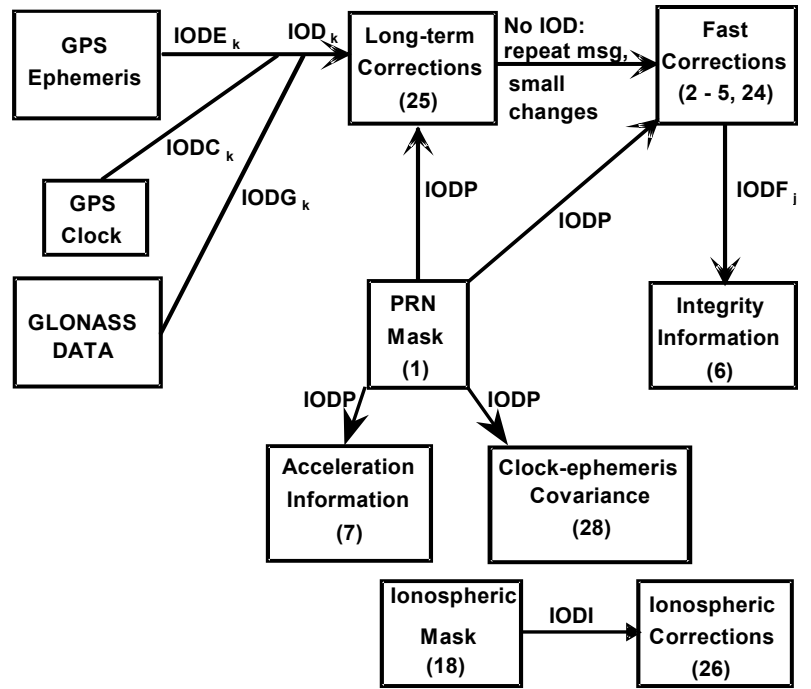

Figure 7. Interrelationships Of Messages

#### 4.4.1 Message Type 0

The first message type, Message Type 0, will only be used during WAAS testing. Users should not use satellite signals (for a given PRN code) for which a Type 0 has been received.

#### 4.4.2 PRN Mask Assignments Message Type 1

The PRN Mask is given in Message Type 1. It consists of 210 ordered slots, each of which indicates if data is provided for the corresponding satellite as defined in Table 3. For example, a one in the fifth slot indicates data is being provided for GPS PRN 5. The mask shall have up to 51 bits set in the 210 slots. Note that the satellites for which corrections are provided must be ordered from 1 to a maximum of 51, in order to decode Message Types 2 - 5, 6, 7, 24, and 25. Data in Message Types 2 - 5, 6, 7 and the fast corrections part of Message Type 24 are provided sequentially. Long term corrections in Message Types 24 and 25 may or may not be provided sequentially, since the PRN Mask number is specified for each correction. The mask will be followed by a 2-bit issue of data PRN (IODP) to indicate the mask's applicability to the corrections and accuracies contained in messages to which the mask applies.

**Table 3. PRN Mask Assignments**

PRN Slot	Assignment
1-37	GPS/GPS Reserved
38-61	GLONASS
62-119	Future GNSS
120-138	GEO/WAAS
139-210	Future GNSS/GEO/WAAS/Pseudolites

**4.4.2.1 PRN Mask Transition**

The transition of the PRN Mask to a new one (which will be infrequent) shall be controlled with the 2-bit IODP, which shall sequence to a number between 0 and 3. The same IODP shall appear in the applicable Message Types 2-5, 7,8, 24, and 25. This transition would probably only occur when a new satellite is launched, or when a satellite fails and is taken out of service permanently. In the latter case, there would be no hurry to do so, unless the slot is needed for another satellite. It could simply be flagged as a "Don't Use" satellite. A degraded satellite may be flagged as a "Don't Use" satellite temporarily.

If the IODP of the mask does not agree with the IODP in the applicable Message Types 2-5, 7,8, 24, and 25, the user will not use the applicable message until a mask with the matching IODPs agree. The change of IODP in the PRN mask message will always occur before the IODP changes in all other messages. During a change-over of the IODP in the PRN mask, the user equipment continues to use the old mask to decode messages, and stores the new mask so that there are no interruptions to service when the new mask becomes effective. As the new mask starts to be used, the user will use some data which correlated with the old mask and some data that correlated with the new mask. However, if the IODP changes in those message types before receipt of the new PRN mask, these message types cannot be used until receipt of the new mask.

**4.4.3 Fast Corrections Message Types 2-5**

The fast corrections message format is illustrated in Figure 8. Message Type 2 contains the fast data sets for the first 13 satellites designated in the PRN mask. Message Type 3 contains the fast data sets for satellites 14 - 26 designated in the PRN mask, etc., through Message Type 5, which contains the fast sets for satellites 40 through 51 designated in the PRN mask. The last data set of Message Type 5 is not used due to the constraint that corrections can only be provided for 51 satellites (see Message Type 6). A fast corrections message type will only be sent if the number of satellites designated in the PRN mask requires it: e.g., Message Type 5 will only be broadcast if 40 or more satellites are designated. Message Types 2-5 contain a 2-bit IODF<sub>j</sub>. The IODF<sub>j</sub>, where j is the fast corrections Message Type (2 - 5), is used to associate the UDRE contained in a Message Type 6. The range of each IODF<sub>j</sub> counter is only [0,2]. An IODF<sub>j</sub>=3 indicates that the UDRE information in a Message Type 6 applies to all active data in the corresponding Message Type (j=2-5), rather than a particular set of fast corrections. If there are 6 or fewer satellites in a block, they may be placed in a mixed corrections message, Type 24. The last half of Message Type 24 is reserved for slow corrections. The fast data set for each satellite consists of 16 bits; a 12-bit fast correction followed by a 4-bit UDRE Indicator

(UDREI). The UDREI is described in Section 4.4.4 of this Appendix. Each message also contains a 2-bit IODP indicating the associated PRN mask. Refer to Paragraph 4.4.2 for the application of IODP.

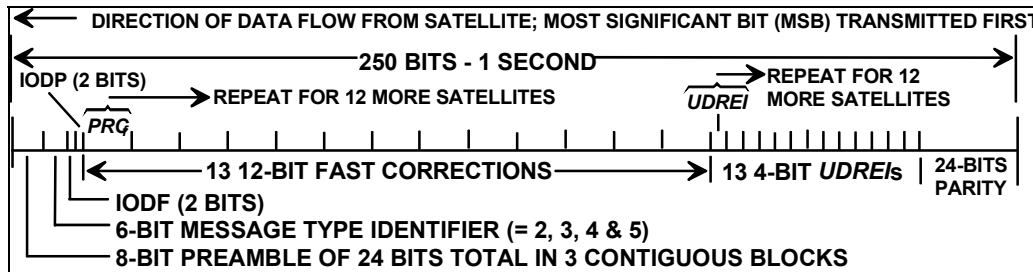

Figure 8. Types 2 - 5 Fast Corrections Messages Format

The 12-bit fast correction ( $PRC_f$ ) has a 0.125 meter resolution, for a [-256.000 m, +255.875 m] valid range. If the range is exceeded, a "Don't Use" indication shall be inserted into the UDREI field. The user should ignore extra data sets not represented in the PRN mask. The time of applicability ( $t_{of}$ ) of the  $PRC_f$  is the start of the epoch of the WNT second that is coincident with the transmission at the GEO satellite of the first bit of the message block.

The Range-rate Corrections ( $RRC$ ) of the fast corrections will not be broadcast. The user should compute these rates-of-change by differencing fast corrections (regardless of IODF<sub>j</sub>) [8]. The total fast correction for a given satellite shall be applied as

$$PR_{corrected}(t) = PR_{measured}(t) + PRC_f(t_{of}) + RRC \times (t - t_{of}) \quad (7)$$

If  $a_i$  (fast correction degradation factor for the  $i^{\text{th}}$  satellite)  $\neq 0$ , the  $RRC$  is computed by the user differencing fast corrections:

$$RRC(t_{of}) = \frac{PRC_{current} - PRC_{previous}}{\Delta t}$$

where:

- $PRC_{current}$  = the most recent fast correction
- $PRC_{previous}$  = a previous fast correction
- $\Delta t$  = ( $t_{of} - t_{of,previous}$ )
- $t_{of}$  = time of applicability of the most recent fast correction
- $t_{of,previous}$  = time of applicability of the  $PRC_{previous}$

If  $a_i = 0$ , the  $RRC$  is equal to zero (0).

The most recent fast correction received ( $PRC_{current}$ ) must be used when computing the  $RRC$ . The range rate correction must time out if  $\Delta t > I_{fc}$  (defined in Message Type 7), which is an identical condition to what causes the fast correction itself to time out. In addition, the user should not continue to use a  $RRC$  longer than  $8\Delta t$ , which is theoretically possible under certain alarm conditions.



In selecting the previous fast correction to be used in determining the RRC, the user should select the fast correction which minimizes the degradation due to fast corrections and range rate corrections (A.4.5.1.1 and A.4.5.1.2). This can be accomplished by selecting a previous fast correction closest to  $I_{fc}/2$  seconds prior to the current fast correction.

Anytime a “don’t use” or “not monitored” indication is received and is then followed by a valid correction, the calculation of the RRC must be reinitialized. During reinitialization, the RRC shall not be used and the associated satellite cannot be used to support precision approach mode. The computation of *RRC* is required even in the case of an identical  $IODF_j$ .

The high degree of resolution of these fast corrections should not be confused with correction accuracy. The actual accuracy provided shall be indicated by the UDRE and GIVE data.

#### 4.4.4 Integrity Information Message Type 6

The integrity information message is shown in Figure 9. Each message includes an  $IODF_j$  for each fast corrections Message Type (2 – 5, 24). The UDRE information for each block of satellites applies to the fast corrections with the corresponding  $IODF_j$ . For example, if  $IODF_3=1$ , then the UDREs for satellites 14-26 apply to the corrections provided in a previously broadcast Type 3 message that had the  $IODF=1$ . An  $IODF_j=3$  indicates that the UDREs apply to all active data from the corresponding message type ( $j=2-5$ ). The remaining 204 bits is divided into 51 slots of 4 bit UDREIs, one for each satellite in the mask. This message format is described in Table 4. Message Type 6 allows the fast corrections of Message Types 2-5 and 24 to be updated infrequently, commensurate with the dynamics of the satellite clock errors. If all fast corrections are being updated at a six second rate, Message Type 6 is not required since the UDREIs are also included in Message Types 2-5 and 24. Message Type 6 can also be used to indicated an alarm condition on multiple satellites.

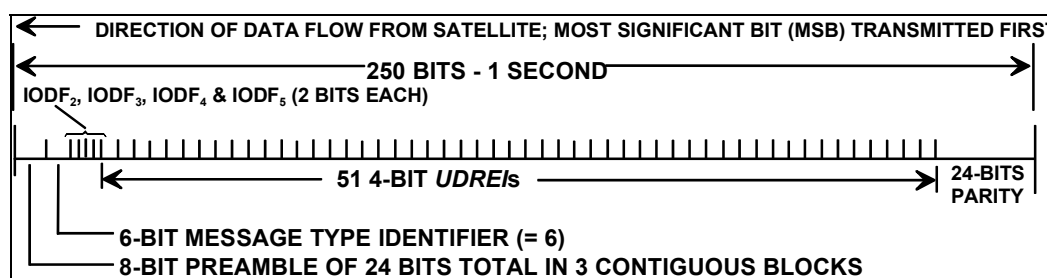

Figure 9. Type 6 Integrity Message Format

The 4-bit UDREIs are used for the evaluation of the UDREs, the 99.9% error of the corrections for the designated satellite, indicating the accuracy of combined fast and slow error corrections, not including the accuracy of the ionospheric delay corrections (GIVES), which are computed from the indicators that are provided separately in Message Type 26. The ephemeris accuracy component is an “equivalent” range accuracy, rather than the accuracy of each of the Earth-Centered-Earth-Fixed (ECEF) components. Evaluation of the 99.9% error values versus indicator value is given in Table 5. The UDRE (in Types 2 - 6 and 24) applies at a particular time and degrades as defined in Section [4.4.5.3.2.1.3.1](#).

**Table 4. Type 6 Integrity Message Content**

<b>Parameter</b>	<b>No. of Bits</b>	<b>Scale Factor (LSB)</b>	<b>Effective Range</b>	<b>Units</b>
IODF <sub>2</sub>	2	1	0 to 3	<a href="#">discreteunitless</a>
IODF <sub>3</sub>	2	1	0 to 3	<a href="#">discreteunitless</a>
IODF <sub>4</sub>	2	1	0 to 3	<a href="#">discreteunitless</a>
IODF <sub>5</sub>	2	1	0 to 3	<a href="#">discreteunitless</a>
For each of 51 satellites	---	---	---	---
UDREI	4	(see Table 5)	(see Table 5)	<a href="#">discreteunitless</a>

**Table 5. Evaluation of UDRE<sub>i</sub>**

UDRE <sub>i</sub>	UDRE <sub>i</sub> Meters	$\sigma^2_{i,UDRE}$ Meters <sup>2</sup>
0	0.75	0.0520
1	1.0	0.0924
2	1.25	0.1444
3	1.75	0.2830
4	2.25	0.4678
5	3.0	0.8315
6	3.75	1.2992
7	4.5	1.8709
8	5.25	2.5465
9	6.0	3.3260
10	7.5	5.1968
11	15.0	20.7870
12	50.0	230.9661
13	150.0	2078.695
14	Not Monitored	Not Monitored
15	Do Not Use	Do Not Use

**4.4.5 Fast Correction Degradation Factor - Message Type 7**

In order to ensure that the most accurate information is available to the airborne equipment, the  $\sigma^2_{UDRE}$  broadcast in Types 2 - 6 and 24 applies at a time prior to the time of applicability of the associated corrections. The Type 7 message specifies the applicable IODP, system latency time,  $t_{lat}$ , and the fast correction degradation factor indicator,  $ai_i$ , for computing the degradation of fast and long term corrections as described in paragraph 4.5.1

The Type 7 message contents are described in Table 6 and its format is shown in Figure 10. Table 7 provides the evaluation of the fast correction degradation factor given the degradation factor indicator,  $ai_j$ ,  $ai_i$ . Table 7 also shows the user time-out interval for fast corrections (Section 4.7). This time-out period is measured from the end of the last valid corrections message received to the end of next valid corrections message received for the satellite of interest.

**Table 6. Type 7 Fast Correction Degradation Factor Message Contents**

Parameter	No. of Bits	Scale Factor (LSB)	Effective Range	Units
System latency ( $t_{lat}$ )	4	1	0 to 15	seconds
IODP	2	1	0 to 3	discrete unitless
Spare	2	---	---	---
For each of 51 satellites	204	---	---	---
Degradation factor indicator ( $a_i$ )	4	1	0 to 15	discrete unitless

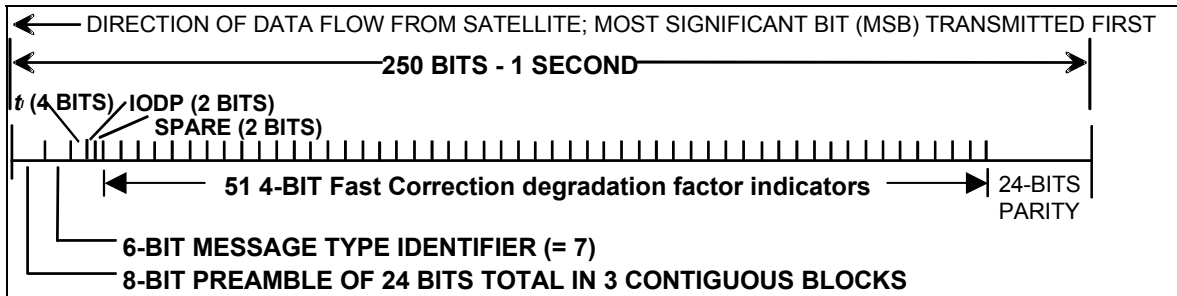
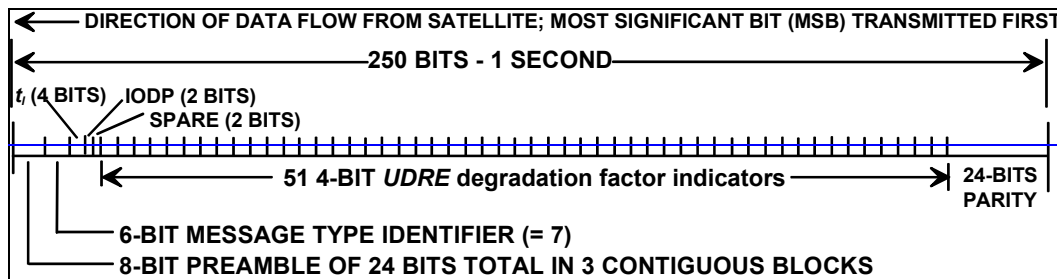

Figure 10. Type 7 Fast Correction Degradation Factor Message Format

Table 7. Fast Correction Degradation Factor and User Time-out Period Evaluation

Fast Correction Degradation Factor Indicator ( $a_i$ )	Fast Corrections Degradation Factor- $(a_i)$ $mm/s^2$	User Time-Out Interval for fast corrections – seconds En Route through Nonprecision Approach	User Time-Out Period for Fast Corrections (seconds) Precision Approach Mode ( $I_{fc}$ )
0	0.0	180	120
1	0.05	180	120
2	0.09	153	102
3	0.12	135	90
4	0.15	135	90
5	0.20	117	78
6	0.30	99	66
7	0.45	81	54

8	0.60	63	42
9	0.90	45	30
10	1.50	45	30
11	2.10	27	18
12	2.70	27	18
13	3.30	27	18
14	4.60	18	12
15	5.80	18	12

**4.4.6 Estimated RMS Error Message Type 8**

The pseudorange RMS error estimate message is shown in Figure 12. The estimates of the RMS pseudorange errors can be used to properly weight the pseudoranges in a weighted-least-squares solution. The message contains an IODP to associate this information with a Type 1 message. Following 6 spare bits, the next 204 bits are divided into 51 slots of 4 bit RMS error indications (RMSIs), one for each satellite in the mask. This message format is described in Table 8.

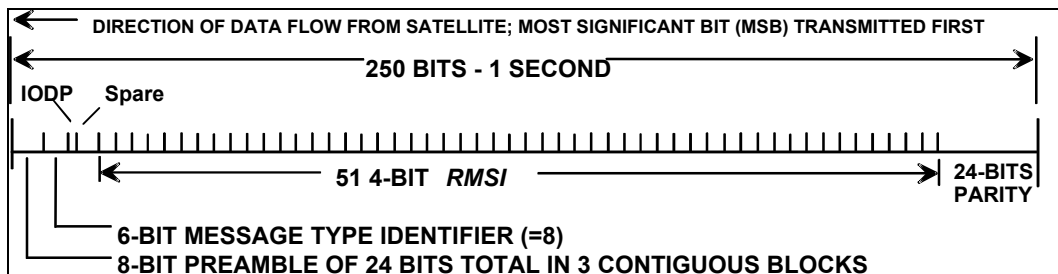

**Figure 12. Type 8 Estimated RMS Error Message Format**

The 4-bit *RMSIs* are used for the evaluation of the RMSs, an estimate of the root-mean square of the corrections for the designated satellite. The estimate includes residual errors of fast and slow error corrections, and does not include residual error of the ionospheric delay corrections. The ephemeris accuracy component is an “equivalent” range accuracy, rather than the accuracy of each of the Earth-Centered-Earth-Fixed (ECEF) components. Evaluation of the RMS values versus RMS indicator value is given in Table 9.

**Table 8. Type 8 Estimated RMS Error Message Content**

Parameter	No. of Bits <sup>1</sup>	Scale Factor (LSB)	Effective Range	Units
IODP	2	1	0-3	<a href="#">discreteunitless</a>
Spare	6	---	---	---
For each of 51 satellites	---	---	---	---
RMSI	4	(see Table 9)	(see Table 9)	---

**Table 9. Evaluation of RMS<sub>i</sub>**

RMS <sub>i</sub>	RMS <sub>i,pr</sub> - Meters
0	0.25
1	0.3
2	0.4
3	0.6
4	0.8
5	1.0
6	1.25
7	1.5
8	1.75
9	2.0
10	2.5
11	4.5
12	8.0
13	15
14	50
15	150

**4.4.7 Long Term Satellite Error Corrections Message Type 25**

Message Type 25 will be broadcast to provide corrections for slow varying satellite ephemeris and clock errors with respect to WGS-84 ECEF coordinates. These long term corrections are not broadcast for the GEO satellites. Instead, the Type 9 GEO Navigation Message will be updated as required to prevent slow varying GEO satellite errors. These corrections are estimated with respect to the GPS broadcast clock and ephemeris parameters.

Table 10 and Figure 13 present the first half of the Type 25 message representing the corrections for the long term satellite position and clock offset errors of two GPS satellites when only those corrections are needed for the required accuracy. Table 11 and Figure 14 present the first half of the Type 25 message representing the corrections for the long term satellite position and velocity and clock offset and drift errors of one GPS satellite when velocity and drift corrections are also needed. Tables 10 and 11 only present the definition of the first 106 bits of the 212 bit message. The second 106 bits have the same definition. The first bit of the 106 bits is a velocity code, indicating whether or not this half-message includes clock drift and velocity

component error estimates. If the velocity code is set to a 1, the message includes clock drift and velocity component estimates; otherwise it consists of only clock offset and position component error estimates, but for 2 satellites, instead of 1. Thus, the entire message can consist of error estimates for 1, 2, 3, or 4 satellites, depending upon the velocity codes for both halves of the message and how many satellites are being corrected. The error estimates are accompanied by the IODP indicating the associated PRN mask. Refer to Paragraph 4.4.2 for the application of the IODP.

**Table 10. Type 25 Long Term Satellite Error Corrections Message Parameters (Half Message) with a Velocity Code Set to 0 (Position and Clock Offset Corrections Only)**

Parameter	No. of Bits	Scale Factor (LSB)	Effective Range (Note 1)	Units
For 2 Satellites	106	---	---	---
Velocity Code = 0	1	1	---	<a href="#">discreteunitless</a>
PRN Mask No. (Note 2)	6	1	0 to 51	---
Issue of Data (Note 3)	8	1	0 to 255	<a href="#">discreteunitless</a>
$\delta x$ (ECEF)	9 (Note 1)	0.125	$\pm 32$	meters
$\delta y$ (ECEF)	9 (Note 1)	0.125	$\pm 32$	meters
$\delta z$ (ECEF)	9 (Note 1)	0.125	$\pm 32$	meters
$\delta a_{f0}$	10 (Note 1)	$2^{-31}$	$\pm 2^{-22}$	seconds
PRN Mask No. (Note 2)	6	1	0 to 51	---
Issue of Data (Note 3)	8	1	0 to 255	<a href="#">discreteunitless</a>
$\delta x$ (ECEF)	9 (Note 1)	0.125	$\pm 32$	meters
$\delta y$ (ECEF)	9 (Note 1)	0.125	$\pm 32$	meters
$\delta z$ (ECEF)	9 (Note 1)	0.125	$\pm 32$	meters
$\delta a_{f0}$	10 (Note 1)	$2^{-31}$	$\pm 2^{-22}$	seconds
IODP	2	1	0 - 3	<a href="#">discreteunitless</a>
Spare	1	---	---	---

Notes:

- (1) All signed values will be coded as two's complement, with the sign bit occupying the MSB. The effective range is smaller than indicated, as the maximum positive value is actually constrained to be one value less (the indicated value minus the resolution).
- (2) Mask sequence. The count of 1's in mask from the first position in mask to the position representing the subject satellite. If set to 0, no satellite represented and the remainder of the message should be ignored.
- (3) The Issue of Data has the format of the 8-bit GPS issue of data-Ephemeris. See [1].

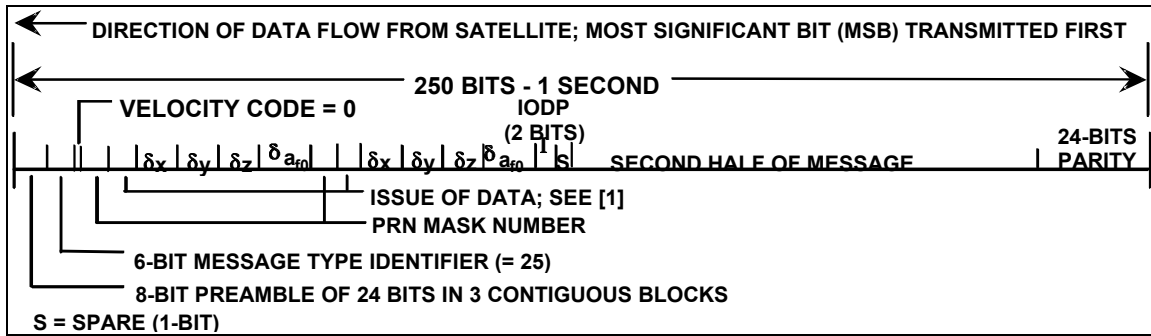

**Figure 13. Type 25 Long Term Satellite Error Corrections - Velocity Code = 0**

The PRN Mask No. is the sequence number of the bits set in the 210 bit mask (that is, between 1 and 51). As opposed to data in Message Types 2-5, the data in this Type 25 message does not have to appear in sequence. Error corrections for satellites with faster changing long term errors can be repeated at a higher rate than ones with slower changing long term errors. The IODP of the message shall agree with the IODP associated PRN mask in Message Type 1.

Note that the ranges of the position and clock offset component error estimates when the velocity code is 0 are less than if the velocity code is 1. The reason for this is for data rate efficiency. Usually, the necessity for velocity and clock drift component error estimates is small. Only the clock offset and position component error estimates will be broadcast, unless any of the errors (position, velocity, offset, or drift) are large enough to warrant their use on a satellite-by-satellite basis.

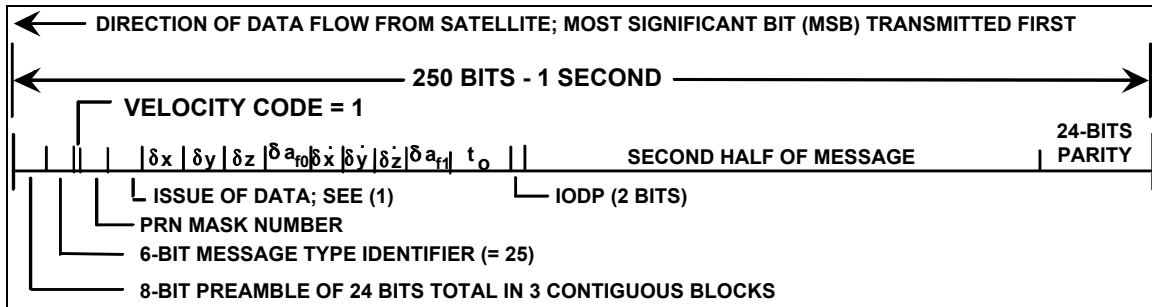

**Table 11. Type 25 Long Term Satellite Error Corrections Half Message  
Parameters with a Velocity Code of 1  
(Velocity and Clock Drift Corrections Included)**

Parameter	No. of Bits (Note 1)	Scale Factor (LSB)	Effective Range (Note 1)	Units
For Satellite	106	---	---	---
Velocity Code = 1	1	1	---	<a href="#">discreteunitless</a>
PRN Mask No. (Note 2)	6	1	0 to 51	---
Issue of Data (Note 3)	8	1	0 to 255	<a href="#">discreteunitless</a>
$\delta x$ (ECEF)	11	0.125	$\pm 128$	meters
$\delta y$ (ECEF)	11	0.125	$\pm 128$	meters
$\delta z$ (ECEF)	11	0.125	$\pm 128$	meters
$\delta a_{f0}$	11	$2^{-31}$	$\pm 2^{-21}$	seconds
$\delta x$ rate-of-change (ECEF)	8	$2^{-11}$	$\pm 0.0625$	meters/sec
$\delta y$ rate-of-change (ECEF)	8	$2^{-11}$	$\pm 0.0625$	meters/sec
$\delta z$ rate-of-change (ECEF)	8	$2^{-11}$	$\pm 0.0625$	meters/sec
$\delta a_{f1}$	8	$2^{-39}$	$\pm 2^{-32}$	seconds/sec
Time of Applicability $t_o$	13	16	0 to 86,384	seconds
IODP	2	1	0 - 3	<a href="#">discreteunitless</a>

- (1) All signed values will be coded as two's complement, with the sign bit occupying the MSB. The effective range is smaller than indicated, as the maximum positive value is actually constrained to be one value less (the indicated value minus the resolution).
- (2) Mask sequence. The count of 1's in mask from the first position in mask to the position representing the subject satellite. If set to 0, no satellite represented.
- (3) The issue of data refers to the 8-bit GPS issue of data-Ephemeris. See [1].

Note that the ranges of the clock offset and position component error estimates when the velocity code is 0 are less than if the velocity code is 1. The reason for this is for data rate efficiency. Usually, the necessity for clock drift and velocity component error estimates is small. Only the clock offset and position component error estimates will be broadcast, unless any of the errors (position, velocity, offset or drift) are large enough to warrant their use on a satellite-by-satellite basis.



**Figure 14. Type 25 Long Term Satellite Error Corrections - Velocity Code = 1**

Figure 13 presents the case where 2 satellite position and clock offset corrections occupy the first half of the message. Figure 14 presents the case where one satellite's position and velocity and clock offset and drift corrections occupy that position. Each could have just as well occupied the second half of the message while the other occupied the first, or one type could occupy both halves.

In case of the clock offset error correction ( $\delta a_{f0}$ ) and clock drift error correction ( $\delta a_{f1}$ ), the user shall compute the clock time error estimate  $\delta \Delta t_{SV}$  at time-of-day  $t_k$  as

$$\delta \Delta t_{SV}(t_k) = \delta a_{f0} + \delta a_{f1}(t_k - t_0) \quad 9)$$

where  $t_0$  is the time of day applicability correcting for rollover if needed.

This correction shall be added to  $\Delta t_{SV}$  as computed in Section 2.5.5.2 of [1]. If the velocity code is set to 0, the  $\delta a_{f1}$  term is simply set to 0. Note that the  $t_0$  provided in the Type 25 message (when velocity code = 1) has nothing to do with the reference times broadcast from the GPS satellites. It is the time of applicability of the error corrections, and not the GPS satellite parameters. This time of applicability will usually be approximately 2 minutes in the future of the transmission time of the message, minimizing resolution errors for at least 4 minutes.

Likewise, the user shall compute the position error correction vector as

$$\begin{bmatrix} \delta x_k \\ \delta y_k \\ \delta z_k \end{bmatrix} = \begin{bmatrix} \delta x \\ \delta y \\ \delta z \end{bmatrix} + \begin{bmatrix} \delta \dot{x} \\ \delta \dot{y} \\ \delta \dot{z} \end{bmatrix} (t_k - t_0) \quad 10)$$

This correction vector shall be added to the satellite position vector  $[x_k \ y_k \ z_k]^T$  (WGS-84 ECEF) computed from the equations in Table 2-15 of [1]. If the velocity code is set to 0, the rate-of-change vector is simply set to 0. The rules on the time of applicability are the same as for the clock error correction computations.

The 8-bit issue of data (IOD) broadcast in the message must match that of the GPS broadcast IODC and IODE (in the case of IODC, the least significant 8 bits). If the GPS broadcast IOD's do not match the IOD broadcast in Message Type 25, it is an indication that the GPS broadcast IODs have changed. The user will continue to use the matched GPS data previously broadcast until a new matching Message Type 24 or 25 is broadcast for that particular satellite. (All satellites do not necessarily have the same IOD.) These new matching messages will be broadcast within the time constraints for user initialization.

Upon GPS transmission of new clock and ephemeris data from GPS, the WAAS shall continue to broadcast corrections to the old long term clock and ephemeris data (marked with the previous IODC and IODE) for a period of 2 to 4 minutes. This delay enables all WAAS users to acquire the new GPS data.

#### 4.4.8 Mixed Fast Correction/GPS Long Term Satellite Error Corrections Messages Type 24

The Type 24 mixed fast/slow message will be broadcast under the conditions described in Paragraph 4.4.3. Figure 15 presents the Type 24 Mixed Fast Correction/Long Term Satellite Error Corrections Message. The first half of the message consists of six fast data sets (12 bits for  $PRC_f$  and 4 for UDREI as defined in 4.4.3) according to the PRN mask sequence, followed by the 2-bit IODP, a 2-bit Block ID indicating which corrections block is provided, and the 2-bit IODF, leaving 4 spare bits, for a total of 106 bits. The Block ID (0, 1, 2, 3) shall indicate whether the Type 24 message contains the fast corrections associated with a Type 2, Type 3, Type 4, or Type 5 message, respectively. The final 106 bits of the data field are composed of a 106-bit half message as described in Section 4.4.7. With this message type, when the total for numbers of satellites being corrected by WAAS is between 1 and 6, 14 and 19, 27 and 32 or 40 and 45, long-term corrections for one or two satellites can be accommodated every time a set of fast error corrections is broadcast for satellites 1 through 6, 14 through 19, 27 through 32 or 40 through 45.

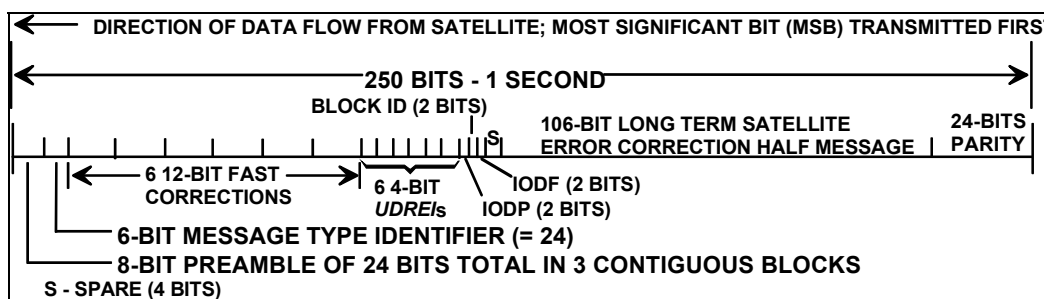

Figure 15. Type 24 Mixed Fast Correction/Long Term Satellite Error Corrections Message Format

#### 4.4.9 Ionospheric Grid Point Mask Message Type 18

The ionospheric delay corrections are broadcast as vertical delay estimates at specified ionospheric grid points (IGPs), applicable to a signal on L1. In order to facilitate flexibility in the location of these IGPs, a fixed definition of densely spaced IGP locations is used, resulting in a large number of possible IGPs. The density of these predefined IGPs, given in Table 12, is dictated by the possible large variation in the ionosphere vertical delay during periods of high

solar activity, especially at lower latitudes. The IGPs used at any time are based upon the current variation between IGP locations. Since it would be impossible to broadcast IGP delays for possible locations, a mask is broadcast to define the IGP locations providing the most efficient model of the ionosphere at the time.

**Table 12. Predefined World-Wide IGP Spacing**

<b>Latitudes Degrees</b>	<b>Latitude Spacing Degrees</b>	<b>Longitude Spacing Degrees</b>
N85	10	90
N75 to N65	10	10
S55 to N55	5	5
S75 to S65	10	10
S85	10	90 (Offset 40° East)

The predefined 1808 possible IGP locations, given in latitude and relative longitude coordinates, are illustrated in Figure 17. These IGP locations must be stored permanently by the user. The IGP locations are denser at lower latitudes because of the fact that the distance between longitudes becomes smaller at higher latitudes. The IGP grid at the equator has 5° spacings, increasing to 10° north of N55° and south of S55°, and finally becoming spaced 90° at N85° and S85° around the poles. The IGPs at S85° are offset by 40° to accommodate an even distribution of bands as described below.

The total IGP grid represents too many IGPs for broadcasting in a single message. Thus, the grid is divided into 9 Bands (numbered 0 to 8), and each message indicates the Band associated with 201 possible IGPs (bands are designated with rectangular areas with bold numbers in Figure 17). Each band covers 40° of longitude. Message Type 18 provides a mask for any one of the 9 bands indicated by the band number. Each message also contains an ionospheric mask issue of data (IODI) to ensure that the ionospheric corrections are properly decoded; the same IODI will be used for all bands. An additional 4-bit number indicates how many band masks are being broadcast by the subject GEO, so that a user knows whether all available data has been received or whether to wait for another band mask. Note that the user only has to collect and save the vertical delays for IGPs located within about ±20° of his location, which would all be located in one or two bands. A given GEO would only broadcast IGPs in bands (up to 6) that cover the observable IGPs visible from the intersection of its footprint and the controlling system's service volume. If the number of bands is 0, the message is used to indicate that no ionospheric delay corrections are being provided, indicating the precision approach service is not being provided by the broadcasting GEO.

Within each band, the IGPs are numbered from 1 to 201 (200 in Band 9), counting up from the southwest corner (bottom-left) up each longitude column of the band (from south to north) and continuing for each column from west to east (left-to-right) from the bottom of each column. For example, in Band 0, IGP #1 is at S75, W180, and IGP #201 is at N55, W145 (See Table 14).

In the mask, a bit set to one (“1”) indicates that ionospheric correction information is being provided for the associated IGP. If the bit is set to zero (“0”), no ionospheric correction information is provided for that IGP.

The IODI shall sequence through the range from 0 to 3, changing each time the IGP mask changes, which is expected to happen rarely. The user will ensure that the IODI of all bands agree and that they agree with the IODI in Message Type 26 before applying the vertical delays to the model. The format of these message types are illustrated in Figure 16 with contents described in Table 13.

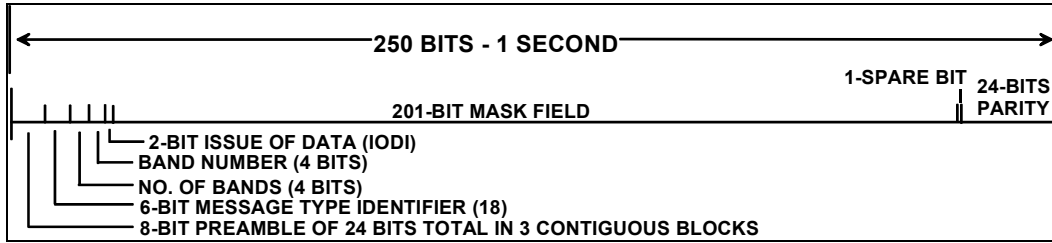

Figure 16. Type 18 IGP Mask Message Format

**Table 13. Type 18 IGP Mask Message Contents**

Parameter	No. of Bits	Scale Factor (LSB)	Effective Range	Units
Number of Bands being broadcast	4	1	0 to 9	<a href="#">discreteunitless</a>
Band Number	4	1	0 to 8	<a href="#">discreteunitless</a>
Issue of Data - Ionosphere (IODI)	2	1	0 to 3	<a href="#">discreteunitless</a>
IGP Mask	201	---	---	<a href="#">discreteunitless</a>
Spare	1	---	---	---

At the edge of the GEO footprint, the ionospheric pierce points (IPPs) could be located beyond the IGPs of the bands being broadcast. However, because of overlap of GEO footprints, those IPPs would be covered by an adjacent GEO broadcasting an adjacent band. The adjacent GEO itself would be at a higher elevation angle.

The Phase 1 IGP mask shall not include IGPs north of 75° North.

The Phase 1 IGP mask shall be such that user equipment will never select IGPs at the corners of a 10° by 10° cell when computing delay and UIVE for a user between 55° South and 55° North.

**Table 14. Ionospheric Mask Bands**

		<b>IGP Number</b>
<b>Band 0</b>		
180 W	75S, 65S, 55S, 50S, 45S, ..., 45N, 50N, 55N, 65N, 75N, 85N	1 to 28
175 W	55S, 50S, 45S, ..., 45N, 50N, 55N	29 to 51
170 W	75S, 65S, 55S, 50S, 45S, ..., 45N, 50N, 55N, 65N, 75N	52 to 78
165 W	55S, 50S, 45S, ..., 45N, 50N, 55N	79 to 101
160 W	75S, 65S, 55S, 50S, 45S, ..., 45N, 50N, 55N, 65N, 75N	102 to 128
155 W	55S, 50S, 45S, ..., 45N, 50N, 55N	129 to 151
150 W	75S, 65S, 55S, 50S, 45S, ..., 45N, 50N, 55N, 65N, 75N	152 to 178
145 W	55S, 50S, 45S, ..., 45N, 50N, 55N	179 to 201
<b>Band 1</b>		
140 W	85S, 75S, 65S, 55S, 50S, 45S, ..., 45N, 50N, 55N, 65N, 75N	1 to 28
135 W	55S, 50S, 45S, ..., 45N, 50N, 55N	29 to 51
130 W	75S, 65S, 55S, 50S, 45S, ..., 45N, 50N, 55N, 65N, 75N	52 to 78
125 W	55S, 50S, 45S, ..., 45N, 50N, 55N	79 to 101
120 W	75S, 65S, 55S, 50S, 45S, ..., 45N, 50N, 55N, 65N, 75N	102 to 128
115 W	55S, 50S, 45S, ..., 45N, 50N, 55N	129 to 151
110 W	75S, 65S, 55S, 50S, 45S, ..., 45N, 50N, 55N, 65N, 75N	152 to 178
105 W	55S, 50S, 45S, ..., 45N, 50N, 55N	179 to 201
<b>Band 2</b>		
100 W	75S, 65S, 55S, 50S, 45S, ..., 45N, 50N, 55N, 65N, 75N	1 to 27
95 W	55S, 50S, 45S, ..., 45N, 50N, 55N	28 to 50
90 W	75S, 65S, 55S, 50S, 45S, ..., 45N, 50N, 55N, 65N, 75N, 85N	51 to 78
85 W	55S, 50S, 45S, ..., 45N, 50N, 55N	79 to 101
80 W	75S, 65S, 55S, 50S, 45S, ..., 45N, 50N, 55N, 65N, 75N	102 to 128
75 W	55S, 50S, 45S, ..., 45N, 50N, 55N	129 to 151
70 W	75S, 65S, 55S, 50S, 45S, ..., 45N, 50N, 55N, 65N, 75N	152 to 178
65 W	55S, 50S, 45S, ..., 45N, 50N, 55N	179 to 201
<b>Band 3</b>		
60 W	75S, 65S, 55S, 50S, 45S, ..., 45N, 50N, 55N, 65N, 75N	1 to 27
55 W	55S, 50S, 45S, ..., 45N, 50N, 55N	28 to 50
50 W	85S, 75S, 65S, 55S, 50S, 45S, ..., 45N, 50N, 55N, 65N, 75N	51 to 78
45 W	55S, 50S, 45S, ..., 45N, 50N, 55N	79 to 101
40 W	75S, 65S, 55S, 50S, 45S, ..., 45N, 50N, 55N, 65N, 75N	102 to 128
35 W	55S, 50S, 45S, ..., 45N, 50N, 55N	129 to 151
30 W	75S, 65S, 55S, 50S, 45S, ..., 45N, 50N, 55N, 65N, 75N	152 to 178
25 W	55S, 50S, 45S, ..., 45N, 50N, 55N	179 to 201
<b>Band 4</b>		
20 W	75S, 65S, 55S, 50S, 45S, ..., 45N, 50N, 55N, 65N, 75N	1 to 27
15 W	55S, 50S, 45S, ..., 45N, 50N, 55N	28 to 50
10 W	75S, 65S, 55S, 50S, 45S, ..., 45N, 50N, 55N, 65N, 75N	51 to 77
5 W	55S, 50S, 45S, ..., 45N, 50N, 55N	78 to 100
0	75S, 65S, 55S, 50S, 45S, ..., 45N, 50N, 55N, 65N, 75N, 85N	101 to 128
5 E	55S, 50S, 45S, ..., 45N, 50N, 55N	129 to 151
10 E	75S, 65S, 55S, 50S, 45S, ..., 45N, 50N, 55N, 65N, 75N	152 to 178
15 E	55S, 50S, 45S, ..., 45N, 50N, 55N	179 to 201

**Table 14. Ionospheric Mask Bands (Continued)**

		IGP Number
<b>Band 5</b>		
20 E	75S, 65S, 55S, 50S, 45S, ..., 45N, 50N, 55N, 65N, 75N	1 to 27
25 E	55S, 50S, 45S, ..., 45N, 50N, 55N	28 to 50
30 E	75S, 65S, 55S, 50S, 45S, ..., 45N, 50N, 55N, 65N, 75N	51 to 77
35 E	55S, 50S, 45S, ..., 45N, 50N, 55N	78 to 100
40 E	85S, 75S, 65S, 55S, 50S, 45S, ..., 45N, 50N, 55N, 65N, 75N	101 to 128
45 E	55S, 50S, 45S, ..., 45N, 50N, 55N	129 to 151
50 E	75S, 65S, 55S, 50S, 45S, ..., 45N, 50N, 55N, 65N, 75N	152 to 178
55 E	55S, 50S, 45S, ..., 45N, 50N, 55N	179 to 201
<b>Band 6</b>		
60 E	75S, 65S, 55S, 50S, 45S, ..., 45N, 50N, 55N, 65N, 75N	1 to 27
65 E	55S, 50S, 45S, ..., 45N, 50N, 55N	28 to 50
70 E	75S, 65S, 55S, 50S, 45S, ..., 45N, 50N, 55N, 65N, 75N	51 to 77
75 E	55S, 50S, 45S, ..., 45N, 50N, 55N	78 to 100
80 E	75S, 65S, 55S, 50S, 45S, ..., 45N, 50N, 55N, 65N, 75N	101 to 127
85 E	55S, 50S, 45S, ..., 45N, 50N, 55N	128 to 150
90 E	75S, 65S, 55S, 50S, 45S, ..., 45N, 50N, 55N, 65N, 75N, 85N	151 to 178
95 E	55S, 50S, 45S, ..., 45N, 50N, 55N	179 to 201
<b>Band 7</b>		
100 E	75S, 65S, 55S, 50S, 45S, ..., 45N, 50N, 55N, 65N, 75N	1 to 27
105 E	55S, 50S, 45S, ..., 45N, 50N, 55N	28 to 50
110 E	75S, 65S, 55S, 50S, 45S, ..., 45N, 50N, 55N, 65N, 75N	51 to 77
115 E	55S, 50S, 45S, ..., 45N, 50N, 55N	78 to 100
120 E	75S, 65S, 55S, 50S, 45S, ..., 45N, 50N, 55N, 65N, 75N	101 to 127
125 E	55S, 50S, 45S, ..., 45N, 50N, 55N	128 to 150
130 E	85S, 75S, 65S, 55S, 50S, 45S, ..., 45N, 50N, 55N, 65N, 75N	151 to 178
135 E	55S, 50S, 45S, ..., 45N, 50N, 55N	179 to 201
<b>Band 8</b>		
140 E	75S, 65S, 55S, 50S, 45S, ..., 45N, 50N, 55N, 65N, 75N	1 to 27
145 E	55S, 50S, 45S, ..., 45N, 50N, 55N	28 to 50
150 E	75S, 65S, 55S, 50S, 45S, ..., 45N, 50N, 55N, 65N, 75N	51 to 77
155 E	55S, 50S, 45S, ..., 45N, 50N, 55N	78 to 100
160 E	75S, 65S, 55S, 50S, 45S, ..., 45N, 50N, 55N, 65N, 75N	101 to 127
165 E	55S, 50S, 45S, ..., 45N, 50N, 55N	128 to 150
170 E	75S, 65S, 55S, 50S, 45S, ..., 45N, 50N, 55N, 65N, 75N	151 to 177
175 E	55S, 50S, 45S, ..., 45N, 50N, 55N	178 to 200



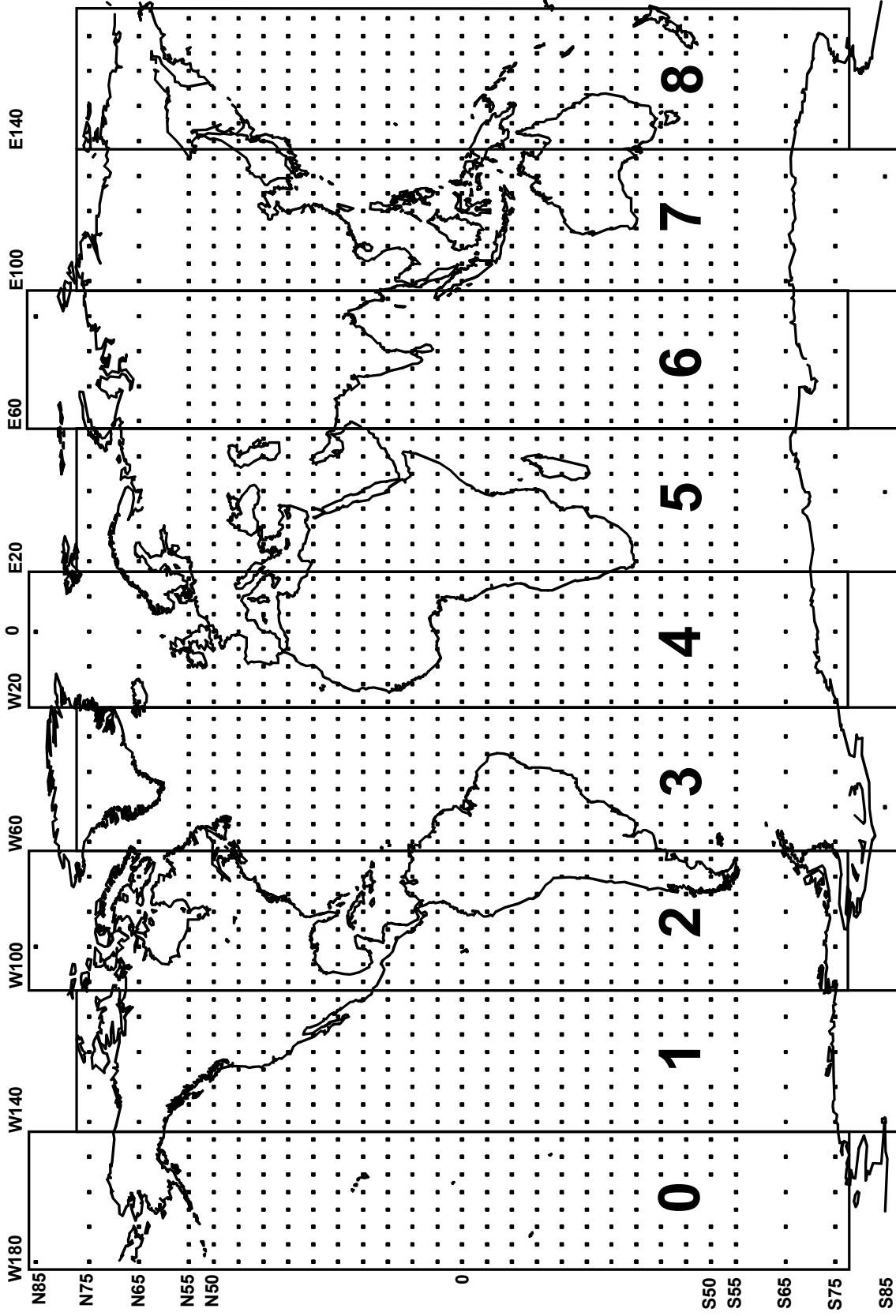

Figure 17. Predefined Global IGP Grid

#### 4.4.10 Ionospheric Delay Corrections Messages Type 26

The Type 26 Ionospheric delay Corrections Message provides the users with vertical delays (relative to an L1 signal) and their 99.9% accuracy (via  $\sigma^2_{GIVE's}$ ) at geographically defined IGP's identified by IGP number in Table 14. The grid points are indicated in Figure 17.

Each message contains a band number and a block ID, which indicates the location of the IGP's in the respective band mask. The 4-bit block ID (0-13) indicates to which IGP's the corrections apply. Block 0 contains the IGP corrections for the first 15 IGP's designated in the band mask. Block 1 contains the IGP corrections for IGP's 16 - 30 designated in the band mask, etc. Each band is therefore divided into a maximum of 14 blocks. Corrections associated with slot numbers that exceed the number of IGP's indicated in the IGP band mask should be ignored. The data content for this message is given in Table 15 with a format presented in Figure 18. The evaluation of the  $\sigma^2_{GIVE's}$  is given in Table 16. These vertical delays and the evaluated  $\sigma^2_{GIVE's}$  will be translated by the user to the IPP of the observed satellite. This computed vertical delay and the associated  $\sigma^2_{UIVE}$  (model variance for user ionospheric vertical error computed from associated  $\sigma^2_{GIVE's}$ ) must then be multiplied by the obliquity factor computed from the elevation angle to the satellite to obtain a slant range correction and the slant range correction error ( $\sigma^2_{UIRE}$ ).

**Table 15. Ionospheric Delay Model Parameters for Message Type 26**

Parameter	No. of Bits	Scale Factor (LSB)	Effective Range	Units
Band Number	4	1	0 to 8	<a href="#">discreteunitless</a>
Block ID	4	1	0 to 13	<a href="#">discreteunitless</a>
For Each of 15 Grid Points	13	---	---	---
IGP Vertical Delay Estimate	9	0.125	0 to 63.875	meters
Grid Ionospheric Vertical Error Indicator (GIVEI)	4	1	0 to 15	<a href="#">discreteunitless</a>
IODI	2	1	0 to 3	<a href="#">discreteunitless</a>
Spare	7	---	---	---

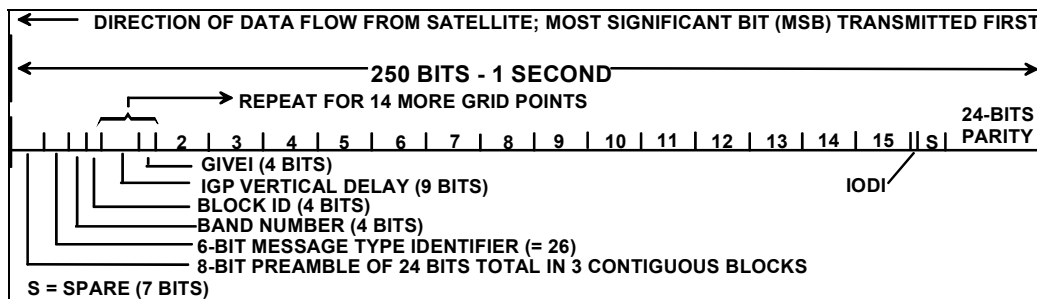

**Figure 18. Type 26 Ionospheric Delay Corrections Message Format**

**Table 16. Evaluation of  $GIVE_j$**

$GIVE_j$	$GIVE_j$ Meters	$\sigma^2_{i,GIVE}$ Meters <sup>2</sup>
0	0.3	0.0084
1	0.6	0.0333
2	0.9	0.0749
3	1.2	0.1331
4	1.5	0.2079
5	1.8	0.2994
6	2.1	0.4075
7	2.4	0.5322
8	2.7	0.6735
9	3.0	0.8315
10	3.6	1.1974
11	4.5	1.8709
12	6.0	3.3260
13	15.0	20.7870
14	45.0	187.0826
15	Not Monitored	Not Monitored

The 9-bit IGP vertical delays have a 0.125 meter resolution, for a 0 to 63.750 meter valid range. A vertical delay of 63.875 meters (11111111) shall indicate Don't Use. That is, there are no IGP vertical delays greater than 63.750 meters. If that range is exceeded, a Don't Use indication shall be used.

**4.4.10.1 Pierce Point Location Determination**

Considering the satellite and user locations, the user must first determine the location of the ionospheric pierce point of the signal path from the satellite. The following equations provide the latitude and longitude of that pierce point. First, the latitude is computed as:

$$\phi_{pp} = \sin^{-1}(\sin \phi_u \cos \psi_{pp} + \cos \phi_u \sin \psi_{pp} \cos A) \text{ radians} \quad 11)$$

where, as illustrated in Figure 17,  $\psi_{pp}$  is the earth's central angle between the user position and the earth projection of the pierce point computed as:

$$\psi_{pp} = \frac{\pi}{2} - E - \sin^{-1}\left(\frac{R_e}{R_e + h_l} \cos E\right) \text{ radians} \quad 12)$$

$A$  and  $E$  are the azimuth and elevation angles of the satellite from the user's location ( $\phi_u, \lambda_u$ ) measured with respect to the local-tangent-plane,  $R_e$  is the approximate radius of the earth's

ellipsoid (taken to be 6378.1363 km), and  $h_I$  is the height of the maximum electron density (assumed to be equal to 350 kilometers). The longitude of the pierce point is then:

$$\lambda_{pp} = \lambda_u + \sin^{-1} \left( \frac{\sin \psi_{pp} \sin A}{\cos \phi_{pp}} \right) \text{ radians} \quad 13)$$

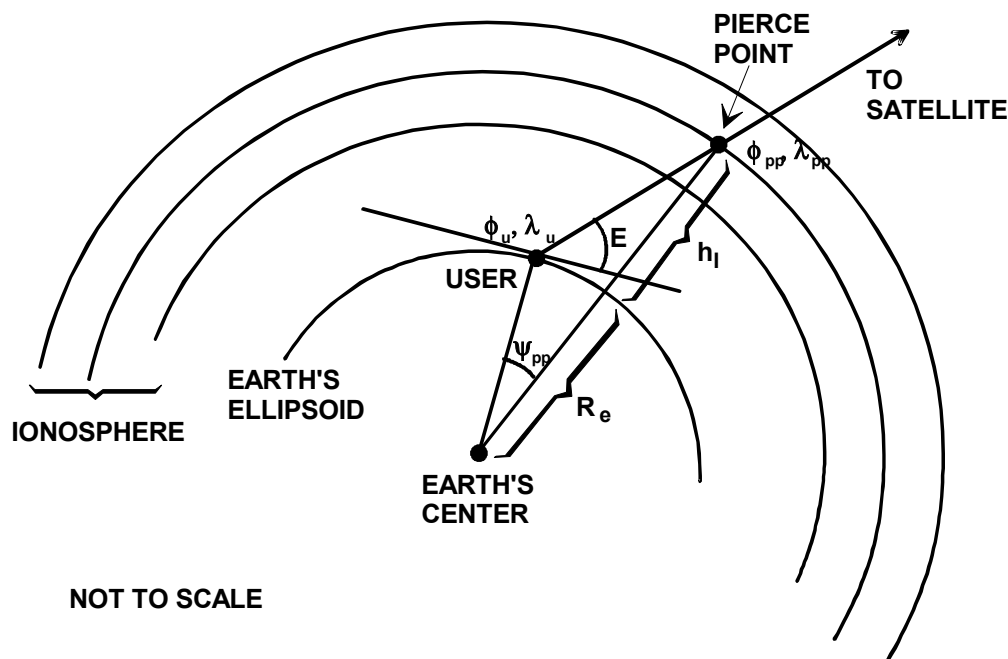

Figure 19. Ionospheric Pierce Point Geometry

#### 4.4.10.2 Selection of Ionospheric Grid Points

After determining the location of the user ionospheric pierce point, the user must select the IGPs to be used to interpolate the ionospheric correction and model variance. This selection is done based only on the information provided in the mask, and must be done without regard to whether or not the selected IGPs are monitored, not monitored, or don't use.

The selection of IGPs is accomplished as follows.

- 1) If the IPP is between N55° and S55°, the following algorithm is used to identify the IGPs:
  - a) four IGPs that define a 5 degree x 5 degree cell around the IPP are selected if the associated bits are set to one in the band mask; else,
  - b) three IGPs that define a 5 degree x 5 degree triangle that circumscribes the IPP are selected (see [Figure 20](#)) if the associated bits are set to one in the band mask; else,
  - c) no ionospheric corrections are available.
  
- 2) If the IPP is between N55° and N75°, or between S55° and S75°, the following algorithm is used to identify the IGPs:
  - a) four IGPs that define a 10 degree x 10 degree cell around the IPP are selected if the associated bits are set to one in the band mask; else,

- b) three IGPs that define a 10 degree x 10 degree triangle that circumscribes the IPP are selected if the associated bits are set to one in the band mask; else,
  - c) no ionospheric corrections are available.
- 3) If the IPP is between N75° and N85°, or between S75° and S85°, no ionospheric corrections are available.
- 4) If the IPP is north of N85° or south of S85°, no ionospheric corrections are available.

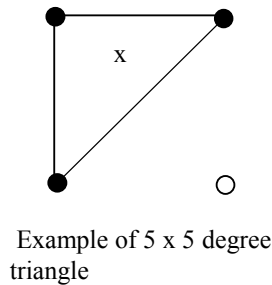

**Figure 20 Ionospheric Grid Point Interpolation**

**4.4.10.3 Ionospheric Pierce Point Vertical Delay and Model Variance Interpolation**

Although the data broadcast to the user is in the form of vertical IGP delays, these points do not generally correspond with the user’s computed ionospheric pierce point locations. Thus, it is necessary for the user to interpolate from the broadcast IGP delays to that at his computed ionospheric pierce point locations. Given three or four nodes of a cell of the IGP grid described above that surround the user's ionospheric pierce point to a satellite, the user can interpolate from those nodes to his pierce point using the algorithm described below.

The IGPs as selected as described in section 4.4.10.2 must be used for interpolation, with one exception. If four IGPs were selected, and one of the four is identified as “not monitored”, then the three-point interpolation should be used if the user’s pierce point is within the triangular region covered by the three corrections that are provided. If one of the four is identified as “don’t use”, the entire square must not be used.

For four-point interpolation, the mathematical formulation for interpolated vertical ionospheric pierce point delay  $\tau_{vpp}(\phi_{pp}, \lambda_{pp})$  as a function of ionospheric pierce point latitude  $\phi_{pp}$  and longitude  $\lambda_{pp}$  is:

$$\tau_{vpp}(\phi_{pp}, \lambda_{pp}) = \sum_{i=1}^4 W_i(x_{pp}, y_{pp}) \tau_{vi} \tag{14}$$

where the general equation for the weighting function is:

$$f(x, y) = xy \quad 15)$$

and  $\tau_{vi}$  are the broadcast pierce point vertical delay values at three or four corners of the IGP grid, as shown in Figure 20. In particular,  $\tau_{vpp}$  is the output value at desired pierce point  $pp$ , whose geographical coordinates are  $\phi_{pp}, \lambda_{pp}$

$$W_1(x, y) = f(x, y) \quad 16)$$

$$W_2(x, y) = f(1-x, y) \quad 17)$$

$$W_3(x, y) = f(1-x, 1-y) \quad 18)$$

$$W_4(x, y) = f(x, 1-y) \quad 19)$$

$$\Delta\lambda_{pp} = \lambda_{pp} - \lambda_1 \quad 20)$$

$$\Delta\phi_{pp} = \phi_{pp} - \phi_1 \quad 21)$$

For IPPs between N75° and S75°,

$$x_{pp} = \frac{\Delta\lambda_{pp}}{\lambda_2 - \lambda_1} \quad 22)$$

$$y_{pp} = \frac{\Delta\phi_{pp}}{\phi_2 - \phi_1} \quad 23)$$

As can be seen from Equations 15 and 16, this interpolation technique involves only simple algebra, and provides a continuous surface.

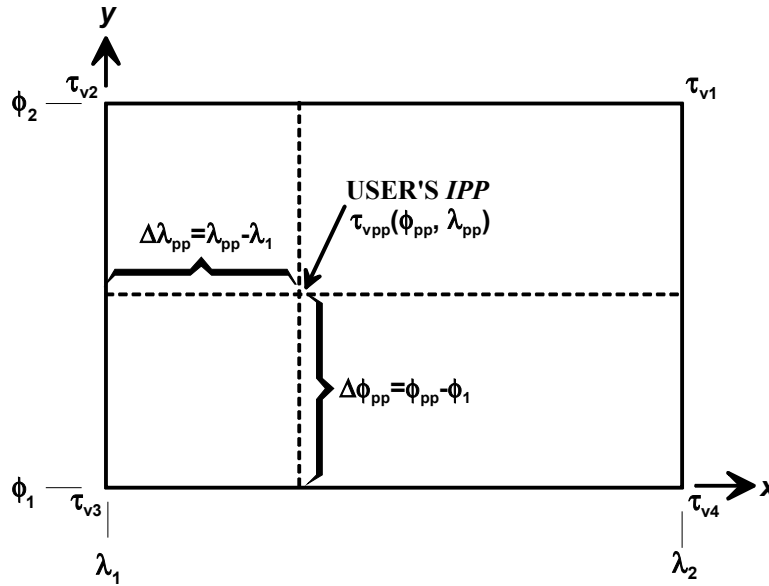

**Figure 21. Four-Point Interpolation Algorithm Definitions**

For three-point interpolation between 75°S and 75°N, a similar algorithm is used:

$$\tau_{vpp}(\phi_{pp}, \lambda_{pp}) = \sum_{i=1}^3 W_i(x_{pp}, y_{pp}) \tau_{vi} \quad 24)$$

$$W_1(x, y) = f(1, y) \quad 25)$$

$$W_2(x, y) = f(1, 1 - x - y) \quad 26)$$

$$W_3(x, y) = f(x, 1) \quad 27)$$

The pierce points are numbered as shown in Figure 22, so that grid point #2 is always the vertex opposite the hypotenuse and the distance-ratios (x, y) are always determined relative to the distance to grid point #2. It should be noted that there are an additional three orientations of the triangle shown in Figure 22.

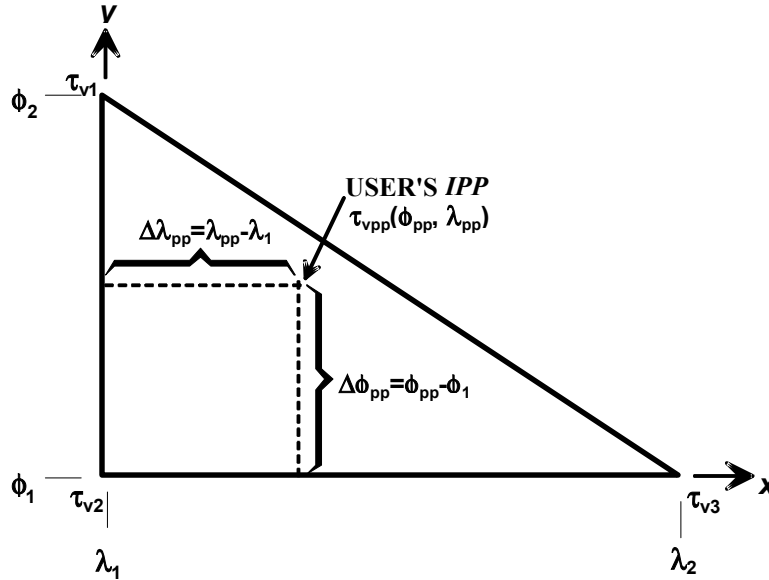

**Figure 22 Three-Point Interpolation Algorithm Definitions**

The UIVE will be interpolated by the users from the GIVEs defined at the IGP's to the IPP as follows:

$$UIVE = \sum_{n=1}^4 W_n(x_{pp}, y_{pp}) \cdot GIVE_n \quad (28)$$

or

$$UIVE = \sum_{n=1}^3 W_n(x_{pp}, y_{pp}) \cdot GIVE_n \quad (29)$$

#### 4.4.10.4 Computing Slant Ionospheric Delay and Ionospheric Model Variance

Once the user establishes the vertical delay at the pierce point, the user can then multiply that vertical delay by the obliquity factor  $F_{pp}$  to obtain the ionospheric correction ( $IC_i$ ) to be added to the pseudorange measurement:

$$IC_i = -\tau_{spp}(\lambda_{pp}, \phi_{pp}) = -F_{pp} \cdot \tau_{vpp}(\lambda_{pp}, \phi_{pp}) \quad (30)$$

where  $\tau_{vpp}$  is the interpolated vertical delay at the user-to-satellite ionospheric pierce point derived as described above, and

$$F_{pp} = \left[ 1 - \left( \frac{R_e \cos E}{R_e + h_I} \right)^2 \right]^{-\frac{1}{2}} \quad (31)$$

The  $\sigma_{UIRE}^2$  is computed as:

$$\sigma_{UIRE}^2 = F_{pp}^2 \cdot \sigma_{UIVE}^2 \quad (32)$$



where  $\sigma_{UIVE}^2$  is the variance of the UIVE.

#### 4.4.11 GEO Navigation Message Type 9

Table 17 and Figure 22-23 present the Type 9 GEO Navigation Message representing the position, velocity, and acceleration of the geostationary satellite in ECEF coordinates, and its apparent clock time and frequency offsets. Also included is the time of applicability  $t_0$ , an Issue of Data (IOD) and an accuracy exponent (URA) representing the estimated accuracy of the message.  $a_{Gf0}$  and  $a_{Gf1}$  shall be an estimate of the time offset and drift with respect to WAAS Network Time. Their combined effect shall be added to the estimate of the satellite's transmit time.

The position and time of the GEO shall be propagated to time-of-day  $t_k$ , corrected for end-of-day cross-over, as:

$$\begin{bmatrix} X_{Gk} \\ Y_{Gk} \\ Z_{Gk} \end{bmatrix} = \begin{bmatrix} X_G \\ Y_G \\ Z_G \end{bmatrix} + \begin{bmatrix} \dot{X}_G \\ \dot{Y}_G \\ \dot{Z}_G \end{bmatrix} (t_k - t_0) + \frac{1}{2} \begin{bmatrix} \ddot{X}_G \\ \ddot{Y}_G \\ \ddot{Z}_G \end{bmatrix} (t_k - t_0)^2 \quad 33)$$

and

$$t_G(t_k) = t_G + \Delta t_G(t_k) = t_G + a_{Gf0} + a_{Gf1}(t_k - t_0) \quad 34)$$

where  $t_0$  is the time ~~after midnight of the current day~~ of applicability of the message. The ranges of the parameters in this message allow for GEO inclination angles of up to  $\pm 8^\circ$ .

In contrast to the time correction for GPS satellites, there is no user correction for general relativity to GEO time. Any general relativity effects will be removed by the earth station controlling the GEO signal.

Table 17. Type 9 GEO Navigation Message Parameters

Parameter	No. of Bits*	Scale Factor (LSB)	Effective Range	Units
Issue of Data	8	1	0 to 255	discrete/unitless
$t_0$ (Time-of-Applicability)	13	16	0 to 86,384	seconds
User Range Accuracy (URA)**	4	**	**	**
$X_G$ (ECEF)	30*	0.08	$\pm 42,949,673$	meters
$Y_G$ (ECEF)	30*	0.08	$\pm 42,949,673$	meters
$Z_G$ (ECEF)	25*	0.4	$\pm 6,710,886.4$	meters
$X_G$ Rate-of-Change	17*	0.000625	$\pm 40.96$	meters/sec
$Y_G$ Rate-of-Change	17*	0.000625	$\pm 40.96$	meters/sec
$Z_G$ Rate-of-Change	18*	0.004	$\pm 524.288$	meters/sec
$X_G$ Acceleration	10*	0.0000125	$\pm 0.0064$	meters/sec <sup>2</sup>
$Y_G$ Acceleration	10*	0.0000125	$\pm 0.0064$	meters/sec <sup>2</sup>
$Z_G$ Acceleration	10*	0.0000625	$\pm 0.032$	meters/sec <sup>2</sup>
$a_{Gf0}$	12*	$2^{-31}$	$\pm 0.9537 \times 10^{-6}$	seconds
$a_{Gf1}$	8*	$2^{-40}$	$\pm 1.1642 \times 10^{-10}$	seconds/sec

\* Parameters so indicated will be two's complement, with the sign bit occupying the MSB. The effective range is smaller than indicated, as the maximum positive value is actually constrained to be one value less (the indicated value minus the resolution).

\*\* See Section 2.5.3 of [1].

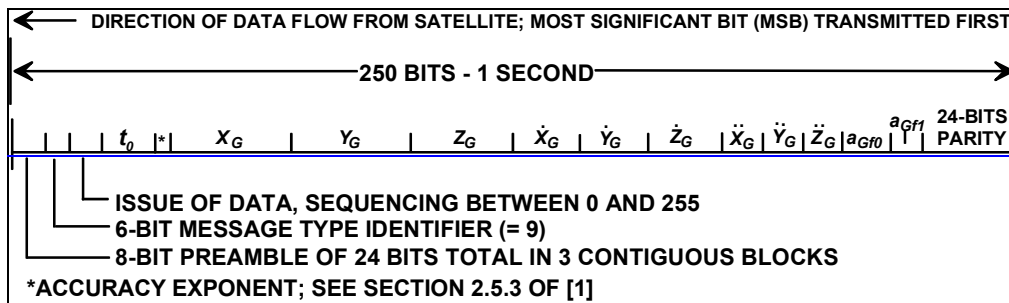

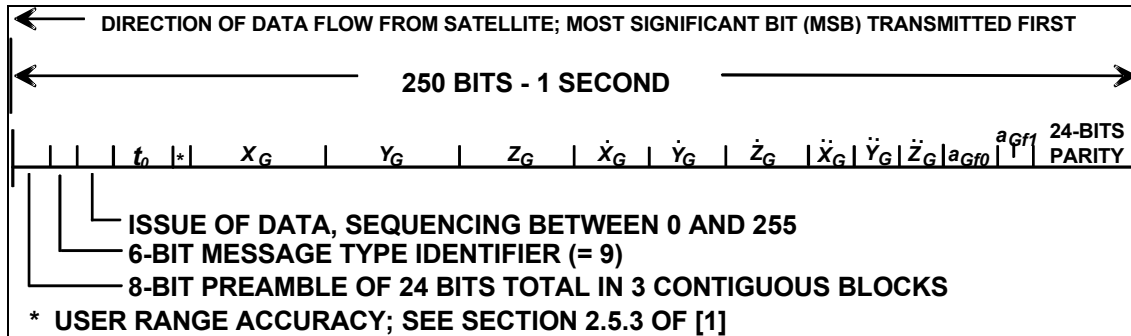

Figure 23. Type 9 GEO Navigation Message Format

4.4.12 GEO Almanacs Message Type 17

Almanacs for all GEOs shall be broadcast periodically to alert the user of their existence, location, the general service provided, and health and status. Almanacs for three satellites shall be broadcast in the GEOs Almanacs Message Type 17 illustrated in Figure 23 and defined in Table 18. These messages shall be repeated to include all GEOs. Unused almanacs shall have a PRN number of 0 and should be ignored.

Table 18. Type 17 GEO Almanacs Message Parameters

Parameter	No. of Bits*	Scale Factor (LSB)	Effective Range	Units
For each of 3 satellites	67	--	--	--
Data ID	2	1	0 to 3	discrete/unitless
PRN Number	8	1	0 - 210	--
Health	8	--	-	discrete/unitless
$X_G$ (ECEF)	15*	2,600	$\pm 42,595,800$	meters
$Y_G$ (ECEF)	15*	2,600	$\pm 42,595,800$	meters
$Z_G$ (ECEF)	9*	26,000	$\pm 6,630,000$	meters
$X_G$ Rate-of-Change	3*	10	$\pm 40$	meters/sec
$Y_G$ Rate-of-Change	3*	10	$\pm 40$	meters/sec
$Z_G$ Rate-of-Change	4*	40.96	$\pm 327.68$	meters/sec
t0 (Time-of-Day)	11	64	0 to 86,336	seconds

\*Parameters so indicated will be two's complement, with the sign bit occupying the MSB. The effective range is smaller than indicated, as the maximum positive value is actually constrained to be one value less (the indicated value minus the resolution).

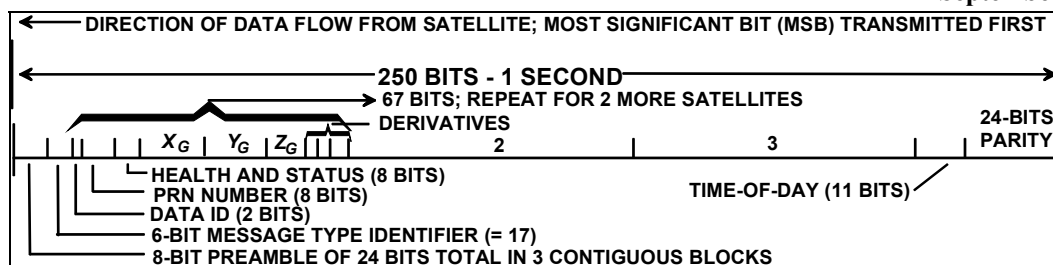

**Figure 24. Type 17 GEO Almanacs Message Format**

The position of a GEO using the parameters of Table 18 shall be evaluated using Equations 33 and 34 with the acceleration components set to 0 and  $t_0$  set to the time-of-day as given in the message.

The Data ID for the current Signal Specification format is 00. Other states of the data ID are reserved for the possibility of future Signal Specification formats.

The health bits are defined as follows:

Bit 0 (LSB)	Ranging On (0), Off (1)
Bit 1	Corrections On (0), Off (1)
Bit 2	Broadcast Integrity On (0), Off (1)
Bit 3	Reserved
Bit 4-7	0

Note that if all bits are 0, the Health and Status are OK for all functions.

#### 4.4.13 Null Message Type 63

The Null Message Type 63 shall be used by the WAAS Ground Earth Station as a filler message if no other message is available for broadcast for the one-second time slot. The user will ignore the data in the Type 63 Message but continue to use the ranging capabilities.

#### 4.4.14 Internal Test Type 62

The Internal Test Type 62 shall be used by the WAAS for testing. The user will ignore the data in the Type 62 message, but will continue to use the ranging capabilities.

#### 4.4.15 WAAS Network Time/UTC Offset Parameters Message Type 12

Message Type 12 shall consist of the 8-bit preamble, a 6-bit message type identifier (=12) followed by 104 information bits for the UTC parameters, then followed by 3 bits to indicate the UTC time standard from which the offset is determined. The next 20 bits are the Time of Week (TOW) in seconds of the beginning of the message, followed by a 10 bit GPS Week number (WN) as defined in Section 2.4.3.1 of [1]. The final 75 bits are spare bits. Table 19 defines the UTC parameters along with the other 33 bits defined above. The definition of the parameters and the applicable algorithms are in Sections 2.4.5.5 and 2.5.6 of [1], with the exception that the UTC parameters shall correlate UTC time with the WAAS network time

rather than with GPS time. The UTC standard which is used is indicated by the three bits following the 104-bit offset data, and shall be interpreted in Table 20.

**Table 19. WAAS Network Time/UTC Parameters**

Parameter	No. of Bits*	Scale Factor (LSB)	Effective Range	Units
$A_{1WNT}$	24*	$2^{-50}$	$\pm 7.45 \times 10^{-9}$	seconds/second
$A_{0WNT}$	32*	$2^{-30}$	$\pm 1$	seconds
$t_{0t}$	8	$2^{12}$	602112	seconds
$WN_t$	8	1	0 to 255	weeks
$\Delta t_{LS}$	8*	1	$\pm 127$	seconds
$WN_{LSF}$	8	1	0 to 255	weeks
$DN$	8**	1	7	days
$\Delta t_{LSF}$	8*	1	$\pm 127$	seconds
UTC Standard Identifier	3	--	--	<a href="#">discrete unitless</a>
GPS Time-of-Week – $TOW$	20	1	604,799	seconds
GPS Week Number	10	1	0 to 1023	weeks
Spare	75	--	--	--

\* Parameters so indicated will be two's complement, with the sign bit occupying the MSB.

\*\* Right Justified.

**Table 20. UTC Standard Identifiers**

UTC Identifier	UTC Standard
0	UTC as operated by the Communications Research Laboratory (CRL), Tokyo, Japan
1	UTC as operated by the National Institute of Standards and Technology (NIST)
2	UTC as operated by the U. S. Naval Observatory (USNO)
3	UTC as operated by the International Bureau of Weights and Measures (BIPM)
4-7	Reserved for future definition

**4.4.16 Degradation Parameters - Message Type 10**

The degradation parameters are described in Table 21. These parameters are used as described in Section 4.5.

**Table-Table 21 TYPE-Type 10 DEGRADATION-Degradation PARAMETERSParameters**

Parameter	No. of Bits	Scale Factor (LSB)	Effective Range	Units
$B_{rrc}$	10	0.002	0 to 2.046	m
$C_{lte\_lsb}$	10	0.002	0 to 2.046	m

$C_{ltc\_v1}$	10	0.00005	0 to 0.05115	m/s
$I_{ltc\_v1}$	9	1	0 to 511	s
$C_{ltc\_v0}$	10	0.002	0 to 2.046	m
$I_{ltc\_v0}$	9	1	0 to 511	s
$C_{geo\_lsb}$	10	0.0005	0 to 0.5115	m
$C_{geo\_v}$	10	0.00005	0 to 0.05115	m/s
$I_{geo}$	9	1	0 to 511	s
$C_{er}$	6	0.5	0 to 31.5	m
$C_{iono\_step}$	10	0.001	0 to 1.023	m
$I_{iono}$	9	1	0 to 511	s
$C_{iono\_ramp}$	10	0.000005	0 to 0.005115	m/s
$RSS_{UDRE}$	1	—	0 to 1	discreteunitless
$RSS_{iono}$	1	—	0 to 1	Discreteunitless
$C_{covariance}$	7	0.1	0 to 12.7	discreteunitless
Spare	8881	—	—	—

Note:       —The spare bits may be used to define degradation parameters applicable to GLONASS satellites.

#### 4.4.17 Clock-Ephemeris Covariance Matrix Message Type 28

Message Type 28 may be broadcast to provide the relative covariance matrix for clock and ephemeris errors. This is an expansion of the information contained in the  $\sigma_{UDRE}$  in that it specifies the correction confidence as a function of user location. Message Type 28 provides increased availability inside the service volume and increased integrity outside.

The covariance matrix is a function of satellite location, reference station observational geometry, and reference station measurement confidence. Consequently, it is a slowly changing function of time. Each covariance matrix only needs to be updated on the same order as the long term corrections. Each message is capable of containing relative covariance matrices for two satellites. This maintains the real-time six-second updates of integrity and scales the matrix to keep it within a reasonable dynamic range.

Cholesky factorization is used to reliably compress the information in the covariance matrix,  $C$ . The matrix Cholesky factor is an upper triangular matrix,  $R$ . This information can be used to reconstruct the relative covariance matrix as  $R^T R = C$ , where the superscript T denotes the matrix transpose. This factorization guarantees that the received covariance matrix remains positive-definite despite quantization errors. Because  $R$  is upper triangular, it contains only 10 non-zero elements for each satellite. These 10 elements are divided by a scale factor (SF) to determine the matrix,  $E$ , and broadcast in half of Message Type 28. The elements of  $R$  can be written as shown in equation 35.

$$\underline{R = E \cdot SF,} \quad E = \begin{bmatrix} E_{1,1} & E_{1,2} & E_{1,3} & E_{1,4} \\ 0 & E_{2,2} & E_{2,3} & E_{2,4} \\ 0 & 0 & E_{3,3} & E_{3,4} \\ 0 & 0 & 0 & E_{4,4} \end{bmatrix} \quad \underline{35)}$$

and  $SF = 2^{(\text{scale exponent} - 5)}$

The relative clock-ephemeris correction covariance is reconstructed as shown in equation 36.

$$\underline{C = R^T \cdot R} \quad \underline{36)}$$

The covariance matrix is used to modify the broadcast UDRE values as a function of user position. The location-specific modifier is specified by equation 37.

$$\underline{\delta UDRE = \sqrt{I^T \cdot C \cdot I} + \epsilon_c} \quad \underline{37)}$$

where I is the 4-D line of sight vector, where the first three components are the unit vector from the user to the satellite in the WGS-84 coordinate frame and the fourth component is a one. The additional term  $\epsilon_c$  is to compensate for the errors introduced by quantization. The  $\epsilon_c$  value is derived from  $C_{\text{covariance}}$  (broadcast in a Type 10 message) as shown in equation 38.

$$\underline{\epsilon_c = C_{\text{covariance}} \cdot SF} \quad \underline{38)}$$

The  $\delta UDRE$  is used in equation 39.

Figure 25 and Table 22 present Type 28 message contents representing the Cholesky factor of the clock-ephemeris covariance matrix for two PRN codes. The covariance matrices are accompanied by the IODP associated with the PRN mask. Refer to Section A.4.4.2 for the application of IODP.

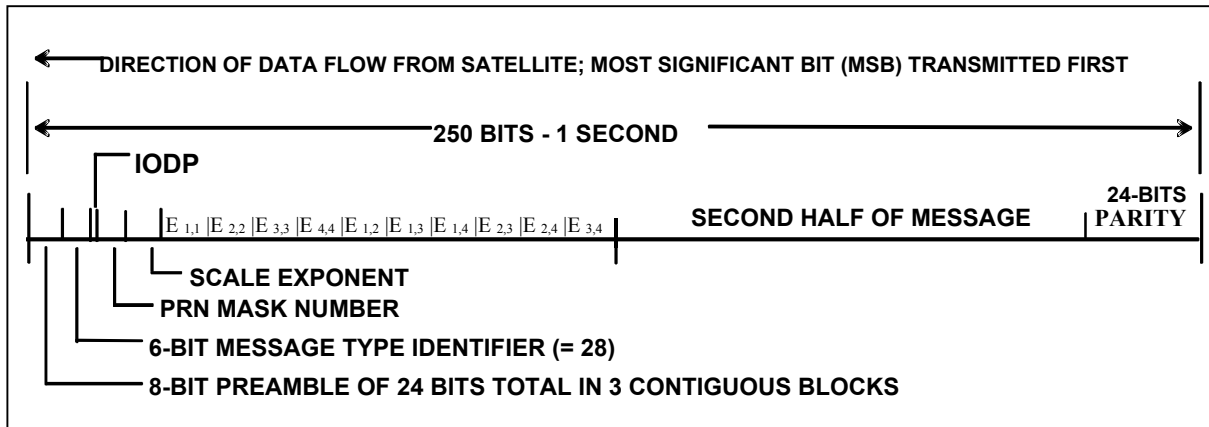

**Figure 25. Type 28 Clock-Ephemeris Covariance Matrix Message Format**

The PRN Mask No. is the sequence number of the bits set in the 210 bit mask (that is, between 1 and 51). The data in this Type 28 message does not have to appear in sequence. The IODP of the message must agree with the IODP associated with the PRN mask in Message Type 1.

Figure 25 shows the Type 28 message contents. There is a single IODP, which will apply to both matrices broadcast in the message. The remainder of the 212 data bits is divided in two matrices for two satellites.



**Table 22. Type 28 Clock-Ephemeris Covariance Matrix Message Parameters**

Parameter	No. of Bits (Note 1)	Scale Factor (LSB)	Effective Range (Note 1)	Units
<u>IODP</u>	<u>2</u>	<u>1</u>	<u>0 to 3</u>	<u>Discreteunitless</u>
<u>PRN Mask No.(Note 2)</u>	<u>6</u>	<u>1</u>	<u>0 to 51</u>	<u>---</u>
<u>Scale exponent</u>	<u>3</u>	<u>1</u>	<u>0 to 7</u>	<u>Discreteunitless</u>
<u>E<sub>1,1</sub></u>	<u>9</u>	<u>1</u>	<u>0 to 511</u>	<u>Discreteunitless</u>
<u>E<sub>2,2</sub></u>	<u>9</u>	<u>1</u>	<u>0 to 511</u>	<u>Discreteunitless</u>
<u>E<sub>3,3</sub></u>	<u>9</u>	<u>1</u>	<u>0 to 511</u>	<u>Discreteunitless</u>
<u>E<sub>4,4</sub></u>	<u>9</u>	<u>1</u>	<u>0 to 511</u>	<u>Discreteunitless</u>
<u>E<sub>1,2</sub></u>	<u>10</u>	<u>1</u>	<u>±512</u>	<u>Discreteunitless</u>
<u>E<sub>1,3</sub></u>	<u>10</u>	<u>1</u>	<u>±512</u>	<u>Discreteunitless</u>
<u>E<sub>1,4</sub></u>	<u>10</u>	<u>1</u>	<u>±512</u>	<u>Discreteunitless</u>
<u>E<sub>2,3</sub></u>	<u>10</u>	<u>1</u>	<u>±512</u>	<u>Discreteunitless</u>
<u>E<sub>2,4</sub></u>	<u>10</u>	<u>1</u>	<u>±512</u>	<u>Discreteunitless</u>
<u>E<sub>3,4</sub></u>	<u>10</u>	<u>1</u>	<u>±512</u>	<u>Discreteunitless</u>
<u>PRN Mask No.(Note 2)</u>	<u>6</u>	<u>1</u>	<u>0 to 51</u>	<u>---</u>
<u>Scale exponent</u>	<u>3</u>	<u>1</u>	<u>0 to 7</u>	<u>Discreteunitless</u>
<u>E<sub>1,1</sub></u>	<u>9</u>	<u>1</u>	<u>0 to 511</u>	<u>Discreteunitless</u>
<u>E<sub>2,2</sub></u>	<u>9</u>	<u>1</u>	<u>0 to 511</u>	<u>Discreteunitless</u>
<u>E<sub>3,3</sub></u>	<u>9</u>	<u>1</u>	<u>0 to 511</u>	<u>Discreteunitless</u>
<u>E<sub>4,4</sub></u>	<u>9</u>	<u>1</u>	<u>0 to 511</u>	<u>Discreteunitless</u>
<u>E<sub>1,2</sub></u>	<u>10</u>	<u>1</u>	<u>±512</u>	<u>Discreteunitless</u>
<u>E<sub>1,3</sub></u>	<u>10</u>	<u>1</u>	<u>±512</u>	<u>Discreteunitless</u>
<u>E<sub>1,4</sub></u>	<u>10</u>	<u>1</u>	<u>±512</u>	<u>Discreteunitless</u>
<u>E<sub>2,3</sub></u>	<u>10</u>	<u>1</u>	<u>±512</u>	<u>Discreteunitless</u>
<u>E<sub>2,4</sub></u>	<u>10</u>	<u>1</u>	<u>±512</u>	<u>Discreteunitless</u>
<u>E<sub>3,4</sub></u>	<u>10</u>	<u>1</u>	<u>±512</u>	<u>Discreteunitless</u>

Notes:

- 1) All signed values are coded as two's complement, with the sign bit occupying the MSB. The effective range is smaller than indicated, as the maximum positive value is actually constrained to be one value less (the indicated value minus the resolution).
- 2) Mask sequence. The count of 1's in mask from the first position in mask to the position representing the subject satellite. If set to 0, no satellite is represented and the remainder of the message should be ignored.

## 4.5 Modeling the Degradation of Data

The fast corrections, long-term corrections, and ionospheric corrections are all designed to provide the most recent information to the user. However, there is always the possibility that the user will fail to receive one of these messages, either due to momentary shadowing or a random bit error. In order to guarantee integrity even when some messages are not received, the user [performing a precision approach operation](#) must apply models of the degradation of this information. The system, in turn, will monitor the old data to ensure that it remains valid until it times out. This section describes the degradation of data.

### 4.5.1 Fast and Long-Term Correction Degradation

The residual error associated with the fast and long-term corrections is characterized by the variance ( $\sigma_{flt}^2$ ) of a model distribution. This term is computed as:

$$\sigma_{flt}^2 = \begin{cases} \left( \sigma_{UDRE} + \varepsilon_{fc} + \varepsilon_{rrc} + \varepsilon_{ltc} + \varepsilon_{er} \right)^2 & \text{if } RSS_{UDRE} = 0 \text{ (Message Type 10)} \\ \sigma_{UDRE}^2 + \varepsilon_{fc}^2 + \varepsilon_{rrc}^2 + \varepsilon_{ltc}^2 + \varepsilon_{er}^2, & \text{if } RSS_{UDRE} = 1 \text{ (Message Type 10)} \end{cases} \quad 35)$$

$$\sigma_{flt}^2 = \begin{cases} \left( \sigma_{UDRE} \cdot (\delta_{UDRE}) + \varepsilon_{fc} + \varepsilon_{rrc} + \varepsilon_{ltc} + \varepsilon_{er} \right)^2 & \text{if } RSS_{UDRE} = 0 \text{ (Message Type 10)} \\ \left[ \left( \sigma_{UDRE} \cdot (\delta_{UDRE}) \right)^2 + \varepsilon_{fc}^2 + \varepsilon_{rrc}^2 + \varepsilon_{ltc}^2 + \varepsilon_{er}^2 \right] & \text{if } RSS_{UDRE} = 1 \text{ (Message Type 10)} \end{cases}$$

$$\sigma_{flt}^2 = \begin{cases} \left[ \left( \sigma_{UDRE} \cdot (\delta_{UDRE}) + \varepsilon_{fc} + \varepsilon_{rrc} + \varepsilon_{ltc} + \varepsilon_{er} \right)^2 \right], & \text{if } RSS_{UDRE} = 0 \text{ (Message Type 10)} \\ \left[ \left( \sigma_{UDRE} \cdot (\delta_{UDRE}) \right)^2 + \varepsilon_{fc}^2 + \varepsilon_{rrc}^2 + \varepsilon_{ltc}^2 + \varepsilon_{er}^2 \right], & \text{if } RSS_{UDRE} = 1 \text{ (Message Type 10)} \end{cases} \quad 39)$$

where:

- $RSS_{UDRE}$  = root-sum-square flag in Message Type 10
- $\sigma_{UDRE}^2$  = **variance of** model parameter from Message Type 2-6, 24 (ref. 4.4.4)
- $\delta_{UDRE}$  =  **$\delta_{UDRE}$  factor for user location, as defined in Message Type 28 (ref. A.4.4.17)**
- $\varepsilon_{fc}$  = degradation parameter for fast correction data (ref. 4.5.1.1)
- $\varepsilon_{rrc}$  = degradation parameter for range rate correction data (ref. 4.5.1.2)
- $\varepsilon_{ltc}$  = degradation parameter for long term correction or GEO navigation message data (ref. 4.5.1.3)
- $\varepsilon_{er}$  = degradation parameter for en route through NPA applications (ref. 4.5.1.4)

*Note: Airborne equipment which does not miss any messages will have a 0 for all degradation terms except for  $\varepsilon_{fc}$ , which will typically be less than 0.35 meters, and  $\varepsilon_{rrc}$ , which will be non-zero following an alarm condition.*

#### 4.5.1.1 Fast Correction Degradation

The degradation parameter for fast correction data is defined as:

$$\varepsilon_{fc} = a(t - t_u + t_{lat})^2 / 2 \quad 3640)$$

where:

- $a$  = the Fast correction degradation factor determined from Message Type 7 (ref. 4.4.5)
- $t$  = the current time
- $t_u$  = the time the last UDRE data (Type 2–6 or 24) was received that matches the IODF of the fast correction being used. For Message Types 2-5 and 24, this time is the same as the time of applicability of the fast corrections ( $t_{fc}$ ) since they are in the same message. For UDREs broadcast in Type 6 and if the IODF = 3, this time also equals the time of applicability of the fast corrections ( $t_{fc}$ ). For UDREs broadcast in Type 6 and IODF  $\neq$  3, this time is defined to be the time of transmission of the first bit of the Type 6 message at the GEO.
- $t_{lat}$  = the system latency determined from Message Type 7 (ref. 4.4.5)

#### 4.5.1.2 Range-Rate Correction Degradation

If the RRC = 0 then the range-rate correction degradation is also equal to zero (i.e.  $\varepsilon_{rrc} = 0$  if  $a_i = 0$ , see section 4.4.3). Otherwise, the range-rate degradation is divided into two cases. The first case covers the situation where the IODFs of both the current and previous fast corrections are not equal to 3. The second case covers the situation where at least one of the IODFs is equal to 3. The following terms are used to define these degradation functions:

- $a$  = the Fast correction degradation factor determined from Message Type 7 (ref. 4.4.5). This parameter is satellite-specific.
- $t$  = the current time
- $I_{fc}$  = the time-out interval of the fast correction determined from Message Type 7. This parameter is the shortest time-out interval for any satellite included in the associated fast corrections message.
- $B_{rrc}$  = a parameter associated with the relative estimation noise and round-off error derived from Message Type 10.
- $IODF_{current}$  = IODF associated with most recent fast correction
- $IODF_{previous}$  = IODF associated with previous fast correction

##### 4.5.1.2.1 Range-Rate Correction Degradation - IODF $\neq$ 3

The degradation parameter for fast correction data is defined as:

$$\varepsilon_{rrc} = \begin{cases} 0, & \text{if } (IODF_{current} - IODF_{previous}) \text{ MOD } 3 = 1 \\ \left( \frac{aI_{fc}}{4} + \frac{B_{rrc}}{\Delta t} \right) (t - t_{of}), & \text{if } (IODF_{current} - IODF_{previous}) \text{ MOD } 3 \neq 1 \end{cases} \quad 3741)$$

#### 4.5.1.2.2 Range-Rate Correction Degradation - Either IODF = 3

The degradation parameter for fast correction data is defined as:

$$\epsilon_{rrc} = \begin{cases} 0, & \text{if } \left| \Delta t - \frac{I_{fc}}{2} \right| = 0 \\ \left( \frac{a \left| \Delta t - I_{fc} / 2 \right|}{2} + \frac{B_{rrc}}{\Delta t} \right) (t - t_{of}), & \text{if } \left| \Delta t - \frac{I_{fc}}{2} \right| \neq 0 \end{cases} \quad (3842)$$

This function will not take on any one value since there are possibly many choices of fast corrections as alarm conditions do not necessarily occur at regularly space intervals.

#### 4.5.1.3 Long Term Correction Degradation

The degradation associated with long-term corrections is covered by two cases depending on whether both offset and velocity (Type 24 and 25 with velocity code=1) or only offset (Type 24 and 25 with velocity code=0) is included in the message.

The degradation associated with the GEO navigation message is described in 4.5.1.3.3. The system will ensure that the resulting degradation protects the user, even during a transition of the velocity code.

##### 4.5.1.3.1 Long Term Correction Degradation - Velocity Code =1

For Velocity Code = 1, the degradation parameter for long-term corrections is:

$$\epsilon_{ltc} = \begin{cases} 0 & \text{if } t_0 < t < t_0 + I_{ltc\_v1} \\ C_{ltc\_lsb} + C_{ltc\_v1} \max(0, t_0 - t, t - t_0 - I_{ltc\_v1}) & \text{otherwise} \end{cases} \quad (3943)$$

where:

- $t$  = the current time
- $t_0$  = the time of applicability for the long term correction (ref. A.4.4.7)
- $I_{ltc\_v1}$  = the update interval for v=1 long term corrections determined from Message Type 10
- $C_{ltc\_lsb}$  = is the maximum round-off error due to the lsb resolution of the orbit and clock information determined from Message Type 10
- $C_{ltc\_v1}$  = is the velocity error bound on the maximum range rate difference of missed messages due to clock and orbit rate differences derived from Message Type 10

*Note: If no long term correction messages are missed, it is always possible to have  $t_0 < t < t_0 + I_{ltc\_v1}$ . If the airborne equipment misses long term correction messages, the equipment may be forced to either use a long term correction before  $t_0$  or use the long term correction after  $t_0 + I_{ltc\_v1}$ . Typically, a long term correction message will be broadcast once before  $t_0$  and two more times after  $t_0$  but before  $t_0 + I_{ltc\_v1}$ . If  $t_0 < t < t_0 + I_{ltc\_v1}$ , then no degradation function is applied.*

#### 4.5.1.3.2 Long Term Correction Degradation - Velocity Code = 0

For Velocity Code = 0, the degradation parameter for long-term corrections is:

$$\epsilon_{ltc} = C_{ltc\_v0} \left\lfloor \frac{t - t_{ltc}}{I_{ltc\_v0}} \right\rfloor \quad 4044)$$

where:

- $t$  = the current time
- $t_{ltc}$  = the time the long term correction message was received
- $I_{ltc\_v0}$  = the minimum update interval for velocity code v=0 long term messages determined from Message Type 10
- $C_{ltc\_v0}$  = is the bound on the update delta between successive long term corrections determined from Message Type 10
- $\lfloor x \rfloor$  = the floor or greatest integer less than x function.

#### 4.5.1.3.3 GEO Navigation Message Degradation

The degradation parameter for GEO navigation message data is:

$$\epsilon_{ltc} = \begin{cases} 0 & t_0 < t < t_0 + I_{geo} \\ C_{geo\_lsb} + C_{geo\_v} \max(0, t_0 - t, t - t_0 - I_{geo}) & otherwise \end{cases} \quad 4145)$$

where:

- $t$  = the current time
- $t_0$  = the time of applicability for the GEO navigation message (ref.4.4.11)
- $I_{geo}$  = the update interval for GEO navigation messages determined from Message Type 10
- $C_{geo\_lsb}$  = is the maximum round-off error due to the lsb resolution of the orbit and clock information determined from Message Type 10
- $C_{geo\_v}$  = is the velocity error bound on the maximum range rate difference of missed messages due to clock and orbit rate differences derived from Message Type 10

This degradation function is similar to that of long term corrections (Velocity Code = 1) and the same principles apply as to the periods of applicability. For example, if  $t_0 < t < t_0 + I_{geo}$  then no degradation function is applied.

#### 4.5.1.4 Degradation for En Route Through NPA

When using fast or long term corrections which have timed out for precision approach, but have not timed out for other navigation modes, an extra “catch-all” degradation factor is applied.

This degradation is:

$$\epsilon_{er} = \begin{cases} 0, & \text{neither fast nor long term corrections} \\ & \text{have timed out for precision approach} \\ C_{er}, & \text{if fast or long term corrections} \\ & \text{have timed out for precision approach} \end{cases} \quad 4246)$$

where:

$C_{er}$  = degradation parameter determined from Message Type 10

#### 4.5.2 Degradation of Ionospheric Corrections

The residual error associated with the ionospheric corrections is characterized by the variance ( $\sigma_{ionogrid}^2$ ) of a model distribution. This parameter is applicable at each ionospheric grid point, and must be interpolated to the user pierce point and translated to slant range (4.4.10). This term is computed as:

$$\sigma_{ionogrid}^2 = \begin{cases} (\sigma_{GIVE} + \varepsilon_{iono})^2 & \text{if } RSS_{iono} = 0 \text{ (Message Type 10)} \\ \sigma_{GIVE}^2 + \varepsilon_{iono}^2 & \text{if } RSS_{iono} = 1 \text{ (Message Type 10)} \end{cases} \quad 4347)$$

where:

$RSS_{iono}$  = root-sum-square flag from Message Type 10

$\sigma_{GIVE}$  = model parameter from Message Type 26 (ref. 4.4.10)

and,

$$\varepsilon_{iono} = C_{iono\_step} \left\lfloor \frac{t - t_{iono}}{I_{iono}} \right\rfloor + C_{iono\_ramp}(t - t_{iono}) \quad 4448)$$

where:

$C_{iono\_step}$  = the bound on the difference between successive ionospheric grid delay values determined from Message Type 10

$t$  = the current time

$t_{iono}$  = the time of transmission of the first bit of the ionospheric correction message at the GEO

$C_{iono\_ramp}$  = the rate of change of the ionospheric corrections determined from Message Type 10

$I_{iono}$  = the minimum update interval for ionospheric correction messages determined from Message Type 10

$\lfloor x \rfloor$  = the floor or greatest integer less than x function

#### 4.6 Principle and Rules for the Generation and Use of Data

The following principles and rules apply for the WAAS capable receiver. From these principles, the necessary message generation rules at the control center may be inferred.

- (1) the CRC must pass on the received block.
- (2) the user must correlate with the entire 24 bits of the preamble, but not necessarily in successive 1-second blocks. This assures frame synchronization while allowing for occasional block errors without repeating a complete synchronization.
- (3) "Use/Don't Use" or error correction data cannot be used until a Type 1 message providing the PRN mask with an issue of data (IODP) applicable to the data have been decoded. However, long term satellite error corrections and UDREIs

can be stored by the users prior to this event and tagged useful once this event and the event in (4) below occurs. Type 1 messages shall be broadcast at a rate sufficient to not degrade the user's first fix capability.

- (4) The embedded Issues of Data (IODs) in the long term satellite error corrections shall match those in use by the receiver prior to use.
- (5) Long term satellite error corrections, ionospheric delay corrections and GEO Navigation Messages shall all be broadcast at a rate sufficient to not degrade the user's first fix capability.

#### 4.7 Timing

Integrity information (UDREs contained in Types 2 - 5, Type 24 or Type 6) shall be broadcast at least once every 6 seconds. All other messages shall be broadcast in-between, meeting the constraints imposed in Paragraph 4.6 above and not exceeding the maximum update interval in Table 2223 below. The required intervals apply to data content, not arbitrary messages.

The maximum update intervals defined in Table 2223 are intended to limit necessary acquisition time and ensure consistent application of data by all users. They do not imply that update rates consistent with Table 2223 will meet all required performance requirements (such as ionospheric delay accuracy). In addition, the data link will broadcast a valid message every second to provide a continuity of signal. The Type 62 and Type 63 messages are valid messages. The user time-out interval limits the time interval of applicability of all correction and integrity data.

In addition to the normal messages listed in Table 2223, every alarm condition (broadcast in a Type 2 - 5, Type 24, Type 6, or Type 26 message) shall be repeated three times after the initial notification of the alarm condition (for a total of four times in four seconds). Subsequent messages can be transmitted at the normal update rate.

The user time-out intervals are defined from the end of the reception of a message until the end of reception of a message which contains replacement information.

**Table 2223. Message Content Broadcast Intervals**

Data	Associated Message Types	Maximum Update Interval (seconds)	En Route, Terminal, NPA Timeout (seconds)	Precision Approach and LNAV/VNAV Timeout (seconds)
<del>WAAS in Test Mode</del> <del>Don't Use for Safety Applications</del>	0	6	N/A (Note 1)	N/A (Note 1)
PRN Mask	1	60 (Note 2)	NONE	NONE
UDREI	2, 3, 4, 5, and 24	6	18	12
Fast Corrections	2, 3, 4, 5, and 24	60	See Table 7	See Table 7
Long Term Corrections	24, 25	120	360	240
GEO Nav. Data	9	120	360	240

Data	Associated Message Types	Maximum Update Interval (seconds)	En Route, Terminal, NPA Timeout (seconds)	Precision Approach and LNAV/VNAV Timeout (seconds)
Fast Correction Degradation	7	120	360	240
Weighting Factors	8	120	240	240
Degradation Parameters	10	120	360	240
Ionospheric Grid Mask	18	300(Note 2)	None	None
Ionospheric Corrections	26	300	600	600
UTC Timing Data	12	300	None	None
Almanac Data	17	300	None	None
<u>Clock-Ephemeris Covariance Matrix</u>	<u>28</u>	<u>120</u>	<u>360</u>	<u>240</u>

Notes:

1) For safety applications, Rreception of a Type 0 message results in de-selection of the WAAS satellite for one minute signal (PRN code) for one minute and all data from that satellite signal is discarded.

2) When the PRN or ionospheric mask is changed, it should be repeated-broadcast at least four times before the new masks are used. This will ensure that all users receive the new mask before it is applied, maintaining high continuity.



## 5.0 References

- (1) Global Positioning System Standard Positioning Service Signal Specification, U. S. Department Of Defense, Washington, DC, June 2 , 1995.
- (2) George C. Clark And J. Bibb Cain, Error Correction Coding For Digital Communications, Plenum Press, New York, 1981.
- (3) J. K. Wolf And R. D. Blakeney II, "An Exact Evaluation Of The Probability Of Undetected Error For Certain Shortened Binary CRC Codes," *Milcom '88 Conference Proceedings*, Vol. 1, Paper 15-2, Washington, DC, 1988, pp. 287 - 292.
- (4) W. W. Peterson And E. J. Weldon, Jr., Error Correcting Codes, The MIT Press, Cambridge, MA, 1972.
- (5) W. W. Peterson And D. T. Brown, "Cyclic Codes For Error Detection," Proceedings of the IRE, January 1961, pp. 228 - 235.
- (6) S. Lin And D. J. Costello, Jr., Error Control Coding: Fundamentals And Applications, Prentice-Hall, Inc., Englewood Cliffs, NJ, 1983.
- (7) W. Stallings, Data And Computer Communications, Macmillan Publishing Co., New York, NY, 1985, pp. 105 - 110.
- (8) Christopher J. Hegarty, "Optimal Differential GPS For A Data Rate Constrained Broadcast Channel," *Proceedings Of The ION GPS-93*, Sixth International Technical Meeting Of The Satellite Division Of The Institute Of Navigation, Salt Lake City, Utah, September 22 - 24, 1993, pp. 1527 - 1535.
- (9) Junkins, Miller And Jancaitis, "A Weighting Function Approach To Modeling Of Irregular Surfaces," Journal Of Geophysical Research, Volume 78, No. 110, April 1973.
- (10) M. B. El-Arini, "Proposed CRC-24 Code for GIC/WADGNSS," a briefing presented to RTCA SC 159 WG2 in Washington, DC on 5 May 1993, RTCA paper number 172-94/SC159-512.
- (11) M. B. El-Arini, J. K. Reagan, T.W. Albertson, R. S. Conker, and J. A. Klobuchar, "Comparison of User's Ionospheric Algorithms for a GPS Wide Area Augmentation System (WAAS)," a briefing presented to RTCA SC 159 WG 2 in Reston, VA on 1 March 1994 paper no. RTCA 171-94/SC 159-511.

## Appendix 3: Verification Requirements Traceability Matrix (VRTM)

### 1.0 Definitions

**Demonstration.** Demonstration is a method of verification where qualitative versus quantitative validation of a requirement is made during a dynamic test of the equipment. Additional definitions applied to this term are:

- a. If a requirement is validate by test during first article qualification testing and the requirement has enough significance that it is "retested" during acceptance test, then this acceptance testing can be indicated in the VRTM as a Demonstration.
- b. In general, software functional requirements are validated by demonstration since the functionality must be observed through some secondary media.

**Inspection.** Inspection is a method of verification to determine compliance with specification requirements and consists primarily of visual observations, or mechanical measurements of the equipment, physical locations, or technical examinations of engineering-support documentation.

**Analysis.** Analysis is a method of verification which consists of comparing hardware or software design with known scientific and technical principles, technical data, or procedures and practices to validate that the proposed design will meet the specified functional or performance requirements.

**Test.** Test is a method of verification that will measure equipment's performance under specific configuration-load conditions and after the controlled application of known stimuli. Quantitative values are measured, compared against previous predicted success criteria and then evaluated to determine the degree of compliance.

Document Title	Paragraph Number	Requirement Description	Contractor Testing				FAA Testing				Remarks	
			DT&E at the Contractor Facility	DT&E using the FVS	DT&E using the initial WAAS	PAT&E (FAT, SAT)	OT&E/ Operational & Integration	OT&E/ Shakedown	Field Shakedown			
WAAS Specification	3.0	SYSTEM REQUIREMENTS										Title
WAAS Specification	3.1	System Definition										Description
WAAS Specification	3.1.1	WAAS Objectives										Description
WAAS Specification	3.1.2	System Modes and States	D	D	D	X	D	D	D	D	D	
WAAS Specification	3.1.2.1	Continuous Service State	D	D	D	X	D	D	D	D	D	
WAAS Specification	3.1.2.2	Military Emergency State	D	D	D	X	D	D	D	D	D	
WAAS Specification	3.1.3	System Functions										Description
WAAS Specification	3.1.3.1	System Functional Relationships										Description
WAAS Specification	3.1.3.2	Data Collection (Function 1)										Lead-In
WAAS Specification	3.1.3.2.1 (a to e)	Inputs										Input Data
WAAS Specification	3.1.3.2.2	Processing										Title
WAAS Specification	3.1.3.2.2.1	Collect raw GPS observables	T	D	D	X	D	D	X	D	D	

Document Title	Paragraph Number	Requirement Description	Contractor Testing				FAA Testing				Remarks
			DT&E at the Contractor Facility	DT&E using the FVS	DT&E using the initial WAAS	PAT&E (FAT, SAT)	OT&E/ Operational & Integration	OT&E/ Shakedown	Field Shakedown		
WAAS Specification	3.1.3.2.2.2	Collect raw GEO observables	T	D	D	X	D	X	D		
WAAS Specification	3.1.3.2.2.3	Location of Antenna phase center	T	D	D	X	D	X	D		
WAAS Specification	3.1.3.2.2.4	Data for Tropospheric Corrections	T	D	D	X	D	X	D		
WAAS Specification	3.1.3.2.2.5	Receiver calibration data	T	D	D	X	D	X	D		
WAAS Specification	3.1.3.2.2.6	Raw data reasonability check	T	D	D	X	D	X	D		
WAAS Specification	3.1.3.2.3 (a to i)	Outputs	T	D	D	X	D	X	D		
WAAS Specification	3.1.3.3	Determine Ionospheric Corrections (Function 2)									Description
WAAS Specification	3.1.3.3.1 (a to e)	Inputs									Input Data
WAAS Specification	3.1.3.3.2	Processing									Title
WAAS Specification	3.1.3.3.2.1	L1 Ionospheric Delay Estimates	T	D	D	X	D	X	D		

Document Title	Paragraph Number	Requirement Description	Contractor Testing				FAA Testing				Remarks
			DT&E at the Contractor Facility	DT&E using the FVS	DT&E using the initial WAAS	PAT&E (FAT, SAT)	OT&E/ Operational & Integration	OT&E/ Shakedown	Field Shakedown		
WAAS Specification	3.1.3.3.2.2	Grid Ionospheric Vertical Error (GIVE)	A,D	D	D	X	D	X	D		
WAAS Specification	3.1.3.3.2.3	IGP selection	T	D	D	X	D	X	D		
WAAS Specification	3.1.3.3.2.4	IGP "Not Monitored" data	T	D	D	X	D	X	D		
WAAS Specification	3.1.3.3.3 (a to c)	Outputs									Output Description
WAAS Specification	3.1.3.4	Satellite Orbit Determination (Function 3)									Description
WAAS Specification	3.1.3.4.1 (a to k)	Inputs									Input Data
WAAS Specification	3.1.3.4.2	Processing									Title
WAAS Specification	3.1.3.4.2.1	Minimize Ionosphere and Troposphere Effects	A,T	T	T	X	D	X	D		
WAAS Specification	3.1.3.4.2.2	GPS orbit determination	A,T	T	T	X	D	X	D		
WAAS Specification	3.1.3.4.2.3	GEO orbit determination	A,T	T	T	X	D	X	D		
WAAS Specification	3.1.3.4.2.4	GEO Satellite Ephemeris Data	A,T	T	T	X	D	X	D		

Document Title	Paragraph Number	Requirement Description	Contractor Testing			FAA Testing				Remarks
			DT&E at the Contractor Facility	DT&E using the FVS	DT&E using the initial WAAS	PAT&E (FAT, SAT)	OT&E/ Operational & Integration	OT&E/ Shakedown	Field Shakedown	
WAAS Specification	3.1.3.4.2.5	GEO Satellite Almanac Data	T	T	T	X	D	X	D	FAA-E- 2892b Change 2 September 21, 1999
WAAS Specification	3.1.3.4.3 (a to d)	Outputs	T	D	D	X	D	X	D	
WAAS Specification	3.1.3.5	Determine Satellite Corrections (Function 4)								Description
WAAS Specification	3.1.3.5.1 (a to j)	Inputs								Input Data
WAAS Specification	3.1.3.5.2	Processing								Title
WAAS Specification	3.1.3.5.2.1	Minimize Ionosphere and Troposphere Effects	A, T	T	T	X	D	X	D	
WAAS Specification	3.1.3.5.2.2	Satellite Long Term Error Corrections	A, T	T	T	X	D	X	D	
WAAS Specification	3.1.3.5.2.3	Satellite Fast Error Corrections	A, T	T	T	X	D	X	D	
WAAS Specification	3.1.3.5.2.4	Satellite User Differential Range Error (UDRE)	A, D	T	T	X	D	X	D	
WAAS Specification	3.1.3.5.2.5	Issue of Data	A, D	T	T	X	D	X	D	
WAAS Specification	3.1.3.5.2.6	Fast Correction Degradation Factor	A, D	T	T	X	D	X	D	

Document Title	Paragraph Number	Requirement Description	Contractor Testing				FAA Testing				Remarks
			DT&E at the Contractor Facility	DT&E using the FVS	DT&E using the initial WAAS	PAT&E (FAT, SAT)	OT&E/ Operational & Integration	OT&E/ Shakedown	Field Shakedown		
WAAS Specification	3.1.3.5.2.7	Estimated RMS Pseudorange Error	A,D	F	F	X	D	X	D		
WAAS Specification	3.1.3.5.2.8	Message Type 10 Degradation Parameters	A,D	T	T	X	D	X	D		
WAAS Specification	3.1.3.5.3 (a to f)	Outputs	T	D	D	X	D	X	D		
WAAS Specification	3.1.3.6	Determine Satellite Integrity (Function 5)									Description
WAAS Specification	3.1.3.6.1 (a to j)	Inputs									Input Data
WAAS Specification	3.1.3.6.2	Processing									Title
WAAS Specification	3.1.3.6.2.1	Satellite Integrity Determination									Sub-Title
WAAS Specification	3.1.3.6.2.1.1	Pseudorange "Don't Use" data	A,T	T	T	X	D	X	D		
WAAS Specification	3.1.3.6.2.1.2	UDRE "Don't Use" data	T	T	T	X	D	X	D		
WAAS Specification	3.1.3.6.2.1.3	Ionospheric "Don't Use" data	A,T	T	T	X	D	X	D		
WAAS Specification	3.1.3.6.2.1.4	GIVE "Don't Use" data	A,T	T	T	X	D	X	D		
WAAS Specification	3.1.3.6.2.2	Satellite Visibility									Sub-Title

Document Title	Paragraph Number	Requirement Description	Contractor Testing				FAA Testing				Remarks
			DT&E at the Contractor Facility	DT&E using the FVS	DT&E using the initial WAAS	PAT&E (FAT, SAT)	OT&E/ Operational & Integration	OT&E/ Shakedown	Field Shakedown		
WAAS Specification	3.1.3.6.2.2.1	Satellite Visibility Determination	T	T	T	X	D	X	D		
WAAS Specification	3.1.3.6.2.2.2	"Not Monitored" data	T	T	T	X	D	X	D		
WAAS Specification	3.1.3.6.3 (a to c)	Outputs	T	D	D	X	D	X	D		
WAAS Specification	3.1.3.7	Independent Data Verification (Function 6)									Description
WAAS Specification	3.1.3.7.1 (a to w)	Inputs									Input Data
WAAS Specification	3.1.3.7.2	Processing									Lead-In
WAAS Specification	3.1.3.7.2.1	Verification of Ionospheric Corrections (Subfunction 1)	A, T	T	T	X	D	X	D		
WAAS Specification	3.1.3.7.2.1.1	Verification Success	T	T	T	X	D	X	D		
WAAS Specification	3.1.3.7.2.1.2	Verification Failure - Accuracy	T	T	T	X	D	X	D		
WAAS Specification	3.1.3.7.2.2	Verification of Satellite Orbits (Subfunction 2)	A, T	T	T	X	D	X	D		
WAAS Specification	3.1.3.7.2.2.1	Verification Success	T	T	T	X	D	X	D		



Document Title	Paragraph Number	Requirement Description	Contractor Testing				FAA Testing				Remarks
			DT&E at the Contractor Facility	DT&E using the FVS	DT&E using the initial WAAS	PAT&E (FAT, SAT)	OT&E/ Operational & Integration	OT&E/ Shakedown	Field Shakedown		
WAAS Specification	3.1.3.7.2.2.2	Verification Failure	T	T	T	X	D	X	D		
WAAS Specification	3.1.3.7.2.3	Verification of Satellite Corrections (Subfunction 3)	A, T	T	T	X	D	X	D		
WAAS Specification	3.1.3.7.2.3.1	Verification Success	T	T	T	X	D	X	D		
WAAS Specification	3.1.3.7.2.3.2	Verification Failure	T	T	T	X	D	X	D		
WAAS Specification	3.1.3.7.2.4	Verification of Satellite Integrity (Subfunction 4)	A, T	T	T	X	D	X	D		
WAAS Specification	3.1.3.7.2.4.1	Verification Success	T	T	T	X	D	X	D		
WAAS Specification	3.1.3.7.2.4.2	Verification Failure	T	T	T	X	D	X	D		
WAAS Specification	3.1.3.7.2.5	Validation of Signal-in-Space Performance (Subfunction 5)	A, T	T	T	X	D	X	D		
WAAS Specification	3.1.3.7.2.5.1	Validation of SIS Performance	T	T	T	X	D	X	D		
WAAS Specification	3.1.3.7.2.5.2	SIS Performance Alerts	T	T	T	X	D	X	D		

Document Title	Paragraph Number	Requirement Description	Contractor Testing				FAA Testing				Remarks
			DT&E at the Contractor Facility	DT&E using the FVS	DT&E using the initial WAAS	PAT&E (FAT, SAT)	OT&E/ Operational & Integration	OT&E/ Shakedown	Field Shakedown		
WAAS Specification	3.1.3.7.3 (a to l)	Outputs	T	D	D	X	D	X	D		
WAAS Specification	3.1.3.8	WAAS Message Broadcast and Ranging (Function 7)									Description
WAAS Specification	3.1.3.8.1 (a to m)	Inputs									Input Data
WAAS Specification	3.1.3.8.2	Processing	A, T	T	T	X	T	X	D		
WAAS Specification	3.1.3.8.2.1	Message Format	T	D	D	X	D	X	D		
WAAS Specification	3.1.3.8.2.2	Repetition of Alarm Messages	T	D	D	X	D	X	D		
WAAS Specification	3.1.3.8.2.3	Message Broadcast and Ranging	A, T	T	T	X	T	X	D		
WAAS Specification	3.1.3.8.2.3.1	Message and Code Combining	T	D	D	X	D	X	D		
WAAS Specification	3.1.3.8.2.3.2	Signal Modulation	T	D	D	X	D	X	D		
WAAS Specification	3.1.3.8.2.3.3	Signal Transmission	T	D	D	X	D	X	D		
WAAS Specification	3.1.3.8.2.3.4	GEO Satellite Reception	A	D	D	X	D	X	D		
WAAS Specification	3.1.3.8.2.3.5	GEO Satellite Translation	A	T	T	X	T	X	D		

Document Title	Paragraph Number	Requirement Description	Contractor Testing				FAA Testing				Remarks
			DT&E at the Contractor Facility	DT&E using the FVS	DT&E using the initial WAAS	PAT&E (FAT, SAT)	OT&E/ Operational & Integration	OT&E/ Shakedown	Field Shakedown		
WAAS Specification	3.1.3.8.2.4	Monitor WAAS Signal Quality	T	T	T	X	D	D	D		
WAAS Specification	3.1.3.8.3 (a to c)	Outputs	T	D	D	X	D	X	D		
WAAS Specification	3.1.3.9	System Operations and Maintenance (Function 8)	T	T	T	X	T	D	D		
WAAS Specification	3.1.3.9.1	System Operations and Maintenance Data Collection (Subfunction 1)									Description
WAAS Specification	3.1.3.9.1.1 (a to i)	Inputs									Input Data
WAAS Specification	3.1.3.9.1.2	Processing									Title
WAAS Specification	3.1.3.9.1.2.1	WAAS Component and Equipment Configuration Data	T	D	D	X	X	D	D		
WAAS Specification	3.1.3.9.1.2.2	WAAS Component and Equipment Status Data	T	D	D	X	X	D	D		
WAAS Specification	3.1.3.9.1.2.3	WAAS Component and Equipment Performance Data	T	D	D	X	X	D	D		
WAAS Specification	3.1.3.9.1.2.4	Function 6 Data	T	D	D	X	X	D	D		

Document Title	Paragraph Number	Requirement Description	Contractor Testing				FAA Testing				Remarks
			DT&E at the Contractor Facility	DT&E using the FVS	DT&E using the initial WAAS	PAT&E (FAT, SAT)	OT&E/ Operational & Integration	OT&E/ Shakedown	Field Shakedown		
WAAS Specification	3.1.3.9.1.2.5	Function 1 Data	T	D	D	X	X	D	D		
WAAS Specification	3.1.3.9.1.2.6	WAAS Signal Quality Parameters	T	D	D	X	X	D	D		
WAAS Specification	3.1.3.9.1.2.7	Process Data Update	T	D	D	X	X	D	D		
WAAS Specification	3.1.3.9.1.2.8	Manual Inputs	T	D	D	X	X	D	D		
WAAS Specification	3.1.3.9.1.3 (a to j)	Outputs	T	D	D	X	X	D	D		
WAAS Specification	3.1.3.9.2	System Monitor and Control (Subfunction 2)									Description
WAAS Specification	3.1.3.9.2.1 (a to h)	Inputs									Input Data
WAAS Specification	3.1.3.9.2.2	Processing									Title
WAAS Specification	3.1.3.9.2.2.1	Continuity of Processing	T	D	D	X	X	D	D		
WAAS Specification	3.1.3.9.2.2.2	Operational Configuration Control and Management	T	D	D	X	X	D	D		
WAAS Specification	3.1.3.9.2.2.3	Data Presentation	T	D	D	X	X	D	D		

Document Title	Paragraph Number	Requirement Description	Contractor Testing				FAA Testing				Remarks
			DT&E at the Contractor Facility	DT&E using the FVS	DT&E using the initial WAAS	PAT&E (FAT, SAT)	OT&E/ Operational & Integration	OT&E/ Shakedown	Field Shakedown		
WAAS Specification 1	3.1.3.9.2.2.3.1	Displays	T	D	D	X	X	D	D	D	
	(1 to 5)										
WAAS Specification	3.1.3.9.2.2.4	Security	T	D	D	X	X	D	D	D	
WAAS Specification	3.1.3.9.2.2.5	Degradation Protection	T	D	D	X	X	D	D	D	
WAAS Specification	3.1.3.9.2.2.6	Alarms	T	D	D	X	X	D	D	D	
WAAS Specification 1	3.1.3.9.2.2.6.1	WAAS Status Reporting	T	D	D	X	X	D	D	D	
WAAS Specification	3.1.3.9.2.2.7	Alerts	T	D	D	X	X	D	D	D	
WAAS Specification	3.1.3.9.2.2.8	Alert and Alarm Latency	T	D	D	X	X	D	D	D	
WAAS Specification 1	3.1.3.9.2.2.8.1	WAAS Status Reporting Latency	T	D	D	X	X	D	D	D	
WAAS Specification	3.1.3.9.2.2.9	Alert and Alarm Acknowledgement	T	D	D	X	X	D	D	D	
WAAS Specification 1	3.1.3.9.2.2.9.1	Status Reporting Acknowledgment	T	D	D	X	X	D	D	D	
WAAS Specification 0	3.1.3.9.2.2.1	System Certification	T	D	D	X	X	D	D	D	
WAAS Specification 1	3.1.3.9.2.2.1	Data Recording, Archiving, and Retrieval									Title

Document Title	Paragraph Number	Requirement Description	Contractor Testing				FAA Testing				Remarks
			DT&E at the Contractor Facility	DT&E using the FVS	DT&E using the initial WAAS	PAT&E (FAT, SAT)	OT&E/ Operational & Integration	OT&E/ Shakedown	Field Shakedown		
WAAS Specification	3.1.3.9.2.2.1 1.1	System Level Recording	T	D	D	X	X	D	D	D	
WAAS Specification	3.1.3.9.2.2.1 1.2	Component Level Recording Content	T	D	D	X	X	D	D	D	
WAAS Specification	3.1.3.9.2.2.1 1.3	Component Level Playback	T	D	D	X	X	D	D	D	
WAAS Specification	3.1.3.9.2.2.1 1.4 (1 to 4)	Component Level Observation Data Recording Content	T	D	D	X	X	D	D	D	
WAAS Specification	3.1.3.9.2.2.1 1.5	Component Level Navigation Data Recording Content	T	D	D	X	X	D	D	D	
WAAS Specification	3.1.3.9.2.2.1 1.6 (1 to 3)	Component Level Tropospheric Data Recording Content	T	D	D	X	X	D	D	D	
WAAS Specification	3.1.3.9.2.2.1 2	WAAS Network Time									Title
WAAS Specification	3.1.3.9.2.2.1 2.1	WAAS Network Time Determination	A,T	T	T	X	T	D	D	D	
WAAS Specification	3.1.3.9.2.2.1 2.2	WNT/UTC Offset Determination	A,T	T	T	X	T	D	D	D	
WAAS Specification	3.1.3.9.2.2.1 3	GEO Satellite Testing	T	D	D	X	X	D	D	D	

Document Title	Paragraph Number	Requirement Description	Contractor Testing				FAA Testing				Remarks
			DT&E at the Contractor Facility	DT&E using the FVS	DT&E using the initial WAAS	PAT&E (FAT, SAT)	OT&E/ Operational & Integration	OT&E/ Shakedown	Field Shakedown		
WAAS Specification	3.1.3.9.2.3 (a to i)	Outputs	T	D	D	X	X	D	D		
WAAS Specification	3.1.3.9.3	Corrective Maintenance (Subfunction 3)									Description
WAAS Specification	3.1.3.9.3.1 (a to j)	Inputs									Input Data
WAAS Specification	3.1.3.9.3.2	Processing									Title
WAAS Specification	3.1.3.9.3.2.1	Fault Detection and Isolation	A, T	D	D	D	D	D	D	X	D
WAAS Specification	3.1.3.9.3.2.2	System Configuration Status	T	D	D	D	D	D	D	D	D
WAAS Specification	3.1.3.9.3.2.3	Maintenance During Normal Operation	T	D	D	D	D	D	D	X	D
WAAS Specification	3.1.3.9.3.2.4	Maintenance Priority Generation	T	D	D	D	X	D	D	X	D
WAAS Specification	3.1.3.9.3.2.6	Remote Initialization	T	D	D	D	D	D	D	X	D
WAAS Specification	3.1.3.9.3.2.7	Remote Reloading of Software and Databases	T	D	D	D	D	D	D	X	D

Document Title	Paragraph Number	Requirement Description	Contractor Testing				FAA Testing				Remarks
			DT&E at the Contractor Facility	DT&E using the FVS	DT&E using the initial WAAS	PAT&E (FAT, SAT)	OT&E/ Operational & Integration	OT&E/ Shakedown	Field Shakedown		
WAAS Specification	3.1.3.9.3.2.8	Off-line Equipment Verification	T	D	D	D	X	D	D		
WAAS Specification	3.1.3.9.3.2.9	Resumption of Operation	T	D	D	D	X	D	D		
WAAS Specification 0	3.1.3.9.3.2.1	Record Keeping	T	D	D	D	X	D	D		
WAAS Specification 1	3.1.3.9.3.2.1	Archival of Maintenance Data	T	D	D	D	X	D	D		
WAAS Specification 2	3.1.3.9.3.2.1	Retrieval of Maintenance Data	T	D	D	D	X	D	D		
WAAS Specification (a to i)	3.1.3.9.3.3	Outputs	T	D	D	D	X	D	D		
WAAS Specification	3.1.3.9.4	Periodic Maintenance (PM) (Subfunction 4)									Description
WAAS Specification	3.1.3.9.4.1 (a to c)	Inputs									Input Data
WAAS Specification	3.1.3.9.4.2	Processing									Title
WAAS Specification	3.1.3.9.4.2.1	Manufacturer's Recommended PM	A	D	D	D	X	D	D		
WAAS Specification	3.1.3.9.4.2.2	Maintenance Coordination	T	D	D	D	X	D	D		



Document Title	Paragraph Number	Requirement Description	Contractor Testing				FAA Testing				Remarks
			DT&E at the Contractor Facility	DT&E using the FVS	DT&E using the initial WAAS	PAT&E (FAT, SAT)	OT&E/ Operational & Integration	OT&E/ Shakedown	Field Shakedown		
WAAS Specification	3.1.3.9.4.2.3	Maintenance During Normal Operations	T	D	D	D	D	X	D	D	
WAAS Specification	3.1.3.9.4.2.4	Maintenance Schedule	T	D	D	D	D	X	D	D	
WAAS Specification	3.1.3.9.4.3 (a to b)	Outputs	T	D	D	X	D	X	D	D	
WAAS Specification	3.1.3.9.5	Remote Maintenance and Monitoring System (RMMS)	A, T	D	D	D	D	D	D	D	Not required for initial WAAS.
WAAS Specification	3.2	System Characteristics									Title
WAAS Specification	3.2.1	Signal-in-Space Requirements									Description
WAAS Specification	3.2.1.1	Performance Characteristics Definitions									Title
WAAS Specification	3.2.1.1.1	Availability									Definition
WAAS Specification	3.2.1.1.2	Accuracy									Definition
WAAS Specification	3.2.1.1.2.1	Horizontal Position Accuracy									Definition
WAAS Specification	3.2.1.1.2.2	Vertical Position Accuracy									Definition

Document Title	Paragraph Number	Requirement Description	Contractor Testing					FAA Testing				Remarks	
			DT&E at the Contractor Facility	DT&E using the FVS	DT&E using the initial WAAS	PAT&E (FAT, SAT)	OT&E/ Operational & Integration	OT&E/ Shakedown	Field Shakedown				
WAAS Specification	3.2.1.1.2.3	Pseudorange Accuracy											Definition
WAAS Specification	3.2.1.1.2.4	User Differential Range Error (UDRE)											Definition
WAAS Specification	3.2.1.1.2.5	User Ionospheric Vertical Error (UIVE)											Definition
WAAS Specification	3.2.1.1.2.6	Grid Ionospheric Vertical Error (GIVE)											Definition
WAAS Specification	3.2.1.1.3	Integrity											Definition
WAAS Specification	3.2.1.1.3.1	Probability of Hazardously Misleading Information (HMI)											Definition
WAAS Specification	3.2.1.1.3.2	Probability of HMI for En Route through Non Precision Approach											Definition
WAAS Specification	3.2.1.1.3.3	Time to Alarm											Definition
WAAS Specification	3.2.1.1.3.4	Alarm Limit											Definition

Document Title	Paragraph Number	Requirement Description	Contractor Testing					FAA Testing				Remarks	
			DT&E at the Contractor Facility	DT&E using the FVS	DT&E using the initial WAAS	PAT&E (FAT, SAT)	OT&E/ Operational & Integration	OT&E/ Shakedown	Field Shakedown				
WAAS Specification	3.2.1.1.4	Continuity of Function											Definition
WAAS Specification	3.2.1.1.4.1	Continuity of Navigation											Definition
WAAS Specification	3.2.1.1.4.2	Continuity of Fault Detection											Definition
WAAS Specification	3.2.1.1.6	Service Volume											Definition
WAAS Specification	3.2.1.2	En Route Through Nonprecision Approach Performance Requirements											Description
WAAS Specification	3.2.1.2.1	Availability	A	D	D	X	D	D	D	D	D		Initial WAAS rqtmt in addendum.
WAAS Specification	3.2.1.2.1.1	Unavailability	A	D	D	X	D	D	D	D	D		
WAAS Specification	3.2.1.2.2	Accuracy											Title
WAAS Specification	3.2.1.2.2.1	95% Horizontal Position Accuracy	A	T	T		T	T	X	D	D		
WAAS Specification	3.2.1.2.2.2	99.999% Horizontal Position Accuracy	A	T	T		T	T	X	D	D		

Document Title	Paragraph Number	Requirement Description	Contractor Testing				FAA Testing				Remarks	
			DT&E at the Contractor Facility	DT&E using the FVS	DT&E using the initial WAAS	PAT&E (FAT, SAT)	OT&E/ Operational & Integration	OT&E/ Shakedown	Field Shakedown			
WAAS Specification	3.2.1.2.3	Integrity										Title
WAAS Specification	3.2.1.2.3.1	Probability of HMI	A	D	D	X	A	X			D	
WAAS Specification	3.2.1.2.3.2	Time to Alarm	T	T	T	X	T	X			D	
WAAS Specification	3.2.1.2.3.3	Alarm Limit	A, T	T	T	X	T	X			D	
WAAS Specification	3.2.1.2.4	Continuity of Function										Title
WAAS Specification	3.2.1.2.4.1	Continuity of Navigation	A	D	D	X	D	X			D	Initial WAAS rqmt in addendum.
WAAS Specification	3.2.1.2.4.2	Continuity of Fault Detection	A	D	D	X	D	X			D	Initial WAAS rqmt in addendum.
WAAS Specification	3.2.1.2.6	Service Volume										Title
WAAS Specification	3.2.1.2.6.1	Full Service	A	D	D	X	D	X			D	Initial WAAS rqmt in addendum.
WAAS Specification	3.2.1.2.6.2	Partial Service	A	D	D	X	D	X			D	
WAAS Specification	3.2.1.3	Precision Approach Performance Requirements										Description

Document Title	Paragraph Number	Requirement Description	Contractor Testing				FAA Testing				Remarks
			DT&E at the Contractor Facility	DT&E using the FVS	DT&E using the initial WAAS	PAT&E (FAT, SAT)	OT&E/ Operational & Integration	OT&E/ Shakedown	Field Shakedown		
WAAS Specification	3.2.1.3.1	Availability	A	D	D	X	X	X	X	X	Initial WAAS rqmt in addendum.
WAAS Specification	3.2.1.3.2	Accuracy									Title
WAAS Specification	3.2.1.3.2.1	Horizontal Position Accuracy	A	T	T	X	T	X	D		
WAAS Specification	3.2.1.3.2.2	Vertical Position Accuracy	A	T	T	X	T	X	D		
WAAS Specification	3.2.1.3.3	Integrity									Title
WAAS Specification	3.2.1.3.3.1	Probability of HMI	A	D	D	X	A	X	D		
WAAS Specification	3.2.1.3.3.2	Time to Alarm	T	T	T	X	T	X	D		Initial WAAS rqmt in addendum.
WAAS Specification	3.2.1.3.3.3	Alarm Limit	A,T	T	T	X	T	X	D		
WAAS Specification	3.2.1.3.4	Continuity of Function	A	D	D	X	D	X	D		Initial WAAS rqmt in addendum.
WAAS Specification	3.2.1.3.6	Service Volume	A	D	D	X	D	X	D		Initial WAAS rqmt in addendum.

Document Title	Paragraph Number	Requirement Description	Contractor Testing				FAA Testing				Remarks	
			DT&E at the Contractor Facility	DT&E using the FVS	DT&E using the initial WAAS	PAT&E (FAT, SAT)	OT&E/ Operational & Integration	OT&E/ Shakedown	Field Shakedown			
WAAS Specification	3.2.2	Antenna Phase Center Location Requirements										Title
WAAS Specification	3.2.2.1	Antenna Phase Center Location Relative To Local Monument	X	X	X	T	X		I		X	
WAAS Specification	3.2.2.2	Local Monument Location Requirements										GFE Monument Accuracy
WAAS Specification	3.2.3	Processing Requirements										Title
WAAS Specification	3.2.3.1	System Capacity	A	D	D	X	I		X		X	
WAAS Specification	3.2.3.1.1	U.S. WAAS	A	D	D	X	D		X		X	
WAAS Specification	3.2.3.1.2	International Expansion	A	D	D	X	D		X		X	
WAAS Specification	3.2.3.2	Software Development Requirements	D	D	D	X	I		X		X	
WAAS Specification	3.2.3.3	Computer Hardware										Title
WAAS Specification	3.2.3.3.1	Computer Resource Reserve Capacity	D	D	D	X	I		X		X	

Document Title	Paragraph Number	Requirement Description	Contractor Testing				FAA Testing				Remarks
			DT&E at the Contractor Facility	DT&E using the FVS	DT&E using the initial WAAS	PAT&E (FAT, SAT)	OT&E/ Operational & Integration	OT&E/ Shakedown	Field Shakedown		
WAAS Specification	3.2.3.3.2	Computer Memory	A	X	X	X	I	X	X		
WAAS Specification	3.2.3.3.2.1	Volatile Memory	A	D	D	X	I	X	X		
WAAS Specification	3.2.3.3.2.2	Non-Volatile Memory	A	X	X	X	I	X	X		
WAAS Specification	3.2.3.3.2.3	Memory Increase Capability	A	X	X	X	I	X	X		
WAAS Specification	3.2.3.3.3	Processing Speed	A	D	D	X	I	X	X		
WAAS Specification	3.2.4	Signal Processing Requirements									Title
WAAS Specification	3.2.4.1	Sensitivity and Dynamic Range									Title
WAAS Specification	3.2.4.1.1	L1-C/A Signal Processing Requirements	A	D	D	X	D	X	D		
WAAS Specification	3.2.4.1.2	L1-P(Y) and L2-P(Y) Signal Processing Requirements	A	D	D	X	D	X	D		
WAAS Specification	3.2.4.2	RF Interference Rejection									Definition
WAAS Specification	3.2.4.2.1	In-Band									Definition

Document Title	Paragraph Number	Requirement Description	Contractor Testing				FAA Testing				Remarks
			DT&E at the Contractor Facility	DT&E using the FVS	DT&E using the initial WAAS	PAT&E (FAT, SAT)	OT&E/ Operational & Integration	OT&E/ Shakedown	Field Shakedown		
WAAS Specification	3.2.4.2.1.1	Interferer Above 5 Degrees Elevation	A,D	D	D	X	D	X	D	Initial WAAS reqmt in addendum.	
WAAS Specification	3.2.4.2.1.2	Interferer Below 2.5 Degrees Elevation	A,D	D	D	X	D	X	D		
WAAS Specification	3.2.4.2.1.3	Interferer Between 2.5 and 5 Degrees Elevation	A,D	D	D	X	D	X	D		
WAAS Specification	3.2.4.2.2	Out-of-band								Definition	
WAAS Specification	3.2.4.2.2.1	CW Interferer above 5 Degrees Elevation	A,D	D	D	X	D	X	D	I	
WAAS Specification	3.2.4.2.2.2	CW Interferer, Below 2.5 Degree Elevation	A,D	D	D	X	D	X	D		
WAAS Specification	3.2.4.2.2.3	CW Interferer, Between 2.5 and 5 Degree Elevation	A,D	D	D	X	D	X	D		
WAAS Specification	3.2.4.2.3	Special Interference Rejection Capability								Description	
WAAS Specification	3.2.4.2.3.1	Spatial Mitigation	A,D	D	D	X	D	X	D	Title	



Document Title	Paragraph Number	Requirement Description	Contractor Testing				FAA Testing				Remarks
			DT&E at the Contractor Facility	DT&E using the FVS	DT&E using the initial WAAS	PAT&E (FAT, SAT)	OT&E/ Operational & Integration	OT&E/ Shakedown	Field Shakedown		
WAAS Specification	3.2.4.2.3.1.1	Dynamic Steering	A,D	D	D	X	D	X	D	Waived for initial WAAS.	
WAAS Specification	3.2.4.2.3.1.2	Antenna Pattern Nulls	A,D	D	D	X	D	X	D	Waived for initial WAAS.	
WAAS Specification	3.2.4.2.3.2	Temporal Mitigation	A,D	D	D	X	D	X	D	Title	
WAAS Specification	3.2.4.2.3.2.1	Temporal Filtering	A,D	D	D	X	D	X	D	Waived for initial WAAS.	
WAAS Specification	3.2.4.2.3.2.2	Temporal Rejection	A,D	D	D	X	D	X	D	Waived for initial WAAS.	
WAAS Specification	3.2.4.2.3.2.3	Temporal Interference Suppression	A,D	D	D	X	D	X	D	Waived for initial WAAS.	
WAAS Specification	3.2.4.2.3.2.4	Pulse Blanking	A,D	D	D	X	D	X	D	Waived for initial WAAS.	
WAAS Specification	3.2.4.2.3.3	Allowable Degradation	A,D	D	D	X	D	X	D	Waived for initial WAAS.	
WAAS Specification	3.2.4.2.4	GEO Uplink Protection	A,D	T	T	T	T	X	D		
WAAS Specification	3.2.4.2.4.1	Interference Protection	A,D	T	T	T	T	X	D		
WAAS Specification	3.2.4.2.4.2	HMI Protection	A,D	T	T	T	T	X	D		
WAAS Specification	3.2.5	Interface Requirements								Title	

Document Title	Paragraph Number	Requirement Description	Contractor Testing				FAA Testing				Remarks	
			DT&E at the Contractor Facility	DT&E using the FVS	DT&E using the initial WAAS	PAT&E (FAT, SAT)	OT&E/ Operational & Integration	OT&E/ Shakedown	Field Shakedown			
WAAS Specification	3.2.5.1 (a to d)	External Interface Requirements										Lead-in
WAAS Specification	3.2.5.1.1	GPS Satellites to the WAAS	T	T	T	X	X	D	D	D		
WAAS Specification	3.2.5.1.2	WAAS to User	T	T	T	X	X	D	D	D		
WAAS Specification	3.2.5.1.3	WAAS to NAS	T	T	T	X	X	D	D	D		
WAAS Specification	3.2.5.1.4	NAS to WAAS	T	T	T	X	X	D	D	D		
WAAS Specification	3.2.5.2	Internal Interface Requirements	D	D	D	X	I	X	X	X	X	
WAAS Specification	3.2.6 (a to d)	Ground Based Electronic Equipment Characteristics	A	X	X	X	I	X	X	X	X	
WAAS Specification	3.2.6.1	Electrical	A	D	D	D	X	I	I	X	X	
WAAS Specification	3.2.6.2	Mechanical	A	D	D	D	X	I	I	X	X	
WAAS Specification	3.2.6.3	Interior Equipment Design Ranges	A	D	D	D	X	I	I	X	X	
WAAS Specification	3.2.6.3.1	Attended Interior Equipment Design Ranges	A	D	D	D	X	I	I	X	X	

Document Title	Paragraph Number	Requirement Description	Contractor Testing				FAA Testing				Remarks
			DT&E at the Contractor Facility	DT&E using the FVS	DT&E using the initial WAAS	PAT&E (FAT, SAT)	OT&E/ Operational & Integration	OT&E/ Shakedown	Field Shakedown		
WAAS Specification	3.2.6.4	Exterior Equipment Design Ranges	A	D	D	D	D	X	I	X	
WAAS Specification	3.2.7	System Quality Factors									Title
WAAS Specification	3.2.7.1	Reliability									Title
WAAS Specification	3.2.7.1.1	WAAS Reliability & Redundancy	A	D	D	D	D	D	D	D	
WAAS Specification	3.2.7.1.2	WAAS Line Replaceable Unit (LRU)	A	D	D	D	D	D	D	D	
WAAS Specification	3.2.7.1.3	WAAS Reliability & Availability	A	D	D	D	D	D	D	D	
WAAS Specification	3.2.7.2	Maintainability	A,D	D	D	D	D	D	D	D	
WAAS Specification	3.2.7.2.1	Mean Time To Repair (MTTR)	A	D	D	D	D	D	D	D	
WAAS Specification	3.2.7.2.2	Initialization time	A,T	D	D	D	D	D	D	D	
WAAS Specification	3.2.7.2.3	Periodic Maintenance Interval	A	D	D	D	D	D	D	D	
WAAS Specification	3.2.7.2.4	PM Service Interruptions	A,T	D	D	D	D	D	D	D	

Document Title	Paragraph Number	Requirement Description	Contractor Testing				FAA Testing				Remarks
			DT&E at the Contractor Facility	DT&E using the FVS	DT&E using the initial WAAS	PAT&E (FAT, SAT)	OT&E/ Operational & Integration	OT&E/ Shakedown	Field Shakedown		
WAAS Specification	3.2.7.2.5	Corrective Maintenance Service Interruption	A, T	D	D	D	D	D	D	D	
WAAS Specification	3.2.7.2.6	Redundant Equipment Switching	A, T	D	D	D	D	D	D	D	
WAAS Specification	3.2.8	WAAS Network Time (WNT)									Title
WAAS Specification	3.2.8.1	WNT/GPS Time Maintenance	A, T	T	T	X	T	X	D	D	
WAAS Specification	3.2.8.2	WNT/UTC Time Maintenance	A, T	T	T	X	T	X	D	D	
WAAS Specification	3.2.8.3	GEO Satellite Link Clock Stability	A	T	T	X	T	X	D	D	
WAAS Specification	3.2.9	Fail-Safe Fail-Soft Operation	A, T	T	T	D	T	X	D	D	
WAAS Specification	3.2.10	Personnel Safety	A	D	D	D	I	I	D	D	
WAAS Specification	3.2.11	Human Engineering	A, D	D	D	D	D	D	D	D	
WAAS Specification	3.2.12	System Security	X	D	D	D	I	I	D	D	

## Appendix 4: Definitions and Acronyms

### 1.0 Definitions

The terms in the section are used throughout this specification and are defined below. Also see FED-STD-1037. The standard DOD GPS terms are described in Section 5.1 - System Overview.

**Accuracy.** The degree of conformance between the estimated or measured position or velocity of a platform at a given time and its true position or velocity. Radionavigation system accuracy is usually presented as a statistical measure of system error. (FRP) (Accuracies, as used in this specification, for horizontal position, vertical position, and pseudorange are defined in paragraph 3.2.1.1.2.)

**Alarm Condition.** Error condition at which an alarm will be generated. (Alarm condition, as used in this specification, is defined in paragraph 3.2.1.1.3.4.)

**Availability.** The availability of a navigation system is the percentage of time that the services of the system are usable. Availability is an indication of the ability of the system to provide usable service within the specified coverage area (volume). Signal availability is the percentage of time that navigational signals transmitted from external sources are available for use. Availability is a function of both the physical characteristics of the environment and the technical capabilities of the transmitter facilities (signal generation). (FRP). (Availability, as used in this specification, is defined in paragraph 3.2.1.1.1.)

**Augmentation (Of GPS).** Technique of providing the GPS with input information, in addition to that derived from the main GPS constellation in use, which provides additional range (pseudorange) inputs or corrections to, or enhancements of, existing pseudorange inputs. This augmentation enables the system to provide performance which is enhanced relative to that possible with the basic GPS satellite information only.

**Barometric Altitude.** Geopotential altitude in the earth's atmosphere above mean standard sea level pressure datum plane, measured by a pressure (barometric) altimeter. (RTCA/DO-208)

**Component (System Component) (Subsystem).** The individual parts of the WAAS, such as WRSs and WMSs.

**Continuity of Function.** The probability that the navigation accuracy and integrity requirements will be supported throughout a flight operation or flight hour given that they are supported at the beginning of the flight operation or flight hour and that the flight operation is initiated and predicated on the operation of the function. (Continuity of function and the associated continuities of navigation and fault detection, as used in this specification, are defined in paragraph 3.2.1.1.4.)

**Correction Messages.** The messages from the WAAS, defined in appendix 2, that contain the fast and slow pseudorange corrections and that are used to correct the user clock, the ephemeris corrections, and the messages that define the ionospheric model that are used to correct the ionospheric errors.

**Coverage.** Surface area of space volume in which the signals are adequate to permit the user to determine position to a specified level of accuracy. Coverage of GPS is influenced by the number of satellites, system geometry, signal power levels, receiver sensitivity, atmospheric noise conditions and other factors which affect signal availability. (FRP) (WAAS coverage is specified by the service volumes in paragraphs 3.2.1.2.6 and 3.2.1.3.6.)

**Differential.** An augmentation for the purpose of improving GPS accuracy by determining GPS position errors at one or more known locations and subsequently transmitting derived correction information to other GPS receivers in order to enhance the accuracy of the position estimate.

**Dilution Of Precision (DOP).** Measure of how satellite geometry affects position determination and time accuracy. It is the ratio of the standard deviation of the position error to the standard deviation of the measurement errors, assuming all measurement errors are statistically independent and have a zero mean and the same standard distribution.

**Distance Root Mean Square (DRMS).** The root-mean-square value of the distances from the true location point of the position fixes in a collection of measurements. (FRP).

**"Don't Use" Message.** The message from the WAAS that tells the user not to use a particular satellite or IGP.

**En Route.** A phase of navigation covering operations between departure and termination phases. En route phase of navigation has two subcategories: en route domestic/continental and en route oceanic. (FRP).

**Ephemeris Data.** Set of data used to predict satellite location at any time.

**Equipment.** The individual items of equipment within a WAAS component, such as a receiver or a processor.

**Failure (maintenance).** A failure is defined as having occurred any time a maintenance alarm or alert is generated.

**Geostationary.** An equatorial satellite orbit that results in a constant fixed position of the satellite over a particular earth surface reference point on the equator.

**Geostationary Earth Orbit (GEO) Satellite.** The communication satellite with a payload that receives the WAAS messages from the Ground Earth Station and transmits them on the GPS L1 frequency, so the appropriately designed user equipment will be able to receive and implement these messages and use the signal as a ranging source.

**Grid Ionospheric Vertical Error (GIVE).** A bound on the residual error of the vertical ionospheric delay at an Ionospheric Grid Point (IGP).

**Ground Earth Station (GES).** The satellite ground station that supports the geostationary relay satellite. It will receive the data for the WAAS messages from the WMS, generate WAAS messages, integrate them with a GPS look-a-like ranging signal, and transmit them to the geostationary relay satellite in the appropriate uplink frequency.

**Hazardously Misleading Information (HMI).** Data that is being used that is invalid.

**Horizontal Radial Error.** The difference between the estimated or measured position, velocity, or time of a platform and its true position, velocity, or time in the horizontal plane.

**Integrity.** The ability of a system to provide timely warnings to users when the system should not be used for navigation (FRP). (Integrity, as used in this specification, is defined in paragraph 3.2.1.1.3.)

**Integrity Message.** For the WAAS there are two integrity messages: (1) "Don't Use" messages that apprise the user not to use a particular satellite or Ionospheric Grid Point (IGP), and (2) "Not Monitored" messages that apprise the user that the WAAS cannot determine the integrity of a particular satellite or IGP.

**Ionospheric Grid Point (IGP).** Geographic points where ionospheric vertical delay estimates are made and corrections will be broadcast depending on an IGP mask. (Appendix 2, paragraph 4.4.9)

**Ionospheric Pierce Point.** Point where the line drawn between the GPS satellite and the receiver pierces the ionosphere. (Appendix 2, paragraph 4.4.10)

**Latency.** Delay between the reception of the measurement of the GPS/WAAS SIS at a data collection site and the arrival of an associated message at a user.

**L-Band.** Portion of the electromagnetic spectrum used by GPS to broadcast its navigation signals. GPS uses two L-Band links: Link 1 At 1575.42 MHz and Link 2 At 1227.6 MHz.

**Line Replaceable Unit (LRU).** An item which may consist of a unit, an assembly (circuit card assembly, electronic component assembly, etc.), a subassembly or part, that is removed and replaced at the site maintenance level in order to restore the system/equipment to its operational status.

**Maintainability.** Ability of a system to be restored to operational readiness within defined time intervals and prescribed personnel, facilities and equipment resources.

**Mask Angle.** The elevation angle measured from the horizontal plane tangent to the earth at the antenna to the minimum angle where the satellites data will be received and processed.

**Mean Time Between Failure (MTBF).** Average length of time for which the system, or a component of the system, works without fault.

**Mean Time To Repair (MTTR).** Average length of time required to perform corrective maintenance on a failed device.

**Navigation.** The means by which an aircraft is given guidance to travel from one known position to another known position. The process involves referencing the actual aircraft position to a desired course. (RTCA/DO-208).

**Nonprecision Approach.** A standard instrument approach procedure in which no glideslope/glidepath is provided. (FAA Document 7110.65).

**"Not Monitored" Message.** The message from the WAAS that tells the user that a particular satellite or IGP is not being monitored by the WAAS.

**Phase Of Flight.** Periods of navigation with different procedures/criteria, such as en route, terminal approach, and landing.

**Phase Of Operation.** Period of navigation with a constant required navigation performance (RNP). (RTCA/DO-217).

**Position Error.** The difference between the measured position and the actual position.

**Precision Approach.** A standard instrument approach procedure in which a course and glideslope/glidepath is provided. (FAA Document 7110.65).

**Pseudorange.** The distance between a user and a satellite as measured by the time of travel of the signal which contains several errors sources, such as clock biases, ephemeris predictions, ionospheric/tropospheric delays, etc.

**Pseudorange Error.** The difference between the pseudorange calculated by the user equipment and the "true" range. The "true" range is defined as the range from the known user equipment antenna location to the satellite position as determined from the corrected satellite ephemeris data from the navigation data message.

**Radionavigation.** The determination of position, or the obtaining of information relating to position, for the purposes of navigation by means of the propagation properties of radio waves. (FRP).

**Range Residual.** The difference between a measured range from a GPS satellite to the user and the "true" range between the GPS satellite and the user.

**Receiver Autonomous Integrity Monitoring (RAIM).** A technique whereby a civil GPS receiver determines the integrity of the GPS navigation signals without reference to sensors or non-DOD integrity systems other than the receiver itself. This determination is achieved by a consistency check among redundant pseudorange measurements. (RTCA/DO-208).



**Required Navigation Performance (RNP) System.** An air navigation system that meets all navigation requirements without the need for any other navigation equipment on board the aircraft. This term is used in place of the more customary sole means navigation system.

**Selective Availability (SA).** A set of techniques for denying the full accuracy and selecting the level of positioning, velocity, and time accuracy of GPS available to users of the Standard Positioning Service signal.

**Sensor Error.** The part of the error budget contributed by the navigation sensor. It is root-sum-squared with the other error components to determine the navigation source error.

**Site.** A location where WAAS components are installed.

**System.** The entire WAAS.

**Supplemental System.** An air navigation system that can be used alone without comparison to another approved navigation system; however, another approved navigation system must be on board the aircraft and usable if the supplemental system is not available.

**Terminal Area.** A general term used to describe airspace in which approach control service or airport traffic control service is provided. (RTCA/DO-208).

**Time To Alarm.** The time from an out-of-tolerance condition until user (pilot) notification. (Time to alarm, as used in this specification, is defined in paragraph 3.2.1.1.3.3.)

**Total System Error.** The root-sum-square of the navigation source error, airborne component error, display error and flight technical error.

**Undetected Error.** An error is undetected if the predicted maximum position error based on the geometry, User Differential Range Error (UDRE), User Ionospheric Vertical Error (UIVE), and estimated avionics error (or based on another means of integrity monitoring such as RAIM) is less than the alarm limit while the actual error exceeds it.

**User Differential Range Error (UDRE).** 99.9% confidence bound of the combination of the long term clock and ephemeris satellite errors and fast corrections error for a designated satellite.

**User Ionospheric Vertical Error (UIVE).** 99.9% confidence bound on the user-computed vertical ionospheric delay error, after correction.

**Validation (of WAAS SIS performance).** Process whereby the SIS performance is monitored and determined to be within specification.

**Verification (of WAAS data).** Process whereby the data provided to WAAS users is either: (1) compared to data derived from independently observed measurements, or (2) combined with independently observed measurements and the results is compared to the expected result.

**Wide-Area Augmentation System (WAAS).** The total FAA system that is being designed and built to meet the mission needs of insuring satellite integrity for using GPS for required navigation performance (RNP) in the NAS and of improving accuracy to support precision approaches using GPS augmented with the WAAS.

**WAAS Messages.** The messages, defined in RTCA Report, "GIC/GNSS User Equipment Interface Equipment Specifications", that the WAAS will broadcast to the GPS aviation users.

**WAAS Receiver, Standard.** A GPS/WAAS receiver complying with the minimum requirements of RTCA/DO-229, Change 3.

**WAAS Signal In Space (SIS).** The WAAS Signal In Space is defined as the total of the signals that are broadcast by the WAAS and are available to the aviation users and meet the WAAS SIS performance requirements.

**Wide Area Master Station (WMS).** Data processing sites which process data from the WRSs.

**Wide Area Reference Stations (WRS).** Widely dispersed sites which collect satellite data from GPS and GEO satellites.

## 2.0 Acronyms

AC	Alternating Current
AF	Airway Facilities
AORW	Atlantic Ocean Region West
BPSK	Binary Phase Shift Keying
BW	Band Width
C/A	Coarse Acquisition
CAI	Contract Acceptance Inspections
CASE	Computer Aided Software Engineering
CONUS	Conterminous United States
COTS	Commercial Off the Shelf
CPU	Central Processing Unit
CRC	Cyclic Redundancy Check
CSCI	Computer Software Configuration Item
CW	Continuous Wave
DGNSS	Differential GNSS (ICAO)
DOD	Department of Defense
DOP	Dilution of Precision
DQT	Design Qualification Testing
DRMS	Distance Root Mean Square
DT&E	Development Test and Evaluation
ECEF	Earth Centered Earth Fixed
FAA	Federal Aviation Administration
FAT	Factory Acceptance Testing
FEC	Forward Error Correction
FRP	Federal Radionavigation Plan
FTE	Flight Technical Error
FVS	Functional Verification System
GEO	Geostationary Earth Orbit
GES	Ground Earth Station
GIVE	Grid Ionospheric Vertical Error
GIVEI	Grid Ionospheric Vertical Error Indicator
GLONASS	Global Navigation Satellite System (Russia)
GNSS	Global Navigation Satellite System (ICAO)
GPS	Global Positioning System
<u>HAL</u>	<u>Horizontal Alert Limit</u>
HDOP	Horizontal Dilution of Precision
HMI	Hazardously Misleading Information
I/S	Interference/Signal
ICD	Interface Control Document
ICMLS	Interim Contractor Maintenance and Logistic Support
IGP	Ionosphere Grid Point
INMARSAT	International Maritime Satellite
IOD	Issuance of Data
IODC	Issuance of Data Clock
IODE	Issuance of Data Ephemeris
IODF	Issue of Data for Fast Corrections
IODI	Issuance of Data Ionosphere

IODP	Issuance of Data PRN
IPP	Ionospheric Pierce Point
L1	Radio Frequency Link 1 (GPS)
L2	Radio Frequency Link 2 (GPS)
<u>LNAV/VNAV</u>	<u>Lateral Navigation/Vertical Navigation</u>
LRU	Line Replaceable Unit
LSB	Least Significant Bit
MSB	Most Significant Bit
MTBF	Mean Time Between Failures
MTP	Master Test Plan
MTTR	Mean Time to Repair
NAS	National Airspace System
NDI	Non-Developmental Items
NPA	Non-Precision Approach
OCC	Operational Control Center
PAT&E	Production Acceptance Test and Evaluation
PM	Periodic Maintenance
PRN	Pseudo-Random Noise
Q	Qualcomm Corporation
QA	Quality Assurance
RAIM	Receiver Autonomous Integrity Monitoring
RAM	Random Access Memory
RF	Radio Frequency
RMMS	Remote Maintenance Monitoring System
RNP	Required Navigation Performance
RRC	Range-rate Corrections
RTCA	RTCA, Incorporated
SA	Selective Availability
SAT	Site Acceptance Testing
SCAT-1	Special Category 1
<u>SF</u>	<u>Scale Factor</u>
SIS	Signal in Space
SPS	Standard Positioning Service
sps	symbols per second
TOW	Time of Week
U.S.	United States
UDRE	User Differential Range Error
UDREI	User Differential Range Error Indicator
UIVE	User Ionospheric Vertical Error
UTC	Universal Coordinated Time
<u>VAL</u>	<u>Vertical Alert Limit</u>
VDOP	Vertical Dilution of Precision
VRTM	Verification Requirements Traceability Matrix
WAAS	Wide Area Augmentation System
WMS	Wide-area Master Station
WN	Week Number
WNT	WAAS Network Time
WRS	Wide-area Reference Station