

# PROCEEDINGS

## Fifth Annual Gulf of Mexico Information Transfer Meeting

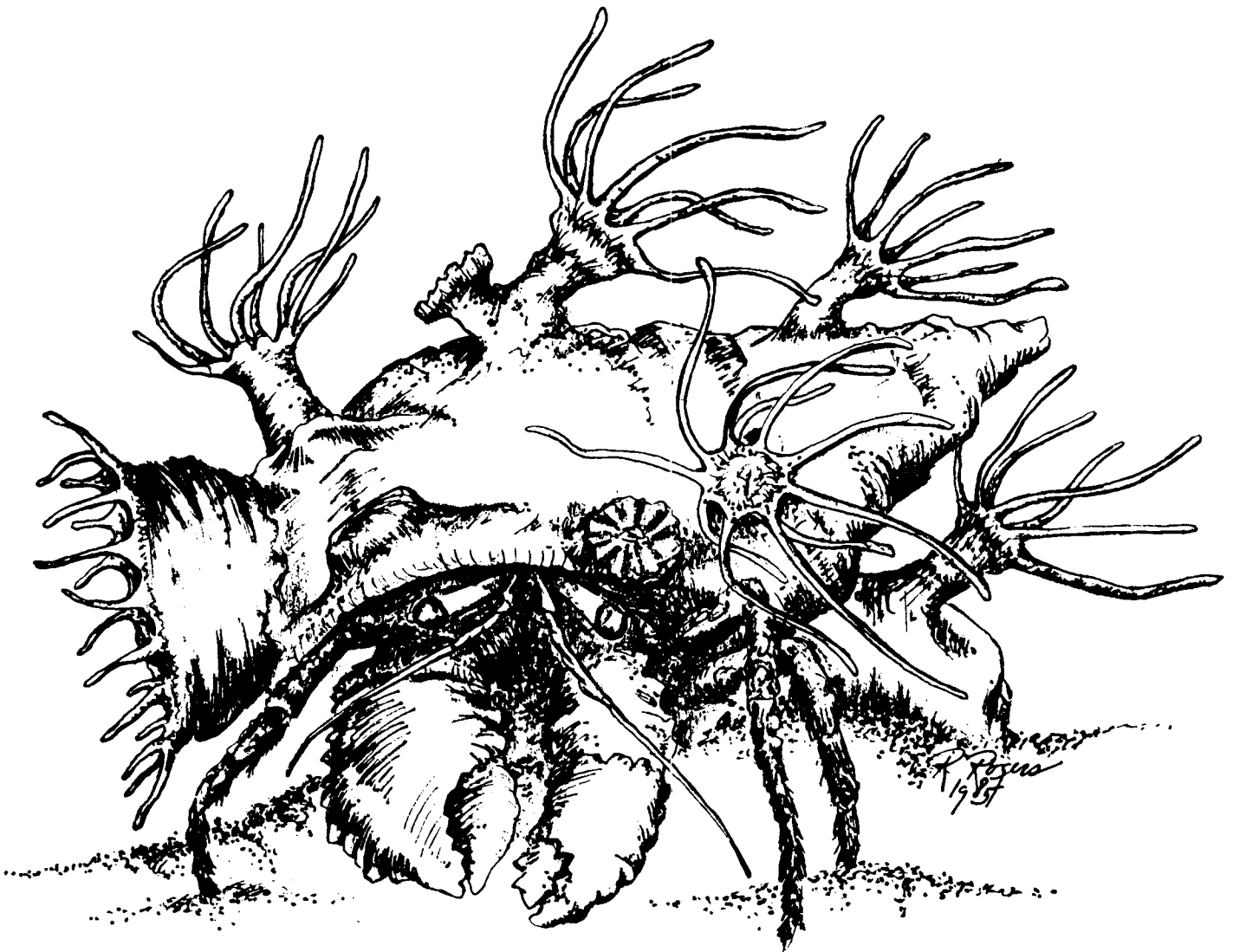

PROCEEDINGS  
FIFTH ANNUAL GULF OF MEXICO  
INFORMATION TRANSFER MEETING

International Hotel  
New Orleans, Louisiana  
27-29 November 1984

SPONSORED BY  
DEPARTMENT OF THE INTERIOR  
MINERALS MANAGEMENT SERVICE  
GULF OF MEXICO OCS REGIONAL OFFICE

Arrangements Handled by

Science Applications Incorporated  
Raleigh, North Carolina

and

Department of Conferences and Workshops  
University of Southern Mississippi  
Long Beach, Mississippi

#### DISCLAIMER

This report has been reviewed by the Minerals Management Service and approved for publication. Approval does not signify that the contents necessarily reflect the views and policies of the Service, nor does mention of trade names or commercial products constitute endorsement or recommendation for use.

#### REPORT AVAILABILITY

Preparation of this report was conducted under Contract between the Minerals Management Service and Science Applications, Inc./University of Southern Mississippi. Extra copies of the report may be obtained from the Public Information Section (Mail Stop OPS-3-4) at the following address:

Minerals Management Service  
Gulf of Mexico OCS Regional Office  
U.S. Department of the Interior  
P.O. Box 7944  
Metairie, Louisiana 70010  
Attn: Public Information Section  
Phone: (504) 838-0519



## PREFACE

The purpose of these Proceedings is to present an overview of major Gulf of Mexico environmental studies programs as presented in the MMS Fifth Annual Information Transfer Meeting held November 27-29, 1984. In order to keep this document to a manageable size, technical description and study results were edited to provide only the briefest description of program objectives. As a result, the Proceedings should be viewed as a reference to studies programs rather than a presentation on their technical content. Further explanations of study objectives and findings should be obtained from either the individual investigator or the responsible government agency. It should be noted that under the presentation titles are the names of the speakers and their respective affiliations. A complete address for all speakers and participants is included in the List of Attendees.

Special thanks are extended to session chairs and speakers, who are responsible for the success of the meeting. The Department of Conferences and Workshops of the University of Southern Mississippi is to be commended for the excellent editorial work done in ensuring the coherence of this document. Special appreciation is also extended to all meeting participants. The active involvement of such an informed group provided the necessary impetus for many stimulating and enlightening exchanges.

Copies of this document may be obtained from the National Technical Information Service (NTIS).

Cover Illustration: "Microbiocoenosis, a community within a community" by  
Dr. Robert Rogers

## TABLE OF CONTENTS

<b>Preface</b>	v
<b>List of Tables</b>	ix
<b>List of Figures</b>	x
<b>Opening Plenary Session, Dr. Richard Defenbaugh, Chair</b>	1
<b>Gulf of Mexico Special Concerns, Mr. William T. Johnstone, Chair</b>	35
<b>Wetlands Loss: Contributing Factors and Potential Mitigating Measures, Dr. Norman Froomer and Dr. Carolyn French, Chairs</b>	49
<b>Commercial Fisheries Concerns Relative to Oil and Gas Activities, Mr. Dan Tabberer and Mr. Jacob Lehman, Chairs</b>	115
<b>Development and Use of Ecological Models, Dr. Robert Rogers and Mr. Lawrence Handley, Chairs</b>	141
<b>Marine Data Archiving and Indexing, Dr. Murray Brown, Chair</b>	165
<b>Technology Assessment and Research Program for Offshore Minerals Operations, Mr. John B. Gregory and Mr. Charles Smith, Chairs</b>	195
<b>Socioeconomics, Mr. John Rodi, Chair</b>	239
<b>Rigs to Reefs, Mr. Villere Reggio, Jr. and Mr. William DuBose, IV, Chairs</b>	295
<b>The Deep Sea, Dr. Robert Avent and Dr. Eenny Gallaway, Chairs</b>	343
<b>Physical Oceanography, Dr. Murray Brown, Chair</b>	383

Current Studies in Underwater Archaeology, Ms. Melanie Stright, Chair	443
Index to Authors	463
List of Attendees	467

## LIST OF TABLES

	Page
Table 1: Connectivity matrix showing inputs outputs, processes and regulators for a continental shelf ecosystem.	155
Table 2: Summary of the regional demersal nekton and environmental data sets integrated into the Tuscaloosa Trend Project data base.	161
Table 3: Information products important in the management of ecological data.	178
Table 4: Ten-year history of lease offering on Texas submerged lands in calendar years.	286
Table 5: Ten years of total revenue from Texas submerged lands by fiscal years.	287
Table 6: Ten year history of income from leasing Texas submerged lands, separated into rental, bonus and royalty.	288
Table 7: Leg 96 drilling sites.	364

## LIST OF FIGURES

	Page
Figure 1. The CO <sub>2</sub> -sea level connection.	62
Figure 2. The rise of global mean sea level compared to atmospheric carbon dioxide.	63
Figure 3. Plot of radiocarbon-dated sea-level indicators (0-16,000 years B.P.) for the northeast coast of the United States. High latitude departures from present sea level indicate post-glacial isostatic rebound while lower latitude excursions represent peripheral bulge subsidence, all indicative of geoidal changes.	66
Figure 4. Location of the 168 radiocarbon-dated sea-level indicators used to plot sea-level data on Figure 5.	67
Figure 5. Elevation/time plot of 168 sea-level indicators for the Gulf Coast region.	68
Figure 6. Composite and individual growth curves of the Mississippi River subdeltas showing their relationship to a 7-year moving average of Mississippi River discharge, 1917-1977, taken from the USACOE gauging station at Vicksburg.	72
Figure 7. Principal areas of marsh losses in Dorchester County, Maryland, showing the approximate location of the Blackwater National Wildlife Refuge.	87
Figure 8. Annual mean-high-water shoreline changes along the western shore of Delaware Bay averaged over the last century.	90
Figure 9. Comprehensive Freshwater Diversion Plan.	110
Figure 10. Status of Comprehensive Freshwater Diversion Plan.	111
Figure 11. The Tuscaloosa Trend study area.	151
Figure 12. Boundaries for Tuscaloosa Trend OCS region.	154
Figure 13. Conceptual representation of Tuscaloosa Trend ecosystem.	156
Figure 14. Conceptual model of East Flower Garden Reef.	164

Figure 15. Pump start-up techniques with choke line friction.	208
Figure 16. Typical choke pressure errors observed during pump start up.	209
Figure 17. Observed and predicted pressure profiles while circulating a 15 bbl gas kick from the well.	210
Figure 18. Effective frictional area for a 1.75-in. Swaco drilling choke.	211
Figure 19. Predicted and measured pressure changes in a vertical choke line flowing gas and mud.	212
Figure 20. The skimming arrangement used to collect the oil.	219
Figure 21. The integral boom-skimmer-ship system for large volume oil collection.	219
Figure 22. The performance of laboratory scale subsurface collectors.	219
Figure 23. A double collector which increases efficiency at non-optimum conditions.	220
Figure 24. Subsurface collector performance including scale effects.	220
Figure 25. Sketch of ship-mounted subsurface collection system.	220
Figure 26. Computer simulation of tension-pile behavior.	231
Figure 27. Typical hysteretic behavior of a model axial segment in clay.	232
Figure 28. Single-slice model for pile installation, consolidation, and loading simulation.	233
Figure 29. One-inch diameter pile test setup.	234
Figure 30. Three-inch diameter pile segment model.	235
Figure 31. 30-inch diameter pile and instrumentation details.	236
Figure 32. Integration of analysis and experiments for pile design.	237
Figure 33. Louisiana Econometric Model.	264
Figure 34. Seasonally adjusted unemployment rates in percent. (Sources: Louisiana Department of Labor and the University of Southwestern Louisiana)	272

Figure 35. Outline of disposition alternatives.	335
Figure 36. Eastern Gulf of Mexico with generalized outline of the youngest fan lobe, submarine fan divisions, main channel, and location of drill sites.	365
Figure 37. South Atlantic Phase 1 sampling design.	379
Figure 38. Mid-Atlantic Monitoring Study, sampling design.	379
Figure 39. Mooring locations during Year 2.	394
Figure 40. Summary of ship/plane tracklines during May 1984 hydrocruise.	394
Figure 41. Trajectory of most recent buoy (No. 3350) released in a Loop Current eddy in April 1984.	395
Figure 42. Current meter locations.	407
Figure 43. Box core locations.	407
Figure 44a. Instantaneous view of the interface deviation in a two-layer simulation of the Gulf of Mexico driven from rest to statistical equilibrium solely by inflow through the Yucatan Straits (Experiment 9).	418
Figure 44b. Depth of the 22 degree isothermal surface, 4-18 August 1966.	418
Figure 45. Instantaneous view of the interface deviation every 90 days, from day 90 of model year 9 to day 0 of model year 10, for Experiment 28 (left) and Experiment 34 (right).	419
Figure 46. Instantaneous view of the interface deviation every 20 days, from day 260 of model year 9 to day 0 of model year 10, for Experiment 34.	420
Figure 47a. Sea surface height variability for the Gulf of Mexico. Based on about 83,000 GEOS-3 and SEASAT crossovers, spanning nearly four years.	421
Figure 47b. Sea surface height variability for the Gulf of Mexico. Based on an ocean model simulation with port forcing only (Experiment 40), measured over three eddy cycles at statistical equilibrium with the free surface sampled every ten days for a total of over 300,000 "observations."	421
Figure 48. Instantaneous view of upper layer averaged velocities from Experiment 60 on model day 2170; velocities above 50 cm/sec are not shown.	422

Figure 49a. Paths of actual and simulated drifters: NDBO drifter 1599 from November 20, 1980, through May 11, 1981.	423
Figure 49b. Paths of actual and simulated drifters: Path of simulated drifter number 3 from model day 1680 to model day 1980 of Experiment 60.	423
Figure 50. Instantaneous view of upper layer averaged velocities from Experiment 68 on model day 3918.	424
Figure 51. Wind stress and wind stress curl for 0000 GMT and 1200 GMT 14 January 1976, and 0000 GMT 15 January 1976.	438
Figure 52. Wind stress and wind stress curl for similar plots for 14 and 15 July 1976.	439
Figure 53. Seasonal climatologies averaged over the period winter and spring 1967-1982.	440
Figure 54. Seasonal climatologies averaged over the period summer and fall 1967-1982.	441



RESPONSIBILITIES AND PRACTICES OF THE  
MMS GULF OF MEXICO REGIONAL OFFICE

Session: OPENING PLENARY  
Chairman: Dr. Richard Defenbaugh  
Date: November 27, 1984

<u>Presentation Title</u>	<u>Speaker/Affiliation</u>
Introduction to MMS Gulf of Mexico Regional Office Overview Presentations	Mr. John Rankin MMS, Gulf of Mexico Region
Keynote Address: The Fisheries Management Council	Mr. John Green Gulf of Mexico Fishery Management Council
Responsibilities and Practices of the Area Office for Offshore District Operations	Mr. William Martin MMS, Gulf of Mexico Region
Responsibilities and Practices of the Area Office for Resource Evaluation	Mr. Richard Scrivener MMS, Gulf of Mexico Region
Responsibilities and Practices of the Area Office for Leasing and Environment	Mr. Harold P. Sieverding MMS, Gulf of Mexico Region
Responsibilities and Practices of the Area Office for Rules and Production	Mr. Donald Solanas MMS, Gulf of Mexico Region
Responsibilities and Practices of the Area Office for Reserves and Development	Mr. Louis McBee MMS, Gulf of Mexico Region

INTRODUCTION TO MMS GULF OF MEXICO REGIONAL OFFICE  
OVERVIEW PRESENTATIONS

Mr. John Rankin  
Regional Director  
MMS, Gulf of Mexico Region

Welcome to this Fifth Annual Information Transfer Meeting. We want to urge your participation as has been so ably pointed out. That's what makes the thing go, your participation. We want to announce to you that the Pacific Region plans its own ITM meeting, I believe, in December; the Atlantic, in the spring or the summer; and Alaska has a continuing series of meetings that they call "synthesis meetings." We want to urge every one of you here that has an interest in those regions to make arrangements to attend these informative meetings.

New Orleans is famous for its food. Each one of you has, in effect, a menu for this meeting. I've looked over this menu carefully several times, and think you can order any item from it and you'll be well-pleased and you won't want your money back.

The first speaker will be Mr. John Green, Chairman of the Gulf of Mexico Fishery Management Council, who will deliver the keynote address. He will be followed by our regional supervisors who will describe in turn the functions of their offices. The first of these speakers is Mr. Harry Sieverding. Following him will be Mr. Richard Scrivener, Mr. Donald Solanas, Mr. Bill Martin, and Mr. Louis Mc3ee. These are gentlemen of long experience and proven ability with whom it has been my pleasure to work for many years. With you, I look forward to the presentations, and to an entirely successful meeting. Thank you.

## THE FISHERIES MANAGEMENT COUNCIL

Mr. John Green

Chairman, Gulf of Mexico Fisheries Management Council

The Fisheries Management Council and the Minerals Management Service have similar responsibilities in the federal exclusive economic zone of the Gulf. We're charged with management of living resources, whereas Minerals Management Service is charged with management of nonrenewable mineral resources. In many instances, our respective responsibilities complement each other. Some resources, such as coral, are a common responsibility to both agencies. And we share responsibility in maintaining and improving environmental conditions that support the living resources.

In this presentation, I'm going to try to weave in our activities as affected by Minerals Management Service's activities in the Gulf. And I think it would be well to bring to mind what the eight regional Fishery Management Councils are charged with.

The Gulf Council was established by Congress in 1976 as one of the eight councils charged with managing the fishery resources in federal waters. The Council is structured like a gulf-wide fisheries commission with representation from state regulatory agencies and from recreational and commercial fishing interests.

Management of fishery resources in the Gulf involves a partnership between the Council, the states, and federal agencies. Included in the membership of the Council is the Department of Interior, represented by the Regional Director of the U.S. Fish and Wildlife Service; the Department of Commerce, through the National Marine Fishery Service; the Department of State, through the Office of Fishery Affairs; the Department of Transportation, currently represented by Admiral William Stewart of the Eighth Coast Guard District, headquartered in New Orleans; and the Gulf States Marine Fisheries Commission. Since almost all of the fisheries occur

in both federal and state jurisdictions, under this partnership we take regulatory action in federal action, and the states implement compatible regulation within their jurisdictions. Also, in many instances, we have adopted state regulations for federal waters. Both the Council and the states are attempting to manage these resources for the greatest benefit to the user group and to the resource.

We also cooperate in the rigs-to-reef program, which was initiated by Secretary James Watt at the request of Minerals Management Service, and which has been carried forward by Secretary William Clark. We have long been active in supporting and advocating an artificial reef program.

In 1980 we began the development of a fishery plan to manage artificial reefs. Under this plan we developed general siting criteria for the placement of such reefs which not only provided for the maximum productivity from the reefs, but also provided safeguards for ensuring that valuable trawling bottoms and navigation interests were protected.

This initial effort at regional planning was short-lived as NOAA's general counsel stated that this was not a fishing activity and, therefore, was not authorized under the act. Under the new legislation our Artificial Reef Committee, which has continued to function and sit on various advisory panels related to the development of the current artificial reef program, will now become active and take part under the legislation in managing artificial reefs in federal waters.

It has been a pleasure for our Council's representatives to attend your Information Transfer Meetings. We especially recognize the importance of the information collected and disseminated by MMS related to fisheries management. Your research efforts provide us with a great deal of biological, economic, and social information that is very useful to us in managing the fishery resources of the exclusive economic zones. A number of these research studies provide us with extremely useful information on fishing effort and catches associated with offshore oil and gas structures. Two such excellent reports are the Open File Report analyzing fishery

utilization of 164 offshore rigs and the more recent publication on fishing offshore platforms in the central Gulf.

The MMS ecological characterization series includes not only important biological and ecological information on the coastal regions of each state, but also includes socio-economic characterization of the populace of these areas. This socio-economic information is also essential to us in assessing potential impacts of our proposed regulatory measures. The environmental impact statements prepared for proposed lease tracts also contain much information useful in preparing or updating fishery management plans.

I could go on citing scientific research and data gathering efforts conducted under MMS programs which provide our Council with needed information. These programs constitute probably the largest and certainly one of the most important research efforts in our region. We therefore are pleased to participate in your meeting and are a grateful recipient of your data.

The Gulf Council has developed management plans for six major fisheries occurring in the federal waters of the Gulf, all of which have been implemented by the Secretary of Commerce. These include plans for shrimp, reef fish, coastal migratory pelagics or mackerels, spiny lobster, stone crab, and coral resources. Plans for regulating swordfish and billfish fisheries are pending implementation. We've also completed draft plans or profiles for shark, ground fish, coastal herring and calico scallop fisheries. We have concluded that these are not necessary and in need of management now, but at such time a need is evidenced we have the profiles prepared and regulations prepared for implementation.

Our coral management plan, which provides for protection and scientific utilization of this ecologically important resource, was implemented as a direct result of loss of regulatory authority over coral sources by the Bureau of Land Management. Previously, BLM regulated how human activities impacted coral resources, but the Fifth Circuit Court of Appeals ruled that BLM regulatory authority applied only to coral in active

OCS lease tracts. Currently, we share regulatory authority over the coral resources, which are so important to reef fishes, with MMS and the Marine Sanctuaries Program of the National Marine Fishery Service.

Although coral resources except for pharmaceutical and scientific purposes are a non-consumptive resource, they are important to the productivity of associated reef fishes. These reefs also have esthetic value to divers, and they should be protected in the national interest.

Unfortunately, our regulations on coral were not implemented in time to provide protection for part of the Bright Bank Complex off Louisiana and Texas. This complex is reported to have been seriously damaged by an activity that under the coral plan is now forbidden. We believe that the current condition of this reef should be evaluated by the scientific community and, if damaged, a determination of its extent should be made. However, the National Marine Fisheries Service and the Gulf Fishery Council lack the funds to support such an activity. And we would hope the groups represented here could, through an interagency agreement, assist in this effort.

If funded, several important benefits would result. First, it would provide a base line to assess further damage if it should occur and allow the appropriate agency to take enforcement action. Second, and most important, it would allow assessment of recovery of the reef over time. And, last, it would also appear to benefit a lease tract holder in that area in documenting the damage that has been caused by others.

Our reef fish management plan regulates snapper and grouper resources throughout their range. MMS and the oil and gas industry have contributed greatly to the enhancement of these resources through the construction of artificial offshore habitats in the use of platforms. Information in our plan indicates that some of the reef fish species, principally red snapper, are being grossly over-fished as a result of excessive fishing pressure in the near-shore waters. Without significant production of additional offshore habitat by the oil and gas industries, this trend would certainly have been intensified. We hope, through programs

like rigs-to-reef, productivity of these offshore stocks could be maintained while we institute remedial measures in the near-shore fishery. Our Council, along with MMS, is involved in this important artificial reef program.

The continued productivity of fisheries, such as shrimp, are indicative that offshore mineral resource extraction could be managed to cause little or no detrimental impact on our living natural resources. These two industries, the shrimp fishery and the oil and gas industry, have co-existed for years in the gulf as good neighbors. We, through our management plan for shrimp, have been able to increase the poundage and value derived by that industry.

Cooperative closures with the states of Texas and Florida to protect juvenile shrimp have provided increased annual monetary yields from this resource. And the closure of all state and federal waters off Texas has been relatively clean and easy to enforce. In the first year of the closure, cases filed by Texas, within its nine-mile limit dropped from 171 to 24. The annual reviews of the Texas closure show that the combined closure is also achieving its goal of optimizing yield. The benefit of the combined closure in 1981 was an additional \$54.5 million for the industry, and in 1982 it was \$41.3. Over time we hope to increase yield for the industry through improved management techniques.

This, of course, emphasizes the importance of meetings such as this one where current research is made available to managers. In the Texas closure, as it is called, the waters off the state of Texas for some 25 years have been closed for an approximately 60-day period, usually in the summer. It has been set by statute to allow for maximization of shrimp yield. Shrimp, when they move in, as all of you are aware, run 5,000 count to the pound. When they leave to go back to deep water to mature, they are usually about 35 to 40 count to the pound. If you let them grow a little longer, then you're going to get a much greater yield. And that's what the Texas closure was all about.

Like all managers, we are constantly striving to improve our management systems through new information and approaches. Our fishery



management plans are, therefore, living documents under constant modification. We're currently involved in completely modifying our coastal pelagics plan based on new monitoring information. Unfortunately, our new information indicated there had been a severe decline in king mackerel stocks in the Gulf; and the stocks would continue to decline without actions to reduce harvest. In order to restore the stocks to production of maximum sustainable yield, we are amending the plan to provide for reduced commercial harvest quotas and recreational bag limits. By implementing these restrictions, annual yield should be increased by four million pounds within three to four years. We're also building in procedures to stabilize the catch at this high level or MSY.

Because the productivity of our fishery resources is so directly linked to the environmental condition of its habitat, we've become involved in examining the environmental consequences of developmental projects that may affect the fisheries we manage. Our habitat and environmental protection committee and the state advisory panels that support it have a good track record in realistically assessing both developmental needs and the environmental needs of the resources. As I indicated earlier, these two needs are not necessarily incompatible. Simply, there are correct ways and incorrect ways for man to utilize our environment. Some uses have minimal impacts on fishery resources and others have longlasting or irreversible impacts. Through our committees, we support those that best ensure continued productivity of these renewable resources.

All of us in this room should recognize the fact that under MMS development of our offshore mineral resources has been carried forward, and the results have been beneficial to the nation. We should also recognize that sensible regulations controlling this development had not protected the environment, but rather, from a fisheries standpoint, enhanced it. We congratulate you. We thank you for the opportunity to be a part of your meeting.

## RESPONSIBILITIES AND PRACTICES OF THE AREA OFFICE FOR OFFSHORE DISTRICT OPERATIONS

Mr. William Martin  
MMS, Gulf of Mexico Region

The regional office and six district offices of Offshore District Operations are responsible for the approval of all drilling, production, workover, and abandonment of operations. We are also responsible for conducting the field inspection program. To perform the functions that we're responsible for, Offshore District Operations is staffed with 40 engineers, geologists, and geophysicists; 57 petroleum engineering technicians--both drilling and production--who go out to inspect the drilling rigs, platforms and some pipelines; and 24 support personnel. This staffing is as of October 31, 1984.

Offshore District Operations supervision begins before any drilling by an operator in the Outer Continental Shelf (OCS) since an operator must submit an application for permit to drill to the appropriate district office. Offshore District Operations also oversees production operations. Production systems analysis includes a review of the proposed mechanical flow and safety systems schematic diagrams of the platform to ensure that the production systems conform to safety standards.

To facilitate the inspection of drilling and production operations the OCS orders have been condensed into a computerized checklist composed of questions that are answered by the inspection team, either positively for compliance, or negatively for non-compliance.

District operation inspection teams of petroleum engineering technicians travel to the OCS facilities daily by helicopter observing the water surface en route for any evidence of pollution. Presently we have ten helicopters, but we will add the eleventh in the Corpus Christi District in the near future. Inspections of drilling rigs and related equipment in the

Gulf of Mexico are conducted at least once during the drilling of each wildcat well and during the drilling of the first development well from a platform. Production facilities are inspected upon commencement of operations, and all platforms are inspected annually.

Here is the organizational chart for district operations for the Gulf of Mexico. They are the Lake Jackson District which is in Lake Jackson, Texas; and Lake Charles, Lafayette, Houma, Metairie, Louisiana. And, as I mentioned, the Corpus Christi District opened recently. We're not ready for business yet. A notice to lessees and operators will be coming out. We hope to start up officially about the middle of January when operators begin sending all their requests and applications.

The staffing of the Lafayette District is typical for all districts. We have the district supervisor, production engineer, drilling engineer, geologist, geophysicist, district clerk, clerk typist, the drilling unit and a production unit of petroleum engineering technicians needed to do inspections. Just recently we've added a person who will work with computers. We now have computers in the districts where we punch in our inspection statistics, well, and bore hole data into the computer in the Metairie Regional Office.

The boundaries of the Texas district will be divided between the new Corpus Christi District and the Lake Jackson District. The Corpus Christi District will include Mustang, Matagorda, North/South Padre, Corpus Christi, and Port Isabel.

Here's a map of the Gulf of Mexico showing where drilling and production activity has taken place. In Florida only drilling has taken place. Close to Mississippi, Alabama, and Louisiana and further on into Texas, we see drilling and production activity.

The following statistics are about one year old. Helicopters in the region fly about 480,000 miles per year. We inspect 3,100 platforms once a year. The statistics show we inspected 225 drilling rigs. Last Friday 262 drilling rigs were operating. Presently operating in the Gulf are 209 drilling

rigs. More than 1.2 million safety device items are inspected per year. Nine percent of the oil and 24% of the gas produced in the United States is produced in the Gulf. Gas is shown more to the western part of the Gulf and oil to the eastern part.

The mission of Offshore District Operations is for the protection of the environment and safety of operations. Betty Laprouse is our district clerk in the Lafayette Office. Nelson Meeks, the geophysicist in the Metairie District, reviews geophysical data for every drilling and platform application. He looks for shallow faults, shallow hazards, and mud slides. Joe Hennessy, our drilling engineer in the Metairie District, reviews all applications to drill and goes through calculations to determine if we feel the application is in compliance with our OCS order number two. Rufus Kirk, the production engineer in the Metairie District, primarily reviews all applications for production facilities to make sure that the application meets the requirements of our OCS order five. All of these facilities are approved by the district supervisor. This is the petroleum engineering drilling inspection team from the Metairie District looking at its board where we keep track of all the rigs presently operating or expected to begin operating in the Metairie District. Again, we show the drilling technicians as they look at a rig out in the Gulf, trying to determine how far out the flight will be for that day. This is T. C. Cabaniss in the Metairie District looking at the production board. We schedule the inspections on the board, and we know which particular inspection is coming up for that day. We try to schedule them a few days ahead of time. This is one of the sites in state waters that we fly over daily to inspect the drilling rigs and platforms. This presents another view flying over the canals. This is a typical helicopter on one of the helipads on a complex facility in the Gulf. This is one of the types of drilling rigs that we inspect. This is a submersible type rig that would be in shallow water, normally at a 30-50-foot range. Another type rig is a jack-up rig which would normally work in water depths ranging 100-200 feet plus, depending upon the size of the jack-up and the demand for that particular jack-up at the time. A work boat is backed up to the jack-up, probably unloading supplies. This is one of the big semi-submersibles. I'm sure most of you know that some of these rigs can work in water depths ranging up to 3,000

feet. Normally, they would very rarely be in a water depth less than 300 feet.

One thing we'd like to emphasize is that industry, as a result of these lease sales, is really making an all-out effort to drill in deep water. And from what we see on reports and logs and what we read in the trade journals, industry is making a number of discoveries in deep water. We made a survey and for 1984: industry expected to drill approximately 75 deep water wells in depths greater than 500 feet during year 1984. About a month ago they had drilled about 51 of these. Recently, I checked a scouting report, and at that time there were 16 rigs drilling in water depths greater than 1,000 feet. So, we're really moving out into the deep water. A few weeks ago I was offshore at a location in 1,500 feet of water, and I was just looking out over the horizon. We counted six other rigs. So, we really are into a new era as far as deep water is concerned.

Another type of rig that we see in the Gulf occasionally is a drilling tender. This is a tender supporting a platform where the drilling itself takes place on the platform, but all of the support equipment, power, mud, storage, and so forth are on the tender. Here is a ship-type rig which, depending on the size of the rig and whether it's dynamic positioned or whether it's anchored, can work in water depths up to 6,000 feet.

This is a blow-out preventer, which is used on all drilling rigs as safety equipment to try to prevent blow-outs. Notice one of our petroleum engineering technicians looking at the blow-out preventer.

On the vertical stand, there in the middle by the draw works, on the drill floor of the rig, is a drill string safety valve. That is one of the items that our drilling technicians check when they go on the rig. We have a checklist for drilling that has about 80 items that we check for safety on each trip to the drilling rig.

The roughneck is checking the kellycock for operation. If flow were coming up the drill pipe, this valve could be closed to prevent any blow-out.

We see a fire here from a well test. The fire is created because the well is being tested and the hydrocarbons are being burned. In most cases pollution is not created. If, by chance, pollution is detected, corrections to prevent that pollution must be made.

This is a complex of platforms. You'll notice two producing drilling rigs and two drilling rigs operating at the same time.

I'll point out the caisson for you who might not be familiar with it. It extends below the platform, and then the drill bit passes through the caisson and penetrates the mud line.

Here's another production platform, one of the smaller types, that our production technicians go on to inspect for compliance. Incidentally, our production checklist contains about 180 items which are inspected.

This is a sub-sea tree which is placed on the bottom to produce the oil. It is designed primarily for deep water. The oil would flow into a pipeline and go to some different platform.

Here is one of the vessels that we find on an offshore platform. At the top is some of the safety equipment which our people inspect. We have the level controls, the pilots, and the relief valves to prevent pollution and to provide a safer operation for the people involved.

Here's a typical facility on a platform showing a lot of the piping and the vessel discharge in salt water. This is a sub-surface safety valve that is installed down-hole. All of the wells in the Gulf of Mexico have to have one. And if a well-head or a valve is knocked off, the safety valve should shut-in preventing well flow. The valve in the hole seals to prevent flow if a ship hits the well-head or if it catches on fire and shut-in capability at the surface is post.

Here is a panel of the safety systems that we see on platforms. It gives the platform operator an idea where he has a problem. You can't see

it, but there are green lights or red lights. A green light means everything's fine; a red light indicates where the problem is, so the platform operator can go to that particular vessel or that particular problem area to correct it.

Here is a Christmas tree on an offshore platform. Notice all of those valves and the flow from the well comes up through this tree and goes on into a pipeline or a flow line.

This is a hydraulic manifold for a surface-operated sub-surface safety valve that keeps hydraulic pressure going down to these valves underground to hold the valve open. The valves are fail-safe closed, so if there's a loss of pressure, the valve closes.

This is a pipeline valve. Notice the vertical line going down toward the water. Oil may be pumped toward the platform or away from it, so the big valve is there to close in case there is a problem. So, if there's a leak in the line, the valve can be closed to keep pollution to a minimum.

This is the control for the level of a vessel. It would prevent an overflow and spillage. If there's a problem, this level control would shut in all the production and stop flow going into that vessel.

There's a pressure relief valve at the top of another vessel, which is one of the items that our technicians inspect daily on the platform.

This is the emergency shut-down, and you can also see a general alarm actuator. On that emergency shut-down, that particular lever can be pulled and everything on the platform will shut-in, including the sub-surface safety valves. If there is a fire or a problem, someone hits this lever and closes the operation down. There's always one at the heliport and one down at the boat landing. We have these emergency shut-down devices at a number of places on the platform, so if an emergency does occur there is more than one station where the platform could be shut-in.

This is the fire fighting unit, where people can fight a fire if one does occur. All the offshore people are trained in fire fighting.

## RESPONSIBILITIES AND PRACTICES OF THE AREA OFFICE FOR RESOURCE EVALUATION

Mr. Richard Scrivener  
MMS, Gulf of Mexico Region

The Resource Evaluation Program for the Gulf of Mexico Region began in 1968. We are a relative newcomer to offshore leasing. The program began in the old Conservation Division of the U.S. Geological Survey. The resource evaluation program was designed specifically to work closely with the Bureau of Land Management's offshore leasing program. The two programs are now both included in the organizational framework of the Minerals Management Service.

The work of resource evaluation in the Gulf of Mexico is keyed directly to the Department of Interior's five year Outer Continental Shelf Leasing Plan. The results of the work provide necessary geological, geophysical, engineering, and economic decision-making information pertinent to the awarding of leases under current agency fair market value policy guidelines and related criteria for the acceptability of bids.

The major functions of Resource Evaluation are: (1) to assess the geologic conditions and evaluate the oil and gas potential of the federal Outer Continental Shelf in the Gulf of Mexico; (2) to acquire, map, analyze geological, geophysical, engineering, and economic data and information to support bid adequacy determinations for the five-year leasing schedule; (3) to receive, process, and approve applications for permits to conduct geological and geophysical explorations for mineral resources and scientific research on unleased offshore acreage; and (4) to provide a data base and also technical support for other regional programs such as the reserve inventory program, section 8(g) matters, and other leasing, lease management, operational, and regulatory functions.



The Resource Evaluation staff has always been its strong suit. I'm proud of the Resource Evaluation staff. We have worked hard over the years to put it together. With our current mix of scientific and technical disciplines along with the depth of experience we have in the Gulf of Mexico, we are recognized nationally as being extremely competent in the field of offshore petroleum property evaluation.

The Resource Evaluation staff consists of 66 full-time and four part-time employees organized into three sections. Most of us are geologists and geophysicists; however, we also have petroleum engineers, paleontologists, statisticians, well log analysts, an economist, secretaries, and physical science technicians. Our professional disciplines are represented by five Ph.D.'s, seventeen Master's degrees, and 28 Bachelor's degrees. I'm the Regional Supervisor and my deputy is Mr. J. Courtney Reed.

To do the work that we have to do in the Gulf of Mexico requires vast amounts of technical data and information, mainly geological and geophysical. In the Gulf of Mexico we enjoy the largest, most detailed and most accurate and reliable data of all the MMS regions. This is not bragging and it's not because of anything that we did that was so great. It's just because we lucked out and are reaping the benefits of 35 years of oil and gas leasing experience in the Gulf of Mexico.

We have available to us for our mission the following types of data.

#### **GEOPHYSICAL DATA**

We currently have over 300,000 line miles of modern seismic exploration data, and to go with this, over 1100 velocity surveys. These data were acquired at a total cost of approximately \$18 million over a 12-year period. This is an average of about \$60 a mile. The Gulf of Mexico Region typically acquires 30-40,000 line miles of these data per year.

## **GEOLOGICAL DATA**

We have available to us approximately 150,000 well logs from over 22,000 wells. The region is currently receiving these well logs at the rate of about 300 per month.

## **PALEONTOLOGICAL DATA**

Don't ask me any questions about this because most of the words in "paleo" I can't even pronounce. But it's a very valuable asset to our evaluation program. We have paleo data from approximately 18,500 wells. We are currently receiving paleo information at the rate of about 1,000 items per year.

## **ENGINEERING AND ECONOMIC DATA**

This rounds out our data base and includes well logs, drilling and production data and reports, and cost data and technical publications.

Most of our data base is proprietary or confidential and requires special handling and storage, as well as restrictions on publications. That may be why you haven't heard too much about us. Certain of these data are periodically released to the public as leases expire or under time frames established by statute or regulation.

Since 1968 the Resource Evaluation program has supported 48 offshore lease sales in the Gulf of Mexico by evaluating 7,475 lease sale tracts comprising over 38 million acres. We have provided resource estimates and geological and geophysical information for all required lease sale environmental documents. We have issued nearly 4,000 geological and geophysical permits (about 400 per year). We have acquired 312,000 line miles of modern seismic exploration data and 130,000 line miles of high resolution geophysical data. (The Resource Evaluation Program no longer acquires or uses high resolution geophysical data.) We have released for public use 99,000 line miles of

high resolution geophysical data through NOAA's data center in Boulder, Colorado. And we have provided needed technical and data support to all other regional programs.

Fiscal year 1984 was a big year for us. It saw three major area-wide lease sales in the Gulf of Mexico. During fiscal year 1984 we evaluated over 1,000 lease sale tracts that resulted in bonus revenues to the government of nearly 2.5 billion. These sales include Sale No. 79 in the eastern Gulf of Mexico last January; Sale No. 81 in the central Gulf, which was held back in April; and Sale No. 84 in the western Gulf in July.

During fiscal year 1984 we also issued 423 geological and geophysical permits at the rate of 30 to 40 a month, which is normal for us. (Some regions only do 30 to 40 per year.) We have started and are well on our way to completing the detailed regional mapping of all the productive trends in the Gulf of Mexico. We expect fiscal year 1985 to be pretty much the same.

## RESPONSIBILITIES AND PRACTICES OF THE AREA OFFICE FOR LEASING AND ENVIRONMENT

Mr. Harold P. Sieverding  
MMS, Gulf of Mexico Region

The Outer Continental Shelf Lands Act of 1953, as amended in 1978, instructs the Secretary of the Interior to develop the oil and gas resources on the Outer Continental Shelf to meet the nation's energy needs, to balance this development with environmental protection, and to ensure an equitable return to the public from the development of these resources. Throughout the process, extensive coordination and consultation with the affected states, other governmental agencies, the oil and gas industry, and the public is called for.

Many other significant statutes affect the secretary's responsibilities on the Outer Continental Shelf. These include the Submerged Lands Act, the National Environmental Policy Act, the Coastal Zone Management Act, the Endangered Species Act, the Energy Policy and Conservation Act, the Clean Air Act, the Marine Mammal Protection Act, the National Historic Preservation Act, the Marine Protection, Research and Sanctuaries Act, and others.

The Secretary of the Interior has directed the Minerals Management Service to carry out his responsibilities on the Outer Continental Shelf. To accomplish its mission, the Minerals Management Service has organized into four regions: the Gulf of Mexico, Atlantic, Pacific, and Alaska.

Within the Gulf of Mexico region, the Office of the Regional Supervisor for Leasing and Environment is one of five offices responsible for the conduct of the region's mission. The other offices within the region are primarily concerned with post-lease administration of operations or evaluation of present or potential oil and gas resources.

The responsibilities of the Office of Leasing and Environment begin with the programmatic Environmental Impact Statement (EIS) and end with the environmental assessment afforded each operational application and/or plan. We develop and maintain a comprehensive environmental information base fed by existing sources and our own contract studies; we develop regional study plans, write the procurement documents and administer the study contracts for the gathering and analysis of environmental data; we participate in the agency-wide writing of the five-year programmatic EIS, developed to assess multi-year leasing schedules; we receive and process the responses to calls for information and comments for specific proposed sales; we develop draft EIS's, hold public hearings, and prepare final EIS's for these sales; we prepare notices of lease sales with their attendant maps and lists; we conduct lease sales and grant leases to successful bidders; we maintain official records identifying lease owners and process requests for changes to that ownership; and we perform an environmental review and assessment on every request for an application and/or plan to conduct operations.

Our responsibilities are carried out through four sections: Leasing Activities, Environmental Assessment, Environmental Studies, and Environmental Operations.

The Leasing Activities Section is responsible for the call for information, area identifications, proposed and final notices of sale, the secretarial issue document, conduct of the lease sale, adjudication of bids and other filings associated with leases, the granting of leases, and the maintenance of the leasing statistical data base.

The Environmental Assessment Section is responsible for maintenance of the environmental information base, identifying information gaps, writing requests for resource reports, coordinating the development of environmental stipulations, writing draft EIS's and conducting public hearings, writing the final EIS, providing the environmental inputs to the secretarial issue document, and serving as technical inspectors for study contracts designed to fill information gaps.

The Environmental Studies Section is responsible for developing study proposals to fill identified information gaps, developing regional study plans and obtaining regional advisory board input to those plans, developing statements of work and requests for proposals, chairing proposal evaluation committees, and serving as contract managers for active studies.

The Environmental Operations Section is responsible for review and analysis of all post lease environmental surveys and reports provided by lessees, assuring lessee's implementation of environmental stipulations contained in the leases, preparation of site specific environmental assessments of all operations conducted on the lease prior to permitting, monitoring of the environmental effects of operations, identifying environmental/operational data gaps, and serving as technical inspectors for study contracts to fill information gaps.

Working within the Office of Leasing and Environment are clerks, biologists, archaeologists, regional and community planners, economists, geographers, oceanographers, geologists, ecologists, geodesists, meteorologists, cartographers, visual information specialists, sociologists, writer-editors, statisticians, recreation specialists, para-legal specialists, zoologists, and mineral leasing specialists.

Much of our time and energy is directed toward identifying and addressing both geographic and topical issues of concern to the general public, federal agencies, and the states. The process we employ is called "scoping." Scoping includes all types of inquiries, from one-on-one discussions to formal public meetings, and is carried on by all members of the Leasing and Environment staff. It takes place continually in an informal way, and formally at specified times associated with a particular environmental impact statement, an individual lease sale, and during development of regional environmental study plans.

For lease sales, we formally request public participation by publishing a call for information in which we ask the industry, the

states, federal agencies, and the public to identify geographic areas of interest and/or issues of concern. The publication of the proposed notice of sale provides an additional opportunity for the public to comment on the proposed areas to be offered for lease and the conditions affecting that offering.

A draft environmental impact statement, which addresses the identified issues and concerns, is published for review and comment by interested parties. A public hearing is conducted prior to preparation of the final environmental impact statement to formally obtain public comment.

Formal input into our environmental studies program is provided by the Outer Continental Shelf Advisory Board through its field component, the Regional Technical Working Group. This group participates in the drafting of our annual regional study plan, identifying studies and the priorities for their accomplishment.

In December 1982, the offshore components of the Bureau of Land Management and the Conservation Division of the U.S. Geological Survey were merged into a new agency, the Minerals Management Service. Since that time, and as of July 25, 1984, the Office of Leasing and Environment has conducted six lease sales, processed 3,420 bids, granted 2,179 new leases, added 13.7 million acres to the total under lease, and contributed \$7.5 billion to the Federal Treasury. We have written four environmental impact statements, 41 environmental assessments, 1,605 environmental reviews for categorical exclusions, and critically reviewed 343 archaeological reports. We have also administered 55 environmental study contracts totaling over \$26 million.

## RESPONSIBILITIES AND PRACTICES OF THE OFFICE FOR RULES AND PRODUCTION

Mr. Donald W. Solanas  
MMS, Gulf of Mexico Region

Last year I gave an introduction to operations programs. This year we're going to talk about what has happened in the past year and what the future looks like. We had a very successful year last year, as Harry Sieverding and Dick Scrivener pointed out, in that more leases were sold and issued than had ever been before, creating a tremendous workload on the operations people. (Over 2,000 leases were issued last year. Most of these leases are for five-year lease terms, but because of deep water conditions there are some ten-year leases.)

There are in my part of the operations area some 50 engineers, mostly petroleum engineers. Don't expect for the next four years, at least, that we're going to have any additional employees, although our workload is going to triple. That means that we're going to have to meet the deadlines that exist and serve the oil and gas lessees in the time-frame that we have worked with in the past.

We operate out of the regional office and have three sections. We cover the plans of exploration and plans of development and production submitted by the lessees. In 1978, it was determined that the public was not getting the necessary information or having it available to them to know the intentions of the federal oil and gas lessees. A regulation was issued which required the oil and gas lessees to submit formal detailed plans of exploration to be followed with detailed plans of development, if there were successes or discoveries on the leases. So from 1978 we have had a large active program of considering and approving the plans of exploration by the federal oil and gas lessees.



I have a few statistics: in fiscal year 1984, 795 plans of exploration were approved by the Minerals Management Service for the Gulf of Mexico. Each year it gets bigger and bigger. There were 240 plans of development approved. These plans are not one-page submittals by the lessees. They are involved engineering and environmental documents. So much so, that over the period from 1978, some 5,000 plans have been submitted by the lessees and have been considered by the Minerals Management Service and approved by my office. We have had a successful operation in the Gulf of Mexico.

In addition to the exploration plan approval, what follows after discovery on leases is the development of those leases. This involves the placement of platforms and pipelines in the Gulf of Mexico. This section considers and approves these.

When a platform is ready to go on production, there is a production approval section which considers the operator's plans for placing the field on production, as to the equipment placed on the platform, and as to the methods of transporting the oil and gas to shore. Practically 95% of oil and gas produced in the Gulf of Mexico OCS is pipelined to shore. The remainder is brought ashore in barging systems.

Another section is called Rules, Standards and Orders Section. These engineers study what is going on in the Gulf of Mexico from an engineering concern and formulate proposed regulations, to regulate fairly and safely the oil and gas operations in the Gulf.

Last year, which was our biggest year, 184 production platforms were installed in the Gulf of Mexico. Because some of the platforms over the thirty-year history of production in the Gulf had served their useful purpose, 45 platforms were removed. We are beginning to consider using these platforms in the rigs-to-reef program, which will further utilize the platforms to increase the fisheries resource.

At the present time, there are some 3,000-plus producing platforms in the Gulf OCS. After all, the operation has been going on for 30 years.

There are 397 pipelines that were approved last year. Now, this doesn't mean that they were the original pipelines. They were additions to existing pipelines. Eight hundred miles of pipeline were approved last year. I have here a figure for the number of pipelines in the Gulf of Mexico. It's over 7,000 pipelines, but these would not necessarily be 7,000 individual pipelines. It would be additions to existing pipelines. There are 14,000 miles of pipeline in the Gulf of Mexico.

I noticed in an editorial in a recent publication that a total of 225 of the newly leased 2,000 leases have been drilled to date. And there have been 22 announced discoveries on these leases that have just come into being as of a year ago. And there are 15 wells that are considered tight holes, which have the potential of being additional discoveries. So, the 2,000 leases that were issued last year are off to a good start.

## RESPONSIBILITIES AND PRACTICES OF THE AREA OFFICE FOR RESERVES AND DEVELOPMENT

Mr. Louis McBee  
MMS, Gulf of Mexico Region

I want to begin by putting into perspective the responsibilities of this area office of Reserves and Development. We supervise over 4,000 leases. Of those leases, over 1,200 are actually producing over 6,500 oil and gas wells. These wells produce about 9% of the nation's oil and 24% of the nation's gas.

The main objectives of the office are to regulate oil and gas operations in a manner that will promote timely and efficient exploration, development and production; to maximize exploitation and production for the benefit of the public; and to independently determine

oil and gas reserves to support the MMS in supervising lease and field development. To help us to reach these objectives, the activities within the regional office are conducted by three organizational sections: The Reserves Section, the Rate Control Section, and the Development and Unitization Section.

As the name implies, the Reserves Section conducts geological and engineering studies to independently estimate original and remaining recoverable oil and gas reserves by reservoir, lease, and field, and maintains an updated inventory of remaining recoverable oil and gas reserves. In this section we have about 39 employees, geologists, petroleum engineers, geophysicists, and physical science technicians.

As of October 1983, the Reserves Section had identified about 554 active oil and gas fields, and of this number we have independently mapped in detail about three-fourths of them. This percentage figure always remains about the same. We always have only about three-fourths of them independently mapped since we don't commence calculating the reserves until after a field is almost fully developed and we have acquired some production history.

The objectives of the Reserves Section are, of course, to determine reserves, update them periodically, prepare reserve reports. We update semi-annually, but we publish the report annually. This published report is widely used in industry and by other government agencies and the general public. The OCS Lands Act requires us to report every other year to Congress on the reserves available in the Gulf of Mexico. And, incidentally, the reserves data developed here are essential to pre- and post-sale lease evaluation. The data are used in other places in our operations but are very essential to that one. All of this detailed reserves information is used to establish values for engineering and geologic parameters, that are projected into the prospects underlying tracts offered for lease.

We currently have about 3.4 billion barrels of oil and 43.7 trillion cubic feet of gas reserves in the Gulf of Mexico, and these reserves are

being produced at the rate of about 950,000 barrels of oil and condensate per day, and 12.5 billion cubic feet of gas per day.

Our Rate Control Section is comprised of about 22 employees that exercise our responsibilities for establishing production rates--the maximum efficient rates for reservoirs and the maximum production rates for wells in the Gulf of Mexico. They also monitor the non-producing well completion activity, monitor gas flaring and as the FERC jurisdictional agency make natural gas well category determinations. They also conduct in-depth oil and gas reservoir studies by classical engineering methods and mathematical reservoir simulations.

As of the first of the year, we had about 4,500 producing reservoirs with approved MER's and 6,500 producing completions with approved MPR's. These MER's are reviewed annually and the MPR's are reviewed semi-annually for gas wells and quarterly for oil wells. The average oil MPR in the Gulf is about 300 barrels of oil per day. The average gas MPR is about 5,000 MCF of gas per day.

In addition to these 6,500 producing wells, we have about 7,500 wells out there that are not producing but have not been abandoned. We need to point out that only about 13% are being deliberately shut-in. That's for two reasons: for conservation reasons or because there's no pipeline or market or the pipeline company is curtailing the production. The other reasons for shut-in are depletion, high water production, sanded up, et cetera. This other 87% is shut-in because they won't produce in spite of anything done to them. So, we keep a good record on what's being shut-in, the reason for it being shut-in, what work would be necessary to bring them back on production, and when this work is anticipated.

The Natural Gas Policy Act designates us as the jurisdictional agency for making gas well category determinations and classifications of gas wells. This is the determination that enables the oil companies to receive a top price for their gas; that is, if they can talk somebody into buying it for that price. This first category, new reservoirs on old

leases, is the one that requires a geologic analysis of an application from a company. We thought that this category would be reduced, maybe, to zero in the last five years--somewhere around 1980 or 1981--but it never has. We still get fifty to sixty applications per month for this category. Processing applications in other categories is fairly easy. In other words, if it's on a new lease it gets a certain price; if it's deep gas below a certain depth it gets a certain price, or if it's stripper gas it get a certain price. Applications in these categories don't take an awful lot of time to process.

We also monitor and control gas flaring in the Gulf of Mexico. We do allow small volume or short-term flaring from low pressure vessels or in cases of emergencies or during well purging, or evaluation tests. Flaring of gas for continuous periods of over 72 hours or for a cumulative period of 144 hours in a calendar month is prohibited without approval from this office. We will allow flaring for times beyond that, but only if every measure is taken to hold volumes down to prevent excess flaring. Gas flaring during well purging and evaluation tests in excess of 24 hours also requires our prior approval.

Going back to extended term flaring approvals, we have approved long-term flaring for periods up to a year when a company has presented a positive plan of action to eliminate the flare altogether, or presented an economic evaluation which shows that to eliminate flaring would prevent them from producing recoverable oil because of early abandonment and would reduce the amount of total energy that could be produced from the reservoir.

In 1974 we started this program for control of gas flaring. At that time about 14% percent of the oil well gas produced in the Gulf was being flared. Currently, less than 4% is being flared. And since oil well gas makes up only about 10% of the total gas produced in the Gulf, less than one-half of 1% of the total gas produced is being flared.

Our third section, the Development and Unitization Section, is involved with the responsibility for unitization and competitive reservoir

operations, pressure maintenance programs, and enhanced oil recovery projects, suspension of production, and the monitoring of development and production activity on varying royalty rate leases.

Unitization activities involve evaluating unit proposals as they are made by the companies and for monitoring development of the unit area through the processing of unit plans that are required to be submitted by the companies annually. The reasons for unitization are for conservation of natural resources and the prevention of waste, protection of the correlative rights of the operators, and protection of the federal government's royalty interests.

A competitive reservoir doesn't always have to be operated under a unitization agreement. It can be operated under a joint development production plan; that is, if the two competing lessees can voluntarily agree on how they will produce from the common reservoir. The thing about a joint development plan is that it usually just controls well density, not the production rate. There's no allocation of production or costs or revenues with a joint development plan. It's just an agreement between the two parties, an agreement that we can go along with.

This office reviews and approves all secondary and tertiary recovery operations in the Gulf of Mexico. Currently, we have about 200 projects that we have approved and are monitoring. With regard to tertiary recovery projects, we expect these to increase in numbers because of the tax reducing benefits provided by the Windfall Profit Tax Act.

Another area of operations is the granting of suspensions of production. A suspension of production has the effect of extending a lease beyond the primary term. Leases in the Gulf of Mexico have primary terms of five or ten years. During the primary term there's no deadline for conducting exploratory or development activities and the lease is kept in effect as long as the terms of the lease agreement are fulfilled. But beyond that primary term the only thing that can hold a lease in effect is production from the lease; drilling, completion, or

workover operations being conducted on the lease, or the lease being a part of an approved unit. However, if any of these operations would cease for a period of ninety days, the lease will automatically terminate, unless we have granted the lessee a suspension of production. We can grant a suspension of production in consideration of difficult or unforeseen environmental or safety issues, to facilitate development of a lease, or to allow for installation of transportation facilities. They may be granted for periods of five years; however, we usually grant them for only about two-year periods so that we can monitor more closely the development that's taking place on the lease. At any point in time we are monitoring the activities of about 100 leases held in effect by approved suspensions of production.

The requirement for a suspension of production is that the lease be nearing the end of its primary term and not yet producing, that there has been sufficient exploration to delineate the areas of production, and that development has started. Commencement of development must be evidenced at a minimum by a discovery of oil and gas in paying quantities and by submission of a reasonable schedule of development activities through the commencement of production.

The other function that's carried on in this Development/Unitization Section is the monitoring of varied royalty rate leases. This involves identifying oil and gas reservoirs common to leases with different royalty rates. We have a crew that's doing this all the time, that is, observing and mapping the high royalty rate tracts for the purpose of preventing drainage of a high royalty lease by production from a low royalty lease. The bottom line, of course, is to protect the federal government's royalty interest.

In the Gulf of Mexico we have about 450 high royalty rate leases. And of that number, I think we have about fifty that are currently producing. That keeps us pretty busy. In fact, monitoring the high royalty rate lease requires monitoring not only what's going on on that lease but what's going on on all the leases around it.

## GULF OF MEXICO SPECIAL CONCERNS



Session: GULF OF MEXICO SPECIAL CONCERNS  
Chairman: Mr. William Johnstone  
Date: November 27, 1984

<u>Presentation Title</u>	<u>Speaker/Affiliation</u>
Session Overview	Mr. William Johnstone MMS, Gulf of Mexico Region
Coral Reef Management in the National Marine Sanctuary Program	Mr. Herbert Kaufman Sanctuary Programs Division, NOAA
Estuarine Modeling for Water Quality in the Gulf of Mexico	C. John Klein III Ocean Assessment Division, NOAA
OCS Military Use Management in the Gulf of Mexico	Ms. Carolita Kallaur Deputy Director for Offshore Leasing, MMS
A Panel Discussion on Coastal Management Concerns of Gulf Coast States	Mr. William Johnstone MMS, Gulf of Mexico Region

## SESSION OVERVIEW: GULF OF MEXICO SPECIAL CONCERN

Mr. Bill Johnstone  
MMS, Gulf of Mexico Region

The Special Concerns Session was a potpourri of subject matter that received considerable attention by those attending this meeting. The subjects discussed had to do with 1) the Marine Sanctuary Program and its progress, 2) the Estuarine Modeling Program in the Gulf of Mexico, 3) Military Space Use Management in the Gulf of Mexico, particularly in the eastern Gulf, and finally 4) the Coastal Management Program, as represented by a panel of representatives from Gulf coastal states who were primarily concerned with coastal zone management or coastal management programming.

Our first speaker was Mr. Herbert Kaufman. Mr. Kaufman is the Deputy Chief of the Sanctuary Program Division at NOAA. He outlined the progress of the program to this point, indicating that six national sanctuary sites have been established following the law enabling this program in 1972.

The first sanctuary was the Monitor National Marine Sanctuary, which contains the remains of the civil war iron-clad ship, the MONITOR. This sanctuary was established in 1975. There followed, the remaining five marine sanctuaries including Key Largo National Marine Sanctuary (1975), Channel Islands National Marine Sanctuary (1980); Gray's Reef (1981); Point Rays (1981); and Lew Keys in the Florida Keys (1981). Three proposed sites are scheduled for recommendation and approval in 1985. Two of those are of particular interest to people in the Gulf of Mexico area: the East Flower Gardens and West Flower Gardens. The establishment of the Flower Gardens as a marine sanctuary will proceed based on a planned schedule of events.

In January 1985, scoping meetings concerning the Flower Garden sanctuaries will be held. In March there will be a draft sanctuary plan and a draft EIS document for each site. In April the final plan is scheduled and a final EIS is scheduled. In August recommendations for action to proclaim each of the Flower Gardens as a sanctuary will be made. By next summer the process may have produced two new marine sanctuaries.

Our second speaker was John Klein of the Ocean Assessment Division of NOAA. Mr. Klein has considerable experience in computer modeling of hydrologic dynamics. He described the National Estuarine Program as a program that consists of three main components, 1) inventorying point and non-point pollution sources, 2) classifying these sources so as to include medium and large estuarine bodies of water, and 3) applying water quality standards to results of a modeling output.

This program develops a strategic and operational ability to evaluate environmental and economic effects of national policy on coastal resources, specifically the estuarine resource.

In the Gulf of Mexico the program includes 17 estuarine systems. A draft report of the preliminary results of the work done on these seventeen systems is scheduled for spring of 1985. The modeling of Gulf estuaries will be followed by a monitoring program to determine whether conditions are changing. In some instances the results of this modeling effort could serve as a means of predicting changes in estuarine systems. An example of this application could be comparing study results from Tampa Bay and Charlotte Harbor so as to determine the estuarine changes that may occur should Charlotte Harbor develop in a fashion parallel to Tampa Bay.

There will be a National Estuarine Atlas available in July of 1985 from NOAA. This publication will have information on 120 estuarine systems in the United States.

Most interesting and probably one of the more knotty problems that was dealt with in the session had to do with military space use management in the Gulf of Mexico. Ms. Carolita Kallaur, Deputy Associate Director, for Offshore Leasing with the Minerals Management Service, spoke on the subject. Prior to 1982, most of the military use areas were deferred from leasing and, therefore, were not a problem. With the advent of area-wide leasing in the Gulf of Mexico, some of these areas have been included in recent lease sales. There have been some hydrocarbon discoveries made on leases that are located within these military use areas. This has created a potential space-use conflict situation.

In July 1983 a memo of understanding (MOU) between the Department of Interior and the Department of Defense was worked out. This agreement allowed an opportunity for the two agencies to have a discourse over how the leasing program and subsequent development activities might affect the military warning and water test areas.

The geographic areas of concern are primarily in the eastern Gulf. Most of the warning areas and water test areas are located in this planning area. The military areas are substantial in size, representing about half of the eastern Gulf planning area.

The "postage stamp" concept was developed under this MOU. This is the informal name given to an exploration plan that allows oil and gas activity to occur in a 30 x 30 mile area in the eastern Gulf. At the present time, only one such area may be active at one time. Industry representatives have been meeting regularly with the Departments of Interior and Defense Officials. Different interests of the oil and gas industry and the military have been discussed. Some options have been suggested to overcome these differences, and negotiations continue between the interested parties. Both sides have important national goals to work toward. The program that the Department of Interior represents is national independence in terms of energy. The program that the military represents is national security. Both have merit and therefore pose difficult problems that require resolution.

A panel discussion, which concluded the session, dealt with resource management in the coastal zone. Four of the five Gulf coastal states were represented on the panel: Florida, Mississippi, Louisiana, and Texas. Initially the moderator presented a description of the coastal zone management program as it exists today. This was a general description based on existing national guidelines. The representatives from each state discussed their state programs and described procedures used to solve resource management problems in their coastal areas.

Questions from the floor followed the formal presentations. As a result of the question and answer period, a number of concerns were expressed by the state representatives relating to resource management and the OCS program. Some of the concerns that were expressed by the states are as follows: 1) the occurrences of oil spills, 2) ocean incineration, 3) effective inter-agency coordination, 4) socio-economic impacts on the local or county/parish level, and 5) concern with the increased pace of leasing in recent years.

## **CORAL REEF MANAGEMENT IN THE NATIONAL MARINE SANCTUARY PROGRAM**

**Mr. Herbert Kaufman, Deputy Chief  
Sanctuary Programs Division, NOAA**

The National Marine Sanctuary Program was created under Title III of the Marine Protection, Research and Sanctuaries Act of 1972, as amended, for the purpose of preserving or restoring the conservational, recreational, ecological, or esthetic values of special ocean areas. Managed by the National Oceanic and Atmospheric Administration through the Office of Ocean and Coastal Resource Management,

Sanctuary Programs Division, national marine sanctuaries are established for public use and benefit, in concert with resource protection.

Coral reefs are an important component of the national marine sanctuary system. Recognized as the most productive and ecologically diverse of all tropical marine systems, coral reefs are one of our nation's most valuable resources. From the barrier reefs along the Florida reef tract to the bank reefs of the Virgin Islands and Puerto Rico and the fringing reefs and atolls of the Hawaiian Islands and the Pacific Trust Territories, some of the finest examples of coral reef formations have been designated or proposed as national marine sanctuaries. These include the 100-square nautical mile Key Largo National Marine Sanctuary and 5-square nautical mile Looe Key National Marine Sanctuary of the Florida reef tract and the proposed La Parguera, Puerto Rico, and Fagatele Bay, American Samoa, sites. Other coral reef sites in need of protective management may be considered for designation in the future. Included in this group are the East and West Flower Garden proposed sanctuaries.

In recent decades, mankind has come to recognize that increasing use of coral reefs and adjacent coastal regions threatens to destroy these valuable resources. The greatest challenge to a coral reef sanctuary manager is creating and maintaining the proper balance between use of a sanctuary and the protection and conservation of its resources. Meeting this challenge requires a thorough scientific understanding of the sanctuary and how it relates to its surrounding areas as well as knowledge of the use of the site and the consequences of these activities. It also requires judicious planning and decisionmaking for determining management issues and for examining options available to resolve the issues, as well as a mechanism for implementing management strategies and evaluating their effectiveness.

## ESTUARINE MODELING FOR WATER QUALITY IN THE GULF OF MEXICO

C. John Klein III, P.E.  
Ocean Assessment Division, NOAA

The Ocean Assessments Division of the National Oceanic and Atmospheric Administration is conducting a national estuarine program. This program consists of three major components: an inventory of all points and non-point sources of pollution entering the coastal environment, a baseline characterization of all medium- and large-sized estuaries, and lastly the application of a generic styled water quality to a sub-set of these systems. Emphasis is placed on the latter with a brief overview of the first two components.

The objective of the modeling is to provide a yard stick against which to compare estuarine systems. Comparisons will be based upon the degree to which systems have been affected by anthropogenic inputs as derived from the discharge inventory and will be adjusted for various management control scenarios. The model is based upon equations reflecting both advective and diffusion processes. Temporal scales are based on seasonal averages. The spatial domain is two-dimensional in the plan view, and resolution varies with application. At present the model addresses only the dissolved and the associated suspended sediment fraction of the constituent.

The model has been set up for seventeen systems within the Gulf of Mexico. A draft report of preliminary results is scheduled for late spring (1985). The emphasis throughout has been the development of a strategic and operational capability to evaluate the environmental and economic effects of national policies on coastal resources.

## OCS MILITARY SPACE USE MANAGEMENT IN THE GULF OF MEXICO

Ms. Carolita Kallaur  
Deputy Associate Director for Offshore Leasing  
Minerals Management Service

Prior to 1982, military use areas in the Gulf of Mexico were deferred on a selective basis from oil and gas leasing or conflicts were mitigated by stipulation. With the advent of areawide leasing, formerly deferred areas have been included for consideration in lease sales. This is consistent with the general policy of the Department of the Interior to assist the Nation in reducing energy dependence in world markets by allowing industry greater flexibility in determining exploration strategies. Military interest in maintaining certain military warning areas, water test areas, and other operating areas relatively free from permanent structures continued to be strong, however, and more intense sale by sale negotiations have begun.

In July 1983, a memorandum of agreement (MOA) between the Departments of the Interior (DOI) and Defense was agreed upon and implemented. The purpose of the MOA is to foster early consultation and resolution of conflicts prior to the proposed notice of sale. The MOA was helpful in addressing the majority of the space-use conflicts in the Western and Central Gulf, but the Eastern Gulf was much more difficult to deal with due to its frontier status in the OCS program, the very large acreage utilized by the military, and the Navy's intent to focus its operations in the Eastern Gulf and "release" the Western Gulf for increasing oil and gas activity.

The MOA was utilized to resolve conflicts with the United States Navy (USN) for Sale 81 (Central Gulf) held in April 1984. The DOI deferred leasing on 30 of 47 Blocks in Warning Area 155 and imposed a "no-surface occupancy" stipulation on 17 others around the deferred blocks. None of these blocks received bids.



The needs of the United States Air Force (USAF) are unique and distinct from the needs of the USN. This has required separate discussions with each of these services. The USAF initially called for deferral of all Water Test Areas in the Eastern Gulf from leasing to allow testing of live ordinance. After discussions with the USAF and industry representatives, the DOI imposed a "time sharing" stipulation on leases from Sale 79 which allows exploration in an area 30 miles by 30 miles at any one time. Approval of drilling plans in the Eastern Gulf lease area would be coordinated with Eglin Air Force Base so siting of structures would not interfere with scheduled military missions. This severely restricts hydrocarbon exploration and has prompted options to be further evaluated not only for implementing the Sale 79 stipulation but also for future use. These alternatives are:

- o three clusters of drilling activities would be permitted, one each in the Destin Dome, DeSoto Canyon, and Gainesville areas
- o a 90-day drilling period in the DeSoto Canyon area to be drilled simultaneously with drilling in Destin Dome area.

While the 30- by 30-mile drilling area remains the only agreed upon procedure as of November 1984, the USAF is considering these options as outlined in correspondence from the DOI.

The USN utilizes Warning Areas 155 and 174 for ship maneuvers, particularly aircraft carrier operations, and for training student aviators.

The USN wishes all future leasing in these warning areas to be deferred. Sale 79 leases have no special stipulations attached, but since then the Navy problems have been further outlined. The following options have been proposed for consideration in future sales and public comment has been solicited:

- o the use of subsea completions for drilling operations

- o specific limits on spacing of drilling units
- o deferring leasing in one or both warning areas
- o restrictions on when drilling may occur, i.e. a specified time period.

Commenters from the industry found such restrictions to be heavily in favor of the military. The USN remains in favor of leasing deferrals. Discussions are still ongoing on multiple-use management of warning areas in the Eastern Gulf as of November 1984.

It is our intent to develop long-term management plans for testing of both current and future leases in the Eastern Gulf areas utilized by the USAF and USN and to benefit from the experience gained over the last several years.

#### A PANEL DISCUSSION ON COASTAL MANAGEMENT CONCERNS OF GULF COAST STATES

Mr. William Johnstone  
MMS, Gulf of Mexico Region

Four of the five Gulf Coast states were represented on the panel. They were Florida, Mississippi, Louisiana, and Texas. The representative from Alabama was unable to attend.

Each state representative addressed the audience on matters concerning his coastal management program and problems that have been encountered. During the individual presentations and the open discussion that followed, a number of concerns were expressed: 1) oilspills and their effect on the environment, 2) ocean incineration and its effect on air

quality, 3) the lack of effective interagency coordination, 4) wetlands loss, 5) the need for more federal funds for environmental studies by Gulf States, and 6) reduction of the pace of leasing in the Gulf of Mexico.

WETLANDS LOSS: CONTRIBUTING FACTORS AND  
POTENTIAL MITIGATING MEASURES

Session: WETLANDS LOSS: CONTRIBUTING FACTORS AND  
POTENTIAL MITIGATING MEASURES

Co-Chairs: Dr. Norman Froomer  
Dr. Carolyn French

Date: November 27 & 28, 1984

<u>Presentation Title</u>	<u>Speaker/Affiliation</u>
Session Overview	Dr. Norman Froomer MMS, Gulf of Mexico Region
PART I: FACTORS CONTRIBUTING TO WETLANDS LOSS	
Recent Rates of Sea Level Change and Implications for the Future	Mr. Robert Etkins Assistant Director for Ocean Research and Technology, NOAA
Holocene Sea Level Changes and Marsh Stability	Dr. Walter S. Newman Department of Earth and Environmental Sciences City University of New York
Geologic Controls in Marsh Deterioration on the Mississippi River Delta	Dr. John T. Wells Institute of Marine Sciences, University of North Carolina at Chapel Hill
Historic Trends of Measured Suspended Sediment Load in the Mississippi River Delta Area	Mr. James R. Tuttle Mississippi River Commission
Fluid Withdrawal and Subsidence: Experience From Coastal Louisiana	Mr. Drukell B. Trahan Louisiana Geological Survey
Canal-Dredge Material Effects on Marsh Water Levels	Mr. Erick M. Swenson Louisiana State University

PART II: POTENTIAL MITIGATING MEASURES FOR WETLANDS LOSS

Plant Stress as a Factor in Marsh Deterioration	Dr. I. A. Mendelssohn and Ms. K. L. McKee Louisiana State University
Losses of Coastal Marshes in the Chesapeake Bay Area	Dr. Michael S. Kearney University of Maryland
Wetlands Loss in the Delaware Bay	Dr. Evelyn M. Maurmeyer Coastal & Estuarine Research, Inc.
Impacts of Pipeline Installations in Coastal Louisiana	Dr. James G. Gosselink Louisiana State University
Current Techniques of Pipeline Emplacement to Minimize Impacts on Wetlands	Mr. Michael A. Krone United Gas Pipe Line Company
Backfilling as an Effective Habitat Mitigative Technique	Dr. Walter Sikora Louisiana State University
Freshwater Diversion into Coastal Louisiana and Mississippi	Mr. Dennis Chew U.S. Army Corps of Engineers
Mitigation Banking: A Concept for Compensating for Fish and Wildlife Damages	Mr. David M. Soileau U.S. Fish & Wildlife Service
Multiple Use of Estuarine Environments for Fishery Resources	Dr. J. Dickson Hoese University of Southwestern Louisiana

## SESSION OVERVIEW: WETLANDS LOSS: CONTRIBUTING FACTORS AND POTENTIAL MITIGATING MEASURES

Dr. Norman Froomer  
MMS, Gulf of Mexico Region

At the beginning of the twentieth century, the Louisiana coastal region, for the first time in recent millenia, changed from an area of net land gain to an area of net land loss. During this century, the rate of land loss has continued to accelerate to the extent that current losses approach 50 square miles annually. Many factors contribute, often in complex, interacting ways, to wetlands loss. Although the relative contribution of the different factors cannot be unequivocally evaluated at this time, the effects of submergence (sea level rise and subsidence), sediment deprivation, and canal installations are considered to be the major causative agents. The possible contribution of canals that have been installed in coastal Louisiana to support OCS oil and gas development is the connection between the Minerals Management Service and the wetlands loss issue. The wetlands loss sessions were organized to provide a perspective on the different factors that contribute to wetlands loss and on different mitigating strategies.

Submergence in coastal Louisiana is occurring more rapidly than along most other coasts, creating a condition in which marsh surfaces, in many instances, cannot accrete rapidly enough to keep pace. The submergence recorded in coastal Louisiana is the combined result of an ongoing global rise in sea level and of local subsidence of the land surface. Although local subsidence has been estimated to account for as much as 90% of the observed submergence, Robert Etkins (NOAA) presented evidence that the ongoing eustatic rate of rise in sea level may become a much more significant component of submergence in Louisiana. Based on his analysis of tide gauge data, he concludes that during the last 100 years, sea level rose at a rate of 15 cm per century. During the past 50 years, however, sea level has been rising at a rate of

23 cm per century. He believes that the more rapid rise in sea level is related to a global warming, perhaps associated with an increase in the carbon dioxide concentration of the atmosphere. Based on historic trends in carbon dioxide concentration increases and theoretical relationships between carbon dioxide concentrations and sea level rise, he postulated that by 1990 the rate of rise in sea level could be 57 cm per century.

Dr. Walter Newman discussed sea level changes that have occurred during the past several thousand years, since the end of the most recent Glacial Age. He emphasized the large amount of disagreement among the different sea level curves that have been constructed from radiocarbon-dated materials. The discrepancies among the curves increase when older dates are compared. These discrepancies can be explained by differential warping of the earth's crust that occurred simultaneously with the post-glacial rise in sea level.

While Dr. Newman emphasized the geographic variability in rates of sea level change, the next speaker, Dr. Dag Nummedal, stressed temporal variability. Rather than the smooth, ever-rising post-glacial sea level curve that is often drawn in the literature, sea level might have oscillated by as much as two meters every few centuries. He then discussed how coastal landforms in Louisiana respond to rapid rates of sea level rise.

One factor that may contribute to the rapid submergence rates observed in coastal Louisiana is land subsidence due to subsurface fluid withdrawals. Dru Trahan reported on his investigations of ground subsidence associated with geo-pressurized geothermal reservoir development. Although he observed subsidence at well sites, the surface rebounded to its original configuration after the drilling equipment was removed. The drilling activity at these sites, however, is not directly comparable to that at a developed oil and gas field as not nearly so much fluid was withdrawn at the geothermal sites. Furthermore, there may be a time lag between withdrawal of the fluid and the occurrence of surface subsidence. More research is needed in coastal Louisiana on the effects of subsurface fluid withdrawals on surface subsidence,



particularly to determine which subsurface parameters influence subsidence.

The effects of submergence on coastal wetlands are influenced by sedimentation rates within the marsh. The critical submergence rate that leads to marsh deterioration will vary with the amount of sediment that is available for vertical marsh accretion. Dr. John Wells described the natural cycle of growth and decay processes associated with subdelta development at the modern Mississippi River Delta and how the cycle is controlled by sedimentation and submergence. Based on his study of several subdeltas that began to develop in the 1800s after crevassing occurred in the lower course of the river, he has discerned a cycle of subdelta growth and decay that spans about 100 to 175 years. During the first phase of this cycle, interdistributary bays are filled. As soon as a submarine channel network becomes established, the second, or growth, phase, which lasts about 50 to 75 years, begins. Rapid subaerial growth of the subdelta and marsh colonization occurs during this phase. With continued extension and bifurcation of channels, sufficient sediment is not delivered to marshes to keep pace with submergence, and the decay phase begins.

The primary source of alluvial sediments for coastal Louisiana is the Mississippi River. Jim Tuttle discussed the changes that have occurred in the sediment load of the Mississippi River during historic times. His research indicates that prior to approximately 1950, the sediment load of the Mississippi River was stable at about 720 ppm. Since 1950, the sediment load near the mouth of the river has decreased by at least 40%, primarily as a result of upstream river bank stabilization and dam construction projects.

Robert Baumann has investigated sedimentation rates in Louisiana coastal marshes using  $CS_{137}$  activity and clay marker horizons as dating techniques. During the past several decades, marshes located away from channel margins have not been accreting as rapidly as submergence has occurred. This accretionary deficit may be associated with the ponding and marsh loss that has been occurring in interior marshes.

The impacts of canals on wetlands include both the direct loss of wetlands due to the canal cut and secondary effects that result from hydrologic changes associated with the canals. Erick Swenson has studied the effects of spoil banks on marsh hydrology. He has monitored water levels in marshes that were semi-impounded by canal spoil banks and in marshes with no spoil banks. In the semi-impounded marshes, the length of time that the marsh was inundated by water was substantially longer than for marshes with no spoil banks. The waterlogging of the soil may damage marsh vegetation, and probably has the same net effect on the vegetation that rapid submergence does.

Dr. Irv Mendelsohn has been investigating marsh plant responses to drainage. Based on field and controlled experiments, he notes that at higher elevations in the marsh there was more aerobic metabolism and more energy available for growth processes. Marsh vegetative growth seems to be controlled by nitrogen utilization, which in turn is affected by soil drainage. Soil waterlogging also limits oxygen availability for roots and increases the presence of soil phytotoxins.

Dr. James Gosselink summarized the direct and indirect impacts of canalization. In practice, actual canal widths are, on the average, about three and a half times wider than the permitted width. Also, canals continue to widen after they are dredged, due to bank erosion. He considers the direct impacts, however, to be minor compared to indirect impacts. Indirect impacts may result from water movement in the deeper and straighter course of canals versus the flow in natural channels; canals funnel more water, often more saline water, into the marsh. Also, canal spoil banks interfere with the overbank deposition of mineral sediments into the marsh.

Wetlands loss is occurring in other estuarine areas, although not at the magnitude that it is occurring in Louisiana. Dr. Michael Kearney reported on wetlands loss on the Lower Eastern Shore of the Chesapeake Bay in Maryland. Interior ponding in these marshes has resulted in the loss of one-third (5,000 acres) of the wetlands there. The marsh peat

overlies on organic ooze that is easily mobilized by wave action once small ponds form. In this area, there is little influx of mineral sediment. The loss of marshes appears to be the result of an accretionary deficit (submergence exceeds sedimentation) perhaps exacerbated by human activities.

Dr. Evelyn Maurmeyer reported on wetlands loss in the Delaware Bay. Here, interior ponding due to an accretionary deficit is not the problem, as the marsh surfaces are accreting vertically in pace with submergence. Rather, the marsh shoreline along the Delaware Bay is eroding under wave attack at rates ranging from one to six meters per year. Some movement of marshes inland onto the upland surface is occurring, but not rapidly enough to balance the rate at which the shoreline is eroding.

Understanding the processes that are involved in wetlands provides a basis for developing effective mitigation procedures. Michael Krone presented the pipeline industry's perspective on pipeline installations through coastal marshes. A pipeline project must strike a balance between environmental regulations and concerns and budgetary constraints. Newer pipeline emplacement techniques cause less environmental damage.

Dr. Walter Sikora discussed canal backfilling as a mitigating technique. Although there is rarely enough fill available to completely restore a canal, backfilling does leave a much shallower ditch. The ecological niche created in a backfilled canal is occupied by a robust, abundant benthic fauna similar in composition to the fauna occupying natural channels. By contrast, in canals that have not been backfilled, the benthic fauna was severely reduced. Although marsh acreage is reduced whether or not a canal is backfilled, a viable estuarine benthic habitat is restored with backfilling.

Several federal agencies have become involved in the mitigation issue. Dennis Chew described the Corps of Engineer's proposed projects to divert freshwater from the Mississippi River into three areas of

coastal Louisiana and Mississippi. While these projects have not been specifically designed to create new marshes since little sediment will be introduced, they will have a beneficial impact through the reduction of saltwater intrusion.

Mitigation banking is a concept developed by the U.S. Fish and Wildlife Service to compensate for fish and wildlife damages that occur as a result of construction projects in wetlands. As described by David Soileau, mitigation banking compensates for actions that disturb habitat by requiring that other actions which enhance the value of a similar habitat elsewhere be performed before the project is permitted. The actions to improve habitat are quantified and serve as a credit that can be drawn upon when actions that damage habitat are proposed, and no other mitigation is possible. The Tenneco mitigation project in coastal Louisiana was described as a case example.

Our final speaker, Dr. J. Dickson Hoese, discussed the adaptability of estuarine organisms to environmental and habitat perturbations. Focusing on mullet and menhaden, he described how both fishes have been able to adapt to the low oxygen conditions that exist in dead end canals, at the expense of other species that used to occupy the area. How we evaluate a damage to the environment may be influenced by what, at the current time, is considered to be a desirable species or a desirable use of that environment.

Following the individual presentations, a panel discussion on "Perspectives on Mitigation" was convened. The panel included Drs. James Coleman, Sherwood Gagliano, C.G. Groat, Gene Gonsoulin, and Gene Turner. The discussion that followed the opening statements of each panelist lasted for over two hours and involved a spirited exchange between the panel and the audience, reflecting the great interest in and concern over the wetlands loss issue.

## PART I: FACTORS CONTRIBUTING TO WETLANDS LOSS

### RECENT RATES OF SEA LEVEL CHANGE AND IMPLICATIONS FOR THE FUTURE

Mr. Robert Etkins

Assistant Director for Ocean Research and Technology, NOAA

The problem of beach erosion and coastline retreat is linked to the phenomenon of sea level rise, which, in turn, seems to be a result of climate warming. Surveys of beach erosion and studies of sea level rise show that these related processes have been occurring on a global scale over the past century, a period during which the concentration of atmospheric carbon dioxide began increasing exponentially.

A recent survey of all countries having sea coasts found that three-fourths of the world's beaches are retreating at a rate of 10 cm or more per year, while about one-third of these are retreating at more than a meter per year.<sup>1</sup> We know also that sea level has been rising on a global scale during this century. Several papers published over the past 40 years describe the rate of sea level rise during the modern era as ranging from 10 to 30 cm per century.<sup>2</sup> A recent study of world-wide tide gauge data has more accurately estimated the global mean sea level record over the past 100 years.<sup>3</sup> It shows an average rate of rise of 14 cm per century, based on a linear regression of the data between 1880 and 1980. When averaged over the recent 50 year period (1930 to 1980), however, the slope of the linear regression showed an increased rate of 23 cm per century.

The most plausible explanation for the increased rate of sea level rise during the last half century is that it is the result of a combination of oceanic thermal expansion and melting of polar ice,<sup>4</sup> a process illustrated schematically in Figure 1. Over the past century, there has in

fact been an increase in the global mean surface temperature of roughly 0.5 C, an increase consistent with the CO<sub>2</sub> greenhouse theory but also within the range of natural climate variability.

Nevertheless, whether the observed global warming is or is not CO<sub>2</sub>-induced, alternative explanations for the rise of sea level (i.e., simultaneous subsidence of the continental margins and mid-ocean islands, or a "spin-down" of the major ocean gyres) seem unlikely.

Certain other types of geophysical observations such as secular trends in the earth's rate of rotation and long-term drift of its spin axis are also consistent with the "ice-melting" hypothesis. Still other evidence favoring this hypothesis can be cited, i.e., an unprecedented widespread freshening of North Atlantic Deep Water (NADW) of 0.02 per mil between 1972 and 1981.<sup>5</sup> The amount of fresh water required to dilute the NADW, which forms at an approximate rate of  $10^7 \text{ m}^3 \text{ sec}^{-1}$ , is  $1.8 \times 10^{11} \text{ m}^3 \text{ year}^{-1}$ . That amount is equivalent to a uniform thinning of the Greenland ice cap at a rate of  $10 \text{ cm year}^{-1}$ . If in fact it is occurring, this rate of thinning would otherwise be hardly noticeable since it contributes only about 0.5 mm per year to the rise of mean sea level, which is about one-fifth of the estimated current rate of rise.

An increase over the next several decades of global surface temperature as a result of the so-called greenhouse effect must be regarded as a distinct likelihood. The atmospheric concentration of CO<sub>2</sub> is not only increasing exponentially, but other trace gases such as fluorocarbons, nitrous oxide, and methane are also increasing. In fact, over the next decade they are expected to have a collective warming effect that will rival carbon dioxide. Thus, we have good reason to expect that sea level will rise more rapidly in the future.

The model shown in Figure 1 relates the rise of sea level quantitatively to the rise of CO<sub>2</sub>, and indicates that sea level increases approximately 2 mm for each ppm increase of atmospheric CO<sub>2</sub>. Figure 2 compares the global sea level record with the 1958-1980 CO<sub>2</sub> curve extrapolated backward to 1880, using a scale relationship of 2 mm

(M.S.L.) equivalent to 1 ppm (CO<sub>2</sub>). The resulting graphical presentation implies a close relationship between 1) the growth of CO<sub>2</sub> and mean sea level over the past century and 2) a significant increase in the rate of sea level rise over the next several decades.

Glaciologists are particularly concerned that the combined effects of surface warming and sea level rise in higher latitudes of the Southern Hemisphere will disturb the unstable marine-based ice sheet in West Antarctica, causing it to surge and melt into the ocean, thereby causing sea level to rise at an unprecedented rate. At present, there is no way of predicting whether or when this might occur. It is possible, however, that the onset of West Antarctic deglaciation might be recognized by a distinctive large scale pattern of sea surface topography (i.e., change in the geoid) coupled with a shrinkage of the ice sheet. Planned altimetric satellites make these techniques appear promising.

For the present, the problem of monitoring sea level is that tide gauges can only be located along coastlines and on islands and therefore cannot be uniformly distributed over the global ocean. Also, vertical motion of the land (uplift and subsidence), to which the gauges are referenced, causes apparent sea level changes (unrelated to changes in ocean volume). NOAA is addressing the latter problem by using advanced geodetic techniques, i.e., Very Long Baseline Interferometry (VLBI) and the Global Positioning System (GPS) to measure, and thus correct for, vertical land motion at selected tide gauge stations. Recently, a joint subcommission of the International Association of Geodesy (IAG) and the Committee on Space Research (OSPAR) adopted a resolution recommending this technique be utilized on a world-wide basis.

## REFERENCES

1. J. Gribbin, *New Scientist*, 10 May 1984.
2. T. P. Barnett, *Climate Change*, 5, (1983).
3. T. P. Barnett, *JG.R* 89 No. C5, 20 Sept. 1984.
4. R. Etkins and E. S. Epstein, *Science* 215, (1982).
5. R. Etkins and E. S. Epstein, *Science*, 219 (1983).

# The CO<sub>2</sub> - Sea Level Connection

62

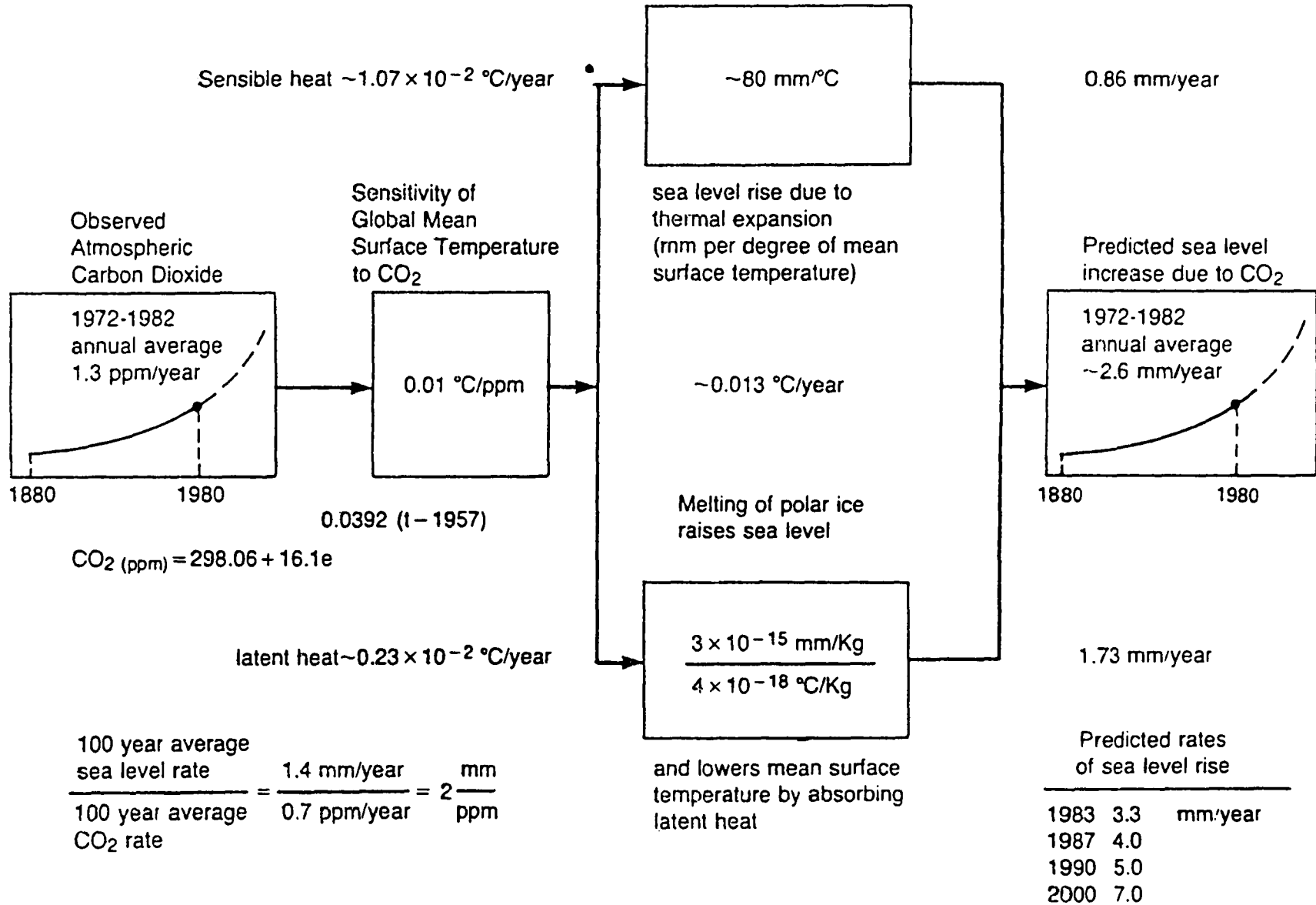

Figure 1. The CO<sub>2</sub>-sea level connection.



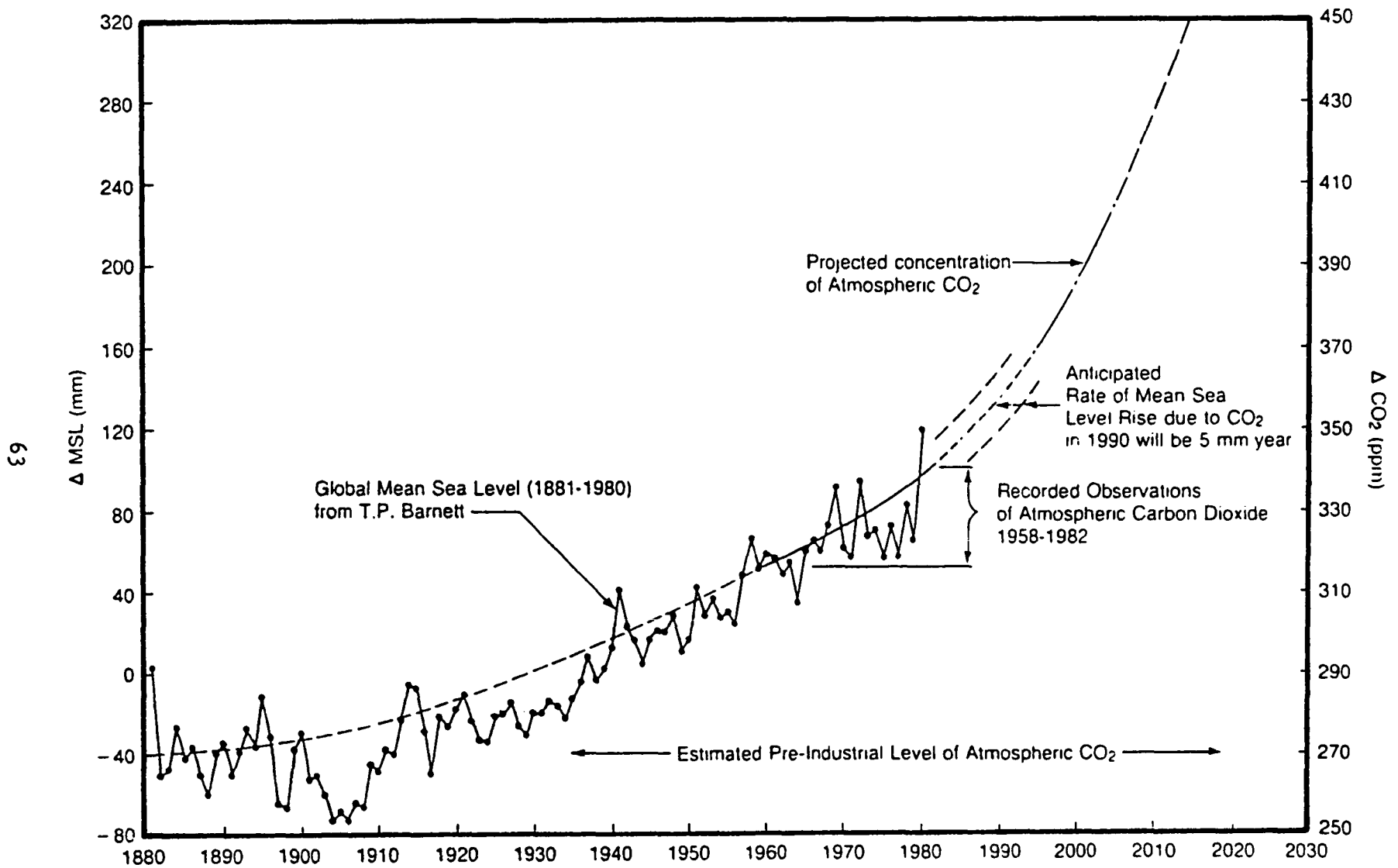

Figure 2. The rise of global mean sea level compared to atmospheric carbon dioxide.

## HOLOCENE SEA LEVEL CHANGES AND MARSH STABILITY

Dr. Walter S. Newman  
Department of Earth and Environmental Sciences  
City University of New York

Contemporary sea level approximates a gravitational equipotential surface--the geoid. The present strandline is the locus of organisms and ecologic zones possessing a more or less firm relationship to the local data. These strandline indicators presumably exhibited similar relationships throughout the Holocene and can be measured relative to the contemporary data in time and elevation. Since isochronous marine surfaces must also have been gravitational equipotential surfaces, they describe the change in shape or deformation of the geoid at a point in time with respect to the present geoid. Marigraph (tide gauge) studies for both the Gulf and Atlantic coasts of the United States generally demonstrate that the sea has been rising at varying rates for the past century. Radiocarbon-dated sea-level indicators for these same coastal reaches support the same conclusion: The sea has been in a transgressive mode of varying rate over the past seven millennia.

For the east coast of the United States during the past 7000 years, sea-level has been in a generally transgressive mode. Along the east coast, ancient sea-levels are most frequently recorded by the radiocarbon dating of marine and brackish water basal peats whose depths are usually measured from the surface of salt- or brackish-water marshes, these surfaces being at or near contemporary mean high water. These tidal marsh surfaces appear to be in equilibrium with the ongoing marine transgression--they appear to both grow upward and outward through time--and east coast tidal marshes are prograding in spite of the sea being in a transgressive mode. Indeed, the accumulation rate of tidal marsh sediments has been demonstrated to be at least as high as one centimeter/year. However, as demonstrated by Michael Kearney (University of Maryland), tidal marsh growth and/or retrogression is acutely sensitive to allochthonous sediment supply.

Figure 3 plots the 414 radiocarbon-dated sea-level indicators available for the northeastern United States and nearby Canada extrapolated onto a line from 36 to 48° North latitude. The dates range as old as 16,000 years. The elevation/distance plot demonstrates that the trace of the sea-level trajectory markedly differs across this 12 degree sector. The earth has clearly changed its shape in this time interval so that transgression (and regression) rates are applicable only locally. The majority of the points plotted are salt- and brackish-water tidal marsh peats, suggesting that these marshes have flourished even during the highest post-glacial marine transgression rate.

Figure 4 locates 168 radiocarbon-dated sea-level indicators for the past 12,000 years along the Gulf Coast littoral and nearby areas. These same points are charted on a elevation/time plot in Figure 5. Divergence back through time once again demonstrates the instability of the geoid. Perhaps the major reason for the apparent marine transgression of the Mississippi Delta is the isostatic adjustment to postglacial sediment loading. The apparent transgression is now in the order of one centimeter or more per year. Until very recently, the delta was generally prograding in spite of the very high transgression rate. James Tuttle (Mississippi River Commission) reported an appreciable decrease in the Mississippi River's suspended load per unit volume over the past few decades. It may be that a major reason for the current catastrophic loss of delta wetlands is sediment starvation. The combination of accumulation of allochthonous sediment and autochthonous organic debris can no longer maintain a dynamic equilibrium of the apparent marine transgression.

Figure 3. Plot of radiocarbon-dated sea-level indicators (0-16,000 years B.P.) for the northeast coast of the United States. High latitude departures from present sea level indicates post-glacial isostatic rebound while lower latitude excursions represent peripheral bulge subsidence, all indicative of geoidal changes.

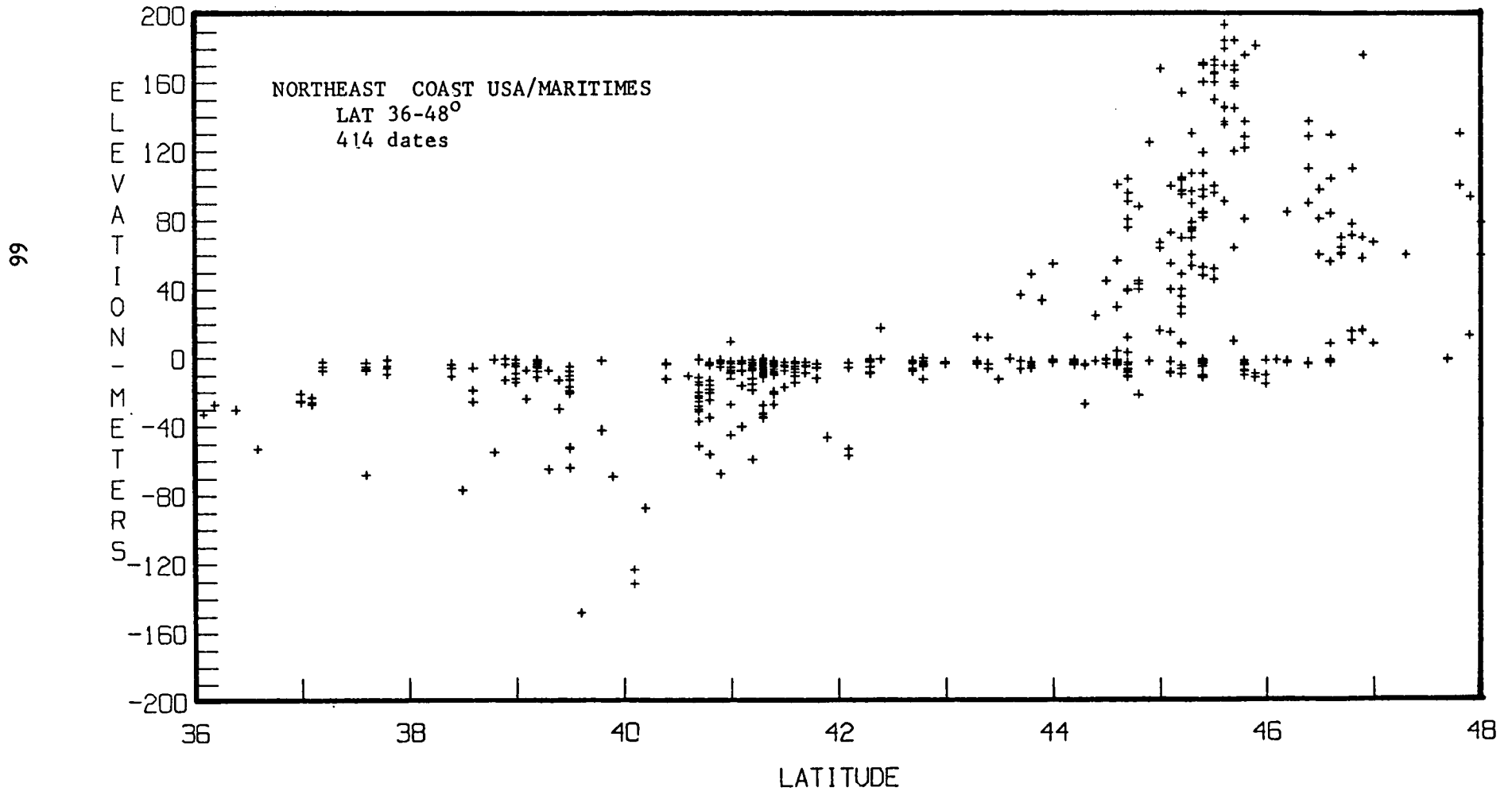

Figure 4. Location of the 168 radiocarbon-dated sea-level indicators used to plot sea-level data on Figure 5.

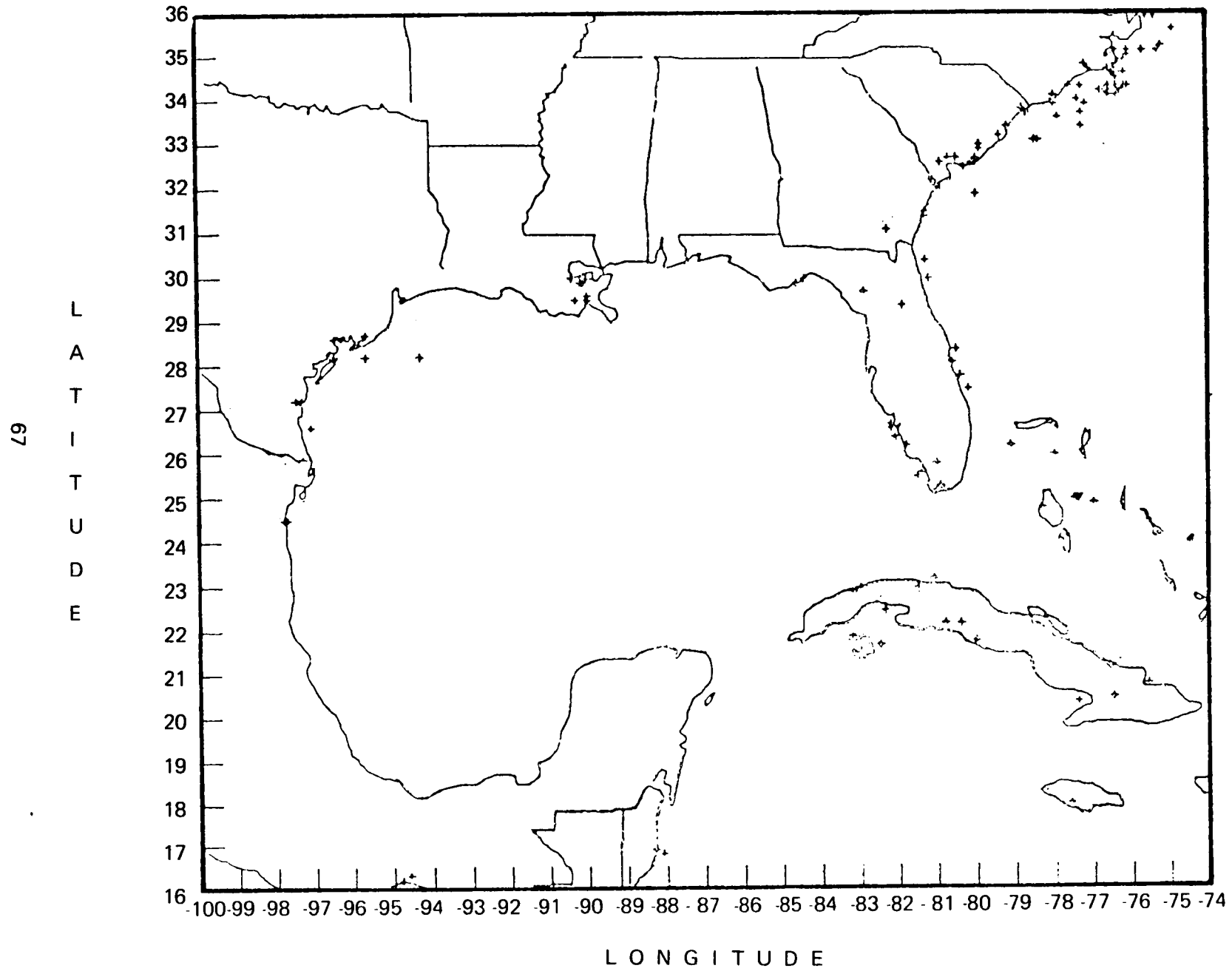
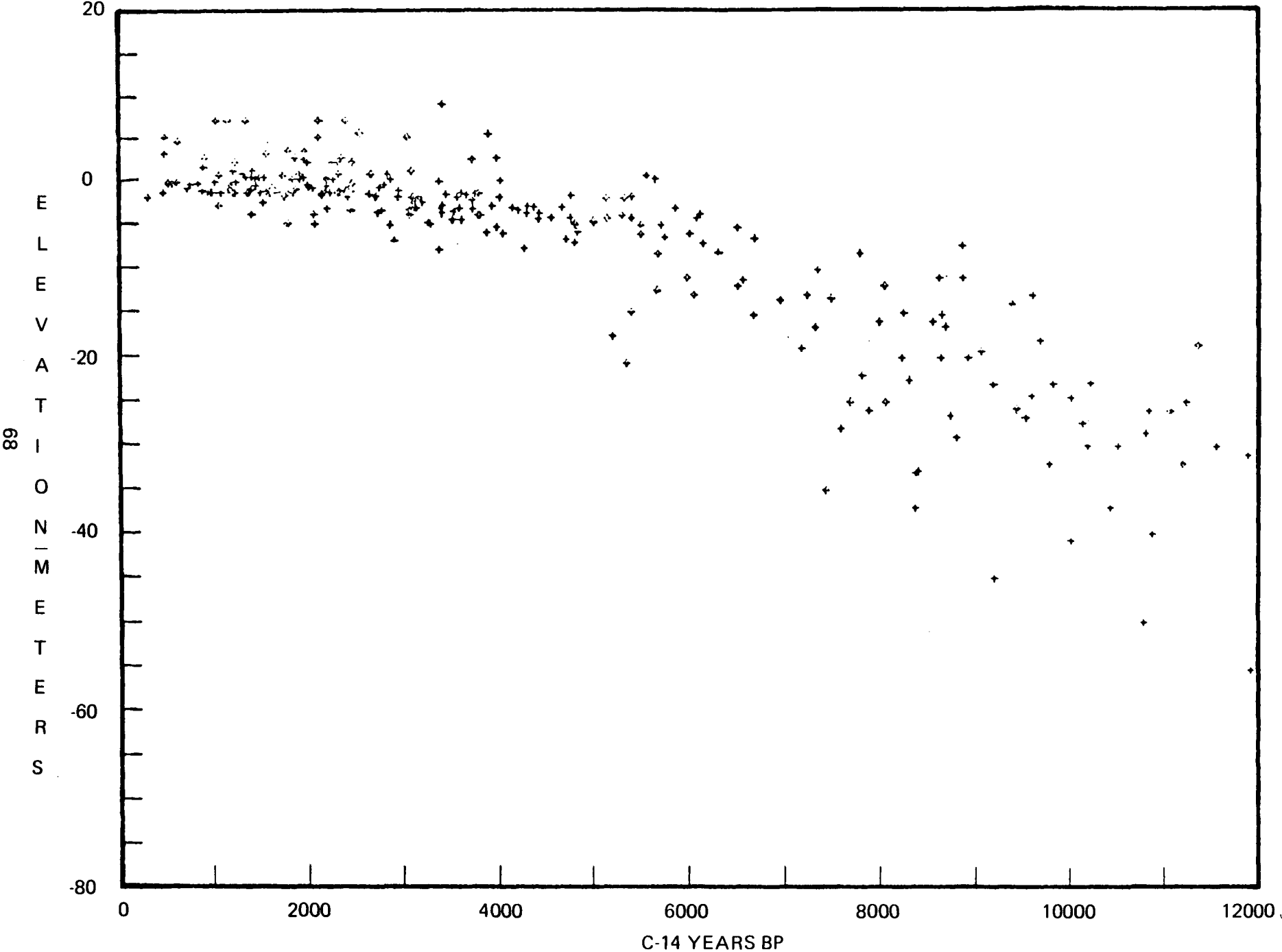

Figure 5. Elevation/Time plot of 168 sea-level indicators for the Gulf Coast region.



## GEOLOGIC CONTROLS IN MARSH DETERIORATION ON THE MISSISSIPPI RIVER DELTA

Dr. John T. Wells  
Institute of Marine Sciences  
University of North Carolina at Chapel Hill

Cyclic sedimentation associated with deltaic processes has occurred in the northern Gulf of Mexico for perhaps the last 65 million years. During this period of time, the edge of the continental shelf has moved steadily gulfward as a result of the seaward migration of oscillating areas of very rapid sedimentation referred to as depocenters. Operating at time scales on the order of millions of years, these depocenters are thick pods of sediment that represent regional accumulation sites of former delta lobes.

Within a depocenter, individual delta lobes may grow and deteriorate at a much higher frequency than the depocenter itself. For example, at least seven major delta lobes, each with a life cycle of approximately 800-1000 years, have built across southeastern Louisiana since the apparent stabilization of sea level some 6000 years ago. This orderly repetition of depositional events and shifting sites of sedimentation by natural processes has led to alternating growth and deterioration of Louisiana's coastal marshes during the Holocene.

The rapid deterioration of marsh vegetation observed during recent years on the modern Mississippi River Delta, the Balize Delta, is controlled in part by subdelta processes of even smaller scale. To examine these small-scale processes, research sponsored by the U.S. Army, Corps of Engineers, and NOAA Sea Grant was undertaken in 1980 to (1) determine the rates of growth and deterioration in the four active subdeltas that make up most of the land mass in the Balize Delta, and (2) relate the deterioration phase of these life cycles to the enormous rates of land loss reported recently in southeastern Louisiana. Utilizing maps,

charts, aerial photographs, and published and unpublished literature, curves were constructed in which land area, sediment volume, and contour advancement were plotted against time for the Baptiste Collette, Cubits Gap, West Bay, and Garden Island Bay subdeltas.

Results indicate that five features are common to the Mississippi River subdeltas: (1) initiation of growth by a crevasse or break in the natural levee system; (2) a well-defined life cycle that includes both growth and deterioration; (3) a life of approximately 115-175 years; (4) continuous infilling and linear growth throughout the destructional phase of the subaerial life cycle; and (5) a new pulse of subaerial growth between the surveys of 1971 and 1978.

During the progradational phase of development in a subdelta of the Mississippi River system, active growth will commence once crevassing takes place, but generally not at a constant rate. An initial break in a natural distributary levee during flood stage will produce deposits of coarse sediment in the vicinity of the break. Fine-grained sediments will infill the bay area, building up a platform for further progradation. At some point in the subaqueous infilling process, channel development by a well-organized pattern of bifurcations takes place, and both progradation and areal extent of the subaerial delta will increase rapidly. As channels elongate and bifurcate, continually carrying sediments to the distal parts of the interdistributary bay, a luxuriant cover of marsh grass will develop. The addition of new land diminishes after 50 to 70 years as channels become too small (through repeated bifurcations) to efficiently transport large volumes of sediment. Eventually land gain and land loss (by erosion and compaction) will reach a point of balance. Finally, the marsh can no longer maintain its growth rate to keep up with compaction, and the marsh cover will begin to open into many small lakes and bays. Inundation by marine waters will then cause the complex to revert back to a shallow marine bay environment, thus completing one infilling and abandonment cycle.

Figure 6 shows this life history sequence for the four subdeltas, together with a composite curve plotted at five-year intervals from 1840



to 1980, and a seven-year moving average of river discharge from the Vicksburg gauging station. Perhaps the most significant features are the abrupt onset of deterioration shown in the composite curve beginning in 1945 and the lack of strong correlation between land growth or deterioration and river discharge. The onset of subdelta deterioration in 1945 is not a result of the extension of the Balize Delta to the continental shelf edge or the construction of artificial levees, as popular accounts would suggest. The Balize Delta was approaching the shelf edge well before its decline in 1945. Moreover, artificial levees end upstream of the four subdeltas and thus do not prevent sediments from entering the subdelta system. In fact, artificial levees may serve as conduits to funnel to the lower delta water and sediment that would ordinarily be lost to overbank flooding.

Although Figure 6 shows that water discharge was lower than average during most of the period of subdelta growth and higher than average at the onset of deterioration, it offers no information on sediment discharge. Data provided in Keown et al. (1981) indicate that suspended sediment reaching the subdeltas is 40% less today than prior to 1965, and that bed material is at present only 30% sand, in contrast to 92% sand in 1932/1934. Therefore, the best explanation for marsh deterioration appears to be tied to sediment load, since sand is the material needed to construct new land at rates sufficient to offset subsidence.

Whereas man's activities, such as canalization, may have changed the rates of land loss, they have not changed the end result of a basic geological process. An important characteristic of the modern Mississippi River has been and will continue to be the orderly repetition of depositional events. The Balize Delta is clearly nearing the end of its natural life cycle and, even if sediment load was restored to its previous level and composition, another 200-300 years might be required for the newest delta lobe, the Atchafalaya Delta, to grow at rates sufficient to offset in southcentral Louisiana the land loss occurring in southeastern Louisiana.

## LITERATURE CITED

Keown, M. P., E. A. Dardeau, Jr., and E. M. Causey. 1981. Characterization of the suspended-sediment regime and bed-material gradation of the Mississippi River Basin. Rept 1, Potamology Program, U.S. Army Corps of Engineers, Vicksburg, MS (2 vols).

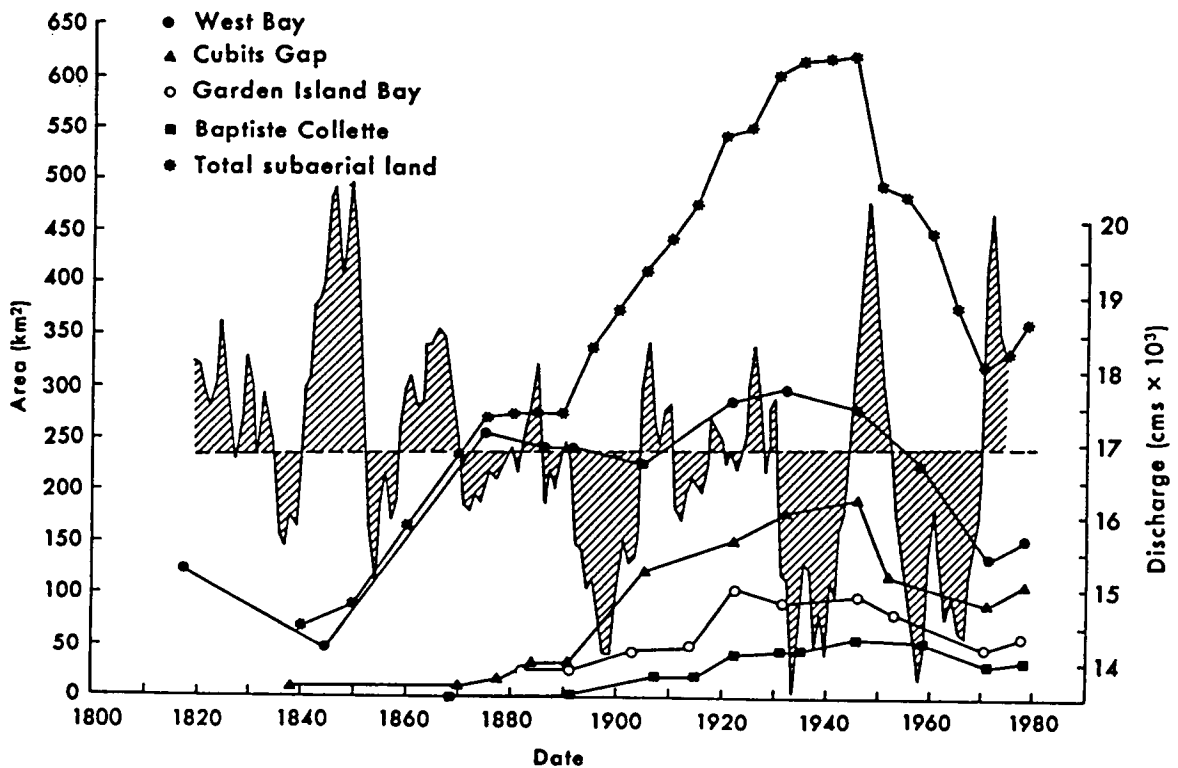

Figure 6. Composite and individual growth curves of the Mississippi River subdeltas showing their relationship to a 7-year moving average of Mississippi River discharge, 1917-1977, taken from the USACOE gauging station at Vicksburg.

## HISTORICAL TRENDS OF MEASURED SUSPENDED SEDIMENT LOAD IN THE MISSISSIPPI RIVER DELTA AREA

Mr. James R. Tuttle  
Lower Mississippi Valley Division  
Mississippi River Commission

The Mississippi River drainage basin is a large and highly diverse area which collects the runoff from all or parts of 31 states and two Canadian provinces. It is an area of 1,246,000 square miles and embodies six major tributary drainage basins--Missouri, Upper Mississippi, Ohio, White, Arkansas, and Red--which contribute flow and sediments in varying amounts to the main stem Mississippi River. The basin is shaped much like a funnel with its spout entering the Gulf of Mexico through the state of Louisiana.

Average annual precipitation over the basin amounts to almost 31 inches varying from a minimum of about 21 inches over the Missouri River drainage area to more than 48 inches over the southern portions of the Mississippi basin. Basin-wide average annual runoff from this precipitation amounts to 8.5 inches, with inputs from major tributary systems varying from a minimum of 2.4 inches from the arid Missouri River basin--to a maximum of 18 inches from the humid Ohio River basin.

Associated with the runoff from the Mississippi River basin is a substantial load of sediments. These sediments are a product of tributary inputs and scour of the bed and banks of the channel network and normally consist of clays, silts, sands, gravels, and cobbles. Modes of transportation include suspension, saltation, and rolling and sliding, all of which are generally occurring simultaneously at a given cross-section of the channel. Some definitions associated with modes of transportation are as follows: "bed load" defines materials moving on or near the channel

bed; "suspended load" defines that portion of the total load that is transported in suspension; and "total load" is composed of suspended load and bed load. Following discussions will address that portion defined as suspended load.

The most reliable data available from which to determine historical trends in measured suspended sediment loads transported by the Mississippi River to the Gulf of Mexico is that which was collected on the main stem Mississippi beginning in 1949 and on the Atchafalaya River in 1951. On the main stem Mississippi, measured suspended sediment loads in tons per year are reported at Tarberts Landing, Mississippi river mile 304.1 above Head of Passes (A.H.P.). On the Atchafalaya River loads in tons per year are reported at Simmesport, Louisiana, (river mile 8.3). The sum of the loads for these two stations provides a best estimate of the sediments reaching the vicinity of the Gulf, exclusive of that portion of material moving near the channel bed. To obtain information on how sediment loads have decreased, the record of data at the two stations was divided into three time periods, and an average load in tons per year was computed for each period. Values computed for each time period are as follows: from 1949 to 1958 the total measured suspended load passing the latitude of Tarberts Landing and Simmesport was 441 million tons per year; from 1959 to 1968 the load decreased to about 284 million tons per year; and from 1969 to 1979 the load further decreased to about 260 million tons per year. Because sediment loads are intricately related to water discharge, records were also examined to determine if the average volume of water per year for each time was reasonably uniform. The findings indicated that the average volumes of water in day-second-feet per year for the first two periods (1949-1958 and 1959-1968) were relatively close; but the most recent period (1969-1979), the period showing the least sediment transport, was higher by approximately 20%. The fact that this period included three major floods, 1973, 1975, 1979, explains the higher average volume of water and also further emphasizes the reduced sediment loads. At any rate, the data clearly demonstrate that average annual measured suspended sediment loads presently transported to the vicinity of the Gulf are approximately half the magnitude of those measured in the

1950s. Similar trends have been identified on both the Missouri and Arkansas Rivers, two rivers that have historically contributed excessive sediment loads to the Mississippi. For example, average annual suspended sediment loads at Hermann, Missouri, on the Missouri River, prior to 1953 were computed to be in excess of 300 million tons. Computed loads at this location decreased to less than 100 million tons per year after 1967 following extensive channel stabilization construction and closure of numerous single and multi-purpose reservoirs. The same trend has been identified on the Arkansas River at Little Rock. At this gauging station the computed average annual load has decreased from near 90 million tons per year to about 11 million tons per year, again following extensive channel stabilization construction and closure of numerous single and multi-purpose reservoirs. Examination of long-term records on the Mississippi and Atchafalaya River clearly demonstrates a reduction in suspended sediment loads since systematic sampling was initiated in the 1940s. Similar reductions on key tributary basins over the same time frame support an apparent basin-wide decrease.

Long-term suspended sediment data, necessary to adequately define average sediment loads prior to the 1940s, are not available. However, random short-term sampling was conducted in the vicinity of New Orleans and near the Head of Passes during the 1800s. These data were examined and a computation made to determine a rough estimate of the suspended sediment load utilizing the long-term average annual discharge for the river. This computation produced an estimated load of approximately 400 million tons per year which checks closely with the average load computed for the 1949 to 1958 time period. Professor Forshey, who collected data for a year near Carrollton, Louisiana, (river mile 102.8, A.H.P.) in 1851, computed an estimated load of 759,242,000,000 pounds or roughly 380 million tons, which checks closely with the above computed estimate. Based on these rough data, it appears that average suspended sediment loads were relatively consistent prior to extensive channel stabilization and reservoir construction and possibly more intensive land-use management techniques since the late 1950s and early 60s.

In summary, average annual measured suspended sediment loads have reduced approximately 50%, and apparently the reduction has occurred over the past approximately three decades. This time frame correlates closely with channel stabilization construction, closure of multipurpose reservoirs, and improved land-use management techniques. Therefore it is reasonable to conclude that these factors are primarily responsible for the reductions. In regard to expectations for future additional reductions there is no clear definite answer. If it is accepted that bank stabilization and reservoir regulation are primary factors and that construction of these features are largely completed, then one could say with some confidence that additional future reductions will be minimal. Acceptance of this conclusion, however, implies that present sources of suspended sediments are unlimited and neglects consideration of future additional land-use conservation and bank stabilization construction throughout the drainage basin. A more realistic conclusion is that there is a potential for future additional reduction suspended loads transported by the Mississippi to the Gulf area, but probably not of the magnitude which has already occurred.

#### **FLUID WITHDRAWAL AND SUBSIDENCE: EXPERIENCE FROM COASTAL LOUISIANA**

**Mr. Drukell B. Trahan**  
Louisiana Geological Survey

A number of investigators have shown through theory and practice that the main factors linking subsurface fluid withdrawal to subsidence are pore pressure reductions, depth and thickness of the producing interval, and formation rock properties such as permeability and compressibility. Subsidence has been associated with oil production in the Wilmington oil field, Long Beach, California, and with groundwater production in Houston, Texas, and Baton Rouge, Louisiana.

High original pressures within geopressed reservoirs make them prime candidates for compactional subsidence, assuming that these original pressures will not be maintained by water ingress at the boundaries of the producing reservoir. Furthermore, thick shales surrounding the geopressed reservoirs are susceptible to dewatering, resulting in additional compaction of the sedimentary column.

Elevation changes during the site preparation and drilling phase at Parcperdue and Rockefeller Refuge indicate anomalous subsidence at each well site. The cause of this subsidence is believed to be related to loading of surficial soils by the weight of drilling equipment. Elevation changes monitored after the drilling phase and during formation testing are consistent with baseline subsidence rates, indicating that loading was temporary and that any production-induced subsidence will lag behind production by at least 2 years.

Baseline subsidence rates include the effects of a number of processes including tectonics and domestic activities such as marsh drainage and historical fluid withdrawal. These effects may be quantified using models which account for the additive impact of natural compaction, loading, historical fluid production and geopressed-geothermal development.

# CANAL-DREDGE MATERIAL EFFECTS ON MARSH WATER LEVELS

Mr. Erick M. Swenson  
Center for Wetland Resources  
Louisiana State University

## INTRODUCTION

Above and below ground water level fluctuations were measured in the marshes west of Golden Meadow, Louisiana, from November 1982 through November 1984. Two study sites were used: a control site, defined as a section of marsh which has a free connection with an adjacent bayou; and a partially-impounded site, defined as an area which has limited connection to an adjacent bayou due to the presence of dredged canal spoil banks. The purpose of the water level measurement program was to define the basic marsh water level regime and to investigate the effects that canal spoil banks may have on the water level regime. In addition to marsh water level data from gauges deployed as part of this study, water levels from the adjacent bayous were obtained from the U. S. Army Corps of Engineers.

## FIELD EFFORT

The study area was located in a section of brackish marshes west of Catfish Lake, Louisiana, in the vicinity of the still active Golden Meadow oil and gas field. The area is of interest since it contains natural bayou/marsh edges as well as edges which have been replaced by spoil banks of various heights. Two sites were used for this study: a control site, which had a natural berm along a major bayou; and a partially-impounded site, which had a dredged material bank surrounding about 75% of the site. This spoil bank varied in height from 20 to 40 cm, in contrast to the natural berm, which was about 10 cm high.



Marsh water levels were measured with a Fischer and Porter Type 1551 punched tape water level gauge. The gauges were installed 50 m from the marsh/bayou edge at both sites. Installation consisted of a plywood platform located about 1 m above the marsh surface. A 30 cm diameter stilling well suspended from the platform housed the measuring float. The stilling well was dug into the marsh, resulting in an operating range from 60 cm below-ground to about 1 m above ground. An elevation survey was used to adjust the gauges to within 2 cm relative to each other. This survey also indicated that the variation in the marsh surface at the site (vegetation clumps vs mud) was about 4 cm. The gauges were serviced on a bi-monthly basis. During servicing, data tapes were collected, the batteries were changed, and the clock was checked. The worst case drift for the clock was 1 hour/month.

After the data tapes were read, the data was entered into the LSU IBM 3083 computer for analysis using SAS. Preliminary data analysis consisted of editing to remove erroneous values, application of correction factors needed to adjust for differences in gauge base levels, and conversion to metric units. Final analysis consisted of plotting the data, computing hours of flooding per month, calculation of flooding event lengths and comparison of marsh and bayou water levels.

## DISCUSSION

The data from both sites showed a general pattern with a distinct diurnal tidal signal superimposed upon other, larger scale events. These larger scale events corresponded to frontal passages. The data also indicated that a substantial amount of water level fluctuation also occurs below-ground. These below-ground fluctuations were also characterized by a diurnal tidal signal.

A comparison of the control site water levels and the impounded site water levels to the bayou water levels indicated that the control site floods and ebbs in a linear fashion relative to the bayou, whereas the impounded site exhibits some sort of hysteresis, particularly at lower water levels. The end result is that the impounded site, once flooded,

drains at a much slower rate than the control site. This results in an increase in the amount of time the marsh is flooded, with a corresponding decrease in the below-ground fluctuations at the impounded site. A comparison of flooding events for each site indicated that flooding events with a length of less than 20 hours occur 80% of the time in the control site, but only 28% of the time in the impounded site. Similarly, flooding events which are greater than 100 hours occur about 10% of the time in the control site, and about 37% of the time in the impounded site. The end result is that, on the average the impounded site is flooded about 141 hours more per month than the control site.

## SUMMARY

This study has shown that the presence of canal spoil banks can indeed influence the marsh water level regime. The presence of spoil banks (even fairly small ones) leads to an increase in the amount of time the marsh is flooded, with a corresponding decrease in the below-ground fluctuations. What is needed now are long-term studies to look at the marsh water level regime in natural areas as well as areas with different degrees of impounding and/or different management practices (weirs, plugs) as they relate to the marsh vegetation and biota. Such data would be invaluable in answering questions as to how the marsh ecosystem functions and would provide a data base for managers which would help them in evaluating various marsh mitigation measures.

## PART II: POTENTIAL MITIGATING MEASURES FOR WETLANDS LOSS

### PLANT STRESS AS A FACTOR IN MARSH DETERIORATION

Dr. I.A. Mendelssohn and Ms. K. L. McKee

Center for Wetland Resources

Louisiana State University

Spartina alterniflora-dominated salt marshes of Louisiana are characterized by large areas of dieback which primarily occur at locations inland of tidal creeks and bayous. These areas of sparse vegetation, low productivity, or often complete vegetative deterioration account for the greatest percentage of the Louisiana salt marsh. Spartina dieback zones are usually identified by their low elevation relative to intact and productive streamside Spartina marshes, standing water, low soil redox potentials (ca. -200mV), and, of course, diminished plant growth. The objectives of this study were (1) to determine the potential causes for the deterioration of Spartina alterniflora-dominated salt marshes and (2) to suggest a possible mitigative procedure.

A number of factors have been suggested as being potentially responsible for salt marsh deterioration, such as tidal inundation, sedimentation, soil water logging, salinity, ion toxicity, and nutrient deficiencies. Many of these parameters are related to the difference in elevation, approximately 8-15 cm, between intact streamside marshes and deteriorating inland marshes. This difference in elevation may be the key factor in determining whether a salt marsh remains stable or deteriorates. This study used a field manipulative experimental approach to test this hypothesis.

An experiment by which marsh elevation was increased or decreased was conducted in the streamside and inland zones of a salt marsh near

Leeville, Louisiana. In the inland marsh, plugs of inland Spartina alterniflora were transplanted at four elevations above the marsh surface: 0, 5, 10, and 15 cm. In the streamside marsh, plugs of streamside Spartina were transplanted at four elevations below the marsh surface: 0, 5, 10, and 15 cm. Hence, the inland marsh elevation was raised to that of the natural streamside zone and the elevation of the streamside marsh was reduced to that of the natural inland zone.

Increasing the elevation of the inland marsh generated a significant increase in both above-ground and below-ground standing crops. Total Spartina standing crop increased three-fold by increasing the elevation of the inland marsh 15 cm. Reducing the elevation of the streamside marsh also had a detrimental effect on plant growth. These results demonstrate that elevation is a major factor controlling Spartina dieback in these salt marshes and inland marshes might be restored or rehabilitated by increasing their elevation.

What parameters associated with elevation have caused this growth difference? The degree of soil water logging, as indicated by soil Eh, decreased as elevation was increased. Associated with this decrease in soil waterlogging was a significant decrease in interstitial sulfide concentrations from a mean of nearly 130 ppm at the inland marsh surface to 1 ppm 15 cm above the marsh surface. This reduced sulfide concentration with increased elevation resulted in a significant decrease in root and leaf sulfur concentrations. This trend, although present in the streamside zone, was most evident in the inland marsh. Soil interstitial ammonium concentrations were lowest at the highest elevations in both streamside and inland zones. This result suggests that nitrogen uptake was greatest at the highest elevations. Hence, at the low elevations of inland marshes, nitrogen uptake may be inhibited, possibly by the high sulfide levels present in the soil.

Plant metabolism may also be affected by differences in soil water logging due to differences in marsh elevation. In this study we were primarily interested in root anaerobic metabolism which could be induced if the plants were experiencing oxygen deficiencies resulting from the

increased water logging at lower elevations. The enzyme alcohol dehydrogenase (ADH) which catalyzes the reduction of acetaldehyde to ethanol during alcoholic fermentation was used as an indicator of waterlogging induced root oxygen deficiencies. Root ADH activities were highest, indicating more severe oxygen deficiencies, at the lowest elevations. Increasing the inland marsh elevation significantly reduced the rate of alcoholic fermentation. These data imply that plant stress due to increased root oxygen deficiencies may be a factor in inland marsh dieback.

In conclusion, elevation is a critical factor in controlling the degree of stress to which Spartina alterniflora is subjected. Low elevations create greater soil waterlogging which stimulates sulfide accumulation and root oxygen deficiencies which, in turn, can inhibit nitrogen uptake and, hence, growth. This conclusion allows the following hypothesis to be stated: Artificially increasing surface elevation may be a means of stimulating salt marsh restoration. On an experimental basis, dredge material obtained from maintenance dredging could be spread onto an inland marsh in order to increase marsh elevation. Plants could be artificially established or allowed to colonize naturally. Here lies a possible means of restoring at least some of our coastal wetlands.

## LOSSES OF COASTAL MARSHES IN THE CHESAPEAKE BAY AREA

Dr. Michael S. Kearney  
University of Maryland

Coastal marshes in Maryland total some 276,000 acres (111,696 ha) (Darmody and Foss, 1979). Floristically, these marshes span a great variety of types, ranging from true salt marshes dominated by Spartina alterniflora and Spartina patens to fresh marshes characterized by Pontedaria cordata (pickereel weed) and Nuphar advena (spatterdock).

Geomorphologically, however, these marshes can be divided into three major groups: backbarrier marshes found on the baysides of Assateague and Fenwick Islands; estuarine or river marshes located along the meanders of major Chesapeake Bay tributaries; and submerged upland marshes which fringe the subsiding margins of the lower Delmarva Peninsula. The total acreages of all these marshes have probably declined in recent decades from increasing shoreline development, although no exact figures on marsh losses are available for most areas. Preliminary estimates, for example, suggest that backbarrier marshes in Sinepuxent Bay behind Fenwick Island have decreased by approximately 36% in the past 40 years (Grace, 1983). Nevertheless, estuarine marshes, the most geographically widespread marsh type, appear to be stable or actually aggrading in the absence of direct human interference. Land clearance and agricultural development following European colonization, have in fact increased both lateral and vertical rates of accretion by increasing sediment yields in many estuarine marshes (Froomer, 1979; Kearney, unpublished data).

As a group, submerged upland marshes, particularly the more extensive brackish variety along the eastern shore of Chesapeake Bay, appear to be rapidly converting to open water. Topographic maps and aerial photographs show that many of these marshes are characterized by large interior ponds, although presently there are no data to substantiate whether the number or size of individual ponds is increasing. Submerged upland marshes have formed by the relatively rapid subsidence of the Delmarva Peninsula ( $20 \text{ cm century}^{-1}$  near Cambridge; Holdahl and Morrison, 1974). Allochthonous sediment input is generally restricted to aperiodic storm deposition off Chesapeake Bay. As a consequence, inadequate inorganic influx in the face of rising sea levels has been invoked as one of the leading causes of the marsh losses. The area of the greatest documented loss of submerged upland marshes is within the Blackwater National Wildlife Refuge (approximately 5000 acres lost since 1938; Pendleton and Stevenson, 1983), and several recent investigations (Pendleton and Stevenson, 1981; Kearney et al., 1983; Stevenson et al., in prep.) have focused on characteristics of marsh sedimentation and erosion in this area (Fig. 7) to explain the causes of the observed losses.

The brackish submerged upland marshes within the Blackwater Wildlife Refuge are bisected by the Blackwater River system, which potentially represents a source of allochthonous sediment for the interior marshes. Ebb tide domination of this estuary nevertheless results in a net sediment export from the marsh of 720,000 metric tons  $\text{yr}^{-1}$  (Stevenson et al., in prep.) and prevents much inorganic sediment from reaching marsh substrates. Occasionally, high sediment loads in the Blackwater system during storms similarly produce little deposition on marsh surfaces. Most of this sediment is stored in shoals for later transport out of the estuary.

The relatively limited role of inorganic sediment influx has resulted in a historic reliance on organic accretion in most areas of the marsh except along the levees of the Blackwater and Little Blackwater Rivers. Vertical accretion rates in areas of active marsh loss, as determined by  $^{210}\text{Pb}$  dating and pollen stratigraphy (Kearney et al., 1983; Kearney, unpublished data), range between 1.7 to 3.6  $\text{mm yr}^{-1}$  and suggest that these sites are barely maintaining elevation with the present local rate of sea level rise (3.9  $\text{mm yr}^{-1}$ ; Hicks and Crosby, 1973). Together, the low rates of organic accretion and the lack of substantial inorganic sediment influx has led to the development of a semi-quaking marsh in most of the refuge, where a thin rhizomatous mat caps 1-4 m of finely divided, organic ooze (Stevenson et al., in prep.). If the mat becomes fragmented, ponds rapidly form, enlarge, and coalesce. Pond enlargement typically accelerates when the ponds reach approximately an acre in size, where wave set-up during major storms is sufficient to produce undercutting of the mat.

Ultimately, marsh losses at the Blackwater Wildlife Refuge (and probably in other brackish submerged upland marshes in Chesapeake Bay) can be seen as broadly linked to the historical development of these marshes and, more specifically, to the recent pervasive degradation of the peat mat. Clearly, the present local rate of sea-level rise, by possibly outstripping the potential vertical accretion rates of the marshes, may be a leading factor in the destruction of the mat from sustained waterlogging of roots and, eventually, root death (Mendelssohn et al.,

1981). Human-induced acceleration (and/or initiation) of these processes, though examined in detail by Pendleton and Stevenson (1983), has not been conclusively established and deserves further study.

## REFERENCES

- Darmody, R.G., and Foss, J.E. 1979. Soil-landscape relationships of the tidal marshes of Maryland. *Soil Sci. Am. Jour.*, 43: 534-541.
- Froemer, N.L. 1979. Geomorphic change in some western shore estuaries during historic times. Ph.D. dissertation, Johns Hopkins University, Baltimore, MD. 217 pp.
- Grace, R.E. 1983. Natural and man-induced changes of the Sinepuxent Bay salt marshes. Senior research paper, Geog. Dept., Univ. Maryland, College Park, 25 pp.
- Hicks, S.D., and Crosby, J.E. 1973. Trends and variability of yearly mean sea level, 1893-1972. NOAA Tech. Memo. Nos. 12, 2 pp.
- Kearney, M.S., Leatherman, S.P., and Wong, G.T.F. 1983. Recent vertical accretion rates at Blackwater Wildlife Refuge. Maryland Water Resources Research Center, Univ. Maryland, Rept. A-064-MD, 43 pp.
- Pendleton, E.C., and Stevenson, J.C. 1983. Investigations of marsh losses at Blackwater Refuge. Horn Point Environmental Laboratories, Univ. Maryland, Ref. No. 83-154-H.P.E.L., 213 pp.
- Stevenson, J.C., Kearney, M.S., and Pendleton, E.C. in preparation. Sedimentation and erosion in a Chesapeake Bay brackish marsh system. Submitted to *Marine Geology*.



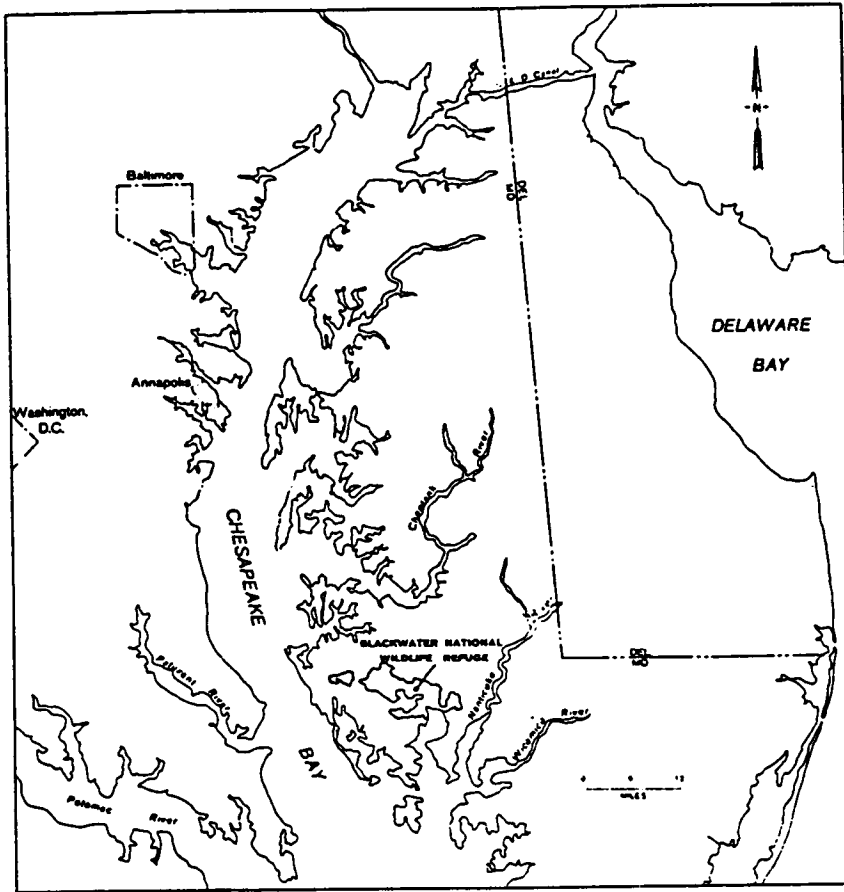

Figure 7. Principal areas of marsh losses in Dorchester County, Maryland, showing the approximate location of the Blackwater National Wildlife Refuge.

## WETLANDS LOSS IN THE DELAWARE BAY

Dr. Evelyn M. Maurmeyer  
Coastal & Estuarine Research, Inc.

### INTRODUCTION

The Delaware Estuary is undergoing a relatively rapid marine transgression in which marsh, beach, and nearshore coastal sedimentary environments are migrating landward in response to coastal erosion and relative sea-level rise. The western shore of Delaware Bay is eroding at average rates of 2-3 m/yr, with highest rates of loss (4-6 m/yr) occurring along marsh shorelines (Figure 8).

### MARSH VEGETATION

Delaware Bay's estuarine shoreline extends from north of Wilmington, Delaware, southward to Cape Henlopen, located at the mouth of the Bay at the Atlantic Ocean, for a total distance of approximately 150 km. Mean tide range in the estuary varies from 1.8 m in the north to 1.2 m in the south. Approximately 29,600 ha (74,000 a.) of wetlands lie along the western shore of Delaware Bay (Daiber and others, 1976). The marshes range in width from several hundred meters to nearly 8 km (Allen, 1977). Wetlands vegetation along the Bay is dominated by Spartina alterniflora, which represents 55% of the marsh vegetation. S. patens and Distichlis spicata together comprise 16% of the areal extent; the reed Phragmites communis accounts for 9%, and the shrubs Baccharis halimifolia and Iva frutescens comprise 3% of the area. The remaining vegetation consists of brackish species including Scripus sp. and Panicum sp. (15%), and fresh-water species, such as Pontederia sp. and Peltandra sp. (2%) (Daiber and others, 1976; Allen, 1977).

## SHORELINE GEOMORPHOLOGY

The Holocene fringing marshes along the Delaware Estuary overlie Pleistocene sands and gravels. The thickness of the marsh unit is highly variable; thicknesses as great as 30 m exist in stream valleys (Richter, 1974). In the northern part of the Bay, marsh banks form the shoreline. Toward the central part of the Bay where local outcrops provide sand and gravel to the littoral zone, and sufficient wave and current energy are available for transport and redistribution of this material, the shoreline is characterized by narrow "perched" beaches. These barriers are typically narrow (<50 m wide) and thin (1 m), and lack dune development. Broad tidal flats, representing the relict marsh surface, crop out seaward of the barriers. In the southern part of the Bay where sediment supply and energy conditions are greatest, the barriers are generally wide (50-100 m) and thick (2-3 m), with well-developed, vegetated dune fields.

## SHORELINE EROSION RATES AND PROCESSES

The western shore of Delaware Bay has a history of almost continuous erosion averaging 2-3 m/yr over the past century (Figure 8). In general, highest rates of erosion have occurred along marsh shorelines in the northern section of the Bay, which have eroded at rates averaging 4-6 m/yr. The marsh banks are subjected to wave erosion, particularly during northeast storms, which results in undercutting and slumping of the marsh. There is no natural post-storm reparation process to restore the marsh to its pre-storm configuration; hence, shoreline retreat incurred during the storm represents net loss.

The marsh shoreline at Port Mahon (Line E, Figure 8) is an example of the rapidity of marsh loss due to wave attack. This site has one of the highest rates of shore erosion along the entire Bay shoreline. Between 1843 and 1956, the shoreline retreated an average of 6 m/yr. The lighthouse at Port Mahon had to be rebuilt three times within forty years during the 19th century due to the encroaching waters of the Bay (Vincent, 1870). Comparison of aerial photographs taken in 1938 and 1968 reveals that parts of Port Mahon eroded at rates as high as 12.3 m/yr

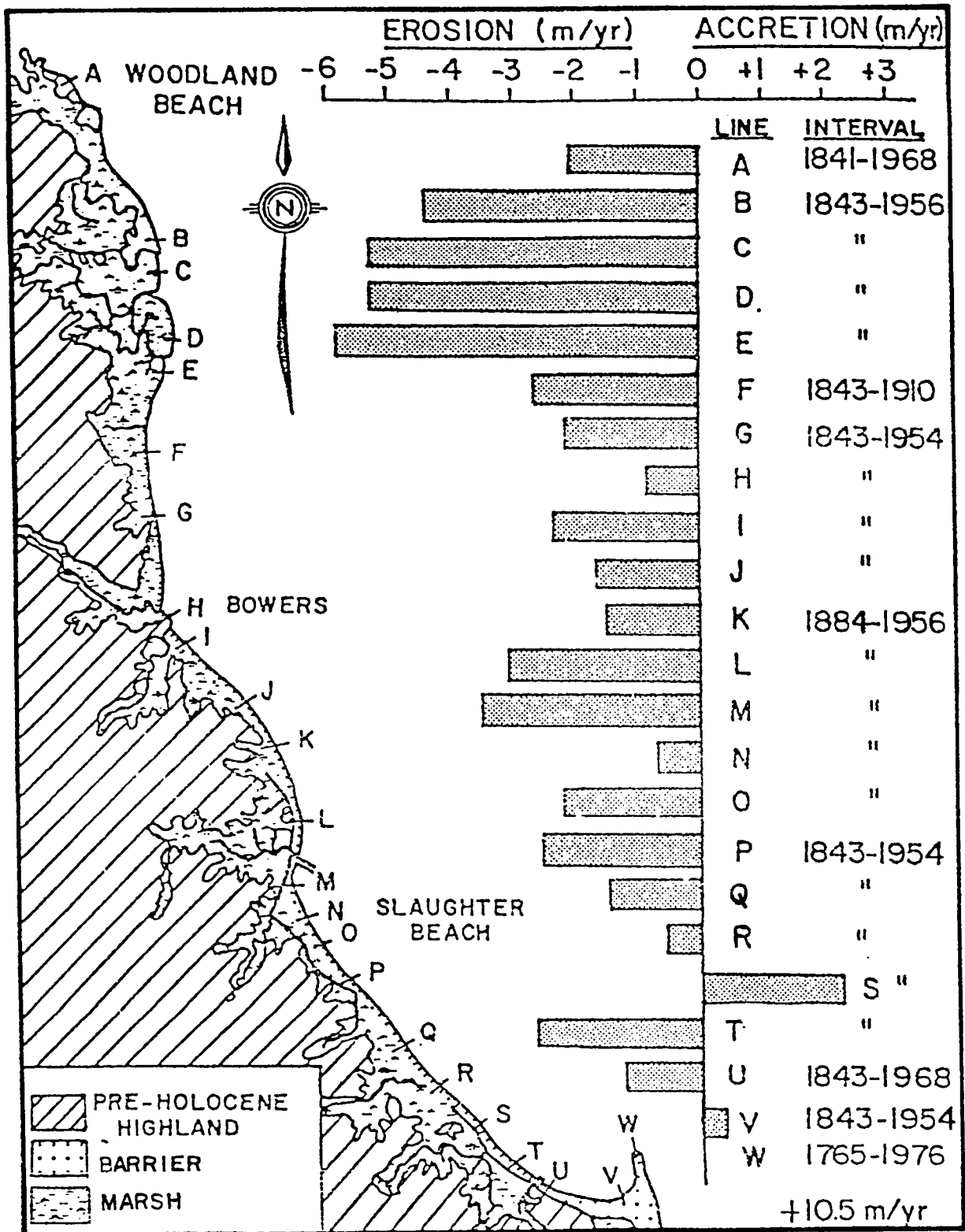

Figure 8. Annual mean-high-water shoreline changes along the western shore of Delaware Bay averaged over the last century (data compiled from U.S. Army Corps of Engineers, 1968). (Maurmeyer, 1978)

during this period (Maurmeyer, 1978). Structural mitigation measures emplaced here in recent years included rip-rap rubble mounds and a massive seawall, but efforts to stabilize the shoreline do not appear to be successful.

In the central and southern portions of the Bay, where sandy barrier beaches are present, shoreline erosion averages 2-3 m/yr. The dominant process of shoreline retreat is storm overwash, where sand is transported landward from the beach and dune to form extensive overwash deposits on the backbarrier marsh surface. Depending on the severity of the storm, the overwash sands may extend 100 m or more into the marsh, and may be over a meter in thickness. Although marsh vegetation can survive burial by a thin layer of sand, deposition of a thick overwash unit may result in complete destruction of the wetlands lying landward of the estuarine barriers.

#### LOCAL RELATIVE SEA-LEVEL RISE

Belknap and Kraft (1977) constructed a local relative sea-level rise curve for coastal Delaware based on radiocarbon dates of basal peats and other organic material. Their results show that sea level has risen continuously for the past 12,000 years. Prior to 5,000 years before present (B.P.), sea level rose at a rate of 29.6 cm per century; between 5,000 and 2,000 years B.P., sea-level rise slowed to 20.7 cm per century; and from 2,000 years B.P. to the present time, the rate of sea-level rise has been 12.5 cm per century. Demarest (1978) examined tide gauge records from Breakwater Harbor, Delaware, and determined that in recent years (1919-1978), sea level has risen 3.3 mm per year, or 33 cm per century.

Local relative sea-level rise in Delaware is due to a number of factors, including eustatic sea-level rise, tectonic effects, water loading, and subsidence due to sediment compaction (Belknap and Kraft, 1977). Belknap (1975) quantified the effect of sediment compaction by examining deformation of the 3,500 and 2,500 years B.P. marsh plane in the Murderkill River valley, which contains 30 meters of Holocene mud.

Results showed that maximum compaction occurred in the axis of the valley, where muds compacted 4.9 m over 3,500 years, for a compaction rate of 14 cm per century. Belknap found "rapid initial compaction and progressive slowing of the compaction rate."

## MARSH SEDIMENTATION RATES

If a marsh is to survive during a period of rising sea level and coastal subsidence, vertical growth of the marsh must keep pace with the rate of sea level rise. Numerous studies utilizing a variety of techniques have been conducted to determine the rate of salt marsh accretion in coastal Delaware. Belknap (1975) compiled all existing data on Holocene sedimentation rates based on radiocarbon analysis of salt marsh peats, and determined that the mean sedimentation rate is 14.5 cm per century (1.45 mm/yr), a rate consistent with the long-term average sea-level rise. Recent studies using short-term accretion rates reveal higher marsh sedimentation rates. Church and others (1981) used  $^{210}\text{Pb}$  to obtain a sedimentation rate of 4.7 mm/yr (47 cm/century) in the Great Marsh, Delaware. Stumpf (1983) determined that the Lewes Creek Marsh in southern Delaware accreted at an average rate of 5.0 mm/yr (50 cm per century) since 1917. These figures all indicate that salt marsh growth has kept pace with or even exceeded the rate of local relative sea-level rise during both the long-term (Holocene Epoch) as well as the recent historic past.

## LANDWARD ENCROACHMENT

As sea level rises and tidal waters encroach farther landward, the lateral extent of salt marshes expands in a landward direction. The rate of landward growth is dependent upon a number of factors, particularly on the slope of the pre-Holocene surface over which the marsh is transgressing. For a given rise in sea level, the areal extent of marsh encroachment will be large in areas where the gradient is low; conversely, the areal extent of marsh growth in steep slopes will be low. Richter (1974) calculated that approximately 5 ha (12.5 a.) of new wetlands form each year due to rising sea level and landward encroachment of marshes onto upland surfaces.

## SUMMARY

Wetlands loss in the Delaware Bay is due to a combination of short-term processes (direct wave erosion of marsh banks cropping out at the Delaware Bay shoreline and burial of backbarrier marshes by sandy overwash deposits during storm events) and the long-term effects of sea-level rise (due to a combination of eustatic sea-level rise, tectonic effects, water loading, and sediment compaction). Studies of salt marsh sedimentation rates indicate that vertical accretion of salt marshes is keeping pace with sea-level rise and subsidence, thereby maintaining the elevation of the marsh surface. While there is landward expansion of salt marshes due to encroachment onto upland areas, preliminary observations suggest that the rate of encroachment is not as great as the rate of loss on the bayward margin. The net result is a decrease over time in the areal extent of wetlands along the Delaware Bay.

## REFERENCES

- Allen, E.A., 1977, Petrology and stratigraphy of Holocene coastal-marsh deposits along the western shore of Delaware Bay: Sea Grant Report DEL-SG-20-77, College of Marine Studies, University of Delaware, Newark, Delaware, 287 p.
- Belknap, D.F., 1975, Dating of Late Pleistocene and Holocene relative sea levels in coastal Delaware: M.S. Thesis, Geology Department, University of Delaware, Newark, Delaware, 95 p.
- Belknap, D.F., and J.C. Kraft, 1977, Holocene relative sea-level changes and coastal stratigraphic units on the northwest flank of the Baltimore Canyon Trough Geosyncline: *Jour. Sed. Petrology*, v. 47, p. 610-629.
- Church, T.M., C.J. Lord, III, and B.L.K. Somayajulu, 1981, Uranium, thorium and lead nuclides in a Delaware salt marsh sediment: *Estuarine, Coastal and Shelf Sci.*, v. 13, p. 267-275.

- Daiber, F.C., L.L. Thornton, K.A. Bolster, T.G. Campbell, O.W. Crichton, G.L. Esposito, D.R. Jones, and J.M. Tyrawski, 1976, An atlas of Delaware's wetlands and estuarine resources: Delaware Coastal Management Program, Tech. Rept. No. 2, Dover, Delaware, 528 p.
- Demarest, J.M., III, 1978, The shoaling of Breakwater Harbor, Cape Henlopen area, Delaware Bay, 1842 to 1971: Sea Grant Report DEL-SG-1-78, College of Marine Studies, University of Delaware, Newark, Delaware, 169 p.
- Maurmeyer, E.M., 1978, Geomorphology and evolution of transgressive estuarine washover barriers along the western shore of Delaware Bay: Ph.D. dissertation, Geology Department, University of Delaware, Newark, Delaware, 274 p.
- Richter, A., 1974, A volumetric analysis of Holocene sediments underlying present Delaware salt marshes inundated by Delaware Bay tides: Sea Grant Report DEL-SG-2-74, College of Marine Studies, University of Delaware, Newark, Delaware, 103 p.
- Stumpf, R.P., 1983, The processes of sedimentation on the surface of a salt marsh: Estuarine, Coastal and Shelf Sci., v. 17, p. 495-508.
- U.S. Army Corps of Engineers, 1968, Delaware Coast, Beach Erosion Control and Hurricane Protection: Senate Doc. 90, 90th Congress, 2nd Session, Philadelphia, Pennsylvania, 110 p.
- Vincent, F., 1870, A history of the State of Delaware: John Campbell, Philadelphia, Pennsylvania, 478 p.



## IMPACTS OF PIPELINE INSTALLATIONS IN COASTAL LOUISIANA

Dr. James G. Gosselink  
Coastal Ecology Institute  
Louisiana State University

Wetland degradation and loss is a serious problem along the Louisiana coast. Except for the active Mississippi and Atchafalaya River deltas, the wetlands in all other coastal basins are disappearing at a net rate estimated at nearly 100 km<sup>2</sup> per year. In the western half of the Barataria Basin this loss was documented by a computerized analysis of aerial imagery dating back to 1945. This study and others in the Barataria basin show that wetland loss has accelerated from a rate of about 0.2% of the existing marsh lost per year in the early part of this century to a current rate of about 1.5% per year.

Wetland degradation is a natural part of the 5000-year cycle of growth and decay of a Mississippi River delta lobe; but the rate of wetland loss has been accelerated by human impact on the delta. One of the human factors implicated is canal dredging within the coastal zone. The area of wetland directly lost to dredging is significant. Including the berm and spoil deposits, the total area directly impacted by canals is typically 3.5 to 5 times the permitted area of the canal. Furthermore canals erode once they are dredged and continue to widen through the years. The rate at which they widen is accelerated by boat traffic in the canal.

Canals dredged for pipelines can be backfilled, although historically most were not. Because spoil material begins to oxidize and is dispersed by storms, there is seldom enough material to fill the canal after the pipe is laid. As a result, most backfilled pipeline canals can be identified as long, straight, shallow aquatic features on the landscape. There seems to be a scale factor operating here. Some pipeline canals radiating from the Louisiana Offshore Oil Port, Inc., facility in the Barataria Basin

have revegetated well, others have not. In general the smaller the pipeline ditch and the shorter the period of time before it is backfilled, the better the recovery. Any effort to backfill appears to be much preferable to leaving the canal open. Our experience with the Louisiana Offshore Oil Port, Inc., pipeline is that in some places, especially in fresh/slightly brackish marshes, the shallow ditch resulting from incomplete backfilling has increased marsh-water interspersion and provided good duck habitat.

Direct wetland loss to canals is only a fraction of the total wetland loss. Studies by others have documented a direct positive relationship between wetland loss rates and canal density. In the Barataria basin study cited above it was shown that the rate of wetland loss and the influence of canals on this loss, varied, depending on the previous history of the wetland area in question. The salt marshes south of the Southwest Louisiana canal have been in a broken-up state since 1945, and have changed only slowly, notwithstanding a high density of canals. The fastest rates of wetland loss have occurred in the marshes adjacent to Bayou Lafourche that were freshwater marshes in 1945, but brackish in 1980. Here large areas of solid marsh have become shallow open brackish lakes. The rapid marsh degradation appears to be a direct result of salt water intrusion, accelerated by deep straight canals that connect saline bays to the freshwater marshes.

## CURRENT TECHNIQUES OF PIPELINE EMLACEMENT TO MINIMIZE IMPACTS ON WETLANDS

Michael A. Krone  
United Gas Pipe Line Company

United Gas Pipe Line Company (United) appreciates this opportunity to discuss current techniques which our industry uses to minimize construction impacts on wetlands. Installing a pipeline is essentially a balancing act where engineering options are measured against economic considerations, safety and environmental requirements, service and market realities, and other factors which directly affect the pipeline, such as landowner preferences in right-of-way (ROW) treatment. Today's presentation will offer examples of how United integrates environmental considerations into new pipeline construction projects.

United's 10,000 miles of interstate natural gas pipe are located throughout the Gulf South including about 4,700 miles of gathering and transmission pipe in Louisiana. Our Louisiana system is part of a major network which transports Louisiana's rich offshore natural gas reserves to onshore distribution networks. Much of this system is located and maintained in brackish marshes and wetlands along Louisiana's coastal zone.

United is not actually in the pipeline construction business, but we do own, operate, and maintain our own system. We manage contractors to ensure that pipeline projects are built to our specifications and quality standards. Our 60 plus years of construction management experience ensures site specific construction practices which are both environmentally sound and cost-effective.

The increasing rate of wetlands loss is a matter of concern. Most of the coastal wetlands in Louisiana are the result of 5,000 years of Mississippi River delta building. In fact, 40% of coastal wetlands in the

contiguous U.S. are found in Louisiana. This long-term deltaic growth process has been reversed in recent history from a complex interaction of physical, chemical, and biological factors. Recent estimates of annual wetlands loss to open water in Louisiana approximate 47 square miles per year (Senate and House Committees on Natural Resources, 1981).

It is currently difficult to predict construction impact on wetlands because there is very little literature published. Most literature (Darnell, 1976, MMS, 1983) suggests that pipeline emplacement impact are localized and of short duration. This suggests that either wetlands are more resilient than previously thought or pipeline emplacement activities are compatible with this environment. Whatever combination of reasons pipelines are the safest, most efficient, and most extensive energy distribution system available today. Some researchers suggest that existing pipeline and navigation canals contribute to the total yearly wetlands loss in Louisiana. Estimates vary from 2-4% (Craig et al., 1979, Wicker et al., 1982) and higher. Natural gas pipeline canals, however, represent the old approach to pipeline emplacement. Canals are generally not acceptable under the current regulatory climate because they tend to erode about 2-14% per year and encourage salt water intrusion.

Recreational and commercial boat traffic creates a shore wash which erodes and widens the canal banks. Pipeline companies cannot control boat traffic, but they do have regular maintenance programs to control erosion on their rights-of-way (ROW's). Where new installations cross existing pipeline canals, we can and do in some cases minimize the problem with the landowner's permission.

Louisiana's wetlands do seem to be under a lot of pressure. The natural causes of wetlands loss in Louisiana include:

- subsidence and rising sea levels which enhance salt water intrusion (Adams et al., 1976, Gagliano, 1981)
- erosion of wetland perimeters and barrier islands (Van Sickle et al., 1976)
- catastrophic events like hurricanes and fires (Johnson, 1981)

- changes in the patterns of sediment deposition (Gordon, 1981)
- natural succession and biotic factors like overgrazing.

The man-induced causes of wetlands loss in Louisiana include:

- land reclamation owing to farming, housing, and landfill (Craig et al., 1979, Gagliano, 1973)
- flood control (Keown et al., 1981) and reservoir construction
- dredging for navigation channels
- canals associated with oil and gas extraction
- strip mining and peat mining
- groundwater extraction and waste disposal.

Regional variations in subsidence and sea level made it difficult to isolate the impact of natural and man-induced factors. What is clear is that the predictability of wetland environmental impacts is not well defined at this time and further research on ecosystem structure, function, and response needs to occur. There is also a critical need to learn how to restore and manipulate degraded wetland environments. These are both areas where the natural gas industry is taking a leadership role.

Compensatory mitigation or the "banking concept" is a new approach to environmental impact which is somewhat controversial. Compensatory mitigation can serve as a positive tool in environmental planning when it is used to balance the unavoidable impact of development against the need for maintaining a relatively pristine coastal environment. Compensatory strategies can take the form of habitat restoration, creation, or enhancement as a means of replacing projected losses of habitat, resources and/or habitat functions.

Numerous laws, including the Fish and Wildlife Coordination Act and the Clean Water Act require that the adverse ecological impacts of a development project be mitigated by the developing agency or individual. The banking concept offers a unique approach to satisfying those requirements because it puts mitigation up front in the permit

process rather than at the end. As a result it should reduce the antagonism that may develop between the developer and the regulator because it allows the developer to budget and plan for mitigation and reduce delay often associated with the permit process. From an environmental standpoint, the "banking concept" can maintain and in some instances enhance the environment (Helvey, 1984, Zagata, 1984).

United attempts to minimize construction impact on all construction projects because (1) we believe in the "good neighbor" policy, (2) we comply with federal and state environmental regulations, and (3) it is cost-effective to address environmental issues in planning stages. Pipeline emplacement in wetlands offers a special challenge because they are considered sensitive, and the environment itself is hostile to a labor intensive activity which uses heavy equipment.

The regulatory arena is also sensitive to wetlands issues. Here are some examples of federal programs which impact wetlands, although no specific wetlands protection legislation exists to date:

- Rivers and Harbors Act (1899)
- Federal Water Pollution Control Act (Clean Water 1972)
- Migratory Birds Acts (1918, 1929, 1934)
- Wetlands Loan Act (1961)
- Land and Water Conservation Fund Act (1965)
- Water Bank Act (1970)
- Fish and Wildlife Coordination Act (1965)
- Coastal Zone Management Act (1972)
- Endangered Species Act (1972)
- Executive Order 11990 (1977)

The intent of this federal legislation is good, but there still exists federal legislation which encourages wetlands conversions, like the Swamp Lands Act and the Agriculture Conservation Program. At United, we make it a point to be aware of, understand, and comply with all appropriate regulations. We plan for this compliance and communicate this attitude to our construction crews. But even given a positive

approach and modern construction techniques, pipeline emplacement does have some short-term environmental impacts.

Pipeline emplacement has the potential to impact wetlands in the following way:

- changes in drainage patterns and tidal flow
- increased turbidity
- changes in soil and soil-water chemistry
- changes in nutrient flow
- damage to archaeological resources
- reduction in esthetic qualities and recreation opportunities
- disturbances of plant and animal community structure.

Short-term impacts like turbidity are minimized by planning and rapidly disappear after the construction crew completes its ROW treatment to our specifications. United evaluates a number of siting and construction guidelines for every potential route to minimize short-term impacts:

- avoiding wetlands where possible
- minimizing clearing on the ROW
- utilizing existing ROW when possible and attempting to cross wetlands at their narrowest point
- timing the construction period with an awareness of wildlife breeding activities and low-water levels to reduce turbidity loads and species impacts (especially oysters).
- implementing stream bank repair immediately following construction to control erosion and salt water intrusion
- contouring to re-establish drainage patterns using bulkheads, culverts, earthen dams, wiers, or other aids
- crossing streams at right angles at the narrowest point in areas of shallow stream banks to minimize riparian construction staging impacts. The higher the stream banks, the more bank has to be cut away so that the pipe has the right amount of cover (3 ft) and construction personnel are

working with a safe grade (2:1)

- minimizing the number of construction vehicles and the frequency of passes to control soil compaction and reduce plant community impacts
- backfilling the trench in a timely manner to avoid canalization and restore contours
- considering double ditching where circumstances call for it
- revegetating high-energy sites like barrier islands or consider directional drilling
- using the push-pull method of construction or other construction techniques to minimize turbidity loads and construction impacts.

Of the above short-term impacts, disruption of plant communities is probably the most obvious environmental impact attributed to pipeline emplacement. The ROW has to be kept free of woody shrubs and trees for safety considerations and access. In most wetland situations however, available studies indicate that rapid recovery, in terms of vegetative cover, occurs within two growing seasons after a pipeline is installed. The natural gas industry is currently sponsoring further research to document the resilience which wetlands exhibit to current pipeline emplacement techniques. New construction techniques which appear to enhance plant recruitment and are cost-effective are incorporated into our mitigative planning measures.

Mitigative planning is the process of siting and regulatory consultation which precedes construction in an attempt to minimize short-term and long-term impacts to the environment. The process at United involves the following:

- Establishing baseline conditions from available in-house resources. United employs environmental analysts to evaluate potential environmental impacts for route alternatives using resources like the MMS Regional Environmental Assessments and Bio-Atlas, Louisiana Wildlife and Fisheries Gulf Coast Ecological Inventories, and the DNR Louisiana Coastal



Resources Atlas. Aerial overflights are helpful in this regard. The route selection process occurs between essentially two fixed points (i.e., the production or processing platform and a pipeline point of connection). If engineering considerations permit, the direct line approach is evaluated to minimize impact. We rely on agency insights during the route selection process to avoid sensitive areas.

- Company personnel normally make a site visit with an engineer before meeting with permit agencies (e.g., MMS, COE, CUP, W&F, SHPO). Pre-application meetings are used to discuss the project, various route considerations, and the type and quality of the terrain to be traversed. The siting guidelines which have already been mentioned are discussed and evaluated for each route.
- Then the construction, ROW, and environmental permits are applied for. Interstate natural gas companies do have the power of eminent domain, which helps ensure that the best route is applied for.
- Meanwhile, bids go out to various construction companies. United can anticipate what a particular project will cost using a computerized data estimation system which weeds out bids when a contractor has bid too low to get the job and still perform the necessary work satisfactorily. An up-to-date referral system also ensures that the successful bidder has quality management. This referral technique works well because we know that the bidder has the equipment, expertise, and the financial strength to complete the job and his track record for previous projects is good. The bids incorporate the mitigative planning measures as construction specifications including the type of equipment desired for use and the various permit requirements. Construction specifications go out as a formal closed bid process to selective companies with proven wetlands expertise. Bids are opened at a predetermined

date and evaluated for cost, construction plan, task comparison, and resources the company plans to use in terms of equipment and manpower.

Part of the mitigative planning sequence is implementation. Our on-site construction inspectors monitor and ensure specification compliance. These United field personnel have the "hands on" responsibility of ensuring the project is completed in full accordance with the plans, specifications, laws and regulations and most importantly in a safe, workmanlike manner. The real success of a wetlands project rests upon the experience and expertise of these project supervisors, field engineers, construction representatives and inspectors.

Current pipeline construction practices in wetlands require digging ditches into which the pipe is floated and subsequently lowered to the bottom of the ditch. This construction method is known as the push method because all welding operations and pipe storage is done at a central staging area to reduce ROW impacts. The push-pull method is another variation where the pipe is pulled as it is floated. The material removed from the ditch, namely marsh substrate, mud, and vegetation, is placed alongside the ditch, and then the ditch is backfilled using this material to cover the pipeline. Frequently, there is inadequate material to backfill owing to losses of plasticity of liquid marsh substrates. The very fluid soil may spread into the adjacent marsh or be reduced in volume by drying and compaction (Farnworth, 1979). The construction crews compensate for this by reducing the number of equipment passes to minimize compaction and backfilling as soon as possible.

Trench backfill methods vary depending on company, type, and quality of marsh. Cost-benefit analysis is employed at this point to determine what degree of reclamation is appropriate and desirable. Our experience suggests that typical construction costs when comparing farmland and wetland indicate that environmental reclamation techniques

tend to be much more expensive in wetlands with no guarantees of plant recruitment success. Typical costs in wetlands include:

Pipe Diameter	Farmland <u>cost/foot to install</u>	Wetlands <u>cost/foot to install</u>
6 inch	7.35	12.00
8 inch	8.00	13.05
10 inch	8.80	14.50
12 inch	10.15	16.25
14 inch	13.70	21.25
double ditching	.60	1.00
revegetation	600.00/acre	2,000-17,000/acre depending on plant density
earthen dams		1,200 each
bulkheads		300/linear foot

Although pipeline companies are willing to give priority to environmental considerations, current environmental reclamation techniques are expensive and can cost 10% of pipeline emplacement costs in wetlands. In addition, reclamation techniques are either labor intensive (revegetation) or use heavy equipment (double ditching) which have their own adverse impacts which should be balanced in the mitigative planning process.

Post construction monitoring also occurs to ensure that mitigative measures are working and maintained. Pipelines are very expensive propositions and it is in our customer's interest that they are environmentally compatible and that they are maintained in excellent condition. New pipeline projects are built using new corrosion resistant materials and coatings and are built to last for decades. Old lines are capped, filled with water, and usually abandoned in place to minimize the environmental impact of removal.

## SUMMARY

- 1) United is concerned about wetlands loss.
- 2) Pipeline emplacement impacts are localized and of short duration.
- 3) Pipeline emplacement impacts are minimal when compared to other factors.
- 4) Pipeline emplacement does have potential to impact wetlands in several ways, but mitigative planning and siting guidelines reduce or avoid impacts.
- 5) Pipeline companies are willing to employ cost-effective measures to ensure that environmental considerations are given priority.
- 6) New construction techniques employed by industry indicate that wetlands are either more resilient than anticipated or pipeline emplacement is compatible.

## BACKFILLING AS AN EFFECTIVE HABITAT MITIGATION TECHNIQUE

Dr. Walter B. Sikora  
Center for Wetland Resources  
Louisiana State University

Backfilling of abandoned oil-access canals in Louisiana coastal marshes has been proposed as a mitigating technique for some time. A major criticism of backfilling access canals is that there is rarely enough material to fill the canal all the way up to the pre-existing marsh level and consequently the dominant marsh grasses (Spartina spp.) rarely recolonize all of the area in a backfilled canal. This presentation is based on the first-year results of a recently concluded study of backfilling sponsored by the Louisiana Department of Natural Resources, Coastal Management Section. This study included plant physiology, hydrography, and the ecology of the

benthos (animals that live in the bottom sediments). I will report on the benthic section of the study.

The benthic community dynamics of a backfilled canal, a bayou, and an unfilled canal near Catfish Lake, western Lafourche Parish, Louisiana, were sampled quarterly for a year. The unfilled canal developed an extremely low oxygen, high hydrogen sulphide bottom and near bottom environment during the warmer parts of the year. This resulted in nearly azoic conditions during August. In the backfilled canal, however, the seasonal dynamics of the benthic community closely resembled that of the benthos in the bayou. The mean annual abundance of macrobenthos in the backfilled canal was not significantly different from that of the bayou, whereas the mean annual abundance of macrobenthos in the unfilled canal was significantly lower.

One of the most important values of coastal marshes is that they function as a nursery ground for many species that are spawned offshore. The estuarine nursery ground provides shelter from predation and food for the juveniles of estuarine species. A vital habitat for estuarine-dependent juveniles is the shallow-edge habitat. Virtually all commercially important estuarine species are benthic feeders when juveniles. The backfilled canal in the present study was colonized by a robust benthic fauna similar to a bayou and thusly by backfilling was transformed into a shallow habitat with abundant food for benthic feeding species.

## FRESHWATER DIVERSION INTO COASTAL LOUISIANA AND MISSISSIPPI

Mr. Dennis Chew  
U.S. Army Corps of Engineers  
New Orleans District

The coastal areas of Louisiana and Mississippi have experienced severe wetland loss and saltwater intrusion because of natural processes such as subsidence, compaction, erosion, storms, and sea level rise. Man's activities including leveeing, channelization, and petroleum exploration have also contributed to wetland loss and tend to accelerate the rate of loss. The coastal marshes were formed as the Mississippi River meandered back and forth depositing sediments and creating a series of deltaic splays. The mainline levees along the River have prohibited overbank flooding and natural distributary flow which historically provided fresh water, sediments, and nutrients, to the adjacent estuarine areas. In addition, saltwater intrusion has caused the conversion of fresh, intermediate, and brackish marshes to more saline marsh types and has also resulted in the loss of substantial areas of wooded swamp. It is currently estimated that wetland loss in coastal Louisiana is occurring at a rate approaching 50 square miles per year.

Saltwater intrusion and loss of wetlands have adversely affected productivity of a variety of fish and wildlife resources. Waterfowl, furbearers, alligators, and many other wildlife species prefer low salinity habitats. The wide variety of finfish and shellfish species which utilize the wetlands as nursery areas require these areas in order to complete their estuarine-dependent life cycles. Recent studies have documented a close correlation between the extent of wetlands and production of these resources. Influx of saline waters is particularly harmful to the American oyster due to increased predation and disease associated with higher salinities.

One way to ameliorate both loss of wetland habitat and rate of saltwater intrusion is timely introduction of fresh water and associated sediments and nutrients into the estuaries. The value of freshwater inflow to these areas has long been recognized. The U.S. Army Corps of Engineers, New Orleans District, through a series of studies authorized by Congress, has developed a comprehensive freshwater diversion plan to accomplish this objective. Three freshwater diversion sites have been proposed (Figure 9).

The Mississippi and Louisiana Estuarine Areas Study investigated the feasibility of diverting fresh water into the Lake Pontchartrain Basin and western Mississippi Sound. Based on this study, it has been recommended that Mississippi River water be diverted into Lake Pontchartrain through a structure located at about river mile 129, just upriver from the Bonnet Carre Spillway.

The Louisiana Coastal Area Study investigated the feasibility of diverting fresh water into the Barataria and Breton Sound Basins. Based on this study, two diversion sites have been proposed. Freshwater would be diverted into the Barataria Basin in the vicinity of Davis Pond at about river mile 118 and into the Breton Sound Basin at Caernarvon which is located at about river mile 81.

Construction of the structure at Caernarvon was authorized by Congress in 1965 under the Mississippi Delta Region Project, but the project was not constructed due to lack of organized local support at that time. The project now has local support. It has been proposed that the structure at Davis Pond can also be constructed under the Mississippi Delta Region Project authority. Construction of the diversion structure at Bonnet Carre would still require Congressional authorization. The current status of the comprehensive freshwater diversion plan is shown in Figure 10.

# FIGURE 9 COMPREHENSIVE FRESHWATER DIVERSION PLAN

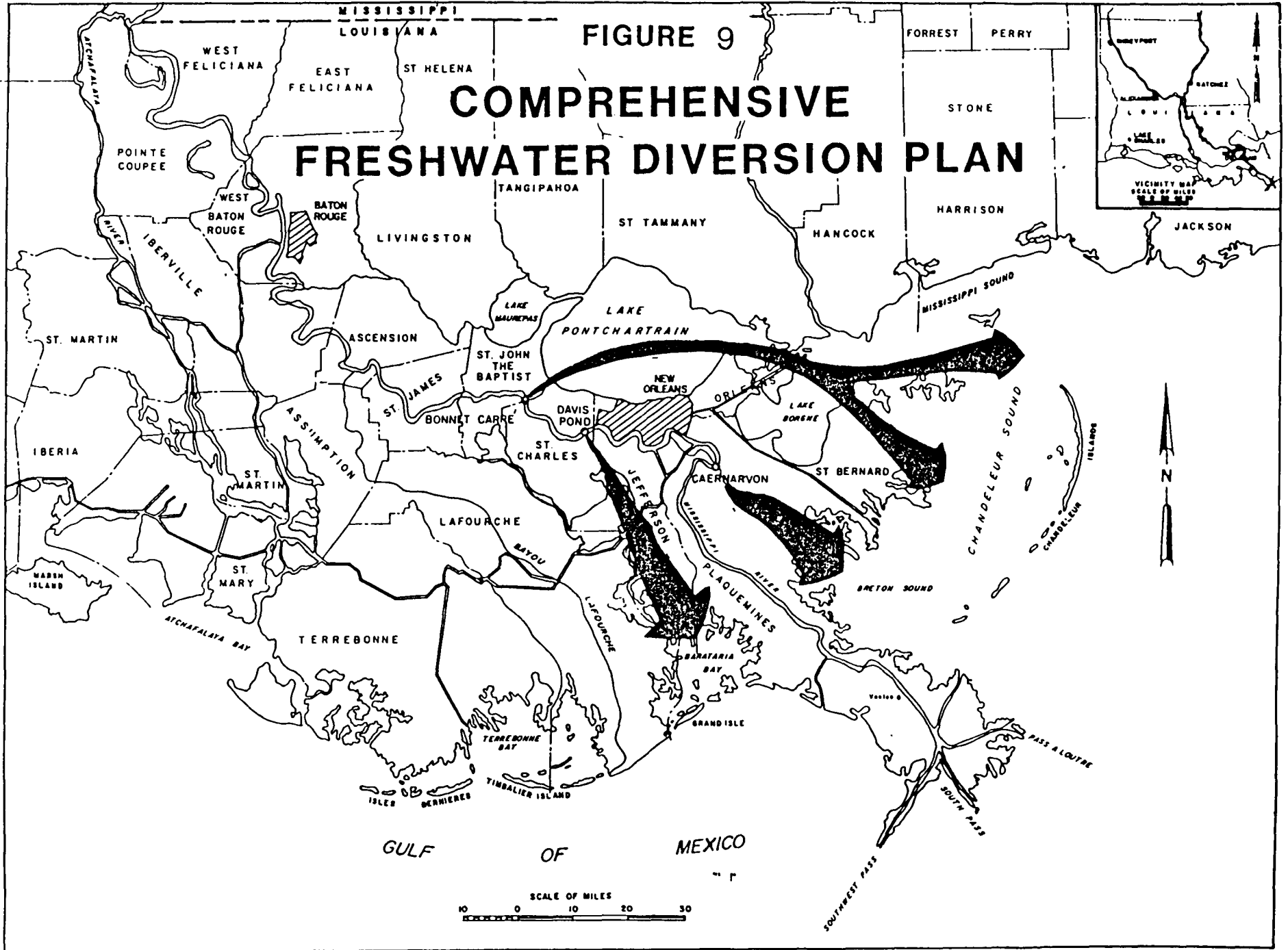



FIGURE 10

STATUS OF COMPREHENSIVE FRESHWATER DIVERSION PLAN

PROJECT SITE	PREPARE FEASIBILITY REPORT AND EIS	REVIEW BY HIGHER AUTHORITY	CONGRESS AUTHORIZES PROJECT	ADVANCED ENGINEERING AND DESIGN STUDIES	FINAL PLANS AND SPECIFICATIONS	CONSTRUCT PROJECT
LOUISIANA COASTAL AREA STUDY AND REAFFIRMATION OF MISSISSIPPI DELTA REGION PROJECT						
CAERNARVON SITE	[Hatched bar spanning from 'PREPARE FEASIBILITY REPORT AND EIS' to 'CONGRESS AUTHORIZES PROJECT']			2 YRS	1 YEAR	2 YEARS
DAVIS POND SITE	[Hatched bar spanning from 'PREPARE FEASIBILITY REPORT AND EIS' to 'REVIEW BY HIGHER AUTHORITY']		<u>1/</u>	2 YEARS	1 YEAR	2 YEARS
MISSISSIPPI AND LOUISIANA ESTUARINE AREAS STUDY						
BONNET CARRE' SITE	[Hatched bar spanning from 'PREPARE FEASIBILITY REPORT AND EIS' to 'REVIEW BY HIGHER AUTHORITY']	1 YEAR	1 YEAR	<sup>2/</sup> 4 YEARS	1 YEAR	2 YEARS

1/ AUTHORIZATION NOT REQUIRED. POSTAUTHORIZATION CHANGE REPORT TO BE APPROVED BY CHIEF OF ENGINEERS.

2/ ADVANCED ENGINEERING AND DESIGN STUDIES INITIATED IN FY 85 UNDER CONTINUING PLANNING AND ENGINEERING AUTHORITY.

111

Figure 10. Status of Comprehensive Freshwater Diversion Plan.

**MITIGATION BANKING: A CONCEPT FOR COMPENSATING FOR FISH  
AND WILDLIFE DAMAGES**

Mr. David M. Soileau  
U.S. Fish and Wildlife Service  
Lafayette, Louisiana

The Fish and Wildlife Coordination Act provides that wildlife conservation be given equal consideration with other features of federal water resource development programs, including any public or private programs performed under federal permit or license. That act also requires the identification of measures for mitigating project-associated damages to fish and wildlife resources. Historically, mitigation has included such options as avoiding adverse impacts by not implementing a development action, minimizing adverse impacts by reducing the scope of the development, restoring adversely impacted habitat onsite, or compensating for unavoidable adverse impacts at an offsite location. In the past few years, a concept known as "mitigation banking" has evolved as a mechanism for achieving mitigation of unavoidable habitat losses associated with water-dependent projects. The concept is most applicable to small projects where unavoidable habitat losses, individually, are relatively minor and cannot be fully mitigated on or are immediately adjacent to the project site.

In mitigation banking, fish and wildlife habitat improvement actions are conducted in advance of project construction, and mitigation credits generated are placed in a mitigation bank account. These credits are later used to compensate habitat losses resulting from actual project construction. As a prime example, the Tenneco Oil Company, under an agreement with several Federal and state agencies, has established a 5,000-acre mitigation bank in coastal Louisiana. This bank involves an intensive marsh management program which will generate mitigation credits that can be used to meet mitigation requirements of future oil- and gas-related development actions.

The credits to be banked by Tenneco were computed by an interagency team via a Fish and Wildlife Service (FWS) Habitat Evaluation Procedures analysis. That analysis considered impact of the management program on both habitat quality and quantity, and yielded a measure of credits in the form of average annual habitat units. Credits were generated in three categories: wildlife, estuarine fish, and freshwater fish. An interagency Memorandum of Agreement mandates the use of mitigation credits for in kind mitigation, such that wildlife, estuarine fishery, and freshwater fishery losses can be offset only with credits available in those same categories. Further, application of credits is warranted only after every feasible means of minimizing and rectifying project damages have been employed onsite.

To industry, the benefits of establishing a mitigation bank are numerous. Among others, they include providing a mechanism for integrating mitigation requirements into future land management operations and reducing the uncertainty involved in obtaining permits. From an FWS standpoint, mitigation banking offers an innovative approach for potentially achieving, for the first time, full mitigation for unavoidable habitat losses associated with oil- and gas-related activities in coastal Louisiana.

## MULTIPLE USE OF ESTUARINE ENVIRONMENTS FOR FISHERY RESOURCES

Dr. J. Dickson Hoese  
University of Southwestern Louisiana

Evidence is presented that northern Gulf estuaries are adapted to multiple fisheries use despite low species diversity because of niche breadth for most harvestable species. Prime examples given are for mullet, Mugil cephalus, and menhaden, Brevoortia patronus, which often feed in dead end canals with low oxygen and anoxic sediments, a type of habitat considered damaged by fisheries and wildlife managers. Both species appear to have adaptations allowing feeding in hypoxic waters, and they account for an estimated half of fish production and at least a quarter of all fisheries products. These may also account for some apparent large fisheries production in damaged systems, perhaps because they are important as prey species to sports and commercial fishes and support very large commercial fisheries.

Mullet offer an extraordinary opportunity for study of a very common species with little exploitation, as well as use for future fisheries. They, along with menhaden and perhaps other species, seem to be able to take advantage of perturbations to the system, suggesting an inherent system that is adaptable to extreme changes.

It is important to verify the facts that lead to these types of conclusions and determine quantitative effects on the populations and the system at large to be able to tell exactly how the system adjusts to natural and man-made changes on estuaries.

COMMERCIAL FISHERIES CONCERNS RELATIVE TO  
OIL AND GAS ACTIVITIES

Session: COMMERCIAL FISHERIES CONCERNS RELATIVE TO  
OIL AND GAS ACTIVITIES

Co-Chairs: Mr. Dan Tabberer  
Mr. Jacob W. Lehman

Date: November 27, 1984

<u>Presentation Title</u>	<u>Speaker/Affiliation</u>
Session Overview	Mr. Dan Tabberer MMS, Gulf of Mexico Region
Relationship of Fisheries Production and Coastal Wetlands: Possible Effects of Oil and Gas Development	Dr. R. Eugene Turner Louisiana State University
Oil and Gas Operations and Fishing Activities in Offshore Waters	Mr. W.S. Perret and Mr. J.E. Rousset Louisiana Department of Wildlife and Fisheries
Coexistence of Commercial Fisheries and Oil Exploration	Mr. Ralph Rayburn Texas Shrimp Association
Assessment of Platform Effects on Snapper Populations and Fisheries	Dr. Benny J. Gallaway LGL Ecological Research Associates, Inc.
Habitat Suitability Index Models: Tools for Environmental Impact Assessment	Dr. Carroll L. Cordes U.S. Fish & Wildlife Service

## SESSION OVERVIEW: COMMERCIAL FISHERIES

Mr. Dan Tabberer  
MMS, Gulf of Mexico Region

Dr. Eugene Turner was our first speaker, substituting for Dr. Boesch. Dr. Turner concentrated on the importance of the estuarine wetlands and commercial fishery production and stated the fact that Louisiana is number two in the U.S. in pounds per capita of fish landed. The coastal marshes are largely responsible for this productivity. He stressed the dependence of the fishery resources on wetlands and commented that in the Netherlands when the estuaries were excluded as nursery areas, the fisheries collapsed. Data was presented that showed a direct positive correlation between acres of vegetated wetlands and shrimp catches, in particular.

Mr. Ralph Rayburn, of the Texas Shrimp Association, and Secretary William Perrett, of Louisiana Department of Wildlife and Fisheries, talked about the general management implications of fishery resources in the Gulf. Such things as gear conflicts have been occurring for some time and have been ameliorated by the Title IV of the Outer Continental Shelf Lands Act, which disbursed \$477,000 in 1984 with a three- to four-month turn-around time. They stated that changing bottoms from pipelines and service platforms are a continuing problem and emphasized that the shrimping industry would like to be more active in the decisions of placement of oil structures. Oil spills were discussed briefly; however, no major data were revealed. In summary of the speakers' comments, the cumulative net impact of the oil and gas industry on the outer continental shelf fishery resources has been beneficial.

Dr. Benny Gallaway talked about the biology and life history of the red snapper and stressed the snapper's dependence on natural and artificial reefs in the Gulf. Catch per unit effort data were discussed: recreational catch per unit effort is declining, whereas commercial catch

per unit effort is increasing. This may be partially due to the way the data are structured. The data indicate that as long as the spawning populations over the natural reefs are maintained, the red snapper population is probably viable. He stated that research is needed to determine if artificial structures increase production or merely concentrate the fish. There was some concern about whether or not unexploited stocks of red snapper exist over soft bottom areas in the Gulf away from the structures.

Our final speaker was Dr. Carroll Cordes of the U.S. Fish and Wildlife Service. He discussed the Fish and Wildlife Service habitat evaluation procedure (HEP), which is an impact assessment tool to compare existing conditions of wildlife habitat against the impact of a development alternative. The Fish and Wildlife Service has been working on these Habitat Suitability Index (HSI) models, which describe the life history and habitat requirements of animals. Habitats representing natural and alternative conditions are ranked on a scale of zero to one. The major advantage of this system is its use to objectively evaluate an alternative. It is field specific, habitat based, and understandable by decision-makers.



RELATIONSHIP OF FISHERIES PRODUCTION AND COASTAL  
WETLANDS: POSSIBLE EFFECTS OF OIL AND GAS DEVELOPMENT  
ACTIVITIES

Dr. R. Eugene Turner  
Department Marine Sciences  
Louisiana State University

Louisiana's oil and gas production is declining, and there is a growing interest in maintaining the renewable natural resources that will support and sustain us. Wetland ecosystems are intimately involved with one of our major natural resource industries, the fishing industry. However, among the 23 coastal states, Louisiana's natural resource agencies are relatively poor. For example, although Louisiana ranks second in pounds landed per capita, fourth in value (\$) per capita, and third in the ratio of fisheries landings value as a percent of the state budget, the Department of Wildlife and Fisheries is first in the resource tonnage per employee but eighteenth in support per employee. There is also a relative scarcity of professional fisheries biologists in the state institutions of higher education. Coastal management is at best difficult and, at worst, incomplete and information-starved under these circumstances. A policy of "benign neglect" or maintaining the status quo towards the present situation is not encouraging when remedies for coastal erosion rates (currently about 0.8% annually) are not developed or proven, and the natural resources agencies are underfunded.

There are several studies which have shown that hydrologic modifications of wetlands contribute to this coastal wetland loss. These modifications are therefore manageable and are implicitly the responsibility of the state and federal agencies, since their permits are required to make these modifications.

Wetland losses are one serious consequence which influences the fishing industry through demonstrable ways. Most of the data indicating

this connection between wetlands and fisheries is correlative. It includes positive relationships between wetland area and fisheries landings on a local, regional, and world-wide scale. Similar relationships with estuarine water surface area have not been demonstrated, indicating that the wetlands, not water surface, limits long-term stock size. Further, when the area of wetland declined in a site in Japan and in Florida, the yields of shrimp and seatrout, respectively, declined proportionately.

The explanation for these correlations is suspected but not well-developed. Wetlands are a food-rich refuge from predators during the critical growth stages of the young (the "nursery ground" concept); in comparison to the open water, the wetland edge is rich in organics and the interior has a high density of benthic prey. Refuge from predators is definitely significant in experimental studies, perhaps more important as a limiting factor than food, which seems abundant. Although useful analogues are to be found in studies of freshwater wetland ecosystems, our knowledge of the causative interrelationships is, at present, based more on correlation and descriptive life history studies than on experimental work which is more comprehensive and useful to management.

The impact of the present coastal wetland losses is not yet evident in the commercially landing statistics because of the wide annual landings variations, which may double in one year. These variations mask the long-term effect and are primarily a result of year-to-year changes in climate. A second variation is due to the increased quantity and quality of fishing effort over the past 30 years; gear types, efficiency, and use have resulted in increased yields in the same geographic area.

Finally, the fishing industry is affected by the cumulative effect of numerous small coastal ecosystem changes. Many of these can be traced back to federal, state and private actions which, by themselves, appear insignificant, but cumulatively lead to a so-called "death by a thousand cuts" for individual wetlands, oyster reefs, and water quality standards.

The shortest path to a remedy is understanding mixed with action. All understanding and no action is as ineffective as all action and no understanding. Experimental studies which take our understanding beyond correlative studies are needed as is increased support for management agencies. There is sufficient information to be concerned about the effect of these wetland losses on fisheries and it is a problem that is not going away.

## OIL AND GAS OPERATIONS AND FISHING ACTIVITIES IN OFFSHORE WATERS

Mr. W.S. Perret and Mr. J.E. Roussel  
Louisiana Department of Wildlife and Fisheries

The fishery resources of the Gulf of Mexico constitute one of the largest known fishery biomasses in the world, exceeded only by those of the Peruvian coast, and the bulk of these resources are located in the inshore, nearshore, and offshore waters of Louisiana. The total commercial harvest by the five Gulf States in 1983 was 2.4 billion pounds with an ex-vessel price (price paid to the fishermen) of \$615 million. Louisiana led all states by producing 71% of this volume (1.7 billion pounds) and accounted for 36% of the value (\$225 million). The Louisiana port of Cameron was the leading U.S. port in quantity of fishery landings while Empire-Venice and Dulac-Chauvin ranked third and fourth, respectively.

The Gulf coastal region is also the site of the greatest concentration of coastal and offshore oil industry activity in the world with over 3000 oil and gas platforms located in Louisiana's territorial waters and the adjacent fishery conservation zone. Petroleum production in the coastal marshes and offshore waters of Louisiana exceeds 400

million barrels of oil and 6 trillion cubic feet of gas per year, making it a major area of oil and gas production in the country.

These two industries have successfully coexisted in Louisiana for over 50 years. The "presence" of petroleum operations in Louisiana is obvious, but the relationship of these operations to commercial fishing activities is difficult to describe. The actual effects of petroleum operations may be physical, chemical, biological, hydrological, or a combination of these. The physical problems may not be ecological in the strictest sense but actually represent competition for space in the water column on the sea floor which is reflected as disruption of navigation or difficulties in harvesting the fishery resources of the area.

Some of the more important management issues associated with oil exploration and production and commercial fishing operations which we have experienced in Louisiana include:

- 1) Seismic methods used in oil exploration.
- 2) Mechanical, physical, and navigational problems associated with the movement of equipment to and from location and the placement of structures.
- 3) Direct and indirect mechanical, hydrological, and physical effects which result in ecological changes.
- 4) Various types of oil pollution resulting from production activities such as oil emulsion drilling muds, odor and taste problems, and the toxicity of oil as a pollutant.

All these problems present different characteristics in offshore and inshore shallow areas with the effects being much more pronounced in inshore areas. This paper focuses on the offshore effects; however, it should be noted that the inshore effects are of great concern since our commercial fisheries are dominated by estuarine dependent species.

Seismic activities initially caused a considerable amount of antagonism between the fishing industry and seismic crews because the area historically belonged to the fishermen, and the detonation of explosives in fishing waters was viewed with great alarm. Numerous studies and field investigations by our department and others led to the development of regulations and guidelines for seismic activities, and these regulations have been effective in combating problems associated with blast effects. Today we get few complaints of problems with seismic operations in offshore waters.

There have been numerous physical and navigational problems which have developed as a result of the two industries competing for space. Confrontations develop on the high seas over the right of way of one group of vessels over the other. Underwater completions have in the past caused problems to trawlers, but subsequent changes in Federal regulations have helped to alleviate this problem (i.e., completions cutoff below mudline). The offshore producing platforms and other above-water structures have reduced the area of fishable sea floor. Initially fishing vessels were forced to stay well clear of the rigs when fishing gear was down to avoid possible collision or the entanglement of gear in underwater materials discarded from the rig. Though rules and regulations now require everything to be brought back in, it is conceivable that high platform density could in time significantly reduce the fishable area of the sea floor. Pipelines in sea beds offshore have not caused serious trouble when they are buried and remain so; however, in new construction, unconsolidated backfill or spoil has sometimes damaged trawling gear.

Petroleum activities in offshore areas appear to have no significant long-term detrimental effects on marine fauna and in some respects have been beneficial. Significant ecological or environmental damage is usually viewed as a permanent long-term change in the ecosystem that reduces its efficiency and subtracts from its overall productivity. Such a change usually results from activities which rearrange the ecosystem enough to affect its basic character and normal productivity. The offshore ecosystem tends to be stable and has qualities which permit it to

cushion, absorb, or rebound from extraneous influences. Actually, the evolution of the petroleum industry in our offshore waters has enhanced the development of many of our offshore finfisheries by providing artificial fishing reefs. Many fish species are now more exploitable because they congregate under and around these offshore structures, though there is still some question as to whether artificial reefs actually enhance fish production. Historically, there have been two divergent schools of thought: The "attraction theory" which states that artificial structure merely concentrates fish by serving as an orientation point; and the "productivity theory" which states the structure, because of a greater food supply and protection from predators, will enhance reproduction and therefore increase both production and yield of fish. Whatever the case may be, some segments of our offshore fishing industry have benefited by the presence of petroleum platforms.

Intensive petroleum activities in Louisiana's offshore waters have increased the potential threat of oil pollution to marine waters. Pollution problems are complex, and include different effects resulting from chronic and accidental pollution, oil emulsion drilling muds, and dispersants and detergents used in cleaning up accidental oil spills. Accidental pollution can be costly, create great public concern, and cause spectacular short-term local environmental disruption, but there is no evidence that accidental oil-pollution has a gross permanent effect on the ecosystem. On the other hand, chronic pollution is a more critical and less understood problem. Daily drips and loss of small amounts of oil or other chemicals overboard do not appear to generate ecological problems because of the relative immensity of the water volumes, but whether such sublethal pollution will eventually accumulate and cause environmental degradation is yet to be determined. One of the most serious and long-lasting types of pollution associated with the petroleum industry occurs when diesel oil is added to the mud system to enhance the drilling of deep wells. If the excess or used mud cuttings from such an operation are accidentally lost overboard, a serious pollution of the substratum may result, since the oil is absorbed onto the heavy mud particles and settles to the bottom. With this type of pollution, visible oil slicks may not occur and pollution may go undetected. Detergents,

dispersants, and other chemicals used to clean up oil spills can cause additional problems. Most of these chemicals are more toxic to marine fauna than oil, and generally we do not permit the use of such chemicals for the cleanup of spills.

In general, offshore petroleum activities when properly regulated have not constituted a serious threat to our commercial fishing industries and in some instances have been beneficial. The coexistence of these two industries has not been trouble free and we have learned much from hindsight, yet our experience has shown that with proper guidelines these two divergent industries can successfully carry out their operations in harmony.

## COEXISTENCE OF COMMERCIAL FISHERIES AND OIL EXPLORATION

Mr. Ralph Rayburn, Executive Director  
Texas Shrimp Association

The Texas Shrimp Association in Austin, Texas, is an industry-supported trade association representing owners of about 400 Gulf shrimp vessels mostly in Texas but also in other Gulf states. In addition the membership includes about 100 support and service companies working with the industry.

## HISTORY

The warm-water shrimp fishery of the United States originated in the bays and estuaries of the Gulf of Mexico. Fishery pioneers used large drag seines set close to shore and hauled by men on horses.

Using this method, shrimp harvesting was worthwhile only when shrimp were near shore. The otter trawl was introduced into the shrimp fishery between 1912 and 1917. However, even using this gear, the fishermen continued to shrimp entirely in the bays and shallow water. The otter trawl did reduce the seasonality of the fishery.

In the mid 1930s, an abundant stock of shrimp were found on the Ship Shoal off Morgan City, Louisiana. The publicity of these successful shrimp catches encouraged new outlets for the product which in turn stimulated construction of larger shrimp trawlers better able to survive in the open Gulf of Mexico.

World War II hindered continued growth of the shrimping industry, but the postwar era has seen it develop into a mature fishery with state of the art equipment and a multi-billion dollar economic impact annually. As the offshore oil industry has experienced its overwhelming growth in the postwar period, the two industries have been forced to coexist in the Gulf of Mexico as the nation developed an ever-increasing level of demand for our products.

The mutual existence of these two industries in a common area has not been without problems. Among the more pronounced conflicts has been the impact on the shrimp fishery of the disposal of oil exploration/exploitation related debris on the Gulf's continental shelf. Since shrimp are harvested by pulling a trawl across the sea bottom, any substantial object will create a bottom obstruction which can damage the trawl or prevent its retrieval, thereby requiring abandonment.

Title IV of the Outer Continental Shelf Act, known as the Fisherman's Contingency Fund, was established in the late 1970s to alleviate this situation. Under this program, shrimp vessel operators encountering a bottom obstruction felt to be related to OCS oil activity can be reimbursed for the lost equipment, time, and related expenses. The money to operate this program is generated from the offshore operators. Amendments to the original bill have streamlined the compensation program. So far in 1984 the National Marine Fisheries



Service, a department of NOAA charged with handling the fund, has serviced 100 claims paying out \$477,704. The cumulative total of \$1,897,000 has been paid in claims, with \$1,297,389 collected from the offshore oil operators. This program has been a major contribution to the reasonably harmonious relationship between the shrimping and oil industries.

There remains a second point of potential conflict between the energy and shrimping industry. This is the establishment of structures on the continental shelf which limit or interfere with routine shrimping operations. These items would include platforms, subsurface production systems, and pipelines. A concern commonly referred to me is the absence of malfunction of navigational aids in conjunction with platforms or subsurface systems. In an active period of oil exploration and exploitation, the characteristics of a once familiar shrimping area can be drastically changed in a few weeks, the time required for a shrimp vessel to return to homeport, unload its catch, perform required maintenance and return to the fishing grounds. These potentially rapid changes dictate a well-maintained navigational aids system to allow for crew safety.

The industry is also sensitive to the interests which would establish a comprehensive artificial reef system utilizing spent rigs and associated equipment. The anxiety over this activity is that it not be used to justify the establishment of areas in the Gulf of Mexico as marine junk yards. The siting of any structure should be well-planned and implemented to insure that sites would enhance naturally occurring structures or "bad bottom."

Finally, our efforts to coexist with the energy industry should not be taken as a sign of apathy toward the Gulf ecosystem. The Gulf of Mexico must not be thought of as a free zone to be used at the will of heavy industry as a waste disposal site.

The shrimp industry has long realized the importance of the offshore energy interests and the need to produce as much energy domestically as possible. We continue to seek "peaceful coexistence" with this industry.

## ASSESSMENT OF PLATFORM EFFECTS ON SNAPPER POPULATIONS AND FISHERIES

Dr. Benny J. Gallaway  
LGL Ecological Research Associates, Inc.

Oil platforms constitute a major portion of the red snapper habitat and fishing ground in the northwestern Gulf, and many of these platforms are soon to be removed. A "rigs-to-reef" program is being contemplated for the northwestern Gulf, seeking to preserve some of these habitats. Selection of habitats to be preserved, however, is presently being based upon gaining optimum utilization of the reefs by recreational users, with little thought being given to the possible ramifications of habitat reduction combined with increased exploitation rates at available habitats on the reef fish stocks.

The coastal fishery for red snapper is of major value in the Gulf of Mexico. The fishery is a complex system with a blend of biological, social, economic, and political factors determining the level of participation in the resource by the major users (commercial fishermen, sports fishermen, and by-catch from shrimping). The fishery is also characterized by a great deal of uncertainty concerning the underlying biological processes which govern the fishery (e.g., whether the spawning stocks are confined mainly to offshore reef habitat; whether the removal of offshore oil platforms will reduce habitats and thereby stocks). There is concern that spawning escapements may soon be or are currently inadequate to maintain the natural productivity of the system.

It is generally believed that red snapper become sexually mature after age two and, in the northwestern Gulf of Mexico, that spawning occurs from June to October. The fish grow rapidly during their first year, attaining fork lengths of about 200 mm, and grow at a rate of about 75 mm/yr thereafter (Bradley and Bryan 1976). Maximum age has been estimated at 20 years with fish attaining a maximum length of about 900 mm and a maximum weight of about 18 kg. Zastrow (1984) describes an argument that suggests that the red snapper do not grow as rapidly during the first year (Age 0 actually represents Ages 0 and 1); and that maturity is not gained until after Age 3.

During the first year, Age 0 red snapper occupy soft bottom habitats where they are subject to considerable pressure from the shrimp fishery (annual by-catch of 78 million red snapper [GMFMC 1980]). The seasonal and spatial distribution of red snapper subject to capture by trawling (presumably mostly Age 0) in the northwestern Gulf of Mexico has been reported by Darnell et al. 1982. Abundance is low during spring and summer, with fish distributed over most of the shelf. Maximum density is attained during fall, corresponding to the end of the spawning season. Apparent concentrations of small fish in fall are evident both near- and offshore in south Texas and along the 40-m depth contour offshore of central Texas. In winter, distributional centers for small red snapper are evident along the 40-m depth contour offshore south and central Texas and Louisiana. The data also suggest that there is a seaward movement during winter, most likely in response to water temperature. The lower lethal temperature for red snapper is about 13°C and the optimal activity temperature is 18°C (GMFMC 1980).

Red snapper apparently prefer, or at least show an attraction to, reef, hard bank, or other areas having topographic relief (e.g., bottom depressions) at the end of their first (or second) year (i.e., between about 185 to 200 mm fork length). This is also the size at which they enter the fishery. Availability of reef habitat (perhaps a limiting factor) between the eastern (Mississippi, Alabama and Florida coasts) and western (Texas and Louisiana coasts) Gulf of Mexico differs greatly. This

is a particularly important point for red snapper management, given the differences in the types and distributions of hard bottom habitats between the two regions. According to calculations by the GMFMC (1980) based upon Visual No. 4 (OCS Lease Sale No. 41) natural reef fish habitat in the Gulf of Mexico is represented by about 39,000 km<sup>2</sup> (15,054 mi<sup>2</sup>). Reviewing Visual No. 4 reveals that approximately two-thirds of this habitat is in the eastern Gulf as compared to about one-third in the western Gulf (not measured, a visual estimate). Assuming this estimate is correct or about so, about 26,000 km<sup>2</sup> of natural snapper habitat would be in the eastern Gulf versus about 13,000 km<sup>2</sup> in the western Gulf. Gallaway (1981) estimated that offshore petroleum platforms (virtually all in the western Gulf) provide an additional 5000 km<sup>2</sup> of reef fish habitat, not including the hundreds of miles of pipelines which also afford good red snapper habitat (Boland et al. 1983). Based upon these estimates, offshore petroleum structures constitute as much as 11% of the total snapper habitat and 28% of the habitat in the western Gulf. The importance of these structures should not be dismissed in any management plan, particularly in the western Gulf. The age of these platforms plus regulatory requirements suggest that large numbers of these habitats are soon to be removed, and the effects are uncertain.

Once red snapper have taken residence at a reef in the northwestern Gulf, there is little evidence to suggest any major migratory movements (e.g., Fable 1979, Gallaway 1980) for at least some unknown period in their life, unless environmental conditions become unfavorable, forcing movement offshore. Fish which have initially occupied banks in shallow waters during warm periods (or years) probably move offshore during cold periods in direct response to temperature.

If such a response occurs, there should be direct evidence from the seasonal temperature record as compared to spatial abundance patterns of red snapper. Typical bottom water temperature in the northwestern Gulf of Mexico for winter was also shown by Darnell et al. (1982). The 18° C isotherm (optimal activity temperature) generally occurs between 40- and 60- m depth contour, corresponding to depths at which trawled red snapper were found most abundant. Further, if such a seasonal

movement pattern is correct, then red snapper at nearshore reefs should be considerably smaller than fish on offshore reefs. Comparisons of size/age distributions of red snapper between a nearshore habitat (Buccaneer Oil Field) and a shelf-edge bank (Flower Garden Banks) show the expected pattern. The nearshore habitat was dominated by Age 2 fish with none of the fish over Age 4. In contrast, age distribution of red snapper at the Flower Garden Banks ranged from Age 2 to Age 8+, with fish of Age 5 being most abundant. Such a pattern could also occur if nearshore habitats were being overfished.

Also of interest is that even though red snapper live to Age 20, no fish over Age 8+ were present in the Flower Garden Banks sample and this has been the general findings of other studies conducted at offshore reefs in the northwestern Gulf of Mexico (e.g., Fable 1979). Where are large red snapper in the northwestern Gulf of Mexico, if there are any remaining?

Results of studies of an emerging long-line fishery (Cody et al. 1981, Prytherch 1983) and sampling of soft bottoms in the vicinity of the Flower Garden Banks (Boland et al. 1983) suggest that there may be a considerable population of large red snapper, previously unexploited, occurring over soft bottoms. Boland et al. (1983) took large specimens in control areas away from the reefs by trapping and by angling, and observed them in this habitat with an underwater television system. Results of bottom long-lining studies conducted by the Texas Parks and Wildlife (Cody et al. 1981) showed large red snapper to have been one of the most abundant species taken, other than sharks. They further reported that in March 1981, approximately 100 trips were made offshore Texas by commercial vessels to long-line, and that a major target of these trips was red snapper.

Prytherch (1983) in a recent description of the emerging bottom long-line fishery in the Gulf of Mexico during 1982, reported interviews of 30 bottom long-line trips in the eastern, northern (both in the eastern Gulf), and western Gulf (offshore Texas). Long-line catches per day fished in each area were 2.4lbs, 75lbs and 542lbs respectively, the latter

value for the Texas area. In the latter area, size composition was estimated from data obtained during a nine-day fishing trip by one vessel which resulted in the taking of 315 red snapper. Of these, 298 were over 14lbs in size, and 15 were between 6 and 14lbs.

From the above information, a possible scenario is that red snapper occupy reef habitats during the mid-portion of their life, with the largest or oldest fish moving from reefs to soft bottoms. If this movement feature is correct, it may be related to changes in diet which occur with age.

The red snapper is carnivorous and food habits change with size or age. Juvenile red snapper while over soft bottoms feed on shrimp and other epifaunal benthic invertebrates. Red snapper at reefs remain basically bottom feeders, but they do feed on some pelagic forms from the water column. With increase in size of the red snapper, fish become more prevalent in their diet. Most of the prey species consumed by red snapper are not reef or rock dwellers, and "therefore the inference can be made that the species feeds away from these areas" (GMFMC 1980). Larger fish may forage further and further from the protective reef habitat as they grow; and, upon reaching a size beyond a "predation window," become independent of the reef altogether.

The red snapper fishery in the Gulf of Mexico consists basically of two major user groups, commercial and recreational fishermen. The latter fishery consists of both small, privately owned boats and charter boats carrying small parties of fishermen, as well as head boats which carry large groups of fishermen to the fishing grounds. Historically, the commercial fishery has been a hand-line fishery and has operated further offshore than the recreational fishery, which is considered a nearshore fishery. In terms of catch, the recreational fishery has been estimated to be much larger than the commercial fishery.

Catch per unit effort (CPUE) trends from the commercial fishery differ between the eastern and western Gulf areas, based upon comparisons of Texas and Louisiana data to that for Florida (Boland et

al. 1983). The Texas and Louisiana data each reflect an oscillating pattern, whereas the data from Florida show a marked decline from peak CPUE in the late 1950s, followed by rather stable catches since that time, at least through 1974. We believe these data evidence the need for regional versus Gulf-wide management practices. A management plan developed in large part based upon eastern Gulf data may or may not be appropriate for the western Gulf.

As compared to the data from the commercial fishery, catch and effort data are virtually non-existent for the recreational fishery. GMFMC (1980) characterize the recreational data as "extremely poor and probably unreliable" with the sample designs not permitting detailed analysis by specific geographical area or by species. They also suggest that the commercial data are similarly unreliable when assessing catch and effort by specific area. The poor quality of all the data will represent a major source of uncertainty in any management scheme that is derived.

Based upon the available data, GMFMC (1980) suggested that recreational red snapper CPUE has declined markedly in the period 1965 to 1974. Interpreting the results of maximum sustainable yield analysis, GMFMC (1980) determined that the U.S. commercial fishery was underfishing its portion of the stock but that, overall, red snapper were definitely being overfished, probably because of the increasing effort in the recreational fishery. They also concluded that the overfishing was probably zonal in nature (nearshore) because the commercial fishery works outside the normal reach of recreational vessels, and the fact that recreational vessels likely fish at the same location more often due to time, distance, and weather factors. One of the major features of the Reef Fish Management Plan was the identification of a stressed area along most of the nearshore zone of the Gulf of Mexico (and around some key offshore reefs) in which certain fishing gears were prohibited.

In the mid-1970s, LGL developed an age class simulation model for the red snapper fishery. The take of the inshore fishery was based on observed fishing pressure at a nearshore oil and gas platform and the

harvest at offshore reefs was based on commercial catch statistics. The loss of Age 0 fish to the shrimp fleet by-catch was not included in the simulation model. In these simulations, the inshore fishery (taking Age Class 2 fish) remained stable while the commercial fishery gradually declined as did age of the fish taken by the commercial fishery. Finally, a marked collapse of the entire fishery occurred owing to the ultimate reduction of spawners from overharvest of pre-recruits by the inshore or recreational fishery. However, the problem with this simulation was that the temporal patterns of the model dynamics suggested that the fishery should have collapsed long before present time. The existence of the then unknown and unexploited population of spawners over soft bottoms in the northwestern Gulf provides a reasonable explanation as to why (assuming model validity) the fishery would not collapse, and that the model may have some credibility given that the soft bottom spawning population is added. In this scenario, as long as adequate escapement from reef habitats into a protected spawning stock is achieved, the fishery can withstand heavy harvest of pre-adults.

In the early 1980s, LGL continued attempts to simulate red snapper populations by applying the Deriso (1980) fishery population dynamics model to the commercial CPUE data for Texas and Louisiana data contained in GMFMC (1980). The Deriso model adequately mimicked the actual dynamics of the Texas and Louisiana CPUE trends. The good fit which was achieved resulted from the assumptions that most fish matured at Age 2 and that the stock-recruitment relationship was represented by a density-dependent Ricker curve. Results of the model analysis indicated that red snapper were fast growing, had relatively low natural mortality, and a large fraction of the spawners were vulnerable to being caught by the fishery (i.e., new recruits were as susceptible to being caught by hand-lining as older, larger fish).

Of these results, only the density-dependent stock-recruitment relationship was unexpected. Red snapper do mature at about Age 2, they are fast growers, natural mortality is not high (see Russel Nelson's work out of the Beaufort NMFS lab) and all size groups beyond Age 1 are quite susceptible to being caught using baited hooks.



Theoretically, however, the recruitment curves should have followed a Beverton-Holt type curve or a Ricker curve with only slight density-dependence, since adult snappers are believed to have a ceiling in abundance imposed by the amount of available reef habitat. The observed dynamics could also occur, however, if there were represented in the Gulf a population of spawners which was not being fished.

Initially, we believed the former explanation (density-dependent stock-recruitment) to be the case (Gazey and Gallaway 1980), suggesting the inshore fishery (recreational and commercial) might harvest the fish in a density-dependent manner, both functionally and numerically. However, projections of the model, past the year 1974, do not agree with recently obtained data for the years 1975 and 1976. Therefore the hypothesis that red snapper dynamics can be represented as a single stock, age-structured population with repeatable natural mortality, growth, and recruitment functions was invalidated.

As described above, however, there is strong evidence that there is represented in the northwestern Gulf a heretofore unexploited population of spawners over soft bottoms and some indications that this group of fish may be the major source of recruits to the fishery. If this scenario is true, any management plan which does not afford protection of this soft bottom spawning population in the northwestern Gulf of Mexico might be ineffective. However, if the scenario is true and the stock is protected, continued heavy harvest of sub-adult fish around platforms would have little deleterious impact on the stock.

## HABITAT SUITABILITY INDEX MODELS: TOOLS FOR ENVIRONMENTAL IMPACT ASSESSMENT

Dr. Carroll L. Cordes  
National Coastal Ecosystems Team  
U.S. Fish and Wildlife Service

For a long time there has been a need for improved methods for quantifying impacts to marine and estuarine fishery resources that result from oil and gas activities. Without objective and quantifiable tools for environmental assessment, it has been difficult for coastal planners and resource managers to identify mitigative measures for protecting these fishery resources.

During the past several years the U.S. Fish and Wildlife Service has developed or funded development of habitat suitability index (HSI) models designed to assist planners and managers with the environmental assessment process. Specifically, these models may be used to quantify impacts to fishery resources in terms of habitat units (HU's) gained or lost as a result of project construction and operation. The HSI models provide measurements of HU's for two general types of comparisons: (1) the relative value of different areas at the same point in time, and (2) the relative value of the same areas at future points in time.

The basic concept underlying the use of these models in environmental impact assessment is simple. The HSI models provide a means for measuring the suitability of an area for a fish species before and after an oil and gas activity takes place. Suitability is measured on a scale of 0 to 1, with "0" representing habitat conditions unfit for the species and a "1" representing optimal conditions. By multiplying the suitability of a habitat by its area in acres, a measure of habitat value in terms of HU's is obtained. Comparing HU's available without the oil and gas activity with those available with the activity allows one to obtain a quantitative measure of net impact to the species.

The HSI models are based on physical habitat features that are thought to limit the species and are likely to be altered by development activities. For example, many of the marine fish models include substrate and salinity variables. All models are developed from best available information and are reviewed by recognized fish species experts. Models for the following finfish and shellfish species are currently available for use in the Gulf of Mexico Region: striped bass, menhaden, croaker, spot, kingfish, red drum, spotted seatrout, white shrimp, brown shrimp, pink shrimp, oyster, and hard clam.

Guidance for applying HSI models in an environmental assessment is found in the following U.S. Fish and Wildlife Service manuals:

- 1) Ecological Services Manual No. 101 -- Habitat as a Basis for Environmental Assessment;
- 2) Ecological Services Manual No. 102 -- Habitat Evaluation Procedures (HEP);
- 3) Ecological Services Manual No. 103 -- Standards for the Development of Habitat Suitability Index Models for Use with the Habitat Evaluation Procedures; and
- 4) Ecological Services Manual No. 104 -- Human Use and Economic Evaluation (HUEE).

Questions regarding the use of HSI models in coastal, estuarine, and marine habitats should be directed to the U.S. Fish and Wildlife Service's HSI modeling group in Slidell. The number is (504) 255-6511 or FTS 685-6511.

## DEVELOPMENT AND USE OF ECOLOGICAL MODELS

Session: DEVELOPMENT AND USE OF ECOLOGICAL MODELS  
Co-Chairs: Dr. Robert Rogers  
Mr. Lawrence Handley  
Date: November 27, 1984

<u>Presentation Title</u>	<u>Speaker/Affiliation</u>
Session Overview	Dr. Robert Rogers MMS, Gulf of Mexico Region
Overview of Ecological Modeling and Its Application to the Tuscaloosa Trend Study	Dr. Charles Comiskey Science Applications International Corporation
Tuscaloosa Trend Regional Conceptual Model and Synthesis Study	Dr. Barry A. Vittor and Mr. J. Kevin Shaw Barry Vittor & Associates, Inc.,
Quantitative Characterization of Demersal Finfish and Shellfish Communities in the Tuscaloosa Trend Region	Mr. Terrell A. Farmer Science Applications International Corporation
Conceptual Modeling Applied to the Flower Gardens Banks	Dr. Rezneat Darnell Texas A&M University

## SESSION OVERVIEW: DEVELOPMENT AND USE OF ECOLOGICAL MODELS

Dr. Robert Rogers  
MMS, Gulf of Mexico Region

This session on ecological modelling largely focuses on an existing environmental studies contract, The Tuscaloosa Trend Data Search and Synthesis. This contract is being conducted by the consulting firm of Barry Vittor & Associates with subcontracts to Quantus, Inc., and Science Applications International, Inc.

The study is designed to gather existing data and information from the study area which is the outer continental shelf of Mississippi, Alabama, and Louisiana. The Tuscaloosa Trend area is a region of active oil and gas exploration interest and an area we would like to study in some detail to understand the processes and driving mechanisms at work.

Early in the planning for this study, it was decided that once the literature and data were gathered and computerized for easy access, then a conceptual model would be developed to organize the information. The model would then be used to (1) identify important processes and (2) identify major information gaps.

This effort should be very useful in saving a great deal of planning time and excessive funding in future field efforts, the first of which is planned to be contracted for this fiscal year. The ongoing contract is nearing completion with draft deliverables due in January. Final reports should be ready for distribution in April 1985.

The session was concluded by a presentation on the development of an ecological model using information gathered from a previous environmental study, the Flower Garden Banks monitoring study. This conceptual model would be particularly useful in the design of future monitoring efforts on these topographic features.

# OVERVIEW OF ECOLOGICAL MODELING AND ITS APPLICATION TO THE TUSCALOOSA TREND STUDY

Dr. Charles Comiskey  
Quantitative Environmental Analysis Section  
Science Applications International Corporation

## INTRODUCTION

An ecosystem is a real world entity consisting of at least two interacting components and exchanging material and/or energy with adjacent ecological entities. Ecosystem analysis is the formalized study of ecosystems and their properties, and an ecological model is an abstraction that expresses our understanding of the ecosystem. Depending on the stage of development, an ecological model can be conceptual (non-numerical) or numerical (simulation models). The Tuscaloosa Trend modeling effort is conceptual in scope.

## OBJECTIVES OF ECOLOGICAL MODELING

An ecological model represents a simplification of the real world. As such the model should emphasize those ecosystem components and processes of primary importance to study objectives. The model should clearly define the temporal, spatial, and conceptual boundaries of the ecosystem and subsystems therein. Once the boundaries of the system have been defined, relationships of the ecosystem to adjacent ecological systems (i.e., input-output relationships) can be delineated, and connections, causalities, and feedback pathways within the ecosystem can be demonstrated. If the goals of the modeling effort are impact-related, the model should identify the interactions of the particular technology and the ecosystem and depict the transport and fate of pollutants in the system.

With specific reference to the Tuscaloosa Trend Study, the conceptual ecological model provides the framework for information gathering, organization, and synthesis. In the process, priorities are identified for research and monitoring efforts in subsequent years of the program. The model could enhance communication and coordination of activities among scientists working on various aspects of the Trend ecosystem study and facilitate communication of results of this multidisciplinary study to managers, decision-makers, and the public. Also, the model should provide the framework for intelligent planning and management of marine resources on the Trend OCS.

All of the objectives defined above can be accomplished to one degree or another with a conceptual ecological model. Other objectives can only or can best be met with a numerical model. First and foremost, a numerical model can provide the capability to predict system responses to natural and man-induced changes. Second, only through simulation modeling can emergent properties of the ecosystem be derived to generate hypotheses for subsequent research. Third, a simulation model can be used to test the validity of field measurements and our assumptions derived from these data. Finally, while a conceptual model can help identify data gaps, ecological simulation techniques such as sensitivity analysis can identify those model parameters that are most important to ecosystem behavior, thereby providing a powerful tool for identifying research priorities.

## **GENERAL ECOSYSTEM MODEL DEVELOPMENT**

Any ecological modeling effort begins with an identification of the system of interest and a clear and unambiguous definition of goals and objectives of the study. These objectives will, to a large degree, determine the structural and functional representations in the model. Once the objectives are defined, development of the conceptual model can be initiated. Steps in conceptual model development include definition of conceptual, spatial, and temporal boundaries and scales; identification of physically and ecologically homogeneous subsystems (discretization); inputs, outputs, and external controlling factors;



selection of state variables (i.e., compartments); and identification of processes within the system and factors controlling these flows. Discretization is a necessary prerequisite to development of spatial models and often involves subdividing the ecosystem along major habitat gradients. Spatial models, in turn, must include transport processes linking the subsystems (through input-output relationships). Conceptual models are most often represented by "wire diagrams" (using either Odum energy circuit language or Forrester symbolism) and interaction or connectivity matrices. The initial conceptual representation generally includes more details than can be incorporated into a numerical model, and is usually "shrunk" to a workable level before being developed into numerical form.

Development of a numerical model begins with a representation of the inputs, outputs, and processes by specific numerical functions (usually differential equations), which can be linear or non-linear (in the state variables). Most recent marine ecosystem models are highly non-linear and are based on a reductionist approach, wherein complex process mechanisms are explicitly expressed in the numerical functions. These models are "data hungry" and are often costly to implement on the computer. As model complexity increases, formulation error decreases but measurement error increases. Therefore, there appears to be a point along the complexity continuum at which total model inaccuracy is lowest. Once the functional model has been developed, the numerical equations are written in computer code (computational representation). The next two stages in model development, calibration and verification, require data from the specific ecosystem under study or, more typically, from similar ecosystems. The calibration stage involves quantifying the inputs, outputs, parameters, and state variables; running the model to steady state; and assessing the reasonableness of the results. Calibration almost always involves "tuning" the parameters of the model to realize reasonable steady state behavior; however, model parameters should never be set to unreasonable values. Such a situation indicates that some changes in model conceptualization or functional representation should be considered. Verification involves running the model with an entirely new set of field data. If the model behaves reasonably, it is thoroughly

documented and can be distributed for general application. Model application can provide feedback to either confirm the conceptual and functional representation of the model or identify areas where improvements are needed.

## APPROACH TO TUSCALOOSA TREND CONCEPTUAL MODEL DEVELOPMENT

The approach to development of the Tuscaloosa Trend conceptual ecosystem model involves (1) review and evaluation of existing marine ecosystem conceptualizations; (2) selection of an appropriate existing conceptualization; and (3) adaptation of the selected model to the Tuscaloosa Trend study area. The review activities have identified the conceptualization of the New York Bight ecosystem by McLaughlin et al. (1975) as being clearly superior to the others studied. This model, developed for the NOAA Marine Ecosystem Analysis (MESA) Program Office, represents an ecosystem approach to marine pollution problems, and can serve as a framework for a scientific research program and as a tool for resource management. Adaptation of this conceptualization to MMS needs is consistent with the goals of the National Marine Pollution Program Plan, which requires that federally funded research be coordinated across agencies and disciplines. Consistent with the MESA approach, the conceptualization of the Tuscaloosa Trend study area is hierarchical, consisting of three levels: Level 1--the whole ecosystem; Level 2--individual subsystems (e.g., physical, sedimentological, biogeochemical and ecological); and, Level 3--specific ecological applications (e.g., nekton life histories, marsh-estuarine interactions, pelagic and benthic food webs).

Preliminary results indicate that the Tuscaloosa Trend OCS differs substantially from the typical continental shelf (e.g., south Texas or southwest Florida OCS's). The physical oceanography of Tuscaloosa Trend system appears to be much more complex than that of a typical shelf system, due primarily to its proximity to the Mississippi delta, the poorly defined and diffuse boundaries with the adjacent terrestrial/estuarine systems, and the periodic influence of the Loop current.

## REFERENCES

McLaughlin, D.B., J.A. Elder, G.T. Orlob, D.F. Kibler and D.E. Evenson.  
1975. A conceptual representation of the New York Bight  
ecosystem. NOAA Tech. Memo ERL MESA-4.

## TUSCALOOSA TREND REGIONAL CONCEPTUAL MODEL AND SYNTHESIS STUDY

Dr. Barry A. Vittor

Mr. J. Kevin Shaw

Barry A. Vittor & Associates, Inc.

Quantus, Inc.

Science Applications, Inc.

Of current interest to oil and gas exploration in the northern Gulf of Mexico is the outer continental shelf area off southeastern Louisiana, Mississippi, and Alabama. The presence of the geologic feature, known as the Tuscaloosa Trend, extends from southern Louisiana into the offshore waters of the Chandeleur Islands, eastward to the DeSoto Canyon, and promises to be highly productive in terms of recoverable oil and natural gas reserves (Figure 11). The waters adjacent to the Chandeleur Islands and within Breton Sound, Mississippi Sound, and Mobile Bay also support a significant recreational and commercial fishery, which is of concern to the adjoining states. Because of industry interest and potential for future ecological impact by accelerated OCS oil and gas activities, the Tuscaloosa Trend region was selected by Minerals Management Service for a thorough environmental characterization and ecosystem modeling effort. The first year's effort consists of a comprehensive survey of available data and literature for synthesis into a report, identification of information/data gaps, and development of an ecosystems model for management purposes.

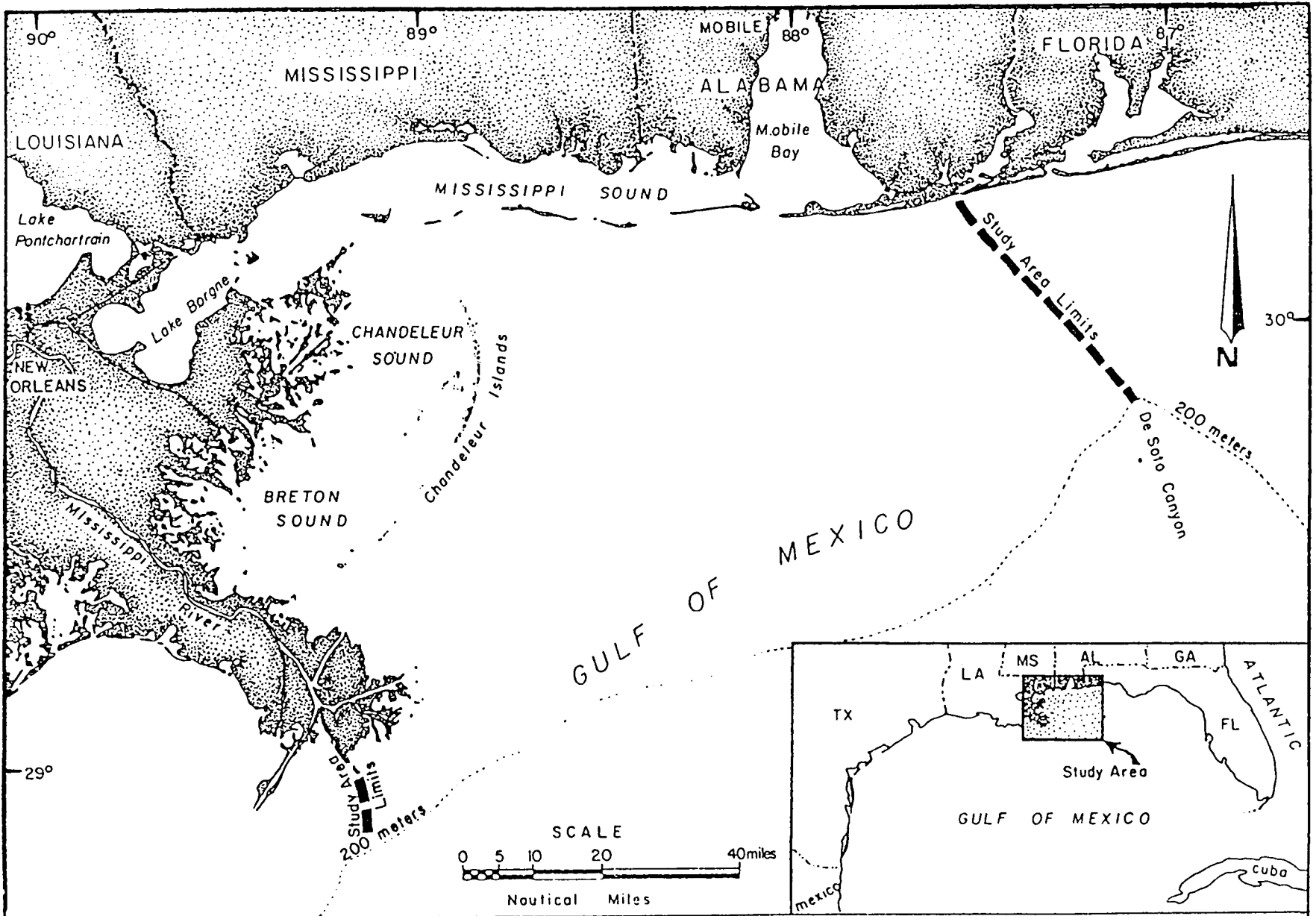

Figure 11. The Tuscaloosa Trend study area.

## INFORMATION COLLECTION AND REVIEW

Information collection involved computer-based literature searches, literature and data collections, and interviews with researchers and managers within academic and governmental agencies within Louisiana, Mississippi, and Alabama. Over two thousand reference citations have been retrieved and cross-referenced. All citations were entered in the NEDRES format, while pertinent references were also annotated. We have completed the review of literature collected and have organized the synthesis into the following topical areas:

- Physiography
- Geology
- Meteorology/Climatology
- Physical Oceanography
- Chemistry
- Biology
- Socioeconomics

The literature review activities have centered on establishing (1) functional relationships among the terrestrial freshwater, estuarine, and coastal/OCS subsystems and (2) their relationship to major sources of inputs and outputs identified within the conceptual ecosystem model.

## CONCEPTUAL ECOSYSTEM MODEL

Concomitant with the comprehensive information survey is the development of a conceptual model which interrelates processes with the various components of the Tuscaloosa Trend ecosystem.

The objectives of the conceptual modeling effort are four-fold:

- 1) To represent the Tuscaloosa Trend OCS region as an integrated system of physical, biogeochemical, and socioeconomic components, stressing functional relationships;
  - 2) To show the important interactions between the Tuscaloosa Trend OCS and other adjoining ecosystems;
  - 3) To provide the context within which the information search and synthesis activities can be conducted and information gaps identified;
- and

4) To form a framework for managing multidisciplinary research activities in subsequent years of the program.

Basically, this dynamic offshore ecosystem is represented as an open system with upcoast, downcoast, estuarine, deep ocean, and atmospheric boundaries and exchanges (Figure 12). The major sources of inputs and outputs, biotic and abiotic compartments, processes, and regulators were identified in a connectivity matrix (Table 1), and the relationships between the physical, biogeochemical and ecological subsystems were incorporated into a conceptual representation of the Tuscaloosa Trend ecosystem (Figure 13).

## INFORMATION SYNTHESIS

Information collected for the Trend area has been synthesized to complement the conceptual ecosystem model. Available data may be identified with system inputs, compartments/processes, and outputs. Inputs include atmosphere, estuarine discharges, transported sediments, wastes, and organic matter, and biological population movements. The available information is generally adequate to describe these inputs, but additional data are required to quantify inputs to the Tuscaloosa Trend study area.

System compartments/processes include components of physical and biological oceanography, sediments, wastes, mineral resources, navigation, and recreation. While good data exist for socioeconomic resources, only limited information has been obtained for other resource categories. Of particular importance are chemical composition of the OCS area, waste levels and fates, and biological populations, including phytoplankton and zooplankton.

System outputs are defined by water mass circulation, sediment dispersion from the Trend OCS area, wastes, biological production (as migrating populations and fishery harvesting) and mineral resource extraction. The information regarding sediment and waste outputs is considered inadequate to characterize relationships between the OCS and adjoining systems. Additional data area also needed for circulation patterns and biological population movements out of the area.

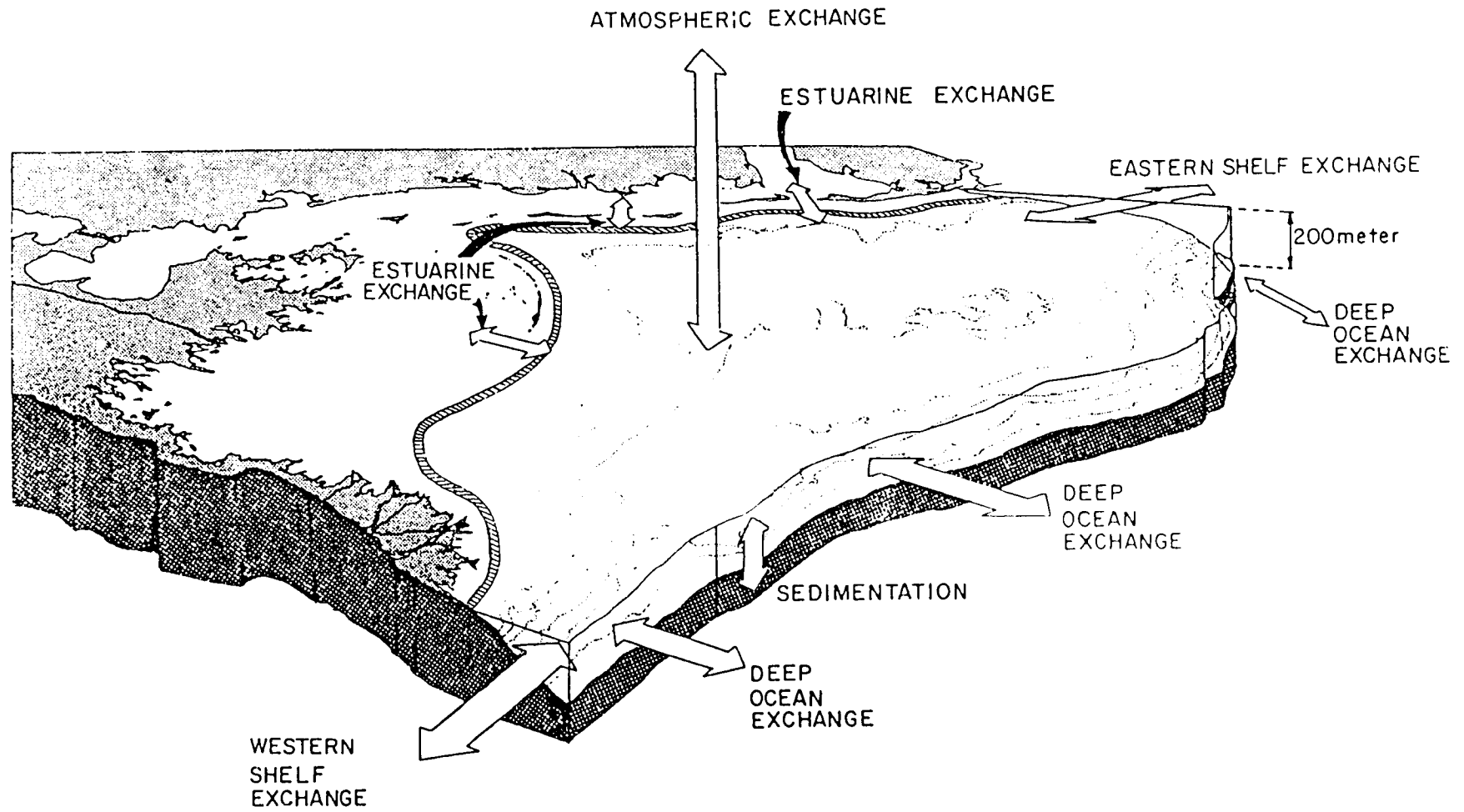

Figure 12. Boundaries for Tuscaloosa Trend OCS region.

		FROM									
		Compartments					Inputs				
		Pelagic Community	Benthic Community	Dissolved Materials	Particulate Material	Sediments	Atmospheric Inputs	Estuarine Inputs	Oceanic Inputs	Man	
To	CONTINENTAL SHELF										
	Pelagic Community	$\phi_1(\beta)$	$\phi_4(\tau, \alpha, \beta)$	$\phi_3(\tau, \beta)$	$\phi_2(\delta, \beta, \tau)$		$\phi_8(\sigma, \tau, \gamma, \alpha, \theta, \beta)$	$\phi_4(\sigma, \tau, \alpha, \beta)$	$\phi_4(\alpha, \tau, \beta)$		
	Benthic Community	$\phi_4(\tau, \beta)$	$\phi_1(\beta)$	$\phi_3(\beta, \tau, \alpha)$	$\phi_2(\delta, \beta, \tau)$	$\phi_2(\gamma, \tau, \theta)$ $\phi_6(\tau, \beta)$		$\phi_4(\sigma, \tau, \alpha, \beta)$	$\phi_4(\alpha, \tau, \beta)$		
	Dissolved Material	$\phi_7(\tau, \beta)$ $\phi_9(\tau, \beta)$	$\phi_7(\tau, \beta)$ $\phi_9(\tau, \beta)$		$\eta_9(\sigma, \tau, \theta)$	$\eta_9(\theta, \delta)$ $\eta_{11}(\alpha, \tau, \lambda)$	$\eta_5(\sigma, \tau, \gamma)$ $\eta_7(\lambda)$	$\eta_3(\theta, \sigma, \rho, \lambda)$	$\eta_3(\rho, \lambda)$	$\eta_{13}$	
	Particulate Material	$\phi_9(\tau, \beta)$	$\phi_9(\tau, \beta)$	$\eta_6(\sigma, \rho, \alpha, \theta)$ $\eta_{10}(\sigma, \tau, \alpha, \theta)$		$\eta_2(\rho, \delta, \alpha, \theta)$	$\eta_7(\lambda)$	$\eta_2(\sigma, \rho, \delta, \theta)$ $\eta_3(\theta, \sigma, \rho)$	$\eta_3(\rho, \lambda)$	$\eta_{13}$	
	Sediments		$\phi_5(\delta, \beta)$ $\phi_6(\tau, \beta)$ $\phi_9(\tau, \beta)$	$\eta_{10}(\sigma, \tau, \alpha, \theta)$	$\eta_1(\rho, \delta, \alpha, \theta)$						
	Atmosphere			$\eta_3(\sigma, \tau, \gamma)$ $\eta_8(\tau, \sigma, \rho)$							
	Estuary	$\phi_4(\sigma, \tau, \alpha, \beta)$	$\phi_4(\sigma, \tau, \alpha, \beta)$	$\eta_3(\sigma, \rho, \lambda)$	$\eta_3(\theta, \rho, \delta)$						
	Ocean	$\phi_4(\alpha, \tau, \beta)$	$\phi_4(\alpha, \tau, \beta)$	$\eta_3(\rho, \lambda)$	$\eta_3(\theta, \rho, \delta)$						
	Man	$\phi_{10}(\lambda, \beta, \gamma)$	$\phi_{10}(\lambda, \beta, \gamma)$								

Processes		Regulators			
<u>Biotic</u>		<u>Physical/Chemical</u>			
$\phi_1$	- biotic interactions	$\eta_1$	- deposition	$\sigma$	- salinity
$\phi_2$	- ingestion	$\eta_2$	- suspension	$\tau$	- temperature
$\phi_3$	- nonfeeding uptake	$\eta_3$	- advection	$\rho$	- water density
$\phi_4$	- spawning, migration and passive dispersal	$\eta_4$	- turbulence	$\delta$	- grain size
$\phi_5$	- bioirurbation	$\eta_5$	- diffusion	$\alpha$	- advection (currents)
$\phi_6$	- decomposition	$\eta_6$	- flocculation	$\theta$	- turbulence
$\phi_7$	- respiration	$\eta_7$	- precipitation	$\gamma$	- water quality
$\phi_8$	- photosynthesis	$\eta_8$	- volatilization	$\beta$	- population dynamics
$\phi_9$	- excretion, egestion, detritus (death)	$\eta_9$	- dissolution	$\lambda$	- climatic factors
$\phi_{10}$	- harvesting	$\eta_{10}$	- absorption		
		$\eta_{11}$	- upwelling		
		$\eta_{12}$	- freshwater intrusion		
		$\eta_{13}$	- dumping and discharging waste		

Table 1. Connectivity matrix showing inputs outputs, processes and regulators for a continental shelf ecosystem.



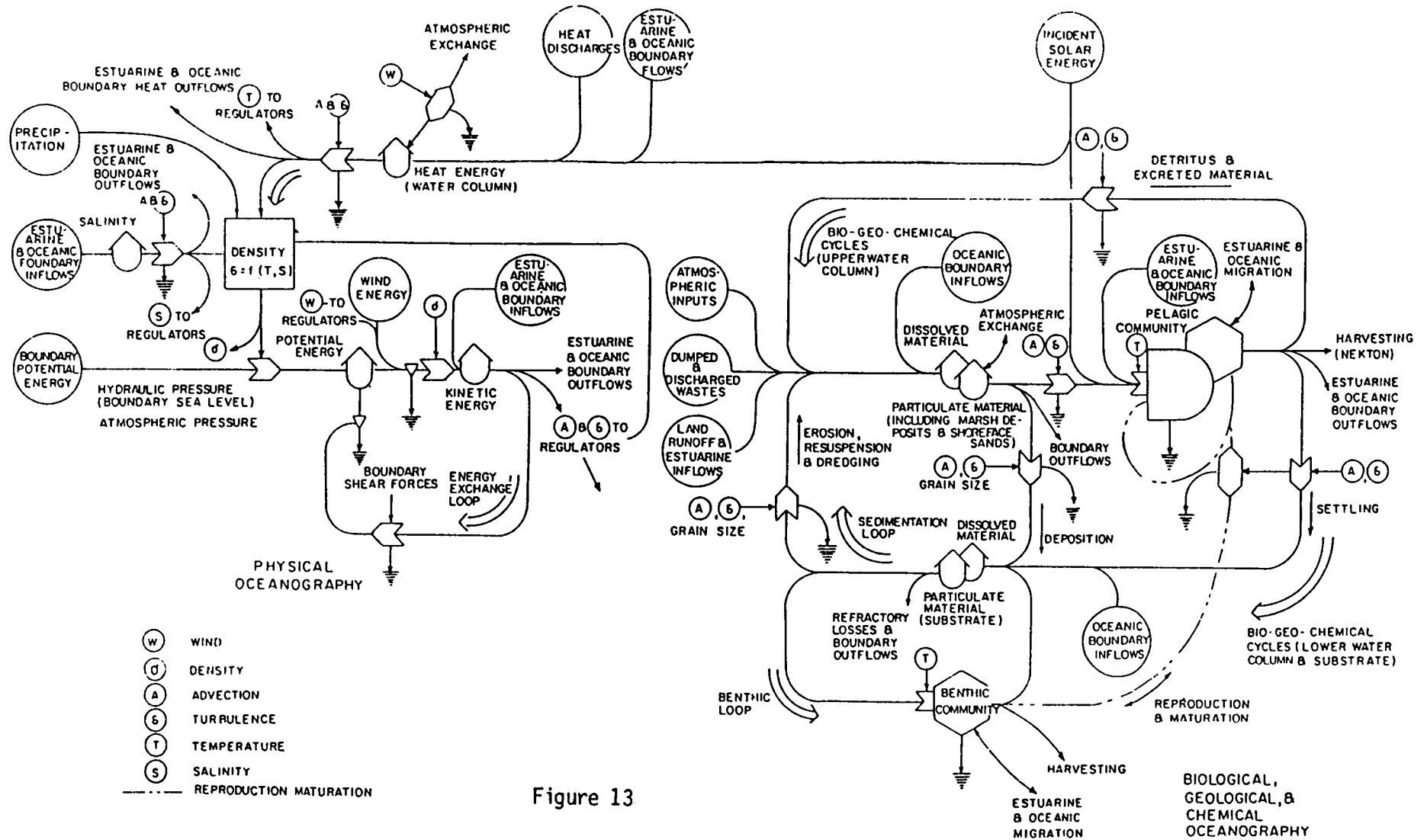

Figure 13

# Conceptual representation of Tuscaloosa Trend ecosystem

# QUANTITATIVE CHARACTERIZATION OF DEMERSAL FINFISH AND SHELLFISH COMMUNITIES IN THE TUSCALOOSA TREND REGION

Mr. Terrell A. Farmer  
Quantitative Environmental Analysis Section  
Science Applications International Corporation

## INTRODUCTION

The Tuscaloosa Trend region is among the most biologically productive areas in the Gulf of Mexico. Many of the ecologically and commercially important finfish and shellfish species are estuarine dependent. Populations of these taxa are strongly related to processes acting on the larval and juvenile life stages, especially those processes related to the transport to the estuaries and subsequent growth and survival in the estuaries. These demersal finfish and shellfish species exemplify the ecologic interrelationships of the outer continental shelf (OCS) and the adjacent coastal areas. The offshore distributions of many of these species are related to hydrographic conditions and sediment type.

Beyond approximately 50 to 100 m depths, the demersal communities are considerably different, with a higher proportion of species that are offshore residents during their entire life cycle. Much less is known about the relationships of these deeper-water species to environmental processes.

The ecological and commercial importance of many of the demersal finfish and shellfish species has fostered the development of long-term data bases by both state and federal agencies which generally encompass taxonomic count, biomass, and environmental data for both estuarine and adjacent OCS areas. Table 2 summarizes the federal and state data bases currently utilized in the quantitative characterization of the demersal finfish and shellfish communities in the Tuscaloosa Trend region. The

analysis and synthesis of these data aid the development of the Tuscaloosa Trend ecosystem conceptual model by identifying the dominant ecological processes and higher-level taxonomic and trophic groupings for model compartmentalization.

## OBJECTIVES

The objectives of the quantitative characterization of demersal finfish and shellfish communities in the Tuscaloosa Trend OCS region follow:

- (1) To characterize the spatial and temporal patterns in the structure of demersal finfish and shellfish assemblages.
- (2) To identify homogeneous habitats of the study area for model discretization.
- (3) To define the relationships of habitats to communities.
- (4) To utilize this community context to identify functional taxa or trophic groupings for model compartmentalization.
- (5) To define the relationships of communities and key taxa to physical and biological processes.
- (6) To determine the degree of variability in those model compartments attributable to temporal, spatial, and random variation.
- (7) To establish correlations between model compartments to identify important causal relationships.

## APPROACH

One quantitative approach to defining the relationships of species and community distributions to environmental processes is to employ an overall analytic framework within which univariate and multivariate statistical techniques can be efficiently integrated. In this approach, community and habitat-level analysis and synthesis activities provide the hypothesis generating context within which major biotic and habitat gradients and homogeneous subregions of the study area can be identified, major processes affecting the individual species and communities can be elucidated, and mathematical formulations can be developed to predict standing stocks from environmental variables. In the

investigation of the demersal finfish and shellfish communities in the Tuscaloosa Trend study area, correlation analysis, regression analysis, cluster analysis, two-way indicator species analysis (TWINSPAN), and factor analysis-principal component analysis are employed.

## PRELIMINARY RESULTS

A preliminary analysis of the demersal finfish and shellfish taxonomic count and associated environmental data from the 1982 SEAMAP program revealed trends in species distributions that were primarily related to hydrographic conditions and sediment type. Penaeus setiferus, Penaeus aztecus, Leiostomus xanthurus, Micropogonias undulatus, Cynoscion arenarius, Trichiurus lepturus, Arius felis and Menticirrhus americanus were most characteristic of the nearshore shallow and intermediate depths (2-30 m) with the lowest salinities and muddy sediments. Callinectes similis, Sicyonia dorsalis, Squilla, Trachypenaeus, Prionotus rubio and Centropristis philadelphicus were most characteristic of intermediate depths (10-30 m) with muddy sediments, whereas Sicyonia brevirostris, Loligo pealii, Bellator militaris, Prionotus roseus, and Prionotus salmonicolor were generally restricted to sandy sediments located in the eastern portion of the study area (i.e., off the Alabama and Florida coasts). Penaeus duorarum, Diplectrum bivittatum, and Stenotomus caprinus were characteristic of the sandy sediments of the eastern portion of the study area and the intermediate depth (10-30 m), muddy habitats, but were excluded from the shallow (2-15 m), muddy habitats.

These results indicate that the complex ecological patterns in the Tuscaloosa Trend ecosystem differ from those of a typical shelf ecosystem. In most shelf ecosystems, gradients of change in hydrographic conditions and sediment type and the associated changes in community structure usually vary in an onshore-offshore direction, with lower salinity waters and coarser-grained (sandy) sediments nearshore grading into higher salinity waters and finer-grained (muddy) sediments offshore. In the Tuscaloosa Trend ecosystem, the influence of the Mississippi River outfall creates longshore gradients in hydrographic conditions and

sediment type, with lower salinity waters and finer-grained sediments near the outfall grading into higher salinity waters and coarser-grained sediments away from the outfall. This unique combination of longshore and onshore-offshore gradients of environmental change produces a complex and dynamic ecosystem.

Table 2 . Summary of the regional demersal nekton and environmental data sets integrated into the Tuscaloosa Trend Project Data Base.

DATA SET	SOURCE	VARIABLES <sup>a</sup>	NUMBER OF STATIONS	TEMPORAL SPAN	FREQUENCY	PHYSICAL FORM
<b>Federal Sources</b>						
Fishery Independent Surveys for Groundfish	Dr. Walter R. Nelson/ Mr. Ken Savastano National Marine Fisheries Service	TC, B, LF, T, S, DO, TU, C XBT4	variable, 5-50 fathom depths	1972-1983	annually during fall, some sea- sonal coverage	magnetic tape
Southeastern Area Monitoring and Assessment Program (SEAMAP) A. Shrimp and Bottom Fish Survey B. Ichthyoplankton Survey C. Environmental Survey	Ms. Nikki Bane SEAMAP Coordinator Gulf States Marine Fisheries Commission	TC, B, LF, T, S, DO, TU, C XBT	variable, 1-50 fathom depths	1982-1983	annually during spring-summer	magnetic tape
Gulf Coast Shrimp Data	Mr. Darrell Tidwell National Marine Fisheries Service	TC, B, NT, DF	statistical area by 5- fathom depth zones	1960-1983	monthly	magnetic tape
River Discharge	U.S. Geological Survey Office of Water Data Coordination		12	1960-1983	monthly	magnetic tape
Precipitation and Winds	Mr. Warren Hatch National Climatic Data Center		4	1960-1983	monthly	magnetic tape
Tides	Ms. Janet Colt National Ocean Survey		1			magnetic tape
Ekman Transport	Dr. Andy Backun National Marine Fisheries Service Pacific Environmental Group		3° grids	1960-1983	monthly	magnetic tape
<b>State Sources</b>						
Louisiana Demersal Fisheries and Environmental Data	Mr. Harry E. Schafer, Jr. Dept. of Wildlife and Fisheries/Dr. Joan Browder National Marine Fisheries Service	TC, B, LF, T, S, DO, TU, NU	variable	1965-1983	monthly or semi-monthly	magnetic tape some hard copy
Mississippi Demersal Fisheries and Environmental Data	Dr. Thomas McIlwain Gulf Coast Research Laboratory	TC, B, T, S, DO	11	1973-1983	monthly or semi-monthly	hard copy
Alabama Demersal Fisheries and Environmental Data	Mr. Walter Tatum/ Mr. Steve Heath Department of Conservation and Natural Resources	TC, B, T, S, DO	15-30	1977-1983	monthly or semi-monthly	hard copy

<sup>a</sup> TC = taxonomic count  
B = biomass  
LF = length/frequency  
NT = number of trips  
DF = days fished  
T = temperature  
S = salinity  
DO = dissolved oxygen  
TU = turbidity  
NU = nutrients  
C = chlorophyll  
XBT = expendable bathythermograph

## CONCEPTUAL MODELING OF THE EAST FLOWER GARDEN BANK

Dr. Rezneat M. Darnell  
Department of Oceanography  
Texas A&M University

The East Flower Garden Reef covers the crest and upper flanks of a high topographic feature on the outer continental shelf directly south of the Texas-Louisiana border. Although well submerged, the reef is within the euphotic zone and, therefore, receives sunlight sufficient for photosynthesis. It is bathed by oceanic water and is subject to advective import and export of materials which are dissolved and suspended in the water column. Larger organisms move through the area, and some become temporary or permanent residents. Attached forms of the reef proper include corals, leafy algae, and coralline algae, as well as a variety of animal consumers such as sponges, worms, bivalve mollusks, and the like. Many animal species constituting the infauna, epifauna, and nekton are found in association with the reef. The coral polyps are subject to pathological disturbance. Considerable calcareous debris falls into the crevices and around the base of the reef. Particulate organic detritus is added by all plants (through death) and all animals (through egestion and death). Hundreds of species are now known from the reef area.

Despite the taxonomic diversity, it has been determined that the reef ecosystem can be adequately represented by a sixteen-compartment model which receives input from sunlight and advection of oceanic water. Among the advected nutrients, nitrogen, phosphorus, and calcium are considered to be most important, the latter because of its role in the formation of calcareous skeletons. Four of the model compartments represent photosynthetic producer groups (phytoplankton, zooxanthellae, leafy algae, and coralline algae). Ten are consumer groups (zooplankton, coral polyps, plankton feeders, pathogens, coralivores, herbivores, detritivores, omnivores, transient predators, and resident predators). Two are storage compartments (particulate organic detritus, including

microbes, and calcareous debris). The system is also subject to advective export of living and non-living organic materials. Although a certain amount of subjective judgment is required to assign individual species to one compartment or another, the basic categories are clear enough.

As a preliminary to the determination of pathways of flow through the system, it was first necessary to establish the input-output characteristics of each compartment. Nitrogen and phosphorus are utilized by all consumer species, and calcium is essential for the formation of calcium carbonate by coralline algae and coral polyps. The symbiotic relationship between zooxanthellae and coral polyps is shown by the fact that each of these compartments both gives and receives from the other. All animal groups show respiratory and fecal loss. Particulate organic detritus is contributed by every living compartment except the zooxanthellae, but these may leave the coral polyps and become part of the phytoplankton subject to advective export.

The above considerations are incorporated into the basic conceptual model of the East Flower Garden Reef system (Figure 14). Here it is shown that light (L), nutrients (N), and temperature (T) are the primary forcing functions for the resident producers. Phytoplankton which impinges on the reef is produced elsewhere and is simply accepted as an advective input. The box encloses the primary attached organisms of the reef (corals containing zooxanthellae, as well as soft and coralline algae). In this model an effort has been made to line up a food resource and its consumer groups on the same horizontal line to facilitate visual comprehension. An intentional but serious omission from this model is the advective recruitment to and advective loss from each compartment (of gametes, eggs, larvae, and adults). To include these import and export lines would obscure the chief features of the system for which the model was constructed.

The conceptual model presented here is described in greater detail in a chapter by R.M. Darnell and T.J. Bright entitled "Ecosystem Dynamics" which appears in the Minerals Management Service Technical Report No. 83-1-T. (Reefs and Banks of the Northwestern Gulf of



Mexico: Their Geological, Biological, and Physical Dynamics. Northern Gulf of Mexico Topographic Features Synthesis). This chapter goes on to present graphical models and elements of a mathematical model. In addition, partial evaluation of the models is attempted by the application of available data from this and related reef systems. It is noted that such modeling efforts are likely to be far more successful when data gathering is planned and conducted with modeling in mind.

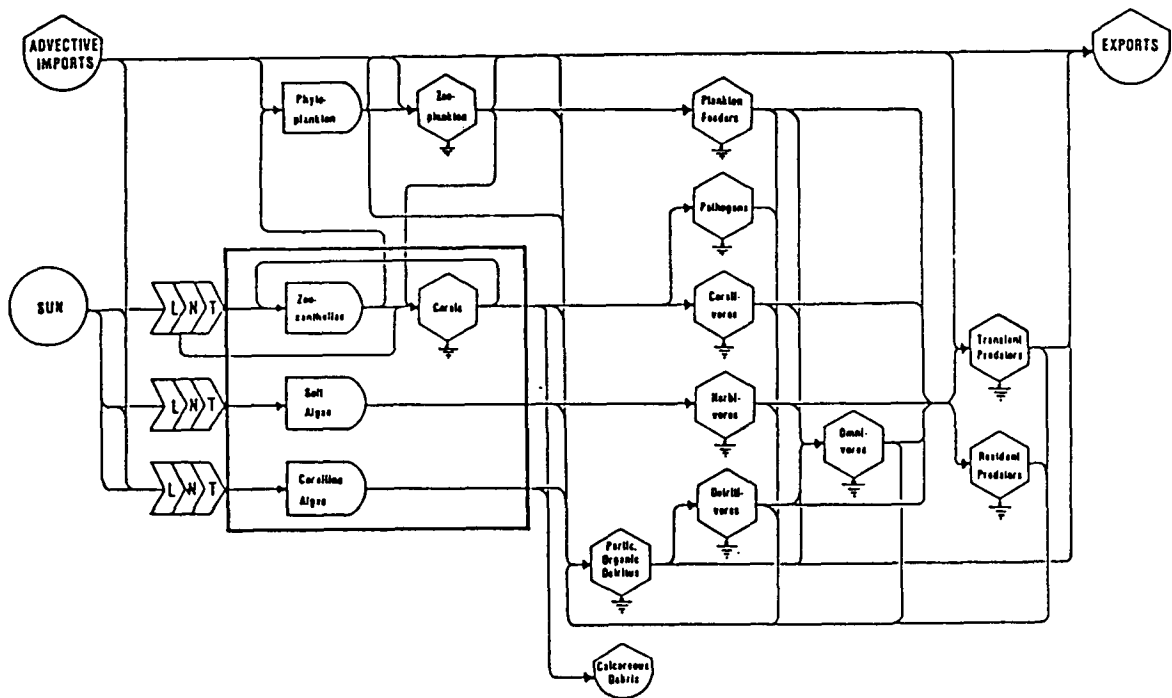

Figure 14. Conceptual model of East Flower Garden Reef.

## MARINE DATA ARCHIVING AND INDEXING

Session: MARINE DATA ARCHIVING AND INDEXING  
 Chairman: Dr. Murray Brown  
 Date: November 27, 1984

<u>Presentation Title</u>	<u>Speaker/Affiliation</u>
Session Overview	Dr. Murray Brown MMS, Gulf of Mexico Region
NODC Data Accession Procedures	Mr. Francis J. Mitchell National Oceanographic Data Center
Biological/Ecological Data: The Contractor's Perspective	Mr. Craig C. Brandt Science Applications International Corporation
Physical-Chemical Data Archiving: The Contractor's Perspective	Mr. Joe Karpen Science Applications International Corporation
NEDRES Index to BLM/MMS Data Bases; Revised ROSCOP Catalog of BLM/MMS Cruises	Mr. Ralph E. Childers Ralph Childers Associates
Marine Geological and Geophysical Data at the National Geophysical Data Center: Types of Data, File Organization, and Management	Mr. Troy L. Holcombe National Geophysical Data Center
The MMS/BLM Biological Collections Archiving Program at The Smithsonian Institution	Ms. Cheryl Bright The Smithsonian Institution

## SESSION OVERVIEW: INFORMATION MANAGEMENT

Dr. Murray Brown  
MMS, Gulf of Mexico Region

The Gulf of Mexico Studies Program also contains a new series that was started two years ago called "Information Management," that is the management of the information that comes from the other series. We are at the most basic stage in that series, trying simply to index and abstract the information that we have obtained from other studies. Some day we'll move into a synthesis stage and try to put the information together on specific disciplinary areas or topics or regions. But right now we're just trying to find out what we've already obtained.

MMS has spent about \$50 million on environmental studies so far in the Gulf of Mexico. That's roughly forty feet of shelf space, but what does that add up to? Perhaps, the most appalling thing that we found two years ago when we asked that question was that there simply was no index to these data. We are very actively seeking to put together the most economical and efficient way of indexing all of our information and ways of abstracting it so that users can know what it is that's supposed to be on that forty-foot shelf.

Mr. Francis Mitchell, NOAA, has handled the data that we submitted to the National Oceanographic Data Center now for a decade, and reported to us on the current status of their program. They receive, process, archive and vend marine environmental data obtained from federal programs. They have produced some good standard formats, reducing the old total from something like 100 down to about 21 standard formats. We're using these rigorously in requiring our contractors to put their data together into usable sets and to archive it with NODC when they're finished.

The major problem at NODC is that they are grossly underfunded. One of the most abusive situations I know of in the federal government is the treatment of marine environmental data, both there and in other agencies, but particularly at NODC where other agencies are supposed to be keeping their marine data. They do not have an adequate data cataloging program for the various files, and they have very minimal in-house treatment of data. In order to render the data useful to future users, it must be originally submitted in standard format by the producing agency, i.e., the Minerals Management Service. Anyone could give them data in non-conforming formats, but NODC would reluctantly just put it on the shelf for lack of funds to reformat it. It would be there forever, probably not useful to anyone unless it's extremely well-documented.

There is a new handbook for NODC that's available, by the way, and you can obtain it by contacting the National Oceanographic Data Center. It describes all of the files, the user protocols, and how to obtain data.

Mr. Craig Brandt, Quantus, Inc., reported on a study for MMS, that they're just completing, taking two of our largest old data sets and reformatting them into NODC format. They are working with data from the old South Texas OCS Program and the old MAFLA Program, which will more than double, perhaps increase by an order of magnitude, many of the data files for the Gulf of Mexico. These are just about to be delivered to NODC.

Mr. Joe Karpen, Science Applications International, gave a talk on problems in managing data by the contractor. He strongly recommended that studies have a rigorously structured quality assurance program developed at the very beginning of the program and that all data be audited and kept track of throughout the entire program.

Mr. Ralph Childers, from Ralph Childers Associates, has a contract with us to take descriptions of all of our studies up to about 1982 and submit them to a new service provided by NOAA called "The National

Environmental Data Referral Service (NEDRES)." This serves as a master card index for information about environmental data bases in the United States. They have about a thousand entries for the Gulf of Mexico, for instance, and we've added about 40 or 50 recently. These are complete citations of exactly what data were collected under various programs and what shape they're in and how you can obtain them. We strongly recommend to the other regions, and to any of you, who have data that you want to let people know about, that you index it in NEDRES.

Mr. Troy Holcombe, the National Geophysical Data Center, talked on problems in archiving geological and geophysical data. Geological data is defined as data taken at a station. Geophysical data is defined as data taken when the ship is underway or steaming. They are located in Boulder, Colorado, and are parallel to the National Oceanographic Data Center in NOAA. They have approximately 100,000 geological stations and many millions of miles of geophysical data. NGDC keeps its data sets intact, by the way, not integrating them into the other data. The reason for this is that they have many mixed sources and many mixed customers and you very rarely see absolute complementarity between different data produced by different sources. So they, as a result, have fewer standard formats than NODC -- about three.

They are presently moving into multi-channel seismic data holding, and also seafloor mapping data bases. Obviously, these are much larger data bases, and they are discouraging that hard copies or analog data be deposited there, because of the problems in holding so much material, looking mainly for digital data bases.

Finally, we had a speaker with a very interesting presentation on what happens to all the little beasties that we collect out there in the net and pick and sort and name that become data in our reports, What happens to them? Several years ago we instituted a program at the national level to archive the voucher specimens and other specimens at the U.S. National Museum of the Smithsonian Institution. Ms. Cheryl Bright came down to talk to us about the problems that those folks face. She told us that all biota, excepting perhaps the fishes which they send

on to the Gulf Coast Research Laboratory, are welcome there, but they have many problems in that the specimens have to be fully documented, well packed, well curated at the source, and, well identified before they can do much with them. We are working those problems out and we have standard specifications to make sure that our samples are in good shape. I guess we're good customers there because she told us that they have received 180,000 sample lots from our program and the prior BLM program. Someone in the session from another MMS region stated that he had a quarter of a million lots ready to send in soon. One of the major problems will be that much of that material will remain unsorted, but we are assured that it's going to be well stored. The Smithsonian is working now with a somewhat outdated system for cataloging these lots, but the system is flexible and it sounded like it still operates acceptably.

The problems that are faced by data managers are horrendous at the end of a program, mainly because of the limited funds usually available at that point in a contract. Very frequently scientist view data the same way they view the glassware, the chemicals, and the other expendable materials: they use them up during the study. That is clearly an unacceptable mode; the data should be considered nearly as valuable as the resource that they are supposed to characterize. Data have gone through people's fingers, fallen through cracks and gone out the window and maybe overboard for many years in all programs. We at MMS are trying very hard to see that this doesn't happen in the Gulf program.

These samples have cost us on the order of \$30 or \$40 million dollars. The thought that data might have been lost is an ugly one when you realize how valuable these will always be to us for purposes of environmental evaluation, for purposes of broad scale syntheses which could be performed, and for purposes of contract management. We believe that the amount of money that's spent on data management should be increased significantly in contracts, perhaps, to the point of ten to twenty percent of overall contract costs. Now, that sounds very high, but we are aware of contracts, where up to one-half of the money was spent on things that were not in the contract, and up to one-half of the things that were actually done onboard the boat were lost or went through the cracks.

So, a data management program, all the way from the beginning where you haul samples over the side and identify them to the final archiving of material with the Smithsonian, at NODC, and at NGDC, should be vigorous; it should be well-structured; it should be thought out ahead of time and it should be managed by a principal player in the conduct of the whole environmental program. In line with that, we recommend that from now on, in our program and in other programs -- whoever out there that is listening -- that taxonomy be given greater scrutiny in the selection of contractors; that taxonomers be principal players in the contract as well; and that they be internationally recognized or nationally recognized rather than just the pickers and sorters in the company that got the contract, because a very high number of samples are arriving at the Smithsonian with identifications that they feel are incorrect.

Finally, we believe that the data managers should be nearly co-equal with the program manager in programs where a great deal of multi-disciplinary data will be collected. Perhaps that's over-stating the case. I don't know. I can think of million dollar contracts that have failed because data management was very far down the priority ladder. Something must be done -- the program does not reach its own stated goal, much less allow the obtaining of data that will meet further inter-programmatic goals or serve purposes further down the road, unless the information generated is accurate, well documented, retrievable, and safeguarded.



## NODC DATA ACCESSION PROCEDURES

Mr. Francis J. Mitchell  
National Oceanographic Data Center

The National Oceanographic Data Center (NODC) accesses data from U.S. and foreign sources in a variety of formats and representations. NODC's original charter (1960) provided that the data center would accept and archive almost any marine environmental data. This has proved to be difficult for responding to data requests. Since incorporation of NODC within the National Oceanic and Atmospheric Administration (NOAA), NODC has been developing new formats, converting medium-to-large data collections to standard formats, and persuading data contributors to use these formats. Many of these formats were developed to accommodate the Minerals Management Service's outer continental shelf programs.

NODC upon receipt of data, and regardless of mixed data types or formats, assigns a single accession number. Individual data sets are separated and inventoried with a unique reference identity number assigned to each data set. Information which describes each data set is entered into an inventory data base. Key processing steps are added to the inventory as the data are processed.

A project or program is assigned a simple code identifier when NODC has determined that the project/program will produce data and that the name/acronym is meaningful in terms of long-term data association.

The Data Center's ability to process, store, and retrieve a common data type is controlled to a degree by input formats. The use of "standard" formats enhances this ability. NODC now uses twenty-one physical, chemical, and biological formats. Several formats exist in which no new data are being submitted or stored.

For the last eight years, NODC has used a taxonomic code especially developed to simplify and systematize processing, storage, and retrieval of marine biological data. NODC requires the use of the code in all marine biological data it accepts for processing. The code links the Linnean system of biological nomenclature to a numerical scheme which contains a maximum of twelve digits. Each two digits represent one or more levels of the taxonomic hierarchy. The fourth edition (August 1984) of this code contains approximately 45,000 taxa.

The data center has in the past printed data catalogs for projects which specifically required this type of public notice. NODC's normal "data catalog" is on computer disk and is part of the Data Inventory Data Base. Selection procedures allow determination of data availability by specific data type, geographical area, date range, water depth, taxonomic code, and particular parameter. Data which have not been processed by NODC can be identified by type and date range, but not depth level, individual parameter or geographical area.

## **BIOLOGICAL/ECOLOGICAL DATA: THE CONTRACTOR'S PERSPECTIVE**

Mr. Craig C. Brandt  
Quantitative Environmental Analysis Section  
Science Applications International Corporation

The ecological data resulting from the Minerals Management Service's Environmental Studies Programs are a valuable resource for future research programs. However, the fact that the data exist does not guarantee their utility to other researchers. In order to be useful, these data must be properly managed, documented, and archived. This paper offers some suggestions on managing ecological data with an emphasis on ensuring their availability and integrity for future users.

It is essential to include a data manager as one of the key personnel on the study team. This person is assigned the responsibility of overseeing the management of all scientific data and related information generated during the study. Major tasks include the following:

1. Advising researchers on the development of research plans including data formats, design of data recording forms, and sampling designs.
2. Implementing a research data management system, consisting of hardware, software, and documented procedures, which is appropriate to the level of the study.
3. Ensuring the quality and accessibility of the various data generated during the study.
4. Overseeing the archival of the data upon completion of the study.

Most ecological research programs consist of four stages: (1) program design, (2) sample collection, (3) laboratory processing, (4) data processing and analysis. Resulting from each of these stages are various information products which are essential to the data management task. Table 3 presents a summary of these products for each stage, and the following discussion outlines the important data management concerns of each stage.

The purpose of the program design stage is to determine the types, spatial location, and temporal frequency of the data needed to fulfill the objectives of the study. From a data management perspective, the important result of this stage is the identification of the types, quantities, and location of the data to be collected. This information is used to assign consistent sample identification codes and design the appropriate data recording forms.

The important concern in the sample collection stage is the proper documentation of the field methods and cruise activities. The field log provides the basic record of all collection efforts, including those which

are unsuccessful. Upon completion of a cruise, a Record of Samples/Observations Collected on Oceanographic Platforms (ROSCOP) should be completed and submitted to the National Atmospheric and Oceanic Administration.

Once collected, the samples are forwarded to the various laboratories for processing. As samples are analyzed, the sample identification information together with the resulting data are entered onto the appropriate recording form. For taxonomic data, it is important to compile a voucher collection which serves as a reference for the taxonomic identifications. This collection can be especially important to secondary users who may need to revise the data based on taxonomic changes which occurred subsequent to the original laboratory processing.

The data processing stage is the main responsibility of the data manager. The important concern in this stage is the accurate conversion of the raw data to computerized form. In addition, the necessary field and laboratory documentation must be assembled and organized. During this stage the data is formatted into the appropriate National Oceanographic Data Center (NODC) file types.

In conclusion, availability of data to both study participants and secondary researchers requires that the data be properly managed and documented. Data management should not be an afterthought which is only addressed at the end of a study. Rather, it should be an integral part of the overall program beginning with the design of the study and extending through data analysis and synthesis.

Table 3. Information Products Important in the Management of Ecological Data.

Stage 1: Program Design

<u>Item</u>	<u>Description</u>
Sampling plan	Describes the types, locations, and times of sampling. The plan forms the basis of the sample list and cruise plan.
Sample list	Contains sample identification codes and intended sampling locations. Use of consistent sample identification codes will ensure that the data can be cross-referenced.
Cruise plan	Describes the implementation and schedule of the sampling plan.
Data recording forms	Forms used to record field and laboratory observations. Ideally, these forms should be consistent in format, thereby minimizing confusion during data entry.
NODC bilateral agreement	Specifies schedules and formats for data archival with NODC.

Stage 2: Sample Collection

<u>Item</u>	<u>Description</u>
Field logs	Documents each sample collection effort. Information to be recorded should include date, time, location, sampling gear, and general comments.

Data recording forms	Completed for all data collected in the field such as hydrography.
Samples	Samples should be permanently labeled with date, location, and identification code. Samples must be properly stored to minimize breakage or spoilage.
Methodology documentation	Describes gear type, sampling methods, and field processing procedures.
ROSCOP	Initial documentation of sampling collection.

### Stage 3: Laboratory Processing

<u>Item</u>	<u>Description</u>
Data recording forms	Completed for all data collected in the laboratory such as taxonomic identifications. Use complete scientific names for chemical and taxonomic observations and also note important qualitative information.
Voucher collection	Serves as a taxonomic identification reference. Each voucher specimen should be documented on an identification card which includes location and collection date of specimen, taxonomy, authority, and keys used in the identification.
Methodology documentation	Describes laboratory procedures, equipment, and calibration data.
Processed samples	Should be retained for use by secondary researchers.

#### Stage 4: Data Processing and Analysis

<u>Item</u>	<u>Description</u>
Computerized data	NODC formats as described in the bilateral agreement.
Data file documentation	Describes the format, record counts, variable names, units, precision, missing value codes, and storage medium.
NEDRES citation	Provides secondary users with information on the content, duration, and location of data.

## PHYSICAL-CHEMICAL DATA ARCHIVING: THE CONTRACTOR'S PERSPECTIVE

Mr. Joe Karpen  
Science Applications International Corp.

SAIC's role in the MMS Gulf of Mexico environmental studies is to obtain and archive all available physical and chemical oceanographic data collected during our study period. The main thrust of our work is to obtain data which we can then use to create data products for our principal investigators doing studies in the Gulf of Mexico. All data are verified and corrected with our QA program before archiving; therefore, the data products for the program's principal investigators are valid. The final verified data are submitted to NODC.

### DATA TRACKING

Several data bases are employed:

- o Data tracking and storage
- o Time series
- o Hydrographic (CTD, XBT, nutrients)
- o Lagrangian drifters

The data tracking and storage data base is used to track the state of our data processing. All data sets are logged by ID, source, and original form. Status of the data is tracked, including the data requestor and received data products.

The time series data base is a relational one used to keep information on the location where each time-series was collected and the forms of processing done to the time series files (filtering, rotation, etc.). Similarly, the hydrographic and Lagrangian data bases keep track of where these data were collected. These data bases contain pointers to the actual data locations used by the analysis programs.



The data processing and archiving are housed on a dedicated super-minicomputer system based around a GOULD 32/27 computer with one mb of memory. System peripherals include a line printer, two 80 mb disk drives, and two 800/1800 bpi tape drives. I/O is either graphic or alphanumeric. For hard copy graphics, B and C size Tektronix flat bed plotters are utilized. High resolution graphics employ a 4051, color graphics a 4107, and Tektronix emulation an IBM PC/XT. The IBM PC is also used for automated real-time access of the ARGOS drifting buoys.

Alphanumeric input uses a variety of terminals and terminal emulators. The IBM Displaywriter is used for report writing and high quality tabular data output.

Data are obtained from many sources and can be handled in any data format. Current meter, hydrography-CTD, AXBT, ARGOS, wind, and tidal data originates on nine-track tape. HP-85 datacassettes used as transfer media bring XBT data, both Bathysystems and Sippican format. The HP-85 system is also used for transcribing Sea-Data microtapes. Current profiler data, either shipbased XCP or air dropped AXCP's, are obtained on HP mini-floppy disks. These are then transcribed to the Gould computer system.

Real-time ARGOS positioning data are automatically obtained with the IBM PC/XT. These data too are transcribed to the Gould computer system. The IBM PC is used to transcribe and clean up Aanderaa current meter tapes before transferring them to the Gould system for final processing.

All of the raw data are plotted to ensure there are no QA problems. Once the data sets are cleaned up, the data is locally archived in a compressed internal format. All data are integrated into a single system. The data base can be searched on any parameter.

## DATA PRODUCTS

A major portion of our responsibility is to generate data products as needed by the various principal investigators: time series plots; maps of data locations; and hydrographic sections, both vertical and horizontal.

## SUMMARY

We have a large, integrated, on-line data base which provides the ability to respond rapidly to requests by principal investigators for standard and specialized data products. Computer model output, in the form of time series, is also integrated into the database for analysis of model results.

### NEDRES INDEX TO BLM/MMS DATA BASES; REVISED ROSCOP CATALOG OF BLM/MMS CRUISES

Ralph E. Childers  
Ralph Childers Associates

For the past decade the Bureau of Land Management (BLM) and the Minerals Management Service (MMS) have formulated research plans, distributed funds, and monitored efforts for one of the most comprehensive environmental evaluations in the United States. Most of these studies were multidisciplinary and involved several principal investigators conducting both spatial and temporal investigations. As a first-level data inventory, the chief scientist on board each cruise was required by contract to complete and submit a Report of

Observations/Samples Collected by Oceanographic Programs (ROSCOP) form. These were archived in the individual report volumes for the contract and also in standard format at NOAA Environmental Data and Information Services (EDIS) centers, principally the National Oceanographic Data Center (NODC). Other data are on file in Minerals Management Service libraries or the National Technical Information Service (NTIS). There was, however, no index to these data bases nor was there any uniform protocol for the completion of the ROSCOP forms.

One of the objectives of the Environmental Information Management Series of the OCS Environmental Studies Program was to provide relevant information to decisionmakers for minerals management programs. Without an adequate index the provision of data is inefficient and incomplete. The National Environmental Data Referral Service (NEDRES), recently developed by NOAA/NESDIS, offers a solution to this dilemma by allowing the creation of a "data base of data bases" to facilitate the data referral process. NEDRES is a catalog of environmental data. It is available on the Bibliographic Retrieval Services, Inc. (BRS) information system. The data base contains descriptions of environmental data files, published data sources, data file documentation references, and organizations that make environmental data available. It contains only descriptions, however, and not the actual data.

The MMS Gulf of Mexico Region elected to implement use of the NEDRES system, and it became necessary to encode the information from completed MMS Gulf Region OCS Environmental Studies into a standard format for convenient entry into the NEDRES system. At the same time the MMS Gulf of Mexico Region elected to recode approximately 150 ROSCOP forms from completed contracts, requiring the development of a standardized protocol and the recoding of each individual ROSCOP form.

In summary, the objectives of the study were to encode the necessary information on 50 completed MMS Gulf of Mexico Region OCS environmental studies, to recode approximately 150 existing ROSCOP

forms from past oceanographic field efforts, and to provide a brief guide to ROSCOP coding. These objectives have been met.

The information from 50 environmental study contracts has been encoded into NEDRES format. Forty-one of these are now online and searchable in the NEDRES data base. A NEDRES record consists of 22 data elements including such items as title, abstract, data collection methods, period of record, geographic names and codes, data set parameters, descriptors, contact, availability, principal investigators, performing organization, program identification, publications, plus other coded information. Guidelines for the coding of NEDRES descriptions are currently included in MMS Contract Specifications.

One hundred forty-three ROSCOP forms have been evaluated and recoded. The recoded ROSCOPs, in digital format, have been forwarded to MMS and NOAA. The draft of a recommended set of guidelines for the coding of ROSCOP forms has been prepared and submitted.

The only significant problems encountered were due to the retrospective nature of the study. It was not possible to ferret out every piece of information for every case; time and resources precluded exhaustive investigation. Nevertheless, we believe that the integrity, if not the complete detail, of the information has been preserved.

There remains much to do. There are, at the very least, 40 MMS Gulf of Mexico environmental studies contracts remaining to be encoded into the NEDRES data base. Interest in NEDRES is expected to grow in other MMS regions, representing many more studies that should be indexed. Finally, the ongoing environmental studies need to implement the standardized protocols for NEDRES and ROSCOP coding and keep the coding current so information is immediately and readily available to other researchers.

MARINE GEOLOGICAL AND GEOPHYSICAL DATA AT THE NATIONAL  
GEOPHYSICAL DATA CENTER: TYPES OF DATA, FILE  
ORGANIZATION, AND MANAGEMENT

Mr. Troy L. Holcombe  
Marine Geology and Geophysics Division  
National Geophysical Data Center

The Marine Geology and Geophysics Division of the National Geophysical Data Center (NGDC) acquires, stores, and disseminates to the public marine geological and geophysical data of all types from all ocean areas. It also provides data products and services on a routine or customized basis.

Geological data include information about sediment samples (mostly piston and gravity cores), dredge hauls, and drilling samples. Well logs are also included within the inventory of geological data. Examples of geological data holdings include (1) sediment descriptions and analyses, from approximately 100,000 sample locations worldwide, (2) geological data files from the drillsites of all 96 legs of the Deep Sea Drilling Project, (3) well logs, provided by the Minerals Management Service (MMS), for 2,700 wells in the Gulf Coast offshore area and 200 wells located off the eastern and western coasts of the U.S. including Alaska, (4) a worldwide igneous petrology and geochemistry file, PETROS, containing data from about 37,000 locations, 4,000 of which are in the marine environment, and (5) analytical results compiled by the CLIMAP program, comprised of microfossil species counts, organic geochemistry data, oxygen and carbon isotope measurements, percentages of carbonates, percentages of organic carbon, and other measurements from 900 sediment cores. Altogether there are over 900 geological data items on file, ranging from large data sets to data reports to bits of information, either in digital or analog form. Each newly acquired data set becomes an incremental addition to this inventory of data items. At the top of the geological data "pyramid" is an inventory file (GEOLIN)

which refers to all geological data held at NGDC by location and data type.

Four "dynamic" digital data bases have been derived from the mass of geological data: a marine core curators data base containing brief lithologic descriptions and age data for sample material archived at major U.S. oceanographic institutions; a marine minerals data base containing mineralogical and geochemical analyses, including geochemical analyses for approximately 7,000 manganese nodule samples; a digital grain size analysis data base; and a digital data base of geotechnical parameters such as shear strength, density and sound velocity. Each of these digital data bases is searchable by area, institution, cruise, date of collection, water depth, and several other search criteria.

Currently, because of the interest and activities aimed at recovery of polymetallic sulfides, iron-manganese nodules, phosphates, and placer mineral deposits from the U.S. Exclusive Economic Zone (EEZ), efforts are focused on rapid development of the marine minerals data base. Accompanying this data base is a marine minerals bibliography, searchable by a number of criteria, which contains over 5,000 entries.

Geophysical data bases include bathymetry, seismic reflection, gravity, and other indirect physical measurements made from a moving platform. The principal geophysical data bases are much larger than the geological data bases, and except for analog seismic reflection records and other acoustic imagery, are entirely digital.

Derived from historic and recent hydrographic surveys conducted by the Coast and Geodetic Survey and more recently by the National Ocean Service (NOS), the digital hydrographic data base is presently the largest single marine data base at NGDC, containing some 30 million soundings. This digital data base is organized by 1-degree latitude/longitude squares. Soundings are principally from U.S. coasts, estuaries, and offshore waters, including Puerto Rico, Alaska, Hawaii, and U.S. Trust Territories. These data form the baseline coastal bathymetry data set for almost any non-navigation application. Hydrographic data can be provided

in digital form, or plotted as contours, color dot-plots, or stereographic pairs at various scales and projections.

Another of the large geophysical data bases is the worldwide geophysical data base (GEODAS). This data base contains trackline navigation (9 million track miles) merged with digital bathymetry (12 million soundings), magnetic field strength measurements (6 million data points), and gravity measurements (3.5 million data points). This data base also contains analog seismic reflection imagery, including single-channel seismic reflection records from deep-ocean areas, and multi-channel seismic reflection records from lease sale areas and other prospective areas of the EEZ. Predominant contributors of data are academia, which has provided most of the worldwide high-seas data, and the U.S. government, principally the U.S. Navy, MMS, and the U.S. Geological Survey (USGS), the latter two of which have provided most of the seismic reflection data from the EEZ. New data sets are added to the GEODAS data base in the order in which they are received, where they remain intact rather than being resorted by area or other criteria. Navigation tracklines and a record of data types are included in an inventory file.

One of the most-utilized geophysical data bases is the U.S. Navy worldwide gridded bathymetry data base (DBDB5), which contains a single depth for each 5-minute by 5-minute grid square. This data base is particularly useful for generating bathymetry contour maps and three-dimensional bottom portrayals of large oceanic areas.

In the future, NGDC expects to start acquiring and disseminating multiple-beam bathymetry. Also NGDC expects to handle large volumes of digital multichannel seismic reflection data, whereas to date only analog records have been handled in large quantities. Large volumes of these data will be collected in the U.S. EEZ by USGS and NOS programs; as a result, the volume of marine geological and geophysical data acquired and disseminated per unit time by NGDC is expected to increase by 1-2 orders of magnitude.

Several digital marine boundary files are maintained at NGDC, including the boundaries of the U.S. EEZ and MMS lease-block boundaries.

Inventories of data bases using various search criteria are usually done free of charge. Actual data are provided at nominal cost, principally the cost of making copies of the data. For new data sets thought to be of broad interest, data announcements are prepared and sent out to potential users. Standard formats, published or unpublished, are well-established for the principal "live" digital data bases. Format specifications, available upon request, also yield adequate documentation if adhered to.

Exchange agreements are regularly made between NGDC and individuals and institutions that are potential contributors of new geophysical data. Such agreements generally entitle the data contributor to receive equivalent amounts of equivalent kinds of data.

A new publication series was recently initiated under the auspices of World Data Center A for Marine Geology and Geophysics which is operated by the Marine Geology and Geophysics Division of NGDC. Reports of this series will be published at irregular intervals and contain scientific data contributions which are judged to be of broad interest to the marine geology and geophysics community.



THE MMS/BLM BIOLOGICAL COLLECTIONS ARCHIVING PROGRAM AT  
THE SMITHSONIAN INSTITUTION

Ms. Cheryl Bright  
The Smithsonian Institution  
U.S. National Museum of Natural History

Since November, 1979, the National Museum of Natural History, Smithsonian Institution, has served as the formal repository for the biological collections and the associated collection data proceeding from the MMS/BLM offshore environmental studies programs. Voucher specimens and other identified or identifiable specimens with their associated collection data are assigned USNM catalogue numbers and are then incorporated into the appropriate collection within the museum. Most of the specimens received to date have been invertebrates retained in the collections of the Department of Invertebrate Zoology. Algal specimens have been transferred to the Department of Botany; the Bryozoa and Foraminifera have been transferred to the Department of Paleobiology; and the fish collections have been transferred to the collections of the Gulf Coast Research Laboratory, Ocean Springs, Mississippi.

The MMS collections received at the museum generally fall into one of three categories. The vouchers formed the basis of the taxonomic subcontractor's reference collection. All incoming material clearly identified as vouchers are given top priority in processing by project personnel. All voucher specimens are clearly marked as vouchers prior to their incorporation into the collections. The general collection contains all other specimens identified and/or enumerated by the taxonomists. These specimens form the bulk of the material received, and the sorting (if needed) and cataloguing of these specimens proceeds only after all voucher specimens have been catalogued. These collections have, since the project's beginning, presented the greatest problem in processing because in many instances little care was taken by the taxonomists in

proper labeling, preservation, and maintenance. The problems have been compounded in some collections since some taxonomists recombined sorted and identified specimens into a single container for storage. This has made it necessary for the project personnel at the museum to duplicate the taxonomist's original work of sorting and, if possible, identification before the specimens can be catalogued and incorporated into the permanent museum collections. The third category, the archive samples, includes bulk, unprocessed samples such as meiofauna, neuston, plankton, dredge, and boxcore samples. The long-term storage of these samples, because of the volume of each sample, has already created a storage problem in the collection facilities on the Mall. As the space problem becomes even more critical, the museum may decline to accept large collections of archive samples for permanent deposit.

During the first five years of this project, the museum has received more than 180,000 lots (i.e., one or more specimens of the same taxon, collected at the same time at exactly the same place using the same method) of specimens from various East Coast and Gulf Coast MMS offshore studies. This lot count is continually revised upward as samples are resorted since it is not uncommon for a single container to hold 20 or more distinct taxa each of which becomes a lot. To date the CABP, LMRS, MAFLA, and NEEB projects have each deposited in excess of 25,000 lots in the USNM collections. The CGPS, SABP, and SOFLA projects have each deposited over 10,000 lots. The BIMP, IXTOC, and STOCS projects have each deposited fewer than 1,000 lots, with most of the STOCS and BIMP material in the form of archive samples.

Of this total, project personnel here have catalogued more than 50,000 lots of specimens and have transferred several thousand lots of fish, algae, bryozoans, and foraminifera to other departments or institutions for processing or archiving. Since all incoming material is accepted by the museum on an "accession or discard" basis, several thousand lots of specimens accompanied by insufficient data or that were poorly preserved have been discarded. Overall, about 40% of all materials received since the project started has been catalogued and incorporated into the appropriate invertebrate zoology collection.

The cataloguing protocol followed by the project staff is identical to the protocol followed for all newly received departmental collections. All taxonomic, geographic, collection, and ecological data pertaining to each lot of specimens is entered into a computerized specimen data file. Currently the Smithsonian utilizes SELGEM as a "batch process" database management software package. SELGEM provides for the creation of a unique computer record for each lot of specimens catalogued. Each record is identified by the same unique catalog number that identifies the corresponding specimen lot. With SELGEM, variable length records can be created which can contain up to 999 data categories or fields each composed of up to 99 lines of data with a maximum of 64 characters per line--a theoretical maximum in excess of  $6 \times 10^6$  characters per record. All data entered into the specimen data file are strictly formatted in accordance with departmental data standards allowing all included data fields to be queried. Summary reports arranged by taxonomic data and/or locality data and/or collection data and/or ecological data can be readily produced for all MMS collections. Mandatory and desirable data fields for cataloguing purposes include USNM number, family, genus, species, subspecies, author, number of specimens, preservative, type/voucher status, exact collecting locality, latitude-longitude, depth, collector and date, gear, vessel, station number, sample number, project/expedition, donor and date, habitat, sediment ( $\Phi$ scale), bottom type, associated fauna, sex, identified by and date, previously identified as, accession number, dissolved oxygen, salinity, temperature, etc. Within the next 6-18 months these catalogue data files will go "on-line" following the installation of a new IBM mainframe computer and an as yet unselected data base management software package. This will allow faster and interactive access to the data in the specimen data files.

Several recurring problems have compromised the integrity of the various MMS offshore studies collections and have had a detrimental effect on the efficient processing of these collections by the museum's project staff. These problems can be minimized if not completely avoided by following these guidelines.

- 1- All MMS material regardless of taxon sent to anyone at the museum for any purpose (identification, verification, evaluation, etc.) must be sent to the intended recipient by way of the project principal investigator, Dr. Meredith L. Jones.
- 2- At the time of deposit at the USNM all collections must be accompanied by five copies of complete station data presented in an approved format.
- 3- Each specimen lot must include a detailed, museum-quality label.
- 4- Samples which have been sorted and enumerated by the contractor must not be recombined. Each taxon from each sample must be properly labeled and stored. Small individual vials of a common taxon may be stored together in a large container but each large container must be clearly marked to indicate its contents.
- 5- While in the custody of the contractor or taxonomic subcontractor, all MMS collections must be adequately preserved, stored in proper containers, periodically checked, and if necessary topped with an appropriate preservative.
- 6- Collections must be carefully packed for transfer to the USNM. The contents of each packing container must be carefully and completely itemized on a packing/inventory list. A copy of the packing list must be placed in the packing carton, the contents of each carton must be clearly marked on the outside of each carton, and the original copies of each packing list should be forwarded under separate cover to the USNM at the time of specimen transfer.

- 7- All specimens including valuable mollusks that are itemized on the species lists presented to MMS in the project reports must be deposited at the USNM.

The MMS contracting officer and project officials will be notified if collections are received that do not conform to these guidelines.

All questions regarding the Smithsonian Institution's MMS Biological Specimens Archiving Project should be addressed to Dr. Meredith L. Jones, Department of Invertebrate Zoology, National Museum of Natural History, Smithsonian Institution, Washington, D.C. 20560. Additional information beyond that available in the RFP concerning collection maintenance and management, collection packing and transfer, and formats for specimen data reports is available upon request. The designated collection manager for each MMS offshore studies project is encouraged to contact the principal investigator for the MMS archiving project during the early phases of each project to facilitate the establishment of effective collection and specimen data management practices.

TECHNOLOGY ASSESSMENT AND RESEARCH PROGRAM  
FOR OFFSHORE MINERALS OPERATIONS

Session: TECHNOLOGY ASSESSMENT AND RESEARCH  
PROGRAM FOR OFFSHORE MINERALS OPERATIONS

Co-Chairs: Mr. John B. Gregory  
Mr. Charles E. Smith

Date: November 27, 1984

Presentation Title	Speaker/Affiliation
Session Overview	Mr. John Gregory MMS, Technology Assessment and Research Branch, Reston, VA
Technology Assessment and Research Program for Offshore Minerals Operations	Mr. John Gregory MMS, Technology Assessment and Research Branch, Reston, VA
Development of Improved Blowout Prevention Procedures for Deepwater Drilling Operations	Dr. A. T. Bourgoyne, Jr. Louisiana State University
Surface & Subsurface Collection of Oil From Blowing Wells	Mr. Jerome H. Milgram Massachusetts Institute of Technology
Dynamic Response of Deepwater Structures to Ocean Waves and Currents	Dr. J. Kim Vandiver Massachusetts Institute of Technology
Foundations for Tension Leg Platforms	Mr. Hudson Matlock The Earth Technology Corporation

SESSION OVERVIEW: TECHNOLOGY ASSESSMENT AND RESEARCH  
PROGRAM FOR OFFSHORE MINERALS OPERATIONS

Mr. John Gregory  
MMS, Technology and Assessment and Research Branch  
Reston, VA

There were four presentations in our technology session as well as a discussion of the way our technology program operates. The discussions were in two parts. The first was on programmatic matters. We discussed our contract research program and how we do business at universities, private companies, and government laboratories--wherever there are the capabilities for doing good research.

Our program supports our operations people and provides an independent assessment of the technologies used on the OCS. If we discover gaps that we think that we need to fill for our own purposes in operating with the industry, we will then conduct applied research.

Through our investigators we have been able to establish a dialogue on the engineering level--not the marketing level or the business level--with the industry, whether it be the support industry or the oil companies.

We make use of an MMS communications network which we call the Operations Technology Assessment Committee System. There is a working group in each regional office and headquarters where we discuss problems and technology.

When the formal technology base that the technology program provides to MMS, in addition to other factors, is combined into this committee network, we think that we literally, and in the spirit of the law, comply with the OCS Lands Act as amended in 1978, which requires the use of the best available and safest technology which is economically feasible.



The second part of our session, the technical presentations, were based on the needs of the Gulf of Mexico Region as OCS operations move into the deeper waters and off the shelf in the Gulf. The first of the four presentors, Dr. Bourgoyne of LSU, discussed deep ocean blow-out prevention procedures. The TA&R Program is conducting research in that area at Louisiana State University. If anyone is interested in deep ocean blow-out prevention procedures (well control procedures) and where our research is directed, I think you'll be very impressed with the experimental facility at LSU, where there is a simulated deep-ocean well and enthusiastic university people. You will also see that industry is supplying most of the equipment to the university so that we are working together on this important aspect of safe drilling in the deep oceans.

Secondly, our session discussed oil spill containment and clean-up as industry moves farther offshore where the logistics become more and more difficult. Our investigator, Dr. Jerry Milgram, who presented this paper, went down to Campeche Bay, Mexico, during the IXTOC-1 blow-out in 1979 and made flow measurements on the upside-down funnel-like "sombbrero" collector that was suspended over the blowing well. Dr. Milgram returned to the laboratory at MIT and eventually concluded his work on collection technology with a quarter-scale demonstration. We think now we know how to collect a good percentage of the oil from a blowing well by use of the "sombbrero" method. However, instead of suspending the upside-down "sombbrero" system from a jacket platform, as was done at IXTOC-1, the latest thinking is to suspend it from a large tank ship so that the oil can be collected and separated, and the entrained water pumped overboard.

Dr. Milgram has also helped us put together a method for towing outrigged oil spill booms on each side of a large tank ship so that it can head into a surface oil spill and collect the oil and pump it into the ship.

With regard to structures, Dr. Kim Vandiver, of MIT, presented problems associated with the new compliant structures that will be used as industry moves off the shelf into the deeper water.

For the seafloor-structure interaction situation, Professor Hudson Matlock discussed soil-pile foundation problems. If one thinks of platforms, one usually visualizes them resting on the sea floor. But in the case of tensioned leg platforms, these pull up out of the bottom, and not enough of the civil engineering technology is known about pilings in tension, especially in the ocean. Professor Matlock presented a summary of what he has done and what has been accomplished by Det Norske Veritas (DNV) and Conoco in pile testing offshore.

If anyone would like any further information, please contact me or come to our seminars. Our next seminar will be in Reston in the spring of 1986. But we're always there, if anyone is interested in the technologies that we and MMS are exploring to assure the public that the offshore operations are safe and pollution-free.

#### TECHNOLOGY ASSESSMENT AND RESEARCH PROGRAM FOR OFFSHORE MINERALS OPERATIONS

Mr. John Gregory, Chief  
Technology and Assessment Research Branch  
MMS, Reston, Virginia

For the first time at an Information Transfer Meeting, the Technology Assessment and Research (TA&R) Program is sponsoring a session. Whereas the other sessions relate to the prelease studies of the Gulf of Mexico Environmental Studies Program, this session and the TA&R Program address the postlease operational needs of the Minerals Management Service (MMS). Another way of putting it is that our studies pertain to the technologies that our regulatory people need to know as they work with an industry that is moving into the frontier areas of the deep oceans and ice infested Arctic. Specifically, these matters relate to

safety and pollution inspections, enforcement actions, accident investigations, operational permits and plan approvals, and well-control training requirements. To support these several functions, the TA&R Program provides an independent formal assessment (apart from the industry) of the status of the offshore technologies and an identification of the operations that require technological improvement. Where deemed necessary original applied research is undertaken. Thus, the expressed intent of the program is to provide a formal base of technology support for the MMS operations personnel to assure that industry operations are safe and pollution free.

Studies are conducted at universities, private companies, and government laboratories--wherever there are promising ideas and capabilities for advancing the "regulatory" technologies. Project investigators provide a necessary and all-important dialog or forum at the engineering level between the industry and MMS personnel. These investigators serve as staff adjuncts to MMS personnel by briefing them through a network of working groups known as Operations Technology Assessment Committees (OTACS). The OTACS are located in headquarters and the regional offices; they discuss operational problems and technologies and make recommendations to management which are intended to improve MMS procedures and regulations.

The TA&R Program, together with the technology transfer network, is a primary means by which MMS assures the use of the "best available and safest technologies. . . . which are economically feasible" (paragraph 21b BAST), which is a requirement of the OCS Lands Act as amended in 1978.

The TA&R Program consists of about 30 or so active projects funded independently or in cooperation with other federal agencies or with the offshore industry. About one-third of the projects of this confirmatory research program are assessments, the remainder being applied research into the processes by which operations are accomplished on the OCS. The average research project requires about 3-4 years to investigate, and each year there are several new starts.

Major emphasis is on the Arctic (the engineering properties of sea ice, ocean bottom permafrost, prevention of ice accretion on structures, etc.) and the deep ocean (deep ocean blowout prevention procedures, drilling riser behavior in a current regime, catastrophic failure modes of tension leg platforms, etc.) About a third of TA&R active projects is participatory with the industry. These participatory projects are proprietary and often very expensive, and TA&R participation is usually the best way for MMS to get the information in a timely manner.

For purposes of management the program is divided into three subsets or categories:

- o blowout prevention
- o oil spill containment and cleanup
- o verification of the integrity structures and pipelines.

For this Information Transfer Meeting we have selected projects from these categories which address operations in OCS waters such as the Gulf of Mexico. Dr. Bourgoyne will discuss his experimental research into improved well-control procedures for deep ocean drilling. Dr. Milgram will address his work on the containment and collection of blowing oil, both on the surface and beneath. Lastly, Dr. Vandiver and Professor Matlock will discuss techniques which pertain to the performance of the tension leg platform structures planned for the deeper waters of the Gulf.

We hope you will enjoy these presentations, and we invite you to take a copy of the TA&R program report entitled Technology Assessment and Research Program for Offshore Minerals Operations, OCS Report MMS 84-001. Lastly, we solicit your comments or questions on our program either at the session or in Reston, Virginia, our home office, telephone (703) 860-7865.

## DEVELOPMENT OF IMPROVED BLOWOUT PREVENTION PROCEDURES FOR DEEPWATER DRILLING OPERATIONS

Dr. A. T. Bourgoyne, Jr.  
Petroleum Engineering Department  
Louisiana State University

The past 10 years have seen the worldwide search for oil and gas move into deep ocean waters to explore the sedimentary basins beneath the rise and slope of continental margins. Since 1974, about 70 wells have been drilled from floating platforms and drillships in water depths greater than 2,000 feet. Likewise, the record water depth for exploratory drilling has increased steadily, the current record being held by the drillship DISCOVERER SEVEN SEAS for a well drilled in the Atlantic Ocean in 6,800 feet of water. In a global sense, at least, deepwater drilling is becoming more commonplace.

A potentially dangerous problem common to both offshore and onshore drilling operations is the control of high-pressure formation fluids. When a permeable formation is penetrated by a drill bit, the pressure of its contained fluids (water, oil, and/or gas) must always be offset or balanced by the hydrostatic pressure of the drilling fluid (mud) in the borehole. Otherwise a threatened blowout or so-called well "kick" will occur. Upon the influx of formation fluid into the borehole, the drilling mud is displaced or kicked up the hole, causing an increased rate of mud return flow at the surface. If this condition is not recognized immediately and proper control procedures initiated, the entire annulus can be voided of mud and the uncontrolled discharge or blowout of formation fluids to the atmosphere can follow a surface blowout of oil or gas. The blowout is usually accompanied by an explosion and fire, resulting in destruction of the drilling system, probable injury or death of drilling personnel, and possibly long-term damage to the environment. Because formation pressures cannot always be predicted in advance of

the drill bit, well kicks can be a frequent drilling experience, though infrequently they develop into disastrous blowouts through human error or perhaps equipment failure.

In shallow-water drilling, where bottom supported jack-up rigs or marine platforms are used, the procedures for blowout prevention are essentially those developed for land-based drilling. Upon the timely detection of a drilling kick, the flow up the wellbore annulus is shut-off by closing the blowout preventers (BOP's). These BOP's are large hydraulically actuated valves designed to close around the drill pipe and effect a high-pressure seal. A build up in pressure below the closed BOP's in combination with the annulus-fluid hydrostatic pressure results in a bottom hole pressure (BHP) sufficient to stop the influx of formation fluids. Before the BOP's can be opened and normal drilling operations resumed, the original mud in the well must be replaced with a new or so-called "kill mud" having a density sufficient to balance formation pressure by virtue of its increased column and weight alone.

This mud-exchange process requires that the formation fluids, together with the original mud, be circulated out of the well while maintaining the BHP constant at a value slightly greater than the formation pressure. Otherwise, a second kick might occur. This circulation is accomplished by routing the return flow from beneath the closed BOP's through a high-pressure flow line which terminates in an adjustable throttling valve called a drilling choke. While pumping the kill mud, the choke is adjusted to provide a controlled backpressure at the wellhead, thus controlling the BHP. Unfortunately, the prevailing BHP can only be inferred from remote gauges located at the surface. Hence a precalculated schedule of changes in drillpipe pressure, in step with the progress of the kill mud, is used by the choke operator to maintain the desired BHP.

Significant modifications in blowout preventer equipment and control procedures are required when drilling in deepwater from floating vessels. This new environment presents many additional well-control problems. First, there is a substantial reduction in the maximum mud

density which can be sustained by the open hole without hydrofracture. With casing set at 3,500 feet into the bottom sediments, the maximum mud density that can be used decreases from about 13.9 lb/gal on shore to about 10.7 lb/gal in 1,500 feet of water, and to only about 9.8 lb/gal in 13,000 feet of water. Next, the wellhead and BOP stack have to be located on the seafloor and must be connected to the surface well-control equipment by means of long vertical flow lines. Designed for high-pressure service, these subsea flow lines have small internal diameters, usually 2 1/2 to 3 1/2 inches, thus resulting in frictional pressure gradients in the range of 50 to 60 psi/1,000 ft and limiting mud flow rates of 200 gal/min. The combination of large frictional pressure losses in the subsea choke line and low fracture resistance of the borehole seriously reduces the tolerance for error by the choke operator when commencing to circulate a kick from a shut-in well.

As kick circulation proceeds, the operator is soon confronted with two more problems. In addition to the pressure developed across the surface choke and the flow friction in the subsea choke line, it is the hydrostatic pressure of the long mud column in this same line which makes the largest contribution to the total back-pressure imposed on the well below the closed BOP's. When circulating out of a gas kick, this hydrostatic pressure will rapidly decrease when the gas reaches the seafloor, exits from the large casing annulus, and proceeds up the small subsea choke line. Coupled with a simultaneous loss of mud-flow frictional pressure in the line, the back pressure at the BOP's will be drastically reduced unless there is a corresponding increase in surface choke pressure to offset these losses. Because rapid changes in choke pressure are required, proper choke operation becomes much more difficult during this critical period. Slow response by the operator will result in a temporary pressure loss in BHP and the influx of a second kick into the well.

The reverse situation awaits the operator once the gas kick has been circulated to the surface. When the choke line begins to refill mud, the additional hydrostatic pressure of the rising mud column adds to the pressure at the wellhead. Then the operator must be prepared to reduce

the pressure across the choke if he hopes to maintain BHP. Failure to react quickly to this new situation will result in excess pressure at the wellhead to be followed by hydrofracture of the borehole.

Until recently, anticipated well-control problems for deepwater operations could only be studied using computer simulations to predict the pressure response of the well to various control procedures being evaluated. Reliable simulations, however, require both an accurate mathematical description of fluid flow behavior in the well and a detailed knowledge of equipment response time. Thus, it is quite difficult to accurately model the flow behavior of mixtures of formation gas and drilling fluid in the complex geometry of a subsea well system.

In July of 1981, a new \$2-million well-control research and training facility at Louisiana State University (LSU) became operational. Initial design and site preparation was begun in 1978 as part of a research contract with the Minerals Management Service. This research facility includes a 6,100-ft-deep well and subsurface equipment to provide essentially full-scale modeling of the flow geometry present for afloat drilling in 3,000 feet of water. Associated surface equipment includes: (1) a choke manifold containing four 15,000 psi adjustable chokes of various manufactures, (2) a high capacity mud-gas separator, (3) two mud tanks having a combined capacity of 550 bbl, (4) three mud degassers of varying designs, (5) a mud mixing system, (6) a 250-hp triplex pump, (7) a control and instrumentation building, and (8) an adjacent classroom building. To simulate a well kick nitrogen gas is injected into the bottom of the simulated drill string.

Special problems being studied with this new research facility include: (1) alternative methods to measure choke line friction, (2) improved procedures for initiating circulation of kick fluids from the well, (3) better methods to control the rapid loss of hydrostatic pressure which occurs when a gas kick is circulated into the subsea flow line, and (4) the pressure drop-flow rate characteristics of mud through various adjustable chokes. Research is also in progress to determine the pressure losses associated with two-phase flow of gas-mud mixtures in vertical



choke lines and drilling chokes. An ultimate goal of these studies is the development of more accurate algorithms for use in computer simulations of the complete well-control operation.

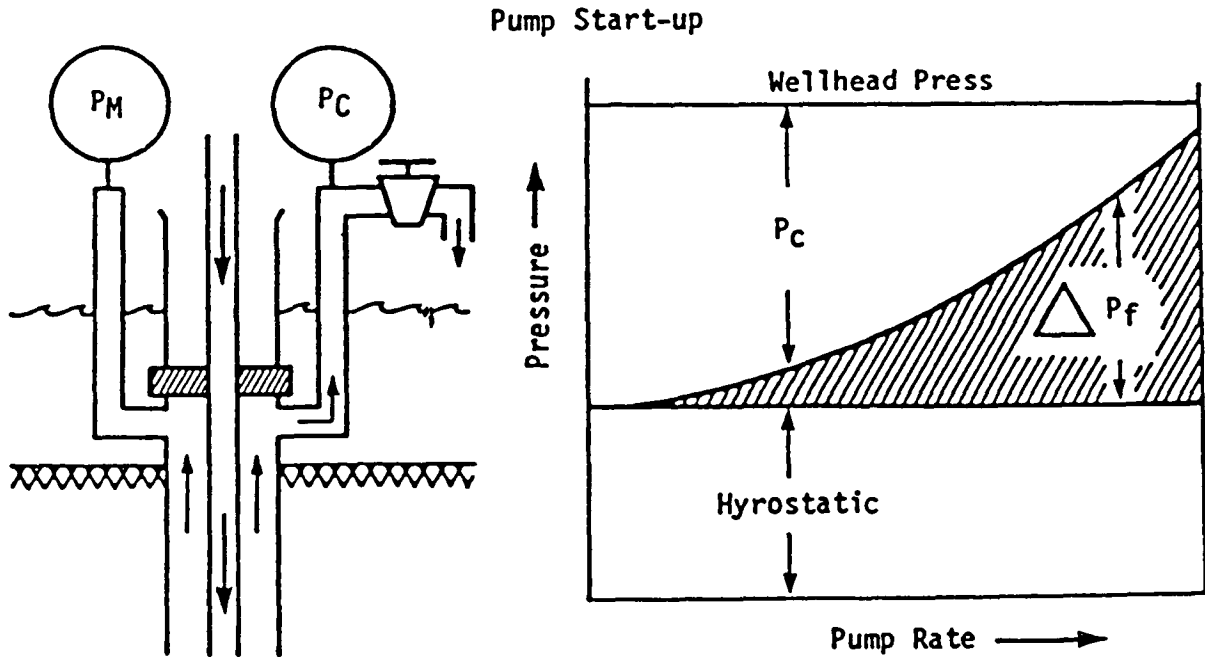

Figure 15. Pump start-up techniques with choke line friction.

Some interesting results have already been realized using this new well facility. For example, the seemingly simple task of opening the choke on a shut-in well when starting to circulate a kick to the surface can present a difficult control problem. Figure 14 is a conceptual diagram for this procedure. To maintain constant wellhead pressure (and therefore constant BHP), the pressure across the choke,  $P_c$ , must be decreased in consonance with an increase in circulation rate to offset the increase in choke line friction pressure,  $P_f$ . This operation requires that choke line friction be known for several intermediate pump rates prior to the well kick. As an alternative, the shut-in pressure in the other flow line,  $P_m$ , can be monitored because, if the wellhead pressure is maintained constant, the pressure on this monitor line,  $P_m$ , will similarly remain steady. A typical result observed during an actual training exercise is shown in Figure 15. Pressure excursions of the order of 200 psi above or below the target pressure are common. Excess

pressures are more serious because they may induce hydrofracture of the borehole.

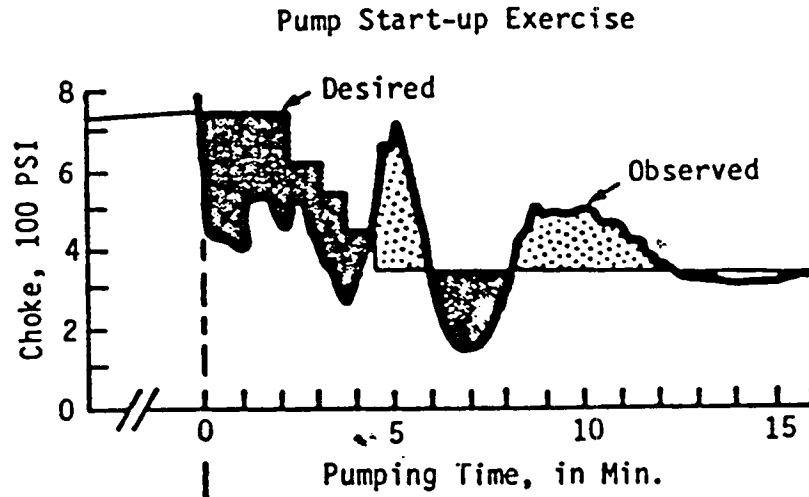

Figure 16. Typical choke pressure errors observed during pump start up.

Figure 16 shows the recorded results of a complete well-control exercise wherein a 15-bbl gas kick was circulated from the research well. Also shown for comparison are the ideal choke pressures which should be maintained as predicted from a computer system. Notice that the peak pressure observed when gas displaces mud from the subsea lines occurred sooner than computed. This disagreement is caused by gas migration through the mud. The magnitude of the pressure peak was also less than that computed because of two-phase flow of mud and gas in the choke line rather than complete displacement of mud by gas. In addition to these discrepancies, the choke operator experiences difficulty in maintaining a constant BHP after the gas kick reached the subsea flowline. Experience shows that many individuals require considerable practice to maintain relatively constant BHP during the period when a gas kick is being circulated through the choke line. Maximum difficulty seems to occur as the trailing end of the kick is being displaced up the line.

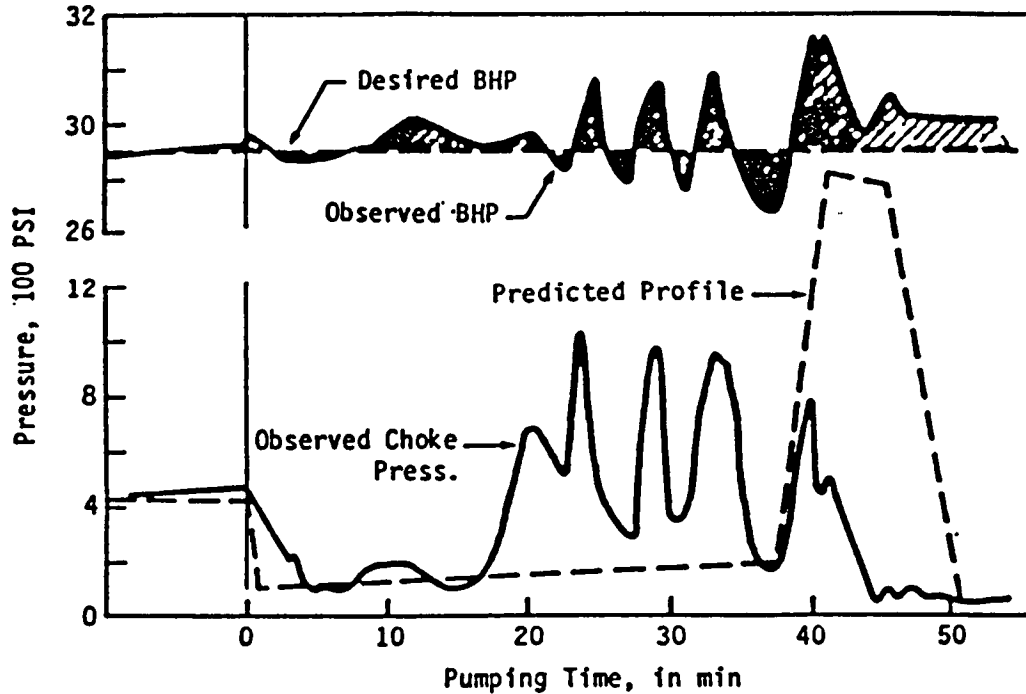

Figure 17. Observed and predicted pressure profiles while circulating a 15 bbl gas kick from the well.

Experimental results obtained from flow tests in one particular drilling choke are shown in figure 17. In addition to water, three unweighted clay-water muds having varying viscosities and two weighted clay-water muds were used. The effective frictional area term is a pseudo area. If this term is used as an orifice area and if upstream velocity is neglected, Bernoulli's equation for frictionless liquid flow will yield a predicted pressure drop equal to that measured. Indications are that frictional area is relatively insensitive to viscosity for common drilling muds. For computer simulation, a single curve of frictional area versus choke setting is considered adequate. This curve probably would shift to the left as choke elements erode. At flow rates normally used in kick control, a small choke opening is required to impose a prescribed pressure on the well. Hence, this pressure is quite sensitive to incremental choke adjustments. Conversely, when it is necessary to pass entrained cuttings in the mud, which otherwise could cause plugging, a choke must provide a large flow area when wide open.

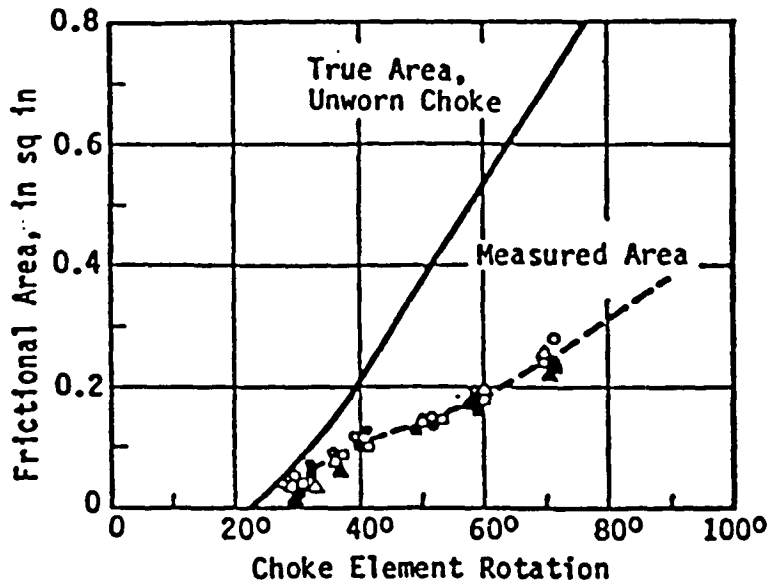

Figure 18. Effective frictional area for a 1.75-in. Swaco drilling choke.

Preliminary studies of two-phase flow of gas-mud mixtures in vertical choke lines indicate that previous correlations developed for mixtures of gas and Newtonian liquids (water and/or oil) can be modified for use with non-Newtonian drilling muds. Figure 18 compares total pressure changes observed in a 3,000-foot vertical length of 2 3/8-inch tubing and those predicted by one popular correlation (Journal of Petroleum Technology, 1965). In all cases predicted pressure changes were within  $\pm 10\%$  of those measured in the well. These studies were limited to flow rates in the range of 0.76 to 2.50 bbl/min, gas-liquid ratios of 260 to 850 SCF/bbl, and unweighted clay-water muds whose densities ranged from 8.6 to 8.8 lb/gal. Additional studies will include weighted drilling muds as well as flow in vertical annular geometries and drilling chokes.

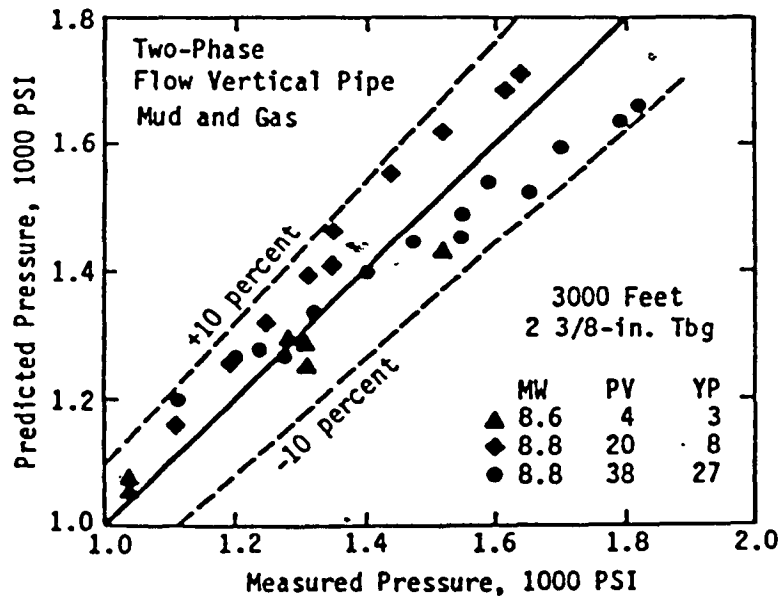

Figure 19. Predicted and measured pressure changes in a vertical choke line flowing gas and mud.

Three new avenues of investigation are in progress. The first involves a proposed automatic system capable of maintaining BHP nearly constant during all phases of well-kick control. The system would assist the choke operator especially during the critical periods of pump start-up and later when a gas kick has been circulated to the subsea BOP stack. Recent advances in measurements while drilling (MWD) technology make it practical to monitor BHP while drilling and to relay this information to the surface by means of mud-pulse telemetry. An automatic choke-control system designed to maintain a preset value of drill pipe (or pump) pressure is already in use at the well, and BHP is monitored by means of a water-filled capillary line which extends to the bottom.

One important limitation of present MWD technology is the speed at which pulse-coded data can be transmitted up the mud column to the surface. The resulting time lag between a change in BHP and when this information is processed by the choke controller could be a significant factor in the development of an automatic control system. It may prove necessary to control the response time and step size of an incremental choke adjustment in keeping with the rate of change in BHP. Some type of microprocessor control would then be required.

A second complication to be studied is the effect of small secondary gas kicks which accompany every excursion of the BHP below that required to balance formation pressure. Because no control system is perfect, the size and frequency of these secondary kicks must be determined in order to define acceptable performance criteria for both the manual and automatic choke control. Some modifications of the existing facility will be required, primarily the installation of about 100 cu ft of 6,000 psi nitrogen gas storage adjacent to the well.

Finally, upon the installation of a recently acquired gas-measurement system, it will be possible to record the volume rate of gas injection and gas return from the well. This will provide a time-resolved record of the changing distribution of gas and mud in the well during the pump-out of a kick. Such information will facilitate mathematical description of the two-phase flow in the annulus and choke line, and thus the information will enhance the development of more accurate algorithms for use in computer simulations of well-control operations.

## REFERENCES AND REPORTS

- Doyle, R. S., 1981, Pressure drop-flow rate characteristics of a spherical type blowout preventer during closure: M.S. Thesis, Department of Petroleum Engineering, LSU, August.
- Elfaghi, F. A., 1982, Pressure losses in subsea choke lines during well-control operations: M.S. Thesis, Department of Petroleum Engineering, LSU, May.

- Holden, W. R., and Bourgoyne, A. T., Jr., 1982, An experimental study of well-control procedures for deep water drilling operations: Offshore Technology Conference, Proceedings, Houston, Tex., Paper No. 4353, May.
- Journal of Petroleum Technology, 1965, Experimental study of pressure gradients occurring during continuous two phase flow in small diameter vertical conduits, April, p. 475.
- Mathews, J. L., 1980, Upward migration of gas kick in a shut-in well: M.S. Thesis, Department of Petroleum Engineering, LSU, May.
- Redmann, K. P., Jr., 1982, Flow characteristics of commercially available drilling chokes used in well-control operations: M.S. Thesis, Department of Petroleum Engineering, LSU, May.
- Surcouf, R.M., Jr., 1981, An examination of blowout prevention equipment and procedures used on floating vessels: M.S. Thesis, Department of Petroleum Engineering, LSU, December.

## **SURFACE & SUBSURFACE COLLECTION OF OIL FROM BLOWING WELLS**

Mr. Jerome H. Milgram  
Massachusetts Institute of Technology

### **SURFACE OIL COLLECTION**

During the period 1970-74, there was considerable optimism about developing a technology for physically removing floating oil from the sea in the vicinity of a polluting accident. The most comprehensive initial development of the technology was sponsored by the United States Coast Guard. I participated in that development and tested an oil boom holding approximately 24,000 gallons of oil with hardly any leakage of oil past the boom. In order to learn the speed limits for holding oil in booms, the

ships towing the boom increased their speed to the point where some oil was lost. Then, a barge and skimmer system was deployed (Figure 20), and 18,000 gallons of oil were recovered. Subsequent tests by the Coast Guard showed that in rough seas, oil loss at rates of a few gallons a minute was unavoidable. However, large leakage rates did not occur if the relative water speed were low enough, if the boom had a certain minimum draft, and if the boom were able to follow the wave motions. The typical maximum relative flow speed was found to be about 1.0 knot.

During the past ten years, most attempts to physically remove large quantities of oil pollution from the sea have failed. The reasons are worth exploring because in the early days of the technology development, the United States Coast Guard showed that recovery of oil from sea was possible. Some of the reasons follow:

1. Usually the funds available for oil recovery operations are far less than what is actually needed to do the job properly.

2. Adequate preparedness requires all the resources to be available on short notice. These resources include booms, skimmers, trained personnel, and ships and boats with the required capabilities, including oil storage. If any one of these elements is absent, the operation is doomed to failure. It should be noted that there have been many instances where failure was guaranteed by lack of adequate on-scene oil storage.

3. If the accident releases all the oil almost at once, the oil can be spread out over a large surface area. When recovery operations are not started very rapidly, the effort and cost involved in collecting the oil become enormous, and grossly exceed total costs of recovering oil at a concentrated source.

In general, the national level of preparedness for collecting oil pollution from the sea is so inadequate that nothing useful can be done. If such oil gets on the shore, partial clean-up of the shoreline is possible. Becoming prepared for large class accidents would be far more



costly than any foreseeable resources. In addition to the cost of thoroughly training personnel, providing adequate ships and storage facilities for the collected oil presents an extremely difficult, costly task. It should be born in mind that the lack of storage facilities for recovered oil has been the major impediment to almost all attempts to recover oil pollution from the sea.

As opposed to the difficulties in preparing to deal with oceanic oil pollution in general, preparations for surface oil collection near a subsea well blowout are more straightforward. The oil is not released all at once, so most of the oil comes from a concentrated source after cleanup systems have arrived. The difficulties related to equipment coordination, personnel training, and oil storage can be minimized in the blowout scenario if all operations are conducted from a single ship which stores the recovered oil in its own tanks. Thus, for moderate to large blowouts, the ship must be a fairly large tanker. Figure 20 portrays a system which can very effectively collect much of the oil at at blowout. By adapting available oil pollution collection technology to a tanker, a system as sketched in Figure 21 can collect, under ideal conditions, the quantity of oil normally emitted from a large blowout. Naturally, most actual scenarios will degrade performance, but a properly operating system of this type can still be expected to collect much of the oil. Smaller systems of this type, with the important difference that the outboard ends of the booms are towed by outriggers from the vessel, now exist and are used successfully for collecting smaller quantities of oil.

All the needed elements of the technology exist. These include skimming boom systems, pumping systems, low speed thrusters for the tanker that control it at the low speeds required for booms to operate effectively, remotely controlled propulsion units for the outer ends of the booms, systems for deploying the boom and the skimmer systems, and air bubble and water jet systems to keep oil out of the area between the inner end of a boom and a tanker. Developing the detailed engineering needed to assemble the various elements of the technology is a considerable task. The Minerals Management Service (MMS) has entered a contract for the first portion of this engineering development.

## SUBSURFACE OIL COLLECTION

The idea of collecting oil above blowing wellheads has existed for along time. However, the first and only attempt at collection was in 1979 at the IXTOC blowout in Campeche Bay. Only a small fraction of the blowout oil was collected in that effort. Beginning in 1979, MMS sponsored a comprehensive research program which has shown how to make such a subsea collection system operate effectively and collect most of the blowout oil.

Measurements made on the system installed in Campeche Bay set the stage for the research program. In addition to revealing the salient technical phenomena involved, many of the practical aspects of the operation of the system became evident as well. The next portion of the research program was a laboratory scale study of subsurface collection systems. The laboratory apparatus was sized at about 1/20 of the full scale. This work aimed to determine the fundamental dimensionless parameters that influenced collection efficiency and the actual relationship between these parameters and the fraction of blowout oil that the system could collect. In Figure 22, a summary graph shows how the percentage of blowout oil collected can be predicted in terms of liquid collection rate, gas collection rate, and the height between the blowing wellhead and the collector. The reader should note that very large collection fractions are achievable for sufficiently large liquid flow rates (oil plus water) in the system and for sufficiently small distances between the collector entrance and the wellhead. Initially, it was surprising to learn that the diameter of the collector hardly influenced the fraction collected; but now we know why this is so.

As Figure 22 shows, collection efficiency is poor under a number of conditions, and in fact, the Froude number and phase ratio for the IXTOC installation corresponded to one of these. Studying the fluid mechanics inside the collector showed that improved results could be obtained during otherwise inefficient conditions by installing one collector inside another and connecting a riser to each of them (Figure-22).

Since such favorable results were obtained in the laboratory scale studies, a 1/4 scale experiment was conducted in a sinkhole spring with a water depth of about 175 feet. The results were similar to, but not exactly the same as, those shown in Figure 22. The combination of the smaller and larger scale experiments revealed two scale-dependent effects. By including these effects in the relationship between the salient independent dimensionless parameters and the fraction of oil collected, the most accurate prediction of collection efficiency could be made. Figure 24 shows this final relationship, which is accurate at both small and large scales because the scale dependent effects are included.

Now the research work on the collection systems is completed, and it is appropriate to develop engineering designs suitable for implementing actual systems. The installation at IXTOC was based on jacket structures which had to be installed before a collection system could be deployed. Naturally, it is better to begin oil collection above a blowing wellhead more quickly than is possible with a system that requires the installation of jackets. To this end, the Minerals Management Service is now sponsoring the development of an engineering design based on a ship-mounted system as sketched in Figure 25.

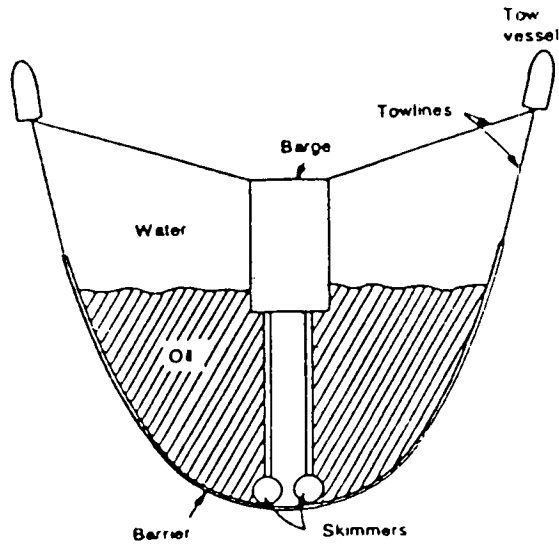

Figure 20. The skimming arrangement used to collect the oil.

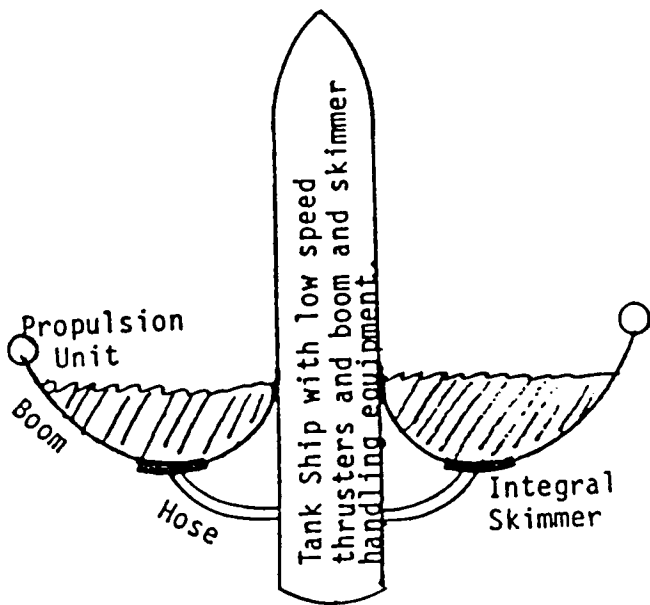

Figure 21. The integral boom-skimmer-ship system for large volume oil collection.

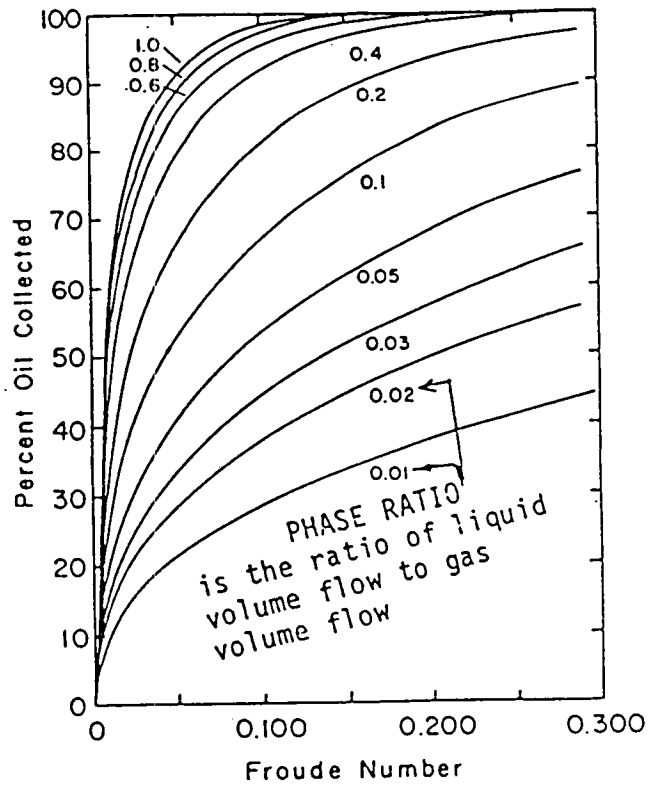

Figure 22. The performance of laboratory scale subsurface collectors.

$$\text{Froude number} = \sqrt{\frac{\text{liquid volume flow}}{g H^5}}$$

$g$  = gravitational acceleration

$H$  = distance from wellhead to collector

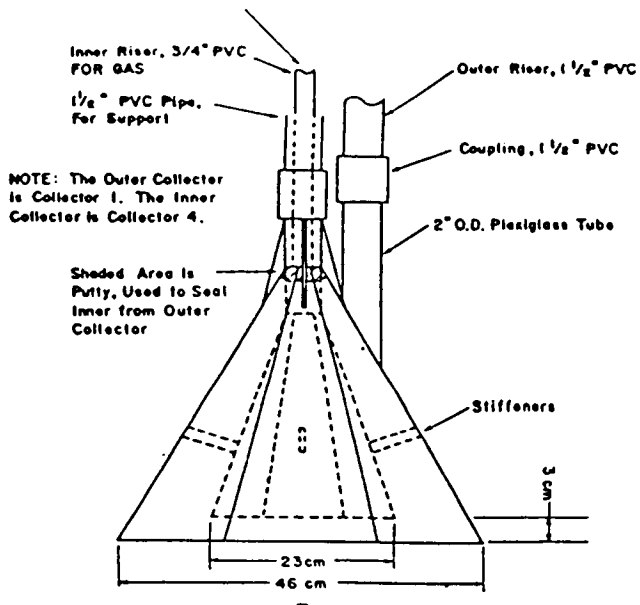

Figure 23. A double collector which increases efficiency at non-optimum conditions.

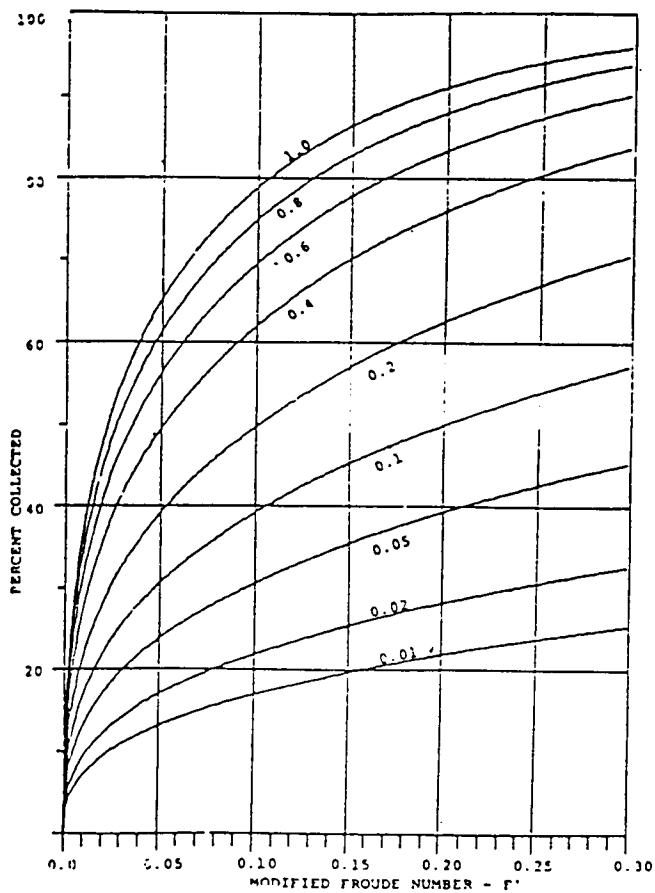

Figure 24. Subsurface collector performance including scale effects.

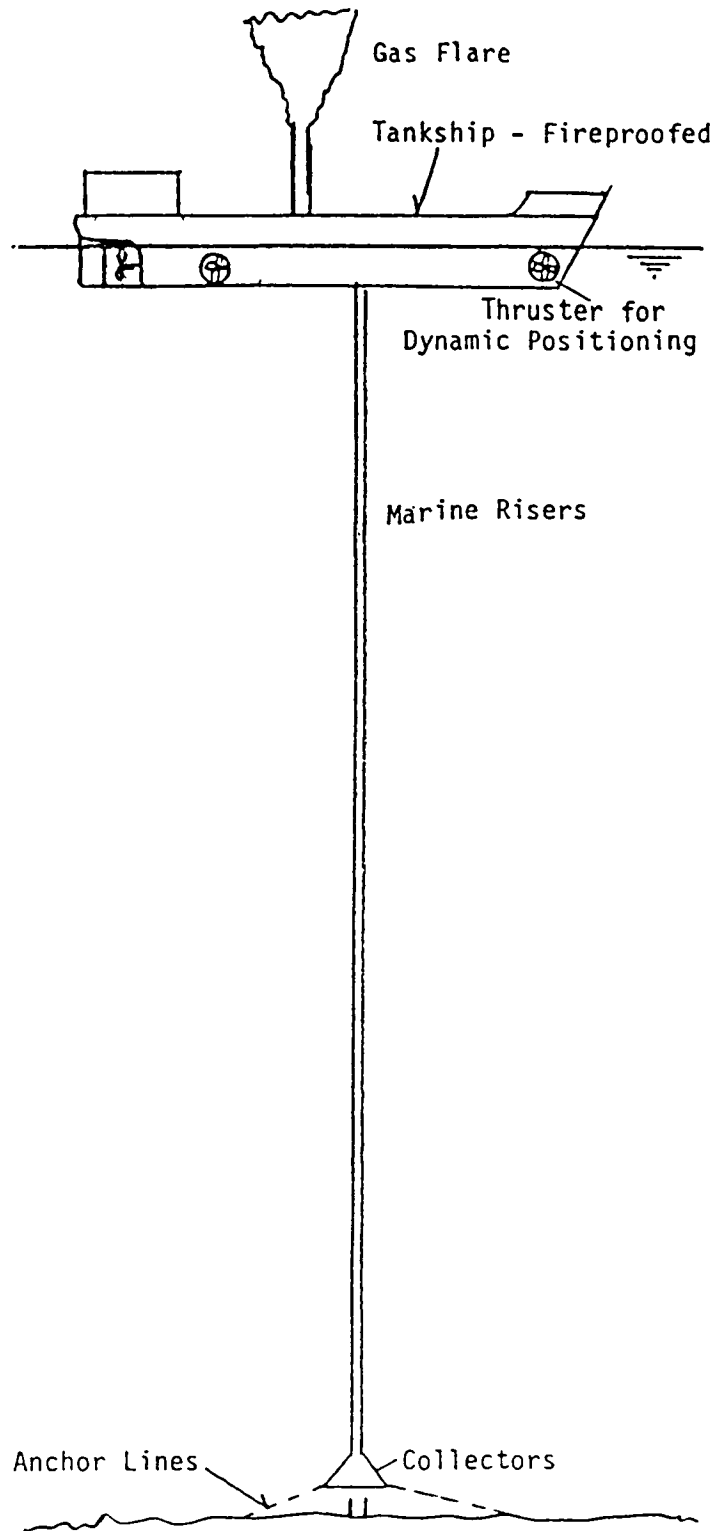

Figure 25. Sketch of ship-mounted subsurface collection system.

# DYNAMIC RESPONSE OF DEEPWATER STRUCTURES TO OCEAN WAVES AND CURRENTS

Prof. J. Kim Vandiver  
Massachusetts Institute of Oceanography

## PROJECT HISTORY

This research project is the latest in a series begun in 1977 with the sponsorship of this program when it was part of the U.S.G.S. At the time, the Cognac deepwater platform project was focussing attention on the problem of fatigue due to dynamic response. For such structures, the longest natural periods in flexure were for the first time exceeding three seconds, and dynamically amplified response to wave excitation was becoming a significant factor in limiting the fatigue life of a structure. Modal damping was recognized as a key issue, and the commonly accepted notion that damping was approximately 5% was recognized as being grossly overestimated.

This project began with an initial emphasis on the measurement and prediction of damping on fixed offshore structures. This began a series of projects which focussed on a variety of subjects, including: damping measurement, response prediction, fatigue life prediction, digital signal processing techniques for evaluation of dynamic response, and numerical simulation of wave forces. The highlights and principal contributions are summarized below, supported by many references provided for additional source material.

The research has had a number of common characteristics which have given it a consistent style and unifying theme over the years: (i) These projects have all had a common purpose: to provide the designer of offshore production and exploration systems with better analytical and numerical tools and better insight in the prediction of dynamic response of structures to wave and current loading. (ii) These projects have all

been conducted by M.I.T. graduate students under the supervision of Prof. J. Kim Vandiver. Many of these students now work in the offshore industry. (iii) These projects have been carefully integrated with research projects sponsored by the U.S. Navy and by numerous companies participating in joint industry sponsored projects. (iv) A broadbased approach to the research has been emphasized. As a result the research has often begun with field measurement programs, progressed to the development of new data reduction and analysis tools, and culminated in the development of new response prediction and fatigue life estimation methods.

### **ACCOMPLISHMENTS AND SIGNIFICANT FINDINGS**

1. Development of single and multiple channel Maximum Entropy Spectral Analysis Techniques for the identification of natural frequencies, damping ratios, and mode shapes from dynamic response data (1, 2, 3, 4).
2. The publication of a mathematical foundation of a widely known empirically developed vibration signature analysis technique known as the "Random Decrement Method" (5).
3. The development of a method for predicting the damping controlled response of a structure at a natural frequency to linear random wave forces. The work revealed the essential role that wave radiation damping occupies in the response prediction problem (6).
4. The response prediction theory mentioned above led to the development of a model testing technique in which wave forces are measured directly on a model held fixed in place. The method was demonstrated on an industry-provided model of a tension leg platform. Such model tests were shown to provide a means of calculating wave radiation damping, as well as account for the effects of wave spreading on dynamic response (7).
5. The linear response prediction method discussed above was extended

to include non-linear drag force excitation. The results include the first frequency domain prediction of the response spectrum of an offshore structure to random waves, including non-linear drag exciting forces (8). A valuable by-product of the solution is a method for the calculation of viscous hydrodynamic damping. This source of damping was shown to increase with sea state, often resulting in lower structural response in higher sea states. This phenomenon was demonstrated in a model test and has been observed on full scale caisson structures at sea.

6. A unique full scale experiment was conducted on a single well caisson structure located in the Gulf of Mexico. Wind wave and response data were collected. Measured response at the 3.1 second flexural natural period was compared to predicted values with excellent agreement. A thorough evaluation of the various sources of damping was conducted (9).
7. The response prediction models described above were applied to the prediction of fatigue life. In particular, the sensitivity of fatigue life calculations to errors in the estimation of structural natural periods, damping ratios and wave spreading were developed (10).
8. Field experiments were conducted on a total of nine fixed offshore platforms. A method was developed to account for the influence of large liquid storage tanks on dynamic response. This theoretical work led to the issuance of a patent on the use of liquid storage tanks as response suppression devices for offshore structures (11).
9. Most of the above work pertains to response of structures to waves. However, current poses a problem for long cylinders such as marine risers, pipelines, and cables due to a phenomenon known as vortex shedding. The resulting flow induced vibration is a significant problem for deepwater exploration and production systems in high current areas. In a series of projects beginning in 1975 and continuing to the present, U.S. Navy, industry, and MMS



sponsorship has led to significant advances in understanding of the vibration of long cylinders in response to flow. Seven field experiments have been conducted. Unique drag coefficient data have been published (12). Present MMS sponsored research is focussing on the development of response prediction techniques for marine risers in sheared flow.

## CURRENT RESEARCH EMPHASIS

The current work emphasizes the development of new methods for structural dynamic response prediction to waves and current. The wave response work emphasizes the development of numerically efficient wave kinematics simulation techniques intended to replace the cumbersome sum of sinusoids techniques. The flow induced vibration work emphasizes numerical response simulation tools and the advancement of the understanding of response in sheared flow. In the next few months two papers will be published describing the most recent experimental and theoretical results.

## REFERENCES

1. Campbell, R.B., and Vandiver, J.K., "The Determination of Modal Damping Ratios from Maximum Entropy Spectral Estimates," Jour. of Dynamic Systems, Measurement, and Control, Vol. 104, March 1982.
2. Briggs, M.J., "Multichannel Maximum Entropy Method of Spectral Analysis Applied to Offshore Structures," OE Thesis, Massachusetts Institute of Technology/Woods Hole Oceanographic Institution Joint Program in Ocean Engineering, 1981.
3. Briggs, M.J., Vandiver, J.K., "Multichannel Maximum Entropy Method of Spectral Analysis Applied to Offshore Platforms," Proceedings of the 1982 Offshore Technology Conference, Paper No. 4286, Houston, May 1982.

4. Lu, X., and Vandiver, J.K., "Damping and Natural Frequency Estimation Using the Least Pth Optimization Technique," Proceedings of the 1982 Offshore Technology Conference, Paper No. 4283, Houston, May 1982.
5. Vandiver, J.K., Dunwoody, A.B., Campbell, R.B., and Cook, M.F., "A Mathematical Basis for the Random Decrement Vibration Signature Analysis Technique," Journal of Mechanical Design, Vol. 104, Number 2, April 1982.
6. Vandiver, J.K., "Prediction of the Damping Controlled Response of Offshore Structures to Random Wave Excitation," Society of Petroleum Engineers Journal, February 1980.
7. Vandiver, J.K., "Direct Wave Force Measurements on a Model Tension Leg Platform," Ocean Science and Engineering, Vol. 7, November 3, 1982.
8. Dunwoody, A.B., and Vandiver, J.K., "The Influence of Separated Flow on the Dynamic Response of Offshore Structures to Random Waves," Proceedings of the Hydrodynamics in Ocean Engineering Conference, Trondheim, Norway, August 1981.
9. Cook, M.F., and Vandiver, J.K., "Measured and Predicted Dynamic Response of a Single Pile Platform to Random Wave Excitation," Proceedings of the 1982 Offshore Technology Conference, Paper No. 4285, Houston, May 1982.
10. Vandiver, J.K., "The Sensitivity of Fatigue Life Estimates to Variations in Structural Natural Periods, Modal Damping Ratios, and Directional Spreading of the Seas," Proceedings of the Third International Conference on the Behavior of Offshore Structures, M.I.T., 1982.
11. Vandiver, J.K. and Mitome, S., "The Effect of Liquid Storage Tanks on the Dynamic Response to Offshore Platforms," Journal of Petroleum Technology, Oct. 1979.

12. Vandiver, J.K., "Drag Coefficients of Long Flexible Cylinders," Proceedings of the 1983 Offshore Technology Conference, Paper No. 4490, Houston, May 1983.

## FOUNDATIONS FOR TENSION-LEG PLATFORMS

Hudson Matlock

Vice-President for Research and Development

The Earth Technology Corporation

The work described is currently nearing completion. All experiments have been successfully performed and data analysis and interpretation of the results are under way. The research is sponsored by Conoco Oil Company through Conoco Norway Research, with participation from Chevron Corporation, the American Bureau of Shipping, and the Mineral Management Service of the U.S. Department of Interior through its Technology Assessment and Research Program. Laboratory model tests and analyses were performed by what is now Veritec, Inc., a subsidiary of det Norske Veritas. The Earth Technology Corporation is conducting the program in the United States working as a designated subcontractor to Veritec. Observers and advisors have come from The Norwegian Technical Institute and the Norwegian Technical University at Trondheim.

During the past decade, the search for oil has been pushed into what are termed frontier areas, wherein very difficult technological challenges must be met. One of these areas showing considerable promise lies on our doorstep in the deeper waters offshore Louisiana.

Present emphasis in the Gulf of Mexico is in the range of depths from 1500 to 2000 feet, but greater depths are also being considered. The limit for bottom-founded fixed structures is thought to be about

1500 feet. Beyond 1000 feet, a structure such as a guyed tower or a tension-leg platform (TLP) offers the important advantages of compliance in accommodating wave and wind effects.

Both of these types impose new and untried regimes of loading on foundation systems. The guyed tower applies a large downward load on a group of very large piles, but it also imposes severe up-and-down motions on the pile heads as the tower tilts. The TLP is a floating structure that is held below its free floating position by its vertical anchoring tendons and thereby imposes a large static bias tension on the anchor piles. To this tension is added random variation due to wave action. A lateral component of force on the piles arises from the lateral displacement of the platform.

Both safety and economics require a high degree of reliability in the foundation system. The amount of direct experimental evidence on axial pile capacity is extremely limited, even for conventional jacket-type platforms. Thus an extensive research program was begun in 1981 by Conoco to establish a firm basis for design of piles for tension-leg platforms.

The immediate focus of the program was on prototype piles to be installed in very soft underconsolidated clay on the outer slopes of the Mississippi Delta in water depths greater than 1500 feet. Driven piles with diameters in the range of 7 to 9 feet were envisioned. Testing of such a pile at the actual location would be virtually impossible. An ideal substitute was found at Conoco's West Delta 58A platform which was being abandoned. The WD58A platform is located about 20 miles west of the delta southwest of Venice.

Soil conditions were very uniform and closely duplicated potential deep-water sites. The water depth was only 50 feet, which greatly facilitated the test arrangements. (Soil in shallow water would exhibit the same behavior as in deep water, the static water pressure being neutral with respect to soil strength properties.)

As a long pile is loaded and unloaded, several inches of movement may occur at the pile top owing to elastic stretching of the steel, even without any movement at the deeply embedded pile tip. In some clay soils, significant loss of resistance may develop on a surface of shear slip which is located a fraction of an inch outside the pile surface. When this happens, more load must be resisted by the soil at greater depths. If the pile is long enough, it will accommodate this adjustment and reach a stable equilibrium response under the bias tension plus wave-induced axial loading variations. If it is too short, it will progressively work its way out of the ground.

A mechanical analog of this process is shown in Figure 26, which is a direct graphical representation of the computer program DRIVE used to analyze and design such pile-soil systems for any given time-history of loading at the top of the pile. The soil response is highly nonlinear and hysteretic, and the peak shear resistance may degrade progressively in some soils. If the proper soil inputs are known, the computer can simulate the whole process and analytically test whether a trial design is adequate.

The key to the solution process is a knowledge of the soil reaction against any short segment along the pile as a function of the time-history of displacement of that segment.

Typical cyclic-loading shear-displacement response of a cylindrical segment laboratory model in soft clay is shown in Figure 27. A loss of more than 50% of the resistance is seen during large-displacement cycling.

Analysis of the segment behavior is accomplished by Program CASH which is depicted in Figure 28. It simulates (1) lateral pressure created by displacement of the soil as the pile is driven into place, (2) the subsequent outward movement of the pore water with consolidation and strengthening of the soil very close to the pile, and (3) the resulting soil shear response under imposed cyclic displacement. The local pile-soil behavior may then be used as input to Program DRIVE. It is emphasized

that these programs are only analytical tools for rational analysis. They make no judgmental choices or selections and are therefore dependent on properties input by the engineer.

As an alternative to performing full-size pile tests, the experimental program was planned as a combination of three types of tests:

- (1) Laboratory model tests using 1.0-inch pile segments in a pressure chamber filled with remolded soil from the WD58A site
- (2) Field tests in the undisturbed soil using 3-inch diameter pile segment tools installed beyond the bottom of boreholes, at different depths
- (3) Driving a 30-inch diameter fully instrumented pile and testing it by reacting against the platform framework and foundation

The model pile set up for the laboratory model tests is shown in Figure 29 a 3-inch tool is shown in Figure 30, and Figure 31 shows the 30-inch pile in place. Measurements were made on each of six segments of the large pile. The total pile length was 360 feet. In all of the experiments, the key measurements were of soil shear resistance as a function of displacement of each pile segment. To aid in interpreting these measurements, the total lateral pressures and the neutral soil pore water pressure were measured. The difference provides the effective intergranular pressure in the soil which assists in interpretation of shear strength.

Figure 32 expresses the overall philosophy of the program, in which interpretations of tests at each size is done by analytical backfitting. The analytical inputs are thus calibrated and used to estimate the behavior of the next level of test. With satisfactory correlation among the three levels of testing, covering a 30-fold spread in diameters, extrapolating by a diameter ratio of 2 or 3 to the prototype size should be possible. This extrapolation is expected to provide a rational basis for confident design of the piles used to anchor a real tension-leg platform.

## REPORTS

Matlock, H., Leake, D.F., and Audibert, J.M.E., Tension Pile Planning Study, Final Technical Report, Earth Technology Corporations, Houston, Texas, August 1981. (Proprietary study.)

Site Investigation and Soil Characterization Study at Block 58 West Delta Area Gulf of Mexico, Earth Technology Corporations, Report No. 82-200-1, April 1982. (Proprietary study.)

Plan for Performing Offshore Small-Diameter Pile Segment Tests, Earth Technology Corporations, Project No. 82-200-02, 19 August 1982. (Proprietary study.)

Final Report on Small-Diameter Pile Segment Tests, Earth Technology Corporations, Report No. 82-200-03, June 1983. (Proprietary study.)





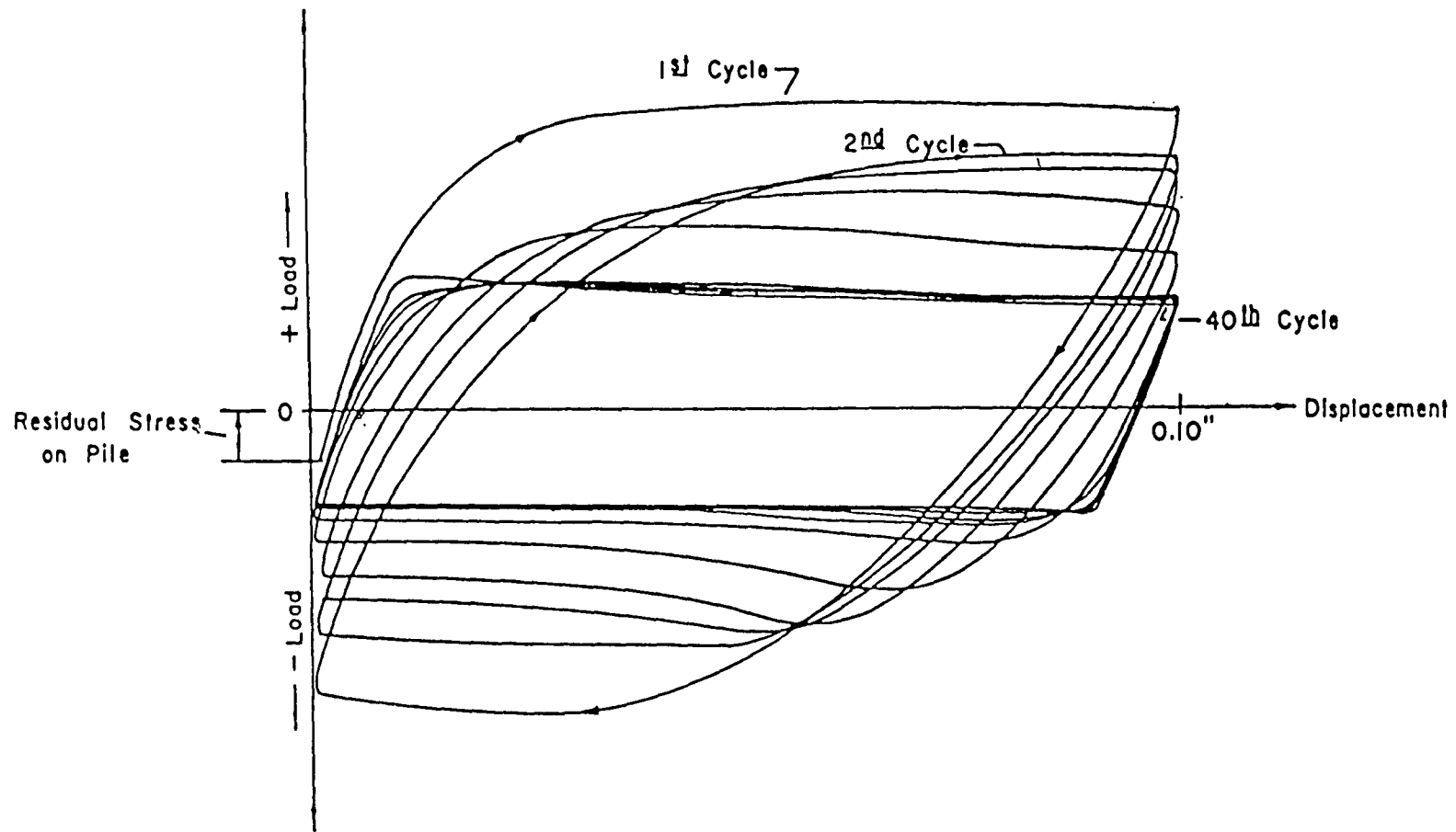

Figure 27. Typical hysteretic behavior of a model axial segment in clay.

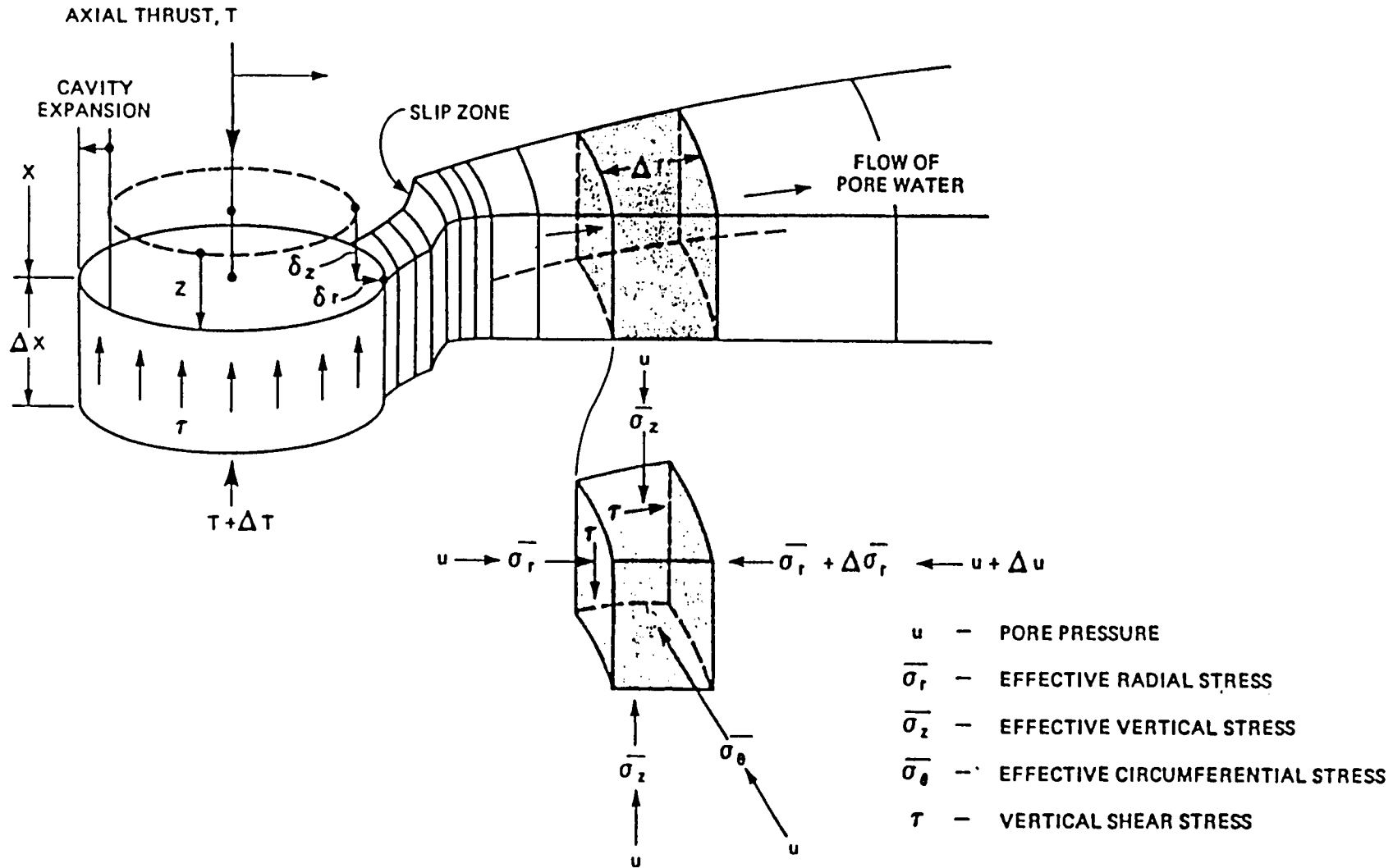

Figure 28. Single-slice model for pile installation, consolidation, and loading simulation.

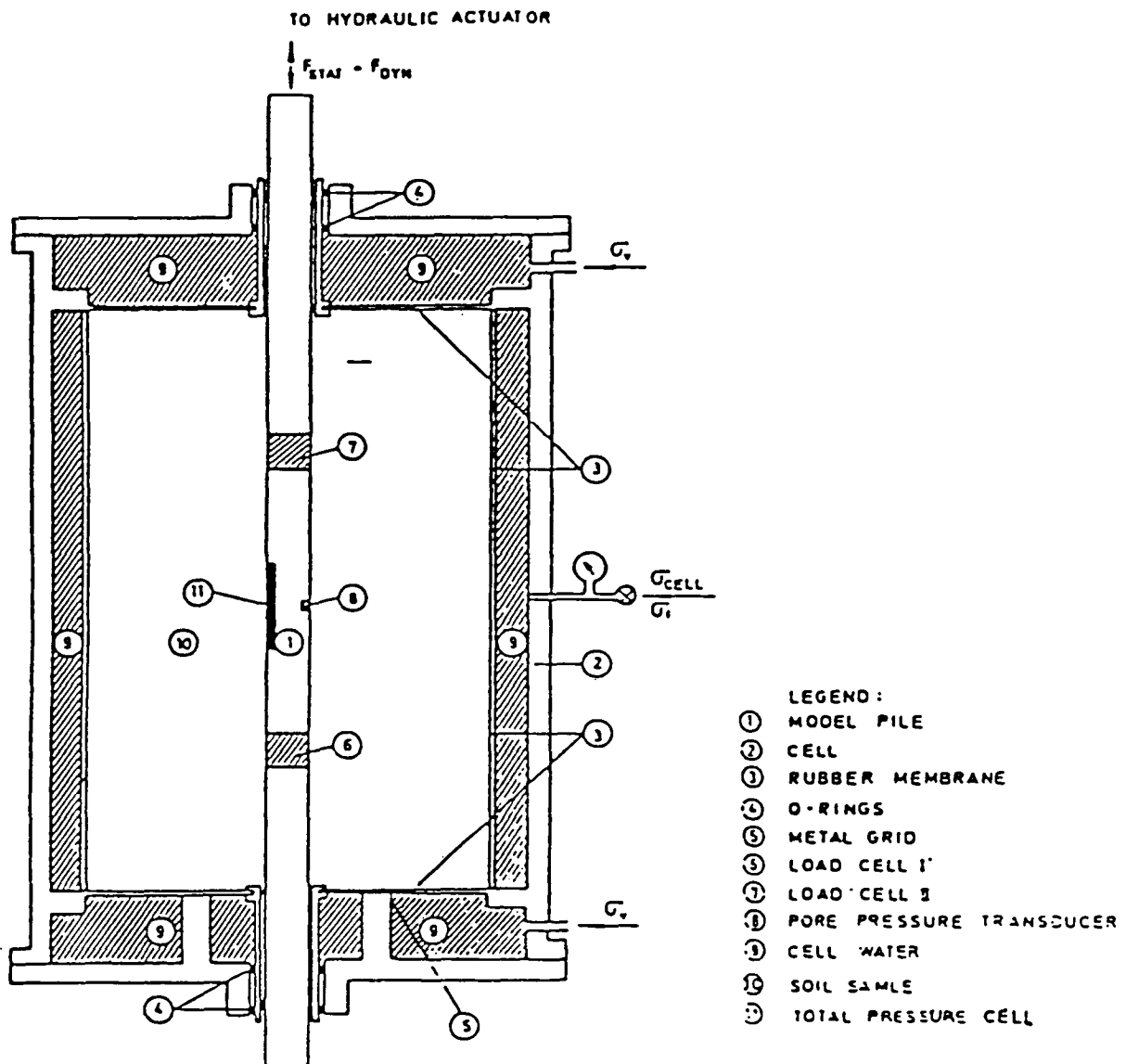

Figure 29. One-inch diameter pile test setup.

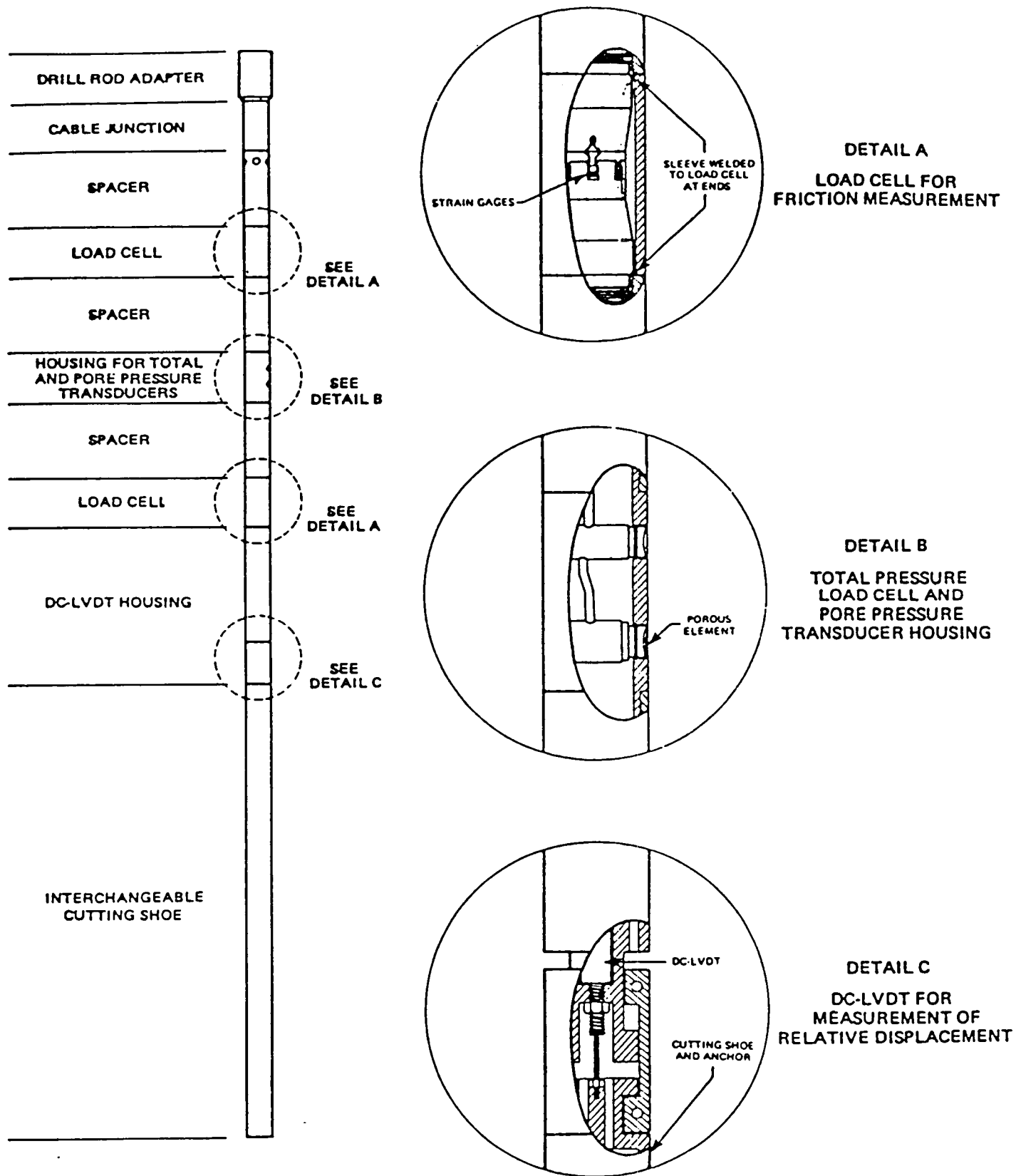

Figure 30. Three-inch diameter pile segment model.

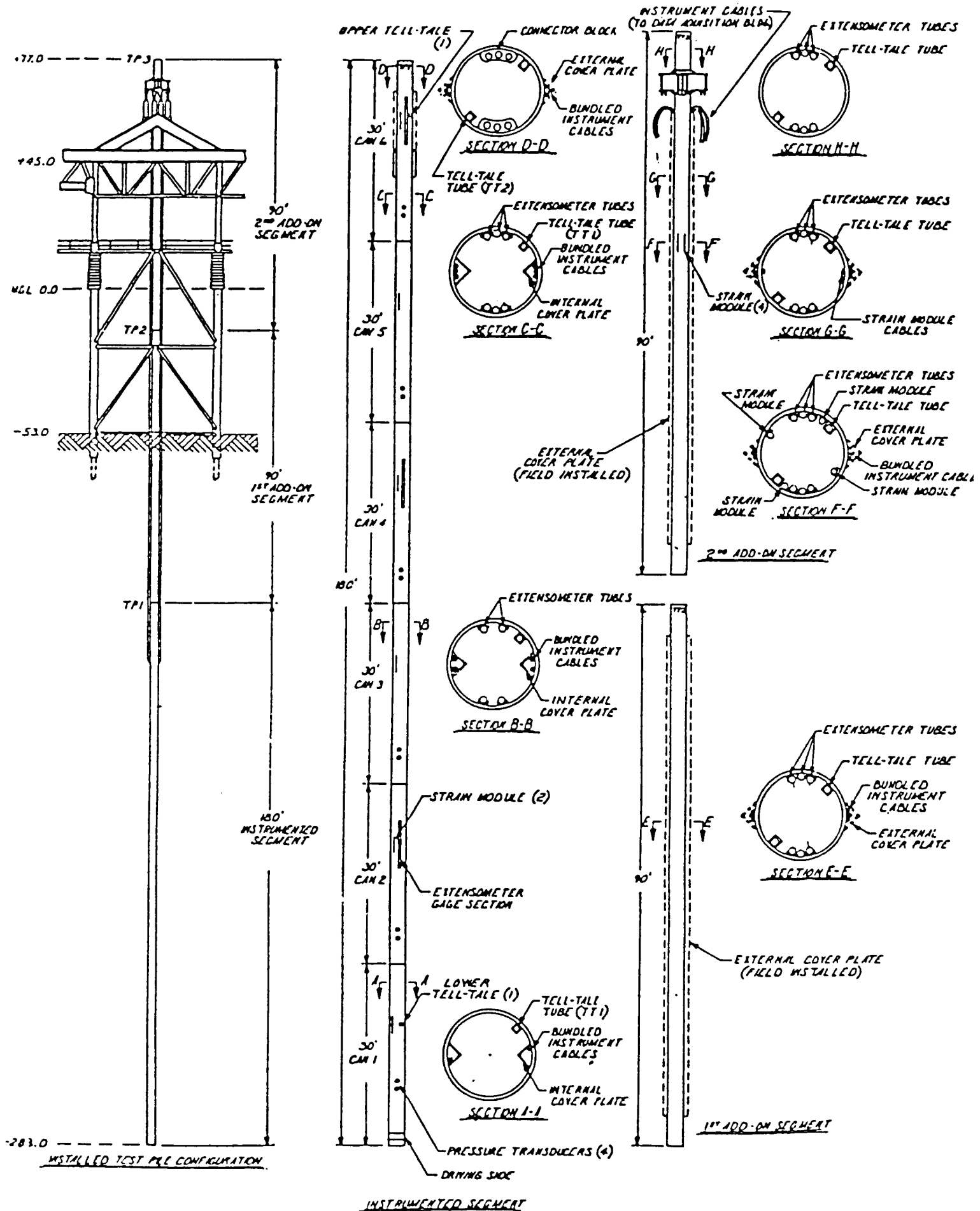
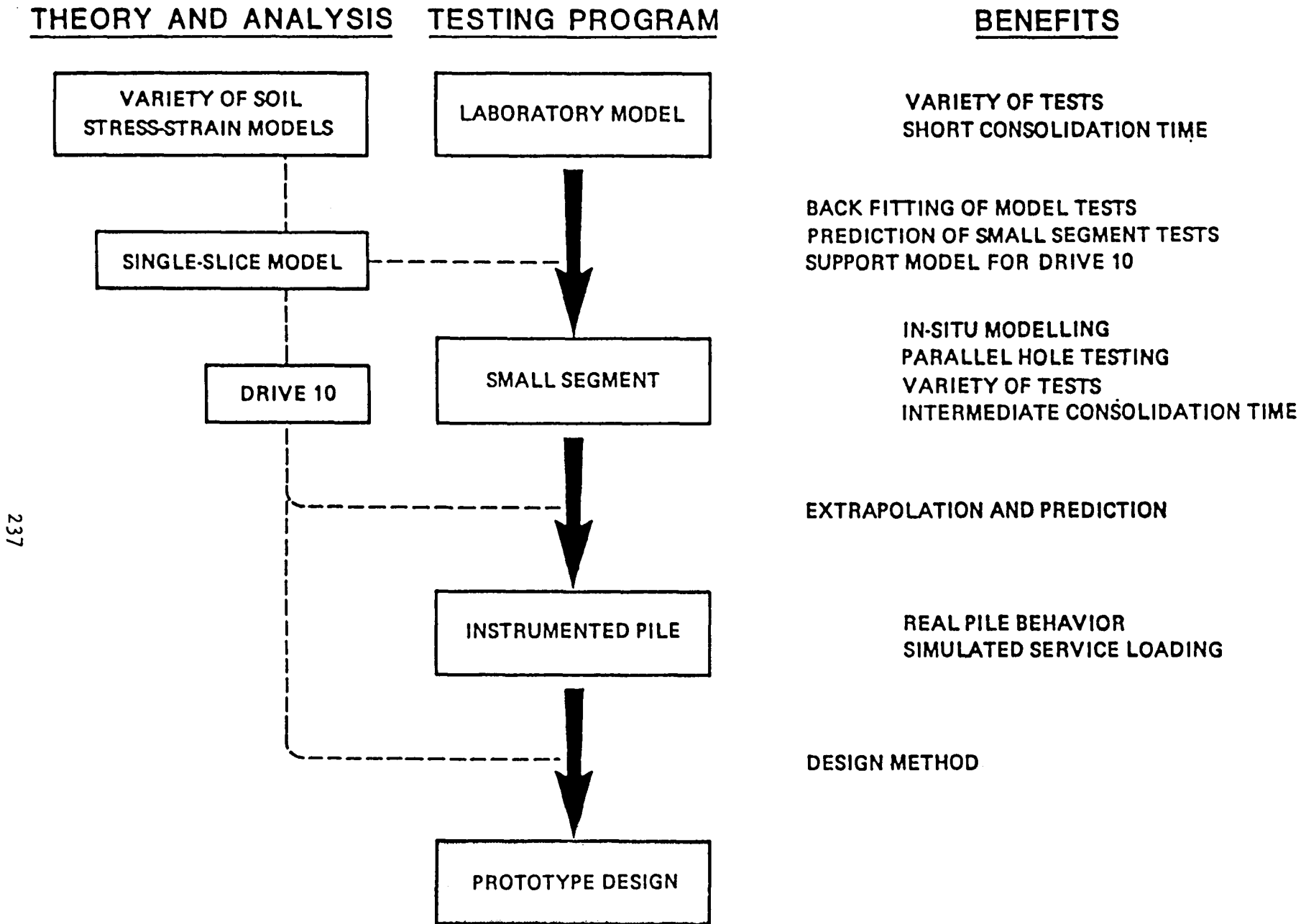

Figure 31. 30-inch diameter pile and instrumentation details.



237

Figure 32. Integration of analysis and experiments for pile design.

## SOCIOECONOMICS

Session: SOCIOECONOMICS  
Chairman: Mr. John Rodi  
Date: November 28, 1984

<u>Presentation Title</u>	<u>Speaker/Affiliation</u>
Session Overview	Mr. John Rodi MMS, Gulf of Mexico Region
PART I: RECENT STUDIES RELATING TO THE SOCIOECONOMIC IMPACTS OF OCS LEASING IN THE GULF OF MEXICO	
Future Supply of OCS Oil and Gas From the Gulf of Mexico	Dr. E. D. Attanasi U.S. Geological Survey
Outlook for Gulf of Mexico Offshore Activity	Mr. G. Allen Brooks Offshore Data Services, Inc.
The Louisiana Econometric Model and the Oil and Gas Industry	Dr. James A. Richardson Louisiana State University
The Oil and Gas Industry of Coastal Louisiana and Its Effect on Land Use and Socioeconomic Patterns	Dr. Donald W. Davis Nicholls State University
Gulf of Mexico Energy Activity and Coastal Louisiana Economic Conditions: 1981-1984	Dr. David Manuel University of Southwestern Louisiana
Project Description of the Minerals Management Service's Study to Develop and Analyze Economic Indicators for Offshore Oil and Gas Activity in the Gulf of Mexico	Mr. Michael Frankel Centaur Associates, Inc.



PART II: PRESENTATIONS AND DISCUSSIONS BY SPEAKERS  
REPRESENTING GULF OF MEXICO COASTAL STATES ON THE OFFSHORE  
LEASING PROGRAMS IN STATE WATERS

Historic and Projected Leasing, Exploration,  
and Development Activity in Alabama State  
Waters

Dr. Scott Mettee  
Alabama Oil and Gas Board

Leasing, Exploration, and Development  
Activity in Mississippi State Waters

Mr. Charles Blalock  
Mississippi Department of  
Natural Resources

Historic Leasing, Exploration and Development  
Activity in Louisiana State Waters

Mr. William E. Howe  
Louisiana Department of  
Natural Resources

Historic Leasing, Exploration and Development  
Activity in Texas State Waters

Dr. E. G. Wermund  
University of Texas

A Review of Offshore Oil and Gas Leasing  
Programs of Gulf Coastal States

Dr. James W. Miller  
Florida Institute of  
Oceanography

## SESSION OVERVIEW: SOCIO-ECONOMIC IMPACTS OF THE OFFSHORE OIL AND GAS INDUSTRY

Mr. John Rodi  
MMS, Gulf of Mexico Region

If there's one fact which seems to continually arise when people talk about socio-economic impacts associated with the offshore oil and gas industry in the Gulf of Mexico, it is that there's always a two-sided conclusion. For every prediction or statement about the economic benefits which you can expect to occur, there's also a warning about the adverse effects.

Since socio-economic impacts deal with the lifeblood of everyone's daily existence--jobs, money, taxes, money, cultural identity, money, et cetera--it seems that the necessary balancing of impacts is difficult to achieve. I feel that all of the presentations and the related discussions that occurred in the sessions this year indicated the true reality of this situation. Perhaps the best way to summarize each of the presentations is with the phrase: There's good news; and, you guessed it, there's bad news.

With regard to the future supply of oil and gas resources in the Gulf of Mexico, Dr. Emil Attanasi, of the U.S. Geological Survey, gave us the bad news that, based on existing information on the Gulf of Mexico OCS, future discoveries will amount to only 15 to 28% of past discoveries. The range is based on a varying resource price per barrel of \$30 to \$50. Even after you increase the favorable conditions regarding drilling costs and production flow rates, the amount is still expected to reach only one-third of past discoveries.

The good news is that this information is for depths less than 200 meters. Obviously, the total expected volume of OCS resources may increase drastically as a result of current and planned deep water

activity. And I'm sure that we are all hoping that there are some successes as a result of the current drilling in that area.

With regard to the future demands for oil and gas equipment in the Gulf of Mexico, Dr. Allen Brooks, of Offshore Data Services, Inc., gave us the good news that drilling activity has significantly increased since the summer of 1983, primarily due to the area-wide sales, and that this restoration of an economy which was practically decimated just two years ago is expected to continue in future years. Furthermore, the world's eyes are again returning to the Gulf of Mexico, where deep-water activity will result in immense technological advances.

The bad news is that due to both past economic problems in the industry as well as the movement of drilling to continually deeper waters, which is increasingly more expensive, the number of participants in the industry, such as platform fabricators, has fallen alarmingly and may be further reduced. The long-run economic implications that go along with the smaller number of firms, i.e., the possible effects of reduced competition, are debatable among economists. This forecast, however, does call for a certain degree of wariness regarding the future.

With regard to the measurement of total economic impact of OCS oil and gas in the State of Louisiana, Dr. James Richardson, of L.S.U., gave us the good news that he is working with the state's econometric model toward the goal of having a predictive tool which can yield detailed and best available estimates of both direct and secondary effects on the state and coastal economies. Such a tool is sorely needed in this area.

The bad news is that the work is far from completed. Also, I'm certain that limitations of time and money will be an important factor in the achievement of this goal.

With regard to the effect of OCS oil and gas activity on land use, Dr. Donald W. Davis, of Nicholls State University, gave us the good news that south Louisiana's alluvial ridges have been turned into gold coasts

and significant increases in the standard of living for communities of Cajuns, Italians, and Yugoslavians have resulted.

He also gave us the bad news that coincident with this oil and gas activity, industries such as sugar cane, oyster fishing, and fur trapping have been reduced, at least relative to national comparisons, and that the same cultures (Cajun, Italian, and Yugoslavian) have been culturally and adversely affected.

With regard to the high unemployment and depressed industry conditions of 1983, Dr. David Manuel, of the University of Southwestern Louisiana, gave us the good news that, at least from a coastal viewpoint, the decline in the offshore area was not as great as onshore and that the recovery offshore has been robust compared to onshore areas.

The bad news is that the non-metropolitan coastal parishes have been the hardest hit in the coastal regions, and that the conditions are far from being healthy despite this recovery.

With regard to the ongoing MMS analyses of economic impact in the coastal regions, Mr. Michael Frankel, of Centaur Associates, gave us the good news, at least from his own standpoint, that his firm has recently been awarded an MMS contract which will generate primary data on factors which affect the measurement and distribution of impacts. Such data will include various analyses of employment, such as place of residence versus place of work, and expenditures.

The bad news is that Centaur has already been buried alive with information from an industry which is very willing to help with this study. Actually this isn't bad news, and we expect that the results of the study will be presented at the Information Transfer Meeting next year.

As the agenda of the second socio-economic session indicates, MMS is also concerned from a cumulative impact standpoint with oil and gas

activity in the state coastal waters of the Gulf of Mexico. Here we have a real mixed bag of leasing histories and projected activity patterns.

In Alabama, Dr. Scott Mettee proudly discussed, and rightfully so, the recent success in leasing in Alabama state waters. A continuation of this success is anticipated.

Mr. Charles Blalock of Mississippi, on the other hand, discussed his state's desire for a successful offshore leasing program, as well as the frustration surrounding unsuccessful attempts to date.

In both cases, more importantly, the states continue to develop leasing programs which incorporate knowledge which is gained from past leasing in states where there have been significant amounts of leasing activities in state coastal waters.

The State of Florida was not represented, presumably due to the ongoing state level discussion regarding the desire and the form for a state offshore leasing program.

In the more experienced State of Louisiana, Mr. William Howe, of the Department of Natural Resources, told us of Louisiana's offshore leasing in state waters since 1915. The data and facts surrounding this leasing program are, as many of you know, endless. The results can be shocking to some, which is that every state offshore lease block has been leased at least once; most, more than once. The future for the state's offshore waters is far from rosy.

Dr. E.G. Wermund, of Texas, likewise presented data for an area steeped in leasing history. The outlook for this region is uncertain, as in Louisiana. The reason, however, is different. The uncertainty surrounds the price of natural gas in an area which is primarily gas prone.

Finally, Dr. James Miller, of the Florida Institute of Oceanography, presented a comparison of all of the state leasing programs. This analysis, which he has recently completed, was commissioned by the

State of Florida for use in its ongoing discussions relating to its own leasing policy. I truly suggest Dr. Miller to anyone interested in state leasing programs as your first point of contact.

In conclusion, I am again very pleased with all of the speakers, the questions asked, and the interest shown in the socio-economic sessions. The Gulf Region is blessed with academicians, industry personnel, and government personnel that care about the socio-economic health of the region. The solutions to our socioeconomic problems may be far from being reached, but I don't think we've lost sight of the goals.

## **PART I: RECENT STUDIES RELATING TO THE SOCIOECONOMIC IMPACTS OF OCS LEASING IN THE GULF OF MEXICO**

### **FUTURE SUPPLY OF OCS OIL AND GAS FROM THE GULF OF MEXICO**

Dr. E. D. Attanasi  
U. S. Geological Survey

#### **INTRODUCTION**

In U.S. Geological Survey Circular 725, "Geological Estimates of Undiscovered Recoverable Oil and Gas Resources in the United States" (Miller and others, 1975), there is an allusion to the possibility that estimates in the report might be significantly affected by changes in oil and gas prices. In mid-1976, the Interagency Oil and Gas Supply Project was established to explore the oil and gas supply and price relationship for several major U.S. petroleum producing areas. The project, which included participation by several federal agencies (with the U.S.

Geological Survey as the lead agency), produced a report on the Permian basin published in 1981 as U.S.G.S. Circular 828. Details of the physical process and economic-engineering models used in the Permian basin study have also been published (see Drew, Root, and Bawiec, 1979, and Attanasi and others, 1981).

The Gulf of Mexico study was primarily conducted by U.S. Geological Survey personnel with important contributions made by John L. Haynes of Global Marine, Inc., and engineers in the Dallas field office of the Energy Information Administration. Results of this study are already published (see Drew, Schuenemeyer, and Bawiec, 1982, and Attanasi and Haynes, 1983), or are in the process of publication (Attanasi and Haynes, 1984).

#### GULF OF MEXICO STUDY: MODELING APPROACH

Discovery process models are used to forecast future rates of discovery for both the Permian and Gulf of Mexico studies. These models predict the number and size distribution of discoveries that can be expected from incremental amounts of exploration effort. The skewed field size distribution and the fact that large fields are typically easier to find than small fields induce a regularity in the discovery process. This regularity can serve as a basis for constructing rather simple analytical models that can reproduce a basin's discovery history and also be used in forecasting.

The discovery process model used here, which as developed by Drew, Schuenemeyer, and Bawiec (1982), is a variation of the well-known Arps and Roberts model. The model asserts that the proportion of undiscovered targets in a given size class declines exponentially with cumulative drilling, that is

$$(1 - F_i(W)/F_i(\infty)) = \exp(-C_i A_i W/B) \quad \text{or} \quad F_i(W) = F_i(\infty) 1 - \exp(-C_i A_i W/B)$$

where  $F_i(W)$  is the expected cumulative number of discoveries in size class  $i$  found by  $W$  wildcat wells,  $F_i(\infty)$  is the ultimate number of fields in size class  $i$ ,  $B$  is the basin area,  $A_i$  is the (average) area of fields in size class  $i$ , and  $C_i$  is the efficiency of discovery of fields in size class

i. Model parameters were estimated from Gulf of Mexico's discovery history. The area of interest was divided into the Miocene-Pliocene trend and the Pleistocene trend (to 656 feet of water depth) and separate models were estimated.

For given increments of wildcat wells, the discovery process model generates a distribution of discoveries by field sizes specified in units of barrels of oil equivalents (BOE's). The costing algorithm classified fields into crude oil and nonassociated gas. Wildcat wells and discoveries were allocated to four water depth intervals using the proportion of total prospective area within each water depth interval. All new discoveries of a specific type (crude oil or nonassociated gas), size, and water depth were added to reserves, if a discounted cash flow analysis indicated the representative field was commercial.

Models were run on successive increments of wildcat wells until their increments were determined no longer to be commercial. For an increment to be commercial, the aggregate positive surplus of net present value obtained by developing expected new discoveries must be sufficient to repay costs of discovery. For the last increment of hydrocarbons produced at the field level, operating costs equal price and exploration proceeds until the cost of new reserves exceeds their expected after-tax net present value. Then for the reserves discovered by the last increment of wildcats, the sum of marginal finding and marginal development and production costs per BOE equal the assumed wellhead price.

## SUMMARY OF FINDINGS

The model results indicate at \$30 per BOE and 15% return, the 360 expected future commercial (after 1976) discoveries will contain 3.68 billion BOE for recovered hydrocarbons. At \$50 per BOE and 15% return, the 1,121 future commercial discoveries will contain 6.94 billion BOE. Prior to forecast period, there had been 25.19 billion BOE's discovered in 422 fields. It is, therefore, likely that future discoveries will amount to only 15 to 28% of past discoveries. Future discoveries will contain



only 17% crude oil, 76% natural gas, and 7% natural gas liquids (in nonassociated gas fields).

Results are sensitive to drilling costs and production well flow rate assumptions. However, even under the most favorable conditions the total future volume of hydrocarbons discovered is unlikely to amount to more than one-third of past discoveries. Many small fields are expected to be discovered. These fields typically have low well productivity. Thus, the decline in future drilling levels in new fields will be much less than the proportionate decline in the amount of hydrocarbons discovered. One extension of the study is to use the partially explored Gulf area as an analogue for the prospective area in the Gulf in water depths beyond 656 feet. Parameters from the discovery process model used in the shallower water area along with results of exploration in the deep water area might be used to forecast future discoveries in the frontier area.

#### REFERENCES

- Attanasi, E. D., Garland, T. M., Wood, J. H., Dietzman, W. D., and Hicks, J. N., 1981. "Economics and resource appraisal - the case of the Permian basin," *Journal of Petroleum Technology* 33, no. 4.
- Attanasi, E. D. and Haynes, J. L., 1983. "Future supply of oil and gas from the Gulf of Mexico," U.S. Geological Survey Professional Paper 1294, 21 p.
- Attanasi, E. D. and Haynes, J. L., 1984. "Economics and the appraisal of conventional oil and gas resources in the Western Gulf of Mexico," *Journal of Petroleum Technology* 36, no. 12.
- Drew, L. J., Root, D. H., and Bawiec, W. J., 1979. "Estimating future rates of petroleum discoveries in the Permian basin." In SPE-AIME Symposium on Economics and Evaluation, 8th, Dallas, Texas, 1979, Proceedings, Dallas: American Institute of Mining, Metallurgical and Petroleum Engineers, Inc., Society of Petroleum Engineers.

Drew, L. J., Schuenemeyer, J. H., and Bawiec, W. J., 1982. "Estimation of the future rates of oil and gas discoveries in the Western Gulf of Mexico," U.S. Geological Survey Professional Paper 1252.

Miller, B. M., Thomsen, H. L., Dolton, G. L., Coury, A. B., Hendricks, T. A., Lennartz, F. E., Powers, R. B., Sable, E. G., and Varnes, K. L., 1975. "Geological estimates of undiscovered recoverable oil and gas resources in the United States," U.S. Geological Survey Circular 725, 78 p.

U.S. Geological Survey, 1980, "Future supply of oil and gas from the Permian basin in west Texas and southwestern New Mexico," U.S. Geological Survey Circular 828, Washington, D.C.

## OUTLOOK FOR GULF OF MEXICO OFFSHORE ACTIVITY

Mr. G. Allen Brooks  
Offshore Data Services, Inc.

As a research, information, and consulting firm, Offshore Data Services concentrates its efforts on tracking and reporting offshore drilling and field development activity as well as forecasting future market activity for companies having to make business and investment decisions. While our interests are worldwide, for the past two years we have focused much of our efforts on the Gulf of Mexico market because that's "where the action is." Since 1983, activity in the Gulf of Mexico has continued to improve. Today, there are 216 mobile rigs drilling in the Gulf, for a 92% overall fleet utilization rate. Some 30 mobile rigs have moved to the Gulf in the last 12 months in direct response to the strength of this market reflected by the shortage of deepwater jackups and floating drilling rigs. At the current time, large jackups that can

operate in over 150 feet of water are 100% utilized. In addition, some 40 floating drilling rigs are working in the Gulf with more on their way here or awaiting start of drilling programs. Some of the floating drilling rigs coming here have had to go through upgrading of drilling equipment to be able to work in the water depths the oil companies wish to drill.

This stronger offshore industry environment lacks only one ingredient for making equipment owners happy, and that is the absence of significant day-rate improvement. In the summer of 1983, as the fleet utilization rate plunged below the 60% level, day-rates came crashing down, since any cash flow became better than the expense of an idle rig. Rates as low as \$6,000 per day were reported for new large jackup drilling rigs costing upwards of \$35 million. Today, these same rigs are able to earn between \$14,000 and \$18,000, which is still not profitable on a P & L basis.

Now with the fleet utilization rate reaching into the low 90% range, the contract drilling industry is on the threshold of a significant upward price move. Some drilling contractors, however, argue that the existence of a significant portion of the mobile rig fleet still operating on well-to-well contracts acts to dampen the pressure for day-rate increases. On the other hand, we would point out that the oil industry has already lost more than a year's time on its 1983 leases and is quickly approaching losing half a year on the 1984 leases. Except for a handful of leases in over 3,000 feet of water that have ten-year terms, the standard Gulf lease is for five years. Since only about 12% of the nearly 2,000 leases purchased in 1983 and 1984 have been drilled, the oil companies have a lot of work to accomplish in a relatively short time. This drilling demand will lift rig day-rates starting next year.

The outlook for drilling and development in the Gulf of Mexico is really a function of three forces. These are the emergence of a true deepwater drilling and field development market; the slowly increasing demand for offshore work in the shallow water areas of the Gulf as a direct result of improving natural gas markets; and the ability of the oil field supply industry to handle higher levels of drilling and field

development work. Each of these forces is having a distinct influence on various market segments and the timing of the offshore recovery. The problem we foresee is the convergence of these three forces in the marketplace within about 12 to 18 months, creating significant pressure for price increases which few industry participants can now envision. But before I get to this conclusion, let me back up and review these three influencing forces individually.

The development of a true deepwater drilling market started with the 1983 lease sales and the drilling activity which immediately preceded this sale. Prior to 1982, there had been some exploratory drilling in water depths of about 1,000 feet of water and there had been several discoveries. These discoveries led to major offshore field development projects such as Shell Oil's Cognac field and Union Oil's Cerveza and Cerveza Linguera fields, along with Exxon's Lena field. All of these fields are located in about 1,000 feet of water, and they established what is now known as the Flexure Trend. Additional drilling and several more discoveries were made during 1982. This information set all the oil companies to having their geologists map this trend along the continental shelf located in water depths ranging from 600 feet to 3,000 feet. In the two area-wide lease sales held in 1983, about 15% of the 1,030 tracts leased by the oil industry were in these water depth ranges. But after the announcement of discoveries which had been classified as tight holes prior to the sale, the oil industry really got excited. In the two area-wide lease sales in 1984 (excluding the Eastern Gulf sale), about 40% of the 814 tracts leased by the oil companies were in the Flexure Trend.

As a direct result of the new acreage put into the oil company inventory, the number of deepwater drilling rigs working in the Gulf has increased. Since January of this year, the number of semisubmersible rigs and drillships active in the Gulf has risen from 22 to 38, or close to a 50% increase. An even more dramatic increase is noted if one focuses exclusively on the number of rigs working in water depths of 600 feet or greater. Here the number went from 9 deepwater rigs to 25, or almost a threefold increase. If oil company drilling intentions are any indication

of future deepwater drilling rig demand, as President Reagan says, "you ain't seen anything yet."

Based on the observations of industry executives and Offshore Data's consulting business, the oil companies spent most of their time during 1983 and 1984 in evaluating and selecting lease tracts to bid on. Now that the industry's exploratory lease inventory has more than doubled from before the area-wide lease sales began, there will be more effort directed toward the exploration of this new acreage and the development of the already announced discoveries than the acquisition of new leases. The federal government still has plans to hold three lease sales in the Gulf of Mexico next year, but more than likely the oil companies will concentrate in picking up open acreage adjacent to interesting exploratory wells. We seriously doubt that the oil industry will actively pursue major acreage accumulation plays.

Important for the offshore drilling industry is the implication of a trend toward less new acreage leasing in 1985. The money the oil companies spent on new acreage these past two years came at the expense of drilling and field development. In 1985, there should be plenty of money available to support a healthy level of drilling and field development work. Almost comically, the oil industry, which recently went through a trimming down phase in an effort to reduce overhead, may now find it needs to staff up in order to get all the work done that it finds necessary.

From what we can tell about exploratory drilling activity this year, there may be over 60 wells spud in water depths greater than 600 feet. In addition, the drillers are side-tracking various exploratory wells in an effort to learn more about discoveries without having to move the drilling rig. By not moving the rig, the oil companies may be saving meaningful sums of money. The ability to handle drilling rig anchors in deepwater has become a major problem for the workboat industry. The amount of anchor chain and the weight of the anchor's being pulled from these various deepwater depths has taxed the winch capacities of vessels active in the Gulf. Some vessels have burned up their equipment or

developed very dangerous situations. These problems have contributed to significant rig downtime problems for the oil companies with attendant operating expense increases.

Of all the deepwater wells drilled to date, we understand there are about 15-20 discoveries with an additional 8-10 tight holes. This great a number of discoveries implies a drilling success rate of about 1 in 3 wells, which is considerably above the 18 to 20% success rate historically experienced in the Gulf of Mexico. Important for the offshore industry is the growing oil company acceptance of the technology to develop the deepwater discoveries. Oil companies believe they can now find and develop hydrocarbons in water depths ranging out to 3,000 feet. While the key to the development of any field in these water depths is the size of the reserves versus the cost to develop the field, the deepwater market outlook is certainly encouraging for all segments of the offshore industry.

Turning to the shallow water market in the Gulf, we find there are two primary forces driving the recovery in this area. First, additional discoveries have opened up new exploration areas. The most prominent new area is the Mobile Bay waters off Alabama. Not only does Mobil Oil have its Mary Ann field there, but now Exxon has announced a major new field and other companies including Shell Oil and Tenneco are planning to drill in these waters soon. The geology of the area is promising since it appears the offshore discoveries are extensions of the onshore gas fields around the Mobile area. Improved seismic data collection techniques have been a main contributor to the oil industry's success in these shallow water discoveries.

Another factor influencing drilling in water depths of less than 300 feet is the shrinking natural gas deliverability bubble. This infamous bubble was the major contributing factor in the start of the exploration industry recession. Offshore field development drilling came to an abrupt end early in 1982 as oil and gas companies found they could not sell all the natural gas being found. Prior to that time anything sold was bought for whatever the market would bear. Now, two and one-half years later,

the ability of offshore pipelines to deliver the volumes of natural gas they have agreed to supply to customers is in jeopardy. Pipeline filings with the Federal Energy Regulatory Commission are showing rapidly declining reserve bases. These declines imply that without new reserves being discovered and developed, some pipelines will have serious problems meeting their customer demands even in normal times. Should the country experience another extremely cold winter such as last year, various sections of the nation could be in for some very tough times.

As a result of the dwindling surplus gas situation offshore, the oil companies are returning to those platforms on which they abruptly ceased development work in early 1982. In addition, the amount of drilling that has gone on in Texas waters, the home of major new natural gas reserves, has been increasing throughout 1984. According to the Offshore Oil Scouts Association, almost as many wildcat wells have been drilled off Texas in the first six months of 1984 as were drilled in all of 1983. Development wells drilled for this same period are running at about half the rate of 1983. This is expected, given the surplus gas situation. But wildcat discoveries off Texas have been substantially greater than for all of last year, with the first half of 1984 experiencing just under a 50% success rate versus only about a 22% success rate in 1983. The improved discovery rate bodes well for future field development work.

The most negative factor affecting the Gulf of Mexico shallow water drilling market is the fact it has been the most heavily leased and explored area in the basin. This means that future drilling activity will have to rely on the continued development of secondary features on acreage already held by production plus the discovery of deeper producing horizons in existing fields. While weak energy prices would act to limit the potential for development of these types of reserves, the existence of production facilities within close proximity greatly improves the economics for development.

The third issue affecting the outlook for the Gulf of Mexico offshore market that I wish to talk about today may be the most

important for the near future of all the offshore support industries. This issue I call the bottleneck problem, or the problem of shrinking capacity in the face of a rapid industry recovery. While we could examine this condition as it affects a number of offshore support industries, I have chosen to focus on the platform fabrication industry. I think this market is of great importance for this audience since there are people here who are responsible for the development of their community's economic plans. What happens to this industry in the future will be repeated in other industries with similar implications for community development.

In Offshore Data's Ocean Construction Locator, we list all known offshore field development projects, their status, and which fabricators have which contracts. According to the October 1981 issue, which reflects the peak of the most recent fabrication market cycle, there were 21 companies working on 84 platforms and 141 deck sections. Admittedly, the numbers for each company are not totally comparable since platforms listed as under construction may be in various stages from final engineering to load out. But for purposes of this comparison, the data base definitions are acceptable. According to the October 1984 issue, only 11 firms were working and they had 38 platforms and 73 deck sections listed as under construction. By this comparison, the business has declined by over 50%.

Let's look at the make-up of the companies engaged in the offshore fabrication business as of these two dates. Of the 10 companies that were not still active in the fabrication business in 1984, several were substantial companies that either had been in the business for a long time or had chosen to get into the business during the boom of the late 1970s. Companies such as Chicago Bridge & Iron, the French Marine Construction Company E.T.P.M., and the long-time participant Ingalls, were all missing from the 1984 list. Also missing were several small companies on the 1981 list such as Twin Brothers, Universal Fabricators, Houma Industries, and Process Facilities. Today, many of these companies are no longer in business, or have withdrawn from the platform fabrication part of the business, usually to concentrate on their traditional business such as the fabrication of production modules or drilling packages.



Looking at the companies on the list in 1984 we find some interesting names. One company, Shaw-Trosclair, new to the 1984 list is presently in Chapter 11 bankruptcy proceedings. Another company, Delta Fabricators, which was on both years' lists, is also in bankruptcy and apparent liquidation. A third company which I cannot name is rumored to have an offer to sell some of its fabrication assets and is also negotiating the sale of its marine construction equipment. Withdrawal of these companies from the fabrication industry will shrink the number of active competitors to eight.

What's wrong with this you ask? Isn't this the way the free enterprise system is supposed to work? I agree, but we will rapidly be returning to the old days when only a few companies controlled this market and dictated who got which business. Whether, this is a good thing for the industry I'm not so sure.

At the same time the platform fabrication industry capacity is diminishing and the development of deepwater discoveries is accelerating, which puts these two forces on a direct collision course. There are only four yards on the Gulf Coast which are capable of fabricating fixed platforms for installation in 1,000 feet, or greater, water depths. As each of these yards gains a contract, there will be a notch upwards in pricing and a scramble by the winning yards for labor.

Industry comments about the impact of the award of Shell Oil's Bullwinkle platform, destined for Green Canyon 65 in 1350 feet of water, are that it will keep some 500 welders busy for two years to build it. From what we can ascertain, no Gulf Coast fabricator has 500 welders on its payroll currently; therefore, it will have to hire most of them when it gets the contract. Of all the oil field welders who have left the oil patch as a result of the recession, how many of them are likely to return? Without an influx of new labor, the only way to obtain the necessary welders will be to bid up their wages. What then becomes of the fabricator who has taken work at low prices but then starts to lose its labor force to competitors offering higher wages? Does it have any alternative but to match the higher rate? No. But in the interim it

will lose money on its contracts. This situation could be the straw that breaks the weaker fabricators.

Some people would suggest that the prospect of better times will bring new entrants into the market. However, they must be well capitalized because no bank or venture capitalist will finance them. Also, bear in mind that the platform fabrication business is capital intensive in the early stages of a contract. The steel has to be bought, and a certain amount of work has to be done before one can expect a progress payment from the customer. If the work is done on a lump-sum basis, there may not be any progress payments. Thus, the ability to fund working capital needs will become a critical factor for new firms as well as existing firms. We ask from where all the necessary cash will come.

Without expansion of fabricating capacity, there will develop a serious bottleneck for the oil industry, which will lead to rapidly escalating platform prices. As was cited to us by industry contacts with respect to the deepwater platforms, the first order gets the best price, the second gets an okay price, the third pays normal market prices, and the last order pays a premium. This progression explains why the oil companies with deepwater discoveries are watching each other to make sure no one gets a jump on the others. It also explains why the oil companies are looking at alternative development schemes for deepwater fields. Since the economics of field development are sensitive to platform costs, being late in the order sequence could affect the oil company's profitability significantly.

As you can tell, we expect the Gulf of Mexico offshore drilling and field development markets to get progressively healthier in the coming years. Currently, 38% of the mobile rig fleet is working in the Gulf. While we expect a few more rigs to be here in the future, we also see the stage being set for a resumption in foreign offshore drilling. Despite an increase in foreign activity, the Gulf will be about the most active market. The emergence of the deepwater drilling and field development markets in the Gulf will cause the world to focus on new technology to solve the problems of these new operating environments.

Until the 1980s, offshore technology flowed from the Gulf of Mexico to other parts of the world. Recently, the center of new offshore technology development was the North Sea because of its harsh operating conditions and progressively deeper water fields. Technology developed there is being brought to the Gulf, but without ever escalating prices, the expensive field development projects which characterized the North Sea are not affordable. Thus, the oil industry must perfect new, cost effective technology. Once accomplished, all deepwater markets worldwide will be opened to the oil industry. Thus, the next several years will witness the first part of the deepwater phase of offshore industry development, and the Gulf of Mexico will have been its birthplace.

## THE LOUISIANA ECONOMETRIC MODEL AND THE OIL AND GAS INDUSTRY

Dr. James A. Richardson  
Professor of Economics  
Louisiana State University

### INTRODUCTION AND PURPOSE

Regional economic models are important vehicles for forecasting regional economic activity and for analyzing economic developments that are likely to have a substantial impact on the regional economy. Offshore oil and gas exploration, development, and production are significant events that undoubtedly do have large repercussions on onshore economic activity. The extent of these repercussions, both

benefits and costs, has not been analyzed within the context of an econometric model for the state of Louisiana. Analyses have been conducted using input-output models and other theoretical approaches, but there has been an ongoing project which could provide estimates of the impact of new leasing procedures or other changes in the exploration, development, and production in offshore Louisiana. Econometric analysis provides the opportunity for continuing evaluation of the economic effects of offshore oil and gas activity.

The purpose of my participation in the Information Transfer Conference sponsored by the Minerals Management Service of the U.S. Department of Interior is to acquaint you with the Louisiana Econometric Model and my interest in expanding this model to specifically allow for a division between onshore and offshore oil and gas activity and their impacts on other sectors of the Louisiana economy. Several words of caution are appropriate. First, at this time the model does not differentiate between onshore and offshore activity. As I will explain, several enhancements of the model have occurred in the last several years, but splitting the impact of onshore and offshore activity has not been done. This, however, is the next desired improvement. Second, the Louisiana Econometric Model focuses primarily on employment and income effects, hence the model will emphasize the benefits of offshore development, but the model will provide information that can be used to develop any costs that may be associated with offshore development.

#### **HISTORY OF THE LOUISIANA ECONOMETRIC MODEL**

The Louisiana Econometric Model was originally initiated in 1975 at the request of the Louisiana Legislative Fiscal Office. The purpose of the model was limited, namely to assist the Legislature in forecasting state revenues. An econometric model was constructed, but with the emphasis on estimating state revenues. It was not until 1981-82 that the model was developed for other purposes. The Louisiana Board of Regents provided a grant to Louisiana State University to update the model and to emphasize forecasting economic variables that could be useful to the private sector of the economy as well as the public sector. The first

step in this project was to update, revise, and improve the employment, and income sectors of the model, construct for the first time financial and population sectors, and initiate work for an energy sector due to the energy production and usage within Louisiana. That step was completed in 1982, and in December 1982 the First Annual Louisiana Economic Conference was held.

Since 1982 additional steps have been taken to upgrade the model and make the forecasts more useful to private firms and public agencies. Energy production was segmented into North Louisiana and South Louisiana, and offshore Louisiana. Federal offshore was not included. Next, the employment sector was divided into more micro units. For example, initially manufacturing was segmented into durables and nondurables. Presently, durables are divided into lumber and wood; furniture and fixtures; stone, clay, and glass; primary metals; fabricated metals; machinery, excluding electrical; electric and electronic machinery; transportation equipment; and other durables. Nondurable manufacturing is similarly segmented. This extra detail makes the model more relevant to users in the private sector and also makes the model more useful in policy analysis. Finally, we added information regarding the major metropolitan statistical areas of the state to the model.

The Louisiana Econometric Model has been steadily expanded and improved, but the one critical factor that is still missing is the differentiation of onshore and offshore activity.

## THE MODEL

The Louisiana Econometric Model is presented diagrammatically in Figure 33. Two major inputs are required to drive the state's economy. First, national economic conditions are a necessary input, and national forecasts are derived from the Wharton Econometric Model. Hence, the Louisiana forecasts are conditioned upon the Wharton forecasts. Second, state characteristics must also be accommodated. In Louisiana, the oil and gas sector, including production and manufacturing processes, are too significant to ignore or to expect that national conditions will properly account for their impacts on the state's economy.

In 1980 Louisiana produced approximately 15% of crude oil production in the United States and over 33% of natural gas production. These estimates include onshore and offshore activity. Petroleum refining capacity in Louisiana represents about 14% of the U.S. refining capacity. Upstream oil and gas activities are significant in Louisiana. Over 55% of the value added originating in the manufacturing sector in Louisiana comes from Chemicals and Allied Products and Petroleum Refining. In comparison for the United States as a whole, the comparable estimate is 12.5%. Finally, nineteen of the top twenty parishes in Louisiana in terms of per capita income are located along the coast or within the southeastern region. The only parish not located within the southeastern region and which has per capita income among the top twenty parishes in the state is Caddo. It is located in the extreme northwestern corner of the state and has a significant oil and gas sector. These facts reinforce the assertion that the oil and gas sector in Louisiana deserves special attention in any state analysis.

Figure 33 does not reveal the interaction of the oil and gas sector within the Louisiana economy. This diagram reveals all of the parts of the model and the broad linkages. But, within the employment sector, employment in the mining sector, which includes oil and gas extraction activities and oil and gas field services, acts as an independent variable in explaining employment in contract construction, machinery, transportation equipment, fabricated metals, primary metals, and petroleum refining. In addition, mining employment and manufacturing employment which includes employment in the petrochemical firms act as independent variables in explaining economic activity in the support industries such as retail and wholesale trade, personal and business services, and financial services. The model equations are available upon request from the author.

## PLANS AND PROSPECTS

The Louisiana Econometric Model has undergone a series of expansions and improvements. Initially the forecasts centered on state revenues. Now the forecasts include detailed employment and income

estimates, energy production and consumption projections, population estimates, and projections of financial activity. The model can also be used for some policy analysis. For example, a change in the price of oil can be inputted in the model, and the repercussions are traced through all sectors of the economy. But, there are still improvements to be made. The most pressing addition that is now needed is to separate the impact of the offshore oil and gas activity on Louisiana's onshore economy. By the time of these meetings in 1985 I hope to report progress on this front.

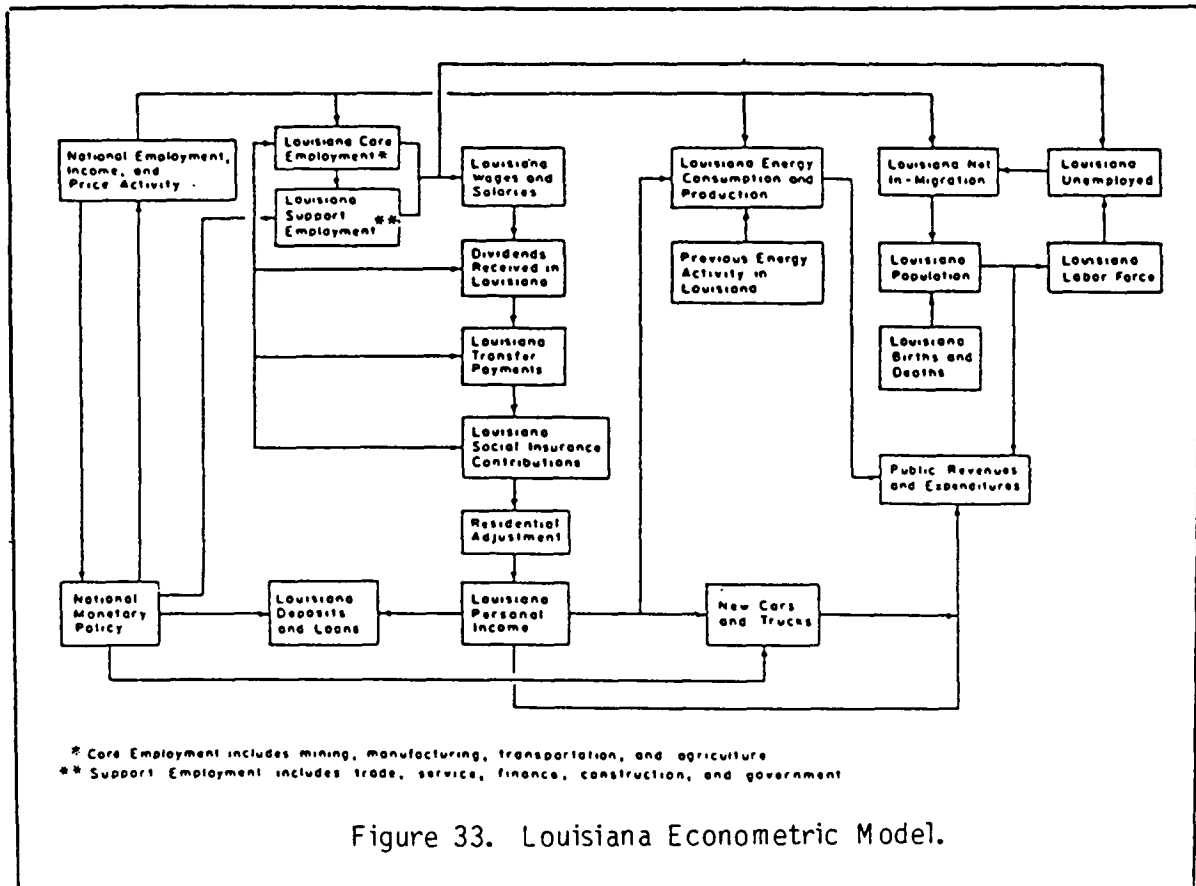

## THE OIL AND GAS INDUSTRY OF COASTAL LOUISIANA AND ITS EFFECT ON LAND USE AND SOCIOECONOMIC PATTERNS

Dr. Donald W. Davis  
Earth Science Department  
Nicholls State University

With discovery of marketable hydrocarbons in Louisiana's alluvial wetlands in 1901, the state witnessed dramatic changes in its lower tier of parishes. These changes were accelerated by the discovery of oil offshore in 1947 and the associated technological developments necessary to drill in water more than 1000 meters deep. Currently, more than 24,000 wells are in offshore waters of the United States; 90% are south of Louisiana. Other states are involved in the industry, but for every 100 producing wells in Louisiana's offshore waters, Texas, for example, has fewer than 10.

Petroleum operators have leased more than 2200 blocks off Louisiana's coast. To develop these leases has required more than 3000 production platforms. In 1982 the number of fixed platforms worldwide was only 3594; therefore, approximately 80% were off Louisiana's coast.

Louisiana's leadership is not surprising, since in 1981 its estimated proven oil reserves in state and federal waters were 2026 million barrels. Its natural gas reserves were estimated at 31,462 billion cubic feet. In addition, the state's offshore oil was valued in 1980 at \$16 billion.

All of this exploration and development activity requires space and influences local industrial land-use and land-cover patterns. Transportation facilities are particularly important, as more than 40% of the world's crewboats, supply vessels, and tugs are owned by Louisiana-based firms. In addition, more than 100 Louisiana shipyards are working to meet the needs of the offshore operators.



These logistic support sites can be seen in many Gulf of Mexico communities, but are best developed in Louisiana. By the mid-1950s there were more than 1100 principal businesses serving the petroleum industry in south Louisiana. By the early 1970s this figure increased to nearly 3600--an addition of more than 100 businesses per year. All of this petroleum-related activity has placed a severe strain on Louisiana's scarcest natural resource--firm, dry land with easy access to offshore lease tracts.

The exploration and development phase, associated with extracting the mineral fluids from offshore, has changed Louisiana's rural character. It has also attracted primary, secondary, and tertiary industries to the region's logistic support centers. Basic services have in many cases been stretched beyond acceptable limits. The region cannot keep up with all of the interrelated socioeconomic issues, most of which are tied directly to the production of hydrocarbons off the state's coast.

In considering the effects of the offshore industry, it can be demonstrated that without question Louisiana has been overwhelmingly impacted by an association of more than 35 years with the offshore business.

- \* Every community in Louisiana's coastal zone has been impacted directly or indirectly by the offshore industry.
- \* In 1980 Louisiana's Outer Continental Shelf production was valued at more than \$16 billion. By comparison, Texas claimed about \$1.7 billion.
- \* The world's deepest offshore well at more than 6700 meters is in Louisiana's Grand Isle Block 25.
- \* There are 14 platform construction sites in Louisiana's coastal zone.
- \* There are more than 100 boat fabrication facilities in the Louisiana's coastal lowlands involved in building the flotilla required by the offshore operators.
- \* Off the state's coast there are 933 producing leases. Nineteen major oil fields are located within these blocks. There are no major fields, for example, off the Texas coast.

- \* It is estimated that 95% of the remaining oil and 80% of the remaining natural gas in the Gulf of Mexico is off Louisiana.
- \* Louisiana boat contractors own 44% of the world's logistic support fleet.
- \* Louisiana's helicopter contractors own 637 of the 720 helicopters based in the Gulf of Mexico.

This list represents a sample of some of the key elements that make Louisiana the nation's leader in the offshore production of hydrocarbons. When one considers, however, all the variables necessary in the complete analysis of a region, those that are indicators of the offshore hydrocarbon industry show clearly that Louisiana is the country's pre-eminent producer of these resources.

Yet as one looks at the research related to socioeconomic issues, it is clear the topic has been ignored. A review of Minerals Management Service (MMS) funding quickly reveals that capital allocations for socioeconomic research is woefully lacking. Why the apparent lack of concern? Have the onshore impacts been forgotten? Why the absence of interest in regional economics after the petroleum/natural gas reserves are depleted? It seems that biophysical issues are in the mainstream. They should not, of course, be ignored. It is apparent that "people" issues are at the lowest level in the order of funding. We need social, economic, and cultural research. Social scientists should be actively involved in putting together MMS's 1986, 1987, 1988 plans, but are they being consulted? Further, are the impacted states' concerns being addressed?

We are faced in south Louisiana with a unique situation; we have one of the country's most friable environments settled by one of its most culturally distinct people. In terms of socioeconomic impacts we must change our focus from short-sighted goals to long-term solutions. There are MMS staff that, if properly funded, could be at the "cutting edge" of socioeconomic research. Unfortunately, the allocations are not there. This is a shame. It is clear there is a problem. Money needs to be allocated immediately. The accepted project contractors should also be

given a realistic time frame to obtain meaningful results. Too often the contract deadlines are unrealistic.

A quick literature review reveals that local administrators are constantly looking for data on the onshore impacts of the offshore industry. The data, unfortunately, are simply not being generated. We need to change our focus. It is time that MMS began to consider some of the cultural consequences of the offshore industry, its regional economic impact, and the long-term socioeconomic consequences of the recent downturn in offshore development and production. We now need to manage the impacts onshore.

**GULF OF MEXICO ENERGY ACTIVITY AND COASTAL LOUISIANA  
ECONOMIC CONDITIONS: 1981 - 1984**

Dr. David P. Manuel  
Professor of Economics  
University of Southwestern Louisiana

**PURPOSE**

This presentation examines the extent of the downturn in offshore energy activity in the Louisiana portion of the Gulf of Mexico and its subsequent impact on economic conditions in Louisiana's ten coastal parishes (Cameron, Iberia, Jefferson, Lafourche, Plaquemines, Terrebonne, St. Bernard, St. Mary, St. Tammany, and Vermilion.)

## ECONOMIC STRUCTURE

There is little doubt that coastal Louisiana employment is heavily dependent on the energy sector, particularly in the service sectors of the oil and gas industry (SIC 1389). This concentration is due partly to offshore activity and partly to the fact that most of the state's onshore reserves of hydrocarbons are in South Louisiana. (Non-metro parishes of the coastal region are more dependent on oil and gas than metro parishes; mining-to-total employment ratios in Cameron = 24.1%, Plaquemines = 22.5%, and Vermilion = 26.2%.)

Overall the coastal parishes' manufacturing sector is smaller than that of the state and the U.S. Certain subsectors, however, are larger than that of the state and the country: petroleum products, fabricated metal products, and transportation equipment. All three of these subsectors tend to be closely tied to offshore energy activity, such as the dependence on ship and boat building, rig fabrication, and platform-jacket construction.

Coastal parishes have a significantly larger transportation sector than the U.S. or the state. This is particularly true of the non-metro parishes such as Terrebonne, St. Mary, and Lafourche. (Water transportation connected with the offshore energy sector has had a significant impact on coastal employment.)

## RIG ACTIVITY

Onshore, rig activity peaked in June 1981 at 321 rigs working, 30.5% higher than the January 1980 level. Subsequent decline in rigs was 57% to 138 working in June 1983. Recovery since June 1983 has been about 25.4% more rigs working, as of October 1984.

Rigs working offshore peaked at 168 in July 1981, 27.3% higher than those in January 1980. The subsequent decline in active rigs was 36.3% to September 1983. Since the bottom in September 1983, offshore rigs have increased 38.3%.

Throughout 1980 and 1981, idle rigs offshore never rose above 4.8% of the fleet, according to Offshore Magazine. Indeed, in early 1982, capacity utilization approached 100%. Soon thereafter, idle offshore rigs began increasing to peak at 34% in July 1982. They have since declined to the 15% range in late 1984.

## LABOR FORCE AND EMPLOYMENT TRENDS

Clearly the non-metro coastal parishes outpaced the state in labor force gains from January 1980 - July 1981, increasing 8.2% compared to 5.3% in the state and 5.4% in all coastal parishes. Not surprisingly, non-metro parishes experienced a 2% decline in labor force compared to a slowing in the state's labor force growth. In the recovery following September 1983 - June 1984, the state's labor force continued to experience a slowing; and while non-metro labor force continued to fall, it did so at a slower rate.

As expected, total coastal employment growth exceeded that of the state; however, non-metro parish employment growth in January 1980 - July 1981 was 8%. Likewise, non-metro coastal employment declined 10% in the July 1981 - September 1983 downturn, compared to only 0.4% in the state and 4.2% in all coastal parishes. Since September 1983, all areas have experienced about the same rate of employment growth.

## UNEMPLOYMENT RATES

Throughout 1981, 1982, and 1983, the state had unemployment rates which exceeded those of the coastal parishes. Not until early 1982 did all regions exhibit significant increases in their respective unemployment rates. Notice that the non-metro coastal parishes experienced rates which were much below those of all coastal parishes and the state. All of the rates peaked at about the same time; however, the state's rate is now below those of all coastal parishes and the non-metro parishes. Indeed, the non-metro parishes have unemployment rates which are above those of the state and all coastal parishes.

## RETAIL SALES

Retail sales increased at surprisingly equal rates from January 1980-July 1981: approximately 27.5% in all three areas; non-metro parishes, however, experienced a slightly faster rate of 28.1%. The period of offshore recession to September 1983 witnessed a 20.9% decrease in non-metro coastal parishes, a 1.2% decline in all coastal parishes, and an 11.5% decline in the state. Since the trough in September 1983, sales have declined 2.6% in the non-metro coastal parishes, increased 4.8% in all coastal parishes, and increased 19.3% in the state.

## CONCLUSIONS

Unquestionably, coastal Louisiana parishes benefitted more than the state proportionately during the energy-led boom and suffered more than proportionately during the ensuing recession. (The same held true for non-metro parishes relative to all coastal parishes.)

Recovery in the coastal parishes has not been as robust as in the state, and, likewise, non-metro parishes are lagging behind metropolitan areas.

Geographically, as one moves inland into parishes which are energy-based for employment, yet are not heavily reliant on offshore activity, one finds that coastal parishes have suffered more during the downturn and not recovered as quickly. (Figure 34)

Coastal Louisiana, particularly the non-metro parishes, are not only dependent on primary exploration activity and related services, but have extensive infrastructures built upon offshore fabrication, ship building/repair, and water transportation. Thus, the decline in offshore activity dealt a relatively more severe blow to the coastal Louisiana region when compared to the state of Louisiana.

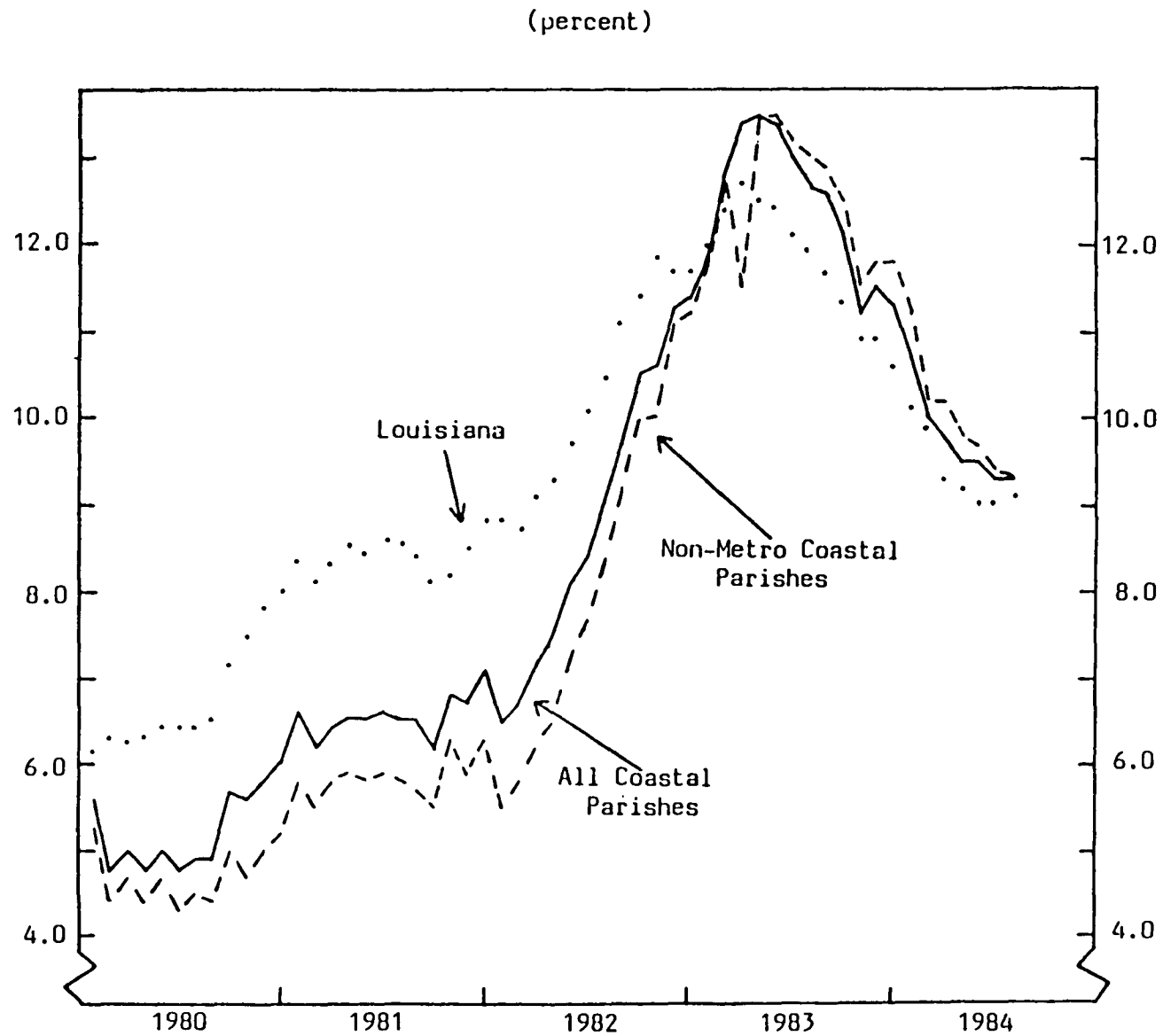

Figure 34. Seasonally adjusted unemployment rates in percent. (Sources: Louisiana Department of Labor and the University of Southwestern Louisiana)

PROJECT DESCRIPTION OF THE MINERALS MANAGEMENT SERVICE'S  
STUDY TO DEVELOP AND ANALYZE ECONOMIC INDICATORS FOR  
OFFSHORE OIL AND GAS ACTIVITY IN THE GULF OF MEXICO

Mr. Michael Frankel  
Centaur Associates, Inc.

The Minerals Management Service has contracted Centaur Associates, Inc., to develop and analyze economic impact indicators for offshore oil and gas development throughout the Gulf of Mexico. This fourteen-month project will primarily utilize information and data supplied by the membership and associate members of the Offshore Operators Committee (OOC). A subcommittee within the OOC has been established to facilitate and coordinate industry participation.

The data solicited from both primary oil and gas producers and the major service contractors includes employment profiles, distribution of employment, and the economic characteristics of various oil and gas exploration and production activities. These data are being manipulated and aggregated to provide the first detailed and comprehensive data on the impact of OCS oil and gas leasing in the Gulf of Mexico. Other factors may be relevant:

- o All information supplied to the OOC subcommittee or Centaur will be treated in confidence. All data used in the report will be camouflaged or aggregated with multiple sources and no information will be attributable to an individual firm.
- o Centaur is designing a data collection approach which places minimum burden on the respondents and allows firms to provide information in whatever format is available.
- o The results of this effort will be a valuable tool for the industry to document the magnitude and geographic extent of offshore leasing to the local economics of the region.
- o Participants will be able to receive a copy of the study findings.



Eventually the data collected and analyzed in this study effort will be used in future studies to determine the indirect and induced economic effects of oil and gas activities on the coastal counties and parishes along the Gulf of Mexico.

PART II: PRESENTATIONS AND DISCUSSIONS BY SPEAKERS  
REPRESENTING GULF OF MEXICO COASTAL STATES ON THE OFFSHORE  
LEASING PROGRAMS IN STATE WATERS

HISTORIC AND PROJECTED LEASING, EXPLORATION, AND  
DEVELOPMENT ACTIVITY IN ALABAMA STATE WATERS

Dr. Scott Mettee  
Alabama Oil and Gas Board

The first drilling operations for hydrocarbons in Mobile Bay were conducted by Gulf Oil in 1951 and 1952. Both operations failed, and the holes were plugged and abandoned. In 1969, Mobil Oil leased four tracts in the mouth of Mobile Bay and some ten years later they discovered dry gas in tract 76. When tested, this gas flowed at a rate of 12.2 million cubic feet per day. One year later in November 1980, the lower Mobile Bay-Mary Ann Field that encompassed tracts 76, 77, 94, and 95 was established. This field was significant for two reasons. First, it was a large field with an estimated reserve in excess of 500 billion cubic feet of gas. Second, it is the first offshore Jurassic discovery in the northern Gulf of Mexico.

The MOEPSI discovery in 1979 caused a significant increase in interest and exploration for hydrocarbons in coastal Alabama waters. Since 1981, 33 additional blocks have been leased in state waters and 54

in nearby federal waters. Over \$1 billion dollars in bonus money has been realized from this area. Slightly less than \$800 million in bonus money has been generated by state leasing as well as \$368 million from leasing of federal blocks. Royalty rates for state leases vary from 16.67 to 28%. All federal tracts have a royalty rate of 16.67%.

Per acre bids for both state and federal blocks have been high and are direct indicators of the intense industrial interest in coastal Alabama waters. The highest per acre prices paid since 1980 were \$31,516.30 per acre for 1,687 acres in Block 111 in state waters and \$9,855.86 per acre for 5,592.51 acres in federal waters. Lowest prices paid for the same period were \$438.00 per acre in Alabama waters and \$153.10 per acre in federal waters.

Drilling activity has been brisk in coastal Alabama waters. Ten wells have been drilled in state blocks since 1979, and two are presently being drilled. Eight wells have been drilled in federal waters since 1974, and four are presently being drilled.

First production of hydrocarbons from coastal waters will probably come from the Mary Ann Field in 1986. Based upon information provided by MOEPSI in a recent news release, hydrocarbon reserves in the Mary Ann Field are estimated to be between 500 and 600 billion cubic feet. At an annual maximum production rate of 23 billion cubic feet, the life of the Mary Ann Field alone is approximately 42 years. Future development of wells and additional fields on the north and south sides of Dauphin Island and in federal waters will undoubtedly push hydrocarbon production in coastal Alabama well into the 21st century.

LEASING, EXPLORATION, AND DEVELOPMENT ACTIVITY IN  
MISSISSIPPI STATE WATERS

Mr. Charles Blalock  
Mississippi Department of Natural Resources

Because of a lack of foresight by our Mississippi ancestors and the peculiarities of geography, the state has limited territorial waters. Since the coast line is quite limited, so are state-controlled waters. In gross area we have about 438,000 offshore acres. I say "approximate" because this includes about 64,000 acres under litigation with the federal government and recognizes the fact that we do not have an agreed-upon boundary for a portion of the boundaries with Louisiana or Alabama.

While there has been for many years a viable offshore oil and gas program in Louisiana and in more recent years in Alabama, interest in Mississippi Sound has been sporadic over the years, and the State did not actively pursue creation of an offshore oil and gas industry prior to 1979.

Prior to 1979 there were five leases for all or a part of Mississippi Sound. These five leases resulted in only three wells, all drilled in the 1950s and all dry. There were the Gulf Melber #1 in 1952 to a depth of 10,571 feet, Floto #1 in 1954 to a depth of 13,024 feet, and J. Willis Hughes in 1956 to a depth of 9,996 feet. No wells have been drilled since 1956.

It was not until 1969 that Mississippi drew its official leasing map. There was some interest in a lease sale in 1970, but after a flurry of seismic activity, interest waned and the sale was never held. A little later in the 70s, there was again a flurry of interest in leasing, but it never developed, apparently due to disagreements with industry on how a sale would be conducted, the form of lease to be used, and concerns raised by coastal residents.

Prior to July 1, 1979, mineral leasing activities in Mississippi were conducted by the Mineral Lease Commission, composed of the Governor, the Secretary of State, and the Attorney General. The commission had no administrative or technical staff.

After a major reorganization of natural resources agencies on July 1, 1979, the mineral leasing function was assigned to the Bureau of Geology, a component of the newly created Department of Natural Resources. Shortly thereafter, Mobil Oil made its initial discovery of gas in the Lower Mobile Bay, Mary Ann Field. This quite naturally led to a sharp increase in activity in Alabama state waters, adjacent federal waters, and a sporadic increase of seismic activities in Mississippi Sound.

About the same time, in reviewing all the functions the Department of Natural Resources had inherited, we found that the old Mineral Lease Commission, lacking an administrative and technical staff, had done little to establish an administrative or technical framework within which an orderly mineral lease offering could be conducted. Recognizing this, we set out in early 1980 to correct these shortcomings. We sought to establish an environment which would encourage investment and exploration and to insure that if leases were sold, there would not be an extended period of internal state agency disagreement on procedures prior to commencement of exploratory operations.

This latter point we felt was particularly significant in view of what had occurred when another state initiated a mineral lease program and recognizing the fact that three entirely different state agencies, operating under totally independent leadership, have a role to play in a viable offshore oil and gas industry in Mississippi. The three agencies involved are the following:

- (1) The Department of Natural Resources, which has sole responsibility for granting leases for offshore lands. However, the lease merely transfers the right to conduct exploration and extract the minerals, if any. Other than ensuring the terms of the lease are fulfilled, the Department of Natural Resources has no further role after the lease sale.

(2) The Department of Wildlife Conservation, Bureau of Marine Resources, is vested with the state's expertise for assessing and protecting the offshore marine environment and ensuring that any oil and gas activity is compatible with the protection of the state's offshore renewable resources as well as the coastal recreation and tourist industry. In fact, under the Mississippi Coastal Plan, this agency must grant approval before any offshore mineral lease sale can be conducted.

(3) The State Oil and Gas Board is charged with day-to-day technical regulation of the oil and gas industry once a lease has been granted, be it public or private.

With this split of state agency responsibility and to anticipate possible problems, we negotiated a formal memorandum of understanding among the three agencies to define clearly the role of each in establishing a viable oil and gas industry. Thus far it has worked well.

Statutes which set forth the authority to lease offshore and onshore state-owned lands are quite general. Basically, they grant to the Commission on Natural Resources the authority to lease state-owned lands however and under whatever conditions the Commission deems appropriate and sets a minimum royalty rate. We sensed considerable uncertainty in industry about how to deal with us. What we needed was an administrative framework defining the procedures under which sales would be conducted, the rights of industry, the prerogatives of the state, and state agency responsibilities. We set forth, therefore, to develop rules and regulations which would provide this guidance. In doing so, we obtained copies of the rules and regulations of the Gulf Coastal States and the Minerals Management Service and tried to use the best of each. While I sometimes thought we were coming up with an unusual combination, after three public hearings and two extended line-by-line reviews with industry representatives, we produced a set of regulations which I think could be characterized as fair but firm.

At the time, the industry in Mississippi used primarily the producer's 88 lease form. We did not feel that form provided adequate

protection to the state. Keeping in mind that in the 70s substantial disagreement between the state and industry of an acceptable lease form was one of the contributing factors to there being no lease offering at that time, we set out to develop a new lease form that both industry and the state could live with. We followed much the same procedure as with the rules and regulations. We drew extensively from currently in-use lease forms of the other coastal states and the federal government. It was our feeling that we wanted, where possible, to use phrases with which the industry was already familiar, rather than create new wording, the meaning of which might not be clear to all parties. Again, after several negotiating sessions with industry, we adopted a lease form which I believe would be characterized as tight but fair.

We undertook one other major effort prior to our first formal offering. In order to give potential bidders the best information we could concerning environmental constraints, we developed a document called "The Environmental Profile and Generic Environmental Guidelines," which identified sensitive environmental areas in substantial detail and provided guidance as to what would and would not be acceptable oil and gas activities in the Sound. We wanted industry to be aware of these constraints prior to submitting bids.

All of these things took some time, of course, and while we were doing them, the economic outlook in the oil and gas industry changed substantially.

After going through a nomination process and following a flurry of seismic activity, the decision was made to offer roughly the southern half of the Sound for lease, i.e., that area from three miles north to three miles south of the Barrier Islands. After adjustments as necessary to recognize the lack of agreement with Alabama on the state's boundary and the federal enclave litigation, the area available was about 220,000 acres.

After a two-month delay at the request of industry, Mississippi's first formal offshore oil and gas sale was held in July 1982. The initial

sale was a cash bonus sale with all other variables being fixed. Royalty was fixed at 20%. The minimum allowable by statute is 18-3/4%. Bids were received on eight tracts, totaling 23,000 acres, about 10% of the offered area. Total high bonus bids were \$5,522,948 or an average of \$239.71 per acre. After analysis, the Commission awarded leases on two tracts of 2880 acres each for \$3,241,000, or \$562.67 per acre. These were five-year term leases issued to Chevron. Thus far, there has been no activity or indication of activity on these lease blocks.

There was some disappointment in the sale, perhaps more than there should have been, most likely because expectations were higher than they should have been in view of Alabama's very successful sale the previous year.

Nevertheless, we made a deliberate effort to analyze why we had not done better, and in this regard talked with a number of industry people. A big reason obviously was the timing in that we caught the downturn in oil and gas activity worldwide. Another reason given, though there was considerable disagreement among geologists, was that the available seismic data was of poor quality. At that time the only kind of seismic data available was collected with air guns as the energy source. We have since issued a number of permits involving drilling and explosives as the energy source.

The foremost reason, however, was that the Sound is a wildcat area. This is very clear in reviewing the results of a sale held two months later in Alabama. In that sale, Alabama accepted only one bid in the amount of \$2,406.95 per acre with a 25% royalty. They rejected eight bids for other blocks, ranging from \$200.04 per acre up to \$931.27 per acre. This certainly illustrates to me at least that while lease money during this period was tight, it was available where industry felt there was a high potential of success.

For some time then we decided the best thing to do was wait for the general economic outlook to improve, and particularly that in the oil and gas industry. While we have waited, successful wells were brought in

in Alabama waters nearer to us, and there has been greater activity in adjacent federal waters.

After a great deal of internal discussions and debate, we also concluded that we were a wildcat area and would remain such until exploration activity occurred. Having come to that conclusion, it followed then that too much emphasis was being placed on upfront bonus money rather than activities designed to enhance exploration.

We decided, therefore, that in order to get exploration initiated we would hold a drilling commitment sale where the emphasis would be placed on a commitment to drill rather than bonus. We know that the major industry leaders disliked this type of sale, but we had enough industry interest to warrant our proceeding. We have begun advertising under this concept, with proposals to be opened on January 16, 1985. Proposers will be asked to specify the following:

(1) The number of days after execution of a lease that the lessee will apply for necessary environmental permits.

(2) The number of days after receipt of such permits that drilling activities will begin.

(3) The proposed depth and formation to which the initial well will be drilled.

(4) The royalty percentage offered.

(5) Amount of compensation to be offered in the event the well is not drilled, such damages being equivalent to the dry hole cost of the proposed test.

(6) Proof of financial capability acceptable to the Commission.

(7) Bonus funds are not required but may be offered. If offered, they will be considered, but the primary consideration is the drilling commitment.

We have no way of knowing how successful we will be in this effort, but we have had a reasonable level of interest. Of course, the real proof of interest, or lack thereof, will be evident on January 16th. However, if we get one hole down as a result of this effort, it will be more than we now have, and we will consider the offering a success.



I should add that this effort should not be interpreted that future sales will be of the same type. We still prefer the lease bonus-type sale and likely will go back to that technique after this sale. Likewise, we are not interested in leasing the entire Sound under this concept. The amount of surface area that can be held by a single commitment is limited, depending on the depth of the horizon to be explored.

## HISTORIC LEASING, EXPLORATION AND DEVELOPMENT ACTIVITY IN LOUISIANA STATE WATERS

Mr. William E. Howe  
Louisiana Department of Natural Resources

Louisiana has been leasing state lands and waterbottoms since 1915. The State has title to approximately 5 million acres, about 4 million of which constitute navigable waters which were granted to the State in 1812 (at statehood) as sovereignty lands. About 40% of Louisiana's lands are under mineral lease. Since leasing began, the state has offered over 21,500 tracts and granted 11,800 leases.

### MAJOR CHANGES IN LEASING PROCEDURES

From 1915 to 1936 authority to lease was with the Governor. In 1936 the legislature created the State Mineral Board and gave it exclusive authority to grant and administer leases for minerals. In 1939 the Board limited the maximum primary term of leases to 3 years. In 1940 leases were limited to 5,000 acres by legislative act. That same year authority was given to the Board to receive portion bids on tracts offered, a practice still followed. In 1966 the Board changed the primary term of offshore leases to 5 years. In 1969 lease sales were begun on a monthly basis and have continued at that frequency. A policy change by

the Board in 1976 limited tract size to 2,500 acres. In 1977 the Department of Natural Resources was created and submission of lease applications was required to be made to the Secretary for review and recommendation to the Board. In 1984 the Board began encouraging bidding of drilling commitments.

## HISTORY AND STATISTICS

The first offshore "modern" lease sale was held on August 8, 1945, by the Louisiana State Mineral Board, although offshore waters had been leased in South Louisiana beginning in 1920. From August 1945, through October 1948, the Board awarded over 900 offshore leases within the state boundaries as established by the Legislature. The first offshore well out of sight of land was drilled in 1947 by Kerr-McGee about 45 miles south of Morgan City. Slightly over 4,000 wells have since been drilled in state offshore waters from which approximately 10 billion barrels of oil, 135 million barrels of condensate, 15 trillion cubic feet of dry gas and 45 billion cubic feet of casinghead gas have been produced.

Approximately \$600 million annually is realized by Louisiana from its oil and gas production in the form of bonuses, rentals, royalties and severance tax.

## PROCEDURES AND REQUIREMENTS

The vast majority of lease tracts are nominated by industry according to statutory requirements. The full amount of the cash consideration must be submitted with a bid. Rentals cannot be less than 1/2 the cash payment. Minimum royalties are 1/8 but have averaged 24 to 26% for the past several years. Lease sales are held the second Wednesday of the month at a time and place specified by the Board. Bids are publicly opened, read, reviewed, and decisions on award are made on the same day.

## RATES OF PRODUCTION

Prior to 1954, 98% of the OCS oil produced came from state waters. The peak year for the state's production was 1968, during which production reached 20% of that for the OCS. By 1982 the state's percentage of OCS oil production had dropped to 8%.

Prior to 1954, 78% of the OCS gas was from state waters. Peak year for state gas was 1969, but this accounted for only 26% of the OCS gas. By 1982 the state's OCS gas production was down to 8%.

## HISTORIC LEASING, EXPLORATION AND DEVELOPMENT ACTIVITY IN TEXAS STATE WATERS

Dr. E. G. Wermund  
University of Texas  
Bureau of Economic Geology

Leasing in Texas state waters is administered by the School Land Board of the Texas General Land Office (GLO). The principal contact for leasing is Mr. Murphy Hawkins, Director of Petroleum and Minerals Development in GLO, who supplied the following information.

Texas submerged lands include those lands between mean high tide and three leagues offshore, or approximately 11.5 miles. The Texas bays and Gulf produce principally gas/condensate to date with only minimal amounts of oil production, and the character of the production strongly influences leasing. The first lease of record occurred in 1922; the next records of leasing appear in a 1945/1947 time frame. First annual records appear in 1958/1959 and reflect the forthcoming 1960 Supreme Court decision which established the Texas/federal continental shelf boundary at three leagues.

Since 1974 (Table 4), there have been 21 lease sales. Generally, there were two lease sales annually, but Texas held three in 1975 and 1977 and only one in 1983. During the ten-year interval 1974 to 1983, 10,467 tracts were offered and 2,669 leases awarded, about 25% of the offering. Some highlights of individual sales include:

Largest offering	941 in 10/79
Smallest offering	32 in 6/75
Largest awarded	276 in 2/79
Smallest awarded	5 in 6/75
Largest percent leased	46 in 4/80
Smallest percent leased	0.3 in 6/76

Since leasing began, the total revenue to Texas from its submerged lands has been \$1.5 billion, \$440 million from bonus payments, \$92 million from rental, and \$925 million from royalties. The largest bonus year was \$53 million in 1964/65; maximum rental was \$14.2 million in 1981/82; and maximum royalties were \$209 million in 1981/82. A ten-year history for total leasing income is given in Table 5 with bonuses, rentals, and royalties itemized in Table 6. There has been a steady increase of lease income to 1981/82, followed by a decline in 1982/83. It is not certain whether the short-term decline reflects a downturn in oil and gas activity and price or a poor gas market. I hope, the negative change does not reflect a continued decline in oil and gas production.

The well status for the most recent decade of drilling wells includes 512 producers and 992 drilled and abandoned, a total of 1,504 wells. There are now 91 platforms on Texas submerged lands. Texas does not have lengthy records of production. However, based on sales records, equivalent barrels of production were 2,906,412 in 1981; 3,702,125 in 1982; and 2,993,216 in 1983. There was clearly a decline in production the last year, which is reflected by royalty income (Table 6).

Finally, I was asked to describe a history for pipelines in state waters. Here the record is incomplete. The General Land Office has granted easements which total 1,362 line miles. There is not an annual

Table 4 . Ten-year history of lease offering on Texas Submerged Lands in calendar years .

<u>Year</u>	<u># of Sales</u>	<u>Tracts Offered</u>	<u>Leases Awarded</u>
1974	2	1,274	275
1975	3	843	89
1976	2	1,177	243
1977	3	1,008	270
1978	2	851	277
1979	2	1,867	500
1980	2	1,178	457
1981	2	701	306
1982	2	818	151
1983	1	750	101

Table 5 . Ten years of total revenue from Texas submerged lands by fiscal years .

73/74	\$ 41,717,669
74/75	27,321,535
75/76	38,747,073
76/77	84,196,226
77/78	118,266,810
78/79	100,410,267
79/80	200,263,802
80/81	219,126,875
81/82	250,824,580
82/83	165,176,933

Table 6. Ten-year history of income from leasing Texas submerged lands, separated into rental, bonus and royalty.

<u>Year</u>	<u>Rental</u>	<u>Bonus</u>	<u>Royalty</u>
1973/74	\$ 1,065,516	\$32,981,619	\$ 7,670,534
1974/75	2,935,295	5,319,762	19,066,478
1975/76	3,222,535	6,197,853	29,326,685
1976/77	2,404,988	41,343,114	40,448,124
1977/78	4,775,509	49,807,750	63,683,551
1978/79	7,318,748	34,578,340	58,513,179
1979/80	10,293,153	34,733,270	155,237,379
1980/81	13,100,484	37,467,196	168,559,195
1981/82	14,214,478	27,529,516	209,080,586
1982/83	11,986,676	10,180,696	143,009,561

record. Moreover, it is not known how many pipelines were actually constructed in the easements. I don't know how many line miles connect directly to the federal OCS lands.

## A REVIEW OF OFFSHORE OIL AND GAS LEASING PROGRAMS OF GULF COASTAL STATES

Dr. James W. Miller  
Florida Institute of Oceanography

### INTRODUCTION

Recognizing that the increasing interest of industry in exploring Florida's Outer Continental Shelf could spread into state waters, the Florida Department of Community Affairs (DCA) proposed in 1982 that a comprehensive study be undertaken of potential oil and gas operations in state waters. As the first step in this program, a grant was awarded by DCA to the Florida Institute of Oceanography (FIO) in May 1983, to review Florida's existing leasing procedures as well as those of Alabama, Alaska, California, Florida, Louisiana, Mississippi, North Carolina, South Carolina, and Texas. The information obtained has been incorporated into specific policy and program recommendations to aid Florida officials in making decisions relevant to the development and implementation of a long range oil and gas program in Florida waters.

Program elements were analyzed for each of the nine states, and the results are contained in a report entitled "Oil and Gas Leasing in Florida Waters" published by FIO in October 1984. Only the five Gulf states are discussed herein.



## LEASING HISTORY

Historically, offshore leasing in the Gulf of Mexico spans about 60 years. Louisiana and Texas issued their first offshore leases in 1920 and 1922 respectively, with Florida following in the 1940s, Alabama in the 1950s, and Mississippi in 1982. As we know, the extent to which leasing has expanded varies among states from the thousands of leases issued in Louisiana resulting in about 40% of offshore submerged lands being under lease as of a year ago, to only two leases awarded in Mississippi totalling just 5760 acres. The largest single lease in the Gulf is one issue by the State of Florida to Coastal Petroleum, which covers 2.3 million acres. Interestingly this lease, which was renegotiated in 1976, remains in effect until the year 2016.

## STATUTORY AUTHORITY AND ANNEXATION

The statutory authority for oil and gas leasing in the Gulf states varies considerably and may be vested in the hands of a single appointed individual, a board of appointees, or, as in the case of Florida, a board of elected officials.

The complexity of the social, political, and environmental issues faced by these boards and individuals varies significantly from state to state. States such as Louisiana with long histories of offshore leasing have evolved routine procedures so that monthly lease sales can be held. In other states, a lease sale is a major undertaking. New issues do arise, however, and they can have major impact on leasing programs. For example, a couple of years ago questions arose in Texas about the extent and boundaries of municipal annexation of adjacent offshore waters. In an age where public officials at every level are competing fiercely for tax dollars, this issue may turn out to be a sleeping giant. Of the five coastal Gulf states, only two address the issue of annexation of offshore waters in state constitutions or statutes. The potential role of local governments in offshore annexation could be a particularly thorny issue for Florida if offshore activities develop in state waters because of its 1350 mile coastline which encompasses 33 coastal counties. If the stakes

become high enough, the litigation resulting from competing annexation laws and local regulations could keep the courts busy for years.

## LEASING AND BIDDING PROCEDURES

A comparison of leasing terms among the Gulf states reveals many similarities. The primary lease term for example is five years in each state, a sharp contrast to California, where the primary term is 20 years, and to Florida's coastal petroleum lease, which is 40 years. The procedures for handling lease extensions, transfers, bidding, advertisements, and proprietary information are similar among the Gulf states. The basis of award, however, does vary. Florida's system of basing an award solely on the high bonus is the least flexible. One of the recommendations in our report is that this practice be reviewed and that a more flexible award basis be considered.

## ENVIRONMENTAL MANAGEMENT

Vast differences in the attitudes toward environmental protection in the Gulf states are reflected in both the spirit and the laws governing offshore oil and gas activities. It is obvious that if oil and gas exploration in the Gulf were commenced for the first time in 1985, the approach and procedures would differ greatly from those used in the 1920s in Texas and Louisiana waters. For example, the current Alabama policy of "qualified zero discharges" would have been heresy 50 years ago.

There is not time to discuss the environmental programs and/or management policies of each state. They are described in the report referred to earlier. It is interesting to note, however, that with all the expressed concern about the need for data and environmental protection, of the five Gulf states, only Mississippi supports a program of environmental research aimed specifically at obtaining data for establishing criteria for environmental decisions affecting oil and gas leasing stipulations. I must hasten to add that other states utilize environmental data in making such decisions, but these data usually are

obtained from existing sources. In contrast, both California and Alaska have dedicated environmental baseline research programs for oil and gas development.

An excellent system for establishing environmental stipulations is used in Texas. Not only does it systematize site-specific environmental data, but it is designed to inform the oil industry of environmental restrictions up-front during the leasing phase. Through the use of "Resource Management Codes" the Texas General Land Office advises potential lessees of environmental restrictions on a tract-by-tract basis.

One of the recommendations in our report on Florida's leasing program is that a similar system be adopted at this time. By establishing an organized offshore environmental network, data can be entered as it becomes available, better decisions on submerged land use can be made, research priorities can be identified, and industry can be kept apprised of potential environmental stipulations. In my opinion, it is important that environmental restraints be designated clearly before or, at least, during the leasing phase, rather than being inserted during the permitting process.

## OIL AND GAS REVENUES

Oil and gas revenues accruing to states generally fall into four categories: royalties, rentals, bonuses, and severance taxes. Minimum royalties set by statute usually are 12 1/2%, with the range of typical royalties actually assessed being 16 2/3% to 25%, although Louisiana's royalties can exceed 30%. Rental fees per acre of leased land run from \$3.50 in Florida for the first two years and \$.50/year increase after second year, to \$5.00 in Alabama. Mississippi has not established a rental rate, and Texas and Louisiana do not charge rent if the leased land is in production. Bonuses usually are by competitive bidding and are set separately for each sale. Severance tax for gas ranges from 5% to 8%, while for oil the range is from 4.6% in Texas to 12.5% in Louisiana.

The distribution of oil and gas revenues varies widely among the five coastal states. In Louisiana and Mississippi, severance tax is lumped with royalties, rentals, and bonuses and distributed accordingly. In Florida, Alabama, and Texas, specific percentages are assigned to special funds, with balances going into the state general fund. The details of oil and gas revenues and their distribution are contained in the report referred to earlier.

In summary, the oil and gas leasing programs of the five Gulf states are similar in many respects. There are, however, significant differences in the manner in which environmental issues are handled. This is not surprising considering the changes in attitude over the past 50 years during which offshore programs have evolved. If exploration in the eastern Gulf is to proceed in a sensible and orderly manner, states such as Florida and Mississippi must take advantage of the lessons learned in Texas and Louisiana. We hope our recommendations regarding Florida's future offshore oil and gas program reflect the knowledge gained from these lessons.

## RIGS TO REEFS

Session: RIGS TO REEFS  
 Co-chairs: Mr. Villere Reggio, Jr.  
 Mr. William DuBose, IV  
 Date: November 28, 1984

<u>Presentation Title</u>	<u>Speaker/Affiliation</u>
Session Overview	Mr. Villere Reggio, Jr. MMS, Gulf of Mexico Region
REEF Task Force	Mr. William P. DuBose, IV National Ocean Industries Association (NOIA)
National Policy on Artificial Reefs	Mr. Richard Krahl MMS, Reston, VA
Smithsonian's SITES Project on Artificial Reefs	Mr. Tom Sullivan Sullivan Productions
Regional Planning Progress	Mr. Larry Simpson Gulf States Marine Fisheries Commission
Artificial Reef Siting Plan	Mr. James Jones Mississippi/Alabama Sea Grant Consortium
Artificial Reef Site Selection to Maximize Recreational Fishing Benefits in the Gulf of Mexico	Mr. DeWitt Myatt The Sport Fishing Institute
Rigs-From-Reefs: The Nuts and Bolts of Conversion	Dr. Heyward Mathews St. Petersburg Junior College

Liability Concerns/Rigs to Reefs	Ms. Patricia Collins The Sport Fishing Institute
Alabama's Artificial Reef Program	Mr. Hugh Swingle Alabama Department of Conservation & Natural Resources
Factors, Considerations, and Trade Offs	Mr. Dana Larson Exxon
National Research Council Study of the Disposition of Offshore Petroleum Platforms	Mr. Griff C. Lee Member National Academy of Engineering
Artificial Reefs: Department of Defense Perspective Issues	CDR John Henriksen Office of the Secretary Of Defense
Potential Impacts of the Removal of Oil and Gas Production Platforms on the Louisiana Shrimp Industry	Mr. Jerald Horst Louisiana Cooperative Extension Service, and Mr. John MialJevich Concerned Shrimpers of Louisiana

## SESSION OVERVIEW: RIGS-TO-REEFS

Mr. Villere C. Reggio, Jr.  
Minerals Management Service

Rigs-to-Reefs, a concept cussed and discussed both in and out of government with increasing frequency over the last several years has finally come of age. Task forces; supportive resolutions from diverse, but organized marine interest groups; biological, social, and economic study reports; extensive expert testimony; popular articles; broad public support; demonstration projects; 30 years of "rig" fishing; political leadership; and good old common sense has led this country to adopt a national policy supporting the proper siting and development of artificial reefs.

The Gulf of Mexico has a continuing supply of oil and gas structures, referred to by the Secretary of the Interior as "de facto" artificial reefs, reaching commercial obsolescence. If we are to maintain and expand on the enhanced fisheries benefits associated with production platforms, we must find the ways and means to keep them as productive resources in the marine environment. We now have a legislative mandate in the National Fishing Enhancement Act of 1984 to move expeditiously yet cautiously toward that objective. Component policies, regulations, plans, and procedures at the national, regional, state, and local levels must be drafted, reviewed, revised, and adopted. Issues must be identified, discussed, studied, reported on, and resolved. In that light we assembled an impressive group of presentors from government, industry, and academia to report on the progress of policy, plans, issues, studies, and projects which will have a direct bearing on a successful Rigs-to-Reefs program dependent on the mutual support and cooperation of the total marine community with interest in the conservation, development, and enjoyment of the resources in the Gulf of Mexico.



It is interesting to note from a fisheries standpoint the great concern, extensive research, and financial support going into understanding, defining, and mitigating the increasing wetlands loss problems in coastal Louisiana, a portion of which can directly and indirectly be attributed to the permitted land and water modifications associated with the access, development, and product transportation requirements of the petroleum extraction industry in the coastal zone.

On the other hand, relatively little concern has been expressed about the costly removal of 400 oil and gas structures from the OCS to date, and the projected removal of 2/3 of the major structures now operating in the Gulf of Mexico over the next 16 years. Dr. Benny Gallaway has determined that oil and gas structures in the nearshore and offshore marine environment currently constitute 28% of the known hard bottom habitat in the Central and Western Gulf of Mexico. There is no doubt the oil and gas industry is responsible for every bit of this habitat, yet we have required that they destroy these reefs once all the threat of pollution has ceased; that is, when they could no longer produce oil and gas, they weren't allowed to produce fish any more either.

I submit that by dedicating just a small portion of our intellectual and financial resources toward recognizing the value and jeopardy of our offshore fishing resources we are now better able to move forward with meaningful, feasible offshore fishery enhancement projects which can take up the slack from resource losses inshore caused by environmental perturbations and ever increasing demand for fun fishing and food fishing. If we are to be successful and make significant progress in reef development in the Gulf of Mexico, it will be because of the oil and gas industry and not in spite of them.

It seems apparent to me from the discussions today and elsewhere that there are biological, social, and economic reasons to retain many if not most oil and gas structures offshore. Policy is emerging which will allow and encourage the retention of obsolete petroleum structures offshore; therefore, it is incumbent upon us all to find the most suitable sites and the ways and means to convert rigs-to-reefs so that the givers,

the takers, and the users will all benefit to the maximum extent possible. If we are able to plan and implement a rigs-to-reefs program where the benefits are mutually shared by all affected, then we will have a successful program.

With a recently proclaimed Exclusive Economic Zone (EEZ), an established and functioning Artificial Reef Development Center, a brand new artificial reef law, and new oil and gas prospects within our continental margins, we can confidently celebrate the Year of the Ocean in anticipation of continued public and private cooperation directed at expanded use and appreciation of our offshore marine environment.

#### REEF TASK FORCE

Mr. William P. DuBose, IV  
National Ocean Industries Association (NOIA)

In August 1983, then Secretary of the Interior James G. Watt created the Recreation, Environmental Enhancement and Fishing in the Seas (REEFS) task force to "pave the way for aggressive movement towards a national Rigs-To-Reefs program which will enhance fishery resources and improve recreational and sport fishing opportunities within America's offshore marine environments." The task force evolved from a series of meetings Secretary Watt held to address the conversion of offshore oil and gas structures and other appropriate materials into artificial reefs.

The task force is comprised of representatives from federal and state governmental agencies, the petroleum and ocean industries, commercial and recreational fishing industries, and academia. Initially, the task force was co-chaired by Secretary Watt and Charles D.

Matthews, President of the National Ocean Industries Association. Today, the group is co-chaired by Mr. Matthews and Secretary of the Interior William P. Clark.

On 10 July 1984, the third meeting of the REEFS task force was held in New Orleans, Louisiana, in conjunction with the 1984 World's Fair. In addition to a full day meeting, task force members were exposed to the fine recreational fishing available around the many producing petroleum platforms in the Gulf of Mexico and a reception and tour of the Petroleum Industry Pavilion at the World's Fair.

The meeting itself consisted of several presentations which focussed on the national perspective with regard to artificial reef development. Secretary Clark and Deputy Assistant Secretary Steve Griles provided the group with an update on the Interior Department's continued support of and interest in artificial reefs development and, specifically, the Rigs-To-Reefs concept. They also discussed, as did Anthony Calio, then Deputy Administrator for the National Oceanic and Atmospheric Administration, the progress the federal governmental agencies had made toward the signing of a memorandum of understanding (MOU) with regard to reef development. That MOU is still unsigned today!

Congressman John Breaux also provided an update as to the progress his artificial reef legislation had made in the Congress. Today, we are aware that the National Fishing Enhancement Act of 1984 was passed by the Congress and signed into law by President Reagan on 8 November 1984. This bill was Title II of H.R. 6342, which will be designated Public Law 98-623. This very important law requires the federal government, under the direction of the Secretary of Commerce, to develop a national artificial reef plan which includes siting criteria, construction criteria, management strategies, and an evaluation of financial incentives for the donation of reef construction materials, including tax credits and the mitigation banking concept.

The reefs law also provides some very important liability language with regard to protecting the donors of artificial reef construction

materials. Specifically, the law states that any entity transferring title to the construction materials to a permitted reef sponsor is not liable for subsequent damages if the materials meet the criteria to be developed under the auspices of the national artificial reef plan and provided that they are not defective at the time the title is transferred.

#### **NOIA/PETROLEUM INDUSTRY SUPPORT**

NOIA is the only national trade association representing the ocean industries of the United States. With our approximate 450 members, we represent a broad cross section of ocean related industries, many of which can provide materials, expertise, and manpower to facilitate the development of artificial reefs. NOIA has been in the forefront for many years in advocating a program of enhancing the ocean's living resources by a realistic program of turning rigs into reefs. We have long believed the intentional use of active and obsolete petroleum production structures on the outer continental shelf as artificial reefs would be beneficial for everyone.

As most of you know, the petroleum industry has supported the Rigs-to-Reefs concept not only by voice but by action. In 1980, Exxon Company, U.S.A., donated a 2,200 ton experimental submerged production system template to the state of Florida. This structure was removed from its site in 170 feet of water offshore Louisiana, towed 300 miles at company expense, and placed at a depth of 110 feet about 35 miles offshore of Apalachicola.

Tenneco, Inc., generously provided Florida with its second reef constructed of an obsolete platform in 1982. After a 275-mile barge trip from its original position 75 miles south of Morgan City, Louisiana, the 500 ton structure was submerged in about 175 feet of water about 22 miles southeast of Pensacola.

More recently, Marathon Oil Company moved a four-leg piled platform from Ship Shoal block 272, in about 220 feet of water offshore Louisiana, to its present position about 60 miles south of Mobile Bay,

Alabama. This was a unique effort, as the jacket's trip of 130 miles from Louisiana to Alabama was done without a barge. Instead, four specially fabricated buoyancy tanks were attached to the structure to allow it to float about five feet below the water surface. It was then towed to the reef site.

As these examples show, petroleum companies have donated not only the reef construction materials but the associated transportation and placement costs too. Clearly, our industry has more than a passing interest in the creation of artificial reefs. In fact, several companies are presently examining the possibility of furthering the Rigs-To-Reefs Program.

In closing, I would like to reaffirm that NOIA and the petroleum industry support the Rigs-to-Reefs concept and look forward to continued participation in a most important program which benefits all Americans.

## NATIONAL POLICY ON ARTIFICIAL REEFS

Mr. Richard Krahl  
Minerals Management Service

At the REEF's task force meeting in July 1984, Secretary William P. Clark stated that "because offshore platform demonstrates our multiple use philosophy, the Department strongly advocates a planned and directed program to encourage proper placement and use of selected and properly removed platforms and artificial reefs for the conservation, management, and enhancement of our marine environments."

MMS is now setting out this policy to our Regional Directors "to encourage the conversion of selected obsolete oil and gas structures to artificial reefs on the OCS to enhance recreational and fishing opportunities with predetermined guidelines and goals." General policy tempered by the "predetermined guideline and goals." This caveat is steered by several actions:

Congress passed and the President signed the National Fishing Enhancement Act of 1984. This is an act initiated by Congressman Breaux to establish national standards for the construction and siting of artificial reefs in the waters of the United States in order to enhance fishing resources and opportunities. It states that: artificial reefs will be sited and managed in a manner to enhance fishing resources; facilitate access and utilization by U.S. fishermen both commercial and recreational; minimize conflicts among competing users; and minimize environmental risks and risks to personal health and property. It requires that within one year after enactment, a long-term plan will be developed by the Department of Commerce with consultation with other specific federal agencies, states, fishing organizations, and the private sector to accomplish the purpose of the act.

As set forth under previous legislation, the Department of the Army (Corps of Engineers) will continue to issue permits for the establishment of artificial reefs, but these permits will be issued under the terms of the act, which includes consideration of the national artificial reefs plan; that the title to the construction material that constitutes the reef is clearly set forth; and that the responsibility for maintenance and any future liability is established.

A parallel, but not unrelated, effort is the development and, perhaps, soon to be executed, memorandum of understanding (MOU) between the federal agencies outlined in the above-quoted act: the Departments of the Interior, Commerce, Transportation, Defense, and the EPA.

The MOU requires that these agencies will develop a national artificial reef program. It also outlines the specific function the various agencies need to perform in line with their statutory responsibilities. It all seems very simple now. We have an act mandating a plan for the creation of artificial reefs in a structured manner. We will soon have an MOU, which upon execution could provide the implementing procedures for fulfilling the legislation mandate.

But, like many other things in government, it is not quite that easy. The MOU has not been signed as yet. Though the general policy expressed in the MOU has been endorsed by all the agencies, some implementing procedures have not been resolved. Meetings to bring this into resolution are being conducted this week. National security issues related to the nonremoval or relocation of platforms on the OCS remains a concern to the Department of Defense. The Department of Commerce, specifically NOAA, has prepared a "Preliminary Federal Programmatic Statement for Artificial Reefs" which has been circulated for review to most of the interested parties, in both the public and private sectors. This could be the basis for the national plan called for under the act. It is general in nature and presents guidelines for state and regional planners to consider in the development of artificial reefs plans. However, from all this there does not seem to be instructions as to the procedures for the determination of where specific reefs should or should not be located.

It would appear that a national artificial reefs plan would include a requirement that in any given offshore area a task force or knowledgeable group should be established, composed of all parties of interest, to determine the specific area where artificial reefs can be established or should not be established under the standards set forth in the national plan and in accordance with the act.

The Department of the Interior policy has been stated as encouraging and being supportive of the Artificial Reefs Program. Concerning the conversion of obsolete platforms (which we call those platforms that are no longer needed for oil and gas production) to reefs,

there are several items that need to be considered: current regulation requires that all obsolete structures be removed to a depth of 15 feet below the sea bottom and that surveys be conducted to ensure there is nothing left that could jeopardize fishing interests. Upon execution of the MOU, modification of this requirement can only be effected after development of a new policy by parties to the MOU. Therefore, approval by MMS for the retention, relocation, rather than complete removal of an obsolete platform can only be granted if it is in accordance with the national artificial reefs plan and more specifically to a local plan developed in accordance with the guidelines set forth in the national plan. This includes the siting at a specific location and establishment of a responsible party for the maintenance or liability who has received concurrence by the signatory agencies to the MOU.

There have been legitimate concerns raised as to the costs and benefits of the removal of platforms or disposing of them offshore in other areas. To explore these, and other issues, we have contracted with the Marine Board of the National Research Council to look at the many facets involved with this question.

In summary, we recognize the demonstrated potential for the enhancement of fishing resources as a result of offshore structures. We support the retention and reuse of obsolete platforms in a manner that would further enhance these resources. This will be implemented in accordance with current laws, regulations, and interagency agreements.



## SMITHSONIAN'S SITES PROJECT ON ARTIFICIAL REEFS

Mr. Tom Sullivan  
Sullivan Productions

The Smithsonian Institution Traveling Exhibition Service (SITES) has endorsed and will sponsor and contribute support to Tom Sullivan's proposal to develop an impressive national exhibit on artificial reefs. Tom explained his project titled "Artificial Reefs: Expanding on Nature's Idea" should be ready for opening in early 1986. The exhibit is currently in the design stage and will consist of 2,500 square feet of exhibit space requiring two tractor trailers to transport. Once complete, the exhibit will be made available to over 7,000 museums, colleges, and institutions throughout the United States during its exhibition life of two to five years and may even travel to foreign countries.

As an educational, enlightenment program, SITES develops films, books, posters, lectures, and workshops in support of its exhibits. Last year SITES exhibits reached over eight million people. Tom indicated each host city will include a lecture series and a one-day workshop.

The planned exhibit will feature the history, biology, technology, and human value of artificial reefs in both marine and freshwater environments. Tom said government involvement in artificial reefs and Rigs-to-Reefs was to be a major feature of the exhibit. He is seeking additional ideas for three dimensional input for the exhibit and would appreciate additional sponsorship interest for the project.

## REGIONAL PLANNING PROGRESS

Mr. Larry B. Simpson  
Gulf States Marine Fisheries Commission

The Gulf States Marine Fisheries Commission has supported regional plans for artificial reefs since the mid-70s. The issue of national standards for construction, placement, maintenance, and liability continues to be of great concern to the commercial bottom trawler. This concern has been exhibited in the form of intensified conflicts between recreational and commercial fishermen. I feel we are closer to resolving some of these conflicts by national artificial reef legislation that will provide standards and policy for construction, placement, maintenance, and liability. National legislation has been passed and was signed by the President on November 9 of this year. This legislation calls for these standards to be established by development of a national plan.

My commission, which as I said has had a long-term involvement in this issue, adopted a resolution at our March 1983 spring meeting in Austin, Texas which called for Congress to enact such a national artificial reef policy act. As a result of this input, Congressman John Breaux introduced legislation in the form of H.R. 3474. This bill included provisions for standards and technical language for tax exemptions for those who donated artificial reef materials. This version was modified, based on comments, by removing the tax exemption language but still calling for a study of exemptions and maintaining the need for a national plan utilizing various agencies and the private sector input for development of standards. This legislation is the version that the President signed (i.e., Title II of P.L. 98-623).

The need for such legislation is abundantly apparent. The history of problems associated with this issue and the Department of Interior's Recreational Environmental Enhancement for Fishing in the Seas (REEFS) program call for national policy guidance. But considering the 4,000 oil

and gas structures in the Gulf of Mexico that will eventually become obsolete and the interest in using them for artificial reefs, we must develop sound national standards with regional and state plans for their utilization.

I must say that initially Secretary James Watt in testimony before the House Merchant and Marine Fisheries subcommittee on H.R. 3474 indicated the legislation was unnecessary. He stated that the Department of Interior could handle the issue of national standards administratively. Time has shown what Congressman Breaux and others were aware of at the first introduction of this legislation. That is the urgent need for the development of national standards embodied in a legislative mandate. The Department of Interior has since reversed its position on the need for this type legislation and now supports H.R. 5447, the current form of the bill.

I feel it is important to emphasize and clarify my commission's position as well as the role of the legislation and national planning efforts. These activities are directed at encouraging national policy and standards for artificial reefs, not development of artificial reefs. This aspect of artificial reefs (i.e., encouraging development) is a function for the permit applicants.

There exists a great deal of effort in the Gulf of Mexico to implement effectively a regional plan for artificial reefs. I have been involved as the chairman of the Gulf of Mexico Fishery Management Council's artificial reef committee and a subcommittee of the marine and estuarine committee of the International Association of Fish and Wildlife Agencies. This latter group of 13 people from across the United States has developed some initial positions with regard to a national plan or policy on artificial reefs. These general comments are summarized as follows:

1. -Final authority for artificial reefs sited in state waters should be a state function.  
-Permits can still be administered by the Army Corps of Engineers.

- States should be closely involved in siting of artificial reefs in FCZ off their coasts.
2. -Siting of reefs should not be on existing trawlable bottoms.
  3. -Some obsolete oil and gas platforms should be left in place rather than removed.
    - Selection should be based on location/availability, productivity, condition, state recommendation, etc.
  4. -The liability issue has not been resolved.
    - Some agencies feel receiving authority should be exempted from liability.
    - Industry feels need to cleanup liability on unmaintained reefs and ones that move, (e.g., tires, incorrectly sited reefs).
    - H.R. 5447 absolves liability if permit conditions have been met.
    - If reef is unmaintained (i.e., no buoys, lights, etc.) and damage to moveable fishing gear occurs, is permittee liable?
  5. -Some form of tax credit for donation of artificial reef materials is appropriate.
    - Credit should be limited to costs involved in removal, transport, placement, research, maintenance, etc.
  6. -No onshore habitat mitigation credits should be given for habitat enhancement as result of development of artificial reefs offshore.
    - Habitat mitigation should be done in same area on same type habitat.
  7. -Standards for materials used in construction of artificial reefs should be developed.
    - Materials must be suitable and proven to have ability to remain in place.

8. -Some research is needed for artificial reefs:
  - Size and configuraion for best results
  - Benefits of construction types
  - Liability issues
  - Number of reefs in area that will be beneficial
  - Catch/effort data on reefs

This is not the only work being done to address regional planning efforts. The National Marine Fisheries Service Southeast Regional Office has worked with the Jacksonville, Florida, District of the Army Corps of Engineers to develop a general permit for artificial reefs. Through Saltonstall-Kennedy grants to the Mississippi-Alabama Sea Grant Consortium and the Sport Fishing Institute, siting plans and economic studies are being developed for the Gulf of Mexico that will be of prime importance to a national/regional plan. Further discussion of these efforts are scheduled for this and other sessions.

Since the President signed artificial reef legislation calling for a national plan, the Washington office of the National Marine Fisheries Service will be charged with its development. People there are currently developing a document titled "Federal Guidelines for Artificial Reefs." It is my understanding that they plan to expand the federal working group in Washington to bring in the necessary expertise on specific issues such as liability, marking and maintenance, state concerns, international issues, defense issues, etc. From this and the work I have previously mentioned being done, coupled with broad public/industry review, the national plan charged to the Secretary of Commerce for development within one year from enactment will develop. It is incumbent on us all to be involved in that development. A national plan for artificial reefs is a complicated task because of the large number of agencies and viewpoints involved.

With passage of the D-J expansion legislation creating a Wallop/Breaux fund for use in marine waters, the states will possibly be able to fund expanded and new artificial reef programs.

The Rigs-to-Reefs program and oil company support should lead to additional artificial reefs. We need a sound, definitive policy for artificial reefs for wise and effective use which will reduce conflicts with moveable fishing gear users.

## ARTIFICIAL REEF SITING PLAN

Dr. James I. Jones, Director  
Mississippi/Alabama Sea Grant Consortium

Dr. Jones informed the session that the Mississippi/Alabama Sea Grant Consortium and Continental Shelf Associates, Inc., with the support of the National Marine Fisheries Service under a Saltonstall-Kennedy Grant will develop comprehensive artificial reef siting plans for the coasts of Mississippi, Alabama, and northwest Florida. The project entails the organization of an advisory group composed of representatives of the co-applicants, affected states, and public and private interests responsible and concerned for marine resources development in the Gulf of Mexico. Principal investigators have been selected to evaluate and report on the legal, social, biological, economic, and operational aspects of artificial reef development associated with the following identified demand centers: Gulfport/Biloxi, Mississippi; Mobile Bay Area (Pascagoula, Mississippi and Dauphin Island and Gulf Shores, Alabama); and the Florida Panhandle (Pensacola, Ft. Walton Beach and Destin). The goal of the project is to develop practical, supportable, artificial reef plans for enhancement of recreational and commercial fishing in consonance with standards and guidelines promulgated in the National Fishing Enhancement Act that will meet the local environmental and permitting requirements of the Corps of Engineers. The end products will consist of three detailed integrated siting plans for each affected Gulf Coast State which will identify and characterize specific artificial reef areas. The practical application of oil

and gas structures as reef development material will be addressed along with other suitable materials likely to be available in the project area. Potential artificial reef sponsoring organizations will be encouraged to use the plan in developing identified project sites. The siting plans should be available by the fall of 1985.

## ARTIFICIAL REEF SITE SELECTION TO MAXIMIZE RECREATIONAL FISHING BENEFITS IN THE GULF OF MEXICO

Mr. DeWitt Myatt  
The Sport Fishing Institute  
Artificial Reef Development Center

Artificial reefs are built for many reasons. Most nations build them for direct economic benefit through commercial harvests. Artificial reefs of the United States are unique when compared with those of other countries because most of our reefs are built to benefit recreational users. While accessibility may not be critical to commercial fishermen, it is an especially important factor in determining the usefulness of public recreational facilities. For this reason, American artificial reef builders need to carefully define their project objectives, then use a systematic process to select reef locations where their goals can be achieved.

The Sport Fishing Institute's (SFI) Artificial Reef Development Center (ARDC) has undertaken a regional study to determine logical sites to build reefs in the Gulf of Mexico. This project, supported by the Saltonstall-Kennedy (S-K) Fishery Development Fund through the National Marine Fisheries Service (NMFS), will provide artificial reef planners with a broad picture of recreational artificial reef fisheries in the Gulf of Mexico region. It will also serve as a guide to public sector decision-making and investment where the cost-benefit ratio is a major

concern. The project also attempts to define narrowly the most important recreational zones off the Gulf Coast, examine the major constraints to building artificial reefs within those areas, and suggests means to minimize or eliminate multiple use conflicts within the selected zones.

The project is oriented primarily toward public recreational fishing reefs that are intended to provide enhanced fisheries to a maximum number of users. Recreational artificial reefs may also be built for other purposes, such as improving local sport fishing for specific user groups, creating a tourist attraction, dispersing fishing pressure to under-utilized areas, enhancing head and charter boat business, and even increasing local real estate values. This project is of most direct value to comprehensive efforts such as Rigs to Reefs, but it also provides a means for placing local projects in a regional perspective.

An exclusionary mapping approach was used to exclude poor locations for artificial reef development--in other words--where reefs should not be built. Through this process of elimination, optimum geographic locations were selected that should provide for maximum benefits to the public. Sites selected through this method offer a high probability of quality recreational fishing from privately owned boats.

Following classic demand theory, recreational facilities at sites near major population areas are normally used to a much greater extent than those at distant sites. Therefore, the best sites for recreational fishing reefs are near areas with the densest populations to ensure maximum use.

Urban areas adjacent to the coastline or within 50 miles of the coast were selected as primary sources of recreational fishermen. In regions where coastal access exists but no urban centers met the preceding criteria, the nearest urban area was selected. U.S. Census data was used to identify a total of 27 metropolitan statistical areas (MSA's) for the Gulf region. This grouping of MSA's accounts for a population of 14,845,000 from a five state population of 32,596,000, or nearly half the



combined populations of Texas, Louisiana, Mississippi, Alabama, and Florida.

In addition to MSA's it was necessary to delineate areas on the Gulf Coast that have a significant seasonal influx of tourists. These seasonal MSA's do not appear on census records because the people utilize secondary residences, hotels, motels, or cottages while in the area. U.S. Travel Data Service economic studies, along with communications with State DNR and Sea Grant personnel, were used to differentiate non-MSA coastal counties with significant seasonal resort populations.

Once coastal population areas were defined, access routes and communities were identified as embarkation points for anglers destined for offshore fishing. NMFS recreational fishing survey intercept data was used to pinpoint and rank coastal access points. State DNR and Sea Grant personnel provided information that was used to refine coastal access site data.

Once land to water access points were defined, the effective points of transition from sheltered water to open Gulf waters were selected as the locus of arc shaped zones of high recreational potential. According to previous research, 20 statute miles were used to represent the mean distance that private boat fishermen are willing to travel offshore in quest of enhanced fisheries. These arcs are intended as a general guide to show where anglers would prefer to fish. Arcs may be reduced or extended, according to local knowledge of the proposed artificial reef's fishing constituency.

Once offshore zones of high recreational potential were defined, constraining features within them were plotted, including the following:

1. Established shipping lanes and fairways
2. Biologically sensitive areas
3. Marine sanctuaries
4. Military areas
5. Traditional bottom trawling areas

6. Oil rigs and pipelines
7. 85-foot clearance required to avoid navigational obstruction status.

In an effort to discourage opposition to reef construction from bottom trawler operators and shipping interests, mitigating factors to constraints within high value recreational zones were highlighted to show which areas could not be used safely for commerce. These are sites worthy of serious consideration for future reef construction because they're already "off limits" where commercial interests are concerned.

Oil rigs and other mineral extraction devices located within high value recreation zones are considered obstructions to some and fishing bonanzas to others. The information provided by this project may be helpful in deciding how to dispose of obsolete rigs without losing valuable recreational fishing habitat in some areas and where to place them, if they must be moved, for maximum recreational benefit.

Offshore oil and gas extraction started in accessible near-shore waters, but moved farther offshore as selling prices for oil increased, technology improved, and old fields were depleted. The near-shore rigs, which are most valuable to recreational fishermen, are thus the most likely to become obsolete. The loss of these rigs to fishermen is not conjecture; it is a fact. Without the habitat provided by oil rigs, the fishery associated with them will also disappear. Obsolete rigs properly placed on carefully selected artificial reef sites will provide a legacy from our oil fields long after the wells run dry.

This project is a broad-based study designed to improve recreational artificial reef planning in the Gulf of Mexico. Oil and gas rigs represent valuable fish habitat in the region. However, recreational demands for enhanced fisheries and mineral deposits do not always coincide. This makes responsible planning essential for insuring that Rigs to Reefs and similar public works projects achieve their intended objectives. Gulf artificial reef planners hope to use this study as a reference tool to provide optimum recreational fisheries on a sound and equitable basis.

## REEFS-FROM-RIGS: THE NUTS AND BOLTS OF CONVERSION

Dr. Heyward Mathews  
St. Petersburg Junior College

Fishermen have known for several thousand years that the site of an old shipwreck soon became an excellent fishing spot. The Japanese were the first to begin sinking ships for the purpose of building artificial reefs in the 1940s, and then with their own ships in the 1950s. It was probably only a few weeks after the first oil rig was put down in coastal waters that oil men discovered the attraction structures of this type have for both benthic and pelagic fish. It doesn't take an oceanographer to tell the oil industry of the fish-attracting ability of an oil or gas structure. The fact that such structures make excellent fish habitat is well documented. The next big question then is how do we make maximum use of these structures as they come available in the future.

Now that a national policy on artificial reefs is finally becoming a reality, the legal and tax benefits to the oil industry should soon become favorable. This could open the door to placing considerable numbers of these obsolete rigs into use as fishing reefs. While my colleague DeWitt Myatt has gone over some of the essential points of site selection, let me just mention a few things that could stand repeating.

The site selection process for any artificial reef is probably the most critical decision in the whole reef building effort. The two oil structures that are in place off Florida waters make an excellent comparison of the right and wrong way to select a site. The Exxon template was placed without any underwater survey of the site prior to the drop. The closest Exxon came to such a survey was a rumor from a diver on someone's staff in Tallahassee that he thought the bottom out there was sand when he dove on the Air Force microwave tower several hundred yards to the east. Fortunately the bottom was quite suitable; however, several miles inshore there are some areas of soft sediment

that would not have been suitable. The real problem with the Exxon site was its accessibility to few fishermen and divers. Most of the sport diving and fishing boats in this area are in the 17 to 21 foot range and not really suitable for making trips out 35 miles into open Gulf waters. If, however, a site off Panama City had been selected, it could have been placed in the same depth of water but only 8 to 10 miles offshore. The Panama City area has a very large commercial sport fishing fleet as well as great numbers of sport anglers and sport divers. The Exxon structure has been in place since 1980, yet in August of this year when I made a visit to the reef, I asked several local bait store operators about the catches of fish over the structure, and they did not even know such a reef existed.

For the Tenneco rig, however, the site was selected by a charter boat captain who is also a diver. The site was surveyed prior to the permit applications and was so located as to be accessible to charter boat fishermen from both Pensacola and Destin-Ft. Walton areas. The Tenneco rig is well known in the Pensacola area to anglers and divers; however it is still relatively hard to obtain the loran numbers. An important consideration here would be to produce a brochure that could be handed out at local bait shops, marinas, and dive shops that describes the rig, its donation, and the exact location so a maximum number of people could use the structure and be aware of the oil companies' interest in improving the offshore marine habitat.

I made surveys of both of these structures in the last few months, and I can assure you that they are both doing an excellent job of attracting large numbers of food and game fish. But the utilization by fishermen and divers is very different. The Tenneco reef is well utilized all year round, while the Exxon reef is known and utilized by few. I assume that one of the corporate considerations in selecting this method of disposal for a rig is the public relations aspects of such a donation. With many areas off Florida to come up for exploration consideration in the future, any good will the oil industry can obtain from fishermen and divers can only help.

While some areas have relatively deep water in easy distance of the ports used by anglers and divers, others may not have the necessary depths to accommodate an entire rig of the size used off Pensacola. For such areas a smaller structure could be used in areas with a more gradual slope to the shelf offshore. Another possibility is to cut the structure lengthwise just prior to the drop. The rig tower portion makes an excellent reef in an "as is" condition, but the upper portion will need to be opened up to provide openings for water to circulate through the structure. Most food and game species will not go into a dark interior area that has poor water circulation. We have found that for most grouper and snapper species, we need shadow to provide the illusion of shelter, yet open access to horizontal water flow. To obtain maximum grouper/snapper habitat, the side walls should be cut open as much as possible without loss of structural integrity. Long narrow cuts that avoid removing the strength elements would be best. Any external structures that increase the overall profile of the reef should be retained if possible.

Another issue that must be decided in the future is whether any of these structures should be left in place to provide fish habitat. There can be no doubt that to remove all these structures at some future date would deprive these waters of the existing habitat they provide. The answer to this problem would be to place some of the rigs after removal in waters accessible to anglers and divers. The present locations were dictated by the location of oil or natural gas bearing strata, not access to anglers and divers. Some of the rigs removed then could be located using the same criteria as used off Florida and Alabama. This would comply with existing regulations about removal of the rigs and prevent any future opposition from environmentalists, shrimpers, and net fishermen.

One last consideration is the tendency among sport anglers to locate reefs in waters too deep for scuba divers. If we are using the tax payers' money, and we are as long as there are any tax benefits to the program, then it is wrong to deliberately exclude one user group. If there is some concern about overharvest, then bag limits can be imposed,

but to build reefs at depths over 200 feet becomes counter productive from a fishery standpoint.

We need someone to keep track of the availability of rigs and to decide where they will be placed. Perhaps, some type of council made up of the various state and federal agencies can be organized to make these decisions. This lack of central coordination may no longer be a problem now that the artificial reefs bill has passed. The State of Florida is ready with permitted sites from the Panhandle down to the Tampa Bay area.

Artificial reefs should be sited on unproductive bottoms and not on already existing obstructions or rough bottom areas. For example, if an artificial reef holds 10,000 fish an acre and a natural reef holds 3000 fish an acre and we drop the artificial reef on the natural reef, the increase would only be about 7000 fish. On the other hand, if we leave the natural reef alone, we can keep the 3000 fish and locate the artificial reef on barren bottom to get a total of 13,000 fish instead of just 10,000. All our studies have shown there doesn't seem to be a leveling off point. If we double the amount of reefs, we'll double the number of fish; double the reefs again and the number of fish will again double. Utilization will affect that somewhat, but the point of diminishing returns has not yet been determined. The more reefs we build, the more fish we get. Our studies have shown these reefs not only concentrate existing fish, which does occur the first two years, but several years down the road the natural reefs which supplied the initial recruitment will recoup normal levels of fish, and the artificial reefs will hold more fish than the natural reefs. Artificial reefs do increase total fish production of an area, in part because of the primary production of algae.

## LIABILITY CONCERNS RIGS TO REEFS

Ms. Patricia Collins  
Sport Fishing Institute  
Artificial Reef Development Center

Artificial reefs enhance fishery resources by aggregating and providing suitable spawning habitat for many fish species. They benefit both the recreational and commercial fishing industry. I recently completed a report entitled "Liability Concerns in Artificial Reef Development." This study was funded by the Sport Fishing Institute through funds from a Saltonstall-Kennedy grant.

Liability concerns often have been a major constraint to artificial reef development. Potential liability for injuries, loss, or damage resulting from construction or maintenance of a reef will involve many different parties and be decided based on federal admiralty law as well as state tort law. Because there is a dearth of case law involving artificial reefs, this study analogizes artificial reef scenarios to similar situations which give cause to legal actions in negligence, nuisance, and strict liability. I researched applicable case law in Florida and Texas because these states have been prime locations for artificial reefs. The research was aimed at aiding in the formulation of responsible development plans.

Assuming that we are able to get over the regulatory hurdle requiring removal of all offshore petroleum platforms, these platforms may become reefs at the lease site either by being toppled, left in place, or transported off-site to another location. The question becomes what legal responsibility exists for personal harm or property damage throughout the reef development process. The concerned parties include material donors, reef contractors, volunteer transporters, permittees, as well as state and federal permitting agencies.

The legal duty of care must be defined during this process, and federal and state statutes as well as common law must be investigated. A state's tort liability may be affected by governmental immunity doctrines, and recent legislation has had a major impact.

In November 1984, the President signed the National Fishing Enhancement Act (P.L. 98-623) which requires the Secretary of Commerce to develop "a long-term plan identifying the optimal design, construction, location and subsequent monitoring of artificial reefs in the navigable waters of the United States." It also authorizes the Secretary of the Army to use this plan as a guideline when authorizing a reef permit.

The Secretary of the Army will determine the terms and conditions of these permits. A permittee must be able to demonstrate financial ability to cover all maintenance and liability costs, yet a permittee or his insurer will not be liable for any damages which are a direct result of compliance with the terms and conditions of the permit. The permittee will be liable under applicable law for any damage which is not the result of compliance with the terms or conditions of the permit. Once the title to the reef materials is transferred, the material donor is no longer liable for any damages as long as the material was not defective at the time of transfer and the material met the criteria specified in the reef plan.

This Act clarifies the existing common law. Responsibility usually travels with dominion and control over an object. But, because this liability language is dependent on the terms of the permit, liability problems will be inextricably linked with conditions set forth in the artificial reef permit.

If the agencies involved in permitting, as well as material donors and permittees, expect to withstand legal action questioning their compliance with regulations and their exercise of due care, then they must become more involved in the siting and planning process of these reefs instead of viewing them as something similar to a pollutant or



dumping site. If the risks are thoroughly evaluated prior to transporting reef materials to a site, then the material title holders, transportation company, and reef permittee can insure against loss or damage and contractually assign much of the liability by designating the responsible party at each stage of control. Adequate planning is essential.

### ALABAMA'S ARTIFICIAL REEF PROGRAM

Mr. Hugh Swingle

Alabama Department of Conservation & Natural Resources

Alabama's artificial reef program began in 1953 as a cooperative effort of the state, the Alabama Drydock and Ship Building Company and the Mobile County Wildlife and Conservation Association with the sinking of a 300-foot wooden drydock off the coast of Alabama. Remnants of this drydock provide relatively good fishing 31 years later. In 1957 more than 1500 old car bodies were sunk along the 10-fathom curve off the Alabama coast. These early reef construction projects had three common elements: (1) they were a cooperative state/industry effort, (2) they were placed in areas without consideration of the traditional shrimping areas, and (3) they were constructed of materials which we would not use today. The wooden drydock refused to sink completely and was actually lost for almost two years. Car bodies have a short life expectancy and are easily moved by currents from their location unless bundled together or anchored in some manner. Shrimp trawls were damaged by these car bodies which had moved quite some distance from their original locations, and adverse criticism from the shrimp industry temporarily ended Alabama's brief reef construction program.

During the 1960s, the Seafoods Division (now Marine Resources) began a new reef construction program after meeting with members of the shrimping industry to select areas with low utilization by this user group. Mobile, as well as most coastal ports, abounds with reef materials such as old barges and boats, concrete pipe and culverts, and other discards from industry. The old barges, boats, and tugs located throughout the coastal area not only are unsightly but also are in many cases obstructing navigational waterways. Also, they are easily obtained. However, most of these old barges and vessels have deteriorated to the state that they are no longer seaworthy and cannot be towed to the gulf without considerable liability. The problem is how to get them from their resting sites to the reef sites. Alabama has never had the funds to pay the costs for towing. During the 1960s and early 1970s, Alabama towing companies and other industries graciously donated this service to our reef program. Increased fuel costs, marine insurance, and other factors caused this to end. From 1957 until 1978, the Marine Resources Division constructed more than 60 separate reefs, or "spots" as fishermen refer to them, at no cost to the citizens of Alabama. Two reef construction projects in 1977 and 1981 cost more than \$65,000 for towing. While this does not seem to be a large amount of money to some, it was to our small operational budget. With the exception of the Dauphin Island Bridge reef complex built at no cost to us after Hurricane Frederic destroyed the bridge in 1979, we constructed no more reefs until Marathon Oil Company constructed one off Alabama in June 1983.

In 1978 I determined that we would not proceed further with Alabama's artificial reef program because of the lack of funds. We could not even afford to fill personnel vacancies or replace equipment. Marathon Oil Company's donation to the fishing community of Alabama gave us renewed interest in a new state/industry cooperative artificial reef program designed to benefit the public. Having been in the artificial reef building business personally for 17 years, I fully recognize the tremendous

effort put forth by Marathon in placing the jacket and deck offshore Alabama.

In this cooperative effort the State of Alabama obtained the permit from the Corps of Engineers and accepted ownership and liability for the platform when it was sunk at the permit site. Marathon accepted the responsibility for transporting the platform to the site and sinking it.

Obsolete production platforms have several advantages over other reef materials often used: (1) they are becoming increasingly abundant as fields go out of production, (2) they have a large surface area which provides attachment area for fouling organisms, which are the start of the reef food web as well as provide many "nooks and crannies" for the reef fishes to gather, (3) they are large structures which are easy to find and provide room for many boats to fish over, (4) they are less likely to sink into soft substrates than are pipes and culverts, and (5) they are long-lived and will provide fishing opportunities for many years. Platforms are ideal reef material; however, Alabama is unfortunately quite far from the source of these obsolete structures, which is the oil and gas fields off Louisiana. The cost of towing them to Alabama is often the cause of selecting other methods of disposal. Since 1980, I have been contacted by Marathon, Chevron, Mobil and Zapata concerning donations of platforms to our reef program. Only Marathon went the extra mile to bring a platform over and sink it. The reason is obvious--towing costs.

Alabama and Florida desperately need these structures, and the oil companies are eager to provide them in a state/industry cooperative effort to increase fishing opportunities in the gulf; however, until there is some type of monetary incentive to do so, through tax credits or other relief, these good intentions may not materialize. A national artificial reef plan can easily be completed in a short time frame by the respective federal

agencies, fishery management councils, and coastal states; however, it will only be an inactive plan without financial incentive to solve the problem of how to get it from there to here.

## FACTORS, CONSIDERATIONS, AND TRADE OFFS

Mr. Dana Larson  
Exxon Company, U.S.A.

The ecosystems surrounding oil and gas platforms are increasingly being recognized as a national asset from both a fish (environmental) and fishing perspective. The creation, protection, and enhancement of these ecosystems is a complex mixture of private and public interests, rights, and obligations. Only a satisfactory resolution of this complex set of factors, considerations, and trade-offs will lead to an acceptable rigs-to-reefs program.

There are basic differences between the ecosystems surrounding a rig from those surrounding an artificial reef. The ecosystem surrounding a platform is a national natural asset created on private property at private expense on OCS lands. The ecosystem surrounding an artificial reef is a national natural asset on public property created or maintained at public expense on the same or different OCS lands. The differences are significant.

The following factors should be incorporated in a rigs-to-reefs plan:

1. The plan should be a case-by-case voluntary, flexible, and cooperative effort to preserve/conserves/enhance the OCS environmental, energy, economic, and social uses.

2. The primary consideration among the retention/relocation/removal criteria of economics, social factors, and environment should be economics.
3. A primary objective of the national plan should be the maximum in-place retention of OCS structures that meet national, regional, and state standards.
4. The donor of reef materials should not be liable for any damages if conditions of transfer have been met. Liability to the artificial reef permit holders should be limited to actual damages associated with the accident caused by their malfeasance. The past owner of the structure should not be liable for any costs or damages after title has transferred, unless mutually agreed upon by both parties.
5. The program should encourage both public and private ownership.
6. Plan criteria should be developed for each major alternative: retention, relocation, temporary abandonment, dual or multiple use, removal, and modification.
7. The federal government should be the permit holder of last resort.
8. There should be no disincentive for participation.
9. The social and environmental values of the 4000+ producing platforms in the GOM should not be overlooked as plans are being made for the estimated 40 platforms per year that cease production.

NATIONAL RESEARCH COUNCIL STUDY OF THE DISPOSITION OF  
OFFSHORE PETROLEUM PLATFORMS

Mr. Griff C. Lee  
Member National Academy of Engineering

In compliance with the 1958 Continental Shelf Convention, the current regulatory requirements governing site clearance for offshore oil and gas leases stipulate the complete removal of all facilities to a depth 15 feet below the mud line. The general practice is to remove all structure elements and return these to a shore facility for salvage or scrap. There have been a limited number of exceptions in which structural portions of offshore facilities were, for special reasons, towed to deep water for deep ocean disposal or placed in specified locations to serve as artificial reefs for enhancement of living resources. There are pressures for change from the current international and national regulatory and practice environment. There are those who argue that complete removal of all the OCS platforms may not be beneficial to the local biological communities. There is increasing support among various constituencies, including fishing interests, for regulation which would enhance the construction of artificial reefs at more locations on the continental shelf. In addition, for very deep waters, complete removal of structures may become very expensive and may not be necessary.

The offshore industry is reaching a state of maturity such that the numbers of platforms to be removed may increase dramatically. Moreover, it is predicted that the installation of large deep water platforms may increase. It is therefore timely to carefully evaluate the impacts, costs, and benefits of leaving platforms that have passed their useful life in place, or removing them partially or totally, and, if they are removed, disposing of them as scrap onshore, or emplacing them elsewhere in the ocean as fishing reefs or for other uses.

At the request of the Minerals Management Service, a committee on Disposition of Offshore Platforms has been convened under the National Research Council to document and assess alternatives for removal, disposal, or reuse of fixed offshore platforms that are past their useful service life, and to make recommendations concerning government policy on their disposition. The platform types included in the scope of study include steel-jacket, tension-leg, concrete, and guyed-tower platforms and also fixed subsea oil and gas structures. Excluded from the study are pipelines and gravel islands. The areal extent of the study is the outer continental shelf of the U.S. (lands under federal jurisdiction). (This fact notwithstanding, much of the analysis of issues will be directly relevant to the disposition of offshore platforms located on offshore lands under state jurisdiction).

The committee is evaluating the disposition alternatives outlined in figure 35. Each of the alternatives is being considered in light of the technical issues. A summary of the issues follows.

- o Size of Problem

- oo What is the number of platforms, characterized by category of platform, age, and water depth?
- oo What is the projected schedule of platform retirements?

- o Engineering and Cost Issues

- oo What are the alternatives for the disposition of offshore oil and gas platforms after they have reached the end of their useful life as oil and gas facilities? What are the opportunities for reusing platforms or sections of platforms, as oil and gas facilities or for other industrial purposes?
- oo What are the design implications of the various alternatives?
- oo What are the technological problems in dismantling, transporting, relocating, and reusing platforms?
- oo How will advances in technology and equipment affect platform disposition?

- oo What is the design life of the platforms in place? What methods are available for predicting the remaining life of offshore platforms?
  - oo The final disposition of offshore platforms is influenced to a great extent by cost considerations, which include the most cost-effective means of removal and transport, the cost of maintaining the structure, scrap prices, and whether tax advantages or other benefits for habitat enrichment are created.
  - oo The cost of platform removal needs to be established. Removal cost will be a function of platform size/type, water depth, and removal method.
  - oo What alternative cost recovery methods might be used to ensure equity and promote reuse of existing platforms?
  - oo What percentage of the cost of offshore resource development can be attributed to platform removal? How might this vary in different regions?
- o Legal Issues
- oo The Law of the Sea Convention, which is likely to be ratified by two-thirds of the world's nations, stipulates that "any installations or structures which are abandoned or disused shall be removed as necessary ...." Standards for platform removal are to be developed by the International Maritime Organization. Because the U.S. has by far the greatest number of offshore structures, and because the age of U.S. structures is on the average greater than structures elsewhere (i.e., the disposal of platforms is a more immediate concern in the U.S. than elsewhere), it is necessary to develop the U.S. perspective on platform disposition for use in international deliberations.
  - oo To what extent do international and national ocean dumping rules apply to the disposal of offshore platforms?
  - oo How is liability for safety, maintenance, marking, and third-party damage affected by the alternative disposal



strategies for offshore platforms?

- oo What is the status of agency jurisdiction and domestic laws and rules concerning the disposal of offshore platforms?
- oo If the rules concerning the disposal of offshore platforms are to be changed, will the new rules apply only to new platforms, or will existing structures be "grandfathered" in?
  
- o Environmental Issues
  - oo What are the positive (enhancement) and adverse (disruption) impacts likely to result from the removal of offshore platforms?
  - oo The question of the reuse of offshore platforms for fisheries habitat enhancement is of widespread interest. To this end, the structures can be left in place, or toppled in place or removed, transported and relocated as an artificial reef. What criteria could be used to identify platforms that have potential for fisheries habitat enhancement?
  
- o Defense
  - oo What is the impact of the "draft DOD position on platform disposition" on the removal process?
  - oo What is the implication of the international aspects of the DOD draft position?
  
- o Safety
  - oo Are the structures hazards to surface navigation?
  - oo Are the structures hazards to submerged navigation?
  - oo Existing structures are used for refuge and navigation by mariners in the vicinity.
    - Are there adverse safety implications associated with the removal of structures?
    - Are any desirable safety implications associated with the removal of structures?

- Are any safety implications associated with other than complete removal?
- Are there significant safety aspects involved in the removal process?

The committee's work will provide a technical basis for U.S. rules concerning offshore platform removal, and also for the formulation of a U.S. position in any international deliberations on the matter. The committee anticipates completing a public report of its work about June, 1985.

#### COMMITTEE ON DISPOSITION OF OFFSHORE PLATFORMS

W.M. Benkert  
U.S. Coast Guard, Ret.  
American Institute of Merchant Shipping,  
Petroferm Marine, Inc.  
(Marine Transportation)

Roger Anderson  
Gulf and Southeast Regional Fisheries Foundation  
(Fisheries)

Robert Ditton  
Texas A&M University  
(Environmental Policy)

Frank P. Dunn  
Shell Oil Co.  
(Offshore Structures)

Griff C. Lee  
McDermott Inc., Ret.  
(Marine Construction)

Maurice Rindskopf  
U.S. Navy, Ret.  
Westinghouse Corp., Ocean Division  
(Naval Operations)

Sidney Wallace  
U.S. Coast Guard, Ret.  
Haight, Gardner, Poor & Havens  
(Ocean Law)

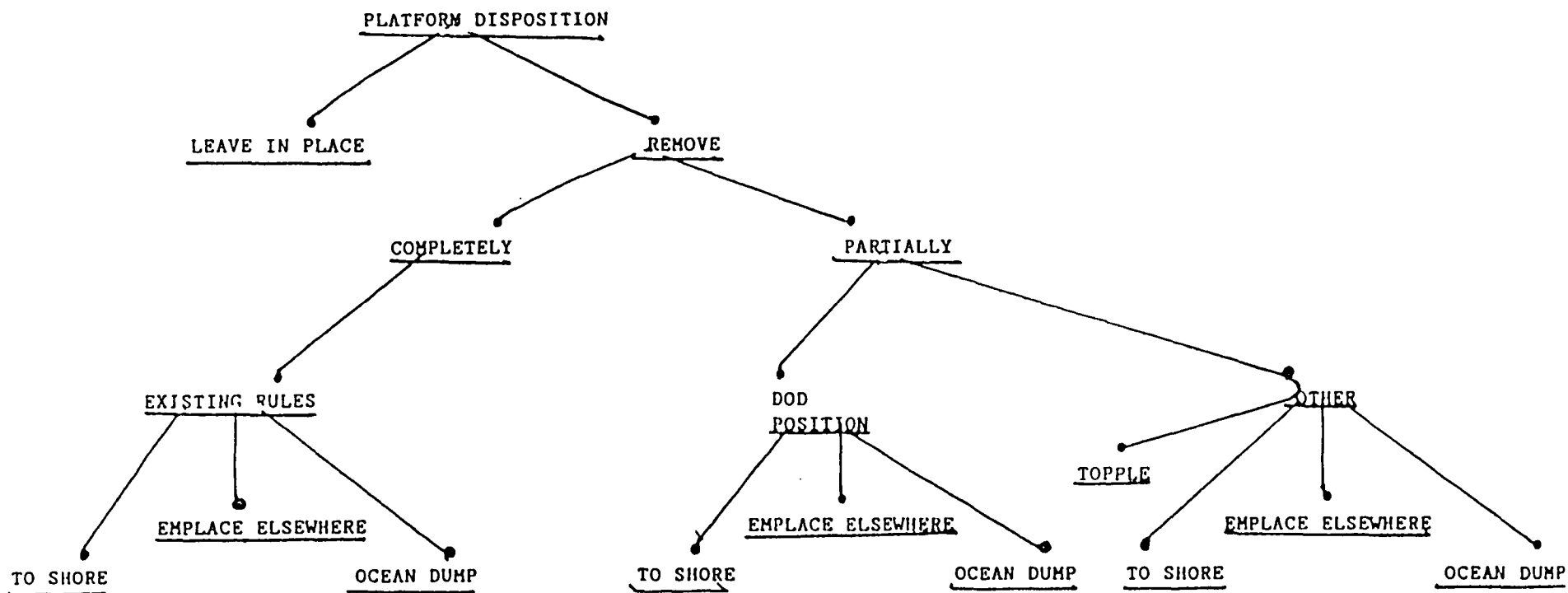

Figure 35. Outline of disposition alternatives. Explanation of Terms .

- o Existing Rules - 15' below mud line
- o DOD Position - Stated in 8/22/84 letter from Secretary of Defense to the American Petroleum Institute
- o Other - Clear to depth suitable for safety of surface navigation, or other alternative to DOD Position
- o Emlace Elsewhere - Locate purposefully at another location, for another use
- o Ocean Dump - Dispose of off the OCS -- requires EPA permit

Provisions include removal to within 5m of sea floor in waters out to 400m depth, and to within 15m of the sea floor in waters from 400m - 2,000m deep.

## ARTIFICIAL REEFS: DEPARTMENT OF DEFENSE PERSPECTIVE ISSUES

CDR John Henriksen  
Office of the Secretary of Defense

Secretary Weinberger strongly advocates the removal of nonproducing rigs because of the operational problems that they create. The rigs restrict submerged mobility by causing acoustical interference and navigational hazards. They provide no shoaling waters or other geographical warnings to approaching submarines. Accordingly, submarine force prohibits submerged operations within 5 nautical miles of the structures; thus, each rig reduces safe, operational area by almost 80 square miles.

The Department of Defense, however, is not an across-the-board adversary of a national artificial reefs program, as evidenced by the lack of objection to Congressman Breaux's recently enacted legislation concerning artificial reef construction. Note, however, that the new act which refers to "design, construction, and siting" of artificial reefs makes no mention of leaving rigs in place.

The Department of Defense has also worked closely with the Department of Interior to find a mutually acceptable memorandum of understanding (MOU) on Artificial Reefs policy. A last minute disagreement between the Army Corps of Engineers and the Department of Transportation has temporarily held up the MOU but a solution may be found within a few days.

The MOU will commit the Departments of Interior, Transportation, Commerce, Defense, and the EPA to the development of an effective national program for artificial reefs and will provide the framework for full federal cooperation with the state, local, and private sectors concerning approval of construction. The federal government will play a supportive role.

The MOU will not, however, sanction the so-called leave-the-rigs-in-place approach. On the contrary, the MOU will serve to promote the removal of nonproducing rigs in compliance with federal and international law, followed by relocation of the rig material to an approved artificial reef site. This is consistent with Secretary Clark's statement that the Department of Interior "strongly advocates a planned and directed program to encourage proper placement and use of selected and properly removed platforms."

The notice of interpretation of July 8, 1983, which would have permitted a leave-them-in-place approach, will be withdrawn. The notice of withdrawal will be forwarded to the Federal Register just as soon as the final language of the MOU has been agreed upon. The withdrawal decision arrived at was due as much to the Department of Defense's objections as the reservations of the National Marine Fisheries Service and the Department of Transportation. Further, the leave-them-standing approach has only mixed support from other interested communities.

Some supporters of the leave-them-standing approach have suggested a selective policy which would avoid serious consequences for navigation, security, and the environment. Once such a precedent was set, however, other coastal countries could come to their own conclusions about what limits were "adequate" or "reasonable," and large areas of ocean could become compromised permanently. Only globally established standards which delimit minimum and maximum depths of removal can protect against abuse by other countries. As Secretary Weinberger has noted, the worldwide interests of the U.S. dictate a stronger removal stand as the hydrocarbon industry moves further offshore. Our position shall not preclude however a coastal state in its territorial sea or in water depths less than 20 meters from seeking exceptions to our leave-it-in-place objections.

In an effort to work with industry toward the development of global standards, the Department of Defense has met periodically with the American Petroleum Institute and other industry officials, but we are not close to a consensus yet, especially on the issue of depth of removal. In the last meeting a few weeks ago, both the Department of Defense and industry representatives agreed to start again in an effort to find a depth standard offering industry more flexibility and accommodating U.S. security interests in submerged navigation as well. Such standards will promote the development of new technology, so that rigs of the future can be easily dismantled and refloated at the end of their hydrocarbon production cycles. Technological advances in the tension leg platform already show great promise. The Department is optimistic that the standards ultimately proposed to the International Maritime Organization will bear the imprimatur of both the federal government and the private sector.

The Department of Defense recognizes the need for some operational constraints in our nation's effort to tap the oil and gas resources off our shores, since energy self-sufficiency is a strategic as well as an economic interest. Consequently, the Department of Defense has entered into a cooperative joint-use agreement with the Department of Interior to permit leasing and exploration of offshore resources to the maximum extent possible, wherever national security interests allow. Once the well has ceased producing, however, national and international considerations dictate that the rig be removed, since both U.S. and private industry were cognizant of the removal requirement upon construction of their rigs.

The cost of removing the rig is factored in before production even begins, and it is money well spent considering the other national interests that are involved. As only a limited number of rigs would meet all criteria for nonremoval (i.e., away from normal navigational routes, outside traditional trawling areas, etc.), the real cost differential is likewise limited.

All of us support a common objective: a strong United States. America needs oil and gas as well as global maritime mobility. Through cooperation, both objectives can be met. A carefully delimited artificial reefs program will benefit not only citizens of the Gulf, but coastal communities and the economy of the United States as a whole.

## POTENTIAL IMPACTS OF THE REMOVAL OF OIL AND GAS PRODUCTION PLATFORMS ON THE LOUISIANA SHRIMP INDUSTRY

Mr. Jerald Horst

Louisiana Cooperative Extension Service

Mr. John MialJevich

Concerned Shrimpers of Louisiana

Commercial shrimp trawling and the construction of artificial fishing reefs are most often considered to be mutually incompatible activities. The shrimp industry is the most important commercial fishery in Louisiana and the United States, worth a half a billion dollars annually. Shrimpers need a smooth clean bottom to operate profitably and effectively. Artificial reefs, by their very nature, are the antithesis of such a bottom. Logic would dictate that the important and powerful shrimp industry would be opposed to the construction of such reefs. This may not, in many instances, be the truism that it appears to be.

The shrimper faces four different types of trawling hazards owing to obstructions: 1) floating objects, 2) emergent structures, 3) immovable bottom obstructions, and 4) movable bottom obstructions. Bottom obstructions, both movable and immovable, can and do result in substantial gear loss to the commercial shrimper. Emergent structures



such as oil and gas production platforms present very little hazard since they are readily visible and easily avoidable.

However, as offshore oil and gas fields are being depleted at an increasing rate, many of these structures are being removed. Removal of oil field platforms generally results in a proliferation of movable obstructions, which are the worst kind of obstructions. Shrimpers in the northern Gulf of Mexico have developed a relatively effective system of obstruction avoidance with the use of Loran C navigational systems and "hang logs."

This system, however, is ineffective for use in avoiding movable obstructions, since before every shrimper can get a loran fix on the position of the obstruction, another shrimper will hang the obstruction with his nets and move it, sometimes as far as a mile, from its previous location.

As long as a platform is in position, all of the accidentally lost equipment and/or purposefully discarded equipment is under or very near the rig. When the platform is removed, one accidental drag over the area by a vessel will move this material into trawling areas where it will be caught and dragged to new areas again and again.

One solution to this problem other than the difficult and very expensive removal of all materials under a platform, is to allow the platforms to remain in place as artificial fishing reefs. Personal conversations with scores of shrimpers have yielded unanimous agreement with this proposition. With proper lighting, the platforms would pose no more of a hazard to navigation than they now do, and they would satisfy the burgeoning need of the recreational fishery for fishing sites.

A minor benefit of maintaining these platforms as artificial reefs would be their use as navigational landmarks and temporary mooring sites by commercial shrimpers and other fishermen.

There is a growing interest in most of the coastal areas of the United States in the construction of artificial reefs for recreational fishing. Use of presently existing oil and gas production platforms would at least partly satisfy these needs off of the Louisiana coast and prevent an increase in bottom obstructions which are detrimental to the most valuable U.S. commercial fishery.

## THE DEEP SEA

Session: THE DEEP SEA  
Co-Chairs: Dr. Robert Avent  
Dr. Benny Gallaway  
Date: November 28, 1984

<u>Presentation Title</u>	<u>Speaker/Affiliation</u>
Session Overview	Dr. Robert Avent and Dr. Benny Gallaway
Technical Aspects of Deep-Sea Exploration Development and Production	Mr. Carl L. Wickizer Shell Offshore, Inc.
Introduction to the Deep-Sea: Its Environment, Processes, and Resources	Dr. Robert R. Hessler Scripps Institution of Oceanography
The Deep Gulf of Mexico Ecosystem	Dr. Willis E. Pequegnat LGL Ecological Research Associates
Recent Results of the Deep-Sea Drilling Program on the Mississippi Fan, Gulf of Mexico	Dr. Arnold H. Bouma Gulf Research and Development Company Dr. James M. Coleman Louisiana State University Dr. William R. Bryant Texas A & M University
Northern Gulf of Mexico Continental Slope Study I. Biology and Environment	Dr. Benny Gallaway Dr. George Lewbel Dr. Linda Pequegnat LGL Ecological Research Associates
Northern Gulf of Mexico Continental Slope Study II. Hydrocarbons	Dr. Mahlon C. Kennicutt II Dr. James M. Brooks Texas A & M University

Study of Biological Processes on the U.S.  
Atlantic Continental Slope and Rise

Dr. James A. Blake  
Dr. Nancy Maciolek-Blake  
Battelle New England  
Marine Research Laboratory

Vent-Type Communities of the Florida  
Escarpment

Dr. Barbara Hecker  
Lamont-Doherty Geological  
Observatory

## SESSION OVERVIEW: DEEP SEA

Dr. Robert Avent  
Dr. Benny Gallaway  
MMS, Gulf of Mexico Region

Nine presentations were given. Dr. Benny Gallaway will discuss those that are the direct results of funding of LGL's research. I'll talk about the rest of them.

The first paper was presented by Mr. Carl Wickizer of Shell Offshore. He discussed the capabilities of the oil industry in the deep sea. It appears that our studies of the deep Gulf of Mexico are only just barely ahead of industry activity. In fact, the oil and gas industry is capable of production right now anywhere in the Gulf of Mexico, so long as the economic and regulatory conditions are conducive.

The technology does exist. The industry has demonstrated this a number of times. The deepest successful drilling to date has been at a depth of nearly 7,000 feet (2,100m) water depth, not counting how far the drill string penetrates the bottom. The deepest production to date, (the Cognac platform) on the other hand, has been at a depth of about 1,000 feet (300m).

He discussed different types of drilling and production systems. To date, there have been 83 wells actually drilled in depths greater than about 2,000 feet (600m). There are now seventeen drilling rigs in the Gulf of Mexico alone capable of working deeper than 2,000 feet of water (600m).

He described dynamic positioning systems used on drill ships, the DISCOVERER SEVEN SEAS as an example, a new vessel working now in about 2,250 feet (610m) of water.

Some production systems, such as semisubmersibles, are good down to about 1500 feet of water; and fixed platform, guyed-tower, and tension-leg systems are capable to depths greater than 2,000 feet.

Produced oil and gas can be lightered, but pipelines can be placed in depths as great as 8,000 feet. So far, 2,000 feet has been the limit.

The industry is quite safety conscious. Disconnecting the drill string from the blow-out preventor (BOP) requires only seconds--less than a minute. It has been done before. He talked further about safety, discussing hurricanes, geological hazards, BOP's and fracture gradients.

Deep-sea oil and gas technology is here; it appears to be safe, and it will be employed in the deep sea as long as the economic potential is there.

The second paper given received quite a bit of acclaim. Dr. Bob Hessler, of Scripps Institute of Oceanography, described the deep sea, its ecology, and its inhabitants in a general talk to acquaint non-oceanographers with what the deep sea is really all about. He gave us the essence of a semester's course in about a half hour.

Among other things, we learned that the deep-sea is dark. That means that there are no plants there and no photosynthesis to mediate the transfer of energy to the benthos. It's cold, down to about  $-2^{\circ}\text{C}$ , in some places. It's deep, so the hydrostatic pressure is high: one atmosphere of pressure for every ten meters' increase in water depth to a maximum of over 1,000 atmospheres. There's very little food to support the organisms; less than 1% of surface energy falls to depths more than 200m. The bottom is typically muddy. Most of the animals are typically small, fragile, and difficult to identify. Most of them predictably are deposit feeders. They have low fecundity, they produce few eggs, and standing crops are quite low. The critters, of course, have developed specific life histories, feeding strategies, and reproductive strategies to carry on life in the deep sea.

Dr. Hessler used hydrothermal vent communities as the exception, which actually proves the rule that availability of food is a prime factor which makes these communities the way they are. Deep-sea communities have a fairly high diversity, which surprises many people. There is vertical faunal zonation in the deep sea. Most of the animals are cosmopolitan at at least the genus and family levels.

He finished by suggesting that it is quite likely that deep animals will be susceptible to fishing pressure. Further, because they live in an area of low historic disturbance, that even small changes in the environment may be destructive, and the recovery times for these communities will probably be quite long.

Dr. Willis Pequegnat, of Texas A&M University for years, discussed the influence of the Mississippi River and various other major features of the Gulf of Mexico which give it its specific character: water masses, the effect of the Mississippi River, the sediment loads, and the Loop Current.

Dr. Walter Nelson, of National Marine Fisheries Service, was unable to attend, but we were able to persuade Dr. Bill Bryant from Texas A&M to relate to us the results of a recent drilling program on Leg 96 of the GLOMAR CHALLENGER. On that study they conducted deep drilling to elucidate the geophysical structure of the most recent lobe of the Mississippi Delta fan, along with the ancient meanderings of the river. The geophysical record clearly showed the location of river channels and levees. Nine sites were drilled, and when they drilled into the highly reflective river channels they found coarse materials--sand and gravel, and in some cases pebble-sized material--that were swept down the Mississippi from as far away as present Wisconsin.

The Gulf MMS Regional Office is not the only office funding deep sea research. The Atlantic office, located in Vienna, Virginia, is doing the same. In fact, they're a little bit ahead of us, and their program is considerably larger. They have much more coastline to study and some areas that are quite distinct from each other in physical character and



biology. Dr. Jim Blake, with Battelle's New England Marine Research Laboratories, described the Atlantic studies underway. They don't have a large data set yet. The taxonomic problems are horrendous, and it takes time to get these data into the computer before it can really be analyzed and interpreted. So, both the Gulf and Atlantic programs are far from complete.

The Atlantic has been divided into three geographical areas for study: the north Atlantic, which is the area seaward of George's Bank; the middle Atlantic, south from there to about Cape Hatteras; and the south Atlantic region, from Cape Hatteras to Georgia. They have many of the same objectives as does our Gulf study--among them to characterize pre-drilling biological, geological, and chemical properties of the benthic environment, to measure background distribution of potential hydrocarbons and trace element pollution, and to attempt to estimate recovery rates of deep-sea communities.

In the south Atlantic studies began in November 1983. Researchers set up a five-station transect off Cape Lookout and additional stations are expected to be located on the Blake Plateau, where potential exists for hard mineral mining.

The mid-Atlantic studies began in April 1984 and consist of a monitoring program at stations around a drilling rig.

In the north Atlantic region the first cruise was conducted in November 1984. The study design depends on station comparisons (e.g., canyon and non-canyon areas, gullies and non-gullies), setting up stations in such a way that they can discern what the effect of all these incisions into the continental slope are having on the distribution of animal communities.

Upon completion of these studies, researchers will have excellent information on 44 stations from the United States-Canada border to Georgia.

The final paper of the day was given by Dr. Barbara Hecker of Lamont-Doherty Geological Observatory. She related to us her recent discovery of a vent-type deep-sea community at the base of the Florida escarpment, about 135 miles southwest of Tampa. She had the deep-diving submersible ALVIN in about 3,200 meters of water and unexpectedly came across the community which she wasn't properly equipped to sample. (At the time she was investigating erosional processes on the deep slope.) The community lies at the very base of the escarpment at about 3,200 meters of water where abyssal muds and the escarpment rocks meet. Dark sediments and some material that later proved to be of a very high pyrite concentration as well as some chemical anomalies in the seep water have been observed.

On the second dive of the ALVIN, the community was located. It looked very similar to some of the deep vent communities that have proved so exciting to scientists in the past few years in the Pacific. There were bacterial mats, mussel beds, archaeogastropods, galatheid crabs, sea anemones, holothurians, and a number of other organisms, including vestimentiferan worms. The latter are large pogonophorans which stand quite erect. In this case, they had stoloniferous soft corals associated with them. There were some taxa present here that are not present elsewhere, and taxa that were absent that have been found elsewhere. These are chemosynthetic communities, which is, of course, why they are so exciting scientifically. This range extension for this type of community, even though there are different genera and species in many cases, suggests they probably exist in many more places where sources of chemical energy are found.

Dr. Benny Gallaway continued the session. The balance of our session dealt with the MMS's Northern Gulf of Mexico Continental Slope Study.

Our program on the Gulf of Mexico and the Continental Shelf is a joint venture between Texas A&M and LGL, with LGL conducting the biological aspects of the program and Texas A&M doing the oceanographic aspects of the program. We have tried to put together a

team which can take advantage of the work that has been done in the Gulf by TAMU, tying together the major geological oceanographic features with the biological features.

The organization includes Dr. Jim Brooks, who is heading up chemical oceanography; Dr. Bill Merrill, doing the physical oceanography study; and Dr. Bill Bryant, doing the geology study.

Our biological group is headed by Dr. George Lewbel, who is assisted by other LGL personnel. The Scientific Advisory Committee includes luminaries from Woods Hole Oceanographic Institution, and Scripps Institution of Oceanography.

Methods include dredging, box-coring, benthic photography, and hydrographic measurements. We're about half-way into the program and have conducted three cruises. The first and second of these cruises characterized faunal and physical zonation in the Gulf of Mexico. We compared eastern, central, and western Gulf of Mexico areas to each other. Future sampling will attempt to sample intermediate transects to test various hypotheses about the effects of habitat change and the presence of hydrocarbons.

Ed Note: Since the conclusion of the 1984 Information Transfer Meeting, vent-type communities have been discovered in the northern Gulf of Mexico at a relatively shallow depth of 600-800 m by Texas A & M University Researchers connected with MMS's Deep Gulf program. LGL personnel have also discovered specimens of a newly described phylum (Loricifera), the first in the Gulf, and the deepest on record.--R.M.A.

## TECHNICAL ASPECTS OF DEEP-SEA EXPLORATION DEVELOPMENT AND PRODUCTION

Mr. Carl L. Wickizer  
Manager Engineering, Frontier Production Group  
Shell Offshore, Inc.

The technology base for deepwater drilling and development in the Gulf of Mexico already exists. The Shell operated exploratory drilling program in record water depths to 6952 feet off the U.S. East Coast has proven industry's capability to safely drill in water depths beyond 6000 feet. The deepwater record for production is currently Shell's Cognac platform in the Mississippi Canyon area in 1025 feet of water. Lack of production from deeper water is due to the lack of commercial discoveries. However, experience and technology derived from numerous fixed leg platforms, subsea completions, submerged pipelines, floating production systems and tanker loading systems in shallower water coupled with extensive research, have provided the oil industry with a solid technological basis for safely employing novel production systems in water depths well beyond 1000 feet. Such production systems will require specific application and extension of proven technology.

The major challenge to development of deepwater reserves is not technology but finding a reservoir of sufficient size and quality to justify the great expense required to drill and produce it. The deepwater Gulf of Mexico appears to some to offer such potential and will undoubtedly see extensive exploratory drilling. Only time will tell if such drilling will result in major discoveries justifying development and production.

# INTRODUCTION TO THE DEEP-SEA: ITS ENVIRONMENT, PROCESSES, AND RESOURCES

Dr. Robert R. Hessler  
Scripps Institution of Oceanography

Understanding the deep-sea is as complicated a problem as with any other environment. Yet certain features are sufficiently outstanding that using them together, one can highlight the uniqueness of the deep sea environment, its fauna, and the implications for man as we consider its exploitation.

## ENVIRONMENTAL FEATURES

1) The deep-sea is dark. Sunlight penetrates only a few hundred meters.

2) It is cold, usually less than a couple of degrees Celsius at abyssal depths. The reason for this is that deep bottom water is the densest available. Today, highest density water results from low temperature. It forms in shallow water at high latitudes, then sinks to the depths.

3) Hydrostatic pressure is high, increasing one atmosphere for every ten meters' depth. Thus at 6000 m in the abyss, the pressure is 600 atm; in deep trenches, it is as high as 1000 atm.

4) The dominant bottom type is mud, because this is the major particle size that is available far from land. Sand-sized particles do exist in the form of tests of radiolarians, foraminiferans, diatoms, and pteropods, but these are usually a proportionally smaller component. In many areas the mud bottom is dotted with manganese nodule concretions. Finally, in many places the rocky mantle pokes through the skin of sediment.

5) Current velocities are slow, typically no more than a few centimeters per second. Yet they are ubiquitous, stemming from pervasive tidal or geostrophic forces.

6) Food is supplied at a very low rate. Plants form the base of most of the world's food chain. Their energy source is sunlight. Thus, the beginning of food chains must reside in shallow water or on land; therefore all the food for the deep sea comes from above. Because of water depth and distance from land, very little of this food ever reaches the bottom.

7) Spatial variation in physical properties is small and changes only gradually. Compared to land or shallow water, the deep sea is a monotonous place. There is a limited variety of conditions, even comparing widely spaced localities, and abrupt discontinuities are rare.

8) Further, conditions vary little or not at all with time. What variation there is (tidal currents, seasonality, etc.) is damped compared to shallow water.

9) The deep sea is ancient. For all practical purposes, it has always been there. However, it is important to note that some of its features have been unlike what we see today. For example, it has not always been cold.

## COMMUNITY CHARACTERISTICS

These environmental features have acted to create communities that have a special suite of characteristics.

1) Standing crop (i.e., the abundance of life) is low, two to three orders of magnitude less than what is typical for shallow water. This results directly from the low rate of food supply, since the amount of available food puts an upper limit on the amount of life an area can support.

2) Individual organisms are small. For any type of organism, its deep-sea representatives are mostly smaller, and animals that tend to be small anyway are more important in the deep sea. The reason for this is unclear but probably stems from low food supply.

3) Metabolism and growth are slower in the deep sea. This applies to the complete range of life, from bacteria to fish. Once again, this is an adaptation to low food supply.

4) Deposit feeders dominate because other modes of feeding are so difficult. Predators are rare because prey are so scarce. Suspension

feeding is discouraged because suspended food is so sparse and because currents are so slow.

5) Fecundity (the number of young per adult female) is low. Reproduction is energetically expensive. Where food is rare, it is difficult to accumulate sufficient material for reproductive products.

6) Planktotrophic development is rare compared to lecithotrophic (i.e., yolk sustaining) or direct development (i.e., beginning life as a miniature adult). That is, few animals produce larvae that swim in the water column, where they search for food. Once again, this is because suspended food particles are so rare. This impinges on the previous point, because it means eggs must be larger, so there can't be as many of them.

7) With all of the difficulties for life in the deep sea, one would expect that few kinds of animals live there. But this is not true; species diversity in individual communities is very high, comparable to what occurs in tropical shallow waters. After years argument, we still do not know the reason for this. Most people suspect the underlying cause is environmental stability, abetted by the vastness of the deep sea.

8) The fauna changes with increasing depth (i.e., depth zonation). This is a result of the fact that most important environmental factors are correlated with depth (light, temperature, pressure, food supply, etc.). Since physical change is more rapid in shallower water, it is not surprising that faunal change is more rapid there as well.

9) Above the taxonomic level of species, the deep-sea fauna tends to be cosmopolitan. One can go anywhere and be able to predict with reasonable accuracy what kinds of animals there are likely to be. This results from the relative uniformity of the deep-sea environment, the few barriers to dispersal, and the long time that has been available for dispersal to take place.

## RESOURCE UTILIZATION

With these aspects of deep-sea communities in mind, what lessons are there for us as we consider utilization of this environment?

1) Because of lower fecundity and slower growth, faunas are likely to be more sensitive to fishing pressure than is the case for shallow water.

2) Because animals living in a world of little physical change tend to be more sensitive to exotic perturbations, deep-sea communities are more likely to suffer when exposed to anthropogenic disturbances, and for the reasons mentioned in the previous point, slower to recover.

3) Because of the ubiquity of the general kinds of deep-sea animals, local disturbances are unlikely to destroy unique communities. This comment does not necessarily apply to species whose distribution could be so local that extinction might be possible.

In considering this overview, one must remember that generalities are always oversimplifications. Specific exceptions can be found for all these points. This is particularly likely to be the case on slopes closer to land and in shallower water. But even with that, for most features the deep-sea will tend to seem extreme in comparison to conditions in shallow water.

## THE DEEP GULF OF MEXICO ECOSYSTEM

Dr. Willis E. Pequegnat  
MMS Continental Slope

In view of the limited amount of critical data at hand, it may seem presumptuous to attempt to describe the deep Gulf ecosystem and analyze how it works. It is admitted that many gaps exist in our knowledge of the offshelf ecosystems, but it is felt that enough information is now available to permit development of rough conceptual models of the composition and dynamics of this complex system.

In principle, the concept of the ecosystem is dimensionless; hence one is justified in discussing the ecosystem of an estuary or of the continental shelf or of the continental slope, or indeed, of all of the



area from the outer shelf to and including the abyssal plain, which is what we propose to do here. A marine ecosystem then is the community of organisms in a given area, including both pelagic and benthic species that are interacting with the physico-chemical environment in such a manner that energy flows through trophic levels of varying diversity and in which mineralization of materials occurs to produce a true cycle from primary producers to top consumer and return.

So far as the geographic emphasis in this study is concerned, the deep Gulf ecosystem is a complex of water and bottom extending from the Mexican border to and including DeSoto Canyon off the Florida panhandle. With the exception of the vicinity of hard banks at the edge of the continental shelf, the sediments are of terrigenous origin. Actually DeSoto Canyon marks the northern contact of clastic sediments with carbonate sediments to the east just as to the south Campeche Canyon runs along a similar contact of clastics with the great carbonaceous Campeche Bank, which runs from Campeche Bay to Yucatan Channel.

Although it might appear that the deep ecosystem of the Gulf in the area of this study is quite uniform, in truth there are some remarkable biotal differences. In fact, the biotal differences justify referring to the western Gulf as the "true" Gulf and the eastern part as a divergence of the Atlantic Ocean via the Caribbean Sea.

It is not clear just where a line separating east from west should be drawn, but the 90 west longitude represents a reasonable compromise. Perhaps a more realistic line would not follow a meridian but would cut obliquely from the easternmost extension of Yucatan Peninsula north-northwestward to the delta of the Mississippi River. The differences between the east and west Gulf are both physico-chemical and biological. Some 187 species of demersal fishes, decapods, and some echinoderms are limited in their distribution to the western Gulf, whereas only 31 species among these same groups occur only in the eastern Gulf. Some of this discrepancy may be due to sampling artifacts, but the separation might well be even greater had more of the less mobile species been included in the tally.

It is not difficult to suggest possible reasons for the relatively high level of endemism among the benthos in the western Gulf as compared with the eastern part. For one thing, residence time of water is greater in the west than in the east. Some of the water entering the Gulf through Yucatan Channel turns westward and becomes incorporated in a southern cyclonic gyre. Moreover, the northern two of the three gyres of the western Gulf are formed by water spinning off from the Loop Current. This water remains sufficiently long here for the development, metamorphosis, and sinking to the bottom of any meroplankters of benthos introduced from the Caribbean. In general this is not so true of the eastern Gulf. Here the Yucatan water often flowing at the rate of 2-4 kts sweeps in and out of the Gulf rather rapidly. Accordingly, holoplankters, meroplankters, and some nekton come into and pass out of the Gulf in a matter of days (note that a 3-knot current travels 72 n miles per day). Assuming an average transit distance of 576 n miles, water in the Loop Current would remain in the Gulf a maximum of 8 days. Actually the effective time for recruitment would be about half of this, simply because in order to reach the bottom before being carried out of the Gulf, pelagic larvae would have to begin their descent during their travel in the ascending (northward) limit of the Loop.

In order to simplify the deep Gulf conceptual ecosystem model, we shall ignore details of the various water masses and consider that any area of the deep ecosystem, is comprised of three functionally distinct but interrelated layers. The uppermost layer, extending from the surface to a depth of about 60 m, is referred to as the euphotic zone, because it receives sufficient sunlight to generate photosynthesis among phytoplankters and fixed plants. Beneath the euphotic zone, and extending to within a meter or so of the bottom, is a huge mass of water which beyond the shelf is largely devoid of sunlight. This is the aphotic zone, where photosynthesis cannot occur and where the processes of food consumption, biological decomposition, and nutrient regeneration take place in the cold, dark waters. The lowermost layer is the bottom itself together with the contiguous water a meter or so in thickness. This is the benthic zone, repository of sediments from above, where nutrient storage and regeneration take place in association with the solid and semi-solid substrate.

In operation, sunlight and nutrients enter the system through photosynthetic activity of the phytoplankton (principally diatoms and dinoflagellates) of the euphotic zone. By various mechanisms the energy and nutrients of the phytoplankton become transferred through the three interlocking food chains associated with each layer. In reality, however, each food chain is a complex food web, rather than a simple chain, and each group of consumer organisms more often than not feeds from several of the reservoirs rather than only from the single reservoir below. Supplementing these sources of energy are reservoirs for dissolved and nonliving particulate organic matter, sediments, and inputs of plant material from the land and shallow marine waters. This plant material and the dissolved organic matter appear to be essential for satisfying the energy budget of the deep sea.

It appears from previous estimates that the energy budget of the deep Gulf cannot be balanced unless the assimilative efficiencies of bacteria and meiofauna are extraordinarily high, which is an unlikely prospect. We are left, therefore, with the conclusions that other sources of organic matter for importation to the deep sea must be found. We believe that there are at least five such sources:

- (1) dissolved organic matter
- (2) deadfalls of animal carcasses
- (3) fallout of terrestrial and shallow marine plants
- (4) transport of animals and organically rich sediments in slumps and turbidity flows
- (5) active foraging of demersal fish and large benthic crustaceans in the midwater region from which they return to the bottom.

We have no evidence that dissolved organic matter is utilized as a source of energy by the bacteria, meiofauna, or any components of the macroinfauna of the deep sea, but it is a good possibility. This could ease the shortfall of energy in the deep-sea system. It must be pointed out, however, that there must be some limitations upon its availability else the deep-sea biomass should be considerably greater. Two possibilities present themselves as explanations. First, it is quite likely

that the compounds involved are available as food primarily to certain bacteria and even then that considerable energy must be expended to convert them to usable materials. It is also possible that for the most part the bacteria-meiofauna link is pretty much a close cycle; hence the energy advantage of uptake of dissolved organic matter by bacteria would not benefit higher trophic levels to a very large extent.

It is still a matter of conjecture as to the importance of large animal carcasses as a source of food for the megafauna. Very few sightings or photographs of deadfalls have ever been made. This, however, is not particularly surprising. Movies taken by baited camera systems have revealed that large fishes and amphipods can dispatch dead fish in a few hours at most. Moreover, when the larger scavengers are finished, bits and pieces are consumed by ophiuroids, echinoids, and various smaller crustaceans. Bruun (1957) suggested that deadfalls, including whales, could sustain the deep-sea fauna for substantial periods of time. Some twenty years later (1977) Haedrich and Rowe suggest "...the megafaunal biomass cannot be supported by the macrofauna. The megafauna must therefore depend to a considerable extent on food arriving from pelagic regions in the form of large, fast-falling packets, that is, the bodies of fishes, whales, squids, and decapods." The apparent ease with which mobile species are rallied around baited cameras suggests that attraction to the odors of dead bodies is a normal event. It is to be noted further that these scavengers themselves die and thus serve as a further link between deadfalls and the infauna of all sizes.

The importation of large packets of plant material to the deep benthic region is another source of organic matter of as yet undetermined significance. Some areas in the Gulf where we have dredged or trawled show substantial amounts of decaying plants. Invariably a rich benthic fauna is found in conjunction with these deposits. In some cases this must result from the refuge for the epifauna formed by the plant mass. All of the evidence that we have collected indicates that if this material is not consumed in its original form, it must be rather quickly transformed into components that are utilized by the infauna. Thus, in spite of large inputs from surface rafts, no large accumulations were ever photographed by us on the bottom.

The transport of the infauna from the shelf break and upper slope into much deeper zones continues to take place in the Gulf of Mexico. The tracers that we have used to demonstrate the occurrence of this phenomenon are the shells of paleotaxodont bivalves. Three regions in the Gulf are known to show definite evidence of slumping. One is in and below DeSoto Canyon. Another is west of the Mississippi Delta. The third is off Brownsville, Texas. Undoubtedly, numerous organisms, particularly polychaetes, small crustaceans, and gastropods would be carried along with bivalves in the slides and in the turbidity currents that would result from the initial slumping. It is likely that many of the displaced organisms would die during transport and their bodies would provide food.

Another phenomenon that undoubtedly assists in supporting parts of the benthic fauna, at least at depths in the Upper Abyssal Zone, is the active foraging upon midwater pelagic life carried out by some demersal fishes. Actually it is not known what the depth limitations of this mode of feeding are, but for the rattail Coryphaenoides armatus it appears to be around 2000 m (Pearcy and Ambler 1974, Haedrich and Henderson 1974). Obviously to occur much deeper than that could require such a large expenditure of energy in the vertical transit as to yield a negative energy flow for the individual.

RECENT RESULTS OF THE DEEP-SEA DRILLING PROGRAM ON THE  
MISSISSIPPI FAN, GULF OF MEXICO

Dr. Arnold H. Bouma  
Gulf Research and Development Company

Dr. James M. Coleman  
Coastal Studies Institute  
Louisiana State University

Dr. William R. Bryant  
Department of Oceanography  
Texas A & M University

Leg 96 of the D/V GLOMAR CHALLENGER (September 29, to November 8, 1983) was dedicated to the study of the Mississippi Fan, one of the world's large deep sea fans. The four major objectives of Leg 96 were to study the distribution of sediment types, analyze the transport processes responsible for redepositing shallow water sediments in the deep sea, study the time framework of the sedimentary sequences, and determine the geochemical and geotechnical characteristics of these deposits. The cruise relied heavily on the use of the advanced piston corer to obtain relatively undisturbed cores with good recovery. In addition, well logs provided a continuous vertical sequence where core recovery was poor.

The Mississippi Fan is a broad, thick, arcuate accumulation of Pleistocene shallow water sediments extending nearly 600 km from near the head of the present Mississippi Canyon onto the Gulf of Mexico abyssal plain. Seismic data show that this accumulation of sediment consists of elongated sediment bodies, called fan lobes, that migrate with time both laterally and seaward. The youngest fan lobe, late Wisconsin in age, was selected for the detailed investigation. This lobe is characterized by a large, sinuous central channel that decreases in width, depth, and sinuosity downfan. Adjacent to the channel are laterally thinning overbank deposits.

Nine sites were drilled in the fan deposits and two sites in the intraslope basins. Four sites were drilled on the middle fan (Sites 621, 622, 617, and 620), one site in a slump deposit on the margin of the fan (Site 616), four sites in the lower fan (Sites 623, 624, 614, and 615), and two sites in the intraslope basins (Site 618 in Orca Basin and Site 619 in Pigmy Basin). Table 7 gives pertinent information on these drill sites, and Figure 36 shows the location of the sites.

Table 7  
Leg 96 Drilling Sites

Site No.	Latitude	Longitude	Water Depth (m)	Penetration (m)
614	25°04.08'N	86°08.21'W	3314	150.3-
615	25°13.59'N	85°59.50'W	3268	523.2
616	26°47.70'N	86°52.80'W	2993	371.0
617	26°41.90'N	88°31.70'W	2467	191.2
618	27°00.68'N	91°15.70'W	2412	92.5
619	27°11.60'N	91°24.50'W	2273	208.7
620	26°50.12'N	88°22.25'W	2602	422.7
621	26°43.86'N	88°29.76'W	2485	214.8
622	26°48.41'N	88°28.82'W	2495	208.0
623	25°46.09'N	86°13.84'W	3188	202.2
624	25°45.24'N	86°16.63'W	3198	190.4

Sites 621 and 622 were drilled in the large sinuous channel characterizing the middle fan. Site 621 was located in the thalweg of the outer bend of the channel, whereas Site 622 was drilled on the concave "point-bar" side of the channel. Adjacent to the channel, side scan sonar data indicated the presence of a zone of ridges and swales. Site 617 was drilled in a swale immediately adjacent to the channel on the concave side of the channel bend. Site 620 was drilled approximately 18 km northeast of the channel sites in overbank sediments.

Site 616 was drilled on the eastern margin of the youngest fan lobe and was located in a region where a massive slump has been reported in

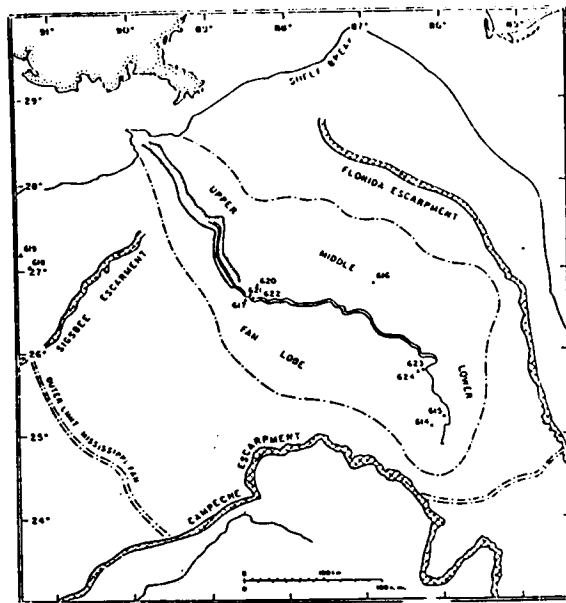

Figure 36. Eastern Gulf of Mexico with generalized outline of the youngest fan lobe, submarine fan divisions, main channel, and location of drill sites.

the literature. The main objective of this site was to determine the nature and thickness of this slump deposit.

In the lower fan, the channel narrows to less than 500 m, decreases in depth (5 to 10 m deep), and becomes less sinuous. Site 623 was drilled on the margin of the small lower-fan channel, and Site 623 was drilled approximately 6 km west of the channel in the overbank sediments. At these sites, the channel is bounded by a very low levee, and it appears that the sediment delivery system is still "channelized." However, side scan sonar data indicate that channel switching is a major process, as several abandoned channels parallel the most recently active channel.

The two most distal sites on the lower fan (Sites 615 and 614) were drilled on the margins of the lower-fan channel to evaluate the nature of the channel and overbank deposits at a point where they cease to be confined by prominent levees. Site 615, the deepest boring, penetrated two fan lobes, both of which display a coarsening-upward trend to blocky sands and are capped by fining-upward sequences. Site 614 was drilled near the terminus of the modern lower-fan channel and penetrated the youngest fan lobe. (This abstract is from a paper presented by Arnold H. Bouma and James M. Coleman before a GCSSEPM Foundation Research Conference, December 2-5, 1984.)



## NORTHERN GULF OF MEXICO CONTINENTAL SLOPE STUDY

Dr. Benny Gallaway

Dr. George Lewbel

Dr. Linda Pequegnat

LGL Ecological Research Associates

The study objectives of this project were reviewed: 1) to determine the abundance, structure, and distribution of animal communities in the deep sea in the Gulf of Mexico, 2) to determine the hydrographic structure of the water column and bottom conditions at selected sites within the study area, 3) to determine and compare sedimentary character at selected sites within the study area, 4) to relate differences in biological communities to hydrographic, sedimentary, and geographic variables, 5) to assess seasonal changes in deep-sea biological communities in terms of abundance, structure, animal size, and reproductive state, 6) to measure present levels of hydrocarbon contamination in the deep-sea sediments and selected animals prior to petroleum resource development beyond the shelf-slope break, and 7) to compare the biological and non-biological character of the deep Gulf of Mexico with that of other temperate and subtropical deep-sea regions.

To date, two sampling cruises have been completed in the northern Gulf of Mexico: (1) a November 1983 cruise sampled five stations along the Central Gulf Transect (adjacent to 90° W longitude) in depths from 320 to 2880 meters and (2) an April 1984 cruise sampled the Central Transect again and in addition sampled at five stations along the Eastern Gulf Transect (adjacent to 86° W longitudes) and five stations along the Western Gulf Transect (adjacent to 94° W longitude).

The major sampling types at each station included hydrography, box cores, trawls, photographic transects, and checks for on-board contaminants.

Hydrography data have been used to determine water mass distribution over each station along the Central Transect. The shallowest station, C1, is located well above the oxygen minimum zone, near the boundary between Gulf Water and Tropical Atlantic Central Water. Station C2 is located in an area usually penetrated by Antarctic Intermediate Water, above the nitrate and phosphate maxima and the salinity minimum. Stations C3, C4, and C5 are located in Deep Gulf Water.

Box cores were examined for sediment texture, sediment chemistry (total organic carbon and high molecular weight hydrocarbons), macroinfauna (those organisms retained on a 300-micron screen), and meiofauna (organisms ranging in size from 63 to 300 microns).

Sediment textures at stations along the Central Transect were highly homogeneous in nature, both within stations and between stations. All of the stations had clay or silty clay sediment, except for Station 4 (at approximately 1400m depth), which had coarser, less homogeneous sediments consisting of sandy clay and silty clay.

Macroinfaunal samples from box cores of Cruises 1 and 2 have been completely sorted and enumerated according to major taxonomic groups. The dominant groups of Cruise 1 macroinfauna have been identified to the species level by taxonomic specialists, but these species level data have not yet been computerized for analysis. Cluster diagrams showing similarities between stations and the relative abundance of the major taxa at each station show the polychaete worms to be the most abundant taxon at every station. In all but one case the nematode worms were the second most abundant group. The next five taxonomic groups of greatest numerical abundance were harpacticoid copepods, Ostracoda, Isopoda, Bivalvia, and Tanaidacea. Cruise 1 (November) Central Transect samples demonstrated fairly constant population densities among the stations, ranging from  $3254/m^2$  at Station C5 to  $5653/m^2$  at Station C3. Central Transect total populations were higher in April than in November ( $33,000/m^2$  and  $21,503/m^2$  respectively). Polychaete population densities were notably different between the two sampling periods at the Central

Transect ( $8843/m^2$  in November compared to  $17,811/m^2$  in April). Polychaetes were the most abundant at the two shallower stations on both cruises at the Central Transect.

Western Transect macroinfaunal populations were lowest ( $22,421/m^2$ ) and Eastern Transect populations were the highest ( $36,021/m^2$ ) of the three transects during the April sampling period. Station 5, the deepest station, at all transects showed the least similarity with other stations along the transect on the basis of the relative composition of the major taxa of macroinfauna. Station 5 also showed the lowest population densities of macroinfauna of all transects. Many new species and some new genera have already been found in the northern Gulf of Mexico continental slope macroinfauna, especially in the isopod and tanaidacean crustaceans and the bryozoans.

Meiofauna from Cruises 1 and 2 have been completely sorted into major taxa. Cruise 1 meiofauna data from the Central Transect have been plotted into cluster diagrams which show the abundance of major taxa at each station and similarity between stations at the Central Transect in November 1983. The stations showed a general decrease in numbers of individuals with depth. The range in density among stations is relatively small, ranging from  $1741/10\text{ cm}^2$  to  $3275/10\text{ cm}^2$ . Stations C1 and C2 showed the closest similarity, followed by Stations 4 and 5. The most abundant meiofaunal taxa, as would be expected, were nematodes, harpacticoid copepods, and foraminifera--accounting for greater than 75% on the density in each sample. Nematodes alone accounted for at least 50% of the density at each station and harpacticoids for about 25% in each sample. Station C5 is an exception, where the ratio of nematodes to harpacticoids is much greater than at the other four stations.

Trawl samples have been analyzed for macroepifaunal organisms according to number, species, wet weight, size, and hydrocarbon determinations on the larger, dominant species at each station. In addition, selected fish species are also examined for gut contents and hydrocarbon determinations on three organ types. Trawl samples at all stations from the two cruises have been sorted into major taxonomic

groups and weighed. The decapod crustaceans and fish have been identified to the species level. The other macroepifaunal taxa are in the process of being identified by taxonomic specialists. The most abundant decapod species were 1) the penaeid shrimp Penaeopsis serrata, taken only at the shallowest stations; 2) the caridean shrimp Nematocarcinus rotundus, taken between 620-1450 m at stations 2, 3, and 4; 3) the pandalid shrimp Plesionika holthuisi, taken at 600-850 m at stations 2 and 3; 4) the goneplacid crab Bathyplox typhla, taken at 600-1450 m at stations 2, 3, and 4; 5) the polychelid lobster Stereomastis sculpta, taken at 600-1450 m at stations 2, 3, and 4; 6) the galatheid crab Munida valida, taken at 600-1170 m at stations 2, 3, and sometimes 4; and 7) the caridean shrimp Glyphocrangon aculeata, taken at 830-2680 m at stations 3, 4, and 5. Combining the decapod crustacean data from Cruises 1 and 2, a total of 19 trawl stations were sampled yielding 2548 individuals representing 69 species. Trawl stations showed a general trend of decreasing numbers of decapod species and individuals with depth. The outstanding exception is Station E4 at the Eastern Transect, a high diversity and high density station with 26 decapod species and 406 individuals. Overall, a higher number of ovigerous female specimens was noted in the April samples compared to the November samples.

The trawl fish data are incomplete at this time, but the most abundant species encountered were (1) the macrourid Coelorinchus caribbaeus, taken at the shallowest station only; (2) the righteye flounder Poecilopsetta beani, taken at stations 1 and 2; (3) the scorpionfish Setarches guentheri, taken at station 1 only; (4) the goby flathead, Bembrops gobioides, taken at stations 1 and 4; and (5) the shortnose greeneye, Chlorophthalmus agassizi, taken at station 1 only.

Photographic transects are made at each station with 35 mm Benthos cameras. Up to 100 frames per station are analyzed for the presence of epifaunal invertebrates, fish, Lebensspuren (i.e., evidence of animal tracks or burrows), geological features, and artifacts. A digital slide analysis system has been devised at LGL whereby computerized results summarizing all of the photos at each station can be obtained from the digitizer on the following parameters: numbers of Lebensspuren,

individual size ranges and mean sizes of each type of Lebensspuren, percent cover and density (converted to no./m<sup>2</sup>) for each type of Lebensspuren, percent cover of all Lebensspuren, numbers of individuals of benthic invertebrates and fishes converted to no./m<sup>2</sup>, and size or length of benthic invertebrates and fishes.

When substantial percentages of taxonomic data are in hand, a broad gauge statistical analysis will be undertaken to verify seasonality, faunal zonation, the relationships between vertical distribution of faunal assemblages, and physicochemical and geological parameters. Until we are able to ascertain the vagaries of "normal" distributional and population data, no evaluation of the impacts on the biota, if any, of hydrocarbon search and exploitation activities is possible. It is anticipated that the initial attempts to develop these analyses will comprise an important section of the final report of the first year's activities.

NORTHERN GULF OF MEXICO CONTINENTAL SLOPE STUDY  
II. HYDROCARBONS

Dr. Mahlon C. Kennicutt II  
Dr. James M. Brooks  
Department of Oceanography  
Texas A&M University

In conjunction with the previously described benthic ecology study, measurements of hydrocarbon levels in sediments, benthic epifauna, and demersal fish tissues from the intraslope region have been undertaken. Data from the first cruise which sampled a central Gulf of Mexico transect in water depths from 350 to 2400 m is presented.

Total average (5-6 replicates/station) hydrocarbon concentrations were determined gravimetrically and gas chromatographically and ranged from 15.6 to 106.4 ppm and 27.7 to 52.6 ppm, respectively. These concentrations are at the lower end of reported values (1 to 3000 ppm), though they are certainly not the lowest reported. Hydrocarbon concentrations in massive seep areas on the intraslope of the Gulf of Mexico can range from 1,000 to >100,000 ppm. Sediment hydrocarbons were both biogenic and petrogenic in source. Biogenic hydrocarbons were predominately plant biowaxes with ~65% of the total resolved hydrocarbons accounted for by the C<sub>23</sub> to C<sub>31</sub> odd carbon normal alkanes. Total resolved alkanes plus the isoprenoids pristane and phytane accounted for only 3-6% of the total hydrocarbon content. The remaining hydrocarbon fraction (~95%) was due to the unresolved complex mixture (ucm) which has a presumed petrogenic source. Sediment hydrocarbon concentrations were highest and most variable at the shallowest station. Molecular compositions were monotonous over the sampling areas and intra-station variability was 1.5 to 2 fold. Hydrocarbon concentrations at all stations overlapped at  $\pm 1\sigma$  confidence level (n=5 or 6). Individual alkane concentrations rarely exceeded 1 ppm. Plant biowaxes were generally in the 100-1,000 ppb range while the

remaining hydrocarbons were in the 10-100 ppb range. No aromatic hydrocarbons were detected in the sediment extracts by GC or GC/MS, but a low level presence (<5 ppb) was inferred from fluorescence spectral characteristics. Previous studies in the Gulf of Mexico and piston cores at the sampling sites suggest that upward migration of deeper reservoired petroleum (natural seepage) may be a significant source of hydrocarbons to the intraslope sediments of this area. Tar mats retrieved in bottom trawls appear to have been weathered at the seawater-air interface. Once their density exceeded that of the surrounding seawater they settled to the sea floor.

Hydrocarbon analysis of benthic organisms confirmed the presence of hydrocarbons in many samples. Total extractable gravimetric weights were not useful in determining the hydrocarbon content of organisms due to the high-lipid content of the tissues analyzed. These gravimetric concentrations are primarily the result of indigenous biogenic lipids. In general, two distinct clusters of peaks were identifiable in the gas chromatograms of tissue extracts. The first envelope contained alkanes from n-C<sub>15</sub> to n-C<sub>20</sub> including pristane, phytane, and an unresolved complex mixture. The second envelope has been tentatively identified as a group of triterpenoid compounds containing 28 to 32 carbons and are of a presumed biological source. Muscle, liver, and gonad tissues from demersal fishes were analyzed. Individual alkanes and isoprenoids were detected in fish muscles at the ppb level (range 0-800 ppb). The distributions were usually dominated by phytane, pristane, or n-C<sub>17</sub>. Concentrations were highly variable within stations as well as within species. Hydrocarbon levels in fish livers were elevated over those in fish muscles, usually by at least a factor of 10. Individual alkane concentrations in liver extracts ranged from 0-6000 ppb. Only a few fish gonad samples were analyzed and often very little tissue was available. Hydrocarbon concentrations in gonad extracts were low level (0-150 ppb). The distributions were generally dominated by pristane and phytane. The distributions observed were similar for all three tissue types, though large quantitative differences were observed. The epifauna analyzed were primarily shrimp. Again the two envelopes of compounds previously described were observed in gas chromatograms. Alkanes and isoprenoids

were in the range of 0-400 ppb and the distributions were dominated by n-C<sub>17</sub>, pristane, n-C<sub>18</sub>, and phytane. A single crab sample analyzed had no detectable hydrocarbons in muscle tissue and 0-120 ppb of individual hydrocarbons in gonadal tissue. The level of individual hydrocarbons was similar in sediments, fish muscle, fish gonads, and shrimp, though molecular level distributions were strikingly different between sediments (C<sub>23</sub>-C<sub>31</sub>) and organisms (C<sub>15</sub>-C<sub>20</sub>). No aromatic hydrocarbons to date have been positively identified in the tissue extracts by GC or GC/MS.

Future directions include the extension of the present, limited data base of both the levels and distribution of hydrocarbons in intraslope sediments and organisms. Cruise II and III samples will be used to assess temporal and areal variability, specifically, hydrocarbon distributions in the eastern, central, and western Gulf of Mexico will be evaluated. These continuing studies will help to establish if the observed hydrocarbon levels are "natural," due to the proximity to the Mississippi River, or due to the proximity to areas of massive natural seepage. Organisms will also be collected in areas of known massive seepage to determine if elevated hydrocarbons are observed in organisms and how this seepage affects the benthic assemblages. Close collaboration with biologists will help to delineate the effect of feeding habits, stage of life cycle, trophic level, and organism mobility on hydrocarbon distributions in the deep sea.



# STUDY OF BIOLOGICAL PROCESSES ON THE U.S. ATLANTIC CONTINENTAL SLOPE AND RISE

Dr. James A. Blake

and

Dr. Nancy Maciolek-Blake

Battelle New England Marine Research Laboratory

## PURPOSE AND SCOPE OF THE PROGRAM

In recent years, the oil industry has shifted some of its interest in offshore exploration to areas lying beyond the continental shelf to the continental slope and rise. These areas include sites which are between 200 and 4000m in depth.

Information to date suggests that unusual environmental disturbances may have significant impacts on deep-water benthic communities, which have been described as some of the most complex and diverse in the marine environment. Data show that individual organisms have slow growth and reproduction rates, low recruitment, and extended life spans, resulting in low colonization potential at the community level. Thus, if disturbed, these communities could require years to recover. Virtually no data exist on the impact of oil and gas drilling activities on these diverse and potentially fragile deep-sea communities.

In order to address these concerns, the Minerals Management Service (MMS) is sponsoring a study with the primary objective of acquiring the background data necessary to assess the potential effects of oil and gas drilling operations on deep-water benthic communities in the North, Mid- and South Atlantic regions of the U.S. Atlantic Continental Slope and Rise. Where drilling has occurred in the Mid-Atlantic region, this study is a monitoring program.

The program is under contract to Battelle New England Marine Research Laboratory with major subcontracts to Woods Hole Oceanographic Institution (WHOI) and the Lamont-Doherty Geological Observatory of Columbia University (LDG). The research team includes Drs. James A. Blake, Nancy Maciolek-Blake, and Paul D. Boehm of Battelle; J. Frederick Grassle and Howard Sanders of WHOI; and Barbara Hecker of LDG. Dr. Michael Bothner of U.S.G.S., Woods Hole, is the principal investigator for trace metal geochemistry under a separate interagency agreement with MMS. Chief scientists for the field program include James A. Blake (South); Rosemarie Petrecca, WHOI (Mid-Atlantic); and George Hampson, WHOI (North). Dr. Grassle is the overall advisor for the field effort.

#### **Mid- and South Atlantic Regions of the U.S. Atlantic Continental Slope**

Although each of the three Atlantic regions has its own specific requirements, the overall objectives of the program may be summarized as follows:

1. To characterize pre-drilling biological, geological, and chemical properties of benthic environments at a limited number of stations within areas of potential oil and gas development on the U.S. Atlantic slope and rise.
2. To monitor potential changes in those properties with time to determine the extent of natural temporal and spatial variation, or changes caused by drilling related activities.
3. To determine the background distribution of materials (such as trace metals and hydrocarbons) that may accumulate at elevated levels during drilling operations.
4. To estimate recovery rates of deep-sea benthic communities potentially affected by drilling-related activities.

During the course of these studies these objectives are met by characterizing or monitoring changes in the following biological, geological, and chemical properties:

1. Structure, composition, distribution, and biomass of infaunal communities.
2. Structure, composition, and distribution of epifaunal communities.
3. Size-frequency distributions and age-size structure of dominant infaunal species.
4. Infaunal colonization rates and the nature of successional events following disturbances.
5. Levels and distribution of trace metals (Al, Hg, Cr, Zn, Pb, Cd, Cu, Fe, Mn, Ni, V, and Ba) in bottom sediments.
6. Levels, composition, and distribution of hydrocarbons in bottom sediments.
7. Levels and composition of hydrocarbons in used drilling fluids.
8. Levels and composition of hydrocarbons and levels of trace metals in benthic fauna.
9. Sediment grain size analysis.
10. Sediment organic matter (CHN)
11. Selected hydrographic data (salinity, temperature, and dissolved oxygen from near-bottom water).

## REGIONAL SAMPLING DESIGNS

### South Atlantic Region (Figure 35)

Studies began in November, 1983. As part of Phase 1, six stations were established off North Carolina in areas of oil industry interest. A 5-station transect was set-up off Cape Lookout in depths of 600m, 1000m, 1500m, 2000m, and 3,000m. A 2,000m station was also established north of the Hatteras Canyon. Three cruises have been completed and Phase 1 data are being analyzed.

Phase 2 will begin in May 1985. A 12-station plan is currently being developed in which 2-3 of the stations sampled in Phase 1 may be reoccupied in order to continue to collect long-term seasonal data. The remaining stations will be established in areas of oil industry interest off Cape Hatteras and Cape Fear. Additional stations (at least 4) will be located on the Blake Plateau in an area of potential hard mineral mining. The second year of Phase 2 (year 3 of the program) will see a shift of some northerly station to sites off the Blake Plateau (Blake Escarpment, Blake Spur).

### Mid-Atlantic Region (Figure 36)

This program began in April, 1984. Unlike previous site-specific station designs, the Mid-Atlantic Monitoring Study encompasses a broad regional approach taking into consideration the amount of time and distance needed for particles discharged at the surface to reach the bottom. Consequently, stations are spread over a 180km north/south distance. Block 372 is at the center of the design, with 3 stations located within 2km of the drill ship, all in the 2100m depth range. Two of the stations are down current and the third is upcurrent. Another two stations are upslope (1500m) and downslope (2500m) from the drill site. Seven additional stations are located north and south of the drill site (all at 2100m). At the southern edge of the sampling design, Station 13 is at the most recent drilling site (Block 93) at 1613m.

## North Atlantic Region

The first cruise in this program was conducted in November 1984. The study as presently conceived is a characterization of areas of potential oil and gas development off Georges Bank. With the recent decision of the World Court resolving the U.S.-Canadian boundary dispute, there is some possibility that future oil exploration in the area may include both Canadian and U.S. efforts. A series of hypotheses was stated to be tested during this study. These hypotheses address the many different potential depositional areas of the variable topography found in deep water off Georges Bank. The study design therefore includes testing canyon/non-canyon differences, gulley/non-gulley differences, and topographic highs and lows, which emphasize small scale variations in depths as well as providing a broad regional characterization of the sediments, fauna, and chemistry. A total of 14 stations were established in the following depths: 250m (1 sta.), 550m (3-4 sta.), 1250-1350m (4 sta.), 2100m (5-6). Where possible, stations were chosen in areas of on-going or past physical oceanographic studies in order to have as broad a data base as possible for evaluating the biological and chemical results.

## Regional Scope

At the end of these studies a broad regional deep-sea data base will have been developed at a total of at least 44 stations from the U.S.-Canadian boundary to areas off Georgia. The depths sampled and the number of stations at each depth includes the following: 250m (2), 550-600m (7-8), 1000-1350m (5), 1500-1600m (3), 2000-2100m (23), 2500m (1), 3000m (2). Epifaunal camera transects in each of the regions will emphasize seasonal changes in the epifauna. It will be possible to compare seasonal phenomena from one region to the next with both the epifaunal and infaunal studies. During 1985, all three regional programs will be on-going simultaneously, providing a unique one-time look at seasonal phenomena over the entire U.S. Atlantic Continental Slope and Rise.

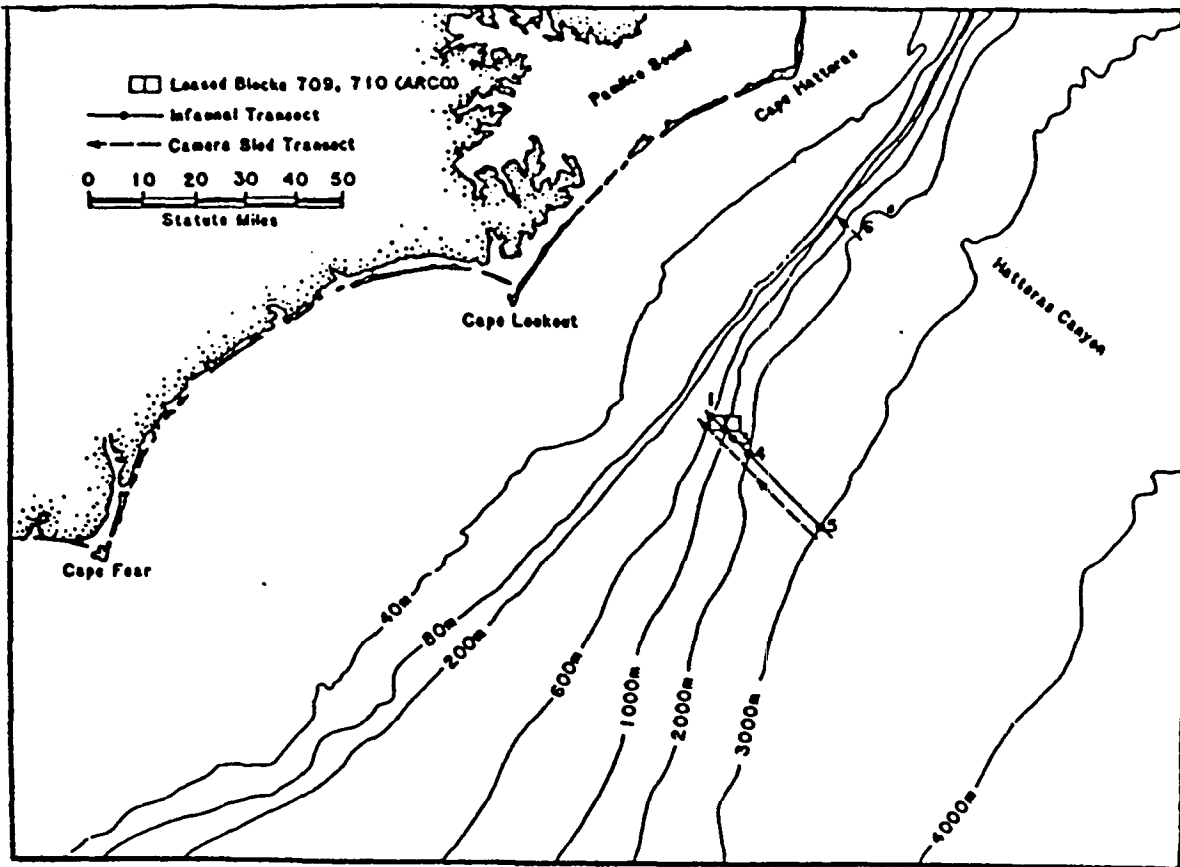

Figure 37. South Atlantic Phase 1 sampling design.

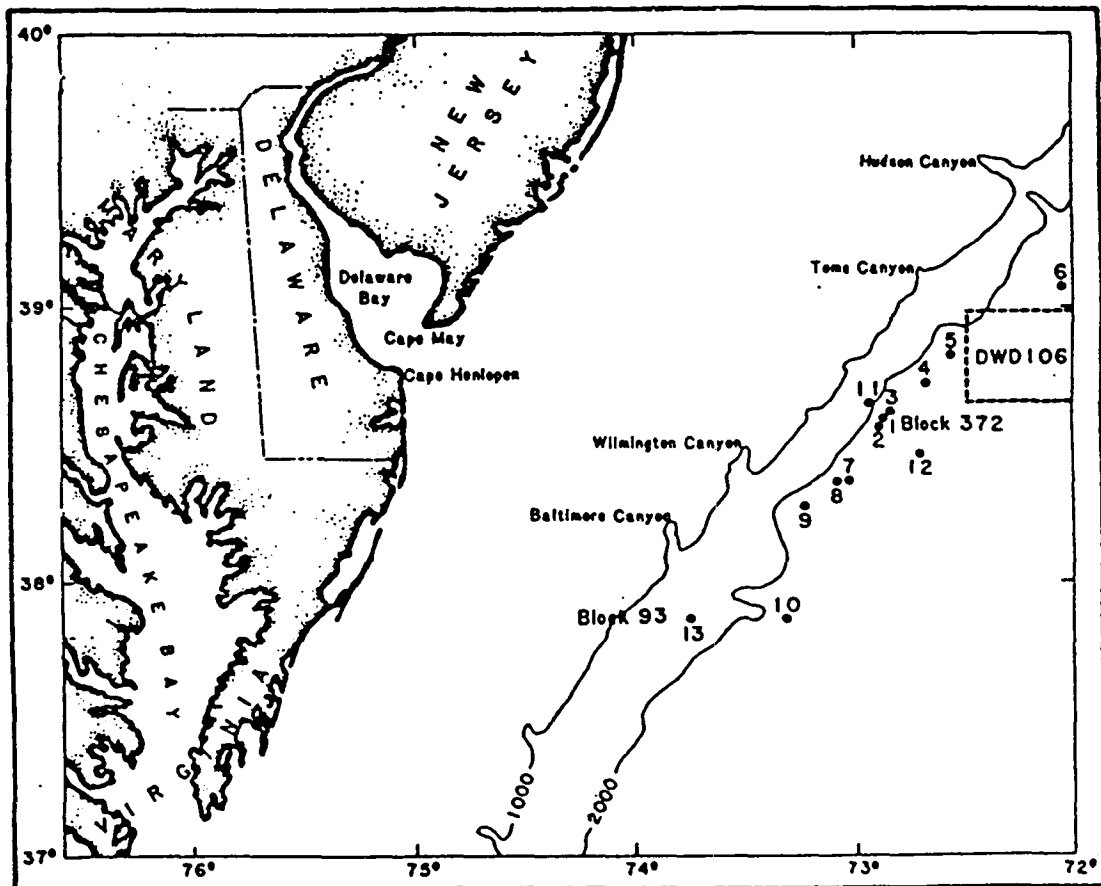

Figure 38. Mid-Atlantic Monitoring Study, sampling design.

## VENT-TYPE COMMUNITIES OF THE FLORIDA ESCARPMENT

Dr. Barbara Hecker

Lamont-Doherty Geological Observatory

Seven years ago geological studies on the Galapagos Rift, an Eastern Pacific spreading center, presented biologists with an exciting enigma. In contrast to the sparse microscopic organisms typically inhabiting abyssal depths, exceptionally dense populations of large exotic organisms were found clustered around hydrothermal vents emanating from newly-formed oceanic crust. Six-foot long tube worms (*Vestimentifera*) with bright red plumes, large red-fleshed vesicomid clams, and 6-7 inch long mussels were frequently the most obvious components of these exciting new communities. Subsequent sampling expeditions uncovered a myriad of smaller organisms also associated with these hydrothermal vents. Taxonomic studies have since defined numerous new families and genera represented by these fascinating organisms. Microbiological and physiological studies of these vent communities have shown that they are mainly supported by chemical energy, rather than the photosynthetic sources that support most of life. This chemical energy is derived from bacterially mediated oxidation of reduced inorganic compounds present in the geothermal effluent. Since the initial Galapagos Rift discovery, numerous other hydrothermal vent-communities have been found along the Eastern Pacific spreading centers.

In March 1984, scientists serendipitously discovered a similar community at 26° 02'N; 84° 55'W in the Gulf of Mexico, while using the research submersible ALVIN. The initial purpose of the NSF-funded expedition was to study the processes involved in the formation and subsequent erosion of the West Florida Escarpment. During the second dive, dense populations of large mussels, vestimentiferans, vesicomid clams, and various associated organisms were found at 3270m at the base of the escarpment. Further investigation during two subsequent dives showed that this community inhabits a 10-20m wide band of

pyrite-enriched sediment along the base of the escarpment where the massive limestone cliff intersects the abyssal seafloor.

The density and size of the organisms, as well as their taxonomic representation, are strikingly reminiscent of Pacific hydrothermal vent-communities, yet the geological setting is surprisingly different. The Gulf of Mexico community is found on a passive continental margin at ambient temperature where sulfide-enriched hypersaline water seeps out of the escarpment onto the abyssal seafloor. This seepage appears to provide sufficient concentrations of reduced inorganic compounds necessary for the support of this chemosynthetically-based community. The geographic extent of the seep-community (along the 1.5 miles explored) indicates that similar communities may exist in other areas of the Gulf of Mexico.

This Gulf of Mexico find suggests several evolutionary implications for the origin and maintenance of chemosynthetically-based communities. While no species are shared between the Pacific hydrothermal vent-communities and the Gulf of Mexico seep-community, which is not surprising in light of their geographic isolation, many of the same taxa are represented. Both communities consist of bacterial mats, mussels, vestimentiferans, vesicomid clams, gastropods, galatheid crabs, and zoarcid fish. At the very least these similarities point to an evolutionary conservatism in the taxa that can adapt to sulfide-enriched environments. However, the familial and generic similarity, with at least five of the seep-taxa being congeners of vent-taxa, points to an even stronger relationship, namely that of a common origin and subsequent evolutionary history.

In terms of maintenance and dispersal of chemosynthetic taxa, this discovery extends the known geographic range of these communities into the Atlantic and the type of habitat in which they might be found. Since many of the vent taxa have larvae with limited dispersal capabilities, they are thought to colonize new areas by being propagated along ridges in a "stepping stone" fashion. Many questions still remain as to how these organisms can span the large distances between the known suitable



habitats. This find of the Gulf of Mexico seep-community indicates that hydrothermal vents are but one mechanism whereby reduced inorganic compounds, capable of supporting chemosynthetic communities, reach the sea-floor. This leads us to believe that many more "islands" of suitable habitats may exist throughout the oceans.

Plans are presently being made to return the the Gulf of Mexico seep-site during 1986 or 1987 when ALVIN returns to the Atlantic. A broad scale biological study of the seep-community is planned in an attempt to elucidate similarities and differences in the fauna of chemosynthetic communities from these different geologic and environmental settings.

## PHYSICAL OCEANOGRAPHY

Session: PHYSICAL OCEANOGRAPHY

Chair: Dr. Murray Brown

Date: November 28, 1984

<u>Presentation Title</u>	<u>Speaker/Affiliation</u>
Session Overview	Dr. Murray Brown MMS, Gulf of Mexico Region
PART I: FIELD MEASUREMENTS PROGRAM REVIEW	
MMS/GOM Physical Oceanography Program - Summary Update	Dr. Evans Waddell Science Applications International Corporation
The MMS Current Meter Program on the West Florida Shelf	Dr. Tony Sturges Florida State University
Hydrographic Surveys of the Eastern Gulf of Mexico	Dr. Larry Atkinson Skidaway Institute of Oceanography
Remote Sensing Studies in the Gulf of Mexico	Dr. Fred M. Vukovich Research Triangle Institute
Satellite-Derived Sea Surface Temperature Products Available from SFSS Miami	Dr. Stephen R. Baig NOAA/National Hurricane Center
Results of a Trial Program to Monitor the Loop Current with AVHRR Data During Summer	Mr. Rhys McDonald Brown and Caldwell, Inc.
Current Measurements Near the Mississippi River Delta	Dr. William J. Wiseman, Jr. Louisiana State University

Storm Sedimentation on the Texas Continental Shelf	Dr. Dag Nummedal and Dr. John W. Snedden Louisiana State University Dr. Anthony F. Amos The University of Texas at Austin
Shipboard Environmental (Data) Acquisition System: Description and Status	Mr. Vince Zegowitz NOAA/National Ocean Service
Sedimentation on the Gulf of Mexico Continental Margin: A Uniformitarian Model for Reservoir Sandstone Deposition in a Muddy Setting	Dr. Marshall H. Orr Sohio Petroleum Company Dr. Donald J. P. Swift ARCO Oil and Gas Company Dr. Arnold Bouma Shell Research and Development Company
PART II: CIRCULATION MODELING PROGRAM REVIEW	
Gulf of Mexico Circulation Modeling Study	Dr. Alan J. Wallcraft Jaycor, Inc.
Dynamic Transfer of Simulated Altimeter Data into Subsurface Information by a Numerical Ocean Model	Dr. Harley E. Hurlburt NORDA
Preliminary Studies Concerning Modeling of the West Florida Shelf and Slope	Dr. Peter Hamilton Science Applications International Corporation
Observations of Gulf of Mexico Inflow and Outflow	Dr. George A. Maul NOAA/Atlantic Oceanographic and Atmospheric Laboratory
The ALVENUS Oil Spill and Circulation on the Texas-Louisiana Shelf: Preliminary Analysis	Dr. Kurt W. Hess NOAA/Marine Environmental Assessment Division
Navy Corrected Geostrophic Wind Set for Use in Gulf of Mexico Circulation Modeling	Mr. Robert C. Rhodes Jaycor, Inc.

## SESSION OVERVIEW: PHYSICAL OCEANOGRAPHY

Dr. Murray Brown  
MMS, Gulf of Mexico Region

In the Physical Oceanography session, we first heard a report from Dr. Van Waddell of Science Applications International. They are our contractors in a multi-year program that has probably reached the "log phase" of increasing information as opposed to a "lag phrase" that you heard about last year. A lot of things that people were about to do, they are doing and interesting and valuable results are being made available.

Dr. Waddell, who is the Program Manager, reported that we are about to enter the Year Three Program, which will concentrate on current meter measurements and hydrographic measurements in the western Gulf of Mexico. This agency is currently procuring Year Four activities which will return to the eastern Gulf of Mexico, where we intend to obtain a total of three years of measurement. A data summary has just been published for the first year of measurements, and it is available to industry and academic researchers.

A May 1984 hydrographic cruise program using six ships was a major success. It is notable that we are finding very significant current reversals in the LOOP current regions which may warrant much further study. Dr. Tony Sturges, Florida State University, reported that the current meter measurements that we are obtaining show very low coherence along the west Florida Shelf, results confirming earlier work by the National Science Foundation. We are getting some insight into the balance of forces between winds and ocean open currents off the shelf. This problem, by the way, is a central problem for understanding circulation in the eastern Gulf of Mexico. It is very good news that the National Science Foundation has funded at least one additional mooring in the same area, so more data than we could ourselves obtain will be available to our program.

Dr. Fred Vukovich, Research Triangle Institute, reported that an imagery analysis for the western Gulf of Mexico is complete now for about a ten-year period and the satellite analysis has also been parameterized to compare with model results.

We have been looking at the eastern wall of the LOOP current since 1982 in a prior marine ecosystem study. Dr. Larry Atkinson, Skidaway Institute of Oceanography, reported on our continuing studies of the effects on biological oceanographic processes of LOOP current intrusion.

It is of concern at NOAA's Satellite Service, as reported by Dr. Steve Baig, that the GOES-East satellite was lost this year. There will not be a new GOES-East until May 1986; in the meantime they have a swing-shift satellite midway between the two former positions. The imagery is not quite as good as it used to be for the eastern Gulf but probably better for the western Gulf.

Daily ocean analyses for the Gulf are still being prepared by NOAA. We receive these for our program, and they are available to all of you. There is a new method for eliminating atmospheric moisture which is quite promising, and it may very well be that the satellite window may increase to a ten-month period instead of about eight or nine right now.

We had a short report from two researchers working at Marathon Oil Company on a new method for processing satellite imagery, which gives very interesting results, although the method is probably best characterized in the "R" part of R and D. It is a promising method and it may increase coverage, but the results are somewhat like early SEASAT results in that they are still ambiguous and difficult to analyze.

At LSU we are co-sponsoring two smaller efforts by Drs. Dag Nummedal and Bill Wiseman to obtain current measurements in the central and western Gulf ahead of the planned Year III concentrated effort. We're not really in that area yet with our major programs, but we have made measurements at the mouth of the Mississippi River and

are currently making measurements off Mustang Island, a cross-shelf transect looking primarily at the effect of storm currents on the formation or modification of sand beds.

The National Ocean Service has recently initiated a new program, called SEAS, reported on by Mr. Vince Zegowitz. SEAS stands for the Shipboard Environmental Data Acquisition System. They are putting real time, satellite relay equipment for data gathering on ships of opportunity. NOAA plans to supply about 80 units, similar to the units that MMS uses on our own ships of opportunity. In fact, NOAA is offering these units to the Gulf marine community on a first-come-first-served basis to any ships that might be regularly cruising in areas of interest, particularly areas where the meteorological data would be useful to the National Weather Service. We may be getting in line soon to borrow some of these units for boats that we identified early on but could not afford to equip.

I strongly recommend that those of you who are in a position to talk to management in oil companies should consider putting units like these on your regular vessel traffic in the Gulf of Mexico, so that data -- you're always looking for data, we're always looking for data -- can be obtained at an extremely low cost. The data will feed back to users through GOES, via the National Weather Service's AFOS computer system. If you're interested in that, please contact me later and I'll get you in contact with the folks at the National Ocean Service.

There is a group called The Consortium for Modern Shelf Studies, consisting of about half a dozen oil companies who have been performing a multi-year study of bed forms on the Atlantic margin as an analog to Cretaceous shelf sedimentation which occurred over the western states. They are interested in current measurements in order to determine what forces form and modify sand beds. They are planning to shift their area of interest to the Gulf of Mexico. Dr. Marshall Orr reported that they are going to work with LSU on a major current meter transect, probably off the coast of central Louisiana. We are interested in participating with them in order to share data.

Dr. Alan Wallcraft from Jaycor, who is the contract manager in our Circulation Modeling Program, has recently delivered to me the second generation of the NORDA/Jaycor circulation model for the Gulf of Mexico at a 0.2 degree resolution. The model has a highly resolved shoreline and realistic bottom topography up to the level of 500 meters; the regional circulation features look very realistic. Of course, there are going to be at least two more generations of product that will follow, improving the resolution and topography, but this is much better than any circulation model available. The drifting buoy trajectory simulations Jaycor has done compare extremely well with the actual results from our own drifter studies.

Dr. Harley Hurlburt reported that at NORDA there are also ambitious plans for integration of circulation modeling with satellite altimeter results. As you may know, a very sophisticated satellite altimeter is due to be launched in early 1985, and the Navy is looking forward to the day when circulation models will actually be initiated using satellite results and periodically updated using satellite results. MMS is more interested in such methods from the point of view of verifying model results, since we're not really in the prognostic modeling business, but it is of note that those data will be available.

Dr. Peter Hamilton, Science Applications International, has been looking at an older model that MMS funded of the west Florida Shelf, which has been sitting on our shelf for a while. We're dusting it off to compare its results with the actual current meter records that have been obtained in the same area.

Dr. George Maul, from NOAA's Miami Laboratory, is in the final stages of a rather exhaustive examination of LOOP Current and Straits of Florida data to determine the eddy shedding frequency of the LOOP Current and perhaps to identify forcing mechanisms. He's also using inverted echo-sounders, a new technology, off the Bahamas and in the Straits of Florida, and has recommended that MMS consider using them in the Gulf program.



A new member of our inter-agency advisory group is Dr. Kurt Hess, who was at the National Weather Service in a cooperative program modeling oil spill trajectories with EPA. He's moved to NOAA/NESDIS now and has taken the program with him. Interestingly enough they have been hindcasting the ALVENUS spill using his algorithms. Dr. Hess' model, which presently covers almost exactly the same zone as our central and western planning areas, concentrates on the physics of the oil/air and oil/water interfaces rather than on the gross circulation picture. Given the calibration and adjustments that modelers must necessarily do, he has obtained good results with the ALVENUS spill.

Finally, we have just seen the completion of the development of a new wind data set for the Gulf of Mexico. Up until this time, as you've seen in a recent flyer that came out of our program, we have been using a very crude wind set, actually ship winds, and they were seasonal. Perhaps the spatial resolution was good, but the temporal solution was terrible. That older product was used to drive the first generation of the Jaycor model, the one that you were able to see last year in our session. This year's Jaycor model is driven by the new wind set, which has been developed from pressure gauge data archived by the Navy. Perhaps an indication of how good the new wind set is, is that the correlation coefficients between the calculations and the actual data from moored buoys at sea average about 0.9. You will also be able to obtain these winds from the National Technical Information Service in digital format.

We have made overtures to the oil industry folks about sharing data, and to a limited degree have started sharing data. We were the first federal program that I know of that has ever unilaterally shared data prior to the publication of any report, prior to the completion of the contract. We are about to make formal contact with the oil companies concerning obtaining their physical oceanographic data from the last two or three years and, say, for the next two years. We'd like very much to get any current meter data or hydrographic data from the central Gulf of Mexico, as well as wind data.

**MMS/GOM PHYSICAL OCEANOGRAPHY PROGRAM - SUMMARY  
UPDATE**

Dr. Evans Waddell  
Science Applications International Corporation

Under contract with Minerals Management Service (MMS), Science Applications International Corporation (SAIC) is conducting a multiyear study of key physical oceanographic conditions and processes in the Gulf of Mexico. This program, as originally proposed, has a phased regional emphasis with Program Years 1 and 2 concentrating on the eastern Gulf with special emphasis on the Loop Current, and Loop Current interaction with and conditions on the West Florida Shelf and slope. Program Year 3 will shift emphasis to the western Gulf with a goal of developing a better understanding of Loop Current eddies in deep water and as they interact with the slope in the northern and western Gulf. Years 4 and 5 will have a Gulf-wide emphasis with additional effort being directed to an integrated process synthesis which transcends the original geographic division.

In November 1984, SAIC has almost completed the second of two years of measurements in the eastern Gulf. Key Year 2 program elements include: subsurface current/temperature measurements (Figure 39); an extensive and intensive coordinated ship and plane hydrographic survey of the Loop Current with special emphasis on conditions adjacent to the West Florida Slope (Figure 40); satellite thermal imagery; satellite tracked Lagrangian (surface) drifters deployed in eddies (Figure 41); and a ship-of-opportunity program (SOOP) which, among others, supported Transect A shown in Figure 40. Some of the Year 1 and 2 results are discussed by the individual principal investigators in other presentations in this session of the 1984 ITM.

Plans for Year 3 in the western Gulf include the same major program elements as in Years 1 and 2; however, sampling schemes will differ. Hydrographic cruises will be designed to resolve conditions existing at the time. The goal is to characterize Loop Current eddies as they move across the central Gulf and interact with adjacent western Gulf slope. Similarly, current meters will be deployed on a schedule and in a pattern which should provide substantial information regarding dynamics and kinematics of ring/slope interaction. Drifting buoy studies will continue with a dual function. They provide valuable information on eddy position during summer when sea-surface temperatures are uniform and eddy position cannot be estimated from satellite thermal imagery. Buoy trajectories also reflect the cumulative influence of a variety of processes. Improved analysis schemes are being applied to isolate and estimate the magnitude of various terms in the dynamic equations. Additional analyses will resolve the velocity field into components due to rotation, translation, and other less obvious modes, (e.g., pulsations). The ongoing SOOP transect will be maintained (Transect A on Figure 40) and on-board equipment will be provided to a joint MMS/Navy supported SOOP transect from Houston to the Yucatan Straits and Dry Tortugas to New Orleans. These will provide useful and valuable observations.

As originally proposed, emphasis following the western Gulf study will be on a Gulf-wide characterization. Design of such a program requires guidance from data analyzed in previous program years. Also, this final year of field measurements will be coordinated with proposed or expected programs funded by several other federal agencies (e.g., NASA, NORDA, USCGS). Year 4 will also involve a more detailed synthesis and integration of the complete multiyear measurement and interpretation program. As in all program years, MMS, SAIC, and all subcontractors make a considerable effort to assure that activities are coordinated with concurrent and compatible Gulf modeling and measurement programs. This assures optimal return for all parties. To date, such coordination has occurred with ONR, NOAA/AOML, NSF, NORDA, NWS/National Hurricane Center, State of Florida, NDBC, NASA, and other MMS studies.

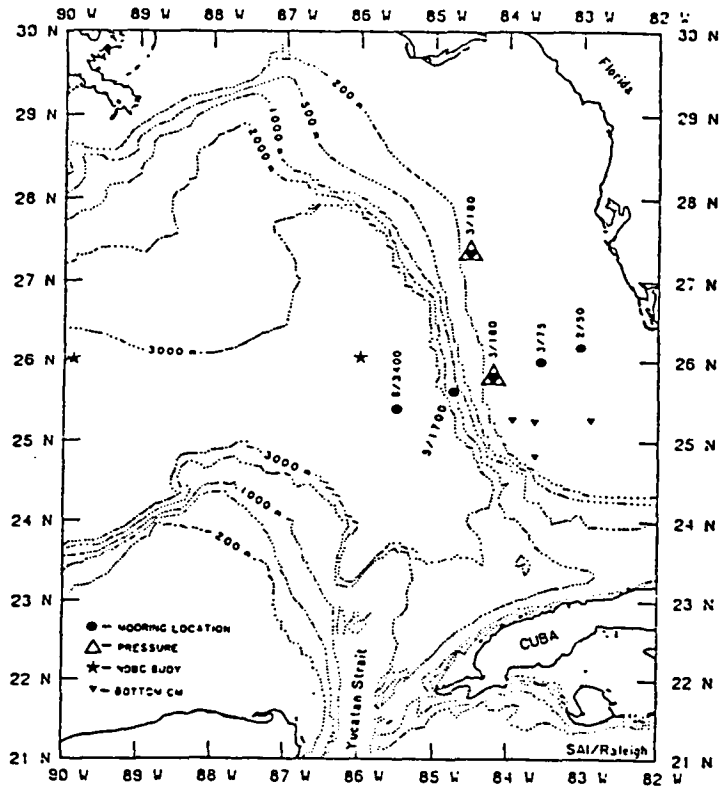

Figure 39. Mooring locations during Year 2. Bottom current meters (inverted triangles) are part of an MMS funded ecological study being conducted by ESE.

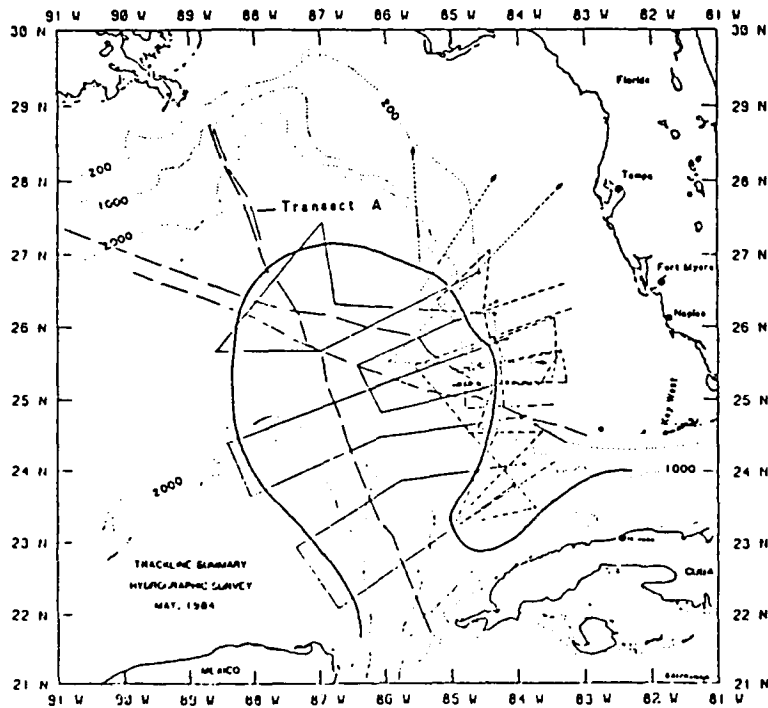

Figure 40. Summary of ship/plane tracklines during May 1984 hydrocruise. Transect A is an MMS funded SOOP line.

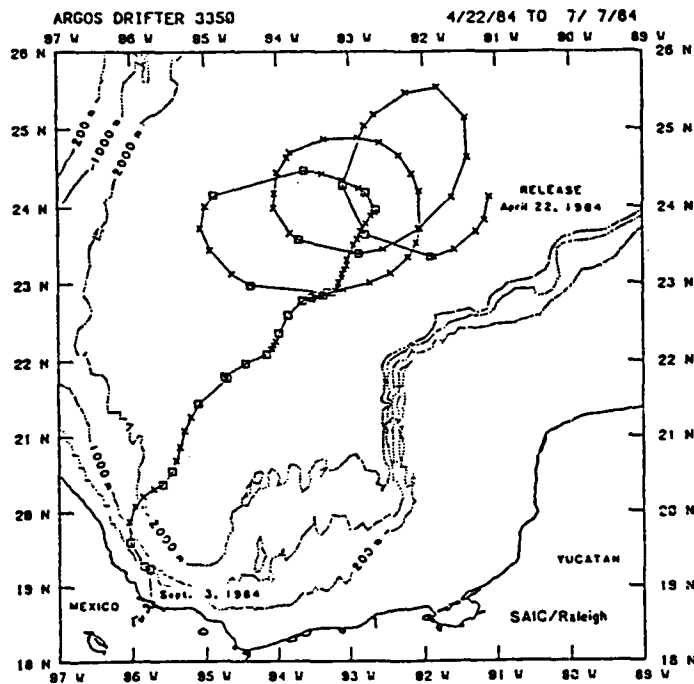

Figure 41. Trajectory of most recent buoy (No. 3350) released in a Loop Current eddy in April 1984.

## THE MMS CURRENT METER PROGRAM ON THE WEST FLORIDA SHELF

Dr. W. Sturges  
Florida State University

Current meter moorings have been in place on the southern part of the west Florida shelf since January 1983. There is a single mooring at the shelf break (180 m) near 27 N, and a line of moorings just south of 26 N extending from mid-shelf out into deep water.

During the first year of data collection, the correlations between wind and currents, as well as between currents observed at various instruments, were surprisingly low compared with what one would expect from a wind-forced response. However, it seems reasonable to expect that the currents on the shelf will be forced by fluctuations in the Loop Current as well as by winds.

Positions of the Loop Current along 25°N were compared with the currents at the upper-most instrument (170 m) at the mooring just beyond the shelf break, in 1700 m, for the first 6 months of 1983 until the Loop Current's position was no longer available from satellite data. The onshore component of current is highly coherent and 90 degrees out of phase, with the Loop Current fluctuations at periods longer than about 20 days. At periods near 10 days, however, a region of high coherence is found, with the two signals essentially in phase. This suggests that the motions on the outer shelf are preferentially responding to the small meandering features on the shoreward edge of the current.

Some inferences can be drawn from this. The wind forcing seems to be clear for periods near 3 days and on the inner shelf. On the outer shelf, the forcing is from both wind and the Loop Current. In the transition region, where the two effects have about the same magnitude but different phases, simple coherence calculations are unable to separate the two effects. Several studies are underway to try to separate them, to examine the Loop Current's forcing in more detail, and to study the effect of the shelf-wave reflections at the south end of the shelf.

## HYDROGRAPHIC SURVEYS OF THE EASTERN GULF OF MEXICO

Dr. Larry Atkinson  
Skidaway Institute of Oceanography

With the completion of the May 1984 cruise in the eastern Gulf of Mexico, we have had several process-oriented observations along the eastern boundary of the Loop Current. The purpose of these cruises was to study further the eddy processes that occur along the Loop Current front and to examine the interaction of the Loop Current and associated frontal eddies with the adjacent continental shelf waters. We had previously hypothesized that these eddies were similar to those found along the Gulf Stream front, and the eastern Gulf of Mexico cruises offered an opportunity to make the critical observations.

Although the final cruise is still under preliminary analysis, we can make some initial statements on our findings:

1. T/S analysis indicates that deeper water in the cold core of a frontal eddy is uplifted Loop Current Water.
2. T/S analysis indicates that water in the upper layer of the cold core of a frontal eddy is cooler and fresher than might be expected, implying a source from diluted slope waters.
3. Interleaving was observed along the boundaries of the dilute shallow waters in the cold core, indicating active mixing.
4. The Loop Current frontal eddies have characteristics similar to the Gulf Stream frontal eddies.
5. Upwelling on the west Florida shelf was less intense than that observed in the Gulf Stream off Georgia and Florida.

The onboard doppler current meter system was operational and appeared to yield excellent data, which should add greatly to our knowledge of the dynamics of the area.

## REMOTE SENSING STUDIES IN THE GULF OF MEXICO

Dr. Fred M. Vukovich  
Research Triangle Institute

NOAA and GOES infrared data were combined with hydrographic data from specialized cruises in the eastern Gulf of Mexico and from Ship-of-Opportunity cruises to study various aspects of two principal phenomena that influenced the dynamics in the Gulf of Mexico in winter and spring 1984: a major warm ring that separated from the Loop Current and the cyclonic cold domes that form on the boundary of the Loop Current. A major warm ring separated from the Loop Current in and around 13 December 1983 and was located at  $24.8^{\circ}\text{N}$  and  $91.5^{\circ}\text{W}$  in the western Gulf of Mexico by mid-June 1984. As it moved westward, the ring size decreased, having a diameter of approximately 300 km in December 1983 and a diameter of approximately 250 km in May of 1984. As the ring moved westward, the speed of translation varied as a damp oscillation having a maximum speed of approximately 6 km per day and a minimum speed of approximately 1 km per day.

On or about 18 March 1984, a major cyclonic perturbation was observed on the northern boundary of the Loop Current. The perturbation moved eastward, then southward, parallel to the west Florida Shelf. The speed of translation decreased with time from an initial value of approximately 19 km per day as it moved eastward along the northern boundary of the Loop Current to approximately 7 km per day as it moved southward approaching the Straits of Florida. When the cold-dome perturbation reached the region west of the Dry Tortugas on or about 13 April 1984, it began to grow and move in a westward fashion. It initially appeared as though another major warm ring was separating from the Loop Current. However, by 7 May 1984, the cold tongue had receded markedly and appeared to be dissipating. The hydrographic data confirmed a cold-dome cyclonic characteristic of the perturbations and described the variations of the cold dome with time.



**SATELLITE-DERIVED SEA SURFACE TEMPERATURE PRODUCTS  
AVAILABLE FROM SFSS MIAMI**

Dr. Stephen R. Baig  
NOAA/National Hurricane Center

A suite of sea surface temperature products is available from the Satellite Field Services Station located at the National Hurricane Center, 1320 South Dixie Highway, Coral Gables, Florida 33146. These products are based mainly on data available from the Geostationary Operational Environmental Satellites maintained (until August, 1984) at 75 West longitude. These data are supplemented with data from Polar Orbiting satellites, ship and buoy observations, and other incidental information.

The data consist of satellite imagery and analysed charts. The satellite images are stored as 16 mm positive film images of satellite images enhanced especially to bring out the subtle differences in both the ocean's thermal gradients and in cloud top temperatures. Each image includes the area from Brownsville, Texas, to the offing of Nova Scotia. Twenty-four or (since 1981) twelve hours of imagery are stored on each separate loop of film. When projected, these loops show the motion of clouds and atmospheric moisture fields which can severely contaminate the sea surface temperature field. This contamination is especially severe over the tropical and sub-tropical oceans. It results in a lowering of both the sea surface temperature and surface temperature gradients as seen by the satellite. The animation technique is the only method available presently to overcome this problem. These film loops are archived at Miami and are available for viewing at the field station.

Analysts prepare charts showing the positions of oceanic thermal gradients by projecting the animated motion picture loops onto base charts with the same scale (about 1:5,000,000). All the data from one week are plotted on a single chart in a different color for each day. These "weekly work charts" are archived at Miami and are available

there for study. On Monday, Wednesday, and Friday, analysts prepare operational charts by tracing current (i.e., since the previous analysis) frontal data from these charts onto a regional chart showing the Eastern Gulf of Mexico, the Straits of Florida, and the Gulf Stream area north to Cape Hatteras, North Carolina. These charts are available via Xerox AutoTelecopier ((305) 661-0738). The portion covering the Eastern Gulf of Mexico and the Straits of Florida is available from 0800 to 1400 and from 2000 to 0200; the portion covering the Straits of Florida and the Southeastern North Atlantic is available at the intervening times. (All times are local Miami time.) A second regional chartlet showing the Gulf Stream and associated features north-east of Cape Hatteras is prepared at the same time. This chartlet is used within NOAA and is not distributed to the public but is available for study. Both these charts are archived at Miami.

At the end of each week a "weekly summary chart" is prepared. These charts, covering the entire analysis area, show all of the most current frontal positions for the week. Areas in which no data were observed that week are left blank. These charts, normally archived at Miami, presently are being digitized at the National Climate Data Center in Asheville, North Carolina.

## RESULTS OF A TRIAL PROGRAM TO MONITOR THE LOOP CURRENT WITH AVHRR DATA DURING SUMMER

Mr. Rhys McDonald  
Brown and Caldwell, Inc.

Brown and Caldwell performed a trial program during September and October 1984 to demonstrate the potential of monitoring the Loop Current system on an operational basis during summer months with advanced very high resolution radiometer (AVHRR) data from the polar orbiting NOAA satellites. The Loop Current is difficult to monitor during the summer months because there is little or no temperature difference between the Loop Current and surrounding Gulf of Mexico waters to detect with infrared remote sensing instruments, and because atmospheric moisture and cloud cover interfere greatly.

The trial program was sponsored by Marathon Oil Company in Houston, Texas, and satellite image data were processed by Geospectra Corporation of Ann Arbor, Michigan. The premise was that features produced by the Loop Current could be identified with enhanced full-resolution AVHRR data even when surface temperatures are nearly equal in the Loop Current and surrounding Gulf of Mexico waters. Expendable bathythermograph (XBT) data from ships of opportunity were used to aid the interpretation of observed features. AVHRR data were chosen over other satellite data because of their relatively high resolution, frequent coverage, and dependability.

Although persistent cloud cover and the masking effect of atmospheric moisture limited the useful information on many images, results from the trial program are encouraging. Distinctive features were observed on several enhanced AVHRR images which correspond to Loop Current fronts detected from ship-of-opportunity XBT data. These features include subtle temperature discontinuities, circular bands of cooler water possibly caused by upwelling along the periphery of the

Loop Current, and sun glint patterns possibly corresponding to wave patterns along the Loop Current boundary.

Recently, there has been significant progress in the development of algorithms to correct for atmospheric moisture, as was demonstrated by another speaker at the information transfer meeting. We expect that with refinement of techniques, particularly the incorporation of these algorithms, AVHRR imagery could become a key tool in an integrated program to monitor the Loop Current on a year-round basis.

#### CURRENT MEASUREMENTS NEAR THE MISSISSIPPI RIVER DELTA

Mr. William J. Wiseman, Jr.  
Coastal Studies Institute  
Louisiana State University

A current meter mooring has been maintained in South Pass Block 55 since March 1984. The mooring is in 80 m of water and consists of meters at depths of 13, 25, 40, and 70 meters. Data return was poor during the first deployment, but has been quite good since May. Mean flows are westward at a few cm/s, but the estimated standard errors about these means are of the same order of magnitude. Longer records are required before it can be determined whether a statistically significant westward mean drift exists in this region. The current records were filtered into three bands, periods shorter than 10 hours, periods between 10 and 38 hours, and periods longer than 38 hours. The intermediate period band contains the tidal and inertial motions as well as the 30 hour natural resonance of the Gulf. The currents were moderately energetic. Variances outside the bottom boundary layer were 200-400  $\text{cm}^2/\text{s}^2$ . Most of this energy was in the low-pass currents. These low-pass currents were topographically steered.

A comparison was made with summer data collected from the west Louisiana shelf southwest of the Atchafalaya Delta in the summer of 1983. Stratification was similar to that observed near the delta below the strong halocline that is present at our delta mooring site. The west Louisiana shelf current variances were about half those observed near the delta. Furthermore, the energy in the intermediate band was much higher than that seen off the delta or seen on the west Louisiana shelf in winter. We believe that significant baroclinic structure is generated during the summer months in this frequency band over the west Louisiana shelf. The low-pass flow was less energetic than offshore of the Mississippi River Delta. Also, except in the very lowest layers of the water column, the low-pass currents appeared to be decoupled from the bathymetry by the stratification.

## STORM SEDIMENTATION ON THE TEXAS CONTINENTAL SHELF

Dr. Dag Nummedal and Dr. John W. Snedden

Department of Geology  
Louisiana State University

Dr. Anthony F. Amos  
Institute of Marine Science  
The University of Texas at Austin

## THE PROBLEM

Interlayered sands and muds are known to constitute the bulk of the aggradational Holocene sedimentary sequence on the Texas continental shelf. The sand layers range in thickness from about one to fifteen centimeters, they generally are fining upwards above a scoured base and are increasingly bioturbated towards the top. These characteristics

indicate that they are deposited during the waning phase of a transient shelf current; most probably a current associated with the passage of a storm event. Such beds are defined as "event strata". The graded nature is consistent with the model proposed by Swift and Rice, which argues that a texturally mixed sediment population (sand and mud) will (1) be entrained in the benthic boundary layer during the accelerating phase of a transient flow event, (2) reach a maximum concentration consistent with the carrying capacity of the flow, and (3) be deposited as a normally graded bed during the decelerating flow phase due to hydraulic fractionation of the particle sizes: coarse bedload is deposited first and the suspended muddy population settles later. Burrowing during the subsequent calm period is initiated from the top, hence an observed downward decrease in degree of bioturbation within the storm bed.

There is general agreement that the Texas shelf sand layers are event strata as described above. There is great contention, however, about the hydrodynamics of the causative flow and the source of the sand. An early model argued that the graded storm beds were due to "ebb-surge" return flow through channels cut across the barrier islands by hurricanes. The sands were thought to have been carried through these temporary "tidal" passes and onto the shelf floor as highly sediment-laden density underflows. The presence of sole marks at the base of many ancient storm beds and the documentation of an internal sequence of sedimentary structures mimicking the Bouma sequence has lead some investigators to argue strongly in favor of a shallow-water "turbidite" mechanism for emplacement of such strata.

An appealing alternative is that such strata are produced by alongshelf, geostrophic storm flows. Studies on the Mid-Atlantic U.S. shelf have clearly demonstrated that such flows are capable of transporting any available bottom sediment. A well-understood mechanism involving the Coriolis deflection of the current generated by the storm-induced shore-normal hydrostatic pressure gradient is capable of generating the observed shelf currents. Current velocities measured on the Texas shelf for such "geostrophic" storm flows associated with recent hurricanes have been found to be greatly in excess of the

entrainment threshold for the sand found in the shelf layers. Morton, therefore, made the specific argument that the Texas shelf sand beds were the product of traction-load deposition from geostrophic storm flows, not shallow-water turbidites.

## EXPERIMENTAL DESIGN

Five ENDECO 105 current meters were deployed across the central Texas continental shelf from the shoreface of Mustang Island to the shelf break (Figure 42). The meters were deployed on July 16/17 and retrieved on December 9, 1984. The linear cross-shelf deployment pattern was used to determine the variability in geostrophic storm flows with depth across the shelf. The sensors were located 1.5 m above the seafloor, well within the bottom boundary layer.

The current meters record the average current velocity over one minute, once an hour. Consequently, higher frequency unsteady current components, such as those associated with the passage of wave-orbital currents, will not be recorded. The passage of a current "pulse" associated with a turbidity current would also have a low probability of detection. As demonstrated in a sample record obtained with an ENDECO 105 meter on the Texas shelf in the fall of 1981, the meter provides excellent records of currents fluctuating on time scales of more than two hours. Thus, currents driven by tropical and extratropical storms, tidal forces, and inertial oscillations will be well documented.

This experimental design cannot be used to disprove the existence of turbidity currents on the continental shelf during storms. It is capable of testing, however, whether geostrophic storm flows generally attain near-bottom current velocities sufficient for sand movement. Also, the directional data will permit computation of characteristic sediment dispersal paths.

No tropical storms or hurricanes affected the western Gulf of Mexico during the 1984 session. A stationary extratropical low pressure system on September 18-20th, however, and many frontal passages in

October and November, were strong enough to have generated currents that we believe were in excess of the shelf sand entrainment threshold.

To document the substrate response to storm-flow passage, a series of box cores have been obtained across the inner Texas continental shelf (Figure 43). The box cores, ranging up to 60 cm in depth, penetrated many graded storm sands. A thick sand, at 15 to 30 cm depth in the sediment column, has been tentatively identified as the Hurricane Carla sand of 1961. We are awaiting <sup>137</sup>Cs-dating to confirm this idea. All box cores are being X-ray radiographed and analyzed for textural trends and bioturbation patterns.

The complete data analysis from the 1984 field experiment is expected to occupy most of 1985.



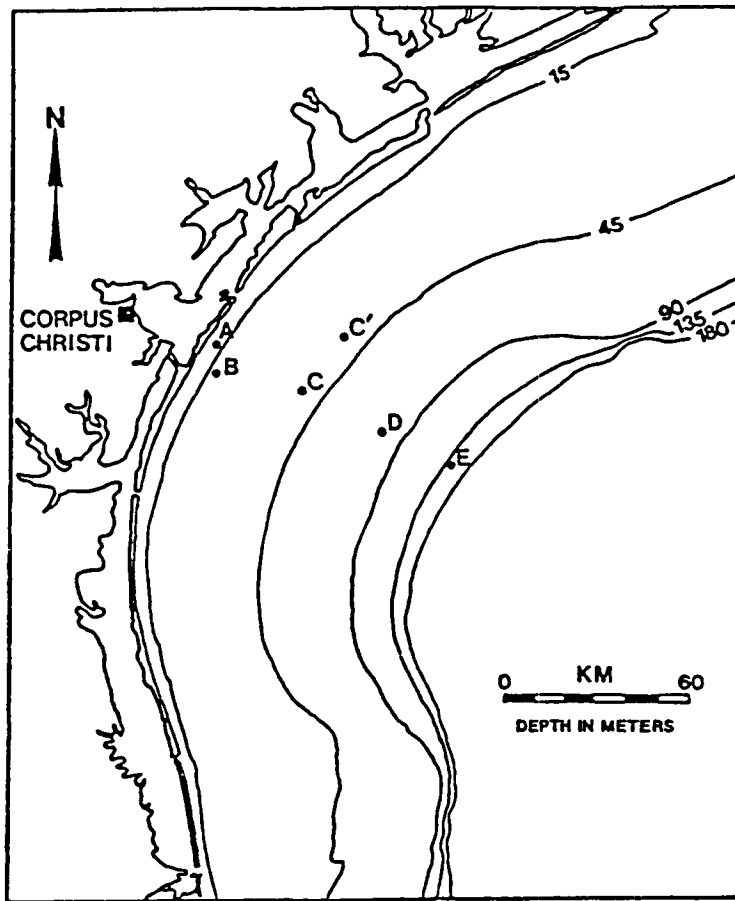
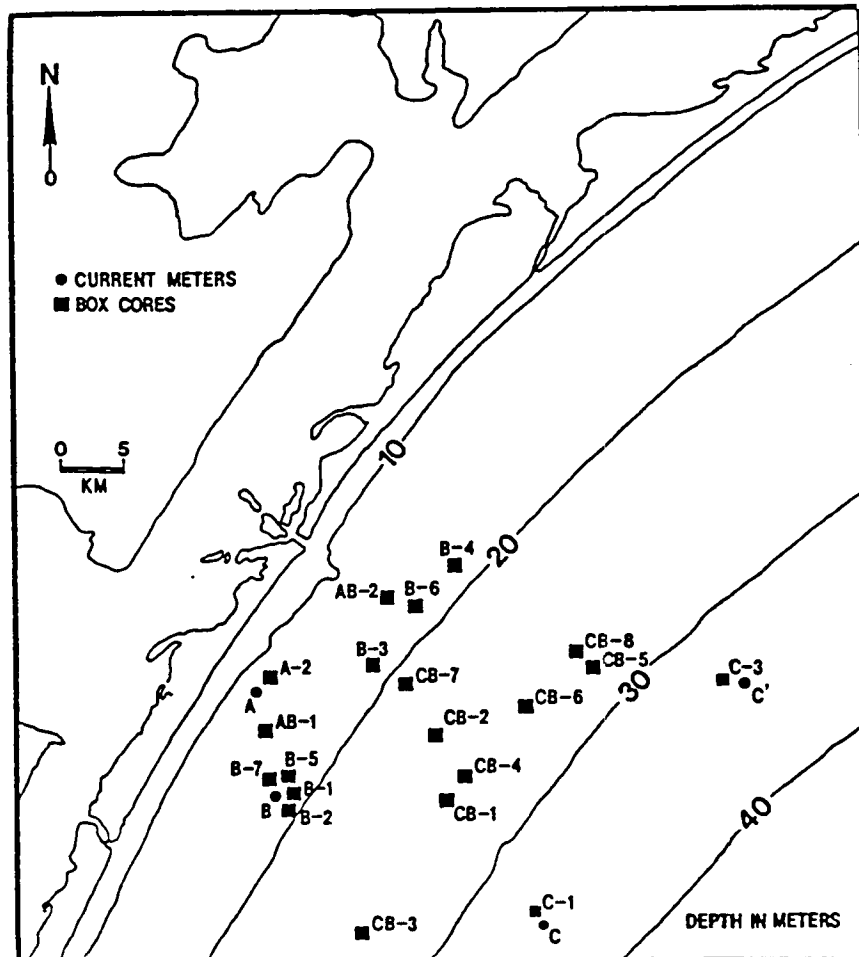

Figure 42. (above) Current meter locations.

Figure 43. (below) Box core locations.



SHIPBOARD ENVIRONMENTAL (DATA) ACQUISITION SYSTEM:  
DESCRIPTION AND STATUS

Mr. Vince Zegowitz  
National Oceanic and Atmospheric Administration  
National Ocean Service  
Office of Ocean Services

The SEAS program has been developed in order to deliver data from ships at sea accurately, quickly, and from selected geographic areas providing the best possible spatial coverage. The method of data delivery utilizes the existing GOES satellite system composed of spacecraft in synchronous equatorial earth orbits. SEAS currently exists in 2 configurations, both of which deliver standard shipboard meteorological observations (WMO Code FM13-VII) and subsurface (XBT) temperature data (WMO Code FM63-V BATHY) to shore-based users. But the compatibility of the system to handle other data types is unlimited.

The path of data delivery is as follows:

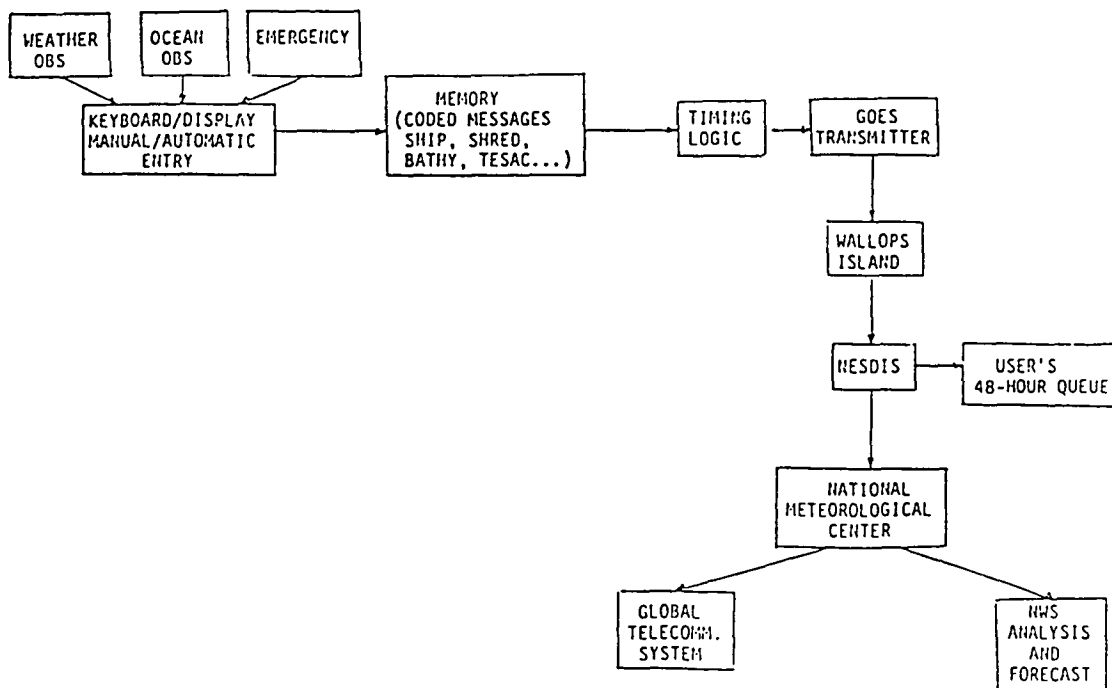

Data are entered into the SEAS units, then automatically transmitted through an assigned satellite, channel, and time slot utilizing a preassigned address necessary for GOES system identification. The data then pass through the ground station at Wallops Island, VA, the NESDIS headquarters in Suitland, MD, and into the NMC's synoptic forecast file for meteorological data and SST analysis file for subsurface (XBT) data. As data pass through Suitland, they are placed in a 48-hour queue available to users having the proper ID codes and a terminal equipped with a phone modem. Only seconds elapse between the time of shipboard transmission and listing the data in both the NMC files and the 48-hour queue.

The SEAS program has taken a two-system approach in satisfying the need for delivering timely, accurate data from sea: a manual entry system and a semi-automated system. The differences result from automating the human element involved in the digitization of data: the higher the degree of automation, the less human error results but also the attendant higher cost per system.

SEAS/MANUAL ENTRY: This unit consists of a GOES Data Collection Platform (DCP), an omnidirectional antenna, 50 feet of coaxial cable, and an input terminal. The DCP itself is composed of modules: a 40-watt GOES transmitter, a master control module (MCM), an uninterruptible power supply (UPS), and a battery pack for maintenance of power to the MCM should there be a loss of primary power. Dimensions of the unit including the input terminal are 15" X 15" X 17" with a weight of 35 pounds. The antenna is 3" in diameter and 15" tall.

The MCM contains software which allows for input of platform identification, time slot, satellite channel assignment, reporting interval, and the start of an internal clock. Once these have been entered, the transmission process is automatic and remains unique to that platform. In the event that the unit is moved from one ship to another, new identification data can be entered.

Currently, software exists for the prompted entry of standard shipboard meteorological observations (SHIPMETOBS) and Expendable Bathothermographic (XBT) observations. The system presents a menu of these data types and the selected program accepts the data through a series of prompting questions. There are three sets of prompting questions per data type tailored for the beginner, the intermediate, and the fully experienced operator. All data entered are subjected to internal quality control checks based on ranges of acceptability.

Messages generated for each data type are automatically placed into internationally acceptable formats. The data are then placed into individual buffers within the DCP and transmitted to the user at specified time intervals. In the present configuration, the XBT data and the weather observations are transmitted hourly, but a variety of transmission intervals and time slots are available for allocations. Installation of the SEAS system consists of plugging in one 115V power lead, positioning the omnidirectional antenna in a suitable location, and attaching the antenna lead.

SEAS/SEMI-AUTOMATED: This unit provides for the prompted collection of meteorological data and also the digitization, compaction, and calculation of inflection points for the XBT data vice, the manual digitization, and data entry in the previously described unit.

The semi-automated SEAS consists of:

- (1) an XBT Controller which provides an interface between XBT probes and an HP-85;
- (2) an HP-85 minicomputer which provides digital recording on magnetic tape, a CRT, and printer;
- (3) a GOES DCP (described previously); and
- (4) an omnidirectional antenna with cables and connectors.

The dimensions are 19" X 14" X 10" with the HP-85 mounted atop the XBT controller and 10" X 10" X 10" for the DCP. Total weight is 40 pounds. Future design calls for the incorporation of all equipment into one unit.

The software capability includes the prompted manual entry of shipboard meteorological observations and the following for XBT data: a recording cycle beginning automatically when an XBT probe enters the water, data storage on separate files to eliminate writeover, real-time plotting and play back capabilities of temperature profiles, data listings (including depths of whole degree isotherms and inflection points), and the generation of additional plots with enlarged depth and/or temperature scales.

Messages are automatically generated in internationally acceptable formats and sent to the buffer where they reside until the proper transmission time. Routing and transmission are the same as described previously. Installation is also the same as the manual unit with the need for a 115V power source, antenna siting, and cable hook up.

At this time there are several manual and semi-automatic SEAS units deployed. Systems have operated in the Atlantic, Pacific, Arctic, and Antarctic Oceans, plus the Gulfs of Alaska and Mexico. They have been deployed upon research vessels, commercial tugs, foreign and American flag vessels, and NOAA ships. Since deployment, these units have provided thousands of synoptic meteorological and XBT observations.

It is becoming more pressing to obtain the necessary additional data within the shortest time possible to increase the accuracy of synoptic marine forecast services. The success of receipt and incorporation of synoptic reports into synoptic forecasts for the SEAS units is nearly 100% as opposed to 20% for reports utilizing normal channels.

Manual SEAS units are 5K and the semi-automated SEAS 18K. The cost is modest, the return considerable. At this point, this cost is totally assumed by NOAA and requires no monetary investment by the shipping lines involved. Interest by private shipping concerns is considerable and requests for units have exceeded our supply.

With the phasing out of the present analog XBT system, the crowding and intermittent reliability of HF communications, and the slow delivery times and error induction in normal channels, the SEAS system offers a proven method of relieving these problems.

**SEDIMENTATION ON THE GULF OF MEXICO CONTINENTAL MARGIN: A  
UNIFORMITARIAN MODEL FOR RESERVOIR SANDSTONE DEPOSITION  
IN A MUDDY SETTING**

1985 Project, Petroleum Research Laboratories Consortium

Dr. Marshall H. Orr

Sohio Petroleum Company

Dr. Donald J. P. Swift

Exploration and Production Research

ARCO Oil and Gas Company

Dr. Arnold Bouma

Gulf Research and Development Company

A consortium of petroleum company research laboratories has met to initiate plans for a study of the northwestern Gulf of Mexico continental margin. The study will develop uniformitarian models of continental margin reservoir sands by studying the formation, geometry, and distribution of sand bodies on the Gulf of Mexico continental shelf, and by comparing modern continental margin sand bodies with reservoir sandstones in the rock record. In an earlier consortium study, sand ridge deposits on the modern New Jersey Shelf were compared with shelf sandstone bodies of sand ridge origin in the Cretaceous western Interior Basin. The Gulf of Mexico continental margin has been selected for the present study, because of a consequence of the relatively high fine

sediment input. Its late Quaternary sedimentary record is analogous to sedimentary sequences in many petroliferous basins.

For the purposes of the study, the central and western Gulf of Mexico continental margin will be divided into two sectors in terms of the sediment dispersal system: the proximal Louisiana margin with its sediment source (Mississippi Delta) and the distal Texas margin, a sediment sink. Shore-normal corridors of more intensive study are being defined for each sector. Coastal, shelf, and slope depositional environments will be studied, although the emphasis may shift from corridor to corridor. The bulk of the effort will be devoted to a study of sediments deposited during the last regressive-transgressive cycle ( $\approx$  last 75,000 years). The deposit will be examined by means of seismic and sidescan sonar profiles and will be sampled by vibracoring and other sampling techniques. In a complementary study, fluid and sediment circulation will be monitored, with emphasis on benthic boundary layer processes.

The current year is seen principally as a planning year. The data collecting and data synthesis effort is expected to continue through 1987.

Companies participating in the initial planning meeting included ARCO, Exxon, Sohio, Chevron, Gulf, Petrocanada, Marathon, Texaco, Mobil, and Cities Services.

## PART II: CIRCULATION MODELING PROGRAM REVIEW

### GULF OF MEXICO CIRCULATION MODELING STUDY

Dr. Alan J. Wallcraft  
Jaycor, Inc.

This presentation is on the first year of a four-year numerical ocean circulation modeling program for the Gulf of Mexico funded by MMS. The aim of the program is to progressively upgrade in modest increments an existing numerical circulation model of the Gulf so that the final model has a horizontal resolution of about 10km and vertical resolution approaching 1 to 10m in the mixed layer, 10m at the thermocline and 100m in the deep water. Throughout the four-year period, the validity of the upgraded model will be continuously tested, and velocity field time series delivered periodically based on the most realistic simulation of Gulf circulation available (JAYCOR, 1983).

Experiments in the first year were with the existing NORDA/JAYCOR two layer hydrodynamic primitive equation ocean circulation model of the Gulf on a 0.2 degree grid (Hurlburt and Thompson, 1980). They concentrated on correctly specifying the coastline and bottom topography for maximum realism in circulation simulation, and on how best to include wind forcing. Details of selected experiments are presented here.

Experiment 9 represents the best (compared to our incomplete knowledge of the real Gulf) simulation available at the beginning of the project. It is forced by flow through the Yucatan Straits only (no wind forcing), and exhibits many of the flow features observed in the Gulf (Figure 44a). Simulated surface currents sampled every ten days for three Loop Current eddy cycles (1140 days) were delivered to MMS at the start of the contract period as an early simulation run.



Experiment 34 is similar to Experiment 9, but with the addition of wind forcing based on a seasonal climatology from ship observations (Elliot, 1979). The basic circulation patterns show far more variability in this case. For example, Figure 45 compares 360 model days from Experiments 28 and 34 (which are identical except that Experiment 28 has no wind forcing). From these snapshots taken every 90 days, one sees little difference between the two experiments. But if Experiment 34 is sampled every 20 days, as in Figure 46, it is apparent that two eddies were shed in the space of about one year. Figure 46 also shows that the circulation pattern in the Western Gulf can change very rapidly at times.

Experiment 40 has no wind forcing and its total inflow transport is identical to that in Experiment 9, but the distribution of transport between the model's two layers has been changed (upper layer transport reduced). It exhibits Loop Current eddies nearer to the size observed in the Gulf (Experiment 9 has rather large eddies), the increased lower layer flow which helps prevent intrusion onto shelf areas, and its sea surface variability which is remarkably similar to that obtained from satellite altimeter crossovers for the Gulf (Figure 47a and b). It replaces Experiment 9 as the baseline experiment against which all future simulations will be compared.

Experiment 60 is identical to Experiment 40 except that the horizontal eddy viscosity has been reduced. Some of the flow features seen in Experiment 9 were less obvious in Experiment 40, but the latter's lower velocities allowed the reduction in eddy viscosity, and Experiment 60 exhibits these features plus some new circulation patterns. For example, Figure 48 shows six or more small eddies in the north eastern Gulf that have been spun off the main Loop Current eddy.

Simulated drifter tracks from Experiment 60 compared well with actual drifter tracks from 1980-1981 (Figure 49a and b). Both track a Loop Current eddy along approximately the same path into the southwest Gulf, where they move northward along the coast of Mexico as the eddy dissipates. The observed average eddy rotation period is between 14 and

17 days, with a westward translation speed of 5 to 10 cm/sec and velocity component speeds of on the order of 50 cm/sec (Kirwan et al., 1984). The simulated eddy has a rotation period of 15 to 16 days, a westward translation speed of 3 to 6 cm/sec and velocity component speeds of on the order of 50 cm/sec.

Experiment 68 is identical to Experiment 40 with the addition of wind forcing from the Navy Corrected Geostrophic Wind data set for the Gulf. This wind set has wind stresses every 12 hours from 1967 to 1982 (Rhodes et al., 1984). The addition of winds increases the velocities encountered, and attempts to add this wind forcing to Experiment 60 were not successful. Simulated surface currents sampled every three days for more than 10 years were delivered to MMS from Experiment 68, representing the best simulation available from the first year effort. Surface current snapshots taken every 30 days (i.e. of every tenth set of fields) were also delivered. Only one of these snapshots is presented here: Figure 50 shows the furthest northward penetration of the Loop Current ever attained by the ocean model. This configuration is often seen in the Gulf.

## REFERENCES

- Elliot, B.A. 1979. Anticyclonic rings and the energetics of the circulation in the Gulf of Mexico. Ph.D. Dissertation, Texas A&M Univ., 188 pp.
- Hurlburt, H.E. and Thompson, J.D. 1980. A numerical study of Loop Current intrusions and eddy shedding. *J. Phys. Oceanogr.* 10:1611-1651.
- JAYCOR 1983. A proposal for a Gulf of Mexico circulation modeling study. JAYCOR Proposal Number 8206-83.
- Kirwan, A.D., Merrell, W.J., Lewis, J.K. and Whitaker, R.E. 1984. Lagrangian observations of an anticyclonic ring in the western Gulf of Mexico. *J. Geophys. Res.* 89:3417-3424.

Leipper, D.F. 1970. A sequence of current patterns in the Gulf of Mexico. *J. Geophys. Res.* 75:637-657.

Marsh, J.G., Cheney, R.E., McCarthy, J.J. and Martin, T.V. 1984. Regional mean sea surfaces based on GEOS-3 and SEASAT altimeter data. *Marine Geodesy* 8:385-402.

Rhodes, R.C., Thompson, J.D. and Wallcraft, A.J. 1984. The Navy Corrected Geostrophic Wind data set for the Gulf of Mexico. NORDA tech. rep. (to appear).

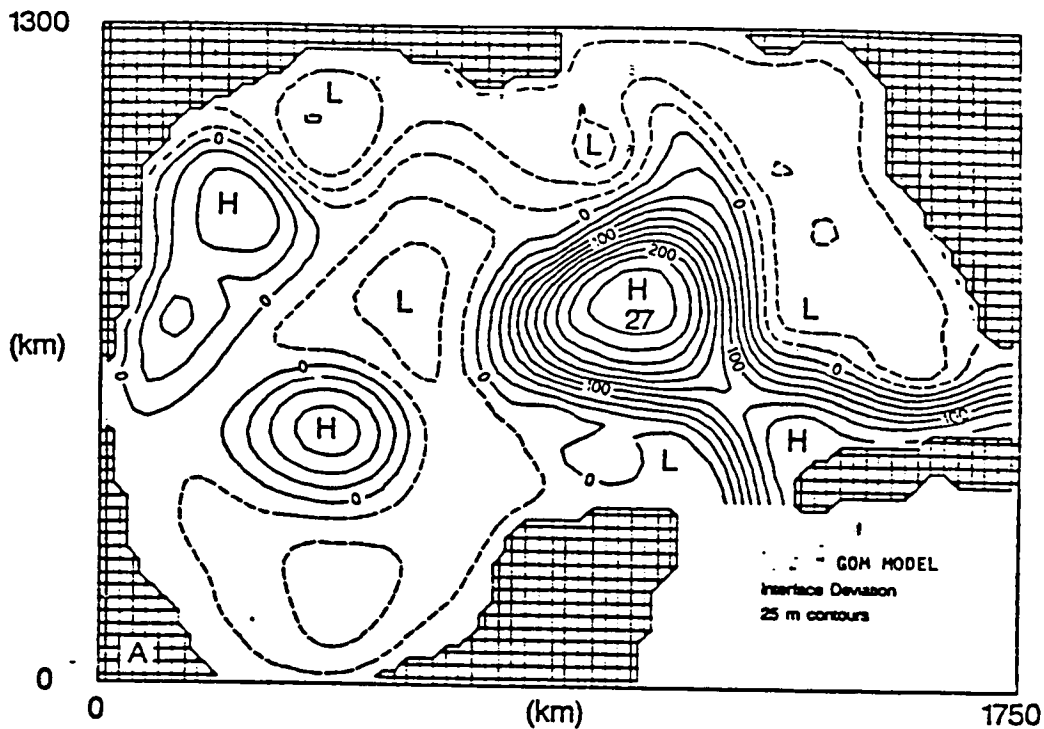

Figure 44a. Instantaneous view of the interface deviation in a two-layer simulation of the Gulf of Mexico driven from rest to statistical equilibrium solely by inflow through the Yucatan Straits (Experiment 9). The contour interval is 25 m, with solid contours representing downward deviations.

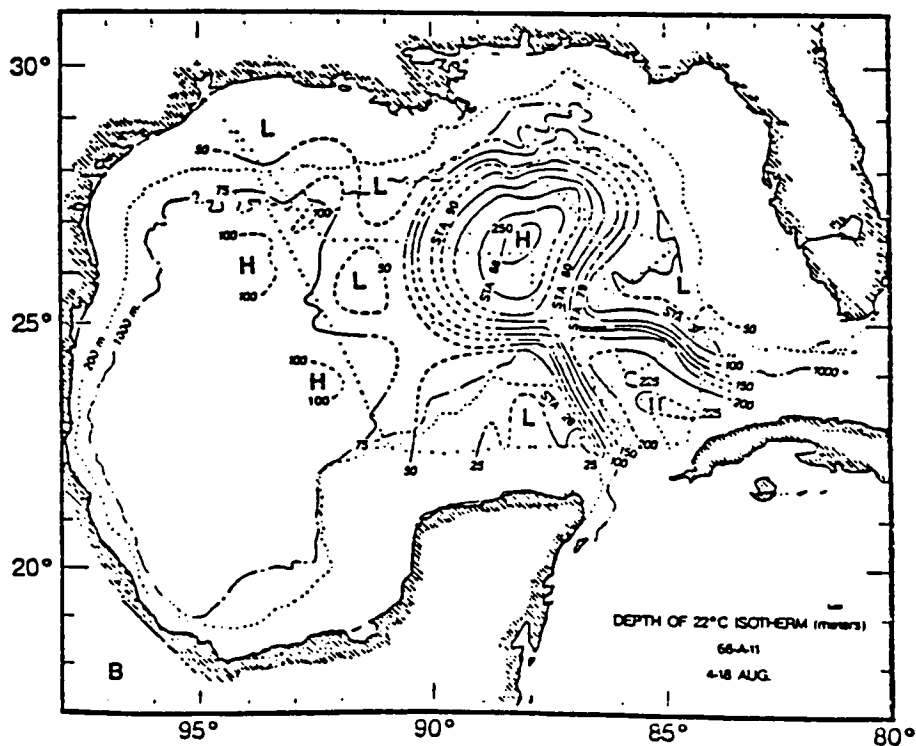

Figure 44b. Depth of the 22 degree isothermal surface, 4-18 August 1966 (Alaminos cruise 66-A-11), from Leipper (1970). The contour interval is 25 m.

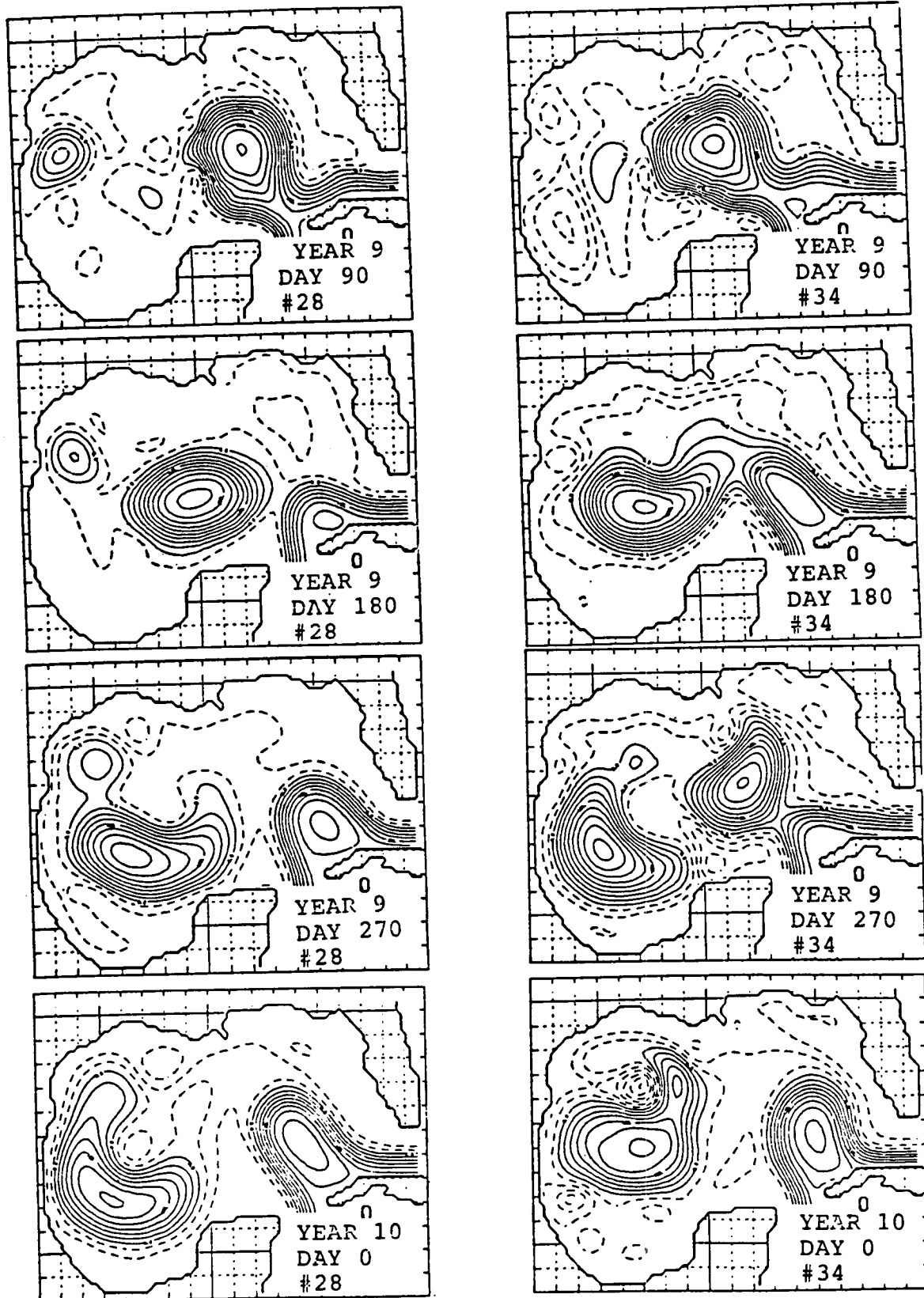

Figure 45. Instantaneous view of the interface deviation every 90 days, from day 90 of model year 9 to day 0 of model year 10, for Experiment 28 (left) and Experiment 34 (right). Experiment 34 is identical to 28 except for the addition of wind forcing. The contour interval is 25 m.

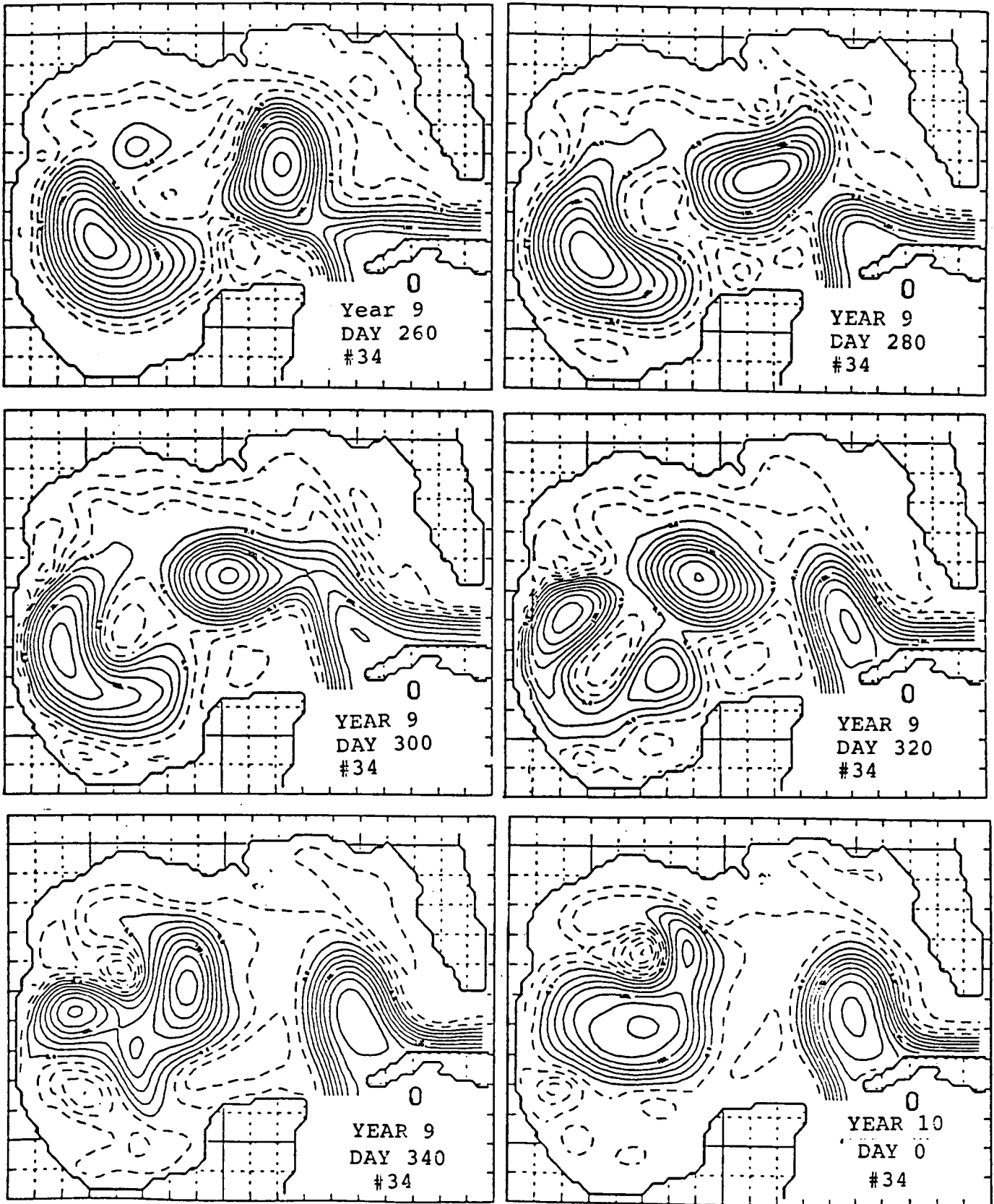

Figure 46. Instantaneous view of the interface deviation every 20 days, from day 260 of model year 9 to day 0 of model year 10, for Experiment 34.

SEA SURFACE VARIABILITY FROM  
GEOS-3 AND SEASAT CROSS OVERS (CM)

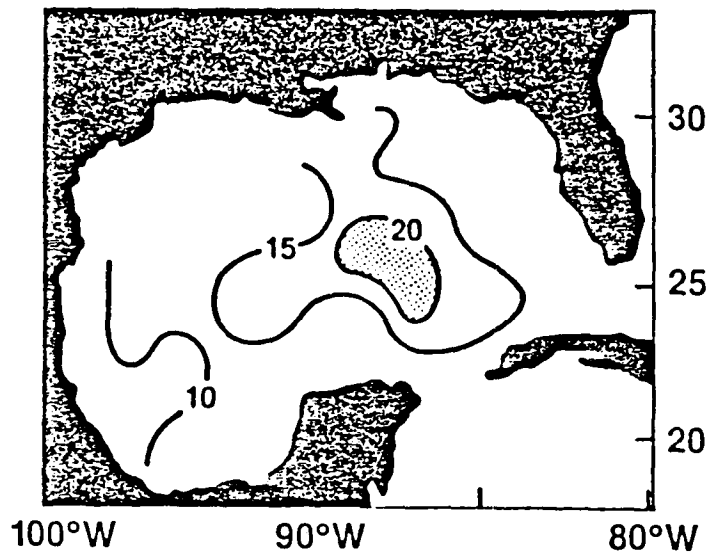

Figure 47a. Sea surface height variability for the Gulf of Mexico. Based on about 83,000 GEOS-3 and SEASAT cross overs, spanning nearly four years (from Marsh, Cheney and McCarthy, 1984).

SEA SURFACE VARIABILITY (CM)  
FROM NORDA MODEL

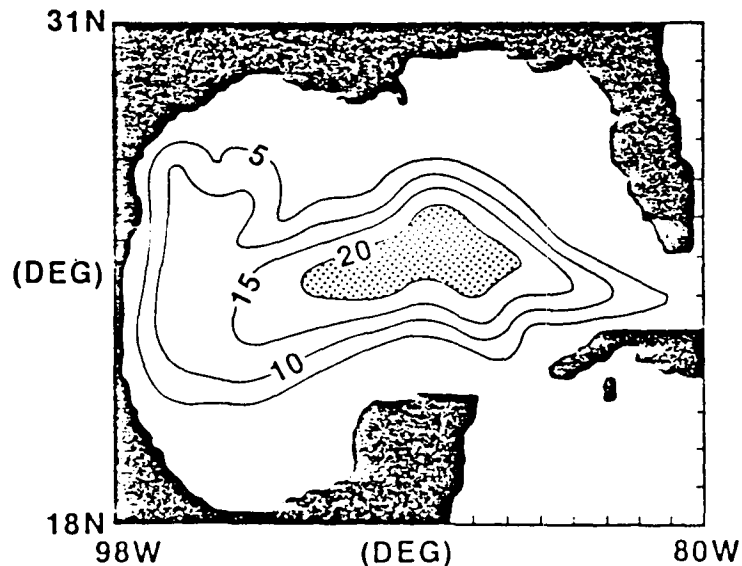
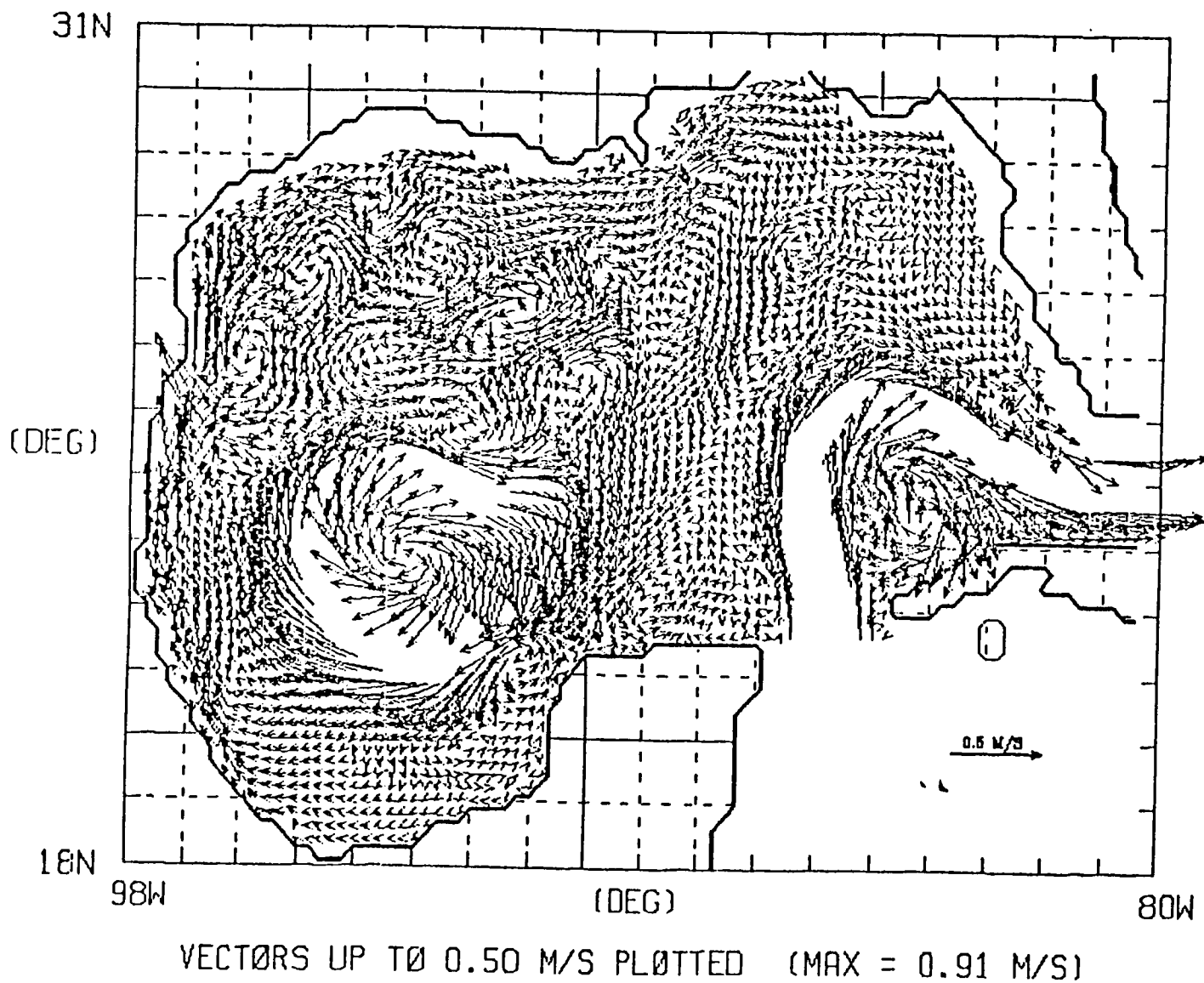

Figure 47b. Sea surface height variability for the Gulf of Mexico. Based on an ocean model simulation with port forcing only (Experiment 40), measured over three eddy cycles at statistical equilibrium with the free surface sampled every ten days for a total of over 300,000 "observations."

GEOSTR. CURRENTS G. OF MEXICO 0, 60  
MODEL DAY = 2170



422

Figure 48. Instantaneous view of upper layer averaged velocities from Experiment 60 on model day 2170; velocities above 50 cm/sec are not shown.



DRIFTER TRAJECTORY G. OF MEXICO 60  
 DRIFTER NO. 3 FROM 1680 TO 1980 (DAYS)

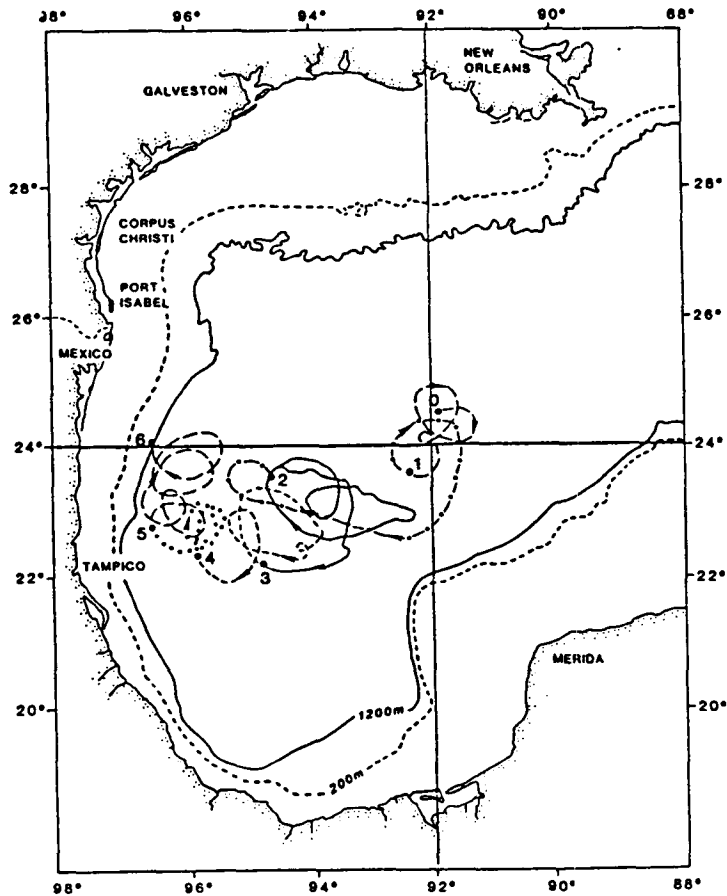

Figure 49a. Paths of actual and simulated drifters: NDBO drifter 1599 from November 20, 1980, through May 11, 1981. The numbers 0 through 6 give the positions on November 20, December 20, January 20, February 20, March 20, April 20, May 11, respectively (from Kirwan et al., 1984).

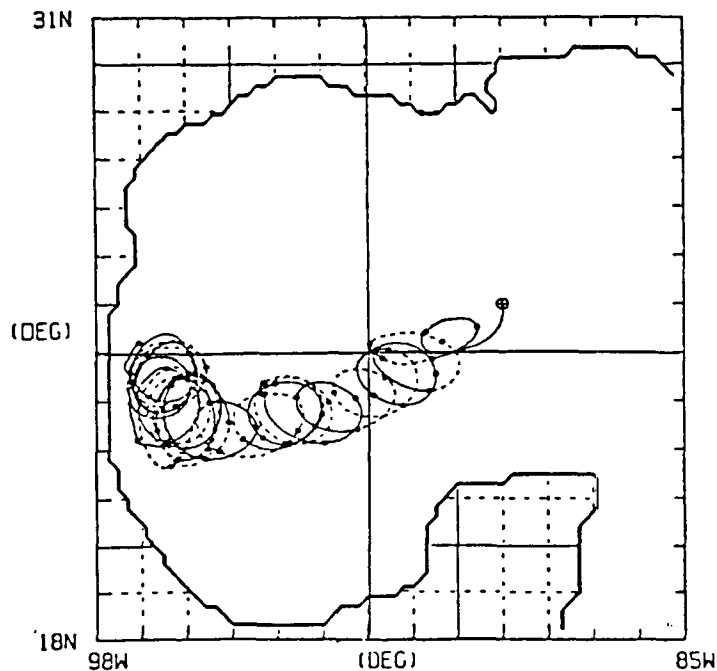

Figure 49b. Paths of actual and simulated drifters: Path of simulated drifter number 3 from model day 1680 to model day 1980 of Experiment 60. The track is drawn as a solid line for 20 days, then dashed for 20 days, and so on. There is a dot for every 5 days.

GEOSTR. CURRENTS  
MODEL DAY = 3918

G. OF MEXICO 0, 68  
WIND DAY = 1967/299

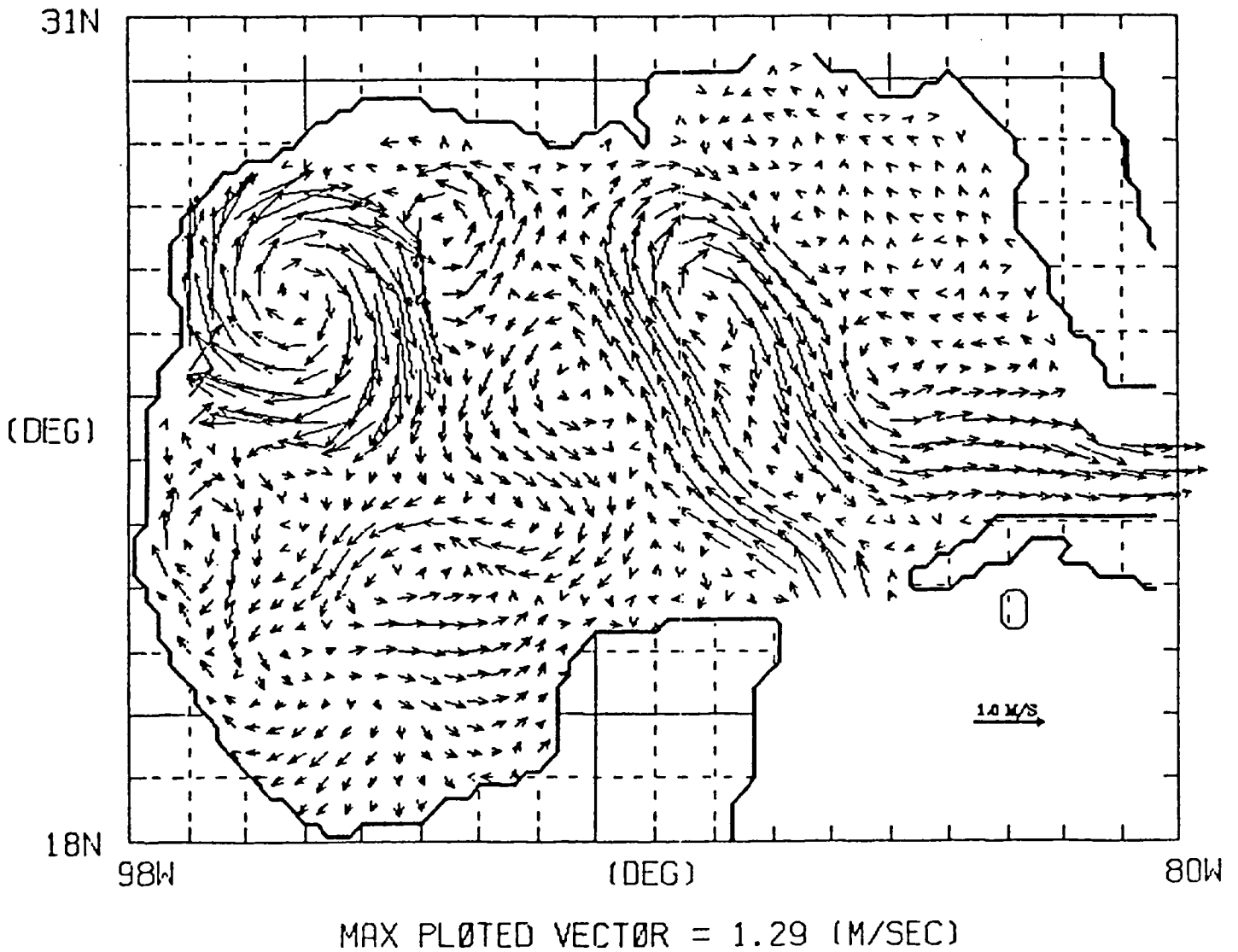

Figure 50. Instantaneous view of upper layer averaged velocities from Experiment 68 on model day 3918. Vectors are only plotted at every second model grid point (i.e., every 0.4 degrees).

# DYNAMIC TRANSFER OF SIMULATED ALTIMETER DATA INTO SUBSURFACE INFORMATION BY A NUMERICAL OCEAN MODEL

Dr. Harley E. Hurlburt  
Ocean Dynamics and Prediction Branch  
Naval Ocean Research and Development Activity

A global, eddy-resolving capability to predict the ocean circulation is technologically feasible within the next decade. For this purpose, the satellite altimeter is the most promising operational source of oceanic data with global coverage, but only at the surface. A comparable source of subsurface data is not on the horizon. This investigation demonstrates the ability of a numerical ocean model to dynamically transfer simulated altimeter data into subsurface information. This was done for a variety of dynamical regimes with (1) barotropic, baroclinic, mixed, and episodic instabilities, (2) flat bottoms or large amplitude topography, (3) relatively vigorous or gentle exchange or energy between the layers, and (4) major time scales short ( $\sim 60$  days), long ( $\sim 1$  year), or both. In all cases the pattern of the deep pressure field is much different from that of the current-related variations in the sea surface elevation, and sometimes is not obviously related to it. The model was able to reconstruct the deep pressure field even in situations with energetic shallow and deep circulations, baroclinic instability, and a vigorous vertical exchange of energy. However, in such experiments the frequency of updating for the free surface elevation was critical. In this study the maximum update interval that allowed successful dynamic surface to subsurface transfer was about half the shortest major time scale (SMTS), which is 50 to 60 days in the experiments with baroclinic instability. Without knowledge of the deep pressure field, numerical predictions of the surface pressure field and the depth of the pycnocline typically beat climatology for  $1/4$  to  $1/2$  the SMTS, but with successful dynamic surface to subsurface transfer, forecasts without updating beat climatology for the SMTS or more. The time scale for predictive skill is substantially longer than the maximum update interval permitted because the update interval must be

short enough to allow decreasing error in the deep pressure field from one free surface update to the next until the error asymptotes at some acceptable level, approximately 30 to 50% in these results. Forecasts of isolated eddies demonstrated predictive skill for three months or more even when the subsurface initial state was unknown.

## PRELIMINARY STUDIES CONCERNING MODELLING OF THE WEST FLORIDA SHELF AND SLOPE

Dr. Peter Hamilton  
Science Applications International Corporation

Two numerical circulation models have been applied to the Gulf of Mexico and the West Florida Shelf. The first is a basin-scale two-layer model (the JAYCOR/NORDA model) designed to simulate the circulations and dynamics associated with the Loop Current and Loop Current eddies. Major limitations are that the interface between the two layers, representing the main pycnocline, is unable to intersect the seabed or the sea surface. Consequently, shelf depths shallower than the pycnocline depth ( $\sim 400\text{m}$ ) have to be excluded from the model, and the upper layer circulations over the West Florida Shelf are probably unrealistic. The model gives good qualitative simulations of the Loop Current which are not, however, true hindcast simulations of the observed circulations, but they do give reasonable descriptions of the statistical properties of the phenomena.

The second model (the NECE shelf model) is a refinement of a shallow water, wind-driven barotropic circulation model to include time-invariant density gradients from seasonal mean hydrographic fields and depth-dependent velocities. Since it is a limited area model applied to the West Florida Shelf, major difficulties arise in determining the

shelf edge boundary conditions. The model has the potential for good hindcast simulations of the observed wind-driven circulation on the inner shelf where the influence of Loop Current processes over the slope and outer shelf is no longer felt and baroclinic current fluctuations coupled to the density field are not important.

It is clear that the principal problems with both models arise at the slope and outer shelf. Therefore, a preliminary study was made of recently acquired MMS data from current meter moorings and hydrographic cruises in an attempt to characterize important dynamic processes which would need to be included in any model of this region. The conclusions of this study are that slope circulations are dominated by the southward flowing Loop Current and an associated northward flowing counter current against the slope. This counter current can reach the surface when the Loop Current is displaced seaward of the shelf break. This displacement of the Loop Current seems to involve the interaction of upwelled colder water (the cold core of an eddy) with the steep continental slope and is associated with eddies imbedded in the Loop Current Surface front. The circulations associated with the Loop Current displacements and eddies often extend to at least the 75m isobath on the shelf (Mooring D); consequently, there is a lack of any solid relationship of the outer shelf and slope currents with wind forcing. The measured currents generally show a lack of coherence between moorings, implying that both the cross-slope and along-slope length scales associated with the Loop Current dynamics are quite small (less than 50 km).

Many aspects of the Loop Current interaction with the slope are ill-defined and not understood. Currently little work has been performed in modelling these circulations. A fruitful line of approach to defining the transport processes and circulations may be in developing and adapting some simple dynamic models of fronts to include a steeply sloping topography.

## OBSERVATIONS OF GULF OF MEXICO INFLOW AND OUTFLOW

Dr. George A. Maul

National Oceanic and Atmospheric Administration  
Atlantic Oceanographic and Atmospheric Laboratory

Sea level measurements from tide gauges at Miami, Florida, and Cat Cay, The Bahamas, and bottom pressure measurements from 50m water depth off Jupiter, Florida, and 10m water depth off Memory Rock, The Bahamas, were correlated with 81 concurrent direct volume transport observations in the Straits of Florida (Maul, et al., 1984). Daily averaged sea level from either gauge on the Bahamian side of the Straits correlated poorly with transport. Bottom pressure off Jupiter had a linear coefficient of determination  $r^2=0.93$ , and Miami sea level, when adjusted for weather effects, had  $r^2=0.74$ ; standard error of estimating transports were  $\pm 1.2 \times 10^6 \text{ m}^3/\text{sec}$  and  $\pm 1.9 \times 10^6 \text{ m}^3/\text{sec}$  respectively. A linear multivariate regression which combined bottom pressure, weather, and the submarine cable observations between Jupiter and The Bahamas, had  $r^2=0.94$  with a standard error of estimating transport of  $\pm 1.1 \times 10^6 \text{ m}^3/\text{sec}$ . These results suggest that a combination of easily obtained observations is capable of adequately monitoring the daily volume transport fluctuations of the Florida Current.

From October 1977 through November 1980 a current meter mooring was maintained in the Yucatan Strait (Maul et al., 1985). The meter was moored half-way between Mexico and Cuba 145m above the sill, or in 1895m of water. Motions of low frequency ( $<14^{-1}$  cycles/day) are oriented approximately parallel to the isobaths, 021 -030 true. Net drift for three years is to the SSW at an average velocity of 1.8 cm/sec. Sustained southward flows at intervals of 8 months, which persisted for several months each, have average velocities of 5 cm/sec with randomly spaced bursts as high as 15 cm/sec. Energy in subtidal frequency bands has significant peaks near  $38^{-1}$  and  $19^{-1}$  cycles/day, with a broad band of energy between  $300^{-1}$  and  $200^{-1}$  cycles/day. The latter peak is

consistent with the approximately 8 month interval between the southward flow events. Comparison with weekly areal coverage of the Gulf Loop Current from Geostationary Operational Environmental Satellite infrared observations shows little covariation except that eight months is typical of some anticyclonic eddy generation. There is little coherence of sill depth velocities with Naples sea level at subtidal frequencies, but with Miami there is coherence at several frequencies, notably  $38^{-1}$  and  $19^{-1}$  cycles/day. In the higher frequencies the principal tidal motions are diurnal and are oriented somewhat across the isobaths toward the northwest,  $346^{\circ}$  -  $349^{\circ}$  true, with counter-rotating  $O_1$  and  $K_1$  constituents. No semidiurnal, inertial, or fortnightly energy is observed above the background continuum.

## REFERENCES

- Maul, G.A., F. Chew, M. Bushnell, and D.A. Mayer. Sea level variation as an indicator of Florida Current volume transport: Comparisons with direct measurements, *Science* (in press), 1984.
- Maul, G.A., D.A. Mayer, and S.R. Baig. A continuous three-year current meter observation at the sill of the Yucatan Strait, *J. Geophys. Res.* (to be submitted), 1985.

## THE ALVENUS OIL SPILL AND CIRCULATION ON THE TEXAS-LOUISIANA SHELF: PRELIMINARY ANALYSIS

Dr. Kurt W. Hess

Marine Environmental Assessment Division, NOAA

The grounding of the tanker ALVENUS at the end of July, 1984, and the resulting oil spill indicates that the northwest Gulf of Mexico coastal current was the dominant factor in the advection of the oil. Advection by wind drift currents was relatively minor, but winds were important for the beaching of the oil. Analysis of the available current meter data confirms that the current was highly correlated to the local wind.

The British tank ALVENUS, loaded with 14.7 million gallons of Venezuelan crude oil and bound for the Conoco refinery in Lake Charles, Louisiana, ran aground in 42 feet of water in or near the Calcasieu Channel approximately 11 miles south of Cameron, Louisiana, at 29 ° 35.0'N, 93 ° 16.9'W, at about 1235 local time (LT) on July 30, 1984. Some of the ship's tanks began leaking immediately, and over the next four days, about 2.3 million gallons of the cargo were spilled. The oil was swept westward along a path roughly parallel to the coast, and tar balls and patches began washing ashore at about 1840 LT on the afternoon of August 3 along the Bolivar Peninsula, just north of the entrance to Galveston Bay. Rollover inlet, Gilchrist, and Crystal Beach received especially heavy amounts of oil. The petroleum began to wash ashore along Galveston Island that night and during the next day, heavily impacting East Beach, Jamaica Beach, and Stewart Beach. Oil beached along Galveston Island in greater amounts than along Bolivar Peninsula. It was estimated by NOAA personnel that about 0.7 million gallons had washed up along the Texas coast, and that an additional 0.3 million gallons remained in the surf zone in the form of tar mats. The remaining oil probably dispersed into the water column, settled to the bottom, evaporated, or was advected along the coast or out to sea undetected.



Local winds and the coastal current were important factors in the advection of the oil. Wind forecasts from the National Weather Service's LFM model are archived by MEAD and are available for a grid point in the region of interest at 29 ° 7.1'N, 93°59.8'W for 6-hourly intervals. Texas A&M University has collected salinity, temperature, and current meter data at two locations near the spill. One is Site D, near the Calcasieu Channel at 29 ° 39.740'N, 93°28.730'W, in 9.4m of water, and the other is Site C, south of Freeport, Texas, at 28° 43.900'N, 95° 14.567'W with a depth of 21.9m. During the first few days of the spill the winds from Site D (sensor elevation of 15 meters), collected by the NOAA Data Buoy Center, averaged about 4.5 m/s toward the west and were moderately offshore. From August 2 through 4 the longshore component of the winds diminished to about 2.0 m/s, and the winds become moderately onshore. Late on the evening of August 3 and continuing into the next morning, a strong burst of onshore winds occurred, with winds speeds reaching 12.0 m/s. After preliminary calculations, it was clear that the winds were not strong enough alone to transport the oil along the coast at the speed observed. Since the oil had reached a point just offshore of Galveston by 900 LT on August 3, it covered a total distance of roughly 140km over a time of 93 hours, for a mean speed of 42 cm/s. During that time the longshore component of the wind at Site D averaged nearly 3.0 m/s. A wind drift current at 3.5% of the wind speed would have a strength of 10 cm/s (assuming the wind acted alone, the "effective" wind speed would have been 14%). Current meter data indeed confirms the presence of a strong coastal current. The Site D top meter, at 3.7m, measured water speeds up to 46 cm/s during the period 1200 July 30 to 1000 August 2 (data is not yet available for later times). The mean strength of the longshore component of the current was about 20 cm/s. The longshore current at the more westerly location, Site C, was significantly stronger, averaging 30 cm/s during the spill event. Water currents of this magnitude combined with wind drift currents of 10 cm/s can account for the oil's celerity.

In order to better understand the shelf circulation, we studied the event using MEAD'S 3-dimensional currents model, presently being developed by the author. The model runs on a square grid mesh with a

fixed number of vertical levels (10) at uniform fractions of the local, total depth (MSL depth plus tide). A grid mesh with 49 kilometer spacing was set up for the northwest portion of the Gulf, so that the northern and western cells represented land, and the southern and eastern boundaries were open water. A simulation with steady easterly winds of 5 m/s with constant density and no non-linear advection or horizontal diffusion gave surface currents at the location representing Site D with a mean value of 21 cm/s. Radiation outflow boundary conditions were used at both open boundaries, so interactions with the central Gulf were suppressed. Preliminary results show that for easterly wind conditions such as those that occurred during the ALVENUS event, the coastal current is strongest along the shallow inner shelf regions from about Atchafalya Bay, Louisiana, westward to roughly Port Aransas, Texas. The current is strongly barotropic and decreases rapidly from the shore outward.

We made several hindcasts of the spill with the National Weather Service's AFOS-based oil spill model. Several conclusions can be made as a result of these runs: First, the LFM wind forecasts for the boundary layer winds over the several days of the spill were generally close, in magnitude and direction, to the observed values at Site D. However, subgrid scale events and land-water boundary effects, which are not included, appear to have been important for determining precisely where the oil beached. Second, as was mentioned above, knowledge of the coastal currents is of major importance. Longshore currents of a high variable nature, both in space and time, were dominant factors in advecting the oil. This situation, although not typical of oil spills, is nearly identical to that during the BURMAH AGATE spill off the entrance to Galveston Bay in 1979. Last, horizontal diffusion of the oil, as simulated by a random current, was minor. Our modeled value of 500 ft<sup>2</sup>/s was probably an order of magnitude too high. The oil slick was frequently described as being one or two long, narrow "ribbons," with shorter slicks appearing as "fingers."

Some general observations concerning risk assessment modeling are in order. There are insufficient data from this spill to show whether the

3.5% rule or the wind stress rule is better. With the 3.5% rule and a coastal current of 30 cm/s, the advection velocity is 40 cm/s. With the wind stress rule, we take 1.8% of the wind speed (about 5 cm/s) and add the surface water velocity (from the 3-D model results, the surface speed is the mid-depth speed plus 6 cm/s for these winds) of 36 cm/s. to get 41 cm/s. Either approach would be equally successful. Then there is the oil deflection angle (the difference between the oil's and the wind's direction). Our hindcasts, with a zero deflection angle, are reasonably good. The actual angle was therefore probably small, in the range of 0 to 10 ° ; but it probably was not as large as 25 ° . Finally, coastal currents will have to be better understood. During the ALVENUS spill, the current at Site C was stronger than at Site D; although both sites were roughly the same distance from shore, Site C at 21 meters was twice as deep. However, during the BURMAH AGATE, the currents in shallower water were stronger. In addition to these local variations, other studies indicate that the coastal current is dependent on wind stress over the whole northwest Gulf of Mexico. The inclusion of these currents in risk assessment simulations will have to be made in a manner compatible with the chosen wind fields.

# NAVY CORRECTED GEOSTROPHIC WIND SET FOR USE IN GULF OF MEXICO CIRCULATION MODELING

Mr. Robert C. Rhodes  
Jaycor, Inc.

## INTRODUCTION

In their climatological analysis of frontal activity in the Gulf, DiMego, Bosart and Endersen (1976) have shown that frontal frequency increases rapidly from September to October with a strong maximum in the winter months with the duration of frontal activity on the order of one to two days. Activity decreases more gradually through the spring with very little frontal activity in the summer months. The frontal activity will be associated with some of the highest wind speeds and stresses. The large variability of the Gulf of Mexico wind field indicates that high resolution wind data will be required both spatially and temporally to represent the weather systems affecting ocean circulation.

Previous data sets have lacked the needed resolution and therefore are far from ideal for use in studying the dynamics of Gulf circulation. The data sets of Franceschini (1953) and Elliott (1979) are both derived from historical ship observations. The Franceschini wind data are monthly-averaged stress climatologies with 2-degree grid resolution, while the Elliott data are seasonally-averaged stress climatologies with 1-degree grid resolution. The data set of Blaha and Sturges (1978), supplied by Bakun (1973), is monthly-averaged values of wind stress derived from surface pressure data extending continuously over the period 1946-1975. In each case the temporal resolution is particularly poor, with at most 12 wind fields to represent a year. Monthly or longer averages cannot possibly represent wind variability, and it would be preferable to let the ocean model do its own more frequent integration of wind data.

## DATA AND METHOD OF ANALYSIS

The most promising sources for frequent synoptic atmospheric data in the Gulf are the atmospheric forecasting centers. The approach taken here is to calculate corrected geostrophic winds from surface pressure analyses. The most desirable data set is the one used to initialize the National Weather Service's limited fine-mesh model because of its high resolution over the Gulf, but only a subset of the surface pressure analysis (that does not cover the entire Gulf) has been archived at the National Center for Atmospheric Research (NCAR). The best readily available data for use in calculating the geostrophic winds are surface pressure fields obtained from the Fleet Numerical Oceanographic Center's (FNOC) 12-hourly analysis, with approximately 280-300 kilometer grid resolution over the Gulf. This data was obtained for all available time periods from 1967 to 1982.

The pressure was interpolated to a spherical grid over the Gulf, and the geostrophic wind was calculated at three buoys in the Gulf for direct comparison with the observed buoy wind. The buoys were located at (26.0°N, 90.0°W), (26.0°N, 93.5°W), and (26.0°N, 86.0°W), and the data were available at either 1-hour or 3-hour intervals from 1977 to 1982.

Ageostrophic corrections were calculated through direct comparison of geostrophic wind and buoy wind by using linear regressions for both magnitude and direction. Blaha and Sturges used constant ageostrophic correction factors of 0.7 for speed and 15 degrees for direction, but these figures were obtained from a study done by Bakun using data from the west coast of the United States. Since the correction factors depend on atmospheric stability, Bakun's correction factors are not necessarily appropriate for the Gulf; however, the corrections calculated from the buoy data are quite similar (see below). Wind stresses were then calculated on a spherical grid over the Gulf from the corrected geostrophic wind using constant atmospheric density and a constant drag coefficient equal to .0013. This calculation is identical to that used by Blaha and Sturges. The geostrophic winds, corrected geostrophic winds, and wind stresses (all on a one degree grid covering the Gulf) will be

available on separate magnetic tapes from the Gulf of Mexico Regional Office of the Minerals Management Service.

## RESULTS

### AGEOSTROPHIC CORRECTIONS

The data from all available years and for the three buoys were combined by month, and the regressions performed to determine seasonal variability. The results showed that the magnitude correction factor had little variability throughout the year, but the direction correction was a function of the month and was shown to have a large sinusoidal component. The angle correction was larger in the winter and smaller in the summer. Therefore, one magnitude correction (.675) was used for the entire year, while the direction correction varied according to:

$$C = 17.5 + 9 \sin 2 i/N \quad i=1,N \quad (1)$$

where  $C$  is the correction factor in degrees,  $N=730$ , the number of observations per year, and  $i = 0$  on October 1st of each year. For simplicity, exactly the same formula is used in leap years, since the variation in  $C$  over one day is negligible.

### WIND STRESS AND WIND STRESS CURL

Figure 51 shows the wind stress and wind stress curl for 0000 GMT, 1200 GMT 14 January 1976, and 0000 GMT 15 January 1976. There is large temporal variability of the wind field during this period, as general easterly flow gives way to strong northerly flow after a frontal passage in just a 24 hour period. The wind stress curl field also shows the rapid change, from a relatively weak field to a very strong field with strong horizontal gradients. Figure 52 shows similar plots for 14 and 15 July 1976. Even in the summer, when flow is generally weaker, significant differences can be seen in a short time period. These strong variations and rapid changes in the wind field indicate why the modeling of Gulf circulation requires wind data on short temporal scales.

Figures 53 and 54 show the seasonal climatologies averaged over the period 1967-1982. The wind stress and wind stress curls are stronger in the winter season than the summer season, as would be expected. There are persistent areas of positive curl over the Yucatan and negative curl in the southwest Gulf in all seasons, which are not seen in any previous study of Gulf wind stresses. Although not seen at all time periods (Figures 53 and 54), these are the dominant features of the instantaneous curl fields.

## REFERENCES

- Bakun, A., 1973. Coastal upwelling indices, west coast of North America, 1948-1971. Tech. Rept. NMFS SSRF 671, NOAA, Seattle.
- Blahe, J.P. and W. Sturges, 1978. Evidence for wind forced circulation in the Gulf of Mexico, Department of Oceanography, Florida State University, 134p.
- Dimego, G.J., L.F. Bosart and G.W. Endersen, 1976. An examination of the frequency and mean conditions surrounding frontal incursions into the Gulf of Mexico and Caribbean Sea, Mon.Wea.Rev., 105:26-36.
- Elliott, B.A., 1979. Anticyclonic rings and the energetics of the circulation of the Gulf of Mexico. Unpublished Ph.D. dissertation, Texas A&M University. 188p.
- Franceschini, G.A., 1953. The distribution of the mean monthly wind stress over the Gulf of Mexico, Texas A&M Research Foundation, College Station, Texas, 18p.

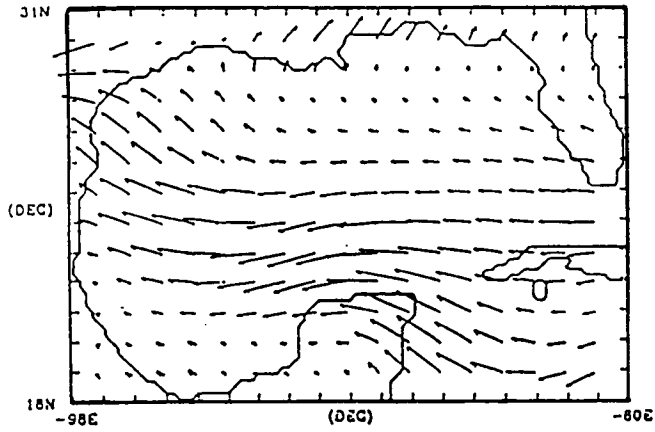

WIND STRESS  
014/1976 AT 0 GMT

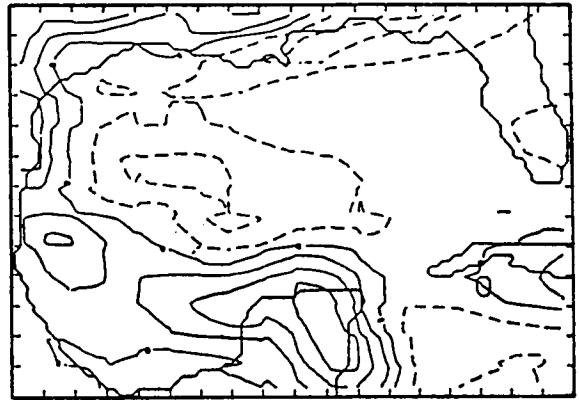

WIND STRESS CURL  
014/1976 AT 0 GMT

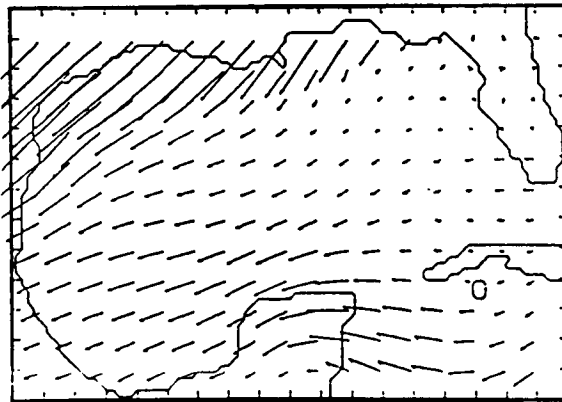

WIND STRESS  
014/1976 AT 12 GMT

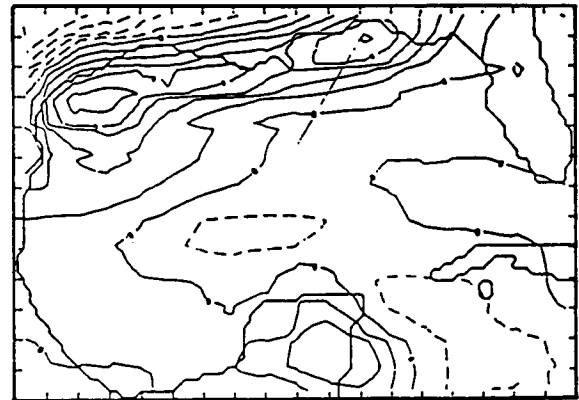

WIND STRESS CURL  
014/1976 AT 12 GMT

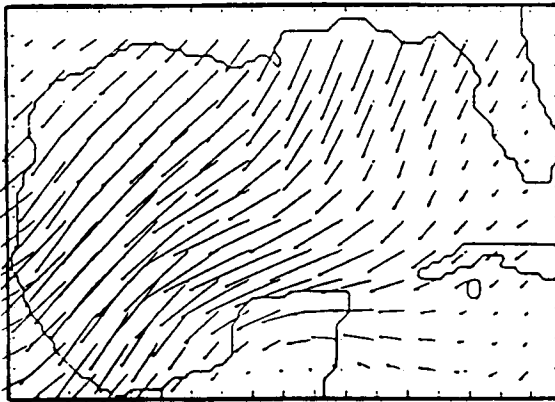

WIND STRESS  
016/1976 AT 0 GMT

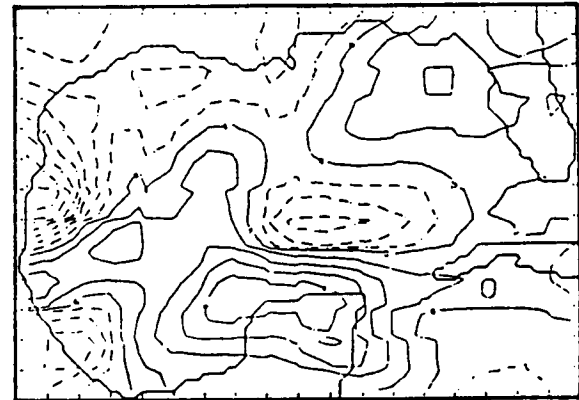

WIND STRESS CURL  
016/1976 AT 0 GMT

Figure 51. Wind stress and wind stress curl for 0000 GMT and 1200 GMT 14 January 1976, and 0000 GMT 15 January 1976.



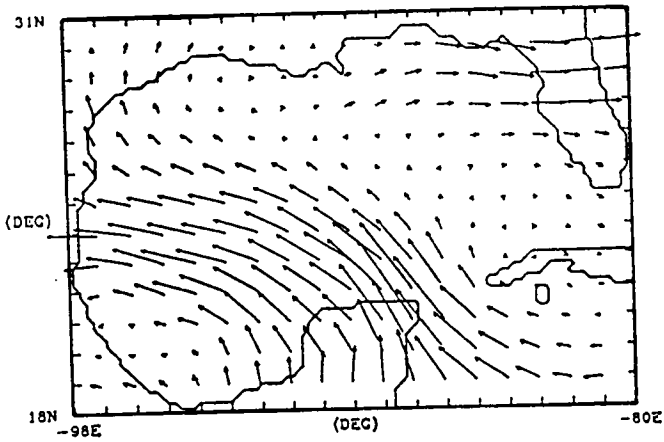

WIND STRESS  
196/1976 AT 0 GMT

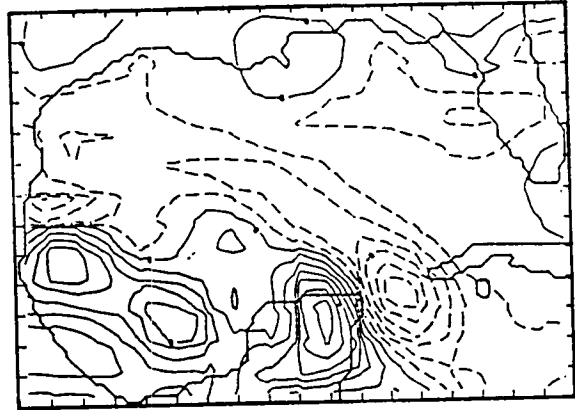

WIND STRESS CURL  
196/1976 AT 0 GMT

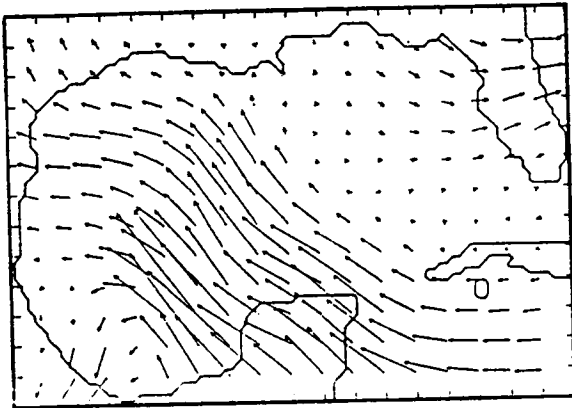

WIND STRESS  
196/1976 AT 12 GMT

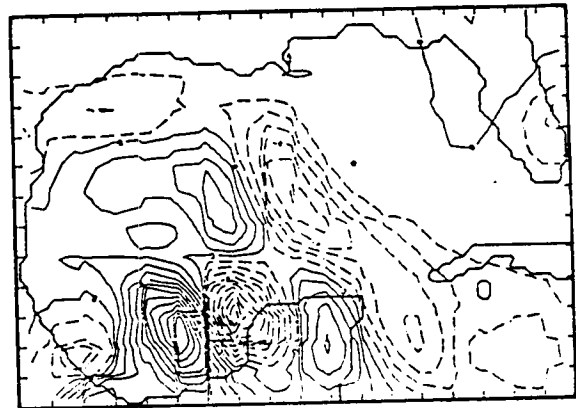

WIND STRESS CURL  
196/1976 AT 12 GMT

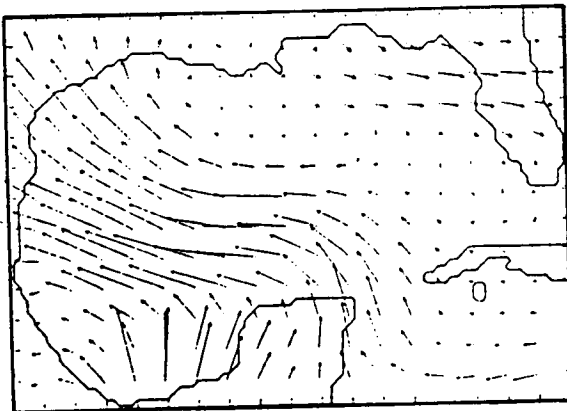

WIND STRESS  
197/1976 AT 0 GMT

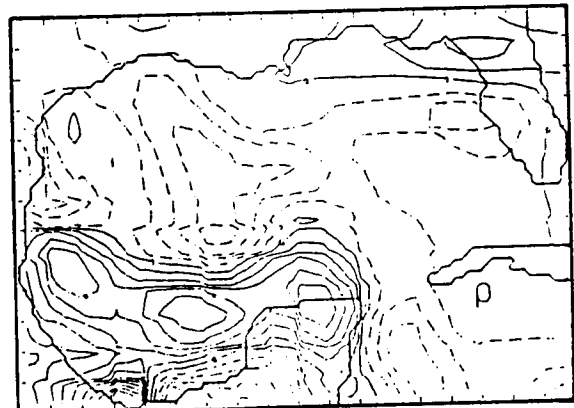

WIND STRESS CURL  
197/1976 AT 0 GMT

Figure 52. Wind stress and wind stress curl for similar plots for 14 and 15 July 1976.

WIND STRESS  
WINTER 1967-1982

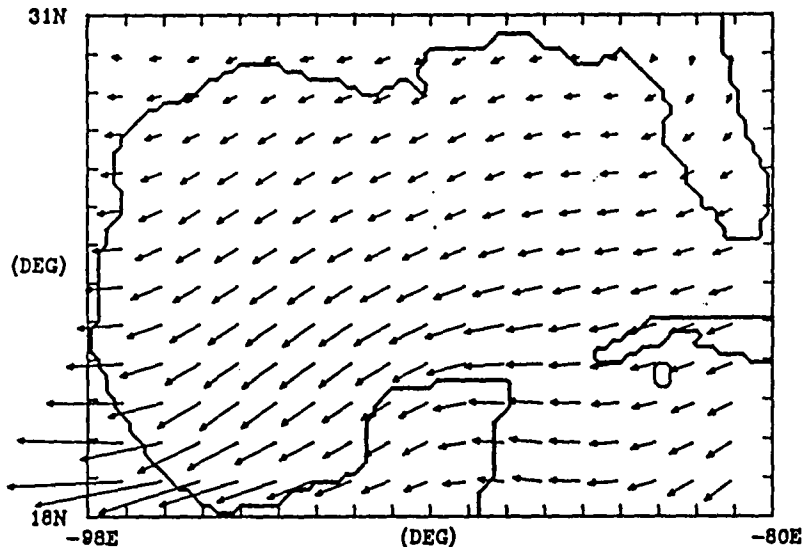

MAXIMUM WIND STRESS = 2.79 DYNES/CM<sup>2</sup>

NOIDA 323 9-OCT-84

WIND STRESS  
SPRING 1967-1982

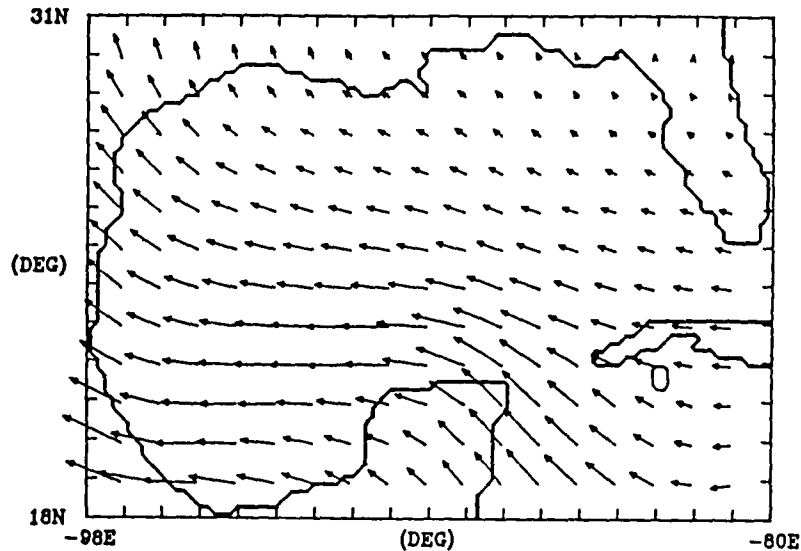

MAXIMUM WIND STRESS = 1.33 DYNES/CM<sup>2</sup>

NOIDA 323 9-OCT-84

WIND STRESS CURL

WINTER 1967-1982 DC = 1.0E-10 MKS

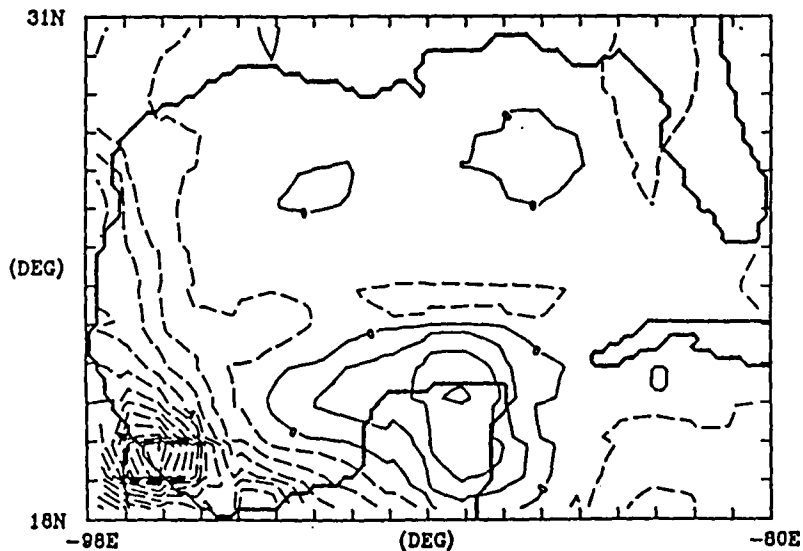

MIN = -1.42E-09 MAX = 3.15E-10

NOIDA 323 9-OCT-84

WIND STRESS CURL

SPRING 1967-1982 DC = 1.0E-10 MKS

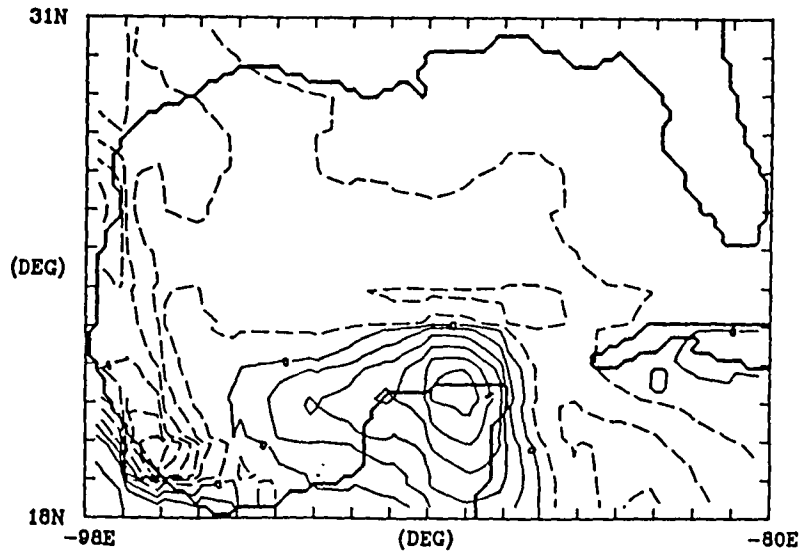

MIN = -7.86E-10 MAX = 5.85E-10

NOIDA 323 9-OCT-84

044

**WIND STRESS**  
SUMMER 1967-1982

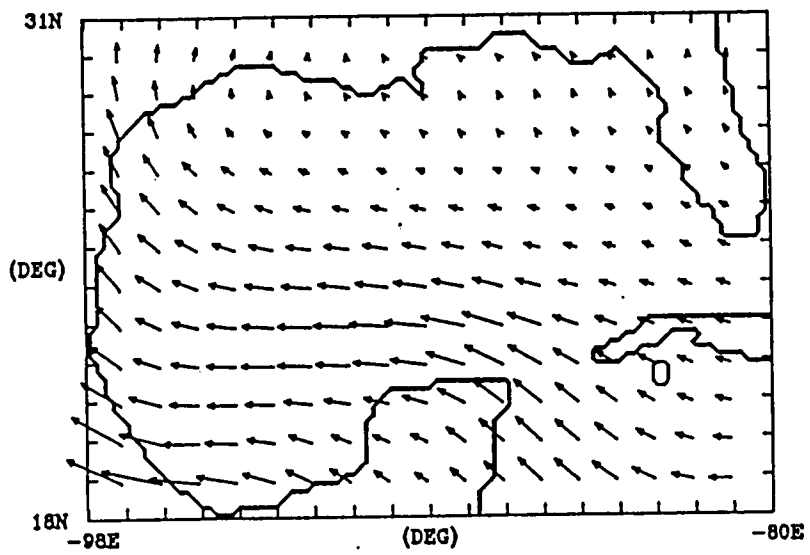

MAXIMUM WIND STRESS = 1.29 DYNES/CM<sup>2</sup>  
NOIDA 273 9-OCT-84

**WIND STRESS**  
FALL 1967-1982

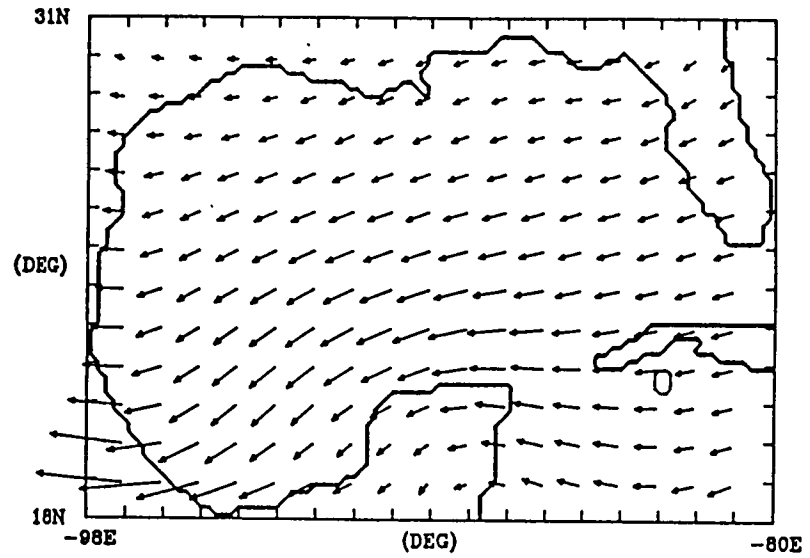

MAXIMUM WIND STRESS = 1.84 DYNES/CM<sup>2</sup>  
NOIDA 273 9-OCT-84

**WIND STRESS CURL**  
SUMMER 1967-1982 DC = 1.0E-10 MKS

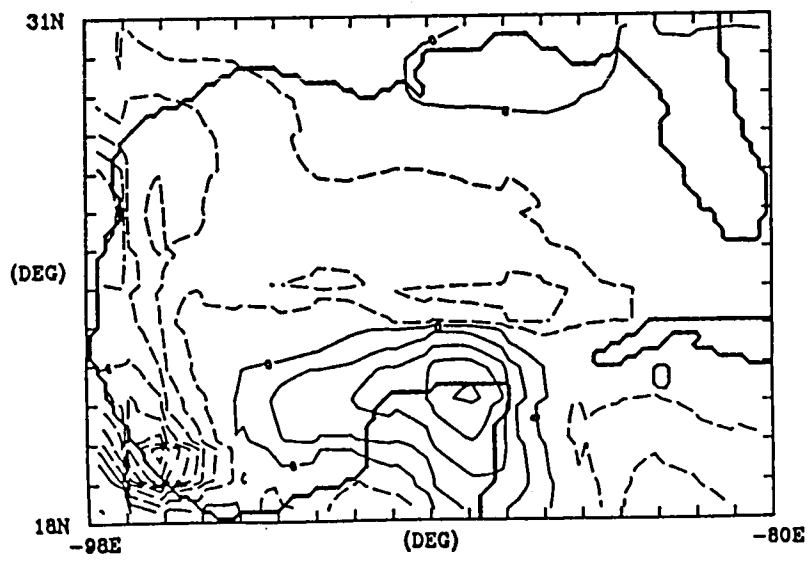

MIN = -8.64E-10 MAX = 4.31E-10  
NOIDA 273 9-OCT-84

**WIND STRESS CURL**  
FALL 1967-1982 DC = 1.0E-10 MKS

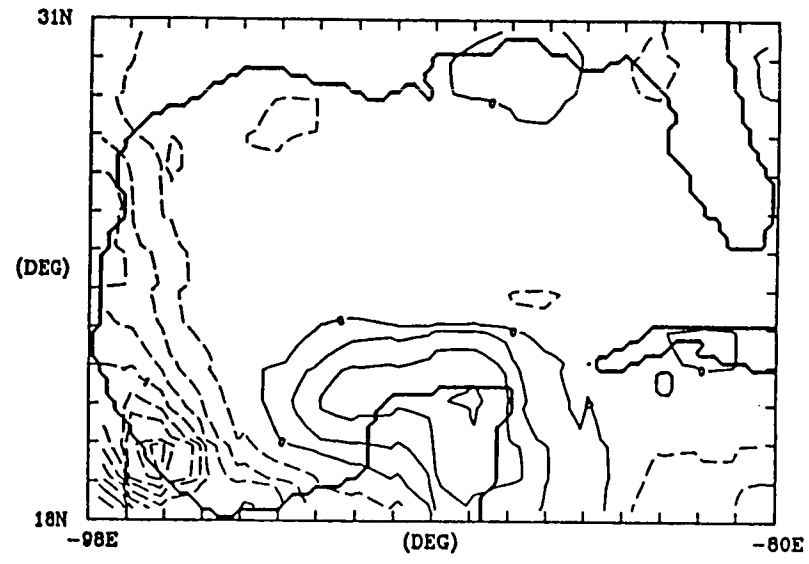

MIN = -9.53E-10 MAX = 3.22E-10  
NOIDA 273 9-OCT-84

147

CURRENT STUDIES IN UNDERWATER ARCHAEOLOGY

Session: CURRENT STUDIES IN UNDERWATER ARCHAEOLOGY  
Chairman: Ms. Melanie Stright  
Date: November 28, 1984

<u>Presentation Title</u>	<u>Speaker/Affiliation</u>
Session Overview	Ms. Melanie Stright MMS, Gulf of Mexico Region
New Ground Reef Shipwreck Investigations in the Eastern Gulf of Mexico	Mr. James Parrent Texas A&M University
Geomorphological Research in the Atchafalaya Basin and Terrebonne Marsh	Dr. Lawson M. Smith U.S. Army Engineer Corps Waterways Experiment Station Mr. Thomas Ryan U.S. Army Engineer District, New Orleans
Survey, Mapping and Site Reconstruction in a Blackwater Environment: A Study in Methods	Mr. Richard J. Anuskiewicz MMS, Gulf of Mexico Region
Initial Geoarcheological Evaluation of the Texas City Channel Site (41 GV 81), Galveston County, Texas	Dr. Lawrence E. Aten National Park Service Ms. Carolyn Good U.S. Army Corps of Engineers, Galveston District

## SESSION OVERVIEW: CURRENT STUDIES IN UNDERWATER ARCHAEOLOGY

Ms. Melanie Stright  
MMS, Gulf of Mexico Region

Our session, Current Studies in Underwater Archaeology, consisted of two papers on historic shipwreck investigations and three papers on studies in prehistoric archaeology.

James Parrent, currently working in the Gulf of Mexico Regional Office on an inter-governmental personnel agreement from Texas A&M University, discussed the recent MMS investigations of 17th century English slave ship on New Ground Reef. This investigation was conducted at the request of the State of Florida for MMS to evaluate the site's eligibility for the National Register of Historic Places. As a result of the MMS on-site investigation it was discovered that there are still portions of the ship's hull in place on the sea floor. Various artifacts observed included two cannons, ivory, and two large metal boxes.

Based on our diver's evaluation of this site, MMS recommended that it not be nominated to the National Register for the following reasons: (1) only a limited number of diagnostic artifacts remain on the site; (2) the integrity of the site has been severely disturbed by treasure hunting activities; and, (3) the continuing activity on the site by treasure hunters will, undoubtedly, further degrade the site.

The second paper on shipwreck archaeology was given by Rick Anuskiewicz, Staff Archaeologist, MMS Environmental Operations Section, formerly of the Army Corps of Engineers in Savannah, Georgia. Mr. Anuskiewicz reported on seven years of work he's conducted on the USS GEORGIA off Savannah. This civil war shipwreck lies along the Corps of Engineers' dredge channel in a black water environment.

Mr. Anuskiewicz's paper demonstrated that not only can proper archaeological techniques be employed in underwater archaeological investigations but also that proper archaeological techniques can be employed in a black water environment. The initial investigation of the site was done by remote sensing, with depth sounders and side scan sonar. Based on the remote sensing data, the wreck site was mapped and a dive plan was formulated.

As work progressed, prior to removal of any objects from the wreck site, the objects were buoyed and shot in with transits in order that their proper locations could be recorded.

Mr. Anuskiewicz indicated that the Corps will have to do more work on this wreck and possibly excavate the entire site due to the Corp's plans to further widen the shipping channel in Savannah harbor. There may be no way to protect the wreck in-situ from future dredging activities.

Our first paper on prehistoric archaeology was delivered by Dr. Lawson Smith, a geomorphologist and Chief of Regional Geologic Studies with the Geotechnical Lab Waterways Experiment Station for the Corps of Engineers in Vicksburg, Mississippi. Dr. Smith reported on current archaeological and geomorphological research in the Atchafalaya Basin and Terrebonne Marsh. This study is designed to reconstruct the paleogeography of the Atchafalaya Basin and Terrebonne Marsh in order to provide the basis for management decisions regarding future archaeological survey requirements, including the level and type of survey which should be employed. The paleoenvironmental reconstruction and predictive modeling approach to prehistoric site location being used in the Corps of Engineers study is very much like the management approach being employed by MMS on the Gulf of Mexico Outer Continental Shelf. In both cases, existing remote sensing data, regional geologic studies, sea level curves, and foundation borings are used for paleogeographic reconstruction. These findings are then used to determine the potential for prehistoric site occurrence and preservation.

In summary, Dr. Smith's paper demonstrates that the archaeological techniques and methods being employed on land for prediction of site locations and for management decisions are identical to those being employed on the Outer Continental Shelf. Only the working environment differs.

Our second paper on prehistoric archaeology was delivered by Dr. Charles Pearson, Project Leader for a current MMS study entitled "Prehistoric Site Evaluation on the Northern Gulf of Mexico OCS: Ground Truth Testing of the Predictive Model." This study was funded by our Washington Office and is designed to test the predictive model for prehistoric site occurrence that's been used as the basis for MMS cultural resources management decisions in the Gulf of Mexico since the cultural resources baseline study in 1977. The study is also designed to test our current technology and methods for evaluation of potential prehistoric site locations on the OCS. During the first phase of this study, original seismic data were collected along the ancient Sabine River Valley, which trends offshore between Louisiana and Texas. Based on these seismic data specific areas having a high potential for prehistoric sites to occur and be preserved were outlined within the ancient river valley. High probability areas identified from the data include several levels of terraces, individual channel courses within the major river valley, point bars, and possible natural levee deposits. Based on these seismic data, more specific areas were identified where vibracores would be collected in order to obtain a soil sample from potential site locations. The vibracoring phase of the study has just been completed. The cores are currently being cut and photographed. The next phase of the study involves coarse-fraction and geochemical analysis of selected samples from the cores in an attempt to identify culturally deposited sediments and material.

The last paper was presented by Dr. Lawrence E. Aten, Chief of the Inter-agency Resources Division of the National Park Service in Washington, D.C. Dr. Aten reported on a site at the Texas City Channel in Galveston Bay, where a Corps of Engineers dredging project has turned up fossil material that appears to have been culturally modified



by percussion flaking. Dr. Aten in consultation with Carolyn Good, archaeologist for the Corps of Engineers in Galveston, has determined that there are numerous artifact types present in the redeposited fossil material.

Apparently the fossilized material, rather than lithic material, was being used by prehistoric man in the local area as a source for tool manufacture. This site, and a site along the extreme eastern Texas coast, the McFadden Beach Site, show that prehistoric man was in the Gulf Coast Region at least 10,000 years ago. It should be noted that these sites are very close to the MMS study area offshore where similar sites would have been inundated as a result of Holocene sea level rise.

At the time these sites were formed, Galveston Bay and McFadden Beach were upland settings, with the shoreline at approximately the 30 meter bathymetric contour. These findings demonstrate that man was in the Gulf Coast area at least 10,000 years ago; and that prehistoric sites can be anticipated on the continental shelf at least out to the -30 isobath. The goal of MMS's current study is to produce evidence of these preserved inundated sites on the OCS.

## NEW GROUND REEF SHIPWRECK INVESTIGATIONS IN THE EASTERN GULF OF MEXICO

Mr. James Parrent  
MMS, Gulf of Mexico Region

In May 1984, an archaeologist working for Treasure Salvors, Inc., contacted the Florida Division of Archives, History and Records Management about the nomination of a shipwreck site to the National Register of Historic Places (NRHP). The shipwreck lies on New Ground Reef about 34 miles west of Key West, Florida. Since this area is outside of state waters, on the outer continental shelf (OCS), Florida officials contacted Dr. Friedman, Minerals Management Service (MMS) Consulting Archaeologist, Washington, D.C., for assistance in the nomination process. In turn, the MMS Gulf of Mexico Regional Office was directed to investigate the site to determine its eligibility for nomination to the NRHP.

I went to Tallahassee, Florida to consult with state archaeologists and conduct a file search on the wreck site. A file search revealed the following:

1. The site consists of a shipwreck dating from approximately 1689 to 1710. Portions of the site have been salvaged under State of Florida Contract S-13. When the site was examined in the early 1970s, large portions of the ship's wooden hull and portions of the ship's frames remained. Most of the wreck was in good physical condition and two cannons and two anchors were located.

2. Judging from the size of the wreck site and from the numbers and types of artifacts recovered, it is estimated that the ship was a small vessel weighing one hundred tons or less, lightly armed, and of English origin. The artifacts recovered included such unique items as pewter bottles of the "onion bottle" type, German silver drinking steins, elephant ivory, and iron shackles. In addition there were swords, small arms, cannon balls, silver spoons, leather fragments, an English copper

coin dated 1689, and a Spanish coin bearing no date.

3. An assessment of the geographic origin of the ship is based on the recovered artifacts. Spanish and Portuguese vessels of this period usually carried more ceramic containers than metallic. It is further speculated that it was either a merchant or pirate vessel, since the wreck site is in a major Spanish shipping corridor and vessels of foreign nationality are known to have preyed upon Spanish fleets. The uniqueness of this particular wreck, therefore, is that it is not a Spanish vessel and there are few recorded early English shipwrecks from this region during this time period.

Between August 1972 and June 1974, the site was worked extensively by treasure hunters under contract with the State of Florida. In 1976, a Supreme Court decision defining Florida State waters placed the wreck outside of Florida's jurisdiction. The shipwreck site lay undisturbed from 1974 until 1982, when Treasure Salvors, Inc., put a subcontractor on the site. It was in 1982 that a bell with the inscription "The Henrietta Marie 1699," was recovered from the site.

I conducted an on site investigation in September 1984. Leasing and Environment, GOM OCS Region (LE), staff members, Mr. Joe Christopher, Environmental Specialist; Mr. Joe Perryman, Oceanographer; and National Park Service (NPS) personnel, Mr. Jack Morehead, Superintendent of Everglades National Park, Mr. Jim Tillmont, Marine Research Scientist, Mr. Cliff Green, Captain of NPS boat ACTIVA; and Mr. David Moore, Archaeologist for Treasure Salvors, participated in the site investigation.

The site was located on the first day, September 14, 1984, and its perimeter was established. On September 15, 1984, artifacts visible on the seafloor were photographed and measured. Surface collecting has depleted the artifact assemblage reported by Larry Murphy in 1972. Mr. Murphy was a Florida State Archaeologist when the site was first discovered and is now a member of NPS Submerged Cultural Resource Unit in Santa Fe, New Mexico.

Our divers identified the following artifacts on the seafloor: 1) two wooden ship frames lying loose; 2) wood ship frames, dead wood, and planking, the upper portions of which protruded from the seafloor; 3) remains of two large metal box-like structures; 4) two ivory tusks, one of which is protruding from under the larger of the metal boxes; 5) two iron cannons about six feet in length; and 6) one pair of slave shackles.

To further complicate the status of the shipwreck site, a treasure salvor, Toney Kopp, on his boat ALLUSION met us at the site on our first day out, September 14, 1984. Mr. Kopp said that Mel Fisher, President of Treasure Salvors, Inc., had given him the Loran coordinates to the site. Mr. Kopp also stated that Mr. Fisher had given him the rights to the shipwreck.

Divers from the ALLUSION were first to discover one of the cannons and placed a buoy on it. The ALLUSION crew was friendly, helpful, and readily shared artifact locations with us. However, they began recovering artifacts from the site and said they planned on working the site for several days. Divers from the ALLUSION made no pretense of conducting any type of archaeological survey, but instead commenced to randomly search for and collect artifacts.

We departed the site Friday afternoon and returned on Saturday morning. The ALLUSION crew was in the water working with an air dredge and metal detector. I observed two divers, one with a metal detector and one with a collecting bag, searching the seafloor and collecting artifacts. There was no control grid or any other observable device which would offer any clue as to where the artifacts had lain before they were bagged. This incident raises questions about the motives and sincerity of Treasure Salvors' nomination of this site to the NRHP.

Wood samples from the ship's frames, strakes, and the bilge pump, which had been removed previously by Treasure Salvors, were sent to the Center for Wood Anatomy, U.S. Forest Products Laboratory, Madison, Wisconsin. The frame and strake were identified as white oak and the bilge pump was constructed from beech wood.

Based on the following reasons, the site was not recommended for nomination to the National Register for Historic Places: 1) only a limited number of diagnostic artifacts remain on the site; 2) the integrity of the site has been severely disturbed; and 3) the continuing activity on the site by treasure hunters will undoubtedly further reduce the artifact assemblage.

## GEOMORPHOLOGICAL RESEARCH IN THE ATCHAFALAYA BASIN AND TERREBONNE MARSH

Dr. Lawson M. Smith  
U.S. Army Engineer Waterways Experiment Station  
Mr. Thomas Ryan  
U.S. Army Engineer District  
New Orleans

The geomorphic investigation of the Atchafalaya Basin and the Terrebonne Marsh of southern Louisiana is the initial step in a multi-phased approach to identifying and managing the area's prehistoric cultural resources. The geomorphic study is designed to provide an environmental framework for estimating site probability areas, to aid in establishing site significance, and to serve as a guide for planning future investigations. Results of the geomorphic study will also serve as the initial planning document for executing a programmatic memorandum of agreement with the Louisiana State Historic Preservation Officer and the Advisory Council on Historic Preservation.

An understanding of the evolution of the physical landscape and the basic landforming processes is critical to the identification and evaluation of the prehistoric cultural resources of a region. In support of future cultural resource surveys of the Atchafalaya Basin and the

Terrebonne Marsh, a geomorphic study of the area is being conducted to provide an outline of landscape evolution. There are two primary objectives of the study. The initial objective is to describe and delineate on detailed maps the geomorphic features (landscape elements) of the study areas. The second objective is to analyze the geomorphic development (landscape evolution) of the study areas, especially as landscape evolution relates to prehistoric man/land relationships.

Description and cartographic delineation of geomorphic features of the study areas was completed in August 1984. Twenty classes of geomorphic features were mapped on fifty-five 1:24,000 U.S. Geological Survey quadrangles. Data used to delineate the geomorphic features consisted primarily of various scales, dates, and types of aerial photographs and LANDSAT imagery. Additional data used to identify geomorphic features included historic maps, charts, and surveys and existing subsurface boring logs.

In pursuit of the second objective, a field investigation program was planned to provide detailed paleoenvironmental data at critical locations in the study areas. Subsurface samples were obtained by vibracoring at 31 locations (to depths of 9 meters) and by traditional rotary methods (to depths of 30 meters) at seven sites. Subsequent laboratory analyses of the cores, including characterization of depositional environment, complete x-radiography, biostratigraphic analyses, and radiocarbon dating, are yielding substantial paleoenvironmental data. These data are being integrated with existing data and the geomorphic maps to provide a geomorphic chronology for the evolution of the study areas during the Holocene.

At the present time, the analysis of field and geomorphic mapping data has just begun, with a preliminary draft of the report scheduled for March 1985. Major questions addressed include the following:

- o Is there a buried pre-Teche Holocene Mississippi River meander belt in the Atchafalaya Basin?
- o What are the depositional processes (and related

paleoenvironments) responsible for the Holocene sedimentary filling of the Atchafalaya Basin?

- o What were the processes and chronology of closure of the Atchafalaya Basin during the Holocene?
- o In the last several thousand years, what has been the history of Grand Lake in the Atchafalaya Basin?
- o In the Terrebonne Marsh, what sedimentary cycles exist, and what are their times of formation?
- o Have any of the Teche distributary channels been occupied later by the Lafourche distributaries or the Red River?
- o Is there a pre-Teche Holocene distributary system in the Terrebonne Marsh?
- o What is the origin of the shell ridges in the Terrebonne Marsh?

Answers to these questions have substantial significance to the development of an environmental framework necessary for the comprehensive and cost effective survey of prehistoric cultural resources in the study areas.

#### **SURVEY, MAPPING AND SITE RECONSTRUCTION IN A BLACKWATER ENVIRONMENT: A STUDY IN METHODS**

Mr. Richard J. Anuskiewicz  
MMS, Gulf of Mexico Region

The basic research goals in underwater archaeology are the same as those in terrestrial archaeology: to pursue and document replicable information through the scientific method. The only differences between the two approaches to gathering information are the methods and the working environment. The focus of this paper will be on the development and operationalization of field techniques to survey, map, and

reconstruct a shipwreck site in a blackwater environment. I define blackwater as the total absence of light as a result of suspended particulates, either organic or inorganic, in the water column. Working and conducting research in zero visibility poses some rather unique methodological problems. This paper will recognize and address many of the problems and offer solutions to a problematic approach to doing archaeology in blackwater. A survey, mapping, and site reconstruction model will be presented using the research data generated by the U. S. Army Corps of Engineers, Savannah District, in their intensive study of the sunken Confederate Ironclad, the C. S. S. GEORGIA. The model presented will include the compilation of traditional remote sensing data (i.e., magnetometrics, side-scan sonar, and sub-bottom profiler) with the integration of computer-generated graphics and the three-dimensional grid element contour display of site model bathymetric data.

**INITIAL GEOARCHEOLOGICAL EVALUATION OF THE TEXAS CITY  
CHANNEL SITE (41 GV 81), GALVESTON COUNTY, TEXAS**

Dr. Lawrence E. Aten

National Park Service

Ms. Carolyn Good

U.S. Army Corps of Engineers, Galveston District

Since the early 1900s, the U.S. Army Corps of Engineers has maintained a navigation channel from Texas City southeastward to the centerline of Galveston Bay on the upper Texas coast. This channel has been maintained by repeated dredging operations, creating the disposal bank known as the Texas City dike. For many years collectors have searched the dike for vertebrate fossils resulting in collections numbering thousands of specimens. Recently, examples of fossils have been recognized that appear to have been modified culturally into



various tool-like forms. Determining whether these fossils are artifacts is a complicated taphonomic problem because the site and the materials have had a complex depositional and post-depositional history.

The focus of our ongoing research at the Texas City Channel Site is to identify the details of the locality's geologic history; to evaluate the nature and significance of these tool-like specimens from a cultural perspective; and to determine, among other things, whether such a site has implications for management of cultural resources on the continental shelf. This has entailed developing discriminating criteria for testing the characteristics of tool-like fossils so that a satisfactory conclusion may be drawn about their origin. If the outcome of this investigation supports the cultural nature of these materials, as now seems to be strongly indicated, the Texas City Channel Site (TCC) has major implications for documenting the cultural history of early populations on the northern Gulf Coast.

## THE MATERIALS

We have examined three separate collections totaling approximately 4,000 fossil specimens. Of these, 42 display evidence of cultural modification. In addition, one of the collections included half of a fossil human femur. Lithic material is extremely rare on the dike; no chipped stone and only 3 unmodified pebbles are known to have been collected.

All of the modified fossils except two display convincing evidence that they were altered after they had become fossils. The criteria used to determine modification relate to surface condition; the color, arrangement, and the shape of flake scars; shape and alignments of cut marks, striations, and wear facets; and the relationship of abrasion wear on alternately hard and soft bone surfaces comprising certain specimens, especially teeth.

The physical character of the modified fossils that conform to our present criteria can be synthesized into 8 categories which we are treating as potential form/function classes. These are described below.

(1) Work platforms: flat, sometimes cylindrical bone surfaces usually bearing numerous cut marks oriented predominantly in one direction. (4 specimens).

(2) Unifacial cutting edge tools: usually flat bones unifacially chipped to a low angle bit of about 45 degrees. (4 specimens).

(3) Bifacial cutting edge tools: fossils with narrow but rounded natural edges that are bifacially flaked to create a typical biface cutting edge. (3 specimens).

(4) Incidental cutting tools: analogous to "used flakes"; usually small, naturally sharp fossil bone elements with unpatterned flakes, microflakes, abrasion, and striations along the used edge. (12 specimens).

(5) Bit scrapers: coarse-textured turtle plastron with a well-developed unifacial rasping bit (about 45 degrees); this tool has other wear facets suggesting it was hafted. (1 specimen).

(6) Mandible scrapers: horizontal ramus sections of carnivore and cervid mandibles on which the molar/premolar cusps have been abraded or shattered; high use angles (about 76 degrees). (7 specimens).

(7) Chopping tools: heavy bison metapodial with a wedged bit formed by the convergence of spiral fractures in the mid-section of the shaft; random microflaking occurs along the distal edge. (1 specimen).

(8) Pounding tools: usually an elongate bone or tooth with one end battered and the opposite end smooth. This group includes a hammerstone and pestle-like tools; others may be spent chopping tools. (8 specimens).

Two additional fossil bones appear to have been modified before fossilization and in a manner different from the probable artifacts described above. One was a horse radius that had been "whittled" to thin the compact bone of the shaft which was then snapped in half. The other appears to be a tapir metapodial which has deep V-shaped grooves cut in the center of the shaft and, again, the bone was snapped in half.

At least three separate types of fossilization are represented on the fossil bones we have examined: (1) those with bone replacement plus extensive secondary carbonate deposition; (2) bone replacement only; and (3) both previous types with pyritization as well. We believe that these

correlate with key phases of the locality's geologic history, as will be discussed below. The majority of the tool-like specimens are fossilized either as type 1 or type 3; the human femur and the two bones that appear to have been modified before fossilization are now fossils of type 2.

## THE SITE SETTING

The fossils have been collected from a section several miles long on the Texas City Dike. We have reviewed core logs from several borings made adjacent to the Texas City Channel, and from others made in the southern part of Galveston Bay. These reveal a sequence of deposition that is readily interpretable in terms of the general geologic framework of the bay. This local depositional history begins with a late phase of the Beaumont Formation--a meander belt of probable Farmdalian age (about 25,000 to 30,000 years ago); this is probably the source of the type 1 fossil bones. This zone is overlain by a basal transgressive sand followed by a sequence of marsh and estuarine deposits apparently representing upper bay facies superimposed by middle bay facies.

We have attempted to reconstruct the area's paleogeography at the time of the Pleistocene/Holocene transition by mapping topographic contours from core data on top of both the Beaumont Formation and the Deweyville channel sediments in the Trinity River trench. This indicates that the Texas City Channel is located near the crest of a ridge about 4-5 kilometers west of the large Deweyville-Trinity River floodplain. The ridge was underlain by Farmdalian Beaumont sediments and was deeply incised by ancestral Highland Bayou, a local drainage tributary to the Trinity. Because the Beaumont Formation meanderbelt ridges in the Galveston Bay area frequently are fossiliferous, we assume that the entrenched streams cutting the ridge exposed older fossil deposits that were collected or mined by early man. Because the Galveston Bay area has no indigenous lithic sources for tool manufacture, it is not unusual for alternative materials such as fossil bone to be collected and put to this use.

Although the age at which the ridge would have been submerged by the enlarging bay can be estimated at circa 5,000 to 6,000 years ago, the presence of extinct tapir and horse bones which appear to have been modified before fossilization (while the majority of other bones appear to have been modified long after fossilization) indicates the age of the cultural activity to be on the order of late Pleistocene, or about 13,000 to 10,000 years ago. Pyritization (type 3 fossils) then occurred after the locality was submerged by the advancing bay fringe marshes during the Holocene.

### SITE RELATIONSHIPS

While we have not yet established the TCC Site as of unequivocal archeological origin, the evidence is mounting to the point that it may be contrasted to other sites of comparable age from the region. Three immediately come to mind: Owen, Salt Mine Valley, and McFaddin Beach.

The nature and significance of each of these sites has been reviewed in Aten (1983: 144-152). Briefly, paleogeographic reconstructions indicate that Owen probably reflects hunting camps in the interior woodlands, Salt Mine Valley reflects the coastal zone, and McFaddin Beach and TCC both reflect activities in the interior near the major riverine habitats of that day. These relationships are illustrated below.

< INTERIOR	><	><	><	> COASTAL
< WOODLANDS	><	><	><	> ZONE
		RIVERINE	PRAIRIE?	

---

* Owen Site	* TCC Site	* none known	* Salt Mine
	* McFaddin B.		Valley

This lateral ecological differentiation is probably at least part of the explanation for tool assemblage differences between these early sites. TCC, if it can be verified, contained a diversified processing tool assemblage, not a hunting assemblage, and is unlike those from the other sites.

## SITE IMPLICATIONS

If we assume, as a preliminary matter, that TCC is indeed an archeological site, its significance will be that it enables us to further describe the technological, settlement, and adaptive characteristics of Paleo-Indian cultures along the continental margin. These remain poorly known because of the inaccessibility of their sites which are now submerged or buried, or both. As a result, cultural reconstructions for that period are strongly biased toward concepts of uplands hunting adaptations.

For OCS management, TCC suggests several additional things. First, it provides new Gulf Coast evidence that archaeological sites may survive transgressions in at least some geomorphic situations; this is an excellent illustration of the lithosome preservation model of Belknap and Kraft (1981). Second, it lends support to the importance of searching for buried archeological sites along the valley margins of major floodplains submerged on the continental shelf as is now being done in the Minerals Management Service's submerged Sabine-Neches Valley ground-truth study. And third, the site setting of both TCC and the McFaddin Beach Site suggests the need to give greater attention to subbottom profile data interpretation of the dissected valley margins along major floodplains.

## REFERENCES

Aten, Lawrence E.

1983 Indians of the Upper Texas Coast. Academic Press.

Belknap, D.F. and J.C. Kraft

1981 Preservation Potential of Transgressive Coastal Lithosomes on the U.S. Atlantic Shelf. Marine Geology 42:429-442.

## INDEX TO AUTHORS

	Page
Anthony Amos . . . . .	403
Richard J. Anuskiewicz . . . . .	456
Lawrence E. Aten . . . . .	457
Larry Atkinson . . . . .	397
E. D. Attanasi . . . . .	247
Robert Avent . . . . .	347
Stephen Baig . . . . .	399
James A. Blake . . . . .	374
Nancy Maciolek-Blake . . . . .	374
Charles Blalock . . . . .	276
Arnold H. Bouma . . . . .	363
Arnold H. Bouma . . . . .	412
A. T. Bourgoyne, Jr. . . . .	204
Craig C. Brandt . . . . .	175
Cheryl Bright . . . . .	190
G. Allen Brooks . . . . .	251
James M. Brooks . . . . .	371
Murray Brown . . . . .	169
Murray Brown . . . . .	387
William R. Bryant . . . . .	363
Dennis Chew . . . . .	108
Ralph E. Childers . . . . .	183
James M. Coleman . . . . .	363
Patricia Collins . . . . .	322
Charles Comiskey . . . . .	146
Carroll L. Cordes . . . . .	138
Rezneat Darnell . . . . .	162
Donald W. Davis . . . . .	265
William P. DuBose, IV . . . . .	301
Robert Etkins . . . . .	59
Terrell A. Farmer . . . . .	157
Michael Frankel . . . . .	273
Norman Froomer . . . . .	53
Benny J. Gallaway . . . . .	130
Benny J. Gallaway . . . . .	347
Benny J. Gallaway . . . . .	366
Carolyn Good . . . . .	457
James G. Gosselink . . . . .	95
John Green . . . . .	6
John Gregory . . . . .	199
John Gregory . . . . .	201
Peter Hamilton . . . . .	426
Barbara Hecker . . . . .	380

John Henriksen . . . . .	336
Kurt W. Hess . . . . .	430
Robert R. Hessler . . . . .	354
J. Dickson Hoese . . . . .	114
Troy L. Holcombe . . . . .	186
Jerald Horst . . . . .	339
William E. Howe . . . . .	282
Harley E. Hurlburt . . . . .	425
William Johnstone . . . . .	39
William Johnstone . . . . .	47
James Jones . . . . .	313
Carolita Kallaur . . . . .	45
Joe Karpen . . . . .	181
Herbert Kaufman . . . . .	42
Michael S. Kearney . . . . .	83
Mahlon C. Kennicutt, II . . . . .	371
C. John Klein, III . . . . .	44
Richard Krahl . . . . .	304
Michael A. Krone . . . . .	97
Dana Larson . . . . .	327
Griff C. Lee . . . . .	329
George Lewbel . . . . .	366
David Manuel . . . . .	268
William Martin . . . . .	12
Heyward Mathews . . . . .	318
Hudson Matlock . . . . .	226
George A. Maul . . . . .	428
Evelyn M. Maurmeyer . . . . .	88
Louis McBee . . . . .	28
Rhys McDonald . . . . .	401
K. L. McKee . . . . .	81
I. A. Mendelssohn . . . . .	81
Scott Mettee . . . . .	274
John Mialjevich . . . . .	339
Jerome H. Milgram . . . . .	214
James W. Miller . . . . .	289
Francis J. Mitchell . . . . .	174
DeWitt Myatt . . . . .	314
Walter S. Newman . . . . .	64
Dag Nummedal . . . . .	403
Marshall H. Orr . . . . .	412
James Parrent . . . . .	451
Linda Pequegnat . . . . .	366
Willis E. Pequegnat . . . . .	357
W.S. Perrett . . . . .	123
John Rankin . . . . .	5
Ralph Rayburn . . . . .	127
Villere Reggio, Jr. . . . .	299
Robert C. Rhodes . . . . .	434
James A. Richardson . . . . .	260
John Rodi . . . . .	243
Robert Rogers . . . . .	145

J. E. Rousel . . . . .	.123
Thomas Ryan . . . . .	.454
Richard Scrivener . . . . .	. 18
J. Kevin Shaw . . . . .	.150
Harold P. Sieverding . . . . .	. 22
Walter Sikora . . . . .	.106
Larry Simpson . . . . .	.309
Lawson M. Smith . . . . .	.454
John W. Snedden . . . . .	.403
David M. Soileau . . . . .	.112
Donald Solanas . . . . .	. 26
Melanie Stright . . . . .	.447
Tony Sturges . . . . .	.395
Tom Sullivan . . . . .	.308
Erick M. Swenson . . . . .	. 78
Donald J. P. Swift . . . . .	.412
Hugh Swingle . . . . .	.324
Dan Tabberer . . . . .	.119
Drukell B. Trahan . . . . .	. 76
R. Eugene Turner . . . . .	.121
James R. Tuttle . . . . .	. 73
J. Kim Vandiver . . . . .	.221
Barry Vittor . . . . .	.150
Fred M. Vukovich . . . . .	.398
Evans Waddell . . . . .	.392
Alan J. Wallcraft . . . . .	.414
John T. Wells . . . . .	. 69
E. G. Wermund . . . . .	.284
Carl L. Wickizer . . . . .	.353
William J. Wiseman, Jr. . . . .	.402
Vince Zegowitz . . . . .	.408



## LIST OF ATTENDEES

Ms. Yvonne Abadie CNG Producing Company Operations Dept.  
1 Canal Place, Suite 3100 New Orleans LA 70130

Mr. Ken Adams MMS GOM Regional Office

.

Mr. Rodney Adams Louisiana State University Center for Wetland Resources  
Wetland Resources Bldg. Baton Rouge LA 70803

Mr. Ralph Ainger Minerals Management Service Atlantic Regional Office  
1951 Kidwell Drive Vienna VA 22180

Mr. Rex Alford Conoco Inc. North America Production Dept.  
P.O. Box 2197 Houston TX 77252

Mr. James Allender Chevron Oil Field Research  
P.O. Box 446 La Habra CA 90631

Mr. Alex Alvarado MMS GOM Regional Office

.

Ms. Cheryl Anderson Minerals Management Service Branch of Environmental Studies (MS 644)  
12203 Sunrise Valley Drive Reston VA 22091

Mr. Louis Andrus Oceanonics, Inc. Western Division  
P.O. Box 60692 Houston TX 77205

Mr. Richard J. Anuskiewicz MMS GOM Regional Office

.

Mr. Martin Arhelger Espey, Huston & Assoc., Inc. Environmental Division  
P.O. Box 519 Austin TX 78767

Ms. Lynn Arneson Texas A&M University  
1009 Milner College Station TX 77840

Dr. Lawrence Aten National Park Service Interagency Resources Division  
18th & C Streets, NW Washington DC 20240

Dr. Larry Atkinson Skidaway Inst. of Oceanography  
P.O. Box 13687 Savannah GA 31416

Dr. Emil Attanasi, Ph.D. U.S. Geological Survey Branch of Resource Analysis  
920 National Center Reston VA 22092

Ms. Michele C. Aubry National Park Service Archeological Assistance Division  
Washington DC 20240

Dr. Robert M. Avent MMS GOM Regional Office

.

Mr. Joseph A. Badickino MMS GOM Regional Office

.

Dr. Steve Baig NOAA/NESDIS Satellite Field Services Station  
1320 So. Dixie Highway Coral Gables FL 33146

Mr. Ford A. Bankston Union Oil Co. Gulf Region  
900 Executive Plaza West Houston TX 77027

Mr. Greg Barbier Mobil Oil Corporation Exploration & Producing Division  
1250 Poydras Bldg. New Orleans LA 70113

Mr. Fred Barker Exxon Offshore District Division  
990 N. Corporate Dr. New Orleans LA 70458

Mr. James Barkuloo U.S. Fish & Wildlife Service Ecological Services Division  
1612 June Avenue Panama City FL 32405

Mr. Larry Barrett G-Tech Services Inc.  
3600A Springs Lane Noveross GA 30092

Mr. Jim Barrett Fla. Dept. of Natural Resources  
3900 Commonwealth Blvd. Tallahassee FL 32303

Mr. Bert Bates Sun Exploration & Production Co.  
P.O. Box 8993 Corpus Christi TX 78412

Mr. Robert Boumann Louisiana State University Center for Energy Studies  
Baton Rouge LA 70803

Mr. James Belden Natural Gas Pipeline Co. of America Environmental Affairs Division  
P.O. Box 1269 Lombard IL 60148

Ms. Colleen Benner MMS Atlantic Regional Office  
1951 Kidwell Drive Vienna VA 22180

Mr. M.E. Benson Kerr-McGee Corporation  
P.O. Box 25861 Oklahoma City OK 73125

Mr. Robert Benway National Marine Fisheries Service Atlantic Environmental Group  
RR7, South Ferry Road Narragansett RI 02883

Mr. Robert Bergeron Shell Offshore Inc. Offshore East Division  
P.O. Box 60159 New Orleans LA 70160

Mr. Patrick Bisese Conoco Inc.  
3500 General DeGaulle New Orleans LA 70114

Dr. James A. Blake Battelle New England Laboratory Marine Research Division  
397 Washington St. Duxbury MA 02332

Mr. Charles Blalock Miss. Dept. of Natural Resources  
P.O. Box 20305 Jackson MS 39209

Mr. Greg S. Boland LGL Ecological Research Assoc.  
1410 Cavitt Street Bryan TX 77801

Mr. Clell L. Bond Espey, Huston & Assoc., Inc.  
P.O. Box 519 Austin TX 78767

Dr. Herbert Boschung University of Alabama Dept. of Biology  
P.O. Box 1927 University AL 35486

Ms. Pamela Boumer LA Dept. of Wildlife & Fisheries Seafood Division  
P.O. Box 15570 Baton Rouge LA 70895

Dr. A.T. Bourgoyne Louisiana State University Petroleum Engineering Dept.  
3523 CEBA Baton Rouge LA 70803

Mr. Duane Bradford FLA Dept. of Natural Resources Education Information Division  
3900 Commonwealth Blvd. Tallahassee FL 32301

Mr. Paul Bradley U.S. Army Corps of Engineers Mobile District  
P.O. Box 2288 Mobile AL 36628

Mr. Craig Brandt Science Applications Inc. Environmental Sciences Division  
Jackson Plaza Tower Oak Ridge TN 37830

Mr. Jerry Brashier MMS GOM Regional Office  
.

Ms. Cheryl Bright Smithsonian Institution U.S. National Museum of Natural History/Worms Div.  
Washington DC 20560

Mr. Matt Brineman Amerada Hess Corp. Offshore Drilling Division  
1100 Milam, 6th Floor Houston TX 77002

Mr. Del Britsch Waterways Experiment Station/COE Coastal Engineering Research Center  
P.O. Box 631 Vicksburg MS 39180

Mr. Autry Britton MMS GOM Regional Office  
.

Dr. David Brooks Texas A&M University Dept. of Oceanography  
College Station TX 77843

Dr. James M. Brooks Texas A&M University Dept. of Oceanography  
College Station TX 77843

Mr. G. Allen Brooks Offshore Data Services, Inc.  
3346 Walnut Bend Houston TX 77024

Mr. Larry Brown Amoco Reg. Facilities Division  
P.O. Box 50879 New Orleans LA 70058

Ms. Karen Brown MMS GOM Regional Office

Dr. Murray Brown MMS GOM Regional Office

CDR. Roger A. Brunell U.S. Coast Guard 8th District  
500 Camp Street New Orleans LA 70053

Mr. William Bryant Texas A&M University Dept. of Oceanography  
College Station TX 77840

Dr. Ernest L. Burdette Triton Systems, Inc.  
P.O. Box 291 Bay St. Louis MS 39520

Mr. Mike Burdette NOAA/National Weather Service  
1120 Old Spanish Trail Slidell LA 70458

Mr. John A. Burgbacher Shell Offshore Inc. Offshore West Division  
P.O. Box 60149 New Orleans LA 70065

Mrs. Lynne B. Burke Sport Fishing Institute Artificial Reef Development Center  
1010 Massachusetts Ave. NW, Suite 100 Washington DC 20001

Dr. Christian J. Byrne University of New Orleans Center for Bio-Organic Studies  
Lakefront New Orleans LA 70148

Dr. Edwin W. Coker, Jr. Gulf Coast Research Laboratory Oyster Biology Section  
P.O. Box AG Ocean Springs MS 39564

Mr. Douglas Cameron Texas A&M University  
P.O. Box 2376 College Station TX 77841

Dr. Robert S. Carney Moss Landing Marine Lab  
2382 45th Ave. San Francisco CA 94116

Dr. Semoon Chang University of South Alabama Dept. of Economics  
Mobile AL 36688

Dr. Raymond Chapman Offshore & Coastal Technology, Inc.  
911 Clay Street Vicksburg MS 39180

Dr. Brian Chapman Corpus Christi State University Dept. of Biology  
Corpus Christi TX 78412

Mr. Dennis Chew U.S. Army Corps of Engineers Planning Div. Environmental Analysis Branch  
P.O. Box 60267 New Orleans LA 70160

Mr. Ralph E. Childers Ralph Childers Associates  
554 Lanecrest Houston TX 77024

Dr. Sherman Chiu SOHIO Petroleum Co. Technology Center  
5400 LBJ Freeway, Suite 1200 Dallas TX 75240

Mr. Fred J. Christadore Texaco Inc.  
P.O. Box 60252 New Orleans LA 70361

Mr. Richard Christian Texas A&M University Recreation & Parks Division  
3205 Crane Bryan TX 77801

Mr. Joe Christopher MMS GOM Regional Office  
.

Mr. Darryl Clark LA Dept. of Natural Resources Coastal Management Division  
P.O. Box 44124 Baton Rouge LA 70804

Ms. Peggy Cleary Chevron USA Production Division  
935 Gravier Street New Orleans LA 70118

Mr. Hubert Clotworthy Texaco Inc.  
P.O. Box 60252 New Orleans LA 70160

Mr. John Cochrane Texas A&M University Dept. of Oceanography  
College Station TX 77843

Dr. James Coleman Louisiana State University Coastal Studies Institute  
Baton Rouge LA 70803

Ms. Pat Collins Sports Fishing Institute Artificial Reef Development Center  
2037 Huidekoper PL N.W. Washington DC 20007

Dr. Charles Comiskey Science Applications Inc. Environmental Sciences Division  
800 Oak Ridge Turnpike Oak Ridge TN 37830

Mr. Barney Congdon MMS GOM Regional Office

Mr. David W. Connolly Texas Engineering Experiment Station  
700 Strand, Room 204 Galveston TX 77550

Mr. William Cook Minerals Management Service OCS Information Program Division  
12203 Sunrise Valley Drive Reston VA 22091

Dr. David Cook Raytheon Service Co.  
Hammarlund Way, Technology Plaza III Middletown RI 02840

Mr. Richard Cooke U.S. Coast Guard Eighth District Aids to Navigation Branch  
500 Camp St. New Orleans LA 70458

Mr. Cort Cooper Conoco Oil Co.  
8377 RDM Ponca City OK 74602

Dr. Carroll Cordes U.S. Fish & Wildlife Service National Coastal Ecosystems Team  
1010 Gause Boulevard Slidell LA 70458

Mr. David Cramer Texaco Inc. Southern Exploration Division  
P.O. Box 60252 New Orleans LA 70361

Mr. Bill Crow ARCO Exploration Company Technology Services Division  
P.O. Box 2819 Dallas TX 75240

Dr. G.T. Csanady Woods Hole Oceanographic Institution  
Woods Hole MA 01563

Mr. Joe Culp Texaco Inc.  
P.O. Box 60252 New Orleans LA 70160

Mr. Rob Cunningham Louisiana State University Center for Wetland Resources  
Baton Rouge LA 70803

Dr. Michael Dagg LUMCON  
Star Route Box 541 Chauvin LA 70344

Dr. Larry Danek Environmental Science & Engineering  
Box ESE Gainesville FL 32602

Mr. Michael Dardeau Dauphin Island Sea Lab  
P.O. Box 369 Dauphin Island AL 36528

Dr. Reznat M. Darnell Texas A&M University Dept. of Oceanography  
College Station TX 77843

Mr. Earl Dauterive ARCO Oil & Gas Co. Environmental & Safety Division  
P.O. Box 51408 Lafayette LA 70505

Mr. Les Dauterive MMS GOM Regional Office  
.

Dr. Donald Davis Nicholls State University Dept. of Earth Science  
P.O. Box 2189 Thibodaux LA 70301

Mr. Pete Debogory Barnett & Casbarian, Inc.  
3129 Edenborn Ave. Metairie LA 70002

Dr. Paul Debrule Science Applications Inc.  
P.O. Box 509 Newport RI 02840

Ms. Monica Defenbaugh  
4708 Chastant Street Metairie LA 70006

Dr. Richard Defenbaugh MMS GOM Regional Office  
.

Mr. Paul S. DeKernion DeKernion Consulting  
P.O. Box 9372 Metairie LA 70055

Mr. John M. Denton Mobil Oil Corp. E&P Division  
1250 Poydras New Orleans LA 70113

Mr. Omar Dewald MMS GOM Regional Office  
.

Dr. Robert B. Ditton Texas A&M University Dept. of Recreation and Parks  
College Station TX 77843

Ms. Barbara Donnell U.S. Army Corps of Engineers Waterways Experiment Station  
P.O. Box 631 Vicksburg MS 39180

Mr. Marvin Drake U.S. Army Corps of Engineers Engineering Division/Hydraulics & Hydrology Br.  
P.O. Box 60267 New Orleans LA 70160

Mr. William P. DuBose IV National Ocean Industries Assn.  
1050 17th St., N.W., Suite 700 Washington DC 20036

Mr. Spencer Dulaney U.S. Army Corps of Engineers New Orleans District  
P.O. Box 60267 New Orleans LA 70160

Mr. Fred Dunham LA Dept. of Wildlife & Fisheries Ecological Studies Division  
P.O. Box 15570 Baton Rouge LA 70895



Mr. Doug Elvers MMS GOM Regional Office

Ms. Beverly Ethridge EPA  
345 Courtland Street Atlanta GA 30365

Mr. Robert Etkins NOAA  
11400 Rockville Pike, Rm 108 Rockville MD 20852

Ms. Jerri Evander Texas A&M University  
P.O. Box 680 College Station TX 77841

Mr. Robert Evangelisti SOHIO Petroleum Company  
P.O. Box 4587 Houston TX 77210

Mr. James C. Evans ODECO Enviro & Govt. Affairs Division  
P.O. Box 61780 New Orleans LA 70161

Mr. Robert Fajkowski Superior Oil Co. OCS Division  
P.O. Box 4100 The Woodlands TX 77380

Mr. Terry Farmer Quantus Inc.  
800 Oak Ridge Turnpike Oak Ridge TN 37830

Mr. Roy Faulk John E. Chance & Associates Regulatory & Environmental Division  
122 Nickerson Parkway Lafayette LA 70501

Mr. Maury Ferguson Texas Parks and Wildlife Coastal Fisheries Division  
4200 Smith School Road Austin TX 78744

Dr. Marion Fischel Shell Oil Company Environmental Affairs Dept.  
P.O. Box 4320 Houston TX 77210

Mr. Max Flandorfer Miss.- Ala. Sea Grant Consortium  
Gulf Coast Research Lab Ocean Springs MS 39564

Mr. Timothy Flynn Aero-Marine Surveys, Inc.  
P.O. Drawer 1230 New London CT 06320

Mr. Jerry Ford Florida A&M University College of Eng.Sci., Tech. & Agriculture  
P.O. Box 338 Tallahassee FL 32307

Dr. Wayne Forman Freeport Sulphur Company Environmental Services Division  
P.O. Box 61520 New Orleans LA 70161

Dr. George Forristall Shell Development  
P.O. Box 481 Houston TX 77001

Mr. Michael Frankel Centaur Assoc.  
1120 Connecticut Ave. Rm. 465 Washington DC 20036

Mr. Jim Franks Miss. Bureau of Marine Resources Scientific/Statistical Division  
P.O. Drawer 959 Long Beach MS 39560

Dr. Carolyn French MMS GOM Regional Office  
.

Dr. William R. Freudenburg Denver University Dept. of Sociology  
Denver CO 80208

Mr. Ed. Friedman Minerals Management Service Branch of Environ. Management Offshore  
600 National Center Reston Virginia 22092

Mr. Raymond L. Fritz U.S. Fish & Wildlife Service Ecological Services Division  
Washington DC 20240

Dr. Norman Froomer MMS GOM Regional Office  
.

Ms. Laura Gabanski MMS GOM Regional Office  
.

Dr. Sherwood M. Gagliano Coastal Environments, Inc.  
1260 Main St. Baton Rouge LA 70802

Dr. Benny J. Galloway LGL Ecological Research Associates  
1410 Cavitt Street Bryan TX 77801

Mr. Bradley W. Gane Alabama Dept. of Enviro. Management Mobile Field Office  
4358 Midmost Drive Mobile AL 36609

Dr. Ervan G. Garrison Texas A&M University Environmental Engineering Dept.  
College Station TX 77843

Mr. Floyd Garrot Exxon Corp. Southeastern Production Division  
P.O. Box 60626 New Orleans LA 70160

Dr. Donald Gartman Columbia Gas System Environmental Affairs Division  
20 Montchanin Road Wilmington DE 19807

Ms. Susan Gaudry MMS GOM Regional Office  
.

Mr. Ivan D. Geddie Kerr-McGee Corp. Oil & Gas Division  
P.O. Box 25861 Oklahoma City OK 73125

Mr. Al Gentry Conoco Inc. Production Division  
P.O. Box 2197 Houston TX 77252

Mr. Keith German CNR Producing Co.  
One Canal Place, Suite 3100 New Orleans LA 70130

Mr. Gerald Gilbert Exxon Company USA Southeastern Production Division  
P.O. Box 60626 New Orleans LA 70160

Dr. Gene Gonsoulin Southern Natural Gas  
P.O. Box 2563 Birmingham AL 35202

Ms. Cornelia Good University of New Orleans Urban Regional Planning Dept.  
Lakefront New Orleans LA 70148

Ms. Carolyn Good U.S. Army Corps of Engineers Galveston District/SWGED-E  
P.O. Box 1229 Galveston TX 77550

Mr. John Gosdin State of Texas Office of the Governor  
P.O. Box 13564 Austin TX 78711

Dr. James Gosselink Louisiana State University Center for Wetland Resources  
Baton Rouge LA 70803

Mr. Ken Graham MMS GOM Regional Office  
.

Dr. Frederick J. Grassle Woods Hole Oceanographic Institution Deep Ocean Search & Survey Dept.  
P.O. Box 373 Woods Hole MA 02543

Mr. John Green Gulf of Mexico Fishery Management Council  
P.O. Box 2095 Beaumont TX 77704

Mr. John B. Gregory Minerals Management Service Technology Assessment and Research Branch  
647 National Center (MS 647) Reston VA 22091

Ms. Lynn F. Griffin FLA. Dept. of Environmental Regulations Division of Permitting  
2600 Blair Stone Rd. Twin Towers Office Bldg. Tallahassee FL 32301

Dr. Thomas A. Grigalunas University of Rhode Island Department of Resource Economics  
Kingston RI 02881

Dr. Charles G. Groat Louisiana Geological Survey  
P.O. Box G, University Station Baton Rouge LA 70893

Mr. David Groce Texaco Southern Exploration Division  
P.O. Box 60252 New Orleans LA 70160

Mr. Charlie Guice MMS GOM Regional Office

Mr. Vince Guillory LA Dept. of Wildlife & Fisheries Seafood Division  
P.O. Box 37 Grand Isle LA 70358

Mr. W.F. Guy Union Oil Co. Corporate Enviro. Sciences Division  
P.O. Box 7600 Los Angeles CA

Mr. Dale Hall U.S. Fish & Wildlife Service Ecological Services Division  
17629 El Camino Real, Suite 211 Houston TX 77058

Dr. Peter Hamilton Science Applications, Inc.  
4900 Water's Edge Drive Raleigh NC 27606

Dr. Gregory Han General Oceanics, Inc.  
1295 NW 163 St. Miami FL 33169

Mr. Max Hancock National Park Service Padre Island National Seashore  
9405 S Padre Island Dr. Corpus Christi TX 78418

Mr. Larry Handley MMS GOM Regional Office

Dr. Donald E. Harper Texas A&M University Marine Laboratory  
Fort Crockett Galveston TX 77550

Dr. Harold Harry  
4612 Evergreen Street Belleire TX 77401

Mr. David Hart University of New Orleans School of Urban & Regional Studies  
Lakefront New Orleans LA 70148

CDR. Chas. R. Havnen U.S. Coast Guard Marine Safety Division  
500 Camp Street New Orleans LA 70130

Mr. John W. Haycock Gulf Oil Corp. South & East Offshore Division  
P.O. Box 31590 New Orleans LA 70161

Dr. Stan Hecker Miss.- Ala. Sea Grant Consortium  
Gulf Coast Research Lab Ocean Springs MS 39564

Dr. Barbara Hecker Lamont - Doherty Geological Observatory  
Palisades NY 10964

Mr. Hosseion Hekmatdoost MMS GOM Regional Office

Mr. Ken Heldebrandt ARCO Oil & Gas Co.  
P.O. Box 2819/Dob 29-092 Dallas TX 75221

Mr. James Helic  
3900 Lake Trail Drive Kenner LA 70065

Mr. George E. Henderson Florida Dept. of Natural Resources Bureau of Marine Research  
100 8th Ave., St. Petersburg FL 33701

CDR John Henriksen Department of Defense Ocean Policy Division  
Office of the Secretary of Defense ISA/PA Washington DC 20301

Mr. Larry Henry Gulf Oil Exploration & Production South & East Offshore Division  
1515 Poydras St. New Orleans LA 70112

Ms. Marietta Herr League of Women Voters  
59 Oriole Street New Orleans LA 70124

Mr. Lew Herrin Amoco Production Company  
1340 Poydras St. New Orleans LA 70113

Mr. David Herrington National Park Service Division of Energy, Mining, & Minerals  
P.O. Box 1114 Denver CO 80757

Dr. Kurt W. Hess NOAA/NESDIS Code E/A13  
3300 Whitehaven St., Rm. 162 Washington DC 20235

Dr. Robert Hessler Scripps Institution of Oceanography  
La Jolla CA 92093

Mr. Preston Hickman Louisiana Land & Exploration Co. Drafting Dept.  
225 Baronne St., Suite 600 New Orleans LA 70160

Mr. Charles Hill MMS GOM Regional Office  
.

Mr. Theodore Hoehn State of Florida Dept. of Environmental Regulation  
Twin Towers, Blair Stone Road Tallahassee FL 32301

Dr. H. Dickson Hoese U of Southwestern Louisiana Dept. of Biology  
Lafayette LA 70501

Mr. Troy Holcombe National Geophysical Data Center Marine Division, Code E/6C3  
325 Broadway Boulder CO 80303

Dr. Charles W. Holmes U.S. Geological Survey Corpus Christi Lab  
P.O. Box 6732 Corpus Christi TX 78411

Mr. Jack Holt MMS GOM Regional Office

.

Mr. Jerald Horst LA Cooperative Extension Service  
1825 Bonnie Ann Dr. Marrero LA 70072

Mr. C. James Houlder, Jr. Texaco USA New Orleans Operations Division  
P.O. Box 60252 New Orleans LA 70160

Mr. Wesley Housholder Exxon Co., USA Production Division  
P.O. Box 60626 New Orleans LA 70160

Mr. Bill Howard Mississippi State University Sociology Dept.  
Rt. 5, Box 273 Columbus MS 39701

Dr. Norman Howden Louisiana State University Coastal Information Repository  
Baton Rouge LA 70803

Mr. William Howe LA Dept. of Natural Resources Division of State Lands  
P.O. Box 44396 Baton Rouge LA 70804

Ms. Dianne Hunt Miss. Bureau of Marine Resources Wetlands Division  
P.O. Drawer 959 Long Beach MS 39560

Dr. Harley Hurlburt NORDA Modelling Branch, Code 323  
NSTL Station MS 39529

Ms. Patricia Ice Texaco New Orleans Division  
P.O. Box 60252 New Orleans LA 70160

Mr. F. Dewayne Insand U.S. Army Corps of Engineers Planning Division  
P.O. Box 2288 Mobile AL 36628

Mr. Bill Jamieson Cities Service Oil & Gas Corp. Regulatory Division  
P.O. Box 27570 Houston TX 77227

Mr. Terence Jernigan State of Florida Resource Management Division  
2571 Executive East Tallahassee FL 32301

Ms. Bonnie Johnson MMS GOM Regional Office

.

Mr. Harland Johnson Exxon Company USA  
P.O. Box 60626 New Orleans LA 70160

Mr. Bill Johnstone MMS GOM Regional Office

.

Mr. A.B. Jones Texaco Inc. Offshore Operations Division  
400 Poydras New Orleans LA 70160

Dr. Robert S. Jones University of Texas Marine Science Institute  
Port Aransas TX 78373

Dr. James Jones Miss. - Ala. Sea Grant Consortium  
Caylor Building Ocean Springs MS 39564

Mr. Randall Jones Shell Offshore Inc.  
P.O. Box 60159 New Orleans LA 70160

Mr. Mike Joseph MMS GOM Regional Office  
.

Ms. Carolita Kallour Minerals Management Service Offshore Minerals Management Directorate  
12203 Sunrise Valley Drive Reston VA 22091

Mr. Joe Karpen Science Applications International, Inc.  
4900 Water's Edge Dr. Raleigh NC 27606

Mr. Herb Kaufman NOAA/Office of Ocean & Coastal Res. Mgt. Sanctuary Programs Division  
3300 Whitehaven St., N.W.e Washington DC 20235

Dr. Michael Kearney University of Maryland Dept. of Geography  
College Park MD 20742

Dr. Walter R. Keithly Louisiana State University Coastal Fisheries Institute  
Baton Rouge LA 70803

Mr. Bob Kelly MMS GOM Regional Office  
.

Lt. Col. Ronald Kelsey U.S. Army Corps of Engineers Attn. CWO-R  
20 Massachusetts Ave., NW Washington DC 20314

Dr. Chuck Kennicutt Texas A&M University Dept. of Oceanography  
College Station TX 77843

Mr. Ronald Kenyon U.S. House of Representatives OCS Subcommittee  
House Annex #2 Rm. 542 Washington DC 20515

Dr. Edwin Keppner National Marine Fisheries Service Environmental Assessment Branch  
3500 Delwood Beach Road Panama City FL 32407

Mr. Wayne Kewley Conoco Inc.  
3500 General de Gaulle Dr. New Orleans LA 70114

Mr. Timothy Killeen LA Dcpt. of Wildlife & Fisheries Seafood Division  
400 Royal Street New Orleans LA 70121

Dr. James B. Kirkwood U.S. Fish & Wildlife Service Technical Services Division  
75 Spring St., SW Atlanta GA 30303

Mr. John Klein NOAA-Ocean Assessments Code N-DMS-31  
11400 Rockville Pike, Rockwall Bldg. Rockville MD 20852

Mr. Richard Krahl Minerals Management Service Offshore Operations Division  
12203 Sunrise Valley Drive Reston VA 22091

Mr. Michael Krone United Gas Pipe Line Co.  
P.O. Box 1478 Houston TX 77001

Mr. Allan Y. Kwok Racal-Decca Survey, Inc.  
10401 Westoffice Drive Houston TX 77042

Mr. Robert LaBelle Minerals Management Service Code 644  
US Geological Survey/National Center, MS 644 Reston VA 22092

Dr. Cornell Ladner Miss. Bureau of Marine Resources  
P.O. Drawer 959 Long Beach MS 39560

Ms. Lynn Lahare MMS GOM Regional Office  
.

Mr. David Lakin Exxon Co. USA Public Affairs Division  
P.O. Box 60626 New Orleans LA 70160

Mr. Wilson Lomb Exxon Production Research Co.  
P.O. Box 2189 Houston TX 77001

Mr. J.C. Landry, Jr. John E. Chance & Associates  
P.O. Box 52029 Lafayette LA 70505

Mr. Jim Lane Minerals Management Service Atlantic OCS Regional Office  
1951 Kidwell Drive Vienna VA

Ms. Carla Langley MMS GOM Regional Office  
.

Mr. Paul Lankford Anadarko Production Company  
16801 Greenspoint Park Drive Houston TX 77060

Mr. Dana Larson Exxon Co., USA Exploration Division  
P.O. Box 4279 Houston Texas 77210



Dr. Anthony Lasko City of New Orleans City Planning Commission  
9 W City Hall New Orleans LA 70112

Mr. Ralph Latapie LA Dept. of Wildlife & Fisheries Seafood Division  
400 Royal Street New Orleans LA 70130

Dr. Stephen Leathermon University of Maryland Dept. of Geography  
College Park MD 20742

Mr. Francis LeBlanc Exxon Co. USA Southeastern Production Division  
P.O. Box 60626 New Orleans LA 70160

Mr. Donald R. LeBlanc Tenneco Oil Co. Eastern Gulf Division  
P.O. Box 39200 Lafayette LA 70503

Mr. David J. LeBlanc Texaco  
P.O. Box 60252 New Orleans LA 70160

Mr. Griff C. Lee Griff Lee Inc.  
P.O. Box 70787 New Orleans LA 70172

Mr. James H. Lee U.S. Dept of the Interior Office of Environmental Project Review  
75 Spring St., SW, Suite 1360 Atlanta GA 30303

Dr. Thomas Lee University of Miami Rosenstil School  
4600 Rickenbacker Causeway Miami FL 33149

Mr. Jake Lehman NMS GOM Regional Office

Mr. Rowdy Lemoine Louisiana Geological Survey  
1534 Court St., Lot 12 Port Allen LA 70767

Dr. George L. Lewbel LGL Ecological Research Assoc., Inc.  
1410 Cavitt Street Bryan TX 77801

Mr. Barry Lewis University of Illinois Department of Anthropology  
109 Davenport Hall, 607 S. Matthews Ave. Urbana IL 61801

Dr. James K. Lewis Science Applications, Inc.  
2902 Lodgepole College Station TX 77840

Mr. Joel Lindsey LA. Dept. of Natural Resources Coastal Management Division  
P.O. Box 1654 Baton Rouge LA 70802

Ms. Dianne Lindstedt Louisiana Geological Survey OCS Division Newsletter  
P.O. BOX 6 Baton Rouge LA 70893

Mr. Thomas Lubbert National Park Service Big Thicket National Preserve  
P.O. Box 7408 Beaumont TX 77706

Mr. Ron Lukens Miss. Sea Grant Advisory Service  
4646 W. Beach Blvd., Suite 1-E Biloxi MS 39564

Mr. Charles H. Lutz Dauphin Island Sea Lab  
P.O. Box 369 Dauphin Island AL 36528

Mr. Christopher Lynch Rogers, Golden & Halpern  
11872-0 Sunrise Valley Drive Reston VA 22091

Mr. Michael Lyons Mid-Continent Oil & Gas Louisiana Division  
333 Laurel St., Suite 740 Baton Rouge LA 70801

Dr. Julia Lytle Gulf Coast Research Laboratory Chemistry Section  
P.O. Box AG Ocean Springs MS 39564

Dr. Thomas F. Lytle Gulf Coast Research Laboratory Chemistry Section  
P.O. Box AG Ocean Springs MS 39564

Mr. Gary Mancuso ODECO Environment & Govt Affairs Division  
P.O. Box 61780 New Orleans LA 70161

Mr. Carl Mangus Shell Offshore Inc. Regulatory Affairs Division  
P.O. Box 60124 New Orleans LA 70160

Mr. Brandt Mannchen Houston Sierra Club Conservation Committee  
1822 Richmond #2 Houston TX 77098

Dr. David Manuel University of Southwestern Louisiana Dept. of Economics and Finance  
P.O. Box 40067 Lafayette LA 70504

Mr. Bill Martin NMS GOM Regional Office  
.

Mr. Jim Martin Mobile Oil Expl. & Prod., SE Inc.  
1250 Paydras New Orleans LA 70113

Dr. Heward Mathews St. Petersburg Junior College Biology Dept.  
2465 Drew St. Clearwater FL 33575

Mr. Hudson Matlock Earth Technology Corporation  
3777 Long Beach Blvd. Long Beach CA 90807

Dr. George A. Maul NOAA Atlantic Oceano. & Met. Lab.  
4301 Rickenbacker Causeway Miami FL 33149

Dr. Evelyn Mourmeyer Coastal & Estuarine Research Inc.  
P.O. Box 674 Lewes DE 19958

Mr. Louis McBee MMS GOM Regional Office

Mr. Tim McCarty U.S. Coast Guard Port Safety Branch  
500 Camp Street New Orleans LA 70130

Mr. Roger McChesney John E. Chance & Associates Marketing Division  
P.O. Box 52029 Lafayette LA 70505

Ms. Bethlyn McCloskey  
5113 Bissonet Dr. Metairie LA 70003

Mr. Rhys McDonald Brown & Caldwell Marine Sciences Division  
P.O. Box 8045 Walnut Creek CA 94596

Mr. Don McGregor Exxon Co. USA Gulf-Atlantic Division  
P.O. Box 4279 Houston TX 77060

Ms. Beth McKenzie Walk, Haydel & Associates  
600 Carondelet Street New Orleans LA 70130

Mr. Terry McMillin Marathon Oil Co. Offshore Division  
P.O. Box 3128 Houston TX 77253

Mr. Don McQuillen Oceanonics Inc. Geophysical Division  
16710 Hedgecraft Street Houston TX 77060

Dr. Irving Mendelsohn Louisiana State University Center for Wetland Resources  
Baton Rouge LA 70803

Dr. Scott Mettee Alabama Geological Survey Environmental Division  
P.O. Drawer 0 University AL 35486

Dr. Jerome Milgram Mass. Institute of Technology Dept. of Ocean Engineering  
77 Massachusetts Ave. Cambridge MA 02139

Dr. James W. Miller Florida Institute of Oceanography  
830 First Street, South St. Petersburg FL 33701

Mr. David Miller Exxon USA Southeastern Division  
P.O. Box 60626 New Orleans LA 70160

Dr. Thomas J. Minello NOAA National Marine fisheries Service  
4700 Avenue U Galveston TX 77550

Mr. Mike Mire Shell Offshore Inc. Offshore East Division  
P.O. Box 60159 New Orleans LA 70160

Dr. Jim Mitchell NORDA Remote Sensing Branch  
NSTL Station MS 39529

Mr. Francis Mitchell NOAA National Ocean Data Center  
2001 Wisconsin Ave. Washington DC 20235

Mr. Thomas Mitchell ARCO Oil & Gas Co.  
P.O. Box 2819, DAB 30-058 Dallas TX 75075

Mr. Frank Monteferrante LA Dept. of Natural Resources Coastal Management Division  
P.O. Box 44124 Baton Rouge LA 70804

Mr. Donald Moore NOAA/NMFS Environmental Assessment Branch  
4700 Avenue U Galveston TX 77550

Mr. Tim Morton John E. Chance & Associates Regulatory & Environmental Division  
P.O. Box 52029 Lafayette LA 70510

Mr. C.R. Moxley Gulf Oil Co. E&P Division  
P.O. Box 2100 Houston TX 77252

Mr. Allan J. Mueller U.S. Fish & Wildlife Service Ecological Services Division  
17629 El Camino Real, Suite 211 Houston TX 77058

Mr. Bill Musser Environmental Protection Agency OWEP (WH-556)  
401 M Street, S.W. Washington DC 20460

Mr. DeWitt Myatt Sport Fishing Institute Artificial Reef Development Center  
6711 N.W. 25th Way Ft. Lauderdale FL 33309

Mr. James Myers Exxon Co. USA Southeastern Production Division  
P.O. Box 60626 New Orleans LA 70160

Mr. George Neusoenger National Park Service Jean Lafitte National Park  
423 Canal Street New Orleans LA 70130

LCDR Frederick V. Newman Jr. U.S. Coast Guard Port Safety Branch  
500 Camp Street New Orleans LA 70130

Dr. Walter Newman Queens College, City University of NY Dept. of Geology  
Flushing NY 11367

Mr. Jack Newton Texaco USA Exploration Division  
P.O. Box 60252 New Orleans LA 70160

Ms. Cynthia Nicholson MMS GOM Regional Office

\*

Dr. Dag Nummedal Louisiana State University Dept. of Geology  
Baton Rouge LA 70803

Ms. Lori Nunn Louisiana Geological Survey  
P.O. Box G University Station Baton Rouge LA 70893

Mr. Art Oberhoffer Synergetics International, Inc.  
3959 Pender Dr., Suite 108 Fairfax VA 22030

Ms. Lizonabah Oetinger  
P.O. Box 336 Mississippi State MS 39762

Mr. Gayle Oglesby Superior Oil Co. Offshore Division  
P.O. Box 4100 The Woodlands TX 77380

Mr. Robert Oja Continental Shelf Associates  
P.O. Box 2267 Galveston TX 77553

Mr. Warren Olds Jr. U.S. Fish & Wildlife Service Habitat Resources Section  
75 Spring Street SW Atlanta GA 30303

Mr. Bill Olewinski LA Dept. of Natural Resources Office of Conservation  
P.O. Box 44275 Baton Rouge LA 70804

Mr. Mike Ong MMS GOM Regional Office

\*

Dr. Marshall H. Orr SOHIO Technology Data Center  
5400 LBJ Freeway, Suite 1200 Dallas TX 75240

Ms. Denise Ostendorf Shell Offshore Inc. Offshore East Division  
P.O. Box 60159 New Orleans LA 70160

Mr. Bennett Padgett National Weather Service  
1180 Old Spanish Trail Slidell LA 70458

Mr. James M. Parrent MMS GOM Regional Office

\*

Mr. James Parrish MMS GOM Regional Office

\*

Mr. L.W. Patterson Tenneco Inc. Environmental Affairs Engineering  
P.O. Box 2511 Houston TX 77001

Mr. Perry Pawlyk Louisiana State University Center for Wetland Resources  
Baton Rouge LA 70803

Mr. J. Rogers Percy MMS GOM Regional Office

Dr. Charles Pearson Coastal Environments, Inc.  
1260 Main Street Baton Rouge LA 70802

Dr. Ed Pendleton U.S. Fish & Wildlife Service National Coastal Ecosystems Team  
1010 Gause Blvd. Slidell LA 70458

Dr. Willis E. Pequegnat  
P.O. Box 2848 College Station TX 77841

Dr. Linda H. Pequegnat  
P.O. Box 2848 College Station TX 77841

Mr. William Perret La. Dept. of Wildlife & Fisheries  
P.O. Box 15570 Baton Rouge LA 70895

Mr. Roy Pettus Intersea Research Corp.  
11760 Sorrento Valley Rd. San Diego CA 92121

Ms. Joan Phillips Sierra Club Wetland Committee  
922 Octavia Street New Orleans LA 70115

Mr. Glen Pilie Adams & Reese  
4500 One Shell Square New Orleans LA 70139

Dr. Fred Piltz Minerals Management Service Environmental Studies Section  
1340 W Sixth Street Los Angeles CA 90017

Mr. R.M. Pitcher Exxon Co. USA Southeastern Production Division  
P.O. Box 60626 New Orleans LA 70160

Mr. Ed Pribyl Shell Western Exploration & Production Onshore East Division  
P.O. Box 61555 New Orleans LA 70160

Mr. Larry Pugh NOAA/N/MPP Marine Pollution Program Office  
11400 Rockville Pike Rockville MD 20852

Mr. Jim Quigel Cities Service Oil Co.  
P.O. Box 27570 Houston TX 77227

Mr. Tom Raabe Gulf Oil Corp. Production Division  
1515 Poydras New Orleans LA 70160

Dr. Nancy N. Rabalais LUMCON  
Star Route, Box 541 Chauvin LA 70344

Ms. Gail Rainey MMS Office of Environmental Project Review  
18th & C St., NW Washington DC 20240

Mr. John Rankin MMS GOM Regional Office  
.

Dr. Jim Ray Shell Oil Co. Environmental Affairs Division  
P.O. Box 4320 Houston TX 77210

Mr. Ralph Rayburn Texas Shrimp Association  
403 Vaughn Bldg. Austin TX 78701

Mr. Michael F. Royle Steimle and Assoc.  
P.O. Box 865 Metairie LA 70004

Mr. D.W. Reed Shell Offshore Inc. Frontier Production Group  
One Shell Square New Orleans LA 70160

LTJg Daphne Reese U.S. Coast Guard Navigation Division G-NSR  
2100 2nd St., SW Washington DC 20593

Mr. Villere Reggio MMS GOM Regional Office  
.

Ms. Janet Reinhardt MMS GOM Regional Office  
.

Dr. Larry Reitsema Newpark Resources Inc.  
4615 Southwest Freeway, Suite 830 Houston TX 77027

Mr. Don Resio Offshore Coastal Technology Inc.  
911 Clay Street Vicksburg MS 39180

Dr. Richard Rezak Texas A&M University Dept. of Oceanography  
College Station TX 77843

Mr. Bob Rhodes Jaycor, Inc. Modelling Branch, Code 323  
NSTL Station MS 39529

Mr. Phillip B. Ribbeck Amoco Production  
P.O. Box 50879 New Orleans LA 70150

Dr. Ted Rice NMFS Beaufort Laboratory  
Beaufort NC 28516

Mr. Jon Richards Exxon Co. USA Southeastern Division  
P.O. Box 60626 New Orleans LA 70160

Dr. James Richardson Louisiana State University Dept. of Economics  
2107 CEBA Baton Rouge LA 70803

Mr. Maurice Rinkel Florida Institute of Oceanography  
830 1st Street South St. Petersburg FL 33701

Mr. Robert Rioux U.S. Geological Survey Office of Energy & Marine Geology  
915 National Center Reston VA 22092

Ms. Alice Roberson NACOA  
3300 Whitehaven St. NW Washington DC 20235

Mr. Eric Robertson U.S. Corps of Engineers Regulatory Division  
P.O. Box 2288 Mobile AL 36628

Mr. John Rodi MMS GOM Regional Office  
.

Dr. Robert Rogers MMS GOM Regional Office  
.

Dr. Richard Rosenblatt Scripps Institution of Oceanography A-008  
La Jolla CA 92093

Mr. Mark Rouse MMS GOM Regional Office  
.

Mr. Ed Rowe Amerada Hess Corp. E&P Division  
1200 Milam 6th FL Houston TX 77002

Mr. Dennis Ruddy EPA Industrial Technology Division  
401 M St. SW Washington DC 20460

Mr. Randy Runnels Texas A&M University Marine Lab  
P.O. Box 1675 Galveston TX 77550

Mr. Dennis J. Ryan Phillips Oil Co.  
P.O. Box 1967 Houston TX 77001

Mr. Al Sage University of Mississippi Law Research Institute  
Law School Box 20 University MS 38677

Mr. Harry Schafer LA Dept. of Wildlife & Fisheries Seafood Division  
P.O. Box 15570 Baton Rouge LA 70895



Mr. Kenneth Schaudt Marathon Oil Co. Offshore Technology Division  
P.O. Box 3128 Houston TX 77253

Mr. Ronald Schaed National Marine Fisheries Service  
9450 Koger Blvd. St. Petersburg FL 33702

Ms. Janet Schmitt National Park Service Environmental Coordination Section  
P.O. Box 728 Santa Fe NM 87501

Mr. Art Schroeder Amoco Production Co.  
1340 Poydras St. New Orleans LA 70150

Mr. Richard L. Scrivener MMS GOM Regional Office  
.

Mr. John Seip Amoco Production Co. Offshore Louisiana Division  
P.O. Box 50879 New Orleans LA 70150

Mr. John Shaughnessy Amoco Production Co.  
P.O. Box 50879 New Orleans LA 70150

Mr. Kevin Shaw Barry Vittor & Associates  
8100 Cottage Hill Road Mobile AL 36609

Mr. Bill Sheppard National Data Buoy Center  
Building 1100 NSTL Station MS 39529

Mr. Rick M. Sherrard Environmental Contracting Service  
P.O. Box 645 Ocean Springs MS 39564

Ms. Lorna Sicarello U.S. Fish & Wildlife Service Ecological Services Division  
1612 June Ave. Panama City FL 32405

Mr. Harry Sieverding MMS GOM Regional Office  
.

Dr. Walter B. Sikora Louisiana State University Center for Wetland Resources  
Baton Rouge LA 70803

Dr. Jean Sikora Louisiana State University Center for Wetland Resources  
Baton Rouge LA 70803

Mr. Larry Simpson Gulf States Marine Fisheries Commission  
P.O. Box 726 Ocean Springs MS 39564

Mr. Byron Sketchler Gulf Oil Corp. South & East Offshore Division  
P.O. Box 61590 New Orleans LA 70161

Ms. Tamsen M. Smith U.S. Corps of Engineers Waterways Exp. Station  
Halls Ferry Road Vicksburg MS 39180

Mr. Charles E. Smith Minerals Management Service Technology Assessment & Research Branch  
MS 647 - National Center Reston VA 22091

Mr. Lawson Smith Waterways Experiment Station Geotechnical Laboratory  
P.O. Box 631 Vicksburg MS 39180

Mr. Brent Smith MMS GOM Regional Office  
.

Dr. David C. Smith, IV Texas A&M University Department of Oceanography  
College Station TX 77843

Mr. Wade Smith Mitre Corporation  
1820 Dolly Madison Blvd. McLean VA 22102

Mr. David Soileau U.S. Fish & Wildlife Service Ecological Services Division  
P.O. Box 4305 Lafayette LA 70582

Mr. Don Solanas MMS GOM Regional Office  
.

Mr. Tom Soniat University of New Orleans Department of Biological Science  
New Orleans LA 70122

Mr. J.R. Spradley NOAA  
Main Commerce Bldg., Rm. 5804 Washington DC 20230

Mr. Dennis Stanczuk Exxon USA Exploration Division  
P.O. Box 4279 Houston TX 77001

Mr. Ted Stechmann MMS GOM Regional Office  
.

Mr. Harvey Stein City of New Orleans City Planning Committee  
9W City Hall New Orleans LA 70130

Dr. Robert E. Stewart, Jr. U.S. Fish & Wildlife Service National Coastal Ecosystems Team  
1010 Gause Blvd Slidell LA 70458

Ms. Gloria Storch ARCO Oil & Gas Co.  
P.O. Box 51408 Lafayette LA 70505

Ms. Carolyn Startstrom Exxon Co. USA Southeastern Production Division  
P.O. Box 60626 New Orleans LA 70160

Mr. David Story Gulf Oil Corp. Environmental Section  
P.O. Drawer 2038 Pittsburgh PA 15230

Ms. Melanie Stright MMS GOM Regional Office  
.

Dr. Tony Sturges Florida State University Dept. of Oceanography  
Tallahassee FL 32306

Mr. Tom Sullivan Sullivan Productions  
P.O. Box 40 Annapolis MD 21146

Mr. Tim Sullivan Minerals Management Service Atlantic Regional Office  
1751 Kidwell Drive Vienna VA

Ms. Nancy Swanton Minerals Management Service Alaska Regional Office  
P.O. Box 10-1159 Anchorage AK 99502

Mr. William Sweet MMS GOM Regional Office  
.

Mr. Erick M. Swenson Louisiana State University Center for Wetland Resources  
Baton Rouge LA 70803

Mr. Hugh Swingle ALA Dept. of Conservation Division of Marine Resources  
P.O. Box 189 Dauphin Island AL 36528

Mr. John Sylvester NOAA/NESDIS  
4301 Rickenbacker Causeway Miami FL 33149

Mr. Dan Tabberer MMS GOM Regional Office  
.

Mr. Edward Tennyson Minerals Management Service  
631 Oak Street Herndon VA 22070

Dr. Gordon Thayer NOAA/NMFS Beaufort Laboratory  
Beaufort NC 28516

Mr. J.E. Thomas  
36 Greenbriar Drive Gulfport MS 39501

Dr. Dana Thompson NORDA Modelling Branch, Code 323  
Bldg. 1100 NSTL Station MS 39529

Dr. Bruce Thompson Louisiana State University Center for Wetland Resources  
Coastal Ecology & Fisheries Institute Baton Rouge LA 70803

Ms. Tamara L. Townsend NORDA  
Code 324 NSTL Station MS 39529

Mr. Drew Trahan Louisiana Geological Survey  
Box G, University Station Baton Rouge LA 70893

Mr. Alan Troy LA Dept. of Natural Resources Office of Conservation  
P.O. Box 44275 Baton Rouge LA 70804

Ms. Deborah Tucker Executive Office of the Governor  
The Capitol Tallahassee FL 32301

Dr. John W. Tunnell Corpus Christi State University College of Sci. and Tech., Div. of Biology  
6300 Ocean Drive Corpus Christi TX 78412

Dr. Eugene Turner Louisiana State University Center for Wetland Resources  
Baton Rouge LA 70803

Mr. Jim Tuttle U.S. Corps of Engineers Mississippi River Commission  
P.O. Box 80 Vicksburg MS 39180

Mr. Marty Von Amoco Production Co. Offshore Division  
P.O. Box 50879 New Orleans LA 70150

Mr. William Van Horn Minerals Management Service Branch of Environmental Evaluation  
12203 Sunrise Valley Drive Reston VA 22091

Dr. J. Kim Vandiver Mass. Institute of Technology Dept. of Ocean Engineering  
77 Massachusetts Ave. Cambridge MA 02139

Ms. Cheryl Vaughan MMS GOM Regional Office

\*

Mr. Syd Verinder MMS GOM Regional Office

\*

Ms. Christine Vilardi Exxon Production Research Co.  
P.O. Box 2189 Houston TX 77074

Dr. Barry A. Vittor Barry Vittor & Associates  
8100 Cottage Hill Road Mobile AL 36609

Dr. Fred Vukovich Research Triangle Institute Geosciences Department  
P.O. Box 12194 Research Triangle Park NC 27609

Dr. Evans Waddell Science Applications, Inc.  
4900 Water's Edge Dr. Raleigh NC 27606

Mr. Edward Wagner LA Dept. of Natural Resources State Lands Division  
P.O. Box 44124 Baton Rouge LA 70804

Mr. Michael Walkovich Texaco Inc. New Orleans Operations Division  
P.O. Box 60252 New Orleans LA 70160

Mr. Ralph Walden Texaco Inc. New Orleans Operations Division  
P.O. Box 60252 New Orleans LA 70160

Ms. Sharon Walker Miss-ALA Seagrant Consortium  
Gulf Coast Research Laboratory Ocean Springs MS 39564

Mr. Carl Walker MMS GOM Regional Office  
.

Dr. Alan Wallcraft Jaycor, Inc. c/o NORDA Modeling Branch, Code 323  
NSTL Station MS 39529

Mr. Dickie Walters Miss. Dept. of Wildlife Conservation Bureau of Marine Research  
P.O. Box 959 Long Beach MS 39560

Mr. Robert Wayland Science Applications Inc.  
4900 Water's Edge Dr., Suite 255 Raleigh NC 27606

Ms. Myron Webb University of Southern Mississippi Dept. of Conferences & Workshops  
Long Beach MS 39560

Dr. John Wells University of North Carolina Institute of Marine Sciences  
1407 Arendell Street Morehead City NC 28557

Dr. E.G. Wermund University of Texas Bureau of Economic Geology  
P.O. Box X University Station Austin TX 78713

Ms. Mary L. White LA Dept. of Natural Resources Coastal Management Division  
1949 Ferndale Ave. Baton Rouge LA 70808

Mr. Carl Wickizer Shell Offshore Inc. Frontier Division  
P.O. Box 4480 Houston TX 77210

Mr. Jeff Wiese Minerals Management Service DIS/OCSIP, MS-640  
12203 Sunrise Valley Drive Reston VA 22091

Mr. Frank Wilem Triton Systems Inc.  
109 E. Scenic Drive Pass Christian MS 39571

LCDR R.C. Willems U.S. Navy Office of Naval Research  
NSTL MS 39529

Mr. Kent Williams Amoco Production Co. Offshore Division  
P.O. Box 50879 New Orleans LA 70150

Ms. Carol Williams MMS GOM Regional Office  
.

Mr. Randall Williams Tenneco Oil Corporation East Gulf Division  
4023 Ambassador Caffery PKwy. Lafayette LA 70503

Mr. Warren Williamsen MMS GOM Regional Office  
.

Mr. Gregory B. Wilson  
206 Briar Lane Lindenhurst IL 60046

Mr. Chuck Wilson Louisiana State University Center for Wetland Resources  
Baton Rouge LA 70803

Mr. Lloyd Wise EPA Water Management Division  
345 Courtland St. Atlanta GA 30365

Dr. William Wiseman, Jr. Louisiana State University Coastal Studies Institute  
Baton Rouge LA 70803

Mr. Robert Witrock MMS GOM Regional Office  
.

Mr. D.L. Woodford Texaco Inc. Operations Division  
P.O. Box 60252 New Orleans LA 70160

Mr. Rob Working John E Chance & Associates  
P.O. Box 52029 Lafayette LA 70505

Mr. Bruce Wright St. Bernard Parish Police Jury Dept. of Planning, Safety, & Permits  
8201 West Judge Perez Dr. Chalmette LA 70043

Dr. Tom Wright U.S. Army Corps of Engineers Waterways Experiment Station/WESEL  
P.O. Box 631 Vicksburg MS 39180

Mr. Robert Youngken U.S. Coast Guard Marine Safety Division  
500 Camp Street New Orleans LA 70130

Mr. Vince Zegowitz NOAA Code N-0511  
6001 Executive Blvd. Rockville MD 20852

Mr. Roger Zimmerman NOAA/NMFS  
4700 Avenue U Galveston TX 77550

Ms. Eleanor Zimmerman Environmental Protection Agency Office of Water Regulations & Standards  
401 M Street SW Washington DC 20460

Mr. Jeffrey Zippin Minerals Management Service Environmental Assessment Division  
12203 Sunrise Valley Drive Reston VA 22091



As the Nation's principal conservation agency, the Department of the Interior has responsibility for most of our nationally owned public lands and natural resources. This includes fostering the wisest use of our land and water resources, protecting our fish and wildlife, preserving the environmental and cultural values of our national parks and historical places, and providing for the enjoyment of life through outdoor recreation. The Department assesses our energy and mineral resources and works to assure that their development is in the best interest of all our people. The Department also has a major responsibility for American Indian reservation communities and for people who live in Island Territories under U.S. administration.

## DEPARTMENT OF THE INTERIOR MINERALS MANAGEMENT SERVICE