

ORDER

8260.40B

**FLIGHT MANAGEMENT SYSTEM (FMS)
INSTRUMENT PROCEDURES DEVELOPMENT**



December 31, 1998

**U. S. DEPARTMENT OF TRANSPORTATION
FEDERAL AVIATION ADMINISTRATION**

Distribution: A-W(SY/PO/UA/AR/ND/AS/AT/FS/AF)-3; AVN-100(150CYS); AOS-200(10CYS); **Initiated By:** AFS-400
AMA-200(80CYS); A-X(FS/AT/AF/AS)-3; A-FFS-4(ALL); AEU-1(10CYS); A-FFS-7(STD);
A-FAF-2/3/7(STD); ZVN-826; ZVS-827; ZAT-423; Special Military and Public Addressees

FOREWORD

This order provides criteria for establishing instrument area navigation (RNAV) approach, transition to instrument landing system (ILS) precision final approach, departure and missed approach procedures for FMS-equipped aircraft, in conjunction with FAA Order 8260.3B, United States Standard for Terminal Instrument Procedures (TERPS), and FAA Order 8260.36A, Civil Utilization of Microwave Landing System (MLS). This order also provides criteria for simultaneous converging ILS approach aided by FMS LNAV missed approach.

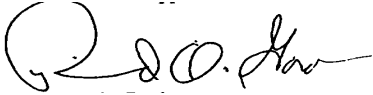

Richard O. Gordon
Acting Director, Flight Standards Service

TABLE OF CONTENTS

	Page No.
CHAPTER 1. ADMINISTRATIVE	1-1
1-1. Purpose.....	1-1
1-2. Distribution.....	1-1
1-3. Cancellation.....	1-1
1-4. Explanation of Changes.....	1-1
1-5. Information Update	1-1
1-6. Definitions	1-2
 CHAPTER 2. GENERAL CRITERIA.....	 2-1
2-1. General Criteria	2-1
2-2. General Procedure Construction Criteria.....	2-1
2-3. Identification of FMS Instrument Procedures	2-4
2-4. Holding.....	2-4
 CHAPTER 3. FMS NONPRECISION APPROACH CRITERIA.....	 3-1
3-1. En Route and Feeder Route Criteria.....	3-1
3-2. Approach Criteria	3-2
 CHAPTER 4. FMS TRANSITION TO ILS FINAL APPROACH SEGMENT	 4-1
4-1. En Route and Feeder Route Criteria.....	4-1
4-2. Approach Criteria	4-1
 CHAPTER 5. FMS DEPARTURE CRITERIA	 5-1
5-1. FMS Departure Criteria	5-1
 CHAPTER 6. FMS MISSED APPROACH CRITERIA.....	 6-1
6-1. FMS Missed Approach (MA) Criteria	6-1
 CHAPTER 7. SIMULTANEOUS CONVERGING ILS APPROACHES AIDED BY FMS LNAV MISSED APPROACH	 7-1
7-1. Simultaneous ILS Converging Approaches Aided by FMS LNAV Missed Approach	7-1
 CHAPTER 8. FMS PROCEDURAL TOOLS.....	 8-1
8-1. Tailored Procedures	8-1
8-2. FMS DME/DME Procedure Screening Model	8-1
 APPENDIX 1. FIGURES AND TABLES (43 pages)	 1

CHAPTER 1. ADMINISTRATIVE

1-1. PURPOSE. This order provides criteria for establishing instrument area navigation (RNAV) approach, transition to instrument landing system (ILS) precision final approach, departure and missed approach procedures for FMS-equipped aircraft, in conjunction with FAA Order 8260.3B, United States Standard for Terminal Instrument Procedures (TERPS), and FAA Order 8260.36, Civil Utilization of Microwave Landing System (MLS). This order also provides criteria for simultaneous converging ILS approach aided by FMS lateral navigation (LNAV) missed approach.

1-2. DISTRIBUTION. This order is distributed in Washington headquarters to the branch level of the Offices of System Safety; Aviation Policy and Plans; Air Traffic Systems Development; Aviation Research; Communications, Navigation, and Surveillance Systems; Airport Safety and Standards; and to Flight Standards, Air Traffic, and Airway Facilities Services; to the National Flight Procedures Office and National Airway Systems Engineering and Regulatory Standards Divisions at the Mike Monroney Aeronautical Center; to the branch level in the regional Flight Standards, Air Traffic, Airway Facilities, and Airports Divisions; to all Flight Inspection Offices; International Flight Inspection Office; the Europe, Africa, and Middle East Area Office; Flight Standards District Offices; Airway Facilities Field Offices; to all addressees on special distribution lists ZVN-826, ZVS-827, and ZAT-423; and special Military and Public addressees.

1-3. CANCELLATION. Order 8260.40A, Flight Management System (FMS) Instrument Procedure Development, dated December 5, 1995, is canceled.

1-4. EXPLANATION OF CHANGES.

- a. **Paragraph numbering format** has been changed and sections have been changed to chapters.
- b. **Chapter 1.** Adds two new definitions.
- c. **Chapter 2.** Changes equipment suffix and adds reference material.
- d. **Chapter 5.** Adds runway update information.
- e. **Chapter 7.** Adds criteria for simultaneous converging ILS approach aided by FMS LNAV missed approach identification of suffix used to establish required levels of system components of FMS for various phases of FMS utilization.
- f. **Chapter 8.** Provides additional information concerning the FMS DME/DME Procedure Screening Model.
- g. **Appendix 1, figure 29.** Adds drawing on converging approach FMS missed approaches.
- h. **Appendix 1, table 6.** Modified to reflect minimum length of FAF final approach segment (NM).

1-5. INFORMATION UPDATE. Any deficiencies found, clarification needed, or improvements to be suggested regarding the content of this order, shall be forwarded for consideration to:

DOT/FAA
ATTN: Flight Procedure Standards Branch, AFS-420
PO Box 25082
Oklahoma City, OK 73125

a. Your Assistance is Welcome. FAA Form 1320-19, Directive Feedback Information, is included at the end of this order for your convenience.

b. Use the "Other Comments" block of this form to provide a complete explanation of why the suggested change is necessary.

1-6. DEFINITIONS.

a. Approach Operations. That portion of flight conducted on charted Instrument Approach Procedures (IAP's) commencing at the initial approach waypoint (IAWP) and concluding at landing or the missed approach holding waypoint (MAHWP). All FMS instrument approaches shall be called up from a data base contained within the FMS itself.

b. Departure End of Runway (DER). The end of the takeoff run available.

c. En Route Operations. That portion of flight conducted on charted VOR routes designated as high or low altitude routes (Jet or Victor) or direct point-to-point operations between defined waypoints.

d. Flight Management System (FMS). An FMS is an onboard computer system which integrates inputs from various subsystems to aid the pilot in controlling the airplane's lateral and vertical paths. In addition to navigation, the FMS may accomplish performance functions such as thrust management and fuel flow monitoring.

e. Instrument Approach Waypoints. Geographical positions, specified in latitude/longitude, used in defining FMS instrument approach procedures. An FMS approach may include some or all of the following waypoints: feeder waypoint (FWP), IAWP, intermediate waypoint (IWP), final approach waypoint (FAWP), missed approach waypoint (MAWP), runway waypoint (RWP) and MAHWP. For purposes of this order, the terms waypoint and fix are used interchangeably.

f. Reference Waypoint. A waypoint of known location used to geodetically compute the location of another waypoint.

g. Roll Anticipation Distance (RAD). The distance traveled by the aircraft while rolling to the bank angle required for a turn.

h. Runway Waypoint (RWP). A waypoint located on the runway centerline at the runway threshold.

i. Segment. A segment or leg is the path between two waypoints. For purposes of this order, a leg is computed and flown by the FMS as a track. All FMS procedures shall be designed using a series of Track to a Fix (TF) legs.

j. Takeoff Run Available (TORA). The runway length declared available for the ground run of an airplane takeoff.

k. Takeoff Waypoint (TOWP). A waypoint located on runway centerline at the beginning of TORA.

l. Terminal Operations. That portion of flight conducted on charted Standard Instrument Departures (SID's), on charted Standard Terminal Arrivals (STAR's), or other flight operations between the last en route waypoint and the IAWP (i.e., feeder routes).

m. Turn Anticipation. The capability of FMS to determine the point along a course, prior to a fly-by waypoint, where a turn is initiated to provide a smooth path to intercept the succeeding course. Turn distance includes roll anticipation distance as well as the distance necessary to make the required turn.

n. Waypoint (WP). A predetermined geographical position used for route definition and/or progress reporting purposes that is defined by latitude/longitude. A fly-by waypoint requires the use of turn anticipation to avoid overshoot of the next flight segment. A fly-over waypoint precludes any turn until the waypoint is overflown and is followed by an intercept maneuver of the next flight segment.

o. Waypoint Displacement Area (WPA). The rectangular area formed around and centered on the plotted position of the waypoint. This describes the region within which the aircraft could be placed when attempting to fly over the waypoint considering all error components. Its dimensions are plus-and-minus the appropriate alongtrack (ATRK) and crosstrack (XTRK) fix displacement tolerance values found in table 1.

CHAPTER 2. GENERAL CRITERIA

2-1. GENERAL CRITERIA.

a. Use of FMS procedures developed in accordance with these criteria shall be limited to aircraft qualifying for the /E or /F equipment suffix. Specific aircraft equipment requirements to qualify for the /E designation and, hence, for procedures developed using the criteria contained herein are:

(1) **Dual FMS** which meets the en route, terminal, and approach specifications of FAA Advisory Circular (AC) 25-15, Approval of Flight Management Systems in Transport Category Airplanes; AC 20-129, Airworthiness Approval of Vertical Navigation (VNAV) Systems for use in the U.S. National Airspace System (NAS) and Alaska; and AC 20-130, Airworthiness Approval of Multi-Sensor Navigation Systems for use in the U.S. National Airspace System (NAS) and Alaska, or equivalent criteria as approved by Flight Standards Service.

(2) **A flight director** and autoflight control system capable of following the designated lateral FMS flightpath.

(3) **Dual or triple inertial reference units (IRU)** updated by distance measuring equipment (DME)/DME or Global Positioning System (GPS) with verification of facility performance and suitable geometry for the route or procedure. When necessary, DME/DME procedures shall be in accordance with expanded service volume (ESV) requirements of Order 8260.19, Flight Procedures and Airspace.

(4) **A database containing the waypoints** and speed/altitude constraints for the route and/or procedure to be flown that once selected by the crew, is automatically loaded into the FMS flight plan.

(5) **The /F equipment suffix** includes a single FMS that meets the requirements of paragraphs 2-1a(1) through (4).

b. Missed approach (MA) and departure procedures should follow the same route. Departure procedures will overlie FAR 121.189 routes to the maximum extent possible.

c. Do not use this order for instrument procedure altitudes above 15,000 feet MSL.

d. Procedures developed in accordance with this order qualify for required navigation performance RNP.3.

2-2. GENERAL PROCEDURE CONSTRUCTION CRITERIA. General FMS procedural construction requirements are as follows:

a. Waypoints. Except in the case of an ILS final approach segment, a WP shall be used to identify the beginning point and ending point of each segment in an FMS procedure. WP's shall also be established at holding fixes or at other points of operational benefit, such as waypoints associated with altitude and/or airspeed restrictions. (ILS final approach segment is as defined in Order 8260.3B, chapter 9, paragraph 930, or Order 8260.36, paragraph 16, for new ILS installations.) The following waypoint guidelines apply:

- (1) **Fly-by waypoints** should be used whenever possible.
- (2) **Fly-over waypoints** should only be used when operationally necessary; e.g., to ensure lateral avoidance of an obstacle on departure, to ensure over fly of the MAWP. Fly-over waypoints shall not be used for the IAWP, IWP, and the FAWP. Table 1 shows which waypoints may be designated as fly-over.
- (3) **Waypoint displacement tolerances** are associated with each waypoint. Displacement tolerance areas for consecutive waypoints shall not overlap. Table 1 contains a summary of waypoint displacement tolerances for each type of waypoint.
- (4) **Procedures should be designed** using the fewest number of waypoints possible.
- (5) **Waypoints shall be designated** where course, speed, or altitude changes occur.
- (6) **Procedures shall be designed** using seamless path construction, and there shall not be any route gaps or discontinuities.
- (7) **Each WP shall be defined** by latitude and longitude in degrees, minutes, and seconds and shall be developed to the nearest hundredth of a second.

b. Segments. FMS RNAV segments begin and end at a WP.

- (1) **The segment area** considered for obstacle clearance begins at the earliest point of the beginning WP displacement area and, except for the final approach segment, ends at the plotted position of the next WP.
- (2) **Segment length**, except for the final approach segment, is based on the distance between the plotted positions of the WP's defining the segment. Final approach segment length is defined in the appropriate section.
- (3) **Minimum segment lengths** are determined using the following guidelines:
 - (a) Unless otherwise stated, minimum segment lengths are functions of waypoint type, aircraft speed, and amount of course change at the waypoint, and are determined from values contained in table 2 (fly-by waypoints) and table 3 (fly-over waypoints). Figures 1A, 1B, 1C, 1D, and 1E show how to apply tables 2 and 3 to various combinations of waypoint types.
 - (b) Table 4 contains speed applicability for the various instrument procedure segments, except the final approach segment. Table 4 is used as an entry key to obtain the appropriate data from tables 2, 3, and 5. Table 6 contains the minimum FMS nonprecision final approach segment length based on the amount of turn at the FAWP. If it is necessary to restrict airspeed to values less than shown in table 4, select the appropriate speed from tables 2, 3, and 5 and annotate the procedure accordingly. An approach segment shall not be designed using a higher airspeed than the preceding segment; e.g., the initial segment designed using 160 KIAS while the intermediate segment designed using 220 KIAS.
 - (c) For consecutive fly-by waypoints with turns in the same direction, the minimum turn distance from table 2 may be reduced by the roll anticipation distance from table 5. (See figure 1E.)

(d) In no case will a segment length be less than the sum of the ATRK waypoint displacement tolerances for the respective waypoints. See table 1 for ATRK waypoint displacement tolerances for the various type waypoints.

(e) The following example illustrates these concepts:

Example: Given the FMS approach as shown in figure 2, determine the minimum length of each segment. Every waypoint is fly-by and the maximum altitude on the approach is 7,000 feet.

En Route Segment (En Route WP - FWP). Since FMS navigation is seamless, the angle of turn, if any, at the en route WP must be known before the minimum distance could be determined.

Feeder Segment (FWP - IAWP). Since this is a feeder segment and the maximum altitude is less than 10,000 feet MSL, table 4 shows that the 250 KIAS column in table 2 is to be used. Since no course change takes place at the FWP, only the 90° course change at the IAWP will figure in the minimum segment length determination. From table 2 for 250 KIAS and 90° course change, the minimum turn distance is 4.91 NM. For this example, this is also the minimum segment length. Remember that the segment length can be no shorter than the sum of the ATRK waypoint displacement tolerances. From table 1, the ATRK waypoint displacement tolerance is 1.7 NM at the FWP and .3 NM at the IAWP. Summing these results in 2.0 NM. Therefore, the 4.91 NM, as previously determined, is the minimum feeder route length for this example.

Initial Segment (IAWP-IWP). From table 4, the 220 KIAS column of table 2 is to be used for the initial segment. Since there is a course change at both the IAWP and the IWP, two minimum turn distances must be determined. First, from table 2 for 220 KIAS and the 90° course change at the IAWP, the minimum turn distance is 4.06 NM. Second, from table 2 for 220 KIAS and the 60° course change at the IWP, the minimum turn distance is 2.63 NM. Adding these two distances together results in a minimum initial segment length of 6.69 NM.

Intermediate Segment (IWP - FAWP). From table 4, the 175 KIAS column of table 2 is to be used for the intermediate segment. Again, course changes take place at both waypoints, thus two minimum turn distances will be determined. From table 2 for 175 KIAS and the 60° course change at the IWP, the minimum turn distance is 1.93 NM. Notice, however, that the turns at the IWP and the FAWP are in the same direction, so the RAD may be subtracted from the minimum turn distance. From table 5 for 175 KIAS, a fly-by waypoint and a 60° course change, the RAD is .56 NM. Therefore, the minimum turn distance for the course transition at the IWP is $1.93 - .56 = 1.37$ NM. The minimum turn distance for the second course transition at the FAWP is determined in a similar manner. From table 2 for 175 KIAS and a 30° course change, the minimum turn distance is 1.37 NM. From table 5 for 175 KIAS, a fly-by waypoint and a 30° course change, the RAD is .37 NM. Therefore, the minimum turn distance for the second transition at the FAWP is $1.37 - .37 = 1.0$ NM. The minimum intermediate segment length is then $1.37 + 1.0 = 2.37$ NM.

Final Segment (FAWP - MAWP). From table 6 with a course change of 30° at the FAWP, the minimum final segment length is 3.5 NM.

c. Waypoint Definition. When segments are aligned on a straight continuous course with no turns between approach segments prior to the MAWP, construct all preceding WP's using the MAWP as the reference WP. When segments are not aligned on a straight course, use the MAWP as the reference WP to

construct the FAWP; use the FAWP to construct preceding WP if preceding segments are on a straight course; or use the IWP as the reference WP to construct the IAWP when there is a turn at the IWP.

d. Course Change at Waypoints. The departure course at a WP is the bearing from that WP to the following WP. The arrival course at the WP is the reciprocal of the course from that WP to the preceding WP, and the difference between the departure course and the arrival course at the WP equals the amount of turn at that WP.

e. Minimum Safe Altitude. A minimum safe altitude shall be established using the MAWP as the reference center. Develop sectors in accordance with Order 8260.3B, paragraph 221.

2-3. IDENTIFICATION OF FMS INSTRUMENT PROCEDURES. All procedures developed in accordance with this order shall be annotated as follows: "FOR USE BY /E OR /F AIRCRAFT ONLY." Instrument Approach Procedures (IAP's), based on FMS, are identified by the prefix "RNAV," followed by the runway number/letter, as appropriate; i.e., RNAV RWY 17, RNAV-A. The IAP shall be annotated as follows: "SPECIAL AUTHORIZATION REQUIRED," "DUAL DME OR GPS UPDATING REQUIRED."

2-4. HOLDING. Order 8260.3B, chapter 2, section 9, applies, except paragraph 292d. When holding is at an FMS WP, the primary area of the selected pattern shall be large enough to contain the entire waypoint displacement area. To establish the area, refer to FAA Order 7130.3A, Holding Pattern Criteria. Use 15 NM distance for terminal holding procedures and 30 NM distance for en route holding. Obtain leg-length information from Order 7130.3A, appendix 1, holding course toward the NAVAID. Outbound-end reduction is not authorized.

CHAPTER 3. FMS NONPRECISION APPROACH CRITERIA

3-1. EN ROUTE AND FEEDER ROUTE CRITERIA. Use en route waypoint displacement tolerances for en route waypoints. Use terminal waypoint displacement tolerances for en route waypoints used as feeder waypoints. For all other purposes, use en route criteria for both en route and feeder route construction. En route obstacle clearance areas are identified as primary and secondary. These designations apply to straight and turning segment obstacle clearance areas. The required angle of turn connecting en route segments to other en route, feeder, or initial approach segments shall not exceed 120°. Where the turn exceeds 15°, expanded turning area construction methods as discussed below apply.

a. Primary Area.

(1) **Width.** Order 8260.3B, chapter 15, paragraphs 1510a(2) and (3) apply.

(2) **Length.** The minimum length of an en route segment is determined as described in paragraph 2-2b(3). There is no maximum length for an en route segment. The fix displacement areas of consecutive waypoints shall not overlap.

b. Secondary Area. Order 8260.3B, chapter 15, paragraphs 1510b(2) and (3) apply.

c. Construction of Expanded Turning Areas. Obstacle clearance areas shall be expanded to accommodate turns of more than 15°. For fly-by waypoints, inside turn expansion is constructed to accommodate turn anticipation. For fly-over waypoints, outside turn expansion is applied to protect for the fly-over maneuver.

(1) **Fly-by Waypoint.** Order 8260.3B, chapter 15, paragraph 1510c(2) applies.

(2) **Fly-over Waypoint.** With reference to figure 3, determine the expanded area at the outside of the turn as follows:

(a) Using the applicable speed (250 KIAS at and below 10,000 feet MSL, 310 KIAS above 10,000 feet MSL) and turn angle, determine the RAD from table 5. Construct a line (ABCD in figure 3) perpendicular to the preceding route centerline the required RAD past the latest point the waypoint can be determined. This line is a baseline for constructing arc boundaries.

(b) Using the applicable speed and turn angle, enter table 3 and determine the radius of turn. From a point (C in figure 3) on the arc base line, strike an outer primary area boundary arc of table 3 radius in the direction of turn beginning at the point (A in figure 3) where an extension of the outer line of the fix displacement area intersects the base line. Strike another arc of the same radius in the direction of turn beginning at the point (B in figure 3) where an extension of the inner line of the fix displacement area intersects the baseline. Connect the two outer primary area boundary arcs with a tangent line.

(c) From table 3 determine the minimum turn distance. From the plotted position of the waypoint, measure along the outbound course centerline the minimum turn distance (E in figure 3). Transfer this point along a line perpendicular to the course line to the outer primary area boundary (F in figure 3). Connect a line from this point tangent to the outermost primary area boundary arc.

(d) From a point (G in figure 3) on the outer primary area boundary perpendicular to the inbound course at the plotted position of the fix, connect a tangent line to the first outer primary area boundary arc.

(e) Establish outer secondary area boundary arcs by striking arcs of table 3 radius plus 2 NM from the center points (C and D in figure 3) used for the primary area expansion. Connect the two outer secondary area boundary arcs with a tangent line.

(f) At the minimum turn distance determined in paragraph 3-1c(2)(c), transfer the turn completion point (E in figure 3) along a line perpendicular to the course line to the outer secondary area boundary (H in figure 3). Connect a tangent line from this point to the outermost secondary area boundary arc.

(g) From a point on the outer secondary area boundary perpendicular to the inbound course at the plotted position of the fix (I in figure 3), connect a tangent line to the first outer secondary area boundary arc.

d. Obstacle Clearance. Order 8260.3B, paragraph 1511, applies.

3-2. APPROACH CRITERIA.

a. Approach Turning Area Expansion. Obstacle clearance areas will be expanded to accommodate turns of more than 15° at the IAWP, IWP and FAWP. See figures 4, 5, and 6. Outside turn expansion is not required at these waypoints. MAWP turn expansion criteria is contained in chapter 6 of this order. Construct the approach turning area expansion as follows:

(1) **Determine the ATRK displacement** tolerance from table 1. Measure this distance from the WP on the inbound course and plot a line perpendicular to the centerline.

(2) **Locate a point on the edge of the primary area** on the inside of the turn at the distance of turn anticipation (DTA) prior to the ATRK displacement line. The DTA is measured parallel to the course leading to the WP and is determined by the following formulas:

For turns greater than 15° and less than or equal to 90°

$$DTA = 2 \times \tan(\text{turn angle} \div 2)$$

For turns greater than 90° and less than or equal to 105°

$$DTA = 2.5 \times \tan(\text{turn angle} \div 2)$$

For turns greater than 105° and less than or equal to 120°

$$DTA = 3 \times \tan(\text{turn angle} \div 2)$$

(3) **From this point**, splay the primary area by an angle equal to half the course change until this line intersects the primary area of a succeeding segment. Depending on procedure geometry, this may not be the primary area of the immediately following segment.

(4) **Construct the secondary area boundary** parallel with the expanded turn anticipation primary area boundary a distance of 1 NM. Extend the secondary area boundary line until it intersects

another secondary segment area. Depending on procedure geometry, this may not be the secondary area of the immediately following segment.

(5) In the case of small turn angles, the primary or secondary turn expansion lines may not intersect another primary or secondary area boundary. In this case join the expanded areas at respective points abeam the succeeding WP.

(6) Evaluate primary and secondary areas using the required obstruction clearance (ROC) of the segment(s) following the turn WP. These general guidelines apply:

(a) Working from the primary area turn expansion line back toward the inside of the turn, connect all points which outline secondary area. This area will become primary area for obstacle evaluation purposes. If more than one segment's secondary area is outlined, divide the area for ROC application at the earliest point the second WP can be determined.

(b) To evaluate the secondary turn expansion area, connect the ends of the secondary turn expansion line to the ends of the primary turn expansion line. The area so enclosed will be evaluated as secondary area of the adjacent reevaluated primary segment. ROC for obstacles within this area is evaluated perpendicular to the primary area turn expansion line.

b. Initial Approach Segment. The initial approach segment begins at the IAWP and ends at the IWP. See figure 4.

(1) Segmented Path. A segmented initial approach segment is defined by multiple straight-line legs that begin and end with defined fly-by waypoints. See figure 6. If any of these waypoints are also defined as an IAWP, then paragraph 3-2b(4) applies and a separate evaluation for the newly defined initial segment is required, including all segment legs. The initial approach segment may contain up to four legs. Waypoints shall be located where the course changes and shall be named. Minimum leg lengths are determined as described in paragraph 2-2b(3) using the 220 KIAS column in table 2. Turning area expansion as described in paragraph 3-2a shall be applied to segmented path waypoints. Evaluate the primary and secondary turn expansion areas for the segment or leg following the turn waypoint. See figure 6.

(2) Alignment. The angle of intercept between initial legs and between an initial leg and the intermediate segment shall not exceed 120°.

(3) Length. The initial approach segment has no standard length. It will be sufficient to permit any altitude changes required by the procedure. Total length of the initial segment including all legs of a segmented path shall not exceed 50 miles. Minimum individual segment length is determined as described in paragraph 2-2b(3).

(4) Width. The width of the initial segment shall remain at en route width until the latest position of the IAWP. The primary area tapers 90° abeam this point inward at 30° relative to centerline until reaching a width of 1 NM. The secondary area tapers to a width of 1 NM. The taper begins at the latest position of the IAWP abeam the point of taper of the primary area and tapers to a point abeam the primary area where it reaches its reduced width.

(5) Obstacle Clearance. Refer to Order 8260.3B, paragraph 232c.

(6) **Descent Gradient.** Refer to Order 8260.3B, paragraphs 232d and 288a.

c. Intermediate Approach Segment. The intermediate segment begins at the IWP and ends at the FAWP.

(1) **Alignment.** The course selected in the intermediate segment should be aligned with the final approach course. When this is not practical, the course change at the FAWP shall not exceed 30°. Paragraph 3-2a applies for turning area expansion.

(2) **Length.** The minimum intermediate segment length is determined as described in paragraph 2-2b(3). The maximum intermediate length is 15 NM.

(3) **Width.**

(a) Primary area is 1 NM each side of centerline.

(b) Secondary area is 1 NM on each side of the primary area.

(4) **Obstacle Clearance.** Order 8260.3B, paragraph 242c, applies.

(5) **Descent Gradient.** Order 8260.3B, paragraph 242d, applies.

d. Final Approach Segment. The final approach segment begins at the FAWP and ends at the MAWP.

(1) **Alignment.**

(a) **Straight-In.** For a straight-in approach, the final approach course (FAC) shall not exceed 15° from the runway centerline (RCL) extended. Optimum FAC is coincident with the RCL. Where the FAC is within 3° of the RCL, the optimum alignment is to the runway threshold. Where the FAC exceeds 3° from the RCL, the optimum alignment is to a point 3,000 feet from runway threshold on the RCL. Where operationally required, optional alignment is authorized to a point between and including the runway threshold and a point 3,000 feet prior to the runway threshold on the RCL, provided alignment is within 15° of the RCL.

1. Except where the alignment is to the runway threshold, the mandatory location of the MAWP is at the intersection of the FAC and the RCL.

2. Where the alignment is to the runway threshold, the optimum location of the MAWP is at the threshold, with optional location of the MAWP anywhere along the FAC between the threshold and the FAWP.

(b) **Circling Alignment.** The optimum FAC alignment is to the center of the landing area, but may be to any portion of the usable landing surface. The optional location of the MAWP is anywhere along the FAC between the FAWP and the point abeam the nearest landing surface.

(2) **Area.** The area (straight and circling) considered for obstacle clearance starts at the earliest point of the FAWP displacement area and ends at the latest point of the MAWP displacement area or the runway threshold or a point abeam the runway threshold, whichever is encountered last. See figure 7. The area extended to the threshold beyond the MAWP, when required, has a constant width for both primary and secondary areas and those dimensions equal the lateral dimensions at the MAWP (see figure 8).

(3) **Length.** The length of the final approach segment is measured from the plotted position of the FAWP to the runway threshold or a point abeam the threshold, whichever is encountered last. The optimum length is 5 NM. The maximum length is 10 NM. The minimum length shall provide adequate distance for an aircraft to meet the required descent and to regain course alignment when a turn is required over the FAWP. Table 6 is used to determine the minimum length of the final approach segment.

(4) **Width.**

(a) The final approach primary area is centered on the final approach course. It is 1 NM wide on each side of the course at the earliest point of the FAWP displacement area. This width remains constant until the latest point of the FAWP displacement area. It then tapers to the width of the XTRK displacement tolerance (0.6 NM on each side of the final approach course) at the latest point of the MAWP displacement.

(b) A secondary area 1 NM wide is established on each side of the primary area.

(5) **Obstacle Clearance.**

(a) **Straight-In.** The minimum required obstruction clearance (ROC) in the primary area is 250 feet. In the secondary area, 250 feet of ROC shall be provided at the inner edge, tapering uniformly to zero feet at the outer edge.

(b) **Circling.** A minimum of 300 feet of ROC shall be provided in the circling approach area. Order 8260.3B, paragraph 260, applies.

(6) **Descent Gradient.** The optimum descent gradient is 318 feet per mile. Where a higher gradient is necessary, the maximum permissible descent gradient is 400 feet per mile.

(7) **Vertical Navigation (VNAV) Descent Angle.** A final approach VNAV descent angle meeting the criteria in Order 8260.3, chapter 2, shall be published.

e. **Obstacle Rich Environment (ORE).** Due to the high degree of reliance on the FMS for navigation, redundant airborne equipment, surveillance, or special procedures may be required for certain procedures. When a procedure is considered to be in an ORE, a waiver must be issued by the FAA Flight Standards Service, Washington, DC.

(1) **Assessment.** Whenever the minimum procedural altitude in an FMS approach procedure containing turns falls below the height of an obstacle located within 6 NM of the course centerline, an ORE assessment shall be made. For each such obstacle there is a "critical point." The critical point is that point on the outer edge of the secondary area having the shortest distance to the obstacle using a 15° splay from course centerline. The ORE assessment consists of determining whether a 40:1 incline starting from the critical point at the minimum procedural altitude clears the obstacle. Obstacles that have a critical point

abeam or after the FAWP or obstacles that have a critical point abeam or prior to the IAWP do not require an ORE assessment.

(2) Method.

(a) Identify each obstacle higher than the minimum procedural altitude and located within 6 NM of the course centerline that requires an ORE assessment.

(b) Locate the critical point for each obstacle identified above. Because the outer edge of the secondary area might not be parallel to the course centerline, the line from the critical point to the obstacle might not be 15° from the edge of the secondary area. However, the line from the critical point to the obstacle is always 105° from a line perpendicular to the course centerline. Consequently, the critical point is located by sliding a 105° template along the outer edge of the secondary area (with its origin, or corner, on the outer edge of the area) until the 105° line touches the closest point of the obstacle (see figure 9).

(c) Determine whether a 40:1 incline starting from the critical point at the minimum procedural altitude clears the obstacle. This is done by measuring the distance in feet between the critical point and the obstacle and dividing that distance by 40. The quotient is added to the elevation of the critical point (i.e., the MINIMUM procedural altitude abeam the critical point) to compute the height of the 40:1 incline at the obstacle. If the elevation of the obstacle is higher than the height of the 40:1 incline, the environment is obstacle rich. A single penetration of the 40:1 incline is sufficient to make the approach environment obstacle rich (see figure 9).

(d) Obstacles A through D in figure 9 are evaluated to determine whether they require an ORE assessment:

1. Obstacle A is below the minimum procedural altitude at its critical point (2,000 feet) and does not require an ORE assessment.

2. Obstacle B is more than 6 NM from initial segment centerline and does not require an ORE assessment.

3. The 2,379-foot obstacle C requires an ORE assessment because it is higher than the minimum procedural altitude abeam its critical point (2,000 feet). The 40:1 incline starts at this same altitude, 2,000 feet, at the critical point. The distance between the critical point and the obstacle is 14,000 feet. $14,000' \div 40 = 350' + 2,000' = 2,350'$ which is 29 feet below the top of the obstacle. The environment is obstacle rich.

4. Although obstacle D is abeam the final approach segment, its critical point is abeam the intermediate segment. In addition, its 1,899-foot height is above the minimum procedural altitude of 1,500 feet. Consequently, it requires an ORE assessment. The 40:1 incline starts at 1,500 feet at the critical point. The distance between the critical point and the obstacle is 15,000 feet. $15,000' \div 40 = 375' + 1,500' = 1,875'$ which is 24 feet below the top of the obstacle. The environment is obstacle rich.

CHAPTER 4. FMS TRANSITION TO ILS FINAL APPROACH SEGMENT

4-1. EN ROUTE AND FEEDER ROUTE CRITERIA. Paragraph 3-1 applies.

4-2. APPROACH CRITERIA. See figure 10.

a. Approach Turning Area Expansion. Paragraph 3-2a applies.

b. Initial Approach Segment. Paragraph 3-2b applies, with the following exceptions:

(1) **Alignment.** The maximum angle of intercept between an initial segment and intermediate is 90°.

(2) **Width.** The width of the initial segment shall remain at en route width until the latest position of the IAWP. The primary area tapers from 90° abeam this point inward at 30° relative to centerline until reaching a width of 1 NM or the maximum half-width of the ILS final approach area, whichever is greater. The ILS final approach area half-width is defined in Order 8260.3B, paragraph 930, and Order 8260.36, paragraph 16, and is found by using the formula $500' + .15(F - 200')$, where F is the distance from the threshold to the glide slope intercept point. The secondary area tapers to a width of 1 NM, beginning abeam the point of taper of the primary area and ending at a point abeam the primary area, where it reaches its reduced width.

c. Intermediate Approach Segment. The intermediate segment begins at the IWP and ends at the ILS glide slope intercept point (GSIP).

(1) **Alignment.** The intermediate segment course shall be an extension of the final approach course.

(2) **Length.** The minimum length of the intermediate segment depends on the angle of turn at the IWP. Table 7 specifies minimum intermediate segment lengths.

(3) **Width.** See figure 11. The primary intermediate segment half-width is 1 NM at the earliest point of the IWP displacement area. This width remains constant until the latest point of the IWP displacement area. It then tapers to the half width of the ILS final approach area at the GSIP. In the case where the maximum half width of the ILS final approach area exceeds 1 NM, then the primary intermediate width is constant at the maximum half-width of the ILS final approach area. The width of the secondary intermediate segment is 1 NM each side of the primary area at the earliest point of the IWP displacement area. This width remains constant until the latest point of the IWP displacement area. It then tapers to the width of the ILS secondary area at the GSIP.

(4) **Obstacle Clearance.** Order 8260.3B, paragraph 242c, applies.

(5) **Descent Gradient.** Order 8260.3B, paragraphs 242d and 923, apply.

(6) **Altitude Selection.** The intermediate segment altitude shall not be less than the glide slope intercept altitude.

(7) IWP Placement. In order to assure localizer course capture, the IWP shall be laterally located in the center of the localizer course and shall be placed no closer to the runway threshold than explained in this paragraph. For approaches where there is a course change of less than 15° at the IWP, the IWP shall be no closer to the threshold than a point where the localizer course half-width is 0.3 NM. For approaches with course changes at the IWP of more than 15°, additional distance to account for turn anticipation shall be added to determine minimum IWP distance from the runway threshold. The minimum IWP distance from runway threshold is determined as follows:

(a) Compute the distance from the runway threshold to the point where the localizer course half-width is 0.3 NM.

$$D_1 = D * \left[\frac{.3}{(1/2 \text{ W at Thld})} - .000164578 \right]$$

Where: D = runway threshold to localizer antenna distance in feet.
 (1/2 W at Thld) = half-width of localizer at runway threshold in feet.
 D₁ = distance in NM from runway threshold to point where localizer course half-width is 0.3 NM.

Where there is a course change of 15° or less at the IWP, D₁ is also the minimum IWP distance from the runway threshold.

Example 1. See figure 12. Given a runway length of 10,000 feet, a localizer antenna to runway end distance of 1,000 feet, a localizer course width of ± 350 feet at the runway threshold and no turn at the IWP, compute the minimum IWP distance.

$$D = 10,000' + 1,000' = 11,000'$$

$$D_1 = 11,000' * \left(\frac{.3}{350'} - .000164578 \right) = 7.62 \text{ NM}$$

Minimum IWP distance is 7.62 NM.

(b) For turns of more than 15° at the IWP, additional distance must be added to D₁ to account for the turn. This additional distance, D₂, is found by entering table 2 with the IWP course change and reading the minimum turn distance from the 175 KIAS column. D₂ is added to D₁ to find the minimum IWP distance.

Example 2. See figure 13. The runway length is 7,000 feet, the localizer course width is tailored ± 350 feet at the threshold and the localizer is located 1,000 feet from the end of the runway. The initial and intermediate segments differ by 30°. Compute the minimum IWP distance.

$$D = 7,000' + 1,000' = 8,000'$$

$$D_1 = 8,000' * \left(\frac{.3}{350'} - .000164578 \right) = 5.54 \text{ NM}$$

$$D_2 = 1.37 \text{ NM (from table 2, 175 KIAS column, turn angle of } 30^\circ)$$

Minimum IWP distance = $D_1 + D_2 = 5.54 + 1.37 = 6.91 \text{ NM}$.

Example 3. See figure 14. The runway length is 10,000 feet, the localizer course width is tailored ± 350 feet at the threshold and the localizer is located 1,000 feet from the end of the runway. The initial and intermediate segments differ by 90° . Compute the minimum IWP distance.

$$D = 10,000' + 1,000' = 11,000'$$

$$D_1 = 11,000' * \left(\frac{.3}{350'} - .000164578 \right) = 7.62 \text{ NM}$$

$$D_2 = 2.93 \text{ NM (from table 2, 175 KIAS column, turn angle of } 90^\circ)$$

Minimum IWP distance = $D_1 + D_2 = 7.62 + 2.93 = 10.55 \text{ NM}$.

d. ILS Final Approach Segment. Order 8260.3B, chapter 9, section 3, or for new ILS installations Order 8260.36, paragraph 16, applies. See figure 11.

e. Obstacle Rich Environment. Paragraph 3-2e applies.

CHAPTER 5. FMS DEPARTURE CRITERIA

5-1. FMS DEPARTURE CRITERIA.

a. Runway Update. Prior to performing an FMS departure procedure, the navigation system position shall be updated to the runway threshold position. Annotate the procedure as follows:

"Prior to departure update navigation position to RW ZZ threshold coordinates NXX XX.XXWYY YY.YY" where ZZ is departure runway, and NXX XX.XXWYY YY.YY are runway threshold coordinates specified in hundredths of a minute.

b. Route. The departure route begins at the TOWP and consists of a sequence of connected straight flight segments. Except in the case of a displaced threshold, the TOWP shall be the RWP. If the threshold is displaced, use the start of the usable runway for the TOWP. A fly-by or fly-over waypoint shall be specified at the beginning and end of each segment. The waypoint at which the route ends shall not be located prior to the point where the aircraft, climbing at the minimum prescribed climb gradient for each segment, reaches the minimum altitude for en route flight. FMS departure and en route flight segments shall be contiguous; i.e., the last waypoint of an FMS departure procedure shall be an en route fix.

(1) **The first segment** in the procedure begins at the TOWP and ends at a waypoint on the extended runway centerline that should be at least 2 NM beyond the departure end of the runway (DER) (see figure 15). In addition, if the first segment terminates at a fly-by waypoint, the minimum turn distance from table 2 must be added. If the first waypoint is less than 2 NM beyond the DER, a climb gradient calculation shall be made using the following formula:

$$G = \frac{400}{D}$$

Where: G = climb gradient (feet NM).
D = distance from DER measured along the route centerline (NM).

Example: The first waypoint is located 1.0 NM beyond the DER. The required climb gradient is:

$$G = \frac{400}{1.0} = 400 \text{ feet NM}$$

(2) **The minimum segment length** for any segment after the first is the greater of 0.6 NM or the minimum turn distance from either table 2 (for segments starting at a fly-by waypoint) or table 3 (for segments starting at a fly-over waypoint). In addition, for segments terminating at a fly-by waypoint, the applicable minimum turn distance from table 2 must be added at the end of the segment. See figures 1A, 1B, 1C, 1D, and 1E.

(3) **The angle of intersection** between adjacent segments shall not exceed 120°.

c. Departure Area.

(1) **Primary Area.** The primary area has a width of 1,000 feet (± 500 feet from centerline) at the DER and splays at an angle of 7.5° relative to runway centerline to a width of ± 0.6 NM

(XTRK fix displacement tolerance). See figure 16. The primary area shall be expanded for turns. The size of the turn expansion area increases with speed. Use 250 KIAS to determine turn radii and distances from tables 2, 3, and 8 when the route ends before the aircraft reaches 10,000 feet MSL and 310 KIAS when the route includes flight above 10,000 feet MSL. If operational advantage can be obtained by using smaller turn radii and distances, restrict airspeed to 160 KIAS, 175 KIAS, 220 KIAS, or 250 KIAS and annotate the procedure accordingly. Departure area construction at turn waypoints depends on whether the primary area 7.5° splay reaches a width of ± 0.6 NM prior to the waypoint.

(a) Fly-by Waypoints (7.5° Splay Incomplete). In this case, the primary area width has not reached ± 0.6 NM prior to reaching the waypoint. Construct the outer edge of the primary area as follows: Transfer the width of the splay abeam the waypoint via an arc to the following segment. The arc is of radius equal to the attained half-width of the preceding segment (CB in figure 17) and is centered at the waypoint. Extend the arc to a line perpendicular to the centerline of the following segment and passing through the waypoint (A'E' in figure 17). Continue the 7.5° splay from that point to a width of ± 0.6 NM (B'F in figure 17). Construct the primary area inside fillet as follows: First, mirror the outer edge of the primary area beyond the waypoint (B'F in figure 17) across the centerline of the segment following the waypoint (D'G in figure 17). For turn angles 10° through 120°, fillet the inside of the primary area using the inside turn expansion radius from table 2 for the maximum selected airspeed. The center of the fillet is constructed on the bisector of the angle formed by edges of the primary area on the inside of the turn; i.e., angle JHI is equal to angle IHG in figure 17. For turn angles less than 10°, no fillet is required on the inside of the turn.

(b) Fly-by Waypoints (7.5° Splay Complete). For turn angles 10° through 120°, fillet the outside of the primary area using the outside turn reduction radius from table 8. Fillet the inside of the primary area using the inside turn expansion radius from table 2 for the maximum selected airspeed. The center of this fillet is constructed on the bisector of the angle formed by the edges of the primary area on the inside of the turn; i.e., angle ABC is equal to angle CBD in figure 18. See figure 18. For turn angles less than 10°, extend the primary area boundaries until they intersect. See figure 19.

(c) Fly-over Waypoints (7.5° Splay Incomplete). In this case, the primary area width has not reached ± 0.6 NM prior to reaching the waypoint. For turn angles less than 10°, extend the primary area boundaries until they intersect. See figure 19. For turn angles 10° or greater, construct the outer edge of the primary area as follows: First, extend the primary area beyond the fly-over waypoint by 0.3 NM (ATRK fix displacement tolerance) plus the roll anticipation distance from table 5 (F and G in figure 20). The width of this extension shall not exceed ± 0.6 NM. Next, construct the outside turn expansion by drawing an arc tangent to the outside extended primary area (F in figure 20). The center of this arc (A in figure 20) is located on a line connecting the endpoints of the extended primary area; i.e., an extension of line FG in figure 20. Determine the radius from table 3 for the maximum selected airspeed. Using this same radius, draw a second arc tangent to the inside extended primary area (G in figure 20). The center of this arc (A' in figure 20) is also located on the line connecting the endpoints of the extended primary area; i.e., the same line as A in figure 20. Connect the two arcs by drawing a line (BB' in figure 20) tangent to the two arcs. Next, construct a line (DD' in figure 20) perpendicular to the centerline of the segment following the fly-over waypoint. Position this line at a distance from the fly-over waypoint specified in the minimum turn distance column of table 3 for the maximum selected airspeed. Points D and D' are located 0.6 NM on either side of the segment centerline, respectively. Draw a line (D'E in figure 20) from the intersection of this perpendicular and the outside primary area boundary tangent to the outermost turn expansion arc. Construct the inner edge of the primary area as follows: Transfer the width of the splay abeam the waypoint via an arc to the following segment. The arc is of radius equal to the attained

half-width of the preceding segment (HI in figure 20) and is centered at the waypoint. Extend the arc to a line perpendicular to the centerline of the following segments and passing through the waypoint (KH in figure 20). Continue the 7.5° splay from that point to a width of ± 0.6 NM.

(d) Fly-over Waypoints (7.5° Splay Complete). In this case, the primary area width has reached ± 0.6 NM prior to reaching the waypoint. For turn angles less than 10°, extend the primary area boundaries until they intersect. See figure 19. For turn angles 10° or greater, construct the outer edge of the primary area as follows: First, extend the primary area beyond the fly-over waypoint by 0.3 NM (ATRK fix displacement tolerance) plus the roll anticipation distance from table 5 (F and G in figure 21). Next, construct the outside turn expansion by drawing an arc tangent to the outside extended primary area (F in figure 21). The center of this arc (A in figure 21) is located on a line connecting the endpoints of the extended primary area; i.e., an extension of line FG in figure 21. Determine the radius from table 3 for the maximum selected airspeed. Using this same radius, draw a second arc tangent to the inside extended primary area (G in figure 21). The center of this arc (A' in figure 21) is also located on the line connecting the endpoints of the extended primary area; i.e., the same line as A in figure 21. Connect the two arcs by drawing a line (BB' in figure 21) tangent to the two arcs. Next, construct a line (DD' in figure 21) perpendicular to the centerline of the segment following the fly-over waypoint. Position this line at a distance from the fly-over waypoint specified in the minimum turn distance column of table 3 for the maximum selected airspeed. Points D and D' are located 0.6 NM on either side of the segment centerline, respectively. Draw a line (D'E in figure 21) from the intersection of this perpendicular and the outside primary area boundary tangent to the outermost turn expansion arc.

(2) Secondary Area. The secondary area is constructed on both sides of the primary area. It begins at the DER and splays at an angle of 7.5° measured from the edge of the primary area. After the splay reaches a width of 1 NM, measured perpendicular to the edge of the primary area, the secondary area width remains 1 NM. See figure 16. Secondary area construction at turn waypoints depends on whether the secondary area 7.5° splay reaches a width of ± 1.0 NM prior to the waypoint.

(a) Fly-by Waypoints (7.5° Splay Incomplete). In this case, the secondary area width has not reached ± 1.0 NM prior to reaching the waypoint. Construct the outer edge of the secondary area as follows: Transfer the width of the splay abeam the waypoint via an arc to the following segment. The arc is of radius equal to the attained half-width of the preceding segment (CA in figure 17) and is centered at the waypoint. Extend the arc to a line perpendicular to the centerline of the following segment and passing through the waypoint (A'E' in figure 17). Continue the 7.5° splay from that point to a width of ± 1.0 NM (A'KL in figure 17). Construct the secondary area inside fillet as follows: First, mirror the outer edge of the secondary area beyond the waypoint (A'K in figure 17) across the centerline of the segment following the waypoint (E'M in figure 17). For turn angles 10° through 120°, fillet the inside of the secondary area using the inside turn expansion radius from table 2 for the maximum selected airspeed. The center of the fillet is constructed on the bisector of the angle formed by edges of the secondary area on the inside of the turn; i.e., angle JE'O is equal to angle OE'M in figure 17. For turn angles less than 10°, no fillet is required on the inside of the turn.

(b) Fly-by Waypoints (7.5° Splay Complete). For turn angles 10° through 120°, fillet the outside of the secondary area using the outside turn reduction radius from table 8. Fillet the inside of the secondary area using the inside turn expansion radius from table 2 for the maximum selected airspeed minus 1 NM. The center of this fillet is constructed on the bisector of the angle formed by the edges of the secondary area on the inside of the turn. See figure 18. For turn angles less than 10°, extend the secondary area boundaries until they intersect. See figure 19.

(c) Fly-over Waypoints (7.5° Splay Incomplete). In this case, the secondary area width has not reached 1.0 NM prior to reaching the waypoint. For turn angles less than 10°, extend the secondary area boundaries until they intersect. See figure 19. For turn angles 10° or greater, construct the outer edge of the secondary area as follows: The secondary area begins at the edge of the primary area at the DER and splays 7.5° from the edge of the primary area. Extend the edge of the secondary area until it joins an arc concentric with the primary area turn expansion (M in figure 20). The concentric arc is constructed using the outside turn expansion radius determined from table 3 for the maximum selected airspeed plus 1 NM. The center of this arc is the same as for the primary outer turn expansion area (A in figure 20). Using this same radius, draw a second arc concentric with the other primary turn expansion arc; i.e., centered at A' in figure 20. Connect the two arcs by drawing a line (PP' in figure 20) tangent to the two arcs. The remainder of the secondary area has a width of 1 NM and is constructed parallel to the edge of the primary area (QR in figure 20). Construct the inner edge of the secondary area as follows: The secondary area begins at the edge of the primary area at the DER and splays 7.5° from the edge of the primary area. Transfer the width of the splay abeam the waypoint via an arc to the following segment. The arc is of radius equal to the attained half-width of the preceding segment (HJ in figure 20) and is centered at the waypoint. Extend the arc to a line perpendicular to the centerline of the following segments and passing through the waypoint (LH in figure 20). Continue the 7.5° splay from that point to a width of 1 NM measured perpendicular to the edge of the primary area.

(d) Fly-over Waypoints (7.5° Splay Complete). In this case, the secondary area width has reached 1.0 NM prior to reaching the waypoint. For turn angles less than 10°, extend the secondary area boundaries until they intersect. See figure 19. For turn angles 10° or greater construct the outer edge of the secondary area as follows: Extend the edge of the secondary area until it joins an arc concentric with the primary area turn expansion. The concentric arc is constructed using the outside turn expansion radius determined from table 3 for the maximum selected airspeed plus 1 NM. The center of this arc is the same as for the primary outer turn expansion area (A in figure 21). Using this same radius, draw a second arc concentric with the other primary turn expansion arc; i.e., centered at A' in figure 21. Connect the two arcs by drawing a line (HH' in figure 21) tangent to the two arcs. The remainder of the secondary area has a width of 1 NM and is constructed parallel to the edge of the primary area (JK in figure 21). Construct the inner edge of the secondary area parallel to the edge of the primary area with a width of 1 NM.

d. Obstacle Clearance. The area considered for obstacle clearance for a flight segment between two waypoints starts at the earliest point the beginning waypoint can be identified and ends at the plotted position of the ending waypoint. Waypoint displacement tolerance for the TOWP need not be considered for departure procedures.

(1) Primary Area. In the primary area, an obstacle identification surface (OIS) of 40:1 is used. Obstacles which penetrate the OIS shall be avoided by specifying a climb gradient that will provide the ROC.

(a) The Obstacle Identification Surface (OIS) (40:1) begins at the height of the DER and rises in the direction of departure. In turn expansion areas, the OIS rises along the shortest distance in the primary area to the obstacle; i.e., the 40:1 surface rises along the shortest possible flightpath within the primary area.

(b) The minimum climb gradient required to clear an obstacle is determined from the formula:

$$G = \frac{48D + H}{D}$$

Where: G = Climb gradient (feet NM).
 H = Height of obstacle above DER (feet).
 D = Distance from DER measured along the shortest distance within the primary area (NM).

(c) The climb gradient applied shall be the greatest of 200 feet NM, the largest gradient required for obstacle clearance from the gradient required by paragraph 4-2a(1), paragraph 5-1c(1)(b), or that requested by the proponent. A climb gradient in excess of 500 feet NM is approved on a case-by-case basis by the FAA Flight Standards Service, Washington, DC.

1. Climb gradients begin at the DER.
2. Climb gradients shall be specified to a height at least 300 feet above the DER.
3. Climb gradients shall be specified (next higher 10 feet NM increments) to an MSL altitude (next higher 100-foot increments) or waypoint where a gradient greater than 200 feet NM is no longer required.
4. Order 8260.3B, paragraph 323a, applies.

(2) **Secondary Area.** The secondary area has a slope of 7:1, perpendicular to the edge of a turn expansion area. When there is no turn expansion area adjacent to the secondary area, the secondary area 7:1 slope is perpendicular to segment centerline. To evaluate an obstacle in the secondary area, determine the height of an equivalent obstacle on the edge of the primary area. Then, evaluate the equivalent obstacle height relative to the 40:1 OIS. The minimum climb gradient required to clear the obstacle is determined, as in paragraph 5-1c(1)(b), for the equivalent obstacle.

(3) **Climb Gradient Example.** Figure 22 shows a climb gradient computation example. The turn angle at the first waypoint is 30°, and because of operational restrictions, 160 KIAS criteria from table 2 is used. A 9,839-foot MSL obstacle is located in the secondary area, 2,700 feet from the edge of the primary area, as shown in figure 22. The height of an equivalent obstacle on the edge of the primary area must first be determined:

$$\begin{array}{r}
 \text{7:1 slope to edge of primary area: } \frac{2,700'}{7} = 385.7' \\
 \\
 \text{Height of equivalent obstacle: } \frac{9,839.0' - 385.7'}{9,453.3'}
 \end{array}$$

Next, the distance (D) of the equivalent obstacle from the DER is determined:

$$D = \overline{AB} + \overline{BC} + \overline{CD} \text{ where A, B, C and D are shown in figure 22.}$$

The distance from A to B (denoted as \overline{AB}) is measured as 7,364 feet. The distance around the arc from B to C (denoted as \overline{BC}) can be computed as follows:

$$\overline{BC} = (\text{arc radius in feet}) \times (\text{angle of turn}) \times (.017453).$$

From table 2 for 160 KIAS and a turn angle of 30° the radius is 3.28 NM or 19,929.6'. Therefore, $\overline{BC} = (19,929.6') \times (30^\circ) \times (.017453) = 10,435'$.

The distance from C to D (denoted as \overline{CD}) is measured as 3,545'. Then,
 $D = 7,364' + 10,435' + 3,545' = 21,344' = 3.51 \text{ NM.}$

Next, the height of the OIS at the equivalent obstacle is determined:

$$40:1 \text{ slope from DER: } \frac{21,344'}{40} = 533.6'$$

Elev DER	7,640.0'
40:1	+533.6'
OIS	<u>8,173.6'</u>

Because the height of the obstacle (9,453.3 feet) is greater than the height of the OIS (8,173.6 feet), an OIS penetration exists. The minimum climb gradient is now computed:

H = Height of equivalent obstacle above DER:

OBST	9,453.3'
Elev DER	- 7,640.0'
H	<u>1,813.3'</u>

$$G = \frac{48D + H}{D} = \frac{48(3.513) + 1813.3}{3.513} = 564.2' \text{ NM}$$

The required climb gradient is: MIN CLIMB OF 570' PER NM TO 9,500'. Since the climb gradient exceeds 500 feet NM, approval from the FAA Flight Standards Service, Washington, DC, is required.

CHAPTER 6. FMS MISSED APPROACH CRITERIA

6-1. FMS MISSED APPROACH (MA) CRITERIA.

a. General. These criteria are applicable to FMS Nonprecision, Microwave Landing System (MLS), Instrument Landing System (ILS), and localizer approaches which satisfy the alignment criteria of this order, paragraph 3-2d; Order 8260.36, paragraph 16a; and Order 8260.3B, paragraphs 930a and 952, respectively.

b. Route. The FMS navigation routing begins at the RWP for precision approaches and at the MAWP for LOC or FMS nonprecision approaches. See figures 23, 24, 25, and 26. The route consists of a sequence of connected straight flight segments. A fly-by or fly-over waypoint shall be specified at the beginning and end of each segment. The waypoint at which the route ends shall not be located prior to the point where the aircraft, climbing at the minimum prescribed climb gradient for each segment, reaches the minimum altitude for en route flight or holding, whichever is appropriate. The missed approach route should be the same as the FMS departure route for the runway served.

(1) **The minimum distance** from the missed approach point to the end of the first segment is 1.5 NM, where the first segment ends at a fly-over waypoint. Where the first segment ends at a fly-by waypoint, the minimum distance from the missed approach point to the end of the first segment is 1.5 NM, plus the applicable minimum turn distance from table 2.

(2) **The minimum segment length** for any segment after the first is the greater of 0.6 NM or the minimum turn distance from table 2 (for segments starting at a fly-by waypoint) or table 3 (for segments starting at a fly-over waypoint). In addition, for segments terminating at a fly-by waypoint, the applicable minimum turn distance from table 2 at the end of the segment must be added. See figures 1A, 1B, 1C, 1D, and 1E.

(3) **For FMS nonprecision missed approach**, turns at the MAWP shall not exceed 3°.

(4) **The angle of intersection** between adjacent segments shall not exceed 120°.

c. Missed Approach Area.

(1) Primary Area.

(a) FMS Nonprecision Procedures. The primary area begins at the earliest point the MAWP can be identified (0.3 NM prior to the waypoint). The width of the missed approach area at the point where the primary area begins is the same as the final approach segment primary area (± 0.6 NM). See figure 23.

(b) Localizer Procedures. The primary area begins at the earliest point the missed approach waypoint can be identified (0.3 NM prior to the waypoint). The width of the missed approach area at the point where the primary area begins is the same as the final approach segment primary area width at that point. The missed approach area splays at 7.5° to a width of 0.6 NM (XTRK fix displacement tolerance). See figure 24.

(c) **ILS and MLS Procedures.** The primary area begins at the missed approach point. The width of the missed approach primary area at the missed approach point is the same as the final approach segment primary area width at that point. The missed approach area splays at 7.5° to a width of 0.6 NM. See figures 25 and 27.

(d) **Construction for Procedures Offset 3° or Less.** The missed approach primary area splays at 7.5° relative to the offset course from a point (B in figures 26 and 28) located on the outside edge of the primary area at the missed approach point. The splay continues to a point (C in figures 26 and 28) located on a line perpendicular to the segment centerline through the RWP. Transfer the attained width (X in figures 26 and 28) to a point (D in figures 26 and 28) on the same perpendicular line extended to the opposite side of segment centerline. From the two points determined above (C and D in figures 26 and 28) continue the 7.5° splays relative to segment centerline to a width of ± 0.6 NM. See figures 26 and 28.

(e) **Turn Expansion Areas.** Paragraphs 5-1b(1)(a) through 5-1b(1)(d) apply to primary area turn expansion.

(2) **Secondary Area.** The secondary area is constructed on both sides of the primary area.

(a) **FMS Nonprecision Procedures.** The secondary area begins at the earliest point the MAWP can be identified (0.3 NM prior to the waypoint). The width of the secondary area is the same as the final approach segment secondary area (1 NM). See figure 23.

(b) **Localizer Procedures.** For localizer approaches, the secondary area begins at the earliest point the missed approach waypoint can be identified (0.3 NM prior to the waypoint). It has zero width at this point. The total segment width increases to ± 0.5 NM at a point 1.5 NM from the missed approach waypoint. Beyond this point, the secondary area splays at an angle of 15° relative to segment centerline until reaching a width of 1 NM, measured perpendicular to the edge of the primary area. Thereafter, the secondary area width is 1 NM. See figure 24.

(c) **ILS and MLS Procedures.** For ILS procedures designed using Order 8260.3B, section 1 is constructed in accordance with paragraph 942a. Similarly, for ILS and MLS procedures designed using Order 8260.36, section 1 is constructed in accordance with paragraph 19a. That portion of section 1 not contained in the primary area is secondary area. See figures 25 and 27. Beyond the end of section 1, the secondary area splays at an angle of 15° relative to segment centerline until reaching a width of 1 NM, measured perpendicular to the primary boundary. Thereafter, the secondary area width is 1 NM.

(d) **Construction for Procedures Offset 3° or Less.** Construct section 1 only on the outside of the turn at the runway waypoint (BE in figures 26 and 28). Construct a line through the outside corner of section 1, perpendicular to the centerline of the segment following the runway waypoint (EF in figure 26). Transfer the width of this line (width "Y" in figures 26 and 28) to the inside of the turn (G in figures 26 and 28). Construct the inside edge of the primary area by drawing a line from the edge of the primary area abeam the missed approach point to this point (AG in figures 26 and 28). The secondary area then splays at an angle of 15° relative to segment centerline, to a width of 1 NM, measured perpendicular from the edge of the primary area.

(e) **Turn Expansion Areas.** Paragraphs 5-1b(2)(a) through 5-1b(2)(d) apply to secondary area turn expansion.

d. Obstacle Clearance.

(1) **Primary Area.** The 40:1 missed approach surface for an FMS nonprecision approach begins at the edge of the MAWP displacement tolerance area (A-B in figure 23). The height of the missed approach surface at its beginning is determined by subtracting the required final approach obstacle clearance and any minima adjustments from the MDA. The 40:1 missed approach surface begins at the height specified in Order 8260.3B, paragraph 957, for localizer approaches. For ILS procedures designed using Order 8260.3B, the 40:1 missed approach surface begins at the height specified in paragraph 944a. For MLS and ILS procedures designed using Order 8260.36, paragraph 19d, applies, and the 40:1 missed approach surface begins at the end of section 1. Obstacles which penetrate the missed approach surface shall be avoided by increasing the MDA or DH or specifying a climb gradient that will provide the ROC.

(a) The minimum climb gradient required to clear an obstacle is determined from the formula:

$$G = \frac{48D + H}{D}$$

Where: G = Climb gradient (feet NM)

H = Height of obstacle above start of the missed approach surface (feet)

D = Distance from the missed approach point for ILS and MLS procedures measured along the shortest distance within the primary area (NM). Distance from the latest point the missed approach point can be identified (0.3 NM beyond the missed approach point) for FMS nonprecision and localizer procedures.

(b) The climb gradient applied shall be the greatest of 200 feet NM, the largest gradient required for obstacle clearance from paragraph 6-1d(1)(a), or that requested by the proponent. Any procedure requiring a missed approach climb gradient in excess of 200 feet NM shall require a waiver issued by Flight Standards Service.

(2) **Secondary Area.** The secondary area has a slope of 7:1, perpendicular to the edge of the turn expansion area. When there is no turn expansion area adjacent to the secondary area, the secondary area 7:1 slope is perpendicular to segment centerline. To evaluate an obstacle in the secondary area, determine the height of an equivalent obstacle on the edge of the primary area. Then, evaluate the equivalent obstacle height relative to the 40:1 OIS.

**CHAPTER 7. SIMULTANEOUS CONVERGING ILS APPROACHES
AIDED BY FMS LNAV MISSED APPROACH**

7-1. SIMULTANEOUS ILS CONVERGING APPROACHES AIDED BY FMS LNAV MISSED APPROACH. This criteria is applied to the missed approach emanating from an ILS which serves a converging runway while the main traffic flow is to one or more authorized simultaneous parallel ILS runway(s). See figure 29. The runway(s) which are approved for simultaneous parallel operation are primary. The runway converging with a runway approved for simultaneous parallel is secondary. The missed approach segment for the ILS aided by FMS LNAV missed approach is made as a combination straight section portion immediately followed by an FMS LNAV computed/directed turning portion, based on RWP position, and flown by flight director assisted manual flight or with the aircraft's autoflight system. See figure 29. The FMS LNAV systems contained in the /E or /F equipment suffix provide turn commands predicated on the distance to the RWP position, the accuracy of which is presented to the FMS through multi-sensor navigation inputs.

a. FMS LNAV Missed Approach (MA) Criteria.

(1) General Requirements.

(a) Equipment. Procedures designed using this criteria are standard procedures and are limited to aircraft qualifying for the /E or /F equipment suffix, or equivalent criteria. The pilot must be able to select this specific ILS contained within the FMS LNAV navigation data base and for compliance with this criteria, the required missed approach routing must be automatically supplied to the pilot. This criteria may be used for design of procedures used by Category D aircraft, provided sufficient runway length exists, and the requirement for /E or /F FMS LNAV with automatic entry of missed approach routing is met.

(b) Minimums. The minimum DH shall be 650 feet.

(c) Applicable Directives/Documents. This criteria is applicable to ILS and MLS approaches which satisfy the alignment criteria of Order 8260.3B, paragraphs 930a and 952, and Order 8260.36A, paragraph 17a.

FAA ORDERS/DOCUMENTS	APPLICATION
Order 8260.3B, paragraph 930 or 8260.36A	ILS/MLS Final Approach Segment
Order 8260.3B, paragraph 931 or 8260.36A	ILS/MLS Final Approach Obstacle Clearance
Order 8260.40B, paragraph 6-1b	FMS LNAV MA Segment
Order 8260.40B, paragraph 7-1a(5)	ILS/FMS LNAV MA Obstacle Clearance Outside the Intended Track
Order 8260.3B, Order 8260.3B, paragraphs 944b, c, and d	ILS/FMS LNAV MA Obstacle Clearance Inside the Intended Track

NOTE: Paragraph 7-1a(5) and Order 8260.3B, paragraphs 944b, c, and d, are applied. Order 8260.3B, paragraph 944c, applies since positive course guidance is provided by the FMS LNAV during the missed approach segment.

(d) **Airport Elevation Limit.** This criteria is restricted to airport elevations up to 1,000 feet MSL.

(e) **MA Holding Point.** The standard ILS procedure to the secondary runway being served by the ILS converging procedure aided by FMS LNAV missed approach shall utilize the same MA holding point as the ILS/FMS LNAV converging procedure.

(f) **Runway Threshold Waypoint.** The RWP specified in paragraph 6-1h shall be a fly-by waypoint.

(g) **Table 2 Application.** The minimum distance requirement of paragraph 6-1b(1) shall not apply.

(2) **MA Route.** The MA procedure is a sequence of waypoints from the DH (MAP), to the RWP, then to the MA holding fix. Additional waypoints may be required between the RWP and the MA holding fix. Establish a turn of 90° or more, from the FAC at the RWP, in a direction away from the primary ILS approach runway. The fix/waypoint at which the MA procedure ends shall not be located prior to the point where the aircraft, climbing at the minimum prescribed climb gradient for each segment, reaches the minimum altitude for en route flight or holding, whichever is appropriate.

(3) **MA Area.**

(a) **Length of Section 1.** The minimum length (L) from the missed approach point to the end of section 1, is calculated by the formula:

$$L = (\text{HAT} / \tan \theta - \text{TCH} / \tan \theta) + 0.3$$

or

$$L = (\text{HAT} / \tan \theta - \text{GPI distance}) + 0.3$$

Where θ is the ILS glidepath angle or MLS elevation angle. Use the formula associated with the *lesser* of $\text{TCH} / \tan \theta$ or GPI distance. (Use the larger value of L, minimum length from missed approach point.)

(b) **Width.** The beginning width of the section 1 MA primary area coincides with the final approach primary area width at the MAP.

1. Primary Area. The section 1 primary area is centered on the final approach course (FAC) and splays from points (p) on each side of the ILS final primary area at the MAP at 7.5° relative to the FAC to reach 0.6 NM width either side of FAC at/before a line L3 perpendicular to the FAC at the threshold. Where the splay reaches 0.6 NM width prior to L3, maintain the 0.6 NM width to points (x) located on line (L3) either side of the FAC. Where the splay would reach 0.6 NM after L3, connect points (p) directly to points (x). The line connecting points (y) is the end of section 1. See figure 29.

a. For the area outside of the turn. The width of 0.6 NM continues from points (x) to points (y) on each side of the FAC on a line perpendicular to the FAC at the extent of the fix displacement tolerance. For a turn, transfer the 0.6 NM width, via a 0.6 NM radius arc, centered at point (a) at the intersection of the section 1 centerline extended and the end of section 1, to point (b) located on the outer primary area boundary. Locate point (b) where a line splaying down at 7.5° relative to the next segment centerline is tangent to the transfer arc. Connect this splay-down line to the outer primary area boundary.

b. For the area inside of the turn. Construct a line offset from the FAC by 0.6 NM to the inside of the turn, connected to the ILS final primary area boundary. Extend this line (L1) to a point 0.6 NM from the centerline of the next segment. From that point, extend the line (L2) parallel to the centerline of the next segment. Construct a fillet inside these two lines using the appropriate radius from table 2 with the fillet center point located on the bisector of the angle between the two segment centerlines. The fillet and its connection to the ILS primary boundary constitute the inner boundary of the turn area. Eliminate lines L1 and L2 from the fillet tangent points to their point of joining.

2. Secondary Area. The secondary area for outside of the turn begins at point (p) on the ILS final approach primary area boundary at the MAP. There is no secondary on the inside of the turn until near turn completion.

Width. The outer secondary area boundary splays from points (pp) on each side of the ILS final primary area at the MAP at 15° relative to the FAS centerline until reaching 1 NM width measured perpendicularly from FAS centerline at 1.5 NM from the DH (MAP). From that point, it continues to splay to a width of 1 NM measured perpendicularly from the primary area boundary. Where the splay reaches 1 NM width prior to L3, maintain the 1 NM width through points (xx) to points (yy). Where the splay would reach 1 NM width after L3, connect points (pp) directly to points (xx). For a 90° turn, transfer the attained width from points (yy) to points (bb) on section 1 centerline extended via an arc centered at point (a). From points (bb), the boundary splays outward at 15° relative to the next segment centerline until reaching a width of 1 NM measured perpendicularly from the primary area boundary. Continue the secondary area boundary in the direction of flight at this 1 NM width. The inner secondary area boundary begins where a line parallel to the next segment centerline and at a distance of 1 NM measured perpendicularly from the primary area boundary, intersects the fillet connecting the primary area boundaries on the inside of the turn. It then extends in the direction of flight at this 1 NM width.

(4) Allowed Procedure. As in FAA Order 7110.98, Simultaneous Converging Instrument Approaches (SCIA), secondary surfaces on the outside of the turn are not applied where the secondary area overlaps the adjacent ILS or the simultaneous ILS/FMS LNAV procedure secondary area. No overlap of the primary surfaces shall be allowed between the primary runway ILS missed approach and the secondary runway missed approach in the converging pair. This requirement is not subject to waiver. To avoid a primary surface overlap condition the ILS missed approach for the primary runway in the converging pair may be turned up to 15° divergent from the secondary runway ILS/FMS LNAV missed approach. Another method to gain some primary surface overlap relief is to reduce the RWP fix displacement tolerance from 0.3 NM to that value verified for a specific location/runway; reference paragraph 8. Both of these methods requires waiver action.

(5) Obstacle Clearance.

Primary Area. The 40:1 missed approach surface begins at the height specified in Order 8260.3B, paragraph 944a for ILS procedures designed using Order 8260.3B. For MLS and ILS procedures designed using Order 8260.36A, paragraph 19d applies, and the 40:1 missed approach surface begins at the end of section 1, however altered in distance by paragraph 7-1a(3)(a) of this order. Obstacles which penetrate the missed approach surface shall be avoided by increasing the DH/A or specifying a climb gradient that will provide the ROC. Any missed approach requiring a climb gradient in excess of 200 feet/NM shall require a waiver.

(6) Procedure Annotation. The SIAP for the ILS/FMS converging approach shall be annotated as follows: "ILS/FMS RWY _____ /E or /F AIRCRAFT CERTIFICATION REQUIRED".

(7) SIAP Briefing Page. A briefing page must accompany the ILS/FMS converging approach procedure citing requirements on how and when to operate the aircraft's FMS LNAV and perform the missed approach to assure optimum desired track containment. Those requirements are listed below. In addition, the briefing page shall have a HEADING TO FLY in the event of FMS LNAV failure after Decision Height (DH) is reached on the ILS or MLS and prior to reaching a point that is not less than one (1) NM inbound to the runway threshold of the runway of intended landing where the FMS-directed turn is required to begin. The HEADING TO FLY shall be the course of the intended FMS route upon missed turn completion. The ILS/FMS LNAV converging approach briefing page notes shall contain, as a minimum, the following items:

(a) LNAV/VNAV is mandatory for the execution of the converging ILS/FMS, RWY _____ /E or /F missed approach.

(b) Vectoring to the ILS inside of any waypoint in the FMS LNAV approach string of waypoints may delete the LNAV required missed approach prediction route. Application of NAV/LNAV without the missed approach prediction route displayed will result in HDG HOLD mode at time of LNAV engagement.

(c) LNAV/VNAV mode must be selected and verified immediately after DH and after selecting Take Off/Go-Around (TOGA), Go-Around Mode.

(d) Do not de-select TOGA nor initiate a speed increase prior to or during the climbing turn of the missed approach.

(e) In the event of LNAV engagement failure when selected after TOGA initiation, turn to HEADING _____ and execute the published missed approach.

CHAPTER 8. FMS PROCEDURAL TOOLS

8-1. TAILORED PROCEDURES. Procedure construction data contained in tables 2, 3, and 5 are derived from a mathematical model. Operational advantage may be obtained by tailoring the parameters of this model to the specific site, aircraft operating characteristics, and other operational limitations; e.g., wind restrictions. A computer program has been developed by the Flight Procedure Standards Branch to generate tailored data in lieu of tables 2, 3, and 5. Use of this program is approved on a case-by-case basis by the FAA Flight Standards Service, Washington, DC.

8-2. FMS DME/DME PROCEDURE SCREENING MODEL. The procedure criteria contained in this order is predicated on the FMS Navigational System Error (NSE) being no greater than 0.3 NM. For FMS relying on DME/DME updating, individual DME availability and geometry between DME/DME pairs can affect the NSE and can cause the NSE to exceed the required 0.3 NM. In order to assist the procedures specialist in determining whether the 0.3 NM NSE can be maintained throughout a particular procedure based on DME/DME, the Flight Procedure Standards Branch has developed a computer program which contains a simple Kalman filter model. The model uses statistical distributions for IRU and DME errors and has access to a database containing information on all DME locations within the United States. The specialist shall enter the route of flight and minimum altitudes for each segment of a proposed procedure, and the program will compute theoretical NSE values along the flightpath. If these model-generated NSE values are less than or equal to 0.3 NM, then, the proposed procedure is feasible for FMS aircraft using DME/DME updating.

If the maintenance of 0.3 NM NSE is based on the availability of one or more individual DME facilities, the model will flag these as being "CRITICAL FACILITIES." A critical facility shall be annotated on the appropriate 8260 form, for example, "When updating using DME and IAH DME OTS, procedure NA."

The program will also output all DME facilities theoretically receivable at the FAF. The list of theoretically receivable facilities shall be flight inspected for coverage at the FAF and FAF altitude. All potentially usable DME facilities shall be screened for necessary expanded service volume (ESV) requirements and, if, required, ESV application, FAA Form 6050-4, submitted. After evaluation and verification by Flight Inspection, those facilities actually receivable at the FAF, shall be shown as an uncharted note on the appropriate 8260 form. Example - "DME facilities receivable at the FAF: IAH, HUB, MHF, DAS."

***NOTE:** The model described above is only a procedure development tool to test the initial feasibility of a proposed procedure. A successful outcome for a particular procedure is not a substitute for flight inspection. Similarly, an unsuccessful outcome is not the final arbiter of the feasibility of any particular procedure. Additional investigation, which may include a test flight by either an FAA Flight Inspection Office or the proponent, shall be accomplished.*

APPENDIX 1. FIGURES AND TABLES

FIGURES	Page No.
1A. Minimum Segment Length- Fly-over to Fly-by	3
1B. Minimum Segment Length- Fly-over to Fly-over	4
1C. Minimum Segment Length- Fly-by to Fly-by	5
1D. Minimum Segment Length- Fly-by to Fly-over	6
1E. Minimum Segment Length- Fly-by to Fly-by (Turn in the same direction)	7
2. Minimum Segment Length Determination	8
3. En route Waypoint Fly-over Expansion	9
4. FMS Nonprecision Approach Criteria	10
5. FMS Nonprecision Approach Criteria, Short Segment Lengths	11
6. Segmented Path Initial Segment	12
7. Final Approach Segment	13
8. Extension of Final Approach Segment to Runway Threshold	14
9. Obstacle Rich Environment Assessment	15
10. FMS Transition to ILS Final	16
11. FMS Intermediate Segment to ILS Final Segment	17
12. IWP Placement, Example 1	18
13. IWP Placement, Example 2	19
14. IWP Placement, Example 3	20
15. Minimum First Segment Length	21
16. Departure Area	22
17. Departure Area, Fly-by Waypoint, Splay Incomplete	23
18. Departure Area, Fly-by Waypoint, Splay Complete	24

FIGURES

Page No.

19. Departure Area, Turn Angles Less Than 10 Degrees.....	25
20. Departure Area, Fly-over Waypoint, Splay Incomplete	26
21. Departure Area, Fly-over Waypoint, Splay Complete.....	27
22. Climb Gradient Computation.....	28
23. FMS Nonprecision Approach Missed Approach Area	29
24. FMS Missed Approach Area for Localizer Final Approach.....	30
25. FMS Missed Approach Area for ILS Final Approach	31
26. FMS Missed Approach Area for ILS Offset 3 Degrees or Less	32
27. FMS Missed Approach Area for MLS Final Approach	33
28. FMS Missed Approach Area for MLS Offset 3 Degrees or Less	34
29. Converging Approach FMS Missed Approach	35

TABLES

1. Waypoint Design Criteria.....	36
2. Fly-By Waypoint Minimum Turn Distance and Radius	37
3. Fly-Over Waypoint Minimum Turn Distance and Radius.....	38
4. Segment vs. Speed.....	39
5. Roll Anticipation Distance (RAD)	40
6. Minimum Length of FAF Final Approach Segment (NM)	41
7. Minimum Intermediate Segment Length for FMS/ILS Approach.....	42
8. Fly-By Waypoint Minimum Turn Radius.....	43

Figure 1A. MINIMUM SEGMENT LENGTH
FLY-OVER TO FLY-BY

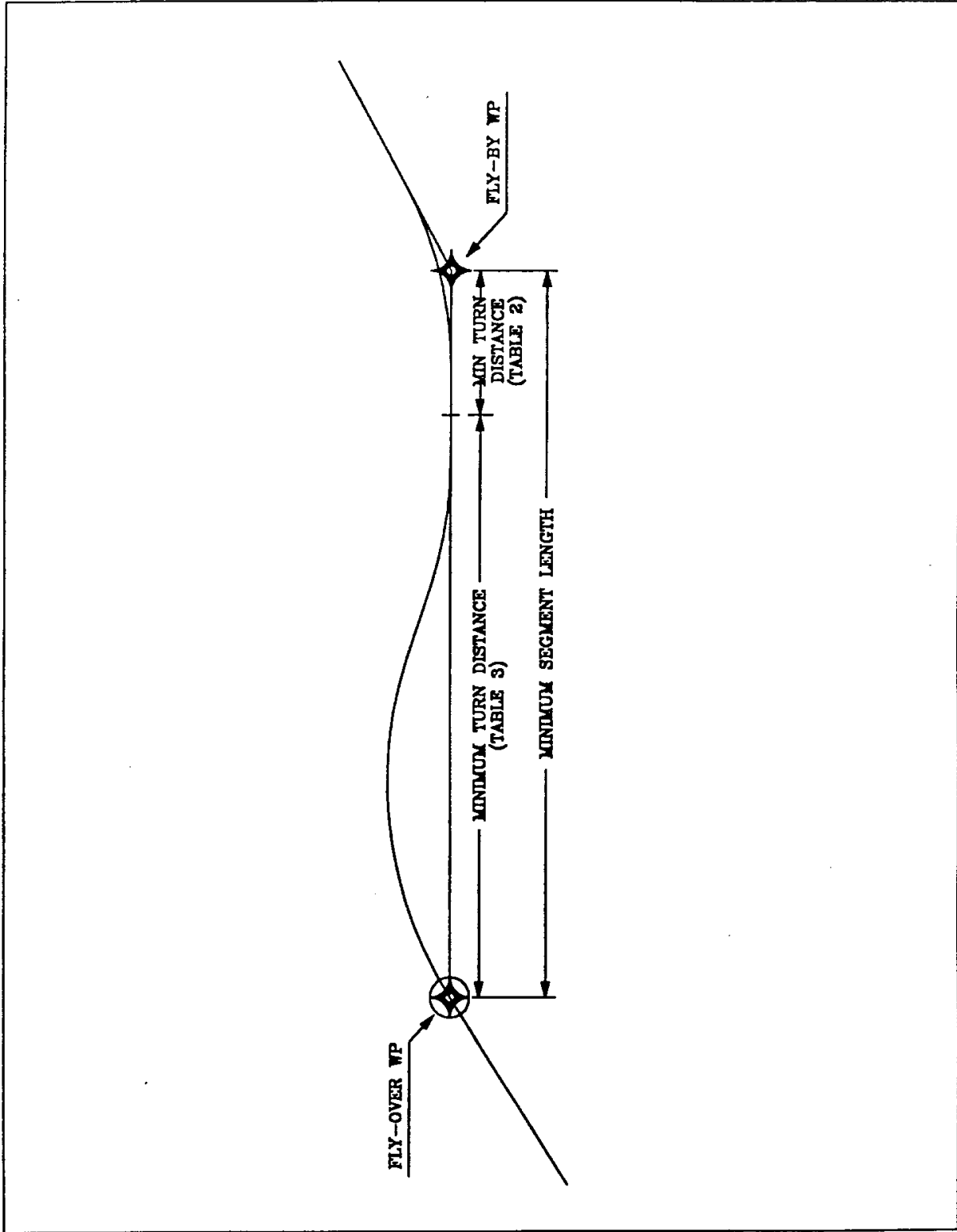

Figure 1B. MINIMUM SEGMENT LENGTH
FLY-OVER TO FLY-OVER

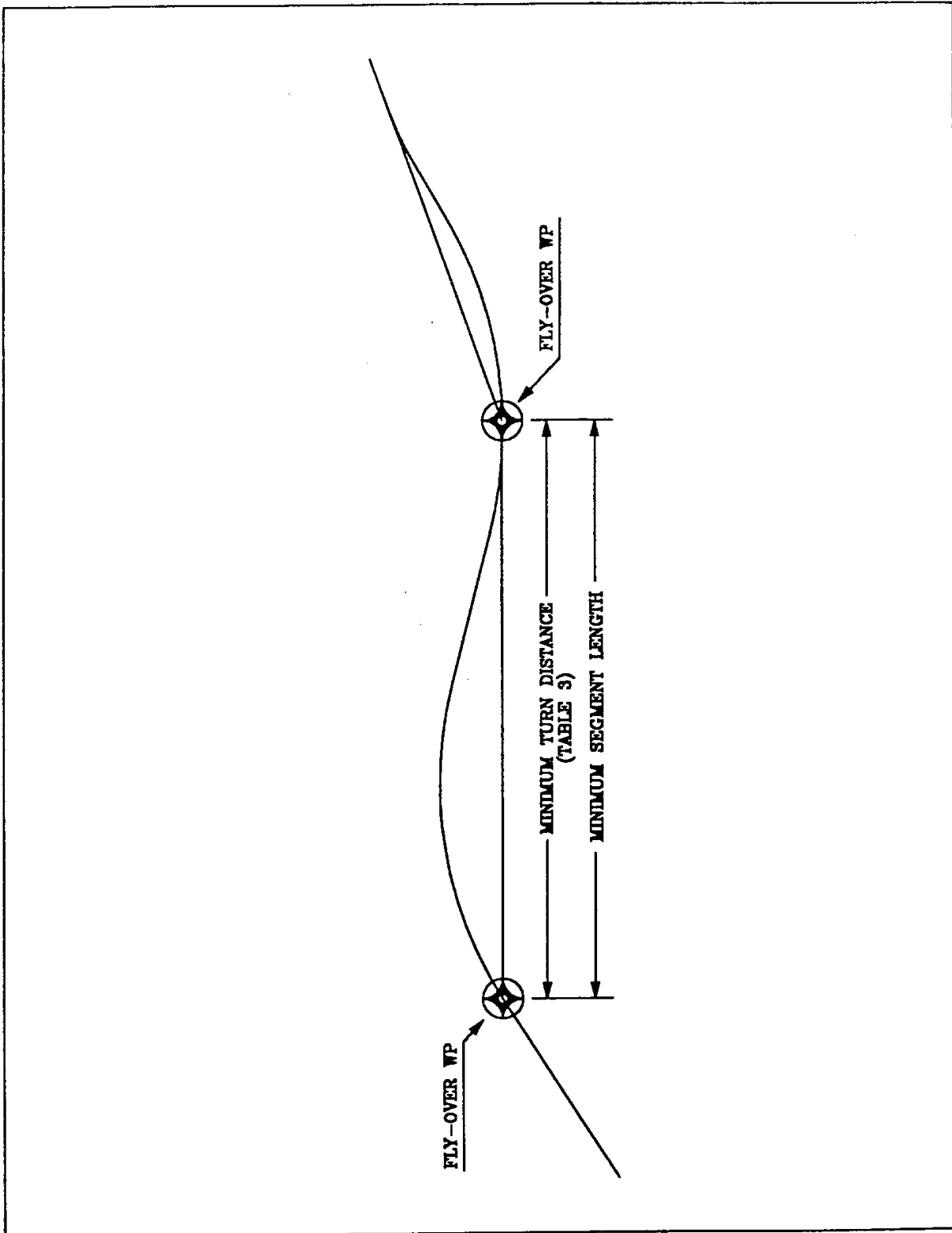

Figure 1C. MINIMUM SEGMENT LENGTH
FLY-BY TO FLY-BY

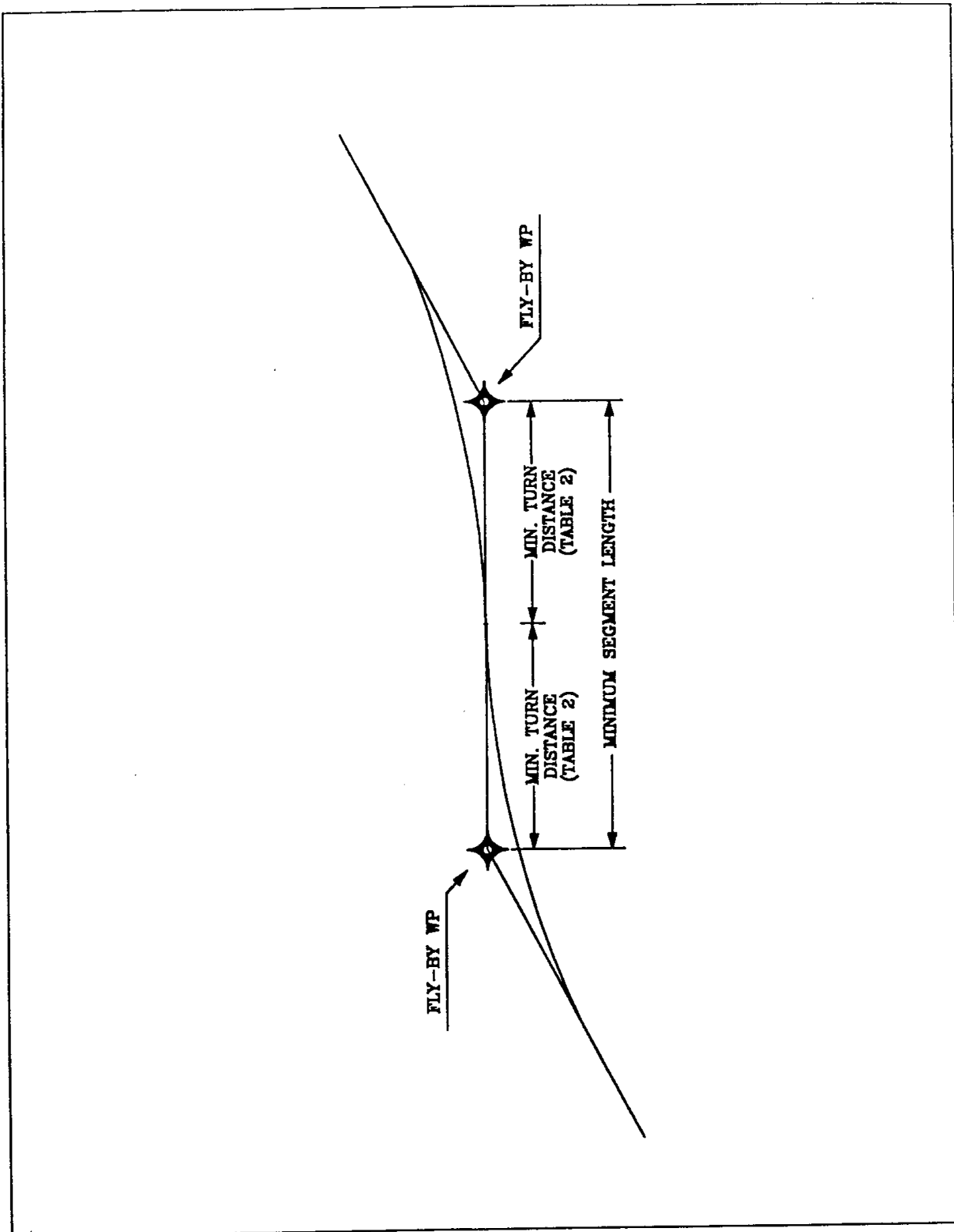

Figure 1D. MINIMUM SEGMENT LENGTH
FLY-BY TO FLY-OVER

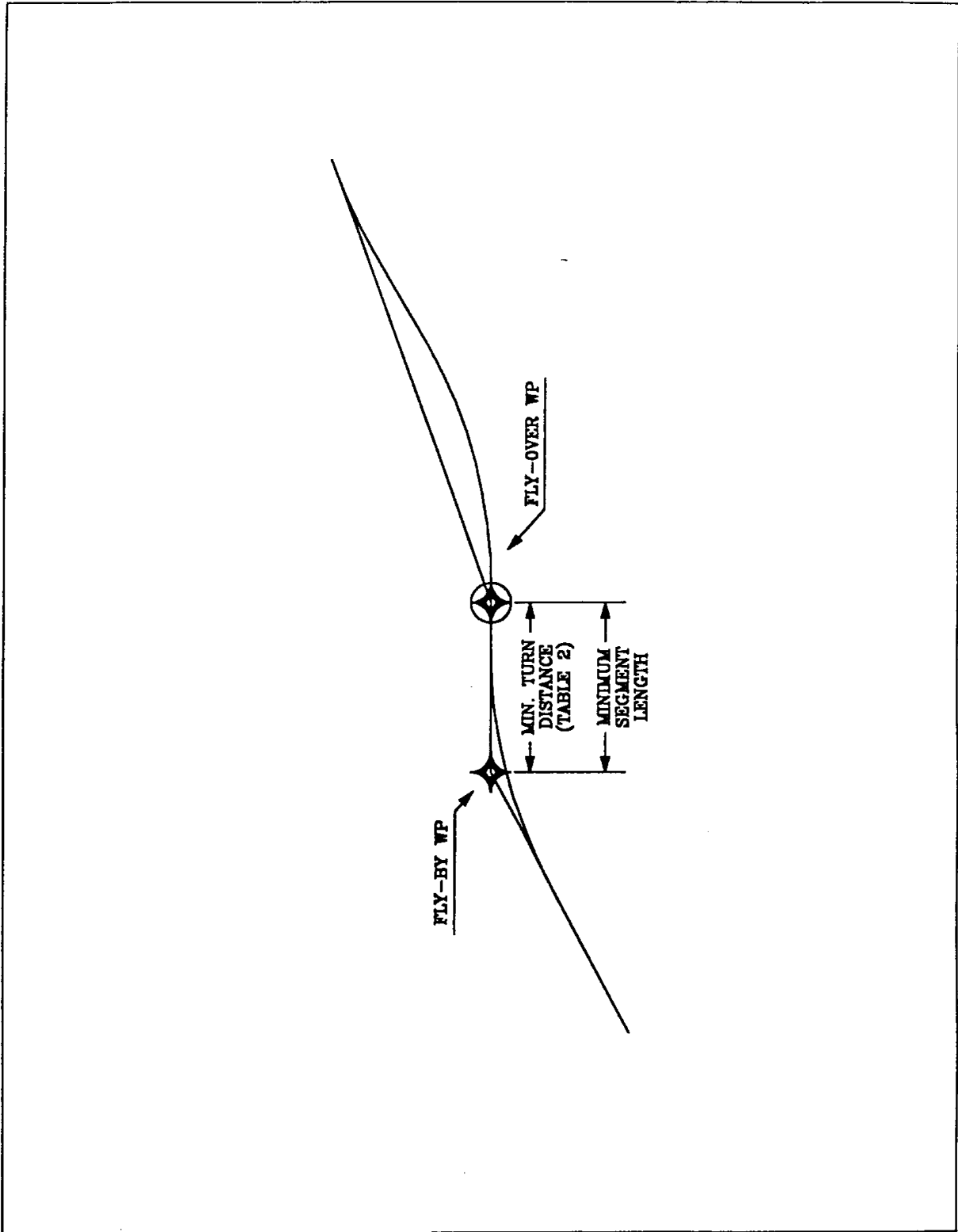

Figure 1E. MINIMUM SEGMENT LENGTH
FLY-BY TO FLY-BY (TURN IN SAME DIRECTION)

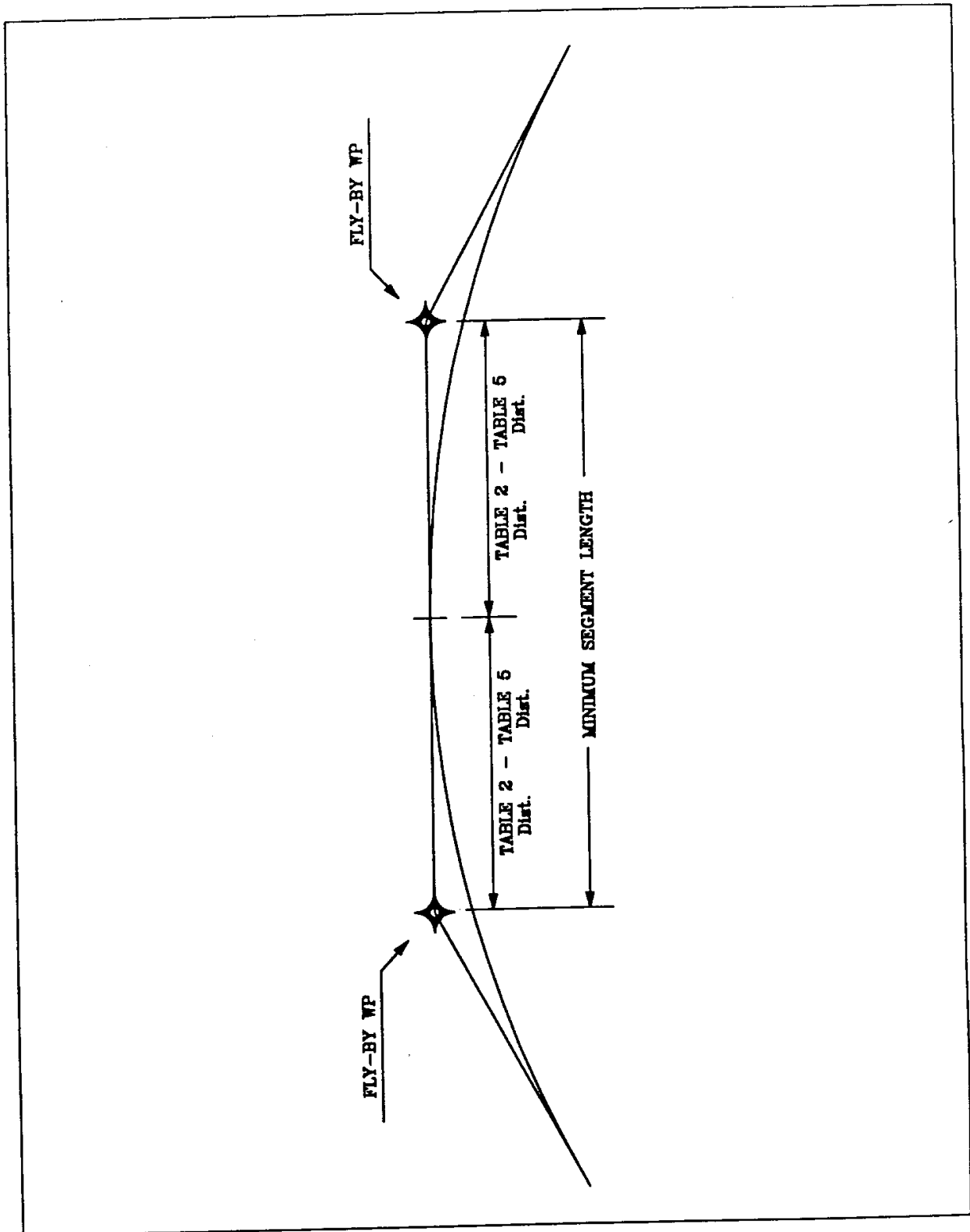

Figure 2. MINIMUM SEGMENT LENGTH DETERMINATION

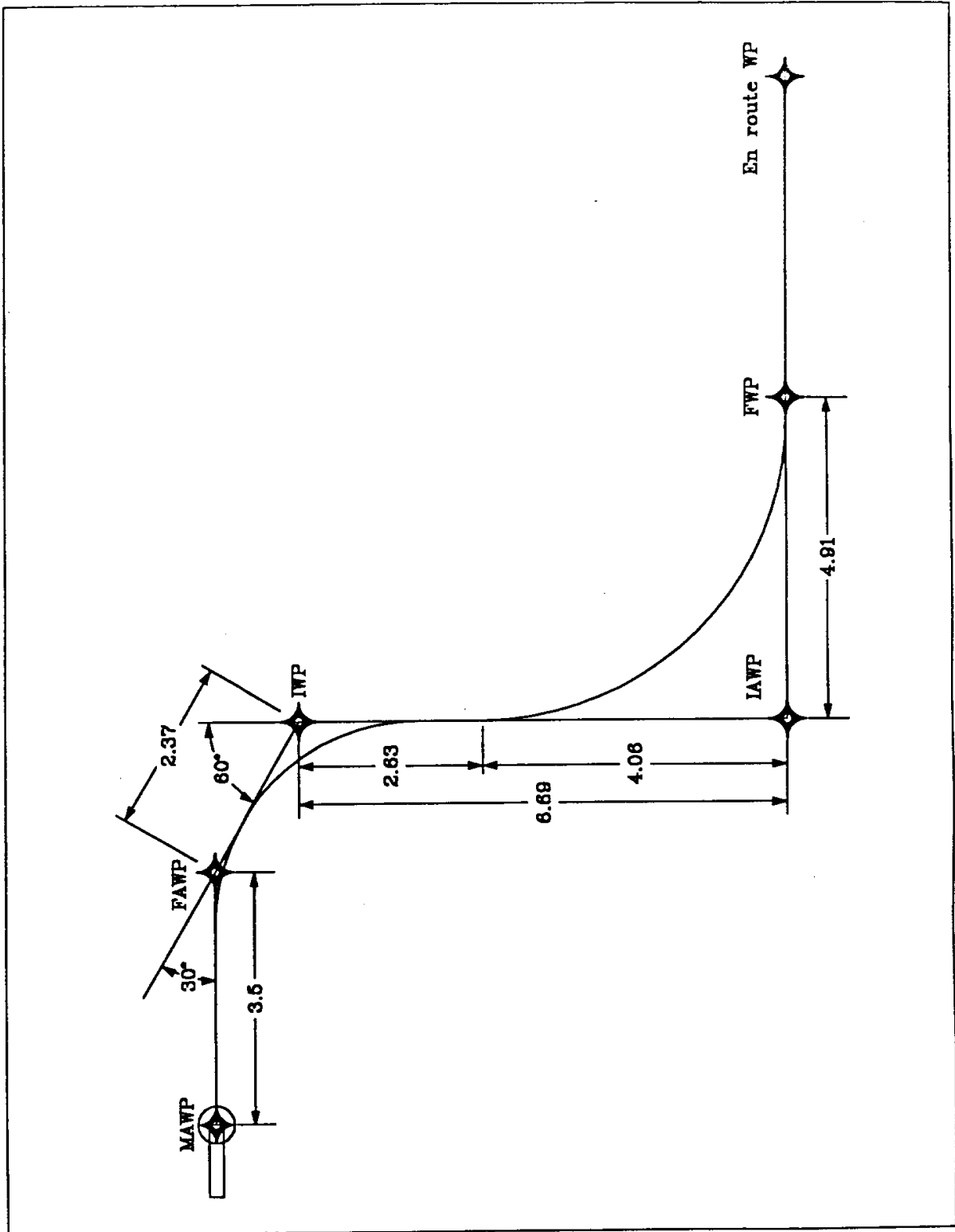

Figure 3. EN ROUTE WAYPOINT FLY-OVER EXPANSION

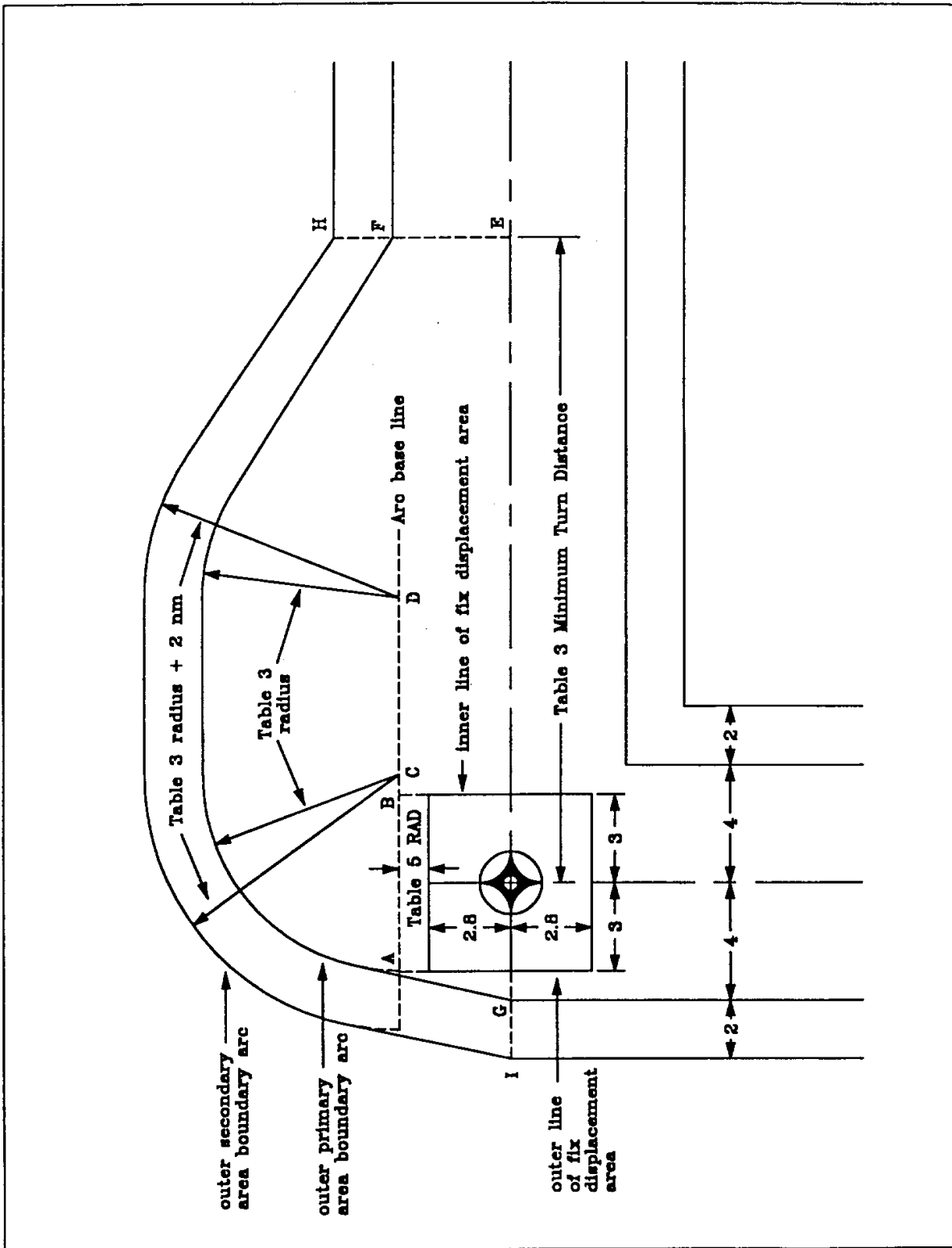

Figure 5. FMS NONPRECISION APPROACH CRITERIA
SHORT SEGMENT LENGTHS

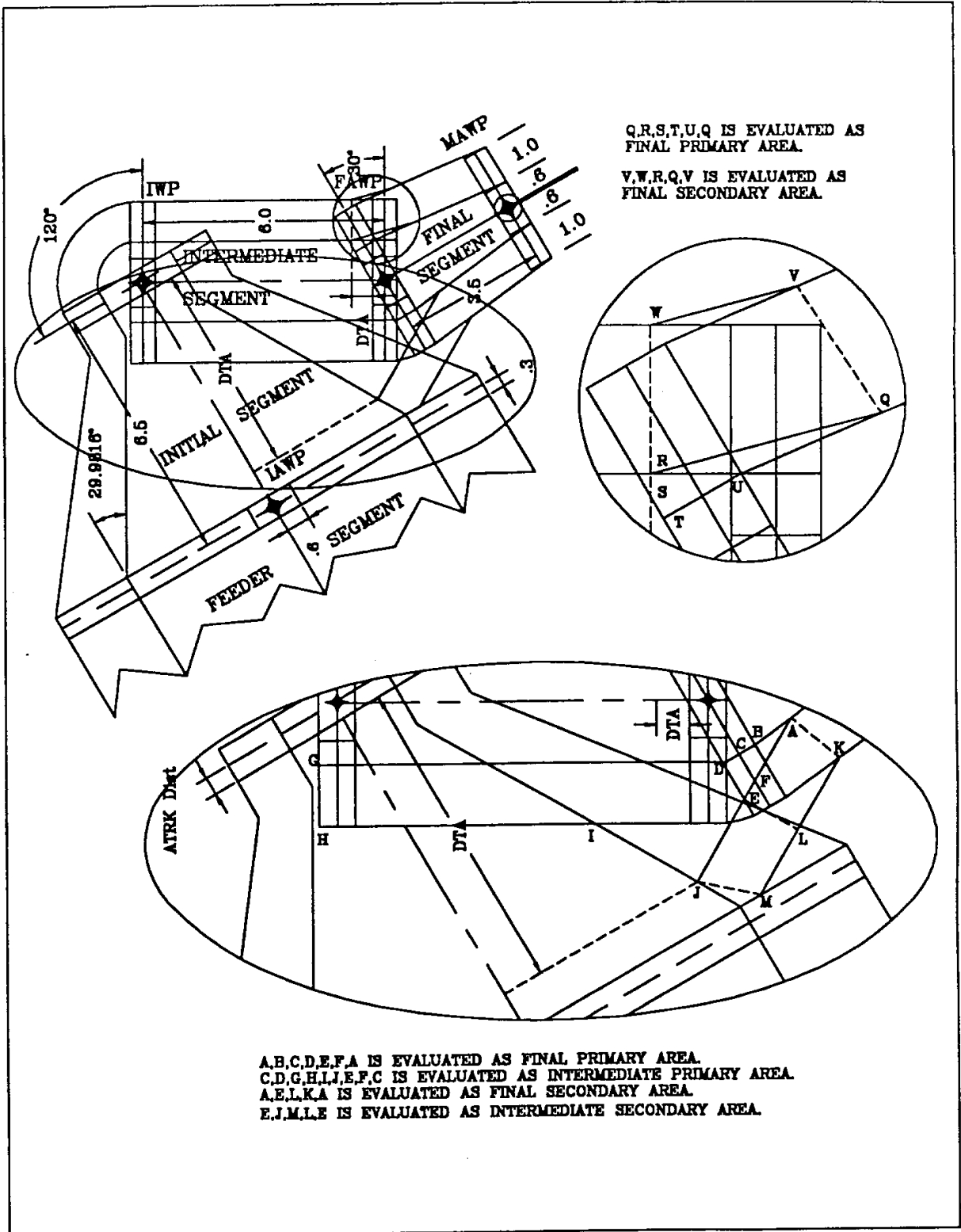

Figure 6. SEGMENTED PATH INITIAL SEGMENT

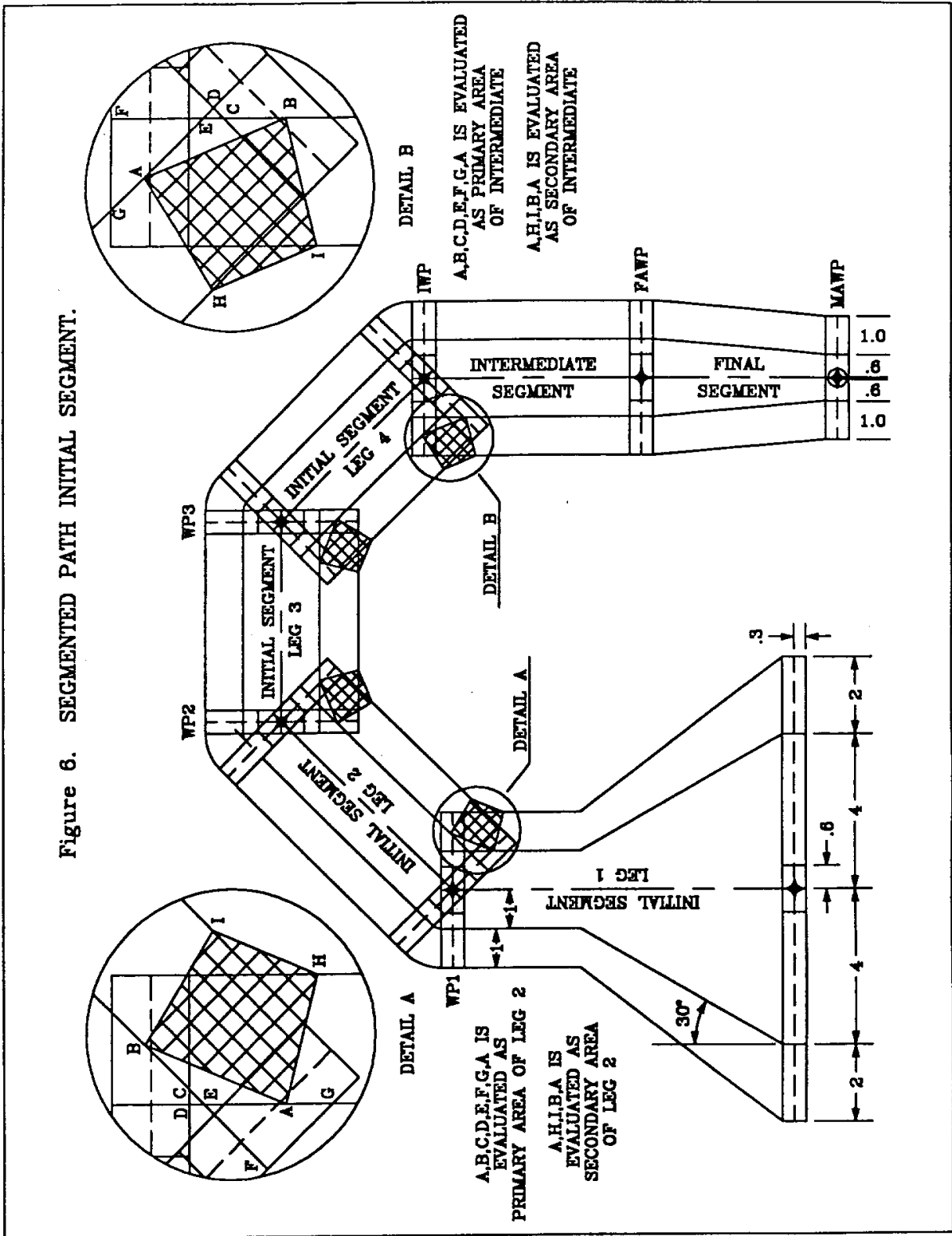

Figure 7. FINAL APPROACH SEGMENT

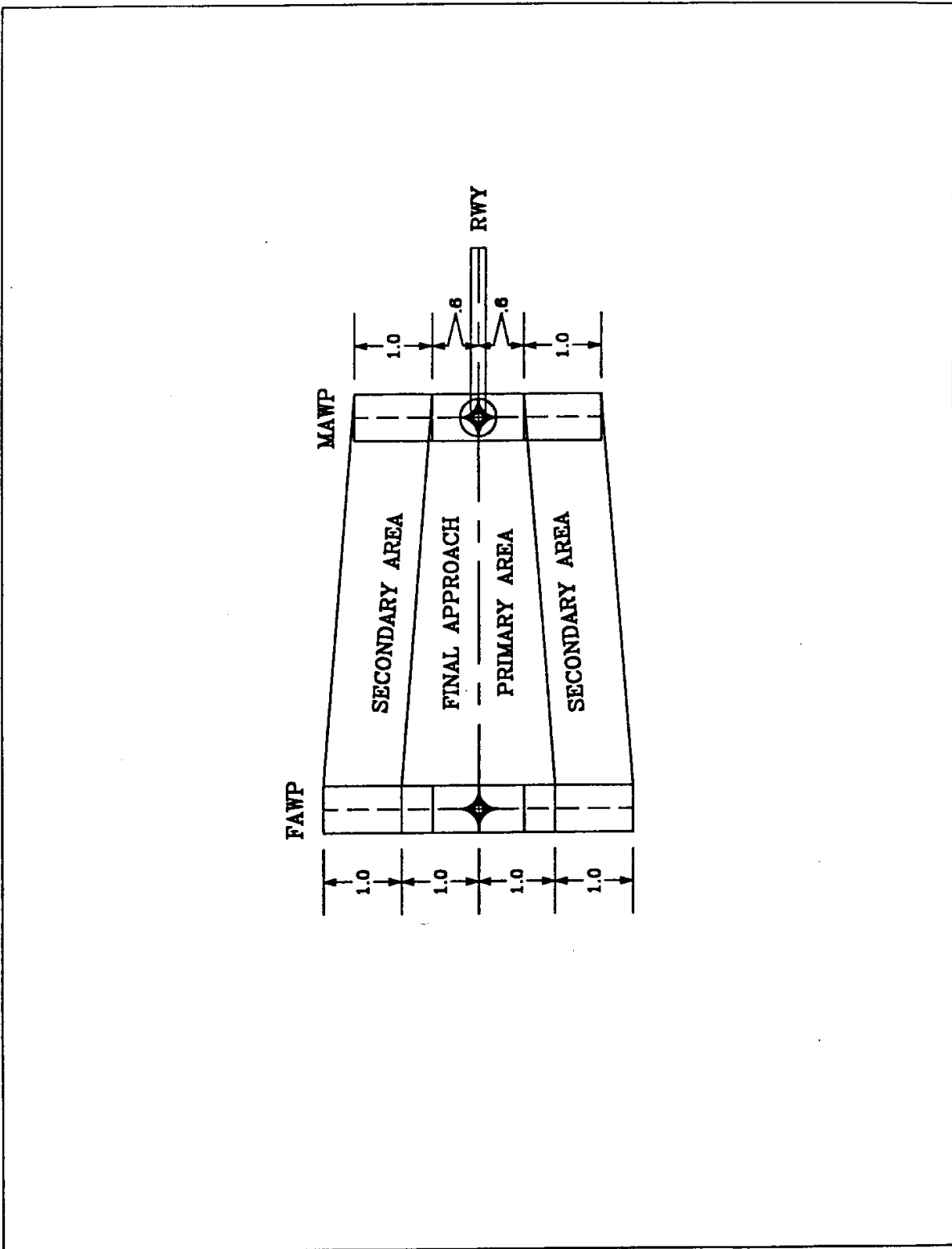

Figure 8. EXTENSION OF FINAL APPROACH SEGMENT TO RUNWAY THRESHOLD

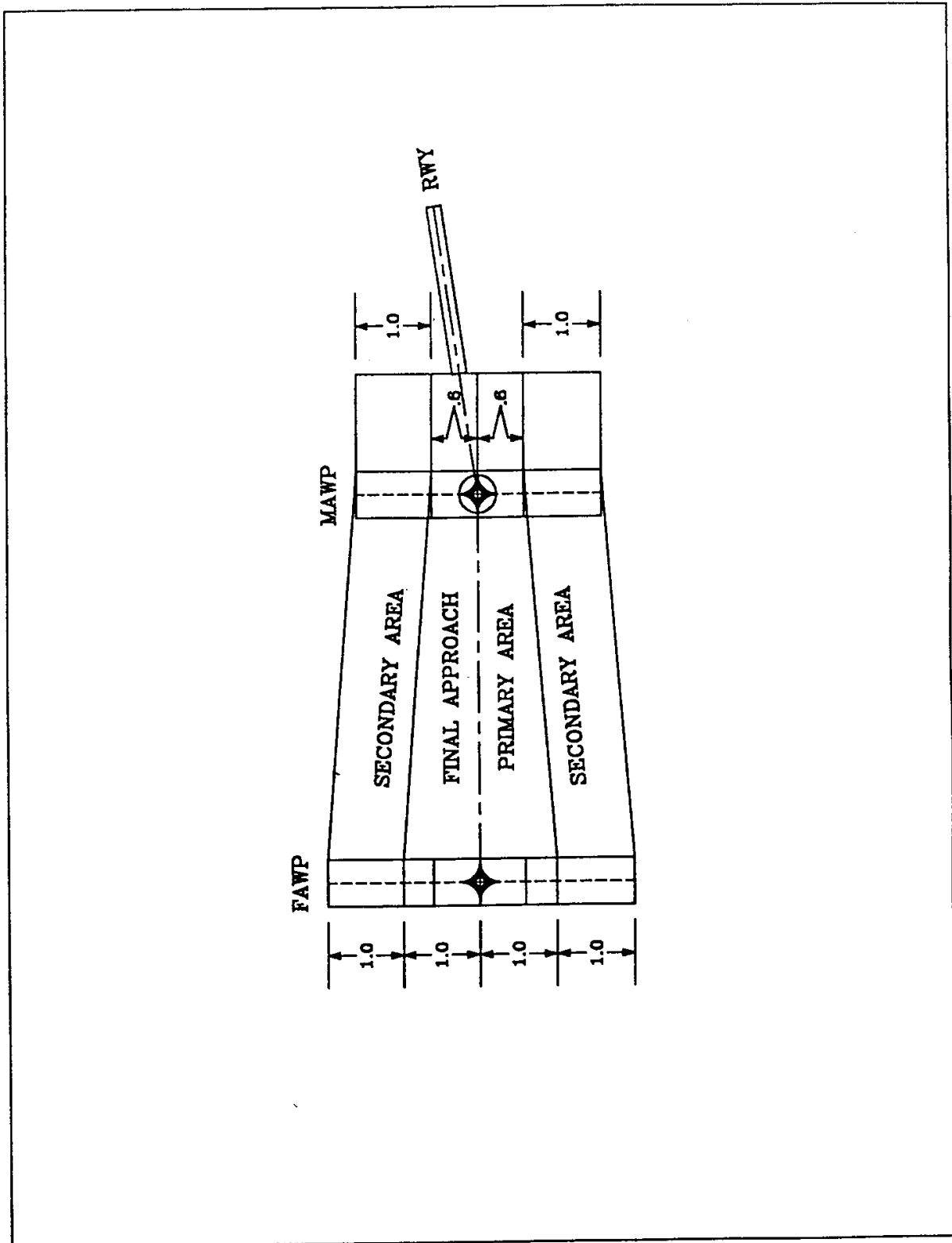

Figure 9. OBSTACLE RICH ENVIRONMENT ASSESSMENT

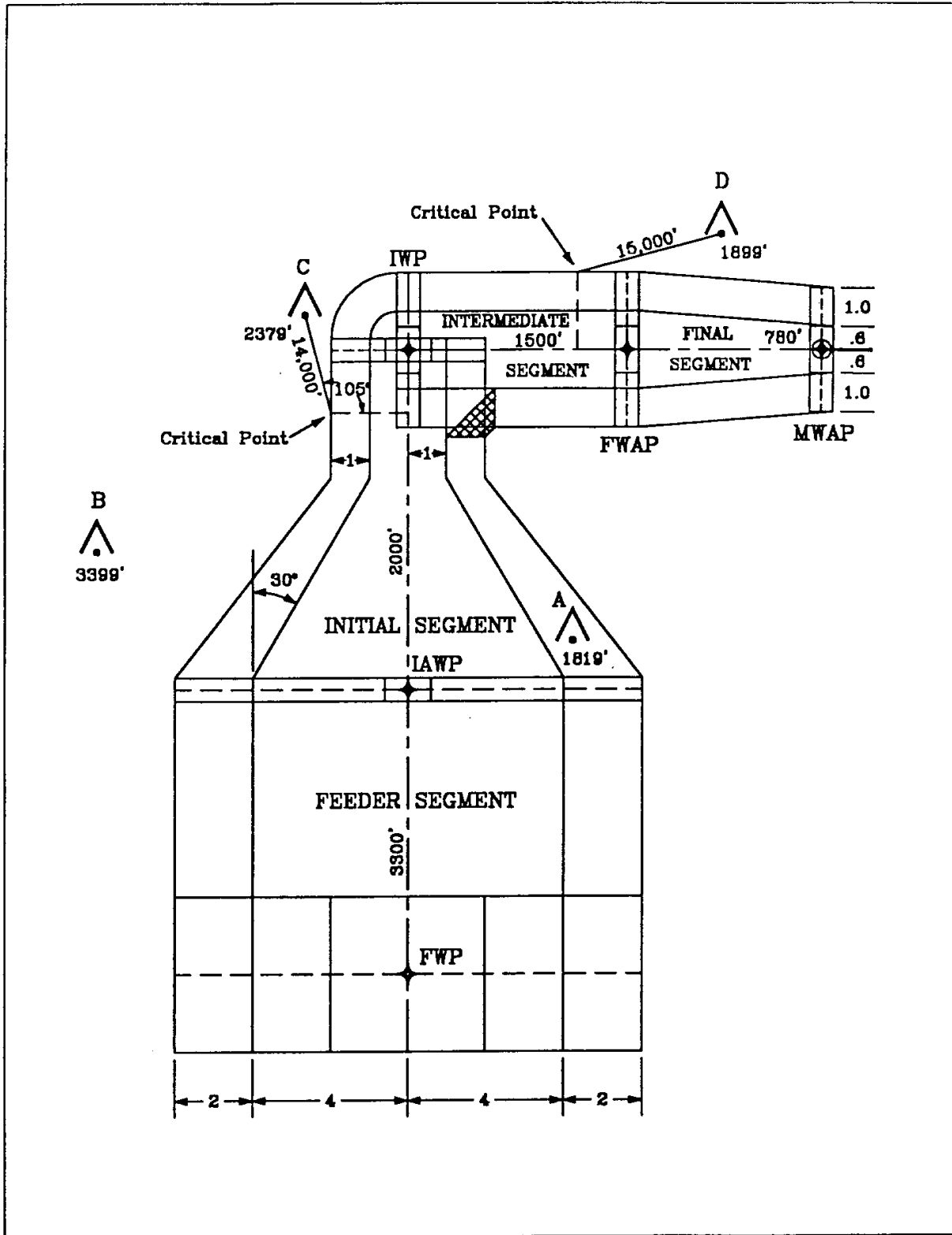

Figure 10. FMS TRANSITION TO ILS FINAL

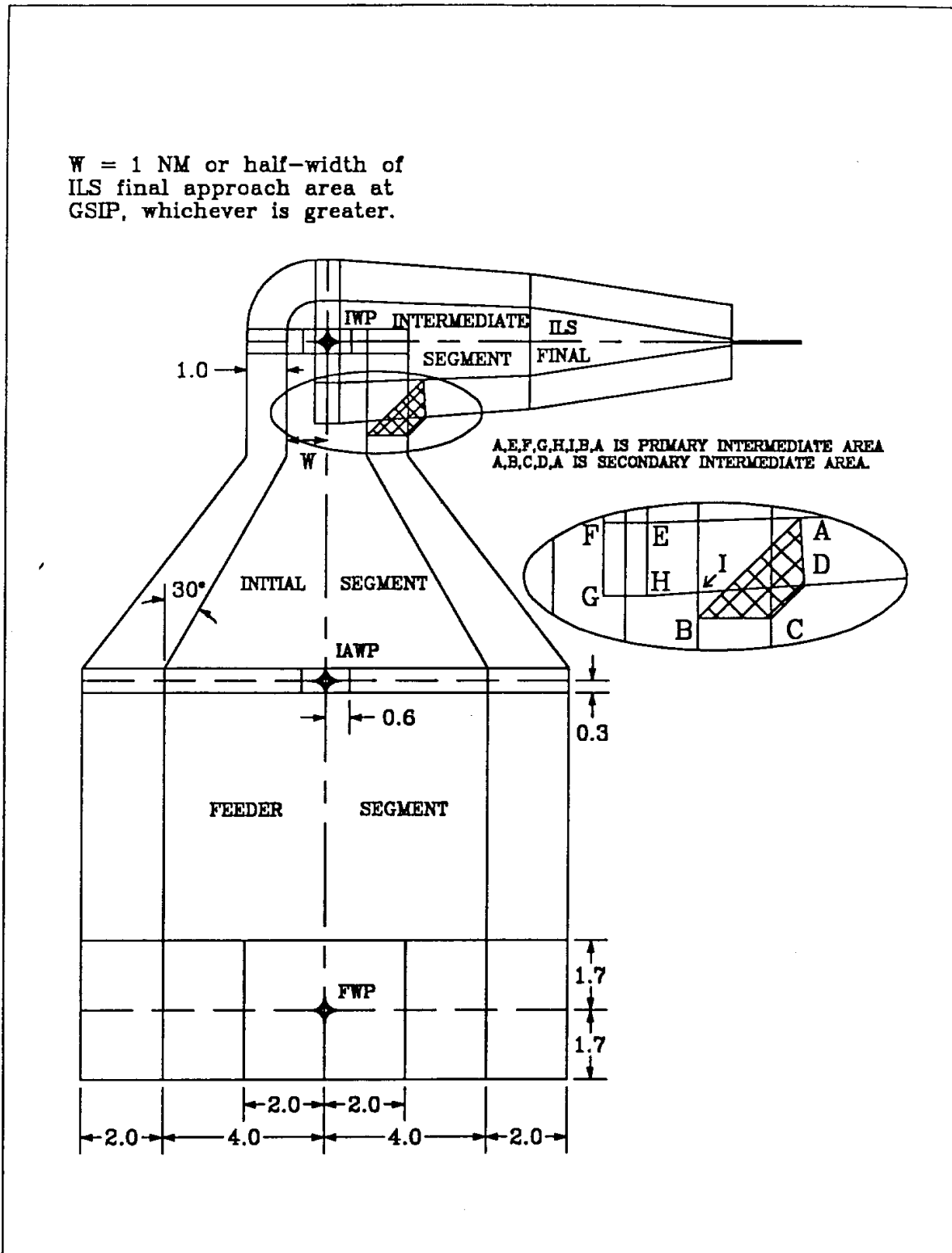
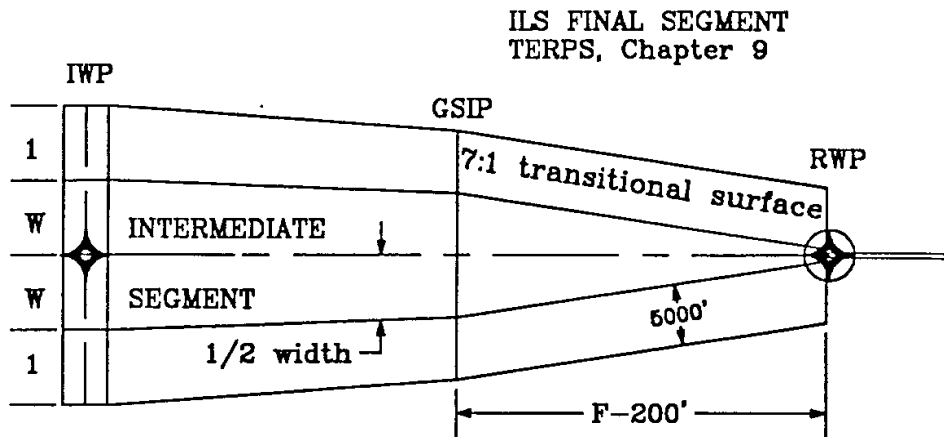

Figure 11. FMS INTERMEDIATE SEGMENT TO ILS FINAL SEGMENT



F = distance from threshold to GSIP

$$1/2 \text{ width} = 0.15(F - 200') + 500'$$

W = 1 NM or half-width of ILS final approach area at GSIP, whichever is greater.

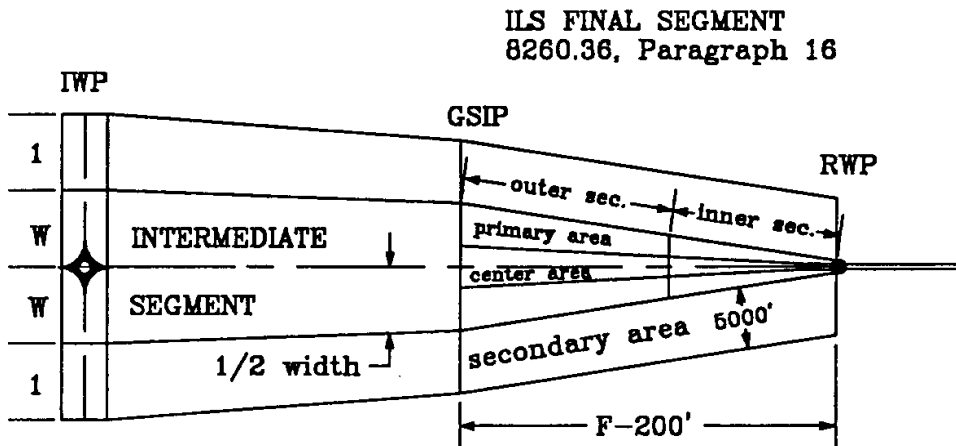

Figure 12. IWP PLACEMENT, EXAMPLE 1

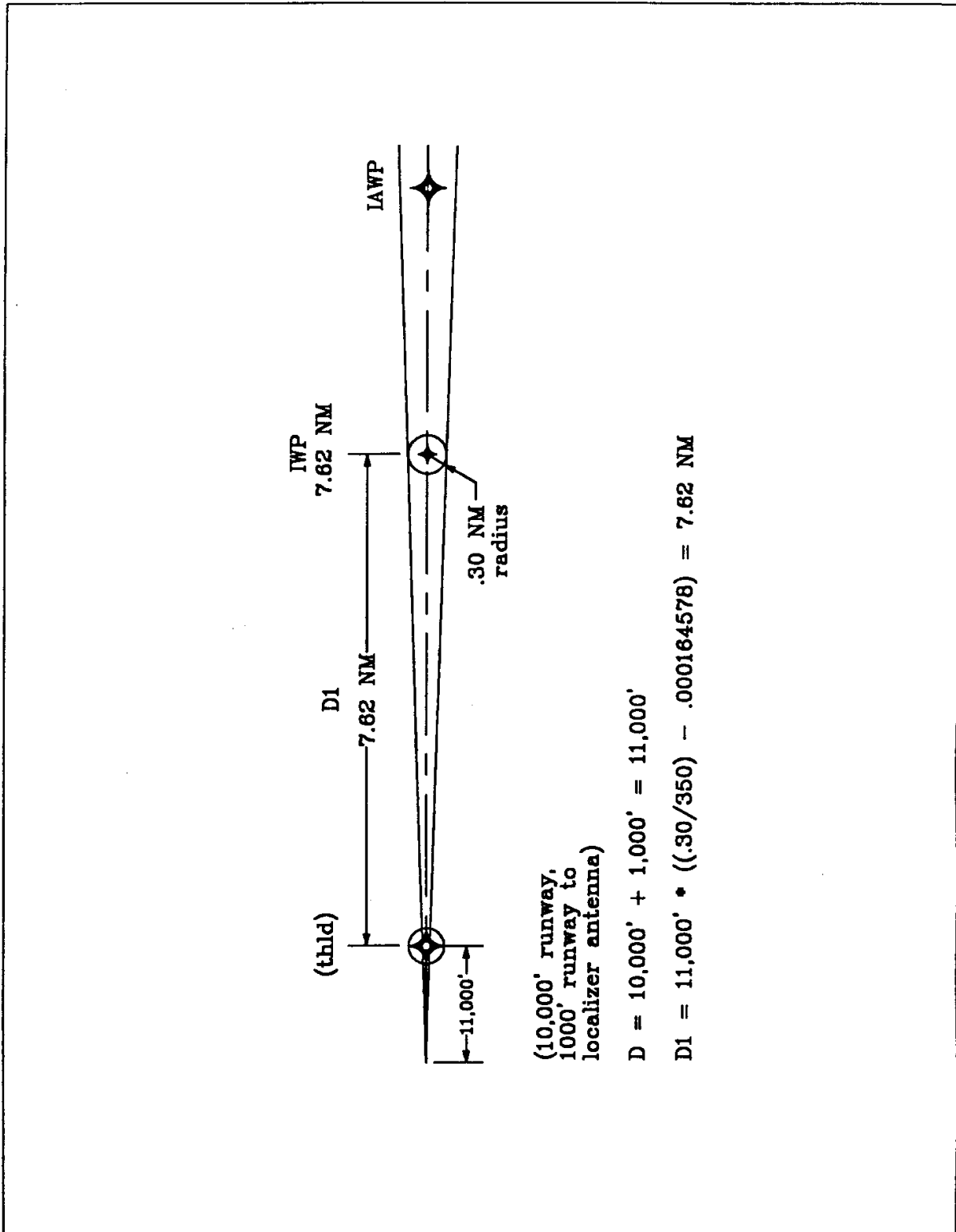

Figure 13. IWP PLACEMENT, EXAMPLE 2

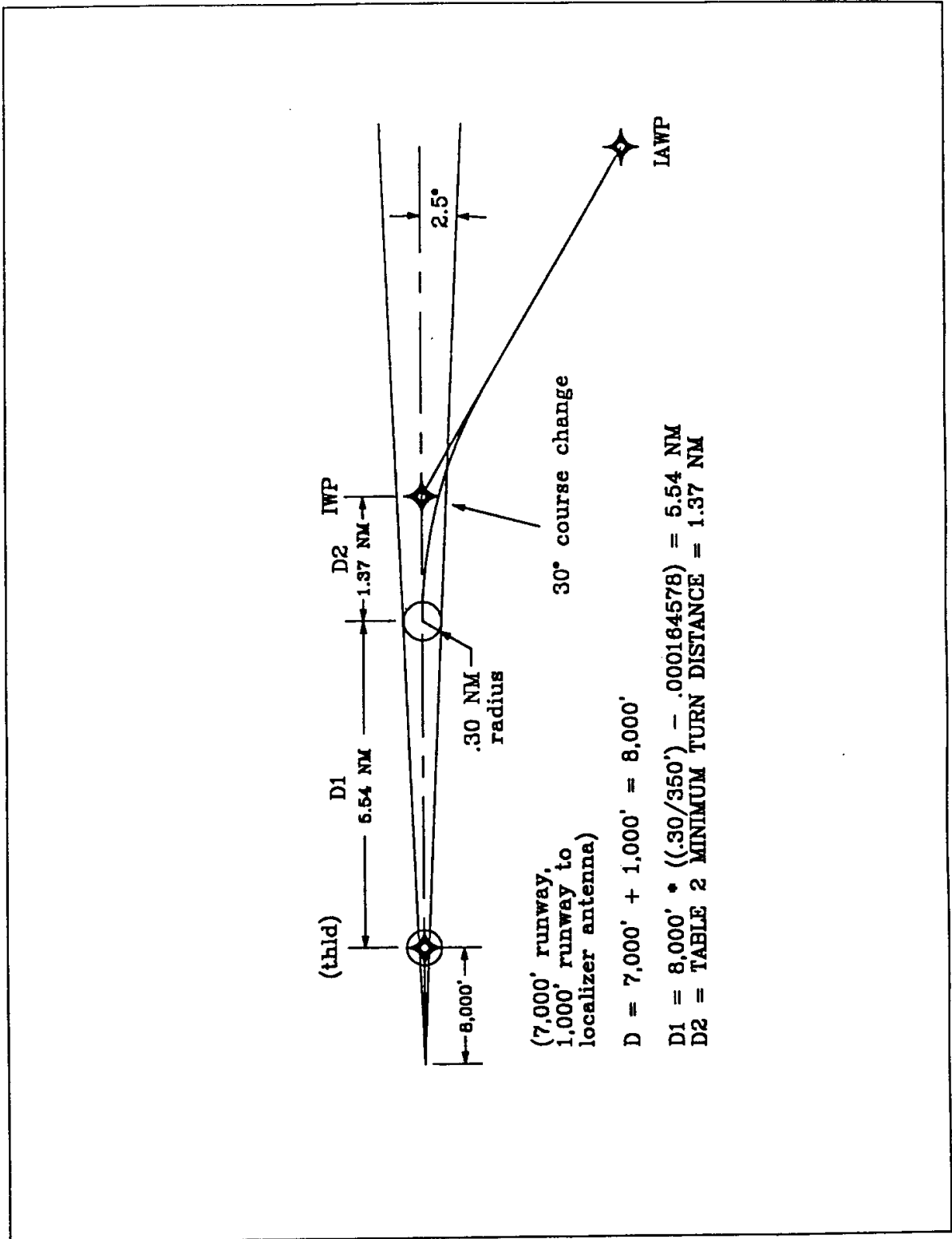

Figure 14. IWP PLACEMENT, EXAMPLE 3

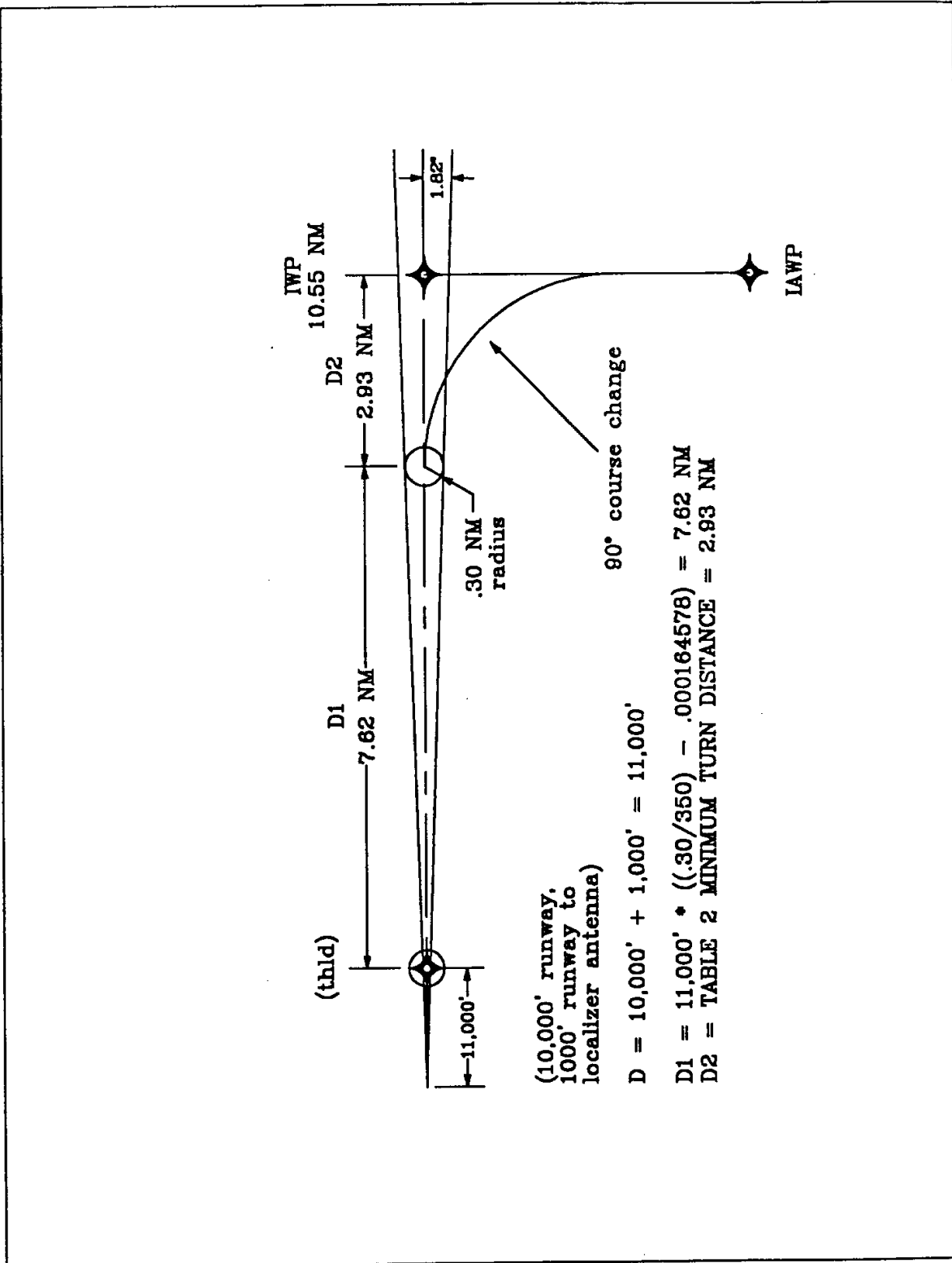

Figure 15. MINIMUM FIRST SEGMENT LENGTH

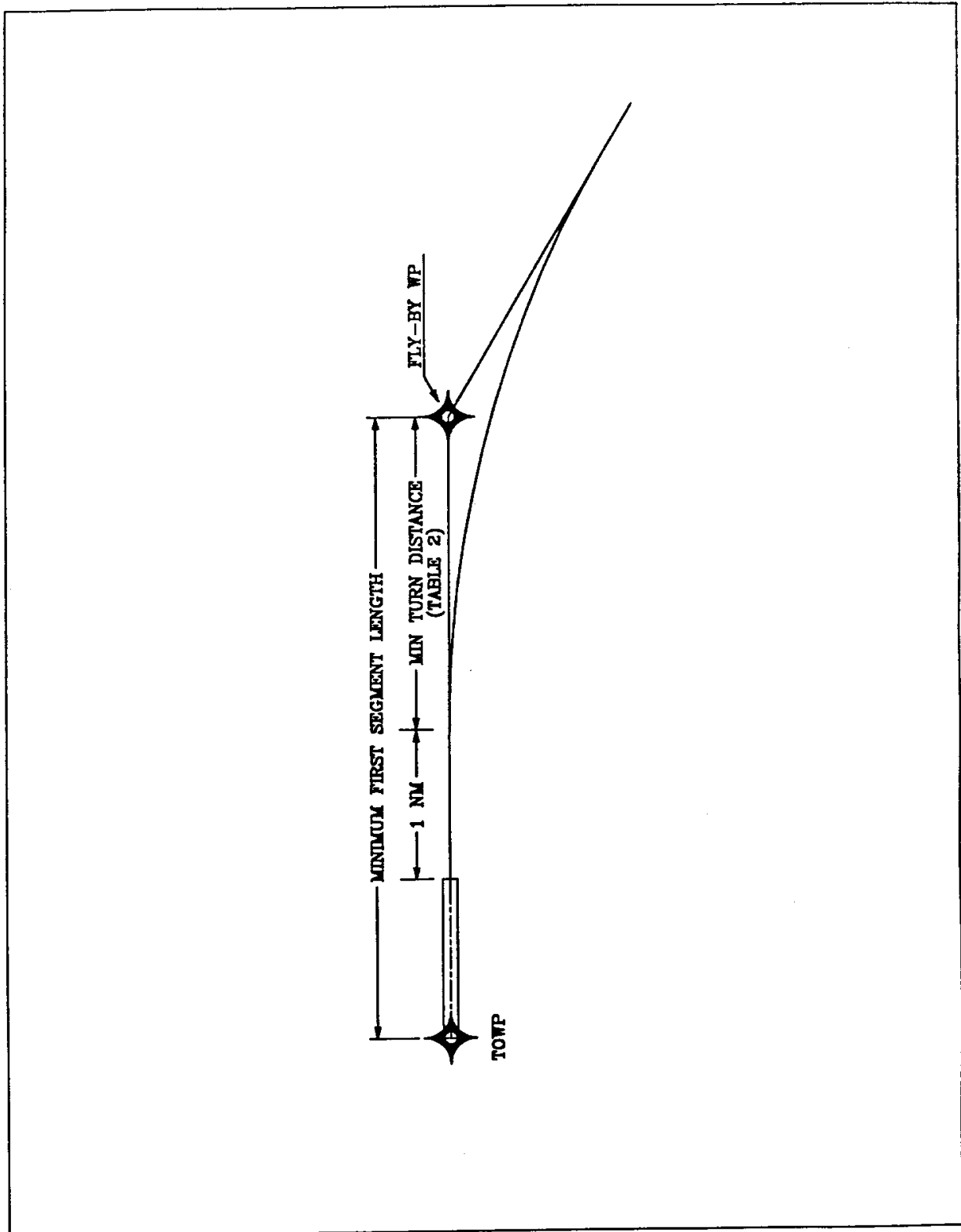

Figure 16. DEPARTURE AREA

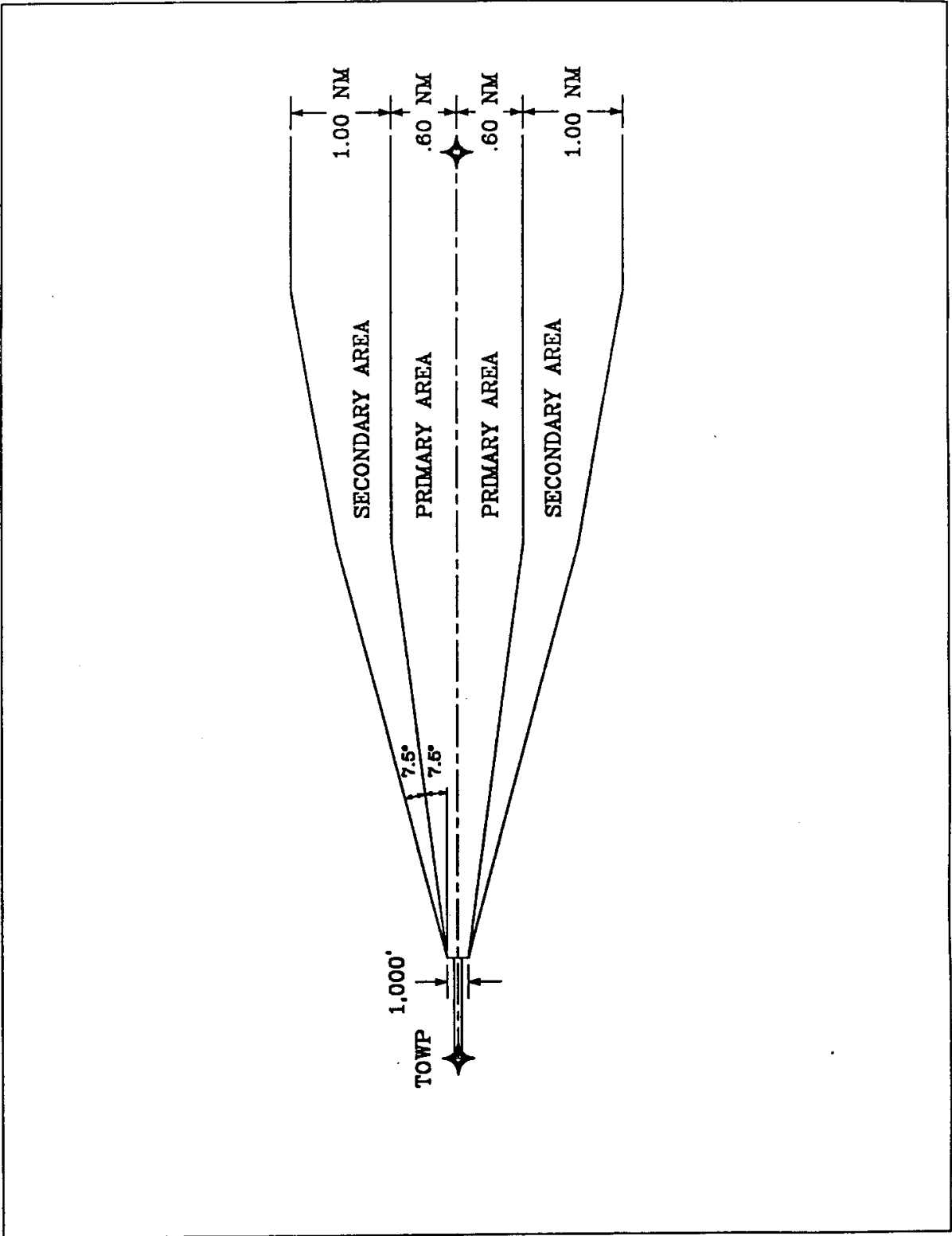

Figure 17. DEPARTURE AREA
FLY-BY WAYPOINT, SPLAY INCOMPLETE

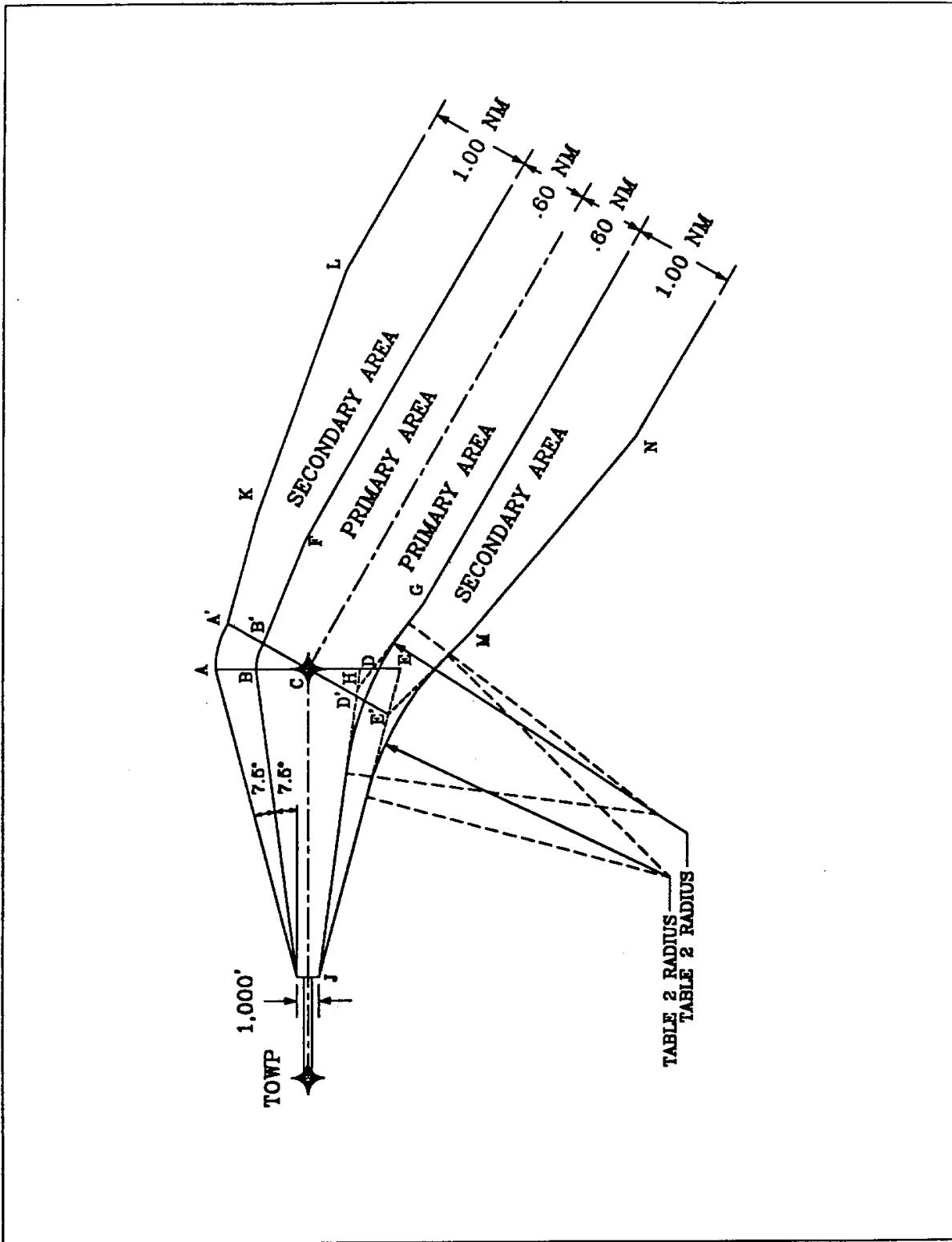

Figure 18. DEPARTURE AREA,
FLY-BY WAYPOINT, SPLAY COMPLETE

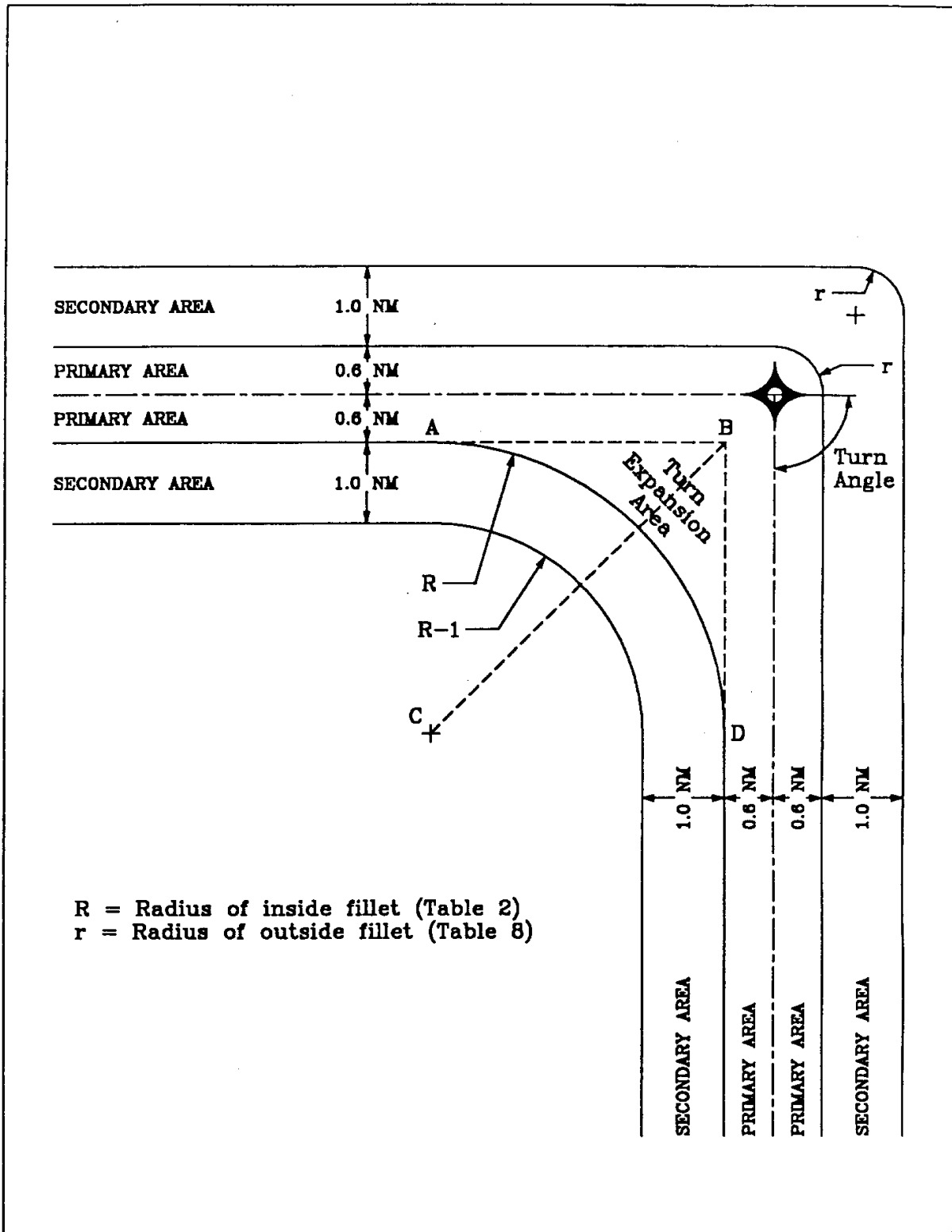

Figure 19. DEPARTURE AREA,
TURN ANGLES LESS THAN 10 DEGREES

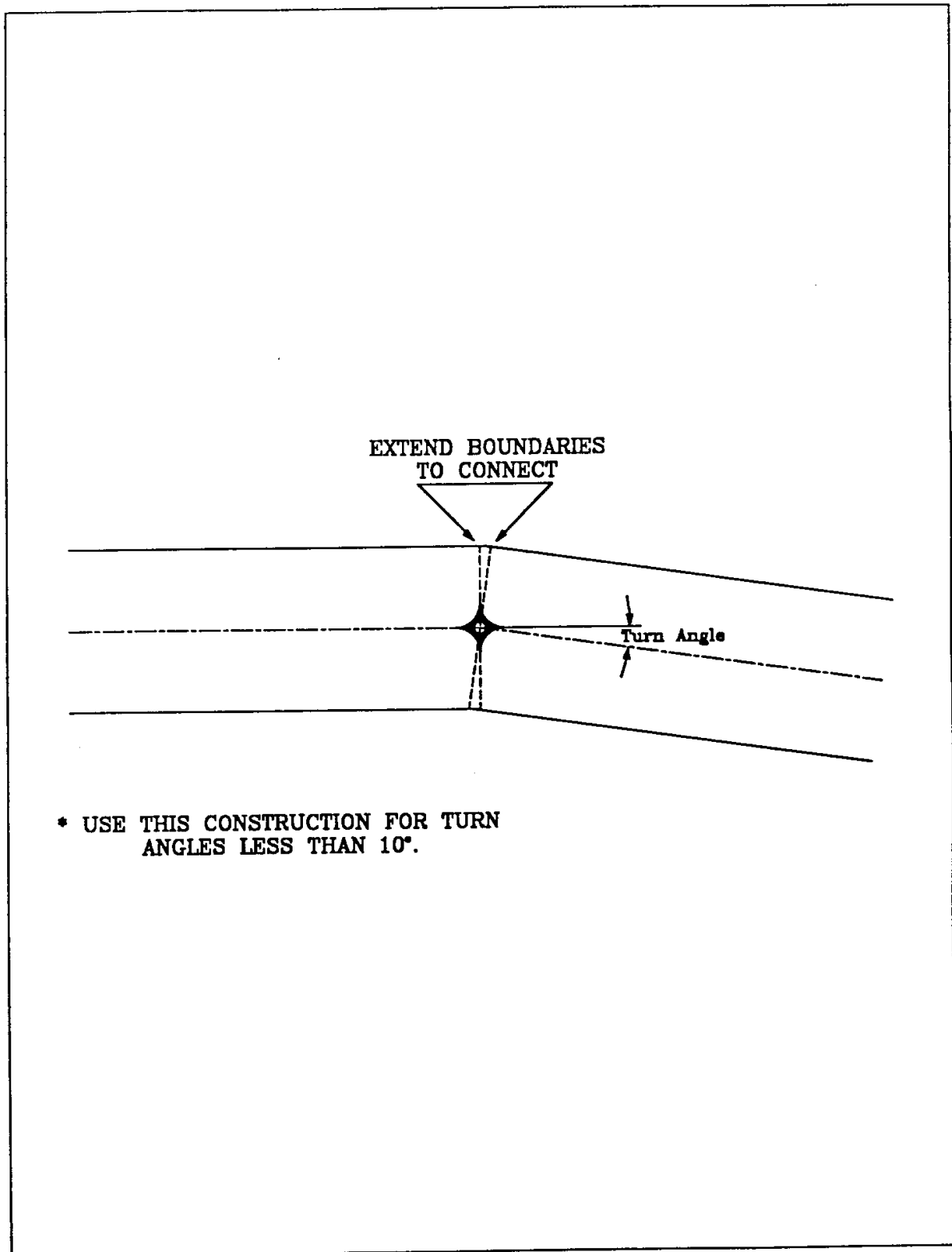

Figure 20. DEPARTURE AREA,
FLY-OVER WAYPOINT, SPLAY INCOMPLETE

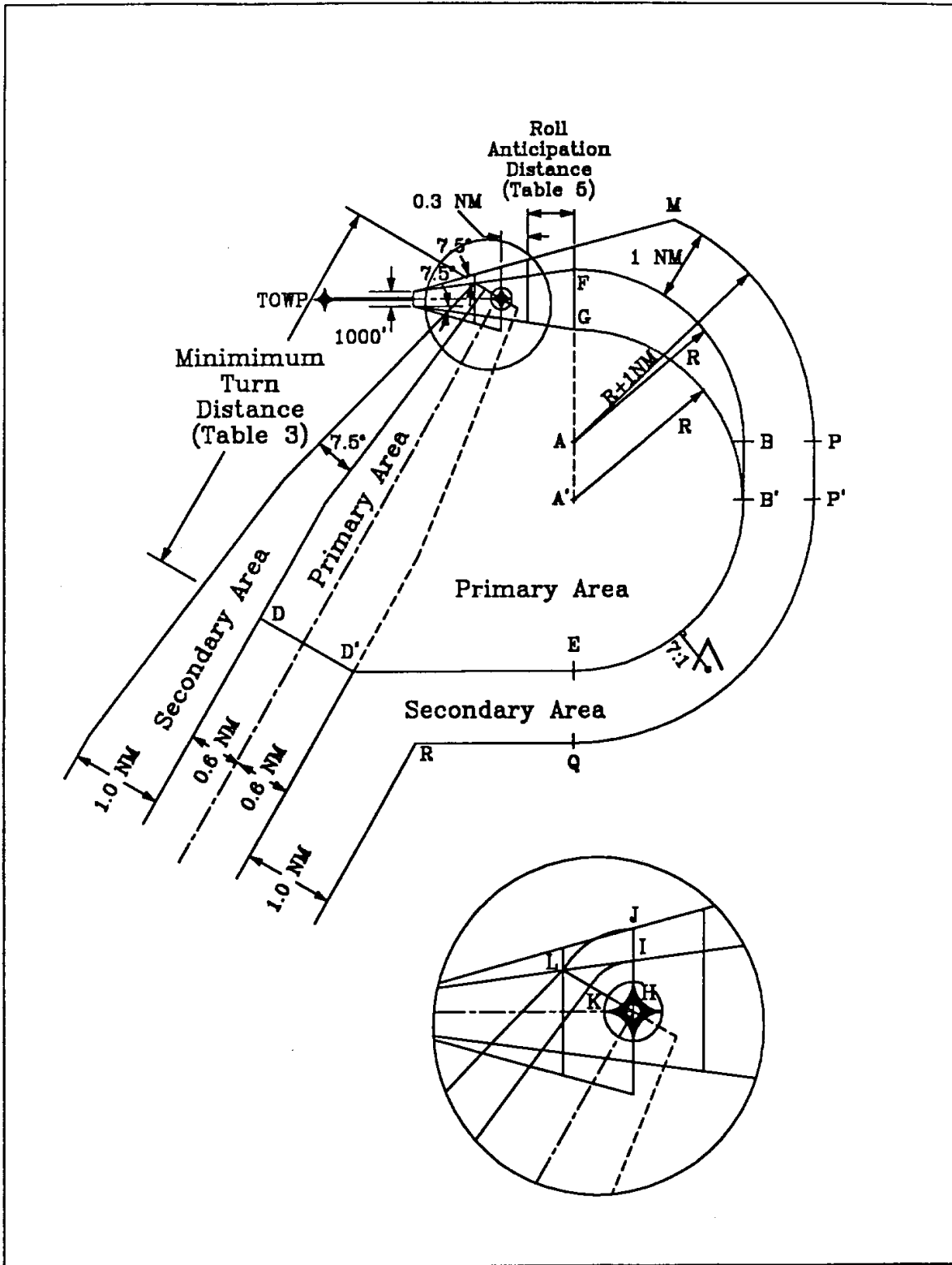

Figure 21. DEPARTURE AREA,
FLY-OVER WAYPOINT, SPLAY COMPLETE

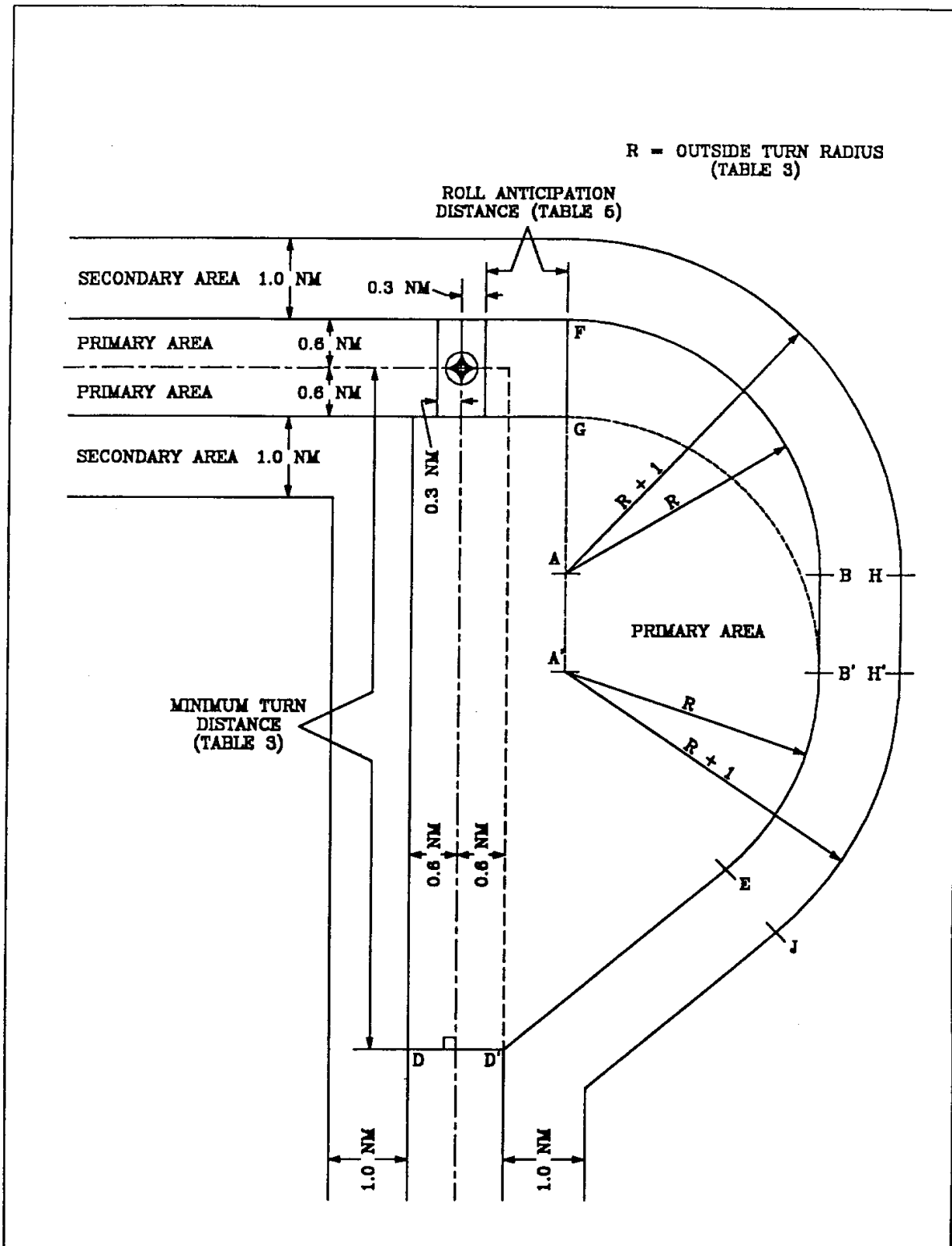

Figure 22. CLIMB GRADIENT COMPUTATION

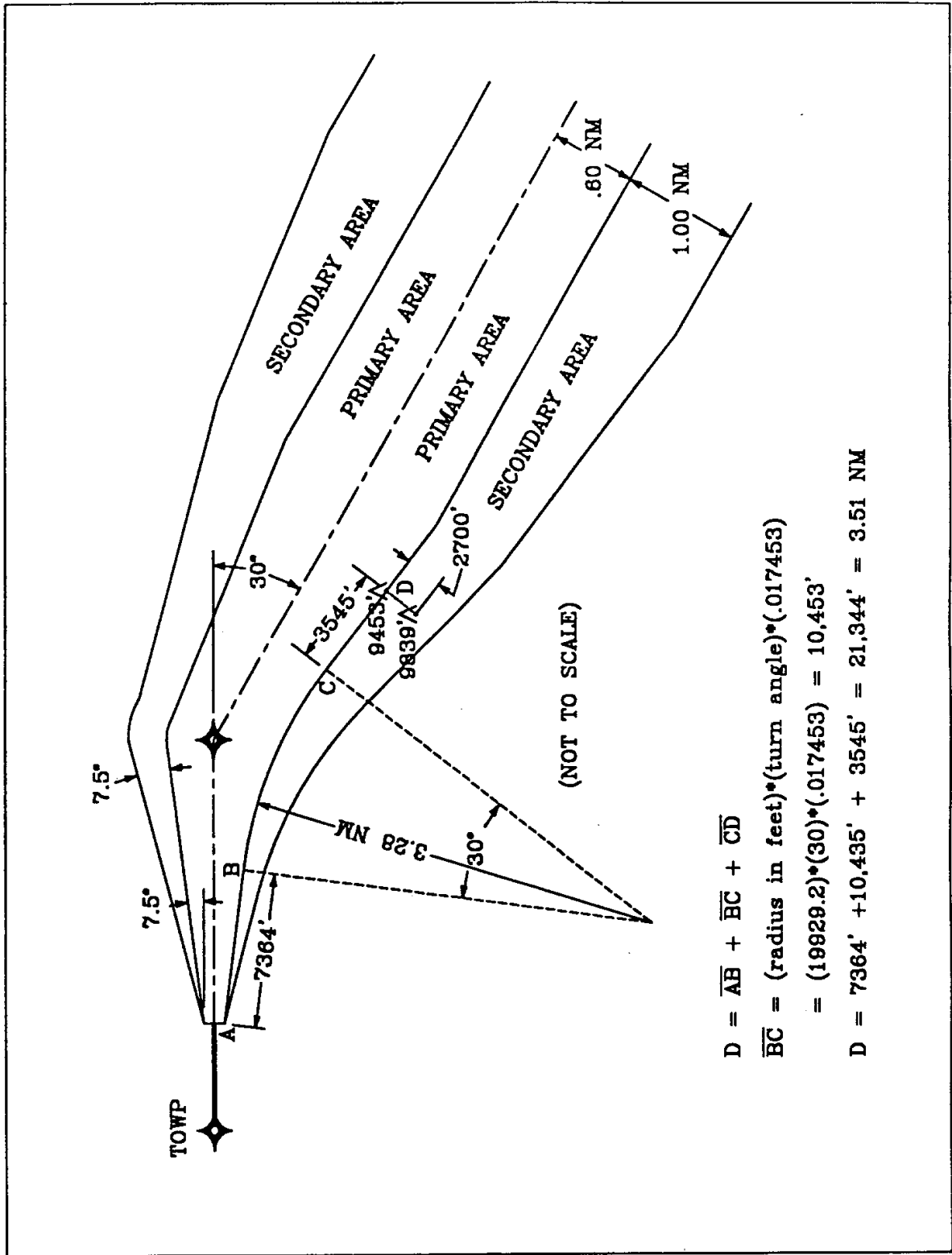

Figure 23. FMS NONPRECISION APPROACH MISSED APPROACH AREA

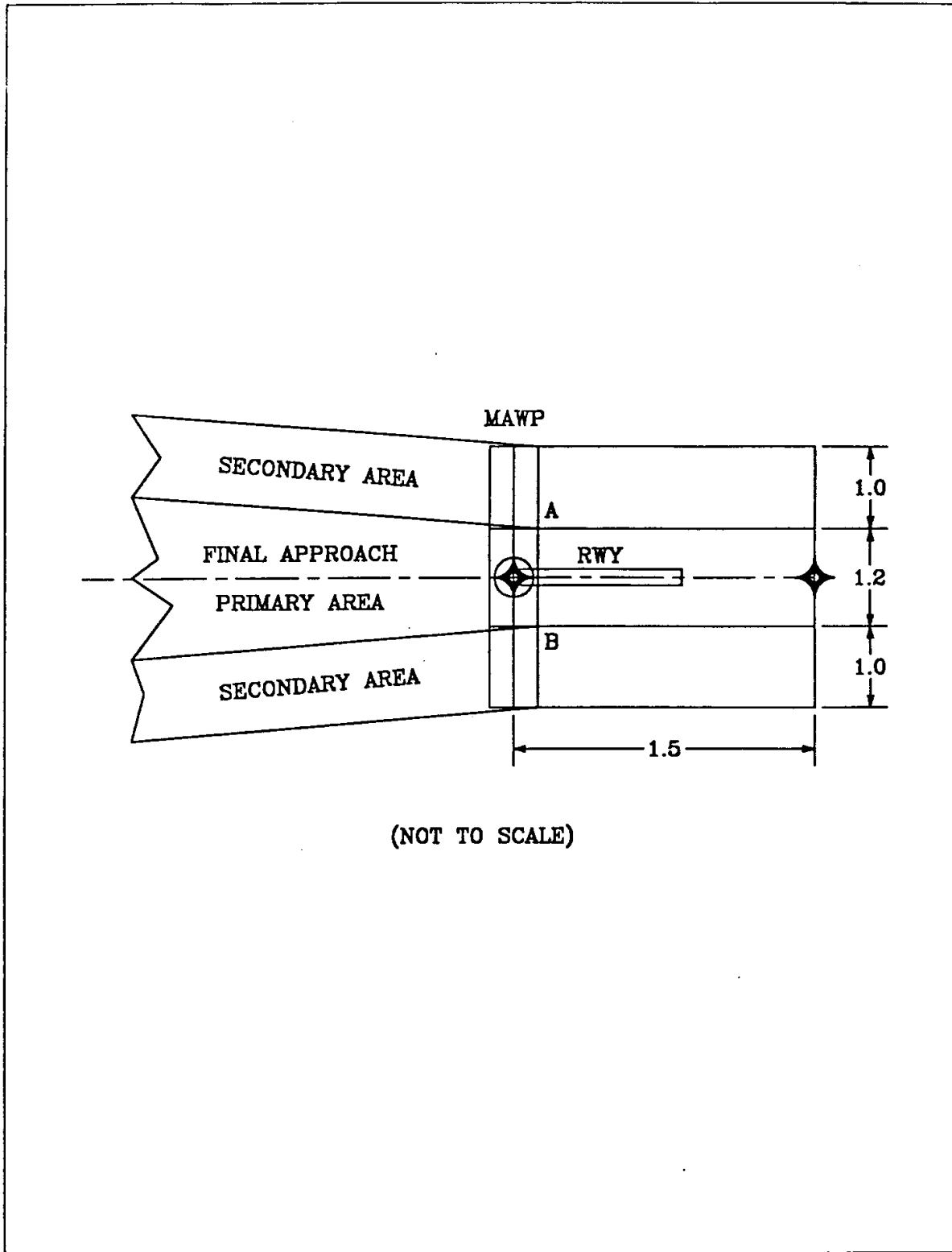

Figure 25. FMS MISSED APPROACH AREA
FOR ILS FINAL APPROACH

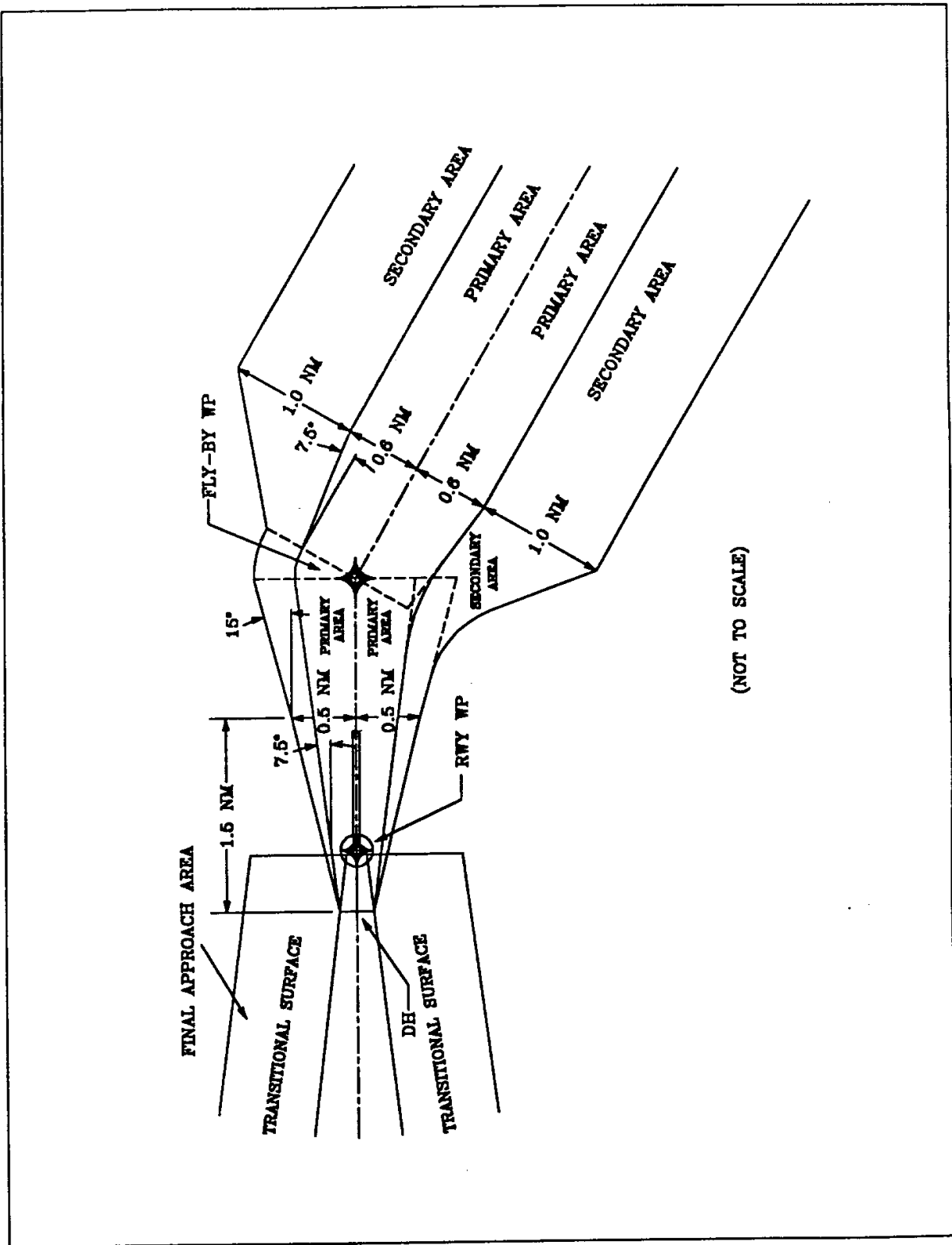

Figure 26. FMS MISSED APPROACH AREA
FOR ILS OFFSET 3 DEGREES OR LESS

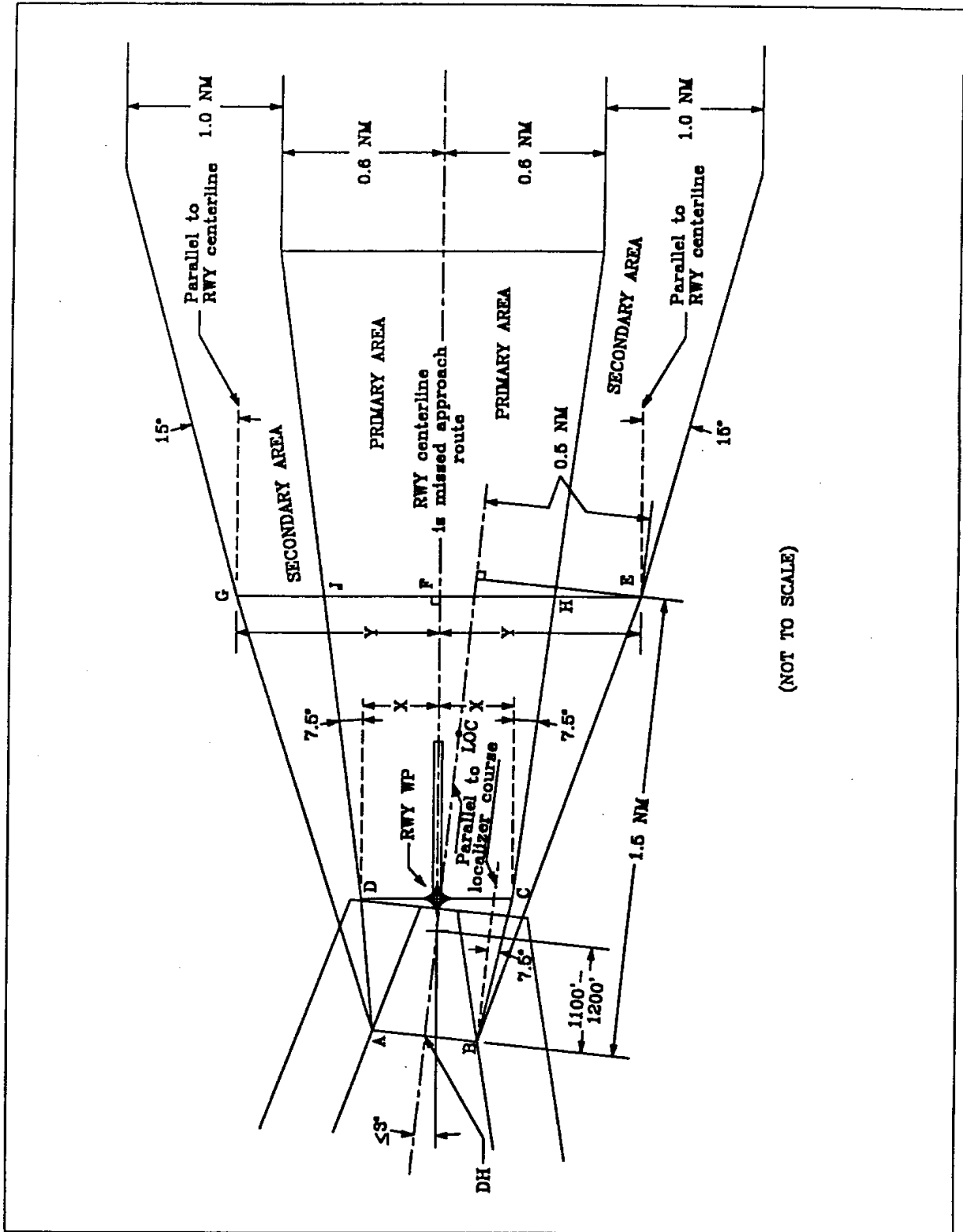

Figure 27. FMS MISSED APPROACH AREA
FOR MLS FINAL APPROACH

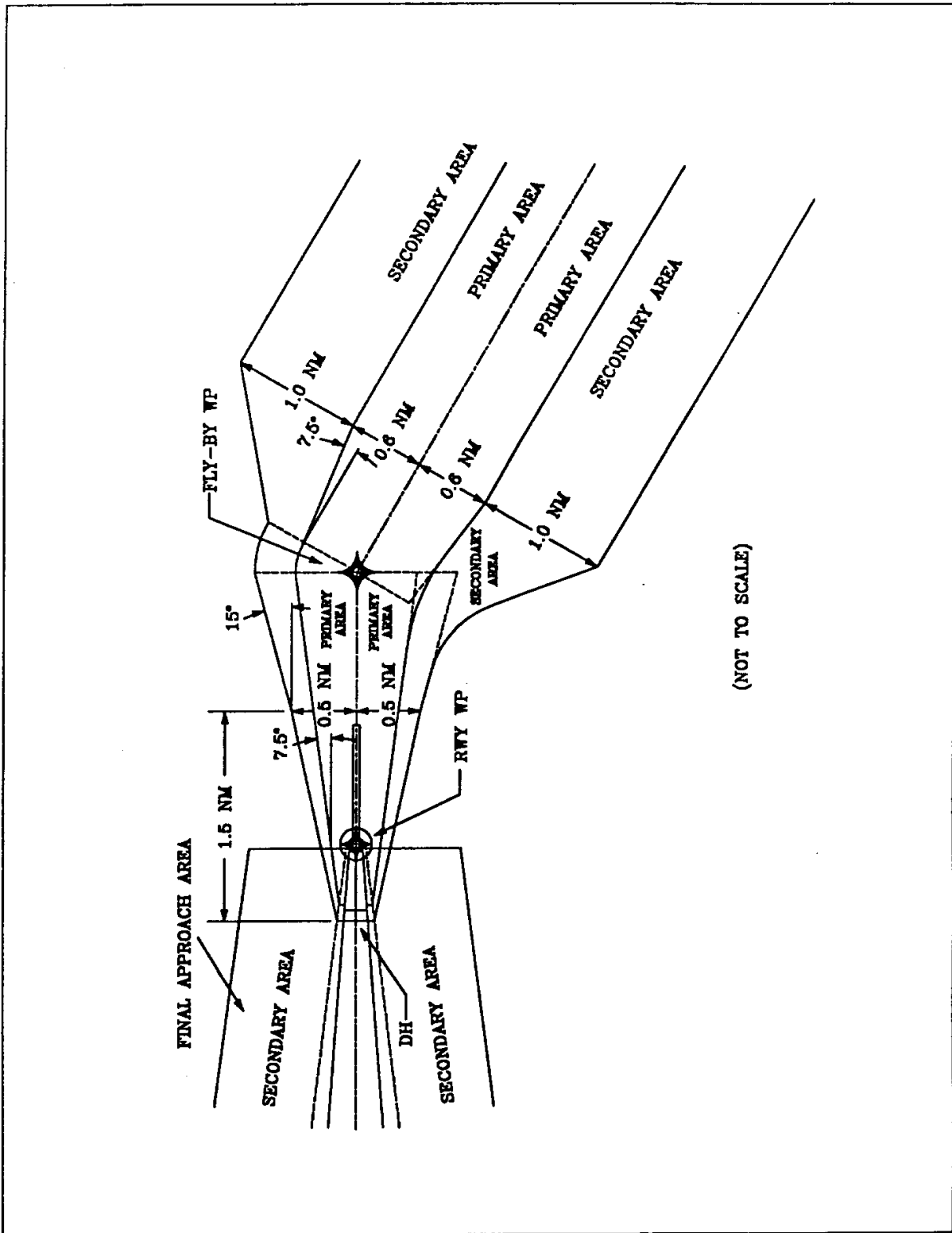

Figure 28. FMS MISSED APPROACH AREA
FOR MLS OFFSET 3 DEGREES OR LESS

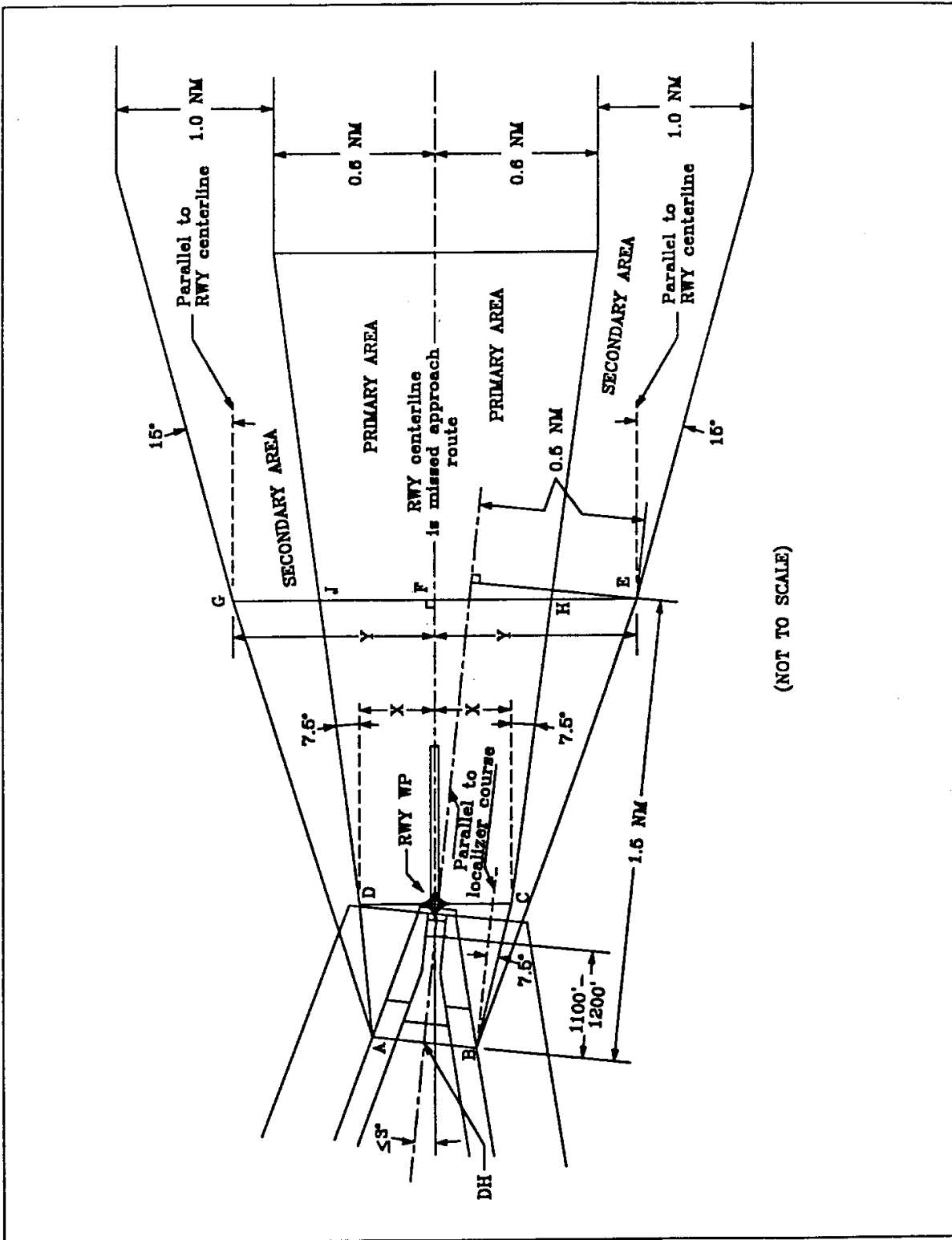

Figure 29. CONVERGING APPROACH FMS MISSED APPROACH

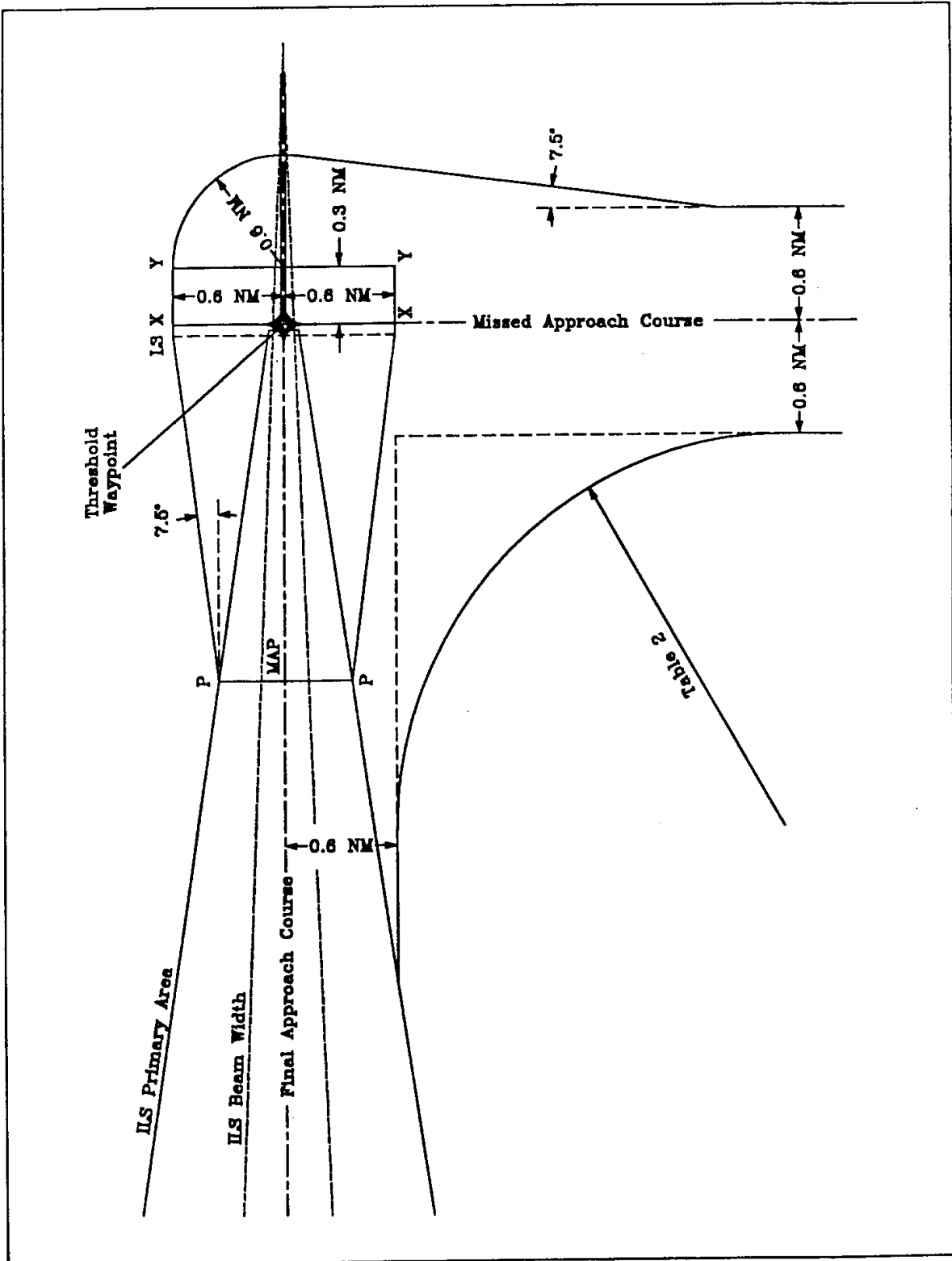

TABLE 1
WAYPOINT DESIGN CRITERIA

WAYPOINT	TYPE	ATRK (NM)	XTRK (NM)	FLY-BY ALLOWED	FLY-OVER ALLOWED
En Route	En Route	+/- 2.8	+/- 3.0	Yes	Yes
FWP	Terminal	+/- 1.7	+/- 2.0	Yes	Yes
IAWP	Approach	+/- 0.3	+/- 0.6	Yes	No
IWP	Approach	+/- 0.3	+/- 0.6	Yes	No
FAWP	Approach	+/- 0.3	+/- 0.6	Yes	No
MAWP	Approach	+/- 0.3	+/- 0.6	No	Yes
MAHWP	Approach	+/- 0.3	+/- 0.6	Yes	Yes

**TABLE 2
FLY-BY WAYPOINT MINIMUM TURN DISTANCE AND RADIUS**

TURN ANGLE (degrees)	INSIDE TURN EXPANSION														
	160 KIAS			175 KIAS			220 KIAS			250 KIAS			310 KIAS		
	RADIUS (nm)	MIN TURN DIST (nm)		RADIUS (nm)	MIN TURN DIST (nm)		RADIUS (nm)	MIN TURN DIST (nm)		RADIUS (nm)	MIN TURN DIST (nm)		RADIUS (nm)	MIN TURN DIST (nm)	
10	10.04	0.99		11.58	1.13		16.46	1.59		20.24	1.93		37.31	3.48	
15	6.67	1.05		7.64	1.19		10.94	1.66		13.45	2.01		24.79	3.59	
20	4.98	1.11		5.71	1.25		8.17	1.73		10.04	2.09		18.51	3.70	
25	3.96	1.16		4.54	1.31		6.50	1.80		7.99	2.17		14.72	3.81	
30	3.28	1.22		3.76	1.37		5.37	1.88		6.61	2.25		12.18	3.92	
35	3.00	1.32		3.43	1.48		4.91	2.02		6.04	2.43		11.14	4.23	
40	2.76	1.41		3.16	1.58		4.52	2.16		5.56	2.59		10.25	4.50	
45	2.55	1.49		2.92	1.67		4.18	2.29		5.14	2.74		9.48	4.76	
50	2.37	1.57		2.72	1.76		3.89	2.40		4.78	2.88		8.81	5.00	
55	2.21	1.64		2.53	1.85		3.63	2.52		4.46	3.02		8.22	5.23	
60	2.07	1.72		2.37	1.93		3.39	2.63		4.17	3.15		7.69	5.45	
65	2.07	1.84		2.37	2.07		3.39	2.83		4.17	3.40		7.69	5.91	
70	2.07	1.97		2.37	2.22		3.39	3.04		4.17	3.66		7.69	6.39	
75	2.07	2.11		2.37	2.38		3.39	3.27		4.17	3.94		7.69	6.91	
80	2.07	2.26		2.37	2.55		3.39	3.52		4.17	4.24		7.69	7.46	
85	2.07	2.42		2.37	2.73		3.39	3.78		4.17	4.56		7.69	8.05	
90	2.07	2.59		2.37	2.93		3.39	4.06		4.17	4.91		7.69	8.70	
95	2.07	2.78		2.37	3.15		3.39	4.37		4.17	5.29		7.69	9.40	
100	2.07	2.99		2.37	3.38		3.39	4.71		4.17	5.71		7.69	10.17	
105	2.07	3.22		2.37	3.65		3.39	5.09		4.17	6.18		7.69	11.03	
110	2.07	3.48		2.37	3.94		3.39	5.51		4.17	6.70		7.69	11.99	
115	2.07	3.77		2.37	4.28		3.39	5.99		4.17	7.29		7.69	13.07	
120	2.07	4.11		2.37	4.66		3.39	6.54		4.17	7.96		7.69	14.32	

NOTE: When turn angle falls between values in table, interpolate or use the next larger value.

**TABLE 3
FLY-OVER WAYPOINT MINIMUM TURN DISTANCE AND RADIUS**

TURN ANGLE (degrees)	INSIDE TURN EXPANSION											
	160 KIAS		175 KIAS		220 KIAS		250 KIAS		310 KIAS			
	RADIUS (nm)	MIN TURN DIST (nm)	RADIUS (nm)	MIN TURN DIST (nm)	RADIUS (nm)	MIN TURN DIST (nm)	RADIUS (nm)	MIN TURN DIST (nm)	RADIUS (nm)	MIN TURN DIST (nm)	RADIUS (nm)	MIN TURN DIST (nm)
10	6.17	4.33	6.60	4.63	7.86	5.60	8.70	6.31	11.67	9.20		
15	4.08	4.83	4.35	5.19	5.17	6.36	5.70	7.20	7.69	10.66		
20	3.02	5.15	3.22	5.55	3.80	6.84	4.17	7.77	7.69	11.57		
25	2.38	5.36	2.53	5.78	3.39	7.15	4.17	8.13	7.69	12.13		
30	2.07	5.49	2.37	5.93	3.39	7.34	4.17	8.35	7.69	12.45		
35	2.07	5.56	2.37	6.01	3.39	7.44	4.17	8.47	7.69	12.60		
40	2.07	5.59	2.37	6.04	3.39	7.48	4.17	8.50	7.69	13.61		
45	2.07	5.59	2.37	6.04	3.39	7.66	4.17	8.96	7.69	14.84		
50	2.07	5.77	2.37	6.32	3.39	8.18	4.17	9.59	7.69	16.00		
55	2.07	6.06	2.37	6.65	3.39	8.65	4.17	10.18	7.69	17.08		
60	2.07	6.33	2.37	6.95	3.39	9.09	4.17	10.72	7.69	18.07		
65	2.07	6.57	2.37	7.23	3.39	9.49	4.17	11.21	7.69	18.98		
70	2.07	6.79	2.37	7.49	3.39	9.85	4.17	11.65	7.69	19.79		
75	2.07	6.98	2.37	7.71	3.39	10.17	4.17	12.04	7.69	20.51		
80	2.07	7.15	2.37	7.90	3.39	10.44	4.17	12.38	7.69	21.13		
85	2.07	7.29	2.37	8.06	3.39	10.67	4.17	12.66	7.69	21.64		
90	2.07	7.40	2.37	8.18	3.39	10.85	4.17	12.88	7.69	22.06		
95	2.07	7.50	2.37	8.30	3.39	11.02	4.17	13.09	7.69	22.45		
100	2.07	7.64	2.37	8.47	3.39	11.26	4.17	13.38	7.69	22.97		
105	2.07	7.77	2.37	8.61	3.39	11.46	4.17	13.63	7.69	23.44		
110	2.07	7.88	2.37	8.73	3.39	11.64	4.17	13.85	7.69	23.84		
115	2.07	7.97	2.37	8.84	3.39	11.78	4.17	14.03	7.69	24.17		
120	2.07	8.04	2.37	8.92	3.39	11.90	4.17	14.17	7.69	24.43		

TABLE 4 SEGMENT VS SPEED

SEGMENT	TABLES 2, 3 & 5 SPEED (KIAS)
Initial Approach	220
Intermediate Approach	175
All others (en route, feeder, missed approach, departure)	
At and below 10,000' MSL	250
Above 10,000' MSL	310

TABLE 5
ROLL ANTICIPATION DISTANCE (RAD)

TURN ANGLE (degrees)	ROLL ANTICIPATION DISTANCE (NM)														
	160 KIAS			175 KIAS			220 KIAS			250 KIAS			310 KIAS		
	Fly-by	Fly-over	Fly-by	Fly-over	Fly-by	Fly-over	Fly-by	Fly-over	Fly-by	Fly-over	Fly-by	Fly-over	Fly-by	Fly-over	
10	0.11	0.18	0.12	0.21	0.15	0.30	0.16	0.37	0.22	0.68					
15	0.17	0.28	0.18	0.32	0.22	0.45	0.24	0.56	0.33	1.01					
20	0.23	0.37	0.24	0.42	0.29	0.60	0.32	0.74	0.44	1.01					
25	0.28	0.46	0.30	0.53	0.36	0.67	0.40	0.74	0.55	1.01					
30	0.34	0.52	0.37	0.56	0.44	0.67	0.48	0.74	0.66	1.01					
35	0.37	0.52	0.40	0.56	0.48	0.67	0.53	0.74	0.72	1.01					
40	0.40	0.52	0.43	0.56	0.51	0.67	0.57	0.74	0.77	1.01					
45	0.43	0.52	0.46	0.56	0.55	0.67	0.61	0.74	0.83	1.01					
50	0.46	0.52	0.49	0.56	0.59	0.67	0.66	0.74	0.89	1.01					
55	0.49	0.52	0.53	0.56	0.63	0.67	0.70	0.74	0.95	1.01					
60	0.52	0.52	0.56	0.56	0.67	0.67	0.74	0.74	1.01	1.01					
65	0.52	0.52	0.56	0.56	0.67	0.67	0.74	0.74	1.01	1.01					
70	0.52	0.52	0.56	0.56	0.67	0.67	0.74	0.74	1.01	1.01					
75	0.52	0.52	0.56	0.56	0.67	0.67	0.74	0.74	1.01	1.01					
80	0.52	0.52	0.56	0.56	0.67	0.67	0.74	0.74	1.01	1.01					
85	0.52	0.52	0.56	0.56	0.67	0.67	0.74	0.74	1.01	1.01					
90	0.52	0.52	0.56	0.56	0.67	0.67	0.74	0.74	1.01	1.01					
95	0.52	0.52	0.56	0.56	0.67	0.67	0.74	0.74	1.01	1.01					
100	0.52	0.52	0.56	0.56	0.67	0.67	0.74	0.74	1.01	1.01					
105	0.52	0.52	0.56	0.56	0.67	0.67	0.74	0.74	1.01	1.01					
110	0.52	0.52	0.56	0.56	0.67	0.67	0.74	0.74	1.01	1.01					
115	0.52	0.52	0.56	0.56	0.67	0.67	0.74	0.74	1.01	1.01					
120	0.52	0.52	0.56	0.56	0.67	0.67	0.74	0.74	1.01	1.01					

TABLE 6
MINIMUM LENGTH OF FAF FINAL APPROACH SEGMENT (NM)

APPROACH CATEGORY	MAGNITUDE OF TURN OVER THE FINAL APPROACH WAYPOINT (FAWP)		
	0° - 5°	>5° - 10°	>10° - 30°
A	1.8	1.8	2.0
B	1.8	2.0	2.5
C	2.0	2.5	3.0
D	2.5	3.0	3.5
E	3.0	3.5	4.0

TABLE 7
MINIMUM INTERMEDIATE
SEGMENT LENGTH FOR
FMS/ILS APPROACH

TURN ANGLE AT IWP (DEGREES)	LENGTH (NM)
15 OR LESS	2.25
30	2.50
45	2.75
60	3.00
75	3.50
90	4.00

TABLE 8
FLY-BY WAYPOINT MINIMUM TURN RADIUS

TURN ANGLE (degrees)	OUTSIDE TURN REDUCTION RADIUS (nm)
10	1.66
15	1.11
20	0.83
25	0.66
30	0.54
35	0.50
40	0.46
45	0.42
50	0.39
55	0.37
60	0.34
65	0.34
70	0.34
75	0.34
80	0.34
85	0.34
90	0.34
95	0.34
100	0.34
105	0.34
110	0.34
115	0.34
120	0.34



U.S. Department
of Transportation

**Federal Aviation
Administration**

Directive Feedback Information

Please submit any written comments or recommendations for improving this directive, or suggest new items or subjects to be added to it. Also, if you find an error, please tell us about it.

Subject: Order 8260.40B, Flight Management Systems (FMS) Instrument Procedures
Development

To: DOT/FAA
ATTN: Flight Procedure Standards Branch, AFS-420
PO Box 25082
Oklahoma City, OK 73125

(Please check all appropriate line items)

An error (procedural or typographical) has been noted in paragraph _____ on page _____.

Recommend paragraph _____ on page _____ be changed as follows:
(attach separate sheet if necessary)

In a future change to this directive, please include coverage on the following subject:
(briefly describe what you want added):

Other comments:

I would like to discuss the above. Please contact me.

Submitted by: _____ Date: _____

FTS Telephone Number: _____ Routing Symbol: _____