

ABRASIVE BLASTING OPERATIONS

Engineering Control and Work Practices Manual

Enviro-Management & Research, Inc.

Washington, D.C. 20001

FINAL REPORT

Contract No. 210-75-0029

U.S. DEPARTMENT OF HEALTH, EDUCATION, AND WELFARE
Public Health Service
Center for Disease Control
National Institute for Occupational Safety and Health
Division of Physical Sciences and Engineering
Cincinnati, Ohio 45226
March 1976

ACKNOWLEDGEMENTS

This contract was conducted by Enviro Management & Research, Inc. under contract COC-210-75-0029 for the Division of Physical Sciences and Engineering, National Institute for Occupational Safety and Health, Center for Disease Control, Department of Health, Education and Welfare. Technical monitoring was provided by Robert T. Hughes, Control Technology Research Branch.

This report is reproduced as received from the contractor. The conclusions and recommendations contained herein represent the opinion of the contractor and do not necessarily constitute NIOSH endorsement.

We acknowledge with grateful appreciation the assistance provided by the American Foundrymen's Society and The American Iron and Steel Institute, various manufacturers of abrasive blasting equipment, and Mr. Robert T. Hughes, Engineering Branch, Division of Physical Sciences and Engineering, National Institute for Occupational Safety and Health.

HEW Publication No. (NIOSH) 76-179

CONTENTS

ABSTRACT	vii
I. INTRODUCTION	1
II. CURRENT METHODS AND OPERATIONS	2
1. Methods of Application	3
1.1 Dry blasting	
1.2 Wet blasting	12
2. Abrasives in common use	
3. Abrasive Blasting Equipment	13
3.1 Portable blast cleaning machines	15
3.2 Hand-operated units in blast cleaning rooms	15
3.3 Hand-operated cabinet type blast cleaning machines	18
3.4 Automatic blast cleaning machines	20
3.5 Wet blast cleaning machines	22
III. POTENTIAL HEALTH AND SAFETY HAZARDS	25
1. Health Hazards	25
1.1 Dust	25
1.2 Noise	29
1.3 Chemical	35
2. Safety Hazards	35
2.1 Specific machine hazards	35
2.2 General safety hazards	54
IV. DETECTION AND EVALUATION OF ABRASIVE BLASTING HAZARDS	
1. Warning Labels and Signs	
2. Perceptible Hazards Detection	57
2.1 Safety hazards	60
2.2 Health hazards	60

3.	Detection through Instrumental Methods	62
3.1	Dust exposures	62
3.2	Noise exposures	67
V.	CONTROL OF ABRASIVE BLASTING HAZARDS	73
1.	Control of Health Hazards	73
1.1	Dust control	73
1.2	Noise control and hearing conservation	97
1.3	Control of chemical hazards	106
2.	Control of Safety Hazards	107
2.1	Controls for spec. abrasive blast. mach. type	107
2.2	General safety controls	125
VI.	DEVELOPING AND MAINTAINING AN EFFECTIVE SAFETY PROGRAM	133
1.	Job Safety Analysis	
2.	Safety Training	134
3.	Individual Contacts	136
4.	General Contacts	137
5.	Safety Observation	138
6.	Accident Investigations	142
7.	Safety Responsibilities	143
VII.	ESTABLISHING AND MAINTAINING A FIRST AID PROGRAM	146
VIII.	SOURCES OF INFORMATION ON ABRASIVE BLASTING	149
	BIBLIOGRAPHY	153

ABRASIVE BLASTING OPERATIONS
ENGINEERING CONTROL AND WORK PRACTICES MANUAL

ABSTRACT

Research indicates that some 100,000 abrasive blasters are exposed to silica dust, inhalation of which can lead to silicosis, for up to 60 million manhours each year. This publication describes in detail typical abrasive blast cleaning practices and equipment; potential health and safety hazards involved; methods to identify hazards; and measures for controlling hazards. It is intended for use by plant safety and industrial hygiene engineers.

* * * * *

ABRASIVE BLASTING OPERATIONS
ENGINEERING CONTROL AND WORK PRACTICES MANUAL

I. INTRODUCTION

The United States Department of Health, Education, and Welfare's National Institute for Occupational Safety and Health (NIOSH) is responsible for conducting research and developing educational and training materials in the field of occupational safety and health as required by the Williams-Steiger Occupational Safety and Health Act of 1970. Abrasive blasting is one of the occupational activities covered by the Act, which NIOSH has been studying.

Recent research indicates that 100,000 abrasive blasters are exposed to silica dust for up to 60 million manhours each year. The personal protective equipment used by these workers is, on the average, poor to marginal. Equipment deficiencies and lack of proper maintenance are commonplace. Workers are likely to receive above-TLV (Threshold Limit Value) quartz exposures and extreme noise exposures. Hazards related to electrical and mechanical equipment are numerous. Nor are abrasive blasters themselves the only ones affected. In certain types of operations, such as open-air abrasive blasting, anyone in close proximity may be exposed to safety and health hazards.

The purpose of this publication is to inform plant safety and industrial hygiene engineers of the most typical abrasive blasting practices; the potential safety and health hazards involved in these practices; and the engineering and administrative techniques available to minimize and control the resultant hazardous conditions.

II. CURRENT METHODS AND OPERATIONS

Abrasive blasting can be defined as a process of cleaning finishing of materials by forceful direction of an abrasive media applied either dry or suspended in a liquid medium, against the surface of the workpiece.

The process of abrasive blasting began in 1904. It is used today to:

- * clean a surface by removing unwanted rust, scale, paint, etc., in preparation for painting, anodizing, welding, or other processes which require a clean surface;
- * deburr, remove tooling marks, or otherwise finish a crude product;
- * change metallurgical properties or stress relieve a part by the peening action of multiple impactions;
- * produce a desired matte or decorative finish;
- * provide actual cutting or inscribing of partially masked parts, such as tombstones, or;
- * remove "flashing"^{ll} (excess material) from molded plastic or rubber.

Abrasive blasting is utilized for many different purposes by foundries, shipyards, steel fabrication plants, special purpose job and machine shops, gas transmission stations, steel mills, structural steel supply yards, building cleaners, wineries, breweries, canneries, rubber manufacturers, painting contractors, plastic manufacturers, welders, wood shops and furniture manufacturers, plating and anodizing shops, aircraft manufacturers, electronic manufacturers, petrochemical companies, memorial monument markers, and many others.

Results of a comprehensive NIOSH survey undertaken for development of the publication "Abrasive Blasting Respiratory Protective Practices" -- and referenced hereafter as the NIOSH survey^{ll} -- indicate that abrasive blasting is used most often to clean iron and/or steel surfaces. Other surfaces commonly treated by abrasive blasting techniques include masonry (brick, stone, concrete, etc.), sand castings, aluminum, copper, brass, wood, glass, and plastic.

The choice of the abrasive to be used and the type of equipment required to do the job depends essentially on the nature of the surface involved (including its pre-cleaned surface condition which may include being covered by paint, rust, etc.), the type of treatment desired (cleaning, deburring, etc.) and related concerns.

Abrasive blast cleaning generally is considered to be an economical process. It is faster than competitive processes of pickling, electrochemical cleaning, or hand finishing, and thus reduces manhours required. In addition, equipment investment is not substantially influenced by model changes, operational procedures, or personnel turnover; training of operators takes place in a minimum amount of time, and in many cases -- the abrasive media, or substantial portions of them, may be recycled for further use.

1. Methods of Application

Methods of applying abrasive materials can be segregated into two distinct types of procedures: dry and wet.

1.1 Dry-blasting: There are two methods used for dry-blast cleaning; mechanical blasting and air pressure blasting.

1.1.1 Mechanical Blasting: Mechanical blasting most frequently employs

the use of cabinet-type equipment. It is available in either batch, semi-automatic or automatic versions. Typically, the cabinet houses one or more blast wheels which direct the abrasive at the workpiece by centrifugal force. The wheel (see Figure 11-1) is positioned to ensure maximum coverage and high efficiency of the blast pattern in consideration of workpiece design. Clean abrasive, generally airwashed and graded, is stored in a hopper. The abrasive flows from the hopper by gravity to a feed funnel and dipper valve which meters the abrasive flow to the impeller. The impeller imparts centrifugal velocity to the abrasive which is then directed through a control cage. The control cage determines the direction and shape of the delivery of the blast pattern on the workpiece.

The wheel generally is enclosed in a protective housing to prevent discharge of stray abrasive. Because such machines are subject to considerable wear -- especially the wheel components and machine interiors parts in many cases are made of a high alloy, wear-resistant cast iron and are designed for easy replacement. Heavy rubber mats often are used on work tables to cushion the impact shock of the abrasive. Different types of wheels are available which permit greater efficiency of operation.

In general, abrasive velocity (approximately 250 feet per second) and volume of abrasive are such that mechanical systems provide a high level of work capacity per unit time. As a result, mechanical blast cabinet equipment can be geared to medium to high production applications. The equipment often is used to descale cast products,

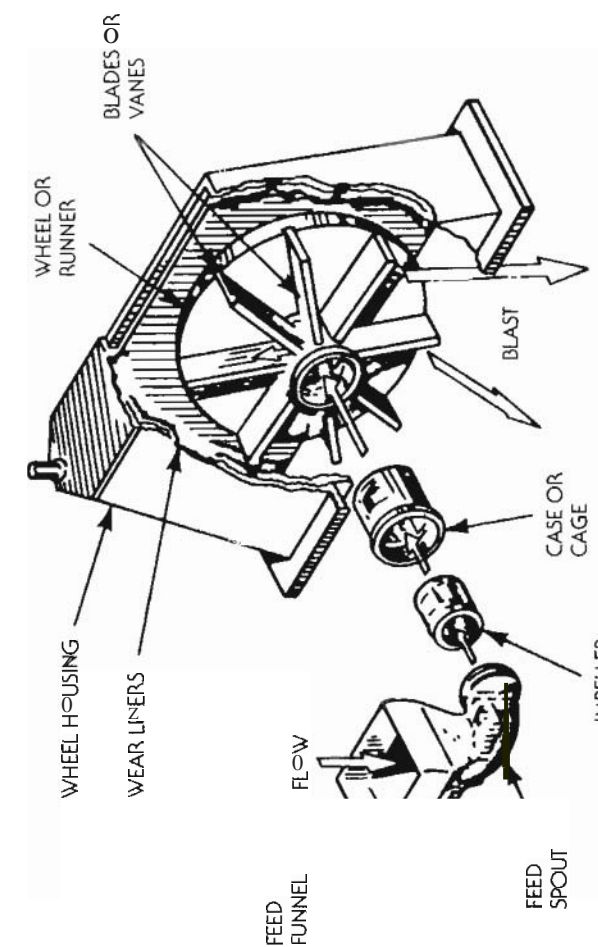

Figure 11-1 Abrasive Wheel -- illustrating the flow of the abrasive

deburr transmission parts, and to clean strip steel and automotive crankshafts, axle shafts, engine blocks and rear axle housings.

1.1.2 Air Pressure Blasting: Air pressure blasting uses compressed air to apply abrasive to a surface. Air pressure blasting uses either a direct pressure or an induction method that may use either the siphon or gravity method as follows:

1.1.2.1 Direct Pressure Method: In direct air pressure blasting, the abrasive is fed from a pressurized container (pressure vessel) into a blast hose, as shown in Figure 11-2. The compressed air line is piped to both the blast hose and upper portion of the pressure vessel. Air pressure (usually 80 to 90 psi) to both the hose and pressure vessel are equal thus permitting the free fall of the abrasive through an aperture (feed point) at the bottom of the pressure vessel. As the abrasive falls through it is picked up by the compressed air and conveyed to the point of operation. In order to maintain air pressure, a valve is fitted at the filling point of the machine and held tightly closed by the air pressure. A metering valve is fitted at the feed point to regulate abrasive flow at a rate suitable to the bore size of the nozzle and air pressure. Direct air pressure blast cleaning machines can be used separately as portable units for site work or they can be built into cabinets or blast rooms. The abrasive is in constant circulation and is stored in the upper portion of the

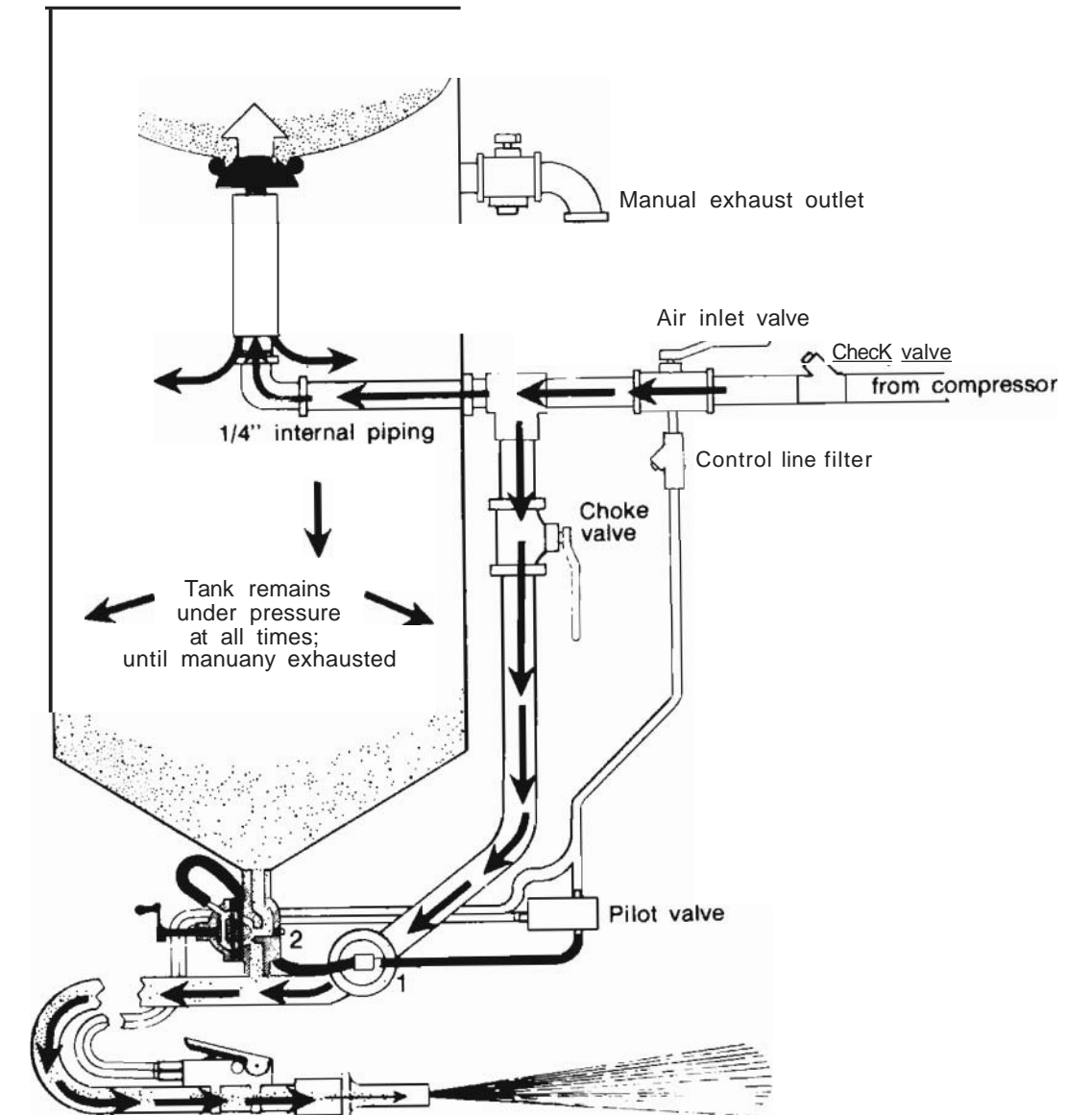

FIGURE II-2 Portable Direct Air Pressure Blast Cleaning Machine

Courtesy of Pauli & Griffin Co., San Francisco, California

pressure vessel above the filler valve. In such cases, when abrasive being used is exhausted, the operator closes both the abrasive and compressed air valves. Air is then exhausted from the pressure vessel and, when it reaches zero pressure, the filler valve drops so the unit is refilled with the abrasive held in reserve

1.1.2.2 Induction-Siphon Method: The blast gun of induction-siphon equipment is connected to a compressed air pipe and a flexible hose which carries the abrasive. The abrasive hose is open to atmospheric air near the base of the machine hopper (see Figure 11-3). As a result, the passage of compressed air through the gun and over the abrasive hose creates a partial vacuum in the hose which, in turn, draws or induces the abrasive into the gun where it is propelled through the nozzle by the jet of compressed air.

The rubber abrasive feed hose is usually six- to eight-foot long between the hopper and the gun.

The abrasive is accelerated by the air stream as it passes through the blast nozzle but does not reach the full velocity of the compressed air stream.

The velocity of the abrasive leaving the nozzle is approximately 40% of a direct pressure machine.

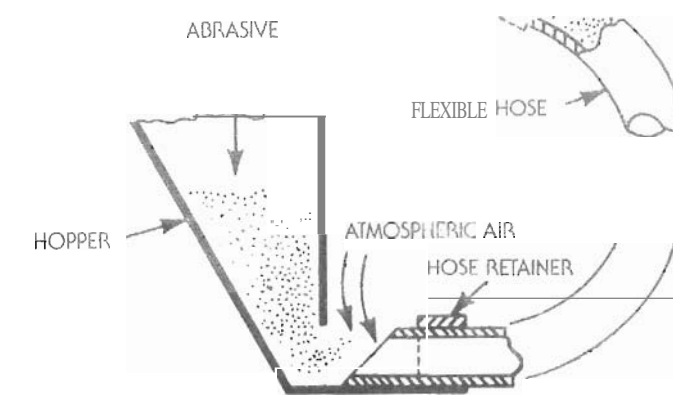

Figure 11-3: Connection of Abrasive Feed hose to the Abrasive Hopper

Induction-siphon systems are used in a wide range of hand-operated abrasive blasting cabinets. Although they also are used in continuous operation automatic equipment, they are generally limited to application of light abrasives.

1.1.2.3 Induction-gravity method: Induction-gravity equipment is very similar to induction-siphon equipment in that a gun is used to mix air and abrasive media (see Figure 11-4). With induction-gravity equipment, however, the media is gravity fed from overhead storage. The air supply enters the gun at that point where abrasive is entrained under a partial vacuum plus the weight of gravity. Rapid expansion of the compressed air as it emerges from the gun gives final acceleration to the abrasive. Induction-gravity systems are not in wide spread use. Although they can be applied for continuous operation, they usually are employed only for specialized applications such as shot peening.

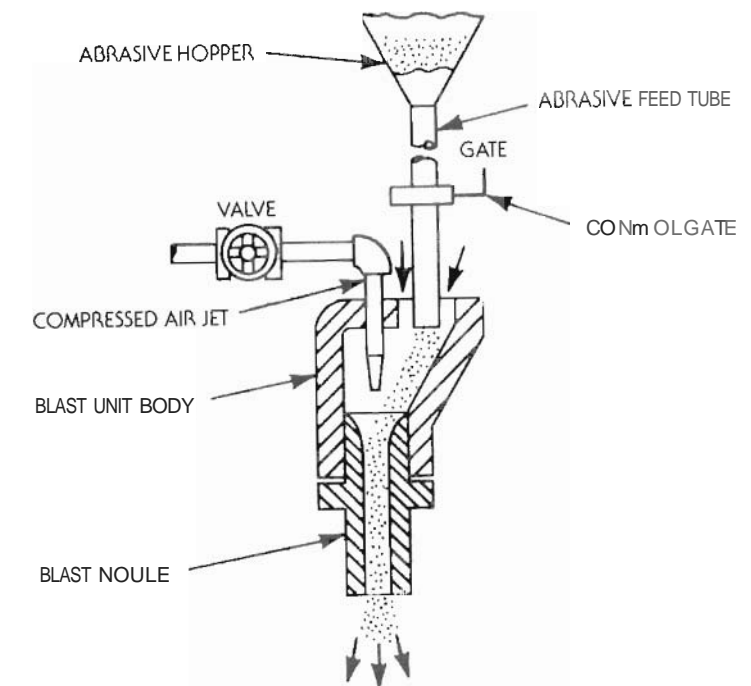

Figure 11-4: Gravity-fed Fixed Blast Nozzle

Mechanical dry blasting equipment is becoming increasingly more popular. Rapidity of surface contaminant removal can be increased by increasing abrasive particle velocity and the quantity of abrasive inputs per unit of time. Installations can be made semi- or fully-automatic with relatively little difficulty.

Air pressure blasting is used when low production requirements or intermittent operations are anticipated. This method of dry blasting is particularly suited for relatively small- to medium-size

parts which have intricate designs and varying cross sections.

1.2 Wet Blasting: Wet blasting involves high-velocity, compressed air propulsion of a slurry directed onto a workpiece. The slurry normally consists of fine abrasive suspended in chemically-treated water. It usually is kept in continuous agitation to prevent settling of the abrasive.

As with direct pressure dry blast units, compressed air is fed to the vessel containing the mixture at a pressure equal to that fed to the blast hose. Equalizing the pressure enables the abrasive mixture to feed through the mixing valve into the air line. The abrasive flow is controlled by a full flow valve situated between the hopper and mixing chamber.

Most wet blast equipment is of the cabinet mounted type and often is modified by auxiliary strippers, take-off conveyors, and wash-rinse dry stations. The basic designs include the vertical Wheel, horizontal plane turntable, shuttle with rail or car extensions, chain or belt conveyors, self-contained turning mechanisms designed for shafts and tubular parts, and combination tumbling-cabinet machines.

The slurry can be propelled against a surface by anyone of three distinct methods:

- a. By a stream of compressed air which raises the slurry through a siphoning action and then projects it through a suitably designed nozzle.
- b. By means of compressed air which propels a gravity-fed slurry to a gun.

- c. By use of a high-pressure centrifugal pump which produces the required speed of projection for the slurry.

Industry uses several variations of wet abrasive methods for specialty processes. Some of these processes have resulted in new process names, even though they all can be categorized under wet blasting. To clarify the confusion so created, the following definitions are provided for commonly-heard methods.

- a. Hydro-blast process: Sand is mixed with water and propelled by water pressure.
- b. Vapor-blast process: Abrasive is suspended in a liquid projected at high velocity by a jet of compressed air.

2. Abrasives in Common Use

A variety of different abrasives are in common use. Selection of a specific type depends primarily on economic, metallurgical and practical engineering factors.

The survey performed by NIOSH indicates (see Table 11-1) that sand is by far the most commonly-utilized abrasive. Other frequently-used abrasives include steel shot, steel grit, aluminum, flint/garnet, glass beads, carbides, slag, and organic materials (such as ground walnut shells, ground corncobs and crushed pecan shells).

3. Abrasive Blasting Equipment

The five types of abrasive blast cleaning systems now in common use are: portable blast cleaning machines; hand-operated units in blast cleaning rooms;

TABLE II-I The NIOSH Survey Results by Abrasive Use

<u>Abrasive</u>	<u>Number Reported</u>	<u>%of Total</u>
Sand	115	44.7
Steel Shot	43	16.7
Steel Grit	25	9.7
Alumina	24	9.3
Flint/Garnet	18	7.0
Glass Beads	12	4.6
Carbides	9	3.5
Slag	8	3.1
Organics (Cobs, Pecan Shells, etc.)	3	1.1
Total	257	

Source: Abrasive Blasting Respiratory Protective Practices.
HEW Publication No. (NIOSH) 74-104

hand-operated cabinet-type blast cleaning machines; automatic blast cleaning machines, and wet-blast cleaning machines.

3.1 Portable Blast Cleaning Machines (Figure 11-5): Portable blast cleaning machines generally require a high-volume air supply (usually in the 90 to 100 psi range); a container or pressure vessel to contain the abrasive; a metering device to control air-to-abrasive ratio and flow; a flexible hose to deliver the abrasive, and a hand-held nozzle to aim the abrasive onto the workpiece. Many portable units also have large hopper-fed storage tanks which enable multiple blasting operations from a single source of supply.

Portable units can be operated either manually or automatically. Manual types generally require a "pot" attendant who manually controls abrasive flow per instructions of the nozzle operator. Automatic machines have controls which start and stop operations by use of a flow control valve or a "deadman" switch on the nozzle. When the operator closes the valve, the machine starts and the air and abrasive mixture is ejected from the nozzle. When the operator releases the flow control valve, the abrasive discharge stops and the machine depressurizes.

In some cases water supply heads are attached to the nozzle to jet water into the dry blast discharge. The water saturates the abrasive and thus converts a dry blast operation into a wet blast operation.

3.2 Hand-Operated Units in Blast Cleaning Rooms (Figure 11-6): Although hand-operated units in blast cleaning rooms usually use a large hopper for storage of abrasive, the units themselves are essentially similar

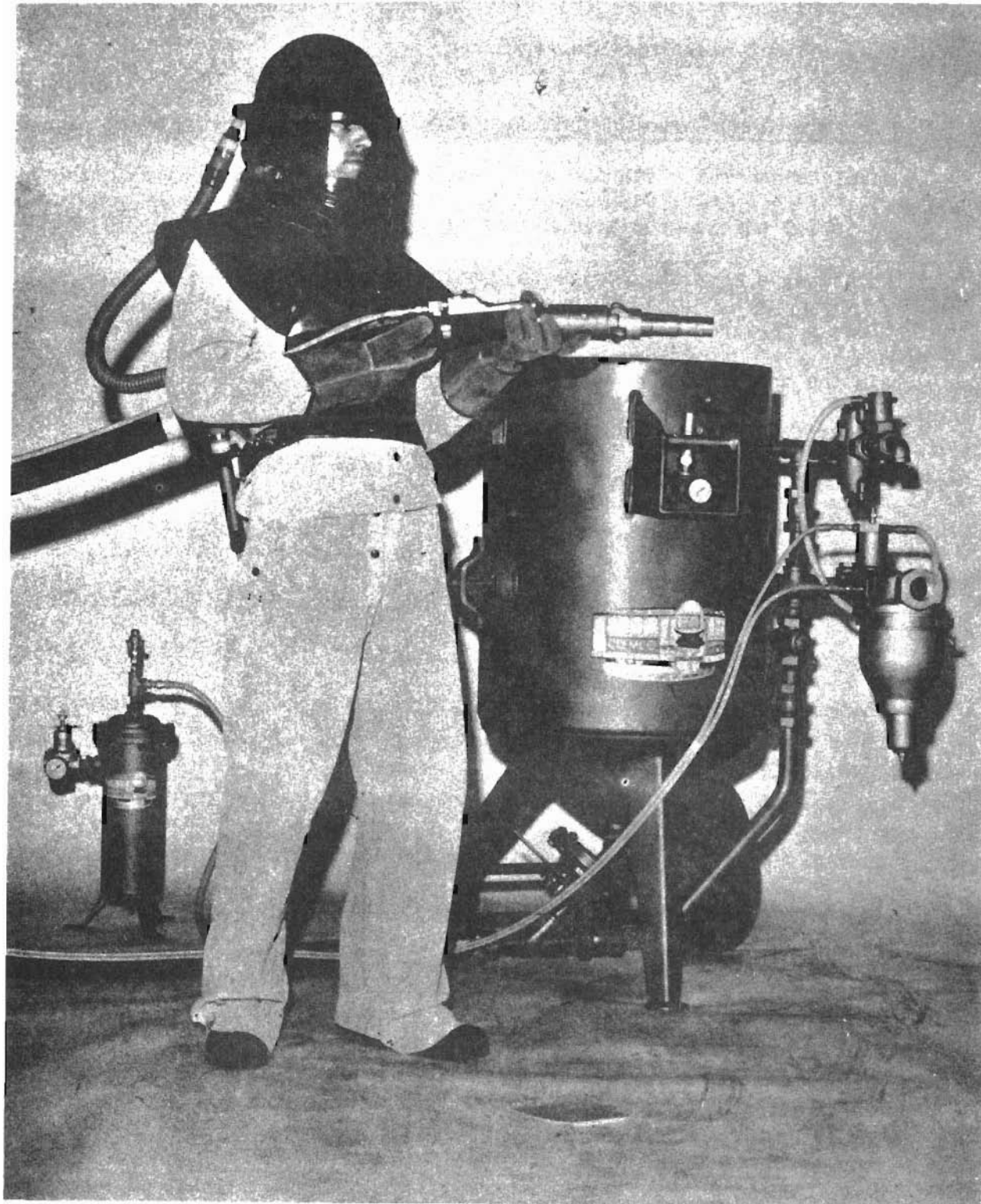

FIGURE 11-5 Portable Blast Cleaning Unit with Operator

Courtesy of Clemco-Clementina, Ltd.

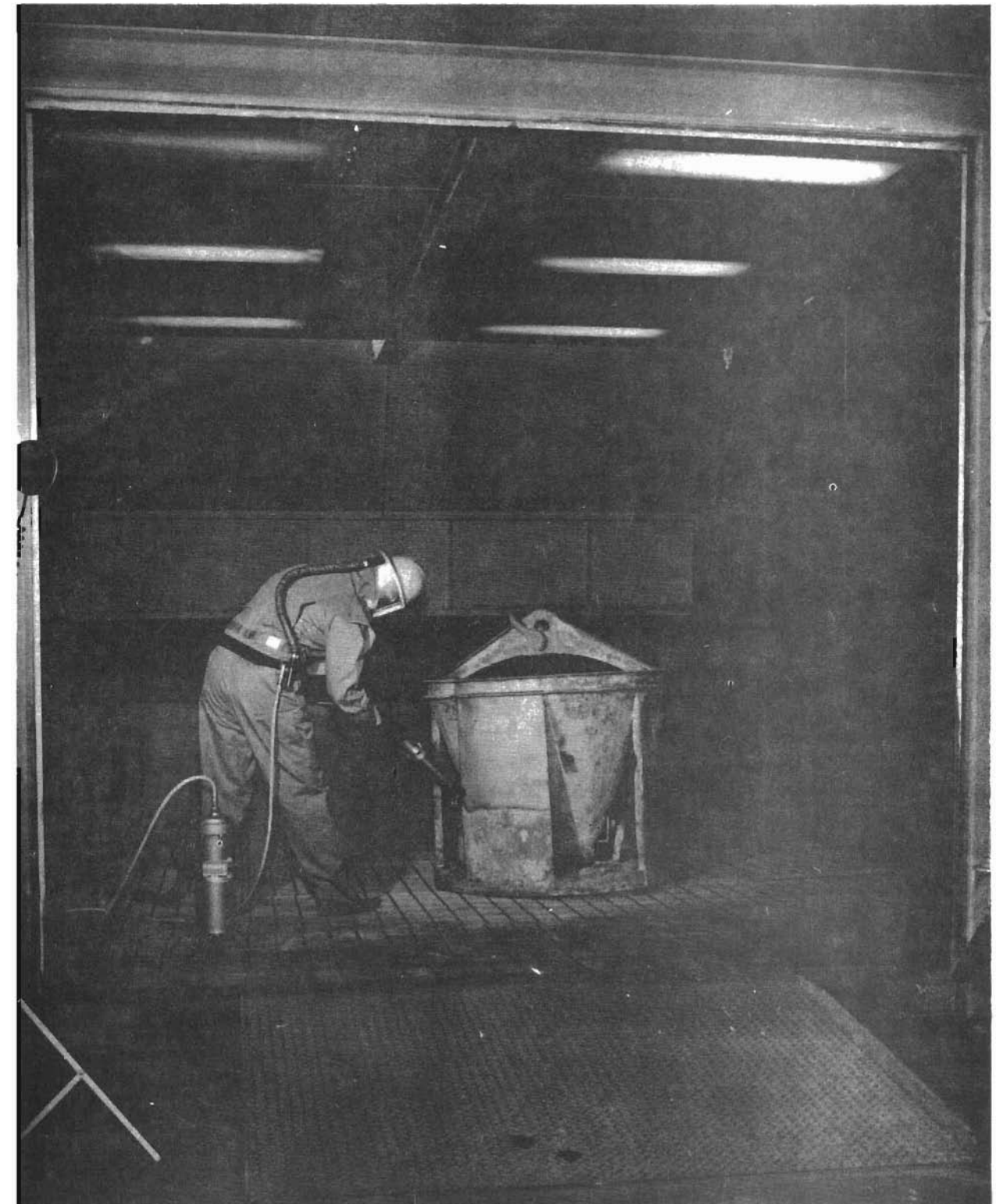

FIGURE 11-6 Interior of Blast Cleaning Room

Courtesy of Clemco-Clementind, Ltd.

to portable units. The principle benefits afforded by blast cleaning rooms are (1) ability to provide and use a dust control ventilation system, (2) cost savings from recycling the abrasive, and (3) containment of dust and debris so they do not spread over large areas and expose other workers and machinery to injury and damage.

Blast cleaning rooms generally are found at plant locations where there is a continual flow of similar objects for cleaning. This permits continued use of a one-material handling system.

Blast cleaning rooms vary in size from single compartments to rooms which permit use of multiple blast cleaning units. Some blast cleaning shops utilize railroad tracks and flat cars to handle pieces to be cleaned. One such shop (in one of the nation's larger shipyards) can pressure blast clean large prefabricated sections of ships.

Exposure to blast cleaning operations in this type unit is very similar to that of portable machines, except an exhaust system aids visibility and helps reduce the possibility of dust inhalation.

Personal protective equipment which should be worn by the blast operator in a blast cleaning room is essentially the same as that worn by the operator of a portable cleaning machine.

- 3.3 Hand-Operated Cabinet Type Blast Cleaning Machines (Figure 11-7): Cabinet type units generally are used for cleaning small parts that can be hand-held or positioned on a rotatable mandril. In such units the job and the abrasive are confined within a metal cabinet. Direction of the abrasive discharge is manually, semi-automatically, or automatically controlled. When automatic machines are involved, the actual cleaning period is timed

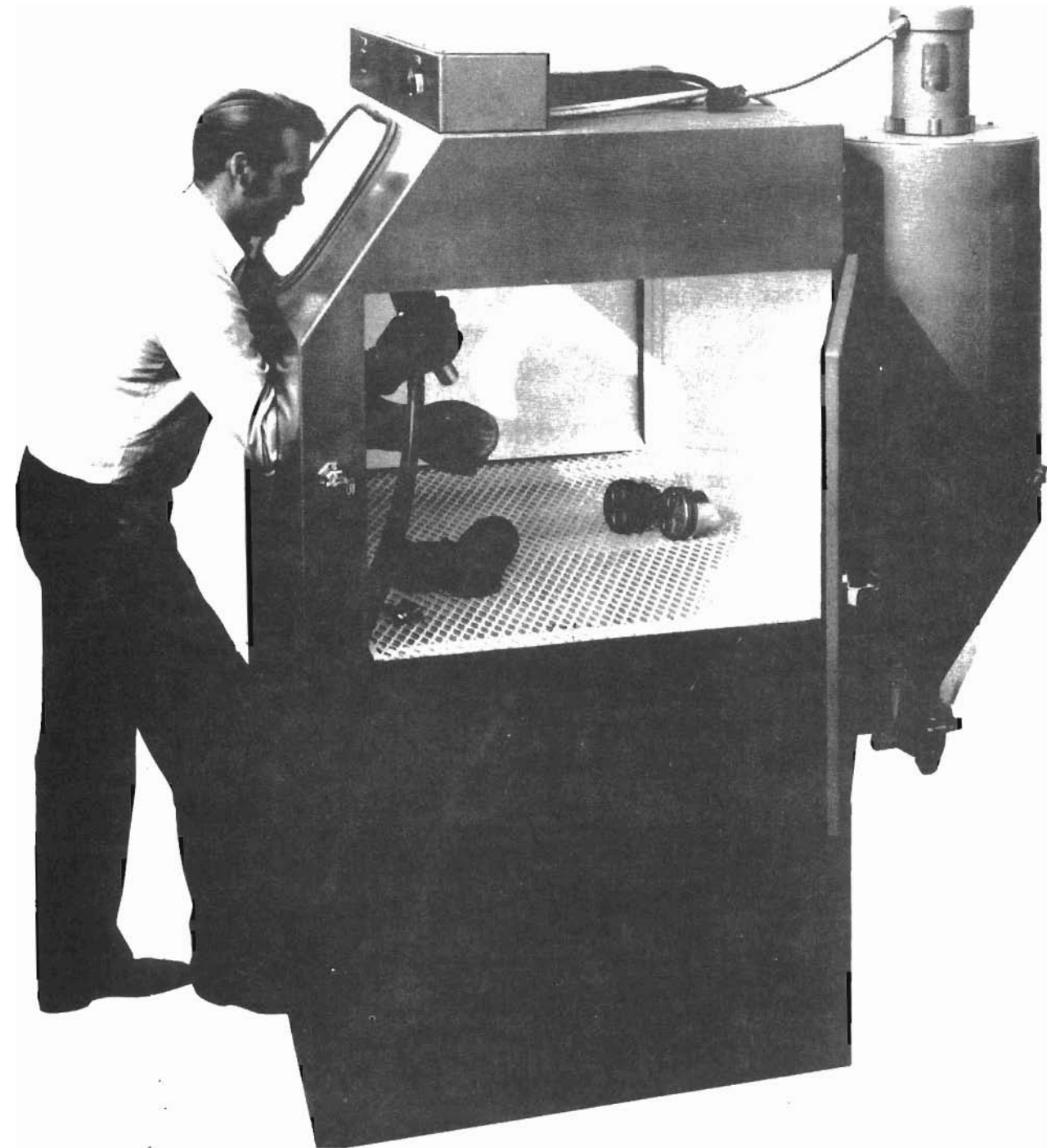

FIGURE II-7 Hand-operated Cabinet Type Blast Cleaning Machine

Courtesy of Empire Abrasive Equipment Corporation

closely and can be shut-off automatically. Manual machines are equipped with a vision glass. Two openings enable the operator to insert his hands and arms into rubber gloves and sleeves which protect him from contact with the abrasive discharge. This type of machine usually is equipped with gasketed doors and is operated under negative internal pressure to contain dust within the confines of the machine. Negative pressure-sensing switches can be used with this type of unit but usually are optional and do not have a long life expectancy due to the abrasive atmosphere within the cabinet. Fingers of the rubber gloves likewise have a short life span.

The machines can be designed for either wet- or dry-blast cleaning. Glass beads frequently are used as an abrasive medium. An average charge weighs approximately 50 lbs. On wet-blast machines, the abrasive-to-water ratio usually is 25%

Free standing cabinets generally are equipped with dust exhaust systems which help maintain internal visibility. Most small benchtop units are not so equipped.

- 3.4 Automatic Blast Cleaning Machines (Figure II-8): These units are larger in dimension and are more heavily constructed than cabinet machines. Most operate on the centrifugal wheel principle and employ timers and automatic shut-off controls to provide the desired amount of abrasive exposure. A workpiece can be placed on either a rotating table or an endless revolving belt that tumbles the job to expose all surfaces to the abrasive. Machines are loaded either mechanically or manually depending on the weight of the job. On tumble blast machines, belt travel can be reversed to automatically unload cleaned parts into tubs or skips. Rotating

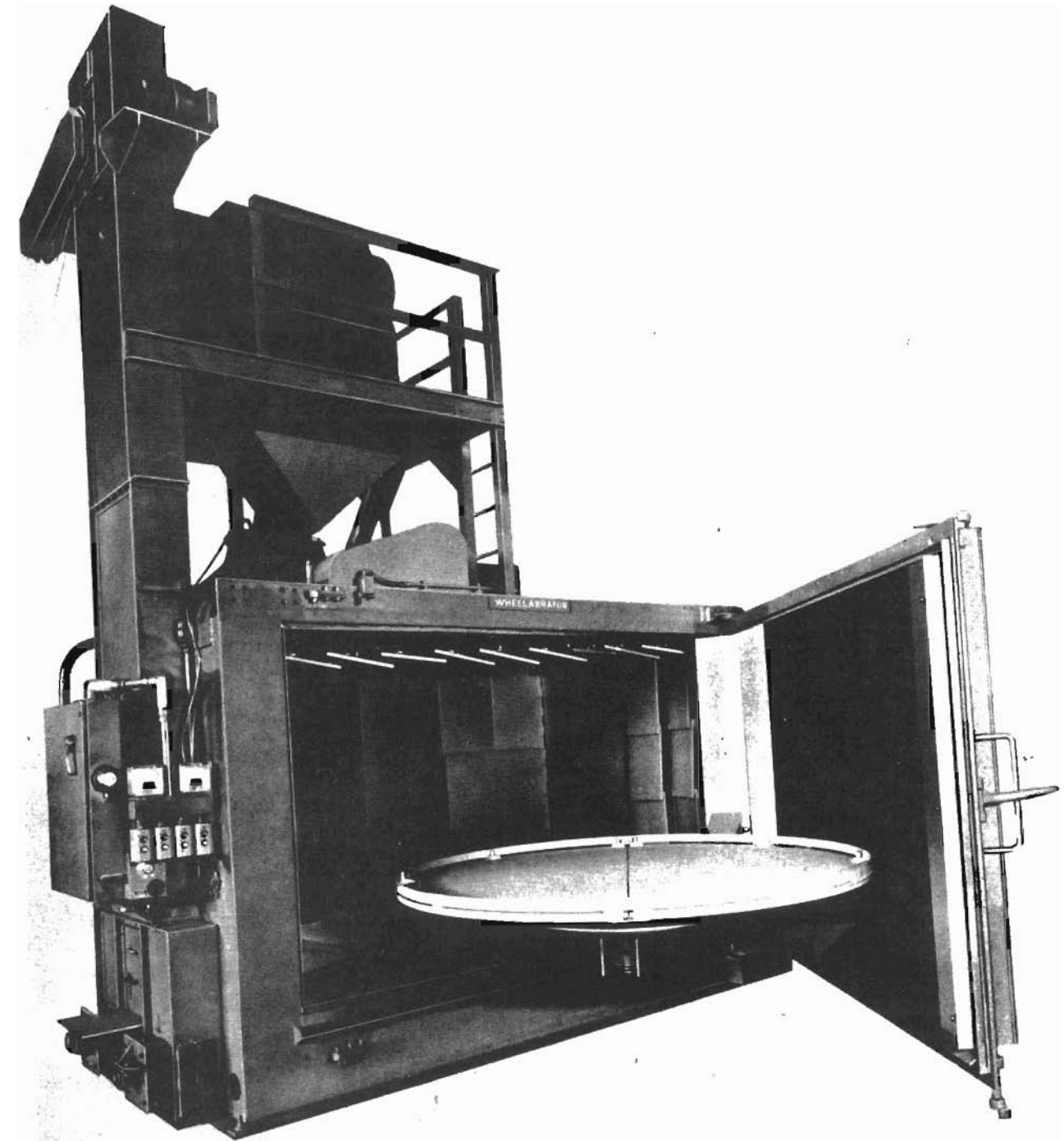

FIGURE II-8 Automatic, Swing Table Blast Cleaning Machine

Courtesy of Wheelabrator-Frye, Inc.

table machines are used to clean very large parts. The table can be swung in and out of the enclosed blasting chamber to facilitate loading and unloading. Cleaning action begins once the doors are closed to confine the dust. Such machines separate debris from usable abrasive (which is recycled until it can no longer be used). There are numerous special purpose machines designed and constructed to perform specific blast cleaning operations. Lengthy sections of structural steel can be passed through a machine for cleaning while heavy hanging rubber skirts contain the dust at the point of exit and entry. Other machines utilize overhead traveling conveyors and enclosed blasting chambers to permit continuous cleaning of parts while passing through the chamber for a carefully timed cleaning cycle.

3.5 Wet-Blast Cleaning Machines (Figure 11-9): This method can be applied to portable machines providing that abrasive is thoroughly mixed with water forming a slurry. Otherwise, heavy-duty compressors and hose lines are required to propel the slurry. Normally, special purpose machines use the wet-blast method continually recycling the slurry. Since rusting of metal parts becomes a problem, rust inhibitors are frequently added to the slurry. A typical use for the wet-blast technique is for cleaning golf balls (300 every five minutes). Balls are poured into a rotating basket within a cabinet-type negative pressure machine. The cleaning slurry is later washed from the balls by a hot and cold water rinse after which they are airdried and conveyed to the packaging section of the machine. Wet-blast operations greatly aid in dust control on portable units but can result in muddy, wet, and slippery floors in the immediate blast cleaning area.

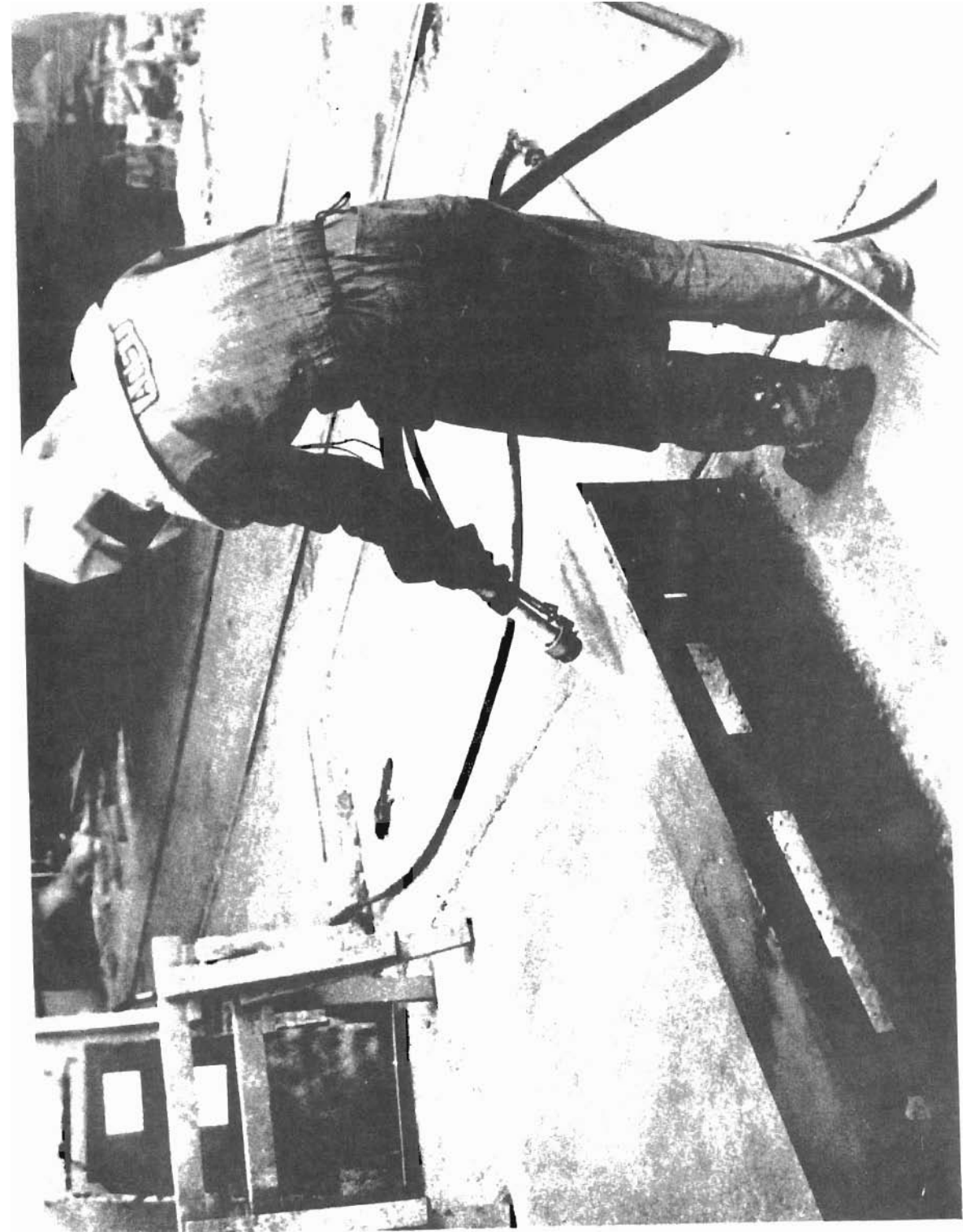

FIGURE 11-9 Portable Wet Blast Cleaning Machine

Some of the newer water-jet blast cleaning machines operate at water pressures up to 10,000 psi. Equipment consists of a power unit and pump, a water filter, a pressure gauge, and a discharge nozzle. Water flow rates of 4 to 14 gpm are developed. High water pressures place considerable strain on the operator. Some units utilize a limited supply of abrasive drawn from an open supply hopper to aid in removal of paint from metal and other materials.

III. POTENTIAL HEALTH AND SAFETY HAZARDS

There are many different hazardous situations and conditions created by blast cleaning operations. As in so many other cases, however, numerous hazards can be greatly minimized if not eliminated altogether by applying known operating and maintenance techniques and engineering controls,

The following discussion is intended to highlight the most prevalent hazards unique to the industry and some of the more serious hazards which are relatively commonplace in most industrial operations and processes.

1. Health Hazards

The three most significant health hazards are those which relate to dust, noise and chemicals. It generally is agreed that dust is the most serious health hazard in abrasive blasting operations.

1.1 Dust: Dusts result from broken-down abrasives, pulverized surface coatings and encrusted substances, and abraded material from the object being blasted,

The solid particles which comprise the dusts range in size from less than one micron (1/25,000 inch) to more than 1000 microns. Under normal conditions, dust particles of 10 microns or more in diameter settle relatively quickly. Those smaller than 10 microns remain airborne longer and are easily inhaled. Smaller dust particles often settle in the lungs and sometimes small soluble particles dissolve into the blood stream.

Toxic dusts of respirable size obviously are a significant health hazard.

Of particular importance is silica dust (SiO₂) created when sand is used as the abrasive material. Silica exposure may cause silicosis} a slowly developing lung disease which often leads to death years after exposure has ceased. The significance of dangers inherent in silica dust becomes all the more apparent when it is recognized that the NIOSH survey (referred to earlier) shows sand to be far and away the most commonly used abrasive and that exposure to silica dust in many of the industries involved is extremely high (see Table III-I).

Another serious health hazard is created when toxic metals or alloys containing toxic metals such as lead, cadmium, zinc or mercury are cleaned. Although the NIOSH survey revealed that these metals are not generally involved, it also showed that many of the materials cleaned are likely to be coated by paint or other substances which could contain such metals or other toxic substances (see Table 111-2).

Inhalation of dust is not the only health hazard involved. Dust particles also can enter the eyes} ears} nose and throat and can cause, at the least, temporary discomfort. Depending on the nature of the dust involved and the orifice affected, immediate or long-term health effects can be far more serious. Dust particles also can enter the body through any small open wound or abrasions; through ingestion (eating dust-affected foods), and (rarely) through skin absorption.

TABLE III-I Sand Exposure by Major SIC Group

SIC Description	Total Blasting Firms in SIC	Total Firms Reporting Use of Sand Abrasive	Percentage Using Sand Abrasive	Total Firms Blasting Sand Castings With- out Sand Abrasive	Total Firms Reporting Use of Sand Abrasive or Blasting Sand Castings	Percentage Sand Dust Exposure Possible
17 Constr Spl Trade Con			100		11	100
Petroleum Refining						
Stone, Glass, concr Prods.	22					
Primary Metals Indus					31	
Fab Mtl Pdts Ex Mach						
Transportation Equip	12					
40 Railroad Transportn			100			100
TOTAL		112				

Source: Abrasive Blasting Respiratory Protective Practices
HEW Publication No. (NIOSH) 74-104

TABLE III-2 The NIOSH Survey Results by Surface Blasted

<u>Surface</u>	<u>Number Reported</u>	<u>%of Total</u>
Iron/Steel	111	44.9
Masonry (brick/stone/ concrete/etc.)	46	18.6
Sand Castings	27	10.9
Metal (not specified or NEC)	23	9.3
Aluminum	14	5.6
Copper/Brass	12	4.8
Wood	9	3.6
Glass	4	1.6
Plastic	1	0.4
TOTAL	247	

Source: "Abrasive Blasting Respiratory Protection Practices"
HEW Publication No. (NIOSH) 74-104

Because dust also is airborne, heavy concentrations may affect those near the work area as well as those located at even a relatively remote distance, depending on the ventilation system or, in the case of open-air blasting, prevailing wind conditions, humidity, etc. The NIOSH survey revealed that, in fact, much of the abrasive blasting performed is undertaken outdoors and in general work areas, neither of which enables easy confinement or control of dust (see Table III-3). As such, the air breathed by those near the blasting area must be a matter of serious concern, as shown in Table III-4. The situation is aggravated further by the extent (in terms of time) of typical blasting operations (see Table III-5).

Dust also can create a health hazard after first settlement. For example, unprotected workers frequently are given the task of beating dust collector bags. As a result, particles once again become airborne and can have serious consequences.

1.2 Noise: Sound levels to which blast operators are exposed are the result of numerous interrelated factors, such as the size and composition of blasting area, the type of equipment (including nozzle) involved, the angle of workpiece, and so on.

With cabinet and automatic room type blasting, the noise problem is or can be made relatively minor with proper engineering controls, (see Table III-6). In almost all cases, however, abrasive blasting hand-operated nozzles (See Table III-7) present a serious noise problem because the nozzle generally is near the operator's ear. Noise created can have serious impact on workers and others nearby and may lead to hearing loss. Breathing-air noise within protective

TABLE 111-3 The NIOSH Survey Results by Blasting Area

Blasting Area	Number Reported	% of Total
Outdoors	92	35.5
Special Room	59	22.7
Cabinet	55	22.2
General Work Area	33	12.7
Other	20	7.7
TOTAL	259	

Source: 'Abrasive Blasting Respiratory Protection Practices
HEW Publication No. (NIOSH) 74-104

TABLE 111-4 ; Summary of Dust Exposures for Different Operations Surveyed

ABRASIVE BLASTING INSTALLATION*	FEDERAL EXPOSURE LIMITATIONS FOR DUST (OSHA, CFR TITLE 29)	RECORDED DUST CONCENTRATIONS													
		AT BLAST OPERATOR						NEARBY AREAS							
		BELOW TLV		ABOVE TLV		BELOW TLV		ABOVE TLV		BELOW TLV		ABOVE TLV			
		TLV.mg/M ³		MODERATE <<2 x TLV)		EXCESSIVE (>2 x TLV)				MODERATE <<2 x TLV)		EXCESSIVE (>2 x TLV)			
ABRASIVE	RESP.	TOTAL	RESP.	TOTAL	RESP.	TOTAL	RESP.	TOTAL	RESP.	TOTAL	RESP.	TOTAL	RESP.	TOTAL	
1. PORTABLE UNITS															
P-1	and	0.1-0.2	0.3-0.5												
P-2	Black Beauty	5	15	●	●					●	●			●	●
P-3	Sand	0.1-0.2	0.3-0.5	●	●									●	●
P-4	Black Beauty	5	15							●	●			●	●
P-5	Sand	0.1-0.2	0.3-0.5	●	●									●	●
P-6	Sand	0.1-0.2	0.3-0.5											●	●
P-7	Sand	0.1-0.2	0.3-0.5											●	●
P-8	Sand/Water	0.1-0.2	0.3-0.5											●	●
P-9	Sand	0.1-0.2	0.3-0.5											●	●
P-10	Black Beauty	5	15							●	●			●	●
2. BLAST CLEANING ROOMS															
R-1	Black Beauty	5	15											●	●
R-2	Steel Shot	5	15		●									●	●
R-3	Steel Shot	5	15							●	●			●	●
R-4	Steel Shot	5	15							●	●			●	●
R-5	Steel Shot	5	15							●	●			●	●
R-6	Steel Shot	5	15							●	●			●	●
R-7	Steel Shot	5	15							●	●			●	●
3. CABINET MACHINES															
C-1	Sand	10.1-0.2	10.3-0.5	●											
4. AUTOMATIC MACHINES															
A-1	Steel Shot	5	15	●	●					●	●			●	●
A-2	Steel Shot	5	15	●	●					●	●			●	●
A-3	Steel Shot	5	15	●	●					●	●			●	●
A-4	Steel Shot	5	15	●	●					●	●			●	●

* Each installation listed represents a different operation.
Source: "Industrial Health and Safety Criteria for Abrasive Blast Cleaning"
HEW Publication No. (NIOSH) 75-122

TABLE 1-5-5 Blasting Area and Hours Reported by Major SIC Group

Average Individual Hours of Blasting Per Month
82
62
36
50
71
55
75
82

TABLE III-7 Sound Levels Near Hand-Operated Nozzles

Installation*	Measurement Distance From	Blasting Range dbA	Blasting Ave. dbA	OSHA Allowable Hours/ Day
R-4(3)	3'-- Outside Blasting Room Walls	96/110	102	1-1/2
P-5(2)	6'-- Blaster Nozzle		94	
P-9(2)	35'-- Blaster Nozzle	92	92	6
P-4(1)	70'-- Blaster Nozzle	87	97	
p-4(2)	70'-- Blaster Nozzle	92/96	94	
P-4(3)	35'-- Blaster Nozzle	99	99	
P-4(4)	40'-- Blaster Nozzle	90/91	90	8
R-5(2)	3'-- Blaster Nozzle	90/104	97	3
P-2(2)	8'-- Blaster Nozzle	102/105	103	
P-2(3)	46'-- Blaster Nozzle	94/98	96	

* Each Installation below represents a different operation. Measurements were taken at different positions from the source.

Source: "Industrial Health and Safety Criteria for Abrasive Blast Cleaning Operations", HEW Publication No. (NIOSH) 75-122

helmets (see Table 111-8) also creates a significant problem.

Permissible noise exposures as defined in current OSHA standards are shown in Table 111-9.

1.J Chemical: Although not a direct element of the abrasive blasting process, the blast operator may be called upon to clean a surface -- particularly an oily surface -- with a chemical such as trichlorethylene. Improper use or storage of this and similar chemicals can lead to serious health hazards through inhalation of vapors or ingestion or skin absorption of the liquid.

2. Safety Hazards

Safety hazards include those associated with the abrasive blasting equipment itself, vision impairment, slipping, flying abrasive, fire, explosion, and static electricity.

2.1 Specific Machine Hazards: Because of the significant differences between the various machine types, it is worthwhile to consider the safety hazards of specific types.

2.1.1 Hand-Operated Portable and Room-Type Blast Cleaning Machine Hazards: Operators of hand-held equipment work in the open when cleaning surfaces of high buildings, swimming pools, hulls and other surfaces of ships, high steel structures, and so on. Equipment used for these and similar tasks comprise a flexible hose and abrasive discharge nozzle, similar to that used in the confines of an enclosed blast cleaning room. Mechanical, electrical, and personal

TABLE III-8 : Noise Exposure Summary

Process/Business/Equipment	Total Number	Ave. Exposure Time (hrs/day)	Ave. Sound Pressure Level (dbA)	Maximum Sound Pressure Level (dbA)
Air-Fed Helmets	56	5.3	100.5	126
Non Air-Fed Hoods	15	5.3	106.1	126
Monument Shops	13	4.8	101.3	112
Shipyards	16	6.0	104.8	126
Painting/Sandblasting Contractors	32	5.6	105.4	118
Primary Metals Industries				
Airless Process	14	3.5	95.5	114
Dry Process	22	4.2	99.1	112

Source: "Abrasive Blasting Respiratory Protective Practices",
HEW Publication No. (NIOSH) 74-104

TABLE III-9 Permissible Noise Exposures

Duration per day, hours	Sound Level dbA SL-w Response
8	92
6	92
4	95
3	97
2	100
1.5	102
1	105
0.5	110
0.25 or less	115

Source: OSHA Standards, Table G-16; 29 CFR 1910.95

protection equipment aspects are detailed below. As can be seen, hand-operated dry-blast equipment involves the most hazards. At the same time, as shown in the NIOSH survey, it is generally the most commonly used blast equipment (see Table 111-10).

- 2.1.1.1 Mechanical: Typical mechanical hazards associated with the use of hand-operated portable and room-type blast cleaning machines include:
- a. Deadman Control: Failure to provide a unit with a deadman or abrasive shut-off control can result in a high-pressure abrasive flow continuing if the nozzle is dropped. A deadman control is a spring-loaded, fail-safe device which, when depressed by the operator, causes the abrasive to flow. When pressure is released, the abrasive flow stops automatically. In this way, should the operator accidentally drop the blast gun, the deadman control automatically deactivates abrasive flow thereby preventing the worker and anyone in range from being sprayed by the abrasive.
 - b. Hoselines: Hoses are subject to internal deterioration from abrasive action. Hoses which are not inspected on a regular basis are subject to leaks and rupture which could have serious consequences.

TABLE III-IO The NIOSH Survey Results by Blasting Process

Process	Number Reported	% of Total
Dry Blast	148	77.0
Centrifugal	30	15.6
Wet Blast	11	5.7
Vacuum	3	1.5
Total	192	

Source: "Abrasive Blasting Respiratory Protective Practices," HEW Publication No. (NIOSH) 74-104.

- c. Metal Pipelines, Joints, etc.: Metal pipelines, joints, bends, valves, connectors and nozzles also are subject to interior deterioration from abrasive action. These, too, are not inspected with sufficient regularity to identify preventive/corrective actions to protect workers and others from the hazards resulting from leakage.
- d. Pressure Vessels: Pressure vessels (or pressure pots) are subject to interior deterioration. They seldom are inspected for repair or replacement which may be needed. Despite the obvious hazards involved, operators still use pressure vessels which lack a removable hand-hole plate which permits internal examination. OSHA regulations require that "Pressure vessels shall be built in accordance with the code for Unfired Pressure Vessels, Section VIII of the ASME Boiler and Pressure Vessel Code 1968."
- e. PoP-Up Valves: Some pressure vessels use pressurizing pop-up valves made of all rubber construction. These are subject to rapid deterioration and resulting malfunction. Such valves should not be used. Rubber covered valves and tank top seals are not inspected as frequently or regularly as they should be. In

- some cases rubber seals are used in conjunction with valves which do not have an internal metal core having a diameter larger than that of the tank top opening creating potential for malfunction.
- f. Fill Head: Pressure vessels without an upper fill head of concave design or which otherwise are poorly designed tend to interfere with entry of the abrasive, induce spilling, and generally cause strains and sprains when the pot is being filled manually.
- g. Blast Cleaning Room Surfaces: When interior floors, ledges and shelf surfaces of blast cleaning rooms are not cleaned of waste abrasive and debris on a regular daily basis, both safety and health hazards can result, especially from interaction of different types of dusts. Persons who perform cleaning, even on an irregular basis, and do not wear suitable respiratory protection for the tasks involved, are subject to health hazards. Failure to inspect for deterioration or distortion of floor surfaces will increase the likelihood of a serious slipping/tripping hazard.
- h. Blast Cleaning Holes/Noise: Blast cleaning rooms frequently develop holes, abraded metal enclosure surfaces, and defective door seals which can

inadequacy, poor circuit design, improper placement or positioning of devices, lack of proper identification, improper grounding, lack of accurate instructional materials, improper or infrequent testing and checking, and lack of sufficient guarding or shielding.

- a. Roseline Grounding: Main abrasive supply hoses in some cases do not have an efficient means for discharge of static charges from the blasting nozzle. Even when suitable grounding is provided -- as through a separate grounding cable or preferably through use of a hose which has a grounding system built in -- ground continuity tests to ensure continued operation and adequacy of these protective devices are not conducted adequately and/or with enough regularity and frequency.
- b. Lighting: Proper lighting essential for safety in blast cleaning operations often is not available due to missing lamps (light bulbs) or glass shades or plates which have become etched and so reduce lighting levels to less than 20 foot candles over all parts of the chamber.
- c. Motors: Electric motors used sometimes are not of dust-proof design and/or are not confined

in dust-tight enclosures which meet provisions of NEMA (National Electrical Manufacturers Association) Specification 12. Motor breakdown feasibly can create a serious safety hazard.

2.1.1.3 Personal Protective Equipment: Use of appropriate personal protective equipment which has been maintained properly is essential for safety with use of portable hand-operated or room-type blast cleaning machines. In many cases improper equipment is used and, in some cases, no protective equipment of any type is utilized. Use of improperly designed or maintained equipment can not only increase exposure to blast operating hazards, but also can create new hazards not associated with blast cleaning itself, for example, use of contaminated air lines for protective helmets.

- a. Helmets: Operators at times will not wear an air-supplied breathing helmet. Failure to do so can lead to numerous hazards from inhalation of dusts, abrasion from ricocheting abrasives, and so on. Operators also will at times use a protective helmet which has been previously worn by someone else and which has not been properly disinfected, or will store

- a. Dust Collecting Systems: Some cabinet machines, especially small bench-top units, lack an adequate exhaust ventilation system required to reduce dust hazard. Others use a gravity-settling system which creates hazards by restricting vision and/or by becoming overpressurized causing abrasive to leak. Systems often are not inspected for blockages on at least an hourly operational basis; collection bags frequently are not inspected often enough, and defective bags sometimes are not discarded as they should be. Lack of adequate dust control can result in numerous hazards.
- b. Foot Controls: Some foot controls do not have a stirrup-type guard. In such cases, the chances of inadvertent activation of the machine and attendant hazards are increased Substantially.
- c. Observation Ports: Observation ports of some hand-operated cabinet machines use other than safety glass and so could result in serious accident if broken by ricocheting abrasives.
- d. Exhaust Fans: Exhaust fans of cabinet machines often are not acoustically engineered. Resulting noise levels are above

the maximum accepted decibel levels.

- e. Open-Front Cabinet Machines: Despite the fact that open-front cabinet machines have been found to be extremely hazardous some still are used -- particularly in the suede preparation and cleaning industry. These machines, even if well ventilated, will permit escape of dust and abrasive blast materials.
- f. Other Hazards: Other hazards associated with hand-operated cabinet machines are the same as those for hand-operated portable and room-type blast cleaning machines. These hazards include those resulting from: defective door seals; deterioration of cabinet surfaces; improperly grounded or ungrounded hoses, and insufficient lighting.

2.1.2.2 Electrical: Electrical hazards associated with the use of hand operated cabinet machines include:

- a. Failsafe Control Protection: In many cases hand-operated cabinet machines were not designed with, or have not been retrofitted with, failsafe control protection such as a negative-pressure control switch (preventing machine operation unless a negative pressure exists within the cabinet) and an electrical interlock

control, preventing operation unless main access door is in the closed position.

- b. Dustproof Operating Controls: Proper operation of equipment can be jeopardized through collection of dust in electrical control circuitry. Nonetheless, operating controls often are not of dustproof design (NEMA Specification 12); control boxes are not kept closed, and control service may not be provided by a competent electrician.

2.1.2.3 Personal Protective Equipment: Failure to use proper personal protective equipment as described in Section 1.1.8 during operation and cleaning of hand-operated cabinet machines can lead to serious health and safety hazards. Although operators may be aware of the hazards involved, many still do not wear complete eye protective equipment, safety boots or toe guards, and an adequate dust respirator.

2.1.3 Automatic Machines: Workpiece is inserted either manually or mechanically and conveyed into an automatic machine which then tumbles or rotates it or passes it through the path of an abrasive discharge which cleans the part during a timed cleaning period. Most automatic machines are custom designed. Items cleaned vary through a range of plastic and synthetic materials to large casting and structural steel beams.

2.1.3.1 Mechanical: Typical mechanical hazards associated with the use of automatic machines include:

- a. Internal Surfaces: Internal surfaces of automatic machines seldom are inspected as thoroughly or as frequently as manufacturers recommend. Accordingly, numerous different inadequacies are created which result in hazards or potential hazards. Typical inadequacies include badly abraded circulating pipes; abraded case hardened wear plates and retaining mats; worn, distorted, or otherwise deteriorated floor plates or gratings (Which create trip/slip/fall hazards); damaged steel-to-steel, steel-to-rubber, or rubber-to-rubber door seals, and abraded casings or other enclosures which can result in escape of abrasives and dusts.
- b. Noise: Exceptionally noisy conditions often are created by dust exhaust fans and shaker-type waste separation systems. Such systems seldom are repaired or re-engineered as required to reduce noise exposures below safe minimums.
- c. Waste Material Discharge Containers: Open bins and other containers often are used to collect discharge of waste materials from magnetic and

other type separators. Lack of covers for these bins results in dust clouds and attendant hazards.

- d. Removable Floor Plates: Removable floor plates which provide access to below-grade shaker-type separators sometimes are not kept in position during blast operations and so create a serious tripping hazard. Openings created for performance of maintenance work often are not barricaded to prevent accidental falls.
- e. Steel Cables: Steel cables used to facilitate opening and closing of doors of automatic machines often are not inspected well or with enough regular frequency (monthly is suggested) to permit discovery of hazardous conditions. Typical hazardous conditions include internal corrosion (exhibited through excessive dryness and an exterior brick dust effect), six or more wire breaks within a lay (one complete wrap), or flattening or abrasion of one or more strands of cable.
- f. Dust Collection Systems: Improper inspection/maintenance of dust collection systems can lead to hazards associated with dirty duct and ventilati^on screens; below-specified air flow rates; bags,

screens, filters and other collection system components in less than peak condition, and improperly closed or enclosed dust collection bins.

- g. Machine Drives: Improperly guarded or unguarded machine drives can create serious hazards as already discussed. Those associated particularly with automatic machines include door-closing belt drives, exhaust fan belt drives, shake conveyor and dust collector vibratory drives.

2.1.3.2 Electrical: Typical electrical hazards associated with automatic machines include:

- a. Electrical Interlocks: Some machines are not equipped with properly operating interlocks which prevent machine operation unless all doors are securely closed. Interlocks or other devices to prevent operation in the event of tumble or rotating table drive belt breakage often are not provided.

2.1.3.3 Personal Protective Equipment: Operators of automatic equipment often fail to use the personal protective equipment required to avoid hazards of operation. Typical equipment not used or used but not maintained and/or stored properly includes complete eye protective equipment, safety

boots or toe guards, clean coveralls, and appropriate dust respirators. A respirator seldom is worn by workers servicing any phase of the dust collecting system which can lead to dust inhalation.

2.2 General Safety Hazards: Several general safety hazards are found where abrasive blast cleaning operations are conducted. These include:

2.2.1 Vision Impairment: When air flow around the operator and work area is not sufficient, a dense dust cloud often develops. This creates vision impairment which may contribute to a serious accident. Etching of glass shades by abrasive contact also can cause vision impairment and associated accident potential.

2.2.2 Slipping Hazard: Settlement of some dusts on floors in work and other areas may lead to a serious slipping hazard, especially so because slippery qualities of the dust may not be readily perceived.

2.2.3 Flying Abrasive Hazards: Ricocheting of abrasives from the work surface obviously can be a serious hazard, especially when larger-diameter abrasives such as steel shot are involved. While the worker himself should be protected by proper clothing and equipment, other unprotected employees or passers-by might be injured.

2.2.4 Fire Hazards: Accumulations of dust can at times lead to fire hazards. As an example, oxidized iron dust (rust) if mixed with fine aluminum dust from another process (such as metal

spraying) can result in a "thermit" mixture. Tests have shown that such a mixture can ignite when exposed to certain ignition sources, such as an electric short from a poorly insulated cable or a globule of hot iron. Failure to clean up excess oil and grease collected on the work surface prior to blasting also can lead to a fire hazard. In two instances at least, oil and grease having settled in the dust collector led to serious fires. Fraying electrical cords, improper storage of flammables, collection of grease and oil on work clothing, etc., and other industrial problems also can lead to fire hazards.

2.2.5 Explosion Hazard: In certain cases, especially when organic abrasives are being used in a closed area, dust clouds can lead to an explosion hazard. The source of ignition might be nothing more than a spark created by a shoe-nail scraping against a metal surface.

2.2.6 Static Electricity Hazard: Application of dry or damp abrasive propelled by air, especially when the hose is improperly grounded, can result in static electricity accumulating on the blast operator's body. Static electric shocks can cause serious health problems for some individuals. Startle reaction to a shock by any worker could result in an accident. In certain circumstances, a small spark created by static electricity could be enough to ignite highly flammable materials or chemicals or to cause an explosion in certain dust environments.

IV. DETECTION AND EVALUATION OF ABRASIVE BLASTING HAZARDS

An effective occupational safety and health program involves, among other things, a comprehensive effort to detect and evaluate the hazards which are inherent in the job itself and in particular to "the specific task, work station, or other element of the job involved.

There are three basic ways of detecting and evaluating hazards; (1) through observance of warning labels and signs; (2) by use of the five senses, and (3) by use of special measuring devices.

1. Warning Labels and Signs

One of the most effective ways of helping to ensure safety when working with various materials is to post signs or utilize labels which clearly identify hazards involved.

In some cases it is difficult to ascertain from labels the ingredients of various products or materials which may be hazardous. NIOSH and OSHA have inaugurated a "Standards Completion Program," expected to be finalized by 1977. The purpose of the program is to convert the simple threshold standards now listed in OSHA regulations CFR 1910.1000 into completely documented and thoroughly outlined instructions regarding the health and safety hazards of materials. Each "standard completion" for each contaminant, will include a section on hazardous material labelling and requirements for posting. Abrasive blasting management should become familiar with special information regarding warning labels for contaminants found in their workplaces. Copies of the new materials will be available at area OSHA offices.

At present, it is relatively easy to learn more about the hazardous material contained in commercial preparations, especially those solvents used in metal cleaning, by submitting to manufacturers and/or suppliers a "Material Safety Data Sheet" such as shown in Figure rV-1 and available from OSHA offices. While most manufacturers are not legally required to complete these forms for customers who submit them, most do. Some also maintain a 24-hour information service to provide information on emergency actions which can be taken in the event of an overexposure. It should be noted that abrasive blasting employers engaged in ship building, ship repairing and ship breaking are legally required to have on hand information on the hazardous material contained in commercial preparations.

2. Perceptible Hazards Detection

Perceptible hazards are those which can be detected by the five senses. While an inspector should obviously look for perceptible hazards, it is most important to realize that many safety and health hazards can be detected only through use of instrumentation. In other words an inspector cannot do a thorough job by use of his five senses alone.

It is recommended that every abrasive blasting employer examine workplaces for hazards on a regular basis, preferably once a month. Comprehensive inspection check lists are available from the National Safety Council, local safety councils, trade associations, and workers' compensation insurers. While these check lists are comprehensive, they cannot possibly cover all eventualities which relate to a given employer or work situation. Accordingly, the inspector should rely upon them but realize that common sense and imagination also are valuable tools. In making the inspection, the

MATERIAL SAFETY DATA SHEET

Required under USDL Safety and Health Regulations for Ship Repairing,
Shipbuilding, and Shipbreaking (29 CFR 1915, 1916, 1917)

SECTION I

MANUFACTURER'S NAME		EMERGENCY TELEPHONE NO.
ADDRESS (Number, Street, City, State, and ZIP Code)		
CHEMICAL NAME AND SYNONYMS		TRADE NAME AND SYNONYMS
CHEMICAL FAMILY	FORMULA	

SECTION II - HAZARDOUS INGREDIENTS

PAINTS, PRESERVATIVES, & SOLVENTS	%	TLV (Units)	ALLOYS AND METALLIC COATINGS	%	TLV (Units)
PIGMENTS			BASE METAL		
CATALYST			ALLOYS		
VEHICLE			METALLIC COATINGS		
SOLVENTS			FILLER METAL PLUS COATING OR CORE FLUX		
ADDITIVES			OTHERS		
OTHERS					
HAZARDOUS MIXTURES OF OTHER LIQUIDS, SOLIDS, OR GASES				%	TLV (Units)

SECTION III - PHYSICAL DATA

BOILING POINT (°F.)	SPECIFIC GRAVITY (H ₂ O=1)
VAPOR PRESSURE (mm Hg.)	PERCENT VOLATILE BY VOLUME (%)
VAPOR DENSITY (AIR=1)	EVAPORATION RATE (_____ =1)
SOLUBILITY IN WATER	
APPEARANCE AND ODOR	

SECTION IV - FIRE AND EXPLOSION HAZARD DATA

FLASH POINT (Method used)	FLAMMABLE LIMITS	LeI	Uel
EXTINGUISHING MEDIA			
SPECIAL FIRE FIGHTING PROCEDURES			
UNUSUAL FIRE AND EXPLOSION HAZARDS			

SECTION V - HEALTH HAZARD DATA

THRESHOLD LIMIT VALUE
EFFECTS OF OVEREXPOSURE
EMERGENCY AND FIRST AID PROCEDURES

SECTION VI - REACTIVITY DATA

STABILITY	UNSTABLE	CONDITIONS TO AVOID
	STABLE	
INCOMPATIBILITY (Materials to avoid)		
HAZARDOUS DECOMPOSITION PRODUCTS		
HAZARDOUS POLYMERIZATION	MAY OCCUR	CONDITIONS TO AVOID
	WILL NOT OCCUR	

SECTION VII - SPILL OR LEAK PROCEDURES

STEPS TO BE TAKEN IN CASE MATERIAL IS RELEASED OR SPILLED
WASTE DISPOSAL METHOD

SECTION VIII - SPECIAL PROTECTION INFORMATION

RESPIRATORY PROTECTION (Specify type)		
VENTILATION	LOCAL EXHAUST	SPECIAL
	MECHANICAL (General)	OTHER
PROTECTIVE GLOVES	EYE PROTECTION	
OTHER PROTECTIVE EQUIPMENT		

SECTION IX - SPECIAL PRECAUTIONS

PRECAUTIONS TO BE TAKEN IN HANDLING AND STORING
OTHER PRECAUTIONS

inspector's attitude must be that, if something possible can happen, it will happen. In fact, many experienced safety personnel cite cases where a long-standing hazard was found, not corrected, and then caused serious injury shortly thereafter.

2.1 Safety Hazards: Safety hazards often occur when shortcuts or new equipment and processes are being used.

2.1.1 Shortcuts: Shortcuts refer to work practices which have been changed to produce greater convenience or time savings. In many cases they lead to injury and death. Typical shortcuts which create hazards include leaving guards off, bypassing limit switches, and wiring down deadman controls.

2.1.2 New Equipment and Processes: New equipment and processes should be examined closely from a "devil's advocate" point of view. It cannot be assumed that the manufacturer anticipated all or even any of the safety problems that may be created by its installed equipment. Accordingly, each new piece of machinery should be inspected carefully before use. All hazards should be corrected.

2.2 Health Hazards: Sense detection of health hazards is unfortunately more difficult than sense detection of hazards that may cause immediate physical injury.

Typically, an inspector will derive clues from his own reaction to a physical agent (noise, heat, or vibration) or a chemical contaminant

in the workplace. If a material has a strong odor pungent, alcoholic, garlic-like, pleasant or fruity, putrid or nauseating the concentration in an employee's breathing zone should be investigated immediately. It must be recognized, of course, that some deadly materials are odorless.

Skin, eye or respiratory irritation also provide immediate indication that concentrations of a material probably are above Threshold Limit Values (TLVs) and require control. Likewise, employee complaints of irritation, cramps, loss of appetite, headache, nausea, choking sensations, and so on, may signal possible health hazards from materials used or derived from processes.

Thorough evaluation of health hazards often requires the services of a qualified industrial hygienist. Some larger operations have industrial hygienists on staff. Others may obtain services from a private industrial hygienist on a consulting basis. Other resources for employers, regardless of size, include state, some local health departments, insurance carriers, and NIOSH. Requests for NIOSH Health Hazards Evaluations should be directed to any of the ten regional NIOSH offices or the NIOSH Division of Surveillance, Hazard Evaluations and Field Studies, Post Office Building, Room 508, Cincinnati, Ohio 45202.

NIOSH, State and local health agencies, will only evaluate the environment to determine the presence of contaminants. They will not recommend specific control measures.

3. Detection through Instrumental Methods

Employers may prefer to seek industrial hygiene instrumental evaluations of their workplaces from private sources mentioned above, or may elect to do it on their own.

Employers who elect to perform monitoring on their own should consider enrolling at least one management-level employee in a minimal one-week course on basic industrial hygiene techniques. Excellent courses are conducted by NIOSH and the American Industrial Hygiene Association. Numerous two-year colleges are expected to offer such courses in the near future. Those responsible for testing in-house also should be familiar with literature on the subject. Environmental Health and Monitoring Manual is a relatively simple "how-to" publication available from U.S. Steel Corporation, P. O. Box 86, Pittsburg, Pennsylvania, 15230. Industrial Hygiene Operations Manual soon will be published by OSHA.

Here follows a brief description of several of the primary monitoring techniques.

3.1 Dust Exposures: Current OSHA dust standards (See Table IV-2)

are based on total or respirable particulate for free silica (sand) containing dust and total particulate for other dusts or fumes. Currently permitted breathing zone levels for silica are based on a formula which considers the percent of silica in the dust.

Full shift samples are collected by placing a preweighed filter in a filter holder in the breathing zone (within one foot of

TABLE IV-2 OSHA Standards for Materials Commonly Associated with Abrasive Blasting

MATERIAL	UNITS OF MEASURE:	mppcf *	mg/m ³
Silica:			
Crystalline Quartz respirable		$\frac{250}{(\%SiO_2+5)}$	$\frac{10}{\%SiO_2+2}$
Crystobalite	Total		$\frac{30}{\%SiO_2+2}$
Tridymite			Use 1/2 value from quartz formula.
Amorphous		20	Use 1/2 value from quartz formula.
Nuisance or biologically inert materials such as iron oxide, slag, steel with less than 1% quartz by wt	respirable)	15	$\frac{80}{\%SiO_2}$
Lead as used in paint	Total	50	5
			15
			20

* Millions of particles per cubic foot of air based on impinger samples collected by right field microscopic technique.

the nose and mouth) of the exposed employee. The filter holder -- usually pinned to the worker's shoulder -- is connected by tubing to a sampling PUMP which typically is mounted in a comfortable position on the employee's belt. The pump is run throughout the working shift at a fixed rate. At the end of the shift the filter is weighed to determine tare weight of the dust collected. The weight of the dust is correlated with the amount of air pulled through the filter during the sampling period to determine concentration of dust in the breathing zone air. These concentrations are usually reported in milligrams per cubic meter (mg/m³).

For testing to be accurate, it is essential that the filter is weighed on a good chemical balance by an experienced technician. Pre-weighed filter cassettes may be purchased. After dust collection, the filter company will re-weigh and report dust tare weight.

It is essential that all employees using hand held blast nozzles for abrasive cleaning in the open air or in blast cleaning rooms be protected by clean-air-respirated, non-leaking helmets. Periodic samples should be collected under the helmet to determine that the system is working properly.

If open air, hand-held blasting is done, employees in the vicinity may be required to wear simple dust respirators approved by NIOSH for silica exposures. Persons regularly employed near open air abrasive blasting must be sampled for excessive dust exposure,

particularly if sand blasting is done. The workman who fills the pot may be particularly vulnerable. Unless it can be shown by sampling that this employee's dust exposure is negligible, respirator wear should be required.

Similarly, employees in work areas in the vicinity of inside blast cleaning rooms and bench enclosures should be monitored periodically for airborne dust concentrations. Defective exhaust systems or leaky enclosure seals may permit sufficient dust to escape, exposing nearby employees to hazardous dust levels. This determination may only be made by regular sampling by the filter and pump method described above.

Those responsible for taking samples should consider these points:

- a. Dust sampling may involve collection of either breathing zone or area (fixed position) samples. Breathing zone samples are obviously the best representation of the contaminant intake by the employee and should therefore be given preference in the sampling plan. Collection system intakes, usually a filter holder or filter holder cyclone combination, should be as close to the employee's nose as possible without creating a nuisance. Typically one foot or less is considered good breathing zone distance and most frequently involves pinning the filter holder near the employee's shoulder.
- b. If fixed-position samples are taken, employee exposure is determined by time-weighting exposure to various concentrations.

For example, if an employee is exposed to $2\text{mg}/\text{m}^3$ of dust for two hours, $1\text{mg}/\text{m}^3$ for four hours, and $0\text{mg}/\text{m}^3$ for two hours, the weighted average eight-hour exposure is $1\text{mg}/\text{m}^3$. The latter figure is the one which is considered to represent the employees exposure and is the exposure used to determine compliance with OSHA standard.

- c. Modern sampling instrumentation, although excellent, is subject to error. For example, sampling rates indicated on a personnel pump rotameter are not necessarily accurate. As a result, arrangements should be made to check their calibration against a secondary standard such as wet or dry test meter. "Bubble" calibrators are now commercially available and may be used outside the laboratory. Instrument calibrating should always be checked with filter and/or cyclone resistance in line to simulate actual sampling conditions.
- d. Process emissions, materials being handled, and work techniques all are Subject to frequent change. Accordingly, it is best to measure exposure at any given operation at least several times to obtain an average. In most cases three eight-hour samples are a minimum. If they show wide variances, however, additional sampling is recommended.
- e. The sampling process requires continual monitoring. In the case of sampling pumps, for example, flow rates must be

adjusted as dust builds on the filter. Pumps also should be inspected to ensure that they are operating properly. Recognize, too, that some employees may sabotage a test by deliberately introducing contaminating materials at the sampling inlet. For these reasons, several sampling devices may be installed on employees in a given area or area sampling devices at closely contiguous areas. In all cases at least one field technician should constantly attend to these devices.

- f. It must be remembered that determination of employee exposure to contaminants is a partnership between the field technician and the laboratory analyst. Careful field sampling technique is to no avail if laboratory work is careless. Even in the area of dust sampling, filters must be weighed carefully before use and after use to determine the accurate tare weight of the dust collected. Similarly, the best laboratory technique is to no avail if field sampling technique is sloppy.

Routine maintenance (cleaning, recalibration, etc.) is required if sampling instruments are to remain in good condition. Manufacturers' materials generally include information on proper maintenance practices. These should be followed closely.

3.2 Noise Exposures: Employee exposure to noise is measured on the "A-weighted" scale of a sound level meter set on "slow response." Instantaneous or time-weighted exposure are reported in "dbA" --

11decibels on the A scale,11 a setting which closely approximates response of the human ear. Current OSHA regulations require that employee maximum 8 hour noise exposure shall not exceed 90 dbA. Higher exposure is permitted for shorter work periods. No exposure is permitted above 115 dbA. Time weighting of exposures to different noise levels may not be done in the same manner used for other contaminants because decibels are logarithmic. A formula for combining different dbA level exposure during the work day is given in OSHA regulations.,

The NIOSH survey mentioned earlier has indicated that abrasive blasting is an inherently noisy operation. Under the current OSHA standard, blast operators without noise protection using hand operated nozzles generally would be permitted less than two hours of noise exposure per day. Even employees outside cabinets or automatic blasting rooms were found to be exposed to levels higher than 90 dbA.

Results of these findings indicate that employers should suspect excessive noise exposure and, accordingly, should institute a program of noise level testing.

Noise level testing undertaken for OSHA purposes requires use of a sound level meter. This sound measuring instrument consists basically of a microphone, amplifier-attenuator circuit, and an indicating meter (see Figure IV-3). The microphone transforms acoustic pressure variations in the air into electrical signals with

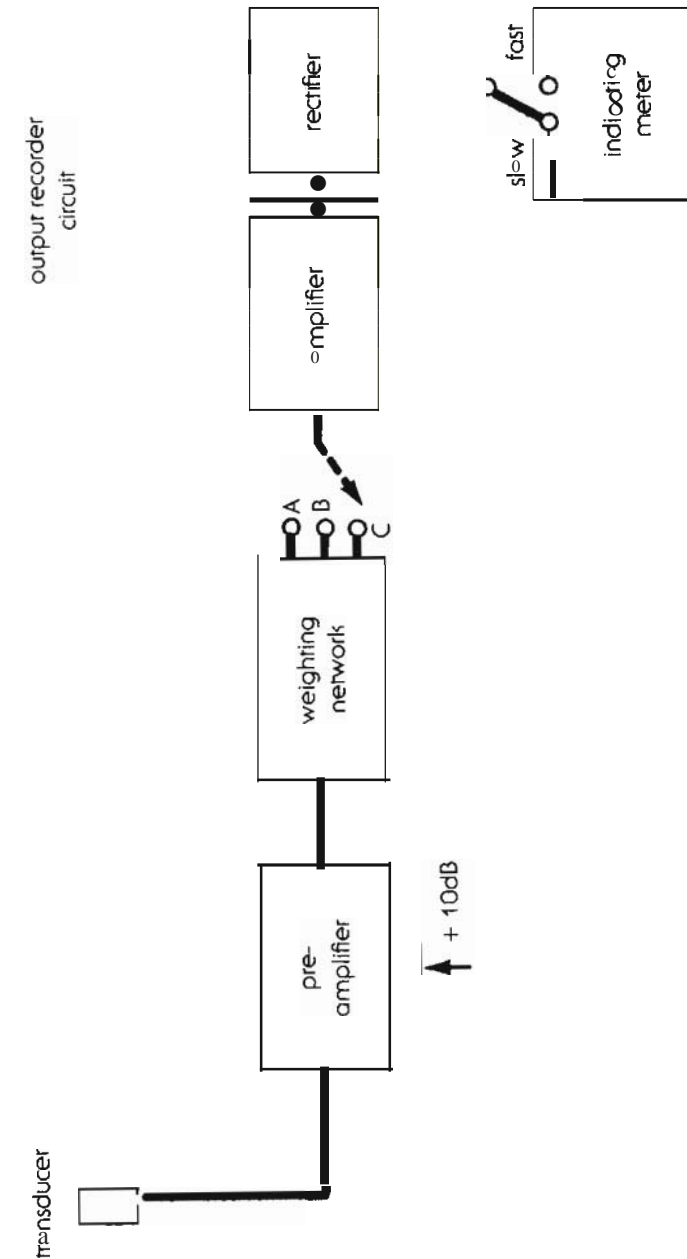

Figure IV-3: Sound Level Meter Circuitry

the same frequency and amplitude characteristics. The signals then are fed into the amplifier-attenuator circuit. The circuit presents the signals to the indicating meter with a read-out indicating sound pressure level referenced to 0.0002 microbars or 20 micro-newtons per square meter.

A relatively new development in the field of OSHA noise level testing involves use of a noise dosimeter. Produced by various manufacturers, this device is carried by an employee in a shirt pocket or on a belt and integrates total daily noise exposure. The readout indicates conformance or nonconformance with OSHA standards.

Before any sound surveys are conducted, the person who uses the instrument should become thoroughly familiar with the manufacturer's operating instructions. In particular, the following precautions should be observed:

- a. Each meter should be calibrated using its companion calibrator, not one for some other meter. Calibration should be made at least before and after each day's measurements. If measurements are made over a full day, an additional calibration should be made half-way through the calibration period.
- b. Sound level meter batteries should be checked before, during and after each day's measurements. Batteries must be in good condition for the measurements to be of value.

- c. Meter settings should be checked. Weighting network switch and meter response should be set to indicate the dbA sound pressure level at slow response.
- d. Follow manufacturer's instructions regarding positioning of the microphone. In some cases the microphone should be pointed directly at the source. In other cases it should be perpendicular to it. Care should be taken to insure that neither the worker nor the person conducting the survey shields the microphone.
- e. When measuring, be certain that the range or attenuation switch is set above the level of the sound being measured. This will prevent damage by electrical overload. A good position to start is at 120 dbA. Then adjust the range switch or attenuation switch until the meter indicates a deflection within the positive side of the scale.
- f. It must be remembered that the level of sound being measured is determined by the sum of the level indicated by the range or attenuation switch plus the meter reading.
- g. Sound level meters are precise and delicate electronic instruments and must be treated as such. If the meter or calibrator is dropped, for example, it must be inspected closely for damage and recalibrated before further use. The meter should be protected from dust and moisture, as by using electrical or masking tape over seams or by placing it in a tightly-sealed plastic bag. Microphone covers should be used between measurements.

Also, a noise level meter should not be kept in a locked car during summer months because high temperatures can damage microphone and batteries.

- h. Several measurements should be made in the immediate area of the worker to insure the sound pressure level is relatively uniform and to make certain the dbA levels recorded are representative for each period of the worker's exposure.

V. CONTROL OF ABRASIVE BLASTING HAZARDS

There are numerous ways in which safety and health hazards of abrasive blasting operations can be minimized if not eliminated altogether. While some of these methods, such as machine safeguarding, can be implemented despite worker actions, most control procedures require employees to recognize and understand the "right way" of doing things, and to be motivated to act in their own best interests. For this reason, many of the recommendations offered in this section must be seen as an element of an overall safety program discussed at length in the following section.

1. Control of Health Hazards

The various measures which can be taken to control the different health hazards are as follows:

1.1 Dust Control: There are a variety of different means by which dust hazards can be effectively controlled. It should be noted that control of dust or its effects for health purposes also results in elimination of certain safety hazards. For example, if dust does not gather on a floor, the chance of slipping on the dust is eliminated. Likewise, if dust is exhausted properly from an enclosure, the vision impairment it otherwise would create is eliminated.

1.1.1 Choice of Abrasive: One of the most serious health hazards associated with abrasive blasting results from inhalation of silica dust. The simplest way of controlling this hazard is substitution of another abrasive. In fact the dangers inherent in use of silica sand are so severe that

Great Britain has banned its use as an abrasive blasting agent since 1948.

Among some of the newer alternatives to silica sand are wet bottom boiler slag ("Black Beauty" type) and copper slag, both of which generally contain less than 1% of free silica. These materials are less fragile than silica sand and, as a result, do not fracture on impact. This results in less dust and greater recycling potential. Because these abrasives also cut faster, either the operator can stand farther away from the work surface or the nozzle can be operated at reduced pressures. Either occurrence enhances safety. On the negative side, it must be recognized that these abrasives will tend to give the blasted object an appearance different from what would have been obtained with silica sand. Also, some employees are reluctant to use the new abrasive due to its black coloration. Some employees feel it is necessary to shower after working with it, whereas white sand generally is considered "clean."

1.1.2 Choice of Application: In some cases alternate types of blasting equipment can be used to help lower the hazards associated with use of sand as an abrasive.

In general, wet blasting methods produce less dust. Nonetheless, it must be recognized that the dust-laden mist

produced also is dangerous because it contains free silica which must be removed from the workers breathing environment.

Vapor-blasting produces only 25% of the dust created by dry blasting techniques. For work out-of-doors, as in a shipyard, a rust inhibiting liquid may be introduced at the nozzle as a dampening medium. This liquid helps prevent rust on the cleaned surface for up to 48 hours and so, in many cases, can be justified on the cost basis.

Centrifugal equipment results in less dust dispersion because compressed air is not used to propel the abrasive. Because centrifugal equipment is stationary, it is most adaptable.

1.1.3 Control by Isolation: Although it is not feasible to completely enclose and exhaust some abrasive blasting operations, such as those undertaken in shipyards, it is possible to isolate many operations to a beneficial degree. Isolation can be implemented by having the blasting operations take place in areas removed as far as possible from other employees or by having the operation take place during an "off shift" when few other employees are working.

In most cases, those employees other than the operator working near the operation should also wear suitable fresh air-supplied respirators. The dust cloud created by blasting will give a fairly good indication of the location of most seriously contaminated air.

1.1.4 Control of Enclosure: If the materials to be blasted are not too large, the entire operation may be enclosed with the operator outside the enclosure. Typical enclosures used for this purpose include centrifugal units, abrasive blasting barrels, hand blast cabinets, and rotary table cabinets. If the enclosure used has an effective ventilation system, the dust hazard is significantly minimized.

If the size of the materials requires that the operator walk around it, so the operation cannot be isolated, a room such as that shown in Figure V-1 must be built. If doors are too large for an operator to open easily, a man-door also must be provided. Good lighting must be provided with lamps preferably being covered by dust-tight cover globes made of hard glass.

1.1.4.1 Ventilation and Exhaust of Enclosures: The construction, installation, inspection and maintenance of exhaust systems should comply with the American National Standard Fundamentals Governing the Design and Operation of Local Exhaust System, 29.2-1960 and ANSI 233.1-1961. When applied to an abrasive blasting enclosure, these standards require that air be exhausted rapidly enough to maintain a slight negative pressure. As a result, outside air is drawn in through any openings rather than having inside, contaminated air leak out. In addition, sufficient fresh air must be circulated so that dust is reduced to enable good visibility for the operator (except in cases of automatic operations where inspection is made after blasting

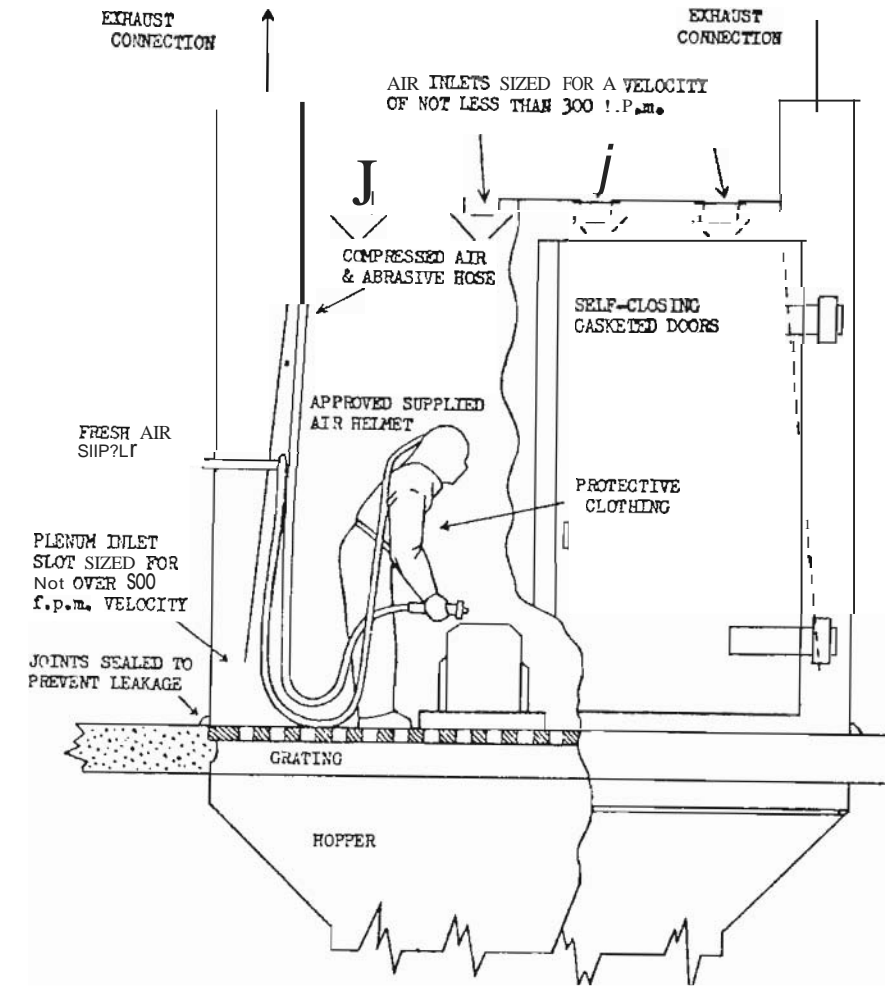

FIGURE V-1 Sand Blast Room

Source: Connecticut State Department of Health

Figure V-1 illustrates an acceptable installation for an abrasive blasting room. Air inlets and exhaust are arranged in such a way that contaminated air is moved away from the operator's breathing zone. Down draft should average approximately 80 FPM (feet per minute) over the entire floor area. Air can be exhausted from such a room either downward or on two sides at the floor line. Also acceptable, but less desirable, is an arrangement which results in cross ventilation with an average 100 FPM velocity over the vertical cross section of the room.

It is recommended that inward velocity at all openings be 500 FPM for cabinet machines, 200-250 FPM for a rotary table, and 300 FPM for an abrasive blasting room. All openings should be baffled to prevent the abrasive from being propelled through the openings.

Air velocity at enclosure exhaust outlet should not be so high (usually no more than 500 FPM) that it carries off good abrasive materials, nor so low that it prevents prompt clearance of dust-laden air after the blasting operation is completed.

- a. Exhaust Air Ductwork: All exhaust ductwork should be well designed and subject to frequent, close inspection for blockage or leaks. In order to prevent dust build-up, which can lead to blockage, the following recommendations should be adhered to:

1. Air flow through ducts should be maintained at 3,000 to 4,000 FPM.
2. Ducts should be well supported to prevent sags where dust can build up.
3. All laps in the ductwork should be in the direction of airflow.
4. Airtight clean-out openings should be provided adjacent to every bend and vertical riser and at approximately 20-foot intervals on a straight run.
5. All bends should have a minimum radius twice the diameter of the pipe. Bends also should be of heavier gauge metal to reduce wear.
6. Ducts should be positioned so they will not be damaged by cranes, hoists, industrial trucks, or other equipment or operations.

Following installation and at regular intervals thereafter static pressure measurements should be taken to determine resistance or pressure drop through hoods, dust collectors and exhaust ductwork. The tool required for a routine check in most cases is a manometer (U-gauge) or an inclined gauge. As dust collects in exhaust system the resistance to air flow increases,

thereby having an adverse effect on exhaust system performance. A significant increase in pressure drop indicates a blockage. When noted, ductwork and other parts of the exhaust system should be cleaned and restored to initial design (or normal operating) conditions.

For additional information on exhaust system design and performance measurement, see "Industrial Ventilation" -- A Manual of Recommended Practice", published by the American Conference of Governmental Industrial Hygienists, Chapters 1, 4, 6 and 9.

Ductwork also should be checked for air leakage.

When leaks are detected, ductwork should be repaired as quickly as possible. Where abrasive is recirculated an abrasive separator not the blast room exhaust ventilation system -- must be used for removal of fines from the spent abrasive.

1.1.4.2 Inspection and Maintenance of Enclosures: All abrasive blasting enclosures should be inspected and maintained on a regular basis. The following check list is recommended for use during inspections. The list itself should be expanded and modified to meet the particular needs of any given installation.

- a. Do doors seal tightly? If not, does normal work involve the nozzle being directed toward the door? If so, inspect for leakage.

- b. Is the joint where the room frame is connected to the hopper or floor tight? If not, has something been done to prevent dust from leaking at that point?
- c. Is the seal at the top and bottom of a hopper under the floor adequate? If not, what type repairs or replacement is required?
- d. Are clean-out access doors dust-tight? If not, how can they be made so?
- e. Does material spill through cracks? If so, does it take more than a few minutes daily to clean it up?
- f. Is the elevator housing in the pit and above floor level dust-tight? If not, what remedial actions are required?
- g. Is dust visibly escaping from the abrasive separator housing? If so, what controls can be used?
- h. Is dust visible as rejected debris falls to the outside receptacle? If so, what can be done to effect better control?
- i. Is there a "brisk" velocity inward through rejection openings?

- j. Is exhaust ductwork free of settled materials?
- k. Does the abrasive pressure tank pressure release valve function efficiently to prevent dust from escaping to the atmosphere?
- l. Are rotary table cabinet curtains maintained well enough to control dust?

1.1.4.3 Dust Collection: The air exhausted from blast cleaning equipment must be discharged through dust collecting equipment. In most cases cloth dust filter, "wet" or washer-type collectors, or cyclone collectors are used. Dust collectors must be designed so the accumulated dust can be emptied and removed without contaminating other areas.

If exhausted air is recirculated where employees may breathe it again, the recirculation system must be designed and maintained to ensure that workers are not exposed to contaminant levels above TLVs.

Cyclone collectors use centrifugal force to separate the dust from the air. As a result, the smaller

particles -- those most likely to be inhaled -- are least likely to be removed from the airstream. Accordingly, a cyclone collector should be located out-of-doors so the exhaust air will be thoroughly diluted with outside air before it returns to the breathing zone of any worker. An effective system often involves use of both a cyclone collector and a cloth filter. The cyclone collector removes the larger dust particles and the exhaust air then is brought to the cloth filter which is most effective in filtering the smaller particles. Cloth filters should be shaken regularly to remove dust (unless they are continually cleaned by a reversed flow).

1.1.5 Abrasive Recovery and Separation: An abrasive recycling system generally consists of conveyors, elevators and screens or separators which separate the useless fines from the abrasive which may be used again, as shown in Figure V-I. Each time the abrasive is re-used it becomes finer, dustier, and less efficient. Accordingly, an effective separation system is necessary. The system usually works by dropping the re-usable abrasive and blowing the fines out to be exhausted to the collector.

1.1.6 Abrasive Handling and Storage: Most abrasive generally contains some fines. As a result, dust usually is created whenever abrasive is transferred, be it by hand shovel or

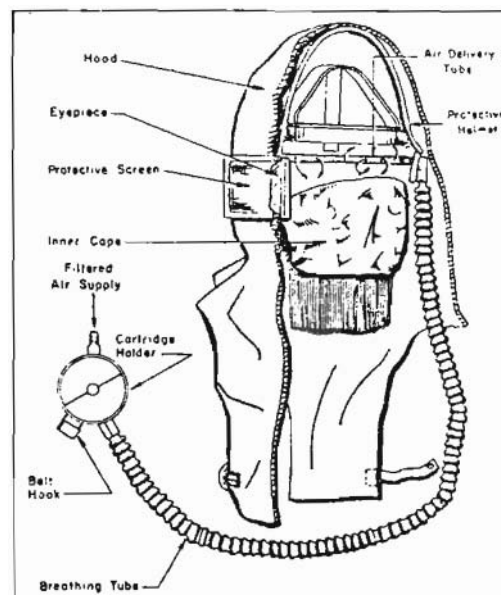

FIGURE V-2 Lightweight Hood for Abrasive Blasting

1.1.8.2 Particulate Filter Respirators: Particulate filter respirators, or dust filter respirators, when properly fitted, may be used for short, intermittent, or occasional dust exposures such as those associated with clean-up, dumping of collectors, transfer of abrasive, or when it is not feasible to control the dust by enclosure, exhaust ventilation, or other means. A dust-filter respirator also may be used to protect the operator during the outside abrasive blasting, but only when non-silica abrasives are used. In some cases eye protection must be worn with particulate filter respirators. When it is, care should be taken to ensure that the respirator and eye protection device do not interfere with one another.

1.1.8.3 Respirator Protection Program: Abrasive blasting employers are responsible for establishing a respiratory protection program -- wherever it is necessary -- for use of respiratory equipment. Requirements for a minimally acceptable program are as follows (and are defined in 29 eFR 1910.134 and .1000 and ANSI 288.2):

- a. Standard operating procedures governing selection and use of respirators must be established and placed in writing.
- b. Respirators must be selected on the basis of hazards to which workers will be exposed.

- c. Those using respirators must be instructed in proper use of the equipment and its limitations.
- d. Where practical, individual respirators should be assigned to individual workers for their exclusive use.
- e. Respirators issued for exclusive use of one worker should be cleaned and disinfected after each day's use. Those used by more than one worker must be cleaned and disinfected after each use.
- f. All respirators must be stored in a convenient, clean and sanitary location.
- g. Respirators that are worn routinely must be inspected during cleaning. Worn or deteriorated parts must be replaced. Respirators used for emergency purposes only must be inspected at least once a month and after every use.
- h. Appropriate surveillance of work area conditions and degree of employee exposure or stress must be maintained.
- i. The program must be checked and evaluated on a regular basis to determine its continued effectiveness.

- j. Workers should not be assigned tasks requiring use of a respirator unless it first has been determined that they are physically able to perform the work and use the respirator. The respirator user's medical status should be reviewed periodically, as on an annual basis. The local physician should determine what health and physical conditions are pertinent.
- k. Respirators must be approved by NIOSH and NIOSH. The respirator furnished to the worker must provide adequate respiratory protection against the particular hazard for which it is designed. Selection of respirators must be made in accordance with the American National Standard Practices for Respiratory Protection 288.2-1969.

1.1.8.4 Air Quality and Supply: Only high purity compressed air or liquid oxygen may be used for respiration. Oxygen must meet requirements of the U.S. Pharmacopoeia for medical or breathing oxygen. Breathing air must meet, as a minimum, requirements of the specification for Grade D breathing air as described in Compressed Gas Association Commodity Specification G-7.1-1966. Compressed oxygen must not be used in either supplied-air respirators or in open circuit self-contained breathing apparatus that have previously used compressed air. Oxygen may never be used with air-line respirators.

Breathing air may be supplied to respirators from cylinders or air compressors. If cylinders are used, they must be tested and maintained in accord with Shipping Container Specification Regulations of the U.S. Department of Transportation (49 CFR Part 178). If a compressor is used for supply air, it must be a breathing air compressor equipped with necessary safety and standby devices. In addition, and in accord with 29 CFR 1910.134:

- a. The compressor must be constructed and located in such a way to avoid entry of contaminated air into the system. Suitable in-line air purifying sorbent beds and filters must be installed to further ensure breathing air quality.
- b. A receiver of sufficient capacity to enable the respirator wearer to escape from a contaminated atmosphere in event of compressor failure must be installed in the system.
- c. Alarms indicating a compressor failure and overheating must be installed in the system.
- d. If an oil-lubricated compressor is used it must have a high-temperature or carbon monoxide alarm, or both. (If only a high-temperature alarm is used the compressor must be tested fre-

frequently for carbon monoxide.)

Air-line couplings of the respirator system must be incompatible with outlets for other gas systems. This prevents inadvertent servicing of air line respirators with non-respirable gases or oxygen.

Breathing gas containers must be marked in accordance with American National Standard Method of Marking Portable Compressed Gas Containers To Identify the Material Contained, 248.1-1954; Federal Specification BB-A-1034a, June 21, 1968, Air, Compressed for Breathing Purposes, or Interim Federal Specification GG-B-00675b, April 27, 1965, Breathing Apparatus, Self-Contained.

Whenever possible, air should be supplied from a separate compressor or nonreciprocating blower, rather than the ordinary shop line. In that way the chance that oil or carbon monoxide may enter the air supply is minimized. If it is not possible to use a separate compressor or blower, the arrangement shown in Figure V-3 is suggested. Note that when using such an arrangement:

- a. A trap and carbon filter must be installed and maintained regularly to remove oil, water, scale and odor.

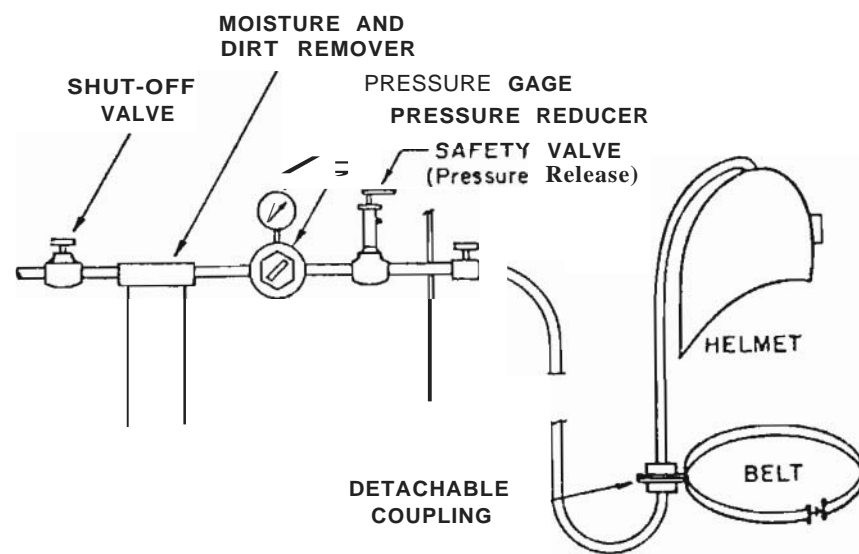

FIGURE V-3 Suitable Arrangement of Air Supply Valves, Pressure Gauge, etc., for High Pressure Air

- b. A pressure-reducing diaphragm or valve must be installed to reduce pressure down to requirements of the particular type of abrasive blasting respirator.
- c. An automatic control must be provided to either sound an alarm or shut down the compressor in case of overheating.
- d. Air supply should be checked for carbon monoxide on at least a daily basis.

1.1.8.5 Use of Respirators: Loose-fitting helmets require a minimum of 6 cfm (cubic feet per minute) to prevent dust from entering. Tight-fitting helmets require 4 cfm. All approved regulator valves are adjustable (by the operator) within a certain range only. When the valve is completely closed the helmet must receive at least 2 cfm to obtain approval. Because the 2 cfm rate is not sufficient to control dust, employees should be supervised closely to ensure that they receive an adequate air supply. This becomes a problem particularly in cold weather when the air has a cooling effect. In some cases it may be feasible to use an electric resistance heater to warm the air. Where a substantial problem arises: however, it may be best to lock the regulator in the desired position.

In this way only the supervisor can adjust the setting.

1.1.8.6 Noise: The noise level in the operator's hearing zone should be checked. Levels in respirators approved under 30 CFR Part II must not exceed 80 dbA. In general, nonmetallic helmets create less noise. Certain fresh air compressors or blowers are far less noisy than others. Orifices for entry of the air into the helmet should be shaped to help minimize noise.

As noted above, employees exposed to dust concentrations less than 5 times the OSHA standard may wear a filter-type respirator approved by MESA and NIOSH for the specific type of dust involved.

In an extremely dusty atmosphere, dust is deposited rapidly on the filter, making breathing difficult.

In such an event the employee should change to an air-supplied respirator.

1.1.8.7 Cleaning and Maintenance: A program for cleaning and maintenance of respirators must be adjusted to the type of plant involved, specific working conditions experienced, hazards, etc. At least the following basic services must be provided:

a. All respirators must be made subject to routine inspection before and after each use. Respirators used only for emergency purposes must be inspected

after each use and at least monthly.

- b. A self-contained breathing apparatus must be checked monthly. Air and oxygen tanks must be fully charged in accordance with the manufacturer's instruction. Regulator and warning devices must be checked for proper operation.
- c. The inspection must cover the tightness of connections and the condition of the face-piece, headbands, valves, connecting tube, and cannisters. Rubber or elastomer parts must be checked for pliability and signs of deterioration. (Stretching and manipulating rubber or elastomer parts with a massaging action will help keep them pliable and flexible.)
- d. A record must be kept of inspection dates and findings for respirators maintained for emergency use.
- e. Respirators used on a routine basis must be collected, cleaned and disinfected as frequently as necessary to ensure proper protection for the wearers. Each worker should be briefed on the cleaning procedure and be assured that he always will receive a properly cleaned and disinfected respirator. Respirators used for

emergency purposes must be cleaned and disinfected after each use. In most cases it is most effective to have one person assigned permanent responsibility for cleaning and disinfecting respirators.

- f. Repairs to respirators may be performed only by qualified persons. Only parts designed for the particular respirator involved may be used. No attempt may be made to replace components or to make adjustment or repairs beyond the manufacturer's recommendations. Reducing or admission valves or regulators must be returned to the manufacturer or given to a trained technician for adjustment or repair.

1.1.8.8 Storage: After inspection, cleaning and necessary repair, respirators must be stored to protect them against dust, sunlight, heat, extreme cold, excessive moisture or damaging chemicals. Respirators placed at stations and work areas for emergency use should be quickly accessible at all times and stored in compartments provided for the purpose. Compartments should be clearly marked.

Routinely used respirators, such as dust respirators may be placed in plastic bags. Respirators should not be stored in lockers or tool boxes or similar

locations unless they are placed in carrying cases or cartons.

Respirators should be packed or stored so the faceplate and exhalation valve will rest in a normal position so function will not be impaired by the elastomer setting in an abnormal position.

In most cases instructions for proper storage of respirators are found in "use and care" instructions mounted inside the carrying case lid.

1.2 Noise Control and Hearing Conservation: A hearing conservation program involves actions to reduce noise levels and/or to protect employees against excessive noise level exposures. Assuming that a noise level survey indicates that the work environment is too noisy for comfort, the hearing conservation program could consist of four elements: application of engineering controls; application of administrative controls; use of personal protective equipment, and institution of an audiometric testing program.

1.2.1 Engineering Controls: Application of engineering controls usually is the most effective noise control approach because it can reduce the intensity of noise either at the source or in the immediate exposure environment. Although many of the procedures possible will require the expert advice and assistance of a competent acoustical consultant, there are several control techniques which can be developed and implemented by industrial hygienists and safety personnel at relatively little expense. Typical examples include:

1.2.1.1 **Positioning:** Increasing the distance between a noise source and worker or simply rotating the source often are practical methods of noise reduction and control.

1.2.1.2 **Vibration Control:** Response of a vibrating member to a driving force can be reduced by damping the member achieved by improving its support, increasing its stiffness, increasing its mass, or shifting its resonance frequency.

Machinery rattles, squeaks and thumps often indicate that proper maintenance has been neglected.. Such noise often can be reduced or eliminated through a program which includes frequent, regular inspection; periodic lubrication of all moving parts; tightening of loose connections; maintenance of proper adjustments; servicing all covers or safety shields on machine; use of proper coolants; replacement of worn or unbalanced parts, and installation of proper damping to reduce unnecessary vibration.

A number of devices are commercially available which are designed to isolate vibrating parts. These include flexible mounts for motors and other types of machinery, flexible hose in pipes or electrical

conduits, and flexible couplings on shafts, among others.

1.2.1.J **Nozzle Adjustment:** The nature of abrasive blasting requires high abrasive flow rates. These generally result in loud noise because sound power output is a high power function of velocity. Reduction of flow rate noise can be achieved by reducing flow velocities to those minimally acceptable for the process. It also is possible to attach a turbulence reduction device to a nozzle to reduce noise (such a device also adds weight to a nozzle and makes it more difficult to manipulate, however). A careful evaluation of these and similar alternatives should be made in light of productivity and cost. If these actions cannot be taken, proper hearing protection should be provided and enforced.

1.2.1.4 **Equipment Selection:** Sometimes it is possible to substitute a quieter machine, process or material. In most cases existing operations were selected primarily because they represented the most economical and efficient means of producing the product or service. As such, noise factors probably receive very little attention. Given current OSHA exposure limits, however, it now may be wiser to purchase more

expensive, quieter equipment instead of less expensive, noisier equipment which will require additional in-plant expenditures for noise reduction and control. When several pieces of equipment are being purchased for operation in proximity to one another, it may be desirable to specify individual equipment operating noise levels lower than OSHA limits to help ensure compliance during simultaneous operation. Quieter operation generally can be assured by specifying belt drives instead of gears.

1.2.1.5 Barriers: Where reduction of noise at the source is unsuccessful or impractical, attenuation of airborne sound may be achieved by erecting a sound barrier to intercept the sound before it reaches the ear.

1.2.2 Administrative Controls: An effective degree of noise control can be achieved by limiting each employee's daily exposure through tight control of work schedules. The following methods should be considered in light of work and productivity factors:

1.2.2.1 Worker Assignments: Three steps can be taken to reduce noise exposure through adjusting worker assignments, as follows:

- a. Arrange work schedules so that employees working the major portion of a day at or very close to

dba limits are not exposed to higher noise levels.

- b. Ensure that employees who have reached the upper limit of duration for a high noise level, work the remainder of the day in an environment with a noise level well below criteria limit.
- c. When the man-hours required for a job exceed the permissible time for one man in one day for the existing sound level, divide the work among two, three or as many workers as needed, to keep individual noise exposure within permissible time limits.

1.2.2.2 Equipment Scheduling: If less than full-time operation of a noisy machine is needed, arrange to run it a portion of each day -- rather than all day -- or part of the week.

1.2.3 Personal Protection: When excessive noise exposure cannot be reduced by other means, personal ear protectors ear plugs or ear muff -- must be worn by workers to provide effective protection. Numerous scientific reports have shown that such devices can provide 24 to 40 db of protection if properly worn. Merely making good protection available to employees does not insure an effective program, however. The person in charge of developing and monitoring the ear protection program must be fully familiar with the employees' various duties and the acoustical environments in which they are performed. He also must evaluate other environmental factors

- d. There will be no unusual reactions, such as skin irritation, from the use of ear protectors, providing they are kept reasonably clean. Ear plugs should be made of soft material such as neoprene, because hard fixed materials can injure the canal.

Most of the available ear protectors, when correctly fitted, provide the same amount of protection. The best ear protector, therefore, is the one that is accepted by the employee and worn properly.

1.2.4 Audiometric Testing: The hearing of each employee should be subjected to an audiometric test at the time of hiring, at periodic intervals during employment, and at the time of job change or leaving employment. The importance of the initial test cannot be overemphasized. Without the data it reveals, there is no way to accurately evaluate changes which may take place over a period of time. The frequency with which subsequent in-service tests are performed depends on several factors, particularly the environment in which the employee works. It is suggested that such tests be performed at least annually.

Variations between tests of ± 5 db are to be expected and have no significance. Larger variations, however, or an identifiable trend toward poorer hearing -- especially at 2000, 4000, or 6000 cps (cycles per second) -- are significant and should be cause for evaluation of noise exposure and/or ear pathology.

1.2.4.1 Test Equipment: Audiometric testing can be performed with either a pure tone audiometer or a speech audiometer. The pure tone audiometer is preferred for industrial use.

Industrial environments are seldom suited for accurate testing, even though the test site may be in a relatively quiet area. Background noise causes interference with the audiometer and so biases test results. In order to avoid this bias, background noise level in the test area must be lower than that which will interfere with the pure tone thresholds of tested frequencies.

Such conditions will not necessarily be achieved simply by covering the wall of a test room with acoustic tile. The problem consists primarily of keeping the noises generated within the room to a minimum and keeping outside noise from entering the room.

The amount of noise attenuation required depends upon the lowest hearing level to be measured in the room, the frequencies to be tested, and the noise level of the particular location. The frequencies generally tested in industrial audiometry are 500, 1000, 2000, 4000 and 6000 Hz.

In many cases it will be least expensive for a facility to purchase its own prefabricated testing rooms or booths which can provide sufficient noise attenuation.

Accurate test results also depend on proper calibration. Calibration of both electronic circuits and earphones should be performed at least annually and more frequently whenever erratic operation or erroneous test results are suspected. Approximate calibrations can be taken on a daily basis by testing the hearing of persons with established audiometric patterns.

Additional information on audiometric measurement and its medical aspects may be obtained from the American Industrial Hygiene Association's publication, "Industrial Noise Manual, Second Edition."

- 1.3 Control of Chemical hazards: Special precaution must be taken whenever organic solvents are used to de-oil or de-grease workpieces. Organic solvents give off toxic vapors which when inhaled in high concentrations or over a long period of time can cause severe illness.

The most effective method for preventing inhalation of vapors from the solvents is to keep the solvent out of the breathing zone. This is done by using an efficient local exhaust ventilation system. Although a good general ventilation system will sometimes be sufficient, effective control of vapors from a highly toxic solvent requires use of local exhaust system. In some cases the use of an air-supplied respirator is an acceptable alternative to the local exhaust system. Care must be taken, however, to protect others in the area who may inadvertently be

exposed to the vapors.

Hazards associated with handling the various organic solvents can be controlled through use of appropriate impermeable protective clothing such as aprons, face shields and gloves and/or the use of mechanical handling devices.

A good working knowledge of the physical properties, nomenclature and effects of exposures is extremely helpful in making a proper assessment of a solvent exposure.

Good personal hygiene is important whenever solvents are used. Spills and splashes should be removed immediately with soap and water. This includes showering and replacing solvent-soaked or splattered clothing with clean clothing immediately or as often as necessary.

Organic solvents should be stored in special safety containers in a well ventilated room to prevent accumulation and build up of flammable or toxic concentrations.

2. Control of Safety Hazards

Because most of the safety hazards found in abrasive blasting operations relate to the type of equipment being used, most of the control measures identified below relate to specific machine types. In addition, a section is provided on control of other commonly-found safety hazards regardless of the type of machinery involved. This results in a small degree of repetition, included purposely for ease of reference.

2.J Controls for Specific Abrasive Blasting Machine Types: The following discussion identifies specific mechanical, electrical and personal protective controls which should or must be utilized to help ensure

safety and health of those operating or in proximity to hand-operated portable and room-type, hand-operated cabinet, and automatic blast cleaning machines. It should be noted that some of the items listed under each type machine are somewhat repetitive of those mentioned earlier. In such cases the repetition is provided primarily to indicate how the various dust, noise and other controls can be applied for a specific type process.

2.1.1 Hand Operated Portable and Room Type Blast Cleaning Machines:

2.1.1.1 Mechanical:

- a. All units should be equipped with a positive fast-acting abrasive shut-off control that must be depressed by the operator to start blasting operations.
- b. Hoselines which are exposed to internal deterioration from abrasive action should be subjected to regular nondestructive integrity testing on an elapsed time basis. The initial test after use can be of greater time span than the subsequent tests which should be conducted more frequently depending on age. Elapsed time between testing should be determined by hose manufacturers based on types of hose construction and type of abrasives for which the hose has been designed or will be used. The user should maintain test records. In addition, the operator should check the hose for deterioration and

leakage before use. In particular, that point two-and-one-half feet from the nozzle -- at the angle where the hose bends upward from the floor to the operator -- should be looked at very closely.

- c. On a time-use basis, all metal pipelines, joints, bends, valves, connectors, and nozzles should be subjected to regular internal inspection to detect deterioration from internal abrasion. Defective parts should be replaced promptly to avoid sudden failure. The time test period should be established by the user on the basis of previous failure and/or past replacement time procedures. The user should maintain test results.
- d. The nozzle should be externally attached to the hose by a fitting which will positively prevent accidental disengagement. No adjustment of the fitting should ever be attempted while the abrasive is flowing. Lengths of hose should also be joined by external metallic connectors so that the flow of abrasive will not erode and weaken the couplings.

- e. Pressure "pots" or vessels used in conjunction with abrasive blast cleaning operations should be examined for internal deterioration at least every two years. Following each five years of operation, the "pot" or pressure vessel should be subjected to a hydrostatic test at a pressure of 1 1/2 X designated maximum working pressure. Such inspection and testing should be conducted and/or witnessed by an individual who has attained proven competency in this work, such as an ASME/National Board Commissioned Inspector, or a state or deputized insurance company inspector. The use of pressure "pots" or vessels which lack a removable hand-hole plate that permits internal examination should be prohibited. All "pots" or vessels should be constructed in accordance with ASME pressure vessel code requirements.
- f. Pop-up valves used to pressurize the "pot" or pressure vessels should not be fabricated of all rubber construction. Rubber seals may be used as long as the valves have an internal metal core of greater diameter than the opening in the tank top. Rubber-covered valves and tank top seals should be checked frequently for

- deterioration. Defective parts should be replaced promptly.
- g. Pressure "pots" or vessels should be designed in a manner which permits free and easy entry of the abrasive) reduces spilling, and generally aids in the prevention of strains and sprains when the "pot" is being filled manually. It is preferable that the upper fill head be of concave design.
- h. The interior floors, ledges, and shelf surfaces (whenever practical the latter two items should be avoided) of blast cleaning rooms should be cleaned of waste abrasive and debris on a regular daily basis whenever the facility is used. Workers conducting cleaning operations should be supplied with and instructed to wear suitable respiratory protection. In addition, all floor surfaces within the room or chamber should be continually examined for abrasive deterioration and distortion. Prompt repairs should be made to provide an even floor surface that will not contribute to slipping and falling accidents.
- i. Blast cleaning rooms should be inspected on a regular weekly basis to detect holes, abraded metal enclosure surfaces, and defective door seals that can permit the escape of abrasive

material. Defective sections should be repaired or replaced. Whenever practical, the interior of blast cleaning rooms should be rubber-lined to reduce operating noise and to protect metal sidewalls from abrasive deterioration.

- j. Division seals of split or divided blast cleaning rooms that permit the entry of work on an overhead traveling crane should be examined at least weekly. Defective seals should be replaced promptly.
- k. Whenever the blast cleaning process entails the cleaning of heavy or bulky objects, workers should be provided with an adequate means of handling them prior to, during, and after blast cleaning.
- l. All doors of a blasting enclosure should be kept closed at all times when blasting is being done. They should be kept closed for a reasonable time after the blasting has ceased.
- m. All moving mechanical devices, conveyor belts, and other mechanical drives should be mechanically guarded to prevent physical contact with moving machinery. Protection by remoteness is not adequate because maintenance personnel can still be injured by the machinery.

- n. Each blast cleaning room should have at least two inspection ports located so operators can be clearly viewed at all times. Internal protective guards or covers for ports should be maintained so they open and close freely and protect vision glass from abrasive etching.
- o. Doors providing entrance and exit for blast cleaning rooms should operate freely, be unobstructed, and in no way restrict fast exit. Doors should not be lockable on the inside or in any way constructed to prevent entry of emergency assistance.
- p. Waste abrasives should be cleared from work areas on a regular daily basis. They should not be permitted to accumulate or stockpile. The method of disposal should not cause environmental problems.

2.1.1.2 Electrical:

- a. All motors used in conjunction with abrasive blast cleaning equipment should be of totally enclosed, dust-proof design.
- b. All electrical controls should be confined in dust-tight enclosures meeting the design criteria of the National Electrical Manufacturers

Association (NEMA) Specification 12.

- c. The main abrasive supply hose line should be provided with an efficient means for the discharge of static charges from the blasting nozzle. It is preferable that the grounding system be built into the hose line. A separate grounding cable attached to the outside of the hose can be easily damaged, and so made worthless. The grounding system should be subjected to a ground continuity test at the beginning of each workweek prior to the commencement of work operations. Test records should be maintained.
- d. All electrical lighting within the confines of blast cleaning rooms should be completely operative at all times. Protective glass shades or plates should be promptly changed when the glass becomes etched or in any way restricts light emission. The illumination within every blasting chamber should not be less than twenty footcandles over all parts of the chamber measured in a horizontal plane at three feet above the floor.

2.1.1.3 Personal Protective Equipment

- a. Each operator should have and be instructed to wear an air-supplied breathing helmet which bears a distinguishing mark indicating that it has been allotted to an individual operator. Each helmet should be subjected to thorough cleaning and disinfecting since last being used.
- b. The air supplied to self-contained breathing helmets may be drawn from the main air supply compressor only when adequate safeguards are provided. A separate oil-free compressor should be used to supply breathing air. Conditioning breathing air to a temperature of 65° - 70° F is desirable. It should be passed through an air purifier before entering the operator's helmet. Each breathing-air supply system should be equipped with an audible alarm that will warn the blast cleaning operator, his helper, or other workers in the vicinity of the breathing supply is contaminated with smoke or carbon monoxide.
- c. Self-contained breathing helmets should be designed to accommodate and permit the use of sound-reducing ear muffs either as built-in protection

or to fit over conventional ear muffs. Until sound reduction techniques within self-contained breathing helmets have been applied, the use of ear muffs and/or ear plugs should be mandatory to insure that the 90 dbA level is not exceeded. This applies to other workers within the high noise level area.

- d. Vision glasses in self-contained breathing helmets should be replaced promptly when the glass becomes etched from abrasive impact. The condition of such glasses should be checked on a weekly basis by the blast cleaning operator's direct work supervisor. The use of protective mylar films over vision glasses is highly recommended.
- e. Abrasive blast cleaning workers should have and be instructed to wear boots or toe guards.
- f. Each operator should be have and be instructed to wear suitable gauntlet gloves and coveralls to prevent abrasive materials from contacting the skin from entry through breaks in clothing. This requirement is in addition to the protection afforded with leather or rubberized capes associated with self-contained breathing helmets and protective leg chaps. The

lower leg of coveralls should be belted and buckled or taped closed around the workers safety boot to prevent the entry of ubrasive.

- g. In addition to the sLipulated personal protective equipment, a suitable, clean locker or container should be provided for each operator to store equipment in a clean condition. Such storage accommodation should be in a dust-free area outside of the blasting area but as close as practical to the area of operations.

2.. 1.2 Hand-Operated Cabinet Machines:

2.1.2.1 Mechanical:

- a. The exhaust fans of cabinet machines should be acoustically engineered so resulting noise level does not exceed 90 dbA.
- b. All cabinet machines, including small bench-top type units, should be equipped with an exhaust ventilation system. Gravity-settling dust collecting systems should be prohibited because they restrict vision and can become overpressured causing leakage of abrasive.
- c. The use of open-front cabinet machines (as used in the suede preparation and cleaning industry) should be prohibited.

- d. The observation port on all hand-operated cabinet machines should utilize safety glass only. Each vision glass should be designed to visually indicate that safety glass observation ports have been provided.
- e. Door seals on cabinet units should be inspected weekly. Defective seals should be replaced promptly.
- f. All metal surfaces within cabinet machines should be designed to eliminate flat dust-collecting surfaces. Angled surfaces should be provided to aid in directing the abrasive and debris into the dust-collecting system.
- g. Dust-collecting systems on cabinet machines should be cleared of blockage on at least an hourly operational basis. Dust collection bags should be inspected on a weekly basis. Defective bags should be replaced promptly.
- h. Foot controls used to activate cabinet machines should be equipped with a stirrup-type guard to prevent accidental operation of the machine.
- j. Internal surfaces of all cabinet machines should be inspected on a regular weekly basis to determine if there has been any thinning of

the metal casing from abrasive action. Deteriorated sections should be repaired or replaced promptly.

2.1.2.2 Electrical:

- a. All machines should be provided with an efficient means for discharge of static electricity from the blasting nozzle. In addition, the cabinet machine operator should be provided with an easily attachable grounding strap that will protect him from static electrical shock.
- b. All cabinet machines should be equipped with with a negative-pressure control switch (to prevent operation of the machine unless a negative pressure is evident within the cabinet) and an electrical interlock control (to prevent machine operation unless the main access door is in the closed position).
- c. All operating controls should be of dust proof NEMA Specification 12 design. Control boxes should be kept closed at all times unless being serviced by a competent electrician.
- d. Electrical lighting within cabinet machines should be adequately maintained. Etched shades or protection glasses that restrict light

emission should be replaced promptly.

2.1.2.3 Personal Protective Equipment

Each machine operator should have and be instructed to wear:

- a. Complete eye protective equipment when operating his machine.
- b. Safety boots or toe guards.
- c. A dust respirator while operating a cabinet machine and when removing abrasive residue and debris from the dust collecting system.

2.1.3 Automatic Machines:

2.1.3.1 Mechanical:

- a. Internal surfaces of all automatic machines should be inspected on a regular weekly basis. The following items should be given special consideration and prompt corrective action:
 1. Badly abraded recirculating pipes should be replaced .
 2. Abraded case-hardened wear plates and especially their retaining nuts should be replaced promptly.

3. Worn, distorted, or otherwise deteriorated floor plates or gratings that can create a trip, slip, or fall hazard should be replaced promptly.
4. Abraded and otherwise damaged steel to steel, steel to rubber, or rubber to rubber door seals should be repaired or replaced promptly.
5. Abraded frames, casings, or other enclosures that can result in escape of abrasives or dust should be repaired or replaced.

- b. Dust exhaust fans and shaker-type abrasive waste separation systems should be re-engineered as necessary until the noise levels meet or are below 90 dbA.
- c. Discharge of waste materials from magnetic and other type separators should not terminate into open bins or containers. Such bins or containers should be covered to effectively control the emission of dust clouds into open work areas.
- d. All machine drives, coupled or belted, should be mechanically guarded to prevent physical contact. Reference is specifically made to door closing belt drives, exhaust fan belt drives,

shaker conveyor and dust collector vibratory drives.

- e. Removable floor plates and/or gratings providing access to below-grade level shaker-type separators should be kept in position at all times during machine operation. During maintenance work such floor openings should be barricaded to effectively restrict access to the maintenance work area and specifically the unprotected floor openings.
- f. All steel cables used to open and close the doors of automatic machines should be examined on a monthly basis. Such cables should be replaced when it is noted that there is excessive dryness and an exterior brick dust effect (indicates internal corrosion working out to the exterior of the cable) or when six or more wire breaks exist within the lay (one complete revolution or wrap) of a single strand of the cable, or when there is indication of flattening or abrasion of one or more strands of the cable.
- g. All dust-collecting systems should be inspected and serviced on a regular weekly basis with prime consideration that:

- 1. all ducts and ventilation screens are clean;
- 2. the maximum manufacturer's air flow rates are maintained at all times;
- 3. bags, screens, filters, and other dust collecting devices are in peak working condition;
- 4. dust collection bins and containers are covered to effectively contain the dust discharge;
- 5. discharge bags between the final hopper discharge and the collection bin or container are in good working order, and;
- 6. no blockage exists at any location within the dust collection system and its ultimate discharge.

2.1.].2 Electrical:

- a. All doors, main, or manual access, should be equipped with electrical interlocks that will prevent operation of the machine unless all doors are tightly closed.
- b. All motors used in conjunction with automatic blast cleaning machines should be of totally closed, dust-proof design.

- c. All electrical controls should be confined in dust-tight enclosures (boxes or cubicles) that meet the design criteria of NEMA Specification 12.
- d. The breaking of a tumble belt or rotating table drive belt should immediately prevent further operation of the machine until the belt is repaired or replaced. In addition to ruining all parts being cleaned, frequent belt failures cause the operator to remain close to the machine where he can be exposed to dust inhalation.

2.1.3.3 Personal Protective Equipment:

- a. Each machine operator and/or attendant or assistant should wear complete eye protection equipment.
- b. Each machine operator and/or attendant or assistant should wear foot protection.
- c. Each machine operator and/or attendant or assistant should wear coveralls that will restrict the entry of abrasive into clothing breaks from which it can make physical contact with the skin.
- d. During machine operation each machine operator and/or attendant or assistant should wear a dust control breathing respirator. Such a device

should also be worn by all workers servicing any phase of the dust collecting system.

2.2 General Safety Controls: The following controls can be implemented to reduce or eliminate general safety hazards commonly found where abrasive blast cleaning operations are conducted.

2.2.1 Machine Safeguarding: People react differently to the same environment because of physical, mental and emotional differences. Some act safely, others unsafely. The behavior of the same person will vary from time to time. As a result, even a well-coordinated and highly trained individual may at times perform unsafe acts leading to injury or death unless machinery in motion is properly guarded to protect him.

All fixed machinery must be secured to prevent movement. The guarding device must be designed and made to prevent the operator from having any part of his body into the danger zone during the operating cycle. Many equipment representatives can assist in obtaining the necessary protective devices. Also a booklet entitled "The Principles and Techniques of Mechanical Guarding" OSHA 2057 may be obtained by writing to the OSHA office in your region.

On automatic blasting equipment, all belts, pulleys, gears, sprockets, chain devices, coupling and projecting shafts within reach must be effectively guarded. The air compressor

must have flywheel and drive pulley enclosed. Any fans located within seven feet of the floor should be guarded with grille or mesh limiting openings to not more than a half inch. The operator position should be such that he is not in the path of the tumbling or rotating movement of automatic blast equipment. All tumbling and rotating equipment should be equipped with a positive lock device to prevent the machine from turning during loading and unloading due to an imbalance or unintentional turning on of power. In addition, equipment should be guarded by an enclosure which is interlocked with the drive mechanism, so that the equipment cannot tumble or rotate unless guard enclosure is in place.

All metal enclosures used for motors and other electrical devices on machinery should be grounded. Electrical equipment and controls should be properly designed for installation.

In general, any effort to institute more effective machine safeguarding should be undertaken in light of the following general suggestions:

- a. The most important purpose of machine guarding is to protect the operator and other personnel working near or passing by. Any measure taken should contribute to control or elimination of the hazard.
- b. Safeguarding measures should not interfere with production nor in any way lower employee's productivity.

- c. Guards should be designed so that: their use and purpose are obvious; they cannot be tampered with or removed; repairs can be made on guarded parts without exposing personnel to moving parts, and so machinery can be lubricated without removing the guard. Oil reservoirs usually can be placed outside the guard, connected to the point of lubrication by an oil line.
- d. Guards should be made of materials at least equal in quality to the materials used for the machinery itself.
- e. Guards should be constructed in a manner that they themselves do not create a hazard. Sharp edges, exposed bolts or jagged or unfinished surfaces can cause cuts and lacerations.
- f. Guards should be secured to the machine tightly.

Engineering controls involved in guarding should be supplemented with an education effort. Workers should be instructed and monitored in safe practices which dictate that:

- a. No guard should be removed by the operator unless specific permission is given by his supervisor, and the operator is trained in how to remove and replace the guard properly, and machine adjustment is considered part of his job,
- b. Guards must be inspected carefully before a machine is started to ensure their satisfactory condition, that is,

no: cracks, looseness, sharp edges, exposed bolts, and so on. Any defective or missing guards should be reported to the foreman immediately.

- c. Whenever safeguards are removed for machine maintenance, adjustment or repair, power to the equipment should be turned off and the main switch should be locked and tagged.
- d. No employee should be permitted to work on or around mechanical equipment while wearing neckties, loose clothing, or jewelry.

2.2.2 Nonrespiratory Personal Protective Equipment: Abrasive blasting operators must be equipped with heavy canvas or leather gloves and aprons and ricochet hoods or the equivalent to protect them from the impact of abrasives.

Safety shoes must be worn to protect operators from foot injury where heavy pieces of work are handled. Such shoes must conform to the American National Standard for Men's Safety-Toe Footwear, 241.1-1967.

Protective devices for the eyes and face must be worn by the operator when the respirator design does not provide such protection. Such equipment also must be worn by personnel working in the vicinity of abrasive blasting operations.

2.2.3 Control of Flammable/Explosive Dusts: Combustible organic abrasives may be used only in automatic blasting systems. Where flammable or explosive dust mixtures may be present, the construction

of the equipment -- including the exhaust system and all electric wiring -- must conform to American National Standard Installation of Blower and Exhaust Systems for Dust, Stock and Vapor Removal or Conveying, Z33.1-1961 (NFPA 91-1961), and American National Standard National Electrical Code, C1-1968 (NFPA 70-1968). In addition, the blast nozzle must be bonded and grounded to prevent static charge build-up and the enclosure, ducts, and dust collectors must be constructed with loose panels or explosion venting areas (located on sides away from any occupied area) to provide pressure relief in case of explosion.

2.2.4 Housekeeping: Good housekeeping plays a key role in a safety protection and health program.

The best housekeeping results when each individual is held responsible for maintaining order in his work area and is supplied with a comprehensive check list of what his specific housekeeping responsibilities are. Time should be set aside for housekeeping when work is scheduled. Necessary housekeeping equipment should be available, and trash cans and special disposable bins should be handy and emptied regularly.

Each worker should:

- a. Clean his machines and equipment of oil, grease, dust and abrasive media after each shift. He should try to keep them reasonably clean while working.
- b. Put all scrap and trash in proper trash bins for easy removal.

- c. Keep the floors and aisles in his work area free of dust, unused material and abrasives (especially steel shot) and unobstructed,
- d. Properly stack and store materials he uses.
- e. Keep floor and equipment surfaces dry.
- f. Empty collector hoppers frequently and routinely.
- g. Maintain all connections through which dust or dust-laden air are conveyed in a dust-tight condition.
- h. Clean, sterilize and repair personal protective devices daily.
- i. Keep the vision glasses on abrasive-blasting enclosures clean and free of dust.
- j. Never use compressed air to clean dust off clothing. Dustless methods of cleaning, such as a vacuuming or washing down with water, should be substituted.

2.2.5 Lighting: Lighting in blasting rooms already has been discussed. General lighting in the work area also is important, however. Proper illumination not only helps control safety hazards, but, tests have shown, also contributes to high productivity.

Illumination levels for a given work situation should be in accord with levels required for the nature of the task and the equipment involved. Illumination levels recommended by the Illuminating Engineering Society (IES) in its "Lighting Handbook" are suggested

for review. Conformance with IES recommendations, or whatever standards are set, should be checked frequently with a light meter. In particularly dusty and/or dirty environments, light meter readings should be taken as frequently as once every two weeks.

Lighting in blast cleaning environments is affected by dust and dirt formation on lamps (bulbs) and lenses, burn-outs, lamp depreciation, and voltage drops. In addition, light is absorbed very quickly by dark surfaces. Surfaces darkened due to dust should be cleaned frequently, perhaps as often as once every other week. Where possible, dark surfaces should be painted a lighter color. If necessary, more efficient light sources should be utilized. If cleaning lamps and surfaces and replacing burnouts with more efficient light sources fails to increase the illumination to standard levels, then a qualified illumination engineer should be called upon to make a complete survey of the present system.

A regular program of complete lamp replacement, regardless of condition, is less costly than replacement of individual lamps as they burn out. The plant electrical maintenance foreman should keep a log of hours of use for lights in all sections of the plant. When the expected hours of service have been reached, complete replacement is recommended.

2.2.6 Site Work: Site work often requires the operator to work at considerable heights and in difficult positions. It is essential therefore, that proper steps are taken prior to commencement of work to help reduce exposure to safety hazards. These steps include:

- a. Scaffolding must be checked to ensure that it is secure.
- b. A safety harness should be used if the operator's vision will be restricted in any way. The condition and general adequacy of the harness should be checked prior to use.
- c. The pressure vessel should be placed as near to the operator as his need for unobstructed movement permits. In the event that the pressure vessel cannot be placed near the operator, as when it must be positioned at ground level, the blast hose must be anchored to a secure part of the structure.
- d. In all cases the blast hose should be properly anchored to eliminate the possibility of the operator being thrown off his feet by the weight of the hose should he momentarily lose his balance or by sudden hose action due to inconstant or interrupted pressure.
- e. The operator should be sure to angle the nozzle to protect himself and others.
- f. When work is being performed in tanks or in other confined areas where dust can be a problem, both protective clothing and a compressed air-fed helmet should be worn.

VI. DEVELOPING AND MAINTAINING AN EFFECTIVE SAFETY PROGRAM

It has been shown in numerous instances that establishment and maintenance of an effective safety program will produce substantial benefits. In addition to reducing the number of injuries and attendant costs, a safety program can result in more efficient operations, more effective management, and improved employee relations.

The following guidelines -- based extensively on a model program developed by the Committee on Safety, American Iron and Steel Institute -- should be considered as a starting point for abrasive blasting management. Each manager should review the guidelines and expand and modify them as required to meet the specific needs of his own organizational structure and operational procedures. It also must be recognized that implementing the program means far more than designing it on paper. All members of the management team charged with administering safety responsibilities must understand the program completely and be well trained. For this to happen, top management must be completely committed to the program and must communicate its commitment to supervisors.

1. Job Safety Analysis

A Job Safety Analysis (JSA) is a document which systematically identifies hazards associated with a given job and the step-by-step procedures which must be followed to eliminate or at least minimize each hazard. As a result, JSAs become the basis for individual safety training and for any follow-up action required.

To minimize the work required to develop JSAs, it is suggested that initial action involve a listing of all tasks performed by personnel in each job

category. It then will become apparent that some tasks are common to two or more jobs. By establishing JSA elements relative to various tasks, it then will be possible to utilize standard JSA elements where applicable from job to job.

It should be noted that the most effective JSAs often are developed through review of tentative JSA with the workers involved. Many can provide valuable insights and ideas which make JSAs that much more meaningful.

In each JSA, the following four basic steps should be observed:

- a. Break a job down into elements (tasks).
- b. Determine the injury contact possibilities.
- c. Eliminate (by physical change) or reduce (by the written procedure) the injury contact possibilities.
- d. Write up the JSA.

2. Safety Training

Employees are most likely to perform work in the most efficient and safest manner when safe work procedures have been communicated to them so they understand them and are motivated to comply. Simply telling an employee how to perform a given job safely does not assure that an employee understands sufficiently to follow the prescribed procedure. There is no substitute for being shown how to do the job followed by practice under supervision. Rechecking then continues at diminishing frequency as the

supervisor becomes more convinced that the employee knows how to do the job safely and efficiently. In summary, the training principle of TELL - SHOW - PRACTICE - CHECK is strongly recommended as the best means of providing basic training.

The ideal source of material for basic training is the JSA. To obtain maximum retention of training instructions, it is recommended that the TELL - SHOW - PRACTICE - CHECK principle be applied separately for each step in the JSA.

In providing basic training to employees with proper related work experience all steps of the job should be reviewed in proper sequence. For those steps where the employee's prior experience is minimal, the TELL - SHOW - PRACTICE - CHECK approach should be followed. For those steps where the employee has prior experience, a brief discussion should suffice. One effective way of doing this is to ask the employee to explain how a step is performed. Any mistakes he makes during the explanation can be corrected by explaining why the prescribed procedure is better. If the employee's ideas presented at such times are better than the JSA procedure, the employee's contribution should be acknowledged and the JSA should be revised.

Once an employee demonstrates that he understands the requirements, the remaining concern is motivation. The employee must want to comply for his safety awareness to be maintained.

Experience has shown that positive incentives are far more effective than negative incentives (such as disciplinary action) in influencing behavior. Positive incentives that can be used effectively include:

- a. Employee participation in developing the JSA.
- b. Asking for employee's ideas on a better way to do the job when something goes wrong.
- c. Explaining why requirements are in effect when providing training.
- d. Discussing accidents that have occurred and how physical safeguards and compliance with JSAs can prevent them from occurring again.
- e. Reflecting a genuine concern for the safety of employees, rather than an attitude of just complying with the requirements of a compulsory program dictated by someone at a higher level in the organization.
- f. When observing employees for compliance with JSA requirements, complimenting them for good performance instead of restricting comments to correcting mistakes.
- g. When correcting mistakes, explaining in terms of the employees own welfare, why the prescribed way is better.
- h. Consistent objective handling of enforcement action when it must be used.

3. Individual Contacts

An individual contact is a planned follow-up training session on the hazard possibilities of each job. Over a period of time, as proficiency and familiarity with the job increase, awareness of injury potentials may

diminish and bad work habits may develop. Individual contacts serve to reinforce basic training on a continuing basis and to maintain safety awareness on all jobs performed.

A schedule of one individual contact per employee per week is recommended. Each contact should consume no more than five minutes and should cover one to three steps of the JSA. It often is more advantageous to have the employee explain the procedure and how the procedure helps him to avoid injurious contact.

Individual contacts should be planned in advance for the purpose of discussing those job steps which are most helpful to the individual employee. Planning of individual contacts over a period of time should provide for complete coverage of all jobs on which each employee works. Such planning should also avoid repetitive coverage of the same item while overlooking completely other job steps being performed by the employee.

4. General Contacts:

General contacts are closely related to individual contacts. They differ only in subject matter. While individual contacts involve discussion of steps of JSAs, general contacts may relate to any subject which will contribute to improve safety performance. Thus, a general contact may be a planned discussion about a recent accident or series of accidents, a reminder of unsafe acts or violations that have been observed, a review of a recent general safety bulletin, a discussion of housekeeping or tool conditions, or anything else that will add to the employee's safety knowledge of his working environment.

5. Safety Observations

There are two types of safety observations: planned and impromptu.

Through planned observations, the supervisor can verify that: proper protective apparel is being worn; safe job procedures are being followed; employees are avoiding points of injurious contact, and are using their safety know-how at all times. It is recommended that supervisors make at least two planned safety observations of each employee each month and that they be planned so they cover all job operations for which the employee has received instruction. If an employee is observed doing anything unsafe, he should be contacted immediately and re-instructed in order to eliminate potential injury.

Impromptu observations are unplanned observations of an unsafe action or condition that requires immediate correction. Regardless of what they may be doing at any time, supervisors should always be alert to unsafe actions and conditions. Use of impromptu observations is one of the most important means of identifying and correcting potential accident causes before an accident occurs.

The findings which can arise from safety observations and the corrective action which should be required are as follows:

5.1 Unsafe Condition: The supervisor should take action to eliminate the condition. If immediate correction is not practical, appropriate JSAs should be modified to provide safeguards. Employees then should be re-instructed.

5.2 Violation: Violations may reflect lack of conformance with JSAs, the Job Safety Analysis, general safety rules (if used), specific instructions, etc., on which the employee has previously received basic training and/or individual or general contacts. The employee should be contacted immediately to eliminate the violation and be re-instructed on the step of the JSA which was violated. Repeated violations by the same employee should not be tolerated.

5.3 Violations - Lack of Instructions: In some cases, employees will violate a safety rule because they have not received necessary instructions. Unless the employee was performing work he was not authorized or directed to perform (a violation), he cannot be held responsible for a practice which he did not know to be a violation. The employee should be promptly instructed concerning the step of the JSA he was performing.

5.4 Unsafe Act: If a supervisor observes an action that is unsafe but is not included in a JSA or in safety rules and has not been covered by a general contact, the unsafe action should be stopped and employees on the job should be contacted and instructed. The supervisor then should take steps to incorporate the necessary requirement in the appropriate JSA and employees should receive individual contacts concerning the JSA revision.

It has long been recognized that safe physical conditions must be established and maintained if accidents and injuries are to be avoided. This requires review of plans and specifications before facilities or equipment are installed or modified to assure that proper conditions are established at the outset.

It also requires periodic inspections to assure that the proper safe conditions are maintained. From administrative and cost standpoints, it is easier and less expensive to prevent the introduction of unsafe conditions than it is to allow them to go unchecked until accidents, inefficiencies, and costs require an all-out effort to identify and correct them.

When establishing plans and specifications for new or modified facilities, engineering personnel must have the responsibility for including all requirements necessary for safety. This includes safeguards to prevent injurious contact with moving equipment or material, prevention of flammable or explosive mixtures, and -- where toxic materials are involved -- prevention of personnel exposure. In those instances where particularly difficult safety problems are involved, the best expert advice should be obtained before proceeding with final plans and specifications.

The next step required to avoid unsafe conditions in new or modified facilities or equipment is a thorough inspection of the completed installations before it is placed into operation. The inspection should be performed at least by representatives of operating, maintenance, safety, and engineering responsibilities. Any unsafe conditions found should be corrected before use or operation of the facilities or equipment is permitted.

The third step is to establish controls to assure that facilities and equipment are properly maintained. This includes the requirement that each worker maintain his immediate work area in a clean, uncluttered, and orderly condition. Periodic management inspections at regular intervals, with specific requirements as to the facilities or equipment to be inspected, can help assure that safe conditions will be maintained.

Other factors should also be considered in establishing inspection schedules. For example, facilities exposed to the weather can be expected to deteriorate faster than comparable facilities located indoors. As a result, they should receive more frequent inspection. Likewise, older equipment on which component parts are already substantially eroded or worn can be expected to fail in service more frequently than new equipment.

Responsible management in each plant should determine what should be inspected, how often it should be inspected, who should do the inspecting, and the controls necessary to see that good inspections are made and that defects are identified and corrected.

There is one other factor that is needed to assure good inspections: each person responsible for inspecting some equipment or facility must know what to look for. Inspection forms which identify items to check should be considered. These also enable higher levels of management to appraise the degree to which supervisors are complying with inspection requirements and correcting inadequacies in the overall inspection procedures.

In order to minimize unsafe conditions, it must be recognized that they are caused by people. Instead of just continuing to correct unsafe conditions, it can be far more productive to ask "Who did something or failed to do something that caused the condition and why did they do it or fail to do it?" Answering this question leads to the indirect cause of unsafe conditions. Correcting the indirect cause can produce substantial benefits which are of a far more permanent nature than just correcting each unsafe condition as it is found.

6. Accident Investigations

When an accident occurs, it generally represents a failure to fully comprehend and cope with all potential injury causes in normal safety activity. Nonetheless, an accident can be viewed positively as an opportunity to pinpoint the causes and incorporate remedial action in safety tools and activity. While fatal injuries and serious accidents usually receive concentrated attention, such cases -- for the purposes of investigation -- are of no greater significance than relatively minor accidents, because:

- a. The severity of an accident or injury is a question of chance and is not controllable.
- b. Fatal injuries are prevented best by identifying and correcting the causes of nonfatal disabling injuries. Disabling injuries are prevented best by identifying and correcting the causes of nondisabling injuries.
- c. Due to the greater number of relatively minor nondisabling injuries, such cases serve to identify a large number of sources of injurious contact. As such, they can help pinpoint the causes of future serious injuries and major noninjury accidents.

The first steps to take after any injury or accident are to ensure that the injured receives prompt medical attention and to secure the area or equipment to prevent any further injury or accident. After that, all pertinent facts concerning the accident should be developed promptly, preferably before the end of the work shift during which the accident occurred.

The employee's supervisor should physically inspect the area, interview witnesses, interview the injured if possible and, if necessary, consult with other management personnel to establish the facts. In order to develop facts, the supervisor should use an accident report form similar to Figure VI-I. Accident reports for all injuries should be reviewed by the supervisor's immediate superior for additional comments, recommendations, and actions. Controls should be established for all injuries and accidents to assure that recommended corrective action is, in fact, completed.

In the case of disabling injuries, an additional investigation should be conducted by a committee consisting of plant management who can contribute to the findings. The committee should be headed by a higher level of management. In the case of fatal injuries and serious incidents, the plant manager should be chairman of the committee.

7. Safety Responsibilities

For a safety program to be effectively administered, responsibility for each of the functions should be specifically assigned to appropriate management personnel. Responsibility for safety functions should be dovetailed into the management organization to coincide with other normal functions of each member of management. It follows that most of the actual "doing" functions must be performed by the first line supervisor (foreman) while progressively higher levels of management must be responsible for guiding and assisting the first line supervisor, appraising performance and results, auditing safety activities to identify and correct deficiencies, maintaining a current record of injury and accident statistics and taking steps to correct adverse trends, and establishing objectives or standards

FIGURE VI-1 Accident Report Form

1. NAME _____ 2. CLOCK NO. _____

3. DEPARTMENT _____ 4. ACCIDENT DATE _____ 5. TIME _____

6. AGE _____ 7. TOTAL CONTINUOUS SERVICE _____ 8. REGULAR OCCUP. _____

9. OCCUPATION WHEN INJURED _____

10. EXPERIENCE ON OCCUP. WHERE INJURY OCCURRED YEARS. _____ MTHS. _____ DAYS

11. WHAT JOB WAS BEING PERFORMED? _____

12. WHAT STEP OF THE JOB WAS IN PROGRESS? _____

13. HAD INJURED RECEIVED BASIC TRAINING AND SAFETY CONTACTS ON THE JOB
BEING PERFORMED? _____ 14. NATURE OF INJURY (IDENTIFY BODY PART) _____

15. WHAT HAPPENED? _____

16. WHAT UNSAFE ACTION WAS INVOLVED? _____

17. WHY WAS THE UNSAFE ACTION COMMITTED? _____

18. WHAT EQUIPMENT AND UNSAFE CONDITION WERE INVOLVED? _____

19. WAS THE JOB COVERED BY A JSA? _ _ IS REVISION OF THE JSA NEEDED? _____

20. RECOMMENDED ACTION TO PREVENT RECURRENCE _____

21. REVIEW ADDITIONAL COMMENTS AND RECOMMENDATIONS _____

22. REVIEWED BY _____ DATE _____

22. DATE ALL RECOMMENDED ACTION COMPLETED _____ SIGNATURE _____

for acceptable performance. Unless objectives and standards for safety performance and activities are established and communicated by top management, lower levels of management have no realistic basis for determining what is acceptable and what is unacceptable in terms of safety administration and results.

VII. ESTABLISHING AND MAINTAINING A FIRST-AID PROGRAM

The vast majority of accidents and injuries which occur in industry are of relatively minor nature. Unless they are treated immediately and competently, however, they can lead to problems of a far more serious nature. For example, if even a small cut is not properly cleansed and bandaged, infection may set in or some type toxic substance may enter the bloodstream. For this reason it is essential that abrasive blasting management provide to workers a source of immediate medical attention.

In cases of large organizations, medical personnel, even including a physician may be on hand during all or most shifts. However, in the absence of staff personnel or an infirmary, clinic, or hospital located in or near the workplace, it is essential that there be available a person or persons adequately trained to render first aid.

First aid should be provided for the treatment of minor cuts, scratches, bruises and burns. It also should be provided to render temporary aid and comfort for more serious injuries until such time as competent medical assistance is obtained.

The following guidelines are recommended or required for establishment and maintenance of an effective first aid program.

- a. One safety officer should be given overall responsibility for establishing and directing the program. He should then determine how many persons should be given first aid training and the extent of training required. This decision should be based on the hazards of the workplace, location of the operation in relation to sources

of immediate medical attention, size of work units, and so on.

- b. The responsible safety officer should identify sources of first aid instruction (such as the Red Cross, State Department of Labor, Consulting Physician, etc.), and those persons who should be instructed. He should see to it that those persons instructed are capable of performing first aid duties and ensure that they take refresher courses from time to time, at least annually. The responsible safety officer also must keep records to ensure that refresher courses are attended and that replacements are made when those with training leave the employ of the company involved, change shifts, etc.
- c. At least one employee trained in first aid should be on duty every shift. Contingency measures should be established in the event that the employee so trained is absent. (In some cases it may be best to have at least two employees trained in first aid on every shift.)
- d. All employees must be required to report any accident or illness -- no matter how small -- to the person assigned first aid responsibility. Records of all reports must be kept.
- e. A first aid kit approved by the consulting physician must be available all times. Typical items to be included in a first aid kit include: burn cream, ammonia inhalant, eye wash solution, bandage compress, aspirin tablets, etc. In most cases kits can be obtained as needed with at least several units of each type item.

The best ones available have the following features:

- * each unit carton wrapped in see-through covering to keep contents clean and indicate whether or not the carton has been opened
 - * instructions and/or diagrams on each unit package to help persons use contents
 - * contents immediately visible and identifiable when kit is opened
 - * weatherproof containers made of steel or high-impact plastic with a carrying handle and wall-mounting brackets.
- f. First aid kits must be located in sufficient number so no employee is more than just a few minutes away. The first aid area not necessarily the kit -- must be painted green.
- g. To prevent pilferage of kit material, each should be placed near a supervisory area such as a foreman's desk. Reserve stocks of materials should be kept under lock and key at all times. Employees should be told that unnecessary removal of items can result in not having them available when a need arises and that such a shortage, in some instances, could mean the difference between life and death.
- h. Instructions on transporting ill or injured employees should be posted near the kit, along with the name and telephone numbers of selected physicians, hospitals, clinics, ambulance services, rescue squads, etc. Such a list should be protected by a sturdy see-through plastic or glass cover.

VIII. SOURCES OF INFORMATION ON ABRASIVE BLASTING

Here follows a list of sources from whom further information on abrasive blasting may be obtained.

1. Associations and Societies

- * Acoustical Society of America,
335 E. 45th Street
New York, N.Y. 10017
- * American Conference of Governmental
Industrial Hygienists
1014 Broadway
Cincinnati, Ohio 45202

American Foundrymen's Society
Golf and Wolf Roads
Des Plaines, Illinois 60016
- * American Industrial Hygiene Association
25711 Southfield Road
Southfield, MI 48085
- * American Insurance Association,
Engineering and Safety Department
85 John Street
New York, N.Y. 10038
- * American Medical Association
Department of Environmental,
Public and Occupational Health
535 North Dearborn Street
Chicago, ILL 60610
- * American National Red Cross, Safety Services
17th and "D" Streets, N.W.
Washington, D.C. 20006
- * American National Standards Institute (ANSI)
1430 Broadway
New York, N.Y. 10018
- * American Society for Abrasive Methods
1049 So. Main Street
Plymouth, MI 48170

- * American Society for Testing and Materials
1916 Race Street
Philadelphia, PA 19103
- * American Society of Safety Engineers
850 Busse Highway
Park Ridge, ILL 69968
- * Industrial Health Foundation
5321 Centre Avenue
Pittsburgh, PA 15232
- * Industrial Safety Equipment Association, Inc.
60 E 42nd Street
New York, N.Y. 10017
- * National Association of Manufacturers
277 Park Avenue
New York, N.Y. 10017
- * National Electrical Manufacturers Association (NEMA)
155 East 44th Street
New York, N.Y. 10017
- * National Safety Council
524 North Michigan Avenue
Chicago, ILL 60611
- 2. U.S. Government Sources
- * NIOSH Regional Offices
- * DREW, Region I
Government Center (JFK Fed. Bldg)
Boston, Massachusetts 02203
Tel.:617/223-6668
- * DHEW, Region II - Federal Building
26 Federal Plaza
New York, New York, 10007
Tel.:212/597-6716
- * DREW, Region III
3525 Market Street, P.O. Box 13716
Philadelphia, Pennsylvania 19101
Tel.:215/597-6716

- * DREW, Region IV
50 Seventh Street, N.E.
Atlanta, Georgia 30323
Tel. :404/526-5474
- * DHEW Region V
300 South Wacker Drive
Chicago, Illinois 60607
Tel. :312/353-1710
- * DREW, Region VI
1114 Commerce Street (Rm. 8-C-53)
Dallas, Texas 75202
Tel. :214/749-2261
- * DHEW, Region VII
601 East 12th Street
Kansas City, Missouri 64106
Tel. :816/374-5332
- * DREW, Region VIII
19th & Stout Streets
9017 Federal Building
Denver, Colorado 80202
Tel. :303/837-3979
- * DHEW, Region IX
50 Fulton Street (245 FOB)
San Francisco, California 94012
Tel. :415/556-3781
- * DHEW, Region X
1321 Second Avenue (Arcade Bldg.)
Seattle, Washington 98101
Tel.:206/442-0530
- * OSHA Regional Offices:
- * Region I
U.S. Department of Labor
Occupational Safety and Health Administration
18 Oliver Street, Fifth Floor
Boston, Massachusetts 02110 Tel.:617/223-6712/3
- * Region II
U.S. Department of Labor
Occupational Safety and Health Administration
1515 Broadway (1 Astor Plaza)
New York, New York 10036 Tel.:212/971-5941/2

- * Region III
U.S. Department of Labor
Occupational Safety and Health Administration
15220 Gateway Center, 3535 Market Street
Philadelphia, Pennsylvania 19104 Tel.: 215/597-1201
- * Region IV
U.S. Department of Labor
Occupational Safety and Health Administration
1375 Peachtree Street, N.E., Suite 587
Atlanta, Georgia 30309 Tel.: 404/526-3574/3 or 2281/2
- * Region V
U.S. Department of Labor
Occupational Safety and Health Administration
300 South Wacker Drive, Room 1201
Chicago, Illinois 60606 Tel.: 317/353-4716/7
- * Region VI
U.S. Department of Labor
Occupational Safety and Health Administration
7th Floor, Texaco Building, 1512 Commerce Street
Dallas, Texas 75201 Tel.: 214/749-2477/8/9 or 2567
- * Region VII
U.S. Department of Labor
Occupational Safety and Health Administration
Waltower Building, Room 300, 823 Walnut Street
Kansas City, Missouri 64106 Tel.: 816/374-5249 or 5240
- * Region VIII
U.S. Department of Labor
Occupational Safety and Health Administration
Federal Building, Room 15010, 1961 Stout Street
Denver, Colorado 80202 Tel.: 303/837-3883
- * Region IX
U.S. Department of Labor
Occupational Safety and Health Administration
9470 Federal Building, 450 Golden Gate Avenue
Post Office Box 36017
San Francisco, California 94102 Tel.: 415/556-0586
- * Region X
U.S. Department of Labor
Occupational Safety and Health Administration
1808 Smith Tower Building, 506 Second Avenue
Seattle, Washington 98104 Tel.: 206/442-5930

* * * * *

BIBLIOGRAPHY

1. Abrasive Blasting Respiratory Protective Practices. U.S. Department of Health, Education and Welfare, Center for Disease Control, National Institute for Occupational Safety and Health, Division of Laboratories and Criteria Development. Cincinnati, Ohio, 1974.
2. Accident Prevention Manual for Industrial Operations, Sixth Edition. National Safety Council, Chicago, Illinois, 1969.
3. Beranek, L.L. Noise and Vibration Control. McGraw-Hill, New York, 1971.
4. Committee on Industrial Ventilation; Industrial Ventilation -- A Manual of Recommended Practice, Edition Thirteen. American Conference of Government Industrial Hygienists, Cincinnati, Ohio, 1974.
5. Criteria for a Recommended Standard -- Occupational Exposure to Crystalline Silica. U.S. Department of Health, Education and Welfare, Center for Disease Control, NIOSH, Cincinnati, Ohio, 1974.
6. Data Sheet 433, Abrasive Blasting. National Safety Council, Chicago, Illinois
7. Environmental Health Monitoring Manuals. Environmental Health Services, United States Steel Corporation 1973.
8. Industrial Health and Safety Criteria for Abrasive Blast Cleaning Operations. U.S. Department of Health, Education and Welfare, Center for Disease Control, National Institute for Occupational Safety and Health, Division of Laboratories and Criteria Development, Cincinnati, Ohio, 1974.
9. Industrial Noise Manual. American Industrial Hygiene Association. Westman, New Jersey, 1966.
10. Leroux, J, Davey ABC, Paillard A; Proposed Standard Methodology for The Evaluation of Silicosis Hazards. American Industrial Hygiene Association Journal 34:409-17, 1973
11. National Bureau of Standards: Fundamentals of Noise: Measurement, Rating Schemes and Standards, U.S. Environmental Protection Agency, Washington D.C.
12. NIOSH Manual of Analytical Methods. U.S. Department of Health, Education and Welfare. Center for Disease Control NIOSH. Cincinnati, Ohio.

13. Oddie, W. Development in Blast Cleaning Plant. Foundry Trade Journal (November 21, 1968, Pgs. 828-834).
14. Olishifiski, J.B., and McElroy, F.E. Fundamentals of Industrial Hygiene, National Safety Council, Chicago, Illinois 1975
15. Peterson, A.P.G. and E.E. Gross Jr.; Handbook of Noise Measurement. General Radio Company, West Cord, Massachusetts, 1974.
16. Plaster, H.J. Blast Cleaning and Allied Process, Vol 142. Available from American Foundrymen's Society, Des Plains, Illinois 1973
17. Safe Practices in Cleaning, Testing and Finishing. American Foundrymen's Society, Des Plaines, Illinois 1970.
18. Spenser, L.S. Abrasive Blasting. Metal Finishing, 1975.
19. The Industrial Environment -- Its Evaluation and Control --, U.S. Department of Health, Education and Welfare. Center for Disease Control NIOSH. Cincinnati, Ohio.

U.S. GOVERNMENT PRINTING OFFICE: 1976-- 657-696/5562