

DOT/FAA/CT-93/51

FAA Technical Center
Atlantic City International Airport,
N.J. 08405

Airport Pavement Test Machine Design and Cost Study

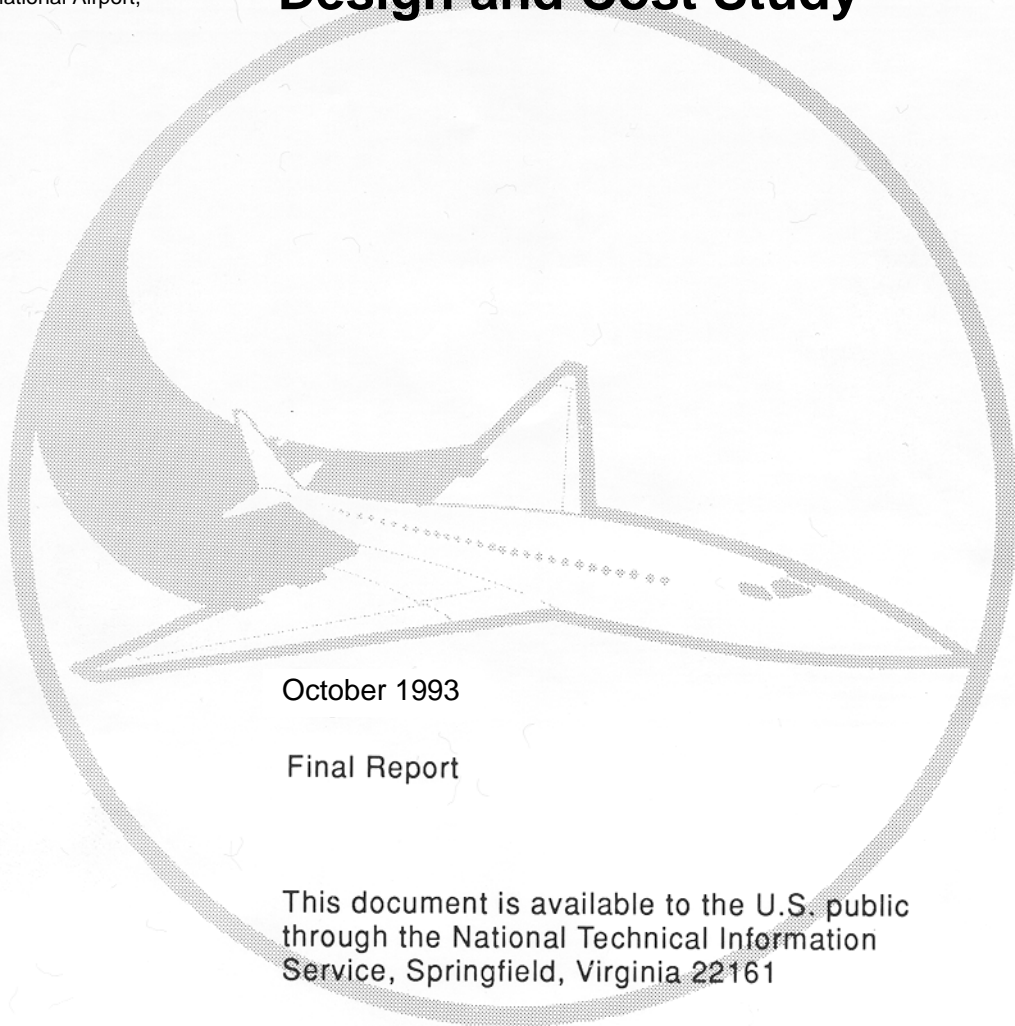

October 1993

Final Report

This document is available to the U.S. public
through the National Technical Information
Service, Springfield, Virginia 22161



U.S. Department of Transportation
Federal Aviation Administration

NOTICE

**This document is disseminated under the sponsorship of the
U.S. Department of Transportation in the interest of information exchange.
The United States Government assumes no liability for the contents or use thereof.**

**The United States Government does not endorse products or manufacturers.
Trade or manufacturers' names appear herein solely because they are
considered essential to the objective of this report.**

1. Report No. DOT/FAA/CT-93/51	2. Government Accession No.	3. Recipient's Catalog No.	
4. Title and Subtitle AIRPORT PAVEMENT TEST MACHINE DESIGN AND COST STUDY		5. Report Date October 1993	
		6. Performing Organization Code	
7. Author(s) Gordon F. Hayhoe, Roy D. McQueen, and Edward H. Guo		8. Performing Organization Report No.	
9. Performing Organization Name and Address Galaxy Scientific Corporation 2500 English Creek Avenue, Building 11 Pleasantville, NJ 08232		10. Work Unit No. (TRAIS)	
		11. Contract or Grant No. DTFA03-89-C-00043	
12. Sponsoring Agency Name and Address U.S. Department of Transportation Federal Aviation Administration Technical Center Atlantic City International Airport, NJ 08405		13. Type of Report and Period Covered Final Report	
		14. Sponsoring Agency Code ACD-110	
15. Supplementary Notes The Sponsoring Agency's Technical Officer was Dr. S.K. Agrawal.			
16. Abstract A design study was conducted to determine the feasibility of constructing and operating a test machine for performing accelerated airport pavement tests. The proposed design for the test machine satisfies the requirements of a comprehensive set of specifications formulated and developed by a government / industry working group. The primary purpose of the tests to be conducted with the test machine is to provide pavement response and performance data to be used in the development of new procedures for designing pavements for the next generation of large civil transport aircraft. The proposed test machine design allows for test pavements 60 feet wide by 900 feet long. Maximum load capacity is twelve wheels operating at 75,000 pounds each, for a maximum applied load of 900,000 pounds. Test speeds are 5 mph for normal testing and a maximum of 15 mph for special studies. Cost estimates were made for designing, constructing, and operating the test machine. The total initial cost required to design and construct the machine was estimated to be \$15,000,000. Maximum annual operating costs after commissioning were estimated to be \$2,300,000. Test pavement reconstruction accounts for \$1,500,000 (65 percent) of the estimated annual operating cost.			
17. Key Words Full-scale pavement testing Pavement testing machines Airport pavement design Heavy aircraft loads Multiple wheel aircraft landing gear		18. Distribution Statement Document is available to the public through the National Technical Information Service, Springfield, Virginia 22161	
19. Security Classif. (of this report) Unclassified	20. Security Classif. (of this page) Unclassified	21. No. of Pages 126	22. Price

PREFACE

This project was performed through the efforts of a working group representing both industry and government interests. The members of the working group provided guidance and direction during all phases of the project, starting with the development and justification of the initial concepts, through to the final draft of the specifications and requirements for the Airport Pavement Test Machine. The participants contributed to both the formation and the consensus gathering represented in this report. The Federal Aviation Administration (FAA) Technical Center gratefully acknowledges the contributions of the working group members listed below.

Satish K. Agrawal	Airport Technology Branch, FAA
John L. Rice	Office of Airport Safety and Standards, FAA
Rudolph R. Hegmon	Pavement Division, Federal Highway Administration
Jim W. Hall, Jr.	Pavements Branch, U.S. Army Corps of Engineers
Jim Murfee	Wright Laboratory, Air Base Systems Branch, Tyndall Air Force Base, Florida
Edward L. Gervais	Airport Technology Group, Boeing Commercial Airplane Company
Orvis W. Preston	Landing Gear / Hydraulics Analysis, Douglas Aircraft Company

The authors of this report would like to acknowledge the help and assistance of Hector Daiutolo, who was the FAA's Technical Officer for the project at its inception but who has since retired from the FAA. Thanks are also due to Bill Deguenther for work on the design of the test vehicle and for preparation of the vehicle design layouts, to Dick Ahlvin, for his constant help and advice, and to the many people who freely gave information on full-scale pavement testing.

TABLE OF CONTENTS

	Page
EXECUTIVE SUMMARY	ix
INTRODUCTION	1-1
SUMMARY OF THE TEST MACHINE DESIGN	2-1
Introduction.....	2-1
Specifications.....	2-1
SUMMARY OF THE COST ESTIMATES.....	3-1
Introduction.....	3-1
Test Pavement Cost Estimates.....	3-1
Test Vehicle Cost Estimate.....	3-2
Side Support Foundation Cost Estimate.....	3-2
Overhead Enclosure Cost Estimate.....	3-2
Test Pavement Instrumentation Cost Estimate.....	3-3
Test Vehicle Electrical Drive Power Cost Estimate.....	3-3
Test Tires and Other Consumables Cost Estimate.....	3-3
Operating Personnel Cost Estimate (contract).....	3-3
Maintenance Cost Estimate (contract).....	3-3
Total Initial Costs.....	3-4
First Year Operational Costs.....	3-4
Following Years' Operational Costs.....	3-4
EXISTING PAVEMENT TEST MACHINES.....	4-1
Introduction.....	4-1
Characteristics of the Test Machines.....	4-1
Summary of Existing Test Machine Characteristics.....	4-2
TEST PAVEMENT DESIGN AND COST ESTIMATE.....	5-1
Overview.....	5-1
Basic Requirements.....	5-1
Test Pavement Geometry.....	5-6
Pavement Design.....	5-10
Pavement Cost Estimates.....	5-11
Test Pavement Instrumentation.....	5-12

TEST VEHICLE DESIGN AND COST ESTIMATE.....	6-1
Introduction.....	6-1
Track Geometry	6-1
Test Wheel Modules	6-3
Cross Support Beams.....	6-5
Side Beams.....	6-5
Dynamic Response of the Structure.....	6-6
Drive Wheel Bogies.....	6-6
Power Requirements and Consumption.....	6-6
Test Tires	6-9
Instrumentation	6-10
 SIDE SUPPORT FOUNDATION DESIGN AND COST ESTIMATE.....	 7-1
General Considerations.....	7-1
Design for Soil Support	7-1
Design of the Box Structure.....	7-3
Cost Estimate	7-3
 PROPOSED TEST PROGRAM.....	 8-1
Introduction.....	8-1
Machine Shake-Down and Development Tests.....	8-1
Pavement Response Tests.....	8-1
Pavement Life Tests for Design.....	8-2
 CONCLUSIONS.....	 9-1
 REFERENCES	 10-1
 GLOSSARY	 11-1
 APPENDIXES	
A - Analysis of the Required Width and Depth of the Test Pavement	
B - Test Pavement Itemized Cost Estimates	
C - Detailed Design of the Foundation Structure	

LIST OF FIGURES

Figure		Page
2-1	General View of the Proposed Test Machine	2-5
5-1	Plan and Profile of Test Pavement Sections (2 sheets)	5-17
5-2	Required Width of the Test Pavement	5-19
5-3	PCC Construction Considerations	5-20
5-4	Subgrade Influence	5-21
5-5	Typical Cross-Section	5-22
5-6	Test Item Length	5-23
5-7	Construction Considerations (item length)	5-23
5-8	Module Concept (interaction tests)	5-24
5-9	Module Concept (life tests)	5-24
5-10	Possible Configuration	5-25
6-1	Plan and Elevations of the Proposed Test Vehicle	6-15
6-2	Oval and Linear Tracks, Example Comparison	6-16
6-3	Time to Complete One Repetition vs. Test Pavement Length	6-17
6-4	Annual Test Repetitions vs. Test Pavement Length	6-18
6-5	Wheel Module Showing Vertical and Steer Mechanisms	6-19
6-6	Truss Model Showing the Nodes and Elements	6-20
7-1	Plan and Two Cross-Sections of the Foundation	7-6
7-2	Assumed Load Transfer Paths	7-7
7-3	A Model for Overturning Analysis	7-8
7-4	Acceptable Soil Properties for Overturning Resistance	7-9
7-5	A Model for Bearing Capacity Analysis	7-10
7-6	Acceptable Properties of Soil for Bearing Capacity	7-11
7-7	Soil Stability Analysis	7-12
7-8	Acceptable Properties of Soil for Stability	7-13

LIST OF TABLES

Table		Page
4-1	Characteristics of Existing Test Machines	4-3
4-2	Characteristics of Existing Test Machines	4-4
5-1	Typical Test Items (FAA Method)	5-15
5-2	Summary of Pavement Related Costs	5-16
6-1	Test Vehicle Cost Estimates, Major Subsystems (3 sheets)	6-11
6-2	Distances and Times During Test Phases	6-14
6-3	Electrical Energy Required During Test Phases	6-14
7-1	Allowable Soil Bearing Stresses, kips/sf	7-4
7-2	Reinforced Concrete Required	7-4
7-3	Structural Steel Beams Required	7-5
7-4	Side Support Foundation Construction Costs	7-5

EXECUTIVE SUMMARY

The next generation of large civil transport aircraft will enter service in 1995 with the introduction of the Boeing B-777 twin-jet. New Federal Aviation Administration (FAA) standards are required to design airport pavements for the heavy and complex loading patterns which will be applied by the landing gear of these aircraft. Alternative pavement design procedures are available, or under development, but none can be adopted as full FAA standards without verification from full-scale test data representative of the new aircraft loading patterns. In response to the requirement for new airport pavement design standards, a working group representing both industry and government was formed to assist the FAA in determining the full-scale testing required to develop and implement the new standards.

The working group met on five separate occasions between January, 1992, and June, 1993. During this time, specifications for a full-scale test machine were developed by the working group and a design and cost study was performed under an independent project sponsored by the FAA. The proposed test machine, designed to satisfy the specifications developed by the working group, allows for test pavements up to 60 feet wide and 900 feet long. The test pavement is divided into twelve to sixteen test items built on three different subgrade strengths so that many "data points" can be obtained in one test series. Maximum load capacity is twelve wheels operating at 75,000 pounds each, for a maximum total applied load of 900,000 pounds. Test speeds are 5 mph for normal testing and a maximum of 15 mph for special studies. It is proposed that the initial series of tests be conducted with two groups of six wheels representative of the Boeing B-777 landing gear layout, and that the initial test pavement should include items representative of current full-depth airport pavement design practice.

Cost estimates were made for detail design, construction, and operation of the test machine. The estimated cost of designing, constructing, and commissioning the test machine, broken down into major systems, is:

Initial Test Pavement (9 Items)	\$3,400,000
Test Vehicle	\$7,000,000
Side Support Foundations	\$2,250,000
Protective Enclosure	\$1,350,000
Pavement Instrumentation	<u>\$1,000,000</u>
Total Initial Cost	\$15,000,000

Annual operating cost was estimated to be \$800,000, excluding pavement reconstruction. Pavement reconstruction costs, not needed until the third year of operation, were estimated to be typically \$1,500,000, depending on the type of construction.

INTRODUCTION

The next generation of large civil transport aircraft is expected to include models which will weigh up to 1.3 million pounds and have complex, multiple-wheel, multiple-truck landing gear systems. Also, by the end of 1995 the Boeing B-777 twin-jet will have entered commercial service. This aircraft will weigh 537,000 pounds in its initial configuration and have two six-wheel landing gear with three dual-wheel axles in tandem. A later stretch version of the B-777 will weigh 650,000 pounds but still have only two landing gear. The type of loading applied to airport pavements by these aircraft will be quite different than the types of loading applied by current generation civil aircraft. New procedures are required to design airport pavements for the heavy and complex loading patterns which will be applied by these aircraft.

The current procedure for flexible airport pavement design (see FAA Advisory Circular AC 150/5320-6C^[1]) is based on the Equivalent Single Wheel Load (ESWL) concept and the California Bearing Ratio (CBR) failure model modified using full-scale test data. Pavement design studies for the new aircraft have shown that the current procedure predicts much higher than expected levels of damage when the pavement loading is from many wheels in close proximity. It is suspected that the ESWL model over-predicts load interaction effects from the closely spaced wheels, but the extent to which this is true cannot be determined because none of the existing full-scale test data was obtained using equivalent loading configurations. The problem is further complicated by the fact that flexible airport pavement failure mechanisms are not very well understood and conducting representative full-scale tests to failure is the only way, at present, to develop models for predicting pavement life. Alternative design procedures are available and their use as replacements for the current flexible pavement design procedure is under development by the FAA. Full-scale test data is urgently needed to complete development and verify the new procedures so that they can be used to design airport pavements for the next generation aircraft.

New procedures are also under development for rigid airport pavement design. The new procedures will be compatible with the flexible pavement procedures and are intended to better represent modern airport pavement construction practices than the current procedure. Full-scale test data for new generation aircraft loading configurations is also not available for rigid pavements, and must be generated for developing and verifying the new procedures. There is also concern that the very high single truck loads from the new aircraft may introduce failure modes in rigid pavements not previously experienced or predicted by existing full-scale test data.

In response to the requirement for development of new FAA airport pavement design procedures, a working group representing both industry and government was formed to assist the FAA in determining the full-scale testing needed to develop and verify the new design procedures. The first planning meeting of the working group was held on January 17, 1992, in Washington, D.C. As a result of this meeting, the composition of the working group was finalized with the following members:

* Numbers in brackets designate References listed in Section 10.

Members of the Working Group

Satish K. Agrawal	FAA Technical Center, ACD-110 (Chairman)
John L. Rice	FAA Office of Airport Safety and Standards, AAS-200
Rudolph R. Hegmon	FHWA Pavement Division, HNR-20
Jim W. Hall	U.S. Army Corps of Engineers, CEWES GP-T
Jim Murfee	U.S. Air Force, WL/FIVCO, Tyndall AFB
Edward L. Gervais	Boeing Commercial Airplane Company
Orvis Preston	Douglas Aircraft Company

The major conclusion from the first meeting was that full-scale test data must be generated for development and verification of the new procedures for designing pavements which will carry the next generation of large civil aircraft. Resolution of the question of load interaction effects on flexible pavements was also seen as an important area where full-scale test data is urgently needed. Subsequent to the meeting, the working group members submitted specifications and requirements for full-scale testing. The most important of the recommendations were that the loading must be full-scale and dynamic, loading configurations must include two fully loaded multiple-wheel trucks at various separations up to 20 feet, and pavement structures must be representative of full-depth large commercial airport practice.

Galaxy Scientific Corporation was then contracted by the FAA to conduct a design feasibility study and to estimate the cost of constructing a test machine capable of satisfying the recommendations of the working group. Other organizations and individuals who worked on the project, as either subcontractors or consultants to Galaxy Scientific Corporation, were:

Richard G. Ahlvin
Roy D. McQueen & Associates
Brown & Root Defense and Industrial
Michael T. McNerney

Further meetings of the industry / government working group were held during the course of the project to review the design proposals prepared by the project team, to resolve technical questions arising during the design process, and to ensure that the final design proposal satisfied the needs of all interested parties. The meetings were held at the following places and times.

Denver, Colorado	April 7, 1992
Denver, Colorado	October 22, 1992
Chicago, Illinois	March 30, 1993
Champaign, Illinois	June 28, 1993

This report describes the specifications and requirements for full-scale testing of airport pavements for the new generation aircraft. A design proposal for a full-scale test machine is presented in sufficient detail to demonstrate feasibility of construction and operation and to allow realistic cost estimates to be made. Cost estimates are provided for construction and operation of the proposed test machine.

SUMMARY OF THE TEST MACHINE DESIGN

INTRODUCTION.

Figure 2-1 shows general views of the proposed test machine. The test machine consists of five major systems:

1. Test pavement
2. Test vehicle
3. Side support foundations
4. Overhead enclosure
5. Pavement Instrumentation system

The proposed design was based on a core set of specifications established by the working group. Additional specifications were added and reviewed by the working group as the design evolved. In many cases, meeting the specifications involved a trade-off between accurately representing operational conditions or satisfying the basic experimental requirement of maintaining consistent test conditions from one set of tests to another. When such a case existed, the resolution was always in favor of maintaining test consistency. Other constraints on operating conditions were imposed by considerations of practicality and cost. Resolution in these cases was in favor of the best (estimated) compromise or by choosing the most critical operating condition.

Each of the major specifications is listed below, together with a brief discussion. Where necessary, further discussion is given under a separate heading later.

SPECIFICATIONS.

1. Pavement loading should be full-scale and representative of new generation heavy civil transport aircraft. Discussed in Chapter 1.
2. The test machine will be used to evaluate pavement response to loads from aircraft landing gear only. Environmentally induced loads should be minimized.

There are two consequences of this specification. First, the test pavement should not suffer any freeze-thaw cycles during a test program. Second, the test pavement should be protected from rain, wind, and sun (heating and ultraviolet effects) by a continuous cover. Ideally, the test pavement would be completely enclosed by a climate controlled building. Including complete climate control was estimated to be too expensive, but the incremental cost of providing a complete enclosure compared to a simple cover (or roof) was small. A complete enclosure would also slow the onset of freezing of the pavement materials during periods of cold weather.

3. The test pavement must contain multiple test items to maximize the number of pavement design cases which can be tested during any given test program.

4. Tests run to pavement failure, for generating design curve data, will last no longer than one year.
5. Pavement test items must include designs representative of full-depth large commercial airport practice. As a guideline, the minimum thickness of the strongest test item should be 75 percent the thickness of an airport pavement typical of the type being tested.

With few exceptions, previous full-scale airport pavement test programs have been conducted on pavements which failed at 4,000 coverages or less. This level of traffic is between one and two orders of magnitude less than is typical of modern large commercial airport practice. Failure modes and mechanisms may be different at the higher traffic levels and test programs must be designed to determine whether this is true. Testing at representative traffic levels will also increase the confidence levels of the design curves. (Designs from the current procedures at representative traffic levels are based on extrapolations of already sparse data sets and the confidence levels are low.)

6. Test speeds to be in the range of 5 to 15 mph.

The critical cases for airport pavement design are always taken to be the low speed areas such as aprons, taxiways, and the ends of runways, with very low speeds considered to represent worst case conditions. The general consensus was that 15 mph is the highest speed necessary for conducting tests to evaluate the effects of speed on pavement response, considering the design difficulties and extra cost associated with operation at higher speeds. For normal testing, 5 mph was selected as the best compromise between critical operating conditions for design and the time required to complete tests to failure.

7. The test pavement and the test vehicle must be designed to accommodate lateral wander patterns typical of airport runway operations.

Successive passes of aircraft on a runway or taxiway occur along paths with different lateral displacement from the runway centerline. The dispersion of lateral displacements is an order of magnitude larger than the width of an aircraft tire and the loading history of any point in the pavement structure can be quite complex, particularly when different landing gear configurations are considered. There is evidence that the highly nonlinear and inelastic response of, at least flexible, airport pavements couples with the complex (wandered) loading patterns and has a direct influence on pavement life. Realistic wander patterns must therefore be included in the test programs in order to obtain design curves with high confidence. Runway wander is greater than taxiway wander and is therefore the worst case for test machine design.

8. The test pavement and the test vehicle must be designed so that load interaction effects can be fully investigated without significant interference from boundary effects or external support loads. This resulted in a test pavement width of 60 feet.
9. The test pavement should be in the form of a linear track, with a maximum test pavement length of 900 feet and a maximum overall length of 1,500 feet. Transition sections should

be constructed between the test sections to reduce boundary effects and isolate failed test sections from adjacent test sections still under test.

Initially, an oval track layout was specified, but further investigation showed that a linear layout was more suitable. Factors which influenced this change of geometry included width of the test pavement, flexibility of test planning, test vehicle design complexity, land use, and test frequency. Reasons for the choice of a linear track are given in more detail later.

10. Rigid vertical walls constraining the sides of the test pavement are acceptable as long as the footings are at least 12 feet below the surface of the test pavement.

11. A rigid horizontal bed below the subgrade of the test pavement is not acceptable.

Rigid constraints bounding the test pavement alter the response of the pavement compared to a typical operational installation. Side walls can be made to have a negligible effect if a sufficiently wide non-loaded boundary is provided in the test pavement. But a horizontal bed constraining vertical movement of the subgrade cannot be made to have an insignificant effect unless built at an impractically large depth. (A horizontal constraint was considered because it would simplify test pavement construction, reconstruction, and mathematical modeling). Constructing a full horizontal constraint would also be extremely expensive considering the width of the test pavement.

12. The test vehicle must be capable of applying wheel loads representative of multiple-wheel and multiple-truck landing gear configurations. Wheel spacing and "truck" spacing must also be variable so that load interaction effects can be investigated. The maximum truck center-line to center-line spacing should be 20 feet longitudinally and 20 feet laterally.

13. The test vehicle will be designed for vertical tire loading only. Longitudinal and lateral tire forces must be reduced as much as possible during operation on the test items.

14. The minimum loading configuration will be two groups of six wheels with each group arranged to be representative of the Boeing B-777 geometry.

The B-777 will start commercial service in 1995, and landing gear with the B-777 configuration have not been included in any previous full-scale tests. Full-scale test results for aircraft with this type of landing gear configuration are urgently needed.

15. The maximum tire size will be 56 x 24 (maximum diameter by maximum width in inches), and the maximum single tire load will be 75,000 pounds. Assuming twelve tires operating at the maximum single tire load gives a maximum total test vehicle load of 900,000 pounds.

The MD-11 and A-340 aircraft have 54 inch and 55 inch diameter main gear tires respectively. The test vehicle should be designed to accommodate tires of at least this size. Very large tire loads are also desirable so that pavement response and performance data can be collected for use

in studies of possible future aircraft and pavement designs. However, most aircraft operations will continue at close to current tire diameters and loads, and 49 x 17 tires were assumed as the normal test tires for costing purposes. Larger tire sizes were assumed to be required for special studies only.

16. The test vehicle will be designed for continuous, automatic operation.

The design must provide for maximum utilization of the test machine in order to reduce operating costs and to reduce the amount of time required to run pavement performance tests. Automatic operation will also help to maintain test consistency.

17. The mechanism for loading the tires must be automatic. Tire loads must be variable over the full design range.

Required to maintain test consistency, reduce dynamic effects, and provide flexibility in the design and conduct of tests.

18. The mechanism for loading the tires must allow for a minimum of 24 inches total travel in the loading direction.

Tire load must be variable over the full design range. Therefore, it must be made possible to lift the tire clear of the pavement and to apply full deflection under all anticipated pavement conditions. This specification was determined by assuming the following travel requirements: 6 inches tire deflection downward, 6 inches rutting and pavement construction allowance downward, 6 inches overlay thickness upward (for pavements which have been overlaid after testing), and 6 inches clearance and construction allowance upward.

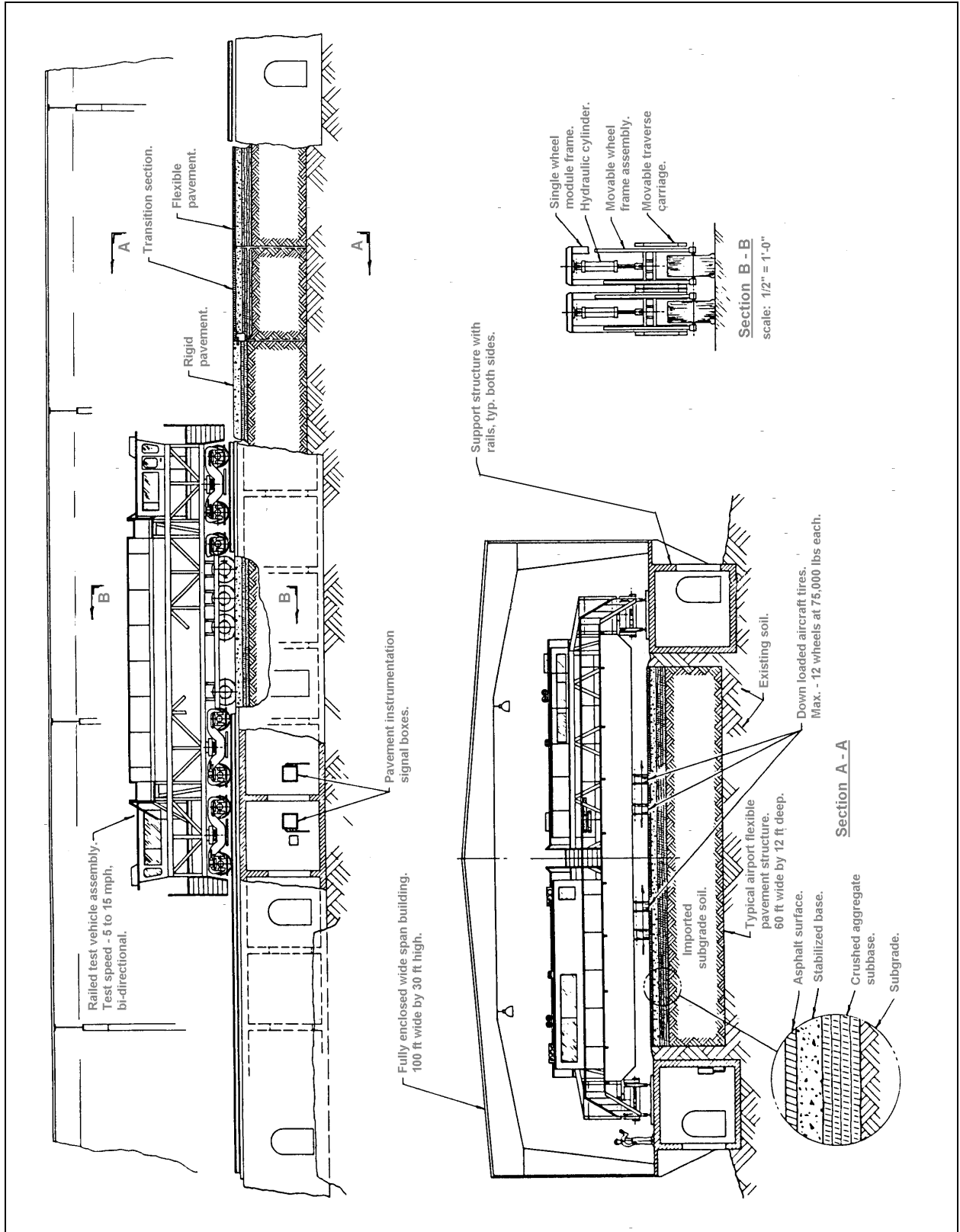

FIGURE 2-1. GENERAL VIEW OF THE PROPOSED TEST MACHINE

SUMMARY OF THE COST ESTIMATES

INTRODUCTION.

Based on the proposed design shown in figure 2-1 and the design specifications listed in Chapter 2, cost estimates were prepared for each of the major systems and for operational costs. The cost estimates are summarized in this chapter in the following categories:

1. Test pavement
2. Test vehicle
3. Side support foundations
4. Overhead enclosure
5. Test pavement instrumentation
6. Test vehicle electrical drive power
7. Test tires and other consumables
8. Operating personnel
9. Maintenance

The total initial and continuing operational costs are then given. The figures given in this Chapter are intended to provide an indication of the relative magnitudes of the costs of the various parts of the test machine as well as the estimates of total and operational costs. With the exception of the overhead enclosure and operating personnel, supporting information can be found in the following Chapters and Appendixes. The costs given include all applicable costs and fees as well as allowances for contingencies where needed. Computed costs were generally rounded up to the nearest \$50,000. Test machine operation during the first year was assumed to consist of machine shake-down and development tests, development of pavement testing procedures, and pavement response tests. Operating costs during the first year are therefore lower than those during the following years.

TEST PAVEMENT COST ESTIMATES.

Test pavement cost estimates were prepared for initial construction based on the assumption that the first set of tests would be performed with B-777 loading configurations. Six flexible and three rigid test items built on subgrades with three different strengths were assumed.

Follow-on test pavement reconstruction costs were based on a composite of flexible and rigid test items built on various types of base and subbase materials. In all cases it was assumed that life tests would be run with a B-777 loading configuration on twelve test items built on subgrades with three different strengths. The following cost estimates, given in 1,000s of dollars, were obtained:

Initial pavement construction	3,400
Pavement reconstruction (typical)	1,500

TEST VEHICLE COST ESTIMATE.

The test vehicle was broken down into major subsystems and each costed separately. The side support rail systems, including sleepers and placement, were costed with the test vehicle because they are part of the test vehicle guidance system.

The following cost estimates were obtained:

Main load carrying structure	900
Traverse carriages	1,200
Loading system (incl. wheels and actuators)	1,050
Drives (incl. wheel sets and electrical motors)	1,050
Side support rails	600
Controls and instrumentation	400
Electrical power supply to motors	200
Spares and consumables	50
Site services	500
Management and design	<u>1,050</u>
TOTAL	7,000

SIDE SUPPORT FOUNDATION COST ESTIMATE.

Two side support foundation structures, each 1,500 feet long, were estimated to require 480,000 pounds of structural steel, 45,000 square feet of steel grating, 870,000 pounds of steel reinforcing bars and 3,264 cubic yards of cast-in-place concrete.

Based on these quantities, the following cost estimates were obtained:

Steel	725
Concrete	1,150
Design, site work, and contingencies	<u>75</u>
TOTAL	2,250

OVERHEAD ENCLOSURE COST ESTIMATE.

The proposed enclosure consists of a modular pre-engineered free-span metal building with full walls and roof. The cost estimate was made from a supplier's quotation and includes engineering fees, 4 inch wall and 6 inch roof insulation, and erection and shipping:

One building, 100 feet wide by 1,500 feet long	1,350
--	--------------

TEST PAVEMENT INSTRUMENTATION COST ESTIMATE.

Test pavement sensors and cabling	600	
Falling Weight Deflectometer		200
Data acquisition system and cabling	<u>200</u>	
TOTAL	1,000	

TEST VEHICLE ELECTRICAL DRIVE POWER COST ESTIMATE.

The test vehicle drive system consists of electric traction motors with the electrical supply taken from the available utility lines. (The cost of operation for the first year was assumed to be one half the typical cost for the follow-on years.)

Typical annual power cost for normal testing		200
--	--	-----

TEST TIRES AND OTHER CONSUMABLES COST ESTIMATE.

The cost of test tires and other consumables for the first year is included in the test vehicle costs.

Typical annual cost of test tires for normal testing	75	
Annual cost of other consumables	<u>25</u>	
TOTAL	100	

OPERATING PERSONNEL COST ESTIMATE (CONTRACT).

Civil engineer, program manager	half-time	
Civil engineering technician	half-time	
Mechanical engineer	full-time	
Electrical engineer / computer programmer	full-time	
Estimated annual cost, TOTAL		350

MAINTENANCE COST ESTIMATE (CONTRACT).

Mechanical, electrical, and casual labor	2,000 hours per year	
Machine shop and electrical shop	1,000 hours per year	
Estimated annual cost, TOTAL		150

TOTAL INITIAL COSTS.

Test pavement	3,400
Test vehicle	7,000
Side support foundations	2,250
Overhead enclosure	1,350
Test pavement instrumentation	<u>1,000</u>
TOTAL	15,000

FIRST YEAR OPERATIONAL COSTS.

Operating personnel	350
Pavement reconstruction	0
Electrical power	100
Maintenance / labor	150
Tires and other consumables	<u>0</u>
TOTAL	600

FOLLOWING YEARS' OPERATIONAL COSTS.

Operating personnel	350
Pavement reconstruction	1,500
Electrical power	200
Maintenance / labor	150
Tires and other consumables	<u>100</u>
TOTAL	2,300

EXISTING PAVEMENT TEST MACHINES

INTRODUCTION.

Existing pavement test machines were examined for their suitability for performing the required airport pavement tests. Visits were made to the following sites where test machines are in regular operation:

- a. FHWA Turner-Fairbanks Research Center, Virginia, USA.
Accelerated Loading Facility (ALF)^[2,3].
- b. Laboratoire Central des Ponts et Chaussées (LCPC), Nantes, France.
Fatigue Test Track^[4].
- c. CEDEX Road Research Center, El Goloso, Spain.
CEDEX Test Track^[5].
- d. Transport Research Laboratory (TRL), Crowthorne, England.
TRL Pavement Test Facility.
- e. University of Nottingham, Nottingham, England.
Full-Scale Accelerated Test Machine.

Visits were also made to the U.S. Army Waterways Experiment Station (WES), Vicksburg, Mississippi (load carts and circular track, not in regular use^[6,7]), and Texas DoT and the University of Texas at Austin, Austin, Texas (Texas Mobile Load Simulator^[8], under construction). Other machines in current use which were examined from published materials included the South African CSIR Heavy Vehicle Simulator^[9] (HVS), the Accelerated Testing System^[10] (ATS) at Purdue University, and the CAPTIF circular track^[11,12] at the University of Canterbury in New Zealand.

CHARACTERISTICS OF THE TEST MACHINES.

The Waterways Experiment Station was the site for the last major program of full-scale accelerated life tests for airport pavements. These tests, the Multiple Wheel Heavy Gear Load (MWHGL) tests, were conducted using Boeing B-747 and Lockheed C5-A Galaxy landing gear mounted on rubber tired and manually operated load carts. Load carts with the same configuration were eliminated from consideration in the current study because of their poor dynamic response, fixed landing gear configuration, and reliance on manual control of speed and lateral position.

The characteristics of other test machines examined are listed in tables 4-1 and 4-2. All of the machines listed are intended for testing highway pavements and have load capacities suitable for simulating heavy truck traffic. Also, with the exception of the LCPC circular track, the maximum track widths and wander widths are smaller than what is typical of airport operations. An interesting trend is that circular tracks have gradually been replaced by linear tracks as test machine development has proceeded over the years. It appears that the advantages of simpler

mechanical design and compact plan area of the circular tracks are outweighed by the disadvantages of high levels of tire scrub and highly curved pavement section design, particularly for rigid jointed pavements. A linear layout is also more suitable for the portable machines currently desired in highway pavement testing, although these necessarily have a restricted pavement test length.

The most common problem encountered during development of the various machines was unsatisfactory dynamic response of the loading system. This typically lead to excessive variation of the applied load along the test section, resulting in nonuniform pavement deterioration and high loads on the test machine components. The method of load application among the machines examined varied from pure dead weight loading to a hydraulic, force controlled, servo system. The hydraulic servo system was installed on the machine at Nottingham University. Although small, this machine has been in essentially continuous operation for almost twenty years, with the servo system operating satisfactorily during that time.

SUMMARY OF EXISTING TEST MACHINE CHARACTERISTICS.

None of the test machines examined are suitable for full-scale testing of full-depth airport pavements because of very low load capacities, compared to aircraft practice, and narrow test widths. All of the large machines required considerable development time, varying from one to seven years according to verbal reports. The most severe of the development problems were associated with the dynamic response of the load and/or vehicle structure.

TABLE 4-1. CHARACTERISTICS OF EXISTING TEST MACHINES

Machine	Type	Pavement Constraint	Load Control
HVS South Africa	Linear / Portable	None	Hydraulic
ALF FHWA Australia	Linear / Portable	None	Dead Weight
TxMLS U.T. Austin Texas DOT	Linear / Portable	None	Spring
ATS Purdue University	Linear / Fixed	Asphalt on Slab — Bottom	Spring
Nottingham University England	Linear / Fixed	Pit	Hydraulic
TRL Crowthorne England	Linear / Fixed	Bottom	Pneumatic over Hydraulic
LCPC Nantes France	Circular / Semi-Fixed	Circular	Pneumatic
CEDEX Madrid Spain	Oval / Fixed	Pit	Dead Weight

TABLE 4-2. CHARACTERISTICS OF EXISTING TEST MACHINES

Machine	Maximum Load (lb)	Test Length (ft)	Maximum Speed (mph)	Days to 10 ⁶ Repetitions	Maximum Wander (ft)
HVS South Africa	22,500	33	9	33	+/- 2.5
ALF FHWA Australia	22,000	33	12	108	+/- 1.2
TxMLS U.T. Austin Texas DOT	25,000	35	25	4	+/- 1.0
ATS Purdue University	20,000	20	5	58	+/- 0.7
Nottingham University England	2,700	15	5	30	None
TRL Crowthorne England	22,500	23	12	42	+/- 1.6
LCPC Nantes France	30,000	360 average	44	22	+/- 8.2
CEDEX Madrid Spain	14,300	400	31	250	+/- 1.3

TEST PAVEMENT DESIGN AND COST ESTIMATE

OVERVIEW.

The test track will be used to perform controlled experiments to better quantify pavement system and material behavior, and provide data to analyze pavement response for the design of new generation aircraft. These requirements will necessitate multiple, sequential sets of experiments over a period of several years.

Therefore, the planning for the test pavement must incorporate the flexibility necessary for multi-year, multiple experiment operation at least cost, while providing the quality of data necessary to develop or validate new design standards. As discussed later, the amount of data required to support specific objectives will require periodic reconstruction of the test pavements without undermining the integrity of the vehicle support foundations. Furthermore, the geometry of the test pavement must consider boundary effects from the loading vehicle foundations.

These and other requirements were studied and presented to the Working Group, resulting in a definitive set of requirements for test track planning, design, and construction. This section of the report discusses these requirements along with such pavement related issues as:

- a. Pavement geometry.
- b. Pavement thickness design.
- c. Pavement construction and periodic reconstruction requirements.
- d. Pavement construction and periodic reconstruction cost estimates.

A dimensioned plan and profile drawing of the proposed test pavement design is shown in figure 5-1.

BASIC REQUIREMENTS.

From the study and the results of periodic review meetings with the Working Group it was determined that the design of the test track must address several basic requirements. These requirements are essentially related to the testing regimen that will be required to provide the quantity and type of data needed to support FAA research needs. Those which relate to the planning for the test pavement include:

- a. Types of experiments.
- b. Need to test pavements constructed on subgrades of varied strength.
- c. Need to test multiple pavement types.
- d. Required number of load passes to test item failure.
- e. Flexibility to test a variety of aircraft gear configurations.

- f. Incorporation of gear wander into the load repetition cycles.
- g. Future utilization of the facility.
- h. Test track configuration.
- i. Test pavement construction.

Although prior full-scale testing programs, such as the "Multiple-Wheel Heavy Gear Load"[6] (MWHGL) tests, provided the basis for much of the current airport design procedures, a knowledge gap with respect to pavement behavior and failure mechanisms still exists. The basic requirements for the test track were developed to fill this knowledge gap to meet the demands of operating the national aviation system in the future.

REVIEW OF MWHGL EXPERIENCE. Airport pavement design today is very much the result of extrapolating empirical methods originally developed for highway pavement design. Some of these methods, like the Westergaard procedures for rigid pavements and the CBR method for flexible pavements, were developed fifty or more years ago.

Over the years, several full-scale testing programs were initiated to adapt these methods to accommodate heavy, multiple wheel aircraft. The most extensive recent full-scale testing program was the MWHGL pavement tests conducted by the military in 1968-1969. Although the MWHGL tests helped to verify the extrapolated highway experience, the program was limited in its scope in several key areas, including the following:

- a. All pavements were constructed on a single strength subgrade, with an average CBR of 4 percent and average Modulus of Subgrade Reaction (k) of about 100 pci.
- b. Only specific multiple-wheel gear were tested to support the C-5A and B-747 aircraft, along with 30 kips and 50 kips single wheel loads.
- c. None of the pavement sections incorporated stabilized base construction, which is currently required by the FAA for aircraft with gross weight over 100,000 lbs.
- d. All flexible pavements consisted of a 3-inch hot mix asphalt surface, a 6-inch crushed stone base, and variable subbase thickness. Such designs are not consistent with current airport practice.
- e. All rigid pavements were constructed on grade (i.e. without aggregate or stabilized subbase), which, again, is not consistent with current practice. Furthermore, only keyed joints were used for concrete construction.
- f. Generally, the coverage levels to failure were less than 3,000, which is much less than the traffic levels currently experienced at civil airports.

FULL-SCALE TESTING REQUIREMENTS. The full-scale testing requirements which were used for the design of the test pavements included the following:

- a. Pavement response tests to characterize wheel and gear interaction and superposition effects for design and evaluation of new landing gear.
- b. Pavement life tests, i.e. number of coverages or passes (n) vs. controlling parameter (e.g. stress, strain, displacement, etc.), to develop failure criteria.
- c. Validation of different design models and procedures (e.g. layered elastic, finite element).
- d. Performance of stabilized base materials and associated design criteria.
- e. Validation of nondestructive testing (NDT) methods.
- f. Concrete jointing and slab size.
- g. Overlay design procedures.
- h. Input data requirements for new design models.
- i. Evaluation of new materials and construction techniques.

The test track, then, should have the flexibility to accomplish these tests, as well as others that may be identified in the future.

SUBGRADE REQUIREMENTS. The vast majority of the data from the MWHGL and other full-scale testing programs was from test pavements constructed on low strength subgrade soils having CBR values of four or less. Since prior research has suggested that the limiting subgrade strain criteria for mechanistic analysis of flexible pavements is a function of subgrade strength, full-scale testing should be performed on subgrades of varying strengths to validate this criteria. Likewise, current FAA criteria for jointing of rigid pavements, as well as the use of a maximum k value of 500 pci, suggests full-scale testing on support systems of varying strength.

Therefore, the pavement test track should incorporate the use of subgrade materials having at least three strengths -- low, medium, and high. For planning purposes, the following subgrade strength requirements were identified:

<u>Approx. CBR (%)</u>	<u>Approx. k (pci)</u>	<u>Approx. E (psi)</u>
5	80	7,500
10	140	15,000
15	200	22,500

Specific requirements should be determined during final design, based on detailed test objectives and the availability of subgrade materials.

PAVEMENT TYPES. The requirements for pavement types are fairly straightforward. Since their primary failure modes are different, response data is needed for both flexible and rigid

pavements. In addition, data on the structural behavior of stabilized base layers is also required to develop failure criteria and/or to validate current FAA equivalency factors. For the initial sets of tests, basic performance data from life tests should be acquired on conventional flexible and rigid pavements with aggregate base and subbase layers. Later tests should include performance data on pavements with stabilized bases, as well as for overlaid pavements.

REQUIRED PASS LEVELS. Since prior full-scale testing programs were generally performed at coverage levels of 3,000 or less, pavement performance data is needed at higher coverage levels to better quantify failure mechanisms. For initial planning purposes, the maximum pass level was assumed to be 200,000 passes (i.e. total number of load repetitions of the load vehicle).

This level is typical of activity levels of air carrier facilities over the design life of the pavement and is consistent with test vehicle operational requirements to achieve the FAA's specified test item failure within a maximum period of one year. For dual and triple tandem landing gear, this would equate to over 100,000 coverages. This would bound the high "n" requirement for pavement life tests, with "n" stepping down to 10,000 passes to bound the low "n" requirement. These requirements should be re-evaluated during final design of the test pavement. However, for planning purposes, the following pass levels were identified to develop failure criteria for different pavement types: 200,000; 100,000; 50,000; 25,000; 10,000. This should provide sufficient data to develop "n" vs. parameter failure criteria, and still be extrapolatable to higher pass levels that may be experienced at large hub or international airports.

GEAR CONFIGURATION. Since the test facility will be used to validate response and performance relationships for both existing and future landing gear, the load vehicle was planned with the flexibility to vary the spacing between individual wheels as well as between wheel groups. The initial response tests will provide data to quantify interaction effects over a broad range of wheel spacings. Therefore, the length and width of the test track should be designed to accommodate relatively wide wheel spacings, as well as have the ability to handle the two separate triple tandem trucks required for future tests.

Since the triple tandem B-777 is scheduled to initiate operation in 1995, with heavier stretch versions anticipated later in the decade, the initial life tests should incorporate triple tandem gear. This will not only provide data for the B-777, but will also enable better evaluation of existing aircraft of the former Soviet Union (e.g. Antonov, Tupolev, Ilyushin) which may operate at U.S. airports.

WANDER. Prior full-scale military tests^[13] have shown that wander can affect pavement performance. The military tests found that where wander was incorporated into the testing procedure, pavements failed earlier than test sections where wander was not incorporated, even for the same number of repetitions^[14]. Therefore, the width of the test track should be designed to allow a reasonable degree of wander. The MWHGL tests used a wander width of 5 feet, which is consistent with the findings in reference 15.

FUTURE UTILIZATION. Due to the varied requirements for data acquisition, it is anticipated that the test facility will be used for multiple sets of tests and experiments over a number of

years. This will require periodic reconstruction of the test track for different materials or test objectives. Therefore, planning for the test track should recognize the need for periodic reconstruction of the pavements.

TEST SEQUENCING. The FAA's requirement for the life tests is failure of a particular test item within a one year period. This was used both in setting the design requirements for the test vehicle and for the maximum "n" required for the life tests.

As discussed, it is preferable to perform the wheel interaction response tests first to obtain basic behavioral data. To minimize costs, since the response tests will be at a relatively low number of load repetitions, the same test items used for the response tests can also be used for the first set of life tests, as well as for acceptance testing and shakedown of the test vehicle.

After completion of the response and first high "n" life tests, the test pavements would be periodically reconstructed to meet the needs of subsequent test programs. Due to the data requirements to support the B-777, it is assumed that the second set of life tests would be on conventional flexible pavements at the four pass levels 100,000; 50,000; 25,000; and 10,000; followed by tests on conventional rigid pavements, flexible/stabilized base and, finally, rigid/stabilized base. These requirements are discussed in more detail later.

TEST PAVEMENT CONFIGURATION. As discussed elsewhere, test vehicle design and operational issues suggested that a linear test track layout would be most cost-effective and would allow for future expansion should that be desired. Therefore, the total length of the test track must consider several variables, including the following:

- a. The need for three subgrade strengths.
- b. The number of different pass levels comprising each life test sequence.
- c. The length of individual test items.
- d. Cost constraints.

The need for three subgrade strengths suggests that a modular concept be employed for the test track. Each module, comprising the requisite number of individual test sections, would be constructed on a particular strength subgrade. This would facilitate both the initial construction and periodic reconstruction of the test pavements.

A total of five pass levels were identified for the life tests. After the response test sequence and first high "n" life test, the test track would be sequentially reconstructed for the remaining life tests for conventional flexible and rigid pavements, and flexible and rigid pavements on stabilized base.

Therefore, the overall length of the facility is based on the length of the individual test items and cost considerations. These issues are discussed in subsequent sections.

TEST PAVEMENT CONSTRUCTION. To eliminate site specific criteria from the design and cost analyses, the pavement design was based on the subgrade being constructed to controlled conditions above existing site grade.

TEST PAVEMENT GEOMETRY

The length and width of the test pavement will be influenced by a number of factors. A series of analyses were performed to optimize the geometry. The following sections summarize the analytical results and present specific recommendations concerning minimum width, depth of test vehicle support foundation, test item length, and overall facility configuration.

WIDTH. As shown in figure 5-2, the width of the test track will be affected by the following factors:

- a. Wheel spacing.
- b. Wander.
- c. Boundary conditions.
- d. Construction considerations.

WHEEL SPACING. A typical test wheel configuration will consist of two "trucks," each comprising one to three dual wheel axles in tandem. In order to study load interaction effects, the maximum lateral spacing between the centerlines of the trucks was specified, by working group consensus, to be at least 20 feet. Wheel spacing on each axle will also be a variable in some tests, and the required spacing between the extreme outside wheels was estimated to be 26 feet.

WANDER. As discussed, based on the MWHGL tests, the results of reference 15, and the analysis in appendix A of this report, an additional 5 feet should be included for wander.

BOUNDARY CONDITIONS. Since the test track will be bounded on both sides by the test vehicle support foundations, the effect that these rigid boundaries may have on the quality of the test data must be considered. The placement of the outer wheel of the test gear should be at a minimum distance, R , from the edge of the foundation wall to prevent the rigid wall from influencing the measured test parameter.

To determine this minimum distance, both layered elastic theory (LET) and finite element method (FEM) analyses were performed on a variety of pavement structures to investigate the decay of critical response parameters with distance.

The key design parameters that were evaluated were surface displacement, tensile stress or strain in asphalt and concrete layers, and subgrade strain. Conceptually, the analytical procedures are depicted in figures A-1 and A-2.

Analysis and results for various pavements and input conditions are contained in appendix A. As shown in the appendix, except for surface displacement in rigid pavement, stress and strain

levels in the pavement materials and the subgrade decay to within 10 to 20 percent of the value under a wheel at a radius of 10 feet from the load center. Concrete surface displacement, which does not govern in the thickness design of rigid pavements, decays less gradually. Therefore, it was decided to keep 10 feet as a minimum from the wheel edge to minimize boundary effects. This would be in addition to the shoulder pavement, planned at 3 feet, on each side of the test pavement.

CONSTRUCTION CONSIDERATIONS. Since the MWHGL tests only considered 25 feet wide slabs with longitudinal keyways, the rigid test pavements should be designed to test other slab sizes and jointing arrangements. Several options are shown in figure 5-3.

Of these, the construction option which allows a 60 foot width (three 20 foot wide slabs, or four 15 foot wide slabs) was chosen. This would not only provide additional data on the performance of rigid pavements, but would provide an additional margin of safety to minimize boundary effects.

RECOMMENDED WIDTH. Referring to figure 5-2, a minimum width of 60 feet can be computed as follows:

Truck width:	$10 \times 2 = 20$ ft
Wheel spacing:	$2.5 \times 2 = 5$ ft
Tire width:	$0.5 \times 2 = 1$ ft
Wander: (2B)	$10 \times 2 = 20$ ft
Minimum boundary effect: (2D)	$7 \times 2 = \underline{14}$ ft
Minimum width	$= 60$ ft

This is the minimum width for the test items. Adding two 3 feet wide shoulders, the total recommended width would be 66 feet, which offers the following advantages for the tests:

- a. During the response tests, the outer wheel of the test gear would be no less than 20 feet from the edge of the test vehicle foundation wall, so that the effect of the wall on the critical responses may be neglected.
- b. During the life tests, the minimum distance between the outer wheel and the foundation wall would no less than 10 feet, which would limit the boundary effect of the foundation wall to a negligible level.
- c. Based on Barker's assumption, the standard deviation of aircraft wander for runways is about 5 feet. Therefore, setting B to 10 feet will allow Gaussian wander representation at about the 95 percent level.

DEPTH OF SUPPORT FOUNDATION. Several factors will influence the depth of the test vehicle support foundation, including:

- a. Effect of subgrade stiffening from foundation loading.
- b. Pavement and subgrade reconstruction for new test items.

Ideally, the support foundation should be sufficiently below the test pavement such that its zone of influence does not affect the quality of the test data. It can be easily shown that, with the 3 foot shoulder and an assumed 60 degree influence line for the foundation stresses, stress stiffening of the subgrade from foundation loading (at normal foundation construction depths) should not be a problem.

However, after failure of a particular test section, reconstruction of the pavement and a partial depth of subgrade would be required for the next set of test items. The depth for subgrade replacement would be the sum of the maximum pavement depth, plus the affected depth of subgrade, plus a construction clearance over the bottom of the foundation. Assuming a maximum pavement depth of 48 inches, plus a minimum 2 foot clearance above the foundation bottom, the remaining variable is the depth of subgrade requiring replacement for the new test item.

To estimate this depth, both layered elastic and finite element computations were performed to evaluate the influence of weaker or stronger layers (by compaction from loading) on key response parameters. This is depicted conceptually in figure 5-4, "Subgrade Influence", with plots of LET and FEM output included in appendix A. These plots show that after approximately 3 feet depth, an underlying layer made weaker or stronger from repetitive test vehicle loading will have a small relative effect on a measured test parameter. This is also consistent with the MWHGL test experience, which found little influence below a 2 foot depth.

Therefore, the minimum foundation depth below the surface of the test pavement can be computed as follows:

Maximum pavement thickness	= 4 ft
Subgrade replacement	= 3 ft
Clearance above foundation bottom	= <u>2 ft</u>
Total depth	= 9 ft

However, based on comments from the Working Group and the fact that the controlled subgrade during the MWHGL tests was 12 feet, it was decided to set the bottom of the test vehicle support foundation at 12 feet below the surface of the test pavement.

TYPICAL CROSS-SECTION. A typical cross-section depicting the minimum width and foundation depth requirements for the test pavement is shown in figure 5-5.

LENGTH. Since a module concept is suggested for test track construction, with each module constructed on a subgrade of a particular design strength, the overall length of each module will depend upon several factors, including:

- a. The length of the individual test items.
- b. The length of the transition pavements between test items.
- c. The number of test items and modules.

Each module would contain the individual test pavement items. Since it was decided to plan the facility with three modules -- one for each subgrade strength -- the overall length of the facility will be the total length of each module, plus a length for run-up of the test vehicle, and a length of ramp for construction and support vehicle access.

TEST ITEM LENGTH. The length of the test items for the response and life tests are necessarily different due to the nature of each test. In both cases, the item length will be a function of:

- a. Truck length.
- b. Boundary conditions.
- c. A "buffer" length for data acquisition.
- d. Construction considerations.

For the response tests, a maximum truck length of 34 feet is envisioned. As discussed elsewhere, this considers two triple tandem gears -- one trailing the other. For the life tests, the maximum truck length is a single triple tandem gear at an overall length of 15 feet.

Boundary conditions have been previously identified as 10 feet per side. To this, a 10 foot buffer is suggested for data acquisition, i.e. to allow time for the test gear to traverse over the instrumentation. As shown in figure 5-6, the minimum length for the response (interaction) tests, excluding the length of transition pavement, is 64 feet, and for the life tests is 45 feet. However, as shown in figure 5-7, concrete joint construction considerations suggest a minimum length of 50 feet for the life tests.

TRANSITION PAVEMENT. Since each module will be constructed of different types of pavement, it is necessary to construct a transition pavement between each item. The transition length should be designed to accommodate the maximum truck length for each type of test to ensure smooth operation of the test vehicle.

Also, during the conduct of the tests there is a likelihood that one section may fail before an adjacent section. Therefore, the test vehicle was designed for the gear to lift over a failed test item, and be lowered on the adjacent transition section. Therefore, the transition section with the buffer should be of sufficient length to allow the gear to be lowered and resume forward travel with minimum bounce.

The transition section then should be at least the length of the truck, or 34 feet for response tests and 15 feet for life tests. However, a longer transition length is preferred for the life tests, since adjacent test items will be designed for significantly different fail times. Therefore, the test gear will be lifted and lowered over failed sections many times. On the other hand, all test items for the response tests will be designed for equal fail times. Although variations in fail times between test items is to be expected, the test gear will be lifted and lowered over far fewer cycles than would be the case for the life tests. An extra allowance of 10 feet was therefore added for the life tests and a rounded value of 35 feet used for the response tests.

Therefore, typical test item lengths for the response and life tests can be computed as follows:

	<u>Response (Interaction) Test</u>	<u>Life Test</u>
Item length	64 ft (use 65 ft.)	50 ft
Transition length	<u>34 ft</u> (use 35 ft.)	<u>25 ft</u>
	100 ft	75 ft

TYPICAL LAYOUTS. Based on the length requirements discussed above, typical module layouts for the response and life tests are shown in figure 5-8, and figure 5-9, respectively. As discussed, the test items for the response tests will also be used for the first high "n" life test item, followed by an additional four test pavements for "n" between 100,000 and 10,000 passes.

An overall schematic layout is shown in figure 5-10. The following sections will provide further detail on facility layout, construction, and estimated cost.

PAVEMENT DESIGN.

Although specific test objectives will dictate detailed pavement design requirements, thickness designs were performed as a part of this study to support the construction cost estimates. Detailed designs using several different design methodologies (e.g. LET, FEM) should be performed as a part of the final design of the test pavement. The thickness designs provided herein are for planning and budgeting purposes only.

The current FAA design procedure contained in AC 150/5320-6C^[1] was used to design flexible and rigid pavements on both aggregate and stabilized bases for the response and life test sequences. Since discussions during Working Group meetings indicated a general belief that the FAA method is conservative as compared to LET and FEM methods, designs by the FAA method should also result in somewhat conservative cost estimates.

As discussed previously, the first sets of full-scale tests should be based on the triple tandem landing gear proposed for the B-777. Since the FAA method does not support triple tandem gear, as a design expediency, the DC-10 aircraft, which has similar truck loads as the B-777, was used as the design aircraft. The DC-10 passes were increased by 50 percent to account for the additional two wheels in the triple tandem assembly as opposed to the dual tandem gear. Again, this should be conservative since, based on MWHGL tests and the origin of the alpha factor used in the modified CBR equation, the pass-coverage ratio for triple tandem gear is probably less than 1.5 times the pass-coverage ratio for dual tandem gear. Therefore, the FAA method will likely represent the upper design limit for the B-777 aircraft, at least for flexible pavements.

The designs were performed at the following equivalent DC-10 pass levels:

<u>Triple Tandem Passes</u>	<u>DC-10 Passes</u>
200,000	300,000
100,000	150,000
50,000	75,000
25,000	37,500
10,000	15,000

The following subgrade strengths were used to generate the thickness designs:

<u>CBR</u>	<u>k</u>	<u>E (for reference)</u>
5	82	7,500
10	141	15,000
15	194	22,500

Flexible pavement stabilized base/subbase conversions were based on an equivalency factor of 1.6:1 for stabilized base/aggregate base and 1.4:1 for crushed aggregate subbase/select subbase. Stabilized base requirements for rigid pavements were based on the use of an equivalent "k" at the top of the stabilized base.

Design output, rounded to the nearest inch, is summarized in table 5-1.

PAVEMENT COST ESTIMATES.

Based on the analyses presented thus far, estimates of pavement related construction costs were generated. Using the thickness design output contained in table 5-1, typical plan and profile drawings were developed for the first response and high "n" life tests, shown in figure 5-1. The drawings depict the following:

- a. Response test pavement sections.
- b. Transition sections.
- c. Fill requirements above existing site grade.

A typical cross-section is shown in figure 5-5.

It is quite difficult to generate a cost estimate for such a specialized facility which is yet to be sited. However, the following simplifying assumptions and experience with similar construction projects enabled reasonable cost estimates to be made:

- a. All soils for controlled subgrade will be imported from within 40 miles of the site.
- b. Due to the variety of pavement types and transition sections, the construction will be dominated by labor, rather than material, costs.

c. Wherever possible, the same pavement types were grouped together to facilitate construction. For example, contiguous asphalt surfaced pavements will enable longer pull lengths during laydown.

d. For pavement reconstruction, the top 3 feet of subgrade will be removed and replaced with new material. Although this may not be necessary in all cases, it is a conservative assumption.

e. Federal Highway Administration (FHWA) experience in constructing full-scale test pavement for their Accelerated Loading Facility (ALF) indicated that test pavement construction costs would be two to three times the cost of normal construction.

f. It was assumed that cement treated base (CTB) would be used for stabilized base (STBS) construction.

g. Pavement materials would conform to the quality requirements contained in FAA AC 150/5370-10A[16].

h. The life test pavements required after the first year, would be constructed with the same pavement type (e.g. flexible, rigid, etc.) designed for different fail times (i.e. different "n").

i. A higher than normal amount of owner acceptance and contractor quality testing would be required to meet the controlled conditions necessary for test item construction. Each test section would likely be treated as a lot.

Based on these assumptions, the experience of the study team, and consultation with contractors experienced in constructing pavements to airport quality standards, construction cost estimates were generated. A summary of construction costs is included in table 5-2, with more detailed estimates included in appendix B.

TEST PAVEMENT INSTRUMENTATION.

The proposed instrumentation system for the pavement test items consists of three subsystems:

- a. Sensors for measuring pavement response and environmental conditions.
- b. Data acquisition and transfer.
- c. Central computers for data archiving, communication with the test vehicle, and monitoring the test data.

The total cost of installing and developing the system was estimated to be \$1,000,000 (after rounding). This cost estimate was based on three main assumptions:

- a. The use of existing sensors.
- b. The cost of replacement sensors for follow-on test programs would be paid from funding for the follow-on programs.
- c. The cost of analyzing the pavement response data would be paid from separate funding.

TEST ITEM SENSORS. Selection of the sensors for measuring test pavement response will depend on the details of the test plan for the first series of tests and on the analysis requirements. Ideally, all of the test items should be comprehensively instrumented. But because of the high cost of typical sensors, distribution of the sensors within the different test items will almost certainly be non-uniform. Some of the pavement sections will be fairly densely instrumented, to enable accurate determination of the characteristic response shapes for the different pavement types. But the majority of the sections will be fairly sparsely instrumented. Estimates of the number of sensors required were based on previous full-scale test programs, bearing in mind the above considerations. Also, it will not be possible to recover some of the sensor types from an old test pavement during reconstruction and these types of sensors will have to be completely replaced if the following test program requires their use. Because of the difficulty of estimating the requirements of follow-on test programs, sensor replacement costs were not included in operating costs beyond the second year. It was, instead, assumed that the cost of sensor replacement would be included in the funds for follow-on projects as needed. Frequent nondestructive testing (NDT) of the test items was also assumed and the cost of a dedicated NDT machine was included under the sensor category. The sensors included in the estimate are as follows:

Sensor Type	Number	Unit Cost (dollars)	Total Cost (dollars)
Multidepth Deflectometer	45 x 3	1,200	162,000
Pressure Cell	162	900	145,800
Carlson Joint Gauge	30	800	24,000
Carlson Strain Gauge	80	800	64,000
TDR Moisture Gauge	8	system	24,000
Falling Weight Deflectometer	1		200,000
Misc. strain, temperature, etc.	-	-	<u>200,000</u>
Total			819,800

DATA ACQUISITION. The data acquisition system consists of four cabinets containing embedded or single board computers, multiplexed signal processing cards, and digitizing cards. The cabinets are equally spaced along the test pavement, within the side foundations, and are connected by a serial bus to the central computers. Estimated cost of the cabinets, including computers, cards, and cables, is \$50,000.

CENTRAL COMPUTER SYSTEM. The central computer system must be capable of controlling the operation of the test vehicle, controlling the four data acquisition system computers, and formatting and archiving the data. With the exception of synchronizing the pavement response data with the positions of the test wheels, these tasks are relatively independent and the use of three separate 486 class personal computers is proposed. The archiving computer can also be used for monitoring the test data and performing any preliminary data analysis which might be required onsite. The majority of the data analysis will, however, be performed by the organization responsible for test design and analysis. It is also expected that the data will be used in multiple projects performed by a number of organizations with different data requirements. A minimum of data reduction should therefore be performed onsite, with raw data

translated to engineering units and provided to the end user in a standard format. To do this, software design and development will be required during construction of the test machine, and in conjunction with the design of the data acquisition system. But thereafter the majority of software required for data analysis will be provided by the end users and specifically tailored to the requirements of their projects. Costs for continuous software development have therefore not been included except as part of the duties of the onsite engineers in performing normal maintenance and upgrades. The breakdown of the estimated costs is:

Item	Number	Unit Cost (dollars)	Total Cost (dollars)
486 class PC	3	2,400	7,200
WORM drive	1	7,200	7,200
Software	-	-	2,500
Design and development	-	-	<u>125,000</u>
Total			141,900

TABLE 5-1. TYPICAL TEST ITEMS (FAA METHOD)

Total TT Passes	Subgr. No.	CBR	k	PCC	AGBS	AC	AGBS	SSBS
200,000	1	5	82	17.0	8.0	5.0	14.0	35.0
	2	10	141	16.0	8.0	5.0	14.0	13.0
	3	15	194	15.0	8.0	5.0	14.0	5.0
100,000	1	5	82	16.5	8.0	5.0	13.0	34.0
	2	10	141	15.0	8.0	5.0	13.0	12.0
	3	15	194	14.5	8.0	5.0	13.0	5.0
50,000	1	5	82	16.0	8.0	5.0	13.0	31.0
	2	10	141	14.5	8.0	5.0	13.0	11.0
	3	15	194	14.0	8.0	5.0	13.0	4.0
25,000	1	5	82	15.0	8.0	5.0	12.0	30.0
	2	10	141	14.0	8.0	5.0	12.0	11.0
	3	15	194	13.0	8.0	5.0	12.0	4.0
10,000	1	5	82	14.5	8.0	5.0	11.0	28.0
	2	10	141	13.0	8.0	5.0	11.0	11.0
	3	15	194	12.5	8.0	5.0	11.0	4.0

Notes: TT = triple dual tandem landing gear
 Wheel load = 52,875 lbs, p = 180 psi
 AC = hot mix asphalt
 PCC = portland cement concrete (R = 650 psi)
 AGBS = crushed aggregate base (equivalency factor = 1.4)
 STBS = stabilized base (equivalency factor = 1.6)
 SSBS = select subbase

TABLE 5-2. SUMMARY OF PAVEMENT RELATED COSTS

Test Sequence	Construction Cost (dollars)	Engineering and QC Cost (dollars)	Total Cost (dollars)
Flexible and rigid pavements for initial interaction tests.	2,900,000	500,000	3,400,000
Reconstruction, flexible pavements for life tests.	1,100,000	200,000	1,300,000
Reconstruction, rigid pavements for life tests.	1,500,000	300,000	1,800,000
Reconstruction, flexible on STBS pavements for life tests.	1,200,000	200,000	1,400,000
Reconstruction, rigid on STBS pavements for life tests.	1,600,000	300,000	1,900,000

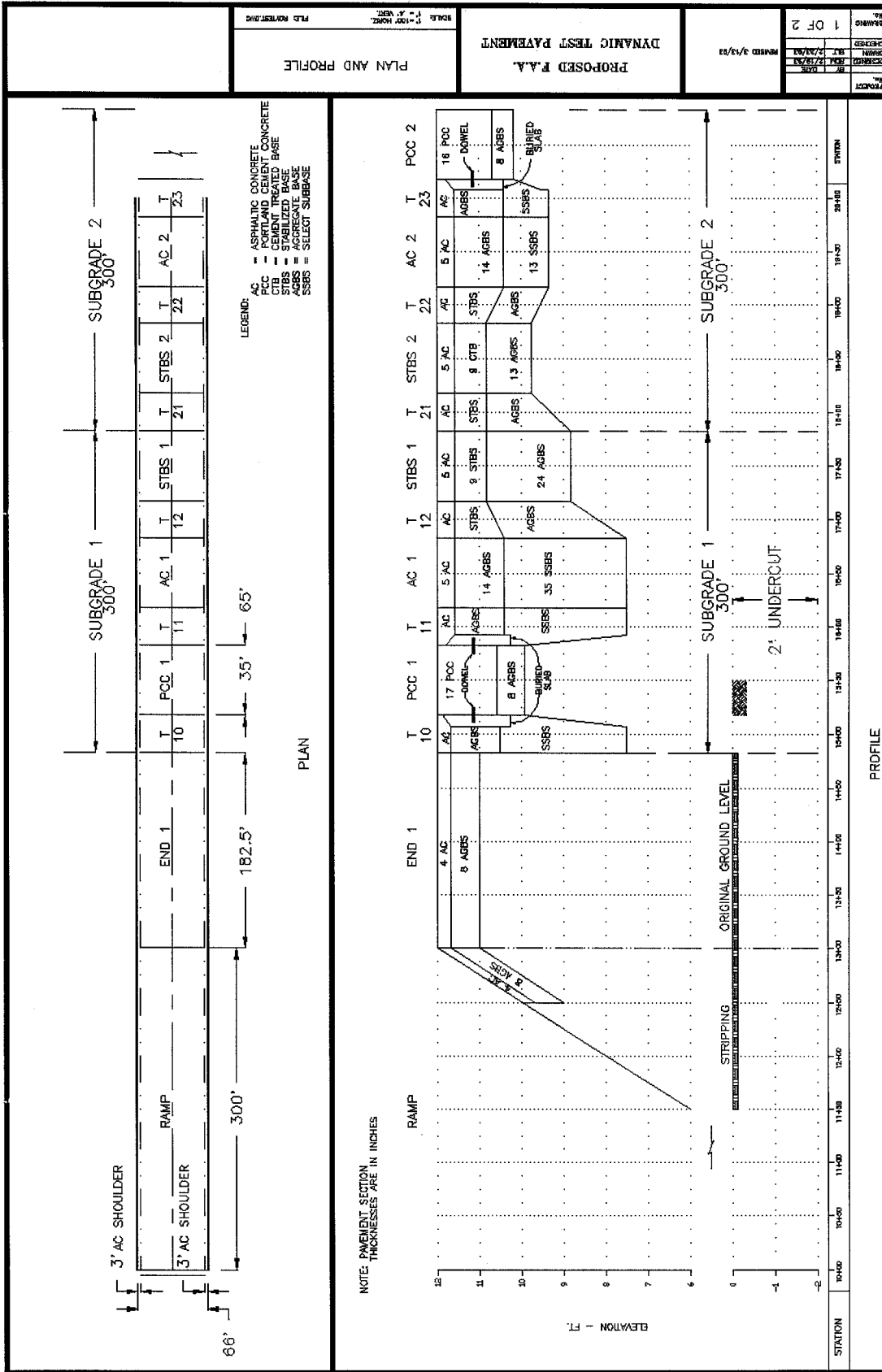

FIGURE 5-1. PLAN AND PROFILE OF TEST PAVEMENT SECTIONS

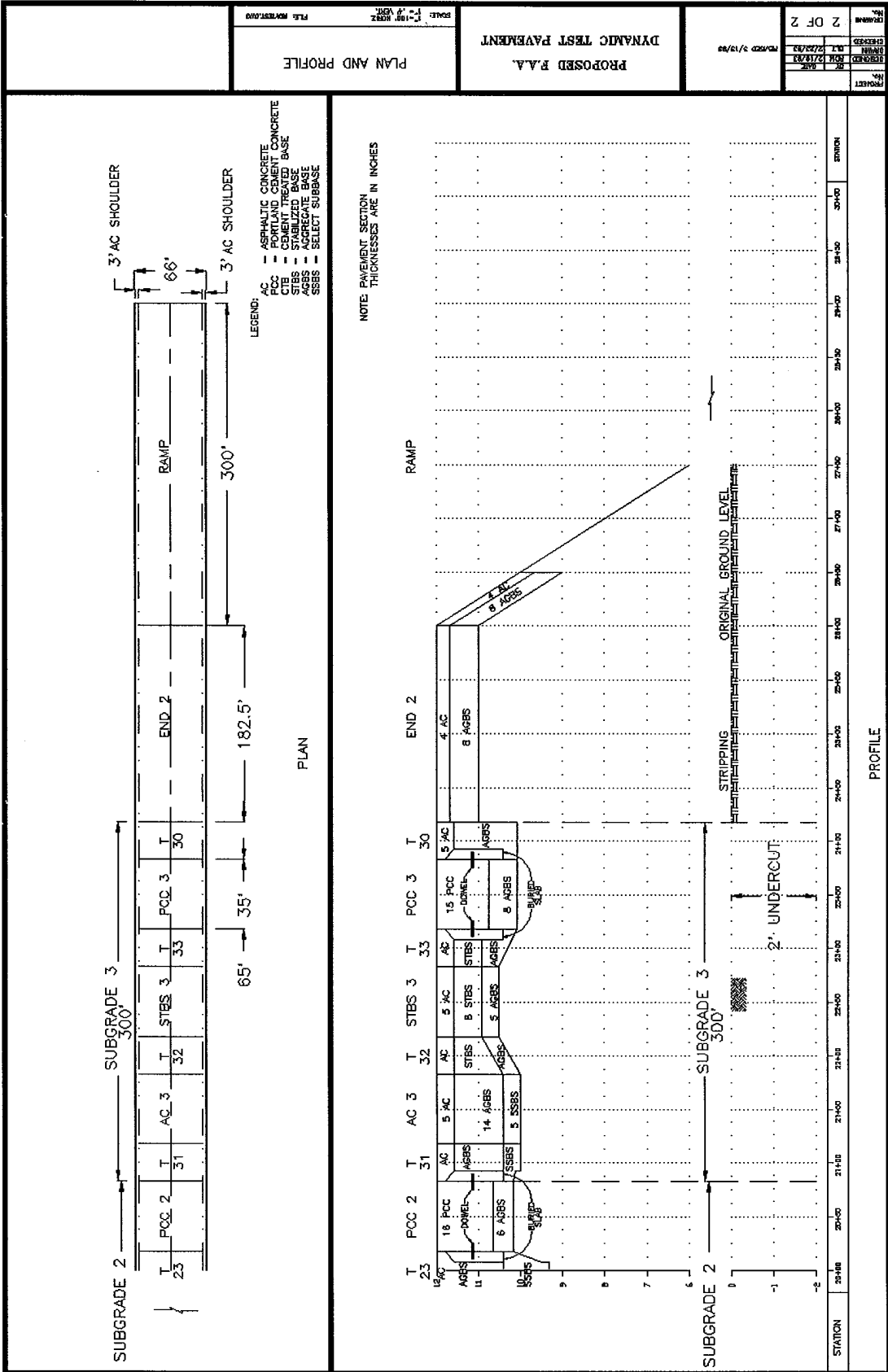

FIGURE 5-1. PLAN AND PROFILE OF TEST PAVEMENT SECTIONS

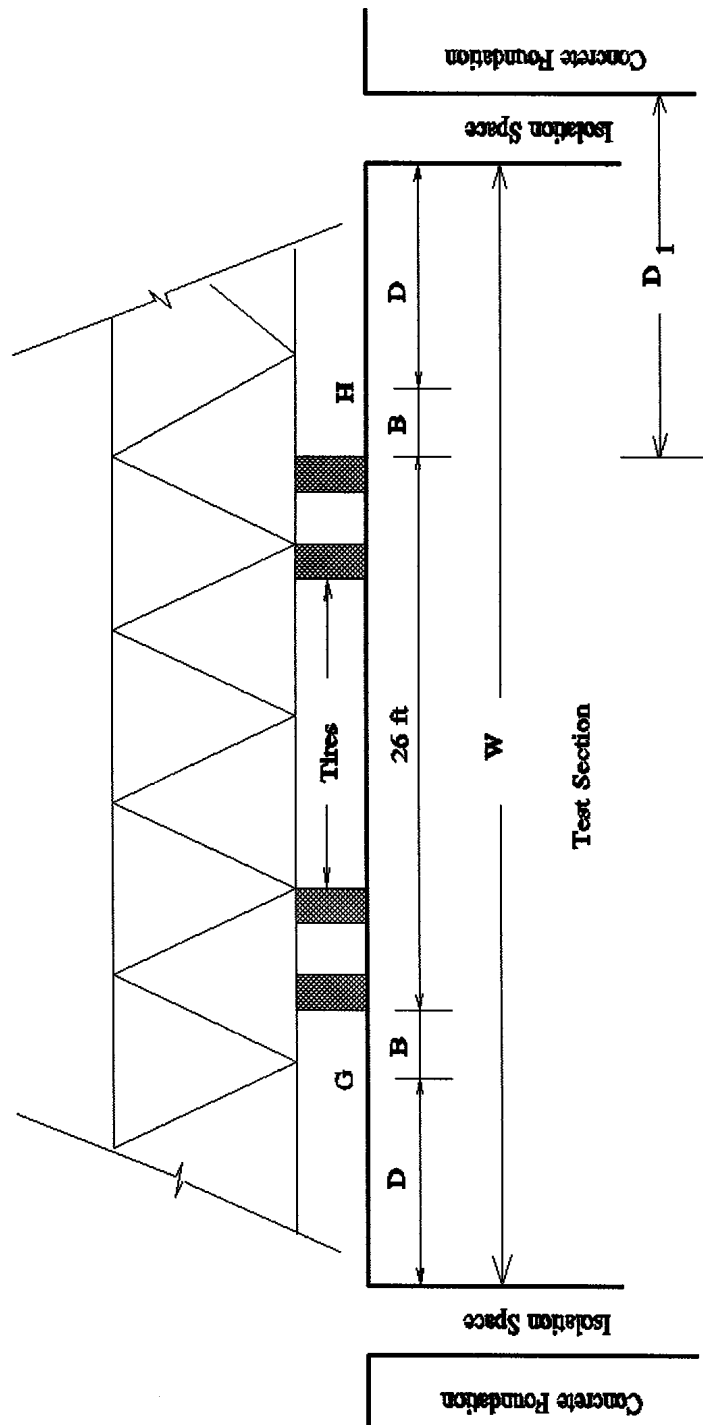
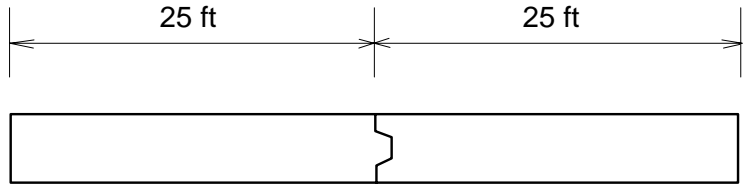
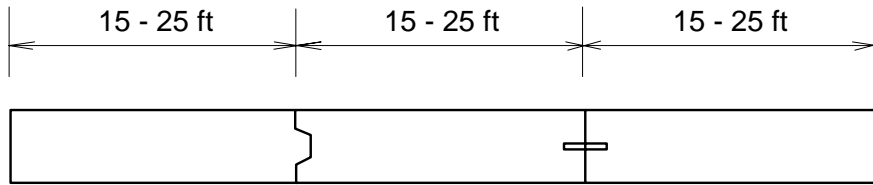

FIGURE 5-2. REQUIRED WIDTH OF THE TEST PAVEMENT



MWHGL



Option One

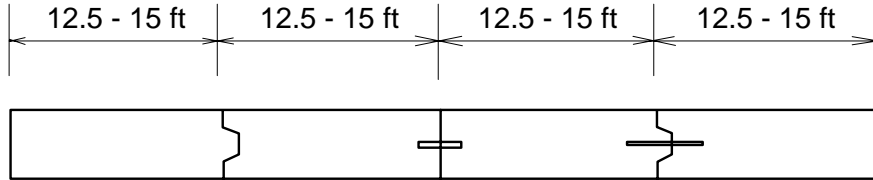

Option Two

FIGURE 5-3. PCC CONSTRUCTION CONSIDERATIONS

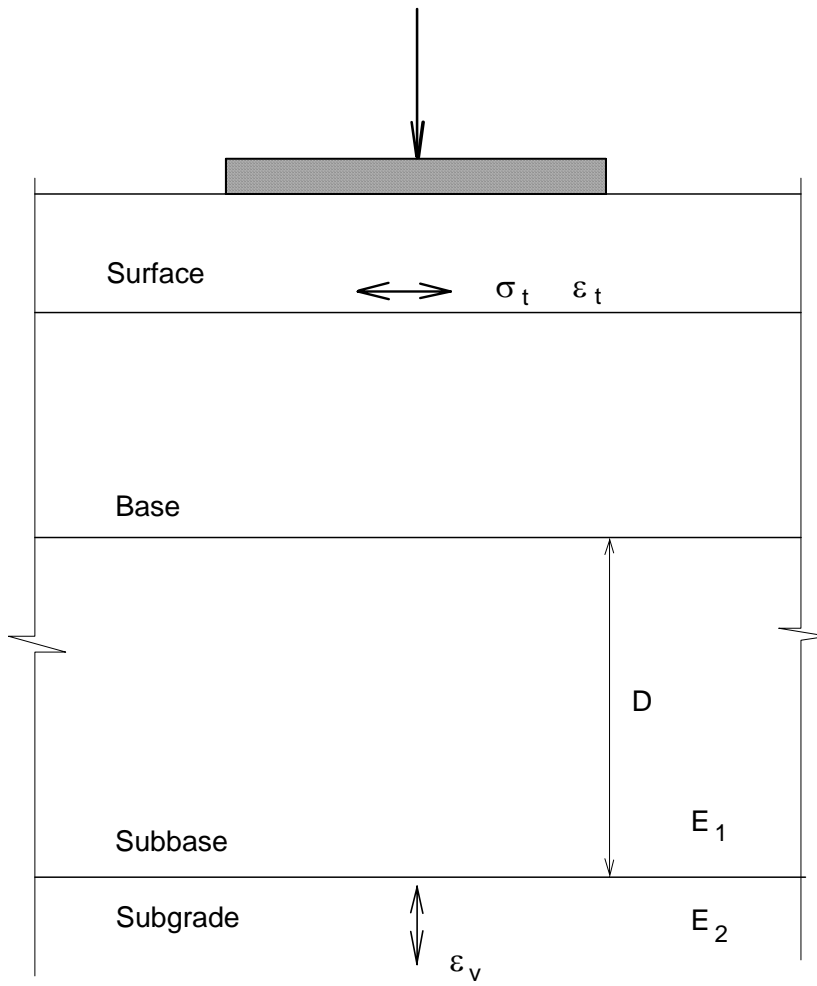
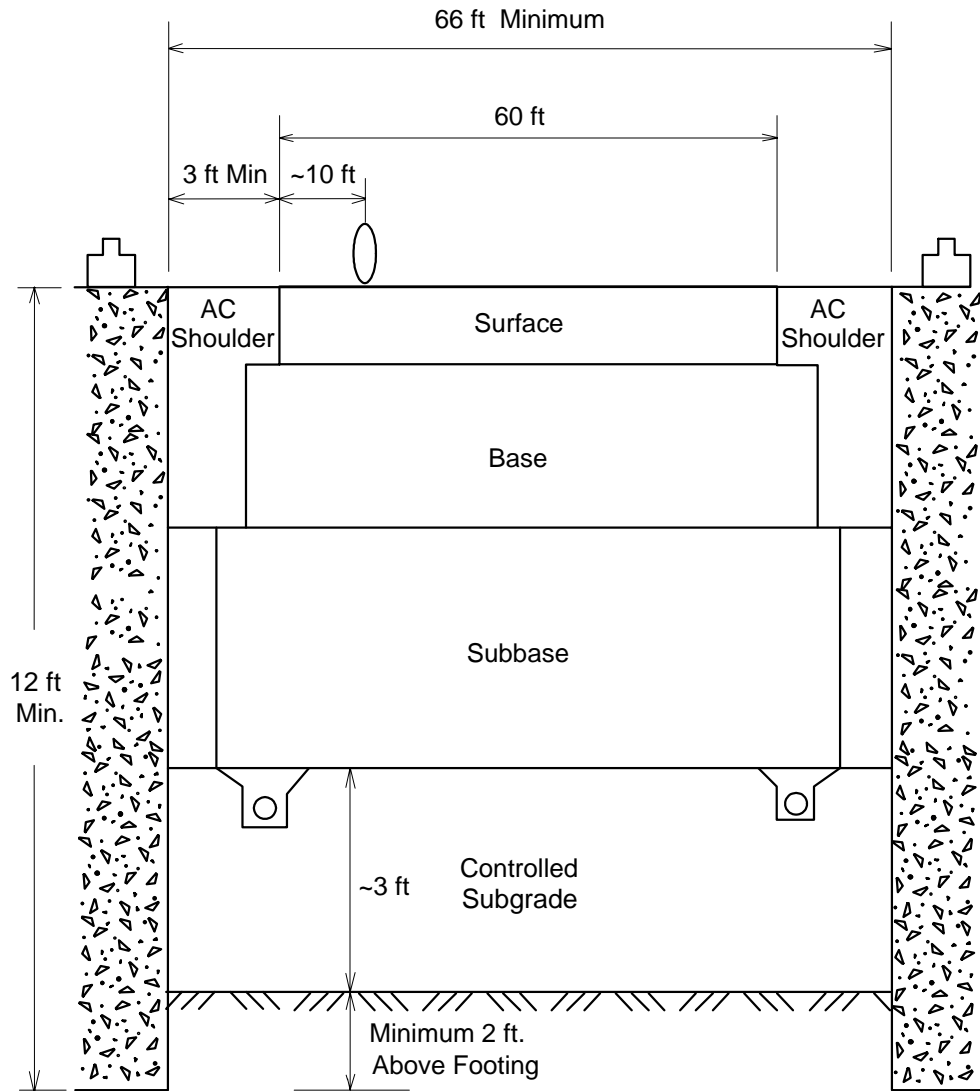
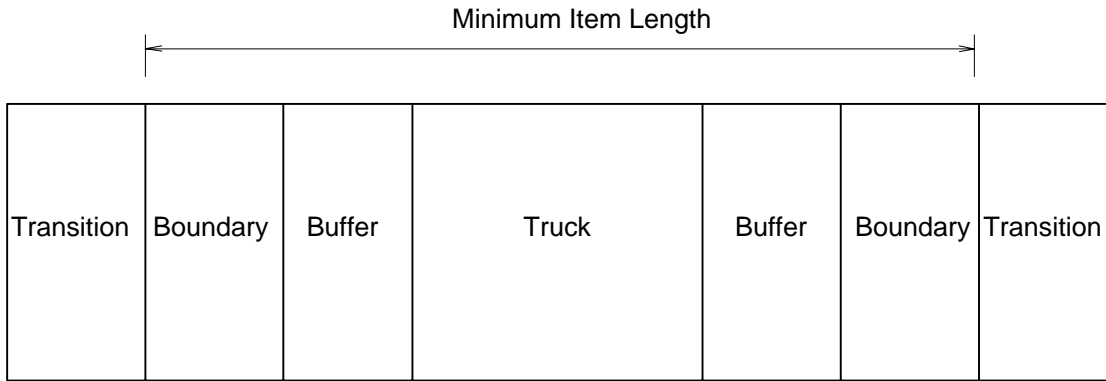

FIGURE 5-4. SUBGRADE INFLUENCE



Not to Scale

FIGURE 5-5. TYPICAL CROSS-SECTION



	Interaction Test	Life Test
Truck	34 ft	15 ft
Buffer	10 ft	10 ft
Boundary	20 ft	20 ft
Minimum Length	64 ft	45 ft

FIGURE 5-6. TEST ITEM LENGTH

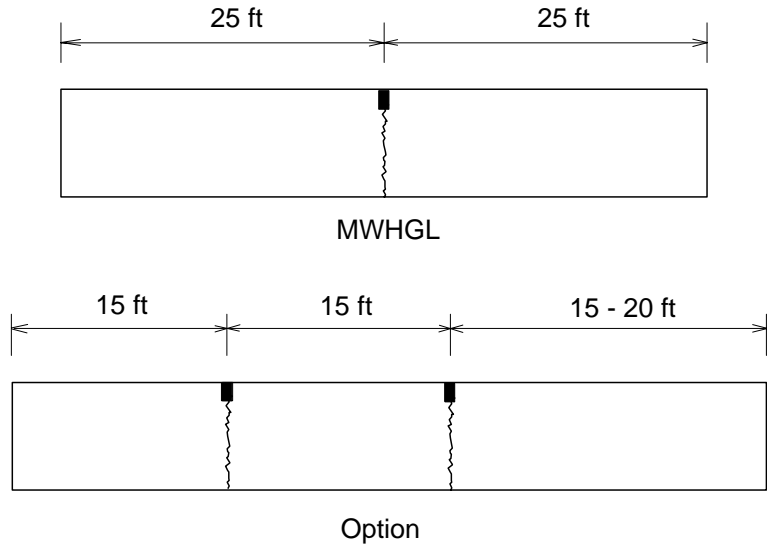
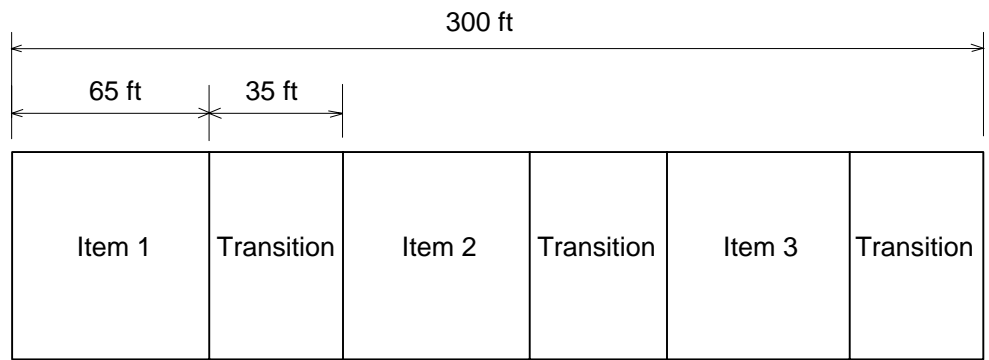

FIGURE 5-7. CONSTRUCTION CONSIDERATIONS (ITEM LENGTH)



Typical Items for each Subgrade Type:

- Item 1. Conventional asphalt.
- Item 2. Stabilized base.
- Item 3. Conventional PCC.

FIGURE 5-8. MODULE CONCEPT (INTERACTION TESTS)

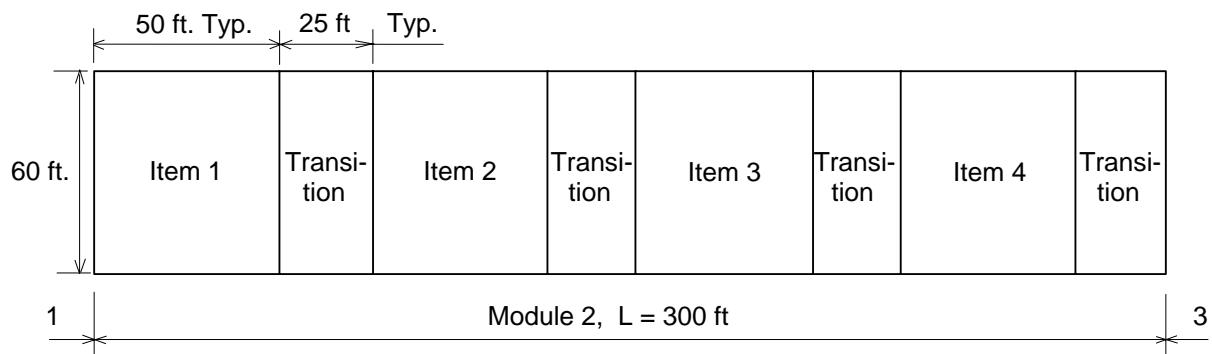

Typical items for each subgrade type:

- Option 1. Same material all items, different fail times.
- Option 2. Different material each item, same fail times.

FIGURE 5-9. MODULE CONCEPT (LIFE TESTS)

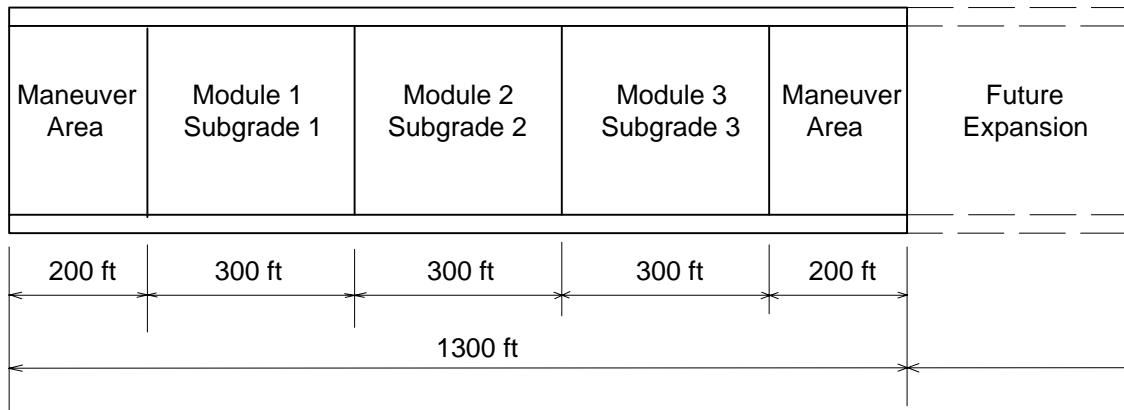

Note: Schematic Only. More detailed requirements contained in "Plan and Profile" drawings, figure 5-1.

FIGURE 5-10. POSSIBLE CONFIGURATION

TEST VEHICLE DESIGN AND COST ESTIMATE

INTRODUCTION.

Figure 6-1 shows plan and elevation views of the proposed test vehicle. Major subsystems are as follows:

1. Load wheel modules and carriage beams.
2. Cross support beams with traverse mechanism.
3. Side beams.
3. Support and drive wheel bogies with rails.
4. Overhead enclosure (see figure 2-1).
5. Instrumentation system.

The vehicle was designed for operation on a linear track. However, for operational efficiency, the original conception was for an oval track with continuous operation in one direction. After initial design layouts had been completed based on the specified test pavement width it became clear that an oval track would require considerably more complication in the vehicle and track design than a linear geometry. Further investigation showed that a linear track would not be less efficient, as originally supposed. Therefore, a linear track was selected. Reasons for its selection are discussed first, followed by descriptions of the test vehicle subsystems, power requirements, and test tire requirements. The subsystem designs were carried through to a degree sufficient for demonstrating feasibility of construction and operation of the test vehicle and to allow reasonable cost estimates to be made. Itemized listings of the estimated costs for the test vehicle subsystems are given in table 6-1. Other estimated costs are itemized in the text where appropriate.

TRACK GEOMETRY.

The test pavement specifications required that the test vehicle have a clear span of more than 60 feet and travel over a minimum continuous length of straight pavement 300 feet long. Test speeds were to be 5 mph for normal testing and 15 mph maximum for speed dependence investigations.

Schematic layouts for oval and linear track geometries are shown in figure 6-2. Assumptions for the oval track were two tangent sections, each being one half the total length of the test pavement items, and semi-circular curves of 150 foot radius. In a practical design the tangent sections would have to be longer than the test items to eliminate lateral movement of the test tires on the last test item as the front support wheels of the test vehicle enter the curve. Test speed was assumed to be constant over the complete circuit.

Assumptions for the linear track were constant speed over the length of the test items and constant acceleration and deceleration of 0.05 g at the ends of the track. (A more practical assumption for the end conditions is constant drive power, but this also requires assumptions for

other operational characteristics not available at the time of the original analysis. For comparison with the simplified oval design, the assumption of constant acceleration is, however, reasonable.)

Travel on the curved sections, or acceleration and deceleration in the case of the linear track, was assumed to occur with the test wheels unloaded.

Two test procedures were considered for the linear track. The first was pavement loading in both directions of travel, with the same vehicle speed in both directions. The second was pavement loading in one direction only, with the test wheels raised on the return run. A 5 mph test according to the second procedure was assumed to consist of acceleration to 5 mph, constant speed along the test items at 5 mph with the test wheels loaded, deceleration to zero speed, acceleration to 15 mph in the reverse direction, constant speed at 15 mph with the test wheels unloaded, and deceleration to zero speed at the end of the test items ready for the next test run. At a test speed of 15 mph the return, unloaded, run would also be at 15 mph.

Figure 6-3 shows the times required for one test under the above assumptions and for total test item lengths of 300 to 900 feet. At a test speed of 5 mph, the times on a linear track are significantly shorter than those on an oval track, for both one-way and two-way testing. At a test speed of 15 mph, the linear track with two-way testing is only slightly faster than the oval track. At 15 mph with one-way testing the linear track is significantly slower. The latter is the only case for which the oval track has better performance than the linear track.

The times for a single test were converted to annual test repetitions by assuming that the test machine would be operated at an efficiency of 85 percent (equivalent to approximately 20 hours per day for 365 days per year or 310 days per year at 24 hours per day). Figure 6-4 shows the number of annual repetitions possible under these assumptions. At the proposed normal test speed of 5 mph and total test items length of 900 feet, the linear track will provide 200,000 repetitions per year for two-way testing and 140,000 repetitions for one-way testing. The oval track will provide 105,000 repetitions per year.

For comparison with airport design practice, the design assumptions for the new Denver International Airport (DIA) were examined. The runway expected to be most heavily trafficked is 16L-34R, at 25,000 equivalent Boeing B-767 annual departures per year or 500,000 equivalent departures over a life of 20 years. (The pavements at Denver were, in fact, designed for a life of 40 years. But the current FAA standard procedure is to design for 20 year life, and 20 year departure levels were assumed for estimating the number of repetitions to failure desired for the strongest test pavements.) Representative full-depth pavement designs should therefore allow for the order of 200,000 to 1,000,000 repetitions to failure, depending on the traffic mix and the design aircraft. Considering the nonlinear nature of the relationship between pavement thickness and repetitions (or coverages) to failure, 140,000 test repetitions to failure will be adequate for satisfying the specification of test pavement item depth at least 75 percent of full-depth designs for large airport pavement design practice. In this respect, one advantage of the linear track is that the test items can be designed to fail first at the ends of the test track and the repetition rate increased as the test items fail. Or, only a short length of the test track can be used if it is desired to test pavements designed for more than 140,000 repetitions. (When considering failure of the

test items at very large numbers of repetitions questions also arise as to failure modes, definition of failure, and the ability to design and construct the items so that they fail within a reasonable range of the target.)

Two-way testing on a linear track will obviously provide more load repetitions per year than one-way testing. But there was no consensus among the working group members on whether one-way and two-way trafficking are equivalent in terms of pavement life or which is the most representative of airport pavement operations. Until more definitive information is available, it has been assumed that tests should be run with one-way trafficking.

A linear track was originally considered instead of an oval track because of the design difficulties presented by operating a very wide vehicle on relatively small radius curves. However, figure 6-4 shows that more annual repetitions are possible with the linear track when operating at the proposed normal test speed. The linear track geometry can therefore be selected solely on this basis. Other disadvantages of the oval track are:

- a. Compound transition curves would be required with different geometry on the inside and outside tracks.
- b. Increased cost because of longer and curved rails and side support foundations.
- c. Increased support wheel wear from travel on the curves.
- d. Discontinuous protection from the overhead enclosure, or increased cost due to the need for a longer and curved structure.
- e. Access to the test items by construction equipment would require special consideration in the design.

TEST WHEEL MODULES.

The specifications for the test wheel loading configurations were:

- a. Representation of two six wheel trucks with the B-777 three duals in tandem layout.
- b. Ability to apply single, dual, and dual tandem wheel loads in addition to the six wheel layout.
- c. Ability to move the wheels so that wheel groups can have up to 20 feet spacing laterally and longitudinally.
- d. Ability to move the wheels laterally in unison to simulate wander.

To satisfy these specifications the proposed design consists of twelve individual wheel modules with three modules mounted inline in each of four carriage beams. The carriage beams move laterally independent of each other by means of rack and pinion traverse mechanisms attached to the cross support beams at the ends of the carriage beams. Movement of the carriage beams will be automatic and additional mechanisms will be provided to lock the carriages to the cross

beams when the wheels are loaded. Longitudinal movement of the modules will be manual, with predrilled bolt holes providing location and alignment.

Figure 6-1 shows the wheels in the B-777 truck configuration with maximum longitudinal separation. Figure 2-1 shows a schematic end view of two modules side-by-side at their minimum separation (for the proposed design) of 44 inches. This corresponds to the wheel spacing on a B-747 main gear truck. The lateral wheel spacings on DC-10, B-767, and B-777 main gear trucks are 54 inches, 45 inches, and 55 inches respectively. Landing gear configurations for the most common wide-body aircraft can therefore be reproduced by the proposed wheel module design. Each module is completely self-contained with axle, vertical suspension mechanism, 75,000 pound capacity hydraulic servo-actuator, and steering mechanism. The module frames are intended to provide stiffness to the carriage beams. Dummy frames could be added if additional stiffness is required away from the module mounting positions. Figure 6-5 shows multiple views of a single module with details of proposals for the suspension and steering mechanisms.

The suspension system consists of heavy duty linear rod and ball bushings on either side of the wheel. The ball bushings on one side are fixed to the frame and the bushings on the other side float laterally, eliminating overloading due to misalignment. Two sets of concave shaped rollers constrain the floating bushing rod and are driven longitudinally by a chain, gearbox, and motor transmission to provide up to 5 degrees of steering in either direction. Radius arm suspension mechanisms were also laid out, but it was very difficult to provide 24 inches of vertical travel and suitable lateral control within the dimensional constraints of the overall design requirements.

The steering mechanism was incorporated in the design to minimize lateral tire forces. By strain gauging either the axle or one of the bushing rods, it will be possible to automatically steer the wheel so that lateral force is kept close to zero as the wheel rolls along the test track. It was felt necessary to allow a means of minimizing lateral force because the carriage beams will be long and narrow and will have limited torsional and lateral stiffness to resist movement due to lateral tire forces. It will also be beneficial to reduce the lateral forces on the traverse mechanism and the support rails (to reduce rail wear and improve yaw control). An equally important consideration is that tire temperature and wear rate will both increase with lateral tire force. Minimizing lateral tire forces will therefore increase tire life and decrease possible down-time required to allow the tires to cool. Significant lateral tire forces would be expected to be caused by:

- a. Misalignment of the loading modules following movement.
- b. Tire ply-steer and conicity.
- c. Pavement cross-slope from rutting or uneven settlement.
- d. Longitudinal joint misalignment in rigid pavements.

Other remedies for inadequate stiffness of the carriage beams would be additional cross support beams and/or additional carriage-to-carriage locking mechanisms. Rotational instability about a longitudinal axis should also be considered in the final design.

The hydraulic actuators will have force servo-control to maintain the wheel loads at the desired value (feed-back from the cylinder pressure will give approximately 2 percent accuracy and force transducers have not been included in the design). Supplementary position control will also be required to raise and lower the wheels.

CROSS SUPPORT BEAMS.

The cross support beams transfer the load from the carriage beams into the support framework for the bogie wheel-sets. The worst case design condition for the beams was taken to be all twelve load wheels grouped as close together as possible at the center of the vehicle with maximum load of 75,000 pounds applied to each wheel. Self-weight of the load wheel modules and the carriage beams was neglected. The beams were designed as space frame trusses with 16 and 12 inch square steel tubing for the chord and diagonal members respectively. Each beam consists of two frames.

Figure 6-6 is a schematic of the truss layout used to check the design for strength and deflection. The loads F were 112,500 pounds for maximum total test load of 900,000 pounds. A finite element program was used to calculate member loads and center span deflection. Truss heights of 8, 10, and 12 feet were used in the calculations. Maximum chord member loads were approximately 250,000 pounds tensile and compressive. Assuming wall thickness for the tubing of 0.5 inches and normal structural steel construction gives a factor of safety of 2.8 for the 8 foot high truss. Center span deflection of the 8 foot truss was 1.1 inches. Increasing the truss height to 12 feet decreased the deflection to 0.7 inches.

A more efficient structure could be designed to carry the specified loads, but the above calculations show that an 8 foot high truss with 1/2 inch wall square tubing in all of the members gives a reasonable structure for layout and costing. Self weight of each of the beams was 70,000 pounds.

The structure supporting the decking shown outside the cross beam spans (see figure 6-1) is attached to the cross beams and provides resistance to spreading of the beams. The walkway connecting the top of the beams at center span is also a structural member and is intended to resist twisting of the beams.

SIDE BEAMS.

The major functions of the side beams are to transfer the load from the cross beams to the bogies, resist lozenging of the complete vehicle structure, and carry ballast weights. This part of the structure does not function as a simple beam and the most important aspects of its design will be to provide the necessary strength and stiffness at the cross beam and bogie connections. The decking structure also provides assistance to the side beams in resisting lozenging. Detail design of the connections is the most important aspect of this part of the structure, but, in terms of material costs, it will not have a large effect on the overall cost of the vehicle. Normal space frame layouts were therefore used to meet the dimensional requirements with what appeared to be adequate sizes for strength.

DYNAMIC RESPONSE OF THE STRUCTURE.

The bogies are shown directly connected to the side beams. In the final design, the attachments could either be through the individual bogie spring suspensions or a walking beam for each set of two bogies could be added (a walking beam with a central yaw bearing is not absolutely necessary because the vehicle does not have to turn corners). Either way the vertical stiffness of the suspensions must be as high as possible to reduce vertical movement of the complete vehicle. The requirements for dynamic control of bogie movement is not as stringent as in railroad operation because of the low speeds involved and the high quality expected from rail alignment.

Total vertical movement of the load wheel module frames will consist of the addition of bogie, cross beam, and carriage beam vertical movements. In the simplest case of pure vertical movement, the combination of the individual structural components will act as a set of springs in series, and the net stiffness will depend on the most flexible component. This, together with the masses of the components, will determine the lowest natural frequency of the structure. Ideally, each component will have equal stiffness and the net stiffness will be one third of the individual stiffnesses.

Considering the requirement for rapid changes in load when starting and stopping test runs, and traversing failed pavement test items, many vibration modes other than the fundamental could be excited during operation. A complete dynamic analysis should therefore be performed during final design work. This should include the force feedback servo-systems to ensure that load control is not adversely affected by structural dynamic response and that there are no conditions under which the system will become unstable.

DRIVE WHEEL BOGIES.

The drive wheel bogies are standard railroad wheel-sets with four wheels per bogie and electric traction motors. Considering the light duty expected from the test vehicle compared to normal railroad operation, refurbished bogies were used as the basis for cost estimation. Rails were assumed to be of normal railroad continuous steel construction with concrete ties directly attached to the steel structure of the side support foundations.

POWER REQUIREMENTS AND CONSUMPTION.

Power requirements were based on the following assumptions:

Total test tire load	=	900,000 lb
Test tire rolling resistance	=	2 percent
Total vehicle weight	=	1,100,000 lb
Rail rolling resistance	=	1 percent
Transmission efficiency	=	85 percent

Therefore, for constant speed with the test tires fully loaded:

Traction force at the rails	=	20,000 lb
Motor power at 5 mph	=	314 hp
Motor power at 15 mph	=	942 hp

Assuming a coefficient of friction at the rails of 0.25^[17]:

$$\text{Required total drive wheel vertical load} = 80,000 \text{ lb}$$

To allow for non-uniform load distribution between the bogies, the assumed total vehicle weight of 1.1 million pounds provides a factor of safety of 2.5 in terms of traction loss at one of the bogies. The maximum rated motor power was also increased to 1200 hp, for 150 hp per bogie.

During normal acceleration and deceleration of the test vehicle, the test wheels will be unloaded and the full weight of the vehicle supported on the drive wheels. Maximum acceleration or deceleration in gravity units will therefore be equal to the rail coefficient of friction, or 0.25 under the above assumption. This means that full rated motor output could be applied at speeds greater than 1.4 mph without breaking traction at the drive wheels. Torque limiting would be required at lower speeds. Such high accelerations would not be of great benefit in terms of reducing total test time. A lower torque limit would probably be advisable to reduce rail and drive wheel wear, reduce weight transfer, and reduce dynamic loads on the vehicle components.

Power consumption and the cost of driving the test vehicle during testing were estimated based on the following assumptions, (in addition to those given above):

Constant power during acceleration		
Total length of the test items	=	900 ft
Electrical efficiency	=	85 percent
Cost of electricity	=	\$0.08 per kWh
No cost reimbursement for regenerative braking		

Assuming constant power during acceleration and deceleration simplifies the calculations without having a significant effect on the cost estimates because a very short amount of time is spent at speeds lower than the torque limit cut-off. A single test run is separated into acceleration/ deceleration and constant speed phases.

ACCELERATION / DECELERATION. During acceleration, the traction motors must provide an effective force at the rails equal to the inertia force resisting acceleration plus the drive wheel and rail rolling resistance force. These forces are:

Effective driving force	=	$550 \times P \times 0.85 / V$
Inertia force	=	$a \times W / g$
Rolling resistance force	=	$0.01 \times W$

where: P = total rated traction motor power in hp
V = instantaneous velocity of the vehicle
a = acceleration in ft/s²
W = total weight of the vehicle in pounds
g = gravitational acceleration = 32.2 ft/s²

solving for acceleration gives:

$$a = \left(550P \frac{0.85}{V} - 0.01W \right) \frac{g}{W} \quad (6-1)$$

Equation 6-1 was solved numerically for the total time and distance required for the vehicle to accelerate to the test speed. The time and distance to decelerate to zero were found in the same way except that the sign of the rolling resistance force was reversed. The energy required to accelerate and decelerate the vehicle was found by multiplying the electrical power for rated motor power by the total time spent accelerating and decelerating.

CONSTANT SPEED. The energy required to drive the vehicle at constant speed was found by multiplying resisting force by the distance traveled and dividing by the mechanical and electrical efficiencies. During the return run for a one-way test at 5 mph it was assumed that acceleration and deceleration to and from 15 mph would be done while the vehicle was over the test items.

ELECTRICITY COST. Table 6-2 shows the times and distances required to execute the different phases of the test runs. Table 6-3 shows the corresponding energies. Based on 85 percent usage, and using the total times and energies given in tables 6-2 and 6-3, the following annual repetitions and costs required to drive the traction motors were calculated:

- a. One-way tests at 5 mph (return at 15 mph) and 151,000 repetitions - \$262,000.
- b. Two-way tests at 5 mph and 212,000 repetitions - \$178,000.
- c. One-way tests at 15 mph and 182,000 repetitions - \$492,000.

Considering the conservative nature of the assumptions, and the fact that maximum load and 15 mph test speed are expected to be used only for special studies, a reasonable estimate for typical annual costs is \$200,000.

ALTERNATIVE POWER SOURCES. The above estimate of electricity cost was based on the use of high voltage three phase power supplied directly from available utility supplies. Initial costs associated with this arrangement were approximately \$200,000 for power pickup rails and cables. A stationary engine electric generator set was also considered. The generator would be mounted directly on the vehicle, or on a separate towed vehicle, to eliminate the pickup rails. Natural gas fuel would almost certainly be required in order to meet air quality standards. The size of the generator set would be approximately 16 feet long by 6 feet wide and its weight would be approximately 25,000 pounds. Cost estimates were made from manufacturers quotations. Initial cost for a 1,080 hp (750 kW) rated natural gas fueled generator was approximately \$350,000 and fuel cost approximately \$0.05 per kWh. Compared with the utility

supply, initial cost would be almost double, but annual energy costs would be lower by 37.5 percent based on the assumption of \$0.08 per kWh for utility power. The use of a stationary generator is therefore a viable alternative and further analysis should be done during final design when better estimates of utility power costs and availability, and other initial costs, are available.

TEST TIRES.

The test tires will be operated almost continuously at high loads over extended periods of time. This is very different than the normal operating cycle for aircraft tires and it was not possible to obtain firm estimates for the expected life of a tire under these testing conditions. Previous pavement tests have not been run continuously under automatic operation as specified for this machine. Tire life was therefore estimated at what was felt to be a very conservative value of 1,000 miles.

Previous experience from airport pavement testing has also shown that tire temperature rise is a serious problem during testing and leads to tire blow-outs if tire temperatures are not monitored and testing suspended when necessary to allow the tires to cool. In fact, controlling temperature rise may be the major factor limiting the number of load repetitions which can be applied per year. Experience also shows that conditions which lead to high tire temperatures also cause high tire wear. Reducing the rate of temperature rise will therefore increase tire life. Steps which can be taken to decrease temperature rise, and increase tire life, include:

- a. Increase inflation pressure and run at 85 percent of the rated load of the tire.
- b. Use larger tires and run at 85 percent of the rated load of the tire (to give approximately the same contact pressure and area as the smaller tire at its rated load).
- c. Alternate load wheels when less than twelve wheels are required for testing.
- d. Minimize lateral tire forces.
- e. Minimize the amount of testing at 15 mph.
- f. Design the test pavements for low surface texture.
- g. Use specially made tires having a longer wearing tread compound and fewer plies than required for certified aircraft operations.

Only a small amount of testing is expected to be done at the full rated load of the test machine and cost estimates were made on the assumption that 49 x 17 bias-ply tires would typically be used. Based on information from tire manufacturers, the average cost of a 49 x 17 tire from new to the end of its useful life after multiple retreads is approximately \$400 per cycle between retreads (new tire cost is approximately \$1,200). The distance traveled by each test wheel was assumed to be 25,500 miles per year (150,000 repetitions over 900 feet), giving:

- a. Estimated cost per wheel per year = \$10,000.
- b. Estimated cost for 8 wheels per year = \$80,000.
- c. Estimated cost for 12 wheels per year = \$120,000.

The typical annual cost of test tires was taken to be \$75,000.

INSTRUMENTATION.

The test vehicle will require instrumentation systems for controlling the test wheels, controlling test vehicle yaw, monitoring tire temperatures and pressures, and communicating with the remote control station. Cost estimates for these systems are included with the estimates for the appropriate mechanical systems.

TABLE 6-1. TEST VEHICLE COST ESTIMATES, MAJOR SUBSYSTEMS (3 SHEETS)

Airport Pavement Test Machine - Test Vehicle		Sheet 1 / 3	
Extent of Supply		Bought Out Equipment & Services	
Description		Qty	Totals (US \$)
1. <u>Structure</u>			
a.	Side Members	2	254,084
b.	Cross Structures	2	299,222
c.	Control Cabins/Air Conditioners/Furniture	2	62,205
d.	Bogie Beam, Platforms	4	101,442
e.	Ladders & Walkways	sets	1
f.	Ballast	ton	130
			\$857,313
2. <u>Traverse Carriages</u>			
a.	Frames, Traverse Carriages	4	442,772
b.	Position Adjustment Drives	8	393,646
c.	Pull-up Locking Mechanisms	8	341,862
			\$1,178,280
3. <u>Hydraulic Land/Unland System</u>			
a.	Wheels	12	137,808
b.	Axles	12	76,560
c.	Support Frame for Axles	12	445,723
d.	Actuators)	
e.	Hydraulic Systems)	
	Pumps (2))	
	Pipe System)	
	Servos)	
	Manifolds)	
	Accumulator)	
f.	Hydraulic Control System & Panel) sets	2
			\$1,025,491
4. <u>Drives (Mechanical)</u>			
a.	Bogies	Wheels)	
		Axles)	
		Bearings)	
		Frames)	
b.	Gear Reduction Unit.)	
c.	Driveshaft Couplings)	
d.	Mechanical Brake) sets	8
			\$476,586
Sheet Total			\$3,537,670

Airport Pavement Test Machine - Test Vehicle

Sheet 2 / 3

Extent of Supply		Bought Out Equipment & Services	
Description		Qty	Totals (US \$)
5. <u>Drives (Electrical)</u>			
a.	Motors c/w Tachometers, 60hp DC		
b.	Thyristor Power Units		
c.	Thyristor Unit Input Circuit Breakers		
d.	Phase Shift Transformers		
e.	Primary Circuit Breakers		
f.	Speed Reference Tachometer & Mount sets	1	551,073
			\$551,073
6. <u>Track System</u>			
a.	Rails (1500 ft))		
	Single Tracks)		
	Steel Ties on Concrete Bed)		
	(Including Installation)) sets	2	565,826
	Ref: MEANS R024-530)		
b.	Proximity Switches	150	35,888
			\$601,714
7. <u>Controls & Instrumentation</u>			
a.	Driver Controls & Panel	2	31,900
b.	Tyre Instrumentation	12	44,820
c.	Programmable Controller	1	39,875
d.	Telemetry Communication	1	7,975
e.	Programmable Controller, Input Device	1	3,988
f.	Cables sets	1	242,440
g.	Hard Wired Emergency System	1	7,975
h.	Shore Based Program Development Device	1	11,165
i.	Shore Based Emergency Stop System	1	7,975
			\$398,112
8. <u>Electrical System.</u>			
a.	Main Input Circuit Breaker.		7,975
b.	Overhead Pick-up System.)		
	Power Rails)		
	Joints)		
	Feeds)		
	Clamps)		
	Collectors) sets	1	77,358
	Overhead Pick-up System.		
	Supports sets	1	110,661
c.	Auxilliary Power Circuit Breaker)		included
	Distribution Board)		
d.	Cables sets	1	included
			\$195,994
Sheet Total			\$1,746,892

Airport Pavement Test Machine - Test Vehicle

Sheet 3 / 3

Extent of Supply		Bought Out Equipment & Services	
Description		Qty	Totals (US \$)
9.	<u>Consumables</u>		
a.	First Fill of Oils	gallons 500	7,250
b.	One Set of Aircraft Tyres	12	
			\$7,250
10.	<u>Spares</u>		31,175
			\$31,175
11.	<u>Site Services</u>		
a.	Delivery of Major Items of Carriage to Site.		excluded at this stage.
b.	<u>Assembly of Carriage on Site</u>		
	Tradesmen	Labor	72,495
	Supervision	Labor	100,962
	Equipment Requirements		46,400
c.	<u>Commissioning & Setting to Work</u>		
	Tradesmen	Labor	12,875
	Supervision & Engineerig		71,853
	Equipment Requirements		8,700
d.	<u>Acceptance Testing</u>		
	Tradesmen		4,289
	Supervision & Engineerig		45,471
	Equipment Requirements		3,625
e.	Installation of Power Rails, including Supports		65,250
f.	Installation of Rail Tracks		included in 6
	Installation of Telemetry Inductive Loop Cable		29,000
			\$460,919
12.	<u>Project Management & Design.</u>		
a.	Engineering Management (Engr. Manager only)		102,008
b.	Scheme Design		129,877
c.	Manufacturing Drawings		173,838
d.	General Documentation		69,947
e.	Electrical & Control		100,920
f.	Safety		14,703
			\$591,292
13.	<u>Engineering Support</u>		
a.	Project Manager		162,481
b.	Procurement		65,859
c.	Quality Assurance/Inspection		37,219
d.	Planning & Expediting		31,529
e.	Estimating & Cost Control		32,468
f.	Project Secretary		81,745
			\$411,301
Sheet Total			\$1,501,938
Grand Total:			\$6,786,500

TABLE 6-2. DISTANCES AND TIMES DURING TEST PHASES

Test Phase	Total Time (sec) and Distance Traveled (ft) for Test Speed			
	5 mph		15 mph	
	Time	Distance	Time	Distance
Acceleration	1.9	9	21.2	324
Deceleration	1.6	7	11.6	164
Constant speed and under load	123.0	900	41.0	900
Constant speed during return at 15 mph	17.9	394	41.0	900
Totals for one repetition in a two-way test	126.5	916	73.8	1,388
Totals for one repetition in a one-way test	177.2	1,832	147.6	2,776

TABLE 6-3. ELECTRICAL ENERGY REQUIRED DURING TEST PHASES

Test Phase	Electrical Energy (kWh) for Test Speed	
	5 mph	15 mph
Acceleration	0.6	6.2
Deceleration	0.5	3.4
Totals for return in a one-way test	11.2	14.8
Totals for one repetition in a two-way test	10.5	19.0
Totals for one repetition in a one-way test	21.7	33.8

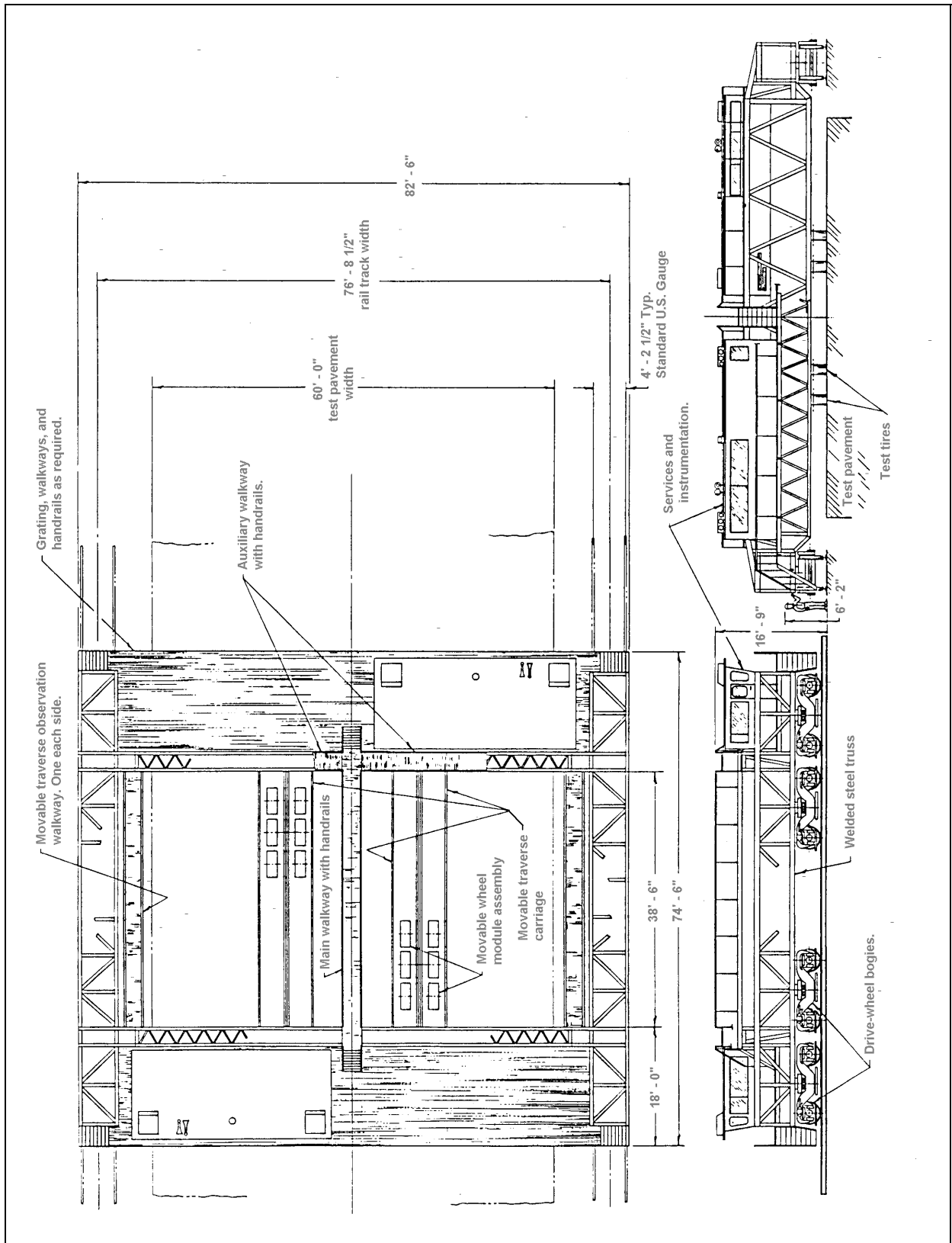
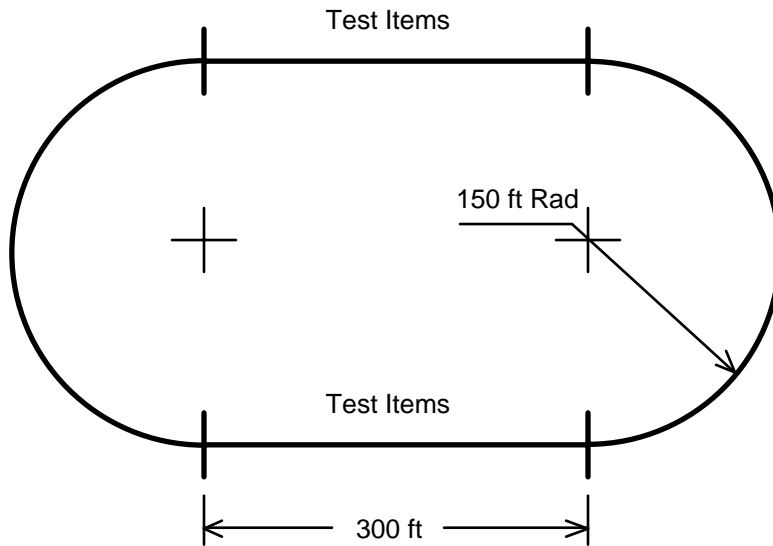
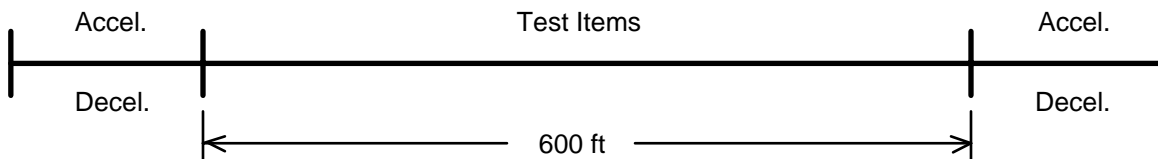

FIGURE 6-1. PLAN AND ELEVATIONS OF THE PROPOSED TEST VEHICLE



Oval Track - curved length = 942 ft



Linear Track - acceleration and deceleration length is 150 ft each end for 15 mph test speed and 0.05 g acceleration and deceleration.

FIGURE 6-2. OVAL AND LINEAR TRACKS, EXAMPLE COMPARISON

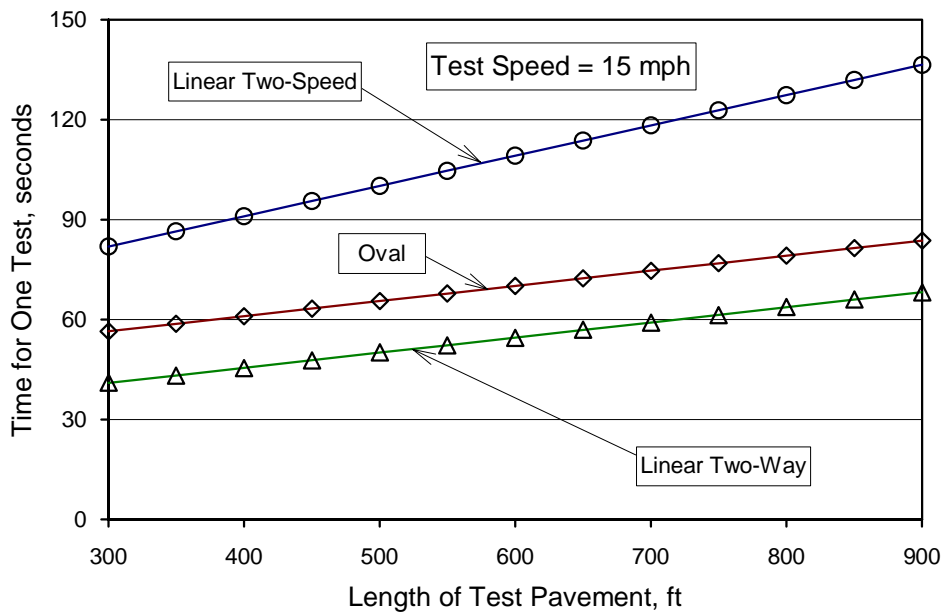
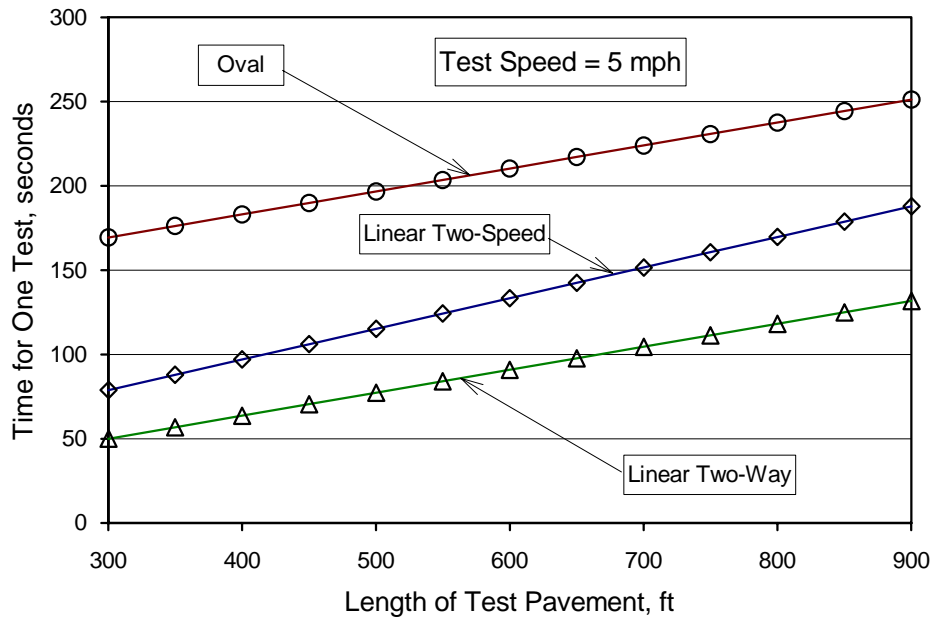

FIGURE 6-3. TIME TO COMPLETE ONE REPETITION vs. TEST PAVEMENT LENGTH, OVAL AND LINEAR TRACKS, TWO TEST SPEEDS

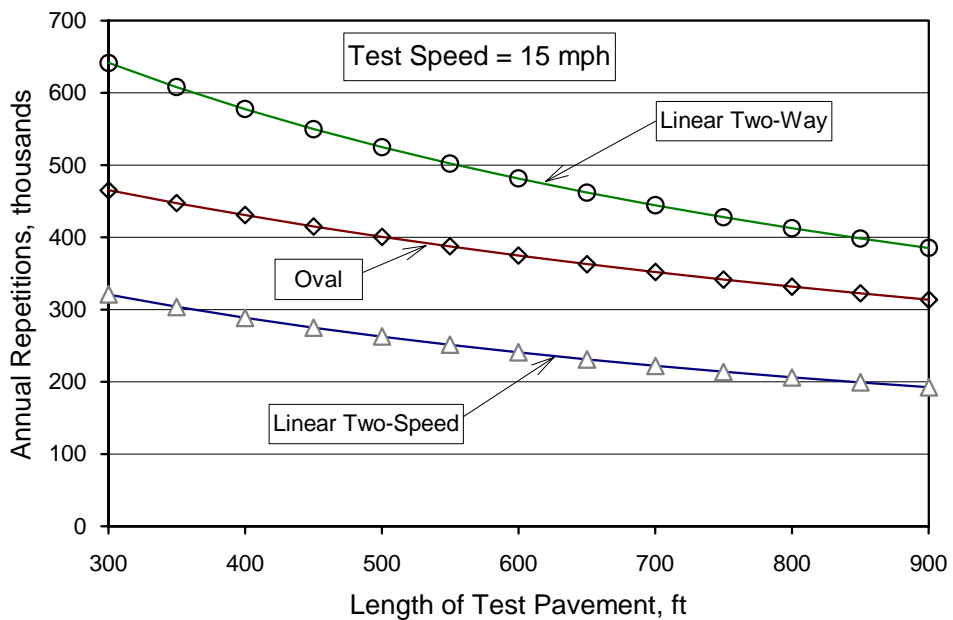
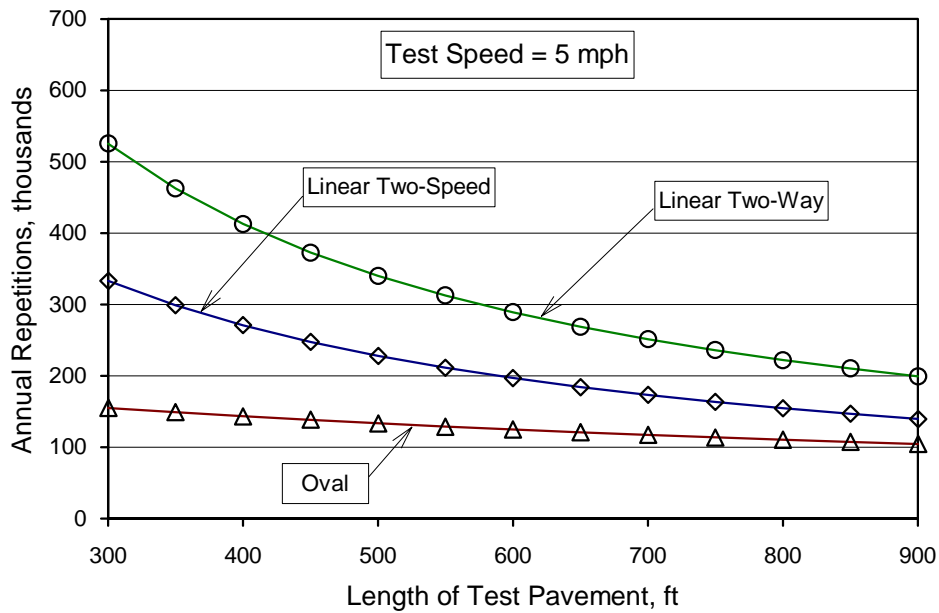

FIGURE 6-4. ANNUAL TEST REPETITIONS vs. TEST PAVEMENT LENGTH, OVAL AND LINEAR TRACKS, TWO TEST SPEEDS

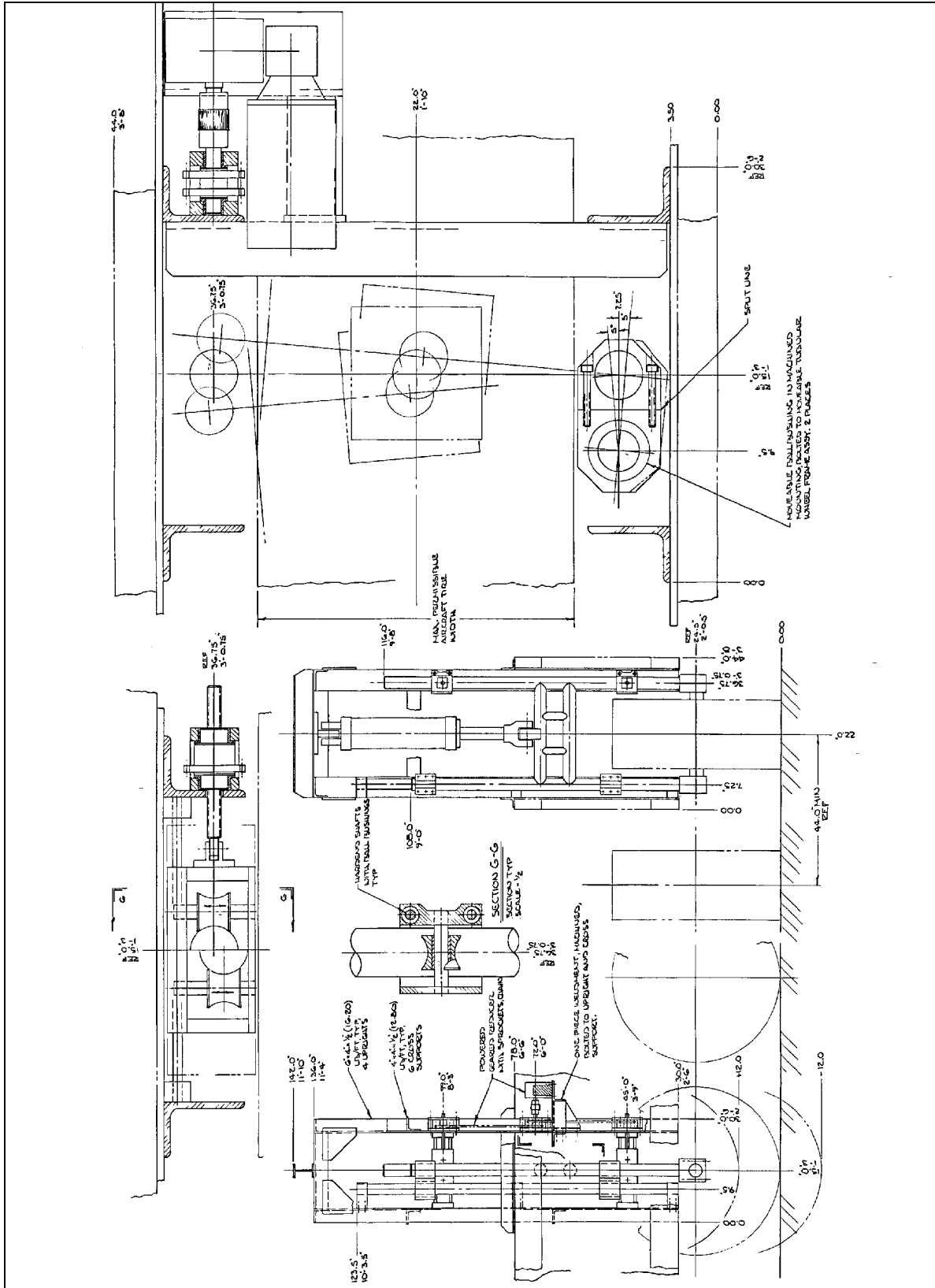

FIGURE 6-5. WHEEL MODULE SHOWING VERTICAL AND STEER MECHANISMS

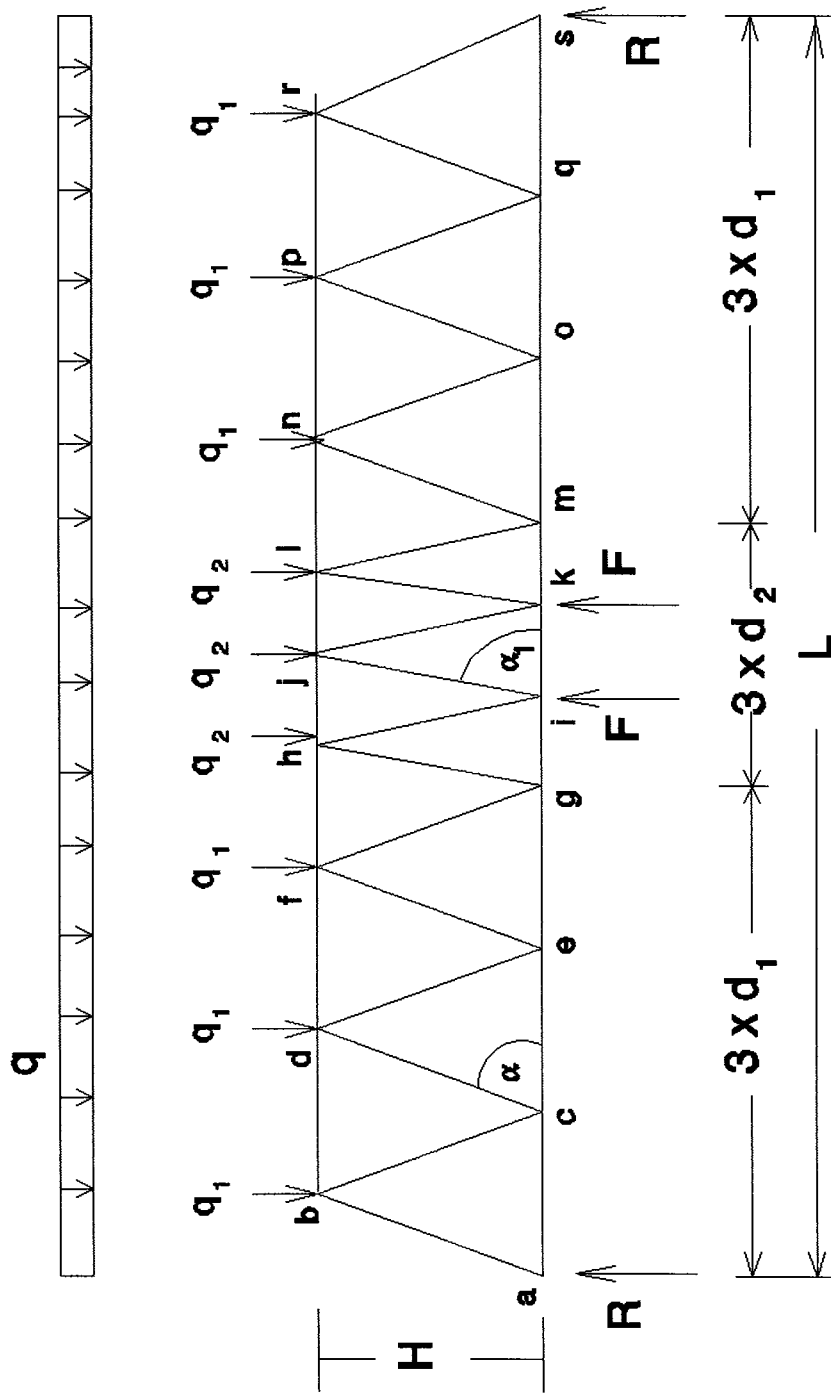

FIGURE 6-6. TRUSS MODEL SHOWING THE NODES AND ELEMENTS

SIDE SUPPORT FOUNDATION DESIGN AND COST ESTIMATE

GENERAL CONSIDERATIONS.

Figure 7-1 shows the plan view and two cross-section views of the foundation structure. The design is based on the following considerations:

- a. The testing machine and the building structure can share the same foundation.
- b. The inside of the foundation can be used to install wires, pipes, and data acquisition equipment.
- c. The test pavement will be built between two foundations and on the existing grade at the site. The side wall restraining the test pavement will therefore sustain 14 foot high earth pressure and the refilled height of the other side will be 2 feet (see figure 2-1). The height of the foundation wall was mainly determined by the required depth of the testing section. (It should be noted that building the foundations completely below grade will result in the same design conditions except that the critical overturning case will be for soil pressure on the outside wall when the test pavement is not in place, either during initial construction or during reconstruction. Intermediate depths of construction will result in different design conditions, with one half depth below grade giving the best compromise.)
- d. Based on the design specifications for the enclosure, the optimal longitudinal distance between two side columns of the enclosure is 30 feet, and the maximum load transferred from each column is assumed to be 20 kips.
- e. Cast-in-place concrete was selected for the construction, so a concrete box with strengthening columns and bottom beams has been proposed as shown in figure 7-1.
- f. The total length of the foundation will be 1,500 feet, so expansion joints are needed to protect the structure from damage by thermal expansion. The AASHTO Code [18] requires that the center-center (C-C) distance of two expansion joints must be less than 90 feet. A length of 60 feet is proposed for the C-C distance between expansion joints. Namely, the 1,500 foot long foundation will be divided into 25 sections, each 60 feet long.
- g. The assumptions for the load transfer path are as shown in figure 7-2.

DESIGN FOR SOIL SUPPORT.

The design is based on the assumption of an equivalent single layer base with uniform properties. Two parameters, friction angle (ϕ) and cohesion coefficient (c) are used to describe the soil properties. Three design cases were analyzed to determine the dimensions and strength requirements for the foundations. They are overturning resistance, soil bearing capacity, and soil stability.

OVERTURNING RESISTANCE. The structure must be strong enough to resist overturning due to earth pressure from the test pavement. The critical case in the overturning analysis is shown in

figure 7-3, where the load from the test pavement is applied and the test machine is not in the section.

The earth pressure on the inner wall is assumed to be "active pressure"[19] and,

$$\sigma_3 = \gamma H_1 \tan^2\left(45^\circ - \frac{\phi}{2}\right) - 2c \tan\left(45^\circ - \frac{\phi}{2}\right) \quad (7-1)$$

The pressure on the outer wall is assumed to be "passive pressure":

$$\sigma_1 = \gamma H_2 \tan^2\left(45^\circ + \frac{\phi}{2}\right) + 2c \tan\left(45^\circ + \frac{\phi}{2}\right) \quad (7-2)$$

where γ is the unit weight of the soil, and H_1 and H_2 are the heights of the refilled materials.

The safety factor is defined by the ratio between the maximum resisting moment and the overturning moment. The acceptable region in terms of the soil properties is given in figure 7-4.

SOIL BEARING CAPACITY. The maximum bearing stress produced by any possible combination of the loads should be smaller than or equal to the allowable bearing strength. A 10 foot long section of the foundation has been taken to conduct the analysis. The critical case is when the test machine is over the section before the test pavement has been constructed or has been excavated for reconstruction (figure 7-5). A safety factor of 3 was used to determine the allowable bearing strength by the Terzaghi method[19]. The allowable bearing stresses versus soil properties are presented in table 7-1.

The center of the forces in figure 7-5 is:

$$\begin{aligned} X_R &= \{92 + 44 \times 12.5 + 20 \times 14.5 \\ &\quad + [0.5 \times 10 \times (14 - 8/12) \times 0.15 \times 2 + 10 \times 8/12 \times 0.15] \times 8 \\ &\quad + 1 \times 1 \times (14 - 8/12) \times 0.15 + 1 \times 3.5 \times (14 - 8/12) \times 0.15 \times 13.75 \\ &\quad + 1 \times 1 \times (16 - 1.5 - 4) \times 0.15 \times 6.75\} / (92 + 44 + 20 + 20 + 16 + 2 + 7 + 1.875) \quad (7-3) \\ &= 6.57 \text{ ft} \end{aligned}$$

Other design assumptions are:

$$\begin{aligned} \text{total force,} \quad R &= 202.9 \text{ kips} \\ \text{and eccentricity,} \quad e &= 8 - 6.57 = 1.43 \text{ ft} \end{aligned} \quad (7-4)$$

The effective area for calculating the ultimate bearing stress is:

$$A = (16 - 2 \times 1.43) \times 10 = 131.4 \text{ ft}^2 \quad (7-5)$$

and the ultimate bearing stress is:

$$q_{ult} = \frac{202.9}{131.4} = 1.55 \frac{kips}{ft^2} \quad (7-6)$$

The acceptable region ($q_{ult} < q_{allow}$), in terms of soil properties ϕ and c , is shown in figure 7-6.

SOIL STABILITY. The soil mass under any possible combination of the loads must be stable and there must not be sliding along any surface due to shear failure of the soil (figure 7-7).

The safety factor for stability analysis is defined as the minimum ratio between the maximum sliding resistance force and the sliding force along any possible surface. The safety factors may be calculated by hand based on several assumed "trial failure surfaces," and the design safety factor will be the minimum ([19], page 564). A computer program entitled "TWSLOPE"[20] has also been used to check the hand calculation results. The acceptable regions, in terms of the soil properties, and for design safety factors of 1.5 and 2.0, are illustrated in figure 7-8.

DESIGN OF THE BOX STRUCTURE.

The box structure consists of structural steel beams encased in cast-in-place concrete with steel reinforcing bars. The structural steel beams transfer the load from the test machine and the enclosure into the existing soil. Steel reinforcing bars are required wherever bending of the walls and base cause tension stresses greater than the strength of the concrete.

Appendix C contains details of the design calculations. However, it should be noted that the calculations were performed to demonstrate feasibility of the design and to estimate the quantity of materials required so that cost estimates could be made. A complete structural analysis would be required for the final design.

COST ESTIMATE.

The total quantity of concrete required for the box structures was calculated to be 3,264 cubic yards. Based on the fact that a great deal of hand work will be required during construction, for making and placing the forms and reinforcing bars, the cost of the concrete placement was estimated to be \$350.00 per cubic yard[21]. The total quantity of reinforcing bars required was estimated to be 435 tons, comprising #4 through #10 size bars in various quantities. From supplier's quotations, an average cost for the bars was estimated to be \$21.00 per 100 pounds. Table 7-2 summarizes the quantities of concrete and reinforcing bars.

Table 7-3 summarize the total quantities of structural steel beams required. For all sizes, the total weight of the beams was estimated to be 240 tons. Quotations provided an average estimated cost of \$0.29 per pound.

Steel grating was also specified to cover the (open) top of the box structure. The cost estimate was based on a requirement of 1 1/2×3/16 in steel grating at a cost of \$4.50 per square foot.

The total estimated cost of constructing both side support foundations, summarized in table 7-4, was \$2,250,000. Site preparation is assumed to be included in the contingencies item, as well as being shared with the costs for construction of the test pavement.

TABLE 7-1. ALLOWABLE SOIL BEARING STRESSES, KIPS/SF

$\phi \setminus c(\text{psi})$	0	100	200	300	400
0	.073	0.26	0.45	0.64	0.83
5.0	0.26	0.51	0.75	0.99	1.24
10.0	0.55	0.87	1.19	1.51	1.83
15.0	1.06	1.49	1.92	2.35	2.78
20.0	2.01	2.60	3.19	3.78	4.37
25.0	3.78	4.61	5.45	6.29	7.12
30.0	7.43	8.67	9.90	11.15	12.39
35.0	13.24	14.99	16.74	18.50	20.25
40.0	15.47	17.40	19.32	21.25	23.18
45.0	35.41	38.60	41.79	44.98	48.17

TABLE 7-2. REINFORCED CONCRETE REQUIRED

I.D. (figure 7-1)	Concrete (ft ³)		Reinforcing Steel (kips)	
	60 ft Section	Total, 2 Sides	60 ft Section	Total, 2 Sides
C ₁	90.4	4,520	3.43	171.5
C ₂	64.6	3,230	2.45	122.5
C ₃	87.3	4,365	0.98	49.0
S ₁	400.0	20,000	1.75	87.6
S ₂	400.0	20,000	1.75	87.6
S ₃	640.0	32,000	5.73	286.5
B ₄	60.0	3,000	0.83	41.5
B ₅	20.0	1,000	0.47	23.3
Totals	1,762.3	88,115	17.39	869.5

TABLE 7-3. STRUCTURAL STEEL BEAMS REQUIRED

I.D. (figure 7-1)	Beam Section	Weight (kips), 60 ft Section	Total Weight (kips), 2 Sides
B ₁	W 12×26	3.12	156.0
B ₂	W 24×68	5.10	255.0
B ₃	W 24×55	1.38	68.8
Totals		9.60	479.8

TABLE 7-4. SIDE SUPPORT FOUNDATION CONSTRUCTION COSTS

Item	Unit	Quantity	Unit Cost (dollars)	Total Cost (dollars)
Concrete	C.Y.	3,264	350.00	1,142,400
Reinforcing bars	lb	870,000	0.21	182,700
Structural steel beams	lb	480,000	0.29	139,200
Steel grating	S.F.	45,000	4.50	202,500
Contractor QC				30,000
Subtotal, construction				1,696,800
Contingencies (10%)				169,700
Total, construction				1,866,500
Design/Engr/Insp (20%)				373,300
Total project cost				2,239,800
			SAY	2,250,000

Notes: C.Y. = Cubic Yard
S.F. = Square Foot

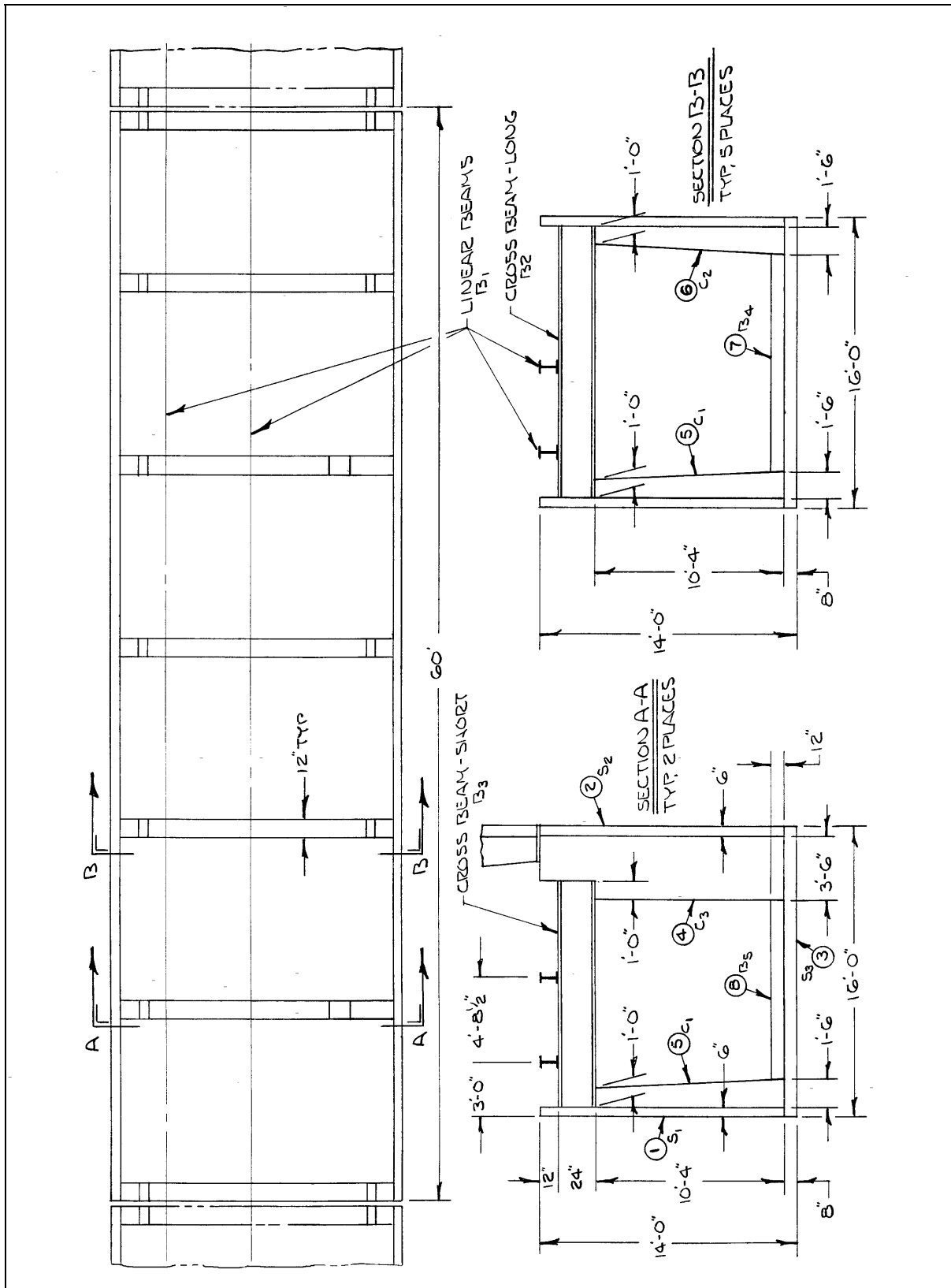

FIGURE 7-1. PLAN AND TWO CROSS-SECTIONS OF THE FOUNDATION

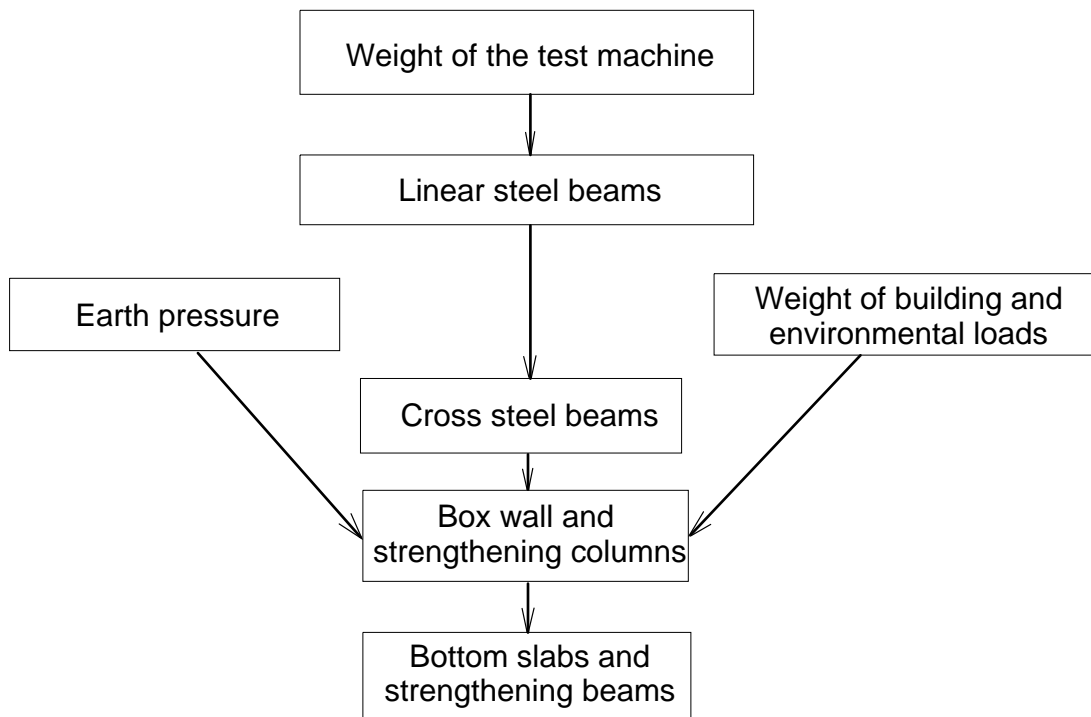

FIGURE 7-2. ASSUMED LOAD TRANSFER PATHS

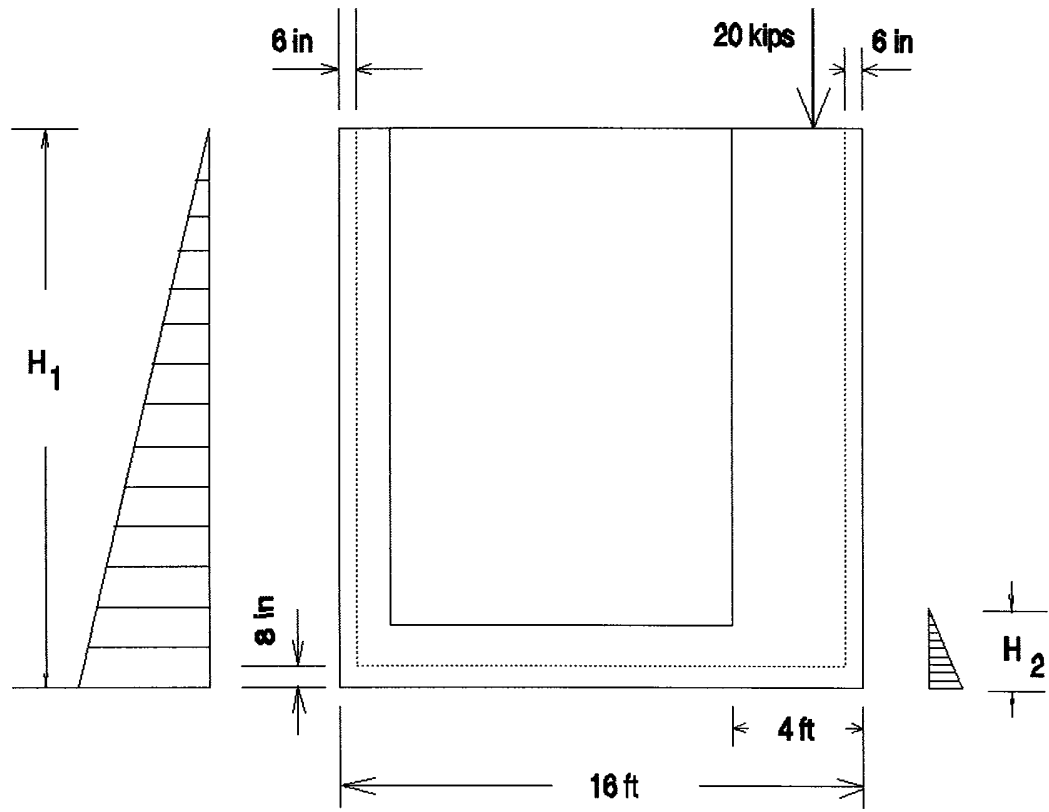

FIGURE 7-3. A MODEL FOR OVERTURNING ANALYSIS

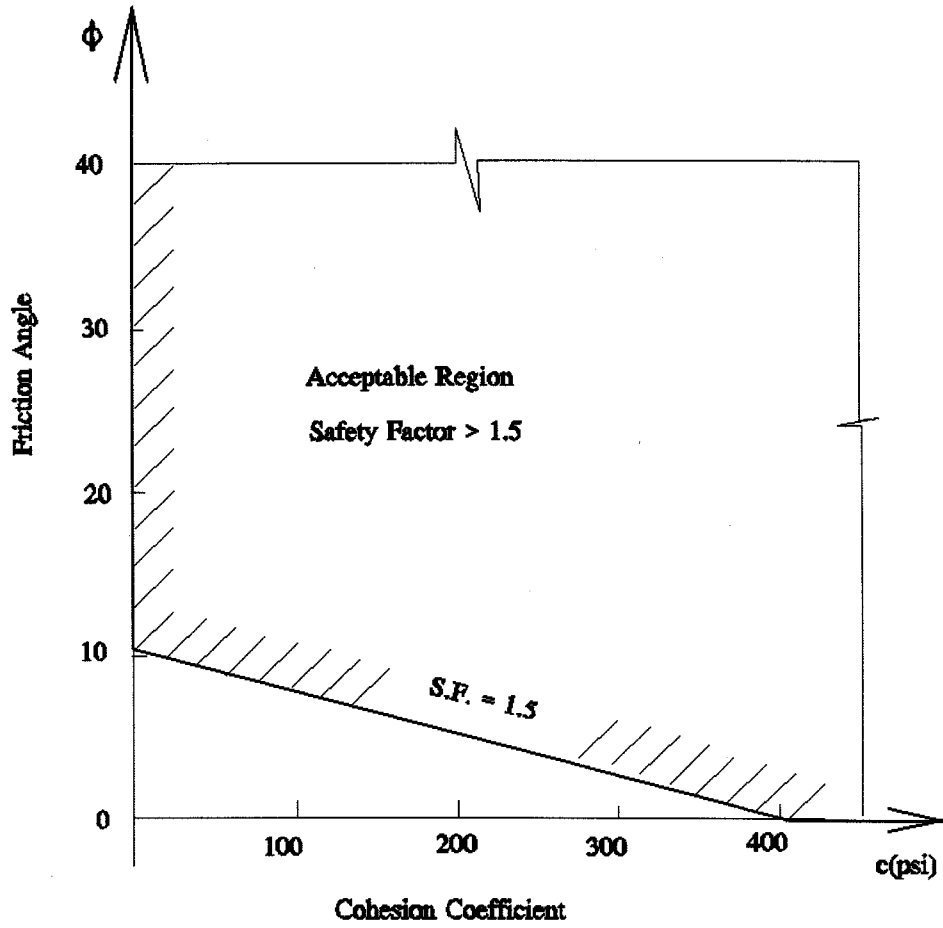

FIGURE 7-4. ACCEPTABLE SOIL PROPERTIES FOR OVERTURNING RESISTANCE

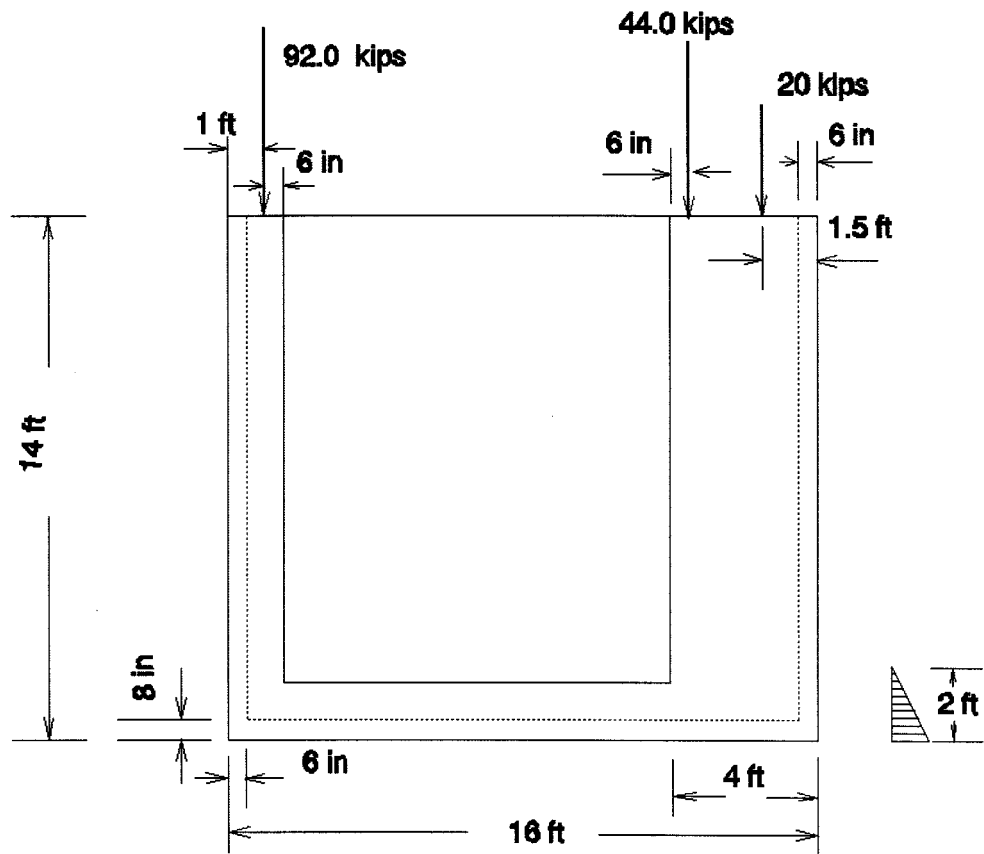

FIGURE 7-5. A MODEL FOR BEARING CAPACITY ANALYSIS

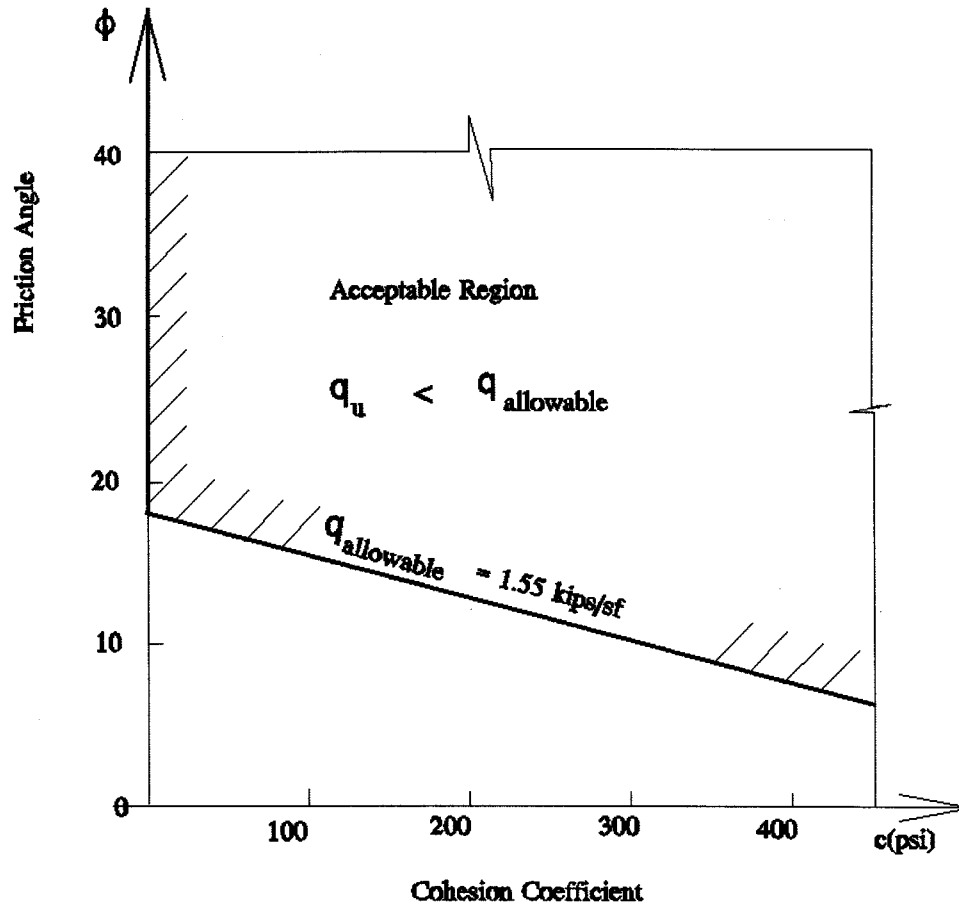

FIGURE 7-6. ACCEPTABLE PROPERTIES OF SOIL FOR BEARING CAPACITY

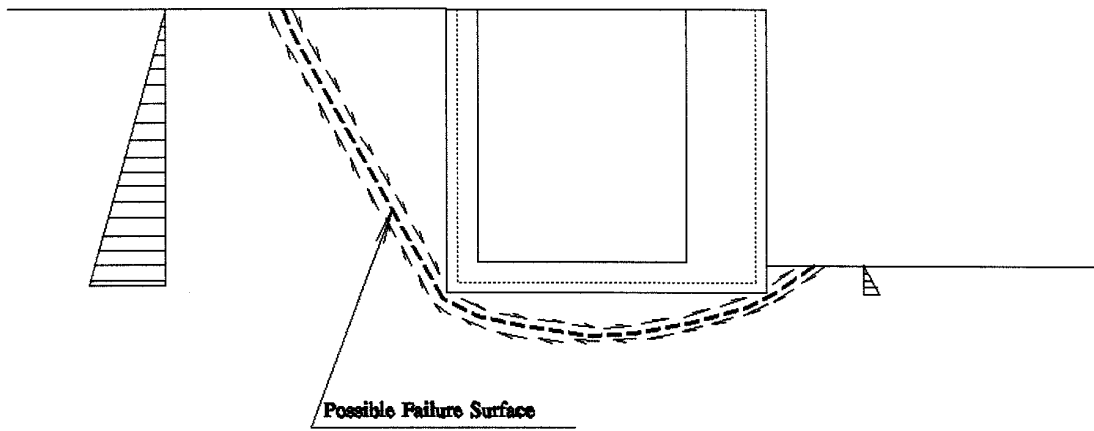

FIGURE 7-7. SOIL STABILITY ANALYSIS

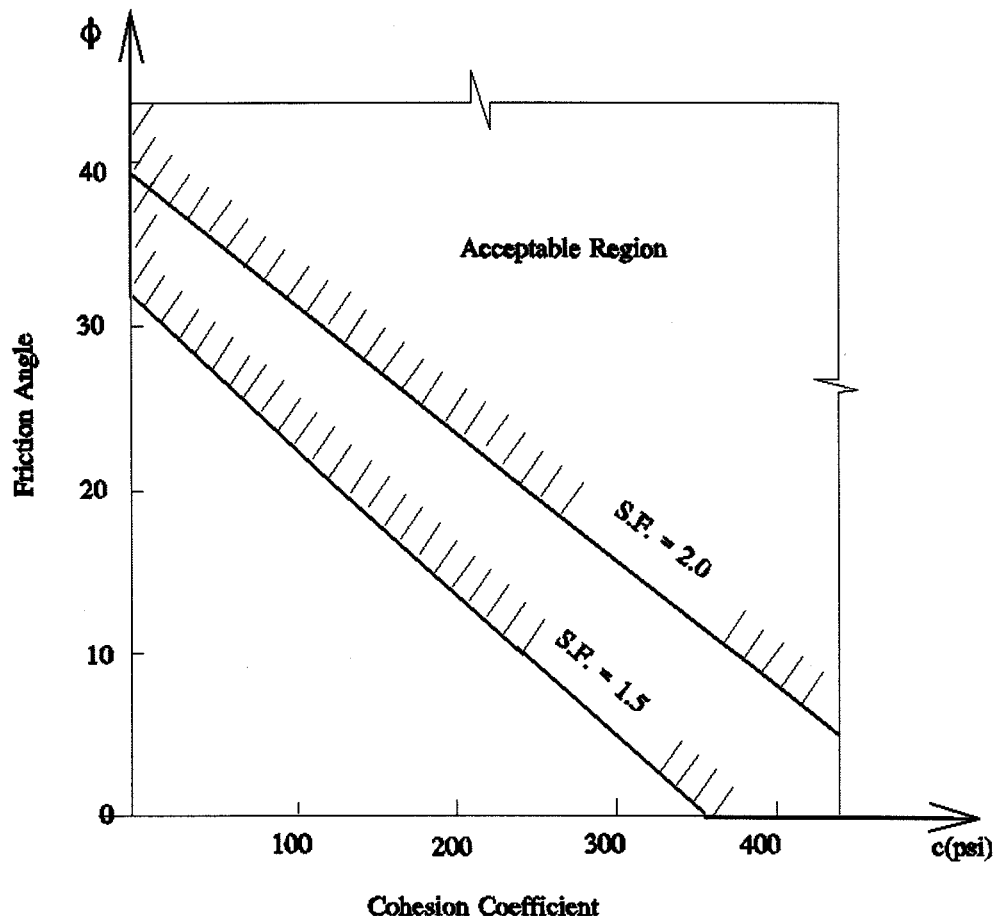

FIGURE 7-8. ACCEPTABLE PROPERTIES OF SOIL FOR STABILITY

PROPOSED TEST PROGRAM

INTRODUCTION.

The test program proposed for the test machine consists of four phases, each with distinct objectives. In the order in which they should be run, the four phases are:

1. Test machine shakedown and development tests.
2. Pavement response tests for design.
3. Pavement life tests for design.
4. Pavement life tests for evaluating materials and construction techniques.

The first two phases should be completed during the first year of operation after commissioning. The third phase should begin during the second year of operation and continue during the following years. Tests falling under the fourth phase category may require dedicated test machine time, but in most cases it should be possible to incorporate the evaluations in the life tests for design after the initial series of tests have been completed.

MACHINE SHAKE-DOWN AND DEVELOPMENT TESTS.

Considering the unique nature of the proposed test machine, there will undoubtedly be unforeseen problems to be solved by development and modification of the systems and operating characteristics. True operating characteristics will also have to be determined for planning test programs. In particular, a series of tests should be planned to measure the temperature and wear characteristics of the test tires under testing conditions. The test pavement instrumentation sensor and data acquisition systems are also expected to require a significant amount of testing and calibration, together with development of data formatting and storage procedures for analysis and distribution.

PAVEMENT RESPONSE TESTS.

The design of the test machine was to a large extent determined by the need to develop pavement design procedures for the new generation of large civil transport aircraft, including the B-777, MD-12 and growth B-747 class aircraft, and the High Speed Civil Transport supersonic aircraft. Current design procedures predict a significant amount of interaction between the loads from the multiple-wheels and close spacing of the trucks which will be used on these aircraft. Replacement procedures which predict smaller amounts of interaction, and less damage, than the current procedures are under development. But the true degree of interaction is not known and measurements from full-scale tests are urgently required to determine how closely wheels and trucks can be spaced without significant load interaction. It is therefore proposed that a series of pavement response tests be planned for the first year of test machine operation, to be run in conjunction with, and possibly as part of, the development tests.

A tentative test plan is to run tests with the following variables:

- a. 1-, 2-, 4-, and 6-wheel truck configurations.
- b. Lateral, longitudinal, and diagonal spacing.
- c. Three wheel loads.

Pavement response (stress, strain, and deflection, as appropriate) would be measured at various depths in each of the pavement test items for each combination of the above variables. To determine the interaction for each combination, the following procedure could be followed:

1. Run a test at maximum wheel group spacing and measure response.
2. Repeat the test a number of times at the same spacing but with a predetermined wander pattern.
3. Decrease the wheel group spacing and repeat 1 and 2.
4. Repeat 1, 2, and 3, except eliminate the wander (multiple wheel passes in the same track for each wheel group spacing).

There are thirty six different combinations to be tested. Spreading the tests over one year would therefore allow ten days to complete each test series. This is probably a reasonable schedule providing the development tests are not excessively time consuming. Data analysis would require considerably more time to plan and complete.

PAVEMENT LIFE TESTS FOR DESIGN.

The general requirements for the pavement life tests are discussed separately in Chapter 5, Test Pavement Design and Cost Estimate.

CONCLUSIONS

A design study was conducted to determine the feasibility of constructing and operating a test machine for performing accelerated airport pavement tests. The proposed design for the test machine satisfies the requirements of a comprehensive set of specifications formulated and developed by a government / industry working group. The primary purpose of the tests to be conducted with the test machine is to provide pavement response and performance data to be used in the development of new procedures for designing pavements for the next generation of large civil transport aircraft.

The proposed test machine design allows for test pavements 60 feet wide by 900 feet long. Maximum load capacity is twelve wheels operating at 75,000 pounds each, for a maximum applied load of 900,000 pounds. Test speeds are 5 mph for normal testing and a maximum of 15 mph for special studies.

Cost estimates were made for designing, constructing, and operating the test machine. The total initial cost required to design and construct the machine was estimated to be \$15,000,000. Maximum annual operating costs after commissioning were estimated to be \$2,300,000. Test pavement reconstruction accounts for \$1,500,000 (65 percent) of the estimated annual operating cost.

REFERENCES

1. **"Airport Pavement Design and Evaluation,"** Advisory Circular AC 150/5320-6C, U.S. Department of Transportation, Federal Aviation Administration, Washington, DC, Dec. 7 1978.
2. Kadar, P., **"Accelerated Full-Scale Testing of Heavy Duty Pavements - Experience with the Australian Accelerated Loading Facility (ALF),"** *Proceedings, Sixth International Conference on the Structural Design of Asphalt Pavements*, Ann Arbor, MI, 1987.
3. Bonaquist, R., **"Summary of Pavement Performance Tests Using the Accelerated Loading Facility 1986 - 1990,"** *Transportation Research Record No. 1354*, Transportation Research Board, Washington, DC, 1992.
4. Autret, P., A.-B. de Boissoudy, and J.-C. Gramsammer, **"The Circular Test Track of the Laboratoire Central des Ponts et Chaussées - First Results,"** *Proceedings, Sixth International Conference on the Structural Design of Asphalt Pavements*, Ann Arbor, MI, 1987.
5. Ruiz, A., R. Romero, and J. Pérez, **"Analysis of Deflections on a Test Track,"** TRB Paper No. NDT-040 (preprint), 1992.
6. Ahlvin, R.G., et al., **"Multiple-Wheel Heavy Gear Load Pavement Tests,"** Report No. AFWL-TR-70-113, Vols. I-IV, Air Force Weapons Laboratory, Kirtland AFB, NM, Nov. 1971.
7. Burns, C.L., et al., **"Comparative Performance of Structural Layers in Pavement Systems, Volume I, Design, Construction, and Behavior Under Traffic of Pavement Test Sections,"** Report No. FAA-RD-73-198 I, Federal Aviation Administration, Washington, DC, June 1974.
8. **"The Texas Mobile Load Simulator,"** Progress Report, Texas Department of Transportation, Austin, TX, March 1992.
9. van Vuuren, D.J., **"Pavement Performance in the S12 Road Experiment, an AASHTO Satellite Test Road in South Africa,"** *Proceedings, Third International Conference on the Structural Design of Asphalt Pavements*, Ann Arbor, MI, 1972.
10. White, T.D., **"An Accelerated Pavement Testing System,"** *Proceedings, Conference on Road and Airport Pavement Response Monitoring Systems*, American Society of Civil Engineers, New York, NY, Sept. 1992.

11. Paterson, W.D.O., "**Deformations in Asphalt Concrete Wearing Courses Caused by Traffic,**" *Proceedings, Third International Conference on the Structural Design of Asphalt Pavements*, Ann Arbor, MI, 1972.
12. "**RTT CAPTIF Accelerated Pavement & Vehicle Test Facility,**" Bulletin RTB012, Road Test Technology, Ltd., Christchurch, New Zealand.
13. "**Certain Requirements for Flexible Pavement Design for B-29 Planes,**" U.S. Army Engineer Waterways Experiment Station, Vicksburg, MS, Aug. 1945.
14. Ahlvin, R.G., "**Origin of Developments for Structural Design of Pavements,**" page 10-7, Technical Report GL-91-26, U.S. Army Waterways Experiment Station, Vicksburg, MS, Dec. 1991.
15. HoSang, V.A., "**Field Survey and Analysis of Aircraft Distribution on Airport Pavements,**" Report No. FAA-RD-74-36, Federal Aviation Administration, Washington, DC, Feb. 1975.
16. "**Standards for Specifying Construction of Airports,**" Advisory Circular AC 150/5370-10A, U.S. Department of Transportation, Federal Aviation Administration, Washington, DC, Feb. 17, 1989.
17. *Marks' Standard Handbook for Mechanical Engineers*, 8th Edition, T. Baumeister, Ed., McGraw-Hill Book Company, 1978.
18. *Standard Specification for Highway Bridges*, 13th edition, American Association of State Highway and Transportation Officials, Washington, D.C., 1983.
19. Bowles, J.E., *Foundation Analysis and Design*, McGraw-Hill Publishing Company, 1988.
20. Wolff, T., "**TWSLOPE,**" Computer Program for Soil Stability Analysis, Course Materials, CE-818, Michigan State University, 1991.
21. *Means Heavy Construction Cost Data, 7th Annual Edition, 1993*, R.S. Means Company, Kingston, MA, 1992.
22. Barker, W.R. & Gonzales, C.R., "**Pavement Design by Elastic Layer Theory,**" U.S. Army Engineer Waterways Experiment Station, 1992.
23. Kurtz, M., *Handbook of Applied Mathematics for Engineers and Scientists*, McGraw-Hill Publishing Company, 1991.

24. Ioannides, A.M., "**Development of User Guidelines for a Three-Dimensional Finite Element Pavement Model,**" *Proceedings, Unified Airport Pavement Design and Analysis Concepts Workshop*, Report No. FAA-RD-92/17, Federal Aviation Administration, Washington, DC, July 1992.
25. Kokkins, S.J., "**FAA Unified Pavement Analysis 3-D Finite Element Method,**" *Proceedings, Unified Airport Pavement Design and Analysis Concepts Workshop*, Report No. FAA-RD-92/17, Federal Aviation Administration, Washington, DC, July 1992.
26. Forte, T., et al., "**Federal Aviation Administration Pavement Modeling,**" *Proceedings, Unified Airport Pavement Design and Analysis Concepts Workshop*, Report No. FAA-RD-92/17, Federal Aviation Administration, Washington, DC, July 1992.
27. Owusu-Antwi, E., et. al., "**Development of a Unified Airport Pavement Analysis and Design System,**" *Proceedings, Unified Airport Pavement Design and Analysis Concepts Workshop*, Report No. FAA-RD-92/17, Federal Aviation Administration, Washington, DC, July 1992.
28. Seaman, L., et. al., "**Unified Airport Pavement Design Procedure,**" *Proceedings, Unified Airport Pavement Design and Analysis Concepts Workshop*, Report No. FAA-RD-92/17, Federal Aviation Administration, Washington, DC, July 1992.
29. Harichandran, R.S., G.Y. Baladi, and M.S. Yeh, "**MICH-PAVE User's Manual,**" Dept. of Civil and Environmental Engineering, Michigan State University, Aug. 1989.
30. Dong, M., "**Modification of Segment 1.2,**" Final Report, Contract No. DTFH61-92-P-01771, Federal Highway Administration, Washington, DC, Dec. 1992.
31. *Building Code Requirements for Reinforcement Concrete*, ACI 318-89 & 318R-89, American Concrete Institute, 1989.
32. *Manual of Steel Construction, Load & Resistance Factor Design*, First Edition, American Institute of Steel Construction, Inc., March 1990.
33. *Design Handbook, Volume I, Beams, One-Way Slabs, Brackets, Footings and Pile Caps*, ACI 340.1R-91, Publication SP-17(91), American Concrete Institute, April 1991.

GLOSSARY

AASHTO	American Association of State Highway and Transportation Officials
AC	Advisory Circular
AC	Asphaltic Concrete
ACI	American Concrete Institute
AGBS	Crushed Aggregate Base
AISC	American Institute of Steel Construction
ALF	Accelerated Loading Facility
ATS	Accelerated Test System
CBR	California Bearing Ratio
CEDEX	CEDEX Road Research Center, El Goloso, Spain
CTB	Cement Treated Base
DOT	Department of Transportation
E	Elastic Modulus
ESWL	Equivalent Single Wheel Load
FAA	Federal Aviation Administration
FEM	Finite Element Method
FHWA	Federal Highway Administration
ft	feet
HVS	Heavy Vehicle Simulator
hp	horse power
in	inches
k	modulus of subgrade reaction, pci
kips	thousand pounds
kW	kiloWatt = 1,000 Watts
kWh	kiloWatt hour
LCPC	Laboratoire Central des Ponts et Chaussées, Nantes, France
LET	Layered Elastic Theory
lb	pound
lbs	pounds
MWHGL	Multiple Wheel Heavy Gear Load
mph	miles per hour
NDT	Nondestructive Testing
n	number of coverages (equivalent load applications at a point)
PCC	Portland Cement Concrete
pci	pounds per cubic inch
psf	pounds per square foot
psi	pounds per square inch
QA	Quality Assurance
QC	Quality Control
Reps	Repetitions
S.F.	Safety Factor
SHRP	Strategic Highway Research Program
SSBS	Select Subbase

STBS	Stabilized Base
sec	second
sf	square foot
TRB	Transportation Research Board
TRL	Transport Research Laboratory, Crowthorne, England
WES	U.S. Army Waterways Experiment Station

ρ	ratio of tension reinforcement
ϕ	friction angle
μ	Poisson's ratio
γ	unit weight of soil
σ_3	earth pressure
A	area
c	soil cohesion coefficient
F_y	yield stress of steel
f_c	compressive strength of concrete
f_y	yield strength of steel
g	gravitational acceleration = 32.2 ft/s ²
K_n	strength coefficient of resistance, psi
l_u	unsupported length of columns
M	bending moment
P_u	ultimate axial load in compression
q	maximum earth pressure
Z_x	plastic modulus

APPENDIX A

ANALYSIS OF THE REQUIRED WIDTH AND DEPTH OF THE TEST PAVEMENT

OBJECTIVE OF THE ANALYSIS.

The objective of the analysis was to determine the required minimum width and depth of the test pavement sections necessary to satisfy the full-scale testing requirements at minimum cost. The testing requirements considered in this analysis were:

- a. Maximum lateral distance between truck centerlines of 20 feet.
- b. Realistic simulation of aircraft wander.
- c. The boundary effects of the structures on the sides and bottom of the test sections should be low enough to not significantly influence the test results.

Rigid pavement response to wheel loading is more localized than flexible pavement response. Flexible pavements therefore represent the worst case for boundary effects, and the analysis considered only flexible pavements.

The basic assumptions used in the analysis were:

- a. The maximum edge-edge distance between tires is 26 ft.
- b. The standard deviation of aircraft wander on taxiways is 30.475 inch, with 75 percent of passes within a width of 70 inches. The standard deviation of aircraft on runways is 60.789, with 75 percent of passes within a width of 140 inches.[22]
- c. Aggregate base and subbase materials.

WANDER WIDTH.

The cross-section of the test pavement is shown in figure 5-1, which indicates that:

$$W = 26 \text{ ft} + 2D + 2B \quad (\text{A-1})$$

where B is the assumed half width of aircraft wander. If the wander is assumed as a Gaussian random variable, the probability of any tire covering the surface to the left of point G or to the right of point H is:

$$P(|X| \geq B) = P(|X| \geq \alpha\sigma) \quad (\text{A-2})$$

If B is selected such that 5 percent or less passes cover the surface outside points G and H , then:

$$P(|X| \geq B) \leq 0.05 \quad (\text{A-3})$$

and, for the taxiway:

$$B = 1.96 \times 30.475 = 59.73 \text{ in}$$

and, for the runway:

$$B = 1.96 \times 60.789 = 119.14 \text{ in (see reference 23, page 9.31, table 9.4)}$$

Based on the above analysis, B was selected as 60 inches for the taxiway and 120 inches for the runway. The effects of less than 5 percent of tire coverages wandering beyond the boundary (left of point G or right of point H in figure. 5-1) are neglected.

EFFECTS OF THE SIDE BOUNDARY CONDITIONS.

An evaluation of the effects of rigid side boundaries on the response of the test pavement was made using layered elastic and finite element computer programs. References 24 to 28 present responses of pavements by using 3-D finite element programs for single and multiple tire loading. From the information in these publications, it was concluded that it would be sufficient to investigate the effects of boundary conditions by analyzing the responses under a single tire load only. Therefore, a 70,000 lbs circular load with contact pressure of 200 psi was used to conduct the analysis. Because the structure and the load are both symmetric, the three dimensional problem may be simplified into an axisymmetric problem which can be solved by using a layered elastic program^[22] or an axisymmetric finite element program such as MICH-PAVE^[29] or AXIS^[30]. The semi-infinite idealization of the pavement structure is shown in figure A-1.

A typical finite element mesh is given in figure A-2. The left side is the axis of symmetry, so the boundary condition $u = 0$ (radial displacements are zero) is applied. The bottom side is assumed fully restrained if the depth of the subgrade is defined deep enough; namely: $u = v = 0$ (radial and vertical displacements are both zero). The right side in figure A-2 indicates the side boundary. Three conditions have been considered in the analysis:

$$u = 0 \tag{A-4}$$

$$u = v = 0 \tag{A-5}$$

$$u \neq 0 \text{ and } v \neq 0 \tag{A-6}$$

The material properties for each layer are listed in table A-1 where the E values of the base and subbase materials were calculated by using the computer program MODULUS in the LEDNEW^[22] package.

Figure A-3 shows relative surface deflection ($[\text{surface deflection}] / [\text{the maximum deflection at the load center}]$) in terms of the distance to the load center. It can be seen that at a distance of 60 inches, the deflection predicted by the AXIS program is about 13 percent of the maximum deflection, but the deflection predicted by LEDNEW and MICH-PAVE is greater than 30 percent of the maximum displacement. Figure A-4 illustrates the decay of the stresses at the bottom of the AC layer. At a distance of 60 inches, the results calculated by all models are reduced to less than 5 percent of the maximum stress in the AC layer. Figure A-5 indicates that the vertical strain at the top of the subgrade predicted by MICH-PAVE and AXIS is reduced to

about 10 percent of the maximum strain, whereas the result obtained by LEDNEW is about 15 percent of the maximum response.

Figures A-6 to A-8 present the effects of the three assumed conditions on the right side boundary (equations A-4 to A-6) obtained by using the AXIS program. The conditions $u = 0$ and $u = v = 0$ predict almost the same results except at the boundary (the deflection at the boundary is not zero by equation A-4 but must be zero by using equation A-5). The boundary conditions of equation A-6 predict that the critical responses for this case are greater than for the other two cases, as follows:

Deflection	= 3.0%
Stress at bottom of the load center	= 1.5%
Vertical strain on top of the subgrade	= 7.0%

The maximum difference between results for the boundary distances 180 inches and 120 inches is 1.1 percent (table A-2).

For investigating runway responses, B in figure A-1 is 10 ft. If D is selected as 7 ft, the total width of the test section will be:

$$\text{Width} = 26 \text{ ft} + 2 \times 10 \text{ ft} + 2 \times 7 \text{ ft} = 60 \text{ ft}$$

If the isolation layer between the test section and the concrete foundation is 3 ft, the boundary distance would be 10 ft when the rightmost tire wanders to the rightmost location (point H in figure A-1). Based on the above analysis, if D increases from 7 ft to 12 ft, the maximum difference between critical responses for the two cases will be less than 1.3 percent. Therefore, $D = 7$ ft should be acceptable (the total width of the test section is 60 ft). For the test simulating the behavior of taxiways, the total width is more than it needs to be because taxiway wander standard deviation is smaller.

EFFECTS OF THE BOTTOM BOUNDARY CONDITION.

Two cases are considered: a rigid boundary at varying depths, and a flexible boundary with varying stiffness.

EFFECTS OF BOUNDARY DEPTH. The finite element program MICH-PAVE was employed to conduct the analysis. The finite element mesh is the same as shown in figure A-2, but the thickness of the subgrade was varied from 36 to 144 inches. The major input parameter values are listed in table A-3.

The results in table A-4 indicate that the critical stresses in the AC layer converge very quickly when the thickness to the rigid bottom increases. However, both maximum deflection on the surface and vertical strain on the subgrade converge very slowly. For example, if a rigid bottom is built 36 inch (3 ft) deep under the subbase, the calculated critical vertical strain would be 27 percent greater than for a rigid bottom located at 144 inches (12 ft) under the subbase. The difference between surface deflections for the subgrade depths 36 and 144 inches is 7.8 percent.

EFFECTS OF THE SUBGRADE MATERIAL PROPERTIES. For this case, the finite element mesh is the same as shown in figure A-2. The subgrade thickness is assumed to be 36 inches and the elastic modulus E varies from 3,000 psi to 15,000 psi. The other major input parameter values are the same as in table A-3. The results calculated by MICH-PAVE are listed in table A-5. It can be seen clearly that the critical stresses in the AC layer are not sensitive to variation of the subgrade material properties, but the critical surface deflection and the vertical strains are.

CONCLUSIONS.

a. The above analysis indicates that if a rigid bottom is designed for the test section, some measured critical responses could be considerably overestimated, such as the vertical strain on top of the subgrade shown in table A-4. Therefore the test section has been proposed to be built on existing grade instead of a rigid bottom foundation.

b. The total depth of the test section has been proposed to be 14 ft. The base, subbase, and subgrade of the section can be designed to appropriately simulate any typical airport pavement structure and can be easily replaced by new materials after completion of a test project.

c. The total width of 60 ft has been selected for the test section. Based on the above analysis the variation of any of the critical responses due to the assumed boundary conditions for the concrete foundations (equations A-4 to A-6) will not be more than 7 percent. Furthermore, if the total width of the test section is increased from 60 ft to 70 ft (the distance between the outer tire edge and the surface of the concrete box D_1 (figure 5-2) increased from 120 inches to 180 inches, including the 3 ft shoulder) the critical response differences between the two cases will not be greater than 1.5 percent. Therefore, 60 ft, or greater, is an appropriate width to be used for the design.

TABLE A-1. MATERIAL PROPERTIES

		Case 1		Case 2	
	h (inch)	E (psi)	u	E (psi)	u
AC	4	200,000	0.40	200,000	0.40
Base	6	64,484	0.35	65,745	0.35
Subbase	35	28,242	0.30	33,265	0.30
Subgrade	36	7500	0.40	15,000	0.40

TABLE A-2. EFFECTS OF SIDE BOUNDARY DISTANCE

E/D_1 (in)	60	90	120	150	180
Maximum deflection (in)					
7,500	-0.0796	-0.0798	-0.8140	-0.0821	-0.0820
15,000	-0.0659	-0.0672	-0.0680	-0.0683	-0.0682
Maximum stress in AC layer (psi)					
7,500	122.0	117.5	117.0	117.3	118.1
15,000	107.7	104.5	104.9	105.5	106.1
Maximum vertical strain on subgrade (10^{-3})					
7,500	0.857	0.904	0.957	0.974	0.968
15,000	0.535	0.591	0.619	0.625	0.621

TABLE A-3. MAJOR INPUT DATA FOR ANALYZING BOTTOM BOUNDARY DISTANCE EFFECTS

Layer	Thickness (in)	E (psi)	Poisson's Ratio
AC	5	250,000	0.40
Base	6	50,000	0.35
Subbase	35	30,000	0.30
Subgrade	Varies	7,500	0.40

TABLE A-4. CRITICAL RESPONSES vs. DIFFERENT BOTTOM BOUNDARY DISTANCES

H(ft)	36	54	72	90	108	126	144
Deflection (in)	-.1131	-.1148	-.1166	-.1186	-.1207	-.1228	-.1249
AC Stresses (psi)	356.2	356.5	356.7	356.8	356.9	356.9	356.9
Subgrade Strains (10 ⁻³)	0.696	0.660	0.632	0.609	0.587	0.567	0.548

TABLE A-5. CRITICAL RESPONSES vs. DIFFERENT SUBGRADE MATERIAL PROPERTIES

E(psi)	3,000	6,000	9,000	12,000	15,000
Deflection (in)	-.1797	-.1247	-.1051	-.0947	-.0882
AC Stresses (psi)	355.0	355.9	356.5	357.0	357.4
Subgrade Strains (10 ⁻³)	0.978	0.763	0.643	0.559	0.495

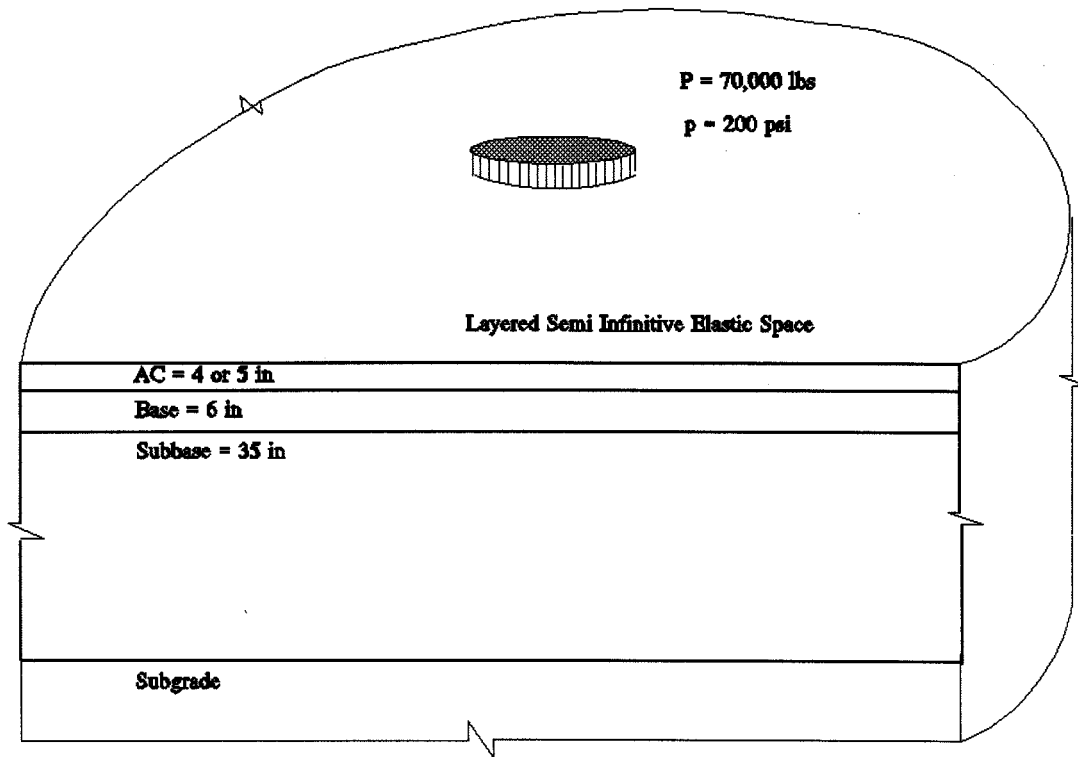

FIGURE A-1. THEORETICAL MODEL FOR BOUNDARY REQUIREMENT ANALYSIS

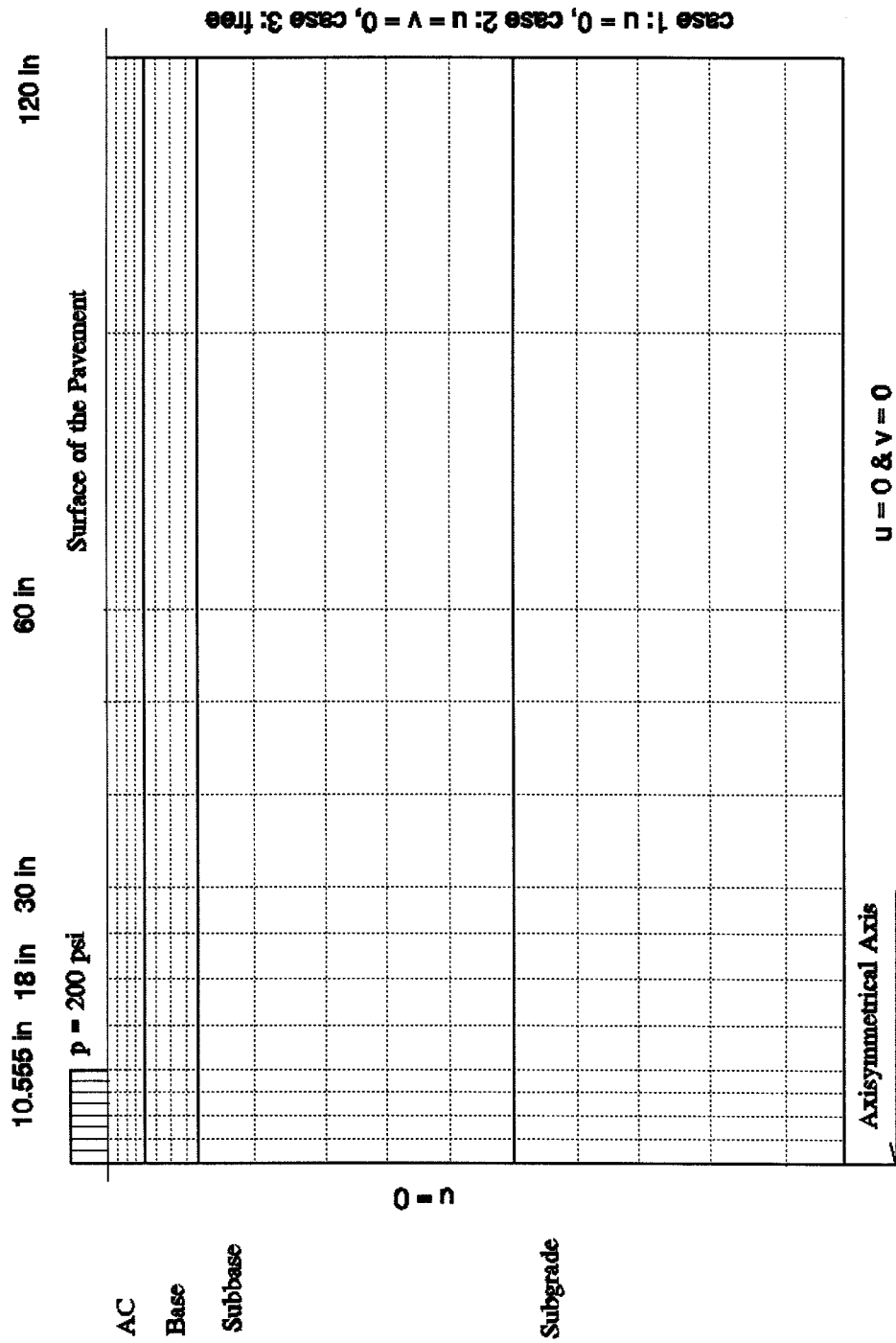

FIGURE A-2. STANDARD FINITE ELEMENT MESH

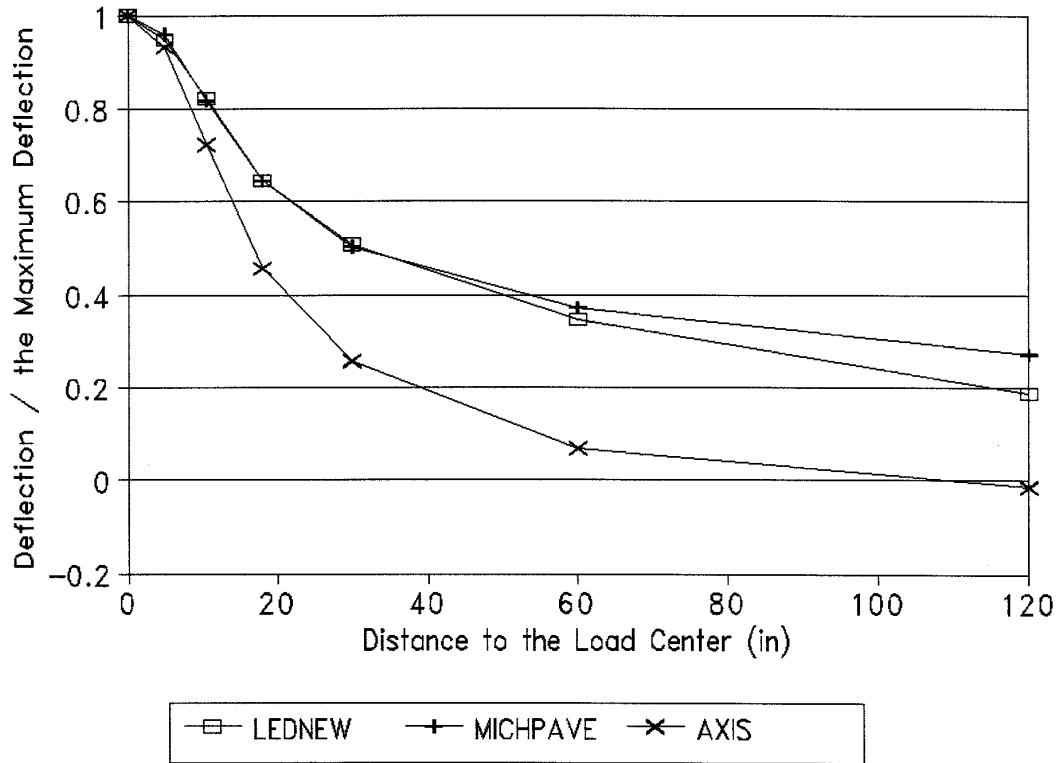

FIGURE A-3. SURFACE DEFLECTION DECAY

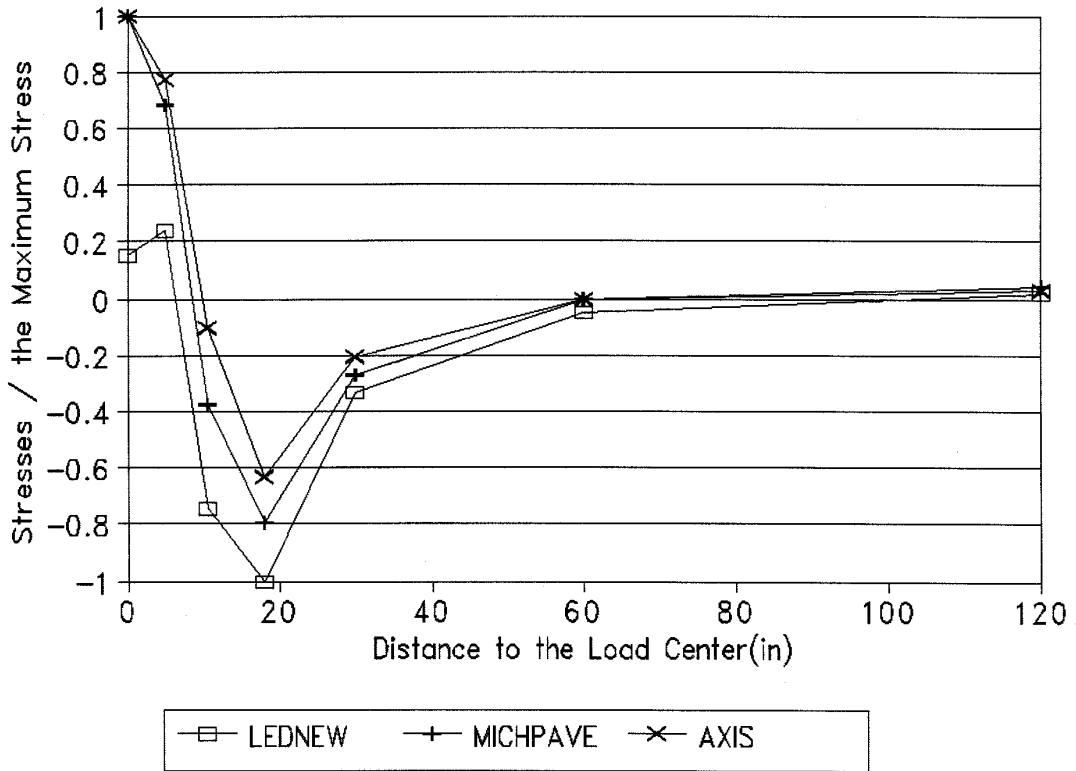

FIGURE A-4. AC STRESS DECAY

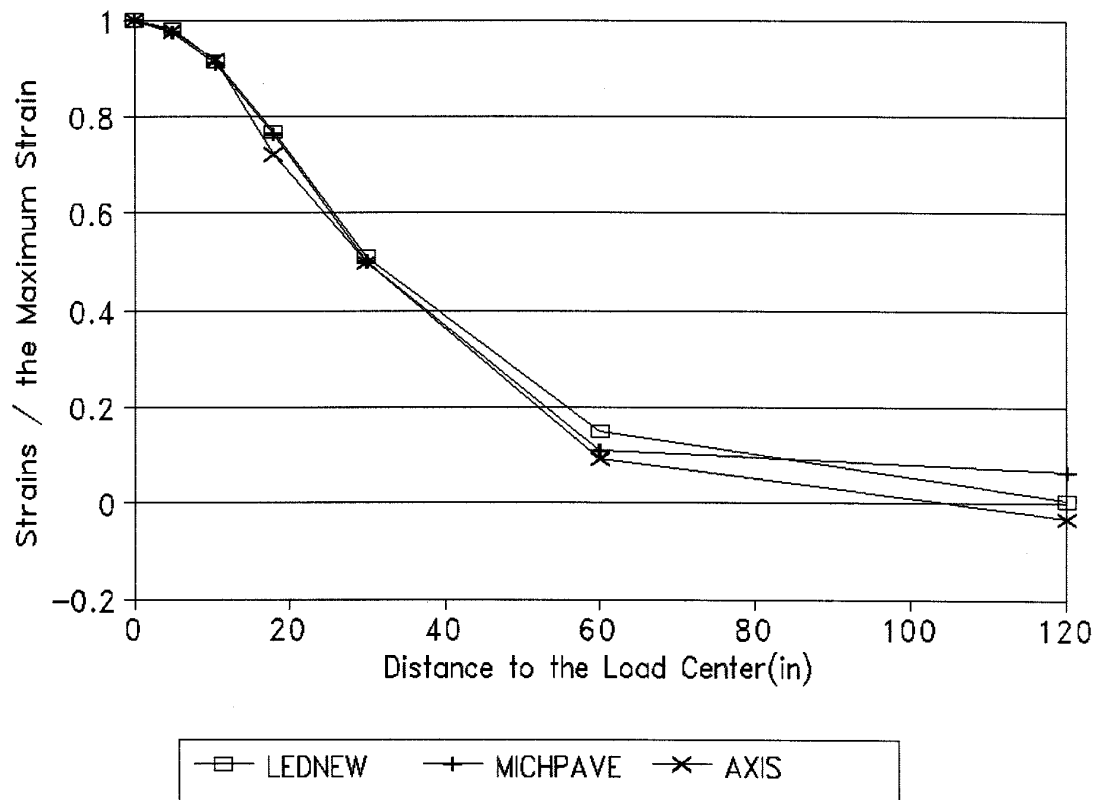
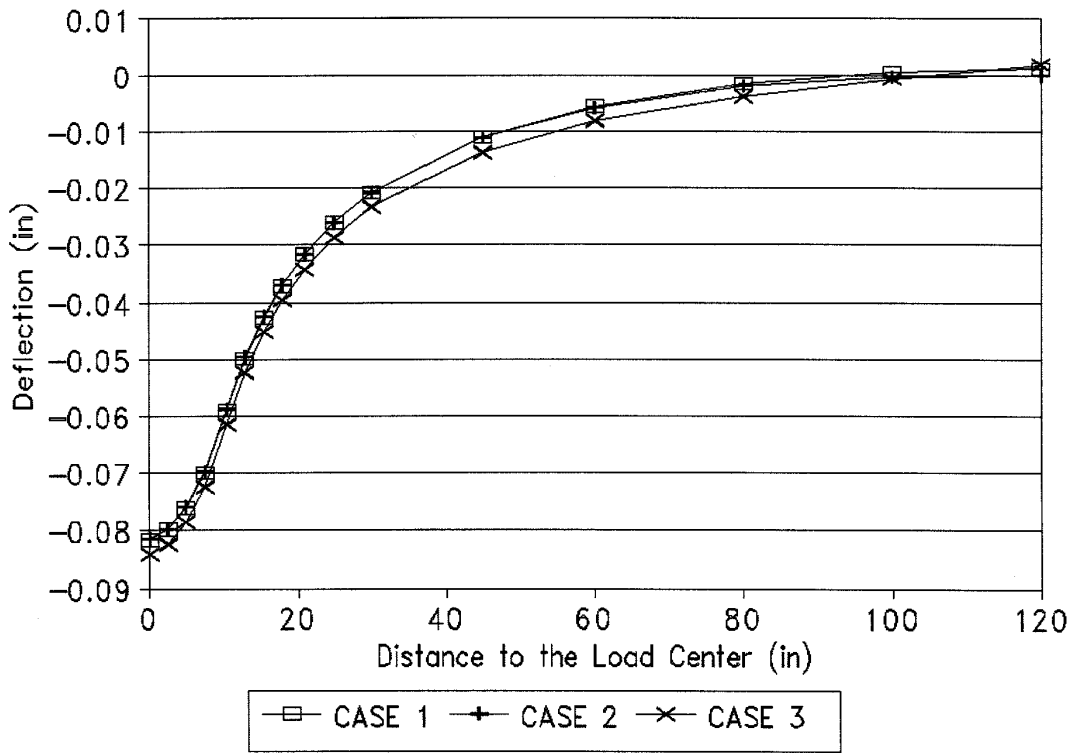

FIGURE A-5. SUBGRADE STRAIN DECAY



SURFACE DEFLECTION

FIGURE A-6. SURFACE DEFLECTION

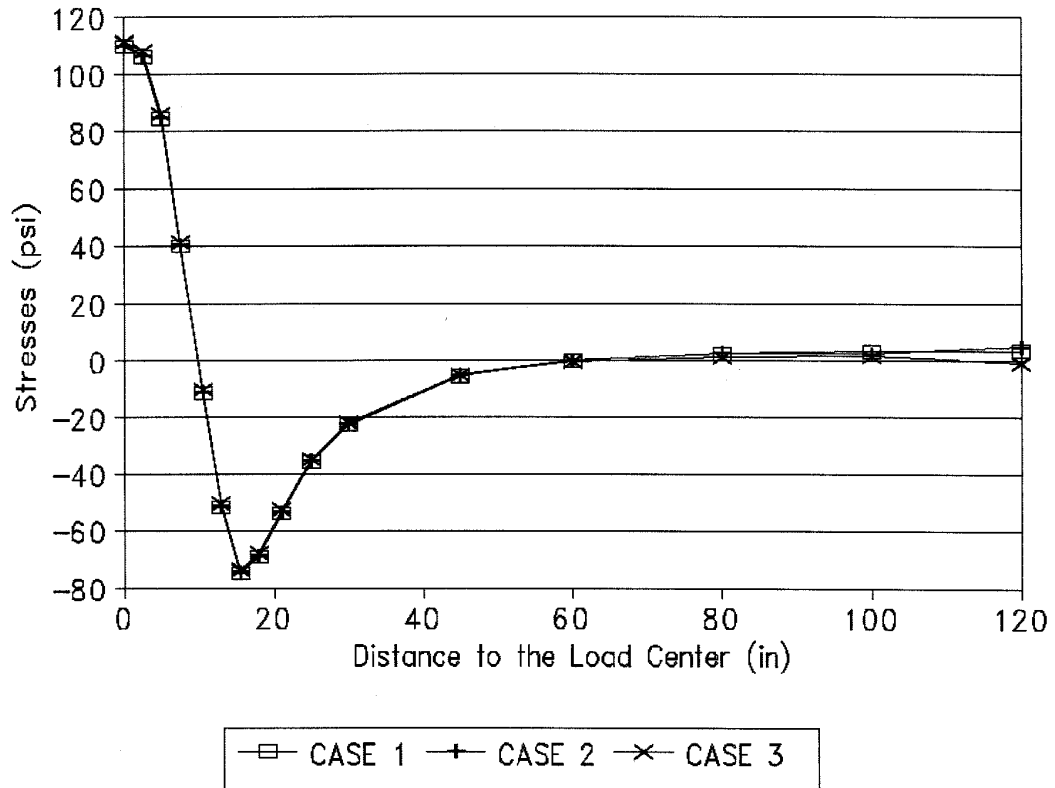

FIGURE A-7. STRESS AT BOTTOM OF AC LAYER

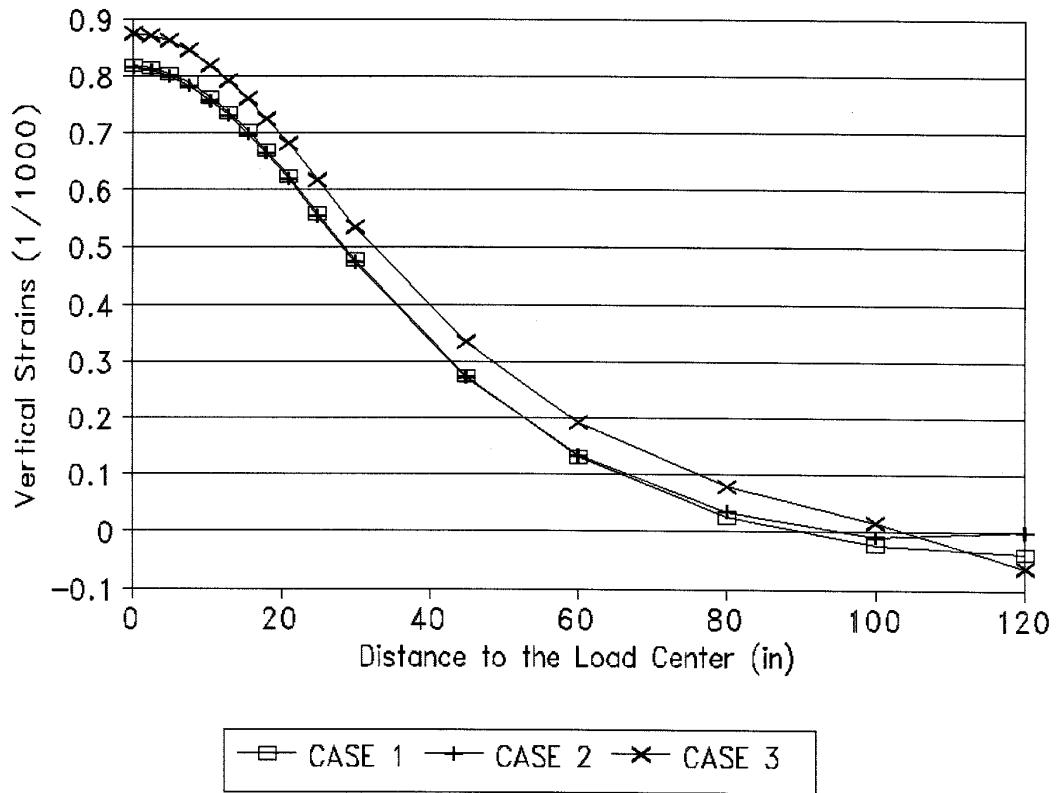

FIGURE A-8. STRAINS AT TOP OF THE SUBGRADE

APPENDIX B

TEST PAVEMENT ITEMIZED COST ESTIMATES

TABLE B-1. INITIAL PAVEMENT CONSTRUCTION COSTS

Item	Unit	Quantity	Unit Cost (dollars)	Total Cost (dollars)
Excavation, test items	C.Y.	4,600	3.00	13,800
Stripping	C.Y.	3,500	1.50	5,250
Common embankment	C.Y.	58,200	7.50	436,500
Select subgrade	C.Y.	16,500	8.50	140,250
Subbase	C.Y.	1,250	40.00	50,000
Aggregate base	C.Y.	3,250	75.00	243,750
Stabilized base	C.Y.	525	100.00	52,500
Hot mix asphalt	TON	3,500	100.00	350,000
PCC	C.Y.	2,000	300.00	600,000
Select subgrade haul	C.Y.	16,500	15.00	247,500
Common fill haul	C.Y.	58,200	4.00	232,800
Mobilization/demobilization	L.S.	1	175,000.00	175,000
Contractor QC	L.S.	1	75,000.00	75,000
Subtotal, construction				2,622,350
Contingencies (10%)				262,235
Total, construction				2,884,585
Engr/Insp/QA test (20%)				524,470
Total project cost				3,409,055
			SAY	3,400,000

Notes: C.Y. = Cubic Yard
 L.S. = Lump Sum

TABLE B-2. PERIODIC RECONSTRUCTION COSTS,
INTERACTION TEST PAVEMENTS

Item	Unit	Quantity	Unit Cost (dollars)	Total Cost (dollars)
Pavement demolition	S.Y.	6,600	15.00	99,000
Excavation	C.Y.	6,600	5.00	33,000
Select subgrade	C.Y.	7,920	8.50	67,320
Subbase	C.Y.	1,250	40.00	50,000
Aggregate base	C.Y.	1,450	75.00	108,750
Stabilized base	C.Y.	525	100.00	52,500
Hot mix asphalt	TON	1,600	100.00	160,000
PCC	C.Y.	2,000	300.00	600,000
Select subgrade haul	C.Y.	7,920	15.00	118,800
Misc. pavement repairs	L.S.	1	50,000.00	50,000
Mobilization/demobilization	L.S.	1	150,000.00	150,000
Contractor QC	L.S.	1	50,000.00	50,000
Subtotal, construction				1,539,370
Contingencies (10%)				153,937
Total, construction				1,693,307
Engr/Insp/QA test (20%)				307,874
Total project cost				2,001,181
			SAY	2,000,000

Notes: S.Y. = Square Yard
C.Y. = Cubic Yard
L.S. = Lump Sum

TABLE B-3. PERIODIC RECONSTRUCTION COSTS,
FLEXIBLE, LIFE TESTS

Item	Unit	Quantity	Unit Cost (dollars)	Total Cost (dollars)
Pavement demolition	S.Y.	6,600	15.00	99,000
Excavation	C.Y.	6,600	5.00	33,000
Select subgrade	C.Y.	7,920	8.50	67,320
Subbase	C.Y.	2,500	40.00	100,000
Aggregate base	C.Y.	2,500	75.00	187,500
Stabilized base	C.Y.	0	100.00	0
Hot mix asphalt	TON	2,000	100.00	200,000
PCC	C.Y.	0	300.00	0
Select subgrade haul	C.Y.	7,920	15.00	118,800
Misc. pavement repairs	L.S.	1	50,000.00	50,000
Mobilization/demobilization	L.S.	1	100,000.00	100,000
Contractor QC	L.S.	1	40,000.00	40,000
Subtotal, construction				995,620
Contingencies (10%)				99,562
Total, construction				1,095,182
Engr/Insp/QA test (20%)				199,124
Total project cost				1,294,306
			SAY	1,300,000

Notes: S.Y. = Square Yard
C.Y. = Cubic Yard
L.S. = Lump Sum

TABLE B-4. PERIODIC RECONSTRUCTION COSTS,
RIGID, LIFE TESTS

Item	Unit	Quantity	Unit Cost (dollars)	Total Cost (dollars)
Pavement demolition	S.Y.	6,600	15.00	99,000
Excavation	C.Y.	6,600	5.00	33,000
Select subgrade	C.Y.	7,920	8.50	67,320
Subbase	C.Y.	0	40.00	0
Aggregate base	C.Y.	1,600	75.00	120,000
Stabilized base	C.Y.	0	100.00	0
Hot mix asphalt	TON	100	150.00	15,000
PCC	C.Y.	2,450	300.00	735,000
Select subgrade haul	C.Y.	7,920	15.00	118,800
Misc. pavement repairs	L.S.	1	50,000.00	50,000
Mobilization/demobilization	L.S.	1	100,000.00	100,000
Contractor QC	L.S.	1	40,000.00	40,000
Subtotal, construction				1,378,120
Contingencies (10%)				137,812
Total, construction				1,515,932
Engr/Insp/Test (20%)				275,624
Total project cost				1,791,556
			SAY	1,800,000

Notes: S.Y. = Square Yard
C.Y. = Cubic Yard
L.S. = Lump Sum

TABLE B-5. PERIODIC RECONSTRUCTION COSTS,
FLEXIBLE ON STBS, LIFE TESTS

Item	Unit	Quantity	Unit Cost (dollars)	Total Cost (dollars)
Pavement demolition	S.Y.	6,600	15.00	99,000
Excavation	C.Y.	6,600	5.00	33,000
Select subgrade	C.Y.	7,920	8.50	67,320
Subbase	C.Y.	0	40.00	0
Aggregate base	C.Y.	2,500	75.00	187,500
Stabilized base	C.Y.	1,600	100.00	160,000
Hot mix asphalt	TON	2,000	100.00	200,000
PCC	C.Y.	0	300.00	0
Select subgrade haul	C.Y.	7,920	15.00	118,800
Misc. pavement repairs	L.S.	1	50,000.00	50,000
Mobilization/demobilization	L.S.	1	100,000.00	100,000
Contractor QC	L.S.	1	40,000.00	40,000
Subtotal, construction				1,055,620
Contingencies (10%)				105,562
Total, construction				1,161,182
Engr/Insp/QA test (20%)				211,124
Total project cost				1,372,306
			SAY	1,400,000

Notes: S.Y. = Square Yard
C.Y. = Cubic Yard
L.S. = Lump Sum

TABLE B-6. PERIODIC RECONSTRUCTION COSTS,
RIGID ON RIGID SUBBASE, LIFE TESTS

Item	Unit	Quantity	Unit Cost (dollars)	Total Cost (dollars)
Pavement demolition	S.Y.	6,600	15.00	99,000
Excavation	C.Y.	6,600	5.00	33,000
Select subgrade	C.Y.	7,920	8.50	67,320
Subbase	C.Y.	0	40.00	0
Aggregate subbase	C.Y.	1,200	75.00	90,000
Stabilized base	C.Y.	1,600	100.00	160,000
Hot mix asphalt	TON	100	150.00	15,000
PCC	C.Y.	2,250	300.00	675,000
Select subgrade haul	C.Y.	7,920	15.00	118,800
Misc. pavement repairs	L.S.	1	50,000.00	50,000
Mobilization/demobilization	L.S.	1	100,000.00	100,000
Contractor QC	L.S.	1	40,000.00	40,000
Subtotal, construction				1,448,120
Contingencies (10%)				144,812
Total, construction				1,592,932
Engr/Insp/QA test (20%)				289,624
Total project cost				1,882,556
			SAY	1,900,000

Notes: S.Y. = Square Yard
C.Y. = Cubic Yard
L.S. = Lump Sum

APPENDIX C

DETAILED DESIGN OF THE FOUNDATION STRUCTURE

GENERAL.

The general design layout of the foundation structure is given figure 7-1. The dimensions of the structure were based on general test track specifications and on requirements for soil bearing capacity and stability. Cast-in-place concrete was selected for construction, with structural steel load bearing beams and reinforcing bars encased in the concrete. To estimate the cost of constructing the foundation structures, and to demonstrate feasibility, design analyses were performed as described below.

DESIGN OF THE STEEL BEAM STRUCTURE.

LONGITUDINAL BEAMS. Two linear steel beams are located under the two rails of the test machine. The loads from the test machine are transferred through the linear beams to the cross beams, and then through the strengthening columns and concrete wall to the bottom slabs and base soil (see the load transfer paths in figure 7-2). The center-to-center (C-C) distance of two cross beams for L = 30, 15, and 10 ft were analyzed and L = 10 ft was selected for the proposed design because it limits the maximum deflection of the beam to no more than 1/750 of the span and provides the most economical design of the three cases.

A group of eight downward loads, 35 kips each, is assumed on the 6-span continuous beam. The maximum responses were calculated by moving the load group along the beam step by step. (Figure C-1, x = 0 ft, 1.25 ft, etc.). A uniformly distributed dead load (from the roof of the foundation) of 50 psf was assumed. On the basis of ACI 318-89^[31], a load factor of 1.2 for the dead load and 1.6 for the live load should be used. For simplifying the conceptual design (without considering wind and snow loads), a load factor of 1.7 was used for calculating the maximum responses of the beams. The maximum bending moments, shear forces, reaction forces, and deflections can be calculated by any structural design program and they are listed in table C-1 in which the bolded values are the maximum responses used for the design.

Using $F_y = 50$ ksi for steel and a load factor of 1.7, and using the AISC manual,^[32] the plastic modulus Z_x is given by:

$$Z_x \geq \frac{932,000 \times 1.7}{0.9 \times 50,000} = 35.2 \text{ in}^3 \quad (\text{C-1})$$

Selecting the lightest design width (W) of 12X26 in the section table on page 3-16 in the manual^[32] gives $Z_x = 37.2$, and $I_x = 204$ (see table on page 1-33 in the manual). The maximum deflection is then calculated to be:

$$d_{\max} = 0.1593 \text{ in} \quad (\text{C-2})$$

$$\frac{d_{\max}}{L} = \frac{0.1593}{10 \times 12} = \frac{1}{753} \leq \frac{1}{750} \quad (\text{C-3})$$

Therefore, a beam section of W12X26 and $F_y = 50$ ksi was selected for the longitudinal beams.

CROSS BEAMS. The maximum reaction forces of the longitudinal beams were used to calculate the maximum response of the cross beam as shown in figure C-2, where (a) and (b) correspond to the cross beams shown in figure 7-1. The same load factor of 1.7 was used in calculating the maximum responses of the cross beams. The maximum bending moments, shear forces, reaction forces, and deflections are listed in table C-2.

Similar to the procedure for the longitudinal beam design:

$$Z_x \geq \frac{3,492,000 \times 1.7}{0.9 \times 50,000} = 132 \text{ in}^3 \quad (\text{C-4})$$

$$Z_x \geq \frac{4,144,000 \times 1.7}{0.9 \times 50,000} = 156 \text{ in}^3 \quad (\text{C-5})$$

W24X55 and W24X68 have been proposed for the short and long cross beams, respectively. The cross-section properties can be found in the referenced manual as:

$$\begin{aligned} d_{x(\text{short})} &= 0.175 \text{ in}, & Z_{x(\text{short})} &= 134 \text{ in}^3, & I_{x(\text{short})} &= 1,350 \text{ in}^4; \\ d_{x(\text{long})} &= 0.233 \text{ in}, & Z_{x(\text{long})} &= 177 \text{ in}^3, & I_{x(\text{long})} &= 1,830 \text{ in}^4. \end{aligned} \quad (\text{C-6})$$

These selected beams satisfy both the strength and the deflection requirements as:

$$\begin{aligned} \frac{d_{\max(\text{short})}}{L_{\text{short}}} &= \frac{0.175}{12.5 \times 12} = \frac{1}{857} \leq \frac{1}{750} \\ \frac{d_{\max(\text{long})}}{L_{\text{long}}} &= \frac{0.233}{15 \times 12} = \frac{1}{806} \leq \frac{1}{750} \end{aligned} \quad (\text{C-7})$$

The maximum responses of the cross beams are listed in table C-2.

DESIGN OF THE CONCRETE BOX.

It should be noted that the design of the concrete box in this section is not a detailed design for construction. The major objectives of this section are to provide a general design plan that will be suitable for supporting the test machine, demonstrate feasibility, and be applicable for estimating the total cost.

A precise estimation of the cost requires detailed calculations for all elements. For example, when the distribution of bending moments has been calculated, the reinforcement needed for the cross-section having maximum bending moment can be calculated following the corresponding code, such as ACI 318/318R^[31]. However, the bending moment varies along the length of the elements so that the reinforcement needed for the maximum response section might not be needed for the other sections. Smaller amounts of reinforcement may be used. In this case, very detailed calculations should be conducted and more specifications have to be checked to decide how much reinforcement is needed for each section and where is the appropriate location to cut a portion of the reinforcement. Such detailed calculation is beyond the scope of this project. Therefore, approximate methods that are slightly conservative have been used to provide a design for the concrete box.

STRENGTHENING COLUMNS IN THE SIDE WALLS. A strengthening column has been used to reduce the quantity of concrete needed to resist the earth pressure and the loads transferred from the cross beams. Figure C-3 presents the model of the column. A 10 ft long section has been analyzed as a plane structure sustaining all earth pressure within the section. For a slightly conservative consideration, only a rectangular cross-section was taken to calculate the required reinforcement for the column.

The maximum earth pressure can be obtained by using equation 7-1 with the assumptions that the friction angle is $\phi = 25^\circ$, the cohesion coefficient is $c = 200$ psi, and the soil density is $\gamma = 100$ lb/in³ to yield:

$$\begin{aligned}\sigma_3 &= 110 \times 14 \times \tan^2\left(45^\circ - \frac{25^\circ}{2}\right) - 2 \times 200 \times \tan\left(45^\circ - \frac{25^\circ}{2}\right) \\ &= 370 \text{ psf}\end{aligned}\tag{C-8}$$

The bending moments acting at the two ends and their ratios are:

$$M_i = 92 \times 3 = 276 \text{ kips - in}\tag{C-9}$$

$$\begin{aligned}M_j &= 276 + \frac{1}{5} \times 370 \times 10 \times 14^2 \times \frac{12}{1,000} \\ &= 856 \text{ kips - in}\end{aligned}\tag{C-10}$$

$$\frac{M_i}{M_j} = 0.32\tag{C-11}$$

Following ACI 340.2R-90^[33], example 1, the allowable kl_u/h can be found to be 9.08 (page 53 of the Handbook). The ratio of kl_u/h for the designed column can be calculated as:

$$\frac{kl_u}{h} = 1.0 \times 12 \times \frac{12}{18} = 6.67 < 9.08\tag{C-12}$$

indicating that the designed column satisfies the required buckling criteria.

Assuming the rectangular section to be $h = 18$ in and $b = 12$ in, the area of the cross-section A_g is 216 in^2 . By using a load factor of 1.7, the required steel reinforcement is calculated to be:

$$P_u = 1.7 \times 92 = 156.4 \text{ kips}$$

$$M_u = 1.7 \times 856 = 1455 \text{ kips-in}$$

$$\frac{P_u}{A_g} = \frac{156.4}{216} = 0.724 \text{ ksi} \quad (\text{C-13})$$

$$\frac{M_u}{A_g h} = \frac{1455}{216 \times 18} = 0.374 \text{ ksi}$$

$$\gamma = \frac{h - 5}{y} = 0.722$$

For $f_c = 4,000$ psi, using "Columns 7.4.3 table," page 82 of the handbook^[33] gives $\rho_g = 0.012$, and the required area of steel $A_{st} = .012 \times 216 = 2.59 \text{ in}^2$.

For $f_c = 6,000$ psi, using "Columns 7.6.3 table, page 86," $\rho = 0.01$ (the minimum requirement for a compression element). A total of 12 vertical reinforcing bars are needed as shown in figure C-3. Selecting 12 #5 bars yields the total area to be $A_s = 3.72 \text{ in}^2 > 2.59 \text{ in}^2$ (the minimum reinforcement required for a compression element is $\rho_g = 0.01$, see ACI 318/318R, 10.9.1, and the minimum number of bars on one side for a rectangular section is four).

Check the bottom cross-section of the column for the bending moment:

$$M = 1.7 \times \frac{856}{12} = 121 \text{ kips-ft},$$

$$h = 18 \text{ in}, \quad b = 12 \text{ in}, \quad \text{and} \quad d = h - 2.5 = 15.5 \text{ in} \quad (\text{C-14})$$

By using flexure 6, page 172 of ACI 340.1R-91, the values F and K_n can be calculated to be $F = 0.24$, $K_n = 121/0.24 = 504$.

If flexure 2.2, page 161, is used, then $\rho_g = 0.0103$ for $f_c = 4,000$ psi.

Or if flexure 2.4, p163, is used, then $\rho_g = 0.01$ for $f_c = 6,000$ psi ($f_y = 60,000$ psi in both cases).

$$A_s = 15.5 \times 12 \times 0.01 = 1.86 \text{ in}^2 = 6 \times 0.31 = 1.86 \text{ in}^2 \quad (\text{C-15})$$

(It may be arranged as shown in figure C-3).

Solution: 12 #5, 4/face, #3 tie bar, spacing 12 in.

DESIGN OF THE SIDE WALL. The model of the wall can be simplified as a 14 ft by 10 ft thin plate with one side (bottom) fixed, two sides (vertical) supported by beams, and the top side a free edge, as shown in figure C-4. The possible critical locations where the maximum bending

may occur are also shown in figure C-4. The maximum bending moments at each of these critical locations are determined as follows:

$$\begin{aligned}
 d_m &= 0.00328 \times ql_x^4 \times \frac{12(1-\mu^2)}{Eh^3} \\
 M_x &= 0.0327 \times ql_x^2 \\
 M_y &= 0.0174 \times ql_x^2 \\
 M_{yo} &= 0.0711 \times ql_x^2 \\
 M_{xo} &= 0.0275 \times ql_x^2
 \end{aligned}
 \tag{C-16}$$

where q is the maximum earth pressure and is equal to 370 psf as defined in equation C-8. It can be found that the dominant bending moments are M_x in the x direction and M_{yo} in the y direction, respectively. By applying the 1.7 load factor to the dominant moments, the required design moments of the side wall can then be obtained as:

$$\begin{aligned}
 M_{x(\text{design})} &= 1.7 M_x = 1.7 \times 0.0327 \times 370 \times 10 \times 10^2 \times 12 = 246,800 \text{ lb-in} = 20.6 \text{ kips-ft} \\
 M_{yo(\text{design})} &= 1.7 M_{yo} = 1.7 \times 0.0711 \times 370 \times 10 \times 10^2 \times 12 = 536,700 \text{ lb-in} = 44.7 \text{ kips-ft}
 \end{aligned}
 \tag{C-17}$$

To simplify the procedure for estimating the quantity of reinforcement, one way slab formulas have been used (see ACI 340.1R-91, flexure example 5, page 61).

By selecting $f_c = 4,000$ psi, $f_y = 60,000$ psi, $b = 12$ in, $d = 8$ in, and $\rho_s = 0.5\rho_b$, the requirement of steel reinforcement can be determined from the design table, flexure 8.6.1, page 186, to be $A_s = 1.4 \text{ in}^2$. Using #8 at spacing 6.0 in results in a steel area of $A_s = 1.58 \text{ in}^2 > 1.4 \text{ in}^2$ (reinforcement 15, page 227). The dimension h can then be calculated as:

$$h > 0.5 + 0.9 + 8 = 9.4 \tag{C-18}$$

where 0.5 is the radius of the #8 steel bar and 0.9 is the required minimum cover. Use $h = 9.5$ in.

If $f_c = 6,000$ psi and $f_y = 60,000$ are used (page 192 of the handbook), it requires that $d = 6.9$ and $A_s = 1.58 \text{ in}^2$ per foot. Hence, using #8 bar at spacing 6.0 requires that $A_s = 1.58 \text{ in}^2$ and $h > 8.3$ in. Use $h = 8.5$ in.

If a load factor of 1.0 is used instead of 1.7, the thickness and reinforcement will be reduced and the results will be as listed in table C-3.

The horizontal reinforcement can be calculated in a similar manner. However, the thickness of the slab should be the same as one of the values specified in table C-3. For example, if $h = 9.5$ and #6 bar is selected, the values of d , F , and K_n can then be evaluated to be:

$$d = 9.5 - 0.375 - 0.75 = 8.375 \text{ in};$$

$$F = 12 \times \frac{8.375^2}{12,000} = 0.7 \quad (\text{C-19})$$

$$K_n = \frac{20.6}{0.07} = 294$$

The required steel reinforcements with $\rho = 0.006$ can then be calculated as:

$$\begin{aligned} A_s &= 8.375 \times 12 \times 0.006 = 0.603 \text{ in}^2 \quad \text{for } f_c = 4,000 \text{ psi and } f_y = 60,000 \text{ psi}; \\ A_s &= 7.375 \times 12 \times 0.006 = 0.531 \text{ in}^2 \quad \text{for } f_c = 6,000 \text{ psi and } f_y = 60,000 \text{ psi}. \end{aligned} \quad (\text{C-20})$$

If the load factor is taken to be 1.0, it can be shown that the values of M_u , F , and K_n are $M_u = 12.1$ kips-ft, $F = 0.064$, and $K_n = 189$. The required reinforcements with $\rho = 0.0036$ are:

$$\begin{aligned} A_s &= 6.375 \times 12 \times 0.0036 = 0.275 \text{ in}^2 \quad \text{for } f_c = 4,000 \text{ psi and } f_y = 60,000 \text{ psi}; \\ A_s &= 5.875 \times 12 \times 0.0036 = 0.254 \text{ in}^2 \quad \text{for } f_c = 6,000 \text{ psi and } f_y = 60,000 \text{ psi}. \end{aligned} \quad (\text{C-21})$$

The calculated results for the horizontal reinforcement required are listed in table C-4.

DESIGN OF THE STRENGTHENING BEAMS UNDER THE BOTTOM. The model of the strengthening beam on the bottom is considered to be a two-ends fixed beam. The geometry of the cross-section of the beam and corresponding bending moment diagram is depicted in figure C-5, where q is the unit pressure load on the beam in lb/ft. The value of unit pressure load can be calculated by using the ultimate bearing pressure as defined in equation 7-6, 1.55 psf, and a slab width of 10 ft, as shown in figure C-6. The maximum bending moment occurs at both ends of the beam and is calculated as:

$$M_e = \frac{1.4 \times 1.55 \times 10 \times 15^2}{12} = 407 \text{ kips-ft} \quad (\text{C-22})$$

where a load factor of 1.4 is used.

By using flexure 6, page 172 of the handbook, the values of d , b , F , and K_n are $d = 15.5$, $b = 48$, $F = 0.961$ and $K_n = 423$, respectively. Using flexure 2.2 in ACI 340 1R-91 for $f_c = 4,000$ psi and 6,000 psi, the value of ρ is found to be $\rho = 0.0082$. The corresponding reinforcement required is then calculated as $A_s = 6.1 \text{ in}^2$.

Because the ratio of the flange thickness to the unit pressure load, $h_f/p = 8/15.5 = 0.516$, is greater than the ratio of the corresponding flange area to the unit pressure load, $A/p = 0.172$, the formula for rectangular section beams can be applied to design the reinforcement of this T-section beam.

By selecting 4 #8 plus 1 #7 for $f_c = 4,000$ psi and $f_c = 6,000$ psi concrete, the required total area of the steel reinforcement is $A_s = 6.16 \text{ in}^2$, in which $f_y = 60,000$ psi is used. In both cases, the net distance between the bar satisfies the requirement described in the specifications in ACI 318/318R-89, 7.6, page 66.

The bending moment at the center of the beam span is calculated to be $M_1 = 204$ kips-ft. The values of F and K_n can be then obtained as $F = 0.24$, $K_n = 850$, respectively. The ρ values for $f_c = 4,000$ psi and $f_c = 6,000$ psi concretes are calculated to be 0.019 and 0.0176, respectively. The required reinforcements can then be determined as:

$$\begin{aligned} A_s &= 0.019 \times 15.5 \times 12 = 3.53 \text{ in}^2 \quad \text{for } f_c = 4,000 \text{ psi;} \\ A_s &= 0.0176 \times 15.5 \times 12 = 3.27 \text{ in}^2 \quad \text{for } f_c = 6,000 \text{ psi.} \end{aligned} \quad (\text{C-23})$$

Both of the above solutions are less than the reinforcement required at the end sections. Therefore, the reinforcement required at the end sections should be used to achieve a relatively conservative estimate of the amount of reinforcement steel required.

DESIGN OF THE BOTTOM SLAB. For the design of the bottom slab, the slab is considered as a plate with two sides simply supported and the other two fixed as shown in figure C-6. The maximum responses of the plate are formulated as follows:

$$\begin{aligned} M_x &= 0.03 \times ql^2 \\ M_y &= 0.0561 \times ql^2 \\ M_{xo} &= 0.109 \times ql^2 \end{aligned} \quad (\text{C-24})$$

It is clear that the maximum bending moment is in the lateral direction, i.e., M_{xo} . Substituting the ultimate bearing pressure, $q_{ult} = 1.55$ lb/sf and dimension $l = 10$ ft into equation C-14 and using a load factor of 1.4 yields:

$$M_{xo} = 1.4 \times 0.109 \times 1.55 \times 10^2 = 23.7 \text{ kips-ft / ft} \quad (\text{C-25})$$

If flexure 8.6.1, page 186 of ACI 340.1R-91, $\rho = 0.5\rho_b$, is used, the required steel reinforcement and slab thickness are $A_s = 1.07 \text{ in}^2$ and $d = 6.1$ in, respectively, for $f_c = 4,000$ psi. When flexure 8.9.1, page 192, is used, the required reinforcement is $A_s = 1.19 \text{ in}^2$ and the slab thickness is $d = 5.4$ in. Hence, a bottom slab of 8 in thickness should be adequate.

Lateral reinforcement of #6 bar at a spacing of 5 in and #7 bar at a spacing of 6 in can be used for the above two cases ($A_s = 1.07 \text{ in}^2$ and $A_s = 1.19 \text{ in}^2$), respectively.

In the longitudinal direction, the maximum bending moment with a loading factor of 1.4 is calculated as:

$$M_y = 1.4 \times 0.0561 \times 1.55 \times 10^2 = 12.2 \text{ kips-ft / ft}$$

For $f_c = 4,000$ psi and using flexure 8.6.1, the required minimum reinforcement is $A_s = 0.6 \text{ in}^2$ with slab thickness $d = 4.2$ in. Hence, #6 bar at a spacing of 8 in can be used for both $f_c = 4,000$ psi or $f_c = 6,000$ psi concretes.

The reinforcement selected is summarized in table C-5.

AN OPTIONAL MODEL.

A more advanced model may be used to conduct the final design as shown in figure C-7. The results calculated above are not in equilibrium in the model. For example, the bending moment acting at the bottom column end should be equal to the bending moment at one end of the bottom beam. The results presented above are only an approximate estimation based on element models considered individually and separately, so the two bending moments are not equal. If the model of figure C-7 is used, the bending moment distribution may be recalculated by any existing structural analysis computer program, and the cross-section of the concrete box and reinforcement needed will be recalculated as well.

SUMMARY OF MATERIAL QUANTITIES REQUIRED.

The total amount of concrete needed for the structure is 3,264 cubic yards, see table 7-2. The reinforcing bars and structural steel beams required for the structure are summarized in tables 7-2 and 7-3. The amounts shown are for two foundations, each 1,500 ft long.

TABLE C-1. MAXIMUM RESPONSES OF A LONGITUDINAL BEAM

x	M _m (kips-in)	Q _m (kips)	R _m (kips)	d _m (in)
0.00	835	37.3	59.0	.0725
1.25	932	52.2	67.5	.0825
2.50	927	44.5	64.9	.0828
3.76	928	37.8	60.6	.0728
5.00	820	47.5	56.7	.0517

TABLE C-2. MAXIMUM RESPONSES OF A CROSS BEAM

Beam	M _m (kips-in)	Q _m (kips)	R _m (kips)	d _{max} (in)
Short	3492	81	81	0.175
Long	4144	92	92	0.223

TABLE C-3. OPTIONAL REINFORCEMENT AND THICKNESS FOR WALL (VERTICAL)

Load Factor	1.7		1.0	
	f _c (psi)	4,000	6,000	4,000
d (in)	8.0	6.9	6.0	5.2
A _s	1.4	1.58	1.07	1.19
Reinforcement needed	#8, 6.5 (1.58in)	#8, 6.5 (1.58in)	#8, 8.0 (1.19in)	#8, 8.0 (1.19in)
h needed	9.5	8.5	7.5	7.0

TABLE C-4. HORIZONTAL REINFORCEMENT

Load Factor	1.7		1.0	
f_c (psi)	4,000	6,000	4,000	6,000
d (in)	8.375	7.375	6.375	5.875
A_s	0.603	0.531	0.275	0.254
Reinf. needed	#4 4 in (0.6 in ²)	#4 4 in (0.6 in ²)	#3 4 in (.33 in ²)	#3 4 in (.33 in ²)

TABLE C-5. REINFORCEMENT NEEDED FOR BOTTOM BEAM AND SLAB

Element	Reinforcement
Beam	4 #8 plus 4 #7 #4 spacing 12 in tie bar
Slab	#6 spacing 5 in for cross reinforcement #6 spacing 8 in for longitudinal reinforcement

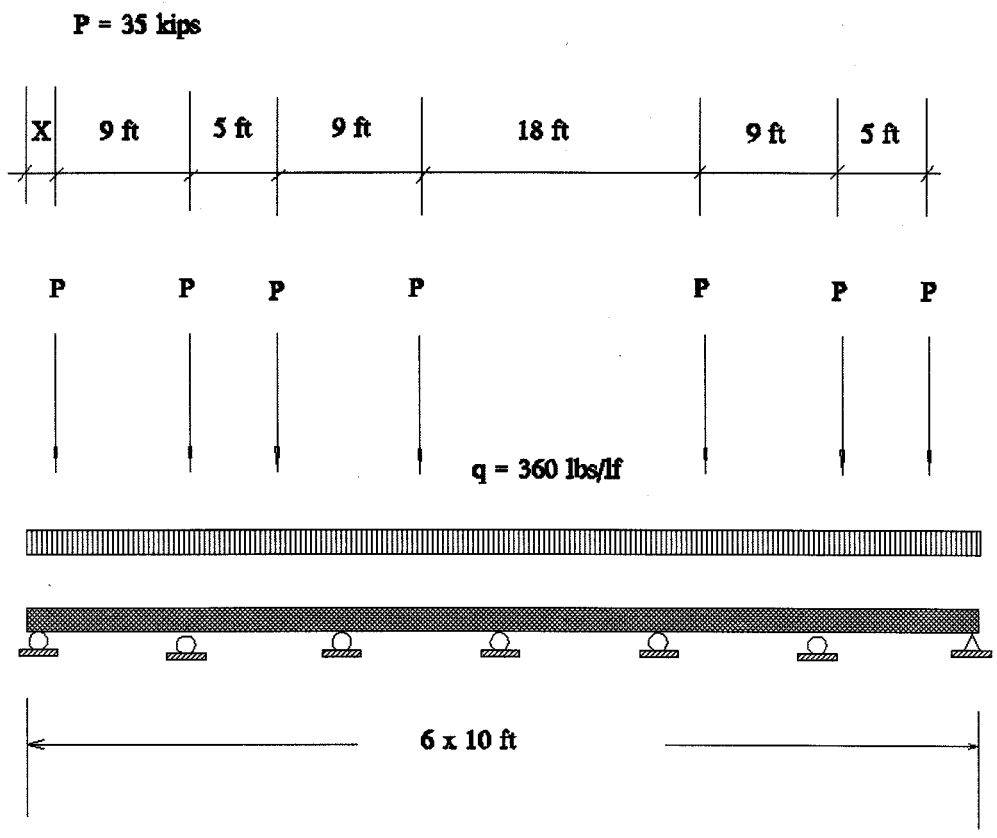

FIGURE C-1. A MODEL FOR LINEAR STEEL BEAM ANALYSIS

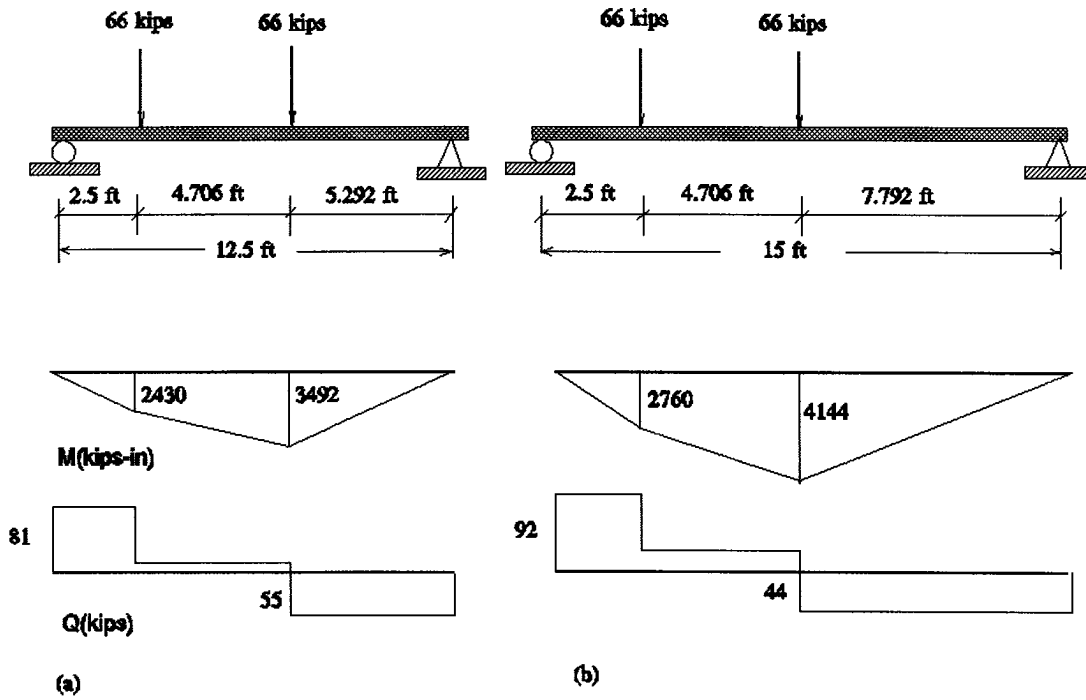

FIGURE C-2. THE MODELS FOR CROSS BEAM ANALYSIS

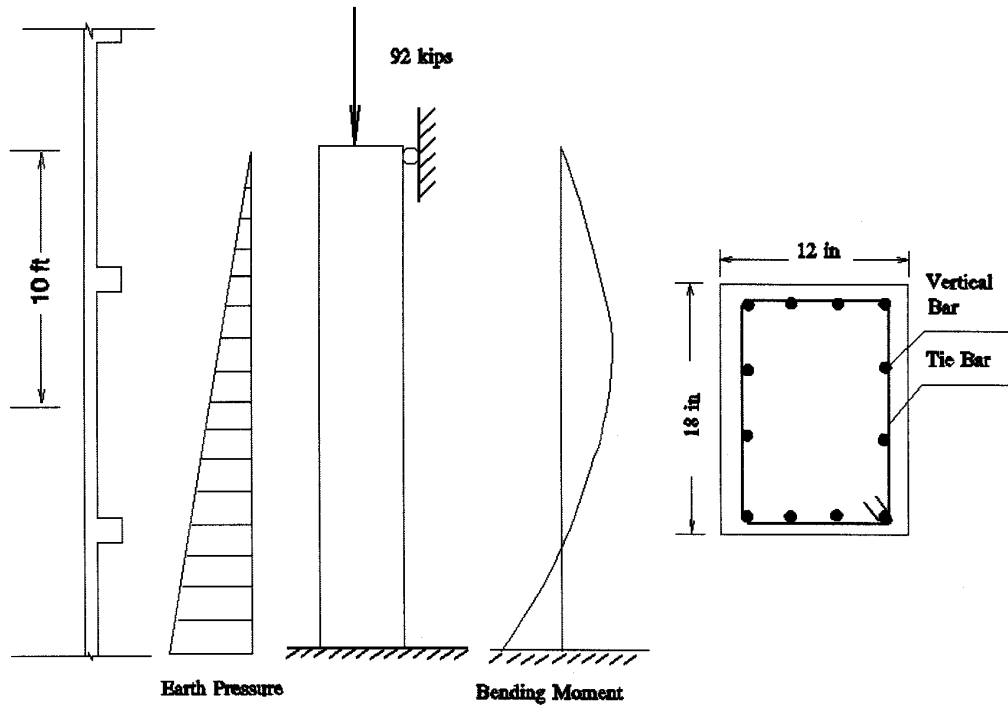

FIGURE C-3. A MODEL FOR THE STRENGTHENING COLUMN OF THE WALL

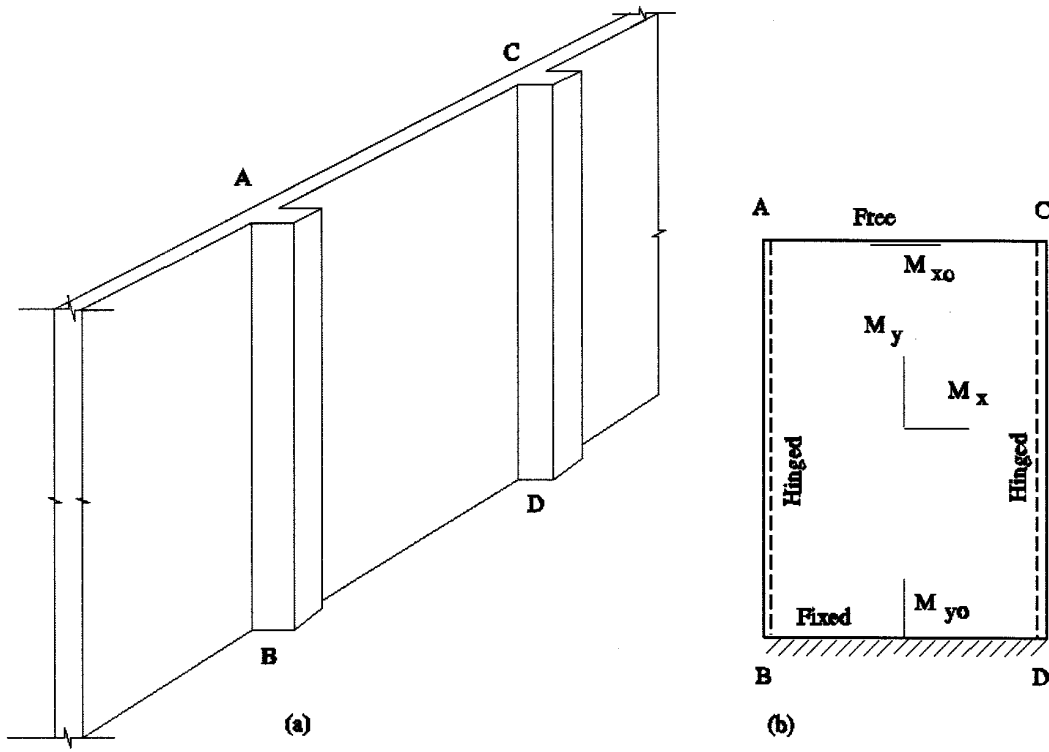

FIGURE C-4. A MODEL FOR THE WALL SLAB AND THE CRITICAL LOCATION OF RESPONSES

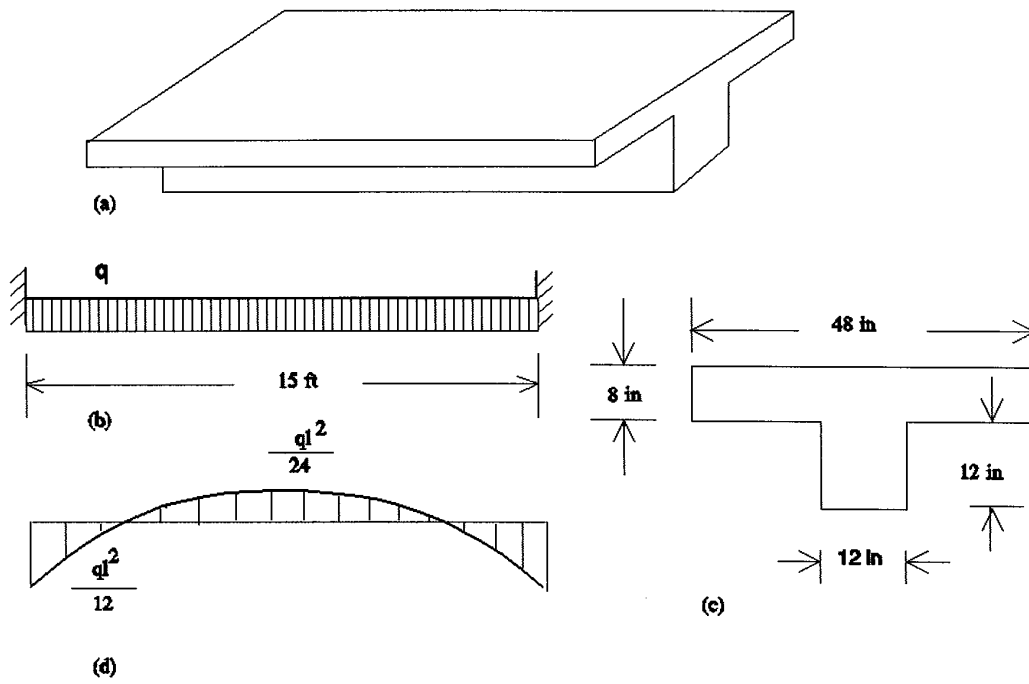

FIGURE C-5. A MODEL FOR THE STRENGTHENING BEAM UNDER THE BOTTOM SLAB

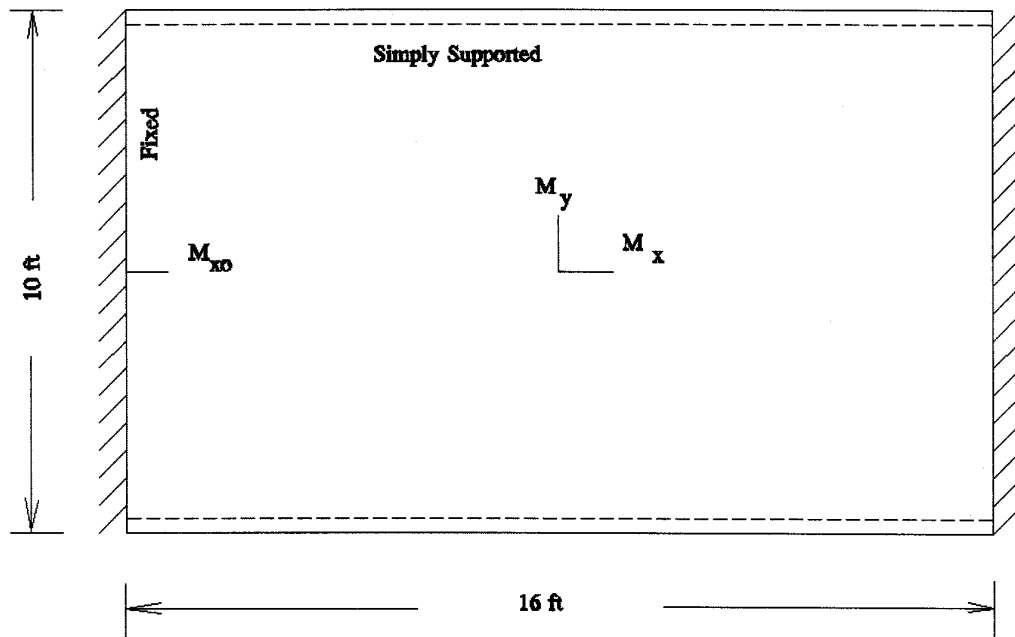

FIGURE C-6. A MODEL FOR THE BOTTOM SLAB

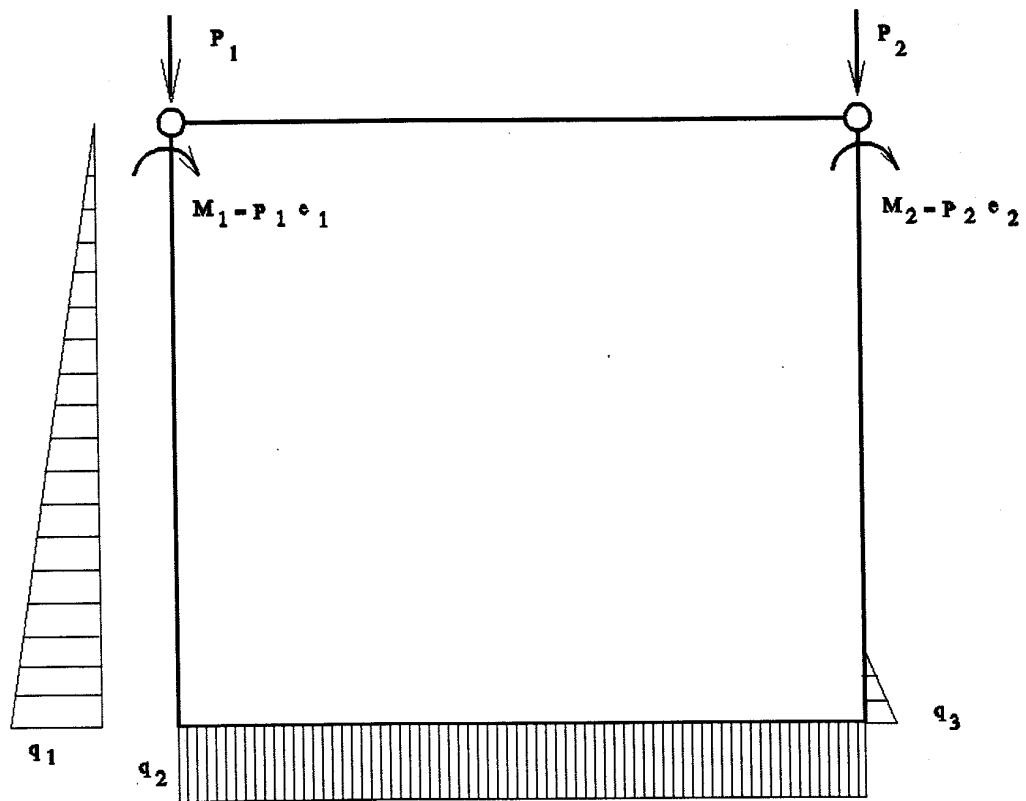

FIGURE C-7. AN ALTERNATIVE MODEL FOR THE CONCRETE FOUNDATION ANALYSIS