

MARKS PUBLISHED FOR OPPOSITION

The following marks are published in compliance with section 12(a) of the Trademark Act of 1946. Applications for the registration of marks in more than one class have been filed as provided in section 30 of said act as amended by Public Law 772, 87th Congress, approved Oct. 9, 1962, 76 Stat. 769. Opposition under section 13 may be filed within thirty days of the date of this publication. See rules 2.101 to 2.105.

A separate fee of two hundred dollars for opposing each mark in each class must accompany the opposition.

SECTION 1.— INTERNATIONAL CLASSIFICATION

The short titles associated below with the international class numbers are terms designed merely for quick identification and are not an official part of the international classification. The full names of international classes are given in section 6.1 of the trademark rules of practice.

The designation "U.S. Cl." appearing in this section refers to the U.S. class in effect prior to Sep. 1, 1973 rather than the international class which applies to applications filed on or after that date. For adoption of international classification see notice in the OFFICIAL GAZETTE of Jun. 26, 1973 (911 O.G. TM 210).

Application in more than one class

SN 76-125,588. GOVERNMENT OF THE NORTHWEST TERRITORIES, THE, SCOTIA CENTRE YELLOWKNIFE, NW TERRITORIES, FILED 9-11-2000.



PRIORITY CLAIMED UNDER SEC. 44(D) ON CANADA APPLICATION NO. 1050364, FILED 3-10-2000, REG. NO. TMA558,214, DATED 2-20-2002, EXPIRES 2-20-2017.

CLASS 6—METAL GOODS

FOR (BASED ON INTENT TO USE) (BASED ON 44(E)) METAL LICENSE PLATES (U.S. CLS. 2, 12, 13, 14, 23, 25 AND 50).

CLASS 35—ADVERTISING AND BUSINESS

FOR (BASED ON INTENT TO USE) PROMOTING TOURISM IN THE NORTHWEST TERRITORIES OF CANADA (U.S. CLS. 100, 101 AND 102).
DEBRA LEE, EXAMINING ATTORNEY

SN 76-370,711. ALFA CORPORATION, MONTGOMERY, AL. FILED 2-14-2002.



OWNER OF U.S. REG. NO. 2,088,673.

CLASS 36—INSURANCE AND FINANCIAL

FOR PROPERTY AND CASUALTY INSURANCE UNDERWRITING SERVICES; REAL ESTATE SERVICES, NAMELY, PROVISION OF COMMERCIAL AND RESIDENTIAL REAL ESTATE BROKERAGE SERVICES (U.S. CLS. 100, 101 AND 102).
FIRST USE 6-0-1988; IN COMMERCE 6-0-1988.

CLASS 37—CONSTRUCTION AND REPAIR

FOR CONSTRUCTION SERVICES, NAMELY, GENERAL CONTRACTING AND BUILDING SERVICES IN THE CONSTRUCTION INDUSTRY OF NEW HOMES, RESIDENTIAL COMMUNITIES AND COMMERCIAL PROPERTIES (U.S. CLS. 100, 103 AND 106).
FIRST USE 6-0-1988; IN COMMERCE 6-0-1988.
KALIE KUNG, EXAMINING ATTORNEY

SN 76-471,730. SPERIAN PROTECTIVE APPAREL LTD./ SPERIAN VETEMENTS DE PROTECTION LTEE, MONTREAL, QUEBEC, CANADA, FILED 11-14-2002.



OWNER OF U.S. REG. NOS. 1,740,960, 2,572,430 AND OTHERS.

CLASS 9—ELECTRICAL AND SCIENTIFIC APPARATUS

FOR PROTECTIVE CLOTHING AGAINST FIRE, HEAT AND CHEMICALS, NAMELY, COATS, HATS, HELMETS, JACKETS, VESTS, PANTS, BOOTS, SHOES, SHIRTS, GLOVES, GOGGLES, GLASSES, MASKS, BELTS, SUSPENDERS, SOCKS, STOCKINGS, UNDER-TOPS, UNDER-BOTTOMS, WET-SUITS, BODY SUITS, OVERALLS AND JUMPSUITS (U.S. CLS. 21, 23, 26, 36 AND 38).

CLASS 24—FABRICS

FOR FIRE RESISTANT FABRICS USED IN THE MANUFACTURE OF PROTECTIVE CLOTHING (U.S. CLS. 42 AND 50).

CLASS 35—ADVERTISING AND BUSINESS

FOR DISTRIBUTORSHIPS AND WHOLESALE STORE SERVICES FEATURING FIRE RESISTANT AND PROTECTIVE APPAREL AND FABRICS THEREFORE, AND FIRE EXTINGUISHING EQUIPMENT AND ACCESSORIES THERETO (U.S. CLS. 100, 101 AND 102).

CLASS 40—MATERIAL TREATMENT

FOR CUSTOM MANUFACTURE FOR OTHERS OF FIRE RESISTANT AND PROTECTIVE APPAREL AND FABRICS THEREFORE AND FIRE EXTINGUISHING EQUIPMENT (U.S. CLS. 100, 103 AND 106).

REBECCA GILBERT, EXAMINING ATTORNEY

SN 76-548,325. SPERIAN PROTECTIVE APPAREL INC./SPERIAN VETEMENTS DE PROTECTION LTEE, MONTREAL, QUEBEC, CANADA, FILED 10-1-2003.

911GEAR SERVICE

OWNER OF U.S. REG. NO. 2,731,214.
NO CLAIM IS MADE TO THE EXCLUSIVE RIGHT TO USE "SERVICE", APART FROM THE MARK AS SHOWN.

CLASS 35—ADVERTISING AND BUSINESS

FOR ARRANGING FOR PICKUP, DELIVERY, STORAGE AND TRANSPORTATION OF PROTECTIVE APPAREL AND ACCESSORIES VIA GROUND AND AIR CARRIERS (U.S. CLS. 100, 101 AND 102).

CLASS 39—TRANSPORTATION AND STORAGE

FOR EXPRESS DELIVERY OF PROTECTIVE APPAREL AND ACCESSORIES BY GROUND OR AIR CARRIERS (U.S. CLS. 100 AND 105).

KATHY DE JONGE, EXAMINING ATTORNEY

SN 76-623,204. TURNBERRY DEVELOPMENT, LLC, AVENURA, FL. FILED 12-6-2004.

TURNBERRY HARBOUR

THE MARK CONSISTS OF STANDARD CHARACTERS WITHOUT CLAIM TO ANY PARTICULAR FONT, STYLE, SIZE, OR COLOR.

OWNER OF U.S. REG. NOS. 1,597,428, 3,010,146 AND OTHERS.

NO CLAIM IS MADE TO THE EXCLUSIVE RIGHT TO USE "HARBOUR", APART FROM THE MARK AS SHOWN.

CLASS 35—ADVERTISING AND BUSINESS

FOR RETAIL STORE SERVICES FEATURING CONVENIENCE ITEMS, CLOTHING, GOLF EQUIPMENT, AND GENERAL MERCHANDISE; PROVIDING FACILITIES FOR BUSINESS MEETINGS (U.S. CLS. 100, 101 AND 102).

CLASS 36—INSURANCE AND FINANCIAL

FOR REAL ESTATE MANAGEMENT AND LEASING SERVICES IN THE FIELD OF RESIDENTIAL HOME AND CONDOMINIUM PROJECTS, COUNTRY CLUBS, AND RECREATIONAL FACILITIES (U.S. CLS. 100, 101 AND 102).

CLASS 37—CONSTRUCTION AND REPAIR

FOR REAL ESTATE DEVELOPMENT AND CONSTRUCTION SERVICES, NAMELY, PLANNING, LAYING OUT AND CONSTRUCTION OF RESIDENTIAL HOME AND CONDOMINIUM PROJECTS, COUNTRY CLUBS, AND RECREATIONAL FACILITIES (U.S. CLS. 100, 103 AND 106).

CLASS 43—HOTEL AND RESTAURANT SERVICES

FOR RESORT HOTEL AND LODGING SERVICES, RESTAURANT AND BAR SERVICES, CATERING SERVICES, PROVIDING CONFERENCE ROOM FACILITIES (U.S. CLS. 100 AND 101).

JOHN KELLY, EXAMINING ATTORNEY

SN 76-652,192. FUJITSU TRANSACTION SOLUTIONS INC., FRISCO, TX. FILED 12-19-2005.

PERVASIVE RETAILING

THE MARK CONSISTS OF STANDARD CHARACTERS WITHOUT CLAIM TO ANY PARTICULAR FONT, STYLE, SIZE, OR COLOR.

NO CLAIM IS MADE TO THE EXCLUSIVE RIGHT TO USE "RETAILING", APART FROM THE MARK AS SHOWN.

CLASS 9—ELECTRICAL AND SCIENTIFIC APPARATUS

FOR COMPUTERIZED RETAIL CHECK-OUT COMPUTER TERMINALS; CUSTOMER SELF SERVICE ELECTRONIC CHECKOUT STATION FOR POINT OF SALE; MOBILE DEVICES, NAMELY, HANDHELD SCANNERS FOR WIRELESS RETAIL APPLICATIONS, SCANNERS, PRINTERS, LIQUID CRYSTAL DISPLAYS, KEYBOARDS AND CASH REGISTERS; PRERECORDED MAGNETIC AND OPTICAL STORAGE MEDIA CONTAINING SOFTWARE AND WRITTEN, AUDIO AND AUDIOVISUAL CONTENT, ALL IN THE FIELD OF BUSINESS OPERATIONS; DOWNLOADABLE SOFTWARE FEATURING WRITTEN, AUDIO AND AUDIOVISUAL CONTENT, ALL IN THE FIELD OF BUSINESS OPERATIONS (U.S. CLS. 21, 23, 26, 36 AND 38).

FIRST USE 12-2-2005; IN COMMERCE 12-2-2005.

CLASS 35—ADVERTISING AND BUSINESS

FOR ADVISORY SERVICES RELATED TO BUSINESS MANAGEMENT, BUSINESS ADMINISTRATION AND BUSINESS OPERATIONS; BUSINESS RESEARCH SERVICES, NAMELY, PROVIDING ANALYSIS OF RETAIL DATA ON SPECIFIC BUSINESS LOCATIONS (U.S. CLS. 100, 101 AND 102).

FIRST USE 12-2-2005; IN COMMERCE 12-2-2005.

CLASS 37—CONSTRUCTION AND REPAIR

FOR BUILDING REPAIR AND INSTALLATION SERVICES IN THE FIELD OF ELECTRONIC NETWORK AND SYSTEMS INSTALLATION AND MAINTENANCE (U.S. CLS. 100, 103 AND 106).

FIRST USE 12-2-2005; IN COMMERCE 12-2-2005.

CLASS 42—SCIENTIFIC AND COMPUTER SERVICES

FOR DESIGN AND DEVELOPMENT OF COMPUTER HARDWARE AND SOFTWARE, ALL IN THE FIELD OF BUSINESS OPERATIONS (U.S. CLS. 100 AND 101).

FIRST USE 12-2-2005; IN COMMERCE 12-2-2005.
TRACY CROSS, EXAMINING ATTORNEY

SN 76-655,172. POLYMERS TECHNOLOGIES, INC., NEWARK, DE. FILED 2-13-2006.

POLYTECH

CLASS 7—MACHINERY

FOR NON-METALLIC FILTERS FOR USE WITH MACHINES FOR PURIFICATION OF GASES, OILS, NATURAL GAS, PROPANE, AIR AND SIMILAR LIQUIDS, NAMELY, GASOLINE, KEROSENE, OIL AND SIMILAR GASES AND LIQUIDS; NON-METALLIC ENGINE GASKETS (U.S. CLS. 13, 19, 21, 23, 31, 34 AND 35).

FIRST USE 10-1-1989; IN COMMERCE 10-1-1990.

CLASS 11—ENVIRONMENTAL CONTROL APPARATUS

FOR NON-METALLIC FILTERS FOR PURIFICATION OF LIQUIDS, NAMELY, WATER AND AQUEOUS SOLUTION, NAMELY, AQUEOUS BASED PROPRIETARY PROCESS SOLUTIONS, WATER BASED SOLUTIONS CONTAINING OIL AND KEROSENE, GASOLINE AND SIMILAR LIQUIDS (U.S. CLS. 13, 21, 23, 31 AND 34).

FIRST USE 10-1-1989; IN COMMERCE 1-1-1990.

CLASS 17—RUBBER GOODS

FOR NON-RIGID THERMAL INSULATING LAMINATED PARTS FOR INSULATION OF ENGINES, INDUSTRIAL EQUIPMENT AND FOR ENGINE ENCLOSURES (U.S. CLS. 1, 5, 12, 13, 35 AND 50).

FIRST USE 10-1-1989; IN COMMERCE 1-1-1990.
DAVID HOFFMAN, EXAMINING ATTORNEY

SN 76-655,794. AHLSTROM WINDSOR LOCKS LLC, WINDSOR LOCKS, CT. FILED 2-28-2006.



THE MARK CONSISTS OF A FACE OF A BEAR REPEATED AS A PATTERN ON THE SURFACE OF THE GOODS.

SEC. 2(F).

CLASS 3—COSMETICS AND CLEANING PREPARATIONS

FOR NONWOVEN MATERIALS, SUBSTRATES OR SPECIALTY PAPERS USED IN WIPING APPLICATIONS, NAMELY, DISPOSABLE WIPES IMPREGNATED WITH CHEMICALS OR COMPOUNDS FOR PERSONAL HYGIENE, DISPOSABLE WIPES IMPREGNATED WITH CHEMICALS OR COMPOUNDS FOR HOUSEHOLD USE IN CLEANING, DISPOSABLE WIPES IMPREGNATED WITH CHEMICALS OR COMPOUNDS FOR INDUSTRIAL USE, BABY WIPES, AND DISPOSABLE WIPES IMPREGNATED WITH CHEMICALS OR COMPOUNDS FOR HOUSEHOLD USE, DISPOSABLE WIPES IMPREGNATED WITH CHEMICALS OR COMPOUNDS FOR HOUSEHOLD USE IN DISINFECTION (U.S. CLS. 1, 4, 6, 50, 51 AND 52).

FIRST USE 0-0-1993; IN COMMERCE 0-0-1993.

CLASS 5—PHARMACEUTICALS

FOR NONWOVEN MATERIALS, SUBSTRATES OR SPECIALTY PAPERS USED IN WIPING APPLICATIONS, NAMELY, SANITIZING WIPES (U.S. CLS. 6, 18, 44, 46, 51 AND 52).

FIRST USE 0-0-1993; IN COMMERCE 0-0-1993.

CLASS 21—HOUSEWARES AND GLASS

FOR NONWOVEN MATERIALS, SUBSTRATES OR SPECIALTY PAPERS USED IN WIPING APPLICATIONS, NAMELY, FABRIC CLEAN ROOM WIPES (U.S. CLS. 2, 13, 23, 29, 30, 33, 40 AND 50).

FIRST USE 0-0-1993; IN COMMERCE 0-0-1993.

CARRIE GENOVESE, EXAMINING ATTORNEY

SN 76-660,488. CAROLYN MINCEY LEARNING CENTER, MORRISVILLE, PA. FILED 5-22-2006.

Don't Hate The Player, Don't Hate The Game **LEARN THE RULES**

THE MARK CONSISTS OF STANDARD CHARACTERS WITHOUT CLAIM TO ANY PARTICULAR FONT, STYLE, SIZE, OR COLOR.

CLASS 25—CLOTHING

FOR CLOTHING, NAMELY, SWEATSHIRTS, SWEATPANTS, T-SHIRTS, JACKETS, COATS, SWEATERS, SHIRTS, PANTS, SHORTS, FOOTWEAR AND HEADGEAR, NAMELY, HATS (U.S. CLS. 22 AND 39).

CLASS 41—EDUCATION AND ENTERTAINMENT

FOR SELF-HELP EDUCATION SERVICES, NAMELY, PROVIDING SEMINARS, COUNSELING AND CONFERENCES AND PROVIDING OF TRAINING IN THE FIELD OF BEHAVIORAL AND EDUCATIONAL COUNSELING (U.S. CLS. 100, 101 AND 107).

AHSEN KHAN, EXAMINING ATTORNEY

SN 76-661,286. WHISPER TECH LIMITED, CHRISTCHURCH, NEW ZEALAND, FILED 6-8-2006.

PRIORITY CLAIMED UNDER SEC. 44(D) ON NEW ZEALAND APPLICATION NO. 748289, FILED 5-22-2006, REG. NO. 748289, DATED 5-22-2006, EXPIRES 5-22-2016.

CLASS 7—MACHINERY

FOR ELECTRICAL GENERATORS, GASEOUS OR LIQUID FUEL-POWERED, ENGINE DRIVEN COGENERATION UNITS FOR USE PRIMARILY IN GENERATING ELECTRICAL POWER, AND ALSO FOR USE IN PRODUCING HEAT; ELECTRIC MOTORS AND ENGINES, NAMELY, DIRECT CURRENT AND ALTERNATING CURRENT MOTORS; ELECTRIC GENERATORS; ELECTRIC GENERATORS FOR USE WITH EXTERNAL COMBUSTION ENGINES FOR THE GENERATION OF ELECTRICITY, HEATING AND COOLING IN HOUSEHOLD AND COMMERCIAL ESTABLISHMENTS; AND PARTS AND FITTINGS FOR THE AFORESAID GOODS (U.S. CLS. 13, 19, 21, 23, 31, 34 AND 35).

CLASS 11—ENVIRONMENTAL CONTROL APPARATUS

FOR COGENERATION UNITS FOR SIMULTANEOUS GENERATION OF HEAT AND ELECTRIC POWER FOR HOUSEHOLD AND COMMERCIAL USE COMPRISED OF A NATURAL GAS OR LIQUID FUEL ENGINE, ELECTRICAL GENERATOR, ENCLOSURE AND WATER STORAGE TANK, AND PARTS AND FITTINGS THEREFOR (U.S. CLS. 13, 21, 23, 31 AND 34).
ALLISON HOLTZ, EXAMINING ATTORNEY

SN 76-667,929. MEGASOFT CONSULTANTS, INC., HERN-
DON, VA. FILED 10-23-2006.

INSTAROAM

THE MARK CONSISTS OF STANDARD CHARACTERS WITHOUT CLAIM TO ANY PARTICULAR FONT, STYLE, SIZE, OR COLOR.

CLASS 9—ELECTRICAL AND SCIENTIFIC APPARATUS

FOR NETWORK-BASED COMPUTER HARDWARE AND SOFTWARE FOR THE TELECOMMUNICATIONS INDUSTRY USED TO PROVIDE HOSTED ROAMING SERVICES (U.S. CLS. 21, 23, 26, 36 AND 38).

CLASS 35—ADVERTISING AND BUSINESS

FOR BUSINESS CONSULTING SERVICES DIRECTED TO TELECOMMUNICATIONS COMPANIES; MANAGED SERVICE OPERATIONS, NAMELY, MANAGEMENT OF A NETWORK OF TELECOMMUNICATIONS ROAMING SERVICE PLATFORMS FOR OTHERS; AND BILLING SERVICES, NAMELY, TRACKING CALLS ROUTED OVER CELLULAR TELECOMMUNICATIONS NETWORKS AND PROVIDING THE INFORMATION TO THE NETWORK PROVIDERS IN ORDER FOR THE CALLERS TO BE BILLED (U.S. CLS. 100, 101 AND 102).

CLASS 38—COMMUNICATION

FOR PROVIDING FIXED AND MOBILE TELEPHONE SERVICES; PROVIDING TELEPHONE ROAMING SERVICES; REAL-TIME VOICE, VIDEO, AUDIO, AND DATA TRANSMISSION; VOICE, VIDEO, AUDIO, AND DATA TRANSMISSION VIA THE INTERNET; COMMUNICATION SERVICES, NAMELY, PROVIDING MULTIPLE-USER ACCESS TO A GLOBAL COMMUNICATION INFORMATION NETWORK; AND ROUTING CELLULAR CALLS OVER THE NETWORKS OF VARIOUS CELLULAR TELECOMMUNICATIONS PROVIDERS (U.S. CLS. 100, 101 AND 104).

CLASS 42—SCIENTIFIC AND COMPUTER SERVICES

FOR CUSTOM DEVELOPMENT, DESIGN, AND INTEGRATION OF TELECOMMUNICATION SYSTEMS FOR OTHERS (U.S. CLS. 100 AND 101).

DAVID C. REIHNER, EXAMINING ATTORNEY

SN 76-667,931. MEGASOFT CONSULTANTS, INC., HERN-
DON, VA. FILED 10-23-2006.

POWERROAM

THE MARK CONSISTS OF STANDARD CHARACTERS WITHOUT CLAIM TO ANY PARTICULAR FONT, STYLE, SIZE, OR COLOR.

CLASS 9—ELECTRICAL AND SCIENTIFIC APPARATUS

FOR NETWORK-BASED COMPUTER HARDWARE AND SOFTWARE FOR THE TELECOMMUNICATIONS INDUSTRY USED TO PROVIDE HOSTED ROAMING SERVICES (U.S. CLS. 21, 23, 26, 36 AND 38).

CLASS 35—ADVERTISING AND BUSINESS

FOR BUSINESS CONSULTING SERVICES DIRECTED TO TELECOMMUNICATIONS COMPANIES; MANAGED SERVICE OPERATIONS, NAMELY, MANAGEMENT OF A NETWORK OF TELECOMMUNICATIONS ROAMING SERVICE PLATFORMS FOR OTHERS; AND BILLING SERVICES, NAMELY, TRACKING CALLS ROUTED OVER CELLULAR TELECOMMUNICATIONS NETWORKS AND PROVIDING THE INFORMATION TO THE NETWORK PROVIDERS IN ORDER FOR THE CALLERS TO BE BILLED (U.S. CLS. 100, 101 AND 102).

CLASS 38—COMMUNICATION

FOR PROVIDING FIXED AND MOBILE TELEPHONE SERVICES; PROVIDING TELEPHONE ROAMING SERVICES; REAL-TIME VOICE, VIDEO, AUDIO, AND DATA TRANSMISSION; VOICE, VIDEO, AUDIO, AND DATA TRANSMISSION VIA THE INTERNET; COMMUNICATION SERVICES, NAMELY, PROVIDING MULTIPLE-USER ACCESS TO A GLOBAL COMMUNICATION INFORMATION NETWORK; AND ROUTING CELLULAR CALLS OVER THE NETWORKS OF VARIOUS CELLULAR TELECOMMUNICATIONS PROVIDERS (U.S. CLS. 100, 101 AND 104).

CLASS 42—SCIENTIFIC AND COMPUTER SERVICES

FOR CUSTOM DEVELOPMENT, DESIGN, AND INTEGRATION OF TELECOMMUNICATION SYSTEMS FOR OTHERS (U.S. CLS. 100 AND 101).

DAVID C. REIHNER, EXAMINING ATTORNEY

SN 76-674,232. CHEMICAL INDUSTRIES ASSOCIATION LIMITED, LONDON, UNITED KINGDOM, FILED 3-16-2007.

REACHREADY

THE MARK CONSISTS OF STANDARD CHARACTERS WITHOUT CLAIM TO ANY PARTICULAR FONT, STYLE, SIZE, OR COLOR.

OWNER OF ERPN CMNTY TM OFC REG. NO. 004946455, DATED 2-6-2007, EXPIRES 3-6-2016.

CLASS 16—PAPER GOODS AND PRINTED MATTER

FOR PRINTED PUBLICATIONS, NAMELY, NON-FICTION BOOKS, BROCHURES, PAMPHLETS, INFORMATION SHEETS, NEWSLETTERS, MAGAZINES, REPORTS AND GUIDES; PRINTED INSTRUCTIONAL AND TEACHING MATERIAL, ALL OF THE FOREGOING BEING IN ALL FIELDS OF THE CHEMICAL, BIOTECHNOLOGY AND PHARMACEUTICAL INDUSTRIES (U.S. CLS. 2, 5, 22, 23, 29, 37, 38 AND 50).

CLASS 41—EDUCATION AND ENTERTAINMENT

FOR PROVIDING SEMINARS AND TRAINING, ARRANGING AND CONDUCTING OF EDUCATIONAL CONFERENCES, CONGRESSES, SEMINARS, SYMPOSIUMS AND WORKSHOPS, PUBLICATION OF BOOKS, PUBLICATION OF ELECTRONIC BOOKS AND JOURNALS ON LINE, PUBLICATION OF TEXTS, ALL OF THE FOREGOING BEING IN ALL FIELDS OF THE CHEMICAL, BIOTECHNOLOGY AND PHARMACEUTICAL INDUSTRIES (U.S. CLS. 100, 101 AND 107).

CLASS 42—SCIENTIFIC AND COMPUTER SERVICES

FOR INDUSTRIAL ANALYSIS IN THE NATURE OF INDUSTRIAL AND SCIENTIFIC RESEARCH, ALL RELATING TO THE CHEMICAL, BIOTECHNOLOGY AND PHARMACEUTICAL INDUSTRIES; INFORMATION, ADVISORY SERVICES, AND CONSULTANCY SERVICES IN CONNECTION WITH THE AFOREMENTIONED SERVICES AND ALL RELATING TO THE CHEMICAL, BIOTECHNOLOGY AND PHARMACEUTICAL INDUSTRIES AND ALL RELATING TO THE CHEMICAL, BIOTECHNOLOGY AND PHARMACEUTICAL INDUSTRIES (U.S. CLS. 100 AND 101).

CLASS 45—PERSONAL AND LEGAL SERVICES

FOR SCIENTIFIC AND TECHNOLOGICAL REGULATORY COMPLIANCE SERVICES, NAMELY, REVIEWING STANDARDS AND PRACTICES TO ASSURE COMPLIANCE WITH LEGAL REGULATIONS GOVERNING RESEARCH PRACTICES IN THE CHEMICAL, BIOTECHNOLOGY AND PHARMACEUTICAL INDUSTRIES; LEGAL SERVICES PROVIDED TO ALL SECTORS OF THE CHEMICAL, BIOTECHNOLOGY AND PHARMACEUTICAL INDUSTRIES (U.S. CLS. 100 AND 101).
MAUREEN DALL, EXAMINING ATTORNEY

SN 76-675,994. NATURAL WELLNESS USA, INC., ARLINGTON, TX. FILED 4-26-2007.

WHAT MAKES YOU FEEL GOOD?

THE MARK CONSISTS OF STANDARD CHARACTERS WITHOUT CLAIM TO ANY PARTICULAR FONT, STYLE, SIZE, OR COLOR.

CLASS 35—ADVERTISING AND BUSINESS

FOR ON-LINE RETAIL STORE SERVICES FEATURING BODY AND BEAUTY CARE COSMETICS, LIP BALMS AND CREAMS, HAIR CARE PRODUCTS AND SKIN CARE PRODUCTS, SKIN CARE AND BATH PRODUCTS FOR INFANTS AND CHILDREN, CANDLES, CLOTHING FOR ADULTS, CHILDREN AND INFANTS, DIETARY AND NUTRITIONAL SUPPLEMENTS, BEVERAGES, PUBLICATIONS, EXERCISE AND YOGA MATS AND EQUIPMENT, AND AUDIO AND VIDEO TAPES, DVDS, CASSETTES, DISCS AND CDS; RETAIL STORE SERVICES FEATURING BODY AND BEAUTY CARE COSMETICS, LIP BALMS AND CREAMS, HAIR CARE PRODUCTS AND SKIN CARE PRODUCTS, SKIN CARE AND BATH PRODUCTS FOR INFANTS AND CHILDREN, CANDLES, CLOTHING FOR ADULTS, CHILDREN AND INFANTS, DIETARY AND NUTRITIONAL SUPPLEMENTS, BEVERAGES, PUBLICATIONS, EXERCISE AND YOGA MATS AND EQUIPMENT, AND AUDIO AND VIDEO TAPES, DVDS, CASSETTES, DISCS AND CDS (U.S. CLS. 100, 101 AND 102).

CLASS 41—EDUCATION AND ENTERTAINMENT

FOR PHYSICAL FITNESS CONSULTATION; PHYSICAL FITNESS CONDITIONING CLASSES; PHYSICAL FITNESS INSTRUCTIONS; PROVIDING FITNESS AND EXERCISE FACILITIES; HEALTH CLUB SERVICES, NAMELY, PROVIDING INSTRUCTION AND EQUIPMENT IN THE FIELD OF PHYSICAL EXERCISE; ENTERTAINMENT IN THE NATURE OF ON-GOING TELEVISION PROGRAMS IN THE FIELDS OF HEALTH, AND WELLNESS; ENTERTAINMENT SERVICES, NAMELY, PROVIDING A TELEVISION PROGRAM IN THE FIELDS OF HEALTH AND WELLNESS VIA A GLOBAL COMPUTER NETWORK; ENTERTAINMENT, NAMELY, A CONTINUING HEALTH AND WELLNESS SHOW BROADCAST OVER TELEVISION, SATELLITE, AUDIO, AND VIDEO MEDIA; AND PRODUCTION AND DISTRIBUTION OF TELEVISION AND AUDIO PROGRAMS; CONSULTING SERVICES IN THE FIELD OF PHYSICAL FITNESS AND EXERCISE; PROVIDING PHYSICAL FITNESS AND EXERCISE INFORMATION VIA THE INTERNET; PROVIDING PHYSICAL FITNESS INFORMATION; PROVIDING A WEBSITE FEATURING INFORMATION IN THE FIELD OF TELEVISION PROGRAMMING; AND PROVIDING INFORMATION ABOUT TELEVISION PROGRAMMING (U.S. CLS. 100, 101 AND 107).

CLASS 44—MEDICAL, BEAUTY AND AGRICULTURAL SERVICES

FOR CONSULTING SERVICES IN THE FIELD OF HEALTH AND WELLNESS; HEALTH SPA SERVICES FOR HEALTH AND WELLNESS OF THE BODY AND SPIRIT OFFERED AT A HEALTH RESORT; PROVIDING HEALTH CARE AND WELLNESS INFORMATION VIA THE INTERNET; PROVIDING INFORMATION ABOUT DIETARY SUPPLEMENTS AND NUTRITION; HEALTH CARE SERVICES, NAMELY, WELLNESS PROGRAMS; HEALTH SPA SERVICES, NAMELY, COSMETIC BODY CARE SERVICES; PROVIDING HEALTH INFORMATION; AND AROMATHERAPY SERVICES; ONLINE SERVICES, NAMELY, PROVIDING A WEBSITE FEATURING INFORMATION ABOUT GENERAL ISSUES IN THE FIELD OF HEALTH AND WELLNESS AND PROVIDING GENERAL INFORMATION IN THE FIELD OF HEALTH AND WELLNESS SERVICES (U.S. CLS. 100 AND 101).

KIMBERLY PERRY, EXAMINING ATTORNEY

SN 76-678,242. CREATIVE PATHWAYS LTD., CINCINNATI, OH. FILED 6-14-2007.

SOUNDS GREAT!

CLASS 9—ELECTRICAL AND SCIENTIFIC APPARATUS

FOR PRERECORDED CDS AND AUDIO TAPES FEATURING ENGLISH LANGUAGE TUTORIALS FOR YOUNG CHILDREN AGES 3-7 (U.S. CLS. 21, 23, 26, 36 AND 38).

FIRST USE 9-0-1994; IN COMMERCE 9-0-1994.

CLASS 16—PAPER GOODS AND PRINTED MATTER

FOR EDUCATIONAL PUBLICATIONS, NAMELY, EDUCATIONAL LEARNING CARDS, FLASH CARDS, ACTIVITY CARDS, WORKBOOKS, TEXTBOOKS, ACTIVITY BOOKS, TEACHER GUIDES, MANUALS, POSTERS, AND EDUCATIONAL BOOKLETS IN THE FIELD OF THE ENGLISH LANGUAGE FOR YOUNG CHILDREN AGES 3-7 (U.S. CLS. 2, 5, 22, 23, 29, 37, 38 AND 50).

FIRST USE 9-0-1994; IN COMMERCE 9-0-1994.
JAMES LOVELACE, EXAMINING ATTORNEY

SN 76-678,494. KITCHEN COFFEE, LLC, LAKEWOOD, WA. FILED 6-21-2007.



NO CLAIM IS MADE TO THE EXCLUSIVE RIGHT TO USE "PUB & GRILL", APART FROM THE MARK AS SHOWN.

THE COLOR(S) WHITE, BLACK AND RUST IS/ARE CLAIMED AS A FEATURE OF THE MARK.

THE MARK CONSIST OF ON THE LEFT SIDE OF THE MARK APPEARS THE WORD "BLACK" AND ON THE RIGHT SIDE OF THE MARK APPEARS THE WORD "STAR", EACH OF WHICH WORDS ARE PRINTED IN WHITE, UPPER-CASE, BLOCK LETTERS THAT ARE RENDERED IN THREE DIMENSIONAL PERSPECTIVE VIEW, BETWEEN THE WORD "BLACK" AND THE WORD "STAR" IS A CIRCULAR EMBLEM THAT INCLUDES A RUST-COLORED, CIRCULAR DISK UPON WHICH IS INSCRIBED A BLACK, FIVE-POINTED STAR; AND A FIRST WHITE CIRCLE THAT BORDERS THE DISK AND BORDERS THE POINTS OF THE STAR. THE EMBLEM FURTHER INCLUDES A SECOND, LARGER, WHITE CIRCLE CONCENTRIC WITH THE FIRST WHITE CIRCLE SUCH THAT THE AREA BETWEEN THE FIRST AND SECOND WHITE CIRCLES IS AN ANNULUS, WHICH ANNULUS IS BLACK; A RUST-COLORED CIRCLE THAT BORDERS THE OUTER PERIPHERY OF THE SECOND WHITE CIRCLE; THE INSCRIPTION "BLACK STAR" IN WHITE, UPPER-CASE TYPE ARRANGED IN A SEMICIRCLE WITHIN THE UPPER HALF OF THE ANNULUS; THE INSCRIPTION "PUB & GRILL" INSCRIBED IN WHITE, UPPER-CASE TYPE ARRANGED IN A SEMICIRCLE WITHIN THE LOWER HALF OF THE ANNULUS. THE MARK FURTHER INCLUDES A FIRST, HORIZONTAL, BLACK STRIPE THAT UNDERLINES THE WORD "BLACK" ON THE LEFT SIDE OF THE MARK; A SECOND, HORIZONTAL, BLACK STRIPE THAT UNDERLINES THE WORD "STAR" ON THE RIGHT SIDE OF THE MARK; AND A HORIZONTAL, RECTANGULAR, RUST-COLORED STRIPE THAT EXTENDS FROM THE LEFT MARGIN TO THE RIGHT MARGIN OF THE MARK AND UNDERLIES A LOWER PORTION OF THE WORD "BLACK", THE EMBLEM, AND THE WORD "STAR".

CLASS 16—PAPER GOODS AND PRINTED MATTER

FOR PAPER PRODUCTS, NAMELY, DRINK COASTERS, GIFT BAGS, PRINTED MENUS, AND PAPER NAPKINS (U.S. CLS. 2, 5, 22, 23, 29, 37, 38 AND 50).

CLASS 21—HOUSEWARES AND GLASS

FOR HOUSEWARES AND GLASS, NAMELY, PLATES, CUPS AND SHOT GLASSES (U.S. CLS. 2, 13, 23, 29, 30, 33, 40 AND 50).

CLASS 43—HOTEL AND RESTAURANT SERVICES

FOR RESTAURANT SERVICES (U.S. CLS. 100 AND 101).

DARRYL SPRUILL, EXAMINING ATTORNEY

SN 76-678,793. CHING, YAN YUEN, SHAM SHUI PO, KOWLOON, HONG KONG, FILED 6-27-2007.

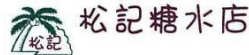

NO CLAIM IS MADE TO THE EXCLUSIVE RIGHT TO USE "THE NON-LATIN CHARACTERS THAT MEAN MARK OR BRAND AND DESSERT SHOP", APART FROM THE MARK AS SHOWN.

THE COLOR(S) GREEN AND BLACK IS/ARE CLAIMED AS A FEATURE OF THE MARK.

THE MARK CONSISTS OF THE COLOR, GREEN, FOR THE PINE TREE AND THE DESIGN PORTION OF THE MARK AND THE COLOR, BLACK, APPEARS IN THE NON-LATIN, CHINESE CHARACTERS IN THE MARK.

"THE NON-LATIN CHARACTER(S) IN THE MARK TRANSLITERATES INTO "CHUNG KEE TANG SHUI DIAN", AND THIS MEANS "PINE BRAND DESSERT SHOP" WITH THE LEFTMOST CHARACTER MEANING "PINE", AND THE SECOND LEFTMOST CHARACTER MEANING "MARK" OR "BRAND", AND THE RIGHTMOST THREE CHARACTERS MEANING "DESSERT SHOP" IN ENGLISH."

CLASS 32—LIGHT BEVERAGES

FOR FOOD, NAMELY, SOFT-DRINKS AND MIXTURES OF FRUIT-FLAVORED DRINKS (U.S. CLS. 45, 46 AND 48).

CLASS 43—HOTEL AND RESTAURANT SERVICES

FOR RESTAURANT SERVICES FEATURING FOOD AND DRINKS (U.S. CLS. 100 AND 101).

RICHARD A. STRASER, EXAMINING ATTORNEY

SN 76-679,409. SALES CHAMPIONS, INC., BEND, OR. FILED 7-12-2007.

Sales²

CLASS 35—ADVERTISING AND BUSINESS

FOR BUSINESS MANAGEMENT CONSULTATION (U.S. CLS. 100, 101 AND 102).

CLASS 36—INSURANCE AND FINANCIAL

FOR REAL ESTATE AFFAIRS, NAMELY, REAL ESTATE CONSULTATION (U.S. CLS. 100, 101 AND 102).

CLASS 41—EDUCATION AND ENTERTAINMENT

FOR EDUCATION SERVICES, NAMELY, PROVIDING SEMINARS AND CONFERENCES IN THE FIELD OF PERSONAL DEVELOPMENT AND DISTRIBUTING BOOKS, PRINTED ARTICLES AND VIDEO AND AUDIO MATERIALS IN CONNECTION THEREWITH; PROVIDING TRAINING IN THE FIELD OF PERSONAL DEVELOPMENT; BUSINESS TRAINING; AND TRAINING SERVICES IN THE FIELD OF BUSINESS MANAGEMENT (U.S. CLS. 100, 101 AND 107).

KATHERINE CHANG, EXAMINING ATTORNEY

SN 76-680,571. KABUSHIKI KAISHA SATO CHISHIKI ZAI-SAN KENKYUSHO, SHIBUYA-KU TOKYO 150-0013, JAPAN, FILED 8-10-2007.

TREE TRAINERS

THE MARK CONSISTS OF STANDARD CHARACTERS WITHOUT CLAIM TO ANY PARTICULAR FONT, STYLE, SIZE, OR COLOR.
SEC. 2(F).

CLASS 16—PAPER GOODS AND PRINTED MATTER

FOR PAPER LABELS (U.S. CLS. 2, 5, 22, 23, 29, 37, 38 AND 50).
FIRST USE 0-0-1990; IN COMMERCE 0-0-1990.

CLASS 20—FURNITURE AND ARTICLES NOT OTHERWISE CLASSIFIED

FOR PLASTIC LABELS (U.S. CLS. 2, 13, 22, 25, 32 AND 50).
FIRST USE 0-0-1990; IN COMMERCE 0-0-1990.
ESTHER BELENKER, EXAMINING ATTORNEY

SN 76-680,911. HILL, SHEILA A., DBA HILL'S CHESTNUT FARM, SAGINAW, MI. FILED 8-20-2007.



"THE COLOR(S) BLACK, WHITE, BROWN, TAN, DARK GREEN, LIGHT GREEN IS/ARE CLAIMED AS A FEATURE OF THE MARK."

THE MARK CONSISTS OF AN ANIMATED DRAWING OF A CHESTNUT WITH A FACE, ARMS AND LEGS. THE COLOR BLACK APPEARS IN THE SHADING OF THE

BODY OF THE NUT, AND IN THE EYES AND MOUTH OF THE NUT; THE COLOR WHITE APPEARS IN THE EYES AND MOUTH OF THE NUT; THE COLOR BROWN APPEARS IN THE BODY OF THE NUT WHERE THE NUT IS SPLIT IN HALF; THE COLOR TAN APPEARS IN THE ARMS AND LEGS OF THE NUT AND INSIDE THE BODY OF THE NUT; THE COLOR DARK GREEN APPEARS IN PART OF THE BODY OF THE NUT, AND THE COLOR LIGHT GREEN APPEARS IN THE RIM OF THE NUT WHERE THE NUT SPLITS IN HALF.

CLASS 29—MEATS AND PROCESSED FOODS

FOR PROCESSED NUTS, NAMELY, CHESTNUTS AS A PROCESSED FOOD PRODUCT IN CHESTNUT BUTTER, NUT FLOUR AND FRUIT CHIPS, WHICH INCLUDE CHESTNUTS AS AN INGREDIENT (U.S. CL. 46).
FIRST USE 5-19-2007; IN COMMERCE 5-19-2007.

CLASS 30—STAPLE FOODS

FOR SALSA AND MEAT TENDERIZER THAT INCLUDE CHESTNUTS AS AN INGREDIENT (U.S. CL. 46).
FIRST USE 5-19-2007; IN COMMERCE 5-19-2007.
CARYN GLASSER, EXAMINING ATTORNEY

SN 76-681,030. ACME PLASTICS INC., WEST PATERSON, NJ. FILED 8-23-2007.



NO CLAIM IS MADE TO THE EXCLUSIVE RIGHT TO USE "PLASTICS INC.", APART FROM THE MARK AS SHOWN.

CLASS 1—CHEMICALS

FOR PLASTIC ADHESIVES, NOT FOR STATIONERY OR HOUSEHOLD PURPOSES (U.S. CLS. 1, 5, 6, 10, 26 AND 46).

CLASS 17—RUBBER GOODS

FOR PLASTIC ARTICLES FOR COMMERCIAL AND INDUSTRIAL USE, NAMELY, PLASTIC IN THE FORM OF SHEETS, FILMS, BARS, RODS, TUBES, AND PLATES; PLASTIC WEATHER STRIPS FOR BUILDINGS; PLASTIC TAPES FOR USE IN FABRICATION OF POINT OF PURCHASE DISPLAYS; SHEETS OF PLASTIC USED FOR SIGNAGE, POINT OF PURCHASE DISPLAYS, GLAZING AND AS AN INFILTRATION BARRIER IN BUILDING CONSTRUCTION; FLEXIBLE PLASTIC TUBING FOR USE IN TRANSPORT OF LIQUIDS AND BIOLOGICALS FOR USE IN THE PHARMACEUTICAL, MEDICAL AND CHEMICAL INDUSTRIES; PLASTIC TUBING FOR POINT OF PURCHASE DISPLAYS (U.S. CLS. 1, 5, 12, 13, 35 AND 50).

CLASS 35—ADVERTISING AND BUSINESS

FOR DISTRIBUTORSHIP AND RETAIL STORE SERVICES IN THE FIELD OF PLASTIC PRODUCTS (U.S. CLS. 100, 101 AND 102).
BENJAMIN OKEKE, EXAMINING ATTORNEY

SN 76-681,248. GRAHAM HART LTD., GRAPEVINE, TX.
FILED 8-28-2007.

NO LOOSE ENDS

THE MARK CONSISTS OF STANDARD CHARACTERS WITHOUT CLAIM TO ANY PARTICULAR FONT, STYLE, SIZE, OR COLOR.

CLASS 37—CONSTRUCTION AND REPAIR

FOR CONSTRUCTION SERVICES, NAMELY, HOME CONSTRUCTION FOR OTHERS; CUSTOM HOME BUILDING FOR OTHERS; HOME BUILDING AND FINISHING, BUILDING INSPECTION IN THE COURSE OF BUILDING, RENOVATION OF HOMES, AND HOME REPAIR SERVICES; REAL ESTATE SITE SELECTION; REAL ESTATE DEVELOPMENT; HOUSING SERVICES, NAMELY, DEVELOPMENT OF REAL PROPERTY, NAMELY, REPAIR, IMPROVEMENT, AND NEW CONSTRUCTION; LAND DEVELOPMENT SERVICES, NAMELY, PLANNING AND LAYING OUT OF RESIDENTIAL AND/OR COMMERCIAL COMMUNITIES (U.S. CLS. 100, 103 AND 106).

CLASS 42—SCIENTIFIC AND COMPUTER SERVICES

FOR HOME DESIGN, NAMELY, ARCHITECTURAL DESIGN SERVICES, RESIDENTIAL BUILDING DESIGN SERVICES, AND INTERIOR DECORATING SERVICES; AND INSPECTIONS OF HOUSES (U.S. CLS. 100 AND 101).

DAVID HOFFMAN, EXAMINING ATTORNEY

SN 76-684,515. CHASEZ, JOSHUA SCOTT, WASHINGTON, DC. FILED 11-30-2007.

JC CHASEZ

THE MARK CONSISTS OF STANDARD CHARACTERS WITHOUT CLAIM TO ANY PARTICULAR FONT, STYLE, SIZE, OR COLOR.

THE NAME "JOSHUA SCOTT CHASEZ" IDENTIFIES A LIVING INDIVIDUAL WHOSE CONSENT IS OF RECORD.

CLASS 9—ELECTRICAL AND SCIENTIFIC APPARATUS

FOR MUSICAL SOUND RECORDINGS; DOWNLOADABLE MUSICAL SOUND RECORDINGS; VIDEO RECORDINGS FEATURING MUSIC; DOWNLOADABLE VIDEO RECORDINGS FEATURING MUSIC; DOWNLOADABLE RING TONES; COMPACT DISCS FEATURING MUSIC; AND AN INTERNET WEB PAGE FEATURING DOWNLOADABLE MUSIC RECORDINGS (U.S. CLS. 21, 23, 26, 36 AND 38).

FIRST USE 0-0-2004; IN COMMERCE 0-0-2004.

CLASS 25—CLOTHING

FOR TEE-SHIRTS (U.S. CLS. 22 AND 39).
FIRST USE 0-0-2004; IN COMMERCE 0-0-2004.

CLASS 41—EDUCATION AND ENTERTAINMENT

FOR ENTERTAINMENT SERVICES, NAMELY, LIVE MUSIC CONCERTS; LIVE PERFORMANCES BY A MUSICAL PERFORMING ARTIST; PERSONAL APPEARANCES BY A MUSICAL PERFORMING ARTIST; TELEVISED AND MOVIE APPEARANCES BY A MUSICAL PERFORMING ARTIST; HOSTING RADIO PROGRAMS FEATURING MUSIC; AN INTERNET WEB PAGE FEATURING NEWS AND INFORMATION CONCERNING A MUSICAL PERFORMING ARTIST, PHOTOGRAPHS OF A MUSICAL PERFORMING ARTIST, AND AN ON-LINE JOURNAL, NAMELY, A BLOG CONCERNING THE ACTIVITIES OF A MUSICAL RECORDING ARTIST; AN INTERNET WEB SITE FEATURING MUSICAL SOUND RECORDINGS AND NEWS AND INFORMATION CONCERNING A MUSICAL RECORDING ARTIST (U.S. CLS. 100, 101 AND 107).

FIRST USE 0-0-2004; IN COMMERCE 0-0-2004.
GEORGE LORENZO, EXAMINING ATTORNEY

SN 76-685,067. AMERICAN PAYROLL INSTITUTE, INC., NEW YORK, NY. FILED 12-18-2007.

PAY NEWS NETWORK

THE MARK CONSISTS OF STANDARD CHARACTERS WITHOUT CLAIM TO ANY PARTICULAR FONT, STYLE, SIZE, OR COLOR.

NO CLAIM IS MADE TO THE EXCLUSIVE RIGHT TO USE "NEWS NETWORK", APART FROM THE MARK AS SHOWN.

CLASS 38—COMMUNICATION

FOR TELECOMMUNICATION SERVICES, NAMELY, TRANSMISSION OF PAYROLL NEWS WEBCASTS (U.S. CLS. 100, 101 AND 104).

CLASS 41—EDUCATION AND ENTERTAINMENT

FOR PROVIDING WEBCASTS OF NEWS AND INFORMATION IN THE FIELD OF PAYROLL (U.S. CLS. 100, 101 AND 107).

TEJBIR SINGH, EXAMINING ATTORNEY

SN 76-686,569. WINCHESTER CAPITAL PARTNERS, LLC, NEW HAVEN, CT. FILED 2-6-2008.

BUYERSCOPE

THE MARK CONSISTS OF STANDARD CHARACTERS WITHOUT CLAIM TO ANY PARTICULAR FONT, STYLE, SIZE, OR COLOR.

CLASS 35—ADVERTISING AND BUSINESS

FOR MANAGERIAL RESEARCH, NAMELY, BUSINESS MANAGEMENT RESEARCH, AND MARKET RESEARCH REGARDING ACQUISITIONS AND CORPORATE DEVELOPMENT (U.S. CLS. 100, 101 AND 102).

FIRST USE 1-20-2008; IN COMMERCE 1-20-2008.

CLASS 36—INSURANCE AND FINANCIAL

FOR FINANCIAL RESEARCH REGARDING MERGERS, ACQUISITIONS, AND CORPORATE DEVELOPMENT (U.S. CLS. 100, 101 AND 102).
FIRST USE 1-20-2008; IN COMMERCE 1-20-2008.
EMILY CARLSEN, EXAMINING ATTORNEY

CLASS 37—CONSTRUCTION AND REPAIR

FOR SERVICES IN THE NATURE OF SIZING AND INSTALLING CAPACITOR BANKS ON ELECTRICAL EQUIPMENT (U.S. CLS. 100, 103 AND 106).
FIRST USE 9-30-1995; IN COMMERCE 9-30-1995.
JILL C. ALT, EXAMINING ATTORNEY

SN 76-686,657. STEPHENS, RICHARD J., VALLEY CENTER, CA. FILED 2-8-2008.

AMEE

THE MARK CONSISTS OF STANDARD CHARACTERS WITHOUT CLAIM TO ANY PARTICULAR FONT, STYLE, SIZE, OR COLOR.

CLASS 6—METAL GOODS

FOR BALLOT BOXES MADE OF METAL (U.S. CLS. 2, 12, 13, 14, 23, 25 AND 50).

CLASS 9—ELECTRICAL AND SCIENTIFIC APPARATUS

FOR ELECTION EQUIPMENT AND SUPPLIES, NAMELY, VOTING BOOTHS, VOTING BOOTH RACKS, AND VOTING CARTS; STORAGE CABINETS FOR VOTING MACHINES; VOTE RECORDING MACHINES AND BALLOT COUNTING MACHINES; COMPUTER SOFTWARE FOR RECORDING VOTES AND BALLOTS FROM VOTING BOOTHS (U.S. CLS. 21, 23, 26, 36 AND 38).

CLASS 20—FURNITURE AND ARTICLES NOT OTHERWISE CLASSIFIED

FOR GENERAL PURPOSE NON-METAL STORAGE CABINETS; NON-METAL BALLOTS BOXES (U.S. CLS. 2, 13, 22, 25, 32 AND 50).
DANNEAN HETZEL, EXAMINING ATTORNEY

SN 76-686,915. TAYLOR, GREGORY G., PORT ORANGE, FL. FILED 2-19-2008.

KVAR ENERGY SAVINGS

THE MARK CONSISTS OF STANDARD CHARACTERS WITHOUT CLAIM TO ANY PARTICULAR FONT, STYLE, SIZE, OR COLOR.

NO CLAIM IS MADE TO THE EXCLUSIVE RIGHT TO USE "ENERGY SAVINGS", APART FROM THE MARK AS SHOWN.

CLASS 9—ELECTRICAL AND SCIENTIFIC APPARATUS

FOR CAPACITOR BANKS FOR INSTALLATION ON ELECTRICAL EQUIPMENT AND SIZING EQUIPMENT FOR SAME (U.S. CLS. 21, 23, 26, 36 AND 38).
FIRST USE 9-30-1995; IN COMMERCE 9-30-1995.

SN 76-687,718. LIFEWAY CHRISTIAN RESOURCES OF THE SOUTHERN BAPTIST CONVENTION, NASHVILLE, TN. FILED 3-14-2008.

DEEPER STILL

THE MARK CONSISTS OF STANDARD CHARACTERS WITHOUT CLAIM TO ANY PARTICULAR FONT, STYLE, SIZE, OR COLOR.

CLASS 16—PAPER GOODS AND PRINTED MATTER

FOR BIBLE STUDY JOURNALS, PRINTED BIBLE STUDY MATERIALS, BIBLE STUDY WORKSHEETS, BOOKS RELATING TO BIBLE STUDY (U.S. CLS. 2, 5, 22, 23, 29, 37, 38 AND 50).

CLASS 41—EDUCATION AND ENTERTAINMENT

FOR EDUCATIONAL SERVICES, NAMELY, CONDUCTING EDUCATIONAL RELIGIOUS CONFERENCES (U.S. CLS. 100, 101 AND 107).
JOHN GARTNER, EXAMINING ATTORNEY

SN 76-687,793. BABY BOOM CONSUMER PRODUCTS, INC., NEW YORK, NY. FILED 3-17-2008.

DESIGNER MAMA

THE MARK CONSISTS OF STANDARD CHARACTERS WITHOUT CLAIM TO ANY PARTICULAR FONT, STYLE, SIZE, OR COLOR.

NO CLAIM IS MADE TO THE EXCLUSIVE RIGHT TO USE "DESIGNER", APART FROM THE MARK AS SHOWN.

CLASS 11—ENVIRONMENTAL CONTROL APPARATUS

FOR LAMPS AND LIGHTING FIXTURES (U.S. CLS. 13, 21, 23, 31 AND 34).

CLASS 20—FURNITURE AND ARTICLES NOT OTHERWISE CLASSIFIED

FOR PILLOWS; BED HEADBOARDS; HAMPERS; NON-METAL FABRIC WALL-HANGING ORGANIZERS; ROCKING CHAIRS AND GLIDERS (U.S. CLS. 2, 13, 22, 25, 32 AND 50).

CLASS 24—FABRICS

FOR FABRIC FOR TEXTILE USE; BEDDING, NAMELY, COMFORTERS, CRIB SHEETS, CRIB BUMPERS, DUST RUFFLES, AND BLANKETS; FABRIC WINDOW VALANCES; DIAPER STACKERS; CHANGING TABLE COVER PADS; TOWELS; HOODED TOWELS; AND WASH CLOTHS (U.S. CLS. 42 AND 50).

CLASS 25—CLOTHING

FOR BABY CLOTHING, NAMELY, TOPS, BOTTOMS, AND ONE PIECE GARMENTS; BATH ROBES (U.S. CLS. 22 AND 39).

CLASS 27—FLOOR COVERINGS

FOR WALL ART, NAMELY, NON-TEXTILE WALL HANGINGS; NON-TEXTILE WALL COVERINGS IN THE NATURE OF WALL BORDERS; AND RUGS (U.S. CLS. 19, 20, 37, 42 AND 50).

CLASS 28—TOYS AND SPORTING GOODS

FOR STUFFED TOY ANIMALS; STUFFED TOY FIGURES; TOY PILLOWS; AND CRIB MOBILES (U.S. CLS. 22, 23, 38 AND 50).
JASON ROTH, EXAMINING ATTORNEY

SN 76-687,940. VIETNAMESE ORPHANS RELIEF FUND, NEWBURGH HEIGHTS, OH. FILED 3-20-2008.

VORF

THE MARK CONSISTS OF STANDARD CHARACTERS WITHOUT CLAIM TO ANY PARTICULAR FONT, STYLE, SIZE, OR COLOR.

CLASS 36—INSURANCE AND FINANCIAL

FOR CHARITABLE FUNDRAISING SERVICES (U.S. CLS. 100, 101 AND 102).
FIRST USE 5-12-2003; IN COMMERCE 5-12-2003.

CLASS 45—PERSONAL AND LEGAL SERVICES

FOR ADOPTION AGENCY AND ADOPTION PLACEMENT SERVICES (U.S. CLS. 100 AND 101).
FIRST USE 5-12-2003; IN COMMERCE 5-12-2003.
DAWN HAN, EXAMINING ATTORNEY

SN 76-687,981. STEPHEN J. SANDERS, INC., DBA STEFAN MANN, SCOTTSDALE, AZ. FILED 3-21-2008.

STEFAN MANN

THE MARK CONSISTS OF STANDARD CHARACTERS WITHOUT CLAIM TO ANY PARTICULAR FONT, STYLE, SIZE, OR COLOR.

THE NAME "STEFAN MANN" DOES NOT IDENTIFY A LIVING INDIVIDUAL.

CLASS 18—LEATHER GOODS

FOR MEN'S AND WOMEN'S LUGGAGE AND LEATHER GOODS, NAMELY, WALLETS, TOILETRY CASES, ATTACHE CASES, CREDIT CARD CASES, PORTFOLIOS, AGENDAS, HANDBAGS, AND LUGGAGE (U.S. CLS. 1, 2, 3, 22 AND 41).
FIRST USE 5-0-1980; IN COMMERCE 5-0-1980.

CLASS 35—ADVERTISING AND BUSINESS

FOR RETAIL STORE SERVICES FEATURING HANDBAGS, LUGGAGE, FINE LEATHER GOODS, GIFT ITEMS, AND RELATED MERCHANDISE (U.S. CLS. 100, 101 AND 102).
FIRST USE 9-0-1980; IN COMMERCE 9-0-1980.
DAWN FELDMAN, EXAMINING ATTORNEY

SN 76-687,995. UPCOMING TM S.A., LUXEMBOURG, LUXEMBOURG, FILED 3-24-2008.

BANDITS DU MONDE

THE MARK CONSISTS OF STANDARD CHARACTERS WITHOUT CLAIM TO ANY PARTICULAR FONT, STYLE, SIZE, OR COLOR.

THE ENGLISH TRANSLATION OF THE SPANISH WORDS "DU MONDE" IN THE MARK IS OF THE WORLD.

CLASS 9—ELECTRICAL AND SCIENTIFIC APPARATUS

FOR EYEGLASSES (U.S. CLS. 21, 23, 26, 36 AND 38).

CLASS 14—JEWELRY

FOR JEWELRY, NAMELY, NECKLACES, BROACHES, BRACELETS, PINS BEING JEWELRY, EARRINGS (U.S. CLS. 2, 27, 28 AND 50).

CLASS 18—LEATHER GOODS

FOR LEATHER BAGS, CARRY-ALL BAGS (U.S. CLS. 1, 2, 3, 22 AND 41).

CLASS 25—CLOTHING

FOR CLOTHING, NAMELY, PANTS, JEANS, SHORTS, T-SHIRTS, SHIRTS, JACKETS, SKIRTS, DRESSES, HOSIERY, SOCKS, HATS, SCARVES, CLOTHING BELTS, LEATHER BELTS (U.S. CLS. 22 AND 39).
ALEX KEAM, EXAMINING ATTORNEY

SN 77-002,389. QUEST INTERNATIONAL SERVICES B.V., 1411 GP NAARDEN, NETHERLANDS, FILED 9-19-2006.

MOOD PORTRAITS

THE MARK CONSISTS OF STANDARD CHARACTERS WITHOUT CLAIM TO ANY PARTICULAR FONT, STYLE, SIZE, OR COLOR.

PRIORITY CLAIMED UNDER SEC. 44(D) ON ERPNCMNTY TM OFC APPLICATION NO. 005297452, FILED 9-6-2006, REG. NO. 005297452, DATED 9-7-2007, EXPIRES 9-6-2016.

CLASS 35—ADVERTISING AND BUSINESS

FOR MARKET RESEARCH SERVICES; CONDUCTING MARKETING STUDIES; BUSINESS RESEARCH; COMPILATION AND SYSTEMIZATION OF INFORMATION INTO COMPUTER DATABASES; OBTAINING, ANALYZING AND REPORTING CONSUMER OPINION INFORMATION (U.S. CLS. 100, 101 AND 102).

CLASS 42—SCIENTIFIC AND COMPUTER SERVICES

FOR PRODUCT DEVELOPMENT CONSULTANCY SERVICES IN THE FIELD OF FRAGRANCE AND FLAVOR DESIGN AND DEVELOPMENT; ANALYSIS OF DATA, RESEARCH AND DEVELOPMENT SERVICES AND PROVISION OF INFORMATION AND ADVICE, ALL IN THE FIELD OF PRODUCT DEVELOPMENT RELATING TO FRAGRANCE AND FLAVOR DESIGN AND DEVELOPMENT; TECHNICAL RESEARCH RELATING TO THE FIELD OF FRAGRANCE AND FLAVOR DESIGN AND DEVELOPMENT; PROVIDING TECHNICAL AND PRODUCT DEVELOPMENT INFORMATION VIA ELECTRONIC MEANS FROM STORED SOURCES, RELATING TO THE FIELD OF FRAGRANCE AND FLAVOR DESIGN AND DEVELOPMENT; PROVIDING AN ONLINE SEARCHABLE COMPUTER DATABASE OF INFORMATION IN THE FIELD OF FRAGRANCE AND FLAVOR DESIGN AND DEVELOPMENT (U.S. CLS. 100 AND 101).

THOMAS MANOR, EXAMINING ATTORNEY

SN 77-003,115. INBEV S.A., BRUXELLES, BELGIUM, FILED 9-20-2006.



OWNER OF U.S. REG. NOS. 1,156,584, 2,763,094 AND OTHERS.

NO CLAIM IS MADE TO THE EXCLUSIVE RIGHT TO USE THE DESIGN OF THE DRINKING GLASS AND THE WORDS "ANNO 1366", APART FROM THE MARK AS SHOWN.

THE COLOR(S) RED, GOLD AND WHITE IS/ARE CLAIMED AS A FEATURE OF THE MARK.

THE MARK CONSISTS OF A TRI-DIMENSIONAL MARK WITH THE WORDS "STELLA ARTOIS" IN WHITE ON A RED AND GOLD BACKGROUND, "ANNO 1366" IN RED WITH A STAR APPEARING BETWEEN IN RED, THE COLOR GOLD APPEARS AT THE TOP RIM OF THE CHALICE GLASS AND IN THREE MEDALLIONS BELOW "STELLA ARTOIS", A ROSE AND DAGGER DESIGN APPEARS ON THE BASE OF THE GLASS IN WHITE.

THE ENGLISH TRANSLATION OF THE WORD "STELLA" IN THE MARK IS STAR. THE ENGLISH TRANSLATION OF THE WORD "ANNO" IN THE MARK IS YEAR.

CLASS 21—HOUSEWARES AND GLASS

FOR DRINKING GLASSES (U.S. CLS. 2, 13, 23, 29, 30, 33, 40 AND 50).

CLASS 32—LIGHT BEVERAGES

FOR BEERS (U.S. CLS. 45, 46 AND 48).
HENRY S. ZAK, EXAMINING ATTORNEY

SN 77-006,664. QUEST INTERNATIONAL SERVICES B.V., 1411 GP NAARDEN, NETHERLANDS, FILED 9-25-2006.

LISA

THE MARK CONSISTS OF STANDARD CHARACTERS WITHOUT CLAIM TO ANY PARTICULAR FONT, STYLE, SIZE, OR COLOR.

PRIORITY CLAIMED UNDER SEC. 44(D) ON ERPN CMNTY TM OFC APPLICATION NO. 5326641, FILED 9-20-2006, REG. NO. 5326641, DATED 12-5-2007, EXPIRES 9-20-2016.

CLASS 9—ELECTRICAL AND SCIENTIFIC APPARATUS

FOR COMPUTER SOFTWARE FOR USE IN THE DESIGN AND DEVELOPMENT AND FLAVORS AND TO PREDICT AND DESIGN CONSUMER PREFERRED FLAVORS (U.S. CLS. 21, 23, 26, 36 AND 38).

CLASS 16—PAPER GOODS AND PRINTED MATTER

FOR PRINTED MATERIAL, NAMELY, BOOKS, BROCHURES, MAGAZINES, NEWSLETTERS AND BULLETINS RELATING TO THE FIELD OF FLAVOR DESIGN AND DEVELOPMENT (U.S. CLS. 2, 5, 22, 23, 29, 37, 38 AND 50).

CLASS 35—ADVERTISING AND BUSINESS

FOR MARKET RESEARCH SERVICES; CONDUCTING MARKETING STUDIES; BUSINESS RESEARCH; COMPILATION AND SYSTEMIZATION OF INFORMATION INTO COMPUTER DATABASES; OBTAINING, ANALYZING AND REPORTING CONSUMER OPINION INFORMATION (U.S. CLS. 100, 101 AND 102).

CLASS 42—SCIENTIFIC AND COMPUTER SERVICES

FOR PRODUCT DEVELOPMENT CONSULTANCY SERVICES IN THE FIELD OF FRAGRANCE AND FLAVOR DESIGN AND DEVELOPMENT; ANALYSIS OF DATA, RESEARCH AND DEVELOPMENT SERVICES AND PROVISION OF INFORMATION AND ADVICE, ALL IN THE FIELD OF PRODUCT DEVELOPMENT RELATING TO FLAVOR DESIGN AND DEVELOPMENT; TECHNICAL RESEARCH RELATING TO THE FIELD OF FLAVOR DESIGN AND DEVELOPMENT; PROVIDING TECHNICAL AND PRODUCT DEVELOPMENT INFORMATION VIA ELECTRONIC MEANS FROM STORED SOURCES, RELATING TO THE FIELD OF FLAVOR DESIGN AND DEVELOPMENT; PROVIDING AN ONLINE SEARCHABLE COMPUTER DATABASE OF INFORMATION IN THE FIELD OF FRAGRANCE AND FLAVOR DESIGN AND DEVELOPMENT (U.S. CLS. 100 AND 101).

THOMAS MANOR, EXAMINING ATTORNEY

SN 77-009,810. MONKEY BUSINESS LLC, NEW YORK, NY.
FILED 9-28-2006.

SN 77-016,111. PENINSULA INTERNATIONAL (USA) LIM-
ITED, WILMINGTON, DE. FILED 10-6-2006.

I-CAMP

THE MARK CONSISTS OF STANDARD CHARACTERS WITHOUT CLAIM TO ANY PARTICULAR FONT, STYLE, SIZE, OR COLOR.

CLASS 20—FURNITURE AND ARTICLES NOT OTHERWISE CLASSIFIED

FOR FURNITURE FOR CAMPING; SLEEPING BAG LINERS; SLEEPING BAGS; SLEEPING BAGS (U.S. CLS. 2, 13, 22, 25, 32 AND 50).

CLASS 21—HOUSEWARES AND GLASS

FOR PORTABLE BEVERAGE COOLERS; PORTABLE COOLERS (U.S. CLS. 2, 13, 23, 29, 30, 33, 40 AND 50).

CLASS 22—CORDAGE AND FIBERS

FOR TENTS; TENTS FOR MOUNTAINEERING OR CAMPING (U.S. CLS. 1, 2, 7, 19, 22, 42 AND 50).
DANIEL BRODY, EXAMINING ATTORNEY

SN 77-014,966. BANGKOK HOME PLUS CO., LTD., BANGKOK, THAILAND, FILED 10-5-2006.

THERAFLEX
SLEEPING SOLUTION

NO CLAIM IS MADE TO THE EXCLUSIVE RIGHT TO USE "SLEEPING SOLUTIONS", APART FROM THE MARK AS SHOWN.

THE MARK CONSISTS OF STYLIZED WORDING OF THE MARK WITH A FANCIFUL UNDERLINE UNDER THE PORTION OF THE TRADEMARK "THERAFLEX".

CLASS 20—FURNITURE AND ARTICLES NOT OTHERWISE CLASSIFIED

FOR SPRING MATTRESSES, DIVANS, BEDS, PILLOWS, BOLSTERS, BEDDING IN THE NATURE OF CUSHIONS (U.S. CLS. 2, 13, 22, 25, 32 AND 50).

CLASS 24—FABRICS

FOR BEDDING, NAMELY, BED SHEETS, BED BLANKETS, BED CLOTHES, NAMELY, SHEETS, PILLOW CASES, BED COVERS, NAMELY, MATTRESS COVERS AND DUVET COVERS, BED LINEN, BEDSPREADS, BED BLANKETS, COVERS FOR CUSHIONS, MATTRESS COVERS AND PILLOWCASES (U.S. CLS. 42 AND 50).
DAWN FELDMAN, EXAMINING ATTORNEY

THE PENINSULA

THE MARK CONSISTS OF STANDARD CHARACTERS WITHOUT CLAIM TO ANY PARTICULAR FONT, STYLE, SIZE, OR COLOR.

OWNER OF U.S. REG. NOS. 1,320,035, 2,976,948 AND OTHERS.

CLASS 29—MEATS AND PROCESSED FOODS

FOR TOMATO EXTRACTS, VEGETABLE AND FRUIT EXTRACTS, MEAT EXTRACTS, INCLUDING POULTRY EXTRACTS, AND FISH EXTRACTS FOR SOUPS; SOUPS, JELLIES, FROZEN OR DEHYDRATED FRUIT AND VEGETABLE PRESERVES; READY-MADE ENTREES CONSISTING PRIMARILY OF MEATS AND VEGETABLES; PREPARED MEALS CONSISTING PRIMARILY OF SEAFOOD AND POULTRY; JAMS; EGGS; MILK; CHEESE; MILK-BASED BEVERAGES CONTAINING FRUIT JUICE, COFFEE, COCOA, TEA, FRUITS; EDIBLE OILS AND FATS; CAVIAR; CLAMS; CRAYFISH, NOT LIVE; FISH, NOT LIVE; HAM; LIVER PATE; LOBSTERS, NOT LIVE; MEAT; BLUE MUSSELS, NOT LIVE; OYSTERS, NOT LIVE; PORK; FRUIT SALADS; VEGETABLE SALADS; SALMON; SAUSAGES; SHELLFISH; SHRIMPS NOT LIVE FOR HUMAN CONSUMPTION; YOGURT; PROCESSED NUTS, INCLUDING PROCESSED PEANUTS; PRESERVED PEAS; PREPARED WALNUTS; PREPARATIONS FOR MAKING ICE CREAM, NAMELY, MILK POWDER AND MILK PROTEINS; FRUIT, SOY AND VEGETABLE BASED SNACK FOODS; DAIRY AND VEGETABLE BASED CHOCOLATE FOOD BEVERAGES; CHOP SUEY IN CAKE FORM; SWEET SOUPS; PROCESSED FRUITS, NAMELY, STEAMED PEARS; ALMOND POWDER; ANCHOVY PASTE (U.S. CL. 46).

CLASS 30—STAPLE FOODS

FOR COFFEE, TEA, COCOA, AND PREPARED COCOA AND COCOA-BASED BEVERAGES; CHOCOLATE, CHOCOLATE BARS, FILLED CHOCOLATE, CHOCOLATE CANDIES, CHOCOLATE POWDER, CHOCOLATE TOPPING, CHOCOLATE TRUFFLES, CHOCOLATE SYRUP, CHOCOLATE PASTE AND CHOCOLATE FONDUE; SUGAR; FLOUR AND PROCESSED CEREALS; CANDY; CANDY BARS; CANDY COATED POPCORN; CANDY CONTAINING COCOA; GUMMY CANDIES; STARCH BASED CANDIES; SUGARLESS CANDIES; BREAD; BISCUITS; COOKIES; CAKES; PASTRIES; ICE CREAM; FLAVORED ICES; ICE; FROZEN CONFECTIONS; FREEZABLE LIQUID FOR USE IN MAKING FLAVORED ICES AND FROZEN CONFECTIONS; HONEY; TREACLE; CEREAL, CORN, RICE AND WHEAT BASED SNACK FOODS; PREPARED MEALS CONSISTING PRIMARILY OF PASTA OR RICE; BAKERY DESERTS, DESSERT PUDDINGS, DESSERT MOUSSE, AND DESSERT SOUFFLES; CHINESE DESSERTS, NAMELY, ALMOND COOKIES, COOKIES IN THE SHAPE OF BOW TIES, CAKES FOR THE CHINESE NEW YEAR, DESSERT CAKES CONTAINING CHOP SUEY, CANDIED WALNUTS, PEKING DUST DESSERT, NAMELY, WHIPPED CREAM DESSERT CONTAINING CHESTNUTS AND RICE PUDDING; CONDIMENTS, NAMELY, PIMENTO USED AS A CONDIMENT, SOYBEAN PASTE, MAYONNAISE, MUSTARD, KETCHUP, HORSE RADISH PASTE, WASABI PASTE; SPICES; BAKING POWDER; SAUCES; VINEGAR; SALT; PEPPER FOR USE AS A SPICE; NON-ALCOHOLIC CHOCOLATE-BASED FOOD BEVERAGES NOT BEING DAIRY OR VEGETABLE BASED; COCOA-BASED BEVERAGES WITH MILK; COFFEE-BASED BEVERAGES CONTAINING MILK; PREPARED COFFEE AND COFFEE BASED BEVERAGES; BUNS; CUSTARD; FLAVORING SYRUP, AND FLAVORING ADDITIVES FOR NON-NUTRITIONAL PURPOSES; FROZEN YOGURT; MEAT GRAVIES; CONFECTIONERY IN THE NATURE OF FRUIT JELLIES; MACARONI; MEAT PIES;

MUESLI; NOODLES; OATMEAL; PANCAKES; PASTA; PIES; PIZZA; POPCORN; QUICHE; SANDWICHES; SEASONINGS; SPAGHETTI; SPRING ROLLS; SUSHI; TACOS; TARTS; TORTILLAS; PASTA, NAMELY, VERMICELLI; WAFFLES; ALMOND CONFECTIONERY, NAMELY, ALMOND CAKE, ALMOND BISCUITS, ALMOND COOKIES; FLAVORINGS FOR BEVERAGES; TEA-BASED BEVERAGES WITH FRUIT FLAVORINGS; CANDY, NAMELY, CANDY FEATURING CARAMEL; NON-MEDICINAL HERBAL INFUSIONS; CANDY MINTS; PUDDINGS; RELISH; SAGO; TOMATO SAUCE; SOY SAUCE; SUGAR CONFECTIONERIES, NAMELY, BONBONS MADE OF SUGAR, CRYSTAL SUGAR PIECES AND SUGAR-COATED HARD CARAMELS; TAPIOCA; ICED TEA; PROCESSED GRAINS, NAMELY, OAT FLAKES; PEANUT CONFECTIONERY, NAMELY, PEANUT BRITTLE AND PEANUT BUTTER CONFECTIONERY CHIPS; PEPPERMINT CANDY; CAKES, NAMELY, PETIT FOURS; SEAFOOD SAUCE; MOON CAKES; READY-MADE ENTREES CONSISTING PRIMARILY OF PASTA OR RICE (U.S. CL. 46).

CLASS 32—LIGHT BEVERAGES

FOR BEER, GINGER BEER; MINERAL WATER; AERATED WATER; LEMONADE; SYRUPS FOR MAKING NON-ALCOHOLIC SOFT DRINKS, ORANGE JUICE FRUIT DRINKS, AND OTHER NON-ALCOHOLIC FRUIT JUICE DRINKS; SOFT DRINKS; ORANGE JUICE FRUIT DRINKS; OTHER NON-ALCOHOLIC FRUIT JUICE DRINKS; EXTRACTS OF HOPS FOR MAKING BEER; WHEY BEVERAGES; VEGETABLE JUICES; NON-ALCOHOLIC COCKTAILS, NAMELY, MOCK TAILS; SORBETS IN THE FORM OF BEVERAGES (U.S. CLS. 45, 46 AND 48).

CLASS 33—WINES AND SPIRITS

FOR ALCOHOLIC BEVERAGES, EXCLUDING BEER, NAMELY, BRANDY, HARD CIDER, PREPARED ALCOHOLIC COCKTAILS, DISTILLED SPIRITS, GIN, LIQUEURS, FERMENTED ALCOHOLIC BEVERAGE MADE FROM PEARS IN THE NATURE OF PERRY, RUM, SAKE, POTABLE SPIRITS, VODKA, WHISKY, WINE, ALCOHOLIC COFFEE BASED BEVERAGES, AND ALCOHOLIC TEA-BASED BEVERAGES; ALCOHOLIC FRUIT EXTRACTS (U.S. CLS. 47 AND 49).
ZHALEH DELANEY, EXAMINING ATTORNEY

SN 77-018,046. BRUNOGUIDI S.R.L., GRIGNASCO (NOVARA), ITALY, FILED 10-10-2006.



OWNER OF ERPN CMNTY TM OFC REG. NO. 4428405, DATED 5-6-2005, EXPIRES 5-6-2015.
THE MARK CONSISTS OF THE LETTER "R" (REVERSED IMAGE) AND THE LETTER "G".

CLASS 6—METAL GOODS

FOR METAL PIPE JUNCTIONS FOR PLUMBING MARINE, INDUSTRIAL AND CIVIL PLANTS; METAL PIPES FOR THE FLOW OF LIQUID FLUIDS; METAL TUBES; PLUMBING FITTINGS OF METAL, NAMELY, ELBOW-SHAPED JOINT, PIPE TO PIPE CONNECTOR, T-SHAPED JOINT, CROSS-SHAPED JOINT, REDUCING STRAIGHT NIPPLE JOINT, PIPE CLOSING PLUG, PIPE TO HOSE CONNECTOR, INCOMING WATER FILTERING GRATE, WATER DISCHARGE PIPE, AIR VENTING PIPE, FLANGED METAL NUT, TANK CLOSING PLUG (U.S. CLS. 2, 12, 13, 14, 23, 25 AND 50).

CLASS 7—MACHINERY

FOR WATER FILTERS BEING PARTS OF WATER COOLING MARINE ENGINES (U.S. CLS. 13, 19, 21, 23, 31, 34 AND 35).

CLASS 11—ENVIRONMENTAL CONTROL APPARATUS

FOR SIPHON BREAK VALVES; WATER FILTERS FOR AIR CONDITIONER CIRCUITS; WATER FILTERS FOR DESALINATION UNITS (U.S. CLS. 13, 21, 23, 31 AND 34).
DAVID HOFFMAN, EXAMINING ATTORNEY

SN 77-022,272. UMAGINATION LABS, LLC, NEWTON, MA.
FILED 10-16-2006.

U-LABS

THE MARK CONSISTS OF STANDARD CHARACTERS WITHOUT CLAIM TO ANY PARTICULAR FONT, STYLE, SIZE, OR COLOR.

CLASS 7—MACHINERY

FOR POWER TOOLS, NAMELY, MOTORIZED WINDOW CLEANING DEVICES, MOTORIZED GARDENING TOOLS, NAMELY, DEVICES FOR CUTTING GRASS, FOR PRUNING SHRUBS AND TREES, FOR WEEDING AND FOR CLEARING DEBRIS FROM GARDEN BEDS, LAWNS, AND BUILDINGS AND WALKWAYS, AND DEVICES FOR CLEANING DEBRIS AND DIRT FROM DRAINAGE CHANNELS FOUND ON BUILDINGS AND WALKWAYS, MOTORIZED EXTENDIBLE GRIPPING AND FASTENING DEVICES FOR REACHING AND CLASPING REMOTELY LOCATED ARTICLES (U.S. CLS. 13, 19, 21, 23, 31, 34 AND 35).

CLASS 8—HAND TOOLS

FOR HAND TOOLS, NAMELY, MANUAL GARDENING TOOLS, NAMELY, DEVICES FOR CUTTING GRASS, FOR PRUNING SHRUBS AND TREES, AND FOR WEEDING; MANUAL EXTENDIBLE GRIPPING AND FASTENING DEVICES FOR REACHING AND CLASPING REMOTELY LOCATED ARTICLES (U.S. CLS. 23, 28 AND 44).

CLASS 9—ELECTRICAL AND SCIENTIFIC APPARATUS

FOR AUTOMATED WATER CONSERVATION DEVICES FOR HOME USE, NAMELY, DEVICES IN THE NATURE OF FLOW METERS AND FLOW REGULATORS DESIGNED TO DETERMINE DURATION OF WATER USE, TO DETERMINE VOLUME OF WATER USAGE, TO ENABLE EFFICIENT WATER USAGE AND TO REGULATE WATER USAGE; AUTOMATED ELECTRICAL POWER CONSERVATION DEVICES FOR HOME USE, NAMELY, DEVICES IN THE NATURE OF ELECTRICAL POWER SWITCHES AND ELECTRICITY FLOW METERS AND REGULATORS DESIGNED TO DETERMINE DURATION OF ELECTRICAL POWER USE, TO DETERMINE KILOWATTS OF ELECTRICAL POWER USAGE, TO ENABLE EFFICIENT ELECTRICAL POWER USAGE AND TO REGULATE ELECTRICAL POWER USAGE (U.S. CLS. 21, 23, 26, 36 AND 38).

CLASS 16—PAPER GOODS AND PRINTED MATTER

FOR DISPOSABLE PLASTIC DIAPER BAGS; MOTORIZED PAINTING TOOLS, NAMELY, AUTOMATED BRUSHES AND PAINT APPLICATOR ROLLERS; MANUAL PAINTING TOOLS, NAMELY, BRUSHES AND PAINT APPLICATOR ROLLERS (U.S. CLS. 2, 5, 22, 23, 29, 37, 38 AND 50).

CLASS 17—RUBBER GOODS

FOR BUILDING AND WINDOW INSULATION (U.S. CLS. 1, 5, 12, 13, 35 AND 50).

CLASS 18—LEATHER GOODS

FOR LUGGAGE WHEELS (U.S. CLS. 1, 2, 3, 22 AND 41).

CLASS 21—HOUSEWARES AND GLASS

FOR CLEANING SPONGES; WINDOW CLEANING SQUEEGEES; DUSTERS; WASHING BRUSHES; ELECTRIC AND NON-ELECTRIC TOOTHBRUSHES; AND DIAPER TRASH CANS (U.S. CLS. 2, 13, 23, 29, 30, 33, 40 AND 50).

MARGARET POWER, EXAMINING ATTORNEY

SN 77-022,297. UMAGINATION LABS, LLC, NEWTON, MA.
FILED 10-16-2006.

UMAGINATION

THE MARK CONSISTS OF STANDARD CHARACTERS WITHOUT CLAIM TO ANY PARTICULAR FONT, STYLE, SIZE, OR COLOR.

CLASS 7—MACHINERY

FOR POWER TOOLS, NAMELY, MOTORIZED WINDOW CLEANING DEVICES, MOTORIZED GARDENING TOOLS, NAMELY, DEVICES FOR CUTTING GRASS, FOR PRUNING SHRUBS AND TREES, FOR WEEDING AND FOR CLEARING DEBRIS FROM GARDEN BEDS, LAWNS, AND BUILDINGS AND WALKWAYS, AND DEVICES FOR CLEANING DEBRIS AND DIRT FROM DRAINAGE CHANNELS FOUND ON BUILDINGS AND WALKWAYS, MOTORIZED EXTENDIBLE GRIPPING AND FASTENING DEVICES FOR REACHING AND CLASPING REMOTELY LOCATED ARTICLES (U.S. CLS. 13, 19, 21, 23, 31, 34 AND 35).

CLASS 8—HAND TOOLS

FOR HAND TOOLS, NAMELY, MANUAL GARDENING TOOLS, NAMELY, DEVICES FOR CUTTING GRASS, FOR PRUNING SHRUBS AND TREES, AND FOR WEEDING; MANUAL EXTENDIBLE GRIPPING AND FASTENING DEVICES FOR REACHING AND CLASPING REMOTELY LOCATED ARTICLES (U.S. CLS. 23, 28 AND 44).

CLASS 9—ELECTRICAL AND SCIENTIFIC APPARATUS

FOR AUTOMATED WATER CONSERVATION DEVICES FOR HOME USE, NAMELY, DEVICES IN THE NATURE OF FLOW METERS AND FLOW REGULATORS DESIGNED TO DETERMINE DURATION OF WATER USE, TO DETERMINE VOLUME OF WATER USAGE, TO ENABLE EFFICIENT WATER USAGE AND TO REGULATE WATER USAGE; AUTOMATED ELECTRICAL POWER CONSERVATION DEVICES FOR HOME USE, NAMELY, DEVICES IN THE NATURE OF ELECTRICAL POWER SWITCHES AND ELECTRICITY FLOW METERS AND REGULATORS DESIGNED TO DETERMINE DURATION OF ELECTRICAL POWER USE, TO DETERMINE KILOWATTS OF ELECTRICAL POWER USAGE, TO ENABLE EFFICIENT ELECTRICAL POWER USAGE AND TO REGULATE ELECTRICAL POWER USAGE (U.S. CLS. 21, 23, 26, 36 AND 38).

CLASS 16—PAPER GOODS AND PRINTED MATTER

FOR DISPOSABLE PLASTIC DIAPER BAGS; MOTORIZED PAINTING TOOLS, NAMELY, AUTOMATED BRUSHES AND PAINT APPLICATOR ROLLERS; MANUAL PAINTING TOOLS, NAMELY, BRUSHES AND PAINT APPLICATOR ROLLERS (U.S. CLS. 2, 5, 22, 23, 29, 37, 38 AND 50).

CLASS 17—RUBBER GOODS

FOR BUILDING AND WINDOW INSULATION (U.S. CLS. 1, 5, 12, 13, 35 AND 50).

CLASS 18—LEATHER GOODS

FOR LUGGAGE WHEELS (U.S. CLS. 1, 2, 3, 22 AND 41).

CLASS 21—HOUSEWARES AND GLASS

FOR CLEANING SPONGES; WINDOW CLEANING SQUEEGEES; DUSTERS; WASHING BRUSHES; ELECTRIC AND NON-ELECTRIC TOOTHBRUSHES; AND DIAPER TRASH CANS (U.S. CLS. 2, 13, 23, 29, 30, 33, 40 AND 50).

MARGARET POWER, EXAMINING ATTORNEY

SN 77-022,309. UMAGINATION LABS, LLC, NEWTON, MA.
FILED 10-16-2006.

UMAGINATION LABS

THE MARK CONSISTS OF STANDARD CHARACTERS WITHOUT CLAIM TO ANY PARTICULAR FONT, STYLE, SIZE, OR COLOR.

CLASS 7—MACHINERY

FOR POWER TOOLS, NAMELY, MOTORIZED WINDOW CLEANING DEVICES, MOTORIZED GARDENING TOOLS, NAMELY, DEVICES FOR CUTTING GRASS, FOR PRUNING SHRUBS AND TREES, FOR WEEDING AND FOR CLEARING DEBRIS FROM GARDEN BEDS, LAWNS, AND BUILDINGS AND WALKWAYS, AND DEVICES FOR CLEANING DEBRIS AND DIRT FROM DRAINAGE CHANNELS FOUND ON BUILDINGS AND WALKWAYS, MOTORIZED EXTENDIBLE GRIPPING AND FASTENING DEVICES FOR REACHING AND CLASPING REMOTELY LOCATED ARTICLES (U.S. CLS. 13, 19, 21, 23, 31, 34 AND 35).

SN 77-024,379. RESOURCE LLC, ST. LOUIS PARK, MN.
FILED 10-18-2006.

SHOREBUDDY

THE MARK CONSISTS OF STANDARD CHARACTERS WITHOUT CLAIM TO ANY PARTICULAR FONT, STYLE, SIZE, OR COLOR.

CLASS 8—HAND TOOLS

FOR HAND TOOLS, NAMELY, MANUAL GARDENING TOOLS, NAMELY, DEVICES FOR CUTTING GRASS, FOR PRUNING SHRUBS AND TREES, AND FOR WEEDING; MANUAL EXTENDIBLE GRIPPING AND FASTENING DEVICES FOR REACHING AND CLASPING REMOTELY LOCATED ARTICLES (U.S. CLS. 23, 28 AND 44).

CLASS 6—METAL GOODS

FOR BOAT DOCKING AND STORING SYSTEMS, NAMELY, KITS WITH COMPONENTS FOR BOAT STORAGE RAMPS, NAMELY, METAL CABLES, METAL BRACKETS, METAL SCREWS, METAL BOLTS, METAL NUTS AND WINCHES ALL SOLD AS A UNIT; METAL LADDERS (U.S. CLS. 2, 12, 13, 14, 23, 25 AND 50).

CLASS 9—ELECTRICAL AND SCIENTIFIC APPARATUS

FOR AUTOMATED WATER CONSERVATION DEVICES FOR HOME USE, NAMELY, DEVICES IN THE NATURE OF FLOW METERS AND FLOW REGULATORS DESIGNED TO DETERMINE DURATION OF WATER USE, TO DETERMINE VOLUME OF WATER USAGE, TO ENABLE EFFICIENT WATER USAGE AND TO REGULATE WATER USAGE; AUTOMATED ELECTRICAL POWER CONSERVATION DEVICES FOR HOME USE, NAMELY, DEVICES IN THE NATURE OF ELECTRICAL POWER SWITCHES AND ELECTRICITY FLOW METERS AND REGULATORS DESIGNED TO DETERMINE DURATION OF ELECTRICAL POWER USE, TO DETERMINE KILOWATTS OF ELECTRICAL POWER USAGE, TO ENABLE EFFICIENT ELECTRICAL POWER USAGE AND TO REGULATE ELECTRICAL POWER USAGE (U.S. CLS. 21, 23, 26, 36 AND 38).

CLASS 12—VEHICLES

FOR BOAT CLEATS; BOAT BUMPERS AND FENDERS (U.S. CLS. 19, 21, 23, 31, 35 AND 44).
LINDA MICKLEBURGH, EXAMINING ATTORNEY

SN 77-025,551. SURFACTORY COMERCIAL IMPORTADORA E EXPORTADORA LTDA, PINHEIROS - S.PAULO, BRAZIL, FILED 10-20-2006.

EVOKE

THE MARK CONSISTS OF STANDARD CHARACTERS WITHOUT CLAIM TO ANY PARTICULAR FONT, STYLE, SIZE, OR COLOR.

OWNER OF U.S. REG. NO. 2,813,891.

CLASS 16—PAPER GOODS AND PRINTED MATTER

FOR DISPOSABLE PLASTIC DIAPER BAGS; MOTORIZED PAINTING TOOLS, NAMELY, AUTOMATED BRUSHES AND PAINT APPLICATOR ROLLERS; MANUAL PAINTING TOOLS, NAMELY, BRUSHES AND PAINT APPLICATOR ROLLERS (U.S. CLS. 2, 5, 22, 23, 29, 37, 38 AND 50).

CLASS 18—LEATHER GOODS

FOR LEATHER BAGS, SUITCASES AND WALLETS; WALLETS WITH CARD COMPARTMENTS; EVENING HANDBAGS; HANDBAGS; HANDBAGS FOR MEN; LEATHER HANDBAGS; COIN PURSES; LEATHER PURSES; MULTI-PURPOSE PURSES; PURSES; SMALL CLUTCH PURSES; SMALL PURSES; WRIST MOUNTED PURSES; KNAPSACKS; SCHOOL KNAPSACKS; HIKING RUCKSACKS; RUCKSACKS; RUCKSACKS FOR MOUNTAINEERS; SMALL RUCKSACKS (U.S. CLS. 1, 2, 3, 22 AND 41).

CLASS 17—RUBBER GOODS

FOR BUILDING AND WINDOW INSULATION (U.S. CLS. 1, 5, 12, 13, 35 AND 50).

CLASS 25—CLOTHING

FOR TROUSERS, PANTS, JEANS, PANTALOONS; CHEMISE, SHIRTS, JERSEY SHIRTS, JEANS SHIRTS, SPORTS SHIRTS, T-SHIRTS; BERMUDA SHORTS, SHORTS, SHORT JEANS, WALKING SHORTS; JACKETS AND JEANS JACKETS; BLAZERS; DRESSES, EVENING DRESSES, WEDDING DRESSES; SKIRTS; SOCKS; STOCKINGS; GLOVES; BATHING SUITS; UNDERWEAR; COATS; WORK SHOES AND BOOTS; WOMEN'S SHOES; TENNIS SHOES; SHOES; LEATHER SHOES; INFANTS' SHOES AND BOOTS; SLIPPERS, LEATHER SLIPPERS (U.S. CLS. 22 AND 39).

MICHAEL LITZAU, EXAMINING ATTORNEY

CLASS 18—LEATHER GOODS

FOR LUGGAGE WHEELS (U.S. CLS. 1, 2, 3, 22 AND 41).

CLASS 21—HOUSEWARES AND GLASS

FOR CLEANING SPONGES; WINDOW CLEANING SQUEEGEES; DUSTERS; WASHING BRUSHES; ELECTRIC AND NON-ELECTRIC TOOTHBRUSHES; AND DIAPER TRASH CANS (U.S. CLS. 2, 13, 23, 29, 30, 33, 40 AND 50).

MARGARET POWER, EXAMINING ATTORNEY

SN 77-029,898. WESTERN INDUSTRIAL RESOURCES CORPORATION, APACHE JUNCTION, AZ. FILED 10-26-2006.



THE MARK CONSISTS OF A FANCIFUL DEPICTION OF THE LETTERS "wi" IN A CIRCLE.

CLASS 35—ADVERTISING AND BUSINESS

FOR EMPLOYMENT AGENCY SERVICES, NAMELY, PROVIDING EMPLOYEES IN THE NATURE OF SUPPLEMENTAL LABOR, ON CONTRACT TO THE PIPELINE INDUSTRY FOR MAINTAINING EXISTING PIPELINES (U.S. CLS. 100, 101 AND 102).

FIRST USE 11-1-1996; IN COMMERCE 11-1-1996.

CLASS 37—CONSTRUCTION AND REPAIR

FOR FACILITIES MAINTENANCE CONTRACTING SERVICES, NAMELY, CORROSION CONTROL; CONSTRUCTION SERVICES, NAMELY, FABRICATION OF WOOD, CONCRETE AND METAL STRUCTURES; INSTALLATION AND REPAIR OF MACHINERY UTILIZED IN REFINERY AND MINING APPLICATIONS; INSTALLATION AND REPAIR OF HVAC SYSTEMS; INSTALLATION AND MAINTENANCE OF ELECTRICAL, LIGHTING, SECURITY, COMMUNICATIONS, GROUNDING GRIDS, AND CONTROL SYSTEMS FOR OTHERS (U.S. CLS. 100, 103 AND 106).

FIRST USE 11-1-1996; IN COMMERCE 11-1-1996.

CLASS 42—SCIENTIFIC AND COMPUTER SERVICES

FOR CONDUCTING GAS MEASUREMENTS FOR OTHERS OF EXISTING PIPELINES AND PREPARING APPROPRIATE EXPERT REPORTS; DESIGN OF ELECTRICAL, LIGHTING, SECURITY, COMMUNICATIONS, GROUNDING GRIDS, AND CONTROL SYSTEMS FOR OTHERS; AND PERFORMING CORROSION CONTROL SERVICES FOR EXISTING PIPELINES, NAMELY, ENGINEERING SERVICES IN THE FIELD OF CORROSION AND PROTECTIVE COATINGS (U.S. CLS. 100 AND 101).

FIRST USE 11-1-1996; IN COMMERCE 11-1-1996.
WANDA KAY PRICE, EXAMINING ATTORNEY

SN 77-031,924. FRALEX THERAPEUTICS INC., TORONTO, CANADA, FILED 10-30-2006.

CNP

THE MARK CONSISTS OF STANDARD CHARACTERS WITHOUT CLAIM TO ANY PARTICULAR FONT, STYLE, SIZE, OR COLOR.

PRIORITY CLAIMED UNDER SEC. 44(D) ON CANADA APPLICATION NO. 1320381, FILED 10-16-2006, REG. NO. TMA709,946, DATED 3-19-2008, EXPIRES 3-19-2023.

CLASS 10—MEDICAL APPARATUS

FOR MEDICAL APPARATUS GENERATING MAGNETIC FIELDS TO TREAT PHYSIOLOGICAL, NEUROLOGICAL AND/OR BEHAVIORAL DISORDERS (U.S. CLS. 26, 39 AND 44).

CLASS 37—CONSTRUCTION AND REPAIR

FOR SERVICING AND REPAIRING SERVICES FOR MEDICAL APPARATUSES FOR GENERATING MAGNETIC FIELDS TO TREAT PHYSIOLOGICAL, NEUROLOGICAL AND/OR BEHAVIORAL DISORDERS (U.S. CLS. 100, 103 AND 106).

KATHERINE STOIDES, EXAMINING ATTORNEY

SN 77-035,340. NORTHWEST LIONS FOUNDATION FOR SIGHT AND HEARING, SEATTLE, WA. FILED 11-2-2006.

SIGHTLIFE

THE MARK CONSISTS OF STANDARD CHARACTERS WITHOUT CLAIM TO ANY PARTICULAR FONT, STYLE, SIZE, OR COLOR.

CLASS 35—ADVERTISING AND BUSINESS

FOR PROMOTING PUBLIC AWARENESS PERTAINING TO EYE BANKS AND THE DONATION OF EYE TISSUE; CONSULTING SERVICES IN THE FIELD OF ESTABLISHING, PROMOTING, AND MAINTAINING EYE BANKS AND EYE TISSUE DONATION (U.S. CLS. 100, 101 AND 102).

FIRST USE 11-0-2006; IN COMMERCE 11-0-2006.

CLASS 44—MEDICAL, BEAUTY AND AGRICULTURAL SERVICES

FOR EYE BANK SERVICES, NAMELY, RECOVERING, PROCESSING AND PROVIDING EYE TISSUE FOR EYE SURGERIES, EYE RESEARCH AND EYE EDUCATION AND EVALUATING AND PROVIDING OCULAR TISSUE PREPARED WITH LASER TECHNOLOGIES AND PROCESSES; PROVIDING INFORMATION PERTAINING TO EYE BANKS AND THE DONATION OF EYE TISSUE (U.S. CLS. 100 AND 101).

FIRST USE 11-0-2006; IN COMMERCE 11-0-2006.
SIMON TENG, EXAMINING ATTORNEY

SN 77-036,358. CAYMAN AIRWAYS LTD., GRAND CAYMAN, CAYMAN ISLANDS, FILED 11-3-2006.



"THE MARK CONSISTS OF A STYLIZED TURTLE WITH ONE PEG LEG; WEARING A HAT, NECKERCHIEF, SCARF, AND BOOT; AND HOLDING A SWORD."

CLASS 39—TRANSPORTATION AND STORAGE

FOR AIR TRANSPORTATION; ARRANGING TRAVEL TOURS (U.S. CLS. 100 AND 105).
FIRST USE 6-0-1977; IN COMMERCE 6-0-1977.

CLASS 43—HOTEL AND RESTAURANT SERVICES

FOR MAKING HOTEL RESERVATIONS FOR OTHERS (U.S. CLS. 100 AND 101).
FIRST USE 6-0-1977; IN COMMERCE 6-0-1977.
PAULA MAHONEY, EXAMINING ATTORNEY

SN 77-039,312. L'OCCITANE SA, MANOSQUE, FRANCE, FILED 11-8-2006.

IMMORTELLE

THE MARK CONSISTS OF STANDARD CHARACTERS WITHOUT CLAIM TO ANY PARTICULAR FONT, STYLE, SIZE, OR COLOR.

THE FOREIGN WORDING IN THE MARK TRANSLATES INTO ENGLISH AS "EVERLASTING FLOWER".

CLASS 3—COSMETICS AND CLEANING PREPARATIONS

FOR COSMETICS; PERFUMERY; SHAMPOOS; AFTER-SHAMPOOS, NAMELY, CONDITIONERS AND RINSES; CREAMS FOR THE BODY AND THE FACE; COSMETIC PREPARATIONS FOR BATHS; SHOWER GELS; AND SOAPS (U.S. CLS. 1, 4, 6, 50, 51 AND 52).

CLASS 4—LUBRICANTS AND FUELS

FOR PERFUMED CANDLES (U.S. CLS. 1, 6 AND 15).

CLASS 5—PHARMACEUTICALS

FOR AIR FRESHENERS (U.S. CLS. 6, 18, 44, 46, 51 AND 52).
GIANCARLO CASTRO, EXAMINING ATTORNEY

SN 77-039,437. PHOSAIC, LLC, HILTON HEAD ISLAND, SC. FILED 11-8-2006.

PHOSAIC

THE MARK CONSISTS OF STANDARD CHARACTERS WITHOUT CLAIM TO ANY PARTICULAR FONT, STYLE, SIZE, OR COLOR.

CLASS 9—ELECTRICAL AND SCIENTIFIC APPARATUS

FOR DIGITAL MEDIA, NAMELY, DOWNLOADABLE DIGITAL IMAGES AND DOWNLOADABLE DIGITAL FILES FEATURING A COLLECTION OF PHOTOGRAPHS OR GRAPHICS (U.S. CLS. 21, 23, 26, 36 AND 38).

CLASS 16—PAPER GOODS AND PRINTED MATTER

FOR PHOTOGRAPHIC PRINTS CREATED FROM A COLLECTION OF PHOTOGRAPHS OR GRAPHICS (U.S. CLS. 2, 5, 22, 23, 29, 37, 38 AND 50).

CLASS 40—MATERIAL TREATMENT

FOR CREATION OF IMAGES BASED ON A COLLECTION OF PHOTOGRAPHS, GRAPHICS, MEDIA, AND OTHER IMAGES (U.S. CLS. 100, 103 AND 106).
FIRST USE 9-10-2002; IN COMMERCE 9-10-2002.
CHERYL CLAYTON, EXAMINING ATTORNEY

SN 77-039,977. VNUS MEDICAL TECHNOLOGIES, INC., SAN JOSE, CA. FILED 11-8-2006.

THE VEIN STORE

THE MARK CONSISTS OF STANDARD CHARACTERS WITHOUT CLAIM TO ANY PARTICULAR FONT, STYLE, SIZE, OR COLOR.

NO CLAIM IS MADE TO THE EXCLUSIVE RIGHT TO USE "STORE", APART FROM THE MARK AS SHOWN.

CLASS 5—PHARMACEUTICALS

FOR GAUZE WITH SPONGE MATERIAL, IODINE, BLOOD VESSEL DILATORS (U.S. CLS. 6, 18, 44, 46, 51 AND 52).

CLASS 10—MEDICAL APPARATUS

FOR SURGICAL AND MEDICAL INSTRUMENTS AND APPARATUS FOR USE IN THE TREATMENT OF BLOOD VESSEL DISEASES, NAMELY, NEEDLES, SYRINGES, SCALPELS, FORCEPS, STERILE ULTRASONIC GEL PACK FOR USE WITH AN ULTRASONIC MEDICAL DIAGNOSTIC APPARATUS, MEDICAL GOWNS, SURGICAL SPONGES IN GAUZE FORM, STERILE SURGICAL DRAPES, FOAM SURGICAL SPONGE STICKS, GUIDEWIRES, CATHETERS, MEDICAL PROBE COVERS AND SHEATHS, AND IV SETS CONSISTING A SYRINGE AND TUBING TO INSTILL TUMESCENT SOLUTIONS; TRAYS FOR SURGICAL PREPARATION (U.S. CLS. 26, 39 AND 44).

CLASS 24—FABRICS

FOR TOWELS (U.S. CLS. 42 AND 50).
KYLE PEETE, EXAMINING ATTORNEY

SN 77-045,856. TMA LIST BROKERAGE & MANAGEMENT,
INC., RESTON, VA. FILED 11-16-2006.

SN 77-045,040. INNOCORP. LTD., VERONA, WI. FILED 11-
15-2006.

SIMULATED IMPAIRED DRIVING
EXPERIENCE

THE MARK CONSISTS OF STANDARD CHARACTERS
WITHOUT CLAIM TO ANY PARTICULAR FONT, STYLE,
SIZE, OR COLOR.
SEC. 2(F).

CLASS 12—VEHICLES

FOR MOTORIZED LAND VEHICLES, NAMELY, VE-
HICLES USED FOR DEMONSTRATING THE EFFECTS
OF IMPAIRED OPERATION OF A VEHICLE (U.S. CLS.
19, 21, 23, 31, 35 AND 44).
FIRST USE 3-13-2003; IN COMMERCE 3-13-2003.

**CLASS 41—EDUCATION AND ENTERTAIN-
MENT**

FOR EDUCATIONAL PROGRAMS IN THE FIELD OF
IMPAIRED OPERATION OF VEHICLES, AND RELATED
MATERIALS (U.S. CLS. 100, 101 AND 107).
FIRST USE 8-0-2003; IN COMMERCE 8-0-2003.
JAY FLOWERS, EXAMINING ATTORNEY

SN 77-045,815. STUDY AUSTRALIA LLC, NOTRE DAME,
IN. FILED 11-16-2006.

STUDY AUSTRALIA

THE MARK CONSISTS OF STANDARD CHARACTERS
WITHOUT CLAIM TO ANY PARTICULAR FONT, STYLE,
SIZE, OR COLOR.

NO CLAIM IS MADE TO THE EXCLUSIVE RIGHT TO
USE "STUDY", APART FROM THE MARK AS SHOWN.
SEC. 2(F).

CLASS 35—ADVERTISING AND BUSINESS

FOR ADMINISTRATION OF CULTURAL AND EDU-
CATIONAL EXCHANGE PROGRAMS, NAMELY,
STUDY ABROAD PROGRAMS (U.S. CLS. 100, 101 AND
102).
FIRST USE 0-0-2002; IN COMMERCE 0-0-2002.

**CLASS 39—TRANSPORTATION AND STO-
RAGE**

FOR ARRANGEMENT OF TRAVEL TOURS IN CON-
NECTION WITH STUDY ABROAD PROGRAMS (U.S.
CLS. 100 AND 105).
FIRST USE 0-0-2002; IN COMMERCE 0-0-2002.
FRANK LATTUCA, EXAMINING ATTORNEY

TMA

THE MARK CONSISTS OF STANDARD CHARACTERS
WITHOUT CLAIM TO ANY PARTICULAR FONT, STYLE,
SIZE, OR COLOR.

CLASS 35—ADVERTISING AND BUSINESS

FOR MARKETING CONSULTING SERVICES, MAR-
KETING DATA MANAGEMENT SERVICES, PROVID-
ING MAILING LISTS AND MARKETING DATA (U.S.
CLS. 100, 101 AND 102).
FIRST USE 5-15-1985; IN COMMERCE 5-15-1985.

CLASS 36—INSURANCE AND FINANCIAL

FOR MAILING LISTS AND MARKETING DATA
BROKERAGE SERVICES (U.S. CLS. 100, 101 AND 102).
FIRST USE 5-15-1985; IN COMMERCE 5-15-1985.
FRANK LATTUCA, EXAMINING ATTORNEY

SN 77-047,144. HYALURON, INC., BURLINGTON, MA.
FILED 11-17-2006.

HYALURON

THE MARK CONSISTS OF STANDARD CHARACTERS
WITHOUT CLAIM TO ANY PARTICULAR FONT, STYLE,
SIZE, OR COLOR.

CLASS 5—PHARMACEUTICALS

FOR BIOMEDICAL PREPARATIONS CONTAINING
HYALURONIC ACID, HYALURONATE OLIGOSAC-
CHARIDES, AND BULK HYALURONATE FOR USE IN
THE TREATMENT OF OSTEOARTHRITIS, EYE DIS-
EASES AND DISORDERS, AND CANCER (U.S. CLS. 6,
18, 44, 46, 51 AND 52).

CLASS 40—MATERIAL TREATMENT

FOR CONTRACT MANUFACTURING IN THE FIELD
OF PHARMACEUTICALS AND BIOPHARMACEUTI-
CALS; CONTRACT MANUFACTURING IN THE FIELD
OF ASEPTICALLY FILLED LIQUID PARENTERAL
VIALS, SYRINGES, MEDICAL VIALS, AND CONTAIN-
ERS; ASSEMBLING OF PRODUCT FOR OTHERS,
NAMELY, FILLING OF VIALS, SYRINGES, AND CUS-
TOM CONTAINERS FOR OTHERS IN THE FIELD OF
PHARMACEUTICAL PRODUCTS OF LIQUID, SEMI-
SOLID, OR SOLID KIND (U.S. CLS. 100, 103 AND 106).
FIRST USE 10-4-1999; IN COMMERCE 10-4-1999.
DAWN HAN, EXAMINING ATTORNEY

SN 77-049,273. TIRE KINGDOM, INC., JUNO BEACH, FL.
FILED 11-21-2006.



OWNER OF U.S. REG. NOS. 1,838,215, 2,864,332 AND OTHERS.

NO CLAIM IS MADE TO THE EXCLUSIVE RIGHT TO USE "TIRES IN AN HOUR OR LESS", APART FROM THE MARK AS SHOWN.

THE COLOR(S) RED, GRAY, BLACK, WHITE AND BLUE IS/ARE CLAIMED AS A FEATURE OF THE MARK.

THE COLORS RED AND WHITE AND BLUE APPEAR ON THE CROWN; THE COLORS RED AND GRAY APPEAR ON THE HANDS OF THE CLOCK; THE COLOR WHITE APPEARS ON THE FACE OF THE CLOCK; THE COLOR BLACK APPEARS ON THE NUMBERS 0, 15, 30 AND 45 ON THE FACE OF THE CLOCK; THE COLOR RED APPEARS ON THE WORDS "OR LESS..." AND THE OUTLINING OF THE WORDS "TIRES IN AN HOUR"; THE COLORS BLACK AND WHITE APPEAR ON THE TIRE TREAD; THE COLOR BLUE APPEARS ON THE OUTLINING OF ALL OF THE LETTERS; THE COLOR WHITE APPEARS ON THE WORDS "MERCHANT'S TIRE TIRES IN AN HOUR"; AND THE COLOR GRAY APPEARS IN THE BLOCK SHAPES IN THE BACKGROUND OF THE LOGO.

CLASS 12—VEHICLES

FOR TIRES (U.S. CLS. 19, 21, 23, 31, 35 AND 44).
FIRST USE 1-5-2006; IN COMMERCE 1-5-2006.

CLASS 35—ADVERTISING AND BUSINESS

FOR RETAIL TIRE STORES (U.S. CLS. 100, 101 AND 102).
FIRST USE 1-5-2006; IN COMMERCE 1-5-2006.

CLASS 37—CONSTRUCTION AND REPAIR

FOR TIRE BALANCING; TIRE ROTATING AND BALANCING (U.S. CLS. 100, 103 AND 106).
FIRST USE 1-5-2006; IN COMMERCE 1-5-2006.
COLLEEN DOMBROW, EXAMINING ATTORNEY

SN 77-051,402. MUNCHKIN, INC., NORTH HILLS, CA.
FILED 11-27-2006.

BAMBOO

THE MARK CONSISTS OF STANDARD CHARACTERS WITHOUT CLAIM TO ANY PARTICULAR FONT, STYLE, SIZE, OR COLOR.

OWNER OF U.S. REG. NOS. 2,898,338, 3,146,970 AND 3,234,118.

CLASS 21—HOUSEWARES AND GLASS

FOR CLOTHES BRUSHES (U.S. CLS. 2, 13, 23, 29, 30, 33, 40 AND 50).

CLASS 27—FLOOR COVERINGS

FOR PET FEEDING MATS (U.S. CLS. 19, 20, 37, 42 AND 50).

CLASS 31—NATURAL AGRICULTURAL PRODUCTS

FOR CAT FOOD; CAT TREATS; CONSUMABLE PET CHEWS; DIGESTIBLE CHEWING BONES FOR DOGS; DOG BISCUITS; DOG FOOD; DOG TREATS; PET BEVERAGES; PET FOOD; PET TREATS (U.S. CLS. 1 AND 46).

TRACY WHITTAKER-BROWN, EXAMINING ATTORNEY

SN 77-052,445. TELEOPTIX S.R.L., CORNATE D'ADDA (MI), ITALY, FILED 11-28-2006.

TELEOPTIX

THE MARK CONSISTS OF STANDARD CHARACTERS WITHOUT CLAIM TO ANY PARTICULAR FONT, STYLE, SIZE, OR COLOR.

PRIORITY CLAIMED UNDER SEC. 44(D) ON ERPNCMNTY TM OFC APPLICATION NO. 005489174, FILED 11-22-2006, REG. NO. 005489174, DATED 11-7-2007, EXPIRES 11-22-2016.

THE WORDING "TELEOPTIX" HAS NO MEANING IN A FOREIGN LANGUAGE.

CLASS 9—ELECTRICAL AND SCIENTIFIC APPARATUS

FOR ELECTRONIC AND OPTICAL INSTRUMENTS, COMPONENTS, DEVICES, AND SYSTEMS FOR TELECOMMUNICATION, IN PARTICULAR IN MILITARY, ENERGY AND TRANSPORTATION INDUSTRY, NAMELY, HIGH FREQUENCY MODULES AND TRANSCIEVERS FOR WIRELESS APPLICATIONS, SYNCHRONOUS DIGITAL HIERARCHY (SDH) HIGH LINEARITY UP-AND-DOWN CONVERTERS, SYNCHRONOUS DIGITAL HIERARCHY (SDH) HIGH POWER TRANSMITTER MODULES, SYNCHRONOUS DIGITAL HIERARCHY (SDH) AND PLESIOCHRONOUS DIGITAL HIERARCHY (PDH) EQUIPMENT, NAMELY, SYNCHRONOUS DIGITAL HIERARCHY (SDH) AND PLESIOCHRONOUS DIGITAL HIERARCHY (PDH) ELECTRONIC AND OPTICAL MODULES AND TRANCEIVERS FOR WIRELESS APPLICATIONS; SYSTEMS AND COMPONENTS FOR RADIO AND OPTICAL FIBER TRANSMISSION, NAMELY, HIGH CAPACITY OPTICAL TRANSMITTERS, RECEIVERS, MODULES AND TRANSCIEVERS FOR OPTICAL FIBER TRANSMISSION SYSTEMS, ACTIVE OPTICAL COMPONENTS, PASSIVE OPTICAL COMPONENTS AND MODULES, ERBIUM DOPED FIBER AMPLIFIER (EDFA) AND OPTICAL AMPLIFIERS, FIBER OPTIC BASED COMPONENTS (U.S. CLS. 21, 23, 26, 36 AND 38).

CLASS 38—COMMUNICATION

FOR TELECOMMUNICATION ACCESS SERVICES (U.S. CLS. 100, 101 AND 104).

CLASS 42—SCIENTIFIC AND COMPUTER SERVICES

FOR ENGINEERING SERVICES, NAMELY, ENGINEERING SERVICES FOR TELECOMMUNICATION APPARATUS AND SYSTEMS, IN PARTICULAR IN MILITARY, ENERGY AND TRANSPORTATION INDUSTRY, DESIGN AND ENGINEERING SERVICES TO DEVELOP PROJECTS AND MANUFACTURING OF WIRELESS HIGH FREQUENCY SYSTEMS AND OPTICAL FIBER SYSTEMS; ENGINEERING SERVICES FOR DESIGNING AND MANUFACTURING OF SUBSTRATES SUCH AS CERAMICS AND HIGH FREQUENCY (HF) LAMINATES, SURFACE MOUNTING DEVICE (SMD) AND DIE ATTACHMENT, SUCH AS BRAZING, REFLOW AND ATTACHMENT TECHNOLOGIES AND MATERIALS, INTERCONNECTION TECHNOLOGIES, SUCH AS CONNECTORIZATION, SOLDERING, WIRE AND RIBBON BONDING, FIBER SPLICING AND RECOATING, PACKAGE SEALING; ENGINEERING SERVICES FOR TESTING WIRELESS HIGH FREQUENCY SYSTEMS AND COMPONENTS THEREOF; ENGINEERING SERVICES FOR TESTING OPTICAL HIGH CAPACITY FIBER OPTIC SYSTEMS AND COMPONENTS THEREOF (U.S. CLS. 100 AND 101).
SUZANNE BLANE, EXAMINING ATTORNEY

SN 77-062,659. SWATZAK, CHRISTOPHER, DBA WORLD INNOVATIONS, MADISON, WI. FILED 12-12-2006.



THE MARK CONSISTS OF A GLOBE WITH OUTLINES OF CONTINENTS AND A DEPICTION OF A LIGHT BULB IN THE CENTER OF THE GLOBE, WITH THE WORDS "WORLD INNOVATIONS" TO THE RIGHT OF THE GLOBE. SEC. 2(F) AS TO "WORLD INNOVATIONS".

CLASS 35—ADVERTISING AND BUSINESS

FOR BUSINESS MARKETING AND BUSINESS CONSULTATION SERVICES IN THE FIELD OF BUSINESS INNOVATIONS (U.S. CLS. 100, 101 AND 102).
FIRST USE 4-10-1996; IN COMMERCE 4-15-1996.

CLASS 42—SCIENTIFIC AND COMPUTER SERVICES

FOR PRODUCT DEVELOPMENT (U.S. CLS. 100 AND 101).
FIRST USE 4-10-1996; IN COMMERCE 4-15-1996.
KATHERINE CHANG, EXAMINING ATTORNEY

SN 77-059,314. CAVINKARE PRIVATE LIMITED, CHENNAI, INDIA, FILED 12-7-2006.

CHINNI'S

THE MARK CONSISTS OF STANDARD CHARACTERS WITHOUT CLAIM TO ANY PARTICULAR FONT, STYLE, SIZE, OR COLOR.

THE WORDING "CHINNI'S" HAS NO MEANING IN A FOREIGN LANGUAGE.

CLASS 29—MEATS AND PROCESSED FOODS

FOR MEAT, FISH, POULTRY AND GAME MEAT EXTRACTS, PRESERVED DRIED AND COOKED FRUITS AND VEGETABLES, JELLIES, JAMS, CRANBERRY SAUCE, APPLESAUCE, EGGS, MILK AND OTHER DAIRY PRODUCTS, NAMELY, DAIRY BASED BEVERAGES, DAIRY BASED DIPS, EDIBLE OILS AND FATS, PRESERVES, NAMELY, FRUIT AND VEGETABLE PRESERVES, PICKLES (U.S. CL. 46).

CLASS 30—STAPLE FOODS

FOR CHIPS, NAMELY, CORN CHIPS, WAFERS, PADDS, NAMELY, TORTILLAS MADE UP OF LENTILS AND SPICES, SNACK FOOD, NAMELY, RICE AND WHEAT BASED SNACK FOODS FOR HUMAN CONSUMPTION, COFFEE, TEA, COCOA, SUGAR, RICE, TAPIOCA, SAGO COFFEE SUBSTITUTES, FLOUR AND PREPARATIONS MADE FROM CEREALS, NAMELY, BREAD, CEREALS BASED SNACK FOODS, BREAD, BISCUITS, CAKES, PASTRY AND CONFECTIONERY, NAMELY, CONFECTIONERY CHIPS FOR BAKING, FRUITS ICES, HONEY, TREACLE, YEAST, BAKING POWDER, SALT, MUSTARD, PEPPER, VINEGAR, SAUCES, SPICES, ICE (U.S. CL. 46).
AHSEN KHAN, EXAMINING ATTORNEY

SN 77-062,688. ALLEN CARR'S EASYWAY (INTERNATIONAL) LTD., LONDON, UNITED KINGDOM, FILED 12-12-2006.

ALLEN CARR

THE MARK CONSISTS OF STANDARD CHARACTERS WITHOUT CLAIM TO ANY PARTICULAR FONT, STYLE, SIZE, OR COLOR.

OWNER OF ERPN CMNTY TM OFC REG. NO. 3395266, DATED 2-4-2005, EXPIRES 10-8-2013.

OWNER OF U.S. REG. NO. 3,128,479.
THE NAME "ALLEN CARR" DOES NOT IDENTIFY A LIVING INDIVIDUAL.

CLASS 9—ELECTRICAL AND SCIENTIFIC APPARATUS

FOR VIDEO AND AUDIO TAPES, DVDS, COMPACT DISCS, AND CD-ROMS RELATING TO OVERCOMING ADDICTIONS, SUCH AS ADDICTIONS TO NICOTINE, ALCOHOL AND NARCOTICS, IN PARTICULAR NICOTINE, STOPPING SMOKING, DRINKING ALCOHOL AND TAKING NARCOTICS, OVERCOMING WEIGHT PROBLEMS, FEARS AND COMPULSIONS, AND TO DEVELOPING PERSONAL CHARACTERISTICS (U.S. CLS. 21, 23, 26, 36 AND 38).

CLASS 16—PAPER GOODS AND PRINTED MATTER

FOR PRINTED PUBLICATIONS, NAMELY, BOOKS, PERIODICALS, NEWSLETTERS, MAGAZINES, BROCHURES, PAMPHLETS AND LEAFLETS RELATING TO OVERCOMING ADDICTIONS, SUCH AS ADDICTIONS TO NICOTINE, ALCOHOL AND NARCOTICS, IN PARTICULAR NICOTINE, STOPPING SMOKING, DRINKING ALCOHOL AND TAKING NARCOTICS, OVERCOMING WEIGHT PROBLEMS, FEARS AND COMPULSIONS, AND TO DEVELOPING PERSONAL CHARACTERISTICS (U.S. CLS. 2, 5, 22, 23, 29, 37, 38 AND 50).

CLASS 41—EDUCATION AND ENTERTAINMENT

FOR EDUCATION SERVICES, NAMELY, PROVIDING COURSES, CONFERENCES, LECTURES, SEMINARS AND WORKSHOPS RELATED TO BUSINESS FRANCHISE MANAGEMENT; EDUCATION SERVICES, NAMELY, PROVIDING SEMINARS, WORKSHOPS, CONFERENCES, COURSES, EDUCATIONAL CLINICS AND LECTURES RELATING TO OVERCOMING ADDICTIONS, SUCH AS ADDICTIONS TO NICOTINE, ALCOHOL AND NARCOTICS, IN PARTICULAR NICOTINE, STOPPING SMOKING, DRINKING ALCOHOL AND TAKING NARCOTICS, OVERCOMING WEIGHT PROBLEMS, FEARS AND COMPULSIONS, AND TO DEVELOPING PERSONAL CHARACTERISTICS; INCLUDING THE CONDUCTING OF SUCH CONFERENCES, COURSES, LECTURES AND SEMINARS VIA THE INTERNET; PUBLICATION OF EDUCATIONAL MATERIAL SUCH AS PRINTED BOOKS, BROCHURES, PAMPHLETS, LEAFLETS AND BROCHURES RELATING TO OVERCOMING ADDICTIONS SUCH AS ADDICTIONS TO NICOTINE, ALCOHOL AND NARCOTICS, IN PARTICULAR NICOTINE, STOPPING SMOKING, DRINKING ALCOHOL AND TAKING NARCOTICS, OVERCOMING WEIGHT PROBLEMS, FEARS AND COMPULSIONS, AND TO DEVELOPING PERSONAL CHARACTERISTICS (U.S. CLS. 100, 101 AND 107).

CLASS 44—MEDICAL, BEAUTY AND AGRICULTURAL SERVICES

FOR MEDICAL SERVICES; MEDICAL CLINIC SERVICES; HEALTH CLINIC SERVICES; ADVICE, COUNSELING, CONSULTANCY, INFORMATION, THERAPY AND HYPNOTHERAPY, RELATING TO OVERCOMING ADDICTIONS AND/OR DEPENDENCY, SUCH AS TO NICOTINE, ALCOHOL AND NARCOTICS, IN PARTICULAR NICOTINE, STOPPING SMOKING, DRINKING ALCOHOL AND TAKING NARCOTICS, OVERCOMING WEIGHT PROBLEMS, FEARS AND COMPULSIONS, AND TO DEVELOPING PERSONAL CHARACTERISTICS (U.S. CLS. 100 AND 101).

INGRID C. EULIN, EXAMINING ATTORNEY

SN 77-063,544, CHARLES SCHWAB & CO., INC., SAN FRANCISCO, CA. FILED 12-13-2006.

YOUR PARTNER IN TAX-SMART
PHILANTHROPY

THE MARK CONSISTS OF STANDARD CHARACTERS WITHOUT CLAIM TO ANY PARTICULAR FONT, STYLE, SIZE, OR COLOR.

CLASS 36—INSURANCE AND FINANCIAL

FOR CHARITABLE SERVICES, NAMELY, PROVIDING DONOR-ADVISED FUND AND CHARITABLE TRUST SERVICES FOR PHILANTHROPIC PURPOSES; PROVIDING CHARITABLE ACCOUNT INFORMATION AND CHARITABLE DONATION INFORMATION REGARDING FINANCIAL CONTRIBUTIONS TO THE ACCOUNT AND GRANT DISTRIBUTIONS FROM THE ACCOUNT; PROVIDING FINANCIAL INFORMATION IN THE FIELD OF CHARITABLE CONTRIBUTION AND CHARITABLE DONATION AND GRANT DISTRIBUTION PLANNING (U.S. CLS. 100, 101 AND 102).

FIRST USE 11-0-2005; IN COMMERCE 11-0-2005.

CLASS 42—SCIENTIFIC AND COMPUTER SERVICES

FOR COMPUTER SERVICES, NAMELY, HOSTING A WEBSITE FEATURING RESEARCH AND ANALYSIS OF OTHERS IN CHARITABLE ORGANIZATIONS VIA A GLOBAL COMPUTER COMMUNICATIONS NETWORK, AND CHARITABLE DONATION INFORMATION (U.S. CLS. 100 AND 101).

FIRST USE 11-0-2005; IN COMMERCE 11-0-2005.

GRETTA YAO, EXAMINING ATTORNEY

SN 77-063,553, CHARLES SCHWAB & CO., INC., SAN FRANCISCO, CA. FILED 12-13-2006.



SCHWAB CHARITABLE

OWNER OF U.S. REG. NOS. 1,516,641, 2,649,841 AND OTHERS.

NO CLAIM IS MADE TO THE EXCLUSIVE RIGHT TO USE "CHARITABLE", APART FROM THE MARK AS SHOWN.

CLASS 36—INSURANCE AND FINANCIAL

FOR CHARITABLE SERVICES, NAMELY, PROVIDING DONOR-ADVISED FUND AND CHARITABLE TRUST SERVICES FOR PHILANTHROPIC PURPOSES; PROVIDING CHARITABLE ACCOUNT INFORMATION AND CHARITABLE DONATION INFORMATION REGARDING FINANCIAL CONTRIBUTIONS TO THE ACCOUNT AND GRANT DISTRIBUTIONS FROM THE ACCOUNT; PROVIDING FINANCIAL INFORMATION IN THE FIELD OF CHARITABLE CONTRIBUTION AND CHARITABLE DONATION AND GRANT DISTRIBUTION PLANNING (U.S. CLS. 100, 101 AND 102).

FIRST USE 9-0-2006; IN COMMERCE 9-0-2006.

CLASS 42—SCIENTIFIC AND COMPUTER SERVICES

FOR COMPUTER SERVICES, NAMELY, HOSTING A WEBSITE FEATURING RESEARCH AND ANALYSIS OF OTHERS IN CHARITABLE ORGANIZATIONS VIA A GLOBAL COMPUTER COMMUNICATIONS NETWORK, AND CHARITABLE DONATION INFORMATION (U.S. CLS. 100 AND 101).

FIRST USE 9-0-2006; IN COMMERCE 9-0-2006.
GRETTA YAO, EXAMINING ATTORNEY

SN 77-064,605. TOM RAGAN & MIKE MASSEY PARTNERSHIP, L.L.C., PONCHATOULA, LA. FILED 12-14-2006.

COMPARE • N • SAVE

CLASS 1—CHEMICALS

FOR LAWN AND GARDEN CHEMICALS, NAMELY, FERTILIZERS (U.S. CLS. 1, 5, 6, 10, 26 AND 46).

CLASS 5—PHARMACEUTICALS

FOR MEDICATED PET SHAMPOOS, PET PESTICIDES; HERBICIDES, INSECTICIDES, PESTICIDES AND FUNGICIDES FOR HOME, GARDEN AND LAWN USE AND FOR PROFESSIONAL USE (U.S. CLS. 6, 18, 44, 46, 51 AND 52).

JAY FLOWERS, EXAMINING ATTORNEY

SN 77-065,799. NEXTWAVE BROADBAND INC., SAN DIEGO, CA. FILED 12-15-2006.

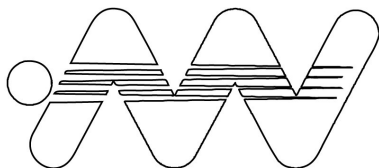

THE MARK CONSISTS OF THE FANCIFUL LETTERS "N" AND "W" WITH THE DEPICTION OF A BALL MOVING QUICKLY ACROSS AND TO THE LEFT OF THE LETTERS.

CLASS 9—ELECTRICAL AND SCIENTIFIC APPARATUS

FOR INTEGRATED CIRCUITS, CELLULAR AND WIRELESS TELEPHONES, AND ELECTRONICS, NAMELY, COMPUTER HARDWARE, DEVICES FOR TRANSPORTING AND AGGREGATING VOICE, DATA AND VIDEO COMMUNICATION ACROSS MULTIPLE NETWORK INFRASTRUCTURES AND COMMUNICATION PROTOCOLS AND COMMUNICATIONS SOFTWARE USED FOR PROVIDING WIRELESS-TELEPHONY AND DATA SERVICES (U.S. CLS. 21, 23, 26, 36 AND 38).

CLASS 36—INSURANCE AND FINANCIAL

FOR TELECOMMUNICATIONS-RESELLER SERVICES, NAMELY, TELECOMMUNICATIONS-AIR-TIME-BROKERAGE SERVICES (U.S. CLS. 100, 101 AND 102).

CLASS 38—COMMUNICATION

FOR WIRELESS-BROADBAND-COMMUNICATION SERVICES; TECHNICAL CONSULTATION IN THE FIELD OF TELECOMMUNICATIONS (U.S. CLS. 100, 101 AND 104).

CLASS 42—SCIENTIFIC AND COMPUTER SERVICES

FOR IMPLEMENTATION, RESEARCH AND DEVELOPMENT OF WIRELESS-TELECOMMUNICATIONS SYSTEMS FOR OTHERS (U.S. CLS. 100 AND 101).

SUSAN RICHARDS, EXAMINING ATTORNEY

SN 77-069,459. METAVERSUM GMBH, D-10179 BERLIN, FED REP GERMANY, FILED 12-21-2006.

TWINITY

THE MARK CONSISTS OF STANDARD CHARACTERS WITHOUT CLAIM TO ANY PARTICULAR FONT, STYLE, SIZE, OR COLOR.

CLASS 9—ELECTRICAL AND SCIENTIFIC APPARATUS

FOR GAME AND SIMULATION PROGRAMS FOR COMPUTERS, NAMELY, PROGRAMS FOR THE THREE-DIMENSIONAL REPRESENTATION OF VIRTUAL REALITIES; COMPUTER PROGRAMS RECORDED ON DATA MEDIA, NAMELY, SOFTWARE, FOR MULTI-PLAYER ACCESS TO THREE-DIMENSIONAL VIRTUAL REALITIES, FOR ONLINE GAMES, COMPUTER GAMES, VIDEO GAMES AND VIRTUAL REALITY GAMES (U.S. CLS. 21, 23, 26, 36 AND 38).

CLASS 35—ADVERTISING AND BUSINESS

FOR ONLINE SERVICES, NAMELY, PROVIDING AN ONLINE DATABASE FEATURING INFORMATION IN THE FIELDS OF BUSINESS AND ECONOMICS (U.S. CLS. 100, 101 AND 102).

CLASS 38—COMMUNICATION

FOR DELIVERY OF MESSAGES BY ELECTRONIC TRANSMISSION; COMMUNICATION SERVICES, NAMELY, PROVIDING ON-LINE FORUMS FOR TRANSMISSION OF MESSAGES AMONG COMPUTER USERS CONCERNING GEOGRAPHY, SPECIAL EVENTS, ECONOMICS AND BUSINESS; PROVIDING AN ONLINE FORUM FOR TRADING VIRTUAL REAL ESTATE (U.S. CLS. 100, 101 AND 104).

CLASS 39—TRANSPORTATION AND STORAGE

FOR ONLINE SERVICES, NAMELY, PROVIDING AN ONLINE DATABASE FEATURING INFORMATION IN THE FIELD OF GEOGRAPHY (U.S. CLS. 100 AND 105).

CLASS 41—EDUCATION AND ENTERTAINMENT

FOR ENTERTAINMENT SERVICES, NAMELY, PROVIDING ONLINE COMPUTER GAMES, VIDEO GAMES AND VIRTUAL REALITY GAMES; ONLINE SERVICES, NAMELY, PROVIDING AN ONLINE DATABASE FEATURING INFORMATION IN THE FIELD OF SPECIAL EVENTS (U.S. CLS. 100, 101 AND 107).

CLASS 42—SCIENTIFIC AND COMPUTER SERVICES

FOR APPLICATION SERVICE PROVIDER FEATURING SOFTWARE FOR USE IN CREATING THREE-DIMENSIONAL REPRESENTATION OF VIRTUAL REALITIES; APPLICATION SERVICE PROVIDER FEATURING SOFTWARE FOR PROVIDING MULTIPLE USER ACCESS TO THREE DIMENSIONAL VIRTUAL REALITIES; APPLICATION SERVICE PROVIDER FEATURING DATABASE SOFTWARE IN THE FIELDS OF BUSINESS, ECONOMICS, GEOGRAPHY AND SPECIAL EVENTS (U.S. CLS. 100 AND 101).

CLASS 45—PERSONAL AND LEGAL SERVICES

FOR ONLINE DATING SERVICE (U.S. CLS. 100 AND 101).

PAUL MORENO, EXAMINING ATTORNEY

SN 77-071,246. MAZMANIAN, VICTOR, MISSION VIEJO, CA. FILED 12-26-2006.

Big John Mazmanian

THE MARK CONSISTS OF STANDARD CHARACTERS WITHOUT CLAIM TO ANY PARTICULAR FONT, STYLE, SIZE, OR COLOR.

NO CLAIM IS MADE TO THE EXCLUSIVE RIGHT TO USE "BIG" OR "JOHN" AND/OR COLLECTIVELY "BIG JOHN", APART FROM THE MARK AS SHOWN.

THE LIKENESS (OR, "PORTRAIT") IN THE MARK DOES NOT IDENTIFY A LIVING INDIVIDUAL.

CLASS 12—VEHICLES

FOR RACING CARS (U.S. CLS. 19, 21, 23, 31, 35 AND 44).

CLASS 28—TOYS AND SPORTING GOODS

FOR MODEL CARS (U.S. CLS. 22, 23, 38 AND 50).
PATRICIA EVANKO, EXAMINING ATTORNEY

SN 77-072,338. BARNHARDT MANUFACTURING COMPANY, DBA NCFI POLYURETHANES, MT. AIRY, NC. FILED 12-28-2006.

BIO-LUX

THE MARK CONSISTS OF STANDARD CHARACTERS WITHOUT CLAIM TO ANY PARTICULAR FONT, STYLE, SIZE, OR COLOR.

CLASS 17—RUBBER GOODS

FOR POLYURETHANE FOAM FOR USE IN MATTRESSES, FURNITURE SEAT AND BACK CUSHIONS (U.S. CLS. 1, 5, 12, 13, 35 AND 50).

FIRST USE 2-28-2007; IN COMMERCE 4-2-2007.

CLASS 20—FURNITURE AND ARTICLES NOT OTHERWISE CLASSIFIED

FOR POLYURETHANE FOAM SEAT AND BACK FURNITURE CUSHIONS AND VISCO-ELASTIC FOAM MATTRESSES (U.S. CLS. 2, 13, 22, 25, 32 AND 50).

FIRST USE 2-28-2007; IN COMMERCE 4-2-2007.

CLASS 27—FLOOR COVERINGS

FOR POLYURETHANE FOAM CARPET PADDING (U.S. CLS. 19, 20, 37, 42 AND 50).

FIRST USE 2-28-2007; IN COMMERCE 4-2-2007.

ELLEN PERKINS, EXAMINING ATTORNEY

SN 77-072,343. TELESIS SOLUTIONS GROUP, INC., MASSAPEQUA PARK, NY. FILED 12-28-2006.

ImProve!

Integrated multimedia Platform for remote operations with visual engagement

NO CLAIM IS MADE TO THE EXCLUSIVE RIGHT TO USE "INTEGRATED MULTIMEDIA PLATFORM FOR REMOTE OPERATIONS WITH VISUAL ENGAGEMENT", APART FROM THE MARK AS SHOWN.

THE MARK CONSISTS OF THE WORDS "IMPROVE!" STYLIZED, AND THE WORDS "INTEGRATED MULTIMEDIA PLATFORM FOR REMOTE OPERATIONS WITH VISUAL ENGAGEMENT" WITH THE FIRST LETTER OF THE WORDS BEING UNDERSCORED TO SPELL THE WORD "IMPROVE".

CLASS 38—COMMUNICATION

FOR ON-DEMAND WEB-BASED TELECOMMUNICATION SOLUTIONS, NAMELY, AUDIO AND VIDEO TELECONFERENCING; BROWSER BASED VISUAL/VIDEO TELECOMMUNICATION SOLUTIONS INTERFACING FOR MULTIPLE USERS, NAMELY, AUDIO AND VIDEO TELECONFERENCING, AND PROVISION OF ACCESS TO DATA AND DOCUMENTS STORED ELECTRONICALLY IN CENTRAL FILES FOR DOCUMENT SHARING AND DOCUMENT COLLABORATION; AND INTER-ACTIVE APPLICATIONS FOR REMOTE OPERATIONS, DISTANCE LEARNING/TRAINING, MEETINGS AND EXCHANGE OF INFORMATION, NAMELY, ELECTRONIC DELIVERY OF IMAGES AND PHOTOGRAPHS VIA GLOBAL COMPUTER NETWORK (U.S. CLS. 100, 101 AND 104).

FIRST USE 11-9-2006; IN COMMERCE 11-9-2006.

CLASS 42—SCIENTIFIC AND COMPUTER SERVICES

FOR ON-DEMAND WEB-BASED TELECOMMUNICATION SOLUTIONS, NAMELY, PROVIDING TEMPORARY USE OF ON-LINE NON-DOWNLOADABLE SOFTWARE FOR INTEGRATING MULTI-MEDIA APPLICATIONS, VIDEO APPLICATIONS, WEBCAM AND DESKTOP VIDEO CONFERENCING; BROWSER BASED VISUAL/VIDEO TELECOMMUNICATION SOLUTIONS, NAMELY, PROVIDING TEMPORARY USE OF ON-LINE NON-DOWNLOADABLE SOFTWARE FOR INTERFACING MULTIPLE USERS; AND INTER-ACTIVE APPLICATIONS, NAMELY, PROVIDING TEMPORARY USE OF ON-LINE NON-DOWNLOADABLE SOFTWARE FOR CONTROLLING REMOTE OPERATIONS, DISTANCE LEARNING/TRAINING, MEETINGS AND EXCHANGE OF INFORMATION (U.S. CLS. 100 AND 101).

FIRST USE 11-9-2006; IN COMMERCE 11-9-2006.

ELLEN PERKINS, EXAMINING ATTORNEY

SN 77-072,438. APPLEBY, ANDREW D., ROCHESTER, MI. AND GENERAL SPORTS & ENTERTAINMENT, LLC, ROCHESTER, MI. FILED 12-28-2006.

GENERALSPTS VENUE

THE MARK CONSISTS OF STANDARD CHARACTERS WITHOUT CLAIM TO ANY PARTICULAR FONT, STYLE, SIZE, OR COLOR.

OWNER OF U.S. REG. NOS. 2,465,105, 2,465,107 AND OTHERS.

NO CLAIM IS MADE TO THE EXCLUSIVE RIGHT TO USE "VENUE", APART FROM THE MARK AS SHOWN.

CLASS 27—FLOOR COVERINGS

FOR SYNTHETIC SURFACING CONSISTING OF RIBBONS OF SYNTHETIC FIBERS ADHERED TO A BACKING AND PARTIALLY COVERED WITH A PARTICULATE INFILL FOR THE PLAYING OF FOOTBALL, SOCCER, GOLF, FIELD HOCKEY, LACROSSE, BASEBALL AND OTHER ATHLETIC ACTIVITIES (U.S. CLS. 19, 20, 37, 42 AND 50).

FIRST USE 6-2-2006; IN COMMERCE 6-2-2006.

CLASS 35—ADVERTISING AND BUSINESS

FOR BUSINESS SERVICES, NAMELY, BUSINESS CONSULTATION, BUSINESS MARKETING SERVICES; OFFERING TECHNICAL ASSISTANCE IN THE ESTABLISHMENT AND/OR OPERATION OF SPORTS FACILITIES (U.S. CLS. 100, 101 AND 102).

FIRST USE 6-2-2006; IN COMMERCE 6-2-2006.

CLASS 37—CONSTRUCTION AND REPAIR

FOR INSTALLATION AND MAINTENANCE OF SYNTHETIC FIBERS ADHERED TO A BACKING AND PARTIALLY COVERED WITH A PARTICULATE INFILL (U.S. CLS. 100, 103 AND 106).

FIRST USE 6-2-2006; IN COMMERCE 6-2-2006.

CLASS 42—SCIENTIFIC AND COMPUTER SERVICES

FOR TECHNICAL ADVICE IN THE FIELD OF ENGINEERING (U.S. CLS. 100 AND 101).

FIRST USE 6-2-2006; IN COMMERCE 6-2-2006.

TEJBIR SINGH, EXAMINING ATTORNEY

SN 77-073,299. JUST DIFY, HOLLYWOOD, CA. FILED 12-29-2006.

JUST DIFY

THE MARK CONSISTS OF STANDARD CHARACTERS WITHOUT CLAIM TO ANY PARTICULAR FONT, STYLE, SIZE, OR COLOR.

CLASS 35—ADVERTISING AND BUSINESS

FOR ONLINE RETAIL STORE SERVICES FEATURING CUSTOMIZED GIFT BASKETS FOR A PARTICULAR OCCASION, THEME, OR LIFE EVENT (U.S. CLS. 100, 101 AND 102).

CLASS 41—EDUCATION AND ENTERTAINMENT

FOR EDUCATIONAL SERVICES, NAMELY, CONDUCTING CLASSES, SEMINARS, CONFERENCES AND WORKSHOPS IN THE FIELDS OF PERSONAL CONCIERGE SERVICES, PERSONAL ARRANGEMENTS AND RESERVATIONS, PRODUCT AND SERVICE RESEARCH, ERRAND RUNNING, EVENT PLANNING, PERSONAL SHOPPING, WAITING SERVICE ASSISTANCE, VACATION, PERSONAL AND BUSINESS TRAVEL ARRANGEMENTS, HOSPITALITY CARE, CHILD AND BABY SITTING CARE, PET CARE, HOUSE SITTING AND ORGANIZATIONAL ASSISTANCE, PROVIDING CUSTOMER SPECIFIC INFORMATION TO MEET INDIVIDUAL NEEDS, AND DISTRIBUTION OF COURSE MATERIAL IN CONNECTION THEREWITH; CONDUCTING ONLINE TRAINING PROGRAMS IN THE FIELDS OF PERSONAL CONCIERGE SERVICES, PERSONAL ARRANGEMENTS AND RESERVATIONS, PRODUCT AND SERVICE RESEARCH, ERRAND RUNNING, EVENT PLANNING, PERSONAL SHOPPING, WAITING SERVICE ASSISTANCE, VACATION, PERSONAL AND BUSINESS TRAVEL ARRANGEMENTS (U.S. CLS. 100, 101 AND 107).

CLASS 45—PERSONAL AND LEGAL SERVICES

FOR BABY SITTING CARE (U.S. CLS. 100 AND 101).
CYNTHIA SLOAN, EXAMINING ATTORNEY

SN 77-076,891. AMERICAN RACING EQUIPMENT, INC., RANCHO DOMINGUEZ, CA. FILED 1-5-2007.

AMERICAN RACING

THE MARK CONSISTS OF STANDARD CHARACTERS WITHOUT CLAIM TO ANY PARTICULAR FONT, STYLE, SIZE, OR COLOR.

OWNER OF U.S. REG. NOS. 863,444, 1,147,598 AND OTHERS.
SEC. 2(F).

CLASS 7—MACHINERY

FOR VEHICLE ENGINE PARTS, NAMELY, CONTACT POINTS, OIL TANKS, CRANKCASE BREATHERS, OIL COOLERS, PUSH RODS, ROCKER ARMS, ENGINE CASES, ENGINE CAM PROTECTORS, THERMOSTATS; POWER TOOLS FOR MAKING, FINISHING, INSTALLING, SERVICING, AND REPAIRING AUTOMOTIVES AND AUTOMOTIVE WHEELS; AIR COMPRESSORS; ELECTRIC DRILLS; POWER DRILLS (U.S. CLS. 13, 19, 21, 23, 31, 34 AND 35).

CLASS 8—HAND TOOLS

FOR HAND AUTOMOTIVE CAR JACKS (U.S. CLS. 23, 28 AND 44).

CLASS 9—ELECTRICAL AND SCIENTIFIC APPARATUS

FOR ODOMETERS; SPEEDOMETERS; AIR PRESSURE GAUGES; TIRE PRESSURE GAUGES; TIRE TREAD PATH GAUGES (U.S. CLS. 21, 23, 26, 36 AND 38).
LINDA POWELL, EXAMINING ATTORNEY

SN 77-077,002. AMERICAN RACING EQUIPMENT, INC.,
RANCHO DOMINGUEZ, CA. FILED 1-5-2007.

AMERICAN RACING PERFORM

THE MARK CONSISTS OF STANDARD CHARACTERS WITHOUT CLAIM TO ANY PARTICULAR FONT, STYLE, SIZE, OR COLOR.

OWNER OF U.S. REG. NOS. 863,444, 1,147,598 AND OTHERS.

SEC. 2(F) "AMERICAN RACING".

CLASS 7—MACHINERY

FOR VEHICLE ENGINE PARTS, NAMELY, CONTACT POINTS, OIL TANKS, CRANKCASE BREATHERS, OIL COOLERS, PUSH RODS, ROCKER ARMS, ENGINE CASES, ENGINE CAM PROTECTORS, THERMOSTATS; POWER TOOLS FOR MAKING, FINISHING, INSTALLING, SERVICING, AND REPAIRING AUTOMOTIVES AND AUTOMOTIVE WHEELS; AIR COMPRESSORS; ELECTRIC DRILLS; POWER DRILLS (U.S. CLS. 13, 19, 21, 23, 31, 34 AND 35).

CLASS 8—HAND TOOLS

FOR HAND AUTOMOTIVE CAR JACKS (U.S. CLS. 23, 28 AND 44).

CLASS 9—ELECTRICAL AND SCIENTIFIC APPARATUS

FOR ODOMETERS; SPEEDOMETERS; AIR PRESSURE GAUGES; TIRE PRESSURE GAUGES; TIRE TREAD PATH GAUGES (U.S. CLS. 21, 23, 26, 36 AND 38).

LINDA POWELL, EXAMINING ATTORNEY

SN 77-077,938. OXFORD INSTRUMENTS PLC, ABINGTON,
OXON, UNITED KINGDOM, FILED 1-8-2007.

OXFORD INSTRUMENTS The Business of Science

OWNER OF UNITED KINGDOM REG. NO. 2432719,
DATED 9-15-2006, EXPIRES 9-15-2016.

OWNER OF U.S. REG. NOS. 1,431,822 AND 2,599,958.

NO CLAIM IS MADE TO THE EXCLUSIVE RIGHT TO USE "INSTRUMENTS", APART FROM THE MARK AS SHOWN.

SEC. 2(F) "OXFORD".

CLASS 9—ELECTRICAL AND SCIENTIFIC APPARATUS

FOR FLEXIBLE PLASMA PROCESSING APPARATUS FOR PLASMA ETCHING AND PLASMA DEPOSITION; FLEXIBLE ION BEAM PROCESSING SYSTEMS FOR ION BEAM ETCHING AND ION BEAM DEPOSITION; HIGH PRECISION MAGNET, CRYOGENIC SYSTEMS COMPOSED OF LABORATORY CRYOSTATS, DILUTION REFRIGERATORS, SUPERCONDUCTING MAGNETS AND SUPERCONDUCTING THIN FILMS AND PARTS THEREFOR FOR NUCLEAR MAGNETIC RESONANCE, FOR ION CYCLOTRON RESONANCE, FOR MAGNETIC RESONANCE IMAGING AND FOR ASSOCIATED APPLICATIONS, NAMELY, ELEMENTAL AND COMPOUND ANALYSIS IN LIFE SCIENCES, MATERIALS, CHARACTERIZATION, CONDENSED MATTER PHYSICS, SCIENTIFIC AND INDUSTRIAL RESEARCH, AND SENSORS AND DETECTION, ALL FOR OTHER THAN MEDICAL PURPOSES; ELECTRON DETECTORS, ELECTRON MICROSCOPE CONTROLLERS; X-RAY PULSE PROCESSORS FOR OTHER THAN MEDICAL PURPOSES; MICROANALYSIS APPARATUS, NAMELY, X-RAY DETECTOR WITH ANALYZER, COMPUTER HARDWARE AND SOFTWARE THEREFOR FOR OTHER THAN MEDICAL PURPOSES; CRYSTALLOGRAPHIC ANALYSIS APPARATUS, NAMELY, X-RAY SOURCE, DETECTOR AND MULTI-AXIS GONIOMETER PARTICLE ACCELERATORS AND PARTS THEREFOR; LABORATORY CRYOSTATS; DILUTION REFRIGERATORS, SUPERCONDUCTING MAGNETS, SUPERCONDUCTING THIN FILMS, ELECTRON MICROSCOPY APPARATUS, NAMELY, ELECTRON BEAM BACKSCATTER DETECTOR, COMPUTER HARDWARE AND SOFTWARE THEREFOR; X-RAYS FLUORESCENCE (XRF) SPECTROMETERS, LOW-FIELD NUCLEAR MAGNETIC RESONANCE (NMR) SPECTROMETERS; DETECTOR MAGNETS (U.S. CLS. 21, 23, 26, 36 AND 38).

CLASS 10—MEDICAL APPARATUS

FOR APPARATUS AND INSTRUMENTS FOR USE IN ELECTROCARDIOGRAPHS, NAMELY, ELECTROCARDIOGRAM (ECG), ELECTROENCEPHALOGRAPHY (EEG), ELECTROMYOGRAPHY (EMG), EVOKED POTENTIALS (EP), INTRA OPERATIVE MONITORING (IOM), AND SLEEP-DISORDER DIAGNOSIS (SLEEP) HOLTZER RECORDING APPARATUS FOR USE IN CARDIOLOGY AND MONITORS FOR FETAL HEART DETECTION; HIGH PRECISION MAGNET, CRYOGENIC SYSTEMS COMPOSED OF VACUUM CHAMBER WITH CRYOGENICALLY COOLED SAMPLE STAGE, COOLING APPARATUS BASED ON MIXED GAS CYCLE TO COOL SAMPLES, WOUND SUPERCONDUCTING WIRE TO PRODUCE HIGH MAGNETIC FIELDS, AND THIN FILMS ELECTRONIC DEVICES AND PARTS THEREFOR, ALL FOR NUCLEAR MAGNETIC RESONANCE, FOR ION CYCLOTRON RESONANCE, FOR MAGNETIC RESONANCE IMAGING AND FOR ASSOCIATED APPLICATIONS, NAMELY, MEDICAL DIAGNOSIS AND ELEMENTAL COMPOUND ANALYSIS IN LIFE SCIENCES, ALL FOR MEDICAL PURPOSES; X-RAY PULSE PROCESSORS FOR MEDICAL PURPOSES; MICROANALYSIS APPARATUS FOR MEDICAL USE, NAMELY, CLINICAL ANALYSIS OF TISSUES FOR DIAGNOSTIC PURPOSES (U.S. CLS. 26, 39 AND 44).

CLASS 42—SCIENTIFIC AND COMPUTER SERVICES

FOR SCIENTIFIC RESEARCH, ADVISORY SERVICES RELATING TO SCIENTIFIC RESEARCH, MEDICAL RESEARCH, DESIGN OF SCIENTIFIC AND MEDICAL APPARATUS AND INSTRUMENTS (U.S. CLS. 100 AND 101).

MARY ROSSMAN, EXAMINING ATTORNEY

SN 77-080,168. APPLEBY, ANDREW D., ROCHESTER, MI. AND GENERAL SPORTS & ENTERTAINMENT, LLC, ROCHESTER, MI. FILED 1-10-2007.

SN 77-083,052. NANOMED PHARMACEUTICALS, INC., LEXINGTON, KY. FILED 1-15-2007.



OWNER OF U.S. REG. NOS. 2,465,105, 2,465,107 AND OTHERS.

NO CLAIM IS MADE TO THE EXCLUSIVE RIGHT TO USE "VENUE", APART FROM THE MARK AS SHOWN.

THE COLOR(S) BLUE AND GRAY IS/ARE CLAIMED AS A FEATURE OF THE MARK.

THE COLORS BLUE AND GRAY APPEAR IN THE STADIUM DESIGN, AND THE COLOR BLUE APPEARS IN THE WORDING.

CLASS 27—FLOOR COVERINGS

FOR SYNTHETIC SURFACING CONSISTING OF RIBBONS OF SYNTHETIC FIBERS ADHERED TO BACKING AND PARTIALLY COVERED WITH A PARTICULATE INFILL FOR THE PLAYING OF FOOTBALL, SOCCER, GOLF, FIELD HOCKEY, LACROSSE, BASEBALL AND OTHER ATHLETIC ACTIVITIES (U.S. CLS. 19, 20, 37, 42 AND 50).

FIRST USE 6-2-2006; IN COMMERCE 6-2-2006.

CLASS 35—ADVERTISING AND BUSINESS

FOR BUSINESS SERVICES, NAMELY, BUSINESS CONSULTATION, BUSINESS MARKETING SERVICES; OFFERING TECHNICAL ASSISTANCE IN THE ESTABLISHMENT AND/OR OPERATION OF SPORTS FACILITIES (U.S. CLS. 100, 101 AND 102).

FIRST USE 6-2-2006; IN COMMERCE 6-2-2006.

CLASS 37—CONSTRUCTION AND REPAIR

FOR INSTALLATION AND MAINTENANCE OF SYNTHETIC FIBERS ADHERED TO A BACKING AND PARTIALLY COVERED WITH A PARTICULATE INFILL (U.S. CLS. 100, 103 AND 106).

FIRST USE 6-2-2006; IN COMMERCE 6-2-2006.

CLASS 42—SCIENTIFIC AND COMPUTER SERVICES

FOR TECHNICAL ADVICE IN THE FIELD OF ENGINEERING (U.S. CLS. 100 AND 101).

FIRST USE 6-2-2006; IN COMMERCE 6-2-2006.
TEJBIR SINGH, EXAMINING ATTORNEY

Nanotemplate Engineering

THE MARK CONSISTS OF STANDARD CHARACTERS WITHOUT CLAIM TO ANY PARTICULAR FONT, STYLE, SIZE, OR COLOR.

NO CLAIM IS MADE TO THE EXCLUSIVE RIGHT TO USE "ENGINEERING", APART FROM THE MARK AS SHOWN.

CLASS 40—MATERIAL TREATMENT

FOR MANUFACTURING SERVICES FOR OTHERS IN THE FIELD OF PHARMACEUTICALS CONTAINING NANOPARTICLES (U.S. CLS. 100, 103 AND 106).

CLASS 42—SCIENTIFIC AND COMPUTER SERVICES

FOR SCIENTIFIC RESEARCH AND DEVELOPMENT IN THE FIELD OF NANOPARTICLES FOR USE IN THE FIELDS OF PHARMACEUTICALS OR DIAGNOSTIC PRODUCTS FOR THE TREATMENT OR DIAGNOSIS OF DISEASES AND RELATED CONDITIONS (U.S. CLS. 100 AND 101).

TEJBIR SINGH, EXAMINING ATTORNEY

SN 77-083,444. EAUX VIVES WATER INC., TORONTO, ONTARIO, CANADA, FILED 1-16-2007.

ESKA

THE MARK CONSISTS OF STANDARD CHARACTERS WITHOUT CLAIM TO ANY PARTICULAR FONT, STYLE, SIZE, OR COLOR.

PRIORITY CLAIMED UNDER SEC. 44(D) ON CANADA APPLICATION NO. 1309911, FILED 7-20-2006, REG. NO. TMA711524, DATED 4-9-2008, EXPIRES 4-9-2023.

THE TERM "ESKA" HAS NO MEANING IN A FOREIGN LANGUAGE

CLASS 5—PHARMACEUTICALS

FOR (BASED ON INTENT TO USE) VITAMIN ENRICHED WATER (U.S. CLS. 6, 18, 44, 46, 51 AND 52).

CLASS 32—LIGHT BEVERAGES

FOR (BASED ON FOREIGN REGISTRATION) BOTTLED WATER; MINERAL WATER; WATER BASED BEVERAGES, NAMELY, BOTTLED SPRING DRINKING WATER; BOTTLED ARTESIAN WATER; (BASED ON INTENT TO USE) FLAVORED AND UN-FLAVORED DRINKING WATER; SWEETENED AND UN-SWEETENED DRINKING WATER; AERATED WATER (U.S. CLS. 45, 46 AND 48).

MICHAEL GAAFAR, EXAMINING ATTORNEY

SN 77-083,830. NUTIVA, INC., SEBASTOPOL, CA. FILED 1-16-2007.

HEMP VALLEY

THE MARK CONSISTS OF STANDARD CHARACTERS WITHOUT CLAIM TO ANY PARTICULAR FONT, STYLE, SIZE, OR COLOR.

NO CLAIM IS MADE TO THE EXCLUSIVE RIGHT TO USE "HEMP", APART FROM THE MARK AS SHOWN.

CLASS 5—PHARMACEUTICALS

FOR DIETARY SUPPLEMENTS AND HEMP PROTEIN POWDERS (U.S. CLS. 6, 18, 44, 46, 51 AND 52).

CLASS 29—MEATS AND PROCESSED FOODS

FOR FOOD PRODUCTS CONTAINING HEMP, NAMELY, PROCESSED FRUIT AND NUT BARS CONTAINING HEMP, HEMP OIL, HEMP SEEDS, HEMP BURGER PATTIES, AND MILK CONTAINING HEMP (U.S. CL. 46).

CLASS 30—STAPLE FOODS

FOR FOOD PRODUCTS CONTAINING HEMP, NAMELY, SALAD DRESSINGS, BAKERY DESSERTS, HEMP BURGER SANDWICHES AND GRAIN BASED AND CEREAL BASED FOOD BARS CONTAINING HEMP (U.S. CL. 46).

GIANCARLO CASTRO, EXAMINING ATTORNEY

SN 77-084,690. METAVERSUM GMBH, BERLIN, FED REP GERMANY, FILED 1-17-2007.

YUMONDO

THE MARK CONSISTS OF STANDARD CHARACTERS WITHOUT CLAIM TO ANY PARTICULAR FONT, STYLE, SIZE, OR COLOR.

CLASS 9—ELECTRICAL AND SCIENTIFIC APPARATUS

FOR GAME AND SIMULATION PROGRAMS FOR COMPUTERS, NAMELY, PROGRAMS FOR THE THREE-DIMENSIONAL REPRESENTATION OF VIRTUAL REALITIES; COMPUTER PROGRAMS RECORDED ON DATA MEDIA, NAMELY, SOFTWARE, FOR MULTI-PLAYER ACCESS TO THREE-DIMENSIONAL VIRTUAL REALITIES, FOR ONLINE GAMES, COMPUTER GAMES, VIDEO GAMES AND VIRTUAL REALITY GAMES (U.S. CLS. 21, 23, 26, 36 AND 38).

CLASS 35—ADVERTISING AND BUSINESS

FOR ONLINE SERVICES, NAMELY, PROVIDING AN ONLINE DATABASE FEATURING INFORMATION IN THE FIELDS OF BUSINESS AND ECONOMICS (U.S. CLS. 100, 101 AND 102).

CLASS 38—COMMUNICATION

FOR DELIVERY OF MESSAGES BY ELECTRONIC TRANSMISSION; COMMUNICATION SERVICES, NAMELY, PROVIDING ON-LINE FORUMS FOR TRANSMISSION OF MESSAGES AMONG COMPUTER USERS CONCERNING GEOGRAPHY, SPECIAL EVENTS, ECONOMICS AND BUSINESS; PROVIDING AN ONLINE FORUM FOR TRADING VIRTUAL REAL ESTATE (U.S. CLS. 100, 101 AND 104).

CLASS 39—TRANSPORTATION AND STORAGE

FOR ONLINE SERVICES, NAMELY, PROVIDING AN ONLINE DATABASE FEATURING INFORMATION IN THE FIELD OF GEOGRAPHY (U.S. CLS. 100 AND 105).

CLASS 41—EDUCATION AND ENTERTAINMENT

FOR ENTERTAINMENT SERVICES, NAMELY, PROVIDING ONLINE COMPUTER GAMES, VIDEO GAMES AND VIRTUAL REALITY GAMES; ONLINE SERVICES, NAMELY, PROVIDING AN ONLINE DATABASE FEATURING INFORMATION IN THE FIELD OF SPECIAL EVENTS (U.S. CLS. 100, 101 AND 107).

CLASS 42—SCIENTIFIC AND COMPUTER SERVICES

FOR APPLICATION SERVICE PROVIDER FEATURING SOFTWARE FOR USE IN CREATING THREE-DIMENSIONAL REPRESENTATION OF VIRTUAL REALITIES; APPLICATION SERVICE PROVIDER FEATURING SOFTWARE FOR PROVIDING MULTIPLE USER ACCESS TO THREE DIMENSIONAL VIRTUAL REALITIES; APPLICATION SERVICE PROVIDER FEATURING DATABASE SOFTWARE IN THE FIELDS OF BUSINESS, ECONOMICS, GEOGRAPHY AND SPECIAL EVENTS (U.S. CLS. 100 AND 101).

CLASS 45—PERSONAL AND LEGAL SERVICES

FOR ONLINE DATING SERVICE (U.S. CLS. 100 AND 101).

PAUL MORENO, EXAMINING ATTORNEY

SN 77-085,815. DIMELO SAS, MEUDON, FRANCE, FILED 1-18-2007.

OWNER OF FRANCE REG. NO. 063420496, DATED 3-29-2006, EXPIRES 3-29-2016.

THE LETTERS "FEE", "ACK" AND THE NUMBER "2.0" ARE IN GRAY; THE LETTER "D" IS ORANGE, AND THE LETTER "B" IS GREEN.

CLASS 9—ELECTRICAL AND SCIENTIFIC APPARATUS

FOR COMPUTER SOFTWARE FOR USE IN CUSTOMER RELATIONSHIP MANAGEMENT (CRM) (U.S. CLS. 21, 23, 26, 36 AND 38).

CLASS 35—ADVERTISING AND BUSINESS

FOR CREATION OF MARKETING TOOLS DESIGNED TO INCREASE A CLIENT COMPANY'S KNOWLEDGE OF CUSTOMER NEEDS, AND ITS COMPETITORS' PRODUCTS AND SERVICES, PRICING, ADVERTISING STRATEGY AND SALES STRATEGY; ON-LINE ADVERTISING AND MARKETING SERVICES; OPERATING ON-LINE MARKETPLACES FOR SELLERS OF GOODS AND/OR SERVICES (U.S. CLS. 100, 101 AND 102).

CLASS 38—COMMUNICATION

FOR PROVIDING ON-LINE FORUMS FOR TRANSMISSION OF MESSAGES AMONG COMPUTER USERS CONCERNING BUSINESS PRODUCTS AND SERVICES (U.S. CLS. 100, 101 AND 104).

CLASS 42—SCIENTIFIC AND COMPUTER SERVICES

FOR APPLICATION SERVICE PROVIDER (ASP) FEATURING SOFTWARE IN THE FIELD OF CUSTOMER RELATIONSHIP MANAGEMENT; COMPUTER SERVICES, NAMELY, CREATING AN ONLINE COMMUNITY FOR REGISTERED USERS TO PARTICIPATE IN COMPETITIONS, SHOWCASE THEIR SKILLS, GET FEEDBACK FROM THEIR PEERS, FORM VIRTUAL COMMUNITIES, ENGAGE IN SOCIAL NETWORKING AND IMPROVE THEIR TALENT; COMPUTER SERVICES, NAMELY, HOSTING ON-LINE WEB FACILITIES FOR OTHERS FOR ORGANIZING AND CONDUCTING ONLINE MEETINGS, GATHERINGS, AND INTERACTIVE DISCUSSIONS (U.S. CLS. 100 AND 101).

BRIAN NEVILLE, EXAMINING ATTORNEY

SN 77-088,786. DORPAN, S.L., PALMA DE MAJORCA, SPAIN, FILED 1-23-2007.



ME
by MELIÀ

PRIORITY CLAIMED UNDER SEC. 44(D) ON SPAIN APPLICATION NO. 2725642, FILED 8-2-2006, REG. NO. 2725642, DATED 2-26-2007, EXPIRES 8-2-2016.

OWNER OF U.S. REG. NOS. 2,124,741, 3,100,367 AND OTHERS.

THE MARK CONSISTS OF THE WORDS "ME BY MELIÀ" IN STYLIZED FONT.

CLASS 16—PAPER GOODS AND PRINTED MATTER

FOR POSTCARDS, STATIONERY; BOOKS, BROCHURES, MAGAZINES AND CATALOGS ON THE SUBJECT OF TRAVEL, TRAVEL DESTINATIONS AND INFORMATION OF INTEREST TO TRAVELERS; POSTERS (U.S. CLS. 2, 5, 22, 23, 29, 37, 38 AND 50).

CLASS 43—HOTEL AND RESTAURANT SERVICES

FOR HOTEL SERVICES, RESTAURANT SERVICES (U.S. CLS. 100 AND 101).

MARIA-VICTORIA SUAREZ, EXAMINING ATTORNEY

SN 77-090,369. NATIONAL WESTMINSTER BANK PLC, LONDON, UNITED KINGDOM, FILED 1-24-2007.

NATIONAL WESTMINSTER

THE MARK CONSISTS OF STANDARD CHARACTERS WITHOUT CLAIM TO ANY PARTICULAR FONT, STYLE, SIZE, OR COLOR.

OWNER OF ERPN CMNTY TM OFC REG. NO. 004319174, DATED 5-17-2006, EXPIRES 3-31-2015.

OWNER OF UNITED KINGDOM REG. NO. 004319174, DATED 5-17-2006, EXPIRES 5-17-2016.

OWNER OF U.S. REG. NOS. 922,574, 2,430,657 AND OTHERS.

SEC. 2(F).

CLASS 9—ELECTRICAL AND SCIENTIFIC APPARATUS

FOR MAGNETICALLY ENCODED CARDS FOR CARRYING DATA, NAMELY, CARDS CONTAINING DATA TO VERIFY AN INDIVIDUAL'S IDENTITY, CREDIT CARDS, DEBIT CARDS AND CARDS FOR USE WITH AUTOMATED TELLER MACHINES (ATM); MULTI-FUNCTION CARDS FOR FINANCIAL SERVICES, NAMELY, MAGNETICALLY ENCODED CREDIT CARDS, MAGNETICALLY ENCODED DEBIT CARDS, MAGNETICALLY ENCODED CARDS FOR USE WITH AUTOMATED TELLER MACHINES (ATM), AND MAGNETICALLY ENCODED CARDS FOR IDENTIFYING USERS OF COMPUTERS, MOBILE PHONES AND AUTOMATED TELLER MACHINES (ATM); MAGNETICALLY ENCODED CHARGE CARDS, CASH CARDS, BANK CARDS, CHECK CARDS, CREDIT CARDS, AND DEBIT CARDS; DOWNLOADABLE COMPUTER SOFTWARE USED IN THE PROVISION OF INSURANCE, FINANCE, BANKING AND CREDIT CARD SERVICES; DOWNLOADABLE PUBLICATIONS, SUPPLIED ON-LINE FROM DATABASES OR FROM WEB PAGES AND WEB SITES ON THE INTERNET, NAMELY, DOWNLOADABLE PAMPHLETS, LEAFLETS, MAGAZINES, NEWSLETTERS, INFORMATION SHEETS AND CIRCULARS IN THE FIELD OF INSURANCE, BANKING, FINANCE AND CREDIT CARD SERVICES; COMPUTER SOFTWARE ENABLING CONNECTION TO ONLINE DATABASES, COMPUTER NETWORKS AND THE INTERNET; TELECOMMUNICATIONS APPARATUS, NAMELY, MODEMS TO ENABLE CONNECTION TO ONLINE DATABASES, COMPUTER NETWORKS AND THE INTERNET; COMPUTER SOFTWARE TO ENABLE SEARCHING OF DATA, NAMELY, SEARCH ENGINE SOFTWARE; HAND-HELD DEVICES FOR PAYMENT AND VALUE EXCHANGE SERVICES AND FOR OTHER PERSONAL INFORMATION SERVICES, NAMELY, MAGNETIC CODED CARD READERS AND PERSONAL DIGITAL ASSISTANTS USED FOR PAYMENT AND VALUE EXCHANGE SERVICES AND FOR OTHER PERSONAL INFORMATION SERVICES; MAGNETICALLY ENCODED SECURITY ACCESS CARDS; MAGNETICALLY ENCODED IDENTIFICATION CARDS; INTEGRATED CHIP CARDS IN THE NATURE OF CARDS CONTAINING INTEGRATED CIRCUIT CHIPS USED FOR SECURITY ACCESS, BANKING, PAYMENT AND VALUE EXCHANGE, AND PERSONAL INFORMATION EXCHANGE; MAGNETICALLY ENCODED PREPAID TELEPHONE CALLING CARDS; ATM MACHINES; MAGNETIC POINT OF SALE ELECTRONIC CARD READERS; REMOTE ACCESS DEVICES, NAMELY, DEVICES FOR ENABLING RETAILERS TO ACCEPT AND VERIFY PAYMENT FOR GOODS BY CREDIT CARD; BLANK MAGNETIC DATA CARRIERS; BLANK ELECTRONIC DATA CARRIERS; COMPUTER HARDWARE AND SOFTWARE USED FOR THE PROVISION OF BANKING SERVICES, FINANCIAL SERVICES, BANK ACCOUNT MANAGEMENT SERVICES, MONETARY TRANSFER SERVICES, PAYMENT SERVICES, FINANCIAL ANALYSIS AND FINANCIAL REPORTS, FINANCIAL MANAGEMENT SERVICES, AND INFORMATION SERVICES RELATING TO BANKING AND FINANCE; COMPUTER SEARCH ENGINE SOFTWARE

TO ENABLE THE SEARCHING OF DATA RELATING TO THE AFOREGOING; ELECTRONIC PUBLICATIONS, NAMELY, NEWSLETTERS, MAGAZINES, PERIODICALS, PAMPHLETS AND LEAFLETS ALL IN THE FIELD OF INSURANCE, BANKING, FINANCE AND CREDIT CARD SERVICES ALL RECORDED ON CD-ROM OR DISKETTE (U.S. CLS. 21, 23, 26, 36 AND 38).

SN 77-090,379. NATIONAL WESTMINSTER BANK PLC, LONDON, UNITED KINGDOM, FILED 1-24-2007.

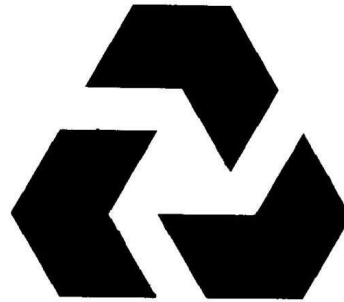

CLASS 16—PAPER GOODS AND PRINTED MATTER

FOR PAPER, PAPER ARTICLES, NAMELY, CARD WITHOUT MAGNETIC CODING IN THE NATURE OF BUSINESS CARDS, AND ADVERTISING MATERIALS, NAMELY, BUSINESS CARDS, POSTERS, AND PAPER BANNERS; PRINTED MATTER, NAMELY, NEWSLETTERS, BOOKS AND CIRCULARS IN THE FIELD OF INSURANCE, BANKING, FINANCE AND CREDIT CARD SERVICES; STATIONERY, NAMELY, PENS, PENCILS, PAPER WALLETS AND ENVELOPES; NEWSPAPERS, PERIODICALS IN THE FIELD OF INSURANCE, BANKING, FINANCE AND CREDIT CARD SERVICES; CHECK BOOKS; PRINTED PUBLICATIONS IN THE NATURE OF FLYERS, BROCHURES, CATALOGS, BOOKLETS, AND INSTRUCTION MANUALS, NEWSLETTERS, MAGAZINES, PAMPHLETS, LEAFLETS ALL IN THE FIELD OF INSURANCE, BANKING, FINANCE AND CREDIT CARD SERVICES; PLASTIC CARDS NOT MAGNETICALLY ENCODED FOR USE IN BUSINESS TRANSACTIONS; PLASTIC COVERED CARDS NOT MAGNETICALLY ENCODED BEARING PRINTED MATTER FOR USE AS IDENTIFY CARDS (U.S. CLS. 2, 5, 22, 23, 29, 37, 38 AND 50).

OWNER OF ERPN CMNTY TM OFC REG. NO. 004318978, DATED 5-4-2006, EXPIRES 3-31-2015.
OWNER OF U.S. REG. NO. 922,574.

CLASS 9—ELECTRICAL AND SCIENTIFIC APPARATUS

FOR MAGNETICALLY ENCODED CARDS FOR CARRYING DATA, NAMELY, CARDS CONTAINING DATA TO VERIFY AN INDIVIDUAL'S IDENTITY, CREDIT CARDS, DEBIT CARDS AND CARDS FOR USE WITH AUTOMATED TELLER MACHINES (ATM); MULTI-FUNCTION CARDS FOR FINANCIAL SERVICES, NAMELY, MAGNETICALLY ENCODED CREDIT CARDS, MAGNETICALLY ENCODED DEBIT CARDS, MAGNETICALLY ENCODED CARDS FOR USE WITH AUTOMATED TELLER MACHINES (ATM), AND MAGNETICALLY ENCODED CARDS FOR IDENTIFYING USERS OF COMPUTERS, MOBILE PHONES AND AUTOMATED TELLER MACHINES (ATM); MAGNETICALLY ENCODED CHARGE CARDS, CASH CARDS, BANK CARDS, CHECK CARDS, CREDIT CARDS, AND DEBIT CARDS; DOWNLOADABLE COMPUTER SOFTWARE USED IN THE PROVISION OF INSURANCE, FINANCE, BANKING AND CREDIT CARD SERVICES; DOWNLOADABLE ELECTRONIC PUBLICATIONS, SUPPLIED ON-LINE FROM DATABASES OR FROM WEB PAGES AND WEB SITES ON THE INTERNET, NAMELY, DOWNLOADABLE PAMPHLETS, LEAFLETS, MAGAZINES, NEWSLETTERS, INFORMATION SHEETS AND CIRCULARS IN THE FIELD OF INSURANCE, BANKING, FINANCE AND CREDIT CARD SERVICES; COMPUTER SOFTWARE ENABLING CONNECTION TO ONLINE DATABASES, COMPUTER NETWORKS AND THE INTERNET; TELECOMMUNICATIONS APPARATUS, NAMELY, MODEMS TO ENABLE CONNECTION TO ONLINE DATABASES, COMPUTER NETWORKS AND THE INTERNET; COMPUTER SOFTWARE TO ENABLE SEARCHING OF DATA, NAMELY, SEARCH ENGINE SOFTWARE; HAND-HELD DEVICES FOR PAYMENT AND VALUE EXCHANGE SERVICES AND FOR OTHER PERSONAL INFORMATION SERVICES, NAMELY, MAGNETIC CODED CARD READERS AND PERSONAL DIGITAL ASSISTANTS USED FOR PAYMENT AND VALUE EXCHANGE SERVICES AND FOR OTHER PERSONAL INFORMATION SERVICES; MAGNETICALLY ENCODED SECURITY ACCESS CARDS; MAGNETICALLY ENCODED IDENTIFICATION CARDS; INTEGRATED CHIP CARDS IN THE NATURE OF CARDS CONTAINING INTEGRATED CIRCUIT CHIPS USED FOR SECURITY ACCESS, BANKING, PAYMENT AND VALUE EXCHANGE, AND PERSONAL INFORMATION EXCHANGE; MAGNETICALLY ENCODED PRE-PAID TELEPHONE CALLING CARDS; ATM MACHINES; MAGNETIC POINT OF SALE ELECTRONIC CARD READERS; REMOTE ACCESS DEVICES, NAMELY, DEVICES FOR ENABLING RETAILERS TO ACCEPT AND VERIFY PAYMENT FOR GOODS BY CREDIT CARD; BLANK MAGNETIC DATA CARRIERS; BLANK ELECTRONIC DATA CARRIERS; COMPUTER HARDWARE AND SOFTWARE USED FOR THE PROVISION OF BANKING SERVICES, FINANCIAL SERVICES, BANK ACCOUNT MANAGEMENT SERVICES, MONETARY TRANSFER SERVICES, PAYMENT SERVICES, FINANCIAL ANALYSIS AND FINANCIAL REPORTS, FINANCIAL MANAGEMENT SERVICES, AND INFOR-

CLASS 35—ADVERTISING AND BUSINESS

FOR ACCOUNTING SERVICES; BOOK-KEEPING; SHARE REGISTRATION SERVICES, NAMELY, REGISTERING THE OWNERSHIP OF STOCKS AND BONDS; PAYROLL PREPARATIONS; BUSINESS APPRAISALS, ENQUIRIES, INVESTIGATIONS, RESEARCH AND BUSINESS MANAGEMENT ADVICE; BUSINESS MANAGEMENT CONSULTING; ADVERTISING AND PROMOTION SERVICES AND INFORMATION SERVICES RELATING THERETO; BUSINESS AND COMMERCIAL INFORMATION SERVICES, ALL PROVIDED ON-LINE FROM A COMPUTER DATABASE, COMPUTER NETWORK, GLOBAL COMPUTER NETWORK OR THE INTERNET; COMPILATION OF ADVERTISEMENTS FOR USE AS WEB PAGES ON THE INTERNET; BUSINESS MANAGEMENT SERVICES; BUSINESS ADVISORY SERVICES; COMPILATION OF DIRECTORIES FOR PUBLISHING ON GLOBAL COMPUTER NETWORKS OR THE INTERNET; COMPILATION OF ADVERTISEMENTS FOR USE ON OR AS WEB PAGES OR WEB SITES ON GLOBAL COMPUTER NETWORKS OR THE INTERNET; PROVISION OF SPACE ON WEB SITES FOR ADVERTISING GOODS AND SERVICES; BUSINESS ADMINISTRATION SERVICES FOR THE PROCESSING OF SALES MADE ON THE INTERNET; BUSINESS PLANNING; MARKET ANALYSIS AND RESEARCH; DATA COLLECTION, STORAGE AND PROCESSING; PERSONNEL SERVICES IN THE NATURE OF PAYROLL PREPARATION AND PAYROLL PROCESSING SERVICES; ADVISORY, CONSULTANCY AND INFORMATION SERVICES RELATING TO ALL OF THE AFORESAID SERVICES (U.S. CLS. 100, 101 AND 102).

SUE LAWRENCE, EXAMINING ATTORNEY

MATION SERVICES RELATING TO BANKING AND FINANCE; COMPUTER SEARCH ENGINE SOFTWARE TO ENABLE THE SEARCHING OF DATA RELATING TO THE AFOREGOING; ELECTRONIC PUBLICATIONS, NAMELY, NEWSLETTERS, MAGAZINES, PERIODICALS, PAMPHLETS AND LEAFLETS ALL IN THE FIELD OF INSURANCE, BANKING, FINANCE AND CREDIT CARD SERVICES ALL RECORDED ON CD-ROM OR DISKETTE (U.S. CLS. 21, 23, 26, 36 AND 38).

SN 77-091.634. NATIONAL WESTMINSTER BANK PLC, LONDON, UNITED KINGDOM, FILED 1-25-2007.



OWNER OF UNITED KINGDOM REG. NO. 2344087, DATED 6-11-2004, EXPIRES 9-24-2013.

OWNER OF UNITED KINGDOM REG. NO. 2344087, DATED 6-11-2004, EXPIRES 9-24-2013.

CLASS 16—PAPER GOODS AND PRINTED MATTER

FOR PAPER, PAPER ARTICLES, NAMELY, CARD WITHOUT MAGNETIC CODING IN THE NATURE OF BUSINESS CARDS, AND ADVERTISING MATERIALS, NAMELY, BUSINESS CARDS, POSTERS, AND PAPER BANNERS; PRINTED MATTER, NAMELY, NEWSLETTERS, BOOKS AND CIRCULARS IN THE FIELD OF INSURANCE, BANKING, FINANCE AND CREDIT CARD SERVICES; STATIONERY, NAMELY, PENS, PENCILS, PAPER WALLETS AND ENVELOPES; NEWSPAPERS, PERIODICALS IN THE FIELD OF INSURANCE, BANKING, FINANCE AND CREDIT CARD SERVICES; CHECK BOOKS; PRINTED PUBLICATIONS IN THE NATURE OF FLYERS, BROCHURES, CATALOGS, BOOKLETS, AND INSTRUCTION MANUALS, NEWSLETTERS, MAGAZINES, PAMPHLETS, LEAFLETS ALL IN THE FIELD OF INSURANCE, BANKING, FINANCE AND CREDIT CARD SERVICES; PLASTIC CARDS NOT MAGNETICALLY ENCODED FOR USE IN BUSINESS TRANSACTIONS; PLASTIC COVERED CARDS NOT MAGNETICALLY ENCODED BEARING PRINTED MATTER FOR USE AS IDENTIFY CARDS (U.S. CLS. 2, 5, 22, 23, 29, 37, 38 AND 50).

CLASS 35—ADVERTISING AND BUSINESS

FOR ACCOUNTING SERVICES; BOOK-KEEPING; SHARE REGISTRATION SERVICES, NAMELY, REGISTERING THE OWNERSHIP OF STOCKS AND BONDS; PAYROLL PREPARATIONS; BUSINESS APPRAISALS, ENQUIRIES, INVESTIGATIONS, RESEARCH AND BUSINESS MANAGEMENT ADVICE; BUSINESS MANAGEMENT CONSULTING; ADVERTISING AND PROMOTION SERVICES AND INFORMATION SERVICES RELATING THERETO; BUSINESS AND COMMERCIAL INFORMATION SERVICES, ALL PROVIDED ON-LINE FROM A COMPUTER DATABASE, COMPUTER NETWORK, GLOBAL COMPUTER NETWORK OR THE INTERNET; COMPILATION OF ADVERTISEMENTS FOR USE AS WEB PAGES ON THE INTERNET; BUSINESS MANAGEMENT SERVICES; BUSINESS ADVISORY SERVICES; COMPILATION OF DIRECTORIES FOR PUBLISHING ON GLOBAL COMPUTER NETWORKS OR THE INTERNET; COMPILATION OF ADVERTISEMENTS FOR USE ON OR AS WEB PAGES OR WEB SITES ON GLOBAL COMPUTER NETWORKS OR THE INTERNET; PROVISION OF SPACE ON WEB SITES FOR ADVERTISING GOODS AND SERVICES; BUSINESS ADMINISTRATION SERVICES FOR THE PROCESSING OF SALES MADE ON THE INTERNET; BUSINESS PLANNING; MARKET ANALYSIS AND RESEARCH; DATA COLLECTION, STORAGE AND PROCESSING; PERSONNEL SERVICES IN THE NATURE OF PAYROLL PREPARATION AND PAYROLL PROCESSING SERVICES; ADVISORY, CONSULTANCY AND INFORMATION SERVICES RELATING TO ALL OF THE AFORESAID SERVICES (U.S. CLS. 100, 101 AND 102).
SUE LAWRENCE, EXAMINING ATTORNEY

CLASS 9—ELECTRICAL AND SCIENTIFIC APPARATUS

FOR MAGNETICALLY ENCODED CARDS FOR CARRYING DATA, NAMELY, CARDS CONTAINING DATA TO VERIFY AN INDIVIDUAL'S IDENTITY, CREDIT CARDS, DEBIT CARDS AND CARDS FOR USE WITH AUTOMATED TELLER MACHINES (ATM); MULTI-FUNCTION CARDS FOR FINANCIAL SERVICES, NAMELY, MAGNETICALLY ENCODED CREDIT CARDS, MAGNETICALLY ENCODED DEBIT CARDS, MAGNETICALLY ENCODED CARDS FOR USE WITH AUTOMATED TELLER MACHINES (ATM), AND MAGNETICALLY ENCODED CARDS FOR IDENTIFYING USERS OF COMPUTERS, MOBILE PHONES AND AUTOMATED TELLER MACHINES (ATM); MAGNETICALLY ENCODED CHARGE CARDS, CASH CARDS, BANK CARDS, CHECK CARDS, CREDIT CARDS, AND DEBIT CARDS; DOWNLOADABLE COMPUTER SOFTWARE USED IN THE PROVISION OF INSURANCE, FINANCE, BANKING AND CREDIT CARD SERVICES; DOWNLOADABLE ELECTRONIC PUBLICATIONS, SUPPLIED ON-LINE FROM DATABASES OR FROM WEB PAGES AND WEB SITES ON THE INTERNET, NAMELY, DOWNLOADABLE PAMPHLETS, LEAFLETS, MAGAZINES, NEWSLETTERS, INFORMATION SHEETS AND CIRCULARS IN THE FIELD OF INSURANCE, BANKING, FINANCE AND CREDIT CARD SERVICES; COMPUTER SOFTWARE ENABLING CONNECTION TO ONLINE DATABASES, COMPUTER NETWORKS AND THE INTERNET; TELECOMMUNICATIONS APPARATUS, NAMELY, MODEMS TO ENABLE CONNECTION TO ONLINE DATABASES, COMPUTER NETWORKS AND THE INTERNET; COMPUTER SOFTWARE TO ENABLE SEARCHING OF DATA, NAMELY, SEARCH ENGINE SOFTWARE; HAND-HELD DEVICES FOR PAYMENT AND VALUE EXCHANGE SERVICES AND FOR OTHER PERSONAL INFORMATION SERVICES, NAMELY, MAGNETIC CODED CARD READERS AND PERSONAL DIGITAL ASSISTANTS USED FOR PAYMENT AND VALUE EXCHANGE SERVICES AND FOR OTHER PERSONAL INFORMATION SERVICES; MAGNETICALLY ENCODED SECURITY ACCESS CARDS; MAGNETICALLY ENCODED IDENTIFICATION CARDS; INTEGRATED CHIP CARDS IN THE NATURE OF CARDS CONTAINING INTEGRATED CIRCUIT CHIPS USED FOR SECURITY ACCESS, BANKING, PAYMENT AND VALUE EXCHANGE, AND PERSONAL INFORMATION EXCHANGE; MAGNETICALLY ENCODED PRE-PAID TELEPHONE CALLING CARDS; ATM MACHINES; MAGNETIC POINT OF SALE ELECTRONIC CARD READERS; REMOTE ACCESS DEVICES, NAMELY, DEVICES FOR ENABLING RETAILERS TO ACCEPT AND VERIFY PAYMENT FOR GOODS BY CREDIT CARD; BLANK MAGNETIC DATA CARRIERS; BLANK ELECTRONIC DATA CARRIERS; COMPUTER HARDWARE AND SOFTWARE USED FOR THE PROVISION OF BANKING SERVICES, FINANCIAL SERVICES, BANK ACCOUNT MANAGEMENT SERVICES, MONETARY TRANSFER SERVICES, PAYMENT SERVICES, FINANCIAL ANALYSIS AND FINANCIAL REPORTS, FINANCIAL MANAGEMENT SERVICES, AND INFORMATION SERVICES RELATING TO BANKING AND FINANCE; COMPUTER SEARCH ENGINE SOFTWARE TO ENABLE THE SEARCHING OF DATA RELATING TO THE AFOREGOING; ELECTRONIC PUBLICATIONS, NAMELY, NEWSLETTERS, MAGAZINES, PERIODICALS, PAMPHLETS AND LEAFLETS ALL IN THE

FIELD OF INSURANCE, BANKING, FINANCE AND CREDIT CARD SERVICES ALL RECORDED ON CD-ROM OR DISKETTE (U.S. CLS. 21, 23, 26, 36 AND 38).

CLASS 16—PAPER GOODS AND PRINTED MATTER

FOR PAPER, PAPER ARTICLES, NAMELY, CARD WITHOUT MAGNETIC CODING IN THE NATURE OF BUSINESS CARDS, AND ADVERTISING MATERIALS, NAMELY, BUSINESS CARDS, POSTERS, AND PAPER BANNERS; PRINTED MATTER, NAMELY, NEWSLETTERS, BOOKS AND CIRCULARS IN THE FIELD OF INSURANCE, BANKING, FINANCE AND CREDIT CARD SERVICES; STATIONERY, NAMELY, PENS, PENCILS, PAPER WALLETS AND ENVELOPES; NEWSPAPERS, PERIODICALS IN THE FIELD OF INSURANCE, BANKING, FINANCE AND CREDIT CARD SERVICES; CHECK BOOKS; PRINTED PUBLICATIONS IN THE NATURE OF FLYERS, BROCHURES, CATALOGS, BOOKLETS, AND INSTRUCTION MANUALS, NEWSLETTERS, MAGAZINES, PAMPHLETS, LEAFLETS ALL IN THE FIELD OF INSURANCE, BANKING, FINANCE AND CREDIT CARD SERVICES; PLASTIC CARDS NOT MAGNETICALLY ENCODED FOR USE IN BUSINESS TRANSACTIONS; PLASTIC COVERED CARDS NOT MAGNETICALLY ENCODED BEARING PRINTED MATTER FOR USE AS IDENTIFY CARDS (U.S. CLS. 2, 5, 22, 23, 29, 37, 38 AND 50).

CLASS 35—ADVERTISING AND BUSINESS

FOR ACCOUNTING SERVICES; BOOK-KEEPING; SHARE REGISTRATION SERVICES, NAMELY, REGISTERING THE OWNERSHIP OF STOCKS AND BONDS; PAYROLL PREPARATIONS; BUSINESS APPRAISALS, ENQUIRIES, INVESTIGATIONS, RESEARCH AND BUSINESS MANAGEMENT ADVICE; BUSINESS MANAGEMENT CONSULTING; ADVERTISING AND PROMOTION SERVICES AND INFORMATION SERVICES RELATING THERETO; BUSINESS AND COMMERCIAL INFORMATION SERVICES, ALL PROVIDED ON-LINE FROM A COMPUTER DATABASE, COMPUTER NETWORK, GLOBAL COMPUTER NETWORK OR THE INTERNET; COMPILATION OF ADVERTISEMENTS FOR USE AS WEB PAGES ON THE INTERNET; BUSINESS MANAGEMENT SERVICES; BUSINESS ADVISORY SERVICES; COMPILATION OF DIRECTORIES FOR PUBLISHING ON GLOBAL COMPUTER NETWORKS OR THE INTERNET; COMPILATION OF ADVERTISEMENTS FOR USE ON OR AS WEB PAGES OR WEB SITES ON GLOBAL COMPUTER NETWORKS OR THE INTERNET; PROVISION OF SPACE ON WEB SITES FOR ADVERTISING GOODS AND SERVICES; BUSINESS ADMINISTRATION SERVICES FOR THE PROCESSING OF SALES MADE ON THE INTERNET; BUSINESS PLANNING; MARKET ANALYSIS AND RESEARCH; DATA COLLECTION, STORAGE AND PROCESSING; PERSONNEL SERVICES IN THE NATURE OF PAYROLL PREPARATION AND PAYROLL PROCESSING SERVICES; ADVISORY, CONSULTANCY AND INFORMATION SERVICES RELATING TO ALL OF THE AFORESAID SERVICES; COMPUTERIZED SERVICES, NAMELY, ACCOUNTING SERVICES (U.S. CLS. 100, 101 AND 102).

CLASS 36—INSURANCE AND FINANCIAL

FOR FINANCIAL SERVICES, NAMELY, FINANCIAL CONSULTING SERVICES; BANKING SERVICES; MONETARY TRANSFER; BILL PAYMENT SERVICES; AUTOMATED BANKING SERVICES; HOME BANKING; INTERNET BANKING; SAVINGS ACCOUNT SERVICES; BILL PAYMENT AND CREDIT SERVICES; CREDIT CARD, DEBIT CARD, CHARGE CARD, CASH CARD AND BANK CARD SERVICES; CASH MANAGEMENT; SAFE DEPOSIT BOX SERVICES; BANKERS' CLEARING SERVICES IN THE NATURE OF FINANCIAL CLEARING HOUSES; ACCOUNTS PAYABLE DEBITING SERVICES; MAINTAINING ESCROW ACCOUNTS FOR INVESTMENTS; CHECK CASHING SERVICES; CREDIT BROKERAGE; AUTOMATIC CASH DISPENSING SERVICES, NAMELY, AUTOMATIC TELLER MACHINE SERVICES; INSURANCE SERVICES, NAMELY, INSURANCE BROKERAGE AND AGENCY SERVICES IN THE FIELD OF CREDIT INSURANCE, LIFE INSUR-

ANCE, HOME INSURANCE AND MEDICAL INSURANCE; FINANCING OF LOANS; SECURITY SERVICES, NAMELY, GUARANTEEING LOANS; FINANCIAL INVESTMENT SERVICES IN THE FIELD OF SECURITIES AND REAL ESTATE SECURITIES; REAL ESTATE MANAGEMENT SERVICES; CAPITAL INVESTMENT SERVICES; TRUSTEE SERVICES IN THE NATURE OF ESTATE TRUST MANAGEMENT; FINANCIAL MANAGEMENT SERVICES; AGENCIES IN THE FIELD OF BONDS AND OTHER SECURITIES; BROKERAGE OF SHARES AND OTHER SECURITIES; FINANCIAL CONSULTATION SERVICES; INVESTMENT ADVICE; FINANCIAL GUARANTEE SERVICES, NAMELY, SURETY SERVICES; FINANCIAL ANALYSIS; FINANCIAL INFORMATION SERVICES; FINANCIAL RESEARCH SERVICES; FINANCING SERVICES, NAMELY, SECURING FUNDS FOR OTHERS; FINANCIAL ADVISORY SERVICES; FINANCIAL SERVICES FOR THE PROVISION AND PURCHASE OF FINANCIAL AND/OR CREDIT INFORMATION, IN THE NATURE OF CREDIT REPORTING SERVICES, FINANCIAL INFORMATION PROCESSING, AND FINANCIAL ANALYSIS AND CONSULTATION; ADMINISTRATION OF FINANCIAL AFFAIRS, NAMELY, FINANCIAL ADMINISTRATION OF RETIREMENT PLANS; COMPUTERIZED FINANCIAL SERVICES IN THE NATURE OF FINANCIAL PORTFOLIO MANAGEMENT SERVICES FOR OTHERS, PROVIDING BANK ACCOUNT INFORMATION ONLINE, SECURITIES TRADING FOR OTHERS VIA THE INTERNET, AND ELECTRONIC COMMERCE PAYMENT SERVICES, NAMELY, ESTABLISHING FUNDED ACCOUNTS USED TO PURCHASE GOODS AND SERVICES ON THE INTERNET; ADVICE AND INQUIRIES REGARDING CREDIT; FINANCIAL SERVICES FOR THE PROVISION OF CREDIT IN THE NATURE OF ISSUING LETTERS OF CREDIT AND PROVIDING CREDIT AGENCY SERVICES FOR BUSINESSES AND INDIVIDUALS; BANKING SERVICES IN THE NATURE OF ACCEPTANCE OF DEPOSITS; CASH FLOW SERVICES, NAMELY, PROVIDING NOTES AT A DISCOUNTED RATE IN RETURN FOR OWNERSHIP OF THE NOTE; COMMERCIAL PAPER TRANSACTIONS, NAMELY, DOMESTIC REMITTANCE, LIABILITY GUARANTEE, ACCEPTANCE OF BILLS, LENDING SECURITIES, ACQUISITION AND TRANSFER OF MONETARY CLAIMS; TRUSTEE SERVICE, NAMELY, TRUST MANAGEMENT ACCOUNTS; TRUSTEESHIP OF MONEY, NAMELY, ESTATE TRUST MANAGEMENT; BROKERAGE OF FUTURES CONTRACTS; TRUSTEESHIP OF SECURITIES, MONETARY CLAIMS, PERSONAL PROPERTY, LAND, RIGHTS ON LAND FIXTURE, SURFACE RIGHTS AND LAND LEASING RIGHTS; MONETARY EXCHANGE, FOREIGN CURRENCY EXCHANGE TRANSACTIONS, CURRENCY EXCHANGE SERVICES, TRAVELERS CHECK ISSUANCE SERVICES; ISSUANCE OF LETTERS OF CREDIT; AGENCIES OR BROKERAGE FOR SECURITIES TRADING, INDEX FUTURES, SECURITIES OPTIONS, OVERSEAS MARKET SECURITIES FUTURES; UNDERWRITING SECURITIES, SELLING SECURITIES, HANDLING SUBSCRIPTIONS AND OFFERINGS OF SECURITIES, PROVIDING STOCK MARKET INFORMATION, LIFE INSURANCE BROKERAGE, LIFE INSURANCE UNDERWRITING, AGENCIES FOR NON-LIFE INSURANCE, CLAIM ADJUSTMENT FOR NON-LIFE INSURANCE, MARINE INSURANCE UNDERWRITING, INSURANCE ACTUARIAL SERVICES; MORTGAGE SERVICES, NAMELY, BUYER PRE-QUALIFICATION OF MORTGAGES FOR MORTGAGE BROKERS AND BANKS; ADVISORY, CONSULTANCY AND INFORMATION SERVICES RELATING TO ALL OF THE AFORESAID SERVICES (U.S. CLS. 100, 101 AND 102).

SUE LAWRENCE, EXAMINING ATTORNEY

SN 77-091,851. THE DANNON RESEARCH INSTITUTE,
WHITE PLAINS, NY. FILED 1-26-2007.

SN 77-092,317. THE DANNON RESEARCH INSTITUTE,
WHITE PLAINS, NY. FILED 1-26-2007.

DANNON CARES

DANNON NEXT GENERATION NUTRITION

THE MARK CONSISTS OF STANDARD CHARACTERS
WITHOUT CLAIM TO ANY PARTICULAR FONT, STYLE,
SIZE, OR COLOR.

NO CLAIM IS MADE TO THE EXCLUSIVE RIGHT TO
USE "NUTRITION", APART FROM THE MARK AS
SHOWN.

CLASS 16—PAPER GOODS AND PRINTED MATTER

FOR PUBLICATIONS, NAMELY, BOOKS, JOURNALS,
BROCHURES AND NEWSLETTERS PERTAINING TO
THE FIELD OF NUTRITION AND HEALTH (U.S. CLS. 2,
5, 22, 23, 29, 37, 38 AND 50).

CLASS 35—ADVERTISING AND BUSINESS

FOR PROMOTING PUBLIC AWARENESS OF THE
BENEFITS OF NUTRITION AND HEALTHY EATING
HABITS (U.S. CLS. 100, 101 AND 102).

CLASS 41—EDUCATION AND ENTERTAIN- MENT

FOR PROVIDING EDUCATIONAL PROGRAMS IN
THE FIELDS OF NUTRITION AND HEALTH; PROVID-
ING ONLINE NON-DOWNLOADABLE PUBLICATIONS,
NAMELY, NEWSLETTERS, BROCHURES AND JOUR-
NALS IN THE FIELD OF NUTRITION AND HEALTH;
EDUCATIONAL RESEARCH ON THE RELATIONSHIP
BETWEEN NUTRITION AND HEALTH; DEVELOPMENT
AND DISSEMINATION OF EDUCATIONAL MATERI-
ALS OF OTHERS IN THE FIELD OF NUTRITION AND
HEALTH; CONDUCTING AN AWARDS PROGRAM
RECOGNIZING EXCELLENCE IN COMMUNITY NU-
TRITION PROGRAMS; OPERATING AN AWARDS PRO-
GRAM TO RECOGNIZE BUSINESSES AND
ORGANIZATIONS THAT HAVE DEMONSTRATED A
COMMITMENT TO THE HEALTH AND NUTRITIONAL
NEEDS OF EMPLOYEES; INFORMATION ABOUT EDU-
CATION, NAMELY, PROVIDING INFORMATION
ABOUT NUTRITION AND HEALTH EDUCATION VIA
THE INTERNET; CHARITABLE SERVICES, NAMELY,
PROVIDING TRAINING IN THE FIELD OF NUTRITION
AND HEALTH (U.S. CLS. 100, 101 AND 107).

CLASS 44—MEDICAL, BEAUTY AND AGRI- CULTURAL SERVICES

FOR PROVIDING HEALTH INFORMATION ON A
WEBSITE ON NUTRITION AND HEALTHY EATING
HABITS (U.S. CLS. 100 AND 101).
B. PARADEWELAI, EXAMINING ATTORNEY

THE MARK CONSISTS OF STANDARD CHARACTERS
WITHOUT CLAIM TO ANY PARTICULAR FONT, STYLE,
SIZE, OR COLOR.

CLASS 16—PAPER GOODS AND PRINTED MATTER

FOR PUBLICATIONS, NAMELY, BOOKS, JOURNALS,
BROCHURES AND NEWSLETTERS PERTAINING TO
THE FIELD OF NUTRITION AND HEALTH (U.S. CLS. 2,
5, 22, 23, 29, 37, 38 AND 50).

FIRST USE 1-31-2003; IN COMMERCE 1-31-2003.

CLASS 35—ADVERTISING AND BUSINESS

FOR PROMOTING PUBLIC AWARENESS OF THE
BENEFITS OF NUTRITION AND HEALTHY HABITS;
CHARITABLE SERVICES, NAMELY, COORDINATION
OF THE PROCUREMENT AND DISTRIBUTION OF
FOOD DONATIONS FROM MANUFACTURERS,
WHOLESALEERS, RETAILERS, AND GOVERNMENT
AGENCIES TO ORGANIZATIONS PROVIDING FREE
FOOD TO NEEDY PEOPLE (U.S. CLS. 100, 101 AND 102).
FIRST USE 1-31-2003; IN COMMERCE 1-31-2003.

CLASS 41—EDUCATION AND ENTERTAIN- MENT

FOR PROVIDING EDUCATIONAL PROGRAMS IN
THE FIELDS OF NUTRITION AND HEALTH; PROVID-
ING ONLINE NON-DOWNLOADABLE PUBLICATIONS,
NAMELY, NEWSLETTERS, BROCHURES AND JOUR-
NALS IN THE FIELD OF NUTRITION AND HEALTH;
EDUCATIONAL RESEARCH ON THE RELATIONSHIP
BETWEEN NUTRITION AND HEALTH; DEVELOPMENT
AND DISSEMINATION OF EDUCATIONAL MATERI-
ALS OF OTHERS IN THE FIELD OF NUTRITION AND
HEALTH; CONDUCTING AN AWARDS PROGRAM
RECOGNIZING EXCELLENCE IN COMMUNITY NU-
TRITION PROGRAMS; OPERATING AN AWARDS PRO-
GRAM TO RECOGNIZE BUSINESS AND
ORGANIZATIONS THAT HAVE DEMONSTRATED A
COMMITMENT TO THE HEALTH AND NUTRITIONAL
NEEDS OF EMPLOYEES; INFORMATION ABOUT EDU-
CATION, NAMELY, PROVIDING INFORMATION
ABOUT NUTRITION AND HEALTH EDUCATION VIA
THE INTERNET; CHARITABLE SERVICES, NAMELY,
PROVIDING TRAINING IN THE FIELD OF NUTRITION
AND HEALTH (U.S. CLS. 100, 101 AND 107).

FIRST USE 1-31-2003; IN COMMERCE 1-31-2003.

CLASS 43—HOTEL AND RESTAURANT SER- VICES

FOR CHARITABLE SERVICES, NAMELY, PROVID-
ING FOOD TO NEEDY PERSONS (U.S. CLS. 100 AND
101).

FIRST USE 1-31-2003; IN COMMERCE 1-31-2003.

CLASS 44—MEDICAL, BEAUTY AND AGRI- CULTURAL SERVICES

FOR PROVIDING HEALTH INFORMATION ON A
WEBSITE ON NUTRITION AND HEALTHY EATING
HABITS (U.S. CLS. 100 AND 101).

FIRST USE 1-31-2003; IN COMMERCE 1-31-2003.

B. PARADEWELAI, EXAMINING ATTORNEY

SN 77-093,965. BOND MANUFACTURING COMPANY, BAY POINT, CA. FILED 1-29-2007.

GARDEN FOR THE CAUSE

THE MARK CONSISTS OF STANDARD CHARACTERS WITHOUT CLAIM TO ANY PARTICULAR FONT, STYLE, SIZE, OR COLOR.

NO CLAIM IS MADE TO THE EXCLUSIVE RIGHT TO USE "GARDEN", APART FROM THE MARK AS SHOWN.

CLASS 8—HAND TOOLS

FOR MANUALLY OPERATED GARDEN TOOLS, NAMELY, PRUNERS, LOPPERS, HEDGE SHEARS, GRASS SHEARS, SCISSORS, TRANSPLANTERS, GARDENING TROWELS, CULTIVATORS, RAKES, HOES, AND SHOVELS (U.S. CLS. 23, 28 AND 44).

CLASS 9—ELECTRICAL AND SCIENTIFIC APPARATUS

FOR GARDENING KNEE PADS (U.S. CLS. 21, 23, 26, 36 AND 38).

CLASS 17—RUBBER GOODS

FOR WATERING HOSES (U.S. CLS. 1, 5, 12, 13, 35 AND 50).

CLASS 21—HOUSEWARES AND GLASS

FOR SPRAYER NOZZLES FOR GARDEN HOSES (U.S. CLS. 2, 13, 23, 29, 30, 33, 40 AND 50).
JENNIFER HETU, EXAMINING ATTORNEY

SN 77-094,276. PHILIP ALAN STEPHENS, LONDON, UNITED KINGDOM, FILED 1-30-2007.

UNCONDITIONAL

THE MARK CONSISTS OF STANDARD CHARACTERS WITHOUT CLAIM TO ANY PARTICULAR FONT, STYLE, SIZE, OR COLOR.

OWNER OF ERPN CMNTY TM OFC REG. NO. 4086997, DATED 3-1-2006, EXPIRES 10-22-2014.

CLASS 18—LEATHER GOODS

FOR LEATHER AND IMITATIONS OF LEATHER, AND GOODS MADE OF THESE MATERIALS AND NOT INCLUDED IN OTHER CLASSES, NAMELY, BRIEFCASES, SUITCASES, RUCKSACKS, WALLETS, HANDBAGS, KEY CASES, KEY CHAINS, PURSES, SHOPPING BAGS AND TRAVELING CASES; HANDBAGS, RUCKSACKS, BRIEFCASES, PURSES, WALLETS, CARD HOLDERS, KEY CASES AND HOLDERS; SUITCASES; ARTICLES OF LUGGAGE, NAMELY, CARRY-ON BAGS, SHOPPING BAGS FOR TRAVEL, TRUNKS AND TRAVELING BAGS, BAGS FOR CARRYING SPORTS IMPLEMENTS AND SPORTS CLOTHING, CARRYING CASES AND BAGS FOR TOILETRIES SOLD EMPTY, BEAUTY CASES, NAMELY, COSMETICS CASES SOLD EMPTY; SHOULDER BELTS MADE OF LEATHER AND IMITATION LEATHER; UMBRELLAS, PARASOLS AND WALKING STICKS (U.S. CLS. 1, 2, 3, 22 AND 41).

CLASS 25—CLOTHING

FOR CLOTHING, NAMELY, WATERPROOF CLOTHING IN THE NATURE OF SHOES, JACKETS AND COATS; T-SHIRTS; SWEATSHIRTS; SWEAT PANTS; SWEATERS; SUITS; SINGLETS; VESTS; HEAD SCARVES; SHIRTS; BLOUSES; GLOVES; STOCKINGS; DRESSING GOWNS; UNDERWEAR; CAPES; SHAWLS; JEANS; PYJAMAS; CHILDREN'S CLOTHING IN THE NATURE OF JACKETS, COATS, JUMPERS, DRESSES, TROUSERS, SHIRTS, SHORTS, SKIRTS, POLO SHIRTS, VESTS, T-SHIRTS, SHOES, UNDERWEAR, SOCKS, SWIMWEAR, WAISTCOATS, SCARVES, HATS, GLOVES, DRESSES, TROUSERS; PULLOVERS; KNITWEAR IN THE NATURE OF V-NECK SWEATERS, POLO NECK SWEATERS, JACKETS, JUMPERS, CARDIGANS, WAISTCOATS, SCARVES, HATS, GLOVES, DRESSES, TROUSERS; JOGGING SUITS; ANORAKS; BOMBER JACKETS; JACKETS; LEATHER JACKETS; DOWN-FILLED JACKETS; WIND-CHEATERS; OVERCOATS; SHORTS; SKIRTS; SOCKS, RUGBY SHIRTS; FLEECE TOPS; JUMPERS; BELTS; POLO SHIRTS; DRESSES; SWIMWEAR; BEACHWEAR; CARDIGANS; COATS; TROUSERS; MINI-SHIRTS; PINAFORES; WAISTCOATS; OVERALLS; DANCE CLOTHING IN THE NATURE OF TUTUS, TROUSERS, TOPS, T-SHIRTS AND LEOTARDS; LEOTARDS; LEGGINGS; SCARVES; TIES; FOOTWEAR; HEADGEAR, NAMELY, CAPS AND BASEBALL CAPS; BANDANNAS; RAIN HATS; KNITTED HATS; FELT HATS; STRAW HATS; HEADBANDS; CLOTHING BELTS MADE OF LEATHER AND IMITATION LEATHER; BOOT BAGS FOR CRUISING BOOTS, ARMY BOOTS, SKI BOOTS, HIKING BOOTS, RUBBER BOOTS, HUNTING BOOTS AND LEATHER ANKLE, KNEE AND THIGH HIGH BOOTS (U.S. CLS. 22 AND 39).
RON FAIRBANKS, EXAMINING ATTORNEY

SN 77-094,682. L & P SWISS HOLDING COMPANY, WITENBACH, SWITZERLAND, FILED 1-30-2007.

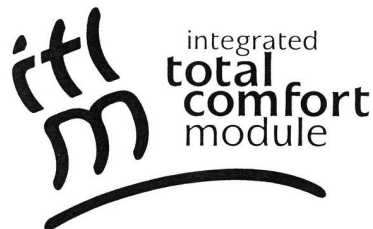

OWNER OF FED REP GERMANY REG. NO. 30647643, DATED 10-19-2006, EXPIRES 8-31-2016.

NO CLAIM IS MADE TO THE EXCLUSIVE RIGHT TO USE "TOTAL COMFORT MODULE", APART FROM THE MARK AS SHOWN.

THE MARK CONSISTS OF THE WORDS "INTEGRATED TOTAL COMFORT MODULE" AND THE LETTERS "I", "T", "C" AND "M" IN FANCIFUL SCRIPT, WITH AN INVERTED CURVED LINE UNDER ALL.

CLASS 10—MEDICAL APPARATUS

FOR SPECIALLY DESIGNED FURNITURE, NAMELY, CHAIRS FOR MEDICAL PURPOSES, NAMELY, FOR MEDICAL PATIENTS; ARMCHAIRS FOR MEDICAL PURPOSES, NAMELY, MEDICAL EXAMINATION; SEAT MODULES, NAMELY, SEAT INSERTS FOR SEAT FRAMES FOR MEDICAL PATIENTS; SEAT COMPONENTS, NAMELY, LUMBAR SUPPORTS AND CUSHIONS FOR MEDICAL PATIENTS; BACKRESTS FOR LORDOSIS PATIENTS; ERGONOMIC REST DEVICES; NAMELY, SEAT AND BACK CUSHIONS FOR LORDOSIS PATIENTS AND RESTS, NAMELY, CUSHIONS FOR LORDOSIS PATIENTS, THE AFOREMENTIONED GOODS DESTINED FOR SPECIALLY DESIGNED FURNITURE FOR MEDICAL PURPOSES (U.S. CLS. 26, 39 AND 44).

CLASS 12—VEHICLES

FOR VEHICLE ACCESSORIES, NAMELY, AUTOMOBILE SEAT CUSHIONS, AUTOMOBILE CARGO RACKS; VEHICLE SEATS; AUTOMOBILE SEAT MODULES, NAMELY, AUTOMOBILE SEAT CUSHIONS; AUTOMOBILE SEAT COMPONENTS, NAMELY, LUMBAR SUPPORTS AND CUSHIONS; AUTOMOBILE BACKRESTS USED FOR VEHICLE SEATS; AUTOMOBILE ERGONOMIC REST DEVICES AND RESTS, NAMELY, AUTOMOBILE SEAT CUSHIONS FOR PASSENGERS TO BE USED FOR VEHICLE SEATS; THE AFOREMENTIONED GOODS DESTINED FOR AUTOMOTIVE SEATS (U.S. CLS. 19, 21, 23, 31, 35 AND 44).

CLASS 20—FURNITURE AND ARTICLES NOT OTHERWISE CLASSIFIED

FOR SITTING FURNITURE; OFFICE FURNITURE; HAIR DRESSER'S FURNITURE; BACKRESTS FOR ARMCHAIRS, SEATS, AND SITTING FURNITURE; SITTING CUSHIONS; SEAT MODULES, NAMELY, SEAT CUSHIONS; SEAT COMPONENTS, NAMELY, LUMBAR SUPPORTS FOR USE WITH CHAIRS AND SEATS; ERGONOMIC REST DEVICES AND RESTS, NAMELY, SEAT CUSHIONS AND LUMBAR SUPPORTS FOR LORDOSIS PATIENTS, DESTINED FOR SITTING FURNITURE AND OFFICE FURNITURE (U.S. CLS. 2, 13, 22, 25, 32 AND 50).

LEIGH CAROLINE CASE, EXAMINING ATTORNEY

CLASS 1—CHEMICALS

FOR REAGENTS FOR SCIENTIFIC OR MEDICAL RESEARCH USE, NAMELY, ENZYMES, NUCLEIC ACIDS, NUCLEOTIDES, PROTEINS, ANTIBODIES, BUFFER SOLUTIONS, BIOLOGICAL REAGENT OR BIOCHEMICALS AND CONJUGATES USED IN MOLECULAR BIOLOGICAL LABORATORIES; AND KITS COMPRISED OF REAGENTS FOR SCIENTIFIC OR MEDICAL RESEARCH USE, NAMELY, BUFFER SOLUTIONS, BIOLOGICAL REAGENT OR BIOCHEMICALS AND CONJUGATES USED IN MOLECULAR BIOLOGICAL LABORATORIES; AND REAGENTS, NAMELY, RESINS USED IN BIOLOGICAL OR BIOCHEMICAL LABORATORY PROCEDURES, NAMELY, CHROMATOGRAPHIC SEPARATION AND PURIFICATION (U.S. CLS. 1, 5, 6, 10, 26 AND 46).

FIRST USE 3-23-1984; IN COMMERCE 3-23-1984.

CLASS 42—SCIENTIFIC AND COMPUTER SERVICES

FOR LABORATORY RESEARCH SERVICES IN THE FIELD OF MOLECULAR BIOLOGY, NAMELY, CUSTOMIZED CDNA LIBRARY CONSTRUCTION, CUSTOMIZED HYBRIDIZATION SERVICES, AND CUSTOMIZED ADENOVIRUS SERVICES (U.S. CLS. 100 AND 101).

FIRST USE 3-23-1984; IN COMMERCE 3-23-1984.

SARA THOMAS, EXAMINING ATTORNEY

SN 77-097,314. RC ART, INC., DENVER, CO. FILED 2-1-2007.

RC ART

SN 77-096,260. CLONTECH LABORATORIES, INC., MOUNTAIN VIEW, CA. FILED 1-31-2007.

CLONTECH

THE MARK CONSISTS OF STANDARD CHARACTERS WITHOUT CLAIM TO ANY PARTICULAR FONT, STYLE, SIZE, OR COLOR.

OWNER OF U.S. REG. NO. 2,429,360.

THE MARK CONSISTS OF STANDARD CHARACTERS WITHOUT CLAIM TO ANY PARTICULAR FONT, STYLE, SIZE, OR COLOR.

NO CLAIM IS MADE TO THE EXCLUSIVE RIGHT TO USE "RC", APART FROM THE MARK AS SHOWN.

CLASS 16—PAPER GOODS AND PRINTED MATTER

FOR PAPER; WRITING PAPER PADS; MARKERS; CRAYONS; HIGHLIGHTER PENS; PENS; PENCILS; COLOR PENCILS; PENCIL BOXES; CHALK; CHALK ERASERS; PAINT BRUSHES (U.S. CLS. 2, 5, 22, 23, 29, 37, 38 AND 50).

CLASS 28—TOYS AND SPORTING GOODS

FOR REMOTE CONTROL TOYS, NAMELY, REMOTE CONTROL INSECTS AND VEHICLES AND INTERCHANGEABLE STRUCTURAL PARTS AND CONTROLLERS THEREFOR (U.S. CLS. 22, 23, 38 AND 50).

BRIAN CALLAGHAN, EXAMINING ATTORNEY

SN 77-097,318. RC ART, INC., DENVER, CO. FILED 2-1-2007.

SN 77-099,014. FLETCHER LEISURE GROUP INC., MONTREAL, QUEBEC, CANADA, FILED 2-5-2007.

RC ART TOYS

THE MARK CONSISTS OF STANDARD CHARACTERS WITHOUT CLAIM TO ANY PARTICULAR FONT, STYLE, SIZE, OR COLOR.

NO CLAIM IS MADE TO THE EXCLUSIVE RIGHT TO USE "RC" AND "TOYS", APART FROM THE MARK AS SHOWN.

CLASS 16—PAPER GOODS AND PRINTED MATTER

FOR PAPER; WRITING PAPER PADS; MARKERS; CRAYONS; HIGHLIGHTER PENS; PENS; PENCILS; COLOR PENCILS; PENCIL BOXES; CHALK; CHALK ERASERS; PAINT BRUSHES (U.S. CLS. 2, 5, 22, 23, 29, 37, 38 AND 50).

CLASS 28—TOYS AND SPORTING GOODS

FOR REMOTE CONTROL TOYS, NAMELY, REMOTE CONTROL INSECTS AND VEHICLES AND INTERCHANGEABLE STRUCTURAL PARTS AND CONTROLLERS THEREFOR (U.S. CLS. 22, 23, 38 AND 50).

BRIAN CALLAGHAN, EXAMINING ATTORNEY

A | U | R

PRIORITY CLAIMED UNDER SEC. 44(D) ON CANADA APPLICATION NO. 1,333,478, FILED 1-31-2007, REG. NO. TMA708,006, DATED 2-21-2008, EXPIRES 2-21-2023.

THE MARK CONSISTS OF THE LETTERS "A", "U" AND "R", WITH TWO LINES, ONE BETWEEN THE "A" AND "U" AND ONE BETWEEN THE "U" AND "R".

CLASS 18—LEATHER GOODS

FOR CARRY-ALL BAGS, TOTE BAGS (U.S. CLS. 1, 2, 3, 22 AND 41).

CLASS 25—CLOTHING

FOR ATHLETIC CLOTHING, NAMELY, SHORTS, SHIRTS, PANTS, VESTS, SKIRTS, SWEATERS, JERSEYS, CASUAL CLOTHING, NAMELY, SHORTS, SHIRTS, PANTS, VESTS, SKIRTS, SWEATERS, JERSEYS, GOLF WEAR, NAMELY, SHORTS, SKIRTS, PANTS, SHIRTS, SWEATERS, VESTS, RAIN SUITS, HATS, GLOVES (U.S. CLS. 22 AND 39).

ELISSA GARBER KON, EXAMINING ATTORNEY

SN 77-097,483. NET2PHONE, INC., NEWARK, NJ. FILED 2-2-2007.

PICUP

THE MARK CONSISTS OF STANDARD CHARACTERS WITHOUT CLAIM TO ANY PARTICULAR FONT, STYLE, SIZE, OR COLOR.

CLASS 35—ADVERTISING AND BUSINESS

FOR PROVIDING ON-LINE DIRECTORY INFORMATION SERVICES ALSO FEATURING HYPERLINKS TO OTHER WEBSITES (U.S. CLS. 100, 101 AND 102).

CLASS 38—COMMUNICATION

FOR PROVIDING VOICE COMMUNICATION SERVICES VIA THE INTERNET (U.S. CLS. 100, 101 AND 104).

CLASS 42—SCIENTIFIC AND COMPUTER SERVICES

FOR DESIGN AND DEVELOPMENT FOR OTHERS OF COMPUTER SOFTWARE FOR INTER-OPERATION BETWEEN APPLICATIONS AND COMMUNICATIONS MEDIA (U.S. CLS. 100 AND 101).

H. M. FISHER, EXAMINING ATTORNEY

SN 77-099,036. CONAGRA FOODS RDM, INC., OMAHA, NE. FILED 2-5-2007.



OWNER OF U.S. REG. NOS. 1,324,849, 2,841,119 AND OTHERS.

NO CLAIM IS MADE TO THE EXCLUSIVE RIGHT TO USE "POPPING CORN", APART FROM THE MARK AS SHOWN.

THE NAME(S), PORTRAIT(S), AND/OR SIGNATURE(S) SHOWN IN THE MARK DOES NOT IDENTIFY A PARTICULAR LIVING INDIVIDUAL.

THE MARK CONSISTS OF A CIRCLE CONTAINING A PORTRAIT OF ORVILLE REDENBACHER ABOVE THE WORDS "ORVILLE REDENBACHER'S" AND THE WORDS "GOURMET POPPING CORN".

SEC. 2(F) AS TO "GOURMET".

CLASS 29—MEATS AND PROCESSED FOODS

FOR VEGETABLE OIL (U.S. CL. 46).

CLASS 30—STAPLE FOODS

FOR POPPED POPCORN; MICROWAVE POPCORN; FLAVORED POPCORN; UNPOPPED POPCORN; POPCORN SEASONINGS; SNACK MIX CONSISTING PRIMARILY OF POPPED POPCORN AND/OR PRETZELS; READY-TO-EAT POPCORN PRODUCTS, NAMELY, POPPED POPCORN AND POPCORN CAKES (U.S. CL. 46).

TASHIA BUNCH, EXAMINING ATTORNEY

SN 77-102,046. LIMBO, INC., BURLINGAME, CA. FILED 2-7-2007.

41414

THE MARK CONSISTS OF STANDARD CHARACTERS WITHOUT CLAIM TO ANY PARTICULAR FONT, STYLE, SIZE, OR COLOR.

SN 77-101,868. BENSUSSEN DEUTSCH & ASSOCIATES, INC., WOODINVILLE, WA. FILED 2-7-2007.

UNLEASH THE POWER OF
MERCHANDISE

THE MARK CONSISTS OF STANDARD CHARACTERS WITHOUT CLAIM TO ANY PARTICULAR FONT, STYLE, SIZE, OR COLOR.

NO CLAIM IS MADE TO THE EXCLUSIVE RIGHT TO USE "MERCHANDISE", APART FROM THE MARK AS SHOWN.

CLASS 35—ADVERTISING AND BUSINESS

FOR ADVERTISING AGENCIES; DEVELOPMENT OF PROMOTIONAL MATERIALS, NAMELY, MATERIALS BEARING LOGOS AND SLOGANS OF OTHERS; ADVERTISING AND MARKETING SERVICES, NAMELY, EXTENDING BRAND ATTRIBUTES VIA PROMOTIONAL CAMPAIGNS FOR BUSINESSES; COOPERATIVE ADVERTISING AND MARKETING; ELECTRONIC CATALOG AND MAIL ORDER CATALOG SERVICES FEATURING GENERAL CONSUMER, BUSINESS, OFFICE, COMPUTER AND ENTERTAINMENT RELATED PRODUCTS BEARING THE LOGOS AND SLOGANS OF OTHERS; DIRECT MAIL ADVERTISING SERVICES; ADVERTISING SERVICES, NAMELY, CREATING AND DEVELOPING CORPORATE LOGOS AND BRAND IDENTITY FOR OTHERS; DISTRIBUTORSHIP SERVICES IN THE FIELD OF PROMOTIONAL MERCHANDISE; AND ORDER FULFILLMENT SERVICES (U.S. CLS. 100, 101 AND 102).

CLASS 42—SCIENTIFIC AND COMPUTER SERVICES

FOR PRODUCT DEVELOPMENT; GRAPHIC ART DESIGN; APPAREL DESIGN SERVICES FOR OTHERS; DESIGN OF NEW PRODUCTS FOR OTHERS IN THE FIELD OF GENERAL CONSUMER, BUSINESS, OFFICE, COMPUTER AND ENTERTAINMENT RELATED GOODS AND SERVICES; GRAPHIC DESIGN SERVICES, NAMELY, PACKAGING DESIGN AND GRAPHIC ART DESIGN FOR OTHERS; WEBSITE DESIGN AND WEBSITE HOSTING SERVICES (U.S. CLS. 100 AND 101).

SIMON TENG, EXAMINING ATTORNEY

CLASS 35—ADVERTISING AND BUSINESS

FOR ADVERTISING SERVICES IN THE NATURE OF PROMOTING AND MARKETING THE GOODS AND SERVICES OF OTHERS THROUGH PUBLIC COMMUNICATION MEANS, NAMELY, THROUGH OVER-THE-AIR TELEVISION, RADIO, SATELLITE, CABLE, INTERNET AND OTHER COMPUTER NETWORKS, AND OTHER VISUAL MEDIA (U.S. CLS. 100, 101 AND 102).

CLASS 38—COMMUNICATION

FOR TELEVISION AND RADIO BROADCASTING SERVICES; SATELLITE AND CABLE TELEVISION AND RADIO BROADCASTING SERVICES; TRANSMISSION OF AUDIOVISUAL DATA AND IMAGES VIA TELEVISION AND RADIO BROADCAST, AND SATELLITE AND CABLE BROADCAST; TRANSMISSION AND DISTRIBUTION OF AUDIOVISUAL DATA AND IMAGES VIA THE INTERNET AND OTHER COMPUTER NETWORKS; TRANSMISSION AND DISTRIBUTION OF AUDIOVISUAL DATA AND IMAGES VIA MULTI-MEDIA MESSAGING SERVICE (MMS) AND WIRELESS APPLICATION PROTOCOL (WAP); VIDEO-ON-DEMAND TRANSMISSION SERVICES; BROADCAST-ON-DEMAND TRANSMISSION OF TELEVISION PROGRAMS, RADIO PROGRAMS, MOTION PICTURE FILMS, AND OTHER AUDIOVISUAL CONTENT VIA TELEVISION AND RADIO BROADCAST, AND SATELLITE AND CABLE TELEVISION AND RADIO BROADCAST; ON-DEMAND TRANSMISSION OF TELEVISION PROGRAMS, RADIO PROGRAMS, MOTION PICTURE FILMS, AND OTHER AUDIOVISUAL CONTENT VIA THE INTERNET AND OTHER COMPUTER NETWORKS (U.S. CLS. 100, 101 AND 104).

CLASS 41—EDUCATION AND ENTERTAINMENT

FOR PRODUCTION, DISTRIBUTION, AND SYNDICATION OF ONE-TIME AND SERIAL TELEVISION PROGRAMS, RADIO PROGRAMS, AND MOTION PICTURE FILMS; ENTERTAINMENT SERVICES, NAMELY, PROVIDING TELEVISION AND RADIO PROGRAMS IN THE FIELD OF GAMES, GAMING, AND SWEEPSTAKES CONTESTS FOR BROADCAST VIA OVER-THE-AIR, TELEVISION, RADIO, SATELLITE, CABLE, INTERNET AND OTHER COMPUTER NETWORKS, AND OTHER VISUAL MEDIA; ENTERTAINMENT SERVICES IN THE NATURE OF TELEVISION AND RADIO GAME SHOWS FOR BROADCAST VIA OVER-THE-AIR, TELEVISION, RADIO, SATELLITE, CABLE, INTERNET AND OTHER COMPUTER NETWORKS, AND OTHER VISUAL MEDIA; ENTERTAINMENT SERVICES IN THE NATURE OF ONE-TIME AND SERIAL REALITY BASED TELEVISION AND RADIO PROGRAMS FOR BROADCAST VIA OVER-THE-AIR, TELEVISION, RADIO, SATELLITE, CABLE, INTERNET AND OTHER COMPUTER NETWORKS, AND OTHER VISUAL MEDIA; ENTERTAINMENT IN THE NATURE OF TELEVISION AND RADIO NEWS AND NEWSMAGAZINE SHOWS, AND NEWS SEGMENTS FOR INSERTION INTO SUCH SHOWS, FOR BROADCAST VIA OVER-THE-AIR TELEVISION, RADIO, SATELLITE, CABLE, INTERNET AND OTHER COMPUTER NETWORKS, AND OTHER VISUAL MEDIA (U.S. CLS. 100, 101 AND 107).

ZHALEH DELANEY, EXAMINING ATTORNEY

SN 77-102,705. HSP GAMING LP, PHILADELPHIA, PA.
FILED 2-8-2007.



CLASS 41—EDUCATION AND ENTERTAINMENT

FOR CASINO SERVICES (U.S. CLS. 100, 101 AND 107).

CLASS 43—HOTEL AND RESTAURANT SERVICES

FOR BAR AND RESTAURANT SERVICES, AND LOUNGES; CARRY-OUT RESTAURANTS; CATERING FOR THE PROVISION OF FOOD AND BEVERAGES (U.S. CLS. 100 AND 101).
JUSTINE D. PARKER, EXAMINING ATTORNEY



SN 77-105,918. JOS. SCHNEIDER OPTISCHE WERKE GMBH, BAD KREUZNACH, FED REP GERMANY, FILED 2-13-2007.

PROVAR

THE MARK CONSISTS OF STANDARD CHARACTERS WITHOUT CLAIM TO ANY PARTICULAR FONT, STYLE, SIZE, OR COLOR.
THE WORDING "PROVAR" HAS NO MEANING IN A FOREIGN LANGUAGE.

CLASS 9—ELECTRICAL AND SCIENTIFIC APPARATUS

FOR SCIENTIFIC, NAUTICAL, SURVEYING, ELECTRIC, ELECTRONIC, OPTO-ELECTRONIC, PHOTOGRAPHIC, CINEMATOGRAPHIC, OPTICAL, WEIGHING, MEASURING, SIGNALING, CHECKING AND SUPERVISION APPARATUS AND INSTRUMENTS, NAMELY, OPTICAL DETECTORS IN THE NATURE OF OPTICAL CHARACTER READERS AND OPTICAL SCANNERS, OPTICAL LENSES FOR SCANNING OR READING CHARACTERS IN A TELEFAXING OR COPYING APPARATUS; PHOTOGRAPHIC, CINEMATOGRAPHIC AND PROJECTION OBJECTIVES, NAMELY, COMBINATIONS OF PHOTOGRAPHIC LENSES FOR USE WITH CAMERAS, ENLARGERS AND PROJECTORS; LIGHT METERS, OPTICAL REFLECTORS, CONDENSERS, DIAPHRAGMS FOR CAMERAS, OPTICAL POWER SPLITTERS, DIGITAL SIGNAL PROCESSORS; PROJECTOR LAMPS AND FLASH LAMPS FOR CAMERAS; APPARATUS FOR RECORDING, TRANSMISSION OR REPRODUCTION OF SOUND AND IMAGES, NAMELY, FILM CAMERAS, VIDEO CAMERAS, PHOTOGRAPHIC PROJECTORS, OPTICAL/ELECTRICAL TRANSDUCERS, ELECTRICAL/OPTICAL TRANSDUCERS, FLAT PANEL DISPLAY SCREENS, ELECTRIC LUMINESCENT DISPLAY PANELS; BLANK MAGNETIC DATA CARRIERS; DATA PROCESSING EQUIPMENT, NAMELY, COMPUTERS, COMPUTER INTERFACE BOARDS, OPTICAL COMPUTER INPUTS, NAMELY, INTERFACES; PRINTED CIRCUIT CARDS FOR INTERFACING COMPUTERS AND OPTICAL CHARACTER RECOGNITION DEVICES, NAMELY INTERFACES; LENSES FOR USE WITH PHOTOGRAPHIC AND CINEMATOGRAPHIC CAMERAS; LENSES FOR USE IN AND FOR USE WITH PHOTOGRAPHIC AND CINEMATOGRAPHIC PROJECTORS; OPTICAL GLASSES, OPTICAL FIBERS SOLD AS A COMPONENT OF FIBER OPTICAL CABLES, FILTERS, NAMELY, OPTICAL FILTERS, CAMERA FILTERS (U.S. CLS. 21, 23, 26, 36 AND 38).

CLASS 42—SCIENTIFIC AND COMPUTER SERVICES

FOR DESIGN OF PHOTOGRAPHIC, CINEMATOGRAPHIC AND PROJECTION OBJECTIVES, NAMELY, COMBINATIONS OF PHOTOGRAPHIC LENSES FOR USE WITH CAMERAS, ENLARGERS AND PROJECTORS AND OF OPTICAL RECORDING, TRANSMISSION AND REPRODUCTION SYSTEMS FOR USERS (U.S. CLS. 100 AND 101).
REBECCA POVARCHUK, EXAMINING ATTORNEY



SN 77-107,858. ENDACE TECHNOLOGY LIMITED, HAMILTON, NEW ZEALAND, FILED 2-14-2007.

NINJAPROBE

THE MARK CONSISTS OF STANDARD CHARACTERS WITHOUT CLAIM TO ANY PARTICULAR FONT, STYLE, SIZE, OR COLOR.

CLASS 9—ELECTRICAL AND SCIENTIFIC APPARATUS

FOR SCIENTIFIC, WEIGHING, MEASURING, SIGNALING, CHECKING AND SUPERVISION APPARATUS AND INSTRUMENTS, NAMELY, COMPUTER APPLIANCE IN THE NATURE OF COMPUTER HARDWARE TO RECEIVE, DETECT, PREVENT, ANALYZE AND INTERCEPT NETWORK TRAFFIC; COMPUTER HARDWARE; COMPUTER SOFTWARE, NAMELY, NETWORK SECURITY AND TRAFFIC ANALYSIS SOFTWARE, COMMUNICATION SOFTWARE TO RECEIVE NETWORK DATA, INTRUSION DETECTION AND PREVENTION SOFTWARE TO DETECT AND PREVENT NETWORK TRAFFIC INTRUSIONS, FLOW ANALYSIS SOFTWARE TO ANALYZE THE FLOW OF NETWORK TRAFFIC, INTERCEPTION SOFTWARE TO INTERCEPT NETWORK TRAFFIC; COMPUTER FIRMWARE, NAMELY, NETWORK SECURITY AND TRAGIC ANALYSIS FIRMWARE, COMMUNICATION FIRMWARE TO RECEIVE NETWORK DATA, INTRUSION DETECTION AND PREVENTION FIRMWARE TO DETECT AND PREVENT NETWORK TRAGIC INTRUSIONS, FLOW ANALYSIS FIRMWARE TO ANALYZE THE FLOW OF NETWORK TRAFFIC; COMPUTER PRODUCTS, NAMELY, COMMUNICATIONS EQUIPMENT TO RECEIVE NETWORK DATA AND MONITORING EQUIPMENT TO MONITOR NETWORK TRAFFIC, NAMELY, COMPUTER APPLIANCES, COMPUTER PLATFORMS, NETWORK CARDS AND NETWORK TAPS; COMPUTER PRODUCTS, NAMELY, COMMUNICATIONS EQUIPMENT TO RECEIVE NETWORK DATA AND MONITORING EQUIPMENT TO MONITOR NETWORK TRAFFIC, NAMELY, COMPUTER APPLIANCES, COMPUTER PLATFORMS, NETWORK CARDS AND NETWORK TAPS, COMPUTER HARDWARE, COMPUTER SOFTWARE AND COMPUTER FIRMWARE FOR NETWORK MEASUREMENT, MONITORING, MANAGEMENT, TESTING, SECURITY AND SURVEILLANCE; COMPUTER MEMORY CARDS, NAMELY, DATA ACQUISITION CARDS; COMPUTER MEMORY CARDS BEARING DATA FOR USE IN COMPUTERS; CARDS BEARING INTEGRATED CIRCUITS; ENCODED ELECTRONIC CHIP CARDS INCORPORATING MICROPROCESSORS FOR PROCESSING NETWORK DATA; NETWORK MEMORY CARDS; ENCODED COMPUTER NETWORK INTERFACE CARDS; HIGH PERFORMANCE ENCODED COMPUTER NETWORK CARDS FOR SECURITY APPLICATIONS (U.S. CLS. 21, 23, 26, 36 AND 38).

CLASS 37—CONSTRUCTION AND REPAIR

FOR INSTALLATION, MAINTENANCE AND REPAIR OF COMPUTER PRODUCTS, NAMELY, COMMUNICATIONS EQUIPMENT TO RECEIVE NETWORK DATA AND MONITORING EQUIPMENT TO MONITOR NETWORK TRAFFIC, NAMELY, COMPUTER APPLIANCES, COMPUTER PLATFORMS, NETWORK CARDS AND NETWORK TAPS (U.S. CLS. 100, 103 AND 106).

CLASS 42—SCIENTIFIC AND COMPUTER SERVICES

FOR CONSULTING, RESEARCH, DESIGN FOR OTHERS AND ADVISORY SERVICES IN RELATION TO COMPUTERS AND COMPUTER SOFTWARE; CONSULTING, RESEARCH, DESIGN FOR OTHERS AND ADVISORY SERVICES IN RELATION TO COMPUTER NETWORK MEASUREMENT, MONITORING, MANAGEMENT, TESTING, SECURITY AND SURVEILLANCE; CONSULTING, RESEARCH, DESIGN FOR OTHERS AND ADVISORY SERVICES IN RELATION TO COMPUTER PRODUCTS, NAMELY, COMMUNICATIONS EQUIPMENT TO RECEIVE NETWORK DATA AND MONITORING EQUIPMENT TO MONITOR NETWORK TRAFFIC, FOR NETWORK MEASUREMENT, MONITORING, MANAGEMENT, TESTING, SECURITY AND SURVEILLANCE, NAMELY, COMPUTER APPLIANCES, COMPUTER PLATFORMS, NETWORK CARDS, AND NETWORK TAPS; RENTAL OF COMPUTER PRODUCTS, NAMELY, COMPUTER HARDWARE, COMPUTER PERIPHERALS, COMPUTER SOFTWARE AND FIRMWARE FOR NETWORK MEASURING, MONITORING, MANAGEMENT, TESTING, SECURITY AND SURVEILLANCE, NETWORK MEMORY CARDS, NETWORK INTERFACE MEMORY CARDS, HIGH PERFORMANCE NETWORK CARDS FOR SECURITY APPLICATIONS;

RENTAL OF COMPUTER HARDWARE AND COMPUTER SOFTWARE; RENTAL OF COMPUTER HARDWARE AND COMPUTER SOFTWARE FOR COMPUTER NETWORK MEASUREMENT, MONITORING, MANAGEMENT, TESTING, SECURITY AND SURVEILLANCE; INSTALLATION, MAINTENANCE AND REPAIR OF COMPUTER SOFTWARE, NAMELY, NETWORK SECURITY AND TRAFFIC ANALYSIS SOFTWARE, COMMUNICATIONS SOFTWARE, INTRUSION DETECTION AND PREVENTION SOFTWARE, FLOW ANALYSIS SOFTWARE, INTERCEPTION SOFTWARE; INSTALLATION, MAINTENANCE AND REPAIR OF COMPUTER SOFTWARE FOR NETWORK MEASUREMENT, MONITORING, MANAGEMENT, TESTING, SECURITY AND SURVEILLANCE (U.S. CLS. 100 AND 101).
HEATHER THOMPSON, EXAMINING ATTORNEY

SN 77-109,686. MONTREAL OSTOMY AND HOMECARE CENTRE INC./CENTRE D'OSTOMIE DE MONTREAL ET EQUIPEMENT POUR SOINS A DOMICILE INC., QUEBEC, CANADA, FILED 2-16-2007.

STOMA-TECH

THE MARK CONSISTS OF STANDARD CHARACTERS WITHOUT CLAIM TO ANY PARTICULAR FONT, STYLE, SIZE, OR COLOR.

PRIORITY CLAIMED UNDER SEC. 44(D) ON CANADA APPLICATION NO. 1324764, FILED 11-7-2006, REG. NO. TMA697547, DATED 9-28-2007, EXPIRES 9-28-2022.

PRIORITY CLAIMED UNDER SEC. 44(D) ON CANADA APPLICATION NO. 1324764, FILED 11-7-2006, REG. NO. TMA697547, DATED 9-28-2007, EXPIRES 9-28-2022.

CLASS 5—PHARMACEUTICALS

FOR OSTOMY PRODUCTS, NAMELY, STOMA PASTE AND LIQUID DEODORANT FOR OSTOMY POUCHES (U.S. CLS. 6, 18, 44, 46, 51 AND 52).

FIRST USE 9-0-1999; IN COMMERCE 3-17-2000.

CLASS 10—MEDICAL APPARATUS

FOR OSTOMY PRODUCTS, NAMELY, HYDROCOLLOID SKIN BARRIER WAFERS AND HYDROCOLLOID OSTO SEALS FOR STOMAS AND OSTOMY POUCHES (U.S. CLS. 26, 39 AND 44).

FIRST USE 9-0-1999; IN COMMERCE 3-17-2000.

KATHERINE CHANG, EXAMINING ATTORNEY

SN 77-111,852. THE BANK OF NOVA SCOTIA, TORONTO, ONTARIO, CANADA, FILED 2-20-2007.

SCOTIA WATEROUS

THE MARK CONSISTS OF STANDARD CHARACTERS WITHOUT CLAIM TO ANY PARTICULAR FONT, STYLE, SIZE, OR COLOR.

OWNER OF U.S. REG. NO. 3,301,748.

CLASS 9—ELECTRICAL AND SCIENTIFIC APPARATUS

FOR COMPUTER SOFTWARE, NAMELY, COMPUTER SOFTWARE FOR ENTRANCE CONTROL AND CONTROLLING ACCESS OF VIRTUAL DATA ROOMS ; COMPUTER SOFTWARE FOR USE IN DATABASE MANAGEMENT, FOR USE AS A SPREADSHEET, AND FOR WORD PROCESSING IN THE FIELD OF INFORMATION AND ADVICE REGARDING MERGERS, ACQUISITIONS, PROMOTION, ANALYSIS, VALUATION, SALE AND PURCHASE OF ASSETS IN THE OIL AND GAS AND PIPELINES SECTORS (U.S. CLS. 21, 23, 26, 36 AND 38).

CLASS 35—ADVERTISING AND BUSINESS

FOR ADVERTISING, MARKETING AND PROMOTION OF FINANCIAL SERVICES ASSOCIATED WITH THE OIL AND GAS AND PIPELINES INDUSTRIES RELATING TO FINANCIAL SERVICES ASSOCIATED WITH MERGERS AND ACQUISITIONS AND WITH THE PROMOTION, ANALYSIS, VALUATION, SALE AND PURCHASE OF ASSETS IN THE OIL AND GAS AND PIPELINES SECTORS (U.S. CLS. 100, 101 AND 102).

CLASS 36—INSURANCE AND FINANCIAL

FOR FINANCIAL SERVICES, NAMELY, PROVIDING FINANCIAL INFORMATION, ANALYSIS, EVALUATION, ADVICE AND CONSULTANCY SERVICES IN RELATION TO MERGERS, ACQUISITIONS, VALUATIONS AND DIVESTITURES PERTAINING TO THE OIL AND GAS AND PIPELINES SECTORS; PROVISION OF SUCH FINANCIAL INFORMATION AND ADVICE ONLINE, VIA EMAIL, VIA VIRTUAL DATA ROOMS AND VIA COMPUTER NETWORKS (U.S. CLS. 100, 101 AND 102).

ELIZABETH KAJUBI, EXAMINING ATTORNEY

SN 77-111,862. THE BANK OF NOVA SCOTIA, TORONTO, ONTARIO, CANADA, FILED 2-20-2007.



OWNER OF U.S. REG. NO. 3,301,748.
THE MARK CONSISTS OF THE WORDS "SCOTIA WATEROUS" AND A STYLIZED "S" WITH A GLOBE IN THE CENTER.

CLASS 9—ELECTRICAL AND SCIENTIFIC APPARATUS

FOR COMPUTER SOFTWARE, NAMELY, COMPUTER SOFTWARE FOR ENTRANCE CONTROL AND CONTROLLING ACCESS TO VIRTUAL DATA ROOMS ; COMPUTER SOFTWARE FOR USE IN DATABASE MANAGEMENT, FOR USE AS A SPREADSHEET, AND FOR WORD PROCESSING IN THE FIELD OF INFORMATION AND ADVICE REGARDING MERGERS, ACQUISITIONS, PROMOTION, ANALYSIS, VALUATION, SALE AND PURCHASE OF ASSETS IN THE OIL AND GAS AND PIPELINES SECTORS (U.S. CLS. 21, 23, 26, 36 AND 38).

CLASS 35—ADVERTISING AND BUSINESS

FOR ADVERTISING, MARKETING AND PROMOTION OF FINANCIAL SERVICES ASSOCIATED WITH THE OIL AND GAS AND PIPELINES INDUSTRIES RELATING TO FINANCIAL SERVICES ASSOCIATED WITH MERGERS AND ACQUISITIONS AND WITH THE PROMOTION, ANALYSIS, VALUATION, SALE AND PURCHASE OF ASSETS IN THE OIL AND GAS AND PIPELINES SECTORS (U.S. CLS. 100, 101 AND 102).

CLASS 36—INSURANCE AND FINANCIAL

FOR FINANCIAL SERVICES, NAMELY, PROVIDING FINANCIAL INFORMATION, ANALYSIS, EVALUATION, ADVICE AND CONSULTANCY SERVICES IN RELATION TO MERGERS, ACQUISITIONS, VALUATIONS AND DIVESTITURES PERTAINING TO THE OIL AND GAS AND PIPELINES SECTORS; PROVISION OF SUCH FINANCIAL INFORMATION AND ADVICE ONLINE, VIA EMAIL, VIA VIRTUAL DATA ROOMS AND VIA COMPUTER NETWORKS (U.S. CLS. 100, 101 AND 102).

ELIZABETH KAJUBI, EXAMINING ATTORNEY

SN 77-112,918. ORANGE BROADBAND, CHARLOTTE, NC. FILED 2-21-2007.

BAJA BROADBAND

THE MARK CONSISTS OF STANDARD CHARACTERS WITHOUT CLAIM TO ANY PARTICULAR FONT, STYLE, SIZE, OR COLOR.

NO CLAIM IS MADE TO THE EXCLUSIVE RIGHT TO USE "BROADBAND", APART FROM THE MARK AS SHOWN.

CLASS 38—COMMUNICATION

FOR WIRELESS BROADBAND COMMUNICATION SERVICES; CABLE TELEVISION TRANSMISSION SERVICES; PROVIDING MULTIPLE-USER ACCESS TO A GLOBAL INFORMATION NETWORK, NAMELY, HIGH SPEED AND DIAL UP INTERNET ACCESS; MOBILE TELEPHONE COMMUNICATION SERVICES; LOCAL AND LONG DISTANCE TELEPHONE SERVICES (U.S. CLS. 100, 101 AND 104).

CLASS 42—SCIENTIFIC AND COMPUTER SERVICES

FOR WEB HOSTING SERVICES (U.S. CLS. 100 AND 101).

BENJAMIN ALLEN, EXAMINING ATTORNEY

SN 77-114,053. TRITON DISTRIBUTION SYSTEMS, INC., SAUSALITO, CA. FILED 2-22-2007.

TRITON TWIST

THE MARK CONSISTS OF STANDARD CHARACTERS WITHOUT CLAIM TO ANY PARTICULAR FONT, STYLE, SIZE, OR COLOR.

CLASS 9—ELECTRICAL AND SCIENTIFIC APPARATUS

FOR COMPUTER SOFTWARE FOR BUSINESSES TO CREATE AN ELECTRONIC CATALOG OF PRODUCTS AND SERVICES TO SEARCH, SHARE, EXCHANGE, MANAGE, DISTRIBUTE AND PROMOTE INFORMATION WITH EACH OTHER AND WITH CONSUMERS REGARDING AVAILABLE PRODUCTS AND SERVICES IN REAL TIME VIA A GLOBAL COMPUTER NETWORK; COMPUTER SOFTWARE FOR SEARCHING, VIEWING AND PURCHASING THIRD PARTY PRODUCTS AND SERVICES AND FOR SEARCHING AND VIEWING INFORMATION ON PRODUCTS AND SERVICES AVAILABLE FOR SALE (U.S. CLS. 21, 23, 26, 36 AND 38).

CLASS 42—SCIENTIFIC AND COMPUTER SERVICES

FOR ONLINE, NON-DOWNLOADABLE SOFTWARE FOR PROVIDING AVAILABILITY OF PRODUCTS AND SERVICES IN REAL TIME AND ACCESSIBLE VIA A GLOBAL COMPUTER NETWORK; PROVIDING ONLINE NON-DOWNLOADABLE SOFTWARE FOR SHARING, EXCHANGING, MANAGING, DISTRIBUTING AND PROMOTING INFORMATION ABOUT AVAILABLE THIRD PARTY PRODUCTS AND SERVICES, FOR USE BY BUSINESSES AND CONSUMERS (U.S. CLS. 100 AND 101).

REBECCA EISINGER, EXAMINING ATTORNEY

SN 77-114,055. TRITON DISTRIBUTION SYSTEMS, INC., SAUSALITO, CA. FILED 2-22-2007.

TRITON TRAVELER

THE MARK CONSISTS OF STANDARD CHARACTERS WITHOUT CLAIM TO ANY PARTICULAR FONT, STYLE, SIZE, OR COLOR.

CLASS 9—ELECTRICAL AND SCIENTIFIC APPARATUS

FOR COMPUTER SOFTWARE FOR BUSINESSES TO CREATE AN ELECTRONIC CATALOG OF PRODUCTS AND SERVICES TO SEARCH, SHARE, EXCHANGE, MANAGE, DISTRIBUTE AND PROMOTE INFORMATION WITH EACH OTHER AND WITH CONSUMERS REGARDING AVAILABLE PRODUCTS AND SERVICES IN REAL TIME VIA A GLOBAL COMPUTER NETWORK; COMPUTER SOFTWARE FOR SEARCHING, VIEWING AND PURCHASING THIRD PARTY PRODUCTS AND SERVICES AND FOR SEARCHING AND VIEWING INFORMATION ON PRODUCTS AND SERVICES AVAILABLE FOR SALE (U.S. CLS. 21, 23, 26, 36 AND 38).

CLASS 42—SCIENTIFIC AND COMPUTER SERVICES

FOR ONLINE, NON-DOWNLOADABLE SOFTWARE FOR PROVIDING AVAILABILITY OF PRODUCTS AND SERVICES IN REAL TIME AND ACCESSIBLE VIA A GLOBAL COMPUTER NETWORK; PROVIDING ONLINE NON-DOWNLOADABLE SOFTWARE FOR SHARING, EXCHANGING, MANAGING, DISTRIBUTING AND PROMOTING INFORMATION ABOUT AVAILABLE THIRD PARTY PRODUCTS AND SERVICES, FOR USE BY BUSINESSES AND CONSUMERS (U.S. CLS. 100 AND 101).

REBECCA EISINGER, EXAMINING ATTORNEY

SN 77-114,061. TRITON DISTRIBUTION SYSTEMS, INC., SAUSALITO, CA. FILED 2-22-2007.

RED DRAGON EXPRESS

THE MARK CONSISTS OF STANDARD CHARACTERS WITHOUT CLAIM TO ANY PARTICULAR FONT, STYLE, SIZE, OR COLOR.

CLASS 9—ELECTRICAL AND SCIENTIFIC APPARATUS

FOR COMPUTER SOFTWARE FOR BUSINESSES TO CREATE AN ELECTRONIC CATALOG OF PRODUCTS AND SERVICES TO SEARCH, SHARE, EXCHANGE, MANAGE, DISTRIBUTE AND PROMOTE INFORMATION WITH EACH OTHER AND WITH CONSUMERS REGARDING AVAILABLE PRODUCTS AND SERVICES IN REAL TIME VIA A GLOBAL COMPUTER NETWORK; COMPUTER SOFTWARE FOR SEARCHING, VIEWING AND PURCHASING THIRD PARTY PRODUCTS AND SERVICES AND FOR SEARCHING AND VIEWING INFORMATION ON PRODUCTS AND SERVICES AVAILABLE FOR SALE (U.S. CLS. 21, 23, 26, 36 AND 38).

CLASS 42—SCIENTIFIC AND COMPUTER SERVICES

FOR ONLINE, NON-DOWNLOADABLE SOFTWARE FOR PROVIDING AVAILABILITY OF PRODUCTS AND SERVICES IN REAL TIME AND ACCESSIBLE VIA A GLOBAL COMPUTER NETWORK; PROVIDING ONLINE NON-DOWNLOADABLE SOFTWARE FOR SHARING, EXCHANGING, MANAGING, DISTRIBUTING AND PROMOTING INFORMATION ABOUT AVAILABLE THIRD PARTY PRODUCTS AND SERVICES, FOR USE BY BUSINESSES AND CONSUMERS (U.S. CLS. 100 AND 101).

REBECCA EISINGER, EXAMINING ATTORNEY

SN 77-114,118. TRITON DISTRIBUTION SYSTEMS, INC., SAUSALITO, CA. FILED 2-22-2007.



THE MARK CONSISTS OF THE FORM OF A WAVE OR DOVE.

CLASS 9—ELECTRICAL AND SCIENTIFIC APPARATUS

FOR COMPUTER SOFTWARE FOR BUSINESSES TO CREATE AN ELECTRONIC CATALOG OF PRODUCTS AND SERVICES TO SEARCH, SHARE, EXCHANGE, MANAGE, DISTRIBUTE AND PROMOTE INFORMATION WITH EACH OTHER AND WITH CONSUMERS REGARDING AVAILABLE PRODUCTS AND SERVICES IN REAL TIME VIA A GLOBAL COMPUTER NETWORK; COMPUTER SOFTWARE FOR SEARCHING, VIEWING AND PURCHASING THIRD PARTY PRODUCTS AND SERVICES AND FOR SEARCHING AND VIEWING INFORMATION ON PRODUCTS AND SERVICES AVAILABLE FOR SALE (U.S. CLS. 21, 23, 26, 36 AND 38).

CLASS 42—SCIENTIFIC AND COMPUTER SERVICES

FOR ONLINE, NON-DOWNLOADABLE SOFTWARE FOR PROVIDING AVAILABILITY OF PRODUCTS AND SERVICES IN REAL TIME AND ACCESSIBLE VIA A GLOBAL COMPUTER NETWORK; PROVIDING ONLINE NON-DOWNLOADABLE SOFTWARE FOR SHARING, EXCHANGING, MANAGING, DISTRIBUTING AND PROMOTING INFORMATION ABOUT AVAILABLE THIRD PARTY PRODUCTS AND SERVICES, FOR USE BY BUSINESSES AND CONSUMERS (U.S. CLS. 100 AND 101).

REBECCA EISINGER, EXAMINING ATTORNEY

SN 77-114,120. TRITON DISTRIBUTION SYSTEMS, INC., SAUSALITO, CA. FILED 2-22-2007.



THE MARK CONSISTS OF A DRAGON SURROUNDED BY STARS WITHIN A CIRCLE.

CLASS 9—ELECTRICAL AND SCIENTIFIC APPARATUS

FOR COMPUTER SOFTWARE FOR BUSINESSES TO CREATE AN ELECTRONIC CATALOG OF PRODUCTS AND SERVICES TO SEARCH, SHARE, EXCHANGE, MANAGE, DISTRIBUTE AND PROMOTE INFORMATION WITH EACH OTHER AND WITH CONSUMERS REGARDING AVAILABLE PRODUCTS AND SERVICES IN REAL TIME VIA A GLOBAL COMPUTER NETWORK; COMPUTER SOFTWARE FOR SEARCHING, VIEWING AND PURCHASING THIRD PARTY PRODUCTS AND SERVICES AND FOR SEARCHING AND VIEWING INFORMATION ON PRODUCTS AND SERVICES AVAILABLE FOR SALE; COMPUTER SOFTWARE TO ALLOW TRAVEL AGENCIES TO CREATE TRAVEL ITINERARIES; COMPUTER SOFTWARE FOR SEARCHING AND VIEWING THIRD-PARTY TRAVEL SERVICES FOR USE BY BUSINESSES AND CONSUMERS; COMPUTER SOFTWARE THAT PROVIDES REAL-TIME, INTEGRATED TRAVEL SERVICES INTELLIGENCE BY COMBINING INFORMATION FROM VARIOUS TRAVEL SERVICE PROVIDERS AND PRESENTING IT IN AN EASY-TO-UNDERSTAND USER INTERFACE; COMPUTER SOFTWARE FOR CREATING SEARCHABLE DATABASES OF INFORMATION AND DATA IN THE FIELD OF TRAVEL SERVICES (U.S. CLS. 21, 23, 26, 36 AND 38).

CLASS 39—TRANSPORTATION AND STORAGE

FOR PROVIDING TRAVEL INFORMATION SERVICES VIA A DATABASE; PROVIDING INFORMATION ABOUT TRAVEL DESTINATIONS VIA A DATABASE; PROVIDING AN INTERACTIVE DATABASE IN THE FIELD OF TRAVEL, NAMELY, A DATABASE FOR BUSINESSES AND CONSUMERS IN THE TRAVEL INDUSTRY TO SEARCH, SHARE, EXCHANGE, MANAGE, DISTRIBUTE, PROMOTE AND BOOK AVAILABLE TRAVEL INVENTORY AND RESERVATIONS; TRAVEL INDUSTRY SERVICES, NAMELY, PROVIDING TRANSPORTATION BOOKING SERVICES FOR TRAVEL AGENTS, TOUR OPERATORS AND OTHER TRAVEL VENDORS THAT GIVES THE AGENTS ACCESS TO TRAVEL INVENTORY (U.S. CLS. 100 AND 105).

CLASS 42—SCIENTIFIC AND COMPUTER SERVICES

FOR ONLINE, NON-DOWNLOADABLE SOFTWARE FOR LISTING AVAILABILITY OF PRODUCTS AND SERVICES IN REAL TIME AND ACCESSIBLE VIA A GLOBAL COMPUTER NETWORK; PROVIDING ONLINE NON-DOWNLOADABLE SOFTWARE FOR SHARING, EXCHANGING, MANAGING, DISTRIBUTING AND PROMOTING INFORMATION ABOUT AVAILABLE THIRD PARTY PRODUCTS AND SERVICES, FOR USE BY BUSINESSES AND CONSUMERS (U.S. CLS. 100 AND 101).

REBECCA EISINGER, EXAMINING ATTORNEY

SN 77-114,389. CABELA'S INCORPORATED, SIDNEY, NE. FILED 2-23-2007.

TROPHY PROPERTIES

THE MARK CONSISTS OF STANDARD CHARACTERS WITHOUT CLAIM TO ANY PARTICULAR FONT, STYLE, SIZE, OR COLOR.

NO CLAIM IS MADE TO THE EXCLUSIVE RIGHT TO USE "PROPERTIES", APART FROM THE MARK AS SHOWN.

CLASS 35—ADVERTISING AND BUSINESS

FOR PROVIDING INFORMATION FOR HABITAT, LAKE AND TIMBER MANAGEMENT (U.S. CLS. 100, 101 AND 102).

FIRST USE 10-15-2004; IN COMMERCE 10-15-2004.

CLASS 42—SCIENTIFIC AND COMPUTER SERVICES

FOR LAND AND WATER MAPPING SERVICES (U.S. CLS. 100 AND 101).

FIRST USE 10-15-2004; IN COMMERCE 10-15-2004.
ROBIN CHOSID, EXAMINING ATTORNEY

SN 77-116,401. DTHC, INC., WILMINGTON, DE. FILED 2-26-2007.

DISCOVERY STUDIOS

SN 77-116,194. DONGGUAN KINGSUN OPTOELECTRONICS CO., LTD., DONGGUAN CITY, CHINA, FILED 2-26-2007.

GARDEN NATURALS

THE MARK CONSISTS OF STANDARD CHARACTERS WITHOUT CLAIM TO ANY PARTICULAR FONT, STYLE, SIZE, OR COLOR.

NO CLAIM IS MADE TO THE EXCLUSIVE RIGHT TO USE "GARDEN", APART FROM THE MARK AS SHOWN.

CLASS 6—METAL GOODS

FOR METAL TRELIS AND OBELISK; METAL FENCING AND GATES; METAL LANDSCAPE EDGING; METAL SHEPHERD'S HOOKS; METAL WALL BRACKETS AND HOOKS; METAL PLANT STAKES (U.S. CLS. 2, 12, 13, 14, 23, 25 AND 50).

CLASS 19—NON-METALLIC BUILDING MATERIALS

FOR NON-METAL TRELIS AND OBELISK; NON-METAL FENCING AND GATES (U.S. CLS. 1, 12, 33 AND 50).

CLASS 20—FURNITURE AND ARTICLES NOT OTHERWISE CLASSIFIED

FOR NON-METAL LANDSCAPE EDGING; NON-METAL SHEPHERD'S HOOKS; NON-METAL WALL BRACKETS AND HOOKS; NON-METAL HOSE REELS; NON-METAL HOSE GUIDES; NON-METAL HOSE HANGERS; NON-METAL HOSE BASKETS; PLANT STAND AND RACKS; NON-METAL PLANT STAKES; WIND CHIMES (U.S. CLS. 2, 13, 22, 25, 32 AND 50).

CLASS 21—HOUSEWARES AND GLASS

FOR PLANTERS FOR FLOWERS AND PLANTS (U.S. CLS. 2, 13, 23, 29, 30, 33, 40 AND 50).

CLASS 27—FLOOR COVERINGS

FOR DOOR MATS (U.S. CLS. 19, 20, 37, 42 AND 50).
MELVIN AXILBUND, EXAMINING ATTORNEY

THE MARK CONSISTS OF STANDARD CHARACTERS WITHOUT CLAIM TO ANY PARTICULAR FONT, STYLE, SIZE, OR COLOR.

NO CLAIM IS MADE TO THE EXCLUSIVE RIGHT TO USE "STUDIOS", APART FROM THE MARK AS SHOWN.

CLASS 9—ELECTRICAL AND SCIENTIFIC APPARATUS

FOR PRE-RECORDED VIDEO DISKS, AUDIO-VISUAL RECORDINGS, VIDEOTAPES, COMPACT DISKS, DVDS AND CD-ROMS, ALL ON THE SUBJECTS OF HISTORY, GEOGRAPHY, EXPLORATION, ARCHITECTURE, SCIENCE, TECHNOLOGY, POLITICS, NATURE, NATURAL HISTORY, CULTURE AND THE ARTS (U.S. CLS. 21, 23, 26, 36 AND 38).

CLASS 16—PAPER GOODS AND PRINTED MATTER

FOR POSTERS; POSTCARDS; MAPS; CALENDARS, NAMELY, DESK CALENDARS, WALL CALENDARS, DAILY CALENDARS; PHOTOGRAPHIC PRINTS; BOOKS AND MAGAZINES IN FIELDS OF GENERAL INTEREST AND EDUCATION; BOOKMARKS; CHILDREN'S ACTIVITY BOOKS; EDUCATIONAL ACTIVITY KITS COMPRISED OF CHILDREN'S BOOKS, CHILDREN'S ACTIVITY BOOKS AND/OR FLASH CARDS; DIARIES; PAPER NAPKINS (U.S. CLS. 2, 5, 22, 23, 29, 37, 38 AND 50).

CLASS 38—COMMUNICATION

FOR BROADCAST SERVICES, NAMELY, TRANSMISSION OF AUDIO-VISUAL CONTENT VIA TELEVISION, SATELLITE, WIRELESS, FIBER OPTICS, CABLE, RADIO AND A GLOBAL COMPUTER NETWORK (U.S. CLS. 100, 101 AND 104).

CLASS 41—EDUCATION AND ENTERTAINMENT

FOR ENTERTAINMENT SERVICES IN THE NATURE OF AUDIO-VISUAL PROGRAMS AND CONTENT, NAMELY, SHOWS ON THE SUBJECTS OF HISTORY, GEOGRAPHY, EXPLORATION, ARCHITECTURE, SCIENCE, TECHNOLOGY, POLITICS, NATURE, NATURAL HISTORY, CULTURE AND THE ARTS, DISTRIBUTED THROUGH AUDIO AND VIDEO MEDIA, NAMELY, TELEVISION, SATELLITE, WIRELESS, FIBER OPTICS, CABLE, RADIO AND A GLOBAL COMPUTER NETWORK; FILM PRODUCTION SERVICES; INFORMATION REGARDING AUDIO-VISUAL SHOWS ON THE SUBJECTS OF HISTORY, GEOGRAPHY, EXPLORATION, ARCHITECTURE, SCIENCE, TECHNOLOGY, POLITICS, NATURE, NATURAL HISTORY, CULTURE AND THE ARTS PROVIDED VIA A GLOBAL COMPUTER NETWORK (U.S. CLS. 100, 101 AND 107).
DANIEL CAPSHAW, EXAMINING ATTORNEY

SN 77-121,695. AURORA MEDICAL LLC, LANCASTER, PA.
FILED 3-3-2007.



NO CLAIM IS MADE TO THE EXCLUSIVE RIGHT TO USE "PAK MD", APART FROM THE MARK AS SHOWN. THE MARK CONSISTS OF A STYLIZED "R" AND FONT CONSISTING OF AN ALTERED VERSION OF MUTLU AND DF TEMPLE.

CLASS 9—ELECTRICAL AND SCIENTIFIC APPARATUS

FOR APPARATUS FOR RECORDING, TRANSMISSION OR REPRODUCTION OF SOUND AND IMAGES; APPARATUS FOR SPEECH RECORDING AND REPLAYING; VIDEO RECORDINGS FEATURING MEDICAL INSTRUCTIONS FROM PHYSICIANS AND PHARMACUETICAL INFORMATION (U.S. CLS. 21, 23, 26, 36 AND 38).

CLASS 44—MEDICAL, BEAUTY AND AGRICULTURAL SERVICES

FOR MAINTAINING FILES AND RECORDS CONCERNING THE MEDICAL CONDITION OF INDIVIDUALS (U.S. CLS. 100 AND 101).
DANIEL CAPSHAW, EXAMINING ATTORNEY

SN 77-122,574. ASSESSMENT TECHNOLOGIES INSTITUTE, L.L.C., STILWELL, KS. FILED 3-5-2007.

ATI TESTING

THE MARK CONSISTS OF STANDARD CHARACTERS WITHOUT CLAIM TO ANY PARTICULAR FONT, STYLE, SIZE, OR COLOR.

OWNER OF U.S. REG. NO. 3,091,102.
NO CLAIM IS MADE TO THE EXCLUSIVE RIGHT TO USE "TESTING", APART FROM THE MARK AS SHOWN.

CLASS 9—ELECTRICAL AND SCIENTIFIC APPARATUS

FOR DVDS FEATURING REVIEWS OF STANDARDIZED TESTS IN THE FIELDS OF NURSING AND RELATED HEALTH (U.S. CLS. 21, 23, 26, 36 AND 38).

CLASS 16—PAPER GOODS AND PRINTED MATTER

FOR TESTS AND MANUALS IN THE FIELDS OF NURSING AND RELATED HEALTH (U.S. CLS. 2, 5, 22, 23, 29, 37, 38 AND 50).

CLASS 41—EDUCATION AND ENTERTAINMENT

FOR EDUCATIONAL ADMISSION TESTING, TESTING REVIEW COURSES FOR STATE EXAMINATIONS AND ADMINISTRATIVE TESTING SERVICES IN THE FIELDS OF NURSING AND RELATED HEALTH (U.S. CLS. 100, 101 AND 107).

BARBARA BROWN, EXAMINING ATTORNEY

SN 77-122,799. SECONDS OUT PRODUCTIONS, LLC, NEW YORK, NY. FILED 3-5-2007.

TOM JONES

THE MARK CONSISTS OF STANDARD CHARACTERS WITHOUT CLAIM TO ANY PARTICULAR FONT, STYLE, SIZE, OR COLOR.

THE NAME(S), PORTRAIT(S), AND/OR SIGNATURE(S) SHOWN IN THE MARK IDENTIFIES "THOMAS J. WOODWARD", WHOSE CONSENT(S) TO REGISTER IS MADE OF RECORD.

CLASS 14—JEWELRY

FOR LEATHER PRODUCTS, NAMELY, LEATHER CHOKERS (U.S. CLS. 2, 27, 28 AND 50).
FIRST USE 7-1-2006; IN COMMERCE 7-1-2006.

CLASS 16—PAPER GOODS AND PRINTED MATTER

FOR PAPER PRODUCTS, NAMELY, PHOTOGRAPHS, POSTERS MADE OF PAPER, COLLECTOR'S PHOTOGRAPHS OF ONE OR MORE ENTERTAINERS, PHOTOGRAPHIC COLLECTIONS, PAPER DESIGNS PORTRAYING ENTERTAINER, PAPER PRINTS IN THE NATURE OF PHOTOGRAPHS; (BASED ON INTENT-TO-USE) PROGRAM BROCHURES FOR LIVE PERFORMANCES BY ONE OR MORE MUSICAL ARTISTS (U.S. CLS. 2, 5, 22, 23, 29, 37, 38 AND 50).
FIRST USE 7-1-2006; IN COMMERCE 7-1-2006.

CLASS 25—CLOTHING

FOR CLOTHING, NAMELY, SHORT-SLEEVED AND LONG-SLEEVED T-SHIRTS; SHIRTS (U.S. CLS. 22 AND 39).
FIRST USE 7-1-2006; IN COMMERCE 7-1-2006.
ALEX KEAM, EXAMINING ATTORNEY

SN 77-123,797. ALEXANDRIA REAL ESTATE EQUITIES, INC., PASADENA, CA. FILED 3-6-2007.

SN 77-125,921. WESTFIELD, LLC, LOS ANGELES, CA. FILED 3-8-2007.

ALEXANDRIA LIFE SCIENCE CENTER

THE MARK CONSISTS OF STANDARD CHARACTERS WITHOUT CLAIM TO ANY PARTICULAR FONT, STYLE, SIZE, OR COLOR.

OWNER OF U.S. REG. NOS. 2,300,322, 2,300,323 AND 2,792,374.

NO CLAIM IS MADE TO THE EXCLUSIVE RIGHT TO USE "LIFE SCIENCE CENTER", APART FROM THE MARK AS SHOWN.

CLASS 35—ADVERTISING AND BUSINESS

FOR BUSINESS ADMINISTRATION SERVICES; BUSINESS MANAGEMENT AND CONSULTATION; BUSINESS MANAGEMENT AND CONSULTING SERVICES; INCUBATOR SERVICES, NAMELY, BUSINESS MANAGEMENT SERVICES; RENTAL AND LEASING OF OFFICE MACHINERY AND EQUIPMENT (U.S. CLS. 100, 101 AND 102).

CLASS 36—INSURANCE AND FINANCIAL

FOR FINANCIAL SERVICES, NAMELY, FINANCIAL CONSULTATION, FINANCIAL ANALYSIS, FINANCIAL PLANNING, FINANCIAL MANAGEMENT, PROVIDING DEBT AND EQUITY CAPITAL, AND TANGIBLE AND INTANGIBLE ASSET FINANCING; INCUBATOR SERVICES, NAMELY, PROVIDING DEBT AND EQUITY FINANCING TO EMERGING AND START-UP COMPANIES; REAL ESTATE SERVICES, NAMELY, REAL ESTATE BROKERAGE, ACQUISITION, RENTAL, LEASING, AND MANAGEMENT SERVICES; ASSET MANAGEMENT SERVICES (U.S. CLS. 100, 101 AND 102).

CLASS 37—CONSTRUCTION AND REPAIR

FOR REAL ESTATE DEVELOPMENT SERVICES; BUILDING CONSTRUCTION AND REPAIR (U.S. CLS. 100, 103 AND 106).

CLASS 39—TRANSPORTATION AND STORAGE

FOR RENTAL OF WAREHOUSE SPACE (U.S. CLS. 100 AND 105).

CLASS 42—SCIENTIFIC AND COMPUTER SERVICES

FOR ARCHITECTURAL DESIGN; ENGINEERING; RENTAL AND LEASING OF COMPUTERS AND LABORATORY EQUIPMENT (U.S. CLS. 100 AND 101). COLLEEN DOMBROW, EXAMINING ATTORNEY

WESTFIELD KIDS

THE MARK CONSISTS OF STANDARD CHARACTERS WITHOUT CLAIM TO ANY PARTICULAR FONT, STYLE, SIZE, OR COLOR.

OWNER OF U.S. REG. NOS. 2,606,308, 3,129,895 AND OTHERS.

NO CLAIM IS MADE TO THE EXCLUSIVE RIGHT TO USE "KIDS" IN INTERNATIONAL CLASS 41, APART FROM THE MARK AS SHOWN.

CLASS 36—INSURANCE AND FINANCIAL

FOR SHOPPING MALL SERVICES, NAMELY, LEASING AND OPERATING REAL PROPERTY MARKETPLACES, NAMELY, SHOPPING MALL SPACE FOR SELLERS AND CONSUMERS OF GOODS AND SERVICES AND FAMILY DINING AREAS (U.S. CLS. 100, 101 AND 102).

CLASS 41—EDUCATION AND ENTERTAINMENT

FOR PROVIDING RECREATIONAL AREAS IN THE NATURE OF CHILDREN'S PLAY AREAS; CONDUCTING EDUCATIONAL EXHIBITS IN THE FIELDS OF SCIENCE, TRAVEL, HISTORY, AND CULTURE AT SHOPPING CENTERS; PROVIDING ENTERTAINMENT AND AMUSEMENT CENTERS, NAMELY, CHILDREN'S INTERACTIVE PLAY AREAS AT SHOPPING CENTERS (U.S. CLS. 100, 101 AND 107).

CLASS 45—PERSONAL AND LEGAL SERVICES

FOR CONCIERGE SERVICES FOR SHOPPING CENTER PATRONS, NAMELY, PROVIDING DIRECTIONS, TELEPHONE NUMBERS, STROLLERS, WHEELCHAIRS AND SHOPPING BAGS FOR SHOPPING CENTER PATRONS (U.S. CLS. 100 AND 101).

ANNE FARRELL, EXAMINING ATTORNEY

SN 77-126,188. BASICGREY, LLC, KAYSVILLE, UT. FILED 3-8-2007.



THE MARK CONSISTS OF A WHITE STYLIZED LETTER "G" WITHIN A BLACK SQUARE BOX IN A WHITE SQUARE BOX.

CLASS 16—PAPER GOODS AND PRINTED MATTER

FOR PRINTED MATTER, NAMELY, BOOKS, MAGAZINES AND NEWSLETTERS, PAMPHLETS, BROCHURES IN THE FIELD OF WOMEN'S INTERESTS, CRAFTS, HOME DÉCOR, SCRAPBOOKING, FABRIC, QUILTING, SEWING, AND CHILDREN'S INTERESTS; COLORING BOOKS, AND CALENDARS; SCRAPBOOKING, CRAFT AND ARTISTIC MATERIALS, NAMELY, BINDERS, STICKERS, APPLIQUES IN THE FORM OF DECALS; PAPER-BASED ADHESIVE PRODUCTS, NAMELY, PAPER AND CARDSTOCK STICKERS, EPOXY STICKERS, DIE-CUT CHIPBOARD STICKERS, ADHESIVES FOR STATIONERY PURPOSES, SCRAPBOOKS, BLANK WRITING JOURNALS, PHOTO ALBUMS; BOOK PLATES, MAGNETIC TACKS; PAPER, NAMELY, DECORATIVE CRAFT PAPER, CARDSTOCK, AND WRAPPING PAPER; PLASTIC MATERIALS, NAMELY, INK STAMPS, PAPER DIE-CUT LETTERS, NUMBERS AND SHAPES, PAPER HOLE PUNCHES; CUTTING MATS, STRAIGHT EDGES, HEAT TRANSFER PAPER, SELF-ADHESIVE PAPER, RUB-ONS, CLEAR INK STAMPS, RUBBER INK STAMPS, STENCILS, PAINT BRUSHES AND APPLICATORS, DOCUMENT PORTFOLIOS, DOCUMENT FILES, PHOTO MOUNTING CORNERS, AND PAPER DRAWING TEMPLATES; PAPER PRESERVATION PRODUCTS, NAMELY, ALBUMS, PAGE PROTECTORS; STATIONERY, NAMELY, ENVELOPES, GREETING CARDS, AND PRINTED ANNOUNCEMENTS, WRITING INSTRUMENTS; AND DECORATIVE WALL DECALS (U.S. CLS. 2, 5, 22, 23, 29, 37, 38 AND 50).

CLASS 24—FABRICS

FOR BED SHEETS, MATTRESS PADS, CHAIR PADS, PILLOW CASES, SHAMS, COMFORTERS, QUILTS, BED SHEETS, DUST RUFFLES, DUVET COVERS, COMFORTER COVERS, BLANKETS, TROWS, AFGHANS, TOWELS, POT HOLDERS, DISH CLOTHS, TABLE CLOTHS, CLOTH NAPKINS, TEXTILE PLACE MATS, UNFITTED FABRIC FURNITURE COVERS, SHOWER CURTAINS; FABRIC WINDOW TREATMENTS, NAMELY, CURTAINS, FABRIC SHADES, CURTAIN VALANCES, DRAPERIES, DECORATIVE FABRICS, NAMELY, COTTON FABRICS, WOOL FABRICS, LINEN FABRICS, POLYESTER FABRICS, POLYESTER BLENDS FABRICS, SILK FABRICS (U.S. CLS. 42 AND 50).

CLASS 27—FLOOR COVERINGS

FOR WALL COVERINGS, NAMELY, WALLPAPER AND DECORATIVE BORDERS; FLOOR COVERINGS, NAMELY, AREA RUGS (U.S. CLS. 19, 20, 37, 42 AND 50).
DEZMONA MIZELLE, EXAMINING ATTORNEY

SN 77-126,380. PANINT ENTERPRISES LIMITED, HONG KONG, HONG KONG, FILED 3-9-2007.

DK PRODUCTS LLC

THE MARK CONSISTS OF STANDARD CHARACTERS WITHOUT CLAIM TO ANY PARTICULAR FONT, STYLE, SIZE, OR COLOR.

NO CLAIM IS MADE TO THE EXCLUSIVE RIGHT TO USE "PRODUCTS LLC", APART FROM THE MARK AS SHOWN.

CLASS 7—MACHINERY

FOR PAINT SPRAYER (U.S. CLS. 13, 19, 21, 23, 31, 34 AND 35).

CLASS 8—HAND TOOLS

FOR ELECTRIC MANICURE SETS (U.S. CLS. 23, 28 AND 44).

CLASS 9—ELECTRICAL AND SCIENTIFIC APPARATUS

FOR OUTLET CIRCUIT TESTER; HOME PHONE ALARM (U.S. CLS. 21, 23, 26, 36 AND 38).

CLASS 11—ENVIRONMENTAL CONTROL APPARATUS

FOR NON-MEDICAL UV LAMP FOR MANICURING NAILS; ELECTRIC COFFEE MAKER; ELECTRIC FOOD HYDRATOR; TEMPERATURE CONTROL HEAT GUN; WAX WARMERS, HEATED WAXING SPAS, PARAFFIN BATHS (U.S. CLS. 13, 21, 23, 31 AND 34).

CLASS 21—HOUSEWARES AND GLASS

FOR PET GROOMING DEVICE COMPRISING A BUILT-IN BRUSH HEAD AND AN ATTACHMENT THAT CONNECTS TO VACUUMS (U.S. CLS. 2, 13, 23, 29, 30, 33, 40 AND 50).

CURTIS FRENCH, EXAMINING ATTORNEY

SN 77-126,851. UNIVERSAL MALLS, INC., FREDERICK, MD. FILED 3-9-2007.

ANTIQUÉ UNIVERSE

THE MARK CONSISTS OF STANDARD CHARACTERS WITHOUT CLAIM TO ANY PARTICULAR FONT, STYLE, SIZE, OR COLOR.

NO CLAIM IS MADE TO THE EXCLUSIVE RIGHT TO USE "ANTIQUÉ", APART FROM THE MARK AS SHOWN.

CLASS 35—ADVERTISING AND BUSINESS

FOR PROVIDING SPACE FOR OTHERS ON A WEBSITE FOR THE PURPOSE OF ADVERTISING, SELLING AND LOCATING ANTIQUES (U.S. CLS. 100, 101 AND 102).

CLASS 42—SCIENTIFIC AND COMPUTER SERVICES

FOR WEBSITE DESIGN SERVICES (U.S. CLS. 100 AND 101).

RICHARD A. STRASER, EXAMINING ATTORNEY

SN 77-127,950. HIGHWINDS NETWORK GROUP, INC., WINTER PARK, FL. FILED 3-12-2007.

HIGHWINDS

THE MARK CONSISTS OF STANDARD CHARACTERS WITHOUT CLAIM TO ANY PARTICULAR FONT, STYLE, SIZE, OR COLOR.

CLASS 38—COMMUNICATION

FOR AUDIO AND VIDEO BROADCASTING SERVICES OVER THE INTERNET OR OTHER COMMUNICATIONS NETWORK, NAMELY, ELECTRONICALLY TRANSMITTING INFORMATION, AUDIO AND VIDEO CONTENT; PROVIDING MULTIPLE USE ACCESS TO GLOBAL COMPUTER INFORMATION NETWORKS, NAMELY, WEBSITES, ON-LINE FORUMS, CHAT ROOMS, LIST-SERVERS AND BLOGS, FOR THE TRANSFER AND DISSEMINATION OF A WIDE RANGE OF INFORMATION; PROVIDING ON-LINE CHAT ROOMS AND ELECTRONIC BULLETIN BOARDS FOR TRANSMISSION OF MESSAGES AMONG USERS IN THE FIELD OF GENERAL INTEREST (U.S. CLS. 100, 101 AND 104).

CLASS 41—EDUCATION AND ENTERTAINMENT

FOR EDUCATION AND ENTERTAINMENT SERVICES, NAMELY, PROVIDING A WEBSITE FEATURING INFORMATION, NEWS, AUDIO CLIPS, VIDEO CLIPS AND COMMENTARY IN THE FIELD OF ENTERTAINMENT, MUSICAL PERFORMANCES, MUSICAL VIDEOS, FILM CLIPS, PHOTOGRAPHS, AND OTHER MULTIMEDIA MATERIALS; ON-LINE JOURNALS, NAMELY, BLOGS FEATURING INFORMATION IN THE FIELD OF GENERAL INTEREST, AUDIO CLIPS, VIDEO CLIPS, MUSICAL PERFORMANCES, MUSICAL VIDEOS, FILM CLIPS, PHOTOGRAPHS, AND OTHER MULTIMEDIA MATERIALS (U.S. CLS. 100, 101 AND 107).

CLASS 42—SCIENTIFIC AND COMPUTER SERVICES

FOR APPLICATION SERVICE PROVIDER (ASP) FEATURING SOFTWARE TO ENABLE UPLOADING, POSTING, SHOWING, DISPLAYING, TAGGING, BLOGGING, SHARING OR OTHERWISE PROVIDING ELECTRONIC MEDIA OR INFORMATION OVER THE INTERNET OR OTHER COMMUNICATIONS NETWORK (U.S. CLS. 100 AND 101).

SKYE YOUNG, EXAMINING ATTORNEY

CLASS 7—MACHINERY

FOR ENGINES OTHER THAN FOR LAND VEHICLES, NAMELY, ENGINES FOR AIRCRAFT, AIR TURBINES, JET ENGINES, TURBOJET ENGINES, TURBO-PROP ENGINES, TURBOCHARGERS FOR AIRCRAFT ENGINES, ENGINES FOR TRAINING AIRCRAFT, ENGINES FOR MISSILES, AND ENGINES FOR HELICOPTERS; TRANSMISSION AND PROPULSION COUPLINGS FOR AIRCRAFT ENGINES; SOLAR-POWERED ELECTRICITY GENERATORS; FUEL-POWERED ELECTRICITY GENERATORS; PUMPING AND COMPRESSION GROUPS, NAMELY, PUMP UNITS PROVIDING GAS UNDER PRESSURE FOR ENGINES USED IN THE AERONAUTICAL FIELD; PUMP FEED MOTORS, COMPRESSORS FOR ELECTRICITY GENERATORS AND AUXILIARY POWER UNITS FOR AIRCRAFT; COGENERATION PLANTS, NAMELY, AUXILIARY POWER UNITS FOR SUPPLYING ELECTRICAL POWER TO HEAT AND POWER GENERATORS (U.S. CLS. 13, 19, 21, 23, 31, 34 AND 35).

CLASS 12—VEHICLES

FOR APPARATUS FOR LOCOMOTION BY LAND, AIR OR WATER, NAMELY, HELICOPTERS, AIRCRAFT, AND LAND VEHICLES; ENGINES FOR LAND VEHICLES (U.S. CLS. 19, 21, 23, 31, 35 AND 44).

CLASS 37—CONSTRUCTION AND REPAIR

FOR TECHNICAL ASSISTANCE IN THE NATURE OF REPAIR, REVISION, MAINTENANCE SERVICING AND MAINTENANCE FOR ALL ENGINES USED ON AIRCRAFT, HELICOPTERS AND IN THE RAILWAY AND NAVAL FIELDS, AND CONSTITUENT PARTS AND FITTINGS THEREFOR; OVERHAULING AND REPLACEMENT INSTALLATION OF ENGINES AND ENGINES UNITS AND ACCESSORIES USED ON AIRCRAFTS, HELICOPTERS, AUXILIARY POWER GROUPS IN THE INDUSTRIAL, RAILWAY AND NAVAL FIELDS; 24-HOURS A DAY, 7-DAYS A WEEK ASSISTANCE SERVICE IN THE REPAIR, REVISION, RECONDITIONING, MAINTENANCE AND STANDARD REPLACEMENT INSTALLATION OF ENGINES AND ENGINE UNITS; REPAIR, REVISION, SERVICING AND MAINTENANCE IN SITU FOR AIRCRAFT ENGINES AND CONSTITUENT PARTS AND FITTINGS THEREFOR (U.S. CLS. 100, 103 AND 106).

SN 77-132,909. TURBOMECA, CEDEX, FRANCE, FILED 3-16-2007.

UPLIFTING EXPERIENCE

THE MARK CONSISTS OF STANDARD CHARACTERS WITHOUT CLAIM TO ANY PARTICULAR FONT, STYLE, SIZE, OR COLOR.

PRIORITY CLAIMED UNDER SEC. 44(D) ON FRANCE APPLICATION NO. 063464937, FILED 11-23-2006, REG. NO. 063464937, DATED 11-23-2006, EXPIRES 11-23-2016.

CLASS 42—SCIENTIFIC AND COMPUTER SERVICES

FOR STUDY OF TECHNICAL PROJECTS, NAMELY, TECHNICAL CONSULTATION IN THE FIELD OF AERONAUTIC ENGINEERING; FLIGHT TESTS FOR AIRCRAFT, HELICOPTERS, AND MISSILES; ENGINE TESTS, NAMELY, PROVIDING SERVICES INTENDED TO TEST THE CORRECT OPERATION AND RELIABILITY OF THESE GOODS; PRODUCT RESEARCH AND DEVELOPMENT IN THE FIELD OF AIRCRAFT AND HELICOPTER ENGINES, AND IN THE FIELD OF AUXILIARY POWER GROUPS IN THE INDUSTRIAL, RAILWAY LOCOMOTIVE, RAILWAY TRAIN AND NAVAL FIELDS; ENGINEERING SERVICES (U.S. CLS. 100 AND 101).

MARK RADEMACHER, EXAMINING ATTORNEY

SN 77-134,127. SURVEILLANCE DATA INC., PLYMOUTH MEETING, PA. FILED 3-19-2007.

SN 77-137,480. HAPPY ZEPPOLE, L.L.C., WEST ORANGE, NJ. FILED 3-22-2007.

AllergyAlert

OWNER OF U.S. REG. NO. 2,610,786.
THE MARK CONSISTS OF THE WORDS "ALLERGY ALERT" IN A STYLIZED FONT.

CLASS 16—PAPER GOODS AND PRINTED MATTER

FOR PRINTED RESEARCH REPORTS FEATURING RESEARCH IN THE FIELD OF DISEASES (U.S. CLS. 2, 5, 22, 23, 29, 37, 38 AND 50).

CLASS 42—SCIENTIFIC AND COMPUTER SERVICES

FOR RESEARCH IN THE FIELD OF DISEASES (U.S. CLS. 100 AND 101).
MARK T. MULLEN, EXAMINING ATTORNEY

SN 77-136,990. LAS VEGAS SANDS CORP., LAS VEGAS, NV. FILED 3-21-2007.

SANDS

THE MARK CONSISTS OF STANDARD CHARACTERS WITHOUT CLAIM TO ANY PARTICULAR FONT, STYLE, SIZE, OR COLOR.
OWNER OF U.S. REG. NO. 1,209,102.

CLASS 43—HOTEL AND RESTAURANT SERVICES

FOR HOTEL, RESTAURANT, BAR SERVICES, CATERING SERVICES, PROVIDING FACILITIES FOR CONVENTIONS, BANQUETS, SOCIAL FUNCTIONS, FUND RAISING AND SPECIAL EVENTS (U.S. CLS. 100 AND 101).

CLASS 45—PERSONAL AND LEGAL SERVICES

FOR HOTEL CONCIERGE SERVICES; SECURITY GUARD SERVICES (U.S. CLS. 100 AND 101).
G. MAYERSCHOFF, EXAMINING ATTORNEY

HAPPY ZEPPOLE!

THE MARK CONSISTS OF STANDARD CHARACTERS WITHOUT CLAIM TO ANY PARTICULAR FONT, STYLE, SIZE, OR COLOR.
NO CLAIM IS MADE TO THE EXCLUSIVE RIGHT TO USE "ZEPPOLE", APART FROM THE MARK AS SHOWN.

CLASS 25—CLOTHING

FOR CLOTHING, NAMELY, SHIRTS, T-SHIRTS, SWEATSHIRTS, HEADWEAR (U.S. CLS. 22 AND 39).

CLASS 30—STAPLE FOODS

FOR DOUGH-BASED POCKETS WITH FILLING CONSISTING PRIMARILY OF MEAT; DOUGH-BASED POCKETS WITH FILLING CONSISTING PRIMARILY OF POULTRY; DOUGH-BASED POCKETS WITH FILLING CONSISTING PRIMARILY OF FISH; DOUGH-BASED POCKETS WITH FILLING CONSISTING PRIMARILY OF FRUIT; DOUGH-BASED POCKETS WITH FILLING CONSISTING PRIMARILY OF VEGETABLES; DOUGH-BASED POCKETS WITH FILLING CONSISTING PRIMARILY OF CHEESE; DOUGH-BASED POCKETS WITH FILLING CONSISTING PRIMARILY OF CHOCOLATE; DOUGH-BASED POCKETS WITH COMBINATIONS OF SELECTED FILLINGS, NAMELY, POULTRY, FISH, FRUIT, VEGETABLES, CHEESE, AND CHOCOLATE; DIPPING SAUCES; PASTRIES; CROUTONS (U.S. CL. 46).

CLASS 43—HOTEL AND RESTAURANT SERVICES

FOR RESTAURANT SERVICES (U.S. CLS. 100 AND 101).
DEZMONA MIZELLE, EXAMINING ATTORNEY

SN 77-138,390. WEISBERG, CHANG, SAN DIMAS, CA. FILED 3-23-2007.



OWNER OF U.S. REG. NO. 3,052,465.
THE MARK CONSISTS OF THE WORDS "ROCK THE BELLS" IN A CASCADING LAYOUT OF ORIGINAL RETRO-STYLIZED LETTERING, WITH THE WORDS "ROCK THE" ON TOP OF THE WORD "BELLS".

CLASS 16—PAPER GOODS AND PRINTED MATTER

FOR (BASED ON USE IN COMMERCE) SOUVENIR MERCHANDISE RELATED TO A LIVE MUSICAL CONCERT FESTIVAL AND TOUR, NAMELY, SOUVENIR PROGRAM GUIDES, NON-FICTION BOOKS AND NON-FICTION PHOTO BOOKS; 2-DIMENSIONAL AND 3-DIMENSIONAL PICTURES AND PHOTOGRAPHS OF ARTIST AND PERFORMERS ON TOUR WITH THE FESTIVAL, NAMELY, PICTURES, PHOTOGRAPHS, ART PRINTS, COLOR PRINTS AND EVENT ALBUMS; POSTERS; PAPER BANNERS; STICKERS; CALENDARS; TOUR SCHEDULES, NAMELY, PRINTED INFORMATIONAL CARDS FEATURING A LIST OF LIVE CONCERT PERFORMANCE DATES FOR A LIVE MUSICAL FESTIVAL AND TOUR; TRADING CARDS; NOTEBOOKS; TEMPORARY TATTOOS; CATALOGS IN THE FIELD OF LIVE MUSICAL FESTIVAL AND TOUR SOUVENIR PRODUCTS; MAGAZINES FEATURING INFORMATION ABOUT AND INTERVIEWS WITH MUSICAL PERFORMERS IN A LIVE MUSICAL FESTIVAL AND TOUR AND INFORMATION ABOUT A LIVE MUSICAL FESTIVAL AND TOUR (U.S. CLS. 2, 5, 22, 23, 29, 37, 38 AND 50).

FIRST USE 12-26-2003; IN COMMERCE 12-26-2003.

CLASS 25—CLOTHING

FOR (BASED ON USE IN COMMERCE) MEN'S, WOMEN'S, AND CHILDREN'S CLOTHING, NAMELY, T-SHIRTS, TANK TOPS, SWEATERS, SWEATSHIRTS, SWEAT PANTS, JERSEYS, JACKETS, CAPS, SHIRTS, BANDANAS AND OTHER HEADWEAR, UNDERWEAR AND LOUNGE WEAR (U.S. CLS. 22 AND 39).

FIRST USE 12-26-2003; IN COMMERCE 12-26-2003.

CLASS 38—COMMUNICATION

FOR (BASED ON INTENT TO USE) STREAMING OF AUDIO AND VIDEO MATERIAL ON THE INTERNET (U.S. CLS. 100, 101 AND 104).

AMY MCMENAMIN, EXAMINING ATTORNEY

SN 77-139,389. ATLAS BARBER SCHOOL INC., NEW YORK, NY. FILED 3-23-2007.



ATLAS
BARBER
SCHOOL

NO CLAIM IS MADE TO THE EXCLUSIVE RIGHT TO USE "BARBER SCHOOL", APART FROM THE MARK AS SHOWN.

THE COLOR(S) RED, WHITE AND BLUE IS/ARE CLAIMED AS A FEATURE OF THE MARK.

THE MARK CONSISTS OF THE WORDING "ATLAS BARBER SCHOOL" IN BLUE AND IN ALL CAPITAL LETTERS WITH "ATLAS" AND "BARBER" UNDERLINED IN RED NEXT TO A BARBER POLE WITH SLANTED STRIPES ALTERNATING RED, WHITE, BLUE, WHITE AND RED.

CLASS 8—HAND TOOLS

FOR (BASED ON INTENT TO USE) SCISSORS; CASES FOR RAZORS; ELECTRIC RAZORS; RAZOR BLADES; RAZOR CASES; RAZOR STROPS; SAFETY RAZORS; STRAIGHT RAZORS (U.S. CLS. 23, 28 AND 44).

CLASS 16—PAPER GOODS AND PRINTED MATTER

FOR (BASED ON INTENT TO USE) EDUCATIONAL PUBLICATIONS, NAMELY, EDUCATIONAL LEARNING CARDS, FLASH CARDS, ACTIVITY CARDS, WORKBOOKS, TEXTBOOKS, ACTIVITY BOOKS, STORY BOOKS, PUZZLE BOOKS, PUZZLES, TEACHER GUIDES, MANUALS, POSTERS, EDUCATIONAL CARD GAMES AND EDUCATIONAL BOOKLETS IN THE FIELD OF BARBERING (U.S. CLS. 2, 5, 22, 23, 29, 37, 38 AND 50).

CLASS 41—EDUCATION AND ENTERTAINMENT

FOR (BASED ON USE IN COMMERCE) EDUCATION SERVICES, NAMELY, PROVIDING CLASSES, SEMINARS AND TUTORIALS IN THE FIELD OF BARBERING (U.S. CLS. 100, 101 AND 107).

FIRST USE 12-1-1948; IN COMMERCE 12-1-1948.

CLASS 44—MEDICAL, BEAUTY AND AGRICULTURAL SERVICES

FOR (BASED ON INTENT TO USE) BARBERING SERVICES (U.S. CLS. 100 AND 101).

DANIEL CAPSHAW, EXAMINING ATTORNEY

SN 77-139,428. MOZES, INC., PALO ALTO, CA. FILED 3-23-2007.

I AM MOBILE

THE MARK CONSISTS OF STANDARD CHARACTERS WITHOUT CLAIM TO ANY PARTICULAR FONT, STYLE, SIZE, OR COLOR.

CLASS 38—COMMUNICATION

FOR TELECOMMUNICATION SERVICES IN THE NATURE OF DIGITAL CONTENT COMMUNICATION, AND DATA COMMUNICATION SERVICES, NAMELY, TRANSMISSION OF ELECTRONIC DATA VIA ELECTRONIC MAIL, SHORT MESSAGE SERVICE ("SMS"), TEXT MESSAGING, TELEPHONE VOICE MESSAGING, AND THE INTERNET VIA COMPUTER NETWORKS (U.S. CLS. 100, 101 AND 104).

CLASS 42—SCIENTIFIC AND COMPUTER SERVICES

FOR PROVIDING TEMPORARY USE OF ONLINE NON-DOWNLOADABLE COMMUNICATION SERVICES SOFTWARE FOR USE IN CONNECTING, SENDING, RECEIVING, SEARCHING, COMPILING, INDEXING, AND ORGANIZING DIGITAL CONTENT AND DATA BETWEEN ELECTRONIC DEVICES AND/OR COMPUTER NETWORKS VIA EMAIL, SHORT MESSAGE SERVICE ("SMS"), TEXT MESSAGING, INSTANT MESSAGING, VOICE MESSAGING, AND COMPUTER NETWORKS, INCLUDING THE INTERNET (U.S. CLS. 100 AND 101).

LINDA POWELL, EXAMINING ATTORNEY

SN 77-145,830. ADAM MISHCON, COCONUT GROVE, FL.
FILED 4-2-2007.

SN 77-148,262. BGL, INC., LOS ANGELES, CA. FILED 4-4-2007.

weird  stranger

PETTUBE

THE MARK CONSISTS OF ARTWORK CONSISTING OF THREE EYES, IN BETWEEN THE WORDS "WEIRD" AND "STRANGER".

THE MARK CONSISTS OF STANDARD CHARACTERS WITHOUT CLAIM TO ANY PARTICULAR FONT, STYLE, SIZE, OR COLOR.

CLASS 25—CLOTHING

FOR SHIRTS (U.S. CLS. 22 AND 39).

CLASS 25—CLOTHING

FOR CLOTHING, NAMELY, T-SHIRTS, SWEAT-SHIRTS, JERSEYS, SHORTS, SWEAT PANTS, JACKETS, JEANS, HATS AND CAPS (U.S. CLS. 22 AND 39).

CLASS 28—TOYS AND SPORTING GOODS

FOR PLUSH TOYS; MODELED PLASTIC TOY FIGURINES (U.S. CLS. 22, 23, 38 AND 50).
REGINA DRUMMOND, EXAMINING ATTORNEY

CLASS 41—EDUCATION AND ENTERTAINMENT

FOR ENTERTAINMENT SERVICES, NAMELY, PROVIDING A WEBSITE FEATURING VIDEO PRESENTATIONS FEATURING PETS (U.S. CLS. 100, 101 AND 107).
STEVEN R. FOSTER, EXAMINING ATTORNEY

SN 77-146,350. WESTFIELD, LLC, LOS ANGELES, CA.
FILED 4-2-2007.

SN 77-148,317. VIRGINIA COBIA FARMS LLC, RICHMOND, VA. FILED 4-4-2007.

WESTFIELD BLUE SKIES

THE MARK CONSISTS OF STANDARD CHARACTERS WITHOUT CLAIM TO ANY PARTICULAR FONT, STYLE, SIZE, OR COLOR.
OWNER OF U.S. REG. NOS. 2,606,308, 3,129,895 AND OTHERS.



CLASS 36—INSURANCE AND FINANCIAL

FOR SHOPPING MALL SERVICES, NAMELY, LEASING AND OPERATING REAL PROPERTY MARKETPLACES, NAMELY, SHOPPING MALL SPACE, FOR SELLERS AND CONSUMERS OF GOODS AND SERVICES AND FAMILY DINING AREAS (U.S. CLS. 100, 101 AND 102).

NO CLAIM IS MADE TO THE EXCLUSIVE RIGHT TO USE "VIRGINIA COBIA FARMS", APART FROM THE MARK AS SHOWN.

THE MARK CONSISTS OF IN PART A DEPICTION OF STYLIZED FISH AND THE WORDS "VIRGINIA COBIA FARMS".

CLASS 41—EDUCATION AND ENTERTAINMENT

FOR PROVIDING RECREATIONAL AREAS IN THE NATURE OF CHILDREN'S PLAY AREAS; CONDUCTING EDUCATIONAL EXHIBITS IN THE FIELDS OF SCIENCE, TRAVEL, HISTORY AND CULTURE AT SHOPPING CENTERS; PROVIDING ENTERTAINMENT AND AMUSEMENT AREAS, NAMELY, CHILDREN'S INTERACTIVE PLAY AREAS AT SHOPPING CENTERS (U.S. CLS. 100, 101 AND 107).

CLASS 29—MEATS AND PROCESSED FOODS

FOR FISH (U.S. CL. 46).

CLASS 45—PERSONAL AND LEGAL SERVICES

FOR CONCIERGE SERVICES FOR SHOPPING CENTER PATRONS, NAMELY, PROVIDING DIRECTIONS, TELEPHONE NUMBERS, STROLLERS, WHEELCHAIRS AND SHOPPING BAGS FOR SHOPPING CENTER PATRONS (U.S. CLS. 100 AND 101).
ANNE FARRELL, EXAMINING ATTORNEY

CLASS 31—NATURAL AGRICULTURAL PRODUCTS

FOR LIVE FISH FOR FOOD PURPOSES (U.S. CLS. 1 AND 46).
ANGELA M. MICHELI, EXAMINING ATTORNEY

SN 77-149,719. APOC RESTAURANT, INC., NEW YORK, NY.
FILED 4-5-2007.



OWNER OF U.S. REG. NOS. 1,210,093 AND 1,280,161.
THE MARK CONSISTS OF THE WORD "COPACABANA"
BENEATH THE FANCIFUL IMAGE OF A WOMAN WEAR-
ING LIPSTICK, A LARGE EARRING, AND A TURBAN
CONTAINING FRUITS, LEAVES AND A RIBBON.

**CLASS 41—EDUCATION AND ENTERTAIN-
MENT**

FOR CABARET SERVICES (U.S. CLS. 100, 101 AND
107).
FIRST USE 12-31-1976; IN COMMERCE 12-31-1976.

**CLASS 43—HOTEL AND RESTAURANT SER-
VICES**

FOR RESTAURANT AND BAR SERVICES (U.S. CLS.
100 AND 101).
FIRST USE 12-31-1976; IN COMMERCE 12-31-1976.
TAMARA FRAZIER, EXAMINING ATTORNEY

SN 77-152,567. LIVING NATURE LIMITED, KERIKERI,
NEW ZEALAND, FILED 4-10-2007.

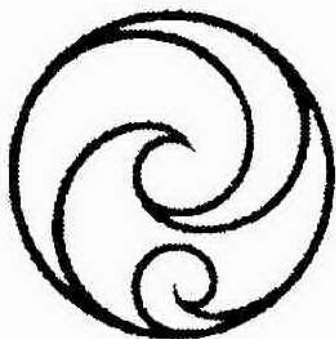

THE MARK CONSISTS OF A ROUNDEL.

**CLASS 3—COSMETICS AND CLEANING PRE-
PARATIONS**

FOR SOAPS FOR BODY CARE, PERFUMERY, ESSEN-
TIAL OILS, COSMETICS, HAIR LOTIONS, DENTI-
FRICES, NON-MEDICATED TOILETRIES, NON-
MEDICATED SKIN CARE PREPARATIONS (U.S. CLS.
1, 4, 6, 50, 51 AND 52).

CLASS 35—ADVERTISING AND BUSINESS

FOR WHOLESALE AND RETAIL STORES FEATUR-
ING SOAPS, PERFUMERY, ESSENTIAL OILS, COS-
METICS, HAIR LOTIONS, DENTIFRICES, TOILETRIES,
SKIN CARE PREPARATIONS (U.S. CLS. 100, 101 AND
102).

HANNO RITTNER, EXAMINING ATTORNEY

SN 77-152,772. LABORATOIRES ARKOPHARMA, CARROS
CEDEX, FRANCE, FILED 4-10-2007.



THE MARK CONSISTS OF THE WORDING "PLANTE
SYSTEM COMPLEXE VEGETAL P.E.S." INSIDE A WHITE
SQUARE. A SMALL BOX WITH LEAVES APPEARS ABOVE
THE WORD "PLANTE".

THE ENGLISH TRANSLATION OF THE WORD "PLANTE
SYSTEM COMPLEXE VEGETAL" IN THE MARK IS PLANT
SYSTEM COMPLEX PLANT.

**CLASS 3—COSMETICS AND CLEANING PRE-
PARATIONS**

FOR COSMETICS, NON-MEDICATED SKIN SOAPS,
PERFUMERY AND NON-MEDICATED SKIN CARE
PREPARATIONS (U.S. CLS. 1, 4, 6, 50, 51 AND 52).
FIRST USE 4-0-2002; IN COMMERCE 3-0-2003.

CLASS 5—PHARMACEUTICALS

FOR NUTRITIONAL SUPPLEMENTS; PHARMACEU-
TICAL PREPARATIONS, NAMELY, ANTIDEPRES-
SANTS, ANTITUSSIVE COLD PREPARATIONS, DIET
CAPSULES, DIET PILLS, DIETARY DRINKS MIX FOR
USE AS A MEAL REPLACEMENT, NUTRITIONAL
DRINK MIX FOR USE AS A MEAL REPLACEMENT,
APPETITE SUPPRESSANTS; DIETARY SUPPLEMENTS
(U.S. CLS. 6, 18, 44, 46, 51 AND 52).

FIRST USE 4-0-2002; IN COMMERCE 3-0-2003.
HOWARD SMIGA, EXAMINING ATTORNEY

SN 77-154,977. MICHAEL SKLOVSKY, WHEELING, IL.
FILED 4-12-2007.

KGBEATS

THE MARK CONSISTS OF STANDARD CHARACTERS
WITHOUT CLAIM TO ANY PARTICULAR FONT, STYLE,
SIZE, OR COLOR.

CLASS 9—ELECTRICAL AND SCIENTIFIC APPARATUS

FOR COMPACT DISCS FEATURING MUSIC; MUSICAL RECORDINGS DOWNLOADABLE VIA THE INTERNET; PRE-RECORDED COMPACT DISCS, RECORDS FEATURING MUSIC; SOUND RECORDINGS (U.S. CLS. 21, 23, 26, 36 AND 38).

FIRST USE 11-1-2001; IN COMMERCE 11-1-2001.

CLASS 41—EDUCATION AND ENTERTAINMENT

FOR ENTERTAINMENT SERVICES, NAMELY, PRESENTATION OF LIVE MUSICAL PERFORMANCES BY MUSICIANS, DISC JOCKEYS; PRESENTATION OF PRE-RECORDED MUSIC VIA THE INTERNET; PRESENTATION OF PRE-RECORDED MUSIC BY MUSICIANS, DISC JOCKEYS IN LIVE MUSIC CONCERTS AND VIA THE INTERNET; PRODUCTION OF MUSICAL RECORDINGS; MUSIC PRODUCTION SERVICES; PLANNING AND ARRANGING OF MUSICAL CONCERTS; PRODUCTION OF LIVE MUSICAL CONCERTS AND SHOWS (U.S. CLS. 100, 101 AND 107).

FIRST USE 5-26-1993; IN COMMERCE 5-26-1993.
DANNEAN HETZEL, EXAMINING ATTORNEY

SN 77-156,280. GLENWILD COMMUNITY ASSOCIATION, INC., PARK CITY, UT. FILED 4-13-2007.



OWNER OF U.S. REG. NO. 2,470,414.
THE MARK CONSISTS OF A STYLIZED VERSION OF THE MARK "GLENWILD" USING A FLOWER IN THE PLACE OF THE "L".

SN 77-155,534. NUTRAMARKS, INC., PARK CITY, UT. FILED 4-12-2007.

ALLVIA

THE MARK CONSISTS OF STANDARD CHARACTERS WITHOUT CLAIM TO ANY PARTICULAR FONT, STYLE, SIZE, OR COLOR.

CLASS 3—COSMETICS AND CLEANING PREPARATIONS

FOR COSMETIC, NON-MEDICATED TOPICAL SKIN CREAM, MOISTURIZERS, GELS AND LOTIONS FOR FACE AND BODY; SKIN CLEANSING CREAMS AND LIQUIDS (U.S. CLS. 1, 4, 6, 50, 51 AND 52).

FIRST USE 6-1-2001; IN COMMERCE 6-1-2001.

CLASS 5—PHARMACEUTICALS

FOR NUTRITIONAL SUPPLEMENTS; HERBAL SUPPLEMENTS; MINERAL SUPPLEMENTS; VITAMINS; VITAMIN SUPPLEMENTS; DIETARY FOOD SUPPLEMENTS; AND MEDICINAL CREAMS FOR SKIN CARE (U.S. CLS. 6, 18, 44, 46, 51 AND 52).

FIRST USE 6-1-2001; IN COMMERCE 6-1-2001.
HEATHER THOMPSON, EXAMINING ATTORNEY

CLASS 16—PAPER GOODS AND PRINTED MATTER

FOR PAPER; PRINTED MATTER, NAMELY, SCORE CARDS; PRINTED PUBLICATIONS, NAMELY, GOLF COURSE GUIDES; NEWSLETTERS, CATALOGUES AND BROCHURES IN THE FIELD OF HOME BUILDING, COMMUNITY LIVING, TENNIS, GOLF AND HEALTH SPAS (U.S. CLS. 2, 5, 22, 23, 29, 37, 38 AND 50).

FIRST USE 8-1-2001; IN COMMERCE 8-1-2001.

CLASS 18—LEATHER GOODS

FOR TRAVEL BAGS; DUFFEL BAGS (U.S. CLS. 1, 2, 3, 22 AND 41).

FIRST USE 8-1-2001; IN COMMERCE 8-1-2001.

CLASS 25—CLOTHING

FOR CLOTHING, NAMELY, SHIRTS, T-SHIRTS, SPORT SHIRTS, JACKETS AND LIGHTWEIGHT WIND-RESISTANT JACKETS, HATS, SWEATERS AND SWEAT-SHIRTS, GOLF SHOES; HEADBANDS, VISORS, WALLETS AND WATERPROOF CLOTHING, NAMELY, SHIRTS, JACKETS, HATS, AND VISORS (U.S. CLS. 22 AND 39).

FIRST USE 8-1-2001; IN COMMERCE 8-1-2001.

CLASS 28—TOYS AND SPORTING GOODS

FOR SPORTING GOODS, NAMELY, GOLF GLOVES, GOLF BALLS, GOLF BAGS, GOLF BAG COVERS, GOLF BAG TAGS, HEAD COVERS FOR GOLF CLUBS, GOLF BALL MARKERS, GOLF ACCESSORY POUCHES, GOLF FLAGS, GOLF BALL MARKERS, DIVOT REPAIR TOOLS, AND NON-MOTORIZED GOLF CLUB CARTS (U.S. CLS. 22, 23, 38 AND 50).

FIRST USE 8-1-2001; IN COMMERCE 8-1-2001.

CLASS 35—ADVERTISING AND BUSINESS

FOR ASSOCIATION SERVICES, NAMELY, PROMOTING THE INTERESTS OF HOMEOWNERS THAT RESIDE IN A COMMUNITY; RETAIL GOLF AND TENNIS STORE SERVICES (U.S. CLS. 100, 101 AND 102).

FIRST USE 1-1-2003; IN COMMERCE 1-1-2003.

CLASS 41—EDUCATION AND ENTERTAINMENT

FOR PROVIDING TENNIS COURT FACILITIES; GOLF COURSES AND INSTRUCTIONS; HEALTH CLUBS SERVICES, NAMELY, PROVIDING INSTRUCTION AND EQUIPMENT IN THE FIELD OF PHYSICAL EXERCISE; PHYSICAL FITNESS FACILITIES AND INSTRUCTION; COUNTRY CLUBS; ENTERTAINMENT, NAMELY, PROVIDING GOLF TOURNAMENTS; COUNTRY CLUB SERVICES, NAMELY, PROVIDING FACILITIES FOR GOLF; ENTERTAINMENT SERVICES, NAMELY, ORGANIZING AND CONDUCTING GOLF TOURNAMENTS; GOLF CLUB SERVICES AND GOLF FACILITIES, NAMELY, PROVIDING GOLF COURSES; PROVIDING HEALTH CLUB FACILITIES, NAMELY, PHYSICAL FITNESS FACILITIES; PROVIDING INSTRUCTION IN THE FIELD OF PHYSICAL EXERCISE; RENTAL OF GOLF EQUIPMENT; PROVIDING RECREATIONAL FACILITIES IN THE NATURE OF CHILDREN'S PLAY AREAS AND POOLS; ARRANGING AND PROVIDING FACILITIES FOR RECREATIONAL ACTIVITIES, NAMELY, INFORMAL COMMUNITY FESTIVALS AND SPORTING TOURNAMENTS; PROVIDING RECREATIONAL OPEN SPACES; ENTERTAINMENT IN THE NATURE OF VISUAL ARTS PERFORMANCES OR LITERARY PERFORMANCES FOR EDUCATIONAL OR ENTERTAINMENT PURPOSES; HEALTH CLUB SERVICES, NAMELY, PROVIDING INSTRUCTION AND EQUIPMENT IN THE FIELD OF PHYSICAL EXERCISE; PROVIDING FACILITIES FOR OUTDOOR RECREATIONAL ACTIVITIES, NAMELY, HIKING, BIKING, JOGGING AND FISHING; PROVIDING VARIOUS FACILITIES FOR AN ARRAY OF SPORTING EVENTS, SPORTS AND ATHLETIC COMPETITIONS; PHYSICAL FITNESS INSTRUCTION; AND PROVIDING FITNESS AND EXERCISE FACILITIES (U.S. CLS. 100, 101 AND 107).

FIRST USE 8-1-2001; IN COMMERCE 8-1-2001.

CLASS 43—HOTEL AND RESTAURANT SERVICES

FOR RESTAURANT, BAR AND COCKTAIL LOUNGE SERVICES (U.S. CLS. 100 AND 101).

FIRST USE 1-16-2002; IN COMMERCE 1-16-2002.

CLASS 44—MEDICAL, BEAUTY AND AGRICULTURAL SERVICES

FOR HEALTH SPA SERVICES FOR HEALTH AND WELLNESS OF BODY AND SPIRIT OFFERED AT A HEALTH RESORT; HEALTH SPA SERVICE, NAMELY, COSMETIC BODY CARE SERVICES; PROVIDING HEALTH SPA FACILITIES, NAMELY, PROVIDING MASSAGE THERAPY AND COSMETIC SKIN AND FULL BODY CARE TREATMENTS (U.S. CLS. 100 AND 101).

FIRST USE 1-16-2002; IN COMMERCE 1-16-2002.
BERNICE MIDDLETON, EXAMINING ATTORNEY

SN 77-156,289, GLENWILD COMMUNITY ASSOCIATION, INC., PARK CITY, UT. FILED 4-13-2007.

GLENWILD

THE MARK CONSISTS OF STANDARD CHARACTERS WITHOUT CLAIM TO ANY PARTICULAR FONT, STYLE, SIZE, OR COLOR.

OWNER OF U.S. REG. NO. 2,470,414.

CLASS 16—PAPER GOODS AND PRINTED MATTER

FOR PAPER; PRINTED MATTER, NAMELY, SCORE CARDS; PRINTED PUBLICATIONS, NAMELY, GOLF COURSE GUIDES; NEWSLETTERS, CATALOGUES AND BROCHURES IN THE FIELD OF HOME BUILDING, COMMUNITY LIVING, TENNIS, GOLF AND HEALTH SPAS (U.S. CLS. 2, 5, 22, 23, 29, 37, 38 AND 50).
FIRST USE 8-1-2001; IN COMMERCE 8-1-2001.

CLASS 18—LEATHER GOODS

FOR TRAVEL BAGS; DUFFEL BAGS (U.S. CLS. 1, 2, 3, 22 AND 41).

FIRST USE 8-1-2001; IN COMMERCE 8-1-2001.

CLASS 25—CLOTHING

FOR CLOTHING, NAMELY, SHIRTS, T-SHIRTS, SPORT SHIRTS, JACKETS AND LIGHTWEIGHT WIND-RESISTANT JACKETS, HATS, SWEATERS AND SWEAT-SHIRTS, GOLF SHOES; HEADBANDS, VISORS, WALLETS AND WATERPROOF CLOTHING, NAMELY, SHIRTS, JACKETS, HATS, AND VISORS (U.S. CLS. 22 AND 39).

FIRST USE 8-1-2001; IN COMMERCE 8-1-2001.

CLASS 28—TOYS AND SPORTING GOODS

FOR SPORTING GOODS, NAMELY, GOLF GLOVES, GOLF BALLS, GOLF BAGS, GOLF BAG COVERS, GOLF BAG TAGS, HEAD COVERS FOR GOLF CLUBS, GOLF BALL MARKERS, GOLF ACCESSORY POUCHES, GOLF FLAGS, GOLF BALL MARKERS, DIVOT REPAIR TOOLS, AND NON-MOTORIZED GOLF CLUB CARTS (U.S. CLS. 22, 23, 38 AND 50).

FIRST USE 8-1-2001; IN COMMERCE 8-1-2001.

CLASS 35—ADVERTISING AND BUSINESS

FOR ASSOCIATION SERVICES, NAMELY, PROMOTING THE INTERESTS OF HOMEOWNERS THAT RESIDE IN A COMMUNITY; RETAIL GOLF AND TENNIS STORE SERVICES (U.S. CLS. 100, 101 AND 102).

FIRST USE 1-1-2003; IN COMMERCE 1-1-2003.

CLASS 41—EDUCATION AND ENTERTAINMENT

FOR PROVIDING TENNIS COURT FACILITIES; GOLF COURSES AND INSTRUCTIONS; HEALTH CLUBS SERVICES, NAMELY, PROVIDING INSTRUCTION AND EQUIPMENT IN THE FIELD OF PHYSICAL EXERCISE; PHYSICAL FITNESS FACILITIES AND INSTRUCTION; COUNTRY CLUBS; ENTERTAINMENT, NAMELY, PROVIDING GOLF TOURNAMENTS; COUNTRY CLUB SERVICES, NAMELY, PROVIDING FACILITIES FOR GOLF; ENTERTAINMENT SERVICES, NAMELY, ORGANIZING AND CONDUCTING GOLF TOURNAMENTS; GOLF CLUB SERVICES AND GOLF FACILITIES, NAMELY, PROVIDING GOLF COURSES; PROVIDING HEALTH CLUB FACILITIES, NAMELY, PHYSICAL FITNESS FACILITIES; PROVIDING INSTRUCTION IN THE FIELD OF PHYSICAL EXERCISE; RENTAL OF GOLF EQUIPMENT; PROVIDING RECREATIONAL FACILITIES IN THE NATURE OF CHILDREN'S PLAY AREAS AND POOLS; ARRANGING AND PROVIDING FACILITIES FOR RECREATIONAL ACTIVITIES, NAMELY, INFORMAL COMMUNITY FESTIVALS AND SPORTING TOURNAMENTS; PROVIDING RECREATIONAL OPEN SPACES; ENTERTAINMENT IN THE NATURE OF VISUAL ARTS PERFORMANCES OR LITERARY PERFORMANCES FOR EDUCATIONAL OR ENTERTAINMENT PURPOSES; HEALTH CLUB SERVICES, NAMELY, PROVIDING INSTRUCTION AND EQUIPMENT IN THE FIELD OF PHYSICAL EXERCISE; PROVIDING FACILITIES FOR OUTDOOR RECREATIONAL ACTIVITIES, NAMELY, HIKING, BIKING, JOGGING AND FISHING; PROVIDING VARIOUS FACILITIES FOR AN ARRAY OF SPORTING EVENTS, SPORTS AND ATHLETIC COMPETITIONS; PHYSICAL FITNESS INSTRUCTION; AND PROVIDING FITNESS AND EXERCISE FACILITIES (U.S. CLS. 100, 101 AND 107).

FIRST USE 8-1-2001; IN COMMERCE 8-1-2001.

CLASS 43—HOTEL AND RESTAURANT SERVICES

FOR RESTAURANT, BAR AND COCKTAIL LOUNGE SERVICES (U.S. CLS. 100 AND 101).

FIRST USE 1-16-2002; IN COMMERCE 1-16-2002.

CLASS 44—MEDICAL, BEAUTY AND AGRICULTURAL SERVICES

FOR HEALTH SPA SERVICES FOR HEALTH AND WELLNESS OF BODY AND SPIRIT OFFERED AT A HEALTH RESORT; HEALTH SPA SERVICE, NAMELY, COSMETIC BODY CARE SERVICES; PROVIDING HEALTH SPA FACILITIES, NAMELY, PROVIDING MASSAGE THERAPY AND COSMETIC SKIN AND FULL BODY CARE TREATMENTS (U.S. CLS. 100 AND 101).

FIRST USE 1-16-2002; IN COMMERCE 1-16-2002.
BERNICE MIDDLETON, EXAMINING ATTORNEY

SN 77-157,940. MATERIALS PROCESSING CORPORATION, EAGAN, MN. FILED 4-16-2007.



THE COLOR(S) GREEN IS/ARE CLAIMED AS A FEATURE OF THE MARK.

THE MARK CONSISTS OF A LOWERCASE "E" SURROUNDED BY THREE ARROWS IN THE SHAPE OF A CIRCLE FOLLOWED BY "CYCLING THE FUTURE", ALL IN THE COLOR GREEN.

CLASS 35—ADVERTISING AND BUSINESS

FOR REMARKETING SERVICES, NAMELY, REMARKETING ELECTRONIC COMPONENTS OF OTHERS (U.S. CLS. 100, 101 AND 102).

FIRST USE 1-18-2007; IN COMMERCE 2-15-2007.

CLASS 40—MATERIAL TREATMENT

FOR RECYCLING SERVICES, NAMELY, ELECTRONIC EQUIPMENT RECYCLING; PRECIOUS METALS RECLAMATION SERVICES (U.S. CLS. 100, 103 AND 106).

FIRST USE 1-18-2007; IN COMMERCE 2-15-2007.

KAREN SEVERSON, EXAMINING ATTORNEY

SN 77-160,577. LABORATOIRE OENOBIOL, PARIS, FRANCE, FILED 4-19-2007.

OENOBIOL

THE MARK CONSISTS OF STANDARD CHARACTERS WITHOUT CLAIM TO ANY PARTICULAR FONT, STYLE, SIZE, OR COLOR.

OWNER OF FRANCE REG. NO. 1464375, DATED 5-10-1988, EXPIRES 12-17-2016.

CLASS 3—COSMETICS AND CLEANING PREPARATIONS

FOR COSMETICS; PREPARATIONS TO THE SKIN, EYES, OR HAIR FOR COSMETIC PURPOSES, NAMELY, SKIN LOTIONS, HAIR LOTIONS, SKIN CONDITIONERS, HAIR CONDITIONERS, HAIR SPRAY, EYELINERS, SKIN GELS AND SKIN LOTIONS FOR ACCELERATING TANS, WRINKLE-REDUCING SKIN CARE PREPARATIONS AND SKIN CREAMS FOR REDUCING WATER AND LIPIDS IN THE LIMBS (U.S. CLS. 1, 4, 6, 50, 51 AND 52).

CLASS 5—PHARMACEUTICALS

FOR NUTRITIONAL SUPPLEMENTS FOR COSMETIC, MEDICAL AND THERAPEUTIC PURPOSES; NUTRITIONAL SUPPLEMENTS INCORPORATING PROTEINS, GLUCIDS, LIPIDS AND FIBERS FOR COSMETIC, MEDICAL AND THERAPEUTIC PURPOSES; NUTRITIONAL SUPPLEMENTS INCORPORATING MICRONUTRIENTS, VITAMINS, MINERALS, AMINO ACIDS, FATTY ACIDS AND VEGETAL ACIDS FOR COSMETIC, MEDICAL AND THERAPEUTIC PURPOSES; DIETETIC PRODUCTS, NAMELY, DIURETIC PREPARATIONS IN LIQUID AND CAPSULE FORM; HEALTH FOOD SUPPLEMENTS; DIETARY SUPPLEMENTS FOR NON-MEDICAL USE (U.S. CLS. 6, 18, 44, 46, 51 AND 52).

AHSEN KHAN, EXAMINING ATTORNEY

SN 77-163,303. PACKETVIDEO CORPORATION, SAN DIEGO, CA. FILED 4-23-2007.

EMILY

THE MARK CONSISTS OF STANDARD CHARACTERS WITHOUT CLAIM TO ANY PARTICULAR FONT, STYLE, SIZE, OR COLOR.

CLASS 9—ELECTRICAL AND SCIENTIFIC APPARATUS

FOR CONSUMER ELECTRONICS DEVICES, SUITABLE FOR USE BY WOMEN, FOR ORGANIZING, RECEIVING, TRANSMITTING, MANIPULATING, AND REVIEWING TEXT, DATA, AND MEDIA FILES, NAMELY, MOBILE PHONES AND MEDIA PLAYERS (U.S. CLS. 21, 23, 26, 36 AND 38).

CLASS 38—COMMUNICATION

FOR COMMUNICATION SERVICES FOR WOMEN IN THE NATURE OF ELECTRONIC TRANSMISSION OF TEXT, DATA AND MEDIA CONTENT; STREAMING OF AUDIO AND VIDEO MATERIAL ON THE INTERNET (U.S. CLS. 100, 101 AND 104).

RUDY R. SINGLETON, EXAMINING ATTORNEY

SN 77-163,379. KAPLAN, LEON, LOS ANGELES, CA. FILED 4-23-2007.

MOTORMAN

THE MARK CONSISTS OF STANDARD CHARACTERS WITHOUT CLAIM TO ANY PARTICULAR FONT, STYLE, SIZE, OR COLOR.

OWNER OF U.S. REG. NO. 1,807,461.

CLASS 7—MACHINERY

FOR AUTOMOTIVE TRUCK AND AUTOMOBILE VEHICLE EQUIPMENT, NAMELY, CAR LIFTS, TOOLS, NAMELY, POWER TOOLS FOR HYDRAULIC AUTOMOTIVE BODY AND FRAME REPAIR, NAMELY, HOISTS, POWER JACKS AND POWERED TIRE CHANGER MACHINES FOR LAND VEHICLES (U.S. CLS. 13, 19, 21, 23, 31, 34 AND 35).

CLASS 41—EDUCATION AND ENTERTAINMENT

FOR ENTERTAINMENT SERVICES, NAMELY, ONGOING RADIO AND TELEVISION PROGRAMS IN THE FIELD OF INTERNAL COMBUSTION ENGINES AND AUTOMOBILES (U.S. CLS. 100, 101 AND 107).

CARYN GLASSER, EXAMINING ATTORNEY

SN 77-164,668. ANTS SOFTWARE INC., BURLINGAME, CA. FILED 4-24-2007.



OWNER OF U.S. REG. NO. 2,669,412.

NO CLAIM IS MADE TO THE EXCLUSIVE RIGHT TO USE "SOFTWARE", APART FROM THE MARK AS SHOWN.

THE COLOR(S) BLUE, GRAY, AND WHITE IS/ARE CLAIMED AS A FEATURE OF THE MARK.

THE MARK CONSISTS OF THE WORDING "ANTS SOFTWARE" IN THE COLOR BLUE, A STYLIZED VERSION OF AN ANT IN THE COLOR GRAY SURROUNDED BY A CURVED LINE IN THE COLOR BLUE, ALL ON A WHITE BACKGROUND.

CLASS 9—ELECTRICAL AND SCIENTIFIC APPARATUS

FOR COMPUTER SOFTWARE FOR USE IN THE DESIGN, DEVELOPMENT, AND MANAGEMENT OF DATABASES; COMPUTER SOFTWARE FOR INTEROPERATING WITH DATABASE SERVER SOFTWARE; COMPUTER SOFTWARE FOR MIGRATING DATA AND METADATA AMONG DATABASES AND DATABASE SERVERS; COMPUTER SOFTWARE FOR PROCESSING DATABASE SQL SYNTAX AND STORED PROCEDURE LANGUAGES (U.S. CLS. 21, 23, 26, 36 AND 38).

FIRST USE 5-8-2003; IN COMMERCE 5-8-2003.

CLASS 42—SCIENTIFIC AND COMPUTER SERVICES

FOR PROFESSIONAL COMPUTER CONSULTATION SERVICES RELATED TO MIGRATING APPLICATIONS AMONG DATABASES AND DATABASE SERVERS (U.S. CLS. 100 AND 101).

ZHALEH DELANEY, EXAMINING ATTORNEY

SN 77-164,675. ANTS SOFTWARE INC., BURLINGAME, CA. FILED 4-24-2007.

ANTS

THE MARK CONSISTS OF STANDARD CHARACTERS WITHOUT CLAIM TO ANY PARTICULAR FONT, STYLE, SIZE, OR COLOR.

OWNER OF U.S. REG. NO. 2,669,412.

CLASS 9—ELECTRICAL AND SCIENTIFIC APPARATUS

FOR COMPUTER SOFTWARE FOR USE IN THE DESIGN, DEVELOPMENT, AND MANAGEMENT OF DATABASES; COMPUTER SOFTWARE FOR INTEROPERATING WITH DATABASE SERVER SOFTWARE; COMPUTER SOFTWARE FOR MIGRATING DATA AND METADATA AMONG DATABASES AND DATABASE SERVERS; COMPUTER SOFTWARE FOR PROCESSING DATABASE SQL SYNTAX AND STORED PROCEDURE LANGUAGES (U.S. CLS. 21, 23, 26, 36 AND 38).

FIRST USE 4-18-2002; IN COMMERCE 4-18-2002.

CLASS 42—SCIENTIFIC AND COMPUTER SERVICES

FOR PROFESSIONAL COMPUTER CONSULTATION SERVICES RELATED TO MIGRATING APPLICATIONS AMONG DATABASES AND DATABASE SERVERS (U.S. CLS. 100 AND 101).

ZHALEH DELANEY, EXAMINING ATTORNEY

SN 77-164,964. ADVENTITY BPO INDIA PVT. LTD, MUMBAI, INDIA, FILED 4-25-2007.

SN 77-166,934. ECHOSTAR SATELLITE LLC, ENGLEWOOD, CO. FILED 4-26-2007.

ADVENTITY

THE MARK CONSISTS OF STANDARD CHARACTERS WITHOUT CLAIM TO ANY PARTICULAR FONT, STYLE, SIZE, OR COLOR.

CLASS 35—ADVERTISING AND BUSINESS

FOR BUSINESS PROCESS OUTSOURCING SERVICES IN THE FIELD OF BANKING, FINANCE, INSURANCE, CREDIT CARDS, INVESTMENT BANKING, PRIVATE EQUITY, HEDGE FUNDS, COLLECTIONS AND MORTGAGES; MANAGEMENT OF AN AIRLINE COMPANY; TRAVEL MANAGEMENT FOR OTHERS; CUSTOMER RELATIONSHIP MANAGEMENT; MANAGEMENT OF TELEPHONE CALL CENTERS FOR OTHERS; TRANSACTION PROCESSING, NAMELY, ELECTRONIC PROCESSING OF ORDERS FOR OTHERS; CUSTOMER ACQUISITIONS, NAMELY, BUSINESS MARKETING SERVICES FEATURING CUSTOMER ACQUISITION PROGRAMS; CUSTOMER CARE, NAMELY, CUSTOMER RELATIONSHIP MANAGEMENT, CUSTOMER SERVICES IN THE FIELD OF ENSURING THE QUALITY OF SERVICES AND PRODUCTS PROVIDED TO CONSUMERS; RECEIVABLES MANAGEMENT, NAMELY, ACCOUNTS RECEIVABLE SERVICES; BUSINESS RESEARCH, AND ANALYTICS; BUSINESS MANAGEMENT SERVICES FOR OTHERS IN THE FIELD OF BANKING, FINANCE, INSURANCE, CREDIT CARDS, INVESTMENT BANKING, PRIVATE EQUITY, HEDGE FUNDS, COLLECTIONS AND MORTGAGES; BUSINESS KNOWLEDGE PROCESS OUTSOURCING SERVICES IN THE FIELD OF BANKING, INVESTMENT BANKING, FINANCE, PRIVATE EQUITY, HEDGE FUNDS, MORTGAGES, INSURANCE, DATABASE BUILDING, DATA MINING AND LEGAL SERVICES (U.S. CLS. 100, 101 AND 102).

FIRST USE 12-22-2003; IN COMMERCE 1-9-2004.

CLASS 36—INSURANCE AND FINANCIAL

FOR CLAIMS PROCESSING, NAMELY, PROCESSING OF CREDIT CARD TRANSACTIONS AND PAYMENT DATA; COLLECTIONS, NAMELY, COLLECTION OF DEBTS, DEBT RECOVERY AND COLLECTION AGENCIES; RECEIVABLES MANAGEMENT, NAMELY, ACCOUNTS RECEIVABLES FINANCING; FINANCIAL RESEARCH AND ANALYTICS; FINANCIAL CONSULTATION IN THE NATURE OF PROVIDING FINANCIAL MODELS (U.S. CLS. 100, 101 AND 102).

FIRST USE 12-22-2003; IN COMMERCE 1-9-2004.

CLASS 45—PERSONAL AND LEGAL SERVICES

FOR LEGAL SERVICES; LEGAL RELATED SERVICES, NAMELY, LEGAL DOCUMENT PREPARATION, RESEARCH SERVICES FOR ATTORNEYS, LITIGATION SUPPORT SERVICES IN THE NATURE OF LITIGATION CODING, LITIGATION SUPPORT, AND INTELLECTUAL PROPERTY DOCUMENT FILING SERVICES (U.S. CLS. 100 AND 101).

B. PARADEWELAI, EXAMINING ATTORNEY



OWNER OF U.S. REG. NOS. 2,075,565, 3,264,300 AND OTHERS.

NO CLAIM IS MADE TO THE EXCLUSIVE RIGHT TO USE "U" FOR CLASS 35 AND 41, APART FROM THE MARK AS SHOWN.

THE MARK CONSISTS OF A STYLIZED LETTER "U" WITH THE WORD "DISH" INSIDE OF IT.

SEC. 2(F) AS TO "DISH".

CLASS 35—ADVERTISING AND BUSINESS

FOR PROVIDING ON-LINE REGISTRATION SERVICES FOR INSTRUCTIONAL CLASSES (U.S. CLS. 100, 101 AND 102).

CLASS 38—COMMUNICATION

FOR AUDIO AND VIDEO BROADCASTING SERVICES OVER THE INTERNET; STREAMING OF VIDEO MATERIAL ON THE INTERNET; COMPUTER AIDED TRANSMISSION OF INFORMATION AND IMAGES OVER THE INTERNET (U.S. CLS. 100, 101 AND 104).

CLASS 41—EDUCATION AND ENTERTAINMENT

FOR BUSINESS TRAINING; COMPUTER EDUCATION TRAINING; COMPUTER EDUCATION TRAINING SERVICES; PROVIDING ON-LINE TRAINING COURSES IN THE FIELD OF RETAIL SERVICES; EDUCATION SERVICES, NAMELY, PROVIDING LIVE AND ON-LINE CLASSES IN THE FIELD OF SALES AND BUSINESS MANAGEMENT (U.S. CLS. 100, 101 AND 107).

AMY HELLA, EXAMINING ATTORNEY

SN 77-168,241. ORACLE DIAGNOSTIC LABORATORIES INC., DAVIE, FL. FILED 4-27-2007.

ORACLE DIAGNOSTIC LABORATORIES

THE MARK CONSISTS OF STANDARD CHARACTERS WITHOUT CLAIM TO ANY PARTICULAR FONT, STYLE, SIZE, OR COLOR.

NO CLAIM IS MADE TO THE EXCLUSIVE RIGHT TO USE "DIAGNOSTIC LABORATORIES", APART FROM THE MARK AS SHOWN.

CLASS 42—SCIENTIFIC AND COMPUTER SERVICES

FOR MEDICAL LABORATORIES (U.S. CLS. 100 AND 101).
FIRST USE 1-20-2000; IN COMMERCE 1-20-2000.

CLASS 44—MEDICAL, BEAUTY AND AGRICULTURAL SERVICES

FOR MEDICAL TESTING (U.S. CLS. 100 AND 101).
FIRST USE 1-20-2000; IN COMMERCE 1-20-2000.
BARBARA BROWN, EXAMINING ATTORNEY

SN 77-171,064. WINDOM, PATRICIA T., WOODACRE, CA.
FILED 5-2-2007.

InSPIRIT

THE MARK CONSISTS OF STANDARD CHARACTERS WITHOUT CLAIM TO ANY PARTICULAR FONT, STYLE, SIZE, OR COLOR.

SN 77-168,432. OPTOS PLC, DUNFERMLINE, FIFE, UNITED KINGDOM, FILED 4-28-2007.

3D WRAP

THE MARK CONSISTS OF STANDARD CHARACTERS WITHOUT CLAIM TO ANY PARTICULAR FONT, STYLE, SIZE, OR COLOR.

PRIORITY CLAIMED UNDER SEC. 44(D) ON UNITED KINGDOM APPLICATION NO. 2437029, FILED 10-28-2006, REG. NO. 2437029, DATED 10-28-2006, EXPIRES 10-28-2016.

NO CLAIM IS MADE TO THE EXCLUSIVE RIGHT TO USE "3D", APART FROM THE MARK AS SHOWN.

CLASS 9—ELECTRICAL AND SCIENTIFIC APPARATUS

FOR COMPUTERS; COMPUTER PROGRAMS FOR IMAGE PROCESSING; COMPUTER SOFTWARE FOR IMAGE PROCESSING; RETINAL IMAGE VIEWING SOFTWARE; COMPUTER SOFTWARE USED FOR IMAGE PROCESSING, FOR USE IN THE FIELD OF OPHTHALMOLOGY, DIAGNOSIS AND OPTOMETRY; COMPUTER OPERATING SYSTEMS USED IN THE FIELD OF OPHTHALMOLOGY, DIAGNOSIS AND OPTOMETRY; COMPUTER HARDWARE; COMPUTER FIRMWARE USED TO MANAGE, MANIPULATE AND FACILITATE THE REVIEW OF DIGITAL IMAGES FOR USE IN THE FIELD OF OPHTHALMOLOGY, DIAGNOSIS AND OPTOMETRY (U.S. CLS. 21, 23, 26, 36 AND 38).

CLASS 10—MEDICAL APPARATUS

FOR OPHTHALMOSCOPES, OPTICAL DIAGNOSTIC MEDICAL APPARATUS AND INSTRUMENTS FOR THE VISUALIZATION AND DOCUMENTATION OF THE RETINA AND FOR THE VISUALIZATION OF THE RETINA FOR DETECTION AND MANAGEMENT OF EYE DISEASE, NAMELY, SCANNING LASER OPHTHALMOSCOPES; DIAGNOSTIC OPHTHALMIC APPARATUS FOR THE VISUALIZATION AND DOCUMENTATION OF THE RETINA AND FOR THE VISUALIZATION OF THE RETINA FOR DETECTION AND MANAGEMENT OF EYE DISEASE, NAMELY, SCANNING LASER OPHTHALMOSCOPES; PARTS AND FITTINGS SOLD THEREWITH (U.S. CLS. 26, 39 AND 44).
JANICE L. MCMORROW, EXAMINING ATTORNEY

CLASS 16—PAPER GOODS AND PRINTED MATTER

FOR GREETING CARDS; CALENDARS; NOTE BOOKS; NOTE PADS; STATIONERY; PENS; PENCILS (U.S. CLS. 2, 5, 22, 23, 29, 37, 38 AND 50).
FIRST USE 5-1-2006; IN COMMERCE 5-1-2006.

CLASS 21—HOUSEWARES AND GLASS

FOR MUGS; DRINKING CUPS; DRINKING GLASSES (U.S. CLS. 2, 13, 23, 29, 30, 33, 40 AND 50).
FIRST USE 5-1-2006; IN COMMERCE 5-1-2006.

CLASS 25—CLOTHING

FOR SHIRTS; T-SHIRTS; SWEAT SHIRTS; HATS; CAPS (U.S. CLS. 22 AND 39).
FIRST USE 5-1-2006; IN COMMERCE 5-1-2006.

CLASS 41—EDUCATION AND ENTERTAINMENT

FOR EDUCATION SERVICES, NAMELY, PROVIDING CLASSES, SEMINARS, WORKSHOPS, TUTORING AND MENTORING IN THE FIELDS OF INTERPERSONAL RELATIONSHIPS, CAREER, PERSONAL GROWTH AND FAMILY, AND DISTRIBUTION OF COURSE MATERIAL IN CONNECTION THEREWITH (U.S. CLS. 100, 101 AND 107).

FIRST USE 5-1-2006; IN COMMERCE 5-1-2006.
YONG KIM, EXAMINING ATTORNEY

SN 77-182,964. MSPOT, INC., PALO ALTO, CA. FILED 5-16-2007.

MSPOT REMIX

THE MARK CONSISTS OF STANDARD CHARACTERS WITHOUT CLAIM TO ANY PARTICULAR FONT, STYLE, SIZE, OR COLOR.

OWNER OF U.S. REG. NO. 3,050,601.

CLASS 9—ELECTRICAL AND SCIENTIFIC APPARATUS

FOR DOWNLOADABLE COMPUTER SOFTWARE FOR WIRELESS TRANSMISSION AND SYNCHRONIZATION OF AUDIO, VIDEO, DATA, AND MULTIMEDIA FILES, AND AUDIO, VIDEO, DATA, AND MULTIMEDIA STREAMS BETWEEN A COMPUTING DEVICE AND A CELL PHONE, MOBILE COMPUTER, OR OTHER MOBILE DEVICE; DOWNLOADABLE COMPUTER SOFTWARE FOR CREATING AND MANAGING A DATABASE OF AUDIO, VIDEO, DATA, AND MULTIMEDIA FILES, AND AUDIO, VIDEO, DATA, AND MULTIMEDIA STREAMS; DOWNLOADABLE COMPUTER SOFTWARE FOR PLAYING, ANNOTATING, SHARING, AND BROADCASTING AUDIO, VIDEO, DATA, AND MULTIMEDIA FILES, AND AUDIO, VIDEO, DATA, AND MULTIMEDIA STREAMS ON A CELL PHONE, MOBILE COMPUTER, OR OTHER MOBILE DEVICE (U.S. CLS. 21, 23, 26, 36 AND 38).

CLASS 38—COMMUNICATION

FOR STREAMING OF AUDIO, VIDEO, AND MULTIMEDIA MATERIALS VIA THE INTERNET AND TELECOMMUNICATIONS NETWORKS TO MOBILE DEVICES (U.S. CLS. 100, 101 AND 104).

CLASS 42—SCIENTIFIC AND COMPUTER SERVICES

FOR PROVIDING ON-LINE NON-DOWNLOADABLE SOFTWARE FOR WIRELESS TRANSMISSION AND SYNCHRONIZATION OF AUDIO, VIDEO, DATA, AND MULTIMEDIA FILES, AND AUDIO, VIDEO, DATA, AND MULTIMEDIA STREAMS BETWEEN A COMPUTING DEVICE AND A CELL PHONE, MOBILE COMPUTER, OR OTHER MOBILE DEVICE; PROVIDING ON-LINE NON-DOWNLOADABLE SOFTWARE FOR CREATING AND MANAGING A DATABASE OF AUDIO, VIDEO, DATA, AND MULTIMEDIA FILES, AND AUDIO, VIDEO, DATA, AND MULTIMEDIA STREAMS; PROVIDING ON-LINE NON-DOWNLOADABLE SOFTWARE FOR PLAYING, ANNOTATING, SHARING, AND BROADCASTING AUDIO, VIDEO, DATA, AND MULTIMEDIA FILES, AND AUDIO, VIDEO, DATA, AND MULTIMEDIA STREAMS ON A CELL PHONE, MOBILE COMPUTER, OR OTHER MOBILE DEVICE (U.S. CLS. 100 AND 101).

KATHERINE E. HALMEN, EXAMINING ATTORNEY

SN 77-187,755. WESSELL, TODD, MOUNT PROSPECT, IL. FILED 5-22-2007.

CHARLES W. "CHIC" HARLEY

THE MARK CONSISTS OF STANDARD CHARACTERS WITHOUT CLAIM TO ANY PARTICULAR FONT, STYLE, SIZE, OR COLOR.

THE NAME(S), PORTRAIT(S), AND/OR SIGNATURE(S) SHOWN IN THE MARK DOES NOT IDENTIFY A PARTICULAR LIVING INDIVIDUAL.

CLASS 25—CLOTHING

FOR CAPS; HATS; PANTS; SHOES; SHORTS; SPORTS JERSEYS; T-SHIRTS (U.S. CLS. 22 AND 39).

CLASS 28—TOYS AND SPORTING GOODS

FOR BASEBALLS; BOBBLE HEAD DOLLS; FOOTBALLS (U.S. CLS. 22, 23, 38 AND 50).

JILL C. ALT, EXAMINING ATTORNEY

SN 77-188,179. DUTCH QUALITY STONE, INC., MOUNT EATON, OH. FILED 5-23-2007.

DUTCH QUALITY STONE

THE MARK CONSISTS OF STANDARD CHARACTERS WITHOUT CLAIM TO ANY PARTICULAR FONT, STYLE, SIZE, OR COLOR.

OWNER OF U.S. REG. NO. 3,001,611.

NO CLAIM IS MADE TO THE EXCLUSIVE RIGHT TO USE "STONE", APART FROM THE MARK AS SHOWN.

CLASS 19—NON-METALLIC BUILDING MATERIALS

FOR BUILDING MATERIALS, NAMELY, MANUFACTURED STONE VENEERS FOR EXTERIOR AND INTERIOR SURFACES OF WALLS AND BUILDINGS AND SYNTHETIC, ARTIFICIAL, MANUFACTURED AND REFORMED STONES (U.S. CLS. 1, 12, 33 AND 50).

FIRST USE 6-1-1996; IN COMMERCE 1-1-1997.

CLASS 40—MATERIAL TREATMENT

FOR CUSTOM MANUFACTURE OF VENEER STONE PRODUCTS, LIGHT-WEIGHT CONCRETE CAST INTO THE APPEARANCE OF STONE, AND RELATED ACCESSORY STONE AND CONCRETE PIECES (U.S. CLS. 100, 103 AND 106).

FIRST USE 6-1-1996; IN COMMERCE 1-1-1997.

JOHN GARTNER, EXAMINING ATTORNEY

SN 77-189,179. PIANO PRODUCTIONS, INC., PHILADELPHIA, PA. FILED 5-24-2007.

Piano4

THE MARK CONSISTS OF STANDARD CHARACTERS WITHOUT CLAIM TO ANY PARTICULAR FONT, STYLE, SIZE, OR COLOR.

CLASS 9—ELECTRICAL AND SCIENTIFIC APPARATUS

FOR MUSICAL SOUND RECORDINGS; MUSICAL VIDEO RECORDINGS (U.S. CLS. 21, 23, 26, 36 AND 38).

FIRST USE 12-1-2000; IN COMMERCE 1-1-2001.

CLASS 41—EDUCATION AND ENTERTAINMENT

FOR ENTERTAINMENT IN THE NATURE OF LIVE PERFORMANCES BY PIANISTS (U.S. CLS. 100, 101 AND 107).

FIRST USE 12-1-2000; IN COMMERCE 1-1-2001.

REBECCA POVARCHUK, EXAMINING ATTORNEY

SN 77-190,294. CGI GROUP INC., MONTREAL, CANADA, FILED 5-25-2007.

MPLAN

THE MARK CONSISTS OF STANDARD CHARACTERS WITHOUT CLAIM TO ANY PARTICULAR FONT, STYLE, SIZE, OR COLOR.

CLASS 9—ELECTRICAL AND SCIENTIFIC APPARATUS

FOR COMPUTER SOFTWARE FOR FINANCIAL CALCULATION OF INVESTMENT GOALS, CASH FLOW, ASSET ALLOCATION, RETIREMENT NEEDS, EDUCATION NEEDS, MORTGAGE AND LENDING DATA, INVESTMENT AND SAVINGS ACCOUNT DATA, INSURANCE AND TAXES, USED IN THE FIELD OF FINANCIAL SERVICES (U.S. CLS. 21, 23, 26, 36 AND 38).

CLASS 41—EDUCATION AND ENTERTAINMENT

FOR TRAINING IN THE FIELD OF COMPUTER SOFTWARE FOR FINANCIAL CALCULATION (U.S. CLS. 100, 101 AND 107).

CLASS 42—SCIENTIFIC AND COMPUTER SERVICES

FOR INSTALLATION AND MAINTENANCE OF COMPUTER SOFTWARE FOR FINANCIAL CALCULATION; PROVIDING INFORMATION ABOUT COMPUTER SOFTWARE FOR FINANCIAL CALCULATION (U.S. CLS. 100 AND 101).
ALEX KEAM, EXAMINING ATTORNEY

SN 77-193,442. UTAH STATE BOARD OF REGENTS, C/O THE OFFICE OF THE COMMISSIONER OF HIGHER EDUCATION, SALT LAKE CITY, UT. FILED 5-30-2007.

CLASS 16—PAPER GOODS AND PRINTED MATTER

FOR PRINTED MATERIALS, NAMELY, CERTIFICATES, AWARDS, BROCHURES IN THE FIELD OF FINANCIAL INVESTMENTS AND EDUCATIONAL SAVINGS PLANS, PAPER BANNERS, PAPER LETTERHEAD, BUSINESS CARDS, NOTE CARDS, ENVELOPES, STATIONARY, NAME TAGS IN THE NATURE OF PAPER NAME BADGES, FOLDERS, POSTCARDS, PRINTED PRESENTATIONS, NAMELY, PRINTED HANDOUTS AND PRINTED PRESENTATIONS OF MOTIVATIONAL AND EDUCATIONAL SPEAKERS IN THE FIELD OF FINANCIAL INVESTMENTS AND EDUCATIONAL SAVINGS PLANS, FORMS, BOOKLETS IN THE FIELD OF FINANCIAL INVESTMENTS AND EDUCATIONAL SAVINGS PLANS, MANUALS IN THE FIELD OF FINANCIAL INVESTMENTS AND EDUCATIONAL SAVINGS PLANS, INFORMATIONAL FLYERS IN THE FIELD OF FINANCIAL INVESTMENTS AND EDUCATIONAL SAVINGS PLANS, LEAFLETS IN THE FIELD OF FINANCIAL INVESTMENTS AND EDUCATIONAL SAVINGS PLANS, POSTERS, MAGAZINES IN THE FIELD OF FINANCIAL INVESTMENTS AND EDUCATIONAL SAVINGS PLANS, GREETING CARDS (U.S. CLS. 2, 5, 22, 23, 29, 37, 38 AND 50).

CLASS 25—CLOTHING

FOR CLOTHING, NAMELY, SHIRTS, SWEATSHIRTS, JACKETS, HATS, TIES (U.S. CLS. 22 AND 39).

CLASS 36—INSURANCE AND FINANCIAL

FOR FINANCIAL SERVICES, NAMELY, FINANCIAL AID CONSULTATION, AND FINANCIAL AID IN THE NATURE OF LOAN FINANCING, PROVIDING EDUCATIONAL SCHOLARSHIPS, PROVIDING GRANTS TO INDIVIDUALS, AND SAVINGS PROGRAMS FOR STUDENTS (U.S. CLS. 100, 101 AND 102).
RAMONA ORTIGA, EXAMINING ATTORNEY

SN 77-193,461. UTAH STATE BOARD OF REGENTS, C/O THE OFFICE OF THE COMMISSIONER OF HIGHER EDUCATION, SALT LAKE CITY, UT. FILED 5-30-2007.

WITH COLLEGE IN THE
FUTURE, HERE'S THE PERFECT
PRESENT.

ARE YOU SAVING YET?

THE MARK CONSISTS OF STANDARD CHARACTERS WITHOUT CLAIM TO ANY PARTICULAR FONT, STYLE, SIZE, OR COLOR.

THE MARK CONSISTS OF STANDARD CHARACTERS WITHOUT CLAIM TO ANY PARTICULAR FONT, STYLE, SIZE, OR COLOR.

CLASS 16—PAPER GOODS AND PRINTED MATTER

FOR PRINTED MATERIALS, NAMELY, CERTIFICATES, AWARDS, BROCHURES IN THE FIELD OF FINANCIAL INVESTMENTS AND EDUCATIONAL SAVINGS PLANS, PAPER BANNERS, PAPER LETTERHEAD, BUSINESS CARDS, NOTE CARDS, ENVELOPES, STATIONARY, NAME TAGS IN THE NATURE OF PAPER NAME BADGES, FOLDERS, POSTCARDS, PRINTED PRESENTATIONS, NAMELY, PRINTED HANDOUTS AND PRINTED PRESENTATIONS OF MOTIVATIONAL AND EDUCATIONAL SPEAKERS IN THE FIELD OF FINANCIAL INVESTMENTS AND EDUCATIONAL SAVINGS PLANS, FORMS, BOOKLETS IN THE FIELD OF FINANCIAL INVESTMENTS AND EDUCATIONAL SAVINGS PLANS, MANUALS IN THE FIELD OF FINANCIAL INVESTMENTS AND EDUCATIONAL SAVINGS PLANS, INFORMATIONAL FLYERS IN THE FIELD OF FINANCIAL INVESTMENTS AND EDUCATIONAL SAVINGS PLANS, LEAFLETS IN THE FIELD OF FINANCIAL INVESTMENTS AND EDUCATIONAL SAVINGS PLANS, POSTERS, MAGAZINES IN THE FIELD OF FINANCIAL INVESTMENTS AND EDUCATIONAL SAVINGS PLANS, GREETING CARDS (U.S. CLS. 2, 5, 22, 23, 29, 37, 38 AND 50).

CLASS 25—CLOTHING

FOR CLOTHING, NAMELY, SHIRTS, SWEATSHIRTS, JACKETS, HATS, TIES (U.S. CLS. 22 AND 39).

CLASS 36—INSURANCE AND FINANCIAL

FOR FINANCIAL SERVICES, NAMELY, FINANCIAL AID CONSULTATION, AND FINANCIAL AID IN THE NATURE OF LOAN FINANCING, PROVIDING EDUCATIONAL SCHOLARSHIPS, PROVIDING GRANTS TO INDIVIDUALS, AND SAVINGS PROGRAMS FOR STUDENTS (U.S. CLS. 100, 101 AND 102).

RAMONA ORTIGA, EXAMINING ATTORNEY

SN 77-193,462. LA POINTIQUE INTERNATIONAL, LTD., TUKWILA, WA. FILED 5-30-2007.



OWNER OF U.S. REG. NO. 1,696,216.
THE MARK CONSISTS OF THE LETTERS "LP" IN A BLOCK WITH THREE HORIZONTAL LINES UNDER THE LETTERS.

CLASS 10—MEDICAL APPARATUS

FOR (BASED ON INTENT TO USE) AIR MATTRESSES AND MEMORY FOAM BED CUSHION FOR MEDICAL PURPOSES; AIR PILLOWS AND MEMORY FOAM PILLOWS FOR MEDICAL PURPOSES; CANES FOR MEDICAL PURPOSES; COMPRESSION HOISERY; FOOT CARE PRODUCTS, NAMELY, ORTHOTICS FOR FEET; SEAT CUSHIONS FOR MEDICAL PURPOSES; INVALID HOISTS; INVALID LIFTS; ORTHOPEDIC FOOTWEAR; (BASED ON USE IN COMMERCE) CHEMICALLY ACTIVATED HOT AND COLD THERAPY WRAPS; AEROSOL DISPENSERS FOR MEDICAL USE, ARCH SUPPORTS FOR BOOTS OR SHOES; BANDAGES FOR ANATOMICAL JOINTS; PROTECTORS AND SUPPORTS FOR MEDICAL USE FOR ANKLE, ARM, BACK, CHEST, ELBOW, FACE, FEET, HAND, HEAD, KNEE, LEG SHIN, SHOULDER, THIGH, WAIST AND WRIST; COMPRESSION BANDAGES; ELASTIC BANDAGES; HEATING PADS FOR MEDICAL PURPOSES; MEDICAL ICE PACKS; MOUTH GUARDS FOR MEDICAL USE; NEOPRENE AND ELASTIC SUPPORTS FOR THE ANKLE, BACK, ELBOW, FEET, HAMSTRING, KNEE, THIGH, SHIN, WAIST AND WRIST; NON MEDICATED COMPRESSES; ORTHOPEDIC BELTS; ORTHOPEDIC BRACES, ORTHOPEDIC SOLES; ORTHOPEDIC SUPPORT BANDAGES; ORTHOPEDIC SUPPORTS, ORTHOPEDIC SUPPORT PADS FOR MEDICAL USE; ORTHOPEDIC SUPPORT BANDAGES, NAMELY, WEARABLE PADS FOR THE ANKLE, ARM, BACK, CHEST, ELBOW, HAND, HEAD, KNEE, SHIN, SHOULDER, THIGHS, WAIST AND WRIST (U.S. CLS. 26, 39 AND 44).

FIRST USE 6-0-1992; IN COMMERCE 5-0-1995.

CLASS 28—TOYS AND SPORTING GOODS

FOR (BASED ON USE IN COMMERCE) SPORTING EQUIPMENT, NAMELY, ELASTIC AND NEOPRENE SUPPORTS FOR THE ANKLE, CALF, ELBOW, HAMSTRING, KNEE, SHIN, THIGH, WAIST AND WRIST; ATHLETIC PROTECTOR EQUIPMENT, NAMELY, PROTECTORS FOR THE ANKLE, ARM, FOOT, KNEE AND ELBOW, LEG, SHIN, THIGH, WAIST AND WRIST; ATHLETIC EQUIPMENT, NAMELY, GUARDS FOR THE ANKLE, ARM, ELBOW, HAND, LEG, THIGH, SHIN, WAIST AND WRIST; ATHLETIC TAPES (U.S. CLS. 22, 23, 38 AND 50).

FIRST USE 6-0-1987; IN COMMERCE 9-0-1987.

MARY BOAGNI, EXAMINING ATTORNEY

SN 77-193,585. UTAH STATE BOARD OF REGENTS, C/O THE OFFICE OF THE COMMISSIONER OF HIGHER EDUCATION, SALT LAKE CITY, UT. FILED 5-30-2007.

COLLEGE IS HARD, BUT
SAVING FOR IT DOESN'T HAVE
TO BE.

THE MARK CONSISTS OF STANDARD CHARACTERS WITHOUT CLAIM TO ANY PARTICULAR FONT, STYLE, SIZE, OR COLOR.

CLASS 16—PAPER GOODS AND PRINTED MATTER

FOR PRINTED MATERIALS, NAMELY, CERTIFICATES, AWARDS, BROCHURES IN THE FIELD OF FINANCIAL INVESTMENTS AND EDUCATIONAL SAVINGS PLANS, PAPER BANNERS, PAPER LETTERHEAD, BUSINESS CARDS, NOTE CARDS, ENVELOPES, STATIONARY, NAME TAGS IN THE NATURE OF PAPER NAME BADGES, FOLDERS, POSTCARDS, PRINTED PRESENTATIONS, NAMELY, PRINTED HANDOUTS AND PRINTED PRESENTATIONS OF MOTIVATIONAL AND EDUCATIONAL SPEAKERS IN THE FIELD OF FINANCIAL INVESTMENTS AND EDUCATIONAL SAVINGS PLANS, FORMS, BOOKLETS IN THE FIELD OF FINANCIAL INVESTMENTS AND EDUCATIONAL SAVINGS PLANS, MANUALS IN THE FIELD OF FINANCIAL INVESTMENTS AND EDUCATIONAL SAVINGS PLANS, INFORMATIONAL FLYERS IN THE FIELD OF FINANCIAL INVESTMENTS AND EDUCATIONAL SAVINGS PLANS, LEAFLETS IN THE FIELD OF FINANCIAL INVESTMENTS AND EDUCATIONAL SAVINGS PLANS, POSTERS, MAGAZINES IN THE FIELD OF FINANCIAL INVESTMENTS AND EDUCATIONAL SAVINGS PLANS, GREETING CARDS (U.S. CLS. 2, 5, 22, 23, 29, 37, 38 AND 50).

CLASS 25—CLOTHING

FOR CLOTHING, NAMELY, SHIRTS, SWEATSHIRTS, JACKETS, HATS, TIES (U.S. CLS. 22 AND 39).

CLASS 36—INSURANCE AND FINANCIAL

FOR FINANCIAL SERVICES, NAMELY, FINANCIAL AID CONSULTATION, AND FINANCIAL AID IN THE NATURE OF LOAN FINANCING, PROVIDING EDUCATIONAL SCHOLARSHIPS, PROVIDING GRANTS TO INDIVIDUALS, AND SAVINGS PROGRAMS FOR STUDENTS (U.S. CLS. 100, 101 AND 102).

RAMONA ORTIGA, EXAMINING ATTORNEY

SN 77-194,272. UNTAMED SPIRIT, CEDAR GLEN, CA. FILED 5-31-2007.

UNTAMED SPIRIT

THE MARK CONSISTS OF STANDARD CHARACTERS WITHOUT CLAIM TO ANY PARTICULAR FONT, STYLE, SIZE, OR COLOR.

CLASS 8—HAND TOOLS

FOR HAND TOOLS FOR USE IN JEWELRY MAKING, NAMELY, HAMMERS, MALLETS, STEEL BENCH BLOCKS, ROUND-NOSE PLIERS, CHAIN-NOSE PLIERS, FLAT-NOSE PLIERS, FORMING PLIERS, FILES, WIRE CUTTERS, AND CRIMPING PLIERS; HAND TOOL KITS FOR USE IN JEWELRY MAKING COMPRISING HAMMERS, MALLETS, ANVILS, STEEL BENCH BLOCKS, SAND BAGS, METAL MANDRELS, ROUND-NOSE PLIERS, CHAIN-NOSE PLIERS, FLAT-NOSE PLIERS, FORMING PLIERS, FILES, WIRE CUTTERS, MULTI-STRAND BEAD-STRINGING BOARDS, SOFT-SURFACE BEAD STRINGING MATS, BEAD REAMERS, CRIMPING PLIERS, AND TWEEZERS, SOLD AS A UNIT (U.S. CLS. 23, 28 AND 44).

CLASS 14—JEWELRY

FOR JEWELRY; JEWELRY MAKING SUPPLY KITS COMPRISED OF BAILS, BEAD CAPS, BEAD CONES, BEADS, BUTTONS, CHAIN, CHARMS, CLASPS, POSTS, EAR WIRES, EYE PINS, HEAD PINS, JUMP RINGS, LOCKETS, PENDANTS, SPACER BEADS, STRINGING CORD, AND WIRE SOLD AS A UNIT; JEWELRY MAKING SUPPLIES, NAMELY, BAILS, BEAD CAPS, BEAD CONES, BEADS, CHAIN, CHARMS, CLASPS, POSTS, EAR WIRES, EYE PINS, HEAD PINS, JUMP RINGS, LOCKETS, PENDANTS, SPACER BEADS, AND METAL WIRE (U.S. CLS. 2, 27, 28 AND 50).

CLASS 16—PAPER GOODS AND PRINTED MATTER

FOR PRINTED MATERIALS, NAMELY, BOOKS, BOOKMARKS, DESIGN JOURNALS, CUSTOM MADE JOURNALS, POSTCARDS, MOTIVATION CARDS, AND STUDIO CALENDARS IN THE CATEGORIES OF JEWELRY, JEWELRY MAKING, JEWELRY DESIGN, GEOLOGY, PERSONAL SUCCESS STRATEGIES AND BUSINESS STRATEGIES (U.S. CLS. 2, 5, 22, 23, 29, 37, 38 AND 50).

CLASS 18—LEATHER GOODS

FOR TOOL BAGS SOLD EMPTY AND TOTE BAGS (U.S. CLS. 1, 2, 3, 22 AND 41).

CLASS 36—INSURANCE AND FINANCIAL

FOR RENTAL OF ART STUDIO SPACE (U.S. CLS. 100, 101 AND 102).

CLASS 41—EDUCATION AND ENTERTAINMENT

FOR EDUCATIONAL SERVICES, NAMELY, PROVIDING LIVE JEWELRY MAKING CLASSES AND ON-LINE CLASSES, SEMINARS, INSTRUCTION AND TUTORIALS IN THE FIELD OF JEWELRY MAKING, JEWELRY BUSINESS SET-UP AND OPERATION, JEWELRY DESIGN, GEMSTONES, JEWELRY SALES AND MARKETING (U.S. CLS. 100, 101 AND 107).

JENNIFER VASQUEZ, EXAMINING ATTORNEY

SN 77-195,810. HARPERCOLLINS PUBLISHERS LIMITED, GLASGOW, UNITED KINGDOM, FILED 6-1-2007.



PRIORITY CLAIMED UNDER SEC. 44(D) ON UNITED KINGDOM APPLICATION NO. 2445622, FILED 2-5-2007, REG. NO. 2445622, DATED 2-5-2007, EXPIRES 2-5-2017.

THE MARK CONSISTS OF A SKULL WEARING A HAT WITH VINES AND THE LETTERS "S" AND "P" IN THE BACKGROUND.

CLASS 9—ELECTRICAL AND SCIENTIFIC APPARATUS

FOR ELECTRONIC PUBLICATIONS, NAMELY, FICTION BOOKS THAT ARE DOWNLOADABLE AND RECORDED ON COMPUTER MEDIA (U.S. CLS. 21, 23, 26, 36 AND 38).

CLASS 16—PAPER GOODS AND PRINTED MATTER

FOR SERIES OF PRINTED FICTION BOOKS (U.S. CLS. 2, 5, 22, 23, 29, 37, 38 AND 50).

CLASS 41—EDUCATION AND ENTERTAINMENT

FOR ONLINE ELECTRONIC PUBLISHING OF BOOKS (U.S. CLS. 100, 101 AND 107).
DANNEAN HETZEL, EXAMINING ATTORNEY

SN 77-195,816. HARPERCOLLINS PUBLISHERS LIMITED, GLASGOW, UNITED KINGDOM, FILED 6-1-2007.



PRIORITY CLAIMED UNDER SEC. 44(D) ON UNITED KINGDOM APPLICATION NO. 2445619, FILED 2-5-2007, REG. NO. 2445619, DATED 2-5-2007, EXPIRES 2-5-2017.

THE MARK CONSISTS OF A SKULL WEARING A HAT.

CLASS 9—ELECTRICAL AND SCIENTIFIC APPARATUS

FOR ELECTRONIC PUBLICATIONS, NAMELY, FICTION BOOKS THAT ARE DOWNLOADABLE AND RECORDED ON COMPUTER MEDIA (U.S. CLS. 21, 23, 26, 36 AND 38).

CLASS 16—PAPER GOODS AND PRINTED MATTER

FOR SERIES OF PRINTED FICTION BOOKS (U.S. CLS. 2, 5, 22, 23, 29, 37, 38 AND 50).

CLASS 41—EDUCATION AND ENTERTAINMENT

FOR ONLINE ELECTRONIC PUBLISHING OF BOOKS (U.S. CLS. 100, 101 AND 107).
DANNEAN HETZEL, EXAMINING ATTORNEY

SN 77-199,552. THE PROCTER & GAMBLE COMPANY, CINCINNATI, OH. FILED 6-6-2007.

SWASH

THE MARK CONSISTS OF STANDARD CHARACTERS WITHOUT CLAIM TO ANY PARTICULAR FONT, STYLE, SIZE, OR COLOR.

CLASS 1—CHEMICALS

FOR CHEMICAL PREPARATIONS USED IN DE-WRINKLING CLOTHING AND FABRICS, UPHOLSTERY AND CARPETS (U.S. CLS. 1, 5, 6, 10, 26 AND 46).

CLASS 3—COSMETICS AND CLEANING PREPARATIONS

FOR PENS, SPRAYS, WIPES AND DRYER SHEETS ALL CONTAINING CLOTHING AND FABRIC STAIN-REMOVING PREPARATIONS; PENS, SPRAYS, WIPES AND DRYER SHEETS ALL CONTAINING CLOTHING AND FABRIC DE-WRINKLING PREPARATIONS; PENS, SPRAYS, WIPES AND DRYER SHEETS ALL CONTAINING CLOTHING AND FABRIC ANTI-STATIC PREPARATIONS; CHEMICAL PREPARATIONS USED IN REMOVING STAINS AND REDUCING STATIC IN CLOTHING, FABRICS, UPHOLSTERY AND CARPETS (U.S. CLS. 1, 4, 6, 50, 51 AND 52).

CLASS 5—PHARMACEUTICALS

FOR PENS, SPRAYS, WIPES AND DRYER SHEETS ALL CONTAINING CLOTHING AND FABRIC DEODORIZING PREPARATIONS; CHEMICAL PREPARATIONS USED IN DEODORIZING CLOTHING, FABRICS, UPHOLSTERY AND CARPETS (U.S. CLS. 6, 18, 44, 46, 51 AND 52).

CLASS 21—HOUSEWARES AND GLASS

FOR LINT ROLLERS AND SCENT-DEPOSITING LINT ROLLERS (U.S. CLS. 2, 13, 23, 29, 30, 33, 40 AND 50).
STEPHANIE ALI, EXAMINING ATTORNEY

SN 77-199,660. CLYDE & COMPANY, GUILDFORD, UNITED KINGDOM, FILED 6-6-2007.

CLYDE

THE MARK CONSISTS OF STANDARD CHARACTERS WITHOUT CLAIM TO ANY PARTICULAR FONT, STYLE, SIZE, OR COLOR.

PRIORITY CLAIMED UNDER SEC. 44(D) ON ERPN CMNTY TM OFC APPLICATION NO. 005529276, FILED 12-6-2006, REG. NO. 005529276, DATED 5-2-2008, EXPIRES 12-6-2016.

CLASS 35—ADVERTISING AND BUSINESS

FOR BUSINESS CONSULTANCY SERVICES; BUSINESS MANAGEMENT ASSISTANCE SERVICES; PROVISION OF INFORMATION RELATING TO BUSINESS; ADVISORY SERVICES RELATING TO BUSINESS MANAGEMENT; BUSINESS ORGANIZATION CONSULTANCY; BUSINESS CONSULTING SERVICES RELATING TO ACQUISITION, MERGERS, AND FRANCHISING; ADVISING IN CONNECTION WITH TAX; PREPARATION OF BUSINESS REPORTS; ARRANGING AND CONDUCTING BUSINESS EXHIBITIONS; PROVISION OF INFORMATION OR ADVISORY SERVICES RELATING TO THE AFORESAID (U.S. CLS. 100, 101 AND 102).

SN 77-199,669. CLYDE & COMPANY, GUILDFORD, UNITED KINGDOM, FILED 6-6-2007.

CLYDES

CLASS 36—INSURANCE AND FINANCIAL

FOR FINANCIAL MANAGEMENT; FINANCIAL APPRAISAL OF BUSINESSES; FINANCIAL ANALYSIS; PROVISION OF INFORMATION AND ADVICE RELATING TO INSURANCE AND REINSURANCE; PROVISION OF FINANCIAL INFORMATION; PROVISION OF INSURANCE INFORMATION; FINANCIAL CONSULTANCY SERVICES; BUSINESS LIQUIDATION SERVICES (U.S. CLS. 100, 101 AND 102).

CLASS 41—EDUCATION AND ENTERTAINMENT

FOR EDUCATION AND TRAINING SERVICES, NAMELY, ARRANGING AND CONDUCTING SEMINARS, CONFERENCES, SYMPOSIUMS AND WORKSHOPS RELATING TO BUSINESS; EDUCATION AND TRAINING SERVICES, NAMELY, ARRANGING AND CONDUCTING CONFERENCES, SEMINARS, EXHIBITIONS, WORKSHOPS, AND ONE-ON-ONE MENTORING AND TRAINING RELATING TO LAW, FINANCE, MEDIA, TELECOMMUNICATIONS, INFORMATION TECHNOLOGY, INTELLECTUAL PROPERTY, MANAGEMENT, BANKING SECURITIES, PROPERTY, TAX, INSURANCE, AVIATION, SHIPPING, AND REGULATORY AFFAIRS (U.S. CLS. 100, 101 AND 107).

CLASS 45—PERSONAL AND LEGAL SERVICES

FOR LEGAL SERVICES; LEGAL SERVICES RELATING TO BUSINESS; LEGAL RESEARCH; PROVISION OF INFORMATION RELATING TO LEGAL SERVICES AND LEGAL RESEARCH; LEGAL SERVICES RELATING TO COMPANY FORMATION AND REGISTRATION SERVICES; LEGAL SERVICES RELATING TO CONVEYANCE OF REAL ESTATE; LEGAL SERVICES RELATING TO AVIATION, JOINT VENTURES, VENTURE CAPITAL, MERGERS AND ACQUISITIONS, CORPORATE FINANCE, ISSUANCE OF FINANCIAL INSTRUMENTS, LISTINGS IN STOCK AND EQUITY MARKETS, BANKING AND FINANCIAL SERVICES, PROPERTY, INTELLECTUAL PROPERTY, INFORMATION TECHNOLOGY, E-COMMERCE, EUROPEAN COMMISSION COMPETITION COMPLIANCE, REGULATORY AFFAIRS, EMPLOYMENT, SPORTS, CORPORATE RECOVERY, RECEIVERSHIP AND LIQUIDATION, SOLVENT AND INSOLVENT RESTRUCTURINGS, ENERGY, PRODUCT LIABILITY, PERSONAL INJURY, CLINICAL NEGLIGENCE, ENTERTAINMENT, INSURANCE AND REINSURANCE, AND INTERNATIONAL FINANCE AND TRADE; MEDIATION AND ARBITRATION SERVICES; PROFESSIONAL CONSULTATION AND ADVISORY SERVICES RELATING TO LEGAL MATTERS (U.S. CLS. 100 AND 101).

DAVID TOOLEY, EXAMINING ATTORNEY

THE MARK CONSISTS OF STANDARD CHARACTERS WITHOUT CLAIM TO ANY PARTICULAR FONT, STYLE, SIZE, OR COLOR.

PRIORITY CLAIMED UNDER SEC. 44(D) ON ERPNTY TM OFC APPLICATION NO. 5529458, FILED 12-6-2006, REG. NO. 5529458, DATED 12-18-2007, EXPIRES 12-6-2016.

CLASS 35—ADVERTISING AND BUSINESS

FOR BUSINESS CONSULTANCY SERVICES; BUSINESS MANAGEMENT ASSISTANCE SERVICES; PROVISION OF INFORMATION RELATING TO BUSINESS; ADVISORY SERVICES RELATING TO BUSINESS MANAGEMENT; BUSINESS ORGANIZATION CONSULTANCY; BUSINESS CONSULTING SERVICES RELATING TO ACQUISITION, MERGERS, AND FRANCHISING; ADVISING IN CONNECTION WITH TAX; PREPARATION OF BUSINESS REPORTS; ARRANGING AND CONDUCTING BUSINESS EXHIBITIONS; PROVISION OF INFORMATION OR ADVISORY SERVICES RELATING TO THE AFORESAID (U.S. CLS. 100, 101 AND 102).

CLASS 36—INSURANCE AND FINANCIAL

FOR FINANCIAL MANAGEMENT; FINANCIAL APPRAISAL OF BUSINESSES; FINANCIAL ANALYSIS; PROVISION OF INFORMATION AND ADVICE RELATING TO INSURANCE AND REINSURANCE; PROVISION OF FINANCIAL INFORMATION; PROVISION OF INSURANCE INFORMATION; FINANCIAL CONSULTANCY SERVICES; BUSINESS LIQUIDATION SERVICES (U.S. CLS. 100, 101 AND 102).

CLASS 41—EDUCATION AND ENTERTAINMENT

FOR EDUCATION AND TRAINING SERVICES, NAMELY, ARRANGING AND CONDUCTING SEMINARS, CONFERENCES, SYMPOSIUMS AND WORKSHOPS RELATING TO BUSINESS; EDUCATION AND TRAINING SERVICES, NAMELY, ARRANGING AND CONDUCTING CONFERENCES, SEMINARS, EXHIBITIONS, WORKSHOPS, AND ONE-ON-ONE MENTORING AND TRAINING RELATING TO LAW, FINANCE, MEDIA, TELECOMMUNICATIONS, INFORMATION TECHNOLOGY, INTELLECTUAL PROPERTY, MANAGEMENT, BANKING SECURITIES, PROPERTY, TAX, INSURANCE, AVIATION, SHIPPING, AND REGULATORY AFFAIRS (U.S. CLS. 100, 101 AND 107).

CLASS 45—PERSONAL AND LEGAL SERVICES

FOR LEGAL SERVICES; LEGAL SERVICES RELATING TO BUSINESS; LEGAL RESEARCH; PROVISION OF INFORMATION RELATING TO LEGAL SERVICES AND LEGAL RESEARCH; LEGAL SERVICES RELATING TO COMPANY FORMATION AND REGISTRATION SERVICES; LEGAL SERVICES RELATING TO CONVEYANCE OF REAL ESTATE; LEGAL SERVICES RELATING TO AVIATION, JOINT VENTURES, VENTURE CAPITAL, MERGERS AND ACQUISITIONS, CORPORATE FINANCE, ISSUANCE OF FINANCIAL INSTRUMENTS, LISTINGS IN STOCK AND EQUITY MARKETS, BANKING AND FINANCIAL SERVICES, PROPERTY, INTELLECTUAL PROPERTY, INFORMATION TECHNOLOGY, E-COMMERCE, EUROPEAN COMMISSION COMPETITION COMPLIANCE, REGULATORY AFFAIRS, EMPLOYMENT, SPORTS, CORPORATE RECOVERY, RECEIVERSHIP AND LIQUIDATION, SOLVENT AND INSOLVENT RESTRUCTURINGS, ENERGY, PRODUCT LIABILITY, PERSONAL INJURY, CLINICAL NEGLIGENCE, ENTERTAINMENT, INSURANCE AND REINSURANCE, AND INTERNATIONAL FINANCE AND TRADE; MEDIATION AND ARBITRATION SERVICES; PROFESSIONAL CONSULTING AND ADVISORY SERVICES RELATING TO LEGAL MATTERS (U.S. CLS. 100 AND 101).

DAVID TOOLEY, EXAMINING ATTORNEY

SN 77-202,854. PTI TECHNOLOGIES INC., OXNARD, CA. FILED 6-11-2007.

DryPak

THE MARK CONSISTS OF STANDARD CHARACTERS WITHOUT CLAIM TO ANY PARTICULAR FONT, STYLE, SIZE, OR COLOR.

CLASS 7—MACHINERY

FOR REUSABLE AND REMOUNTABLE FILTER HOUSING, NAMELY, FILTERS FOR FILTERING AIR, HYDRAULIC FLUID, OIL, AND FUEL IN MOTORS, ENGINES AND MACHINES IN INDUSTRIAL AND COMMERCIAL APPLICATIONS; HYDRAULIC FLUID FILTERS; OIL FILTERS; FUEL FILTERS (U.S. CLS. 13, 19, 21, 23, 31, 34 AND 35).

CLASS 11—ENVIRONMENTAL CONTROL APPARATUS

FOR REUSABLE AND REMOUNTABLE FILTRATION HOUSING UNIT FOR FILTERING AIR IN INDUSTRIAL AND COMMERCIAL APPLICATIONS, NAMELY, AIR FILTERS FOR INDUSTRIAL INSTALLATIONS (U.S. CLS. 13, 21, 23, 31 AND 34).

SOPHIA S. KIM, EXAMINING ATTORNEY

SN 77-200,746. TARANTELLI, PAULA, HORSEHEADS, NY. FILED 6-7-2007.



THE MARK CONSISTS OF THE WORD "ELEKASA" IN A STYLIZED TEXT. "ELEKASA" HAS NO MEANING IN A FOREIGN LANGUAGE.

CLASS 18—LEATHER GOODS

FOR PET CLOTHING (U.S. CLS. 1, 2, 3, 22 AND 41).

CLASS 20—FURNITURE AND ARTICLES NOT OTHERWISE CLASSIFIED

FOR WINDOW SHADES (U.S. CLS. 2, 13, 22, 25, 32 AND 50).

CLASS 28—TOYS AND SPORTING GOODS

FOR CHRISTMAS STOCKINGS (U.S. CLS. 22, 23, 38 AND 50).

REBECCA EISINGER, EXAMINING ATTORNEY

SN 77-203,066. NEW POKER, L.L.C., LAS VEGAS, NV. FILED 6-11-2007.

ROYAL NO RIVER

THE MARK CONSISTS OF STANDARD CHARACTERS WITHOUT CLAIM TO ANY PARTICULAR FONT, STYLE, SIZE, OR COLOR.

NO CLAIM IS MADE TO THE EXCLUSIVE RIGHT TO USE "NO RIVER", APART FROM THE MARK AS SHOWN.

CLASS 9—ELECTRICAL AND SCIENTIFIC APPARATUS

FOR GAMING MACHINES (U.S. CLS. 21, 23, 26, 36 AND 38).

CLASS 28—TOYS AND SPORTING GOODS

FOR CARD GAMES (U.S. CLS. 22, 23, 38 AND 50).

CLASS 41—EDUCATION AND ENTERTAINMENT

FOR PROVIDING ON-LINE CARD GAMES (U.S. CLS. 100, 101 AND 107).

REBECCA EISINGER, EXAMINING ATTORNEY

SN 77-206,977. DISANTO, ROBERT B., NAPLES, FL. FILED 6-15-2007.

SN 77-208,615. CORTES, JORGE, WESTON, FL. FILED 6-18-2007.



STONE TONE

THE MARK CONSISTS OF STANDARD CHARACTERS WITHOUT CLAIM TO ANY PARTICULAR FONT, STYLE, SIZE, OR COLOR.

CLASS 15—MUSICAL INSTRUMENTS

FOR GUITARS; GUITAR ACCESSORIES, NAMELY, GUITAR STRINGS, GUITAR STRAPS, GUITAR PICKS, GUITAR STANDS AND TREMLO BLOCKS (U.S. CLS. 2, 21 AND 36).

CLASS 16—PAPER GOODS AND PRINTED MATTER

FOR PRINTED MATTER, NAMELY, STICKERS, BUMPER STICKERS, POSTERS, PAPER BANNERS AND MESSAGE PADS (U.S. CLS. 2, 5, 22, 23, 29, 37, 38 AND 50).

CLASS 25—CLOTHING

FOR CLOTHING, NAMELY, T-SHIRTS, SHIRTS, TANK TOPS, SHORTS, HATS, JACKETS, SWEATERS, SWEAT SHIRTS, SWEAT PANTS, HEADBANDS, WRIST BANDS, SHOES AND GLOVES (U.S. CLS. 22 AND 39).

CLASS 35—ADVERTISING AND BUSINESS

FOR RETAIL STORE SERVICES FEATURING GUITARS; PROVIDING ONLINE RETAIL STORE SERVICES FEATURING GUITARS (U.S. CLS. 100, 101 AND 102).

CLASS 41—EDUCATION AND ENTERTAINMENT

FOR ENTERTAINMENT SERVICES, NAMELY, LIVE MUSIC CONCERTS (U.S. CLS. 100, 101 AND 107).
HEATHER SAPP, EXAMINING ATTORNEY

NO CLAIM IS MADE TO THE EXCLUSIVE RIGHT TO USE "PRODUCTOS", APART FROM THE MARK AS SHOWN.

"THE NAME(S), PORTRAIT(S), AND/OR SIGNATURE(S) SHOWN IN THE MARK DOES NOT IDENTIFY A PARTICULAR LIVING INDIVIDUAL."

"THE COLOR(S) RED, GOLD, SEPIA BROWN, BLACK, WHITE, AND GRAY IS/ARE CLAIMED AS A FEATURE OF THE MARK."

"THE MARK CONSISTS OF THE SEPIA BROWN TONED FACE OF A WOMAN WITH BLACK HAIR AND CLOTHING WITHIN A GRAY OVAL THAT IS OUTLINED IN GOLD WITH AN INNER BAND IN WHITE, APPEARING ABOVE A RED BANNER THAT IS OUTLINED IN GOLD WITH AN INNER BAND IN WHITE WITH THE STYLIZED WORDS "PRODUCTOS" IN BLACK AND "CHELITA" IN WHITE DISPLAYED ON THE BANNER, ON A RED DIAMOND-SHAPED BACKGROUND WITH A BAND OF GOLD WITHIN AN OUTER BAND OF RED."

THE FOREIGN WORDING IN THE MARK TRANSLATES INTO ENGLISH AS PRODUCTS.

CLASS 29—MEATS AND PROCESSED FOODS

FOR FROZEN FRUITS, FROZEN FRUIT CONSERVES, FROZEN FRUIT PULPS, PREPARED AND FROZEN VEGETABLES, PREPARED AND FROZEN STUFFED POTATOES, AND PREPARED AND FROZEN VEGETABLE, CHICKEN, MEAT, FISH, AND POTATO CROQUETTES (U.S. CL. 46).

FIRST USE 3-31-2007; IN COMMERCE 3-31-2007.

CLASS 30—STAPLE FOODS

FOR FRUIT ICE BARS, BAKERY PRODUCTS, BEVERAGES MADE OF COFFEE, COFFEE, DULCE DE LECHE, EMPANADAS, AND FROZEN BREADS (U.S. CL. 46).

FIRST USE 3-31-2007; IN COMMERCE 3-31-2007.
ALICIA COLLINS, EXAMINING ATTORNEY

SN 77-208,939. SHOCKING TECHNOLOGIES, INC., SAN JOSE, CA. FILED 6-18-2007.

XSEED

THE MARK CONSISTS OF STANDARD CHARACTERS WITHOUT CLAIM TO ANY PARTICULAR FONT, STYLE, SIZE, OR COLOR.

CLASS 9—ELECTRICAL AND SCIENTIFIC APPARATUS

FOR PRINTED CIRCUIT BOARDS; INTEGRATED CIRCUITS; SEMICONDUCTOR DEVICES; LIQUID CRYSTAL DISPLAYS (LCDS); LIGHT EMITTING DIODES (LEDS); LIGHT EMITTING DIODE (LED) DISPLAYS; ORGANIC LIGHT EMITTING DIODE (OLED) DEVICES, NAMELY, DISPLAYS FOR TELEVISIONS AND COMPUTER MONITORS, CELL PHONE DISPLAYS, MP3 PLAYER DISPLAYS, DVD PLAYER DISPLAYS, RADIO DISPLAYS, GAME CONSOLE DISPLAYS, DIGITAL CAMERA DISPLAYS, NAVIGATION DEVICE DISPLAYS, VEHICLE AUDIO DISPLAYS, DRIVER INFORMATION DISPLAYS, PASSENGER ENTERTAINMENT SYSTEM DISPLAYS, VIDEO CAMERA DISPLAYS, HAND HELD DEVICE DISPLAYS; RADIO FREQUENCY IDENTIFICATION (RFID) DEVICES, NAMELY, TAGS, AND READERS; ELECTRO CHROMIC DISPLAYS; ELECTROPHERETIC DISPLAYS; FLEXIBLE LED AND OLED DISPLAYS; ACTIVE MATRIX DISPLAYS; THIN FILM TRANSISTOR (TFT) DISPLAYS; PASSIVE MATRIX DISPLAYS; PRINTED CIRCUIT BOARD SUBSTRATES; MATERIALS FOR USE IN MANUFACTURING INTEGRATED CIRCUITS; MATERIALS FOR USE IN MANUFACTURING SEMICONDUCTOR DEVICES; MATERIALS FOR USE IN MANUFACTURING PRINTED CIRCUIT BOARDS, PRINTED CIRCUIT BOARD SUBSTRATES INTEGRATED CIRCUITS, SEMICONDUCTOR DEVICES, AND EMBEDDED PRINTED CIRCUIT BOARD MATERIAL, NAMELY, STATIC VOLTAGE REGULATORS AND VOLTAGE SURGE PROTECTORS, EMBEDDED PRINTED CIRCUIT BOARD MATERIALS; MATERIALS FOR DISCHARGE PROTECTION AND OVERVOLTAGE PROTECTION, NAMELY, STATIC VOLTAGE REGULATORS AND VOLTAGE SURGE PROTECTORS (U.S. CLS. 21, 23, 26, 36 AND 38).

CLASS 17—RUBBER GOODS

FOR DIELECTRIC MATERIALS, NAMELY, CONDUCTIVE INSULATING POLYMERS; MATERIALS FOR ELECTROSTATIC AND OVERVOLTAGE PROTECTION, NAMELY, INSULATING DIELECTRIC MATERIALS; MATERIALS FOR USE IN MANUFACTURING PRINTED CIRCUIT BOARDS, INTEGRATED CIRCUITS, SEMICONDUCTOR DEVICES AND EMBEDDED PRINTED CIRCUIT BOARDS, NAMELY, INSULATING DIELECTRIC MATERIALS (U.S. CLS. 1, 5, 12, 13, 35 AND 50).

CLASS 42—SCIENTIFIC AND COMPUTER SERVICES

FOR DESIGN AND ENGINEERING SERVICES FOR OTHERS IN THE FIELD OF DIELECTRIC MATERIALS AND REGARDING THE MANUFACTURE OF PRINTED CIRCUIT BOARDS, INTEGRATED CIRCUITS, AND SEMICONDUCTOR DEVICES (U.S. CLS. 100 AND 101).
TOBY BULLOFF, EXAMINING ATTORNEY

SN 77-208,985, SHOCKING TECHNOLOGIES, INC., SAN JOSE, CA. FILED 6-18-2007.

SHOCKING TECHNOLOGIES

THE MARK CONSISTS OF STANDARD CHARACTERS WITHOUT CLAIM TO ANY PARTICULAR FONT, STYLE, SIZE, OR COLOR.

NO CLAIM IS MADE TO THE EXCLUSIVE RIGHT TO USE "TECHNOLOGIES", APART FROM THE MARK AS SHOWN.

CLASS 9—ELECTRICAL AND SCIENTIFIC APPARATUS

FOR PRINTED CIRCUIT BOARDS; INTEGRATED CIRCUITS; SEMICONDUCTOR DEVICES; LIQUID CRYSTAL DISPLAYS (LCDS); LIGHT EMITTING DIODES (LEDS); LIGHT EMITTING DIODE (LED) DISPLAYS; ORGANIC LIGHT EMITTING DIODE (OLED) DEVICES, NAMELY, DISPLAYS FOR TELEVISIONS AND COMPUTER MONITORS, CELL PHONE DISPLAYS, MP3 PLAYER DISPLAYS, DVD PLAYER DISPLAYS, RADIO DISPLAYS, GAME CONSOLE DISPLAYS, DIGITAL CAMERA DISPLAYS, NAVIGATION DEVICE DISPLAYS, VEHICLE AUDIO DISPLAYS, DRIVER INFORMATION DISPLAYS, PASSENGER ENTERTAINMENT SYSTEM DISPLAYS, VIDEO CAMERA DISPLAYS, HAND HELD DEVICE DISPLAYS; RADIO FREQUENCY IDENTIFICATION (RFID) DEVICES, NAMELY, TAGS, AND READERS; ELECTRO CHROMIC DISPLAYS; ELECTROPHERETIC DISPLAYS; FLEXIBLE LED AND OLED DISPLAYS; ACTIVE MATRIX DISPLAYS; THIN FILM TRANSISTOR (TFT) DISPLAYS; PASSIVE MATRIX DISPLAYS; PRINTED CIRCUIT BOARD SUBSTRATES; MATERIALS FOR USE IN MANUFACTURING INTEGRATED CIRCUITS; MATERIALS FOR USE IN MANUFACTURING SEMICONDUCTOR DEVICES; MATERIALS FOR USE IN MANUFACTURING PRINTED CIRCUIT BOARDS, PRINTED CIRCUIT BOARD SUBSTRATES INTEGRATED CIRCUITS, SEMICONDUCTOR DEVICES, AND EMBEDDED PRINTED CIRCUIT BOARD MATERIAL, NAMELY, STATIC VOLTAGE REGULATORS AND VOLTAGE SURGE PROTECTORS, EMBEDDED PRINTED CIRCUIT BOARD MATERIALS; MATERIALS FOR DISCHARGE PROTECTION AND OVERVOLTAGE PROTECTION, NAMELY, STATIC VOLTAGE REGULATORS AND VOLTAGE SURGE PROTECTORS (U.S. CLS. 21, 23, 26, 36 AND 38).

CLASS 17—RUBBER GOODS

FOR DIELECTRIC MATERIALS, NAMELY, CONDUCTIVE INSULATING POLYMERS; MATERIALS FOR ELECTROSTATIC AND OVERVOLTAGE PROTECTION, NAMELY INSULATING DIELECTRIC MATERIALS; MATERIALS FOR USE IN MANUFACTURING PRINTED CIRCUIT BOARDS, INTEGRATED CIRCUITS, SEMICONDUCTOR DEVICES AND EMBEDDED PRINTED CIRCUIT BOARDS, NAMELY, INSULATING DIELECTRIC MATERIALS (U.S. CLS. 1, 5, 12, 13, 35 AND 50).

CLASS 42—SCIENTIFIC AND COMPUTER SERVICES

FOR DESIGN AND ENGINEERING SERVICES FOR OTHERS IN THE FIELD OF DIELECTRIC MATERIALS AND REGARDING THE MANUFACTURE OF PRINTED CIRCUIT BOARDS, INTEGRATED CIRCUITS, AND SEMICONDUCTOR DEVICES; TECHNICAL CONSULTATION IN THE FIELD OF DIELECTRIC MATERIALS AND REGARDING THE MANUFACTURE OF PRINTED CIRCUIT BOARDS, INTEGRATED CIRCUITS, AND SEMICONDUCTOR (U.S. CLS. 100 AND 101).

CLASS 45—PERSONAL AND LEGAL SERVICES

FOR LICENSING OF INTELLECTUAL PROPERTY (U.S. CLS. 100 AND 101).
TOBY BULLOFF, EXAMINING ATTORNEY

SN 77-210,854. ROBERT B. DISANTO, NAPLES, FL. FILED 6-20-2007.



THE MARK CONSISTS OF THE WORD "STONE" ABOVE THE WORD "TONE" WHEREIN THE "O" IN "STONE" IS LOCATED OVER THE "O" IN "TONE" AND A TREBLE CLEF IS LOCATED OVER BOTH "O'S" AND "MUSIC OF THE EARTH" IS IN SCRIPT FORM BENEATH THE WORD "TONE".

CLASS 15—MUSICAL INSTRUMENTS

FOR GUITARS; GUITAR ACCESSORIES, NAMELY, GUITAR STRINGS, GUITAR STRAPS, GUITAR PICKS, GUITAR STANDS AND TREMLO BLOCKS (U.S. CLS. 2, 21 AND 36).

CLASS 16—PAPER GOODS AND PRINTED MATTER

FOR PRINTED MATTER, NAMELY, STICKERS, BUMPER STICKERS, POSTERS, PAPER BANNERS AND MESSAGE PADS (U.S. CLS. 2, 5, 22, 23, 29, 37, 38 AND 50).

CLASS 25—CLOTHING

FOR CLOTHING, NAMELY, T-SHIRTS, SHIRTS, TANK TOPS, SHORTS, HATS, JACKETS, SWEATERS, SWEAT SHIRTS, SWEAT PANTS, HEADBANDS, WRIST BANDS, SHOES AND GLOVES (U.S. CLS. 22 AND 39).

CLASS 35—ADVERTISING AND BUSINESS

FOR RETAIL STORE SERVICES FEATURING GUITARS; PROVIDING ONLINE RETAIL STORE SERVICES FEATURING GUITARS (U.S. CLS. 100, 101 AND 102).

CLASS 41—EDUCATION AND ENTERTAINMENT

FOR ENTERTAINMENT SERVICES, NAMELY, LIVE MUSIC CONCERTS (U.S. CLS. 100, 101 AND 107).
HEATHER SAPP, EXAMINING ATTORNEY

SN 77-210,935. HEIDELBERGER DRUCKMASCHINEN AG, HEIDELBERG, FED REP GERMANY, FILED 6-20-2007.

Intellistart

THE MARK CONSISTS OF STANDARD CHARACTERS WITHOUT CLAIM TO ANY PARTICULAR FONT, STYLE, SIZE, OR COLOR.

OWNER OF ERPN CMNTY TM OFC REG. NO. 005719398, DATED 2-15-2008, EXPIRES 2-27-2017.

CLASS 7—MACHINERY

FOR PRINT SHOP MACHINES FOR THE GRAPHICS INDUSTRY, NAMELY, PRINTING MACHINES AND MACHINERY CONTROL DEVICES AND PARTS FOR THE AFOREMENTIONED GOODS SOLD AS COMPONENT PARTS OF THE MACHINERY (U.S. CLS. 13, 19, 21, 23, 31, 34 AND 35).

CLASS 9—ELECTRICAL AND SCIENTIFIC APPARATUS

FOR ELECTRONIC CONTROL DEVICES, NAMELY, CONTROLLERS FOR CONTROLLING, REGULATING, SUPPLYING AND NETWORKING THE PRINTING PROCESS OF PRINTING MACHINES, AND FOR RECORDING, TRANSMITTING AND REPRODUCING IMAGES AND INFORMATION; COMPUTER SOFTWARE FOR OPERATING PRINT SHOP MACHINES, FOR CONTROLLING AND REGULATING THE PRINTING PROCESS IN A PRINT SHOP, FOR CREATING DIGITAL PRINT COPIES, FOR COLOR CALIBRATION, FOR PROCESSING IMAGES AND GRAPHICS, AND FOR CONTROLLING WORK PROCESSES IN CONNECTION WITH THE PRODUCTION OF PRINT JOB PRODUCTS; DIGITAL DATA CARRIERS FEATURING SOFTWARE FOR USE IN OPERATING PRINT SHOP MACHINES AND IN MACHINES FOR THE FURTHER PROCESSING OF PRINT JOB PRODUCTS AND IN PREPRESS EQUIPMENT, NAMELY, IMAGE SETTERS AND COMPUTERS CONTROLLING THE PREPRESS PROCESS; CONTROL CONSOLES AND ELECTRONIC CONTROL DEVICES FOR OPERATING PRINT SHOP MACHINES, FOR CONTROLLING, REGULATING, AND NETWORKING THE PRINTING PROCESS; SCREENS, NAMELY, PROJECTION SCREENS, FLAT PANEL DISPLAY SCREENS, AND CRT DISPLAYS (U.S. CLS. 21, 23, 26, 36 AND 38).
ESTHER BELENKER, EXAMINING ATTORNEY

SN 77-211,852. RODALE INC., EMMAUS, PA. FILED 6-21-2007.

URBANATHLETE

THE MARK CONSISTS OF STANDARD CHARACTERS WITHOUT CLAIM TO ANY PARTICULAR FONT, STYLE, SIZE, OR COLOR.

OWNER OF U.S. REG. NO. 3,241,571.

CLASS 16—PAPER GOODS AND PRINTED MATTER

FOR PRINTED INSTRUCTIONAL AND EDUCATIONAL MATERIALS IN THE FIELDS OF OUTDOOR RECREATION, HEALTH, FITNESS, DIET, EXERCISE, LIFESTYLE, PRODUCTS, GEAR, APPAREL AND EQUIPMENT; PRINTED VISUALS IN THE NATURE OF PROMOTIONAL MATERIALS (U.S. CLS. 2, 5, 22, 23, 29, 37, 38 AND 50).

CLASS 41—EDUCATION AND ENTERTAINMENT

FOR EDUCATIONAL SERVICES, NAMELY, WORKSHOPS AND SEMINARS IN THE FIELDS OF OUTDOOR RECREATION, HEALTH, FITNESS, DIET, EXERCISE AND LIFESTYLE, AND OUTDOOR PRODUCTS, NAMELY, OUTDOOR GEAR, APPAREL AND EQUIPMENT; ENTERTAINMENT SERVICES, NAMELY, ARRANGING CONTESTS AND CONDUCTING SHOWS AND EVENTS FEATURING OUTDOOR RECREATION, HEALTH, FITNESS, DIET, EXERCISE AND LIFESTYLE, AND OUTDOOR PRODUCTS, NAMELY, OUTDOOR GEAR, APPAREL AND EQUIPMENT; ENCOURAGING AMATEUR SPORTS AND PHYSICAL EDUCATION BY ORGANIZING AND PROMOTING, SPONSORING, SANCTIONING, CONDUCTING AND ADMINISTERING AMATEUR ATHLETIC PROGRAMS AND ACTIVITIES (U.S. CLS. 100, 101 AND 107).

JACQUELINE A. LAVINE, EXAMINING ATTORNEY

SN 77-212,734. ACCURA HEALTH LIMITED, IRVINE, AYRSHIRE, UNITED KINGDOM, FILED 6-22-2007.



THE MARK CONSISTS OF A REPRESENTATION OF AN ANGEL CONSISTING OF A FACE, WINGS AND A HALO LOCATED ABOVE THE WORDS "AM:ANGEL".

CLASS 5—PHARMACEUTICALS

FOR DIETARY FOOD AND NUTRITIONAL SUPPLEMENTS; NON-MEDICATED FOOD SUPPLEMENTS CONTAINING AMINO ACIDS, AMINO ACID DERIVATIVES, VITAMINS AND MINERALS; NON-PRESCRIPTION DIETARY SUPPLEMENTS CONSISTING OF AMINO ACIDS AND AMINO ACID DERIVATIVES, MINERALS, VITAMINS, TRACE ELEMENTS; HEALTH FOOD SUPPLEMENTS MADE PRINCIPALLY OF AMINO ACIDS AND AMINO ACID DERIVATIVES; HEALTH FOOD SUPPLEMENTS MADE OF VITAMINS; HEALTH FOOD SUPPLEMENTS MADE OF MINERALS; FOOD SUPPLEMENTS ADAPTED FOR MEDICAL PURPOSES; MEDICATED FOOD SUPPLEMENTS; VITAMIN SUPPLEMENTS; DIETETIC DRINKS ADAPTED FOR MEDICAL PURPOSES; DRINKS PREDOMINANTLY OF AMINO ACIDS, MINERALS AND VITAMINS; DIETARY FOOD AND NUTRITIONAL SUPPLEMENTS IN LIQUID FORM; DIETARY FOOD AND NUTRITIONAL SUPPLEMENTS IN TABLET FORM; DIETARY FOOD AND NUTRITIONAL SUPPLEMENTS IN CAPSULE FORM; DIETARY SUPPLEMENTS OTHER THAN FOR MEDICAL USE; FOOD SUPPLEMENT PREPARATIONS IN LIQUID FORM; FOOD SUPPLEMENT PREPARATIONS IN POWDERED FORM; NON-MEDICATED DRINKS CONTAINING AMINO ACIDS; AMINO ACIDS DERIVATIVES, VITAMINS AND MINERALS (U.S. CLS. 6, 18, 44, 46, 51 AND 52).

CLASS 32—LIGHT BEVERAGES

FOR NON-ALCOHOLIC DRINKS, NAMELY, FRUIT DRINKS AND SOFT DRINKS; PREPARATIONS IN THE FORM OF POWDER FOR MAKING FRUIT DRINKS AND SOFT DRINKS; CONCENTRATES FOR USE IN THE PREPARATION OF SOFT DRINKS (U.S. CLS. 45, 46 AND 48).

GIANCARLO CASTRO, EXAMINING ATTORNEY

SN 77-219,233. BREAKING THE CHAIN FOUNDATION, WASHINGTON, DC. FILED 6-29-2007.

BREAKING THE CHAIN FOUNDATION

THE MARK CONSISTS OF STANDARD CHARACTERS WITHOUT CLAIM TO ANY PARTICULAR FONT, STYLE, SIZE, OR COLOR.

NO CLAIM IS MADE TO THE EXCLUSIVE RIGHT TO USE "FOUNDATION", APART FROM THE MARK AS SHOWN.

CLASS 35—ADVERTISING AND BUSINESS

FOR REFERRALS FOR AT-RISK CHILDREN IN THE FIELD OF SOCIAL SERVICES (U.S. CLS. 100, 101 AND 102).

FIRST USE 7-13-2003; IN COMMERCE 7-31-2004.

CLASS 36—INSURANCE AND FINANCIAL

FOR CHARITABLE FUND RAISING SERVICES, NAMELY, FUND RAISING FOR AT-RISK CHILDREN AND THEIR FAMILIES; FINANCIAL SPONSORSHIP OF YOUTH PROGRAMS (U.S. CLS. 100, 101 AND 102).

FIRST USE 7-13-2003; IN COMMERCE 7-31-2004.

CLASS 41—EDUCATION AND ENTERTAINMENT

FOR EDUCATIONAL AND CHARITABLE SERVICES, NAMELY, PROVIDING EDUCATIONAL MENTORING AND EDUCATIONAL COUNSELING TO AT-RISK CHILDREN, AND TUTORING AND HOMEWORK ASSISTANCE TO AT-RISK CHILDREN (U.S. CLS. 100, 101 AND 107).

FIRST USE 7-13-2003; IN COMMERCE 7-31-2004.

SANJEEV VOHRA, EXAMINING ATTORNEY

SN 77-219,787. OCTAVIAN INTERNATIONAL LIMITED, WOODFORD GREEN, UNITED KINGDOM, FILED 6-30-2007.

SYMPHONY

THE MARK CONSISTS OF STANDARD CHARACTERS WITHOUT CLAIM TO ANY PARTICULAR FONT, STYLE, SIZE, OR COLOR.

PRIORITY CLAIMED UNDER SEC. 44(D) ON ERPNCMNTY TM OFC APPLICATION NO. 005811468, FILED 4-4-2007, REG. NO. 005811468, DATED 5-3-2008, EXPIRES 5-3-2018.

CLASS 9—ELECTRICAL AND SCIENTIFIC APPARATUS

FOR COMPUTER OPERATING PROGRAMS AND COMPUTER OPERATING SYSTEMS FOR OPERATING MACHINES DEDICATED TO ARCADE GAMES AND ELECTRONIC GAMES; COMPUTER SOFTWARE, NAMELY, OPERATING SYSTEM PROGRAMS AND UTILITIES FOR GAMES OF CHANCE, CASINO OR AMUSEMENT GAMES ADAPTED FOR USE WITH TELEVISION RECEIVERS OR ON COMPUTERIZED PLATFORMS, NAMELY, DEDICATED GAMING MACHINES (U.S. CLS. 21, 23, 26, 36 AND 38).

CLASS 28—TOYS AND SPORTING GOODS

FOR COIN-OPERATED AMUSEMENT GAME MACHINES; FLOOR-STANDING OR TABLETOP UNITS FOR PLAYING ELECTRONIC GAMES OTHER THAN IN CONJUNCTION WITH A TELEVISION OR COMPUTER; GAMING CHIPS; ELECTRONIC ARCADE GAMES (U.S. CLS. 22, 23, 38 AND 50).

CLASS 41—EDUCATION AND ENTERTAINMENT

FOR RENTAL OF GAMING MACHINES; CASINO SERVICES (U.S. CLS. 100, 101 AND 107).
CHRISTINE COOPER, EXAMINING ATTORNEY

SN 77-221,404. DER GRUNE PUNKT - DUALES SYSTEM DEUTSCHLAND GMBH, COLOGNE, FED REP GERMANY, FILED 7-3-2007.

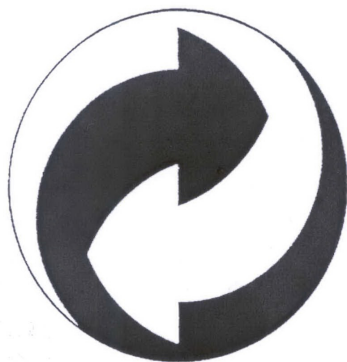

OWNER OF FED REP GERMANY REG. NO. 2001158, DATED 4-17-1991, EXPIRES 12-7-2010.

OWNER OF U.S. REG. NOS. 2,013,156, 2,212,057 AND 2,868,283.

THE MARK CONSISTS OF ARROWS FORMING A CIRCLE OR AN ARC OF A CIRCLE.

CLASS 35—ADVERTISING AND BUSINESS

FOR BUSINESS MANAGEMENT AND ORGANIZATION CONSULTING, NAMELY, CONSULTATION TO COMPANIES THAT MANUFACTURE PACKAGING AND/OR PACKAGING MATERIALS, IN THE DEVELOPMENT, SELECTION AND USE OF MORE ECOLOGICALLY COMPATIBLE AND ECONOMICALLY USABLE PACKAGING AND PACKAGING MATERIALS, AND IN THE LABELING OF SUCH PACKAGING AND PACKAGING MATERIALS; CONSULTATION FOR CONSUMERS REGARDING THE PURCHASE OF ECOLOGICALLY COMPATIBLE PACKAGING AND PACKAGING MATERIALS (U.S. CLS. 100, 101 AND 102).

CLASS 36—INSURANCE AND FINANCIAL

FOR FINANCING SERVICES, NAMELY, NEGOTIATING FUNDS ON BEHALF OF OTHERS FOR INVESTMENT IN FACTORIES, PLANTS, EQUIPMENT, AND SERVICES WHICH SPECIALIZE IN THE COLLECTION, TRANSPORTATION, SORTING AND USE OF WASTE AND SECONDARY RAW MATERIALS, NAMELY, RECYCLABLE PACKAGING AND PACKAGING MATERIALS MADE FROM GLASS, PAPER, CARDBOARD, ALUMINUM, PLASTIC, AND COMPOSITES OF PAPER, CARDBOARD, PLASTIC, AND ALUMINUM (U.S. CLS. 100, 101 AND 102).

CLASS 39—TRANSPORTATION AND STORAGE

FOR TRANSPORTATION OF WASTE AND SECONDARY RAW MATERIALS, NAMELY, RECYCLABLE PACKAGING AND PACKAGING MATERIALS MADE FROM GLASS, PAPER, CARDBOARD, ALUMINUM, PLASTIC, AND COMPOSITES OF PAPER, CARDBOARD, PLASTIC, AND ALUMINUM, BY TRUCK, RAIL AND BARGE (U.S. CLS. 100 AND 105).

CLASS 40—MATERIAL TREATMENT

FOR SORTING OF WASTE AND SECONDARY RAW MATERIALS FOR OTHERS, BY MEANS OF CHEMICAL, PHYSICAL AND/OR BIOLOGICAL PROCESSES; SORTING FOR OTHERS OF RECYCLABLE WASTE AND SECONDARY RAW MATERIALS, NAMELY, RECYCLABLE PACKAGING AND PACKAGING MATERIALS MADE FROM GLASS, PAPER, CARDBOARD, ALUMINUM, PLASTIC, AND COMPOSITES OF PAPER, CARDBOARD, PLASTIC, AND ALUMINUM, BY MEANS OF CHEMICAL, PHYSICAL, AND/OR BIOLOGICAL PROCESSES; CONSULTATION FOR CONSUMERS REGARDING THE RECYCLING OF ECOLOGICALLY COMPATIBLE PACKAGING AND PACKAGING MATERIALS (U.S. CLS. 100, 103 AND 106).

CLASS 42—SCIENTIFIC AND COMPUTER SERVICES

FOR CONDUCTING TECHNICAL FEASIBILITY STUDIES FOR CONSUMERS REGARDING ECOLOGICALLY COMPATIBLE PACKAGING AND PACKAGING MATERIALS (U.S. CLS. 100 AND 101).

BARBARA GAYNOR, EXAMINING ATTORNEY

SN 77-223,210. EVOLUTION FITNESS CORPORATION, CALGARY, AB, CANADA, FILED 7-6-2007.

IFlow

THE MARK CONSISTS OF STANDARD CHARACTERS WITHOUT CLAIM TO ANY PARTICULAR FONT, STYLE, SIZE, OR COLOR.

PRIORITY CLAIMED UNDER SEC. 44(D) ON CANADA APPLICATION NO. 1344260, FILED 4-20-2007, REG. NO. TMA716,775, DATED 6-17-2008, EXPIRES 6-17-2023.

CLASS 9—ELECTRICAL AND SCIENTIFIC APPARATUS

FOR DIGITAL MEDIA, NAMELY, DVDS FEATURING THE TOPIC OF EXERCISE (U.S. CLS. 21, 23, 26, 36 AND 38).

CLASS 28—TOYS AND SPORTING GOODS

FOR MANUALLY-OPERATED EXERCISE EQUIPMENT, NAMELY, WEIGHT, STRENGTH AND FLEXIBILITY TRAINING EQUIPMENT (U.S. CLS. 22, 23, 38 AND 50).

CLASS 41—EDUCATION AND ENTERTAINMENT

FOR CONDUCTING WORKSHOPS AND SEMINARS IN THE FIELD OF EXERCISE (U.S. CLS. 100, 101 AND 107).

SETH A. RAPPAPORT, EXAMINING ATTORNEY

SN 77-223,473. IDEAVATION PRODUCTS COMPANY, LLC,
UNIONTOWN, OH. FILED 7-6-2007.

SN 77-225,013. ALIOTTA, DEBORAH, STATEN ISLAND, NY,
NY. FILED 7-9-2007.

C2VATION

THE MARK CONSISTS OF STANDARD CHARACTERS WITHOUT CLAIM TO ANY PARTICULAR FONT, STYLE, SIZE, OR COLOR.

CLASS 20—FURNITURE AND ARTICLES NOT OTHERWISE CLASSIFIED

FOR FOOD SERVICE PRODUCTS, NAMELY, DISPOSABLE PLASTIC LIDS AND DRINKING STRAWS (U.S. CLS. 2, 13, 22, 25, 32 AND 50).

CLASS 21—HOUSEWARES AND GLASS

FOR FOOD SERVICE PRODUCTS, NAMELY, DISPOSABLE BEVERAGE AND FOOD CONTAINERS, NAMELY, PLASTIC CUPS, PAPER CUPS, PLASTIC PLATES, PAPER PLATES, PLASTIC BOWLS AND PAPER BOWLS (U.S. CLS. 2, 13, 23, 29, 30, 33, 40 AND 50).
KATHERINE CHANG, EXAMINING ATTORNEY

SN 77-223,519. IDEAVATION PRODUCTS COMPANY, LLC,
UNIONTOWN, OH. FILED 7-6-2007.

C2

THE MARK CONSISTS OF STANDARD CHARACTERS WITHOUT CLAIM TO ANY PARTICULAR FONT, STYLE, SIZE, OR COLOR.

CLASS 20—FURNITURE AND ARTICLES NOT OTHERWISE CLASSIFIED

FOR FOOD SERVICE PRODUCTS, NAMELY, DISPOSABLE PLASTIC LIDS AND DRINKING STRAWS (U.S. CLS. 2, 13, 22, 25, 32 AND 50).

CLASS 21—HOUSEWARES AND GLASS

FOR FOOD SERVICE PRODUCTS, NAMELY, DISPOSABLE BEVERAGE AND FOOD CONTAINERS, NAMELY, PLASTIC CUPS, PAPER CUPS, PLASTIC PLATES, PAPER PLATES, PLASTIC BOWLS AND PAPER BOWLS (U.S. CLS. 2, 13, 23, 29, 30, 33, 40 AND 50).
KATHERINE CHANG, EXAMINING ATTORNEY

Famous Ben's Pizza of Soho

THE MARK CONSISTS OF STANDARD CHARACTERS WITHOUT CLAIM TO ANY PARTICULAR FONT, STYLE, SIZE, OR COLOR.

NO CLAIM IS MADE TO THE EXCLUSIVE RIGHT TO USE "PIZZA OF SOHO", APART FROM THE MARK AS SHOWN.

CLASS 30—STAPLE FOODS

FOR PIZZA, TOMATO AND SPAGHETTI SAUCE (U.S. CL. 46).

CLASS 43—HOTEL AND RESTAURANT SERVICES

FOR RESTAURANT SERVICES (U.S. CLS. 100 AND 101).

HENRY S. ZAK, EXAMINING ATTORNEY

SN 77-225,167. ROSS, FRASER, LOS ANGELES, CA. FILED 7-9-2007.

KITSON LA

THE MARK CONSISTS OF STANDARD CHARACTERS WITHOUT CLAIM TO ANY PARTICULAR FONT, STYLE, SIZE, OR COLOR.

OWNER OF U.S. REG. NO. 3,217,006.

NO CLAIM IS MADE TO THE EXCLUSIVE RIGHT TO USE "LA", APART FROM THE MARK AS SHOWN.
"KITSON" HAS NO MEANING IN A FOREIGN LANGUAGE.

CLASS 20—FURNITURE AND ARTICLES NOT OTHERWISE CLASSIFIED

FOR PICTURE FRAMES, NAMELY, PICTURE FRAMES NOT OF PRECIOUS METAL, PICTURE FRAMES OF PRECIOUS METAL, PICTURE FRAME MOULDINGS, PAPER PICTURE FRAMES, LEATHER PICTURE FRAMES, AND PLASTIC AND/OR WOOD DECORATIVE BOXES; DECORATIVE PILLOWS; SHOWER CURTAIN HARDWARE, NAMELY, CURTAIN RODS AND HOOKS (U.S. CLS. 2, 13, 22, 25, 32 AND 50).

CLASS 21—HOUSEWARES AND GLASS

FOR TRAYS, NAMELY, SERVING TRAYS, SERVING TRAYS NOT OF PRECIOUS METAL, SERVING TRAYS OF PRECIOUS METAL, TRAYS NOT OF PRECIOUS METAL (U.S. CLS. 2, 13, 23, 29, 30, 33, 40 AND 50).

CLASS 24—FABRICS

FOR BEDDING, TOP OF BED, NAMELY, COMFORTERS, BED SKIRTS, SHAMS, BLANKETS, DUVET COVERS AND THROWS, BED SHEETS, INCLUDING FLAT AND FITTED SHEETS, PILLOWCASES, DECORATIVE THROWS, DECORATIVE BLANKET THROWS, DECORATIVE BED BLANKETS; BATH LINENS AND RELATED ACCESSORIES, NAMELY, TOWELS, SHOWER CURTAINS; TEXTILE TABLE LINENS, NAMELY, PLACEMATS, TABLE CLOTHS, NAPKINS; FABRIC WINDOW COVERINGS, NAMELY, DRAPERIES, SHEERS, VALANCES (U.S. CLS. 42 AND 50).

SUE LAWRENCE, EXAMINING ATTORNEY

SN 77-226,157. FILA LUXEMBOURG S.A. R.L, LUXEMBOURG, LUXEMBOURG, FILED 7-10-2007.



S P O R T

SN 77-226,139. FILA LUXEMBOURG S.A. R.L, LUXEMBOURG, LUXEMBOURG, FILED 7-10-2007.



OWNER OF U.S. REG. NOS. 1,032,383, 1,196,746 AND OTHERS.

NO CLAIM IS MADE TO THE EXCLUSIVE RIGHT TO USE SPORT, APART FROM THE MARK AS SHOWN.

THE COLOR(S) RED, WHITE, AND BLUE IS/ARE CLAIMED AS A FEATURE OF THE MARK.

THE MARK CONSISTS OF A STYLIZED LETTER "F" IN BLUE WITH THE TOP LINE OF THE LETTER IN RED AND CONTAINING THE WORD "SPORT" IN WHITE.

CLASS 9—ELECTRICAL AND SCIENTIFIC APPARATUS

FOR EYEWEAR (U.S. CLS. 21, 23, 26, 36 AND 38).

CLASS 18—LEATHER GOODS

FOR HANDBAGS, LUGGAGE, GYM BAGS, ALL-PURPOSE ATHLETIC BAGS, CARRY-ALL BAGS, BACKPACKS (U.S. CLS. 1, 2, 3, 22 AND 41).

CLASS 24—FABRICS

FOR TOWELS, BED SHEETS, WASH CLOTHS, HOUSEHOLD LINENS (U.S. CLS. 42 AND 50).

CLASS 25—CLOTHING

FOR CLOTHING AND APPAREL, NAMELY, SHIRTS, SWEAT-SHIRTS, SHORTS, PANTS, SWIMWEAR, OUTERWEAR, NAMELY, COATS, JACKETS, VESTS, FLEECES, SWEATERS, UNDERWEAR, ROBES, SKIRTS, DRESSES, WARM-UPS, SLEEPWEAR, WRISTBANDS, SOCKS, FOOTWEAR, HOSIERY, BELTS, SCARVES, HEADGEAR, NAMELY, HEADBANDS, VISORS, HATS, AND CAPS (U.S. CLS. 22 AND 39).

PAUL F. GAST, EXAMINING ATTORNEY

OWNER OF U.S. REG. NOS. 1,032,383, 1,196,746 AND OTHERS.

NO CLAIM IS MADE TO THE EXCLUSIVE RIGHT TO USE "SPORT", APART FROM THE MARK AS SHOWN.

THE COLOR(S) RED AND BLUE IS/ARE CLAIMED AS A FEATURE OF THE MARK.

THE MARK CONSISTS OF A STYLIZED LETTER "F" IN BLUE WITH THE TOP LINE OF THE LETTER IN RED AND THE WORD "SPORT" IN BLUE BELOW THE LETTER "F".

CLASS 9—ELECTRICAL AND SCIENTIFIC APPARATUS

FOR EYEWEAR (U.S. CLS. 21, 23, 26, 36 AND 38).

CLASS 18—LEATHER GOODS

FOR HANDBAGS, LUGGAGE, GYM BAGS, ALL-PURPOSE ATHLETIC BAGS, CARRY-ALL BAGS, BACKPACKS (U.S. CLS. 1, 2, 3, 22 AND 41).

CLASS 24—FABRICS

FOR TOWELS, BED SHEETS, WASH CLOTHS, HOUSEHOLD LINENS (U.S. CLS. 42 AND 50).

CLASS 25—CLOTHING

FOR CLOTHING AND APPAREL, NAMELY, SHIRTS, SWEAT-SHIRTS, SHORTS, PANTS, SWIMWEAR, OUTERWEAR, NAMELY, COATS, JACKETS, VESTS, FLEECES, SWEATERS, UNDERWEAR, ROBES, SKIRTS, DRESSES, WARM-UPS, SLEEPWEAR, WRISTBANDS, SOCKS, FOOTWEAR, HOSIERY, BELTS, SCARVES, HEADGEAR, NAMELY, HEADBANDS, VISORS, HATS, AND CAPS (U.S. CLS. 22 AND 39).

PAUL F. GAST, EXAMINING ATTORNEY

SN 77-226,417. SIGN SETTERS FRANCHISE CO., PHOENIX, AZ. FILED 7-10-2007.



OWNER OF U.S. REG. NO. 3,380,471. SEC. 2(F) AS TO "SIGN SETTERS".

CLASS 35—ADVERTISING AND BUSINESS

FOR ON-LINE SERVICES, NAMELY, ORDERING AND INVENTORY MONITORING OF THE SIGNS OWNED AND/OR USED BY REAL ESTATE AGENTS (U.S. CLS. 100, 101 AND 102).

CLASS 37—CONSTRUCTION AND REPAIR

FOR PLACEMENT AND REMOVAL OF SIGNS FOR REAL ESTATE AGENTS (U.S. CLS. 100, 103 AND 106).
KATHERINE CHANG, EXAMINING ATTORNEY

SN 77-226,740. FLUIDESIGN COMPOSITES INC., LONDON, CANADA, FILED 7-11-2007.



PRIORITY CLAIMED UNDER SEC. 44(D) ON CANADA APPLICATION NO. 1342272, FILED 3-27-2007, REG. NO. TMA708080, DATED 2-22-2008, EXPIRES 2-22-2023.

THE MARK CONSISTS OF A DESIGN OF A RACING SHELL STYLED ROWING BOAT.

CLASS 12—VEHICLES

FOR RACING SHELLS; NAMELY, ROWING BOATS (U.S. CLS. 19, 21, 23, 31, 35 AND 44).
FIRST USE 6-30-2000; IN COMMERCE 6-30-2000.

CLASS 25—CLOTHING

FOR CLOTHING, NAMELY, CAPS, T-SHIRTS, CASUAL SHIRTS AND LIGHT JACKETS AND ATHLETIC CLOTHING, NAMELY, SWEATSHIRTS, SPORT SHORTS AND SOCKS (U.S. CLS. 22 AND 39).
SCOTT BIBB, EXAMINING ATTORNEY

SN 77-227,833. ANTE-HOLZ GMBH, BROMSKIRCHEN, FED REP GERMANY, FILED 7-12-2007.

ante-holz

THE COLOR(S) BLACK, WHITE, YELLOW, RED, GREEN, BLUE, ORANGE IS/ARE CLAIMED AS A FEATURE OF THE MARK.

THE MARK CONSISTS OF STYLIZED ANTE-HOLZ IN WHITE WITH BLACK OUTLINE, COLOR BLOCKS UNDER ANTE-HOLZ IN YELLOW, RED, GREEN, BLUE, AND ORANGE.

CLASS 4—LUBRICANTS AND FUELS

FOR FUEL PRODUCTS MADE OF WOOD, NAMELY, WOOD HEATING PELLETS AND WOOD BRIQUETTES; WOOD SPLINTS FOR USE AS FUEL (U.S. CLS. 1, 6 AND 15).

CLASS 19—NON-METALLIC BUILDING MATERIALS

FOR BUILDING MATERIALS, NAMELY, SEMI-WORKED WOODS, PRE-FABRICATED LOG HOMES MADE OF DEAL BOARDS; PRE-FABRICATED ELEMENTS FOR PRE-FABRICATED HOUSES, GARDEN HOUSES AND TOOL SHEDS, NOT OF METAL, NAMELY, CONCRETE, STONES, SEMI-WORKED WOOD PAVING STONES, AND TILES OF CLAY, GLASS, GYPSUM, CERAMIC OR EARTHENWARE; PRE-FABRICATED BUILDINGS, NAMELY, GARDEN HOUSES AND TOOL SHEDS, NOT OF METAL, SOLD IN KIT FORM; NON-METAL ROOF COVERINGS; TRANSPORTABLE BUILDINGS, MADE OF WOOD; ROOF-TRUSSES MADE OF WOOD; SEMI-WORKED WOOD, NAMELY, WOOD BEAMS, PLANED WOOD BOARDS, PLYWOOD BOARDS; WOODBOARDS, NON-METALLIC REINFORCEMENTS FOR CONCRETE AND WOOD BUILDING CONSTRUCTION, NAMELY, WOODEN PLATES; WOODEN SCANTLINGS, NAMELY, SMALL TIMBERS USED IN CARPENTRY CONSTRUCTION; HALF-ROUNDED TIMBERS; ALIGNMENT WALERS, CONSTRUCTION TIMBER; FLOORBOARDS OF WOOD; WOOD TILE FLOORING; WINDOW AND DOOR SILLS MADE OF WOOD; WOODEN PAVING TILES; CARPORTS OF WOOD; NON-METAL FENCES; NON-METAL TRELLISES; PERGOLAS NOT PRIMARILY OF METAL; NON-METAL EXTERIOR BLINDS; NON-METAL BUILDING MATERIALS, NAMELY, PARTITIONS; GAZEBOS NOT PRIMARILY OF METAL; COMPOSTERS NOT OF METAL; PALINGS AND POSTS, NOT OF METAL; WOOD PALISADES; BUILDING MATERIAL, NAMELY, ESPALIER BATTENS FOR USE AS WOOD BOARDS (U.S. CLS. 1, 12, 33 AND 50).

CLASS 20—FURNITURE AND ARTICLES NOT OTHERWISE CLASSIFIED

FOR PEGS MADE OF WOOD; FURNITURE; GARDEN FURNITURE; TABLES; AND WOODEN STORAGE RACKS; WINDOW BLINDS FOR INTERIOR USE (U.S. CLS. 2, 13, 22, 25, 32 AND 50).

TAMARA FRAZIER, EXAMINING ATTORNEY

SN 77-228,251. ENVIRONMENTAL PACKAGING TECHNOLOGIES LIMITED, HOUSTON, TX. FILED 7-12-2007.

BIG RED PACKAGING

THE MARK CONSISTS OF STANDARD CHARACTERS WITHOUT CLAIM TO ANY PARTICULAR FONT, STYLE, SIZE, OR COLOR.

NO CLAIM IS MADE TO THE EXCLUSIVE RIGHT TO USE "PACKAGING", APART FROM THE MARK AS SHOWN.

CLASS 37—CONSTRUCTION AND REPAIR

FOR SERVICING OF STACKABLE, COLLAPSIBLE, UNIVERSAL BULK PACKING CONTAINERS FOR STORING AND SHIPPING NON-HAZARDOUS, HAZARDOUS AND FOOD GRADE PRODUCTS IN THE FORM OF LIQUIDS, SOLIDS, SLURRIES OR FLUIDS, NAMELY, REFITTING OF CONTAINERS FOR RE-USE (U.S. CLS. 100, 103 AND 106).

CLASS 39—TRANSPORTATION AND STORAGE

FOR LEASING OF STACKABLE, COLLAPSIBLE, UNIVERSAL BULK PACKING CONTAINERS FOR STORING AND SHIPPING NON-HAZARDOUS, HAZARDOUS AND FOOD GRADE PRODUCTS IN THE FORM OF LIQUIDS, SOLIDS, SLURRIES OR FLUIDS (U.S. CLS. 100 AND 105).

CLASS 40—MATERIAL TREATMENT

FOR ENVIRONMENTAL RECOVERY SERVICES IN THE FIELD OF STACKABLE, COLLAPSIBLE, UNIVERSAL BULK PACKING CONTAINERS FOR STORING AND SHIPPING NON-HAZARDOUS, HAZARDOUS AND FOOD GRADE PRODUCTS IN THE FORM OF LIQUIDS, SOLIDS, SLURRIES AND FLUIDS, NAMELY, RECYCLING OF STACKABLE, COLLAPSIBLE, UNIVERSAL BULK PACKING CONTAINERS FOR STORING AND SHIPPING NON-HAZARDOUS, HAZARDOUS AND FOOD GRADE PRODUCTS IN THE FORM OF LIQUIDS, SOLIDS, SLURRIES OR FLUIDS (U.S. CLS. 100, 103 AND 106).

SETH A. RAPPAPORT, EXAMINING ATTORNEY

SN 77-228,900. PURUS AB, SJOBO, SWEDEN, FILED 7-13-2007.

PURUS

THE MARK CONSISTS OF STANDARD CHARACTERS WITHOUT CLAIM TO ANY PARTICULAR FONT, STYLE, SIZE, OR COLOR.

CLASS 6—METAL GOODS

FOR WATER AND DISCHARGE CONDUITS, WATER AND EXIT PIPES AND STRUCTURAL PARTS THERETO, PIPE CLIPS AND CLAMPS AND CLIPS AND CLAMPS FOR WATER AND DISCHARGE CONDUITS AS WELL AS WATER AND EXIT PIPES FOR SANITARY INSTALLATIONS, WATERSEALS, INSERT RINGS FOR MOUNTING OF WATERSEAL INSERTS IN FLOOR DRAINS AND SCUPPERS, EXTENSION RINGS AND WIRE ROPE FITTINGS OF METAL, NAMELY, SOCKETS, FOR FLOOR DRAINS AND SCUPPERS, GRATINGS AND COVERS FOR FLOOR DRAINS AND SCUPPERS, MOUNTING PLATES FOR FLOOR DRAINS AND SCUPPERS, DRAIN PIPES, NAMELY, DRAINAGE GULLIES AND DISCHARGE CHUTES AND GRATES THEREFOR, OIL GUARDS, NAMELY, METAL GUARD BARRIERS FOR KEEPING OIL FROM ENTERING DRAINS, METAL CONDUITS, NAMELY, WASH CHUTES AND GULLIES, ALL OF THE PRECEDING GOODS MADE OF METAL (U.S. CLS. 2, 12, 13, 14, 23, 25 AND 50).

CLASS 11—ENVIRONMENTAL CONTROL APPARATUS

FOR PLUMBING FITTINGS, NAMELY, DRAINS, FLOOR DRAINS, AND SCUPPERS; WATER AND EXIT PIPES AND STRUCTURAL PARTS THERETO BEING PARTS OF SANITARY INSTALLATIONS; WATER FILTER DEVICES AND WATER FILTERS; WATER-PURIFICATION APPARATUS; SINKS; DISCHARGE OR SETTLING SINKS; SINKS, NAMELY, WASH BASINS; WATER-CLOSETS AND URINALS; OVERFLOW PROTECTIONS, NAMELY, TUB OVERFLOWS (U.S. CLS. 13, 21, 23, 31 AND 34).

CLASS 17—RUBBER GOODS

FOR WATER AND DISCHARGE CONDUITS FOR SANITARY INSTALLATIONS, NAMELY, PLASTIC CONDUITS FOR PLUMBING USE; PLASTIC WATER AND DISCHARGE CONDUITS FOR PLUMBING USE; RINGS OF RUBBER FOR USE AS PIPE CONNECTION SEALS, NAMELY, EXTENSION RINGS FOR EXTENSION OF FLOOR DRAINS AND SCUPPERS, CLAMPING RINGS FOR CLAMPING FLOOR COVERINGS TO FLOOR DRAINS AND SCUPPERS, INSERT RINGS FOR MOUNTING OF WATERSEAL INSERTS IN FLOOR DRAINS AND SCUPPERS AND MOUNTING PLATES FOR FLOOR DRAINS AND SCUPPERS; NON-METAL SEALS FOR USE IN PLUMBING, NAMELY, WATERSEALS AND WATERSEAL INSERTS; SEALING PLUGS MADE PRIMARILY FROM RUBBER, NAMELY, MUD PLUGS; PLASTIC CONDUITS FOR PLUMBING USE, NAMELY, WASH CHUTES AND GULLIES (U.S. CLS. 1, 5, 12, 13, 35 AND 50).

CLASS 19—NON-METALLIC BUILDING MATERIALS

FOR WATER AND DISCHARGE CONDUITS, NAMELY, PLASTIC CONDUITS FOR DRAINAGE, NON-METALLIC WATER AND EXIT PIPES AND STRUCTURAL PARTS THERETO; NON-METALLIC CONSTRUCTION MATERIALS, NAMELY, DRAINAGE DEVICES IN THE NATURE OF OVERFLOW PROTECTIONS AND OIL GUARDS; NON-METAL VENTILATING DUCTS, NAMELY, AIR VENTS FOR DRAINAGE SYSTEMS; PLASTIC CONDUITS FOR DRAINAGE, NAMELY, WASH CHUTES AND GULLIES; NON-METALLIC DRAINS, NAMELY, NON-METAL FLOOR DRAINS AND SCUPPERS (U.S. CLS. 1, 12, 33 AND 50).

CLASS 20—FURNITURE AND ARTICLES NOT OTHERWISE CLASSIFIED

FOR NON-METALLIC PIPE CLIPS AND CLAMPS, AND NON-METALLIC CLIPS AND CLAMPS FOR WATER AND DISCHARGE CONDUITS AS WELL AS WATER AND EXIT PIPES FOR SANITARY INSTALLATIONS (U.S. CLS. 2, 13, 22, 25, 32 AND 50).

ALLISON SCHRODY, EXAMINING ATTORNEY

SN 77-230,920. TWENTIETH CENTURY FOX FILM CORPORATION, LOS ANGELES, CA. FILED 7-16-2007.

FOX BUSINESS NETWORK

THE MARK CONSISTS OF STANDARD CHARACTERS WITHOUT CLAIM TO ANY PARTICULAR FONT, STYLE, SIZE, OR COLOR.

OWNER OF U.S. REG. NOS. 2,697,436, 2,945,312 AND OTHERS.

NO CLAIM IS MADE TO THE EXCLUSIVE RIGHT TO USE "BUSINESS NETWORK", APART FROM THE MARK AS SHOWN.

CLASS 36—INSURANCE AND FINANCIAL

FOR PROVIDING ON-LINE FINANCIAL INFORMATION VIA WIRELESS COMMUNICATION DEVICES, NAMELY, CELL PHONES, PERSONAL DIGITAL ASSISTANTS, COMPUTERS, AND WIRELESS HANDHELDS (U.S. CLS. 100, 101 AND 102).

CLASS 41—EDUCATION AND ENTERTAINMENT

FOR ENTERTAINMENT SERVICES IN THE NATURE OF ON-GOING TELEVISION PROGRAMS FEATURING NEWS, BUSINESS AND FINANCE; ENTERTAINMENT SERVICES IN THE NATURE OF PRODUCTION AND DISTRIBUTION OF TELEVISION PROGRAMS IN THE FIELD OF NEWS, BUSINESS AND FINANCE; ENTERTAINMENT SERVICES IN THE NATURE OF ON-GOING RADIO PROGRAMS FEATURING NEWS, BUSINESS AND FINANCE; ENTERTAINMENT SERVICES IN THE NATURE OF PRODUCTION AND DISTRIBUTION OF RADIO PROGRAMS FEATURING NEWS, BUSINESS AND FINANCE (U.S. CLS. 100, 101 AND 107).

LANA PHAM, EXAMINING ATTORNEY

CLASS 39—TRANSPORTATION AND STORAGE

FOR TRANSMISSION THROUGH PIPELINE, TRUCK, AND TANKER OF PETROLEUM PRODUCTS AND CONDENSATES; TERMINALING SERVICES IN THE NATURE OF PROVIDING PIPELINES TO ENABLE THE TRANSFER OF PETROLEUM PRODUCTS INTO AND OUT OF PIPELINE SYSTEMS; TRANSPORTATION OF PETROLEUM PRODUCTS AND CONDENSATES FOR OTHERS; STORAGE AND HANDLING OF PETROLEUM PRODUCTS AND CONDENSATES; TRANSPORTATION OF PETROLEUM PRODUCTS AND CONDENSATES THROUGH PIPELINES; TRANSPORTATION AND STORAGE OF CRUDE OIL AND CONDENSATES; RENTAL OF SERVICE VEHICLES FOR THE RETRIEVAL, TRANSPORTATION, AND DELIVERY OF CRUDE OIL (U.S. CLS. 100 AND 105).

FIRST USE 3-15-2004; IN COMMERCE 3-15-2004.

CLASS 40—MATERIAL TREATMENT

FOR PROCESSING OF CRUDE OIL, LIQUID PETROLEUM GAS, AND CONDENSATES (U.S. CLS. 100, 103 AND 106).

FIRST USE 3-15-2004; IN COMMERCE 3-15-2004.

CLASS 42—SCIENTIFIC AND COMPUTER SERVICES

FOR OILFIELD SERVICES, NAMELY, TECHNOLOGY CONSULTATION IN THE FIELD OF OPERATION OF PIPELINE TRUCK INJECTION STATIONS (U.S. CLS. 100 AND 101).

JESSICA A. POWERS, EXAMINING ATTORNEY

SN 77-231,763. SEMGROUP, L.P., TULSA, OK. FILED 7-17-2007.



OWNER OF U.S. REG. NOS. 3,291,763 AND 3,291,764. THE COLOR(S) RED, BLACK AND GRAY IS/ARE CLAIMED AS A FEATURE OF THE MARK.

THE MARK CONSISTS OF A CUBE-SHAPED LOGO CONSISTING OF THREE RED STYLIZED LETTER "S"'S, TO THE RIGHT OF WHICH IS THE WORDING "SEM-CRUDE" WITH "SEM" IN BLACK THE "CRUDE" IN GRAY.

THE WORDING "SEM" OR "SEMCRUDE" HAS NO MEANING IN A FOREIGN LANGUAGE.

CLASS 35—ADVERTISING AND BUSINESS

FOR ADVERTISING AND MARKETING AND DISTRIBUTION AND DISSEMINATION OF ADVERTISING MATERIALS RELATED TO THE CRUDE OIL AND CONDENSATE GATHERING INDUSTRY; ADVERTISING AND MARKETING SERVICES IN THE FIELD OF PETROLEUM PRODUCTS AND CONDENSATES; OIL AND CONDENSATE MARKET ANALYSIS AND MARKET RESEARCH SERVICES; EXCHANGE SERVICES, NAMELY BARTERING OF GOODS FOR OTHERS (U.S. CLS. 100, 101 AND 102).

CLASS 37—CONSTRUCTION AND REPAIR

FOR GATHERING IN THE NATURE OF DRILLING AND PUMPING OF PETROLEUM PRODUCTS AND CONDENSATES; INSTALLATION AND MAINTENANCE OF CONDENSATE, CRUDE OIL, AND PETROLEUM PRODUCT PIPELINE (U.S. CLS. 100, 103 AND 106).

FIRST USE 3-15-2004; IN COMMERCE 3-15-2004.

SN 77-235,632. EQUIPMENT ACQUISITION RESOURCES, INC., PALATINE, IL. FILED 7-22-2007.

EAR TECHNOLOGY

THE MARK CONSISTS OF STANDARD CHARACTERS WITHOUT CLAIM TO ANY PARTICULAR FONT, STYLE, SIZE, OR COLOR.

NO CLAIM IS MADE TO THE EXCLUSIVE RIGHT TO USE "TECHNOLOGY", APART FROM THE MARK AS SHOWN.

CLASS 7—MACHINERY

FOR (BASED ON INTENT TO USE) MACHINES FOR SLICING, DICING, LAPPING, GRINDING, POLISHING, LACQUERING AND COATING SUBSTRATES AND DISKS; MACHINES FOR THE HARDENING OF COATINGS AND LACQUERS; MACHINES FOR THE CLEANING OF SUBSTRATES, DISKS, AND MASKS; MACHINES FOR THE INSPECTION OF SUBSTRATES AND DISKS; MACHINES FOR THE ETCHING OF LAYERS ON SUBSTRATES; AND MACHINES FOR THE MANUFACTURING, LACQUERING, AND COATING OF OPTICAL INFORMATION STORAGE MEDIA, ALL ABOVE LISTED MACHINES IN THE FIELDS OF SEMICONDUCTOR MANUFACTURING, NANOTECHNOLOGY, NANOSCIENCES AND ADVANCED MATERIALS (U.S. CLS. 13, 19, 21, 23, 31, 34 AND 35).

CLASS 35—ADVERTISING AND BUSINESS

FOR (BASED ON USE IN COMMERCE) ONLINE STORE SERVICES FEATURING NEW AND REFURBISHED EQUIPMENT AND MATERIALS IN THE FIELDS OF SEMICONDUCTOR MANUFACTURING, NANOTECHNOLOGY, NANOSCIENCES AND ADVANCED MATERIALS (U.S. CLS. 100, 101 AND 102).
FIRST USE 6-1-2007; IN COMMERCE 6-1-2007.

CLASS 40—MATERIAL TREATMENT

FOR (BASED ON USE IN COMMERCE) PROTOTYPE FABRICATION OF NEW PRODUCTS FOR OTHERS; PILOT MANUFACTURING, NAMELY, MANUFACTURING NEW PRODUCTS TO THE ORDER AND SPECIFICATION OF OTHERS, ALL IN THE FIELDS OF SEMICONDUCTOR MANUFACTURING, NANOTECHNOLOGY, NANOSCIENCES AND ADVANCED MATERIALS (U.S. CLS. 100, 103 AND 106).
FIRST USE 6-1-2007; IN COMMERCE 6-1-2007.

CLASS 42—SCIENTIFIC AND COMPUTER SERVICES

FOR (BASED ON USE IN COMMERCE) SCIENTIFIC RESEARCH AND DEVELOPMENT; NEW TECHNOLOGY DEVELOPMENT FOR OTHERS IN THE FIELDS OF SEMICONDUCTOR MANUFACTURING, NANOTECHNOLOGY, NANOSCIENCES AND ADVANCED MATERIALS; PRODUCT DEVELOPMENT FOR OTHERS; NEW MATERIALS DEVELOPMENT FOR OTHERS; CHARACTERIZATION AND TESTING OF PRODUCTS AND MATERIALS FOR OTHERS; TECHNOLOGY COMMERCIALIZATION SERVICES, NAMELY, ASSISTING BUSINESSES IN TRANSFORMING IDEAS INTO COMMERCIAL PRODUCTS IN THE NATURE OF PRODUCT DEVELOPMENT FOR OTHERS; ENGINEERING AND TECHNOLOGICAL CONSULTING SERVICES FOR OTHERS; DESIGN AND TESTING OF MANUFACTURING APPLICATIONS AND PROCESSES, ALL IN THE FIELDS OF SEMICONDUCTOR MANUFACTURING, NANOTECHNOLOGY, NANOSCIENCES AND ADVANCED MATERIALS (U.S. CLS. 100 AND 101).
FIRST USE 6-1-2007; IN COMMERCE 6-1-2007.
RAUL CORDOVA, EXAMINING ATTORNEY

SN 77-235,748. LG CHEM, LTD., SEOUL, REPUBLIC OF KOREA, FILED 7-23-2007.

LOVELLO

THE MARK CONSISTS OF STANDARD CHARACTERS WITHOUT CLAIM TO ANY PARTICULAR FONT, STYLE, SIZE, OR COLOR.

OWNER OF REPUBLIC OF KOREA REG. NO. 0702011, DATED 3-14-2007, EXPIRES 3-14-2017.

OWNER OF REPUBLIC OF KOREA REG. NO. 0702009, DATED 3-14-2007, EXPIRES 3-14-2017.

CLASS 11—ENVIRONMENTAL CONTROL APPARATUS

FOR PREFABRICATED BATHROOM KITS CONSISTING OF BATHTUB AND BATHROOM SINK; SHOWERS; BOWLS OF LAVATORY; LAVATORIES; BATH TUBS; SHOWER CUBICLES; SINKS; TOPS OF KITCHEN SINKS, NAMELY, COVERINGS AND COATINGS FOR SURFACE OF KITCHEN SINKS SOLD AS A COMPONENT PART OF THE SINKS; GAS RANGE TABLES; TOILET BOWLS; BIDETS (U.S. CLS. 13, 21, 23, 31 AND 34).

CLASS 19—NON-METALLIC BUILDING MATERIALS

FOR WOOD VENEERS; NON-METALLIC OUTER DOORS; NON-METALLIC DOOR PANELS; NON-METALLIC GATES; NON-METALLIC DOOR FRAMES; ARTIFICIAL STONE; ARTIFICIAL MARBLE; NON-METALLIC BUILDING PANELS; NON-METALLIC FLOORING, NAMELY, LAMINATE FLOORING, RUBBER FLOORING, AND WOODEN FLOORING; SYNTHETIC RESINS-FACED SHEETS, NAMELY, SYNTHETIC DECORATIVE OR WATERPROOFING SHEETS FOR USE AS BUILDING MATERIALS; NON-METALLIC CEILING BOARDS; NON-METALLIC WINDOW FRAMES; NON-METALLIC CASEMENT WINDOWS; VINYL TILES; PLASTIC TILES; TOPS OF KITCHEN SINKS, NAMELY, NON-METAL COVERINGS AND COATINGS FOR SURFACE OF KITCHEN SINKS; KITCHEN WORKTOPS, NAMELY, NON-METAL KITCHEN COUNTERS FOR FURTHER INSTALLATION (U.S. CLS. 1, 12, 33 AND 50).
JENNY PARK, EXAMINING ATTORNEY

SN 77-239,185. HACKETT PRECISION COMPANY, INC., NASHVILLE, TN. FILED 7-26-2007.



THE COLOR(S) BLUE, GREEN AND ORANGE IS/ARE CLAIMED AS A FEATURE OF THE MARK.

THE MARK CONSISTS OF THREE SIX SIDED POLYGONS, EACH COMPLETELY SHADED/COLORED IN BLUE, GREEN AND ORANGE.

CLASS 40—MATERIAL TREATMENT

FOR CUSTOM CONSTRUCTION OF MACHINERY FEATURING AUTOMATION AND ROBOTICS FOR USE IN PRODUCTION MANUFACTURING FACILITIES, NAMELY, EQUIPMENT THAT PERMITS CUSTOM INTEGRATION OF MANUFACTURING FACILITIES, AUTOMATED ASSEMBLY AND TEST SYSTEMS, AUTOMATED WELDING SYSTEMS, AUTOMATED METAL REMOVAL SYSTEMS, AUTOMATED MATERIAL HANDLING MACHINERY, MACHINERY THAT PERMITS AUTOMATION AND INTEGRATION OF PROCESSES IN MANUFACTURING FACILITIES, ROBOTIC ASSEMBLY AND PACKAGING MACHINERY, TOOLING MACHINERY, AND FIXTURING EQUIPMENT, NAMELY, EQUIPMENT UTILIZING CUSTOM ENGINEERED EQUIPMENT OR ROBOTICS FOR THE ASSEMBLY OR SUBASSEMBLY OF MANUFACTURE GOODS (U.S. CLS. 100, 103 AND 106).
FIRST USE 7-11-2007; IN COMMERCE 7-11-2007.

CLASS 42—SCIENTIFIC AND COMPUTER SERVICES

FOR CUSTOM DESIGN AND ENGINEERING OF MACHINERY FEATURING AUTOMATION AND ROBOTICS FOR USE IN PRODUCTION MANUFACTURING FACILITIES, NAMELY, EQUIPMENT THAT PERMITS CUSTOM INTEGRATION OF MANUFACTURING FACILITIES, AUTOMATED ASSEMBLY AND TEST SYSTEMS, AUTOMATED WELDING SYSTEMS, AUTOMATED METAL REMOVAL SYSTEMS, AUTOMATED MATERIAL HANDLING MACHINERY, MACHINERY THAT PERMITS AUTOMATION AND INTEGRATION OF PROCESSES IN MANUFACTURING FACILITIES, ROBOTIC ASSEMBLY AND PACKAGING MACHINERY, TOOLING MACHINERY, AND FIXTURING EQUIPMENT, NAMELY, EQUIPMENT UTILIZING CUSTOM ENGINEERED EQUIPMENT OR ROBOTICS FOR THE ASSEMBLY OR SUBASSEMBLY OF MANUFACTURE GOODS (U.S. CLS. 100 AND 101).

FIRST USE 7-11-2007; IN COMMERCE 7-11-2007.
MARY ROSSMAN, EXAMINING ATTORNEY

SN 77-239,730. ASK MY SISTER NETWORK, INC., NEW YORK, NY. FILED 7-26-2007.

ASK MY SISTER

THE MARK CONSISTS OF STANDARD CHARACTERS WITHOUT CLAIM TO ANY PARTICULAR FONT, STYLE, SIZE, OR COLOR.

CLASS 35—ADVERTISING AND BUSINESS

FOR PROVIDING A WEB SITE WHERE USERS CAN POST RATINGS, REVIEWS AND RECOMMENDATIONS ON PRODUCTS AND SERVICES; PROVIDING A WEB SITE FEATURING INFORMATION ON SHOPPING; PROVIDING CAREER INFORMATION VIA A GLOBAL COMPUTER NETWORK (U.S. CLS. 100, 101 AND 102).

CLASS 38—COMMUNICATION

FOR PROVIDING ON-LINE CHAT ROOMS AND LISTSERVERS FOR REGISTERED USERS FOR THE TRANSMISSION OF MESSAGES AMONG COMPUTER USERS CONCERNING GENERAL ENTERTAINMENT, MOVIES, ART, THEATRE, PHOTOGRAPHY, SPORTS, LITERATURE, RESTAURANTS, SHOPPING, BEAUTY, FASHION, AND PROFESSIONAL AND CAREER ADVICE; PROVIDING ON-LINE CHAT ROOMS AND ELECTRONIC BULLETIN BOARDS FOR REGISTERED USERS FOR TRANSMISSION OF MESSAGES AMONG COMPUTER USERS REGARDING THE PROMOTION OF CAREER NETWORKING, PHOTO SHARING, AND PHOTOGRAPHIC IMAGES; PROVIDING ON-LINE FORUMS FOR TRANSMISSION OF MESSAGES AMONG COMPUTER USERS CONCERNING GENERAL ENTERTAINMENT, MOVIES, ART, THEATRE, PHOTOGRAPHY, SPORTS, LITERATURE, RESTAURANTS, SHOPPING, BEAUTY, FASHION, AND PROFESSIONAL AND CAREER ADVICE; PROVIDING ON-LINE CHAT ROOMS AND ELECTRONIC BULLETIN BOARDS FOR TRANSMISSION OF MESSAGES AMONG COMPUTER USERS IN THE FIELD OF GENERAL INTEREST; STREAMING OF AUDIO AND VIDEO MATERIAL ON THE INTERNET; WEB MESSAGING; WEB CASTING SERVICES; VIRTUAL CHAT ROOMS ESTABLISHED VIA TEXT MESSAGING; PROVIDING MULTIPLE USER ACCESS TO GLOBAL COMPUTER INFORMATION NETWORKS; VIDEO BROADCASTING SERVICES; PROVIDING E-MAIL AND INSTANT MESSAGING SERVICES (U.S. CLS. 100, 101 AND 104).

MICHAEL GAAFAR, EXAMINING ATTORNEY

SN 77-240,249. INNOTRODE, LLC, KENILWORTH, IL. FILED 7-27-2007.

INNOTRODE

THE MARK CONSISTS OF STANDARD CHARACTERS WITHOUT CLAIM TO ANY PARTICULAR FONT, STYLE, SIZE, OR COLOR.

CLASS 35—ADVERTISING AND BUSINESS

FOR BUSINESS MANAGEMENT SERVICES AND ADMINISTRATIVE SERVICES IN THE FIELD OF MEDICINE, NAMELY, MANAGING LOGISTICS, ORDERING AND INVENTORY MANAGEMENT IN THE FIELD OF MEDICAL SUPPLIES, BOOKKEEPING, AND BUSINESS PLANNING (U.S. CLS. 100, 101 AND 102).

CLASS 36—INSURANCE AND FINANCIAL

FOR FINANCIAL MANAGEMENT SERVICES (U.S. CLS. 100, 101 AND 102).
TOBY BULLOFF, EXAMINING ATTORNEY

SN 77-240,761. PENNSYLVANIA ASSOCIATION OF FIRE EQUIPMENT DISTRIBUTORS, INC., ERIE, PA. FILED 7-27-2007.



OWNER OF U.S. REG. NO. 3,053,068.

NO CLAIM IS MADE TO THE EXCLUSIVE RIGHT TO USE "PENNSYLVANIA ASSOCIATION OF FIRE EQUIPMENT DISTRIBUTORS" AND "CERTIFIED TECHNICIANS" AND "ESTABLISHED 1988", APART FROM THE MARK AS SHOWN.

CLASS 16—PAPER GOODS AND PRINTED MATTER

FOR PRINTED PUBLICATIONS, NAMELY, NEWSLETTERS, BROCHURES, AND PAMPHLETS FEATURING INFORMATION IN THE FIELD OF FIRE SUPPRESSION (U.S. CLS. 2, 5, 22, 23, 29, 37, 38 AND 50).
FIRST USE 12-0-2005; IN COMMERCE 12-0-2005.

CLASS 41—EDUCATION AND ENTERTAINMENT

FOR EDUCATION SERVICES, NAMELY, PROVIDING CONFERENCE SEMINARS IN THE FIELD OF FIRE SUPPRESSION (U.S. CLS. 100, 101 AND 107).
JAMES LOVELACE, EXAMINING ATTORNEY

SN 77-241,031. GREEN BLUE INSTITUTE, DBA GREEN-BLUE, CHARLOTTESVILLE, VA. FILED 7-27-2007.

SN 77-242,331. AMAZON TECHNOLOGIES, INC., RENO, NV. FILED 7-30-2007.

Sustainable Packaging Coalition

THE MARK CONSISTS OF STANDARD CHARACTERS WITHOUT CLAIM TO ANY PARTICULAR FONT, STYLE, SIZE, OR COLOR.
SEC. 2(F).

CLASS 35—ADVERTISING AND BUSINESS

FOR INFORMATION SERVICES IN THE FIELD OF SUSTAINABLE BUSINESS SOLUTIONS (U.S. CLS. 100, 101 AND 102).

FIRST USE 11-7-2003; IN COMMERCE 3-31-2004.

CLASS 41—EDUCATION AND ENTERTAINMENT

FOR EDUCATION SERVICES, NAMELY, PROVIDING LIVE AND ON-LINE CONFERENCES AND SEMINARS IN THE FIELD OF SUSTAINABLE BUSINESS SOLUTIONS, AND DISTRIBUTION OF PRINTED AND PRINTABLE MATERIAL THEREWITH (U.S. CLS. 100, 101 AND 107).

FIRST USE 11-7-2003; IN COMMERCE 3-31-2004.

ANNE E. GUSTASON, EXAMINING ATTORNEY

SN 77-241,699. JAMES AUSTIN COMPANY, MARS, PA. FILED 7-30-2007.

AUSTIN'S

THE MARK CONSISTS OF STANDARD CHARACTERS WITHOUT CLAIM TO ANY PARTICULAR FONT, STYLE, SIZE, OR COLOR.

OWNER OF U.S. REG. NOS. 591,426, 728,750 AND 1,924,982.

CLASS 3—COSMETICS AND CLEANING PREPARATIONS

FOR HOUSEHOLD CLEANING PREPARATIONS, NAMELY, AMMONIA, GLASS AND WINDOW CLEANER, PINE OIL CLEANER FOR GENERAL CLEANING PURPOSES, LAUNDRY DETERGENT, FABRIC SOFTENER, DISH DETERGENT, LAUNDRY AND GENERAL CLEANING BLEACH, CARPET AND UPHOLSTERY CLEANER, WINDSHIELD WASHER FLUID, DEGREASER PREPARATION NOT USED IN THE MANUFACTURING PROCESS BUT FOR USE ON KITCHEN COUNTER TOPS AND OVENS, HAND SOAP, OVEN AND GRILL CLEANER, LAUNDRY STARCH, MULTI-PURPOSE CLEANER (U.S. CLS. 1, 4, 6, 50, 51 AND 52).

FIRST USE 1-1-1889; IN COMMERCE 1-1-1889.

CLASS 5—PHARMACEUTICALS

FOR SWIMMING POOL SHOCK, NAMELY, PREPARATIONS FOR DISINFECTING WATER IN SWIMMING POOLS, SPAS AND HOT TUBS (U.S. CLS. 6, 18, 44, 46, 51 AND 52).

FIRST USE 1-1-1889; IN COMMERCE 1-1-1889.

DAVID MURRAY, EXAMINING ATTORNEY

CREATESPACE

THE MARK CONSISTS OF STANDARD CHARACTERS WITHOUT CLAIM TO ANY PARTICULAR FONT, STYLE, SIZE, OR COLOR.

CLASS 35—ADVERTISING AND BUSINESS

FOR DISTRIBUTORSHIP SERVICES FEATURING BOOKS MUSIC, MOTION PICTURES, TELEVISION PROGRAMS AND MULTIMEDIA PRODUCTS OF OTHERS IN THE FORM OF PRINTED MATTER, AUDIO RECORDINGS, VIDEO RECORDINGS, DVDS AND COMPACT DISKS; ADVERTISING, MARKETING AND PROMOTION SERVICES; CREATIVE MARKETING DESIGN SERVICES; MERCHANDISE PACKAGING; ORDER FULFILLMENT SERVICES (U.S. CLS. 100, 101 AND 102).

FIRST USE 8-8-2007; IN COMMERCE 8-8-2007.

CLASS 40—MATERIAL TREATMENT

FOR MANUFACTURE OF VIDEO AND AUDIO DISCS AND DVDS TO THE ORDER AND SPECIFICATION OF OTHERS; DUPLICATION OF VIDEO AND AUDIO TAPES, DISCS AND DVDS TO THE ORDER AND SPECIFICATION OF OTHERS (U.S. CLS. 100, 103 AND 106).

FIRST USE 8-8-2007; IN COMMERCE 8-8-2007.

CLASS 41—EDUCATION AND ENTERTAINMENT

FOR PUBLISHING OF BOOKS AND OTHER PRINTED MATTER; VIDEO, AUDIO AND MULTIMEDIA PUBLISHING SERVICES; PRODUCTION OF VIDEO AND AUDIO DISCS OR DVDS FOR OTHERS (U.S. CLS. 100, 101 AND 107).

FIRST USE 8-8-2007; IN COMMERCE 8-8-2007.

DOMINIC J. FERRAIUOLO, EXAMINING ATTORNEY

SN 77-242,376. GOOD WORK STUDIOS, LLC, FRANKLIN, TN. FILED 7-30-2007.

GOOD WORK STUDIOS

THE MARK CONSISTS OF STANDARD CHARACTERS WITHOUT CLAIM TO ANY PARTICULAR FONT, STYLE, SIZE, OR COLOR.

NO CLAIM IS MADE TO THE EXCLUSIVE RIGHT TO USE "STUDIOS", APART FROM THE MARK AS SHOWN.

CLASS 35—ADVERTISING AND BUSINESS

FOR CONSULTING SERVICES IN THE FIELD OF BOOKKEEPING, INTERNAL AUDITING, AND BUSINESS ADMINISTRATION; CONSULTING SERVICES IN THE FIELD OF BUSINESS OPERATIONS, ORGANIZATION, AND MANAGEMENT (U.S. CLS. 100, 101 AND 102).

CLASS 41—EDUCATION AND ENTERTAINMENT

FOR MEDIA PRODUCTION SERVICES, NAMELY, VIDEO AND FILM PRODUCTION (U.S. CLS. 100, 101 AND 107).

CLASS 42—SCIENTIFIC AND COMPUTER SERVICES

FOR CONSULTING SERVICES IN THE FIELD OF FINANCIAL SOFTWARE DEVELOPMENT AND DESIGN; CONSULTING SERVICES IN THE FIELD OF BUSINESS OPERATIONS SOFTWARE DEVELOPMENT AND DESIGN (U.S. CLS. 100 AND 101).

PAUL MORENO, EXAMINING ATTORNEY

SN 77-242,713. E-CLICK HOME SEARCH, INC., OLATHE, KS. FILED 7-31-2007.

ECLICK HOME SEARCH

THE MARK CONSISTS OF STANDARD CHARACTERS WITHOUT CLAIM TO ANY PARTICULAR FONT, STYLE, SIZE, OR COLOR.

NO CLAIM IS MADE TO THE EXCLUSIVE RIGHT TO USE "HOME SEARCH", APART FROM THE MARK AS SHOWN.

CLASS 35—ADVERTISING AND BUSINESS

FOR REAL ESTATE ADVERTISING SERVICES IN THE FOR SALE BY OWNER SECTOR (U.S. CLS. 100, 101 AND 102).

CLASS 36—INSURANCE AND FINANCIAL

FOR REAL ESTATE LISTING SERVICES IN THE FOR SALE BY OWNER SECTOR (U.S. CLS. 100, 101 AND 102).

LESLIE RICHARDS, EXAMINING ATTORNEY

SN 77-242,860. VARSITY NEWSROOM.COM, LTD., PARMA HEIGHTS, OH. FILED 7-31-2007.

VARSITY NEWSROOM

THE MARK CONSISTS OF STANDARD CHARACTERS WITHOUT CLAIM TO ANY PARTICULAR FONT, STYLE, SIZE, OR COLOR.

NO CLAIM IS MADE TO THE EXCLUSIVE RIGHT TO USE "VARSITY", APART FROM THE MARK AS SHOWN.

CLASS 38—COMMUNICATION

FOR AUDIO AND VIDEO BROADCASTING SERVICES OVER THE INTERNET, NAMELY, STREAMING AND ELECTRONICALLY TRANSMITTING INFORMATION, AUDIO, VIDEO, MOVIES, MUSIC, VIDEO CLIPS, AUDIO CLIPS, FILM CLIPS, AUDIO AND VIDEO CONTENT, AND OTHER MULTIMEDIA MATERIALS; PROVIDING ACCESS TO INFORMATION, AUDIO, VIDEO, MOVIES, MUSIC, VIDEO CLIPS, AUDIO CLIPS, FILM CLIPS, AND AUDIO AND VIDEO CONTENT, AND OTHER MULTIMEDIA MATERIALS VIA A WEBSITE; PROVIDING ONLINE FORUMS, CHAT ROOMS, AND ELECTRONIC BULLETIN BOARDS FOR TRANSMISSION OF INFORMATION AND MESSAGES IN THE FIELD OF EDUCATION, ACADEMICS, SPORTS, ACADEMIC AND SPORTING EXTRACURRICULAR ACTIVITIES, NON-PROFIT CLUBS AND ORGANIZATIONS, AND GENERAL INTEREST (U.S. CLS. 100, 101 AND 104).

CLASS 41—EDUCATION AND ENTERTAINMENT

FOR EDUCATION AND ENTERTAINMENT SERVICES, NAMELY, PROVIDING A WEBSITE FEATURING INFORMATION ABOUT ACADEMICS, ATHLETICS, THE ARTS, AND COMMUNITY CULTURAL EVENTS IN THE NATURE OF NON-DOWNLOADABLE AUDIO, VIDEO, MOVIES, MUSIC, VIDEO CLIPS, AUDIO CLIPS, FILM CLIPS, AUDIO AND VIDEO CONTENT, AND OTHER MULTIMEDIA MATERIALS, CONTESTS, COMPETITIONS, NEWS, AND ARTICLES IN THE FIELD OF EDUCATION, ACADEMICS, SPORTS, EXTRACURRICULAR ACTIVITIES, CONTESTS AND COMPETITIONS, NON-PROFIT CLUBS AND ORGANIZATIONS, AND GENERAL INTEREST; ON-LINE JOURNALS, NAMELY, BLOGS IN THE FIELD OF EDUCATION, ACADEMICS, SPORTS, EXTRACURRICULAR ACTIVITIES, CONTESTS AND COMPETITIONS, NON-PROFIT CLUBS AND ORGANIZATIONS, AND GENERAL INTEREST (U.S. CLS. 100, 101 AND 107).

STEPHEN AQUILA, EXAMINING ATTORNEY

SN 77-242,863. VARSITY NEWSROOM.COM, LTD., PARMA HEIGHTS, OH. FILED 7-31-2007.

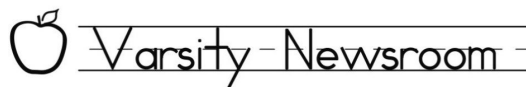

NO CLAIM IS MADE TO THE EXCLUSIVE RIGHT TO USE "VARSITY", APART FROM THE MARK AS SHOWN.

THE MARK CONSISTS OF PRINTED LETTERS ON THE CHALKBOARD WITH A CHALK-DRAWN APPLE IMAGE.

CLASS 38—COMMUNICATION

FOR AUDIO AND VIDEO BROADCASTING SERVICES OVER THE INTERNET, NAMELY, STREAMING AND ELECTRONICALLY TRANSMITTING INFORMATION, AUDIO, VIDEO, MOVIES, MUSIC, VIDEO CLIPS, AUDIO CLIPS, FILM CLIPS, AUDIO AND VIDEO CONTENT, AND OTHER MULTIMEDIA MATERIALS; PROVIDING ACCESS TO INFORMATION, AUDIO, VIDEO, MOVIES, MUSIC, VIDEO CLIPS, AUDIO CLIPS, FILM CLIPS, AND AUDIO AND VIDEO CONTENT, AND OTHER MULTIMEDIA MATERIALS VIA A WEBSITE; PROVIDING ONLINE FORUMS, CHAT ROOMS, AND ELECTRONIC BULLETIN BOARDS FOR TRANSMISSION OF INFORMATION AND MESSAGES IN THE FIELD OF EDUCATION, ACADEMICS, SPORTS, ACADEMIC AND SPORTING EXTRACURRICULAR ACTIVITIES, NON-PROFIT CLUBS AND ORGANIZATIONS, AND GENERAL INTEREST (U.S. CLS. 100, 101 AND 104).

CLASS 41—EDUCATION AND ENTERTAINMENT

FOR EDUCATION AND ENTERTAINMENT SERVICES, NAMELY, PROVIDING A WEBSITE FEATURING INFORMATION ABOUT ACADEMICS, ATHLETICS, THE ARTS, AND COMMUNITY CULTURAL EVENTS IN THE NATURE OF NON-DOWNLOADABLE AUDIO, VIDEO, MOVIES, MUSIC, VIDEO CLIPS, AUDIO CLIPS, FILM CLIPS, AUDIO AND VIDEO CONTENT, AND OTHER MULTIMEDIA MATERIALS, CONTESTS, COMPETITIONS, NEWS, AND ARTICLES IN THE FIELD OF EDUCATION, ACADEMICS, SPORTS, EXTRACURRICULAR ACTIVITIES, CONTESTS AND COMPETITIONS, NON-PROFIT CLUBS AND ORGANIZATIONS, AND GENERAL INTEREST; ON-LINE JOURNALS, NAMELY, BLOGS IN THE FIELD OF EDUCATION, ACADEMICS, SPORTS, EXTRACURRICULAR ACTIVITIES, CONTESTS AND COMPETITIONS, NON-PROFIT CLUBS AND ORGANIZATIONS, AND GENERAL INTEREST (U.S. CLS. 100, 101 AND 107).

STEPHEN AQUILA, EXAMINING ATTORNEY

CLASS 35—ADVERTISING AND BUSINESS

FOR ADVERTISING AND MARKETING SERVICES; BUSINESS MANAGEMENT; BUSINESS ADMINISTRATION; PROVIDING OFFICE FUNCTIONS; RETAIL STORE SERVICES IN THE FIELD OF WOMEN'S CLOTHING AND FASHION (U.S. CLS. 100, 101 AND 102).

CLASS 36—INSURANCE AND FINANCIAL

FOR CREDIT CARD SERVICES (U.S. CLS. 100, 101 AND 102).

DAVID H. STINE, EXAMINING ATTORNEY

SN 77-244,271. CACHE, INC., NEW YORK, NY. FILED 8-1-2007.

SN 77-247,886. TOGGIN LLC, FARMINGTON HILLS, MI. FILED 8-6-2007.



TOGGIN

THE MARK CONSISTS OF STANDARD CHARACTERS WITHOUT CLAIM TO ANY PARTICULAR FONT, STYLE, SIZE, OR COLOR.

CLASS 9—ELECTRICAL AND SCIENTIFIC APPARATUS

FOR MAGNETICALLY-ENCODED CREDIT CARDS; SUNGLASSES (U.S. CLS. 21, 23, 26, 36 AND 38).

CLASS 14—JEWELRY

FOR JEWELRY; PRECIOUS STONES; HOROLOGICAL AND CHRONOMETRIC INSTRUMENTS (U.S. CLS. 2, 27, 28 AND 50).

CLASS 16—PAPER GOODS AND PRINTED MATTER

FOR STATIONERY (U.S. CLS. 2, 5, 22, 23, 29, 37, 38 AND 50).

CLASS 18—LEATHER GOODS

FOR HANDBAGS, PURSES AND WALLETS (U.S. CLS. 1, 2, 3, 22 AND 41).

CLASS 25—CLOTHING

FOR CLOTHING, NAMELY, JEANS, SKIRTS, PANTS, T-SHIRTS AND TOPS; HEADWEAR (U.S. CLS. 22 AND 39).

CLASS 26—FANCY GOODS

FOR LACE AND EMBROIDERY, RIBBONS AND BRAID; BUTTONS FOR CLOTHING, HOOKS AND EYES (U.S. CLS. 37, 39, 40, 42 AND 50).

CLASS 35—ADVERTISING AND BUSINESS

FOR PROVIDING AN ONLINE DIRECTORY INFORMATION SERVICE FEATURING INFORMATION REGARDING, AND IN THE NATURE OF, COLLEGIATE LIFE, GENERAL INTEREST, CLASSIFIEDS, VIRTUAL COMMUNITY, SOCIAL NETWORKING, PHOTO SHARING, CONTESTS, AND TRANSMISSION OF PHOTOGRAPHIC IMAGES; ADVERTISING AND INFORMATION DISTRIBUTION SERVICES, NAMELY, PROVIDING CLASSIFIED ADVERTISING SPACE VIA THE GLOBAL COMPUTER NETWORK; PROMOTING THE GOODS AND SERVICES OF OTHERS OVER THE INTERNET; PROVIDING ON-LINE COMPUTER DATABASES AND ON-LINE SEARCHABLE DATABASES IN THE FIELD OF CLASSIFIED ADVERTISEMENTS (U.S. CLS. 100, 101 AND 102).

CLASS 42—SCIENTIFIC AND COMPUTER SERVICES

FOR COMPUTER SERVICES, NAMELY, HOSTING ONLINE WEB FACILITIES FOR OTHERS FOR ORGANIZING AND CONDUCTING ONLINE MEETINGS, FORUMS, GATHERINGS, INTERACTIVE DISCUSSIONS, CONTESTS, AND SOCIAL NETWORKING; AND COMPUTER SERVICES IN THE NATURE OF CUSTOMIZED WEB PAGES FEATURING USER-DEFINED INFORMATION, PERSONAL PROFILES AND INFORMATION; PROVIDING TEMPORARY USE OF NON-DOWNLOADABLE SOFTWARE APPLICATIONS FOR USE IN CREATING AND POSTING CLASSIFIED ADS ON THE INTERNET, CREATING VIRTUAL COMMUNITY COMPRISING USER-DEFINED WEB PAGES, CREATING WEB PAGES FOR USE IN SOCIAL NETWORKING, FOR USE IN POSTING OF PHOTOS AND VIDEOS FOR SHARING WITH OTHERS OVER THE INTERNET, AND TRANSMISSION OF PHOTOGRAPHIC IMAGES VIA THE INTERNET (U.S. CLS. 100 AND 101).

MARY CRAWFORD, EXAMINING ATTORNEY

SN 77-248,521. DEEP ROOT PARTNERS, L.P., SAN FRANCISCO, CA. FILED 8-6-2007.

SN 77-250,153. AGUILA RECORDS, INC., WEST CHICAGO, IL. FILED 8-8-2007.



SKANDALO MUSICAL

OWNER OF U.S. REG. NOS. 1,849,915 AND 1,957,516.
THE MARK CONSISTS OF THE WORD "DEEPROOT" WITH THE APEX OF A TRIANGLE PENETRATING THE TOP OF THE "R".

THE MARK CONSISTS OF STANDARD CHARACTERS WITHOUT CLAIM TO ANY PARTICULAR FONT, STYLE, SIZE, OR COLOR.

NO CLAIM IS MADE TO THE EXCLUSIVE RIGHT TO USE "MUSICAL", APART FROM THE MARK AS SHOWN. "SKANDALO" HAS NO MEANING IN A FOREIGN LANGUAGE.

CLASS 6—METAL GOODS

FOR TREE ANCHORING KITS CONSISTING ESSENTIALLY OF STEEL STAKES AND POLYPROPYLENE TIES FOR STAKING AND GUYING TREES (U.S. CLS. 2, 12, 13, 14, 23, 25 AND 50).

FIRST USE 7-31-2001; IN COMMERCE 5-1-2007.

CLASS 9—ELECTRICAL AND SCIENTIFIC APPARATUS

FOR PRERECORDED COMPACT DISKS FEATURING MUSICAL RECORDINGS (U.S. CLS. 21, 23, 26, 36 AND 38).

CLASS 22—CORDAGE AND FIBERS

FOR BULK ROLLS OF POLYPROPYLENE CORD FOR USE IN STAKING AND GUYING TREES (U.S. CLS. 1, 2, 7, 19, 22, 42 AND 50).

FIRST USE 7-31-2001; IN COMMERCE 7-31-2001.
JOHN E. MICHOS, EXAMINING ATTORNEY

CLASS 25—CLOTHING

FOR MEN'S, WOMEN'S AND CHILDREN'S CLOTHING, NAMELY, T-SHIRTS, HATS AND JACKETS (U.S. CLS. 22 AND 39).

SN 77-249,456. THE RIGHTS WORKSHOP, INC., SAN FRANCISCO, CA. FILED 8-7-2007.

CLASS 41—EDUCATION AND ENTERTAINMENT

FOR ENTERTAINMENT SERVICES, NAMELY, LIVE MUSICAL PERFORMANCES BY A MUSICAL GROUP (U.S. CLS. 100, 101 AND 107).

PAM WILLIS, EXAMINING ATTORNEY

TheRightsWorkshop

SN 77-251,959. HANCOCK FABRICS, INC., BALDWIN, MS. FILED 8-10-2007.

THE MARK CONSISTS OF STANDARD CHARACTERS WITHOUT CLAIM TO ANY PARTICULAR FONT, STYLE, SIZE, OR COLOR.
SEC. 2(F).

Wishes & Dreams

CLASS 35—ADVERTISING AND BUSINESS

FOR DEVELOPMENT OF LICENSING STRATEGY FOR THE COMMERCIAL ADMINISTRATION OF THE LICENSING OF THE GOODS AND SERVICES OF OTHERS; NEGOTIATION OF CONTRACTS FOR COPYRIGHTS OF MUSIC; INTELLECTUAL PROPERTY MANAGEMENT AGENCY INVOLVED IN THE MANAGEMENT OF COPYRIGHTS, LICENSING AND REPRESENTATION OF CONTENT CREATED BY MUSICIANS, NAMELY, CONSULTING SERVICES IN THE FIELD OF MANAGING INTELLECTUAL PROPERTIES, AND COMMERCIAL ADMINISTRATION OF LICENSES (U.S. CLS. 100, 101 AND 102).

FIRST USE 5-1-2002; IN COMMERCE 5-1-2002.

THE MARK CONSISTS OF STANDARD CHARACTERS WITHOUT CLAIM TO ANY PARTICULAR FONT, STYLE, SIZE, OR COLOR.

CLASS 25—CLOTHING

FOR MASQUERADE COSTUMES FOR CHILDREN (U.S. CLS. 22 AND 39).

CLASS 41—EDUCATION AND ENTERTAINMENT

FOR CONDUCTING SEMINARS AND WORKSHOPS IN THE FIELDS OF MUSIC LICENSING AND MUSIC COPYRIGHTS (U.S. CLS. 100, 101 AND 107).

FIRST USE 5-1-2002; IN COMMERCE 5-1-2002.
BRIAN PINO, EXAMINING ATTORNEY

CLASS 28—TOYS AND SPORTING GOODS

FOR COSTUME ACCESSORIES FOR CHILDREN, NAMELY, CROWNS, TOY HEADPIECES, WINGS, AND WANDS (U.S. CLS. 22, 23, 38 AND 50).

BONNIE LUKEN, EXAMINING ATTORNEY

SN 77-252,257. ARK INNOVATIONS, LLC, SCHAUMBURG, IL. FILED 8-10-2007.

ARK

THE MARK CONSISTS OF STANDARD CHARACTERS WITHOUT CLAIM TO ANY PARTICULAR FONT, STYLE, SIZE, OR COLOR.

CLASS 9—ELECTRICAL AND SCIENTIFIC APPARATUS

FOR VENDING MACHINES (U.S. CLS. 21, 23, 26, 36 AND 38).

FIRST USE 12-1-2006; IN COMMERCE 12-1-2006.

CLASS 35—ADVERTISING AND BUSINESS

FOR VENDING IN THE FIELD OF CELLULAR TELEPHONES, TELEPHONE ACCESSORIES, PREPAID TELEPHONE CALLING CARDS, SIM CARDS, PREPAID DEBIT CARDS AND PROVIDING ADVERTISING SPACE FOR OTHERS VIA DIGITAL MONITOR DISPLAY ADVERTISING ON VENDING MACHINES (U.S. CLS. 100, 101 AND 102).

FIRST USE 12-1-2006; IN COMMERCE 12-1-2006.

CLASS 36—INSURANCE AND FINANCIAL

FOR BILL PAYMENT SERVICES, CHECK CASHING SERVICES, PREPAID DEBIT CARD SERVICES, AND WIRE TRANSFER SERVICES RENDERED THROUGH VENDING MACHINES (U.S. CLS. 100, 101 AND 102).

FIRST USE 12-1-2006; IN COMMERCE 12-1-2006.

PAULA MAHONEY, EXAMINING ATTORNEY

SN 77-253,732. TACO METALS, INC., MIAMI, FL. FILED 8-13-2007.

TACO

THE MARK CONSISTS OF STANDARD CHARACTERS WITHOUT CLAIM TO ANY PARTICULAR FONT, STYLE, SIZE, OR COLOR.

CLASS 6—METAL GOODS

FOR NON-STRUCTURAL METAL MARINE HARDWARE, NAMELY, HINGES, LATCHES, METAL TUBING FOR BOAT RAILS AND BIMINI TOPS; NON-STRUCTURAL PARTS OF MARINE CRAFT AND BOATS IN THE NATURE OF METAL SKI TOWER HARDWARE AND COMPONENTS, NAMELY, PINS, SWIVELS, KNOBS, BALL AND SOCKET FITTINGS, EYE ENDS, JAW SLIDES, DECK HINGES, SLIDE TRACKS, EYE STRAPS, RAIL FITTINGS, HANDRAILS, FITTINGS, GRAB RAILS, LEANING POSTS, LEANING POST BACKRESTS, POLING PLATFORMS, SEAT COLUMNS, SEAT SUPPORTS, SEAT BASES, SEAT PEDESTALS, SEATING, SEATING FEATURING A REMOVABLE STORAGE BAG AS A COMPONENT PART OF SAID SEAT, FOOT RESTS, T-TOPS (U.S. CLS. 2, 12, 13, 14, 23, 25 AND 50).

FIRST USE 12-7-1959; IN COMMERCE 12-7-1959.

CLASS 12—VEHICLES

FOR STRUCTURAL PARTS OF MARINE CRAFT AND BOATS, NAMELY, PROTECTIVE MOLDINGS, METAL HINGES AND LATCHES, TUBING FOR BOAT RAILS AND BIMINI TOPS, MARINE PADS FOR BOAT RAILS AND BIMINI TOPS AND T-TOPS, FISHING ROD DISPLAY RACKS, FISHING ROD HANGER RACKS, FISHING ROD RACKS, FISHING TACKLE RACKS; STRUCTURAL PARTS OF MARINE CRAFT AND BOATS IN THE NATURE OF SKI TOWER HARDWARE AND COMPONENTS, NAMELY, PINS, SWIVELS, KNOBS, BALL AND SOCKET FITTINGS, EYE ENDS, JAW SLIDES, DECK HINGES, SLIDE TRACKS, EYE STRAPS, RAIL FITTINGS, HANDRAILS, FITTINGS, GRAB RAILS, LEANING POSTS, LEANING POST BACKRESTS, POLING PLATFORMS, SEAT COLUMNS, SEAT SUPPORTS, SEAT BASES, SEAT PEDESTALS, SEATING, FOOT RESTS, T-TOPS; MARINE CRAFT AND BOAT PRODUCTS, NAMELY, OUTRIGGERS, MOUNTING PLATES FOR T-TOPS, CLAMP ON MOUNTING PLATES FOR T-TOPS, OUTRIGGER BASES AND MOUNTS, PLATES FOR RECEIVING MARINE PRODUCTS AND ATTACHMENTS TO STRUCTURAL PARTS, OUTRIGGER MOUNTS, T-TOP EXTRUSIONS, RUB RAILS, BOAT TRIMS, MARINE DRINK HOLDERS (U.S. CLS. 19, 21, 23, 31, 35 AND 44).

FIRST USE 12-7-1959; IN COMMERCE 12-7-1959.

CLASS 28—TOYS AND SPORTING GOODS

FOR HAND-HELD FISHING NETS, NAMELY, CAST NETS AND BAIT NETS; FISHING ROD RACKS, FISHING ROD HANGERS, FISHING ROD HOLDERS, CLAMP-ON FISHING ROD HOLDERS, FISHING REEL HANGERS; FISHING ROD CLUSTERS IN THE NATURE OF FISHING ROD HOLDERS; WAKEBOARD STORAGE RACKS, FISHING ROD DISPLAY RACKS, FISHING ROD HANGER RACKS, FISHING ROD RACKS, FISHING TACKLE RACKS; RIGGING KITS COMPRISED OF ROLLERS, BUNGEEES, RELEASE CLIPS, GLASS EYES, AND CORKS (U.S. CLS. 22, 23, 38 AND 50).

FIRST USE 12-7-1959; IN COMMERCE 12-7-1959.

CHRISTINE COOPER, EXAMINING ATTORNEY

SN 77-253,842. A&E TELEVISION NETWORKS, NEW YORK, NY. FILED 8-13-2007.

MYBIO

THE MARK CONSISTS OF STANDARD CHARACTERS WITHOUT CLAIM TO ANY PARTICULAR FONT, STYLE, SIZE, OR COLOR.

CLASS 38—COMMUNICATION

FOR PROVIDING ELECTRONIC MEDIA OR INFORMATION OVER THE INTERNET, TELEVISION OR OTHER COMMUNICATIONS NETWORK, NAMELY, TRANSMISSION OF ENTERTAINMENT MESSAGES OVER ELECTRONIC MEDIA, PROVIDING ONLINE AND WIRELESS CHAT ROOMS, ELECTRONIC BULLETIN BOARDS, EMAIL AND INSTANT MESSAGING SERVICES RELATING TO ENTERTAINMENT, AND BROADCASTING SERVICES, NAMELY, VIDEO BROADCASTING, INTERNET, AND TELEVISION BROADCASTING SERVICES (U.S. CLS. 100, 101 AND 104).

CLASS 41—EDUCATION AND ENTERTAINMENT

SN 77-254,420. WGBH EDUCATIONAL FOUNDATION, BOSTON, MA. FILED 8-14-2007.

FOR EDUCATION AND ENTERTAINMENT SERVICES FOR PROVIDING ELECTRONIC MEDIA OR INFORMATION OVER THE INTERNET, TELEVISION OR OTHER COMMUNICATIONS NETWORK, NAMELY, PROVIDING ONLINE CLASSES, SEMINARS AND WORKSHOPS IN THE FIELDS OF ELECTRONIC MEDIA, HOW TO OBTAIN AND PROVIDE INFORMATION OVER THE INTERNET, AND REGARDING TELEVISION OR OTHER COMMUNICATIONS NETWORKS, PROVIDING INFORMATION IN THE FIELD OF ENTERTAINMENT, FEATURING THE LIVES OF FAMOUS, HISTORICAL AND NOTEWORTHY INDIVIDUALS RENDERED BY MEANS OF THE INTERNET, TELEVISION, OR OTHER COMMUNICATIONS NETWORK (U.S. CLS. 100, 101 AND 107).

MARGARET POWER, EXAMINING ATTORNEY

Engineer Your Life

THE MARK CONSISTS OF STANDARD CHARACTERS WITHOUT CLAIM TO ANY PARTICULAR FONT, STYLE, SIZE, OR COLOR.

NO CLAIM IS MADE TO THE EXCLUSIVE RIGHT TO USE "ENGINEER" FOR CLASSES 9 AND 41, APART FROM THE MARK AS SHOWN.

CLASS 9—ELECTRICAL AND SCIENTIFIC APPARATUS

FOR DIGITAL MATERIALS, NAMELY, DOWNLOADABLE VIDEO FEATURING ENGINEERING AND THE PROMOTION OF ENGINEERING FOR GIRLS (U.S. CLS. 21, 23, 26, 36 AND 38).

CLASS 38—COMMUNICATION

FOR STREAMING OF VIDEO MATERIAL ON THE INTERNET (U.S. CLS. 100, 101 AND 104).

CLASS 41—EDUCATION AND ENTERTAINMENT

FOR ENTERTAINMENT SERVICES, NAMELY, PROVIDING A WEBSITE FEATURING PHOTOGRAPHIC, AUDIO, VIDEO AND PROSE PRESENTATIONS FEATURING ENGINEERING FOR GIRLS; EDUCATIONAL SERVICES, NAMELY, CONDUCTING ONLINE AND LIVE WORKSHOPS AND SEMINARS IN THE FIELD OF PROMOTING ENGINEERING FOR GIRLS AND DISTRIBUTION OF COURSE MATERIAL IN CONNECTION THEREWITH (U.S. CLS. 100, 101 AND 107).

TINA BROWN, EXAMINING ATTORNEY

SN 77-253,857. TACO METALS, INC., MIAMI, FL. FILED 8-13-2007.

TACO METALS

THE MARK CONSISTS OF STANDARD CHARACTERS WITHOUT CLAIM TO ANY PARTICULAR FONT, STYLE, SIZE, OR COLOR.

NO CLAIM IS MADE TO THE EXCLUSIVE RIGHT TO USE "METALS", APART FROM THE MARK AS SHOWN.

CLASS 35—ADVERTISING AND BUSINESS

FOR ELECTRONIC CATALOGUE SERVICES FEATURING MARINE PRODUCTS; INVENTORY MANAGEMENT FOR OTHERS IN THE FIELD OF MARINE PRODUCTS; PROVIDING CONSUMER PRODUCT INFORMATION IN THE FIELD OF MARINE PRODUCTS VIA THE INTERNET (U.S. CLS. 100, 101 AND 102).

FIRST USE 12-7-1959; IN COMMERCE 12-7-1959.

CLASS 39—TRANSPORTATION AND STORAGE

FOR DISTRIBUTION SERVICES, NAMELY, DELIVERY OF CUSTOM MANUFACTURED MARINE PRODUCTS FOR OTHERS (U.S. CLS. 100 AND 105).

FIRST USE 12-7-1959; IN COMMERCE 12-7-1959.

SN 77-254,654. AUGUSTA SYSTEMS, INC., MORGANTOWN, WV. FILED 8-14-2007.

CLASS 40—MATERIAL TREATMENT

FOR CUSTOM MANUFACTURING, FABRICATION AND FINISHING OF MARINE PRODUCTS FOR OTHERS (U.S. CLS. 100, 103 AND 106).

FIRST USE 12-7-1959; IN COMMERCE 12-7-1959.

CLASS 42—SCIENTIFIC AND COMPUTER SERVICES

FOR PROVIDING TECHNOLOGICAL INFORMATION TO OTHERS IN THE FIELD OF MARINE PRODUCTS FOR THE MANUFACTURING, ENGINEERING, DESIGN, FABRICATION AND FINISHING OF MARINE PRODUCTS VIA THE GLOBAL COMPUTER NETWORK; CUSTOM DESIGN AND ENGINEERING OF MARINE PRODUCTS FOR OTHERS (U.S. CLS. 100 AND 101).

FIRST USE 12-7-1959; IN COMMERCE 12-7-1959.
CHRISTINE COOPER, EXAMINING ATTORNEY

EDGEFRONTIER

THE MARK CONSISTS OF STANDARD CHARACTERS WITHOUT CLAIM TO ANY PARTICULAR FONT, STYLE, SIZE, OR COLOR.

CLASS 9—ELECTRICAL AND SCIENTIFIC APPARATUS

FOR COMPUTER SOFTWARE FOR DATA AGGREGATION AND CONSOLIDATION FOR USE IN THE FIELDS OF COMPUTER MONITORING, INTELLIGENCE, DEFENSE, AVIATION, ENERGY, ENVIRONMENTAL RESEARCH, COMMUNICATIONS, SOFTWARE DEVELOPMENT, APPLICATION DEVELOPMENT, ENGINEERING, INFORMATION PROCESSING, AND INFORMATION TECHNOLOGY; COMPUTER SOFTWARE FOR DATA AGGREGATION, COMPILATION, AND DISPLAY THAT INCORPORATE SENSORS OR SENSOR NETWORKS, ACCESS SENSOR OR SENSOR NETWORK DATA, PROCESS SENSOR OR SENSOR NETWORK DATA, FILTER SENSOR OR SENSOR NETWORK DATA, ALIGN SENSOR OR SENSOR NETWORK DATA, AND TRANSMIT SENSOR OR SENSOR NETWORK DATA IN THE FIELDS OF MONITORING, INTELLIGENCE, SECURITY, DEFENSE, ENERGY, ENVIRONMENTAL, COMMUNICATIONS, SOFTWARE DEVELOPMENT, APPLICATION DEVELOPMENT ENGINEERING, INFORMATION PROCESSING, AND INFORMATION TECHNOLOGY (U.S. CLS. 21, 23, 26, 36 AND 38).

FIRST USE 5-17-2007; IN COMMERCE 5-17-2007.

CLASS 42—SCIENTIFIC AND COMPUTER SERVICES

FOR COMPUTER SYSTEMS AND SOFTWARE CONSULTATION, RESEARCH, DESIGN AND DEVELOPMENT IN THE FIELDS OF INTELLIGENCE AND SECURITY, INFORMATION PROCESSING, INFORMATION TECHNOLOGY AND SPECIALIZED TECHNOLOGY APPLICATIONS; BASIC AND APPLIED RESEARCH IN COMPUTING AND SOFTWARE PRODUCTS THAT INCORPORATE SENSORS OR SENSOR NETWORKS, PROCESS SENSOR OR SENSOR NETWORK DATA, FILTER SENSOR OR SENSOR NETWORK DATA, ALIGN SENSOR OR SENSOR NETWORK DATA AND TRANSMIT SENSOR OR SENSOR NETWORK DATA; TECHNICAL ENGINEERING AND TECHNOLOGY CONSULTATION SERVICES IN THE FIELDS OF INTELLIGENCE AND SECURITY, SOFTWARE DEVELOPMENT, APPLICATION DEVELOPMENT, INFORMATION PROCESSING AND INFORMATION TECHNOLOGY (U.S. CLS. 100 AND 101).

FIRST USE 5-17-2007; IN COMMERCE 5-17-2007.
COLLEEN KEARNEY, EXAMINING ATTORNEY

CLASS 16—PAPER GOODS AND PRINTED MATTER

FOR PRINTED MATTER, NAMELY, BOOKLETS, BROCHURES, COMIC BOOKS AND NEWSPAPER COMIC STRIPS, JOURNALS, LEAFLETS, NEWSLETTERS, MAGAZINES AND TRAINING MANUALS ALL FEATURING DIET, EMOTIONAL STRESSES, EXERCISE, HEALTH, LIFESTYLE, PHYSICAL CHALLENGES AND PHYSICAL FITNESS, RELATIONSHIPS, SPIRITUALITY, AND CHARITABLE FUND RAISING ACTIVITIES; ADDRESS BOOKS, ALBUMS, NAMELY, PHOTOGRAPH AND SCRAPBOOK, CALENDARS; DIARIES; GREETING CARDS; PAPER BANNERS; POSTCARDS; SERIES OF NON-FICTION BOOKS IN THE FIELD OF DIET, EMOTIONAL STRESSES, EXERCISE, HEALTH, LIFESTYLE, PHYSICAL CHALLENGES AND PHYSICAL FITNESS, RELATIONSHIPS, SPIRITUALITY, AND CHARITABLE FUND RAISING ACTIVITIES; MOUNTED AND UNMOUNTED PHOTOGRAPHS; DECALS AND STICKERS (U.S. CLS. 2, 5, 22, 23, 29, 37, 38 AND 50).

CLASS 35—ADVERTISING AND BUSINESS

FOR PROMOTING PUBLIC AWARENESS IN THE FIELD OF DIET, EMOTIONAL STRESSES, EXERCISE, HEALTH, LIFESTYLE, PHYSICAL CHALLENGES AND PHYSICAL FITNESS, RELATIONSHIPS, SPIRITUALITY, AND CHARITABLE FUND RAISING ACTIVITIES; ARRANGING AND CONDUCTING BUSINESS CONFERENCES AND MEETINGS IN THE FIELD OF DIET, EMOTIONAL STRESSES, EXERCISE, HEALTH, LIFESTYLE, PHYSICAL CHALLENGES AND PHYSICAL FITNESS, RELATIONSHIPS, SPIRITUALITY, AND CHARITABLE FUND RAISING ACTIVITIES (U.S. CLS. 100, 101 AND 102).

CLASS 41—EDUCATION AND ENTERTAINMENT

FOR EDUCATIONAL SERVICES, NAMELY, ARRANGING AND CONDUCTING CLASSES, CONFERENCES, DISCUSSION GROUPS, SEMINARS AND WORKSHOPS IN THE FIELD OF DIET, EMOTIONAL STRESSES, EXERCISE, HEALTH, LIFESTYLE, PHYSICAL CHALLENGES AND PHYSICAL FITNESS, RELATIONSHIPS, SPIRITUALITY AND CHARITABLE FUND RAISING ACTIVITIES; EDUCATIONAL AND ENTERTAINMENT SERVICES, NAMELY, PROVIDING LIVE MOTIVATIONAL AND EDUCATIONAL SPEAKING ENGAGEMENTS IN THE FIELD OF DIET, EMOTIONAL STRESSES, EXERCISE, HEALTH, LIFESTYLE, PHYSICAL CHALLENGES AND PHYSICAL FITNESS, RELATIONSHIPS, SPIRITUALITY, AND CHARITABLE FUND RAISING ACTIVITIES; ARRANGING AND CONDUCTING ATHLETIC COMPETITIONS (U.S. CLS. 100, 101 AND 107).

JAMES A. RAUEN, EXAMINING ATTORNEY

SN 77-254,737. JACOBSON, PAUL A., LAKE MARY, FL.
FILED 8-14-2007.

SN 77-254,751. AUGUSTA SYSTEMS, INC., MORGANTOWN,
WV. FILED 8-14-2007.

ENDORPHOMANIC

THE MARK CONSISTS OF STANDARD CHARACTERS WITHOUT CLAIM TO ANY PARTICULAR FONT, STYLE, SIZE, OR COLOR.

**INTELLIGENT NETWORKS FROM
EDGE TO CORE**

THE MARK CONSISTS OF STANDARD CHARACTERS WITHOUT CLAIM TO ANY PARTICULAR FONT, STYLE, SIZE, OR COLOR.

CLASS 9—ELECTRICAL AND SCIENTIFIC APPARATUS

FOR COMPUTER SOFTWARE FOR DATA AGGREGATION AND CONSOLIDATION FOR USE IN THE FIELDS OF COMPUTER MONITORING, INTELLIGENCE, DEFENSE, AVIATION, ENERGY, ENVIRONMENTAL RESEARCH, COMMUNICATIONS, SOFTWARE DEVELOPMENT, APPLICATION DEVELOPMENT, ENGINEERING, INFORMATION PROCESSING, AND INFORMATION TECHNOLOGY; COMPUTER SOFTWARE FOR DATA AGGREGATION, COMPILATION, AND DISPLAY THAT INCORPORATE SENSORS OR SENSOR NETWORKS, ACCESS SENSOR OR SENSOR NETWORK DATA, PROCESS SENSOR OR SENSOR NETWORK DATA, FILTER SENSOR OR SENSOR NETWORK DATA, ALIGN SENSOR OR SENSOR NETWORK DATA, AND TRANSMIT SENSOR OR SENSOR NETWORK DATA IN THE FIELDS OF MONITORING, INTELLIGENCE, SECURITY, DEFENSE, ENERGY, ENVIRONMENTAL, COMMUNICATIONS, SOFTWARE DEVELOPMENT, APPLICATION DEVELOPMENT ENGINEERING, INFORMATION PROCESSING, AND INFORMATION TECHNOLOGY (U.S. CLS. 21, 23, 26, 36 AND 38).

FIRST USE 5-17-2007; IN COMMERCE 5-17-2007.

CLASS 42—SCIENTIFIC AND COMPUTER SERVICES

FOR COMPUTER SYSTEMS AND SOFTWARE CONSULTATION, RESEARCH, DESIGN AND DEVELOPMENT IN THE FIELDS OF INTELLIGENCE AND SECURITY, INFORMATION PROCESSING, INFORMATION TECHNOLOGY AND SPECIALIZED TECHNOLOGY APPLICATIONS; BASIC AND APPLIED RESEARCH IN COMPUTING AND SOFTWARE PRODUCTS THAT INCORPORATE SENSORS OR SENSOR NETWORKS, PROCESS SENSOR OR SENSOR NETWORK DATA, FILTER SENSOR OR SENSOR NETWORK DATA, ALIGN SENSOR OR SENSOR NETWORK DATA AND TRANSMIT SENSOR OR SENSOR NETWORK DATA; TECHNICAL ENGINEERING AND TECHNOLOGY CONSULTATION SERVICES IN THE FIELDS OF INTELLIGENCE AND SECURITY, SOFTWARE DEVELOPMENT, APPLICATION DEVELOPMENT, INFORMATION PROCESSING AND INFORMATION TECHNOLOGY (U.S. CLS. 100 AND 101).

FIRST USE 5-17-2007; IN COMMERCE 5-17-2007.
COLLEEN KEARNEY, EXAMINING ATTORNEY

SN 77-255,478. CAPITOL NEWS COMPANY LLC, ARLINGTON, VA. FILED 8-15-2007.

LA POLITICA

THE MARK CONSISTS OF STANDARD CHARACTERS WITHOUT CLAIM TO ANY PARTICULAR FONT, STYLE, SIZE, OR COLOR.

OWNER OF U.S. REG. NO. 3,350,909.

THE FOREIGN WORDING IN THE MARK TRANSLATES INTO ENGLISH AS THE POLITICO.

CLASS 16—PAPER GOODS AND PRINTED MATTER

FOR NEWSPAPER REPORTING ON THE ACTIVITIES OF THE LEGISLATIVE AND EXECUTIVE BRANCHES OF THE FEDERAL GOVERNMENT, OFFICIALS AND EMPLOYEES OF THE EXECUTIVE AND LEGISLATIVE BRANCHES OF THE FEDERAL GOVERNMENT, MEMBERS OF CONGRESS AND THEIR CAMPAIGNS, AND OTHER MATTERS OF INTEREST TO PEOPLE WHO WORK FOR OR WITH THE FEDERAL GOVERNMENT (U.S. CLS. 2, 5, 22, 23, 29, 37, 38 AND 50).

CLASS 41—EDUCATION AND ENTERTAINMENT

FOR PROVIDING NEWS AND INFORMATION VIA THE INTERNET IN THE NATURE OF CURRENT EVENT REPORTING ABOUT THE ACTIVITIES OF THE LEGISLATIVE AND EXECUTIVE BRANCHES OF THE FEDERAL GOVERNMENT, OFFICIALS AND EMPLOYEES OF THE EXECUTIVE AND LEGISLATIVE BRANCHES OF THE FEDERAL GOVERNMENT, MEMBERS OF CONGRESS AND THEIR CAMPAIGNS, AND OTHER MATTERS OF INTEREST TO PEOPLE WHO WORK FOR OR WITH THE FEDERAL GOVERNMENT (U.S. CLS. 100, 101 AND 107).

MARGARET POWER, EXAMINING ATTORNEY

SN 77-257,078. NASH, TERIUS, NEW YORK, NY. FILED 8-16-2007.

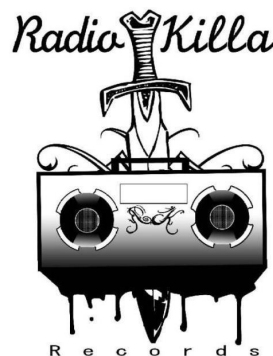

NO CLAIM IS MADE TO THE EXCLUSIVE RIGHT TO USE "RECORDS", APART FROM THE MARK AS SHOWN.

THE MARK CONSISTS OF THE WORDS "RADIO KILLA RECORDS" AND A DESIGN OF A RADIO IMPALED BY A SWORD.

CLASS 9—ELECTRICAL AND SCIENTIFIC APPARATUS

FOR MUSICAL SOUND RECORDINGS; MUSICAL VIDEO RECORDINGS; DOWNLOADABLE MUSICAL SOUND RECORDINGS; DOWNLOADABLE VIDEO RECORDINGS FEATURING MUSIC; DOWNLOADABLE TELEPHONE RING TONES FEATURING MUSIC VIA THE INTERNET AND WIRELESS DEVICES (U.S. CLS. 21, 23, 26, 36 AND 38).

CLASS 41—EDUCATION AND ENTERTAINMENT

FOR RECORD PRODUCTION; MUSIC PRODUCTION; AUDIO RECORDING AND PRODUCTION; PRODUCTION OF VIDEO DISCS FOR OTHERS; ENTERTAINMENT SERVICES, NAMELY, PROVIDING A WEB SITE FEATURING MUSICAL PERFORMANCES, MUSICAL VIDEOS, RELATED FILM CLIPS, PHOTOGRAPHS, AND OTHER MULTIMEDIA MATERIALS; ENTERTAINMENT SERVICES, NAMELY, PROVIDING PRERECORDED MUSIC, INFORMATION IN THE FIELD OF MUSIC, COMMENTARY AND ARTICLES ABOUT MUSIC, ALL ONLINE VIA A GLOBAL COMPUTER NETWORK (U.S. CLS. 100, 101 AND 107).

DAVID YONTEF, EXAMINING ATTORNEY

SN 77-257,827. STUDENTS STANDING STRONG, FORT WORTH, TX. FILED 8-17-2007.

SN 77-258,004. JOHNSON & JOHNSON, NEW BRUNSWICK, NJ. FILED 8-17-2007.

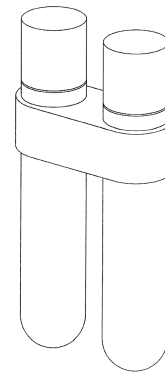

NO CLAIM IS MADE TO THE EXCLUSIVE RIGHT TO USE "I COR. 15:58", APART FROM THE MARK AS SHOWN. THE COLOR(S) GRAY, WHITE, AND RED IS/ARE CLAIMED AS A FEATURE OF THE MARK.

THE MARK CONSISTS OF A CROSS WITH GRAY SHADING AROUND THE EDGES AND A WHITE CENTER, THE LETTER "S" IN WHITE ON TOP OF THE CROSS, WITH THE NUMBER "3" IN RED AT THE UPPER RIGHT HAND CORNER OF THE IMAGE. UNDERNEATH THE CROSS IS A SCRIPTURE REFERENCE "I COR. 15:58" IN GRAY.

CLASS 16—PAPER GOODS AND PRINTED MATTER

FOR PRINTED MATERIALS, NAMELY, NEWSLETTERS, PAMPHLETS, JOURNALS, BOOKS, BROCHURES, AND NOTEPADS WITH INFORMATION ABOUT MINISTRY ACTIVITIES, MINISTRY PROGRAMS, AND MINISTRY TO STUDENTS (U.S. CLS. 2, 5, 22, 23, 29, 37, 38 AND 50).

CLASS 25—CLOTHING

FOR MEN'S AND WOMEN'S CLOTHING, NAMELY, SHIRTS, T-SHIRTS, SWEATSHIRTS, SWEAT PANTS, SHORTS, POLO-STYLE SHIRTS, AND BASEBALL-STYLE CAPS (U.S. CLS. 22 AND 39).
LESLIE RICHARDS, EXAMINING ATTORNEY

NO CLAIM IS MADE TO THE EXCLUSIVE RIGHT TO USE THE ROUND SCREW-ON CAP CONFIGURATION USED ON THE VIALS, APART FROM THE MARK AS SHOWN.

THE MARK CONSISTS OF THE OVERALL CONTOURED CONFIGURATION OF A CONTAINER CONSISTING OF TWO VIAL-SHAPED BOTTLES OF EQUAL SIZE, ROUNDED ON THE BOTTOM AND SIDES AND SLIGHTLY ROUNDED TO A FLAT TOP. THE TWO VIALS ARE CONNECTED TO EACH OTHER APPROXIMATELY ONE-THIRD FROM THE TOP BY AN OVAL-SHAPED BAND WHICH CONTAINS TWO HOLES WHICH HOLD THE TWO VIALS.

CLASS 3—COSMETICS AND CLEANING PREPARATIONS

FOR MASSAGE OILS (U.S. CLS. 1, 4, 6, 50, 51 AND 52).

CLASS 5—PHARMACEUTICALS

FOR PERSONAL LUBRICANTS (U.S. CLS. 6, 18, 44, 46, 51 AND 52).
DAVID H. STINE, EXAMINING ATTORNEY

SN 77-258,011. JOHNSON & JOHNSON, NEW BRUNSWICK, NJ. FILED 8-17-2007.

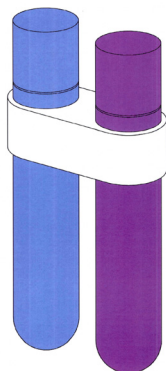

NO CLAIM IS MADE TO THE EXCLUSIVE RIGHT TO USE THE ROUND SCREW-ON CAP CONFIGURATION USED ON THE VIALS, APART FROM THE MARK AS SHOWN.

THE COLOR(S) BLUE, PURPLE AND WHITE IS/ARE CLAIMED AS A FEATURE OF THE MARK.

THE MARK CONSISTS OF THE OVERALL CONTOURED CONFIGURATION OF A CONTAINER CONSISTING OF TWO VIAL-SHAPED BOTTLES OF EQUAL SIZE, ROUNDED ON THE BOTTOM AND SIDES AND SLIGHTLY ROUNDED TO A FLAT TOP. THE TWO VIALS ARE CONNECTED TO EACH OTHER APPROXIMATELY ONE-THIRD FROM THE TOP BY AN OVAL-SHAPED BAND WHICH CONTAINS TWO HOLES WHICH HOLD THE TWO VIALS. ONE VIAL IS BLUE, THE OTHER VIAL IS PURPLE AND THE BAND HOLDING THE TWO VIALS IS WHITE.

CLASS 3—COSMETICS AND CLEANING PREPARATIONS

FOR MASSAGE OILS (U.S. CLS. 1, 4, 6, 50, 51 AND 52).

CLASS 5—PHARMACEUTICALS

FOR PERSONAL LUBRICANTS (U.S. CLS. 6, 18, 44, 46, 51 AND 52).

DAVID H. STINE, EXAMINING ATTORNEY

SN 77-258,168. BEYOND SLATS AND DRAPERY, LLC, HILLIARD, OH. FILED 8-17-2007.



The window treatment store that comes to your door.

NO CLAIM IS MADE TO THE EXCLUSIVE RIGHT TO USE "SLATS", APART FROM THE MARK AS SHOWN.

THE COLOR(S) DARK BROWN, WHITE AND GRAY IS/ARE CLAIMED AS A FEATURE OF THE MARK.

THE MARK CONSISTS OF A DARK BROWN DRAWING OF AN ARCHED WINDOW FEATURING BLINDS. THE WORDS "BEYOND SLATS" APPEAR TO THE RIGHT OF THE WINDOW IN DARK BROWN, AND THE PHRASE "THE WINDOW TREATMENT STORE THAT COMES TO YOUR DOOR" APPEARS BELOW IN GRAY. THE WHITE AREAS OF THE WINDOW CONSTITUTE BACKGROUND.

CLASS 24—FABRICS

FOR FABRIC WINDOW COVERINGS AND TREATMENTS, NAMELY, CURTAINS, DRAPERIES, SHEERS, SWAGS AND VALANCES (U.S. CLS. 42 AND 50).

CLASS 37—CONSTRUCTION AND REPAIR

FOR (BASED ON INTENT TO USE) WINDOW BLIND INSTALLATION AND REPAIR (U.S. CLS. 100, 103 AND 106).

DOMINICK J. SALEMI, EXAMINING ATTORNEY

SN 77-258,259. HAWKINS COOKERS LIMITED, MUMBAI, INDIA, FILED 8-17-2007.



OWNER OF U.S. REG. NOS. 1,890,552 AND 2,337,324.

CLASS 11—ENVIRONMENTAL CONTROL APPARATUS

FOR ELECTRIC PRESSURE COOKERS; ELECTRIC COOKWARE, NAMELY, BROILERS AND ROASTERS (U.S. CLS. 13, 21, 23, 31 AND 34).

FIRST USE 6-0-2004; IN COMMERCE 6-0-2004.

CLASS 21—HOUSEWARES AND GLASS

FOR NON-ELECTRIC PRESSURE COOKERS; NON-ELECTRIC COOKWARE, NAMELY, POTS AND PANS (U.S. CLS. 2, 13, 23, 29, 30, 33, 40 AND 50).

FIRST USE 6-0-2004; IN COMMERCE 6-0-2004.

SALLY SHIH, EXAMINING ATTORNEY

SN 77-258,290. SOFT SWITCHING TECHNOLOGIES CORPORATION, MIDDLETON, WI. FILED 8-17-2007.

GRID ALERT

THE MARK CONSISTS OF STANDARD CHARACTERS WITHOUT CLAIM TO ANY PARTICULAR FONT, STYLE, SIZE, OR COLOR.

NO CLAIM IS MADE TO THE EXCLUSIVE RIGHT TO USE "ALERT", APART FROM THE MARK AS SHOWN.

CLASS 9—ELECTRICAL AND SCIENTIFIC APPARATUS

FOR COMPUTER SOFTWARE FOR ACCESSING AND PERFORMING TREND ANALYSIS ON POWER QUALITY EVENTS, NAMELY, INTERRUPTIONS, OUTAGES AND VOLTAGE SAGS AND SURGES, ENERGY CONSUMPTION INFORMATION AVAILABLE ON A GLOBAL COMPUTER NETWORK (U.S. CLS. 21, 23, 26, 36 AND 38).

CLASS 42—SCIENTIFIC AND COMPUTER SERVICES

FOR ELECTRONIC MONITORING SERVICES IN THE FIELD OF EXAMINATION OF POWER QUALITY EVENTS, NAMELY, INTERRUPTIONS, OUTAGES AND VOLTAGE SAGS AND SURGES, AND ENERGY CONSUMPTION BY A NETWORK OF GEOGRAPHICALLY-DISPERSED POWER QUALITY MONITORS; PROVIDING A WEBSITE FEATURING POWER QUALITY EVENTS, NAMELY, INTERRUPTIONS, OUTAGES AND VOLTAGE SAGS AND SURGES, AND ENERGY CONSUMPTION INFORMATION (U.S. CLS. 100 AND 101).

MARLENE BELL, EXAMINING ATTORNEY

CLASS 28—TOYS AND SPORTING GOODS

FOR TOYS, NAMELY, MODEL TRAIN SETS, WHISTLES, KALEIDOSCOPIES, POSITIONABLE WOODEN AND PLASTIC FIGURES FOR USE IN WOODEN AND PLASTIC PUZZLES; CARD AND BOARD GAMES; AND PUZZLES (U.S. CLS. 22, 23, 38 AND 50).

CLASS 41—EDUCATION AND ENTERTAINMENT

FOR MUSEUMS; RUNNING OF MUSEUMS (U.S. CLS. 100, 101 AND 107).

PAUL F. GAST, EXAMINING ATTORNEY

SN 77-258,461. WALT DISNEY FAMILY FOUNDATION, WOODLAND HILLS, CA. FILED 8-17-2007.



THE TERM "CAROLWOOD" DOES NOT IDENTIFY A LIVING INDIVIDUAL.

THE MARK CONSISTS OF A CIRCULAR DESIGN WITH THE WORDS "CAROLWOOD PACIFIC" WITHIN THE BORDER OF THE CIRCLE. THE INSIDE OF THE CIRCLE CONSISTS OF A TRAIN AND TRAIN TRACKS WITH THE WORDS "FAIR WEATHER ROUTE ACROSS" THE CENTER.

CLASS 14—JEWELRY

FOR ORNAMENTAL PINS AND ORNAMENTAL BADGES OF PRECIOUS METAL (U.S. CLS. 2, 27, 28 AND 50).

CLASS 16—PAPER GOODS AND PRINTED MATTER

FOR PRINTED MATTER, NAMELY, STATIONERY, NOTEPADS, SCRIBBLE PADS, BLANK JOURNALS, ADDRESS BOOKS, FLIP BOOKS, DECALS, PAPER COASTERS, BOXED UNIVERSAL GREETING AND CORRESPONDENCE CARD SETS, PHOTO ALBUMS, SCRAPBOOKS, COLORING BOOKS, POSTERS, CALENDARS, STICKERS; BOOKLETS IN THE FIELD OF RAILROADING AND ANIMATION AND ABOUT WALT DISNEY; RUBBER STAMPS, PAPER SIGNS, PENCILS, AND PENS (U.S. CLS. 2, 5, 22, 23, 29, 37, 38 AND 50).

CLASS 25—CLOTHING

FOR CLOTHING, NAMELY, CAPS, T-SHIRTS, SPORT SHIRTS, POLO SHIRTS, SWEATSHIRTS, SUSPENDERS, BANDANA, AND COSTUMES FOR RAILROAD ENGINEERS (U.S. CLS. 22 AND 39).

CLASS 26—FANCY GOODS

FOR ORNAMENTAL NOVELTY BADGES (U.S. CLS. 37, 39, 40, 42 AND 50).

SN 77-258,583. KIDDIE'S PARADISE INC., TAIPEI, TAIWAN, FILED 8-17-2007.



THE MARK CONSISTS OF AN IRREGULAR CIRCLE.

CLASS 9—ELECTRICAL AND SCIENTIFIC APPARATUS

FOR DIGITAL MEDIA, NAMELY, CDS, DVDS, AND VCDs FEATURING EDUCATIONAL AND INSTRUCTIONAL MATERIALS FOR CHILDREN IN THE FIELD OF ACTIVITY GAMES (U.S. CLS. 21, 23, 26, 36 AND 38).

FIRST USE 1-1-2006; IN COMMERCE 1-1-2006.

CLASS 10—MEDICAL APPARATUS

FOR THERAPY EQUIPMENT FOR PHYSICAL AND COGNITIVE PURPOSES, NAMELY, BALANCING BOARDS, BALANCING CLIMBERS, TWIN WALKERS, TACTILE PATH BLOCKS, MASSAGE ROLLS, MASSAGE RINGS, MASSAGE BALLS WITH STICK, VISUAL RINGS AND INFINITE LOOPS (U.S. CLS. 26, 39 AND 44).

FIRST USE 1-1-2006; IN COMMERCE 1-1-2006.

CLASS 12—VEHICLES

FOR BICYCLES; TRICYCLES; BICYCLE TRAILERS; NON-MOTORIZED SCOOTERS (U.S. CLS. 19, 21, 23, 31, 35 AND 44).

FIRST USE 1-1-2006; IN COMMERCE 1-1-2006.

CLASS 16—PAPER GOODS AND PRINTED MATTER

FOR CHILDREN BOOKS; BOOKS FEATURING INFORMATION IN THE FIELDS OF EDUCATION AND ACTIVITY GAMES (U.S. CLS. 2, 5, 22, 23, 29, 37, 38 AND 50).

FIRST USE 1-1-2006; IN COMMERCE 1-1-2006.

CLASS 20—FURNITURE AND ARTICLES NOT OTHERWISE CLASSIFIED

FOR FURNITURE; CUSHIONS; BALL CHAIRS (U.S. CLS. 2, 13, 22, 25, 32 AND 50).

FIRST USE 1-1-2006; IN COMMERCE 1-1-2006.

CLASS 28—TOYS AND SPORTING GOODS

FOR CHILDREN'S MULTIPLE ACTIVITY EDUCATIONAL TOYS; PLAYGROUND EQUIPMENT, NAMELY, CLIMBERS, SWINGS, SAND AND WATER TABLES; GYM EQUIPMENT, NAMELY, GYM BALLS, GYM ROLLS, JUMPING BALLS, VAULTING BOXES AND EXERCISE MATS; TOYS; TOY SCOOTERS; TOY FURNITURE AND TOY WALKERS (U.S. CLS. 22, 23, 38 AND 50).

FIRST USE 1-1-2006; IN COMMERCE 1-1-2006.
RONALD AIKENS, EXAMINING ATTORNEY

SN 77-258,890. LOWSON, LINDA M., HUNTINGTON, NY.
FILED 8-19-2007.

SOCIAL RESPONSIBILITY CHANNEL

THE MARK CONSISTS OF STANDARD CHARACTERS WITHOUT CLAIM TO ANY PARTICULAR FONT, STYLE, SIZE, OR COLOR.

NO CLAIM IS MADE TO THE EXCLUSIVE RIGHT TO USE CHANNEL, APART FROM THE MARK AS SHOWN.

CLASS 9—ELECTRICAL AND SCIENTIFIC APPARATUS

FOR DIGITAL MEDIA, NAMELY, CD-ROMS, DVDS, VIDEO TAPES, LASER DISKS, AUDIO RECORDINGS, VIDEO RECORDINGS, AUDIO AND VIDEO RECORDINGS, MOVIES, MOTION PICTURE FILMS, ELECTRONIC PUBLICATIONS IN THE NATURE OF BOOKS AND PERIODICALS, COMPUTER GAMES, VIDEO GAMES, COMPUTER SOFTWARE, AND VIDEO RECORDINGS FEATURING TELEVISION PROGRAMS BROADCAST ON TELEVISION NETWORKS, CABLE NETWORKS, SATELLITE NETWORKS, RADIO NETWORKS, WIRELESS DEVICES, AND THE INTERNET, ALL FEATURING THEMES PERTAINING TO A BROAD RANGE OF SUBJECT MATTER AREAS, NAMELY, SOCIAL, CULTURAL, DEMOGRAPHIC, ECONOMIC, FINANCIAL, POLITICAL, ENVIRONMENTAL, SCIENTIFIC, TECHNOLOGICAL, HEALTH CARE, EDUCATION, ANIMAL WELFARE, WILDLIFE PRESERVATION, ECOTOURISM, CONSERVATION AND SUSTAINABLE DEVELOPMENT SUBJECT MATTER AREAS; DOWNLOADABLE MOVIES, MOTION PICTURE FILMS, BOOKS, ELECTRONIC PUBLICATIONS IN THE NATURE OF PERIODICALS, TEXT, RING TONES, MUSIC, AUDIO RECORDINGS, VIDEO RECORDINGS, AUDIO AND VIDEO RECORDINGS, COMPUTER GAMES, VIDEO GAMES, EDUCATIONAL TOOLS IN THE NATURE OF TEACHING AND INSTRUCTIONAL MATERIALS, AND VIDEO RECORDINGS FEATURING TELEVISION PROGRAMS BROADCAST ON TELEVISION NETWORKS, CABLE NETWORKS, SATELLITE NETWORKS, RADIO NETWORKS, WIRELESS DEVICES, AND THE INTERNET, VIA THE INTERNET AND WIRELESS DEVICES, ALL FEATURING THEMES PERTAINING TO A BROAD RANGE OF SUBJECT MATTER AREAS, NAMELY, SOCIAL, CULTURAL, DEMOGRAPHIC, ECONOMIC, FINANCIAL, POLITICAL, ENVIRONMENTAL, SCIENTIFIC, TECHNOLOGICAL, HEALTH CARE, EDUCATION, ANIMAL WELFARE, WILDLIFE PRESERVATION, ECOTOURISM, CONSERVATION AND SUSTAINABLE DEVELOPMENT SUBJECT MATTER AREAS; EDUCATIONAL SOFTWARE FEATURING INSTRUCTION IN A BROAD RANGE OF SUBJECT MATTER AREAS, NAMELY, SOCIAL, CULTURAL, DEMOGRAPHIC, ECONOMIC, FINANCIAL, POLITICAL, ENVIRONMENTAL, SCIENTIFIC, TECHNOLOGICAL, HEALTH CARE, EDUCATION, ANIMAL WELFARE, WILDLIFE PRESERVATION, ECOTOURISM, CONSERVATION AND SUSTAINABLE DEVELOPMENT SUBJECT MATTER AREAS; ELECTRONIC DATABASE IN THE FIELD OF A BROAD RANGE OF SUBJECT MATTER AREAS, NAMELY, SOCIAL, CULTURAL, DE-

MOGRAPHIC, ECONOMIC, FINANCIAL, POLITICAL, ENVIRONMENTAL, SCIENTIFIC, TECHNOLOGICAL, HEALTH CARE, EDUCATION, ANIMAL WELFARE, WILDLIFE PRESERVATION, ECOTOURISM, CONSERVATION AND SUSTAINABLE DEVELOPMENT SUBJECT MATTER AREAS RECORDED ON COMPUTER MEDIA; ELECTRONIC GAME PROGRAMS; ELECTRONIC GAME SOFTWARE; VIDEO GAME SOFTWARE; INTERACTIVE VIDEO GAME PROGRAMS; INTERACTIVE VIDEO GAMES OF VIRTUAL REALITY COMPRISED OF COMPUTER HARDWARE AND SOFTWARE (U.S. CLS. 21, 23, 26, 36 AND 38).

CLASS 38—COMMUNICATION

FOR (BASED ON INTENT TO USE) CABLE TELEVISION BROADCASTING; SATELLITE TELEVISION BROADCASTING; RADIO BROADCASTING; TELEVISION AND RADIO BROADCASTING SERVICES; INTERNET BROADCASTING SERVICES; COMMUNICATIONS SERVICES, NAMELY, TRANSMITTING STREAMED SOUND AND AUDIO-VISUAL RECORDINGS VIA THE INTERNET; MOBILE MEDIA SERVICES IN THE NATURE OF ELECTRONIC TRANSMISSION OF ENTERTAINMENT MEDIA CONTENT (U.S. CLS. 100, 101 AND 104).

CLASS 41—EDUCATION AND ENTERTAINMENT

FOR (BASED ON INTENT TO USE) CONSULTATION IN THE FIELD OF K-12 EDUCATIONAL SYSTEMS; CONTINUING PUBLIC SERVICE PROGRAMS IN THE FIELD OF A BROAD RANGE OF SUBJECT MATTER AREAS, NAMELY, SOCIAL, CULTURAL, DEMOGRAPHIC, ECONOMIC, FINANCIAL, POLITICAL, ENVIRONMENTAL, SCIENTIFIC, TECHNOLOGICAL, HEALTH CARE, EDUCATION, ANIMAL WELFARE, WILDLIFE PRESERVATION, ECOTOURISM, CONSERVATION AND SUSTAINABLE DEVELOPMENT SUBJECT MATTER AREAS, PRODUCED AND DISTRIBUTED OVER TELEVISION, SATELLITE, FILM, AUDIO, VIDEO, INTERNET, AND 3-D VIRTUAL REALITY MEDIA; EDUCATIONAL AND ENTERTAINMENT SERVICES, NAMELY, A CONTINUING PROGRAM ABOUT A BROAD RANGE OF SUBJECT MATTER AREAS, NAMELY, SOCIAL, CULTURAL, DEMOGRAPHIC, ECONOMIC, FINANCIAL, POLITICAL, ENVIRONMENTAL, SCIENTIFIC, TECHNOLOGICAL, HEALTH CARE, EDUCATION, ANIMAL WELFARE, WILDLIFE PRESERVATION, ECOTOURISM, CONSERVATION AND SUSTAINABLE DEVELOPMENT SUBJECT MATTER AREAS, ACCESSIBLE BY RADIO, TELEVISION, SATELLITE, AUDIO, VIDEO AND COMPUTER NETWORKS; EDUCATIONAL SERVICES, NAMELY, PROVIDING CONFERENCES, SEMINARS, WORKSHOPS, EXHIBITIONS, CLASSES, AND COURSES OF INSTRUCTION IN THE FIELDS OF A BROAD RANGE OF SUBJECT MATTER AREAS, NAMELY, SOCIAL, CULTURAL, DEMOGRAPHIC, ECONOMIC, FINANCIAL, POLITICAL, ENVIRONMENTAL, SCIENTIFIC, TECHNOLOGICAL, HEALTH CARE, EDUCATION, ANIMAL WELFARE, WILDLIFE PRESERVATION, ECOTOURISM, CONSERVATION AND SUSTAINABLE DEVELOPMENT SUBJECT MATTER AREAS; ENTERTAINMENT SERVICES, NAMELY, PROVIDING ON-LINE COMPUTER GAMES; ENTERTAINMENT SERVICES, NAMELY, PROVIDING ON-LINE REVIEWS OF MOVIES, MOTION PICTURE FILMS, BOOKS, MAGAZINES, ELECTRONIC PUBLICATIONS, AUDIO AND VIDEO RECORDINGS, COMPUTER GAMES, VIDEO GAMES, COMPUTER SOFTWARE, EDUCATIONAL TOOLS, AND PROGRAMS BROADCAST ON TELEVISION NETWORKS, CABLE NETWORKS, SATELLITE NETWORKS, RADIO NETWORKS, WIRELESS DEVICES, AND THE INTERNET; ENTERTAINMENT SERVICES, NAMELY, PROVIDING PODCASTS IN THE FIELD OF A BROAD RANGE OF SUBJECT MATTER AREAS, NAMELY, SOCIAL, CULTURAL, DEMOGRAPHIC, ECONOMIC, FINANCIAL, POLITICAL, ENVIRONMENTAL, SCIENTIFIC, TECHNOLOGICAL, HEALTH CARE, EDUCATION, ANIMAL WELFARE, WILDLIFE PRESERVATION, ECOTOURISM, CONSERVATION AND SUSTAINABLE DEVELOPMENT SUBJECT MATTER AREAS; ENTERTAINMENT SERVICES, NAMELY, PROVIDING WEB CASTS IN THE FIELD OF A BROAD

RANGE OF SUBJECT MATTER AREAS, NAMELY, SOCIAL, CULTURAL, DEMOGRAPHIC, ECONOMIC, FINANCIAL, POLITICAL, ENVIRONMENTAL, SCIENTIFIC, TECHNOLOGICAL, HEALTH CARE, EDUCATION, ANIMAL WELFARE, WILDLIFE PRESERVATION, ECOTOURISM, CONSERVATION AND SUSTAINABLE DEVELOPMENT SUBJECT MATTER AREAS; MOBILE MEDIA AND ENTERTAINMENT SERVICES IN THE NATURE OF CONTENT PREPARATION; MULTIMEDIA ENTERTAINMENT SERVICES IN THE NATURE OF RECORDING, PRODUCTION AND POST-PRODUCTION SERVICES IN THE FIELDS OF MUSIC, VIDEO, AND FILMS; MULTIMEDIA ENTERTAINMENT SOFTWARE PRODUCTION SERVICES; PRODUCTION AND DISTRIBUTION OF RADIO PROGRAMS; TELEVISION AND RADIO PROGRAMMING; PRODUCTION AND DISTRIBUTION OF TELEVISION SHOWS AND MOVIES; DISTRIBUTION OF TELEVISION PROGRAMS FOR OTHERS; PRODUCTION OF VIDEO AND COMPUTER GAME SOFTWARE; PROVIDING RATINGS FOR TELEVISION, MOVIE, MUSIC, VIDEO AND VIDEO GAME CONTENT; PROVIDING A WEB SITE WHERE USERS CAN POST RATINGS, REVIEWS AND RECOMMENDATIONS ON EVENTS AND ACTIVITIES IN THE FIELD OF ENTERTAINMENT AND EDUCATION (U.S. CLS. 100, 101 AND 107).

ALICE BENMAMAN, EXAMINING ATTORNEY

CLASS 25—CLOTHING

FOR CLOTHING, NAMELY, CAPS, T-SHIRTS, SPORT SHIRTS; POLO SHIRTS, SWEATSHIRTS, SWEATSHIRTS, SUSPENDERS, BANDANA, AND COSTUMES FOR RAILROAD ENGINEERS (U.S. CLS. 22 AND 39).

CLASS 26—FANCY GOODS

FOR ORNAMENTAL NOVELTY BADGES (U.S. CLS. 37, 39, 40, 42 AND 50).

CLASS 28—TOYS AND SPORTING GOODS

FOR TOYS, NAMELY, MODEL TRAIN SETS, WHISTLES, KALEIDOSCOPES, POSITIONABLE WOODEN AND PLASTIC FIGURES FOR USE IN WOODEN AND PLASTIC PUZZLES; CARD AND BOARD GAMES; AND PUZZLES (U.S. CLS. 22, 23, 38 AND 50).

CLASS 41—EDUCATION AND ENTERTAINMENT

FOR MUSEUMS; RUNNING OF MUSEUMS (U.S. CLS. 100, 101 AND 107).

PAUL F. GAST, EXAMINING ATTORNEY

SN 77-259,172. WALT DISNEY FAMILY FOUNDATION, WOODLAND HILLS, CA. FILED 8-20-2007.

SN 77-259,420. YAP DESIGNS, INC., SAN FRANCISCO, CA. FILED 8-20-2007.



NO CLAIM IS MADE TO THE EXCLUSIVE RIGHT TO USE "HISTORICAL SOCIETY", APART FROM THE MARK AS SHOWN.

THE TERM "CAROLWOOD" DOES NOT IDENTIFY A LIVING INDIVIDUAL.

THE MARK CONSISTS OF A CIRCULAR DESIGN WITH THE WORDS "CAROLWOOD PACIFIC" WITHIN THE BORDER OF THE CIRCLE. THE INSIDE OF THE CIRCLE CONSISTS OF A TRAIN AND TRAIN TRACKS WITH THE WORDS "HISTORICAL SOCIETY" ACROSS THE CENTER.

CLASS 14—JEWELRY

FOR ORNAMENTAL PINS AND ORNAMENTAL BADGES OF PRECIOUS METAL (U.S. CLS. 2, 27, 28 AND 50).

CLASS 16—PAPER GOODS AND PRINTED MATTER

FOR PRINTED MATTER, NAMELY, STATIONERY, NOTEPADS, SCRIBBLE PADS, BLANK JOURNALS, ADDRESS BOOKS, FLIP BOOKS, DECALS, PAPER COASTERS, BOXED UNIVERSAL GREETING AND CORRESPONDENCE CARD SETS, PHOTO ALBUMS, SCRAPBOOKS, COLORING BOOKS, POSTERS, CALENDARS, STICKERS; BOOKLETS IN THE FIELD OF RAILROADING AND ANIMATION AND ABOUT WALT DISNEY; RUBBER STAMPS, PAPER SIGNS, PENCILS, AND PENS (U.S. CLS. 2, 5, 22, 23, 29, 37, 38 AND 50).

YAP

THE MARK CONSISTS OF STANDARD CHARACTERS WITHOUT CLAIM TO ANY PARTICULAR FONT, STYLE, SIZE, OR COLOR.

OWNER OF U.S. REG. NO. 3,274,562.

CLASS 3—COSMETICS AND CLEANING PREPARATIONS

FOR NON-MEDICATED GROOMING PREPARATIONS FOR PETS, NAMELY, PET SHAMPOOS, PET HAIR CONDITIONER, PET BATH AND BODY OILS, PET FRAGRANCES, PET ODOR REMOVERS, AND DISPOSABLE WIPES (U.S. CLS. 1, 4, 6, 50, 51 AND 52).

CLASS 14—JEWELRY

FOR PET JEWELRY (U.S. CLS. 2, 27, 28 AND 50).

CLASS 18—LEATHER GOODS

FOR COLLARS FOR PETS; ANIMAL CARRIERS; PET CLOTHING; LEASHES FOR ANIMALS; RAWHIDE CHEWS FOR DOGS (U.S. CLS. 1, 2, 3, 22 AND 41).

CLASS 25—CLOTHING

FOR BELTS; CHILDREN'S AND INFANTS' CLOTH BIBS; TOPS; BOTTOMS; SHIRTS; TIES; SUSPENDERS; JACKETS; FOOTWEAR; SLEEPWEAR; SWIM WEAR; HOSIERY; HEADWEAR; SUITS; PANTS; UNDERGARMENTS; SHORTS; SKIRTS (U.S. CLS. 22 AND 39).

CLASS 35—ADVERTISING AND BUSINESS

FOR ON-LINE RETAIL STORE SERVICES FEATURING PET PRODUCTS; RETAIL STORE SERVICES FEATURING PET PRODUCTS (U.S. CLS. 100, 101 AND 102).

MARY ROSSMAN, EXAMINING ATTORNEY

SN 77-259,507. FREE STORE/FOOD BANK, INC., CINCINNATI, OH. FILED 8-20-2007.



THE MARK CONSISTS OF THE WORDS "LIBERTY PANTRY EASY, GREAT-TASTING FOODS" WITH A DESIGN OF 3 LEAVES ABOUT THE WORDS.

CLASS 5—PHARMACEUTICALS

FOR NUTRITIONAL DRINK MIXES FOR USE AS A MEAL SUPPLEMENT (U.S. CLS. 6, 18, 44, 46, 51 AND 52).

CLASS 29—MEATS AND PROCESSED FOODS

FOR PACKAGED ENTREES CONSISTING PRIMARILY OF VEGETABLES, MEAT OR BEANS (U.S. CL. 46).

CLASS 30—STAPLE FOODS

FOR RICE AND OATMEAL; AND PACKAGED ENTREES CONSISTING PRIMARILY OF RICE (U.S. CL. 46).

BRENDAN REGAN, EXAMINING ATTORNEY

SN 77-259,957. ANY QUESTION INC., WHEATLEY HEIGHTS, NY. FILED 8-20-2007.

ANY QUESTION

THE MARK CONSISTS OF STANDARD CHARACTERS WITHOUT CLAIM TO ANY PARTICULAR FONT, STYLE, SIZE, OR COLOR.

OWNER OF U.S. REG. NOS. 2,358,206 AND 2,365,378.

CLASS 18—LEATHER GOODS

FOR ALL PURPOSE SPORT BAGS; ALL-PURPOSE ATHLETIC BAGS; TOTE BAGS, SHOULDER BAGS, TRAVEL ACCESSORY BAGS, SACK PACKS, RESERVOIR BACKPACKS, WAIST PACKS, CREDIT CARD HOLDERS, CREDIT CARD CASES, HANDBAGS, BEACH BAGS, BRIEF BAGS, COSMETIC BAGS SOLD EMPTY, RUCKSACKS, TRAVEL BAGS, SUITCASES, WALLETS, PURSES, ZIPPED WALLETS, BILLFOLD WALLETS, BOOK BAGS, BACKPACKS, DUFFEL BAGS, KEY CASES, UMBRELLAS, BACKPACKS, BILLFOLDS, BRIEFCASES, BRIEF CASE TYPE PORTFOLIOS, ATTACHES, BUSINESS CARD CASES, CHANGE PURSES, FANNY PACKS, GYM BAGS, KEY CASES, KNAPSACKS, LUGGAGE, POCKETBOOKS, SCHOOL BAGS, STRAPS FOR HANDBAGS AND LUGGAGE AND ACCESSORIES USED THEREWITH, NAMELY, SHOULDER STRAP PADS, HOLDERS, AND POUCHES; GOODS MADE OF LEATHER AND IMITATIONS OF LEATHER, NAMELY, KEY CHAINS, HANDBAGS, WALLETS, CASES, BILLFOLDS, COSMETIC BAGS SOLD EMPTY, BRIEFCASES, BRIEF CASE TYPE PORTFOLIOS, ATTACHES, TOTES, TRUNKS AND TRAVELING BAGS; GARMENT BAGS FOR TRAVEL; SHOE BAGS FOR TRAVEL (U.S. CLS. 1, 2, 3, 22 AND 41).

FIRST USE 8-28-2006; IN COMMERCE 8-30-2006.

CLASS 25—CLOTHING

FOR CLOTHING AND APPAREL FOR MEN, WOMEN, YOUNG ADULTS, CHILDREN AND INFANTS, NAMELY, SHIRTS, EMBROIDERED SHIRTS, TEE SHIRTS, SHORTS, SPORT SHIRTS, MOCK NECKS, TURTLE NECKS, ARM WARMERS, HOODS, SKULL CAPS, SKULL WRAPS, ATHLETIC SLEEVES, LEGGINGS, HEAD WEAR FOR WINTER AND SUMMER, SWEATSHIRTS, SWEATPANTS, TENNIS WEAR, SWIM WEARS, BATHING SUITS, SOCKS, VESTS, BELTS, LOUNGEWEAR, SLEEPWEAR, UNDERGARMENTS, UNDERPANTS, UNDERSHIRTS, BATHROBES, FOOTWEAR, UNDERWEAR, GIRDLES, SWIMSUITS, BEACH COVER-UPS, WARM-UP SUITS, JACKETS, JERSEYS, TANK TOPS, SWEATERS, PANTS, JEANS, VESTS, SUITS, SPORT COATS, COATS, HEAD BANDS, OVERCOATS, RAIN COATS, RAIN SUITS, TOP COATS, JACKETS, PARKAS, TIES, BOW TIES, NECKWEAR, VESTS, SCARVES, BANDANNAS, PAJAMAS, NIGHT SHIRTS, SUSPENDERS, GLOVES, HEADWEAR, HATS, BASEBALL CAPS, EMBROIDERED CAPS, KNITTED HATS, FOOTWEAR, SHOES, SLIPPERS, BOOTS, SANDALS, SNEAKERS, BODY SUITS, JUMPSUITS; CLOTHING FOR WOMEN AND YOUNG ADULTS, NAMELY, BRASSIERES, BUS TIERS, CAMISOLES, CHEMISES, BRAS, SPORTS BRAS, CORSELETS, CORSETS, FOUNDATION GARMENTS, DRESSING GOWNS, DUSTERS, GARTER BELTS, GIRDLES, HOUSECOATS, LINGERIE, NEGLIGEEES, NIGHT GOWNS, NIGHT SHIRTS, PAJAMAS, PEIGNOIRS, ROBES, TEDDIES, PANTIES, BLOUSES, DRESSES, SKIRTS, TOPS, SCARVES, SARONGS, HALTER TOPS, HOSIERY, JUMPERS, SHAWLS, STOLEES, SCARVES, SHRUGS, BOLEROS, AND WRAPS; INFANT WEAR (U.S. CLS. 22 AND 39).

FIRST USE 8-28-2006; IN COMMERCE 8-30-2006.

CLASS 35—ADVERTISING AND BUSINESS

FOR ADVERTISING, PROMOTING, MARKETING AND PUBLIC RELATIONS SERVICES, NAMELY, PROMOTING THE GOODS, SERVICES AND BRAND IDENTITIES OF OTHERS, BY MEANS OF BROADCAST COMMERCIALS, NEWS, PRINT MEDIA, AUDIO RECORDINGS, RADIO, TELEVISION, VIDEO RECORDINGS, DIGITAL MEDIA, THE INTERNET, COMPUTER SOFTWARE, LASER, CS-ROM, DIVX AND DVD DISCS AND IN CONNECTION WITH SPORTING, ENTERTAINMENT AND CULTURAL EVENTS; MANAGING AND CREATING THE COMMUNICATIONS OF BUSINESSES, CORPORATIONS AND INDIVIDUALS TO THE PUBLIC, INCLUDING THE DISSEMINATION OF DECLARATIONS, ANNOUNCEMENTS, PROSPECTUSES; CREATING ADVERTISING, MARKETING AND PROMOTIONAL CAMPAIGNS FOR OTHERS; SUPERVISING MEDIA PLACEMENT OF ADVERTISING FOR OTHERS (U.S. CLS. 100, 101 AND 102).

FIRST USE 8-28-2006; IN COMMERCE 8-30-2006.

JILL C. ALT, EXAMINING ATTORNEY

SN 77-260,211. SAS IP, INC., CHEYENNE, WY. FILED 8-21-2007.



THE MARK CONSISTS OF A STYLIZED REPRESENTATION OF THE LETTER "A".

CLASS 9—ELECTRICAL AND SCIENTIFIC APPARATUS

FOR COMPUTER PROGRAMS FOR COMPUTER AIDED ENGINEERING IN THE FIELD OF ENGINEERING ANALYSIS (U.S. CLS. 21, 23, 26, 36 AND 38).
FIRST USE 6-28-1996; IN COMMERCE 6-28-1996.

CLASS 42—SCIENTIFIC AND COMPUTER SERVICES

FOR (BASED ON INTENT TO USE) COMPUTERIZED ENGINEERING ANALYSIS SERVICES IN THE NATURE OF COMPUTER AIDED ENGINEERING SERVICES FOR OTHERS (U.S. CLS. 100 AND 101).
MARK RADEMACHER, EXAMINING ATTORNEY

SN 77-260,416. ASSUREIMMUNE, LLC, BOCA RATON, FL. FILED 8-21-2007.

Your cells today. Your
chance tomorrow.

THE MARK CONSISTS OF STANDARD CHARACTERS WITHOUT CLAIM TO ANY PARTICULAR FONT, STYLE, SIZE, OR COLOR.

CLASS 39—TRANSPORTATION AND STORAGE

FOR STORAGE OF STEM CELLS FOR MEDICAL USE (U.S. CLS. 100 AND 105).

CLASS 40—MATERIAL TREATMENT

FOR PROCESSING OF CELLS, NAMELY, THE SEPARATION OF STEM CELLS FROM BLOOD PLASMA AND RED BLOOD CELLS (U.S. CLS. 100, 103 AND 106).

CLASS 44—MEDICAL, BEAUTY AND AGRICULTURAL SERVICES

FOR MEDICAL SERVICES, NAMELY, STEM CELL COLLECTION AND PRESERVATION (U.S. CLS. 100 AND 101).
JAMES A. RAUEN, EXAMINING ATTORNEY

SN 77-261,255. SELECT APPOINTMENTS (HOLDINGS) LIMITED, ST. ALBANS, UNITED KINGDOM, FILED 8-22-2007.



OWNER OF U.S. REG. NOS. 2,514,874 AND 2,514,875.
THE COLOR(S) YELLOW AND LIGHT GREEN IS/ARE CLAIMED AS A FEATURE OF THE MARK.

THE MARK CONSISTS OF A ROW OF THREE YELLOW BOXES ABOVE TWO ROWS OF FOUR BOXES AND ROW OF THREE BOXES. THE FIRST THREE BOXES OF THE SECOND LINE ARE LIGHT GREEN AND THE FOURTH BOX IS YELLOW. THE THIRD BOXES OF THE THIRD AND FOURTH ROWS ARE LIGHT GREEN AND THE OTHERS ARE YELLOW. THE WORD "DELTA" APPEARS TO THE RIGHT IN YELLOW. THE LETTER "A" IS A GREEK DELTA.

CLASS 35—ADVERTISING AND BUSINESS

FOR EMPLOYMENT AGENCY SERVICES; EMPLOYMENT CONSULTANCY SERVICES; EMPLOYMENT COUNSELING; INFORMATION SERVICES RELATING TO JOBS AND CAREER OPPORTUNITIES; PLACING JOB ADVERTISEMENTS FOR OTHERS; PROVIDING AN ON-LINE WEBSITE FEATURING JOB ADVERTISEMENTS; PERSONNEL MANAGEMENT SERVICES; PERSONNEL RECRUITMENT; TESTING FOR THE SELECTION OF PERSONNEL; EMPLOYMENT RECRUITMENT, EMPLOYEE PLACEMENT, STAFFING AND OUTSOURCING SERVICES PRINCIPALLY FOCUSED ON LIFE SCIENCES; EMPLOYEE RECRUITMENT, EMPLOYEE PLACEMENT, STAFFING AND OUTSOURCING OF CLINICAL SERVICES FOR ORGANIZATIONS IN THE FIELDS OF PHARMACEUTICALS, BIOTECHNOLOGY, MEDICAL EQUIPMENT MANUFACTURERS, CLINICAL TRIALS AND HEALTHCARE; PROVIDING INFORMATION AND ADVISORY SERVICES IN THE AFOREMENTIONED FIELDS (U.S. CLS. 100, 101 AND 102).
FIRST USE 6-16-2003; IN COMMERCE 6-16-2003.

CLASS 42—SCIENTIFIC AND COMPUTER SERVICES

FOR COMPUTER SERVICES, NAMELY, CREATING AND MAINTAINING INTERNET APPLICATIONS FOR OTHERS; COMPUTER SOFTWARE DESIGN AND IMPLEMENTATION FOR OTHERS; APPLICATION SERVICE PROVIDER (ASP) FEATURING SOFTWARE FOR USE IN THE FIELD OF CONTINGENT WORKFORCE MANAGEMENT, NAMELY, SOFTWARE FOR PROCESSING INFORMATION REGARDING JOB OPPORTUNITIES, PLACEMENT OF EMPLOYEES, AND TIME ENTRY, ATTENDANCE, AND PERFORMANCE OF WORKERS (U.S. CLS. 100 AND 101).
FIRST USE 6-16-2003; IN COMMERCE 6-16-2003.
JENNY PARK, EXAMINING ATTORNEY

SN 77-261,333. WGBH EDUCATIONAL FOUNDATION, BOSTON, MA. FILED 8-22-2007.

Engineer your Life
Dream Big. Love What You
Do.

THE MARK CONSISTS OF STANDARD CHARACTERS WITHOUT CLAIM TO ANY PARTICULAR FONT, STYLE, SIZE, OR COLOR.

NO CLAIM IS MADE TO THE EXCLUSIVE RIGHT TO USE "ENGINEER" FOR CLASSES 9 AND 41, APART FROM THE MARK AS SHOWN.

CLASS 9—ELECTRICAL AND SCIENTIFIC APPARATUS

FOR DIGITAL MATERIALS, NAMELY, DOWNLOADABLE VIDEO FEATURING ENGINEERING AND THE PROMOTION OF ENGINEERING FOR GIRLS (U.S. CLS. 21, 23, 26, 36 AND 38).

CLASS 38—COMMUNICATION

FOR STREAMING OF VIDEO MATERIAL ON THE INTERNET (U.S. CLS. 100, 101 AND 104).

CLASS 41—EDUCATION AND ENTERTAINMENT

FOR ENTERTAINMENT SERVICES, NAMELY, PROVIDING A WEBSITE FEATURING, PHOTOGRAPHIC, AUDIO, VIDEO AND PROSE PRESENTATIONS FEATURING ENGINEERING FOR GIRLS; EDUCATIONAL SERVICES, NAMELY, CONDUCTING ONLINE AND LIVE SEMINARS AND WORKSHOPS IN THE FIELD OF PROMOTING ENGINEERING FOR GIRLS AND DISTRIBUTION OF COURSE MATERIAL IN CONNECTION THEREWITH (U.S. CLS. 100, 101 AND 107).

TINA BROWN, EXAMINING ATTORNEY

SN 77-261,550. UNION SQUARE HOSPITALITY GROUP, LLC, NEW YORK, NY. FILED 8-22-2007.

TABLA

THE MARK CONSISTS OF STANDARD CHARACTERS WITHOUT CLAIM TO ANY PARTICULAR FONT, STYLE, SIZE, OR COLOR.

OWNER OF U.S. REG. NO. 2,404,904.

CLASS 29—MEATS AND PROCESSED FOODS

FOR PREPARED MEALS CONSISTING PRIMARILY OF MEAT, FISH, POULTRY, SEAFOOD OR VEGETABLES; PACKAGED MEALS CONSISTING PRIMARILY OF MEAT, FISH, POULTRY SEAFOOD OR VEGETABLES; MEAT; FISH; SEAFOOD; POULTRY; VEGETABLES, NAMELY, COOKED VEGETABLES, PRESERVED VEGETABLES, PROCESSED VEGETABLES; PREPARED MEAT, FISH, SEAFOOD, POULTRY OR VEGETABLES; SEASONED MEAT, SEAFOOD, FISH, POULTRY OR VEGETABLES; PROCESSED MEATS (U.S. CL. 46).

CLASS 30—STAPLE FOODS

FOR PREPARED MEALS CONSISTING PRIMARILY OF PASTA OR RICE; PACKAGED MEALS CONSISTING PRIMARILY OF PASTA OR RICE (U.S. CL. 46).

CLASS 32—LIGHT BEVERAGES

FOR NON-ALCOHOLIC COCKTAIL MIXES (U.S. CLS. 45, 46 AND 48).

MICHAEL LEWIS, EXAMINING ATTORNEY

SN 77-261,921. BARTELL, KATHERINE, CAVE CREEK, AZ. FILED 8-22-2007.

TEE CANDY

THE MARK CONSISTS OF STANDARD CHARACTERS WITHOUT CLAIM TO ANY PARTICULAR FONT, STYLE, SIZE, OR COLOR.

CLASS 25—CLOTHING

FOR MEN'S, WOMEN'S, AND CHILDREN'S SPORT CLOTHING IN THE NATURE OF GOLFING APPAREL, NAMELY, SHIRTS, PANTS, SHORTS, DRESSES, SOCKS, SHOES, HATS, GLOVES, HEADBANDS, VISORS, CAPS, BELTS, UNDERGARMENTS, SWEATSHIRTS, SWEATERS, VESTS, JACKETS, COATS, SWEAT PANTS, AND FOUL WEATHER GEAR (U.S. CLS. 22 AND 39).

CLASS 35—ADVERTISING AND BUSINESS

FOR RETAIL OUTLET, MAIL ORDER SERVICES, AND ONLINE RETAIL STORE, ALL FEATURING GOLF CLOTHING, EQUIPMENT FOR PLAYING GOLF, AND GOLFING ACCESSORIES (U.S. CLS. 100, 101 AND 102).

B. PARADEWELAI, EXAMINING ATTORNEY

SN 77-262,921. CANADIAN AGRA INC., KINCARDINE, ONTARIO, CANADA, FILED 8-23-2007.



THE MARK CONSISTS OF THE STYLIZED LETTERS "CA" WITH LINES APPEARING IN THE INTERIOR FOR THE APPEARANCE OF VISUAL DEPTH WITH PORTIONS OF A LEAF ON THE LEFT AND RIGHT SIDES, THE WORDING "CANADIAN AGRA" APPEARING BELOW IN SMALLER LETTERING, THE WORDING "BIO-CUBE" APPEARING BENEATH THIS IN VERY LARGE LETTERING AND THE PROFILE OF TWO HORSES FACING EACH OTHER ON EACH SIDE OF THE "CA CANADIAN AGRA BIO-CUBE" WORDING.

SEC. 2(F).

CLASS 31—NATURAL AGRICULTURAL PRODUCTS

FOR ANIMAL FEED (U.S. CLS. 1 AND 46).
FIRST USE 5-0-1993; IN COMMERCE 5-0-1993.

CLASS 39—TRANSPORTATION AND STORAGE

FOR DISTRIBUTION SERVICES, NAMELY, DELIVERY OF ANIMAL FEED (U.S. CLS. 100 AND 105).
FIRST USE 5-0-1993; IN COMMERCE 5-0-1993.
GENE MACIOL, EXAMINING ATTORNEY

CLASS 35—ADVERTISING AND BUSINESS

FOR RETAIL STORE SERVICES, ONLINE STORE SERVICES, CATALOG ORDERING SERVICES FOR PET PRODUCTS, SUPPLIES AND GIFTS (U.S. CLS. 100, 101 AND 102).

CLASS 41—EDUCATION AND ENTERTAINMENT

FOR EDUCATION SERVICES, NAMELY, CONDUCTING WORKSHOPS AND CLASSES ABOUT PETS AND PET CARE; OBEDIENCE SCHOOL TRAINING FOR ANIMALS; PROVIDING ANIMAL EXERCISE (U.S. CLS. 100, 101 AND 107).

CLASS 43—HOTEL AND RESTAURANT SERVICES

FOR KENNEL SERVICES, PET DAY CARE AND BOARDING (U.S. CLS. 100 AND 101).

CLASS 44—MEDICAL, BEAUTY AND AGRICULTURAL SERVICES

FOR ANIMAL GROOMING, ANIMAL MASSAGE AND BATHING SERVICES (U.S. CLS. 100 AND 101).
DAVID COLLIER, EXAMINING ATTORNEY

SN 77-262,947. MEDICAL REIMBURSEMENT SYSTEMS, INC., WOBURN, MA. FILED 8-23-2007.

MRSI

THE MARK CONSISTS OF STANDARD CHARACTERS WITHOUT CLAIM TO ANY PARTICULAR FONT, STYLE, SIZE, OR COLOR.

CLASS 35—ADVERTISING AND BUSINESS

FOR BILLING, NAMELY, HOSPITAL EMERGENCY DEPARTMENT MEDICAL BILLING AND BILLING SUPPORT SERVICES; ADMINISTRATION, BILLING, AND RECONCILIATION OF ACCOUNTS ON BEHALF OF HOSPITAL EMERGENCY DEPARTMENTS, RECORDS MANAGEMENT SERVICES, NAMELY, DOCUMENT INDEXING FOR HOSPITAL EMERGENCY DEPARTMENTS; HOSPITAL EMERGENCY DEPARTMENT ADMINISTRATION SERVICES; HOSPITAL EMERGENCY DEPARTMENT MANAGEMENT (U.S. CLS. 100, 101 AND 102).
FIRST USE 9-21-2001; IN COMMERCE 9-21-2001.

SN 77-264,227. WAG HOTELS, INC., WEST SACRAMENTO, CA. FILED 8-24-2007.

ZOEBES WAG

THE MARK CONSISTS OF STANDARD CHARACTERS WITHOUT CLAIM TO ANY PARTICULAR FONT, STYLE, SIZE, OR COLOR.

CLASS 44—MEDICAL, BEAUTY AND AGRICULTURAL SERVICES

FOR MAINTAINING HOSPITAL EMERGENCY DEPARTMENT ELECTRONIC FILES AND RECORDS CONCERNING THE MEDICAL CONDITION OF INDIVIDUALS; EMERGENCY ROOM HOSPITAL SERVICES (U.S. CLS. 100 AND 101).
FIRST USE 9-29-2001; IN COMMERCE 9-29-2001.
MARILYN IZZI, EXAMINING ATTORNEY

CLASS 16—PAPER GOODS AND PRINTED MATTER

FOR PRINTED PUBLICATIONS, NAMELY, MAGAZINES, NEWSLETTER AND BROCHURES FEATURING INFORMATION ON PETS AND PET PRODUCTS AND SERVICES (U.S. CLS. 2, 5, 22, 23, 29, 37, 38 AND 50).

SN 77-264,221. WAG HOTELS, INC., WEST SACRAMENTO, CA. FILED 8-24-2007.

ZOEBES

THE MARK CONSISTS OF STANDARD CHARACTERS WITHOUT CLAIM TO ANY PARTICULAR FONT, STYLE, SIZE, OR COLOR.

CLASS 16—PAPER GOODS AND PRINTED MATTER

FOR PRINTED PUBLICATIONS, NAMELY, MAGAZINES, NEWSLETTER AND BROCHURES FEATURING INFORMATION ON PETS AND PET PRODUCTS AND SERVICES (U.S. CLS. 2, 5, 22, 23, 29, 37, 38 AND 50).

CLASS 35—ADVERTISING AND BUSINESS

FOR RETAIL STORE SERVICES, ONLINE STORE SERVICES, CATALOG ORDERING SERVICES FOR PET PRODUCTS, SUPPLIES AND GIFTS (U.S. CLS. 100, 101 AND 102).

CLASS 41—EDUCATION AND ENTERTAINMENT

FOR EDUCATION SERVICES, NAMELY, CONDUCTING WORKSHOPS AND CLASSES ABOUT PETS AND PET CARE; OBEDIENCE SCHOOL TRAINING FOR ANIMALS; PROVIDING ANIMAL EXERCISE (U.S. CLS. 100, 101 AND 107).

CLASS 43—HOTEL AND RESTAURANT SERVICES

FOR KENNEL SERVICES, PET DAY CARE AND BOARDING (U.S. CLS. 100 AND 101).

CLASS 44—MEDICAL, BEAUTY AND AGRICULTURAL SERVICES

FOR ANIMAL GROOMING, ANIMAL MASSAGE AND BATHING SERVICES (U.S. CLS. 100 AND 101).
DAVID COLLIER, EXAMINING ATTORNEY

SN 77-264,238. MOTTER, ROSLYN J., EPPING 2121, AUSTRALIA, FILED 8-24-2007.

Doofuzz Dudes

THE MARK CONSISTS OF STANDARD CHARACTERS WITHOUT CLAIM TO ANY PARTICULAR FONT, STYLE, SIZE, OR COLOR.

OWNER OF AUSTRALIA REG. NO. 1119730, DATED 6-21-2006, EXPIRES 6-21-2016.

CLASS 9—ELECTRICAL AND SCIENTIFIC APPARATUS

FOR COMPUTER GAME CARTRIDGES; COMPUTER GAME CASSETTES; CHILDREN'S EDUCATIONAL GAME EQUIPMENT CONTAINING MEMORY DEVICES, NAMELY, DISCS; COMPUTER GAME JOYSTICKS; COMPUTER GAME PROGRAMS; COMPUTER GAME SOFTWARE; COMPUTER GAME SOFTWARE, NAMELY, A COMPUTER CRAPS GAME; COMPUTER GAME TAPES; COMPUTER GRAPHICS BOARDS; COMPUTER GRAPHICS SOFTWARE; COMPUTER HARDWARE AND COMPUTER SOFTWARE PROGRAMS FOR THE INTEGRATION OF TEXT, AUDIO, GRAPHICS, STILL IMAGES AND MOVING PICTURES INTO AN INTERACTIVE DELIVERY FOR MULTIMEDIA APPLICATIONS; COMPUTER JOYSTICKS; COMPUTER KEYBOARDS; COMPUTER KEYPADS; COMPUTER MOUSE; COMPUTER PROGRAMS FOR EDITING IMAGES, SOUND AND VIDEO; COMPUTER PROGRAMS FOR PRE-RECORDED GAMES; COMPUTER SOFTWARE AND FIRMWARE FOR GAMES OF CHANCE ON ANY COMPUTERIZED PLATFORM, INCLUDING DEDICATED GAMING CONSOLES, VIDEO BASED SLOT MACHINES, REEL BASED SLOT MACHINES, AND VIDEO LOTTERY TERMINALS; COMPUTER SOFTWARE TO ENHANCE THE AUDIO-VISUAL CAPABILITIES OF MULTIMEDIA APPLICATIONS, NAMELY, FOR THE INTEGRATION OF TEXT, AUDIO, GRAPHICS, STILL IMAGES AND MOVING PICTURES; COMPUTER SOFTWARE, NAMELY, SOFTWARE DEVELOPMENT TOOLS FOR THE CREATION OF MOBILE INTERNET APPLICATIONS AND CLIENT INTERFACES; ELECTRONIC COMPUTERS; ELECTRONIC GAME SOFTWARE; ELECTRONIC GAME SOFTWARE FOR CELLULAR TELEPHONES; ELECTRONIC GAME SOFTWARE FOR HAND HELD ELECTRONIC DEVICES; ELECTRONIC GAME SOFTWARE FOR WIRELESS DEVICES; ELECTRONIC GAME SOFTWARE, NAMELY, AN ELECTRONIC CRAPS GAME; ELECTRONIC GAME SOFTWARE, NAMELY, AN ELECTRONIC VIDEO CRAPS GAME; ELECTRONIC PUBLICATIONS, NAMELY, BOOK, MAGAZINE FEATURING FICTIONAL STORIES FEATURING THE DOOFUZZ DUDES BOOKS RECORDED ON COMPUTER MEDIA; ENTERTAINMENT SYSTEM COMPRISING A COMPUTER, MULTIPLE DISPLAY SCREEN, MULTIPLE INPUT DEVICES AND A PRINTER; GAME CONTROLLERS FOR COMPUTER GAMES; GAME SOFTWARE; HAND HELD COMPUTERS; INTERACTIVE MULTIMEDIA COMPUTER GAME PROGRAM; INTERACTIVE VIDEO GAMES OF VIRTUAL REALITY COMPRISED OF COMPUTER HARDWARE AND SOFTWARE; JACKETS FOR COMPUTER DISKS; MOUSE PADS; NOTEBOOK COMPUTER COOLING PADS; POCKET COMPUTERS FOR NOTE-TAKING; TRADING CARDS RECORDED ON COMPUTER DISCS; VIDEO GAME SOFTWARE; VIDEO GAME SOFTWARE, NAMELY, A

VIDEO CRAPS GAME; VIRTUAL REALITY GAME SOFTWARE; VIRTUAL REALITY SOFTWARE FOR PLAYING DOOFUZZ DUDES COMPUTER GAMES; WRIST RESTS FOR COMPUTER MOUSE USERS; WRIST RESTS FOR USE WITH COMPUTERS; WRIST SUPPORTS FOR COMPUTER MOUSE USERS (U.S. CLS. 21, 23, 26, 36 AND 38).

FIRST USE 6-21-2006; IN COMMERCE 6-21-2006.

CLASS 16—PAPER GOODS AND PRINTED MATTER

FOR WRITING PAPER PADS; XEROGRAPHIC PAPER; THERMOSENSITIVE PAPER; THICK JAPANESE PAPER; TISSUE PAPER; TISSUE PAPER FOR USE AS MATERIAL OF STENCIL PAPER (GANPISHI); TOILET PAPER; TOILET SEAT COVER PAPER; TRACING PAPER; TRADING CARD DISCS OF PAPER OR CARDBOARD; TREATED PAPER FOR WRAPPING FLOWERS AND FLORAL DISPLAYS; TYPEWRITER PAPER; UNFITTED FURNITURE COVERS OF PAPER; UNPRINTED PAPER; UNSENSITIZED PHOTO PAPER; WATERPROOF PAPER; WAX BOND PAPER; WAX PAPER; WORKS OF ART MADE FROM CUSTOM MANUFACTURED PAPER; WRAPPING PAPER; WRITING PAPER; WRITING PAPER HOLDERS; RULED PAPER; SAFETY PAPER; SCENTED PAPER DRAWER LINERS; SCHOOL SUPPLY KITS CONTAINING VARIOUS COMBINATIONS OF SELECTED SCHOOL SUPPLIES, NAMELY, WRITING INSTRUMENTS, PENS, PENCILS, MECHANICAL PENCILS, ERASERS, MARKERS, CRAYONS, HIGH LIGHTERS, FOLDERS, NOTEBOOKS, PAPER, GRADUATED RULERS, PROTRACTORS, PAPER CLIPS, PENCIL SHARPENERS, WRITING GRIPS, GLUE AND BOOK MARKS; SEMI-PROCESSED PAPER; SHELF PAPER; SPECIALTY PAPERS, NAMELY, VEGETABLE PARCHMENT, FOR USE IN FOOD WRAPPING, PREPARATION, PROCESSING AND PACKAGING APPLICATIONS; STATIONERY WRITING PAPER AND ENVELOPES; STENCIL PAPER; STENCILS AND PATTERNS, BEING OF PAPER AND PLASTIC, FOR THE TRANSFERRING OF GRAPHIC DESIGNS TO PUMPKINS, MINI-PUMPKINS, GOURDS, AND OTHER FRUITS AND VEGETABLES; STORAGE CONTAINERS MADE OF PAPER; STRIPS OF FANCY PAPER (TANZAKU); SUPERCALANDERED PRINTING PAPER; SYNTHETIC BOND PAPER; SYNTHETIC PAPER; TABLE CLOTHS OF PAPER; TABLE LINENS OF PAPER; TABLE MATS OF PAPER; TABLE NAPKINS OF PAPER; PLASTIC OR PAPER BAGS FOR MERCHANDISE PACKAGING; PLASTIC-COATED COPYING PAPER; PLOTTING PAPERS; POLYESTER FILM FOR USE AS A PAPER SUBSTITUTE FOR DRY TONER XEROGRAPHIC IMAGING, NAMELY, LASER PRINTING, COLOR COPIER PRINTING, DRY TONER PRINTING, SCREEN PRINTING, AND OFFSET PRINTING; POSTCARD PAPER; POSTERS MADE OF PAPER; PRINTED PAPER LABELS; PRINTED PAPER SIGNS; PRINTED PAPER SIGNS, NAMELY, TABLE TENTS; PRINTING PAPER; PRINTING PAPERS; PROOFING PAPER; PROTECTIVE COVERS FOR SHEETS OR PAPER AND PAGES OF BOOKS AND THE LIKE; PUBLICATION PAPER; RECYCLED BOND PAPER; RECYCLED PAPER; REEL PAPER FOR PRINTERS; REPRODUCTION PAPER; RICE PAPER; RUBBISH BAGS MADE OF PAPER OR PLASTIC MATERIALS; PAPER TAPES FOR CALCULATORS; PAPER TEACHING MATERIALS IN THE FIELD OF ENGLISH LANGUAGE CLASSES; PAPER TOWELS; PAPER TRANSPARENCIES; PAPER TRAY COVERS; PAPER WASHCLOTHS; PAPER WINE GIFT BAGS; PAPER-FEEDING MACHINES FOR OFFICE USE; PAPERS FOR HOUSEHOLD AND INDUSTRIAL USE; PAPERS FOR USE IN THE GRAPHIC ARTS INDUSTRY; PARAFINED PAPER; PARCHMENT PAPER; PARTY GOODIE BAGS OF PAPER OR PLASTIC; PARTY ORNAMENTS OF PAPER; PHOTOCOPY PAPERS; PICTURE MOUNTS OF PAPER; PLACARDS OF PAPER OR CARDBOARD; PLACE MATS OF PAPER; PLASTIC COATED COPYING PAPER; PLASTIC OR PAPER BAGS FOR HOUSEHOLD USE; PAPER RACKS; PAPER REFUSE BAGS; PAPER REPORT COVERS; PAPER RIBBONS; PAPER ROLLS FOR CALCULATING MACHINES; PAPER SHEETS FOR NOTE TAKING; PAPER SHOPPING BAGS; PAPER SHREDDERS; PAPER SIGN HOLDERS; PAPER STAPLERS; PAPER STAPLES; PAPER STATIONERY; PAPER STOCK; PAPER TABLE CLOTHS; PAPER TABLE LINENS; PAPER TAGS; PAPER TAKE-OUT CARTONS FOR FOOD; PAPER TAPE; PAPER TAPES; PAPER

TAPES FOR CALCULATING MACHINES; PAPER NAME BADGES; PAPER NAPKINS; PAPER NOTE TABLETS; PAPER NOTEBOOKS; PAPER PACKAGING AND CONTAINERS FOR FOOD AND BEVERAGES COMPRISED OF MATERIALS DESIGNED TO LESSEN ADVERSE EFFECTS ON THE ENVIRONMENT; PAPER PADDING; PAPER PADS FOR CHANGING DIAPERS; PAPER PARTY BAGS; PAPER PARTY DECORATIONS; PAPER PARTY FAVORS; PAPER PATCHES FOR CLOTHING; PAPER PENNANTS; PAPER PET CRATE MATS; PAPER PICTURE MOUNTS; PAPER PILLOWCASES; PAPER PLACE MATS; PAPER POUCHES FOR PACKAGING; PAPER PRODUCTS, NAMELY, PAPER TUBES; PAPER PRODUCTS, NAMELY, PAPER TUBES AND PAPER CORES; PAPER GIFT WRAP BOWS; PAPER GIFT WRAPPING RIBBONS; PAPER HAND-TOWELS; PAPER HANDKERCHIEFS; PAPER HAND TOWELS; PAPER HANG TAGS; PAPER HOLE PUNCHES; PAPER IDENTIFICATION TAGS; PAPER ILLUSTRATION BOARDS; PAPER KNIVES; PAPER LABELS; PAPER LACE; PAPER LETTERS AND NUMBER FOR USE IN MAKING SIGNS, POSTERS; PAPER LINERS FOR DIAPERS; PAPER MACHE; PAPER MACHE FIGURINES; PAPER MADE FROM PAPER MULBERRY (KOHZO-GAMI); PAPER MADE FROM PAPER MULBERRY (TENGUJOSI); PAPER MAIL POUCHES; PAPER MATS; PAPER FOLDERS; PAPER FOLDING MACHINES AS OFFICE REQUISITES; PAPER FOLDING MACHINES FOR OFFICE USE; PAPER FOR JAPANESE INDOOR SLIDING PARTITIONS (FUSUMA-GAMI); PAPER FOR JAPANESE SLIDING SCREENS (SHOJI-GAMI); PAPER FOR BAGS AND SACKS; PAPER FOR PHOTOCOPIES; PAPER FOR PHOTOCOPYING; PAPER FOR RECORDING MACHINES; PAPER FOR USE AS MATERIAL OF STOCK CERTIFICATES (SHOKENSHI); PAPER FOR USE IN THE GRAPHIC ARTS INDUSTRY; PAPER FOR USE IN THE MANUFACTURE OF WALLPAPER; PAPER FOR WRAPPING AND PACKAGING; PAPER FUTON COVERS; PAPER GARBAGE BAGS; PAPER GIFT BAGS; PAPER GIFT BAGS FOR WINE; PAPER GIFT TAGS; PAPER GIFT WRAP; PAPER CONTAINERS; PAPER CONTAINING MICA; PAPER COVERS FOR TELEPHONE RECEIVERS; PAPER CUTTERS; PAPER DIAPERS; PAPER DIE CUT SHAPES; PAPER DISPLAY BOXES; PAPER DOILIES; PAPER DROP CLOTHS; PAPER EGG CARTONS; PAPER EMBLEMS; PAPER EMBOSSEERS; PAPER ENVELOPES FOR PACKAGING; PAPER EXPANDING FILES; PAPER FASTENERS; PAPER FILE JACKETS; PAPER FILTERS FOR COFFEE MAKERS; PAPER FLAGS; PAPER FLOOR MATS; PAPER FLOWER POT COVERS; PAPER AND CARDBOARD; PAPER BABY BIBS; PAPER BADGES; PAPER BAGS; PAPER BAGS AND SACKS; PAPER BAGS FOR PACKAGING; PAPER BANNERS; PAPER BOARD; PAPER BOARDS; PAPER BOWS FOR GIFT WRAP; PAPER BOXES; PAPER BOXES FOR STORING GREETING CARDS; PAPER BUNTING; PAPER CAKE DECORATIONS; PAPER CARTON SEALING TAPE; PAPER CARTONS FOR DELIVERING GOODS; PAPER CLIP HOLDERS; PAPER CLIPS; PAPER CLOSURES FOR CONTAINERS; PAPER CLOSURES FOR SEALING CONTAINERS; MIMEOGRAPH PAPER; MODELING MATERIALS FOR USE IN MAKING CAST PAPER SCULPTURED FLOWERS; MOISTURE PROOF CELLOPHANE PAPER; MULCH PAPER; NAPKIN PAPER; NEWSPRINT PAPER; NOTE PAPER; NOTE PAPERS; NOTEBOOK PAPER; OFFICE PAPER DRILL MACHINES; OFFICE PAPER STATIONERY; OFFSET PAPER; OFFSET PRINTING PAPER FOR PAMPHLETS; OILED PAPER FOR PAPER UMBRELLAS (KASAGAMI); OIL PROOF PAPER; ONION SKIN PAPER; OPAQUE PAPER; PACKAGING AND CONTAINERS COMPRISED OF STARCH-BASED MATERIALS IN THE NATURE OF A PAPER SUBSTITUTE FOR FOOD, BEVERAGES AND CONSUMER PRODUCTS; PACKING PAPER; PAPER; JAPANESE HANDICRAFT PAPER; JAPANESE PAPER; JAPANESE PAPER (TORINOKOGAMI); KRAFT PAPER; LABEL PAPER; LAMINATED PAPER; LASER PRINT PAPER; LASER PRINTING PAPER; LETTER PAPER; LETTERHEAD PAPER; LINING PAPER; LOOSE LEAF PAPER; LUMINOUS PAPER; MAGAZINE PAPER; MAGNETIC PAPER; MANIFOLD PAPER; MASKING PAPER; METALLIC GIFT WRAPPING PAPER; METALLIC PAPER PARTY DECORATIONS; MILDEW PROOF PAPER; GARBAGE BAGS OF PAPER; GIFT WRAP PAPER; GIFT WRAPPING PAPER; GLASSINE PAPER; GRAPH PAPER; GROCERY PAPER; GUMMED PAPER; GUNPOWDER WRAPPING PAPER; HALLOWEEN GOODIE BAGS OF PAPER OR PLASTIC;

HAND TOWELS OF PAPER; HAT BOXES OF PAPER; HEAT SENSITIVE PAPER; HEAT TRANSFER PAPER; HONEYCOMB PAPER; HYGIENIC PAPER; ILLUSTRATION PAPER; IMITATION LEATHER PAPER; INDIA PAPER; INDUSTRIAL PACKAGING CONTAINERS OF PAPER; JAPANESE CEREMONIAL PAPER STRINGS (MIZUHIKI); DIGITAL PRINTING PAPER; DIRECTORY PAPER; DISPOSABLE PAPER SHEETS FOR PERSONAL HYGIENIC USE IN THE NATURE OF DISPOSABLE HEADREST COVERS NOT FOR MEDICAL USE; DRAWING PAPER; DUPLICATING PAPER; DYE-SUBLIMATION PRINT PAPER; EKG PAPER; ELECTROCARDIOGRAPH PAPER; ELECTROSTATIC PAPER; EMBROIDERY DESIGN PATTERNS; ENVELOPE PAPER; ENVELOPE PAPERS; FACSIMILE TRANSMISSION PAPER; FIBER PAPER; FILLER PAPER; FILTER PAPER; FLUORESCENT PAPER; FLUTING PAPER; FREE-STANDING AND WALL-MOUNTED PAPER AND CARDBOARD BOXES FOR DEPOSITING A WRITTEN MESSAGE OR PRAYER WISHING A LOVED ONE WELL, FOR USE IN HOSPITALS, ELDER CARE RESIDENCES, SCHOOLS, AND INSTITUTIONS FOR CHILDREN WITH SPECIAL NEEDS; CARBON PAPER; CARDBOARD MADE FROM PAPER MULBERRY (SENKASI); CARRYING CASES MADE OF PAPER; CELLOPHANE PAPER; COASTERS MADE OF PAPER; COLLAPSIBLE BOXES OF PAPER; COMPUTER PAPER; CONSTRUCTION PAPER; CONTAINERS FOR ICE MADE OF PAPER OR CARDBOARD; COPIER PAPER; COPY PAPER; CORRUGATED BOARD AND PAPER CONTAINERS; CORRUGATED PAPER; COSMETIC REMOVING PAPER; CRAFT PAPER; CREPE PAPER; CREPE PAPER FOR MEDICAL, SANITARY OR DOMESTIC USE; CUSHIONING OR PADDING MADE OF PAPER FOR PACKING PURPOSES; DECORATIVE PAPER CENTERPIECES; ALUMINUM FOIL LAMINATED PAPER FOR PRINTING PURPOSES; ART PAPER; AUTOMATIC PAPER CLIP DISPENSING MACHINES FOR OFFICE OR STATIONERY USE; BABIES DIAPERS OF PAPER; BANNERS OF PAPER; BIODEGRADABLE PAPER PULP-BASED TO-GO CONTAINERS FOR FOOD; BLANK OR PARTIALLY PRINTED PAPER LABELS; BLANK PAPER COMPUTER TAPES; BLANK PAPER COMPUTER TAPES FOR RECORDING PROGRAMS; BLANK PAPER NOTEBOOKS; BLANK PAPER TAPES AND CARDS FOR THE RECORDING OF COMPUTER PROGRAMS; BLOTTING PAPER; BOND PAPER; BOOKCOVER PAPER; BOXES OF PAPER; BOXES OF PAPER OR CARDBOARD; BURP PADS OF PAPER; BUSINESS CARD PAPER; CALENDAR-FINISHED PAPER; CALLIGRAPHY PAPER; ABSORBENT PADS OF PAPER AND CELLULOSE FOR USE IN FOOD PACKAGING; ACID-RESISTANT PAPER; ADDING MACHINE PAPER; ADHESIVE NOTE PAPER; ADVERTISING BOARDS OF PAPER OR CARDBOARD; ADVERTISING SIGNS OF PAPER OR CARDBOARD (U.S. CLS. 2, 5, 22, 23, 29, 37, 38 AND 50).

FIRST USE 6-21-2006; IN COMMERCE 6-21-2006.

CLASS 25—CLOTHING

FOR A-SHIRTS; BUTTON-FRONT ALOHA SHIRTS; CAMP SHIRTS; DRESS SHIRTS; KNIT SHIRTS; LONG-SLEEVED SHIRTS; NIGHT SHIRTS; OPEN-NECKED SHIRTS; PIQUE SHIRTS; POLO SHIRTS; SHIRT FRONTS; SHIRT YOKES; SHIRTS; SHIRTS FOR SUITS; SHORT-SLEEVED OR LONG-SLEEVED T-SHIRTS; SHORT-SLEEVED SHIRTS; SLEEP SHIRTS; SPORT SHIRTS; SPORTS SHIRTS; SPORTS SHIRTS WITH SHORT SLEEVES; SWEAT SHIRTS; T-SHIRTS; TEE SHIRTS; WIND SHIRTS; YOGA SHIRTS (U.S. CLS. 22 AND 39).

FIRST USE 6-21-2006; IN COMMERCE 6-21-2006.

CLASS 28—TOYS AND SPORTING GOODS

FOR PAPER PARTY HATS; FANTASY CHARACTER TOYS; COLLECTABLE TOY FIGURES; PLASTIC CHARACTER TOYS; STUFFED DOLLS AND ANIMALS; STUFFED TOY ANIMALS; ARROWS; BABY MULTIPLE ACTIVITY TOYS; BATH TOYS; BATHTUB TOYS; BATTERY OPERATED ACTION TOYS; BENDABLE TOYS; CAPS FOR TOY PISTOLS; CASES FOR TOY STRUCTURES; CASES FOR TOY VEHICLES; CAT TOYS; CHILDREN'S ACTIVITY TABLES CONTAINING MANIPULATIVE TOYS WHICH CONVERT TO EASELS; CHILDREN'S MULTIPLE ACTIVITY TOYS; CHILDREN'S MULTIPLE ACTIVITY TOYS SOLD AS A UNIT WITH PRINTED BOOKS; CHILDREN'S WIRE CONSTRUCTION AND ART ACTIVITY TOYS; CLOCKWORK TOYS; CONSTRUCTION TOYS; CRIB TOYS; DISC TOSS TOYS; DOG TOYS; DRAWING TOYS; EDUCATIONAL TOY FOR THE PURPOSE OF THE DEMONSTRATION OF ALTERNATIVE ENERGY SOURCES; ELECTRIC ACTION TOYS; ELECTRIC EDUCATIONAL TOY USED TO DEMONSTRATE ALTERNATIVE ENERGY SOURCES; ELECTRIC TOY TRAIN TRANSFORMERS; ELECTRONIC ACTION TOYS; ELECTRONIC LEARNING TOYS; ELECTRONIC TOY BUILDING BLOCKS THAT LIGHT UP AS A NIGHT LIGHT; ELECTRONIC TOY VEHICLES; ELECTRONICALLY OPERATED TOY MOTOR VEHICLES; FLYING SAUCERS; INFANT ACTION CRIB TOYS; INFANT DEVELOPMENT TOYS; INFANT TOYS; INFLATABLE BATH TOYS; INFLATABLE RIDE-ON TOYS; INFLATABLE THIN RUBBER TOYS; INFLATABLE TOYS; INFLATABLE TOYS SHOWING DECORATIVE PICTURES; LEVER ACTION TOYS; MECHANICAL ACTION TOYS; MECHANICAL TOYS; MINIATURE TOY HELMETS; MODEL TOY STEAM ENGINES; MODEL TOY STEAM OPERATED TRACTION ENGINES; MODELED PLASTIC TOY FIGURINES; MOLDED TOY FIGURES; MUSIC BOX TOYS; MUSICAL TOYS; NON-ELECTRONIC TOY VEHICLES; NON-RIDING TRANSPORTATION TOYS; PARTY FAVORS IN THE NATURE OF SMALL TOYS; PET TOYS; PET TOYS CONTAINING CATNIP; PET TOYS MADE OF ROPE; PLASTIC TOY HOOPS; PLAY MATS CONTAINING INFANT TOYS; PLAY MATS FOR USE WITH TOY VEHICLES; PLUSH TOYS; POP UP TOYS; POSITIONABLE PRINTED TOY FIGURES FOR USE IN GAMES; POSITIONABLE PRINTED TOY FIGURES FOR USE IN PUZZLES; POSITIONABLE THREE DIMENSIONAL TOYS FOR USE IN GAMES; POSITIONABLE TOY FIGURES; POSITIONABLE TWO DIMENSIONAL TOYS FOR USE IN GAMES; PRINTED POSITIONABLE TOYS FOR USE IN CHILDREN'S BOARD GAMES; PRINTING TOYS; PULL TOYS; PUNCHING TOYS; PUSH TOYS; RADIO CONTROLLED TOY VEHICLES; RADIO TRANSMITTERS FOR USE WITH RADIO-CONTROLLED TOYS; REMOTE CONTROL TOYS, NAMELY, CARS, RACE CARS AND BOATS; RIDE-ON TOYS; RUBBER CHARACTER TOYS; SAND TOYS; SANDBOX TOYS; SKETCHING TOYS; SOFT SCULPTURE PLUSH TOYS; SOFT SCULPTURE TOYS; SQUEEZABLE SQUEAKING TOYS; SQUEEZE TOYS; STACKING TOYS; STUFFED PUPPETS; STUFFED TOY BEARS; STUFFED TOYS; TALKING TOYS; TESSELATION TOYS; TOSSING DISC TOYS; TOY CHRISTMAS TREES; TOY ACTION FIGURES; TOY ACTION FIGURES AND ACCESSORIES THEREFOR; TOY AIRPLANES; TOY ANIMALS AND ACCESSORIES THEREFOR; TOY ARMOR; TOY ARTIFICIAL FINGERNAILS; TOY BAKE WARE AND COOKWARE; TOY BALLOONS; TOY BANKS; TOY BOWS AND ARROWS; TOY BOXES; TOY BUILDING BLOCKS; TOY BUILDING BLOCKS CAPABLE OF INTERCONNECTION; TOY BUILDINGS AND ACCESSORIES THEREFOR; TOY BUTTERFLY NETS; TOY CAP PISTOLS; TOY CLOCKS AND WATCHES; TOY CONSTRUCTION BLOCKS; TOY CONSTRUCTION SETS; TOY FIGURES; TOY FILM CARTRIDGES AND VIEWERS; TOY FURNITURE; TOY GLIDERS; TOY GLOCKENSPIELS; TOY GUNS; TOY HARMONICAS; TOY HOLSTERS; TOY HOOP SETS; TOY HOUSES; TOY MAIL BOXES; TOY MASKS; TOY MOBILES; TOY MODEL CARS; TOY MODEL HOBBY CRAFT KITS; TOY MODEL KIT CARS; TOY MODEL TRAIN SETS; TOY MODEL VEHICLES AND RELATED ACCESSORIES SOLD AS UNITS; TOY MODELING DOUGH; TOY MUSIC BOXES; TOY NOISEMAKERS; TOY PIANOS; TOY PIANOS, SOLD AS A UNIT WITH PRINTED BOOKS IN THE FIELD OF MUSIC EDUCATION; TOY PISTOLS; TOY PRISM GLASSES; TOY PUTTY; TOY RECORD PLAYERS; TOY ROBOTS; TOY ROCKETS; TOY SCOOTERS; TOY SETS OF CARPEN-

TERS' TOOLS; TOY SNOW GLOBES; TOY STAMPS; TOY SWORDS; TOY TRAINS AND PARTS AND ACCESSORIES THEREFOR; TOY VEHICLE TRACK SETS AND ROADWAYS AND ACCESSORIES THEREFOR; TOY VEHICLES; TOY VEHICLES AND ACCESSORIES THEREFOR; TOY VEHICLES WITH TRANSFORMING PARTS; TOY WATCHES; TOY WATER GLOBES; TOY WEAPONS; TOY WIND SOCKS; TOY XYLOPHONES; TOY ZIP GUNS; TOY, NAMELY, BATTERY-POWERED COMPUTER GAME WITH LCD SCREEN WHICH FEATURES ANIMATION AND SOUND EFFECTS; TOYS DESIGNED TO BE ATTACHED TO CAR SEATS AND HIGH CHAIRS; TOYS, NAMELY, CHILDREN'S DRESS-UP ACCESSORIES; TOYS, NAMELY, A DISK TO TOSS IN PLAYING A GAME WHEREIN OTHER DISKS ARE FLIPPED AND COLLECTED; TRANSFORMING ROBOTIC TOY VEHICLES; TRANSFORMING ROBOTIC TOYS; WATER SQUIRTING TOYS; WIND-UP TOYS; WIND-UP WALKING TOYS (U.S. CLS. 22, 23, 38 AND 50).

FIRST USE 6-21-2006; IN COMMERCE 6-21-2006.
BENJAMIN OKEKE, EXAMINING ATTORNEY

SN 77-264,652. WYVERN ASSOCIATES, HONG KONG, CHINA, FILED 8-27-2007.



PRIORITY CLAIMED UNDER SEC. 44(D) ON HONG KONG APPLICATION NO. 300827523, FILED 3-8-2007, REG. NO. 300827523, DATED 3-8-2007, EXPIRES 3-7-2017.

NO CLAIM IS MADE TO THE EXCLUSIVE RIGHT TO USE "DESIGNS", APART FROM THE MARK AS SHOWN.

THE MARK CONSISTS OF THE WORDS "WAGTRADE DESIGNS" INSIDE THE DESIGN OF A DOG'S HEAD.

CLASS 14—JEWELRY

FOR PRECIOUS METALS AND THEIR ALLOYS; GOODS IN PRECIOUS METALS OR COATED THEREWITH, NAMELY, STERLING SILVER DOG CHARMS, STERLING SILVER AND CRYSTAL DOG CHARMS, PEARL NECKLACES FOR DOGS, PASTE COSTUME JEWELRY FOR DOGS AND DOG THEMED KEY RINGS; JEWELRY FOR ANIMALS; PRECIOUS STONES AND ORNAMENTS OF PRECIOUS METALS FOR ANIMALS; HOROLOGICAL AND CHRONOMETRIC INSTRUMENTS; BADGES OF PRECIOUS METAL; JEWELRY CHAINS AND JEWELRY CHARMS; DIAMONDS; EARRINGS; HAT ORNAMENTS OF PRECIOUS METAL; IVORY JEWELRY; JEWEL CASES OF PRECIOUS METAL; JEWELRY OF YELLOW AMBER; PASTE JEWELRY AND PASTE COSTUME JEWELRY; JEWELRY MEDALLIONS; MEDALS; JEWELRY NECKLACES; ORNAMENTAL PINS; JEWELRY ORNAMENTS; JEWELRY PEARLS; PEARLS MADE OF AMBROID, NAMELY, PRESSED AMBER; JEWELRY PINS, PLATED ARTICLES OF PRECIOUS METAL PLATING, NAMELY, STERLING SILVER DOG CHARMS, STERLING SILVER AND CRYSTAL DOG CHARMS, PEARL NECKLACES FOR DOGS, PASTE COSTUME JEWELRY FOR DOGS AND DOG THEMED KEY RINGS; BEADS FOR USE IN THE MANUFACTURE OF JEWELRY; JEWELRY ROPE CHAIN FOR NECKLACES, JEWELRY CHAIN OF PRECIOUS METAL FOR NECKLACES (U.S. CLS. 2, 27, 28 AND 50).

SN 77-264,844. COIHUE LLC, MIAMI LAKES, FL. FILED 8-27-2007.

PAYCARGO

THE MARK CONSISTS OF STANDARD CHARACTERS WITHOUT CLAIM TO ANY PARTICULAR FONT, STYLE, SIZE, OR COLOR.

OWNER OF U.S. REG. NO. 3,347,315.

CLASS 35—ADVERTISING AND BUSINESS

FOR INFORMATION MANAGEMENT IN THE NATURE OF FINANCIAL RECORDS MANAGEMENT FOR THE FREIGHT INDUSTRY THROUGH ELECTRONIC MEANS; FINANCIAL RECORDS MANAGEMENT SERVICES, NAMELY, MATCHING OF CASH AND CREDIT CARD TRANSACTION DATA WITH INVOICES AND ORDERS THROUGH ELECTRONIC MEANS; CUSTOMER SERVICE IN THE FIELD OF NON-LEGAL INVOICE AND RELATED BILLING ONLINE DISPUTE RESOLUTION (U.S. CLS. 100, 101 AND 102).

FIRST USE 2-2-2003; IN COMMERCE 10-18-2003.

CLASS 36—INSURANCE AND FINANCIAL

FOR ELECTRONIC PAYMENT, NAMELY, ELECTRONIC PROCESSING AND TRANSMISSION OF BILL PAYMENT DATA FOR THE FREIGHT INDUSTRY; PROCESSING AND TRANSMISSION OF CASH AND CREDIT CARD TRANSACTION DATA THROUGH ELECTRONIC MEANS; PROVISION AND MANAGEMENT OF CREDIT LOANS THROUGH ELECTRONIC MEANS (U.S. CLS. 100, 101 AND 102).

FIRST USE 2-2-2003; IN COMMERCE 10-18-2003.

JEAN IM, EXAMINING ATTORNEY

CLASS 18—LEATHER GOODS

FOR LEATHER AND IMITATIONS OF LEATHER, AND GOODS MADE OF THESE MATERIALS AND NOT INCLUDED IN OTHER CLASSES, NAMELY, DOG COLLARS, DOG LEADS/LEASHES, DOG HARNESES AND DOG TRAVELING BAGS; COATS FOR DOGS; ANIMAL SKINS AND HIDES; TRUNKS AND TRAVELING BAGS; UMBRELLAS, PARASOLS AND WALKING STICKS; WHIPS, HARNESES AND SADDLERY; CLOTHING FOR DOMESTIC PETS; DOG SHOES, DOG COLLARS, DOG CLOTHES; DOG CLOTHS, NAMELY, DOG BLANKETS FOR COVERING A DOG AND/OR ON WHICH A DOG CAN LIE; DOG BELLYBANDS; POUCHES OF LEATHER; ALL-PURPOSE CARRYING BAGS, FOLDING BRIEFCASES, SHOULDER BAGS, BRIEFCASES, SUITCASES, CARRY-ON BAGS, TRUNKS, HANDBAGS, SCHOOLCHILDREN'S BACKPACKS AND BACKPACKS; CHARM BAGS; BUSINESS CARD CASES; TEXTILE SHOPPING BAGS AND WHEELED SHOPPING BAGS; PURSES NOT OF PRECIOUS METAL; KEY CASES; WALLETS NOT OF PRECIOUS METAL; COMMUTATION-TICKET HOLDERS; UNFITTED VANITY CASES; UMBRELLAS AND THEIR PARTS; TELESCOPIC UMBRELLAS, RAINPROOF PARASOLS, BEACH UMBRELLAS, BEACH PARASOLS, SUN UMBRELLAS AND PARASOLS; UMBRELLA COVERS, UMBRELLAS HANDLES, METAL PARTS OF UMBRELLAS, FRAMES FOR UMBRELLAS AND BAGS FOR UMBRELLAS; WALKING STICKS, CANES, METAL PARTS OF CANES AND WALKING-STICKS, HANDLES OF CANES AND WALKING-STICKS (U.S. CLS. 1, 2, 3, 22 AND 41).

WILLIAM P. SHANAHAN, EXAMINING ATTORNEY

SN 77-266,346. RANDE G INC., MALIBU, CA. FILED 8-28-2007.

ROCK VODKA

THE MARK CONSISTS OF STANDARD CHARACTERS WITHOUT CLAIM TO ANY PARTICULAR FONT, STYLE, SIZE, OR COLOR.

CLASS 21—HOUSEWARES AND GLASS

FOR DRINKING GLASSES AND FLASKS (U.S. CLS. 2, 13, 23, 29, 30, 33, 40 AND 50).

CLASS 25—CLOTHING

FOR CLOTHING, NAMELY, T-SHIRTS, POLO SHIRTS, SWEATSHIRTS, SPORT SHIRTS, JACKETS, HATS, CAPS, BELTS, AND SUN VISORS (U.S. CLS. 22 AND 39).

KATHY DE JONGE, EXAMINING ATTORNEY

SN 77-266,393. CARY MARINE, INC., HALLANDALE BEACH, FL. FILED 8-28-2007.

CARY

THE MARK CONSISTS OF STANDARD CHARACTERS WITHOUT CLAIM TO ANY PARTICULAR FONT, STYLE, SIZE, OR COLOR.
OWNER OF U.S. REG. NO. 2,858,517.

CLASS 12—VEHICLES

FOR BOATS AND YACHTS (U.S. CLS. 19, 21, 23, 31, 35 AND 44).
FIRST USE 8-9-1993; IN COMMERCE 8-9-1993.

CLASS 40—MATERIAL TREATMENT

FOR CUSTOM MANUFACTURE OF BOATS AND YACHTS (U.S. CLS. 100, 103 AND 106).
FIRST USE 8-9-1993; IN COMMERCE 8-9-1993.
SETH A. RAPPAPORT, EXAMINING ATTORNEY

CLASS 42—SCIENTIFIC AND COMPUTER SERVICES

FOR PROFESSIONAL TECHNOLOGICAL CONSULTANCY SERVICES IN THE FIELD OF MEDICAL APPARATUS AND INSTRUMENTS; PROFESSIONAL TECHNOLOGICAL CONSULTANCY SERVICES IN THE FIELD OF MEDICAL DRUG DELIVERY APPARATUS AND INSTRUMENTS; DESIGN, DEVELOPMENT AND CUSTOMIZATION OF DRUG DELIVERY APPARATUS AND INSTRUMENTS, INCLUDING MEDICAL INHALERS, AEROSOL DISPENSERS, NEBULIZERS, POWDER INJECTORS AND ASPIRATORS; TECHNOLOGICAL EVALUATION OF PREPARATION OF TECHNOLOGICAL REPORTS ON, AND PROVISION OF TECHNOLOGICAL INFORMATION IN RELATION TO MEDICAL DRUG DELIVERY APPARATUS AND INSTRUMENTS, INCLUDING INHALERS, AEROSOL DISPENSERS, NEBULIZERS, POWDER INJECTORS AND ASPIRATORS (U.S. CLS. 100 AND 101).

CYNTHIA SLOAN, EXAMINING ATTORNEY

SN 77-267,394. BARTON, BENNY, PLANO, TX. FILED 8-29-2007.

LEARN PLAY EXPLORE SAFELY

SN 77-266,432. CAMBRIDGE CONSULTANTS LIMITED, CAMBRIDGE, UNITED KINGDOM, FILED 8-28-2007.

GEN-X

THE MARK CONSISTS OF STANDARD CHARACTERS WITHOUT CLAIM TO ANY PARTICULAR FONT, STYLE, SIZE, OR COLOR.

PRIORITY CLAIMED UNDER SEC. 44(D) ON UNITED KINGDOM APPLICATION NO. 2450537, FILED 3-23-2007, REG. NO. 2450537, DATED 3-23-2007, EXPIRES 3-23-2017.

CLASS 10—MEDICAL APPARATUS

FOR MEDICAL DRUG DELIVERY APPARATUS AND INSTRUMENTS; MEDICAL INHALERS, INCLUDING DISPOSABLE INHALERS; MEDICAL AEROSOL DISPENSERS; MEDICAL NEBULIZERS; MEDICAL POWDER INJECTORS SOLD EMPTY; MEDICAL ASPIRATORS; ALL THE AFORESAID GOODS SOLD EMPTY; REPLACEMENT PARTS FOR ALL THE AFORESAID GOODS (U.S. CLS. 26, 39 AND 44).

THE MARK CONSISTS OF STANDARD CHARACTERS WITHOUT CLAIM TO ANY PARTICULAR FONT, STYLE, SIZE, OR COLOR.

NO CLAIM IS MADE TO THE EXCLUSIVE RIGHT TO USE "LEARN PLAY", APART FROM THE MARK AS SHOWN.

CLASS 9—ELECTRICAL AND SCIENTIFIC APPARATUS

FOR CHILDREN'S EDUCATIONAL SOFTWARE; CHILDREN'S ENTERTAINMENT SOFTWARE, NAMELY, INTERACTIVE VIDEO GAME PROGRAMS, COMPUTER GAME SOFTWARE, AND INTERACTIVE SOFTWARE FEATURING ANIMATED CHARACTERS, CHILDREN'S STORIES AND EDUCATIONAL GAMES AND QUIZZES; COMPUTER HARDWARE AND COMPUTER SOFTWARE PROGRAMS FOR THE INTEGRATION OF TEXT, AUDIO, GRAPHICS, STILL IMAGES AND MOVING PICTURES INTO AN INTERACTIVE DELIVERY FOR MULTIMEDIA APPLICATIONS; COMPUTER SOFTWARE FOR THE COLLECTION, EDITING, ORGANIZING, MODIFYING, BOOK MARKING, TRANSMISSION, STORAGE AND SHARING OF DATA AND INFORMATION; EDUCATIONAL SOFTWARE FEATURING INSTRUCTION IN READING, SCIENCE, MATHEMATICS, SOCIAL STUDIES, AND LANGUAGE ARTS; DOWNLOADABLE CHILDREN'S EDUCATIONAL SOFTWARE; DOWNLOADABLE CHILDREN'S ENTERTAINMENT SOFTWARE, NAMELY, ENTERTAINMENT SOFTWARE FOR USE WITH COMPUTERS, FEATURING ANIMATED CHARACTERS, CHILDREN'S STORIES AND EDUCATIONAL GAMES AND QUIZZES, INTERACTIVE VIDEO GAME PROGRAMS, AND COMPUTER GAME SOFTWARE (U.S. CLS. 21, 23, 26, 36 AND 38).

FIRST USE 8-1-2007; IN COMMERCE 8-1-2007.

CLASS 41—EDUCATION AND ENTERTAINMENT

FOR ENTERTAINMENT SERVICES, NAMELY, PROVIDING ON-LINE COMPUTER GAMES; PROVIDING A WEB SITE WHERE USERS CAN POST RATINGS, REVIEWS AND RECOMMENDATIONS ON EVENTS AND ACTIVITIES IN THE FIELD OF CHILDREN'S ENTERTAINMENT AND EDUCATION; EDUCATION AND ENTERTAINMENT SERVICES, NAMELY, PROVIDING A WEBSITE FEATURING INFORMATION IN THE FIELD OF CHILDREN'S EDUCATION AND ENTERTAINMENT FEATURING AUDIO CLIPS, VIDEO CLIPS, MUSICAL VIDEOS, FILM CLIPS, PHOTOGRAPHS, AND OTHER MULTIMEDIA MATERIALS; BLOGS FEATURING INFORMATION IN THE FIELD OF CHILDREN'S EDUCATION AND ENTERTAINMENT AND WHICH MAY INCLUDE AUDIO CLIPS, VIDEO CLIPS, MUSICAL VIDEOS, FILM CLIPS, PHOTOGRAPHS, AND OTHER MULTIMEDIA MATERIALS (U.S. CLS. 100, 101 AND 107).

FIRST USE 8-1-2007; IN COMMERCE 8-1-2007.

CLASS 42—SCIENTIFIC AND COMPUTER SERVICES

FOR COMPUTER SECURITY SERVICE, NAMELY, RESTRICTING ACCESS TO AND BY COMPUTER NETWORKS TO AND OF UNDESIRED WEBSITES, MEDIA AND INDIVIDUALS AND FACILITIES; CREATION AND PROVISION OF WEB PAGES TO AND FOR THIRD PARTIES; COMPUTER SERVICES, NAMELY, HOSTING ONLINE WEB FACILITIES FOR OTHERS FOR ORGANIZING AND CONDUCTING ONLINE MEETINGS AND INTERACTIVE DISCUSSIONS, SHARING PHOTOGRAPHS AND STORIES; COMPUTER SERVICES IN THE NATURE OF CUSTOMIZED WEB PAGES FEATURING USER-DEFINED INFORMATION, PERSONAL PROFILES AND INFORMATION; PROVIDING ONLINE NON-DOWNLOADABLE CHILDREN'S EDUCATIONAL SOFTWARE; PROVIDING ONLINE NON-DOWNLOADABLE CHILDREN'S ENTERTAINMENT SOFTWARE, NAMELY, INTERACTIVE VIDEO GAME PROGRAMS, COMPUTER GAME SOFTWARE AND ENTERTAINMENT SOFTWARE FOR USE WITH COMPUTERS, FEATURING ANIMATED CHARACTERS, CHILDREN'S STORIES AND EDUCATIONAL GAMES AND QUIZZES (U.S. CLS. 100 AND 101).

FIRST USE 8-1-2007; IN COMMERCE 8-1-2007.
AHSEN KHAN, EXAMINING ATTORNEY

SN 77-267,605. UNITED COUNTRY REAL ESTATE, INC., KANSAS CITY, MO. FILED 8-29-2007.

FIRST NEIGHBOR

THE MARK CONSISTS OF STANDARD CHARACTERS WITHOUT CLAIM TO ANY PARTICULAR FONT, STYLE, SIZE, OR COLOR.

CLASS 35—ADVERTISING AND BUSINESS

FOR FRANCHISE SERVICES, NAMELY, OFFERING TECHNICAL ASSISTANCE IN THE ESTABLISHMENT AND/OR OPERATION OF REAL ESTATE BROKERAGES; ADVERTISING AND ADVERTISEMENT SERVICES (U.S. CLS. 100, 101 AND 102).

CLASS 36—INSURANCE AND FINANCIAL

FOR REAL ESTATE BROKERAGE SERVICES (U.S. CLS. 100, 101 AND 102).
JOHN KELLY, EXAMINING ATTORNEY

SN 77-268,205. WEINBERGER, MICHAEL, NEW YORK, NY. FILED 8-30-2007.

NATURAL FLAME

THE MARK CONSISTS OF STANDARD CHARACTERS WITHOUT CLAIM TO ANY PARTICULAR FONT, STYLE, SIZE, OR COLOR.

NO CLAIM IS MADE TO THE EXCLUSIVE RIGHT TO USE "FLAME", APART FROM THE MARK AS SHOWN.

CLASS 4—LUBRICANTS AND FUELS

FOR FUEL CARTRIDGES ENCLOSING ALCOHOL GEL FOR USE IN FIREPLACES (U.S. CLS. 1, 6 AND 15).
FIRST USE 5-0-2006; IN COMMERCE 5-0-2006.

CLASS 11—ENVIRONMENTAL CONTROL APPARATUS

FOR FIREPLACE INSERTS IN THE NATURE OF METAL CONVERSION STANDS TO HOLD FUEL CARTRIDGES (U.S. CLS. 13, 21, 23, 31 AND 34).

FIRST USE 5-0-2006; IN COMMERCE 5-0-2006.
CAROLYN CATALDO, EXAMINING ATTORNEY

SN 77-268,272. SOCIETE DES PRODUITS NESTLE, S.A., 1800 VEVEY, SWITZERLAND, FILED 8-30-2007.

JENNY'S CUISINE

THE MARK CONSISTS OF STANDARD CHARACTERS WITHOUT CLAIM TO ANY PARTICULAR FONT, STYLE, SIZE, OR COLOR.

NO CLAIM IS MADE TO THE EXCLUSIVE RIGHT TO USE CUISINE, APART FROM THE MARK AS SHOWN.

CLASS 29—MEATS AND PROCESSED FOODS

FOR PREPARED REDUCED CALORIE FOODS, NAMELY, PREPARED AND FROZEN ENTREES CONSISTING PRIMARILY OF POULTRY, FISH, SEAFOOD, MEATS OR VEGETABLES, TUNA SALAD, CHICKEN SALAD, SOUPS, YOGURT, PRESERVED OR STEWED FRUITS, AND CHOCOLATE FLAVORED DAIRY-BASED BEVERAGES (U.S. CL. 46).

FIRST USE 1-0-1988; IN COMMERCE 1-0-1988.

CLASS 30—STAPLE FOODS

FOR PREPARED REDUCED CALORIE FOODS, NAMELY, PROCESSED CEREALS, MUFFINS, PANCAKE MIX, NOODLES AND PASTA, PIZZAS, POPCORN, WAFFLES, FRENCH TOAST, AND RICE-BASED SNACK BARS; SALAD DRESSINGS (U.S. CL. 46).

FIRST USE 1-0-1988; IN COMMERCE 1-0-1988.
MICHAEL LEWIS, EXAMINING ATTORNEY

SN 77-268,605. BARTON, BENNY, PLANO, TX. FILED 8-30-2007.



NO CLAIM IS MADE TO THE EXCLUSIVE RIGHT TO USE "LEARN PLAY", APART FROM THE MARK AS SHOWN.

THE MARK CONSISTS OF THE STYLIZED WORDS "NOODLENET" AND "LEARN PLAY EXPLORE SAFELY" WITH A CHILD-LIKE BALLOON CHARACTER STANDING BEHIND THE FIRST LETTER "N", ANOTHER CHILD-LIKE BALLOON CHARACTER WITH ITS ARMS RAISED BEHIND THE LETTERS "OO", AND, ANOTHER CHILD-LIKE BALLOON CHARACTER SITTING ON THE SECOND "N".

CLASS 9—ELECTRICAL AND SCIENTIFIC APPARATUS

FOR CHILDREN'S EDUCATIONAL SOFTWARE; CHILDREN'S ENTERTAINMENT SOFTWARE, NAMELY, INTERACTIVE VIDEO GAME PROGRAMS, COMPUTER GAME SOFTWARE, AND INTERACTIVE SOFTWARE FEATURING ANIMATED CHARACTERS, CHILDREN'S STORIES AND EDUCATIONAL GAMES AND QUIZZES; COMPUTER HARDWARE AND COMPUTER SOFTWARE PROGRAMS FOR THE INTEGRATION OF TEXT, AUDIO, GRAPHICS, STILL IMAGES AND MOVING PICTURES INTO AN INTERACTIVE DELIVERY FOR MULTIMEDIA APPLICATIONS; COMPUTER SOFTWARE FOR THE COLLECTION, EDITING, ORGANIZING, MODIFYING, BOOK MARKING, TRANSMISSION, STORAGE AND SHARING OF DATA AND INFORMATION; EDUCATIONAL SOFTWARE FEATURING INSTRUCTION IN READING, SCIENCE, MATHEMATICS, SOCIAL STUDIES, AND LANGUAGE ARTS; DOWNLOADABLE CHILDREN'S EDUCATIONAL SOFTWARE; DOWNLOADABLE CHILDREN'S ENTERTAINMENT SOFTWARE, NAMELY, ENTERTAINMENT SOFTWARE FOR USE WITH COMPUTERS, FEATURING ANIMATED CHARACTERS, CHILDREN'S STORIES AND EDUCATIONAL GAMES AND QUIZZES, INTERACTIVE VIDEO GAME PROGRAMS, AND COMPUTER GAME SOFTWARE (U.S. CLS. 21, 23, 26, 36 AND 38).

FIRST USE 8-1-2007; IN COMMERCE 8-1-2007.

CLASS 41—EDUCATION AND ENTERTAINMENT

FOR ENTERTAINMENT SERVICES, NAMELY, PROVIDING ON-LINE COMPUTER GAMES; PROVIDING A WEB SITE WHERE USERS CAN POST RATINGS, REVIEWS AND RECOMMENDATIONS ON EVENTS AND ACTIVITIES IN THE FIELD OF CHILDREN'S ENTERTAINMENT AND EDUCATION; EDUCATION AND ENTERTAINMENT SERVICES, NAMELY, PROVIDING A WEBSITE FEATURING INFORMATION IN THE FIELD OF CHILDREN'S EDUCATION AND ENTERTAINMENT FEATURING AUDIO CLIPS, VIDEO CLIPS, MUSICAL VIDEOS, FILM CLIPS, PHOTOGRAPHS, AND OTHER MULTIMEDIA MATERIALS; BLOGS FEATURING INFORMATION IN THE FIELD OF CHILDREN'S EDUCATION AND ENTERTAINMENT AND WHICH MAY INCLUDE AUDIO CLIPS, VIDEO CLIPS, MUSICAL VIDEOS, FILM CLIPS, PHOTOGRAPHS, AND OTHER MULTIMEDIA MATERIALS (U.S. CLS. 100, 101 AND 107).

FIRST USE 8-1-2007; IN COMMERCE 8-1-2007.

CLASS 42—SCIENTIFIC AND COMPUTER SERVICES

FOR COMPUTER SECURITY SERVICE, NAMELY, RESTRICTING ACCESS TO AND BY COMPUTER NETWORKS TO AND OF UNDESIRED WEBSITES, MEDIA AND INDIVIDUALS AND FACILITIES; CREATION AND PROVISION OF WEB PAGES TO AND FOR THIRD PARTIES; COMPUTER SERVICES, NAMELY, HOSTING ONLINE WEB FACILITIES FOR OTHERS FOR ORGANIZING AND CONDUCTING ONLINE MEETINGS AND INTERACTIVE DISCUSSIONS, SHARING PHOTOGRAPHS AND STORIES; COMPUTER SERVICES IN THE NATURE OF CUSTOMIZED WEB PAGES FEATURING USER-DEFINED INFORMATION, PERSONAL PROFILES AND INFORMATION; PROVIDING ONLINE NON-DOWNLOADABLE CHILDREN'S EDUCATIONAL SOFTWARE; PROVIDING ONLINE NON-DOWNLOADABLE CHILDREN'S ENTERTAINMENT SOFTWARE, NAMELY, INTERACTIVE VIDEO GAME PROGRAMS, COMPUTER GAME SOFTWARE AND ENTERTAINMENT SOFTWARE FOR USE WITH COMPUTERS, FEATURING ANIMATED CHARACTERS, CHILDREN'S STORIES AND EDUCATIONAL GAMES AND QUIZZES (U.S. CLS. 100 AND 101).

FIRST USE 8-1-2007; IN COMMERCE 8-1-2007.

AHSEN KHAN, EXAMINING ATTORNEY

SN 77-268,669. HOWEY, DAVID C., JR., ORLAND PARK, IL. FILED 8-30-2007.

DON'T LET THE FOOD WIN

THE MARK CONSISTS OF STANDARD CHARACTERS WITHOUT CLAIM TO ANY PARTICULAR FONT, STYLE, SIZE, OR COLOR.

CLASS 14—JEWELRY

FOR BRACELETS (U.S. CLS. 2, 27, 28 AND 50).

CLASS 44—MEDICAL, BEAUTY AND AGRICULTURAL SERVICES

FOR WEIGHT REDUCTION DIET PLANNING AND SUPERVISION; PROVIDING INFORMATION ABOUT DIETARY SUPPLEMENTS AND NUTRITION (U.S. CLS. 100 AND 101).

ALEXANDER L. POWERS, EXAMINING ATTORNEY

SN 77-268,962. MICHAELS, DAVID, HENDERSON, NV.
FILED 8-31-2007.



POP LAS VEGAS

NO CLAIM IS MADE TO THE EXCLUSIVE RIGHT TO USE "POP LAS VEGAS", APART FROM THE MARK AS SHOWN.

THE MARK CONSISTS OF ONE LARGE AND ONE SMALL CIRCLE, WITH THE SMALLER CIRCLE OVERLAPPING THE LARGER CIRCLE, TOGETHER WITH THE WORDS "POP LAS VEGAS".

CLASS 41—EDUCATION AND ENTERTAINMENT

FOR THEATRICAL AND MUSICAL FLOOR SHOWS PROVIDED AT DISCOTHEQUES AND NIGHTCLUBS; NIGHT CLUBS; CASINOS; CONDUCTING AND PROVIDING FACILITIES FOR SPECIAL EVENTS FEATURING CASINO AND GAMING CONTESTS AND TOURNAMENTS; PROVIDING CASINO FACILITIES (U.S. CLS. 100, 101 AND 107).

CLASS 43—HOTEL AND RESTAURANT SERVICES

FOR HOTEL SERVICES; HOTEL, BAR AND RESTAURANT SERVICES; HOTELS; RESORT HOTELS; BAR SERVICES; COFFEE-HOUSE AND SNACK-BAR SERVICES; RESTAURANT AND BAR SERVICES; WINE BARS (U.S. CLS. 100 AND 101).

TIMOTHY FINNEGAN, EXAMINING ATTORNEY

SN 77-270,036. LA NETA CO., PHOENIX, AZ. FILED 8-31-2007.

LANETA

THE MARK CONSISTS OF STANDARD CHARACTERS WITHOUT CLAIM TO ANY PARTICULAR FONT, STYLE, SIZE, OR COLOR.

CLASS 35—ADVERTISING AND BUSINESS

FOR PROMOTING A WEB SITE WHICH FEATURES ADVERTISEMENTS FOR THE GOODS AND SERVICES OF OTHERS ON A GLOBAL COMPUTER NETWORK, DISSEMINATION OF ADVERTISING FOR OTHERS VIA AN ON-LINE NETWORK ON THE INTERNET (U.S. CLS. 100, 101 AND 102).

CLASS 38—COMMUNICATION

FOR PROVIDING ON-LINE FORUMS FOR TRANSMISSION OF MESSAGES AMONG COMPUTER USERS CONCERNING GENERAL INTEREST NEWS AND ENTERTAINMENT INFORMATION, AND THE ELECTRONIC TRANSMISSION OF MESSAGES AND DATA (U.S. CLS. 100, 101 AND 104).

CLASS 41—EDUCATION AND ENTERTAINMENT

FOR PROVIDING GENERAL INTEREST NEWS, ENTERTAINMENT, AND EDUCATIONAL INFORMATION VIA A GLOBAL COMPUTER NETWORK IN THE FIELD OF CURRENT EVENT REPORTING AND ENTERTAINMENT (U.S. CLS. 100, 101 AND 107).

DAVID I. EXAMINING ATTORNEY

SN 77-270,596. APPLIANCE RECYCLING CENTERS OF AMERICA, INC., MINNEAPOLIS, MN. FILED 9-4-2007.

REFRIGERATOR ROUNDUP

THE MARK CONSISTS OF STANDARD CHARACTERS WITHOUT CLAIM TO ANY PARTICULAR FONT, STYLE, SIZE, OR COLOR.

NO CLAIM IS MADE TO THE EXCLUSIVE RIGHT TO USE "REFRIGERATOR", APART FROM THE MARK AS SHOWN.

CLASS 37—CONSTRUCTION AND REPAIR

FOR COLLECTION OF USED APPLIANCES FOR RECYCLING (U.S. CLS. 100, 103 AND 106).
FIRST USE 9-2-2007; IN COMMERCE 9-2-2007.

CLASS 40—MATERIAL TREATMENT

FOR RECYCLING SERVICES IN THE FIELD OF USED APPLIANCES (U.S. CLS. 100, 103 AND 106).
FIRST USE 9-5-2007; IN COMMERCE 9-5-2007.
STEPHEN AQUILA, EXAMINING ATTORNEY

SN 77-270,921. SEARS BRANDS, LLC, HOFFMAN ESTATES, IL. FILED 9-4-2007.

KB SPORT

THE MARK CONSISTS OF STANDARD CHARACTERS WITHOUT CLAIM TO ANY PARTICULAR FONT, STYLE, SIZE, OR COLOR.

NO CLAIM IS MADE TO THE EXCLUSIVE RIGHT TO USE "SPORT", APART FROM THE MARK AS SHOWN.

CLASS 25—CLOTHING

FOR CLOTHING FOR MEN AND BOYS, NAMELY, SHIRTS, PANTS, SHORTS, T-SHIRTS, SWEATERS, COATS AND JACKETS, SOCKS (U.S. CLS. 22 AND 39).

CLASS 35—ADVERTISING AND BUSINESS

FOR RETAIL STORE SERVICES FEATURING CLOTHING; RETAIL DEPARTMENT STORE SERVICES (U.S. CLS. 100, 101 AND 102).
PATRICIA EVANKO, EXAMINING ATTORNEY

SN 77-272,167. THE AMYOTROPHIC LATERAL SCLEROSIS ASSOCIATION, CALABASAS HILLS, CA. FILED 9-5-2007.

Ks FOR A CURE

THE MARK CONSISTS OF STANDARD CHARACTERS WITHOUT CLAIM TO ANY PARTICULAR FONT, STYLE, SIZE, OR COLOR.

CLASS 35—ADVERTISING AND BUSINESS

FOR ASSOCIATION SERVICES, NAMELY, PROMOTING PUBLIC AWARENESS OF THE NEED FOR RESEARCH AND FUNDING FOR AMYOTROPHIC LATERAL SCLEROSIS BY PROVIDING INFORMATION IN THE FIELD OF AMYOTROPHIC LATERAL SCLEROSIS (U.S. CLS. 100, 101 AND 102).

CLASS 36—INSURANCE AND FINANCIAL

FOR CHARITABLE FUND RAISING; CHARITABLE FUND RAISING SERVICES FOR FUNDING RESEARCH PROGRAMS, PATIENT SERVICES PROGRAMS, CLINICAL CENTERS, AND RELATED PROGRAMS AND ACTIVITIES RELATING TO THE TREATMENT OF AND FINDING A CURE OF AMYOTROPHIC LATERAL SCLEROSIS; FINANCIAL SPONSORSHIP OF RESEARCH IN THE FIELD OF AMYOTROPHIC LATERAL SCLEROSIS (U.S. CLS. 100, 101 AND 102).

DAVID YONTEF, EXAMINING ATTORNEY

SN 77-272,468. SONY COMPUTER ENTERTAINMENT EUROPE LIMITED, LONDON, UNITED KINGDOM, FILED 9-5-2007.

LittleBigPlanet

PRIORITY CLAIMED UNDER SEC. 44(D) ON UNITED KINGDOM APPLICATION NO. 2448670B.ORI, FILED 3-7-2007, REG. NO. 2448670B, DATED 12-28-2007, EXPIRES 3-7-2017.

CLASS 38—COMMUNICATION

FOR PROVIDING ON-LINE CHAT ROOMS AND ELECTRONIC BULLETIN BOARDS FOR TRANSMISSION OF MESSAGES AMONG USERS IN THE FIELD OF GENERAL INTEREST; PROVIDING ON-LINE ACCESS TO COMPUTER NETWORKS, COMPUTER DATABASES, THE INTERNET, ON-LINE BULLETIN BOARDS, VIRTUAL WORLDS AND LIBRARIES OF TEXT, GRAPHICS AND AUDIO-VISUAL AND MULTIMEDIA INFORMATION AND ENTERTAINMENT (U.S. CLS. 100, 101 AND 104).

CLASS 41—EDUCATION AND ENTERTAINMENT

FOR ENTERTAINMENT SERVICES, NAMELY, PROVIDING ELECTRONIC GAMES SERVICES PROVIDED BY MEANS OF THE INTERNET; ENTERTAINMENT SERVICES PROVIDED ONLINE AND/OR VIA A COMPUTER DATABASE FOR MATCHING USERS FOR THE TRANSFER OR SHARING OF MUSIC, VIDEO AND AUDIO RECORDINGS VIA COMMUNICATIONS NETWORKS; ENTERTAINMENT SERVICES, NAMELY, ORGANIZING, STAGING AND CONDUCTING ONLINE ELECTRONIC GAME TOURNAMENTS; ENTERTAINMENT SERVICES, NAMELY, WIRELESS TELEVISION BROADCASTS FEATURING ONLINE ELECTRONIC GAMES (U.S. CLS. 100, 101 AND 107).

CLASS 42—SCIENTIFIC AND COMPUTER SERVICES

FOR COMPUTER SERVICES, NAMELY, PROVIDING AN ON-LINE COMMUNITY ENABLING PHYSICALLY REMOTE PLAYERS OF AN ELECTRONIC GAME TO SEARCH ON-LINE FOR OTHER PLAYERS AND TO COMMUNICATE WITH SELECTED PLAYERS DURING THE GAME (U.S. CLS. 100 AND 101).

CLASS 45—PERSONAL AND LEGAL SERVICES

FOR INTRODUCTION AND SOCIAL NETWORKING SERVICES, NAMELY, INTRODUCING ELECTRONIC GAME PLAYERS TO OTHER GAME PLAYERS (U.S. CLS. 100 AND 101).

JOHN E. MICHOS, EXAMINING ATTORNEY

SN 77-272,546. ANTARCTICA FILMS, INC., MIAMI, FL. FILED 9-5-2007.



NO CLAIM IS MADE TO THE EXCLUSIVE RIGHT TO USE "BLOGS", APART FROM THE MARK AS SHOWN. THE COLOR(S) GREEN, SILVER, BLACK AND GREY IS/ARE CLAIMED AS A FEATURE OF THE MARK.

THE MARK CONSISTS OF THE WORD "BLOGZ" AND AN EMBLEM OF "Z" WITH A CIRCLE AROUND IT, LOCATED TO THE RIGHT OF THE EXPRESSION "BLOGZ". "BLOGZ" IS WRITTEN VERTICALLY FROM BOTTOM TO TOP WITH THE WORD "BLOG" IN GREEN AND "Z" IN BLACK. THE CIRCLE EMBLEM IS OUTLINED BY A THICK BLACK SURROUNDING WITH A "Z" IN THE CENTER, AND A GREEN AND BLACK BACKGROUND. THERE IS A GREY SHADOW UNDERNEATH THE EMBLEM CIRCLE.

CLASS 9—ELECTRICAL AND SCIENTIFIC APPARATUS

FOR COMMUNICATIONS SOFTWARE FOR CONNECTING PEOPLE OVER THE INTERNET AND OTHER COMMUNICATIONS NETWORKS (U.S. CLS. 21, 23, 26, 36 AND 38).

CLASS 38—COMMUNICATION

FOR BROADCASTING PROGRAMS VIA A GLOBAL COMPUTER NETWORK, AUDIO AND VIDEO BROADCASTING SERVICES OVER THE INTERNET, BROADCASTING OF CABLE TELEVISION PROGRAMS, CABLE TELEVISION BROADCASTING, SATELLITE TELEVISION BROADCASTING, TELEVISION BROADCASTING, VOICE CHAT SERVICES, PROVIDING ONLINE CHAT ROOMS AND ELECTRONIC BULLETIN BOARDS FOR TRANSMISSION OF MESSAGES AMONG USERS IN THE FIELD OF GENERAL INTEREST, INSTANT MESSAGING SERVICES, AND TRANSMISSION OF SOUND, VIDEO AND INFORMATION FROM WEB CAMS, VIDEO CAMERA OR MOBILE PHONES, ALL FEATURING LIVE OR RECORDED MATERIALS (U.S. CLS. 100, 101 AND 104).

CLASS 41—EDUCATION AND ENTERTAINMENT

FOR ONLINE JOURNALS, NAMELY, BLOGS FEATURING INFORMATION IN THE FIELD OF ART, BUSINESS, CULTURE, EDUCATION, ENTERTAINMENT, ENVIRONMENT, FASHION, HEALTH, HISTORY, HOME AND GARDEN, JOBS, MUSIC, NEWS, PARANORMAL PHENOMENA, POLITICS, REAL ESTATE, SCIENCE, SPORTS, TECHNOLOGY, TRAVEL AND WEATHER (U.S. CLS. 100, 101 AND 107).

CLASS 42—SCIENTIFIC AND COMPUTER SERVICES

FOR PROVIDING A WEB SITE FEATURING TEMPORARY USE OF NON DOWNLOADABLE SOFTWARE ALLOWING WEBSITE USERS TO UPLOAD, POST AND DISPLAY ONLINE VIDEOS FOR SHARING WITH OTHERS FOR ENTERTAINMENT PURPOSES (U.S. CLS. 100 AND 101).

BARBARA BROWN, EXAMINING ATTORNEY

SN 77-273,286. THE BRUNTON COMPANY, RIVERTON, WY. FILED 9-6-2007.

BRUNTON

THE MARK CONSISTS OF STANDARD CHARACTERS WITHOUT CLAIM TO ANY PARTICULAR FONT, STYLE, SIZE, OR COLOR.
SEC. 2(F).

CLASS 4—LUBRICANTS AND FUELS

FOR CANISTERS OF FUEL (U.S. CLS. 1, 6 AND 15).
FIRST USE 12-31-2003; IN COMMERCE 12-31-2003.

CLASS 7—MACHINERY

FOR SOLAR POWERED ELECTRICITY GENERATORS (U.S. CLS. 13, 19, 21, 23, 31, 34 AND 35).
FIRST USE 12-31-2002; IN COMMERCE 12-31-2002.

CLASS 8—HAND TOOLS

FOR CUTLERY, NAMELY, FORKS, SPOONS, KNIVES, AND SPORKS (U.S. CLS. 23, 28 AND 44).
FIRST USE 12-31-2004; IN COMMERCE 12-31-2004.

CLASS 9—ELECTRICAL AND SCIENTIFIC APPARATUS

FOR DIRECTIONAL COMPASSES; OPTICAL INSTRUMENTS, NAMELY, BINOCULARS, MONOCULARS, SPOTTING SCOPES, POCKET SCOPES, NAMELY, POCKET-SIZED MONOCULARS; TRIPODS FOR USE WITH OPTICAL INSTRUMENTS SUCH AS SPOTTING SCOPES AND BINOCULARS; BATTERY CHARGERS; SATELLITE NAVIGATIONAL SYSTEM, NAMELY, A GLOBAL POSITIONING SYSTEM (GPS); PROTECTIVE CARRYING CASES SPECIALLY ADAPTED FOR GLOBAL POSITIONING SYSTEM (GPS) APPARATUS; COMPUTER SOFTWARE FOR USE WITH GLOBAL POSITIONING SYSTEMS (GPS) AND MAPS; ELECTRICAL CABLES FOR USE WITH GLOBAL POSITIONING SYSTEMS (GPS) APPARATUS; TWO-WAY RADIOS; ALTIMETERS, BAROMETERS; THERMOMETERS; ANEMOMETERS; PEDOMETERS; ANALOG AND DIGITAL MAP MEASURERS FOR USE IN ESTIMATING DISTANCES BETWEEN TWO POINTS ON A MAP; POCKET TRANSITS, NAMELY, INSTRUMENTS FOR USE IN BASIC FIELD MAPPING; PROTECTIVE CARRYING CASES SPECIALLY ADAPTED FOR POCKET TRANSITS; PROTRACTORS; AND HEIGHT METERS FOR USE IN MEASURING HEIGHT DISTANCES (U.S. CLS. 21, 23, 26, 36 AND 38).

FIRST USE 12-31-1972; IN COMMERCE 12-31-1972.

CLASS 11—ENVIRONMENTAL CONTROL APPARATUS

FOR GAS STOVES; GAS GRILLS; GAS LANTERNS; ELECTRIC LANTERNS; FLASHLIGHTS; AND ELECTRIC HEAD LAMPS (U.S. CLS. 13, 21, 23, 31 AND 34).

FIRST USE 12-31-2002; IN COMMERCE 12-31-2002.

CLASS 14—JEWELRY

FOR STOPWATCHES (U.S. CLS. 2, 27, 28 AND 50).

FIRST USE 5-31-2007; IN COMMERCE 5-31-2007.

CLASS 21—HOUSEWARES AND GLASS

FOR WASH BASINS; COOKWARE, NAMELY SPATULAS, LADLES, SERVING SPOONS, SERVING FORKS; SPORTS BOTTLES, SOLD EMPTY; AND CHOPSTICKS (U.S. CLS. 2, 13, 23, 29, 30, 33, 40 AND 50).

FIRST USE 12-31-2002; IN COMMERCE 12-31-2002.

CHERYL CLAYTON, EXAMINING ATTORNEY

SN 77-274,001. DIGITAL DOWNLOAD, INC., NEW YORK, NY. FILED 9-7-2007.

NIGHT FLIGHT

THE MARK CONSISTS OF STANDARD CHARACTERS WITHOUT CLAIM TO ANY PARTICULAR FONT, STYLE, SIZE, OR COLOR.

OWNER OF U.S. REG. NO. 1,280,182.

CLASS 25—CLOTHING

FOR CLOTHING RELATED TO ENTERTAINMENT SERVICES, NAMELY, T-SHIRTS, SWEAT SHIRTS, POLO SHIRTS, ATHLETIC WEAR, AND HATS (U.S. CLS. 22 AND 39).

CLASS 41—EDUCATION AND ENTERTAINMENT

FOR ENTERTAINMENT AND ENTERTAINMENT SERVICES, NAMELY, VISUAL AND AUDIO PROGRAMMING, PERFORMANCES, SHOWS, AND A TELEVISION SERIES IN THE NATURE OF A VARIETY SHOW, ENTERTAINMENT NEWS, SEGMENT CLIPS, AND FEATURE FILMS OF INTEREST TO MUSICAL AUDIENCES DISTRIBUTED ON TELEVISION, ENTERTAINMENT OUTLETS, OVER THE INTERNET, AND MOBILE DEVICES, SUCH AS CELLULAR PHONES (U.S. CLS. 100, 101 AND 107).

RICHARD A. STRASER, EXAMINING ATTORNEY

SN 77-274,622. PHORM UK, INC., DBA 121MEDIA, INC., NEW YORK, NY. FILED 9-7-2007.

BETTER BROWSING INITIATIVE

THE MARK CONSISTS OF STANDARD CHARACTERS WITHOUT CLAIM TO ANY PARTICULAR FONT, STYLE, SIZE, OR COLOR.

NO CLAIM IS MADE TO THE EXCLUSIVE RIGHT TO USE "BETTER BROWSING", APART FROM THE MARK AS SHOWN.

CLASS 9—ELECTRICAL AND SCIENTIFIC APPARATUS

FOR SOFTWARE AND COMPUTER HARDWARE FOR ELECTRONICALLY DELIVERING MARKETING CONTENT TO A NETWORKED COMPUTER; SOFTWARE AND COMPUTER HARDWARE FOR MONITORING WEB-BROWSING BEHAVIOR OF A NETWORKED COMPUTER (U.S. CLS. 21, 23, 26, 36 AND 38).

CLASS 35—ADVERTISING AND BUSINESS

FOR INTERNET ADVERTISING SERVICES; BUSINESS INFORMATION SERVICES IN THE FIELD OF ADVERTISING AND COMMERCIAL INFORMATION SERVICES VIA THE INTERNET; BUSINESS INFORMATION SERVICES IN THE FIELD OF DISSEMINATION OF ADVERTISING FOR OTHERS VIA THE INTERNET (U.S. CLS. 100, 101 AND 102).

CLASS 42—SCIENTIFIC AND COMPUTER SERVICES

FOR COMPUTER SERVICES, NAMELY, TRACKING AND MONITORING WEB-BROWSING BEHAVIOR OF NETWORKED COMPUTERS (U.S. CLS. 100 AND 101).

LINDA POWELL, EXAMINING ATTORNEY

SN 77-275,969. WRIGHT, KENNETH W., LOS ANGELES, CA. FILED 9-10-2007.

HBG

THE MARK CONSISTS OF STANDARD CHARACTERS WITHOUT CLAIM TO ANY PARTICULAR FONT, STYLE, SIZE, OR COLOR.

CLASS 29—MEATS AND PROCESSED FOODS

FOR HEALTH FOOD, NAMELY, POTATO-BASED SNACK FOODS (U.S. CL. 46).

CLASS 30—STAPLE FOODS

FOR HEALTH FOOD, NAMELY, BAKERY GOODS AND CORN-BASED SNACK FOODS (U.S. CL. 46).

DANIEL CAPSHAW, EXAMINING ATTORNEY

SN 77-275,982. WRIGHT, KENNETH W., LOS ANGELES, CA. FILED 9-10-2007.

HEALTHY BUT GOOD

THE MARK CONSISTS OF STANDARD CHARACTERS WITHOUT CLAIM TO ANY PARTICULAR FONT, STYLE, SIZE, OR COLOR.

CLASS 29—MEATS AND PROCESSED FOODS

FOR HEALTH FOOD, NAMELY, POTATO-BASED SNACK FOODS (U.S. CL. 46).

CLASS 30—STAPLE FOODS

FOR HEALTH FOOD, NAMELY, BAKERY GOODS AND CORN-BASED SNACK FOODS (U.S. CL. 46).

DANIEL CAPSHAW, EXAMINING ATTORNEY

SN 77-276,004. MTR FOODS LIMITED, BANGALORE, INDIA, FILED 9-10-2007.



OWNER OF U.S. REG. NOS. 1,883,740, 1,952,165 AND 2,688,146.

NO CLAIM IS MADE TO THE EXCLUSIVE RIGHT TO USE "SINCE 1924", APART FROM THE MARK AS SHOWN. THE COLOR(S) RED AND WHITE IS/ARE CLAIMED AS A FEATURE OF THE MARK.

THE MARK CONSISTS OF THE COLOR WHITE APPEARS IN THE WORDS "PURE AND PERFECT, MTR", AND "SINCE 1924" AND IN THE WHITE BORDER. THE COLOR RED APPEARS ON THE OVAL BACKGROUND.

CLASS 29—MEATS AND PROCESSED FOODS

FOR IMPORTED PICKLES, NAMELY, MANGO (AVAKAI) PICKLES IN OIL, SLICED MANGO PICKLES IN OIL, MANGO PICKLES IN BRINE, TOMATO PICKLES IN OIL, LIME PICKLES IN OIL, MIXED PICKLES IN BRINE, AND HOG-PLUM PICKLES IN OIL; PICKLES; SOUPS; DISH MADE PRIMARILY OF GROUND CHICK PEAS (DHOKLA); MEALS CONSISTING PRIMARILY OF VEGETABLES (BISIBELBATH); MEALS CONSISTING PRIMARILY OF LENTILS (DAL FRY); FRIED CHEESE (PANEER); FRIED MEATS AND FRIED VEGETABLES (PAKORA); MEALS CONSISTING PRIMARILY OF MEATS AND CURRY SAUCE; MEALS CONSISTING PRIMARILY OF VEGETABLES AND CURRY SAUCE; AND INSTANT MIXES FOR SOUP, STEW, CHOWDER MIXES, POTATO-BASED SNACK FOODS, AND VEGETABLE-BASED SNACK FOODS (U.S. CL. 46).

CLASS 30—STAPLE FOODS

FOR SPICES; SPICE BLENDS; PACKAGED RICE; PROCESSED GRAIN; PROCESSED GRAIN MIXES; MIXES FOR MAKING BAKERY DESSERTS; DOUGH MIX FOR GULAB JAMUN FRIED DOUGH DESSERT; INSTANT MIXES FOR PUDDING; RICE-BASED SNACK FOODS (MURUKU); WHEAT-BASED SNACK FOODS; WAFERS (PAPADS), RICE STICKS; PACKAGED MEALS CONSISTING PRIMARILY OF WHEAT (KHARABATH AND KESARIBATH); MEALS CONSISTING PRIMARILY OF RICE (PONGAL); BREAD AND FLATBREAD; FROZEN BREAD AND FLATBREAD; FROZEN CONFECTIONS; TEA; AND INSTANT MIXES FOR RICE CAKE, CREPES (DOSA); RICE PUDDING, DISH MADE PRIMARILY OF PROCESSED WHEAT (UPMA), INDIAN PANCAKES, INSTANT NOODLES, SAUCES, SEASONING PASTES, CURRY POWDERS, AND CURRY PASTES (U.S. CL. 46).

CLASS 32—LIGHT BEVERAGES

FOR CONCENTRATES, SYRUPS OR POWDERS USED IN THE PREPARATION OF SOFT DRINKS; CONCENTRATES, SYRUPS OR POWDERS USED IN THE PREPARATION OF VEGETABLE-BASED DRINKS; SOFT DRINKS; VEGETABLE-BASED DRINKS (U.S. CLS. 45, 46 AND 48).

GRETTA YAO, EXAMINING ATTORNEY

SN 77-276,103. CONNECTIVHEALTH, INC., BRENTWOOD, TN. FILED 9-11-2007.

CLASS 38—COMMUNICATION

FOR PROVIDING ON-LINE CHAT ROOMS AND ELECTRONIC BULLETIN BOARDS FOR TRANSMISSION OF MESSAGES AMONG COMPUTER USERS, ENABLING THEM TO COMMENT ON AND REFINED THE CRITERIA FOR WEBSITE CONTENT, LINKS, AND WEB PAGES PROVIDED TO THEM; PROVIDING ON-LINE CHAT ROOMS AND ELECTRONIC BULLETIN BOARDS FOR TRANSMISSION OF MESSAGES AMONG COMPUTER USERS ENABLING THEM TO SHARE WEBSITE CONTENT, LINKS AND WEB PAGES WITH OTHERS VIA A GLOBAL COMPUTER NETWORK; PROVIDING ONLINE CHAT SERVICES AND A BULLETIN BOARD FOR COMPUTER USERS TO DISCUSS TOPICS OF INTEREST TO PHYSICIANS, NURSE PRACTITIONERS, AND PHYSICIAN ASSISTANTS, AND CONTENT, LINKS AND WEB PAGES THAT THEY HAVE SHARED WITH EACH OTHER (U.S. CLS. 100, 101 AND 104).

CLASS 42—SCIENTIFIC AND COMPUTER SERVICES

FOR COMPUTER SERVICE, NAMELY, ACTING AS AN APPLICATION SERVICE PROVIDER IN THE FIELD OF KNOWLEDGE MANAGEMENT TO HOST COMPUTER SOFTWARE FOR THE COLLECTION, EDITING, ORGANIZING, MODIFYING, BOOK MARKING, TRANSMISSION, STORAGE AND SHARING OF DATA AND INFORMATION, NAMELY, PROVIDING A BOOK MARKING SERVICE WHICH ALLOWS SUBSCRIBERS TO MARK ARTICLES, RETRIEVE SEARCHES AND SAVE THE CONTENT IN A FORMAT ALLOWING THE CONTENT TO BE REUSED AND SHARED AMONG A DESIGNATED USER COMMUNITY (U.S. CLS. 100 AND 101).

TIMOTHY FINNEGAN, EXAMINING ATTORNEY

SN 77-276,407. SAINT FRANCIS COMMUNITY SERVICES, INC., SALINA, KS. FILED 9-11-2007.

SAINT FRANCIS COMMUNITY
SERVICES

PEERCLIP

THE MARK CONSISTS OF STANDARD CHARACTERS WITHOUT CLAIM TO ANY PARTICULAR FONT, STYLE, SIZE, OR COLOR.

OWNER OF U.S. REG. NO. 1,680,810.

NO CLAIM IS MADE TO THE EXCLUSIVE RIGHT TO USE "COMMUNITY SERVICES", APART FROM THE MARK AS SHOWN.

THE MARK CONSISTS OF STANDARD CHARACTERS WITHOUT CLAIM TO ANY PARTICULAR FONT, STYLE, SIZE, OR COLOR.

CLASS 35—ADVERTISING AND BUSINESS

FOR MEDICAL REFERRALS FOR FAMILIES (U.S. CLS. 100, 101 AND 102).

CLASS 41—EDUCATION AND ENTERTAINMENT

FOR EDUCATIONAL SERVICES, NAMELY, CONDUCTING IN-HOME CLASSES, SEMINARS, CONFERENCES, AND WORKSHOPS FOR FAMILIES IN THE FIELDS OF MONEY MANAGEMENT, NUTRITION, COOKING, HOUSEKEEPING, HOME MAINTENANCE, CHILD DEVELOPMENT, AGE APPROPRIATE DISCIPLINE TECHNIQUES, BEHAVIOR MANAGEMENT, NEGOTIATION SKILLS, ACCESSING AND USING VARIOUS STATE AND LOCAL SERVICE SYSTEMS, AND SELF-CARE; PARENT EDUCATION CLASSES, NAMELY, CONDUCTING CLASSES, SEMINARS, CONFERENCES, AND WORKSHOPS FOR PARENTS IN THE FIELDS OF PARENTING SKILLS AND CHILD DEVELOPMENT; EDUCATIONAL SERVICES, NAMELY, OFFERING PROGRAMS IN THE FIELD OF DRUG AND ALCOHOL EDUCATION AND RISK REDUCTION; EDUCATIONAL SERVICES, NAMELY, CONDUCTING CLASSES, SEMINARS, CONFERENCES, AND WORKSHOPS IN THE FIELD OF DRUG AND ALCOHOL ABUSE AND THEIR PREVENTION; EDUCATIONAL SERVICES, NAMELY, CONDUCTING CLASSES, SEMINARS, CONFERENCES, AND WORKSHOPS IN THE FIELD OF THE EFFECTS OF VIOLENCE ON CHILDREN (U.S. CLS. 100, 101 AND 107).

CLASS 43—HOTEL AND RESTAURANT SERVICES

FOR PROVIDING ASSISTED LIVING FACILITIES; PROVIDING CONGREGATE LIVING FACILITIES; CHILD WELFARE SERVICES, NAMELY, PROVIDING RESIDENTIAL HOMES AND HOUSING FOR AT-RISK CHILDREN AND YOUTH; PROVIDING JUVENILE CORRECTIONS SERVICES, NAMELY, SHORT- AND LONG-TERM RESIDENTIAL SERVICES TO HELP COURT-ORDERED YOUTHS (U.S. CLS. 100 AND 101).

CLASS 44—MEDICAL, BEAUTY AND AGRICULTURAL SERVICES

FOR MENTAL HEALTH SERVICES; PSYCHOTHERAPY AND PSYCHOTHERAPY COUNSELING FOR CHILDREN AND ADULTS IN INDIVIDUAL AND FAMILY SESSIONS; DRUG TESTING FOR SUBSTANCE ABUSE; REHABILITATION OF DRUG ADDICTED PATIENTS; REHABILITATION OF ALCOHOL ADDICTED PATIENTS; INFORMATION ABOUT PARENTING TOPICS, NAMELY, DRUG AND ALCOHOL AWARENESS; PROVIDING A WEBSITE FEATURING EDUCATIONAL INFORMATION REGARDING DRUG AND ALCOHOL ABUSE; MEDICAL COUNSELING IN THE NATURE OF DRUG AND ALCOHOL COUNSELING (U.S. CLS. 100 AND 101).

CLASS 45—PERSONAL AND LEGAL SERVICES

FOR CASE MANAGEMENT SERVICES, NAMELY, COORDINATION OF LEGAL, SOCIAL AND PSYCHOLOGICAL SERVICES FOR DOMESTICALLY ABUSED PERSONS; ADOPTION AGENCIES; ADOPTION PLACEMENT; ADOPTION COUNSELING; FOSTER CARE; PERSONAL CARE ASSISTANCE OF ACTIVITIES OF DAILY LIVING, SUCH AS BATHING, GROOMING AND PERSONAL MOBILITY FOR MENTALLY OR PHYSICALLY CHALLENGED PEOPLE; CRIME VICTIM SERVICES, NAMELY, SUPPORTIVE EMOTIONAL COUNSELING; INFORMATION AND REFERRAL SERVICES TO ASSIST FAMILIES IN ACCESSING COMMUNITY RESOURCES, NAMELY, PROVIDING HELP WITH

MEDICAL FORMS TO FAMILIES OF PATIENTS WITH LIFE THREATENING DISORDERS; CASE MANAGEMENT SERVICES, NAMELY, THE COORDINATION OF NECESSARY MEDICAL SERVICES, VOCATIONAL ISSUES AND EDUCATIONAL SERVICES FOR PERSONS INJURED AT WORK; FAMILY CRISIS INTERVENTION SERVICES IN THE NATURE OF PROVIDING COUNSELING FOR VICTIMS OF BATTERY OR ABUSE COMPRISING INTERVIEWING THE VICTIM, IDENTIFYING WHAT THE PROBLEM IS, AND SUGGESTING WHERE HELP CAN BE OBTAINED (U.S. CLS. 100 AND 101).

MARCIE MILONE, EXAMINING ATTORNEY

SN 77-276,846. SYLVAN SMART, NEW BRITAIN, CT. FILED 9-11-2007.

ZSKETZH

THE MARK CONSISTS OF STANDARD CHARACTERS WITHOUT CLAIM TO ANY PARTICULAR FONT, STYLE, SIZE, OR COLOR.

CLASS 25—CLOTHING

FOR SHIRTS; SHORT SETS; SHOULDER WRAPS; TIES; TOPS; WRAPS; CLOTHING, NAMELY, WRAP-AROUNDS; HOODS; JERSEYS; LEATHER BELTS; MANTLES; MUFFLERS; BELTS; BIBS NOT OF CLOTH OR PAPER; CAPS; CHILDREN'S AND INFANTS' CLOTH BIBS; CHILDREN'S CLOTH EATING BIBS; CLOTH BIBS; CLOTH DIAPERS; CLOTHING, NAMELY, FOLK COSTUMES; CLOTHING, NAMELY, HAND-WARMERS; CLOTHING, NAMELY, KNEE WARMERS; DRESS SHIRTS; GOLF SHIRTS; KNIT SHIRTS; LONG-SLEEVED SHIRTS; NIGHT SHIRTS; PIQUE SHIRTS; POLO SHIRTS; SHIRTS; SHORT-SLEEVED OR LONG-SLEEVED T-SHIRTS; SHORT-SLEEVED SHIRTS; SLEEP SHIRTS; SPORT SHIRTS; SWEAT SHIRTS; T-SHIRTS; WIND SHIRTS; BATHING SUITS; BODY SUITS; DRESS SUITS; DRY SUITS; GYM SUITS; JOGGING SUITS; LADIES' SUITS; MEN'S SUITS; MEN'S SUITS, WOMEN'S SUITS; PLAY SUITS; RAIN SUITS; SUIT COATS; SUITS; SWEAT SUITS; TRACK SUITS; TRAINING SUITS; WARM UP SUITS; WET SUITS; PANTS; WATERPROOF JACKETS AND PANTS; YOGA PANTS; DENIMS; JEANS; JACKETS; SPORTS JACKETS; WIND RESISTANT JACKETS; BATH SLIPPERS; BATHING TRUNKS; SWIMMING CAPS; BRIEFS; KNITTED UNDERWEAR; LADIES' UNDERWEAR; THERMAL UNDERWEAR; THONGS; UNDERWEAR; HATS; HEADBANDS AGAINST SWEATING; STOCKINGS; SWEAT BANDS; SWEAT PANTS; SWEAT SHORTS; SHOES; SANDAL-CLOGS; SANDALS; FLIP FLOPS; THONGS; ROBES; PAJAMAS; ATHLETIC FOOTWEAR; ATHLETIC SHOES; ATHLETIC UNIFORMS; SCHOOL UNIFORMS; UNIFORMS; SOCKS; DRESSES; BLOUSES; BEACHWEAR; BERMUDA SHORTS; BOARD SHORTS; BOXER SHORTS; SHORTS; SURF WEAR; SLEEPWEAR; COATS; CAPRIS; BABY BODYSUITS; BABY BOTTOMS; BABY TOPS; CLOTHING, NAMELY, NECK TUBES; INFANT AND TODDLER ONE PIECE CLOTHING; INFANT CLOTH DIAPERS; SPORTS JERSEYS; PONCHOS; RAIN BOOTS; RAIN COATS; RAIN JACKETS; RAIN SLICKERS; RAIN TROUSERS; UNDERSHIRTS; BRAS; LINGERIE (U.S. CLS. 22 AND 39).

CLASS 42—SCIENTIFIC AND COMPUTER SERVICES

FOR GRAPHIC ART DESIGN; GRAPHIC DESIGN SERVICES; GRAPHIC ILLUSTRATION SERVICES FOR OTHERS; FURNITURE DESIGN SERVICES; COMMERCIAL ART DESIGN; COMPUTER AIDED DESIGN FOR OTHERS; COMPUTER GRAPHICS SERVICES; CUSTOM DESIGN OF WEARABLE APPAREL AND PAPER GOODS BASED ON PERSONAL SELECTIONS MADE BY THE CUSTOMER; DESIGN FOR OTHERS IN THE FIELD OF FURNITURE AND CLOTHING; DESIGN OF HOMEPAGES AND WEB-SITES; DESIGN OF HOMEPAGES AND WEBSITES; PACKAGING DESIGN FOR OTHERS (U.S. CLS. 100 AND 101).

KELLY BOULTON, EXAMINING ATTORNEY

SN 77-277,471. JOHNS, DAVID, EL PASO, TX. FILED 9-12-2007.

WHATS IN YOUR CITY

THE MARK CONSISTS OF STANDARD CHARACTERS WITHOUT CLAIM TO ANY PARTICULAR FONT, STYLE, SIZE, OR COLOR.

CLASS 35—ADVERTISING AND BUSINESS

FOR PROVIDING A WEBSITE FEATURING LOCAL BUSINESS INFORMATION; ADVERTISING SERVICES FOR OTHERS; MEMBERSHIP CLUB SERVICES PROVIDING DISCOUNTS AND PROCESSING REBATES FOR THE SERVICES OF OTHERS AND BUSINESS NETWORKING SERVICES (U.S. CLS. 100, 101 AND 102).

FIRST USE 5-1-2007; IN COMMERCE 5-20-2007.

SN 77-276,914. BOISE WHITE PAPER, L.L.C., BOISE, ID. FILED 9-11-2007.

BEYOND WHAT'S EXPECTED.

THE MARK CONSISTS OF STANDARD CHARACTERS WITHOUT CLAIM TO ANY PARTICULAR FONT, STYLE, SIZE, OR COLOR.

CLASS 16—PAPER GOODS AND PRINTED MATTER

FOR PAPER (U.S. CLS. 2, 5, 22, 23, 29, 37, 38 AND 50).

FIRST USE 1-1-2006; IN COMMERCE 1-1-2006.

CLASS 39—TRANSPORTATION AND STORAGE

FOR DISTRIBUTION SERVICES, NAMELY, DELIVERY OF PAPER (U.S. CLS. 100 AND 105).

FIRST USE 1-1-2006; IN COMMERCE 1-1-2006.

KATHERINE CONNOLLY, EXAMINING ATTORNEY

CLASS 42—SCIENTIFIC AND COMPUTER SERVICES

FOR HOSTING THE WEBSITES OF OTHERS ON A COMPUTER SERVER FOR A GLOBAL COMPUTER NETWORK (U.S. CLS. 100 AND 101).

FIRST USE 5-1-2007; IN COMMERCE 5-20-2007.

CLASS 45—PERSONAL AND LEGAL SERVICES

FOR PROVIDING A WEBSITE FEATURING ELECTRONIC SECURITY CAMERA MONITORING SERVICES FOR SECURITY PURPOSES IN THE FIELD OF BUSINESSES AND COMMERCIAL PROPERTIES (U.S. CLS. 100 AND 101).

FIRST USE 3-3-2008; IN COMMERCE 6-10-2008.

RENEE MCCRAY, EXAMINING ATTORNEY

SN 77-277,264. MULTI-VET LTEE, SAINT-HYACINTHE, CANADA, FILED 9-12-2007.

SLIMCAT

THE MARK CONSISTS OF STANDARD CHARACTERS WITHOUT CLAIM TO ANY PARTICULAR FONT, STYLE, SIZE, OR COLOR.

CLASS 21—HOUSEWARES AND GLASS

FOR PET ACCESSORIES, NAMELY, FOOD DISPENSERS (U.S. CLS. 2, 13, 23, 29, 30, 33, 40 AND 50).

CLASS 28—TOYS AND SPORTING GOODS

FOR PET ACCESSORIES, NAMELY, TOYS (U.S. CLS. 22, 23, 38 AND 50).

HEATHER THOMPSON, EXAMINING ATTORNEY

SN 77-277,869. GESTION PREMIERE MOISSON INC., DORION, CANADA, FILED 9-12-2007.



OWNER OF CANADA REG. NO. TMA518127, DATED 10-19-1999, EXPIRES 10-19-2014.

OWNER OF U.S. REG. NO. 2,486,492.

NO CLAIM IS MADE TO THE EXCLUSIVE RIGHT TO USE "BOULANGERIE", APART FROM THE MARK AS SHOWN.

THE MARK CONSISTS OF THE WORD "BOULANGERIE" OVER A MAN IN A WHEAT FIELD OVER THE WORDS "PREMIERE MOISSON".

THE FOREIGN WORDING IN THE MARK TRANSLATES INTO ENGLISH AS BAKERY AND FIRST HARVEST.

CLASS 29—MEATS AND PROCESSED FOODS

FOR DELICATESSEN ITEMS, NAMELY, PATES AND HAMS; PICKLES; SALADS, NAMELY, VEGETABLE SALADS, LEGUMINOUS SALADS, AND SALADS MADE OF MEAT, POULTRY, OR FISH; PRECOOKED DISHES, NAMELY, MEAT DISHES, FISH DISHES, SEAFOODS DISHES, GAME DISHES, SAUSAGE DISHES ALL PREPARED TOGETHER WITH RICE, VEGETABLES, POTATOES, EGGS AND/OR CHEESE; AND GROCERY ITEMS, NAMELY, JAMS (U.S. CL. 46).

CLASS 30—STAPLE FOODS

FOR BAKERY PRODUCTS; PASTRIES AND CAKES; DELICATESSEN ITEMS, NAMELY, MEAT PIES; CONFECTIONERY ITEMS, NAMELY, CHOCOLATES AND CANDIES; READY TO EAT ITEMS, NAMELY SANDWICHES, PRESERVED ITEMS, NAMELY, SPAGHETTI SAUCES, TOMATO SAUCES AND PASTA SAUCES; AND PASTA SALADS (U.S. CL. 46).

CLASS 35—ADVERTISING AND BUSINESS

FOR RETAIL SHOPS FEATURING DELICATESSEN ITEMS, BAKERY PRODUCTS, PASTRY ITEMS, MEATS, PRESERVES AND GROCERY PRODUCTS (U.S. CLS. 100, 101 AND 102).

DOMINIC J. FERRAIUOLO, EXAMINING ATTORNEY

CLASS 28—TOYS AND SPORTING GOODS

FOR PLUSH TOYS; STUFFED TOYS; TALKING TOYS; TOY, NAMELY, BATTERY-POWERED COMPUTER GAME WITH LCD SCREEN WHICH FEATURES ANIMATION AND SOUND EFFECTS; TOY ANIMALS AND ACCESSORIES THEREFOR; ACTION SKILL GAMES; ARCADE-TYPE ELECTRONIC VIDEO GAMES; BOARD GAMES; PARLOR GAMES; ROLE PLAYING GAMES; PUZZLES (U.S. CLS. 22, 23, 38 AND 50).

CLASS 35—ADVERTISING AND BUSINESS

FOR ADVERTISING, MARKETING AND PROMOTION SERVICES; ARRANGING AND CONDUCTING BUSINESS CONFERENCES; BUSINESS CONSULTING AND INFORMATION SERVICES; BUSINESS RESEARCH AND SURVEYS; MARKET RESEARCH SERVICES; BUSINESS SERVICES, NAMELY, PROVIDING COMPUTER DATABASES REGARDING THE PURCHASE AND SALE OF A WIDE VARIETY OF PRODUCTS AND SERVICES OF OTHERS; CATALOG ORDERING SERVICE FEATURING A BROAD RANGE OF PRODUCTS AND SERVICES, NAMELY, CLOTHING, SHOES, COSMETICS, CARRYING BAGS, CLOTHING FOR ANIMALS, HOUSEHOLD APPLIANCES, GARDENING TOOLS, BOOKS, DVDS, CD-ROMS, ELECTRONIC PUBLICATIONS, MOVIES, AUDIO RECORDINGS, VIDEO RECORDINGS, COMPUTER SOFTWARE, COMPUTER GAMES, VIDEO GAMES, BOARD GAMES, TOYS, PHOTOGRAPHIC PRINTS, AND EDUCATIONAL TEACHING MATERIALS; ELECTRONIC COMMERCE SERVICES, NAMELY, PROVIDING INFORMATION ABOUT PRODUCTS VIA TELECOMMUNICATION NETWORKS FOR ADVERTISING AND SALES PURPOSES; LOBBYING SERVICES, NAMELY, PROMOTING THE INTERESTS OF NON-PROFIT ORGANIZATIONS IN THE FIELDS OF LEGISLATION AND REGULATION; POLITICAL CONSULTANCY; PROMOTING PUBLIC AWARENESS OF NON-PROFIT ORGANIZATIONS AND A BROAD RANGE OF SOCIAL, CULTURAL, ECONOMIC, ENVIRONMENTAL, POLITICAL, SCIENTIFIC, EDUCATION, AND HEALTH CARE ISSUES; PROVIDING A WEB SITE WHERE USERS CAN POST RATINGS, REVIEWS AND RECOMMENDATIONS ON PRODUCTS AND SERVICES; PROVIDING A WEBSITE FEATURING PRODUCT RATINGS OF THE CONSUMER GOODS AND SERVICES OF OTHERS IN THE FIELD OF A BROAD RANGE OF SUBJECT MATTER AREAS, NAMELY, CLOTHING, SHOES, COSMETICS, CARRYING BAGS, CLOTHING FOR ANIMALS, HOUSEHOLD APPLIANCES, GARDENING TOOLS, BOOKS, DVDS, CD-ROMS, ELECTRONIC PUBLICATIONS, MOVIES, AUDIO RECORDINGS, VIDEO RECORDINGS, COMPUTER SOFTWARE, COMPUTER GAMES, VIDEO GAMES, BOARD GAMES, TOYS, PHOTOGRAPHIC PRINTS, AND EDUCATIONAL TEACHING MATERIALS; RETAIL STORE SERVICES, AVAILABLE THROUGH COMPUTER COMMUNICATIONS AND INTERACTIVE TELEVISION, FEATURING A BROAD RANGE OF PRODUCTS AND SERVICES, NAMELY, CLOTHING, SHOES, COSMETICS, CARRYING BAGS, CLOTHING FOR ANIMALS, HOUSEHOLD APPLIANCES, GARDENING TOOLS, BOOKS, DVDS, CD-ROMS, ELECTRONIC PUBLICATIONS, MOVIES, AUDIO RECORDINGS, VIDEO RECORDINGS, COMPUTER SOFTWARE, COMPUTER GAMES, VIDEO GAMES, BOARD GAMES, TOYS, PHOTOGRAPHIC PRINTS, AND EDUCATIONAL TEACHING MATERIALS; ORGANIZING EXHIBITIONS FOR COMMERCIAL OR ADVERTISING PURPOSES; PRODUCTION AND DISTRIBUTION OF RADIO AND TELEVISION COMMERCIALS; BUSINESS SERVICES, NAMELY, REGISTERING, SCREENING, CREDENTIALING, AND ORGANIZING THIRD-PARTY VENDORS, SUPPLIERS, AND CONTRACTORS, AND DOCUMENTATION AND INFORMATION ON BEHALF OF OTHERS (U.S. CLS. 100, 101 AND 102).

ALICE BENMAMAN, EXAMINING ATTORNEY

SN 77-278,280. LOWSON, LINDA M., HUNTINGTON, NY.
FILED 9-12-2007.

SOCIAL RESPONSIBILITY CHANNEL

THE MARK CONSISTS OF STANDARD CHARACTERS WITHOUT CLAIM TO ANY PARTICULAR FONT, STYLE, SIZE, OR COLOR.

NO CLAIM IS MADE TO THE EXCLUSIVE RIGHT TO USE "CHANNEL", APART FROM THE MARK AS SHOWN.

CLASS 16—PAPER GOODS AND PRINTED MATTER

FOR ART PICTURES; ART PRINTS; CALENDARS; CHILDREN'S BOOKS; CHILDREN'S INTERACTIVE EDUCATIONAL BOOKS; PHOTOGRAPHIC PRINTS; POSTERS; PRINTED INSTRUCTIONAL, EDUCATIONAL, AND TEACHING MATERIALS IN THE FIELD OF A BROAD RANGE OF SUBJECT MATTER AREAS, NAMELY, SOCIAL, CULTURAL, DEMOGRAPHIC, ECONOMIC, FINANCIAL, POLITICAL, ENVIRONMENTAL, SCIENTIFIC, TECHNOLOGICAL, HEALTH CARE, EDUCATION, ANIMAL WELFARE, WILDLIFE PRESERVATION, ECOTOURISM, CONSERVATION AND SUSTAINABLE DEVELOPMENT SUBJECT MATTER AREAS; PRINTED PERIODICALS IN THE FIELD OF A BROAD RANGE OF SUBJECT MATTER AREAS, NAMELY, SOCIAL, CULTURAL, DEMOGRAPHIC, ECONOMIC, FINANCIAL, POLITICAL, ENVIRONMENTAL, SCIENTIFIC, TECHNOLOGICAL, HEALTH CARE, EDUCATION, ANIMAL WELFARE, WILDLIFE PRESERVATION, ECOTOURISM, CONSERVATION AND SUSTAINABLE DEVELOPMENT SUBJECT MATTER AREAS; QUESTIONNAIRES ON A BROAD RANGE OF SUBJECT MATTER AREAS, NAMELY, SOCIAL, CULTURAL, DEMOGRAPHIC, ECONOMIC, FINANCIAL, POLITICAL, ENVIRONMENTAL, SCIENTIFIC, TECHNOLOGICAL, HEALTH CARE, EDUCATION, ANIMAL WELFARE, WILDLIFE PRESERVATION, ECOTOURISM, CONSERVATION AND SUSTAINABLE DEVELOPMENT SUBJECT MATTER AREAS (U.S. CLS. 2, 5, 22, 23, 29, 37, 38 AND 50).

SN 77-278,479. HARTFORD FIRE INSURANCE COMPANY, HARTFORD, CT. FILED 9-13-2007.

HARTFORD EMPLOYMENT LIABILITY PREVENTION

THE MARK CONSISTS OF STANDARD CHARACTERS WITHOUT CLAIM TO ANY PARTICULAR FONT, STYLE, SIZE, OR COLOR.

OWNER OF U.S. REG. NOS. 2,264,317, 2,495,783 AND OTHERS.

NO CLAIM IS MADE TO THE EXCLUSIVE RIGHT TO USE "EMPLOYMENT LIABILITY PREVENTION", APART FROM THE MARK AS SHOWN.

SEC. 2(F) AS TO "HARTFORD".

CLASS 9—ELECTRICAL AND SCIENTIFIC APPARATUS

FOR DOWNLOADABLE MULTIMEDIA FILES, TEXT FILES, WRITTEN DOCUMENTS, AUDIO MATERIAL, AND VIDEO MATERIAL, ALL CONSTITUTING FORMS, POLICIES AND PROCEDURES RELATING TO EMPLOYMENT AND THE WORKPLACE (U.S. CLS. 21, 23, 26, 36 AND 38).

FIRST USE 9-23-2006; IN COMMERCE 9-23-2006.

CLASS 41—EDUCATION AND ENTERTAINMENT

FOR WEB-BASED TRAINING RELATING TO EMPLOYMENT AND WORKPLACE ISSUES; PROVIDING ONLINE ARTICLES AND E-MAIL NEWSLETTERS IN THE FIELDS OF WORKPLACE ISSUES SUCH AS LEADERSHIP, HEALTH, WELLNESS, AND SAFETY (U.S. CLS. 100, 101 AND 107).

FIRST USE 9-23-2006; IN COMMERCE 9-23-2006.

BRENDAN REGAN, EXAMINING ATTORNEY

SN 77-278,980. XCELLENCE, INC., DBA XACT DATA DISCOVERY, MISSION, KS. FILED 9-13-2007.

XACT DATA DISCOVERY

THE MARK CONSISTS OF STANDARD CHARACTERS WITHOUT CLAIM TO ANY PARTICULAR FONT, STYLE, SIZE, OR COLOR.

OWNER OF U.S. REG. NO. 2,894,604.

NO CLAIM IS MADE TO THE EXCLUSIVE RIGHT TO USE "DATA DISCOVERY", APART FROM THE MARK AS SHOWN.

CLASS 42—SCIENTIFIC AND COMPUTER SERVICES

FOR ELECTRONIC DISCOVERY SERVICES FOR LAWYERS, CORPORATIONS AND GOVERNMENT AGENCIES (U.S. CLS. 100 AND 101).

FIRST USE 4-1-2007; IN COMMERCE 4-1-2007.

CLASS 45—PERSONAL AND LEGAL SERVICES

FOR LITIGATION SUPPORT SERVICES (U.S. CLS. 100 AND 101).

FIRST USE 4-1-2007; IN COMMERCE 4-1-2007.

SANJEEV VOHRA, EXAMINING ATTORNEY

SN 77-278,995. XCELLENCE, INC., DBA XACT DATA DISCOVERY, MISSION, KS. FILED 9-13-2007.



XACT DATA DISCOVERY

Because you need to know

OWNER OF U.S. REG. NO. 2,894,604.

NO CLAIM IS MADE TO THE EXCLUSIVE RIGHT TO USE "DATA DISCOVERY", APART FROM THE MARK AS SHOWN.

THE MARK CONSISTS OF THE LETTERS "X D D" WITH THE TOP CORNER OF THE "X" MAKING THE LETTER "D" AND THE BOTTOM CORNER OF THE "X" MAKING THE SECOND LETTER "D". THE WORDS "XACT DATA DISCOVERY" ABOVE THE WORDS "BECAUSE YOU NEED TO KNOW".

CLASS 42—SCIENTIFIC AND COMPUTER SERVICES

FOR ELECTRONIC DISCOVERY SERVICES FOR LAWYERS, CORPORATIONS AND GOVERNMENT AGENCIES (U.S. CLS. 100 AND 101).

FIRST USE 4-1-2007; IN COMMERCE 4-1-2007.

CLASS 45—PERSONAL AND LEGAL SERVICES

FOR LITIGATION SUPPORT SERVICES (U.S. CLS. 100 AND 101).

FIRST USE 4-1-2007; IN COMMERCE 4-1-2007.

SANJEEV VOHRA, EXAMINING ATTORNEY

SN 77-279,145. OCEAN TOMO, LLC, CHICAGO, IL. FILED 9-13-2007.

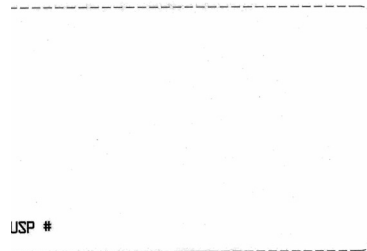

THE MARK CONSISTS OF THE LITERAL ELEMENT "USP #" IN THE BOTTOM LEFT-HAND CORNER OF A CREDIT CARD. THE MATTER SHOWN BY THE DOTTED LINES IS NOT PART OF THE MARK AND SERVES ONLY TO SHOW THE POSITION OF THE MARK ON THE CARD.

CLASS 35—ADVERTISING AND BUSINESS

FOR PROMOTING THE SALE OF CREDIT CARD ACCOUNTS THROUGH THE ADMINISTRATION OF AN INCENTIVE AWARD PROGRAM (U.S. CLS. 100, 101 AND 102).

SN 77-279,727. DOTSON, JR., ROBERT E., ORANGE, CA. FILED 9-14-2007.

CLASS 36—INSURANCE AND FINANCIAL

FOR BANKING AND CREDIT CARD SERVICES (U.S. CLS. 100, 101 AND 102).
KIMBERLY FRYE, EXAMINING ATTORNEY

GFL GANGSTA FOR LIFE

THE MARK CONSISTS OF STANDARD CHARACTERS WITHOUT CLAIM TO ANY PARTICULAR FONT, STYLE, SIZE, OR COLOR.

SN 77-279,383. C.U.S.H. CARIBBEAN UNITED SISTERS HELP INC., BROOKLYN, NY. FILED 9-14-2007.

CLASS 9—ELECTRICAL AND SCIENTIFIC APPARATUS

FOR (BASED ON INTENT TO USE) SUNGLASSES (U.S. CLS. 21, 23, 26, 36 AND 38).

CLASS 25—CLOTHING

FOR (BASED ON USE IN COMMERCE) FOOTWEAR; HATS; HEADWEAR; PANTS; SHIRTS; SHOES; SHORTS; T-SHIRTS (U.S. CLS. 22 AND 39).

FIRST USE 1-27-2001; IN COMMERCE 1-27-2001.
AHSEN KHAN, EXAMINING ATTORNEY



SN 77-279,942. GEL HOMECARE, INC., WEST PALM BEACH, FL. FILED 9-14-2007.

NO CLAIM IS MADE TO THE EXCLUSIVE RIGHT TO USE "CARIBBEAN" AND "HELPING TO CLOTHE & FEED THE HOMELESS AND IMPOVERISHED", APART FROM THE MARK AS SHOWN.

THE COLOR(S) BLACK, BROWN, ORANGE, GOLD, GREEN AND RED. IS/ARE CLAIMED AS A FEATURE OF THE MARK.

THE MARK CONSISTS OF THE WORDS, "CARIBBEAN UNITED SISTERS HELP" AND THE TAG LINE, "HELPING TO FEED THE HOMELESS & IMPOVERISHED" IN BLACK TEXT. A CENTERED TREE THAT HAS BROWN AT THE TOP WHICH BLEEDS INTO ORANGE, THEN GOLD, AND FINALLY GREEN. UNDERNEATH ALL OF WHICH IS THE TEXT, "CUSH" IN RED.

GEL HOMECARE

THE MARK CONSISTS OF STANDARD CHARACTERS WITHOUT CLAIM TO ANY PARTICULAR FONT, STYLE, SIZE, OR COLOR.

NO CLAIM IS MADE TO THE EXCLUSIVE RIGHT TO USE "HOMECARE", APART FROM THE MARK AS SHOWN.

CLASS 43—HOTEL AND RESTAURANT SERVICES

FOR SUPPLYING MEALS TO THE HOMELESS OR UNDERPRIVILEGED (U.S. CLS. 100 AND 101).
FIRST USE 8-31-2006; IN COMMERCE 10-24-2006.

CLASS 44—MEDICAL, BEAUTY AND AGRICULTURAL SERVICES

FOR MEDICAL SERVICES, NAMELY, PHYSICAL EXAMINATION, PROVIDING MEDICAL INFORMATION; DISPENSING OF MEDICATIONS; DIETARY AND NUTRITIONAL GUIDANCE SERVICES; COORDINATION OF HOME MEDICAL EQUIPMENT, NAMELY, LEASING OF HOME MEDICAL EQUIPMENT; SKILLED NURSING AND HOME HEALTHCARE SERVICES TO MENTALLY OR PHYSICALLY CHALLENGED PEOPLE; PROVIDING HEALTH CARE SERVICES TO PATIENTS IN THEIR HOMES; OCCUPATIONAL THERAPY, RESPIRATORY THERAPY, SPEECH THERAPY AND BEHAVIORAL THERAPY (U.S. CLS. 100 AND 101).
FIRST USE 9-30-2001; IN COMMERCE 6-15-2008.

CLASS 45—PERSONAL AND LEGAL SERVICES

FOR CHARITABLE SERVICES, NAMELY, PROVIDING CLOTHING TO NEEDY PERSONS (U.S. CLS. 100 AND 101).
FIRST USE 8-31-2006; IN COMMERCE 10-24-2006.
MARK RADEMACHER, EXAMINING ATTORNEY

CLASS 45—PERSONAL AND LEGAL SERVICES

FOR HOME ATTENDANT CARE, NAMELY, PERSONAL CARE ASSISTANCE FOR ACTIVITIES OF DAILY LIVING SUCH AS BATHING, GROOMING AND PERSONAL MOBILITY FOR 'DENTALLY OR PHYSICALLY CHALLENGED PEOPLE; PERSONAL SERVICE, NAMELY, COMPANIONSHIP SERVICES FOR ELDERLY, HANDICAPPED AND HOME-BOUND INDIVIDUALS; SERVICES PROVIDED TO INDIVIDUALS RELATING TO SOCIAL EVENTS, SUCH AS SOCIAL ESCORT SERVICES; HOMEMAKER SERVICES, NAMELY, ORGANIZATIONAL SERVICES FOR HOME OR PERSONAL PURPOSES, NAMELY, ORGANIZING CLOSET SPACE AND PERSONAL SCHEDULES, AND PERSONAL SHOPPING FOR OTHERS (U.S. CLS. 100 AND 101).

FIRST USE 9-30-2001; IN COMMERCE 6-15-2008.
SAMUEL E. SHARPER JR., EXAMINING ATTORNEY

SN 77-281,456. LUCOMM TECHNOLOGIES INC., BELLEVUE, WA. FILED 9-17-2007.

LUCOMM

THE MARK CONSISTS OF STANDARD CHARACTERS WITHOUT CLAIM TO ANY PARTICULAR FONT, STYLE, SIZE, OR COLOR.

CLASS 9—ELECTRICAL AND SCIENTIFIC APPARATUS

FOR BUILDING SECURITY SYSTEMS COMPRISING SOFTWARE AND HARDWARE FOR PROVIDING PICTURE, VIDEO, ALARM STATUS, BUILDING PLANS, AND OTHER INFORMATION TO A REMOTE STATION; COMPUTER HARDWARE AND SOFTWARE SYSTEM FOR REMOTELY MONITORING ENVIRONMENTAL CONDITIONS AND CONTROLLING DEVICES WITHIN A BUILDING, FACILITY, GROUNDS, OR DESIGNATED SPATIAL AREA; COMPUTER HARDWARE AND SOFTWARE, FOR USE WITH MEDICAL PATIENT MONITORING EQUIPMENT, FOR RECEIVING, PROCESSING, TRANSMITTING AND DISPLAYING DATA; COMPUTER SOFTWARE FOR CONTROLLING AND MANAGING PATIENT MEDICAL INFORMATION; COMPUTER SOFTWARE FOR PROVIDING AN ON-LINE DATABASE IN THE FIELD OF TRANSACTION PROCESSING TO UPLOAD TRANSACTIONAL DATA, PROVIDE STATISTICAL ANALYSIS, AND PRODUCE NOTIFICATIONS AND REPORTS; COMPUTER SOFTWARE FOR THE COLLECTION, EDITING, ORGANIZING, MODIFYING, BOOK MARKING, TRANSMISSION, STORAGE AND SHARING OF DATA AND INFORMATION; COMPUTER SOFTWARE FOR THE FIELD OF WAREHOUSING AND DISTRIBUTION, TO MANAGE TRANSACTIONAL DATA, PROVIDE STATISTICAL ANALYSIS, AND PRODUCE NOTIFICATIONS AND REPORTS; COMPUTER SOFTWARE FOR WIRELESS CONTENT DELIVERY; FACILITIES MANAGEMENT SOFTWARE, NAMELY, SOFTWARE TO CONTROL BUILDING ENVIRONMENT, ACCESS AND SECURITY SYSTEMS; FACTORY AUTOMATION SOFTWARE, NAMELY, SOFTWARE TO INTEGRATE MANUFACTURING MACHINE OPERATIONS, TRACK PROBLEMS AND GENERATE PRODUCTION REPORTS; GLOBAL POSITIONING SYSTEM (GPS) CONSISTING OF COMPUTERS, COMPUTER SOFTWARE, TRANSMITTERS, RECEIVERS, AND NETWORK INTERFACE DEVICES; HOME AND OFFICE AUTOMATION SYSTEMS COMPRISING WIRELESS AND WIRED CONTROLLERS, CONTROLLED DEVICES, AND SOFTWARE FOR LIGHTING, HVAC, SECURITY, SAFETY AND OTHER HOME AND OFFICE MONITORING AND CONTROL APPLICATIONS; LIGHTING CONTROL SOFTWARE FOR USE IN COMMERCIAL AND INDUSTRIAL FACIL-

ITIES; MEDICAL SOFTWARE FOR PROCESSING AND DISPLAYING IMAGES ON ULTRASOUND MEDICAL IMAGING MACHINES; SOFTWARE FOR MEDICAL IMAGING EQUIPMENT, NAMELY, FOR INTERPRETING THE RESULTS OF CT SCANNERS (U.S. CLS. 21, 23, 26, 36 AND 38).

CLASS 42—SCIENTIFIC AND COMPUTER SERVICES

FOR APPLICATION SERVICE PROVIDER FEATURING SOFTWARE FOR PROVIDING AN ON-LINE DATABASE IN THE FIELD OF TRANSACTION PROCESSING TO UPLOAD TRANSACTIONAL DATA, PROVIDE STATISTICAL ANALYSIS, AND PRODUCE NOTIFICATIONS AND REPORTS; APPLICATION SERVICE PROVIDER, NAMELY, PROVIDING, HOSTING, MANAGING, DEVELOPING, AND MAINTAINING APPLICATIONS, SOFTWARE, WEBSITES, AND DATABASES IN THE FIELDS OF PERSONAL PRODUCTIVITY, WIRELESS COMMUNICATION, MOBILE INFORMATION ACCESS, AND REMOTE DATA MANAGEMENT FOR WIRELESS DELIVERY OF CONTENT TO HANDHELD COMPUTERS, LAPTOPS AND MOBILE ELECTRONIC DEVICES; DEVELOPMENT OF SOFTWARE FOR SECURE NETWORK OPERATIONS; RESEARCH AND DEVELOPMENT AND CONSULTATION RELATED THERETO IN THE FIELD OF WIRELESS AND RADIO FREQUENCY DEVICES; INDUSTRIAL RESEARCH IN THE FIELD OF RADIO FREQUENCY IDENTIFICATION; MEDICAL AND SCIENTIFIC RESEARCH IN THE FIELD OF MEDICAL IMAGING (U.S. CLS. 100 AND 101).

LINDSEY RUBIN, EXAMINING ATTORNEY

SN 77-281,493. LINDA J. FORRISTAL, GREENBELT, MD. FILED 9-17-2007.



THE MARK CONSISTS OF A DESIGN DEPICTING, IN STYLED FORM, A WOMAN HOLDING A BOWL OF APPLES OR FRUIT STANDING AMIDST PUMPKINS AND GOURDS AND SURROUNDED BY A CIRCULAR LEAF MOTIF.

CLASS 16—PAPER GOODS AND PRINTED MATTER

FOR COOK BOOKS (U.S. CLS. 2, 5, 22, 23, 29, 37, 38 AND 50).

FIRST USE 0-0-1993; IN COMMERCE 0-0-1993.

CLASS 39—TRANSPORTATION AND STORAGE

FOR PROVIDING A WEBSITE IN THE FIELD OF CULTURAL HERITAGE TOURISM (U.S. CLS. 100 AND 105).

FIRST USE 0-0-1998; IN COMMERCE 0-0-1998.
ESTHER BELENKER, EXAMINING ATTORNEY

SN 77-281,597. RENTON COIL SPRING COMPANY, RENTON, WA. FILED 9-17-2007.



THE MARK CONSISTS OF A DEPICTION OF A COIL OVERLYING A RHOMBUS NEXT TO THE LETTERS "RCS".

CLASS 9—ELECTRICAL AND SCIENTIFIC APPARATUS

FOR SPRINGS BEING PARTS OF VEHICLE CONTROL SYSTEMS; SPRINGS BEING PARTS OF AIRCRAFT OPERATOR CONTROLS, ACTUATOR AND AIRCRAFT CONTROL SYSTEMS; SPRINGS FOR AIRCRAFT SURFACE CONTROL ACTUATOR SYSTEMS (U.S. CLS. 21, 23, 26, 36 AND 38).

FIRST USE 6-30-2002; IN COMMERCE 6-30-2002.

CLASS 12—VEHICLES

FOR SPRINGS FOR VEHICLES, NAMELY, SUSPENSION SPRINGS, CONTROL SPRINGS BEING COMPONENTS PARTS, DRIVE SYSTEM SPRINGS; SPRINGS FOR AIRCRAFT LANDING GEAR AND DOORS (U.S. CLS. 19, 21, 23, 31, 35 AND 44).

FIRST USE 6-30-2002; IN COMMERCE 6-30-2002.
MATTHEW PAPPAS, EXAMINING ATTORNEY

SN 77-282,244. KODIAK INDUSTRIAL SYSTEMS INC., BURNABY, CANADA, FILED 9-18-2007.

KODIAK ENTERTAINMENT

THE MARK CONSISTS OF STANDARD CHARACTERS WITHOUT CLAIM TO ANY PARTICULAR FONT, STYLE, SIZE, OR COLOR.

OWNER OF CANADA REG. NO. TMA713,926, DATED 5-8-2008, EXPIRES 5-8-2023.

NO CLAIM IS MADE TO THE EXCLUSIVE RIGHT TO USE "ENTERTAINMENT", APART FROM THE MARK AS SHOWN.

CLASS 9—ELECTRICAL AND SCIENTIFIC APPARATUS

FOR GAMING MACHINES; ELECTRONIC GAMING SYSTEMS CONSISTING OF GAMING MACHINES AND CUSTOMIZED GAMING SOFTWARE; COMPUTER SOFTWARE AND FIRMWARE FOR GAMES OF CHANCE AND SKILL GAMES ON ANY COMPUTERIZED PLATFORM, INCLUDING DEDICATED GAMING CONSOLES, VIDEO BASED SLOT MACHINES, REEL BASED SLOT MACHINES, BINGO MACHINES AND VIDEO LOTTERY TERMINALS; COMPUTER GAMING SOFTWARE (U.S. CLS. 21, 23, 26, 36 AND 38).

CLASS 28—TOYS AND SPORTING GOODS

FOR BINGO GAME PLAYING EQUIPMENT (U.S. CLS. 22, 23, 38 AND 50).

CLASS 35—ADVERTISING AND BUSINESS

FOR DISTRIBUTORSHIP SERVICES IN THE FIELD OF ELECTRONIC GAMING SYSTEMS (U.S. CLS. 100, 101 AND 102).

CLASS 37—CONSTRUCTION AND REPAIR

FOR MAINTENANCE OF ELECTRONIC GAMING SYSTEMS; INSTALLATION OF ELECTRONIC GAMING SYSTEMS (U.S. CLS. 100, 103 AND 106).

CLASS 41—EDUCATION AND ENTERTAINMENT

FOR LEASING OF ELECTRONIC GAMING MACHINES; TRAINING IN THE FIELD OF OPERATION OF ELECTRONIC GAMING SYSTEMS (U.S. CLS. 100, 101 AND 107).

CLASS 42—SCIENTIFIC AND COMPUTER SERVICES

FOR TECHNICAL SUPPORT SERVICES, NAMELY, TROUBLESHOOTING OF ELECTRONIC GAMING SYSTEMS PROBLEMS; INTEGRATION OF ELECTRONIC GAMING COMPUTER SYSTEMS AND NETWORKS (U.S. CLS. 100 AND 101).

DOMINIC FATHY, EXAMINING ATTORNEY

SN 77-282,437. MOLINO DI FERRO S.P.A., FANZOLO DE VEDEL, ITALY, FILED 9-18-2007.

LE VENEZIANE

THE MARK CONSISTS OF STANDARD CHARACTERS WITHOUT CLAIM TO ANY PARTICULAR FONT, STYLE, SIZE, OR COLOR.

PRIORITY CLAIMED UNDER SEC. 44(D) ON ERPN CMNTY TM OFC APPLICATION NO. 005783394, FILED 9-18-2007, REG. NO. 005783394, DATED 4-24-2008, EXPIRES 3-14-2017.

OWNER OF U.S. REG. NO. 3,058,365.

THE FOREIGN WORDING IN THE MARK TRANSLATES INTO ENGLISH AS "FEMALE CITIZENS OF VENICE".

CLASS 5—PHARMACEUTICALS

FOR DIETETIC FOODS ADAPTED FOR MEDICAL USE, EXCLUDING CANDIES, PASTRIES, AND OTHER SWEETS; DIETETIC FOODS ADAPTED FOR MEDICAL USE, NAMELY, PASTA CONTAINING CORN FLOUR (U.S. CLS. 6, 18, 44, 46, 51 AND 52).

CLASS 29—MEATS AND PROCESSED FOODS

FOR MEAT, FISH, POULTRY AND GAME; MEAT EXTRACTS; PRESERVED, DRIED AND COOKED FRUITS AND VEGETABLES; EGGS, MILK AND MILK PRODUCTS, EXCLUDING ICE CREAM, ICE MILK AND FROZEN YOGURT; EDIBLE OILS AND FATS, ALL OF THE ABOVE EXCLUDING CANDIES, PASTRIES, AND OTHER SWEETS (U.S. CL. 46).

DAWN FELDMAN, EXAMINING ATTORNEY

SN 77-282,533. CLEANBRANDS, LLC, EAST PROVIDENCE, RI. FILED 9-18-2007.

BENESLEEP

THE MARK CONSISTS OF STANDARD CHARACTERS WITHOUT CLAIM TO ANY PARTICULAR FONT, STYLE, SIZE, OR COLOR.

CLASS 20—FURNITURE AND ARTICLES NOT OTHERWISE CLASSIFIED

FOR PILLOWS; BABY HEAD SUPPORT CUSHIONS (U.S. CLS. 2, 13, 22, 25, 32 AND 50).

CLASS 24—FABRICS

FOR MATTRESS ENCASEMENTS, NAMELY, MATTRESS COVERS; PILLOW ENCASEMENTS, NAMELY, PILLOW CASES AND PILLOW SHAMS; DUVET ENCASEMENTS, NAMELY, DUVET COVERS; CRIB MATTRESS ENCASEMENTS, NAMELY, MATTRESS COVERS FOR CRIB MATTRESSES; BOX SPRING ENCASEMENTS, NAMELY, BOX SPRING COVERS; COMFORTERS; BABY CRIB BUMPERS; WATERPROOF AND WATER ABSORBING MATTRESS PADS; TEXTILE BABY CHANGING PADS (U.S. CLS. 42 AND 50).

JUSTINE D. PARKER, EXAMINING ATTORNEY

SN 77-283,370. LIVESAY, LENNON, PEMBROKE PINES, FL. FILED 9-19-2007.

BLANK TAPE

THE MARK CONSISTS OF STANDARD CHARACTERS WITHOUT CLAIM TO ANY PARTICULAR FONT, STYLE, SIZE, OR COLOR.

CLASS 9—ELECTRICAL AND SCIENTIFIC APPARATUS

FOR AUDIO RECORDINGS FEATURING MUSIC; MUSICAL AUDIO RECORDINGS; PRE-RECORDED CD'S FEATURING MUSIC; SOUND RECORDINGS FEATURING MUSIC; PRERECORDED COMPACT DISKS FEATURING MUSIC; PRE-RECORDED MUSICAL SOUND RECORDINGS (U.S. CLS. 21, 23, 26, 36 AND 38).
FIRST USE 12-31-2006; IN COMMERCE 12-31-2006.

CLASS 41—EDUCATION AND ENTERTAINMENT

FOR PROVIDING ENTERTAINMENT SERVICES IN THE NATURE OF AUDIO AND VISUAL PERFORMANCES, NAMELY, MUSICAL GROUP PERFORMANCES; ENTERTAINMENT, NAMELY, LIVE PERFORMANCES BY A MUSICAL GROUP; LIVE MUSICAL PERFORMANCES BY A MUSICAL GROUP; ENTERTAINMENT SERVICES, NAMELY, PROVIDING PRERECORDED MUSIC ONLINE VIA A GLOBAL COMPUTER NETWORK; ONLINE ENTERTAINMENT RENDERED BY A MUSICAL BAND, NAMELY, PROVIDING A WEB SITE FEATURING MUSICAL PERFORMANCES, PHOTOGRAPHS AND OTHER BAND RELATED INFORMATION (U.S. CLS. 100, 101 AND 107).

FIRST USE 12-10-2004; IN COMMERCE 9-30-2005.
SHARON MEIER, EXAMINING ATTORNEY

SN 77-283,534. WELLS FARGO BANK, N.A., MINNEAPOLIS, MN. FILED 9-19-2007.

Wells Fargo Foundation
Connecting with community.

OWNER OF U.S. REG. NOS. 2,800,811, 3,320,784 AND OTHERS.

NO CLAIM IS MADE TO THE EXCLUSIVE RIGHT TO USE "FOUNDATION", APART FROM THE MARK AS SHOWN.

THE MARK CONSISTS OF BOLDED "WELLS FARGO FOUNDATION" SITTING ABOVE A LINE; AND NON-BOLDED "CONNECTING WITH COMMUNITY" BELOW THE LINE.

CLASS 35—ADVERTISING AND BUSINESS

FOR CHARITABLE SERVICES, NAMELY, ORGANIZING AND CONDUCTING VOLUNTEER PROGRAMS AND COMMUNITY SERVICE PROJECTS; CHARITABLE SERVICES, NAMELY, THE ORGANIZATION, COORDINATION AND ADMINISTRATION OF ALL VOLUNTEER EFFORT WITHIN A CORPORATION; ORGANIZATION AND SUPERVISION OF VOLUNTEERS FOR COMMUNITY SERVICE; CHARITABLE SERVICES, NAMELY, INVOLVING INDIVIDUALS AND GROUPS IN COMMUNITY-BASED SERVICE AND CHARITABLE ACTIVITIES (U.S. CLS. 100, 101 AND 102).
FIRST USE 9-1-2005; IN COMMERCE 9-1-2005.

CLASS 36—INSURANCE AND FINANCIAL

FOR PROVIDING GRANTS TO ORGANIZATIONS IN THE FIELDS OF ARTS AND CULTURE, ECONOMIC DEVELOPMENT, FINANCIAL LITERACY AND COMMUNITY DEVELOPMENT; AND PROVIDING EDUCATIONAL SCHOLARSHIPS (U.S. CLS. 100, 101 AND 102).
FIRST USE 9-1-2005; IN COMMERCE 9-1-2005.
LINDA ESTRADA, EXAMINING ATTORNEY

SN 77-283,563. GOLDEN DRAGON ASSOCIATION, INC.,
TALLAHASSEE, FL. FILED 9-19-2007.

SN 77-283,613. MICHELLE LEE BASILOTTO, PORT CHAR-
LOTTE, FL. FILED 9-19-2007.

GOLDEN LIGHTING

THE MARK CONSISTS OF STANDARD CHARACTERS WITHOUT CLAIM TO ANY PARTICULAR FONT, STYLE, SIZE, OR COLOR.

NO CLAIM IS MADE TO THE EXCLUSIVE RIGHT TO USE "LIGHTING", APART FROM THE MARK AS SHOWN.

CLASS 11—ENVIRONMENTAL CONTROL AP- PARATUS

FOR LIGHTING FIXTURES (U.S. CLS. 13, 21, 23, 31 AND 34).

FIRST USE 0-0-1982; IN COMMERCE 0-0-1982.

CLASS 35—ADVERTISING AND BUSINESS

FOR WHOLESALE DISTRIBUTORSHIP FEATURING LIGHTING FIXTURES (U.S. CLS. 100, 101 AND 102).

FIRST USE 0-0-1982; IN COMMERCE 0-0-1982.

ALEXANDER L. POWERS, EXAMINING ATTORNEY

SN 77-283,601. AGILE SCIENCES, INC., RALEIGH, NC.
FILED 9-19-2007.

AGILYTE

THE MARK CONSISTS OF STANDARD CHARACTERS WITHOUT CLAIM TO ANY PARTICULAR FONT, STYLE, SIZE, OR COLOR.

CLASS 1—CHEMICALS

FOR CHEMICAL PREPARATIONS COMPOSED OF ORGANIC COMPOUNDS TO PREVENT BACTERIAL BIOFILMS IN A WIDE VARIETY OF INDUSTRIES, NAMELY, THE MARINE, PETROLEUM, CONVENTIONAL AND NUCLEAR POWER PLANT, AND MEDICAL DEVICE INDUSTRIES (U.S. CLS. 1, 5, 6, 10, 26 AND 46).

CLASS 2—PAINTS

FOR SEALER COATINGS FOR USE IN THE CONSTRUCTION INDUSTRY, AUTOMOTIVE INDUSTRY, AEROSPACE INDUSTRY, SHIP INDUSTRY, PAINTING INDUSTRY, PIPING INDUSTRY; SEALER COATINGS FOR USE IN ROADS, INDUSTRIAL PRODUCTS, CONSUMER PRODUCTS, PULP AND PAPER PRODUCTION, AND GROUND WATER REMEDIATION (U.S. CLS. 6, 11 AND 16).

CLASS 5—PHARMACEUTICALS

FOR ANTIMICROBIAL COATINGS TO TREAT THE GROWTH OF MOLD, MILDEW, BACTERIA AND FUNGUS ON VARIOUS SURFACES; SEALER COATINGS FOR USE IN THE DENTAL INDUSTRY ON DENTAL PATIENTS (U.S. CLS. 6, 18, 44, 46, 51 AND 52).

JILL PRATER, EXAMINING ATTORNEY

Grinds & Wines

THE MARK CONSISTS OF STANDARD CHARACTERS WITHOUT CLAIM TO ANY PARTICULAR FONT, STYLE, SIZE, OR COLOR.

CLASS 30—STAPLE FOODS

FOR FROZEN DESSERT CONSISTING OF FRUIT AND CREAM OR CREAM SUBSTITUTES; FRUIT COBBLERS; FRUIT FLAVORINGS, EXCEPT ESSENCES; FRUIT ICES; FRUIT PIES; FRUIT TEAS; HAMBURGER SANDWICHES; HOT DOG SANDWICHES; ICE CREAM SANDWICHES; MACARONI AND CHEESE; MACARONI SALAD; SALAD DRESSINGS; SANDWICHES; SANDWICHES NAMELY, CHICKEN SANDWICHES, TURKEY SANDWICHES, CLUB SANDWICHES, ROAST BEEF SANDWICHES, SUB SANDWICHES, WRAP SANDWICHES; TEA BASED BEVERAGES WITH FRUIT FLAVORING; BEVERAGES MADE OF COFFEE; BEVERAGES MADE OF TEA; CAFFEINE-FREE COFFEE; COCOA BEVERAGES WITH MILK; COFFEE BEANS; COFFEE FLAVORED SYRUP USED IN MAKING FOOD BEVERAGES; COFFEE-BASED BEVERAGE CONTAINING MILK; FLAVOR ENHANCERS USED IN FOOD AND BEVERAGE PRODUCTS; FLAVORINGS FOR BEVERAGES; GROUND COFFEE BEANS; INSTANT COFFEE; MIXES IN THE NATURE OF CONCENTRATES, SYRUPS OR POWDERS USED IN THE PREPARATION OF TEA BASED BEVERAGES; PREPARED COCOA AND COCOA-BASED BEVERAGES; PREPARED COFFEE AND COFFEE-BASED BEVERAGES; ROASTED COFFEE BEANS; SCENTED WATER FOR FLAVORING BEVERAGES; SUGAR-COATED COFFEE BEANS (U.S. CL. 46).

CLASS 32—LIGHT BEVERAGES

FOR FROZEN FRUIT BEVERAGES; FRUIT BEVERAGES; FRUIT DRINKS; FRUIT FLAVORED SOFT DRINKS; FRUIT JUICE BASES; FRUIT-FLAVORED BEVERAGES; FRUIT-FLAVORED DRINKS; ICED FRUIT BEVERAGES; NON-ALCOHOLIC BEVERAGES CONTAINING FRUIT JUICES (U.S. CLS. 45, 46 AND 48).

CLASS 33—WINES AND SPIRITS

FOR ALCOHOLIC BEVERAGES OF FRUIT; ALCOHOLIC FRUIT EXTRACTS; APERITIF WINES; APERITIFS WITH A WINE BASE; COOKING WINE; FRUIT WINE; GRAPE WINE; KITS FOR MAKING WINE; NATURAL SPARKLING WINES; PORT WINES; PREPARED WINE COCKTAILS; RED WINE; SPARKLING FRUIT WINE; SPARKLING GRAPE WINE; SPARKLING WINES; STRAWBERRY WINE; SWEET WINES; TABLE WINES; TONIC SWEET GRAPE WINE CONTAINING EXTRACTS FROM GINSENG AND CONCHONA BARK (NINJIN-KINATETSU WINE); WHITE WINE; WINE COOLERS; WINE PUNCH; WINE PUNCHES; WINES (U.S. CLS. 47 AND 49).

JANET LEE, EXAMINING ATTORNEY

SN 77-283,778. GARAN SERVICES CORP., WILMINGTON, DE. FILED 9-19-2007.

Garanimals

OWNER OF U.S. REG. NOS. 1,162,044, 1,393,358 AND OTHERS.

THE MARK CONSISTS OF THE WORDING "GARANIMALS" WITH A PAW PRINT DESIGN APPEARING OVER THE LETTER "I" AND ANTENNA APPEARING OVER THE LETTER "L".

CLASS 14—JEWELRY

FOR JEWELRY, NAMELY, NECKLACES, BRACELETS, WATCHES, RINGS AND EARRINGS (U.S. CLS. 2, 27, 28 AND 50).

CLASS 25—CLOTHING

FOR CLOTHING, NAMELY, TOPS AND BOTTOMS, SWEATERS, SWEATSHIRTS, PANTS, JEANS, SWEATPANTS, SHORTS, LEGGINGS, CAPRIS, BATHING SUITS, SWIMWEAR, SLEEPWEAR, LEOTARDS, TIGHTS, ROMPERS, UNDERWEAR, HOSIERY, DRESSES, HOODS, CREEPERS; OUTERWEAR, NAMELY, COATS, JACKETS, SCARVES; HEADWEAR, NAMELY, HATS, EARMUFFS, SKI MASKS; GLOVES, BELTS, SOCKS; AND FOOTWEAR, NAMELY, SHOES, BOOTS, SANDALS, SNEAKERS (U.S. CLS. 22 AND 39).
JAY FLOWERS, EXAMINING ATTORNEY

SN 77-283,779. WASHINGTON IRVING; CITIZEN OF THE WORLD, LLC, HASTINGS-ON-HUDSON, NY. FILED 9-19-2007.

WASHINGTON IRVING; CITIZEN
OF THE WORLD

THE MARK CONSISTS OF STANDARD CHARACTERS WITHOUT CLAIM TO ANY PARTICULAR FONT, STYLE, SIZE, OR COLOR.

NO CLAIM IS MADE TO THE EXCLUSIVE RIGHT TO USE "WASHINGTON IRVING" WITH RESPECT TO "COFFEE TABLE BOOKS FEATURING BIOGRAPHICAL MATTER," IN INTERNATIONAL CLASS 16., APART FROM THE MARK AS SHOWN.

CLASS 16—PAPER GOODS AND PRINTED MATTER

FOR PICTURE BOOKS; COFFEE TABLE BOOKS FEATURING BIOGRAPHICAL AND FICTIONAL MATTER, PHOTOGRAPHS AND ART; POSTCARDS AND PICTURE POSTCARDS; GREETING CARDS; BOOK-HOLDERS (U.S. CLS. 2, 5, 22, 23, 29, 37, 38 AND 50).

CLASS 21—HOUSEWARES AND GLASS

FOR COFFEE MUGS; GLASS MUGS (U.S. CLS. 2, 13, 23, 29, 30, 33, 40 AND 50).

CLASS 25—CLOTHING

FOR BASEBALL CAPS; VISORS AND CAPS WITH VISORS; GOLF CAPS; T-SHIRTS (U.S. CLS. 22 AND 39).

CLASS 41—EDUCATION AND ENTERTAINMENT

FOR ENTERTAINMENT SERVICES, NAMELY, PRODUCTION AND DISTRIBUTION OF MOTION PICTURES; MULTIMEDIA PUBLISHING OF BOOKS, MAGAZINES, JOURNALS, SOFTWARE, GAMES, MUSIC, AND ELECTRONIC PUBLICATIONS (U.S. CLS. 100, 101 AND 107).

BARNEY CHARLON, EXAMINING ATTORNEY

SN 77-283,787. AREVA NP GMBH, 91058 ERLANGEN, FED REP GERMANY, FILED 9-19-2007.

DIWA

THE MARK CONSISTS OF STANDARD CHARACTERS WITHOUT CLAIM TO ANY PARTICULAR FONT, STYLE, SIZE, OR COLOR.

OWNER OF FED REP GERMANY REG. NO. 1097141, DATED 10-1-1986, EXPIRES 3-31-2016.

THE MARK HAS NO MEANING IN A FOREIGN LANGUAGE.

CLASS 9—ELECTRICAL AND SCIENTIFIC APPARATUS

FOR DIAGNOSTIC COMPUTER SOFTWARE FOR USE IN DETECTION, LOCALIZATION AND CORRECTION OF DISTURBANCES AND POTENTIAL DISTURBANCES IN INDUSTRIAL AND POWER GENERATING PROCESSES, NAMELY, DISTURBANCES RELATING TO WATER CHEMISTRY IN WATER-STEAM CYCLES (U.S. CLS. 21, 23, 26, 36 AND 38).

CLASS 42—SCIENTIFIC AND COMPUTER SERVICES

FOR DEVELOPMENT OF DATA PROCESSING PROGRAMS FOR OTHERS; RENTAL OF COMPUTER SOFTWARE FOR DATA PROCESSING (U.S. CLS. 100 AND 101).

NAPOLEON SHARMA, EXAMINING ATTORNEY

SN 77-283,808. AUTHENTIVERSE, INC., BOTHELL, WA. FILED 9-19-2007.

AUTHENTIVERSE

THE MARK CONSISTS OF STANDARD CHARACTERS WITHOUT CLAIM TO ANY PARTICULAR FONT, STYLE, SIZE, OR COLOR.

CLASS 9—ELECTRICAL AND SCIENTIFIC APPARATUS

FOR COMPUTER HARDWARE; BIOMETRICAL IDENTIFICATION APPARATUS, NAMELY, IRIS IDENTIFICATION SECURITY DEVICES AND FINGERPRINT IDENTIFICATION SECURITY DEVICES; COMPUTER HARDWARE, TOUCH SCREENS, THUMBPRINT READERS, MOTHERBOARDS, IDENTIFICATION SCANNERS, HANDHELD SCANNERS AND DOWNLOADABLE COMPUTER SOFTWARE AND DATABASES FOR SECURITY CLEARANCE AND AUTHENTICATION USING BIOMETRIC CHARACTERISTICS, NAMELY, FINGERPRINT, PALM PRINT, FACIAL FEATURES, IRIS, RETINA, AND SIGNATURE; DOWNLOADABLE COMPUTER SOFTWARE PLATFORM FOR USE WITH BIOMETRIC ALGORITHMS FOR THE USE IN THE IDENTIFICATION AND AUTHENTICATION OF INDIVIDUALS BASED ON THEIR UNIQUE CHARACTERISTICS, NAMELY, FINGERPRINT, PALM PRINT, FACIAL FEATURES, IRIS, RETINA AND SIGNATURE; DOWNLOADABLE COMPUTER SOFTWARE, NAMELY, COMPUTER SOFTWARE FOR USE IN CONNECTION WITH A BIOMETRIC IDENTIFICATION DEVICE FOR SECURITY CLEARANCE AND AUTHENTICATION USING BIOMETRIC CHARACTERISTICS, NAMELY, FINGERPRINT, PALM PRINT, FACIAL FEATURES, IRIS, RETINA, AND SIGNATURE; DOWNLOADABLE COMPUTER SOFTWARE, NAMELY, COMPUTER SOFTWARE FOR COLLECTING, STORING, SECURING AND ACCESSING DOCUMENTS AND INFORMATION VIA A GLOBAL COMPUTER NETWORK, FOR TRANSMITTING ELECTRONIC DATA, FOR CONNECTING USERS TO A GLOBAL COMPUTER NETWORK TO CONDUCT BUSINESS TRANSACTIONS AND ACCESS INFORMATION, TO ALLOW USERS TO PERFORM ELECTRONIC BUSINESS TRANSACTIONS, FOR ACCESSING INFORMATION DIRECTORIES THAT MAY BE DOWNLOADED FROM THE GLOBAL COMPUTER NETWORK, FOR THE COLLECTION, EDITING, ORGANIZING, MODIFYING, BOOK MARKING, TRANSMISSION, STORAGE AND SHARING OF DATA, INFORMATION AND IMAGES, FOR USE IN THE SAFEGUARDING, ENCRYPTION AND DECRYPTION OF DIGITAL FILES, INCLUDING AUDIO, VIDEO, TEXT, BINARY, STILL IMAGES, GRAPHICS AND MULTIMEDIA FILES (U.S. CLS. 21, 23, 26, 36 AND 38).

CLASS 39—TRANSPORTATION AND STORAGE

FOR ELECTRONIC STORAGE OF DIGITAL DATA, NAMELY, FINANCIAL, PERSONAL AND BUSINESS DATA (U.S. CLS. 100 AND 105).

CLASS 42—SCIENTIFIC AND COMPUTER SERVICES

FOR PROVIDING TEMPORARY USE OF ONLINE, NON-DOWNLOADABLE COMPUTER SOFTWARE AND DATABASES FOR SECURITY CLEARANCE AND AUTHENTICATION USING BIOMETRIC CHARACTERISTICS, NAMELY, FINGERPRINT, PALM PRINT, FACIAL FEATURES, IRIS, RETINA AND SIGNATURE; PROVIDING TEMPORARY USE OF ONLINE, NON-DOWNLOADABLE COMPUTER SOFTWARE PLATFORM FOR USE WITH BIOMETRIC ALGORITHMS FOR THE USE IN THE IDENTIFICATION AND AUTHENTICATION OF INDIVIDUALS BASED ON THEIR UNIQUE CHARACTERISTICS, NAMELY, FINGERPRINT, PALM PRINT, FACIAL FEATURES, IRIS, RETINA AND SIGNATURE; PROVIDING TEMPORARY USE OF ONLINE, NON-DOWNLOADABLE COMPUTER SOFTWARE, NAMELY, COMPUTER SOFTWARE FOR USE IN CONNECTION WITH A BIOMETRIC IDENTIFICATION DEVICE FOR SECURITY CLEARANCE AND AUTHENTICATION USING BIOMETRIC CHARACTERISTICS, NAMELY, FINGERPRINT, PALM PRINT, FACIAL FEATURES, IRIS, RETINA, AND SIGNATURE; PROVIDING TEMPORARY USE OF ONLINE, NON-DOWNLOADABLE COMPUTER SOFTWARE, NAMELY, COMPUTER SOFTWARE FOR COLLECTING, STORING, SECURING AND ACCESSING DOCUMENTS AND INFORMATION VIA A GLOBAL COMPUTER NETWORK, FOR TRANSMITTING ELECTRONIC DATA, FOR CONNECTING USERS TO A GLOBAL COMPUTER NETWORK TO CONDUCT BUSINESS TRANSACTIONS

AND ACCESS INFORMATION, TO ALLOW USERS TO PERFORM ELECTRONIC BUSINESS TRANSACTIONS, FOR ACCESSING INFORMATION DIRECTORIES THAT MAY BE DOWNLOADED FROM THE GLOBAL COMPUTER NETWORK, FOR THE COLLECTION, EDITING, ORGANIZING, MODIFYING, BOOK MARKING, TRANSMISSION, STORAGE AND SHARING OF DATA, INFORMATION AND IMAGES, FOR USE IN THE SAFEGUARDING, ENCRYPTION AND DECRYPTION OF DIGITAL FILES, INCLUDING AUDIO, VIDEO, TEXT, BINARY, STILL IMAGES, GRAPHICS AND MULTIMEDIA FILES; COMPUTER SERVICES, NAMELY, HOSTING COMPUTER APPLICATION SOFTWARE FOR THE COLLECTION, EDITING, ORGANIZING, MODIFYING, BOOK MARKING, TRANSMISSION, STORAGE AND SHARING OF DATA AND INFORMATION; COMPUTER SOFTWARE DESIGN AND COMPUTER SOFTWARE PROGRAMMING; COMPUTER HARDWARE DESIGN; DESIGN AND DEVELOPMENT OF COMPUTER SOFTWARE AND HARDWARE SYSTEMS, NAMELY, PROVIDING INFRASTRUCTURE FOR COMPUTER TECHNOLOGY SYSTEMS FOR THE SUPPLY OF INFORMATION AND DOCUMENTS, TRANSMISSION OF TEXTS, ELECTRONIC DOCUMENTS, DATABASES, GRAPHICS AND AUDIOVISUAL INFORMATION BY OPERATING AND CONNECTING TO A GLOBAL NETWORK OF OFFICES AND CLIENTS (U.S. CLS. 100 AND 101).

CLASS 45—PERSONAL AND LEGAL SERVICES

FOR COMPUTER SECURITY SERVICES IN THE NATURE OF PROVIDING AN INTERNET TRUST CENTER, NAMELY, COMPUTER SECURITY ASSURANCE AND ADMINISTRATION OF DIGITAL KEYS AND DIGITAL CERTIFICATES; PROVIDING COMPUTER AND COMPUTER SOFTWARE SECURITY SERVICES IN THE NATURE OF USER AUTHENTICATION FOR ELECTRONIC TRANSACTIONS OF ELECTRONICALLY STORED PERSONAL, FINANCIAL AND COMMERCIAL INFORMATION; SECURITY SERVICES FOR COMPANIES AND INDIVIDUALS FOR INTERNET AND IN-PERSON TRANSACTIONS, NAMELY, STORING PERSONAL, FINANCIAL AND COMMERCIAL INFORMATION AND RELEASING PERSONAL FINANCIAL AND COMMERCIAL INFORMATION TO AUTHORIZED USERS WHOSE IDENTITY HAS BEEN AUTHENTICATED THROUGH USE OF BIOMETRIC CHARACTERISTICS, NAMELY, FINGERPRINT, PALM PRINT, FACIAL FEATURES, IRIS, RETINA, AND SIGNATURE; SECURITY CLEARANCE AND AUTHENTICATION SERVICES FOR COMPANIES AND INDIVIDUALS FOR INTERNET AND IN-PERSON TRANSACTIONS (U.S. CLS. 100 AND 101).

AISHA CLARKE, EXAMINING ATTORNEY

SN 77-284.163. BAKER & DANIELS LLP, INDIANAPOLIS, IN. FILED 9-20-2007.

AT THE NEXUS OF SOUND
POLICY AND EDUCATIONAL
PRACTICE

THE MARK CONSISTS OF STANDARD CHARACTERS WITHOUT CLAIM TO ANY PARTICULAR FONT, STYLE, SIZE, OR COLOR.

CLASS 35—ADVERTISING AND BUSINESS

FOR PROVIDING BUSINESS MARKETING INFORMATION ON PRODUCTS IN THE FIELD OF EDUCATION; PREPARING PROMOTIONAL MATERIALS FOR OTHERS; BUSINESS CONSULTING SERVICES, NAMELY, PERFORMANCE EVALUATION AND DEFICIENCY DIAGNOSIS, IMPROVEMENT PLANNING AND COORDINATING AND IMPLEMENTATION OF IMPROVEMENT PLANS, BUSINESS AND PRICING STRATEGY DEVELOPMENT FOR OTHERS, PRODUCT POSITIONING AND MARKET RESEARCH IN THE FIELD OF EDUCATION; LOBBYING AND CAMPAIGNING, NAMELY, PROMOTING THE LEGISLATIVE AND REGULATORY INTERESTS OF THOSE IN THE FIELD OF EDUCATION; GRASS ROOTS ADVOCACY, NAMELY, PROMOTING THE INTERESTS OF BUSINESS IN THE FIELD OF EDUCATION; DEVELOPING PROMOTIONAL CAMPAIGNS FOR THOSE IN THE FIELD OF EDUCATION; BUSINESS SERVICES, NAMELY, NON-LEGAL REPRESENTATION OF OTHERS BEFORE ADMINISTRATIVE AND GOVERNMENTAL BODIES; BUSINESS SERVICES, NAMELY, REPRESENTING OTHERS IN TRADE ASSOCIATIONS IN THE FIELD OF EDUCATION; FACILITATING TECHNOLOGY TRANSFER FOR OTHERS, NAMELY, PROVIDING BUSINESS ADVICE IN THE FIELD OF TECHNOLOGY TRANSFER; CONDUCTING DUE DILIGENCE AND COMPLIANCE BUSINESS AUDITS FOR OTHERS RELATING TO BUSINESS OVERSIGHT AND BUSINESS MERGERS IN THE FIELD OF EDUCATION; PUBLIC RELATIONS; BUSINESS CONSULTATION IN THE AREA OF PUBLIC AFFAIRS; BUSINESS CONSULTATION IN THE NATURE OF PUBLIC POLICY ANALYSIS; BUSINESS MARKETING CONSULTING SERVICES FOR OTHERS IN THE FIELD OF EDUCATION; PUBLIC OPINION POLLS AND MARKET OPINION POLLING STUDIES; BUSINESS MANAGEMENT CONSULTATION IN THE AREA OF STRATEGIC PLANNING; MARKET ANALYSIS AND MARKETING CONSULTING; BUSINESS MONITORING SERVICES, NAMELY, TRACKING WEBSITES OF OTHERS AND MONITORING CONSTITUENT FEEDBACK; WRITING OF GRANT PROPOSALS FOR EDUCATIONAL INSTITUTIONS; TRACKING LEGISLATION AND REGULATIONS FOR OTHERS IN THE FIELD OF EDUCATION FOR MONITORING COMPLIANCE, AND INFLUENCING POLICY ON BEHALF OF CLIENT INTERESTS (U.S. CLS. 100, 101 AND 102).

CLASS 41—EDUCATION AND ENTERTAINMENT

FOR EDUCATIONAL SERVICES, NAMELY, CONDUCTING SEMINARS AND WORKSHOPS IN THE FIELD OF EDUCATION, AND DISTRIBUTING COURSE MATERIALS IN CONNECTION THEREWITH (U.S. CLS. 100, 101 AND 107).

CLASS 45—PERSONAL AND LEGAL SERVICES

FOR DRAFTING LEGISLATION AND REGULATIONS FOR OTHERS IN THE FIELD OF EDUCATION (U.S. CLS. 100 AND 101).
WILLIAM VERHOSEK, EXAMINING ATTORNEY

SN 77-284,261. FIRST NIAGARA FINANCIAL GROUP, INC., LOCKPORT, NY. FILED 9-20-2007.

THE POWER TO GET MORE OUT
OF YOUR MONEY. THE POWER
OF FIRST NIAGARA.

THE MARK CONSISTS OF STANDARD CHARACTERS WITHOUT CLAIM TO ANY PARTICULAR FONT, STYLE, SIZE, OR COLOR.

CLASS 35—ADVERTISING AND BUSINESS

FOR LEASING OF OFFICE EQUIPMENT (U.S. CLS. 100, 101 AND 102).

CLASS 36—INSURANCE AND FINANCIAL

FOR BANKING SERVICES; CHECKING ACCOUNT SERVICES; SAVINGS ACCOUNT SERVICES; MONEY MARKET DEPOSIT ACCOUNT SERVICES; CERTIFICATE OF DEPOSIT ACCOUNT SERVICES; CASH MANAGEMENT SERVICES; MUTUAL FUNDS AND 529 PLANS; HEALTH SAVINGS ACCOUNTS; REMOTE DEPOSIT CAPTURE SERVICES; DEBIT CARD SERVICES; PROVIDING REWARDS FOR DEBIT CARD USE AS A PART OF A CUSTOMER LOYALTY PROGRAM; HOME EQUITY LOAN SERVICES AND HOME EQUITY LINE OF CREDIT SERVICES; MORTGAGE LENDING SERVICES; MORTGAGE LENDING SERVICES WITHOUT THE NEED FOR PRIVATE MORTGAGE INSURANCE; STUDENT LENDING PRODUCTS AND SERVICES; AUTOMOBILE AND PERSONAL LOANS; ADMINISTRATION OF RETIREMENT AND PENSION PLANS; INDIVIDUAL RETIREMENT ACCOUNTS; PROVIDING ELECTRONIC BANKING SERVICES TO CUSTOMERS VIA THE INTERNET; FINANCIAL SERVICES, NAMELY, FINANCIAL AND INVESTMENT CONSULTING, MANAGEMENT AND ADVISORY SERVICES; INVESTMENT AND SECURITIES BROKERAGE SERVICES; PROVIDING INFORMATION ON INVESTMENT AND SECURITIES PERFORMANCE; ANNUITIES SERVICES; CHARITABLE FUNDRAISING SERVICES; SERVICES IN PROVIDING FINANCIAL GRANTS TO NOT-FOR-PROFIT ORGANIZATIONS; EMPLOYEE BENEFITS CONSULTING SERVICES INCLUDING THIRD PARTY ADMINISTRATION; ADMINISTRATION OF EMPLOYEE BENEFIT PLANS; COMPENSATION CONSULTING; CONSULTATION SERVICES IN THE FIELD OF EXECUTIVE COMPENSATION; CONSULTING FOR RETIREMENT AND EMPLOYEE WELFARE PLANS; ADMINISTRATIVE SERVICES FOR DEFINED CONTRIBUTION AND BENEFIT PLANS; ACTUARIAL SERVICES (U.S. CLS. 100, 101 AND 102).

CLASS 37—CONSTRUCTION AND REPAIR

FOR LEASING OF CONSTRUCTION EQUIPMENT AND BUILDING MACHINERY (U.S. CLS. 100, 103 AND 106).

CLASS 39—TRANSPORTATION AND STORAGE

FOR LEASING OF MOTOR VEHICLES (U.S. CLS. 100 AND 105).
KARANENDRA S. CHHINA, EXAMINING ATTORNEY

SN 77-284,723. CRYSTAL FLASH PETROLEUM, LLC, INDIANAPOLIS, IN. FILED 9-20-2007.



OWNER OF U.S. REG. NOS. 2,255,391 AND 2,418,561.
THE MARK CONSISTS OF THE WORDS "CRYSTAL" AND "FLASH" WITH A SPARKLE BETWEEN THE WORDS "CRYSTAL" AND "FLASH".

CLASS 35—ADVERTISING AND BUSINESS

FOR RETAIL STORE SERVICES FEATURING CONVENIENCE STORE ITEMS AND GASOLINE (U.S. CLS. 100, 101 AND 102).
FIRST USE 5-6-2007; IN COMMERCE 5-6-2007.

CLASS 39—TRANSPORTATION AND STORAGE

FOR TRANSPORTATION AND STORAGE OF FUELS (U.S. CLS. 100 AND 105).
RAMONA ORTIGA, EXAMINING ATTORNEY

SN 77-284,782. HORTUS, LTD., LITTLE ROCK, AR. FILED 9-20-2007.

1-2-3-DONE

THE MARK CONSISTS OF STANDARD CHARACTERS WITHOUT CLAIM TO ANY PARTICULAR FONT, STYLE, SIZE, OR COLOR.

CLASS 16—PAPER GOODS AND PRINTED MATTER

FOR BOOKS AND MAGAZINE COLUMNS CONCERNING HORTICULTURE AND DO-IT-YOURSELF GARDEN AND YARD PROJECTS (U.S. CLS. 2, 5, 22, 23, 29, 37, 38 AND 50).

CLASS 44—MEDICAL, BEAUTY AND AGRICULTURAL SERVICES

FOR DISSEMINATING EDUCATIONAL INFORMATION TO OTHERS IN THE FIELDS OF HORTICULTURE AND DO-IT-YOURSELF LANDSCAPE GARDENING AND YARD CARE BY MEANS OF A COMPUTER NETWORK (U.S. CLS. 100 AND 101).

NELSON SNYDER, EXAMINING ATTORNEY

SN 77-284,804. BEYER DYNAMIC GMBH & CO. KG, HEILBRONN, FED REP GERMANY, FILED 9-20-2007.

HEADZONE

THE MARK CONSISTS OF STANDARD CHARACTERS WITHOUT CLAIM TO ANY PARTICULAR FONT, STYLE, SIZE, OR COLOR.

OWNER OF ERPN CMNTY TM OFC REG. NO. 005308770, DATED 7-31-2007, EXPIRES 8-25-2016.

CLASS 9—ELECTRICAL AND SCIENTIFIC APPARATUS

FOR ELECTRIC AND ELECTRONIC DEVICES, EQUIPMENT AND INSTRUMENTS IN THE FIELD OF ELECTRO-ACOUSTIC TECHNOLOGY AND FOR DETECTING AUDIO SIGNALS, NAMELY, ELECTRO-ACOUSTIC TRANSDUCERS, HEADPHONES, DYNAMIC HEADPHONES, ELECTROSTATIC HEADPHONES, WIRELESS HEADPHONES, HEADPHONES FOR USE IN VEHICLES ESPECIALLY WITH INFRARED TRANSMISSION, HEADPHONES WITH ACTIVE NOISE COMPENSATION, LOUDSPEAKERS, PARTS AND ACCESSORIES FOR ELECTRO-ACOUSTIC TRANSDUCERS AND HEADPHONES, NAMELY, EAR PADS, VOLUME CONTROLS, AMPLIFIERS, ULTRASOUND HEAD TRACKING SYSTEMS COMPRISED OF HEADSETS INCORPORATING MOTION SENSORS, CONNECTING CABLES, AND RELATED OPERATING SOFTWARE, AND EARPHONE SYSTEMS COMPRISED OF EARPHONES AND RELATED SOFTWARE FOR REPRODUCING 5.1 CHANNEL STEREO SURROUND SOUND FOR STUDIO APPLICATIONS; ULTRASOUND TRANSDUCERS, ESPECIALLY FOR USE IN HEAD TRACKING SYSTEMS FOR HEADPHONES; DEVICES FOR THE TRANSMISSION OF SOUND AND VIDEO SIGNALS; DEVICES AND INSTRUMENTS IN THE FIELD OF STUDIO ENGINEERING, NAMELY, MICROPHONES, ELECTRO-ACOUSTIC TRANSDUCERS, HEADPHONES, DYNAMIC HEADPHONES, ELECTROSTATIC HEADPHONES, WIRELESS HEADPHONES, LOUDSPEAKERS, PARTS AND ACCESSORIES FOR ELECTRO-ACOUSTIC TRANSDUCERS AND HEADPHONES, NAMELY, EAR PADS, VOLUME CONTROLS, AMPLIFIERS, CONNECTING CABLES, AND RELATED OPERATING SOFTWARE, AND EARPHONE SYSTEMS COMPRISED OF EARPHONES AND RELATED SOFTWARE FOR REPRODUCING 5.1 CHANNEL STEREO SURROUND SOUND FOR STUDIO APPLICATIONS; DEVICES AND INSTRUMENTS IN THE FIELD OF CONFERENCE AND TELECOMMUNICATIONS TECHNOLOGY, NAMELY, MICROPHONES, ELECTRO-ACOUSTIC TRANSDUCERS, HEADPHONES, DYNAMIC HEADPHONES, ELECTROSTATIC HEADPHONES, WIRELESS HEADPHONES, LOUDSPEAKERS, PARTS AND ACCESSORIES FOR ELECTRO-ACOUSTIC TRANSDUCERS AND HEADPHONES, NAMELY, EAR PADS, VOLUME CONTROLS, AMPLIFIERS, CONNECTING CABLES, AND RELATED OPERATING SOFTWARE; SOUND RECORDING EQUIPMENT, ESPECIALLY FOR USE IN MOBILE UNITS; DEVICES FOR SOUND TRANSMISSION ENGINEERING, NAMELY, TRANSMITTERS, SINGLE-CHANNEL TRANSMITTERS, MULTI-CHANNEL TRANSMITTERS, INFRARED TRANSMITTERS, RECEIVERS, SINGLE-CHANNEL RECEIVERS, MULTI-CHANNEL RECEIVERS, TWO-CHANNEL RECEIVERS, INFRARED RECEIVERS, HEAD PHONE RECEIVERS AND PARTS OF SUCH GOODS (U.S. CLS. 21, 23, 26, 36 AND 38).

CLASS 16—PAPER GOODS AND PRINTED MATTER

FOR PRINT PRODUCTS, NAMELY, CATALOGUES FEATURING HEADPHONES, EARPHONES, HEAD-TRACKING, SOUND-RECORDING, SOUND-TRANSMITTING AND ACOUSTIC EQUIPMENT, INSTRUCTIONAL MANUALS FOR HEADPHONES, EARPHONES, HEAD-TRACKING, SOUND-RECORDING, SOUND-TRANSMITTING AND ACOUSTIC EQUIPMENT, PRINTED EVENT PROGRAMS, PRINTED SOUVENIR PROGRAMS (U.S. CLS. 2, 5, 22, 23, 29, 37, 38 AND 50).

MARY ROSSMAN, EXAMINING ATTORNEY

SN 77-284,895. PROCAPS L.P., VILLE ST. LAURENT, QUEBEC, FILED 9-20-2007.



OWNER OF U.S. REG. NOS. 2,968,809, 3,187,243 AND OTHERS.

NO CLAIM IS MADE TO THE EXCLUSIVE RIGHT TO USE "PAINTBALL", APART FROM THE MARK AS SHOWN.

THE MARK CONSISTS OF A BALL THAT HAS A FACE AND HORNS CENTERED ABOVE THE STYLIZED WORDS "XBALL PAINTBALL".

CLASS 3—COSMETICS AND CLEANING PREPARATIONS

FOR CLEANING PREPARATIONS FOR PAINTBALL GUN BARRELS (U.S. CLS. 1, 4, 6, 50, 51 AND 52).

CLASS 4—LUBRICANTS AND FUELS

FOR PAINTBALL BARREL LUBRICATING OIL (U.S. CLS. 1, 6 AND 15).

CLASS 25—CLOTHING

FOR CLOTHING, NAMELY, PANTS, SWEATPANTS, GLOVES, AND SOCKS; FOOTWEAR; HEADWEAR, NAMELY, VISORS; PAINTBALL GLOVES; SKI AND SNOWBOARD GLOVES, PANTS, BOOTS, AND JERSEYS; AND MOTORCYCLE AND MOTOCROSS GLOVES, PANTS, BOOTS, AND JERSEYS (U.S. CLS. 22 AND 39).

CLASS 28—TOYS AND SPORTING GOODS

FOR PAINTBALL EQUIPMENT, NAMELY, PNEUMATIC GUNS FOR FIRING OF PAINTBALLS, PAINTBALL MARKERS, PAINTBALL HOPPERS, PAINTBALL LOADING EQUIPMENT, HARNESSSES, AND PAINTBALL BARRELS; PAINTBALL ACCESSORIES, NAMELY, EQUIPMENT BELTS, PROTECTIVE PADDING, AND PROTECTIVE FACE MASKS; SPORTING GOODS, NAMELY, SKI AND SNOWBOARD PROTECTIVE PADDING AND PROTECTIVE FACE MASKS; SPORTING GOODS, NAMELY, MOTORCYCLE AND MOTOCROSS PROTECTIVE PADDING AND PROTECTIVE FACE MASKS (U.S. CLS. 22, 23, 38 AND 50).

JOHN DWYER, EXAMINING ATTORNEY

SN 77-284,945. DIAGEO NORTH AMERICA, INC., NORWALK, CT. FILED 9-20-2007.

SOMETHING TO SHARE

THE MARK CONSISTS OF STANDARD CHARACTERS WITHOUT CLAIM TO ANY PARTICULAR FONT, STYLE, SIZE, OR COLOR.

CLASS 25—CLOTHING

FOR CLOTHING, NAMELY, TIES, SCARVES AND POCKET SQUARES (U.S. CLS. 22 AND 39).

CLASS 36—INSURANCE AND FINANCIAL

FOR CHARITABLE FUND-RAISING SERVICES (U.S. CLS. 100, 101 AND 102).
RON FAIRBANKS, EXAMINING ATTORNEY

SN 77-285,278. THE HOUSE ON F STREET, LLC, CLEVELAND, OH. FILED 9-21-2007.

SPY ADVENTURE

THE MARK CONSISTS OF STANDARD CHARACTERS WITHOUT CLAIM TO ANY PARTICULAR FONT, STYLE, SIZE, OR COLOR.

CLASS 9—ELECTRICAL AND SCIENTIFIC APPARATUS

FOR ELECTRONIC INTERACTIVE BOARD GAMES FOR USE WITH EXTERNAL MONITOR, HAND HELD JOY STICK UNITS FOR PLAYING VIDEO GAMES AND ELECTRONIC GAME SOFTWARE (U.S. CLS. 21, 23, 26, 36 AND 38).

CLASS 28—TOYS AND SPORTING GOODS

FOR TOYS, NAMELY, TOY STUFFED ANIMALS, TOY BALLS, TOY CARDS, TOY FINGERPRINT KITS, AND TOY SECRET NOTE KITS, AND BOARD GAMES (U.S. CLS. 22, 23, 38 AND 50).

ANTHONY RINKER, EXAMINING ATTORNEY

SN 77-285,789. BENSON FERRY LLC, LODI, CA. FILED 9-21-2007.

ART OF ZIN

THE MARK CONSISTS OF STANDARD CHARACTERS WITHOUT CLAIM TO ANY PARTICULAR FONT, STYLE, SIZE, OR COLOR.

NO CLAIM IS MADE TO THE EXCLUSIVE RIGHT TO USE "ZIN", APART FROM THE MARK AS SHOWN.

CLASS 16—PAPER GOODS AND PRINTED MATTER

FOR COOKBOOKS (U.S. CLS. 2, 5, 22, 23, 29, 37, 38 AND 50).

CLASS 33—WINES AND SPIRITS

FOR WINES (U.S. CLS. 47 AND 49).
BILL DAWE, EXAMINING ATTORNEY

SN 77-286,247. COHILLS BUILDING SPECIALTIES, INC., PHOENIX, AZ. FILED 9-21-2007.

SN 77-286,329. SILVERFLASH, INC., DBA SEAVID, LA JOLLA, CA. FILED 9-21-2007.

COHILLS PRO SERIES

THE MARK CONSISTS OF STANDARD CHARACTERS WITHOUT CLAIM TO ANY PARTICULAR FONT, STYLE, SIZE, OR COLOR.

OWNER OF U.S. REG. NOS. 3,092,773, 3,161,838 AND 3,254,884.

NO CLAIM IS MADE TO THE EXCLUSIVE RIGHT TO USE "PRO SERIES", APART FROM THE MARK AS SHOWN.

CLASS 1—CHEMICALS

FOR MOLD RELEASE AGENTS FOR USE IN CONCRETE FABRICATION AND APPLYING DECORATIVE FINISHES TO CONCRETE; WATER BASED DEGREASING AGENTS; AND, CONCRETE ADDITIVES AND ADMIXTURES (U.S. CLS. 1, 5, 6, 10, 26 AND 46).

CLASS 2—PAINTS

FOR CONCRETE COLOR ADDITIVES; COLOR HARDENERS FOR CONCRETE; CONCRETE COLORINGS AND COATINGS, NAMELY, CHEMICAL AND ACID STAINS; EPOXY COATINGS FOR USE ON CONCRETE; ACRYLIC BASED COATINGS FOR EXTERIOR WALLS; AND, POLYURETHANE COATINGS IN THE NATURE OF PAINTS FOR CONCRETE FLOORS (U.S. CLS. 6, 11 AND 16).

CLASS 3—COSMETICS AND CLEANING PREPARATIONS

FOR ACRYLIC FLOOR POLISHES; ACRYLIC COATING REMOVERS; FLOOR STRIPPING AGENTS; CONCRETE CLEANERS; PENETRATING CONCRETE CLEANERS; WATER BASED ALL PURPOSE CLEANERS; CONCRETE DEBONDING AGENTS; AND, ADHESIVE REMOVAL PRODUCTS, NAMELY, GLUE AND MASTIC REMOVERS (U.S. CLS. 1, 4, 6, 50, 51 AND 52).

CLASS 8—HAND TOOLS

FOR HAND TOOLS, NAMELY, METAL AND NON-METAL CONCRETE STAMPING TOOLS (U.S. CLS. 23, 28 AND 44).

CLASS 17—RUBBER GOODS

FOR COLOR AND CLEAR SEALANTS USED TO SEAL AND REPAIR CONCRETE; ACRYLIC BASED SEALANTS FOR CONSTRUCTION PARTICULARLY FOR USE IN GLAZING SIDING AND TRIM; AND, GENERAL PURPOSE POLYURETHANE SEALANTS (U.S. CLS. 1, 5, 12, 13, 35 AND 50).

CLASS 19—NON-METALLIC BUILDING MATERIALS

FOR CONCRETE; SPECIALIZED CONCRETE MIXTURES; AND, CONCRETE MIXTURES FOR COUNTERTOPS (U.S. CLS. 1, 12, 33 AND 50).

CIMMERIAN COLEMAN, EXAMINING ATTORNEY

SEAVID

THE MARK CONSISTS OF STANDARD CHARACTERS WITHOUT CLAIM TO ANY PARTICULAR FONT, STYLE, SIZE, OR COLOR.

OWNER OF U.S. REG. NOS. 2,144,539, 2,335,119 AND 2,473,703.

CLASS 9—ELECTRICAL AND SCIENTIFIC APPARATUS

FOR PRERECORDED MULTI-MEDIA PRODUCTS, NAMELY, DVDS, HD DVDS, MP3S, CD-ROMS, VIDEO-TAPES, OPTICAL AND MAGNETO-OPTICAL DISCS, AND PORTABLE AND HANDHELD DIGITAL ELECTRONIC DEVICES FOR RECORDING, ORGANIZING, TRANSMITTING, MANIPULATING, AND REVIEWING TEXT, DATA, AUDIO AND VIDEO FILES FEATURING TRAVEL AND VACATION GUIDANCE INFORMATION FOR THE GENERAL PUBLIC, AND FEATURING MARKETING, SALES AND TRAINING INFORMATION FOR PROFESSIONALS IN THE TRAVEL INDUSTRY; COMPUTER SOFTWARE FOR USE IN ORGANIZING, TRANSMITTING, MANIPULATING, AND REVIEWING TEXT, DATA, AUDIO AND VIDEO FILES ON PORTABLE AND HAND HELD DIGITAL ELECTRONIC DEVICES, NAMELY, PORTABLE AUDIO, VIDEO, MULTIMEDIA AND DIGITAL DEVICES, FEATURING TRAVEL AND VACATION GUIDANCE INFORMATION FOR THE GENERAL PUBLIC, AND FEATURING MARKETING, SALES AND TRAINING INFORMATION FOR PROFESSIONALS IN THE TRAVEL INDUSTRY; DOWNLOADABLE TRAVEL AND VACATION GUIDANCE INFORMATION VIA THE INTERNET TO BE VIEWED VIA A PORTABLE MEDIA PLAYER (U.S. CLS. 21, 23, 26, 36 AND 38).

FIRST USE 8-31-1986; IN COMMERCE 6-30-1987.

CLASS 39—TRANSPORTATION AND STORAGE

FOR PROVIDING TRAVEL INFORMATION ON A GLOBAL COMPUTER NETWORK (U.S. CLS. 100 AND 105).

FIRST USE 8-31-1986; IN COMMERCE 3-15-2004.

CLASS 41—EDUCATION AND ENTERTAINMENT

FOR ENTERTAINMENT AND EDUCATIONAL SERVICES, NAMELY, PROVIDING VACATION GUIDANCE INFORMATION, NAMELY, ENTERTAINMENT INFORMATION AND VACATION EDUCATIONAL INFORMATION, NAMELY, LOCATION HISTORICAL INFORMATION TO BE VIEWED VIA A PORTABLE MEDIA PLAYER; VIDEOTAPING PRODUCTION SERVICES (U.S. CLS. 100, 101 AND 107).

FIRST USE 6-10-2006; IN COMMERCE 6-10-2006.
SHAUNIA CARLYLE, EXAMINING ATTORNEY

SN 77-286,357. ECOTALITY, INC., SCOTTSDALE, AZ. FILED 9-21-2007.

HYDRALITY

THE MARK CONSISTS OF STANDARD CHARACTERS WITHOUT CLAIM TO ANY PARTICULAR FONT, STYLE, SIZE, OR COLOR.

CLASS 9—ELECTRICAL AND SCIENTIFIC APPARATUS

FOR FUEL CELLS (U.S. CLS. 21, 23, 26, 36 AND 38).

CLASS 11—ENVIRONMENTAL CONTROL APPARATUS

FOR HYDROGEN GENERATORS; HYDROGEN PRODUCTION, STORAGE AND DISTRIBUTION APPARATUS IN THE NATURE OF A REACTOR THAT PRODUCES HYDROGEN USING WATER AND MAGNESIUM COMPOUNDS AND RELEASES THE HYDROGEN ON DEMAND THROUGH A FUEL CELL TO PRODUCE ELECTRICITY AND STORES ENERGY PRODUCED BY RENEWABLE SOURCES SUCH AS WIND AND WATER (U.S. CLS. 13, 21, 23, 31 AND 34).

CLASS 42—SCIENTIFIC AND COMPUTER SERVICES

FOR RESEARCH AND DEVELOPMENT AND CONSULTATION IN THE FIELD OF FUEL CELL SYSTEMS, HYDROGEN GENERATION SYSTEMS, HYDROGEN REACTORS, HYDROGEN PRODUCTION, STORAGE AND DISTRIBUTION SYSTEMS; RESEARCH AND DEVELOPMENT IN THE FIELD OF REGENERATION AND RECYCLING OF METAL COMPOUNDS AND OTHER ENERGY CARRIERS (U.S. CLS. 100 AND 101).
MARK RADEMACHER, EXAMINING ATTORNEY

SN 77-286,358. ECOTALITY, INC., SCOTTSDALE, AZ. FILED 9-21-2007.

MAKING HYDROGEN POWER A REALITY

THE MARK CONSISTS OF STANDARD CHARACTERS WITHOUT CLAIM TO ANY PARTICULAR FONT, STYLE, SIZE, OR COLOR.

CLASS 9—ELECTRICAL AND SCIENTIFIC APPARATUS

FOR FUEL CELLS (U.S. CLS. 21, 23, 26, 36 AND 38).

CLASS 11—ENVIRONMENTAL CONTROL APPARATUS

FOR HYDROGEN GENERATORS; HYDROGEN PRODUCTION, STORAGE AND DISTRIBUTION APPARATUS IN THE NATURE OF A REACTOR THAT PRODUCES HYDROGEN USING WATER AND MAGNESIUM COMPOUNDS AND RELEASES THE HYDROGEN ON DEMAND THROUGH A FUEL CELL TO PRODUCE ELECTRICITY AND STORES ENERGY PRODUCED BY RENEWABLE SOURCES SUCH AS WIND AND WATER (U.S. CLS. 13, 21, 23, 31 AND 34).

CLASS 42—SCIENTIFIC AND COMPUTER SERVICES

FOR RESEARCH AND DEVELOPMENT AND CONSULTATION IN THE FIELD OF FUEL CELL SYSTEMS, HYDROGEN GENERATION SYSTEMS, HYDROGEN REACTORS, HYDROGEN PRODUCTION, STORAGE AND DISTRIBUTION SYSTEMS; RESEARCH AND DEVELOPMENT IN THE FIELD OF REGENERATION AND RECYCLING OF METAL COMPOUNDS AND OTHER ENERGY CARRIERS (U.S. CLS. 100 AND 101).
MARK RADEMACHER, EXAMINING ATTORNEY

SN 77-286,360. ECOTALITY, INC., SCOTTSDALE, AZ. FILED 9-21-2007.



CLASS 9—ELECTRICAL AND SCIENTIFIC APPARATUS

FOR FUEL CELLS (U.S. CLS. 21, 23, 26, 36 AND 38).

CLASS 11—ENVIRONMENTAL CONTROL APPARATUS

FOR HYDROGEN GENERATORS; HYDROGEN PRODUCTION, STORAGE AND DISTRIBUTION APPARATUS IN THE NATURE OF A REACTOR THAT PRODUCES HYDROGEN USING WATER AND MAGNESIUM COMPOUNDS AND RELEASES THE HYDROGEN ON DEMAND THROUGH A FUEL CELL TO PRODUCE ELECTRICITY AND STORES ENERGY PRODUCED BY RENEWABLE SOURCES SUCH AS WIND AND WATER (U.S. CLS. 13, 21, 23, 31 AND 34).

CLASS 42—SCIENTIFIC AND COMPUTER SERVICES

FOR RESEARCH AND DEVELOPMENT AND CONSULTATION IN THE FIELD OF FUEL CELL SYSTEMS, HYDROGEN GENERATION SYSTEMS, HYDROGEN REACTORS, HYDROGEN PRODUCTION, STORAGE AND DISTRIBUTION SYSTEMS; RESEARCH AND DEVELOPMENT IN THE FIELD OF REGENERATION AND RECYCLING OF METAL COMPOUNDS AND OTHER ENERGY CARRIERS (U.S. CLS. 100 AND 101).
MARK RADEMACHER, EXAMINING ATTORNEY

SN 77-286,806. PACKETVIDEO CORPORATION, SAN DIEGO, CA. FILED 9-24-2007.

SMART MUSIC

THE MARK CONSISTS OF STANDARD CHARACTERS WITHOUT CLAIM TO ANY PARTICULAR FONT, STYLE, SIZE, OR COLOR.

NO CLAIM IS MADE TO THE EXCLUSIVE RIGHT TO USE "MUSIC", APART FROM THE MARK AS SHOWN.

CLASS 38—COMMUNICATION

FOR COMMUNICATION SERVICES IN THE NATURE OF ELECTRONIC TRANSMISSION OF TEXT, DATA AND MEDIA CONTENT; STREAMING OF AUDIO AND VIDEO MATERIAL ON THE INTERNET (U.S. CLS. 100, 101 AND 104).

CLASS 42—SCIENTIFIC AND COMPUTER SERVICES

FOR APPLICATION SERVICE PROVIDER, NAMELY, PROVIDING, HOSTING, MANAGING, DEVELOPING, AND MAINTAINING CONSUMER APPLICATIONS, SOFTWARE AND WEBSITES IN THE FIELDS OF MEDIA, INFORMATION AND ENTERTAINMENT ACCESS ON CONSUMER ELECTRONICS DEVICES, AND REMOTE DATA MANAGEMENT FOR DELIVERY OF CONTENT TO CONSUMER ELECTRONICS DEVICES (U.S. CLS. 100 AND 101).

RICHARD WHITE, EXAMINING ATTORNEY

CLASS 41—EDUCATION AND ENTERTAINMENT

FOR ENTERTAINMENT SERVICES, NAMELY, PRODUCTION AND DISTRIBUTION OF MOTION PICTURES, COMEDY, MUSICAL AND DRAMATIC TELEVISION SERIES, DOCUMENTARIES, TELEVISION SERIES FEATURING SPORTING EVENTS RENDERED THROUGH THE MEDIA OF TELEVISION, CABLE, SATELLITE, RADIO, TELEPHONE AND BROADBAND OPTICAL OR WIRELESS NETWORKS, AND VIA THE INTERNET AND PORTABLE AND WIRELESS COMMUNICATION DEVICES IN HIGH DEFINITION FORMAT (U.S. CLS. 100, 101 AND 107).

CAROL SPILS, EXAMINING ATTORNEY

SN 77-287,189. SPORTSMD, LLC, EASTON, CT. FILED 9-24-2007.



SN 77-286,871. SHOWTIME NETWORKS INC., NEW YORK, NY. FILED 9-24-2007.



OWNER OF U.S. REG. NOS. 2,496,208, 2,897,169 AND OTHERS.

NO CLAIM IS MADE TO THE EXCLUSIVE RIGHT TO USE "HD", APART FROM THE MARK AS SHOWN.

THE MARK CONSISTS OF "SHO" TERM IS WITHIN A CIRCLE THE "HD" LETTERS ARE BETWEEN 2 LINES ABOVE AND BELOW THE LETTERS.

SEC. 2(F).

CLASS 38—COMMUNICATION

FOR BROADCASTING SERVICES RENDERED THROUGH THE MEDIA OF TELEVISION, CABLE TELEVISION, SATELLITE, TELEPHONE AND BROADBAND OPTICAL OR WIRELESS NETWORKS, AND VIA THE INTERNET AND PORTABLE AND WIRELESS COMMUNICATION DEVICES DELIVERED IN HIGH DEFINITION FORMAT (U.S. CLS. 100, 101 AND 104).

CLASS 35—ADVERTISING AND BUSINESS

FOR ON-LINE ORDERING SERVICES FEATURING NATURAL DIETARY SUPPLEMENTS; ON-LINE RETAIL STORE SERVICES FEATURING NATURAL DIETARY SUPPLEMENTS (U.S. CLS. 100, 101 AND 102).

CLASS 44—MEDICAL, BEAUTY AND AGRICULTURAL SERVICES

FOR PROVIDING ON-LINE WEB SITE FEATURING HEALTH AND WELLNESS INFORMATION VIA AN ON-LINE COMPUTER NETWORK (U.S. CLS. 100 AND 101).

DOMINIC J. FERRAIUOLO, EXAMINING ATTORNEY

SN 77-287,207. SPORTSMD, LLC, EASTON, CT. FILED 9-24-2007.

SN 77-287,237. SPORTSMD, LLC, EASTON, CT. FILED 9-24-2007.



CLASS 35—ADVERTISING AND BUSINESS

FOR ON-LINE ORDERING SERVICES FEATURING NATURAL DIETARY SUPPLEMENTS; ON-LINE RETAIL STORE SERVICES FEATURING NATURAL DIETARY SUPPLEMENTS (U.S. CLS. 100, 101 AND 102).

CLASS 35—ADVERTISING AND BUSINESS

FOR ON-LINE ORDERING SERVICES FEATURING NATURAL DIETARY SUPPLEMENTS; ON-LINE RETAIL STORE SERVICES FEATURING NATURAL DIETARY SUPPLEMENTS (U.S. CLS. 100, 101 AND 102).

CLASS 44—MEDICAL, BEAUTY AND AGRICULTURAL SERVICES

FOR PROVIDING ON-LINE WEB SITE FEATURING HEALTH AND WELLNESS INFORMATION VIA AN ON-LINE COMPUTER NETWORK (U.S. CLS. 100 AND 101).
DOMINIC J. FERRAIUOLO, EXAMINING ATTORNEY

CLASS 44—MEDICAL, BEAUTY AND AGRICULTURAL SERVICES

FOR PROVIDING ON-LINE WEB SITE FEATURING HEALTH AND WELLNESS INFORMATION VIA AN ON-LINE COMPUTER NETWORK (U.S. CLS. 100 AND 101).
DOMINIC J. FERRAIUOLO, EXAMINING ATTORNEY

SN 77-287,227. SPORTSMD, LLC, EASTON, CT. FILED 9-24-2007.

SN 77-287,248. SPORTSMD, LLC, EASTON, CT. FILED 9-24-2007.



CLASS 35—ADVERTISING AND BUSINESS

FOR ON-LINE ORDERING SERVICES FEATURING NATURAL DIETARY SUPPLEMENTS; ON-LINE RETAIL STORE SERVICES FEATURING NATURAL DIETARY SUPPLEMENTS (U.S. CLS. 100, 101 AND 102).

CLASS 35—ADVERTISING AND BUSINESS

FOR ON-LINE ORDERING SERVICES FEATURING NATURAL DIETARY SUPPLEMENTS; ON-LINE RETAIL STORE SERVICES FEATURING NATURAL DIETARY SUPPLEMENTS (U.S. CLS. 100, 101 AND 102).

CLASS 44—MEDICAL, BEAUTY AND AGRICULTURAL SERVICES

FOR PROVIDING ON-LINE WEB SITE FEATURING HEALTH AND WELLNESS INFORMATION VIA AN ON-LINE COMPUTER NETWORK (U.S. CLS. 100 AND 101).
DOMINIC J. FERRAIUOLO, EXAMINING ATTORNEY

CLASS 44—MEDICAL, BEAUTY AND AGRICULTURAL SERVICES

FOR PROVIDING ON-LINE WEB SITE FEATURING HEALTH AND WELLNESS INFORMATION VIA AN ON-LINE COMPUTER NETWORK (U.S. CLS. 100 AND 101).
DOMINIC J. FERRAIUOLO, EXAMINING ATTORNEY

SN 77-287,328. MILLIKEN & COMPANY, SPARTANBURG, SC. FILED 9-24-2007.

SN 77-287,478. CASHSTREAM, INC., SANTA ANA, CA. FILED 9-24-2007.

MILLIKEN PERFORMANCE SOLUTIONS

THE MARK CONSISTS OF STANDARD CHARACTERS WITHOUT CLAIM TO ANY PARTICULAR FONT, STYLE, SIZE, OR COLOR.

NO CLAIM IS MADE TO THE EXCLUSIVE RIGHT TO USE "PERFORMANCE SOLUTIONS", APART FROM THE MARK AS SHOWN.

CLASS 35—ADVERTISING AND BUSINESS

FOR MANAGEMENT AND BUSINESS CONSULTING SERVICES IN THE FIELD OF MANUFACTURING AND PERFORMANCE IMPROVEMENT (U.S. CLS. 100, 101 AND 102).

CLASS 45—PERSONAL AND LEGAL SERVICES

FOR CONSULTING IN THE FIELD OF WORKPLACE SAFETY (U.S. CLS. 100 AND 101).
MICHAEL LEWIS, EXAMINING ATTORNEY

SN 77-287,380. ROBERTA RODRIGUEZ-HAVENS, SAN FRANCISCO, CA. FILED 9-24-2007.

OPEN PATH

THE MARK CONSISTS OF STANDARD CHARACTERS WITHOUT CLAIM TO ANY PARTICULAR FONT, STYLE, SIZE, OR COLOR.

CLASS 16—PAPER GOODS AND PRINTED MATTER

FOR PRINTED MATTER, NAMELY, BOOKS, BOOKLETS, NEWSLETTERS, NEWSPAPERS, PERIODICALS, PHOTOGRAPHS, MAGAZINES, BROCHURES, PAMPHLETS, MANUALS, AND COURSE MATERIALS ALL IN THE FIELDS OF FERTILITY AND ADOPTION (U.S. CLS. 2, 5, 22, 23, 29, 37, 38 AND 50).

CLASS 35—ADVERTISING AND BUSINESS

FOR REFERRAL SERVICES, NAMELY, PROVIDING REFERRALS IN THE FIELDS OF FERTILITY AND ADOPTION (U.S. CLS. 100, 101 AND 102).

CLASS 41—EDUCATION AND ENTERTAINMENT

FOR EDUCATIONAL SERVICES, NAMELY, PROVIDING CLASSES, SEMINARS, AND WORKSHOPS IN THE FIELDS OF FERTILITY AND ADOPTION; EDUCATIONAL SERVICES, NAMELY, ORGANIZING AND CONDUCTING CLASSES, CONFERENCES, SEMINARS, WORKSHOPS, PROGRAMS IN THE FIELDS OF FERTILITY AND ADOPTION (U.S. CLS. 100, 101 AND 107).
SIMON TENG, EXAMINING ATTORNEY

Givewell

THE MARK CONSISTS OF STANDARD CHARACTERS WITHOUT CLAIM TO ANY PARTICULAR FONT, STYLE, SIZE, OR COLOR.

CLASS 9—ELECTRICAL AND SCIENTIFIC APPARATUS

FOR MAGNETIC CODED GIFT CARDS (U.S. CLS. 21, 23, 26, 36 AND 38).

CLASS 16—PAPER GOODS AND PRINTED MATTER

FOR GIFT CARDS (U.S. CLS. 2, 5, 22, 23, 29, 37, 38 AND 50).
TEJBIR SINGH, EXAMINING ATTORNEY

SN 77-288,135. THE NISSHIN OILIO GROUP, LTD., TOKYO 104-8285, JAPAN, FILED 9-25-2007.



OWNER OF U.S. REG. NO. 3,002,454.
NO CLAIM IS MADE TO THE EXCLUSIVE RIGHT TO USE THE NON-LATIN CHARACTERS THAT MEAN "HEALTHY", APART FROM THE MARK AS SHOWN.

THE MARK CONSISTS OF THE WORDING "HEALTHY RESETTA" IN KATAKANA CHARACTERS.

THE NON-LATIN CHARACTER(S) IN THE MARK TRANSLITERATES INTO "HERUSHII" AND "RESETTA", AND THIS MEANS HEALTHY RESETTA IN ENGLISH.

CLASS 29—MEATS AND PROCESSED FOODS

FOR EDIBLE OILS; EDIBLE FATS; MARGARINE; FAT SPREAD, CONSISTING PRIMARILY OF EDIBLE FATS OR EDIBLE OILS (U.S. CL. 46).

CLASS 30—STAPLE FOODS

FOR DRESSINGS FOR SALAD; MAYONNAISE (U.S. CL. 46).
MARY ROSSMAN, EXAMINING ATTORNEY

SN 77-288,265. MANGINO PONTIAC-BUICK, INC., BALLSTON SPA, NY. FILED 9-25-2007.

SN 77-288,736. CORPORACIÓN INDUSTRIAL ALIMENTICIA, S.A. DE C.V., EL TRÉ BOL, PARQUE, MEXICO, FILED 9-25-2007.

MANGINO

THE MARK CONSISTS OF STANDARD CHARACTERS WITHOUT CLAIM TO ANY PARTICULAR FONT, STYLE, SIZE, OR COLOR.
SEC. 2(F).

CLASS 35—ADVERTISING AND BUSINESS

FOR RETAIL STORE SERVICES FEATURING AUTOMOBILES, AUTOMOBILE PARTS AND ACCESSORIES (U.S. CLS. 100, 101 AND 102).
FIRST USE 11-1-1978; IN COMMERCE 11-1-1978.

CLASS 37—CONSTRUCTION AND REPAIR

FOR AUTOMOBILE MAINTENANCE AND REPAIR SERVICES (U.S. CLS. 100, 103 AND 106).
FIRST USE 11-1-1978; IN COMMERCE 11-1-1978.
TRACY CROSS, EXAMINING ATTORNEY

SN 77-288,554. ORBIMAGE SI OPCO INC., DBA GEOEYE, DULLES, VA. FILED 9-25-2007.

MJ HARDEN

THE MARK CONSISTS OF STANDARD CHARACTERS WITHOUT CLAIM TO ANY PARTICULAR FONT, STYLE, SIZE, OR COLOR.

THE NAME(S), PORTRAIT(S), AND/OR SIGNATURE(S) SHOWN IN THE MARK DOES NOT IDENTIFY A PARTICULAR LIVING INDIVIDUAL.

CLASS 41—EDUCATION AND ENTERTAINMENT

FOR DIGITAL AERIAL IMAGING AND PHOTOGRAPHY (U.S. CLS. 100, 101 AND 107).
FIRST USE 0-0-1956; IN COMMERCE 0-0-1956.

CLASS 42—SCIENTIFIC AND COMPUTER SERVICES

FOR PHOTOGRAMMETRY SERVICES; GEOSPATIAL SERVICES, NAMELY, MAKING MAPS AND SCALE DRAWINGS FROM AERIAL AND SATELLITE PHOTOGRAPHS (U.S. CLS. 100 AND 101).
FIRST USE 0-0-1956; IN COMMERCE 0-0-1956.
JULIE WATSON, EXAMINING ATTORNEY



The logo for 'Klass Pulpa' features the word 'Klass' in a stylized, outlined font with a horizontal line underneath, followed by the word 'Pulpa' in a bold, rounded, sans-serif font.

OWNER OF U.S. REG. NOS. 2,805,356, 3,156,781 AND OTHERS.

NO CLAIM IS MADE TO THE EXCLUSIVE RIGHT TO USE "PULPA", APART FROM THE MARK AS SHOWN.

THE MARK CONSISTS OF THE WORDING "KLASS PULPA" WITH UNDERLINING UNDER THE WORD "KLASS".

THE FOREIGN WORDING IN THE MARK TRANSLATES INTO ENGLISH AS PULP.

CLASS 29—MEATS AND PROCESSED FOODS

FOR FOOD ITEMS, NAMELY, FRUIT PULPS AND FRUIT SPREADS; FRUIT PULPS FOR USE AS A BEVERAGE INGREDIENT (U.S. CL. 46).

CLASS 32—LIGHT BEVERAGES

FOR BEVERAGE ITEMS, NAMELY, FRUIT JUICE CONCENTRATES (U.S. CLS. 45, 46 AND 48).
JAY FLOWERS, EXAMINING ATTORNEY

SN 77-288,823. IBIQUITY DIGITAL CORPORATION, COLUMBIA, MD. FILED 9-25-2007.



The logo for 'tag' features the word 'tag' in a lowercase, bold, sans-serif font. To the right of the text is a thick orange semi-circular arc that starts at the top of the letter 'g' and curves around to the right, ending at the top of the letter 'g'.

OWNER OF U.S. REG. NOS. 2,860,944, 2,867,407 AND OTHERS.

NO CLAIM IS MADE TO THE EXCLUSIVE RIGHT TO USE "TAG", APART FROM THE MARK AS SHOWN.

THE COLOR(S) ORANGE AND BLACK IS/ARE CLAIMED AS A FEATURE OF THE MARK.

THE MARK CONSISTS OF THE WORD "TAG" IN BLACK LOWERCASE LETTERS BOUNDED ON THE RIGHT END BY AN ORANGE SEMI-CIRCULAR ARC WITH A CURVED LEADING EDGE AT THE TOP OF THE ARC AND A STRAIGHT LEADING EDGE AT THE BOTTOM OF THE ARC.

CLASS 9—ELECTRICAL AND SCIENTIFIC APPARATUS

FOR DIGITAL RADIO BROADCASTING EQUIPMENT, DIGITAL RADIO RECEIVERS, DIGITAL RADIO RECEIVERS INCORPORATING MP3-PLAYER DOCKS, AND COMPUTER SOFTWARE THEREFOR CAPABLE OF TRANSMITTING, RECEIVING, RECOGNIZING AND STORING PROGRAM INFORMATION FOR THE PURPOSE OF SELECTION, REVIEW AND PURCHASE OF BROADCAST CONTENT (U.S. CLS. 21, 23, 26, 36 AND 38).

CLASS 38—COMMUNICATION

FOR RADIO BROADCASTING SERVICES, NAMELY, TRANSMISSION OF DIGITAL RADIO SIGNALS INCORPORATING PROGRAM INFORMATION TO ENABLE THE SELECTION, REVIEW AND PURCHASE OF BROADCAST CONTENT (U.S. CLS. 100, 101 AND 104).

RAMONA ORTIGA, EXAMINING ATTORNEY

CLASS 35—ADVERTISING AND BUSINESS

FOR ADVERTISING, MARKETING AND PROMOTION SERVICES, NAMELY, PROVIDING MARKETING AND PROMOTING SPECIAL EVENTS OF THE MILITARY AND OTHER ORGANIZATIONS (U.S. CLS. 100, 101 AND 102).

FIRST USE 3-1-2000; IN COMMERCE 3-1-2000.

REGINA DRUMMOND, EXAMINING ATTORNEY

SN 77-289,175. CELEBRATE FREEDOM FOUNDATION, DBA CELEBRATE FREEDOM FOUNDATION, COLUMBIA, SC. FILED 9-26-2007.



NO CLAIM IS MADE TO THE EXCLUSIVE RIGHT TO USE "FOUNDATION" AND "EST. 1999", APART FROM THE MARK AS SHOWN.

THE COLOR(S) RED, WHITE AND BLUE IS/ARE CLAIMED AS A FEATURE OF THE MARK.

THE MARK CONSISTS OF A CIRCLE OUTLINED IN BLUE WITH THE WORDS "CELEBRATE FREEDOM FOUNDATION" AROUND THE INSIDE TOP EDGE OF THE CIRCLE AND CENTERED. "EST. 1999" IS CENTERED ALONG THE INSIDE BOTTOM OF THE CIRCLE WITH THREE RED STARS BEFORE AND THREE RED STARS AFTER. THE INTERIOR OF THE CIRCLE CONSISTS OF A STYLIZED UNITED STATES FLAG WITH A BLUE FIELD IN THE UPPER LEFT WITH THIRTEEN WHITE STARS; TO THE RIGHT AND BELOW THE BLUE FIELD ARE THIRTEEN ALTERNATING RED (7) AND WHITE (6) STRIPES.

CLASS 16—PAPER GOODS AND PRINTED MATTER

FOR ENVELOPES FOR STATIONERY USE; OFFICE STATIONERY; EDUCATIONAL PUBLICATIONS, NAMELY, EDUCATIONAL LEARNING CARDS, FLASH CARDS, ACTIVITY CARDS, WORKBOOKS, TEXTBOOKS, ACTIVITY BOOKS, STORY BOOKS, PUZZLE BOOKS, TEACHER GUIDES, MANUALS, POSTERS, EDUCATIONAL CARD GAMES AND EDUCATIONAL BOOKLETS IN THE FIELD OF HISTORY, MILITARY SUPPORT AND PATRIOTISM; NEWSLETTERS IN THE FIELD OF HISTORY, MILITARY SUPPORT AND PATRIOTISM; FOLDERS; PUBLICATIONS, NAMELY, BROCHURES, BOOKLETS, AND TEACHING MATERIALS IN THE FIELD OF HISTORY, MILITARY SUPPORT AND PATRIOTISM (U.S. CLS. 2, 5, 22, 23, 29, 37, 38 AND 50).

FIRST USE 12-31-1999; IN COMMERCE 3-31-2000.

CLASS 25—CLOTHING

FOR SHORT-SLEEVED OR LONG-SLEEVED T-SHIRTS; HEADGEAR, NAMELY, BASEBALL CAPS AND/OR VISORS (U.S. CLS. 22 AND 39).

FIRST USE 12-31-1999; IN COMMERCE 3-31-2000.

SN 77-289,766. SADICK, NEIL, NEW YORK, NY. FILED 9-26-2007.

AT HOME TECHNOLOGIES

THE MARK CONSISTS OF STANDARD CHARACTERS WITHOUT CLAIM TO ANY PARTICULAR FONT, STYLE, SIZE, OR COLOR.

NO CLAIM IS MADE TO THE EXCLUSIVE RIGHT TO USE "TECHNOLOGIES", APART FROM THE MARK AS SHOWN.

CLASS 3—COSMETICS AND CLEANING PREPARATIONS

FOR NON-MEDICATED SKIN CARE PREPARATIONS; SKIN-CARE PRODUCTS, NAMELY, NON-MEDICATED ACNE TREATMENT PREPARATIONS; FACIAL MASKS; FACIAL SCRUBS; FACIAL WASHES; COSMETIC FACIAL BLOTTER PAPER; FACIAL EMULSIONS; SKIN SOAPS; SKIN ABRASIVE PREPARATIONS; NON-MEDICATED STIMULATING LOTIONS FOR THE SKIN; LOTIONS FOR THE SKIN, HAIR, BODY AND FACE; EXFOLIANTS FOR THE SKIN AND BODY; SKIN CONDITIONERS; MOISTURIZERS FOR THE SKIN AND BODY; WRINKLE REMOVING SKIN CARE PREPARATIONS; TOPICAL SKIN SPRAYS FOR COSMETIC PURPOSES; BEAUTY CREAMS FOR BODY CARE; HAIR CARE PREPARATIONS (U.S. CLS. 1, 4, 6, 50, 51 AND 52).

CLASS 8—HAND TOOLS

FOR ELECTRIC BODY AND HAIR CARE PRODUCTS, NAMELY, ELECTRIC HAIR TRIMMERS; ELECTRIC RAZORS; ELECTRIC HAIR CLIPPERS; ELECTROLYSIS APPARATUS FOR HAIR REMOVAL (U.S. CLS. 23, 28 AND 44).

CLASS 11—ENVIRONMENTAL CONTROL APPARATUS

FOR ELECTRIC HAIR DRYERS; ELECTRIC FACIAL APPARATUS, NAMELY, FACIAL STEAMERS, FACIAL SAUNAS; BATTERY OPERATED FACIAL APPARATUS, NAMELY, FACIAL STEAMERS, FACIAL SAUNAS (U.S. CLS. 13, 21, 23, 31 AND 34).

LEIGH CAROLINE CASE, EXAMINING ATTORNEY

SN 77-289,799. GUILLORY, JOSEPH, DBA LOVER'S LOCK LLC, HOUSTON, TX. FILED 9-26-2007.

SN 77-290,563. GARAN SERVICES CORP., WILMINGTON, DE. FILED 9-27-2007.

ROSETTE

THE MARK CONSISTS OF STANDARD CHARACTERS WITHOUT CLAIM TO ANY PARTICULAR FONT, STYLE, SIZE, OR COLOR.

CLASS 42—SCIENTIFIC AND COMPUTER SERVICES

FOR HOSTING AN ONLINE COMMUNITY WEBSITE FEATURING PERSONAL WEB PAGES FOR MEMBERS, PERSONAL PROFILES OF MEMBERS, ARCHIVES OF MEMBERS' ACCOUNT ACTIVITIES, AND ONLINE MAIL SERVICES (U.S. CLS. 100 AND 101).

CLASS 45—PERSONAL AND LEGAL SERVICES

FOR DATING SERVICES (U.S. CLS. 100 AND 101).
SANJEEV VOHRA, EXAMINING ATTORNEY

SN 77-290,554. GARAN SERVICES CORP., WILMINGTON, DE. FILED 9-27-2007.



THE COLOR(S) GREY, WHITE, BLUE, RED, ORANGE, GREEN, PINK, PURPLE AND YELLOW IS/ARE CLAIMED AS A FEATURE OF THE MARK.

THE MARK CONSISTS OF THE COLORS GREY, BLUE, WHITE AND PINK WHICH APPEAR IN THE DESIGN OF THE HIPPO. THE COLORS PINK, BLUE, ORANGE, PURPLE, YELLOW, GREEN AND WHITE APPEAR IN THE BUILDING BLOCKS DESIGN.

CLASS 14—JEWELRY

FOR JEWELRY, NAMELY, NECKLACES, BRACELETS, WATCHES, RINGS AND EARRINGS (U.S. CLS. 2, 27, 28 AND 50).

CLASS 25—CLOTHING

FOR CLOTHING, NAMELY, TOPS AND BOTTOMS, SWEATERS, SWEATSHIRTS, PANTS, JEANS, SWEATPANTS, SHORTS, LEGGINGS, CAPRIS, BATHING SUITS, SWIMWEAR, SLEEPWEAR, LEOTARDS, TIGHTS, ROMPERS, UNDERWEAR, HOSIERY, DRESSES, HOODS, CREEPERS; OUTERWEAR, NAMELY, COATS, JACKETS, SCARVES; HEADWEAR, NAMELY, HATS, EARMUFFS, SKI MASKS; GLOVES, BELTS, SOCKS; AND FOOTWEAR, NAMELY, SHOES, BOOTS, SANDALS, SNEAKERS (U.S. CLS. 22 AND 39).
JAY FLOWERS, EXAMINING ATTORNEY



THE COLOR(S) GREY, PINK, GOLD AND BLACK IS/ARE CLAIMED AS A FEATURE OF THE MARK.

THE MARK CONSISTS OF THE COLORS GREY, BLACK AND PINK APPEAR IN THE HIPPO DESIGN AND THE COLORS GOLD AND PINK APPEAR IN THE BRACELET.

CLASS 14—JEWELRY

FOR JEWELRY, NAMELY, NECKLACES, BRACELETS, WATCHES, RINGS AND EARRINGS (U.S. CLS. 2, 27, 28 AND 50).

CLASS 25—CLOTHING

FOR CLOTHING, NAMELY, TOPS AND BOTTOMS, SWEATERS, SWEATSHIRTS, PANTS, JEANS, SWEATPANTS, SHORTS, LEGGINGS, CAPRIS, BATHING SUITS, SWIMWEAR, SLEEPWEAR, LEOTARDS, TIGHTS, ROMPERS, UNDERWEAR, HOSIERY, DRESSES, HOODS, CREEPERS; OUTERWEAR, NAMELY, COATS, JACKETS, SCARVES; HEADWEAR, NAMELY, HATS, EARMUFFS, SKI MASKS; GLOVES, BELTS, SOCKS; AND FOOTWEAR, NAMELY, SHOES, BOOTS, SANDALS, SNEAKERS (U.S. CLS. 22 AND 39).
JAY FLOWERS, EXAMINING ATTORNEY

SN 77-290,569. GARAN SERVICES CORP., WILMINGTON, DE. FILED 9-27-2007.



THE COLOR(S) GREY, WHITE, BLUE, RED, YELLOW, GOLD, GREEN AND PINK IS/ARE CLAIMED AS A FEATURE OF THE MARK.

THE MARK CONSISTS OF THE COLORS GREY, BLACK, BLUE, WHITE AND PINK WHICH APPEAR IN THE HIPPO DESIGN, THE COLORS YELLOW, GREEN AND PINK APPEAR IN THE FLOWER DESIGN, THE COLORS BLUE AND WHITE APPEAR IN THE DRESS AND SHOES AND THE COLORS PINK AND GOLD APPEAR IN THE JEWELRY.

CLASS 14—JEWELRY

FOR JEWELRY, NAMELY, NECKLACES, BRACELETS, WATCHES, RINGS AND EARRINGS (U.S. CLS. 2, 27, 28 AND 50).

SN 77-290,587. GARAN SERVICES CORP., WILMINGTON, DE. FILED 9-27-2007.

CLASS 25—CLOTHING

FOR CLOTHING, NAMELY, TOPS AND BOTTOMS, SWEATERS, SWEATSHIRTS, PANTS, JEANS, SWEATPANTS, SHORTS, LEGGINGS, CAPRIS, BATHING SUITS, SWIMWEAR, SLEEPWEAR, LEOTARDS, TIGHTS, ROMPERS, UNDERWEAR, HOSIERY, DRESSES, HOODS, CREEPERS; OUTERWEAR, NAMELY, COATS, JACKETS, SCARVES; HEADWEAR, NAMELY, HATS, EARMUFFS, SKI MASKS; GLOVES, BELTS, SOCKS; AND FOOTWEAR, NAMELY, SHOES, BOOTS, SANDALS, SNEAKERS (U.S. CLS. 22 AND 39).
JAY FLOWERS, EXAMINING ATTORNEY

SN 77-290,583. GARAN SERVICES CORP., WILMINGTON, DE. FILED 9-27-2007.



THE COLOR(S) YELLOW, BROWN, BLUE, WHITE, PINK, PURPLE AND BLACK IS/ARE CLAIMED AS A FEATURE OF THE MARK.

THE MARK CONSISTS OF THE COLORS YELLOW, BROWN, BLUE, BLACK WHITE AND PINK WHICH APPEAR IN THE GIRAFFE DESIGN AND THE COLORS WHITE, PURPLE AND PINK APPEAR IN THE KETTLE AND TEA CUPS.

CLASS 14—JEWELRY

FOR JEWELRY, NAMELY, NECKLACES, BRACELETS, WATCHES, RINGS AND EARRINGS (U.S. CLS. 2, 27, 28 AND 50).

CLASS 25—CLOTHING

FOR CLOTHING, NAMELY, TOPS AND BOTTOMS, SWEATERS, SWEATSHIRTS, PANTS, JEANS, SWEATPANTS, SHORTS, LEGGINGS, CAPRIS, BATHING SUITS, SWIMWEAR, SLEEPWEAR, LEOTARDS, TIGHTS, ROMPERS, UNDERWEAR, HOSIERY, DRESSES, HOODS, CREEPERS; OUTERWEAR, NAMELY, COATS, JACKETS, SCARVES; HEADWEAR, NAMELY, HATS, EARMUFFS, SKI MASKS; GLOVES, BELTS, SOCKS; AND FOOTWEAR, NAMELY, SHOES, BOOTS, SANDALS, SNEAKERS (U.S. CLS. 22 AND 39).
JAY FLOWERS, EXAMINING ATTORNEY

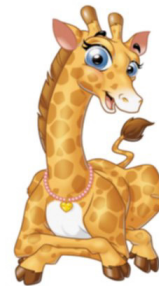

THE COLOR(S) YELLOW, BROWN, WHITE, PINK, BLUE, AND BLACK IS/ARE CLAIMED AS A FEATURE OF THE MARK.

THE MARK CONSISTS OF THE COLORS BLACK, BROWN, YELLOW, BLUE, WHITE AND PINK WHICH APPEAR IN THE GIRAFFE DESIGN AND THE COLORS YELLOW AND PINK APPEAR IN THE JEWELRY.

CLASS 14—JEWELRY

FOR JEWELRY, NAMELY, NECKLACES, BRACELETS, WATCHES, RINGS AND EARRINGS (U.S. CLS. 2, 27, 28 AND 50).

CLASS 25—CLOTHING

FOR CLOTHING, NAMELY, TOPS AND BOTTOMS, SWEATERS, SWEATSHIRTS, PANTS, JEANS, SWEATPANTS, SHORTS, LEGGINGS, CAPRIS, BATHING SUITS, SWIMWEAR, SLEEPWEAR, LEOTARDS, TIGHTS, ROMPERS, UNDERWEAR, HOSIERY, DRESSES, HOODS, CREEPERS; OUTERWEAR, NAMELY, COATS, JACKETS, SCARVES; HEADWEAR, NAMELY, HATS, EARMUFFS, SKI MASKS; GLOVES, BELTS, SOCKS; AND FOOTWEAR, NAMELY, SHOES, BOOTS, SANDALS, SNEAKERS (U.S. CLS. 22 AND 39).
JAY FLOWERS, EXAMINING ATTORNEY

SN 77-290,592. GARAN SERVICES CORP., WILMINGTON, DE. FILED 9-27-2007.

SN 77-290,613. GARAN SERVICES CORP., WILMINGTON, DE. FILED 9-27-2007.



THE COLOR(S) YELLOW, BROWN, WHITE, PINK, BLUE, GREEN, PURPLE, GREY AND BLACK IS/ARE CLAIMED AS A FEATURE OF THE MARK.

THE MARK CONSISTS OF THE COLORS YELLOW, BROWN, BLUE, BLACK WHITE, GREEN AND PINK WHICH APPEAR IN THE GIRAFFE DESIGN, THE COLORS GREEN AND PINK APPEAR IN THE BOOTS, THE COLORS BLUE AND BLACK APPEAR IN THE DRESS AND THE COLORS WHITE AND PINK APPEAR IN THE ACCESSORIES.

CLASS 14—JEWELRY

FOR JEWELRY, NAMELY, NECKLACES, BRACELETS, WATCHES, RINGS AND EARRINGS (U.S. CLS. 2, 27, 28 AND 50).

CLASS 25—CLOTHING

FOR CLOTHING, NAMELY, TOPS AND BOTTOMS, SWEATERS, SWEATSHIRTS, PANTS, JEANS, SWEATPANTS, SHORTS, LEGGINGS, CAPRIS, BATHING SUITS, SWIMWEAR, SLEEPWEAR, LEOTARDS, TIGHTS, ROMPERS, UNDERWEAR, HOSIERY, DRESSES, HOODS, CREEPERS; OUTERWEAR, NAMELY, COATS, JACKETS, SCARVES; HEADWEAR, NAMELY, HATS, EARMUFFS, SKI MASKS; GLOVES, BELTS, SOCKS; AND FOOTWEAR, NAMELY, SHOES, BOOTS, SANDALS, SNEAKERS (U.S. CLS. 22 AND 39).
JAY FLOWERS, EXAMINING ATTORNEY

"THE COLOR(S) BLACK, WHITE, GOLD, GREEN AND PURPLE IS/ARE CLAIMED AS A FEATURE OF THE MARK."

THE MARK CONSISTS OF THE COLORS BLACK, WHITE AND PURPLE WHICH APPEAR IN THE DESIGN OF THE PANDA BEAR, THE COLORS WHITE AND PURPLE APPEAR IN THE BUBBLE DESIGN AND THE BUBBLE HOLDER AND THE COLORS PURPLE, GOLD AND GREEN APPEAR IN THE FLOWER DESIGN.

CLASS 14—JEWELRY

FOR JEWELRY, NAMELY, NECKLACES, BRACELETS, WATCHES, RINGS AND EARRINGS (U.S. CLS. 2, 27, 28 AND 50).

CLASS 25—CLOTHING

FOR CLOTHING, NAMELY, TOPS AND BOTTOMS, SWEATERS, SWEATSHIRTS, PANTS, JEANS, SWEATPANTS, SHORTS, LEGGINGS, CAPRIS, BATHING SUITS, SWIMWEAR, SLEEPWEAR, LEOTARDS, TIGHTS, ROMPERS, UNDERWEAR, HOSIERY, DRESSES, HOODS, CREEPERS; OUTERWEAR, NAMELY, COATS, JACKETS, SCARVES; HEADWEAR, NAMELY, HATS, EARMUFFS, SKI MASKS; GLOVES, BELTS, SOCKS; AND FOOTWEAR, NAMELY, SHOES, BOOTS, SANDALS, SNEAKERS (U.S. CLS. 22 AND 39).
JAY FLOWERS, EXAMINING ATTORNEY

SN 77-290,630. GARAN SERVICES CORP., WILMINGTON, DE. FILED 9-27-2007.

SN 77-290,644. GARAN SERVICES CORP., WILMINGTON, DE. FILED 9-27-2007.



THE COLOR(S) THE COLORS BLACK, WHITE, GOLD, GREEN AND PURPLE IS/ARE CLAIMED AS A FEATURE OF THE MARK.

THE MARK CONSISTS OF THE COLORS BLACK, WHITE AND PURPLE WHICH APPEAR IN THE DESIGN OF THE PANDA BEAR AND THE COLORS PURPLE, GOLD AND GREEN APPEAR IN THE FLOWER DESIGN.

CLASS 14—JEWELRY

FOR JEWELRY, NAMELY, NECKLACES, BRACELETS, WATCHES, RINGS AND EARRINGS (U.S. CLS. 2, 27, 28 AND 50).

CLASS 25—CLOTHING

FOR CLOTHING, NAMELY, TOPS AND BOTTOMS, SWEATERS, SWEATSHIRTS, PANTS, JEANS, SWEATPANTS, SHORTS, LEGGINGS, CAPRIS, BATHING SUITS, SWIMWEAR, SLEEPWEAR, LEOTARDS, TIGHTS, ROMPERS, UNDERWEAR, HOSIERY, DRESSES, HOODS, CREEPERS; OUTERWEAR, NAMELY, COATS, JACKETS, SCARVES; HEADWEAR, NAMELY, HATS, EARMUFFS, SKI MASKS; GLOVES, BELTS, SOCKS; AND FOOTWEAR, NAMELY, SHOES, BOOTS, SANDALS, SNEAKERS (U.S. CLS. 22 AND 39).
JAY FLOWERS, EXAMINING ATTORNEY



THE COLOR(S) BLACK, WHITE, GREY, ORANGE, BLUE, GREEN, RED, YELLOW, PINK AND PURPLE IS/ARE CLAIMED AS A FEATURE OF THE MARK.

THE MARK CONSISTS OF THE COLORS BLACK, WHITE, YELLOW, BLUE AND PURPLE WHICH APPEAR IN THE DESIGN OF THE PANDA BEAR, THE COLORS BLACK AND WHITE APPEAR IN THE DRESS, THE COLORS RED AND WHITE APPEAR IN THE HANDBAG DESIGN, THE COLORS, WHITE, PINK AND YELLOW APPEAR IN THE SHOES, THE COLOR BLACK APPEARS IN THE SUNGLASSES AND THE COLORS BLACK, WHITE, GREY, ORANGE, BLUE, GREEN, RED, YELLOW, PINK AND PURPLE IN THE BAGS AND ACCESSORIES.

CLASS 14—JEWELRY

FOR JEWELRY, NAMELY, NECKLACES, BRACELETS, WATCHES, RINGS AND EARRINGS (U.S. CLS. 2, 27, 28 AND 50).

CLASS 25—CLOTHING

FOR CLOTHING, NAMELY, TOPS AND BOTTOMS, SWEATERS, SWEATSHIRTS, PANTS, JEANS, SWEATPANTS, SHORTS, LEGGINGS, CAPRIS, BATHING SUITS, SWIMWEAR, SLEEPWEAR, LEOTARDS, TIGHTS, ROMPERS, UNDERWEAR, HOSIERY, DRESSES, HOODS, CREEPERS; OUTERWEAR, NAMELY, COATS, JACKETS, SCARVES; HEADWEAR, NAMELY, HATS, EARMUFFS, SKI MASKS; GLOVES, BELTS, SOCKS; AND FOOTWEAR, NAMELY, SHOES, BOOTS, SANDALS, SNEAKERS (U.S. CLS. 22 AND 39).
JAY FLOWERS, EXAMINING ATTORNEY

SN 77-290,658. GARAN SERVICES CORP., WILMINGTON, DE. FILED 9-27-2007.



THE COLOR(S) BLACK, WHITE, PINK, BLUE, GREY AND RED IS/ARE CLAIMED AS A FEATURE OF THE MARK.

THE MARK CONSISTS OF THE COLORS BLACK, WHITE, PINK, AND GREY WHICH APPEAR IN THE DESIGN OF THE ZEBRA; THE COLORS WHITE, BLUE AND RED APPEAR IN THE DESIGN OF THE CRAYONS; THE COLORS WHITE AND BLUE APPEAR IN THE DESIGN OF THE CRAYON DRAWING; AND THE COLOR PINK APPEARS IN THE RIBBON.

CLASS 14—JEWELRY

FOR JEWELRY, NAMELY, NECKLACES, BRACELETS, WATCHES, RINGS AND EARRINGS (U.S. CLS. 2, 27, 28 AND 50).

CLASS 25—CLOTHING

FOR CLOTHING, NAMELY, TOPS AND BOTTOMS, SWEATERS, SWEATSHIRTS, PANTS, JEANS, SWEATPANTS, SHORTS, LEGGINGS, CAPRIS, BATHING SUITS, SWIMWEAR, SLEEPWEAR, LEOTARDS, TIGHTS, ROMPERS, UNDERWEAR, HOSIERY, DRESSES, HOODS, CREEPERS; OUTERWEAR, NAMELY, COATS, JACKETS, SCARVES; HEADWEAR, NAMELY, HATS, EARMUFFS, SKI MASKS; GLOVES, BELTS, SOCKS; AND FOOTWEAR, NAMELY, SHOES, BOOTS, SANDALS, SNEAKERS (U.S. CLS. 22 AND 39).
YAT SYE, LEE, EXAMINING ATTORNEY

SN 77-290,665. GARAN SERVICES CORP., WILMINGTON, DE. FILED 9-27-2007.



THE COLOR(S) BLACK, WHITE, PINK, YELLOW AND GREY IS/ARE CLAIMED AS A FEATURE OF THE MARK. THE MARK CONSISTS OF THE COLORS BLACK, WHITE, PINK, AND GREY WHICH APPEAR IN THE DESIGN OF THE ZEBRA; THE COLORS PINK AND YELLOW APPEAR IN THE DESIGN OF THE BUTTERFLY.

CLASS 14—JEWELRY

FOR JEWELRY, NAMELY, NECKLACES, BRACELETS, WATCHES, RINGS AND EARRINGS (U.S. CLS. 2, 27, 28 AND 50).

CLASS 25—CLOTHING

FOR CLOTHING, NAMELY, TOPS AND BOTTOMS, SWEATERS, SWEATSHIRTS, PANTS, JEANS, SWEATPANTS, SHORTS, LEGGINGS, CAPRIS, BATHING SUITS, SWIMWEAR, SLEEPWEAR, LEOTARDS, TIGHTS, ROMPERS, UNDERWEAR, HOSIERY, DRESSES, HOODS, CREEPERS; OUTERWEAR, NAMELY, COATS, JACKETS, SCARVES; HEADWEAR, NAMELY, HATS, EARMUFFS, SKI MASKS; GLOVES, BELTS, SOCKS; AND FOOTWEAR, NAMELY, SHOES, BOOTS, SANDALS, SNEAKERS (U.S. CLS. 22 AND 39).
YAT SYE, LEE, EXAMINING ATTORNEY

SN 77-290,673. GARAN SERVICES CORP., WILMINGTON, DE. FILED 9-27-2007.



THE COLOR(S) BLACK, WHITE, BLUE, GREY, ORANGE, AND PINK IS/ARE CLAIMED AS A FEATURE OF THE MARK.

THE MARK CONSISTS OF THE COLORS BLACK, WHITE, ORANGE, AND GREY WHICH APPEAR IN THE DESIGN OF THE ZEBRA; THE COLORS PINK AND GREY APPEAR IN THE DESIGNS OF THE GUITAR, SHIRT, AND BELT; AND THE COLOR BLUE APPEARS IN THE DESIGNS OF THE SCARF, HEADBAND, AND NECKLACE.

CLASS 14—JEWELRY

FOR JEWELRY, NAMELY, NECKLACES, BRACELETS, WATCHES, RINGS AND EARRINGS (U.S. CLS. 2, 27, 28 AND 50).

CLASS 25—CLOTHING

FOR CLOTHING, NAMELY, TOPS AND BOTTOMS, SWEATERS, SWEATSHIRTS, PANTS, JEANS, SWEATPANTS, SHORTS, LEGGINGS, CAPRIS, BATHING SUITS, SWIMWEAR, SLEEPWEAR, LEOTARDS, TIGHTS, ROMPERS, UNDERWEAR, HOSIERY, DRESSES, HOODS, CREEPERS; OUTERWEAR, NAMELY, COATS, JACKETS, SCARVES; HEADWEAR, NAMELY, HATS, EARMUFFS, SKI MASKS; GLOVES, BELTS, SOCKS; AND FOOTWEAR, NAMELY, SHOES, BOOTS, SANDALS, SNEAKERS (U.S. CLS. 22 AND 39).
YAT SYE, LEE, EXAMINING ATTORNEY

SN 77-290,699. GARAN SERVICES CORP., WILMINGTON, DE. FILED 9-27-2007.



THE COLOR(S) GREY, BLACK, BLUE, WHITE, PINK AND YELLOW IS/ARE CLAIMED AS A FEATURE OF THE MARK.

THE MARK CONSISTS OF THE COLORS GREY, BLACK, WHITE, PINK, AND BLUE WHICH APPEAR IN THE DESIGN OF THE RHINOCEROS; THE COLORS BLUE, BLACK, WHITE, GREY, AND YELLOW APPEAR IN THE DESIGN OF THE CAR.

CLASS 14—JEWELRY

FOR JEWELRY, NAMELY, BRACELETS, WATCHES AND RINGS (U.S. CLS. 2, 27, 28 AND 50).

CLASS 25—CLOTHING

FOR CLOTHING, NAMELY, TOPS AND BOTTOMS, SWEATERS, SWEATSHIRTS, PANTS, JEANS, SWEAT-PANTS, SHORTS, BATHING SUITS, SWIMWEAR, SLEEPWEAR, ROMPERS, UNDERWEAR, HOSIERY, HOODS, CREEPERS; OUTERWEAR, NAMELY, COATS, JACKETS, SCARVES; HEADWEAR, NAMELY, HATS, EARMUFFS, SKI MASKS; GLOVES, BELTS, SOCKS; AND FOOTWEAR, NAMELY, SHOES, BOOTS, SANDALS, SNEAKERS (U.S. CLS. 22 AND 39).

YAT SYE, LEE, EXAMINING ATTORNEY

CLASS 14—JEWELRY

FOR JEWELRY, NAMELY, BRACELETS, WATCHES AND RINGS (U.S. CLS. 2, 27, 28 AND 50).

CLASS 25—CLOTHING

FOR CLOTHING, NAMELY, TOPS AND BOTTOMS, SWEATERS, SWEATSHIRTS, PANTS, JEANS, SWEAT-PANTS, SHORTS, BATHING SUITS, SWIMWEAR, SLEEPWEAR, ROMPERS, UNDERWEAR, HOSIERY, HOODS, CREEPERS; OUTERWEAR, NAMELY, COATS, JACKETS, SCARVES; HEADWEAR, NAMELY, HATS, EARMUFFS, SKI MASKS; GLOVES, BELTS, SOCKS; AND FOOTWEAR, NAMELY, SHOES, BOOTS, SANDALS, SNEAKERS (U.S. CLS. 22 AND 39).

YAT SYE, LEE, EXAMINING ATTORNEY

SN 77-290,725. GARAN SERVICES CORP., WILMINGTON, DE. FILED 9-27-2007.



SN 77-290,707. GARAN SERVICES CORP., WILMINGTON, DE. FILED 9-27-2007.



THE COLOR(S) GREY, BLACK, BLUE, WHITE, PINK, RED AND BROWN IS/ARE CLAIMED AS A FEATURE OF THE MARK.

THE MARK CONSISTS OF THE COLORS GREY, BLACK, BLUE, WHITE, AND PINK WHICH APPEAR IN THE DESIGN OF THE RHINOCEROS; THE COLORS WHITE AND BLUE APPEAR IN THE DESIGN OF THE CAP; THE COLOR BROWN APPEARS IN THE DESIGN OF THE BASEBALL BAT; AND THE COLORS WHITE AND RED APPEAR IN THE DESIGN OF THE BASEBALL.

CLASS 14—JEWELRY

FOR JEWELRY, NAMELY, BRACELETS, WATCHES AND RINGS (U.S. CLS. 2, 27, 28 AND 50).

CLASS 25—CLOTHING

FOR CLOTHING, NAMELY, TOPS AND BOTTOMS, SWEATERS, SWEATSHIRTS, PANTS, JEANS, SWEAT-PANTS, SHORTS, BATHING SUITS, SWIMWEAR, SLEEPWEAR, ROMPERS, UNDERWEAR, HOSIERY, HOODS, CREEPERS; OUTERWEAR, NAMELY, COATS, JACKETS, SCARVES; HEADWEAR, NAMELY, HATS, EARMUFFS, SKI MASKS; GLOVES, BELTS, SOCKS; AND FOOTWEAR, NAMELY, SHOES, BOOTS, SANDALS, SNEAKERS (U.S. CLS. 22 AND 39).

YAT SYE, LEE, EXAMINING ATTORNEY

THE COLOR(S) GREY, BLACK, BLUE, WHITE, PINK, RED AND BROWN IS/ARE CLAIMED AS A FEATURE OF THE MARK.

THE MARK CONSISTS OF THE COLORS GREY, BLACK, BLUE, WHITE, AND PINK WHICH APPEAR IN THE DESIGN OF THE RHINOCEROS; THE COLORS WHITE AND RED APPEAR IN THE DESIGN OF THE CAP; AND THE COLOR BROWN APPEARS IN THE DESIGN OF THE BASEBALL BAT.

SN 77-290,729. GARAN SERVICES CORP., WILMINGTON, DE. FILED 9-27-2007.



THE COLOR(S) YELLOW, ORANGE, BLACK, RED, BLUE, WHITE, PINK AND GREEN IS/ARE CLAIMED AS A FEATURE OF THE MARK.

THE MARK CONSISTS OF THE COLORS ORANGE, BLACK, GREEN, WHITE, AND PINK WHICH APPEAR IN THE DESIGN OF THE TIGER; THE COLORS RED, BLUE, WHITE, AND YELLOW APPEAR IN THE DESIGN OF THE DRUM; AND THE COLOR ORANGE APPEARS IN THE DESIGN OF THE DRUMSTICKS.

CLASS 14—JEWELRY

FOR JEWELRY, NAMELY, BRACELETS, WATCHES AND RINGS (U.S. CLS. 2, 27, 28 AND 50).

CLASS 25—CLOTHING

FOR CLOTHING, NAMELY, TOPS AND BOTTOMS, SWEATERS, SWEATSHIRTS, PANTS, JEANS, SWEAT-PANTS, SHORTS, BATHING SUITS, SWIMWEAR, SLEEPWEAR, ROMPERS, UNDERWEAR, HOSIERY, HOODS, CREEPERS; OUTERWEAR, NAMELY, COATS, JACKETS, SCARVES; HEADWEAR, NAMELY, HATS, EARMUFFS, SKI MASKS; GLOVES, BELTS, SOCKS; AND FOOTWEAR, NAMELY, SHOES, BOOTS, SANDALS, SNEAKERS (U.S. CLS. 22 AND 39).
YAT SYE, LEE, EXAMINING ATTORNEY

CLASS 25—CLOTHING

FOR CLOTHING, NAMELY, TOPS AND BOTTOMS, SWEATERS, SWEATSHIRTS, PANTS, JEANS, SWEAT-PANTS, SHORTS, BATHING SUITS, SWIMWEAR, SLEEPWEAR, ROMPERS, UNDERWEAR, HOSIERY, HOODS, CREEPERS; OUTERWEAR, NAMELY, COATS, JACKETS, SCARVES; HEADWEAR, NAMELY, HATS, EARMUFFS, SKI MASKS; GLOVES, BELTS, SOCKS; AND FOOTWEAR, NAMELY, SHOES, BOOTS, SANDALS, SNEAKERS (U.S. CLS. 22 AND 39).
YAT SYE, LEE, EXAMINING ATTORNEY

SN 77-290,740. GARAN SERVICES CORP., WILMINGTON, DE. FILED 9-27-2007.



SN 77-290,737. GARAN SERVICES CORP., WILMINGTON, DE. FILED 9-27-2007.



THE COLOR(S) ORANGE, BLACK, BROWN, WHITE, PINK AND GREEN IS/ARE CLAIMED AS A FEATURE OF THE MARK.

THE MARK CONSISTS OF THE COLORS ORANGE, BLACK, GREEN, PINK, AND WHITE WHICH APPEAR IN THE DESIGN OF THE TIGER; THE COLORS BROWN AND BLACK APPEAR IN THE DESIGN OF THE BASKETBALL.

CLASS 14—JEWELRY

FOR JEWELRY, NAMELY, BRACELETS, WATCHES AND RINGS (U.S. CLS. 2, 27, 28 AND 50).

THE COLOR(S) ORANGE, BROWN, BLACK, RED, WHITE, PINK AND GREEN IS/ARE CLAIMED AS A FEATURE OF THE MARK.

THE MARK CONSISTS OF THE COLORS ORANGE, BLACK, GREEN, PINK, AND WHITE WHICH APPEAR IN THE DESIGN OF THE TIGER; THE COLORS BROWN AND BLACK APPEAR IN THE DESIGN OF THE BASKETBALL; THE COLORS RED AND WHITE APPEAR IN THE DESIGNS OF THE HEADBAND AND WRISTBANDS.

CLASS 14—JEWELRY

FOR JEWELRY, NAMELY, BRACELETS, WATCHES AND RINGS (U.S. CLS. 2, 27, 28 AND 50).

CLASS 25—CLOTHING

FOR CLOTHING, NAMELY, TOPS AND BOTTOMS, SWEATERS, SWEATSHIRTS, PANTS, JEANS, SWEAT-PANTS, SHORTS, BATHING SUITS, SWIMWEAR, SLEEPWEAR, ROMPERS, UNDERWEAR, HOSIERY, HOODS, CREEPERS; OUTERWEAR, NAMELY, COATS, JACKETS, SCARVES; HEADWEAR, NAMELY, HATS, EARMUFFS, SKI MASKS; GLOVES, BELTS, SOCKS; AND FOOTWEAR, NAMELY, SHOES, BOOTS, SANDALS, SNEAKERS (U.S. CLS. 22 AND 39).
YAT SYE, LEE, EXAMINING ATTORNEY

SN 77-290,781. PROLACTO MICH INC., LEWES, DE. FILED 9-27-2007.



NO CLAIM IS MADE TO THE EXCLUSIVE RIGHT TO USE "PRODUCTOS LACTEOS TOCUMBO", APART FROM THE MARK AS SHOWN.

THE COLOR(S) GREEN, BROWN AND WHITE IS/ARE CLAIMED AS A FEATURE OF THE MARK.

THE MARK CONSISTS OF STYLIZED LETTERS IN BROWN FOR THE WORDS "PROLACTO MICH PRODUCTOS LACTEOS TOCUMBO" AT THE LEFT SIDE OF THE DESIGN. THE COLOR GREEN APPEARS IN THE DESIGN AS SHADING FOR A GREEN BRIDGE WITHIN A FIELD, AS OUTLINING AND PARTIAL SHADING FOR A COW AND AS OUTLINING FOR A FARMER AND THE STICK THE FARMER IS HOLDING. THE COLOR GREEN ALSO APPEARS IN THE DESIGN AS SHADING FOR THE CYLINDRICAL FIGURE APPEARING BELOW THE STICK THE FARMER IS HOLDING, AS SHADING FOR THE LEAVES APPEARING IN THE FIELD, AND AS SHADING FOR THE GEOMETRIC FIGURE ENCOMPASSING THE FARMER AND THE COW. THE COLOR WHITE APPEARS IN THE DESIGN AS PARTIAL SHADING FOR THE COW, AS SHADING FOR THE FARMER, AS SHADING FOR THE FIGURE APPEARING BELOW THE STICK THE FARMER IS HOLDING AND AS SHADING FOR THE FIELD ENCOMPASSING THE FARMER AND THE COW.

THE ENGLISH TRANSLATION OF THE SPANISH WORDING "PRODUCTOS LACTEOS TOCUMBO" IN THE MARK IS MILK PRODUCTS FROM TOCUMBO.

CLASS 16—PAPER GOODS AND PRINTED MATTER

FOR CONTAINERS FOR ICE MADE OF PAPER OR CARDBOARD (U.S. CLS. 2, 5, 22, 23, 29, 37, 38 AND 50).

CLASS 21—HOUSEWARES AND GLASS

FOR DRINKING GLASSES (U.S. CLS. 2, 13, 23, 29, 30, 33, 40 AND 50).

CLASS 25—CLOTHING

FOR BLOUSES; CAMP SHIRTS; CAP VISORS; DRESS SHIRTS; POLO SHIRTS; SHIRTS; SHORT-SLEEVED OR LONG-SLEEVED T-SHIRTS; SWEAT SHIRTS; WIND SHIRTS; HATS; HEADGEAR, NAMELY, HATS, CAPS; JACKETS; JERSEYS; PANTS; SWEAT PANTS; SHORTS; COATS; SPORT COATS; SUIT COATS; SWEATERS; TANK TOPS; TOPS; SPORT SHIRTS; T-SHIRTS (U.S. CLS. 22 AND 39).

CLASS 29—MEATS AND PROCESSED FOODS

FOR FROZEN FRUITS; FRUIT PULPS; MILK BEVERAGES CONTAINING FRUITS; MILK DRINKS CONTAINING FRUITS; MILK; MILK BASED BEVERAGES CONTAINING FRUIT JUICE; MILK BEVERAGES WITH HIGH MILK CONTENT; MILK PRODUCTS EXCLUDING ICE CREAM, ICE MILK AND FROZEN YOGURT (U.S. CL. 46).

CLASS 30—STAPLE FOODS

FOR CONES FOR ICE CREAM; FLAVORED ICES; FROZEN DESSERT CONSISTING OF FRUIT AND CREAM OR CREAM SUBSTITUTES; FROZEN YOGHURT; FRUIT ICE; FRUIT ICE BAR; FRUIT ICES; ICE; ICE CANDIES; ICE CREAM; ICE CREAM DRINKS; ICE CREAM MIXES; ICE CREAM POWDER; ICE CREAM SANDWICHES; ICE MILK; ICE MILK BARS; ICE-CREAM CAKES (U.S. CL. 46).

CLASS 32—LIGHT BEVERAGES

FOR DRINKING WATER; FLAVORED WATERS; FLAVORED WATERS; FROZEN FRUIT BEVERAGES; FROZEN FRUIT-BASED BEVERAGES; FRUIT BEVERAGES; FRUIT-FLAVORED BEVERAGES; FRUIT-FLAVORED BEVERAGES; FRUIT DRINKS (U.S. CLS. 45, 46 AND 48).

CLASS 35—ADVERTISING AND BUSINESS

FOR RETAIL CONSIGNMENT STORES FEATURING MILK PRODUCTS, ICE-CREAM AND FLAVORED WATERS; RETAIL SHOPS FEATURING MILK PRODUCTS, ICE-CREAM AND FLAVORED WATERS; RETAIL STORE SERVICES FEATURING A WIDE VARIETY OF CONSUMER GOODS OF OTHERS; RETAIL VARIETY STORES (U.S. CLS. 100, 101 AND 102).

CLASS 39—TRANSPORTATION AND STORAGE

FOR TRANSPORT OF GOODS; TRANSPORTATION AND STORAGE OF GOODS (U.S. CLS. 100 AND 105).

CLASS 43—HOTEL AND RESTAURANT SERVICES

FOR SERVING FOOD AND DRINKS; SERVING OF FOOD AND DRINK/BEVERAGES (U.S. CLS. 100 AND 101).

BRIAN CALLAGHAN, EXAMINING ATTORNEY

SN 77-290,792. SERVICE STRATEGIES CORPORATION, SAN DIEGO, CA. FILED 9-27-2007.



OWNER OF U.S. REG. NO. 2,561,007.

NO CLAIM IS MADE TO THE EXCLUSIVE RIGHT TO USE "SERVICE" AND "STANDARDS", APART FROM THE MARK AS SHOWN.

CLASS 16—PAPER GOODS AND PRINTED MATTER

FOR PRINTED MATERIALS, NAMELY, BOOKS, PAMPHLETS AND FLIERS FEATURING INFORMATION ABOUT STANDARDS, CERTIFICATION AND BEST PRACTICES IN TECHNOLOGY SERVICE AND SUPPORT (U.S. CLS. 2, 5, 22, 23, 29, 37, 38 AND 50).

CLASS 41—EDUCATION AND ENTERTAINMENT

FOR COMPUTER EDUCATION TRAINING SERVICES IN THE FIELD OF INFORMATION TECHNOLOGY (U.S. CLS. 100, 101 AND 107).

CLASS 42—SCIENTIFIC AND COMPUTER SERVICES

FOR TECHNICAL SUPPORT SERVICES, NAMELY, TROUBLESHOOTING OF COMPUTER HARDWARE AND SOFTWARE PROBLEMS AND MONITORING OF NETWORK SYSTEMS IN THE FIELD OF INFORMATION TECHNOLOGY; AND ACCREDITATION SERVICES, NAMELY, DEVELOPING, EVALUATING, AND TESTING STANDARDS FOR TECHNICAL SUPPORT AND SERVICES FOR THE PURPOSE OF ACCREDITATION (U.S. CLS. 100 AND 101).

TASNEEM HUSSAIN, EXAMINING ATTORNEY

SN 77-290,821. SERVICE STRATEGIES CORPORATION, SAN DIEGO, CA. FILED 9-27-2007.



OWNER OF U.S. REG. NO. 2,561,007.

NO CLAIM IS MADE TO THE EXCLUSIVE RIGHT TO USE "SERVICE" AND "CERTIFIED", APART FROM THE MARK AS SHOWN.

SN 77-290,812. GARAN SERVICES CORP., WILMINGTON, DE. FILED 9-27-2007.

CLASS 16—PAPER GOODS AND PRINTED MATTER

FOR PRINTED MATERIALS, NAMELY, BOOKS, PAMPHLETS AND FLIERS FEATURING INFORMATION ABOUT STANDARDS, CERTIFICATION AND BEST PRACTICES IN TECHNOLOGY SERVICE AND SUPPORT (U.S. CLS. 2, 5, 22, 23, 29, 37, 38 AND 50).

CLASS 41—EDUCATION AND ENTERTAINMENT

FOR COMPUTER EDUCATION TRAINING SERVICES IN THE FIELD OF INFORMATION TECHNOLOGY (U.S. CLS. 100, 101 AND 107).

**CLASS 42—SCIENTIFIC AND COMPUTER SERVICES**

FOR TECHNICAL SUPPORT SERVICES, NAMELY, TROUBLESHOOTING OF COMPUTER HARDWARE AND SOFTWARE PROBLEMS AND MONITORING OF NETWORK SYSTEMS IN THE FIELD OF INFORMATION TECHNOLOGY; AND ACCREDITATION SERVICES, NAMELY, DEVELOPING, EVALUATING, AND TESTING STANDARDS FOR TECHNICAL SUPPORT AND SERVICES FOR THE PURPOSE OF ACCREDITATION (U.S. CLS. 100 AND 101).

TASNEEM HUSSAIN, EXAMINING ATTORNEY

THE COLOR(S) BROWN, WHITE, TAN, BLACK, PINK, GREEN AND GREY IS/ARE CLAIMED AS A FEATURE OF THE MARK.

THE MARK CONSISTS OF THE COLORS BROWN, WHITE, TAN, BLACK, PINK AND GREEN WHICH APPEAR IN THE DESIGN OF THE BEAR; THE COLORS BROWN AND WHITE APPEAR IN THE DESIGN OF THE FOOTBALL; THE COLOR GREY APPEARS IN THE DESIGN OF THE CHEST PADS.

CLASS 14—JEWELRY

FOR JEWELRY, NAMELY, BRACELETS, WATCHES AND RINGS (U.S. CLS. 2, 27, 28 AND 50).

CLASS 25—CLOTHING

FOR CLOTHING, NAMELY, TOPS AND BOTTOMS, SWEATERS, SWEATSHIRTS, PANTS, JEANS, SWEATPANTS, SHORTS, BATHING SUITS, SWIMWEAR, SLEEPWEAR, ROMPERS, UNDERWEAR, HOSIERY, HOODS, CREEPERS; OUTERWEAR, NAMELY, COATS, JACKETS, SCARVES; HEADWEAR, NAMELY, HATS, EARMUFFS, SKI MASKS; GLOVES, BELTS, SOCKS; AND FOOTWEAR, NAMELY, SHOES, BOOTS, SANDALS, SNEAKERS (U.S. CLS. 22 AND 39).

YAT SYE, LEE, EXAMINING ATTORNEY

SN 77-290,830. RHINO LININGS USA, INC., SAN DIEGO, CA. FILED 9-27-2007.

HARDLINE

THE MARK CONSISTS OF STANDARD CHARACTERS WITHOUT CLAIM TO ANY PARTICULAR FONT, STYLE, SIZE, OR COLOR.

CLASS 2—PAINTS

FOR SPRAYABLE POLYURETHANE COATING FOR APPLICATION ON A WIDE RANGE OF COMMERCIAL, INDUSTRIAL AND CONSUMER PRODUCTS, NAMELY, VEHICLE TRAILERS, VAN FLOORS, BUILDINGS, SIDEWALKS, COMMERCIAL EQUIPMENT AND TRUCK BEDS (U.S. CLS. 6, 11 AND 16).

FIRST USE 10-2-2006; IN COMMERCE 10-2-2006.

CLASS 40—MATERIAL TREATMENT

FOR APPLYING PROTECTIVE POLYURETHANE COATINGS TO A WIDE RANGE OF COMMERCIAL, INDUSTRIAL AND CONSUMER METAL, CONCRETE, WOOD AND FIBERGLASS SURFACES, NAMELY, VEHICLE TRAILERS, VAN FLOORS, BUILDINGS, SIDEWALKS, COMMERCIAL EQUIPMENT AND TRUCK BEDS (U.S. CLS. 100, 103 AND 106).

FIRST USE 10-2-2006; IN COMMERCE 10-2-2006.
RENEE MCCRAY, EXAMINING ATTORNEY

SN 77-290,866. RHINO LININGS USA, INC., SAN DIEGO, CA.
FILED 9-27-2007.

SOLARMAX

THE MARK CONSISTS OF STANDARD CHARACTERS WITHOUT CLAIM TO ANY PARTICULAR FONT, STYLE, SIZE, OR COLOR.

CLASS 2—PAINTS

FOR SPRAYABLE POLYURETHANE COATING FOR APPLICATION ON A WIDE RANGE OF COMMERCIAL, INDUSTRIAL AND CONSUMER PRODUCTS, NAMELY, VEHICLE TRAILERS, VAN FLOORS, BUILDINGS, SIDEWALKS, COMMERCIAL EQUIPMENT AND TRUCK BEDS (U.S. CLS. 6, 11 AND 16).

FIRST USE 10-2-2006; IN COMMERCE 10-2-2006.

SN 77-290,843. SERVICE STRATEGIES CORPORATION, SAN DIEGO, CA. FILED 9-27-2007.

**CLASS 40—MATERIAL TREATMENT**

FOR APPLYING PROTECTIVE POLYURETHANE COATINGS TO A WIDE RANGE OF COMMERCIAL, INDUSTRIAL AND CONSUMER METAL, CONCRETE, WOOD AND FIBERGLASS SURFACES, NAMELY, VEHICLE TRAILERS, VAN FLOORS, BUILDINGS, SIDEWALKS, COMMERCIAL EQUIPMENT AND TRUCK BEDS (U.S. CLS. 100, 103 AND 106).

FIRST USE 10-2-2006; IN COMMERCE 10-2-2006.
RENEE MCCRAY, EXAMINING ATTORNEY

SN 77-291,196. ITOOKTHISONMYPHONE.COM, INC., CINCINNATI, OH. FILED 9-28-2007.

ITOOKTHISONMYPHONE

OWNER OF U.S. REG. NO. 2,561,007.
NO CLAIM IS MADE TO THE EXCLUSIVE RIGHT TO USE "SERVICE" AND "CAREER CERTIFICATION", APART FROM THE MARK AS SHOWN.

THE MARK CONSISTS OF STANDARD CHARACTERS WITHOUT CLAIM TO ANY PARTICULAR FONT, STYLE, SIZE, OR COLOR.

CLASS 16—PAPER GOODS AND PRINTED MATTER

FOR PRINTED MATERIALS, NAMELY, BOOKS, PAMPHLETS AND FLIERS FEATURING INFORMATION ABOUT STANDARDS, CERTIFICATION TRAINING AND BEST PRACTICES IN TECHNOLOGY SERVICE AND SUPPORT (U.S. CLS. 2, 5, 22, 23, 29, 37, 38 AND 50).

CLASS 38—COMMUNICATION

FOR COMPUTER AIDED TRANSMISSION OF IMAGES (U.S. CLS. 100, 101 AND 104).
FIRST USE 10-25-2007; IN COMMERCE 10-25-2007.

CLASS 41—EDUCATION AND ENTERTAINMENT

FOR COMPUTER EDUCATION TRAINING SERVICES IN THE FIELD OF INFORMATION TECHNOLOGY (U.S. CLS. 100, 101 AND 107).

CLASS 39—TRANSPORTATION AND STORAGE

FOR STORAGE SERVICES FOR ARCHIVING DATABASES AND IMAGES (U.S. CLS. 100 AND 105).
FIRST USE 10-25-2007; IN COMMERCE 10-25-2007.

CLASS 42—SCIENTIFIC AND COMPUTER SERVICES

FOR TECHNICAL SUPPORT SERVICES, NAMELY, TROUBLESHOOTING OF COMPUTER HARDWARE AND SOFTWARE PROBLEMS AND MONITORING OF NETWORK SYSTEMS IN THE FIELD OF INFORMATION TECHNOLOGY; AND ACCREDITATION SERVICES, NAMELY, DEVELOPING, EVALUATING, AND TESTING STANDARDS FOR TECHNICAL SUPPORT AND SERVICES FOR THE PURPOSE OF ACCREDITATION (U.S. CLS. 100 AND 101).

TASNEEM HUSSAIN, EXAMINING ATTORNEY

CLASS 42—SCIENTIFIC AND COMPUTER SERVICES

FOR COMPUTER SERVICES, NAMELY, INTERACTIVE HOSTING SERVICES WHICH ALLOW THE USER TO PUBLISH AND SHARE THEIR OWN IMAGES ONLINE (U.S. CLS. 100 AND 101).

FIRST USE 10-25-2007; IN COMMERCE 10-25-2007.
JAMES LOVELACE, EXAMINING ATTORNEY

SN 77-291,238. STIEFEL LABORATORIES, INC., CORAL GABLES, FL. FILED 9-28-2007.



OWNER OF U.S. REG. NOS. 622,452, 2,269,048 AND 2,956,534.

NO CLAIM IS MADE TO THE EXCLUSIVE RIGHT TO USE "CARE", APART FROM THE MARK AS SHOWN.

CLASS 35—ADVERTISING AND BUSINESS

FOR ADMINISTERING A REIMBURSEMENT PROGRAM RELATING TO PHARMACEUTICAL PRODUCTS (U.S. CLS. 100, 101 AND 102).

CLASS 36—INSURANCE AND FINANCIAL

FOR INSURANCE CONSULTATION RELATING TO PHARMACEUTICAL PRODUCTS (U.S. CLS. 100, 101 AND 102).

CLASS 45—PERSONAL AND LEGAL SERVICES

FOR PROVIDING PATIENT ADVOCATE SERVICES TO DERMATOLOGY PATIENTS ON SKIN CARE PRODUCTS AND DERMATOLOGICALS BY PROVIDING ASSISTANCE WITH MEDICAL AND INSURANCE VERIFICATION, COMPLETION OF INSURANCE FORMS, AND COMPILING INFORMATION FOR INSURANCE PURPOSES (U.S. CLS. 100 AND 101).

KYLE PEETE, EXAMINING ATTORNEY

SN 77-291,456. L.T. J. DIFFUSION, COLOMBES, FRANCE, FILED 9-28-2007.

LTJ ARTHUR

THE MARK CONSISTS OF STANDARD CHARACTERS WITHOUT CLAIM TO ANY PARTICULAR FONT, STYLE, SIZE, OR COLOR.

THE NAME(S), PORTRAIT(S), AND/OR SIGNATURE(S) SHOWN IN THE MARK DOES NOT IDENTIFY A PARTICULAR LIVING INDIVIDUAL.

CLASS 25—CLOTHING

FOR UNDERWEAR AND NIGHTWEAR, NAMELY, PAJAMAS, BOXER SHORTS, T-SHIRTS, PAJAMA TROUSERS, NIGHT GOWNS, BATHROBES, KIMONOS, NIGHT CAPS, SLEEPWEAR FOR BABIES; SHIRTS; BERMUDA SHORTS; SWIM WEAR, NAMELY, SWIM TRUNKS, SWIMSUITS, BEACH DRESSES; SLIPPERS, SOCKS; DRESSES; JUMPSUITS; CAPRIS; BLOOMERS; SHORTS; TROUSERS (U.S. CLS. 22 AND 39).

CLASS 35—ADVERTISING AND BUSINESS

FOR RETAIL STORE SERVICES, ONLINE RETAIL STORE SERVICES, WHOLESALE STORE SERVICES, AND WHOLESALE DISTRIBUTORSHIP SERVICES IN THE FIELD OF CLOTHING, FOOTWEAR AND HEADWEAR (U.S. CLS. 100, 101 AND 102).

MATTHEW MCDOWELL, EXAMINING ATTORNEY

SN 77-291,757. KIDS FOR THE WORLD INC., NEW YORK, NY. FILED 9-28-2007.



NO CLAIM IS MADE TO THE EXCLUSIVE RIGHT TO USE "KIDS", APART FROM THE MARK AS SHOWN. THE STIPPLING IS FOR SHADING PURPOSES ONLY.

CLASS 25—CLOTHING

FOR CLOTHING, NAMELY, T-SHIRTS (U.S. CLS. 22 AND 39).

FIRST USE 4-8-2006; IN COMMERCE 4-8-2006.

CLASS 36—INSURANCE AND FINANCIAL

FOR CHARITABLE FUND-RAISING SERVICES; ELEEMOSYNARY SERVICES, NAMELY PROVIDING FINANCIAL AID TO IMPOVERISHED CHILDREN AND THEIR FAMILIES (U.S. CLS. 100, 101 AND 102).

FIRST USE 4-8-2006; IN COMMERCE 4-8-2006.

ALEX KEAM, EXAMINING ATTORNEY

SN 77-291,901. JOTT NETWORKS, INC., SEATTLE, WA, FILED 9-28-2007.

JOTT THE VOTE

THE MARK CONSISTS OF STANDARD CHARACTERS WITHOUT CLAIM TO ANY PARTICULAR FONT, STYLE, SIZE, OR COLOR.

CLASS 9—ELECTRICAL AND SCIENTIFIC APPARATUS

FOR COMPUTER SOFTWARE FOR IMPLEMENTING COMMUNICATIONS BY AND BETWEEN MOBILE PHONES, PERSONAL DIGITAL ASSISTANTS (PDAS), SEARCH ENGINES, THE INTERNET AND OTHER TECHNOLOGY FOR RECORDING, SAVING AND SENDING VOICE AND DATA NOTES AND MESSAGES AS AN INTEGRATED MEMORY AID SYSTEM, ALL FOR USE IN CONNECTION WITH CONTACTING POLITICIANS, POLITICAL CANDIDATES, OR OTHER INDIVIDUALS AND ENTITIES INVOLVED IN THE POLITICAL PROCESS (U.S. CLS. 21, 23, 26, 36 AND 38).

CLASS 38—COMMUNICATION

FOR WEB-BASED COMMUNICATION AND ORGANIZATION SERVICES, NAMELY, RECORDING, SAVING AND TRANSMITTING VOICE AND DATA NOTES AND MESSAGES VIA MOBILE PHONES, PERSONAL DIGITAL ASSISTANTS (PDAS), SEARCH ENGINES, THE INTERNET AND OTHER TECHNOLOGY, ALL FOR USE IN CONNECTION WITH CONTACTING POLITICIANS, POLITICAL CANDIDATES, OR OTHER INDIVIDUALS AND ENTITIES INVOLVED IN THE POLITICAL PROCESS (U.S. CLS. 100, 101 AND 104).

RONALD MCMORROW, EXAMINING ATTORNEY

CLASS 41—EDUCATION AND ENTERTAINMENT

FOR EDUCATION SERVICES, NAMELY, CONDUCTING INFORMATIONAL TRAINING AND EDUCATIONAL PROGRAMS FOR THE PURPOSE OF EDUCATING AND ADVISING BORROWERS AND THE FINANCIAL AID AND ASSISTANCE AND STUDENT LENDING COMMUNITIES, VIA CLASSES, WORKSHOPS, SYMPOSIA AND ONLINE VIA THE GLOBAL COMPUTER NETWORK (U.S. CLS. 100, 101 AND 107).

GINA FINK, EXAMINING ATTORNEY

SN 77-291,914. MASSACHUSETTS HIGHER EDUCATION ASSISTANCE CORPORATION, DBA AMERICAN STUDENT ASSISTANCE, BOSTON, MA. FILED 9-28-2007.



OWNER OF U.S. REG. NO. 3,330,058.

NO CLAIM IS MADE TO THE EXCLUSIVE RIGHT TO USE "EDUCATION DEBT", APART FROM THE MARK AS SHOWN.

THE STIPPLING IS A FEATURE OF THE MARK.

THE COLOR(S) PMS 138 ORANGE, PMS 301 BLUE, GRAY, WHITE AND BLACK IS/ARE CLAIMED AS A FEATURE OF THE MARK.

THE MARK CONSISTS OF A GRAY MAMMOTH CHARACTER WITH WHITE TUSKS AND OUTLINED IN BLACK STANDING UPRIGHT, WEARING A SCARF AROUND ITS NECK. THE WORDS ON THE SCARF ARE "EDUCATION DEBT" IN THE COLOR BLACK. THE SCARF AROUND THE MAMMOTH'S NECK CONSISTS OF THE FOLLOWING COLORS: PMS 138 ORANGE AS THE DOMINANT COLOR WITH TWO PMS 301 BLUE STRIPES, A WHITE BACKGROUND STRIPE FOR THE WORDING AND OUTLINED IN BLACK.

CLASS 35—ADVERTISING AND BUSINESS

FOR ADVERTISING THE FINANCIAL SERVICES PROVIDED BY LENDERS AND GUARANTORS OF STUDENT LENDING AND FINANCIAL ASSISTANCE VIA DISSEMINATION OF PRINTED ADVERTISING AND PROMOTIONAL MATERIALS; BUSINESS SERVICES, NAMELY, PROVIDING LENDERS AND GUARANTORS AND CONSUMERS WITH BUSINESS INFORMATION AND GUIDANCE IN THE MANAGEMENT AND UNDERTAKING OF STUDENT LENDING AND FINANCIAL ASSISTANCE; AND PROVIDING BUSINESS INFORMATION IN THE FIELD OF FINANCIAL AID AND ASSISTANCE TO THE FINANCIAL AID AND ASSISTANCE AND STUDENT LENDING COMMUNITIES (U.S. CLS. 100, 101 AND 102).

CLASS 36—INSURANCE AND FINANCIAL

FOR FINANCIAL SERVICES, NAMELY, ASSISTING, ADVISING, AND COUNSELING BORROWERS AND THE FINANCIAL AID AND ASSISTANCE AND STUDENT LENDING COMMUNITIES ON ISSUES OF AND RELATING TO STUDENT LOANS, LOAN REPAYMENT AND REHABILITATION (U.S. CLS. 100, 101 AND 102).

SN 77-292,038. ISLAND CREEK OYSTERS, INC., DUXBURY, MA. FILED 9-28-2007.

ISLAND CREEK OYSTERS

THE MARK CONSISTS OF STANDARD CHARACTERS WITHOUT CLAIM TO ANY PARTICULAR FONT, STYLE, SIZE, OR COLOR.

NO CLAIM IS MADE TO THE EXCLUSIVE RIGHT TO USE "OYSTERS", APART FROM THE MARK AS SHOWN.

CLASS 29—MEATS AND PROCESSED FOODS

FOR SHELLFISH, NAMELY, OYSTERS, SHRIMP, PRAWNS, CLAMS, MUSSELS AND LOBSTERS (U.S. CL. 46).

CLASS 31—NATURAL AGRICULTURAL PRODUCTS

FOR LIVE SHELLFISH, NAMELY, LIVE OYSTERS, CLAMS, MUSSELS AND LOBSTERS (U.S. CLS. 1 AND 46).

MARK T. MULLEN, EXAMINING ATTORNEY

SN 77-292,572. L.T.J. DIFFUSION, COLOMBES, FRANCE, FILED 10-1-2007.

La fiancée d'Arthur

THE MARK CONSISTS OF STANDARD CHARACTERS WITHOUT CLAIM TO ANY PARTICULAR FONT, STYLE, SIZE, OR COLOR.

CLASS 25—CLOTHING

FOR UNDERWEAR AND NIGHTWEAR, NAMELY, PAJAMAS, BOXER SHORTS, T-SHIRTS, PAJAMA TROUSERS; PANTIES, CAMISOLES, NIGHTIES, BATHROBES; SWIM WEAR, NAMELY, SWIMSUITS AND BEACH DRESSES; SLIPPERS; SHIRTS; DRESSES; JUMPSUITS; CAPRIS; BLOOMERS; SHORTS; TROUSERS (U.S. CLS. 22 AND 39).

CLASS 35—ADVERTISING AND BUSINESS

FOR RETAIL STORE SERVICES, ONLINE RETAIL STORE SERVICES, WHOLESALE STORE SERVICES, AND WHOLESALE DISTRIBUTORSHIP SERVICES IN THE FIELD OF CLOTHING, FOOTWEAR AND HEADWEAR (U.S. CLS. 100, 101 AND 102).

MATTHEW MCDOWELL, EXAMINING ATTORNEY

CLASS 10—MEDICAL APPARATUS

FOR BONE AUGMENTATION MATERIAL, NAMELY, IMPLANTABLE SYNTHETIC COMPOSITE COMPRISED OF POLYMER RESIN AND FILLERS, AND CARTRIDGE, DISPENSER, AND MIXING ATTACHMENTS FOR THE DELIVERY OF BIOMATERIAL PREPARATIONS FOR ORTHOPEDIC, MEDICAL AND SURGICAL USE (U.S. CLS. 26, 39 AND 44).

MELISSA VALLILLO, EXAMINING ATTORNEY

SN 77-292,643. VITA SPECIAL PURPOSE CORP. II, MALVERN, PA. FILED 10-1-2007.



OWNER OF U.S. REG. NO. 2,646,320.
THE MARK CONSISTS OF THE WORDING "CORTOSS" AND A LARGE CIRCLE FEATURING THREE SMALLER CIRCLES.

CLASS 5—PHARMACEUTICALS

FOR ORTHOPEDIC, MEDICAL AND SURGICAL SUPPLIES AND MATERIALS, NAMELY, BONE CEMENT FOR USE IN THE REPAIR AND REPLACEMENT OF BONES (U.S. CLS. 6, 18, 44, 46, 51 AND 52).

CLASS 10—MEDICAL APPARATUS

FOR BONE AUGMENTATION MATERIAL, NAMELY, IMPLANTABLE SYNTHETIC COMPOSITE COMPRISED OF POLYMER RESIN AND FILLERS, AND CARTRIDGE, DISPENSER, AND MIXING ATTACHMENTS FOR THE DELIVERY OF BIOMATERIAL PREPARATIONS FOR ORTHOPEDIC, MEDICAL AND SURGICAL USE (U.S. CLS. 26, 39 AND 44).

MELISSA VALLILLO, EXAMINING ATTORNEY

SN 77-292,914. SPORTSMD, LLC, EASTON, CT. FILED 10-1-2007.

HEALTH=PERFORMANCE

THE MARK CONSISTS OF STANDARD CHARACTERS WITHOUT CLAIM TO ANY PARTICULAR FONT, STYLE, SIZE, OR COLOR.

CLASS 35—ADVERTISING AND BUSINESS

FOR ON-LINE ORDERING SERVICES FEATURING NATURAL DIETARY SUPPLEMENTS; ON-LINE RETAIL STORE SERVICES FEATURING NATURAL DIETARY SUPPLEMENTS (U.S. CLS. 100, 101 AND 102).

CLASS 44—MEDICAL, BEAUTY AND AGRICULTURAL SERVICES

FOR PROVIDING ON-LINE WEB SITE FEATURING HEALTH AND WELLNESS INFORMATION VIA AN ON-LINE COMPUTER NETWORK (U.S. CLS. 100 AND 101).

DOMINIC J. FERRAIUOLO, EXAMINING ATTORNEY

SN 77-292,649. VITA SPECIAL PURPOSE CORP. II, MALVERN, PA. FILED 10-1-2007.



THE MARK CONSISTS OF A LARGE CIRCLE FEATURING THREE SMALLER CIRCLES.

CLASS 5—PHARMACEUTICALS

FOR ORTHOPEDIC, MEDICAL AND SURGICAL SUPPLIES AND MATERIALS, NAMELY, BONE CEMENT FOR USE IN THE REPAIR AND REPLACEMENT OF BONES (U.S. CLS. 6, 18, 44, 46, 51 AND 52).

SN 77-293,174. CAMPANARIO ENTERTAINMENT, LLC, WOODLAND HILLS, CA. FILED 10-1-2007.

SOLTRAVIESO

THE MARK CONSISTS OF STANDARD CHARACTERS WITHOUT CLAIM TO ANY PARTICULAR FONT, STYLE, SIZE, OR COLOR.

THE ENGLISH TRANSLATION OF THE WORD "SOL" IN THE MARK IS SUN AND THE ENGLISH TRANSLATION OF THE WORD "TRAVIESO" IN THE MARK IS MISCHIEVOUS.

CLASS 9—ELECTRICAL AND SCIENTIFIC APPARATUS

FOR CHILDREN'S EDUCATIONAL MUSIC CDS AND DVDS (U.S. CLS. 21, 23, 26, 36 AND 38).

CLASS 16—PAPER GOODS AND PRINTED MATTER

FOR PAPER GOODS AND PRINTED MATERIAL, NAMELY, POSTERS, CALENDARS, CHILDREN'S BOOKS, NOTE PADS, GIFT WRAP, STICKERS, PAPER PARTY HATS, PAPER NAPKINS, PAPER TABLE COVERINGS, AND PAPER BANNERS (U.S. CLS. 2, 5, 22, 23, 29, 37, 38 AND 50).

CLASS 21—HOUSEWARES AND GLASS

FOR HOUSEWARES, NAMELY, PLATES, BOWLS, CUPS, DRINKING GLASSES, MUGS, LUNCHBOXES, HAIR BRUSHES, TOOTHBRUSHES, TOOTH BRUSH HOLDERS, AND CONTAINERS FOR STORING FOOD (U.S. CLS. 2, 13, 23, 29, 30, 33, 40 AND 50).

CLASS 24—FABRICS

FOR LINENS, NAMELY, COMFORTERS, PILLOW CASES, PILLOW SHAMS, BED SHEETS, DUST RUFFLES, CURTAINS, TEXTILE SHOWER CURTAINS, AND TEXTILE PLACEMATS (U.S. CLS. 42 AND 50).

CLASS 25—CLOTHING

FOR CLOTHING, NAMELY, SWEATSHIRTS, T-SHIRTS, PANTS, SHORTS, SOCKS, TIGHTS, CLOTH BIBS, BATHING SUITS, BEACH COVER-UPS, BOOTS, SHOES, UNDERWEAR, PAJAMAS, NIGHTGOWNS, DRESSES, SKIRTS, JACKETS, AND HATS (U.S. CLS. 22 AND 39).

CLASS 28—TOYS AND SPORTING GOODS

FOR TOYS, GAMES AND PLAYTHINGS, NAMELY, STUFFED TOYS, PLUSH TOYS, ACTION FIGURES, JIGSAW PUZZLES, INFANT'S RATTLES, MUSICAL TOYS, BOARD GAMES, BUILDING BLOCKS, BALLOONS, AND PLAYGROUND BALLS (U.S. CLS. 22, 23, 38 AND 50).

CLASS 41—EDUCATION AND ENTERTAINMENT

FOR ENTERTAINMENT SERVICES, NAMELY, PRODUCTION OF CHILDREN'S EDUCATIONAL PROGRAMMING FOR TELEVISION OR CABLE BROADCAST (U.S. CLS. 100, 101 AND 107).

GRETTA YAO, EXAMINING ATTORNEY

SN 77-293,190. CAMPANARIO ENTERTAINMENT, LLC, WOODLAND HILLS, CA. FILED 10-1-2007.

SOLECITA

THE MARK CONSISTS OF STANDARD CHARACTERS WITHOUT CLAIM TO ANY PARTICULAR FONT, STYLE, SIZE, OR COLOR.

THE ENGLISH TRANSLATION OF THE WORD "SOLECITA" IN THE MARK IS LITTLE SUN.

CLASS 9—ELECTRICAL AND SCIENTIFIC APPARATUS

FOR CHILDREN'S EDUCATIONAL MUSIC CDS AND DVDS (U.S. CLS. 21, 23, 26, 36 AND 38).

CLASS 16—PAPER GOODS AND PRINTED MATTER

FOR PAPER GOODS AND PRINTED MATERIAL, NAMELY, POSTERS, CALENDARS, CHILDREN'S BOOKS, NOTE PADS, GIFT WRAP, STICKERS, PAPER PARTY HATS, PAPER NAPKINS, PAPER TABLE COVERINGS, AND PAPER BANNERS (U.S. CLS. 2, 5, 22, 23, 29, 37, 38 AND 50).

CLASS 21—HOUSEWARES AND GLASS

FOR HOUSEWARES, NAMELY, PLATES, BOWLS, CUPS, DRINKING GLASSES, MUGS, LUNCHBOXES, HAIR BRUSHES, TOOTHBRUSHES, TOOTH BRUSH HOLDERS, AND CONTAINERS FOR STORING FOOD (U.S. CLS. 2, 13, 23, 29, 30, 33, 40 AND 50).

CLASS 24—FABRICS

FOR LINENS, NAMELY, COMFORTERS, PILLOW CASES, PILLOW SHAMS, BED SHEETS, DUST RUFFLES, CURTAINS, TEXTILE SHOWER CURTAINS, AND TEXTILE PLACEMATS (U.S. CLS. 42 AND 50).

CLASS 25—CLOTHING

FOR CLOTHING, NAMELY, SWEATSHIRTS, T-SHIRTS, PANTS, SHORTS, SOCKS, TIGHTS, CLOTH BIBS, BATHING SUITS, BEACH COVER-UPS, BOOTS, SHOES, UNDERWEAR, PAJAMAS, NIGHTGOWNS, DRESSES, SKIRTS, JACKETS, AND HATS (U.S. CLS. 22 AND 39).

CLASS 28—TOYS AND SPORTING GOODS

FOR TOYS, GAMES AND PLAYTHINGS, NAMELY, STUFFED TOYS, PLUSH TOYS, ACTION FIGURES, JIGSAW PUZZLES, INFANT'S RATTLES, MUSICAL TOYS, BOARD GAMES, BUILDING BLOCKS, BALLOONS, AND PLAYGROUND BALLS (U.S. CLS. 22, 23, 38 AND 50).

CLASS 41—EDUCATION AND ENTERTAINMENT

FOR ENTERTAINMENT SERVICES, NAMELY, PRODUCTION OF CHILDREN'S EDUCATIONAL PROGRAMMING FOR TELEVISION OR CABLE BROADCAST (U.S. CLS. 100, 101 AND 107).

GRETTA YAO, EXAMINING ATTORNEY

SN 77-293,202. CAMPANARIO ENTERTAINMENT, LLC, WOODLAND HILLS, CA. FILED 10-1-2007.

SOLBRILLANTE

THE MARK CONSISTS OF STANDARD CHARACTERS WITHOUT CLAIM TO ANY PARTICULAR FONT, STYLE, SIZE, OR COLOR.

THE ENGLISH TRANSLATION OF THE WORD "SOL" IN THE MARK IS SUN AND THE ENGLISH TRANSLATION OF THE WORD "BRILLANTE" IN THE MARK IS BRIGHT.

CLASS 9—ELECTRICAL AND SCIENTIFIC APPARATUS

FOR CHILDREN'S EDUCATIONAL MUSIC CDS AND DVDS (U.S. CLS. 21, 23, 26, 36 AND 38).

CLASS 16—PAPER GOODS AND PRINTED MATTER

FOR PAPER GOODS AND PRINTED MATERIAL, NAMELY, POSTERS, CALENDARS, CHILDREN'S BOOKS, NOTE PADS, GIFT WRAP, STICKERS, PAPER PARTY HATS, PAPER NAPKINS, PAPER TABLE COVERINGS, AND PAPER BANNERS (U.S. CLS. 2, 5, 22, 23, 29, 37, 38 AND 50).

CLASS 21—HOUSEWARES AND GLASS

FOR HOUSEWARES, NAMELY, PLATES, BOWLS, CUPS, DRINKING GLASSES, MUGS, LUNCHBOXES, HAIR BRUSHES, TOOTHBRUSHES, TOOTH BRUSH HOLDERS, AND CONTAINERS FOR STORING FOOD (U.S. CLS. 2, 13, 23, 29, 30, 33, 40 AND 50).

CLASS 24—FABRICS

FOR LINENS, NAMELY, COMFORTERS, PILLOW CASES, PILLOW SHAMS, BED SHEETS, DUST RUFFLES, CURTAINS, TEXTILE SHOWER CURTAINS, AND TEXTILE PLACEMATS (U.S. CLS. 42 AND 50).

CLASS 25—CLOTHING

FOR CLOTHING, NAMELY, SWEATSHIRTS, T-SHIRTS, PANTS, SHORTS, SOCKS, TIGHTS, CLOTH BIBS, BATHING SUITS, BEACH COVER-UPS, BOOTS, SHOES, UNDERWEAR, PAJAMAS, NIGHTGOWNS, DRESSES, SKIRTS, JACKETS, AND HATS (U.S. CLS. 22 AND 39).

CLASS 28—TOYS AND SPORTING GOODS

FOR TOYS, GAMES AND PLAYTHINGS, NAMELY, STUFFED TOYS, PLUSH TOYS, ACTION FIGURES, JIGSAW PUZZLES, INFANT'S RATTLES, MUSICAL TOYS, BOARD GAMES, BUILDING BLOCKS, BALLOONS, AND PLAYGROUND BALLS (U.S. CLS. 22, 23, 38 AND 50).

CLASS 41—EDUCATION AND ENTERTAINMENT

FOR ENTERTAINMENT SERVICES, NAMELY, PRODUCTION OF CHILDREN'S EDUCATIONAL PROGRAMMING FOR TELEVISION OR CABLE BROADCAST (U.S. CLS. 100, 101 AND 107).

GRETTA YAO, EXAMINING ATTORNEY

SN 77-294,402. COOK COMMUNICATIONS MINISTRIES, COLORADO SPRINGS, CO. FILED 10-2-2007.

WILDWOOD FOREST

THE MARK CONSISTS OF STANDARD CHARACTERS WITHOUT CLAIM TO ANY PARTICULAR FONT, STYLE, SIZE, OR COLOR.

CLASS 16—PAPER GOODS AND PRINTED MATTER

FOR A SERIES OF BOOKS, WRITTEN ARTICLES, HANDOUTS AND WORKSHEETS IN THE FIELD OF CHRISTIAN FAITH; CHILDREN'S ACTIVITY BOOKS; CHILDREN'S BOOKS; CHILDREN'S INTERACTIVE EDUCATIONAL BOOKS; COLORING BOOKS; COMIC BOOKS; PICTURE BOOKS; PRINTED MUSIC BOOKS; RELIGIOUS BOOKS (U.S. CLS. 2, 5, 22, 23, 29, 37, 38 AND 50).

CLASS 28—TOYS AND SPORTING GOODS

FOR BATH TOYS; CHILDREN'S MULTIPLE ACTIVITY TOYS; COLLECTABLE TOY FIGURES; FLYING SAUCERS; INFLATABLE TOYS; PLASTIC CHARACTER TOYS; PLAY MATS CONTAINING INFANT TOYS; PLUSH TOYS; POP UP TOYS; SANDBOX TOYS; SQUEEZE TOYS (U.S. CLS. 22, 23, 38 AND 50).

ELLEN B. AWRICH, EXAMINING ATTORNEY

SN 77-294,819. INTERNATIONAL BUSINESS MACHINES CORPORATION, ARMONK, NY. FILED 10-3-2007.

MAXIMO

THE MARK CONSISTS OF STANDARD CHARACTERS WITHOUT CLAIM TO ANY PARTICULAR FONT, STYLE, SIZE, OR COLOR.

OWNER OF U.S. REG. NO. 1,378,985.

CLASS 9—ELECTRICAL AND SCIENTIFIC APPARATUS

FOR COMPUTER SOFTWARE, NAMELY, COMPUTER SOFTWARE APPLICATIONS FOR USE IN ASSET MANAGEMENT, WORK MANAGEMENT, SERVICE MANAGEMENT, CONTRACTS MANAGEMENT, MATERIALS MANAGEMENT, AND PROCUREMENT MANAGEMENT; AND INSTRUCTIONAL MANUALS SOLD AS A UNIT THEREWITH (U.S. CLS. 21, 23, 26, 36 AND 38).

CLASS 16—PAPER GOODS AND PRINTED MATTER

FOR PRINTED MATTER, NAMELY, INSTRUCTIONAL MANUALS, INFORMATIONAL BROCHURES, AND TEACHING MATERIALS IN THE FIELD OF COMPUTER SOFTWARE (U.S. CLS. 2, 5, 22, 23, 29, 37, 38 AND 50).

CLASS 42—SCIENTIFIC AND COMPUTER SERVICES

FOR COMPUTER TECHNICAL SUPPORT SERVICES, NAMELY, TROUBLESHOOTING OF COMPUTER SOFTWARE PROBLEMS; COMPUTER SOFTWARE DESIGN FOR OTHERS; INSTALLATION, UPDATING AND MAINTENANCE OF COMPUTER SOFTWARE; CONSULTING SERVICES IN THE FIELD OF COMPUTER SOFTWARE (U.S. CLS. 100 AND 101).

TEJBIR SINGH, EXAMINING ATTORNEY

SN 77-295,153. DOUGLAS J. NILL, LLC, MINNEAPOLIS, MN. FILED 10-3-2007.

WEE WINKLES

THE MARK CONSISTS OF STANDARD CHARACTERS WITHOUT CLAIM TO ANY PARTICULAR FONT, STYLE, SIZE, OR COLOR.

CLASS 16—PAPER GOODS AND PRINTED MATTER

FOR CHILDREN'S BOOKS AND POSTERS (U.S. CLS. 2, 5, 22, 23, 29, 37, 38 AND 50).

CLASS 28—TOYS AND SPORTING GOODS

FOR DOLLS, DOLL ACCESSORIES (U.S. CLS. 22, 23, 38 AND 50).

MARK T. MULLEN, EXAMINING ATTORNEY

SN 77-295,192. DOUGLAS J. NILL, LLC, MINNEAPOLIS, MN. FILED 10-3-2007.

FAIRYWINKLES

THE MARK CONSISTS OF STANDARD CHARACTERS WITHOUT CLAIM TO ANY PARTICULAR FONT, STYLE, SIZE, OR COLOR.

CLASS 16—PAPER GOODS AND PRINTED MATTER

FOR CHILDREN'S BOOKS AND POSTERS (U.S. CLS. 2, 5, 22, 23, 29, 37, 38 AND 50).

CLASS 28—TOYS AND SPORTING GOODS

FOR DOLLS, DOLL ACCESSORIES (U.S. CLS. 22, 23, 38 AND 50).

MARK T. MULLEN, EXAMINING ATTORNEY

SN 77-295,218. 1E LIMITED, LONDON, UNITED KINGDOM, FILED 10-3-2007.

DROWSY SERVER

THE MARK CONSISTS OF STANDARD CHARACTERS WITHOUT CLAIM TO ANY PARTICULAR FONT, STYLE, SIZE, OR COLOR.

NO CLAIM IS MADE TO THE EXCLUSIVE RIGHT TO USE "SERVER", APART FROM THE MARK AS SHOWN.

CLASS 9—ELECTRICAL AND SCIENTIFIC APPARATUS

FOR COMPUTER SOFTWARE FOR MONITORING AND CONTROLLING SERVER CAPACITY; COMPUTER SOFTWARE FOR REDUCING POWER CONSUMPTION; DOWNLOADABLE ELECTRONIC PUBLICATIONS IN THE NATURE OF BROCHURES, INFORMATION LEAFLETS AND MANUALS IN THE FIELD OF MONITORING AND CONTROLLING SERVER CAPACITY (U.S. CLS. 21, 23, 26, 36 AND 38).

CLASS 41—EDUCATION AND ENTERTAINMENT

FOR ON-LINE AND IN-PERSON TRAINING SERVICES ON THE SUBJECT OF MONITORING AND CONTROLLING SERVER CAPACITY AND REDUCING POWER CONSUMPTION; ON-LINE AND IN-PERSON TRAINING SERVICES ON THE SUBJECT OF THE USE OF COMPUTER SOFTWARE FOR MONITORING AND CONTROLLING SERVER CAPACITY AND COMPUTER SOFTWARE FOR REDUCING POWER CONSUMPTION; PLANNING, ARRANGING AND CONDUCTING OF SEMINARS ON THE SUBJECT OF MONITORING AND CONTROLLING SERVER CAPACITY AND REDUCING POWER CONSUMPTION; PLANNING, ARRANGING AND CONDUCTING OF SEMINARS ON THE SUBJECT OF THE USE OF COMPUTER SOFTWARE FOR MONITORING AND CONTROLLING SERVER CAPACITY AND COMPUTER SOFTWARE FOR REDUCING POWER CONSUMPTION; PUBLICATION OF ELECTRONIC BROCHURES, INFORMATION LEAFLETS AND MANUALS IN THE FIELD OF MONITORING AND CONTROLLING SERVER CAPACITY (U.S. CLS. 100, 101 AND 107).

CLASS 42—SCIENTIFIC AND COMPUTER SERVICES

FOR DESIGN, DEVELOPMENT, INSTALLATION AND MAINTENANCE OF COMPUTER SOFTWARE FOR MONITORING AND CONTROLLING SERVER CAPACITY AND COMPUTER SOFTWARE FOR REDUCING POWER CONSUMPTION; PROVIDING TECHNICAL SUPPORT SERVICES IN RELATION TO COMPUTER SOFTWARE FOR MONITORING AND CONTROLLING SERVER CAPACITY AND COMPUTER SOFTWARE FOR REDUCING POWER CONSUMPTION; PROVIDING TECHNICAL SUPPORT SERVICES IN RELATION TO COMPUTER SOFTWARE FOR MONITORING AND CONTROLLING SERVER CAPACITY AND COMPUTER SOFTWARE FOR REDUCING POWER CONSUMPTION, NAMELY, TROUBLESHOOTING OF COMPUTER HARDWARE AND SOFTWARE PROBLEMS AND MONITORING COMPUTER NETWORK SYSTEMS; CONSULTANCY SERVICES IN RELATION TO MONITORING AND CONTROLLING SERVER CAPACITY AND REDUCING POWER CONSUMPTION; CONSULTANCY SERVICES IN RELATION TO THE USE OF AND TROUBLESHOOTING COMPUTER SOFTWARE FOR MONITORING AND CONTROLLING SERVER CAPACITY AND COMPUTER SOFTWARE FOR REDUCING POWER CONSUMPTION (U.S. CLS. 100 AND 101).

NAPOLEON SHARMA, EXAMINING ATTORNEY

SN 77-295,380. ENSIGN U.S.DRILLING INC., DENVER, CO. FILED 10-3-2007.

ENSIGN HAZARD MASTER

THE MARK CONSISTS OF STANDARD CHARACTERS WITHOUT CLAIM TO ANY PARTICULAR FONT, STYLE, SIZE, OR COLOR.

NO CLAIM IS MADE TO THE EXCLUSIVE RIGHT TO USE "HAZARD", APART FROM THE MARK AS SHOWN.

CLASS 9—ELECTRICAL AND SCIENTIFIC APPARATUS

FOR COMPUTER SOFTWARE FOR RECEIVING, STORING, MANAGING, INTERPRETING AND REPORTING DATA AND INFORMATION RELATED TO JOB SAFETY, FIELD INCIDENTS, UNSAFE ACTS AND ANALYSIS THEREOF, IN THE FIELDS OF CONSTRUCTION, OIL, GAS AND NATURAL RESOURCES (U.S. CLS. 21, 23, 26, 36 AND 38).

CLASS 45—PERSONAL AND LEGAL SERVICES

FOR CONSULTING IN THE FIELD OF WORKPLACE SAFETY (U.S. CLS. 100 AND 101).
DAVID MURRAY, EXAMINING ATTORNEY

SN 77-296,191. NONNIE'S TRADITIONAL SOUTHERN, LLC, DBA NONNIE WALLER'S, SPRING VALLEY, OH. FILED 10-4-2007.

PARLOR CHOCOLATES

THE MARK CONSISTS OF STANDARD CHARACTERS WITHOUT CLAIM TO ANY PARTICULAR FONT, STYLE, SIZE, OR COLOR.

NO CLAIM IS MADE TO THE EXCLUSIVE RIGHT TO USE "CHOCOLATES", APART FROM THE MARK AS SHOWN.

SN 77-296,184. PERKINELMER LAS, INC., WALTHAM, MA. FILED 10-4-2007.

EcoAnalytix

THE MARK CONSISTS OF STANDARD CHARACTERS WITHOUT CLAIM TO ANY PARTICULAR FONT, STYLE, SIZE, OR COLOR.

CLASS 1—CHEMICALS

FOR ASSAYS AND REAGENTS FOR RESEARCH USE (U.S. CLS. 1, 5, 6, 10, 26 AND 46).

CLASS 9—ELECTRICAL AND SCIENTIFIC APPARATUS

FOR SCIENTIFIC INSTRUMENTS AND APPARATUS, FOR USE IN THE FIELDS OF BIOFUELS, ENVIRONMENTAL SCIENCE, FOODS AND BEVERAGES, FORENSICS, CHEMICALS, HYDROCARBON PROCESSING, MATERIALS CHARACTERIZATION, NANOMATERIALS, PHARMACEUTICALS AND SEMICONDUCTORS, NAMELY, ANALYZERS FOR TESTING FOODS, BEVERAGES AND DRINKING WATER FOR THE PRESENCE OF CONTAMINANTS, ANALYZERS FOR TESTING FUELS FOR THE PRESENCE OF CONTAMINANTS AND FOR CORRECT COMPOSITION OF THE FUELS; SCIENTIFIC INSTRUMENTS, NAMELY, ELECTRONIC ANALYZERS FOR TESTING CONSUMER PRODUCTS FOR THE PRESENCE OF CONTAMINANTS; SCIENTIFIC INSTRUMENTS, NAMELY, ELECTRONIC ANALYZERS FOR MEASURING, TESTING AND DETECTING CONTAMINANTS AND ENVIRONMENTAL POLLUTANTS; COMPUTER HARDWARE; COMPUTER SOFTWARE FOR USE IN THE FIELDS OF BIOFUELS, ENVIRONMENTAL SCIENCE, FOODS AND BEVERAGES, FORENSICS, CHEMICALS, HYDROCARBON PROCESSING, MATERIALS CHARACTERIZATION, NANOMATERIALS, PHARMACEUTICALS AND SEMICONDUCTORS, NAMELY, SOFTWARE FOR OPERATING LABORATORY ANALYZERS AND FOR THE COLLECTION, STORAGE, MANAGEMENT AND REPORTING OF LABORATORY TESTING AND ANALYSIS DATA (U.S. CLS. 21, 23, 26, 36 AND 38).

CLASS 41—EDUCATION AND ENTERTAINMENT

FOR TRAINING IN THE USE AND OPERATION OF SCIENTIFIC INSTRUMENTS FOR LABORATORY ANALYSIS, TESTING AND RESEARCH, AND IN THE USE AND OPERATION OF COMPUTER SOFTWARE; PROVIDING RECOGNITION AND INCENTIVES BY WAY OF AWARDS TO DEMONSTRATE EXCELLENCE IN THE FIELDS OF SCIENCE AND LABORATORY SKILLS (U.S. CLS. 100, 101 AND 107).

ANDREA K. NADELMAN, EXAMINING ATTORNEY

CLASS 30—STAPLE FOODS

FOR BAKERY DESSERTS; CAKES; CANDIES; CHOCOLATES; CONFECTIONERY, NAMELY, SWEETS, FUDGE, PRALINES, CARAMELS, MARZIPAN, NOUGATS, CHEWING GUM, PASTILLES, GELATIN DESSERTS, CHOCOLATE TRUFFLES, TARTS, TOPPING SYRUPS, SAUCES, HOT CHOCOLATE MIX, PUDDINGS, DESSERT MOUSSES, FRUIT JELLIES, PASTILLES, AND MIXES FOR BAKERY GOODS; CONFECTIONERY, NAMELY, CHOCOLATE OR CANDY COATED FRUITS AND DRIED FRUITS, COOKIES, MARSHMALLOWS, PASTRIES, PETITE FOURS, POPCORN, PRETZELS AND NUTS; CONFECTIONERY, NAMELY, CHOCOLATE OR CANDY COVERED SNACKS, NAMELY, FRUIT, POTATO, SOY, VEGETABLE, CEREAL, CORN, GRANOLA, RICE OR WHEAT BASED SNACK FOODS; CONFECTIONERY, NAMELY, COFFEE BEANS, CHOCOLATE OR CANDY COVERED COFFEE BEANS AND PASTRIES; THE FOREGOING ALL SOLD IN AND SEPARATELY FROM DECORATIVE GIFT BOXES (U.S. CL. 46).

CLASS 35—ADVERTISING AND BUSINESS

FOR MAIL ORDER CATALOG SERVICES AND ONLINE RETAIL STORE SERVICES FEATURING GIFT BOXES CONTAINING BAKERY DESSERTS, CAKES, CANDIES, CHOCOLATES, CONFECTIONERY, OR PASTRIES WITH OR WITHOUT FRESH FLOWER ARRANGEMENTS (U.S. CLS. 100, 101 AND 102).

RICHARD WHITE, EXAMINING ATTORNEY

SN 77-296,267. NONNIE'S TRADITIONAL SOUTHERN, LLC, DBA NONNIE WALLER'S, SPRING VALLEY, OH. FILED 10-4-2007.

NONNIE WALLER'S PARLOR

THE MARK CONSISTS OF STANDARD CHARACTERS WITHOUT CLAIM TO ANY PARTICULAR FONT, STYLE, SIZE, OR COLOR.

OWNER OF U.S. REG. NOS. 3,010,422 AND 3,130,364.

THE NAME "NONNIE WALLER" DOES NOT IDENTIFY A LIVING INDIVIDUAL.

CLASS 16—PAPER GOODS AND PRINTED MATTER

FOR DECORATIVE GIFT BOXES SOLD EMPTY AND DESIGNED TO BE FILLED WITH GIFTS (U.S. CLS. 2, 5, 22, 23, 29, 37, 38 AND 50).

CLASS 30—STAPLE FOODS

FOR BAKERY DESSERTS; CAKES; CANDIES; CHOCOLATES; CONFECTIONERY, NAMELY, SWEETS, FUDGE, PRALINES, CARAMELS, MARZIPAN, NOUGATS, CHEWING GUM, PASTILLES, GELATIN DESSERTS, CHOCOLATE TRUFFLES, TARTS, TOPPING SYRUPS, SAUCES, HOT CHOCOLATE MIX, PUDDINGS, DESSERT MOUSSES, FRUIT JELLIES, PASTILLES, AND MIXES FOR BAKERY GOODS; CONFECTIONERY, NAMELY, CHOCOLATE OR CANDY COATED FRUITS AND DRIED FRUITS, COOKIES, MARSHMALLOWS, PASTRIES, PETITE FOURS, POPCORN, PRETZELS AND NUTS; CONFECTIONERY, NAMELY, CHOCOLATE OR CANDY COVERED SNACKS, NAMELY, FRUIT, POTATO, SOY, VEGETABLE, CEREAL, CORN, GRANOLA, RICE OR WHEAT BASED SNACK FOODS; CONFECTIONERY, NAMELY, COFFEE BEANS, CHOCOLATE OR CANDY COVERED COFFEE BEANS AND PASTRIES; THE FOREGOING ALL SOLD IN AND SEPARATELY FROM DECORATIVE GIFT BOXES (U.S. CL. 46).

SN 77-296,286. CACHE, INC., NEW YORK, NY. FILED 10-4-2007.

**CLASS 35—ADVERTISING AND BUSINESS**

FOR MAIL ORDER CATALOG SERVICES AND ONLINE RETAIL STORE SERVICES FEATURING DECORATIVE GIFT BOXES CONTAINING BAKERY DESSERTS, CAKES, CANDIES, CHOCOLATES, CONFECTIONERY, OR PASTRIES WITH OR WITHOUT FRESH FLOWER ARRANGEMENTS (U.S. CLS. 100, 101 AND 102).

RICHARD WHITE, EXAMINING ATTORNEY

CLASS 9—ELECTRICAL AND SCIENTIFIC APPARATUS

FOR MAGNETICALLY ENCODED CREDIT CARDS; SUNGLASSES (U.S. CLS. 21, 23, 26, 36 AND 38).

CLASS 14—JEWELRY

FOR JEWELRY; PRECIOUS STONES; HOROLOGICAL AND CHRONOMETRIC INSTRUMENTS (U.S. CLS. 2, 27, 28 AND 50).

CLASS 16—PAPER GOODS AND PRINTED MATTER

FOR STATIONERY (U.S. CLS. 2, 5, 22, 23, 29, 37, 38 AND 50).

CLASS 18—LEATHER GOODS

FOR HANDBAGS, PURSES AND WALLETS (U.S. CLS. 1, 2, 3, 22 AND 41).

CLASS 25—CLOTHING

FOR CLOTHING, NAMELY, JEANS, SKIRTS, PANTS, T-SHIRTS AND TOPS; HEADWEAR (U.S. CLS. 22 AND 39).

CLASS 26—FANCY GOODS

FOR LACE AND EMBROIDERY, RIBBONS AND BRAIDS; BUTTONS, HOOKS AND EYES (U.S. CLS. 37, 39, 40, 42 AND 50).

CLASS 35—ADVERTISING AND BUSINESS

FOR ADVERTISING; BUSINESS MANAGEMENT; BUSINESS ADMINISTRATION AND MANAGEMENT; PROVIDING OFFICE FUNCTIONS; RETAIL STORE SERVICES FEATURING WOMEN'S CLOTHING AND FASHION (U.S. CLS. 100, 101 AND 102).

CLASS 36—INSURANCE AND FINANCIAL

FOR CREDIT CARD SERVICES (U.S. CLS. 100, 101 AND 102).

SUNG IN, EXAMINING ATTORNEY

SN 77-296,275. OTA FINANCIAL GROUP LP, PURCHASE, NY. FILED 10-4-2007.

OTR

THE MARK CONSISTS OF STANDARD CHARACTERS WITHOUT CLAIM TO ANY PARTICULAR FONT, STYLE, SIZE, OR COLOR.

OWNER OF U.S. REG. NO. 2,865,996.

CLASS 35—ADVERTISING AND BUSINESS

FOR ANALYZING AND COMPILING DATA FOR MEASURING THE PERFORMANCE OF FINANCIAL MARKETS, NAMELY COMPILING FINANCIAL INFORMATION FROM NONTRADITIONAL SOURCES, ANALYZING FINANCIAL INFORMATION FOR DISLOCATIONS OR INFLECTION POINTS THAT PROVIDE INVESTMENT OPPORTUNITIES FOR FINANCIAL INSTITUTIONS (U.S. CLS. 100, 101 AND 102).

FIRST USE 1-31-1996; IN COMMERCE 1-31-1996.

CLASS 36—INSURANCE AND FINANCIAL

FOR FINANCIAL RESEARCH AND FINANCIAL CONSULTATION, NAMELY, PROVIDING MARKETPLACE-BASED EQUITY RESEARCH FOR FINANCIAL INSTITUTIONS (U.S. CLS. 100, 101 AND 102).

FIRST USE 1-31-1996; IN COMMERCE 1-31-1996.
LINDA POWELL, EXAMINING ATTORNEY

SN 77-296,293. CACHE, INC., NEW YORK, NY. FILED 10-4-2007.

SN 77-296,946. GUY HARVEY, INC., DAVIE, FL. FILED 10-5-2007.

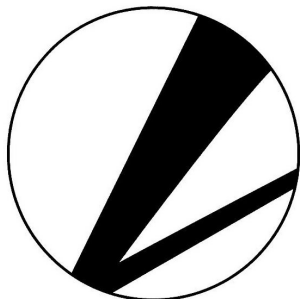

GUY HARVEY

THE MARK CONSISTS OF STANDARD CHARACTERS WITHOUT CLAIM TO ANY PARTICULAR FONT, STYLE, SIZE, OR COLOR.

OWNER OF U.S. REG. NOS. 1,616,722, 2,582,750 AND OTHERS.

THE NAME(S), PORTRAIT(S), AND/OR SIGNATURE(S) SHOWN IN THE MARK IDENTIFIES "GUY HARVEY", WHOSE CONSENT(S) TO REGISTER IS MADE OF RECORD.

CLASS 9—ELECTRICAL AND SCIENTIFIC APPARATUS

FOR MAGNETICALLY ENCODED CREDIT CARDS; SUNGLASSES (U.S. CLS. 21, 23, 26, 36 AND 38).

CLASS 14—JEWELRY

FOR JEWELRY; PRECIOUS STONES; HOROLOGICAL AND CHRONOMETRIC INSTRUMENTS (U.S. CLS. 2, 27, 28 AND 50).

CLASS 16—PAPER GOODS AND PRINTED MATTER

FOR STATIONERY (U.S. CLS. 2, 5, 22, 23, 29, 37, 38 AND 50).

CLASS 18—LEATHER GOODS

FOR HANDBAGS, PURSES AND WALLETS (U.S. CLS. 1, 2, 3, 22 AND 41).

CLASS 25—CLOTHING

FOR CLOTHING, NAMELY, JEANS, SKIRTS, PANTS, T-SHIRTS AND TOPS; HEADWEAR (U.S. CLS. 22 AND 39).

CLASS 26—FANCY GOODS

FOR LACE AND EMBROIDERY, RIBBONS AND BRAIDS; BUTTONS, HOOKS AND EYES (U.S. CLS. 37, 39, 40, 42 AND 50).

CLASS 35—ADVERTISING AND BUSINESS

FOR ADVERTISING; BUSINESS MANAGEMENT; BUSINESS ADMINISTRATION AND MANAGEMENT; PROVIDING OFFICE FUNCTIONS; RETAIL STORE SERVICES FEATURING WOMEN'S CLOTHING AND FASHION ACCESSORIES (U.S. CLS. 100, 101 AND 102).

CLASS 36—INSURANCE AND FINANCIAL

FOR CREDIT CARD SERVICES (U.S. CLS. 100, 101 AND 102).
SUNG IN, EXAMINING ATTORNEY

CLASS 14—JEWELRY

FOR CLOCKS AND WATCHES (U.S. CLS. 2, 27, 28 AND 50).

FIRST USE 9-1-2003; IN COMMERCE 9-1-2003.

CLASS 16—PAPER GOODS AND PRINTED MATTER

FOR PAINTINGS AND THEIR REPRODUCTIONS, PHOTOGRAPHIC ART PRINTS, MOUNTED POSTERS, POSTERS MADE OF PAPER, DECALS, COFFEE TABLE BOOKS FEATURING MARINE LIFE ART AND UNDERWATER PHOTOS (U.S. CLS. 2, 5, 22, 23, 29, 37, 38 AND 50).

FIRST USE 10-1-1985; IN COMMERCE 10-1-1985.

CLASS 20—FURNITURE AND ARTICLES NOT OTHERWISE CLASSIFIED

FOR FURNITURE MADE OF METAL (U.S. CLS. 2, 13, 22, 25, 32 AND 50).

FIRST USE 11-1-2006; IN COMMERCE 11-1-2006.

CLASS 21—HOUSEWARES AND GLASS

FOR HOUSEWARES AND GLASS, NAMELY, MUGS, BEVERAGE WARE, BEVERAGE GLASSWARE, DRINKING GLASSES, BEER MUGS, COASTERS NOT OF PAPER AND NOT BEING TABLE LINEN, INSULATING SLEEVE HOLDERS FOR BEVERAGE CANS, AND DINERWARE, NAMELY, PLATES, BOWLS, CUPS AND SAUCERS (U.S. CLS. 2, 13, 23, 29, 30, 33, 40 AND 50).

FIRST USE 6-1-2002; IN COMMERCE 6-1-2002.

CLASS 25—CLOTHING

FOR CLOTHING, NAMELY, SHORT-SLEEVED AND LONG-SLEEVED T-SHIRTS, TANK TOPS, SWEAT SHIRTS, SWEAT PANTS, SPORT SHIRTS, CAMP SHIRTS, GOLF SHIRTS, KNIT SHIRTS, OPEN-NECKED SHIRTS, POLO SHIRTS, SLEEP SHIRTS, SWEATERS, JACKETS, PANTS, CAPRI PANTS, SHORTS, DRESSES, SKIRTS, FABRIC BELTS, LEATHER BELTS, CAPS, SUN VISORS, SCARVES, AND SWIM WEAR (U.S. CLS. 22 AND 39).

FIRST USE 6-15-1988; IN COMMERCE 6-15-1988.

CLASS 27—FLOOR COVERINGS

FOR RUGS (U.S. CLS. 19, 20, 37, 42 AND 50).
FIRST USE 1-2-2003; IN COMMERCE 1-2-2003.

CLASS 30—STAPLE FOODS

FOR SPICES AND SEASONINGS (U.S. CL. 46).
FIRST USE 1-2-2007; IN COMMERCE 1-2-2007.

CLASS 33—WINES AND SPIRITS

FOR WINE (U.S. CLS. 47 AND 49).
FIRST USE 1-2-2007; IN COMMERCE 1-2-2007.

SN 77-297,290. ADAMS RESPIRATORY OPERATIONS, INC.,
FORT WORTH, TX. FILED 10-5-2007.

CLASS 34—SMOKERS' ARTICLES

FOR LIGHTERS FOR SMOKERS (U.S. CLS. 2, 8, 9 AND
17).
FIRST USE 1-2-2002; IN COMMERCE 1-2-2002.
MARIAM MAHMOUDI, EXAMINING ATTORNEY



SN 77-297,037. INTELLECTUAL EQUITIES, INC., CLEVELAND,
OH. FILED 10-5-2007.

NO CLAIM IS MADE TO THE EXCLUSIVE RIGHT TO
USE "12H MUCUS EXPECTORATOR", APART FROM THE
MARK AS SHOWN.

THE MARK CONSISTS OF A MALE CARTOON CHARACTER
WITH BULGING MUSCLES AND A ELONGATED CHIN,
WEARING A TANK TOP, PANTS WITH A STRIPE
DOWN THE LEG AND SHOES.

CLASS 16—PAPER GOODS AND PRINTED MATTER

FOR PRINTED MATERIAL, NAMELY, NEWSLETTERS
AND BROCHURES CONCERNING RESPIRATORY
AND PULMONARY CONDITIONS (U.S. CLS. 2,
5, 22, 23, 29, 37, 38 AND 50).

CREATING MEGA RESULTS**CLASS 44—MEDICAL, BEAUTY AND AGRICULTURAL SERVICES**

FOR PROVIDING MEDICAL INFORMATION IN THE
FIELD OF RESPIRATORY AND PULMONARY
CONDITIONS (U.S. CLS. 100 AND 101).
PATRICIA EVANKO, EXAMINING ATTORNEY

THE MARK CONSISTS OF STANDARD CHARACTERS
WITHOUT CLAIM TO ANY PARTICULAR FONT, STYLE,
SIZE, OR COLOR.

CLASS 9—ELECTRICAL AND SCIENTIFIC APPARATUS

FOR PRE-RECORDED VIDEO TAPES, COMPACT
DISCS, AUDIO TAPES AND DVDS, FEATURING
INSTRUCTION, DISCUSSION, INTERVIEWS AND
INSTRUCTIONAL LESSONS IN THE FIELD OF
BUSINESS AND PERSONAL DEVELOPMENT (U.S.
CLS. 21, 23, 26, 36 AND 38).
FIRST USE 9-17-2007; IN COMMERCE 9-17-2007.

SN 77-297,707. CRUMP GROUP, INC., ROSELAND, NJ.
FILED 10-5-2007.

ASCENSUS

THE MARK CONSISTS OF STANDARD CHARACTERS
WITHOUT CLAIM TO ANY PARTICULAR FONT, STYLE,
SIZE, OR COLOR.
THE FOREIGN WORDING IN THE MARK TRANSLATES
INTO ENGLISH AS "A MOVING UPWARD"

CLASS 41—EDUCATION AND ENTERTAINMENT

FOR EDUCATIONAL SERVICES, NAMELY, CONDUCTING
SEMINARS AND WORKSHOPS IN THE
FIELDS OF PERFORMANCE MOTIVATION, TEAMWORK,
BUSINESS MANAGEMENT, PROBLEM SOLVING
AND CREATIVE THINKING SKILLS (U.S. CLS.
100, 101 AND 107).
FIRST USE 9-17-2007; IN COMMERCE 9-17-2007.
MICHAEL TANNER, EXAMINING ATTORNEY

CLASS 9—ELECTRICAL AND SCIENTIFIC APPARATUS

FOR SOFTWARE FOR USE IN RETIREMENT
PLANNING AND RETIREMENT EDUCATION;
PROVIDING DOWNLOADABLE ELECTRONIC
BENEFIT PLAN, RETIREMENT ACCOUNT,
AND HEALTH SAVINGS ACCOUNT FORMS
AND DOCUMENTS; CD-ROMS CONTAINING
BENEFIT PLAN, RETIREMENT ACCOUNT,
AND HEALTH SAVINGS ACCOUNT FORMS
AND DOCUMENTS (U.S. CLS. 21, 23, 26, 36
AND 38).

CLASS 16—PAPER GOODS AND PRINTED MATTER

FOR PRINTED BENEFIT PLAN, RETIREMENT ACCOUNT, AND HEALTH SAVINGS ACCOUNT FORMS AND DOCUMENTS (U.S. CLS. 2, 5, 22, 23, 29, 37, 38 AND 50).

CLASS 36—INSURANCE AND FINANCIAL

FOR RECORDKEEPING AND ADMINISTRATION OF RETIREMENT PLANS, HEALTH SAVINGS ACCOUNTS AND BENEFIT PLANS FOR OTHERS; RECORDKEEPING AND ADMINISTRATION OF RETIREMENT ACCOUNTS FOR OTHERS; RETIREMENT PLAN TRUSTEE SERVICES; RETIREMENT PLAN CUSTODIAL SERVICES, NAMELY, HOLDING, ADMINISTERING AND TRANSFERRING CASH, SECURITIES, AND OTHER RETIREMENT PLAN ASSETS; PROVIDING BENEFIT PLAN, HEALTH SAVINGS ACCOUNT AND RETIREMENT ACCOUNT INFORMATION BY TELEPHONE AND VIA THE INTERNET; CONSULTATION IN THE FIELD OF ESTABLISHMENT AND MAINTENANCE OF BENEFIT PLANS, HEALTH SAVINGS ACCOUNTS AND RETIREMENT ACCOUNTS; CONSULTATION IN THE FIELD OF ENROLLMENT IN BENEFIT PLANS (U.S. CLS. 100, 101 AND 102).

CLASS 41—EDUCATION AND ENTERTAINMENT

FOR EDUCATIONAL SERVICES, NAMELY, CLASSES, COURSES, AND SEMINARS IN THE FIELDS OF RETIREMENT PLANNING AND HEALTH SAVINGS ACCOUNTS, AND DISTRIBUTING COURSE MATERIALS IN CONNECTION THEREWITH; TRAINING IN THE FIELDS OF RETIREMENT PLANNING AND HEALTH SAVINGS ACCOUNTS; PROVIDING ON-LINE NON-DOWNLOADABLE PUBLICATIONS, NAMELY, BENEFIT PLAN, RETIREMENT ACCOUNT, AND HEALTH SAVINGS ACCOUNT FORMS AND DOCUMENTS (U.S. CLS. 100, 101 AND 107).

CLASS 42—SCIENTIFIC AND COMPUTER SERVICES

FOR PROVIDING ON-LINE TEMPORARY USE OF NON-DOWNLOADABLE SOFTWARE FOR USE IN RETIREMENT PLANNING AND RETIREMENT EDUCATION; PROVIDING ON-LINE TEMPORARY USE OF NON-DOWNLOADABLE SOFTWARE FOR USE IN ADMINISTERING HEALTH SAVINGS ACCOUNTS; PROVIDING TEMPORARY USE OF NON-DOWNLOADABLE SOFTWARE FOR USE IN CHANGING AND MODIFYING BENEFIT PLANS, HEALTH SAVINGS ACCOUNTS, AND RETIREMENT ACCOUNTS (U.S. CLS. 100 AND 101).

JENNIFER VASQUEZ, EXAMINING ATTORNEY

SN 77-300,172. THE OAK GROUP, INC., WAYLAND, MA. FILED 10-10-2007.

MCAP

THE MARK CONSISTS OF STANDARD CHARACTERS WITHOUT CLAIM TO ANY PARTICULAR FONT, STYLE, SIZE, OR COLOR.

OWNER OF U.S. REG. NOS. 1,919,423 AND 1,985,849.

CLASS 41—EDUCATION AND ENTERTAINMENT

FOR EDUCATION AND TRAINING SERVICES, NAMELY, PROVIDING COURSES, SEMINARS, WORKSHOPS AND ON-LINE TRAINING PROVIDED VIA THE INTERNET, IN THE FIELDS OF COMPUTER SOFTWARE USED IN THE HEALTHCARE INDUSTRY AND BUSINESS MANAGEMENT AND DECISION SUPPORT IN THE HEALTHCARE INDUSTRY (U.S. CLS. 100, 101 AND 107).

FIRST USE 2-16-1996; IN COMMERCE 2-16-1996.

CLASS 42—SCIENTIFIC AND COMPUTER SERVICES

FOR CLINICAL AND TECHNICAL SUPPORT SERVICES, NAMELY, TROUBLESHOOTING OF COMPUTER SOFTWARE USED IN THE HEALTHCARE INDUSTRY (U.S. CLS. 100 AND 101).

FIRST USE 2-16-1996; IN COMMERCE 2-16-1996.

DOMINIC FATHY, EXAMINING ATTORNEY

SN 77-300,688. L & P SWISS HOLDING COMPANY, WIT- TENBACH, SWITZERLAND, FILED 10-10-2007.

PX

THE MARK CONSISTS OF STANDARD CHARACTERS WITHOUT CLAIM TO ANY PARTICULAR FONT, STYLE, SIZE, OR COLOR.

PRIORITY CLAIMED UNDER SEC. 44(D) ON ERPNCMNTY TM OFC APPLICATION NO. 005885231, FILED 4-24-2007, REG. NO. 005885231, DATED 5-21-2008, EXPIRES 4-24-2017.

CLASS 10—MEDICAL APPARATUS

FOR FURNITURE FOR MEDICAL AND DENTAL PURPOSES, NAMELY, MEDICAL AND DENTAL EXAMINATION CHAIRS; CHAIRS FOR MEDICAL AND DENTAL PURPOSES, NAMELY, MEDICAL AND DENTAL EXAMINATION CHAIRS, MASSAGE CHAIRS; SPECIAL FURNITURE FOR MEDICAL USE, NAMELY, SEAT COMPONENTS IN THE NATURE OF BACKREST CUSHIONS, ERGONOMIC REST CUSHIONS AND REST CUSHIONS FOR LORDOSIS PATIENTS; PARTS AND FITTINGS FOR ALL THE AFORESAID GOODS (U.S. CLS. 26, 39 AND 44).

CLASS 12—VEHICLES

FOR SEATS FOR VEHICLES; BACK SUPPORT CUSHIONS, BACK SUPPORTS AND BACK LEANER CUSHIONS FOR VEHICLE SEATS; LUMBAR SUPPORT DEVICES FOR VEHICLE SEATS; PULL-CABLE ARRANGEMENTS SPECIFICALLY ADAPTED FOR USE IN VEHICLES AND ACTUATORS FOR ACTUATING SUCH PULL-CABLE ARRANGEMENTS, ALL FOR ADJUSTING VEHICLE SEATS, HEADRESTS OF VEHICLES OR PARTS THEREOF; PARTS AND FITTINGS FOR ALL THE AFORESAID GOODS (U.S. CLS. 19, 21, 23, 31, 35 AND 44).

CLASS 20—FURNITURE AND ARTICLES NOT OTHERWISE CLASSIFIED

FOR FURNITURE; CHAIRS AND SEATS; SEAT FURNITURE; OFFICE FURNITURE; BACK SUPPORT CUSHIONS AND BACK LEANER CUSHIONS, NOT FOR MEDICAL PURPOSES, FOR CHAIRS, SEATS AND SEAT FURNITURE; CUSHIONS; LUMBAR SUPPORT CUSHIONS FOR CHAIRS, SEATS AND SEAT FURNITURE; PARTS AND FITTINGS FOR ALL THE AFORESAID GOODS (U.S. CLS. 2, 13, 22, 25, 32 AND 50).
KEVIN DINALLO, EXAMINING ATTORNEY

SN 77-300,769. MISSION ONE, INC., SCOTTSDALE, AZ. FILED 10-10-2007.

Mission One

SN 77-300,720. L & P SWISS HOLDING COMPANY, WITTENBACH, SWITZERLAND, FILED 10-10-2007.

P3

THE MARK CONSISTS OF STANDARD CHARACTERS WITHOUT CLAIM TO ANY PARTICULAR FONT, STYLE, SIZE, OR COLOR.

PRIORITY CLAIMED UNDER SEC. 44(D) ON ERPNCMNTY TM OFC APPLICATION NO. 006064356, FILED 6-26-2007, REG. NO. 006064356, DATED 5-19-2008, EXPIRES 6-26-2017.

CLASS 10—MEDICAL APPARATUS

FOR SPECIALLY DESIGNED FURNITURE FOR MEDICAL AND DENTAL PURPOSES, NAMELY, MEDICAL AND DENTAL EXAMINATION CHAIRS; CHAIRS FOR MEDICAL AND DENTAL PURPOSES, NAMELY, MEDICAL AND DENTAL EXAMINATION CHAIRS, MASSAGE CHAIRS; SPECIALLY DESIGNED SEAT COMPONENTS FOR MEDICAL USE, NAMELY, BACKRESTS CUSHIONS, ERGONOMIC REST CUSHIONS AND REST CUSHIONS FOR LORDOSIS PATIENTS; PARTS AND FITTINGS FOR ALL THE AFORESAID GOODS (U.S. CLS. 26, 39 AND 44).

CLASS 12—VEHICLES

FOR SEATS FOR VEHICLES; BACK SUPPORT APPARATUS, BACK SUPPORTS AND BACK LEANER CUSHIONS ALL FOR VEHICLE SEATS; LUMBAR SUPPORT DEVICES FOR VEHICLE SEATS; PULL-CABLE ARRANGEMENTS SPECIFICALLY ADAPTED FOR USE IN VEHICLES AND ACTUATORS FOR ACTUATING SUCH PULL-CABLE ARRANGEMENTS, ALL FOR ADJUSTING VEHICLE SEATS, HEADRESTS OF VEHICLES OR PARTS THEREOF; PARTS AND FITTINGS FOR ALL THE AFORESAID GOODS (U.S. CLS. 19, 21, 23, 31, 35 AND 44).

CLASS 20—FURNITURE AND ARTICLES NOT OTHERWISE CLASSIFIED

FOR FURNITURE; CHAIRS AND SEATS; SEAT FURNITURE; OFFICE FURNITURE; BACK SUPPORT CUSHIONS AND BACK LEANER CUSHIONS, NOT FOR MEDICAL PURPOSES, FOR CHAIRS, SEATS AND SEAT FURNITURE; CUSHIONS; LUMBAR SUPPORT DEVICES FOR CHAIRS, SEATS AND SEAT FURNITURE; PARTS AND FITTINGS FOR ALL THE AFORESAID GOODS (U.S. CLS. 2, 13, 22, 25, 32 AND 50).
KEVIN DINALLO, EXAMINING ATTORNEY

THE MARK CONSISTS OF STANDARD CHARACTERS WITHOUT CLAIM TO ANY PARTICULAR FONT, STYLE, SIZE, OR COLOR.

NO CLAIM IS MADE TO THE EXCLUSIVE RIGHT TO USE "MISSION", APART FROM THE MARK AS SHOWN.

CLASS 36—INSURANCE AND FINANCIAL

FOR MISSIONARY AND MISSION DEVELOPMENT SERVICES, NAMELY, CHARITABLE FUNDRAISING (U.S. CLS. 100, 101 AND 102).
FIRST USE 7-22-1991; IN COMMERCE 7-22-1991.

CLASS 41—EDUCATION AND ENTERTAINMENT

FOR DEVELOPMENT SERVICES, NAMELY, TRAINING AND MENTORING RELIGIOUS MISSIONARIES AND EDUCATION SERVICES, NAMELY, PROVIDING CLASSES AND TUTORING IN THE FIELD OF BIBLICAL INSTRUCTION, CULTURES, UNDERLYING CULTURAL ASSUMPTIONS, AND THE CHRISTIAN MISSION MOVEMENT (U.S. CLS. 100, 101 AND 107).
FIRST USE 7-22-1991; IN COMMERCE 7-22-1991.

CLASS 45—PERSONAL AND LEGAL SERVICES

FOR RELIGIOUS MINISTERIAL SERVICES, NAMELY, EVANGELISM, MISSIONARY SERVICES, AND PROVIDING INFORMATION CONCERNING MISSIONARIES, MISSIONS, AND MISSIONARY PROJECTS (U.S. CLS. 100 AND 101).
FIRST USE 7-22-1991; IN COMMERCE 7-22-1991.
KATHLEEN LORENZO, EXAMINING ATTORNEY

SN 77-302,742. BOARD OF REGENTS OF THE UNIVERSITY SYSTEM OF GEORGIA, ATLANTA, GA. FILED 10-12-2007.

GEORGIA ONMYLINE

THE MARK CONSISTS OF STANDARD CHARACTERS WITHOUT CLAIM TO ANY PARTICULAR FONT, STYLE, SIZE, OR COLOR.

OWNER OF U.S. REG. NOS. 1,298,360, 3,025,570 AND OTHERS.
SEC. 2(F) "GEORGIA".

CLASS 35—ADVERTISING AND BUSINESS

FOR ADVERTISING SERVICES, NAMELY, PROMOTING AND MARKETING THROUGH TELEVISION, PRINT, CD-ROM, WEB DESIGN AND ALL PUBLIC COMMUNICATION MEANS; ON-LINE ADVERTISING AND MARKETING OF ONLINE COURSES AT THE COLLEGE AND GRADUATE LEVELS AND DEGREE PROGRAMS; ENROLLING STUDENTS IN THE EDUCATIONAL PROGRAMS OF OTHERS, NAMELY, ONLINE COURSES AT THE COLLEGE AND GRADUATE LEVELS AND DEGREE PROGRAMS (U.S. CLS. 100, 101 AND 102).

CLASS 41—EDUCATION AND ENTERTAINMENT

FOR PROVIDING INFORMATION OVER A GLOBAL COMPUTER NETWORK IN THE FIELD OF EDUCATION, NAMELY, INFORMATION RELATED TO SEARCHING FOR ONLINE COURSES AT THE COLLEGE AND GRADUATE LEVELS AND DEGREE PROGRAMS (U.S. CLS. 100, 101 AND 107).

JUSTINE D. PARKER, EXAMINING ATTORNEY

SN 77-304,298. THE POWER OF WE, LLC, WILMINGTON, DE. FILED 10-15-2007.

BEYOND THE BOARDROOM

THE MARK CONSISTS OF STANDARD CHARACTERS WITHOUT CLAIM TO ANY PARTICULAR FONT, STYLE, SIZE, OR COLOR.

CLASS 16—PAPER GOODS AND PRINTED MATTER

FOR BOOKS, BOOKLETS, BROCHURES, JOURNALS, MAGAZINES IN THE FIELDS OF PERSONAL RELATIONSHIPS, PERSONAL IMPROVEMENT, PARTNERSHIPS, MANAGEMENT, LEADERSHIP AND MOTIVATION; CALENDARS (U.S. CLS. 2, 5, 22, 23, 29, 37, 38 AND 50).

CLASS 41—EDUCATION AND ENTERTAINMENT

FOR EDUCATIONAL AND ENTERTAINMENT SERVICES, NAMELY, PRODUCTION OF TELEVISION AND CABLE TELEVISION PROGRAMS IN THE FIELDS OF PERSONAL RELATIONSHIPS, PERSONAL IMPROVEMENT, PARTNERSHIPS, MANAGEMENT, LEADERSHIP AND MOTIVATION (U.S. CLS. 100, 101 AND 107).

LOURDES AYALA, EXAMINING ATTORNEY

SN 77-303,369. JOTT NETWORKS, INC., SEATTLE, WA. FILED 10-12-2007.



THE MARK CONSISTS OF THE WORDS "JOTT THE VOTE"; THE LETTER "O" IN THE WORD "VOTE" CONTAINS A CHECK MARK; AND TWO CURVED ARCS ARE ABOVE AND BELOW THE LETTER "O" IN THE WORD "VOTE"

CLASS 9—ELECTRICAL AND SCIENTIFIC APPARATUS

FOR COMPUTER SOFTWARE FOR IMPLEMENTING COMMUNICATIONS BY AND BETWEEN MOBILE PHONES, PERSONAL DIGITAL ASSISTANTS (PDAS), SEARCH ENGINES, THE INTERNET AND OTHER TECHNOLOGY FOR RECORDING, SAVING AND SENDING VOICE AND DATA NOTES AND MESSAGES AS AN INTEGRATED MEMORY AID SYSTEM (U.S. CLS. 21, 23, 26, 36 AND 38).

CLASS 38—COMMUNICATION

FOR WEB-BASED COMMUNICATION AND ORGANIZATION SERVICES, NAMELY, RECORDING, SAVING AND TRANSMITTING VOICE AND DATA NOTES AND MESSAGES VIA MOBILE PHONES, PERSONAL DIGITAL ASSISTANTS (PDAS), SEARCH ENGINES, THE INTERNET AND OTHER TECHNOLOGY (U.S. CLS. 100, 101 AND 104).

RONALD MCMORROW, EXAMINING ATTORNEY

SN 77-304,721. SONY COMPUTER ENTERTAINMENT AMERICA INC., FOSTER CITY, CA. FILED 10-15-2007.

SOCOM

THE MARK CONSISTS OF STANDARD CHARACTERS WITHOUT CLAIM TO ANY PARTICULAR FONT, STYLE, SIZE, OR COLOR.

THE WORD "SOCOM" HAS NO MEANING IN A FOREIGN LANGUAGE

CLASS 9—ELECTRICAL AND SCIENTIFIC APPARATUS

FOR COMPUTER GAME SOFTWARE AND VIDEO GAME SOFTWARE (U.S. CLS. 21, 23, 26, 36 AND 38).

CLASS 41—EDUCATION AND ENTERTAINMENT

FOR ENTERTAINMENT, NAMELY, PROVIDING AN ONLINE COMPUTER GAME (U.S. CLS. 100, 101 AND 107).

BILL DAWE, EXAMINING ATTORNEY

SN 77-305,294. RAFFLES INTERNATIONAL LIMITED, SINGAPORE, SINGAPORE, FILED 10-16-2007.

NEW ASIA BAR & GRILL

THE MARK CONSISTS OF STANDARD CHARACTERS WITHOUT CLAIM TO ANY PARTICULAR FONT, STYLE, SIZE, OR COLOR.

NO CLAIM IS MADE TO THE EXCLUSIVE RIGHT TO USE "BAR & GRILL", APART FROM THE MARK AS SHOWN.

CLASS 35—ADVERTISING AND BUSINESS

FOR BUSINESS MANAGEMENT OF FOOD OUTLETS AND BEVERAGE OUTLETS; BUSINESS MANAGEMENT CONSULTING SERVICES RELATING TO FOOD OUTLETS AND BEVERAGE OUTLETS; THE BRINGING TOGETHER, FOR THE BENEFIT OF OTHERS, OF A VARIETY OF GOODS, ENABLING CUSTOMERS TO CONVENIENTLY VIEW AND PURCHASE THOSE GOODS IN THE FIELD OF FOODS AND BEVERAGES; ADVISORY AND CONSULTING SERVICES RELATING TO ALL THE AFORESAID SERVICES (U.S. CLS. 100, 101 AND 102).

CLASS 43—HOTEL AND RESTAURANT SERVICES

FOR PROVIDING BANQUETING SERVICES AND FOOD AND BEVERAGE FACILITIES; CAFES, BAR SERVICES, COCKTAIL LOUNGES, RESTAURANTS, BISTRO, BRASSERIE, AND COFFEE SHOPS AND SERVICES RELATED TO THE FOREGOING, NAMELY, PROVIDING FOOD AND DRINK; FOOD PREPARATION SERVICES; CARRY-OUT AND TAKE-OUT RESTAURANT SERVICES; PROVISION OF FOOD AND DRINK CATERING SERVICES AT MEETINGS, CONFERENCES, CONVENTIONS, EXHIBITIONS AND SOCIAL FUNCTIONS; HOTEL CATERING SERVICES; CONSULTING SERVICES IN THE FIELD OF HOSPITALITY AND/OR CULINARY ARTS (U.S. CLS. 100 AND 101).

JAY FLOWERS, EXAMINING ATTORNEY

SN 77-307,886. PUNKIN SEED, INC., YPSILANIT, MI. FILED 10-18-2007.



THE MARK CONSISTS OF THREE SPACED PUMPKIN SEEDS ARRANGED ABOUT A FOCAL POINT AND HAVING AN UPPER PUMPKIN SEED ILLUSTRATED WITH A PAIR OF EYES, A CURL OF HAIR AND A PACIFIER.

CLASS 24—FABRICS

FOR EMBROIDERED FABRICS, NAMELY, BURP CLOTHS, TOWELS, HOODED TOWELS AND CHILDREN'S BLANKETS (U.S. CLS. 42 AND 50).
FIRST USE 7-20-2007; IN COMMERCE 7-20-2007.

CLASS 25—CLOTHING

FOR CHILDREN'S CLOTHING, NAMELY, CLOTH BIBS, WITH TAGS, AS USED IN COMMERCE (U.S. CLS. 22 AND 39).
FIRST USE 7-20-2007; IN COMMERCE 7-20-2007.
JOHN GARTNER, EXAMINING ATTORNEY

SN 77-309,364. LOWSON, LINDA M., HUNTINGTON, NY. FILED 10-21-2007.

SOCIAL RESPONSIBILITY CHANNEL

THE MARK CONSISTS OF STANDARD CHARACTERS WITHOUT CLAIM TO ANY PARTICULAR FONT, STYLE, SIZE, OR COLOR.

NO CLAIM IS MADE TO THE EXCLUSIVE RIGHT TO USE NO CLAIM IS MADE TO THE EXCLUSIVE RIGHT TO USE "CHANNEL" APART FROM THE MARK AS SHOWN, FOR INTERNATIONAL CLASS 42, APART FROM THE MARK AS SHOWN.

CLASS 18—LEATHER GOODS

FOR ALL PURPOSE SPORT BAGS; ALL-PURPOSE CARRYING BAGS; ANIMAL CARRIERS; ANIMAL HARNESES; ANIMAL LEASHES; BABY CARRYING BAGS; BACKPACKS; BEACH BAGS; BEACH UMBRELLAS; BOOK BAGS; BRIEFCASES; CANVAS SHOPPING BAGS; CARRY-ALL BAGS; CLOTHING FOR ANIMALS; COLLARS FOR PETS; DUFFLE BAGS; GYM BAGS; HANDBAGS; KEY CASES; MULTI-PURPOSE PURSES; PET CLOTHING; SCHOOL BAGS; SHOULDER BAGS; TOTE BAGS; TRAVEL BAGS; UMBRELLAS; WALLETS (U.S. CLS. 1, 2, 3, 22 AND 41).

CLASS 25—CLOTHING

FOR (BASED ON INTENT TO USE) HEADGEAR, NAMELY, CAPS, HATS, HEADBANDS, EAR MUFFS, AND SCARVES; INFANTWEAR; JACKETS; JEANS; JERSEYS; JOGGING OUTFITS; PULLOVERS; SHIRTS; SPORTS JACKETS; SPORTS SHIRTS; SWEATBANDS; TANK TOPS; TEE SHIRTS; TENNIS WEAR; WIND-JACKETS; BEACHWEAR; COVERALLS; INFANT AND TODDLER ONE PIECE CLOTHING; RAINWEAR; SHORT SETS; SKI WEAR; SLEEPWEAR; SWEAT SUITS; SWIMWEAR; TRACKSUITS; V-NECK SWEATERS; VESTS; WET SUITS; WRISTBANDS; YOGA PANTS; YOGA SHIRTS (U.S. CLS. 22 AND 39).

CLASS 42—SCIENTIFIC AND COMPUTER SERVICES

FOR (BASED ON INTENT TO USE) DESIGN AND DEVELOPMENT OF MULTIMEDIA PRODUCTS; HOSTING AN ONLINE COMMUNITY WEBSITE FEATURING BUSINESS AND SOCIAL NETWORKING SERVICES; PROVIDING CUSTOMIZED ON-LINE WEB PAGES FEATURING USER-DEFINED INFORMATION, WHICH INCLUDES SEARCH ENGINES AND ON-LINE WEB LINKS TO OTHER WEB SITES; PROVIDING INFORMATION AT THE SPECIFIC REQUEST OF END-USERS BY MEANS OF TELEPHONE OR GLOBAL COMPUTER NETWORKS; WEB SITE HOSTING SERVICES; CONSULTING SERVICES IN THE FIELD OF FENG SHUI (U.S. CLS. 100 AND 101).

ALICE BENMAMAN, EXAMINING ATTORNEY

SN 77-309,805. GHARABEGIAN, ARMEN, GLENDALE, CA. FILED 10-22-2007.

BAMBOOBABY.COM

THE MARK CONSISTS OF STANDARD CHARACTERS WITHOUT CLAIM TO ANY PARTICULAR FONT, STYLE, SIZE, OR COLOR.

CLASS 35—ADVERTISING AND BUSINESS

FOR ON-LINE RETAIL STORE SERVICES FEATURING BABY FURNITURE, LIGHTING AND HOME DECOR ITEMS (U.S. CLS. 100, 101 AND 102).

CLASS 42—SCIENTIFIC AND COMPUTER SERVICES

FOR PROVIDING INFORMATION IN THE FIELD OF FURNITURE DESIGN, NAMELY, BABY FURNITURE, VIA A GLOBAL COMMUNICATION NETWORK SUCH AS THE INTERNET (U.S. CLS. 100 AND 101).

STEPHEN AQUILA, EXAMINING ATTORNEY

SN 77-309,898. BAYER AKTIENGESELLSCHAFT, LEVERKUSEN-BAYERWERK, FED REP GERMANY, FILED 10-22-2007.

FIBERMAX

THE MARK CONSISTS OF STANDARD CHARACTERS WITHOUT CLAIM TO ANY PARTICULAR FONT, STYLE, SIZE, OR COLOR.

OWNER OF U.S. REG. NOS. 2,991,782 AND 3,057,126.

CLASS 24—FABRICS

FOR TEXTILES AND TEXTILE GOODS, NAMELY, BED SHEETS, PILLOW CASES, DUVET COVERS, BED COVERS, BED BLANKETS, FABRIC VALANCES, TABLE CLOTHS, PLACEMATS MADE OF TEXTILE MATERIALS AND NAPKINS MADE OF TEXTILE MATERIALS; EMBROIDERY PRODUCTS, NAMELY, CANVAS FOR EMBROIDERY; TOWELS, BATH TOWELS, HANDKERCHIEFS, CLOTH-MADE PENNANTS AND FLAGS (U.S. CLS. 42 AND 50).

CLASS 25—CLOTHING

FOR CLOTHING, NAMELY, SHIRTS, SHORTS AND DRESSES; FOOTWEAR, NAMELY, CLOTH SHOES, BEACH SHOES, SOCKS, STOCKINGS; HEADGEAR, NAMELY, HATS, CAPS, SCARVES, TURBANS; TIES, BOW TIES (U.S. CLS. 22 AND 39).

CLASS 26—FANCY GOODS

FOR LACE PRODUCTS, NAMELY, LACE AND LACE TRIMMING; EMBROIDERY PRODUCTS, NAMELY, EMBROIDERY (U.S. CLS. 37, 39, 40, 42 AND 50).

CLASS 27—FLOOR COVERINGS

FOR COTTON RUGS (U.S. CLS. 19, 20, 37, 42 AND 50).
GENE MACIOL, EXAMINING ATTORNEY

SN 77-310,552. SKYUNION HONG KONG HOLDING LIMITED, HONG KONG, CHINA, FILED 10-23-2007.



THE COLOR(S) YELLOW, WHITE, ORANGE AND BLACK IS/ARE CLAIMED AS A FEATURE OF THE MARK.

THE MARK CONSISTS OF THE CAPITAL LETTERS "IGG". THE "I" AND THE LETTER "G" IS YELLOW AND BORDERED IN ORANGE AND BLACK. THE LETTER "G" ON THE RIGHT IS WHITE AND BORDERED IN YELLOW AND BLACK. THERE IS A PAIR OF EYES OVERLAPPING THE TWO LETTER "G'S" THAT ARE WHITE AND BORDERED IN BLACK.

CLASS 9—ELECTRICAL AND SCIENTIFIC APPARATUS

FOR COMPUTER GAME CARTRIDGES; COMPUTER GAME CASSETTES; COMPUTER GAME DISCS; COMPUTER GAME EQUIPMENT CONTAINING MEMORY DEVICES NAMELY, DISCS; COMPUTER GAME JOYSTICKS; COMPUTER GAME PROGRAMS; COMPUTER GAME SOFTWARE; COMPUTER GAME SOFTWARE, NAMELY A COMPUTER CRAPS GAME; COMPUTER GAME TAPES; COMPUTER HARDWARE AND COMPUTER SOFTWARE PROGRAMS FOR THE INTEGRATION OF TEXT, AUDIO, GRAPHICS, STILL IMAGES AND MOVING PICTURES INTO AN INTERACTIVE DELIVERY FOR MULTIMEDIA APPLICATIONS; COMPUTER HARDWARE AND SOFTWARE FOR SETTING UP AND CONFIGURING LOCAL AREA NETWORKS; COMPUTER HARDWARE AND SOFTWARE FOR SETTING UP AND CONFIGURING WIDE AREA NETWORKS; COMPUTER PROGRAMS FOR PRE-RECORDED GAMES; COMPUTER PROGRAMS FOR SEARCHING THE CONTENTS OF COMPUTERS AND COMPUTER NETWORKS BY REMOTE CONTROL; COMPUTER PROGRAMS FOR THE ENABLING OF ACCESS OR ENTRANCE CONTROL; COMPUTER SOFTWARE AND FIRMWARE FOR GAMES OF CHANCE ON ANY COMPUTERIZED PLATFORM, INCLUDING DEDICATED GAMING CONSOLES, VIDEO BASED SLOT MACHINES, REEL BASED SLOT MACHINES, AND VIDEO LOTTERY TERMINALS; COMPUTER SOFTWARE FOR ACCESSING INFORMATION DIRECTORIES THAT MAY BE DOWNLOADED FROM THE GLOBAL COMPUTER NETWORK; COMPUTER SOFTWARE FOR ADMINISTRATION OF COMPUTER LOCAL AREA NETWORKS; COMPUTER SOFTWARE FOR ADMINISTRATION OF COMPUTER NETWORKS; COMPUTER SOFTWARE FOR COMMUNICATING WITH USERS OF HAND-HELD COMPUTERS; COMPUTER SOFTWARE FOR COMPUTER SYSTEM AND APPLICATION DEVELOPMENT, DEPLOYMENT AND MANAGEMENT; COMPUTER SOFTWARE FOR CONTROLLING AND MANAGING ACCESS SERVER APPLICATIONS; COMPUTER SOFTWARE FOR CONTROLLING AND MANAGING PATIENT MEDICAL INFORMATION; COMPUTER SOFTWARE FOR REDISTRICTING, NAMELY, AGGREGATING SMALLER GEOGRAPHICAL AREAS INTO MULTIPLE LARGER AREAS; COMPUTER SOFTWARE FOR THE CREATION OF FIREWALLS; COMPUTER SOFTWARE FOR THE FIELD OF WAREHOUSING AND DISTRIBUTION, TO MANAGE TRANSACTIONAL DATA, PROVIDE STATISTICAL ANALYSIS, AND PRODUCE NOTIFICATIONS AND REPORTS; COMPUTER SOFTWARE FOR THE MANAGEMENT OF COMMERCIAL PRINTING COMPANIES IN THE FIELD OF COST ESTIMATING, PRODUCTION PLANNING, SCHEDULING PRODUCTION, BINDING, SHIPPING AND ANALYSIS OF THE PRINTING JOB (U.S. CLS. 21, 23, 26, 36 AND 38).

FIRST USE 5-20-2006; IN COMMERCE 5-20-2006.

CLASS 41—EDUCATION AND ENTERTAINMENT

FOR ON-LINE PUBLICATION OF BOOKS; PROVIDING ON-LINE PUBLICATIONS IN THE NATURE OF NEWSLETTERS IN THE FIELD OF COMPUTER GAMES; PUBLICATION OF BOOKS; PUBLICATION OF BOOKS, MAGAZINES, ALMANACS AND JOURNALS; PUBLICATION OF BOOKS, OF MAGAZINES, OF JOURNALS, OF NEWSPAPERS, OF PERIODICALS, OF CATALOGS, OF BROCHURES; PUBLICATION OF BOOKS, REVIEWS; PUBLICATION OF BROCHURES; PUBLICATION OF ELECTRONIC MAGAZINES; PUBLICATION OF ELECTRONIC NEWSPAPERS ACCESSIBLE VIA A GLOBAL COMPUTER NETWORK; PUBLICATION OF JOURNALS; PUBLICATION OF LEAFLETS; PUBLICATION OF MAGAZINES; PUBLICATION OF MANUALS; PUBLICATION OF MUSICAL TEXTS; PUBLICATION OF PERIODICALS; PUBLICATION OF PRINTED MATTER; PUBLICATION OF TEXT BOOKS; PUBLICATION OF TEXTS, BOOKS, JOURNALS; PUBLICATION OF TEXTS, BOOKS, MAGAZINES AND OTHER PRINTED MATTER; PUBLICATION OF TEXTS OR MAGAZINES; PUBLISHING OF ELECTRONIC PUBLICATIONS (U.S. CLS. 100, 101 AND 107).

FIRST USE 5-20-2006; IN COMMERCE 5-20-2006.
MICHAEL KEATING, EXAMINING ATTORNEY

SN 77-313,232. JARROW FORMULAS, INC., LOS ANGELES, CA. FILED 10-25-2007.

JARROW SKIN HEALTH SYSTEM

THE MARK CONSISTS OF STANDARD CHARACTERS WITHOUT CLAIM TO ANY PARTICULAR FONT, STYLE, SIZE, OR COLOR.

OWNER OF U.S. REG. NOS. 2,752,977, 3,339,174 AND OTHERS.

NO CLAIM IS MADE TO THE EXCLUSIVE RIGHT TO USE "SKIN HEALTH SYSTEM", APART FROM THE MARK AS SHOWN.

CLASS 3—COSMETICS AND CLEANING PREPARATIONS

FOR SKIN CARE PRODUCTS, NAMELY, NON-MEDICATED PREPARATIONS FOR TOPICAL USE, NAMELY, SERUMS, LOTIONS, CREAMS, BALMS, GELS, OILS, TONERS, TEXTURIZERS, CLEANSERS, MASKS AND PEELS (U.S. CLS. 1, 4, 6, 50, 51 AND 52).

CLASS 5—PHARMACEUTICALS

FOR DIETARY AND NUTRITIONAL SUPPLEMENTS (U.S. CLS. 6, 18, 44, 46, 51 AND 52).

JAMES STEIN, EXAMINING ATTORNEY

SN 77-313,291. PERKINELMER LAS, INC., WALTHAM, MA. FILED 10-25-2007.



THE COLOR(S) GREEN AND BLUE IS/ARE CLAIMED AS A FEATURE OF THE MARK.

THE MARK CONSISTS OF THE WORDING "E ECOANALYTIX", WITH THE LETTERS "E" AND "ECO" SHOWN IN GREEN, AND "ANALYTIX" SHOWN IN BLUE.

CLASS 1—CHEMICALS

FOR ASSAYS AND REAGENTS FOR RESEARCH USE (U.S. CLS. 1, 5, 6, 10, 26 AND 46).

CLASS 9—ELECTRICAL AND SCIENTIFIC APPARATUS

FOR SCIENTIFIC INSTRUMENTS AND APPARATUS, FOR USE IN THE FIELDS OF BIOFUELS, ENVIRONMENTAL SCIENCE, FOODS AND BEVERAGES, FORENSICS, CHEMICALS, HYDROCARBON PROCESSING, MATERIALS CHARACTERIZATION, NANOMATERIALS, PHARMACEUTICALS AND SEMICONDUCTORS, NAMELY, ANALYZERS FOR TESTING FOODS, BEVERAGES AND DRINKING WATER FOR THE PRESENCE OF CONTAMINANTS, ANALYZERS FOR TESTING FUELS FOR THE PRESENCE OF CONTAMINANTS AND FOR CORRECT COMPOSITION OF THE FUELS; SCIENTIFIC INSTRUMENTS, NAMELY, ELECTRONIC ANALYZERS FOR TESTING CONSUMER PRODUCTS FOR THE PRESENCE OF CONTAMINANTS; SCIENTIFIC INSTRUMENTS, NAMELY, ELECTRONIC ANALYZERS FOR MEASURING, TESTING AND DETECTING CONTAMINANTS AND ENVIRONMENTAL POLLUTANTS; COMPUTER HARDWARE; COMPUTER SOFTWARE FOR USE IN THE FIELDS OF BIOFUELS, ENVIRONMENTAL SCIENCE, FOODS AND BEVERAGES, FORENSICS, CHEMICALS, HYDROCARBON PROCESSING, MATERIALS CHARACTERIZATION, NANOMATERIALS, PHARMACEUTICALS AND SEMICONDUCTORS, NAMELY, SOFTWARE FOR OPERATING LABORATORY ANALYZERS AND FOR THE COLLECTION, STORAGE, MANAGEMENT AND REPORTING OF LABORATORY TESTING AND ANALYSIS DATA (U.S. CLS. 21, 23, 26, 36 AND 38).

CLASS 41—EDUCATION AND ENTERTAINMENT

FOR TRAINING IN THE USE AND OPERATION OF SCIENTIFIC INSTRUMENTS FOR LABORATORY ANALYSIS, TESTING AND RESEARCH, AND IN THE USE AND OPERATION OF COMPUTER SOFTWARE; PROVIDING RECOGNITION AND INCENTIVES BY WAY OF AWARDS TO DEMONSTRATE EXCELLENCE IN THE FIELDS OF SCIENCE AND LABORATORY SKILLS (U.S. CLS. 100, 101 AND 107).

ANDREA K. NADELMAN, EXAMINING ATTORNEY

SN 77-314,615. BUNN-O-MATIC CORPORATION, SPRINGFIELD, IL. FILED 10-26-2007.



OWNER OF U.S. REG. NOS. 2,172,863, 3,307,727 AND OTHERS.

CLASS 35—ADVERTISING AND BUSINESS

FOR MANAGED SERVICE PROGRAM, NAMELY, PERFORMING INVENTORY INSPECTIONS, SERVICE DISPATCHING, MAINTENANCE PROGRAM PLANNING, EQUIPMENT LEASING PROGRAMS; AND MAINTAINING RECORDS OF PURCHASES, PRODUCTIVITY, MAINTENANCE HISTORY, ACCOUNT HISTORY, AND LOCATION AND DISPOSITION OF CUSTOMERS' ASSETS, NAMELY, BEVERAGE PREPARATION AND SERVICE EQUIPMENT (U.S. CLS. 100, 101 AND 102).

FIRST USE 3-27-2006; IN COMMERCE 3-27-2006.

CLASS 37—CONSTRUCTION AND REPAIR

FOR REPAIR, RESTORATION, MAINTENANCE AND INSTALLATION OF BEVERAGE PREPARATION AND DISPENSING EQUIPMENT, NAMELY, ELECTRIC COFFEE MAKERS, TEA BREWERS, WATER HEATER MACHINES, ESPRESSO MACHINES, JUICE MACHINES, POWDERED BEVERAGE MACHINES, FROZEN AND SEMI-FROZEN BEVERAGE MACHINES, BEVERAGE SERVERS, HEATED AND REFRIGERATED BEVERAGE UNITS, WATER TREATMENT EQUIPMENT, MILK FOAMERS, MILK FROTHING UNITS, COFFEE GRINDERS (U.S. CLS. 100, 103 AND 106).

FIRST USE 3-27-2006; IN COMMERCE 3-27-2006.

KATHLEEN LORENZO, EXAMINING ATTORNEY

SN 77-314,746. ALENE KORBY, PALOS HEIGHTS, IL. FILED 10-26-2007.

PLUM SUITE

THE MARK CONSISTS OF STANDARD CHARACTERS WITHOUT CLAIM TO ANY PARTICULAR FONT, STYLE, SIZE, OR COLOR.

NO CLAIM IS MADE TO THE EXCLUSIVE RIGHT TO USE "SUITE", APART FROM THE MARK AS SHOWN.

CLASS 37—CONSTRUCTION AND REPAIR

FOR CONSULTING SERVICES IN THE FIELD OF RESIDENTIAL AND COMMERCIAL CONSTRUCTION AND RENOVATION (U.S. CLS. 100, 103 AND 106).

CLASS 42—SCIENTIFIC AND COMPUTER SERVICES

FOR DESIGN AND TESTING OF PRODUCTS FOR OTHERS; DESIGN FOR OTHERS IN THE FIELD OF RESIDENTIAL AND COMMERCIAL CONSTRUCTION AND RENOVATION (U.S. CLS. 100 AND 101).

TRACY CROSS, EXAMINING ATTORNEY

SN 77-314,767. NICKEY CHICAGO, INC., ST. CHARLES, IL. FILED 10-26-2007.



OWNER OF U.S. REG. NOS. 2,502,627, 2,889,108 AND OTHERS.

NO CLAIM IS MADE TO THE EXCLUSIVE RIGHT TO USE "CHICAGO", APART FROM THE MARK AS SHOWN.

THE MARK CONSISTS OF STYLIZED LETTERS SPELLING "NICKEY", IN WHICH THE LETTER "K" IS BACKWARDS; THE WORD "NICKEY" IS INSIDE A RECTANGLE DESIGN WHICH IS LONGER ON THE TOP IN RELATION TO THE BOTTOM WITH INDENTED SIDES; THE WORD "CHICAGO" IS SITUATED BELOW THE WORD "NICKEY".

CLASS 37—CONSTRUCTION AND REPAIR

FOR RESTORATION AND CUSTOM REBUILDING OF EXISTING LAND VEHICLES AND PARTS THEREFOR (U.S. CLS. 100, 103 AND 106).

FIRST USE 9-1-2006; IN COMMERCE 9-1-2006.

CLASS 40—MATERIAL TREATMENT

FOR CUSTOM MANUFACTURE OF AUTOMOBILES (U.S. CLS. 100, 103 AND 106).
FIRST USE 9-1-2006; IN COMMERCE 9-1-2006.
MELISSA VALLILLO, EXAMINING ATTORNEY

SN 77-314,778. ALENE KORBY, PALOS HEIGHTS, IL. FILED 10-26-2007.

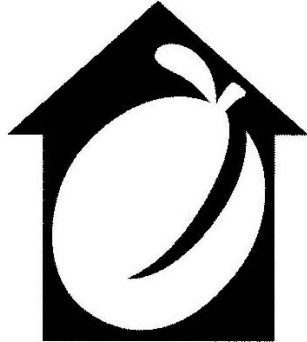

THE MARK CONSISTS OF A FANCIFUL DESIGN THAT INCLUDES A DISTINCTIVE PLUM IN A HOUSE SHAPE.

CLASS 37—CONSTRUCTION AND REPAIR

FOR CONSULTING SERVICES IN THE FIELD OF RESIDENTIAL AND COMMERCIAL CONSTRUCTION AND RENOVATION (U.S. CLS. 100, 103 AND 106).

CLASS 42—SCIENTIFIC AND COMPUTER SERVICES

FOR DESIGN AND TESTING OF PRODUCTS FOR OTHERS; DESIGN FOR OTHERS IN THE FIELD OF RESIDENTIAL AND COMMERCIAL CONSTRUCTION AND RENOVATION (U.S. CLS. 100 AND 101).
TRACY CROSS, EXAMINING ATTORNEY

SN 77-316,730. CRUMP GROUP, INC., ROSELAND, NJ. FILED 10-30-2007.

PEOPLE MATTER. QUALITY
FIRST. INTEGRITY ALWAYS.

THE MARK CONSISTS OF STANDARD CHARACTERS WITHOUT CLAIM TO ANY PARTICULAR FONT, STYLE, SIZE, OR COLOR.

CLASS 9—ELECTRICAL AND SCIENTIFIC APPARATUS

FOR SOFTWARE FOR USE IN RETIREMENT PLANNING AND RETIREMENT EDUCATION; PROVIDING DOWNLOADABLE ELECTRONIC BENEFIT PLAN, RETIREMENT ACCOUNT, AND HEALTH SAVINGS ACCOUNT FORMS AND DOCUMENTS; CD-ROMS CONTAINING BENEFIT PLAN, RETIREMENT ACCOUNT, AND HEALTH SAVINGS ACCOUNT FORMS AND DOCUMENTS (U.S. CLS. 21, 23, 26, 36 AND 38).

CLASS 16—PAPER GOODS AND PRINTED MATTER

FOR PRINTED BENEFIT PLAN, RETIREMENT ACCOUNT, AND HEALTH SAVINGS ACCOUNT FORMS AND DOCUMENTS (U.S. CLS. 2, 5, 22, 23, 29, 37, 38 AND 50).

CLASS 35—ADVERTISING AND BUSINESS

FOR BUSINESS RISK MANAGEMENT SERVICES (U.S. CLS. 100, 101 AND 102).

CLASS 36—INSURANCE AND FINANCIAL

FOR UNDERWRITING OF SURPLUS LINES INSURANCE; UNDERWRITING OF EXCESS INSURANCE; UNDERWRITING OF PROPERTY AND CASUALTY INSURANCE; UNDERWRITING OF WORKERS COMPENSATION INSURANCE; UNDERWRITING OF REINSURANCE; BROKERAGE OF LIFE INSURANCE; BROKERAGE OF DISABILITY INSURANCE; BROKERAGE OF LONG-TERM CARE INSURANCE; BROKERAGE OF HEALTH INSURANCE; BROKERAGE OF SURPLUS LINES INSURANCE; BROKERAGE OF EXCESS INSURANCE; BROKERAGE OF PROPERTY AND CASUALTY INSURANCE; BROKERAGE OF WORKERS COMPENSATION INSURANCE; BROKERAGE OF REINSURANCE; BROKERAGE OF ANNUITIES; PROVIDING THIRD PARTY ADMINISTRATION SERVICES IN THE FIELDS OF LIFE INSURANCE AND PROPERTY AND CASUALTY INSURANCE; INSURANCE SERVICES IN THE NATURE OF LOSS CONTROL MANAGEMENT FOR OTHERS; FINANCIAL RISK MANAGEMENT SERVICES; RECORDKEEPING AND ADMINISTRATION OF RETIREMENT PLANS, HEALTH SAVINGS ACCOUNTS AND BENEFIT PLANS FOR OTHERS; RECORDKEEPING AND ADMINISTRATION OF RETIREMENT ACCOUNTS FOR OTHERS; RETIREMENT PLAN TRUSTEE SERVICES; RETIREMENT PLAN CUSTODIAL SERVICES, NAMELY, HOLDING, ADMINISTERING AND TRANSFERRING CASH, SECURITIES, AND OTHER RETIREMENT PLAN ASSETS; PROVIDING BENEFIT PLAN, HEALTH SAVINGS ACCOUNT AND RETIREMENT ACCOUNT INFORMATION BY TELEPHONE AND VIA THE INTERNET; CONSULTATION IN THE FIELD OF ESTABLISHMENT AND MAINTENANCE OF BENEFIT PLANS, HEALTH SAVINGS ACCOUNTS AND RETIREMENT ACCOUNTS; CONSULTATION IN THE FIELD OF ENROLLMENT IN BENEFIT PLANS (U.S. CLS. 100, 101 AND 102).

CLASS 41—EDUCATION AND ENTERTAINMENT

FOR EDUCATIONAL SERVICES, NAMELY, CLASSES, COURSES, AND SEMINARS IN THE FIELDS OF RETIREMENT PLANNING AND HEALTH SAVINGS ACCOUNTS, AND DISTRIBUTING COURSE MATERIALS IN CONNECTION THEREWITH; TRAINING IN THE FIELDS OF RETIREMENT PLANNING AND HEALTH SAVINGS ACCOUNTS; PROVIDING ON-LINE NON-DOWNLOADABLE PUBLICATIONS, NAMELY, BENEFIT PLAN, RETIREMENT ACCOUNT, AND HEALTH SAVINGS ACCOUNT FORMS AND DOCUMENTS (U.S. CLS. 100, 101 AND 107).

CLASS 42—SCIENTIFIC AND COMPUTER SERVICES

FOR PROVIDING ON-LINE TEMPORARY USE OF NON-DOWNLOADABLE SOFTWARE FOR USE IN RETIREMENT PLANNING AND RETIREMENT EDUCATION; PROVIDING ON-LINE TEMPORARY USE OF NON-DOWNLOADABLE SOFTWARE FOR USE IN ADMINISTERING HEALTH SAVINGS ACCOUNTS; PROVIDING ON-LINE TEMPORARY USE OF NON-DOWNLOADABLE CLIENT RELATIONSHIP MANAGEMENT SOFTWARE; PROVIDING ON-LINE TEMPORARY USE OF NON-DOWNLOADABLE SOFTWARE FOR USE IN INSURANCE ADMINISTRATION; PROVIDING ON-LINE TEMPORARY USE OF NON-DOWNLOADABLE SOFTWARE FOR USE IN INSURANCE PROCESSING; PROVIDING ON-LINE TEMPORARY USE OF NON-DOWNLOADABLE SOFTWARE FOR USE IN CHANGING AND MODIFYING BENEFIT PLANS, HEALTH SAVINGS ACCOUNTS, AND RETIREMENT ACCOUNTS (U.S. CLS. 100 AND 101).

AHSEN KHAN, EXAMINING ATTORNEY

SN 77-319,984. KOMMONWEALTH, INC., LOS ANGELES, CA. FILED 11-2-2007.



THE MARK CONSISTS OF THE NUMBER "8" WITH A WING ON EACH SIDE AND LETTER "C" AND "R" IN EACH CRUX OF THE NUMBER "8".

CLASS 14—JEWELRY

FOR JEWELRY AND WATCHES (U.S. CLS. 2, 27, 28 AND 50).

CLASS 18—LEATHER GOODS

FOR HANDBAGS (U.S. CLS. 1, 2, 3, 22 AND 41).

CLASS 25—CLOTHING

FOR CLOTHING FOR WOMEN AND MEN, NAMELY, SHIRTS, WOVEN SHIRTS, POLO SHIRTS, T-SHIRTS, JACKETS, SWEATERS, SWEATSHIRTS, SHORTS, PANTS, JEANS, SOCKS, UNDERWEAR, WRIST BANDS, HEAD BANDS, COATS, SWEAT SUITS, TRACK SUITS, TANK TOPS, TRENCH COATS, RAIN COATS, CAPES, THERMAL SHIRTS AND PANTS, GLOVES, DRESS, SKIRTS, SUITS, KNICKERS, COVERALLS, OVERALLS, LEG WARMERS, WRAPS, BATHING SUITS, SWIM TRUNKS, SCARVES, HEAD WRAPS, JUMPERS, TIES, AND HATS AND CAPS (U.S. CLS. 22 AND 39).

CHRISTOPHER BUONGIORNO, EXAMINING ATTORNEY

SN 77-316,880. L.C.B. COMPANY S.R.L., SEE ADDNL. STMT., ITALY, FILED 10-30-2007.

MIRACLE MILE

THE MARK CONSISTS OF STANDARD CHARACTERS WITHOUT CLAIM TO ANY PARTICULAR FONT, STYLE, SIZE, OR COLOR.

OWNER OF ERPN CMNTY TM OFC REG. NO. 003975711, DATED 12-1-2005, EXPIRES 8-6-2014.

CLASS 18—LEATHER GOODS

FOR HANDBAGS; LUGGAGE; SHOULDER BAGS; BEACH BAGS; CLUTCH BAGS; ALL PURPOSE SPORTS BAGS; ATTACHE CASES; SCHOOL BAGS; TOTE BAGS; TRAVELLING BAGS; TRAVELING CASES OF LEATHER OR LEATHERBOARD AND IMITATION LEATHER; BUSINESS CARD CASES OF LEATHER OR LEATHERBOARD AND IMITATION LEATHER; DOCUMENT CASES OF LEATHER OR LEATHERBOARD AND IMITATION LEATHER; COSMETIC CASES SOLD EMPTY; KEYCASES; KNAPSACKS; RUCKSACKS; BRIEFCASES; PURSES; WALLETS; TRAVELLING TRUNKS; SUITCASES; UMBRELLAS; PARASOLS; WALKING STICKS (U.S. CLS. 1, 2, 3, 22 AND 41).

CLASS 25—CLOTHING

FOR PULLOVERS; GLOVES; CARDIGANS; JERSEYS; NECKWEAR; SWEATERS; SOCKS; STOCKINGS; TIGHTS; TROUSERS; LEGGINGS; SKIRTS; JACKETS; JERKINS; SHIRTS; VESTS; WAISTCOATS; JUMPERS; TRACK SUITS; BLOUSES; BLOUSONS; JEANS; SWEAT PANTS; GYM SUITS; KNICKERS; PANTS; SHORTS; T-SHIRTS; SWEAT-SHIRTS; SUITS AND DRESSES; OVERCOATS; COATS; ANORAKS; RAINCOATS; BELTS; SUSPENDERS; LOUNGEWEAR; UNDERWEAR; BEACHWEAR; SLEEPWEAR; FOOTWEAR; HEADWEAR; HOSIERY (U.S. CLS. 22 AND 39).

MICHAEL SOUDERS, EXAMINING ATTORNEY

SN 77-322,312. TOM MIRANDA OUTDOORS INC., ENGLEWOOD, FL. FILED 11-6-2007.

DOMINATE BUCKS

THE MARK CONSISTS OF STANDARD CHARACTERS WITHOUT CLAIM TO ANY PARTICULAR FONT, STYLE, SIZE, OR COLOR.

NO CLAIM IS MADE TO THE EXCLUSIVE RIGHT TO USE "BUCKS", APART FROM THE MARK AS SHOWN.

CLASS 9—ELECTRICAL AND SCIENTIFIC APPARATUS

FOR DVDS, VIDEOTAPES, AUDIOTAPES, DOWNLOADABLE VIDEO AND AUDIO FILES ALL IN THE FIELD OF HUNTING (U.S. CLS. 21, 23, 26, 36 AND 38).

CLASS 41—EDUCATION AND ENTERTAINMENT

FOR ENTERTAINMENT SERVICES, NAMELY, A SERIES IN THE FIELD OF HUNTING PROVIDED THROUGH SATELLITE TELEVISION, TELEVISION BROADCAST, CABLE TELEVISION (U.S. CLS. 100, 101 AND 107).

ANDREA HACK, EXAMINING ATTORNEY

CLASS 41—EDUCATION AND ENTERTAINMENT

FOR PHYSICAL FITNESS CONDITIONING CLASSES; PHYSICAL FITNESS INSTRUCTION; PROVIDING FITNESS AND EXERCISE FACILITIES (U.S. CLS. 100, 101 AND 107).

DARRYL SPRUILL, EXAMINING ATTORNEY

SN 77-322,632. PSS WORLD MEDICAL, INC., JACKSONVILLE, FL. FILED 11-6-2007.

CONSULT
diagnostics 

NO CLAIM IS MADE TO THE EXCLUSIVE RIGHT TO USE "DIAGNOSTICS", APART FROM THE MARK AS SHOWN.

THE STIPPLING IS FOR SHADING PURPOSES ONLY.

THE MARK CONSISTS OF THE PHRASE "CONSULT" IN BOLD, CAPITAL LETTERS ABOVE THE PHRASE "DIAGNOSTICS" IN LOWER CASE LETTERS WITH A FADING CIRCLE SHAPE AT THE END.

CLASS 5—PHARMACEUTICALS

FOR IN VITRO MEDICAL DIAGNOSTIC TEST KITS CONSISTING PRIMARILY OF MEDICAL DIAGNOSTIC REAGENTS AND MEDICAL DIAGNOSTIC REAGENT TEST STRIPS FOR USE IN BLOOD GLUCOSE TESTING AND TESTING FOR STREPTOCOCCAL BACTERIA, PREGNANCY, H-PYLORI, MONONUCLEOSIS AND FOR USE IN URINALYSIS AND ALSO INCLUDING TEST EQUIPMENT, NAMELY, BLOOD GLUCOSE METERS FOR MONITORING CONDITIONS OR DIAGNOSING DISEASE (U.S. CLS. 6, 18, 44, 46, 51 AND 52).

CLASS 10—MEDICAL APPARATUS

FOR MEDICAL BLOOD GLUCOSE TESTING KITS CONSISTING PRIMARILY OF TEST EQUIPMENT, NAMELY, BLOOD GLUCOSE TESTING METERS AND ALSO INCLUDING BLOOD GLUCOSE TESTING STRIPS AND BLOOD GLUCOSE CONTROL SOLUTION FOR USE IN THE FIELD OF BLOOD GLUCOSE MONITORING (U.S. CLS. 26, 39 AND 44).

ROBIN MITTLER, EXAMINING ATTORNEY

SN 77-323,054. COOPER, JEFFREY S., EDWARDSVILLE, IL. FILED 11-6-2007.

H.I.T. SQUAD

THE MARK CONSISTS OF STANDARD CHARACTERS WITHOUT CLAIM TO ANY PARTICULAR FONT, STYLE, SIZE, OR COLOR.

CLASS 25—CLOTHING

FOR CLOTHING, NAMELY, SHIRTS, T-SHIRTS, SWEAT SHIRTS, HEADWEAR, SWEAT PANTS AND JACKETS (U.S. CLS. 22 AND 39).

SN 77-323,630. ZOKU SALON, LLC, SUMMIT, NJ. FILED 11-7-2007.

ZOKU

THE MARK CONSISTS OF STANDARD CHARACTERS WITHOUT CLAIM TO ANY PARTICULAR FONT, STYLE, SIZE, OR COLOR.

CLASS 3—COSMETICS AND CLEANING PREPARATIONS

FOR HAIR CARE PRODUCTS, NAMELY, SHAMPOOS, HAIR CONDITIONERS AND DETANGLERS; HAIR COLOR, SEMI-PERMANENT, PERMANENT HAIR COLOR, COLORING SHAMPOO, BLEACHING CREAM, BLEACHING POWDER, HIGHLIGHTING GELS AND SOLUTIONS; GELS, SPRAYS, MOUSSES AND BALMS FOR HAIR STYLING AND HAIR CARE; HAIR COLORING, BLEACHING AND DECOLORANT PREPARATIONS; PERMANENT WAVING AND CURLING PREPARATIONS; COSMETICS, NAMELY, CREAMS, MILKS, LOTIONS, GELS AND POWDERS FOR THE FACE, THE BODY AND THE HANDS; ROUGE; LIPSTICK, LIP GLOSSES, EYE SHADOW, PRESSED FACE POWDER, BLUSHER UNDER-EYE CONCEALER, LOOSE FACE POWDER, MASCARA, EYELINER, LIP LINER, EYE BROW PENCIL, NON-MEDICATED ACNE CONCEALER, PERFUME, COLOGNE, NAIL POLISH, BATH AND SHOWER GELS AND BATH SALTS; FACIAL AND BODY SOAPS; BODY DEODORANTS; SUN CARE PREPARATIONS, NAMELY, SUN BLOCK, SUN SCREEN, SUN CREAMS, SUNTAN LOTION, TANNING PREPARATIONS, SUN TAN GEL AND SUN TAN OIL; ESSENTIAL OILS FOR PERSONAL USE; DENTIFRICES; NAIL CARE PREPARATIONS (U.S. CLS. 1, 4, 6, 50, 51 AND 52).

CLASS 35—ADVERTISING AND BUSINESS

FOR RETAIL STORE SERVICES FEATURING AND ADVERTISING SERVICES FEATURING HAIR CARE PRODUCTS, NAMELY, SHAMPOOS, HAIR CONDITIONERS AND DETANGLERS; HAIR COLORING PRODUCTS, GELS, SPRAYS, MOUSSES AND BALMS FOR HAIR STYLING AND HAIR CARE; HAIR COLORING, BLEACHING AND DECOLORANT PREPARATIONS; PERMANENT WAVING AND CURLING PREPARATIONS; COSMETICS, NAMELY, CREAMS, MILKS, LOTIONS, GELS AND POWDERS FOR THE FACE, THE BODY AND THE HANDS; ROUGE; LIPSTICK, LIP GLOSSES, EYE SHADOW, PRESSED FACE POWDER, BLUSHER UNDER-EYE CONCEALER, LOOSE FACE POWDER, MASCARA, EYELINER, LIP LINER, EYE BROW PENCIL, NON-MEDICATED ACNE CONCEALER, PERFUME, COLOGNE, NAIL POLISH, BATH AND SHOWER GELS AND BATH SALTS; FACIAL AND BODY SOAPS; BODY DEODORANTS; SUN CARE PREPARATIONS, NAMELY, SUN BLOCK, SUN SCREEN, SUN CREAMS, SUNTAN LOTION, TANNING PREPARATIONS, SUN TAN GEL AND SUN TAN OIL; ESSENTIAL OILS FOR PERSONAL USE; DENTIFRICES; NAIL CARE PREPARATIONS (U.S. CLS. 100, 101 AND 102).

FIRST USE 8-14-2007; IN COMMERCE 8-28-2007.

CLASS 44—MEDICAL, BEAUTY AND AGRICULTURAL SERVICES

FOR BEAUTY SALONS; BEAUTY CARE SERVICES IN THE NATURE OF COSMETIC BODY CARE SERVICES, SKIN CARE, HAIR CARE, HAIR COLORING, NAIL CARE AND COSMETIC MAKEUP SERVICES; CONSULTING SERVICES AND ADVISORY SERVICES RELATED TO HEALTH AND BEAUTY, NAMELY, CONSULTING AND ADVISORY SERVICES IN THE FIELDS OF MAKEUP, HAIR STYLING, NAIL AND SKIN CARE AND WELLNESS (U.S. CLS. 100 AND 101).

FIRST USE 8-14-2007; IN COMMERCE 8-28-2007.
CAROLYN CATALDO, EXAMINING ATTORNEY

CLASS 16—PAPER GOODS AND PRINTED MATTER

FOR PRINTED TEACHING AND TUTORING MATERIALS IN THE FIELD OF MATHEMATICS, LANGUAGE ARTS, SCIENCE AND SOCIAL STUDIES; EDUCATIONAL PUBLICATIONS, NAMELY, BOOKS, HAND-OUTS, WORKBOOKS, FLASH CARDS, ACTIVITY CARDS, LEARNING CARDS, TEXTBOOKS, STORY BOOKS, BOOKLETS, AND EDUCATIONAL GAMES IN THE FIELDS OF MATHEMATICS, LANGUAGE ARTS, SCIENCE AND SOCIAL STUDIES (U.S. CLS. 2, 5, 22, 23, 29, 37, 38 AND 50).

FIRST USE 10-18-2007; IN COMMERCE 10-18-2007.
AISHA CLARKE, EXAMINING ATTORNEY

SN 77-326,409. A-1 DOMESTIC PROFESSIONAL SERVICES, INC., SANTA FE SPRINGS, CA. FILED 11-9-2007.

SN 77-326,699. LOGIS INC., LAREDO, TX. FILED 11-11-2007.

It Takes Two Helping Hands
and a Golden Heart to Serve
Others

THE MARK CONSISTS OF STANDARD CHARACTERS WITHOUT CLAIM TO ANY PARTICULAR FONT, STYLE, SIZE, OR COLOR.

CLASS 44—MEDICAL, BEAUTY AND AGRICULTURAL SERVICES

FOR PROVIDING RESIDENTIAL HOME HEALTH CARE SERVICES (U.S. CLS. 100 AND 101).

FIRST USE 9-1-1991; IN COMMERCE 9-1-1991.

CLASS 45—PERSONAL AND LEGAL SERVICES

FOR SOCIAL SERVICE, NAMELY, COMPANIONSHIP SERVICES FOR ELDERLY, HANDICAPPED, HOME BOUND (U.S. CLS. 100 AND 101).

FIRST USE 9-1-1991; IN COMMERCE 9-1-1991.
JOHN KELLY, EXAMINING ATTORNEY

SN 77-326,593. WHALE WRITTEN PUBLICATIONS, AUBURN, WA. FILED 11-10-2007.

FACTURES4LEARNING

THE MARK CONSISTS OF STANDARD CHARACTERS WITHOUT CLAIM TO ANY PARTICULAR FONT, STYLE, SIZE, OR COLOR.

CLASS 9—ELECTRICAL AND SCIENTIFIC APPARATUS

FOR ELECTRONIC PUBLICATIONS, NAMELY, E-BOOKS IN THE FIELD OF MATHEMATICS, LANGUAGE ARTS, SCIENCE AND SOCIAL STUDIES RECORDED ON COMPUTER MEDIA; DOWNLOADABLE ELECTRONIC PUBLICATIONS IN THE NATURE OF E-BOOKS IN THE FIELD OF MATHEMATICS, LANGUAGE ARTS, SCIENCE AND SOCIAL STUDIES; EDUCATION COMPUTER GAME SOFTWARE (U.S. CLS. 21, 23, 26, 36 AND 38).

FIRST USE 10-18-2007; IN COMMERCE 10-18-2007.

LOGIS

THE MARK CONSISTS OF STANDARD CHARACTERS WITHOUT CLAIM TO ANY PARTICULAR FONT, STYLE, SIZE, OR COLOR.

CLASS 35—ADVERTISING AND BUSINESS

FOR TRANSPORTATION LOGISTICS SERVICES, NAMELY, ARRANGING THE TRANSPORTATION OF GOODS FOR OTHERS (U.S. CLS. 100, 101 AND 102).

FIRST USE 1-1-1995; IN COMMERCE 1-1-1995.

CLASS 36—INSURANCE AND FINANCIAL

FOR CUSTOMS BROKERAGE (U.S. CLS. 100, 101 AND 102).

FIRST USE 1-1-1995; IN COMMERCE 1-1-1995.

CLASS 39—TRANSPORTATION AND STORAGE

FOR FREIGHT FORWARDING; WAREHOUSING SERVICES, NAMELY, STORAGE, DISTRIBUTION, PICK-UP, PACKING, AND SHIPPING OF GOODS INTO MEXICO; FREIGHT BROKERAGE; FREIGHT TRANSPORTATION BY TRACTOR-TRAILER (U.S. CLS. 100 AND 105).

FIRST USE 1-1-1995; IN COMMERCE 1-1-1995.
FRANK LATTUCA, EXAMINING ATTORNEY

SN 77-327,444. BROYHILL, J. EDGAR, WINSTON-SALEM, NC. FILED 11-12-2007.

XSELLNET

THE MARK CONSISTS OF THE STYLIZED WORD "XSELLNET".

CLASS 35—ADVERTISING AND BUSINESS

FOR PROVIDING A WEBSITE FEATURING BUSINESS MARKETING SERVICES, OFFERING PRODUCTS FOR SALE, AND INFORMATION IN THE FIELD OF AUTOMOBILES FOR SALE; ADVERTISING AND PUBLICITY SERVICES, NAMELY, PROMOTING THE GOODS, SERVICES, BRAND IDENTITY AND COMMERCIAL INFORMATION AND NEWS OF THIRD PARTIES THROUGH PRINT, AUDIO, VIDEO, DIGITAL AND ON-LINE MEDIUM (U.S. CLS. 100, 101 AND 102).

FIRST USE 12-1-2006; IN COMMERCE 12-1-2006.

CLASS 36—INSURANCE AND FINANCIAL

FOR PROVIDING A WEBSITE FEATURING FINANCIAL AND INSURANCE SERVICES AND INFORMATION IN THE FIELD OF FINANCIAL AND INSURANCE SERVICES (U.S. CLS. 100, 101 AND 102).

FIRST USE 12-1-2006; IN COMMERCE 12-1-2006.

CLASS 42—SCIENTIFIC AND COMPUTER SERVICES

FOR INSTALLATION OF COMPUTER SOFTWARE (U.S. CLS. 100 AND 101).

FIRST USE 12-1-2006; IN COMMERCE 12-1-2006.

JAMES A. RAUEN, EXAMINING ATTORNEY

SN 77-327,482. BARA ISHIDU INTERNATIONAL CORPORATION, LYFORD CAY, BAHAMAS, FILED 11-12-2007.

ROUNDPOINT

THE MARK CONSISTS OF STANDARD CHARACTERS WITHOUT CLAIM TO ANY PARTICULAR FONT, STYLE, SIZE, OR COLOR.

CLASS 36—INSURANCE AND FINANCIAL

FOR FINANCIAL SERVICES, NAMELY, MORTGAGE PLANNING; MORTGAGE BANKING SERVICES, NAMELY, ORIGINATION, ACQUISITION, SERVICING, SECURITIZATION AND BROKERAGE OF MORTGAGE LOANS; MORTGAGE LENDING; MORTGAGE PROCUREMENT FOR OTHERS; REAL ESTATE BROKERAGE; REAL ESTATE AGENCIES; REAL ESTATE APPRAISAL; HOME APPRAISAL SERVICES; LOAN FINANCING; INSURANCE AGENCY SERVICES (U.S. CLS. 100, 101 AND 102).

CLASS 45—PERSONAL AND LEGAL SERVICES

FOR TITLE SEARCHING (U.S. CLS. 100 AND 101).
ROBERT C. CLARK JR., EXAMINING ATTORNEY

SN 77-329,206. ORACEUTICAL LLC, LEE, MA. FILED 11-14-2007.

PHYTO-GEL

THE MARK CONSISTS OF STANDARD CHARACTERS WITHOUT CLAIM TO ANY PARTICULAR FONT, STYLE, SIZE, OR COLOR.

CLASS 3—COSMETICS AND CLEANING PREPARATIONS

FOR SKIN AND BODY TOPICAL LOTIONS, CREAMS AND OILS FOR COSMETIC USE; TOPICAL SKIN SPRAYS FOR COSMETIC PURPOSES; NON-MEDICATED OINTMENTS FOR THE PREVENTION AND TREATMENT OF SUNBURN (U.S. CLS. 1, 4, 6, 50, 51 AND 52).

CLASS 5—PHARMACEUTICALS

FOR DRESSINGS FOR WOUNDS; MEDICAL CLEANSERS FOR SKIN AND WOUNDS; TOPICAL PHARMACEUTICAL PREPARATIONS FOR WOUNDS; WOUND DRESSINGS; PLANT EXTRACT TOPICAL PREPARATIONS FOR MEDICAL, VETERINARY AND PHARMACEUTICAL PURPOSES; VETERINARY PREPARATIONS FOR HORSES, DOGS AND CATS; VETERINARY PREPARATIONS, NAMELY, ANTIOXIDANTS; VETERINARY PREPARATIONS, NAMELY, PAIN RELIEF MEDICATION; TOPICAL ANALGESICS; TOPICAL ANESTHETICS; TOPICAL FIRST AID GEL; ANTI-ITCH OINTMENT; ANTIBIOTIC OINTMENTS; HERBAL ANTI-ITCH AND SORE SKIN OINTMENT FOR PETS; MEDICATED SKIN CARE PREPARATIONS, NAMELY, CREAMS, LOTIONS, GELS, TONERS, CLEANERS AND PEELS; TOPICAL GEL FOR MEDICAL AND THERAPEUTIC TREATMENT OF CUTS, SCRAPES AND ABRASIONS; ALOE VERA GEL FOR THERAPEUTIC PURPOSES (U.S. CLS. 6, 18, 44, 46, 51 AND 52).

LEIGH CAROLINE CASE, EXAMINING ATTORNEY

SN 77-330,457. MJS DESIGNS, INC., PHOENIX, AZ. FILED 11-15-2007.

MJS DESIGNS ELECTRONICS SOLUTIONS ON A FAST TRACK

THE MARK CONSISTS OF STANDARD CHARACTERS WITHOUT CLAIM TO ANY PARTICULAR FONT, STYLE, SIZE, OR COLOR.

NO CLAIM IS MADE TO THE EXCLUSIVE RIGHT TO USE "DESIGNS" AND "ELECTRONICS SOLUTIONS", APART FROM THE MARK AS SHOWN.

CLASS 40—MATERIAL TREATMENT

FOR MANUFACTURE AND ASSEMBLY OF ELECTRONIC HARDWARE AND ELECTRONIC CIRCUITS TO THE ORDER AND /OR SPECIFICATION OF OTHERS (U.S. CLS. 100, 103 AND 106).

FIRST USE 2-28-2006; IN COMMERCE 2-28-2006.

CLASS 42—SCIENTIFIC AND COMPUTER SERVICES

FOR DESIGN FOR OTHERS IN THE FIELD OF ELECTRONIC HARDWARE AND ELECTRONIC CIRCUITS; DESIGN OF COMPUTER SOFTWARE (U.S. CLS. 100 AND 101).

FIRST USE 2-28-2006; IN COMMERCE 2-28-2006.
STEVEN R. FINE, EXAMINING ATTORNEY

SN 77-330,835. WEISSENBERG, CATHERINE A., SANTA BARBARA, CA. FILED 11-15-2007.

ONE SIMPLE YES

THE MARK CONSISTS OF STANDARD CHARACTERS WITHOUT CLAIM TO ANY PARTICULAR FONT, STYLE, SIZE, OR COLOR.

CLASS 16—PAPER GOODS AND PRINTED MATTER

FOR BOOKS IN THE FIELD OF SELF HELP FOR PERSONAL GROWTH; WORK BOOKS DIRECTED TO SELF HELP FOR PERSONAL GROWTH; GREETING CARDS; FLASH CARDS; STATIONERY; PRINTED TEACHING AND EDUCATIONAL MATERIAL IN THE FIELD OF SELF HELP FOR PERSONAL GROWTH; DECORATIVE WRAPPING PAPER AND GIFT BOXES (U.S. CLS. 2, 5, 22, 23, 29, 37, 38 AND 50).

CLASS 25—CLOTHING

FOR T-SHIRTS, SHIRTS, SWEAT SHIRTS, PAJAMAS, HATS, BASEBALL CAPS, UNDERWEAR, SOCKS, PANTS, SCARVES, TRACK SUITS, HEADBANDS, JACKETS (U.S. CLS. 22 AND 39).

TRACY CROSS, EXAMINING ATTORNEY

SN 77-331,541. 24/8 LLC, WATERBURY, CT. FILED 11-16-2007.

NTELLIPAD

THE MARK CONSISTS OF STANDARD CHARACTERS WITHOUT CLAIM TO ANY PARTICULAR FONT, STYLE, SIZE, OR COLOR.

CLASS 9—ELECTRICAL AND SCIENTIFIC APPARATUS

FOR APPARATUS FOR MEASURING, RECORDING, AND ANALYSIS OF PRESSURE EXERTED BY HUMAN BODY OR OTHER OBJECT AND COMPUTER SOFTWARE FOR THE ANALYSIS OF MEASURED AND RECORDED PRESSURE DATA (U.S. CLS. 21, 23, 26, 36 AND 38).

CLASS 38—COMMUNICATION

FOR WIRELESS COMMUNICATIONS SERVICES, NAMELY, THE WIRELESS TRANSMISSION OF RECORDED INFORMATION (U.S. CLS. 100, 101 AND 104).
KATINA MISTER, EXAMINING ATTORNEY

SN 77-332,433. HOTEL VILLA MOZART, INC., SHORT HILLS, NJ. FILED 11-18-2007.

SLOWDOWN ORGANIC

THE MARK CONSISTS OF STANDARD CHARACTERS WITHOUT CLAIM TO ANY PARTICULAR FONT, STYLE, SIZE, OR COLOR.

NO CLAIM IS MADE TO THE EXCLUSIVE RIGHT TO USE "ORGANIC", APART FROM THE MARK AS SHOWN.

CLASS 30—STAPLE FOODS

FOR COFFEE; COFFEE; COFFEE BEANS; ROASTED COFFEE BEANS; COOKIES; COOKIES AND CRACKERS (U.S. CL. 46).

FIRST USE 9-1-2007; IN COMMERCE 9-1-2007.

CLASS 43—HOTEL AND RESTAURANT SERVICES

FOR COFFEE SHOPS; COFFEE-HOUSE AND SNACK-BAR SERVICES (U.S. CLS. 100 AND 101).

FIRST USE 11-1-2007; IN COMMERCE 11-1-2007.

SOPHIA S. KIM, EXAMINING ATTORNEY

SN 77-333,005. L.T.J. DIFFUSION, COLOMBES, FRANCE, FILED 11-19-2007.

La fiancée
D'ARTHUR

THE MARK CONSISTS OF STYLIZED WORDING "LA FIANCÉE D'ARTHUR".

CLASS 25—CLOTHING

FOR UNDERWEAR AND NIGHTWEAR, NAMELY, PAJAMAS, BOXER SHORTS, T-SHIRTS, PAJAMA TROUSERS; PANTIES, CAMISOLES, NIGHTIES, BATHROBES; SWIM WEAR, NAMELY, SWIMSUITS AND BEACH DRESSES; SLIPPERS; SHIRTS; DRESSES; JUMPSUITS; CAPRIS; BLOOMERS; SHORTS; TROUSERS (U.S. CLS. 22 AND 39).

CLASS 35—ADVERTISING AND BUSINESS

FOR RETAIL STORE SERVICES, ONLINE RETAIL STORE SERVICES, WHOLESALE STORE SERVICES, AND WHOLESALE DISTRIBUTORSHIP SERVICES IN THE FIELD OF CLOTHING, FOOTWEAR AND HEADWEAR (U.S. CLS. 100, 101 AND 102).

MATTHEW MCDOWELL, EXAMINING ATTORNEY

SN 77-333,008. L.T.J. DIFFUSION, COLOMBES, FRANCE, FILED 11-19-2007.

SN 77-333,548. PEBBLE LIMITED PARTNERSHIP, ANCHORAGE, AK. FILED 11-19-2007.

LTJ
ARTHUR

THE NAME(S), PORTRAIT(S), AND/OR SIGNATURE(S) SHOWN IN THE MARK DOES NOT IDENTIFY A PARTICULAR LIVING INDIVIDUAL.

THE MARK CONSISTS OF STYLIZED WORDING "LTJ ARTHUR".

CLASS 25—CLOTHING

FOR UNDERWEAR AND NIGHTWEAR, NAMELY, PAJAMAS, BOXER SHORTS, T-SHIRTS, PAJAMA TROUSERS, NIGHT GOWNS, BATHROBES, KIMONOS, NIGHT CAPS, SLEEPWEAR FOR BABIES; SHIRTS; BERMUDA SHORTS; SWIM WEAR, NAMELY, SWIM TRUNKS, SWIMSUITS, BEACH DRESSES; SLIPPERS, SOCKS; DRESSES; JUMPSUITS; CAPRIS; BLOOMERS; SHORTS; TROUSERS (U.S. CLS. 22 AND 39).

CLASS 35—ADVERTISING AND BUSINESS

FOR RETAIL STORE SERVICES, ONLINE RETAIL STORE SERVICES, WHOLESALE STORE SERVICES, AND WHOLESALE DISTRIBUTORSHIP SERVICES IN THE FIELD OF CLOTHING, FOOTWEAR AND HEADWEAR (U.S. CLS. 100, 101 AND 102).

MATTHEW MCDOWELL, EXAMINING ATTORNEY

SN 77-333,496. PEBBLE LIMITED PARTNERSHIP, ANCHORAGE, AK. FILED 11-19-2007.

THE PEBBLE PARTNERSHIP

THE MARK CONSISTS OF STANDARD CHARACTERS WITHOUT CLAIM TO ANY PARTICULAR FONT, STYLE, SIZE, OR COLOR.

NO CLAIM IS MADE TO THE EXCLUSIVE RIGHT TO USE "PARTNERSHIP", APART FROM THE MARK AS SHOWN.

CLASS 37—CONSTRUCTION AND REPAIR

FOR MINING EXTRACTION (U.S. CLS. 100, 103 AND 106).

CLASS 42—SCIENTIFIC AND COMPUTER SERVICES

FOR MINING EXPLORATION AND MINERAL EXPLORATION SERVICES (U.S. CLS. 100 AND 101).
TEJBIR SINGH, EXAMINING ATTORNEY

THE
pebble
PARTNERSHIP

NO CLAIM IS MADE TO THE EXCLUSIVE RIGHT TO USE "PARTNERSHIP", APART FROM THE MARK AS SHOWN.

CLASS 37—CONSTRUCTION AND REPAIR

FOR MINING EXTRACTION (U.S. CLS. 100, 103 AND 106).

CLASS 42—SCIENTIFIC AND COMPUTER SERVICES

FOR MINING EXPLORATION AND MINERAL EXPLORATION SERVICES (U.S. CLS. 100 AND 101).
TEJBIR SINGH, EXAMINING ATTORNEY

SN 77-333,989. FARLEY'S & SATHERS CANDY COMPANY, INC., ROUND LAKE, MN. FILED 11-20-2007.

JUJUBES

THE MARK CONSISTS OF STANDARD CHARACTERS WITHOUT CLAIM TO ANY PARTICULAR FONT, STYLE, SIZE, OR COLOR.

OWNER OF U.S. REG. NOS. 3,310,868, 3,310,869 AND 3,310,870.

CLASS 16—PAPER GOODS AND PRINTED MATTER

FOR POSTERS, STICKERS, PENS, PENCILS, PENCIL CASES, PEN CASES, NOTE PADS, FOLDERS, WRITING PAPER, PAPER NAPKINS, GREETING CARDS (U.S. CLS. 2, 5, 22, 23, 29, 37, 38 AND 50).

CLASS 20—FURNITURE AND ARTICLES NOT OTHERWISE CLASSIFIED

FOR PLASTIC KEY CHAINS, PILLOWS, PICTURE FRAMES, PLASTIC HOLIDAY ORNAMENTS (U.S. CLS. 2, 13, 22, 25, 32 AND 50).

CLASS 25—CLOTHING

FOR CLOTHING, NAMELY, HATS, T-SHIRTS, SOCKS, SWEATSHIRTS, SWEATPANTS, PANTS, SHORTS AND BASEBALL CAPS (U.S. CLS. 22 AND 39).
JOHN SCHUYLER YARD, EXAMINING ATTORNEY

SN 77-334,989. WATKINS, JEREMY G, DBA TENDER LOVING CARE HOME SOLUTIONS, INC., MONROE, GA. FILED 11-21-2007.

SN 77-335,231. BUD BEHLING LEASING, INC., BRIDGEVILLE, PA. FILED 11-21-2007.



THE COLOR(S) RED PURPLE GOLD BROWN BLACK IS/ ARE CLAIMED AS A FEATURE OF THE MARK.

THE MARK CONSISTS OF STYLIZED DESIGN OF A RED CAPED (WITH A GOLD BUTTON) AND GOLD ARMORED GREEK/ROMAN SOLDIER WITH A BROWN SKIN TONE WEARING A GOLD HELMET WITH A BLACK PLUME. SOLDIER'S LEFT ARM IS RAISED WITH A GOLD SHIELD WHILE ALSO HOLDING A GOLD SPEAR IN HIS RIGHT HAND. A BROWN CROSS IS IN THE BACKGROUND. TWO BLACK ARROWS APPEAR ABOVE THE SHIELD IN FLIGHT TOWARD THE SOLDIER. ONE BLACK ARROW APPEARS BELOW THE RAISED ARM IN FLIGHT TOWARD THE SOLDIER. THE STYLIZED WORD "BACHELOR'S" IS RED WHILE THE OTHER WORDS ARE BLACK. PURPLE RAYS OF LIGHT EMIT FROM BEHIND THE SOLDIER. STARS OF GOLD AND PURPLE ARRAY AROUND THE IMAGE OF THE SOLDIER. THE CROSS HAS RED BLOOD STAINS. THE IMAGE IS BOUNDED BY A BLACK CIRCLE. THE ARMOR, SHIELD, HELMET, CAPE, CROSS, SPEAR AND SOLDIER ARE ALSO BORDERED BY BLACK.

CLASS 9—ELECTRICAL AND SCIENTIFIC APPARATUS

FOR ELECTRONIC PUBLICATIONS, NAMELY, BOOKS FEATURING RELATIONSHIPS AND PRE-MARITAL PREPARATION MANUSCRIPTS RECORDED ON COMPUTER MEDIA (U.S. CLS. 21, 23, 26, 36 AND 38).

CLASS 16—PAPER GOODS AND PRINTED MATTER

FOR A SERIES OF BOOKS, WRITTEN ARTICLES, HANDOUTS AND WORKSHEETS IN THE FIELD OF RELATIONSHIPS AND PRE-MARITAL PREPARATION (U.S. CLS. 2, 5, 22, 23, 29, 37, 38 AND 50).

KATINA MISTER, EXAMINING ATTORNEY

TOTAL FLEET MANAGEMENT

THE MARK CONSISTS OF STANDARD CHARACTERS WITHOUT CLAIM TO ANY PARTICULAR FONT, STYLE, SIZE, OR COLOR.

NO CLAIM IS MADE TO THE EXCLUSIVE RIGHT TO USE FLEET MANAGEMENT, APART FROM THE MARK AS SHOWN.

SEC. 2(F).

CLASS 35—ADVERTISING AND BUSINESS

FOR BUSINESS MANAGEMENT AND CONSULTING IN THE FIELD OF VEHICLE FLEET LEASING OPERATIONS; STATE VEHICULAR REGISTRATION AND TITLE TRANSFER; PROCUREMENT SERVICES, NAMELY, PURCHASING FUEL FOR OTHERS; PROCUREMENT SERVICES, NAMELY, ACQUISITION OF VEHICLES FOR OTHERS; REMARKETING OF VEHICLES FOR OTHERS (U.S. CLS. 100, 101 AND 102).

FIRST USE 1-1-2003; IN COMMERCE 1-1-2003.

CLASS 36—INSURANCE AND FINANCIAL

FOR FINANCING RELATED TO AUTOMOBILES (U.S. CLS. 100, 101 AND 102).

FIRST USE 1-1-2003; IN COMMERCE 1-1-2003.

CLASS 37—CONSTRUCTION AND REPAIR

FOR VEHICLE REPAIR AND MAINTENANCE; EMERGENCY ROADSIDE ASSISTANCE SERVICES, NAMELY, RESPONDING TO CALLS FOR ROADSIDE ASSISTANCE, FLAT TIRE CHANGING, EMERGENCY FUEL SUPPLYING, AND BATTERY JUMP STARTING; REFUELING SERVICES FOR A VEHICLE FLEET (U.S. CLS. 100, 103 AND 106).

FIRST USE 1-1-2003; IN COMMERCE 1-1-2003.

CLASS 39—TRANSPORTATION AND STORAGE

FOR VEHICLE LEASING SERVICES (U.S. CLS. 100 AND 105).

FIRST USE 1-1-2003; IN COMMERCE 1-1-2003.

CLASS 42—SCIENTIFIC AND COMPUTER SERVICES

FOR PROVIDING TEMPORARY USE OF ONLINE NON-DOWNLOADABLE SOFTWARE FOR MANAGEMENT OF FIXED AND VARIABLE COSTS ASSOCIATED WITH A VEHICLE FLEET (U.S. CLS. 100 AND 101).

FIRST USE 1-1-2003; IN COMMERCE 1-1-2003.

KATHY DE JONGE, EXAMINING ATTORNEY

SN 77-336,697. VENTURE ON DEMAND, LLC, PITTSBURGH, PA. FILED 11-26-2007.

VENTURE ON DEMAND

THE MARK CONSISTS OF STANDARD CHARACTERS WITHOUT CLAIM TO ANY PARTICULAR FONT, STYLE, SIZE, OR COLOR.

CLASS 39—TRANSPORTATION AND STORAGE

FOR PROVIDING AND DISSEMINATING INFORMATION TO OTHERS CONCERNING TRAVEL DESTINATION POINTS OF INTEREST AND RELATED INFORMATION FOR SELF-GUIDED TOURS (U.S. CLS. 100 AND 105).

CLASS 41—EDUCATION AND ENTERTAINMENT

FOR ENTERTAINMENT IN THE NATURE OF ONGOING TELEVISION PROGRAMS IN THE FIELD OF TRAVEL DESTINATION AND OUTDOOR POINTS OF INTEREST AND MAKING SELF-GUIDED TOURS; MOTION PICTURE FILM PRODUCTION FOCUSED ON TRAVEL DESTINATION AND OUTDOOR POINTS OF INTEREST AND SELF-GUIDED TOURS; PRODUCTION OF LASER DVDS, VIDEOTAPES AND AUDIO TAPES AND TELEVISION PROGRAMS FEATURING INFORMATION RELATED TO TRAVEL DESTINATION AND POINTS OF INTEREST AND MAKING SELF-GUIDED TOURS (U.S. CLS. 100, 101 AND 107).

CAROL SPILS, EXAMINING ATTORNEY

SN 77-337,562. CONNAUGHT REAL ESTATE FINANCE LLC, CHICAGO, IL. FILED 11-27-2007.

CONNAUGHT REAL ESTATE FINANCE LLC

THE MARK CONSISTS OF STANDARD CHARACTERS WITHOUT CLAIM TO ANY PARTICULAR FONT, STYLE, SIZE, OR COLOR.

NO CLAIM IS MADE TO THE EXCLUSIVE RIGHT TO USE "REAL ESTATE FINANCE LLC", APART FROM THE MARK AS SHOWN.

CLASS 36—INSURANCE AND FINANCIAL

FOR FINANCIAL SERVICES, NAMELY, HEDGE FUND MANAGEMENT SERVICES; FINANCIAL SERVICES, NAMELY, THE FACILITATING AND ARRANGING OF FINANCING IN THE FIELD OF REAL ESTATE, NAMELY, FINANCIAL REAL ESTATE CONSULTATION; REAL ESTATE MANAGEMENT (U.S. CLS. 100, 101 AND 102).

FIRST USE 9-1-2006; IN COMMERCE 9-1-2006.

CLASS 42—SCIENTIFIC AND COMPUTER SERVICES

FOR APPLICATION SERVICE PROVIDER FEATURING DATABASE MANAGEMENT SOFTWARE IN THE FIELD OF REAL ESTATE FINANCE FOR PURPOSES OF FACILITATING REAL ESTATE TRANSACTIONS (U.S. CLS. 100 AND 101).

FIRST USE 11-0-2007; IN COMMERCE 11-0-2007.
TRACY WHITTAKER-BROWN, EXAMINING ATTORNEY

SN 77-337,829. CLEANBRANDS, LLC, EAST PROVIDENCE, RI. FILED 11-27-2007.

HEALTHYZZZ

THE MARK CONSISTS OF STANDARD CHARACTERS WITHOUT CLAIM TO ANY PARTICULAR FONT, STYLE, SIZE, OR COLOR.

CLASS 5—PHARMACEUTICALS

FOR INCONTINENCE PADS (U.S. CLS. 6, 18, 44, 46, 51 AND 52).

CLASS 10—MEDICAL APPARATUS

FOR INCONTINENCE BED PADS AND SHEETS (U.S. CLS. 26, 39 AND 44).

CLASS 20—FURNITURE AND ARTICLES NOT OTHERWISE CLASSIFIED

FOR MATTRESSES, BOX SPRINGS, PILLOWS; FURNITURE, NAMELY, CHAIRS, CHAIR PADS, COUCHES AND SOFAS; BABY SUPPORT PILLOWS (U.S. CLS. 2, 13, 22, 25, 32 AND 50).

CLASS 24—FABRICS

FOR MATTRESS ENCASEMENTS, MATTRESS PADS, BOX SPRING ENCASEMENTS, PILLOW ENCASEMENTS, PILLOW CASES, PILLOW COVERS, PILLOW SHAMS, DUVETS, DUVET COVERS, COMFORTERS, COMFORTER ENCASEMENTS, COMFORTER COVERS, CRIB BUMPERS, AND DIAPER CHANGING PADS NOT OF PAPER (U.S. CLS. 42 AND 50).

JULIE GUTTADAURO, EXAMINING ATTORNEY

SN 77-337,978. THE READER'S DIGEST ASSOCIATION, INC., PLEASANTVILLE, NY. FILED 11-27-2007.

Reader's Digest

OWNER OF U.S. REG. NOS. 746,933, 1,042,251 AND OTHERS.
SEC. 2(F).

CLASS 9—ELECTRICAL AND SCIENTIFIC APPARATUS

FOR MUSICAL SOUND RECORDINGS AND PRE-RECORDED VIDEO TAPES AND DVD'S FEATURING DOCUMENTARY AND ENTERTAINMENT PROGRAMMING (U.S. CLS. 21, 23, 26, 36 AND 38).

CLASS 16—PAPER GOODS AND PRINTED MATTER

FOR PERIODICAL GENERAL INTEREST MAGAZINES, CONDENSED FICTION BOOKS, CONDENSED NON-FICTION BOOKS, ADULT NON-FICTION BOOKS ON A WIDE VARIETY OF SUBJECTS AND CHILDREN'S BOOKS (U.S. CLS. 2, 5, 22, 23, 29, 37, 38 AND 50).

MATTHEW MCDOWELL, EXAMINING ATTORNEY

SN 77-339,199. PREMIERE COMMISSION, INC., NEW YORK, NY. FILED 11-28-2007.

PREMIERE COMMISSION

THE MARK CONSISTS OF STANDARD CHARACTERS WITHOUT CLAIM TO ANY PARTICULAR FONT, STYLE, SIZE, OR COLOR.

CLASS 9—ELECTRICAL AND SCIENTIFIC APPARATUS

FOR MUSICAL SOUND RECORDINGS; AUDIO-VISUAL RECORDINGS, NAMELY, PRERECORDED COMPACT DISCS, TAPE CASSETTES, AUDIO CASSETTES, AUDIO TAPES, AUDIO DISCS, RECORDS, CD-ROMS, VIDEO TAPES, VIDEO CASSETTES, VIDEO DISCS, DVDS, DATS, MP3S, AND LASER DISCS, ALL FEATURING MUSIC; DOWNLOADABLE MUSICAL SOUND RECORDINGS; DOWNLOADABLE VIDEO RECORDINGS FEATURING MUSIC (U.S. CLS. 21, 23, 26, 36 AND 38).

CLASS 35—ADVERTISING AND BUSINESS

FOR DISTRIBUTORSHIP SERVICES IN THE FIELD OF RECORDED MUSICAL AUDIO AND VIDEO RECORDINGS FOR BROADCAST (U.S. CLS. 100, 101 AND 102).

CLASS 41—EDUCATION AND ENTERTAINMENT

FOR RECORD PRODUCTION; MUSIC PRODUCTION; AUDIO RECORDING AND PRODUCTION; MOTION PICTURE SONG PRODUCTION; RECORDING STUDIOS; ENTERTAINMENT SERVICES, NAMELY, PRODUCING MUSICAL AUDIO AND VIDEO PROGRAMS; MUSIC COMPOSITION AND TRANSCRIPTION FOR OTHERS; SONG WRITING SERVICES; ENTERTAINMENT IN THE NATURE OF A LIVE MUSICAL PERFORMER, MUSICAL BAND OR MUSICAL GROUP; ENTERTAINMENT IN THE NATURE OF LIVE PERFORMANCES BY A MUSICAL ARTIST, MUSICAL GROUP OR MUSICAL BAND; ENTERTAINMENT IN THE NATURE OF VISUAL AND AUDIO PERFORMANCES BY A MUSICAL ARTIST, MUSICAL GROUP AND MUSICAL BAND; ENTERTAINMENT, NAMELY, LIVE MUSIC CONCERTS; ENTERTAINMENT, NAMELY, PERSONAL APPEARANCES BY A MUSICIAN, MUSICAL GROUP OR MUSICAL BAND; ENTERTAINMENT SERVICES, NAMELY, PROVIDING A WEB SITE FEATURING MUSICAL PERFORMANCES, MUSICAL VIDEOS, RELATED FILM CLIPS, PHOTOGRAPHS, AND OTHER MULTIMEDIA MATERIALS; ENTERTAINMENT SERVICES, NAMELY, PROVIDING PRERECORDED MUSIC, INFORMATION IN THE FIELD OF MUSIC, COMMENTARY AND ARTICLES ABOUT MUSIC, ALL ONLINE VIA A GLOBAL COMPUTER NETWORK; ENTERTAINMENT IN THE NATURE OF LIVE MUSICAL PERFORMANCES PERFORMED BY ARTISTS ON TOUR (U.S. CLS. 100, 101 AND 107).

BONNIE LUKEN, EXAMINING ATTORNEY

SN 77-339,488. CHRISTOPHERSON, EVELINA L., LOS ANGELES, CA. FILED 11-28-2007.

COZI CAZA

THE MARK CONSISTS OF STANDARD CHARACTERS WITHOUT CLAIM TO ANY PARTICULAR FONT, STYLE, SIZE, OR COLOR.

THE FOREIGN WORDING IN THE MARK TRANSLATES INTO ENGLISH AS COZY HOME.

CLASS 29—MEATS AND PROCESSED FOODS

FOR PREPARED AND PACKAGED READY TO COOK FOOD PRODUCTS, NAMELY, MEAT, POULTRY, SEAFOOD, PREPARED VEGETABLES, NAMELY, COOKED VEGETABLES AND FROZEN VEGETABLES, SOUPS, PREPARED APPETIZERS CONSISTING PRIMARILY OF MEAT, POULTRY, SEAFOOD, OR VEGETABLES, AND PREPARED ENTREES CONSISTING PRIMARILY OF MEAT, POULTRY, SEAFOOD, OR VEGETABLES (U.S. CL. 46).

CLASS 30—STAPLE FOODS

FOR PREPARED AND PACKAGED READY TO COOK FOOD PRODUCTS, NAMELY, PASTA, PREPARED APPETIZERS CONSISTING PRIMARILY OF PASTA, RICE, OR PROCESSED CEREALS, AND PREPARED ENTREES CONSISTING PRIMARILY OF PASTA, RICE, OR PROCESSED CEREALS (U.S. CL. 46).

CLASS 33—WINES AND SPIRITS

FOR ALCOHOLIC BEVERAGES EXCEPT BEERS (U.S. CLS. 47 AND 49).

CLASS 35—ADVERTISING AND BUSINESS

FOR RETAIL STORE SERVICES, AVAILABLE THROUGH ON-LINE COMPUTER COMMUNICATIONS, PHONE-IN ORDER, MAIL ORDER AND DIRECT SOLICITATION BY SALES AGENTS IN THE FIELD OF FOOD AND GROCERY PRODUCTS (U.S. CLS. 100, 101 AND 102).

KATHERINE CHANG, EXAMINING ATTORNEY

SN 77-341,396. LOESS HILLS LODGE, LLC, LAS VEGAS, NV. FILED 11-30-2007.



NO CLAIM IS MADE TO THE EXCLUSIVE RIGHT TO USE "LOESS HILLS LODGE", APART FROM THE MARK AS SHOWN.

THE COLOR(S) MAROON IS/ARE CLAIMED AS A FEATURE OF THE MARK.

THE MARK CONSISTS OF THREE ABSTRACT DRAWINGS OF TREES IN A MAROON HUE WITH THE NAME "LOESS HILLS LODGE" UNDERNEATH.

CLASS 36—INSURANCE AND FINANCIAL

FOR REAL ESTATE MANAGEMENT (U.S. CLS. 100, 101 AND 102).

FIRST USE 10-1-2006; IN COMMERCE 3-1-2007.

CLASS 37—CONSTRUCTION AND REPAIR

FOR REAL ESTATE DEVELOPMENT (U.S. CLS. 100, 103 AND 106).

FIRST USE 10-1-2006; IN COMMERCE 3-1-2007.
SOPHIA S. KIM, EXAMINING ATTORNEY

SN 77-342,731. INTEGRA LIFESCIENCES CORPORATION, PLAINSBORO, NJ. FILED 12-3-2007.

TREL-XC

THE MARK CONSISTS OF STANDARD CHARACTERS WITHOUT CLAIM TO ANY PARTICULAR FONT, STYLE, SIZE, OR COLOR.

CLASS 5—PHARMACEUTICALS

FOR TISSUE REGENERATION MEMBRANES; IMPLANTABLE LIVING TISSUE; AND BONE IMPLANTS COMPRISED OF LIVING TISSUE (U.S. CLS. 6, 18, 44, 46, 51 AND 52).

CLASS 10—MEDICAL APPARATUS

FOR SURGICAL IMPLANTS, NAMELY, BONE IMPLANTS COMPRISED OF ARTIFICIAL MATERIALS; CARRIER MEDIA FOR IMPLANTS, NAMELY, POLOXAMERS, BLOCK COPOLYMERS, POLY(OXYALKYLENE) BLOCK COPOLYMERS, POLOXAMERS DISPERSED IN SOLVENT, BLOCK COPOLYMERS DISPERSED IN SOLVENT, POLY(OXYALKYLENE) BLOCK COPOLYMERS DISPERSED IN SOLVENT. SOLD AS AN INTEGRAL COMPONENT OF BONE REGENERATION TISSUE PRODUCT COMPRISED ARTIFICIAL MATERIAL (U.S. CLS. 26, 39 AND 44).

DANIEL CAPSHAW, EXAMINING ATTORNEY

SN 77-342,902. INKTREE, INC., CHARLOTTESVILLE, VA. FILED 12-3-2007.

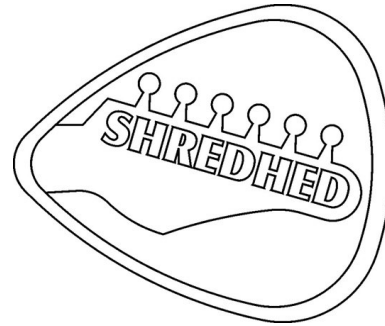

THE MARK CONSISTS OF THE LETTERS "SHREDHED" WITHIN THE OUTLINE OF A GUITAR HEADSTOCK ALL WITHIN A BORDER SHAPED LIKE A GUITAR PICK.

CLASS 16—PAPER GOODS AND PRINTED MATTER

FOR PRESENTATION BOARDS; PRESENTATION FOLDERS; DRY ERASE WRITING BOARDS AND WRITING SURFACES; FOLDERS; FOLDABLE POSTER BOARDS FOR DISPLAY OF PRINTED INSTRUCTIONAL, EDUCATIONAL, AND TEACHING MATERIALS; PRINTED PRODUCTS, NAMELY, INSTRUCTIONAL, EDUCATIONAL, AND TEACHING MATERIALS IN THE FIELDS OF MUSIC, MUSICAL EDUCATION AND MUSICAL INSTRUCTION (U.S. CLS. 2, 5, 22, 23, 29, 37, 38 AND 50).

CLASS 38—COMMUNICATION

FOR SOCIAL NETWORKING TOOLS FOR COMMUNICATION AMONGST ONLINE COMPUTER USERS, NAMELY, PROVIDING ONLINE CHAT ROOMS, LIST-SERVERS, AND ELECTRONIC BULLETIN BOARDS FOR TRANSMISSION OF MESSAGES AMONG COMPUTER USERS, PROVIDING ONLINE FACILITIES FOR REAL-TIME INTERACTION WITH OTHER COMPUTER USERS, AND PROVIDING AN ONLINE FORUM FOR SHOWCASE, DISPLAY, AND DISCUSSION OF PRODUCTS AND EVENTS, ALL OF THE ABOVE CONCERNING MUSIC, MUSICIANS, INTERVIEWS WITH MUSICIANS AND OTHER MUSIC RELATED TOPICS, MUSICAL INSTRUMENTS, PLAYING MUSIC, LEARNING MUSIC, MUSICAL EDUCATION AND INSTRUCTION, AND INSTRUCTIONAL, EDUCATIONAL, AND TEACHING MATERIALS IN THE FIELDS OF MUSIC, MUSICAL EDUCATION AND MUSICAL INSTRUCTION (U.S. CLS. 100, 101 AND 104).

RAMONA ORTIGA, EXAMINING ATTORNEY

SN 77-343,975. BOX.NET, INC., PALO ALTO, CA. FILED 12-4-2007.

BOX

THE MARK CONSISTS OF STANDARD CHARACTERS WITHOUT CLAIM TO ANY PARTICULAR FONT, STYLE, SIZE, OR COLOR.

CLASS 35—ADVERTISING AND BUSINESS

FOR (BASED ON INTENT TO USE) ADVERTISING THE GOODS AND SERVICES OF OTHERS VIA THE INTERNET (U.S. CLS. 100, 101 AND 102).

CLASS 41—EDUCATION AND ENTERTAINMENT

FOR ON-LINE JOURNALS, NAMELY, BLOGS DISCUSSING TECHNOLOGY AND BUSINESS (U.S. CLS. 100, 101 AND 107).

FIRST USE 1-1-2007; IN COMMERCE 1-1-2007.
RAMONA ORTIGA, EXAMINING ATTORNEY

SN 77-344,030. BOX.NET, INC., PALO ALTO, CA. FILED 12-4-2007.

OPENBOX

THE MARK CONSISTS OF STANDARD CHARACTERS WITHOUT CLAIM TO ANY PARTICULAR FONT, STYLE, SIZE, OR COLOR.

CLASS 9—ELECTRICAL AND SCIENTIFIC APPARATUS

FOR (BASED ON INTENT TO USE) COMPUTER SOFTWARE, NAMELY, SOFTWARE DEVELOPMENT TOOLS; COMPUTER SOFTWARE FOR TRACKING CHANGES AND MODIFICATIONS TO SOFTWARE AND FOR MANAGING SOFTWARE DEVELOPMENT PROJECTS; COMPUTER SOFTWARE, NAMELY, APPLICATION INTERFACES, PLUGINS, AND PROTOCOL INTERFACES AND COMPUTER SOFTWARE DEVELOPMENT TOOLS FOR DESIGN AND DEVELOPMENT OF OPEN-SOURCE AND PROPRIETARY SOFTWARE PROGRAMS (U.S. CLS. 21, 23, 26, 36 AND 38).

CLASS 35—ADVERTISING AND BUSINESS

FOR (BASED ON INTENT TO USE) ADVERTISING THE GOODS AND SERVICES OF OTHERS VIA THE INTERNET (U.S. CLS. 100, 101 AND 102).

CLASS 41—EDUCATION AND ENTERTAINMENT

FOR (BASED ON INTENT TO USE) ON-LINE JOURNALS, NAMELY, BLOGS DISCUSSING TECHNOLOGY AND BUSINESS (U.S. CLS. 100, 101 AND 107).

CLASS 42—SCIENTIFIC AND COMPUTER SERVICES

FOR COMPUTER SERVICES, NAMELY, ACTING AS AN APPLICATION SERVICE PROVIDER IN THE FIELD OF KNOWLEDGE MANAGEMENT TO HOST COMPUTER APPLICATION SOFTWARE FOR THE COLLECTION EDITING, ORGANIZING, MODIFYING, BOOK MARKING, TRANSMISSION, STORAGE, AND SHARING OF DATA AND INFORMATION, COMPUTER SERVICES, NAMELY, PROVIDING CUSTOMIZED ON-LINE WEB PAGES FEATURING USER-DEFINED INFORMATION, THE WEB PAGES PROVIDING AN INTERFACE FOR THE COLLECTION (U.S. CLS. 100 AND 101).

FIRST USE 11-1-2007; IN COMMERCE 11-1-2007.
RAMONA ORTIGA, EXAMINING ATTORNEY

SN 77-345,548. DOMAIN7 SOLUTIONS INC., ABBOTSFORD, CANADA, FILED 12-6-2007.

DOMAIN7

THE MARK CONSISTS OF STANDARD CHARACTERS WITHOUT CLAIM TO ANY PARTICULAR FONT, STYLE, SIZE, OR COLOR.

OWNER OF CANADA REG. NO. TMA606818, DATED 4-1-2004, EXPIRES 4-1-2019.

CLASS 9—ELECTRICAL AND SCIENTIFIC APPARATUS

FOR COMPUTER SOFTWARE APPLICATIONS THAT MANAGE AND CREATE BACK END INFRASTRUCTURE FOR INTERNET-BASED BUSINESSES, INCLUDING CUSTOMER CARE, SUPPORT, REPORTING, ACTIVITY, TRACKING, RATING, BILLING AND ACCOUNT MANAGEMENT ACCESSIBLE AND CUSTOMIZABLE OVER THE GLOBAL INTERNET NETWORK; COMPUTER SOFTWARE DEVELOPMENT TOOLS AND COMPUTER SOFTWARE APPLICATIONS THAT ENABLE THIRD PARTIES TO MANAGE ONLINE CONTENT, DATABASES, AND COMMUNICATIONS FOR INTERNET, INTRANET AND EXTRANET BASED ASPECTS OF THEIR BUSINESSES (U.S. CLS. 21, 23, 26, 36 AND 38).

CLASS 42—SCIENTIFIC AND COMPUTER SERVICES

FOR WEBSITE HOSTING SERVICES FOR THIRD PARTIES; INTERNET SERVICES, NAMELY CREATING WEB-SITES AND PROGRAMMING WEBSITES, NAMELY, HOME PAGES; DESIGN AND DEVELOPMENT OF INTERNET-RELATED SOFTWARE, NAMELY SOFTWARE USED TO CREATE, MODIFY, OPERATE, SUPPORT AND MAINTAIN NETWORK APPLICATIONS, SOFTWARE USED TO ACCESS, BROWSE, DISPLAY, SEARCH, SORT, FORMAT, INPUT, PRINT, TRANSLATE, GENERATE AND MANAGE INFORMATION AND DOCUMENTS STORED IN INTERNET-BASED DATA REPOSITORIES, INTERNET, INTRANET, AND EXTRANET WEB PLATFORM SOFTWARE, SOFTWARE FOR ACCESSING, DISPLAYING AND SEARCHING THE INTERNET, SOFTWARE USED TO GENERATE, OPERATE, MONITOR, SUPPORT AND MAINTAIN WEB-PAGES AND WEBSITES AND SOFTWARE TO CREATE INTERACTIVE INTERNET APPLICATIONS; COMPUTER SYSTEMS ANALYSIS, NAMELY, SYSTEMS ANALYSIS FOR COMPUTERS AND COMPUTERS WITH INTERNET ACCESS; MAINTENANCE OF INTERNET COMPUTER SOFTWARE; PROFESSIONAL CONSULTANCY SERVICES IN THE FIELDS OF COMPUTER HARDWARE AND SOFTWARE FOR ACCESSING THE INTERNET, WEB-BASED COMPUTER NETWORKS, AND COMPUTER INFORMATION SYSTEMS; TECHNICAL RESEARCH IN THE FIELDS OF INTERNET TELECOMMUNICATIONS, COMPUTER HARDWARE AND SOFTWARE FOR ACCESSING THE INTERNET, WEB-BASED COMPUTER NETWORKS, AND COMPUTER INFORMATION SYSTEMS; WEB SITE DESIGN, DRAWING UP OF PLANS AND ENGINEERING DRAWINGS AND TECHNICAL WRITING FOR OTHERS, ALL FOR THE COMPILATION OF WEB PAGES ON THE INTERNET; TECHNICAL SUPPORT SERVICES, NAMELY, TROUBLESHOOTING OF COMPUTER INTERNET SOFTWARE PROBLEMS; COMPUTER SOFTWARE CONSULTATION SERVICES (U.S. CLS. 100 AND 101).

FIRST USE 12-31-1999; IN COMMERCE 12-31-1999.
SETH A. RAPPAPORT, EXAMINING ATTORNEY

CLASS 44—MEDICAL, BEAUTY AND AGRICULTURAL SERVICES

FOR MEDICAL SERVICES, NAMELY, PROVIDING MEDICAL INFORMATION ON CYSTIC FIBROSIS AND ON AVAILABLE TREATMENTS FOR PATIENTS THROUGH GLOBAL COMPUTER NETWORKS, RADIO AND TELEVISION PUBLIC SERVICE ANNOUNCEMENTS AND THROUGH SEMINARS AND CONFERENCES; CONDUCTING PATIENT SCREENING PROGRAMS FOR THE PURPOSE OF RAISING PUBLIC AWARENESS OF THE NEED FOR TREATMENT AND MANAGEMENT OF CYSTIC FIBROSIS (U.S. CLS. 100 AND 101).

DOMINIC FATHY, EXAMINING ATTORNEY

SN 77-345,757. NOVARTIS AG, BASEL, SWITZERLAND,
FILED 12-6-2007.

ZUDE

SN 77-345,753. NOVARTIS AG, BASEL, SWITZERLAND,
FILED 12-6-2007.

MISS SLIPPERY

THE MARK CONSISTS OF STANDARD CHARACTERS WITHOUT CLAIM TO ANY PARTICULAR FONT, STYLE, SIZE, OR COLOR.

CLASS 41—EDUCATION AND ENTERTAINMENT

FOR EDUCATIONAL SERVICES, NAMELY, CONDUCTING PROGRAMS IN THE FIELD OF DOCTOR AND PATIENT EDUCATION, PATIENT SUPPORT AND PATIENT BENEFIT RELATING TO CYSTIC FIBROSIS (U.S. CLS. 100, 101 AND 107).

THE MARK CONSISTS OF STANDARD CHARACTERS WITHOUT CLAIM TO ANY PARTICULAR FONT, STYLE, SIZE, OR COLOR.

CLASS 41—EDUCATION AND ENTERTAINMENT

FOR EDUCATIONAL SERVICES, NAMELY, CONDUCTING PROGRAMS IN THE FIELD OF DOCTOR AND PATIENT EDUCATION, PATIENT SUPPORT AND PATIENT BENEFIT RELATING TO CYSTIC FIBROSIS (U.S. CLS. 100, 101 AND 107).

CLASS 44—MEDICAL, BEAUTY AND AGRICULTURAL SERVICES

FOR MEDICAL SERVICES, NAMELY, PROVIDING MEDICAL INFORMATION ON CYSTIC FIBROSIS AND ON AVAILABLE TREATMENTS FOR PATIENTS THROUGH GLOBAL COMPUTER NETWORKS, RADIO AND TELEVISION PUBLIC SERVICE ANNOUNCEMENTS AND THROUGH SEMINARS AND CONFERENCES; CONDUCTING PATIENT SCREENING PROGRAMS FOR THE PURPOSE OF RAISING PUBLIC AWARENESS OF THE NEED FOR TREATMENT AND MANAGEMENT OF CYSTIC FIBROSIS (U.S. CLS. 100 AND 101).

DOMINIC FATHY, EXAMINING ATTORNEY

SN 77-345,758. NOVARTIS AG, BASEL, SWITZERLAND, FILED 12-6-2007.



CLASS 41—EDUCATION AND ENTERTAINMENT

FOR EDUCATIONAL SERVICES, NAMELY, CONDUCTING PROGRAMS IN THE FIELD OF DOCTOR AND PATIENT EDUCATION, PATIENT SUPPORT AND PATIENT BENEFIT RELATING TO CYSTIC FIBROSIS (U.S. CLS. 100, 101 AND 107).

CLASS 44—MEDICAL, BEAUTY AND AGRICULTURAL SERVICES

FOR MEDICAL SERVICES, NAMELY, PROVIDING MEDICAL INFORMATION ON CYSTIC FIBROSIS AND ON AVAILABLE TREATMENTS FOR PATIENTS THROUGH GLOBAL COMPUTER NETWORKS, RADIO AND TELEVISION PUBLIC SERVICE ANNOUNCEMENTS AND THROUGH SEMINARS AND CONFERENCES; CONDUCTING PATIENT SCREENING PROGRAMS FOR THE PURPOSE OF RAISING PUBLIC AWARENESS OF THE NEED FOR TREATMENT AND MANAGEMENT OF CYSTIC FIBROSIS (U.S. CLS. 100 AND 101).

DOMINIC FATHY, EXAMINING ATTORNEY

SN 77-345,763. NOVARTIS AG, BASEL, SWITZERLAND, FILED 12-6-2007.



THE COLOR GRAY IS INTENDED TO SHOW SHADING OR CONTRAST ONLY.
THE MARK CONSISTS OF A DANCING GIRL WEARING A BIG HAT.

CLASS 41—EDUCATION AND ENTERTAINMENT

FOR ENTERTAINMENT SERVICES AND EDUCATIONAL SERVICES, NAMELY, CONDUCTING PROGRAMS IN THE FIELD OF DOCTOR AND PATIENT EDUCATION RELATING TO CYSTIC FIBROSIS; CONDUCTING EDUCATIONAL SEMINARS AND CONFERENCES IN THE FIELD OF CYSTIC FIBROSIS, INCLUDING AVAILABLE TREATMENTS FOR PATIENTS (U.S. CLS. 100, 101 AND 107).

CLASS 44—MEDICAL, BEAUTY AND AGRICULTURAL SERVICES

FOR MEDICAL SERVICES, NAMELY, PROVIDING INFORMATION ON CYSTIC FIBROSIS AND ON AVAILABLE TREATMENTS FOR PATIENTS THROUGH GLOBAL COMPUTER NETWORKS; CONDUCTING PATIENT SCREENING PROGRAMS FOR THE PURPOSE OF RAISING PUBLIC AWARENESS OF THE NEED FOR TREATMENT AND MANAGEMENT OF CYSTIC FIBROSIS (U.S. CLS. 100 AND 101).

Laurie Kaufman, Examining Attorney

SN 77-345,765. NOVARTIS AG, BASEL, SWITZERLAND, FILED 12-6-2007.



THE COLOR GRAY IS INTENDED TO SHOW SHADING OR CONTRAST ONLY.
THE MARK CONSISTS OF A GELATINOUS CHARACTER INSIDE A TRANSPARENT CONTAINER SURROUNDED BY A LIQUID SPILL.

CLASS 41—EDUCATION AND ENTERTAINMENT

FOR ENTERTAINMENT SERVICES AND EDUCATIONAL SERVICES, NAMELY, CONDUCTING PROGRAMS IN THE FIELD OF DOCTOR AND PATIENT EDUCATION RELATING TO CYSTIC FIBROSIS; CONDUCTING EDUCATIONAL SEMINARS AND CONFERENCES IN THE FIELD OF CYSTIC FIBROSIS, INCLUDING AVAILABLE TREATMENTS FOR PATIENTS (U.S. CLS. 100, 101 AND 107).

CLASS 44—MEDICAL, BEAUTY AND AGRICULTURAL SERVICES

FOR MEDICAL SERVICES, NAMELY, PROVIDING INFORMATION ON CYSTIC FIBROSIS AND ON AVAILABLE TREATMENTS FOR PATIENTS THROUGH GLOBAL COMPUTER NETWORKS; CONDUCTING PATIENT SCREENING PROGRAMS FOR THE PURPOSE OF RAISING PUBLIC AWARENESS OF THE NEED FOR TREATMENT AND MANAGEMENT OF CYSTIC FIBROSIS (U.S. CLS. 100 AND 101).

Laurie Kaufman, Examining Attorney

SN 77-347,328. JAIME PUJOL, MIAMI, FL. FILED S.R. 12-8-2007; AM. P.R. 7-2-2008.

SN 77-348,817. NOVARTIS AG, BASEL, SWITZERLAND, FILED 12-11-2007.

UNSINKABLE STARS AND STRIPES

THE MARK CONSISTS OF STANDARD CHARACTERS WITHOUT CLAIM TO ANY PARTICULAR FONT, STYLE, SIZE, OR COLOR.

CLASS 9—ELECTRICAL AND SCIENTIFIC APPARATUS

FOR LIFE PRESERVERS (U.S. CLS. 21, 23, 26, 36 AND 38).

CLASS 12—VEHICLES

FOR RAFTS (U.S. CLS. 19, 21, 23, 31, 35 AND 44).
DAVID MILLER, EXAMINING ATTORNEY

SN 77-347,611. TIEMANN, MICHAEL, CHAPEL HILL, NC. FILED 12-9-2007.

MANIFOLD RECORDING

THE MARK CONSISTS OF STANDARD CHARACTERS WITHOUT CLAIM TO ANY PARTICULAR FONT, STYLE, SIZE, OR COLOR.

NO CLAIM IS MADE TO THE EXCLUSIVE RIGHT TO USE "RECORDING", APART FROM THE MARK AS SHOWN.

CLASS 38—COMMUNICATION

FOR AUDIO AND VIDEO BROADCASTING SERVICES OVER THE INTERNET (U.S. CLS. 100, 101 AND 104).

CLASS 41—EDUCATION AND ENTERTAINMENT

FOR MUSIC, AUDIO AND VIDEOTAPE PRODUCTION; AUDIO AND VIDEO RECORDING SERVICES; MUSIC PRODUCTION SERVICES FEATURING LIVE PERFORMANCES WITH AN AUDIENCE (U.S. CLS. 100, 101 AND 107).

PAM WILLIS, EXAMINING ATTORNEY

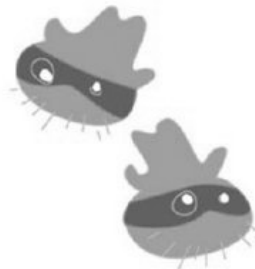

THE COLOR GRAY IS INTENDED TO SHOW SHADING OR CONTRAST ONLY.

THE MARK CONSISTS OF TWO BEWHISKERED FORMS WEARING MASKS AND COWBOYS HATS.

CLASS 41—EDUCATION AND ENTERTAINMENT

FOR ENTERTAINMENT SERVICES AND EDUCATIONAL SERVICES, NAMELY, CONDUCTING PROGRAMS IN THE FIELD OF DOCTOR AND PATIENT EDUCATION RELATING TO CYSTIC FIBROSIS; CONDUCTING EDUCATIONAL SEMINARS AND CONFERENCES IN THE FIELD OF CYSTIC FIBROSIS, INCLUDING AVAILABLE TREATMENTS FOR PATIENTS (U.S. CLS. 100, 101 AND 107).

CLASS 44—MEDICAL, BEAUTY AND AGRICULTURAL SERVICES

FOR MEDICAL SERVICES, NAMELY, PROVIDING INFORMATION ON CYSTIC FIBROSIS AND ON AVAILABLE TREATMENTS FOR PATIENTS THROUGH GLOBAL COMPUTER NETWORKS; CONDUCTING PATIENT SCREENING PROGRAMS FOR THE PURPOSE OF RAISING PUBLIC AWARENESS OF THE NEED FOR TREATMENT AND MANAGEMENT OF CYSTIC FIBROSIS (U.S. CLS. 100 AND 101).

LAURIE KAUFMAN, EXAMINING ATTORNEY

SN 77-348,821. NOVARTIS AG, BASEL, SWITZERLAND, FILED 12-11-2007.

MR. STICKY

THE MARK CONSISTS OF STANDARD CHARACTERS WITHOUT CLAIM TO ANY PARTICULAR FONT, STYLE, SIZE, OR COLOR.

CLASS 41—EDUCATION AND ENTERTAINMENT

FOR ENTERTAINMENT SERVICES AND EDUCATIONAL SERVICES, NAMELY, CONDUCTING PROGRAMS IN THE FIELD OF DOCTOR AND PATIENT EDUCATION RELATING TO CYSTIC FIBROSIS; CONDUCTING EDUCATIONAL SEMINARS AND CONFERENCES IN THE FIELD OF CYSTIC FIBROSIS, INCLUDING AVAILABLE TREATMENTS FOR PATIENTS (U.S. CLS. 100, 101 AND 107).

CLASS 44—MEDICAL, BEAUTY AND AGRICULTURAL SERVICES

FOR MEDICAL SERVICES, NAMELY, PROVIDING INFORMATION ON CYSTIC FIBROSIS AND ON AVAILABLE TREATMENTS FOR PATIENTS THROUGH GLOBAL COMPUTER NETWORKS; CONDUCTING PATIENT SCREENING PROGRAMS FOR THE PURPOSE OF RAISING PUBLIC AWARENESS OF THE NEED FOR TREATMENT AND MANAGEMENT OF CYSTIC FIBROSIS (U.S. CLS. 100 AND 101).

LAURIE KAUFMAN, EXAMINING ATTORNEY

SN 77-348,823, NOVARTIS AG, BASEL, SWITZERLAND, FILED 12-11-2007.

STINKY PACIAS

THE MARK CONSISTS OF STANDARD CHARACTERS WITHOUT CLAIM TO ANY PARTICULAR FONT, STYLE, SIZE, OR COLOR.

CLASS 41—EDUCATION AND ENTERTAINMENT

FOR ENTERTAINMENT SERVICES AND EDUCATIONAL SERVICES, NAMELY, CONDUCTING PROGRAMS IN THE FIELD OF DOCTOR AND PATIENT EDUCATION RELATING TO CYSTIC FIBROSIS; CONDUCTING EDUCATIONAL SEMINARS AND CONFERENCES IN THE FIELD OF CYSTIC FIBROSIS, INCLUDING AVAILABLE TREATMENTS FOR PATIENTS (U.S. CLS. 100, 101 AND 107).

CLASS 44—MEDICAL, BEAUTY AND AGRICULTURAL SERVICES

FOR MEDICAL SERVICES, NAMELY, PROVIDING INFORMATION ON CYSTIC FIBROSIS AND ON AVAILABLE TREATMENTS FOR PATIENTS THROUGH GLOBAL COMPUTER NETWORKS; CONDUCTING PATIENT SCREENING PROGRAMS FOR THE PURPOSE OF RAISING PUBLIC AWARENESS OF THE NEED FOR TREATMENT AND MANAGEMENT OF CYSTIC FIBROSIS (U.S. CLS. 100 AND 101).

LAURIE KAUFMAN, EXAMINING ATTORNEY

SN 77-348,824, NOVARTIS AG, BASEL, SWITZERLAND, FILED 12-11-2007.

GRUBBY MONAS

THE MARK CONSISTS OF STANDARD CHARACTERS WITHOUT CLAIM TO ANY PARTICULAR FONT, STYLE, SIZE, OR COLOR.

CLASS 41—EDUCATION AND ENTERTAINMENT

FOR ENTERTAINMENT SERVICES AND EDUCATIONAL SERVICES, NAMELY, CONDUCTING PROGRAMS IN THE FIELD OF DOCTOR AND PATIENT EDUCATION RELATING TO CYSTIC FIBROSIS; CONDUCTING EDUCATIONAL SEMINARS AND CONFERENCES IN THE FIELD OF CYSTIC FIBROSIS, INCLUDING AVAILABLE TREATMENTS FOR PATIENTS (U.S. CLS. 100, 101 AND 107).

CLASS 44—MEDICAL, BEAUTY AND AGRICULTURAL SERVICES

FOR MEDICAL SERVICES, NAMELY, PROVIDING INFORMATION ON CYSTIC FIBROSIS AND ON AVAILABLE TREATMENTS FOR PATIENTS THROUGH GLOBAL COMPUTER NETWORKS; CONDUCTING PATIENT SCREENING PROGRAMS FOR THE PURPOSE OF RAISING PUBLIC AWARENESS OF THE NEED FOR TREATMENT AND MANAGEMENT OF CYSTIC FIBROSIS (U.S. CLS. 100 AND 101).

LAURIE KAUFMAN, EXAMINING ATTORNEY

SN 77-349,063, RETAIL PROPERTY SOLUTIONS, LLC, ATLANTA, GA. FILED 12-11-2007.

RETAIL PROPERTY
 Solutions

NO CLAIM IS MADE TO THE EXCLUSIVE RIGHT TO USE "RETAIL PROPERTY", APART FROM THE MARK AS SHOWN.

THE COLOR(S) LIGHT BLUE AND DARK BLUE IS/ARE CLAIMED AS A FEATURE OF THE MARK.

THE MARK CONSISTS OF THE WORDS "RETAIL PROPERTY" IN ALL CAPITAL LETTERS IN DARK BLUE WITH A DESIGN OF A PUZZLE IN LIGHT BLUE UNDERNEATH IT AND THE WORD "SOLUTIONS" IN DARK BLUE NEXT TO IT.

CLASS 36—INSURANCE AND FINANCIAL

FOR REAL ESTATE CONSULTATION; REAL ESTATE MANAGEMENT CONSULTATION; ASSESSMENT AND MANAGEMENT OF REAL ESTATE (U.S. CLS. 100, 101 AND 102).

FIRST USE 9-1-2005; IN COMMERCE 9-1-2005.

CLASS 37—CONSTRUCTION AND REPAIR

FOR REAL ESTATE DEVELOPMENT SERVICES; REAL ESTATE SITE SELECTION SERVICES (U.S. CLS. 100, 103 AND 106).

FIRST USE 9-1-2005; IN COMMERCE 9-1-2005.

RICHARD A. STRASER, EXAMINING ATTORNEY

SN 77-349,156. RETAIL PROPERTY SOLUTIONS, LLC,
ATLANTA, GA. FILED 12-11-2007.

RETAIL PROPERTY SOLUTIONS

THE MARK CONSISTS OF STANDARD CHARACTERS WITHOUT CLAIM TO ANY PARTICULAR FONT, STYLE, SIZE, OR COLOR.

NO CLAIM IS MADE TO THE EXCLUSIVE RIGHT TO USE "RETAIL PROPERTY", APART FROM THE MARK AS SHOWN.

CLASS 36—INSURANCE AND FINANCIAL

FOR REAL ESTATE CONSULTATION; REAL ESTATE MANAGEMENT CONSULTATION; ASSESSMENT AND MANAGEMENT OF REAL ESTATE (U.S. CLS. 100, 101 AND 102).

FIRST USE 9-1-2005; IN COMMERCE 9-1-2005.

CLASS 37—CONSTRUCTION AND REPAIR

FOR REAL ESTATE DEVELOPMENT SERVICES; REAL ESTATE SITE SELECTION SERVICES (U.S. CLS. 100, 103 AND 106).

FIRST USE 9-1-2005; IN COMMERCE 9-1-2005.

RICHARD A. STRASER, EXAMINING ATTORNEY

SN 77-351,326. WEST PHARMACEUTICAL SERVICES, INC.,
LIONVILLE, PA. FILED 12-13-2007.



OWNER OF U.S. REG. NOS. 1,413,968, 3,037,381 AND OTHERS.

THE MARK CONSISTS OF THE WORD "WEST" FOLLOWED BY A DIAMOND SHAPED DESIGN.

CLASS 6—METAL GOODS

FOR METAL CLOSURES FOR CONTAINERS; METAL SEALS (U.S. CLS. 2, 12, 13, 14, 23, 25 AND 50).

CLASS 10—MEDICAL APPARATUS

FOR DROPPERS FOR ADMINISTERING MEDICATION, SOLD EMPTY; INFUSION AND INJECTION DEVICES FOR ADMINISTERING DRUGS; MEDICAL SYRINGES; DRUG DELIVERY SYSTEMS; BABY BOTTLE NIPPLES (U.S. CLS. 26, 39 AND 44).

CLASS 17—RUBBER GOODS

FOR RUBBER STOPPERS FOR PHARMACEUTICAL CONTAINERS; NON-METAL SEALS FOR USE ON CONTAINERS (U.S. CLS. 1, 5, 12, 13, 35 AND 50).

CLASS 20—FURNITURE AND ARTICLES NOT OTHERWISE CLASSIFIED

FOR NON-METALLIC CLOSURES FOR CONTAINERS; VIALS AND CONTAINERS FOR MEDICATIONS, SOLD EMPTY (U.S. CLS. 2, 13, 22, 25, 32 AND 50).

CLASS 42—SCIENTIFIC AND COMPUTER SERVICES

FOR RESEARCH AND DEVELOPMENT AND CONSULTATION RELATED THERETO IN THE FIELDS OF PHARMACEUTICAL PACKAGING, DRUG STABILITY, MEDICAL DEVICE ANALYSIS, ADMINISTRATION OF DRUGS, AND DRUG DELIVERY SYSTEMS; MATERIALS TESTING AND EVALUATION (U.S. CLS. 100 AND 101).

MARK PILARO, EXAMINING ATTORNEY

SN 77-352,078. TERRA GROUP, LLC, NAPPANEE, IN. FILED
12-14-2007.



NO CLAIM IS MADE TO THE EXCLUSIVE RIGHT TO USE "ENERGY TECHNOLOGIES", APART FROM THE MARK AS SHOWN.

THE MARK CONSISTS OF THE WORDS "LUCID ENERGY TECHNOLOGIES" WITH A FLOWER-LIKE DESIGN TO THE RIGHT AND SLIGHTLY BELOW THE WORD "TECHNOLOGIES".

CLASS 7—MACHINERY

FOR WIND TURBINES; HYDROKINETIC TURBINES; GENERATORS FOR WIND TURBINES; ELECTRIC GENERATORS (U.S. CLS. 13, 19, 21, 23, 31, 34 AND 35).

CLASS 37—CONSTRUCTION AND REPAIR

FOR INSTALLATION AND MAINTENANCE OF ELECTRIC GENERATORS (U.S. CLS. 100, 103 AND 106).

CLASS 40—MATERIAL TREATMENT

FOR GENERATION OF POWER (U.S. CLS. 100, 103 AND 106).

CLASS 42—SCIENTIFIC AND COMPUTER SERVICES

FOR ENGINEERING AND ENGINEERING CONSULTATION SERVICES IN THE FIELDS OF SITE EVALUATION, SITE DESIGN AND CUSTOM COMPONENTS DESIGN OF POWER GENERATING SYSTEMS FOR OTHERS (U.S. CLS. 100 AND 101).

ALEXANDER L. POWERS, EXAMINING ATTORNEY

SN 77-356,203. KEVIN PROPPER, DBA PROPPER DESIGN GROUP, COSTA MESA, CA. FILED 12-19-2007.

Bumm Wrap

THE MARK CONSISTS OF STANDARD CHARACTERS WITHOUT CLAIM TO ANY PARTICULAR FONT, STYLE, SIZE, OR COLOR.

NO CLAIM IS MADE TO THE EXCLUSIVE RIGHT TO USE "WRAP", APART FROM THE MARK AS SHOWN.

CLASS 24—FABRICS

FOR BATH TOWELS; BEACH TOWELS; CHILDREN'S TOWELS; HOODED TOWELS; LARGE BATH TOWELS; TERRY TOWELS; TOWELS; TOWELS; CURTAINS AND TOWELS; FACE TOWELS; GOLF TOWELS; HAND TOWELS; HAND TOWELS OF TEXTILE; HAND-TOWELS MADE OF TEXTILE FABRICS; JAPANESE COTTON TOWELS (TENUGUI); KITCHEN TOWELS; TEA TOWELS; TOWEL SETS; TOWELLING COVERLETS (U.S. CLS. 42 AND 50).

CLASS 25—CLOTHING

FOR CLOTHING, NAMELY, WRAP-AROUNDS; HOODS; SHOULDER WRAPS; TOPS; TRIATHLON CLOTHING, NAMELY, TRIATHLON TIGHTS, TRIATHLON SHORTS, TRIATHLON SINGLET, TRIATHLON SHIRTS, TRIATHLON SUITS; WRAPS; SWADDLING CLOTHES; TIES; UNDERARM CLOTHING SHIELDS; CORSETS; DUSTERS; FOULARDS; INFANT AND TODDLER ONE PIECE CLOTHING; INFANT CLOTH DIAPERS; JERSEYS; LEATHER BELTS; MANTLES; MUFFLERS; NON-DISPOSABLE CLOTH TRAINING PANTS; PAPER HATS FOR USE AS CLOTHING ITEMS; PARTS OF CLOTHING, NAMELY, GUSSETS FOR TIGHTS, GUSSETS FOR STOCKINGS, GUSSETS FOR BATHING SUITS, GUSSETS FOR UNDERWEAR, GUSSETS FOR LEOTARDS AND GUSSETS FOR FOOTLETS; PERSPIRATION ABSORBENT UNDERWEAR CLOTHING; SHIRTS; SHORT SETS; BELTS; BIBS NOT OF CLOTH OR PAPER; CAPS; CHILDREN'S AND INFANTS' CLOTH BIBS; CHILDREN'S CLOTH EATING BIBS; CLOTH BIBS; CLOTH BIBS FOR ADULT DINERS; CLOTH BIBS FOR USE BY SENIOR CITIZENS OR PHYSICALLY- OR MENTALLY-CHALLENGED PERSONS; CLOTH DIAPERS; CLOTHING FOR WEAR IN JUDO PRACTICES; CLOTHING FOR WEAR IN WRESTLING GAMES; CLOTHING, NAMELY, ARM WARMERS; CLOTHING, NAMELY, FOLK COSTUMES; CLOTHING, NAMELY, HAND-WARMERS; CLOTHING, NAMELY, KNEE WARMERS; CLOTHING, NAMELY, NECK TUBES; CLOTHING, NAMELY, THOBES (U.S. CLS. 22 AND 39).

ANTHONY RINKER, EXAMINING ATTORNEY

SN 77-358,076. MEDIZINE, LLC, NEW YORK, NY. FILED 12-21-2007.

REMEDYLIFE

THE MARK CONSISTS OF STANDARD CHARACTERS WITHOUT CLAIM TO ANY PARTICULAR FONT, STYLE, SIZE, OR COLOR.

OWNER OF U.S. REG. NO. 2,615,377.

CLASS 35—ADVERTISING AND BUSINESS

FOR ARRANGING FOR DISCOUNTS ON HEALTH-RELATED PRODUCTS AND SERVICES FOR SUBSCRIBING MEMBERS; MARKETING SERVICES IN THE FIELD OF HEALTH, NAMELY, PROMOTING THE HEALTH-RELATED PRODUCTS OR SERVICES OF OTHERS; CONDUCTING ONLINE SURVEYS IN THE FIELD OF HEALTH; CONDUCTING ONLINE POLLS IN THE FIELD OF HEALTH (U.S. CLS. 100, 101 AND 102).

FIRST USE 12-15-2007; IN COMMERCE 12-15-2007.

CLASS 44—MEDICAL, BEAUTY AND AGRICULTURAL SERVICES

FOR PROVIDING ONLINE HEALTH INFORMATION (U.S. CLS. 100 AND 101).

FIRST USE 12-15-2007; IN COMMERCE 12-15-2007.
STEPHEN AQUILA, EXAMINING ATTORNEY

SN 77-358,185. ZIMMER, INC., WARSAW, IN. FILED 12-21-2007.

ZIMMER

THE MARK CONSISTS OF STANDARD CHARACTERS WITHOUT CLAIM TO ANY PARTICULAR FONT, STYLE, SIZE, OR COLOR.

PRIORITY CLAIMED UNDER SEC. 44(D) ON SWITZERLAND APPLICATION NO. 56853/2007, FILED 6-26-2007, REG. NO. 562955, DATED 10-16-2007, EXPIRES 6-26-2017.

OWNER OF U.S. REG. NOS. 647,921, 1,633,088 AND OTHERS.

SEC. 2(F).

CLASS 9—ELECTRICAL AND SCIENTIFIC APPARATUS

FOR COMPUTER SOFTWARE IN THE FIELD OF COMPUTER-ASSISTED OPERATION NAVIGATION, OF PREOPERATIVE AND PERIOPERATIVE PLANNING, OF OPERATION SIMULATION AND OF INTRAOPERATIVE CONTROL; COMPUTER PERIPHERALS WITH HAPTIC, THAT IS, SENSITIVE TO THE SENSE OF TOUCH; COMPUTER HARDWARE CONSISTING OF ULTRASOUND APPARATUS, LASER APPARATUS, COMPUTER INPUT PERIPHERALS WITH HAPTIC, THAT IS, SENSITIVE TO THE SENSE OF TOUCH, COMPUTERS, INPUT APPARATUS, DISK DRIVES, SCREENS, TOUCH-SCREEN MONITORS AND KEYBOARDS; ELECTRONIC CONTROLS FOR SURGICAL AND MEDICAL DEVICES AND APPARATUS; ELECTRONIC NAVIGATION APPARATUS; ELECTRONIC DIRECTION FINDERS, ELECTRONIC POSITION DETERMINATION APPARATUS, ELECTRONIC ORIENTATION DETERMINATION APPARATUS FOR LOCALIZATION AND SUBSEQUENT TRACKING OF THE POSITION OF A PATIENT AS WELL AS OF INSTRUMENTS DURING THE IMAGE-MANAGED SURGERY; SYSTEMS FOR THE AUTOMATIC IDENTIFICATION OF OBJECTS VIA RADIO, RFID TECHNOLOGY, CONSISTING OF A TRANSMITTER-RECEIVER UNIT, TRANSPONDER, READING APPARATUS, ANTENNA, HOUSING AND MICROCHIP (U.S. CLS. 21, 23, 26, 36 AND 38).

CLASS 10—MEDICAL APPARATUS

FOR SURGICAL ROBOT ARMS (U.S. CLS. 26, 39 AND 44).

RICHARD A. STRASER, EXAMINING ATTORNEY

SN 77-360,060. INFODESK, INC., TARRYTOWN, NY. FILED 12-27-2007.

INFOVIEWER

THE MARK CONSISTS OF STANDARD CHARACTERS WITHOUT CLAIM TO ANY PARTICULAR FONT, STYLE, SIZE, OR COLOR.

SEC. 2(F).

CLASS 9—ELECTRICAL AND SCIENTIFIC APPARATUS

FOR COMPUTER SOFTWARE FOR MANAGEMENT, DISPLAY AND DELIVERY OVER ELECTRONIC COMMUNICATIONS NETWORKS, OF DIGITAL CONTENT, INCLUDING VIDEO, AUDIO, TEXT AND GRAPHICS (U.S. CLS. 21, 23, 26, 36 AND 38).

FIRST USE 4-1-2001; IN COMMERCE 4-1-2001.

CLASS 42—SCIENTIFIC AND COMPUTER SERVICES

FOR PROVIDING ON-LINE NON-DOWNLOADABLE SOFTWARE FOR MANAGEMENT, DISPLAY AND DELIVERY OVER ELECTRONIC COMMUNICATIONS NETWORKS, OF DIGITAL CONTENT, INCLUDING VIDEO, AUDIO, TEXT AND GRAPHICS (U.S. CLS. 100 AND 101).

FIRST USE 4-1-2001; IN COMMERCE 4-1-2001.
SUNG IN, EXAMINING ATTORNEY

SN 77-360,584. CINTEX INTERNATIONAL (CANADA) LIMITED, DBA MUD RIVER DOG PRODUCTS, MISSISSAUGA, CANADA, FILED 12-27-2007.

MUD RIVER DOG PRODUCTS

THE MARK CONSISTS OF STANDARD CHARACTERS WITHOUT CLAIM TO ANY PARTICULAR FONT, STYLE, SIZE, OR COLOR.

NO CLAIM IS MADE TO THE EXCLUSIVE RIGHT TO USE "DOG PRODUCTS", APART FROM THE MARK AS SHOWN.

CLASS 18—LEATHER GOODS

FOR ALL-PURPOSE CARRYING BAGS, DOG LEASHES; DOG APPAREL; DOG COATS; DOG COLLARS; DOG COLLARS AND LEADS; DOG PARKAS; DOG SHOES (U.S. CLS. 1, 2, 3, 22 AND 41).

FIRST USE 8-1-2006; IN COMMERCE 9-1-2006.

CLASS 20—FURNITURE AND ARTICLES NOT OTHERWISE CLASSIFIED

FOR CRATE COVERS FOR PETS; PORTABLE BEDS FOR PETS (U.S. CLS. 2, 13, 22, 25, 32 AND 50).

FIRST USE 8-1-2006; IN COMMERCE 9-1-2006.
SANDRA MANIOS, EXAMINING ATTORNEY

SN 77-361,045. ULTIMATE BALANCE, INC., WINCHESTER, MA. FILED 12-28-2007.

NPAM

THE MARK CONSISTS OF STANDARD CHARACTERS WITHOUT CLAIM TO ANY PARTICULAR FONT, STYLE, SIZE, OR COLOR.

CLASS 10—MEDICAL APPARATUS

FOR WEARABLE DEVICES FOR MEASURING AND MONITORING PHYSICAL ACTIVITY LEVELS COMPRISED OF MULTI-ACCESS ACCELERATION SENSORS AND DATA PROCESSORS, AND SOFTWARE INCORPORATED THEREIN, SAID DEVICES USED TO ELECTRONICALLY MEASURE AND ANALYZE THE OUTPUT FROM SUCH SENSORS AND CALCULATE DEVICE ORIENTATION, USER'S POSTURE, MOVEMENT, STEP COUNT, ACTIVITY-RELATED CALORIC EXPENDITURE, AND OTHER MEASURES OF ACTIVITY LEVELS, THE FOREGOING FOR MEDICAL DIAGNOSTIC AND THERAPEUTIC USE (U.S. CLS. 26, 39 AND 44).

CLASS 28—TOYS AND SPORTING GOODS

FOR WEARABLE DEVICES FOR MEASURING AND MONITORING PHYSICAL ACTIVITY LEVELS COMPRISED OF MULTI-ACCESS ACCELERATION SENSORS AND DATA PROCESSORS, AND SOFTWARE INCORPORATED THEREIN, SAID DEVICES USED TO ELECTRONICALLY MEASURE AND ANALYZE THE OUTPUT FROM SUCH SENSORS AND CALCULATE DEVICE ORIENTATION, USER'S POSTURE, MOVEMENT, STEP COUNT, ACTIVITY-RELATED CALORIC EXPENDITURE, AND OTHER MEASURES OF ACTIVITY LEVELS, THE FOREGOING FOR USE IN TRAINING AND COACHING SPORTING, RECREATIONAL, AND FITNESS ACTIVITIES (U.S. CLS. 22, 23, 38 AND 50).

NANCY CLARKE, EXAMINING ATTORNEY

SN 77-361,442. WOODSTREAM CORPORATION, LITITZ, PA. FILED 12-29-2007.

PERKY-PET

THE MARK CONSISTS OF STANDARD CHARACTERS WITHOUT CLAIM TO ANY PARTICULAR FONT, STYLE, SIZE, OR COLOR.

OWNER OF U.S. REG. NOS. 1,642,105 AND 3,240,372.

CLASS 6—METAL GOODS

FOR METAL BIRD BATHS; METAL HOOKS, POLES AND CHAINS FOR HANGING BIRD FEEDERS (U.S. CLS. 2, 12, 13, 14, 23, 25 AND 50).

FIRST USE 0-0-1998; IN COMMERCE 0-0-1998.

CLASS 21—HOUSEWARES AND GLASS

FOR BIRD FEEDERS; BIRD HOUSES; PARTS AND ACCESSORIES FOR BIRD FEEDERS, NAMELY, BEE GUARDS, FOAM CLEANING MOPPS FOR HUMMINGBIRD FEEDERS; SCOOPS FOR FILLING BIRD FEEDERS WITH BIRDSEED, BAFFLERS AND GUARDS FOR BIRD FEEDERS (U.S. CLS. 2, 13, 23, 29, 30, 33, 40 AND 50).

FIRST USE 6-30-1958; IN COMMERCE 6-30-1958.

CLASS 31—NATURAL AGRICULTURAL PRODUCTS

FOR PET FOOD, NAMELY, BIRD FOOD (U.S. CLS. 1 AND 46).

FIRST USE 7-31-1960; IN COMMERCE 7-31-1960.
CHERYL CLAYTON, EXAMINING ATTORNEY

SN 77-361,486. CHRISTOPHER D. SMITHERS FOUNDATION, MILL NECK, NY. FILED 12-29-2007.

SN 77-362,054. OGAWA SEIKI KABUSHIKI KAISHA, DBA O.S. ENGINES MFG. CO., LTD., OSAKA, JAPAN, FILED 12-31-2007.

O.S. MAX

SMITHERS ALCOHOLISM TREATMENT AND TRAINING CENTER

THE MARK CONSISTS OF STANDARD CHARACTERS WITHOUT CLAIM TO ANY PARTICULAR FONT, STYLE, SIZE, OR COLOR.

NO CLAIM IS MADE TO THE EXCLUSIVE RIGHT TO USE "ALCOHOLISM TREATMENT AND TRAINING CENTER", APART FROM THE MARK AS SHOWN.

THE NAME "SMITHERS" DOES NOT IDENTIFY A LIVING INDIVIDUAL.

CLASS 35—ADVERTISING AND BUSINESS

FOR PROVIDING EMPLOYMENT OUTPLACEMENT SERVICES FOR RECOVERED ALCOHOLICS AND OTHER SUBSTANCE ABUSERS; PROMOTING THE PUBLIC AWARENESS AND UNDERSTANDING OF THE EFFECTS OF ALCOHOLISM AND THE NEED FOR PREVENTION, CARE, AND TREATMENT THEREOF (U.S. CLS. 100, 101 AND 102).

CLASS 41—EDUCATION AND ENTERTAINMENT

FOR PROVIDING COMMUNITY EDUCATION, NAMELY, CONDUCTING CLASSES, LECTURES, SEMINARS AND WORKSHOPS IN THE FIELD OF COUNSELING, RECOGNIZING, AND TREATING ADDICTIVE DISEASES, AND IN THE FIELD OF INDUSTRIAL ALCOHOLISM PROGRAMS IN THE WORKPLACE, AND DISTRIBUTING WRITTEN MATERIALS USED IN CONNECTION THEREWITH; TRAINING FOR PHYSICIANS, MEDICAL STUDENTS, NURSES, COUNSELORS AND OTHER HEALTH PROFESSIONALS TO TREAT ALCOHOLISM (U.S. CLS. 100, 101 AND 107).

CLASS 42—SCIENTIFIC AND COMPUTER SERVICES

FOR RESEARCH IN THE FIELD OF THE IMPACT AND EFFECTS OF ALCOHOLISM, AND THE EFFICACY OF TREATMENTS FOR ALCOHOLISM (U.S. CLS. 100 AND 101).

CLASS 44—MEDICAL, BEAUTY AND AGRICULTURAL SERVICES

FOR INPATIENT AND OUTPATIENT DETOXIFICATION RELATED TREATMENT, REHABILITATION AND RECOVERY SERVICES FOR ALCOHOL AND NARCOTIC ADDICTED PATIENTS; COUNSELING IN THE FIELD OF SUBSTANCE ABUSE, CHEMICAL DEPENDENCY AND DRUG OR ALCOHOL REHABILITATION (U.S. CLS. 100 AND 101).

CHERYL CLAYTON, EXAMINING ATTORNEY

THE MARK CONSISTS OF STANDARD CHARACTERS WITHOUT CLAIM TO ANY PARTICULAR FONT, STYLE, SIZE, OR COLOR.

THE WORDING "O.S. MAX" HAS NO MEANING IN A FOREIGN LANGUAGE.

CLASS 7—MACHINERY

FOR MACHINE PARTS, NAMELY, ENGINES, MOTORS, STARTERS FOR MOTORS AND ENGINES; ENGINE PARTS AND ACCESSORIES IN THE NATURE OF CYLINDER CASE, CYLINDER HEAD, PISTON, PISTON RING, CYLINDER LINER, CONNECTING ROD, CRANK SHAFT, BALL BEARING, CARBURETOR, GLOW PLUG, SILENCER, AIR CLEANER, CAMSHAFT, MANIFOLD, EXHAUST PIPE, VALVE SPRING, ENGINE MOUNT, EXHAUST MANIFOLD, INTAKE VALVE AND EXHAUST VALVE; ELECTRIC GENERATORS; BEARINGS, NAMELY, ENGINE BEARINGS (U.S. CLS. 13, 19, 21, 23, 31, 34 AND 35).

FIRST USE 4-1-1957; IN COMMERCE 4-1-1957.

CLASS 28—TOYS AND SPORTING GOODS

FOR TOY MODEL VEHICLES, NAMELY, TOY MODEL AIRPLANES AND HELICOPTERS, CARS, LOCOMOTIVES AND BOATS; AND ENGINES AND MOTORS THEREFOR SOLD AS A UNIT (U.S. CLS. 22, 23, 38 AND 50).

FIRST USE 4-1-1957; IN COMMERCE 4-1-1957.

SETH A. RAPPAPORT, EXAMINING ATTORNEY

SN 77-363,160. TELEFONOS DE MEXICO, S.A. DE C.V., MEXICO CITY D.F., MEXICO, FILED 1-3-2008.

LADA POR COBRAR

THE MARK CONSISTS OF STANDARD CHARACTERS WITHOUT CLAIM TO ANY PARTICULAR FONT, STYLE, SIZE, OR COLOR.

OWNER OF MEXICO REG. NO. 543724, DATED 2-3-1997, EXPIRES 2-3-2017.

OWNER OF MEXICO REG. NO. 543726, DATED 2-3-1997, EXPIRES 2-3-2017.

OWNER OF MEXICO REG. NO. 543725, DATED 2-3-1997, EXPIRES 2-3-2017.

OWNER OF U.S. REG. NO. 3,227,272.

THE ENGLISH TRANSLATION OF "POR COBRAR" IS "TO CHARGE".

CLASS 9—ELECTRICAL AND SCIENTIFIC APPARATUS

FOR ELECTRIC APPARATUS, NAMELY, INTEGRATED CIRCUITS, CAPACITORS, RESISTORS AND ELECTRICAL CONTROLLERS FOR USE IN TELECOMMUNICATION APPARATUS; SCIENTIFIC APPARATUS, NAMELY, SENSING AND SIGNALING DEVICES FOR MEASUREMENT AND QUALITY CONTROL OF MATERIALS PROCESSING BY LASER; APPARATUS FOR RECORDING, TRANSMISSION OR REPRODUCTION OF SOUND OR IMAGES; DATA PROCESSOR FOR DATA TREATMENT EQUIPMENT; COMPUTER HARDWARE FOR DATA TREATMENT EQUIPMENT; WIRELESS TELEPHONY APPARATUS; TELEPHONES; RECEIVER CAPS, NAMELY, COVERS FOR RECEIVERS NOT MADE OF PAPER; MAGNETIC TELEPHONE WIRES; BLANK INTEGRATED CIRCUITS; PRINTED CIRCUITS; INTERCOMMUNICATION APPARATUS AND INSTRUMENTS, NAMELY, TELEPHONES, CELLULAR TELEPHONES, INTERCOMS, TELEPHONE RECEIVERS, TELEPHONE TRANSMITTERS, TELEPHONE WIRES; ELBOW RESTS FOR USE WITH TELEPHONES; ELECTROSTATIC EMISSION CONTROL DEVICES, NAMELY, ELECTROSTATIC PRECIPITATORS FOR REDUCING PARTICULATE EMISSION IN INDUSTRIAL APPLICATIONS; CROSS-CONNECTING TERMINAL DEVICES, NAMELY, CABLE MODEMS; ANALOGOUS AND DIGITAL CENTRAL OFFICE SWITCHING, NAMELY, AUTOMATIC SWITCHING APPARATUS FOR TELECOMMUNICATIONS; METERING APPARATUS AND QUALITY CONTROL APPARATUS FOR THE TELEPHONE PUBLIC SERVICES, ACOUSTIC METERS (U.S. CLS. 21, 23, 26, 36 AND 38).

CLASS 35—ADVERTISING AND BUSINESS

FOR ADVERTISING AND MARKETING FOR THE TELECOMMUNICATIONS INDUSTRY (U.S. CLS. 100, 101 AND 102).

CLASS 38—COMMUNICATION

FOR BASIC TELEPHONE COMMUNICATION SERVICES; FINAL TELECOMMUNICATION SERVICES, NAMELY, LOCAL AND LONG DISTANCE TRANSMISSION OF VOICE, DATA, GRAPHICS BY MEANS OF TELEPHONE, TELEGRAPHIC, CABLE, AND SATELLITE TRANSMISSIONS; TRANSMISSION OF SOUND, PICTURE AND DATA SIGNALS FOR VIDEO CONFERENCES AND VIDEO TELEPHONE FOR PUBLIC, LOCAL, URBAN, SUBURBAN, RURAL, NATIONAL AND INTERNATIONAL LONG DISTANCE TELEVISION, VIA SATELLITE; SIGNALS DISTRIBUTING SERVICES, NAMELY, RADIO AND TELEVISION BROADCASTING SERVICES; DATA COMMUNICATION BY ELECTRONIC MAIL; RENTAL OF TELECOMMUNICATIONS EQUIPMENT IN THE FORM OF PRIVATE CIRCUITS AND TELEPHONE LINES; RENTAL OF TELEPHONE BOOTHS; MOBILE TELEPHONY; COMMUNICATION VIA RADIO TRANSMISSION; RADIO PAGING; AND TELEVISION BROADCASTING (U.S. CLS. 100, 101 AND 104).

MELVIN AXILBUND, EXAMINING ATTORNEY

SN 77-364,716. THE TASSOS GROUP LLC, POWAY, CA. FILED 1-4-2008.

EFACTOR MEDIA

THE MARK CONSISTS OF STANDARD CHARACTERS WITHOUT CLAIM TO ANY PARTICULAR FONT, STYLE, SIZE, OR COLOR.

NO CLAIM IS MADE TO THE EXCLUSIVE RIGHT TO USE "MEDIA", APART FROM THE MARK AS SHOWN.

CLASS 35—ADVERTISING AND BUSINESS

FOR ADVERTISING SERVICES, PUBLIC RELATIONS AND MARKETING SERVICES, NAMELY, PROMOTING AND MARKETING THE GOODS AND SERVICES OF OTHERS THROUGH ALL PUBLIC COMMUNICATION MEANS; ADVERTISING SERVICES, NAMELY, CREATING CORPORATE AND BRAND IDENTITY FOR OTHERS; ON-LINE ADVERTISING AND MARKETING SERVICES; SERVICES TO DETERMINE THE AUDIENCE AFFECTED BY ADVERTISEMENTS; CUSTOMER RELATIONSHIP MANAGEMENT (U.S. CLS. 100, 101 AND 102). FIRST USE 6-30-1997; IN COMMERCE 6-30-1997.

CLASS 42—SCIENTIFIC AND COMPUTER SERVICES

FOR WEBSITE DESIGN; DESIGN AND CREATION OF INTERACTIVE MEDIA AND CONTENT, NAMELY, CREATION OF WEB PAGES FOR OTHERS; GRAPHIC DESIGN (U.S. CLS. 100 AND 101).

FIRST USE 6-30-1997; IN COMMERCE 6-30-1997.
INGA ERVIN, EXAMINING ATTORNEY

SN 77-365,173. MELTON, DONNIE K., NEW MIDDLETOWN, IN. AND MELTON, REVA L., NEW MIDDLETOWN, IN. FILED 1-7-2008.

DONNIE'S FAMOUS CHILI

THE MARK CONSISTS OF STANDARD CHARACTERS WITHOUT CLAIM TO ANY PARTICULAR FONT, STYLE, SIZE, OR COLOR.

NO CLAIM IS MADE TO THE EXCLUSIVE RIGHT TO USE "FAMOUS CHILI", APART FROM THE MARK AS SHOWN.

CLASS 29—MEATS AND PROCESSED FOODS

FOR CANNED AND PREPACKAGED CHILI (U.S. CL. 46). FIRST USE 3-31-2002; IN COMMERCE 3-31-2002.

CLASS 43—HOTEL AND RESTAURANT SERVICES

FOR RESTAURANT SERVICES (U.S. CLS. 100 AND 101). FIRST USE 3-31-2002; IN COMMERCE 3-31-2002.
JIM RINGLE, EXAMINING ATTORNEY

SN 77-368,513. LIVING PEACE, LLC, WINCHESTER, MA. FILED 1-10-2008.

**Bringing Peaceful Order to
Everyday Life**

THE MARK CONSISTS OF STANDARD CHARACTERS WITHOUT CLAIM TO ANY PARTICULAR FONT, STYLE, SIZE, OR COLOR.

CLASS 35—ADVERTISING AND BUSINESS

FOR PROVIDING ORGANIZING SERVICES FOR INDIVIDUALS AT HOME, IN HOME OFFICES AND IN BUSINESS OFFICES, THAT PROVIDES HELP WITH TIME AND PAPER MANAGEMENT (U.S. CLS. 100, 101 AND 102).

FIRST USE 7-1-2003; IN COMMERCE 7-1-2003.

CLASS 41—EDUCATION AND ENTERTAINMENT

FOR TRAINING SERVICES IN THE FIELD OF PERSONAL AND BUSINESS ORGANIZATION AND TIME MANAGEMENT (U.S. CLS. 100, 101 AND 107).

FIRST USE 7-1-2003; IN COMMERCE 7-1-2003.
ALYSSA PALADINO, EXAMINING ATTORNEY

SN 77-370,632. BAILAC, LLC, TOOELE, UT. FILED 1-14-2008.

PASCUAL

THE MARK CONSISTS OF STANDARD CHARACTERS WITHOUT CLAIM TO ANY PARTICULAR FONT, STYLE, SIZE, OR COLOR.

CLASS 9—ELECTRICAL AND SCIENTIFIC APPARATUS

FOR COMPUTER SOFTWARE FOR MANAGING THE LIFECYCLE OF INDUSTRIAL TIRES, RIMS, AND CHAINS (U.S. CLS. 21, 23, 26, 36 AND 38).

CLASS 42—SCIENTIFIC AND COMPUTER SERVICES

FOR PROVIDING TEMPORARY USE OF ONLINE, NON-DOWNLOADABLE SOFTWARE FOR MANAGING THE LIFECYCLE OF INDUSTRIAL TIRES, RIMS, AND CHAINS THROUGH A WEBSITE (U.S. CLS. 100 AND 101).

SETH A. RAPPAPORT, EXAMINING ATTORNEY

SN 77-368,760. SECOA, INC., CHAMPLIN, MN. FILED 1-10-2008.

SECOA

THE MARK CONSISTS OF STANDARD CHARACTERS WITHOUT CLAIM TO ANY PARTICULAR FONT, STYLE, SIZE, OR COLOR.

OWNER OF U.S. REG. NO. 1,285,577.

CLASS 35—ADVERTISING AND BUSINESS

FOR DISTRIBUTORSHIP SERVICES FOR STAGE, STUDIO, CONVENTION CENTER AND ARENA EQUIPMENT AND SUPPLIES, NAMELY, RIGGING, CURTAINS, ELECTRIC DISTRIBUTION EQUIPMENT, ORCHESTRA SHELLS, ACOUSTICAL CEILINGS, WALL PANELS AND ACOUSTICAL CURTAINS, MOTORIZED ACOUSTICAL CEILINGS, WALL PANELS AND ACOUSTICAL CURTAINS AND CONTROLS, PORTABLE STAGING, MODULAR STAGING AND ORCHESTRA PIT FILLER, MOTORIZED RIGGING AND CONTROLS, LIGHTING EQUIPMENT, SEATING EQUIPMENT, AND ORCHESTRA PIT LIFT EQUIPMENT (U.S. CLS. 100, 101 AND 102).

FIRST USE 7-1-1957; IN COMMERCE 7-1-1957.

CLASS 37—CONSTRUCTION AND REPAIR

FOR CONSTRUCTION AND INSTALLATION OF STAGE, STUDIO, CONVENTION CENTER AND ARENA EQUIPMENT AND SUPPLIES, NAMELY, RIGGING, CURTAINS, ELECTRIC DISTRIBUTION EQUIPMENT, ORCHESTRA SHELLS, ACOUSTICAL CEILINGS, WALL PANELS AND ACOUSTICAL CURTAINS, MOTORIZED ACOUSTICAL CEILINGS, WALL PANELS AND ACOUSTICAL CURTAINS AND CONTROLS, PORTABLE STAGING, MODULAR STAGING AND ORCHESTRA PIT FILLER, MOTORIZED RIGGING AND CONTROLS, LIGHTING EQUIPMENT, SEATING EQUIPMENT, AND ORCHESTRA PIT LIFT EQUIPMENT (U.S. CLS. 100, 103 AND 106).

FIRST USE 7-1-1957; IN COMMERCE 7-1-1957.
DANNEAN HETZEL, EXAMINING ATTORNEY

SN 77-372,614. IVANKO, RUSSELL, IRMO, SC. AND SUTLEMYRE, WAYNE, IRMO, SC. FILED 1-15-2008.

**CLASS 9—ELECTRICAL AND SCIENTIFIC APPARATUS**

FOR PRERECORDED CDS FEATURING MUSIC (U.S. CLS. 21, 23, 26, 36 AND 38).

FIRST USE 1-1-2000; IN COMMERCE 1-1-2000.

CLASS 41—EDUCATION AND ENTERTAINMENT

FOR ENTERTAINMENT IN THE NATURE OF LIVE PERFORMANCES BY A MUSICAL GROUP (U.S. CLS. 100, 101 AND 107).

FIRST USE 1-1-2000; IN COMMERCE 1-1-2000.
GRETTA YAO, EXAMINING ATTORNEY

SN 77-372,866. PIKE, CHARLES, OAKLAND, FL. FILED 1-16-2008.



NO CLAIM IS MADE TO THE EXCLUSIVE RIGHT TO USE "DENTAL", APART FROM THE MARK AS SHOWN.

THE COLOR(S) RED, BLACK AND GRAY IS/ARE CLAIMED AS A FEATURE OF THE MARK.

THE MARK CONSISTS OF THE WORDS "ALL ASPECTS" WITH THE WORD "ALL" ABOVE THE WORD "ASPECTS", BOTH WORDS ARE RED WITH BLACK SHADOWING WITH A SINGLE LARGE A FORMING THE FIRST LETTER OF BOTH THE WORDS "ALL" AND "ASPECTS". THE MARK ALSO CONTAINS THE IMAGE OF A GRAY TOOTH TO THE RIGHT OF THE WORD "ALL". THE WORD "DENTAL" IS IN BLACK LETTERS AND A THIN BLACK LINE SEPARATES THE WORDS "ASPECTS" AND "DENTAL".

CLASS 40—MATERIAL TREATMENT

FOR DENTAL TECHNICIAN SERVICES (U.S. CLS. 100, 103 AND 106).

FIRST USE 9-30-2007; IN COMMERCE 9-30-2007.

CLASS 44—MEDICAL, BEAUTY AND AGRICULTURAL SERVICES

FOR DENTAL HYGIENIST SERVICES; DENTIST SERVICES (U.S. CLS. 100 AND 101).

FIRST USE 9-30-2007; IN COMMERCE 9-30-2007.
LYDIA BELZER, EXAMINING ATTORNEY

SN 77-375,149. MONITISE GROUP LIMITED, LONDON, UNITED KINGDOM, FILED 1-18-2008.

MoniPay

THE MARK CONSISTS OF STANDARD CHARACTERS WITHOUT CLAIM TO ANY PARTICULAR FONT, STYLE, SIZE, OR COLOR.

PRIORITY CLAIMED UNDER SEC. 44(D) ON UNITED KINGDOM APPLICATION NO. 2472062, FILED 11-12-2007, REG. NO. 2472062, DATED 11-12-2007, EXPIRES 11-12-2017.

CLASS 9—ELECTRICAL AND SCIENTIFIC APPARATUS

FOR COMPUTER SOFTWARE FOR ENABLING MOBILE BANKING AND PAYMENTS AND FOR FACILITATING COMMUNICATION TO A GLOBAL COMPUTER NETWORK (U.S. CLS. 21, 23, 26, 36 AND 38).

CLASS 36—INSURANCE AND FINANCIAL

FOR BANKING AND FINANCIAL INFORMATION AND PAYMENT SERVICES PROVIDED VIA ELECTRONIC MEANS (U.S. CLS. 100, 101 AND 102).
TRACY CROSS, EXAMINING ATTORNEY

SN 77-376,029. SMOOTH COMMUNICATIONS, BURBANK, CA. FILED 1-19-2008.

HUBkap

THE MARK CONSISTS OF STANDARD CHARACTERS WITHOUT CLAIM TO ANY PARTICULAR FONT, STYLE, SIZE, OR COLOR.

CLASS 9—ELECTRICAL AND SCIENTIFIC APPARATUS

FOR COMPUTER SOFTWARE FOR USE AS AN ELECTRONIC ORGANIZER AND COMMUNICATION TOOL, NAMELY, AN ELECTRONIC CALENDAR, TASK MANAGER, E-MAIL, AND CONTACT MANAGER THAT ANALYZES PERSONAL DATA TO ADVERTISE AND PROMOTE GOODS AND SERVICES FROM INTERACTIVE CONTENT STORED IN A DATABASE, THAT MAY BE DOWNLOADED FROM A GLOBAL COMPUTER NETWORK; DOWNLOADABLE COMPUTER SOFTWARE FOR USE AS AN ELECTRONIC ORGANIZER AND COMMUNICATION TOOL, NAMELY, AN ELECTRONIC CALENDAR, TASK MANAGER, E-MAIL, AND CONTACT MANAGER THAT ANALYZES PERSONAL DATA TO ADVERTISE AND PROMOTE GOODS AND SERVICES FROM INTERACTIVE CONTENT STORED IN A DATABASE (U.S. CLS. 21, 23, 26, 36 AND 38).

CLASS 42—SCIENTIFIC AND COMPUTER SERVICES

FOR COMPUTER SERVICES, NAMELY, HOSTING ON-LINE INTERACTIVE PUBLIC CALENDARS THAT ALLOW MULTIPLE PARTICIPANTS TO SHARE EVENT SCHEDULES, FACILITY RESERVATIONS, AND TRANSPORTATION REQUESTS; APPLICATION SERVICE PROVIDER (ASP) FEATURING SOFTWARE FOR USE AS AN ONLINE ORGANIZER AND COMMUNICATION TOOL, NAMELY, AN ELECTRONIC CALENDAR, TASK MANAGER, E-MAIL, AND CONTACT MANAGER THAT ANALYZES PERSONAL DATA TO ADVERTISE AND PROMOTE SERVICES FROM INTERACTIVE CONTENT STORED IN A DATABASE; PROVIDING ON-LINE NON-DOWNLOADABLE SOFTWARE FOR USE AS AN ONLINE ORGANIZER AND COMMUNICATION TOOL, NAMELY, AN ELECTRONIC CALENDAR, TASK MANAGER, E-MAIL, AND CONTACT MANAGER THAT ANALYZES PERSONAL DATA BASED ON LOCATION, ACTIVITY, TIMING, PERSONAL PREFERENCES AND PROFILE TO ADVERTISE AND PROMOTE GOODS AND SERVICES FROM INTERACTIVE CONTENT STORED IN A DATABASE (U.S. CLS. 100 AND 101).

MARY MUNSON, EXAMINING ATTORNEY

SN 77-376,620. MARK HUNTER'S, LTD., ELK GROVE, IL. FILED 1-21-2008.

HUNTERS NIGHTCLUBS

THE MARK CONSISTS OF STANDARD CHARACTERS WITHOUT CLAIM TO ANY PARTICULAR FONT, STYLE, SIZE, OR COLOR.

NO CLAIM IS MADE TO THE EXCLUSIVE RIGHT TO USE "NIGHTCLUBS", APART FROM THE MARK AS SHOWN.

CLASS 41—EDUCATION AND ENTERTAINMENT

FOR NIGHT CLUBS; ENTERTAINMENT SERVICES, NAMELY, KARAOKE SINGING COMPETITIONS, DANCE PERFORMANCES, LIVE PERFORMANCES BY EXOTIC DANCERS, DANCE COMPETITIONS, LIVE DISC JOCKEY MUSIC AND VIDEO JOCKEY MUSIC, AND DANCE THEATER (U.S. CLS. 100, 101 AND 107).
FIRST USE 10-20-1982; IN COMMERCE 10-20-1982.

CLASS 43—HOTEL AND RESTAURANT SERVICES

FOR BAR SERVICES; TAVERN SERVICES (U.S. CLS. 100 AND 101).
FIRST USE 10-20-1982; IN COMMERCE 10-20-1982.
TINA KUAN, EXAMINING ATTORNEY

SN 77-376,662. DAIRYLAND HEALTHCARE SOLUTIONS, INC., GLENWOOD, MN. FILED 1-21-2008.

HEALTHLAND

THE MARK CONSISTS OF STANDARD CHARACTERS WITHOUT CLAIM TO ANY PARTICULAR FONT, STYLE, SIZE, OR COLOR.

CLASS 9—ELECTRICAL AND SCIENTIFIC APPARATUS

FOR COMPUTER SOFTWARE AND SYSTEMS, NAMELY, COMPUTER SOFTWARE AND SYSTEMS IN THE FIELD OF HEALTHCARE, NAMELY, COMPUTER SOFTWARE AND COMPUTER OPERATING SYSTEMS FOR USE IN DATABASE MANAGEMENT IN THE FIELD OF HEALTHCARE (U.S. CLS. 21, 23, 26, 36 AND 38).

CLASS 35—ADVERTISING AND BUSINESS

FOR BUSINESS CONSULTANCY SERVICES, NAMELY, BUSINESS MANAGEMENT CONSULTING, BUSINESS MARKETING CONSULTING, AND BUSINESS INFORMATION SERVICES IN THE FIELD OF HEALTHCARE; PROFESSIONAL BUSINESS CONSULTING SERVICES, NAMELY, PREPARING CUSTOMIZED BUSINESS REPORTS, DESIGNING CUSTOMIZED ELECTRONIC BUSINESS FORMS, FINANCIAL SYSTEM COST ASSESSMENT, CLINICAL SYSTEM COST ASSESSMENT, NETWORK AND INFRASTRUCTURE COST ASSESSMENT, AND MAIL SORTING, HANDLING, AND RECEIVING, AND BILLING SERVICES IN THE FIELD OF HEALTHCARE (U.S. CLS. 100, 101 AND 102).

CLASS 40—MATERIAL TREATMENT

FOR PRINTING SERVICES IN THE FIELD OF HEALTHCARE (U.S. CLS. 100, 103 AND 106).

CLASS 41—EDUCATION AND ENTERTAINMENT

FOR COMPUTER SOFTWARE AND COMPUTER SYSTEM EDUCATION TRAINING SERVICES (U.S. CLS. 100, 101 AND 107).

CLASS 42—SCIENTIFIC AND COMPUTER SERVICES

FOR COMPUTER SOFTWARE AND SYSTEMS SERVICES, NAMELY, DESIGN FOR OTHERS, COMPUTER PROJECT MANAGEMENT, MAINTENANCE, UPDATING, UPGRADING, DEVELOPMENT, INSTALLATION, DUPLICATION, PLANNING OF ELECTRONIC COMMUNICATION NETWORKS, AND CONSULTANCY OF COMPUTER SOFTWARE AND COMPUTER SOFTWARE SYSTEMS IN THE FIELD OF HEALTHCARE FOR OTHERS; LEASING OF COMPUTERS; ANALYSIS OF COMPUTER PROGRAMMING AND COMPUTER SYSTEMS; DATA RECOVERY SERVICES; COMPUTER PROGRAMMING; SOFTWARE ENGINEERING; TECHNICAL CONSULTATION IN THE FIELD OF SOFTWARE ENGINEERING; TECHNICAL SUPPORT SERVICES, NAMELY, MONITORING OF NETWORK SYSTEMS, PROVIDING BACK-UP COMPUTER PROGRAMS AND FACILITIES, AND TROUBLESHOOTING OF COMPUTER HARDWARE AND SOFTWARE PROBLEMS; COMPUTERIZED DATABASE MANAGEMENT; DATABASE DEVELOPMENT SERVICES; IMPLEMENTATION SERVICES, NAMELY, CONSULTATION SERVICES IN THE FIELDS OF DATABASE IMPLEMENTATION AND INSTALLATION OF COMPUTER SOFTWARE; COMPUTER SOFTWARE AND SYSTEMS TRAINING SERVICES; MAINTENANCE OF COMPUTER SOFTWARE THROUGH CONVERSION OF COMPUTER PROGRAM DATA OR INFORMATION; COMPUTER SERVICES, NAMELY, CREATING INDICES OF INFORMATION, SITES AND OTHER RESOURCES AVAILABLE ON COMPUTER NETWORKS; COMPUTER DATA RECOVERY SERVICES; AND INTEGRATION OF COMPUTER SYSTEMS AND NETWORKS (U.S. CLS. 100 AND 101).
KAPIL BHANOT, EXAMINING ATTORNEY

SN 77-376,672. DAIRYLAND HEALTHCARE SOLUTIONS, INC., GLENWOOD, MN. FILED 1-21-2008.

HEALTHLAND SOFTWARE

THE MARK CONSISTS OF STANDARD CHARACTERS WITHOUT CLAIM TO ANY PARTICULAR FONT, STYLE, SIZE, OR COLOR.

NO CLAIM IS MADE TO THE EXCLUSIVE RIGHT TO USE "SOFTWARE", APART FROM THE MARK AS SHOWN.

CLASS 9—ELECTRICAL AND SCIENTIFIC APPARATUS

FOR COMPUTER SOFTWARE AND SYSTEMS, NAMELY, COMPUTER SOFTWARE AND SYSTEMS IN THE FIELD OF HEALTHCARE, NAMELY, COMPUTER SOFTWARE AND COMPUTER OPERATING SYSTEMS FOR USE IN DATABASE MANAGEMENT IN THE FIELD OF HEALTHCARE (U.S. CLS. 21, 23, 26, 36 AND 38).

CLASS 35—ADVERTISING AND BUSINESS

FOR BUSINESS CONSULTANCY SERVICES, NAMELY, BUSINESS MANAGEMENT CONSULTING, BUSINESS MARKETING CONSULTING, AND BUSINESS INFORMATION SERVICES IN THE FIELD OF HEALTHCARE; PROFESSIONAL BUSINESS CONSULTING SERVICES, NAMELY, PREPARING CUSTOMIZED BUSINESS REPORTS, DESIGNING CUSTOMIZED ELECTRONIC BUSINESS FORMS, FINANCIAL SYSTEM COST ASSESSMENT, CLINICAL SYSTEM COST ASSESSMENT, NETWORK AND INFRASTRUCTURE COST ASSESSMENT, AND MAIL SORTING, HANDLING, AND RECEIVING, AND BILLING SERVICES IN THE FIELD OF HEALTHCARE (U.S. CLS. 100, 101 AND 102).

CLASS 40—MATERIAL TREATMENT

FOR PRINTING SERVICES IN THE FIELD OF HEALTHCARE (U.S. CLS. 100, 103 AND 106).

CLASS 41—EDUCATION AND ENTERTAINMENT

FOR COMPUTER SOFTWARE AND COMPUTER SYSTEM EDUCATION TRAINING SERVICES (U.S. CLS. 100, 101 AND 107).

CLASS 42—SCIENTIFIC AND COMPUTER SERVICES

FOR COMPUTER SOFTWARE AND SYSTEMS SERVICES, NAMELY, DESIGN FOR OTHERS, COMPUTER PROJECT MANAGEMENT, MAINTENANCE, UPDATING, UPGRADING, DEVELOPMENT, INSTALLATION, DUPLICATION, PLANNING OF ELECTRONIC COMMUNICATION NETWORKS, AND CONSULTANCY OF COMPUTER SOFTWARE AND COMPUTER SOFTWARE SYSTEMS IN THE FIELD OF HEALTHCARE FOR OTHERS; LEASING OF COMPUTERS; ANALYSIS OF COMPUTER PROGRAMMING AND COMPUTER SYSTEMS; DATA RECOVERY SERVICES; COMPUTER PROGRAMMING; SOFTWARE ENGINEERING; TECHNICAL CONSULTATION IN THE FIELD OF SOFTWARE ENGINEERING; TECHNICAL SUPPORT SERVICES, NAMELY, MONITORING OF NETWORK SYSTEMS, PROVIDING BACK-UP COMPUTER PROGRAMS AND FACILITIES, AND TROUBLESHOOTING OF COMPUTER HARDWARE AND SOFTWARE PROBLEMS; COMPUTERIZED DATABASE MANAGEMENT; DATABASE DEVELOPMENT SERVICES; IMPLEMENTATION SERVICES, NAMELY, CONSULTATION SERVICES IN THE FIELDS OF DATABASE IMPLEMENTATION AND INSTALLATION OF COMPUTER SOFTWARE; COMPUTER SOFTWARE AND SYSTEMS TRAINING SERVICES; MAINTENANCE OF COMPUTER SOFTWARE THROUGH CONVERSION OF COMPUTER PROGRAM DATA OR INFORMATION; COMPUTER SERVICES, NAMELY, CREATING INDICES OF INFORMATION, SITES AND OTHER RESOURCES AVAILABLE ON COMPUTER NETWORKS; COMPUTER DATA RECOVERY SERVICES; AND INTEGRATION OF COMPUTER SYSTEMS AND NETWORKS (U.S. CLS. 100 AND 101).

KAPIL BHANOT, EXAMINING ATTORNEY

SN 77-376,686. DAIRYLAND HEALTHCARE SOLUTIONS, INC., MINNEAPOLIS, MN. FILED 1-21-2008.

HEALTHLAND SOFTWARE SOLUTIONS

THE MARK CONSISTS OF STANDARD CHARACTERS WITHOUT CLAIM TO ANY PARTICULAR FONT, STYLE, SIZE, OR COLOR.

NO CLAIM IS MADE TO THE EXCLUSIVE RIGHT TO USE "SOFTWARE SOLUTIONS", APART FROM THE MARK AS SHOWN.

CLASS 9—ELECTRICAL AND SCIENTIFIC APPARATUS

FOR COMPUTER SOFTWARE AND SYSTEMS, NAMELY, COMPUTER SOFTWARE AND SYSTEMS IN THE FIELD OF HEALTHCARE, NAMELY, COMPUTER SOFTWARE AND COMPUTER OPERATING SYSTEMS FOR USE IN DATABASE MANAGEMENT IN THE FIELD OF HEALTHCARE (U.S. CLS. 21, 23, 26, 36 AND 38).

CLASS 35—ADVERTISING AND BUSINESS

FOR BUSINESS CONSULTANCY SERVICES, NAMELY, BUSINESS MANAGEMENT CONSULTING, BUSINESS MARKETING CONSULTING, AND BUSINESS INFORMATION SERVICES IN THE FIELD OF HEALTHCARE; PROFESSIONAL BUSINESS CONSULTING SERVICES, NAMELY, PREPARING CUSTOMIZED BUSINESS REPORTS, DESIGNING CUSTOMIZED ELECTRONIC BUSINESS FORMS, FINANCIAL SYSTEM COST ASSESSMENT, CLINICAL SYSTEM COST ASSESSMENT, NETWORK AND INFRASTRUCTURE COST ASSESSMENT, AND MAIL SORTING, HANDLING, AND RECEIVING, AND BILLING SERVICES IN THE FIELD OF HEALTHCARE (U.S. CLS. 100, 101 AND 102).

CLASS 40—MATERIAL TREATMENT

FOR PRINTING SERVICES IN THE FIELD OF HEALTHCARE (U.S. CLS. 100, 103 AND 106).

CLASS 41—EDUCATION AND ENTERTAINMENT

FOR COMPUTER SOFTWARE AND COMPUTER SYSTEM EDUCATION TRAINING SERVICES (U.S. CLS. 100, 101 AND 107).

CLASS 42—SCIENTIFIC AND COMPUTER SERVICES

FOR COMPUTER SOFTWARE AND SYSTEMS SERVICES, NAMELY, DESIGN FOR OTHERS, COMPUTER PROJECT MANAGEMENT, MAINTENANCE, UPDATING, UPGRADING, DEVELOPMENT, INSTALLATION, DUPLICATION, PLANNING OF ELECTRONIC COMMUNICATION NETWORKS, AND CONSULTANCY OF COMPUTER SOFTWARE AND COMPUTER SOFTWARE SYSTEMS IN THE FIELD OF HEALTHCARE FOR OTHERS; LEASING OF COMPUTERS; ANALYSIS OF COMPUTER PROGRAMMING AND COMPUTER SYSTEMS; DATA RECOVERY SERVICES; COMPUTER PROGRAMMING; SOFTWARE ENGINEERING; TECHNICAL CONSULTATION IN THE FIELD OF SOFTWARE ENGINEERING; TECHNICAL SUPPORT SERVICES, NAMELY, MONITORING OF NETWORK SYSTEMS, PROVIDING BACK-UP COMPUTER PROGRAMS AND FACILITIES, AND TROUBLESHOOTING OF COMPUTER HARDWARE AND SOFTWARE PROBLEMS; COMPUTERIZED DATABASE MANAGEMENT; DATABASE DEVELOPMENT SERVICES; IMPLEMENTATION SERVICES, NAMELY, CONSULTATION SERVICES IN THE FIELDS OF DATABASE IMPLEMENTATION AND INSTALLATION OF COMPUTER SOFTWARE; COMPUTER SOFTWARE AND SYSTEMS TRAINING SERVICES; MAINTENANCE OF COMPUTER SOFTWARE THROUGH CONVERSION OF COMPUTER PROGRAM DATA OR INFORMATION; COMPUTER SERVICES, NAMELY, CREATING INDICES OF INFORMATION, SITES AND OTHER RESOURCES AVAILABLE ON COMPUTER NETWORKS; COMPUTER DATA RECOVERY SERVICES; AND INTEGRATION OF COMPUTER SYSTEMS AND NETWORKS (U.S. CLS. 100 AND 101).

KAPIL BHANOT, EXAMINING ATTORNEY

SN 77-377,428. BLUESTAR PR, SAN FRANCISCO, CA. FILED 1-22-2008.

Only in Israel

THE MARK CONSISTS OF STANDARD CHARACTERS WITHOUT CLAIM TO ANY PARTICULAR FONT, STYLE, SIZE, OR COLOR.

NO CLAIM IS MADE TO THE EXCLUSIVE RIGHT TO USE "ISRAEL", APART FROM THE MARK AS SHOWN.

CLASS 16—PAPER GOODS AND PRINTED MATTER

FOR EDUCATIONAL POSTERS, ADVERTISEMENTS, NAMELY, POSTCARDS, PAPER BANNERS, ADVERTISING SIGNS OF PAPER OR CARDBOARD, AND PRINTED TEACHING MATERIALS IN THE FIELD OF PROMOTING POSITIVE PUBLIC AWARENESS OF ISSUES RELATING TO ISRAEL AND JUDAISM (U.S. CLS. 2, 5, 22, 23, 29, 37, 38 AND 50).

CLASS 35—ADVERTISING AND BUSINESS

FOR ADVERTISING AND PROMOTIONAL SERVICES THAT FOSTER POSITIVE PUBLIC AWARENESS OF ISSUES RELATING TO ISRAEL AND JUDAISM (U.S. CLS. 100, 101 AND 102).
ANNE FARRELL, EXAMINING ATTORNEY

SN 77-382,248. KARL STORZ GMBH & CO. KG, D-78532 TUTTLINGEN, FED REP GERMANY, FILED 1-28-2008.

CARTCUT

THE MARK CONSISTS OF STANDARD CHARACTERS WITHOUT CLAIM TO ANY PARTICULAR FONT, STYLE, SIZE, OR COLOR.

PRIORITY CLAIMED UNDER SEC. 44(D) ON FED REP GERMANY APPLICATION NO. 30749012.2, FILED 7-26-2007, REG. NO. 30749012, DATED 9-28-2007, EXPIRES 7-31-2017.

CLASS 10—MEDICAL APPARATUS

FOR MEDICAL INSTRUMENTS AND APPARATUS, NAMELY, SURGICAL INSTRUMENTS AND APPARATUS (U.S. CLS. 26, 39 AND 44).

SN 77-379,844. DELTA PHI SCRAPPA, LLC, MOTLEY, MN. FILED 1-24-2008.

CLASS 16—PAPER GOODS AND PRINTED MATTER

FOR PRINTED INFORMATIONAL MATERIALS, NAMELY, BROCHURES AND INFORMATIONAL FLYERS, LETTERS, AND SHEETS IN THE FIELDS OF MEDICAL TECHNOLOGY (U.S. CLS. 2, 5, 22, 23, 29, 37, 38 AND 50).

SUE LAWRENCE, EXAMINING ATTORNEY

DELTA PHI SCRAPPA

SN 77-384,871. PERRITT, HENRY H., JR., DBA PERRITT, HANK, GLENCOE, IL. FILED 1-30-2008.

THE MARK CONSISTS OF STANDARD CHARACTERS WITHOUT CLAIM TO ANY PARTICULAR FONT, STYLE, SIZE, OR COLOR.

CLASS 25—CLOTHING

FOR CLOTHING, NAMELY, SHIRTS, T-SHIRTS, SWEATPANTS, SWEATSHIRTS, ZIPPER HOODED SWEATSHIRTS, AND HATS (U.S. CLS. 22 AND 39).
FIRST USE 9-30-2005; IN COMMERCE 6-30-2006.

modofac

CLASS 41—EDUCATION AND ENTERTAINMENT

FOR EDUCATIONAL AND ENTERTAINMENT SERVICES IN THE NATURE OF CONDUCTING WORKSHOPS, EXHIBITIONS, MEETINGS AND RETREATS IN THE FIELD OF SCRAPBOOKING (U.S. CLS. 100, 101 AND 107).
FIRST USE 3-30-2005; IN COMMERCE 4-27-2006.

THE MARK CONSISTS OF STANDARD CHARACTERS WITHOUT CLAIM TO ANY PARTICULAR FONT, STYLE, SIZE, OR COLOR.

CLASS 200—COLLECTIVE MEMBERSHIP

FOR INDICATING MEMBERSHIP IN A SISTERHOOD OR SORORITY OF SCRAPBOOKERS.
FIRST USE 3-30-2005; IN COMMERCE 4-27-2006.
TRICIA SONNEBORN, EXAMINING ATTORNEY

CLASS 9—ELECTRICAL AND SCIENTIFIC APPARATUS

FOR DOWNLOADABLE MUSICAL SOUND RECORDINGS; MUSICAL SOUND RECORDINGS (U.S. CLS. 21, 23, 26, 36 AND 38).
FIRST USE 5-1-2007; IN COMMERCE 5-1-2007.

CLASS 41—EDUCATION AND ENTERTAINMENT

FOR ENTERTAINMENT IN THE NATURE OF VISUAL AND AUDIO PERFORMANCES, NAMELY, MUSICAL BAND, ROCK GROUP, GYMNASIAC, DANCE, AND BALLET PERFORMANCES; ENTERTAINMENT SERVICES, NAMELY, PROVIDING A WEB SITE FEATURING MUSICAL PERFORMANCES, MUSICAL VIDEOS, RELATED FILM CLIPS, PHOTOGRAPHS, AND OTHER MULTIMEDIA MATERIALS; ENTERTAINMENT SERVICES, NAMELY, PROVIDING PRERECORDED MUSIC, INFORMATION IN THE FIELD OF MUSIC, AND COMMENTARY AND ARTICLES ABOUT MUSIC, ALL ON-LINE VIA A GLOBAL COMPUTER NETWORK; ENTERTAINMENT, NAMELY, LIVE PERFORMANCES BY A MUSICAL BAND; ENTERTAINMENT, NAMELY, LIVE PERFORMANCES BY MUSICAL BANDS; PRESENTATION OF MUSICAL PERFORMANCE (U.S. CLS. 100, 101 AND 107).

FIRST USE 5-1-2007; IN COMMERCE 5-1-2007.
HEATHER SAPP, EXAMINING ATTORNEY

SN 77-386,762. RECOVERY SOLUTIONS, INC., CHESAPEAKE, VA. FILED 2-1-2008.

RECOVERY SOLUTIONS

THE MARK CONSISTS OF STANDARD CHARACTERS WITHOUT CLAIM TO ANY PARTICULAR FONT, STYLE, SIZE, OR COLOR.
SEC. 2(F).

CLASS 7—MACHINERY

FOR WRECKERS (U.S. CLS. 13, 19, 21, 23, 31, 34 AND 35).
FIRST USE 1-1-1997; IN COMMERCE 1-1-1997.

CLASS 12—VEHICLES

FOR TRUCKS; TRUCKS AND STRUCTURAL PARTS THEREFOR (U.S. CLS. 19, 21, 23, 31, 35 AND 44).
FIRST USE 1-1-1997; IN COMMERCE 1-1-1997.
KATHERINE CHANG, EXAMINING ATTORNEY

SN 77-386,489. ANSWERS IN GENESIS OF KENTUCKY, INC., DBA ANSWERS IN GENESIS, HEBRON, KY. FILED 2-1-2008.

Answers Research Journal

THE MARK CONSISTS OF STANDARD CHARACTERS WITHOUT CLAIM TO ANY PARTICULAR FONT, STYLE, SIZE, OR COLOR.

OWNER OF U.S. REG. NOS. 3,214,151, 3,247,230 AND OTHERS.

NO CLAIM IS MADE TO THE EXCLUSIVE RIGHT TO USE "RESEARCH JOURNAL", APART FROM THE MARK AS SHOWN.

CLASS 9—ELECTRICAL AND SCIENTIFIC APPARATUS

FOR DOWNLOADABLE ELECTRONIC PUBLICATION IN THE NATURE OF TECHNICAL JOURNALS FEATURING INTERDISCIPLINARY SCIENTIFIC AND OTHER RELEVANT RESEARCH IN THE FIELDS OF CREATION AND THE GLOBAL FLOOD WITHIN THE BIBLICAL FRAMEWORK (U.S. CLS. 21, 23, 26, 36 AND 38).

FIRST USE 1-9-2008; IN COMMERCE 1-9-2008.

CLASS 41—EDUCATION AND ENTERTAINMENT

FOR PROVIDING NON-DOWNLOADABLE ON-LINE PUBLICATIONS IN THE NATURE OF TECHNICAL JOURNALS FEATURING INTERDISCIPLINARY SCIENTIFIC AND OTHER RELEVANT RESEARCH IN THE FIELD OF CREATION AND THE GLOBAL FLOOD WITHIN THE BIBLICAL FRAMEWORK (U.S. CLS. 100, 101 AND 107).

FIRST USE 1-9-2008; IN COMMERCE 1-9-2008.
KAELIE KUNG, EXAMINING ATTORNEY

SN 77-388,130. COLES, STEVEN, FREDERICK, MD. FILED 2-4-2008.



NO CLAIM IS MADE TO THE EXCLUSIVE RIGHT TO USE "GLOBAL RUNNING CLUB", APART FROM THE MARK AS SHOWN.

THE STIPPLING IS FOR SHADING PURPOSES ONLY.
THE MARK CONSISTS OF A GLOBE WITH WATER AND CONTINENTS. ABOVE THE GLOBES ARE THE WORDS "GLOBAL RUNNING CLUB" IN A BLOCK OUTLINE. THE "R" IN "RUNNING" APPEARS WITH SNEAKERS ON THE LEGS OF THE LETTER. THERE ARE ALSO THREE NON-DESCRIPT CARICATURES OF HUMANS RUNNING ON TOP OF EACH WORD.

CLASS 25—CLOTHING

FOR CAPS; HATS; HEADBANDS; RASH GUARDS; SHIRTS; SOCKS; SWEAT PANTS; SWEAT SHIRTS; T-SHIRTS; WARM UP SUITS; WRIST BANDS (U.S. CLS. 22 AND 39).

CLASS 35—ADVERTISING AND BUSINESS

FOR CLUB SERVICES, NAMELY, PROMOTING THE INTERESTS OF RUNNERS AND WALKERS (U.S. CLS. 100, 101 AND 102).

CLASS 41—EDUCATION AND ENTERTAINMENT

FOR INSTRUCTION IN THE FIELD OF HEALTH AND PHYSICAL FITNESS; TRAINING SERVICES IN THE FIELD OF HEALTH AND PHYSICAL FITNESS (U.S. CLS. 100, 101 AND 107).

ALYSSA PALADINO, EXAMINING ATTORNEY

SN 77-388,221. ROW 44, INC., WESTLAKE VILLAGE, CA. FILED 2-4-2008.

ROW 44

THE MARK CONSISTS OF STANDARD CHARACTERS WITHOUT CLAIM TO ANY PARTICULAR FONT, STYLE, SIZE, OR COLOR.

CLASS 9—ELECTRICAL AND SCIENTIFIC APPARATUS

FOR EQUIPMENT FOR BROADBAND CONNECTIVITY ABOARD COMMERCIAL AIRCRAFT, NAMELY, AN AIRCRAFT SATELLITE ANTENNA SYSTEM COMPRISING SATELLITE DISHES AND AMPLIFIERS, COMPUTER SERVER MANAGEMENT UNIT IN THE NATURE OF A COMPUTER, SATELLITE MODEM, FLIGHT ATTENDANT CONTROL PANEL, WI-FI ROUTER(S) AND NETWORK OPERATIONS CENTER COMPUTER SERVERS, SWITCHES AND ROUTERS (U.S. CLS. 21, 23, 26, 36 AND 38).

CLASS 38—COMMUNICATION

FOR SERVICES FOR BROADBAND CONNECTIVITY ABOARD COMMERCIAL AIRCRAFT, NAMELY, PROVIDING ELECTRONIC TELECOMMUNICATION CONNECTIONS (U.S. CLS. 100, 101 AND 104).

ALEX KEAM, EXAMINING ATTORNEY

SN 77-389,009. THE MCGRAW-HILL COMPANIES, INC., NEW YORK, NY. FILED 2-5-2008.

EXPRESSIONS

THE MARK CONSISTS OF STANDARD CHARACTERS WITHOUT CLAIM TO ANY PARTICULAR FONT, STYLE, SIZE, OR COLOR.

CLASS 9—ELECTRICAL AND SCIENTIFIC APPARATUS

FOR CD-ROMS AND AUDIO RECORDINGS CONTAINING FICTION AND NONFICTION FOR USE IN TEACHING LANGUAGE DEVELOPMENT (U.S. CLS. 21, 23, 26, 36 AND 38).

CLASS 16—PAPER GOODS AND PRINTED MATTER

FOR PRINTED EDUCATIONAL MATERIALS, NAMELY, A SERIES OF BOOKS CONTAINING FICTION AND NONFICTION FOR USE IN TEACHING LANGUAGE DEVELOPMENT (U.S. CLS. 2, 5, 22, 23, 29, 37, 38 AND 50).

CLASS 41—EDUCATION AND ENTERTAINMENT

FOR PROVIDING A WEB SITE FEATURING NON-DOWNLOADABLE FICTION AND NONFICTION EXCERPTS FROM BOOKS FOR USE IN TEACHING LANGUAGE DEVELOPMENT (U.S. CLS. 100, 101 AND 107).

DAVID TOOLEY, EXAMINING ATTORNEY

SN 77-389,146. NOVEMBER 15, LLC, NEW YORK, NY. FILED 2-5-2008.



THE NAME(S), PORTRAIT(S), AND/OR SIGNATURE(S) SHOWN IN THE MARK DOES NOT IDENTIFY A PARTICULAR LIVING INDIVIDUAL.

THE MARK CONSISTS OF THE STYLIZED LETTERS "D" AND "K" ATOP THE WORDS "DANITY KANE".

CLASS 14—JEWELRY

FOR JEWELRY; WATCHES AND JEWELRY; NECKLACES; PENDANTS (U.S. CLS. 2, 27, 28 AND 50).

CLASS 25—CLOTHING

FOR SHIRTS; HATS; SWEAT SHIRTS (U.S. CLS. 22 AND 39).

FIRST USE 2-0-2007; IN COMMERCE 2-0-2007.

THEODORE MCBRIDE, EXAMINING ATTORNEY

SN 77-389,310. KKT GROUP SERVICES, INC., CHICAGO, IL. FILED 2-5-2008.

LOU MITCHELL'S

THE MARK CONSISTS OF STANDARD CHARACTERS WITHOUT CLAIM TO ANY PARTICULAR FONT, STYLE, SIZE, OR COLOR.

OWNER OF U.S. REG. NOS. 1,851,609, 1,940,224 AND 2,679,796.

THE NAME(S), PORTRAIT(S), AND/OR SIGNATURE(S) SHOWN IN THE MARK DOES NOT IDENTIFY A PARTICULAR LIVING INDIVIDUAL.

CLASS 21—HOUSEWARES AND GLASS

FOR CUPS AND MUGS (U.S. CLS. 2, 13, 23, 29, 30, 33, 40 AND 50).
FIRST USE 0-0-1997; IN COMMERCE 0-0-1997.

CLASS 25—CLOTHING

FOR T-SHIRTS; HATS; VISORS (U.S. CLS. 22 AND 39).
FIRST USE 0-0-1999; IN COMMERCE 0-0-1999.

CLASS 29—MEATS AND PROCESSED FOODS

FOR MARMALADE (U.S. CL. 46).
FIRST USE 0-0-1997; IN COMMERCE 0-0-1997.

CLASS 30—STAPLE FOODS

FOR MAPLE SYRUP; COFFEE; BREAD; PASTRIES;
BAKERY PRODUCTS (U.S. CL. 46).
FIRST USE 0-0-1997; IN COMMERCE 0-0-1997.

CLASS 35—ADVERTISING AND BUSINESS

FOR (BASED ON USE IN COMMERCE) TAKE-OUT BAKERY SERVICES; RETAIL BAKERY SHOPS; (BASED ON INTENT TO USE) FRANCHISING, NAMELY, CONSULTATION AND ASSISTANCE IN BUSINESS MANAGEMENT, ORGANIZATION AND PROMOTION; FRANCHISING, NAMELY, OFFERING TECHNICAL ASSISTANCE IN THE ESTABLISHMENT AND/OR OPERATION OF RESTAURANTS; RESTAURANT FRANCHISING; FRANCHISE SERVICES, NAMELY, OFFERING BUSINESS MANAGEMENT ASSISTANCE IN THE ESTABLISHMENT AND OPERATION OF RESTAURANTS (U.S. CLS. 100, 101 AND 102).
FIRST USE 0-0-1955; IN COMMERCE 0-0-1955.

CLASS 43—HOTEL AND RESTAURANT SERVICES

FOR RESTAURANT AND CATERING SERVICES;
CARRY-OUT RESTAURANTS (U.S. CLS. 100 AND 101).
FIRST USE 0-0-1955; IN COMMERCE 0-0-1955.
ROBIN MITTLER, EXAMINING ATTORNEY

SN 77-389,333. KKT GROUP SERVICES, INC., CHICAGO, IL.
FILED 2-5-2008.



OWNER OF U.S. REG. NOS. 1,851,609, 1,940,224 AND 2,679,796.

NO CLAIM IS MADE TO THE EXCLUSIVE RIGHT TO USE "RESTAURANT & BAKERY", APART FROM THE MARK AS SHOWN.

THE NAME(S), PORTRAIT(S), AND/OR SIGNATURE(S) SHOWN IN THE MARK DOES NOT IDENTIFY A PARTICULAR LIVING INDIVIDUAL.

THE MARK CONSISTS OF THE WORDS "LOU MITCHELL'S" IN STYLIZED FORM NEXT TO A CHEF, WITH THE WORDS "RESTAURANT & BAKERY" IN THE LOWER RIGHT CORNER, ALL OVER A SQUARE GRID.

CLASS 30—STAPLE FOODS

FOR COFFEE; BREAD; PASTRIES; BAKERY PRODUCTS (U.S. CL. 46).
FIRST USE 0-0-1997; IN COMMERCE 0-0-1997.

CLASS 35—ADVERTISING AND BUSINESS

FOR (BASED ON USE IN COMMERCE) TAKE-OUT BAKERY SERVICES; RETAIL BAKERY SHOPS; (BASED ON INTENT TO USE) FRANCHISING, NAMELY, CONSULTATION AND ASSISTANCE IN BUSINESS MANAGEMENT, ORGANIZATION AND PROMOTION; FRANCHISING, NAMELY, OFFERING TECHNICAL ASSISTANCE IN THE ESTABLISHMENT AND/OR OPERATION OF RESTAURANTS; RESTAURANT FRANCHISING; FRANCHISE SERVICES, NAMELY, OFFERING BUSINESS MANAGEMENT ASSISTANCE IN THE ESTABLISHMENT AND OPERATION OF RESTAURANTS (U.S. CLS. 100, 101 AND 102).
FIRST USE 0-0-1997; IN COMMERCE 0-0-1997.

CLASS 43—HOTEL AND RESTAURANT SERVICES

FOR CARRY-OUT RESTAURANTS; RESTAURANT AND CATERING SERVICES (U.S. CLS. 100 AND 101).
FIRST USE 0-0-1997; IN COMMERCE 0-0-1997.
ROBIN MITTLER, EXAMINING ATTORNEY

SN 77-391,222. PLAY N TRADE FRANCHISE, INC., NEWPORT BEACH, CA. FILED 2-7-2008.



THE MARK CONSISTS OF A STYLIZED LETTER N.

CLASS 9—ELECTRICAL AND SCIENTIFIC APPARATUS

FOR GAME CONTROLLERS FOR COMPUTER AND VIDEO GAMES; MEMORY CARDS (U.S. CLS. 21, 23, 26, 36 AND 38).

CLASS 35—ADVERTISING AND BUSINESS

FOR RETAIL STORE SERVICES FEATURING ELECTRONIC VIDEO AND COMPUTER GAMES, DVDS AND CDS FOR PURCHASE, SALE, OR TRADE, GAME CONTROLLERS FOR COMPUTER AND VIDEO GAMES, MEMORY CARDS, AND ACCESSORIES FOR VIDEO AND COMPUTER GAMES; ON-LINE RETAIL STORE SERVICES FEATURING ELECTRONIC VIDEO AND COMPUTER GAMES, DVDS, AND CDS, GAME CONTROLLERS FOR COMPUTER AND VIDEO GAMES, MEMORY CARDS, AND ACCESSORIES FOR VIDEO AND COMPUTER GAMES (U.S. CLS. 100, 101 AND 102).
KIMBERLY PERRY, EXAMINING ATTORNEY

SN 77-391,622. THE 17/21 GROUP, LLC, LOS ANGELES, CA.
FILED 2-7-2008.

STONE LOVE

THE MARK CONSISTS OF STANDARD CHARACTERS WITHOUT CLAIM TO ANY PARTICULAR FONT, STYLE, SIZE, OR COLOR.

CLASS 18—LEATHER GOODS

FOR HANDBAGS, PURSES AND BACKPACKS (U.S. CLS. 1, 2, 3, 22 AND 41).

CLASS 25—CLOTHING

FOR APPAREL, NAMELY, JEANS, PANTS, SHORTS, SKIRTS, JACKETS, SHIRTS, T-SHIRTS, VESTS, OVERALLS, COVERALLS, BOTTOMS, SHORTALLS, SKORTS, SWEAT PANTS, SWEAT SHIRTS, TOPS, TANK TOPS, TROUSERS, BATHING SUITS, BATHING TRUNKS, BATH ROBES, BEACHWEAR, BIKINIS, BLAZERS, BLOUSES, CAPS, COATS, COVER-UPS, DRESSES, GLOVES, HATS, HEAD WEAR, LINGERIE, PAJAMAS, RAINWEAR, SCARVES, SKIWEAR, SLEEPWEAR, SOCKS, SURF WEAR, SWEATERS, SWIM WEAR, UNDERWEAR, BELTS AND FOOTWEAR (U.S. CLS. 22 AND 39).

HEATHER THOMPSON, EXAMINING ATTORNEY

SN 77-391,991. MCWHINNEY HOLDING COMPANY, LLLP,
LOVELAND, CO. FILED 2-8-2008.

MCWHINNEY

THE MARK CONSISTS OF STANDARD CHARACTERS WITHOUT CLAIM TO ANY PARTICULAR FONT, STYLE, SIZE, OR COLOR.
SEC. 2(F).

CLASS 36—INSURANCE AND FINANCIAL

FOR REAL ESTATE MANAGEMENT; REAL ESTATE LISTING; REAL ESTATE BROKERAGE; REAL ESTATE AGENCIES; REAL ESTATE INVESTMENT; LEASING OF REAL PROPERTY; LEASING OF RESIDENTIAL AND COMMERCIAL REAL ESTATE; SHOPPING CENTER SERVICES, NAMELY, RENTAL OF SHOPPING CENTER SPACE; LEASING OF SHOPPING MALL SPACE (U.S. CLS. 100, 101 AND 102).

FIRST USE 10-31-2005; IN COMMERCE 10-31-2005.

CLASS 37—CONSTRUCTION AND REPAIR

FOR REAL ESTATE DEVELOPMENT SERVICES; LAND DEVELOPMENT SERVICES, NAMELY, PLANNING AND LAYING OUT OF COMMERCIAL AND RESIDENTIAL COMMUNITIES; RESIDENTIAL AND COMMERCIAL BUILDING CONSTRUCTION AND REPAIR; CUSTOM CONSTRUCTION AND BUILDING RENOVATION; RESIDENTIAL REAL ESTATE DEVELOPMENT, CONSTRUCTION AND REPAIR; COMMERCIAL REAL ESTATE DEVELOPMENT, CONSTRUCTION AND REPAIR; SHOPPING CENTER REAL ESTATE DEVELOPMENT, CONSTRUCTION AND REPAIR (U.S. CLS. 100, 103 AND 106).

FIRST USE 10-31-2005; IN COMMERCE 10-31-2005.

LOURDES AYALA, EXAMINING ATTORNEY

SN 77-392,121. MEDITERRANEAN DELIGHTS, INC., PORT JEFFERSON, NY. FILED 2-8-2008.

ZALIA

THE MARK CONSISTS OF STANDARD CHARACTERS WITHOUT CLAIM TO ANY PARTICULAR FONT, STYLE, SIZE, OR COLOR.

CLASS 29—MEATS AND PROCESSED FOODS

FOR SANDWICH SPREADS, NAMELY, VEGETABLE-BASED SPREADS; DIPS (U.S. CL. 46).

CLASS 30—STAPLE FOODS

FOR SAUCES; SAUCES AS CONDIMENTS; SALAD DRESSINGS (U.S. CL. 46).

ALLISON SCHRODY, EXAMINING ATTORNEY

SN 77-392,337. SURFJAR, INC., SHERWOOD, OR. FILED 2-8-2008.

SURFJAR

THE MARK CONSISTS OF STANDARD CHARACTERS WITHOUT CLAIM TO ANY PARTICULAR FONT, STYLE, SIZE, OR COLOR.

CLASS 9—ELECTRICAL AND SCIENTIFIC APPARATUS

FOR DOWNLOADABLE INTERNET BROWSER PLUGINS AND CLIENT SERVER APPLICATIONS IN THE NATURE OF MULTI-FUNCTION TOOL BAR PLUG-INS; PROVIDING ON-LINE DOWNLOADABLE SOFTWARE FOR USE IN PROVIDING SEARCH ENGINE SERVICES WHICH ARE PROVIDED THROUGH A BROWSER TOOL BAR (U.S. CLS. 21, 23, 26, 36 AND 38).

CLASS 35—ADVERTISING AND BUSINESS

FOR MARKETING SERVICES, NAMELY, PROVIDING SEARCH ENGINE MARKETING SERVICES, STRATEGIES AND PROCESSES, INCLUDING PAID PLACEMENT, PAID INCLUSION, SEARCH ENGINE RESULTS OPTIMIZATION, BID MANAGEMENT, LEAD GENERATION, AND OTHER PERFORMANCE-BASED ONLINE MARKETING; ONLINE ADVERTISING AND MARKETING SERVICES, NAMELY, TRACKING AND ANALYZING WEBSITE TRAFFIC FOR USE IN THE DISSEMINATION OF TARGETED ADVERTISEMENTS AND MARKETING MESSAGES TO WEBSITE VISITORS (U.S. CLS. 100, 101 AND 102).

CLASS 42—SCIENTIFIC AND COMPUTER SERVICES

FOR PROVIDING ON-LINE NON-DOWNLOADABLE SOFTWARE TO ENABLE SUBSCRIBING TO AND DOWNLOADING ON-LINE DOWNLOADABLE SOFTWARE FOR USE IN AUGMENTING SEARCH ENGINE SERVICES THROUGH THE USE OF A BROWSER TOOL BAR, TAGGING SELECTED ON-LINE ENTRIES FROM SEARCH ENGINE RESULTS WITH ONE OR MORE CLICKABLE ICONOGRAPHIC REWARD AND/OR POINT INDICATORS, DOWNLOADING ADVERTISER INFORMATION TO THE TOOL BAR, AND RECONCILING REWARD ACCOUNTS AS AMONG THE PROVIDER, THE USER AND THE ADVERTISER OVER THE INTERNET OR OTHER COMMUNICATIONS NETWORK (U.S. CLS. 100 AND 101).

KATHLEEN LORENZO, EXAMINING ATTORNEY

SN 77-392,885. THEFUNDED, INCORPORATED, NEW YORK, NY. FILED 2-8-2008.



THE COLOR(S) WHITE AND GREEN IS/ARE CLAIMED AS A FEATURE OF THE MARK.

THE MARK CONSISTS OF THE WORDING "THE FUNDED" IN WHITE OUTLINED IN GREEN WITH A GREEN SHADED RECTANGULAR BACKGROUND.

CLASS 35—ADVERTISING AND BUSINESS

FOR PROVIDING A WEB SITE FEATURING USER-CREATED RATINGS, REVIEWS AND RECOMMENDATIONS OF VENTURE CAPITAL FIRMS (U.S. CLS. 100, 101 AND 102).

FIRST USE 6-13-2007; IN COMMERCE 6-13-2007.

CLASS 38—COMMUNICATION

FOR PROVIDING ON-LINE FORUMS FOR TRANSMISSION OF MESSAGES AMONG COMPUTER USERS CONCERNING ISSUES RELATED TO RAISING CAPITAL FOR PRIVATE AND PUBLIC COMPANIES (U.S. CLS. 100, 101 AND 104).

FIRST USE 6-13-2007; IN COMMERCE 6-13-2007.
DANIEL CAPSHAW, EXAMINING ATTORNEY

SN 77-393,401. WEINDLING INTERNATIONAL LLC, NEW YORK, NY. FILED 2-11-2008.

THE LOVE WE SHARE

THE MARK CONSISTS OF STANDARD CHARACTERS WITHOUT CLAIM TO ANY PARTICULAR FONT, STYLE, SIZE, OR COLOR.

CLASS 16—PAPER GOODS AND PRINTED MATTER

FOR PRINTED PUBLICATIONS, NAMELY, RETAIL CATALOGS FEATURING JEWELRY, WATCHES, PERFUMES, COGNES, SKIN CARE PREPARATIONS AND COSMETICS (U.S. CLS. 2, 5, 22, 23, 29, 37, 38 AND 50).

CLASS 41—EDUCATION AND ENTERTAINMENT

FOR PUBLICATION OF PRINTED PUBLICATIONS IN THE NATURE OF RETAIL CATALOGS FEATURING JEWELRY, WATCHES, PERFUMES, COGNES, SKIN CARE PREPARATIONS AND COSMETICS; AND PUBLICATION OF ONLINE PUBLICATIONS IN THE NATURE OF RETAIL CATALOGS FEATURING JEWELRY, WATCHES, PERFUMES, COGNES, SKIN CARE PREPARATIONS AND COSMETICS (U.S. CLS. 100, 101 AND 107).

KATHERINE STOIDES, EXAMINING ATTORNEY

SN 77-393,770. THE PALEY CENTER FOR MEDIA, NEW YORK, NY. FILED 2-11-2008.



NO CLAIM IS MADE TO THE EXCLUSIVE RIGHT TO USE "CENTER FOR MEDIA", APART FROM THE MARK AS SHOWN.

THE MARK CONSISTS OF THE WORDS "THE PALEY CENTER FOR MEDIA" IN CIRCULAR DESIGNS.

CLASS 9—ELECTRICAL AND SCIENTIFIC APPARATUS

FOR SOUND AND VIDEO RECORDINGS, NAMELY, PRE-RECORDED AUDIO AND VIDEO DISCS, CDS AND DVDS ALL FEATURING ENTERTAINMENT AND INFORMATION IN THE FIELDS OF RADIO AND TELEVISION INDUSTRIES AND DIGITAL MEDIA ARTS; DOWNLOADABLE AUDIO AND VIDEO RECORDINGS ALL FEATURING ENTERTAINMENT AND INFORMATION IN THE FIELDS OF RADIO AND TELEVISION INDUSTRIES AND DIGITAL MEDIA ARTS (U.S. CLS. 21, 23, 26, 36 AND 38).

CLASS 16—PAPER GOODS AND PRINTED MATTER

FOR PRINTED MATTER, NAMELY, BROCHURES, PAMPHLETS, NEWSLETTERS, INFORMATIONAL FLYERS AND BOOKS, ALL RELATED TO THE FIELDS OF RADIO AND TELEVISION INDUSTRIES AND DIGITAL MEDIA ARTS, BIOGRAPHIES AND HISTORY; BLANK JOURNALS; NOTEPADS; STATIONERY; POSTCARDS; GREETING CARDS; NOTE CARDS (U.S. CLS. 2, 5, 22, 23, 29, 37, 38 AND 50).

CLASS 21—HOUSEWARES AND GLASS

FOR COFFEE CUPS, TEA CUPS AND MUGS (U.S. CLS. 2, 13, 23, 29, 30, 33, 40 AND 50).

CLASS 25—CLOTHING

FOR CLOTHING, NAMELY, SHIRTS, JACKETS, AND HATS (U.S. CLS. 22 AND 39).

CLASS 35—ADVERTISING AND BUSINESS

FOR RETAIL STORE AND ONLINE RETAIL STORE SERVICES AND MAIL-ORDER CATALOGUE SERVICES ALL FEATURING GENERAL CONSUMER MERCHANDISE AND MISCELLANEOUS GIFT ITEMS (U.S. CLS. 100, 101 AND 102).

CLASS 41—EDUCATION AND ENTERTAINMENT

FOR MUSEUM SERVICES; LIBRARY SERVICES; EDUCATIONAL SERVICES, NAMELY, CONDUCTING CLASSES, SEMINARS, WORKSHOPS, AND LECTURES ON THE SUBJECT OF RADIO AND TELEVISION INDUSTRIES AND DIGITAL MEDIA ARTS; CONDUCTING EXHIBITIONS IN THE NATURE OF ART SHOWS AND LIVE PRESENTATIONS FEATURING RADIO AND TELEVISION INDUSTRIES AND DIGITAL MEDIA ARTS; ONLINE SERVICES, NAMELY, PROVIDING ONLINE EDUCATIONAL SERVICES IN THE FORM OF CLASSES, SEMINARS AND WORKSHOPS ON THE SUBJECT OF RADIO AND TELEVISION INDUSTRIES AND DIGITAL MEDIA ARTS; ENTERTAINMENT SERVICES, NAMELY, PRODUCTION OF TELEVISION PROGRAMS, SERIES, DOCUMENTARIES AND SPECIALS ON THE SUBJECT OF RADIO AND TELEVISION INDUSTRIES AND DIGITAL MEDIA ARTS; DISTRIBUTION OF TELEVISION PROGRAMS FOR OTHERS (U.S. CLS. 100, 101 AND 107).

CLASS 43—HOTEL AND RESTAURANT SERVICES

FOR RESTAURANT AND CAFÉ SERVICES (U.S. CLS. 100 AND 101).
JENNIFER HETU, EXAMINING ATTORNEY

SN 77-395,931. MXT CARD SERVICES, NEW CASTLE, DE. FILED S.R. 2-13-2008; AM. P.R. 6-6-2008.



WILDERNESS REWARDS

NO CLAIM IS MADE TO THE EXCLUSIVE RIGHT TO USE "REWARDS", APART FROM THE MARK AS SHOWN. THE COLOR(S) PANTONE WARM GREY 9, WHITE, AND PANTONE 576 IS/ARE CLAIMED AS A FEATURE OF THE MARK.

THE MARK CONSISTS OF A DIAMOND SHAPE OUTLINED IN GREY WITH A SECOND INNER OUTLINE IN WHITE. THE CENTER OF THE DIAMOND IS GREEN WITH A WHITE CIRCULAR CUT-OUT, A WHITE LETTER "W" SHAPE CUT-OUT, AND A WHITE INSERTED TRIANGLE CUT-OUT WITH THE WORDS "WILDERNESS REWARDS" TO THE SIDE APPEARING IN GREY.

CLASS 35—ADVERTISING AND BUSINESS

FOR ARRANGING AND CONDUCTING INCENTIVE REWARD PROGRAMS TO PROMOTE THE SALE OF CREDIT CARDS; CONTESTS AND INCENTIVE AWARD PROGRAMS TO PROMOTE THE SALE OF PRODUCTS AND SERVICES OF OTHERS; PROMOTING THE SALE OF CREDIT CARD ACCOUNTS THROUGH THE ADMINISTRATION OF INCENTIVE AWARD PROGRAMS (U.S. CLS. 100, 101 AND 102).
FIRST USE 12-1-2007; IN COMMERCE 2-1-2008.

CLASS 36—INSURANCE AND FINANCIAL

FOR CREDIT CARD SERVICES; ISSUING CREDIT CARDS (U.S. CLS. 100, 101 AND 102).
FIRST USE 12-1-2007; IN COMMERCE 2-1-2008.
NORA BUCHANAN WILL, EXAMINING ATTORNEY

SN 77-395,993. DECRANE AEROSPACE, INC., COLUMBUS, OH. FILED 2-13-2008.

DECRANE AEROSPACE

THE MARK CONSISTS OF STANDARD CHARACTERS WITHOUT CLAIM TO ANY PARTICULAR FONT, STYLE, SIZE, OR COLOR.

OWNER OF U.S. REG. NO. 2,617,181.

NO CLAIM IS MADE TO THE EXCLUSIVE RIGHT TO USE "AEROSPACE", APART FROM THE MARK AS SHOWN.

SEC. 2(F).

CLASS 37—CONSTRUCTION AND REPAIR

FOR UPGRADING AND RETROFITTING OF PRODUCTS FOR THE CORPORATE AIRCRAFT INDUSTRY, NAMELY, AIRCRAFT AND CABIN FURNISHINGS, LIGHTING, COMMUNICATION SYSTEMS, IN-FLIGHT ENTERTAINMENT EQUIPMENT, FUEL TANK SYSTEMS AND POWER UNITS, CABIN SHELLS, SIDEWALLS AND PARTITIONS, AUDIO-VISUAL EQUIPMENT, FLIGHT DECK INSTRUMENTATION AND INSTRUMENTATION DISPLAY COMPONENTS, GLOBAL POSITIONING EQUIPMENT AND TRAFFIC COLLISION AVOIDANCE EQUIPMENT, AND AVIONICS SYSTEMS (U.S. CLS. 100, 103 AND 106).
FIRST USE 4-18-2007; IN COMMERCE 4-18-2007.

CLASS 40—MATERIAL TREATMENT

FOR CUSTOM MANUFACTURE OF PRODUCTS FOR THE CORPORATE AIRCRAFT INDUSTRY, NAMELY, AIRCRAFT AND CABIN FURNISHINGS, LIGHTING, COMMUNICATION SYSTEMS, IN-FLIGHT ENTERTAINMENT EQUIPMENT, FULE TANK SYSTEMS AND POWER UNITS, CABIN SHELLS, SIDEWALLS AND PARTITIONS, AUDIO-VISUAL EQUIPMENT, FLIGHT DECK INSTRUMENTATION AND INSTRUMENTATION DISPLAY COMPONENTS, GLOBAL POSITIONING EQUIPMENT AND TRAFFIC COLLISION AVOIDANCE EQUIPMENT, AND AVIONICS SYSTEMS (U.S. CLS. 100, 103 AND 106).

FIRST USE 4-18-2007; IN COMMERCE 4-18-2007.

CLASS 42—SCIENTIFIC AND COMPUTER SERVICES

FOR AIRCRAFT EQUIPMENT DESIGN AND AIRCRAFT INTERIOR DESIGN FOR THE CORPORATE AIRCRAFT INDUSTRY, NAMELY, DEVELOPING AND ENGINEERING AIRCRAFT AND CABIN FURNISHINGS, LIGHTING, COMMUNICATION SYSTEMS, IN-FLIGHT ENTERTAINMENT EQUIPMENT, FUEL TANK SYSTEMS AND POWER UNITS, CABIN SHELLS, SIDEWALLS AND PARTITIONS, AUDIO-VISUAL EQUIPMENT, FLIGHT DECK INSTRUMENTATION AND INSTRUMENTATION DISPLAY COMPONENTS, GLOBAL POSITIONING EQUIPMENT AND TRAFFIC COLLISION AVOIDANCE EQUIPMENT, AVIONICS SYSTEMS, ENGINEERING SERVICES, PRODUCT DEVELOPMENT SERVICES FOR OTHERS IN THE CORPORATE AIRCRAFT INDUSTRY, TESTING, ANALYSIS AND EVALUATION OF THE GOODS AND SERVICES OF OTHERS IN THE CORPORATE AIRCRAFT INDUSTRY FOR THE PURPOSE OF CERTIFICATION (U.S. CLS. 100 AND 101).

FIRST USE 4-18-2007; IN COMMERCE 4-18-2007.

LINDA ESTRADA, EXAMINING ATTORNEY

CLASS 9—ELECTRICAL AND SCIENTIFIC APPARATUS

FOR COMPUTER GAME SOFTWARE AND COMPUTER PERIPHERALS FOR USE IN SIMULATING BICYCLE RIDING EXPERIENCES; COMPUTER HARDWARE; DOWNLOADABLE COMPUTER GAMES AND COMPUTER SOFTWARE FOR USE IN SIMULATING BICYCLE RIDING EXPERIENCES; COMPUTERS AND COMPUTER PERIPHERALS THEREFORE FOR USE WITH PHYSICAL REHABILITATION, PHYSICAL THERAPY, SPORTS MEDICINE, AND PHYSICAL TRAINING; COMPUTER SOFTWARE FOR USE WITH EXERCISE AND FITNESS MACHINES; COMPUTER SOFTWARE FOR MONITORING CARDIOVASCULAR CONDITIONING, BALANCE, STABILITY AND WEIGHT BEARING CAPACITIES, REACTION TIME, STRIKE AND MOVEMENT, RANGE OF MOTION, STRENGTH, EXTENSION AND FLEXION AND INSTRUCTION MANUALS IN ELECTRONIC FORMAT SOLD AS A UNIT THEREWITH, AVAILABLE BOTH BY DOWNLOAD AND ON RECORDED COMPUTER MEDIA; COMPUTER GAME PROGRAMS; COMPUTER GAME CARTRIDGES, SOFTWARE, DISCS, TAPES, AND INSTRUCTION MANUALS IN ELECTRONIC FORMAT SOLD TOGETHER AS A UNIT THEREWITH; COMPUTER GAME PROGRAMS THAT MAY BE DOWNLOADABLE FROM A GLOBAL COMPUTER NETWORK; EDUCATIONAL SOFTWARE IN THE FORM OF A VIDEO GAME THAT MAY BE DOWNLOADED FROM A GLOBAL COMPUTER NETWORK; EDUCATIONAL SOFTWARE IN THE FIELD OF VIDEO GAMES THAT MAY BE DOWNLOADED FROM A GLOBAL COMPUTER NETWORK; COMPUTER GAMES THAT MAY BE DOWNLOADED FROM A GLOBAL COMPUTER NETWORK; INTERACTIVE MULTI-MEDIA COMPUTER GAMES COMPRISED OF COMPUTER HARDWARE AND COMPUTER GAMES SOFTWARE; COMPUTER JOYSTICKS, COMPUTER GAME TAPES, DISC AND CASSETTES; VIDEO GAME TAPE CASSETTES AND DISCS; COMPUTER SOFTWARE GAME SIMULATION CONTROLS, NAMELY, HANDLEBAR AND SEAT JOYSTICKS FOR CONTROLLING STEERING, BALANCE AND WEIGHT DISTRIBUTION IN THE USE OF PEDAL DRIVEN CROSS-TRAINING EQUIPMENT; COMPUTER GAME SOFTWARE INTERFACE CONTROLS FOR SIMULATING STEERING, BALANCE AND WEIGHT DISTRIBUTION IN THE USE OF PEDAL DRIVEN CROSS-TRAINING EQUIPMENT; COMPUTER CONTROLLERS, NAMELY, WEIGHT DISTRIBUTION MONITORS, PHYSIOLOGICAL MONITORS, AND BALANCE MONITORS; AND COMPUTER JOYSTICKS FOR USE WITH ASSOCIATED COMPUTER GAME HARDWARE AND SOFTWARE; CDS FEATURING MUSIC; DVDS WITH INSTRUCTIONAL VIDEOS RECORDED THEREON FOR USE WITH PEDAL DRIVEN CROSS-TRAINING FITNESS EQUIPMENT; CD ROMS WITH INSTRUCTIONAL VIDEOS RECORDED THEREON FOR USE WITH PROVIDE INSTRUCTION ON USE OF PEDAL DRIVEN CROSS-TRAINING FITNESS EQUIPMENT (U.S. CLS. 21, 23, 26, 36 AND 38).

FIRST USE 10-1-2003; IN COMMERCE 10-1-2003.

SN 77-396,152. TRIXTER DEVELOPMENTS LIMITED PLC, GLOUCESTERSHIRE, UNITED KINGDOM, FILED 2-13-2008.

TRIXTER

THE MARK CONSISTS OF STANDARD CHARACTERS WITHOUT CLAIM TO ANY PARTICULAR FONT, STYLE, SIZE, OR COLOR.

CLASS 28—TOYS AND SPORTING GOODS

FOR FITNESS AND EXERCISE MACHINES, NAMELY, PEDAL DRIVEN CROSS-TRAINING FITNESS MACHINE (U.S. CLS. 22, 23, 38 AND 50).

FIRST USE 10-1-2003; IN COMMERCE 10-1-2003.

SHAUNIA CARLYLE, EXAMINING ATTORNEY

SN 77-396,843. SONY ERICSSON MOBILE COMMUNICATIONS AB, LUND, SWEDEN, FILED 2-14-2008.

X1

THE MARK CONSISTS OF STANDARD CHARACTERS WITHOUT CLAIM TO ANY PARTICULAR FONT, STYLE, SIZE, OR COLOR.

CLASS 9—ELECTRICAL AND SCIENTIFIC APPARATUS

FOR CELLULAR OR MOBILE PHONES; CELLULAR OR MOBILE PHONES FEATURING THE CAPACITY TO FUNCTION IN ANY NUMBER OF EXTRA WAYS BEYOND JUST AS A PHONE, NAMELY, TO FUNCTION AS A CAMERA, TO PERFORM INSTANT MESSAGING, TO CONDUCT MULTIMEDIA MESSAGING, TO ACCESS AND COMMUNICATE WITH E-MAIL, TO ACCESS AND COMMUNICATE WITH THE INTERNET, TO ACCESS AND COMMUNICATE WITH INTRANETS OR PRIVATE COMPUTER NETWORKS, TO ACCESS AND COMMUNICATE DATA, TO FUNCTION AS A RADIO, TO RECORD, PLAY, TRANSMIT, RECEIVE, AND/OR MANAGE MUSIC, TO RECORD, PLAY, TRANSMIT, RECEIVE, EDIT, AND/OR MANAGE AUDIO OR VOICE, TO RECORD, PLAY, TRANSMIT, RECEIVE, EDIT, AND/OR MANAGE VIDEO, TO CREATE, VIEW, TRANSMIT, RECEIVE, EDIT, AND/OR MANAGE PHOTOGRAPHS OR PICTURES, TO UPLOAD, VIEW, TRANSMIT, RECEIVE, EDIT, AND/OR MANAGE GRAPHICS OR IMAGES, TO PLAY ELECTRONIC GAMES, TO UPLOAD PHOTOGRAPHS AND TEXT ONTO ONLINE JOURNALS OR WEB LOGS ALSO KNOWN AS BLOGS, TO MANAGE A CALENDAR AND CONTACT INFORMATION AND OTHERWISE FUNCTION AS A PERSONAL DIGITAL ASSISTANT (PDA), TO EFFECTUATE MOBILE PRINTING, TO PERFORM SATELLITE NAVIGATION, TO VIEW ELECTRONIC CITY GUIDES, TO FUNCTION AS A REMOTE CONTROL FOR COMPUTERS AND RUN MULTIMEDIA PRESENTATIONS, AND/OR TO TRANSMIT VIDEO, SOUND, AND/OR DATA TO WEBSITES; DOWNLOADABLE ELECTRONIC MANUALS IN THE FIELD OF CELLULAR OR MOBILE PHONES; MEMORY CARDS AND STICKS FOR CELLULAR OR MOBILE PHONES; PERSONAL COMPUTER CARDS THAT ENABLE COMPUTERS AND LAPTOP COMPUTERS TO GAIN WIRELESS ACCESS TO, AND COMMUNICATE WITH, E-MAIL, THE INTERNET, INTRANETS, OR PRIVATE COMPUTER NETWORKS; COMPUTER APPLICATION SOFTWARE FOR CELLULAR OR MOBILE PHONES; DOWNLOADABLE COMPUTER APPLICATION SOFTWARE IN THE FIELD OF CELLULAR OR MOBILE PHONES; DOWNLOADABLE RING TONES, GRAPHICS, GAMES, AUDIO AND VIDEO CLIPS, ALL DOWNLOADABLE TO COMPUTERS AND CELLULAR OR MOBILE PHONES VIA THE INTERNET; CAMERA DEVICES ADAPTED FOR USE WITH CELLULAR OR MOBILE PHONES; DEVICES THAT ALLOW IMAGES FROM CELLULAR OR MOBILE PHONES TO BE SHOWN ON TELEVISIONS, DISPLAY SCREENS OR COMPUTER MONITORS; DEVICES THAT ALLOW AUDIO FROM CELLULAR OR MOBILE PHONES TO BE HEARD ON STEREO SYSTEMS; AUDIO SPEAKERS FOR LISTENING TO MUSIC OR AUDIO FROM MOBILE OR CELLULAR PHONES; COMBINATION AMPLIFIER AND SPEAKER SYSTEM FOR LISTENING TO MUSIC OR AUDIO FROM MOBILE OR CELLULAR PHONES; RADIO TRANSMITTERS; COMPUTER GAMES FOR USE WITH CELLULAR OR MOBILE PHONES; ACCESSORIES FOR CELLULAR OR MOBILE PHONES IN THE NATURE OF HEADSETS AND DEVICES FOR HANDS-FREE PHONE USE; ACCESSORIES FOR CELLULAR OR MOBILE PHONES IN THE NATURE OF CHARGERS, BATTERIES, CASES, COVERS, HOLDERS, DOCKING STANDS, AND CABLES; AND PRINTED CIRCUIT BOARDS (U.S. CLS. 21, 23, 26, 36 AND 38).

CLASS 38—COMMUNICATION

FOR TELECOMMUNICATIONS SERVICES IN THE NATURE OF TRANSMISSION OF SOUND, PICTURE, IMAGE, VIDEO, AND DATA SIGNALS, SUCH TRANSMISSION ENABLED BY MEANS OF THE INTERNET AND WIRELESS TECHNOLOGY, PROVIDED IN RESPONSE TO COMMANDS FROM CELLULAR OR MOBILE PHONES; TRANSMISSION OF SOUND, PICTURE, IMAGE, VIDEO, AND DATA SIGNALS TO PERSONALIZE OR ENHANCE CELLULAR OR MOBILE PHONES, SUCH TRANSMISSION ENABLED BY MEANS OF THE INTERNET AND WIRELESS TECHNOLOGY, PROVIDED IN RESPONSE TO COMMANDS FROM CELLULAR OR MOBILE PHONES; TELECOMMUNICATIONS SERVICES, NAMELY, PROVIDING A WEBSITE THAT ENABLES TRANSMISSION OF SOUND, PICTURE, GRAPHIC, IMAGE, AND VIDEO SIGNALS TO THE WEBSITE, WHERE THE SIGNALS MAY BE EDITED AND THEN TRANSMITTED TO CELLULAR OR MOBILE PHONES; AND PROVIDING INFORMATION ON CALLING PLANS AND SERVICES OF OTHERS IN THE FIELD OF CELLULAR OR MOBILE PHONES (U.S. CLS. 100, 101 AND 104).

ZACHARY BELLO, EXAMINING ATTORNEY

SN 77-398,318. KING FISH MEDIA, LLC, SALEM, MA, FILED 2-15-2008.

OWN YOUR MEDIA CHANNEL

THE MARK CONSISTS OF STANDARD CHARACTERS WITHOUT CLAIM TO ANY PARTICULAR FONT, STYLE, SIZE, OR COLOR.

CLASS 35—ADVERTISING AND BUSINESS

FOR PUBLISHING OF ADVERTISING TEXTS, NAMELY, BROCHURES AND PROMOTIONAL LITERATURE; PROVIDING ADVERTISING AND MARKETING SERVICES, NAMELY, PROMOTING THE GOODS AND SERVICES OF CLIENT COMPANIES THROUGH PLANNING, DEVELOPING, CREATING, IMPLEMENTING AND DISTRIBUTING MARKETING AND ADVERTISING MATERIALS; RESEARCH AND CONSULTATION SERVICES IN THE FIELD OF SALES, PROMOTIONS AND MARKETING (U.S. CLS. 100, 101 AND 102).

CLASS 38—COMMUNICATION

FOR WEBCASTING SERVICES (U.S. CLS. 100, 101 AND 104).

CLASS 42—SCIENTIFIC AND COMPUTER SERVICES

FOR GRAPHIC ART DESIGN OF BROCHURES, JOURNALS, NEWSLETTERS, ELECTRONIC NEWSLETTERS, PROMOTIONAL LITERATURE, AND MAGAZINES (U.S. CLS. 100 AND 101).

KRISTIN CARLSON, EXAMINING ATTORNEY

SN 77-399,210. RONI REBELO, DBA THE OFFICES OF RONI REBELO, PALMETTO BAY, FL. FILED 2-17-2008.

SN 77-400,199. INDO POLY (THAILAND) LTD., NAKORN-PATHOM 73120, THAILAND, FILED 2-19-2008.

Marketing & Brokerage Objectives
Mortgage & Financing Solutions
Provided By



Marketeers & Purveyors of
Exceptional Real Estate Services

NO CLAIM IS MADE TO THE EXCLUSIVE RIGHT TO USE "MARKETING & BROKERAGE OBJECTIVES MORTGAGE & FINANCING SOLUTIONS PROVIDED BY MARKETTERS & PURVEYORS OF EXCEPTIONAL REAL ESTATE SERVICES", APART FROM THE MARK AS SHOWN.

THE NAME "RONI REBELO" IDENTIFIES A LIVING INDIVIDUAL WHOSE CONSENT IS OF RECORD.

THE COLOR(S) WHITE, BLUE, AND GOLD IS/ARE CLAIMED AS A FEATURE OF THE MARK.

THE MARK CONSISTS OF THE TEXT ABOVE THE RECTANGULAR PORTION OF LOGO, "MARKETING & BROKERAGE OBJECTIVES MORTGAGE & FINANCING SOLUTIONS PROVIDED BY", IN BLUE; OUTER RECTANGULAR OUTLINE IN BLUE; INNER RECTANGULAR OUTLINE IN GOLD; WHITE SPACE BETWEEN OUTER BLUE AND INNER GOLD RECTANGULAR OUTLINES; INNER-MOST RECTANGULAR BOX CONTAINING THE LETTERS "RR", IN BLUE; THE LETTERS "RR" IN WHITE WITH THE ENDS OF THE "RR" PART OF THE WHITE SPACE OF THE AREA BETWEEN THE INNER GOLD RECTANGULAR OUTLINE AND INNER-MOST RECTANGULAR BLUE BOX; THE NAME "RONI REBELO" IS IN BLUE AND IS LOCATED BELOW INNER-MOST BLUE RECTANGULAR BOX AND ABOVE THE INNER GOLD RECTANGULAR OUTLINE; THE TEXT BELOW THE RECTANGULAR PORTION OF THE LOGO, "MARKETTERS & PURVEYORS OF EXCEPTIONAL REAL ESTATE SERVICES", IN BLUE.

CLASS 35—ADVERTISING AND BUSINESS

FOR REAL ESTATE MARKETING SERVICES IN THE FIELD OF REAL ESTATE BROKERAGE, AND MORTGAGE AND FINANCING OF RESIDENTIAL REAL ESTATE, COMMERCIAL REAL ESTATE, VACANT/RAW LAND AND ACREAGE REAL ESTATE, AND BUSINESS REAL ESTATE AND OPPORTUNITIES (U.S. CLS. 100, 101 AND 102).

FIRST USE 1-0-2008; IN COMMERCE 1-0-2008.

CLASS 36—INSURANCE AND FINANCIAL

FOR REAL ESTATE BROKERAGE; FACILITATING AND ARRANGING FOR THE FINANCING OF RESIDENTIAL REAL ESTATE, COMMERCIAL REAL ESTATE, VACANT/RAW LAND AND ACREAGE REAL ESTATE, AND BUSINESS REAL ESTATE AND OPPORTUNITIES; MORTGAGE BROKERAGE; MORTGAGE PROCUREMENT FOR OTHERS (U.S. CLS. 100, 101 AND 102).

FIRST USE 1-0-2008; IN COMMERCE 1-0-2008.

JENNIFER MARTIN, EXAMINING ATTORNEY

COLYAR

THE MARK CONSISTS OF STANDARD CHARACTERS WITHOUT CLAIM TO ANY PARTICULAR FONT, STYLE, SIZE, OR COLOR.

CLASS 22—CORDAGE AND FIBERS

FOR YARN FIBERS; SYNTHETIC FIBERS AND FILAMENT FOR USE IN MANUFACTURE OF FABRICS, TEXTILES, YARNS AND CARPETS (U.S. CLS. 1, 2, 7, 19, 22, 42 AND 50).

CLASS 23—YARNS AND THREADS

FOR SYNTHETIC FIBER THREAD AND YARN (U.S. CL. 43).

GEORGIA CARTY, EXAMINING ATTORNEY

SN 77-400,230. HAWAII WINTER BASEBALL, INC., HONOLULU, HI. FILED 2-19-2008.



THE MARK CONSISTS OF A TURTLE PROFILE IN FRONT OF AN ELLIPSE HOLDING A BASEBALL BAT AND WEARING A HAT.

CLASS 25—CLOTHING

FOR CLOTHING, NAMELY, HATS, T-SHIRTS AND POLO SHIRTS (U.S. CLS. 22 AND 39).

FIRST USE 10-0-2006; IN COMMERCE 10-0-2006.

CLASS 41—EDUCATION AND ENTERTAINMENT

FOR ENTERTAINMENT, IN THE NATURE OF BASEBALL GAMES (U.S. CLS. 100, 101 AND 107).

FIRST USE 10-0-2006; IN COMMERCE 10-0-2006.

CURTIS FRENCH, EXAMINING ATTORNEY

SN 77-401,233. HOLDONE, LLC, BEDMINSTER, NJ. FILED 2-20-2008.

The Beautiful Child

THE MARK CONSISTS OF STANDARD CHARACTERS WITHOUT CLAIM TO ANY PARTICULAR FONT, STYLE, SIZE, OR COLOR.

NO CLAIM IS MADE TO THE EXCLUSIVE RIGHT TO USE "CHILD", APART FROM THE MARK AS SHOWN.

CLASS 9—ELECTRICAL AND SCIENTIFIC APPARATUS

FOR DIGITAL MATERIALS, NAMELY, CDS, DVDS, DOWNLOADABLE AUDIO FILES, DOWNLOADABLE VIDEO FILES, AND DOWNLOADABLE MULTIMEDIA FILES, FEATURING EDUCATIONAL MATERIALS FOR CAREGIVERS OF CHILDREN IN THE FIELD OF HUMAN PHYSICAL AND MENTAL DEVELOPMENT (U.S. CLS. 21, 23, 26, 36 AND 38).

CLASS 16—PAPER GOODS AND PRINTED MATTER

FOR PRINTED EDUCATIONAL MATERIALS FOR CAREGIVERS OF CHILDREN IN THE FIELD OF HUMAN PHYSICAL AND MENTAL DEVELOPMENT (U.S. CLS. 2, 5, 22, 23, 29, 37, 38 AND 50).

STEPHEN AQUILA, EXAMINING ATTORNEY

SN 77-401,934. MIROSHINCHENKO, ALEX, PALO ALTO, CA. AND LAVRISHINA, NATLIA, PALO ALTO, CA. FILED 2-20-2008.

GOT OUTFIT

THE MARK CONSISTS OF STANDARD CHARACTERS WITHOUT CLAIM TO ANY PARTICULAR FONT, STYLE, SIZE, OR COLOR.

CLASS 35—ADVERTISING AND BUSINESS

FOR PROVIDING NEWS AND INFORMATION IN THE FIELD OF SHOPPING; PROVISION OF A WEB SITE FEATURING INFORMATION ON SHOPPING (U.S. CLS. 100, 101 AND 102).

CLASS 42—SCIENTIFIC AND COMPUTER SERVICES

FOR PROVISION OF A WEB SITE WHERE USERS CAN UPLOAD AND SHARE PHOTOS AND VIDEOS IN THE FIELDS OF FASHION, STYLE, CLOTHING, ACCESSORIES AND SHOPPING (U.S. CLS. 100 AND 101).

CLASS 45—PERSONAL AND LEGAL SERVICES

FOR ONLINE SOCIAL NETWORKING SERVICES; PROVIDING NEWS AND INFORMATION IN THE FIELDS OF FASHION, STYLE, CLOTHING AND ACCESSORIES; PROVISION OF A WEB SITE FEATURING INFORMATION ON FASHION, STYLE, CLOTHING AND ACCESSORIES (U.S. CLS. 100 AND 101).

KATHERINE CHANG, EXAMINING ATTORNEY

SN 77-402,699. LUTRON ELECTRONICS CO., INC., COOPERSBURG, PA. FILED 2-21-2008.

GREEN GLANCE

THE MARK CONSISTS OF STANDARD CHARACTERS WITHOUT CLAIM TO ANY PARTICULAR FONT, STYLE, SIZE, OR COLOR.

NO CLAIM IS MADE TO THE EXCLUSIVE RIGHT TO USE "GREEN", APART FROM THE MARK AS SHOWN.

CLASS 9—ELECTRICAL AND SCIENTIFIC APPARATUS

FOR COMPUTER SOFTWARE THAT PROVIDES REAL-TIME LIGHTING ENERGY SAVINGS AND LIGHTING POWER SAVINGS (U.S. CLS. 21, 23, 26, 36 AND 38).

FIRST USE 12-0-2006; IN COMMERCE 5-0-2007.

CLASS 35—ADVERTISING AND BUSINESS

FOR PROVIDING INFORMATION IN THE FIELD OF LIGHTING ENERGY EFFICIENCY (U.S. CLS. 100, 101 AND 102).

FIRST USE 12-0-2006; IN COMMERCE 5-0-2007.

PAM WILLIS, EXAMINING ATTORNEY

SN 77-402,701. INDO POLY (THAILAND) LTD., NAKORN-PATHOM 73120, THAILAND, FILED 2-21-2008.



NO CLAIM IS MADE TO THE EXCLUSIVE RIGHT TO USE "PERFORMANCE YARN BY INDOPOLY", APART FROM THE MARK AS SHOWN.

CLASS 22—CORDAGE AND FIBERS

FOR YARN FIBERS; SYNTHETIC FIBERS AND FILAMENT FOR USE IN MANUFACTURE OF FABRICS, TEXTILES, YARNS AND CARPETS (U.S. CLS. 1, 2, 7, 19, 22, 42 AND 50).

CLASS 23—YARNS AND THREADS

FOR SYNTHETIC FIBER THREAD AND YARN (U.S. CL. 43).

GEORGIA CARTY, EXAMINING ATTORNEY

SN 77-403,169. SUN CHEMICAL B.V., WEESP, NETHERLANDS, FILED 2-21-2008.

SN 77-403,849. NBI, INC., ALTOONA, WI. FILED 2-22-2008.

THE WHITE ZONE

THE MARK CONSISTS OF STANDARD CHARACTERS WITHOUT CLAIM TO ANY PARTICULAR FONT, STYLE, SIZE, OR COLOR.

CLASS 35—ADVERTISING AND BUSINESS

FOR DESIGN OF ADVERTISING MATERIALS FOR OTHERS; SERVICES RELATING TO THE ANALYSIS, EVALUATION, CREATION AND BRAND ESTABLISHMENT OF TRADEMARKS, TRADE NAMES AND DOMAIN NAMES (U.S. CLS. 100, 101 AND 102).

CLASS 42—SCIENTIFIC AND COMPUTER SERVICES

FOR PACKAGING DESIGN FOR OTHERS, DESIGN SKETCHING OF PACKAGING, GRAPHIC DESIGN SERVICES (U.S. CLS. 100 AND 101).
IRA J. GOODSaid, EXAMINING ATTORNEY

SN 77-403,269. JESSUP MANUFACTURING COMPANY, MCHENRY, IL. FILED 2-21-2008.

GLO BRITE ECO EXIT

THE MARK CONSISTS OF STANDARD CHARACTERS WITHOUT CLAIM TO ANY PARTICULAR FONT, STYLE, SIZE, OR COLOR.

OWNER OF U.S. REG. NOS. 2,254,280 AND 3,336,855.
NO CLAIM IS MADE TO THE EXCLUSIVE RIGHT TO USE "GLOW", "BRIGHT" AND "EXIT", APART FROM THE MARK AS SHOWN.

CLASS 9—ELECTRICAL AND SCIENTIFIC APPARATUS

FOR PHOTOLUMINESCENT EXIT SIGNS (U.S. CLS. 21, 23, 26, 36 AND 38).

CLASS 17—RUBBER GOODS

FOR PHOTOLUMINESCENT FILMS WITH AND WITHOUT ADHESIVE BACKING, FOR USE AS SIGNAGE, DIRECTIONAL IDENTIFICATION, WARNING LABELS, IDENTIFICATION LABELS, DECORATION, SAFETY DEVICES, FLOOR MARKINGS, WALL MARKINGS, PROMOTIONAL STICKERS, AND NOVELTY ITEMS (U.S. CLS. 1, 5, 12, 13, 35 AND 50).
BRIAN PINO, EXAMINING ATTORNEY



OWNER OF U.S. REG. NOS. 2,790,771, 2,819,229 AND 2,822,524.

NO CLAIM IS MADE TO THE EXCLUSIVE RIGHT TO USE "NATIONAL BUSINESS INSTITUTE", APART FROM THE MARK AS SHOWN.

CLASS 9—ELECTRICAL AND SCIENTIFIC APPARATUS

FOR AUDIO TAPES, VIDEO TAPES AND COMPACT DISCS FEATURING PARALEGAL EDUCATION (U.S. CLS. 21, 23, 26, 36 AND 38).
FIRST USE 2-12-2007; IN COMMERCE 2-12-2007.

CLASS 16—PAPER GOODS AND PRINTED MATTER

FOR PRINTED EDUCATIONAL AND INSTRUCTIONAL MATERIALS AND AIDS IN THE FIELD OF PARALEGAL EDUCATION (U.S. CLS. 2, 5, 22, 23, 29, 37, 38 AND 50).
FIRST USE 2-12-2007; IN COMMERCE 2-12-2007.

CLASS 41—EDUCATION AND ENTERTAINMENT

FOR EDUCATIONAL SERVICES, NAMELY, CONDUCTING SEMINARS, CONFERENCES, WORKSHOPS OR CONTINUING EDUCATION CLASSES IN THE FIELD OF PARALEGAL EDUCATION AND DISTRIBUTING COURSE MATERIALS IN CONNECTION THEREWITH (U.S. CLS. 100, 101 AND 107).
FIRST USE 2-12-2007; IN COMMERCE 2-12-2007.
HOWARD FRIEDMAN, EXAMINING ATTORNEY

SN 77-403,904. NBI, INC., ALTOONA, WI. FILED 2-22-2008.



OWNER OF U.S. REG. NOS. 2,819,228, 2,822,525 AND OTHERS.

NO CLAIM IS MADE TO THE EXCLUSIVE RIGHT TO USE "INSTITUTE FOR PARALEGAL EDUCATION", APART FROM THE MARK AS SHOWN.

CLASS 9—ELECTRICAL AND SCIENTIFIC APPARATUS

FOR AUDIO TAPES, VIDEO TAPES AND COMPACT DISCS FEATURING PARALEGAL EDUCATION (U.S. CLS. 21, 23, 26, 36 AND 38).
FIRST USE 6-5-2007; IN COMMERCE 6-5-2007.

CLASS 16—PAPER GOODS AND PRINTED MATTER

FOR PRINTED EDUCATIONAL AND INSTRUCTIONAL MATERIALS AND AIDS IN THE FIELD OF PARALEGAL EDUCATION (U.S. CLS. 2, 5, 22, 23, 29, 37, 38 AND 50).

FIRST USE 6-5-2007; IN COMMERCE 6-5-2007.

CLASS 41—EDUCATION AND ENTERTAINMENT

FOR EDUCATIONAL SERVICES, NAMELY, CONDUCTING SEMINARS, CONFERENCES, WORKSHOPS OR CONTINUING EDUCATION CLASSES IN THE FIELD OF PARALEGAL EDUCATION AND DISTRIBUTING COURSE MATERIALS IN CONNECTION THEREWITH (U.S. CLS. 100, 101 AND 107).

FIRST USE 6-5-2007; IN COMMERCE 6-5-2007.

HOWARD FRIEDMAN, EXAMINING ATTORNEY

SN 77-403,935. JEANIE C. LINDERS FUND, INC., WINTER PARK, FL. FILED 2-22-2008.

The Yellow Brick Road Project

THE MARK CONSISTS OF STANDARD CHARACTERS WITHOUT CLAIM TO ANY PARTICULAR FONT, STYLE, SIZE, OR COLOR.

NO CLAIM IS MADE TO THE EXCLUSIVE RIGHT TO USE "PROJECT" AS TO CLASS 37, APART FROM THE MARK AS SHOWN.

CLASS 25—CLOTHING

FOR SHORT-SLEEVED OR LONG-SLEEVED T-SHIRTS; T-SHIRTS (U.S. CLS. 22 AND 39).

CLASS 37—CONSTRUCTION AND REPAIR

FOR HOUSE BUILDING AND REPAIR (U.S. CLS. 100, 103 AND 106).

ALYSSA PALADINO, EXAMINING ATTORNEY

SN 77-406,064. POLYMER SURFACES GROUP LLC, JACKSONVILLE, FL. FILED 2-26-2008.

advanced home actives

NO CLAIM IS MADE TO THE EXCLUSIVE RIGHT TO USE "ADVANCED HOME ACTIVES", APART FROM THE MARK AS SHOWN.

THE MARK CONSISTS OF THE WORDS "ADVANCED HOME ACTIVES" ALL IN LOWER CASE LETTERS. THE FIRST LETTER OF EACH WORD IS LARGER THAN THE LETTERS OF THE REST OF THE WORD.

CLASS 3—COSMETICS AND CLEANING PREPARATIONS

FOR NON-MEDICATED SKINCARE PREPARATIONS, NAMELY, MILKS, LOTIONS, GELS AND CREAMS FOR THE FACE; MILKS, LOTIONS, GELS AND CREAMS FOR THE BODY; MILKS, LOTIONS, GELS AND CREAMS FOR THE HANDS; NON-MEDICATED SKINCARE PREPARATIONS, NAMELY, CHEMICAL PEELS; SUN CARE PREPARATIONS, NAMELY, SUN BLOCK, SUNSCREEN, SUN CREAM, SUN TAN LOTION, SUN TAN GEL, SUN TAN OIL, SKIN BRONZER; HAIR CARE PREPARATIONS, NAMELY, HAIR SHAMPOO, HAIR DETANGLER, HAIR MOUSSE, HAIR STYLING BALM, HAIR CONDITIONER; MAKE-UP, NAMELY, FOUNDATION MAKE-UP, PRESSED FACE POWDER, LOOSE FACE POWDER, BATH POWDER, BODY POWDER, DUSTING POWDER, BLUSH, ROUGE, LIPSTICK, LIP GLOSS, LIP LINER, EYE MAKE-UP, EYE SHADOW, UNDER EYE CONCEALER, MASCARA, EYELINER, AND EYEBROW PENCIL; NAIL CARE PREPARATIONS, NAMELY, NAIL POLISH, NAIL ENAMEL; CLEANING AND BATHING PREPARATIONS, NAMELY, BATH AND SHOWER GELS, BATH SALTS, TOILET SOAP; FRAGRANCES, NAMELY, PERFUME, COLOGNE; PERSONAL HYGIENE PRODUCTS, NAMELY, BODY DEODORANT FOR PERSONAL USE, ANTIPERSPIRANT FOR PERSONAL USE (U.S. CLS. 1, 4, 6, 50, 51 AND 52).

CLASS 5—PHARMACEUTICALS

FOR MEDICATED SKIN PREPARATIONS, NAMELY, ACNE TREATMENT PREPARATIONS, ANTIBIOTIC PREPARATIONS, ANTI-INFECTIVES, ANTIFUNGAL PREPARATIONS, CHEMICAL PEELS, PREPARATIONS FOR TREATMENT OF INFLAMMATORY SKIN DISORDERS, PREPARATIONS FOR TREATMENT OF ROSACEA, PREPARATIONS FOR TREATMENT OF PIGMENTATION DISORDERS, ANTI-AGING SKIN CREAMS AND SERUMS; AND MEDICATED HAIR CARE PREPARATIONS, NAMELY, MEDICATED SHAMPOO (U.S. CLS. 6, 18, 44, 46, 51 AND 52).

LINDA M. KING, EXAMINING ATTORNEY

SN 77-407,221. NIELSEN BUSINESS MEDIA, INC., NEW YORK, NY. FILED 2-27-2008.

THE HOLLYWOOD REPORTER

THE MARK CONSISTS OF STANDARD CHARACTERS WITHOUT CLAIM TO ANY PARTICULAR FONT, STYLE, SIZE, OR COLOR.

OWNER OF U.S. REG. NOS. 856,584, 2,245,657 AND OTHERS.

NO CLAIM IS MADE TO THE EXCLUSIVE RIGHT TO USE "REPORTER", APART FROM THE MARK AS SHOWN. SEC. 2(F).

CLASS 16—PAPER GOODS AND PRINTED MATTER

FOR PRINTED NEWSPAPERS, MAGAZINES, AND PERIODICALS IN THE FIELD OF THE ENTERTAINMENT INDUSTRY (U.S. CLS. 2, 5, 22, 23, 29, 37, 38 AND 50).

FIRST USE 9-3-1930; IN COMMERCE 9-3-1930.

CLASS 41—EDUCATION AND ENTERTAINMENT

FOR PROVIDING INFORMATION IN THE FIELD OF FILM, TELEVISION, MUSIC AND ENTERTAINMENT VIA THE INTERNET (U.S. CLS. 100, 101 AND 107).

FIRST USE 7-24-1995; IN COMMERCE 7-24-1995.
ANTHONY RINKER, EXAMINING ATTORNEY

SN 77-407,361. FAT GOOSE, INC., SAN FRANCISCO, CA. FILED 2-27-2008.



THE MARK CONSISTS OF A RUNNING GOOSE WITH THE WORDS "FAT" AND "GOOSE" IN A STYLIZED FONT TO THE LEFT AND RIGHT OF IT, RESPECTIVELY.

CLASS 9—ELECTRICAL AND SCIENTIFIC APPARATUS

FOR COMPUTER SOFTWARE FOR USE IN WEBSITE DEVELOPMENT (U.S. CLS. 21, 23, 26, 36 AND 38).

CLASS 42—SCIENTIFIC AND COMPUTER SERVICES

FOR COMPUTER SERVICES, NAMELY, HOSTING THE WEBSITES OF OTHERS ON A COMPUTER SERVER FOR A GLOBAL COMPUTER NETWORK; APPLICATION SERVICE PROVIDER (ASP) FEATURING SOFTWARE FOR USE IN DEVELOPING WEBSITES (U.S. CLS. 100 AND 101).

CLASS 45—PERSONAL AND LEGAL SERVICES

FOR ONLINE SOCIAL NETWORKING SERVICES (U.S. CLS. 100 AND 101).
RENEE MCCRAY, EXAMINING ATTORNEY

SN 77-409,912. AIR PRODUCTS AND CHEMICALS, INC., ALLENTOWN, PA. FILED 2-29-2008.

XeCovery

THE MARK CONSISTS OF STANDARD CHARACTERS WITHOUT CLAIM TO ANY PARTICULAR FONT, STYLE, SIZE, OR COLOR.

CLASS 37—CONSTRUCTION AND REPAIR

FOR COLLECTION OF CHEMICALS FOR THE PURPOSE OF REFUSE CLEAN-UP (U.S. CLS. 100, 103 AND 106).

CLASS 39—TRANSPORTATION AND STORAGE

FOR PACKAGING AND STORAGE OF GOODS, NAMELY, COLLECTION AND PACKAGING OF CHEMICALS FOR THE PURPOSE OF TRANSPORTING, AND STORAGE OF CHEMICALS (U.S. CLS. 100 AND 105).

CLASS 40—MATERIAL TREATMENT

FOR TREATMENT OF MATERIALS, NAMELY, PURIFICATION AND RECYCLING OF CHEMICALS (U.S. CLS. 100, 103 AND 106).

AISHA SALEM, EXAMINING ATTORNEY

SN 77-410,218. THE HARTZ MOUNTAIN CORPORATION, SECAUCUS, NJ. FILED 2-29-2008.

HARTZ FOR THE HOLIDAYS

THE MARK CONSISTS OF STANDARD CHARACTERS WITHOUT CLAIM TO ANY PARTICULAR FONT, STYLE, SIZE, OR COLOR.

OWNER OF U.S. REG. NOS. 2,524,782, 3,222,910 AND OTHERS.

CLASS 18—LEATHER GOODS

FOR RAWHIDE CHEWS FOR DOGS (U.S. CLS. 1, 2, 3, 22 AND 41).

CLASS 28—TOYS AND SPORTING GOODS

FOR PET TOYS (U.S. CLS. 22, 23, 38 AND 50).
MAYUR VAGHANI, EXAMINING ATTORNEY

SN 77-410,424. XINGTONE, LLC, SUNNYVALE, CA. FILED 2-29-2008.

ZINGTONE

THE MARK CONSISTS OF STANDARD CHARACTERS WITHOUT CLAIM TO ANY PARTICULAR FONT, STYLE, SIZE, OR COLOR.

OWNER OF U.S. REG. NO. 3,392,883.

CLASS 9—ELECTRICAL AND SCIENTIFIC APPARATUS

FOR COMPUTER SOFTWARE FOR DOWNLOADING GRAPHICS AND RING TONES TO MOBILE PHONES; COMPUTER SOFTWARE FOR RING TONE PRODUCTION; COMPUTER SOFTWARE FOR CONVERSION OF PRE-EXISTING AUDIO INTO CELLULAR RING TONES AND INSTRUCTION MANUALS SOLD AS A UNIT WITH EACH OF THE FOREGOING (U.S. CLS. 21, 23, 26, 36 AND 38).

CLASS 35—ADVERTISING AND BUSINESS

FOR ON-LINE RETAIL STORE SERVICES FEATURING DOWNLOADABLE PRE-RECORDED MUSIC AND VIDEO FOR USE PRIMARILY BY WIRELESS PHONE USERS (U.S. CLS. 100, 101 AND 102).

CLASS 38—COMMUNICATION

FOR WIRELESS ELECTRONIC TRANSMISSION OF GRAPHICS, ANIMATIONS, VIDEO AND AUDIO TO MOBILE COMMUNICATIONS DEVICES; STREAMING OF AUDIO AND VIDEO MATERIAL ON THE INTERNET, NAMELY, TRANSMITTING STREAMED MUSICAL SOUND RECORDINGS FOR CONSUMER PERSONAL USE VIA WIRELESS DEVICES AND THE GLOBAL COMPUTER NETWORK (U.S. CLS. 100, 101 AND 104).

REBECCA EISINGER, EXAMINING ATTORNEY

SN 77-411,190. HEARTS&MINDS LLC, DBA HEALTHY DELIGHT FOODS LLC, NAPERVILLE, IL. FILED 3-3-2008.

WINNING NEVER TASTED SO GOOD!

THE MARK CONSISTS OF STANDARD CHARACTERS WITHOUT CLAIM TO ANY PARTICULAR FONT, STYLE, SIZE, OR COLOR.

CLASS 29—MEATS AND PROCESSED FOODS

FOR PEANUT BUTTER (U.S. CL. 46).
FIRST USE 1-15-2008; IN COMMERCE 1-25-2008.

CLASS 30—STAPLE FOODS

FOR MAYONNAISE (U.S. CL. 46).
DEZMONA MIZELLE, EXAMINING ATTORNEY

SN 77-411,416. MENOPAUSIA EL MUSICAL, INC., WINTER PARK, FL. FILED 3-3-2008.

Pasaporte A Su Salud

THE MARK CONSISTS OF STANDARD CHARACTERS WITHOUT CLAIM TO ANY PARTICULAR FONT, STYLE, SIZE, OR COLOR.

THE FOREIGN WORDING IN THE MARK TRANSLATES INTO ENGLISH AS "PASSPORT TO YOUR HEALTH".

CLASS 16—PAPER GOODS AND PRINTED MATTER

FOR ADVERTISING BOARDS OF PAPER OR CARDBOARD; ADVERTISING PAMPHLETS; ADVERTISING SIGNS OF PAPER OR CARDBOARD; BROCHURES ABOUT HISPANIC HEALTH; INFORMATIONAL FLYERS FEATURING HISPANIC HEALTH TIPS; INFORMATIONAL SHEETS ABOUT HISPANIC HEALTH; LEAFLETS ABOUT HISPANIC HEALTH (U.S. CLS. 2, 5, 22, 23, 29, 37, 38 AND 50).

CLASS 25—CLOTHING

FOR LONG-SLEEVED SHIRTS; NIGHT SHIRTS; OPEN-NECKED SHIRTS; POLO SHIRTS; SHIRTS; SHORT-SLEEVED OR LONG-SLEEVED T-SHIRTS; SHORT-SLEEVED SHIRTS; SLEEP SHIRTS; T-SHIRTS; TEE SHIRTS (U.S. CLS. 22 AND 39).

DOMINICK J. SALEMI, EXAMINING ATTORNEY

SN 77-412,257. MONEY MANAGEMENT INTERNATIONAL, INC., HOUSTON, TX. FILED 3-4-2008.

IMPROVING LIVES THROUGH FINANCIAL EDUCATION

THE MARK CONSISTS OF STANDARD CHARACTERS WITHOUT CLAIM TO ANY PARTICULAR FONT, STYLE, SIZE, OR COLOR.

NO CLAIM IS MADE TO THE EXCLUSIVE RIGHT TO USE "FINANCIAL EDUCATION", APART FROM THE MARK AS SHOWN.

CLASS 36—INSURANCE AND FINANCIAL

FOR DEBT COUNSELING SERVICES; FINANCIAL MANAGEMENT, NAMELY, MONEY MANAGEMENT SERVICES; CREDIT CONSULTATION; FINANCIAL ANALYSIS AND CONSULTATION; DEBT MANAGEMENT CONSULTATION (U.S. CLS. 100, 101 AND 102).
FIRST USE 8-31-2007; IN COMMERCE 8-31-2007.

CLASS 41—EDUCATION AND ENTERTAINMENT

FOR EDUCATIONAL SERVICES, NAMELY, CONDUCTING CLASSES, COURSES, WORKSHOPS, AND SEMINARS IN THE FIELDS OF MONEY AND DEBT MANAGEMENT, CREDIT AND DEBT EDUCATION IN THE FIELDS OF BANKRUPTCY AND HOUSING (U.S. CLS. 100, 101 AND 107).

FIRST USE 8-31-2007; IN COMMERCE 8-31-2007.
CURTIS FRENCH, EXAMINING ATTORNEY

SN 77-412,276. FRONT ROW SYSTEMS, INC., MONROE, GA. FILED 3-4-2008.

Front Row

THE COLOR(S) RED IS/ARE CLAIMED AS A FEATURE OF THE MARK.

THE MARK CONSISTS OF A STYLIZED FORM OF THE WORDS "FRONT ROW" IN RED LETTERS.

CLASS 9—ELECTRICAL AND SCIENTIFIC APPARATUS

FOR TAX MANAGEMENT DATA COLLECTION SOFTWARE FOR CORPORATE TAX AND ACCOUNTING DEPARTMENTS (U.S. CLS. 21, 23, 26, 36 AND 38).
FIRST USE 6-1-1993; IN COMMERCE 6-1-1993.

CLASS 42—SCIENTIFIC AND COMPUTER SERVICES

FOR CONSULTING SERVICES IN THE FIELD OF COMPUTER-BASED INFORMATION SYSTEMS FOR BUSINESSES; COMPUTER SOFTWARE DESIGN, COMPUTER PROGRAMMING, OR MAINTENANCE OF COMPUTER SOFTWARE; ALL OF THE FORGOING FOR CORPORATE TAX AND ACCOUNTING DEPARTMENTS (U.S. CLS. 100 AND 101).

FIRST USE 6-1-1993; IN COMMERCE 6-1-1993.
G. MAYERSCHOFF, EXAMINING ATTORNEY

SN 77-412,302. JAQUA GIRLS, INC., CARPINTERIA, CA.
FILED 3-4-2008.

ALL DAMSEL, NO DISTRESS

THE MARK CONSISTS OF STANDARD CHARACTERS WITHOUT CLAIM TO ANY PARTICULAR FONT, STYLE, SIZE, OR COLOR.

CLASS 3—COSMETICS AND CLEANING PREPARATIONS

FOR BEAUTY PRODUCTS, NAMELY, BODY, FACIAL AND FOOT LOTIONS AND CREAMS, BODY GELS, SKIN EXFOLIATORS, BATH SOAKS, FACIAL AND BODY SOAPS, LIP GLOSS, SCENTED BODY SPRAYS, BODY BUTTER, AND KITS CONTAINING COMBINATIONS OF THE ABOVE SOLD AS A UNIT (U.S. CLS. 1, 4, 6, 50, 51 AND 52).

CLASS 18—LEATHER GOODS

FOR TOTE BAGS, OVERNIGHT BAGS, COSMETICS BAGS SOLD EMPTY, TRAVEL ACCESSORY BAGS SOLD EMPTY AND LUGGAGE (U.S. CLS. 1, 2, 3, 22 AND 41).

CLASS 25—CLOTHING

FOR T-SHIRTS, SLIPPERS, SOCKS, GLOVES, LOUNGEWEAR, PAJAMAS, HATS, ROBES, SCARVES (U.S. CLS. 22 AND 39).

CHARLES L. JENKINS, EXAMINING ATTORNEY

SN 77-412,463. CAFE ICEBERRY CO., LTD., SEOUL, REPUBLIC OF KOREA, FILED 3-4-2008.

COOL & WARM

THE MARK CONSISTS OF STANDARD CHARACTERS WITHOUT CLAIM TO ANY PARTICULAR FONT, STYLE, SIZE, OR COLOR.

CLASS 30—STAPLE FOODS

FOR BAKERY PRODUCTS, NAMELY, CAKES, PIES, PASTRIES, BUNS AND BREAD, CONFECTIONS, NAMELY, COCOA-BASED INGREDIENT IN CONFECTIONERY PRODUCTS, CONFECTIONERY CHIPS FOR BAKING, FROZEN YOGURT CONFECTIONERY ICES, FRUIT JELLIES CANDY, CHOCOLATE, SWEETMEATS AND PUDDINGS; FROZEN CONFECTIONS, NAMELY, ICE, FROZEN CAKES, FROZEN CANDY, AND ICE CREAM; NON-ALCOHOLIC BEVERAGES, NAMELY, COFFEE, TEA, COFFEE BASED BEVERAGES, TEA BASED BEVERAGES, ICE WATER BASED BEVERAGES, AND FLAVORINGS FOR THE AFORESAID BEVERAGES (U.S. CL. 46).

CLASS 35—ADVERTISING AND BUSINESS

FOR RESTAURANT FRANCHISING SERVICES; RETAIL BAKERY SHOPS (U.S. CLS. 100, 101 AND 102).

CLASS 42—SCIENTIFIC AND COMPUTER SERVICES

FOR CONSULTATION SERVICES IN THE FIELD OF FOOD TECHNOLOGY; FOOD SAFETY TESTING AND CONSULTATION; PROVIDING QUALITY CONTROL SERVICES FOR THE FOOD HYGIENE INDUSTRY; QUALITY CONTROL FOR OTHERS, NAMELY, PROVIDING INFORMATION WITH RESPECT TO QUALITY CONTROL OF FOOD HYGIENE FOR THE FOOD INDUSTRY (U.S. CLS. 100 AND 101).

CLASS 43—HOTEL AND RESTAURANT SERVICES

FOR CAFE, SNACK BAR, CAFETERIA AND RESTAURANT SERVICES; CATERING SERVICES, CONSULTING SERVICES IN THE FIELD OF HOSPITALITY (U.S. CLS. 100 AND 101).

RON FAIRBANKS, EXAMINING ATTORNEY

SN 77-412,513. NEBRASKA METHODIST HEALTH SYSTEM, INC., OMAHA, NE. FILED 3-4-2008.

Access Best Care

THE MARK CONSISTS OF STANDARD CHARACTERS WITHOUT CLAIM TO ANY PARTICULAR FONT, STYLE, SIZE, OR COLOR.

NO CLAIM IS MADE TO THE EXCLUSIVE RIGHT TO USE "BEST CARE", APART FROM THE MARK AS SHOWN.

CLASS 35—ADVERTISING AND BUSINESS

FOR ADMINISTRATION OF A PROGRAM FOR ENABLING PARTICIPANTS TO OBTAIN DISCOUNTS ON GOODS AND SERVICES THROUGH USE OF A DISCOUNT MEMBERSHIP CARD AND MEDICAL BILLING SUPPORT SERVICES, NAMELY, PROVIDING ASSISTANCE WITH MANAGEMENT AND RESOLUTION OF MEDICAL BILLING QUESTIONS (U.S. CLS. 100, 101 AND 102).

FIRST USE 1-7-2008; IN COMMERCE 1-7-2008.

CLASS 41—EDUCATION AND ENTERTAINMENT

FOR PROVIDING AN ONLINE MAGAZINE WITH INFORMATIONAL HEALTH ARTICLES AND ARRANGING AND CONDUCTING CLASSES AND SEMINARS COVERING HEALTH AND LIFESTYLE IMPROVEMENT RELATED SUBJECTS (U.S. CLS. 100, 101 AND 107).

FIRST USE 1-7-2008; IN COMMERCE 1-7-2008.
MARK SPARACINO, EXAMINING ATTORNEY

CLASS 41—EDUCATION AND ENTERTAINMENT

FOR EDUCATIONAL SERVICES FOR SALES AND MARKETING PROFESSIONALS IN THE NATURE OF CONFERENCES, SEMINARS, LECTURES, AND CLASSES IN THE FIELDS OF SALES AND MARKETING (U.S. CLS. 100, 101 AND 107).

FIRST USE 9-15-2002; IN COMMERCE 9-15-2002.
STEPHEN AQUILA, EXAMINING ATTORNEY

SN 77-412,886. GOT POWER, INC., MARTINEZ, CA. FILED 3-4-2008.



THE MARK CONSISTS OF THE STYLIZED LETTERS AND WORD "CD & POWER". A ZIG ZAG IS LOCATED BETWEEN THE LETTER "C" AND "D".

CLASS 35—ADVERTISING AND BUSINESS

FOR (BASED ON USE IN COMMERCE) RETAIL STORES FEATURING ELECTRIC POWER GENERATORS; WHOLESALE STORES FEATURING ELECTRIC POWER GENERATORS (BASED ON INTENT TO USE) ON-LINE RETAIL STORE SERVICES FEATURING ELECTRIC POWER GENERATORS (U.S. CLS. 100, 101 AND 102).

FIRST USE 2-15-2007; IN COMMERCE 2-15-2007.

CLASS 37—CONSTRUCTION AND REPAIR

FOR INSTALLATION OF ELECTRIC POWER GENERATORS; MAINTENANCE AND/OR REPAIR OF ELECTRIC POWER GENERATORS AND DIESEL ENGINES (U.S. CLS. 100, 103 AND 106).

FIRST USE 2-15-2007; IN COMMERCE 2-15-2007.
ANNE FARRELL, EXAMINING ATTORNEY

SN 77-414,419. SALES AND MARKETING EXECUTIVES INTERNATIONAL, INC., SUMAS, WA. FILED 3-6-2008.



THE MARK CONSISTS OF THREE INTERSECTING CRESCENTS, A DOT AND THE LETTERS "SMEI".

CLASS 35—ADVERTISING AND BUSINESS

FOR PROMOTING THE INTERESTS AND CONCERNS OF SALES AND MARKETING PROFESSIONALS (U.S. CLS. 100, 101 AND 102).

FIRST USE 9-15-2002; IN COMMERCE 9-15-2002.

SN 77-414,600. AMERICAN RESIDENTIAL SERVICES, LLC, MEMPHIS, TN. FILED 3-6-2008.



OWNER OF U.S. REG. NOS. 2,120,965, 3,135,942 AND OTHERS.

THE COLOR(S) RED, WHITE AND BLUE IS/ARE CLAIMED AS A FEATURE OF THE MARK.

THE MARK CONSISTS OF THE LETTERS "ARS" IN WHITE INSIDE A RECTANGULAR BLUE BOX WITH A RED STAR IN THE UPPER RIGHT CORNER OF THE BOX.

CLASS 36—INSURANCE AND FINANCIAL

FOR PROVIDING EXTENDED WARRANTIES AND EXTENDED PREPAID SERVICE CONTRACTS IN CONNECTION WITH AIR CONDITIONING AND HEATING EQUIPMENT, PLUMBING AND ELECTRICAL SYSTEMS AND APPLIANCES (U.S. CLS. 100, 101 AND 102).

CLASS 37—CONSTRUCTION AND REPAIR

FOR INSTALLATION, MAINTENANCE, REPAIR AND REPLACEMENT OF AIR CONDITIONING AND HEATING EQUIPMENT, PLUMBING AND ELECTRICAL SYSTEMS, AND APPLIANCES (U.S. CLS. 100, 103 AND 106).

CLASS 42—SCIENTIFIC AND COMPUTER SERVICES

FOR WATER QUALITY CONTROL SERVICES; ENVIRONMENTAL SERVICES, NAMELY, AIR QUALITY CONSULTING (U.S. CLS. 100 AND 101).

PATRICIA EVANKO, EXAMINING ATTORNEY

SN 77-414,640. AMERICAN RESIDENTIAL SERVICES, LLC,
MEMPHIS, TN. FILED 3-6-2008.



OWNER OF U.S. REG. NOS. 1,053,076, 2,139,085 AND OTHERS.

NO CLAIM IS MADE TO THE EXCLUSIVE RIGHT TO USE "ROOTER", APART FROM THE MARK AS SHOWN.

THE COLOR(S) RED, WHITE AND BLUE IS/ARE CLAIMED AS A FEATURE OF THE MARK.

THE MARK CONSISTS OF THE LETTERS "ARS" IN WHITE INSIDE A BLUE RECTANGULAR BOX TO THE LEFT OF A RED RECTANGULAR BOX CONTAINING THE WORDS "RESCUE ROOTER" IN WHITE WITH A RED STAR IN THE CENTER SEPARATING THE TWO BOXES.

CLASS 36—INSURANCE AND FINANCIAL

FOR PROVIDING EXTENDED WARRANTIES AND EXTENDED PREPAID SERVICE CONTRACTS IN CONNECTION WITH AIR CONDITIONING AND HEATING EQUIPMENT, PLUMBING AND ELECTRICAL SYSTEMS AND APPLIANCES (U.S. CLS. 100, 101 AND 102).

CLASS 37—CONSTRUCTION AND REPAIR

FOR INSTALLATION, MAINTENANCE, REPAIR AND REPLACEMENT OF AIR CONDITIONING AND HEATING EQUIPMENT, PLUMBING AND ELECTRICAL SYSTEMS AND APPLIANCES; PLUMBING REPAIR, SEWER AND DRAIN CLEANING SERVICES (U.S. CLS. 100, 103 AND 106).

CLASS 42—SCIENTIFIC AND COMPUTER SERVICES

FOR WATER QUALITY CONTROL SERVICES; ENVIRONMENTAL SERVICES, NAMELY, AIR QUALITY CONSULTING (U.S. CLS. 100 AND 101).

PATRICIA EVANKO, EXAMINING ATTORNEY

SN 77-414,960. VERACITY WORLDWIDE LLC, NEW YORK, NY. FILED 3-6-2008.



NO CLAIM IS MADE TO THE EXCLUSIVE RIGHT TO USE "WORLDWIDE" AND "GLOBAL MARKET INTELLIGENCE", APART FROM THE MARK AS SHOWN.

THE MARK CONSISTS OF STYLIZED IMAGE OF A SEXTANT BETWEEN THE WORDS "VERACITY" AND "WORLDWIDE".

CLASS 35—ADVERTISING AND BUSINESS

FOR BUSINESS INVESTIGATIONS; BUSINESS RISK MANAGEMENT CONSULTATION (U.S. CLS. 100, 101 AND 102).

FIRST USE 2-1-2007; IN COMMERCE 4-1-2007.

CLASS 36—INSURANCE AND FINANCIAL

FOR FINANCIAL DUE DILIGENCE (U.S. CLS. 100, 101 AND 102).

FIRST USE 2-1-2007; IN COMMERCE 4-1-2007.

JAY FLOWERS, EXAMINING ATTORNEY

SN 77-415,090. RED-WHITE VALVE CORP., LAKE FOREST, CA. FILED 3-6-2008.

RWVC

THE MARK CONSISTS OF STANDARD CHARACTERS WITHOUT CLAIM TO ANY PARTICULAR FONT, STYLE, SIZE, OR COLOR.

OWNER OF U.S. REG. NOS. 1,769,093 AND 2,044,058.

CLASS 6—METAL GOODS

FOR MANUALLY-OPERATED METAL VALVES FOR FLUID CONTROL (U.S. CLS. 2, 12, 13, 14, 23, 25 AND 50).

CLASS 11—ENVIRONMENTAL CONTROL APPARATUS

FOR PLUMBING FITTINGS, NAMELY, FLUID CONTROL VALVES FOR SHOWERS AND TUBS (U.S. CLS. 13, 21, 23, 31 AND 34).

KATHERINE M. DUBRAY, EXAMINING ATTORNEY

SN 77-415,280. TRI TOOL INC., RANCHO CORDOVA, CA. FILED 3-6-2008.

DualArc

THE MARK CONSISTS OF STANDARD CHARACTERS WITHOUT CLAIM TO ANY PARTICULAR FONT, STYLE, SIZE, OR COLOR.

CLASS 7—MACHINERY

FOR WELD HEADS, EACH COMPRISING A CARRIAGE ASSEMBLY, A TORCH ASSEMBLY, CABLES, WIRES, ELECTRIC MOTORS, AND GEARING MECHANISMS; WELD HEADS AS COMPONENTS OF WELDING MACHINES; ELECTRIC ARC WELDING MACHINES, ELECTRIC WELDING MACHINES, GAS-OPERATED WELDING MACHINES, LASER WELDING MACHINES, COMPUTER CONTROLLED GAS WELDING MACHINES; COMPUTER CONTROLLED ELECTRIC ARC WELDING MACHINES; WELD HEADS, EACH COMPRISING A CARRIAGE ASSEMBLY, CABLES, WIRES, ELECTRIC MOTORS, GEARING MECHANISMS, PRINTED CIRCUIT ASSEMBLIES, WELD HEADS FOR GTAW (GAS TUNGSTEN ARC WELDING) AND FOR GMAW (GAS METAL ARC WELDING), AND REPLACEMENT STRUCTURAL PARTS FOR THE FOREGOING (U.S. CLS. 13, 19, 21, 23, 31, 34 AND 35).

CLASS 9—ELECTRICAL AND SCIENTIFIC APPARATUS

FOR ELECTRIC ARC WELDERS; ELECTRONIC CONTROLLERS AND COMPUTER SOFTWARE FOR WELDING APPARATUS, AND REPLACEMENT PARTS FOR THE FOREGOING, NAMELY, CABLE HARNESSSES, POWER SUPPLIES, COOLING FANS, KEYBOARDS, LIQUID CRYSTAL DISPLAYS (LCDS), CONTROL BUTTONS, CONTROL SWITCHES, AND PRINTED CIRCUIT BOARDS, NAMELY, AUTOMATIC VOLTAGE CONTROL (AVC) PRINTED CIRCUIT BOARDS, BACK PLANE PRINTED CIRCUIT BOARDS, HOST INPUT/OUTPUT (I/O) PRINTED CIRCUIT BOARDS, WELD POWER CURRENT PRINTED CIRCUIT BOARDS, OSCILLATION/STEERING PRINTED CIRCUIT BOARDS, SINGLE BOARD COMPUTER (SBC) PRINTED CIRCUIT BOARDS, AND TRAVEL AND WIRE FILLER PRINTED CIRCUIT BOARDS (U.S. CLS. 21, 23, 26, 36 AND 38).

FLORENTINA BLANDU, EXAMINING ATTORNEY

SN 77-416,372. NWT NEW WORLD ARTS, INC., DBA NEW WORLD TRADING, CATHEDRAL CITY, CA. FILED 3-7-2008.

NEW WORLD TRADING

THE MARK CONSISTS OF STANDARD CHARACTERS WITHOUT CLAIM TO ANY PARTICULAR FONT, STYLE, SIZE, OR COLOR.

NO CLAIM IS MADE TO THE EXCLUSIVE RIGHT TO USE "TRADING", APART FROM THE MARK AS SHOWN.

CLASS 35—ADVERTISING AND BUSINESS

FOR WHOLESALE STORE SERVICES, WHOLESALE DISTRIBUTORSHIP SERVICES, AND ON-LINE RETAIL AND WHOLESALE STORE SERVICES FEATURING FURNITURE, MIRRORS, PICTURE FRAMES, WASTEBASKETS, HAND-TOOLED LEATHER FURNITURE, FURNITURE CHESTS, FURNITURE MADE FROM WOOD, DECORATIVE PLATES, HAND-TOOLED LEATHER LIGHTING FIXTURES, PILLOWS, SERVING TRAYS, KEY HOLDERS, COASTERS, STORAGE BOXES, PICTURE FRAMES, TRUNKS, TISSUE HOLDERS, WINE HOLDERS (U.S. CLS. 100, 101 AND 102).

FIRST USE 2-0-1997; IN COMMERCE 2-0-1997.

CLASS 40—MATERIAL TREATMENT

FOR CUSTOM MANUFACTURE OF FURNITURE, MIRRORS, PICTURE FRAMES, WASTEBASKETS, HAND-TOOLED LEATHER FURNITURE, FURNITURE CHESTS, FURNITURE MADE FROM WOOD, DECORATIVE PLATES, HAND-TOOLED LEATHER LIGHTING FIXTURES, PILLOWS, SERVING TRAYS, KEY HOLDERS, COASTERS, STORAGE BOXES, PICTURE FRAMES, TRUNKS, TISSUE HOLDERS, WINE HOLDERS (U.S. CLS. 100, 103 AND 106).

FIRST USE 8-0-1997; IN COMMERCE 8-0-1997.

SHANNON TWOHIG, EXAMINING ATTORNEY

SN 77-415,932. LIGHTHOUSE MARKETING INC., IRVINE, CA. FILED 3-7-2008.



THE COLOR(S) BLUE, BLACK, WHITE, RED AND GRAY IS/ARE CLAIMED AS A FEATURE OF THE MARK.

THE MARK HAS BLUE COLOR AND BLACK COLOR AS THE BACKGROUND. THE BLUE COLOR IS ON TOP OF THE BLACK COLOR. THE COLOR OF THE WORD "SOUND" IS WHITE AND LOCATED ON THE BLUE BACKGROUND; THE COLOR OF WORD "CHARGE" IS RED AND LOCATED ON THE BLACK BACKGROUND; THE COLOR OF WORD "AND" IS GRAY AND LOCATED RIGHT BETWEEN THE WORD "SOUND" AND THE WORD "CHARGE" SHARING THE BLUE AND BLACK BACKGROUND.

CLASS 9—ELECTRICAL AND SCIENTIFIC APPARATUS

FOR CONSUMER ELECTRONIC PRODUCTS, NAMELY, AUDIO AMPLIFIERS, AUDIO SPEAKERS, AUDIO RECEIVERS, ELECTRICAL AUDIO AND SPEAKER CABLES AND CONNECTORS, HOME THEATER SYSTEMS, AUDIO DECODERS, VIDEO DECODERS, SPEAKERS, POWER CONVERSION DEVICES, POWER CONVERTERS, AND POWER INVERTERS; BATTERY CHARGE DEVICES; HEADSETS FOR TELEPHONES; HEADSETS FOR USE WITH COMPUTERS (U.S. CLS. 21, 23, 26, 36 AND 38).

CLASS 16—PAPER GOODS AND PRINTED MATTER

FOR HOLDERS FOR DESK ACCESSORIES (U.S. CLS. 2, 5, 22, 23, 29, 37, 38 AND 50).

DAVID MILLER, EXAMINING ATTORNEY

SN 77-416,872. SERENITY CHANNEL LLC, BATTLE CREEK, MI. FILED 3-8-2008.

Serenity Channel

THE MARK CONSISTS OF STANDARD CHARACTERS WITHOUT CLAIM TO ANY PARTICULAR FONT, STYLE, SIZE, OR COLOR.

NO CLAIM IS MADE TO THE EXCLUSIVE RIGHT TO USE "CHANNEL", APART FROM THE MARK AS SHOWN.

CLASS 38—COMMUNICATION

FOR BROADCASTING PROGRAMS VIA A GLOBAL COMPUTER NETWORK; CABLE RADIO BROADCASTING; CABLE TELEVISION BROADCASTING; PODCASTING SERVICES; PROVIDING ON-LINE CHAT ROOMS AND ELECTRONIC BULLETIN BOARDS FOR TRANSMISSION OF MESSAGES AMONG USERS IN THE FIELD OF GENERAL INTEREST; SATELLITE TELEVISION BROADCASTING; SATELLITE, CABLE, NETWORK TRANSMISSION OF SOUNDS, IMAGES, SIGNALS AND DATA; STREAMING OF AUDIO MATERIAL ON THE INTERNET; STREAMING OF VIDEO MATERIAL ON THE INTERNET; VIDEO BROADCASTING; VIDEO-ON-DEMAND TRANSMISSION SERVICES; WEBCASTING SERVICES; TELEVISION AND RADIO BROADCASTING SERVICES (U.S. CLS. 100, 101 AND 104).

FIRST USE 10-12-2007; IN COMMERCE 3-7-2008.

CLASS 41—EDUCATION AND ENTERTAINMENT

FOR ENTERTAINMENT SERVICES, NAMELY, PRODUCTION OF TELEVISION SHOWS; ENTERTAINMENT SERVICES, NAMELY, PROVIDING TELEVISION PROGRAMS IN THE FIELD OF SCENES FROM NATURE VIA A GLOBAL COMPUTER NETWORK; PRODUCTION OF RADIO OR TELEVISION PROGRAMS; ENTERTAINMENT IN THE NATURE OF ON-GOING TELEVISION PROGRAMS FEATURING NATURE SCENES BROADCAST OVER TELEVISION, SATELLITE, AUDIO, AND VIDEO MEDIA (U.S. CLS. 100, 101 AND 107).

FIRST USE 10-12-2007; IN COMMERCE 3-7-2008.
DAVID MURRAY, EXAMINING ATTORNEY

SN 77-417,629. CAJUN FUNDING CORPORATION, ATLANTA, GA. FILED 3-10-2008.

CHURCH'S

THE MARK CONSISTS OF STANDARD CHARACTERS WITHOUT CLAIM TO ANY PARTICULAR FONT, STYLE, SIZE, OR COLOR.

OWNER OF U.S. REG. NOS. 815,076, 2,721,849 AND OTHERS.

CLASS 29—MEATS AND PROCESSED FOODS

FOR PREPARED MEALS CONSISTING PRIMARILY OF CHICKEN FOR CONSUMPTION ON OR OFF THE PREMISES (U.S. CL. 46).

FIRST USE 0-0-1952; IN COMMERCE 0-0-1952.

CLASS 43—HOTEL AND RESTAURANT SERVICES

FOR RESTAURANT SERVICES (U.S. CLS. 100 AND 101).

FIRST USE 0-0-1952; IN COMMERCE 0-0-1952.
BARBARA GAYNOR, EXAMINING ATTORNEY

SN 77-417,559. BEST IN SHOW PET RESORT, GARDEN CITY, NY. FILED 3-10-2008.



NO CLAIM IS MADE TO THE EXCLUSIVE RIGHT TO USE "PET RESORT", APART FROM THE MARK AS SHOWN.

CLASS 43—HOTEL AND RESTAURANT SERVICES

FOR PET BOARDING SERVICES; PET DAY CARE SERVICES (U.S. CLS. 100 AND 101).

CLASS 44—MEDICAL, BEAUTY AND AGRICULTURAL SERVICES

FOR ANIMAL GROOMING; VETERINARY SERVICES (U.S. CLS. 100 AND 101).
BRIAN CALLAGHAN, EXAMINING ATTORNEY

SN 77-417,785. LOUNGE22, GLENDALE, CA. FILED 3-10-2008.

1123

THE MARK CONSISTS OF STANDARD CHARACTERS WITHOUT CLAIM TO ANY PARTICULAR FONT, STYLE, SIZE, OR COLOR.

CLASS 35—ADVERTISING AND BUSINESS

FOR DESIGN AND DEVELOPMENT OF INTERACTIVE WEB CONTENT, NAMELY, DESIGN OF INTERNET ADVERTISING FOR OTHERS; ADVERTISING SERVICES, NAMELY, CREATING CORPORATE AND BRAND IDENTITY FOR OTHERS; CONCEPT AND BRAND DEVELOPMENT IN THE FIELD OF AUTOMOTIVES, MANUFACTURING, RESTAURANTS, RETAIL, AND HIGH TECHNOLOGY COMPANIES; DESIGN OF ADVERTISING MATERIAL FOR OTHERS; ADVICE IN THE FIELD OF BUSINESS MANAGEMENT AND MARKETING; BUSINESS CONSULTATION AND MANAGEMENT REGARDING MARKETING ACTIVITIES AND LAUNCHING OF NEW PRODUCTS; CREATING MARKETING DESIGN SERVICES; DEVELOPMENT OF MARKETING STRATEGIES AND CONCEPTS; BUSINESS MANAGEMENT CONSULTING WITH RELATION TO STRATEGY, MARKETING, PRODUCTION, PERSONNEL AND RETAIL SALES MATTERS; AND MARKETING CONSULTING, PROMOTION AND MARKETING SERVICES AND RELATED CONSULTING (U.S. CLS. 100, 101 AND 102).

CLASS 42—SCIENTIFIC AND COMPUTER SERVICES

FOR DESIGN AND DEVELOPMENT OF MULTIMEDIA PRODUCTS; DESIGN OF MULTIMEDIA GRAPHICS FOR OTHERS, FOR USE IN DIGITAL MEDIA SHOWS, INTERACTIVE WEB CONTENT, CONVENTIONS, PRODUCT LAUNCHES, TRADE SHOWS, KEY NOTE ADDRESSES, AND AWARD CEREMONIES (U.S. CLS. 100 AND 101).

JORDAN BAKER, EXAMINING ATTORNEY

SN 77-417,803. WIJESIRIWARDANA, RAVINDRA, BENTONVILLE, AR. FILED 3-10-2008.

**CLASS 9—ELECTRICAL AND SCIENTIFIC APPARATUS**

FOR ACCELERATION SENSORS; AN OPTICAL METROLOGY INSPECTION SYSTEM COMPRISED OF A LIGHT SOURCE, ONE OR MORE CAMERAS AND SENSORS IN COMMUNICATION WITH COMPUTER SOFTWARE AND HARDWARE; AVIONIC SENSOR SYSTEMS, NAMELY, AIRCRAFT AIRSPEED SENSORS; AVIONIC SENSOR SYSTEMS, NAMELY, AIRCRAFT ALTITUDE INDICATORS; AVIONIC SENSOR SYSTEMS, NAMELY, NAVIGATION SYSTEMS; CAMERA CONTAINING A LINEAR IMAGE SENSOR; ELECTRIC OR ELECTRONIC SENSORS FOR ENVIRONMENTAL INFORMATION MONITORING; ELECTRIC, ELECTRONIC, OR ELECTROCHEMICAL OXYGEN MONITORS AND SENSORS FOR ENVIRONMENTAL USE; ELECTRONIC DATA RELAYS FOR SENSORS; ELECTRONIC MAGNETOSTRICTIVE EQUIPMENT, NAMELY, A WAVE GENERATOR, WAVE SENSOR AND WAVE ANALYZER; ELECTRONIC MOTOR VEHICLE IGNITION TUNING KITS COMPRISED OF AN ELECTRONIC CONTROL UNIT THAT MONITORS ENGINE PERFORMANCES AND DELIVERS RE-CALCULATED SENSOR VALUES TO THE ORIGINAL ENGINE CONTROL UNIT TO INCREASE ENGINE PERFORMANCE; ELECTRONIC PLANT MOISTURE SENSOR; ELECTRONIC PROXIMITY SENSORS AND SWITCHES; ELECTRONICAL SENSORS FOR MEASURING SOLAR RADIATION; ENVIRONMENTAL MONITORING SYSTEM COMPRISED OF METERS AND SENSORS THAT MEASURE PRESSURE, HUMIDITY, TEMPERATURE AND INCLUDES ALARM AND REPORTING FUNCTIONS; GAS SENSORS FOR MEASURING GAS CONCENTRATION; HANDHELD DEVICE COMPRISED OF CHEMICAL AND HEAT SENSORS FOR THE DETECTION OF EXPLOSIVES; LEAK DETECTING DEVICE FOR WATER SUPPLIED HOME APPLIANCES CONSISTING OF WATER SENSOR, CONTROL UNIT WITH AUDIBLE ALARM AND WATER VALVES; LIQUID LEVEL SENSORS; OIL LEVEL SENSORS; POLLUTANT SENSORS; PRESSURE SENSORS; PROXIMITY SENSORS; SAFETY SENSORS, NAMELY, CARBON MONOXIDE DETECTORS, SMOKE DETECTORS, AND COMBINATION CARBON MONOXIDE AND SMOKE DETECTORS; SENSOR ACTIVATED FIRE EXTINGUISHER FOR USE IN CLOTHING DRYERS; SENSOR CARDS FOR DATA ACQUISITION; SENSOR CHIPS FOR SCIENTIFIC USE; SENSORS AND DETECTOR UNITS FOR USE IN CONTROLLING THE ACTUATION

AND OPERATION OF AUTOMOTIVE SAFETY APPARATUS AND EQUIPMENT; SENSORS FOR THE DETERMINATION OF TEMPERATURES, POSITIONS AND DISTANCES; TELECOMMUNICATIONS HARDWARE AND SOFTWARE FOR MONITORING AND ALERTING REMOTE SENSOR STATUS VIA THE INTERNET; TEMPERATURE SENSORS; TEMPERATURE SENSORS USED IN THE MEDICAL FIELD TO MEASURE TEMPERATURE OF MEDICAL SOLUTIONS; TIMING SENSORS; ULTRASONIC SENSORS; VEHICLE MOUNTED GPS SENSOR FOR DETERMINING THE RATE OF MOTION FOR A VEHICLE; VEHICLE SAFETY EQUIPMENT, NAMELY, BACK-UP SENSORS AND CAMERAS; VIBRATION SENSORS FOR INSTALLATION IN WIND MILL HOUSINGS (U.S. CLS. 21, 23, 26, 36 AND 38).

CLASS 10—MEDICAL APPARATUS

FOR ALARMS AND SENSORS TO BE WORN ON A PERSON WHILE EXERCISING FOR THE PURPOSE OF MONITORING HEART RATE; DIGITAL SENSOR USED FOR TAKING DIGITAL DENTAL RADIOGRAPHS; ELECTROCHEMICAL SENSORS FOR DETERMINATION OF ANALYTE CONCENTRATIONS IN FLUIDS FOR MEDICAL PURPOSES; HEALTH MONITORS COMPRISING SENSOR THAT MONITOR THE HEALTH OF THE ELDERLY OR HANDICAPPED IN THEIR OWN HOMES; MEDICAL PRODUCTS, NAMELY, BIOFEEDBACK SENSORS; PATIENT MONITORING SENSORS AND ALARMS; ELECTRIC OR ELECTRONIC SENSORS FOR MONITORING PATIENT PHYSIOLOGICAL INFORMATION (U.S. CLS. 26, 39 AND 44).

EVELYN BRADLEY, EXAMINING ATTORNEY

SN 77-417,817. LOUNGE 22, GLENDALE, CA. FILED 3-10-2008.

ELEVEN23

THE MARK CONSISTS OF STANDARD CHARACTERS WITHOUT CLAIM TO ANY PARTICULAR FONT, STYLE, SIZE, OR COLOR.

CLASS 35—ADVERTISING AND BUSINESS

FOR DESIGN AND DEVELOPMENT OF INTERACTIVE WEB CONTENT, NAMELY, DESIGN OF INTERNET ADVERTISING FOR OTHERS; ADVERTISING SERVICES, NAMELY, CREATING CORPORATE AND BRAND IDENTITY FOR OTHERS; CONCEPT AND BRAND DEVELOPMENT IN THE FIELD OF AUTOMOTIVES, MANUFACTURING, RESTAURANTS, RETAIL, AND HIGH TECHNOLOGY COMPANIES; DESIGN OF ADVERTISING MATERIAL FOR OTHERS; ADVICE IN THE FIELD OF BUSINESS MANAGEMENT AND MARKETING; BUSINESS CONSULTATION AND MANAGEMENT REGARDING MARKETING ACTIVITIES AND LAUNCHING OF NEW PRODUCTS; CREATING MARKETING DESIGN SERVICES; DEVELOPMENT OF MARKETING STRATEGIES AND CONCEPTS; BUSINESS MANAGEMENT CONSULTING WITH RELATION TO STRATEGY, MARKETING, PRODUCTION, PERSONNEL AND RETAIL SALES MATTERS; AND MARKETING CONSULTING, PROMOTION AND MARKETING SERVICES AND RELATED CONSULTING (U.S. CLS. 100, 101 AND 102).

CLASS 42—SCIENTIFIC AND COMPUTER SERVICES

FOR DESIGN AND DEVELOPMENT OF MULTIMEDIA PRODUCTS; DESIGN OF MULTIMEDIA GRAPHICS FOR OTHERS, FOR USE IN DIGITAL MEDIA SHOWS, INTERACTIVE WEB CONTENT, CONVENTIONS, PRODUCT LAUNCHES, TRADE SHOWS, KEY NOTE ADDRESSES, AND AWARD CEREMONIES (U.S. CLS. 100 AND 101).

JORDAN BAKER, EXAMINING ATTORNEY

SN 77-418,468. CAJUN FUNDING CORPORATION, ATLANTA, GA. FILED 3-11-2008.

CHURCH'S CHICKEN

THE MARK CONSISTS OF STANDARD CHARACTERS WITHOUT CLAIM TO ANY PARTICULAR FONT, STYLE, SIZE, OR COLOR.

OWNER OF U.S. REG. NOS. 815,076, 2,721,849 AND OTHERS.

NO CLAIM IS MADE TO THE EXCLUSIVE RIGHT TO USE "CHICKEN", APART FROM THE MARK AS SHOWN.

CLASS 29—MEATS AND PROCESSED FOODS

FOR PREPARED MEALS CONSISTING PRIMARILY OF CHICKEN FOR CONSUMPTION ON OR OFF THE PREMISES (U.S. CL. 46).

FIRST USE 0-0-1952; IN COMMERCE 0-0-1952.

CLASS 43—HOTEL AND RESTAURANT SERVICES

FOR RESTAURANT SERVICES (U.S. CLS. 100 AND 101).

FIRST USE 0-0-1952; IN COMMERCE 0-0-1952.

BARBARA GAYNOR, EXAMINING ATTORNEY

SN 77-419,130. FRANKLIN COVEY CO., SALT LAKE CITY, UT. FILED 3-11-2008.

THE LEADER IN ME

THE MARK CONSISTS OF STANDARD CHARACTERS WITHOUT CLAIM TO ANY PARTICULAR FONT, STYLE, SIZE, OR COLOR.

CLASS 9—ELECTRICAL AND SCIENTIFIC APPARATUS

FOR PRE-RECORDED ELECTRONIC MEDIA FEATURING INFORMATION AND SELF-PACED TRAINING PROGRAMS IN THE FIELDS OF TIME MANAGEMENT, LEADERSHIP, COMMUNICATION AND PERSONAL DEVELOPMENT (U.S. CLS. 21, 23, 26, 36 AND 38).

CLASS 16—PAPER GOODS AND PRINTED MATTER

FOR PRINTED MATERIALS, NAMELY, MANUALS, REFERENCE GUIDES AND PAMPHLETS IN THE FIELDS OF TIME MANAGEMENT, LEADERSHIP, COMMUNICATION AND PERSONAL DEVELOPMENT; PROJECT PLANNERS, TIME PLANNERS, CALENDARS, PERSONAL ORGANIZERS, BINDERS, NOTEBOOKS, POUCHES FOR PRINTED MATERIALS FOR STORAGE OF BUSINESS AND PERSONAL RECORD DOCUMENTS (U.S. CLS. 2, 5, 22, 23, 29, 37, 38 AND 50).

CLASS 41—EDUCATION AND ENTERTAINMENT

FOR EDUCATIONAL SERVICES, NAMELY, CONDUCTING SEMINARS, WORKSHOPS, LECTURES AND CLASSES IN THE FIELDS OF TIME MANAGEMENT, LEADERSHIP, COMMUNICATION AND PERSONAL DEVELOPMENT, AND DISTRIBUTION OF COURSE MATERIALS IN CONNECTION THEREWITH (U.S. CLS. 100, 101 AND 107).

HANNO RITTNER, EXAMINING ATTORNEY

SN 77-419,369. OLIVER, TYLER, DERRY, NH. FILED 3-11-2008.

voice of vision

THE MARK CONSISTS OF STANDARD CHARACTERS WITHOUT CLAIM TO ANY PARTICULAR FONT, STYLE, SIZE, OR COLOR.

CLASS 9—ELECTRICAL AND SCIENTIFIC APPARATUS

FOR PRERECORDED CD'S, MP3'S AND DVD'S FEATURING MUSIC AND MUSICAL VIDEOS (U.S. CLS. 21, 23, 26, 36 AND 38).

FIRST USE 10-25-2004; IN COMMERCE 9-1-2005.

CLASS 41—EDUCATION AND ENTERTAINMENT

FOR ENTERTAINMENT, NAMELY, LIVE AUDIO AND VISUAL PERFORMANCE BY A MUSICAL GROUP; A WEB SITE FEATURING MUSICAL PERFORMANCES, MUSICAL VIDEOS, RELATED FILM CLIPS, PHOTOGRAPHS, AND OTHER MULTIMEDIA MATERIALS (U.S. CLS. 100, 101 AND 107).

FIRST USE 10-25-2004; IN COMMERCE 9-1-2005.

LINDA M. KING, EXAMINING ATTORNEY

SN 77-419,644. THE ENTERPRISE STRATEGY GROUP, INC., MILFORD, MA. FILED 3-12-2008.

STRATEGY LIFECYCLE

THE MARK CONSISTS OF STANDARD CHARACTERS WITHOUT CLAIM TO ANY PARTICULAR FONT, STYLE, SIZE, OR COLOR.

CLASS 35—ADVERTISING AND BUSINESS

FOR BUSINESS CONSULTING SERVICES IN THE FIELD OF INFORMATION TECHNOLOGY (U.S. CLS. 100, 101 AND 102).

CLASS 42—SCIENTIFIC AND COMPUTER SERVICES

FOR CONSULTING SERVICES IN THE FIELDS OF INFORMATION TECHNOLOGY, INFORMATION SECURITY AND INFORMATION STORAGE MANAGEMENT AND PROVIDING NEW PRODUCT TESTING OF THE FOREGOING FOR OTHERS (U.S. CLS. 100 AND 101).

H. M. FISHER, EXAMINING ATTORNEY

SN 77-419,648. THE ENTERPRISE STRATEGY GROUP, INC., MILFORD, MA. FILED 3-12-2008.

ESG STRATEGY LIFECYCLE

THE MARK CONSISTS OF STANDARD CHARACTERS WITHOUT CLAIM TO ANY PARTICULAR FONT, STYLE, SIZE, OR COLOR.

CLASS 35—ADVERTISING AND BUSINESS

FOR BUSINESS CONSULTING SERVICES IN THE FIELD OF INFORMATION TECHNOLOGY (U.S. CLS. 100, 101 AND 102).

CLASS 42—SCIENTIFIC AND COMPUTER SERVICES

FOR CONSULTING SERVICES IN THE FIELDS OF INFORMATION TECHNOLOGY, INFORMATION SECURITY AND INFORMATION STORAGE MANAGEMENT AND PROVIDING NEW PRODUCT TESTING OF THE FOREGOING FOR OTHERS (U.S. CLS. 100 AND 101).

H. M. FISHER, EXAMINING ATTORNEY

SN 77-419,676. DEXUS INDUSTRIAL PROPERTIES INC., CHICAGO, IL. FILED 3-12-2008.

DEXUS

THE MARK CONSISTS OF STANDARD CHARACTERS WITHOUT CLAIM TO ANY PARTICULAR FONT, STYLE, SIZE, OR COLOR.

CLASS 36—INSURANCE AND FINANCIAL

FOR REAL ESTATE MANAGEMENT SERVICES, NAMELY, LISTING, BROKERAGE, AND MANAGEMENT OF COMMERCIAL, INDUSTRIAL, AND RETAIL PROPERTIES; REAL ESTATE LEASING SERVICES; REAL ESTATE INVESTMENT SERVICES, NAMELY, ASSET ACQUISITION, DEVELOPMENT, AND MANAGEMENT SERVICES (U.S. CLS. 100, 101 AND 102).

FIRST USE 2-21-2008; IN COMMERCE 2-21-2008.

CLASS 37—CONSTRUCTION AND REPAIR

FOR COMMERCIAL, INDUSTRIAL, AND RETAIL REAL ESTATE DEVELOPMENT SERVICES (U.S. CLS. 100, 103 AND 106).

FIRST USE 2-21-2008; IN COMMERCE 2-21-2008.
DARRYL SPRUILL, EXAMINING ATTORNEY

SN 77-420,318. DONOMA, INC., BLACKSBURG, VA. FILED 3-12-2008.

DONOMA SOFTWARE

THE MARK CONSISTS OF STANDARD CHARACTERS WITHOUT CLAIM TO ANY PARTICULAR FONT, STYLE, SIZE, OR COLOR.

NO CLAIM IS MADE TO THE EXCLUSIVE RIGHT TO USE "SOFTWARE", APART FROM THE MARK AS SHOWN.

CLASS 9—ELECTRICAL AND SCIENTIFIC APPARATUS

FOR DOWNLOADABLE SOFTWARE FOR VOICE-MAIL AND E-MAIL SYNCHRONIZATION AND ELECTRONIC SOFTWARE UPDATES THEREFOR, NAMELY, DOWNLOADABLE COMPUTER SOFTWARE AND ASSOCIATED DATA FILES FOR UPDATING THE AFOREMENTIONED COMPUTER SOFTWARE, PROVIDED VIA COMPUTER AND GLOBAL NETWORKS (U.S. CLS. 21, 23, 26, 36 AND 38).

CLASS 42—SCIENTIFIC AND COMPUTER SERVICES

FOR MAINTENANCE OF COMPUTER SOFTWARE; TECHNICAL SUPPORT SERVICES, NAMELY, TROUBLESHOOTING OF COMPUTER SOFTWARE PROBLEMS (U.S. CLS. 100 AND 101).

YONG KIM, EXAMINING ATTORNEY

SN 77-420,624. ANDERSON, JUDY L., SPARKS, NV. FILED 3-13-2008.

Table Shark

THE MARK CONSISTS OF STANDARD CHARACTERS WITHOUT CLAIM TO ANY PARTICULAR FONT, STYLE, SIZE, OR COLOR.

CLASS 21—HOUSEWARES AND GLASS

FOR DISHES (U.S. CLS. 2, 13, 23, 29, 30, 33, 40 AND 50).

CLASS 25—CLOTHING

FOR CLOTHING, NAMELY, PANTS, SHIRTS, T-SHIRTS, HATS, SHORTS, AND DRESSES (U.S. CLS. 22 AND 39).

JOHN KELLY, EXAMINING ATTORNEY

SN 77-420,670. I LOVE REWARDS INC., TORONTO, CANADA, FILED 3-13-2008.

SN 77-421,192. CEDAR RAPIDS PROFESSIONAL BASEBALL CLUB, INC., WEST CEDAR RAPIDS, IA. FILED 3-13-2008.

RETHINK REWARDS

THE MARK CONSISTS OF STANDARD CHARACTERS WITHOUT CLAIM TO ANY PARTICULAR FONT, STYLE, SIZE, OR COLOR.

NO CLAIM IS MADE TO THE EXCLUSIVE RIGHT TO USE "REWARDS", APART FROM THE MARK AS SHOWN.

CLASS 9—ELECTRICAL AND SCIENTIFIC APPARATUS

FOR SOFTWARE FOR ONLINE POINTS-BASED REWARD PROGRAMS THAT DRIVE THE EMPLOYEE BEHAVIORS AND MOTIVATE EMPLOYEES THROUGH EMPLOYEE RECOGNITION AND SALES INCENTIVES (U.S. CLS. 21, 23, 26, 36 AND 38).

CLASS 35—ADVERTISING AND BUSINESS

FOR BUSINESS CONSULTING SERVICE FOR MANAGING EMPLOYEE INCENTIVE PROGRAMS, NAMELY, BUILDING ONLINE POINTS-BASED REWARD PROGRAMS FOR OTHERS (U.S. CLS. 100, 101 AND 102).
CYNTHIA SLOAN, EXAMINING ATTORNEY

SN 77-420,873. OAPSPP LLC, STRONGSVILLE, OH. FILED 3-13-2008.

PetStyling.com

NO CLAIM IS MADE TO THE EXCLUSIVE RIGHT TO USE "PETSTYLING.COM", APART FROM THE MARK AS SHOWN.

THE MARK CONSISTS OF THE STYLIZED WORDING "PETSTYLING.COM", WITH THE DOT ON THE LETTER "I" DEPICTED AS TO RENDER THE FOOTPRINT OF A PET, AND THE DEPICTION OF THE SILHOUETTE OF A GROOMED DOG WITHIN THE LETTER "O".

CLASS 35—ADVERTISING AND BUSINESS

FOR ADVERTISING AND MARKETING (U.S. CLS. 100, 101 AND 102).

CLASS 41—EDUCATION AND ENTERTAINMENT

FOR EDUCATIONAL SERVICES, NAMELY, PROVIDING CLASSES AND COURSES IN THE FIELDS OF PETS GROOMING AND BEAUTIFICATION; ENTERTAINMENT IN THE NATURE OF COMPETITIONS IN THE FIELD OF PETS GROOMING AND BEAUTIFICATION; DOG SHOWS (U.S. CLS. 100, 101 AND 107).

FIRST USE 3-1-1999; IN COMMERCE 3-1-1999.
LAURA HAMMEL, EXAMINING ATTORNEY



OWNER OF U.S. REG. NOS. 1,938,747 AND 1,938,748.

NO CLAIM IS MADE TO THE EXCLUSIVE RIGHT TO USE "CEDAR RAPIDS", APART FROM THE MARK AS SHOWN.

THE MARK CONSISTS OF A STYLIZED "KERNELS" WITH CEDAR RAPIDS ABOVE. ALL TEXT IN FRONT OF AN ANIMATED CORN COB BAT.

CLASS 16—PAPER GOODS AND PRINTED MATTER

FOR PAPER GOODS AND PRINTED MATTER, NAMELY, BASEBALL PROGRAMS AND MEDIA GUIDES, BASEBALL TRADING CARDS, ENVELOPES, NEWSLETTERS RELATING TO BASEBALL, BUMPER STICKERS, PENS, PENCILS, STATIONERY, POSTERS, PRINTED PAPER SIGNS, SCORECARDS, SCORESHEETS, BASEBALL REFERENCE BOOKS, MERCHANDISE BAGS, PRINTED GAME TICKETS, PRINTED GAME SCHEDULES, STICKERS, DECALS (U.S. CLS. 2, 5, 22, 23, 29, 37, 38 AND 50).

FIRST USE 11-1-2006; IN COMMERCE 11-1-2006.

CLASS 25—CLOTHING

FOR CLOTHING, NAMELY, ATHLETIC UNIFORMS, SHIRTS, CAPS, HATS, SHORTS, T-SHIRTS, JACKETS, SWEATSHIRTS, JERSEYS, CLOTH DIAPER SETS WITH UNDERSHIRT AND DIAPER COVER, BABY BIBS, BABY HATS, GOLF SHIRTS, VISORS, KNIT SHIRTS, TANK TOPS, RAINWEAR (U.S. CLS. 22 AND 39).

FIRST USE 11-1-2006; IN COMMERCE 11-1-2006.

JOHN SCHUYLER YARD, EXAMINING ATTORNEY

SN 77-421,290. CARDINAL HOUSE PRODUCTIONS, INC., DBA ANGELS ON MY PILLOW, MCKINNEY, TX. FILED 3-13-2008.

ANGELS ON MY PILLOW

THE MARK CONSISTS OF STANDARD CHARACTERS WITHOUT CLAIM TO ANY PARTICULAR FONT, STYLE, SIZE, OR COLOR.

CLASS 20—FURNITURE AND ARTICLES NOT OTHERWISE CLASSIFIED

FOR PILLOWS (U.S. CLS. 2, 13, 22, 25, 32 AND 50).

CLASS 24—FABRICS

FOR BED LINEN, NAMELY, PILLOW CASES, PILLOW TOPPERS, POCKETS FOR PILLOW CASES, SHEETS, AND COMFORTERS (U.S. CLS. 42 AND 50).

SN 77-421,412. RIGHT BY NATURE, LLC, ASPINWALL, PA. FILED 3-13-2008.

CLASS 25—CLOTHING

FOR CLOTHING, NAMELY, T-SHIRTS, SLEEP WEAR, AND HATS (U.S. CLS. 22 AND 39).
BENJAMIN ALLEN, EXAMINING ATTORNEY

Right By Nature

SN 77-421,297. HANDMARK, INC., KANSAS CITY, MO. FILED 3-13-2008.

HANDMARKET

THE MARK CONSISTS OF STANDARD CHARACTERS WITHOUT CLAIM TO ANY PARTICULAR FONT, STYLE, SIZE, OR COLOR.

THE MARK CONSISTS OF STANDARD CHARACTERS WITHOUT CLAIM TO ANY PARTICULAR FONT, STYLE, SIZE, OR COLOR.

CLASS 35—ADVERTISING AND BUSINESS

FOR RETAIL GROCERY STORE SERVICES; RETAIL VITAMIN AND HEALTH FOOD STORE SERVICES; RETAIL DELICATESSEN SERVICES; RETAIL BAKERY SHOPS; RETAIL FLORIST SHOPS (U.S. CLS. 100, 101 AND 102).

CLASS 43—HOTEL AND RESTAURANT SERVICES

FOR CAFE SERVICES (U.S. CLS. 100 AND 101).
REBECCA POVARCHUK, EXAMINING ATTORNEY

CLASS 9—ELECTRICAL AND SCIENTIFIC APPARATUS

FOR COMPUTER SOFTWARE FOR WIRELESS AGGREGATION AND CONTENT DELIVERY; COMPUTER SOFTWARE AND DOWNLOADABLE COMPUTER SOFTWARE FOR HANDHELD COMPUTERS AND MOBILE TELEPHONES AND WIRELESS COMMUNICATION APPARATUS FOR PRODUCTIVITY APPLICATIONS, FINANCIAL APPLICATIONS, EDUCATIONAL APPLICATIONS, DATABASE MANAGEMENT AND TRAVEL; COMPUTER GAME SOFTWARE AND DOWNLOADABLE COMPUTER GAME SOFTWARE FOR MOBILE TELEPHONES AND WIRELESS COMMUNICATION APPARATUS; ELECTRONIC PUBLICATIONS, NAMELY, BOOKS, SHORT STORIES, MAGAZINES, MANUALS, ARTICLES, FEATURES, REPORTS, RESPONSES, AUDIO FILES AND IMAGES FEATURING REFERENCE INFORMATION, EDUCATIONAL MATERIALS, FICTION, NON-FICTION, HUMOR, CURRENT EVENTS, NEWS, SPORTS, PERSONAL INTEREST, WEATHER, DIRECTIONS, MAPS, SCHEDULES, REVIEWS AND RATINGS AND GAMES RECORDED ON PRE-RECORDED FLASH MEMORY CARDS AND MEMORY STICKS (U.S. CLS. 21, 23, 26, 36 AND 38).

SN 77-421,416. THE MATHWORKS, INC., NATICK, MA. FILED 3-13-2008.

POLYSPACE

CLASS 35—ADVERTISING AND BUSINESS

FOR ON-LINE RETAIL STORE SERVICES FEATURING COMPUTER SOFTWARE AND ELECTRONIC PUBLICATIONS FOR MOBILE TELEPHONES AND WIRELESS COMMUNICATION APPARATUS (U.S. CLS. 100, 101 AND 102).

THE MARK CONSISTS OF STANDARD CHARACTERS WITHOUT CLAIM TO ANY PARTICULAR FONT, STYLE, SIZE, OR COLOR.

CLASS 38—COMMUNICATION

FOR WIRELESS ELECTRONIC TRANSMISSION OF MESSAGES AND DATA; WIRELESS TRANSMISSION OF ELECTRONIC CONTENT IN THE NATURE OF MESSAGES, SOUNDS AND IMAGES, PHOTOGRAPHS, DOCUMENTS, TEXT AND OTHER DATA TO MOBILE TELEPHONES AND WIRELESS COMMUNICATION APPARATUS (U.S. CLS. 100, 101 AND 104).
BENJAMIN ALLEN, EXAMINING ATTORNEY

CLASS 9—ELECTRICAL AND SCIENTIFIC APPARATUS

FOR PRERECORDED MAGNETIC DATA CARRIERS, PRERECORDED DISKS, PRERECORDED CDROMS, PRERECORDED COMPUTER SOFTWARE, ALL FEATURING PROGRAMS FOR COMPUTER SOFTWARE DEVELOPMENT AND COMPUTER SOFTWARE VERIFICATION AND VALIDATION (U.S. CLS. 21, 23, 26, 36 AND 38).
FIRST USE 9-30-1999; IN COMMERCE 7-26-2000.

CLASS 16—PAPER GOODS AND PRINTED MATTER

FOR PRINTED TECHNICAL AND COMPUTER MANUALS, GUIDES AND DOCUMENTATION FOR COMPUTER SOFTWARE DEVELOPMENT AND COMPUTER SOFTWARE VERIFICATION AND VALIDATION; PRINTED INSTRUCTIONAL MATERIAL ON COMPUTER SOFTWARE DEVELOPMENT, AND COMPUTER SOFTWARE VERIFICATION AND VALIDATION; PRINTED INSTRUCTIONAL, EDUCATIONAL, AND TEACHING MATERIALS IN THE FIELD OF COMPUTER SOFTWARE DEVELOPMENT AND COMPUTER SOFTWARE VERIFICATION AND VALIDATION; PRINTED EVALUATION REPORTS IN THE FIELD OF COMPUTER SOFTWARE DEVELOPMENT AND COMPUTER SOFTWARE VERIFICATION AND VALIDATION, AND EDUCATIONAL PUBLICATIONS, NAMELY, TRAINING MANUALS IN THE FIELD OF COMPUTER SOFTWARE DEVELOPMENT AND COMPUTER SOFTWARE VERIFICATION AND VALIDATION (U.S. CLS. 2, 5, 22, 23, 29, 37, 38 AND 50).

FIRST USE 9-30-1999; IN COMMERCE 7-26-2000.

CLASS 41—EDUCATION AND ENTERTAINMENT

FOR TRAINING SERVICES IN THE FIELD OF COMPUTER SOFTWARE DEVELOPMENT, AND COMPUTER SOFTWARE VERIFICATION AND VALIDATION, EDUCATIONAL SERVICES, NAMELY, CONDUCTING SEMINARS, SYMPOSIUMS, AND WORKSHOPS IN THE FIELD OF COMPUTER SOFTWARE DEVELOPMENT, AND COMPUTER SOFTWARE VERIFICATION AND VALIDATION, AND DISTRIBUTION OF MATERIALS IN CONNECTION THEREWITH (U.S. CLS. 100, 101 AND 107).

FIRST USE 9-30-1999; IN COMMERCE 7-26-2000.

CLASS 42—SCIENTIFIC AND COMPUTER SERVICES

FOR COMPUTER SOFTWARE CONSULTATION; COMPUTER SOFTWARE DESIGN FOR OTHERS; COMPUTER SOFTWARE DEVELOPMENT; CONSULTING SERVICES IN THE FIELD OF DESIGN, SELECTION, IMPLEMENTATION AND USE OF COMPUTER SOFTWARE SYSTEMS FOR OTHERS; INSTALLATION OF COMPUTER SOFTWARE, MAINTENANCE OF COMPUTER SOFTWARE, AND DEVELOPMENT OF COMPUTER SOFTWARE DEVELOPMENT TOOLS AND COMPUTER SOFTWARE UTILITIES FOR OTHERS; DEVELOPMENT OF COMPUTER SOFTWARE LIBRARIES USED TO MODEL COMPUTER SOFTWARE FUNCTIONS; TECHNICAL SUPPORT SERVICES, NAMELY, TROUBLESHOOTING OF COMPUTER SOFTWARE PROBLEMS, UPDATING OF COMPUTER SOFTWARE FOR OTHERS, AND PROVIDING INFORMATION IN THE FIELD OF COMPUTER SOFTWARE DEVELOPMENT AND COMPUTER SOFTWARE VERIFICATION AND VALIDATION (U.S. CLS. 100 AND 101).

FIRST USE 9-30-1999; IN COMMERCE 7-26-2000.
HEATHER THOMPSON, EXAMINING ATTORNEY

SN 77-421,613. ALL THINGS RENTAL, LLC, COHUTTA, GA. FILED 3-13-2008.

ALL THINGS RENTAL

THE MARK CONSISTS OF STANDARD CHARACTERS WITHOUT CLAIM TO ANY PARTICULAR FONT, STYLE, SIZE, OR COLOR.

NO CLAIM IS MADE TO THE EXCLUSIVE RIGHT TO USE "RENTAL", APART FROM THE MARK AS SHOWN.

CLASS 35—ADVERTISING AND BUSINESS

FOR ADVERTISING AND MARKETING THE RENTAL OF GOODS AND SERVICES OF OTHERS AND PROVIDING ON-LINE COMPUTER DATABASES AND ON-LINE SEARCHABLE DATABASES FEATURING CLASSIFIED LISTINGS REGARDING THE RENTAL OF GOODS AND SERVICES OF OTHERS (U.S. CLS. 100, 101 AND 102).

CLASS 36—INSURANCE AND FINANCIAL

FOR PROVIDING ON-LINE COMPUTER DATABASES AND ON-LINE SEARCHABLE DATABASES FEATURING INFORMATION REGARDING RENTAL AND LEASING OF HOUSING, APARTMENTS, CONDOMINIUMS, TOWN HOMES, COMMERCIAL REAL ESTATE (U.S. CLS. 100, 101 AND 102).

CLASS 38—COMMUNICATION

FOR PROVIDING ON-LINE ELECTRONIC BULLETIN BOARDS FOR TRANSMISSION OF MESSAGES AMONG COMPUTER USERS CONCERNING CLASSIFIED LISTINGS REGARDING THE RENTAL OF GOODS AND SERVICES (U.S. CLS. 100, 101 AND 104).

BARNEY CHARLON, EXAMINING ATTORNEY

SN 77-421,713. NORMAN LOVE CONFECTIONS, INC., FORT MYERS, FL. FILED 3-13-2008.

**NORMAN LOVE CONFECTIONS
BLACK**

THE MARK CONSISTS OF STANDARD CHARACTERS WITHOUT CLAIM TO ANY PARTICULAR FONT, STYLE, SIZE, OR COLOR.

OWNER OF U.S. REG. NOS. 3,026,858, 3,141,215 AND OTHERS.

NO CLAIM IS MADE TO THE EXCLUSIVE RIGHT TO USE "CONFECTIONS", APART FROM THE MARK AS SHOWN.

THE NAME "NORMAN LOVE" IDENTIFIES A LIVING INDIVIDUAL WHOSE CONSENT IS OF RECORD.

CLASS 30—STAPLE FOODS

FOR CANDIES AND CHOCOLATES; HAND-CRAFTED CANDY AND CHOCOLATES; BAKERY DESSERTS; DESSERT MOUSSE; DESSERT PUDDINGS; PASTRIES; CAKES; BROWNIES; COOKIES; CANDY AND CHOCOLATES, NAMELY, CREAMS AND NOUGATS; BOXED CANDIES AND CHOCOLATES; INDIVIDUAL DESSERT AND SPECIALTY CAKES; CHOCOLATES, NAMELY, CHOCOLATE NOVELTIES; AND CANDY AND CHOCOLATE BARS; SPECIALTY COFFEES; CROISSANTS; MUFFINS; DANISHES; CAPPUCCINOS; BISCOTTI; HOT CHOCOLATE; HOT TEA; AND ICED TEA; ICE CREAM; ICE CREAM DESSERTS; GELATO; FROZEN DESSERTS OF CREAM OR CHOCOLATE (U.S. CL. 46).

CLASS 35—ADVERTISING AND BUSINESS

FOR WHOLESALE AND RETAIL STORE AND ON-LINE WHOLESALE AND RETAIL STORE SERVICES FEATURING CANDY, CHOCOLATES, CAKES, BAKERY DESSERTS, BROWNIES, COOKIES, BOXED CANDIES AND CHOCOLATES, PASTRIES, CHOCOLATE NOVELTIES, ICE CREAM, ICE CREAM DESSERTS, GELATO, FROZEN DESSERTS OF CREAM AND/OR CHOCOLATE, SMOOTHIES, SPECIALTY COFFEES, CROISSANTS, MUFFINS, DANISHES, CAPPUCINOS, BISCOTTI, HOT CHOCOLATE, HOT TEA, ICED TEA AND GIFT BASKETS FILLED WITH SOME OR ALL OF THE FOREGOING (U.S. CLS. 100, 101 AND 102).
YAT SYE, LEE, EXAMINING ATTORNEY

SN 77-421,995. THE COCA-COLA COMPANY, ATLANTA, GA. FILED 3-14-2008.



THE MARK CONSISTS OF TWO ARROWS FORMING THE SHAPE OF A RUNNING MAN DEPICTED WITH A HEART DESIGN.

SN 77-421,887. VELEZ CAPITAL MANAGEMENT, LLC, NEW YORK, NY. FILED 3-14-2008.

CLASS 32—LIGHT BEVERAGES

FOR NON-ALCOHOLIC BEVERAGES, NAMELY, DRINKING WATERS, FLAVORED WATERS, SOFT DRINKS, ENERGY DRINKS, SPORTS DRINKS, FRUIT DRINKS AND FRUIT JUICES (U.S. CLS. 45, 46 AND 48).

TRADE FOR LIFE**CLASS 35—ADVERTISING AND BUSINESS**

FOR PUBLIC ADVOCACY TO PROMOTE AWARENESS OF COMMUNITY, ENVIRONMENTAL AND HEALTH AND WELLNESS ISSUES (U.S. CLS. 100, 101 AND 102).

THE MARK CONSISTS OF STANDARD CHARACTERS WITHOUT CLAIM TO ANY PARTICULAR FONT, STYLE, SIZE, OR COLOR.

NO CLAIM IS MADE TO THE EXCLUSIVE RIGHT TO USE "TRADE", APART FROM THE MARK AS SHOWN.

CLASS 41—EDUCATION AND ENTERTAINMENT

FOR EDUCATIONAL SERVICES, NAMELY, PROVIDING SEMINARS, WORKSHOPS, AND LECTURES IN THE FIELD OF ENVIRONMENTAL AND WELLNESS ISSUES (U.S. CLS. 100, 101 AND 107).
ADA HAN, EXAMINING ATTORNEY

CLASS 35—ADVERTISING AND BUSINESS

FOR BUSINESS INFORMATION IN THE FIELD OF STOCK PICKS, TRADING OF STOCKS AND MARKET ANALYSIS (U.S. CLS. 100, 101 AND 102).

FIRST USE 2-19-2007; IN COMMERCE 2-19-2007.

SN 77-422,265. JUSTICK IP (PTY) LTD, CENTURION 0046, SOUTH AFRICA, FILED 3-14-2008.

CLASS 36—INSURANCE AND FINANCIAL

FOR AGENCIES OR BROKERAGE FOR TRADING OF SECURITIES, SECURITIES INDEX FUTURES, SECURITIES OPTIONS, AND OVERSEAS MARKET SECURITIES FUTURES; SECURITIES TRADING AND INVESTING SERVICES FOR OTHERS VIA THE INTERNET (U.S. CLS. 100, 101 AND 102).

FIRST USE 2-19-2007; IN COMMERCE 2-19-2007.

JUSTICK

CLASS 41—EDUCATION AND ENTERTAINMENT

FOR ARRANGING PROFESSIONAL WORKSHOP AND TRAINING COURSES; BUSINESS TRAINING; TEACHING AND TRAINING IN BUSINESS, INDUSTRY AND INFORMATION TECHNOLOGY; TRAINING SERVICES IN THE FIELD OF STOCK PICKS, TRADING OF STOCKS AND MARKET ANALYSIS (U.S. CLS. 100, 101 AND 107).

FIRST USE 2-19-2007; IN COMMERCE 2-19-2007.
TASNEEM HUSSAIN, EXAMINING ATTORNEY

THE MARK CONSISTS OF STANDARD CHARACTERS WITHOUT CLAIM TO ANY PARTICULAR FONT, STYLE, SIZE, OR COLOR.

CLASS 9—ELECTRICAL AND SCIENTIFIC APPARATUS

FOR ELECTRONIC MOTHER BOARDS (U.S. CLS. 21, 23, 26, 36 AND 38).

CLASS 20—FURNITURE AND ARTICLES NOT OTHERWISE CLASSIFIED

FOR DISPLAY BOARDS; DISPLAY STANDS; DISPLAY CASES ON WHICH METAL AND/OR NON-METAL ARTICLES MAY BE REMOVABLY ARRANGED AND/OR ADHERED FOR DISPLAY PURPOSES (U.S. CLS. 2, 13, 22, 25, 32 AND 50).

JUDITH HELFMAN, EXAMINING ATTORNEY

CLASS 45—PERSONAL AND LEGAL SERVICES

FOR ONLINE SOCIAL NETWORKING SERVICES (U.S. CLS. 100 AND 101).

HEATHER THOMPSON, EXAMINING ATTORNEY

SN 77-422,438. LEARNING & LITERACY SYSTEMS, LLC, HEATHRIDGE, TX. FILED 3-14-2008.

SN 77-422,314. JAY HALPERN, ATLANTA, GA. FILED 3-14-2008.



THE MARK CONSISTS OF THE STYLIZED WORD "BUSTER" AND A PAW PRINT DESIGN.

THE MOTHER NATURE NETWORK

THE MARK CONSISTS OF STANDARD CHARACTERS WITHOUT CLAIM TO ANY PARTICULAR FONT, STYLE, SIZE, OR COLOR.

NO CLAIM IS MADE TO THE EXCLUSIVE RIGHT TO USE "NETWORK", APART FROM THE MARK AS SHOWN.

CLASS 35—ADVERTISING AND BUSINESS

FOR PROVIDING A WEBSITE THAT ALLOWS USERS TO POST, EXCHANGE AND VIEW INFORMATION, RATINGS, REVIEWS AND COMMENTARY ABOUT ENVIRONMENTAL PRODUCTS AND SERVICES; PROMOTING PUBLIC AWARENESS OF ENVIRONMENTAL MATTERS, ENVIRONMENTAL PRODUCTS AND SERVICES AND ENVIRONMENTALLY-CONSCIOUS AND GREEN INNOVATIONS; PROVIDING CONSUMER INFORMATION AND RELATED NEWS IN THE FIELD OF ENVIRONMENTAL MATTERS, ENVIRONMENTAL PRODUCTS AND SERVICES AND ENVIRONMENTALLY-CONSCIOUS AND GREEN INNOVATIONS (U.S. CLS. 100, 101 AND 102).

CLASS 42—SCIENTIFIC AND COMPUTER SERVICES

FOR COMPUTER SERVICES, NAMELY, CREATING AN ONLINE COMMUNITY FOR REGISTERED USERS TO PROVIDE AND RECEIVE FEEDBACK TO AND FROM THEIR PEERS, FROM VIRTUAL COMMUNITIES, ENGAGE IN SOCIAL NETWORKING, POST, EXCHANGE AND VIEW INFORMATION, RATINGS, REVIEWS AND COMMENTARY ABOUT ENVIRONMENTAL MATTERS, ENVIRONMENTAL PRODUCTS AND SERVICES AND ENVIRONMENTALLY-CONSCIOUS AND GREEN INNOVATIONS; HOSTING AN ONLINE COMMUNITY WEBSITE FEATURING A FORUM THAT ALLOWS USERS TO POST, EXCHANGE AND VIEW INFORMATION, RATINGS, REVIEWS AND COMMENTARY ABOUT ENVIRONMENTAL MATTERS, ENVIRONMENTAL PRODUCTS AND SERVICES AND ENVIRONMENTALLY-CONSCIOUS AND GREEN INNOVATIONS, FORM VIRTUAL COMMUNITIES AND ENGAGE IN SOCIAL NETWORKING; PROVIDING INFORMATION IN THE FIELD OF ENVIRONMENTAL MATTERS, ENVIRONMENTAL PRODUCTS AND SERVICES AND ENVIRONMENTALLY-CONSCIOUS AND GREEN INNOVATIONS, VIA THE INTERNET; PROVIDING A WEBSITE THAT ALLOWS USERS TO POST, EXCHANGE AND VIEW TECHNOLOGICAL AND SCIENTIFIC INFORMATION ABOUT ENVIRONMENTALLY-CONSCIOUS AND GREEN INNOVATIONS (U.S. CLS. 100 AND 101).

CLASS 9—ELECTRICAL AND SCIENTIFIC APPARATUS

FOR ELECTRONIC PUBLICATIONS, NAMELY, BOOKS FEATURING READING TRAINING RECORDED ON COMPUTER MEDIA (U.S. CLS. 21, 23, 26, 36 AND 38).

CLASS 16—PAPER GOODS AND PRINTED MATTER

FOR (BASED ON USE IN COMMERCE) EDUCATIONAL BOOKS FEATURING READING EXERCISES (BASED ON INTENT TO USE) CHILDREN'S BOOKS; EDUCATIONAL PUBLICATIONS, NAMELY, EDUCATIONAL LEARNING CARDS, FLASH CARDS, ACTIVITY CARDS, WORKBOOKS, TEXTBOOKS, ACTIVITY BOOKS, STORY BOOKS, PUZZLE BOOKS, PRINTED PUZZLES, TEACHER GUIDES, MANUALS, POSTERS, AND EDUCATIONAL BOOKLETS IN THE FIELD OF READING; EDUCATIONAL PUBLICATIONS, NAMELY, TRAINING MANUALS IN THE FIELD OF READING EDUCATION (U.S. CLS. 2, 5, 22, 23, 29, 37, 38 AND 50).

FIRST USE 3-1-2008; IN COMMERCE 3-1-2008.

CLASS 28—TOYS AND SPORTING GOODS

FOR CHILDREN'S MULTIPLE ACTIVITY TOYS; CHILDREN'S MULTIPLE ACTIVITY TOYS SOLD AS A UNIT WITH PRINTED BOOKS; PLUSH TOYS AND EDUCATIONAL CARD GAMES (U.S. CLS. 22, 23, 38 AND 50).

CLASS 35—ADVERTISING AND BUSINESS

FOR MULTI-LEVEL MARKETING BUSINESS SERVICES; BUSINESS DEVELOPMENT SERVICES, NAMELY, PROVIDING START-UP SUPPORT FOR BUSINESSES OF OTHERS; BUSINESS ORGANIZATION AND OPERATION CONSULTANCY (U.S. CLS. 100, 101 AND 102).

CLASS 41—EDUCATION AND ENTERTAINMENT

FOR PROVIDING INFORMATION AND NEWS IN THE FIELD OF TEACHING METHODOLOGY AND EDUCATION; TEACHING IN THE FIELD OF READING; EDUCATION SERVICES, NAMELY, PROVIDING SEMINARS IN THE FIELDS OF READING EDUCATION; CONDUCTING EDUCATIONAL EXHIBITIONS IN THE NATURE OF READING EDUCATION (U.S. CLS. 100, 101 AND 107).

SUSAN RICHARDS, EXAMINING ATTORNEY

SN 77-422,610. THE ENTERPRISE STRATEGY GROUP, INC., MILFORD, MA. FILED 3-14-2008.

THE MARK CONSISTS OF STANDARD CHARACTERS WITHOUT CLAIM TO ANY PARTICULAR FONT, STYLE, SIZE, OR COLOR.

CLASS 35—ADVERTISING AND BUSINESS

FOR BUSINESS CONSULTING SERVICES IN THE FIELD OF INFORMATION TECHNOLOGY (U.S. CLS. 100, 101 AND 102).

FIRST USE 11-9-1999; IN COMMERCE 11-9-1999.

CLASS 42—SCIENTIFIC AND COMPUTER SERVICES

FOR CONSULTING SERVICES IN THE FIELDS OF INFORMATION TECHNOLOGY, INFORMATION SECURITY AND INFORMATION STORAGE MANAGEMENT AND PROVIDING NEW PRODUCT TESTING OF THE FOREGOING FOR OTHERS (U.S. CLS. 100 AND 101).

FIRST USE 11-9-1999; IN COMMERCE 11-9-1999.
H. M. FISHER, EXAMINING ATTORNEY

SN 77-422,771. MARK SHAFFER, DBA 4-U ENTERPRISES, DANVILLE, CA. FILED 3-14-2008.



THE MARK CONSISTS OF AN UPSIDE-DOWN PARODIED VERSION OF AN ICHTHYS SYMBOL WITH 2 REPTILE FEET ON TOP, ENCLOSING THE STYLIZED WORDS, "DAR-LOSE", WHICH MIMIC THE SHAPE OF THE ICHTHYS SYMBOL.

CLASS 16—PAPER GOODS AND PRINTED MATTER

FOR BUMPER STICKERS; PAPER EMBLEMS; PRINTED EMBLEMS; PRESSURE SENSITIVE GRAPHICS FOR APPLICATION TO AUTOMOBILES (U.S. CLS. 2, 5, 22, 23, 29, 37, 38 AND 50).

CLASS 25—CLOTHING

FOR DRESS SHIRTS; DRESSES; PANTS; SHIRTS; SHORT-SLEEVED OR LONG-SLEEVED T-SHIRTS; T-SHIRTS; POLO SHIRTS; HEADGEAR, NAMELY, HATS, CAPS, BASEBALL CAPS (U.S. CLS. 22 AND 39).

STEVEN PEREZ, EXAMINING ATTORNEY

SN 77-422,829. INTERZONE ENTERTAINMENT, LLC, SPRINGFIELD, MO. FILED 3-14-2008.



THE STIPLING IS A FEATURE OF THE MARK AND DOES NOT INDICATE COLOR.

THE MARK CONSISTS OF THE STYLIZED LETTERS "IZ" SURROUNDED BY A CIRCLE.

CLASS 39—TRANSPORTATION AND STORAGE

FOR DISTRIBUTION SERVICES, NAMELY, DELIVERY OF COMPUTER SOFTWARE AND MULTIMEDIA PRODUCTS, NAMELY, COMPUTER GAMES, VIDEO GAMES, AND ON-LINE COMPUTER GAMES (U.S. CLS. 100 AND 105).

CLASS 41—EDUCATION AND ENTERTAINMENT

FOR ENTERTAINMENT SERVICES, NAMELY, PROVIDING ON-LINE COMPUTER GAMES; PROVIDING A COMPUTER GAME THAT MAY BE ACCESSED NETWORK-WIDE BY NETWORK USERS; ELECTRONIC PUBLISHING SERVICES, NAMELY, PUBLICATION OF TEXT AND GRAPHIC WORKS OF OTHERS ON-LINE AND ON CDS AND DVDS FEATURING COMPUTER SOFTWARE AND MULTIMEDIA PRODUCTS, NAMELY, COMPUTER GAMES, VIDEO GAMES, AND ON-LINE COMPUTER GAMES (U.S. CLS. 100, 101 AND 107).

PRISCILLA MILTON, EXAMINING ATTORNEY

SN 77-422,868. NOBLE INSIGHT, INC., DECATUR, GA. FILED 3-14-2008.

NO CLAIM IS MADE TO THE EXCLUSIVE RIGHT TO USE "THINK OR FACTOR", APART FROM THE MARK AS SHOWN.

THE COLOR(S) BLACK AND LIGHT GREEN (PANTONE 368) IS/ARE CLAIMED AS A FEATURE OF THE MARK.

THE MARK CONSISTS OF THE COMBINED WORD THINKFACTOR CONSISTING OF "THINK" IN BLACK (EXCEPT THE DOT OF THE "I") IN THE FONT HELVETICA NEUE LT STD BLACK CONDENSED AND "FACTOR" IN LIGHT GREEN (PANTONE 368) IN THE FONT ADOBE GARAMOND ITALIC. THE DOT OF THE "I" IN "THINK" IS IN LIGHT GREEN (PANTONE 368) AND THE UPPERMOST PORTION OF THE VERTICAL BAR OF THE "I" IS CURVED TO MATCH THE SHAPE OF THE "DOT" OF THE "I".

CLASS 9—ELECTRICAL AND SCIENTIFIC APPARATUS

FOR PRE-RECORDED DVDS, COMPACT DISCS, CD-ROMS, videocassettes, videotapes and audiotapes, all containing educational and training materials related to critical thinking skills, logic and reasoning abilities, and public speaking skills (U.S. CLS. 21, 23, 26, 36 AND 38).

CLASS 41—EDUCATION AND ENTERTAINMENT

FOR TRAINING SERVICES FOR STUDENTS OF ALL AGES INTENDED TO STRENGTHEN CRITICAL THINKING SKILLS, LOGIC AND REASONING ABILITIES, AND PUBLIC SPEAKING SKILLS (U.S. CLS. 100, 101 AND 107).

FIRST USE 2-11-2008; IN COMMERCE 2-11-2008.
YONG KIM, EXAMINING ATTORNEY

SN 77-423,639. POINTONE SYSTEMS, LLC, WAUWATOSA, WI. FILED 3-17-2008.

BRIDGING DATA AND RELEVANCE

THE MARK CONSISTS OF STANDARD CHARACTERS WITHOUT CLAIM TO ANY PARTICULAR FONT, STYLE, SIZE, OR COLOR.

NO CLAIM IS MADE TO THE EXCLUSIVE RIGHT TO USE "DATA", APART FROM THE MARK AS SHOWN.

CLASS 9—ELECTRICAL AND SCIENTIFIC APPARATUS

FOR SOFTWARE FOR PROCESSING HEALTH DATA ANALYTICS TO PROVIDE INFORMATION, SERVICES, DIAGNOSIS AND TREATMENT (U.S. CLS. 21, 23, 26, 36 AND 38).

CLASS 44—MEDICAL, BEAUTY AND AGRICULTURAL SERVICES

FOR PROVIDING ELECTRONIC AND ONLINE HEALTH DATA ANALYSIS SERVICES DESIGNED TO PROVIDE CUSTOMERS WITH CUSTOM-TAILORED INFORMATION ABOUT INDIVIDUAL HEALTH, POSSIBLE DIAGNOSES, THERAPIES, NEXT STEPS AND HEALTH INFORMATION (U.S. CLS. 100 AND 101).

CHRISTINA SOBRAL, EXAMINING ATTORNEY

SN 77-423,284. ALISA A. MARTIN, SAN DIEGO, CA. FILED 3-17-2008.

Royal Demi Rockers

SN 77-423,685. MORRIS, CASSANDRA L, BELMAR, NJ. FILED 3-17-2008.

THE MARK CONSISTS OF STANDARD CHARACTERS WITHOUT CLAIM TO ANY PARTICULAR FONT, STYLE, SIZE, OR COLOR.

CLASS 18—LEATHER GOODS

FOR BABY BACKPACKS; BAGS FOR CARRYING BABIES' ACCESSORIES; BAGS FOR SPORTS; CARRY-ALL BAGS; COSMETIC BAGS SOLD EMPTY; DIAPER BAGS; DUFFEL BAGS; GARMENT BAGS FOR TRAVEL; MESSENGER BAGS; OVERNIGHT BAGS; SCHOOL BAGS; TOTE BAGS; TRAVEL BAGS (U.S. CLS. 1, 2, 3, 22 AND 41).

CLASS 24—FABRICS

FOR CHILDREN'S BLANKETS; CHILDREN'S TOWELS; DIAPER CHANGING PADS NOT OF PAPER; RECEIVING BLANKETS; BED BLANKETS; BLANKET THROWS (U.S. CLS. 42 AND 50).

CLASS 25—CLOTHING

FOR BABY BIBS NOT OF PAPER; BABY BOTTOMS; BABY TOPS; CHILDREN'S AND INFANTS' CLOTH BIBS; INFANT AND TODDLER ONE PIECE CLOTHING; INFANT SLEEPERS; INFANT WEAR; CHILDREN'S HEADWEAR; BOOTIES; FOOTWEAR; BEANIES; SHORT-SLEEVED OR LONG-SLEEVED T-SHIRTS; HOODED SWEAT SHIRTS; SWEAT SHIRTS; BELTS (U.S. CLS. 22 AND 39).

JOHN DWYER, EXAMINING ATTORNEY

Love & Lipgloss

THE MARK CONSISTS OF STANDARD CHARACTERS WITHOUT CLAIM TO ANY PARTICULAR FONT, STYLE, SIZE, OR COLOR.

CLASS 25—CLOTHING

FOR (BASED ON USE IN COMMERCE) SHIRTS(-BASED ON INTENT TO USE) PANTS; HATS; SHOES; SHORTS; SOCKS; JACKETS (U.S. CLS. 22 AND 39).

FIRST USE 3-15-2008; IN COMMERCE 3-15-2008.

CLASS 41—EDUCATION AND ENTERTAINMENT

FOR (BASED ON USE IN COMMERCE) ON-LINE JOURNALS, NAMELY, BLOGS FEATURING PERSONAL STORIES, RELATIONSHIP TALK, ADVICE, FASHION, MEDIA COMMENTARY, SOCIAL COMMENTARY AND OTHER TOPICS OF INTEREST TO FEMALES(BASED ON INTENT TO USE) PUBLICATION OF BOOKS, OF MAGAZINES, OF JOURNALS, OF NEWSPAPERS, OF PERIODICALS, OF CATALOGS, OF BROCHURES; PUBLISHING OF WEB MAGAZINES (U.S. CLS. 100, 101 AND 107).

FIRST USE 3-18-2002; IN COMMERCE 3-18-2002.
RENEE SERVANCE, EXAMINING ATTORNEY

SN 77-423,729. B-SPLINE CONSULTING INC., UPTON, MA.
FILED 3-17-2008.

cvWatch

THE MARK CONSISTS OF STANDARD CHARACTERS WITHOUT CLAIM TO ANY PARTICULAR FONT, STYLE, SIZE, OR COLOR.

CLASS 9—ELECTRICAL AND SCIENTIFIC APPARATUS

FOR BUILDING SECURITY SYSTEMS COMPRISING SOFTWARE AND HARDWARE FOR PROVIDING PICTURE, VIDEO, ALARM STATUS, BUILDING PLANS, AND OTHER INFORMATION TO A REMOTE STATION (U.S. CLS. 21, 23, 26, 36 AND 38).

CLASS 42—SCIENTIFIC AND COMPUTER SERVICES

FOR NETWORKING OF HOME CONTROLS, NAMELY, WIRELESS AND WIRED LIGHTING CONTROLS, THERMOSTAT AND HEATING CONTROLS, ROLLING SHUTTERS AND DOOR CONTROLS, APPLIANCE CONTROLS, NAMELY, OVEN, WASHER, DRYER, REFRIGERATOR, DISHWASHER, LAWN AND GARDEN IRRIGATION CONTROLS, HOME AUDIO AND VIDEO CONTROLS; PROCESSING OF VIDEO DATA, NAMELY, INTERPRETING VIDEO CONTENT AND IDENTIFYING SEGMENTS THAT CONTAIN PRE-DEFINED KEY EVENTS (U.S. CLS. 100 AND 101).

CAROLYN CATALDO, EXAMINING ATTORNEY

SN 77-423,809. TITIAN ENTERPRISES INC., NEW YORK, NY. FILED 3-17-2008.

RUBY ET VIOLETTE

THE MARK CONSISTS OF STANDARD CHARACTERS WITHOUT CLAIM TO ANY PARTICULAR FONT, STYLE, SIZE, OR COLOR.

OWNER OF U.S. REG. NO. 2,842,847.

THE ENGLISH TRANSLATION OF THE WORD "VIOLETTE" IN THE MARK IS "VIOLET".

CLASS 16—PAPER GOODS AND PRINTED MATTER

FOR CHILDREN'S BOOKS (U.S. CLS. 2, 5, 22, 23, 29, 37, 38 AND 50).

CLASS 18—LEATHER GOODS

FOR TOTE BAGS (U.S. CLS. 1, 2, 3, 22 AND 41).

CLASS 21—HOUSEWARES AND GLASS

FOR BEVERAGEWARE, NAMELY, MUGS AND GLASSES; PLATES (U.S. CLS. 2, 13, 23, 29, 30, 33, 40 AND 50).

CLASS 25—CLOTHING

FOR CLOTHING, NAMELY, TEE SHIRTS, TANK TOPS AND INFANT BODYSUITS AND UNDERGARMENTS; HEADWARE, NAMELY, HATS AND CAPS; APRONS (U.S. CLS. 22 AND 39).

CLASS 29—MEATS AND PROCESSED FOODS

FOR CHOCOLATE MILK (U.S. CL. 46).

CLASS 30—STAPLE FOODS

FOR BAKERY GOODS, NAMELY, CAKES, TARTS, AND BROWNIES; CHOCOLATE BEVERAGES, NAMELY, HOT CHOCOLATE; PREPARED COFFEE AND COFFEE-BASED BEVERAGES; PREPARED ESPRESSO AND ESPRESSO-BASED BEVERAGES; FROZEN CONFECTIONS, NAMELY, ICE CREAM; GIFT PACKAGES CONTAINING BAKERY GOODS (U.S. CL. 46).

CLASS 35—ADVERTISING AND BUSINESS

FOR RETAIL AND ONLINE RETAIL STORE SERVICES FEATURING A WIDE VARIETY OF CONSUMER GOODS, IN THE NATURE OF CHILDREN'S BOOKS, TOTE BAGS, BEVERAGEWARE, NAMELY, MUGS AND GLASSES, PLATES, CLOTHING, NAMELY, TEE SHIRTS, TANK TOPS AND INFANT BODYSUITS AND UNDERGARMENTS, HEADWEAR, NAMELY, HATS, CAPS, APRONS, CHOCOLATE MILK, BAKERY GOODS, NAMELY, COOKIES, CAKES, TARTS, AND BROWNIES, CHOCOLATE BEVERAGES, NAMELY, HOT CHOCOLATE, PREPARED COFFEE AND COFFEE-BASED BEVERAGES, PREPARED ESPRESSO AND ESPRESSO-BASED BEVERAGES, FROZEN CONFECTIONS, NAMELY, ICE CREAM, GIFT PACKAGES CONTAINING BAKERY GOODS (U.S. CLS. 100, 101 AND 102).

CLASS 43—HOTEL AND RESTAURANT SERVICES

FOR RESTAURANT AND RESTAURANT SERVICES (U.S. CLS. 100 AND 101).

KHANH LE, EXAMINING ATTORNEY

SN 77-423,861. TITIAN ENTERPRISES INC., NEW YORK, NY. FILED 3-17-2008.



OWNER OF U.S. REG. NO. 2,842,847.

THE MARK CONSISTS OF THE WORDS "RUBY ET VIOLETTE" ENCLOSED IN AN OVAL SURROUNDED BY LITTLE DOTS.

THE ENGLISH TRANSLATION OF THE WORD "VIOLETTE" IN THE MARK IS "VIOLET".

CLASS 16—PAPER GOODS AND PRINTED MATTER

FOR CHILDREN'S BOOKS (U.S. CLS. 2, 5, 22, 23, 29, 37, 38 AND 50).

CLASS 18—LEATHER GOODS

FOR TOTE BAGS (U.S. CLS. 1, 2, 3, 22 AND 41).

SN 77-424,012. CATAMARAN SALES, INC., MIAMI, FL.
FILED 3-17-2008.**CLASS 21—HOUSEWARES AND GLASS**

FOR BEVERAGEWARE, NAMELY, MUGS AND GLASSES; PLATES (U.S. CLS. 2, 13, 23, 29, 30, 33, 40 AND 50).

CLASS 25—CLOTHING

FOR CLOTHING, NAMELY, TEE SHIRTS, TANK TOPS AND INFANT BODYSUITS AND UNDERGARMENTS; HEADWARE, NAMELY, HATS AND CAPS; APRONS (U.S. CLS. 22 AND 39).

CLASS 29—MEATS AND PROCESSED FOODS

FOR CHOCOLATE MILK (U.S. CL. 46).

CLASS 30—STAPLE FOODS

FOR BAKERY GOODS, NAMELY, COOKIES, CAKES, TARTS, AND BROWNIES; CHOCOLATE BEVERAGES, NAMELY, HOT CHOCOLATE; PREPARED COFFEE AND COFFEE-BASED BEVERAGES; PREPARED ESPRESSO AND ESPRESSO-BASED BEVERAGES; FROZEN CONFECTIONS, NAMELY ICE CREAM; GIFT PACKAGES CONTAINING BAKERY GOODS (U.S. CL. 46).

CLASS 35—ADVERTISING AND BUSINESS

FOR RETAIL AND ONLINE RETAIL STORE SERVICES FEATURING A WIDE VARIETY OF CONSUMER GOODS, IN THE NATURE OF CHILDREN'S BOOKS, TOTE BAGS, BEVERAGEWARE, NAMELY, MUGS AND GLASSES, PLATES, CLOTHING, NAMELY, TEE SHIRTS, TANK TOPS AND INFANT BODYSUITS AND UNDERGARMENTS, HEADWEAR, NAMELY, HATS, CAPS, APRONS, CHOCOLATE MILK, BAKERY GOODS, NAMELY, COOKIES, CAKES, TARTS, AND BROWNIES, CHOCOLATE BEVERAGES, NAMELY, HOT CHOCOLATE, PREPARED COFFEE AND COFFEE-BASED BEVERAGES, PREPARED ESPRESSO AND ESPRESSO-BASED BEVERAGES, FROZEN CONFECTIONS, NAMELY, ICE CREAM, GIFT PACKAGES CONTAINING BAKERY GOODS (U.S. CLS. 100, 101 AND 102).

CLASS 43—HOTEL AND RESTAURANT SERVICESFOR RESTAURANT AND RESTAURANT SERVICES (U.S. CLS. 100 AND 101).
KHANH LE, EXAMINING ATTORNEYTHE **CATAMARAN** COMPANY

NO CLAIM IS MADE TO THE EXCLUSIVE RIGHT TO USE "THE CATAMARAN COMPANY", APART FROM THE MARK AS SHOWN.

THE COLOR(S) BLACK, WHITE AND BLUE IS/ARE CLAIMED AS A FEATURE OF THE MARK.

THE MARK CONSISTS OF A CIRCLE, THE LEFT HALF OF WHICH IS BLUE, THE RIGHT HALF OF WHICH IS BLACK WITH A WHITE LINE CUTTING THROUGH THE CENTER OF THE CIRCLE FROM THE TOP OF THE CIRCLE TO THE BOTTOM, THROUGH THAT LINE AND BOTH HALVES OF THE CIRCLE IS A WHITE CUT OUT OF A CATAMARAN BOAT. CENTERED UNDERNEATH THE CIRCLE IS THE BLACK LETTERS "THE" FOLLOWED BY "CATAMARAN" IN BLUE AND "COMPANY" IN BLACK.

CLASS 35—ADVERTISING AND BUSINESS

FOR BOAT DEALERSHIPS (U.S. CLS. 100, 101 AND 102).

FIRST USE 6-1-2004; IN COMMERCE 6-1-2004.

CLASS 36—INSURANCE AND FINANCIAL

FOR YACHT BROKERAGE (U.S. CLS. 100, 101 AND 102).

FIRST USE 6-1-2004; IN COMMERCE 6-1-2004.

CLASS 37—CONSTRUCTION AND REPAIR

FOR MAINTENANCE AND/OR REPAIR OF BOATS & YACHTS (U.S. CLS. 100, 103 AND 106).

FIRST USE 6-1-2004; IN COMMERCE 6-1-2004.

CLASS 39—TRANSPORTATION AND STORAGE

FOR CHARTERING OF YACHTS AND BOATS, BOAT STORAGE, LEASING OF BOAT SLIPS (U.S. CLS. 100 AND 105).

FIRST USE 6-1-2004; IN COMMERCE 6-1-2004.

APRIL HESIK, EXAMINING ATTORNEY

SN 77-424,121. CONNECTYOURCARE LLC, HUNT VALLEY, MD. FILED 3-17-2008.

HSA EXPRESS

THE MARK CONSISTS OF STANDARD CHARACTERS WITHOUT CLAIM TO ANY PARTICULAR FONT, STYLE, SIZE, OR COLOR.

NO CLAIM IS MADE TO THE EXCLUSIVE RIGHT TO USE "HSA", APART FROM THE MARK AS SHOWN.

CLASS 36—INSURANCE AND FINANCIAL

FOR DEBIT CARD SERVICES, NAMELY, PROVIDING DEBIT CARDS FOR USE IN RELATION TO HEALTH CARE ACCOUNTS AND PROVIDING HEALTH CARE DEBIT CARD ACCOUNT INFORMATION OVER THE INTERNET; ADMINISTRATION AND PROCESSING OF HEALTH CARE INSURANCE REIMBURSEMENT CLAIMS (U.S. CLS. 100, 101 AND 102).

FIRST USE 12-0-2006; IN COMMERCE 12-0-2006.

CLASS 44—MEDICAL, BEAUTY AND AGRICULTURAL SERVICES

FOR PROVIDING HEALTH CARE INFORMATION OVER THE INTERNET (U.S. CLS. 100 AND 101).

FIRST USE 12-0-2006; IN COMMERCE 12-0-2006.
MARK T. MULLEN, EXAMINING ATTORNEY

SN 77-424,128. GLOBAL LEADERSHIP ADVENTURES, INC., SANTA MONICA, CA. FILED 3-17-2008.



NO CLAIM IS MADE TO THE EXCLUSIVE RIGHT TO USE "GLOBAL LEADERSHIP" AND "FOR HIGH SCHOOL STUDENTS", APART FROM THE MARK AS SHOWN.

THE COLOR(S) WHITE, BLACK, RED, ORANGE, LIGHT BLUE, DARK TAN AND TAN IS/ARE CLAIMED AS A FEATURE OF THE MARK.

THE MARK CONSISTS OF THE LETTERS "GLA" IN THE COLOR WHITE INSIDE A SHIELD LINED IN BLACK. THE TOP HALF OF THE SHIELD IS RED WITH A WHITE BORDER. THE BOTTOM OF THE SHIELD CONSISTS OF A PORTION OF A GLOBE IN THE COLOR LIGHT BLUE FADING INTO WHITE FROM THE BOTTOM UP WITH BLACK GRID LINES. A DARK TAN LINE EXTENDS FROM THE BOTTOM HALF OF THE SHIELD AND FADES OUT TO THE END OF THE MARK ON THE RIGHT. THE WORDING "GLOBAL LEADERSHIP ADVENTURES" APPEARS IN THE COLOR TAN ABOVE THE LINE. THE WORDING "LIFE-CHANGING JOURNEYS FOR HIGH SCHOOL STUDENTS" APPEARS BELOW THE LINE. THE ENTIRE MARK IS ON A RED RECTANGLE THAT FADES INTO ORANGE FROM TOP TO BOTTOM.

CLASS 39—TRANSPORTATION AND STORAGE

FOR ORGANIZATION OF EXCURSIONS, SIGHTSEEING TOURS, TOURS, TRAVEL, INTERNATIONAL EDUCATION AND LEADERSHIP TRAINING FOR HIGH SCHOOL STUDENTS (U.S. CLS. 100 AND 105).

FIRST USE 9-26-2006; IN COMMERCE 9-26-2006.

CLASS 41—EDUCATION AND ENTERTAINMENT

FOR INTERNATIONAL EDUCATION AND LEADERSHIP TRAINING, ALL FOR HIGH SCHOOL STUDENTS (U.S. CLS. 100, 101 AND 107).

FIRST USE 9-26-2006; IN COMMERCE 9-26-2006.
SANDRA MANIOS, EXAMINING ATTORNEY

SN 77-424,610. HOBBS JR.ZACHARY L, EGG HARBOR TOWNSHIP, NJ. FILED 3-18-2008.



NO CLAIM IS MADE TO THE EXCLUSIVE RIGHT TO USE "SPORTS BAR & GRILL", APART FROM THE MARK AS SHOWN.

THE COLOR(S) BROWN, BLACK, GRAY, WHITE, BRONZE, YELLOW AND BLUE IS/ARE CLAIMED AS A FEATURE OF THE MARK.

THE MARK CONSISTS OF THE WORDS "ANY ONES GAME! FOR FAMILY FUN, SPORTS BAR & GRILL" WITH THE LETTER "O" IN THE WORD "ONES" REPRESENTED WITH A COIN-LIKE FIGURE AND THE WORD "ONES" FORMED VERTICALLY. THE COLOR BRONZE APPEARS IN THE FACE OF THE COIN-FIGURE; THE COLOR BROWN APPEARS IN THE SHOES OF THE COIN FIGURE; THE COLOR WHITE APPEARS IN THE EYES, SOCKS, AND HANDS OF THE COIN FIGURE; THE COLOR GREY APPEARS IN THE EYES OF THE COIN FIGURE, THE COLOR BLACK APPEARS IN THE EYES, MOUTH AND OUTLINE OF THE HANDS AND SOCKS OF THE COIN FIGURE; AND THE LETTERS OF THE WORDS AND SYMBOL "ANY GAME S ! FOR FAMILY FUN, SPORTS BAR & GRILL" ARE YELLOW OUTLINED IN BLUE

CLASS 41—EDUCATION AND ENTERTAINMENT

FOR AMUSEMENT ARCADES (U.S. CLS. 100, 101 AND 107).

CLASS 43—HOTEL AND RESTAURANT SERVICES

FOR BAR AND RESTAURANT SERVICES (U.S. CLS. 100 AND 101).

CARYN GLASSER, EXAMINING ATTORNEY

SN 77-424,696. MILK PRODUCTS, LLC, CHILTON, WI. FILED 3-18-2008.

MAGIC CRYSTALS FOR EASY MIXING

THE MARK CONSISTS OF STANDARD CHARACTERS WITHOUT CLAIM TO ANY PARTICULAR FONT, STYLE, SIZE, OR COLOR.

CLASS 5—PHARMACEUTICALS

FOR MEDICATED ANIMAL FEED (U.S. CLS. 6, 18, 44, 46, 51 AND 52).

CLASS 31—NATURAL AGRICULTURAL PRODUCTS

FOR ANIMAL FEED (U.S. CLS. 1 AND 46).
STEVEN R. FOSTER, EXAMINING ATTORNEY

SN 77-424,755. STEPS 2 WELLTH, SMYRNA, GA. FILED 3-18-2008.

SN 77-425,001. HYTEC II COLLISION CENTERS, INC., DBA HYTEC COLLISION CENTER, BIRCH RUN, MI. FILED 3-18-2008.

Steps2WELLth

THE MARK CONSISTS OF STANDARD CHARACTERS WITHOUT CLAIM TO ANY PARTICULAR FONT, STYLE, SIZE, OR COLOR.

CLASS 36—INSURANCE AND FINANCIAL

FOR ADMINISTRATION OF EMPLOYEE WELFARE BENEFIT PLANS (U.S. CLS. 100, 101 AND 102).
FIRST USE 1-15-2007; IN COMMERCE 1-15-2007.

CLASS 44—MEDICAL, BEAUTY AND AGRICULTURAL SERVICES

FOR COUNSELING SERVICES IN THE FIELDS OF HEALTH, NUTRITION AND LIFESTYLE WELLNESS; HEALTH CARE SERVICES, NAMELY, DISEASE MANAGEMENT PROGRAMS; MEDICAL CLINICS (U.S. CLS. 100 AND 101).

FIRST USE 1-15-2007; IN COMMERCE 1-15-2007.
JAY FLOWERS, EXAMINING ATTORNEY

SN 77-424,981. BILLINGS MOTORCYCLE CLUB, BILLINGS, MT. FILED 3-18-2008.



NO CLAIM IS MADE TO THE EXCLUSIVE RIGHT TO USE "BILLINGS MOTORCYCLE CLUB", APART FROM THE MARK AS SHOWN.

THE MARK CONSISTS OF THE WORDS "BILLINGS MOTORCYCLE CLUB" NEXT TO A GRAPHIC DEPICTION OF PART OF A MOTORCYCLE WHEEL.

CLASS 9—ELECTRICAL AND SCIENTIFIC APPARATUS

FOR DIGITAL MEDIA, NAMELY, DVDS FEATURING MOTORCYCLE EVENTS (U.S. CLS. 21, 23, 26, 36 AND 38).

CLASS 25—CLOTHING

FOR SHIRTS, T-SHIRTS, SWEATSHIRTS, HOODIES, TOPS, HATS, CAPS, SHORTS, SWEAT PANTS, UNDERWEAR, SWIM TRUNKS (U.S. CLS. 22 AND 39).

CLASS 41—EDUCATION AND ENTERTAINMENT

FOR ENTERTAINMENT IN THE NATURE OF MOTORCYCLE AND QUAD OFF-ROAD EVENTS, NAMELY, MOTORCYCLE HILL CLIMB EVENTS, SCRAMBLES, CROSS-COUNTRY RACES, MOTOCROSS EVENTS, SUPERCROSS EVENTS, ARENA CROSS EVENTS, FLAT TRACK RACES, DIRT DRAG RACES AND TRIALS (U.S. CLS. 100, 101 AND 107).

JANICE L. MCMORROW, EXAMINING ATTORNEY

ULTRA SERVE

THE MARK CONSISTS OF STANDARD CHARACTERS WITHOUT CLAIM TO ANY PARTICULAR FONT, STYLE, SIZE, OR COLOR.

CLASS 35—ADVERTISING AND BUSINESS

FOR ARRANGING THE TRANSPORT OF VEHICLES OF INSURED PARTIES ON BEHALF OF THEIR INSURANCE COMPANIES FOR RESOLUTION OF INSURANCE CLAIMS; PROMOTION OF FINANCIAL AND INSURANCE SERVICES, ON BEHALF OF THIRD PARTIES (U.S. CLS. 100, 101 AND 102).

CLASS 36—INSURANCE AND FINANCIAL

FOR APPRAISALS FOR INSURANCE CLAIMS OF PERSONAL PROPERTY (U.S. CLS. 100, 101 AND 102).

CLASS 45—PERSONAL AND LEGAL SERVICES

FOR COMPILING INVENTORIES OF PERSONAL ITEMS FOR OTHERS FOR INSURANCE OR SECURITY PURPOSES (U.S. CLS. 100 AND 101).

JUDITH HELFMAN, EXAMINING ATTORNEY

SN 77-425,070. ALLEN PRESS, INC., LAWRENCE, KS. FILED 3-18-2008.



NO CLAIM IS MADE TO THE EXCLUSIVE RIGHT TO USE "PRESS", APART FROM THE MARK AS SHOWN.

THE MARK CONSISTS OF THE NAME "ALLEN PRESS" IN STYLIZED TYPE UNDERLINED BY A STYLIZED STROKE WITH A STAR BETWEEN THE TWO WORDS.

CLASS 35—ADVERTISING AND BUSINESS

FOR SUBSCRIPTIONS TO ELECTRONIC JOURNALS (U.S. CLS. 100, 101 AND 102).
FIRST USE 6-1-2007; IN COMMERCE 6-1-2007.

CLASS 40—MATERIAL TREATMENT

FOR BINDERY SERVICES FOR OTHERS, NAMELY, COLLATING, FOLDING, STAPLING, PERFORATING, CUTTING AND BINDING OF PRINTED, PHOTOCOPIED AND TYPEWRITTEN MATERIALS; DESIGN PRINTING FOR OTHERS; PRINTING (U.S. CLS. 100, 103 AND 106).

FIRST USE 6-1-2007; IN COMMERCE 6-1-2007.

CLASS 41—EDUCATION AND ENTERTAINMENT

FOR PUBLICATION OF PRINTED MATTER; CONDUCTING WORKSHOPS AND SEMINARS IN FIELD OF SCHOLARLY PUBLISHING; ON-LINE PUBLICATION OF JOURNALS; ONLINE ELECTRONIC PUBLISHING OF BOOKS AND PERIODICALS; PUBLICATION OF JOURNALS (U.S. CLS. 100, 101 AND 107).

FIRST USE 6-1-2007; IN COMMERCE 6-1-2007.

CLASS 42—SCIENTIFIC AND COMPUTER SERVICES

FOR COMPUTER SERVICES, NAMELY, INTERACTIVE HOSTING SERVICES WHICH ALLOW THE USER TO PUBLISH AND SHARE THEIR OWN CONTENT AND IMAGES ONLINE (U.S. CLS. 100 AND 101).

FIRST USE 6-1-2007; IN COMMERCE 6-1-2007.

MICHAEL KEATING, EXAMINING ATTORNEY

SN 77-425,124. ALLEN PRESS, INC., LAWRENCE, KS. FILED 3-18-2008.

Allen Press

THE MARK CONSISTS OF STANDARD CHARACTERS WITHOUT CLAIM TO ANY PARTICULAR FONT, STYLE, SIZE, OR COLOR.

NO CLAIM IS MADE TO THE EXCLUSIVE RIGHT TO USE "PRESS", APART FROM THE MARK AS SHOWN.

CLASS 35—ADVERTISING AND BUSINESS

FOR SUBSCRIPTIONS TO ELECTRONIC JOURNALS (U.S. CLS. 100, 101 AND 102).

FIRST USE 12-15-1935; IN COMMERCE 12-15-1997.

CLASS 40—MATERIAL TREATMENT

FOR BINDERY SERVICES FOR OTHERS, NAMELY, COLLATING, FOLDING, STAPLING, PERFORATING, CUTTING AND BINDING OF PRINTED, PHOTOCOPIED AND TYPEWRITTEN MATERIALS; DESIGN PRINTING FOR OTHERS; PRINTING (U.S. CLS. 100, 103 AND 106).

FIRST USE 12-15-1935; IN COMMERCE 12-15-1935.

CLASS 41—EDUCATION AND ENTERTAINMENT

FOR PUBLICATION AND EDITING OF PRINTED MATTER; CONDUCTING WORKSHOPS AND SEMINARS IN FIELD OF SCHOLARLY PUBLISHING; ON-LINE PUBLICATION OF JOURNALS; ONLINE ELECTRONIC PUBLISHING OF BOOKS AND PERIODICALS; PUBLICATION OF JOURNALS (U.S. CLS. 100, 101 AND 107).

FIRST USE 12-15-1935; IN COMMERCE 12-15-1935.

CLASS 42—SCIENTIFIC AND COMPUTER SERVICES

FOR COMPUTER SERVICES, NAMELY, INTERACTIVE HOSTING SERVICES WHICH ALLOW THE USER TO PUBLISH AND SHARE THEIR OWN CONTENT AND IMAGES ONLINE (U.S. CLS. 100 AND 101).

FIRST USE 12-15-1935; IN COMMERCE 12-15-1997.

MICHAEL KEATING, EXAMINING ATTORNEY

SN 77-425,083. BILLINGS MOTORCYCLE CLUB, BILLINGS, MT. FILED 3-18-2008.

MOTORCYCLE HILL CLIMBING
CAPITAL OF THE WORLD

THE MARK CONSISTS OF STANDARD CHARACTERS WITHOUT CLAIM TO ANY PARTICULAR FONT, STYLE, SIZE, OR COLOR.

NO CLAIM IS MADE TO THE EXCLUSIVE RIGHT TO USE "MOTORCYCLE HILL CLIMBING", APART FROM THE MARK AS SHOWN.

CLASS 9—ELECTRICAL AND SCIENTIFIC APPARATUS

FOR DIGITAL MEDIA, NAMELY, DVDS FEATURING MOTORCYCLE EVENTS (U.S. CLS. 21, 23, 26, 36 AND 38).

CLASS 25—CLOTHING

FOR SHIRTS, T-SHIRTS, SWEATSHIRTS, HOODIES, TOPS, HATS, CAPS, SHORTS, SWEAT PANTS, UNDERWEAR, SWIM TRUNKS (U.S. CLS. 22 AND 39).

CLASS 41—EDUCATION AND ENTERTAINMENT

FOR ENTERTAINMENT IN THE NATURE OF MOTORCYCLE AND QUAD OFF-ROAD EVENTS, NAMELY, MOTORCYCLE HILL CLIMB EVENTS, SCRAMBLES, CROSS-COUNTRY RACES, MOTOCROSS EVENTS, SUPERCROSS EVENTS, ARENA CROSS EVENTS, FLAT TRACK RACES, DIRT DRAG RACES AND TRIALS (U.S. CLS. 100, 101 AND 107).

JANICE L. MCMORROW, EXAMINING ATTORNEY

SN 77-425,695. I SAW YOU ON TV, LLC, EDINBURGH, IN. FILED 3-19-2008.

I SAW YOU ON TV

THE MARK CONSISTS OF STANDARD CHARACTERS WITHOUT CLAIM TO ANY PARTICULAR FONT, STYLE, SIZE, OR COLOR.

CLASS 16—PAPER GOODS AND PRINTED MATTER

FOR STICKERS; POSTERS (U.S. CLS. 2, 5, 22, 23, 29, 37, 38 AND 50).

CLASS 25—CLOTHING

FOR T-SHIRTS (U.S. CLS. 22 AND 39).

CLASS 41—EDUCATION AND ENTERTAINMENT

FOR MULTIMEDIA ENTERTAINMENT SERVICES IN THE NATURE OF RECORDING, PRODUCTION AND POST-PRODUCTION SERVICES IN THE FIELDS OF MUSIC, VIDEO, AND FILMS (U.S. CLS. 100, 101 AND 107).

LINDSEY RUBIN, EXAMINING ATTORNEY

SN 77-425,909. GRAHAM W. KALISH, ST. LOUIS, MO. FILED 3-19-2008.

BEARROW

THE MARK CONSISTS OF STANDARD CHARACTERS WITHOUT CLAIM TO ANY PARTICULAR FONT, STYLE, SIZE, OR COLOR.

CLASS 3—COSMETICS AND CLEANING PREPARATIONS

FOR COLOGNE (U.S. CLS. 1, 4, 6, 50, 51 AND 52).

CLASS 9—ELECTRICAL AND SCIENTIFIC APPARATUS

FOR SUNGLASSES (U.S. CLS. 21, 23, 26, 36 AND 38).

CLASS 25—CLOTHING

FOR CLOTHING, NAMELY, DRESS SHORTS, KHAKIS, SLACKS, CORDUROY, POLO SHIRTS, CASUAL BUTTON-DOWN SHIRTS, BALL CAPS, BEANIES, SWEAT BANDS, BELTS, FLIP-FLOPS, SWEATERS, HOODED SWEATSHIRTS, RAIN JACKET SHELLS, FLEECE JACKETS, LONG SLEEVE T-SHIRTS, SHORT SLEEVE T-SHIRTS, 3/4 SLEEVE T-SHIRTS, TIES, BOXERS (U.S. CLS. 22 AND 39).

STEVEN JACKSON, EXAMINING ATTORNEY

SN 77-425,998. PICKY GIRLS, LLC., PORTLAND, OR. FILED 3-19-2008.



LLC.

NO CLAIM IS MADE TO THE EXCLUSIVE RIGHT TO USE "LLC", APART FROM THE MARK AS SHOWN.

CLASS 25—CLOTHING

FOR CLOTHING, NAMELY, T-SHIRTS, HATS, PAJAMAS (U.S. CLS. 22 AND 39).

CLASS 35—ADVERTISING AND BUSINESS

FOR PROMOTING THE GOODS AND SERVICES OF OTHERS BY PROVIDING A WIDE RANGE OF INFORMATION OVER GLOBAL COMPUTER COMMUNICATION NETWORKS CONCERNING PRODUCTS, SERVICES, EVENTS, ACTIVITIES, ATTRACTIONS AND FACILITIES IN PARTICULAR GEOGRAPHIC LOCATIONS (U.S. CLS. 100, 101 AND 102).

RENEE MCCRAY, EXAMINING ATTORNEY

SN 77-426,128. ROBERTS, LORI L., BURIEN, WA. AND ROBERTS, KENNETH S., BURIEN, WA. FILED 3-19-2008.

Bow Wow Bling

THE MARK CONSISTS OF STANDARD CHARACTERS WITHOUT CLAIM TO ANY PARTICULAR FONT, STYLE, SIZE, OR COLOR.

CLASS 14—JEWELRY

FOR PET JEWELRY (U.S. CLS. 2, 27, 28 AND 50).

CLASS 18—LEATHER GOODS

FOR COLLARS FOR PETS; PET COLLAR ACCESSORIES, NAMELY, BOWS AND CHARMS (U.S. CLS. 1, 2, 3, 22 AND 41).

DAWN HAN, EXAMINING ATTORNEY

SN 77-426,312. DIA CENTER FOR THE ARTS, INC., NEW YORK, NY. FILED 3-19-2008.

DIA

THE MARK CONSISTS OF STANDARD CHARACTERS WITHOUT CLAIM TO ANY PARTICULAR FONT, STYLE, SIZE, OR COLOR.

THE ENGLISH TRANSLATION OF THE GERMAN WORD "DIA" IN THE MARK IS "SLIDE".

CLASS 35—ADVERTISING AND BUSINESS

FOR ART GALLERIES (U.S. CLS. 100, 101 AND 102). FIRST USE 12-0-1974; IN COMMERCE 12-0-1974.

CLASS 36—INSURANCE AND FINANCIAL

FOR REAL ESTATE SERVICES, NAMELY, LEASING OF REAL ESTATE, RENTAL OF REAL ESTATE AND REAL ESTATE MANAGEMENT (U.S. CLS. 100, 101 AND 102).

FIRST USE 12-0-1974; IN COMMERCE 12-0-1974. ELLEN BURNS, EXAMINING ATTORNEY

SN 77-426,630. KALLIMANIS PAOLO GIOVANNI, HONOLULU, HI. FILED 3-19-2008.



NO CLAIM IS MADE TO THE EXCLUSIVE RIGHT TO USE "THE OUTLINE OF THE HAWAIIAN ISLANDS", APART FROM THE MARK AS SHOWN.

THE COLOR(S) BLACK, WHITE, AND BLUE. IS/ARE CLAIMED AS A FEATURE OF THE MARK.

THE MARK CONSISTS OF BLACK IS FOR THE OUTLINE OF BOTH TRIANGLES, OUTLINE OF HAWAIIAN ISLANDS, AND WORDS "BLUE HAZARD". WHITE IS THE FILL COLOR INSIDE THE TRIANGLES. BLUE IS THE FILL COLOR FOR THE HAWAIIAN ISLANDS.

CLASS 16—PAPER GOODS AND PRINTED MATTER

FOR STICKERS AND TRANSFERS (U.S. CLS. 2, 5, 22, 23, 29, 37, 38 AND 50).

CLASS 25—CLOTHING

FOR SHORT-SLEEVED OR LONG-SLEEVED T-SHIRTS; SWEAT SHIRTS; HATS; PANTS; BOARD SHORTS; SHORTS; RASH GUARDS (U.S. CLS. 22 AND 39).

CLASS 28—TOYS AND SPORTING GOODS

FOR SURFBOARDS (U.S. CLS. 22, 23, 38 AND 50).
DORITT L. CARROLL, EXAMINING ATTORNEY

SN 77-426,937. WILD GOOSE HOLDING CO., INC., WILMINGTON, DE. FILED 3-20-2008.

HOAGIEFEST

THE MARK CONSISTS OF STANDARD CHARACTERS WITHOUT CLAIM TO ANY PARTICULAR FONT, STYLE, SIZE, OR COLOR.

CLASS 30—STAPLE FOODS

FOR SANDWICHES (U.S. CL. 46).

CLASS 35—ADVERTISING AND BUSINESS

FOR RETAIL STORE SERVICES FEATURING SANDWICHES (U.S. CLS. 100, 101 AND 102).
SANDRA MANIOS, EXAMINING ATTORNEY

SN 77-426,945. FRY'S ELECTRONICS, INC., SAN JOSE, CA. FILED 3-20-2008.

FRY'S

THE MARK CONSISTS OF STANDARD CHARACTERS WITHOUT CLAIM TO ANY PARTICULAR FONT, STYLE, SIZE, OR COLOR.

OWNER OF U.S. REG. NOS. 2,031,351 AND 2,102,637.
SEC. 2(F).

CLASS 9—ELECTRICAL AND SCIENTIFIC APPARATUS

FOR COMPUTERS (U.S. CLS. 21, 23, 26, 36 AND 38).
FIRST USE 5-17-1985; IN COMMERCE 5-17-1985.

CLASS 35—ADVERTISING AND BUSINESS

FOR RETAIL STORE SERVICES AND WHOLESALE STORES FEATURING PERSONAL COMPUTERS, COMPUTER HARDWARE, COMPONENTS AND ACCESSORIES, AND RELATED MERCHANDISE, PHOTOCOPY MACHINES AND SCANNERS, HOME OFFICE PRODUCTS AND FURNISHINGS, TELECOMMUNICATION EQUIPMENT, DEVICES AND ACCESSORIES, NETWORKING EQUIPMENT, DEVICES AND ACCESSORIES, PHOTOGRAPHIC EQUIPMENT, DEVICES AND ACCESSORIES, VIDEO EQUIPMENT, DEVICES, ACCESSORIES AND RECORDINGS, VIDEO GAMES, TELEVISIONS, PROJECTORS, MONITORS AND DISPLAYS, IMAGING EQUIPMENT, AUDIO EQUIPMENT, DEVICES, ACCESSORIES AND RECORDINGS, MULTIMEDIA EQUIPMENT, DEVICES, ACCESSORIES AND RECORDINGS, CONSUMER ELECTRONICS, ELECTRONIC EQUIPMENT, DEVICES AND ACCESSORIES, DIGITAL EQUIPMENT, DEVICES AND ACCESSORIES, STORAGE MEDIA, MUSICAL INSTRUMENTS, AUTOMOTIVE AUDIO EQUIPMENT, DEVICES AND ACCESSORIES, HOUSEHOLD APPLIANCES, BOOKS AND MAGAZINES, TOYS, HEALTH CARE, SKIN CARE, PERSONAL CARE, PERSONAL SAFETY, PERSONAL HOME COMFORT AND THERAPY PRODUCTS, SPA PRODUCTS, CLOTHING AND FOOD AND BEVERAGES (U.S. CLS. 100, 101 AND 102).

FIRST USE 5-17-1985; IN COMMERCE 5-17-1985.
LEIGH CAROLINE CASE, EXAMINING ATTORNEY

SN 77-426,955. FRY'S ELECTRONICS, INC., SAN JOSE, CA. FILED 3-20-2008.



OWNER OF U.S. REG. NOS. 2,031,351 AND 2,102,637.
NO CLAIM IS MADE TO THE EXCLUSIVE RIGHT TO USE "ELECTRONICS", APART FROM THE MARK AS SHOWN.

THE COLOR(S) RED IS/ARE CLAIMED AS A FEATURE OF THE MARK.

THE WORDING APPEARS IN RED.
SEC. 2(F).

CLASS 9—ELECTRICAL AND SCIENTIFIC APPARATUS

FOR ELECTRONIC COMPONENTS AND SUPPLIES, NAMELY, SEMICONDUCTOR DEVICES, ELECTRICAL CONNECTORS, ELECTRIC CABLING, RESISTORS, CAPACITORS, INDUCTORS, HEAT SINKS, TEST CLIPS, TEST LEADS AND WIRE WRAPS (U.S. CLS. 21, 23, 26, 36 AND 38).

FIRST USE 5-17-1985; IN COMMERCE 5-17-1985.

CLASS 35—ADVERTISING AND BUSINESS

FOR RETAIL STORE SERVICES AND WHOLESALE STORES FEATURING PERSONAL COMPUTERS, COMPUTER HARDWARE, COMPONENTS AND ACCESSORIES, AND RELATED MERCHANDISE, PHOTOCOPY MACHINES AND SCANNERS, HOME OFFICE PRODUCTS AND FURNISHINGS, TELECOMMUNICATION EQUIPMENT, DEVICES AND ACCESSORIES, NETWORKING EQUIPMENT, DEVICES AND ACCESSORIES, PHOTOGRAPHIC EQUIPMENT, DEVICES AND ACCESSORIES, VIDEO EQUIPMENT, DEVICES, ACCESSORIES AND RECORDINGS, VIDEO GAMES, TELEVISIONS, PROJECTORS, MONITORS AND DISPLAYS, IMAGING EQUIPMENT, AUDIO EQUIPMENT, DEVICES, ACCESSORIES AND RECORDINGS, MULTIMEDIA EQUIPMENT, DEVICES, ACCESSORIES AND RECORDINGS, CONSUMER ELECTRONICS, ELECTRONIC EQUIPMENT, DEVICES AND ACCESSORIES, DIGITAL EQUIPMENT, DEVICES AND ACCESSORIES, STORAGE MEDIA, MUSICAL INSTRUMENTS, AUTOMOTIVE AUDIO EQUIPMENT, DEVICES AND ACCESSORIES, HOUSEHOLD APPLIANCES, BOOKS AND MAGAZINES, TOYS, HEALTH CARE, SKIN CARE, PERSONAL CARE, PERSONAL SAFETY, PERSONAL HOME COMFORT AND THERAPY PRODUCTS, SPA PRODUCTS, CLOTHING AND FOOD AND BEVERAGES (U.S. CLS. 100, 101 AND 102).

FIRST USE 5-17-1985; IN COMMERCE 5-17-1985.
LEIGH CAROLINE CASE, EXAMINING ATTORNEY

SN 77-426,965. FRY'S ELECTRONICS, INC., SAN JOSE, CA.
FILED 3-20-2008.



OWNER OF U.S. REG. NOS. 2,031,351 AND 2,102,637.
THE COLOR(S) RED IS/ARE CLAIMED AS A FEATURE OF THE MARK.
THE WORDING APPEARS IN RED.
SEC. 2(F).

CLASS 9—ELECTRICAL AND SCIENTIFIC APPARATUS

FOR ELECTRONIC COMPONENTS AND SUPPLIES, NAMELY, SEMICONDUCTOR DEVICES, ELECTRICAL CONNECTORS, ELECTRIC CABLING, RESISTORS, CAPACITORS, INDUCTORS, HEAT SINKS, TEST CLIPS, TEST LEADS, WIRE WRAPS, AND COMPUTERS (U.S. CLS. 21, 23, 26, 36 AND 38).

FIRST USE 5-17-1985; IN COMMERCE 5-17-1985.

CLASS 35—ADVERTISING AND BUSINESS

FOR RETAIL STORE SERVICES AND WHOLESALE STORES FEATURING PERSONAL COMPUTERS, COMPUTER HARDWARE, COMPONENTS AND ACCESSORIES, AND RELATED MERCHANDISE, PHOTOCOPY MACHINES AND SCANNERS, HOME OFFICE PRODUCTS AND FURNISHINGS, TELECOMMUNICATION EQUIPMENT, DEVICES AND ACCESSORIES, NETWORKING EQUIPMENT, DEVICES AND ACCESSORIES, PHOTOGRAPHIC EQUIPMENT, DEVICES AND ACCESSORIES, VIDEO EQUIPMENT, DEVICES, ACCESSORIES AND RECORDINGS, VIDEO GAMES, TELEVISIONS, PROJECTORS, MONITORS AND DISPLAYS, IMAGING EQUIPMENT, AUDIO EQUIPMENT, DEVICES, ACCESSORIES AND RECORDINGS, MULTIMEDIA EQUIPMENT, DEVICES, ACCESSORIES AND RECORDINGS, CONSUMER ELECTRONICS, ELECTRONIC EQUIPMENT, DEVICES AND ACCESSORIES, DIGITAL EQUIPMENT, DEVICES AND ACCESSORIES, STORAGE MEDIA, MUSICAL INSTRUMENTS, AUTOMOTIVE AUDIO EQUIPMENT, DEVICES AND ACCESSORIES, HOUSEHOLD APPLIANCES, BOOKS AND MAGAZINES, TOYS, HEALTH CARE, SKIN CARE, PERSONAL CARE, PERSONAL SAFETY, PERSONAL HOME COMFORT AND THERAPY PRODUCTS, SPA PRODUCTS, CLOTHING AND FOOD AND BEVERAGES (U.S. CLS. 100, 101 AND 102).

FIRST USE 5-17-1985; IN COMMERCE 5-17-1985.
LEIGH CAROLINE CASE, EXAMINING ATTORNEY

SN 77-427,209. MENTUS, ROBERT J., CUMMING, GA.
FILED 3-20-2008.

E-ZSCAN

THE MARK CONSISTS OF STANDARD CHARACTERS WITHOUT CLAIM TO ANY PARTICULAR FONT, STYLE, SIZE, OR COLOR.

CLASS 9—ELECTRICAL AND SCIENTIFIC APPARATUS

FOR COMPUTER SOFTWARE FOR SCANNING AND INDEXING (U.S. CLS. 21, 23, 26, 36 AND 38).

CLASS 40—MATERIAL TREATMENT

FOR ELECTRONIC IMAGING, SCANNING, DIGITIZING, ALTERATION AND/OR RETOUCHING OF PAPER DOCUMENTS (U.S. CLS. 100, 103 AND 106).

CHRISTINE BLOMQUIST, EXAMINING ATTORNEY

SN 77-427,210. DIMDIM INC., BURLINGTON, MA. FILED 3-20-2008.

DIMDIM

THE MARK CONSISTS OF STANDARD CHARACTERS WITHOUT CLAIM TO ANY PARTICULAR FONT, STYLE, SIZE, OR COLOR.

CLASS 38—COMMUNICATION

FOR WEB CONFERENCING SERVICES (U.S. CLS. 100, 101 AND 104).
FIRST USE 8-5-2006; IN COMMERCE 8-5-2006.

CLASS 42—SCIENTIFIC AND COMPUTER SERVICES

FOR COMPUTER SERVICES, NAMELY, HOSTING ON-LINE WEB FACILITIES FOR OTHERS FOR ORGANIZING AND CONDUCTING ON-LINE MEETINGS, GATHERINGS, AND INTERACTIVE DISCUSSIONS; TECHNICAL SUPPORT SERVICES, NAMELY, MONITORING AND TROUBLESHOOTING OF NETWORK SYSTEMS AND COMPUTER SOFTWARE PROBLEMS (U.S. CLS. 100 AND 101).

FIRST USE 8-5-2006; IN COMMERCE 8-5-2006.
JAY FLOWERS, EXAMINING ATTORNEY

SN 77-427,216. LEAN TEEN INC., SANTA MONICA, CA. FILED 3-20-2008.

The Lean Teen Challenge

THE MARK CONSISTS OF STANDARD CHARACTERS WITHOUT CLAIM TO ANY PARTICULAR FONT, STYLE, SIZE, OR COLOR.

NO CLAIM IS MADE TO THE EXCLUSIVE RIGHT TO USE "TEEN", APART FROM THE MARK AS SHOWN.

CLASS 41—EDUCATION AND ENTERTAINMENT

FOR PHYSICAL FITNESS CONDITIONING CLASSES; PHYSICAL FITNESS CONSULTATION; PHYSICAL FITNESS INSTRUCTION (U.S. CLS. 100, 101 AND 107).

CLASS 44—MEDICAL, BEAUTY AND AGRICULTURAL SERVICES

FOR FOOD NUTRITION CONSULTATION; NUTRITION COUNSELING (U.S. CLS. 100 AND 101).
CARYN GLASSER, EXAMINING ATTORNEY

SN 77-427,335. CELEBDIRECT, INC., HUNTINGTON BEACH, CA. FILED 3-20-2008.

EXTREME MACHINE

THE MARK CONSISTS OF STANDARD CHARACTERS WITHOUT CLAIM TO ANY PARTICULAR FONT, STYLE, SIZE, OR COLOR.

NO CLAIM IS MADE TO THE EXCLUSIVE RIGHT TO USE "MACHINE", APART FROM THE MARK AS SHOWN.

CLASS 10—MEDICAL APPARATUS

FOR EXERCISE MACHINES FOR THERAPEUTIC PURPOSES (U.S. CLS. 26, 39 AND 44).

CLASS 28—TOYS AND SPORTING GOODS

FOR EXERCISE MACHINES; MANUAL LEG EXERCISERS; MANUALLY-OPERATED EXERCISE EQUIPMENT (U.S. CLS. 22, 23, 38 AND 50).

MELVIN AXILBUND, EXAMINING ATTORNEY

SN 77-427,347. ABRAMS, CLEM, LA JOLLA, CA. FILED 3-20-2008.

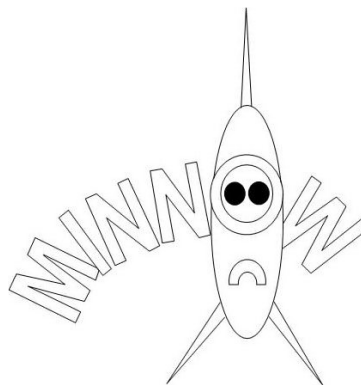

THE MARK CONSISTS OF THE WORD "MINNOW" AND A FRONT VIEW OF A MINNOW SWIMMING.

CLASS 9—ELECTRICAL AND SCIENTIFIC APPARATUS

FOR COMPUTERS; COMPUTER HARDWARE, NAMELY, KEYBOARDS; ELECTRONIC ATTACHMENT DEVICES FOR KEYBOARDS THAT MAKE IT EASIER TO OPERATE THE COMPUTER, NAMELY, A COMPUTER POINTING DEVICE THAT IS IN THE FORM OF A TWO JOYSTICKS ATTACHED TO THE KEYBOARD NEAR THE SPACE BAR AND IS OPERATED WITH THE THUMB SO THE FINGERS DO NOT HAVE TO MOVE FROM THE REGION OF THE KEYS; LAPTOP COMPUTERS, ELECTRONIC ATTACHMENT DEVICES FOR LAPTOP KEYBOARDS THAT MAKE IT EASIER TO OPERATE THE LAPTOP, NAMELY, A COMPUTER POINTING DEVICE THAT IS IN THE FORM OF A TWO JOYSTICKS ATTACHED TO THE LAPTOP KEYBOARD NEAR THE SPACE BAR AND IS OPERATED WITH THE THUMB SO THE FINGERS DO NOT HAVE TO MOVE FROM THE REGION OF THE KEYS; COMPUTER SOFTWARE FOR USE IN PROGRAMMING A COMPUTER TO ACCEPT AN ATTACHMENT DEVICE FOR KEYBOARDS THAT MAKES IT EASIER TO OPERATE THE COMPUTER; COMPUTER SOFTWARE FOR PROGRAMMING A LAPTOP TO ACCEPT AN ATTACHMENT DEVICE FOR LAPTOPS THAT MAKES IT EASIER TO OPERATE THE LAPTOP; EYE GLASSES, SPORTS GLASSES AND SUNGLASSES (U.S. CLS. 21, 23, 26, 36 AND 38).

CLASS 16—PAPER GOODS AND PRINTED MATTER

FOR PENCILS, PENS, PAPER WEIGHTS, DRAFTING RULERS, DRAWING RULERS, AND STAPLERS (U.S. CLS. 2, 5, 22, 23, 29, 37, 38 AND 50).

CLASS 25—CLOTHING

FOR CLOTHING, NAMELY, SHIRTS, T-SHIRTS, SWEATERS, CAPS AND HATS (U.S. CLS. 22 AND 39).

CLASS 28—TOYS AND SPORTING GOODS

FOR SPORTING GOODS, NAMELY, BALLS FOR GAMES, FOOTBALLS, GOLF BALLS GOLF TEES, TENNIS BALLS, TENNIS RACQUETS, AND GOLF CLUBS (U.S. CLS. 22, 23, 38 AND 50).

GINA FINK, EXAMINING ATTORNEY

SN 77-427,358. UNITED BISCUITS (UK) LIMITED, HAYES, MIDDLESEX, UNITED KINGDOM, FILED 3-20-2008.

McVITIE'S FRUIT & FORM

THE MARK CONSISTS OF STANDARD CHARACTERS WITHOUT CLAIM TO ANY PARTICULAR FONT, STYLE, SIZE, OR COLOR.

OWNER OF U.S. REG. NO. 2,814,215.

NO CLAIM IS MADE TO THE EXCLUSIVE RIGHT TO USE "FRUIT", APART FROM THE MARK AS SHOWN.

CLASS 29—MEATS AND PROCESSED FOODS

FOR PREPARED, PRESERVED, DRIED AND COOKED FRUIT, FRUIT PRESERVES, JAMS, JELLIES, PROCESSED NUTS (U.S. CL. 46).

CLASS 30—STAPLE FOODS

FOR BREAD, BISCUITS, CAKES, WAFFLES, PASTRIES, SHORTBREAD, CHOCOLATE; PREPARATIONS MADE FROM CEREALS AND FLOUR, NAMELY, READY TO EAT, CEREAL DERIVED FOOD BARS; CEREAL BASED SNACK FOOD (U.S. CL. 46).

DAWN FELDMAN, EXAMINING ATTORNEY

SN 77-427,415. GROWERS AND NOMADS, INC., SAN RAFAEL, CA. FILED 3-20-2008.

GROWERS AND NOMADS

THE MARK CONSISTS OF STANDARD CHARACTERS WITHOUT CLAIM TO ANY PARTICULAR FONT, STYLE, SIZE, OR COLOR.

CLASS 9—ELECTRICAL AND SCIENTIFIC APPARATUS

FOR DOWNLOADABLE ELECTRONIC PUBLICATIONS IN THE NATURE OF NEWSLETTER IN THE FIELD OF HOME PRODUCTS AND SERVICES (U.S. CLS. 21, 23, 26, 36 AND 38).

CLASS 16—PAPER GOODS AND PRINTED MATTER

FOR PUBLICATIONS, NAMELY, MAGAZINES IN THE FIELDS OF HOME PRODUCTS AND SERVICES (U.S. CLS. 2, 5, 22, 23, 29, 37, 38 AND 50).

CLASS 35—ADVERTISING AND BUSINESS

FOR ADVERTISING, MARKETING AND PROMOTION SERVICES; ADVICE IN THE FIELD OF BUSINESS MANAGEMENT AND MARKETING; BUSINESS CONSULTATION AND MANAGEMENT REGARDING MARKETING ACTIVITIES AND LAUNCHING OF NEW PRODUCTS; BUSINESS MARKETING CONSULTING SERVICES; BUSINESS MARKETING SERVICES; CREATIVE MARKETING DESIGN SERVICES; DEVELOPMENT OF MARKETING STRATEGIES AND CONCEPTS; GENERAL BUSINESS MERCHANDISING SERVICES, NAMELY, MARKETING; MARKETING CONSULTING; PROMOTION AND MARKETING SERVICES AND RELATED CONSULTING; ADVERTISING SERVICES, NAMELY, CREATING CORPORATE AND BRAND IDENTITY FOR OTHERS; SERVICES RELATING TO THE ANALYSIS, EVALUATION, CREATION AND BRAND ESTABLISHMENT OF TRADEMARKS, TRADE NAMES AND DOMAIN NAMES (U.S. CLS. 100, 101 AND 102).

FIRST USE 9-0-2001; IN COMMERCE 10-0-2001.

CLASS 41—EDUCATION AND ENTERTAINMENT

FOR PROVING ON-LINE PUBLICATIONS IN THE NATURE OF MAGAZINE AND NEWSLETTER IN THE FIELD OF HOME PRODUCTS AND SERVICES; BUSINESS TRAINING; TRAINING IN THE FIELD OF DESIGN, ADVERTISING AND COMMUNICATION TECHNOLOGIES; TRAINING SERVICES IN THE FIELD OF BRAND DEVELOPMENT, BUSINESS GROWTH STRATEGIES, MARKETING, AND ORGANIZATIONAL DEVELOPMENT (U.S. CLS. 100, 101 AND 107).

SUSAN RICHARDS, EXAMINING ATTORNEY

SN 77-427,501. LOOK OUT WORLD, LLC, NEW YORK, NY. FILED 3-20-2008.

**Look Out World
Here I Come**

THE MARK CONSISTS OF STANDARD CHARACTERS WITHOUT CLAIM TO ANY PARTICULAR FONT, STYLE, SIZE, OR COLOR.

CLASS 16—PAPER GOODS AND PRINTED MATTER

FOR CHILDREN'S BOOKS (U.S. CLS. 2, 5, 22, 23, 29, 37, 38 AND 50).

CLASS 25—CLOTHING

FOR SHIRTS (U.S. CLS. 22 AND 39).

CLASS 28—TOYS AND SPORTING GOODS

FOR STUFFED AND PLUSH TOYS (U.S. CLS. 22, 23, 38 AND 50).

PAUL CROWLEY, EXAMINING ATTORNEY

SN 77-427,806. SAVAGE DESIGNS, INC., TOPANGA, CA.
FILED 3-20-2008.

SAVAGE DESIGNS

THE MARK CONSISTS OF STANDARD CHARACTERS WITHOUT CLAIM TO ANY PARTICULAR FONT, STYLE, SIZE, OR COLOR.

NO CLAIM IS MADE TO THE EXCLUSIVE RIGHT TO USE "DESIGNS", APART FROM THE MARK AS SHOWN.

CLASS 24—FABRICS

FOR CURTAINS AND DRAPERIES; TABLE LINENS, NAMELY, TABLE CLOTHS, COASTERS, NAPKINS, PLACE MATS (U.S. CLS. 42 AND 50).

CLASS 27—FLOOR COVERINGS

FOR CARPETS AND RUGS; THROW RUGS; AREA RUGS (U.S. CLS. 19, 20, 37, 42 AND 50).

TANYA AMOS, EXAMINING ATTORNEY

SN 77-427,951. OPEN SPORTS NETWORK, INC., BOCA RATON, FL. FILED 3-20-2008.

The Future of Sports on the Web is OPEN

THE MARK CONSISTS OF STANDARD CHARACTERS WITHOUT CLAIM TO ANY PARTICULAR FONT, STYLE, SIZE, OR COLOR.

CLASS 16—PAPER GOODS AND PRINTED MATTER

FOR PUBLICATIONS, NAMELY, MAGAZINES FEATURING INFORMATION ON SPORTS, NAMELY, NEWS, SCORES, STATISTICS, ODDS, ANALYSIS, EDITORIAL, BLOGS AND FANTASY SPORTS COMPETITIONS, AND IN THE FIELD OF SOCIAL NETWORKING (U.S. CLS. 2, 5, 22, 23, 29, 37, 38 AND 50).

CLASS 25—CLOTHING

FOR CLOTHING, NAMELY, T-SHIRTS, SWEAT-SHIRTS, CAPS, POLO SHIRTS, SWEAT PANTS, HATS (U.S. CLS. 22 AND 39).

CLASS 38—COMMUNICATION

FOR RADIO, TELEVISION AND INTERNET BROADCASTING SERVICES FEATURING INFORMATION ON SPORTS, NAMELY, NEWS, SCORES, STATISTICS, ODDS, ANALYSIS, EDITORIAL, BLOGS AND FANTASY SPORTS COMPETITIONS AND RELATING TO SOCIAL NETWORKING (U.S. CLS. 100, 101 AND 104).

CLASS 41—EDUCATION AND ENTERTAINMENT

FOR ENTERTAINMENT SERVICES IN THE NATURE OF FANTASY SPORTS LEAGUES; SPECIAL EVENT PLANNING (U.S. CLS. 100, 101 AND 107).

CLASS 42—SCIENTIFIC AND COMPUTER SERVICES

FOR COMPUTER SERVICES, NAMELY, CREATING AN ONLINE COMMUNITY FOR REGISTERED USERS TO PARTICIPATE IN SPORTS RELATED ACTIVITIES AND FANTASY SPORTS COMPETITIONS, FORM VIRTUAL COMMUNITIES, ENGAGE IN SOCIAL NETWORKING AND IMPROVE THEIR TALENT (U.S. CLS. 100 AND 101).

CLASS 45—PERSONAL AND LEGAL SERVICES

FOR ONLINE SPORTS THEMED SOCIAL NETWORKING SERVICES (U.S. CLS. 100 AND 101).

TEJBIR SINGH, EXAMINING ATTORNEY

SN 77-427,954. ELINA NUBARYAN, ORLANDO, FL. FILED 3-21-2008.

FROSTIBERRY

THE MARK CONSISTS OF STANDARD CHARACTERS WITHOUT CLAIM TO ANY PARTICULAR FONT, STYLE, SIZE, OR COLOR.

CLASS 30—STAPLE FOODS

FOR FROZEN YOGHURT; FROZEN YOGURT; FROZEN YOGURT MIXES; FROZEN CONFECTIONERY; FROZEN CONFECTIONS; FROZEN CONFECTIONS, NAMELY, FREEZER POPS; FROZEN CUSTARDS; FROZEN DESSERT CONSISTING OF FRUIT AND CREAM OR CREAM SUBSTITUTES; FROZEN FLAVOURED WATERS; FROZEN PIE CRUSTS; ICE CUBES; ICE FOR REFRESHMENT; ICE MILK; ICE MILK BARS; ICE-CREAM; ICE-CREAM CAKES; ICED CAKES; ICED COFFEE; ICED TEA; ICES AND ICE CREAMS; ICING; ICING MIXES; ITALIAN ICE; SHAVED ICE CONFECTIONS; WATER ICE; CREAM PUFFS; EDIBLE FRUIT ICES; EDIBLE ICES; FLAVORED ICES; FRUIT ICE; FRUIT ICE BAR; FRUIT ICES; ICE; ICE CANDIES; ICE CREAM; ICE CREAM DRINKS; ICE CREAM MIXES; ICE CREAM POWDER; ICE CREAM SANDWICHES; ICE CREAM SUBSTITUTE; ICE CREAMS; CONES FOR ICE CREAM; CONES FOR ICECREAM; TEA-BASED BEVERAGES WITH FRUIT FLAVORING; FRUIT CAKES; FRUIT JELLIES; FRUIT PIES; FRUIT SAUCES EXCLUDING CRANBERRY SAUCE AND APPLESAUCE; FRUIT TEAS; FRUIT TURNOVERS; APPLE TURNOVERS; CANDY COATED APPLES; BEVERAGES MADE OF TEA; BLACK TEA; COFFEE AND TEA; FLAVOURINGS OF TEA; GREEN TEA; HERB TEA; HERBAL TEA; JAPANESE GREEN TEA; LIME TEA; TEA; TEA FOR INFUSIONS; BEVERAGES MADE OF COFFEE; CAFFEINE-FREE COFFEE; PREPARED COFFEE AND COFFEE-BASED BEVERAGES; CHOCOLATE FOOD BEVERAGES NOT BEING DAIRY-BASED OR VEGETABLE BASED; BASES FOR MAKING MILK SHAKES; COCOA BEVERAGES WITH MILK; COFFEE BEVERAGES WITH MILK; COFFEE-BASED BEVERAGE CONTAINING MILK; MILK CHOCOLATE; MILK SHAKES; COCOA-BASED BEVERAGES; COFFEE BASED BEVERAGES; COFFEE-BASED BEVERAGES; PREPARED COCOA AND COCOA-BASED BEVERAGES; SHAKES; CANDY BARS; CHOCOLATE BARS; CHOCOLATE-BASED READY-TO-EAT FOOD BARS; GRANOLA-BASED SNACK BARS; READY TO EAT, CEREAL DERIVED FOOD BARS; COFFEE; COFFEE AND ARTIFICIAL COFFEE; COFFEE AND COFFEE SUBSTITUTES (U.S. CL. 46).

CLASS 43—HOTEL AND RESTAURANT SERVICES

FOR CAFE; CAFE AND RESTAURANT SERVICES; CAFE-RESTAURANTS; CAFES; RESTAURANT AND CAFE SERVICES; CAFETERIA AND RESTAURANT SERVICES; CARRY-OUT RESTAURANTS; FAST FOOD AND NON-STOP RESTAURANT SERVICES; FAST-FOOD RESTAURANTS; FAST-FOOD RESTAURANTS AND SNACKBARS; ICE CREAM SHOP SERVICES IN THE NATURE OF A RESTAURANT; RESTAURANT; RESTAURANT SERVICES; RESTAURANTS; SELF SERVICE RESTAURANTS; SELF-SERVICE RESTAURANTS; TAKE-OUT RESTAURANT SERVICES; RESTAURANT SERVICES, INCLUDING SIT-DOWN SERVICE OF FOOD AND TAKE-OUT RESTAURANT SERVICES; COFFEE SHOPS; COFFEE-HOUSE AND SNACK-BAR SERVICES; DAIRY BAR SERVICES; CATERING OF FOOD AND DRINKS; PROVIDING OF FOOD AND DRINK; SERVING FOOD AND DRINKS; SERVING OF FOOD AND DRINK/BEVERAGES; JUICE BAR SERVICES; RESTAURANT AND BAR SERVICES; RESTAURANT, BAR AND CATERING SERVICES; SNACK BARS; SNACK-BARS (U.S. CLS. 100 AND 101).

LAURIE KAUFMAN, EXAMINING ATTORNEY

SN 77-428,033. HEAD, ANTHONY C, SAN MARCOS, TX. FILED 3-21-2008.

The Armchair Oenophile

THE MARK CONSISTS OF STANDARD CHARACTERS WITHOUT CLAIM TO ANY PARTICULAR FONT, STYLE, SIZE, OR COLOR.

NO CLAIM IS MADE TO THE EXCLUSIVE RIGHT TO USE "OENOPHILE", APART FROM THE MARK AS SHOWN.

CLASS 41—EDUCATION AND ENTERTAINMENT

FOR PUBLICATION AND EDITING OF PRINTED MATTER; PUBLICATION OF BOOKS, MAGAZINES, ALMANACS AND JOURNALS; PUBLICATION OF TEXTS, BOOKS, MAGAZINES AND OTHER PRINTED MATTER; PUBLISHING OF BOOKS AND REVIEWS (U.S. CLS. 100, 101 AND 107).

CLASS 43—HOTEL AND RESTAURANT SERVICES

FOR PROVIDING INFORMATION ABOUT WINE CHARACTERISTICS; PROVIDING INFORMATION, NEWS AND COMMENTARY IN THE FIELD OF DINING; SOMMELIER SERVICES, NAMELY, PROVIDING ADVICE ON WINE AND WINE AND FOOD PAIRING (U.S. CLS. 100 AND 101).

CHARLES L. JENKINS, EXAMINING ATTORNEY

SN 77-428,041. ITOOKTHISONMYPHONE.COM, INC., CINCINNATI, OH. FILED 3-21-2008.

A LIFETIME OF MOBILE PHOTOS IN ONE SAFE PLACE

THE MARK CONSISTS OF STANDARD CHARACTERS WITHOUT CLAIM TO ANY PARTICULAR FONT, STYLE, SIZE, OR COLOR.

CLASS 38—COMMUNICATION

FOR COMPUTER AIDED TRANSMISSION OF INFORMATION AND IMAGES (U.S. CLS. 100, 101 AND 104). FIRST USE 10-25-2007; IN COMMERCE 10-25-2007.

CLASS 39—TRANSPORTATION AND STORAGE

FOR STORAGE SERVICES FOR ARCHIVING DATABASES, IMAGES AND OTHER ELECTRONIC DATA (U.S. CLS. 100 AND 105).

FIRST USE 10-25-2007; IN COMMERCE 10-25-2007.

CLASS 42—SCIENTIFIC AND COMPUTER SERVICES

FOR COMPUTER SERVICES, NAMELY, INTERACTIVE HOSTING SERVICES WHICH ALLOW THE USER TO PUBLISH AND SHARE THEIR OWN CONTENT AND IMAGES ON-LINE (U.S. CLS. 100 AND 101).

FIRST USE 10-25-2007; IN COMMERCE 10-25-2007.

LEIGH CAROLINE CASE, EXAMINING ATTORNEY

SN 77-428,081. RESTAHEAD HOLDING APS, SKODSBORG, DENMARK, FILED 3-21-2008.

RESTAHEAD

THE MARK CONSISTS OF STANDARD CHARACTERS WITHOUT CLAIM TO ANY PARTICULAR FONT, STYLE, SIZE, OR COLOR.

CLASS 20—FURNITURE AND ARTICLES NOT OTHERWISE CLASSIFIED

FOR PILLOWS, NAMELY, HEAD AND NECK SUPPORTING PILLOWS (U.S. CLS. 2, 13, 22, 25, 32 AND 50).

CLASS 24—FABRICS

FOR PILLOW CASES AND PILLOW COVERS (U.S. CLS. 42 AND 50).

BRENDAN MCCAULEY, EXAMINING ATTORNEY

SN 77-428,143. ALWAYS BELIEVE IN CHILDREN, LLC, FINKSBURG, MD. FILED 3-21-2008.

Always
Believe in
Children

CLASS 41—EDUCATION AND ENTERTAINMENT

FOR SUMMER CAMPS (U.S. CLS. 100, 101 AND 107).

CLASS 43—HOTEL AND RESTAURANT SERVICES

FOR CHILD CARE SERVICES (U.S. CLS. 100 AND 101). RAUL CORDOVA, EXAMINING ATTORNEY

SN 77-428,157. FIBE, LLC, ATLANTA, GA. FILED 3-21-2008.

FIBE

THE MARK CONSISTS OF STANDARD CHARACTERS WITHOUT CLAIM TO ANY PARTICULAR FONT, STYLE, SIZE, OR COLOR.

CLASS 5—PHARMACEUTICALS

FOR NUTRITIONAL AND/OR VITAMIN ENRICHED WATER (U.S. CLS. 6, 18, 44, 46, 51 AND 52).

CLASS 32—LIGHT BEVERAGES

FOR BOTTLED WATER (U.S. CLS. 45, 46 AND 48). TOBY BULLOFF, EXAMINING ATTORNEY

SN 77-428,308. REDBONE, INC., FLORENCE, SC. FILED 3-21-2008.

REDBONE ALLEY

THE MARK CONSISTS OF STANDARD CHARACTERS WITHOUT CLAIM TO ANY PARTICULAR FONT, STYLE, SIZE, OR COLOR.
OWNER OF U.S. REG. NO. 1,829,734.

CLASS 29—MEATS AND PROCESSED FOODS

FOR COMPOUND BUTTER, NAMELY, FLAVORED BUTTER IN THE NATURE OF DIJON HORSERADISH BUTTER, SCAMPI BUTTER, LEMON HERB BUTTER, AND BLUE CHEESE PEPPERCORN BUTTER (U.S. CL. 46).

FIRST USE 2-1-2007; IN COMMERCE 3-14-2008.

CLASS 30—STAPLE FOODS

FOR RUBBING SPICES, CONDIMENTS, NAMELY, AIOLI AND FLAVORED MAYONNAISE (U.S. CL. 46). FIRST USE 8-20-2007; IN COMMERCE 9-13-2007. JAY FLOWERS, EXAMINING ATTORNEY

SN 77-428,315. THE WELLNESS COMMUNITY, WASHINGTON, DC. FILED 3-21-2008.

THE WELLNESS COMMUNITY
INTERNATIONAL

THE MARK CONSISTS OF STANDARD CHARACTERS WITHOUT CLAIM TO ANY PARTICULAR FONT, STYLE, SIZE, OR COLOR.

OWNER OF U.S. REG. NO. 2,881,398.

NO CLAIM IS MADE TO THE EXCLUSIVE RIGHT TO USE "INTERNATIONAL", APART FROM THE MARK AS SHOWN.

SEC. 2(F) AS TO THE WELLNESS COMMUNITY.

CLASS 41—EDUCATION AND ENTERTAINMENT

FOR EDUCATIONAL SERVICES, NAMELY, CONDUCTING LECTURES, PROGRAMS AND SEMINARS IN THE SOCIAL AND PSYCHOLOGICAL TREATMENT OF CANCER AND OTHER MEDICAL CONDITIONS (U.S. CLS. 100, 101 AND 107).

CLASS 44—MEDICAL, BEAUTY AND AGRICULTURAL SERVICES

FOR PROVIDING PSYCHO-SOCIAL GROUP COUNSELING REGARDING THE PHYSICAL, SOCIAL, AND PSYCHOLOGICAL TREATMENT OF CANCER (U.S. CLS. 100 AND 101).

AMEETA JORDAN, EXAMINING ATTORNEY

SN 77-428,377. NGUYEN, THUY THI BICH, DBA OOH, INC, OKLAHOMA CITY, OK. FILED 3-21-2008.

OBSSESSED OVER HAIR OOH

THE MARK CONSISTS OF STANDARD CHARACTERS WITHOUT CLAIM TO ANY PARTICULAR FONT, STYLE, SIZE, OR COLOR.

CLASS 3—COSMETICS AND CLEANING PREPARATIONS

FOR HAIR BLEACHING PREPARATIONS; HAIR CARE CREAMS; HAIR CARE LOTIONS; HAIR CARE PREPARATIONS; HAIR CLEANING PREPARATIONS; HAIR COLORING PREPARATIONS; HAIR CONDITIONERS; HAIR DRESSINGS FOR MEN; HAIR DRESSINGS FOR WOMEN; HAIR DYE; HAIR EMOLLIENTS; HAIR FROSTS; HAIR GEL AND HAIR MOUSSE; HAIR LIGHTENERS; HAIR LOTION; HAIR MOUSSE; HAIR NOURISHERS; HAIR RELAXING PREPARATIONS; HAIR SHAMPOOS AND CONDITIONERS; HAIR SPRAY (U.S. CLS. 1, 4, 6, 50, 51 AND 52).

CLASS 44—MEDICAL, BEAUTY AND AGRICULTURAL SERVICES

FOR BEAUTY SALONS; HAIR SALON SERVICES; HAIR SALON SERVICES, NAMELY, HAIR CUTTING, STYLING, COLORING, AND HAIR EXTENSION SERVICES; HAIR SALON SERVICES, NAMELY, TREATMENTS TO PROTECT HAIR FROM EFFECTS OF EXPOSURE TO SUNLIGHT, HEAT, HUMIDITY AND CHLORINATED WATER; HAIRDRESSING SALONS; NAIL CARE SALONS; SALON SERVICES, NAMELY, FACIALS, MANICURES AND MASSAGES THAT ARE PROVIDED IN A TRAILER OUTFITTED WITH CHAIR, TABLE AND SINK ACCESSORIES; SKIN CARE SALONS (U.S. CLS. 100 AND 101).

FIRST USE 8-1-2004; IN COMMERCE 8-1-2004.
SANJEEV VOHRA, EXAMINING ATTORNEY

SN 77-428,396. DAVID R. BONOMI & ASSOCIATES, INC., AUSTIN, TX. FILED 3-21-2008.

PHASE 2 LEADERSHIP

THE MARK CONSISTS OF STANDARD CHARACTERS WITHOUT CLAIM TO ANY PARTICULAR FONT, STYLE, SIZE, OR COLOR.

NO CLAIM IS MADE TO THE EXCLUSIVE RIGHT TO USE "LEADERSHIP", APART FROM THE MARK AS SHOWN.

CLASS 35—ADVERTISING AND BUSINESS

FOR BUSINESS LEADERSHIP, MANAGEMENT, AND ORGANIZATION CONSULTING (U.S. CLS. 100, 101 AND 102).

CLASS 41—EDUCATION AND ENTERTAINMENT

FOR LEADERSHIP AND MANAGEMENT TRAINING (U.S. CLS. 100, 101 AND 107).
LINDSEY RUBIN, EXAMINING ATTORNEY

SN 77-428,419. ARTHRODYNAMIC TECHNOLOGIES, ANIMAL HEALTH DIVISION, INC., DBA ARTHRODYNAMIC TECHNOLOGIES, LLC, LEXINGTON, KY. FILED 3-21-2008.

ARTHRODYNAMIC

THE MARK CONSISTS OF STANDARD CHARACTERS WITHOUT CLAIM TO ANY PARTICULAR FONT, STYLE, SIZE, OR COLOR.

CLASS 5—PHARMACEUTICALS

FOR PHARMACEUTICAL PREPARATIONS FOR USE IN THE PREVENTION AND TREATMENT OF OSTEOARTHRITIS, OSTEOCHONDROSIS DESSICANS, SYNOVITIS, INFLAMMATORY ARTHRITIS, SEPTIC ARTHRITIS, DEGENERATIVE JOINT DISEASE, INFLAMMATION AND SURGICAL TRAUMA (U.S. CLS. 6, 18, 44, 46, 51 AND 52).

FIRST USE 1-0-2006; IN COMMERCE 1-0-2006.

CLASS 42—SCIENTIFIC AND COMPUTER SERVICES

FOR RESEARCH AND DEVELOPMENT IN THE FIELD OF PHARMACEUTICALS (U.S. CLS. 100 AND 101).

FIRST USE 1-0-2006; IN COMMERCE 1-0-2006.
JOHN WILKE, EXAMINING ATTORNEY

SN 77-428,562. M.J.C. TEXTILE, INC., LOS ANGELES, CA. FILED 3-21-2008.

MJC

THE MARK CONSISTS OF STANDARD CHARACTERS WITHOUT CLAIM TO ANY PARTICULAR FONT, STYLE, SIZE, OR COLOR.

CLASS 25—CLOTHING

FOR DRESS SHIRTS; SHIRTS; SHORT-SLEEVED OR LONG-SLEEVED T-SHIRTS; SPORTS SHIRTS; SWEAT SHIRTS; T-SHIRTS; SHORTS; SWEATERS; PANTS; JEANS; JACKETS; COATS; BRIEFS; UNDERWEAR; NECKWEAR; FOOTWEAR; HEADWEAR; HATS; SOCKS (U.S. CLS. 22 AND 39).

FIRST USE 9-1-2007; IN COMMERCE 9-1-2007.

CLASS 35—ADVERTISING AND BUSINESS

FOR ON-LINE RETAIL STORE SERVICES FEATURING CLOTHING; RETAIL CLOTHING STORES; WHOLESALE DISTRIBUTORSHIPS FEATURING CLOTHING; WHOLESALE STORES FEATURING CLOTHING (U.S. CLS. 100, 101 AND 102).

FIRST USE 12-1-2007; IN COMMERCE 12-1-2007.
BRIAN CALLAGHAN, EXAMINING ATTORNEY

SN 77-428,580. CLEAR CHANNEL BROADCASTING, INC.,
SAN ANTONIO, TX. FILED 3-21-2008.

SN 77-428,588. CLEAR CHANNEL BROADCASTING, INC.,
SAN ANTONIO, TX. FILED 3-21-2008.

I HEART MUSIC

THE MARK CONSISTS OF STANDARD CHARACTERS WITHOUT CLAIM TO ANY PARTICULAR FONT, STYLE, SIZE, OR COLOR.

NO CLAIM IS MADE TO THE EXCLUSIVE RIGHT TO USE "MUSIC", APART FROM THE MARK AS SHOWN.

CLASS 38—COMMUNICATION

FOR BROADCASTING SERVICES VIA THE RADIO, TELEVISION, AND THE WORLDWIDE WEB; TELECOMMUNICATIONS SERVICES, NAMELY, PROVIDING TRANSMISSION OF VOICE, DATA, VIDEO, AND MEDIA CONTENT VIA A GLOBAL COMPUTER NETWORK (U.S. CLS. 100, 101 AND 104).

CLASS 41—EDUCATION AND ENTERTAINMENT

FOR ENTERTAINMENT SERVICES, NAMELY, PROVIDING A WEB SITE FEATURING MUSICAL PERFORMANCES, MUSICAL VIDEOS, RELATED FILM CLIPS, PHOTOGRAPHS, AND OTHER MULTIMEDIA MATERIALS; PROVIDING PRERECORDED MUSIC, INFORMATION IN THE FIELD OF MUSIC, AND COMMENTARY AND ARTICLES ABOUT MUSIC, ALL ON-LINE VIA A GLOBAL COMPUTER NETWORK (U.S. CLS. 100, 101 AND 107).

APRIL HESIK, EXAMINING ATTORNEY

SN 77-428,583. CLEAR CHANNEL BROADCASTING, INC.,
SAN ANTONIO, TX. FILED 3-21-2008.

I HEART GOSSIP

THE MARK CONSISTS OF STANDARD CHARACTERS WITHOUT CLAIM TO ANY PARTICULAR FONT, STYLE, SIZE, OR COLOR.

CLASS 38—COMMUNICATION

FOR BROADCASTING SERVICES VIA THE RADIO, TELEVISION, AND THE WORLDWIDE WEB; TELECOMMUNICATIONS SERVICES, NAMELY, PROVIDING TRANSMISSION OF VOICE, DATA, VIDEO, AND MEDIA CONTENT VIA A GLOBAL COMPUTER NETWORK (U.S. CLS. 100, 101 AND 104).

CLASS 41—EDUCATION AND ENTERTAINMENT

FOR ENTERTAINMENT SERVICES, NAMELY, PROVIDING A WEB SITE FEATURING MUSICAL PERFORMANCES, MUSICAL VIDEOS, RELATED FILM CLIPS, PHOTOGRAPHS, AND OTHER MULTIMEDIA MATERIALS; PROVIDING PRERECORDED MUSIC, INFORMATION IN THE FIELD OF MUSIC, AND COMMENTARY AND ARTICLES ABOUT MUSIC, ALL ON-LINE VIA A GLOBAL COMPUTER NETWORK (U.S. CLS. 100, 101 AND 107).

APRIL HESIK, EXAMINING ATTORNEY

I ♥ GOSSIP

THE MARK CONSISTS OF A HEART DESIGN SURROUNDED BY THE WORDS "I" AND "GOSSIP".

CLASS 38—COMMUNICATION

FOR BROADCASTING SERVICES VIA THE RADIO, TELEVISION, AND THE WORLDWIDE WEB; TELECOMMUNICATIONS SERVICES, NAMELY, PROVIDING TRANSMISSION OF VOICE, DATA, VIDEO, AND MEDIA CONTENT VIA A GLOBAL COMPUTER NETWORK (U.S. CLS. 100, 101 AND 104).

CLASS 41—EDUCATION AND ENTERTAINMENT

FOR ENTERTAINMENT SERVICES, NAMELY, PROVIDING A WEB SITE FEATURING MUSICAL PERFORMANCES, MUSICAL VIDEOS, RELATED FILM CLIPS, PHOTOGRAPHS, AND OTHER MULTIMEDIA MATERIALS; PROVIDING PRERECORDED MUSIC, INFORMATION IN THE FIELD OF MUSIC, AND COMMENTARY AND ARTICLES ABOUT MUSIC, ALL ON-LINE VIA A GLOBAL COMPUTER NETWORK (U.S. CLS. 100, 101 AND 107).

APRIL HESIK, EXAMINING ATTORNEY

SN 77-428,590. CLEAR CHANNEL BROADCASTING, INC.,
SAN ANTONIO, TX. FILED 3-21-2008.

IHEARTMUSIC.COM

THE MARK CONSISTS OF STANDARD CHARACTERS WITHOUT CLAIM TO ANY PARTICULAR FONT, STYLE, SIZE, OR COLOR.

CLASS 38—COMMUNICATION

FOR BROADCASTING SERVICES VIA THE RADIO, TELEVISION, AND THE WORLDWIDE WEB; TELECOMMUNICATIONS SERVICES, NAMELY, PROVIDING TRANSMISSION OF VOICE, DATA, VIDEO, AND MEDIA CONTENT VIA A GLOBAL COMPUTER NETWORK (U.S. CLS. 100, 101 AND 104).

CLASS 41—EDUCATION AND ENTERTAINMENT

FOR ENTERTAINMENT SERVICES, NAMELY, PROVIDING A WEB SITE FEATURING MUSICAL PERFORMANCES, MUSICAL VIDEOS, RELATED FILM CLIPS, PHOTOGRAPHS, AND OTHER MULTIMEDIA MATERIALS; PROVIDING PRERECORDED MUSIC, INFORMATION IN THE FIELD OF MUSIC, AND COMMENTARY AND ARTICLES ABOUT MUSIC, ALL ON-LINE VIA A GLOBAL COMPUTER NETWORK (U.S. CLS. 100, 101 AND 107).

APRIL HESIK, EXAMINING ATTORNEY

SN 77-428,610. ARNOLD, SUZZAN HUNT, CARMICHAEL,
CA. FILED 3-21-2008.

SN 77-428,691. ARCTIC STORM, INC., SEATTLE, WA. FILED
3-21-2008.



CHRISTOPHER HUNT

THE NAME IN THE MARK "CHRISTOPHER HUNT"
DOES NOT IDENTIFY A LIVE INDIVIDUAL.

THE MARK CONSISTS OF A NAME, "CHRISTOPHER
HUNT", INITIALS "CH", AND A LINE DESIGN.

CLASS 14—JEWELRY

FOR JEWELRY, BRACELETS, RINGS, NECKLACES
(U.S. CLS. 2, 27, 28 AND 50).

CLASS 18—LEATHER GOODS

FOR LEATHER GOODS, NAMELY, PURSES (U.S. CLS.
1, 2, 3, 22 AND 41).
RICHARD A. STRASER, EXAMINING ATTORNEY



OWNER OF U.S. REG. NO. 1,471,541.

CLASS 29—MEATS AND PROCESSED FOODS

FOR SEAFOOD, NAMELY, WHOLE FISH, DRESSED
FISH, FISH FILLETS, MINCED FISH, AND FISH ROE
(U.S. CL. 46).

FIRST USE 2-0-1987; IN COMMERCE 2-0-1987.

CLASS 31—NATURAL AGRICULTURAL PRO- DUCTS

FOR FISH MEAL FOR ANIMAL FEED (U.S. CLS. 1
AND 46).

FIRST USE 2-0-1987; IN COMMERCE 2-0-1987.

ANDREA HACK, EXAMINING ATTORNEY

SN 77-428,688. ARCTIC STORM, INC., SEATTLE, WA. FILED
3-21-2008.

ARCTIC STORM

THE MARK CONSISTS OF STANDARD CHARACTERS
WITHOUT CLAIM TO ANY PARTICULAR FONT, STYLE,
SIZE, OR COLOR.

OWNER OF U.S. REG. NO. 1,474,339.

CLASS 29—MEATS AND PROCESSED FOODS

FOR SEAFOOD, NAMELY, WHOLE FISH, DRESSED
FISH, FISH FILLETS, MINCED FISH, AND FISH ROE
(U.S. CL. 46).

FIRST USE 2-0-1987; IN COMMERCE 2-0-1987.

CLASS 31—NATURAL AGRICULTURAL PRO- DUCTS

FOR FISH MEAL FOR ANIMAL FEED (U.S. CLS. 1
AND 46).

FIRST USE 2-0-1987; IN COMMERCE 2-0-1987.

ANDREA HACK, EXAMINING ATTORNEY

SN 77-428,706. SPIRITUAL CINEMA, INC., BROOMFIELD,
CO. FILED 3-21-2008.

EARTH CINEMA CIRCLE

THE MARK CONSISTS OF STANDARD CHARACTERS
WITHOUT CLAIM TO ANY PARTICULAR FONT, STYLE,
SIZE, OR COLOR.

NO CLAIM IS MADE TO THE EXCLUSIVE RIGHT TO
USE "CINEMA", APART FROM THE MARK AS SHOWN.

CLASS 9—ELECTRICAL AND SCIENTIFIC APPARATUS

FOR PRE-RECORDED AUDIO-VISUAL PRODUCTS,
NAMELY, VIDEOCASSETTES, VIDEOTAPES, DIGITAL
VIDEO DISKS, AND MOTION PICTURE FILMS FEAT-
URING DOCUMENTARY, COMEDY, DRAMA, AC-
TION, THRILLER, MUSIC, ADVENTURE AND/OR
ANIMATION (U.S. CLS. 21, 23, 26, 36 AND 38).

CLASS 35—ADVERTISING AND BUSINESS

FOR PROVIDING MAIL-ORDER DVD CLUB SER-
VICES TO OTHERS; COMPUTERIZED ON-LINE RETAIL
STORE SERVICES IN THE FIELD OF DOWNLOADABLE
SOUND, MUSIC, IMAGE, VIDEO AND GAME FILES
(U.S. CLS. 100, 101 AND 102).

CLASS 38—COMMUNICATION

FOR VIDEO-ON-DEMAND TRANSMISSION SERVICES; VIDEO BROADCASTING; ELECTRONIC TRANSMISSION OF VOICE, DATA, IMAGES, SIGNALS, MESSAGES AND INFORMATION; STREAMING OF MOTION PICTURE FILMS FEATURING DOCUMENTARY, COMEDY, DRAMA, ACTION, THRILLER, MUSIC, ADVENTURE AND/OR ANIMATION OVER THE INTERNET; CABLE, SATELLITE AND OVER-THE-AIR TELEVISION BROADCASTING (U.S. CLS. 100, 101 AND 104).

CHARLES L. JENKINS, EXAMINING ATTORNEY



SN 77-428,867. MARTINEZ, LYNNA, MONTCLAIR, NJ. FILED 3-22-2008.

quick but authentic

THE MARK CONSISTS OF STANDARD CHARACTERS WITHOUT CLAIM TO ANY PARTICULAR FONT, STYLE, SIZE, OR COLOR.

CLASS 35—ADVERTISING AND BUSINESS

FOR ON-LINE ORDERING SERVICES IN THE FIELD OF RESTAURANT TAKE-OUT AND DELIVERY; RESTAURANT FRANCHISING (U.S. CLS. 100, 101 AND 102).

CLASS 43—HOTEL AND RESTAURANT SERVICES

FOR RESTAURANT SERVICES (U.S. CLS. 100 AND 101).

KEVIN DINALLO, EXAMINING ATTORNEY



SN 77-428,877. GREGG APPLIANCES, INC., INDIANAPOLIS, IN. FILED 3-22-2008.

HHGREGG

THE MARK CONSISTS OF STANDARD CHARACTERS WITHOUT CLAIM TO ANY PARTICULAR FONT, STYLE, SIZE, OR COLOR.

CLASS 35—ADVERTISING AND BUSINESS

FOR ON-LINE RETAIL STORE SERVICES FEATURING CONSUMER APPLIANCES, ELECTRONICS, PHOTOGRAPHIC EQUIPMENT, TELECOMMUNICATION EQUIPMENT, VIDEO EQUIPMENT, AUDIO EQUIPMENT, SATELLITE RECEIVING EQUIPMENT, HOME OFFICE EQUIPMENT, CAR EQUIPMENT, COMPUTER HARDWARE, COMPUTER SOFTWARE, ENTERTAINMENT SOFTWARE, AND RELATED EQUIPMENT AND MERCHANDISE; RETAIL STORE SERVICES FEATURING CONSUMER APPLIANCES, ELECTRONICS, PHOTOGRAPHIC EQUIPMENT, TELECOMMUNICATION EQUIPMENT, VIDEO EQUIPMENT, AUDIO EQUIPMENT, SATELLITE RECEIVING EQUIPMENT, HOME OFFICE EQUIPMENT, CAR EQUIPMENT, COMPUTER HARDWARE, COMPUTER SOFTWARE, ENTERTAINMENT SOFTWARE, AND RELATED EQUIPMENT AND MERCHANDISE (U.S. CLS. 100, 101 AND 102).

FIRST USE 12-0-1999; IN COMMERCE 12-0-1999.

CLASS 36—INSURANCE AND FINANCIAL

FOR CREDIT CARD SERVICES; PROVIDING EXTENDED WARRANTIES ON ON ELECTRONICS, EQUIPMENT, APPLIANCES, COMPUTERS AND RELATED MERCHANDISE; FACILITATING AND ARRANGING FOR THE FINANCING OF ELECTRONICS, EQUIPMENT, APPLIANCES, COMPUTERS AND RELATED MERCHANDISE (U.S. CLS. 100, 101 AND 102).

FIRST USE 12-0-1999; IN COMMERCE 12-0-1999.

CLASS 37—CONSTRUCTION AND REPAIR

FOR INSTALLATION, MAINTENANCE AND REPAIR OF ELECTRONICS, EQUIPMENT, APPLIANCES, COMPUTERS AND RELATED MERCHANDISE (U.S. CLS. 100, 103 AND 106).

FIRST USE 12-0-1999; IN COMMERCE 12-0-1999.

CLASS 39—TRANSPORTATION AND STORAGE

FOR DISTRIBUTION SERVICES, NAMELY, DELIVERY OF ELECTRONICS, EQUIPMENT, APPLIANCES, COMPUTERS AND RELATED MERCHANDISE (U.S. CLS. 100 AND 105).

FIRST USE 12-0-1999; IN COMMERCE 12-0-1999.

DAVID TAYLOR, EXAMINING ATTORNEY



SN 77-428,955. LANGER, JANET, SHERMAN OAKS, CA. FILED 3-22-2008.

Funkanometry

THE MARK CONSISTS OF STANDARD CHARACTERS WITHOUT CLAIM TO ANY PARTICULAR FONT, STYLE, SIZE, OR COLOR.

CLASS 25—CLOTHING

FOR BALLROOM DANCING SHOES; DANCE COSTUMES; DANCE SHOES (U.S. CLS. 22 AND 39).

CLASS 41—EDUCATION AND ENTERTAINMENT

FOR DANCE EVENTS; DANCE INSTRUCTION; DANCE INSTRUCTION FOR CHILDREN; DANCE SCHOOLS; DANCE STUDIOS; ENTERTAINMENT IN THE NATURE OF DANCE PERFORMANCES; ENTERTAINMENT IN THE NATURE OF VISUAL AND AUDIO PERFORMANCES, NAMELY, MUSICAL BAND, ROCK GROUP, GYMNASTIC, DANCE, AND BALLET PERFORMANCES; ORGANIZATION OF DANCING EVENTS; ORGANIZING COMMUNITY FESTIVALS FEATURING A VARIETY OF ACTIVITIES, NAMELY, ART EXHIBITIONS, HERITAGE MARKETS, ETHNIC DANCES, AND THE LIKE; ORGANIZING COMMUNITY FESTIVALS FEATURING A VARIETY OF ACTIVITIES, NAMELY, SPORTING EVENTS, ART EXHIBITIONS, FLEA MARKETS, ETHNIC DANCES AND THE LIKE; PROVIDING DANCE HALLS; RENTAL OF DANCE FLOORS; TRAINING OF DANCE INSTRUCTORS (U.S. CLS. 100, 101 AND 107).

KARANENDRA S. CHHINA, EXAMINING ATTORNEY

SN 77-429,007. NAZARI, JOSEPH, CHATSWORTH, CA. FILED 3-23-2008.

EchoMate

THE MARK CONSISTS OF STANDARD CHARACTERS WITHOUT CLAIM TO ANY PARTICULAR FONT, STYLE, SIZE, OR COLOR.

CLASS 16—PAPER GOODS AND PRINTED MATTER

FOR CORRUGATED BOARD; CORRUGATED CARDBOARD; CORRUGATED PAPER; LINERBOARD FOR CORRUGATED CARDBOARD (U.S. CLS. 2, 5, 22, 23, 29, 37, 38 AND 50).

CLASS 20—FURNITURE AND ARTICLES NOT OTHERWISE CLASSIFIED

FOR COMMERCIAL PACKAGING MATERIALS, NAMELY, CORRUGATED PLASTIC BINS; COMMERCIAL PACKAGING MATERIALS, NAMELY, CORRUGATED PLASTIC BOXES; COMMERCIAL PACKAGING MATERIALS, NAMELY, CORRUGATED PLASTIC TRAYS; HANGERS FOR CLOTHES (U.S. CLS. 2, 13, 22, 25, 32 AND 50).

CYNTHIA TRIPI, EXAMINING ATTORNEY

SN 77-429,055. KASARJIAN, JACK ALBERT, CAMARILLO, CA. FILED 3-23-2008.

XProTeX

THE MARK CONSISTS OF STANDARD CHARACTERS WITHOUT CLAIM TO ANY PARTICULAR FONT, STYLE, SIZE, OR COLOR.

CLASS 9—ELECTRICAL AND SCIENTIFIC APPARATUS

FOR GLOVES FOR PROTECTION AGAINST ACCIDENTS; PROTECTIVE GLOVES FOR INDUSTRIAL USE; PROTECTIVE WORK GLOVES; HARD HATS; BASEBALL BATTING HELMETS; CATCHERS' HELMETS; CLOTHING FOR PROTECTION AGAINST ACCIDENTS, IRRADIATION AND FIRE; PROTECTIVE ARMOR PANELS FOR PROTECTING AGAINST BALLISTIC PROJECTILES AND EXPLOSIVE FRAGMENTS INSTALLED IN OR ATTACHED TO VEHICLES, BUILDINGS OR OTHER STRUCTURES; PROTECTIVE CLOTHING; PROTECTIVE CLOTHING AND HEADGEAR; PROTECTIVE EAR COVERINGS; PROTECTIVE EYE PIECES; PROTECTIVE EYEGLASSES; PROTECTIVE EYEWEAR; PROTECTIVE EYEWEAR AND COMPONENT PARTS THEREOF; PROTECTIVE FACE-SHIELDS FOR PROTECTIVE HELMETS; PROTECTIVE HEAD GUARDS FOR INDUSTRIAL PURPOSES; PROTECTIVE HEADGEAR FOR BOXING; PROTECTIVE HELMETS; PROTECTIVE HELMETS FOR SPORTS (U.S. CLS. 21, 23, 26, 36 AND 38).

CLASS 17—RUBBER GOODS

FOR PADDING FOR IMPACT PROTECTION, COMFORT AND FIT, COMPOSED OF BONDED MICROSPHERES USED IN INDUSTRY; PLASTIC PADDING FOR IMPACT PROTECTION (U.S. CLS. 1, 5, 12, 13, 35 AND 50).

CLASS 18—LEATHER GOODS

FOR HORSE FLANKS AND SHANKS, NAMELY, HORSE PROTECTIVE PADDING, BRACES, AND LEG BOOTS FOR THE FLANKS AND LEGS (U.S. CLS. 1, 2, 3, 22 AND 41).

CLASS 21—HOUSEWARES AND GLASS

FOR WORK GLOVES (U.S. CLS. 2, 13, 23, 29, 30, 33, 40 AND 50).

CLASS 25—CLOTHING

FOR BICYCLE GLOVES; BICYCLING GLOVES; CROSS-COUNTRY GLOVES; GLOVES; GLOVES INCLUDING THOSE MADE OF SKIN, HIDE OR FUR; MOTORCYCLE GLOVES; OUTDOOR GLOVES; RIDING GLOVES; SKI GLOVES; SNOWBOARD GLOVES; BASEBALL CAPS; CAPS; HEADGEAR, NAMELY, CAPS AND HATS USED IN SPORTS AND RECREATION ACTIVITIES; SKULL CAPS; TOBOGGAN HATS, PANTS AND CAPS; HATS; LONG-SLEEVED SHIRTS; RUGBY SHIRTS; SPORT SHIRTS; SPORTS SHIRTS; SPORTS SHIRTS WITH SHORT SLEEVES; SWEAT SHIRTS; T-SHIRTS; TEE SHIRTS; BOARD SHORTS; GYM SHORTS; RUGBY SHORTS; SHORTS; SLIDING SHORTS; SWEAT SHORTS; UNDERWEAR, NAMELY, BOY SHORTS; PANTS; SKI PANTS; SNOW PANTS; SNOWBOARD PANTS; SWEAT PANTS; FITTED SHOE OR BOOT COVERING TO PROTECT THE SHOES OR BOOT FROM WATER OR OTHER DAMAGE (U.S. CLS. 22 AND 39).

CLASS 28—TOYS AND SPORTING GOODS

FOR BASEBALL BATTING GLOVES; BASEBALL GLOVES; BATTING GLOVES; GOALKEEPERS' GLOVES; HANDBALL GLOVES; HOCKEY GLOVES; RACQUET BALL GLOVES; SOFTBALL GLOVES; WATERSKI GLOVES; WINDSURFING GLOVES; WORK-OUT GLOVES; GRIP TAPES FOR BASEBALL BATS; CATCHERS' MASKS; CATCHERS' MITTS; CHEST PROTECTORS; CHEST PROTECTORS FOR SPORTS; FOOTBALL BODY PROTECTORS; FOOTBALL CHEST PADS; THROAT PROTECTORS FOR ATHLETIC USE; ARM GUARDS FOR ATHLETIC USE; ATHLETIC EQUIPMENT, NAMELY, GUARDS FOR THE MOUTH, THE NOSE, THE CHIN, SHOULDERS, ELBOWS, RIBS, HEART, HIPS, KNEES, SHINS, AND FOOT USED IN BASEBALL, SOFTBALL, HOCKEY, LACROSSE, EQUESTRIAN, MILITARY, SKIING, SNOWBOARDING, ALL CONTACT SPORTS, MOTOR SPORTS, BICYCLING; ELBOW GUARDS FOR ATHLETIC USE; KNEE GUARDS

FOR ATHLETIC USE; LEG GUARDS FOR ATHLETIC USE; MOUTH GUARDS FOR ATHLETIC USE; SHIN GUARDS FOR ATHLETIC USE; SHIN PADS FOR ATHLETIC USE; SHIN PADS FOR USE IN BASEBALL, SOFTBALL, HOCKEY, LACROSSE, EQUESTRIAN, MILITARY, SKIING, SNOWBOARDING, ALL CONTACT SPORTS, MOTOR SPORTS, BICYCLING; ATHLETIC PROTECTIVE PADS FOR BASEBALL, SOFTBALL, HOCKEY, LACROSSE, EQUESTRIAN, MILITARY, SKIING, SNOWBOARDING, ALL CONTACT SPORTS, MOTOR SPORTS, BICYCLING; PROTECTIVE ATHLETIC CUPS; PROTECTIVE PADDING FOR PLAYING BASEBALL, SOFTBALL, HOCKEY, LACROSSE, EQUESTRIAN, MILITARY, SKIING, SNOWBOARDING, ALL CONTACT SPORTS, MOTOR SPORTS, BICYCLING; SPORTS EQUIPMENT FOR BOXING, MARTIAL ARTS, AND THE LIKE, NAMELY, PROTECTIVE BRAS; UMPIRE PROTECTION EQUIPMENT FOR FACE, CHEST, SHOULDERS, ARMS, THIGHS, KNEES, SHINS, FEET (U.S. CLS. 22, 23, 38 AND 50).

CLASS 45—PERSONAL AND LEGAL SERVICES

FOR POLICE AND CIVIL PROTECTION SERVICES; POLICE PROTECTION (U.S. CLS. 100 AND 101).
ELIZABETH KAJUBI, EXAMINING ATTORNEY

SN 77-429,069. SKELETON CREW MOTORCYCLE CLUB, FREMONT, CA. FILED 3-23-2008.

SCMC

THE MARK CONSISTS OF STANDARD CHARACTERS WITHOUT CLAIM TO ANY PARTICULAR FONT, STYLE, SIZE, OR COLOR.

CLASS 14—JEWELRY

FOR JEWELRY (U.S. CLS. 2, 27, 28 AND 50).

CLASS 25—CLOTHING

FOR HATS; HOODED SWEAT SHIRTS; SHORT-SLEEVED OR LONG-SLEEVED T-SHIRTS; SWEAT SHIRTS; T-SHIRTS; TEE SHIRTS; WOOLLY HATS (U.S. CLS. 22 AND 39).

ELLEN PERKINS, EXAMINING ATTORNEY

SN 77-429,169. PAOLONI, KAREN, SYDNEY, AUSTRALIA, FILED 3-24-2008.

docsports

THE MARK CONSISTS OF STANDARD CHARACTERS WITHOUT CLAIM TO ANY PARTICULAR FONT, STYLE, SIZE, OR COLOR.

CLASS 41—EDUCATION AND ENTERTAINMENT

FOR EDUCATIONAL AND ENTERTAINMENT SERVICES, NAMELY, A CONTINUING PROGRAM ABOUT SPORTS MEDICINE AND SPORTS INJURY ACCESSIBLE BY RADIO, TELEVISION, SATELLITE, AUDIO, VIDEO AND COMPUTER NETWORKS (U.S. CLS. 100, 101 AND 107).

CLASS 44—MEDICAL, BEAUTY AND AGRICULTURAL SERVICES

FOR PROVIDING A WEB SITE FEATURING INFORMATION ON HEALTH AND NUTRITION; PROVIDING MEDICAL INFORMATION (U.S. CLS. 100 AND 101).

TARA PATE, EXAMINING ATTORNEY

SN 77-429,178. MOMENTVILLE PTY. LTD., QUEENSLIFF, AUSTRALIA, FILED 3-24-2008.

MomentVille

THE MARK CONSISTS OF STANDARD CHARACTERS WITHOUT CLAIM TO ANY PARTICULAR FONT, STYLE, SIZE, OR COLOR.

CLASS 9—ELECTRICAL AND SCIENTIFIC APPARATUS

FOR WEB SITE DEVELOPMENT SOFTWARE (U.S. CLS. 21, 23, 26, 36 AND 38).

FIRST USE 3-31-2007; IN COMMERCE 8-26-2007.

CLASS 35—ADVERTISING AND BUSINESS

FOR ADVERTISING AND COMMERCIAL INFORMATION SERVICES, VIA THE INTERNET; ADVERTISING VIA ELECTRONIC MEDIA AND SPECIFICALLY THE INTERNET; PROVIDING AN ON-LINE COMMERCIAL INFORMATION DIRECTORY ON THE INTERNET; PROVIDING CONSUMER PRODUCT INFORMATION VIA THE INTERNET; PROVIDING A WEB SITE FEATURING PRODUCT RATINGS OF THE CONSUMER GOODS AND SERVICES OF OTHERS IN THE FIELD OF WEDDINGS, ANNIVERSARIES, BIRTHS, BIRTHDAYS, AND SPECIAL EVENTS; PROVIDING ON-LINE DIRECTORY INFORMATION SERVICES ALSO FEATURING HYPERLINKS TO OTHER WEB SITES (U.S. CLS. 100, 101 AND 102).

CLASS 42—SCIENTIFIC AND COMPUTER SERVICES

FOR DESIGN, CREATION, HOSTING AND MAINTENANCE OF INTERNET SITES FOR THIRD PARTIES; DESIGNING AND DEVELOPING WEBPAGES ON THE INTERNET; HOSTING OF DIGITAL CONTENT ON THE INTERNET; PROVIDING CUSTOMER-DEFINED GENERATED CONTENT AND CONTENT OF OTHERS AUTOMATICALLY SELECTED AND CUSTOMIZED BASED ON THE KNOWN OR ESTIMATED GEOGRAPHICAL LOCATION OF AN INTERNET, MOBILE TELEPHONE OR OTHER WIRED OR WIRELESS DIGITAL NETWORK BASED CUSTOMER; COMPUTER SERVICES IN THE NATURE OF CUSTOMIZED WEB PAGES FEATURING USER-DEFINED INFORMATION, PERSONAL PROFILES AND INFORMATION; COMPUTER SERVICES, NAMELY DESIGNING AND IMPLEMENTING ON DEMAND WEBSITES IN THE NATURE OF TURNKEY PACKAGES ALLOWING CUSTOMERS TO CREATE ECOMMERCE WEB SITES FOR THE PURPOSE OF UPLOADING PHOTOS AND CREATING GIFTS; COMPUTER SERVICES, NAMELY, CREATING AND MAINTAINING WEB SITES FOR OTHERS; COMPUTER SERVICES, NAMELY, DESIGNING AND IMPLEMENTING WEB SITES FOR OTHERS; COMPUTER SERVICES, NAMELY, MANAGING WEB SITES FOR OTHERS; CREATING OR MAINTAINING WEB SITES FOR OTHERS; CREATING, DESIGNING AND MAINTAINING WEB SITES; CREATION AND MAINTENANCE OF WEB SITES FOR OTHERS; CREATION AND PROVISION OF WEB PAGES TO AND FOR THIRD PARTIES; DESIGN OF HOME PAGES AND WEB SITES; DESIGN OF HOME PAGES, COMPUTER SOFTWARE AND WEB SITES; DESIGN OF HOMEPAGES AND WEB-SITES; DISPLAYING THE WEB SITES AND IMAGES OF OTHERS ON A COMPUTER SERVER; HOSTING OF WEB SITES; PROVIDING CUSTOMIZED ON-LINE WEB PAGES FEATURING USER-DEFINED INFORMATION, WHICH INCLUDES SEARCH ENGINES AND ON-LINE WEB LINKS TO OTHER WEB SITES; WEB SITE DESIGN; WEB SITE DEVELOPMENT FOR OTHERS; WEB SITE HOSTING SERVICES (U.S. CLS. 100 AND 101).

FIRST USE 3-31-2007; IN COMMERCE 8-26-2007.
SANJEEV VOHRA, EXAMINING ATTORNEY

SN 77-429,202. JOHNSON & JOHNSON, NEW BRUNSWICK, NJ. FILED 3-24-2008.

MORE POWER TO YOU

THE MARK CONSISTS OF STANDARD CHARACTERS WITHOUT CLAIM TO ANY PARTICULAR FONT, STYLE, SIZE, OR COLOR.

CLASS 10—MEDICAL APPARATUS

FOR BLOOD GLUCOSE METERS (U.S. CLS. 26, 39 AND 44).

CLASS 16—PAPER GOODS AND PRINTED MATTER

FOR PRINTED MATERIALS, NAMELY, FLYERS, PAMPHLETS AND BROCHURES RELATING TO DIABETES AND GLUCOSE TESTING (U.S. CLS. 2, 5, 22, 23, 29, 37, 38 AND 50).

EDWARD FENNESSY, EXAMINING ATTORNEY

SN 77-429,229. JOHNSON & JOHNSON, NEW BRUNSWICK, NJ. FILED 3-24-2008.

REAL WHITENING, REAL EASY

THE MARK CONSISTS OF STANDARD CHARACTERS WITHOUT CLAIM TO ANY PARTICULAR FONT, STYLE, SIZE, OR COLOR.

CLASS 3—COSMETICS AND CLEANING PREPARATIONS

FOR MOUTHWASH; NON-MEDICATED PRE-BRUSH MOUTH RINSE; TOOTH WHITENING STRIPS; BREATH FRESHENERS (U.S. CLS. 1, 4, 6, 50, 51 AND 52).

CLASS 5—PHARMACEUTICALS

FOR MEDICATED MOUTHWASH AND MOUTH RINSE (U.S. CLS. 6, 18, 44, 46, 51 AND 52).
JERI J. FICKES, EXAMINING ATTORNEY

SN 77-429,233. KING, SHEERAN HOWARD, LOUISVILLE, KY. AND KING, KENNETH DANIEL, LOUISVILLE, KY. FILED 3-24-2008.

Nasty Car

THE MARK CONSISTS OF STANDARD CHARACTERS WITHOUT CLAIM TO ANY PARTICULAR FONT, STYLE, SIZE, OR COLOR.

CLASS 21—HOUSEWARES AND GLASS

FOR COFFEE MUGS, FOAM DRINK HOLDERS, INSULATING SLEEVE HOLDERS FOR BEVERAGE CANS; PLASTIC CUPS, PLATES, PLASTIC PLATES, PAPER PLATES, DINNERWARE, NAMELY, PLATES, CUPS, SAUCERS; DECORATIVE PLATES; SOUVENIR PLATES (U.S. CLS. 2, 13, 23, 29, 30, 33, 40 AND 50).

CLASS 25—CLOTHING

FOR CLOTHING, NAMELY, T-SHIRTS, TANK TOPS, SWEAT SHIRTS, JACKETS, HATS (U.S. CLS. 22 AND 39).
ANNE FARRELL, EXAMINING ATTORNEY

SN 77-429,235. JOHNSON & JOHNSON, NEW BRUNSWICK, NJ. FILED 3-24-2008.

KEEP LIFE SEXY

THE MARK CONSISTS OF STANDARD CHARACTERS WITHOUT CLAIM TO ANY PARTICULAR FONT, STYLE, SIZE, OR COLOR.

CLASS 3—COSMETICS AND CLEANING PREPARATIONS

FOR MASSAGE OILS AND LOTIONS (U.S. CLS. 1, 4, 6, 50, 51 AND 52).

CLASS 5—PHARMACEUTICALS

FOR PERSONAL LUBRICANTS (U.S. CLS. 6, 18, 44, 46, 51 AND 52).
JERI J. FICKES, EXAMINING ATTORNEY

SN 77-429,332. DELTA DENTAL OF KANSAS, INC., WICHITA, KS. FILED 3-24-2008.



THE MARK CONSISTS OF THE LETTER "S" IN A CYLINDRICAL, THREE DIMENSIONAL DESIGN .

CLASS 35—ADVERTISING AND BUSINESS

FOR PROVIDING INSURANCE AGENT REFERRALS; ADVERTISING AND MARKETING OF INSURANCE PRODUCTS (U.S. CLS. 100, 101 AND 102).

CLASS 36—INSURANCE AND FINANCIAL

FOR INSURANCE ADMINISTRATION; INSURANCE CLAIMS ADMINISTRATION; INSURANCE CLAIMS PROCESSING; INSURANCE UNDERWRITING IN THE FIELD OF HEALTH INSURANCE, VISION INSURANCE, DENTAL INSURANCE, LIFE INSURANCE, SHORT-TERM DISABILITY INSURANCE, AND LONG-TERM DISABILITY INSURANCE; INSURANCE CONSULTATION; FINANCIAL EVALUATION FOR INSURANCE PURPOSES; PROVIDING INFORMATION ON INSURANCE MATTERS; PROVIDING A WEBSITE AND ON-LINE INTERFACES CONTAINING INFORMATION ON INSURANCE MATTERS (U.S. CLS. 100, 101 AND 102).
CAROL SPILS, EXAMINING ATTORNEY

SN 77-429,366. JOHNSON & JOHNSON, NEW BRUNSWICK, NJ. FILED 3-24-2008.

COMFORTING MOMENTS

THE MARK CONSISTS OF STANDARD CHARACTERS WITHOUT CLAIM TO ANY PARTICULAR FONT, STYLE, SIZE, OR COLOR.

CLASS 5—PHARMACEUTICALS

FOR TABLETS FOR USE IN THE SHOWER FOR CONGESTION; AIR FRESHENER; REFILLS FOR AIR FRESHENERS; ANTIHISTAMINES, ANALGESICS AND DECONGESTANTS; SINUS AND ALLERGY PREPARATIONS (U.S. CLS. 6, 18, 44, 46, 51 AND 52).

CLASS 11—ENVIRONMENTAL CONTROL APPARATUS

FOR ELECTRICAL DISPENSER FOR AIR FRESHENER AND DEODORIZER TO BE PLUGGED INTO WALL OUTLETS (U.S. CLS. 13, 21, 23, 31 AND 34).
JERI J. FICKES, EXAMINING ATTORNEY

SN 77-429,506. KASARJIAN, JACK ALBERT, CAMARILLO, CA. FILED 3-24-2008.

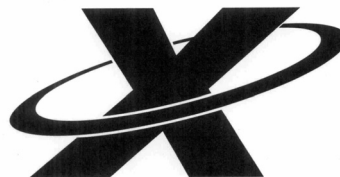

OWNER OF U.S. REG. NO. 3,308,916.
THE MARK CONSISTS OF A STYLIZED "X" WITH A DIAGONAL OVAL RING AROUND THE "X".

CLASS 9—ELECTRICAL AND SCIENTIFIC APPARATUS

FOR GLOVES FOR PROTECTION AGAINST ACCIDENTS; PROTECTIVE GLOVES FOR INDUSTRIAL USE; PROTECTIVE WORK GLOVES; HARD HATS; BASEBALL BATTING HELMETS; CATCHERS' HELMETS; CLOTHING FOR PROTECTION AGAINST ACCIDENTS, IRRADIATION AND FIRE; PROTECTIVE ARMOR PANELS FOR PROTECTING AGAINST BALLISTIC PROJECTILES AND EXPLOSIVE FRAGMENTS INSTALLED IN OR ATTACHED TO VEHICLES, BUILDINGS OR OTHER STRUCTURES; PROTECTIVE CLOTHING; PROTECTIVE CLOTHING AND HEADGEAR; PROTECTIVE EAR COVERINGS; PROTECTIVE EYE PIECES; PROTECTIVE EYEGLASSES; PROTECTIVE EYEWEAR; PROTECTIVE EYEWEAR AND COMPONENT PARTS THEREOF; PROTECTIVE FACE-SHIELDS FOR PROTECTIVE HELMETS; PROTECTIVE HEAD GUARDS FOR INDUSTRIAL PURPOSES; PROTECTIVE HEADGEAR FOR BOXING; PROTECTIVE HELMETS; PROTECTIVE HELMETS FOR SPORTS (U.S. CLS. 21, 23, 26, 36 AND 38).

CLASS 17—RUBBER GOODS

FOR PADDING FOR IMPACT PROTECTION, COMFORT AND FIT, COMPOSED OF BONDED MICROSPHERES USED IN INDUSTRY; PLASTIC PADDING FOR IMPACT PROTECTION (U.S. CLS. 1, 5, 12, 13, 35 AND 50).

CLASS 18—LEATHER GOODS

FOR HORSE FLANKS AND SHANKS, NAMELY, HORSE PROTECTIVE PADDING, BRACES, AND LEG BOOTS FOR THE FLANKS AND LEGS (U.S. CLS. 1, 2, 3, 22 AND 41).

CLASS 21—HOUSEWARES AND GLASS

FOR WORK GLOVES (U.S. CLS. 2, 13, 23, 29, 30, 33, 40 AND 50).

CLASS 25—CLOTHING

FOR BICYCLE GLOVES; BICYCLING GLOVES; CROSS-COUNTRY GLOVES; GLOVES; GLOVES INCLUDING THOSE MADE OF SKIN, HIDE OR FUR; MOTORCYCLE GLOVES; OUTDOOR GLOVES; RIDING GLOVES; SKI GLOVES; SNOWBOARD GLOVES; BASEBALL CAPS; CAPS; HEADGEAR, NAMELY, CAPS AND HATS USED IN SPORTS AND RECREATION ACTIVITIES; SKULL CAPS; TOBOGGAN HATS, PANTS AND CAPS; HATS; LONG-SLEEVED SHIRTS; RUGBY SHIRTS; SPORT SHIRTS; SPORTS SHIRTS; SPORTS SHIRTS WITH SHORT SLEEVES; SWEAT SHIRTS; T-SHIRTS; TEE SHIRTS; BOARD SHORTS; GYM SHORTS; RUGBY SHORTS; SHORTS; SLIDING SHORTS; SWEAT SHORTS; UNDERWEAR, NAMELY, BOY SHORTS; PANTS; SKI PANTS; SNOW PANTS; SNOWBOARD PANTS; SWEAT PANTS; FITTED SHOE OR BOOT COVERING TO PROTECT THE SHOES OR BOOT FROM WATER OR OTHER DAMAGE (U.S. CLS. 22 AND 39).

SN 77-429,533. DELGADO, ROBERT, NEWARK, DE. FILED 3-24-2008.

TITAN BODY

THE MARK CONSISTS OF STANDARD CHARACTERS WITHOUT CLAIM TO ANY PARTICULAR FONT, STYLE, SIZE, OR COLOR.

CLASS 25—CLOTHING

FOR BEANIES; COATS; DRESS SHIRTS; FLEECE PULLOVERS; HATS; HEADBANDS; JACKETS; JOGGING SUITS; RASH GUARDS; SHOES; SKULL CAPS; SWEAT PANTS; SWEAT SHIRTS; T-SHIRTS; TANK TOPS; TIGHTS; WRIST BANDS (U.S. CLS. 22 AND 39).

CLASS 28—TOYS AND SPORTING GOODS

FOR BASEBALL BATting GLOVES; BASEBALL GLOVES; BATting GLOVES; GOALKEEPERS' GLOVES; HANDBALL GLOVES; HOCKEY GLOVES; RACQUET BALL GLOVES; SOFTBALL GLOVES; WATERSKI GLOVES; WINDSURFING GLOVES; WORK-OUT GLOVES; GRIP TAPES FOR BASEBALL BATS; CATCHERS' MASKS; CATCHERS' MITTS; CHEST PROTECTORS; CHEST PROTECTORS FOR SPORTS; FOOTBALL BODY PROTECTORS; FOOTBALL CHEST PADS; THROAT PROTECTORS FOR ATHLETIC USE; ARM GUARDS FOR ATHLETIC USE; ATHLETIC EQUIPMENT, NAMELY, GUARDS FOR THE MOUTH, THE NOSE, THE CHIN, THE FACE, SHOULDERS, ELBOWS, RIBS, HEART, HIPS, KNEES, SHINS AND FOOT USED IN BASEBALL, SOFTBALL, HOCKEY, LACROSSE, EQUESTRIAN, MILITARY, SKIING, SNOWBOARDING, ALL CONTACT SPORTS, MOTOR SPORTS, BICYCLING; ELBOW GUARDS FOR ATHLETIC USE; KNEE GUARDS FOR ATHLETIC USE; LEG GUARDS FOR ATHLETIC USE; MOUTH GUARDS FOR ATHLETIC USE; SHIN GUARDS FOR ATHLETIC USE; SHIN PADS FOR ATHLETIC USE; SHIN PADS FOR USE IN BASEBALL, SOFTBALL, HOCKEY, LACROSSE, EQUESTRIAN, MILITARY, SKIING, SNOWBOARDING, ALL CONTACT SPORTS, MOTOR SPORTS, BICYCLING; ATHLETIC PROTECTIVE PADS FOR BASEBALL, SOFTBALL, HOCKEY, LACROSSE, EQUESTRIAN, MILITARY, SKIING, SNOWBOARDING, ALL CONTACT SPORTS, MOTOR SPORTS, BICYCLING; PROTECTIVE ATHLETIC CUPS; PROTECTIVE PADDING FOR PLAYING BASEBALL, SOFTBALL, HOCKEY, LACROSSE, EQUESTRIAN, MILITARY, SKIING, SNOWBOARDING, ALL CONTACT SPORTS, MOTOR SPORTS, BICYCLING; SPORTS EQUIPMENT FOR BOXING, MARTIAL ARTS, AND THE LIKE, NAMELY, PROTECTIVE BRAS; UMPIRE PROTECTION EQUIPMENT FOR FACE, CHEST, SHOULDERS, ARMS, THIGHS, KNEES, SHINS, FEET (U.S. CLS. 22, 23, 38 AND 50).

CLASS 35—ADVERTISING AND BUSINESS

FOR ADVERTISING, MARKETING AND PROMOTION SERVICES; PROMOTING SPORTS COMPETITIONS AND/OR EVENTS OF OTHERS (U.S. CLS. 100, 101 AND 102).

BENJAMIN OKEKE, EXAMINING ATTORNEY

SN 77-429,534. CHAMISH, KEITH, WESLEY HILLS, NY. FILED 3-24-2008.

FIT FRAPP

THE MARK CONSISTS OF STANDARD CHARACTERS WITHOUT CLAIM TO ANY PARTICULAR FONT, STYLE, SIZE, OR COLOR.

CLASS 30—STAPLE FOODS

FOR BEVERAGES MADE OF COFFEE; COFFEE BASED BEVERAGES; COFFEE BEVERAGES WITH MILK; COFFEE-BASED BEVERAGE CONTAINING MILK; ICED COFFEE; PREPARED COFFEE AND COFFEE-BASED BEVERAGES (U.S. CL. 46).

CLASS 45—PERSONAL AND LEGAL SERVICES

FOR POLICE AND CIVIL PROTECTION SERVICES; POLICE PROTECTION (U.S. CLS. 100 AND 101).
ELIZABETH KAJUBI, EXAMINING ATTORNEY

CLASS 32—LIGHT BEVERAGES

FOR COFFEE-FLAVORED SOFT DRINK (U.S. CLS. 45, 46 AND 48).
HOWARD B. LEVINE, EXAMINING ATTORNEY

SN 77-429,537. MASCIA, MICHAEL, SWEDEN, ME. FILED 3-24-2008.

SN 77-429,666. BR CONSULTING, INC., SEDONA, AZ. FILED 3-24-2008.

PADD-A-PART

THE MARK CONSISTS OF STANDARD CHARACTERS WITHOUT CLAIM TO ANY PARTICULAR FONT, STYLE, SIZE, OR COLOR.

CLASS 9—ELECTRICAL AND SCIENTIFIC APPARATUS

FOR MULTIPLE-LAYER PROTECTIVE PAD ASSEMBLY FOR USE IN PROTECTING JOINTS AND OTHER BODY PARTS FROM TRAUMA, NAMELY, PROTECTIVE PADDING FOR USE IN CONNECTION WITH COMPUTERS (U.S. CLS. 21, 23, 26, 36 AND 38).

CLASS 28—TOYS AND SPORTING GOODS

FOR MULTIPLE-LAYER PROTECTIVE PAD ASSEMBLY FOR USE IN PROTECTING JOINTS AND OTHER BODY PARTS FROM TRAUMA, NAMELY, PROTECTIVE PADDING FOR USE IN CONNECTION WITH VARIOUS SPORTS AND ATHLETIC EVENTS AND ASSOCIATED EQUIPMENT (U.S. CLS. 22, 23, 38 AND 50).

ALICIA COLLINS, EXAMINING ATTORNEY

SN 77-429,659. CHOICE HOTELS INTERNATIONAL, INC., SILVER SPRING, MD. FILED 3-24-2008.

CHOICE DESTINATIONS

THE MARK CONSISTS OF STANDARD CHARACTERS WITHOUT CLAIM TO ANY PARTICULAR FONT, STYLE, SIZE, OR COLOR.

OWNER OF U.S. REG. NOS. 2,638,841, 3,068,858 AND OTHERS.

NO CLAIM IS MADE TO THE EXCLUSIVE RIGHT TO USE "DESTINATIONS", APART FROM THE MARK AS SHOWN.

CLASS 39—TRANSPORTATION AND STORAGE

FOR TRAVEL GUIDE AND TRAVEL INFORMATION SERVICES (U.S. CLS. 100 AND 105).
FIRST USE 1-1-2001; IN COMMERCE 1-1-2001.

CLASS 43—HOTEL AND RESTAURANT SERVICES

FOR HOTEL AND MOTEL RESERVATION SERVICES FOR OTHERS; ONLINE HOTEL AND MOTEL RESERVATION SERVICES FOR OTHERS; PROVIDING INFORMATION ON HOTELS AND TEMPORARY ACCOMMODATIONS (U.S. CLS. 100 AND 101).

FIRST USE 6-4-2006; IN COMMERCE 6-4-2006.
NATALIE POLZER, EXAMINING ATTORNEY

HONOR'S HAVEN

THE MARK CONSISTS OF STANDARD CHARACTERS WITHOUT CLAIM TO ANY PARTICULAR FONT, STYLE, SIZE, OR COLOR.

CLASS 43—HOTEL AND RESTAURANT SERVICES

FOR HEALTH RESORT SERVICES, NAMELY, PROVIDING FOOD AND LODGING THAT SPECIALIZE IN PROMOTING PATRONS' GENERAL HEALTH AND WELL-BEING (U.S. CLS. 100 AND 101).

CLASS 44—MEDICAL, BEAUTY AND AGRICULTURAL SERVICES

FOR HEALTH SPA SERVICES FOR HEALTH AND WELLNESS OF THE BODY AND SPIRIT OFFERED AT A HEALTH RESORT (U.S. CLS. 100 AND 101).

KATHY DE JONGE, EXAMINING ATTORNEY

SN 77-429,709. HDA, INC., HAZELWOOD, MO. FILED 3-24-2008.

HOUSEPLANSANDMORE

THE MARK CONSISTS OF STANDARD CHARACTERS WITHOUT CLAIM TO ANY PARTICULAR FONT, STYLE, SIZE, OR COLOR.

CLASS 16—PAPER GOODS AND PRINTED MATTER

FOR PRINTED PERIODICALS IN THE FIELD OF ARCHITECTURAL PLANS; SERIES OF NONFICTION BOOKS IN THE FIELD OF ARCHITECTURAL PLANS; ARCHITECTURAL PLANS (U.S. CLS. 2, 5, 22, 23, 29, 37, 38 AND 50).

CLASS 42—SCIENTIFIC AND COMPUTER SERVICES

FOR ARCHITECTURAL DESIGN SERVICES IN THE NATURE OF ARCHITECTURAL PLANS, PROVIDED VIA THE INTERNET (U.S. CLS. 100 AND 101).

MARCIE MILONE, EXAMINING ATTORNEY

SN 77-429,726. CHOI, YONG, HOUSTON, TX. AND CHOI, HYUN, HOUSTON, TX. FILED 3-24-2008.

SN 77-429,745. CHOI, YONG, HOUSTON, TX. AND CHOI, HYUN, HOUSTON, TX. FILED 3-24-2008.

BE SQUAREHEAD

THE MARK CONSISTS OF STANDARD CHARACTERS WITHOUT CLAIM TO ANY PARTICULAR FONT, STYLE, SIZE, OR COLOR.

CLASS 25—CLOTHING

FOR SHIRTS; HATS; CAPS; PANTS; SOCKS (U.S. CLS. 22 AND 39).

CLASS 40—MATERIAL TREATMENT

FOR IMPRINTING MESSAGES ON ITEMS OF CLOTHING; EMBROIDERING SERVICES (U.S. CLS. 100, 103 AND 106).

MARCIE MILONE, EXAMINING ATTORNEY

SQUAREHEAD

THE MARK CONSISTS OF STANDARD CHARACTERS WITHOUT CLAIM TO ANY PARTICULAR FONT, STYLE, SIZE, OR COLOR.

CLASS 25—CLOTHING

FOR SHIRTS; HATS; CAPS; PANTS; SOCKS (U.S. CLS. 22 AND 39).

CLASS 40—MATERIAL TREATMENT

FOR IMPRINTING MESSAGES ON ITEMS OF CLOTHING; EMBROIDERING SERVICES (U.S. CLS. 100, 103 AND 106).

MARCIE MILONE, EXAMINING ATTORNEY

SN 77-429,859. THE HERITAGE FOUNDATION, WASHINGTON, DC. FILED 3-24-2008.

SN 77-429,728. STARGUY'S HARMONIOUS HEARTS, LLC, OREGON, OH. FILED 3-24-2008.

KATIE KIND

THE MARK CONSISTS OF STANDARD CHARACTERS WITHOUT CLAIM TO ANY PARTICULAR FONT, STYLE, SIZE, OR COLOR.

THE NAME "KATIE KIND" DOES NOT IDENTIFY A LIVING INDIVIDUAL.

CLASS 41—EDUCATION AND ENTERTAINMENT

FOR PHYSICAL FITNESS CONSULTATION; PHYSICAL FITNESS INSTRUCTION (U.S. CLS. 100, 101 AND 107).

CLASS 44—MEDICAL, BEAUTY AND AGRICULTURAL SERVICES

FOR FOOD NUTRITION CONSULTATION (U.S. CLS. 100 AND 101).

CLASS 45—PERSONAL AND LEGAL SERVICES

FOR PERSONAL GROWTH AND MOTIVATION CONSULTING SERVICES (U.S. CLS. 100 AND 101).
DORITT L. CARROLL, EXAMINING ATTORNEY



THE COLOR(S) BLACK, WHITE AND RED IS/ARE CLAIMED AS A FEATURE OF THE MARK.

THE MARK CONSISTS OF A RED RECTANGLE DESIGN WITH WHITE WORDING "THE HERITAGE FOUNDATION PRESENTS" AND BLACK BELL DESIGNS ACROSS THE TOP AND THE BLACK NUMBER "33" AND "MINUTES" SEPARATED BY TWO HORIZONTAL BLACK MISSILE DESIGNS IN THE MIDDLE AND THE RED WORDING "PROTECTING AMERICA IN THE NEW MISSILE AGE" AGAINST A BLACK BACKGROUND BELOW.

CLASS 9—ELECTRICAL AND SCIENTIFIC APPARATUS

FOR PRE-RECORDED CDS, VIDEO TAPES, LASER DISKS AND DVDS FEATURING MISSILE DEFENSE INFORMATION (U.S. CLS. 21, 23, 26, 36 AND 38).

CLASS 16—PAPER GOODS AND PRINTED MATTER

FOR COLOR PRINTS; GRAPHIC PRINTS AND REPRESENTATIONS; PRINT LETTERS AND BLOCKS (U.S. CLS. 2, 5, 22, 23, 29, 37, 38 AND 50).

CLASS 25—CLOTHING

FOR SHORT-SLEEVED OR LONG-SLEEVED T-SHIRTS (U.S. CLS. 22 AND 39).

CLASS 41—EDUCATION AND ENTERTAINMENT

FOR PUBLICATION OF TEXTS, BOOKS, MAGAZINES AND OTHER PRINTED MATTER; MULTIMEDIA PUBLISHING OF BOOKS, MAGAZINES, JOURNALS, SOFTWARE, GAMES, MUSIC, AND ELECTRONIC PUBLICATIONS (U.S. CLS. 100, 101 AND 107).
BARBARA BROWN, EXAMINING ATTORNEY

SN 77-429,870. STRUMBONO II, L.L.C., HOUSTON, TX. FILED 3-24-2008.

CORPORATE CARE

THE MARK CONSISTS OF STANDARD CHARACTERS WITHOUT CLAIM TO ANY PARTICULAR FONT, STYLE, SIZE, OR COLOR.

CLASS 37—CONSTRUCTION AND REPAIR

FOR CLEANING, REPAIR, MAINTENANCE, AND RESTORATION OF CARPETS, UPHOLSTERED FURNISHINGS, WALL FABRICS, TEXTILES, LEVEL FLOOR SURFACES AND HARD SURFACES (U.S. CLS. 100, 103 AND 106).
FIRST USE 8-0-1983; IN COMMERCE 8-0-1983.

CLASS 40—MATERIAL TREATMENT

FOR TOPICAL PROTECTIVE TREATMENT AND FLAME RETARDANT TREATMENT OF CARPETS, UPHOLSTERED FURNISHINGS, WALL FABRICS, TEXTILES, LEVEL FLOOR SURFACES, AND HARD SURFACES (U.S. CLS. 100, 103 AND 106).
FIRST USE 8-0-1983; IN COMMERCE 8-0-1983.
WANDA KAY PRICE, EXAMINING ATTORNEY

SN 77-429,913. SISTERS OF THE HOLY SPIRIT, GARFIELD HEIGHTS, OH. FILED 3-24-2008.



OWNER OF U.S. REG. NOS. 3,156,334 AND 3,180,723.
THE MARK CONSISTS OF THE WORDS "NUN BETTER" AND A CARICATURE OF A SMILING NUN HOLDING A TRAY OF COOKIES.

CLASS 21—HOUSEWARES AND GLASS

FOR MUGS (U.S. CLS. 2, 13, 23, 29, 30, 33, 40 AND 50).
FIRST USE 5-0-2005; IN COMMERCE 9-0-2007.

CLASS 25—CLOTHING

FOR APRONS (U.S. CLS. 22 AND 39).
FIRST USE 3-0-2006; IN COMMERCE 9-0-2007.
MICHAEL TANNER, EXAMINING ATTORNEY

SN 77-429,982. SISTERS OF THE HOLY SPIRIT, GARFIELD HEIGHTS, OH. FILED 3-24-2008.

NUN BETTER

THE MARK CONSISTS OF STANDARD CHARACTERS WITHOUT CLAIM TO ANY PARTICULAR FONT, STYLE, SIZE, OR COLOR.
OWNER OF U.S. REG. NOS. 3,156,334 AND 3,180,723.

CLASS 21—HOUSEWARES AND GLASS

FOR MUGS; COOKIE JARS (U.S. CLS. 2, 13, 23, 29, 30, 33, 40 AND 50).
FIRST USE 5-0-2005; IN COMMERCE 4-0-2007.

CLASS 25—CLOTHING

FOR APRONS (U.S. CLS. 22 AND 39).
FIRST USE 3-0-2006; IN COMMERCE 9-0-2007.
MICHAEL TANNER, EXAMINING ATTORNEY

SN 77-430,007. TRAVELLINGWAVE, INC., SEATTLE, WA. FILED 3-24-2008.

ALWAYS LISTENING

THE MARK CONSISTS OF STANDARD CHARACTERS WITHOUT CLAIM TO ANY PARTICULAR FONT, STYLE, SIZE, OR COLOR.

CLASS 9—ELECTRICAL AND SCIENTIFIC APPARATUS

FOR COMPUTER SOFTWARE FOR COMMUNICATING WITH USERS OF HAND-HELD COMPUTERS; COMPUTER SOFTWARE FOR VOICE RECOGNITION OVER CELL PHONES, INCLUDING BUT NOT LIMITED TO SMS AND TEXT MESSAGES; COMPUTER SOFTWARE PLATFORMS FOR VOICE RECOGNITION OVER CELL PHONES, INCLUDING BUT NOT LIMITED TO SMS AND TEXT MESSAGES; COMPUTER SOFTWARE, NAMELY, SOFTWARE DEVELOPMENT TOOLS FOR THE CREATION OF MOBILE INTERNET APPLICATIONS AND CLIENT INTERFACES (U.S. CLS. 21, 23, 26, 36 AND 38).

CLASS 38—COMMUNICATION

FOR COMMUNICATIONS BY MEANS OF MOBILE PHONES; COMMUNICATIONS BY MOBILE PHONES; TELECOMMUNICATION SERVICES, NAMELY, TRANSMISSION OF VOICE, DATA AND DOCUMENTS, IN THE FIELD OF AIR TRAFFIC CONTROL, AERONAUTICAL AND AIRCRAFT NAVIGATION, AERONAUTICAL TELECOMMUNICATIONS, AND AERONAUTICAL INFORMATION; TELEPHONE VOICE MESSAGING SERVICES; VOICE-ACTIVATED DIALING SERVICES (U.S. CLS. 100, 101 AND 104).

JOHN SCHUYLER YARD, EXAMINING ATTORNEY

SN 77-430,080. UNITED STATES CELLULAR CORPORATION, CHICAGO, IL. FILED 3-24-2008.

BELIEVE IN SOMETHING BETTER

SN 77-430,021. BRONWYN EDWARDS CRYER, SEATTLE, WA. FILED 3-24-2008.

A BASSET IS AN ASSET

THE MARK CONSISTS OF STANDARD CHARACTERS WITHOUT CLAIM TO ANY PARTICULAR FONT, STYLE, SIZE, OR COLOR.

CLASS 25—CLOTHING

FOR CLOTHING, NAMELY, SHIRTS, T-SHIRTS, SWEATSHIRTS, HATS AND CAPS (U.S. CLS. 22 AND 39).

CLASS 35—ADVERTISING AND BUSINESS

FOR PUBLIC ADVOCACY TO PROMOTE AWARENESS OF ANIMAL RESCUE AND WELFARE (U.S. CLS. 100, 101 AND 102).

JOHN SCHUYLER YARD, EXAMINING ATTORNEY

THE MARK CONSISTS OF STANDARD CHARACTERS WITHOUT CLAIM TO ANY PARTICULAR FONT, STYLE, SIZE, OR COLOR.

CLASS 9—ELECTRICAL AND SCIENTIFIC APPARATUS

FOR CELLULAR TELEPHONES, CELLULAR TELEPHONE ACCESSORIES, NAMELY, BATTERIES AND ELECTRICAL BATTERY CHARGERS, AND RADIO PAGERS (U.S. CLS. 21, 23, 26, 36 AND 38).

CLASS 38—COMMUNICATION

FOR WIRELESS COMMUNICATION SERVICES, NAMELY, CELLULAR TELEPHONE COMMUNICATIONS SERVICES, PAGING SERVICES, VOICE ACTIVATED DIALING SERVICES, CALL FORWARDING AND VOICE MAIL SERVICES, DATA TRANSMISSION SERVICES, AND SATELLITE TRANSMISSION SERVICES (U.S. CLS. 100, 101 AND 104).

STEPHANIE ALI, EXAMINING ATTORNEY

SN 77-430,100. EAGLE COFFEE COMPANY, INC., BALTIMORE, MD. FILED 3-24-2008.

SN 77-430,079. REGINA, LISA, NEW YORK, NY. FILED 3-24-2008.

so you wanna be a wiseguy

THE MARK CONSISTS OF STANDARD CHARACTERS WITHOUT CLAIM TO ANY PARTICULAR FONT, STYLE, SIZE, OR COLOR.

CLASS 25—CLOTHING

FOR SHIRTS; CAPS; JACKETS (U.S. CLS. 22 AND 39).

CLASS 41—EDUCATION AND ENTERTAINMENT

FOR TELEVISION AND RADIO PROGRAMMING; TELEVISION PRODUCTION; TELEVISION PROGRAM SYNDICATION; TELEVISION PROGRAMMING; TELEVISION SHOW PRODUCTION (U.S. CLS. 100, 101 AND 107).

TAMARA FRAZIER, EXAMINING ATTORNEY

EAGLE COFFEE

THE MARK CONSISTS OF STANDARD CHARACTERS WITHOUT CLAIM TO ANY PARTICULAR FONT, STYLE, SIZE, OR COLOR.

OWNER OF U.S. REG. NO. 3,133,135.

NO CLAIM IS MADE TO THE EXCLUSIVE RIGHT TO USE "COFFEE", APART FROM THE MARK AS SHOWN.

CLASS 30—STAPLE FOODS

FOR ROASTED COFFEE BEANS; GROUND COFFEE (U.S. CL. 46).

FIRST USE 1-1-1921; IN COMMERCE 1-1-1921.

CLASS 35—ADVERTISING AND BUSINESS

FOR ONLINE RETAIL STORE SERVICES AND DISTRIBUTORSHIP SERVICES FOR COFFEE, TEA, SYRUPS, COFFEE EQUIPMENT, GOURMET PRODUCTS (U.S. CLS. 100, 101 AND 102).

FIRST USE 1-1-1999; IN COMMERCE 1-1-1999.

KYLE PEETE, EXAMINING ATTORNEY

SN 77-430,132. ETHNOGRAPHIC MEDIA, INC., OKLAHOMA CITY, OK. FILED 3-24-2008.

SN 77-430,224. HITTELL, DORIS P., DELTONA, FL. FILED 3-24-2008.

TRUTH IN MOTION

THE MARK CONSISTS OF STANDARD CHARACTERS WITHOUT CLAIM TO ANY PARTICULAR FONT, STYLE, SIZE, OR COLOR.

CLASS 16—PAPER GOODS AND PRINTED MATTER

FOR PRINTED VISUALS IN THE NATURE OF PROMOTIONAL MATERIALS; PRINTED INSTRUCTIONAL, EDUCATIONAL, AND TEACHING MATERIALS IN THE FIELD OF ENTERTAINMENT; GRAPHIC NOVELS (U.S. CLS. 2, 5, 22, 23, 29, 37, 38 AND 50).

CLASS 41—EDUCATION AND ENTERTAINMENT

FOR PRODUCTION OF VISUAL EFFECTS FOR VIDEOS, DVDS, TELEVISION AND FOR INTERNET WEB SITES; ENTERTAINMENT SERVICES, NAMELY, PROVIDING A WEB SITE FEATURING PHOTOGRAPHIC, AUDIO, VIDEO AND PROSE PRESENTATIONS FEATURING TELEVISION PROGRAMMING AND MOTION PICTURES (U.S. CLS. 100, 101 AND 107).

KELLY BOULTON, EXAMINING ATTORNEY

SN 77-430,180. ISPBX LLC, DENVER, NJ. FILED 3-24-2008.

cogoblue

THE MARK CONSISTS OF STANDARD CHARACTERS WITHOUT CLAIM TO ANY PARTICULAR FONT, STYLE, SIZE, OR COLOR.

CLASS 9—ELECTRICAL AND SCIENTIFIC APPARATUS

FOR COMPUTER HARDWARE AND SOFTWARE FOR SETTING UP AND CONFIGURING LOCAL AREA NETWORKS; COMPUTER HARDWARE AND SOFTWARE FOR SETTING UP AND CONFIGURING WIDE AREA NETWORKS; TELEPHONE CALL ROUTER, FOR HOME AND OFFICE TOUCHTONE PHONES, FOR INTERNATIONAL AND LONG DISTANCE CALLS MADE FROM VARIOUS TELEPHONY PLATFORMS INCLUDING VOIP PLATFORM WITHOUT THE REQUIREMENT FOR INTERNET; TELEPHONE CALL ROUTERS FOR LONG DISTANCE CALLS MADE THROUGH PSTN AND VOIP PLATFORMS FROM ANY TOUCHTONE PHONE WITHOUT A REQUIREMENT FOR INTERNET ACCESS (U.S. CLS. 21, 23, 26, 36 AND 38).

FIRST USE 1-25-2006; IN COMMERCE 1-25-2006.

CLASS 38—COMMUNICATION

FOR VOICE OVER INTERNET PROTOCOL (VOIP) SERVICES (U.S. CLS. 100, 101 AND 104).

FIRST USE 1-25-2006; IN COMMERCE 1-25-2006.
ANNE E. GUSTASON, EXAMINING ATTORNEY

Hater Blockers

THE MARK CONSISTS OF STANDARD CHARACTERS WITHOUT CLAIM TO ANY PARTICULAR FONT, STYLE, SIZE, OR COLOR.

CLASS 9—ELECTRICAL AND SCIENTIFIC APPARATUS

FOR SUNGLASSES (U.S. CLS. 21, 23, 26, 36 AND 38).

CLASS 25—CLOTHING

FOR CAPRI PANTS; CARGO PANTS; DENIMS; HEADGEAR, NAMELY, BASEBALL CAPS; HOODED SWEAT SHIRTS; JOGGING PANTS; LONG-SLEEVED SHIRTS; NIGHT SHIRTS; OPEN-NECKED SHIRTS; PANTS; SHIRT FRONTS; SHIRTS; SHORT-SLEEVED OR LONG-SLEEVED T-SHIRTS; SHORT-SLEEVED SHIRTS; SLEEP SHIRTS; STRETCH PANTS; SWEAT PANTS; SWEAT SHIRTS; T-SHIRTS; TEE SHIRTS; TOBOGGAN HATS, PANTS AND CAPS (U.S. CLS. 22 AND 39).

MICHELE SWAIN, EXAMINING ATTORNEY

SN 77-430,254. LEVEL FIVE SOLUTIONS, INC., CALABASAS, CA. FILED 3-24-2008.

panopsis

THE MARK CONSISTS OF STANDARD CHARACTERS WITHOUT CLAIM TO ANY PARTICULAR FONT, STYLE, SIZE, OR COLOR.

CLASS 38—COMMUNICATION

FOR COMMUNICATIONS SERVICES, NAMELY, TRANSMITTING STREAMED SOUND AND AUDIOVISUAL RECORDINGS VIA THE INTERNET; ELECTRONIC, ELECTRIC, AND DIGITAL TRANSMISSION OF VOICE, DATA, IMAGES, SIGNALS, AND MESSAGES (U.S. CLS. 100, 101 AND 104).

CLASS 42—SCIENTIFIC AND COMPUTER SERVICES

FOR COMPUTER SERVICES, NAMELY, MONITORING, TESTING, ANALYZING, AND REPORTING ON THE INTERNET TRAFFIC CONTROL AND CONTENT CONTROL OF THE WEB SITES OF OTHERS (U.S. CLS. 100 AND 101).

JILL C. ALT, EXAMINING ATTORNEY

SN 77-430,255. ARCHETYPE MEDIA, INC., CAMARILLO, CA. FILED 3-24-2008.



The logo for 'socialvibe' features the word 'social' in a lowercase, sans-serif font, followed by a pink circle containing a white star, and then the word 'vibe' in a bold, lowercase, sans-serif font.

THE COLOR(S) PINK IS/ARE CLAIMED AS A FEATURE OF THE MARK.

THE MARK CONSISTS OF A FANCIFUL RENDITION OF THE LITERAL ELEMENT, WITH THE LETTER "O" REPRESENTED BY A COLORED BALL WITH A WHITE STAR IMPRINTED UPON IT.

CLASS 35—ADVERTISING AND BUSINESS

FOR ELECTRONIC COMMERCE SERVICES, NAMELY, PROVIDING INFORMATION ABOUT PRODUCTS VIA TELECOMMUNICATION NETWORKS FOR ADVERTISING AND SALES PURPOSES; PROMOTING THE GOODS AND SERVICES OF OTHERS BY PROVIDING A COMMUNITY-DRIVEN WEBSITE FEATURING USER-SUBMITTED CONTENT IN THE NATURE OF COUPONS, REBATES, PRICE-COMPARISON INFORMATION, PRODUCT REVIEWS, LINKS TO THE RETAIL WEBSITES OF OTHERS, AND DISCOUNT INFO; PROVIDING AN ONLINE DIRECTORY INFORMATION SERVICE FEATURING INFORMATION REGARDING LIFESTYLE AND SOCIAL NETWORKING ISSUES; PROVIDING INFORMATION IN THE FIELD OF MARKETING AND ON-LINE MARKETING MEDIA VIA THE INTERNET (U.S. CLS. 100, 101 AND 102).

CLASS 42—SCIENTIFIC AND COMPUTER SERVICES

FOR COMPUTER SERVICES, NAMELY, CREATING AN ONLINE COMMUNITY FOR REGISTERED USERS TO PARTICIPATE IN COMPETITIONS, SHOWCASE THEIR SKILLS, GET FEEDBACK FROM THEIR PEERS, FORM VIRTUAL COMMUNITIES, ENGAGE IN SOCIAL NETWORKING AND IMPROVE THEIR TALENT (U.S. CLS. 100 AND 101).

JILL C. ALT, EXAMINING ATTORNEY

SN 77-430,288. CHUTKAN, ROBYNNE, WASHINGTON, DC. FILED 3-24-2008.

Eating Outside the Box

THE MARK CONSISTS OF STANDARD CHARACTERS WITHOUT CLAIM TO ANY PARTICULAR FONT, STYLE, SIZE, OR COLOR.

CLASS 5—PHARMACEUTICALS

FOR DIETARY AND NUTRITIONAL SUPPLEMENTS (U.S. CLS. 6, 18, 44, 46, 51 AND 52).

CLASS 16—PAPER GOODS AND PRINTED MATTER

FOR MAGAZINE COLUMNS ABOUT HEALTH AND NUTRITION (U.S. CLS. 2, 5, 22, 23, 29, 37, 38 AND 50).

CLASS 35—ADVERTISING AND BUSINESS

FOR PROVIDING ASSISTANCE, FITNESS EVALUATION AND CONSULTATION TO CORPORATE CLIENTS TO HELP THEIR EMPLOYEES MAKE HEALTH, WELLNESS AND NUTRITIONAL CHANGES IN THEIR DAILY LIVING TO INCREASE PRODUCTIVITY AND LOWER HEALTH CARE COSTS (U.S. CLS. 100, 101 AND 102).

CLASS 41—EDUCATION AND ENTERTAINMENT

FOR ENTERTAINMENT SERVICES, NAMELY, PROVIDING PODCASTS IN THE FIELD OF HEALTH AND NUTRITION; ENTERTAINMENT SERVICES, NAMELY, PROVIDING WEBCASTS IN THE FIELD OF HEALTH AND NUTRITION; ENTERTAINMENT SERVICES, NAMELY, PROVIDING A TELEVISION PROGRAM IN THE FIELD OF HEALTH AND NUTRITION VIA A GLOBAL COMPUTER NETWORK (U.S. CLS. 100, 101 AND 107).

CLASS 42—SCIENTIFIC AND COMPUTER SERVICES

FOR SCIENTIFIC AND TECHNICAL CONSULTING AND RESEARCH SERVICES RELATING TO FOODS AND DIETARY SUPPLEMENTS (U.S. CLS. 100 AND 101).

CLASS 43—HOTEL AND RESTAURANT SERVICES

FOR HEALTH RESORT SERVICES, NAMELY, PROVIDING FOOD AND LODGING THAT SPECIALIZE IN PROMOTING PATRONS' GENERAL HEALTH AND WELL-BEING; MAKING RESERVATIONS AND BOOKINGS FOR OTHERS FOR ACCOMMODATIONS AND MEALS AT HEALTH SPAS; SPA SERVICES, NAMELY, PROVIDING TEMPORARY ACCOMMODATIONS AND MEALS TO CLIENTS OF A HEALTH OR BEAUTY SPA (U.S. CLS. 100 AND 101).

CLASS 44—MEDICAL, BEAUTY AND AGRICULTURAL SERVICES

FOR CONSULTING SERVICES IN THE FIELD OF WOMEN'S HEALTH; COUNSELING SERVICES IN THE FIELDS OF HEALTH, HERBALISM, AND LIFESTYLE WELLNESS; COUNSELING SERVICES IN THE FIELDS OF HEALTH, NUTRITION AND LIFESTYLE WELLNESS; HEALTH CARE SERVICES, NAMELY, WELLNESS PROGRAMS; HEALTH SPA SERVICES FOR HEALTH AND WELLNESS OF THE BODY AND SPIRIT OFFERED AT A HEALTH RESORT; HEALTH SPA SERVICES FOR HEALTH AND WELLNESS OF THE MIND, BODY AND SPIRIT OFFERED IN OR FROM A REMOTE, MOBILE OR TEMPORARY ON-SITE LOCATION; PROVIDING A WEB SITE FEATURING INFORMATION ON HEALTH AND NUTRITION; PROVIDING ASSISTANCE, FITNESS EVALUATION AND CONSULTATION TO CORPORATE CLIENTS TO HELP THEIR EMPLOYEES MAKE HEALTH, WELLNESS AND NUTRITIONAL CHANGES IN THEIR DAILY LIVING TO IMPROVE HEALTH; PROVIDING ASSISTANCE, FITNESS EVALUATION AND CONSULTATION TO INDIVIDUALS TO HELP THEM MAKE HEALTH, WELLNESS AND NUTRITIONAL CHANGES IN THEIR DAILY LIVING TO IMPROVE HEALTH; PROVIDING HEALTH INFORMATION; DIETARY AND NUTRITIONAL GUIDANCE; FOOD NUTRITION CONSULTATION; NUTRITION COUNSELING; PROVIDING INFORMATION ABOUT DIETARY SUPPLEMENTS AND NUTRITION; PROVIDING MEDICAL INFORMATION, CONSULTANCY AND ADVISORY SERVICES (U.S. CLS. 100 AND 101).

AISHA SALEM, EXAMINING ATTORNEY

SN 77-430,307. CHENG, PENGZI, KENMORE, WA. FILED 3-24-2008.

SN 77-430,362. COLLIER, JOSEPH, G., WEST HAVEN, CT. FILED 3-25-2008.

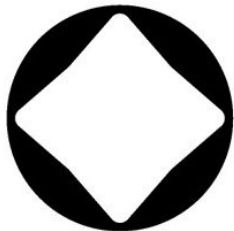

THE MARK CONSISTS OF BLACK FILLED CIRCLE WITH AN ALTERED WHITE DIAMOND SHAPE CUT OUT 4 EDGES OF THE DIAMOND SHAPE ARE IN THE SAME LENGTHEN WITH EACH CURVED INWARDS.

CLASS 14—JEWELRY

FOR BEADS FOR USE IN THE MANUFACTURE OF JEWELRY; BRACELETS; BRONZE JEWELRY; BROOCHES; CHARMS; COSTUME JEWELRY; DIAMOND JEWELRY; GEMSTONE JEWELRY; IDENTIFICATION BRACELETS; JEWELRY; JEWELRY AND IMITATION JEWELRY; JEWELRY BOXES; JEWELRY BOXES NOT OF METAL; JEWELRY BOXES OF METAL; JEWELRY BOXES OF PRECIOUS METAL; JEWELRY CASES; JEWELRY CASES NOT OF PRECIOUS METAL; JEWELRY CASES OF PRECIOUS METAL; JEWELRY CASKETS; JEWELRY CASKETS OF PRECIOUS METAL; JEWELRY CHAINS; JEWELRY FINDINGS; JEWELRY FOR ATTACHMENT TO CLOTHING; JEWELRY FOR THE HEAD; JEWELRY IN THE NATURE OF ARMBANDS; JEWELRY ORGANIZERS; JEWELRY PINS FOR USE ON HATS; JEWELRY RING HOLDERS; JEWELRY TO BE AFFIXED TO BIKINIS; JEWELRY WATCHES; JEWELRY, NAMELY, AMULETS; JEWELRY, NAMELY, CROSSES; JEWELRY, NAMELY, PRECIOUS METAL PLATED REAL LEAVES AND FLOWERS; LAPEL PINS; LEATHER JEWELRY AND ACCESSORY BOXES; METAL WIRE FOR USE IN THE MAKING OF JEWELRY, NAMELY, JEWELRY CABLE; PET JEWELRY; PINS BEING JEWELRY; PLASTIC BRACELETS IN THE NATURE OF JEWELRY; RINGS; RINGS BEING JEWELRY; WATCHES AND JEWELRY; WATCHES, CLOCKS, JEWELRY AND IMITATION JEWELRY (U.S. CLS. 2, 27, 28 AND 50).

CLASS 35—ADVERTISING AND BUSINESS

FOR MAIL ORDER SERVICES FEATURING JEWELRY, CLOTHING ACCESSORIES; RETAIL JEWELRY STORES; STREET VENDOR SERVICES FEATURING JEWELRY, CLOTHING ACCESSORIES; VENDING IN THE FIELD OF JEWELRY, CLOTHING ACCESSORIES; WHOLESALE STORES FEATURING JEWELRY, CLOTHING ACCESSORIES (U.S. CLS. 100, 101 AND 102).

ROBERT C. CLARK JR., EXAMINING ATTORNEY



NO CLAIM IS MADE TO THE EXCLUSIVE RIGHT TO USE "SAVIN ROCK ROASTING COMPANY NEIGHBORHOOD BAR & GRILL", APART FROM THE MARK AS SHOWN.

THE COLOR(S) BEIGE, BURGUNDY, RED, BLACK, ORANGE IS/ARE CLAIMED AS A FEATURE OF THE MARK.

THE MARK CONSISTS OF "SAVIN ROCK ROASTING COMPANY" IN BURGUNDY LETTERING WITH AN ORANGE AND RED FLAME CENTERED BEHIND IT, WITH "NEIGHBORHOOD BAR & GRILL" IN BLACK LETTERING BELOW IT, WITH THE ENTIRE MARK ON A BEIGE BACKGROUND WITH A BURGUNDY BORDER.

CLASS 35—ADVERTISING AND BUSINESS

FOR ADVERTISING SERVICES, NAMELY, PROMOTING AND MARKETING THE GOODS AND SERVICES OF OTHERS IN THE FIELD OF UPSCALE CHOICES SUCH AS CULTURAL EVENTS, RESTAURANTS, SHOPPING, AND TRAVEL VIA PRINT AND ELECTRONIC MEDIA; ASSOCIATION SERVICES, NAMELY, PROMOTING DIVERSITY IN THE RESTAURANT AND HOTEL INDUSTRIES ON BEHALF OF EMPLOYEES, VENDORS, MANAGEMENT, AND OWNERS; FRANCHISING, NAMELY, OFFERING TECHNICAL ASSISTANCE IN THE ESTABLISHMENT AND/OR OPERATION OF RESTAURANTS; OFFERING TECHNICAL ASSISTANCE IN THE ESTABLISHMENT AND/OR OPERATION OF RESTAURANTS; ON-LINE ORDERING SERVICES IN THE FIELD OF RESTAURANT TAKE-OUT AND DELIVERY; RESTAURANT FRANCHISING; RESTAURANT MANAGEMENT FOR OTHERS (U.S. CLS. 100, 101 AND 102).

CLASS 43—HOTEL AND RESTAURANT SERVICES

FOR BAR AND RESTAURANT SERVICES; CAFE AND RESTAURANT SERVICES; CAFE-RESTAURANTS; CAFETERIA AND RESTAURANT SERVICES; CARRY-OUT RESTAURANTS; DELICATESSENS; FAST FOOD AND NON-STOP RESTAURANT SERVICES; FAST-FOOD RESTAURANTS; FAST-FOOD RESTAURANTS AND SNACKBARS; HOTEL AND RESTAURANT RESERVATION SERVICES; HOTEL AND RESTAURANT SERVICES; HOTEL, BAR AND RESTAURANT SERVICES; HOTEL, MOTEL, RESTAURANT, BAR AND CATERING SERVICES; HOTEL, RESTAURANT AND BAR SERVICES; HOTEL, RESTAURANT AND CATERING SERVICES; RESTAURANT; RESTAURANT AND BAR SERVICES; RESTAURANT AND CAFE SERVICES; RESTAURANT AND CATERING SERVICES; RESTAURANT AND HOTEL SERVICES; RESTAURANT SERVICES; RESTAURANT SERVICES FEATURING SANDWICHES; RESTAURANT SERVICES, INCLUDING SIT-DOWN SERVICE OF FOOD AND TAKE-OUT RESTAURANT SERVICES; RESTAURANT, BAR AND CATERING SERVICES; RESTAURANTS; RESTAURANTS FEATURING HOME DELIVERY; SELF SERVICE RESTAURANTS; SELF-SERVICE RESTAURANTS; TAKE-OUT RESTAURANT SERVICES (U.S. CLS. 100 AND 101).

STEPHEN AQUILA, EXAMINING ATTORNEY

SN 77-430,485. W STERNOFF LLC, BELLEVUE, WA. FILED 3-25-2008.

SN 77-430,615. THE WEINBERG GROUP INC., WASHINGTON, DC. FILED 3-25-2008.

MEDI GLIDE

THE MARK CONSISTS OF STANDARD CHARACTERS WITHOUT CLAIM TO ANY PARTICULAR FONT, STYLE, SIZE, OR COLOR.

OWNER OF U.S. REG. NOS. 2,060,911, 2,307,753 AND 3,163,053.

CLASS 3—COSMETICS AND CLEANING PREPARATIONS

FOR NON-MEDICATED SKIN CARE PREPARATIONS (U.S. CLS. 1, 4, 6, 50, 51 AND 52).

CLASS 5—PHARMACEUTICALS

FOR MEDICATED SKIN CARE PREPARATIONS (U.S. CLS. 6, 18, 44, 46, 51 AND 52).

SANJEEV VOHRA, EXAMINING ATTORNEY

SN 77-430,516. CARPENTER, JOSEPH L., LAS VEGAS, NV. FILED 3-25-2008.

QUICK VALVE

THE MARK CONSISTS OF STANDARD CHARACTERS WITHOUT CLAIM TO ANY PARTICULAR FONT, STYLE, SIZE, OR COLOR.

NO CLAIM IS MADE TO THE EXCLUSIVE RIGHT TO USE "VALVE", APART FROM THE MARK AS SHOWN.

CLASS 9—ELECTRICAL AND SCIENTIFIC APPARATUS

FOR ELECTRONIC IRRIGATION CONTROLLERS AND SOLENOID CONTROLLED VALVES (U.S. CLS. 21, 23, 26, 36 AND 38).

CLASS 11—ENVIRONMENTAL CONTROL APPARATUS

FOR TURF AND AGRICULTURAL IRRIGATION SYSTEMS COMPRISED OF SPRINKLERS, VALVES, CONTROLLERS, HOSES AND TUBING AND FITTINGS THEREFOR, EMITTERS AND PARTS THEREFOR (U.S. CLS. 13, 21, 23, 31 AND 34).

RENEE MCCRAY, EXAMINING ATTORNEY

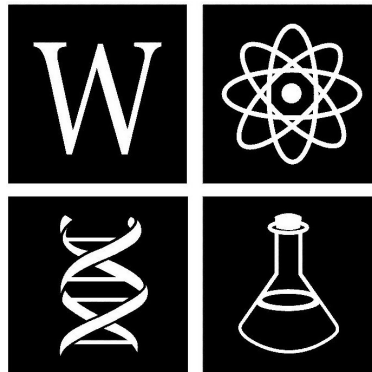

OWNER OF U.S. REG. NO. 3,075,159.

THE MARK CONSISTS OF FOUR ADJACENT SQUARES. THE TOP LEFT SQUARE CONTAINS THE LETTER "W"; THE TOP RIGHT SQUARE CONTAINS A STYLIZED ATOM; THE BOTTOM LEFT SQUARE CONTAINS A STYLIZED DNA DOUBLE HELIX; AND THE BOTTOM RIGHT SQUARE CONTAINS A STYLIZED FLASK WITH LIQUID IN IT.

CLASS 35—ADVERTISING AND BUSINESS

FOR LEGISLATIVE SUPPORT CONSULTING SERVICES, NAMELY, CRITICAL ANALYSIS OF THE SCIENTIFIC, ECONOMIC, BUSINESS, MARKET, AND SOCIO-POLITICAL ASPECTS OF ISSUES RAISED IN LEGISLATION, FOR COMPANIES IN THE FIELDS OF PHARMACEUTICALS, MEDICAL EQUIPMENT AND TECHNOLOGY, BIOTECH, TOXICOLOGY, CONSUMER PRODUCTS, COSMETICS AND TOILETRIES, DIETARY SUPPLEMENTS, FOODS, ELECTRONICS, CHEMICALS, EMISSIONS AND WASTE PRODUCTS, PESTICIDES, AGRICULTURE AND UTILITIES; BUSINESS MARKETING CONSULTATION AND ECONOMIC ANALYSIS AND EVALUATION FOR COMPANIES IN THE FIELDS OF PHARMACEUTICALS, MEDICAL EQUIPMENT AND TECHNOLOGY, BIOTECH, TOXICOLOGY, CONSUMER PRODUCTS, COSMETICS AND TOILETRIES, DIETARY SUPPLEMENTS, FOODS, ELECTRONICS, CHEMICALS, EMISSIONS AND WASTE PRODUCTS, PESTICIDES, AGRICULTURE AND UTILITIES (U.S. CLS. 100, 101 AND 102).

FIRST USE 2-25-2008; IN COMMERCE 2-25-2008.

CLASS 42—SCIENTIFIC AND COMPUTER SERVICES

FOR SCIENTIFIC ANALYSIS, SCIENTIFIC RESEARCH, PHARMACEUTICAL RESEARCH SERVICES, PRODUCT DEVELOPMENT CONSULTATION, GOVERNMENT REGULATORY COMPLIANCE, AND LITIGATION SUPPORT CONSULTING SERVICES; RISK ASSESSMENT, NAMELY, RESEARCH, ANALYSIS AND EVALUATION OF POTENTIAL RISKS OF PRODUCTS, SUBSTANCES, AND MANUFACTURING PROCESSES TO HEALTH, SAFETY AND THE ENVIRONMENT, ALL FOR COMPANIES IN THE FIELDS OF PHARMACEUTICALS, MEDICAL EQUIPMENT AND TECHNOLOGY, BIOTECH, TOXICOLOGY, CONSUMER PRODUCTS, COSMETICS AND TOILETRIES, DIETARY SUPPLEMENTS, FOODS, ELECTRONICS, CHEMICALS, EMISSIONS AND WASTE PRODUCTS, PESTICIDES, AGRICULTURE AND UTILITIES (U.S. CLS. 100 AND 101).

FIRST USE 2-25-2008; IN COMMERCE 2-25-2008.

JOHN SCHUYLER YARD, EXAMINING ATTORNEY

SN 77-430,618. COFFEE MATTERS, BROOKLYN PARK, MN. FILED 3-25-2008.



THE MARK CONSISTS OF A PICTURE OF A COFFEE STAIN.

CLASS 18—LEATHER GOODS

FOR DOG APPAREL (U.S. CLS. 1, 2, 3, 22 AND 41).

CLASS 40—MATERIAL TREATMENT

FOR IMPRINTING MESSAGES ON WEARING APPAREL, ACCESSORIES AND MUGS (U.S. CLS. 100, 103 AND 106).
JASON TURNER, EXAMINING ATTORNEY

SN 77-430,669. INTEGRATED SOLUTIONS CONSULTING, CORP., CHICAGO, IL. FILED 3-25-2008.

Odysseus

THE MARK CONSISTS OF STANDARD CHARACTERS WITHOUT CLAIM TO ANY PARTICULAR FONT, STYLE, SIZE, OR COLOR.

CLASS 9—ELECTRICAL AND SCIENTIFIC APPARATUS

FOR COMPUTER SOFTWARE FOR THE COLLECTION, EDITING, ORGANIZING, MODIFYING, BOOK MARKING, TRANSMISSION, STORAGE AND SHARING OF DATA AND INFORMATION; COMPUTER SOFTWARE THAT PROVIDES REAL-TIME, INTEGRATED BUSINESS MANAGEMENT INTELLIGENCE BY COMBINING INFORMATION FROM VARIOUS DATABASES AND PRESENTING IT IN AN EASY-TO-UNDERSTAND USER INTERFACE (U.S. CLS. 21, 23, 26, 36 AND 38).

CLASS 42—SCIENTIFIC AND COMPUTER SERVICES

FOR COMPUTER SERVICE, NAMELY, ACTING AS AN APPLICATION SERVICE PROVIDER IN THE FIELD OF KNOWLEDGE MANAGEMENT TO HOST COMPUTER APPLICATION SOFTWARE FOR CREATING SEARCHABLE DATABASES OF INFORMATION AND DATA (U.S. CLS. 100 AND 101).

CLASS 45—PERSONAL AND LEGAL SERVICES

FOR SECURITY SERVICES, NAMELY, THREAT SIMULATION VULNERABILITY ANALYSIS AND MITIGATION AND EMERGENCY AND CRISIS RESPONSE (U.S. CLS. 100 AND 101).
ESTHER BELENKER, EXAMINING ATTORNEY

SN 77-430,763. HEATEC, INC., CHATTANOOGA, TN. FILED 3-25-2008.



THE MARK CONSISTS OF A REPRESENTATION OF A FLAME.

CLASS 6—METAL GOODS

FOR METAL TANKS FOR STORAGE OF ASPHALT CEMENT; METAL TANKS FOR STORAGE OF FUEL (U.S. CLS. 2, 12, 13, 14, 23, 25 AND 50).
FIRST USE 7-31-2001; IN COMMERCE 7-31-2001.

CLASS 11—ENVIRONMENTAL CONTROL APPARATUS

FOR THERMAL FLUID HEATERS FOR USE IN CONNECTION WITH THE PRODUCTION OF ASPHALT; THERMAL FLUID HEATERS FOR INDUSTRIAL USE; WATER HEATERS FOR INDUSTRIAL USE; THERMAL FLUID HEATERS FOR COMMERCIAL USE FOR PREHEATING FUEL STORAGE TANKS; ELECTRIC HEATERS FOR COMMERCIAL USE FOR PREHEATING FUEL STORAGE TANKS; ELECTRICALLY HEATED METAL STORAGE TANKS; ELECTRICALLY HEATED STEAM GENERATORS (U.S. CLS. 13, 21, 23, 31 AND 34).
FIRST USE 12-28-2000; IN COMMERCE 12-28-2000.
DAVID YONTEF, EXAMINING ATTORNEY

SN 77-430,792. GENESYS TELECOMMUNICATIONS LABORATORIES, INC., DALY CITY, CA. FILED 3-25-2008.

ICFD

THE MARK CONSISTS OF STANDARD CHARACTERS WITHOUT CLAIM TO ANY PARTICULAR FONT, STYLE, SIZE, OR COLOR.

CLASS 9—ELECTRICAL AND SCIENTIFIC APPARATUS

FOR COMPUTER SOFTWARE FOR CONTACT CENTER MANAGEMENT (U.S. CLS. 21, 23, 26, 36 AND 38).

CLASS 42—SCIENTIFIC AND COMPUTER SERVICES

FOR CUSTOMIZATION AND IMPLEMENTATION OF COMPUTER SOFTWARE FOR CONTACT CENTER MANAGEMENT (U.S. CLS. 100 AND 101).
COLLEEN KEARNEY, EXAMINING ATTORNEY

SN 77-430,831. SURECRETE DESIGN PRODUCTS, INC., DADE CITY, FL. FILED 3-25-2008.



NO CLAIM IS MADE TO THE EXCLUSIVE RIGHT TO USE "SERIES", APART FROM THE MARK AS SHOWN. THE MARK CONSISTS OF THE WORD "SERIES" APPEARS ON A HORIZONTAL LINE BELOW A STYLIZED PRESENTATION OF THE WORD "XTREME".

SN 77-430,797. GLOBUS MEDICAL, INC., AUDUBON, PA. FILED 3-25-2008.

THINKSPINE

CLASS 1—CHEMICALS

FOR ADDITIVES FOR CONCRETE (U.S. CLS. 1, 5, 6, 10, 26 AND 46).

CLASS 2—PAINTS

FOR CLEAR AND PIGMENTED SEALERS FOR USE IN COATING CONCRETE (U.S. CLS. 6, 11 AND 16).

CLASS 19—NON-METALLIC BUILDING MATERIALS

FOR DRY CONCRETE MIXES (U.S. CLS. 1, 12, 33 AND 50).
BARBARA BROWN, EXAMINING ATTORNEY

THE MARK CONSISTS OF STANDARD CHARACTERS WITHOUT CLAIM TO ANY PARTICULAR FONT, STYLE, SIZE, OR COLOR.

SN 77-430,839. HENRIQUES, STEPHEN, COHEN, NEW YORK, NY. FILED 3-25-2008.

CLASS 38—COMMUNICATION

FOR PROVIDING ONLINE FORUMS FOR TRANSMISSION OF MESSAGES AMONG COMPUTER USERS CONCERNING SPINAL SURGERY TOPICS, RESEARCH AND PRODUCT DEVELOPMENT (U.S. CLS. 100, 101 AND 104).

Tiger's troops

CLASS 41—EDUCATION AND ENTERTAINMENT

FOR EDUCATIONAL SERVICES, NAMELY, CONDUCTING SEMINARS AND WORKSHOPS IN THE FIELD OF SPINAL SURGERY, RESEARCH AND PRODUCT DEVELOPMENT (U.S. CLS. 100, 101 AND 107).

THE MARK CONSISTS OF STANDARD CHARACTERS WITHOUT CLAIM TO ANY PARTICULAR FONT, STYLE, SIZE, OR COLOR.

CLASS 42—SCIENTIFIC AND COMPUTER SERVICES

FOR COMPUTER SERVICES, NAMELY, HOSTING ON-LINE WEB FACILITIES FOR OTHERS FOR ARRANGING AND CONDUCTING ONLINE MEETINGS, GATHERINGS AND INTERACTIVE DISCUSSIONS; HOSTING AN ONLINE COMMUNITY WEB SITE FEATURING A FORUM FOR DISCUSSING CASES THROUGH A BULLETIN BOARD OR IN REAL TIME, FINDING INFORMATION ON AND TO SPINE RELATED EVENTS (U.S. CLS. 100 AND 101).
PAM WILLIS, EXAMINING ATTORNEY

CLASS 35—ADVERTISING AND BUSINESS

FOR RETAIL APPAREL STORES (U.S. CLS. 100, 101 AND 102).

CLASS 40—MATERIAL TREATMENT

FOR IMPRINTING MESSAGES ON WEARING APPAREL, ACCESSORIES AND MUGS (U.S. CLS. 100, 103 AND 106).
CHERYL CLAYTON, EXAMINING ATTORNEY

SN 77-430,859. GLOBUS MEDICAL, INC., AUDUBON, PA. FILED 3-25-2008.



The logo for ThinkSpine features the word "Think" in a black sans-serif font, followed by a stylized blue spine graphic composed of several overlapping circles of varying sizes, and then the word "Spine" in a black sans-serif font.

THE COLOR(S) BLUE, BLACK AND WHITE IS/ARE CLAIMED AS A FEATURE OF THE MARK.

THE MARK CONSISTS OF AN ANIMATED BLUE SPINE WITH WHITE ACCENTS, WHICH SEPARATES THE WORD "THINK" FROM THE WORD "SPINE". THE WORDS "THINK" AND "SPINE" ARE IN BLACK.

CLASS 38—COMMUNICATION

FOR PROVIDING ONLINE FORUMS FOR TRANSMISSION OF MESSAGES AMONG COMPUTER USERS CONCERNING SPINAL SURGERY TOPICS, RESEARCH AND PRODUCT DEVELOPMENT (U.S. CLS. 100, 101 AND 104).

CLASS 41—EDUCATION AND ENTERTAINMENT

FOR EDUCATIONAL SERVICES, NAMELY, CONDUCTING SEMINARS AND WORKSHOPS IN THE FIELD OF SPINAL SURGERY, RESEARCH AND PRODUCT DEVELOPMENT (U.S. CLS. 100, 101 AND 107).

CLASS 42—SCIENTIFIC AND COMPUTER SERVICES

FOR COMPUTER SERVICES, NAMELY, HOSTING ON-LINE WEB FACILITIES FOR OTHERS FOR ARRANGING AND CONDUCTING ONLINE MEETINGS, GATHERINGS AND INTERACTIVE DISCUSSIONS; HOSTING AN ONLINE COMMUNITY WEB SITE FEATURING A FORUM FOR DISCUSSING CASES THROUGH A BULLETIN BOARD OR IN REAL TIME, FINDING INFORMATION ON AND TO SPINE RELATED EVENTS (U.S. CLS. 100 AND 101).

PAM WILLIS, EXAMINING ATTORNEY

SN 77-430,861. PEOPLE'S CITY MISSION HOME, THE, LINCOLN, NE. FILED 3-25-2008.

GREAT COFFEE FOR THE GREATER GOOD

THE MARK CONSISTS OF STANDARD CHARACTERS WITHOUT CLAIM TO ANY PARTICULAR FONT, STYLE, SIZE, OR COLOR.

CLASS 30—STAPLE FOODS

FOR COFFEE (U.S. CL. 46).

CLASS 35—ADVERTISING AND BUSINESS

FOR RETAIL STORE SERVICES FEATURING COFFEE (U.S. CLS. 100, 101 AND 102).

NANCY CLARKE, EXAMINING ATTORNEY

SN 77-430,864. MIDDLE EAST BROADCASTING NETWORKS, INC., SPRINGFIELD, VA. FILED 3-25-2008.



THE MARK CONSISTS OF A STYLIZED DESIGN OF A BIRD.

CLASS 38—COMMUNICATION

FOR TELEVISION BROADCASTING, TELEVISION TRANSMISSION AND SATELLITE TRANSMISSION SERVICES (U.S. CLS. 100, 101 AND 104).

CLASS 41—EDUCATION AND ENTERTAINMENT

FOR ENTERTAINMENT SERVICES, NAMELY, A CONTINUING NEWS, INFORMATION AND VARIETY SHOW BROADCAST OVER TELEVISION, SATELLITE, AUDIO, AND VIDEO MEDIA AND ENTERTAINMENT SERVICES, NAMELY, PROVIDING A TELEVISION PROGRAM IN THE FIELD OF NEWS, INFORMATION AND VARIETY VIA A GLOBAL COMPUTER NETWORK (U.S. CLS. 100, 101 AND 107).

WILLIAM P. SHANAHAN, EXAMINING ATTORNEY

SN 77-430,976. PARAGON BIOSERVICES, INC., BALTIMORE, MD. FILED 3-25-2008.

PARAGON BIOSERVICES

THE MARK CONSISTS OF STANDARD CHARACTERS WITHOUT CLAIM TO ANY PARTICULAR FONT, STYLE, SIZE, OR COLOR.

OWNER OF U.S. REG. NO. 2,490,138.

CLASS 5—PHARMACEUTICALS

FOR PHARMACEUTICAL PRODUCTS, NAMELY, MEDICAL DIAGNOSTIC REAGENTS FOR USE IN IMMUNO PURIFICATION, IMAGING AND ASSAYS, BACTERIOLOGICAL CULTURE MEDIA FOR MEDICAL USE (U.S. CLS. 6, 18, 44, 46, 51 AND 52).

FIRST USE 3-1-1999; IN COMMERCE 3-1-1999.

CLASS 42—SCIENTIFIC AND COMPUTER SERVICES

FOR PHARMACEUTICAL RESEARCH AND PRODUCT DEVELOPMENT SERVICES FOR OTHERS, NAMELY, PRECLINICAL CONTRACT RESEARCH, CURRENT GOOD MANUFACTURING AND PRODUCT DEVELOPMENT FOR PHARMACEUTICAL AND BIOTECHNOLOGY COMPANIES (U.S. CLS. 100 AND 101).

FIRST USE 3-1-1999; IN COMMERCE 3-1-1999.
AISHA CLARKE, EXAMINING ATTORNEY

SN 77-431,020. PARAGON BIOSERVICES, INC., WASHINGTON, DC. FILED 3-25-2008.



OWNER OF U.S. REG. NO. 2,490,138.
THE MARK CONSISTS OF A PARTIALLY SHADED CIRCLE THAT LOOKS LIKE A PEARL WITH A SHADOW BENEATH THE PARTIALLY SHADED CIRCLE.

CLASS 5—PHARMACEUTICALS

FOR PHARMACEUTICAL PRODUCTS, NAMELY, MEDICAL DIAGNOSTIC REAGENTS FOR USE IN IMMUNO PURIFICATION, IMAGING AND ASSAYS, BACTERIOLOGICAL CULTURE MEDIA FOR MEDICAL USE (U.S. CLS. 6, 18, 44, 46, 51 AND 52).

FIRST USE 3-1-1999; IN COMMERCE 3-1-1999.

CLASS 42—SCIENTIFIC AND COMPUTER SERVICES

FOR PHARMACEUTICAL RESEARCH AND PRODUCT DEVELOPMENT SERVICES FOR OTHERS, NAMELY, PRECLINICAL CONTRACT RESEARCH, CURRENT GOOD MANUFACTURING AND PRODUCT DEVELOPMENT FOR PHARMACEUTICAL AND BIOTECHNOLOGY COMPANIES (U.S. CLS. 100 AND 101).

FIRST USE 3-1-1999; IN COMMERCE 3-1-1999.
AISHA CLARKE, EXAMINING ATTORNEY

SN 77-431,070. WDI INTERNATIONAL, INC., IRVINE, CA. FILED 3-25-2008.

QUICKCONNECT

THE MARK CONSISTS OF STANDARD CHARACTERS WITHOUT CLAIM TO ANY PARTICULAR FONT, STYLE, SIZE, OR COLOR.

CLASS 6—METAL GOODS

FOR METAL FASTENERS, NAMELY, NUTS AND BOLTS (U.S. CLS. 2, 12, 13, 14, 23, 25 AND 50).

CLASS 20—FURNITURE AND ARTICLES NOT OTHERWISE CLASSIFIED

FOR PLASTIC FASTENERS, NAMELY, NUTS AND BOLTS (U.S. CLS. 2, 13, 22, 25, 32 AND 50).
CYNTHIA SLOAN, EXAMINING ATTORNEY

SN 77-431,095. CHS INC., INVER GROVE HEIGHTS, MN. FILED 3-25-2008.

CENEX

THE MARK CONSISTS OF STANDARD CHARACTERS WITHOUT CLAIM TO ANY PARTICULAR FONT, STYLE, SIZE, OR COLOR.

OWNER OF U.S. REG. NOS. 1,070,076, 1,591,300 AND OTHERS.

CLASS 4—LUBRICANTS AND FUELS

FOR FUELS, NAMELY, GASOLINE, DIESEL, BIODIESEL, PROPANE AND FUEL OIL; LUBRICATING OILS AND GREASES FOR VEHICLES AND MACHINES (U.S. CLS. 1, 6 AND 15).

FIRST USE 0-0-1973; IN COMMERCE 0-0-1973.

CLASS 25—CLOTHING

FOR CLOTHING, NAMELY, GLOVES, HATS, SHIRTS, SWEATERS, JACKETS, CAPS (U.S. CLS. 22 AND 39).

FIRST USE 0-0-1973; IN COMMERCE 0-0-1973.

CLASS 35—ADVERTISING AND BUSINESS

FOR RETAIL STORE SERVICES FEATURING AGRICULTURAL PRODUCTS AND SUPPLIES, OILS, FUELS, ALTERNATIVE FUELS AND LUBRICANTS; DISTRIBUTORSHIP SERVICES FEATURING AGRICULTURAL PRODUCTS AND SUPPLIES, OILS, FUELS, ALTERNATIVE FUELS AND LUBRICANTS; RETAIL MOTOR VEHICLE FUEL SUPPLY SERVICES BY MEANS OF PUMP ISLAND CREDIT CARD READERS; RETAIL STORE SERVICES FEATURING CONVENIENCE STORE ITEMS AND MOTOR FUELS; COOPERATIVE AND DEALER ADVERTISING AND MARKETING FOR FUEL PRODUCT PRODUCERS; DISTRIBUTORSHIPS IN THE FIELD OF REFINED FUELS, LUBRICANTS, PROPANE AND ALTERNATIVE FUELS; ASSOCIATION SERVICES, NAMELY, PROMOTING THE INTERESTS OF COOPERATIVE MEMBERS AND DEALERS (U.S. CLS. 100, 101 AND 102).

FIRST USE 0-0-1973; IN COMMERCE 0-0-1973.

CLASS 36—INSURANCE AND FINANCIAL

FOR FINANCIAL RISK MANAGEMENT SERVICES IN THE PROPANE, FUELS AND LUBRICANTS INDUSTRY (U.S. CLS. 100, 101 AND 102).

FIRST USE 0-0-1973; IN COMMERCE 0-0-1973.

CLASS 37—CONSTRUCTION AND REPAIR

FOR AUTOMOBILE SERVICE STATION SERVICES (U.S. CLS. 100, 103 AND 106).

FIRST USE 0-0-1973; IN COMMERCE 0-0-1973.

CLASS 39—TRANSPORTATION AND STORAGE

FOR STORAGE AND TRANSPORTATION OF GOODS BY RAILROAD AND TRUCK; STORAGE, DISTRIBUTION, AND TRANSPORTATION OF NATURAL GAS, PROPANE, FUELS, OILS, AMMONIA AND LUBRICANTS; PUBLIC UTILITY SERVICES IN THE NATURE OF NATURAL GAS AND PROPANE DISTRIBUTION (U.S. CLS. 100 AND 105).

FIRST USE 0-0-1975; IN COMMERCE 0-0-1975.

CLASS 45—PERSONAL AND LEGAL SERVICES

FOR CONSULTATION SERVICES IN THE FIELD OF NATURAL GAS, FUELS AND PROPANE SAFETY (U.S. CLS. 100 AND 101).

FIRST USE 0-0-1973; IN COMMERCE 0-0-1973.

DOMINICK J. SALEMI, EXAMINING ATTORNEY

CLASS 35—ADVERTISING AND BUSINESS

FOR SPECIALTY MERCHANDISING SERVICES, NAMELY, PROMOTING THE GOODS AND SERVICES OF OTHERS THROUGH THE DISTRIBUTION OF CUSTOMIZED ADVERTISING MATERIALS, NAMELY, CHOCOLATE MOLDED IN THE SHAPE OF A MAZE (U.S. CLS. 100, 101 AND 102).

BARNEY CHARLON, EXAMINING ATTORNEY

SN 77-431,153. HACHMANN, JEFFREY, STOWE, VT. FILED 3-25-2008.

AMAZING STATE

THE MARK CONSISTS OF STANDARD CHARACTERS WITHOUT CLAIM TO ANY PARTICULAR FONT, STYLE, SIZE, OR COLOR.

CLASS 30—STAPLE FOODS

FOR CHOCOLATE MOLDED IN THE SHAPE OF A MAZE (U.S. CL. 46).

CLASS 35—ADVERTISING AND BUSINESS

FOR SPECIALTY MERCHANDISING SERVICES, NAMELY, PROMOTING BUSINESS AND TOURISM IN A PARTICULAR STATE IN THE UNITED STATES THROUGH THE DISTRIBUTION OF CUSTOMIZED ADVERTISING MATERIALS, NAMELY, CHOCOLATE MOLDED IN THE SHAPE OF A MAZE (U.S. CLS. 100, 101 AND 102).

BARNEY CHARLON, EXAMINING ATTORNEY

SN 77-431,166. WAIKALAND, FORT MYERS, FL. FILED 3-25-2008.

WAIKALAND

THE MARK CONSISTS OF STANDARD CHARACTERS WITHOUT CLAIM TO ANY PARTICULAR FONT, STYLE, SIZE, OR COLOR.

CLASS 5—PHARMACEUTICALS

FOR DIETARY AND NUTRITIONAL SUPPLEMENTS; VITAMIN SUPPLEMENTS (U.S. CLS. 6, 18, 44, 46, 51 AND 52).

FIRST USE 3-25-2008; IN COMMERCE 3-25-2008.

CLASS 29—MEATS AND PROCESSED FOODS

FOR FRUIT-BASED FOOD BEVERAGE; SOY-BASED FOOD BEVERAGE USED AS A MILK SUBSTITUTE (U.S. CL. 46).

FIRST USE 3-25-2008; IN COMMERCE 3-25-2008.

SN 77-431,139. LADEN, DON, CINCINNATI, OH. FILED 3-25-2008.

CHI-NNATIS

THE MARK CONSISTS OF STANDARD CHARACTERS WITHOUT CLAIM TO ANY PARTICULAR FONT, STYLE, SIZE, OR COLOR.

CLASS 35—ADVERTISING AND BUSINESS

FOR ON-LINE ORDERING SERVICES IN THE FIELD OF RESTAURANT TAKE-OUT AND DELIVERY (U.S. CLS. 100, 101 AND 102).

CLASS 43—HOTEL AND RESTAURANT SERVICES

FOR RESTAURANT SERVICES (U.S. CLS. 100 AND 101).

CHRISTINE BLOMQUIST, EXAMINING ATTORNEY

SN 77-431,147. HACHMANN, JEFFREY, STOWE, VT. FILED 3-25-2008.

THE AMAZING DESTINATION

THE MARK CONSISTS OF STANDARD CHARACTERS WITHOUT CLAIM TO ANY PARTICULAR FONT, STYLE, SIZE, OR COLOR.

CLASS 30—STAPLE FOODS

FOR CHOCOLATE MOLDED IN THE SHAPE OF A MAZE (U.S. CL. 46).

CLASS 32—LIGHT BEVERAGES

FOR ENERGY DRINKS (U.S. CLS. 45, 46 AND 48).
FIRST USE 3-25-2008; IN COMMERCE 3-25-2008.
DANNAN HETZEL, EXAMINING ATTORNEY

SN 77-431,323. DOTNETNUKE CORPORATION, SEATTLE,
WA. FILED 3-25-2008.

DOTNETNUKE

THE MARK CONSISTS OF STANDARD CHARACTERS
WITHOUT CLAIM TO ANY PARTICULAR FONT, STYLE,
SIZE, OR COLOR.
OWNER OF U.S. REG. NO. 3,206,060.

CLASS 9—ELECTRICAL AND SCIENTIFIC APPARATUS

FOR COMPUTER SOFTWARE FOR MANAGING,
STORING, RETRIEVING, ACCESSING, TRACKING,
PROFILING, CATEGORIZING, SEARCHING, ARCHIV-
ING AND DELIVERING COMPUTER FILES, DATA,
DOCUMENTS, IMAGES, AUDIO FILES, VIDEO AND
FILM (U.S. CLS. 21, 23, 26, 36 AND 38).
FIRST USE 2-28-2003; IN COMMERCE 2-28-2003.

CLASS 42—SCIENTIFIC AND COMPUTER SERVICES

FOR COMPUTER PROGRAMMING; SOFTWARE DE-
SIGN AND DEVELOPMENT; COMPUTER ADVICE AND
CONSULTANCY RELATING TO COMPUTER SYSTEMS
AND COMPUTER SOFTWARE; TECHNICAL SUPPORT
SERVICES FOR TROUBLE SHOOTING OF COMPUTER
HARDWARE AND SOFTWARE PROBLEMS, UPDATING
OF COMPUTER SOFTWARE; COMPUTER CONSUL-
TANCY, RENTAL OF COMPUTER SOFTWARE, COM-
PUTER SYSTEMS INTEGRATION AND
CONFIGURATION SERVICES, AND INSTALLATION,
MAINTENANCE AND REPAIR OF COMPUTER SOFT-
WARE, WEB SITE HOSTING SERVICES, ALL IN RELA-
TION TO COMPUTER SOFTWARE FOR MANAGING,
STORING, RETRIEVING, ACCESSING, TRACKING,
PROFILING, CATEGORIZING, SEARCHING, ARCHIV-
ING AND DELIVERING COMPUTER FILES, DATA,
DOCUMENTS, IMAGES, AUDIO FILES, VIDEO AND
FILM (U.S. CLS. 100 AND 101).
FIRST USE 2-28-2003; IN COMMERCE 2-28-2003.
WENDY JUN, EXAMINING ATTORNEY

SN 77-431,328. JIM HARDY, INC., HOUSTON, TX. FILED 3-
25-2008.

THE PLANE TRUTH

THE MARK CONSISTS OF STANDARD CHARACTERS
WITHOUT CLAIM TO ANY PARTICULAR FONT, STYLE,
SIZE, OR COLOR.

CLASS 9—ELECTRICAL AND SCIENTIFIC APPARATUS

FOR PRE-RECORDED CD'S, VIDEO TAPES, AUDIO
TAPES, LASER DISKS AND DVD'S FEATURING GOLF
INSTRUCTION; DOWNLOADABLE VIDEO RECORD-
INGS FEATURING GOLF INSTRUCTION; EDUCA-
TIONAL SOFTWARE FEATURING INSTRUCTION IN
GOLF (U.S. CLS. 21, 23, 26, 36 AND 38).
FIRST USE 3-1-2005; IN COMMERCE 7-1-2006.

CLASS 41—EDUCATION AND ENTERTAINMENT

FOR EDUCATIONAL SERVICES, NAMELY, CON-
DUCTING CLASSES, DEMONSTRATIONS, SEMINARS,
AND WORKSHOPS IN THE FIELD OF GOLF; PROVID-
ING GOLF INSTRUCTION; ONLINE INFORMATIONAL
SERVICES IN THE FIELD OF GOLF OFFERED VIA A
GLOBAL COMPUTER NETWORK (U.S. CLS. 100, 101
AND 107).
FIRST USE 3-1-2005; IN COMMERCE 3-1-2005.
FRED MANDIR, EXAMINING ATTORNEY

SN 77-431,376. LEE, GARY L., CHICAGO, IL. AND MCWAL-
TERS, THOMAS J., CHICAGO, IL. FILED 3-25-2008.

TG COUTURE

THE MARK CONSISTS OF STANDARD CHARACTERS
WITHOUT CLAIM TO ANY PARTICULAR FONT, STYLE,
SIZE, OR COLOR.
NO CLAIM IS MADE TO THE EXCLUSIVE RIGHT TO
USE "COUTURE", APART FROM THE MARK AS SHOWN.

CLASS 20—FURNITURE AND ARTICLES NOT OTHERWISE CLASSIFIED

FOR FURNITURE (U.S. CLS. 2, 13, 22, 25, 32 AND 50).

CLASS 35—ADVERTISING AND BUSINESS

FOR FURNITURE STORE SERVICES FOR THOSE IN
THE INTERIOR DESIGN INDUSTRY (U.S. CLS. 100, 101
AND 102).

CLASS 42—SCIENTIFIC AND COMPUTER SERVICES

FOR FURNITURE DESIGN SERVICES (U.S. CLS. 100
AND 101).
ALEX KEAM, EXAMINING ATTORNEY

SN 77-431,392. UNITED TRADEMARK HOLDINGS, INC., BEVERLY HILLS, CA. FILED 3-25-2008.



THE STIPLING IS FOR SHADING PURPOSES ONLY. THE MARK CONSISTS OF THE STYLIZED TEXT "JUNIOR ELF FAIRYTALE PRINCESS" ABOVE AN IMAGE OF THREE FAIRYTALE PRINCESSES.

CLASS 10—MEDICAL APPARATUS

FOR BABY BOTTLES; PACIFIERS FOR BABIES (U.S. CLS. 26, 39 AND 44).
FIRST USE 1-1-2008; IN COMMERCE 1-1-2008.

CLASS 14—JEWELRY

FOR COSTUME JEWELRY (U.S. CLS. 2, 27, 28 AND 50).
FIRST USE 1-1-2008; IN COMMERCE 1-1-2008.

CLASS 25—CLOTHING

FOR BELTS; CHILDREN'S AND INFANTS' CLOTH BIBS; FLIP FLOPS; FOOTWEAR; GLOVES; HATS; MITTENS; SANDALS; SCARVES (U.S. CLS. 22 AND 39).
FIRST USE 1-1-2008; IN COMMERCE 1-1-2008.

CLASS 26—FANCY GOODS

FOR BARRETTES; HAIR BANDS; HAIR CLIPS; HAIR PINS; HAIR SCRUNCHIES; PONYTAIL HOLDERS (U.S. CLS. 37, 39, 40, 42 AND 50).
FIRST USE 1-1-2008; IN COMMERCE 1-1-2008.

CLASS 28—TOYS AND SPORTING GOODS

FOR CHILDREN'S PLAY COSMETICS (U.S. CLS. 22, 23, 38 AND 50).
FIRST USE 1-1-2008; IN COMMERCE 1-1-2008.
ALEX KEAM, EXAMINING ATTORNEY

CLASS 18—LEATHER GOODS

FOR BACKPACKS, BOOK BAGS, SPORTS BAGS, BUM BAGS, WALLETS AND HANDBAGS (U.S. CLS. 1, 2, 3, 22 AND 41).

CLASS 25—CLOTHING

FOR TOPS (U.S. CLS. 22 AND 39).
SUNG IN, EXAMINING ATTORNEY

SN 77-431,590. HENRI BENDEL, INC., NEW YORK, NY. FILED 3-26-2008.

CENTENNIAL STRIPE

THE MARK CONSISTS OF STANDARD CHARACTERS WITHOUT CLAIM TO ANY PARTICULAR FONT, STYLE, SIZE, OR COLOR.

NO CLAIM IS MADE TO THE EXCLUSIVE RIGHT TO USE "STRIPE", APART FROM THE MARK AS SHOWN.

CLASS 14—JEWELRY

FOR RINGS, EARRINGS, BRACELETS, NECKLACES AND JEWELRY BOXES (U.S. CLS. 2, 27, 28 AND 50).

CLASS 16—PAPER GOODS AND PRINTED MATTER

FOR CHECKBOOK AND PASSBOOK WALLETS; PASSPORT HOLDERS (U.S. CLS. 2, 5, 22, 23, 29, 37, 38 AND 50).

CLASS 18—LEATHER GOODS

FOR HANDBAGS, LEATHER BAGS, WALLETS, PURSES, AND ANIMAL CARRIERS (U.S. CLS. 1, 2, 3, 22 AND 41).

CLASS 20—FURNITURE AND ARTICLES NOT OTHERWISE CLASSIFIED

FOR KEY FOBS, NOT OF METAL AND PICTURE FRAMES (U.S. CLS. 2, 13, 22, 25, 32 AND 50).
H. M. FISHER, EXAMINING ATTORNEY

SN 77-431,498. SHOTA, MARY, DBA SHO CREATIONS, KANEOHE, HI. FILED 3-26-2008.

Seven Continents

THE MARK CONSISTS OF STANDARD CHARACTERS WITHOUT CLAIM TO ANY PARTICULAR FONT, STYLE, SIZE, OR COLOR.

SN 77-431,595. APPRISS INC., LOUISVILLE, KY. FILED 3-26-2008.

DATABRIDGE

THE MARK CONSISTS OF STANDARD CHARACTERS WITHOUT CLAIM TO ANY PARTICULAR FONT, STYLE, SIZE, OR COLOR.

CLASS 9—ELECTRICAL AND SCIENTIFIC APPARATUS

FOR ELECTRONIC DATABASES IN THE FIELD OF CRIMINAL JUSTICE RECORDED ON COMPUTER MEDIA (U.S. CLS. 21, 23, 26, 36 AND 38).

CLASS 38—COMMUNICATION

FOR ELECTRONIC TRANSMISSION OF DATA RELATED TO CRIMINAL JUSTICE (U.S. CLS. 100, 101 AND 104).

SUNG IN, EXAMINING ATTORNEY

SN 77-431,607. HENRI BENDEL, INC., NEW YORK, NY. FILED 3-26-2008.

HATBOX WEBBING

THE MARK CONSISTS OF STANDARD CHARACTERS WITHOUT CLAIM TO ANY PARTICULAR FONT, STYLE, SIZE, OR COLOR.

NO CLAIM IS MADE TO THE EXCLUSIVE RIGHT TO USE "WEBBING", APART FROM THE MARK AS SHOWN.

CLASS 14—JEWELRY

FOR RINGS, EARRINGS, BRACELETS, NECKLACES AND JEWELRY BOXES (U.S. CLS. 2, 27, 28 AND 50).

CLASS 16—PAPER GOODS AND PRINTED MATTER

FOR CHECKBOOK AND PASSBOOK WALLETS; PASSPORT HOLDERS (U.S. CLS. 2, 5, 22, 23, 29, 37, 38 AND 50).

CLASS 18—LEATHER GOODS

FOR HANDBAGS, LEATHER BAGS, WALLETS, PURSES, AND ANIMAL CARRIERS (U.S. CLS. 1, 2, 3, 22 AND 41).

CLASS 20—FURNITURE AND ARTICLES NOT OTHERWISE CLASSIFIED

FOR KEY FOBS, NOT OF METAL AND PICTURE FRAMES (U.S. CLS. 2, 13, 22, 25, 32 AND 50).

H. M. FISHER, EXAMINING ATTORNEY

SN 77-431,626. ABI-KHALIL J, CONCORD, CANADA, FILED 3-26-2008.



THE COLOR(S) BLACK, GREEN AND WHITE IS/ARE CLAIMED AS A FEATURE OF THE MARK.

THE MARK CONSISTS OF THE WORD "STAANN" IN WHITE SURROUNDED BY A BLACK RECTANGLE. TO THE RIGHT OF THE RECTANGLE IS A WHITE STAR INSIDE OF A GREEN SQUARE. THERE IS A WHITE STRIPE SEPARATING THE RECTANGLE AND THE SQUARE.

CLASS 3—COSMETICS AND CLEANING PREPARATIONS

FOR AROMATHERAPY BODY CARE PRODUCTS, NAMELY, BODY LOTION, SHOWER GEL, CUTICLE CREAM, SHAMPOO, CONDITIONER, NON-MEDICATED LIP BALM, SOAP, BODY POLISH, BODY AND FOOT SCRUB AND NON-MEDICATED FOOT CREAM; AUTOMOBILE POLISH; AUTOMOBILE POLISHES; BOOT POLISH; CHROME POLISH; CLEANING AND POLISHING PAPER; CLEANING AND POLISHING PREPARATIONS; CLEANING, POLISHING AND SCOURING PREPARATIONS; CLEANING, SCOURING AND POLISHING PREPARATIONS AND SUBSTANCES; CLEANING, WASHING AND POLISHING PREPARATIONS; CLEANING AND POLISHING PREPARATIONS; FLOOR POLISH; FLOOR POLISHES; FURNITURE POLISH; FURNITURE POLISHES; GENERAL PURPOSE CLEANING, POLISHING, AND ABRASIVE LIQUIDS AND POWDERS; IMPREGNATED CLEANING, DUSTING OR POLISHING CLOTHS; IMPREGNATED CLOTHS FOR POLISHING; NAIL POLISH; NAIL POLISH BASE COAT; NAIL POLISH REMOVER; NAIL POLISH REMOVERS; NAIL POLISH TOP COAT; NAIL-POLISH REMOVERS; POLISH FOR MUSICAL INSTRUMENTS; POLISHING POWDERS; POLISHING PREPARATIONS; POLISHING STONES; POLISHING WAX; POLISHING, SCOURING AND ABRASIVE PREPARATIONS; SHINING PREPARATIONS; SHOE AND BOOT POLISH; SHOE BLACK; SHOE CREAMS AND POLISHES; SHOE POLISH; SHOE POLISH AND CREAMS; LEATHER POLISHES; LIP POLISHER; SHOE POLISH APPLICATORS CONTAINING SHOE POLISH; SKIN CARE PREPARATION, NAMELY, BODY POLISH; SKIN POLISHING RICE BRAN (ARAI-NUKA); STONE POLISHERS; STONE POLISHES; STONE POLISHING PREPARATIONS; TOOTH POLISH (U.S. CLS. 1, 4, 6, 50, 51 AND 52).

CLASS 7—MACHINERY

FOR AIR FILTERS FOR MECHANICAL PURPOSES; AIR FILTERS FOR VEHICLE MOTORS AND ENGINES; AIR-INTAKE TUBES AND FILTERS FOR AFTER-MARKET INSTALLATION OF AUTOMOTIVE ENGINES; FILTER ROD MAKING MACHINES; FILTERS AND PURIFIERS FOR MACHINES, NAMELY, FILTERS AND PURIFIERS FOR REMOVING CONTAMINANTS FROM GASES USED IN THE SEMICONDUCTOR INDUSTRY; FILTERS FOR ENGINES, PUMPS MACHINES; FUEL FILTERS; OIL FILTER ADAPTERS; OIL FILTERS; OIL FILTERS FOR MECHANICAL PURPOSES; OIL FILTERS FOR MOTORS AND ENGINES; WATER PUMPS FOR SPAS, BATHS, WHIRPOOLS, SWIMMING POOLS, WATER FILTERING UNITS; OIL, AIR, GAS, HYDRAULIC, FUEL, AIR SEPARATORS FILTERS FOR MOTORS AND ENGINES (U.S. CLS. 13, 19, 21, 23, 31, 34 AND 35).

CLASS 9—ELECTRICAL AND SCIENTIFIC APPARATUS

FOR ACCUMULATORS; ACCUMULATORS AND BATTERIES; ACIDIMETERS FOR BATTERIES; ANODE BATTERIES; BATTERIES; BATTERIES AND BATTERY CHARGERS; BATTERIES FOR LIGHTING; BATTERIES FOR POCKETLAMPS; BATTERIES FOR VEHICLES; BATTERIES, ELECTRIC; BATTERIES, ELECTRIC, FOR VEHICLES; BATTERY BOXES; BATTERY CABLES; BATTERY CASES; BATTERY CHARGE DEVICES; BATTERY CHARGERS; BATTERY PACKS; BATTERY TERMINAL CONNECTOR CLAMPS; CELL PHONE BATTERY CHARGERS; CELL PHONE BATTERY CHARGERS FOR USE IN VEHICLES; CHARGERS FOR ELECTRIC BATTERIES; COMPONENT PARTS OF BATTERIES, NAMELY, VENT CAPS; DRY CELLS AND BATTERIES; ELECTRIC BATTERIES; ELECTRIC STORAGE BATTERIES; ELECTRICAL CELLS AND BATTERIES; ELECTRICAL STORAGE BATTERIES; EMERGENCY AUTO KITS COMPRISED OF A HAND HELD SPOTLIGHT AND BATTERY CHARGER; GALVANIC BATTERIES; GATE OPERATORS POWERED BY BATTERY, ELECTRICITY OR SOLAR POWER; GRIDS FOR BATTERIES; HIGH TENSION BATTERIES; IGNITION BATTERIES; INTEGRATED BATTERY BACKUP SYSTEMS COMPRISING A BATTERY, AN ELECTRONIC MEASUREMENT APPARATUS FOR USE IN THE MEASUREMENT OF BATTERY HEALTH AND PERFORMANCE, AND A

REMOTE COMPUTER SOFTWARE PROGRAM THAT USES THE FOREGOING DATA TO TREND, PREDICT, AND STORE DATA RELATED TO THE HEALTH OF THE BATTERY; LITHIUM IRON PHOSPHATE BATTERIES; LITHIUM PHOSPHATE BATTERIES; MOBILE TELEPHONE BATTERIES; NICKEL-CADMIUM STORAGE BATTERIES; PLATES FOR BATTERIES; RECHARGEABLE ELECTRIC BATTERIES; RENEWABLE BATTERY SYSTEM TO PROVIDE BACKUP POWER; SOLAR BATTERIES; SOLAR RECHARGING BATTERY PACK FOR DIGITAL CAMERAS; WET CELL BATTERIES (U.S. CLS. 21, 23, 26, 36 AND 38).

TRACY CROSS, EXAMINING ATTORNEY

SN 77-431,631. HENRI BENDEL, INC., NEW YORK, NY. FILED 3-26-2008.

BENDELIRIOUS

THE MARK CONSISTS OF STANDARD CHARACTERS WITHOUT CLAIM TO ANY PARTICULAR FONT, STYLE, SIZE, OR COLOR.

CLASS 3—COSMETICS AND CLEANING PREPARATIONS

FOR PERSONAL CARE PRODUCTS, NAMELY, BATH BEADS, BATH CREAM, BATH CUBES, BATH FIZZIES, BATH FOAM, BATH MILK, BATH OIL, BATH SALTS, BATH SOAKS, BODY BUTTER, BODY CREAM, BODY GEL, BODY LOTION, BODY SCRUB, BODY WASH, BUBBLE BATH, COLOGNE, CREAM BODY WASH, FOAM BATH, HAND CREAM, HAND LOTION, HAND SOAP, ROOM FRAGRANCE SPRAY, SACHETS, SALT SCRUB, SEA SALT EXFOLIATOR, SHEA BUTTER HAND CREAM, SHOWER CREAM, SHOWER FOAM, SHOWER GEL, SHOWER SCRUB, SUGAR SCRUB (U.S. CLS. 1, 4, 6, 50, 51 AND 52).

CLASS 4—LUBRICANTS AND FUELS

FOR CANDLES (U.S. CLS. 1, 6 AND 15).
H. M. FISHER, EXAMINING ATTORNEY

SN 77-431,666. DAVID ISAACS, BROOKLYN, NY. FILED 3-26-2008.

HI-HELLO the Flying Turtle

THE MARK CONSISTS OF STANDARD CHARACTERS WITHOUT CLAIM TO ANY PARTICULAR FONT, STYLE, SIZE, OR COLOR.

CLASS 16—PAPER GOODS AND PRINTED MATTER

FOR CHILDREN'S BOOKS; CHILDREN'S ACTIVITY BOOKS; COLORING BOOKS; COMIC BOOKS; TALKING CHILDREN'S BOOKS; TRAVEL BOOKS; SERIES OF FICTION BOOKS; SONG BOOKS; STORY BOOKS; NOTE BOOKS; CHILDREN'S INTERACTIVE EDUCATIONAL BOOKS; FLIP BOOKS; EDUCATIONAL PUBLICATIONS, NAMELY, EDUCATIONAL LEARNING CARDS, FLASH CARDS, ACTIVITY CARDS, WORKBOOKS, TEXTBOOKS, ACTIVITY BOOKS, STORY BOOKS, PUZZLE BOOKS, PRINTED PUZZLES, TEACHER GUIDES, MANUALS, POSTERS, EDUCATIONAL CARD GAMES AND EDUCATIONAL BOOKLETS IN THE FIELD OF TRAVEL AND ECOLOGICAL AND ENVIRONMENTAL AWARENESS; COMIC STRIPS; MAPS; GUIDE BOOKS FEATURING TRAVEL; ATLASES; GLOBES; DISPOSABLE SWIM PANTS FOR CHILDREN AND INFANTS; POSTERS; STICKERS; STATIONERY; BLANK JOURNALS; CALENDARS; DIARIES; INK STAMPS; STAMP ALBUMS; EVENT ALBUMS; PHOTOGRAPH ALBUMS; STICKER ALBUMS; POSTCARDS; PAINT BOXES AND BRUSHES; PAINTING SETS FOR CHILDREN; MODELING CLAY FOR CHILDREN; COLOR PENCILS; DECORATIONS FOR PENCILS; PENCIL CASES; PENCILS; FLASH CARDS; GREETING CARDS; HOLIDAY CARDS; INVITATION CARDS; MOTIVATIONAL CARDS; MUSICAL GREETING CARDS; OCCASION CARDS; GIFT CARDS; POST CARDS; TRADING CARDS; BANNERS OF PAPER; GIFT WRAPPING PAPER; HALLOWEEN GOODIE BAGS OF PAPER OR PLASTIC; PAPER BABY BIBS; PAPER BOWS FOR GIFT WRAP; PAPER CAKE DECORATIONS; PAPER GIFT WRAPPING RIBBONS; PAPER NAPKINS; PAPER PARTY BAGS; PAPER PARTY DECORATIONS; PAPER PARTY FAVORS; PAPER PLACE MATS; PAPER TABLE LINENS; PARTY GOODIE BAGS OF PAPER OR PLASTIC; SCHOOL SUPPLY KITS CONTAINING VARIOUS COMBINATIONS OF SELECTED SCHOOL SUPPLIES, NAMELY, WRITING INSTRUMENTS, PENS, PENCILS, MECHANICAL PENCILS, ERASERS, MARKERS, CRAYONS, HIGHLIGHTERS, FOLDERS, NOTEBOOKS, PAPER, GRADUATED RULERS, PROTRACTORS, PAPER CLIPS, PENCIL SHARPENERS, WRITING GRIPS, GLUE AND BOOK MARKS; DECORATIVE PAPER CENTERPIECES (U.S. CLS. 2, 5, 22, 23, 29, 37, 38 AND 50).

CLASS 25—CLOTHING

FOR CHILDREN'S AND INFANTS' CLOTH BIBS; INFANT AND TODDLER ONE PIECE CLOTHING; BATHING SUITS; PAJAMAS; SHIRTS; PANTS; UNDERWEAR; SOCKS; DRESSES; SKIRTS; SWEATERS; COATS; JACKETS; HEADWEAR; FOOTWEAR (U.S. CLS. 22 AND 39).

CLASS 41—EDUCATION AND ENTERTAINMENT

FOR EDUCATIONAL AND ENTERTAINMENT SERVICES, NAMELY, A CONTINUING PROGRAM FEATURING CHILDREN'S ENTERTAINMENT ACCESSIBLE BY RADIO, TELEVISION, SATELLITE, AUDIO, VIDEO AND COMPUTER NETWORKS; ENTERTAINMENT SERVICES IN THE NATURE OF ON-GOING TELEVISION PROGRAMS IN THE FIELD OF CHILDREN'S ENTERTAINMENT; ENTERTAINMENT SERVICES, NAMELY, LIVE, TELEVISED AND MOVIE APPEARANCES BY A PROFESSIONAL ENTERTAINER; ENTERTAINMENT SERVICES, NAMELY, PROVIDING A WEB SITE FEATURING PHOTOGRAPHIC, AUDIO, VIDEO AND PROSE PRESENTATIONS FEATURING CHILDREN'S ENTERTAINMENT; ENTERTAINMENT SERVICES, NAMELY, CONDUCTING PARTIES; ENTERTAINMENT SERVICES, NAMELY, PROVIDING A TELEVISION PROGRAM IN THE FIELD OF CHILDREN'S ENTERTAINMENT VIA A GLOBAL COMPUTER NETWORK; ENTERTAINMENT SERVICES, NAMELY, PROVIDING A WEB SITE FEATURING MUSICAL PERFORMANCES, MUSICAL VIDEOS, RELATED FILM CLIPS, PHOTOGRAPHS, AND OTHER MULTIMEDIA MATERIALS; ENTERTAINMENT SERVICES, NAMELY, PROVIDING ON-LINE COMPUTER GAMES; ENTERTAINMENT SERVICES, NAMELY, PROVIDING PODCASTS IN THE FIELD OF CHILDREN'S ENTERTAINMENT; PROVIDING A WEB SITE FEATUR-

ING ONLINE PUBLICATIONS IN THE FIELD OF NEWS ARTICLES FOR CHILDREN; PRODUCTION OF DVDS, VIDEOTAPES AND TELEVISION PROGRAMS FEATURING CHILDREN'S ENTERTAINMENT; PRODUCTION OF CABLE TELEVISION PROGRAMS; PRODUCTION OF FILMS; PRODUCTION OF RADIO PROGRAMS; PRODUCTION OF SOUND AND MUSIC VIDEO RECORDINGS; PRODUCTION OF SOUND RECORDINGS; PRODUCTION OF TELEVISION PROGRAMS; PRODUCTION OF VIDEO AND COMPUTER GAME SOFTWARE; PRODUCTION OF VIDEO CASSETTES; FILM AND VIDEO TAPE FILM PRODUCTION; CHILDREN'S ENTERTAINMENT AND AMUSEMENT CENTERS, NAMELY, INTERACTIVE PLAY AREAS; ENTERTAINMENT SERVICES, NAMELY, PROVIDING WEBCASTS IN THE FIELD OF CHILDREN'S ENTERTAINMENT (U.S. CLS. 100, 101 AND 107).

JOHN SCHUYLER YARD, EXAMINING ATTORNEY

SN 77-431,687. VERABRIDGE, LLC, ATLANTA, GA. FILED 3-26-2008.

VeraBridge

THE MARK CONSISTS OF STANDARD CHARACTERS WITHOUT CLAIM TO ANY PARTICULAR FONT, STYLE, SIZE, OR COLOR.

CLASS 35—ADVERTISING AND BUSINESS

FOR CONSULTING SERVICES, NAMELY, ADVISING FINANCIAL SERVICE COMPANIES AND INSTITUTIONS IN THE FIELD OF CUSTOMER BUYING BEHAVIOR AND ESTABLISHMENT OF OPTIMAL PRICING STRATEGIES FOR GOODS AND SERVICES SOLD BY FINANCIAL SERVICE COMPANIES AND INSTITUTIONS (U.S. CLS. 100, 101 AND 102).

FIRST USE 2-11-2008; IN COMMERCE 3-25-2008.

CLASS 42—SCIENTIFIC AND COMPUTER SERVICES

FOR COMPUTER SERVICES, NAMELY, HOSTING AND PROVIDING A CUSTOMIZABLE ONLINE WEB SITE FOR FINANCIAL SERVICE COMPANIES AND INSTITUTIONS THAT ENABLES SUCH COMPANIES TO IDENTIFYING, TRACK, AND ANALYZE CUSTOMER BUYING BEHAVIOR AND TO OPTIMIZE PRICING STRATEGIES FOR GOODS AND SERVICES SOLD BY FINANCIAL SERVICE COMPANIES AND INSTITUTIONS (U.S. CLS. 100 AND 101).

FIRST USE 2-11-2008; IN COMMERCE 3-25-2008.

JOHN SCHUYLER YARD, EXAMINING ATTORNEY

SN 77-431,731. SUNBURST TECHNOLOGY CORPORATION, ELGIN, IL. FILED 3-26-2008.

TYPE TO LEARN

THE MARK CONSISTS OF STANDARD CHARACTERS WITHOUT CLAIM TO ANY PARTICULAR FONT, STYLE, SIZE, OR COLOR.

NO CLAIM IS MADE TO THE EXCLUSIVE RIGHT TO USE "TYPE", APART FROM THE MARK AS SHOWN.

CLASS 9—ELECTRICAL AND SCIENTIFIC APPARATUS

FOR CD-ROM-BASED COMPUTER SOFTWARE PROGRAMS FOR USE IN TEACHING KEYBOARD TECHNIQUES FOR THE COMPUTER (U.S. CLS. 21, 23, 26, 36 AND 38).

FIRST USE 6-0-1986; IN COMMERCE 6-0-1986.

CLASS 16—PAPER GOODS AND PRINTED MATTER

FOR PRINTED INSTRUCTIONAL, EDUCATIONAL, AND TEACHING MATERIALS FOR USE IN TEACHING KEYBOARDING TECHNIQUES FOR THE COMPUTER (U.S. CLS. 2, 5, 22, 23, 29, 37, 38 AND 50).

FIRST USE 6-0-1986; IN COMMERCE 6-0-1986.

MARIA-VICTORIA SUAREZ, EXAMINING ATTORNEY

SN 77-431,741. STUDENT LIFE, INC., BIRMINGHAM, AL. FILED 3-26-2008.

31 Verses Every Teenager Should Know

THE MARK CONSISTS OF STANDARD CHARACTERS WITHOUT CLAIM TO ANY PARTICULAR FONT, STYLE, SIZE, OR COLOR.

CLASS 9—ELECTRICAL AND SCIENTIFIC APPARATUS

FOR DOWNLOADABLE ELECTRONIC PUBLICATIONS IN THE NATURE OF MANUALS, PAMPHLETS, BROCHURES, TEACHING MATERIALS AND BIBLE STUDY LESSONS IN THE FIELD OF CHRISTIANITY (U.S. CLS. 21, 23, 26, 36 AND 38).

CLASS 16—PAPER GOODS AND PRINTED MATTER

FOR A SERIES OF BOOKS IN THE FIELD OF CHRISTIANITY (U.S. CLS. 2, 5, 22, 23, 29, 37, 38 AND 50).

CLASS 41—EDUCATION AND ENTERTAINMENT

FOR NON-DENOMINATIONAL EDUCATIONAL SERVICES, NAMELY, CONDUCTING BIBLE STUDY CLASSES AND DISTRIBUTION OF EDUCATIONAL MATERIALS IN CONNECTION THEREWITH; NON-DENOMINATIONAL ENTERTAINMENT SERVICES IN THE NATURE OF YOUTH AND FAMILY VACATION CAMPS AND PRESENTATION OF PLAYS (U.S. CLS. 100, 101 AND 107).

MAUREEN DALL, EXAMINING ATTORNEY

SN 77-431,799. WELL HEELED BABY LLC, NEW CANAAN, CT. FILED 3-26-2008.

SN 77-431,866. GOLD, KEN, LIVINGSTON, NJ. FILED 3-26-2008.

SPOTDOTS

THE MARK CONSISTS OF STANDARD CHARACTERS WITHOUT CLAIM TO ANY PARTICULAR FONT, STYLE, SIZE, OR COLOR.

CLASS 16—PAPER GOODS AND PRINTED MATTER

FOR BUMPER STICKERS; STICKERS; STICKERS AND DECALCOMANIAS; STICKERS AND TRANSFERS (U.S. CLS. 2, 5, 22, 23, 29, 37, 38 AND 50).

CLASS 18—LEATHER GOODS

FOR LUGGAGE TAGS (U.S. CLS. 1, 2, 3, 22 AND 41). WILLIAM P. SHANAHAN, EXAMINING ATTORNEY



THE MARK CONSISTS OF A CHARACTERIZED VERSION OF THE LETTER "I" THAT IS ALSO A SMILEY FACE.

CLASS 18—LEATHER GOODS

FOR BACKPACKS; TOTE BAGS (U.S. CLS. 1, 2, 3, 22 AND 41).

CLASS 25—CLOTHING

FOR T-SHIRTS; TANK TOPS; SWEAT SHORTS; BOARD SHORTS; SHORTS; SKIRTS; DRESSES; SKORTS; CAPRI PANTS; SHIRTS; PAJAMA BOTTOMS; PAJAMAS; UNDERWEAR (U.S. CLS. 22 AND 39). PETER B. BROMAGHIM, EXAMINING ATTORNEY

SN 77-431,858. GOLD, KEN, LIVINGSTON, NJ. FILED 3-26-2008.



THE MARK CONSISTS OF THE WORD MARK "LIKE-WEAR", WITH A CHARACTERIZED VERSION OF THE LETTER "I" AND AN OVAL AROUND THE ENTIRE WORD.

CLASS 18—LEATHER GOODS

FOR BACKPACKS; TOTE BAGS (U.S. CLS. 1, 2, 3, 22 AND 41). FIRST USE 4-30-2007; IN COMMERCE 4-30-2007.

CLASS 25—CLOTHING

FOR T-SHIRTS; TANK TOPS; SWEAT SHORTS; BOARD SHORTS; SHORTS; SKIRTS; DRESSES; SKORTS; CAPRI PANTS; SHIRTS; PAJAMA BOTTOMS; PAJAMAS; UNDERWEAR (U.S. CLS. 22 AND 39). FIRST USE 4-30-2007; IN COMMERCE 4-30-2007. PETER B. BROMAGHIM, EXAMINING ATTORNEY

SN 77-431,879. GOLD, KEN, LIVINGSTON, NJ. FILED 3-26-2008.

WEAR WHAT YOU LIKE

THE MARK CONSISTS OF STANDARD CHARACTERS WITHOUT CLAIM TO ANY PARTICULAR FONT, STYLE, SIZE, OR COLOR.

CLASS 18—LEATHER GOODS

FOR BACKPACKS; TOTE BAGS (U.S. CLS. 1, 2, 3, 22 AND 41). FIRST USE 4-30-2007; IN COMMERCE 4-30-2007.

CLASS 25—CLOTHING

FOR T-SHIRTS; TANK TOPS; SWEAT SHORTS; BOARD SHORTS; SHORTS; SKIRTS; DRESSES; SKORTS; CAPRI PANTS; SHIRTS; PAJAMA BOTTOMS; PAJAMAS; UNDERWEAR (U.S. CLS. 22 AND 39). FIRST USE 4-30-2007; IN COMMERCE 4-30-2007. PETER B. BROMAGHIM, EXAMINING ATTORNEY

SN 77-432,020. JUMEIRAH INTERNATIONAL LLC, AL-SUFOUH AREA, UNITED ARAB EMIR., FILED 3-26-2008.



THE COLOR(S) SILVER AND GOLD IS/ARE CLAIMED AS A FEATURE OF THE MARK.

THE MARK CONSISTS OF THE WORD "SIRIUS" IN THE COLOR OF SILVER AND THE BEACON DESIGN IN THE COLOR OF GOLD.

CLASS 16—PAPER GOODS AND PRINTED MATTER

FOR MAGAZINES IN THE FIELD OF TOURISM, TRAVEL, HOTELS AND RESTAURANTS (U.S. CLS. 2, 5, 22, 23, 29, 37, 38 AND 50).

CLASS 35—ADVERTISING AND BUSINESS

FOR CUSTOMER INCENTIVE PROGRAMS TO PROMOTE THE SALE OF PRODUCTS AND SERVICES OF OTHERS, NAMELY, ARRANGING, CONDUCTING, MANAGING LOYALTY REWARD PROGRAMS AND ADMINISTERING THE BENEFITS AND REWARDS CONNECTED WITH THESE PROGRAMS FOR OTHERS; MANAGEMENT OF HOTEL INCENTIVE PROGRAMS FOR OTHERS; PROMOTING THE HOTELS, RESTAURANTS, FOOD, BEVERAGES, RESORTS, SPAS, GOLF COURSES, SPORTING EVENTS, TRAVEL PACKAGES, TRAVEL TOURS AND THEME PARKS OF OTHERS BY MEANS OF A PREFERRED CUSTOMER PROGRAM FEATURING A MAGNETIC CARD WHICH FACILITATES THE ACCUMULATION OF POINTS WHICH MAY BE REDEEMED FOR GOODS OR SERVICES (U.S. CLS. 100, 101 AND 102).

RUDY R. SINGLETON, EXAMINING ATTORNEY

SN 77-432,137. CORNERSTONE DEVELOPERS, SAUGUS, MA. FILED 3-26-2008.

"Green saves Green"

THE MARK CONSISTS OF STANDARD CHARACTERS WITHOUT CLAIM TO ANY PARTICULAR FONT, STYLE, SIZE, OR COLOR.

CLASS 17—RUBBER GOODS

FOR BUILDING INSULATION; SOUNDPROOFING MATERIALS FOR BUILDINGS (U.S. CLS. 1, 5, 12, 13, 35 AND 50).

CLASS 37—CONSTRUCTION AND REPAIR

FOR BUILDING CONSTRUCTION SERVICES; CONSTRUCTION OF BUILDINGS; CONSTRUCTION AND RENOVATION OF BUILDINGS; CUSTOM CONSTRUCTION AND BUILDING RENOVATION; HOUSE AND BUILDING DEMOLITION; HOUSE BUILDING AND REPAIR; RENOVATION AND RESTORATION OF BUILDINGS; RENTAL OF BUILDING SCAFFOLDS, WORKING AND BUILDING PLATFORMS (U.S. CLS. 100, 103 AND 106).

DOMINIC J. FERRAIUOLO, EXAMINING ATTORNEY

SN 77-432,146. GOVERNORS HIGHWAY SAFETY ASSOCIATION, WASHINGTON, DC. FILED 3-26-2008.

GOVERNORS HIGHWAY SAFETY ASSOCIATION

THE MARK CONSISTS OF STANDARD CHARACTERS WITHOUT CLAIM TO ANY PARTICULAR FONT, STYLE, SIZE, OR COLOR.

NO CLAIM IS MADE TO THE EXCLUSIVE RIGHT TO USE "ASSOCIATION", APART FROM THE MARK AS SHOWN.

SEC. 2(F).

CLASS 35—ADVERTISING AND BUSINESS

FOR PROMOTING PUBLIC AWARENESS OF HIGHWAY AND TRAFFIC SAFETY ISSUES; PUBLIC ADVOCACY TO PROMOTE AWARENESS OF HIGHWAY AND TRAFFIC SAFETY ISSUES; LOBBYING SERVICES, NAMELY, PROMOTING THE INTERESTS OF STATE AND TERRITORIAL HIGHWAY SAFETY OFFICES IN THE FIELDS OF LEGISLATION AND REGULATION (U.S. CLS. 100, 101 AND 102).

FIRST USE 9-22-2002; IN COMMERCE 9-22-2002.

CLASS 45—PERSONAL AND LEGAL SERVICES

FOR PROVIDING INFORMATION IN THE FIELD OF HIGHWAY AND TRAFFIC SAFETY (U.S. CLS. 100 AND 101).

FIRST USE 9-22-2002; IN COMMERCE 9-22-2002.

MICHAEL TANNER, EXAMINING ATTORNEY

SN 77-432,162. AUTOQUAKE, INC., WILMINGTON, DE. FILED 3-26-2008.



OWNER OF U.S. REG. NOS. 3,390,665 AND 3,390,666.

THE MARK CONSISTS OF THE WORD "AUTOQUAKE" REPRESENTED IN A STYLIZED MANNER.

CLASS 35—ADVERTISING AND BUSINESS

FOR PROMOTING THE GOODS AND SERVICES OF OTHERS BY PREPARING AND PLACING ELECTRONIC ADVERTISEMENTS ACCESSED THROUGH A GLOBAL COMPUTER NETWORK IN THE FIELD OF AUTOMOBILES, BOATS, HELICOPTERS, SCOOTERS, MOPEDS, MOTORCYCLES, OTHER MOTOR VEHICLES, AND VEHICLE PARTS AND ACCESSORIES; PROMOTING AND MARKETING THE GOODS AND SERVICES OF OTHERS THROUGH ALL PUBLIC COMMUNICATION MEANS IN THE FIELD OF AUTOMOBILES, BOATS, HELICOPTERS, SCOOTERS, MOPEDS, MOTORCYCLES, OTHER MOTOR VEHICLES, AND VEHICLE PARTS AND ACCESSORIES; REFERRALS IN THE FIELD OF AUTO INSURANCE; PROVIDING INFORMATION IN THE FIELD OF MARKETING OF AUTOMOBILES, BOATS, HELICOPTERS, SCOOTERS, MOPEDS, MOTORCYCLES, OTHER MOTOR VEHICLES, AND VEHICLE PARTS AND ACCESSORIES; PROVIDING ON-LINE STORE AND DEALERSHIP SERVICES IN THE FIELD OF AUTOMOBILES AND MOTOR VEHICLES (U.S. CLS. 100, 101 AND 102).

CLASS 36—INSURANCE AND FINANCIAL

FOR FINANCING RELATING TO AUTOMOBILES, BOATS, HELICOPTERS, SCOOTERS, MOPEDS, MOTORCYCLES AND OTHER MOTOR VEHICLES; INSURANCE BROKERAGE IN THE FIELD OF AUTOMOBILE AND MOTOR VEHICLE INSURANCE (U.S. CLS. 100, 101 AND 102).

EUGENIA MARTIN, EXAMINING ATTORNEY

SN 77-432,165. AUTOQUAKE, INC., WILMINGTON, DE. FILED 3-26-2008.

SIMPLY A BETTER WAY TO BUY
A USED CAR

THE MARK CONSISTS OF STANDARD CHARACTERS WITHOUT CLAIM TO ANY PARTICULAR FONT, STYLE, SIZE, OR COLOR.

CLASS 35—ADVERTISING AND BUSINESS

FOR PROMOTING THE GOODS AND SERVICES OF OTHERS BY PREPARING AND PLACING ELECTRONIC ADVERTISEMENTS ACCESSED THROUGH A GLOBAL COMPUTER NETWORK IN THE FIELD OF AUTOMOBILES, BOATS, HELICOPTERS, SCOOTERS, MOPEDS, MOTORCYCLES, OTHER MOTOR VEHICLES, AND VEHICLE PARTS AND ACCESSORIES; PROMOTING AND MARKETING THE GOODS AND SERVICES OF OTHERS THROUGH ALL PUBLIC COMMUNICATION MEANS IN THE FIELD OF AUTOMOBILES, BOATS, HELICOPTERS, SCOOTERS, MOPEDS, MOTORCYCLES, OTHER MOTOR VEHICLES, AND VEHICLE PARTS AND ACCESSORIES; REFERRALS IN THE FIELD OF AUTO INSURANCE; PROVIDING INFORMATION IN THE FIELD OF MARKETING OF AUTOMOBILES, BOATS, HELICOPTERS, SCOOTERS, MOPEDS, MOTORCYCLES, OTHER MOTOR VEHICLES, AND VEHICLE PARTS AND ACCESSORIES; PROVIDING ON-LINE STORE AND DEALERSHIP SERVICES IN THE FIELD OF AUTOMOBILES AND MOTOR VEHICLES (U.S. CLS. 100, 101 AND 102).

CLASS 36—INSURANCE AND FINANCIAL

FOR FINANCING RELATING TO AUTOMOBILES, BOATS, HELICOPTERS, SCOOTERS, MOPEDS, MOTORCYCLES AND OTHER MOTOR VEHICLES; INSURANCE BROKERAGE IN THE FIELD OF AUTOMOBILE AND MOTOR VEHICLE INSURANCE (U.S. CLS. 100, 101 AND 102).

EUGENIA MARTIN, EXAMINING ATTORNEY

SN 77-432,189. CORPORATE NETWORKING COLLABORATIVE, INC. DBA MY EVENT GURU, BOSTON, MA. FILED 3-26-2008.

My Event Guru

THE MARK CONSISTS OF STANDARD CHARACTERS WITHOUT CLAIM TO ANY PARTICULAR FONT, STYLE, SIZE, OR COLOR.

CLASS 35—ADVERTISING AND BUSINESS

FOR PROVIDING MARKETING AND PROMOTION OF SPECIAL EVENTS; PROVIDING ON-LINE REGISTRATION SERVICES FOR EVENTS; ADVERTISING AND BUSINESS SERVICES, NAMELY, SECURING AIR-TIME ON ALL FORMS OF MEDIA COMMUNICATIONS STATIONS, SYSTEMS, NETWORKS, AND SERVICES FOR THE PURPOSE OF PROMOTING THE GOODS AND SERVICES OF OTHERS; BUSINESS NETWORKING; ONLINE BUSINESS NETWORKING SERVICES; DISSEMINATION OF ADVERTISING, SCHEDULING AND MANAGING OF TRAINING COURSES AND PROGRAMS FOR OTHERS VIA A GLOBAL COMPUTER NETWORK (U.S. CLS. 100, 101 AND 102).

FIRST USE 2-1-2007; IN COMMERCE 2-1-2007.

CLASS 41—EDUCATION AND ENTERTAINMENT

FOR PROVIDING A WEB SITE WHERE USERS CAN POST RATINGS, REVIEWS AND RECOMMENDATIONS ON EVENTS AND ACTIVITIES IN THE FIELD OF ENTERTAINMENT AND EDUCATION (U.S. CLS. 100, 101 AND 107).

FIRST USE 2-1-2007; IN COMMERCE 2-1-2007.

CLASS 45—PERSONAL AND LEGAL SERVICES

FOR PROVIDING AN INTERACTIVE WEB SITE FOR PERSONS TO LOCATE OTHER INDIVIDUALS WITH SIMILAR INTERESTS TO PARTICIPATE WITH THEM IN, OR ACCOMPANY THEM TO, EVENTS AND ACTIVITIES (U.S. CLS. 100 AND 101).

FIRST USE 2-1-2007; IN COMMERCE 2-1-2007.

SUNG IN, EXAMINING ATTORNEY

SN 77-432,246. PETERSON, GREGORY A., ROCHESTER, MN. FILED 3-26-2008.

MACHINERY PETE

THE MARK CONSISTS OF STANDARD CHARACTERS WITHOUT CLAIM TO ANY PARTICULAR FONT, STYLE, SIZE, OR COLOR.

NO CLAIM IS MADE TO THE EXCLUSIVE RIGHT TO USE "MACHINERY", APART FROM THE MARK AS SHOWN.

CLASS 16—PAPER GOODS AND PRINTED MATTER

FOR PRINTED PUBLICATIONS, NAMELY, BOOKS, ARTICLES, AND COLUMNS FEATURING INFORMATION REGARDING MARKET TRENDS, AUCTIONS, AND PRICING INFORMATION FOR USED EQUIPMENT AND MACHINERY (U.S. CLS. 2, 5, 22, 23, 29, 37, 38 AND 50).

FIRST USE 1-0-2001; IN COMMERCE 1-0-2001.

CLASS 35—ADVERTISING AND BUSINESS

FOR PROVIDING AUCTION AND PRICING INFORMATION FOR USED EQUIPMENT AND MACHINERY TO SUBSCRIBERS; PROVIDING COMMENTARY ON MARKET TRENDS, AUCTIONS, AND PRICING INFORMATION FOR USED EQUIPMENT AND MACHINERY (U.S. CLS. 100, 101 AND 102).

FIRST USE 3-0-2000; IN COMMERCE 3-0-2000.

CLASS 41—EDUCATION AND ENTERTAINMENT

FOR PROVIDING ON-LINE PUBLICATIONS, NAMELY, ARTICLES AND COLUMNS FEATURING INFORMATION REGARDING MARKET TRENDS, AUCTIONS, AND PRICING INFORMATION FOR USED EQUIPMENT AND MACHINERY (U.S. CLS. 100, 101 AND 107).

FIRST USE 11-0-2007; IN COMMERCE 11-0-2007.
LEIGH CAROLINE CASE, EXAMINING ATTORNEY

CLASS 42—SCIENTIFIC AND COMPUTER SERVICES

FOR WEB SITE DESIGN (U.S. CLS. 100 AND 101).
FIRST USE 2-18-2006; IN COMMERCE 2-18-2006.
NICHOLAS ALTREE, EXAMINING ATTORNEY

SN 77-432,314. MOUNTAIN HARDWEAR, INC., PORTLAND, OR. FILED 3-26-2008.

SN 77-432,342. BUSINESS INNOVATIVE GROUP, LLC, MIAMI, FL. FILED 3-26-2008.

CONDUIT

THE MARK CONSISTS OF STANDARD CHARACTERS WITHOUT CLAIM TO ANY PARTICULAR FONT, STYLE, SIZE, OR COLOR.

CLASS 20—FURNITURE AND ARTICLES NOT OTHERWISE CLASSIFIED

FOR SLEEPING BAGS (U.S. CLS. 2, 13, 22, 25, 32 AND 50).
FIRST USE 12-0-1997; IN COMMERCE 12-0-1997.

CLASS 25—CLOTHING

FOR JACKETS; PARKAS; COATS; PANTS; SKI BIBS; SNOW SUITS; GLOVES; MITTENS; GAITERS; HEADWEAR (U.S. CLS. 22 AND 39).
FIRST USE 7-0-1997; IN COMMERCE 7-0-1997.
BRENDAN REGAN, EXAMINING ATTORNEY

SN 77-432,338. WILK, SANFORD, DBA EIC DESIGN, NEW YORK, NY. FILED 3-26-2008.

EIC

THE MARK CONSISTS OF STANDARD CHARACTERS WITHOUT CLAIM TO ANY PARTICULAR FONT, STYLE, SIZE, OR COLOR.

CLASS 35—ADVERTISING AND BUSINESS

FOR ADVERTISING AND PUBLICITY SERVICES, NAMELY, PROMOTING THE GOODS, SERVICES, BRAND IDENTITY AND COMMERCIAL INFORMATION AND NEWS OF THIRD PARTIES THROUGH PRINT, AUDIO, VIDEO, DIGITAL AND ON-LINE MEDIUM; BUSINESS CONSULTATION AND MANAGEMENT REGARDING MARKETING ACTIVITIES AND LAUNCHING OF NEW PRODUCTS (U.S. CLS. 100, 101 AND 102).

FIRST USE 2-18-2006; IN COMMERCE 2-18-2006.



THE COLOR(S) RED, GREEN, BLACK, BLUE AND YELLOW IS/ARE CLAIMED AS A FEATURE OF THE MARK.

THE MARK CONSISTS OF A STYLIZED "H" COMPRISING FIVE COLORED RECTANGLES WHEREBY THE THE UPPER LEFT PORTION OF THE "H" IS A RED VERTICAL RECTANGLE OUTLINED IN BLACK AND THE UPPER RIGHT PORTION OF THE "H" IS A GREEN VERTICAL RECTANGLE OUTLINED IN BLACK, THE HORIZONTAL LINE OF THE "H" IS A BLACK HORIZONTAL RECTANGLE AND THE LOWER LEFT PORTION OF THE "H" IS A BLUE RECTANGLE OUTLINED IN BLACK AND THE LOWER RIGHT PORTION OF THE "H" IS A VERTICAL YELLOW RECTANGLE OUTLINED IN BLACK.

CLASS 16—PAPER GOODS AND PRINTED MATTER

FOR EDUCATIONAL PUBLICATIONS, NAMELY, MAGAZINES, PAMPHLETS, BROCHURES, BOOKS, AND CATALOGS IN THE FIELDS OF BUSINESS, FINANCE, FINANCIAL SERVICES, STOCK TRADING AND STOCK TRADING MATTERS; PUBLICATIONS, NAMELY, BROCHURES, BOOKLETS, AND TEACHING MATERIALS IN THE FIELD OF HIP HOP MUSIC AND THE HIP HOP MUSIC COMMUNITY; PUBLICATIONS, NAMELY, MAGAZINES, PAMPHLETS, BROCHURES, BOOKS, AND CATALOGS IN THE FIELDS OF BUSINESS, FINANCE, FINANCIAL SERVICES, STOCK TRADING AND STOCK TRADING MATTERS (U.S. CLS. 2, 5, 22, 23, 29, 37, 38 AND 50).

CLASS 25—CLOTHING

FOR SPORTS SHIRTS; SPORTS SHIRTS WITH SHORT SLEEVES; SWEAT SHIRTS; T-SHIRTS; HEADGEAR, NAMELY, HATS, HEAD BANDS, SKULL CAPS; CARGO PANTS; DENIMS; JOGGING PANTS; PANTS; SWEAT PANTS; BELTS; SHOES; SOCKS; SWIMWEAR (U.S. CLS. 22 AND 39).

CLASS 35—ADVERTISING AND BUSINESS

FOR ADVERTISING SERVICES OF A RADIO AND TELEVISION ADVERTISING AGENCY; PROVIDING TELEVISION ADVERTISING FOR OTHERS; ADVERTISING AGENCIES, NAMELY, PROMOTING THE GOODS AND SERVICES OF OTHERS; ADVERTISING AGENCIES, NAMELY, PROMOTING THE SERVICES OF HIP HOP ARTISTS AND THE HIP HOP COMMUNITY THROUGH THE DISTRIBUTION OF PRINTED AND AUDIO PROMOTIONAL MATERIALS AND BY RENDERING SALES PROMOTION ADVICE; ADVERTISING AND ADVERTISEMENT SERVICES; ADVERTISING CONSULTATION; ADVERTISING SERVICES; ADVERTISING SERVICES FOR PROMOTING THE BROKERAGE OF STOCKS AND OTHER SECURITIES; ADVERTISING SERVICES, NAMELY, PROMOTING AND MARKETING THE GOODS AND SERVICES OF OTHERS THROUGH ALL PUBLIC COMMUNICATION MEANS (U.S. CLS. 100, 101 AND 102).

SN 77-432,422. COWAMONGUS, LLC, GRAND PRAIRIE, TX. FILED 3-26-2008.

COWAMONGUS

THE MARK CONSISTS OF STANDARD CHARACTERS WITHOUT CLAIM TO ANY PARTICULAR FONT, STYLE, SIZE, OR COLOR.

CLASS 41—EDUCATION AND ENTERTAINMENT

FOR EDUCATIONAL AND ENTERTAINMENT SERVICES, NAMELY, A CONTINUING PROGRAM ABOUT BUSINESS, FINANCE, FINANCIAL SERVICES, STOCK TRADING AND STOCK TRADING MATTERS ACCESSIBLE BY RADIO, TELEVISION, SATELLITE, AUDIO, VIDEO AND COMPUTER NETWORKS; PROVIDING INFORMATION, NEWS AND COMMENTARY IN THE FIELD OF ENTERTAINMENT; ENTERTAINMENT SERVICES, NAMELY, AN ON-GOING SERIES FEATURING HIP HOP ARTISTS PROVIDED THROUGH THE INTERNET; ENTERTAINMENT IN THE NATURE OF ONLINE INFORMATION RELATED TO HIP HOP ARTISTS AND THE HIP HOP COMMUNITY; ENTERTAINMENT SERVICES, NAMELY, PROVIDING A WEB SITE FEATURING MUSICAL PERFORMANCES, MUSICAL VIDEOS, RELATED FILM CLIPS, PHOTOGRAPHS, AND OTHER MULTIMEDIA MATERIALS (U.S. CLS. 100, 101 AND 107).

FIRST USE 11-24-2006; IN COMMERCE 4-3-2007.
DEZMONA MIZELLE, EXAMINING ATTORNEY

CLASS 29—MEATS AND PROCESSED FOODS

FOR FRUIT TOPPING; DAIRY-BASED BEVERAGES; MEAT, NAMELY, BEEF, CHICKEN AND PORK (U.S. CL. 46).

FIRST USE 3-1-2005; IN COMMERCE 3-1-2005.

CLASS 30—STAPLE FOODS

FOR FROZEN CUSTARD, ICE CREAM, FROZEN YOGURT, FROZEN CONFECTIONS, SAUCES, CHOCOLATE TOPPING, COFFEE, AND COFFEE-BASED BEVERAGES (U.S. CL. 46).

FIRST USE 3-1-2005; IN COMMERCE 3-1-2005.

CLASS 43—HOTEL AND RESTAURANT SERVICES

FOR RESTAURANT SERVICES (U.S. CLS. 100 AND 101).

FIRST USE 3-1-2005; IN COMMERCE 3-1-2005.
RUDY R. SINGLETON, EXAMINING ATTORNEY

SN 77-432,404. AGRIWISE, INC., SAN RAMON, CA. FILED 3-26-2008.

Trace-It: Powered by AgriWise

THE MARK CONSISTS OF STANDARD CHARACTERS WITHOUT CLAIM TO ANY PARTICULAR FONT, STYLE, SIZE, OR COLOR.

CLASS 16—PAPER GOODS AND PRINTED MATTER

FOR BAR CODE LABELS (U.S. CLS. 2, 5, 22, 23, 29, 37, 38 AND 50).

CLASS 35—ADVERTISING AND BUSINESS

FOR ADVERTISING PARTICULARLY SERVICES FOR THE PROMOTION OF GOODS; CREATING AND UPDATING ADVERTISING MATERIAL (U.S. CLS. 100, 101 AND 102).

SUNG IN, EXAMINING ATTORNEY

SN 77-432,470. EDGEFASHION, QUEEN CREEK, AZ. FILED 3-26-2008.

C SWEENEY

THE MARK CONSISTS OF STANDARD CHARACTERS WITHOUT CLAIM TO ANY PARTICULAR FONT, STYLE, SIZE, OR COLOR.

CLASS 3—COSMETICS AND CLEANING PREPARATIONS

FOR PERFUME; COLOGNE (U.S. CLS. 1, 4, 6, 50, 51 AND 52).

CLASS 25—CLOTHING

FOR CLOTHING, NAMELY, T-SHIRTS, PANTS, JACKETS, SHOES, SUITS, SWEAT PANTS, SWEAT SHIRTS, SOCKS, HATS, DRESSES, BELTS, TIES (U.S. CLS. 22 AND 39).

KARANENDRA S. CHHINA, EXAMINING ATTORNEY

SN 77-432,478. HMS FABRICS, NEW YORK, NY. FILED 3-26-2008.

SN 77-432,612. THE MAGIC STOP LLC, PAHRUMP, NV. FILED 3-26-2008.

BACK NINE

THE MARK CONSISTS OF STANDARD CHARACTERS WITHOUT CLAIM TO ANY PARTICULAR FONT, STYLE, SIZE, OR COLOR.

CLASS 22—CORDAGE AND FIBERS

FOR WOOL (U.S. CLS. 1, 2, 7, 19, 22, 42 AND 50).

CLASS 24—FABRICS

FOR WOOL BASE MIXED FABRICS (U.S. CLS. 42 AND 50).
KATHERINE STOIDES, EXAMINING ATTORNEY

SN 77-432,590. EASY-TURF, INC., ESCONDIDO, CA. FILED 3-26-2008.

EASYTURF

THE MARK CONSISTS OF STANDARD CHARACTERS WITHOUT CLAIM TO ANY PARTICULAR FONT, STYLE, SIZE, OR COLOR.

CLASS 35—ADVERTISING AND BUSINESS

FOR ON-LINE RETAIL STORE SERVICES FEATURING SYNTHETIC LAWNS, SYNTHETIC PUTTING GREENS, AND ARTIFICIAL GRASS SURFACES, FOR RESIDENTIAL AND COMMERCIAL USES; RETAIL STORE SERVICES FEATURING SYNTHETIC LAWNS, SYNTHETIC PUTTING GREENS, AND ARTIFICIAL GRASS SURFACES, FOR RESIDENTIAL AND COMMERCIAL USES (U.S. CLS. 100, 101 AND 102).
FIRST USE 6-1-2000; IN COMMERCE 8-21-2006.

CLASS 37—CONSTRUCTION AND REPAIR

FOR INSTALLATION OF SYNTHETIC LAWNS, SYNTHETIC PUTTING GREENS, AND ARTIFICIAL GRASS SURFACES, FOR RESIDENTIAL AND COMMERCIAL USES (U.S. CLS. 100, 103 AND 106).
FIRST USE 6-1-2000; IN COMMERCE 8-21-2006.
ARETHA SOMERVILLE, EXAMINING ATTORNEY

Inner-Secrets for the Everyday

THE MARK CONSISTS OF STANDARD CHARACTERS WITHOUT CLAIM TO ANY PARTICULAR FONT, STYLE, SIZE, OR COLOR.

CLASS 9—ELECTRICAL AND SCIENTIFIC APPARATUS

FOR PRE-RECORDED CDS, DVDS, AND DOWNLOADABLE AUDIO FILES FEATURING REAL ESTATE AND FINANCIAL INVESTING (U.S. CLS. 21, 23, 26, 36 AND 38).

CLASS 16—PAPER GOODS AND PRINTED MATTER

FOR SERIES OF NON-FICTION BOOKS IN THE FIELD OF REAL ESTATE AND FINANCIAL INVESTING (U.S. CLS. 2, 5, 22, 23, 29, 37, 38 AND 50).

CLASS 41—EDUCATION AND ENTERTAINMENT

FOR EDUCATION SERVICES, NAMELY, PROVIDING SEMINARS, CLASSES, AND TRAINING SERVICES IN THE FIELDS OF REAL ESTATE AND FINANCIAL INVESTING (U.S. CLS. 100, 101 AND 107).
ODESSA BIBBINS, EXAMINING ATTORNEY

SN 77-432,651. THE WELLNESS CENTER, PC, NEW BUFFALO, MI. FILED 3-26-2008.

Wellness Breakthrough Experience

THE MARK CONSISTS OF STANDARD CHARACTERS WITHOUT CLAIM TO ANY PARTICULAR FONT, STYLE, SIZE, OR COLOR.

NO CLAIM IS MADE TO THE EXCLUSIVE RIGHT TO USE "WELLNESS", APART FROM THE MARK AS SHOWN.

CLASS 35—ADVERTISING AND BUSINESS

FOR PROVIDING ASSISTANCE, FITNESS EVALUATION AND CONSULTATION TO CORPORATE CLIENTS TO HELP THEIR EMPLOYEES MAKE HEALTH, WELLNESS AND NUTRITIONAL CHANGES IN THEIR DAILY LIVING TO INCREASE PRODUCTIVITY AND LOWER HEALTH CARE COSTS (U.S. CLS. 100, 101 AND 102).

CLASS 44—MEDICAL, BEAUTY AND AGRICULTURAL SERVICES

FOR HEALTHCARE (U.S. CLS. 100 AND 101).
HEATHER BIDDULPH, EXAMINING ATTORNEY

SN 77-432,681. HYPERSTRIKE, INC., CUPERTINO, CA.
FILED 3-26-2008.

WORKOUT NATION

THE MARK CONSISTS OF STANDARD CHARACTERS WITHOUT CLAIM TO ANY PARTICULAR FONT, STYLE, SIZE, OR COLOR.

NO CLAIM IS MADE TO THE EXCLUSIVE RIGHT TO USE "WORKOUT", APART FROM THE MARK AS SHOWN.

CLASS 38—COMMUNICATION

FOR PROVIDING ON-LINE ELECTRONIC BULLETIN BOARDS FOR TRANSMISSION OF MESSAGES AMONG COMPUTER USERS CONCERNING EXERCISE AND FITNESS; PROVIDING ON-LINE FORUMS FOR TRANSMISSION OF MESSAGES AMONG COMPUTER USERS CONCERNING EXERCISE AND FITNESS (U.S. CLS. 100, 101 AND 104).

CLASS 41—EDUCATION AND ENTERTAINMENT

FOR ON-LINE JOURNALS, NAMELY, BLOGS FEATURING EXERCISE AND FITNESS; PROVIDING A WEB SITE FEATURING INFORMATION ON EXERCISE AND FITNESS; PROVIDING AN ON-LINE COMPUTER DATABASE FEATURING INFORMATION REGARDING EXERCISE AND FITNESS; PROVIDING INFORMATION IN THE FIELD OF EXERCISE TRAINING (U.S. CLS. 100, 101 AND 107).

CLASS 45—PERSONAL AND LEGAL SERVICES

FOR ONLINE SOCIAL NETWORKING SERVICES (U.S. CLS. 100 AND 101).
ALEXANDER L. POWERS, EXAMINING ATTORNEY

SN 77-432,693. 1000 MARKETS, INC., EASTSOUND, WA.
FILED 3-26-2008.

1000M

THE MARK CONSISTS OF STANDARD CHARACTERS WITHOUT CLAIM TO ANY PARTICULAR FONT, STYLE, SIZE, OR COLOR.

CLASS 35—ADVERTISING AND BUSINESS

FOR THE BRINGING TOGETHER, FOR THE BENEFIT OF OTHERS, OF A VARIETY OF GOODS AND SERVICES, ENABLING CUSTOMERS TO CONVENIENTLY VIEW AND PURCHASE THOSE GOODS AND SERVICES FROM AN INTERNET WEBSITE (U.S. CLS. 100, 101 AND 102).

CLASS 42—SCIENTIFIC AND COMPUTER SERVICES

FOR COMPUTER SERVICES, NAMELY, INTERACTIVE HOSTING SERVICES WHICH ALLOW THE USER TO PUBLISH AND SHARE THEIR OWN CONTENT AND IMAGES ONLINE; COMPUTER SERVICES, NAMELY, HOSTING ONLINE WEB FACILITIES FOR OTHERS FOR ORGANIZING AND CONDUCTING ONLINE MEETINGS, GATHERINGS, AND INTERACTIVE DISCUSSIONS; AND COMPUTER SERVICES IN THE NATURE OF CUSTOMIZED WEB PAGES FEATURING USER-DEFINED INFORMATION, PERSONAL PROFILES AND INFORMATION (U.S. CLS. 100 AND 101).

MONIQUE MILLER, EXAMINING ATTORNEY

SN 77-432,724. EXARI SYSTEMS, INC., DBA SPEEDLEGAL, INC., BOSTON, MA. FILED 3-27-2008.

EXARI

THE MARK CONSISTS OF STANDARD CHARACTERS WITHOUT CLAIM TO ANY PARTICULAR FONT, STYLE, SIZE, OR COLOR.

CLASS 9—ELECTRICAL AND SCIENTIFIC APPARATUS

FOR COMPUTER SOFTWARE FOR CONTRACT LIFE-CYCLE MANAGEMENT AND DOCUMENT ASSEMBLY; COMPUTER PROGRAMMES FOR DOCUMENT MANAGEMENT; COMPUTER SOFTWARE FOR THE COLLECTION, EDITING, ORGANIZING, MODIFYING, BOOK MARKING, TRANSMISSION, STORAGE AND SHARING OF DATA AND INFORMATION; COMPUTER SOFTWARE THAT PROVIDES REAL-TIME, INTEGRATED BUSINESS MANAGEMENT INTELLIGENCE BY COMBINING INFORMATION FROM VARIOUS DATABASES AND PRESENTING IT IN AN EASY-TO-UNDERSTAND USER INTERFACE; DATA AND WORD PROCESSORS; COMPUTER SOFTWARE FOR CREATING SEARCHABLE DATABASES OF INFORMATION AND DATA (U.S. CLS. 21, 23, 26, 36 AND 38).

FIRST USE 9-6-2005; IN COMMERCE 9-6-2005.

CLASS 38—COMMUNICATION

FOR COMMUNICATION SERVICES, NAMELY, ELECTRONIC TRANSMISSION OF DATA AND DOCUMENTS AMONG USERS OF COMPUTERS; ELECTRONIC DELIVERY OF LOAN DOCUMENTS; ELECTRONIC TRANSMISSION OF DATA AND DOCUMENTS VIA COMPUTER TERMINALS; ELECTRONIC TRANSMISSION OF MESSAGES AND DATA; ON-LINE DOCUMENT DELIVERY VIA A GLOBAL COMPUTER NETWORK; PROVISION OF ACCESS TO A GLOBAL COMPUTER NETWORK; PROVISION OF ACCESS TO DATA OR DOCUMENTS STORED ELECTRONICALLY IN CENTRAL FILES FOR REMOTE CONSULTATION; PROVISION OF ACCESS TO ELECTRONIC SITES (U.S. CLS. 100, 101 AND 104).

FIRST USE 9-6-2005; IN COMMERCE 9-6-2005.

CLASS 42—SCIENTIFIC AND COMPUTER SERVICES

FOR APPLICATION SERVICE PROVIDER (ASP) FEATURING SOFTWARE FOR USE IN DOCUMENT ASSEMBLY AND LIFECYCLE CONTRACT MANAGEMENT; PROVIDING ON-LINE NON-DOWNLOADABLE SOFTWARE FOR USE IN DOCUMENT ASSEMBLY AND CONTRACT LIFECYCLE MANAGEMENT; COMPUTER HARDWARE AND SOFTWARE CONSULTING SERVICES; COMPUTER SOFTWARE CONSULTANCY; COMPUTER PROGRAMMING SERVICES; PROVIDING COMPUTER PROGRAMMING SERVICES TO CUSTOMERS THAT ENABLES THE CUSTOMER'S WEB-SITE TO PROCESS NATURAL LANGUAGE QUERIES; COMPUTER PROGRAMMING AND COMPUTER SYSTEM ANALYSIS; COMPUTER PROGRAMMING AND MAINTENANCE OF COMPUTER PROGRAMS; COMPUTER PROGRAMMING AND SOFTWARE DESIGN; COMPUTER PROJECT MANAGEMENT SERVICES; TECHNICAL SUPPORT SERVICES, NAMELY, TROUBLESHOOTING OF COMPUTER HARDWARE AND SOFTWARE PROBLEMS; TECHNICAL SUPPORT SERVICES, NAMELY, TROUBLESHOOTING OF COMPUTER SOFTWARE PROBLEMS; TECHNICAL SUPPORT SERVICES, NAMELY, TROUBLESHOOTING OF INDUSTRIAL PROCESS CONTROL COMPUTER SOFTWARE PROBLEMS; UP-DATING OF COMPUTER SOFTWARE; UPDATING AND DESIGN OF COMPUTER SOFTWARE; DEVELOPMENT, UPDATING AND MAINTENANCE OF SOFTWARE AND DATA BASES; UPDATING AND MAINTENANCE OF COMPUTER SOFTWARE; DESIGN, MAINTENANCE, DEVELOPMENT AND UPDATING OF COMPUTER SOFTWARE; DEVELOPING AND UPDATING COMPUTER SOFTWARE; DEVELOPING COMPUTER SOFTWARE; COMPUTER SOFTWARE INSTALLATION AND MAINTENANCE; INSTALLATION AND MAINTENANCE OF COMPUTER SOFTWARE; INSTALLATION, MAINTENANCE AND REPAIR OF COMPUTER SOFTWARE; INSTALLATION, REPAIR AND MAINTENANCE OF COMPUTER SOFTWARE; MAINTENANCE AND UPDATING OF COMPUTER SOFTWARE; MAINTENANCE AND UPGRADING OF COMPUTER SOFTWARE; COMPUTER SOFTWARE DESIGN, COMPUTER PROGRAMMING, OR MAINTENANCE OF COMPUTER SOFTWARE; DESIGN AND MAINTENANCE OF COMPUTER SITES FOR THIRD PARTIES; MAINTENANCE OF COMPUTER SOFTWARE; COMPUTER SOFTWARE DESIGN; COMPUTER SOFTWARE DEVELOPMENT; DESIGN AND DEVELOPMENT OF ON-LINE COMPUTER SOFTWARE SYSTEMS; DESIGN OF HOME PAGES; DESIGN OF HOME PAGES AND WEB SITES; DESIGN OF HOME PAGES, COMPUTER SOFTWARE AND WEB SITES; COMPUTER SERVICE, NAMELY, ACTING AS AN APPLICATION SERVICE PROVIDER IN THE FIELD OF KNOWLEDGE MANAGEMENT TO HOST COMPUTER APPLICATION SOFTWARE FOR CREATING SEARCHABLE DATABASES OF INFORMATION AND DATA; CONVERSION OF DATA OR DOCUMENTS FROM PHYSICAL TO ELECTRONIC MEDIA; DOCUMENT DATA TRANSFER FROM ONE COMPUTER FORMAT TO ANOTHER; APPLICATION SERVICE PROVIDER FEATURING SOFTWARE FOR PROVIDING AN ON-LINE DATABASE IN THE FIELD OF TRANSACTION PROCESSING TO UPLOAD TRANSACTIONAL DATA, PROVIDE STATISTICAL ANALYSIS, AND PRODUCE NOTIFICATIONS AND REPORTS; COMPUTER SERVICE, NAMELY, ACTING AS AN APPLICATION SERVICE PROVIDER IN THE FIELD OF KNOWLEDGE MANAGEMENT TO HOST COMPUTER APPLICATION SOFTWARE FOR SEARCHING AND RETRIEVING INFORMATION FROM DATABASES AND COMPUTER NETWORKS; COMPUTER SERVICE, NAMELY, ACTING AS AN APPLICATION SERVICE PROVIDER IN THE FIELD OF KNOWLEDGE MANAGEMENT TO HOST COMPUTER APPLICATION SOFTWARE FOR THE COLLECTION, EDITING, ORGANIZING, MODIFYING, BOOK MARKING, TRANSMISSION, STORAGE AND SHARING OF DATA AND INFORMATION; COMPUTER SERVICES, NAMELY, INTERACTIVE HOSTING SERVICES WHICH ALLOW THE USER TO PUBLISH AND SHARE THEIR OWN CONTENT AND IMAGES ONLINE (U.S. CLS. 100 AND 101).

FIRST USE 9-6-2005; IN COMMERCE 9-6-2005.
KAREN BRACEY, EXAMINING ATTORNEY

SN 77-432,858. RUSNAK, JOEL, NEWBURYPORT, MA.
FILED 3-27-2008.

POLLIWALKS

THE MARK CONSISTS OF STANDARD CHARACTERS WITHOUT CLAIM TO ANY PARTICULAR FONT, STYLE, SIZE, OR COLOR.

CLASS 9—ELECTRICAL AND SCIENTIFIC APPARATUS

FOR SUNGLASSES (U.S. CLS. 21, 23, 26, 36 AND 38).

CLASS 18—LEATHER GOODS

FOR BACKPACKS (U.S. CLS. 1, 2, 3, 22 AND 41).
JESSICA A. POWERS, EXAMINING ATTORNEY

SN 77-432,859. MOORE, ROBERT P., SR., GENESEO, NY.
AND MOORE, NOREEN O., GENESEO, NY. FILED 3-27-2008.

RED OSIER

THE MARK CONSISTS OF STANDARD CHARACTERS WITHOUT CLAIM TO ANY PARTICULAR FONT, STYLE, SIZE, OR COLOR.

THE FOREIGN WORDING IN THE MARK TRANSLATES INTO ENGLISH AS "WICKER".

CLASS 29—MEATS AND PROCESSED FOODS

FOR MEAT, MEAT JUICES, PREPARED MEAT, PROCESSED MEAT, LUNCHEON MEATS, PREPARED NON-FROZEN MEAT ENTREES (U.S. CL. 46).
FIRST USE 12-27-1979; IN COMMERCE 2-1-2003.

CLASS 30—STAPLE FOODS

FOR MEAT GRAVIES, CONDIMENTS, NAMELY, AU JUS MEAT SAUCE AND HORSERADISH-MAYONNAISE SAUCE (U.S. CL. 46).
FIRST USE 12-27-1979; IN COMMERCE 2-1-2003.

CLASS 35—ADVERTISING AND BUSINESS

FOR FOOD KIOSK SERVICES (U.S. CLS. 100, 101 AND 102).
FIRST USE 12-27-1979; IN COMMERCE 2-1-2003.

CLASS 43—HOTEL AND RESTAURANT SERVICES

FOR RESTAURANT SERVICES, CATERING SERVICES, SNACK BAR AND CANTEEN SERVICES (U.S. CLS. 100 AND 101).
FIRST USE 12-27-1979; IN COMMERCE 2-1-2003.
JORDAN BAKER, EXAMINING ATTORNEY

SN 77-433,072. HT2, INC., CARLTON, OR. FILED 3-27-2008.

SN 77-433,139. SUMITOMO CHEMICAL CO., LTD., TOKYO, JAPAN, FILED 3-27-2008.



THE MARK CONSISTS OF TREE IN CIRCLE.

CLASS 3—COSMETICS AND CLEANING PREPARATIONS

FOR EXFOLIANT CREAMS; ESSENTIAL OILS (U.S. CLS. 1, 4, 6, 50, 51 AND 52).

CLASS 5—PHARMACEUTICALS

FOR MEDICATED BATH PREPARATIONS; MEDICATED BRUSH-ON ORAL CARE GELS; MEDICATED DIAPER RASH OINTMENTS AND LOTIONS; MEDICATED HAIR CARE PREPARATIONS; MEDICATED HAND WASH; MEDICATED LIP BALM; MEDICATED LOTIONS FOR SKIN, HAIR, SUNBURN, FACE, BODY; MEDICATED MOUTH CARE AND TREATMENT PREPARATIONS; MEDICATED SHAMPOO; MEDICATED SHAVING PREPARATIONS; MEDICATED SKIN CARE PREPARATIONS; MEDICATED SKIN CARE PREPARATIONS, NAMELY, CREAMS, LOTIONS, GELS, TONERS, CLEANSERS AND PEELS; MEDICATED SUN CARE PREPARATIONS; ANTI-ITCH OINTMENT; ANTIBIOTIC OINTMENTS; ANTIBACTERIAL CLEANSERS; ANTIBACTERIAL HAND LOTIONS; ANTIBACTERIAL HANDWASH; ANTIBACTERIAL SPRAY; MEDICAL CLEANSERS FOR SKIN AND WOUNDS; FUNGAL MEDICATIONS (U.S. CLS. 6, 18, 44, 46, 51 AND 52).
SANJEEV VOHRA, EXAMINING ATTORNEY

SN 77-433,136. ALLRED, SHANNON R., WEST TAWAKONI, TX. FILED 3-27-2008.

PSYCHO BITCH

THE MARK CONSISTS OF STANDARD CHARACTERS WITHOUT CLAIM TO ANY PARTICULAR FONT, STYLE, SIZE, OR COLOR.

CLASS 18—LEATHER GOODS

FOR PURSES (U.S. CLS. 1, 2, 3, 22 AND 41).

CLASS 25—CLOTHING

FOR SHIRTS (U.S. CLS. 22 AND 39).
SUNG IN, EXAMINING ATTORNEY

INSIDE

THE MARK CONSISTS OF STANDARD CHARACTERS WITHOUT CLAIM TO ANY PARTICULAR FONT, STYLE, SIZE, OR COLOR.

CLASS 1—CHEMICALS

FOR CHEMICALS FOR USE IN THE MANUFACTURE OF INSECTICIDES, FUNGICIDES AND HERBICIDES (U.S. CLS. 1, 5, 6, 10, 26 AND 46).

CLASS 5—PHARMACEUTICALS

FOR INSECTICIDES, FUNGICIDES, HERBICIDES, AND PREPARATIONS FOR KILLING WEEDS AND DESTROYING VERMIN (U.S. CLS. 6, 18, 44, 46, 51 AND 52).

SUNG IN, EXAMINING ATTORNEY

SN 77-433,163. THINK SMART, S.A., 28108 - MADRID, SPAIN, FILED 3-27-2008.



THE COLOR(S) BLACK, GREY AND BLUE IS/ARE CLAIMED AS A FEATURE OF THE MARK.

THE MARK CONSISTS OF THE WORD "THINK" IN GREY POSITIONED ON A BLACK BACKGROUND. THE NUMBER "4" IS BLACK POSITIONED IN A SHADED GREY BUBBLE ON A BLACK BACKGROUND. THE BUBBLE HAS A GENERALLY SQUARE OUTLINE WITH TWO OPPOSITE CORNERS ROUNDED. A SIMILAR SMALLER GREY BUBBLE IS POSITIONED ON THE BLACK BACKGROUND ADJACENT AN UPPER NON-ROUNDED CORNER OF THE FIRST BUBBLE. THE WORD "INCENTIVES" IS BLUE POSITIONED ON A BLACK BACKGROUND.

CLASS 16—PAPER GOODS AND PRINTED MATTER

FOR PUBLICATIONS, NAMELY, BROCHURES, CATALOGUES, NEWSLETTERS, INSTRUCTIONAL AND TEACHING PAGES RELATIVE TO BUSINESS CONSULTING AND MARKETING (U.S. CLS. 2, 5, 22, 23, 29, 37, 38 AND 50).

CLASS 35—ADVERTISING AND BUSINESS

FOR PUBLICITY AND SALES PROMOTION SERVICES; MARKET RESEARCH; MARKETING CONSULTING; ECONOMIC FORECASTING AND ANALYSIS; ASSISTANCE IN BUSINESS MANAGEMENT AND PRODUCTS COMMERCIALIZATION, WITHIN THE FRAMEWORK OF A FRANCHISE CONTRACT; ORGANIZING AND CONDUCTING FAIRS FOR COMMERCIAL OR ADVERTISING PURPOSES (U.S. CLS. 100, 101 AND 102).
LAURIE KAUFMAN, EXAMINING ATTORNEY

SN 77-433,267. PDG ADVANTAGE, INC., JACKSONVILLE, FL. FILED 3-27-2008.

SN 77-433,431. MANOOSH ELAGANTE, LLC, WEST HOLLYWOOD, CA. FILED 3-27-2008.

PDG Advantage

THE MARK CONSISTS OF STANDARD CHARACTERS WITHOUT CLAIM TO ANY PARTICULAR FONT, STYLE, SIZE, OR COLOR.

CLASS 35—ADVERTISING AND BUSINESS

FOR FRANCHISE SERVICES, NAMELY, OFFERING BUSINESS MANAGEMENT ASSISTANCE IN THE ESTABLISHMENT AND OPERATION OF A HOME RENOVATION AND IMPROVEMENT BUSINESS (U.S. CLS. 100, 101 AND 102).

CLASS 37—CONSTRUCTION AND REPAIR

FOR RENOVATION AND RESTORATION OF BUILDINGS (U.S. CLS. 100, 103 AND 106).
ZHALEH DELANEY, EXAMINING ATTORNEY

SN 77-433,369. COYOTE LOGISTICS, LLC, LAKE FOREST, IL. FILED 3-27-2008.



THE MARK CONSISTS OF A SILHOUETTE OF A COYOTE HEAD HOWLING. THE SILHOUETTE OF THE COYOTE HEAD IS WITHIN A HALF MOON SHAPE WHICH ALSO CONTAINS STARS ABOVE THE COYOTE HEAD.

CLASS 35—ADVERTISING AND BUSINESS

FOR TRANSPORTATION LOGISTIC SERVICES, NAMELY, ARRANGING FOR THE TRANSPORTATION OF GOODS FOR OTHERS (U.S. CLS. 100, 101 AND 102).
FIRST USE 4-20-2007; IN COMMERCE 4-20-2007.

CLASS 39—TRANSPORTATION AND STORAGE

FOR FREIGHT FORWARDING, BROKERING AND LOGISTIC SERVICES RELATING TO THE TRANSPORTATION OF FREIGHT AND PROPERTY BY LAND, SEA, AIR OR RAIL; DELIVERY OF GOODS BY TRUCK (U.S. CLS. 100 AND 105).
FIRST USE 4-20-2007; IN COMMERCE 4-20-2007.
KAREN BRACEY, EXAMINING ATTORNEY



THE NAME "MANOOSHAH SHIRIBABADI" IDENTIFIES A LIVING INDIVIDUAL WHOSE CONSENT IS OF RECORD.

THE MARK CONSISTS OF THE WORD "MANOOSHAH", WRITTEN IN AN ELABORATE AND STYLIZED CURSIVE FORM.

CLASS 14—JEWELRY

FOR BRACELETS; CHARMS; DIAMOND JEWELRY; GEMSTONE JEWELRY; JEWELRY; JEWELRY AND IMITATION JEWELRY; JEWELRY CHAINS; RINGS; NECKLACES (U.S. CLS. 2, 27, 28 AND 50).

CLASS 18—LEATHER GOODS

FOR EVENING HANDBAGS; HANDBAGS; LEATHER HANDBAGS; PURSES AND WALLETS (U.S. CLS. 1, 2, 3, 22 AND 41).

CLASS 25—CLOTHING

FOR LEATHER BELTS; TOPS; HATS; DRESS SHIRTS; SHIRTS; DRESSES; EVENING DRESSES; SKIRTS AND DRESSES; TROUSERS; SWEATERS; JACKETS; LEATHER JACKETS; MEN AND WOMEN JACKETS; COATS, TROUSERS, VESTS; DENIMS; THONGS; UNDERWEAR; SHOES (U.S. CLS. 22 AND 39).

GISELLE AGOSTO, EXAMINING ATTORNEY

SN 77-433,447. CHINA FOUNDATION, THE, VISTA, CA. FILED 3-27-2008.

China Foundation

THE MARK CONSISTS OF STANDARD CHARACTERS WITHOUT CLAIM TO ANY PARTICULAR FONT, STYLE, SIZE, OR COLOR.

NO CLAIM IS MADE TO THE EXCLUSIVE RIGHT TO USE "FOUNDATION", APART FROM THE MARK AS SHOWN.
SEC. 2(F).

CLASS 35—ADVERTISING AND BUSINESS

FOR CHARITABLE SERVICES, NAMELY, ORGANIZING AND CONDUCTING VOLUNTEER PROGRAMS AND COMMUNITY SERVICE PROJECTS (U.S. CLS. 100, 101 AND 102).
FIRST USE 5-0-2000; IN COMMERCE 5-0-2000.

CLASS 36—INSURANCE AND FINANCIAL

FOR CHARITABLE FUND RAISING; ACCEPTING AND ADMINISTERING MONETARY CHARITABLE CONTRIBUTIONS; CHARITABLE SERVICES, NAMELY, GRANTING FUNDS TO SCHOOLS; PROVIDING PROJECT GRANTS FOR ENVIRONMENTAL AND HIV/AIDS PROJECTS (U.S. CLS. 100, 101 AND 102).
FIRST USE 11-0-1999; IN COMMERCE 11-0-1999.

CLASS 41—EDUCATION AND ENTERTAINMENT

FOR ARRANGING AND CONDUCTING EDUCATIONAL CONFERENCES; ORGANIZING CONFERENCES IN THE FIELD OF PUBLIC HEALTH AND MEDICAL SCIENCE (U.S. CLS. 100, 101 AND 107).
FIRST USE 11-0-1999; IN COMMERCE 11-0-1999.
MICHAEL KEATING, EXAMINING ATTORNEY

SN 77-433,524. WEYERHAEUSER REAL ESTATE DEVELOPMENT COMPANY, MADISON, GA. FILED 3-27-2008.

STATESIDE

THE MARK CONSISTS OF STANDARD CHARACTERS WITHOUT CLAIM TO ANY PARTICULAR FONT, STYLE, SIZE, OR COLOR.

CLASS 35—ADVERTISING AND BUSINESS

FOR REAL ESTATE SERVICES, NAMELY, ADVERTISING AND MARKETING OF RESIDENTIAL AND COMMERCIAL PROPERTIES, AND RECREATIONAL AMENITIES (U.S. CLS. 100, 101 AND 102).

CLASS 37—CONSTRUCTION AND REPAIR

FOR LAND DEVELOPMENT AND CONSTRUCTION SERVICES, NAMELY, PLANNING, LAYING OUT, AND CONSTRUCTION OF RESIDENTIAL AND COMMERCIAL PROPERTIES WITHIN A PLANNED COMMUNITY; REAL ESTATE DEVELOPMENT AND CONSTRUCTION SERVICES, NAMELY, PLANNING, LAYING OUT AND CUSTOM CONSTRUCTION OF RESIDENTIAL AND COMMERCIAL COMMUNITIES (U.S. CLS. 100, 103 AND 106).
MARK T. MULLEN, EXAMINING ATTORNEY

SN 77-433,489. DEBORAH MILLER, DENHOFF, ND. AND RANDY MILLER, DENHOFF, ND. FILED 3-27-2008.

FLAX TRAX

THE MARK CONSISTS OF STANDARD CHARACTERS WITHOUT CLAIM TO ANY PARTICULAR FONT, STYLE, SIZE, OR COLOR.
NO CLAIM IS MADE TO THE EXCLUSIVE RIGHT TO USE FLAX, APART FROM THE MARK AS SHOWN.

CLASS 5—PHARMACEUTICALS

FOR NUTRITIONAL SUPPLEMENTS CONTAINING OMEGAS AND ARTIFICIALLY MANUFACTURED OMEGAS, NAMELY, FLAXSEED AND FLAX LIGNANS IN THE NATURE OF EDIBLE FLAXSEED OIL, EDIBLE MILLED FLAXSEED, EDIBLE COLD MILLED FLAXSEED, EDIBLE WHOLE SEED FLAXSEED, EDIBLE PREGROUND FLAXSEED AND EDIBLE LIGNANS (U.S. CLS. 6, 18, 44, 46, 51 AND 52).

CLASS 29—MEATS AND PROCESSED FOODS

FOR PROCESSED EDIBLE FLAX, NAMELY, EDIBLE MILLED FLAXSEED, EDIBLE COLD MILLED FLAXSEED, EDIBLE WHOLE SEED FLAXSEED, EDIBLE PREGROUND FLAXSEED, AND EDIBLE FLAX LIGNANS; EDIBLE FLAXSEED OIL (U.S. CL. 46).

CLASS 31—NATURAL AGRICULTURAL PRODUCTS

FOR FOODSTUFFS FOR ANIMALS; ANIMAL FEED, NAMELY, DOG BISCUITS AND MEALS FOR ANIMALS (U.S. CLS. 1 AND 46).
SCOTT BIBB, EXAMINING ATTORNEY

SN 77-433,526. DEBORAH MILLER, DENHOFF, ND. AND RANDY MILLER, DENHOFF, ND. FILED 3-27-2008.

LIGNAN BOOST

THE MARK CONSISTS OF STANDARD CHARACTERS WITHOUT CLAIM TO ANY PARTICULAR FONT, STYLE, SIZE, OR COLOR.
NO CLAIM IS MADE TO THE EXCLUSIVE RIGHT TO USE "LIGNAN", APART FROM THE MARK AS SHOWN.

CLASS 5—PHARMACEUTICALS

FOR NUTRITIONAL SUPPLEMENTS CONTAINING OMEGAS AND ARTIFICIALLY MANUFACTURED OMEGAS, NAMELY, FLAXSEED AND FLAX LIGNANS IN THE NATURE OF EDIBLE FLAXSEED OIL, EDIBLE MILLED FLAXSEED, EDIBLE COLD MILLED FLAXSEED, EDIBLE WHOLE SEED FLAXSEED, EDIBLE PREGROUND FLAXSEED AND EDIBLE LIGNANS (U.S. CLS. 6, 18, 44, 46, 51 AND 52).

CLASS 29—MEATS AND PROCESSED FOODS

FOR PROCESSED EDIBLE FLAX, NAMELY, EDIBLE MILLED FLAXSEED, EDIBLE COLD MILLED FLAXSEED, EDIBLE WHOLE SEED FLAXSEED, EDIBLE PREGROUND FLAXSEED, AND EDIBLE FLAX LIGNANS; EDIBLE FLAXSEED OIL (U.S. CL. 46).

CLASS 31—NATURAL AGRICULTURAL PRODUCTS

FOR FOODSTUFFS FOR ANIMALS; ANIMAL FEED, NAMELY, DOG BISCUITS AND MEALS FOR ANIMALS (U.S. CLS. 1 AND 46).

SCOTT BIBB, EXAMINING ATTORNEY

CLASS 35—ADVERTISING AND BUSINESS

FOR PROVIDING INFORMATION ABOUT AND MAKING REFERRALS IN THE FIELD OF CONSUMER PRODUCTS AND SERVICES FOR RETAIL SERVICES CONCERNING PRODUCTS, SERVICES, EVENTS, ACTIVITIES, ATTRACTIONS AND FACILITIES IN PARTICULAR GEOGRAPHIC LOCATIONS; PROVIDING AN ON-LINE COMPUTER DATABASE IN THE FIELD OF LOCATING PRODUCTS, DESCRIBING PRODUCTS, RATING PRODUCTS, PRICING PRODUCTS AND COMPARING PRICES OF PRODUCTS; PROVIDING CONSUMER INFORMATION SERVICES AND MAKING REFERRALS IN THE FIELD OF ENTERTAINMENT SERVICES FOR PRODUCTS, SERVICES, EVENTS, ACTIVITIES, FACILITIES AND LOCATIONS; PREPARING AND PLACING OF ADVERTISEMENTS; BUSINESS NETWORKING; DISSEMINATION OF ADVERTISING MATTER; ELECTRONIC COMMERCE SERVICES, NAMELY, PROVIDING INFORMATION ABOUT PRODUCTS VIA TELECOMMUNICATION NETWORKS FOR ADVERTISING AND SALES PURPOSES; GENERAL BUSINESS NETWORKING REFERRAL SERVICES, NAMELY, PROMOTING THE GOODS AND SERVICES OF OTHERS BY PASSING BUSINESS LEADS AND REFERRALS AMONG GROUP MEMBERS; MATCHING CONSUMERS WITH PROFESSIONALS IN THE FIELD OF RESIDENTIAL AND COMMERCIAL SERVICES VIA COMPUTER NETWORK; PROMOTING THE GOODS AND SERVICES OF OTHERS VIA A GLOBAL COMPUTER NETWORK; PROVIDING INFORMATION ABOUT COMMERCIAL BUSINESS AND COMMERCIAL INFORMATION VIA THE GLOBAL COMPUTER NETWORK (U.S. CLS. 100, 101 AND 102).

SN 77-433,709, MENON, KRISHNAN, LOS ANGELES, CA. FILED 3-27-2008.

TELEVUTION

THE MARK CONSISTS OF STANDARD CHARACTERS WITHOUT CLAIM TO ANY PARTICULAR FONT, STYLE, SIZE, OR COLOR.

CLASS 35—ADVERTISING AND BUSINESS

FOR MARKETING CONSULTATION IN THE FIELD OF ENTERTAINMENT, MEDIA, INTERNET, BRANDED ENTERTAINMENT AND SOCIAL NETWORKS (U.S. CLS. 100, 101 AND 102).

FIRST USE 4-21-2005; IN COMMERCE 4-26-2007.

CLASS 41—EDUCATION AND ENTERTAINMENT

FOR ON-LINE JOURNALS, NAMELY, BLOGS FEATURING MEDIA, ENTERTAINMENT, ENTERTAINMENT TECHNOLOGY AND MARKETING (U.S. CLS. 100, 101 AND 107).

FIRST USE 3-21-2004; IN COMMERCE 5-26-2007.

RUDY R. SINGLETON, EXAMINING ATTORNEY

CLASS 42—SCIENTIFIC AND COMPUTER SERVICES

FOR COMPUTER SERVICES IN THE NATURE OF CUSTOMIZED WEB PAGES FEATURING USER-DEFINED INFORMATION, PERSONAL PROFILES AND INFORMATION; COMPUTER SERVICES, NAMELY, CREATING AN ONLINE COMMUNITY FOR REGISTERED USERS TO PARTICIPATE IN COMPETITIONS, SHOWCASE THEIR SKILLS, GET FEEDBACK FROM THEIR PEERS, FORM VIRTUAL COMMUNITIES, ENGAGE IN SOCIAL NETWORKING AND IMPROVE THEIR TALENT; COMPUTER SERVICES, NAMELY, CREATING INDEXES OF INFORMATION, SITES AND OTHER RESOURCES AVAILABLE ON COMPUTER NETWORKS; COMPUTER SERVICES, NAMELY, PROVIDING SEARCH ENGINES FOR OBTAINING DATA ON A GLOBAL COMPUTER NETWORK; COMPUTER SERVICES, NAMELY, DESIGNING AND IMPLEMENTING NETWORK WEB PAGES FOR OTHERS; COMPUTER SERVICES, NAMELY, HOSTING AND MAINTAINING AN ONLINE WEB SITE FOR OTHERS TO INTERACT WITH OTHERS; COMPUTER SERVICES, NAMELY, HOSTING ON-LINE INTERACTIVE PUBLIC CALENDARS THAT ALLOW MULTIPLE PARTICIPANTS TO SHARE EVENT SCHEDULES, FACILITY RESERVATIONS, AND TRANSPORTATION REQUESTS; COMPUTER SERVICES, NAMELY, HOSTING ON-LINE WEB FACILITIES FOR OTHERS FOR ORGANIZING AND CONDUCTING ONLINE MEETINGS, GATHERINGS, AND INTERACTIVE DISCUSSIONS; COMPUTER SERVICES, NAMELY, INTERACTIVE HOSTING SERVICES WHICH ALLOW THE USER TO PUBLISH AND SHARE THEIR OWN CONTENT AND IMAGES ONLINE; HOSTING AN ONLINE COMMUNITY WEB SITE FEATURING LOCALIZED CONTENT FOR AND FROM USERS AND BUSINESSES; HOSTING THE WEB SITES OF OTHERS ON A COMPUTER SERVER FOR A GLOBAL COMPUTER NETWORK; PROVIDING CUSTOMER-DEFINED GENERATED CONTENT AND CONTENT OF OTHERS AUTOMATICALLY SELECTED AND CUSTOMIZED BASED ON THE KNOWN OR ESTIMATED GEOGRAPHICAL LOCATION OF AN INTERNET, MOBILE TELEPHONE OR OTHER WIRED OR WIRELESS DIGITAL NETWORK BASED CUSTOMER; PROVIDING INFORMATION AT THE SPECIFIC REQUEST OF END-USERS BY MEANS OF TELEPHONE OR GLOBAL COMPUTER NETWORKS; MAPPING (U.S. CLS. 100 AND 101).

SN 77-433,808, FATDOOR INC., DBA CENTER'D CORPORATION, PALO ALTO, CA. FILED 3-27-2008.

CENTER'D

THE MARK CONSISTS OF STANDARD CHARACTERS WITHOUT CLAIM TO ANY PARTICULAR FONT, STYLE, SIZE, OR COLOR.

CLASS 45—PERSONAL AND LEGAL SERVICES

FOR PROVIDING AN INTERACTIVE WEB SITE FOR PERSONS TO LOCATE OTHER INDIVIDUALS WITH SIMILAR INTERESTS TO PARTICIPATE WITH THEM IN, OR ACCOMPANY THEM TO, EVENTS AND ACTIVITIES; ONLINE SOCIAL NETWORKING SERVICES; PROVIDING INFORMATION CONCERNING CHARITABLE CAUSES AND HUMANITARIAN EFFORTS IN THE FIELD OF SOCIAL JUSTICE (U.S. CLS. 100 AND 101).
CHARLOTTE CORWIN, EXAMINING ATTORNEY

SN 77-433,841. SPA CASTLE, INC., COLLEGE POINT, NY.
FILED 3-27-2008.



NO CLAIM IS MADE TO THE EXCLUSIVE RIGHT TO USE "SPA", APART FROM THE MARK AS SHOWN.

THE COLOR(S) GREEN AND BLACK IS/ARE CLAIMED AS A FEATURE OF THE MARK.

THE MARK CONSISTS OF THE STYLIZED WORDING "SPA CASTLE" APPEARING IN BLACK. A GREEN LEAFLET TILTED TO THE RIGHT APPEARS ABOVE THE LETTER "A" IN THE WORD "SPA."

SN 77-433,811. HYI, COVINA, CA. FILED 3-27-2008.

Open Water

THE MARK CONSISTS OF STANDARD CHARACTERS WITHOUT CLAIM TO ANY PARTICULAR FONT, STYLE, SIZE, OR COLOR.

OWNER OF U.S. REG. NO. 3,207,921.

CLASS 8—HAND TOOLS

FOR HAND TOOLS, NAMELY, BILLY CLUBS, KNIVES, KNIFE SHEATHS, PLIERS, FORCEPS, CRIMPERS AND FISHING LINE CUTTERS (U.S. CLS. 23, 28 AND 44).

FIRST USE 10-12-2005; IN COMMERCE 10-12-2005.

CLASS 9—ELECTRICAL AND SCIENTIFIC APPARATUS

FOR ELECTRICAL AND SCIENTIFIC APPARATUS, NAMELY, SUNGLASSES AND STRAPS (U.S. CLS. 21, 23, 26, 36 AND 38).

FIRST USE 10-12-2005; IN COMMERCE 10-12-2005.

CLASS 18—LEATHER GOODS

FOR NON-LEATHER ALL PURPOSE ATHLETIC BAGS, NAMELY, NYLON ALL-PURPOSE ATHLETIC BAGS; NON-LEATHER BACKPACKS, NAMELY, NYLON BACKPACKS (U.S. CLS. 1, 2, 3, 22 AND 41).

FIRST USE 10-12-2005; IN COMMERCE 10-12-2005.

CLASS 28—TOYS AND SPORTING GOODS

FOR SPORTING GOODS, NAMELY, FISHING TACKLE BAGS, FISHING TACKLE BOXES, UTILITY BOXES FOR FISHING WEIGHTS, FISHING LURES AND FISHING HOOKS, FISHING REEL COVERS, FISHING ROD HOLDERS, FISHING ROD GUARDS, FISHING ROD WRAPS AND NON-LEATHER FISHING JIG TUBE BAGS (U.S. CLS. 22, 23, 38 AND 50).

FIRST USE 10-12-2005; IN COMMERCE 10-12-2005.
JILL C. ALT, EXAMINING ATTORNEY

CLASS 41—EDUCATION AND ENTERTAINMENT

FOR HEALTH CLUB SERVICES, NAMELY, PROVIDING INSTRUCTION AND EQUIPMENT IN THE FIELD OF PHYSICAL EXERCISE (U.S. CLS. 100, 101 AND 107).

CLASS 44—MEDICAL, BEAUTY AND AGRICULTURAL SERVICES

FOR HEALTH SPA SERVICES, NAMELY, COSMETIC BODY CARE SERVICES; SAUNA SERVICES (U.S. CLS. 100 AND 101).

ANDREA HACK, EXAMINING ATTORNEY

SN 77-433,866. FAMILY EYE CLINIC & CONTACT LENS CENTER, PA, PLYMOUTH, MN. FILED 3-27-2008.



THE MARK CONSISTS OF AN ABSTRACT DESIGN OF AN EYE.

CLASS 35—ADVERTISING AND BUSINESS

FOR RETAIL STORE SERVICES FEATURING SPECTACLE FRAMES AND LENSES, CONTACT LENSES, AND OPTICALLY RELATED GOODS (U.S. CLS. 100, 101 AND 102).

FIRST USE 4-1-2005; IN COMMERCE 4-1-2005.

CLASS 44—MEDICAL, BEAUTY AND AGRICULTURAL SERVICES

FOR OPTOMETRY SERVICES (U.S. CLS. 100 AND 101).
FIRST USE 4-1-2005; IN COMMERCE 4-1-2005.
G. MAYERSCHOFF, EXAMINING ATTORNEY

SN 77-433,886. BRIO MANAGEMENT, LLC, DOYLESTOWN, PA. FILED 3-27-2008.

SN 77-434,125. GENERATION KANE RECORDS LLC, ESTERO, FL. FILED 3-28-2008.

LOAD THE BASES

THE MARK CONSISTS OF STANDARD CHARACTERS WITHOUT CLAIM TO ANY PARTICULAR FONT, STYLE, SIZE, OR COLOR.

CLASS 16—PAPER GOODS AND PRINTED MATTER

FOR A SERIES OF BOOKS, WRITTEN ARTICLES, HANDOUTS, NEWSLETTERS, WORKSHEETS AND PRINTED INSTRUCTIONAL, EDUCATIONAL AND TEACHING MATERIALS IN THE FIELD OF FINANCIAL PLANNING (U.S. CLS. 2, 5, 22, 23, 29, 37, 38 AND 50).

CLASS 41—EDUCATION AND ENTERTAINMENT

FOR EDUCATIONAL SERVICES, NAMELY, CONDUCTING SEMINARS AND WORKSHOPS IN THE FIELD OF FINANCIAL PLANNING AND WEALTH BUILDING AND DISTRIBUTION OF COURSE MATERIAL IN CONNECTION THEREWITH (U.S. CLS. 100, 101 AND 107).

NORA BUCHANAN WILL, EXAMINING ATTORNEY

SN 77-433,985. SMITHKLINE BEECHAM P.L.C., BRENTFORD, MIDDLESEX, ENGLAND, FILED 3-28-2008.

ONCE DAILY FOR MORE TIME
IN MOTION

THE MARK CONSISTS OF STANDARD CHARACTERS WITHOUT CLAIM TO ANY PARTICULAR FONT, STYLE, SIZE, OR COLOR.

CLASS 16—PAPER GOODS AND PRINTED MATTER

FOR PRINTED EDUCATIONAL MATERIALS PERTAINING TO THE TREATMENT OF PARKINSON'S DISEASE (U.S. CLS. 2, 5, 22, 23, 29, 37, 38 AND 50).

CLASS 44—MEDICAL, BEAUTY AND AGRICULTURAL SERVICES

FOR ONLINE INFORMATION SERVICES PERTAINING TO THE TREATMENT OF PARKINSON'S DISEASE (U.S. CLS. 100 AND 101).

SUSAN RICHARDS, EXAMINING ATTORNEY

NATE KANE

THE MARK CONSISTS OF STANDARD CHARACTERS WITHOUT CLAIM TO ANY PARTICULAR FONT, STYLE, SIZE, OR COLOR.

THE NAME "NATE KANE" IDENTIFIES A LIVING INDIVIDUAL WHOSE CONSENT IS OF RECORD.

CLASS 9—ELECTRICAL AND SCIENTIFIC APPARATUS

FOR DOWNLOADABLE MUSICAL SOUND RECORDINGS; MUSICAL SOUND RECORDINGS (U.S. CLS. 21, 23, 26, 36 AND 38).

CLASS 41—EDUCATION AND ENTERTAINMENT

FOR ENTERTAINMENT IN THE NATURE OF LIVE PERFORMANCES BY A MUSICAL ARTIST AND A MUSICAL BAND (U.S. CLS. 100, 101 AND 107).

DOUGLAS LEE, EXAMINING ATTORNEY

SN 77-434,323. UNICUS PERFORMANCE TRAINING, LLC, INDIAN HEAD PARK, IL. FILED 3-28-2008.

UNICUS FITNESS

THE MARK CONSISTS OF STANDARD CHARACTERS WITHOUT CLAIM TO ANY PARTICULAR FONT, STYLE, SIZE, OR COLOR.

NO CLAIM IS MADE TO THE EXCLUSIVE RIGHT TO USE "FITNESS", APART FROM THE MARK AS SHOWN.

CLASS 9—ELECTRICAL AND SCIENTIFIC APPARATUS

FOR PRE-RECORDED DVDS FEATURING FITNESS TRAINING PROGRAMS (U.S. CLS. 21, 23, 26, 36 AND 38).

FIRST USE 1-2-2005; IN COMMERCE 1-2-2005.

CLASS 41—EDUCATION AND ENTERTAINMENT

FOR PHYSICAL FITNESS INSTRUCTION, PERSONAL FITNESS TRAINING AND PHYSICAL FITNESS CONSULTATION (U.S. CLS. 100, 101 AND 107).

FIRST USE 1-2-2005; IN COMMERCE 1-2-2005.

HAI-LY LAM, EXAMINING ATTORNEY

SN 77-434,341. COLGATE-PALMOLIVE COMPANY, NEW YORK, NY. FILED 3-28-2008.

A WHOLE NEW DIMENSION OF
FRESHNESS

THE MARK CONSISTS OF STANDARD CHARACTERS WITHOUT CLAIM TO ANY PARTICULAR FONT, STYLE, SIZE, OR COLOR.

CLASS 3—COSMETICS AND CLEANING PREPARATIONS

FOR TOOTHPASTE, MOUTHWASH (U.S. CLS. 1, 4, 6, 50, 51 AND 52).

CLASS 21—HOUSEWARES AND GLASS

FOR TOOTHBRUSHES (U.S. CLS. 2, 13, 23, 29, 30, 33, 40 AND 50).

JOHN GARTNER, EXAMINING ATTORNEY

SN 77-434,532. WIDELoad GAMES INC., CHICAGO, IL. FILED 3-28-2008.

GRR

THE MARK CONSISTS OF STANDARD CHARACTERS WITHOUT CLAIM TO ANY PARTICULAR FONT, STYLE, SIZE, OR COLOR.

CLASS 9—ELECTRICAL AND SCIENTIFIC APPARATUS

FOR VIDEO AND COMPUTER GAME PROGRAMS; VIDEO AND COMPUTER GAME SOFTWARE; VIDEO AND COMPUTER GAME CARTRIDGES, CASSETTES, TAPES AND DISKS; ELECTRONIC GAME SOFTWARE; ELECTRONIC GAME PROGRAMS; VIDEO, COMPUTER AND ELECTRONIC GAME CARTRIDGES FOR HANDHELD DEVICES; VIDEO, COMPUTER AND ELECTRONIC GAME SOFTWARE FOR HANDHELD DEVICES; VIDEO, COMPUTER AND ELECTRONIC GAME PROGRAMS FOR HANDHELD DEVICES (U.S. CLS. 21, 23, 26, 36 AND 38).

FIRST USE 6-1-2006; IN COMMERCE 12-1-2007.

CLASS 41—EDUCATION AND ENTERTAINMENT

FOR PROVIDING INFORMATION, NEWS AND COMMENTARY IN THE FIELD OF ENTERTAINMENT, NAMELY, VIDEO, COMPUTER AND ELECTRONIC GAMES; PROVIDING INFORMATION, NEWS AND COMMENTARY IN THE FIELD OF RECREATION AND LEISURE ACTIVITIES, NAMELY, VIDEO, COMPUTER AND ELECTRONIC GAMES; PROVIDING A WEB SITE FEATURING INFORMATION, NEWS AND COMMENTARY IN THE FIELD OF ENTERTAINMENT, RECREATION AND LEISURE ACTIVITIES, NAMELY, VIDEO, COMPUTER AND ELECTRONIC GAMES; PROVIDING ONLINE INFORMATION ON VIDEO, COMPUTER AND ELECTRONIC GAMES (U.S. CLS. 100, 101 AND 107).

FIRST USE 6-1-2006; IN COMMERCE 12-1-2007.

DAVID MILLER, EXAMINING ATTORNEY

SN 77-434,562. MKS-MPC, INC, MARATHON, FL. FILED 3-28-2008.

Family My Way

THE MARK CONSISTS OF STANDARD CHARACTERS WITHOUT CLAIM TO ANY PARTICULAR FONT, STYLE, SIZE, OR COLOR.

CLASS 16—PAPER GOODS AND PRINTED MATTER

FOR BUMPER STICKERS; DECORATIVE STICKERS FOR HELMETS; STICKERS; STICKERS AND TRANSFERS; BABY BOOKS; BLACKBOARDS AND SCRAP BOOKS; BLANK JOURNAL BOOKS; BALL PENS; BALL POINT PENS; BALL-POINT PENS; BALLPOINT PENS; COLOURED PENS; FOUNTAIN PENS; GEL ROLLER PENS; HIGHLIGHTER PENS; HIGHLIGHTING PENS; INK PENS; PENS; BRAG BOOKS (U.S. CLS. 2, 5, 22, 23, 29, 37, 38 AND 50).

CLASS 24—FABRICS

FOR BATH TOWELS; BEACH TOWELS; CHILDREN'S TOWELS; GOLF TOWELS; HAND TOWELS; TOWELS (U.S. CLS. 42 AND 50).

CLASS 25—CLOTHING

FOR DRESS SHIRTS; GOLF SHIRTS; HOODED SWEAT SHIRTS; KNIT SHIRTS; LONG-SLEEVED SHIRTS; NIGHT SHIRTS; OPEN-NECKED SHIRTS; POLO SHIRTS; SHIRTS; SHORT-SLEEVED OR LONG-SLEEVED T-SHIRTS; HATS; PANTS (U.S. CLS. 22 AND 39).

MELVIN AXILBUND, EXAMINING ATTORNEY

SN 77-434,565. KONAMI DIGITAL ENTERTAINMENT CO., LTD., TOKYO, JAPAN, FILED 3-28-2008.

Castlevania
Order of Ecclesia

OWNER OF U.S. REG. NOS. 1,478,852, 1,713,890 AND OTHERS.

CLASS 9—ELECTRICAL AND SCIENTIFIC APPARATUS

FOR VIDEO GAME SOFTWARE, VIDEO GAME PROGRAMS, COMPUTER GAME SOFTWARE, COMPUTER GAME PROGRAMS, ELECTRONIC GAME PROGRAMS (U.S. CLS. 21, 23, 26, 36 AND 38).

CLASS 41—EDUCATION AND ENTERTAINMENT

FOR ENTERTAINMENT SERVICES, NAMELY, PROVIDING ON-LINE VIDEO GAMES (U.S. CLS. 100, 101 AND 107).
MICHAEL LITZAU, EXAMINING ATTORNEY

CLASS 39—TRANSPORTATION AND STORAGE

FOR PROVIDING AN ON-LINE COMPUTER DATABASE IN THE FIELD OF TRAVEL INFORMATION SERVICES; TRAVEL AGENCY SERVICES, NAMELY, MAKING RESERVATIONS AND BOOKINGS FOR TRANSPORTATION (U.S. CLS. 100 AND 105).

CLASS 43—HOTEL AND RESTAURANT SERVICES

FOR PROVIDING PERSONALIZED INFORMATION ABOUT HOTELS AND TEMPORARY ACCOMMODATIONS FOR TRAVEL VIA THE INTERNET; PROVIDING TRAVEL LODGING INFORMATION SERVICES AND TRAVEL LODGING BOOKING AGENCY SERVICES FOR TRAVELERS; TRAVEL AGENCY SERVICES, NAMELY, MAKING RESERVATIONS AND BOOKING FOR TEMPORARY LODGING (U.S. CLS. 100 AND 101).
GEOFFREY FOSDICK, EXAMINING ATTORNEY

SN 77-434,633. ZENOSS, INC., ANNAPOLIS, MD. FILED 3-28-2008.

Zenōss

SN 77-434,818. ARISE VIRTUAL SOLUTIONS INC., MIRAMAR, FL. FILED 3-28-2008.

THE MARK CONSISTS OF THE WORD "ZENOSS" IN AKZIDENZ FONT, INITIAL LETTER CAPITALIZED, WITH THE "O" DRAWN AS A BRUSHSTROKE CIRCLE WITH VARYING OPACITY AND FEATHERING. ABOVE THE "O" IS A SUPERSCRIPT BRUSHSTROKE ACCENT THAT FADES FROM LEFT TO RIGHT.

CLASS 9—ELECTRICAL AND SCIENTIFIC APPARATUS

FOR COMPUTER SOFTWARE FOR MONITORING AND MANAGING ENTERPRISE INFORMATION TECHNOLOGY SYSTEMS (U.S. CLS. 21, 23, 26, 36 AND 38).
FIRST USE 5-1-2006; IN COMMERCE 5-1-2006.

CLASS 42—SCIENTIFIC AND COMPUTER SERVICES

FOR COMPUTER SERVICES, NAMELY, INSTALLATION, INTEGRATION, MAINTENANCE, AND TROUBLE-SHOOTING OF COMPUTER SOFTWARE IN THE FIELD OF INFORMATION TECHNOLOGY SYSTEMS; CUSTOM DESIGN OF COMPUTER SOFTWARE FOR OTHERS (U.S. CLS. 100 AND 101).
FIRST USE 5-1-2006; IN COMMERCE 5-1-2006.
GEOFFREY FOSDICK, EXAMINING ATTORNEY

ARISE

THE MARK CONSISTS OF STANDARD CHARACTERS WITHOUT CLAIM TO ANY PARTICULAR FONT, STYLE, SIZE, OR COLOR.

CLASS 35—ADVERTISING AND BUSINESS

FOR OUTSOURCING SERVICES, NAMELY, CONNECTING BUSINESSES WITH REMOTE CUSTOMER SERVICES REPRESENTATIVES CERTIFIED TO WORK IN THE FIELDS OF TELEPHONE AND ELECTRONIC CONTACT CENTER SERVICES, CUSTOMER SERVICE, CUSTOMER SATISFACTION, SALES, TECHNICAL SUPPORT, AND DATA PROCESSING AND MANAGEMENT (U.S. CLS. 100, 101 AND 102).
FIRST USE 2-0-2007; IN COMMERCE 2-0-2007.

SN 77-434,639. MOUNTAIN RESERVATIONS, INC., SALT LAKE CITY, UT. FILED 3-28-2008.

VACATIONROOST

CLASS 41—EDUCATION AND ENTERTAINMENT

FOR EDUCATIONAL SERVICES, NAMELY, PROVIDING INSTRUCTION VIA WEB BASED COURSES FOR CERTIFICATION AND CONTINUING EDUCATION OF CUSTOMER SERVICE REPRESENTATIVES IN THE FIELDS OF TELEPHONE AND ELECTRONIC CONTACT CENTER SERVICES, CUSTOMER SERVICE, CUSTOMER SATISFACTION, SALES, TECHNICAL SUPPORT, AND DATA PROCESSING AND MANAGEMENT (U.S. CLS. 100, 101 AND 107).
FIRST USE 2-0-2007; IN COMMERCE 2-0-2007.
SHAUNIA CARLYLE, EXAMINING ATTORNEY

THE MARK CONSISTS OF STANDARD CHARACTERS WITHOUT CLAIM TO ANY PARTICULAR FONT, STYLE, SIZE, OR COLOR.

SN 77-434,840. ARISE VIRTUAL SOLUTIONS INC., MIRAMAR, FL. FILED 3-28-2008.

**WORK. FREEDOM. TRUST.
RESULTS.**

THE MARK CONSISTS OF STANDARD CHARACTERS WITHOUT CLAIM TO ANY PARTICULAR FONT, STYLE, SIZE, OR COLOR.

CLASS 35—ADVERTISING AND BUSINESS

FOR OUTSOURCING SERVICES, NAMELY, CONNECTING BUSINESSES WITH REMOTE CUSTOMER SERVICES REPRESENTATIVES CERTIFIED TO WORK IN THE FIELDS OF TELEPHONE AND ELECTRONIC CONTACT CENTER SERVICES, CUSTOMER SERVICE, CUSTOMER SATISFACTION, SALES, TECHNICAL SUPPORT, AND DATA PROCESSING AND MANAGEMENT (U.S. CLS. 100, 101 AND 102).

FIRST USE 2-0-2007; IN COMMERCE 2-0-2007.

CLASS 41—EDUCATION AND ENTERTAINMENT

FOR EDUCATIONAL SERVICES, NAMELY, PROVIDING INSTRUCTION VIA WEB BASED COURSES FOR CERTIFICATION AND CONTINUING EDUCATION OF CUSTOMER SERVICE REPRESENTATIVES IN THE FIELDS OF TELEPHONE AND ELECTRONIC CONTACT CENTER SERVICES, CUSTOMER SERVICE, CUSTOMER SATISFACTION, SALES, TECHNICAL SUPPORT, AND DATA PROCESSING AND MANAGEMENT (U.S. CLS. 100, 101 AND 107).

FIRST USE 2-0-2007; IN COMMERCE 2-0-2007.
SHAUNIA CARLYLE, EXAMINING ATTORNEY

SN 77-435,759. HYI, COVINA, CA. FILED 3-31-2008.



OWNER OF U.S. REG. NO. 3,207,921.

CLASS 8—HAND TOOLS

FOR HAND TOOLS, NAMELY, BILLY CLUBS, KNIVES, KNIFE SHEATHS, PLIERS, FORCEPS, CRIMPERS AND FISHING LINE CUTTERS (U.S. CLS. 23, 28 AND 44).

CLASS 9—ELECTRICAL AND SCIENTIFIC APPARATUS

FOR ELECTRICAL AND SCIENTIFIC APPARATUS, NAMELY, SUNGLASSES AND STRAPS (U.S. CLS. 21, 23, 26, 36 AND 38).

CLASS 18—LEATHER GOODS

FOR NON-LEATHER ALL PURPOSE ATHLETIC BAGS, NAMELY, NYLON ALL-PURPOSE ATHLETIC BAGS; NON-LEATHER BACKPACKS, NAMELY, NYLON BACKPACKS (U.S. CLS. 1, 2, 3, 22 AND 41).

CLASS 28—TOYS AND SPORTING GOODS

FOR SPORTING GOODS, NAMELY, FISHING TACKLE BAGS, FISHING TACKLE BOXES, UTILITY BOXES FOR FISHING WEIGHTS, FISHING LURES AND FISHING HOOKS, FISHING REEL COVERS, FISHING ROD HOLDERS, FISHING ROD GUARDS, FISHING ROD WRAPS AND NON-LEATHER FISHING JIG TUBE BAGS (U.S. CLS. 22, 23, 38 AND 50).

JILL C. ALT, EXAMINING ATTORNEY

SN 77-436,011. MCMONIGLE, JOHN, IRVINE, CA. FILED 3-31-2008.

**THE McMONIGLE GROUP—REAL
ESTATE'S BEST ADDRESS**

THE MARK CONSISTS OF STANDARD CHARACTERS WITHOUT CLAIM TO ANY PARTICULAR FONT, STYLE, SIZE, OR COLOR.

CLASS 35—ADVERTISING AND BUSINESS

FOR ON-LINE RETAIL STORE SERVICES FEATURING HOME FURNISHINGS AND DECOR, JEWELRY, CLOTHING (U.S. CLS. 100, 101 AND 102).

CLASS 36—INSURANCE AND FINANCIAL

FOR REAL ESTATE BROKERAGE; REAL ESTATE INVESTMENTS (U.S. CLS. 100, 101 AND 102).

JILL PRATER, EXAMINING ATTORNEY

SN 77-436,698. DIAL BRANDS, INC., SCOTTSDALE, AZ. FILED 4-1-2008.

ACSCENTS

THE MARK CONSISTS OF STANDARD CHARACTERS WITHOUT CLAIM TO ANY PARTICULAR FONT, STYLE, SIZE, OR COLOR.

CLASS 4—LUBRICANTS AND FUELS

FOR CANDLES (U.S. CLS. 1, 6 AND 15).

CLASS 5—PHARMACEUTICALS

FOR AIR FRESHENERS AND AIR FRESHENING PREPARATIONS; ODOR NEUTRALIZING PREPARATIONS FOR USE ON CARPETS, TEXTILES, UPHOLSTERY AND IN THE AIR; AIR DEODORIZER; HOUSEHOLD DEODORIZER (U.S. CLS. 6, 18, 44, 46, 51 AND 52).

KAREN SEVERSON, EXAMINING ATTORNEY

SN 77-437,264. CLAFFEY, DANIEL F., STEVENSON RANCH, CA. FILED 4-1-2008.

SN 77-437,619. BIO-LAB, INC., LAWRENCEVILLE, GA. FILED 4-2-2008.

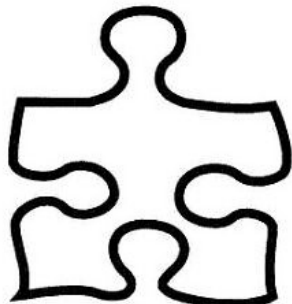

THE MARK CONSISTS OF AN OUTLINE OF A PUZZLE PIECE.

CLASS 16—PAPER GOODS AND PRINTED MATTER

FOR WRAPPING PAPER; FABRIC GIFT BAGS; PAPER GIFT BAGS; DECALS; IMPRESSION STAMPS; INK STAMPS; MARKING STAMPS; RUBBER STAMPS; STICKERS; TEMPORARY TATTOOS; ENVELOPES; STATIONERY; PAPER NAPKINS; PAPER TABLE CLOTHS; NOTE PADS; PLACE MATS OF PAPER (U.S. CLS. 2, 5, 22, 23, 29, 37, 38 AND 50).

CLASS 18—LEATHER GOODS

FOR BACKPACKS, BOOK BAGS, SPORTS BAGS, BUM BAGS, WALLETS AND HANDBAGS; ALL-PURPOSE CARRYING BAGS (U.S. CLS. 1, 2, 3, 22 AND 41).

CLASS 20—FURNITURE AND ARTICLES NOT OTHERWISE CLASSIFIED

FOR FURNITURE (U.S. CLS. 2, 13, 22, 25, 32 AND 50).

CLASS 21—HOUSEWARES AND GLASS

FOR MUGS; DRINKING GLASSES; HOUSEHOLD UTENSILS, NAMELY, POT AND PAN SCRAPERS, ROLLING PINS, SPATULAS, DINNERWARE, POTS, AND PANS; PAPER PLATES AND PAPER CUPS; TRIVETS (U.S. CLS. 2, 13, 23, 29, 30, 33, 40 AND 50).

CLASS 24—FABRICS

FOR BATH SHEETS; BED SHEETS; PILLOW CASES; TOWELS; TABLECLOTHS, NOT OF PAPER; PLASTIC PLACE MATS; TEXTILE PLACE MATS; VINYL PLACE MATS; POT HOLDERS; BATH TOWELS; BEACH TOWELS; HAND TOWELS; TEA TOWELS (U.S. CLS. 42 AND 50).

CLASS 27—FLOOR COVERINGS

FOR RUGS; CARPETS; LINOLEUM FOR USE ON FLOORS; FLOOR MATS; BEACH MATS; DOOR MATS; PET FEEDING MATS (U.S. CLS. 19, 20, 37, 42 AND 50).

CLASS 28—TOYS AND SPORTING GOODS

FOR PUZZLES; CHRISTMAS TREE ORNAMENTS AND DECORATIONS; BOARD GAMES; CRIB TOYS; BATH TOYS; MOLDED TOY FIGURES; PET TOYS; PLUSH TOYS (U.S. CLS. 22, 23, 38 AND 50).
KATINA MISTER, EXAMINING ATTORNEY

OPTIMUM

THE MARK CONSISTS OF STANDARD CHARACTERS WITHOUT CLAIM TO ANY PARTICULAR FONT, STYLE, SIZE, OR COLOR.

CLASS 1—CHEMICALS

FOR WATER TREATMENT CHEMICALS AND CHEMICAL BLENDS FOR USE IN SWIMMING POOLS AND SPAS, NAMELY SHOCK TREATMENT CHEMICALS, CHLORINE AND CHLORINE COMPOUNDS (U.S. CLS. 1, 5, 6, 10, 26 AND 46).

CLASS 5—PHARMACEUTICALS

FOR ALGAEICIDES FOR USE IN SWIMMING POOLS (U.S. CLS. 6, 18, 44, 46, 51 AND 52).

CLASS 11—ENVIRONMENTAL CONTROL APPARATUS

FOR FLOATING SWIMMING POOL CHEMICAL FEEDER AND STERILIZATION UNITS FOR RELEASING CHEMICALS INTO SWIMMING POOLS (U.S. CLS. 13, 21, 23, 31 AND 34).
RICHARD WHITE, EXAMINING ATTORNEY

SN 77-437,987. LINDEN RESEARCH, INC., SAN FRANCISCO, CA. FILED 4-2-2008.

YOUR WORLD, YOUR WAY.

THE MARK CONSISTS OF STANDARD CHARACTERS WITHOUT CLAIM TO ANY PARTICULAR FONT, STYLE, SIZE, OR COLOR.

CLASS 9—ELECTRICAL AND SCIENTIFIC APPARATUS

FOR COMPUTER SOFTWARE AND SOFTWARE DIGITAL PLATFORMS FOR USE IN ACCESSING AND BUILDING THREE DIMENSIONAL VIRTUAL ENVIRONMENTS (U.S. CLS. 21, 23, 26, 36 AND 38).

CLASS 42—SCIENTIFIC AND COMPUTER SERVICES

FOR PROVIDING ON-LINE NON-DOWNLOADABLE SOFTWARE AND SOFTWARE DIGITAL PLATFORMS FOR USE IN BUILDING THREE DIMENSIONAL VIRTUAL ENVIRONMENTS (U.S. CLS. 100 AND 101).
RON FAIRBANKS, EXAMINING ATTORNEY

SN 77-438,452. HY GORGEOUS, LLC, BLOOMFIELD, NJ.
FILED 4-2-2008.

SN 77-441,427. JOHNSON & JOHNSON, NEW BRUNSWICK,
NJ. FILED 4-7-2008.



THE STIPLING IS FOR SHADING PURPOSES ONLY.
THE MARK CONSISTS OF TWO HEARTS WITH TWO
STEMS AND A LEAF.

CLASS 3—COSMETICS AND CLEANING PREPARATIONS

FOR NAIL POLISH ; MAKE-UP (U.S. CLS. 1, 4, 6, 50, 51
AND 52).
FIRST USE 3-17-2007; IN COMMERCE 3-17-2007.

CLASS 18—LEATHER GOODS

FOR HANDBAGS (U.S. CLS. 1, 2, 3, 22 AND 41).
FIRST USE 3-17-2007; IN COMMERCE 3-17-2007.

CLASS 25—CLOTHING

FOR T-SHIRTS, DRESSES, PANTS, LINGERIE, SHOES,
SHIRTS (U.S. CLS. 22 AND 39).
FIRST USE 3-17-2007; IN COMMERCE 3-17-2007.
GISELLE AGOSTO, EXAMINING ATTORNEY

SN 77-439,484. MCMONIGLE, JOHN, IRVINE, CA. FILED 4-
3-2008.

McMonigleGroup.com - Real
Estate's Best Address

THE MARK CONSISTS OF STANDARD CHARACTERS
WITHOUT CLAIM TO ANY PARTICULAR FONT, STYLE,
SIZE, OR COLOR.

CLASS 35—ADVERTISING AND BUSINESS

FOR ON-LINE RETAIL STORE SERVICES FEATUR-
ING HOME FURNISHINGS AND DECOR, JEWELRY,
CLOTHING (U.S. CLS. 100, 101 AND 102).

CLASS 36—INSURANCE AND FINANCIAL

FOR REAL ESTATE BROKERAGE; REAL ESTATE
INVESTMENTS (U.S. CLS. 100, 101 AND 102).
JILL PRATER, EXAMINING ATTORNEY

HELPS BEAT THE BLUR

THE MARK CONSISTS OF STANDARD CHARACTERS
WITHOUT CLAIM TO ANY PARTICULAR FONT, STYLE,
SIZE, OR COLOR.

CLASS 9—ELECTRICAL AND SCIENTIFIC APPARATUS

FOR CONTACT LENSES (U.S. CLS. 21, 23, 26, 36 AND
38).

CLASS 44—MEDICAL, BEAUTY AND AGRICULTURAL SERVICES

FOR WEBSITE PROVIDING INFORMATION ON EYE
HEALTH AND CONTACT LENSES (U.S. CLS. 100 AND
101).
JERI J. FICKES, EXAMINING ATTORNEY

SN 77-441,819. CARDO MEDICAL LLC, LOS ANGELES, CA.
FILED 4-7-2008.

ALIGN 360

THE MARK CONSISTS OF STANDARD CHARACTERS
WITHOUT CLAIM TO ANY PARTICULAR FONT, STYLE,
SIZE, OR COLOR.

NO CLAIM IS MADE TO THE EXCLUSIVE RIGHT TO
USE "ALIGN", APART FROM THE MARK AS SHOWN.

CLASS 10—MEDICAL APPARATUS

FOR MEDICAL AND SURGICAL APPARATUS AND
INSTRUMENTS FOR KNEE SURGERY; KNEE SURGI-
CAL IMPLANTS COMPRISING ARTIFICIAL MATERIAL
AND ASSOCIATED SURGICAL INSTRUMENT SETS;
SURGICAL INSTRUMENTS FOR USE IN KNEE SUR-
GERY; MEDICAL INSTRUMENTS FOR USE IN KNEE
SURGERY; MEDICAL IMPLANTS OF ARTIFICIAL MA-
TERIAL IN PARTICULAR FOR ANCHORING KNEE
JOINT CAPSULE COMPONENTS AND KNEE LIGAM-
ENT TENDON STRUCTURES; ORTHOPEDIC KNEE
JOINT IMPLANTS (U.S. CLS. 26, 39 AND 44).

CLASS 44—MEDICAL, BEAUTY AND AGRICULTURAL SERVICES

FOR KNEE SURGERY (U.S. CLS. 100 AND 101).
JOHN SCHUYLER YARD, EXAMINING ATTORNEY

SN 77-445,104. CURTISS-WRIGHT FLOW CONTROL CORPORATION, FALLS CHURCH, VA. FILED 4-10-2008.

SN 77-446,112. KONAMI DIGITAL ENTERTAINMENT CO., LTD., TOKYO, JAPAN, FILED 4-11-2008.



Farris Authorized Service Team

NO CLAIM IS MADE TO THE EXCLUSIVE RIGHT TO USE "AUTHORIZED SERVICE TEAM", APART FROM THE MARK AS SHOWN.

THE MARK CONSISTS OF THE WORD "FAST", BEFORE WHICH IS AN INCOMPLETE CIRCLE EXTENDING TO THE LETTER "S" IN THE WORD "FAST"; THE WORD FAST CONTAINS LINES THAT DEPICT SPEED OR WIND; UNDERNEATH THE WORD "FAST" ARE THE WORDS "FARRIS AUTHORIZED SERVICE TEAM".

CLASS 9—ELECTRICAL AND SCIENTIFIC APPARATUS

FOR PRESSURE RELIEF VALVES FOR INDUSTRIAL APPLICATIONS (U.S. CLS. 21, 23, 26, 36 AND 38).
FIRST USE 6-0-2005; IN COMMERCE 6-0-2005.

CLASS 37—CONSTRUCTION AND REPAIR

FOR REPAIR AND MAINTENANCE OF PRESSURE RELIEF VALVES (U.S. CLS. 100, 103 AND 106).
FIRST USE 6-0-2005; IN COMMERCE 6-0-2005.
JORDAN BAKER, EXAMINING ATTORNEY

SN 77-445,227. REMA FOODS, INC., ENGLEWOOD CLIFFS, NJ. FILED 4-10-2008.

DUET

THE MARK CONSISTS OF STANDARD CHARACTERS WITHOUT CLAIM TO ANY PARTICULAR FONT, STYLE, SIZE, OR COLOR.

OWNER OF U.S. REG. NOS. 789,400, 1,653,812 AND OTHERS.

CLASS 8—HAND TOOLS

FOR PLASTIC TABLEWARE, NAMELY, PLASTIC KNIVES, PLASTIC FORKS AND PLASTIC SPOONS (U.S. CLS. 23, 28 AND 44).

CLASS 21—HOUSEWARES AND GLASS

FOR PAPER PLATES AND PAPER CUPS; RUBBER HOUSEHOLD GLOVES; HOUSEHOLD PLASTIC GLOVES; DISPOSABLE PLASTIC GLOVES FOR USE IN THE FOOD SERVICE INDUSTRY (U.S. CLS. 2, 13, 23, 29, 30, 33, 40 AND 50).

JAMES STEIN, EXAMINING ATTORNEY

Castlevania Judgment

THE MARK CONSISTS OF STANDARD CHARACTERS WITHOUT CLAIM TO ANY PARTICULAR FONT, STYLE, SIZE, OR COLOR.

OWNER OF U.S. REG. NOS. 1,478,852, 1,713,890 AND OTHERS.

CLASS 9—ELECTRICAL AND SCIENTIFIC APPARATUS

FOR VIDEO GAME SOFTWARE, VIDEO GAME PROGRAMS, COMPUTER GAME SOFTWARE, COMPUTER GAME PROGRAMS, ELECTRONIC GAME PROGRAMS (U.S. CLS. 21, 23, 26, 36 AND 38).

CLASS 41—EDUCATION AND ENTERTAINMENT

FOR ENTERTAINMENT SERVICES, NAMELY, PROVIDING ON-LINE VIDEO GAMES; PROVIDING INFORMATION TO GAME PLAYERS ABOUT THE RANKING OF THEIR SCORES OF GAMES (U.S. CLS. 100, 101 AND 107).

MICHAEL LITZAU, EXAMINING ATTORNEY

SN 77-447,336. JELD-WEN, INC., KLAMATH FALLS, OR. FILED 4-14-2008.



OWNER OF U.S. REG. NOS. 1,388,339, 3,072,535 AND OTHERS.

THE MARK CONSISTS OF THE WORD "JELD-WEN" IN A STYLIZED LARGER FONT ABOVE THE WORD "TRADITION" IN SMALLER FONT, BOTH WORDS UNDERNEATH THE DESIGN OF A WINDOW PANE. THE SHADED BORDER OF THE WINDOW PANE DESIGN CONTAINS A CURVED UPPER HALF AND BOTTOM HALF WITH STRAIGHT SIDES AND BOTTOM EDGE. THE UPPER BORDER OF THE WINDOW PANE BISECTS THE DESIGN OF A GOLF FLAG ATTACHED TO A GOLF COURSE FLAGSTICK. INSIDE THE WINDOW PANE IS THE DESIGN OF THE SAME GOLF FLAGSTICK IN A SHADED GOLF HOLE ON THE SHADED DESIGN OF A PUTTING GREEN. THE PUTTING SURFACE HAS A CURVED UPPER AND LEFT EDGE, AND BORDERS THE SHADED DESIGN OF A GOLF COURSE PLAYING SURFACE. ABOVE THIS PLAYING SURFACE IS A THINNER CURVED AREA REPRESENTING A GOLF COURSE BUNKER. ABOVE THE BUNKER DESIGN, THE UPPER HALF OF THE DESIGN INSIDE THE WINDOW PANE IS SHADED AND REPRESENTS THE SKY.

CLASS 25—CLOTHING

FOR CLOTHING, NAMELY, HATS, VISORS, SHIRTS AND JACKETS (U.S. CLS. 22 AND 39).

FIRST USE 5-31-2007; IN COMMERCE 5-31-2007.

CLASS 36—INSURANCE AND FINANCIAL

FOR CHARITABLE FUND RAISING SERVICES (U.S. CLS. 100, 101 AND 102).
FIRST USE 11-30-2006; IN COMMERCE 11-30-2006.

CLASS 41—EDUCATION AND ENTERTAINMENT

FOR ENTERTAINMENT SERVICES, NAMELY, ORGANIZING, PROMOTING AND CONDUCTING A GOLF TOURNAMENT (U.S. CLS. 100, 101 AND 107).
FIRST USE 11-30-2006; IN COMMERCE 11-30-2006.
CHRISTINE COOPER, EXAMINING ATTORNEY

CLASS 41—EDUCATION AND ENTERTAINMENT

FOR EDUCATIONAL SERVICES, NAMELY, CONDUCTING WORKSHOPS, SEMINARS, PROGRAMS AND CLASSES IN THE FIELDS OF HEALTH CARE AND WELLNESS FEATURING THE PROMOTION OF HEALTH AND WELLNESS THROUGH HEALTH EDUCATION AND PHYSICIAN INTERVENTION DIRECTED TO THE PREVENTION AND TREATMENT OF CHRONIC DISEASES AND CONDITIONS; CONDUCTING WELLNESS EDUCATIONAL PROGRAMS AND DISTRIBUTING PUBLICATIONS ASSOCIATED THEREWITH FOR NOT-FOR-PROFIT GROUPS AND CORPORATE BUSINESSES (U.S. CLS. 100, 101 AND 107).

CLASS 44—MEDICAL, BEAUTY AND AGRICULTURAL SERVICES

FOR HEALTHCARE SERVICES, NAMELY, PROVIDING MANAGED HEALTHCARE SERVICES, HEALTH SCREENING AND DIAGNOSTIC CARE, PROVIDING HEALTH ASSESSMENTS IN THE NATURE OF MEDICAL EVALUATIONS OF INDIVIDUALS, TESTING OF THE HEALTH STATUS OF INDIVIDUALS, NUTRITIONAL COUNSELING, AND MASSAGE THERAPY; AND PROVIDING SELF-SCORING WELLNESS, BLOOD PRESSURE, BODY MASS INDEX, BODY FAT COMPOSITION, AND GRIP STRENGTH ASSESSMENTS, ALL FOR HEALTH CARE AND WELLNESS PURPOSES (U.S. CLS. 100 AND 101).

JUDITH HELFMAN, EXAMINING ATTORNEY

SN 77-447,670. COYOTE LOGISTICS, LLC, LAKE FOREST, IL. FILED 4-14-2008.

EXPERIENCE DRIVEN INNOVATION

THE MARK CONSISTS OF STANDARD CHARACTERS WITHOUT CLAIM TO ANY PARTICULAR FONT, STYLE, SIZE, OR COLOR.

CLASS 35—ADVERTISING AND BUSINESS

FOR TRANSPORTATION LOGISTIC SERVICES, NAMELY, ARRANGING FOR THE TRANSPORTATION OF GOODS FOR OTHERS (U.S. CLS. 100, 101 AND 102).
FIRST USE 11-0-2004; IN COMMERCE 11-0-2004.

CLASS 39—TRANSPORTATION AND STORAGE

FOR FREIGHT FORWARDING, BROKERING AND LOGISTIC SERVICES RELATING TO THE TRANSPORTATION OF FREIGHT AND PROPERTY BY LAND, SEA, AIR OR RAIL; DELIVERY OF GOODS BY TRUCK (U.S. CLS. 100 AND 105).
FIRST USE 11-0-2004; IN COMMERCE 11-0-2004.
KAREN BRACEY, EXAMINING ATTORNEY

SN 77-451,148. HARD ROCK CAFE INTERNATIONAL (USA), INC., ORLANDO, FL. FILED 4-17-2008.

MARCH ON STAGE

THE MARK CONSISTS OF STANDARD CHARACTERS WITHOUT CLAIM TO ANY PARTICULAR FONT, STYLE, SIZE, OR COLOR.

CLASS 36—INSURANCE AND FINANCIAL

FOR CHARITABLE FUND RAISING SERVICES, NAMELY, PRESENTATION OF LIVE MUSIC CONCERTS WITH PROCEEDS BENEFITING MUSIC-RELATED CHARITIES (U.S. CLS. 100, 101 AND 102).
FIRST USE 3-1-2007; IN COMMERCE 3-1-2007.

SN 77-449,864. CLEVELAND CLINIC FOUNDATION, CLEVELAND, OH. FILED 4-16-2008.

LEVEL

THE MARK CONSISTS OF STANDARD CHARACTERS WITHOUT CLAIM TO ANY PARTICULAR FONT, STYLE, SIZE, OR COLOR.

CLASS 36—INSURANCE AND FINANCIAL

FOR ADMINISTRATION OF HEALTH AND EMPLOYEE BENEFIT PROVIDER PLANS IN THE FIELDS OF INTEGRATIVE, COMPLEMENTARY AND ALTERNATIVE MEDICINE, HEALTH, DIET AND NUTRITION, WEIGHT LOSS, SMOKING CESSATION, WELLNESS, AND FITNESS (U.S. CLS. 100, 101 AND 102).

CLASS 41—EDUCATION AND ENTERTAINMENT

FOR ENTERTAINMENT SERVICES, NAMELY, PRESENTATION OF LIVE MUSIC CONCERTS (U.S. CLS. 100, 101 AND 107).
FIRST USE 3-1-2007; IN COMMERCE 3-1-2007.
JIM RINGLE, EXAMINING ATTORNEY

SN 77-451,310. HARD ROCK CAFE INTERNATIONAL (USA), INC., ORLANDO, FL. FILED 4-17-2008.

SN 77-453,091. ISAGENIX WORLDWIDE, LLC, CHANDLER, AZ. FILED 4-21-2008.

CATHEDRAL OF ROCK

THE MARK CONSISTS OF STANDARD CHARACTERS WITHOUT CLAIM TO ANY PARTICULAR FONT, STYLE, SIZE, OR COLOR.

NO CLAIM IS MADE TO THE EXCLUSIVE RIGHT TO USE "ROCK", APART FROM THE MARK AS SHOWN.

CLASS 35—ADVERTISING AND BUSINESS

FOR RETAIL STORE SERVICES FEATURING SOUVENIR MERCHANDISE FROM APPLICANT'S RESTAURANTS, HOTELS AND CASINOS (U.S. CLS. 100, 101 AND 102).

CLASS 41—EDUCATION AND ENTERTAINMENT

FOR ENTERTAINMENT SERVICES, NAMELY, PRESENTATION OF MUSICAL PERFORMANCE AND LIVE MUSIC CONCERTS (U.S. CLS. 100, 101 AND 107).

CLASS 43—HOTEL AND RESTAURANT SERVICES

FOR HOTEL, BAR AND RESTAURANT SERVICES (U.S. CLS. 100 AND 101).
JIM RINGLE, EXAMINING ATTORNEY

SN 77-452,683. ISAGENIX WORLDWIDE, LLC, CHANDLER, AZ. FILED 4-18-2008.

HAPPY CHOCOLATES THAT SATISFY

THE MARK CONSISTS OF STANDARD CHARACTERS WITHOUT CLAIM TO ANY PARTICULAR FONT, STYLE, SIZE, OR COLOR.

CLASS 5—PHARMACEUTICALS

FOR NUTRITIONAL AND DIETARY SUPPLEMENTS (U.S. CLS. 6, 18, 44, 46, 51 AND 52).
FIRST USE 1-18-2008; IN COMMERCE 1-18-2008.

CLASS 30—STAPLE FOODS

FOR CHOCOLATES FORTIFIED WITH VITAMINS, MINERALS, AND TRACE ELEMENTS (U.S. CL. 46).
FIRST USE 1-18-2008; IN COMMERCE 1-18-2008.
ALICE SUE CARRUTHERS, EXAMINING ATTORNEY

ISADELIGHT

THE MARK CONSISTS OF STANDARD CHARACTERS WITHOUT CLAIM TO ANY PARTICULAR FONT, STYLE, SIZE, OR COLOR.

OWNER OF U.S. REG. NOS. 2,198,293, 3,339,556 AND OTHERS.

CLASS 5—PHARMACEUTICALS

FOR NUTRITIONAL AND DIETARY SUPPLEMENTS (U.S. CLS. 6, 18, 44, 46, 51 AND 52).
FIRST USE 1-18-2008; IN COMMERCE 1-18-2008.

CLASS 30—STAPLE FOODS

FOR CHOCOLATES (U.S. CL. 46).
FIRST USE 1-18-2008; IN COMMERCE 1-18-2008.
ALICE SUE CARRUTHERS, EXAMINING ATTORNEY

SN 77-454,088. EXARI SYSTEMS, INC., DBA SPEEDLEGAL, INC., BOSTON, MA. FILED 4-21-2008.

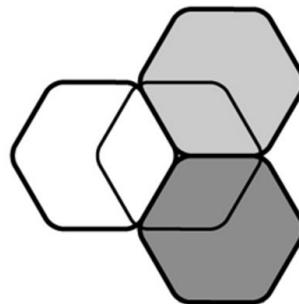

THE MARK CONSISTS OF HONEYCOMB OF 4 OVERLAPPING HEXAGONS WITH SHADING OF DIFFERENT DEPTHS IN TWO OF THE HEXAGONS.

CLASS 9—ELECTRICAL AND SCIENTIFIC APPARATUS

FOR COMPUTER SOFTWARE FOR CONTRACT LIFE-CYCLE MANAGEMENT AND DOCUMENT ASSEMBLY; COMPUTER PROGRAMMES FOR DOCUMENT MANAGEMENT; COMPUTER SOFTWARE FOR THE COLLECTION, EDITING, ORGANIZING, MODIFYING, BOOK MARKING, TRANSMISSION, STORAGE AND SHARING OF DATA AND INFORMATION; COMPUTER SOFTWARE THAT PROVIDES REAL-TIME, INTEGRATED BUSINESS MANAGEMENT INTELLIGENCE BY COMBINING INFORMATION FROM VARIOUS DATABASES AND PRESENTING IT IN AN EASY-TO-UNDERSTAND USER INTERFACE; DATA AND WORD PROCESSORS; COMPUTER SOFTWARE FOR CREATING SEARCHABLE DATABASES OF INFORMATION AND DATA (U.S. CLS. 21, 23, 26, 36 AND 38).
FIRST USE 9-6-2005; IN COMMERCE 9-6-2005.

CLASS 38—COMMUNICATION

FOR COMMUNICATION SERVICES, NAMELY, ELECTRONIC TRANSMISSION OF DATA AND DOCUMENTS AMONG USERS OF COMPUTERS; ELECTRONIC DELIVERY OF LOAN DOCUMENTS; ELECTRONIC TRANSMISSION OF DATA AND DOCUMENTS VIA COMPUTER TERMINALS; ELECTRONIC TRANSMISSION OF MESSAGES AND DATA; ON-LINE DOCUMENT DELIVERY VIA A GLOBAL COMPUTER NETWORK; PROVISION OF ACCESS TO A GLOBAL COMPUTER NETWORK; PROVISION OF ACCESS TO DATA OR DOCUMENTS STORED ELECTRONICALLY IN CENTRAL FILES FOR REMOTE CONSULTATION; PROVISION OF ACCESS TO ELECTRONIC SITES (U.S. CLS. 100, 101 AND 104).

FIRST USE 9-6-2005; IN COMMERCE 9-6-2005.

CLASS 42—SCIENTIFIC AND COMPUTER SERVICES

FOR APPLICATION SERVICE PROVIDER (ASP) FEATURING SOFTWARE FOR USE IN DOCUMENT ASSEMBLY AND LIFECYCLE CONTRACT MANAGEMENT; PROVIDING ON-LINE NON-DOWNLOADABLE SOFTWARE FOR USE IN DOCUMENT ASSEMBLY AND CONTRACT LIFECYCLE MANAGEMENT; COMPUTER HARDWARE AND SOFTWARE CONSULTING SERVICES; COMPUTER SOFTWARE CONSULTANCY; COMPUTER PROGRAMMING SERVICES; PROVIDING COMPUTER PROGRAMMING SERVICES TO CUSTOMERS THAT ENABLES THE CUSTOMER'S WEB-SITE TO PROCESS NATURAL LANGUAGE QUERIES; COMPUTER PROGRAMMING AND COMPUTER SYSTEM ANALYSIS; COMPUTER PROGRAMMING AND MAINTENANCE OF COMPUTER PROGRAMS; COMPUTER PROGRAMMING AND SOFTWARE DESIGN; COMPUTER PROJECT MANAGEMENT SERVICES; TECHNICAL SUPPORT SERVICES, NAMELY, TROUBLESHOOTING OF COMPUTER HARDWARE AND SOFTWARE PROBLEMS; TECHNICAL SUPPORT SERVICES, NAMELY, TROUBLESHOOTING OF COMPUTER SOFTWARE PROBLEMS; TECHNICAL SUPPORT SERVICES, NAMELY, TROUBLESHOOTING OF INDUSTRIAL PROCESS CONTROL COMPUTER SOFTWARE PROBLEMS; UP-DATING OF COMPUTER SOFTWARE; UP-DATING AND DESIGN OF COMPUTER SOFTWARE; DEVELOPMENT, UP-DATING AND MAINTENANCE OF SOFTWARE AND DATA BASES; UP-DATING AND MAINTENANCE OF COMPUTER SOFTWARE; DESIGN, MAINTENANCE, DEVELOPMENT AND UP-DATING OF COMPUTER SOFTWARE; DEVELOPING AND UP-DATING COMPUTER SOFTWARE; DEVELOPING COMPUTER SOFTWARE; COMPUTER SOFTWARE INSTALLATION AND MAINTENANCE; INSTALLATION AND MAINTENANCE OF COMPUTER SOFTWARE; INSTALLATION, MAINTENANCE AND REPAIR OF COMPUTER SOFTWARE; INSTALLATION, REPAIR AND MAINTENANCE OF COMPUTER SOFTWARE; MAINTENANCE AND UP-DATING OF COMPUTER SOFTWARE; MAINTENANCE AND UP-DATING OF COMPUTER SOFTWARE; MAINTENANCE AND UP-DATING OF COMPUTER SOFTWARE; DESIGN AND MAINTENANCE OF COMPUTER SITES FOR THIRD PARTIES; MAINTENANCE OF COMPUTER SOFTWARE; COMPUTER SOFTWARE DESIGN; COMPUTER SOFTWARE DEVELOPMENT; DESIGN AND DEVELOPMENT OF ON-LINE COMPUTER SOFTWARE SYSTEMS; DESIGN OF HOME PAGES; DESIGN OF HOME PAGES AND WEB SITES; DESIGN OF HOME PAGES, COMPUTER SOFTWARE AND WEB SITES; COMPUTER SERVICE, NAMELY, ACTING AS AN APPLICATION SERVICE PROVIDER IN THE FIELD OF KNOWLEDGE MANAGEMENT TO HOST COMPUTER APPLICATION SOFTWARE FOR CREATING SEARCHABLE DATABASES OF INFORMATION AND DATA; CONVERSION OF DATA OR DOCUMENTS FROM PHYSICAL TO ELECTRONIC MEDIA; DOCUMENT DATA TRANSFER FROM ONE COMPUTER FORMAT TO ANOTHER; APPLICATION SERVICE PROVIDER FEATURING SOFTWARE FOR PROVIDING AN ON-LINE DATABASE IN THE FIELD OF TRANSACTION PROCESSING TO UPLOAD TRANSACTIONAL DATA, PROVIDE STATISTICAL ANALYSIS, AND PRODUCE NOTIFICATIONS AND REPORTS; COMPUTER SERVICE, NAMELY, ACTING AS AN APPLICATION SERVICE PROVIDER IN THE FIELD OF KNOWLEDGE

MANAGEMENT TO HOST COMPUTER APPLICATION SOFTWARE FOR SEARCHING AND RETRIEVING INFORMATION FROM DATABASES AND COMPUTER NETWORKS; COMPUTER SERVICE, NAMELY, ACTING AS AN APPLICATION SERVICE PROVIDER IN THE FIELD OF KNOWLEDGE MANAGEMENT TO HOST COMPUTER APPLICATION SOFTWARE FOR THE COLLECTION, EDITING, ORGANIZING, MODIFYING, BOOK MARKING, TRANSMISSION, STORAGE AND SHARING OF DATA AND INFORMATION; COMPUTER SERVICES, NAMELY, INTERACTIVE HOSTING SERVICES WHICH ALLOW THE USER TO PUBLISH AND SHARE THEIR OWN CONTENT AND IMAGES ONLINE (U.S. CLS. 100 AND 101).

FIRST USE 9-6-2005; IN COMMERCE 9-6-2005.
KAREN BRACEY, EXAMINING ATTORNEY

SN 77-457,090. OTG MANAGEMENT, INC., PHILADELPHIA, PA. FILED 4-24-2008.



OWNER OF U.S. REG. NO. 2,908,809.

NO CLAIM IS MADE TO THE EXCLUSIVE RIGHT TO USE "INTERACTIVE", APART FROM THE MARK AS SHOWN.

THE COLOR(S) ORANGE IS/ARE CLAIMED AS A FEATURE OF THE MARK.

THE MARK CONSISTS OF THE LETTERS "OTG" WITH THE WORD INTERACTIVE BELOW IT.

CLASS 35—ADVERTISING AND BUSINESS

FOR MANAGEMENT AND OPERATION OF RETAIL STORES AND KIOSKS FOR OTHERS FEATURING COMPUTERS AND INFORMATION TECHNOLOGY EQUIPMENT AT AIRPORTS (U.S. CLS. 100, 101 AND 102).

CLASS 42—SCIENTIFIC AND COMPUTER SERVICES

FOR INFORMATION TECHNOLOGY CONSULTING SERVICES; COMPUTER SERVICES, NAMELY, REMOTE AND ON-SITE MANAGEMENT OF COMPUTER AND INFORMATION TECHNOLOGY APPLICATIONS FOR OTHERS (U.S. CLS. 100 AND 101).

DARRYL SPRUILL, EXAMINING ATTORNEY

SN 77-458,331. AGC, LLC, CLEVELAND, OH. FILED 4-25-2008.

CUPID'S CROSSING

THE MARK CONSISTS OF STANDARD CHARACTERS WITHOUT CLAIM TO ANY PARTICULAR FONT, STYLE, SIZE, OR COLOR.

OWNER OF U.S. REG. NO. 2,592,902.

CLASS 16—PAPER GOODS AND PRINTED MATTER

FOR PAPER GIFT BAGS; GIFT WRAP PAPER; STICKERS (U.S. CLS. 2, 5, 22, 23, 29, 37, 38 AND 50).

CLASS 26—FANCY GOODS

FOR BOWS FOR GIFT WRAPPING (U.S. CLS. 37, 39, 40, 42 AND 50).
JUDITH HELFMAN, EXAMINING ATTORNEY

SN 77-462,821. PSS WORLD MEDICAL, INC., JACKSONVILLE, FL. FILED 5-1-2008.



LUMEON

THE MARK CONSISTS OF "LUMEON" WITH A STYLIZED LETTER "O".

CLASS 9—ELECTRICAL AND SCIENTIFIC APPARATUS

FOR MICROSCOPES (U.S. CLS. 21, 23, 26, 36 AND 38).

CLASS 10—MEDICAL APPARATUS

FOR MEDICAL DEVICES, NAMELY, VITAL SIGNS MONITORS AND COLPOSCOPES (U.S. CLS. 26, 39 AND 44).
HAI-LY LAM, EXAMINING ATTORNEY

SN 77-463,501. THE QUADRANT CORPORATION, BELLEVUE, WA. FILED 5-1-2008.



THE MARK CONSISTS OF THE WORDS "AUTUMN WOODS" IN WHITE LETTERING TO THE RIGHT OF A STYLIZED IMAGE OF ACORNS ON A BLACK RECTANGULAR BACKGROUND.

CLASS 36—INSURANCE AND FINANCIAL

FOR REAL ESTATE BROKERAGE (U.S. CLS. 100, 101 AND 102).
FIRST USE 12-1-2006; IN COMMERCE 12-1-2006.

CLASS 37—CONSTRUCTION AND REPAIR

FOR BUILDING CONSTRUCTION SERVICES; REAL ESTATE DEVELOPMENT (U.S. CLS. 100, 103 AND 106).
FIRST USE 12-1-2006; IN COMMERCE 12-1-2006.
PETER B. BROMAGHIM, EXAMINING ATTORNEY

SN 77-465,529. FERNDALE IP, INC., FERNDALE, MI. FILED 5-5-2008.

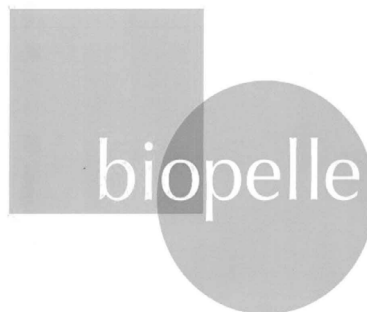

OWNER OF U.S. REG. NO. 3,218,885.
THE MARK CONSISTS OF AN OVERLAPPING BOX AND CIRCLE BEHIND THE WORD "BIOPELLE" IN STYLIZED LETTERS.

CLASS 3—COSMETICS AND CLEANING PREPARATIONS

FOR COSMETICS, BEAUTY AIDS, NAMELY, BEAUTY CARE PREPARATIONS, NON-MEDICATED SKIN CARE PREPARATIONS, SKIN CREAMS, SKIN CLARIFIERS, NAMELY, CLARIFYING GELS, FACIAL PEELS (U.S. CLS. 1, 4, 6, 50, 51 AND 52).
FIRST USE 12-8-2005; IN COMMERCE 12-8-2005.

CLASS 5—PHARMACEUTICALS

FOR MEDICATED SKIN CARE PREPARATIONS, SKIN CREAMS, TOPICAL ANESTHETICS (U.S. CLS. 6, 18, 44, 46, 51 AND 52).
FIRST USE 12-8-2005; IN COMMERCE 12-8-2005.
NANCY CLARKE, EXAMINING ATTORNEY

SN 77-466,895. AMERICAN CHEMICAL SOCIETY, DBA ACS, WASHINGTON, DC. FILED 5-6-2008.

CHEMISTRY FOR YOUR LIFE

THE MARK CONSISTS OF STANDARD CHARACTERS WITHOUT CLAIM TO ANY PARTICULAR FONT, STYLE, SIZE, OR COLOR.

NO CLAIM IS MADE TO THE EXCLUSIVE RIGHT TO USE "CHEMISTRY", APART FROM THE MARK AS SHOWN.

CLASS 16—PAPER GOODS AND PRINTED MATTER

FOR PRINTED MATERIALS AND PUBLICATIONS, NAMELY, SCIENTIFIC JOURNALS AND PERIODICALS, PAMPHLETS, MANUALS, BOOKS, CATALOGS, AND NEWSLETTERS IN THE FIELD OF CHEMISTRY; LETTERHEAD PAPER (U.S. CLS. 2, 5, 22, 23, 29, 37, 38 AND 50).

CLASS 41—EDUCATION AND ENTERTAINMENT

FOR PUBLICATION OF JOURNALS, PERIODICALS, BROCHURES, PAMPHLETS, MANUALS, BOOKS, CATALOGS, AND NEWSLETTERS IN THE FIELD OF CHEMISTRY; EDUCATIONAL SERVICES, NAMELY, CONDUCTING SEMINARS AND WORKSHOPS IN THE FIELD OF CHEMISTRY (U.S. CLS. 100, 101 AND 107).
MONIQUE MILLER, EXAMINING ATTORNEY

CLASS 44—MEDICAL, BEAUTY AND AGRICULTURAL SERVICES

FOR MANAGED HEALTH CARE SERVICES; MANAGED DENTAL CARE SERVICES; HEALTH CARE IN THE NATURE OF HEALTH MAINTENANCE ORGANIZATIONS (HMOS), PREFERRED PROVIDER ORGANIZATIONS (PPOS), AND CONSUMER DIRECTED HEALTH PLANS (U.S. CLS. 100 AND 101).
JUDITH HELFMAN, EXAMINING ATTORNEY

SN 77-467,217. SHOPKO STORES OPERATING CO., LLC, GREEN BAY, WI. FILED 5-6-2008.



THE MARK CONSISTS OF STYLIZED LETTERS "EZ".

CLASS 18—LEATHER GOODS

FOR (BASED ON USE IN COMMERCE) ALL PURPOSE SPORT BAGS(BASED ON INTENT TO USE) BACK PACKS (U.S. CLS. 1, 2, 3, 22 AND 41).
FIRST USE 2-13-2008; IN COMMERCE 2-13-2008.

CLASS 25—CLOTHING

FOR TANK-TOPS; JACKETS; SPORTS BRAS; CAPRIS; SHORTS; PANTS; SHIRTS; GLOVES; HATS; SWIMWEAR; FLIP FLOPS; BASEBALL CAPS (U.S. CLS. 22 AND 39).
DAWN HAN, EXAMINING ATTORNEY

SN 77-467,274. UNITEDHEALTH GROUP INCORPORATED, MINNETONKA, MN. FILED 5-6-2008.

CHOICES YOU WANT. COVERAGE
YOU NEED.

THE MARK CONSISTS OF STANDARD CHARACTERS WITHOUT CLAIM TO ANY PARTICULAR FONT, STYLE, SIZE, OR COLOR.

CLASS 36—INSURANCE AND FINANCIAL

FOR INSURANCE SERVICES, NAMELY, ORGANIZING, ADMINISTERING, AND UNDERWRITING INSURANCE PLANS AND PROGRAMS IN THE FIELDS OF HEALTH, DENTAL AND LIFE INSURANCE; ORGANIZATION AND ADMINISTRATION OF PREPAID HEALTH CARE PLANS AND PREPAID DENTAL CARE PLANS; ORGANIZATION AND ADMINISTRATION OF HEALTH CARE BENEFIT PLANS AND DENTAL CARE BENEFIT PLANS; INSURANCE UNDERWRITING IN THE FIELDS OF HEALTH, DENTAL AND LIFE INSURANCE (U.S. CLS. 100, 101 AND 102).

SN 77-469,827. AUDIGIER, CHRISTIAN GEORGES, CULVER CITY, CA. FILED 5-8-2008.



THE MARK CONSISTS OF THE LETTERS "C" AND "A" WITH A PEACE SYMBOL CONTAINED WITHIN THE LETTER "C" AND A HORIZONTAL BAR TO THE RIGHT OF THE "C".

CLASS 3—COSMETICS AND CLEANING PREPARATIONS

FOR BATH FOAMS; BATH OILS; BODY CREAM; PERFUME; COLOGNE; EAU DE PARFUM; EAU DE TOILETTE; ESSENTIAL OILS FOR PERSONAL USE; SKIN MOISTURIZER; HAIR SHAMPOO; SOAPS (U.S. CLS. 1, 4, 6, 50, 51 AND 52).

CLASS 9—ELECTRICAL AND SCIENTIFIC APPARATUS

FOR SUNGLASSES; EYEGLASSES; EYEGLASS FRAMES; EYEGLASS CASES; GOGGLES FOR SPORTS (U.S. CLS. 21, 23, 26, 36 AND 38).

CLASS 18—LEATHER GOODS

FOR HANDBAGS; TOTE BAGS; CLUTCH BAGS; LUGGAGE; TRAVELING BAGS; WALLET; PURSES; COIN PURSES; KEY CASES; CREDIT CARD CASES; BUSINESS CARD CASES (U.S. CLS. 1, 2, 3, 22 AND 41).

CLASS 25—CLOTHING

FOR CLOTHING, NAMELY, SHORTS, DRESSES, JUMPERS, SHIRTS, BLOUSES, JACKETS, COATS, T-SHIRTS, PANTS, JEANS, SWEAT PANTS, SWEAT SHORTS, SWEAT JACKETS, HOODED SWEAT SHIRTS, UNDERWEAR, SLEEPWEAR, LOUNGEWEAR, SWIM WEAR, OVERALLS, COVERALLS, SKIWEAR, VESTS, SWEATERS, LEGGINGS, NECKWEAR, BELTS, SUSPENDERS, CLOTH BIBS, SOCKS, WRISTBANDS; FOOTWEAR; HEADWEAR (U.S. CLS. 22 AND 39).

CLASS 26—FANCY GOODS

FOR BELT BUCKLES (U.S. CLS. 37, 39, 40, 42 AND 50).
TEJBIR SINGH, EXAMINING ATTORNEY

SN 77-469,835. AUDIGIER, CHRISTIAN GEORGES, CULVER CITY, CA. FILED 5-8-2008.

SN 77-471,103. SBE ENTERTAINMENT GROUP, LOS ANGELES, CA. FILED 5-9-2008.



OWNER OF U.S. REG. NO. 3,348,997.
THE NAME "CHRISTIAN GEORGES AUDIGIER" IDENTIFIES A LIVING INDIVIDUAL WHOSE CONSENT IS OF RECORD.

THE MARK CONSISTS OF THE WORDS "C BAR A LOVESTOCK RANCH BY CHRISTIAN AUDIGIER" ON A BACKGROUND OF STARS AND VERTICAL RADIATING LINES.

CLASS 3—COSMETICS AND CLEANING PREPARATIONS

FOR BATH FOAMS; BATH OILS; BODY CREAM; PERFUME; COLOGNE; EAU DE PARFUM; EAU DE TOILETTE; ESSENTIAL OILS FOR PERSONAL USE; SKIN MOISTURIZER; HAIR SHAMPOO; SOAPS (U.S. CLS. 1, 4, 6, 50, 51 AND 52).

CLASS 9—ELECTRICAL AND SCIENTIFIC APPARATUS

FOR SUNGLASSES; EYEGLASSES; EYEGLASS FRAMES; EYEGLASS CASES; GOGGLES FOR SPORTS (U.S. CLS. 21, 23, 26, 36 AND 38).

CLASS 18—LEATHER GOODS

FOR HANDBAGS; TOTE BAGS; CLUTCH BAGS; LUGGAGE; TRAVELING BAGS; WALLETS; PURSES; COIN PURSES; KEY CASES; CREDIT CARD CASES; BUSINESS CARD CASES (U.S. CLS. 1, 2, 3, 22 AND 41).

CLASS 25—CLOTHING

FOR CLOTHING, NAMELY, SHORTS, DRESSES, JUMPERS, SHIRTS, BLOUSES, JACKETS, COATS, T-SHIRTS, PANTS, JEANS, SWEAT PANTS, SWEAT SHORTS, SWEAT JACKETS, HOODED SWEAT SHIRTS, UNDERWEAR, SLEEPWEAR, LOUNGEWEAR, SWIM WEAR, OVERALLS, COVERALLS, SKIWEAR, VESTS, SWEATERS, LEGGINGS, NECKWEAR, BELTS, SUSPENDERS, CLOTH BIBS, SOCKS, WRISTBANDS; FOOTWEAR; HEADWEAR (U.S. CLS. 22 AND 39).

CLASS 26—FANCY GOODS

FOR BELT BUCKLES (U.S. CLS. 37, 39, 40, 42 AND 50).
TEJBIR SINGH, EXAMINING ATTORNEY

ALTITUDE

THE MARK CONSISTS OF STANDARD CHARACTERS WITHOUT CLAIM TO ANY PARTICULAR FONT, STYLE, SIZE, OR COLOR.

CLASS 41—EDUCATION AND ENTERTAINMENT

FOR PROVIDING RECREATIONAL SERVICES IN THE NATURE OF POOLS, PROVIDING SWIMMING POOLS, PROVIDING SWIMMING POOLS AT A HOTEL, PROVIDING PERSONAL TRAINING, NAMELY, STRENGTH AND CONDITIONING TRAINING AND PROVIDING EXERCISE FACILITIES (U.S. CLS. 100, 101 AND 107).

CLASS 44—MEDICAL, BEAUTY AND AGRICULTURAL SERVICES

FOR MASSAGE (U.S. CLS. 100 AND 101).
BARBARA BROWN, EXAMINING ATTORNEY

SN 77-471,105. SBE ENTERTAINMENT GROUP, LOS ANGELES, CA. FILED 5-10-2008.

ALTITUDE AT SLS

THE MARK CONSISTS OF STANDARD CHARACTERS WITHOUT CLAIM TO ANY PARTICULAR FONT, STYLE, SIZE, OR COLOR.

CLASS 41—EDUCATION AND ENTERTAINMENT

FOR PROVIDING RECREATIONAL SERVICES IN THE NATURE OF POOLS, PROVIDING SWIMMING POOLS, PROVIDING SWIMMING POOLS AT A HOTEL, PROVIDING PERSONAL TRAINING, NAMELY, STRENGTH AND CONDITIONING TRAINING AND PROVIDING EXERCISE FACILITIES (U.S. CLS. 100, 101 AND 107).

CLASS 44—MEDICAL, BEAUTY AND AGRICULTURAL SERVICES

FOR MASSAGE (U.S. CLS. 100 AND 101).
BARBARA BROWN, EXAMINING ATTORNEY

SN 77-472,187. CGG, L.L.C., WILMINGTON, DE. FILED 5-12-2008.

P AND Q

THE MARK CONSISTS OF STANDARD CHARACTERS WITHOUT CLAIM TO ANY PARTICULAR FONT, STYLE, SIZE, OR COLOR.

CLASS 35—ADVERTISING AND BUSINESS

FOR HOTEL MANAGEMENT FOR OTHERS; BUSINESS MANAGEMENT AND CONSULTATION IN THE HOTEL INDUSTRY (U.S. CLS. 100, 101 AND 102).

CLASS 36—INSURANCE AND FINANCIAL

FOR LEASING, RENTAL, AND MANAGEMENT OF CONDOMINIUMS, APARTMENTS, VILLAS AND RESIDENTIAL HOMES; LEASING, RENTAL, AND MANAGEMENT OF CONDOMINIUMS, APARTMENTS, VILLAS AND RESIDENTIAL HOMES IN VACATION AND RESORT COMMUNITIES; REAL ESTATE BROKERAGE SERVICES (U.S. CLS. 100, 101 AND 102).

CLASS 37—CONSTRUCTION AND REPAIR

FOR HOTEL DEVELOPMENT FOR OTHERS (U.S. CLS. 100, 103 AND 106).

CLASS 43—HOTEL AND RESTAURANT SERVICES

FOR HOTELS; CONDOMINIUM HOTELS; HOTEL SERVICES; RESORT HOTEL SERVICES; SPA SERVICES, NAMELY, PROVIDING TEMPORARY ACCOMMODATIONS AND MEALS TO CLIENTS OF A HEALTH OR BEAUTY SPA; RESTAURANTS; BAR SERVICES; RESTAURANT AND BAR SERVICES (U.S. CLS. 100 AND 101).

H. M. FISHER, EXAMINING ATTORNEY

SN 77-473,146. CALIFORNIA ACADEMY OF SCIENCES, SAN FRANCISCO, CA. FILED 5-13-2008.

WHERE LIFE COMES TO LIFE

THE MARK CONSISTS OF STANDARD CHARACTERS WITHOUT CLAIM TO ANY PARTICULAR FONT, STYLE, SIZE, OR COLOR.

CLASS 16—PAPER GOODS AND PRINTED MATTER

FOR MAGAZINE IN THE FIELD OF NATURAL SCIENCES (U.S. CLS. 2, 5, 22, 23, 29, 37, 38 AND 50).

CLASS 41—EDUCATION AND ENTERTAINMENT

FOR MUSEUMS; EDUCATIONAL AND ENTERTAINMENT SERVICES, NAMELY, PROVIDING AQUARIUM FACILITIES TO THE PUBLIC; PLANETARIUM SERVICES (U.S. CLS. 100, 101 AND 107).
SETH A. RAPPAPORT, EXAMINING ATTORNEY

SN 77-474,455. THE COCA-COLA COMPANY, ATLANTA, GA. FILED 5-14-2008.



THE MARK CONSISTS OF TWO ARROWS FORMING THE SHAPE OF A MAN WITH A SEMI-CIRCLE.

CLASS 32—LIGHT BEVERAGES

FOR NON-ALCOHOLIC BEVERAGES, NAMELY, DRINKING WATERS, FLAVORED WATERS, SOFT DRINKS, ENERGY DRINKS, SPORTS DRINKS, FRUIT DRINKS AND FRUIT JUICES (U.S. CLS. 45, 46 AND 48).

CLASS 35—ADVERTISING AND BUSINESS

FOR PUBLIC ADVOCACY TO PROMOTE AWARENESS OF COMMUNITY, ENVIRONMENTAL AND HEALTH AND WELLNESS ISSUES (U.S. CLS. 100, 101 AND 102).

CLASS 41—EDUCATION AND ENTERTAINMENT

FOR EDUCATIONAL SERVICES, NAMELY, PROVIDING SEMINARS, WORKSHOPS, AND LECTURES IN THE FIELD OF ENVIRONMENTAL AND WELLNESS ISSUES (U.S. CLS. 100, 101 AND 107).
LANA PHAM, EXAMINING ATTORNEY

SN 77-474,503. THE COCA-COLA COMPANY, ATLANTA, GA. FILED 5-14-2008.



THE MARK CONSISTS OF TWO ARROWS FORMING THE SHAPE OF HEARTS SIDE-BY-SIDE.

CLASS 32—LIGHT BEVERAGES

FOR NON-ALCOHOLIC BEVERAGES, NAMELY, DRINKING WATERS, FLAVORED WATERS, SOFT DRINKS, ENERGY DRINKS, SPORTS DRINKS, FRUIT DRINKS AND FRUIT JUICES (U.S. CLS. 45, 46 AND 48).

CLASS 35—ADVERTISING AND BUSINESS

FOR PUBLIC ADVOCACY TO PROMOTE AWARENESS OF COMMUNITY, ENVIRONMENTAL AND HEALTH AND WELLNESS ISSUES (U.S. CLS. 100, 101 AND 102).

CLASS 41—EDUCATION AND ENTERTAINMENT

FOR EDUCATIONAL SERVICES, NAMELY, PROVIDING SEMINARS, WORKSHOPS, AND LECTURES IN THE FIELD OF ENVIRONMENTAL AND WELLNESS ISSUES (U.S. CLS. 100, 101 AND 107).

LANA PHAM, EXAMINING ATTORNEY

SN 77-477,092. AMERICAN HEART ASSOCIATION, INC., DALLAS, TX. FILED 5-16-2008.

APRENDE Y VIVE

THE MARK CONSISTS OF STANDARD CHARACTERS WITHOUT CLAIM TO ANY PARTICULAR FONT, STYLE, SIZE, OR COLOR.

OWNER OF U.S. REG. NOS. 3,169,137 AND 3,234,169.

THE FOREIGN WORDING IN THE MARK TRANSLATES INTO ENGLISH AS LEARN AND LIVE.

CLASS 16—PAPER GOODS AND PRINTED MATTER

FOR PRINTED PAMPHLETS, BROCHURES, MANUALS, BOOKS, BOOKLETS COMPRISING ONE OR MORE OF THE FOREGOING MATERIALS, ALL RELATING TO THE PROMOTION OF CARDIOVASCULAR HEALTH, FITNESS AND NUTRITION, AND/OR THE PREVENTION OR REDUCTION OF CARDIOVASCULAR DISEASE AND STROKE (U.S. CLS. 2, 5, 22, 23, 29, 37, 38 AND 50).

CLASS 35—ADVERTISING AND BUSINESS

FOR ASSOCIATION SERVICES, NAMELY, PROMOTING PUBLIC AWARENESS OF CARDIOVASCULAR HEALTH, FITNESS AND NUTRITION AND/OR THE PREVENTION OR REDUCTION OF CARDIOVASCULAR DISEASE AND STROKE; PRODUCING RADIO AND TELEVISION ADVERTISEMENTS RELATING TO CARDIOVASCULAR HEALTH, FITNESS AND NUTRITION, AND/OR PREVENTION OR REDUCTION OF CARDIOVASCULAR DISEASE AND STROKE (U.S. CLS. 100, 101 AND 102).

CLASS 36—INSURANCE AND FINANCIAL

FOR CHARITABLE FUND RAISING SERVICES FOR PROMOTING RESEARCH, EDUCATION AND OTHER ACTIVITIES RELATING TO CARDIOVASCULAR HEALTH, FITNESS AND NUTRITION, AND/OR THE PREVENTION OR REDUCTION OF CARDIOVASCULAR DISEASE AND STROKE; CHARITABLE FUND RAISING SERVICES FOR MEMORIAL DONATIONS TO CARDIOVASCULAR CHARITY (U.S. CLS. 100, 101 AND 102).

CLASS 38—COMMUNICATION

FOR OPERATING AN INTERNET WEB SITE FOR THE TRANSMISSION OF MESSAGES, AND ONLINE CONFERENCING SERVICES, ALL IN THE FIELD OF CARDIOVASCULAR HEALTH, FITNESS AND NUTRITION, AND/OR THE PREVENTION OR REDUCTION OF CARDIOVASCULAR DISEASE AND STROKE (U.S. CLS. 100, 101 AND 104).

KELLY BOULTON, EXAMINING ATTORNEY

SN 77-477,999. HYI, COVINA, CA. FILED 5-19-2008.

THE STIPPLING IS FOR SHADING PURPOSES ONLY. THE MARK CONSISTS OF "ROCK RIVER" AND A DESIGN.

CLASS 8—HAND TOOLS

FOR HAND TOOLS, NAMELY, KNIVES, KNIFE SHEATHS, PLIERS, FORCEPS, CRIMPERS AND FISHING LINE CUTTERS (U.S. CLS. 23, 28 AND 44).

CLASS 18—LEATHER GOODS

FOR NON-LEATHER ALL PURPOSE ATHLETIC BAGS, NAMELY, NYLON ALL-PURPOSE ATHLETIC BAGS; NON-LEATHER BACKPACKS, NAMELY, NYLON BACKPACKS (U.S. CLS. 1, 2, 3, 22 AND 41).

CLASS 28—TOYS AND SPORTING GOODS

FOR SPORTING GOODS, NAMELY, FISHING TACKLE BAGS, FISHING TACKLE BOXES, UTILITY BOXES FOR FISHING WEIGHTS, FISHING LURES AND FISHING HOOKS, ROD STORAGE, REEL STORAGE AND ROLLER TACKLE STORAGE, FISHING REEL COVERS, FISHING ROD HOLDERS, FISHING ROD GUARDS, FISHING ROD WRAPS AND NON-LEATHER FISHING JIG TUBE BAGS (U.S. CLS. 22, 23, 38 AND 50).

JILL C. ALT, EXAMINING ATTORNEY

SN 77-481,172. CHS INC., INVER GROVE HEIGHTS, MN.
FILED 5-22-2008.

SN 77-484,257. COWAMONGUS, LLC, GRAND PRAIRIE, TX.
FILED 5-27-2008.

CENEX ZIP TRIP

THE MARK CONSISTS OF STANDARD CHARACTERS WITHOUT CLAIM TO ANY PARTICULAR FONT, STYLE, SIZE, OR COLOR.

OWNER OF U.S. REG. NOS. 1,070,076, 1,591,300 AND OTHERS.

CLASS 35—ADVERTISING AND BUSINESS

FOR RETAIL MOTOR VEHICLE FUEL SUPPLY SERVICES BY MEANS OF PUMP ISLAND CREDIT CARD READERS; RETAIL STORE SERVICES FEATURING CONVENIENCE STORE ITEMS AND GASOLINE AND DIESEL (U.S. CLS. 100, 101 AND 102).

CLASS 37—CONSTRUCTION AND REPAIR

FOR GASOLINE SERVICE STATION SERVICES IN THE NATURE OF AUTOMOBILE SERVICE STATION SERVICES (U.S. CLS. 100, 103 AND 106).

DOMINICK J. SALEMI, EXAMINING ATTORNEY

VINTAGE FARMS

THE MARK CONSISTS OF STANDARD CHARACTERS WITHOUT CLAIM TO ANY PARTICULAR FONT, STYLE, SIZE, OR COLOR.

OWNER OF U.S. REG. NO. 3,067,394.

CLASS 29—MEATS AND PROCESSED FOODS

FOR FRUIT TOPPINGS; FRUIT-BASED PIE FILLING; JAMS, JELLIES, AND PRESERVES; AND SOUPS (U.S. CL. 46).

FIRST USE 12-31-2004; IN COMMERCE 12-31-2004.

CLASS 30—STAPLE FOODS

FOR SAUCES; SALSAS; SALAD DRESSINGS; AND CONDIMENTS, NAMELY KETCHUP AND MAYONNAISE (U.S. CL. 46).

FIRST USE 12-31-2004; IN COMMERCE 12-31-2004.

RUDY R. SINGLETON, EXAMINING ATTORNEY

SN 77-481,842. INTERNATIONAL DERMAL INSTITUTE, INC., CARSON, CA. FILED 5-22-2008.

SN 77-486,919. SMITHKLINE BEECHAM P.L.C., BRENTFORD, MIDDLESEX, ENGLAND, FILED 5-30-2008.

CalmSTAT

THE MARK CONSISTS OF STANDARD CHARACTERS WITHOUT CLAIM TO ANY PARTICULAR FONT, STYLE, SIZE, OR COLOR.

CLASS 3—COSMETICS AND CLEANING PREPARATIONS

FOR BODY CREAMS; BODY OILS; BODY WASHES; NON-MEDICATED SKIN CARE PREPARATIONS; SKIN CARE BOOSTERS, NAMELY, CONCENTRATED NON-MEDICATED SKIN CARE PREPARATIONS FOR TREATMENT OF A VARIETY OF SKIN CONDITIONS; SKIN CLEANSERS; SKIN CONDITIONERS; SKIN CREAMS; SKIN MASKS; SKIN MOISTURIZERS; SKIN SCRUBS; SUN BLOCK PREPARATIONS; SUN CARE LOTIONS; AND SUN SCREEN PREPARATIONS (U.S. CLS. 1, 4, 6, 50, 51 AND 52).

CLASS 5—PHARMACEUTICALS

FOR MEDICATED SKIN CARE PREPARATIONS; ANTI-INFLAMMATORY PREPARATIONS (U.S. CLS. 6, 18, 44, 46, 51 AND 52).

MONIQUE MILLER, EXAMINING ATTORNEY

COREG CR CONNECT

THE MARK CONSISTS OF STANDARD CHARACTERS WITHOUT CLAIM TO ANY PARTICULAR FONT, STYLE, SIZE, OR COLOR.

OWNER OF U.S. REG. NOS. 2,000,337 AND 3,370,463.

CLASS 16—PAPER GOODS AND PRINTED MATTER

FOR PRINTED EDUCATIONAL MATERIALS PERTAINING TO THE TREATMENT OF CARDIOVASCULAR DISEASE (U.S. CLS. 2, 5, 22, 23, 29, 37, 38 AND 50).

CLASS 44—MEDICAL, BEAUTY AND AGRICULTURAL SERVICES

FOR ONLINE INFORMATION SERVICES PERTAINING TO THE TREATMENT OF CARDIOVASCULAR DISEASE (U.S. CLS. 100 AND 101).

SUSAN RICHARDS, EXAMINING ATTORNEY

SN 77-489,838. AMERICAN AUTOMOBILE ASSOCIATION, INC., HEATHROW, FL. FILED 6-3-2008.

SN 77-507,213. BRIO MANAGEMENT, LLC, DOYLESTOWN, PA. FILED 6-24-2008.

AAA TOTAL REPAIR CARE

THE MARK CONSISTS OF STANDARD CHARACTERS WITHOUT CLAIM TO ANY PARTICULAR FONT, STYLE, SIZE, OR COLOR.

CLASS 35—ADVERTISING AND BUSINESS

FOR ARRANGING FOR DISCOUNTED AUTOMOBILE REPAIR SERVICES FOR MEMBERS OF AN ASSOCIATION (U.S. CLS. 100, 101 AND 102).

CLASS 37—CONSTRUCTION AND REPAIR

FOR MOTOR VEHICLE DIAGNOSIS AND REPAIR SERVICES (U.S. CLS. 100, 103 AND 106).

CLASS 39—TRANSPORTATION AND STORAGE

FOR ARRANGING FOR TRANSPORTATION OF INDIVIDUALS WHOSE VEHICLES ARE UNDER REPAIR (U.S. CLS. 100 AND 105).

NORA BUCHANAN WILL, EXAMINING ATTORNEY

SN 77-498,223. NEW PENDULUM CORP., WILMINGTON, DE. FILED 6-13-2008.



THE MARK CONSISTS OF THE WORD "SUNSAFE" IN CAPITAL BLOCK LETTERS WITH AN OUTLINE OF SUN RAYS PRECEDING AND PARTIALLY SURROUNDING THE FIRST LETTER "S" OF THE WORD "SUNSAFE".

CLASS 17—RUBBER GOODS

FOR TEXTILES AND ABSORBENTS SOLD IN ROLLS AND PADS FOR ABSORBING INDUSTRIAL LIQUIDS (U.S. CLS. 1, 5, 12, 13, 35 AND 50).

FIRST USE 5-16-2008; IN COMMERCE 5-16-2008.

CLASS 21—HOUSEWARES AND GLASS

FOR CLEANING PADS AND WIPES MADE OF SYNTHETIC AND NATURAL ABSORBENT TEXTILES FOR ABSORBING INDUSTRIAL LIQUIDS (U.S. CLS. 2, 13, 23, 29, 30, 33, 40 AND 50).

FIRST USE 5-16-2008; IN COMMERCE 5-16-2008.
STEPHANIE ALI, EXAMINING ATTORNEY

LOAD THE BASES

THE MARK CONSISTS OF STANDARD CHARACTERS WITHOUT CLAIM TO ANY PARTICULAR FONT, STYLE, SIZE, OR COLOR.

CLASS 16—PAPER GOODS AND PRINTED MATTER

FOR A SERIES OF BOOKS, WRITTEN ARTICLES, HANDOUTS, NEWSLETTERS, WORKSHEETS, IN THE FIELDS OF OR TOPICS OF BUSINESS, ENTREPRENEURSHIP, STARTING A BUSINESS, LEADERSHIP, MARKETING, ADVERTISING, MANAGEMENT, RELATIONSHIPS, BUSINESS COACHING, SPORTS COACHING, CAREER COACHING, LIFE COACHING, LAW, ACCOUNTING, SALES, REAL ESTATE, HEALTH, FITNESS, SPORTS, SELF-IMPROVEMENT, SPIRITUAL RENEWAL, PARENTING, ETIQUETTE, CAREER PLANNING, DEBT MANAGEMENT INVESTING, ESTATE PLANNING, RETIREMENT PLANNING, SAFE DRIVING, CHOOSING A COLLEGE, GETTING INTO COLLEGE, POLITICS, PSYCHOLOGY, ECONOMICS, GOVERNMENT, SOCIAL SCIENCES, PHILOSOPHY, MOTIVATION, PERSONAL TRANSFORMATION, TIME-MANAGEMENT, PERSONAL ORGANIZATION, PROJECT MANAGEMENT, PROPERTY MANAGEMENT, HOW TO ENJOY RETIREMENT, HUMAN RESOURCES, VACATION PLANNING, NEGOTIATION, CHANGE MANAGEMENT, STRESS MANAGEMENT, OVERCOMING ADVERSITY, GOAL-SETTING (U.S. CLS. 2, 5, 22, 23, 29, 37, 38 AND 50).

CLASS 41—EDUCATION AND ENTERTAINMENT

FOR EDUCATIONAL SERVICES, NAMELY, CONDUCTING SEMINARS AND WORKSHOPS IN THE FIELDS OF OR TOPICS OF BUSINESS, ENTREPRENEURSHIP, STARTING A BUSINESS, LEADERSHIP, MARKETING, ADVERTISING, MANAGEMENT, RELATIONSHIPS, BUSINESS COACHING, SPORTS COACHING, CAREER COACHING, LIFE COACHING, LAW, ACCOUNTING, SALES, REAL ESTATE, HEALTH, FITNESS, SPORTS, SELF-IMPROVEMENT, SPIRITUAL RENEWAL, PARENTING, ETIQUETTE, CAREER PLANNING, DEBT MANAGEMENT INVESTING, ESTATE PLANNING, RETIREMENT PLANNING, SAFE DRIVING, CHOOSING A COLLEGE, GETTING INTO COLLEGE, POLITICS, PSYCHOLOGY, ECONOMICS, GOVERNMENT, SOCIAL SCIENCES, PHILOSOPHY, MOTIVATION, PERSONAL TRANSFORMATION, TIME-MANAGEMENT, PERSONAL ORGANIZATION, PROJECT MANAGEMENT, PROPERTY MANAGEMENT, HOW TO ENJOY RETIREMENT, HUMAN RESOURCES, VACATION PLANNING, NEGOTIATION, CHANGE MANAGEMENT, STRESS MANAGEMENT, OVERCOMING ADVERSITY, GOAL-SETTING, AND DISTRIBUTION OF COURSE MATERIAL IN CONNECTION THEREWITH (U.S. CLS. 100, 101 AND 107).

NORA BUCHANAN WILL, EXAMINING ATTORNEY

SN 77-975,142. NISSAN JIDOSHA KABUSHIKI KAISHA, TA NISSAN MOTOR CO., LTD., YOKOHAMA-SHI, JAPAN, FILED 3-27-2007.

NISSAN GT-R

THE MARK CONSISTS OF STANDARD CHARACTERS WITHOUT CLAIM TO ANY PARTICULAR FONT, STYLE, SIZE, OR COLOR.
OWNER OF U.S. REG. NOS. 686,587, 2,055,075 AND OTHERS.

CLASS 8—HAND TOOLS

FOR HAND TOOLS, NAMELY, DRILLS, HAMMERS, SCREWDRIVERS, SPANNERS, WRENCHES, VICES, NIPPERS AND PLIERS (U.S. CLS. 23, 28 AND 44).

CLASS 11—ENVIRONMENTAL CONTROL APPARATUS

FOR POCKET SEARCH LIGHTS (U.S. CLS. 13, 21, 23, 31 AND 34).

CLASS 16—PAPER GOODS AND PRINTED MATTER

FOR PRINTED MATERIALS, NAMELY, GRAPHIC ART REPRODUCTIONS, DECALS, PENS, PENCILS, PEN AND PENCIL HOLDERS, CALENDARS, STATIONERY-TYPE WRITING PORTFOLIOS, POSTERS, PHOTO ALBUMS AND POCKET DIARIES (U.S. CLS. 2, 5, 22, 23, 29, 37, 38 AND 50).

CLASS 18—LEATHER GOODS

FOR LUGGAGE, LUGGAGE TAGS, BACKPACKS, WALLETS, BUSINESS CARD CASES, UMBRELLAS (U.S. CLS. 1, 2, 3, 22 AND 41).

CLASS 20—FURNITURE AND ARTICLES NOT OTHERWISE CLASSIFIED

FOR FURNITURE, NAMELY, CHAIRS; PICTURE FRAMES; NON-METALLIC BOTTLE STOPPERS (U.S. CLS. 2, 13, 22, 25, 32 AND 50).

CLASS 21—HOUSEWARES AND GLASS

FOR HOUSEWARES AND BEVERAGEWARE, NAMELY, MUGS, CUPS AND BEVERAGE GLASSWARE, THERMAL INSULATED BEVERAGE CONTAINERS, PLASTIC WATER BOTTLES SOLD EMPTY AND FOAM DRINK HOLDERS IN THE NATURE OF INSULATING SLEEVE HOLDERS FOR BEVERAGE CANS; PORTABLE COOLERS; COASTERS NOT OF PAPER AND NOT BEING TABLE LINEN, AND CORK SCREWS; FITTED PICNIC BASKETS; CAMPING GRILLS (U.S. CLS. 2, 13, 23, 29, 30, 33, 40 AND 50).

CLASS 24—FABRICS

FOR TOWELS AND CLOTH COASTERS (U.S. CLS. 42 AND 50).

CLASS 26—FANCY GOODS

FOR ORNAMENTAL CLOTH PATCHES AND EMBROIDERED EMBLEMS (U.S. CLS. 37, 39, 40, 42 AND 50).

CLASS 27—FLOOR COVERINGS

FOR FLOOR MATS FOR MOTOR VEHICLES (U.S. CLS. 19, 20, 37, 42 AND 50).

CLASS 28—TOYS AND SPORTING GOODS

FOR TOYS AND PLAYTHINGS, NAMELY, DIE CAST TOY VEHICLES, BATTERY OPERATED REMOTE CONTROL TOY VEHICLES, PLASTIC HOBBY CRAFT KITS FOR CONSTRUCTING TOY AND SCALE MODEL VEHICLES, RIDE-ON TOY VEHICLES; LIGHT AND SOUND TOY VEHICLE, NAMELY, LED LIGHT MINIATURE CARS; PLUSH TOYS; STAND ALONE GAMES IN THE NATURE OF FLOOR STANDING UNITS FOR PLAYING ELECTRONIC GAMES OTHER THAN IN CONJUNCTION WITH A TELEVISION OR COMPUTER; AND ARCADE GAMES (U.S. CLS. 22, 23, 38 AND 50).

CLASS 34—SMOKERS' ARTICLES

FOR CIGARETTE LIGHTERS NOT FOR LAND VEHICLES; ASHTRAYS (U.S. CLS. 2, 8, 9 AND 17).
ANDREA K. NADELMAN, EXAMINING ATTORNEY

SN 77-975,588. INDEPENDENT STATIONERS, INC., INDIANAPOLIS, IN. FILED 8-6-2007.

LEGACY

THE MARK CONSISTS OF STANDARD CHARACTERS WITHOUT CLAIM TO ANY PARTICULAR FONT, STYLE, SIZE, OR COLOR.
OWNER OF U.S. REG. NO. 2,960,044.

CLASS 2—PAINTS

FOR INK JET CARTRIDGES, TONER CARTRIDGES (U.S. CLS. 6, 11 AND 16).

CLASS 3—COSMETICS AND CLEANING PREPARATIONS

FOR DISPOSABLE WIPES IMPREGNATED WITH CLEANSING COMPOUNDS FOR USE ON COMPUTERS, TELEPHONES, AND COMPUTER SCREENS; CANNED PRESSURIZED AIR FOR DUSTING AND CLEANING PURPOSES, NAMELY, GAS BLAST DUSTERS FOR CLEANING COMPUTERS AND HOME AND OFFICE ELECTRONIC EQUIPMENT; CLEANER FOR USE ON WHITE BOARDS (U.S. CLS. 1, 4, 6, 50, 51 AND 52).

CLASS 8—HAND TOOLS

FOR SCISSORS (U.S. CLS. 23, 28 AND 44).

CLASS 9—ELECTRICAL AND SCIENTIFIC APPARATUS

FOR CD CASES DVD CASES, MOUSE PADS (U.S. CLS. 21, 23, 26, 36 AND 38).

CLASS 16—PAPER GOODS AND PRINTED MATTER

FOR OFFICE PRODUCTS, NAMELY, BINDERS, BULLETIN BOARDS, BOOKENDS, FILE BOXES FOR STORAGE OF BUSINESS AND PERSONAL RECORDS, INDEX CARDS, PAPER FASTENERS, CORRECTION FLUIDS, PENS, AND TAPE FOR DOCUMENTS, PAPER CUTTERS, PAPER CLIP DISPENSERS, ADHESIVE TAPE DISPENSERS, INDEX DIVIDERS, NOTEBOOK DIVIDERS, ENVELOPES, TAPE FLAGS, GLUE STICKS, ADDRESS LABELS, LETTER OPENERS, HIGHLIGHTING MARKERS, PERMANENT MARKERS, ADHESIVE NOTE PADS, EASEL PADS, SCRATCH PADS, WRITING PAPER PADS, COMPUTER PAPER, REEL PAPER FOR PRINTERS, DISPOSABLE WIPES NOT IMPREGNATED WITH CHEMICALS OR COMPOUNDS; BALL POINT PENS, ROLLER BALL PENS, GEL ROLLER PENS, PENCILS, FILE POCKETS, PAPER HOLE PUNCHES, STAPLES, PAPER STAPLERS, STAPLE REMOVERS, BINDER CLIPS, ADHESIVES FOR STATIONARY OR HOUSEHOLD PURPOSES, ADHESIVE TAPES FOR STATIONARY PURPOSES; REPORT COVERS, PAPER CLIPS, PROTECTIVE COVERS FOR SHEETS OF PAPER, THUMB TACKS, PUSH PINS, CLIP BOARDS, RUBBER BANDS, STRING ENVELOPES, PAPER CUTTERS, EXPANDING FILES, FILE FOLDERS, HANGING FILE FOLDER FRAMES, PHOTO ALBUMS, DOCUMENT HOLDERS, CORRECTION TAPE FOR TYPE, CORRECTION FLUID FOR TYPE, EXPANDING FILE FOLDERS, FINGER MOISTENERS, STAMP PADS, TRIPPLICATE BOOKS, LOOSE LEAF RING BINDERS, DRY ERASE WRITING BOARDS AND MARKERS, DRAWING RULERS, DRAFTING RULERS, DIVIDED NOTEBOOKS, AND RUBBER STAMPS (U.S. CLS. 2, 5, 22, 23, 29, 37, 38 AND 50).

CLASS 17—RUBBER GOODS

FOR ADHESIVE PACKING TAPE FOR INDUSTRIAL OR COMMERCIAL USE; ADHESIVE TAPE FOR COMMERCIAL USE (U.S. CLS. 1, 5, 12, 13, 35 AND 50).
SANJEEV VOHRA, EXAMINING ATTORNEY

CLASS 5—PHARMACEUTICALS

FOR PHARMACEUTICAL PREPARATIONS; MEDICAL PREPARATIONS; AND DRUG DELIVERY SYSTEMS, PHARMACEUTICAL MODIFIED RELEASE SYSTEMS, AND CONTROLLED RELEASE SYSTEMS, COMPRISED OF TABLETS, GRANULES, PILLS, SACHETS, POWDERS, AND CAPSULES; ALL OF THE ABOVE FOR USE IN THE TREATMENT OF MENTAL AND PHYSICAL DISORDERS, TRAUMAS AND EMERGENCIES, ADDICTIONS, AGING, ALLERGY/IMMUNOLOGY, BURNS, DISEASES OF THE HEART AND BLOOD VESSELS, DENTAL AND GUM DISEASES, SKIN DISEASES, NUTRITIONAL AND DIETARY DISEASES, DISEASES OF THE ENDOCRINOLOGICAL SYSTEM AND PANCREATIC DISEASES, DIABETES, EPIDEMICAL DISEASES, DISEASES AND AFFLICTIONS OF THE GASTROENTEROLOGICAL SYSTEM, DISEASES OF THE BLOOD, INFECTIOUS DISEASES, NEUROLOGICAL DISEASES, NEPHROLOGICAL DISEASES, DISEASES IN THE OBSTETRICAL- AND GYNECOLOGICAL FIELD, CANCER, OPHTHALMOLOGICAL DISEASES, DISEASES AND AFFLICTIONS AFFECTING THE BONES, JOINTS, CARTILAGE MATERIAL AND MUSCLES, DISEASES AND AFFLICTIONS OF THE EAR, NOSE AND THROAT, DISEASES AND AFFLICTIONS IN THE PSYCHIATRIC FIELD, PULMONOLOGICAL DISEASES AND AFFLICTIONS, RHEUMATISM, UROLOGICAL DISEASES AND AFFLICTIONS AND GENERALISED PAIN (U.S. CLS. 6, 18, 44, 46, 51 AND 52).

CLASS 40—MATERIAL TREATMENT

FOR TREATMENT OF MATERIALS, NAMELY, MILLING, GRINDING, MIXING, COMPRESSING, AND MELTING OF PHARMACEUTICAL, MEDICINAL, BIOTECHNICAL AND BACTERIOLOGICAL SUBSTANCES, PREPARATIONS, FORMULATIONS, SOLUTIONS, FOR USE IN THE PHARMACEUTICAL AND MEDICAL INDUSTRIES (U.S. CLS. 100, 103 AND 106).

CLASS 41—EDUCATION AND ENTERTAINMENT

FOR EDUCATIONAL TRAINING SERVICES, NAMELY, ARRANGING AND CONDUCTING OF SEMINARS, WORKSHOPS, CONFERENCES, LECTURES AND CONGRESSES, ALL IN THE MEDICAL, CHEMICAL AND PHARMACEUTICAL FIELDS (U.S. CLS. 100, 101 AND 107).

CLASS 42—SCIENTIFIC AND COMPUTER SERVICES

FOR SCIENTIFIC RESEARCH WITHIN THE MEDICAL, PHARMACEUTICAL, BIOTECHNICAL AND BACTERIOLOGICAL AREAS AND PROVIDING CONSULTATION AND INFORMATION RELATING THERETO; CONDUCTING OF TESTS REGARDING MEDICAL APPLICATIONS; PACKAGING DESIGN FOR OTHERS; DESIGNING AND DEVELOPMENT OF MEDICAL EQUIPMENT; DESIGNING PHARMACEUTICAL MEDICAL PREPARATIONS; PREPARATION OF PHARMACEUTICAL FORMULATIONS; DESIGN AND DEVELOPMENT OF GRANULATION TECHNOLOGY AND TABLET TECHNOLOGY AND PROVIDING CONSULTATION AND INFORMATION THERETO; AND MATERIALS TESTING FOR THE PHARMACEUTICAL AND MEDICAL INDUSTRIES. (U.S. CLS. 100 AND 101).
ALICIA COLLINS, EXAMINING ATTORNEY

SN 78-250,680. LIFECYCLE PHARMA A/S, DK-2970 HORSHOLM, DENMARK, FILED 5-16-2003.

LIFECYCLE PHARMA

OWNER OF DENMARK REG. NO. VR200302449, DATED 7-11-2003, EXPIRES 7-11-2013.

SN 78-297,060. SAFETY-KLEEN SYSTEMS, INC., PLANO, TX. FILED 9-8-2003.



PRIORITY CLAIMED UNDER SEC. 44(D) ON CANADA APPLICATION NO. 1169952, FILED 3-7-2003, REG. NO. TMA714103, DATED 5-9-2008, EXPIRES 5-9-2023.

COLOR IS NOT CLAIMED AS A FEATURE OF THE MARK.

THE MARK CONSISTS OF "ECOPOWER" AND ATOM DESIGN.

CLASS 1—CHEMICALS

FOR CHEMICAL ADDITIVES FOR FUEL TREATMENT; CHEMICAL MOTOR OIL ADDITIVES, CHEMICAL TRANSMISSION FLUID ADDITIVES (U.S. CLS. 1, 5, 6, 10, 26 AND 46).

CLASS 4—LUBRICANTS AND FUELS

FOR AUTOMOTIVE GREASES, GREASE FOR MACHINES; AUTOMOTIVE LUBRICANTS; NON-CHEMICAL ADDITIVES FOR FUEL TREATMENT; NON-CHEMICAL MOTOR OIL ADDITIVES, NON-CHEMICAL TRANSMISSION FLUID ADDITIVES; ALL PURPOSE LUBRICANTS; INDUSTRIAL LUBRICANTS IN THE NATURE OF PENETRATING AND EXTREME PRESSURE LUBRICANTS (U.S. CLS. 1, 6 AND 15).

AMY HELLA, EXAMINING ATTORNEY

SN 78-319,672. PIKONO S.R.L., GORIZIA, ITALY, FILED 10-28-2003.



NO CLAIM IS MADE TO THE EXCLUSIVE RIGHT TO USE "PIZZA", APART FROM THE MARK AS SHOWN.

THE STIPPLING IS FOR SHADING PURPOSES ONLY. COLOR IS NOT CLAIMED AS A FEATURE OF THE MARK.

CLASS 25—CLOTHING

FOR SHIRTS; PANTS; FOOTWEAR; HEADGEAR, NAMELY, HATS AND CAPS (U.S. CLS. 22 AND 39).

CLASS 30—STAPLE FOODS

FOR COFFEE, TEA, COCOA, SUGAR, RICE, TAPIOCA, SAGO, ARTIFICIAL COFFEE; FLOUR AND PREPARATIONS MADE FROM CEREALS, BREAD, PASTRY AND CONFECTIONERY, NAMELY, CANDIES, CHOCOLATE CHIPS, FLAVORED ICES; HONEY, TREACLE; YEAST, BAKING POWDER; SALT, MUSTARD, VINEGAR, SAUCES; SPICES; ICE (U.S. CL. 46).

CLASS 39—TRANSPORTATION AND STORAGE

FOR TRANSPORT BY AIR, CAR, VAN, TRUCK, TRAIN, SHIP; PACKAGING ARTICLES FOR TRANSPORTATION; STORAGE OF GOODS FOR OTHERS; ARRANGING TRAVEL TOURS (U.S. CLS. 100 AND 105).

CLASS 43—HOTEL AND RESTAURANT SERVICES

FOR RESTAURANT SERVICES; ARRANGING TEMPORARY HOUSING ACCOMMODATIONS; PROVIDING TEMPORARY HOUSING ACCOMMODATIONS (U.S. CLS. 100 AND 101).

MARK SPARACINO, EXAMINING ATTORNEY

SN 78-366,919. MARY C. ORWIG, ELLENDALE, ND. AND STEVE ORWIG, ELLENDALE, ND. FILED 2-12-2004.



CLASS 5—PHARMACEUTICALS

FOR FEED SUPPLEMENTS FOR LIVESTOCK (U.S. CLS. 6, 18, 44, 46, 51 AND 52).

FIRST USE 1-0-1990; IN COMMERCE 1-0-1990.

CLASS 35—ADVERTISING AND BUSINESS

FOR DISTRIBUTORSHIP SERVICES IN THE FIELD OF FEED SUPPLEMENTS FOR LIVESTOCK (U.S. CLS. 100, 101 AND 102).

FIRST USE 7-0-1989; IN COMMERCE 1-0-1990. LESLEY LAMOTHE, EXAMINING ATTORNEY

SN 78-391,685. SECOND CITY, INC., CHICAGO, IL. FILED 3-26-2004.

SECOND CITY TELEVISION NETWORK

THE MARK CONSISTS OF STANDARD CHARACTERS WITHOUT CLAIM TO ANY PARTICULAR FONT, STYLE, SIZE, OR COLOR.

PRIORITY CLAIMED UNDER SEC. 44(D) ON CANADA APPLICATION NO. 1203158, FILED 1-12-2004, REG. NO. TMA712853, DATED 4-25-2008, EXPIRES 4-25-2023.

OWNER OF U.S. REG. NOS. 1,413,702 AND 1,472,660.

NO CLAIM IS MADE TO THE EXCLUSIVE RIGHT TO USE "TELEVISION NETWORK", APART FROM THE MARK AS SHOWN.

SEC. 2(F) AS TO "SECOND CITY".

CLASS 9—ELECTRICAL AND SCIENTIFIC APPARATUS

FOR (BASED ON USE IN COMMERCE) (BASED ON 44(E)) CINEMATOGRAPHIC FILMS FEATURING TELEVIEWED DRAMATIC, MUSICAL, ANIMATED, ARTISTIC AND LITERARY WORKS (U.S. CLS. 21, 23, 26, 36 AND 38).

FIRST USE 0-0-1976; IN COMMERCE 0-0-1976.

CLASS 41—EDUCATION AND ENTERTAINMENT

FOR (BASED ON 44(E)) ENTERTAINMENT SERVICES IN THE NATURE OF AN ON-GOING TELEVISION PROGRAM FEATURING DRAMATIC, MUSICAL, ANIMATED, ARTISTIC AND LITERARY WORKS (U.S. CLS. 100, 101 AND 107).

REBECCA POVARCHUK, EXAMINING ATTORNEY

SN 78-430,127. ORION MULTISYSTEMS INC., SANTA CLARA, CA. FILED 6-4-2004.

ORION MULTISYSTEMS

THE MARK CONSISTS OF STANDARD CHARACTERS WITHOUT CLAIM TO ANY PARTICULAR FONT, STYLE, SIZE, OR COLOR.

NO CLAIM IS MADE TO THE EXCLUSIVE RIGHT TO USE "MULTISYSTEMS", APART FROM THE MARK AS SHOWN.

CLASS 9—ELECTRICAL AND SCIENTIFIC APPARATUS

FOR COMPUTER WORKSTATIONS, COMPRISING INTERNAL CLUSTERS OF MULTIPLE PROCESSORS, MEMORY, AND DISK DRIVES, SOLD AS A UNIT; COMPUTERS (U.S. CLS. 21, 23, 26, 36 AND 38).

CLASS 41—EDUCATION AND ENTERTAINMENT

FOR TRAINING SERVICES IN THE FIELD OF COMPUTERS AND COMPUTER WORKSTATIONS (U.S. CLS. 100, 101 AND 107).

CLASS 42—SCIENTIFIC AND COMPUTER SERVICES

FOR TECHNICAL SUPPORT SERVICES, NAMELY, TROUBLESHOOTING OF COMPUTER, COMPUTER WORKSTATION, AND COMPUTER HARDWARE PROBLEMS (U.S. CLS. 100 AND 101).

LEIGH LOWRY, EXAMINING ATTORNEY

SN 78-438,529. ORION MULTISYSTEMS INC., SANTA CLARA, CA. FILED 6-21-2004.



NO CLAIM IS MADE TO THE EXCLUSIVE RIGHT TO USE "MULTISYSTEMS", APART FROM THE MARK AS SHOWN.

CLASS 41—EDUCATION AND ENTERTAINMENT

FOR TRAINING SERVICES IN THE FIELD OF COMPUTERS AND COMPUTER WORKSTATIONS (U.S. CLS. 100, 101 AND 107).

CLASS 42—SCIENTIFIC AND COMPUTER SERVICES

FOR TECHNICAL SUPPORT SERVICES, NAMELY, TROUBLESHOOTING OF COMPUTER, COMPUTER WORKSTATION, AND COMPUTER HARDWARE PROBLEMS (U.S. CLS. 100 AND 101).

LEIGH LOWRY, EXAMINING ATTORNEY

SN 78-449,417. WAR-RJG INVESTMENTS LLC, SANTA BARBARA, CA. FILED 7-12-2004.

Vegas Chips

THE MARK CONSISTS OF STANDARD CHARACTERS WITHOUT CLAIM TO ANY PARTICULAR FONT, STYLE, SIZE, OR COLOR.

NO CLAIM IS MADE TO THE EXCLUSIVE RIGHT TO USE "CHIPS", APART FROM THE MARK AS SHOWN.

CLASS 14—JEWELRY

FOR COMMEMORATIVE COINS (U.S. CLS. 2, 27, 28 AND 50).

CLASS 25—CLOTHING

FOR CLOTHING, NAMELY, SHIRTS, HATS, PANTS, SWEATERS, SPORTSWEAR, NAMELY, SWEAT SHIRTS, SWEAT PANTS, AND SHORTS (U.S. CLS. 22 AND 39).

MICHAEL WEBSTER, EXAMINING ATTORNEY

SN 78-524,432. ZEPLOWITZ, DAVID M., D/B/A JOHNNY FLAMINGO ENTERPRISES, TAMPA, FL. FILED 11-30-2004.

JOHNNY FLAMINGO

THE MARK CONSISTS OF STANDARD CHARACTERS WITHOUT CLAIM TO ANY PARTICULAR FONT, STYLE, SIZE, OR COLOR.

THE NAME "JOHNNY FLAMINGO" DOES NOT IDENTIFY ANY LIVING INDIVIDUAL.

CLASS 25—CLOTHING

FOR MEN'S CLOTHING, NAMELY, SHIRTS, PANTS, SHORTS, SWEATERS, JACKETS, SUITS, COATS, FOOTWEAR, UNDERWEAR, HEADWEAR, SWIMWEAR, PJAMAS, GLOVES, AND BELTS (U.S. CLS. 22 AND 39).

CLASS 32—LIGHT BEVERAGES

FOR ALCOHOLIC BEVERAGES, NAMELY, BEER (U.S. CLS. 45, 46 AND 48).

CLASS 33—WINES AND SPIRITS

FOR ALCOHOLIC BEVERAGES, NAMELY, SPIRITS, RUM, SCOTCH (U.S. CLS. 47 AND 49).

CLASS 34—SMOKERS' ARTICLES

FOR CIGARS (U.S. CLS. 2, 8, 9 AND 17).
AHSEN KHAN, EXAMINING ATTORNEY

SN 78-586,428. 804935 ONTARIO LTD., JORDAN STATION, CANADA, FILED 3-14-2005.

PLANTS WITH PERSONALITY

THE MARK CONSISTS OF STANDARD CHARACTERS WITHOUT CLAIM TO ANY PARTICULAR FONT, STYLE, SIZE, OR COLOR.

PRIORITY CLAIMED UNDER SEC. 44(D) ON CANADA APPLICATION NO. 1250146, FILED 3-10-2005, REG. NO. TMA709959, DATED 3-19-2008, EXPIRES 3-19-2023.

NO CLAIM IS MADE TO THE EXCLUSIVE RIGHT TO USE "PLANTS", APART FROM THE MARK AS SHOWN.

SN 78-554,097. UNION HARBOUR LTD., HONG KONG, HONG KONG, FILED 1-26-2005.

CLASS 31—NATURAL AGRICULTURAL PRODUCTS

FOR LIVE POTTED PLANTS; LIVE PLANT BULBS; FLORAL ARRANGEMENTS CONSISTING OF LIVE OR CUT FLOWERS OR LIVE PLANTS OR PLANT CUTTINGS OR COMBINATIONS THEREOF; PLANT ARRANGEMENTS CONSISTING OF LIVE OR CUT FLOWERS OR LIVE PLANTS OR PLANT CUTTINGS OR COMBINATIONS THEREOF; CUT FLOWERS (U.S. CLS. 1 AND 46).



OWNER OF HONG KONG REG. NO. 300436662AA, DATED 6-10-2005, EXPIRES 6-10-2015.

THE MARK CONSISTS OF THREE VERTICALLY ALIGNED STYLIZED LIONS, SEPARATED BY A VERTICAL LINE FROM THE VERTICALLY ALIGNED WORDS GEORGE / GINA & / LUCY (IN WHICH THE "/" HERE INDICATES SEPARATE LINES ON WHICH THESE WORDS OCCUR IN THE VERTICAL ALIGNMENT BUT DOES NOT APPEAR IN THE ACTUAL MARK).

CLASS 41—EDUCATION AND ENTERTAINMENT

FOR EDUCATIONAL SERVICES, NAMELY, CONDUCTING ON-LINE EXHIBITIONS AND DISPLAYS AND INTERACTIVE EXHIBITS IN THE FIELD OF FLOWERS AND PLANTS (U.S. CLS. 100, 101 AND 107).

KAPIL BHANOT, EXAMINING ATTORNEY

CLASS 14—JEWELRY

FOR PRECIOUS METALS AND THEIR ALLOYS AND GOODS IN PRECIOUS METALS OR COATED THEREWITH, NOT INCLUDED IN OTHER CLASSES, NAMELY, BADGES, KEY RINGS, AND KEY BANDS; JEWELRY, PRECIOUS STONES, HOROLOGICAL AND CHRONOMETRIC INSTRUMENTS, NAMELY WATCHES AND JEWELRY (U.S. CLS. 2, 27, 28 AND 50).

CLASS 16—PAPER GOODS AND PRINTED MATTER

FOR PAPER AND PLASTIC SHOPPING BAGS (U.S. CLS. 2, 5, 22, 23, 29, 37, 38 AND 50).

CLASS 18—LEATHER GOODS

FOR LEATHER AND MESH SHOPPING BAGS; BRIEF-CASES; BEACH BAGS; POCKET WALLETS; BAGS FOR CAMPERS; PURSES; PURSES NOT OF PRECIOUS METAL; VALISES; HANDBAGS; HUNTERS' GAME BAGS; GARMENT BAGS FOR TRAVEL; VANITY CASES NOT FITTED; TRAVELING TRUNKS; TRAVELING BAGS; SPORT BAGS, SCHOOL BAGS, SCHOOL SATCHELS, BOOK BAGS, KNAPSACKS, BACKPACKS; BAGS FOR CLIMBERS; HAVERSACKS (U.S. CLS. 1, 2, 3, 22 AND 41).
JASON ROTH, EXAMINING ATTORNEY

SN 78-598,923. VALIANT ENTERTAINMENT, INC., ROAD TOWN, BR. VIRGIN ISLANDS, FILED 3-31-2005.

VALIANT

THE MARK CONSISTS OF STANDARD CHARACTERS WITHOUT CLAIM TO ANY PARTICULAR FONT, STYLE, SIZE, OR COLOR.

CLASS 9—ELECTRICAL AND SCIENTIFIC APPARATUS

FOR ANIMATED MOTION PICTURE FILMS AND MADE-FOR-TELEVISION MOTION PICTURES FEATURING ACTION ADVENTURE HEROES; PRE-RECORDED VIDEOTAPES, DIGITAL VIDEODISCS AND DIGITAL VERSATILE DISCS FEATURING ACTION ADVENTURE HEROES (U.S. CLS. 21, 23, 26, 36 AND 38).

CLASS 16—PAPER GOODS AND PRINTED MATTER

FOR PRINTED MATTER, NAMELY, COMIC BOOKS; GRAPHIC NOVELS; BOOKS FEATURING STORIES IN ILLUSTRATED FORM; BOOKS RELATING TO COMIC BOOK CHARACTERS; COMIC STRIPS; POSTERS; ART PRINTS; LITHOGRAPHIC PRINTS; SERIGRAPHIC PRINTS; LIMITED EDITION PRINTS; COLLECTOR'S CARDS FEATURING COMIC BOOK CHARACTERS; TRADING CARDS; TRADING CARD ALBUMS (U.S. CLS. 2, 5, 22, 23, 29, 37, 38 AND 50).

CLASS 20—FURNITURE AND ARTICLES NOT OTHERWISE CLASSIFIED

FOR BUSTS, FIGURINES, STATUES AND SCULPTURES MADE OF COLD CAST RESIN (U.S. CLS. 2, 13, 22, 25, 32 AND 50).

CLASS 28—TOYS AND SPORTING GOODS

FOR TOY ACTION FIGURES (U.S. CLS. 22, 23, 38 AND 50).

CLASS 41—EDUCATION AND ENTERTAINMENT

FOR ENTERTAINMENT IN THE NATURE OF AN ONGOING TELEVISION PROGRAM FEATURING ACTION ADVENTURE HEROES (U.S. CLS. 100, 101 AND 107).
COLLEEN KEARNEY, EXAMINING ATTORNEY

CLASS 16—PAPER GOODS AND PRINTED MATTER

FOR PUBLICATIONS, NAMELY, BOOKS, MAGAZINES, PAMPHLETS, BOOKLETS, BROCHURES IN THE FIELDS OF ARCHITECTURAL DESIGN, CONSTRUCTION, BUILDING, INTERIOR DESIGN, AND LANDSCAPE DESIGN; AND DRAFTING INSTRUMENTS (U.S. CLS. 2, 5, 22, 23, 29, 37, 38 AND 50).

CLASS 19—NON-METALLIC BUILDING MATERIALS

FOR BUILDING MATERIALS, NAMELY, SEMI-WORKED WOODS AND MARBLE; ARBORS AND TRELLISES MADE OF WOOD; BALCONY ENCLOSURES; BALUSTRADES; DOOR CASINGS, NOT OF METAL; DOOR FRAMES, NOT OF METAL; DOOR JAMBS, NOT OF METAL; DOOR PANELS, NOT OF METAL; FIREPLACE MANTELS; FIREPLACE SURROUNDS; MANUFACTURED HOMES; MANUFACTURED HOUSING, NAMELY, MOBILE HOMES; MILLWORK EXCLUSIVE OF CABINETS; MODULAR HOMES; NON-METALLIC TRANSPORTABLE BUILDINGS; NON-METALLIC TRANSPORTABLE CONSTRUCTION; NON-METAL CORNICES; NON-METAL COVE BASES; NON-METAL DOOR FRAMES; NON-METAL DOOR PANELS; NON-METAL DOOR UNITS; NON-METAL DOORS; NON-METAL FENCE PANELS AND FENCE POSTS; GARAGE DOORS; NON-METAL MANTELS FOR FIREPLACES; NON-METAL PATIO DOORS; NON-METAL STORAGE SHEDS; NON-METAL WINDOW CASEMENTS; NON-METAL WINDOW FRAMES; NON-METAL WINDOW SCREENS; NON-METAL WINDOW SHUTTERS; NON-METAL WINDOW SILLS; NON-METAL WINDOWS; NON-METAL WIRE FENCING; PREFABRICATED NON-METAL BUILDINGS; PREFABRICATED NON-METAL STORAGE SHEDS; PREFABRICATED HOMES; PREFABRICATED NON-METAL ARCHITECTURAL COLUMNS; NON-METAL FASCIA AND SOFFITS; PREFABRICATED NON-METAL PANELIZED HOUSES AND HOUSE KITS COMPRISED PRIMARILY OF WOOD, CONCRETE, STRUCTURALLY INSULATED PANEL, OR MASONRY (U.S. CLS. 1, 12, 33 AND 50).

SN 78-601,906. CUSATO, MARIANNE, NEW YORK, NY.
FILED 4-5-2005.

GET YOUR HOUSE RIGHT

THE MARK CONSISTS OF STANDARD CHARACTERS WITHOUT CLAIM TO ANY PARTICULAR FONT, STYLE, SIZE, OR COLOR.

CLASS 9—ELECTRICAL AND SCIENTIFIC APPARATUS

FOR COMPUTER PROGRAMS FOR DRAFTING AND IMAGING IN THE FIELDS OF ARCHITECTURAL DESIGN, CONSTRUCTION, BUILDING, INTERIOR DESIGN AND LANDSCAPE DESIGN; PRE-RECORDED INSTRUCTIONAL VIDEO TAPES AND DVDS IN THE FIELDS OF ARCHITECTURAL DESIGN, CONSTRUCTION, BUILDING, INTERIOR DESIGN, AND LANDSCAPE DESIGN (U.S. CLS. 21, 23, 26, 36 AND 38).

CLASS 41—EDUCATION AND ENTERTAINMENT

FOR ENTERTAINMENT SERVICES, NAMELY, PROVIDING ON GOING TELEVISION PROGRAMS IN THE FIELDS OF CONSTRUCTION, BUILDING, INTERIOR DESIGN, AND LANDSCAPE DESIGN; EDUCATION SERVICES, NAMELY, PROVIDING LECTURES, CLASSES, SEMINARS, WORKSHOPS IN THE FIELDS OF ARCHITECTURAL DESIGN, CONSTRUCTION, BUILDING, INTERIOR DESIGN, AND LANDSCAPE DESIGN (U.S. CLS. 100, 101 AND 107).

CLASS 42—SCIENTIFIC AND COMPUTER SERVICES

FOR ARCHITECTURAL DESIGN SERVICES; INTERIOR DESIGN SERVICES FOR COMMERCIAL AND RESIDENTIAL BUILDINGS; AND LANDSCAPE ARCHITECTURAL DESIGN SERVICES (U.S. CLS. 100 AND 101).
MICHAEL WEBSTER, EXAMINING ATTORNEY

SN 78-674,217. FRAUNHOFER-GESELLSCHAFT ZUR FÖRDERUNG DER ANGEWANDTEN FORSCHUNG E.V., 80686 MUNICH, FED REP GERMANY, FILED 7-20-2005.

Structure Health Control

THE MARK CONSISTS OF STANDARD CHARACTERS WITHOUT CLAIM TO ANY PARTICULAR FONT, STYLE, SIZE, OR COLOR.

PRIORITY CLAIMED UNDER SEC. 44(D) ON FED REP GERMANY APPLICATION NO. 30509005.4, FILED 2-16-2005, REG. NO. 30509005, DATED 9-12-2005, EXPIRES 2-28-2015.

CLASS 7—MACHINERY

FOR CONSTRUCTION MACHINES; MACHINES FOR MINING; MACHINES FOR THE PAPER AND PRINTING INDUSTRY FOR INDUSTRIAL USE; MACHINES FOR THE CHEMICAL INDUSTRY FOR PROCESSING; MACHINES FOR AGRICULTURE AND FORESTRY FOR USE IN HARVESTING AND PROCESSING; MACHINES FOR THE FOOD AND BEVERAGES INDUSTRY FOR USE IN PROCESSING OF FOOD AND BEVERAGES AS WELL AS PACKAGING; CLEANING MACHINES AND APPARATUS FOR CARPET AND FLOOR; INDUSTRIAL ROBOTS; TEXTILE MACHINES; PACKAGING MACHINES; MACHINES FOR VACUUM TECHNOLOGY; PUMPS, NAMELY, ELECTRIC PUMPS, PNEUMATIC PUMPS, BILGE PUMPS, CENTRIFUGAL PUMPS, COMPRESSED AIR PUMPS, FUEL PUMPS FOR LAND VEHICLES, OIL PUMPS FOR LAND VEHICLES, OIL PUMPS FOR USE IN MOTORS AND ENGINES, PUMPS FOR COOLING ENGINES, ROTARY PUMPS, SCREW PUMPS, SUCTION PUMPS, VACUUM PUMPS, WATER PUMPS FOR LAND VEHICLES, WATER PUMPS FOR USE IN MOTORS AND ENGINES, WINDMILL PUMPS; CENTRIFUGES; METAL, WOOD AND PLASTICS PROCESSING MACHINES; MACHINES FOR MAKING HAND TOOLS; MACHINES FOR PROPULSION AND CONVEYER TECHNOLOGY; MACHINES FOR HOUSEHOLD APPLIANCES, NAMELY, BORING MACHINES, DRILLING MACHINES, SCREWING MACHINES, WASHING MACHINES; MACHINE TOOLS, NAMELY, MACHINES AND MACHINE TOOLS FOR THE CUTTING AND FORMING OF MATERIALS, AND METAL-WORKING MACHINE TOOLS; BEARINGS BEING MACHINE PARTS; MACHINE HOUSINGS AND COVERINGS; MOTORS FOR ELEVATORS, BOATS, AUTOMOBILES, AIRPLANES, REFRIGERATORS, FREEZERS; CLUTCHES, TRANSMISSIONS AND DEVICES FOR POWER TRANSMISSION FOR MACHINES AND POWER TRANSMISSIONS AND GEARING FOR MACHINES, NAMELY, BEARINGS, GEARS, ENCLOSED DRIVES AND BELTS FOR INDUSTRIAL MACHINES, BELTS FOR INDUSTRIAL APPLICATIONS (U.S. CLS. 13, 19, 21, 23, 31, 34 AND 35).

CLASS 9—ELECTRICAL AND SCIENTIFIC APPARATUS

FOR APPARATUS AND INSTRUMENTS FOR CONDUCTING, SWITCHING, TRANSFORMING, ACCUMULATING, REGULATING AND CONTROLLING ELECTRICITY; STORED AND DOWNLOADABLE COMPUTER PROGRAMS AND SOFTWARE FOR USE IN MATERIALS TESTING; MATERIAL TESTING INSTRUMENTS AND MACHINES, NAMELY, METAL COMPRESSION TESTING MACHINES, METAL HARDNESS TESTING MACHINES, METAL STRENGTH TESTING MACHINES, PLASTIC TESTING MACHINES, TEXTILE TESTING MACHINES; DYNAMOMETERS (U.S. CLS. 21, 23, 26, 36 AND 38).

CLASS 12—VEHICLES

FOR VEHICLES, NAMELY, AUTOMOBILES, BUSES, ALL TERRAIN VEHICLES, TRUCKS, MINIVANS, VANS; APPARATUS FOR LOCOMOTION BY LAND, AIR, WATER OR ON RAILS, NAMELY, AIRPLANES, GLIDERS, HELICOPTERS, BOATS, TRAINS, CARS, RAIL BOUND VEHICLES, RAILCARS, WATER SCOOTERS, BICYCLES, MOPEDS, MOTORCYCLES, MOTORIZED SCOOTERS, SAILBOATS, SHIPS, YACHTS; PARTS AND ACCESSORIES FOR APPARATUS FOR LOCOMOTION BY LAND, AIR, WATER OR ON RAILS, NAMELY, AIRPLANE PARTS, NAMELY, FUSELAGES, LANDING GEAR, PROPELLERS AND WINGS OR PARTS OF WINGS, AUTOMOBILE BODIES, AUTOMOBILE BUMPERS, AUTOMOBILE CHASSIS, AUTOMOBILE DOOR HANDLES, AUTOMOBILE ENGINES, AUTOMOBILE HOODS, BRAKE SYSTEMS FOR VEHICLES, DASHBOARDS, ENGINES FOR LAND VEHICLES, GEAR SHIFTS, GEAR WHEELS, GEAR BOXES, LUGGAGE CARRIERS FOR VEHICLES, STRUCTURAL PARTS FOR AIRPLANES, AUTOMOBILES, BOATS, BUSES, GLIDERS, HELICOPTERS, MOTORCYCLES, TRUCKS AND VANS, TOW BARS FOR VEHICLES, TRAILER HITCHES, TRANSMISSION BELTS FOR LAND VEHICLES, TRANSMISSION CASES FOR LAND VEHICLES, TRANSMISSION MECHANISMS FOR LAND VEHICLES, TRANSMISSION MOUNTING PLATES FOR LAND VEHICLES, TRANSMISSION TOP COVERS FOR LAND VEHICLES, TRUCK BED LINERS, TRUCK BED STORAGE ORGANIZERS, VEHICLE PARTS, NAMELY, SUSPENSION STRUTS, BALL JOINTS, IDLER ARMS, SHOCK ABSORBERS, STEERING WHEELS, VEHICLE ROLL BARS, VEHICLE PROPELLERS, VEHICLE SEATS, VEHICLE TOW BARS, WHEEL BEARINGS, WHEEL HUBS, WHEEL RIMS, WHEEL SPROCKETS, WHEEL SUSPENSIONS, WINDSCREENS (U.S. CLS. 19, 21, 23, 31, 35 AND 44).

CLASS 37—CONSTRUCTION AND REPAIR

FOR BUILDING CONSTRUCTION AND REPAIR; MAINTENANCE AND REPAIR OF MACHINES, NAMELY, MACHINES FOR MINING, MACHINES FOR THE PAPER AND PRINTING INDUSTRY, MACHINES FOR THE CHEMICAL INDUSTRY, MACHINES FOR AGRICULTURE AND FORESTRY, MACHINES FOR THE FOOD AND BEVERAGES INDUSTRY, CLEANING MACHINES AND APPARATUS, ROBOTS, TEXTILE MACHINES, PACKAGING MACHINES, MACHINES FOR VACUUM TECHNOLOGY, PUMPS, CENTRIFUGES, METAL, WOOD AND PLASTICS PROCESSING MACHINES, MACHINES FOR MAKING HAND TOOLS, MACHINES FOR PROPULSION AND CONVEYER TECHNOLOGY, MACHINES FOR HOUSEHOLD APPLIANCES (U.S. CLS. 100, 103 AND 106).

CLASS 42—SCIENTIFIC AND COMPUTER SERVICES

FOR SCIENTIFIC RESEARCH; RESEARCH IN THE FIELD OF TECHNOLOGY; RESEARCH IN THE FIELD OF MECHANICAL ENGINEERING; PERFORMANCE OF SCIENTIFIC TESTS; DEVELOPMENT SERVICES AND RESEARCH SERVICES WITH REGARD TO NEW PRODUCTS; PROVIDING SERVICES OF A PHYSICIST; PROVIDING SERVICES OF AN ENGINEER; PROVIDING SERVICES OF A TECHNICAL MEASUREMENT AND TEST LABORATORY; PERFORMANCE OF TECHNICAL MEASUREMENTS; PERFORMANCE OF TECHNICAL TESTS AND EXAMINATIONS; TESTING; QUALITY TESTING; MATERIALS TESTING; RESEARCH ON CONSTRUCTION PLANNING; RESEARCH ON TECHNICAL PROJECT PLANNING; TECHNICAL CONSULTING; PREPARATION OF TECHNICAL OPINIONS IN THE FIELD OF ENGINEERING, AUTOMOTIVE ENGINEERING, AERONAUTICS, TRAINS, SHIPS, PLANTS; PREPARATION OF SCIENTIFIC OPINIONS IN THE FIELD OF SCIENTIFIC RESEARCH AND DEVELOPMENT; DESIGN AND DEVELOPMENT OF COMPUTER HARDWARE AND SOFTWARE (U.S. CLS. 100 AND 101).

ZACHARY BELLO, EXAMINING ATTORNEY

SN 78-691,542. ZILA PHARMACEUTICALS, INC., PHOENIX, AZ. FILED 8-12-2005.

VIZITEST

THE MARK CONSISTS OF STANDARD CHARACTERS WITHOUT CLAIM TO ANY PARTICULAR FONT, STYLE, SIZE, OR COLOR.

"VIZITEST" HAS NO MEANING IN A FOREIGN LANGUAGE.

CLASS 5—PHARMACEUTICALS

FOR DIAGNOSTIC PREPARATIONS FOR MEDICAL USE, NAMELY, PREPARATIONS FOR DETECTING ABNORMALITIES IN ORAL MUCOSA MARKETED TO DENTAL PROFESSIONALS (U.S. CLS. 6, 18, 44, 46, 51 AND 52).

CLASS 10—MEDICAL APPARATUS

FOR MEDICAL EXAMINATION KITS COMPRISED OF A LIGHT SOURCE, A RETRACTOR TO HOLD THE LIGHT SOURCE AND A RINSE SOLUTION FOR DETECTING ABNORMALITIES IN ORAL MUCOSA, MARKETED TO DENTAL PROFESSIONALS; AND MEDICAL APPARATUS FOR DETECTING ABNORMALITIES IN ORAL MUCOSA, MARKETED TO DENTAL PROFESSIONALS (U.S. CLS. 26, 39 AND 44).

WILLIAM VERHOSEK, EXAMINING ATTORNEY

SN 78-705,546. J-KOM MEDIA GROUP, INC., BRENTWOOD, TN. FILED 9-1-2005.

AMERICAN MUSIC CHANNEL

THE MARK CONSISTS OF STANDARD CHARACTERS WITHOUT CLAIM TO ANY PARTICULAR FONT, STYLE, SIZE, OR COLOR.

NO CLAIM IS MADE TO THE EXCLUSIVE RIGHT TO USE "MUSIC", APART FROM THE MARK AS SHOWN. SEC. 2(F).

CLASS 35—ADVERTISING AND BUSINESS

FOR ON-LINE RETAIL STORE SERVICES IN THE GENRE OF COUNTRY, BLUEGRASS, AMERICANA, AND CONTEMPORARY CHRISTIAN MUSIC FEATURING DOWNLOADABLE PRERECORDED MUSIC AND VIDEOS, RECORDS, COMPACT DISCS, TAPES, DVDS AND VIDEOTAPES (U.S. CLS. 100, 101 AND 102).

FIRST USE 4-1-2000; IN COMMERCE 4-1-2000.

CLASS 38—COMMUNICATION

FOR COMMUNICATION SERVICES, NAMELY, TRANSMITTING STREAMED SOUND AND AUDIO-VISUAL RECORDINGS VIA THE INTERNET (U.S. CLS. 100, 101 AND 104).

FIRST USE 4-1-2000; IN COMMERCE 4-1-2000.

CLASS 41—EDUCATION AND ENTERTAINMENT

FOR ON-LINE ENTERTAINMENT SERVICES, NAMELY, PROVIDING PRERECORDED MUSIC, INFORMATION IN THE FIELD OF COUNTRY, BLUEGRASS, AMERICANA, AND CONTEMPORARY CHRISTIAN MUSIC, AND COMMENTARY AND ARTICLES ABOUT COUNTRY, BLUEGRASS, AMERICANA, AND CONTEMPORARY CHRISTIAN MUSIC, VIA A GLOBAL COMPUTER NETWORK; PROVIDING NEWSLETTERS IN THE FIELD OF COUNTRY, BLUEGRASS, AMERICANA, AND CONTEMPORARY CHRISTIAN MUSIC VIA E-MAIL; ON-LINE ENTERTAINMENT SERVICES, NAMELY, PROVIDING TELEVISION PROGRAMMING AND PRODUCTION SERVICES VIA A GLOBAL COMPUTER NETWORK (U.S. CLS. 100, 101 AND 107).

FIRST USE 4-1-2000; IN COMMERCE 4-1-2000.
BONNIE LUKEN, EXAMINING ATTORNEY

SN 78-723,528. METHVEN LIMITED, AVONDALE, NEW ZEALAND, FILED 9-29-2005.

KISSED BY WATER

THE MARK CONSISTS OF STANDARD CHARACTERS WITHOUT CLAIM TO ANY PARTICULAR FONT, STYLE, SIZE, OR COLOR.

OWNER OF NEW ZEALAND REG. NO. 732051, DATED 2-14-2008, EXPIRES 7-1-2015.

CLASS 6—METAL GOODS

FOR MANUALLY OPERATED METAL PIPES AND PLUMBING EQUIPMENT, NAMELY, METAL PIPES FOR PLUMBING USE (U.S. CLS. 2, 12, 13, 14, 23, 25 AND 50).

CLASS 11—ENVIRONMENTAL CONTROL APPARATUS

FOR HEATING EQUIPMENT, NAMELY, PIPES FOR HEATING BOILERS, THERMOSTATIC VALVES, STEAM GENERATION EQUIPMENT, NAMELY, STEAM GENERATORS, STEAM VALVES, SANITARY EQUIPMENT, NAMELY, PIPES BEING PARTS OF SANITARY FACILITIES AND WATER SUPPLY EQUIPMENT, NAMELY, WATER FAUCET SPOUT, WATER COOLERS; MANUALLY OPERATED METAL VALVES FOR PLUMBING USE (U.S. CLS. 13, 21, 23, 31 AND 34).

CLASS 35—ADVERTISING AND BUSINESS

FOR WHOLESALE DISTRIBUTORSHIPS IN THE FIELD OF PLUMBING AND WATER SUPPLY, RETAIL STORE SERVICES IN THE FIELD OF PLUMBING AND WATER SUPPLY; ADVERTISING SERVICES, NAMELY, CREATING CORPORATE MARKETING CAMPAIGNS FOR OTHERS IN THE FIELD OF PLUMBING AND WATER SUPPLY; BUSINESS MARKETING SERVICES FOR OTHERS IN THE FIELD OF PLUMBING AND WATER SUPPLY, DEMONSTRATION DISPLAY, NAMELY, BUSINESS MERCHANDISING DISPLAY SERVICES IN THE FIELD OF PLUMBING AND WATER SUPPLY; BUSINESS APPRAISALS IN THE FIELD OF PLUMBING AND WATER SUPPLY, AND MARKET, CONSUMER RESEARCH SERVICES IN THE FIELD OF PLUMBING AND WATER SUPPLY; AND FRANCHISING, NAMELY, OFFERING TECHNICAL ASSISTANCE IN THE ESTABLISHMENT AND/OR OPERATION OF PLUMBING STORES; LICENSING OF FLUID CONTROL ENGINEERING, SHOWER TECHNOLOGY, JET TECHNOLOGY AND WATER SUPPLY ENGINEERING IN THE PLUMBING INDUSTRY (U.S. CLS. 100, 101 AND 102).

CLASS 42—SCIENTIFIC AND COMPUTER SERVICES

FOR DESIGN FOR OTHERS IN THE FIELDS OF FLUID CONTROL ENGINEERING, SHOWER TECHNOLOGY, JET TECHNOLOGY AND WATER SUPPLY ENGINEERING; TECHNOLOGY CONSULTATION AND RESEARCH IN THE FIELDS OF FLUID CONTROL ENGINEERING, SHOWER TECHNOLOGY, JET TECHNOLOGY AND WATER SUPPLY ENGINEERING (U.S. CLS. 100 AND 101).

REBECCA EISINGER, EXAMINING ATTORNEY

SN 78-731,444. ANGELINI WINE, LTD., CENTERBROOK, CT. FILED 10-12-2005.

Angelini

THE MARK CONSISTS OF STANDARD CHARACTERS WITHOUT CLAIM TO ANY PARTICULAR FONT, STYLE, SIZE, OR COLOR.
SEC. 2(F).

CLASS 29—MEATS AND PROCESSED FOODS

FOR OLIVE OIL (U.S. CL. 46).

CLASS 33—WINES AND SPIRITS

FOR WINE; WINES (U.S. CLS. 47 AND 49).
FIRST USE 4-7-1986; IN COMMERCE 4-7-1986.
MICHAEL ENGEL, EXAMINING ATTORNEY

SN 78-746,199. SUGARTOWN WORLDWIDE, INC., KING OF PRUSSIA, PA. FILED 11-3-2005.

OLDIES BUT GOODIES

THE MARK CONSISTS OF STANDARD CHARACTERS WITHOUT CLAIM TO ANY PARTICULAR FONT, STYLE, SIZE, OR COLOR.

CLASS 3—COSMETICS AND CLEANING PREPARATIONS

FOR PERFUME, COLOGNE, FRAGRANCES FOR PERSONAL USE AND COSMETICS, NAMELY, FOUNDATION MAKEUP, MASCARA, LIPSTICK, BLUSH, EYE SHADOW, EYELINER, FACE POWDER, LIP LINER; HAND, FACE AND BODY CREAMS AND SKIN CLEANSERS; ESSENTIAL OILS FOR PERSONAL USE, SHAMPOO AND TOILET SOAPS (U.S. CLS. 1, 4, 6, 50, 51 AND 52).

CLASS 9—ELECTRICAL AND SCIENTIFIC APPARATUS

FOR EYEGLASSES, SUNGLASSES AND EYEWEAR CASES (U.S. CLS. 21, 23, 26, 36 AND 38).

CLASS 14—JEWELRY

FOR PRECIOUS AND NON-PRECIOUS JEWELRY; WATCHES (U.S. CLS. 2, 27, 28 AND 50).

CLASS 16—PAPER GOODS AND PRINTED MATTER

FOR AGENDA AND NOTEBOOK PLANNER BOOKS (U.S. CLS. 2, 5, 22, 23, 29, 37, 38 AND 50).

CLASS 18—LEATHER GOODS

FOR TOTE BAGS, HANDBAGS, UMBRELLAS AND KNAPSACKS (U.S. CLS. 1, 2, 3, 22 AND 41).

CLASS 20—FURNITURE AND ARTICLES NOT OTHERWISE CLASSIFIED

FOR FABRIC PICTURE FRAMES (U.S. CLS. 2, 13, 22, 25, 32 AND 50).

CLASS 24—FABRICS

FOR HOUSEHOLD LINENS; FABRICS, NAMELY, COTTON, SILK CLOTH, NYLON, POLYESTER, RAYON AND WOOL FABRIC; HOME FURNISHINGS, NAMELY, BED SHEETS, PILLOW CASES, TABLECLOTHS NOT OF PAPER, DRAPERY, BEDDINGS, NAMELY, BED SPREADS, DUVET COVERS, PILLOW SHAMS AND DUST RUFFLES; BED LINENS, AND TOWELS; KITCHEN TEXTILES, NAMELY, TABLE LINENS, TEXTILE NAPKINS, TEXTILE PLACEMATS AND OVEN MITTS; (U.S. CLS. 42 AND 50).

CLASS 25—CLOTHING

FOR CLOTHING, NAMELY, JEANS, PANTS, SLACKS, SHIRTS, BELTS, JACKETS, SKIRTS, SHORTS, DRESSES, SWEATERS, BLOUSES, SWIMWEAR, GOWNS, SLEEPWEAR, ROBES, RAINCOATS; HEADWEAR, NAMELY, VISORS; CHILDREN'S WEAR, NAMELY, DRESSES, SWEATERS, BLOUSES, SHIRTS, SKIRTS, JEANS, PANTS, SLACKS, AND SHORTS; FOOTWEAR; MEN'S CLOTHING, NAMELY, SWIM TRUNKS, TIES AND BOXER SHORTS (U.S. CLS. 22 AND 39).

CLASS 35—ADVERTISING AND BUSINESS

FOR RETAIL CLOTHING STORES (U.S. CLS. 100, 101 AND 102).
TEJBIR SINGH, EXAMINING ATTORNEY

SN 78-756,053. MOLEIRO, MANUEL, 08021 BARCELONA, SPAIN, FILED 11-17-2005.

SN 78-755,994. MOLEIRO, MANUEL, 08021 BARCELONA, SPAIN, FILED 11-17-2005.

THE ART OF PERFECTION

THE MARK CONSISTS OF STANDARD CHARACTERS WITHOUT CLAIM TO ANY PARTICULAR FONT, STYLE, SIZE, OR COLOR.

CLASS 16—PAPER GOODS AND PRINTED MATTER

FOR BOOKS IN THE FIELD OF ART, HISTORY, RELIGION, ALCHEMY AND/OR BIBLIOPHILY; MANUSCRIPT BOOKS, NON-FICTION AND/OR FICTION BOOKS AND/OR PRINTS AND/OR CALENDARS AND/OR CHARTS ON ART, HISTORY, RELIGION, ALCHEMY AND/OR BIBLIOPHILY; POSTCARDS; CARDBOARD; NOVELS; BIBLES; PRAYER BOOKS; PORTRAITS; PARCHMENT PAPER; BOOK BINDINGS; PRINTED ART REPRODUCTIONS; PAPER; PAINTINGS; MAGAZINES IN THE FIELD OF ART, HISTORY, RELIGION, ALCHEMY AND/OR BIBLIOPHILY; ENGRAVINGS AND THEIR REPRODUCTIONS, GRAPHIC ART REPRODUCTIONS; PAINTINGS AND THEIR REPRODUCTIONS AND/OR REPRODUCTION PAPER IN THE FIELD OF ART, HISTORY, RELIGION, ALCHEMY AND/OR BIBLIOPHILY (U.S. CLS. 2, 5, 22, 23, 29, 37, 38 AND 50).
FIRST USE 10-21-2004; IN COMMERCE 10-21-2004.

CLASS 35—ADVERTISING AND BUSINESS

FOR ADVERTISING AND ADVERTISEMENT SERVICES; COMMERCIAL MANAGEMENT; PUBLICATION OF PUBLICITY TEXTS; PUBLICATION OF ADVERTISING TEXTS; PROMOTING THE GOODS AND SERVICES OF OTHERS BY MEANS OF OPERATING AN ON-LINE SHOPPING MALL; BUSINESS INTERMEDIARY AND ADVISORY SERVICES IN THE FIELD OF SELLING PRODUCTS AND RENDERING SERVICES; EXPORT AND IMPORT AGENCIES; ADMINISTRATION OF CULTURAL AND EDUCATIONAL EXCHANGE PROGRAMS; PRODUCT MERCHANDISING; ELECTRONIC RETAILING SERVICES VIA COMPUTER FEATURING PRINTED PRODUCTS, NAMELY, BOOKS, CHARTS, MAPS, AND SCULPTURES; DOCUMENT REPRODUCTION (U.S. CLS. 100, 101 AND 102).
FIRST USE 10-21-2004; IN COMMERCE 10-21-2004.

CLASS 41—EDUCATION AND ENTERTAINMENT

FOR MAGAZINE PUBLISHING; PUBLICATION OF BOOKS, OF MAGAZINES, OF JOURNALS, OF NEWSPAPERS, OF PERIODICALS, OF CATALOGS, OF BROCHURES, OF TEXTS, OF ALMANACS AND JOURNALS AND ORGANIZING EXHIBITIONS ON ART, HISTORY, RELIGION, ALCHEMY AND/OR BIBLIOPHILY; EDUCATIONAL AND ENTERTAINMENT SERVICES, NAMELY, PROVIDING MOTIVATIONAL AND EDUCATIONAL SPEAKERS IN THE FIELD OF ART, HISTORY, RELIGION, ALCHEMY AND/OR BIBLIOPHILY (U.S. CLS. 100, 101 AND 107).
FIRST USE 10-21-2004; IN COMMERCE 10-21-2004.
ROBIN CHOSID, EXAMINING ATTORNEY



THE MARK CONSIST IN TWO OPPOSITE 90 DEGREES ROTATED TRIANGLES ACCOMPANIED BY TWO BALLS. IT'S AN ABSTRACT SYMBOL AND DOESN'T HAVE A PARTICULAR SENSE.

CLASS 16—PAPER GOODS AND PRINTED MATTER

FOR BOOKS IN THE FIELD OF ART, HISTORY, RELIGION, ALCHEMY AND/OR BIBLIOPHILY; MANUSCRIPT BOOKS, NON-FICTION AND/OR FICTION BOOKS AND/OR PRINTS AND/OR CALENDARS AND/OR CHARTS ON ART, HISTORY, RELIGION, ALCHEMY AND/OR BIBLIOPHILY; POSTCARDS; CARDBOARD; NOVELS; BIBLES; PRAYER BOOKS; PORTRAITS; PARCHMENT PAPER; BOOK BINDINGS; PRINTED ART REPRODUCTIONS; PAPER; PAINTINGS; MAGAZINES IN THE FIELD OF ART, HISTORY, RELIGION, ALCHEMY AND/OR BIBLIOPHILY; ENGRAVINGS AND THEIR REPRODUCTIONS, GRAPHIC ART REPRODUCTIONS; PAINTINGS AND THEIR REPRODUCTIONS AND/OR REPRODUCTION PAPER IN THE FIELD OF ART, HISTORY, RELIGION, ALCHEMY AND/OR BIBLIOPHILY (U.S. CLS. 2, 5, 22, 23, 29, 37, 38 AND 50).
FIRST USE 10-21-2004; IN COMMERCE 10-21-2004.

CLASS 35—ADVERTISING AND BUSINESS

FOR ADVERTISING AND ADVERTISEMENT SERVICES; COMMERCIAL MANAGEMENT; PUBLICATION OF PUBLICITY TEXTS; PUBLICATION OF ADVERTISING TEXTS; PROMOTING THE GOODS AND SERVICES OF OTHERS BY MEANS OF OPERATING AN ON-LINE SHOPPING MALL; BUSINESS INTERMEDIARY AND ADVISORY SERVICES IN THE FIELD OF SELLING PRODUCTS AND RENDERING SERVICES; EXPORT AND IMPORT AGENCIES; ADMINISTRATION OF CULTURAL AND EDUCATIONAL EXCHANGE PROGRAMS; PRODUCT MERCHANDISING; ELECTRONIC RETAILING SERVICES VIA COMPUTER FEATURING PRINTED PRODUCTS, NAMELY, BOOKS, CHARTS, MAPS, AND SCULPTURES; DOCUMENT REPRODUCTION (U.S. CLS. 100, 101 AND 102).
FIRST USE 10-21-2004; IN COMMERCE 10-21-2004.

CLASS 41—EDUCATION AND ENTERTAINMENT

FOR MAGAZINE PUBLISHING; PUBLICATION OF BOOKS, OF MAGAZINES, OF JOURNALS, OF NEWSPAPERS, OF PERIODICALS, OF CATALOGS, OF BROCHURES, OF TEXTS, OF ALMANACS AND JOURNALS AND ORGANIZING EXHIBITIONS ON ART, HISTORY, RELIGION, ALCHEMY AND/OR BIBLIOPHILY; EDUCATIONAL AND ENTERTAINMENT SERVICES, NAMELY, PROVIDING MOTIVATIONAL AND EDUCATIONAL SPEAKERS IN THE FIELD OF ART, HISTORY, RELIGION, ALCHEMY AND/OR BIBLIOPHILY (U.S. CLS. 100, 101 AND 107).

FIRST USE 10-21-2004; IN COMMERCE 10-21-2004.
ROBIN CHOSID, EXAMINING ATTORNEY

SN 78-769,375. LIMBO, INC., SAN MATEO, CA. FILED 12-8-2005.

HOW LOW CAN YOU GO?

THE MARK CONSISTS OF STANDARD CHARACTERS WITHOUT CLAIM TO ANY PARTICULAR FONT, STYLE, SIZE, OR COLOR.

SN 78-766,812. ARIGEN PHARMACEUTICALS, INC., TOKYO, JAPAN, FILED 12-5-2005.

aRigen

THE MARK CONSISTS OF STANDARD CHARACTERS WITHOUT CLAIM TO ANY PARTICULAR FONT, STYLE, SIZE, OR COLOR.

OWNER OF JAPAN REG. NO. 5129189, DATED 4-18-2008, EXPIRES 4-18-2018.

CLASS 3—COSMETICS AND CLEANING PREPARATIONS

FOR COSMETICS (U.S. CLS. 1, 4, 6, 50, 51 AND 52).

CLASS 5—PHARMACEUTICALS

FOR MEDICINES, NAMELY, ANTIPROTOZOAL PHARMACEUTICALS, ANTIVIRAL PHARMACEUTICALS, SYNTHETIC ANTIBACTERIALS, AND ANTIBIOTICS ALL FOR THE TREATMENT OF INFECTIOUS DISEASES IN HUMANS (U.S. CLS. 6, 18, 44, 46, 51 AND 52).

CLASS 42—SCIENTIFIC AND COMPUTER SERVICES

FOR TESTING, INSPECTION OR RESEARCH OF PHARMACEUTICALS, COSMETICS OR FOODSTUFFS; RESEARCH ON BUILDING CONSTRUCTION OR CITY PLANNING; TESTING OR RESEARCH ON PREVENTION OF POLLUTION; TESTING OR RESEARCH ON ELECTRICITY; TESTING OR RESEARCH ON CIVIL ENGINEERING; TESTING, INSPECTION OR RESEARCH ON AGRICULTURE, LIVESTOCK BREEDING OR FISHERIES; TESTING OR RESEARCH ON MACHINES, APPARATUS AND INSTRUMENTS (U.S. CLS. 100 AND 101).

ALLISON HOLTZ, EXAMINING ATTORNEY

CLASS 35—ADVERTISING AND BUSINESS

FOR PROVIDING INFORMATION DIRECTORY SERVICES FOR A WIDE VARIETY OF TOPICS IN THE FIELDS OF SHOPPING, RETAILING, ELECTRONIC COMMERCE, MOBILE COMMUNICATION PRODUCTS AND SERVICES, AND ENTERTAINMENT PRODUCTS, PROGRAMMING, AND SERVICES; PROVIDING REFERRALS TO WEB SITES THAT PROVIDE A WIDE VARIETY OF INFORMATION, PRODUCTS AND SERVICES IN THE FIELDS OF SHOPPING, RETAILING, AND ELECTRONIC COMMERCE, AND MOBILE COMMUNICATION PRODUCTS AND SERVICES; PROVIDING REFERRALS TO WEB SITES THAT PROVIDE A WIDE VARIETY OF INFORMATION, PRODUCTS AND SERVICES IN THE FIELD OF ENTERTAINMENT PRODUCTS, PROGRAMMING, AND SERVICES; AUCTION AND REVERSE AUCTION SERVICES; CONDUCTING, ORGANIZING, AND HOSTING AUCTIONS ACCESSIBLE VIA MOBILE PHONES; CONDUCTING, ORGANIZING AND HOSTING AUCTIONS ACCESSIBLE VIA COMPUTER AND TELECOMMUNICATION NETWORKS; CUSTOMER LOYALTY PROGRAM PROVIDING POINTS OR CREDITS TO SERVICE USERS THAT CAN BE REDEEMED FOR A WIDE VARIETY OF GOODS AND SERVICES; REDEMPTION SERVICES ALLOWING POINTS OR CREDITS ACCRUED BY SERVICE USERS TO BE REDEEMED FOR A WIDE VARIETY OF GOODS AND SERVICES; PROVIDING A MARKETPLACE FOR THE SALE, TRADE, AND PURCHASE OF GOODS AND SERVICES ACCESSIBLE VIA MOBILE PHONES AND COMPUTER AND TELECOMMUNICATION NETWORKS; PROVIDING ELECTRONIC COMMUNICATIONS NETWORK SITES FOR THE SALE, TRADE, AND PURCHASE OF GOODS AND SERVICES; FACILITATING THE SALE, TRADE, AND PURCHASE OF GOODS AND SERVICES BY OTHERS VIA ELECTRONIC COMMUNICATIONS NETWORKS; EXCHANGE SERVICES, NAMELY ARRANGING AND COORDINATING EXCHANGES, TRADES, AND DISPOSAL OF GOODS AND SERVICES; ONLINE RETAIL STORE SERVICES FEATURING APPAREL, CDS, DVDS, COMPUTER GRAPHICS AND IMAGES, SOUND FILES AND RING TONES, BOOKS, COMIC BOOKS, TOYS, CONSUMER AND OFFICE ELECTRONICS PRODUCTS, TRAVEL AND VACATION PRODUCTS, ACTIVITY AND EXPERIENCE PRODUCTS, LUXURY GOODS, VEHICLES AND GENERAL MERCHANDISE; ORDER FULFILLMENT SERVICES; OFFERING SUBSCRIPTIONS TO RECEIVE ALERTS AND UPDATES, INCLUDING NEWS, TRIVIA, HUMOR QUOTATIONS, PREDICTIONS, AND FORECASTS, VIA MOBILE PHONES, WEBSITES, AND NETWORK-ENABLED APPLICATIONS (U.S. CLS. 100, 101 AND 102).

CLASS 38—COMMUNICATION

FOR CHAT AND INSTANT MESSAGING SERVICES ACCESSIBLE VIA MOBILE PHONES, AND COMPUTER AND TELECOMMUNICATION NETWORKS (U.S. CLS. 100, 101 AND 104).

CLASS 41—EDUCATION AND ENTERTAINMENT

FOR PROVIDING SWEEPSTAKES AND CONTESTS VIA MOBILE PHONES AND COMPUTER AND TELECOMMUNICATION NETWORKS; ENTERTAINMENT SERVICES, NAMELY, PROVIDING COMPETITIONS FOR PRIZES VIA TEXT MESSAGING AND NETWORK-ENABLED APPLICATIONS USING MOBILE PHONES, AND VIA WEB SITES AND NETWORK-ENABLED APPLICATIONS ON COMPUTER AND TELECOMMUNICATION NETWORKS (U.S. CLS. 100, 101 AND 107).

CLASS 42—SCIENTIFIC AND COMPUTER SERVICES

FOR PROVIDING A WEBSITE ENABLING USERS TO VIEW, COMMENT ON, POST AND SHARE PHOTOS, VIDEOS, AUDIO, MUSIC, MULTIMEDIA CONTENT, BLOGS, PERSONAL PAGES, COMMUNITY AND USER-CONTRIBUTED CONTENT VIA MOBILE PHONES AND COMPUTER AND TELECOMMUNICATION NETWORKS (U.S. CLS. 100 AND 101).

ALICE SUE CARRUTHERS, EXAMINING ATTORNEY

SN 78-780,487. HSP GAMING, LP, PHILADELPHIA, PA. FILED 12-23-2005.

SUGAR HOUSE CASINO

THE MARK CONSISTS OF STANDARD CHARACTERS WITHOUT CLAIM TO ANY PARTICULAR FONT, STYLE, SIZE, OR COLOR.

NO CLAIM IS MADE TO THE EXCLUSIVE RIGHT TO USE "CASINO", APART FROM THE MARK AS SHOWN.

CLASS 41—EDUCATION AND ENTERTAINMENT

FOR CASINO SERVICES (U.S. CLS. 100, 101 AND 107).

CLASS 43—HOTEL AND RESTAURANT SERVICES

FOR HOTEL BAR AND RESTAURANT SERVICES, AND COCKTAIL LOUNGES; CARRY-OUT RESTAURANTS; CATERING FOR THE PROVISION OF FOOD AND BEVERAGES (U.S. CLS. 100 AND 101).

JUSTINE D. PARKER, EXAMINING ATTORNEY

SN 78-784,813. HOME BOX OFFICE, INC., NEW YORK, NY. FILED 1-4-2006.

CATHOUSE

THE MARK CONSISTS OF STANDARD CHARACTERS WITHOUT CLAIM TO ANY PARTICULAR FONT, STYLE, SIZE, OR COLOR.

SEC. 2(F).

CLASS 9—ELECTRICAL AND SCIENTIFIC APPARATUS

FOR PRE-RECORDED DVD'S FEATURING CONTENT FROM OR RELATING TO A DRAMATIC TELEVISION SERIES CONCERNING A LEGAL BROTHEL. (U.S. CLS. 21, 23, 26, 36 AND 38).

FIRST USE 6-7-2005; IN COMMERCE 6-7-2005.

CLASS 41—EDUCATION AND ENTERTAINMENT

FOR ENTERTAINMENT SERVICES IN THE NATURE OF AN ONGOING DRAMATIC TELEVISION PROGRAM SERIES (U.S. CLS. 100, 101 AND 107).

FIRST USE 12-8-2002; IN COMMERCE 12-8-2002.
MELVIN AXILBUND, EXAMINING ATTORNEY

SN 78-789,844. NORTHWEST FARM CREDIT SERVICES, ACA, SPOKANE, WA. FILED 1-11-2006.



OWNER OF U.S. REG. NOS. 2,344,215 AND 2,559,903.
NO CLAIM IS MADE TO THE EXCLUSIVE RIGHT TO USE "FARM CREDIT SERVICES", APART FROM THE MARK AS SHOWN.

THE MARK CONSISTS OF THE WORDS "NORTHWEST FARM CREDIT SERVICES" AS SHOWN AND WITH THE BIOSTAR.

CLASS 36—INSURANCE AND FINANCIAL

FOR BANKING SERVICES; MORTGAGE LENDING SERVICES; AGRICULTURAL, FISHING AND TIMBER LOANS, NAMELY, INSTALLMENTS LOANS, REAL PROPERTY LOANS, TIMBER LOANS, OPERATIONS LOANS, FACILITIES LOANS, PRODUCTION LOANS, MACHINERY LOANS, EQUIPMENT LOANS, MARKETING LOANS AND WORKING CAPITAL LOANS; LOAN FINANCING; PROVIDING LOAN FINANCING AND CREDIT SERVICES, AND LOAN EVALUATION AND PROCESSING SERVICES, TO DIRECT SUPPLIERS AND LENDERS OF AGRICULTURAL PRODUCTS; EXTENDING CREDIT FOR THE PURCHASE OF AGRICULTURAL PRODUCTS; LEASE PURCHASE FINANCING AND LOANS; LEASING SERVICES FOR VEHICLES FOR USE IN AGRICULTURAL, FISHING AND TIMBER OPERATIONS (U.S. CLS. 100, 101 AND 102).

FIRST USE 12-30-2005; IN COMMERCE 12-30-2005.

CLASS 39—TRANSPORTATION AND STORAGE

FOR LEASING SERVICES FOR VEHICLES, NAMELY, TRUCKS, HARVESTERS, TRACTORS, COMBINES, AND SERVICE TRUCKS, FOR USE IN AGRICULTURAL AND TIMBER OPERATIONS; AND/OR LEASING SERVICES FOR VEHICLES, NAMELY, BOATS, FOR USE IN FISHING OPERATIONS (U.S. CLS. 100 AND 105).

PAULA MAHONEY, EXAMINING ATTORNEY

SN 78-792,580. BROADCOM CORPORATION, IRVINE, CA.
FILED 1-16-2006.

POWERED BY BROADVOICE

THE MARK CONSISTS OF STANDARD CHARACTERS WITHOUT CLAIM TO ANY PARTICULAR FONT, STYLE, SIZE, OR COLOR.
OWNER OF U.S. REG. NO. 2,913,502.

CLASS 9—ELECTRICAL AND SCIENTIFIC APPARATUS

FOR COMPUTER HARDWARE; INTEGRATED CIRCUITS; COMPUTER SOFTWARE FOR USE WITH VOICE OVER INTERNET PROTOCOL TECHNOLOGY; COMMUNICATION, INTEROPERABILITY AND CONNECTIVITY, AND FOR CONTROLLING AND USING INTEGRATED CIRCUITS; COMPUTER TELEPHONY SOFTWARE THAT ENABLES TELEPHONE ACTIVITIES TO BE PERFORMED THROUGH A COMPUTER; VOICE COMPRESSION AND DECOMPRESSION COMPUTER SOFTWARE (U.S. CLS. 21, 23, 26, 36 AND 38).

CLASS 42—SCIENTIFIC AND COMPUTER SERVICES

FOR DESIGN FOR OTHERS OF COMPUTER HARDWARE, INTEGRATED CIRCUITS, COMPUTER SOFTWARE, AND NETWORKING SYSTEMS (U.S. CLS. 100 AND 101).
PAUL F. GAST, EXAMINING ATTORNEY

SN 78-798,645. KRONOSPAN TECHNICAL COMPANY, LTD., ENGOMI, CYPRUS, FILED 1-24-2006.

Krono Original

THE MARK CONSISTS OF STANDARD CHARACTERS WITHOUT CLAIM TO ANY PARTICULAR FONT, STYLE, SIZE, OR COLOR.
OWNER OF U.S. REG. NOS. 2,425,454, 2,480,225 AND 2,508,923.

NO CLAIM IS MADE TO THE EXCLUSIVE RIGHT TO USE "ORIGINAL", APART FROM THE MARK AS SHOWN.

CLASS 19—NON-METALLIC BUILDING MATERIALS

FOR NON-METALLIC BUILDING MATERIALS WHOLLY OR MAINLY OF WOOD, NAMELY, PANELS, STRIPS, RODS AND SLABS FOR BUILDING PURPOSES; GLUED HARDBOARD, CHIPBOARD AND FIBREBOARD; PARQUET FLOORING AND PARQUET SLABS, WHOLLY OR MAINLY OF WOOD; HIGH PRESSURE LAMINATES FOR FLOOR COVERINGS; LUMBER; LAMINATED AND NON-LAMINATED MEDIUM DENSITY FIBREBOARD PLATES, HIGH DENSITY FIBREBOARD PLATES, ORIENTED STRAND BOARDS, AND PRESS BOARDS; NON-METAL DOOR FRAMES; PLANKS; NON-METALLIC BUILDING SEPARATING PLATES; NON-METAL ROOF SHINGLES; WALLBOARDS; PAPERBOARDS FOR CONSTRUCTION; WOOD VENEER; NON-METALLIC FENCES; NON-METALLIC WINDOW FRAMES; WOOD STRIPS FOR USE IN BUILDING AND CONSTRUCTION; NON-METALLIC DOORS AND DOOR PANELS (U.S. CLS. 1, 12, 33 AND 50).

CLASS 27—FLOOR COVERINGS

FOR CARPETS, RUGS, MATS AND MATTING, LINOLEUM FOR COVERING EXISTING FLOORS; DOORMATS OF TEXTILE, PLASTIC AND NON-TEXTILE FIBERS; WOOD AND WOOD SUBSTITUTE, NAMELY, FIBREBOARD, PLASTIC LINOLEUM AND CORK FOR USE AS FLOOR COVERINGS; PROTECTIVE AND VINYL FLOOR COVERINGS; LAMINATE PANELS USED AS FLOOR COVERINGS (U.S. CLS. 19, 20, 37, 42 AND 50).

MICHAEL LEWIS, EXAMINING ATTORNEY

SN 78-812,571. CENTRO DE TECNOLOGIA DE LAS COMUNICACIONES, S.A., CAMPANILLAS (MALAGA), SPAIN, FILED 2-10-2006.



PRIORITY CLAIMED UNDER SEC. 44(D) ON SPAIN APPLICATION NO. 2.682.412, FILED 11-29-2005.

OWNER OF SPAIN REG. NO. 2682412, DATED 10-26-2006, EXPIRES 11-29-2015.

NO CLAIM IS MADE TO THE EXCLUSIVE RIGHT TO USE "WIRELESS", APART FROM THE MARK AS SHOWN.

THE COLOR(S) DARK BLUE, BLUE, LIGHT BLUE, AND GREEN IS/ARE CLAIMED AS A FEATURE OF THE MARK.

THE MARK CONSISTS OF THE WORDING "AT4 WIRELESS" APPEARING IN DARK BLUE. A DESIGN CONSISTING OF VARIOUS INCOMPLETE CIRCLES WITHIN ONE ANOTHER ALTERNATING IN BLUE, LIGHT BLUE, AND GREEN WITH A GREEN CHECK-MARK ALONG THE EDGE APPEARS TO THE RIGHT OF THE WORDING "AT4" AND ABOVE "WIRELESS".

CLASS 9—ELECTRICAL AND SCIENTIFIC APPARATUS

FOR SOFTWARE FOR OPERATING MOBILE TELEPHONES, WIRELESS TELEPHONY, AND SHORT-RANGE RADIO TECHNOLOGY FOR WIRELESS PERSONAL AREA NETWORKS (PANS) IN THE FIELD OF TELECOMMUNICATIONS; SOFTWARE FOR CONTROLLING AND TESTING MOBILE TELEPHONES, WIRELESS TELEPHONY, AND SHORT-RANGE RADIO TECHNOLOGY FOR WIRELESS PAN SYSTEMS IN THE FIELD OF TELECOMMUNICATIONS; TESTING APPARATUS FOR MOBILE TELEPHONY, WIRELESS TELEPHONY, AND SHORT-RANGE RADIO TECHNOLOGY FOR WIRELESS PAN SYSTEMS IN CONNECTION WITH CONFORMANCE AND CERTIFICATION REQUIREMENTS FOR WORLDWIDE INTEROPERABILITY FOR MICROWAVE ACCESS (WIMAX), WIRELESS PERSONAL AREA NETWORKS (WPAN), RADIO FREQUENCY IDENTIFICATION (RFID) AND GLOBAL SYSTEM FOR MOBILE COMMUNICATIONS (GSM), UNIVERSAL MOBILE TELECOMMUNICATIONS SYSTEM (UMTS) RELATED TECHNOLOGIES; MEASURING AND CONTROL DEVICES FOR MOBILE TELEPHONES, WIRELESS TELEPHONY, AND SHORT-RANGE RADIO TECHNOLOGY FOR WIRELESS PAN SYSTEMS IN CONNECTION WITH CONFORMANCE AND CERTIFICATION REQUIREMENTS FOR WIMAX, WPAN, RFID AND GSM, UMTS RELATED TECHNOLOGIES; COMPUTER COMPONENTS TESTING AND CALIBRATING EQUIPMENTS (U.S. CLS. 21, 23, 26, 36 AND 38).

CLASS 42—SCIENTIFIC AND COMPUTER SERVICES

FOR TECHNICAL CONSULTATION IN THE FIELD OF TELECOMMUNICATIONS EQUIPMENT; CONSULTATION IN THE FIELD OF GOVERNMENT REGULATION OF TELECOMMUNICATIONS, AND CONSULTATIONS IN THE FIELD OF REGULATORY APPROVAL PAPERWORK FOR TELECOMMUNICATIONS EQUIPMENT AND PROJECTS; TESTING, ANALYSIS AND EVALUATION OF THE GOODS AND SERVICES OF OTHERS, IN THE FIELD OF TELECOMMUNICATIONS, FOR THE PURPOSE OF CERTIFICATION; COMPUTER-AIDED ENGINEERING SERVICES FOR OTHERS; ENGINEERING SERVICES IN THE FIELD OF TELECOMMUNICATION APPARATUS, MOBILE TELEPHONY, WIRELESS TELEPHONY AND SHORT-RANGE RADIO TECHNOLOGY FOR WIRELESS PAN SYSTEMS; ACCREDITATION SERVICES, NAMELY, DEVELOPING, EVALUATING, AND TESTING STANDARDS FOR TELECOMMUNICATION APPARATUS FOR THE PURPOSE OF ACCREDITATION; TESTING OR RESEARCH ON MACHINES, APPARATUS AND INSTRUMENTS; TESTING, ANALYSIS AND EVALUATION OF THE GOODS AND SERVICES OF THE OTHERS FOR THE PURPOSE OF CERTIFICATION (U.S. CLS. 100 AND 101).

SANDRA MANIOS, EXAMINING ATTORNEY

CLASS 29—MEATS AND PROCESSED FOODS

FOR SOUPS, NAMELY, READY TO EAT SOUPS, INSTANT SOUP MIXES; RAMEN NOODLE SOUP PROVIDED IN CUPS; INSTANT SOUP PROVIDED IN CUPS; DRY MIX FOR PREPARING INSTANT BLACK BEANS AND REFRIED BEANS; DRY MIXES CONSISTING PRIMARILY OF DEHYDRATED POTATOES, DEHYDRATED VEGETABLES AND SEASONINGS, TO BE USED IN MAKING POTATO DISHES; DRY MIX FOR PREPARING INSTANT HUMMUS; PACKAGED, READY TO EAT, HEAT AND SERVE SHELF STABLE VEGETARIAN MEALS CONSISTING PRIMARILY OF VEGETABLES, NOODLES AND SAUCES, RICE, PASTA, AND PROCESSED BEANS; VEGETABLE BASED SNACK FOOD; DRY PREPARED CHILI MIX CONTAINING PROCESSED WHOLE GRAINS, DEHYDRATED VEGETABLES, SPICES AND SOY FLOUR; DRY MIXES CONSISTING PRIMARILY OF PROCESSED WHOLE GRAINS, SPICES, HERBS AND FLOURS, USED TO MAKE FALAFEL; DRY MIXES CONSISTING PRIMARILY OF PROCESSED GRAINS, PROCESSED EDIBLE SEEDS, PROCESSED PEANUTS, DEHYDRATED VEGETABLES AND SEASONINGS TO BE USED IN MAKING MEATLESS BURGERS (U.S. CL. 46).

CLASS 30—STAPLE FOODS

FOR DRY MIXES CONSISTING PRIMARILY OF RICE, PROCESSED BEANS, LENTILS, DEHYDRATED VEGETABLES AND SEASONINGS, TO BE USED IN MAKING MEALS IN A CUP; DRY MIXES CONSISTING PRIMARILY OF PROCESSED GRAINS AND DRIED FRUIT FOR MAKING HOT CEREAL IN A CUP; DRY MIX FOR PREPARING RICE, MULTIPLE GRAIN RICE, AND COUSCOUS PILAF, COUSCOUS AND COUSCOUS MIX; WILD RICE; BASMATI RICE; JASMINE RICE; ARBORIO RICE; PASTA SALAD MIX; DRY MIXES CONSISTING PRIMARILY OF PASTA NOODLES, DEHYDRATED VEGETABLES AND SEASONINGS, TO BE USED IN MEATLESS DISHES; DRY MIXES CONSISTING PRIMARILY OF PASTA NOODLES, CHEESE AND SEASONINGS, TO BE USED IN MAKING MACARONI AND CHEESE DISHES; AND DRY MIXES CONSISTING PRIMARILY OF GROUND YELLOW CORN, DEHYDRATED VEGETABLES, CHEESES AND SEASONINGS, TO BE USED IN MAKING POLENTA; RICE, NAMELY, READY TO EAT RICE; PASTA; READY TO EAT PASTA NOODLES; DRY MIX FOR PREPARING TABOULI SALAD (U.S. CL. 46).

CLASS 43—HOTEL AND RESTAURANT SERVICES

FOR SNACK BARS (U.S. CLS. 100 AND 101).
MELISSA VALLILLO, EXAMINING ATTORNEY

SN 78-814,555. FANTASTIC FOODS, INC., NAPA, CA. FILED 2-14-2006.



OWNER OF U.S. REG. NOS. 1,656,369, 2,070,953 AND 2,916,377.

NO CLAIM IS MADE TO THE EXCLUSIVE RIGHT TO USE "FOODS", APART FROM THE MARK AS SHOWN.

SN 78-832,666. PELAGO, INC., SEATTLE, WA. FILED 3-8-2006.

PELAGO

THE MARK CONSISTS OF STANDARD CHARACTERS WITHOUT CLAIM TO ANY PARTICULAR FONT, STYLE, SIZE, OR COLOR.

THE FOREIGN WORDING IN THE MARK TRANSLATES INTO ENGLISH AS "SEA".

CLASS 9—ELECTRICAL AND SCIENTIFIC APPARATUS

FOR SOCIAL NETWORKING SOFTWARE APPLICATIONS ON MOBILE AND FIXED COMPUTING DEVICES ENABLING USERS TO LOCATE AND INTERACT WITH OTHER USERS AND GROUPS SHARING SIMILAR INTERESTS OR LOCATIONS; MOBILE AND FIXED SOFTWARE APPLICATIONS TO RENDER VOICE, DATA, IMAGES, AND MESSAGES REGARDING POINTS OF INTEREST, ENTERTAINMENT AND EDUCATION VENUES AND EVENTS, CIVIC EVENTS AND COMMERCIAL ESTABLISHMENTS AND INDIVIDUALS, ALL FOR SOCIAL NETWORKING AND OTHER PURPOSES (U.S. CLS. 21, 23, 26, 36 AND 38).

CLASS 35—ADVERTISING AND BUSINESS

FOR PROVIDING A WEBSITE FEATURING INFORMATION ON COMMERCIAL ESTABLISHMENTS; PROVIDING PURCHASING INFORMATION ON WIRELESS AND WIRED DEVICES IN THE FIELD OF COMMERCIAL ESTABLISHMENTS, ALL FOR SOCIAL NETWORKING AND OTHER PURPOSES (U.S. CLS. 100, 101 AND 102).

CLASS 38—COMMUNICATION

FOR WIRELESS TELECOMMUNICATION SERVICES, NAMELY, TRANSMISSION OF VOICE, DATA, IMAGES, SIGNALS, AND MESSAGES, ALL FOR SOCIAL NETWORKING AND OTHER PURPOSES (U.S. CLS. 100, 101 AND 104).

CLASS 39—TRANSPORTATION AND STORAGE

FOR WIRELESS AND FIXED COMPUTER SERVICES PROVIDING MAPS AND DIRECTIONS BETWEEN LOCATIONS; PROVIDING INFORMATION REGARDING POINTS OF INTEREST, NAMELY, TRAVEL INFORMATION, ALL FOR SOCIAL NETWORKING AND OTHER PURPOSES (U.S. CLS. 100 AND 105).

CLASS 41—EDUCATION AND ENTERTAINMENT

FOR ENTERTAINMENT SERVICES, NAMELY, ARRANGING FOR TICKET RESERVATIONS FOR MOVIES, CONCERTS, SHOWS AND OTHER CIVIC AND OTHER ENTERTAINMENT EVENTS; PROVIDING A WEBSITE FEATURING INFORMATION ON POINTS OF INTEREST, ENTERTAINMENT AND EDUCATION VENUES AND EVENTS, AND CIVIC EVENTS; PROVIDING INFORMATION ON WIRELESS AND WIRED DEVICES IN THE FIELD OF POINTS OF INTEREST, ENTERTAINMENT AND EDUCATION VENUES AND EVENTS, AND CIVIC EVENTS, ALL FOR SOCIAL NETWORKING AND OTHER PURPOSES (U.S. CLS. 100, 101 AND 107).

CLASS 42—SCIENTIFIC AND COMPUTER SERVICES

FOR PROVIDING SEARCH ENGINE SERVICES FOR USER-DEFINED SEARCHING, ALL FOR SOCIAL NETWORKING AND OTHER PURPOSES (U.S. CLS. 100 AND 101).

CLASS 43—HOTEL AND RESTAURANT SERVICES

FOR ARRANGING FOR RESTAURANT RESERVATIONS; PROVIDING INFORMATION ABOUT RESTAURANTS, ALL FOR SOCIAL NETWORKING AND OTHER PURPOSES (U.S. CLS. 100 AND 101).

CLASS 45—PERSONAL AND LEGAL SERVICES

FOR ONLINE SOCIAL NETWORKING SERVICES; PROVIDING A WEBSITE FEATURING INFORMATION ON INDIVIDUALS FOR SOCIAL NETWORKING PURPOSES AND PROVIDING INFORMATION ON INDIVIDUALS FOR SOCIAL NETWORKING PURPOSES (U.S. CLS. 100 AND 101).

LEIGH CAROLINE CASE, EXAMINING ATTORNEY

SN 78-834,829. LIGHTSPEED MANAGEMENT COMPANY L.L.C., MENLO PARK, CA. FILED 3-10-2006.

LIGHTSPEED CAPITAL

THE MARK CONSISTS OF STANDARD CHARACTERS WITHOUT CLAIM TO ANY PARTICULAR FONT, STYLE, SIZE, OR COLOR.

NO CLAIM IS MADE TO THE EXCLUSIVE RIGHT TO USE "CAPITAL", APART FROM THE MARK AS SHOWN.

CLASS 35—ADVERTISING AND BUSINESS

FOR BUSINESS CONSULTATION SERVICES (U.S. CLS. 100, 101 AND 102).

CLASS 36—INSURANCE AND FINANCIAL

FOR VENTURE CAPITAL INVESTMENT SERVICES, VENTURE CAPITAL SERVICES, NAMELY, PROVIDING FINANCING TO EMERGING AND START-UP COMPANIES; INVESTMENT BANKING SERVICES; PRIVATE EQUITY SERVICES, NAMELY, PRIVATE EQUITY INVESTMENT AND FINANCING SERVICES, STRUCTURING AND PARTICIPATING IN EQUITY AND DEBT FINANCINGS, SOURCING INVESTMENTS, IDENTIFICATION OF INVESTORS, ADVISING ON FUND RAISING MATERIALS, IDENTIFYING POTENTIAL ACQUISITIONS AND ACQUISITION TARGETS, ADVISING ON IPO PLANNING AND EXECUTION AND RAISING FUNDS FROM INSTITUTIONAL AND INDIVIDUAL INVESTORS AND PROVIDING FUND MANAGEMENT SERVICES (U.S. CLS. 100, 101 AND 102).

INGRID C. EULIN, EXAMINING ATTORNEY

SN 78-844,220. HASHIMA CO., LTD., GIFU-CITY, JAPAN, FILED 3-23-2006.

WING ISLAND

THE MARK CONSISTS OF STANDARD CHARACTERS WITHOUT CLAIM TO ANY PARTICULAR FONT, STYLE, SIZE, OR COLOR.

CLASS 2—PAINTS

FOR DYESTUFFS; INK JET CARTRIDGES FILLED; INK JET PRINTER INK; INK CARTRIDGES FOR COMPUTER PRINTERS; INK SUBLIMED BY HEATING, NAMELY, SUBLIMATION DYE; DRY INKS (U.S. CLS. 6, 11 AND 16).

CLASS 7—MACHINERY

FOR ELECTRIC CLOTHING HOT PRESSES; ROLLER PRESSES FOR USE IN PRESSING TEXTILES, CLOTHING, AND FABRICS; ROLLER PRESSES FOR TRANSFERRING PATTERNS, DESIGNS, PICTURES, AND COLORS TO TEXTILES, CLOTHING, FABRICS, TILES, SIGN BOARDS AND CONTAINERS; MACHINES, NAMELY, HEAT TRANSFER PRESSES; MACHINES, NAMELY, SUBLIMATION HEAT TRANSFER PRESSES (U.S. CLS. 13, 19, 21, 23, 31, 34 AND 35).

CLASS 40—MATERIAL TREATMENT

FOR PRINTING OF PATTERNS, DESIGNS, PICTURES, AND COLORS ON TEXTILES, CLOTHING, OR FABRICS; DYEING OF TEXTILES, CLOTHING OR FABRICS; THERMAL TRANSFER PRINTING OF PATTERNS, DESIGNS, PICTURES, AND COLORS ON TEXTILES, CLOTHING, FABRICS, TILES, SIGN BOARDS, AND CONTAINERS; SUBLIMATION HEAT TRANSFER PRINTING OF PATTERNS, DESIGNS, PICTURES, AND COLORS ON TEXTILES, CLOTHING, TILES, SIGN BOARDS AND CONTAINERS (U.S. CLS. 100, 103 AND 106).

PAUL CROWLEY, EXAMINING ATTORNEY

CLASS 9—ELECTRICAL AND SCIENTIFIC APPARATUS

FOR DOWNLOADABLE DIGITAL MEDIA, NAMELY, DOWNLOADABLE PHOTOGRAPHIC, VIDEO, AUDIO AND TEXT FILES FEATURING THE SUBJECT MATTER OF MAN AND HUMANITY, WILDLIFE, NATURE, GEOGRAPHY, ARCHITECTURE, ART, CULTURE, THE ABSTRACT, CONCEPTUALIZATION, SCIENCE, TRANSPORTATION, SPORTS, TRAVEL, INDUSTRY, COMMERCE AND OTHER SUBJECTS OF PHOTOGRAPHY INTENDED FOR PUBLICATION IN PRINTED AND ELECTRONIC FORM, OVER AN ELECTRONIC COMMUNICATIONS NETWORK (U.S. CLS. 21, 23, 26, 36 AND 38).

CLASS 41—EDUCATION AND ENTERTAINMENT

FOR ENTERTAINMENT SERVICES, NAMELY, PROVIDING AN ON-LINE GALLERY WEBSITE FEATURING PHOTOGRAPHIC PRESENTATIONS IN THE FIELD OF PHOTOGRAPHY AND PROVIDING AN ON-LINE COMPUTER DATABASE FEATURING INFORMATION REGARDING PHOTOGRAPHY AND ART VIA A GLOBAL COMMUNICATION NETWORK AND COMPUTER NETWORK (U.S. CLS. 100, 101 AND 107).

CLASS 42—SCIENTIFIC AND COMPUTER SERVICES

FOR COMPUTER SERVICES, NAMELY, PROVIDING SEARCH ENGINES AND IMAGE BASED SEARCH ENGINES FOR OBTAINING DATA FROM AN IMAGE DATABASE AND ACCESSIBLE VIA A GLOBAL COMPUTER NETWORK (U.S. CLS. 100 AND 101).

WILLIAM ROSSMAN, EXAMINING ATTORNEY

SN 78-845,654. YO BRANDS, LLC, CHARLOTTE, NC. FILED 3-24-2006.

YO!

THE MARK CONSISTS OF STANDARD CHARACTERS WITHOUT CLAIM TO ANY PARTICULAR FONT, STYLE, SIZE, OR COLOR.

CLASS 5—PHARMACEUTICALS

FOR NUTRACEUTICALS, NAMELY, ENERGY BARS IN THE NATURE OF VITAMIN AND MINERALS FORMED AND PACKAGED AS BARS, CHEWABLE TABLETS, NAMELY, CHEWABLE VITAMIN TABLETS; DIETARY SUPPLEMENTS, NUTRITIONAL SUPPLEMENTS, AND FOOD SUPPLEMENTS (U.S. CLS. 6, 18, 44, 46, 51 AND 52).

CLASS 32—LIGHT BEVERAGES

FOR ENERGY DRINKS (U.S. CLS. 45, 46 AND 48).
ANDREA K. NADELMAN, EXAMINING ATTORNEY

SN 78-862,374. HOWLETT, IAN, GRAHAM, OXFORD, UNITED KINGDOM, FILED 4-16-2006.

The Faculty of Trading

SN 78-855,306. ALAMY LIMITED, ABINGDON, UNITED KINGDOM, FILED 4-6-2006.

ALAMY SPEEDLOAD

THE MARK CONSISTS OF STANDARD CHARACTERS WITHOUT CLAIM TO ANY PARTICULAR FONT, STYLE, SIZE, OR COLOR.

OWNER OF UNITED KINGDOM REG. NO. 2403349, DATED 3-24-2006, EXPIRES 3-24-2016.

THE MARK CONSISTS OF STANDARD CHARACTERS WITHOUT CLAIM TO ANY PARTICULAR FONT, STYLE, SIZE, OR COLOR.

PRIORITY CLAIMED UNDER SEC. 44(D) ON UNITED KINGDOM APPLICATION NO. REF200650266, FILED 4-16-2006.

OWNER OF UNITED KINGDOM REG. NO. 2419478, DATED 4-18-2006, EXPIRES 4-16-2016.

NO CLAIM IS MADE TO THE EXCLUSIVE RIGHT TO USE "TRADING", APART FROM THE MARK AS SHOWN.

CLASS 9—ELECTRICAL AND SCIENTIFIC APPARATUS

FOR COMPUTER GAME PROGRAMS; COMPUTER GAME SOFTWARE; COMPUTER PROGRAMS FOR THE PROVISION OF FINANCIAL TRAINING; COMPUTER SOFTWARE FOR ACCESSING INFORMATION DIRECTORIES THAT MAY BE DOWNLOADED FROM THE GLOBAL COMPUTER NETWORK; COMPUTER SOFTWARE FOR APPLICATION AND DATABASE INTEGRATION; COMPUTER SOFTWARE FOR CREATING SEARCHABLE DATABASES OF INFORMATION AND DATA; COMPUTER SOFTWARE FOR PROVIDING AN ONLINE DATABASE IN THE FIELD OF TRANSACTION PROCESSING TO UPLOAD TRANSACTIONAL DATA, PROVIDE STATISTICAL ANALYSIS, AND PRODUCE NOTIFICATIONS AND REPORTS; COMPUTER SOFTWARE FOR THE PROVISION OF FINANCIAL TRAINING; COMPUTER SOFTWARE FOR THE PROVISION OF FINANCIAL TRAINING THAT MAY BE DOWNLOADED FROM A GLOBAL COMPUTER NETWORK; COMPUTER SOFTWARE PLATFORMS FOR THE PROVISION OF FINANCIAL TRAINING; ELECTRONIC PUBLICATIONS, NAMELY, MANUALS, BOOKS, PAPERS, MAGAZINES, NEWSLETTERS, JOURNALS, PERIODICALS AND BROCHURES FEATURING FINANCIAL TRAINING RECORDED ON COMPUTER MEDIA; ENCODED MICRO PARTICULATES, TAGS AND TAGGANTS OF PLASTIC, METAL OR SILICATE FOR USE IN THE FIELD OF PASSIVE LABELING, TRACING OR TRACKING OF PERSONS, ANIMALS, VEHICLES OR GOODS OF ANY KIND (U.S. CLS. 21, 23, 26, 36 AND 38).

CLASS 36—INSURANCE AND FINANCIAL

FOR ADVICE RELATING TO INVESTMENTS; COMMODITY INVESTMENT ADVICE; FINANCIAL ANALYSIS AND CONSULTATION; FINANCIAL CONSULTATION; FINANCIAL INFORMATION PROCESSING; FINANCIAL INFORMATION PROVIDED BY ELECTRONIC MEANS; FINANCIAL MANAGEMENT; FINANCIAL PLANNING; FINANCIAL PLANNING CONSULTATION; FINANCIAL PLANNING, NAMELY, THE CREATION OF PERSONALIZED STRATEGIES TO ACHIEVE FINANCIAL INDEPENDENCE; FINANCIAL PORTFOLIO MANAGEMENT; FINANCIAL RESEARCH; FINANCIAL RISK MANAGEMENT; INVESTMENT ADVICE; INVESTMENT ADVISORY SERVICES; INVESTMENT CONSULTATION; INVESTMENT MANAGEMENT; PROVIDING ON-LINE FINANCIAL CALCULATORS; PROVIDING STOCK MARKET INFORMATION; PROVIDING STOCK/SECURITIES MARKET INFORMATION; RISK MANAGEMENT; RISK MANAGEMENT CONSULTATION; STOCK EXCHANGE PRICE QUOTATIONS (U.S. CLS. 100, 101 AND 102).

CLASS 41—EDUCATION AND ENTERTAINMENT

FOR ARRANGING OF SEMINARS AND CONFERENCES; ARRANGING PROFESSIONAL WORKSHOP AND TRAINING COURSES; BOOK AND REVIEW PUBLISHING; BUSINESS TRAINING; COMPUTER EDUCATION TRAINING; COMPUTER EDUCATION TRAINING SERVICES; CONDUCTING EDUCATIONAL EXHIBITIONS IN THE NATURE OF FINANCIAL TRADING; CONDUCTING WORKSHOPS AND SEMINARS IN FINANCIAL TRADING; CORRESPONDENCE SCHOOLS; EDUCATION IN THE FIELD OF FINANCIAL TRADING RENDERED THROUGH CORRESPONDENCE COURSES; EDUCATION SERVICES, NAMELY, MENTORING IN THE FIELD OF FINANCIAL TRADING; EDUCATION SERVICES, NAMELY, ONE-ON-ONE MENTORING IN THE FIELD OF FINANCIAL TRADING; EDUCATION SERVICES, NAMELY, PROVIDING TUTORIAL SESSIONS IN THE FIELD OF FINANCIAL TRADING; EDUCATION SERVICES, NAMELY, PROVIDING TUTORING IN THE FIELD OF FINANCIAL TRADING; EDUCATION SERVICES, NAMELY, PROVIDING CLASSES, SEMINARS, WORKSHOPS, CONFERENCES AND EVENTS IN THE FIELD OF FINANCIAL TRADING; EDUCATIONAL DEMONSTRATIONS; EDUCATIONAL RESEARCH; EDUCATIONAL SERVICES, NAMELY, CONDUCTING PROGRAMS IN THE FIELD OF FINANCIAL TRADING; EDUCATIONAL SERVICES, NAMELY, CONDUCTING ON-LINE EXHIBITIONS AND DISPLAYS AND INTERACTIVE EXHIBITS IN THE

FIELD OF FINANCIAL TRADING; EDUCATIONAL SERVICES, NAMELY, PROVIDING COURSES OF INSTRUCTION AT THE PROFESSIONAL AND NON-PROFESSIONAL LEVEL ; EDUCATIONAL SERVICES, NAMELY, CONDUCTING CLASSES, SEMINARS, WORKSHOPS, CONFERENCES AND EVENTS IN THE FIELD OF FINANCIAL TRADING ; EDUCATIONAL TESTING; ELECTRONIC PUBLISHING SERVICES, NAMELY, PUBLICATION OF TEXT AND GRAPHIC WORKS OF OTHERS ON CD, DVD AND ONLINE FEATURING FINANCIAL TRADING; ENTERTAINMENT SERVICES, NAMELY, PROVIDING AN ON-LINE COMPUTER GAME; ENTERTAINMENT SERVICES, NAMELY, PROVIDING ON-LINE COMPUTER GAMES; INFORMATION ABOUT EDUCATION; INFORMATION ON EDUCATION; ON-LINE EDUCATION CREDIT AND DEGREE EVALUATION AND COMPARISON SERVICES; ON-LINE PUBLICATION OF FINANCIAL TRADING INFORMATION; ONLINE JOURNALS, NAMELY, BLOGS FEATURING FINANCIAL TRADING; ORGANIZING EXHIBITIONS FOR FINANCIAL TRADING; PROVIDING A COMPUTER GAME THAT MAY BE ACCESSED NETWORK-WIDE BY NETWORK USERS; PROVIDING COURSES OF INSTRUCTION AT THE PROFESSIONAL AND NON-PROFESSIONAL LEVEL; PROVIDING NEWSLETTERS IN THE FIELD OF FINANCIAL TRADING VIA E-MAIL; PROVIDING ON-LINE MANUALS, BOOKS, PAPERS, MAGAZINES, NEWSLETTERS, JOURNALS, PERIODICALS AND BROCHURES IN THE FIELD OF FINANCIAL TRADING ; PUBLICATION OF BOOKS; PUBLICATION OF BOOKS, MAGAZINES, ALMANACS AND JOURNALS; PUBLICATION OF BOOKS, OF MAGAZINES, OF JOURNALS, OF NEWSPAPERS, OF PERIODICALS, OF CATALOGS, OF BROCHURES; PUBLICATION OF BROCHURES; PUBLICATION OF DOCUMENTS IN THE FIELD OF TRAINING, SCIENCE, PUBLIC LAW AND SOCIAL AFFAIRS; PUBLICATION OF ELECTRONIC MAGAZINES; PUBLICATION OF ELECTRONIC NEWSPAPERS ACCESSIBLE VIA A GLOBAL COMPUTER NETWORK; PUBLICATION OF JOURNALS; PUBLICATION OF LEAFLETS; PUBLICATION OF MAGAZINES; PUBLICATION OF MANUALS; PUBLICATION OF PRINTED MATTER; PUBLICATION OF TEXT BOOKS; PUBLICATION OF TEXTS, BOOKS, JOURNALS; PUBLICATION OF TEXTS, BOOKS, MAGAZINES AND OTHER PRINTED MATTER; PUBLICATION OF THE EDITORIAL CONTENT OF SITES ACCESSIBLE VIA A GLOBAL COMPUTER NETWORK; TRAINING COURSES IN STRATEGIC PLANNING RELATING TO ADVERTISING, PROMOTION, MARKETING AND BUSINESS; TRAINING IN THE USE AND OPERATION OF FINANCIAL TRADING SYSTEMS; TRAINING SERVICES IN THE FIELD OF FINANCIAL TRADING; WORKSHOPS AND SEMINARS IN THE FIELD OF FINANCIAL TRADING (U.S. CLS. 100, 101 AND 107).

CHERYL CLAYTON, EXAMINING ATTORNEY

SN 78-865,283. BELLAMY, NICHOLAS, FERNY GROVE, AUSTRALIA, FILED 4-19-2006.

WOMAC

THE MARK CONSISTS OF STANDARD CHARACTERS WITHOUT CLAIM TO ANY PARTICULAR FONT, STYLE, SIZE, OR COLOR.

CLASS 16—PAPER GOODS AND PRINTED MATTER

FOR EDUCATIONAL PUBLICATIONS, NAMELY, MANUALS, BROCHURES, BOOKLETS, PAMPHLETS AND MAGAZINES, AND QUESTIONNAIRES IN PAPER FORM IN THE FIELD OF OSTEOARTHRITIS (U.S. CLS. 2, 5, 22, 23, 29, 37, 38 AND 50).

FIRST USE 2-0-1999; IN COMMERCE 2-0-1999.

CLASS 42—SCIENTIFIC AND COMPUTER SERVICES

FOR PROVIDING ONLINE QUESTIONNAIRES IN THE FIELD OF OSTEOARTHRITIS FOR ASSESSING THE SEVERITY OF PAIN, STIFFNESS AND PHYSICAL DISABILITY DUE TO OSTEOARTHRITIS (U.S. CLS. 100 AND 101).

FIRST USE 2-0-1999; IN COMMERCE 2-0-1999.

CLASS 44—MEDICAL, BEAUTY AND AGRICULTURAL SERVICES

FOR CONSULTING SERVICES IN THE FIELD OF HEALTH CARE (U.S. CLS. 100 AND 101).

FIRST USE 2-0-1999; IN COMMERCE 2-0-1999.
DANNEAN HETZEL, EXAMINING ATTORNEY

SN 78-867,120. EOS GMBH ELECTRO OPTICAL SYSTEMS, KRAILLING/MUNCHEN, FED REP GERMANY, FILED 4-21-2006.



Any shape • Anytime • Anywhere

PRIORITY CLAIMED UNDER SEC. 44(D) ON ERPN CMNTY TM OFC APPLICATION NO. CTM004737409, FILED 11-4-2005, REG. NO. CTM004737409, DATED 1-9-2008, EXPIRES 11-4-2015.

OWNER OF U.S. REG. NOS. 1,999,384, 2,754,691 AND 3,018,918.

CLASS 1—CHEMICALS

FOR CHEMICALS USED IN INDUSTRY AND SCIENCE, IN PARTICULAR POWDERS OF PLASTIC FOR THE CONSTRUCTION OF OBJECTS IN A LAYER WISE FASHION BY MEANS OF SELECTIVE THERMAL SOLIDIFICATION; UNPROCESSED ARTIFICIAL RESINS FOR LAYER WISE GENERATIVE BUILDING OF OBJECTS BY SELECTIVE THERMAL SOLIDIFICATION; UNPROCESSED PLASTICS; CERAMIC COMPOUNDS IN GRANULES AND POWDERS FOR THERMAL SOLIDIFICATION (U.S. CLS. 1, 5, 6, 10, 26 AND 46).

CLASS 6—METAL GOODS

FOR SINTERING POWDERS OF METAL OR CONTAINING METAL, IN PARTICULAR FOR THE CONSTRUCTION OF OBJECTS IN A LAYER WISE FASHION BY MEANS OF SELECTIVE THERMAL SOLIDIFICATION; FOUNDRY MOULDS OF METAL (U.S. CLS. 2, 12, 13, 14, 23, 25 AND 50).

CLASS 7—MACHINERY

FOR MACHINES FOR MODEL BUILDING AND SERIES MANUFACTURING, IN PARTICULAR LASER SINTERING MACHINES AND MACHINES FOR THE CONSTRUCTION OF PARTS IN A LAYER WISE FASHION BY THE ACTION OF LASERS OR ANOTHER HEAT SOURCE ON A SOLIDIFIABLE MATERIAL (U.S. CLS. 13, 19, 21, 23, 31, 34 AND 35).

CLASS 9—ELECTRICAL AND SCIENTIFIC APPARATUS

FOR MEASURING, SIGNALING, CHECKING AND SUPERVISION INSTRUMENTS, NAMELY, AS PLCS (PROGRAMMABLE LOGICAL CONTROLLERS), COMPUTERS, AND EMBEDDED CONTROLLERS FOR USE IN MACHINES FOR LAYER WISE GENERATIVE BUILDING OF OBJECTS BY SELECTIVE THERMAL SOLIDIFICATION USED FOR THE GENERATIVE PRODUCTION OF PARTS, PROTOTYPES, MODELS, MOULDS AND TOOLS AND OTHER KINDS OF THREE-DIMENSIONAL OBJECTS; LASERS NOT FOR MEDICAL PURPOSES; APPARATUS FOR RECORDING, TRANSMISSION OR REPRODUCTION OF SOUND OR IMAGES; RECORDED AND UNRECORDED DATA CARRIERS, NAMELY, OPTICAL DISCS, NAMELY, CD'S, CD-ROMS, CD(RW)'S, DVDS, MAGNETO-OPTICAL DISCS, MAGNETIC TAPES, MEMORY CARDS, HARD DISCS, CHANGEABLE HARD DISCS, FLOPPY DISCS, THE RECORDED DISCS FEATURING RECORDED DIGITIZED DATA FOR PRODUCT DESIGNS, MATHEMATICAL AND SCIENTIFIC DATA, SCANNED OR OTHERWISE DIGITIZED REPRESENTATIONS OF PHYSICAL OBJECTS, NAMELY, HUMAN BODIES OR PARTS THEREOF, BUILDINGS, STRUCTURES, GEOGRAPHICAL AND GEOLOGICAL FEATURES; DATA-PROCESSING EQUIPMENT AND COMPUTERS; COMPUTER PROGRAMS FOR USE IN DATA-PROCESSING (U.S. CLS. 21, 23, 26, 36 AND 38).

SN 78-865,534. ADERANT HOLDINGS, INC., ATLANTA, GA. FILED 4-20-2006.

ADERANT

THE MARK CONSISTS OF STANDARD CHARACTERS WITHOUT CLAIM TO ANY PARTICULAR FONT, STYLE, SIZE, OR COLOR.

CLASS 9—ELECTRICAL AND SCIENTIFIC APPARATUS

FOR (BASED ON INTENT TO USE) COMPUTER SOFTWARE FOR PROFESSIONAL FIRMS' CLIENT INTERACTION MANAGEMENT, TIME AND EXPENSE ENTRY, REMOTE TIME AND EXPENSE ENTRY, BILLING, ACCOUNTING AND FINANCIAL MANAGEMENT, BUDGETING AND PROFITABILITY ANALYSIS, DATA WAREHOUSING AND FRAMEWORK TECHNOLOGY FOUNDATION FOR COMPUTER SOFTWARE (U.S. CLS. 21, 23, 26, 36 AND 38).

CLASS 42—SCIENTIFIC AND COMPUTER SERVICES

FOR (BASED ON USE IN COMMERCE) COMPUTER SOFTWARE DEVELOPMENT; PROFESSIONAL CONSULTING SERVICES AND ADVICE ABOUT COMPUTERS AND COMPUTER SOFTWARE AND THE SELECTION, IMPLEMENTATION AND USE OF COMPUTER HARDWARE AND SOFTWARE SYSTEMS FOR OTHERS; MAINTENANCE OF COMPUTER SOFTWARE (U.S. CLS. 100 AND 101).

FIRST USE 8-0-2004; IN COMMERCE 8-0-2004.
MARILYN IZZI, EXAMINING ATTORNEY

CLASS 19—NON-METALLIC BUILDING MATERIALS

FOR FOUNDRY MOULDS, NOT OF METAL (U.S. CLS. 1, 12, 33 AND 50).
ANNE FARRELL, EXAMINING ATTORNEY

SN 78-867,138. EOS GMBH ELECTRO OPTICAL SYSTEMS, KRAILLING/MUNCHEN, FED REP GERMANY, FILED 4-21-2006.

CarbonMide

THE MARK CONSISTS OF STANDARD CHARACTERS WITHOUT CLAIM TO ANY PARTICULAR FONT, STYLE, SIZE, OR COLOR.

PRIORITY CLAIMED UNDER SEC. 44(D) ON FED REP GERMANY APPLICATION NO. CTM4715355, FILED 10-31-2005, REG. NO. 004715355, DATED 1-9-2006, EXPIRES 1-9-2016.

OWNER OF U.S. REG. NO. 3,011,625.

CLASS 1—CHEMICALS

FOR CHEMICALS USED IN INDUSTRY AND SCIENCE, IN PARTICULAR POWDERS OF PLASTIC FOR THE CONSTRUCTION OF OBJECTS IN A LAYER-WISE FASHION BY MEANS OF SELECTIVE THERMAL SOLIDIFICATION; UNPROCESSED ARTIFICIAL RESINS FOR LAYERWISE GENERATIVE BUILDING OF OBJECTS BY SELECTIVE THERMAL SOLIDIFICATION; UNPROCESSED PLASTICS; CERAMIC COMPOUNDS IN GRANULES AND POWDERS FOR THERMAL SOLIDIFICATION (U.S. CLS. 1, 5, 6, 10, 26 AND 46).

CLASS 6—METAL GOODS

FOR SINTERING POWDERS OF METAL OR CONTAINING METAL, IN PARTICULAR FOR THE CONSTRUCTION OF OBJECTS IN A LAYER-WISE FASHION BY MEANS OF SELECTIVE THERMAL SOLIDIFICATION; FOUNDRY MOULDS OF METAL (U.S. CLS. 2, 12, 13, 14, 23, 25 AND 50).

ANNE FARRELL, EXAMINING ATTORNEY

SN 78-871,342. DHX MEDIA LTD., HALIFAX, NOVA SCOTIA, CANADA, FILED 4-27-2006.

DHX MEDIA

THE MARK CONSISTS OF STANDARD CHARACTERS WITHOUT CLAIM TO ANY PARTICULAR FONT, STYLE, SIZE, OR COLOR.

NO CLAIM IS MADE TO THE EXCLUSIVE RIGHT TO USE "MEDIA", APART FROM THE MARK AS SHOWN.

CLASS 9—ELECTRICAL AND SCIENTIFIC APPARATUS

FOR PRE-RECORDED VIDEOS AND DVDS FEATURING DRAMATIC AND COMEDIC PERFORMANCES (U.S. CLS. 21, 23, 26, 36 AND 38).

CLASS 16—PAPER GOODS AND PRINTED MATTER

FOR PRINTED MATTERS, NAMELY, BOOKS AND MAGAZINES FEATURING INFORMATION ON TELEVISION PROGRAMS; PHOTOGRAPHS, PRINTS, POSTERS, STICKERS, STATIONERY, CALENDARS, PAPER BADGES, DIARIES, PERSONAL ORGANIZERS, MAPS, BOOK MARKS, PENCILS, PENS, MARKERS; ARTS AND CRAFTS PAINT KITS; ARTS AND CRAFTS CLAY KITS; TRADING CARDS (U.S. CLS. 2, 5, 22, 23, 29, 37, 38 AND 50).

CLASS 20—FURNITURE AND ARTICLES NOT OTHERWISE CLASSIFIED

FOR SLEEPING BAGS, SLUMBER BAGS (U.S. CLS. 2, 13, 22, 25, 32 AND 50).

CLASS 28—TOYS AND SPORTING GOODS

FOR TOYS, GAMES AND PLAYTHINGS, NAMELY, TOY MODEL HOBBYCRAFT KITS, TOY MODEL CAR KITS; TOY DIE-CAST VEHICLES AND MODEL CARS AND TRAINS; FLYING DISCS, PLAY MAKEUP AND PLAY MASKS, KITES; PLAYING CARDS, PLUSH AND STUFFED TOYS, PUPPETS, PUZZLES, RADIO CONTROLLED TOY VEHICLES, RIDE-ON TOYS; ROBOTIC TOYS, NAMELY, ROBOTIC TOY VEHICLES, TOY ROBOTS, AND TRANSFORMING ROBOTIC TOYS; PLUSH TOYS INCORPORATING SOUND CHIPS; PLAY FIGURES AND ACCESSORIES THEREFOR; ACTION FIGURES AND ACCESSORIES THEREFOR; INFLATABLE WATER TOYS, BATH TOYS, ELECTRONIC LEARNING TOYS; CONSTRUCTION TOYS, NAMELY, TOY BUILDING BLOCKS; TOY VEHICLES, TOY WATCHES, MULTIPLE ACTIVITY TOYS, PARTY FAVORS IN THE NATURE OF SMALL TOYS, WIND-UP TOYS, WATER SQUIRTING TOYS; CARD GAMES, ROLE-PLAYING GAMES, BOARD GAMES; PLAYGROUND BALLS; GYMNASIAC AND SPORTING ARTICLES AND EQUIPMENT, NAMELY, GAME BALLS, PERSONAL FITNESS EXERCISE MATS, EXERCISE BALLS, EXERCISE TRAMPOLINES AND WEIGHTS, FOOTBALLS, BASKETBALLS, BASEBALLS, GOLF BALLS, ICE SKATES, SCOOTERS, ROLLER SKATES, SKATEBOARDS, TOY VINYL POOLS FOR RECREATIONAL USE, AND WATER SLIDES (U.S. CLS. 22, 23, 38 AND 50).

CLASS 35—ADVERTISING AND BUSINESS

FOR COMMERCIAL ADMINISTRATION OF THE FILM AND TELEVISION SERIES LICENSING OF OTHERS (U.S. CLS. 100, 101 AND 102).

CLASS 41—EDUCATION AND ENTERTAINMENT

FOR PRODUCTION AND DISTRIBUTION OF FILMS AND TELEVISION PROGRAMS, PRODUCTION OF FILMS, TELEVISION PROGRAMS, AUDIO VISUAL WORKS, AND VISUAL EFFECTS FOR FILMS, VIDEOS, DVDS, AND TELEVISION (U.S. CLS. 100, 101 AND 107).

CLASS 45—PERSONAL AND LEGAL SERVICES

FOR LICENSING OF FILM AND TELEVISION PROGRAM SERIES (U.S. CLS. 100 AND 101).
ALEXANDER L. POWERS, EXAMINING ATTORNEY

SN 78-874,771, PROVENT HOLDINGS LTD., TORTOLA, BR. VIRGIN ISLANDS, FILED 5-2-2006.



NO CLAIM IS MADE TO THE EXCLUSIVE RIGHT TO USE "SPEED POKER", APART FROM THE MARK AS SHOWN.

CLASS 9—ELECTRICAL AND SCIENTIFIC APPARATUS

FOR DOWNLOADABLE ELECTRONIC PUBLICATIONS PROVIDED ON-LINE FROM DATABASES, THE INTERNET, OR BY ELECTRONIC MAIL IN THE NATURE OF MAGAZINES, JOURNALS, NEWSLETTERS, AND NEWS FLASHES IN THE FIELD OF GAMING INFORMATION, SPORTS EVENTS RESULTS, NEWS EVENTS, OFFERS OF BETS, AND BETTING ODDS; COMPUTER PROGRAMS FOR INTERACTIVE DATA PROCESSING IN THE FIELD OF GAMING INFORMATION, SPORTS EVENTS RESULTS, NEWS EVENTS, OFFERS OF BETS, AND BETTING ODDS; COMPUTERS HAVING INTERACTIVE DATA PROCESSING SYSTEM FUNCTIONS; INTERACTIVE VIDEO GAMES OF VIRTUAL REALITY COMPRISED OF COMPUTER HARDWARE AND SOFTWARE; COMPUTER HARDWARE; COMPUTER GAME PROGRAMS IN THE FIELD OF GAMING AND SPORTS; VIDEO GAME CARTRIDGES; ELECTRONIC AND ELECTROMECHANICAL GAMING TABLE-TOPS WITH VIDEO OUTPUT; DATA PROCESSORS AND COMPACT DISCS FEATURING VIDEO ENTERTAINMENT REGARDING POKER AND INSTRUCTIONAL VIDEO ON POKER GAMES; ELECTRIC TIMER; COUNTDOWN TIMER; GAMING MACHINES, NAMELY, SLOT AND POKER MACHINES (U.S. CLS. 21, 23, 26, 36 AND 38).

CLASS 28—TOYS AND SPORTING GOODS

FOR FLOOR-STANDING UNITS FOR PLAYING ELECTRONIC GAMES OTHER THAN IN CONJUNCTION WITH A TELEVISION OR COMPUTER; PLAYING CARDS; GAMING EQUIPMENT, NAMELY, POKER CHIPS, ROULETTE CHIPS, AND BLACK JACK TABLES; GAMES, NAMELY, BOARD GAMES, ACTION SKILL GAMES, CARD GAMES, ARCADE GAMES, COIN-OPERATED VIDEO GAMES, DICE GAMES, CARD GAMES AND GAMING TABLES FOR BLACKJACK, KENO, CRAPS, ROULETTE, POKER, PONTOON, BOULE, BACCARAT, PUNTO BANCO, CHEMIN DE FER, MINI-DICE, FAN TAN, SIC BO, PAI GOW, PAI GOW POKER, LUCKY WHEEL, CASINO CARD GAME BASED ON CHILDREN'S GAME OF WAR, AND RED DOG; EQUIPMENT SOLD AS A UNIT FOR PLAYING CARD AND BOARD GAMES, PARLOR GAMES, AND PARTY GAMES; APPARATUS FOR ELECTRONIC GAMES OTHER THAN THOSE ADAPTED FOR USE WITH TELEVISION RECEIVERS ONLY, NAMELY, HAND HELD UNIT FOR PLAYING ELECTRONIC AND VIDEO GAMES AND GAMES WITH LIQUID CRYSTAL DISPLAYS; COUNTERS, NAMELY, GAMING EQUIPMENT IN THE FORM OF CHIPS (U.S. CLS. 22, 23, 38 AND 50).

CLASS 35—ADVERTISING AND BUSINESS

FOR ON-LINE ADVERTISING ON THE INTERNET FOR OTHERS; COMPILATION OF COMPUTER DATABASES; MARKETING, ADVERTISING AND PROMOTIONAL SERVICES; PROVISION OF ON-LINE BUSINESS AND COMMERCIAL INFORMATION; PROMOTION OF LIVE ENTERTAINMENT AND POKER TOURNAMENTS; BUSINESS MANAGEMENT OF ENTERTAINMENT FACILITIES (U.S. CLS. 100, 101 AND 102).

CLASS 38—COMMUNICATION

FOR TRANSMISSION OF INFORMATION OVER A GLOBAL COMPUTER NETWORK SUCH AS THE INTERNET INCLUDING MESSAGES, IMAGES AND INFORMATION PERTAINING TO SPORTING EVENTS SUCH AS GAMING AND BETTING INFORMATION INCLUDING ODDS, DIVIDENDS, AND RESULTS, COMMENTARIES AND REPORTS; TRANSMISSION OF SOUND AND VIDEO VIA INTERACTIVE MULTIMEDIA NETWORKS PROVIDING ACCESS AND TELECOMMUNICATIONS CONNECTIONS TO INTERACTIVE COMPUTER DATABASES AND THE INTERNET AND PROVIDING ONLINE COMMUNICATIONS LINKS WHICH TRANSFER THE WEBSITE USER TO OTHER LOCAL AND GLOBAL WEB PAGES; PROVISION OF ACCESS TO AN INFORMATION DATABASE STORED ELECTRONICALLY FOR REMOTE CONSULTATION; PROVIDING TELECOMMUNICATIONS ACCESS TO A DATABASE STORING INFORMATION RELATING TO A VARIETY OF GOODS (U.S. CLS. 100, 101 AND 104).

CLASS 41—EDUCATION AND ENTERTAINMENT

FOR COMPILATION OF SPORTING STATISTICS AND OTHER GAMING STATISTICS, INCLUDING ODDS; NEWS REPORTING SERVICES VIA GLOBAL COMPUTER NETWORK; CASINO FACILITIES; GAMBLING FACILITIES; GAMBLING SERVICES; CONDUCTING AND PROVIDING FACILITIES FOR GAMING EVENTS FEATURING VIDEO POKER MACHINES; PROVIDING FACILITIES FOR GAMING; PROVIDING GAMING MACHINE ENTERTAINMENT PARLORS; COUNTRY CLUBS FOR ENTERTAINMENT OR EDUCATION; PROVISION OF CLUB RECREATION FACILITIES; NIGHT CLUBS; NIGHT CLUB SERVICES; ENTERTAINMENT IN THE NATURE OF VISUAL AND AUDIO PERFORMANCES AND MUSICAL AND VARIETY SHOWS FOR CRUISE SHIPS; ENTERTAINMENT SERVICES, NAMELY, CONDUCTING CONTESTS RELATING TO AMUSEMENT MACHINES; PROVISION OF ENTERTAINMENT FACILITIES, NAMELY, THE PROVISION OF AMUSEMENT FACILITIES PROVIDING ON-LINE ELECTRONIC NON-DOWNLOADABLE PUBLICATIONS, NAMELY, MAGAZINES, JOURNALS, NEWSLETTERS, NEWS FLASHES IN RELATION TO GAMING INFORMATION, SPORTING EVENTS RESULTS, NEWS EVENTS, OFFERS OF BETS, AND BETTING ODDS; PUBLICATION OF ELECTRONIC BOOKS AND JOURNALS ON-LINE; ENTERTAINMENT SERVICES, NAMELY, PROVIDING ON-LINE COMPUTER GAMES BY MEANS OF THE INTERNET; ENTERTAINMENT SERVICES, NAMELY, PROVIDING NON-DOWNLOADABLE COMPUTER GAMES VIA THE INTERNET; PROVISION OF GAMES BY MEANS OF A COMPUTER BASED SYSTEM; PROVISION OF ELECTRONIC GAMING, GAMBLING AND BETTING SERVICES TRANSMITTED VIA A GLOBAL COMPUTER NETWORK SUCH AS THE INTERNET; CASINO SERVICES; PROVISION OF INFORMATION RELATING TO SPORTS, BETTING AND GAMING SERVICES ACCESSIBLE VIA A GLOBAL COMPUTER NETWORK; PROVIDING FACILITIES FOR GAMING, AND PROVIDING GAMBLING, LOTTERY, AND BOOKMAKING SERVICES; PROVISION OF GAMING NEWS ARID INFORMATION OVER A GLOBAL COMPUTER NETWORK SUCH AS THE INTERNET; CREDIT CARD BETTING; PROVIDING ELECTRONIC INFORMATION RELATING TO ENTERTAINMENT, NAMELY, GAMING EVENTS; PROVISION OF ENTERTAINMENT INFORMATION IN THE FIELD OF GAMING, GAMBLING EVENTS; ON-LINE GAMING AND GAMBLING, PROVIDED ON-LINE FROM A COMPUTER DATABASE OR VIA THE INTERNET; PROVIDING INFORMATION, ADVICE, AND ASSISTANCE IN THE FIELD OF PLANNING SPECIAL EVENTS; ORGANIZATION OF POKER TOURNAMENTS; ENTERTAINMENT, NAMELY, A CONTINUING NEWS AND GAMING CABLE TELEVISION AND TELEVISION SHOW; CABLE TELEVISION AND TELEVISION SHOW PRODUCTION; PROVIDING FACILITIES FOR RECREATIONAL ACTIVITIES; PUBLICATION OF NON-DOWNLOADABLE ON LINE ELECTRONIC PUBLICATIONS, NAMELY, MAGAZINES, NEWSLETTERS, BROCHURES AND FLYERS IN THE FIELD OF ENTERTAINMENT (U.S. CLS. 100, 101 AND 107).

MICHELLE DUBOIS, EXAMINING ATTORNEY

SN 78-874,781, PROVENT HOLDINGS LTD., TORTOLA,
BR. VIRGIN ISLANDS, FILED 5-2-2006.



NO CLAIM IS MADE TO THE EXCLUSIVE RIGHT TO USE "SPEED POKER", APART FROM THE MARK AS SHOWN.

CLASS 9—ELECTRICAL AND SCIENTIFIC APPARATUS

FOR DOWNLOADABLE ELECTRONIC PUBLICATIONS PROVIDED ON-LINE FROM DATABASES, THE INTERNET, OR BY ELECTRONIC MAIL IN THE NATURE OF MAGAZINES, JOURNALS, NEWSLETTERS, ARID NEWS FLASHES IN THE FIELD OF GAMING INFORMATION, SPORTS EVENTS RESULTS, NEWS EVENTS, OFFERS OF BETS, AND BETTING ODDS; COMPUTER PROGRAMS FOR INTERACTIVE DATA PROCESSING IN THE FIELD OF GAMING INFORMATION, SPORTS EVENTS RESULTS, NEWS EVENTS, OFFERS OF BETS, AND BETTING ODDS; COMPUTERS HAVING INTERACTIVE DATA PROCESSING SYSTEM FUNCTIONS; INTERACTIVE VIDEO GAMES OF VIRTUAL REALITY COMPRISED OF COMPUTER HARDWARE AND SOFTWARE; COMPUTER HARDWARE; COMPUTER GAME PROGRAMS IN THE FIELD OF GAMING AND SPORTS; VIDEO GAME CARTRIDGES; ELECTRONIC AND ELECTROMECHANICAL GAMING TABLE-TOPS WITH VIDEO OUTPUT; DATA PROCESSORS AND COMPACT DISCS FEATURING VIDEO ENTERTAINMENT REGARDING POKER AND INSTRUCTIONAL VIDEO ON POKER GAMES; ELECTRIC TIMER; COUNTDOWN TIMER; GAMING MACHINES, NAMELY, SLOT AND POKER MACHINES (U.S. CLS. 21, 23, 26, 36 AND 38).

CLASS 28—TOYS AND SPORTING GOODS

FOR FLOOR-STANDING UNITS FOR PLAYING ELECTRONIC GAMES OTHER THAN IN CONJUNCTION WITH A TELEVISION OR COMPUTER; PLAYING CARDS; GAMING EQUIPMENT, NAMELY, POKER CHIPS, ROULETTE CHIPS, AND BLACK JACK TABLES; GAMES, NAMELY, BOARD GAMES, ACTION SKILL GAMES, CARD GAMES, ARCADE GAMES, COIN-OPERATED VIDEO GAMES, DICE GAMES, CARD GAMES AND GAMING TABLES FOR BLACKJACK, KENO, CRAPS, ROULETTE, POKER, PONTOON, BOULE, BACCARAT, PUNTO BANCO, CHEMIN DE FER, MINI-DICE, FAN TAN, SIC BO, PAI GOW, PAI GOW POKER, LUCKY WHEEL, CASINO CARD GAME BASED ON CHILDREN'S GAME OF WAR, AND RED DOG; EQUIPMENT SOLD AS A UNIT FOR PLAYING CARD AND BOARD GAMES, PARLOR GAMES, AND PARTY GAMES; APPARATUS FOR ELECTRONIC GAMES OTHER THAN THOSE ADAPTED FOR USE WITH TELEVISION RECEIVERS ONLY, NAMELY, HAND HELD UNIT FOR PLAYING ELECTRONIC AND VIDEO GAMES AND GAMES WITH LIQUID CRYSTAL DISPLAYS; COUNTERS, NAMELY, GAMING EQUIPMENT IN THE FORM OF CHIPS (U.S. CLS. 22, 23, 38 AND 50).

CLASS 35—ADVERTISING AND BUSINESS

FOR ON-LINE ADVERTISING ON THE INTERNET FOR OTHERS; COMPILATION OF COMPUTER DATABASES; MARKETING, ADVERTISING AND PROMOTIONAL SERVICES; PROVISION OF ON-LINE BUSINESS AND COMMERCIAL INFORMATION; PROMOTION OF LIVE ENTERTAINMENT AND POKER TOURNAMENTS; BUSINESS MANAGEMENT OF ENTERTAINMENT FACILITIES (U.S. CLS. 100, 101 AND 102).

CLASS 38—COMMUNICATION

FOR TRANSMISSION OF INFORMATION OVER A GLOBAL COMPUTER NETWORK SUCH AS THE INTERNET INCLUDING MESSAGES, IMAGES AND INFORMATION PERTAINING TO SPORTING EVENTS SUCH AS GAMING AND BETTING INFORMATION INCLUDING ODDS, DIVIDENDS, AND RESULTS, COMMENTARIES AND REPORTS; TRANSMISSION OF SOUND AND VIDEO VIA INTERACTIVE MULTIMEDIA NETWORKS PROVIDING ACCESS AND TELECOMMUNICATIONS CONNECTIONS TO INTERACTIVE COMPUTER DATABASES AND THE INTERNET AND PROVIDING ONLINE COMMUNICATIONS LINKS WHICH TRANSFER THE WEBSITE USER TO OTHER LOCAL AND GLOBAL WEB PAGES; PROVISION OF ACCESS TO AN INFORMATION DATABASE STORED ELECTRONICALLY FOR REMOTE CONSULTATION; PROVIDING TELECOMMUNICATIONS ACCESS TO A DATABASE STORING INFORMATION RELATING TO A VARIETY OF GOODS (U.S. CLS. 100, 101 AND 104).

CLASS 41—EDUCATION AND ENTERTAINMENT

FOR COMPILATION OF SPORTING STATISTICS AND OTHER GAMING STATISTICS, INCLUDING ODDS; NEWS REPORTING SERVICES VIA A GLOBAL COMPUTER NETWORK; CASINO FACILITIES; GAMBLING FACILITIES; GAMBLING SERVICES; CONDUCTING AND PROVIDING FACILITIES FOR GAMING EVENTS FEATURING VIDEO POKER MACHINES; PROVIDING FACILITIES FOR GAMING; PROVIDING GAMING MACHINE ENTERTAINMENT PARLORS; COUNTRY CLUBS FOR ENTERTAINMENT OR EDUCATION; PROVISION OF CLUB RECREATION FACILITIES; NIGHT CLUBS; NIGHT CLUB SERVICES; ENTERTAINMENT IN THE NATURE OF VISUAL AND AUDIO PERFORMANCES AND MUSICAL AND VARIETY SHOWS FOR CRUISE SHIPS; ENTERTAINMENT SERVICES, NAMELY, CONDUCTING CONTESTS RELATING TO AMUSEMENT MACHINES; PROVISION OF ENTERTAINMENT FACILITIES, NAMELY, THE PROVISION OF AMUSEMENT FACILITIES; PROVIDING ON-LINE ELECTRONIC NON-DOWNLOADABLE PUBLICATIONS, NAMELY, MAGAZINES, JOURNALS, NEWSLETTERS, NEWS FLASHES IN RELATION TO GAMING INFORMATION, SPORTING EVENTS RESULTS, NEWS EVENTS, OFFERS OF BETS, AND BETTING ODDS; PUBLICATION OF ELECTRONIC BOOKS AND JOURNALS ON-LINE; ENTERTAINMENT SERVICES, NAMELY, PROVIDING ON-LINE COMPUTER GAMES BY MEANS OF THE INTERNET; ENTERTAINMENT SERVICES, NAMELY, PROVIDING NON-DOWNLOADABLE COMPUTER GAMES VIA THE INTERNET; PROVISION OF GAMES BY MEANS OF A COMPUTER BASED SYSTEM; PROVISION OF ELECTRONIC GAMING, GAMBLING AND BETTING SERVICES TRANSMITTED VIA A GLOBAL COMPUTER NETWORK SUCH AS THE INTERNET; CASINO SERVICES; PROVISION OF INFORMATION RELATING TO SPORTS, BETTING AND GAMING SERVICES ACCESSIBLE VIA A GLOBAL COMPUTER NETWORK; PROVIDING FACILITIES FOR GAMING, AND PROVIDING GAMBLING, LOTTERY, AND BOOKMAKING SERVICES; PROVISION OF GAMING NEWS AND INFORMATION OVER A GLOBAL COMPUTER NETWORK SUCH AS THE INTERNET; CREDIT CARD BETTING; PROVIDING ELECTRONIC INFORMATION RELATING TO ENTERTAINMENT, NAMELY, GAMING EVENTS; PROVISION OF ENTERTAINMENT INFORMATION IN THE FIELD OF GAMING, GAMBLING EVENTS; ON-LINE GAMING AND GAMBLING, PROVIDED ON-LINE FROM A COMPUTER DATABASE OR VIA THE INTERNET; PROVIDING INFORMATION, ADVICE, AND ASSISTANCE IN THE FIELD OF PLANNING SPECIAL EVENTS; ORGANIZATION OF POKER TOURNAMENTS; ENTERTAINMENT, NAMELY, A CONTINUING NEWS AND GAMING CABLE TELEVISION AND TELEVISION SHOW; CABLE TELEVISION AND TELEVISION SHOW PRODUCTION; PROVIDING FACILITIES FOR RECREATIONAL ACTIVITIES; PUBLICATION OF NON-DOWNLOADABLE ON LINE ELECTRONIC PUBLICATIONS, NAMELY, MAGAZINES, NEWSLETTERS, BROCHURES AND FLYERS IN THE FIELD OF ENTERTAINMENT (U.S. CLS. 100, 101 AND 107).

MICHELLE DUBOIS, EXAMINING ATTORNEY

SN 78-877,323. SALLY J. COXE, WASHINGTON, DC. FILED 5-5-2006.

SN 78-880,140. CASTELLINI S.P.A., CASTEL MAGGIORE (BO), ITALY, FILED 5-10-2006.

Bonobo Brew

THE MARK CONSISTS OF STANDARD CHARACTERS WITHOUT CLAIM TO ANY PARTICULAR FONT, STYLE, SIZE, OR COLOR.

NO CLAIM IS MADE TO THE EXCLUSIVE RIGHT TO USE "BREW", APART FROM THE MARK AS SHOWN.

CLASS 30—STAPLE FOODS

FOR COFFEE SOLD IN CONNECTION WITH RAISING FUNDS FOR, AND AWARENESS OF, THE BONOBO AND ITS HABITAT (U.S. CL. 46).

FIRST USE 1-10-2005; IN COMMERCE 2-0-2006.

CLASS 32—LIGHT BEVERAGES

FOR BEER SOLD IN CONNECTION WITH RAISING FUNDS FOR, AND AWARENESS OF, THE BONOBO AND ITS HABITAT (U.S. CLS. 45, 46 AND 48).

FIRST USE 1-10-2005; IN COMMERCE 2-0-2006.

CORY BOONE, EXAMINING ATTORNEY



PRIORITY CLAIMED UNDER SEC. 44(D) ON ITALY APPLICATION NO. BO2006C00057, FILED 4-28-2006, REG. NO. 1009982, DATED 4-28-2006, EXPIRES 4-28-2016.

NO CLAIM IS MADE TO THE EXCLUSIVE RIGHT TO USE "VALIDATE METHOD", APART FROM THE MARK AS SHOWN.

CLASS 5—PHARMACEUTICALS

FOR PRODUCTS FOR DISINFECTING, STERILIZING, AND MAKING ASEPTIC, NAMELY, DISINFECTANTS FOR HYGIENIC PURPOSES AND SANITARY STERILIZING PREPARATIONS (U.S. CLS. 6, 18, 44, 46, 51 AND 52).

CLASS 10—MEDICAL APPARATUS

FOR DENTAL UNITS, NAMELY, ORAL IRRIGATORS; DENTAL EXAMINATION CHAIRS, DENTAL INSTRUMENTS, NAMELY, BURRS, PICKS, AND MIRRORS; SPECIAL FURNITURE FOR MEDICAL USE, NAMELY, PATIENT EXAMINATION TABLES; MASKS AND GLOVES FOR USE BY MEDICAL PERSONNEL; MEDICAL SYRINGES; AND CONTAINERS FOR MEDICAL WASTE (U.S. CLS. 26, 39 AND 44).

ELLEN B. AWRICH, EXAMINING ATTORNEY

SN 78-879,340. CASTELLINI S.P.A., CASTEL MAGGIORE (BO), ITALY, FILED 5-9-2006.

AUTOSTERIL

THE MARK CONSISTS OF STANDARD CHARACTERS WITHOUT CLAIM TO ANY PARTICULAR FONT, STYLE, SIZE, OR COLOR.

PRIORITY CLAIMED UNDER SEC. 44(D) ON ITALY APPLICATION NO. BO2006C00057, FILED 4-28-2006, REG. NO. 1009983, DATED 4-28-2006, EXPIRES 4-28-2016.

CLASS 5—PHARMACEUTICALS

FOR PRODUCTS FOR DISINFECTING, STERILIZING, AND MAKING ASEPTIC, NAMELY, DISINFECTANTS FOR HYGIENIC PURPOSES AND SANITARY STERILIZING PREPARATIONS (U.S. CLS. 6, 18, 44, 46, 51 AND 52).

CLASS 10—MEDICAL APPARATUS

FOR DENTAL UNITS, NAMELY, ORAL IRRIGATORS; DENTAL EXAMINATION CHAIRS, DENTAL INSTRUMENTS, NAMELY, BURRS, PICKS, AND MIRRORS; SPECIAL FURNITURE FOR MEDICAL USE, NAMELY, PATIENT EXAMINATION TABLES; MASKS AND GLOVES FOR USE BY MEDICAL PERSONNEL; MEDICAL SYRINGES; AND CONTAINERS FOR MEDICAL WASTE (U.S. CLS. 26, 39 AND 44).

ELLEN B. AWRICH, EXAMINING ATTORNEY

SN 78-881,951. ALTERNATIVE TECHNOLOGY, INC., ENGLEWOOD, CO. FILED 5-11-2006.

Follow the Wire

THE MARK CONSISTS OF STANDARD CHARACTERS WITHOUT CLAIM TO ANY PARTICULAR FONT, STYLE, SIZE, OR COLOR.

CLASS 35—ADVERTISING AND BUSINESS

FOR OUTSOURCING SERVICES FOR OTHERS IN THE FIELD OF COMPUTER NETWORK SYSTEMS; PROVIDING OF INFORMATION RELATING TO BUSINESS MANAGEMENT, EFFICIENCY OF BUSINESS OPERATIONS, AND BUSINESS TRANSACTIONS BETWEEN COMPANIES; PROVIDING COMMUNICATION CARRIERS WITH INFORMATION IN THE FIELD OF CUSTOMER RELATIONS MANAGEMENT; PROVIDING MANUFACTURERS AND DISTRIBUTORS WITH INFORMATION RELATING TO SUPPLY CHAIN MANAGEMENT AND DEMAND CHAIN MANAGEMENT; BUSINESS MANAGEMENT, NAMELY, ASSISTING OTHERS IN MANAGING WIRELESS ELECTRONIC COMPUTING AND WIRELESS ELECTRONIC COMMERCE; DATABASE MANAGEMENT FOR USE IN ASSISTING VALUE ADDED RESELLERS IN SERVICING RETAIL CUSTOMERS (U.S. CLS. 100, 101 AND 102).

FIRST USE 6-8-2005; IN COMMERCE 6-8-2005.

CLASS 37—CONSTRUCTION AND REPAIR

FOR MAINTENANCE AND REPAIR OF COMPUTERS, COMPUTER HARDWARE, COMPUTER HARDWARE SYSTEMS, COMPUTER NETWORKS, AND COMMUNICATIONS NETWORKS; COMPUTER INSTALLATION; MAINTENANCE AND REPAIR OF COMPUTER HARDWARE AND NETWORKS USED FOR ORGANIZING, DIRECTING, AND CONTROLLING COMMUNICATION, INFORMATION, TASKS, AND INTERACTION BETWEEN REMOTE SITES AND BETWEEN REMOTE SITES AND A CENTRAL LOCATION; MAINTENANCE OF COMPUTERS (U.S. CLS. 100, 103 AND 106).

FIRST USE 6-8-2005; IN COMMERCE 6-8-2005.

CLASS 41—EDUCATION AND ENTERTAINMENT

FOR EDUCATION SERVICES, NAMELY, CONDUCTING CLASSES, SEMINARS, CONFERENCES, AND WORKSHOPS IN THE FIELD OF COMPUTERS, COMPUTER PERIPHERALS, AND COMPUTER SOFTWARE RELATED TO THIN-CLIENT/SERVER BASED COMPUTING, COMPUTER INFRASTRUCTURE, NETWORK SECURITY AND MANAGEMENT, AND WIRELESS ELECTRONIC COMPUTING AND COMMERCE (U.S. CLS. 100, 101 AND 107).

FIRST USE 6-8-2005; IN COMMERCE 6-8-2005.

CLASS 42—SCIENTIFIC AND COMPUTER SERVICES

FOR TECHNICAL SUPPORT, NAMELY, TROUBLESHOOTING OF COMPUTER HARDWARE, SOFTWARE, AND NETWORK PROBLEMS; MONITORING OF NETWORK SYSTEMS; TECHNICAL SUPPORT OF ELECTRONIC COMMUNICATIONS NETWORKS AND WIRELESS ELECTRONIC COMMUNICATIONS NETWORKS; MAINTENANCE AND REPAIR OF COMPUTER SOFTWARE AND COMPUTER PORTALS; INSTALLATION OF COMPUTER SOFTWARE USED FOR ORGANIZING, DIRECTING, AND CONTROLLING COMMUNICATION, INFORMATION, TASKS, AND INTERACTION BETWEEN REMOTE SITES AND BETWEEN REMOTE SITES AND A CENTRAL LOCATION; TECHNICAL SUPPORT SERVICES, NAMELY, TROUBLE SHOOTING OF PROBLEMS WITH COMPUTER HARDWARE, SOFTWARE, AND NETWORKS USED FOR ORGANIZING, DIRECTING, AND CONTROLLING COMMUNICATION, INFORMATION, TASKS, AND INTERACTION BETWEEN REMOTE SITES AND BETWEEN REMOTE SITES AND A CENTRAL LOCATION; MAINTENANCE AND REPAIR OF COMPUTER SOFTWARE USED FOR ORGANIZING, DIRECTING, AND CONTROLLING COMMUNICATION, INFORMATION, TASKS, AND INTERACTION BETWEEN REMOTE SITES AND BETWEEN REMOTE SITES AND A CENTRAL LOCATION (U.S. CLS. 100 AND 101).

FIRST USE 6-8-2005; IN COMMERCE 6-8-2005.

TRACY WHITTAKER-BROWN, EXAMINING ATTORNEY

SN 78-881,963. ALTERNATIVE TECHNOLOGY, INC., ENGLEWOOD, CO. FILED 5-11-2006.

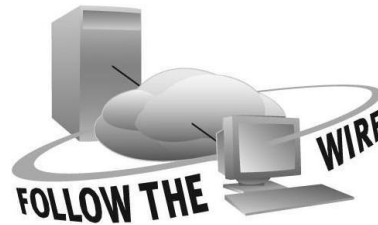

THE MARK CONSISTS OF A COMPUTER SERVER CONNECTED WITH A DESKTOP COMPUTER VIA A NETWORK CLOUD IMAGE. THE NETWORK CLOUD IS SURROUNDED BY AN OVAL RING THAT PIERCES THE MONITOR IN THE DESKTOP COMPUTER. THE WORDS "FOLLOW THE WIRE" APPEAR BENEATH THE OVAL AND FOLLOW THE PATH OF THE OVAL. THE WORDS "FOLLOW THE" APPEAR ON THE LEFT SIDE OF THE DESKTOP COMPUTER AND THE WORD "WIRE" APPEARS ON THE RIGHT SIDE OF THE DESKTOP COMPUTER.

CLASS 35—ADVERTISING AND BUSINESS

FOR OUTSOURCING SERVICES FOR OTHERS IN THE FIELD OF COMPUTER NETWORK SYSTEMS; PROVIDING OF INFORMATION RELATING TO BUSINESS MANAGEMENT, EFFICIENCY OF BUSINESS OPERATIONS, AND BUSINESS TRANSACTIONS BETWEEN COMPANIES; PROVIDING COMMUNICATION CARRIERS WITH INFORMATION IN THE FIELD OF CUSTOMER RELATIONS MANAGEMENT; PROVIDING MANUFACTURERS AND DISTRIBUTORS WITH INFORMATION RELATING TO SUPPLY CHAIN MANAGEMENT AND DEMAND CHAIN MANAGEMENT; BUSINESS MANAGEMENT, NAMELY, ASSISTING OTHERS IN MANAGING WIRELESS ELECTRONIC COMPUTING AND WIRELESS ELECTRONIC COMMERCE; DATABASE MANAGEMENT FOR USE IN ASSISTING VALUE ADDED RESELLERS IN SERVICING RETAIL CUSTOMERS (U.S. CLS. 100, 101 AND 102).

FIRST USE 6-8-2005; IN COMMERCE 6-8-2005.

CLASS 37—CONSTRUCTION AND REPAIR

FOR MAINTENANCE AND REPAIR OF COMPUTERS, COMPUTER HARDWARE, COMPUTER HARDWARE SYSTEMS, COMPUTER NETWORKS, AND COMMUNICATIONS NETWORKS; COMPUTER INSTALLATION; MAINTENANCE AND REPAIR OF COMPUTER HARDWARE AND NETWORKS USED FOR ORGANIZING, DIRECTING, AND CONTROLLING COMMUNICATION, INFORMATION, TASKS, AND INTERACTION BETWEEN REMOTE SITES AND BETWEEN REMOTE SITES AND A CENTRAL LOCATION; MAINTENANCE OF COMPUTERS (U.S. CLS. 100, 103 AND 106).

FIRST USE 6-8-2005; IN COMMERCE 6-8-2005.

CLASS 41—EDUCATION AND ENTERTAINMENT

FOR EDUCATION SERVICES, NAMELY, CONDUCTING CLASSES, SEMINARS, CONFERENCES, AND WORKSHOPS IN THE FIELD OF COMPUTERS, COMPUTER PERIPHERALS, AND COMPUTER SOFTWARE RELATED TO THIN-CLIENT/SERVER BASED COMPUTING, COMPUTER INFRASTRUCTURE, NETWORK SECURITY AND MANAGEMENT, AND WIRELESS ELECTRONIC COMPUTING AND COMMERCE (U.S. CLS. 100, 101 AND 107).

FIRST USE 6-8-2005; IN COMMERCE 6-8-2005.

CLASS 42—SCIENTIFIC AND COMPUTER SERVICES

FOR TECHNICAL SUPPORT, NAMELY, TROUBLESHOOTING OF COMPUTER HARDWARE, SOFTWARE, AND NETWORK PROBLEMS; MONITORING OF NETWORK SYSTEMS; TECHNICAL SUPPORT OF ELECTRONIC COMMUNICATIONS NETWORKS AND WIRELESS ELECTRONIC COMMUNICATIONS NETWORKS; MAINTENANCE AND REPAIR OF COMPUTER SOFTWARE AND COMPUTER PORTALS; INSTALLATION OF COMPUTER SOFTWARE USED FOR ORGANIZING, DIRECTING, AND CONTROLLING COMMUNICATION, INFORMATION, TASKS, AND INTERACTION BETWEEN REMOTE SITES AND BETWEEN REMOTE SITES AND A CENTRAL LOCATION; TECHNICAL SUPPORT SERVICES, NAMELY, TROUBLE SHOOTING OF PROBLEMS WITH COMPUTER HARDWARE, SOFTWARE, AND NETWORKS USED FOR ORGANIZING, DIRECTING, AND CONTROLLING COMMUNICATION, INFORMATION, TASKS, AND INTERACTION BETWEEN REMOTE SITES AND BETWEEN REMOTE SITES AND A CENTRAL LOCATION (U.S. CLS. 100 AND 101).

FIRST USE 6-8-2005; IN COMMERCE 6-8-2005.
TRACY WHITTAKER-BROWN, EXAMINING ATTORNEY

SN 78-887,478. CAROLINA SPICE COMPANY, LLC, LEXINGTON, SC. FILED 5-19-2006.



NO CLAIM IS MADE TO THE EXCLUSIVE RIGHT TO USE "WINGS" IN INTERNATIONAL CLASS 043, APART FROM THE MARK AS SHOWN.
SEC. 2(F).

CLASS 25—CLOTHING

FOR BASEBALL CAPS; CAP VISORS; CAPS WITH VISORS; GOLF CAPS; GOLF SHIRTS; KNIT SHIRTS; OPEN-NECKED SHIRTS; POLO SHIRTS; SHIRTS; SPORT SHIRT; SWEAT SHIRTS; T-SHIRTS (U.S. CLS. 22 AND 39).

FIRST USE 3-18-1996; IN COMMERCE 3-18-1996.

CLASS 43—HOTEL AND RESTAURANT SERVICES

FOR CARRY-OUT RESTAURANTS; FAST-FOOD RESTAURANTS; PREPARATION OF FOOD AND BEVERAGES; RESTAURANT AND BAR SERVICES; RESTAURANT SERVICES; RESTAURANTS; SERVING OF FOOD AND DRINK/BEVERAGES; TAKE-OUT RESTAURANT SERVICES (U.S. CLS. 100 AND 101).

FIRST USE 3-18-1996; IN COMMERCE 3-18-1996.
HELENE LIWINSKI, EXAMINING ATTORNEY

SN 78-885,451. YO BRANDS, LLC, CHARLOTTE, NC. FILED 5-17-2006.

YO!TEA

THE MARK CONSISTS OF STANDARD CHARACTERS WITHOUT CLAIM TO ANY PARTICULAR FONT, STYLE, SIZE, OR COLOR.

CLASS 5—PHARMACEUTICALS

FOR LOOSE LEAF TEA, TEA BAGS AND BOTTLED HERBAL ENERGY TEA FOR MEDICINAL PURPOSES (U.S. CLS. 6, 18, 44, 46, 51 AND 52).

CLASS 30—STAPLE FOODS

FOR LOOSE LEAF TEA, TEA BAGS AND BOTTLED HERBAL ENERGY TEA (U.S. CL. 46).
PAM WILLIS, EXAMINING ATTORNEY

SN 78-900,435. FEDERAL-MOGUL NURNBERG, GMBH, NUREMBERG, FED REP GERMANY, FILED 6-5-2006.

THERMOFAT

THE MARK CONSISTS OF STANDARD CHARACTERS WITHOUT CLAIM TO ANY PARTICULAR FONT, STYLE, SIZE, OR COLOR.

OWNER OF FED REP GERMANY REG. NO. DE30572471, DATED 12-6-2005, EXPIRES 12-6-2015.

CLASS 6—METAL GOODS

FOR FINISHED CAST MOLDED PARTS, NAMELY, METAL BOLTS FOR AIR AND WATER INTERNATIONAL COMBUSTION ENGINES (U.S. CLS. 2, 12, 13, 14, 23, 25 AND 50).

CLASS 7—MACHINERY

FOR UNFINISHED DEAD-MOLD CAST LIGHT METAL MACHINE PARTS, NAMELY, PISTONS, PISTON RINGS, PISTON LOCKING RINGS AND BEARING HOUSING FOR PARTS OF INTERNAL COMBUSTION ENGINES FOR AIR, WATER AND AUTOMOTIVE VEHICLES (U.S. CLS. 13, 19, 21, 23, 31, 34 AND 35).

CLASS 40—MATERIAL TREATMENT

FOR MATERIAL PROCESSING, NAMELY, CUSTOM TREATMENT OF MATERIALS BY LASER BEAM, NAMELY, LIGHT METALS AND THEIR ALLOYS FOR INTERNAL COMBUSTION ENGINES OF AIR, WATER, AND LAND VEHICLES (U.S. CLS. 100, 103 AND 106).

CLASS 42—SCIENTIFIC AND COMPUTER SERVICES

FOR ENGINEERING SERVICES; NEW PRODUCT MATERIALS DEVELOPMENT FOR THIRD PARTIES IN THE FIELD OF AUTOMOTIVE TECHNOLOGY, IN PARTICULAR PISTONS AND PARTS THEREOF FOR INTERNAL COMBUSTION ENGINES AND COMPRESSORS; INDUSTRIAL RESEARCH AND TECHNICAL RESEARCH, NAMELY, CALCULATIONS FOR NEW PRODUCT DEVELOPMENT FOR OTHERS IN THE FIELD OF AUTOMOBILE TECHNOLOGY, IN PARTICULAR PISTONS AND PARTS THEREOF FOR INTERNAL COMBUSTION ENGINES AND COMPRESSORS (U.S. CLS. 100 AND 101).

JASON TURNER, EXAMINING ATTORNEY

CLASS 42—SCIENTIFIC AND COMPUTER SERVICES

FOR ENGINEERING SERVICES; NEW PRODUCT MATERIALS DEVELOPMENT FOR THIRD PARTIES IN THE FIELD OF AUTOMOTIVE TECHNOLOGY, IN PARTICULAR PISTONS AND PARTS THEREOF FOR INTERNAL COMBUSTION ENGINES AND COMPRESSORS; INDUSTRIAL RESEARCH AND TECHNICAL RESEARCH, NAMELY, CALCULATIONS FOR NEW PRODUCT DEVELOPMENT FOR OTHERS IN THE FIELD OF AUTOMOBILE TECHNOLOGY, IN PARTICULAR PISTONS AND PARTS THEREOF FOR INTERNAL COMBUSTION ENGINES AND COMPRESSORS (U.S. CLS. 100 AND 101).

JASON TURNER, EXAMINING ATTORNEY

SN 78-900,540. FEDERAL-MOGUL NURNBERG GMBH, NUREMBERG, FED REP GERMANY, FILED 6-5-2006.

SN 78-900,511. FEDERAL-MOGUL NURNBERG GMBH, NUREMBERG, FED REP GERMANY, FILED 6-5-2006.

GASOLITE

THE MARK CONSISTS OF STANDARD CHARACTERS WITHOUT CLAIM TO ANY PARTICULAR FONT, STYLE, SIZE, OR COLOR.

OWNER OF FED REP GERMANY REG. NO. 30572474, DATED 4-13-2006, EXPIRES 12-31-2015.

CLASS 6—METAL GOODS

FOR FINISHED CAST MOLDED PARTS, NAMELY, METAL BOLTS FOR AIR AND WATER INTERNATIONAL COMBUSTION ENGINES (U.S. CLS. 2, 12, 13, 14, 23, 25 AND 50).

CLASS 7—MACHINERY

FOR UNFINISHED DEAD-MOLD CAST LIGHT METAL MACHINE PARTS, NAMELY, PISTONS, PISTON RINGS, PISTON LOCKING RINGS AND BEARING HOUSING FOR PARTS OF INTERNAL COMBUSTION ENGINES FOR AIR, WATER AND AUTOMOTIVE VEHICLES (U.S. CLS. 13, 19, 21, 23, 31, 34 AND 35).

CLASS 40—MATERIAL TREATMENT

FOR MATERIAL PROCESSING, NAMELY, CUSTOM TREATMENT OF MATERIALS BY LASER BEAM, NAMELY, LIGHT METALS AND THEIR ALLOYS FOR INTERNAL COMBUSTION ENGINES OF AIR, WATER AND LAND VEHICLES FOR OTHERS (U.S. CLS. 100, 103 AND 106).

FORCEGROOVE

THE MARK CONSISTS OF STANDARD CHARACTERS WITHOUT CLAIM TO ANY PARTICULAR FONT, STYLE, SIZE, OR COLOR.

OWNER OF FED REP GERMANY REG. NO. 30572473, DATED 4-13-2006, EXPIRES 12-31-2015.

CLASS 6—METAL GOODS

FOR FINISHED CAST MOLDED PARTS, NAMELY, METAL BOLTS FOR AIR AND WATER INTERNATIONAL COMBUSTION ENGINES (U.S. CLS. 2, 12, 13, 14, 23, 25 AND 50).

CLASS 7—MACHINERY

FOR UNFINISHED DEAD-MOLD CAST LIGHT METAL MACHINE PARTS, NAMELY, PISTONS, PISTON RINGS, PISTON LOCKING RINGS AND BEARING HOUSING FOR PARTS OF INTERNAL COMBUSTION ENGINES FOR AIR, WATER VEHICLES AND AUTOMOTIVE VEHICLES (U.S. CLS. 13, 19, 21, 23, 31, 34 AND 35).

CLASS 40—MATERIAL TREATMENT

FOR MATERIAL PROCESSING, NAMELY, CUSTOM TREATMENT OF MATERIALS BY LASER BEAM, NAMELY, LIGHT METALS AND THEIR ALLOYS FOR INTERNAL COMBUSTION ENGINES OF AIR, WATER, AND LAND VEHICLES (U.S. CLS. 100, 103 AND 106).

CLASS 42—SCIENTIFIC AND COMPUTER SERVICES

FOR ENGINEERING SERVICES; NEW PRODUCT MATERIALS DEVELOPMENT FOR THIRD PARTIES IN THE FIELD OF AUTOMOTIVE TECHNOLOGY, IN PARTICULAR PISTONS AND PARTS THEREOF FOR INTERNAL COMBUSTION ENGINES AND COMPRESSORS; INDUSTRIAL RESEARCH AND TECHNICAL RESEARCH, NAMELY, CALCULATIONS FOR NEW PRODUCT DEVELOPMENT FOR OTHERS IN THE FIELD OF AUTOMOBILE TECHNOLOGY, IN PARTICULAR PISTONS AND PARTS THEREOF FOR INTERNAL COMBUSTION ENGINES AND COMPRESSORS (U.S. CLS. 100 AND 101).

JASON TURNER, EXAMINING ATTORNEY

SN 78-900,584. FEDERAL-MOGUL NURNBERG GMBH, NUREMBERG, FED REP GERMANY, FILED 6-5-2006.

DURABOWL

THE MARK CONSISTS OF STANDARD CHARACTERS WITHOUT CLAIM TO ANY PARTICULAR FONT, STYLE, SIZE, OR COLOR.

OWNER OF FED REP GERMANY REG. NO. 30572468, DATED 4-13-2006, EXPIRES 12-31-2015.

CLASS 6—METAL GOODS

FOR FINISHED CAST MOLDED PARTS, NAMELY, METAL BOLTS FOR AIR AND WATER INTERNATIONAL COMBUSTION ENGINES (U.S. CLS. 2, 12, 13, 14, 23, 25 AND 50).

CLASS 7—MACHINERY

FOR UNFINISHED DEAD-MOLD CAST LIGHT METAL MACHINE PARTS, NAMELY, PISTONS, PISTON RINGS, PISTON LOCKING RINGS AND BEARING HOUSING FOR PARTS OF INTERNAL COMBUSTION ENGINES FOR AIR, WATER AND AUTOMOTIVE VEHICLES (U.S. CLS. 13, 19, 21, 23, 31, 34 AND 35).

CLASS 40—MATERIAL TREATMENT

FOR MATERIAL PROCESSING, NAMELY, CUSTOM TREATMENT OF MATERIALS BY LASER BEAM, NAMELY, LIGHT METALS AND THEIR ALLOYS FOR INTERNAL COMBUSTION ENGINES OF AIR, WATER, AND LAND VEHICLES (U.S. CLS. 100, 103 AND 106).

CLASS 42—SCIENTIFIC AND COMPUTER SERVICES

FOR ENGINEERING SERVICES; NEW PRODUCT MATERIALS DEVELOPMENT FOR THIRD PARTIES IN THE FIELD OF AUTOMOTIVE TECHNOLOGY, IN PARTICULAR PISTONS AND PARTS THEREOF FOR INTERNAL COMBUSTION ENGINES AND COMPRESSORS; INDUSTRIAL RESEARCH AND TECHNICAL RESEARCH, NAMELY, CALCULATIONS FOR NEW PRODUCT DEVELOPMENT FOR OTHERS IN THE FIELD OF AUTOMOBILE TECHNOLOGY, IN PARTICULAR PISTONS AND PARTS THEREOF FOR INTERNAL COMBUSTION ENGINES AND COMPRESSORS (U.S. CLS. 100 AND 101).

JASON TURNER, EXAMINING ATTORNEY

SN 78-900,609. FEDERAL-MOGUL NURNBERG GMBH, NUREMBERG, FED REP GERMANY, FILED 6-5-2006.

CARBODUR

THE MARK CONSISTS OF STANDARD CHARACTERS WITHOUT CLAIM TO ANY PARTICULAR FONT, STYLE, SIZE, OR COLOR.

PRIORITY CLAIMED UNDER SEC. 44(D) ON FED REP GERMANY APPLICATION NO. 305758969, FILED 12-21-2005, REG. NO. 305758969, DATED 12-21-2005, EXPIRES 12-31-2015.

CLASS 6—METAL GOODS

FOR FINISHED CAST MOLDED PARTS, NAMELY, METAL BOLTS FOR AIR AND WATER INTERNATIONAL COMBUSTION ENGINES (U.S. CLS. 2, 12, 13, 14, 23, 25 AND 50).

CLASS 7—MACHINERY

FOR UNFINISHED DEAD-MOLD CAST LIGHT METAL MACHINE PARTS, NAMELY, PISTONS, PISTON RINGS, PISTON LOCKING RINGS AND BEARING HOUSING FOR PARTS OF INTERNAL COMBUSTION ENGINES FOR AIR, WATER AND AUTOMOTIVE VEHICLES (U.S. CLS. 13, 19, 21, 23, 31, 34 AND 35).

CLASS 40—MATERIAL TREATMENT

FOR MATERIAL PROCESSING, NAMELY, CUSTOM TREATMENT OF MATERIALS BY LASER BEAM, NAMELY, LIGHT METALS AND THEIR ALLOYS FOR INTERNAL COMBUSTION ENGINES OF AIR, WATER AND LAND VEHICLES (U.S. CLS. 100, 103 AND 106).

CLASS 42—SCIENTIFIC AND COMPUTER SERVICES

FOR ENGINEERING SERVICES; NEW PRODUCT MATERIALS DEVELOPMENT FOR THIRD PARTIES IN THE FIELD OF AUTOMOTIVE TECHNOLOGY, IN PARTICULAR PISTONS AND PARTS THEREOF FOR INTERNAL COMBUSTION ENGINES AND COMPRESSORS; INDUSTRIAL RESEARCH AND TECHNICAL RESEARCH, NAMELY, CALCULATIONS FOR NEW PRODUCT DEVELOPMENT FOR OTHERS IN THE FIELD OF AUTOMOBILE TECHNOLOGY, IN PARTICULAR PISTONS AND PARTS THEREOF FOR INTERNAL COMBUSTION ENGINES AND COMPRESSORS (U.S. CLS. 100 AND 101).

JASON TURNER, EXAMINING ATTORNEY

SN 78-904,844. DISSING TRADING A/S, SKANDERBORG, DENMARK, FILED 6-9-2006.

RED HORSE

THE MARK CONSISTS OF STANDARD CHARACTERS WITHOUT CLAIM TO ANY PARTICULAR FONT, STYLE, SIZE, OR COLOR.

PRIORITY CLAIMED UNDER SEC. 44(D) ON DENMARK APPLICATION NO. VA20050561, FILED 12-9-2005, REG. NO. VR20060099, DATED 3-16-2006, EXPIRES 3-16-2016.

CLASS 1—CHEMICALS

FOR CHEMICALS USED IN INDUSTRY, SCIENCE AND PHOTOGRAPHY; CHEMICALS USED FOR POWDER PAINTING AND LACKING; UNPROCESSED ARTIFICIAL RESINS FOR THE BUILDING AND CONSTRUCTION INDUSTRY; UNPROCESSED PLASTICS; MANURERS; FIRE EXTINGUISHING COMPOSITIONS; TEMPERING CHEMICALS FOR USE IN METAL WORKING AND SOLDERING; ADHESIVES USED IN THE CONSTRUCTION INDUSTRY (U.S. CLS. 1, 5, 6, 10, 26 AND 46).

CLASS 6—METAL GOODS

FOR METAL FASTENERS, NAMELY, SCREWS, RIVETS ANCHORS, PLUGS, INJECTION BOLTS, METAL CABLE CLIPS, METAL JUNCTIONS FOR PIPES, METAL SHELF BRACKETS, AND NAILS; NON-ELECTRIC CABLES AND WIRES OF COMMON METAL; IRON-MONGERY, NAMELY, SCREWS RIVETS PIPES AND TUBES OF METAL, METAL SAFES (U.S. CLS. 2, 12, 13, 14, 23, 25 AND 50).

CLASS 7—MACHINERY

FOR MACHINE AND MACHINE TOOLS, NAMELY, ELECTRIC HAND TOOLS, NAMELY, PERCUSSION DRILLS, HAMMER DRILLS, DRILL CHISEL, DEMOLITION HAMMERS, DRILL/SCREW DRIVERS, BORING MACHINES, PLATE SHEARS, RIGHT-ANGLED BORING, BAYONET SAWS, ANGLE GRINDERS; RIVET HAMMERS, PLANING MACHINES FOR METALWORKING, DIAMOND DRILLING MACHINES, ELECTRIC BELT SANDERS, CIRCULAR SAWS, COMPASS SAWS, POWER DRILLS AND DIAMOND-POINTED METAL CUTTING TOOLS, NAMELY, DIAMOND CUTTING DISCS, DIAMOND THROUGH-DRILLING MACHINES, DIAMOND GRINDING HEADS, POWER-OPERATED DIAMOND DRILLS, POWER HAMMER DRILLS, ELECTRIC BELT SANDERS, POWER-OPERATED POLISHER, POWER-OPERATED TOOLS, NAMELY, HAMMERS AND SCREWDRIVERS (U.S. CLS. 13, 19, 21, 23, 31, 34 AND 35).

CLASS 8—HAND TOOLS

FOR HAND TOOLS AND BITS FOR USE IN THE FASTENING INDUSTRY, NAMELY, MANUAL DRILLS, MANUALLY OPERATED HAND TOOLS, NAMELY, HAMMERS AND SCREWDRIVERS, SPANNERS, TORQUE WRENCHES, SHEET PLIERS, AND BELT SANDERS; MANUAL CONCRETE CHISELS, MANUAL WALL DRILLS, MANUAL SHEET DRILLS, MANUAL SINGLE AND MANUAL DOUBLE DRILLS, BLADES FOR HAND COMPASS SAWS, BLADES FOR HAND BAYONET SAWS AND HAND TOOLS, AND MANUALLY-OPERATED GRINDING WHEELS (U.S. CLS. 23, 28 AND 44).

CLASS 19—NON-METALLIC BUILDING MATERIALS

FOR NON-METALLIC BUILDING MATERIALS, NAMELY, WINDOWS; NON-METALLIC RIGID PIPES FOR BUILDING; ASPHALT AND PITCH (U.S. CLS. 1, 12, 33 AND 50).

CLASS 20—FURNITURE AND ARTICLES NOT OTHERWISE CLASSIFIED

FOR FURNITURE, MIRRORS, PICTURE FRAMES OF WOOD, CORK, REED, CANE, WICKER, HORN, BONE, IVORY, WHALEBONE, SHELL, AMBER, MOTHER-OF-PEARL, MEERSCHAUM AND SUBSTITUTES FOR ALL THESE MATERIALS, OR OF PLASTICS (U.S. CLS. 2, 13, 22, 25, 32 AND 50).

CLASS 35—ADVERTISING AND BUSINESS

FOR ADVERTISING AND MARKETING; BUSINESS MANAGEMENT; BUSINESS ADMINISTRATION AND MANAGEMENT; PROVIDING OFFICE FUNCTIONS (U.S. CLS. 100, 101 AND 102).

CLASS 37—CONSTRUCTION AND REPAIR

FOR RESIDENTIAL AND COMMERCIAL BUILDING CONSTRUCTION (U.S. CLS. 100, 103 AND 106).

CLASS 42—SCIENTIFIC AND COMPUTER SERVICES

FOR DESIGN OF COMPUTER HARDWARE AND SOFTWARE FOR OTHERS, DEVELOPMENT OF COMPUTER HARDWARE AND SOFTWARE (U.S. CLS. 100 AND 101).

KATHERINE STOIDES, EXAMINING ATTORNEY

SN 78-909,377. STATE OF UTAH, SALT LAKE CITY, UT. FILED 6-15-2006.



NO CLAIM IS MADE TO THE EXCLUSIVE RIGHT TO USE "VOTE" AS TO CLASS 35, APART FROM THE MARK AS SHOWN.

CLASS 25—CLOTHING

FOR CLOTHING, NAMELY, T-SHIRTS (U.S. CLS. 22 AND 39).

CLASS 35—ADVERTISING AND BUSINESS

FOR VOTING SERVICES, NAMELY, ORGANIZING VOTER REGISTRATION DRIVES, PROVIDING INFORMATION REGARDING POLITICAL ISSUES, KNOWING HOW TO VOTE AND KNOWING HOW TO REGISTER TO VOTE; PROMOTION OF ELECTRONIC VOTING (U.S. CLS. 100, 101 AND 102).

HEATHER BIDDULPH, EXAMINING ATTORNEY

SN 78-916,673. SOURCE MEDIA INC., NEW YORK, NY. FILED 6-26-2006.

NRS ComplianceEssentials

THE MARK CONSISTS OF STANDARD CHARACTERS WITHOUT CLAIM TO ANY PARTICULAR FONT, STYLE, SIZE, OR COLOR.

OWNER OF U.S. REG. NOS. 2,084,118, 2,084,121 AND 2,084,122.

CLASS 36—INSURANCE AND FINANCIAL

FOR PROVIDING FINANCIAL INFORMATION, NAMELY, PROVIDING A DATABASE FEATURING FINANCIAL COMPLIANCE INFORMATION (U.S. CLS. 100, 101 AND 102).

CLASS 42—SCIENTIFIC AND COMPUTER SERVICES

FOR WEB-BASED FINANCIAL COMPLIANCE TOOLS, NAMELY, PROVIDING TEMPORARY USE OF ONLINE NON-DOWNLOADABLE SOFTWARE FOR OBTAINING AND USING MODEL FORMS, POLICIES, SOFTWARE FORMS, GUIDES, CHECKLISTS, RESEARCH LIBRARY AND DATABASE OF SECURITIES LAWS AND REGULATIONS, AND FOR ACCESSING AND NAVIGATING A DATA MANAGEMENT SYSTEM FOR DOCUMENTS AND OTHER FORMS AND TOOLS TO ASSIST WITH COMPLIANCE AND REGULATORY REQUIREMENTS, ALL IN THE FIELD OF FINANCIAL COMPLIANCE IN THE FIELD OF SECURITIES (U.S. CLS. 100 AND 101).
KRISTINA MORRIS, EXAMINING ATTORNEY

SN 78-925,481. CEVA SANTE ANIMALE, LIBOURNE, FRANCE, FILED 7-10-2006.

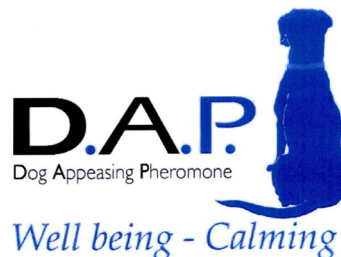

OWNER OF U.S. REG. NO. 2,776,511.

NO CLAIM IS MADE TO THE EXCLUSIVE RIGHT TO USE "DOG APPEASING PHEROMONE WELL BEING-CALMING", APART FROM THE MARK AS SHOWN.

THE COLOR(S) BLACK AND BLUE IS/ARE CLAIMED AS A FEATURE OF THE MARK.

THE MARK CONSISTS OF THE LITERAL ELEMENT "D.A.P. DOG APPEASING PHEROMONE WELL BEING-CALMING" AND DESIGN OF A DOG. THE COLOR BLACK APPEARS IN THE LETTERS "D" AND "A", AND IN THE WORDING "DOG APPEASING PHEROMONE". THE COLOR BLUE APPEARS IN THE LETTER "P", THE PUNCTUATION, THE DESIGN OF THE DOG AND IN THE WORDING "WELL BEING-CALMING".

SN 78-919,262. MEGA BUILDING SYSTEMS LTD., SURREY, CANADA, FILED 6-28-2006.

MEGA SYSTEMS

THE MARK CONSISTS OF STANDARD CHARACTERS WITHOUT CLAIM TO ANY PARTICULAR FONT, STYLE, SIZE, OR COLOR.

OWNER OF U.S. REG. NO. 2,508,406.

NO CLAIM IS MADE TO THE EXCLUSIVE RIGHT TO USE "SYSTEMS", APART FROM THE MARK AS SHOWN.

CLASS 6—METAL GOODS

FOR LIGHT GAUGE STEEL FRAMING SYSTEMS CONSISTING PRIMARILY OF BUILDING WALL FRAMING MADE PRIMARILY OF METAL; AND STEEL FLOOR SYSTEMS CONSISTING PRIMARILY OF METAL FLOORS (U.S. CLS. 2, 12, 13, 14, 23, 25 AND 50).

CLASS 19—NON-METALLIC BUILDING MATERIALS

FOR CONCRETE FLOORING SYSTEMS CONSISTING PRIMARILY OF CONCRETE FLOORS (U.S. CLS. 1, 12, 33 AND 50).

CLASS 35—ADVERTISING AND BUSINESS

FOR RETAIL SERVICES BY DIRECT SOLICITATION BY SALES AGENTS IN THE FIELD OF LIGHT GAUGE STEEL FRAMING SYSTEMS AND STEEL AND CONCRETE FLOOR SYSTEMS (U.S. CLS. 100, 101 AND 102).

CLASS 37—CONSTRUCTION AND REPAIR

FOR CUSTOM CONSTRUCTION, NAMELY, ERECTION OR INSTALLATION OF LIGHT GAUGE STEEL FRAMING SYSTEMS AND STEEL AND CONCRETE FLOOR SYSTEMS (U.S. CLS. 100, 103 AND 106).

CLASS 42—SCIENTIFIC AND COMPUTER SERVICES

FOR DESIGN OF LIGHT GAUGE STEEL FRAMING SYSTEMS AND STEEL AND CONCRETE FLOORS FOR OTHERS (U.S. CLS. 100 AND 101).
SAIMA MAKHOOM, EXAMINING ATTORNEY

CLASS 5—PHARMACEUTICALS

FOR VETERINARY PREPARATIONS FOR BEHAVIORAL CONTROL FOR DOGS (U.S. CLS. 6, 18, 44, 46, 51 AND 52).

CLASS 10—MEDICAL APPARATUS

FOR VETERINARY APPARATUS, NAMELY, A DEVICE FOR THE DIFFUSION OF MEDICATION (U.S. CLS. 26, 39 AND 44).

JANET LEE, EXAMINING ATTORNEY

SN 78-927,798. PRO-LIQUITECH, LLC, DBA PRO-LIQUITECH INTERNATIONAL, LLC, LOUISVILLE, KY. FILED 7-12-2006.

FUNCTION FIRST

THE MARK CONSISTS OF STANDARD CHARACTERS WITHOUT CLAIM TO ANY PARTICULAR FONT, STYLE, SIZE, OR COLOR.

CLASS 1—CHEMICALS

FOR ACIDULANTS FOR USE IN SOFT DRINKS AND OTHER BEVERAGES (U.S. CLS. 1, 5, 6, 10, 26 AND 46).

CLASS 5—PHARMACEUTICALS

FOR VITAMINS, MINERALS, AMINO ACIDS, MEDICINAL HERBS, MEDICINAL HERB EXTRACTS AND PROTEINS FOR USE AS A NUTRITIONAL SUPPLEMENT IN SOFT DRINKS AND OTHER BEVERAGES (U.S. CLS. 6, 18, 44, 46, 51 AND 52).

CLASS 30—STAPLE FOODS

FOR NATURAL SWEETENERS FOR USE AS AN INGREDIENT IN SOFT DRINKS AND OTHER BEVERAGES; FLAVORING ADDITIVES FOR NON-NUTRITIONAL PURPOSES FOR USE AS AN INGREDIENT IN SOFT DRINKS AND OTHER BEVERAGES (U.S. CL. 46).

CLASS 42—SCIENTIFIC AND COMPUTER SERVICES

FOR PRODUCT DEVELOPMENT SERVICES, NAMELY, SERVICES FOR THE DEVELOPMENT OF SOFT DRINKS AND OTHER BEVERAGES AND THE DEVELOPMENT OF FLAVORINGS AND INGREDIENTS USED IN SOFT DRINKS AND OTHER BEVERAGES (U.S. CLS. 100 AND 101).

CHARLES L. JENKINS, EXAMINING ATTORNEY

SN 78-949,485. CHARMIE INVESTMENTS LIMITED, ROAD TOWN, TORTOLA, BR.VIRGIN ISLANDS, FILED 8-10-2006.

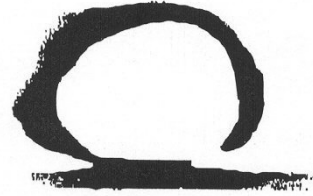

OWNER OF U.S. REG. NO. 3,070,191.
THE MARK CONSISTS OF AN ABSTRACT OPEN CIRCULAR DESIGN WITH A LINE BENEATH IT.

CLASS 16—PAPER GOODS AND PRINTED MATTER

FOR PAPER, CARDBOARD AND GOODS MADE FROM THESE MATERIALS, NAMELY, ANNOUNCEMENT CARDS, BUSINESS CARDS, CORRESPONDENCE CARDS, INVITATION CARDS, POST CARDS, OCCASION CARDS, LEAFLETS FEATURING INFORMATION ON HEALTH AND WELLNESS, SKIN AND BEAUTY CARE SERVICES AND SPA SERVICES; PRINTED MATTER, NAMELY, PRINTED FORMS, PRINTED INVITATIONS, PRINTED MAIL RESPONSE CARDS RELATING TO HEALTH AND WELLNESS, SKIN AND BEAUTY CARE SERVICES AND SPA SERVICES; PRINTED MATERIALS, NAMELY, PRESS RELEASES FEATURING HEALTH AND WELLNESS, SKIN AND BEAUTY CARE SERVICES AND SPA SERVICES; BOOKBINDING MATERIAL, NAMELY, BOOKBINDINGS, BOOKBINDING WIRE, BOOKBINDING TAPE; PHOTOGRAPHS; STATIONERY; ARTISTS' MATERIALS, NAMELY, ARTISTS' BRUSHES, ARTISTS' PASTELS; PAINT BRUSHES; PRINTED INSTRUCTIONAL AND TEACHING MATERIAL IN THE FIELD OF SKIN AND BEAUTY CARE SERVICES AND SPA SERVICES; PLASTIC MATERIALS FOR PACKAGING, NAMELY, PLASTIC BAGS, PLASTIC BUBBLE PACKS; PRINTERS' TYPE; PRINTING BLOCKS; ADVERTISING SIGNS OF PAPER OR CARDBOARD; ALBUMS FOR PHOTOGRAPHS, STAMPS, COINS; GROCERY, PAPER AND TRASH BAGS; ENVELOPES FOR STATIONERY USE; BAGS OF PAPER OR PLASTIC FOR PACKAGING; LOOSE-LEAF BINDERS; BOOKLETS IN THE FIELD OF SKIN AND BEAUTY CARE SERVICES AND SPA SERVICES; BOOKS IN THE FIELD OF SKIN AND BEAUTY CARE SERVICES AND SPA SERVICES; BOXES OF CARDBOARD OR PAPER; DESKTOP CABINETS FOR STATIONERY; PRINTED CALCULATING TABLES FOR COMMERCIAL USE IN THE FIELD OF HEALTH AND WELLNESS, SKIN AND BEAUTY CARE SERVICES AND SPA SERVICES; CALENDARS; CARDBOARD ARTICLES, NAMELY, CARDBOARD CONTAINERS AND CARRIERS FOR COSMETICS, SKIN CARE, SPA AND BEAUTY PRODUCTS; CARDS, NAMELY, GREETING CARDS, NOTE CARD; SCRATCH CARDS; CATALOGUES IN THE FIELD OF BEAUTY AND SKIN CARE AND SPA SERVICES; PRINTED CHARTS; CHECKBOOKS; COMIC BOOKS; COPY PAPER; COVERS, NAMELY, DOCUMENT COVERS; PRINTED DIAGRAMS FOR MARKETING AND LECTURING; DOCUMENT FILES; DRAWING BOARDS; DRAWING MATERIALS, NAMELY, DRAWING PADS, DRAWING PENS, DRAWING INSTRUMENTS; ENGRAVINGS; FACE TOWELS OF PAPER; STATIONERY FOLDERS; FOLDERS FOR PAPERS; PRINTED FORMS; GRAPHIC PRINTS; PRINTED VISUALS IN THE NATURE OF INFORMATION GRAPHICS AND PROMOTIONAL MATERIALS; GRAPHIC ART REPRODUCTIONS; HANDBOOKS AND MANUALS IN THE FIELD OF SKIN AND BEAUTY CARE SERVICES AND SPA SERVICES; CATALOG INDEX BOOKS, PROMOTIONAL MATERIALS INDEX BOOKS; PRINTED PAPER LABELS; LEDGER BOOKS; PRINTING TYPE; MAGAZINES AND PERIODICALS IN THE FIELD OF SKIN AND BEAUTY CARE SERVICES AND SPA SERVICES; NEWSLETTERS IN THE FIELD OF SKIN AND

SN 78-943,700. WORTHEN, MICHELLE I., ALBUQUERQUE, NM. FILED 8-3-2006.



THE NAME IN THE MARK DOES NOT IDENTIFY A LIVING INDIVIDUAL.

CLASS 9—ELECTRICAL AND SCIENTIFIC APPARATUS

FOR PRE-RECORDED COMPACT DISCS AND SOUND RECORDINGS FEATURING MUSIC AND COMPUTER SOFTWARE FOR PROCESSING DIGITAL MUSIC FILES; COMPUTER SOFTWARE FOR MUSIC COMPOSITION AND ELECTRONIC PUBLICATIONS, NAMELY, BOOKS ON THE SUBJECT OF GAMING SOFTWARE RECORDED ON COMPUTER MEDIA (U.S. CLS. 21, 23, 26, 36 AND 38).

CLASS 16—PAPER GOODS AND PRINTED MATTER

FOR SERIES OF FICTION BOOKS AND A SERIES OF NON-FICTION BOOKS ON THE SUBJECTS OF MUSIC, ARTISTS AND BIOGRAPHIES; GENERAL FEATURE MAGAZINES; NEWSPAPERS (U.S. CLS. 2, 5, 22, 23, 29, 37, 38 AND 50).

CLASS 25—CLOTHING

FOR CLOTHING, NAMELY, SWEATERS, STOCKINGS, VISORS, BRAS, GIRDLES, UNDERWEAR, PAJAMAS, LINGERIE, SHOES, HATS, DRESSES, PANTS, SHIRTS, T-SHIRTS, SKIRTS, SHORTS, JACKETS, COATS, SOCKS AND BLOUSES (U.S. CLS. 22 AND 39).

NORA BUCHANAN WILL, EXAMINING ATTORNEY

BEAUTY CARE SERVICES AND SPA SERVICES; NEWS-PAPERS; NOTE BOOKS; NOTE PADS; PAMPHLETS IN THE FIELD OF SKIN AND BEAUTY CARE SERVICES AND SPA SERVICES; PAPER; PENCIL HOLDERS; PENCILS; PEN HOLDERS; PHOTO-ENGRAVINGS; PHOTOGRAPH STANDS; PHOTOGRAPHS; PRINTED PLANS; PORTRAITS; PRINTED TIMETABLES; PRINTED PROSPECTUSES IN THE FIELD OF SKIN AND BEAUTY CARE SERVICES AND SPA SERVICES; SCHOOL SUPPLIES, NAMELY, CRAYONS, PENCILS AND STATIONERY; SCRAPBOOKS; SIGNBOARDS OF PAPER OR CARDBOARD; PRINTED TEACHING MATERIALS IN THE FIELD OF SKIN AND BEAUTY CARE SERVICES AND SPA SERVICES; PRINTED TICKETS; WRAPPING PAPER; WRITING MATERIALS, NAMELY, WRITING PADS, WRITING PAPER (U.S. CLS. 2, 5, 22, 23, 29, 37, 38 AND 50).

CLASS 20—FURNITURE AND ARTICLES NOT OTHERWISE CLASSIFIED

FOR PLASTIC BOXES (U.S. CLS. 2, 13, 22, 25, 32 AND 50).

CLASS 35—ADVERTISING AND BUSINESS

FOR ADVERTISING SERVICES; BUSINESS MANAGEMENT; BUSINESS ADMINISTRATION AND MANAGEMENT; PROVIDING OFFICE FUNCTIONS; ACCOUNTING; FINANCIAL STATEMENT PREPARATION AND ANALYSIS FOR BUSINESSES; DIRECT MAIL ADVERTISING; DISSEMINATION OF ADVERTISING MATTER; RENTAL OF ADVERTISING SPACE; COSTS PRICE ANALYSIS; BUSINESS APPRAISALS; PROFESSIONAL BUSINESS CONSULTANCY; BUSINESS ADVICE AND INFORMATION; BUSINESS INFORMATION AND INQUIRIES; BUSINESS ORGANIZATION CONSULTANCY; ASSISTANCE WITH BUSINESS MANAGEMENT AND PLANNING; BUSINESS MANAGEMENT CONSULTANCY; BUSINESS ORGANIZATION CONSULTANCY; BUSINESS RESEARCH; COMMERCIAL INFORMATION AGENCIES; COMPILATION AND SYSTEMIZATION OF INFORMATION INTO COMPUTER DATABASES; DISTRIBUTION OF SAMPLES; DOCUMENT REPRODUCTION; ECONOMIC FORECASTING AND ANALYSIS; ORGANIZING EXHIBITIONS FOR COMMERCIAL PURPOSES; PREPARING AND PLACING OUTDOOR ADVERTISING FOR OTHERS; PERSONNEL MANAGEMENT CONSULTANCY; PHOTOCOPYING; WORD PROCESSING; PUBLICATION OF PUBLICITY TEXTS; TYPING; CREATING AND UPDATING OF ADVERTISING MATERIAL; WHOLESALE DISTRIBUTORSHIPS, RETAIL STORES AND MAIL ORDER SERVICES FEATURING COSMETICS, SKIN CARE PRODUCTS AND BEAUTY PRODUCTS (U.S. CLS. 100, 101 AND 102).

KATHERINE STOIDES, EXAMINING ATTORNEY

CLASS 1—CHEMICALS

FOR BULLET CASTING FLUX, NAMELY, COMPOUNDS FOR USE IN SEPARATING DROSS FROM LEAD IN THE CASTING OF BULLETS (U.S. CLS. 1, 5, 6, 10, 26 AND 46).

FIRST USE 3-12-1998; IN COMMERCE 3-12-1998.

CLASS 3—COSMETICS AND CLEANING PREPARATIONS

FOR AMMUNITION LOADING AND RELOADING EQUIPMENT, NAMELY, CLEANING PREPARATIONS FOR BULLET MOLDS (U.S. CLS. 1, 4, 6, 50, 51 AND 52).

FIRST USE 3-12-1998; IN COMMERCE 3-12-1998.

CLASS 4—LUBRICANTS AND FUELS

FOR AMMUNITION LOADING AND RELOADING EQUIPMENT, NAMELY, CASE LUBRICANT AND BULLET MOLD LUBRICANT (U.S. CLS. 1, 6 AND 15).

FIRST USE 3-12-1998; IN COMMERCE 3-12-1998.

CLASS 9—ELECTRICAL AND SCIENTIFIC APPARATUS

FOR AMMUNITION LOADING AND RELOADING EQUIPMENT, NAMELY, RELOADING MICROMETERS AND RELOADING CALIPERS (U.S. CLS. 21, 23, 26, 36 AND 38).

FIRST USE 3-12-1998; IN COMMERCE 3-12-1998.

CLASS 13—FIREARMS

FOR AMMUNITION LOADING AND RELOADING EQUIPMENT, NAMELY, CARTRIDGE GAGES, TUMBLERS, NAMELY, VIBRATORY DEVICES THAT CLEAN CARTRIDGES AFTER FIRING; COMPONENT PARTS FOR TUMBLERS, NAMELY, TUMBLER NUTS AND TUMBLER BOWLS; CASE CLEANING MEDIA, MEDIA SEPARATORS, SIFTERS, PORTABLE RELOADING STANDS, POWDER FUNNELS, BULLET PULLERS, PRIMER TUBE FILLERS, AMMUNITION BOXES, RELOADING PRESSES, AND RELOADING TRAYS (U.S. CLS. 2 AND 9).

FIRST USE 3-12-1998; IN COMMERCE 3-12-1998.

MARK PILARO, EXAMINING ATTORNEY

SN 78-952,775. SN SYSTEMS LTD., BRISTOL, UNITED KINGDOM, FILED 8-15-2006.

SN 78-951,749. BATTENFELD TECHNOLOGIES, INC., COLUMBIA, MO. FILED 8-14-2006.



FRANKFORD ARSENAL

THE MARK CONSISTS OF STANDARD CHARACTERS WITHOUT CLAIM TO ANY PARTICULAR FONT, STYLE, SIZE, OR COLOR.

NO CLAIM IS MADE TO THE EXCLUSIVE RIGHT TO USE "ARSENAL", APART FROM THE MARK AS SHOWN.

PRIORITY CLAIMED UNDER SEC. 44(D) ON UNITED KINGDOM APPLICATION NO. 2424175, FILED 6-12-2006, REG. NO. 2424175, DATED 7-27-2007, EXPIRES 6-12-2016.

OWNER OF U.S. REG. NO. 2,651,142.

CLASS 9—ELECTRICAL AND SCIENTIFIC APPARATUS

FOR COMPUTERS; COMPUTER SOFTWARE AND FIRMWARE, NAMELY, MIDDLE WARE AND GAME SOFTWARE DEVELOPMENT TOOLS FOR GAMES OF CHANCE AND GAMES FOR EDUCATION AND/OR ENTERTAINMENT PURPOSES ON ANY COMPUTERIZED PLATFORM, INCLUDING DEDICATED GAMING CONSOLES; VIDEO GAMES FOR USE WITH TELEVISIONS; INTERACTIVE VIDEO GAME PROGRAMS; COMPUTER HARDWARE; PERIPHERAL ITEMS FOR COMPUTERS, NAMELY, MICE, KEYBOARDS, SPEAKERS, PRINTERS; VIDEO GAME MACHINES FOR USE WITH TELEVISIONS; VIDEO GAME SOFTWARE; BLANK MAGNETIC DATA CARRIERS; RECORDED MAGNETIC DATA CARRIERS FEATURING GAME SOFTWARE DEVELOPMENT TOOLS; BLANK VIDEO DISCS AND RECORDED VIDEO DISCS FEATURING GAME SOFTWARE DEVELOPMENT TOOLS; BLANK OPTICAL DISCS AND RECORDED OPTICAL DISCS FEATURING GAME SOFTWARE DEVELOPMENT TOOLS; BLANK DVD-ROMS AND RECORDED DVD-ROMS FEATURING GAME SOFTWARE DEVELOPMENT TOOLS; BLANK COMPACT DISCS AND RECORDED COMPACT DISCS FEATURING GAME SOFTWARE DEVELOPMENT TOOLS; COMPUTER SOFTWARE DEVELOPMENT TOOLS (U.S. CLS. 21, 23, 26, 36 AND 38).

CLASS 42—SCIENTIFIC AND COMPUTER SERVICES

FOR LICENSING OF INTELLECTUAL PROPERTY; ADVICE AND/OR CONSULTANCY SERVICES RELATING TO THE LICENSING OF INTELLECTUAL PROPERTY; COMPUTER SOFTWARE DESIGN, DEVELOPMENT, IMPLEMENTATION, UPDATING, CONFIGURATION, MAINTENANCE AND CONSULTANCY SERVICES RELATED TO THE FOREGOING; COMPUTER HARDWARE DESIGN, DEVELOPMENT, IMPLEMENTATION, UPDATING, CONFIGURATION, MAINTENANCE AND CONSULTANCY SERVICES RELATED TO THE FOREGOING; ADVISORY AND/OR CONSULTANCY SERVICES RELATING TO COMPUTER HARDWARE AND/OR SOFTWARE, NAMELY, MIDDLE WARE AND GAME SOFTWARE DEVELOPMENT TOOLS FOR GAMES OF CHANCE AND GAMES FOR EDUCATION AND/OR ENTERTAINMENT PURPOSES ON ANY COMPUTERIZED PLATFORM INCLUDING DEDICATED GAMING CONSOLES; LEGAL SERVICES RELATED TO DESIGN AND DEVELOPMENT SERVICES FOR MULTIMEDIA PRODUCTS; PRODUCT DEVELOPMENT SERVICES FOR THIRD PARTIES (U.S. CLS. 100 AND 101).

MICHAEL KEATING, EXAMINING ATTORNEY

SN 78-961,582. COOLIT SYSTEMS INC., CALGARY, CANADA, FILED 8-28-2006.



OWNER OF CANADA REG. NO. 703307, DATED 12-17-2007, EXPIRES 12-17-2017.

THE MARK CONSISTS OF THE STYLIZED LETTERS "LI".

CLASS 9—ELECTRICAL AND SCIENTIFIC APPARATUS

FOR COOLING DEVICE, NAMELY, A COOLER FOR COOLING ELECTRONIC COMPONENTS, NAMELY, PROCESSORS AND INTEGRATED CIRCUITS (U.S. CLS. 21, 23, 26, 36 AND 38).

FIRST USE 6-0-2003; IN COMMERCE 6-0-2003.

CLASS 42—SCIENTIFIC AND COMPUTER SERVICES

FOR TECHNOLOGY CONSULTATION AND RESEARCH IN THE FIELD OF COOLING DEVICES AND SYSTEMS, NAMELY, COOLING ELECTRONIC COMPONENTS, NAMELY, PROCESSORS AND INTEGRATED CIRCUITS (U.S. CLS. 100 AND 101).

FIRST USE 6-0-2003; IN COMMERCE 6-0-2003.
LOURDES AYALA, EXAMINING ATTORNEY

SN 78-974,626. COMPTOIRS DU SUD INC., MONTREAL, CANADA, FILED 9-14-2006.

SOUTH SEA TRADERS

THE MARK CONSISTS OF STANDARD CHARACTERS WITHOUT CLAIM TO ANY PARTICULAR FONT, STYLE, SIZE, OR COLOR.

OWNER OF CANADA REG. NO. 463396, DATED 9-13-1996, EXPIRES 9-13-2011.

NO CLAIM IS MADE TO THE EXCLUSIVE RIGHT TO USE "TRADERS", APART FROM THE MARK AS SHOWN.

CLASS 30—STAPLE FOODS

FOR (BASED ON 44(E)) COFFEES, TEAS (U.S. CL. 46).

CLASS 35—ADVERTISING AND BUSINESS

FOR (BASED ON INTENT TO USE) DISTRIBUTORSHIP SERVICES FEATURING COFFEE TORREFACTION ROASTERS AND COFFEE; DISTRIBUTORSHIP SERVICES FEATURING TEA, TEA LEAVES AND TEA BAGS (U.S. CLS. 100, 101 AND 102).

TRICIA SONNEBORN, EXAMINING ATTORNEY

SN 78-980,323. ERIC HADDAD KOENIG, MEXICO, D.F., MEXICO, FILED 7-6-2006.

ALL.COM

THE MARK CONSISTS OF STANDARD CHARACTERS WITHOUT CLAIM TO ANY PARTICULAR FONT, STYLE, SIZE, OR COLOR.

CLASS 35—ADVERTISING AND BUSINESS

FOR MARKETING SERVICES RELATED TO ENTERTAINMENT AND RECREATION; PROVIDING OFFICE FUNCTIONS; PROMOTIONAL SERVICES, VIA A GLOBAL COMPUTER NETWORK, OF THE GOODS AND SERVICES OF OTHERS (U.S. CLS. 100, 101 AND 102).

CLASS 38—COMMUNICATION

FOR PERSONAL COMMUNICATION SERVICES, ISDN SERVICES, TELECOMMUNICATION ACCESS SERVICES DATA TRANSMISSION AND RECEPTION SERVICES VIA TELECOMMUNICATION MEANS, TELECOMMUNICATIONS GATEWAY SERVICES (U.S. CLS. 100, 101 AND 104).

GISELLE AGOSTO, EXAMINING ATTORNEY

SN 78-980,376. GRM INFORMATION MANAGEMENT SERVICES, INC., JERSEY CITY, NJ. FILED 7-28-2006.

ONECLICK CAPTURE

THE MARK CONSISTS OF STANDARD CHARACTERS WITHOUT CLAIM TO ANY PARTICULAR FONT, STYLE, SIZE, OR COLOR.

CLASS 38—COMMUNICATION

FOR COMMUNICATION SERVICES, NAMELY, ELECTRONIC TRANSMISSION OF DATA AND DOCUMENTS AMONG USERS OF COMPUTERS; ELECTRONIC DELIVERY OF IMAGES AND PHOTOGRAPHS VIA A GLOBAL COMPUTER NETWORK; ELECTRONIC TRANSMISSION OF DATA AND DOCUMENTS VIA COMPUTER TERMINALS; ELECTRONIC, ELECTRIC, AND DIGITAL TRANSMISSION OF VOICE, DATA, IMAGES, SIGNALS, AND MESSAGES; INFORMATION TRANSMISSION SERVICES VIA DIGITAL NETWORKS; ON-LINE DOCUMENT DELIVERY VIA A GLOBAL COMPUTER NETWORK (U.S. CLS. 100, 101 AND 104).

FIRST USE 8-31-2006; IN COMMERCE 8-31-2006.

CLASS 40—MATERIAL TREATMENT

FOR DOCUMENT SHREDDING SERVICES (U.S. CLS. 100, 103 AND 106).

FIRST USE 8-31-2006; IN COMMERCE 8-31-2006.
DAWN FELDMAN, EXAMINING ATTORNEY

SN 79-004,437. GALAXY PUBLICATIONS LIMITED, UNITED KINGDOM, FILED 6-21-2004.

RUDE BRITANNIA

THE MARK CONSISTS OF STANDARD CHARACTERS WITHOUT CLAIM TO ANY PARTICULAR FONT, STYLE, SIZE, OR COLOR.

PRIORITY DATE OF 1-20-2004 IS CLAIMED.

OWNER OF INTERNATIONAL REGISTRATION 0830713 DATED 6-21-2004, EXPIRES 6-21-2014.

NO CLAIM IS MADE TO THE EXCLUSIVE RIGHT TO USE "BRITANNIA", APART FROM THE MARK AS SHOWN.

CLASS 9—ELECTRICAL AND SCIENTIFIC APPARATUS

FOR ADULT VIDEO RECORDINGS; DOWNLOADABLE ADULT VIDEO RECORDINGS; ELECTRONIC PUBLICATIONS, NAMELY, MAGAZINES, NEWSLETTERS, PICTURES FEATURING ADULT SUBJECT MATTER; DOWNLOADABLE ELECTRONIC PUBLICATIONS, NAMELY, MAGAZINES, NEWSLETTERS, PICTURES FEATURING ADULT SUBJECT MATTER; DVDS FEATURING ADULT SUBJECT MATTER; MULTI-MEDIA SOFTWARE RECORDED ON CD-ROM FEATURING ADULT SUBJECT MATTER (U.S. CLS. 21, 23, 26, 36 AND 38).

CLASS 16—PAPER GOODS AND PRINTED MATTER

FOR PRINTED MATTER AND PUBLICATIONS, NAMELY, ADULT MAGAZINES; CALENDARS; PHOTOGRAPHS; PICTURES; CARTOON STRIPS (U.S. CLS. 2, 5, 22, 23, 29, 37, 38 AND 50).

CHRISIE B. KING, EXAMINING ATTORNEY

SN 79-006,760. GSI GROUND SERVICE INTERNATIONAL GMBH, FED REP GERMANY, FILED 2-5-2004.



gsi • groundservice international

PRIORITY DATE OF 8-21-2003 IS CLAIMED.
OWNER OF INTERNATIONAL REGISTRATION 0837283 DATED 2-5-2004, EXPIRES 2-5-2014.

NO CLAIM IS MADE TO THE EXCLUSIVE RIGHT TO USE "GROUND SERVICE INTERNATIONAL", APART FROM THE MARK AS SHOWN.

CLASS 37—CONSTRUCTION AND REPAIR

FOR AIRCRAFT AND AIRPORT CLEANING SERVICES; INSTALLATION AND MAINTENANCE OF DRINK AND SNACK DISPENSERS (U.S. CLS. 100, 103 AND 106).

CLASS 39—TRANSPORTATION AND STORAGE

FOR PROVIDING PASSENGER CHECK-IN, GATE HANDLING AND AIRCRAFT BOARDING SERVICES; PROVIDING INFORMATION FOR PASSENGERS BEFORE AND AFTER FLIGHTS IN THE NATURE OF INFORMATION RELATED TO ARRIVING AND DEPARTING FLIGHTS, CONNECTING FLIGHT INFORMATION AND GROUND TRANSPORTATION SERVICES; PROVIDING TRANSPORTATION SERVICES FOR HANDICAPPED PASSENGERS BETWEEN DEPARTURE LOUNGES AND AIRPLANES VIA WHEEL CHAIRS; PROVIDING RESERVATION SERVICES FOR TRAVEL BY AIR; PROVIDING BAGGAGE CART RENTALS FOR AIR PASSENGERS (U.S. CLS. 100 AND 105).

CLASS 41—EDUCATION AND ENTERTAINMENT

FOR EDUCATIONAL SERVICES, NAMELY, PROVIDING SEMINARS IN THE FIELDS OF AIRPLANE SERVICING, GROUND HANDLING SERVICES AND COMMUNICATIONS (U.S. CLS. 100, 101 AND 107).

CLASS 43—HOTEL AND RESTAURANT SERVICES

FOR MAKING HOTEL RESERVATIONS FOR OTHERS (U.S. CLS. 100 AND 101).

CLASS 45—PERSONAL AND LEGAL SERVICES

FOR ADMISSION CONTROL AND IDENTITY CHECK OF PERSONS AT AIRPORTS AND IN AIRPLANES, AND X-RAY INSPECTION OF PERSONS AND OF LUGGAGE (U.S. CLS. 100 AND 101).

NANCY CLARKE, EXAMINING ATTORNEY

SN 79-013,654. DI NALLO EGERIA, I-40136 BOLOGNA (BO), ITALY, FILED 4-28-2005.



PRIORITY DATE OF 12-15-2004 IS CLAIMED. OWNER OF INTERNATIONAL REGISTRATION 0857438 DATED 4-28-2005, EXPIRES 4-28-2015.

NO CLAIM IS MADE TO THE EXCLUSIVE RIGHT TO USE "HOME FOOD" AS TO CLASSES 29, 30, 31, 32 AND 43, APART FROM THE MARK AS SHOWN.

THE MARK CONSISTS OF A CARTOON OF A WOMAN WHOSE BODY IS IN PROFILE WHILE HER FACE IS SEEN FROM THE FRONT. THE WOMAN IS WEARING A SHORT DRESS, WITH A TRIM AND AN APRON, AND A CHEF'S HAT. THE WOMAN IS SMILING AND SHE IS PRESENTING A DISH OF STEAMING HOT PASTA IN HER HANDS; THE STEAM RISING FROM THE HOT PASTA FORMS THE SHAPE OF A HEART. DIRECTLY BENEATH THIS PICTURE THERE ARE THE WORDS "LE CESARINE" WRITTEN IN A SCRIPT FONT WHERE THE DOT OF THE "I" IS REPLACED WITH THE IMAGE OF A SMALL TOMATO. "HOME FOOD" IS DIRECTLY UNDERNEATH THE TERMS "LE CESARINE".

THE FOREIGN WORDING IN THE MARK TRANSLATES INTO ENGLISH AS "WOMEN OF THE HOME WHO PRESERVE ITALIAN COOKING AND FOOD TRADITIONS AND CULTURE".

SN 79-010,914. GIORGIO ARMANI S.P.A., I-20121 MILANO, ITALY, FILED 9-10-2004.

EMPORIO  ARMANI
CAFFÈ

OWNER OF INTERNATIONAL REGISTRATION 0849600 DATED 9-10-2004, EXPIRES 9-10-2014.

NO CLAIM IS MADE TO THE EXCLUSIVE RIGHT TO USE "EMPORIO" AND "CAFFE", APART FROM THE MARK AS SHOWN.

THE LINING SHOWN IN THE DRAWING IS A FEATURE OF THE MARK.

THE MARK CONSISTS IN PART OF A STYLIZED EAGLE DESIGN WITH THE LETTERS "GA".

THE ENGLISH TRANSLATION OF "EMPORIO" AND "CAFFE" IS EMPORIUM AND CAFE.

CLASS 35—ADVERTISING AND BUSINESS

FOR ADVERTISING SERVICES, BUSINESS MANAGEMENT, BUSINESS ADMINISTRATION, PROVIDING OFFICE FUNCTIONS (U.S. CLS. 100, 101 AND 102).

CLASS 43—HOTEL AND RESTAURANT SERVICES

FOR SERVING FOOD AND DRINKS; PROVIDING TEMPORARY ACCOMMODATIONS (U.S. CLS. 100 AND 101).

ALEX KEAM, EXAMINING ATTORNEY

CLASS 8—HAND TOOLS

FOR MANUALLY OPERATED HAND TOOLS TO BE USED IN A KITCHEN, ESPECIALLY FOR PREPARING AND COOKING ANY KIND OF FOOD, NAMELY, KNIVES, CAN OPENERS, KITCHEN PINCERS; CUTLERY, NAMELY, SPOONS, FORKS, KNIVES (U.S. CLS. 23, 28 AND 44).

CLASS 16—PAPER GOODS AND PRINTED MATTER

FOR PAPER; CARDBOARD; PAPER GOODS, NAMELY, BAGS, KITCHEN ROLLS, BLOTting PAPER, TABLE CLOTHS, NAPKINS, TABLE MATS, BABY BIBS, BANNERS, FESTOONS, GIFT WRAPPING PAPER, DRAWING PAPER, CARDS, CALENDARS, POSTERS, EXERCISE BOOKS; CARDBOARD GOODS, NAMELY, CARTONS, BOXES; PRINTED MATTER, NAMELY, RECIPE BOOKS, GUIDES, LESSONS, MAIL RESPONSE CARDS RELATING TO FOOD AND DRINK AND TO THE ITALIAN TRADITIONAL GASTRONOMIC LEGACY AND KNOW-HOW AS TO FOOD CULTURE AND CUSTOMS, PRESS RELEASES, PRODUCT GUIDES AND REPORTS FEATURING THE ITALIAN TRADITIONAL GASTRONOMIC LEGACY AND KNOW-HOW AS TO FOOD CULTURE AND CUSTOMS; PHOTOGRAPHS; STATIONERY; PENS AND PENCILS; ADHESIVES FOR STATIONERY OR HOUSEHOLD PURPOSES; PRINTED INSTRUCTIONAL AND TEACHING MATERIALS IN THE FIELD OF ITALIAN TRADITIONAL GASTRONOMIC LEGACY AND KNOW-HOW AS TO FOOD CULTURE AND CUSTOMS; PLASTIC MATERIALS FOR PACKAGING, NAMELY, PLASTIC BAGS; ARTISTS' MATERIALS, NAMELY, PENCILS, PENS, ERASERS (U.S. CLS. 2, 5, 22, 23, 29, 37, 38 AND 50).

CLASS 21—HOUSEWARES AND GLASS

FOR HOUSEHOLD OR KITCHEN UTENSILS, NAMELY, POTS AND PANS, SCRAPERS, ROLLING PINS, SPATULAS, TURNERS, WHISKS; CONTAINERS NOT OF PRECIOUS METAL OR COATED THEREWITH FOR HOUSEHOLD AND KITCHEN USE, NAMELY, SETS OF PAPER PLATES AND CUPS; KITCHEN BRUSHES; CLEANING SPONGES; ARTICLES FOR CLEANING PURPOSES, NAMELY, CLEANING CLOTH, SPONGES, METAL WOOL, MITTS OF FABRIC; STEEL-WOOL; UNWORKED OR SEMI-WORKED GLASS NOT FOR BUILDING; GLASSWARE, CONTAINERS FOR HOUSEHOLD OR KITCHEN USE, POTS, PANS AND DISHES MADE OF PORCELAIN, PAPER AND EARTH-WARE; BOTTLE OPENERS; COOKING GRATERS (U.S. CLS. 2, 13, 23, 29, 30, 33, 40 AND 50).

CLASS 24—FABRICS

FOR TEXTILES AND TEXTILE GOODS, NAMELY, FACE TOWELS MADE OF TEXTILE MATERIALS, QUILTS OF TEXTILES, TEXTILE NAPKINS, TEXTILE PLACE MATS; TEXTILE BED COVERS; TABLE CLOTHS NOT OF PAPER (U.S. CLS. 42 AND 50).

CLASS 29—MEATS AND PROCESSED FOODS

FOR MEAT, FISH, POULTRY AND BIRD GAME, LAND GAME AND SEA GAME AS INGREDIENTS OF TRADITIONAL ITALIAN RECIPES; MEAT EXTRACTS; PRESERVED, DRIED AND COOKED FRUITS AND VEGETABLES; JELLIES, JAMS, COMPOTES; EGGS, MILK AND MILK PRODUCTS EXCLUDING ICE CREAM, ICE MILK AND FROZEN YOGURT; EDIBLE OILS AND FATS; ASPICS (U.S. CL. 46).

CLASS 30—STAPLE FOODS

FOR COFFEE, TEA, COCOA, SUGAR, RICE, TAPIOCA, SAGO, ARTIFICIAL COFFEE; FLOUR AND PREPARATIONS MADE FROM PROCESSED CEREALS, BREAD, PASTRY AND CONFECTIONERY, NAMELY, FROZEN YOGURT, FRUIT JELLY, ASPICS, EDIBLE FRUIT FLAVORED, FRUIT OR CREAM ICES, NAMELY, HOME-MADE ICE CREAMS, SORBETS, COLD DESSERTS, NAMELY, DESSERT MOUSSE, DESSERT PUDDINGS, DESSERT SOUFFLES, CARAMEL CREAM PUDDING, DESSERT CAKES; HONEY, TREACLE; YEAST, BAKING-POWDER; SALT, MUSTARD; VINEGAR, SAUCES; SPICES; ICE (U.S. CL. 46).

CLASS 31—NATURAL AGRICULTURAL PRODUCTS

FOR SEEDS AND GRAINS OF WHEAT, BARLEY, CORN AND RICE; LIVE ANIMALS; FRESH FRUITS AND VEGETABLES; APPLE TREE SEEDS, LIVING PLANTS AND FLOWERS; MALTS FOR BREWING AND DISTILLING; FRESH, RAW OR UNPROCESSED FRUITS, FRESH, RAW OR UNPROCESSED VEGETABLES, LIVING PLANTS AND FLOWERS ALL USED FOR TABLE DECORATIONS (U.S. CLS. 1 AND 46).

CLASS 32—LIGHT BEVERAGES

FOR BEERS; MINERAL AND AERATED WATERS AND OTHER NON-ALCOHOLIC DRINKS, NAMELY, NON-ALCOHOLIC BEER, CARBONATED BEVERAGES, BEVERAGES WITH TEA FLAVOR, MALT BEVERAGES, MALT COOLERS; FRUIT DRINKS AND FRUIT JUICES; SYRUPS AND OTHER PREPARATIONS FOR MAKING FRUIT DRINKS (U.S. CLS. 45, 46 AND 48).

CLASS 33—WINES AND SPIRITS

FOR ALCOHOLIC BEVERAGES, NAMELY, MULLED WINE, SWEET WINE, LIQUEURS, APERITIFS BITTERS, BITTERS, ESSENCES, GRAPPAS, FRUIT EXTRACTS, PUNCH, MALT COOLERS (U.S. CLS. 47 AND 49).

CLASS 41—EDUCATION AND ENTERTAINMENT

FOR EDUCATION SERVICES, NAMELY, PROVIDING CLASS, SEMINARS, WORKSHOPS, CONVENTIONS IN THE FIELD OF ITALIAN TRADITIONAL GASTRONOMIC LEGACY AND KNOW-HOW AS TO FOOD CULTURE AND CUSTOMS; TRAINING THROUGH BOTH PRACTICAL COURSES AND COMPUTER COURSES IN THE FIELD OF ITALIAN TRADITIONAL GASTRONOMIC LEGACY AND KNOW-HOW AS TO FOOD CULTURE AND CUSTOMS; ENTERTAINMENT, NAMELY, ART EXHIBITIONS, FOOD AND WINE TASTINGS, COOKING COURSES, ETHNIC FESTIVALS; ORGANIZING CULTURAL EVENTS SUCH AS EXHIBITIONS, CHARITABLE EXHIBITIONS, LECTURES, CONGRESSES, CONCERTS, MEETINGS, BOOK PRESENTATIONS, PARTIES TO PROMOTE AND PRESERVE ITALIAN TRADITIONAL GASTRONOMIC LEGACY AND KNOW-HOW AS TO FOOD CULTURE AND CUSTOMS (U.S. CLS. 100, 101 AND 107).

CLASS 43—HOTEL AND RESTAURANT SERVICES

FOR PROVIDING TEMPORARY ACCOMMODATIONS, BAR SERVICES, CAFETERIAS, CAFES, CANTEENS, CATERING, RESTAURANTS, SELF-SERVICE RESTAURANTS, SNACK-BARS ALL OF WHICH FEATURING HOME-MADE ITALIAN FOOD AND DRINK SERVED TO MEMBERS OF CLUBS AND ASSOCIATIONS AND TO THE MEMBERS' HOSTS (U.S. CLS. 100 AND 101).

RENEE SERVANCE, EXAMINING ATTORNEY

SN 79-013,672. AK-WORLD AG, CH-6301 ZUG, SWITZERLAND, FILED 7-12-2005.

USB-House

THE MARK CONSISTS OF STANDARD CHARACTERS WITHOUT CLAIM TO ANY PARTICULAR FONT, STYLE, SIZE, OR COLOR.

PRIORITY DATE OF 5-13-2005 IS CLAIMED.
OWNER OF INTERNATIONAL REGISTRATION 0857497
DATED 7-12-2005, EXPIRES 7-12-2015.

CLASS 2—PAINTS

FOR PRINTERS' INK; PHOTOCOPIER TONER AND/OR PHOTOCOPIER TONER IN CARTRIDGES OR COPYING INKS (U.S. CLS. 6, 11 AND 16).

CLASS 9—ELECTRICAL AND SCIENTIFIC APPARATUS

FOR PHOTOGRAPHIC APPARATUS AND INSTRUMENTS, NAMELY, DIGITAL CAMERAS, ACCESSORIES FOR DIGITAL CAMERAS, NAMELY, ELECTRICAL POWER ADAPTERS, CABLES, FLASHES, BAGS; MEASURING APPARATUS AND INSTRUMENTS FOR MEASURING POWER MEASUREMENTS AND NETWORK MEASUREMENTS; APPARATUS AND INSTRUMENTS FOR CONDUCTING, SWITCHING, TRANSFORMING, ACCUMULATING, REGULATING OR CONTROLLING ELECTRICITY, NAMELY, POWER ADAPTERS FOR COMPUTERS; APPARATUS FOR RECORDING, TRANSMITTING AND REPRODUCING SOUND OR IMAGES, NAMELY, SOUND CARDS, MP3 PLAYERS, SOUND TRANSMITTERS, DVD AND CD BURNERS, AUDIO CONVERTER; BLANK RECORDING DISCS, NAMELY DVDS AND CDS FOR SOUND OR VIDEO RECORDING, HARD DISCS FOR COMPUTERS, MEMORY CARDS, FLASH COMPUTER DISCS; AUTOMATIC VENDING MACHINES AND MECHANISMS FOR COIN-OPERATED APPARATUS, CASH REGISTERS, AND CALCULATING MACHINES, NAMELY, AUTOMATIC ANSWERING MACHINES, AUTOMATIC TELLER MACHINES; DATA PROCESSING AND COMPUTER EQUIPMENT, NAMELY, NOTEBOOK COMPUTERS, PDAS, PERSONAL COMPUTERS, COMMUNICATION SERVERS, INTERNET PHONES; TELEVISION APPARATUS, NAMELY, MONITORS AND ANTENNAS; COMPUTER INTEGRATED CD-ROM PLAYERS, NAMELY, CD-PLAYERS, DVD-PLAYERS, PORTABLE DVD PLAYERS, VIDEO AND COMPACT DISC PLAYERS WITH DVD, CD- AND DVD-RECORDERS; COMPACT DISCS, NAMELY, CD-R AND CD-RW TO STORE DATA OR MUSIC; COMPUTER GAME PROGRAMS; FLOPPY DISC DRIVES FOR COMPUTERS; INTERNAL AND EXTERNAL FLOPPY DISC DRIVES TO STORE DATA; COMPUTER SOFTWARE FOR USE IN DATABASE MANAGEMENT, USE AS A SPREADSHEET, WORD PROCESSING, SOFTWARE FOR OFFICE USE, BACKUP, FLOWCHART, PROJECTS, SECURITY AND ANTI-VIRUS; SPECTACLES (U.S. CLS. 21, 23, 26, 36 AND 38).

CLASS 16—PAPER GOODS AND PRINTED MATTER

FOR BOND PAPER, ART PAPER, PHOTO, LASER, COPY AND OFFICE PAPER; PRINTED MATTER, NAMELY, STICKERS, POSTERS, DECALS, POST CARDS, CHARTS; CARDBOARD; CARDBOARD GOODS, NAMELY, CARDBOARD CARTONS, CARDBOARD BOXES, CARDBOARD CONTAINERS; PAPER SHREDDERS FOR OFFICE USE; STATIONERY, NAMELY, PENS, PENCILS, MARKING PENS, STICKERS, LABELS, ADHESIVE LABELS, ADHESIVE FOILS, ADHESIVE TAPE (U.S. CLS. 2, 5, 22, 23, 29, 37, 38 AND 50).

CLASS 28—TOYS AND SPORTING GOODS

FOR ACTION SKILL, ACTION TARGET, BOARD AND ARCADE GAMES, TOYS, NAMELY, DOLLS, PLUSH TOYS, STUFFED TOYS, COLLECTIBLE FIGURINES; GYMNASIAC AND SPORTING ARTICLES, NAMELY, BALANCE BEAMS, RINGS, PARALLEL BARS, SPRING BOARDS, TENNIS RACKETS, BASEBALLS AND BASEBALL BATS; CHEST PROTECTORS, HURDLES FOR TRACK SPORTS, BOUNCING SPORT BALLS, BASEBALLS, BASKETBALLS, SOCCER BALLS, FOOTBALLS, DISCUSSES FOR FIELD SPORT; PLAYING CARDS; ELECTRONIC GAMES NOT USED WITH TELEVISION SETS, NAMELY, ARCADE-TYPE ELECTRONIC VIDEO GAMES (U.S. CLS. 22, 23, 38 AND 50).

TRACY WHITTAKER-BROWN, EXAMINING ATTORNEY

SN 79-013,906. GIAN CHRISTIAN, SOUTH YARRA VIC 3141, AUSTRALIA, AND DINA MCPHERSON, SOUTH YARRA VIC 3141, AUSTRALIA, FILED 5-2-2005.

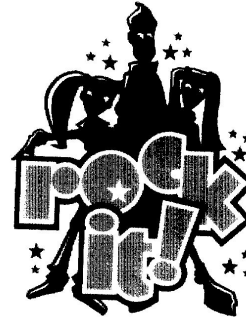

OWNER OF INTERNATIONAL REGISTRATION 0858053 DATED 5-2-2005, EXPIRES 5-2-2015.

CLASS 9—ELECTRICAL AND SCIENTIFIC APPARATUS

FOR CDS, DVDS, RECORDS, CASSETTE TAPES, VIDEO TAPES AND/OR CD ROMS FEATURING SOUND AND/OR VIDEO RECORDINGS IN THE NATURE OF SONGS, MUSICAL PERFORMANCES AND PROGRAMS FOR CHILDREN; BLANK RECORD DISCS; BLANK RECORDABLE OPTICAL DISCS; AUTOMATIC VENDING MACHINES; COMPUTERS; COMPUTER GAME DISCS AND PROGRAMS; ALL OF THE FOREGOING SPECIFICALLY FOR CHILDREN AND NONE OF THE FOREGOING GOODS USED IN CONNECTION WITH OR FOR THE PROMOTION OF THE SPORT OF BASKETBALL (U.S. CLS. 21, 23, 26, 36 AND 38).

CLASS 28—TOYS AND SPORTING GOODS

FOR GAMES AND PLAYTHINGS, NAMELY, BOARD GAMES, ACTION FIGURES, COLLECTABLE TOY FIGURES, ACTION SKILL GAMES, CARD GAMES, PLAYING CARDS, CHESS SETS, MANIPULATIVE GAMES, PUZZLES JIGSAW PUZZLES, PARTY GAMES, DOLLS, PAPER DOLLS, SOFT SCULPTURE DOLLS, DOLLS' HOUSES, DOLL CLOTHING, DOLL ACCESSORIES, DOLL PLAYSETS, BEAN BAG DOLLS, PUPPETS, PLUSH TOYS, PLUSH TOY ANIMALS, SOFT TOYS, FINGER PUPPETS, STUFFED TOYS, STUFFED TOY ANIMALS, CRIB TOYS, SQUEEZE TOYS, TEDDY BEARS, PLAY SWIMMING POOLS, SURF BOARDS, SKATEBOARDS, BOWLING BALLS, SPORT BALLS, BEACH BALLS, INFLATABLE TOYS, INFLATABLE POOL TOYS, INFLATABLE MASCOTS, INFLATABLE BALLS, INFLATABLE CARS, SPINNING TOPS, KITES, BALLOONS, BATH TOYS, BATH TUB TOYS, INFLATABLE BATH TOYS, MUSICAL TOYS, MUSIC BOX TOYS, TOY MICROPHONES, TOY DRUM KITS, TOY CYMBALS, TOY GUITARS, TOY ELECTRONIC KEYBOARDS, TOY MONEY BANKS, TOY VEHICLES, TOY CARS AND TRUCKS, TOY CAR PARTS, TOY SCOOTERS, TOY TRICK NOISEMAKERS, TOY MOBILES, TOY MODEL HOBBY CRAFT KITS, TOY STAMPS, TOY WATCHES, WIND-UP TOYS, YO-YOS, KALEIDOSCOPES; BUBBLE MAKING WANDS AND SOLUTION SETS, CHILDREN'S PLAY COSMETICS, GOLF BALLS, GOLF GLOVES, GOLF BALL MARKERS, BAND HELD UNIT FOR PLAYING ELECTRONIC GAMES, MAGIC TRICKS, MARBLES, MECHANICAL TOYS, PARLOR GAMES, ROLLER SKATES, RUBBER BALLS, TABLE TENNIS TABLES, TARGET GAMES, TENNIS BALLS, TOY BUCKET AND SHOVEL SETS. ALL OF THE FOREGOING SPECIFICALLY FOR CHILDREN AND NONE OF THE FOREGOING GOODS USED IN CONNECTION WITH OR FOR THE PROMOTION OF THE SPORT OF BASKETBALL (U.S. CLS. 22, 23, 38 AND 50).

CLASS 32—LIGHT BEVERAGES

FOR SOFT DRINKS, MINERAL AND AERATED WATERS; FRUIT DRINKS AND FRUIT JUICES; CONCENTRATES, SYRUPS OR POWDERS USED IN THE PREPARATION OF SOFT DRINKS; ALL OF THE FOREGOING SPECIFICALLY FOR CHILDREN AND NONE OF THE FOREGOING USED IN CONNECTION WITH OR FOR THE PROMOTION OR THE SPORT OF BASKETBALL (U.S. CLS. 45, 46 AND 48).

CLASS 41—EDUCATION AND ENTERTAINMENT

FOR EDUCATIONAL SERVICES, NAMELY, PROVIDING COURSES OF INSTRUCTION AND SEMINARS IN THE FIELD OF CHILD EDUCATION; ENTERTAINMENT SERVICES, NAMELY, AMUSEMENT ARCADES AND PARKS, BOOKING OF SEATS FOR SHOWS, MOTION PICTURE FILM PRODUCTION, LIVE PERFORMANCES BY A MUSICAL GROUP, MUSIC COMPOSITION, MUSIC PUBLISHING, PRODUCTION OF MUSIC, PRODUCTION OF RADIO AND TELEVISION PROGRAMS, PUBLICATION OF BOOKS, SCRIPT WRITING AND SCRIPT WRITING SERVICES, SOUND RECORDING, ENTERTAINMENT SERVICES IN THE NATURE OF ON-GOING TELEVISION PROGRAMS IN THE FIELD OF CHILDREN'S ENTERTAINMENT, THEATRE PRODUCTIONS, VIDEO TAPE AND VIDEO DISC PRODUCTION, VIDEO TAPE EDITING AND FILMING, RADIO AND TELEVISION ENTERTAINMENT PRODUCTION; LIVE PERFORMANCES FEATURING COSTUMED CHARACTERS; PROVIDING ONLINE ENTERTAINMENT FOR CHILDREN IN THE NATURE OF SONGS, STORIES, DRAMA AND GAMES; PRODUCTION, PRESENTATION, DISTRIBUTION OF CHILDREN'S ENTERTAINMENT SHOWS AND INTERACTIVE PROGRAMS FOR DISTRIBUTION VIA TELEVISION, CABLE, SATELLITE, AND ELECTRONIC MEANS OVER A GLOBAL COMPUTER NETWORK; PRODUCTION OF CHILDREN'S ENTERTAINMENT SHOWS AND INTERACTIVE PROGRAMS FOR AUDIO AND VIDEO MEDIA, NAMELY, CASSETTES, CARTRIDGES, CDS, DVDS, DIGITAL VERSATILE DISCS, LASERDISCS AND COMPUTER DISCS; ALL OF THE FOREGOING SPECIFICALLY FOR CHILDREN AND NONE OF THE FOREGOING GOODS USED IN CONNECTION WITH OR FOR THE PROMOTION OF THE SPORT OF BASKETBALL (U.S. CLS. 100, 101 AND 107).
DANIEL CAPSHAW, EXAMINING ATTORNEY

SN 79-019.906. ZAUGG AG EGGIWIL, CH-3537 EGGIWIL, SWITZERLAND, FILED 11-7-2005.

ZAUGG

THE MARK CONSISTS OF STANDARD CHARACTERS WITHOUT CLAIM TO ANY PARTICULAR FONT, STYLE, SIZE, OR COLOR.

PRIORITY DATE OF 8-19-2005 IS CLAIMED.
OWNER OF INTERNATIONAL REGISTRATION 0874059 DATED 11-7-2005, EXPIRES 11-7-2015.
SEC. 2(F).

CLASS 7—MACHINERY

FOR AGRICULTURAL MACHINES AND INSTRUMENTS, NAMELY, TRACTORS, CULTIVATORS, PLOWS, DISK HARROWS, ROTOTILLERS, SPADING MACHINES, SUBSOILERS, SEEDERS, PLANTERS, SEED DRILLS, FERTILIZER SPREADERS, HARVESTERS, BALERS, MOWER, LOADERS, WHICH ARE NOT HAND-OPERATED, MOTOR-OPERATED INSTRUMENTS, NAMELY, SNOW PLOWS, SNOW BLOWERS, SNOW THROWERS, FOR REMOVING SNOW FROM ROADS, RAILWAYS AND RUNWAYS, MACHINES FOR CLEARING ROADS, NAMELY, ROAD SWEEPING MACHINES, EDGE TRIMMERS, ROTARY WEEDERS, MOWERS, GRADERS, SNOWPLOWS, SNOW AND ICE CUTTERS AS MACHINE PARTS; MACHINES, NAMELY, SNOW BLOWERS, FULLY TRACKED VEHICLE DESIGNED TO MOVE ON SNOW FOR GROOMING SKI TRAILS AND SNOW MOBILE TRAILS, GROOMERS, FOR PREPARING SKI RUNS, MACHINES, NAMELY, ROLLERS, CUTTERS, MILLING MACHINES, PAVEMENT BREAKERS, PAYERS, FOR PREPARING ROADS, ELECTRICALLY OPERATED BRUSHES, BEING PARTS OF MACHINES, ROAD MAINTENANCE MACHINES, NAMELY, ROAD SWEEPING MACHINES, EDGE TRIMMERS, ROTARY WEEDERS, MOWERS, GRADERS, FLATTENING MACHINES FOR COMPACTING SURFACES, NAMELY, SOIL AND ROAD PAVEMENT; SELF-PROPELLED SNOW AND ICE MACHINE CUTTERS; SPECIAL VEHICLES, NAMELY, SNOW PLOWS, SNOW BLOWERS, SNOW THROWERS, ROAD SWEEPING MACHINES, EDGE TRIMMERS, ROTARY WEEDERS, MOWERS, GRADERS, FOR SNOW AND ROAD CLEARANCE (U.S. CLS. 13, 19, 21, 23, 31, 34 AND 35).

CLASS 12—VEHICLES

FOR VEHICLES, NAMELY, CARS, VANS, TRUCKS, PICK-UP TRUCKS, BOATS, SNOW CRAFTS, NAMELY, SNOW MOBILES, ALL-TERRAIN VEHICLES, AMPHIBIOUS VEHICLES, CRAWLER TYPE VEHICLES, NAMELY, ALL-TERRAIN TRACKED VEHICLES, TRACTORS, VEHICLES FOR LOCOMOTION ON RAILS, NAMELY, TRAINS AND STRUCTURAL PARTS THEREFOR, AND TRAILERS (U.S. CLS. 19, 21, 23, 31, 35 AND 44).

CLASS 37—CONSTRUCTION AND REPAIR

FOR VEHICLE REPAIR AND MAINTENANCE, REPAIR OR MAINTENANCE OF MACHINES, NAMELY, SNOW PLOWS, SNOW BLOWERS, SNOW THROWERS, ROAD SWEEPING MACHINES, EDGE TRIMMERS, ROTARY WEEDERS, MOWERS, GRADERS, FLATTENING MACHINES, SELF-PROPELLED SNOW AND ICE MACHINE CUTTERS (U.S. CLS. 100, 103 AND 106).

CLASS 42—SCIENTIFIC AND COMPUTER SERVICES

FOR DEVELOPMENT OF NEW MACHINES, NAMELY, DEVELOPMENT OF MACHINES FOR REMOVING SNOW AND CLEARING ROADS, FOR SNOW TREATMENT AND FOR PREPARING SKI RUNS FOR OTHERS (U.S. CLS. 100 AND 101).

ALICE BENMAMAN, EXAMINING ATTORNEY

SN 79-023,130. RICO DESIGN GMBH & CO. KG, FED REP GERMANY, FILED 12-22-2005.

RICO

DESIGN

OWNER OF INTERNATIONAL REGISTRATION 0882979 DATED 12-22-2005, EXPIRES 12-22-2015.

NO CLAIM IS MADE TO THE EXCLUSIVE RIGHT TO USE "DESIGN", APART FROM THE MARK AS SHOWN.

CLASS 2—PAINTS

FOR PAINTS, LACQUERS, COLORANTS EXCLUSIVELY FOR CREATIVE PAINTING BY HAND USING A PAINTBRUSH OR PENCILS (U.S. CLS. 6, 11 AND 16).

CLASS 4—LUBRICANTS AND FUELS

FOR FUELS, CANDLES, AND WICKS FOR LIGHTING; ILLUMINANTS, NAMELY, OIL, WAX, WAX POWDER, WAX GRANULATE AND GEL ALL FOR USE AS FUEL FOR ILLUMINATING FIRE TORCHES (U.S. CLS. 1, 6 AND 15).

CLASS 16—PAPER GOODS AND PRINTED MATTER

FOR HANDICRAFT MATERIAL, NAMELY, PAPER AND CARDBOARD AND GOODS MADE FROM THESE MATERIALS IN THE FORM OF ART PAPER, BOOK COVER PAPER, CALLIGRAPHY PAPER, ORIGAMI PAPER, DECORATIVE PAPER CENTERPIECES, DRAWING PAPER, GIFT WRAP PAPER, GUMMED PAPER, HEAT TRANSFER PAPER, KRAFT PAPER, PAPER BUNTING, PAPER CAKE DECORATIONS, PAPER DOILIES, PAPER FLAGS, PAPER FLOWER POT COVERS, PAPER GIFT BAGS, PAPER LACE, PAPER MACHE, PAPER PARTY DECORATIONS, PAPER RIBBONS, PAPER FOR USE IN THE GRAPHIC ARTS INDUSTRY FOR USE IN THE PREPARATION OF HANDICRAFTS, ARTISTS TOOLS IN THE NATURE OF HANDHELD PERFORATORS AND PUNCHES FOR USE IN PERFORATION OF HANDICRAFTS; PRINTED INSTRUCTIONAL AND TEACHING MATERIAL RELATED TO HANDICRAFTS; PLASTIC BAGS FOR PACKAGING, PRINTER'S TYPE, PRINTER'S BLOCKS; ENVELOPES, BOXES AND BAGS OF PAPER AND CARDBOARD, STICKERS, MEMO PADS, MEMO BLOCKS, STENCILS, PAPER AND CARDBOARD FOR SCRAP BOOKS AND FOR DECOUPAGE; PAPER NAPKINS, ADHESIVES FOR STATIONERY OR HOUSEHOLD PURPOSES; ARTISTS MATERIAL, NAMELY, BRUSHES, PASTELS, PENCILS, CANVAS PANELS, PAINTING SETS CUTTING PENCILS, PAINTBRUSHES; OFFICE REQUISITES, NAMELY, TAPE DISPENSERS, AUTOMATIC PAPER CLIP DISPENSING MACHINES, DOCUMENT BINDING MACHINES, DOCUMENT LAMINATORS FOR OFFICE AND HANDICRAFT USE; LABELING MACHINES FOR OFFICE AND HANDICRAFT USE; BOOK BINDING; PHOTOGRAPHS; STATIONERY (U.S. CLS. 2, 5, 22, 23, 29, 37, 38 AND 50).

CLASS 20—FURNITURE AND ARTICLES NOT OTHERWISE CLASSIFIED

FOR MIRRORS, PICTURE FRAMES; HANDICRAFT PRODUCTS MADE FROM WOOD, CORK, REED, CANE, WICKER, HORN, BONE, IVORY AND WHALE BONE, SHELL, AMBER, MOTHER OF PEARL, MEERSCHAUM, AND SUBSTITUTES THEREFORE, NAMELY, VINYL APPLIQUES FOR ATTACHMENT TO WINDOWS, MIRRORS AND OTHER SOLID SURFACES, ORNAMENTS AND THREE DIMENSIONAL ORNAMENTS NOT FOR CHRISTMAS TREES (U.S. CLS. 2, 13, 22, 25, 32 AND 50).

CLASS 23—YARNS AND THREADS

FOR YARNS (U.S. CL. 43).

CLASS 24—FABRICS

FOR TEXTILES AND TEXTILE GOODS, NAMELY, TABLE LINENS AND KITCHEN LINENS AS FAR AS INCLUDED IN THIS CLASS EXCEPT BED COVERS; TABLE COVERS NOT OF PAPER (U.S. CLS. 42 AND 50).

CLASS 26—FANCY GOODS

FOR LACE AND EMBROIDERY, RIBBONS AND BRAID; BUTTONS FOR CLOTHING, HOOKS AND EYES, ARTIFICIAL FLOWERS (U.S. CLS. 37, 39, 40, 42 AND 50).

HEATHER THOMPSON, EXAMINING ATTORNEY

SN 79-023,131. RICO DESIGN GMBH & CO. KG, BRAKEL, FED REP GERMANY, FILED 12-22-2005.

RICO

OWNER OF INTERNATIONAL REGISTRATION 0882993 DATED 12-22-2005, EXPIRES 12-22-2015.

CLASS 2—PAINTS

FOR PAINTS, LACQUERS, COLORANTS EXCLUSIVELY FOR CREATIVE PAINTING BY HAND USING A PAINTBRUSH OR PENCILS (U.S. CLS. 6, 11 AND 16).

CLASS 4—LUBRICANTS AND FUELS

FOR FUELS CANDLES, AND WICKS FOR LIGHTING; ILLUMINANTS, NAMELY, OIL, WAX, WAX POWDER, WAX GRANULATE AND GEL ALL FOR USE AS FUEL FOR ILLUMINATING FIRE TORCHES (U.S. CLS. 1, 6 AND 15).

CLASS 16—PAPER GOODS AND PRINTED MATTER

FOR HANDICRAFT MATERIAL, NAMELY, PAPER AND CARDBOARD AND GOODS MADE FROM THESE MATERIALS IN THE FORM OF ART PAPER, BOOK COVER PAPER, CALLIGRAPHY PAPER, ORIGAMI PAPER, DECORATIVE PAPER CENTERPIECES, DRAWING PAPER, GIFT WRAP PAPER, GUMMED PAPER, HEAT TRANSFER PAPER, KRAFT PAPER, PAPER BUNTING, PAPER CAKE DECORATIONS, PAPER DOILIES, PAPER FLAGS, PAPER FLOWERPOT COVERS, PAPER GIFT BAGS, PAPER LACE, PAPER MACHE, PAPER PARTY DECORATIONS, PAPER RIBBONS, PAPER FOR USE IN THE GRAPHIC ARTS INDUSTRY FOR USE IN THE PREPARATION OF HANDICRAFTS, ARTISTS TOOLS IN THE NATURE OF HANDHELD PERFORATORS AND PUNCHES FOR USE IN PERFORATION OF HANDICRAFTS; PRINTED INSTRUCTIONAL AND TEACHING MATERIAL RELATED TO HANDICRAFTS; PLASTIC BAGS FOR PACKAGING, PRINTER'S TYPE, PRINTER'S BLOCKS; ENVELOPES, BAGS AND BOXES OF PAPER AND CARDBOARD, STICKERS, MEMO PADS, MEMO BLOCKS, STENCILS, PAPER AND CARDBOARD FOR SCRAP BOOKS AND FOR DECOUPAGE; PAPER NAPKINS, ADHESIVES FOR STATIONERY OR HOUSEHOLD PURPOSES; ARTISTS MATERIAL, NAMELY, BRUSHES, PASTELS, PENCILS, CANVAS PANELS, PAINTING SETS, CUTTING PENCILS, PAINT BRUSHES; OFFICE REQUISITES, NAMELY, TAPE DISPENSERS, AUTOMATIC PAPER CLIP DISPENSING MACHINES, DOCUMENT BINDING MACHINES, DOCUMENT LAMINATORS FOR OFFICE AND HANDICRAFT USE; LABELING MACHINES FOR OFFICE AND HANDICRAFT USE; BOOK BINDING; PHOTOGRAPHS; STATIONERY (U.S. CLS. 2, 5, 22, 23, 29, 37, 38 AND 50).

CLASS 20—FURNITURE AND ARTICLES NOT OTHERWISE CLASSIFIED

FOR MIRRORS, PICTURE FRAMES; HANDICRAFT PRODUCTS MADE FROM WOOD, CORK, REED, CANE, WICKER, HORN, BONE, IVORY AND WHALE BONE, SHELL, EMBER, MOTHER OF PEARL, MEERSCHAUM, AND SUBSTITUTES THEREFORE, NAMELY, VINYL APPLIQUES FOR ATTACHMENT TO WINDOWS, MIRRORS AND OTHER SOLID SURFACES, ORNAMENTS AND THREE DIMENSIONAL ORNAMENTS NOT FOR CHRISTMAS TREES (U.S. CLS. 2, 13, 22, 25, 32 AND 50).
HEATHER THOMPSON, EXAMINING ATTORNEY

SN 79-026,475. DIGITOTE SOFTWARE GMBH DEUTSCHLAND, FED REP GERMANY, FILED 6-22-2005.



PRIORITY DATE OF 12-28-2004 IS CLAIMED.
OWNER OF INTERNATIONAL REGISTRATION 0892109
DATED 6-22-2005, EXPIRES 6-22-2015.
"DIGIBET" HAS NO MEANING IN A FOREIGN LANGUAGE.

CLASS 9—ELECTRICAL AND SCIENTIFIC APPARATUS

FOR COMPUTER HARDWARE AND SOFTWARE USED FOR BOOKMAKING, LOTTERIES, GAMES OF CHANCE, SPORTS BETTING AND OTHER BETTING SYSTEMS; COMPUTER-BASED BETTING TERMINALS; COMPUTER-BASED BETTING TERMINALS WITH SELF-SERVICE FUNCTIONS; TOTALISATORS; AUTOMATIC GAMING MACHINES; AUTOMATIC GAMING MACHINES FOR INTERACTIVE GAMES FOR USE WITH TELEVISION RECEIVERS; AUTOMATIC GAMES OF CHANCE MACHINES FOR USE WITH TELEVISION RECEIVERS; AUTOMATIC GAMES OF CHANCE MACHINES WITH SELF-SERVICE FUNCTIONS FOR USE WITH TELEVISION RECEIVERS; GAMES OF CHANCE AND BETTING GAMES RECORDED ON VISUAL DATA CARRIERS; ELECTRIC AND ELECTRONIC CONTROL AND MONITORING APPARATUS, NAMELY, CONTROL SYSTEMS FOR MACHINES, GATEWAY ROUTERS IN THE NATURE OF COMPUTER CONTROL HARDWARE, VIDEO GAME INTERACTIVE HAND HELD REMOTE CONTROLS FOR PLAYING ELECTRONIC GAMES, COMPUTER TERMINALS, VIDEO LOTTERY TERMINALS (U.S. CLS. 21, 23, 26, 36 AND 38).

CLASS 16—PAPER GOODS AND PRINTED MATTER

FOR PRINTED MATERIALS, NAMELY, LISTS FEATURING BETTING FORECASTS FOR HORSE RACING, DOG RACING, AND SPORTING COMPETITIONS, NEWSPAPERS IN THE FIELD OF RACE TRACKS (U.S. CLS. 2, 5, 22, 23, 29, 37, 38 AND 50).

CLASS 28—TOYS AND SPORTING GOODS

FOR ARCADE-TYPE AUTOMATIC AND ELECTRONIC VIDEO GAMING MACHINES; AUTOMATIC AND ELECTRONIC GAMING MACHINES FOR INTERACTIVE GAMES; AUTOMATIC GAMES OF CHANCE MACHINES; AUTOMATIC GAMES OF CHANCE MACHINES WITH SELF-SERVICE FUNCTIONS; THE AFOREMENTIONED GOODS NOT BEING ADAPTED FOR USE WITH TELEVISION RECEIVERS (U.S. CLS. 22, 23, 38 AND 50).

CLASS 37—CONSTRUCTION AND REPAIR

FOR SETTING UP, INSTALLATION, MAINTENANCE, AND REPAIR OF OFFICE EQUIPMENT AND COMPUTER HARDWARE, NAMELY, THE SETTING UP AND MAINTENANCE OF ELECTRONIC LOTTERY, BOOKMAKING, SPORTS BETTING AND OTHER BETTING SYSTEMS AND BETTING TERMINALS AND GAMING MACHINES (U.S. CLS. 100, 103 AND 106).

CLASS 38—COMMUNICATION

FOR TRANSMISSION OF SPORTS NEWS AND SPORTS AND BETTING RESULTS VIA RADIO AND TELEVISION, BY COMPUTER OR BY MEANS OF OTHER ELECTRONIC TRANSMISSION APPARATUS (U.S. CLS. 100, 101 AND 104).

CLASS 41—EDUCATION AND ENTERTAINMENT

FOR BETTING SERVICES, NAMELY, BOOKMAKING, OFF-TRACK BETTING FACILITIES; BETTING OFFICES, CASINOS AND SPORTS FACILITIES, ORGANIZATION OF SPORTS EVENTS IN THE FIELDS OF HORSE RACING, DOG RACING, TEAM SPORTS, OLYMPIC SPORTS, WATER SPORTS, SOLO SPORTS, ADVENTURE SPORTS, PROFESSIONAL SPORTS, SNOW SPORTS; PUBLICATION OF SPORTS NEWS AND SPORT BETTING RESULTS VIA PRINT MEDIA; RENTAL OF BETTING TERMINALS, NAMELY, THOSE WITH SELF-SERVICE FUNCTIONS, TOTALISATORS, GAMING MACHINES, AUTOMATIC GAMES OF CHANCE MACHINES WITH SELF-SERVICE FUNCTIONS AND GAMES OF CHANCE AND BETTING GAMES RECORDED ON VISUAL DATA CARRIERS (U.S. CLS. 100, 101 AND 107).

CLASS 42—SCIENTIFIC AND COMPUTER SERVICES

FOR DEVELOPMENT OF SECTOR-SPECIFIC COMPUTER SOFTWARE, NAMELY, FOR BOOKMAKING, RACE TRACKS, SPORTS EVENT ORGANISERS, LOTTERIES, GAMES OF CHANCE, SPORTS BETTING AND OTHER BETTING SYSTEMS (U.S. CLS. 100 AND 101).

SUZANNE BLANE, EXAMINING ATTORNEY

SN 79-027,718. ADVANCED MEDICAL OPTICS UPPSALA AB, SWEDEN, FILED 7-12-2006.

HEALON D

PRIORITY DATE OF 7-10-2006 IS CLAIMED.
OWNER OF INTERNATIONAL REGISTRATION 0895500 DATED 7-12-2006, EXPIRES 7-12-2016.
OWNER OF U.S. REG. NOS. 940,849, 1,812,655 AND 2,716,012.

CLASS 5—PHARMACEUTICALS

FOR PHARMACEUTICAL PREPARATIONS AND SUBSTANCES FOR USE DURING PHACOEMULSIFICATION SURGERY; PHARMACEUTICAL PREPARATIONS IN THE NATURE OF HYALURONIC ACID FOR USE IN OPHTHALMIC SURGERY (U.S. CLS. 6, 18, 44, 46, 51 AND 52).

CLASS 10—MEDICAL APPARATUS

FOR MEDICAL AND SURGICAL EQUIPMENT AND APPARATUS, NAMELY, FOR USE DURING PHACOEMULSIFICATION SURGERY (U.S. CLS. 26, 39 AND 44).

HEATHER THOMPSON, EXAMINING ATTORNEY

SN 79-028,463. DECISION NEWS MEDIA SAS, F-34000 MONTPELLIER, FRANCE, FILED 3-24-2006.

COSMETICSDESIGN

THE MARK CONSISTS OF STANDARD CHARACTERS WITHOUT CLAIM TO ANY PARTICULAR FONT, STYLE, SIZE, OR COLOR.

PRIORITY DATE OF 9-26-2005 IS CLAIMED.
OWNER OF INTERNATIONAL REGISTRATION 0897396 DATED 3-24-2006, EXPIRES 3-24-2016.
SEC. 2(F).

CLASS 9—ELECTRICAL AND SCIENTIFIC APPARATUS

FOR COMPUTER PROGRAMS AND SOFTWARE FOR CREATING, PUBLISHING AND MANAGING ONLINE CONTENT IN THE FORM OF MESSAGES, DATA, TEXTS, IMAGES AND VIDEOS AND RELATING TO THE PUBLICATION OF INFORMATION FOR PROFESSIONALS IN THE COSMETICS AND BEAUTY PRODUCTS INDUSTRY, DOWNLOADABLE FROM AN EXTERNAL COMPUTER NETWORK OR FROM THE INTERNET; DOWNLOADABLE PUBLICATIONS, NAMELY, NEWSLETTERS, NEWS ARTICLES, AND MARKET REPORTS IN THE FIELD OF COSMETICS IN ELECTRONIC FORM SUPPLIED FROM A DATABASE OR FROM THE INTERNET (U.S. CLS. 21, 23, 26, 36 AND 38).

CLASS 35—ADVERTISING AND BUSINESS

FOR ADVERTISING; BUSINESS PROMOTION AND INFORMATION SERVICES THROUGH THE INTERNET, NAMELY, PROMOTING THE BUSINESS OF OTHERS IN THE COSMETICS BUSINESS AND PROVIDING BUSINESS INFORMATION SERVICES RELATING TO THE COSMETICS BUSINESS; COMPILING BUSINESS ADVERTISEMENTS FOR THIRD PARTIES, NAMELY, DISPLAYING ADVERTISEMENTS FOR OTHERS; RENTAL OF ADVERTISING SPACE ONLINE FOR PROMOTING GOODS AND SERVICES BETWEEN PROFESSIONALS (U.S. CLS. 100, 101 AND 102).

CLASS 38—COMMUNICATION

FOR TELECOMMUNICATION SERVICES, NAMELY, ELECTRONIC MESSAGING SERVICES VIA THE INTERNET FOR TECHNICAL, SCIENTIFIC AND PROFESSIONAL NEWS AND INFORMATION ABOUT THE COSMETICS AND BEAUTY PRODUCTS INDUSTRY; TRANSMISSION OF MESSAGES, DATA, TEXTS AND IMAGES BY ELECTRONIC MEANS; COMMUNICATIONS BY COMPUTER TERMINALS; TRANSMISSION OF INFORMATION HELD IN A DATABASE OR ON THE INTERNET VIA EMAIL (U.S. CLS. 100, 101 AND 104).

CLASS 41—EDUCATION AND ENTERTAINMENT

FOR PUBLISHING SERVICES FOR NEWS ARTICLES, NEWSLETTERS, AND MARKET REPORTS FEATURING SCIENTIFIC, INDUSTRIAL AND TECHNICAL INFORMATION AND NEWS FOR PROFESSIONALS IN THE COSMETICS INDUSTRY INVOLVED IN MANUFACTURING TECHNOLOGIES FOR COSMETICS PRODUCTS (U.S. CLS. 100, 101 AND 107).

CLASS 42—SCIENTIFIC AND COMPUTER SERVICES

FOR DESIGN AND DEVELOPMENT OF WEBSITES FOR OTHERS; COMPILATION FOR OTHERS OF WEB PAGES ON THE INTERNET, NAMELY, PROVIDING LINKS TO WEB SITES OF OTHERS FEATURING THE DESIGN AND DEVELOPMENT OF COSMETICS; RENTAL OF A DATABASE SERVER TO THIRD PARTIES (U.S. CLS. 100 AND 101).

REBECCA POVARCHUK, EXAMINING ATTORNEY

SN 79-030,075. NEOPOST S.A., BAGNEUX, FRANCE, FILED 2-2-2006.

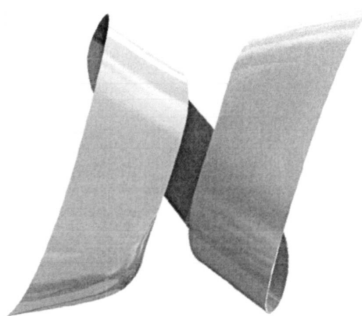

PRIORITY DATE OF 8-8-2005 IS CLAIMED.
OWNER OF INTERNATIONAL REGISTRATION 0901477 DATED 2-2-2006, EXPIRES 2-2-2016.

CLASS 7—MACHINERY

FOR MACHINES FOR PROCESSING MAIL, NAMELY, FEEDERS, CONVEYORS, FOLDERS, INSERTERS, STACKERS, PARTS AND COMPONENTS OF THE ABOVE MACHINES, LETTER SORTING MACHINES, BURSTERS, NAMELY, PAPER PROCESSING MACHINES DESIGNED TO AUTOMATICALLY SEPARATE DOCUMENTS PRODUCED BY COMPUTERS IN A CONTINUOUS TAPE, EXTRACTORS, NAMELY, MACHINES FOR OPENING LETTERS AND EXTRACTING THEIR CONTENT AUTOMATICALLY; MAIL PROCESSING EQUIPMENT, APPARATUS AND DEVICES, NAMELY, MACHINES FOR PRINTING, IN PARTICULAR ADDRESS PRINTING, WITH OR WITHOUT POSTAGE METERING IMPRESSION; COUNTER EQUIPMENT FOR FRANKING APPLICATIONS, NAMELY, LETTER SORTING MACHINES, BAR CODING EQUIPMENT FOR APPLICATIONS FOR MAIL PURPOSES, NAMELY, CODING MACHINE (U.S. CLS. 13, 19, 21, 23, 31, 34 AND 35).

CLASS 9—ELECTRICAL AND SCIENTIFIC APPARATUS

FOR ELECTRONIC APPARATUS FOR MAIL PROCESSING, NAMELY, COMPUTER SOFTWARE AND HARDWARE, ELECTRONIC DATA PROCESSING APPARATUS DESIGNED FOR PREPARING MAIL, NAMELY, LETTERS AND PACKAGES FOR DISPATCH, NAMELY, APPARATUS FOR FOLDING AND INSERTING LETTERS IN ENVELOPES, ELECTRONIC APPARATUS FOR PROGRAMMING AND CONTROLLING APPARATUS FOR FOLDING AND INSERTING, POSTAL CALCULATING SCALES, RECORDED COMPUTER PROGRAMS FOR PROCESSING MAIL, PACKAGES AND FOR TRACKING THEIR ROUTING AND DELIVERY; RECORDED COMPUTER PROGRAMS FOR PROCESSING POSTAL ADDRESSES; RECORDED COMPUTER PROGRAMS FOR OPTIMIZING TARIFFS FOR DISPATCH OF PACKAGES, MAIL AND EXPENDITURE MANAGEMENT; RECORDED COMPUTER PROGRAMS FOR UPDATING MAILING TARIFFS AND DATA; RECORDED COMPUTER PROGRAMS FOR ENABLING OF ACCESS TO REMOTE POSTAL SERVICES; RECORDED COMPUTER PROGRAMS FOR CONVERTING DATA FROM A PHYSICAL MEDIUM TO AN ELECTRONIC MEDIUM; MAIL PROCESSING EQUIPMENT, APPARATUS AND DEVICES, NAMELY, DATERS, POSTAL MACHINES FOR POST OFFICES, NAMELY, DISPENSERS OF POSTAL ITEMS, AUTOMATED FRANKING MACHINES, COUNTER EQUIPMENT FOR FRANKING APPLICATIONS, NAMELY, ELECTRONIC APPLIANCES FOR VERIFYING FRANKING PARTICULARLY DESIGNED FOR COUNTER-TOP USE; MAIL PROCESSING APPARATUS FOR USE IN CONJUNCTION WITH COMPUTERS, NAMELY, ELECTRONIC APPARATUS TO CHECK FRANKING, APPARATUS FOR CANCELING FRANKING, FOLDING/INSERTING MAIL; COMPUTER EQUIPMENT FOR DATA PROCESSING, NAMELY, CENTRAL DATA PROCESSING UNITS, APPARATUS FOR RECORDING, TRANSMITTING AND REPRODUCING IMAGES, COMPUTER PRINTERS, MACHINES AND APPARATUS FOR FRANKING CONTROL, READING BAR-CODES, MAIL PROCESSING, FRANKING AND RELATED DOCUMENT MANAGEMENT SOFTWARE, PROGRAMS ENABLING ACCESS TO COMPUTER SERVICES VIA THE INTERNET OR OTHER COMPUTER TELECOMMUNICATIONS NETWORKS; ELECTRONIC APPARATUS, NAMELY, SOFTWARE AND PRINTERS FOR FRANKING, NAMELY, PAYMENT AND REGISTRATION OF POSTAL OR CARRIAGE FOR PRIVATE DISPATCH SERVICES COSTS FOR LETTERS AND PACKAGES, INCLUDING VIA REMOTE CONTROL AND DOWNLOADING, VIA INTERNET OR INTRANET NETWORKS; COMPUTERS AND THEIR PERIPHERAL DEVICES, NAMELY, PRINTERS AND DIGITIZERS (U.S. CLS. 21, 23, 26, 36 AND 38).

CLASS 16—PAPER GOODS AND PRINTED MATTER

FOR LABELS FOR LETTERS AND PARCELS, NAMELY, ADDRESS LABELS, SHIPPING LABELS, BAR CODE LABELS, LABEL PRINTING MACHINES AND APPARATUS FOR PRINTING ADDRESSES, USER MANUALS AND RELATED DOCUMENTS IN THE FIELD OF MAIL PROCESSING; MACHINES FOR PROCESSING MAIL, NAMELY, FRANKING MACHINES, ELECTRONIC PREPAID DISPENSERS FOR FRANKING LETTERS AND PARCELS DISPATCHED BY POSTAL SERVICES OR BY PRIVATE CARRIERS, DOCUMENT SHREDDERS; EQUIPMENT, APPARATUS AND DEVICES FOR PROCESSING MAIL, NAMELY, FRANKING MACHINES, FRANKING BASES AND HEADS, AND SPARE COMPONENTS AND PARTS OF FRANKING MACHINES; COUNTER EQUIPMENT FOR FRANKING APPLICATIONS, NAMELY, FRANKING MACHINES; ADDRESSING EQUIPMENT, NAMELY, ADDRESSING MACHINES; LETTER OPENERS (U.S. CLS. 2, 5, 22, 23, 29, 37, 38 AND 50).

CLASS 20—FURNITURE AND ARTICLES NOT OTHERWISE CLASSIFIED

FOR OFFICE FURNITURE ESPECIALLY ADAPTED FOR MAIL PROCESSING EQUIPMENT, APPARATUS AND DEVICES (U.S. CLS. 2, 13, 22, 25, 32 AND 50).

CLASS 35—ADVERTISING AND BUSINESS

FOR COMPUTER-ASSISTED MAIL FRANKING SERVICES, MAIL FRANKING SERVICES USING THE INTERNET; BUSINESS MARKETING AND DIRECT MAIL CONSULTING SERVICES, NAMELY, SERVICES OF SELECTION AND PROCESSING OF PRIVATE AND COMPANY ADDRESSES BY MEANS OF COMPUTER NETWORKS, ASSISTANCE AND CONSULTING SERVICES IN THE FIELD OF MAIL MANAGEMENT, BUSINESS MANAGEMENT AND CONSULTATION IN THE FIELDS OF LOGISTICS, TRANSPORT, ROUTING OF GOODS, PACKAGES AND MAIL; DOCUMENT REPRODUCTION SERVICES; BUSINESS CONSULTATION, NAMELY, ASSISTANCE TO COMPANIES IN OPTIMIZATION OF DISPATCH TARIFFS FOR PACKAGES AND MAIL AND IN THEIR EXPENDITURE MANAGEMENT, THE SAID SERVICES ALSO AVAILABLE ONLINE; MANAGEMENT OF COMPUTERIZED FILES; MANAGEMENT AND COMPILATION OF INFORMATION INTO COMPUTER DATABASES, THESE SERVICES ALSO AVAILABLE ONLINE; BUSINESS CONSULTATION, NAMELY, ASSISTANCE TO COMPANIES IN MANAGEMENT OF THEIR LETTER OR PARCEL DISPATCH SERVICES, THESE SERVICES ALSO AVAILABLE ONLINE; PROVISION FOR OTHERS OF PERSONNEL PERFORMING MAIL PROCESSING OPERATIONS, NAMELY, PROVIDING INFORMATION FOR OTHERS AS TO PERSONNEL PERFORMING MAIL PROCESSING OPERATIONS (U.S. CLS. 100, 101 AND 102).

CLASS 36—INSURANCE AND FINANCIAL

FOR FINANCIAL ACCOUNT MANAGEMENT SERVICES FOR REMOTE FRANKING OF LETTERS AND PACKAGES; FINANCIAL SERVICES, NAMELY, RECHARGING OF POSTAL CREDIT; FINANCIAL SERVICES, NAMELY, PROCESSING OF TRANSFERS AND DIRECT DEBIT OF FRANKING COSTS FOR LETTERS AND PACKAGES; LEASING AND RENTAL WITH OR WITHOUT PROMISE OF SALE OF ALL EQUIPMENT, MACHINES, APPARATUS AND DEVICES CONNECTED WITH THE PROCESSING, TRANSPORT AND DELIVERY OF MAIL FOR FACTORIES, WORKSHOPS AND OFFICES; FINANCIAL PORTFOLIO MANAGEMENT, NAMELY, MANAGEMENT OF A PORTFOLIO OF HOLDINGS AND SECURITIES AND OPERATIONS RELATED THERETO, REAL ESTATE MANAGEMENT (U.S. CLS. 100, 101 AND 102).

CLASS 37—CONSTRUCTION AND REPAIR

FOR INSTALLATION, MAINTENANCE AND REPAIR OF MAIL PROCESSING, TRANSPORT AND DELIVERY MACHINES, EQUIPMENT, APPARATUS AND DEVICES, THESE SERVICES ALSO AVAILABLE ONLINE (U.S. CLS. 100, 103 AND 106).

CLASS 38—COMMUNICATION

FOR PROVIDING ACCESS TO COMPUTER TELE-COMMUNICATION NETWORKS, PROVIDING MULTIPLE-USER ACCESS TO A GLOBAL COMPUTER INFORMATION NETWORK BY MEANS OF COMPUTERS GROUPED ON A GLOBAL COMMUNICATION NETWORK OTHERWISE KNOWN AS AN INTRANET, OR A PRIVATE OR RESERVED ACCESS NETWORK (U.S. CLS. 100, 101 AND 104).

CLASS 42—SCIENTIFIC AND COMPUTER SERVICES

FOR COMPUTER SOFTWARE DESIGN AND DEVELOPMENT FOR OTHERS; MAINTENANCE OF COMPUTER SOFTWARE; TECHNICAL RESEARCH AND TECHNICAL EXPERTISE SERVICES IN THE FIELD OF MAIL AND PACKAGES PROCESSING TECHNIQUES, NAMELY, TROUBLESHOOTING OF COMPUTER HARDWARE AND SOFTWARE PROBLEMS, TROUBLESHOOTING OF INDUSTRIAL PROCESS CONTROL COMPUTER SOFTWARE PROBLEMS; INSTALLATION OF COMPUTER SOFTWARE, NAMELY, ADVICE AND ASSISTANCE FOR THE INSTALLATION, MAINTENANCE AND UPDATING OF SOFTWARE FOR THE ELECTRONIC PROCESSING OF DATA USED FOR TRACKING, MONITORING AND LOCATING OF PACKAGES, MAIL AND PALLETS DURING THEIR PROCESSING, TRANSPORT AND DELIVERY, TECHNICAL CONSULTING SERVICES FOR THE INSTALLATION OF SOFTWARE FOR ELECTRONIC PROCESSING OF DATA USED FOR TRACKING AND LOCATING PACKAGES, MAIL AND PALLETS DURING THEIR TRANSPORT AND DELIVERY; DATA CONVERSION OF COMPUTER PROGRAM DATA OR INFORMATION; CONVERSION OF DATA AND DOCUMENTS FROM PHYSICAL TO ELECTRONIC MEDIA (U.S. CLS. 100 AND 101).

DOMINIC FATHY, EXAMINING ATTORNEY

CLASS 11—ENVIRONMENTAL CONTROL APPARATUS

FOR SHOWER TOILETS AND STRUCTURAL PARTS THEREFOR; TOILET SEATS, TOILET SEATS WITH WASHING WATER SQUIRTER; TOILET BOWLS, TOILET BOWLS EQUIPPED WITH WASHING WATER SQUIRTER; TOILET SEATS FOR HEATING, WASHING AND DRYING BODY PARTS; BIDETS AND REMOTE CONTROLS FOR USE WITH BIDETS, SOLD TOGETHER AS A UNIT; WATER CLOSETS AND REMOTE CONTROLS FOR USE WITH WATER CLOSETS, SOLD TOGETHER AS A UNIT; TOILET TANKS AND STRUCTURAL PARTS THEREFOR; TOILET TANK ASSEMBLIES COMPRISED OF TOILET TANK BOWLS FOR FLUSHING TOILET TANKS; TOILETS AND REMOTE CONTROLS FOR USE WITH TOILETS, SOLD TOGETHER AS A UNIT; TANKS, NAMELY, CISTERN TANKS FOR TOILETS; TOILET TANK BALLS; TAP WATER FAUCETS; FIXED SPOUTS USED DIRECTLY IN BIDETS AND TOILETS; PLUMBING FIXTURES, NAMELY, SHOWER HEAD SPRAYERS FOR USE WITH TOILETS AND BIDETS; BIDET NOZZLES; ELECTRIC HAND DRYING APPARATUS FOR WASHROOMS, NAMELY, ELECTRIC HOT AIR HAND DRYERS; ELECTRIC WATER WARMER, NAMELY, WATER HEATERS; HOT WATER HEATER USING GAS AND STRUCTURAL PARTS THEREFOR; HOT WATER HEATER USING OIL AND STRUCTURAL PANS THEREFOR; WASHBOWLS BEING PARTS OF SANITARY INSTALLATIONS; HANDLES FOR FLUSHING TOILET WATER OPERATED BY REMOTE CONTROL; CONTROL VALVES FOR TOILET FLUSHING WATER; SINKS; BATH FITTINGS, NAMELY, BATH TUBS WITH WASHING PLACE; BATH TUBS WITH BUBBLE GENERATION APPARATUS; SHOWERS; BATH TUBS; HOT WATER HEATERS FOR BATH TUBS; WATER PURIFIERS FOR HOUSEHOLD USE; BATH UNITS, NAMELY, PRE-FABRICATED BATH ROOMS CONTAINING A FAUCET, BATH TUB, FLOOR, WALLS, CEILING BOARD AND SHOWER; WASTE WATER PURIFICATION TANKS; SEPTIC TANKS FOR HUMAN WASTE; HOUSEHOLD WASTE WATER PURIFICATION TANKS; HOUSEHOLD SEPTIC TANKS FOR HUMAN WASTE; FLOOR HEATING APPARATUS, NAMELY, ELECTRIC FLOOR RADIANT HEATERS; HEATING AND COOLING APPARATUS, NAMELY, AIR-CONDITIONERS, ELECTRIC FOOT RADIANT HEATERS AND ELECTRIC RADIANT HEATERS FOR TOILETS; LAVATORIES (U.S. CLS. 13, 21, 23, 31 AND 34).

SN 79-030,179. INAX CORPORATION, AICHI-KEN 479-0838, JAPAN, FILED 9-17-2004.

 The logo for INAX features a stylized, bold letter 'L' on the left, followed by the word 'INAX' in a large, bold, sans-serif font.

PRIORITY DATE OF 5-26-2004 IS CLAIMED.
OWNER OF INTERNATIONAL REGISTRATION 0901766
DATED 9-17-2004, EXPIRES 9-17-2014.
OWNER OF U.S. REG. NOS. 1,519,833 AND 2,643,566.

CLASS 19—NON-METALLIC BUILDING MATERIALS

FOR CERAMIC MATERIALS, NAMELY, WALL BOARDS MADE OF CERAMIC, USED EXCLUSIVELY FOR BUILDING, BRICKS; REFRACTORY CONSTRUCTION MATERIALS, NOT OF METAL; BUILDING MATERIAL NOT OF METAL, NAMELY, DOORS FOR BATHROOMS AND WALL-MOUNTED PANEL UNITS FOR PARTITIONING BATHROOMS; CEMENTS AND THE PRODUCTS MADE OF CEMENTS, NAMELY, WALL PANELS MADE OF CEMENTS, STONES, NAMELY, BUILDING STONES; ARTIFICIAL STONES; NON-METAL RAILS, NAMELY, HANDRAILS, NOT OF METAL; BUILDING TIMBER; BUILDING GLASSES, NAMELY, GLASS PANELS FOR BUILDING CONSTRUCTION PURPOSES; NON-METALLIC MINERALS FOR BUILDINGS/OR CONSTRUCTION; REAL CERAMIC TILED PANELS FOR BUILDINGS; CERAMIC TILES; WALL PANELS NOT OF METAL, NAMELY, WALL PANELS MADE OF RESIN FOR BATHROOM; FLOOR PANELS MADE OF RESIN FOR BATHROOM; WALL PANELS MADE OF CEMENT FOR BATHROOM; MOLDS FOR FORMING CEMENT PRODUCTS, NOT OF METAL, NAMELY, NON-METAL CASTINGS (U.S. CLS. 1, 12, 33 AND 50).

JESSICA FATHY, EXAMINING ATTORNEY

SN 79-033,465. GIANFRANCO FERRE' S.P.A., MILANO, ITALY, FILED 8-18-2005.

**GIANFRANCO
FERRE**

OWNER OF INTERNATIONAL REGISTRATION 0631102 DATED 1-24-1995, EXPIRES 1-24-2015.

OWNER OF U.S. REG. NOS. 1,278,049, 1,616,353 AND OTHERS.

THE NAME "GIANFRANCO FERRE" IDENTIFIES A LIVING INDIVIDUAL WHOSE CONSENT IS OF RECORD.

CLASS 3—COSMETICS AND CLEANING PREPARATIONS

FOR PERFUMES, TOILET WATER, PERSONAL DEODORANTS, ESSENTIAL OILS FOR PERSONAL USE, BODY LOTIONS, AFTER SHAVE LOTIONS, SHAVING BALMS, SHAVING CREAM, SHOWER GEL, BUBBLE BATH, BATH PEARLS, SKIN SOAPS, EYE SHADOWS, COSMETIC PENCILS, FOUNDATION MAKE-UP, FACE POWDERS, TALCUM POWDER, ROUGES, LIPSTICKS, MASCARAS, SKIN CLEANSING CREAMS, SKIN CLEANSING LOTIONS, SUN SCREEN PREPARATION, NAIL POLISH, BEAUTY MASKS, FACIAL SCRUBS, FACE CREAMS, BODY CREAMS; COSMETIC CREAMS, CREAMS AND GELS ALL FOR WEIGHT REDUCTION OR SLIMMING PURPOSES; COSMETIC CREAMS, CREAMS AND GELS ALL FOR THE PREVENTION, REDUCTION AND ELIMINATION OF CELLULITE; HAIR SHAMPOOS, HAIR SPRAYS, HAIR LOTIONS, HAIR DYE, HAIR RINSES, HAIR LIGHTENERS, HAIR CONDITIONERS, HAIR MOISTURIZERS, HAIR STYLING FOAM AND GELS, DENTIFRICES (U.S. CLS. 1, 4, 6, 50, 51 AND 52).

CLASS 9—ELECTRICAL AND SCIENTIFIC APPARATUS

FOR EYEGLASSES, SUNGLASSES, CASES FOR GLASSES, SPORT GLASSES, FRAMES FOR GLASSES, LENSES FOR GLASSES, PINCE-NEZ (U.S. CLS. 21, 23, 26, 36 AND 38).

CLASS 14—JEWELRY

FOR EARRINGS, BRACELETS, NECKLACES, RINGS, PENDANTS, BROOCHES, JEWELRY CHAINS, PINS BEING JEWELRY, DIADEMS, MEDALLIONS, CUFFLINKS, TIE CLIPS, JEWELRY, IMITATION JEWELRY; WATCHES, CLOCKS, CHRONOMETERS, WATCH STRAPS; JEWELRY AND WATCH CASES MADE OF PRECIOUS METALS, TRAYS AND ASHTRAYS OF PRECIOUS METALS, CIGARETTE BOXES OF PRECIOUS METALS, NAPKIN RINGS OF PRECIOUS METALS (U.S. CLS. 2, 27, 28 AND 50).

CLASS 18—LEATHER GOODS

FOR HANDBAGS, LUGGAGE, SHOULDER BAGS, BEACH BAGS, CLUTCH BAGS, ALL PURPOSE SPORTS BAGS, ATTACHE CASES, SCHOOL BAGS, TOTE BAGS, TRAVELLING BAGS, DOCUMENT CASES, COSMETIC CASES SOLD EMPTY, KEY CASES, KNAPSACKS, RUCKSACKS, BRIEFCASES, PURSES, WALLETS, TRAVELLING TRUNKS, SUITCASES, UMBRELLAS, PARASOLS, WALKING STICKS (U.S. CLS. 1, 2, 3, 22 AND 41).

CLASS 25—CLOTHING

FOR BRASSIERES, CORSETS, SINGLETS, PETTI-COATS, NIGHTGOWNS, PYJAMAS, DRESSING GOWNS, PULLOVERS, BATH ROBES, BATHING SUITS, GLOVES, CARDIGANS, JERSEYS, NECKTIES, NECKERCHIEFS; SCARVES, SWEATERS, SOCKS, STOCKINGS, TIGHTS, TROUSERS, LEGGINGS, SKIRTS, JACKETS, JERKINS, SHIRTS, VESTS, WAISTCOATS, JUMPERS, TRACK SUITS, BLOUSES, JEANS, PANTIES, UNDERPANTS, BERMUDA SHORTS, T-SHIRTS, SWEAT-SHIRTS, SUITS AND DRESSES, OVERCOATS, ANORAKS, COATS, RAINCOATS, BELTS, SUSPENDERS, PAREUS, SHOES, BOOTS, SLIPPERS, HATS, CAPS (U.S. CLS. 22 AND 39).

SETH A. RAPPAPORT, EXAMINING ATTORNEY

SN 79-033,481. HORTEX HOLDING S.A., PL-00-034 WARSZAWA, POLAND, FILED 4-6-2006.



OWNER OF INTERNATIONAL REGISTRATION 0859148 DATED 6-6-2005, EXPIRES 6-6-2015.

OWNER OF U.S. REG. NOS. 771,973, 2,378,344 AND 2,811,978.

THE COLOR(S) GREEN, RED AND WHITE IS/ARE CLAIMED AS A FEATURE OF THE MARK.

THE MARK CONSISTS OF A SEMI-CIRCULAR FRAMING MADE IN GREEN COLOR CONTAINING INSIDE A CENTRALLY LOCATED WORD "HORTEX" IN CAPITAL LETTERS AND BOLD TYPE FONT IN RED COLOR AND OF A FANCY FLOWER DESIGN ABOVE THE WORD "HORTEX" HAVING GREEN PETALS AND A ROUND RED CENTER TOWARD THE FRAMING, WORD AND FLOWER DESIGN ARE PLACED AGAINST A WHITE BACKGROUND.

CLASS 29—MEATS AND PROCESSED FOODS

FOR MEAT, MEAT PRODUCTS, NAMELY, BUTCHER'S MEAT, SAUSAGES, FISH, POULTRY, GAME, MEAT EXTRACTS; STOCK IN THE NATURE OF BEEF, CHICKEN, MUSHROOM AND FISH STOCK; PRESERVED, DRIED AND COOKED FRUITS AND VEGETABLES, FRUITS AND VEGETABLES PRESERVED IN ALCOHOL; BREAD SPREADS IN THE FORM OF JELLIES AND FRUIT JELLIES, JAMS; COMPOTES; EGGS, POWDERED EGGS; MILK, DAIRY PRODUCTS, NAMELY, MILK BEVERAGES WITH MILK PREDOMINATING, YOGURT, MILK BEVERAGE IN THE NATURE OF KEPHIR, MILK BASED BEVERAGES CONTAINING FRUIT JUICE, MILK BASED BEVERAGES CONTAINING FRUITS, CHEESES; EDIBLE OILS AND FATS, BUTTER, COCOA BUTTER FOR FOOD PURPOSES, COCONUT BUTTER, MARGARINE, LARD; FRUIT AND VEGETABLE PRODUCTS, NAMELY, FROZEN FRUITS AND VEGETABLES, MIXTURES OF FROZEN FRUITS OR VEGETABLES, VEGETARIAN PREPARED AND DEEP-FROZEN DISHES MADE WITH VEGETABLES, PREPARED AND DEEP-FROZEN DISHES MADE WITH MEAT; FRUIT MOUSSES, FRUIT AND VEGETABLE PUREES, FRUIT AND VEGETABLE SALADS, FRUIT PEELS, FRUIT PULP, UNFLAVORED, UNSWEETENED GELATIN FOR FOOD, FRUIT CHIPS, CANDIED FRUITS, FRUIT AND VEGETABLE PRESERVES, CRYSTALLIZED FRUIT; SEAFOOD, NAMELY, SHELLFISH, CRABMEAT, CRAWFISH, OCTOPUS, SHRIMP, PRAWNS; SOUPS, NAMELY, THICK SOUPS, INSTANT OR PRE-COOKED SOUPS, INGREDIENTS FOR PREPARING SOUPS, NAMELY, BROTHS AND MEAT AND VEGETABLE EXTRACTS FOR SOUPS; PRESERVED MUSHROOMS; DIETETIC FOODSTUFFS, NAMELY, FRUIT-BASED ORGANIC FOOD BARS, FRUIT-BASED FOOD BARS ALSO CONTAINING DRIED FRUIT, PROCESSED FRUIT, FRUITS JUICE, GRAINS, VEGETABLES, NUTS, SEEDS, CHOCOLATE, SOY-BASED SNACK FOODS, VEGETABLE-BASED SNACK FOODS, SOY-BASED LOW CALORIE FOOD BARS AND FOODSTUFFS REDUCED IN FAT, SUGAR AND CHOLESTEROL, NAMELY, PRE-PACKAGED COMBINATION DINNERS PRIMARILY CONSISTING OF MEAT AND PROCESSED FRUIT OR VEGETABLES; TOMATO CONCENTRATE USED AS A FOOD INGREDIENT; EDIBLE PROCESSED POLLEN FOR FOOD PURPOSES, PROCESSED, PRESERVED AND DRIED GRAPES; ALMONDS, NAMELY, PROCESSED AND GROUND ALMONDS (U.S. CL. 46).

CLASS 32—LIGHT BEVERAGES

FOR BEERS; NON-CARBONATED AND CARBONATED WATER, MINERAL WATER, TABLE WATERS, SOFT DRINKS, NON-ALCOHOLIC BEVERAGES, NAMELY, FRUIT JUICES, BEVERAGES AND NECTARS, VEGETABLE JUICES, BEVERAGES AND NECTARS, MIXED FRUIT-VEGETABLE JUICES, BEVERAGES AND NECTARS, CONDENSED FRUIT AND VEGETABLE JUICES, FRUIT AND VEGETABLE PUREE JUICES, MIXED FRUIT-VEGETABLE PUREE JUICES, LOW-ENERGY JUICES AND BEVERAGES, FRUIT AND VEGETABLE AS WELL AS MIXED FRUIT-VEGETABLE BEVERAGES AND JUICES, ENRICHED WITH VITAMINS AND CALCIUM, SORBETS IN THE FORM OF BEVERAGES, ISOTONIC BEVERAGES, ENERGY DRINKS, WHEY BEVERAGES, SYRUPS AND PREPARATIONS FOR PREPARATION OF BEVERAGES, ESSENCES FOR BEVERAGES, EXTRACTS FOR BEVERAGES, NAMELY, NON-ALCOHOLIC FRUIT EXTRACTS (U.S. CLS. 45, 46 AND 48).

LINDA ESTRADA, EXAMINING ATTORNEY

SN 79-033,988. A.M.A. S.P.A., ITALY, FILED 5-30-2006.



PRIORITY DATE OF 3-3-2006 IS CLAIMED.

OWNER OF INTERNATIONAL REGISTRATION 0911674 DATED 5-30-2006, EXPIRES 5-30-2016.

THE COLOR(S) WHITE, BLUE IS/ARE CLAIMED AS A FEATURE OF THE MARK.

THE MARK CONSISTS OF THE WORD "AMA" IN FANCY CHARACTERS, IN FULL BORDER, IN WHITE COLOUR PUT INSIDE AN OVAL GEOMETRICAL FIGURE IN FULL BORDER, IN BLUE COLOUR.

CLASS 6—METAL GOODS

FOR METAL CONSTRUCTION MATERIALS, NAMELY, BRACES, SUPPORTS, SHORES; METAL WINDOW AND DOOR FRAMES AND PARTS, NAMELY, DOOR JAMBS, METAL WINDOW PULLEYS; METAL HARDWARE, NAMELY, WASHERS, SPRINGS, THIMBLES, HIGH SECURITY LOCKS; METAL NAILS, METAL SCREWS, METAL NUTS, METAL RIVETS; METAL CONSTRUCTION ELEMENTS, NAMELY, SHORES, SUPPORTS, BRACES; METAL BOXES, METAL CONTAINERS FOR THE STORAGE AND TRANSPORTATION OF GOODS, METAL CONTAINERS FOR COMPRESSED GAS OR LIQUID AIR, METAL HOOKS, METAL PIPES, METAL PIPE FITTINGS, METAL BINDING STRIPS USED ON PACKAGING, NON-ELECTRICAL METAL CABLES AND WIRES (U.S. CLS. 2, 12, 13, 14, 23, 25 AND 50).

CLASS 7—MACHINERY

FOR MACHINES AND MACHINE TOOLS, NAMELY, PULPING MACHINES, ROVING MACHINES, AGRICULTURAL MACHINES, NAMELY, CULTIVATORS, HARVESTERS, DISK HARROWS, SEEDERS, AGRICULTURAL SEED PLANTING MACHINES, COMBINES, THRESHERS, TILLERS, WIND ROWERS, REAPERS, EARTH COMPACTING MACHINES, EARTH MOVING MACHINES, NAMELY, SCARIFIERS, SCRAPERS, EXCAVATORS, BACKHOES, GRADERS, LOADERS, HARVEST DRYING MACHINES, EXCAVATING MACHINES, ENGRAVING MACHINES; TOOL BITS FOR MACHINES; ENGINES NOT FOR LAND VEHICLES; ENGINE PARTS AND SPARE PARTS, NAMELY, CONTACT POINTS, ELECTRONIC FUEL INJECTION MODULES, FUEL INJECTOR PARTS FOR LAND VEHICLE ENGINES, PISTONS, PISTON RINGS, CONDENSERS, CONTACT POINTS, CONNECTING RODS, ENGINE SEALS, CAM COVERS, COILS, DISTRIBUTOR ROTORS, DISTRIBUTOR CAPS, AIR CLEANERS, OIL TANKS, OIL TANK PLUGS AND CAPS, CRANKCASE BREATHERS, OIL COOLERS, PUSH RODS, ROCKER ARMS; JOINTS AND TRANSMISSION ELEMENTS, NAMELY, POWER TRANSMISSION BELTS FOR MACHINES, TRANSMISSION GEARS FOR MACHINES, POWER TRANSMISSION BELTS FOR MACHINES, MOTORS AND ENGINES USED IN INDUSTRIAL APPLICATIONS; UNIVERSAL JOINTS FOR LAND VEHICLES; POWER TRANSMISSIONS FOR MACHINES; MACHINE PARTS, NAMELY, CHAINS FOR ELEVATORS; DRIVE CHAINS OTHER THAN THOSE FOR LAND-BASED VEHICLES; AGRICULTURAL TOOLS OTHER THAN THOSE CONTROLLED MANUALLY, THEIR PARTS AND SPARE PARTS, NAMELY, TILLERS, BALERS; GARDENING MACHINES, THEIR PARTS AND SPARE PARTS, NAMELY, CHIPPERS, SHREDDERS, LAWN AND GARDEN TILLING MACHINES; MACHINES FOR WORKING LAWNS AND GARDENS, THEIR PARTS AND SPARE PARTS, NAMELY, LAWN AND GARDEN EDGERS, LAWN AND GARDEN STRING TRIMMERS; MACHINES, NAMELY, LAWNMOWERS; MACHINES, NAMELY, BUSH-CUTTERS; MACHINES, NAMELY, ELECTRIC RECHARGEABLE HEDGE-CUTTERS, THEIR PARTS AND SPARE PARTS; MANUAL CLIPPERS,

NAMELY, HAND-HELD POWER-OPERATED CLIPPERS; PLOUGHS AND SPARE PARTS FOR PLOUGHS; MACHINES, NAMELY, CIRCULAR SAWS, JIG SAWS AND CHAIN SAWS; POWER CHIPPERS FOR LAWN AND GARDEN; POWER SHREDDERS FOR LAWN AND GARDEN; CLEANING MACHINES AND EQUIPMENT, NAMELY, MACHINES FOR CLEANING SURFACES USING HIGH PRESSURE WATER, STEAM CLEANING MACHINES, SAND CLEANING MACHINES, CARPET CLEANING MACHINES; SNOW PLOWS, MECHANICAL BRUSHES FOR SNOW, POWER OPERATED BRUSHES BEING PARTS OF MACHINES, ROTARY BRUSHES FOR MACHINES, ELECTRICALLY OPERATED BRUSHES, BEING PARTS OF MACHINES, WIRE BRUSHES FOR USE IN MACHINES; ENSILAGE BLOWERS OF FORAGE; RIDING LAWN AND TRACTOR-TOWED AGRICULTURAL IMPLEMENTS, NAMELY, PLOWS, HARROWS, REAPERS, HARVESTERS, HAY RAKES, HAY BALERS, BROADCAST SEEDERS, MANURE SPREADERS, FERTILIZER DISTRIBUTORS, CORN HUSKERS, ROLLERS, MOWERS, TRACTOR-TOWED FERTILIZER APPLICATORS, TRACTOR-TOWED HARROWS; MACHINES, NAMELY, ELECTRIC, CENTRIFUGAL PUMPS, FUEL PUMPS FOR LAND VEHICLES, OIL PUMPS FOR LAND VEHICLES, PNEUMATIC PUMPS, MACHINE PARTS AND MOTORS, NAMELY, ENGINE COOLING, COMPRESSED AIR PUMPS, OIL PUMPS FOR USE IN MOTORS AND ENGINES, PUMPS FOR COOLING ENGINES; HYDRAULIC PUMPS; HYDRAULIC GEAR PUMPS; HYDRAULIC CYLINDERS; INSTRUMENTS FOR DEVIATING THE FLOW IN PIPING ON HYDRAULIC SYSTEMS, NAMELY, JETAVATORS; PARTS AND COMPONENTS FOR THE ENGINES OF LAND-BASED VEHICLES, NAMELY, DISTRIBUTOR CAPS, COILS, FUEL INJECTOR PARTS FOR LAND VEHICLE ENGINES, CONNECTING RODS, DISTRIBUTOR ROTORS, OIL TANKS, OIL TANK PLUGS AND CAPS, OIL COOLERS, PUSH RODS, CRANKCASE BREATHERS, ROCKER ARMS, ENGINE CASES (U.S. CLS. 13, 19, 21, 23, 31, 34 AND 35).

CLASS 8—HAND TOOLS

FOR TOOLS AND INSTRUMENTS OPERATED MANUALLY, NAMELY, HAMMERS, CLAMPS, SHOVELS, WRENCHES, SCREWDRIVERS, DRILLS, MANUALLY-OPERATED GRINDING WHEELS; MANUAL CUTTING TOOLS FOR GARDENING AND PARKLAND MAINTENANCE; AGRICULTURAL TOOLS OPERATED MANUALLY, NAMELY, HATCHETS, CULTIVATORS, TROWELS, WEEDING FORKS, CHIPPERS, SHREDDERS; MANUAL BUSH-CUTTERS; MANUAL LAWNMOWERS AND HEDGE CUTTERS; TOOLS, NAMELY, HAND, CROSSCUT SAW BLADES; TOOLS, NAMELY, HAND OPERATED SAWS, SCISSORS; GARDENING EQUIPMENT, NAMELY, SPADES, RAKES, HOES; METAL AND NON-METAL TOOLBOXES SOLD WITH TOOLS (U.S. CLS. 23, 28 AND 44).

CLASS 9—ELECTRICAL AND SCIENTIFIC APPARATUS

FOR ELECTRICAL CABLES AND WIRES; ELECTRICAL INSTRUMENTS, NAMELY, ELECTRIC COILS, ELECTRIC CORDS, ELECTRIC AND ELECTRICAL CONNECTORS, ELECTRIC CONTROL PANELS; PROTECTIVE GOGGLES AND VISORS, PROTECTIVE HELMETS, PROTECTIVE CLOTHING FOR PROTECTION AGAINST ACCIDENTS, RADIATION AND FIRE, PROTECTIVE GLOVES FOR PROTECTION AGAINST ACCIDENTS; ELECTRONIC SPEED CONTROLLERS FOR VEHICLES; ODOMETERS FOR VEHICLES; VOLTMETERS FOR VEHICLES; EQUIPMENT FOR RECORDING, TRANSMISSION AND PLAYBACK OF SOUND AND IMAGES FOR INSTALLATION IN SLOW-MOVING MACHINES AND LAND-BASED VEHICLES IN GENERAL; ELECTRICAL AND SIGNALING EQUIPMENT FOR

USE WITH SLOW-MOVING MACHINES AND LAND-BASED VEHICLES IN GENERAL, NAMELY, SIGNAL WHISTLES, SIGNAL PROCESSORS, ELECTRICAL WIRES; COMPUTER PROGRAMS FOR INSTALLATION IN SLOW-MOVING MACHINES AND LAND-BASED VEHICLES IN GENERAL USED FOR CONTROLLING INSTRUMENTS OF MACHINES, NAMELY, ODOMETERS, HOUR COUNTERS, ANTI-OVERTURNING SYSTEM, AND FOR MOVEMENT CHECK AND MONITORING OF SEVERAL MOTOR PARAMETERS; ACOUSTIC INDICATORS FOR VEHICLES, NAMELY, ACOUSTIC CONDUITS (U.S. CLS. 21, 23, 26, 36 AND 38).

CLASS 11—ENVIRONMENTAL CONTROL APPARATUS

FOR LIGHTING EQUIPMENT FOR VEHICLES, NAMELY, RUNNING LIGHTS FOR LAND VEHICLES, BACKUP LIGHTS FOR LAND VEHICLES, LIGHTS FOR VEHICLES, TAIL LIGHTS FOR LAND VEHICLES, TAIL LIGHTS FOR VEHICLES; HEADLIGHTS AND REAR LIGHTS FOR VEHICLES; HEATING AND AIR CONDITIONING SYSTEMS FOR VEHICLES, COMPOSED OF AIR CONDITIONERS, FANS, ELECTRIC HEATERS, AND VALVES; REFLECTORS FOR VEHICLES; REVERSING LIGHTS FOR VEHICLES (U.S. CLS. 13, 21, 23, 31 AND 34).

CLASS 12—VEHICLES

FOR COMPONENTS FOR LAND VEHICLES, NAMELY, TIRE CHAINS, WINDSHIELDS, FENDERS, WHEELS, TRANSMISSIONS, DIFFERENTIALS, FENDER FLARES, DRIVE BELTS, DRIVE GEARS, MUDGUARDS, RUNNING BOARDS; SHOCK ABSORBERS FOR VEHICLES; ANTITHEFT DEVICES FOR MOTORCARS; TRUNKS FOR VEHICLES; GEARS FOR LAND-BASED VEHICLES; VEHICLE BODYWORK, NAMELY, AUTOMOBILE BODIES AND TRUCK BODIES, LAND VEHICLE BODIES; VEHICLE CANOPIES, WHEEL RIMS FOR VEHICLES; WHEEL SPOKES FOR VEHICLES; SEAT BELTS AND SAFETY BELTS FOR VEHICLE SEATS; SLEEPING BERTHS FOR VEHICLES; ENGINES FOR LAND VEHICLES; BRAKES FOR VEHICLES AND THEIR PARTS, NAMELY, BRAKE DRUMS, BRAKE CYLINDERS, BRAKE BLOCKS FOR LAND VEHICLES, BRAKE DISCS, BRAKE FACINGS FOR VEHICLES, BRAKE HARDWARE FOR VEHICLES, BRAKE LINES FOR VEHICLES, BRAKE LINING FOR LAND VEHICLES, BRAKE SYSTEMS FOR VEHICLES; INDICATORS FOR VEHICLES, NAMELY, TURN SIGNALS; WINDSCREENS, WINDOWS, CAR DOORS, PANELS FOR DOORS, PARTITIONS FOR DIVIDING CARGO AREAS IN VEHICLES AND FOR SEPARATING PASSENGER AREAS FROM CARGO AREAS IN VEHICLES, ALL FOR VEHICLES; VEHICLE TIRES, TIRES AND INNER TUBES FOR TIRES AND VEHICLE TIRES; TRAILERS; TRAILER ATTACHMENTS FOR VEHICLES, NAMELY, TRAILER HITCHES; VEHICLE SEATS, THEIR PARTS AND ACCESSORIES, NAMELY, VEHICLE SEAT COVERS, BOOSTER SEATS FOR USE IN VEHICLES, SEAT BELTS FOR USE IN VEHICLES, AIR SPRINGS FOR VEHICLE SUSPENSION COMPONENTS FOR CUSHIONING DRIVERS' SEATS AND CABS, MECHANICAL AND AIR SUSPENSION COMPONENTS FOR SEATS, ARM AND HEAD RESTS FOR SEATS; COVERINGS FOR VEHICLE SEATS; VEHICLE CHASSIS; BUMPERS FOR VEHICLES; STEERING WHEELS FOR VEHICLES; DRIVE CHAINS FOR LAND-BASED VEHICLES (U.S. CLS. 19, 21, 23, 31, 35 AND 44).

MARK PILARO, EXAMINING ATTORNEY

SN 79-034,314. GRAFFER SEGGIOVIE S.R.L., GARDOLO TN, ITALY, FILED 11-30-2006.

GRAFFER

THE MARK CONSISTS OF STANDARD CHARACTERS WITHOUT CLAIM TO ANY PARTICULAR FONT, STYLE, SIZE, OR COLOR.

OWNER OF INTERNATIONAL REGISTRATION 0912691 DATED 11-30-2006, EXPIRES 11-30-2016.

THE WORDING "GRAFFER" HAS NO MEANING IN A FOREIGN LANGUAGE.

CLASS 12—VEHICLES

FOR SKI LIFTS, CHAIR LIFTS, CABLE CARS, SLEDGE LIFTS AND SKI-TOWS, NAMELY, SKI LIFTS COMPRISED OF MOVING CABLES FOR TOWING SKIERS AND SLEDGES UP A MOUNTAIN (U.S. CLS. 19, 21, 23, 31, 35 AND 44).

CLASS 41—EDUCATION AND ENTERTAINMENT

FOR ORGANIZATION AND DIRECTION OF EDUCATIONAL COURSES AND SEMINARS IN THE FIELD OF SKIING; ARRANGING ATHLETIC COMPETITIONS; ORGANIZING AND DIRECTING ENTERTAINMENT IN THE NATURE OF SKI RACES (U.S. CLS. 100, 101 AND 107).

NELSON SNYDER, EXAMINING ATTORNEY

SN 79-034,419. BIOTISSUE TECHNOLOGIES GMBH, 79108 FREIBURG, FED REP GERMANY, FILED 12-22-2006.



PRIORITY DATE OF 6-26-2006 IS CLAIMED.

OWNER OF INTERNATIONAL REGISTRATION 0912957 DATED 12-22-2006, EXPIRES 12-22-2016.

NO CLAIM IS MADE TO THE EXCLUSIVE RIGHT TO USE "CHONDROTISSUE", APART FROM THE MARK AS SHOWN.

THE MARK CONSISTS OF A CIRCLE SEPARATED INTO TWO PARTS BY A CURVILINEAR LINE NEXT TO THE TERM "CHONDROTISSUE".

CLASS 5—PHARMACEUTICALS

FOR POLYMER-BASED PHARMACEUTICAL PREPARATIONS FOR USE IN TISSUE AND ORGAN TRANSPLANTATION, NAMELY, REGENERATIVE, REPARATIVE AND HEMOSTATIC PREPARATIONS, CONSISTING OF HYALURONIC ACID AND BIORESORBABLE POLYGLYCOLIC ACID POLYMERS; BIOMEDICAL POLYMER-BASED PHARMACEUTICAL PREPARATIONS, NAMELY, PREPARATIONS FOR USE IN TISSUE AND ORGAN TRANSPLANTATION, NAMELY REGENERATIVE, REPARATIVE AND HEMOSTATIC PREPARATIONS, CONSISTING OF HYALURONIC ACID AND BIORESORBABLE POLYGLYCOLIC ACID POLYMERS (U.S. CLS. 6, 18, 44, 46, 51 AND 52).

CLASS 10—MEDICAL APPARATUS

FOR MEDICAL DEVICES IN THE NATURE OF SURGICAL IMPLANTS PRIMARILY COMPRISING ARTIFICIAL TISSUE, ALSO CONSISTING OF BIOLOGICAL CARTILAGE, INTERVERTEBRAL DISC, MENISCUS, TENDON, LIGAMENT, BONE AND CONNECTIVE TISSUE SUBSTITUTES INTENDED FOR SUBSEQUENT IMPLANTATION, ALL SOLD AS A UNIT; SURGICAL IMPLANTS PRIMARILY COMPRISING ARTIFICIAL TISSUE, ALSO CONSISTING OF HYALURONIC ACID, BIOLOGICAL POLYMERS, BIORESORBABLE POLYMERS AND COMBINATIONS THEREOF, ALL SOLD AS A UNIT; BIOLOGICAL SURGICAL IMPLANTS PRIMARILY COMPRISING ARTIFICIAL TISSUE ALSO CONSISTING OF HYALURONIC ACID, BIOLOGICAL POLYMERS, BIORESORBABLE POLYMERS AND COMBINATIONS THEREOF, ALL SOLD AS A UNIT; HEALTH CARE PRODUCTS IN THE NATURE OF SURGICAL IMPLANTS PRIMARILY COMPRISING ARTIFICIAL TISSUE, ALSO CONSISTING OF BIOLOGICAL CARTILAGE, INTERVERTEBRAL DISC, MENISCUS, TENDON, LIGAMENT, BONE AND CONNECTIVE TISSUE SUBSTITUTES INTENDED FOR SUBSEQUENT IMPLANTATION, ALL SOLD AS A UNIT; PRODUCTS OF TISSUE ENGINEERING, NAMELY, SURGICAL IMPLANTS AND MODIFIED SURGICAL IMPLANTS PRIMARILY COMPRISING ARTIFICIAL MATERIAL, ALSO CONSISTING OF BIOLOGICAL MATERIALS, ALL SOLD AS A UNIT; TISSUE PRECURSORS, NAMELY, SURGICAL IMPLANTS PRIMARILY COMPRISING ARTIFICIAL MATERIAL ALSO CONSISTING OF MOLECULES, NAMELY, HYALURONIC ACID, BIOLOGICAL POLYMERS, BIORESORBABLE POLYMERS AND COMBINATIONS THEREOF PRODUCED IN VITRO FOR REPLACING AND SUPPORTING THE FUNCTION OF ABSENT OR INJURED BODY PARTS, ALL SOLD AS A UNIT; ARTIFICIAL CARTILAGE REPLACEMENTS AND TISSUE REPLACEMENTS, NAMELY, PRIMARILY ARTIFICIAL SUBSTITUTES FOR BONES, CARTILAGE, LIGAMENTS, AND TENDONS, ALSO CONSISTING OF IMPLANTS OF HYALURONIC ACID, BIOLOGICAL POLYMERS, BIORESORBABLE POLYMERS AND COMBINATIONS THEREOF, ALL SOLD AS A UNIT; BIOLOGICAL REPLACEMENT AND BIOLOGICAL PROTECTION OF MESENCHYMAL TISSUE, NAMELY, PRIMARILY ARTIFICIAL SUBSTITUTES FOR BONES, CARTILAGE, LIGAMENTS AND TENDONS ALSO CONSISTING OF IMPLANTS OF HYALURONIC ACID, BIOLOGICAL POLYMERS, BIORESORBABLE POLYMERS AND COMBINATIONS THEREOF, ALL SOLD AS A UNIT (U.S. CLS. 26, 39 AND 44).

CLASS 42—SCIENTIFIC AND COMPUTER SERVICES

FOR RESEARCH AND DEVELOPMENT OF PHARMACEUTICAL PREPARATIONS AND MEDICINES; CONSULTANCY IN THE FIELD OF BIOMEDICINE (U.S. CLS. 100 AND 101).

JAMES STEIN, EXAMINING ATTORNEY

SN 79-034,784. SAN PATRICK, S.L., SPAIN, FILED 2-1-2007.

SP LA SPOSA

OWNER OF INTERNATIONAL REGISTRATION 0854750 DATED 7-15-2005, EXPIRES 7-15-2015.

NO CLAIM IS MADE TO THE EXCLUSIVE RIGHT TO USE "LA SPOSA", APART FROM THE MARK AS SHOWN.

THE ENGLISH TRANSLATION OF "LA SPOSA" IS "THE BRIDE".

CLASS 25—CLOTHING

FOR CLOTHING, NAMELY, WEDDING DRESSES AND GOWNS, AND EVENING DRESSES; FOOTWEAR; HEADWEAR, NAMELY, VEILS (U.S. CLS. 22 AND 39).

CLASS 26—FANCY GOODS

FOR LACE AND EMBROIDERY, RIBBONS AND BRAID; BUTTONS FOR CLOTHING, HOOKS AND EYES, HAIR PINS AND NEEDLES; ARTIFICIAL FLOWERS (U.S. CLS. 37, 39, 40, 42 AND 50).

NELSON SNYDER, EXAMINING ATTORNEY

CLASS 8—HAND TOOLS

FOR HAND-OPERATED TOOLS AND INSTRUMENTS, NAMELY, MANUALLY OPERATED HAND-HELD TOOL FOR THE PURPOSE OF DISPENSING PLASTIC WRAP AROUND PALLETS OR PRODUCT FOR THE PURPOSE OF SHIPPING, TRANSPORTING OR STORAGE; HAND-OPERATED TOOLS AND INSTRUMENTS, NAMELY, ADZES, AUGERS, AWLS, CLAMPS, CRIMPING IRONS, DIES, DRILLS, FILES, HAMMERS, HAND JACKS, MANUALLY-OPERATED GRINDING WHEELS, MITRE BOXES, MANUALLY-OPERATED SHARPENING WHEELS, PICKS, PLANERS, PLANES, PUNCHES, RASPS, RATCHET WRENCHES, REAMERS, SAWS, SCRAPERS, SCREWDRIVERS, SOCKET SETS, SHEET METAL SHRINKING AND STRETCHING DEVICES, TAPS, TONGS, WRENCHES, HAND-OPERATED REACHING DEVICES FOR PICKING UP AND REMOVING TRASH AND OBJECTS, RIPPING BARS, SANDERS, BOLT CUTTERS, WIRE STRIPPERS, PAINT SCRAPERS, WIRE CRIMPER, SHOVELS (U.S. CLS. 23, 28 AND 44).

CLASS 9—ELECTRICAL AND SCIENTIFIC APPARATUS

FOR STRUCTURAL PARTS AND COMPONENTS MADE OF PLASTIC, IN PARTICULAR MOULDED PLASTIC, INCLUDING PTFE, FEP, PFA, PVDE OR PEEK PLASTICS, BEING PARTS AND COMPONENTS OF, AND SOLD AS A UNIT WITH, RADIOS, TELEVISIONS AND TELEVISION SETS; STRUCTURAL PARTS AND COMPONENTS MADE OF PLASTIC, IN PARTICULAR MOULDED PLASTIC, INCLUDING PTFE, FEP, PFA, PVDE OR PEEK PLASTICS, BEING PARTS AND COMPONENTS OF, AND SOLD AS A UNIT WITH, SPEAKING MACHINES IN THE NATURE OF APPARATUS FOR RECORDING, TRANSMISSION OR REPRODUCTION OF SOUND AND IMAGES, ELECTRONIC TESTING EQUIPMENT, NAMELY, SOUND LEVEL METERS, PERSONAL HEADPHONES FOR USE WITH SOUND TRANSMITTING SYSTEMS, SOUND AMPLIFIERS, SOUND BOARD, SOUND CARDS, SOUND MIXERS, SOUND RECORDING APPARATUS AND INSTRUMENTS, DVD PLAYERS, CD PLAYERS; STRUCTURAL PARTS AND COMPONENTS MADE OF PLASTIC, IN PARTICULAR MOULDED PLASTIC, INCLUDING PTFE, FEP, PFA, PVDE OR PEEK PLASTICS, BEING PARTS AND COMPONENTS OF, AND SOLD AS A UNIT WITH, PHOTOGRAPHIC APPARATUS IN THE NATURE OF CAMERAS AND VIDEO CAMERAS; STRUCTURAL PARTS AND COMPONENTS MADE OF PLASTIC, IN PARTICULAR MOULDED PLASTIC, INCLUDING PTFE, FEP, PFA, PVDE OR PEEK PLASTICS, BEING PARTS AND COMPONENTS OF, AND SOLD AS A UNIT WITH, CINEMATOGRAPHIC APPARATUS IN THE NATURE OF SOUND AND VIDEO RECORDING AND PLAYBACK MACHINES; STRUCTURAL PARTS AND COMPONENTS MADE OF PLASTIC, IN PARTICULAR MOULDED PLASTIC, INCLUDING PTFE, FEP, PFA, PVDE OR PEEK PLASTICS, BEING PARTS AND COMPONENTS OF, AND SOLD AS A UNIT WITH, OPTICAL APPARATUS IN THE NATURE OF ELECTRONIC AND OPTICAL COMMUNICATIONS INSTRUMENTS AND COMPONENTS, NAMELY, OPTICAL TRANSMITTERS, RECEIVERS, OPTICAL DISC DRIVES, OPTICAL DATA LINKS, OPTICAL CABLES, OPTICAL FIBER CABLES, OPTICAL FILTERS, OPTICAL REFLECTORS, SCANNERS, OPTICAL SHUTTERS, OPTICAL MIRRORS, NON-STOP ELECTRICAL OPTICAL DETECTORS OF THE FILLING UP RATE OF TRASH CONTAINERS; STRUCTURAL PARTS AND COMPONENTS MADE OF PLASTIC, IN PARTICULAR MOULDED PLASTIC, INCLUDING PTFE, FEP, PFA, PVDE OR PEEK PLASTICS, BEING PARTS AND COMPONENTS OF, AND SOLD AS A UNIT WITH, WEIGHING APPARATUS IN THE NATURE OF SCALES AND BALANCES; STRUCTURAL PARTS AND COMPONENTS MADE OF PLASTIC, IN PARTICULAR MOULDED PLASTIC, INCLUDING PTFE, FEP, PFA, PVDE OR PEEK PLASTICS, BEING PARTS AND COMPONENTS OF, AND SOLD AS A UNIT WITH, MEASURING APPARATUS IN THE NATURE OF APPARATUS FOR MEASURING CHEMICAL COMPONENTS IN PAINTINGS, APPARATUS FOR MEASURING THE SPREADING OF PAINTINGS ON A SURFACE, APPARATUS TO MEASURE THE WEARING SURFACE AND RESISTANCE OF PLASTIC PARTS AND COMPONENTS, FOR INSTANCE TO LIGHT, HEAT, COLD, HUMIDITY AND SHOCKS IN THE NATURE OF COLLISIONS,

SN 79-035,221. COMPAGNIE PLASTIC OMNIUM, FRANCE,
FILED 10-11-2006.

PLASTIC OMNIUM

OWNER OF INTERNATIONAL REGISTRATION 0915488
DATED 10-11-2006, EXPIRES 10-11-2016.

OWNER OF U.S. REG. NO. 1,119,507.

NO CLAIM IS MADE TO THE EXCLUSIVE RIGHT TO USE "PLASTIC", APART FROM THE MARK AS SHOWN.

CLASS 1—CHEMICALS

FOR UNPROCESSED PLASTICS, UNPROCESSED ARTIFICIAL RESINS AND SYNTHETIC RESINS FOR USE IN MANUFACTURE, ADHESIVES FOR INDUSTRIAL PURPOSES (U.S. CLS. 1, 5, 6, 10, 26 AND 46).

CLASS 6—METAL GOODS

FOR METALLIC TUBES AND PIPES COVERED WITH OR SHEATHED WITH PLASTIC, IN PARTICULAR PTFE, FEP, PVDF OR PEEK PLASTICS; ELBOW PIPES; METAL PIPE CONNECTORS AND PLASTIC-COATED METALLIC CONNECTORS FOR PIPE LINES; GENERAL PURPOSE METAL STORAGE CONTAINERS IN THE NATURE OF FIXED AND WHEELED BINS AND CONTAINERS; NON-LUMINOUS AND NON-MECHANICAL METAL SIGNS AND SIGNALING PANELS (U.S. CLS. 2, 12, 13, 14, 23, 25 AND 50).

CLASS 7—MACHINERY

FOR METAL MOULDS FOR MOULDING OF PLASTIC MATERIAL; MACHINE PARTS AND COMPONENTS MADE OF PLASTIC INCLUDING MOULDED PLASTIC, FOR USE WITH DOMESTIC MACHINES, INDUSTRIAL MACHINES AND MACHINE TOOLS, NAMELY, BUSHINGS, BEARINGS, BEARING INSERTS, GUIDE HANDLES, SWITCHES, TOOL HOLDERS, PULLEY SAFETY GUARDS, TABLES, BASES, COLUMNS; VALVES AND SLIDE VALVES BEING MACHINE PARTS FOR INJECTION PLASTIC MOULDING MACHINES AND FOR POLISHING MACHINES FOR USE IN GRINDING AND POLISHING METAL, WOOD, CERAMICS AND PLASTICS (U.S. CLS. 13, 19, 21, 23, 31, 34 AND 35).

APPARATUS TO TEST THE RESISTANCE OF THE FOREGOING GOODS; STRUCTURAL PARTS AND COMPONENTS MADE OF PLASTIC, IN PARTICULAR MOULDED PLASTIC, INCLUDING PTFE, FEP, PFA, PVDE OR PEEK PLASTICS, BEING PARTS AND COMPONENTS OF, AND SOLD AS A UNIT WITH, SIGNALING APPARATUS IN THE NATURE OF ROTATING LIGHTS, SIGNALING BUOYS, TRAFFIC LIGHT APPARATUS, ELECTRONIC EQUIPMENT FOR INSPECTION AND DETECTION OF FOREIGN MATERIAL WITHIN CONTAINERS; STRUCTURAL PARTS AND COMPONENTS MADE OF PLASTIC, IN PARTICULAR MOULDED PLASTIC, INCLUDING PTFE, FEP, PFA, PVDE OR PEEK PLASTICS, BEING PARTS AND COMPONENTS OF, AND SOLD AS A UNIT WITH, CONTROL APPARATUS IN THE NATURE OF ELECTRIC CONTROL PANELS AND INDUSTRIAL AUTOMATION CONTROLS FOR USE IN THE FIELDS OF GARBAGE COLLECTION AND RUBBISH/GARBAGE PROCESSING, VEHICLE SAFETY, DESIGN OF VEHICLES' PARTS AND COMPONENTS, ENVIRONMENTALLY FRIENDLY PRODUCT DESIGN AND ENVIRONMENTAL POLICY; STRUCTURAL PARTS AND COMPONENTS MADE OF PLASTIC, IN PARTICULAR MOULDED PLASTIC, INCLUDING PTFE, FEP, PFA, PVDE OR PEEK PLASTICS, BEING PARTS AND COMPONENTS OF, AND SOLD AS A UNIT WITH, LABORATORY CONTAINERS IN THE NATURE OF BEAKERS, STORAGE TUBES, FLASKS, TEST TUBES, BURETTES, AND LABORATORY UTENSILS OF PLASTIC IN THE NATURE OF STERILE FORKS, MEASURING CUPS AND BOWLS, BUCKETS WITH COVER SOLD AS A UNIT THEREWITH; LUMINOUS SIGNS; MECHANICAL SIGNS; STRUCTURAL PARTS AND COMPONENTS MADE OF PLASTIC, IN PARTICULAR MOULDED PLASTIC, INCLUDING PTFE, FEP, PFA, PVDE OR PEEK PLASTICS, BEING PARTS AND COMPONENTS OF, AND SOLD AS A UNIT WITH, TEACHING APPARATUS IN THE NATURE OF COMPUTER DISKS, CD ROMS AND DVD'S FOR SOFTWARE, ELECTRONIC GAME PROGRAMS, VEHICLE DRIVING SIMULATORS, AND EDUCATIONAL GARBAGE AND RUBBISH SORTING SIMULATORS, ALL FOR USE IN THE FIELDS OF GARBAGE COLLECTION AND RUBBISH/GARBAGE PROCESSING, VEHICLE SAFETY, DESIGN OF VEHICLES' PARTS AND COMPONENTS, ENVIRONMENTALLY FRIENDLY PRODUCT DESIGN AND ENVIRONMENTAL POLICY (U.S. CLS. 21, 23, 26, 36 AND 38).

CLASS 11—ENVIRONMENTAL CONTROL APPARATUS

FOR STRUCTURAL PARTS AND COMPONENTS MADE OF PLASTIC IN PARTICULAR MOULDED PLASTIC, BEING PARTS AND COMPONENTS OF, AND SOLD AS A UNIT WITH, HOUSEHOLD APPLIANCES IN THE NATURE OF DEHUMIDIFIERS; STRUCTURAL PARTS AND COMPONENTS MADE OF PLASTIC IN PARTICULAR MOULDED PLASTIC, BEING PARTS AND COMPONENTS OF, AND SOLD AS A UNIT WITH, LIGHTING APPLIANCES IN THE NATURE OF ELECTRIC LIGHTING FIXTURES; STRUCTURAL PARTS AND COMPONENTS MADE OF PLASTIC IN PARTICULAR MOULDED PLASTIC, BEING PARTS AND COMPONENTS OF, AND SOLD AS A UNIT WITH, HEATING APPLIANCES IN THE NATURE OF ELECTRIC HEATING FANS, FURNACES; STRUCTURAL PARTS AND COMPONENTS MADE OF PLASTIC IN PARTICULAR MOULDED PLASTIC, BEING PARTS AND COMPONENTS OF, AND SOLD AS A UNIT WITH, STEAM GENERATING APPLIANCES IN THE NATURE OF STEAM GENERATORS; STRUCTURAL PARTS AND COMPONENTS MADE OF PLASTIC IN PARTICULAR MOULDED PLASTIC, BEING PARTS AND COMPONENTS OF, AND SOLD AS A UNIT WITH, COOKING APPLIANCES IN THE NATURE OF ELECTRIC, GAS OR MICROWAVE OVENS AND COOKTOPS; STRUCTURAL PARTS AND COMPONENTS MADE OF PLASTIC IN PARTICULAR MOULDED PLASTIC, BEING PARTS AND COMPONENTS OF, AND SOLD AS

A UNIT WITH, REFRIGERATING APPLIANCES IN THE NATURE OF ELECTRIC REFRIGERATORS AND REFRIGERATION UNITS FOR FOOD AND BEVERAGE CHILLING; STRUCTURAL PARTS AND COMPONENTS MADE OF PLASTIC IN PARTICULAR MOULDED PLASTIC, BEING PARTS AND COMPONENTS OF, AND SOLD AS A UNIT WITH, DRYING APPLIANCES IN THE NATURE OF CLOTHES DRYERS, HAIR DRYERS; STRUCTURAL PARTS AND COMPONENTS MADE OF PLASTIC IN PARTICULAR MOULDED PLASTIC, BEING PARTS AND COMPONENTS OF, AND SOLD AS A UNIT WITH, VENTILATING APPLIANCES IN THE NATURE OF AIR CONDITIONERS AND FANS; STRUCTURAL PARTS AND COMPONENTS MADE OF PLASTIC IN PARTICULAR MOULDED PLASTIC, BEING PARTS AND COMPONENTS OF, AND SOLD AS A UNIT WITH, WATER SUPPLY INSTALLATIONS, IN THE NATURE OF WATER FILTERING UNITS; AND STRUCTURAL PARTS AND COMPONENTS MADE OF PLASTIC IN PARTICULAR MOULDED PLASTIC, BEING PARTS AND COMPONENTS OF, AND SOLD AS A UNIT WITH, SANITARY INSTALLATIONS IN THE NATURE OF TOILETS; VALVES AND VALVING OF PLASTIC, OR COVERED WITH PLASTIC FOR INDUSTRY, NAMELY, VALVES AS PARTS OF RADIATORS, VALVES FOR AIR CONDITIONERS AND STEAM VALVES (U.S. CLS. 13, 21, 23, 31 AND 34).

CLASS 12—VEHICLES

FOR STRUCTURAL PARTS MADE OF PLASTIC, IN PARTICULAR MOULDED PLASTIC, BEING PARTS FOR VEHICLES, NAMELY, AIRPLANES, HELICOPTERS, AND AUTOMOBILES; COMPONENTS MADE OF PLASTIC, IN PARTICULAR MOULDED PLASTIC, BEING PARTS AND COMPONENTS OF, AND SOLD AS A UNIT WITH, VEHICLES, NAMELY, AIRPLANES, HELICOPTERS, AND AUTOMOBILES; FUEL TANKS FOR VEHICLES, NAMELY, AUTOMOBILES AND TRUCKS; WASTE BIN CARRIER TROLLEYS, WHEELED CONTAINERS IN THE NATURE OF CARTS (U.S. CLS. 19, 21, 23, 31, 35 AND 44).

CLASS 16—PAPER GOODS AND PRINTED MATTER

FOR STRUCTURAL PARTS AND COMPONENTS MADE OF PLASTIC, IN PARTICULAR MOULDED PLASTIC, BEING PARTS AND COMPONENTS OF, AND SOLD AS A UNIT WITH, TYPEWRITERS AND OFFICE MACHINES IN THE NATURE OF LABELING MACHINES AND DOCUMENT BINDING MACHINES FOR OFFICE USE, ADHESIVE APPLYING MACHINES, AUTOMATIC PAPER CLIP DISPENSING MACHINES, CD AND PAPER SHREDDING MACHINES, ELECTRIC STAPLERS; OFFICE ARTICLES MADE OF PLASTIC, NAMELY, DESK STANDS, HOLDERS FOR PENS, PENCILS AND INK, DRAWING RULERS, HOLE PUNCHERS, STAPLERS, AND BINDERS; WASTE BAGS MADE OF PLASTIC (U.S. CLS. 2, 5, 22, 23, 29, 37, 38 AND 50).

CLASS 17—RUBBER GOODS

FOR SEMI-FINISHED PRODUCTS, NAMELY, SHEETS, PLATES, RODS, STICKS, TAPES, STRIPS, CANES, TUBES, FLEXIBLE HOSES, UNLINED PIPES, COUPLINGS, BRIDLES, WEDGES, GASKET SEALS, AND CASINGS FOR CABLES, ALL MADE OF PLASTIC AND PTFE, FEP, PFA, PVDF, OR PEEK, FOR USE IN PUMPS, VALVES, COMPRESSORS, SEMICONDUCTORS, FLUID CONDUCTORS, NON-METALLIC FLEXIBLE TUBES; BRAIDS AND LININGS OF PTFE, FEP, PFA, PVDF, OR PEEK FOR USE IN VEHICLES AND AERONAUTICS (U.S. CLS. 1, 5, 12, 13, 35 AND 50).

CLASS 19—NON-METALLIC BUILDING MATERIALS

FOR URBAN FURNITURE IN THE NATURE OF NON-METAL SHELTER STRUCTURES; NON-LUMINOUS, NON-MECHANICAL SIGNS NOT OF METAL; NON-METAL TELEPHONE BOOTHS; PIPES OF RIGID PLASTIC, EARTHENWARE, CEMENT, AND SANDSTONE FOR BUILDING; NON-METALLIC, RIGID TUBES AND PIPES (U.S. CLS. 1, 12, 33 AND 50).

CLASS 20—FURNITURE AND ARTICLES NOT OTHERWISE CLASSIFIED

FOR PLASTIC FLUID STORAGE TANKS AND WASTE AND STORAGE CONTAINERS FOR INDUSTRY, TRANSPORT AND INDUSTRIAL HANDLING (U.S. CLS. 2, 13, 22, 25, 32 AND 50).

CLASS 21—HOUSEWARES AND GLASS

FOR SMALL PLASTIC HOUSEHOLD UTENSILS, NAMELY, PAN SCRAPERS, ROLLING PINS, SPATULAS, TURNERS, WHISKS, SERVING SPOONS, BOTTLE OPENERS; AND RECEPTACLES OF PLASTIC, NAMELY, STORAGE CONTAINERS FOR DOMESTIC USE OR TRASH CANS, BUCKETS, COMPOST BINS FOR HOUSEHOLD USE; BINS AND CONTAINERS FOR WASTE, REFUSE, OR GLASS, MADE OF METAL OR PLASTIC; WASTE PAPER BASKET (U.S. CLS. 2, 13, 23, 29, 30, 33, 40 AND 50).

CLASS 40—MATERIAL TREATMENT

FOR MATERIALS PROCESSING OF PLASTICS BY MOULDING, INJECTION, EXTRUSION, BLOWING, FOAMING, CALENDARING ROTATIONAL MOULDING TO THE ORDER AND/OR SPECIFICATION OF OTHERS; METAL PLATING OF PLASTIC PARTS AND APPLYING PROTECTIVE COATING TO PLASTIC PARTS (U.S. CLS. 100, 103 AND 106).

KALIE KUNG, EXAMINING ATTORNEY

SN 79-036,067. JENNY LEGGE, AUSTRALIA, FILED 4-21-2006.



OWNER OF INTERNATIONAL REGISTRATION 0917616 DATED 4-21-2006, EXPIRES 4-21-2016.

NO CLAIM IS MADE TO THE EXCLUSIVE RIGHT TO USE "JOB FIT SYSTEM", APART FROM THE MARK AS SHOWN.

THE MARK CONSISTS OF THE WORD JOB ENCLOSED WITHIN A PUZZLE PIECE DESIGN TO THE LEFT OF THE WORD FIT ENCLOSED WITHIN A PUZZLE PIECE DESIGN. THE WORD "SYSTEM" IS LOCATED BELOW THE WORDING "JOB" AND "FIT".

CLASS 9—ELECTRICAL AND SCIENTIFIC APPARATUS

FOR COMPUTER SOFTWARE FOR RECORDING AND COMPARING PHYSICAL ASPECTS OF WORKERS AND JOBS FOR USE IN WORKPLACE INJURY REHABILITATION, PRE-EMPLOYMENT FUNCTIONAL CAPABILITY AND PHYSICAL AGILITY TESTING, IDENTIFICATION OF WORKPLACE INJURY AND ILLNESS RISK FACTORS, EMPLOYMENT ALLOCATION FOR HEALTH IMPAIRED WORKERS, HEALTH SURVEILLANCE MANAGEMENT (U.S. CLS. 21, 23, 26, 36 AND 38).

CLASS 41—EDUCATION AND ENTERTAINMENT

FOR TRAINING SERVICES, NAMELY, COMPUTER SOFTWARE EDUCATION TRAINING (U.S. CLS. 100, 101 AND 107).

CLASS 44—MEDICAL, BEAUTY AND AGRICULTURAL SERVICES

FOR MEDICAL SERVICES IN THE FIELD OF OCCUPATIONAL REHABILITATION AND INJURY PREVENTION AND PHYSIOTHERAPY AND EMPLOYEE PHYSICAL REHABILITATION, MEDICAL REHABILITATION CONSULTANCY, REHABILITATION MANAGEMENT, NAMELY, ASSESSING FUNCTIONAL CAPACITY OF WORKERS TO BE ENTERED INTO A REHABILITATION PROGRAM, MONITORING REHABILITATION OF WORKERS DURING EMPLOYMENT AND MONITORING OCCUPATIONAL HEALTH OF WORKERS DURING EMPLOYMENT, PHYSICAL REHABILITATION FOR INJURED WORKERS, PROVIDING EMPLOYMENT WELLNESS SERVICES FOR HEALTH IMPAIRED WORKERS, NAMELY, PROVIDING STANDARDIZED WORKER ASSESSMENTS AND TASK ANALYSIS PROGRAMS TO ASSIST WITH EMPLOYMENT ALLOCATION FOR HEALTH IMPAIRED WORKERS, HEALTH SURVEILLANCE MANAGEMENT SERVICES, NAMELY, EMPLOYEE HEALTH AND WELLNESS MONITORING AND ASSESSMENT SERVICES, PROVIDING WELLNESS SERVICES, NAMELY, RISK MANAGEMENT ASSESSMENT FOR INDIVIDUALS INCLUDING EMPLOYEES, NAMELY, PROVIDING STANDARDIZED WORKER ASSESSMENTS AND TASK ANALYSIS PROGRAMS TO MONITOR EMPLOYEE HEALTH AND WELLNESS DURING EMPLOYMENT (U.S. CLS. 100 AND 101).

DOMINIC FATHY, EXAMINING ATTORNEY

SN 79-036,220. CCS DIGITAL—FABRIC GMBH, FED REP GERMANY, FILED 3-27-2006.

CCS digital_fabric

THE MARK CONSISTS OF STANDARD CHARACTERS WITHOUT CLAIM TO ANY PARTICULAR FONT, STYLE, SIZE, OR COLOR.

OWNER OF INTERNATIONAL REGISTRATION 0918068 DATED 3-27-2006, EXPIRES 3-27-2016.

CLASS 6—METAL GOODS

FOR PARTITION WALLS OF METAL, AFORESAID PARTITION WALLS IN PARTICULAR DISMOUNTABLE; STATIONERY OR MOBILE PARTITION WALLS PRIMARILY COMPOSED OF METAL; REMOVABLE PARTITION WALLS OF METAL; REMOVABLE PARTITION WALLS PRIMARILY COMPOSED OF METAL FOR FAIRS (U.S. CLS. 2, 12, 13, 14, 23, 25 AND 50).

CLASS 16—PAPER GOODS AND PRINTED MATTER

FOR ADVERTISING SIGNS OF PAPER OR CARDBOARD; PHOTOGRAPH STANDS OF PLASTICS OR METALS; POSTERS; PRINTED MATTER, PRODUCED BY DIGITAL PRINTING MACHINES, NAMELY, WALL CALENDARS, ILLUSTRATION BOARDS, PHOTO PRINTS; BANNERS AND POSTERS (U.S. CLS. 2, 5, 22, 23, 29, 37, 38 AND 50).

CLASS 20—FURNITURE AND ARTICLES NOT OTHERWISE CLASSIFIED

FOR PICTURE FRAMES; PICTURE FRAME BRACKETS; POINT OF PURCHASE DISPLAYS AND DISPLAY BOARDS; DISPLAY STANDS (U.S. CLS. 2, 13, 22, 25, 32 AND 50).

CLASS 35—ADVERTISING AND BUSINESS

FOR PHOTOCOPYING; PREPARATION OF COLOUR DOCUMENT REPRODUCTIONS (U.S. CLS. 100, 101 AND 102).

DOMINIC FATHY, EXAMINING ATTORNEY

SN 79-036,506. BWT AKTIENGESELLSCHAFT, AUSTRIA, FILED 12-21-2006.



PRIORITY DATE OF 6-26-2006 IS CLAIMED. OWNER OF INTERNATIONAL REGISTRATION 0918857 DATED 12-21-2006, EXPIRES 12-21-2016.

OWNER OF U.S. REG. NOS. 2,443,895 AND 2,525,470. "THE COLOR(S) WHITE AND ORANGE IS/ARE CLAIMED AS A FEATURE OF THE MARK."

THE MARK CONSISTS OF THE LETTERS "W BY BWT" AND THE DROPLET DESIGN IN WHITE INSIDE AN ORANGE RECTANGLE.

CLASS 1—CHEMICALS

FOR INDUSTRIAL CHEMICALS FOR TREATING, CLARIFYING, SOFTENING, DESALINATING, CLEANING, DE-ACIDIFYING AND DISINFECTING WATER (U.S. CLS. 1, 5, 6, 10, 26 AND 46).

CLASS 5—PHARMACEUTICALS

FOR PRODUCTS FOR DESTROYING ALGAE AND BACTERIA, NAMELY, ANTIMICROBIAL COATINGS TO TREAT THE GROWTH OF ALGAE AND BACTERIA; BIOCIDES (U.S. CLS. 6, 18, 44, 46, 51 AND 52).

CLASS 6—METAL GOODS

FOR METAL POOLS FOR SWIMMING AND BATHING; WATER PIPES OF METAL; MANUALLY OPERATED METAL VALVES FOR WATER PIPES (U.S. CLS. 2, 12, 13, 14, 23, 25 AND 50).

CLASS 7—MACHINERY

FOR DEVICES FOR SWIMMING POOLS, NAMELY, CIRCULATING PUMP FACILITIES IN THE NATURE OF WATER PUMPS FOR SWIMMING POOLS, VALVES FOR PUMPS; STRUCTURAL COMPONENT PARTS OF ALL THE AFORESAID GOODS; SUCTION APPARATUS FOR CLEANING THE BOTTOM OF POOLS FOR SWIMMING AND BATHING, NAMELY, SWIMMING POOL SWEEPERS (U.S. CLS. 13, 19, 21, 23, 31, 34 AND 35).

CLASS 9—ELECTRICAL AND SCIENTIFIC APPARATUS

FOR PHYSICAL AND CHEMICAL APPARATUS FOR FILTERING AND METERING SOLID, PASTY, LIQUID AND GASEOUS MATERIALS, NAMELY, MASS METERS, FLOW METERS; WATER METERS; WATER FILTER CONTROLLERS; WATER PURIFIERS; LEVELING APPARATUS, NAMELY, LEVELING RODS; STRUCTURAL COMPONENT PARTS OF ALL THE AFORESAID GOODS, NOT INCLUDED IN OTHER CLASSES (U.S. CLS. 21, 23, 26, 36 AND 38).

CLASS 11—ENVIRONMENTAL CONTROL APPARATUS

FOR BATH INSTALLATIONS, NAMELY, TAPS; BATH-TUBS; INSTALLATIONS AND APPARATUS FOR TREATING, CLARIFYING, WASTEWATER, FOR SOFTENING, DESALINATING SEA WATER, FOR CLEANING, DE-ACIDIFYING, DE-CHLORINATING AND DISINFECTING WATER, NAMELY, FILTERING UNITS FOR WATER FILTRATION, INDUSTRIAL WATER PURIFYING APPARATUS, INDUSTRIAL WATER PURIFYING APPARATUS AND WASTE WATER PURIFICATION UNITS; METERED VALVES FOR WATER SUPPLY; OZONE SANITIZERS FOR WATER; WATER FILTERS; WATER TREATMENT EQUIPMENT, NAMELY, ULTRAVIOLET STERILIZATION UNITS; INDUSTRIAL WATER PURIFYING APPARATUS; FILTERING UNITS FOR PRODUCING POTABLE WATER FOR DOMESTIC UNITS; REGULATING ACCESSORIES FOR WATER SUPPLY, NAMELY, METERED VALVES; WATER SOFTENING UNITS; SUCTION APPARATUS FOR CLEANING THE BOTTOM OF POOLS FOR SWIMMING AND BATHING, NAMELY, POOL SKIMMER DIVERTER; STRUCTURAL COMPONENT PARTS OF ALL THE AFORESAID GOODS NOT INCLUDED IN OTHER CLASSES (U.S. CLS. 13, 21, 23, 31 AND 34).

CLASS 19—NON-METALLIC BUILDING MATERIALS

FOR PLASTIC AND NON-METAL POOLS FOR SWIMMING AND BATHING; WATER PIPES OF PLASTIC MATERIALS; STRUCTURAL COMPONENT PARTS OF ALL THE AFORESAID GOODS NOT INCLUDED IN OTHER CLASSES (U.S. CLS. 1, 12, 33 AND 50).

ROBERT STRUCK, EXAMINING ATTORNEY

SN 79-036,507. BWT AKTIENGESELLSCHAFT, AUSTRIA, FILED 12-21-2006.



PRIORITY DATE OF 6-26-2006 IS CLAIMED. OWNER OF INTERNATIONAL REGISTRATION 0918858 DATED 12-21-2006, EXPIRES 12-21-2016.

OWNER OF U.S. REG. NOS. 2,443,895 AND 2,525,470. "THE COLOR(S) WHITE, ORANGE AND BLUE IS/ARE CLAIMED AS A FEATURE OF THE MARK."

THE MARK CONSISTS OF THE LETTERS "W BY BWT" AND THE DROPLET DESIGN IN WHITE AGAINST AN ORANGE RECTANGLE. THE WORDING "WATER + MORE" IS IN BLUE.

CLASS 1—CHEMICALS

FOR INDUSTRIAL CHEMICALS FOR TREATING, CLARIFYING, SOFTENING, DESALINATING, CLEANING, DE-ACIDIFYING AND DISINFECTING WATER (U.S. CLS. 1, 5, 6, 10, 26 AND 46).

CLASS 5—PHARMACEUTICALS

FOR PRODUCTS FOR DESTROYING ALGAE AND BACTERIA, NAMELY, ANTIMICROBIAL COATINGS TO TREAT THE GROWTH OF ALGAE AND BACTERIA; BIOCIDES (U.S. CLS. 6, 18, 44, 46, 51 AND 52).

CLASS 6—METAL GOODS

FOR METAL POOLS FOR SWIMMING AND BATHING; WATER PIPES OF METAL; MANUALLY OPERATED METAL VALVES FOR WATER PIPES (U.S. CLS. 2, 12, 13, 14, 23, 25 AND 50).

CLASS 7—MACHINERY

FOR DEVICES FOR SWIMMING POOLS, NAMELY, CIRCULATING PUMP FACILITIES IN THE NATURE OF WATER PUMPS FOR SWIMMING POOLS, VALVES FOR PUMPS; STRUCTURAL COMPONENT PARTS OF ALL THE AFORESAID GOODS; SUCTION APPARATUS FOR CLEANING THE BOTTOM OF POOLS FOR SWIMMING AND BATHING, NAMELY, SWIMMING POOL SWEEPERS (U.S. CLS. 13, 19, 21, 23, 31, 34 AND 35).

CLASS 9—ELECTRICAL AND SCIENTIFIC APPARATUS

FOR PHYSICAL AND CHEMICAL APPARATUS FOR FILTERING AND METERING SOLID, PASTY, LIQUID AND GASEOUS MATERIALS, NAMELY, MASS METERS, FLOW METERS; WATER METERS; WATER FILTER CONTROLLERS; WATER PURIFIERS; LEVELING APPARATUS, NAMELY, LEVELING RODS; STRUCTURAL COMPONENT PARTS OF ALL THE AFORESAID GOODS, NOT INCLUDED IN OTHER CLASSES (U.S. CLS. 21, 23, 26, 36 AND 38).

CLASS 11—ENVIRONMENTAL CONTROL APPARATUS

FOR BATH INSTALLATIONS, NAMELY, TAPS; BATH-TUBS; INSTALLATIONS AND APPARATUS FOR TREATING, CLARIFYING, WASTEWATER, FOR SOFTENING, DESALINATING SEA WATER, FOR CLEANING, DE-ACIDIFYING, DE-CHLORINATING AND DISINFECTING WATER, NAMELY, FILTERING UNITS FOR WATER FILTRATION, INDUSTRIAL WATER PURIFYING APPARATUS, INDUSTRIAL WATER PURIFYING APPARATUS AND WASTE WATER PURIFICATION UNITS; METERED VALVES FOR WATER SUPPLY; OZONE SANITIZERS FOR WATER; WATER FILTERS; WATER TREATMENT EQUIPMENT, NAMELY, ULTRAVIOLET STERILIZATION UNITS; INDUSTRIAL WATER PURIFYING APPARATUS; FILTERING UNITS FOR PRODUCING POTABLE WATER FOR DOMESTIC UNITS; REGULATING ACCESSORIES FOR WATER SUPPLY, NAMELY, METERED VALVES; WATER SOFTENING UNITS; SUCTION APPARATUS FOR CLEANING THE BOTTOM OF POOLS FOR SWIMMING AND BATHING, NAMELY, POOL SKIMMER DIVERTER; STRUCTURAL COMPONENT PARTS OF ALL THE AFORESAID GOODS NOT INCLUDED IN OTHER CLASSES (U.S. CLS. 13, 21, 23, 31 AND 34).

CLASS 19—NON-METALLIC BUILDING MATERIALS

FOR PLASTIC AND NON-METAL POOLS FOR SWIMMING AND BATHING; WATER PIPES OF PLASTIC MATERIALS; STRUCTURAL COMPONENT PARTS OF ALL THE AFORESAID GOODS NOT INCLUDED IN OTHER CLASSES (U.S. CLS. 1, 12, 33 AND 50).

ROBERT STRUCK, EXAMINING ATTORNEY

SN 79-036,759. BIGMOUTHMEDIA LTD., EDINBURGH EH6 6QH, UNITED KINGDOM, FILED 10-14-2006.

BIGMOUTHMEDIA

THE MARK CONSISTS OF STANDARD CHARACTERS WITHOUT CLAIM TO ANY PARTICULAR FONT, STYLE, SIZE, OR COLOR.

PRIORITY DATE OF 5-8-2006 IS CLAIMED.

OWNER OF INTERNATIONAL REGISTRATION 0919689 DATED 10-14-2006, EXPIRES 10-14-2016.

CLASS 9—ELECTRICAL AND SCIENTIFIC APPARATUS

FOR COMPUTER PROGRAMS FOR USE IN SEARCH ENGINE OPTIMIZATION, WEB ADVERTISING AND WEB TRAFFIC ANALYSIS; SOFTWARE PRODUCTS IN THE FIELD OF WEBSITE OPTIMIZATION AND WEB CONTENT MANAGEMENT, NAMELY, COMPUTER SOFTWARE FOR USE IN DATABASE MANAGEMENT AND WEBSITE OPTIMIZATION; SEARCH ENGINE OPTIMIZATION PRODUCTS AND WEB TRAFFIC TRACKING PRODUCTS, NAMELY, COMPUTER SEARCH ENGINE SOFTWARE AND COMPUTER SOFTWARE FOR TRACKING WEB TRAFFIC; COMPUTER SOFTWARE FOR USE IN WEB SITE OPTIMIZATION AND DATA BASE MANAGEMENT FOR USE IN CONNECTION WITH THE INTERNET AND THE WORLD WIDE WEB THAT MAY BE DOWNLOADED FROM A GLOBAL COMPUTER NETWORK; APPARATUS FOR RECORDING, TRANSMISSION OR REPRODUCTION OF SOUND, DATA AND IMAGES; ELECTRONIC APPARATUS AND INSTRUMENTS, NAMELY, ELECTRONIC CIRCUIT BOARDS AND ELECTRONIC CARD READERS, BLANK MAGNETIC COMPUTER TAPES; BLANK MAGNETIC DISCS FOR COMPUTERS; BLANK MAGNETIC DATA CARRIERS; INFORMATION STORAGE DEVICES, NAMELY, COMPUTER STORAGE DEVICES, NAMELY, JUMP DRIVES, FLASH DRIVES AND PORTABLE COMPUTER MEMORIES FOR DATA STORAGE; BLANK CD ROM'S FOR SOUND OR VIDEO RECORDING; DOWNLOADABLE ELECTRONIC PUBLICATIONS IN THE NATURE OF NEWSLETTERS, MANUALS AND BROCHURES IN THE FIELD OF SEARCH ENGINE MARKETING, MULTILINGUAL SEARCH ENGINE OPTIMIZATION, PAY PER CLICK MANAGEMENT, SEO CONSULTANCY, PARTNERSHIPS, BRAND NOISE, MARKETING FOR REBRANDS, SEARCH ENGINE POSITIONS, TRACKING AND WEB TRAFFIC ANALYSIS IN THE FIELD OF WEB SITE AND SEARCH ENGINE OPTIMIZATION THAT ARE AVAILABLE ON-LINE FROM DATABASES OR VIA THE INTERNET; ELECTRONIC PUBLICATIONS, NAMELY, BOOKS, MAGAZINES AND MANUALS FEATURING SEARCH ENGINE MARKETING, MULTILINGUAL SEARCH ENGINE OPTIMIZATION, PAY PER CLICK MANAGEMENT, SEO CONSULTANCY, PARTNERSHIPS, BRAND NOISE, MARKETING FOR REBRANDS, SEARCH ENGINE POSITIONS, TRACKING AND WEB TRAFFIC ANALYSIS RECORDED ON COMPUTER MEDIA AND PROVIDED BY ELECTRONIC MAIL; COMMUNICATIONS HARDWARE AND SOFTWARE, NAMELY, COMMUNICATION SERVERS, COMMUNICATIONS SOFTWARE FOR CONNECTING COMPUTER NETWORK USERS AND GLOBAL COMPUTER NETWORKS; INTERACTIVE COMPUTER SYSTEMS COMPRISED OF COMPUTERS, COMPUTER HARDWARE AND COMPUTER PERIPHERALS; INTERACTIVE ELECTRONIC APPARATUS, NAMELY, ELECTRONIC CIRCUIT BOARDS AND ELECTRONIC CARD READERS, AND BLANK MAGNETIC COMPUTER TAPES (U.S. CLS. 21, 23, 26, 36 AND 38).

CLASS 16—PAPER GOODS AND PRINTED MATTER

FOR PRINTED MATTER, NAMELY, PRINTED VISUALS IN THE NATURE OF PROMOTIONAL MATERIAL; PUBLICATIONS, NAMELY, BROCHURES, BOOKLETS AND TEACHING MATERIALS IN THE FIELD OF SEARCH ENGINE OPTIMIZATION AND WEB ADVERTISING; ALMANACS; BOOKS IN THE FIELD OF SEARCH ENGINE OPTIMIZATION AND WEB ADVERTISING; DIARIES; DIRECTORIES; PRINTED GUIDES FOR USE IN RELATION TO SEARCH ENGINE OPTIMIZATION AND WEB ADVERTISING; HANDBOOKS IN THE FIELD OF SEARCH ENGINE OPTIMIZATION AND WEB ADVERTISING; JOURNALS CONCERNING SEARCH ENGINE OPTIMIZATION AND WEB ADVERTISING; LEAFLETS ABOUT SEARCH ENGINE OPTIMIZATION AND WEB ADVERTISING; NOTEBOOKS; PAMPHLETS IN THE FIELD OF SEARCH ENGINE OPTIMIZATION AND WEB ADVERTISING; MANUALS IN THE FIELD OF SEARCH ENGINE OPTIMIZATION AND WEB ADVERTISING; PRINTED PERIODICALS IN THE FIELD OF SEARCH ENGINE OPTIMIZATION AND WEB ADVERTISING; PRINTED REPORTS FEATURING SEARCH ENGINE MARKETING, MULTILINGUAL SEARCH ENGINE OPTIMIZATION, PAY PER CLICK MANAGEMENT, SEO CONSULTANCY, PARTNERSHIPS, BRAND NOISE, MARKETING FOR REBRANDS, SEARCH ENGINE POSITIONS, TRACKING AND WEB TRAFFIC ANALYSIS IN THE FIELD OF WEB SITE AND SEARCH ENGINE OPTIMIZATION; PRINTED PRODUCTS, NAMELY, LISTS FEATURING SEARCH ENGINE MARKETING, MULTILINGUAL SEARCH ENGINE OPTIMIZATION, PAY PER CLICK MANAGEMENT, SEO CONSULTANCY, PARTNERSHIPS, BRAND NOISE, MARKETING FOR REBRANDS, SEARCH ENGINE POSITIONS, TRACKING AND WEB TRAFFIC ANALYSIS IN THE FIELD OF WEB SITE AND SEARCH ENGINE OPTIMIZATION; BOOKS IN THE FIELD OF SEARCH ENGINE MARKETING, MULTILINGUAL SEARCH ENGINE OPTIMIZATION, PAY PER CLICK MANAGEMENT, SEO CONSULTANCY, PARTNERSHIPS, BRAND NOISE, MARKETING FOR REBRANDS, SEARCH ENGINE POSITIONS, TRACKING AND WEB TRAFFIC ANALYSIS IN THE FIELD OF WEB SITE AND SEARCH ENGINE OPTIMIZATION; PAMPHLETS IN THE FIELD OF SEARCH ENGINE MARKETING, MULTILINGUAL SEARCH ENGINE OPTIMIZATION, PAY PER CLICK MANAGEMENT, SEO CONSULTANCY, PARTNERSHIPS, BRAND NOISE, MARKETING FOR REBRANDS, SEARCH ENGINE POSITIONS, TRACKING AND WEB TRAFFIC ANALYSIS IN THE FIELD OF WEB SITE AND SEARCH ENGINE OPTIMIZATION; PUBLICATIONS, NAMELY, BROCHURES, BOOKLETS AND TEACHING MATERIALS IN THE FIELD OF SEARCH ENGINE MARKETING, MULTILINGUAL SEARCH ENGINE OPTIMIZATION, PAY PER CLICK MANAGEMENT, SEO CONSULTANCY, PARTNERSHIPS, BRAND NOISE, MARKETING FOR REBRANDS, SEARCH ENGINE POSITIONS, TRACKING AND WEB TRAFFIC ANALYSIS IN THE FIELD OF WEB SITE AND SEARCH ENGINE OPTIMIZATION; PRINTED PERIODICALS IN THE FIELD OF SEARCH ENGINE MARKETING, MULTILINGUAL SEARCH ENGINE OPTIMIZATION, PAY PER CLICK MANAGEMENT, SEO CONSULTANCY, PARTNERSHIPS, BRAND NOISE, MARKETING FOR REBRANDS, SEARCH ENGINE POSITIONS, TRACKING AND WEB TRAFFIC ANALYSIS IN THE FIELD OF WEB SITE AND SEARCH ENGINE OPTIMIZATION; COMPUTER PRINT OUTS, NAMELY, PRINTED REPORTS FEATURING SEARCH ENGINE MARKETING, MULTILINGUAL SEARCH ENGINE OPTIMIZATION, PAY PER CLICK MANAGEMENT, SEO CONSULTANCY, PARTNERSHIPS, BRAND NOISE,

MARKETING FOR REBRANDS, SEARCH ENGINE POSITIONS, TRACKING AND WEB TRAFFIC ANALYSIS IN THE FIELD OF WEB SITE AND SEARCH ENGINE OPTIMIZATION; PRINTED VISUALS IN THE NATURE OF PROMOTIONAL MATERIAL; PRINTED VISUALS IN THE NATURE OF BROCHURES ABOUT SEARCH ENGINE OPTIMIZATION AND WEB ADVERTISING; STATIONERY AND PRINTED FORMS; PRINTED INSTRUCTIONAL AND TEACHING MATERIALS IN THE FIELD OF SEARCH ENGINE MARKETING, MULTILINGUAL SEARCH ENGINE OPTIMIZATION, PAY PER CLICK MANAGEMENT, SEO CONSULTANCY, PARTNERSHIPS, BRAND NOISE, MARKETING FOR REBRANDS, SEARCH ENGINE POSITIONS, TRACKING AND WEB TRAFFIC ANALYSIS IN THE FIELD OF WEB SITE AND SEARCH ENGINE OPTIMIZATION; GOODS MADE OF PAPER AND CARDBOARD, NAMELY, CARDBOARD CONTAINERS, CARDBOARD PACKAGING, ADVERTISING BOARDS MADE OF CARDBOARD OR PAPER; HANDBOOKS IN THE FIELD OF WEB SITE OPTIMIZATION AND SEARCH ENGINE OPTIMIZATION; PUBLICATIONS, NAMELY, BROCHURES, BOOKLETS, AND TEACHING MATERIALS IN THE FIELD OF WEB SITE OPTIMIZATION AND SEARCH ENGINE OPTIMIZATION; COMPUTER REFERENCE MANUALS FOR WEB SITE OPTIMIZATION AND SEARCH ENGINE OPTIMIZATION; COMPUTER USERS GUIDES FOR WEB SITE OPTIMIZATION AND SEARCH ENGINE OPTIMIZATION; COMPUTER INSTRUCTION MANUALS FOR WEB SITE OPTIMIZATION AND SEARCH ENGINE OPTIMIZATION; COMPUTER MANUALS FOR WEB SITE OPTIMIZATION AND SEARCH ENGINE OPTIMIZATION; PRINTED PUBLICATIONS IN THE NATURE OF BOOKS, PERIODICALS, MAGAZINES, BROCHURES AND MANUALS IN THE FIELD OF SEARCH ENGINE OPTIMIZATION, WEB ADVERTISING, WEB TRAFFIC ANALYSIS, TECHNOLOGY, DIGITAL TERMINOLOGY AND GADGETS (U.S. CLS. 2, 5, 22, 23, 29, 37, 38 AND 50).

CLASS 35—ADVERTISING AND BUSINESS

FOR BUSINESS INFORMATION MANAGEMENT, NAMELY, COMPILATION, MONITORING, STORAGE, MANAGEMENT, ANALYSIS, EVALUATION AND RETRIEVAL OF COMMERCIAL AND BUSINESS INFORMATION, DATA AND STATISTICS RELATING TO SEARCH ENGINE OPTIMIZATION; THE BRINGING TOGETHER FOR THE BENEFIT OF OTHERS OF A VARIETY OF GOODS AND SERVICES RELATING TO SEARCH ENGINE OPTIMIZATION, ENABLING CUSTOMERS TO CONVENIENTLY VIEW AND PURCHASE THOSE GOODS AND SERVICES FROM AN INTERNET WEBSITE (U.S. CLS. 100, 101 AND 102).

CLASS 42—SCIENTIFIC AND COMPUTER SERVICES

FOR INTERNET SERVICES, NAMELY, THE HOSTING OF DIGITAL CONTENT ON THE INTERNET; INTERNET ADVICE SERVICES, NAMELY, TECHNOLOGY ADVICE PROVIDED TO INTERNET USERS BY MEANS OF A SUPPORT HOTLINE; DATA LINKS SERVICES, NAMELY, COMPUTER DATA RECOVERY SERVICES, COMPUTER HARD DRIVE DATA BACKUP SERVICES, NETWORKING TECHNICAL SUPPORT SERVICES, NAMELY, MONITORING OF NETWORK SYSTEMS; INTERNET SECURITY AND SURVEILLANCE SERVICES, NAMELY, RESTRICTING ACCESS TO AND BY COMPUTER NETWORKS TO AND OF UNDESIRABLE WEB SITES, MEDIA AND INDIVIDUALS AND FACILITIES; COMPUTER RESEARCH, DEVELOPMENT, ADVISORY AND CONSULTANCY SERVICES; COMPILATION OF SCIENTIFIC INFORMATION IN THE FIELD OF SEARCH ENGINE OPTIMIZATION, WEB ADVERTISING AND WEB TRAFFIC ANALYSIS; TECHNICAL RESEARCH IN THE FIELD OF COMPUTING, NAMELY, DOCUMENTARY RESEARCH RELATING TO INFORMATION STORAGE AND DOCUMENTARY RESEARCH RELATING TO INFORMATION RETRIEVAL; COMPUTER SYSTEMS ANALYSIS; PROVIDING TECHNOLOGY INFORMATION IN THE FIELD OF SEARCH ENGINE OPTIMIZATION, WEB ADVERTISING AND WEB TRAFFIC ANALYSIS; COMPUTER HELPLINE SERVICES, NAMELY, TECHNOLOGY ADVICE PROVIDED TO INTERNET USERS BY MEANS OF A SUPPORT HOTLINE; COMPUTER

HARDWARE AND SOFTWARE SUPPORT SERVICES, NAMELY, TECHNICAL SUPPORT SERVICES IN THE NATURE OF TROUBLE SHOOTING OF COMPUTER HARDWARE AND SOFTWARE PROBLEMS; PROVIDING INFORMATION IN THE FIELD OF COMPUTERS; DATABASE SERVICES, NAMELY, DATABASE DEVELOPMENT AND DESIGN SERVICES; EVALUATIONS, ASSESSMENTS AND RESEARCH IN THE FIELDS OF SCIENCE AND TECHNOLOGY PROVIDED BY ENGINEERS; DESIGN, DEVELOPMENT, INSTALLATION, UPDATING AND MAINTENANCE OF SOFTWARE; SCIENTIFIC AND TECHNOLOGY SERVICES AND RESEARCH AND DESIGN RELATING THERETO, NAMELY, SCIENTIFIC RESEARCH AND TECHNOLOGICAL RESEARCH IN THE FIELD OF COMPUTERS AND COMPUTER SOFTWARE; INDUSTRIAL ANALYSIS AND RESEARCH IN THE FIELD OF SEARCH ENGINE OPTIMIZATION, WEB ADVERTISING AND WEB TRAFFIC ANALYSIS; DESIGN AND DEVELOPMENT OF COMPUTER HARDWARE AND SOFTWARE; COMPUTER HARDWARE AND SOFTWARE CONSULTING SERVICES; RENTAL OF COMPUTER HARDWARE AND SOFTWARE; MULTIMEDIA AND AUDIO-VISUAL SOFTWARE CONSULTING SERVICES; COMPUTER PROGRAMMING; COMPUTER CONSULTATION, NAMELY, SUPPORT CONSULTATION SERVICES FOR DEVELOPING COMPUTER SYSTEMS, DATABASES AND APPLICATIONS; GRAPHIC DESIGN SERVICES FOR THE COMPILATION OF WEB PAGES ON THE INTERNET; PROVIDING INFORMATION IN THE FIELD OF COMPUTER HARDWARE OR SOFTWARE VIA ONLINE GLOBAL COMPUTER NETWORKS OR THE INTERNET; CREATING AND MAINTAINING WEB SITES FOR OTHERS; PROVIDING A WEBSITE THAT FEATURES INFORMATION ON COMPUTER TECHNOLOGY AND PROGRAMMING USING MULTIMEDIA MATERIALS; WEB SITE HOSTING SERVICES FOR OTHERS; LICENSING OF INTELLECTUAL PROPERTY; COMPUTER SERVICES, NAMELY, PROVIDING SEARCH ENGINES FOR OBTAINING DATA VIA COMMUNICATIONS NETWORKS; PROVIDING DATABASES IN THE FIELD OF SEARCH ENGINE OPTIMIZATION, WEB ADVERTISING AND WEB TRAFFIC ANALYSIS VIA COMMUNICATIONS NETWORKS FOR OBTAINING DATA; APPLICATION SERVICE PROVIDER (ASP) SERVICES FEATURING SOFTWARE FOR USE IN CONNECTION WITH ONLINE DATABASE SERVICES, NAMELY, FOR USE IN DATABASE MANAGEMENT; INTERNET SERVICES, CREATING INDEXES OF INFORMATION RECEIVED FROM USERS OF GLOBAL COMPUTER NETWORKS FOR OTHERS; PROVIDING USERS OF ELECTRONIC COMMUNICATIONS NETWORKS WITH MEANS OF IDENTIFYING, LOCATING, GROUPING, DISTRIBUTING AND MANAGING DATA, NAMELY, BY PROVIDING COMPUTER SEARCH ENGINES FOR OBTAINING DATA ON A GLOBAL COMPUTER NETWORK; ORGANIZING CONTENT OF INFORMATION PROVIDED OVER A GLOBAL COMPUTER NETWORK AND STORING AND DISSEMINATING SUCH INFORMATION, NAMELY ACTING AS AN APPLICATION SERVICE PROVIDER IN THE FIELD OF KNOWLEDGE MANAGEMENT TO HOST COMPUTER APPLICATION SOFTWARE FOR THE ORGANIZING, STORING AND DISSEMINATING OF INFORMATION; PROVIDING COMPUTER DATABASES IN THE FIELD OF COMPUTERS; INFORMATION, ADVISORY AND CONSULTANCY SERVICES RELATING TO ALL THE AFORESAID (U.S. CLS. 100 AND 101).

KATHERINE E. HALMEN, EXAMINING ATTORNEY

SN 79-037,065, IBC SOLAR AG, 96231 BAD STAFFELSTEIN, FED REP GERMANY, FILED 1-31-2007.

MEGAFIX

PRIORITY DATE OF 8-1-2006 IS CLAIMED.
OWNER OF INTERNATIONAL REGISTRATION 0920418
DATED 1-31-2007, EXPIRES 1-31-2017.

CLASS 6—METAL GOODS

FOR METAL BUILDING MATERIALS, NAMELY, METAL SHEETS, METAL MOUNTINGS, METAL MOUNTING SHEETS, CROSSBEAMS, RETAINING TUBES, FRONT PLATES, PROFILES, CARRIER RAILS; IRONMONGERY IN THE NATURE OF SMALL ITEMS OF METAL HARDWARE, NAMELY, RIVETS, METAL BOLTS, RETAINING ANGLES, MOUNTING CORNERS, ROOF HOOKS; PIPES AND TUBES OF METAL; GOODS OF COMMON METAL NOT INCLUDED IN OTHER CLASSES, NAMELY, ANCHORS, GUTTERS, INTERCONNECTION PIECES FOR ROOFS; BUILDINGS OF METAL, NAMELY, STRUCTURES FOR PHOTOVOLTAIC SOLAR OR SOLAR HEATING MODULES; COTTER PINS; CLIPS OF METAL, NAMELY, METAL CLAMPS; FRAMEWORK OF METAL FOR BUILDING; CLADDING OF METAL FOR BUILDING (U.S. CLS. 2, 12, 13, 14, 23, 25 AND 50).

CLASS 9—ELECTRICAL AND SCIENTIFIC APPARATUS

FOR APPARATUS AND INSTRUMENTS FOR CONDUCTING, SWITCHING, TRANSFORMING, ACCUMULATING, REGULATING OR CONTROLLING ELECTRICITY, NAMELY, INVERTERS, MONITORING AND MEASURING EQUIPMENT FOR SOLAR POWER AND HEATING SYSTEMS IN THE NATURE OF POWER INVERTERS AND ELECTRIC LUMINESCENT DISPLAY PANELS FEATURING YIELD, POWER, AND AVOIDED EMISSIONS INFORMATION, CHARGE REGULATORS, ELECTRONIC CONTROLS FOR ELECTRICITY SYSTEMS, SOLAR CHARGE REGULATORS, CONVERTERS, TRANSFORMERS, ELECTRIC ACTUATORS; ELECTRIC WIRES; ELECTRIC CABLES; SOLAR MODULES, NAMELY, PHOTOVOLTAIC SOLAR MODULES FOR CONVERTING ELECTRONIC RADIATION TO ELECTRICAL ENERGY (U.S. CLS. 21, 23, 26, 36 AND 38).

CLASS 19—NON-METALLIC BUILDING MATERIALS

FOR NON-METAL BUILDING MATERIALS, NAMELY, NON-METAL SHEETS, NON-METAL MOUNTINGS, NONMETAL MOUNTING SHEETS, NON-METAL FRONT PLATES, NON-METAL PROFILES AND CARRIER RAILS, NON-METAL GUTTERS; NON-METAL RIGID PIPES FOR BUILDINGS, BUILDINGS NOT OF METAL, NAMELY, STRUCTURES FOR PHOTOVOLTAIC SOLAR OR SOLAR HEATING MODULES; FRAMEWORK NOT OF METAL, FOR BUILDING; BRACKETS, SUPPORTS AND PROPS NOT OF METAL FOR BUILDING, NAMELY, NON-METAL RIVETS, NON-METAL CLAMPS, NON-METAL BOLTS, NON-METAL INTERCONNECTION PIECES FOR ROOFS, NON-METAL ANCHORS, ASPHALT IMPREGNATED FOAM SEALANT STRIPS USED FOR EXPANSION JOINTS; SURFACING NOT OF METAL FOR BUILDING, NAMELY, NON-METAL ROOFING, SOLAR MODULES FOR USE AS BUILDING MATERIALS OF POLY AND MONOCRYSTALLINE AND SILICON USED AS NON-METAL ROOF COVERINGS INCORPORATING SOLAR CELLS (U.S. CLS. 1, 12, 33 AND 50).

DAYNA BROWNE, EXAMINING ATTORNEY

SN 79-037,608, WALTER FEUCHT, 89081 ULM, FED REP GERMANY, FILED 10-20-2006.

POMP DUCK
AND CIRCUMSTANCE

Hell's Kitchen

OWNER OF INTERNATIONAL REGISTRATION 0921771
DATED 10-20-2006, EXPIRES 10-20-2016.

NO CLAIM IS MADE TO THE EXCLUSIVE RIGHT TO USE "HELL'S KITCHEN", APART FROM THE MARK AS SHOWN.

CLASS 41—EDUCATION AND ENTERTAINMENT

FOR EDUCATION SERVICES, NAMELY, PROVIDING CLASSES, SEMINARS, WORKSHOPS IN THE FIELD OF PROVIDING FOOD AND DRINK AND TEMPORARY ACCOMMODATION; PROVIDING OF TRAINING IN THE FIELD OF PROVIDING FOOD AND DRINK AND TEMPORARY ACCOMMODATION; ENTERTAINMENT IN THE NATURE OF LIVE MUSIC SHOWS; ENTERTAINMENT IN THE NATURE OF LIVE MUSICAL GROUP PERFORMANCES, ETHNIC FESTIVALS; ENTERTAINMENT IN THE NATURE OF LIVE MUSICAL PERFORMANCES; ENTERTAINMENT IN THE NATURE OF THEATRE PRODUCTIONS; ORGANIZING COMMUNITY SPORTING AND CULTURAL EVENTS (U.S. CLS. 100, 101 AND 107).

CLASS 43—HOTEL AND RESTAURANT SERVICES

FOR SERVICES FOR PROVIDING FOOD AND DRINK; PROVIDING TEMPORARY ACCOMMODATION (U.S. CLS. 100 AND 101).
 PETER B. BROMAGHIM, EXAMINING ATTORNEY

CLASS 5—PHARMACEUTICALS

FOR ANTI-BACTERIAL AND MEDICATED FACE, HAND AND SKIN WASHES; MEDICATED SKIN CARE PREPARATIONS FOR THE FACE, HANDS AND SKIN; ABRASIVE FLUIDS FOR DENTAL USE; ABRASIVE MATERIALS FOR DENTAL USE OTHER THAN FLOSS; ABRASIVE MEDIA FOR DENTAL PURPOSES OTHER THAN FLOSS; ABRASIVE PADS FOR DENTAL USE; ABRASIVE PASTE FOR DENTAL USE; ABRASIVE POWDER FOR DENTAL USE; ABRASIVE SUBSTANCES FOR DENTAL USE OTHER THAN FLOSS; DENTAL ABRASIVES; ADHESION PROMOTERS FOR DENTAL USE; ADHESIVE CEMENTS FOR DENTAL USE; ADHESIVE COMPOSITIONS AND PREPARATIONS FOR DENTAL USE; ADHESIVES FOR AFFIXING DENTAL PROSTHESIS; ADHESIVES FOR DENTAL USE; ANTI-MICROBIAL, ANTISEPTIC AND MEDICAL MOUTHWASH PREPARATIONS AND GARGLES FOR ORAL HYGIENE PURPOSES; COLOURING REAGENTS FOR REVEALING DENTAL PLAQUE; COTTON FOR DENTAL PURPOSES; DENTAL BONDING MATERIAL; MEDICATED DENTAL HEALTH GUM; MEDICATED DENTAL RINSES; TABLETS FOR DENTAL USE IN INDICATING TARTAR ON THE TEETH (U.S. CLS. 6, 18, 44, 46, 51 AND 52).
 REBECCA POVARCHUK, EXAMINING ATTORNEY

SN 79-037,911. THE LITTLE WING; TRADING COMPANY LIMITED, UNITED KINGDOM, FILED 3-14-2007.

SN 79-037,968. MENCK GMBH, FED REP GERMANY, FILED 8-21-2006.

BULLDOG

THE MARK CONSISTS OF STANDARD CHARACTERS WITHOUT CLAIM TO ANY PARTICULAR FONT, STYLE, SIZE, OR COLOR.
 OWNER OF INTERNATIONAL REGISTRATION 0922601 DATED 3-14-2007, EXPIRES 3-14-2017.

CLASS 3—COSMETICS AND CLEANING PREPARATIONS

FOR NON-MEDICATED TOILETRIES; BODY DEODORANT, ANTI-PERSPIRANTS, SHOWER GEL; BODY WASH, FACIAL CLEANSER, FACIAL SCRUB; FACIAL WASH, HAND WASH, SOAPS; NON-MEDICATED SKINCARE PREPARATIONS; BODY MIST SPRAY; SPOT STICKS, NAMELY, NON-MEDICATED ACNE TREATMENT PREPARATIONS; SKIN MOISTURISERS; BODY LOTION, BODY MOISTURISER, FACIAL MOISTURISER; SHAVING GEL, SHAVING OIL, SHAVING CREAM, SHAVING FOAM, SHAVING SPRITZ, SHAVING SOAP, AFTER-SHAVE; AFTER-SHAVE GEL, AFTER-SHAVE BALM; HAIR REMOVAL PREPARATIONS AND CREAMS, DEPILATORY PREPARATIONS, DEPILATORY WAX; SHAMPOO, CONDITIONER, PERFUMERY; EAU DE TOILETTE; ESSENTIAL OILS; DENTIFRICES; LIP BALM; MOUSTACHE WAX; SUNSCREEN PREPARATIONS (U.S. CLS. 1, 4, 6, 50, 51 AND 52).



YOUR SUCCESS - BASED ON MENCK

OWNER OF INTERNATIONAL REGISTRATION 0817804 DATED 9-12-2003, EXPIRES 9-12-2013.
 OWNER OF U.S. REG. NO. 2,677,205.

CLASS 7—MACHINERY

FOR WINCHES AND REPLACEMENT PARTS THEREFOR; DRIVES FOR MACHINES AND MOTORS, NAMELY, DIESEL ENGINES, ELECTRIC MOTORS, AND VARIABLE FREQUENCY DRIVES FOR LARGE POWER MACHINES AND MACHINE MOTOR APPLICATIONS IN THE OIL AND GAS, METAL, MARINE, WIND TURBINE AND OTHER INDUSTRIES, AND REPLACEMENT PARTS THEREFOR; MECHANICAL PILE-DRIVING EQUIPMENT, NAMELY, OFFSHORE AND ONSHORE HYDRAULIC HAMMERS, HYDRAULIC UNDERWATER HAMMERS, STEAM POWERED HAMMERS, AIR POWERED HAMMERS, DOUBLE-ACTING PNEUMATIC HAMMERS, PILE DRIVERS, PNEUMATIC PILE HAMMERS, AND WINCHES; CRANES, MECHANICAL ROCK-BREAKING MACHINES, NAMELY, ROCK-CRUSHERS, AND REPLACEMENT PARTS THEREFOR; HYDRAULIC EXCAVATORS AND REPLACEMENT PARTS THEREFOR; EARTH MOVING MACHINES, NAMELY, EXCAVATORS AND REPLACEMENT PARTS THEREFOR; MACHINERY FOR SOIL AND HYDRAULIC ENGINEERING, NAMELY, SCRAPERS, CABLE CRANE SCRAPERS, TRACKED SCRAPERS, CRAWLER-TRACKED LOADERS; STEAM ENGINES AND REPLACEMENT PARTS THEREFOR; HYDRAULIC PUMPS, COMPRESSED AIR PUMPS, BILGE PUMPS, CENTRIFUGAL PUMPS, ELECTRIC PUMPS, MACERATOR PUMPS, PNEUMATIC PUMPS, POSITIVE DISPLACEMENT PUMPS, SILT PUMPS, SLUDGE PUMPS, SUBMERSIBLE PUMPS, SUCTION PUMPS, SUMP PUMPS, VERTICAL TURBINE PUMPS, AND REPLACEMENT PARTS FOR THE AFORESAID GOODS; COMPRESSORS FOR MACHINES AND REPLACEMENT PARTS THEREFOR; NON-METAL STEAM DUCTS AND STEAM PIPES SOLD AS INTEGRAL COMPONENTS OF FINISHED STEAM POWERED PILE DRIVERS; STEAM POWERED PILE DRIVERS AND REPLACEMENT PARTS THEREFOR; MACHINE-DRIVEN POWER SUPPLIES FOR HYDRAULIC OR PNEUMATIC MACHINES, NAMELY, DIESEL ENGINES, ELECTRIC MOTORS, AND VARIABLE FREQUENCY DRIVES FOR LARGE POWER MACHINES AND MACHINE MOTOR APPLICATIONS IN THE OIL AND GAS, METAL, MARINE, WIND TURBINE AND OTHER INDUSTRIES (U.S. CLS. 13, 19, 21, 23, 31, 34 AND 35).

CLASS 9—ELECTRICAL AND SCIENTIFIC APPARATUS

FOR ELECTRO-MECHANICAL CONTROLS FOR MOTORS; ELECTRICAL CONTROL DEVICES FOR HEATING AND ENERGY MANAGEMENT; MECHANICAL, ELECTRICAL, HYDRAULIC AND PNEUMATIC CONTROL APPARATUS, NAMELY, MONITORS AND DOCUMENTATION SYSTEMS COMPRISED OF ELECTRIC OR ELECTRONIC SENSORS FOR DIFFERENTIAL PRESSURE, OIL PRESSURE, TEMPERATURE, VOLTAGE, AMPERAGE, OIL LEVEL AND OUTPUT DEVICES IN THE NATURE OF ELECTRIC LUMINESCENT DISPLAY PANELS AND PRINTERS; ELECTROMECHANICAL CONTROLS FOR USE IN CONTROLLING AND MONITORING HYDRAULIC EXCAVATORS, PNEUMATIC CONVEYORS, HYDRAULIC HAMMERS, DEEP WATER HYDRAULIC AND PNEUMATIC PILE DRIVING EQUIPMENT, AND REPLACEMENT PARTS THEREFOR (U.S. CLS. 21, 23, 26, 36 AND 38).

CLASS 35—ADVERTISING AND BUSINESS

FOR PRODUCT MERCHANDISING; BUSINESS MANAGEMENT CONSULTATION TO INDUSTRIAL COMPANIES IN THE FIELDS OF STRUCTURAL FOUNDATION WORK AND SOIL AND HYDRAULIC ENGINEERING (U.S. CLS. 100, 101 AND 102).

CLASS 37—CONSTRUCTION AND REPAIR

FOR INSTALLATION, MAINTENANCE AND REPAIR OF MECHANICAL PILE-DRIVING EQUIPMENT, IMPACT TRANSFER DEVICES FOR MECHANICAL PILE-DRIVING EQUIPMENT, NON-FLOATING CRANES, MECHANICAL ROCK-BREAKING DEVICES, EXCAVATORS, MACHINERY FOR SOIL AND HYDRAULIC ENGINEERING, STEAM ENGINES, HYDRAULIC PUMPS, COMPRESSED AIR PUMPS, BILGE PUMPS, CENTRIFUGAL PUMPS, ELECTRIC PUMPS, MACERATOR PUMPS, PNEUMATIC PUMPS, POSITIVE DISPLACEMENT PUMPS, SILT PUMPS, SLUDGE PUMPS, SUBMERSIBLE PUMPS, SUCTION PUMPS, SUMP PUMPS, VERTICAL TURBINE PUMPS, COMPRESSORS AS MACHINES, VALVES AS MECHANICAL, ELECTRICAL, HYDRAULIC OR PNEUMATIC CONTROL APPARATUS, AND ELECTRO MECHANICAL APPARATUS; RENTAL OF CONSTRUCTION EQUIPMENT FOR STRUCTURAL FOUNDATION WORK AND SOIL AND HYDRAULIC-ENGINEERING (U.S. CLS. 100, 103 AND 106).

CLASS 42—SCIENTIFIC AND COMPUTER SERVICES

FOR TECHNICAL CONSULTATION IN THE FIELDS OF STRUCTURAL FOUNDATION ENGINEERING AND SOIL AND HYDRAULIC ENGINEERING (U.S. CLS. 100 AND 101).

NELSON SNYDER, EXAMINING ATTORNEY

SN 79-038,700, HAWLE ARMATUREN GMBH, 83395 FREILASSING, FED REP GERMANY, FILED 12-11-2006.

TELE-HYDRANT

THE MARK CONSISTS OF STANDARD CHARACTERS WITHOUT CLAIM TO ANY PARTICULAR FONT, STYLE, SIZE, OR COLOR.

PRIORITY DATE OF 8-16-2006 IS CLAIMED.
OWNER OF INTERNATIONAL REGISTRATION 0924773
DATED 12-11-2006, EXPIRES 12-11-2016.

CLASS 6—METAL GOODS

FOR GAS AND LIQUID PIPING AND PIPELINE COMPONENTS MADE PREDOMINANTLY OF METAL, NAMELY, SLEEVES, SHUTTERS, SLEEVE SHUTTERS, STRAPS, SHACKLES, CAPS, FLANGES, PIPES, PIPE FITTINGS, PIPE CLIPS, PIPE COLLARS, PIPE CONNECTORS, PIPE COUPLINGS AND JOINTS, JUNCTIONS FOR PIPES, PIPE MUFFS, MANUALLY OPERATED VALVES, SEALING RINGS, GASKET RINGS, BALL LOCK PINS, CAPS FOR PIPES AND PIPE ENDS, CLOSURES FOR PIPES AND PIPE ENDS, LIDS, PLUGS, SEALS, MANHOLE COVERS, PIPE SAFETY FITTINGS THAT MINIMIZE TRACTION, DIRT, AND ROTATION, HAND WHEELS, NON-ELECTRIC POSITION INDICATORS BEING PARTS OF PIPE VALVES, DUMMY COVERS, INSERTION PIPES, NIPPLES, GASKET RINGS; METAL SHAFT COVERS, METAL HEIGHT-ADJUSTABLE AND METAL LEVELLABLE SHAFT COVERS AND THEIR METAL BASE COMPONENTS AND FRAMES, METAL BRACKETS, AND METAL SADDLES FOR USE IN THE CONSTRUCTION, ASSEMBLY AND INSTALLATION OF PIPING (U.S. CLS. 2, 12, 13, 14, 23, 25 AND 50).

CLASS 8—HAND TOOLS

FOR HAND-OPERATED TOOLS FOR ASSEMBLING AND DISASSEMBLING, MAINTAINING AND REPAIRING PIPES AND PIPE BRACKETS, NAMELY, HAND HELD CUTTING TOOLS, PINCHERS, WRENCHES, PLIERS, PIPE BEVELING DEVICES IN THE NATURE OF PIPE CUTTERS, TAPS, HEX KEY WRENCHES, EXTENSIONS FOR HAND TOOLS (U.S. CLS. 23, 28 AND 44).

CLASS 11—ENVIRONMENTAL CONTROL APPARATUS

FOR HYDRANTS, PLUMBING FITTINGS, NAMELY, VENTILATING AND EVACUATING VALVES AND CONTROL VALVES (U.S. CLS. 13, 21, 23, 31 AND 34).

CLASS 17—RUBBER GOODS

FOR PARTS, PREDOMINANTLY MADE OF METAL, FOR GAS AND LIQUID BRACES, NAMELY, GASKETS (U.S. CLS. 1, 5, 12, 13, 35 AND 50).

CLASS 37—CONSTRUCTION AND REPAIR

FOR ASSEMBLING AND DISASSEMBLING PLUMBING FITTINGS AND METAL PIPE FITTINGS FOR GAS AND WATER PIPING AND PIPELINES, AND GAS AND LIQUID CONDUCTION SYSTEMS (U.S. CLS. 100, 103 AND 106).

CLASS 42—SCIENTIFIC AND COMPUTER SERVICES

FOR TECHNICAL PLANNING OF GAS AND LIQUID PIPING AND PIPELINES; TECHNICAL PLANNING SERVICES IN THE NATURE OF INDUSTRIAL DESIGN OF PLUMBING FITTINGS AND METAL PIPE FITTINGS; TECHNICAL PLANNING OF GAS AND LIQUID CONDUCTION SYSTEMS (U.S. CLS. 100 AND 101).

DEBRA LEE, EXAMINING ATTORNEY

SN 79-038,954, WACHIFIELD LICENSING, INC., JAPAN, FILED 2-9-2007.



OWNER OF INTERNATIONAL REGISTRATION 0925356 DATED 2-9-2007, EXPIRES 2-9-2017.

CLASS 16—PAPER GOODS AND PRINTED MATTER

FOR FOOD WRAPPING PLASTIC FILM FOR HOUSEHOLD USE; GARBAGE BAGS OF PAPER FOR HOUSE BOLD USE; GARBAGE BAGS OF PLASTICS FOR HOUSE BOLD USE; EMBROIDERY DESIGN PATTERNS PRINTED ON PAPER; TAILORS' CHALK; BANNERS OF PAPER; FLAGS OF PAPER; HYGIENIC PAPER; TOWELS OF PAPER; TABLE NAPKINS OF PAPER; HAND TOWELS OF PAPER; HANDKERCHIEFS OF PAPER; BAGGAGE TAGS; TABLE CLOTHS OF PAPER; PAPER AND CARDBOARD, NAMELY, PRINTING PAPER, INDIA PAPER, CARBON PAPER, GLASSINE PAPER, NEWS-PRINT PAPER, BLOTTER, TYPEWRITING PAPER, TOILET PAPER, WRITING PAPER, WRAPPING PAPER, RICE PAPER, PARCHMENT PAPER, FILTER PAPER, IVORY MANILA BOARD, COLORBOARD COLORED PAPERBOARD, STRAWBOARD, WHITE PAPERBOARD, FLUTING PAPER, CORRUGATING MEDIUM, LINERBOARD FOR CORRUGATED CARDBOARD, CHIPBOARD, MILLBOARD, POSTCARD PAPER, JAPANESE PAPER, MULCH PAPER, OILED PAPER FOR PAPER UMBRELLAS (KASA-GAMI), GUNPOWDER WRAPPING PAPER, TISSUE PAPER FOR USE AS MATERIAL OF STENCIL PAPER (GANPISHI), JAPANESE HANDICRAFT PAPER, PAPER MADE FROM PAPER MULBERRY (KOHZO-GAMI), PAPER FOR USE AS MATERIAL OF STOCK CERTIFICATES (SHOKENSHI), PAPER FOR

JAPANESE SLIDING SCREENS (SHOJI-GAMI), CALLIGRAPHY PAPER, CARDBOARD MADE FROM PAPER MULBERRY (SENKASI), COARSE TISSUE (FOR TOILETRY USE), PAPER MADE FROM PAPER MULBERRY (TENGUJOSI), STENCIL PAPER MIMEOGRAPH PAPER, JAPANESE PAPER (TORINOKO-GAMI), NAPKIN PAPER, DUPLICATING PAPER, THICK JAPANESE PAPER (HOSHO-GAMI), CONVERTED PAPER PROCESSED PAPER, PAPER LACE, IMITATION LEATHER PAPER, PERFORATED CARDS FOR JACQUARD LOOMS, ACID-RESISTANT PAPER, CORRUGATED CARDBOARD, PARAFFIN COATED PAPER WAXED PAPER, PAPER FOR JAPANESE INDOOR SLIDING PARTITIONS (FUSUMA-GAMI), FIRE PROOF PAPER, MILDEW PROOF PAPER, WATER PROOF PAPER, OIL PROOF PAPER, LUMINOUS PAPER, CELLOPHANE PAPER, ORDINARY CELLOPHANE PAPER, MOISTUREPROOF CELLOPHANE PAPER AND SYNTHETIC PAPER; MISCELLANEOUS PRINTED MATTER, NAMELY, PICTURE POSTCARDS, SHEET MUSIC, SONG BOOKS, CATALOGUES IN THE FIELD OF TOYS, CATALOGUES IN THE FIELD OF BAGS, CALENDARS, POSTERS, PRINTED TIMETABLES, PICTURE BOOKS, STORY BOOKS, NEWSPAPERS, GEOGRAPHICAL MAPS, DIARIES, NEWSLETTERS IN THE FIELD OF TOYS, NEWSLETTERS IN THE FIELD OF BAGS; MAGAZINES IN THE FIELD OF TOYS, MAGAZINES IN THE FIELD OF BAGS AND PAMPHLETS IN THE FIELD OF TOYS, PAMPHLETS IN THE FIELD OF BAGS; STATIONERY AND STUDY MATERIALS, NAMELY, PAPER STATIONERY, EVENT ALBUMS, NOTE CARDS, CARDS FOR PLAYING CARDS; CARDS FOR JAPANESE PLAYING CARDS (HANAFUDA AND UTAGARUTA); SCRAPBOOKS, SKETCH BOOKS, SCORE CARDS, SCORE BOOKS, ACCOUNT BOOKS, POCKET MEMORANDUM BOOKS, ACCOUNT SLIP PADS, NOTE BOOKS, WRITING PADS, ENVELOPES, PLOTTING PAPER, GRAPH PAPER AS FINISHED PRODUCT, SEMI-FINISHED BUSINESS CARD PAPER, FINISHED LETTER PAPER PRODUCTS, NAMELY, LETTER PAPER, LOOSE-LEAF PADS, WRITING IMPLEMENTS WRITING INSTRUMENTS, PENCILS, PENCIL POINT PROTECTORS, FELT WRITING PENS, MECHANICAL PENCILS, SLATE PENCILS, STEEL PENS, STYLUSES, STENCIL PENS, CHALK, FELT MARKING PENS, PEN NIBS, PEN-HOLDERS, BALL-POINT PENS, FOUNTAIN PENS, WRITING BRUSHES, PAINTERS' EASELS, DRAWING BOARDS, PAINTERS' ARTICLES, NAMELY, PAINT BOXES, CANVAS FOR PAINTING, CRAYONS, PAINT-BRUSHES, PASTELS, PALETTES FOR PAINTERS, CHARCOAL PENCILS, WRITING INK, INK ERASERS, INKWELLS, RUBBER STAMPS, SEALING STAMPS, STAMP CASES, STAMP STANDS, SEAL INK PADS, PENCIL SHARPENERS, THUMB TACKS, PAPER CLIPS, RUBBER ERASERS, BLACKBOARDS, BLACKBOARD ERASERS, CHALK ERASERS, PAPER TAGS, SEALS FOR STATIONERY, BOOKMARKERS, UNDERLAYS FOR WRITING PAPER, CORRECTING FLUID FOR TYPE, UNGRADUATED RULERS, LETTER RACKS, PAPER FOLDERS, INK STONES, INK RESERVOIRS, INKING PADS, STICKERS FOR STATIONERY, INK STICKS (SUMI), WRITING SLATES, ADHESIVE TAPES FOR STATIONERY OR HOUSEHOLD PURPOSES, ADHESIVE TAPE DISPENSERS, STRIPS OF FANCY PAPER (TANZAKU), TERRESTRIAL GLOBES, PRICE TAGS, NUMBERING STAMPS, DATE STAMPS, STANDS FOR PEN AND PENCIL, PEN AND PENCIL CASES AND BOXES, PAPERWEIGHTS, PAPER KNIVES, LETTER OPENERS, INDIAN INK, STAPLING PRESSES NON-ELECTRIC STAPLERS, JAPANESE CEREMONIAL PAPER STRINGS (MIZUHIKI), FINGER-STALLS AND NON-TEXTILE PAPER LABELS; PHOTOGRAPHS; PHOTOGRAPH STANDS; BABIES' DIAPERS OF PAPER; INDUSTRIAL PACKAGING CONTAINERS OF PAPER, NAMELY, PAPERBOARD BOXES FOR INDUSTRIAL PACKAGING, PAPER BAGS AND SACKS, CORRUGATED CARDBOARD BOXES AND FIBERBOARD BOXES; COLORING BOOKS (U.S. CLS. 2, 5, 22, 23, 29, 37, 38 AND 50).

CLASS 18—LEATHER GOODS

FOR CLOTHING FOR DOMESTIC PETS, NAMELY, DOG SHOES, DOG COLLARS, CLOTHING FOR DOGS, DOG BELLY BANDS, CAT SHOES, CAT COLLARS, CLOTHING FOR CATS AND CAT BELLY BANDS; BAGS AND THE LIKE, NAMELY, FOLDING BRIEFCASES, SHOULDER BAGS, GLADSTONE BAGS, JAPANESE WICKER TRUNKS (KORI), BRIEFCASES, SUITCASES, CARRY-ON BAGS, TRUNKS, HANDBAGS, BOSTON BAGS, SCHOOLCHILDREN'S BACKPACKS AND BACKPACKS, RUCKSACKS; POUCHES AND THE LIKE, NAMELY, CHARM BAGS (OMAMORI-IRE), NOTE CARD CASES, SHOPPING BAGS WITH WHEELS ATTACHED, PURSES, KEY CASES, WALLETS, JAPANESE UTILITY POUCHES (SHINGEN-BUKURO), WALLETS FOR COMMUTATION TICKETS AND BUSINESS CARDS; VANITY CASES SOLD EMPTY; UMBRELLAS AND THEIR PARTS, NAMELY, TELESCOPIC UMBRELLAS, JAPANESE PAPER UMBRELLAS (KARAKASA), JAPANESE OILED PAPER UMBRELLAS (JANOME-GASA), RAINPROOF PARASOLS, BEACH UMBRELLAS, BEACH PARASOLS, PARASOLS, SUN UMBRELLAS, UMBRELLAS, UMBRELLA COVERS, UMBRELLA HANDLES, METAL PARTS OF UMBRELLAS, FRAMES FOR UMBRELLAS AND BAGS FOR UMBRELLAS; WALKING STICKS; CANES; METAL PARTS OF CANES AND WALKING-STICKS; HANDLES OF CANES AND WALKING-STICKS (U.S. CLS. 1, 2, 3, 22 AND 41).

CLASS 21—HOUSEWARES AND GLASS

FOR COOKING POTS AND PANS, NAMELY, NON-ELECTRIC RICE COOKING POTS, GRIDDLES, COOKING PANS, MESS-TINS, RICE COOKING CANTEENS, FRYING PANS AND COOKING STEAMERS; NON-ELECTRIC COFFEE-POTS; JAPANESE CAST IRON KETTLES (TETSUBIN); NON-ELECTRIC KETTLES; TABLEWARE, NAMELY, SOUP BOWLS, CUPS AND MUGS, JAPANESE STYLE TEA-SERVING POTS (KYUSU), DRINKING CUPS, SAKE CUPS, DISHES AND PLATES, SALAD BOWLS, JAPANESE NESTS OF FOOD BOXES (JUBAKO), JAPANESE RICE BOWLS NOT OF PRECIOUS METAL (CHAWAN), DISH COVERS, DECANTERS, SAKE SERVING BOTTLES (TOKKURI), SERVING BOWLS (HACHI), BEER MUGS, LUNCH-BOXES, JUGS (NOT OF PRECIOUS METAL), TEACUPS (YUNOMI), JAPANESE STYLE SOUP SERVING BOWLS (WAN), CONTAINERS FOR HOUSEHOLD USE, NAMELY, CANS FOR CONFECTIONERY, KITCHEN KEGS AND BARRELS, TEA CANISTERS, KITCHEN URNS AND BREAD CASES FOR KITCHEN USE; PORTABLE, NON-ELECTRIC COLDBOXES; RICE CHESTS; FOOD PRESERVING JARS OF GLASS; TRAVEL DRINKING FLASKS; VACUUM BOTTLES, INSULATED FLASKS; CONTAINERS OF GLASS, PLASTIC, CERAMIC FOR FOOD PRESERVING; PORTABLE COOKING KITS FOR OUTDOOR USE; ICE PAILS; NON-ELECTRIC WHISKS; COOKING STRAINERS; PEPPER POTS; SUGAR BOWLS; SALT SHAKERS; EGG CUPS; NAPKIN HOLDERS; NAPKIN RINGS; SERVING TRAYS; TOOTHPICK HOLDERS; COLANDERS; SALT SHAKERS; JAPANESE STYLE COOKED RICE SCOOPS (SHAMOJI); HAND-OPERATED COFFEE GRINDERS AND PEPPER MILLS; COOKING FUNNELS; JAPANESE STYLE WOODEN PESTLES (SURIKOGI); JAPANESE STYLE EARTHENWARE MORTARS (SURIBACHI); JAPANESE STYLE PERSONAL DINING TRAYS OR STANDS (ZEN); BOTTLE OPENERS; COOKING GRATERS; PAN-MATS; CHOPSTICKS; CHOPSTICK CASES; LADLES; COOKING SIEVES AND SIFTERS; CHOPPING BOARDS FOR KITCHEN USE; ROLLING PINS OR COOKING PURPOSES; GRILLS; COOKING UTENSILS; TOOTHPICKS; LEMON SQUEEZERS; CITRUS JUICERS; NON-ELECTRIC WAFFLE IRONS; SPICE RACKS; CLEANING TOOLS AND WASHING UTENSILS, NAMELY, WASHING BOARDS, CLOTHES PEGS, CLOTHES PINS, WASHING BRUSHES, WASH BASINS, DUSTING OR CLEANING CLOTHS, WASH-TUBS, SCRUBBING BRUSHES, WASTE BASKETS, DUST-PANS, BUCKETS, DUSTERS, DRYING BOARDS FOR WASHED, STARCHED AND THEN STRETCHED PIECES OF KIMONO (HARI-ITA), BROOMS, MOPS, CLOTHES HANGING RODS USED AS WASHING LINES AND CLOTHES DRYING HANGERS, GLOVES FOR HOUSEHOLD PURPOSES, STIRRERS FOR HOT BATH-TUB WATER (YUKAKIBO); BATHROOM PAILS; BATH TUBS FOR BABIES; CANDLE EXTINGUISHERS; CANDLESTICKS; CINDER SIFTERS FOR HOUSEHOLD PUR-

POSES; COAL SCUTTLES; MOUSE TRAPS; FLOWER POTS; WATERING CANS; FEEDING VESSELS FOR PETS; BRUSHES FOR PETS; BIRD CAGES; BIRD BATHS; GLASS BOWLS FOR LIVE GOLDFISH; CLOTHES BRUSHES; TOILET PAPER HOLDERS; NON-METAL PIGGY BANKS; BOXES OF METAL FOR DISPENSING PAPER TOWELS; BOOT JACKS; SOAP DISPENSERS; FLOWER VASES; FLOWER BOWLS; WIND CHIMES; SHOE BRUSHES; SHOE HORNS; SHOE SHINE CLOTHS; HANDY SHOE SHINERS; SHOE-TREES; SHOE STRETCHERS; COSMETIC AND TOILET UTENSILS, NAMELY, PERSONAL WASHING CLOTHS, FACE-POWDER CASES SOLD EMPTY, COMBS, COMB CASES, COSMETIC CREAM CASES SOLD EMPTY, TOILET SPONGES, TOILET BRUSHES, FITTED VANITY CASES, PERFUME SPRAYERS SOLD EMPTY, POWDER COMPACTS, SOAP HOLDERS AND BOXES, NAIL BRUSHES, POWDER PUFFS, NON-ELECTRIC TOOTHBRUSHES, NON-ELECTRIC, TOOTHBRUSH CASES, SHAVING BRUSHES, SHAVING BRUSH STANDS, HAIR BRUSHES, LIP BRUSHES AND EYEBROW BRUSHES; IRONING BOARDS; AND IRONING BOARDS (KOTEDAI) (U.S. CLS. 2, 13, 23, 29, 30, 33, 40 AND 50).

CLASS 25—CLOTHING

FOR NON-JAPANESE STYLE OUTERWEAR, OUTER-CLOTHING, NAMELY, EVENING DRESSES, SCHOOL UNIFORMS, JACKETS, JOGGING PANTS, SWEATPANTS, SUITS, SKIRTS, SKI JACKETS, SKI PANTS, TROUSERS, SMOCKS; COATS, NAMELY, OVERCOATS, TOPCOATS, MANTLES AND RAINCOATS; SWEATERS AND THE LIKE, NAMELY, CARDIGANS, SWEATERS, VESTS AND WAISTCOATS; SHIRTS AND THE LIKE, NAMELY, OPEN-NECKED SHIRTS, CUFFS, COLLARS FOR CLOTHING, SPORT SHIRTS, BLOUSES, POLO SHIRTS AND SHIRTS FOR SUITS; NIGHTWEAR, NAMELY, NIGHT GOWNS, NEGLIGENCE, JAPANESE SLEEPING ROBES (NEMAKI), PAJAMAS AND BATH ROBES; UNDERWEAR; UNDERCLOTHING, NAMELY, CAMISOLES, CORSETS, CLOTHING COMBINATIONS, UNDERSHIRTS, CHEMISES, DRAWERS AND UNDERPANTS, SLIPS, PANTIES, SHORTS AND BRIEFS, BRASSIERES AND PETTICOATS; SWIMWEAR; BATHING SUITS; SWIMMING CAPS; BATHING CAPS; JAPANESE TRADITIONAL CLOTHING, NAMELY, INFORMAL KIMONOS IN SUMMER (YUKATA), INFORMAL KIMONOS FOR SUMMER (JINBEI), JAPANESE TRADITIONAL KIMONO FOR FESTIVAL (HAPPI), SASH BANDS FOR KIMONO (OBI), BUSTLE HOLDER BANDS FOR OBI (OBIAGE), BUSTLES FOR OBI-KNOTS (OBIAGE-SHIN), WAIST STRINGS FOR KIMONOS (KOSBIHIMO), UNDERSHIRTS FOR KIMONOS (KOSHIMAKI), UNDERSHIRTS FOR KIMONOS (JUBAN), TIGHTENING-UP STRINGS FOR KIMONOS (DATEJIME), WRAP BELTS FOR KIMONOS (DATEMAKI), FULL-LENGTH KIMONOS (NAGAGI), SHORT OVERCOAT FOR KIMONO (HAORI), STRING FASTENERS FOR HAORI (HAORIHIMO), PLEATED SKIRTS FOR FORMAL KIMONOS (HAKAMA) AND DETACHABLE NECKPIECES FOR KIMONOS (HANERI); APRONS COLLAR PROTECTORS FOR WEAR; SOCKS AND STOCKINGS; PUTTEES AND GAITERS; FUR STOLEES; SHAWLS; SCARVES; SCARFS; JAPANESE STYLE SOCKS (TABI); JAPANESE STYLE SOCKS (TABI COVERS); GLOVES AND MITTENS; BABIES' DIAPERS OF TEXTILE; NECKTIES; NECKERCHIEVES; BANDANAS; NECKERCHIEFS; MUFFLERS; EAR MUFFS; HOODS; NIGHTCAPS; HATS; CAPS, SUNVISORS CLOTHING, NAMELY, SUN VISORS; GARTERS; SOCK SUSPENDERS; SUSPENDERS; BRACES; WAISTBANDS; BELTS FOR CLOTHING; RAIN BOOTS; LACE BOOTS; TRAINING SHOES; OVERSHOES; WOODEN SHOES; WORK SHOES AND BOOTS; SANDAL; SHOES; SHOES; JAPANESE SPLIT-TOED WORK FOOTWEAR (JIKATABI); ANGLERS' SHOES; BOOTS; HALF-BOOTS; WOMEN'S SHOES; WINTER BOOTS; HOSIERY SHOES; CANVAS SHOES; INFANTS' SHOES AND BOOTS; INNER SOLES FOR SHOES AND BOOTS; HEELPIECES FOR SHOES AND BOOTS; INSOLES FOR SHOES AND BOOTS; WELTS FOR SHOES AND BOOTS; RUBBER SOLES FOR JIKATABI; FOOTWEAR UPPERS; TIPS FOR FOOTWEAR; SHOE SOLES FOR REPAIR; SHOE DOWELS; SHOE PEGS; TONGUE OR PULLS TRAP FOR SHOES AND BOOTS; HOBNAILS; PROTECTIVE METAL MEMBERS FOR SHOES AND BOOTS; JAPANESE STYLE WOODEN CLOGS (GETA), NAMELY, HIGH RAIN CLOGS (ASHIDA), LOW WOODEN CLOGS

(KOMA-GETA), SANDAL-CLOGS, LOW WOODEN CLOGS (HIYORI-GETA); METAL FITTINGS FOR JAPANESE STYLE WOODEN CLOGS; WOODEN MAIN BODIES OF JAPANESE STYLE WOODEN CLOGS; WOODEN SUPPORTS OF JAPANESE STYLE WOODEN CLOGS; TOE STRAPS FOR JAPANESE STYLE WOODEN CLOGS; JAPANESE STYLE SANDALS (ZORI), NAMELY, JAPANESE TOE-STRAP SANDALS (ASAURA-ZORI), JAPANESE STYLE SANDALS OF LEATHER, SLIPPERS, JAPANESE STYLE SANDALS OF FELT AND JAPANESE FOOTWEAR OF RICE STRAW (WARAJI); SLIPPER SOLES; UPPERS FOR JAPANESE STYLE SANDALS; SOLES FOR JAPANESE STYLE SANDALS; TOE STRAPS FOR JAPANESE STYLE SANDALS; UPPERS OF WOVEN RATTAN FOR JAPANESE STYLE SANDALS; MASQUERADE COSTUMES; CLOTHES FOR SPORTS, NAMELY, ANORAKS, KARATE SUITS, SPORTS OVER-UNIFORMS, KENDO OUTFITS, JUDO SUITS, SKI SUITS FOR COMPETITION, HEADBANDS CLOTHING, WIND-JACKETS, SPECIAL SPORTSWEAR UNIFORMS AND STOCKINGS AND WRISTBANDS; BOOTS FOR SPORTS, NAMELY, GOLF SHOES, SOCCER SHOES, SKI BOOTS, GYMNASTIC SHOES, TENNIS SHOES, CLIMBING BOOTS, MOUNTAINEERING BOOTS, BASKETBALL SNEAKERS, VOLLEYBALL SHOES, HANDBALL SHOES, BOWLING SHOES, BOXING SHOES, HOCKEY SHOES, BASEBALL SHOES, RUGBY SHOES, FOOTWEAR FOR TRACK AND FIELD ATHLETICS; HORSE-RIDING BOOTS (U.S. CLS. 22 AND 39).

CLASS 28—TOYS AND SPORTING GOODS

FOR TOY FIGURES; METAL TOYS, NAMELY, ROLLER TOYS, METAL CLOCKWORK TOYS, TOY WHISTLES AND LEVER ACTION TOYS; WOODEN OR BAMBOO TOYS, PAPER TOYS, NAMELY, PAPER BALLOONS, JAPANESE KARUTA PLAYING CARDS, SETS OF SHEET-PAPER DOLLS AND CHANGING CLOTHES THEREFOR, PLUSH TOYS, NAMELY, STUFFED TOYS; PLASTIC TOYS, NAMELY, PLASTIC CLOCKWORK TOYS, RUBBER BALLS, MUSICAL TOYS, HOLLOW RUBBER TOYS FORMED BY BONDING AND SOLID RUBBER TOYS FORMED BY MOULDING PROCESS; MUSICAL TOYS, NAMELY, MUSICAL BOXES, TOY GLOCKENSPIELS, TOY HARMONICAS, TOY PIANOS AND TOY XYLOPHONES; TOY SETS, NAMELY, TOY CONSTRUCTION SETS, TOY SETS OF CARPENTERS' TOOLS AND HOUSEKEEPING PLAY SETS; TOY BEANBAGS (OTEDAMA); MARBLES; TOY PISTOLS; TOY MASKS; TOY FIREWORKS; CORN STEM TOYS (KIBIGARA); TOY CHRISTMAS TREES; HAND-HELD GAMES WITH LIQUID CRYSTAL DISPLAYS; TOY KOI-NOBORI STREAMERS; TOY SCOOTERS; JIGSAW PUZZLES; FOUR-WHEELED GO-CARTS; KITES; SHUTTLECOCKS FOR HAGOITA GAME; BODHIDHARMA DOLLS WITH CLOSED EYES (MENASHI-DARUMA); ROCKING HORSES; TRICYCLES FOR INFANTS; INFLATABLE SWIMMING POOLS; RING GAMES; DOLLS, NAMELY, JAPANESE TRADITIONAL DOLLS, DOLLS IN SITTING POSTURE (OSUWARI DOUS), BOYS' FESTIVAL DOLLS AND THEIR FITTINGS, KOKESHI DOLLS, SAKURA DOLLS, CLOTHES FOR JAPANESE TRADITIONAL DOLLS, GIRLS' FESTIVAL DOLLS AND THEIR FITTINGS, EUROPEAN STYLE DOLLS AND CUTE FIGURES FOR DECORATING PERSONAL SPACE; GO GAMES, NAMELY, GO STONES, STONE PIECES POTS FOR GO GAME (GOKE POTS), AND GO BOARDS; JAPANESE CHESS (SHOGI GAMES), NAMELY, WOODEN PIECES FOR SHOGI GAME (KOMA), STANDS FOR SHOGI PIECES (KOMA-DAI) AND SHOGI BOARDS; DICE; JAPANESE DICE GAMES (SUGOROKU); DICE CUPS; DIAMOND GAMES; CHESS GAMES; CHECKERS (CHECKER SETS); DOMINOES; MAH-JONG; BOARD GAMES; GAME MACHINES AND APPARATUS, NAMELY, HORIZONTAL PINBALL MACHINE; KORINTO-GAME MACHINES, JAPANESE HORIZONTAL PINBALL MACHINES; SMARTBALL MACHINES, SLOT MACHINES; AMUSEMENT MACHINES, LOTTERY WHEELS AND JAPANESE VERTICAL PINBALL MACHINE; PACHINKO MACHINES; BILLIARD EQUIPMENT, NAMELY, BILLIARD CUES, CHALK FOR BILLIARD CUES, BILLIARD BALLS, BILLIARD MARKERS AND BILLIARD TABLES; TOYS FOR DOMESTIC PETS (U.S. CLS. 22, 23, 38 AND 50).

MARK SPARACINO, EXAMINING ATTORNEY

SN 79-039,042. ASAN SECURITY TECHNOLOGIES OY, FINLAND, FILED 4-18-2007.

ASANTECH

THE MARK CONSISTS OF STANDARD CHARACTERS WITHOUT CLAIM TO ANY PARTICULAR FONT, STYLE, SIZE, OR COLOR.

PRIORITY DATE OF 3-27-2007 IS CLAIMED.

OWNER OF INTERNATIONAL REGISTRATION 0925569 DATED 4-18-2007, EXPIRES 4-18-2017.

CLASS 9—ELECTRICAL AND SCIENTIFIC APPARATUS

FOR VIDEO SURVEILLANCE AND MONITORING SYSTEMS USED TO MANAGE, CONTROL AND OPERATE NETWORK VIDEO RECORDERS AND SYSTEMS USED FOR SURVEILLANCE AND MONITORING OF ENVIRONMENTS, LARGE VESSELS AND TRANSPORTATION EQUIPMENT, PARKING FACILITIES, INDUSTRIAL AND OTHER PROPERTY FACILITIES AND INDUSTRIAL EQUIPMENT, COMPRISED OF COMPUTER SERVERS, VIDEO CAMERAS, INTERFACE CIRCUITS FOR VIDEO CAMERAS, LIGHTS FOR USE ON VIDEO CAMERAS, PORTABLE VIDEO CAMERAS WITH BUILT-IN VIDEOCASSETTE RECORDERS, PRE-RECORDED MAGNETIC DATA CARRIERS AND RECORDING DISCS FEATURING COMPUTER SOFTWARE, NETWORK VIDEO RECORDER SOFTWARE, VIDEO SYSTEM MANAGEMENT AND MONITORING SOFTWARE AND INTELLIGENT VIDEO ANALYSIS SOFTWARE (U.S. CLS. 21, 23, 26, 36 AND 38).

CLASS 42—SCIENTIFIC AND COMPUTER SERVICES

FOR RESEARCH, DEVELOPMENT, AND CONSULTATION RELATED THERETO IN THE FIELD OF NETWORK VIDEO RECORDERS USED FOR SURVEILLANCE AND MONITORING OF ENVIRONMENTS AND OF LARGE VESSELS AND TRANSPORTATION EQUIPMENT, THE FIELD OF NETWORK VIDEO SURVEILLANCE SYSTEMS FOR PARKING FACILITY MANAGEMENT, THE FIELD OF PROPERTY AND INDUSTRIAL ACCESS MANAGEMENT, AND THE FIELD OF MONITORING SOLUTIONS AND PLATFORMS FOR LARGE SCALE VIDEO SURVEILLANCE ENVIRONMENTS; DESIGN AND DEVELOPMENT OF HARDWARE AND SOFTWARE USED IN SAID FIELDS (U.S. CLS. 100 AND 101).

CLASS 45—PERSONAL AND LEGAL SERVICES

FOR SECURITY GUARDING SERVICES FOR THE PROTECTION OF LARGE SCALE VIDEO SURVEILLANCE ENVIRONMENTS, LARGE VESSELS AND TRANSPORTATION EQUIPMENT, PARKING FACILITIES, INDUSTRIAL AND OTHER PROPERTY FACILITIES (U.S. CLS. 100 AND 101).

GILBERT SWIFT, EXAMINING ATTORNEY

SN 79-039,177. YANTAI WANHUA; POLYURETHANES CO., LTD, CHINA, FILED 2-14-2007.

SN 79-039,484. WILO AG, FED REP GERMANY, FILED 5-11-2007.



OWNER OF INTERNATIONAL REGISTRATION 0925888
DATED 2-14-2007, EXPIRES 2-14-2017.

CLASS 1—CHEMICALS

FOR INDUSTRIAL CHEMICALS, NAMELY, ISOCYANATE, ESTER, SULPHURIC ACID, POLYURETHANE, HYDROCHLORIC ACID, ANILINE, ADHESIVES FOR INDUSTRIAL PURPOSES; FOUNDRY MOLDING PREPARATIONS, NAMELY, FOUNDRY SAND; UNPROCESSED ARTIFICIAL RESINS (U.S. CLS. 1, 5, 6, 10, 26 AND 46).

CLASS 17—RUBBER GOODS

FOR NATURAL RAW OR PARTLY PROCESSED RUBBER GUM; CHEMICAL COMPOSITIONS FOR REPAIRING LEAKS, NAMELY, GENERAL PURPOSE SILICONE RUBBER SEALANT, GROUT SEALANT, ADHESIVE SEALANTS FOR GENERAL USE; PIPE JACKETS NOT OF METAL FOR PLASTIC, RUBBER PIPES; JUNCTIONS NOT OF METAL FOR PLASTIC, RUBBER PIPES; SEMI-FINISHED ARTIFICIAL RESINS, NAMELY, ARTIFICIAL THERMOPLASTIC ELASTOMER RESINS IN BARS, BLOCKS, PELLETS, RODS, SHEETS AND TUBES FOR USE IN FURTHER MANUFACTURE; WATERING HOSE; NON-CONDUCTING MATERIALS FOR RETAINING HEAT, NAMELY, POLYURETHANE FILM FOR USE IN SEALING AND INSULATING; SOUNDPROOFING MATERIALS FOR BUILDINGS; INSULATING MATERIALS, NAMELY, POLYURETHANE FOAM AND POLYETHYLENE FOAM; WATERPROOF PACKINGS FOR PREVENTING PLUMBING LEAKS, ISOLATION OF ELECTRICAL WIRES AND CAULKING GLAZINGS (U.S. CLS. 1, 5, 12, 13, 35 AND 50).

CLASS 18—LEATHER GOODS

FOR IMITATION LEATHER; UNWORKED OR SEMI-WORKED LEATHER; IMITATION LEATHER, NAMELY, MOLESKIN; CASES OF IMITATION LEATHER; BANDOLIERS; UMBRELLAS; WALKING STICKS; HARNESS TRACES; GUT FOR MAKING SAUSAGES (U.S. CLS. 1, 2, 3, 22 AND 41).

KEVIN CORWIN, EXAMINING ATTORNEY

OWNER OF INTERNATIONAL REGISTRATION 0926671
DATED 5-11-2007, EXPIRES 5-11-2017.

OWNER OF U.S. REG. NO. 3,179,232.

THE WORDING "WILO" HAS NO MEANING IN A FOREIGN LANGUAGE.

CLASS 7—MACHINERY

FOR PUMPS EXCEPT FOR PUMPS FOR MEDICAL PURPOSES, NAMELY, PUMPS FOR HEATING UNITS, AGRICULTURAL PUMPS, SUBMERSIBLE PUMPS, BOREHOLE PUMPS, HIGH PRESSURE CENTRIFUGAL PUMPS, PUMPS FOR PRESSURE BOOSTING, HEATING INSTALLATION PUMPS, COOLING INSTALLATION PUMPS, PUMPS FOR MACHINES EXCEPT PUMPS FOR MEDICAL PURPOSES, HIGH PRESSURE PUMPS FOR WASHING APPLIANCES AND INSTALLATIONS; BUILDING INSTALLATION PUMPS, NAMELY, PUMPS FOR HEATING INSTALLATIONS, COOLING INSTALLATIONS, FRESH WATER SUPPLY INSTALLATIONS, WASTEWATER INSTALLATIONS, SEWAGE AND FECES TREATMENT INSTALLATIONS; ELECTRICAL WATER PUMPS EXCEPT FOR PUMPS FOR MEDICAL PURPOSES, NAMELY, WATER SUPPLY PUMPS, SEWAGE TREATMENT PUMPS, PUMPS FOR SWIMMING POOLS, WHIRLPOOLS, BATHS, PONDS, WATER FILTERING UNITS; INDUSTRIAL ELECTRIC MOTORS OTHER THAN FOR LAND VEHICLES, NAMELY, ELECTRIC MOTORS FOR MACHINES AND PUMPS; SPARE PARTS FOR ELECTRIC PUMPS, NAMELY, FILTERS (U.S. CLS. 13, 19, 21, 23, 31, 34 AND 35).

CLASS 9—ELECTRICAL AND SCIENTIFIC APPARATUS

FOR REGULATING AND CONTROLLING APPARATUS, NAMELY, SWITCHING DEVICES FOR THE OPERATION OF ONE OR MORE PUMPS WITH A DRIVE MOTOR, CONTROL UNITS IN THE NATURE OF SWITCH BOXES AND OPERATING UNITS FOR THE ELECTRICAL CONNECTION OF AC AND THREE PHASE PUMPS, FLOW REGULATORS FOR COMMERCIAL AND DOMESTIC USE, ELECTRONIC FLOW AND PRESSURE CONTROLLERS; ELECTRO-TECHNICAL APPARATUS AND INSTRUMENTS, NAMELY, DRY-RUNNING PROTECTION SWITCHES, PRESSURE SWITCHES, FLOAT SWITCHES, IMMERSION PROBES, ELECTRIC COILS, TIME SWITCHES, PRESSURE SENSORS, ELECTRIC CONTROL PANELS, SWITCH GEARS FOR APPLICATION AS CONTRACTOR FOR AC AND THREE-PHASE CURRENT PUMPS; OPERATIONAL MONITORING MEANS FOR SYSTEMS COMPRISING AT LEAST A PUMP OR A MOTOR, FOR MEASURING, TEMPERATURE, CURRENT, PRESSURE OR WATER LEVEL, FOR MONITORING AND INDICATING OPERATING STATUS OF THE PUMP OR MOTOR, AND FOR PROVIDING A WARNING SIGNAL IN CASE OF REACHING A CERTAIN MEASURED VALUE; ELECTRONIC OPERATIONAL MONITORING UNITS FOR CONTROL AND CHECK OF OPERATING STATUS OF ELECTRIC PUMPS; ELECTRICAL CONNECTION PARTS, NAMELY, INSULATED ELECTRICAL CONNECTORS; FIRE-FIGHTING EQUIPMENT, NAMELY, SPRINKLERS; LABORATORY EQUIPMENT FOR MEASURING AND EVALUATING WATER QUALITY, NAMELY, ELECTRONIC WATER QUALITY ANALYZER; FUEL CELLS; COMPUTER SOFTWARE FOR USE IN CONTROL AND MONITORING OF PUMPS AND MOTORS, SOFTWARE FOR USE IN DATABASE MANAGEMENT (U.S. CLS. 21, 23, 26, 36 AND 38).

CLASS 11—ENVIRONMENTAL CONTROL APPARATUS

FOR HEATING INSTALLATIONS, NAMELY, HOT WATER HEATING INSTALLATIONS COMPRISING RADIATORS, ELECTRIC HEATING CABLES, HEATING BOILERS, HEAT PUMPS, HEAT AND STEAM ACCUMULATORS, HEAT-EXCHANGERS AND SOLAR COLLECTORS AS COMPONENTS OF HEATING INSTALLATIONS; HOT-WATER SPACE HEATING APPARATUS COMPRISING PUMPS FOR DOMESTIC HOT WATER CIRCULATORS, SECONDARY CIRCULATORS FOR MECHANICAL BUILDING AND INDUSTRIAL SERVICES, SOLAR THERMIC PUMPS AND PARTS THEREFOR AS COMPONENTS OF THE HOT WATER SPACE HEATING APPARATUS; HOT-WATER HEATERS COMPRISING CENTRAL HOT WATER HEATERS, HOT WATER CIRCULATING PUMPS FOR HOT WATER CIRCULATORS, SECONDARY AND SERVICE WATER HEATERS AND OPEN CONDENSATION WATER HEATERS, GLANDLESS PUMPS FOR HOT WATER HEATERS OF ALL KINDS, CLOSED CHILLED WATER CIRCULATORS, INDUSTRIAL CIRCULATORS AND PARTS THEREFOR; HOT WATER APPARATUS, NAMELY, HOT WATER TANKS, HEATING BOILERS, NAMELY, ELECTRICAL BOILERS, FURNACE BOILERS, INDUSTRIAL BOILERS; HEATING ELEMENTS, NAMELY, ELECTRICAL HEATING CABLES; AIR CONDITIONING INSTALLATIONS; AIR CONDITIONING INSTALLATIONS COMPRISING GLANDLESS PUMPS AS COMPONENTS OF THE INSTALLATIONS; HEAT PUMPS, HEAT ACCUMULATORS AND PRESSURE ACCUMULATORS AS COMPONENTS OF HEATING AND WATER CONDUIT INSTALLATION, NAMELY, HEAT ACCUMULATORS, STEAM ACCUMULATORS; INSULATION TUBES AND PUMPS SOLD AS A COMPONENT OF HEATING AND/OR WATER CONDUIT INSTALLATIONS, NAMELY, CERAMIC ENAMEL FIBER INSULATION FOR PUMPS AS COMPONENTS OF HEATING AND/OR WATER CONDUITS INSTALLATIONS, GLASS FIBER INSULATION FOR PUMPS AS COMPONENTS OF HEATING AND/OR WATER CONDUITS INSTALLATIONS, GLASS AND MINERAL WOOL INSULATION FOR PUMPS AS COMPONENTS OF HEATING AND/OR WATER CONDUITS INSTALLATIONS, THERMAL INSULATION FOR PUMPS AS COMPONENTS OF HEATING AND/OR WATER CONDUITS INSTALLATIONS (U.S. CLS. 13, 21, 23, 31 AND 34).

SUZANNE BLANE, EXAMINING ATTORNEY

SN 79-039,522. ANGST & PFISTER AG, SWITZERLAND, FILED 3-8-2007.

APSODRIVE

THE MARK CONSISTS OF STANDARD CHARACTERS WITHOUT CLAIM TO ANY PARTICULAR FONT, STYLE, SIZE, OR COLOR.

PRIORITY DATE OF 1-17-2007 IS CLAIMED.

OWNER OF INTERNATIONAL REGISTRATION 0926740 DATED 3-8-2007, EXPIRES 3-8-2017.

THE WORDING "APSODRIVE" HAS NO MEANING IN A FOREIGN LANGUAGE.

CLASS 7—MACHINERY

FOR MACHINES, AND MACHINE TOOLS FOR THE CUTTING AND FORMING OF MATERIALS; MACHINE ELEMENTS IN THE NATURE OF SPRINGS AND PARTS OF SPRINGS, AIR FILTERS FOR MACHINES FOR MECHANICAL PURPOSES; PNEUMATIC CONTROLS FOR MACHINES, MOTORS AND ENGINES; MOTORS AND DRIVING MOTORS OTHER THAN FOR LAND VEHICLES; POWER TRANSMISSION SHAFT COUPLINGS FOR INDUSTRIAL MACHINES AND PARTS THEREFORE; AC VARIABLE FREQUENCY DRIVES THAT ARE USED TO CONTROL SMALL AND MEDIUM-SIZED MOTORS IN APPLICATION SUCH AS MANUFACTURING PROCESSES, HVAC AND PUMPS; MACHINE PARTS, NAMELY, V-BELT DRIVES, SYNCHRONOUS BELT DRIVES AND METAL BELT DRIVES; FIXTURES FOR POWER TRANSMISSION OTHER THAN FOR LAND VEHICLES IN THE NATURE OF COUPLINGS AND JIGS; MACHINE PARTS, NAMELY, IMPULSE COUPLING DEVICES AND HYDRAULIC CLUTCHES OTHER THAN FOR LAND VEHICLES (U.S. CLS. 13, 19, 21, 23, 31, 34 AND 35).

CLASS 9—ELECTRICAL AND SCIENTIFIC APPARATUS

FOR MEASURING APPARATUS, NAMELY, PRESSURE GAUGES AND PRESSURE MEASURING SENSORS; APPARATUS FOR DISTRIBUTING, ACCUMULATING, REGULATING AND CONTROLLING ELECTRICITY, NAMELY, CONTROL UNITS FOR REGULATING START-UP ELECTRICAL MOTORS (U.S. CLS. 21, 23, 26, 36 AND 38).

CLASS 17—RUBBER GOODS

FOR RUBBER, GUTTA-PERCHA, GUM AND GOODS MADE FROM THESE MATERIALS, NAMELY, STOPS OF RUBBER, RINGS OF RUBBER, V-BELTS, VIBRATING BUFFERS FOR INDUSTRIAL MACHINERY, ADHESIVE BANDS OTHER THAN STATIONERY AND NOT FOR MEDICAL OR HOUSEHOLD PURPOSES; DRAUGHT EXCLUDER STRIPS, NAMELY, NON-METAL WEATHER STRIPS FOR BUILDINGS; PLASTICS IN EXTRUDED FORM FOR USE IN MANUFACTURE; FILTER MATERIALS, NAMELY, SEMI-FINISHED PLASTICS, SYNTHETIC PLASTIC AS SEMI-FINISHED PRODUCTS IN THE FORM OF FOILS, PLATES, RODS, PROFILES, HOSES, TUBES, BLOCKS, INDUSTRIAL COATINGS, NAMELY, NATURAL AND LIQUID RUBBER; THERMOPLASTIC ELASTOMER RESINS IN PELLET FORM FOR USE IN FURTHER MANUFACTURE; PACKING, STOPPING AND INSULATING MATERIALS, NAMELY, SHEETS OF GRAPHITE-BASED MATERIAL FOR USE AS GASKETS, SEALS, PACKINGS, AND HEAT INSULATORS; GASKET MATERIAL IN SHEETS FOR USE IN BUILDING; GASKET SEALER FOR USE IN PLUMBING; WEATHERSTRIPPING SEALANTS IN THE NATURE OF CAULK; SOUNDPROOFING MATERIALS FOR BUILDINGS AND MACHINERY; FLEXIBLE TUBES OF PLASTIC FOR INDUSTRIAL USE; FLEXIBLE COMPRESSED AIR PIPE FITTINGS, NOT OF METAL; NON-METAL REINFORCING MATERIALS FOR PIPES, NAMELY, SEMI-WORKED SYNTHETIC PLASTICS AS SEMI-FINISHED PRODUCTS IN THE FORM OF FOILS, PLATES, RODS, PROFILES, HOSES, TUBES, BLOCKS; PIPE MUFFS, NOT OF METAL; JUNCTIONS, NOT OF METAL, FOR PLASTIC PIPES (U.S. CLS. 1, 5, 12, 13, 35 AND 50).

LINDA ESTRADA, EXAMINING ATTORNEY

SN 79-040,002. INDUSTRIA DE DISEÑO TEXTIL, S.A.; (INDITEX, S.A.), SPAIN, FILED 9-13-2006.



clear to wear

PRIORITY DATE OF 9-13-2006 IS CLAIMED.
OWNER OF INTERNATIONAL REGISTRATION 0928166
DATED 9-13-2006, EXPIRES 9-13-2016.

CLASS 3—COSMETICS AND CLEANING PREPARATIONS

FOR BLEACHING PREPARATIONS AND OTHER SUBSTANCES FOR LAUNDRY USE, NAMELY, GENERAL PURPOSE DETERGENT, BLEACH, FABRIC SOFTENER, STAIN REMOVER, AND STARCH; ALL PURPOSE CLEANING PREPARATIONS, SCOURING POWDER, AND ABRASIVE PASTE FOR KITCHEN, BATHROOM, LAUNDRY, AND HOUSEHOLD USE; PERFUMERY, ESSENTIAL OILS, AND HAIR LOTIONS; DENTIFRICES; EAU DE TOILETTE; COTTON STICKS FOR COSMETIC PURPOSES; HAIR COLORANTS AND DYES; POLISH AND CREAM FOR FOOTWEAR; SHAMPOOS; COSMETIC KITS COMPRISED OF BLUSH, ROUGE, MASCARA, EYE SHADOW, EYELINER, EYEBROW PENCILS, LIP GLOSS, AND LIPSTICKS; DEODORANTS FOR PERSONAL USE IN THE NATURE OF PERFUMERY; HAIR SPRAYS; NAIL POLISH REMOVER; MAKE-UP PRODUCTS, NAMELY, BLUSH, ROUGE, MASCARA, EYE SHADOW, EYELINER, EYEBROW PENCILS, LIP GLOSS, AND LIPSTICKS; POMADES FOR COSMETIC PURPOSES; SACHETS FOR PERFUMING LINEN; NAIL POLISH; COBBLER'S WAX; SHOE CREAMS; INCENSE; DECORATIVE TRANSFERS FOR COSMETIC PURPOSES; FALSE NAILS AND EYELASHES; PUMICE STONES FOR PERSONAL USE; POTPOURRI; HAIR WAVING LOTIONS; NON-MEDICATED MOUTH CARE PRODUCTS, NAMELY, MOUTH WASH; OILS FOR TOILETRY PURPOSES; EAU DE COLOGNE (U.S. CLS. 1, 4, 6, 50, 51 AND 52).

CLASS 8—HAND TOOLS

FOR TABLEWARE, NAMELY, KNIVES, SPOONS, AND FORKS; ELECTRIC AND NON-ELECTRIC RAZORS; NON-ELECTRIC CAN OPENERS; OYSTER OPENERS; NON-ELECTRIC HAND IMPLEMENTS FOR HAIR CURLING; ELECTRICALLY OPERATED AND NON-ELECTRICALLY OPERATED APPLIANCES FOR DEPILATORY PURPOSES; NON-PRECIOUS METAL NUTCRACKERS; ELECTRIC AND NON-ELECTRIC NAIL CLIPPERS; NON-ELECTRIC PIZZA CUTTERS; VEGETABLE SLICERS; CUTLERY; SCALING KNIVES; MANICURE SETS; ELECTRIC MANICURE SETS; PEDICURE SETS; CASES AND COVERS FOR RAZOR KNIVES; RAZOR BLADES; NAIL FILES; ELECTRIC AND NON-ELECTRIC HAIR CLIPPERS FOR PERSONAL USE; NON-ELECTRIC EGG-SLICERS; NON-ELECTRIC CHEESE-SLICERS; HAIR CLIPPERS FOR BEARDS; HAIR-REMOVING TWEEZERS; NAIL CLIPPERS; CUTICLE NIPPERS; SUGAR TONGS; EYELASH CURLERS; SCISSORS (U.S. CLS. 23, 28 AND 44).

CLASS 9—ELECTRICAL AND SCIENTIFIC APPARATUS

FOR PRE-RECORDED COMPACT DISCS FEATURING MUSIC; CALCULATORS; ANTI-GLARE SPECTACLES; EYEGLASSES; OPTICAL LENSES; PINCE-NEZ CHAINS; CONTACT LENSES; PINCE-NEZ CORDS; SPECTACLES; CASES FOR SPECTACLES; SPECTACLE FRAMES AND LENSES; SUNGLASSES; CASES FOR EYEGLASSES AND FOR CONTACT LENSES; LIFESAVING JACKETS; SURVIVAL SUITS, NAMELY, INSULATED OVERALL WET SUITS; TELEPHONE SETS; PERSONAL SCALES FOR USE AS A WEIGHING APPARATUS; PROTECTIVE HELMETS; CHRONOGRAPHS FOR USE AS SPECIAL TIME RECORDING APPARATUS; MEASURING SPOONS; PEDOMETERS; TEMPERATURE INDICATORS; ELECTRONIC GAMES PROGRAMS; COMPUTER SOFTWARE FOR GAMES, SCREEN SAVERS, WORD PROCESSING; NON-MEDICAL THERMOMETERS; WALKIE-TALKIES; BABY INTERCOM MONITORS (U.S. CLS. 21, 23, 26, 36 AND 38).

CLASS 10—MEDICAL APPARATUS

FOR TEETHING RINGS; BABIES' BOTTLES; FEEDING BOTTLE VALVES IN THE NATURE OF NIPPLES; FEEDING BOTTLE TEATS; BABIES' PACIFIERS; BREAST PUMPS; ORTHOPEDIC FOOTWEAR; ARCH SUPPORTS FOR BOOTS AND SHOES (U.S. CLS. 26, 39 AND 44).

CLASS 12—VEHICLES

FOR SAFETY SEATS FOR CHILDREN FOR VEHICLES; BICYCLES; BABY STROLLERS; PRAMS; SLEIGHS (U.S. CLS. 19, 21, 23, 31, 35 AND 44).

CLASS 14—JEWELRY

FOR JEWELRY; PRECIOUS STONES; HOROLOGICAL AND OTHER CHRONOMETRIC INSTRUMENTS; ORNAMENTAL PINS; TIE PINS; NEEDLE CASES OF PRECIOUS METAL; NAPKIN RINGS OF PRECIOUS METAL; WORKS OF ART OF PRECIOUS METAL; FANCY KEY RINGS OF PRECIOUS METAL; SILVER AND GOLD-PLATED ITEMS, NAMELY, SERVING PLATTERS, CANDLESTICKS; ORNAMENTS OF PRECIOUS METAL FOR FOOTWEAR AND HATS; ASHTRAYS OF PRECIOUS METAL FOR SMOKERS; CUFF LINKS (U.S. CLS. 2, 27, 28 AND 50).

CLASS 18—LEATHER GOODS

FOR LEATHER AND ARTIFICIAL LEATHER; TRUNKS AND SUITCASES; UMBRELLAS, PARASOLS AND WALKING STICKS; ALL PURPOSE BAGS AND DUFFEL BAGS FOR USE WHILE CAMPING AND HIKING; BEACH BAGS; HANDBAG FRAMES; FRAMES FOR UMBRELLAS OR PARASOLS; PURSES; HANDBAGS; TRAVELING BAGS; TRAVELING CASES AND KEY CASES OF LEATHER; COLLEGE SATCHELS; GARMENT BAGS FOR TRAVEL; HAT BOXES OF LEATHER FOR TRAVEL; SLING BAGS FOR CARRYING INFANTS; WHEELED SHOPPING BAGS; CONTAINERS AND BOXES OF LEATHER FOR STORING GREETING CARDS; SCHOOL BAGS; POCKETBOOKS; BRIEFCASES; UNFITTED VANITY CASES; ANIMAL COLLARS; LEATHER LEASHES FOR ANIMALS; UMBRELLA COVERS; HAVERSACKS; RUCKSACKS; LEATHER BAGS FOR MERCHANDISE PACKAGING (U.S. CLS. 1, 2, 3, 22 AND 41).

CLASS 20—FURNITURE AND ARTICLES NOT OTHERWISE CLASSIFIED

FOR FURNITURE; MIRRORS; PICTURE FRAMES; HAND-HELD FANS; PILLOWS; CURTAIN RINGS; WOOD AND PLASTIC CRATES; CUPBOARDS; LECTERNS; BENCHES; TABLE TOPS OTHER THAN FOR CRAPS TABLES; SCREENS; TRUNKS IN THE NATURE OF FURNITURE; BOXES OF WOOD OR PLASTIC; CHESTS FOR TOYS; BEDS; BED HEADBOARDS; TEA CARTS; FURNITURE IN THE NATURE OF WINE BOTTLE RACKS; NON-METALLIC BAKER'S BREAD BASKETS; CUSHIONS; MATTRESSES; BAMBOO BLINDS; COTS; WIND CHIMES FOR USE AS DECORATION; DECORATIVE MOBILES; DIVANS; BOOK-SHELVES; CLOTHING COVERS BEING FOR STORAGE AND WARDROBE USE; HAMMOCKS; FLOWER STANDS; JEWELRY BOXES NOT OF METAL; WORKS OF ART OF WOOD, WAX, PLASTER OR PLASTIC; STRAWS FOR DRINKING; UMBRELLA STANDS; PLAYPENS FOR BABIES; HANGERS FOR COATS AND HATS; COAT STANDS; DESKS; MAGAZINE RACKS; SLEEPING BAGS FOR CAMPING; CHAIRS; ARMCHAIRS; SOFAS; STOOLS; NON-METALLIC STOPPERS FOR BOTTLES; EMBROIDERY FRAMES; HIGH CHAIRS FOR BABIES; INFANT WALKERS; DECK CHAIRS (U.S. CLS. 2, 13, 22, 25, 32 AND 50).

CLASS 21—HOUSEWARES AND GLASS

FOR HAIR COMBS; BATH SPONGES; HAIR BRUSHES; COSMETIC BRUSHES; BRUSH-MAKING MATERIALS; UNWORKED OR SEMI-WORKED GLASS EXCEPT CONSTRUCTION GLASS; STEEL WOOL FOR CLEANING; BEVERAGE GLASSWARE; DECORATIVE PORCELAIN AND EARTHENWARE IN THE NATURE OF STATUARY, FIGURINES, ORNAMENTS, PLATES, VASES AND BOWLS; BOTTLE OPENERS; OIL BOTTLES SOLD EMPTY; COCKTAIL SHAKERS; CANDLE SNUFFERS; SUGAR BOWLS; TRAYS; PORTABLE BABY BATH TUBS; CLOTHS FOR WASHING FLOORS; GLASS BOWLS; TEA BALLS; CANDY DISHES; BOTTLES SOLD EMPTY; SHAVING BRUSHES; POTTERY DISHES; COFFEE MACHINES IN THE NATURE OF HAND-OPERATED COFFEE GRINDERS; NON-ELECTRIC BOTTLE WARMERS FOR BABIES; SHOE HORNS; NON-ELECTRIC CANDELABRAS; WINE TASTERS; FLYCATCHERS; TABLE CENTERPIECES IN THE NATURE OF VASES; SHOE BRUSHES; PLANT BASKETS; TEA STRAINERS; TROUSER STRETCHERS; ICE BUCKETS; TIE PRESSES; DOOR HANDLES OF PORCELAIN; COMB CASES; SHAPED IRONING BOARD COVERS; GARDENING GLOVES; GLOVES FOR DOMESTIC USE; POLISHING GLOVES; SHOE TREES; PIGGY BANKS NOT OF METAL; SOAP DISHES; CARAFES; BIRD CAGES FOR DOMESTIC BIRDS; BUTTER DISHES; WORKS OF ART OF PORCELAIN, TERRA COTTA AND GLASS; TOOTH-PICK CONTAINERS; BREAD BOXES; PEPPER POTS; PLATES; FEATHER DUSTERS; FACE POWDER CASES IN THE NATURE OF VANITY CASES; SHAVING BRUSH HOLDERS; SPONGE HOLDERS; TOILET ROLL HOLDERS; PERFUME SPRAYERS AND VAPORIZERS SOLD EMPTY; NON-ELECTRIC GRATERS FOR HOUSEHOLD PURPOSES; CRUMB TRAYS; COASTERS FOR

BOTTLES NOT OF PAPER AND NOT BEING TABLE LINEN; TRIVETS; BOOT JACKS; SALT CELLARS; CLOTHES DRYING RACKS; COFFEE AND TEA SERVICES; NAPKIN HOLDERS; WASHING AND IRONING BOARDS; BREAD BOARDS; CARVING BOARDS; CUPS; SHIRT STRETCHERS; TEA POTS; FLOWER POTS; THERMALLY INSULATED CONTAINERS FOR FOOD AND BEVERAGES; CLOTHS IMPREGNATED WITH A DETERGENT FOR CLEANING; TOOTHBRUSHES; ELECTRIC TOOTHBRUSHES; DENTAL FLOSS; NON-ELECTRIC JUICERS (U.S. CLS. 2, 13, 23, 29, 30, 33, 40 AND 50).

CLASS 24—FABRICS

FOR TEXTILES AND TEXTILE GOODS, NAMELY, BED SHEETS, BED BLANKETS, PILLOW COVERS, PILLOW SHAMS, DUST RUFFLES, DUVET COVERS, QUILTS, COMFORTERS, AFGHANS, CRIB BUMPERS, BED SPREADS, PLACEMATS, NAPKINS, OVEN MITTS, POT HOLDERS, TEA TOWELS, TABLE CLOTHS NOT MADE OF PAPER; BATH LINEN NOT INCLUDING CLOTHING; TISSUES OF TEXTILE FOR REMOVING MAKE-UP; LABELS OF TEXTILE; TEXTILE USED AS LINING FOR CLOTHING; TOILET GLOVES, NAMELY, BATH GLOVES; WALL HANGINGS OF TEXTILE; HANDKERCHIEFS OF TEXTILE; CURTAINS OF TEXTILE OR PLASTIC; HOUSEHOLD LINEN; TOWELS OF TEXTILE; NET CURTAINS; CURTAIN HOLDERS OF TEXTILE MATERIALS, NAMELY, CURTAIN TIE BACKS; FABRIC FLAGS; EIDERDOWNS; UNFITTED PROTECTIVE FURNITURE COVERS NOT OF PAPER; COVERS FOR CUSHIONS; MOSQUITO NETS; TEXTILE CLOTHS FOR CLEANING GLASS; BILLIARD CLOTH; TRACED CLOTH FOR EMBROIDERY; UPHOLSTERY FABRICS; FACE TOWELS OF TEXTILE; SLEEPING BAGS (U.S. CLS. 42 AND 50).

CLASS 25—CLOTHING

FOR MEN'S, WOMEN'S AND CHILDREN'S READY-TO-WEAR CLOTHING, NAMELY, OVERALLS, TOPS, VESTS, UNDERSHIRTS, UNDERPANTS, TROUSERS, SKIRTS, DRESSES, SLACKS, PANTS, BLOUSES, SHIRTS, T-SHIRTS, SWEATERS, WAISTCOATS, PULLOVERS, CARDIGANS, JERSEYS, JACKETS, SUITS, TUXEDOS, OVERCOATS, COATS, HUNTING JACKETS, TRACK SUITS, ASCOTS, PONCHOS; FOOTWEAR, NOT INCLUDING ORTHOPEDIC FOOTWEAR; HEADGEAR, NAMELY, HATS, SCARVES, KERCHIEFS, EAR MUFFS, CAPS, HEADBANDS, CAP VISORS; CLOTHING FOR MOTORISTS AND CYCLISTS, NAMELY, JACKETS, MOTORCYCLE GLOVES; BIBS, NOT OF PAPER; BATHROBES; SWIMWEAR; BATHING CAPS AND SANDALS; BOAS; UNDERWEAR; DISPOSABLE NAPPIES; SCARVES; FOOTWEAR FOR SPORTS; BEACH FOOTWEAR; HOODS; SHAWLS; BELTS FOR CLOTHING; MONEY BELTS; WET SUITS; TIES; CORSETS; FUR STOLES; GIRDLES; FOULARDS; GLOVES; WATER-PROOF CLOTHING, NAMELY, RAINCOATS; MANTILLAS; STOCKINGS; SOCKS; NECKERCHIEFS; TEXTILE NAPPIES; DRESS HANDKERCHIEFS; FUR COATS; PAJAMAS; SOLES FOR FOOTWEAR; HEELS; VEILS; BRACES IN THE NATURE OF SUSPENDERS; PAPER CLOTHING, NAMELY, PAPER HATS; LEOTARDS; LAYETTES; COLLARS; SINGLET; INSOLES; BOW TIES; PAREUS; WRISTBANDS FOR WEAR; DRESS SHIELDS; CARNIVAL COSTUMES, NOT INCLUDING COSTUME MASKS (U.S. CLS. 22 AND 39).

CLASS 26—FANCY GOODS

FOR LACE AND EMBROIDERY, RIBBONS AND BRAIDS; BUTTONS FOR CLOTHING; HOOKS AND EYES; NEEDLES; ARTIFICIAL FLOWERS; PIN CUSHIONS; HAT AND SHOE ORNAMENTS NOT OF PRECIOUS METAL; HAT PINS; HAIR ORNAMENTS; HAIR BANDS; REINS FOR GUIDING CHILDREN; BROOCHES BEING CLOTHING ACCESSORIES; SEWING BOXES; BELT CLASPS; SHOE LACES; WREATHS OF ARTIFICIAL FLOWERS; TEA COSIES; ORNAMENTAL NOVELTY BADGES; SEWING THIMBLES; BOWS FOR THE HAIR; NEEDLE CASES, NOT OF PRECIOUS METAL; BUCKLES FOR USE AS CLOTHING ACCESSORIES; SHOE BUCKLES; SHOULDER PADS FOR CLOTHING, HAIR PINS, BODKINS, HAIR CLIPS; LACE TRIMMINGS; FEATHERS FOR USE AS CLOTHING ACCESSORIES; ARTS AND CRAFTS FINDINGS, NAMELY, POMPOMS; ZIPPER FASTENERS (U.S. CLS. 37, 39, 40, 42 AND 50).

CLASS 28—TOYS AND SPORTING GOODS

FOR GAMES, NAMELY, CARD GAMES, SKILL GAMES, BOARD GAMES; TOYS, NAMELY, ROCKING HORSES; TOY VEHICLES, TOY BUILDING BLOCKS, TOY MOBILES, CONSTRUCTION TOYS, MECHANICAL ACTION TOYS, BATTERY-OPERATED TOYS, CHILDREN'S MULTIPLE ACTIVITY TOYS, BATH TOYS, SPORT BALLS, PLUSH AND STUFFED TOYS; SPORTS ARTICLES, NAMELY, SKATEBOARDS, ROLLER AND ICE SKATES; AUTOMATIC GAMES APPARATUS FOR ELECTRONIC GAMES NOT ADAPTED FOR USE WITH TELEVISION RECEIVERS OR EXTERNAL DISPLAY SCREENS OR MONITORS OF ANY NATURE; CHRISTMAS TREE DECORATIONS; CARNIVAL AND THEATRE MASKS; DOLLS' HOUSES; PARTY FAVORS IN THE NATURE OF SMALL TOYS; MARIONETTE PUPPETS; CHRISTMAS TREES OF SYNTHETIC MATERIAL; KITES; BABY RATTLES; KALEIDOSCOPES; TEDDY BEARS; DOLLS; DOLL'S CLOTHES (U.S. CLS. 22, 23, 38 AND 50).

REGINA DRUMMOND, EXAMINING ATTORNEY

CLASS 10—MEDICAL APPARATUS

FOR DENTAL CHAIRS AND UNITS IN THE NATURE OF DENTAL MIRRORS, DENTAL SWIVEL STOOLS, NEONATAL INCUBATORS, REHABILITATION BEDS, PATIENT EXAMINATION TABLES, GYNECOLOGICAL AND BIRTHING DELIVERY CHAIRS, BIRTHING DELIVERY CHAIRS, BIRTHING DELIVERY BEDS, STRETCHERS FOR PATIENT TRANSPORT, PATIENT EXAMINATION COUCHES, REHABILITATION COUCHES, CHAIRS FOR BLOOD DONATION, OPHTHALMIC AND LARYNGOLOGICAL CHAIRS, EQUIPMENT FOR OPERATING THEATRES, NAMELY, OPERATING AND TREATMENT TABLES, EQUIPMENT FOR HOSPITAL WARDS, NAMELY, GEL MATTRESSES, CHAIRS FOR DIALYSIS, STANDS FOR INFUSION HOLDERS, PROSTHETIC TABLES, MEDICAL DIAGNOSTIC DEVICES, NAMELY, APPARATUS FOR CLINICAL DIAGNOSIS, CRUTCHES FOR DISABLED PERSONS, STRETCHERS, ROLL-AWAY STRETCHERS, CONTROL TABLES FOR TREATMENT OF PATIENTS, STRETCHERS FOR NEONATES, STRETCHERS FOR BABIES, TREATMENT TABLES FOR BABIES (U.S. CLS. 26, 39 AND 44).

CLASS 12—VEHICLES

FOR HOSPITAL CARTS FOR OPERATING AND TREATMENT APPARATUS AND INSTRUMENTS; TRANSPORT CARTS FOR DIRTY CLOTHES AND LINEN, ASSISTS CUPBOARDS, NAMELY, MOBILE STORAGE CARTS FEATURING CUPBOARDS FOR DOMESTIC AND COMMERCIAL USE (U.S. CLS. 19, 21, 23, 31, 35 AND 44).

CLASS 20—FURNITURE AND ARTICLES NOT OTHERWISE CLASSIFIED

FOR HOSPITAL BEDS, CHILDREN'S BEDS, SCREENS, DESKS, ROOM FURNITURE, CHAIRS, STOOLS, BEDSIDE LOCKERS, BEDSIDE TABLES (U.S. CLS. 2, 13, 22, 25, 32 AND 50).

TASHIA BUNCH, EXAMINING ATTORNEY

SN 79-040,010, ZYWIECKA FABRYKA SPRZETU; SZPITAL-NEGO FAMED SPOLKA AKCYJNA, ZYWIEC, POLAND, FILED 3-19-2007.

SN 79-040,148, THE TINTOMETER LIMITED, UNITED KINGDOM, FILED 3-8-2007.



OWNER OF INTERNATIONAL REGISTRATION 0928182 DATED 3-19-2007, EXPIRES 3-19-2017.

NO CLAIM IS MADE TO THE EXCLUSIVE RIGHT TO USE "ZYWIEC", APART FROM THE MARK AS SHOWN.

THE COLOR(S) BLUE AND WHITE IS/ARE CLAIMED AS A FEATURE OF THE MARK.

THE MARK CONSISTS OF A BLUE OVAL OUTLINED IN WHITE AND THEN OUTLINED AGAIN IN BLUE. THE COLOR WHITE ALSO APPEARS IN THE WORDING "FAMED ZYWIEC" WITHIN THE BLUE OVAL.

TINTOMETER

OWNER OF INTERNATIONAL REGISTRATION 0928562 DATED 3-8-2007, EXPIRES 3-8-2017.

CLASS 1—CHEMICALS

FOR CHEMICAL REAGENTS FOR NON-MEDICAL TRADE, INDUSTRIAL, COMMERCIAL, SCIENTIFIC, LABORATORY AND FIELD USE; CHEMICAL REAGENTS FOR USE WITH SAMPLE TESTING, LIQUID TESTING, WATER TESTING, EFFLUENT TESTING, ION SPECIFIC TESTING, PH TESTING, TURBIDITY TESTING, WATER CONDITIONING, WATER PURIFICATION, OPTICAL TESTING; COLOR TESTING, ALL FOR NON-MEDICAL PURPOSES; CHEMICAL REAGENTS FOR USE WITH OPTICAL TEST APPARATUS AND TEST CELLS FOR NON-MEDICAL PURPOSES; CHEMICAL REAGENTS FOR NON-MEDICAL PURPOSES IN TABLET, POWDER IN CAPSULE AND LIQUID IN CAPSULE FORM (U.S. CLS. 1, 5, 6, 10, 26 AND 46).

CLASS 9—ELECTRICAL AND SCIENTIFIC APPARATUS

FOR SCIENTIFIC, LABORATORY, TRADE, COMMERCIAL, INDUSTRIAL AND FIELD MEASUREMENT AND TESTING APPARATUS AND INSTRUMENTATION, NAMELY, TITRATION APPARATUS, BIOLOGICAL OXYGEN DEMAND METERS, HEATERS FOR SAMPLE SOFTENING IN OPTICAL AND COLOR MEASUREMENT APPARATUS, TURBIDITY METERS, FLOCCULATION AND SEDIMENTATION METERS, CHEMICAL OXYGEN DEMAND METERS, REDOX METERS, P11-VALUE METERS, THERMOMETERS, OXYGEN SATURATION AND CONCENTRATION METERS, SALINITY METERS, CHLORINE METERS, AND WATER HARDNESS METERS; COLOR COMPARATORS, NAMELY, NESSLERIZERS; SPECTROPHOTOMETERS; COLOR ANALYTICAL INSTRUMENTATION, NAMELY, COLORIMETERS AND SPECTROPHOTOMETERS; COLOR MEASUREMENT APPARATUS IN THE NATURE OF COLORIMETERS, CAMERAS AND IMAGE PROCESSING SOFTWARE SOLD AS A UNIT; COLOR TEST APPARATUS IN THE NATURE OF SPECTROPHOTOMETERS AND COLORIMETERS; COLOR REFERENCE AND COLOR STANDARD TEST APPARATUS IN THE NATURE OF VISUAL AND AUTOMATIC COLORIMETERS; SCIENTIFIC, LABORATORY AND FIELD APPARATUS FOR COMPARING COLORS OF LIQUIDS AND SOLIDS WITH PERMANENT COLOR REFERENCE STANDARDS; COLOR REFERENCE STANDARDS IN THE NATURE OF COLORED GLASSES, TRANSPARENCIES, FILMS, SLIDES AND DISCS, FOR USE IN COLOR MEASUREMENT, COMPARISON AND TESTING; FILTERS FOR OPTICAL DEVICES; COLORIMETERS; COLORIMETRIC ANALYTICAL INSTRUMENTS, NAMELY, OPTICAL TEST APPARATUS FOR COMPARING COLORS TO PERMANENT COLOR STANDARDS; COLOR GRADING INSTRUMENTS IN THE NATURE OF COMPARATORS FOR IDENTIFYING A SAMPLE BY A SPECIFIED COLOR GRADE; COLOR COMPARATORS; COMPARATORS; COLOR TEST CELLS IN THE FORM OF TRANSPARENCIES, FILMS, SLIDES, AND DISCS FOR TESTING USING SPECTROPHOTOMETRY, PHOTOMETRY AND FLUORESCENCE; WATER TEST APPARATUS FOR MONITORING AND DETECTING CONTAMINATION, INORGANIC AND ORGANIC COMPONENTS AND PHYSICAL AND ELECTROCHEMICAL PARAMETERS; WATER QUALITY PARAMETER TEST APPARATUS FOR MONITORING AND DETECTING CONTAMINATION, INORGANIC AND ORGANIC COMPONENTS AND PHYSICAL AND ELECTROCHEMICAL PARAMETERS; PHOTOMETERS; PORTABLE PHOTOMETRIC TEST KITS COMPRISES OF TEST CELLS IN THE FORM OF TRANSPARENCIES, FILMS, SLIDES, AND DISCS AND PHOTOMETRY AND SPECTROPHOTOMETER APPARATUS; ION SPECIFIC PHOTOMETRIC ANALYTICAL INSTRUMENTS; PARAMETRIC CONCENTRATION MEASUREMENT APPARATUS IN THE NATURE OF PHOTOMETERS AND SPECTROPHOTOMETERS; LABORATORY EQUIPMENT IN THE NATURE OF LIGHTING CABINETS AND LAMPS FOR OPTICAL AND COLOR MEASUREMENT, COMPARISON AND TESTING; LABORATORY EQUIPMENT IN THE NATURE OF HEATERS FOR SAMPLE SOFTENING IN OPTICAL AND COLOR MEASUREMENT, COMPARISON AND TESTING; COMPUTER PROGRAMS AND SOFTWARE IN CONNECTION WITH OPTICAL TESTING, COLOR TESTING, COLORIMETRY, COLOR COMPARATORS, SPECTROPHOTOMETRY, PHOTOMETRY, WATER TESTING AND CONDITIONING (U.S. CLS. 21, 23, 26, 36 AND 38).

ANDREA K. NADELMAN, EXAMINING ATTORNEY

SN 79-040,255. AXEL JOHNSON AB, SWEDEN, FILED 1-25-2007.



PRIORITY DATE OF 12-20-2006 IS CLAIMED.
OWNER OF INTERNATIONAL REGISTRATION 0928847
DATED 1-25-2007, EXPIRES 1-25-2017.
OWNER OF U.S. REG. NO. 2,470,857.

CLASS 7—MACHINERY

FOR BALL-BEARINGS FOR MACHINES, COMPRESSORS, LAWN MOWERS AND HAND TOOLS; HOISTS; WINCHES, ELECTRIC PUMPS MACHINES; MACHINE COMPONENTS, NAMELY, TRANSMISSION COMPONENTS FOR MACHINES, COMPRESSORS, LAWN MOWERS AND HAND TOOLS; EQUIPMENT FOR HANDLING LIQUIDS, NAMELY, MECHANICAL AND HYDRAULIC PUMPS AND VALVE ACTUATORS, AND PARTS AND FITTINGS THERETO (U.S. CLS. 13, 19, 21, 23, 31, 34 AND 35).

CLASS 9—ELECTRICAL AND SCIENTIFIC APPARATUS

FOR ELECTRIC GASOLINE PUMPS; MEASURING INSTRUMENTS TO MEASURE FLOW, PRESSURE, TEMPERATURE AND LEVEL OF LIQUIDS AND GASES; TELEPHONE APPARATUS, NAMELY, CELLULAR TELEPHONES, CORDLESS TELEPHONES AND STATIONARY TELEPHONES; FACSIMILE MACHINES, MODEMS, TELEPHONE SWITCHBOARDS, MAGNETICALLY ENCODED CASH CARDS FOR TELEPHONES (U.S. CLS. 21, 23, 26, 36 AND 38).

CLASS 10—MEDICAL APPARATUS

FOR MEDICAL AND VETERINARY APPARATUS AND INSTRUMENTS, NAMELY, DIGITAL X-RAYS AND APPARATUS AND INSTRUMENTS FOR MAMMOGRAPHY AND DIAGNOSTIC RADIOLOGY (U.S. CLS. 26, 39 AND 44).

CLASS 11—ENVIRONMENTAL CONTROL APPARATUS

FOR APPARATUS FOR WATER SUPPLY AND SANITARY PURPOSES AND FOR SUPERVISION AND TREATMENT OF DRAINS AND DRAIN PIPES, NAMELY, WASTEWATER TREATMENT SYSTEMS COMPRISED OF BASINS, AERATION DIFFUSERS AND CLARIFIER AND SETTLING TANK; SEWAGE INFLUENT CLEANING MACHINE; BELT FILTER PRESSES FOR DE-WATERING SLUDGE; MACHINE FOR USE IN WASTEWATER TREATMENT SYSTEM FOR THE REDUCTION OF BIOLOGICAL SOLID WASTE TO A LIQUID; COMBINATION SCREEN AND COMPACTOR USED IN WASTEWATER TREATMENT SYSTEMS; MOVING AERATION CHAINS WHICH SUPPORT CERTAIN APPARATUS, NAMELY, FINE BUBBLE DIFFUSERS, AIR PIPING MANIFOLD, BLOWERS, PARTITION WALLS, SLUDGE REMOVERS, RAKES AND OVERFLOW WEIRS TO PROVIDE MIXING AND AERATION IN BIOLOGICAL TREATMENT WASTEWATER SYSTEMS; AND HEAT EXCHANGERS, NOT BEING PART OF MACHINES (U.S. CLS. 13, 21, 23, 31 AND 34).

CLASS 17—RUBBER GOODS

FOR PACKING MATERIALS FOR FORMING SEALS, STOPPING MATERIALS, NAMELY, RUBBER STOPPERS; INSULATING MATERIALS, NAMELY, SOUND ABSORBING SHEETS; FLEXIBLE PIPES, NOT OF METAL (U.S. CLS. 1, 5, 12, 13, 35 AND 50).

CLASS 35—ADVERTISING AND BUSINESS

FOR IMPORT-EXPORT AGENCIES; RETAIL STORE SERVICES IN THE FIELD OF TELECOMMUNICATIONS, FLUID HANDLING EQUIPMENT, PUMPS, BALL-BEARINGS, TRANSMISSIONS, MECHANICAL GEARS, SEALS, PHOTOGRAPHIC EQUIPMENT AND PHOTOGRAPHIC EQUIPMENT CONSUMABLES, GRAPHIC ARTS EQUIPMENT AND GRAPHIC ARTS EQUIPMENT CONSUMABLES, MEDICAL IMAGING EQUIPMENT AND MEDICAL IMAGING EQUIPMENT COMPONENTS, COMPONENTS TO HEAVY DUTY VEHICLES, EQUIPMENT AND COMPONENTS FOR LASHING, STEEL WIRES, ROPES, LIFTING, HARNESES AND STRAPPING; BUSINESS MANAGEMENT AND ORGANIZATION CONSULTANCY; COMMERCIAL OR INDUSTRIAL MANAGEMENT ASSISTANCE; BUSINESS APPRAISALS; BUSINESS INVESTIGATIONS; COMPUTERIZED BUSINESS MANAGEMENT FOR OTHERS; COMPUTERIZED COMPILATION OF ORDER LISTS; OFFICE ADMINISTRATION; BUSINESS RESEARCH; RELOCATION SERVICES FOR BUSINESSES; COMPILATION OF INFORMATION INTO COMPUTER DATABASES; BUSINESS ADMINISTRATION; ELECTRONIC TRACKING OF FREIGHT AND GOODS BY COMPUTER (U.S. CLS. 100, 101 AND 102).

CLASS 36—INSURANCE AND FINANCIAL

FOR REAL ESTATE MANAGEMENT; RENTAL OF OFFICES; LEASING OF REAL ESTATE AND BUILDINGS; BROKERAGE OF REAL ESTATE; REAL ESTATE AGENCIES; REAL ESTATE APPRAISAL; VENTURE CAPITAL SERVICES, NAMELY, PROVIDING FINANCING TO EMERGING AND START-UP COMPANIES; FINANCIAL MANAGEMENT; CUSTOMS BROKERAGE; ELECTRONIC FUNDS TRANSFER (U.S. CLS. 100, 101 AND 102).

CLASS 37—CONSTRUCTION AND REPAIR

FOR CONSULTANCY SERVICES RELATING TO CONSTRUCTION OF REAL ESTATE PROPERTY AND BUILDINGS FOR INVESTMENT AND SALE; INSTALLATION, REPAIR AND MAINTENANCE OF EACH OF THE FOLLOWING: BALL-BEARINGS FOR MACHINES, COMPRESSORS, LAWN MOWERS AND HAND TOOLS, HOISTS, WINCHES, ELECTRIC PUMP MACHINES, MACHINE COMPONENTS, NAMELY, TRANSMISSION COMPONENTS FOR MACHINES, COMPRESSORS, LAWN MOWERS AND HAND TOOLS; EQUIPMENT FOR HANDLING LIQUIDS, NAMELY, MECHANICAL AND HYDRAULIC PUMPS AND VALVE ACTUATORS, AND PARTS AND FITTINGS THERETO, AND ELECTRIC GASOLINE PUMPS; FLOW, PRESSURE, TEMPERATURE AND LEVEL-MEASURING INSTRUMENTS; TELEPHONE APPARATUS, NAMELY, CELLULAR TELEPHONES, CORDLESS TELEPHONES AND STATIONARY TELEPHONES; FACSIMILE MACHINES, MODEMS, TELEPHONE SWITCHBOARDS, MEDICAL AND VETERINARY APPARATUS AND INSTRUMENTS, NAMELY, DIGITAL X-RAYS AND APPARATUS AND INSTRUMENTS FOR MAMMOGRAPHY AND RADIOLOGY; APPARATUS FOR WATER SUPPLY AND SANITARY PURPOSES AND FOR SUPERVISION AND TREATMENT OF DRAINS AND DRAIN PIPES, NAMELY, WASTEWATER TREATMENT SYSTEMS COMPRISED OF BASINS, AERATION DIFFUSERS AND CLARIFIER AND SETTLING TANK; SEWAGE INFLUENT CLEANING MACHINE; BELT FILTER PRESSES FOR DE-WATERING SLUDGE; MACHINE FOR USE IN WASTEWATER TREATMENT SYSTEM FOR THE REDUCTION OF BIOLOGICAL SOLID WASTE TO A LIQUID; COMBINATION SCREEN AND COMPACTOR USED IN WASTEWATER TREATMENT SYSTEMS; MOVING AERATION CHAINS WHICH SUPPORT CERTAIN APPARATUSES, NAMELY, FINE BUBBLE DIFFUSERS, AIR PIPING MANIFOLD, BLOWERS, PARTITION WALLS, SLUDGE REMOVERS, RAKES AND OVER-

FLOW WEIRS WHICH PROVIDE MIXING AND AERATION IN BIOLOGICAL TREATMENT WASTEWATER SYSTEMS; AND HEAT EXCHANGERS, NOT BEING PART OF MACHINES (U.S. CLS. 100, 103 AND 106).

ANDREA SAUNDERS, EXAMINING ATTORNEY

SN 79-040,501. ZIP CREATIVE LICENSING LIMITED, UNITED KINGDOM, FILED 4-19-2007.

WISPLURKER

THE MARK CONSISTS OF STANDARD CHARACTERS WITHOUT CLAIM TO ANY PARTICULAR FONT, STYLE, SIZE, OR COLOR.

PRIORITY DATE OF 12-23-2006 IS CLAIMED.

OWNER OF INTERNATIONAL REGISTRATION 0929411 DATED 4-19-2007, EXPIRES 4-19-2017.

CLASS 9—ELECTRICAL AND SCIENTIFIC APPARATUS

FOR COMPUTER GAMES, NAMELY, COMPUTER GAME CARTRIDGES, COMPUTER GAME DISKS, COMPUTER GAME SOFTWARE; ENTERTAINMENT SOFTWARE, NAMELY, INTERACTIVE MULTIMEDIA COMPUTER GAME PROGRAMS, COMPUTER GAME PROGRAMS; COMPUTER GAME SOFTWARE FOR PLAYING A COMPUTER CRAPS GAME; COMPUTER GAME PROGRAMS; COMPUTER GAMES SOFTWARE; PRERECORDED VIDEOS, DVDS, AND VIDEO CASSETTES FEATURING MUSIC, CARTOONS AND CHILDREN'S PROGRAMS; PRERECORDED DVDS AND VIDEOCASSETTES FEATURING ANIMATIONS; GAMES, VIDEOS AND ANIMATIONS FOR MOBILE TELEPHONES, NAMELY, ELECTRONIC GAME SOFTWARE FOR MOBILE PHONES, COMPUTER GAME SOFTWARE DOWNLOADABLE BY MOBILE TELEPHONES, DOWNLOADABLE VIDEOS FOR MOBILE PHONES FEATURING MUSIC AND ANIMATION; DOWNLOADABLE MOBILE PHONE RING TONES; BATTERIES; CASES SPECIFICALLY ADAPTED TO CARRY MOBILE TELEPHONES; BLANK CDS, DVDS, CASSETTES, AND VIDEOCASSETTES; PRERECORDED CDS, DVDS, CASSETTES, VIDEOCASSETTES FEATURING MUSIC, CHILDREN'S STORIES, ANIMATION; MUSIC VIDEO RECORDINGS AND MUSICAL SOUND RECORDINGS FOR MOBILE TELEPHONES (U.S. CLS. 21, 23, 26, 36 AND 38).

CLASS 16—PAPER GOODS AND PRINTED MATTER

FOR PAPER, NAMELY, CRAFT PAPER, GIFT WRAPPING PAPER AND COPY PAPER, CARDBOARD; PRINTED MATTER, NAMELY, MAPS, PRINTED GUIDE BOOKS FEATURING TRAVEL, NEWSPAPERS, CHILDREN'S MAGAZINES, COMIC BOOKS AND STRIPS; PRINTED PERIODICALS IN THE FIELD OF MUSIC, DANCE, MOVIES, CARTOONS; PHOTOGRAPHS; STATIONERY; ADHESIVES FOR STATIONERY OR HOUSEHOLD PURPOSES; INSTRUCTIONAL AND TEACHING MATERIAL, NAMELY, INSTRUCTION SHEETS, INSTRUCTIONAL AND TEACHING BOOKS FOR MATHS, ENGLISH, SCIENCE, GEOGRAPHY, HISTORY, FOREIGN LANGUAGES, ARTS AND CRAFTS; PLASTIC MATERIALS FOR PACKAGING, NAMELY, PLASTIC BAGS FOR PACKAGING, PLASTIC BUBBLE PACKS FOR WRAPPING OR PACKAGING; POSTERS; PENS; BOOKMARKS; CALENDARS; WRAPPING PAPER; NOTEPADS; GREETING CARDS; ADHESIVE PRINTED STICKERS; ADHESIVE PRINTED MATTER, NAMELY, ADHESIVE PATCHES TO BE PRINTED WITH AN INDIVIDUAL WEARER'S MEDICAL AND PERSONAL INFORMATION; ALBUMS FOR COINS, PHOTOGRAPHS, AND STICKERS; ANNUALS, NAMELY, CHILDREN'S BOOKS IN THE FIELD OF MUSIC, DANCE, MOVIES, STORIES; ART PRINTS; ARTICLES FOR WRITING AND DRAWING, NAMELY, PENS, PENCILS, STENCILS, COMPASSES, ERASERS; CHILDREN'S MAGAZINES IN THE FIELD OF MUSIC, DANCE, MOVIES, STORIES; COMIC BOOKS, COMIC STRIPS; COMPUTER USER MANUALS; DRAWINGS; EDUCATIONAL MATERIAL, NAMELY, CHILDREN'S INTERACTIVE EDUCATIONAL BOOKS FOR MATHS, ENGLISH, SCIENCE, GEOGRAPHY, HISTORY, FOREIGN LANGUAGES, ARTS AND CRAFTS; GRAPHIC PRINTS, ILLUSTRATIONS; ADDRESS LABELS, PAPER LABELS; WALL PLANNERS, NAMELY, WALL CALENDARS (U.S. CLS. 2, 5, 22, 23, 29, 37, 38 AND 50).

CLASS 20—FURNITURE AND ARTICLES NOT OTHERWISE CLASSIFIED

FOR FIGURINES, WORKS OF ART, AND MODELS OF WOOD, WAX, PLASTER AND PLASTIC (U.S. CLS. 2, 13, 22, 25, 32 AND 50).

CLASS 21—HOUSEWARES AND GLASS

FOR BATH COMBS, BLACKING COMBS, PET COMBS, CAKE COMBS, CLOTHES COMBS, COSMETIC COMBS AND BRUSHES; GLASSWARE, NAMELY, SCULPTURES, BEVERAGE GLASSWARE; PORCELAIN AND EARTHENWARE, NAMELY, PORCELAIN MUGS, PORCELAIN SCULPTURES, PORCELAIN DOORKNOBS, EARTHENWARE MUGS, EARTHENWARE FIGURINES, EARTHENWARE JARS FOR JAMS AND JELLIES; DRINKING GLASSES, MUGS (U.S. CLS. 2, 13, 23, 29, 30, 33, 40 AND 50).

CLASS 25—CLOTHING

FOR CLOTHING, NAMELY, SHIRTS, PANTS, SKIRTS, DRESSES, SHORTS, TIES, UNDERWEAR, JUMPERS, SHIRTS, T-SHIRTS, VESTS, SWIMWEAR; FOOTWEAR; HEADGEAR, NAMELY, HATS, CAPS (U.S. CLS. 22 AND 39).

CLASS 28—TOYS AND SPORTING GOODS

FOR TOYS, GAMES AND PLAYTHINGS, NAMELY, CRIB TOYS, INFANT TOYS, MECHANICAL TOYS, MUSICAL TOYS, TOY VEHICLES, ACTION SKILL GAMES, CARD GAMES, BOARD GAMES, ARCADE GAMES; PLAYING CARDS (U.S. CLS. 22, 23, 38 AND 50).

CLASS 41—EDUCATION AND ENTERTAINMENT

FOR ENTERTAINMENT BY FILM, NAMELY, MOTION PICTURE FILM PRODUCTION, FILM STUDIOS, PLANNING AND CONDUCTING A SERIES OF FILM FESTIVALS; ENTERTAINMENT BY RADIO, NAMELY, RADIO PROGRAMS FEATURING PERFORMANCES BY FICTIONAL CHARACTERS, CHILDREN'S STORIES; ENTERTAINMENT BY TELEVISION, NAMELY, ENTERTAINMENT IN THE NATURE OF CONTINUING TELEVISION FEATURING NEWS, COMEDY VARIETY, AND CHILDREN'S PROGRAMMES; ENTERTAINMENT IN THE NATURE OF THEATRE PRODUCTION; ENTERTAINMENT BY LIVE PERFORMANCES, NAMELY, LIVE MUSIC CONCERTS, LIVE PERFORMANCES BY A PROFESSIONAL ENTERTAINER; ENTERTAINMENT PROVIDED BY TELEVISION PROGRAMMES, CABLES TELEVISION AND INTERNET TELEVISION, NAMELY, ENTERTAINMENT IN THE NATURE OF CONTINUING TELEVISION FEATURING CHILDREN'S PROGRAMMES, NEWS, COMEDY, AND VARIETY; ENTERTAINMENT SERVICES FOR CHILDREN IN THE NATURE OF FASHION SHOWS, ONGOING CHILDREN'S TELEVISION PROGRAMMES AND ONGOING CHILDREN'S ANIMATED TELEVISION PROGRAMMES; ELECTRONIC GAME SERVICES PROVIDED BY MEANS OF THE INTERNET, NAMELY, ONLINE COMPUTER GAMES; PROVISION OF ONLINE NON-DOWNLOADABLE PUBLICATIONS IN THE NATURE OF BOOKS FEATURING ANIMATION; PROVISION OF ONLINE NON-DOWNLOADABLE INSTRUCTIONAL AND EDUCATIONAL PUBLICATIONS IN THE FIELD OF MATHS, ENGLISH, SCIENCE, GEOGRAPHY, HISTORY, FOREIGN LANGUAGES, ARTS AND CRAFTS, AND DIGITAL MUSIC, FROM THE INTERNET (U.S. CLS. 100, 101 AND 107).

REBECCA POVARCHUK, EXAMINING ATTORNEY

SN 79-040,520. FOBOX AS, OSLO, NORWAY, FILED 1-15-2007.

FONET

THE MARK CONSISTS OF STANDARD CHARACTERS WITHOUT CLAIM TO ANY PARTICULAR FONT, STYLE, SIZE, OR COLOR.

OWNER OF INTERNATIONAL REGISTRATION 0929456 DATED 1-15-2007, EXPIRES 1-15-2017.

CLASS 7—MACHINERY

FOR DRILLING TOWERS, DRILLING RIGS AND WAVE DAMPENERS AS INTEGRATED PARTS OF FLOATING AND NON-FLOATING OFFSHORE OIL AND GAS DRILLING AND PRODUCTION PLATFORMS; ELECTRIC AND HYDRAULIC GENERATORS AND BORING MACHINES; ELECTRIC AND HYDRAULIC MOTORS FOR MACHINES AND ENGINES OTHER THAN FOR LAND VEHICLES; GENERATORS FOR ELECTRICITY (U.S. CLS. 13, 19, 21, 23, 31, 34 AND 35).

CLASS 9—ELECTRICAL AND SCIENTIFIC APPARATUS

FOR APPARATUS AND INSTRUMENTS FOR CONDUCTING, SWITCHING, TRANSFORMING, ACCUMULATING, PRODUCING, REGULATING OR CONTROLLING ELECTRICITY, NAMELY, ELECTRICAL WIRES, TRANSFORMERS, BATTERIES; HYDRAULIC, ELECTRIC AND/OR MECHANICAL APPARATUS AND INSTRUMENTS FOR CONVERTING WAVE POWER TO ELECTRIC ENERGY, NAMELY, APPARATUS FOR ABSORBING ENERGY FROM WAVES AND TRANSFERRING THE ENERGY TO A HYDRAULIC OR ELECTRIC GENERATOR; MATERIALS FOR TRANSMISSION OF ELECTRICITY, NAMELY, ELECTRIC WIRES AND CABLES (U.S. CLS. 21, 23, 26, 36 AND 38).

CLASS 22—CORDAGE AND FIBERS

FOR TOW ROPE; NETS FOR UNDERWATER USE IN ANCHORING, HAULING UP AND TOWING LOADS, AND FOR SEPARATING SEA TRAFFIC (U.S. CLS. 1, 2, 7, 19, 22, 42 AND 50).

CLASS 39—TRANSPORTATION AND STORAGE

FOR DISTRIBUTION OF ELECTRIC POWER; OFFSHORE SUPPLY AND DISTRIBUTION OF FRESH WATER; TRANSPORT OF OIL, GAS, CHEMICALS, CONTAINERIZED GOODS, AND PERSONNEL BY SHIP AND PIPELINES, PACKAGING OF CONTAINERIZED GOODS FOR TRANSPORTATION; STORAGE OF CONTAINERIZED GOODS (U.S. CLS. 100 AND 105).

CLASS 40—MATERIAL TREATMENT

FOR PRODUCTION OF ELECTRIC POWER; WATER TREATMENT (U.S. CLS. 100, 103 AND 106).

CLASS 44—MEDICAL, BEAUTY AND AGRICULTURAL SERVICES

FOR ANIMAL BREEDING, NAMELY, BREEDING OF FISH AND SHELLFISH (U.S. CLS. 100 AND 101).
AHSEN KHAN, EXAMINING ATTORNEY

SN 79-040,815. AST GMBH, FED REP GERMANY, FILED 4-17-2007.

LithoSpace

PRIORITY DATE OF 12-8-2006 IS CLAIMED.
OWNER OF INTERNATIONAL REGISTRATION 0930200 DATED 4-17-2007, EXPIRES 4-17-2017.

CLASS 9—ELECTRICAL AND SCIENTIFIC APPARATUS

FOR APPARATUS AND INSTRUMENTS FOR CONVERTING ELECTRICITY, IN PARTICULAR FOR GENERATING SHOCK WAVES, NAMELY, SHOCK WAVE GENERATORS; SOFTWARE FOR OPERATING NAVIGATION DEVICES IN THE NATURE OF DIAGNOSTIC ULTRASOUND MACHINES AND VEHICLE NAVIGATION SYSTEMS (U.S. CLS. 21, 23, 26, 36 AND 38).

CLASS 10—MEDICAL APPARATUS

FOR MEDICAL EQUIPMENT FOR FRAGMENTING HUMAN KIDNEY STONES OR FOR IMPROVING BLOOD SUPPLY TO BONES, NAMELY, LITHOTRIPTERS; MEDICAL APPARATUS AND INSTRUMENTS FOR FRAGMENTING HUMAN KIDNEY STONES AND FOR IMPROVING BLOOD SUPPLY TO THE BONES; MEDICAL SHOCK WAVE GENERATORS; NAVIGATION DEVICES FOR LOCATING ORGANS, BONES, OR KIDNEY STONES IN HUMAN OR ANIMAL BODIES, NAMELY, MEDICAL ULTRASOUND DEVICES (U.S. CLS. 26, 39 AND 44).

LEIGH LOWRY, EXAMINING ATTORNEY

SN 79-041,013. BUCCHI S.R.L., I-48022 LUGO (RA), ITALY, FILED 4-5-2007.



OWNER OF INTERNATIONAL REGISTRATION 0930512 DATED 4-5-2007, EXPIRES 4-5-2017.

THE COLOR(S) RED AND GRAY IS/ARE CLAIMED AS A FEATURE OF THE MARK.

THE MARK CONSISTS OF THE GRAPHIC COMPOSITION FORMED BY THE MARK "BD FAST" WRITTEN IN ELECTROBAZAR POLICE TYPE FONT, WHERE THE LETTERS "BD" ARE IN RED AND THE WORD "FAST" IS IN GRAY; THE TWO NAMES ARE INTERCONNECTED BY THE IMAGE OF TWO STYLIZED ARROWS, ONE POINTING UPWARDS AND THE OTHER DOWNWARDS, WHICH ARE RED AND GRAY IN COLOR. THE WHITE AREAS OF THE DRAWING INDICATE TRANSPARENCY.

THE WORDING "BD FAST" HAS NO MEANING IN A FOREIGN LANGUAGE.

CLASS 7—MACHINERY

FOR TAPS AND VALVES MADE OF METAL AND MADE OF PLASTIC BEING PARTS OF MACHINES USED FOR CIRCULATION OF WATER AND OTHER LIQUIDS (U.S. CLS. 13, 19, 21, 23, 31, 34 AND 35).

CLASS 17—RUBBER GOODS

FOR FLEXIBLE PLASTIC PLUMBING PIPES, PLASTIC CONNECTORS FOR PIPES; PLASTIC SEALS FOR NON-METAL PIPE CONNECTIONS; PLASTIC COUPLINGS FOR PIPES (U.S. CLS. 1, 5, 12, 13, 35 AND 50).

CLASS 20—FURNITURE AND ARTICLES NOT OTHERWISE CLASSIFIED

FOR WATER-PIPE VALVES OF PLASTIC (U.S. CLS. 2, 13, 22, 25, 32 AND 50).
DEBRA LEE, EXAMINING ATTORNEY

SN 79-041,090. SIGER, RABAT, MOROCCO, FILED 4-4-2007.

ROYAL MANSOUR

PRIORITY DATE OF 10-4-2006 IS CLAIMED.
OWNER OF INTERNATIONAL REGISTRATION 0930728
DATED 4-4-2007, EXPIRES 4-4-2017.

CLASS 39—TRANSPORTATION AND STORAGE

FOR TRANSPORT OF GOODS; PACKAGING AND STORAGE OF GOODS, NAMELY, FURNITURE, CLOTHES, LUGGAGE, PIECES OF ART AND JEWELS FOR TRANSPORTATION; PACKAGING OF ARTICLES FOR TRANSPORTATION; STORAGE OF FURNITURE, CLOTHES, LUGGAGE, PIECES OF ART, AND JEWELS; ARRANGING OF TRAVEL TOURS (U.S. CLS. 100 AND 105).

CLASS 43—HOTEL AND RESTAURANT SERVICES

FOR SERVICES FOR PROVIDING FOOD AND DRINK; PROVIDING TEMPORARY ACCOMMODATION (U.S. CLS. 100 AND 101).

CLASS 44—MEDICAL, BEAUTY AND AGRICULTURAL SERVICES

FOR MEDICAL SERVICES; VETERINARY SERVICES; SALON SERVICES, NAMELY, HYGIENIC AND BEAUTY CARE FOR HUMAN BEINGS AND ANIMALS; AGRICULTURE, HORTICULTURE AND FORESTRY SERVICES, NAMELY, PROVIDING GARDENING AND FLORIST SERVICES IN THE NATURE OF FLOWER ARRANGING AND GARDEN AND FLOWERBED CARE (U.S. CLS. 100 AND 101).

DAVID HOFFMAN, EXAMINING ATTORNEY

SN 79-041,104. TUTIMA UHRENFABRIK GMBH, FED REP GERMANY, FILED 4-28-2007.

Tutima

THE MARK CONSISTS OF STANDARD CHARACTERS WITHOUT CLAIM TO ANY PARTICULAR FONT, STYLE, SIZE, OR COLOR.

PRIORITY DATE OF 1-31-2007 IS CLAIMED.
OWNER OF INTERNATIONAL REGISTRATION 0930758
DATED 4-28-2007, EXPIRES 4-28-2017.
OWNER OF U.S. REG. NO. 1,174,121.

CLASS 9—ELECTRICAL AND SCIENTIFIC APPARATUS

FOR SPECTACLES, SUNGLASSES, SPECTACLE FRAMES, SPECTACLE GLASSES, SPECTACLE CASES; ELECTRIC NAVIGATIONAL INSTRUMENTS; TIME RECORDING APPARATUS; APPARATUS FOR RECORDING, TRANSMISSION OR REPRODUCTION OF DATA, SOUND OR IMAGES; MOBILE PHONES; BLANK OPTICAL OR MAGNETIC DATA CARRIERS; CALCULATING MACHINES, NAMELY, CALCULATORS, DATA PROCESSING EQUIPMENT, NAMELY, COMPUTERS AND COMPUTER PERIPHERAL EQUIPMENT; CASES AND BAGS FOR THE AFORESAID GOODS, NAMELY, FOR MOBILE PHONES, HANDHELD OR NOTEBOOK COMPUTERS; STRUCTURAL PARTS AND FITTINGS OF THE AFORESAID GOODS (U.S. CLS. 21, 23, 26, 36 AND 38).

CLASS 14—JEWELRY

FOR DIAMONDS, PRECIOUS STONES, SEMI-PRECIOUS STONES, PEARLS; JEWELLERY; CUFF LINKS; HOROLOGICAL AND CHRONOMETRIC INSTRUMENTS, DIALS, MOVEMENTS, WRIST WATCHES, POCKET WATCHES, WATCH BANDS, WATCH BRACELETS, WATCH STRAPS, WATCH CHAINS, WATCH CASES, WATCH GLASSES, WATCH WINDERS; BOXES AND CASES FOR JEWELLERY OR HOROLOGICAL AND CHRONOMETRIC INSTRUMENTS; STRUCTURAL PARTS AND FITTINGS FOR THE AFORESAID GOODS (U.S. CLS. 2, 27, 28 AND 50).

CLASS 16—PAPER GOODS AND PRINTED MATTER

FOR PAPER, CARDBOARD AND GOODS MADE FROM THESE MATERIALS, NAMELY, BOXES AND CARRYING CASES OF CARDBOARD OR PAPER; PRINTED MATTER, NAMELY, CATALOGUES, BROCHURES AND BOOKLETS IN THE FIELD OF OPTICS, ELECTRONICS, JEWELRY, WATCHES AND TIMEPIECES, STATIONERY, WRITING INSTRUMENTS, AS WELL AS LEATHER GOODS; POSTERS; PHOTOGRAPHS; STATIONERY; WRITING INSTRUMENTS, NAMELY, FOUNTAIN PENS, ROLLERBALL PENS, BALLPOINT PENS, FELT-TIP PENS, FIBRETIP PENS, MECHANICAL PENCILS; BOXES AND CASES FOR WRITING INSTRUMENTS; HOLDERS AND TRAYS FOR WRITING INSTRUMENTS; STATIONERY-TYPE PORTFOLIOS; WRITING PADS, PAPERWEIGHTS, LETTER TRAYS, PEN INK, INKWELLS, PEN INK CARTRIDGES; DRAWING INSTRUMENTS, DRAWING CASES FOR DRAWING INSTRUMENTS; PAINT BRUSHES; TYPEWRITERS, NAMELY, ELECTRIC AND NON-ELECTRIC TYPEWRITERS; STRUCTURAL PARTS AND FITTINGS FOR THE AFORESAID GOODS (U.S. CLS. 2, 5, 22, 23, 29, 37, 38 AND 50).

CLASS 18—LEATHER GOODS

FOR LEATHER AND IMITATIONS OF LEATHER, AND GOODS MADE OF THESE MATERIALS, NAMELY, BAGS AND CASES, BACKPACKS, BOXES, BRIEFCASES, BRIEFCASE-TYPE PORTFOLIOS FOR DOCUMENTS, CARRYING CASES FOR DOCUMENTS, HANDBAGS, KEY CASES, KNAPSACKS, MONEY BAGS, POUCHES, PURSES, SATCHELS, SCHOOL BAGS, SHOPPING BAGS, SPORTS BAGS, SUITCASES, TRUNKS, TRAVELLING BAGS, VANITY CASES SOLD EMPTY, WALLETS; BAGS AND CASES, NAMELY, BACKPACKS, BRIEFCASES, BRIEFCASE-TYPE PORTFOLIOS FOR DOCUMENTS, CARRYING CASES FOR DOCUMENTS, HANDBAGS, KEY CASES, KNAPSACKS, MONEY BAGS, POUCHES, PURSES, SATCHELS, SCHOOL BAGS, TEXTILE SHOPPING BAGS, SPORTS BAGS; SUITCASES, TRUNKS, TRAVELLING BAGS, VANITY CASES SOLD EMPTY, WALLETS; SHOULDER STRAPS; UMBRELLAS, PARASOLS AND WALKING STICKS; ANIMAL SKINS, HIDES; WHIPS, HARNESS AND SADDLERY; STRUCTURAL PARTS AND FITTINGS FOR THE AFORESAID GOODS (U.S. CLS. 1, 2, 3, 22 AND 41).

DOMINIC FATHY, EXAMINING ATTORNEY

SN 79-041,105. TUTIMA UHRENFABRIK GMBH, FED REP GERMANY, FILED 4-28-2007.

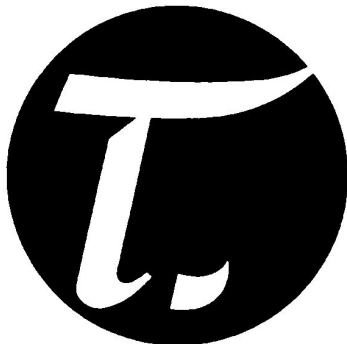

PRIORITY DATE OF 1-31-2007 IS CLAIMED.
OWNER OF INTERNATIONAL REGISTRATION 0930759
DATED 4-28-2007, EXPIRES 4-28-2017.

CLASS 9—ELECTRICAL AND SCIENTIFIC APPARATUS

FOR SPECTACLES, SUNGLASSES, SPECTACLE FRAMES, SPECTACLE GLASSES, SPECTACLE CASES; STRUCTURAL PARTS AND FITTINGS OF THE AFORESAID GOODS (U.S. CLS. 21, 23, 26, 36 AND 38).

CLASS 14—JEWELRY

FOR DIAMONDS, PRECIOUS STONES, SEMI-PRECIOUS STONES, PEARLS; JEWELLERY; CUFF LINKS; HOROLOGICAL AND CHRONOMETRIC INSTRUMENTS, DIALS, MOVEMENTS, WRIST WATCHES, POCKET WATCHES, WATCH BANDS, WATCH BRACELETS, WATCH STRAPS, WATCH CHAINS, WATCH CASES, WATCH GLASSES, WATCH WINDERS; STRUCTURAL PARTS AND FITTINGS FOR THE AFORESAID GOODS; BOXES AND CASES FOR JEWELLERY OR HOROLOGICAL AND CHRONOMETRIC INSTRUMENTS (U.S. CLS. 2, 27, 28 AND 50).

CLASS 16—PAPER GOODS AND PRINTED MATTER

FOR WRITING INSTRUMENTS, NAMELY, FOUNTAIN PENS, ROLLERBALL PENS, BALLPOINT PENS, FELT-TIP PENS, FIBRETIP PENS, MECHANICAL PENCILS; BOXES AND CASES FOR WRITING INSTRUMENTS; HOLDERS AND TRAYS FOR WRITING INSTRUMENTS; PEN INK, INKWELLS, PEN INK CARTRIDGES; STRUCTURAL PARTS AND FITTINGS FOR THE AFORESAID GOODS (U.S. CLS. 2, 5, 22, 23, 29, 37, 38 AND 50).

CLASS 18—LEATHER GOODS

FOR LEATHER AND IMITATIONS OF LEATHER, AND GOODS MADE OF THESE MATERIALS, NAMELY, BAGS AND CASES, BACKPACKS, BOXES, BRIEFCASES, BRIEFCASE-TYPE PORTFOLIOS FOR DOCUMENTS, CARRYING CASES FOR DOCUMENTS, HANDBAGS, KEY CASES, KNAPSACKS, MONEY BAGS, POUCHES, PURSES, SATCHELS, SCHOOL BAGS, SHOPPING BAGS, SPORTS BAGS, SUITCASES, TRUNKS, TRAVELLING BAGS, VANITY CASES SOLD EMPTY, WALLETS; BAGS AND CASES, NAMELY, BACKPACKS, BRIEFCASES, BRIEFCASE-TYPE PORTFOLIOS FOR DOCUMENTS, CARRYING CASES FOR DOCUMENTS, HANDBAGS, KEY CASES, KNAPSACKS, MONEY BAGS, POUCHES, PURSES, SATCHELS, SCHOOL BAGS, TEXTILE SHOPPING BAGS, SPORTS BAGS; SUITCASES, TRUNKS, TRAVELLING BAGS, VANITY CASES SOLD EMPTY, WALLETS, SHOULDER STRAPS; UMBRELLAS, PARASOLS AND WALKING STICKS; ANIMAL SKINS, HIDES; WHIPS, HARNESS AND SADDLERY; STRUCTURAL PARTS AND FITTINGS FOR THE AFORESAID GOODS (U.S. CLS. 1, 2, 3, 22 AND 41).

DOMINIC FATHY, EXAMINING ATTORNEY

SN 79-041,110. LABORATORIUM KOSMETYCZNE DR IR-ENA ERIS SPOLKA AKCYJNA, POLAND, FILED 5-18-2007.

pharmaceris

THE MARK CONSISTS OF STANDARD CHARACTERS WITHOUT CLAIM TO ANY PARTICULAR FONT, STYLE, SIZE, OR COLOR.

OWNER OF INTERNATIONAL REGISTRATION 0930772
DATED 5-18-2007, EXPIRES 5-18-2017.

CLASS 3—COSMETICS AND CLEANING PREPARATIONS

FOR COSMETICS FOR CARE OF THE SKIN, BODY AND HAIR, NAMELY, COSMETIC PREPARATIONS FOR BODY CARE; SKIN CREAMS, FACIAL CREAMS, BODY EMULSIONS, FACIAL EMULSIONS, SKIN LOTIONS, FACIAL LOTIONS, SKIN GELS, FACIAL GELS, SKIN OILS AND BALSAMS; SOAPS; NON-MEDICATED BATH PREPARATIONS, HAIR CARE PREPARATIONS, HAIR CLEANING PREPARATIONS NAMELY, SHAMPOOS, HAIR CLEANING PREPARATIONS IN FORM OF LIQUIDS, GELS, EMULSIONS; PERFUMERY PRODUCTS, NAMELY, PERFUMES; TOILET WATERS, EAU DE COLOGNES, EAU DE TOILETTE; ESSENTIAL OILS; PERSONAL DEODORANTS AND ANTIPERSPIRANTS; MAKE-UP POWDER AND MAKE-UP REMOVING PREPARATIONS; NON-MEDICATED LIP CARE PREPARATIONS, LIP MAKE-UP PREPARATIONS, NAMELY, LIPSTICKS, LIP GLOSSES, LIP PENCILS; NAIL CARE PREPARATIONS, NAIL COLORING PREPARATIONS, NAMELY, NAIL POLISH AND NAIL ENAMELS; SUNTAN PREPARATIONS, NAMELY, SUNTAN CREAMS, SUNTAN LOTIONS, SUNTAN GELS, SUNTAN EMULSIONS, SUNTAN OILS, SUNTAN BALSAMS, SUNTAN PREPARATIONS PROTECTING AGAINST UV, NAMELY, SUNBLOCK PREPARATIONS; SELF-TAN PREPARATIONS; DEPILATORY PREPARATIONS, NAMELY, DEPILATORY CREAMS AND DEPILATORY WAXES; AFTER-BATH POWDERS; HYGIENIC POWDERS, NAMELY, TALCUM POWDER; DENTIFRICES, PREPARATIONS FOR ORAL CARE, NAMELY, TOOTH-PASTE, NON-MEDICATED TOILETRIES (U.S. CLS. 1, 4, 6, 50, 51 AND 52).

CLASS 5—PHARMACEUTICALS

FOR COSMETICS FOR MEDICAL USE, NAMELY, MEDICINAL CREAMS, BODY EMULSIONS, FACIAL EMULSIONS, SKIN CREAMS IN LIQUID FORM, SKIN GELS, FACIAL GELS, SKIN OILS, SKIN BALSAMS, BATH SALTS FOR MEDICAL USE AND MEDICAL BATHS, PHARMACEUTICAL SKIN LOTIONS, ALL OF THE FOREGOING FOR THE TREATMENT OF SKIN DISEASES (U.S. CLS. 6, 18, 44, 46, 51 AND 52).

TINA KUAN, EXAMINING ATTORNEY

SN 79-041,233. SIEMENS ENTERPRISE COMMUNICATIONS; GMBH & CO. KG, FED REP GERMANY, FILED 5-18-2007.

HiPath Open

THE MARK CONSISTS OF STANDARD CHARACTERS WITHOUT CLAIM TO ANY PARTICULAR FONT, STYLE, SIZE, OR COLOR.

PRIORITY DATE OF 1-16-2007 IS CLAIMED.

OWNER OF INTERNATIONAL REGISTRATION 0931271 DATED 5-18-2007, EXPIRES 5-18-2017.

OWNER OF U.S. REG. NOS. 2,875,915 AND 3,006,048.

CLASS 9—ELECTRICAL AND SCIENTIFIC APPARATUS

FOR OPTICAL, ELECTROTECHNICAL AND ELECTRONIC APPARATUS AND DEVICES, AND ELECTRICAL DEVICES FOR RECORDING, EMISSION, TRANSMISSION, SWITCHING, RECEPTION AND REPRODUCTION AND PROCESSING OF SOUNDS, SIGNALS, CHARACTERS AND IMAGES, NAMELY, COMMUNICATION SERVERS, ROUTERS, SWITCHES, AND GATEWAYS; DEVICES, NAMELY, ROUTERS, SWITCHES, AND GATEWAYS FOR THE INTEGRATION OF VOICE, IMAGE, TEXT, DATA, MULTIMEDIA, FULL-MOTION VIDEO COMMUNICATIONS IN COMPUTER AND TELECOMMUNICATION NETWORKS; COMMUNICATIONS COMPUTERS; SOFTWARE, NAMELY, COMPUTER SOFTWARE FOR MANAGEMENT AND INTEGRATION OF TELECOMMUNICATIONS NETWORKS, COMPUTER SOFTWARE FOR USE IN THE OPERATION AND MAINTENANCE OF TELECOMMUNICATIONS EQUIPMENT, COMPUTER TELEPHONY SOFTWARE, COMPUTER SOFTWARE FOR THE INTEGRATION OF VOICE AND DATA, COMPUTER SOFTWARE FOR USE IN THE OPERATION AND MAINTENANCE OF COMPUTER NETWORKS; OPTICAL, ELECTROTECHNICAL AND ELECTRONIC EQUIPMENT FOR VOICE, IMAGE, TEXT, DATA, MULTIMEDIA AND FULL-MOTION VIDEO NAMELY COMMUNICATION SERVERS, ROUTERS, SWITCHES AND GATEWAYS; AUTOMATIC TELEPHONE DIALING DEVICES; TELEPHONES, VIDEO-PHONES, AND VOICE BOXES; DOMESTIC TELEPHONE SYSTEMS COMPRISING PRIVATE AUTOMATIC BRANCH EXCHANGES; PHOTOCOPIERS; TELECOMMUNICATION NETWORKS CONSISTING OF EXCHANGE AND TRANSMISSION EQUIPMENT, INDIVIDUAL MODULES AND COMPONENTS OF SUCH EQUIPMENT, NAMELY, POWER SUPPLY UNITS, TRANSMISSION MEDIA IN THE NATURE OF TELECOMMUNICATION CABLES AND OPTICAL FIBERS AND CONNECTION ELEMENTS IN THE NATURE OF CABLE AND ELECTRICAL CONNECTORS; WIRELESS TRANSMISSION MEDIA, NAMELY, INFRARED RECEIVERS AND TRANSMITTERS AND RADIO TELEPHONES FOR WIRELESS COMMUNICATION; AND STRUCTURAL PARTS FOR ALL OF THE AFORESAID GOODS (U.S. CLS. 21, 23, 26, 36 AND 38).

CLASS 37—CONSTRUCTION AND REPAIR

FOR INSTALLATION, MOUNTING, MAINTENANCE AND REPAIR OF TELECOMMUNICATION DEVICES, SYSTEMS AND NETWORKS, NAMELY, COMPUTERS AND COMPUTER HARDWARE SYSTEMS AND NETWORKS (U.S. CLS. 100, 103 AND 106).

CLASS 38—COMMUNICATION

FOR OPERATION OF TELECOMMUNICATION SYSTEMS AND TELECOMMUNICATION NETWORKS, NAMELY, TELECOMMUNICATION GATEWAY SERVICES, TECHNICAL OPERATION AND MONITORING OF TELECOMMUNICATION SYSTEMS AND NETWORKS OF OTHERS AND PROVIDING BACK-UP COMPUTER PROGRAMS AND FACILITIES; CONSULTATION IN THE SETTING-UP OF TELECOMMUNICATION SYSTEMS, DATA PROCESSING SYSTEMS AND TELECOMMUNICATION NETWORKS; RENTAL OF TELECOMMUNICATION EQUIPMENT AND NETWORKS (U.S. CLS. 100, 101 AND 104).

CLASS 41—EDUCATION AND ENTERTAINMENT

FOR TRAINING IN THE SETTING-UP AND OPERATION OF TELECOMMUNICATION SYSTEMS AND TELECOMMUNICATION NETWORKS (U.S. CLS. 100, 101 AND 107).

CLASS 42—SCIENTIFIC AND COMPUTER SERVICES

FOR TECHNICAL DEVELOPMENT AND PROJECT DESIGN OF TELECOMMUNICATION AND INFORMATION PROCESSING NETWORKS; PROJECT DESIGN OF TELECOMMUNICATIONS AND DATA PROCESSING SYSTEMS; DESIGN AND DEVELOPMENT OF DATA PROCESSING COMPUTER PROGRAMS FOR TELECOMMUNICATION SYSTEMS FOR OTHERS; RENTAL OF DATA PROCESSING COMPUTER PROGRAMS FOR TELECOMMUNICATION SYSTEMS (U.S. CLS. 100 AND 101).

TINA KUAN, EXAMINING ATTORNEY

SN 79-041,805. OBSHCHESTVO S OGRANICHENNOI; OTVETSTVENNOSTJU "KOMPANIA ZOLOTOTI TEREM", RUSSIAN FED., FILED 12-25-2006.



PRIORITY DATE OF 7-27-2006 IS CLAIMED.

OWNER OF INTERNATIONAL REGISTRATION 0932498 DATED 12-25-2006, EXPIRES 12-25-2016.

OWNER OF U.S. REG. NO. 3,280,202.

THE COLOR(S) WHITE, LIGHT YELLOW, YELLOW, DARK YELLOW, RED, BROWN IS/ARE CLAIMED AS A FEATURE OF THE MARK.

THE COLOR WHITE APPEARS IN THE CENTER OF THE SUN; THE COLOR LIGHT YELLOW APPEARS IN THE WORDING AND IN THE BORDER OF CIRCLE AND RECTANGLE; THE COLOR YELLOW APPEARS IN THE WORDING, THE SUN, THE CIRCLE, AND THE OUTLINE OF THE RECTANGLE; THE COLOR DARK YELLOW APPEARS IN THE SHADOW OF THE SUN AND THE EDGE OF THE CIRCLE; THE COLOR RED APPEARS IN THE TOP OF THE RECTANGLE AND THE TIPS OF THE SUN'S RAYS; AND THE COLOR BROWN APPEARS IN THE BOTTOM OF THE RECTANGLE.

"BARENTSEV" HAS NO MEANING IN A FOREIGN LANGUAGE.

THE TRANSLITERATION OF THE NON-LATIN CHARACTERS IN THE MARK IS: "BARENTSEV".

CLASS 29—MEATS AND PROCESSED FOODS

FOR PROCESSED ANCHOVIES; PEANUTS, PROCESSED; MUSHROOMS, PRESERVED; GAME, DEAD; MEAT JELLIES; JELLIES FOR BREAD; FRUIT JELLIES BEING BREAD SPREADS; SAUSAGES; CAVIAR; CANNED MEAT; CANNED VEGETABLES; CANNED FISH; CANNED FRUITS; GHERKINS; PRAWNS, NOT LIVE; FISH CROQUETTES; LOBSTERS, NOT LIVE; SALMON; MARMALADE; SUNFLOWER OIL FOR FOOD; BUTTER; MUSSELS, NOT LIVE; ALMONDS, GROUND; SHELLFISH, NOT LIVE; MILK; MEAT; VEGETABLES, COOKED; POTATO FRITTERS; NUTS, PREPARED; TOMATO PUREE; LIVER PASTES; PICKLES; HAM; MILK PRODUCTS EXCLUDING ICE CREAM, ICE MILK AND FROZEN YOGURT; FOODS PREPARED FROM FISH, NAMELY, SALTED FISH AND DRIED FISH; CRAYFISH, NOT LIVE; FISH, NOT LIVE; VEGETABLE SALADS; FRUIT SALADS; SARDINES; HERINGS; VEGETABLE JUICES FOR COOKING; SOUPS; CHEESE; GARDEN HERBS, PRESERVED; TUNA FISH; OYSTERS, NOT LIVE; FRUIT, PRESERVED; FROZEN FRUITS; POTATO FLAKES; POTATO CHIPS; FRUIT CHIPS (U.S. CL. 46).

CLASS 30—STAPLE FOODS

FOR COOKIES; PANCAKES; BREAD ROLLS; WAFLES; VERMICELLI; MUSTARD; CONFECTIONERY FOR DECORATING CHRISTMAS TREES, NAMELY, CANDY; CAKES; PASTRIES; PEANUT CONFECTIONERY, NAMELY, CANDY CONTAINING PEANUTS; ALMOND CONFECTIONERY, NAMELY, CANDY CONTAINING ALMONDS; FARINACEOUS FOOD PASTES FOR HUMAN CONSUMPTION; PASTY; COCOA PRODUCTS, NAMELY, COCOA MIXES, COCOA SPREADS; CARAMELS; SWEETMEATS; CRACKERS; PROCESSED GROATS FOR HUMAN FOOD; CORN, ROASTED; MUESLI; CRUSHED OATS; HUSKED OATS; CANDY FOR FOOD; HONEY; FRUIT JELLIES BEING CONFECTIONERY; CORN FLOUR; NUTMEGS; BISCUITS; POPCORN; CEREAL PREPARATIONS, NAMELY, BREAKFAST CEREALS, CEREAL BASED SNACK FOODS; FLOUR-MILLING PRODUCTS, NAMELY, RICE FLOUR, SOYA FLOUR; CHEWING GUM, NOT FOR MEDICAL PURPOSES; OAT-BASED FOOD, NAMELY, OATMEAL; CONFECTIONERY, NAMELY, PEANUT BUTTER CONFECTIONERY CHIPS, CANDY; SPAGHETTI; RUSKS; BREADCRUMBS; BREAD; TEA; CHOCOLATE; CORN FLAKES (U.S. CL. 46).

CLASS 31—NATURAL AGRICULTURAL PRODUCTS

FOR UNPROCESSED ORANGES; UNPROCESSED PEANUTS, UNPROCESSED FRUITS; BEANS, FRESH; GRAPES, FRESH; DOG BISCUITS; PEAS, FRESH; MUSHROOMS, FRESH; SOD; LIVE TREES; ADDITIVES TO ANIMAL FODDER, NOT FOR MEDICAL PURPOSES; LIVE CHRISTMAS TREES; LIVE ANIMALS; LIVESTOCK FEED, NAMELY, OIL CAKE; UNPROCESSED GRAINS AND CEREALS; FISH SPAWN; POTATOES, FRESH; ANIMAL FOODSTUFFS; PET FOOD; BIRD FOOD; ROOTS FOR PET FOOD; LIVE PLANTS IN THE NATURE OF NETTLES; GROATS FOR POULTRY FOOD; LIVE BUSHES; FRESH ONIONS, FRESH VEGETABLES; FLOWER BULBS; ANIMAL LITTER; MUSSELS, LIVE; SHELLFISH, LIVE; MEAL FOR ANIMALS; UNPROCESSED OATS; VEGETABLE, FRESH; UNPROCESSED NUTS, FRESH FRUITS; UNPROCESSED BRAN; BRAN MASH FOR ANIMAL CONSUMPTION; ANIMAL FAT-TENING PREPARATIONS, NAMELY, ANIMAL FEED; POULTRY, LIVE; UNPROCESSED WHEAT; CRAYFISH, LIVE; LIVE PLANTS; PLANTS, DRIED, FOR DECORATION; UNPROCESSED RYE; UNPROCESSED BEET; UNPROCESSED GRAINS; HAY; STRAW LITTER, NAMELY, CHOPPED STRAW FOR ANIMAL BEDDING; UNPROCESSED HAZELNUTS; FLOWERS, NATURAL; PINE CONES; BERRIES, BEING FRESH FRUITS; FLOWERS, DRIED, FOR DECORATION (U.S. CLS. 1 AND 46).

CLASS 32—LIGHT BEVERAGES

FOR APERITIFS, NON-ALCOHOLIC; TABLE WATER; COCKTAILS, NON-ALCOHOLIC; LEMONADES; BEVERAGES, NON-ALCOHOLIC, NAMELY, SOFT DRINKS; WHEY BEVERAGES; FRUIT JUICE BEVERAGES, NON-ALCOHOLIC; FRUIT NECTARS, NON-ALCOHOLIC; BEER; POWDERS USED IN PREPARATION OF EFFERVESCING BEVERAGES IN THE NATURE OF SOFT DRINKS; TOMATO JUICE; CIDER, NON-ALCOHOLIC; FRUIT JUICES; PREPARATIONS FOR MAKING AERATED WATER; PREPARATIONS FOR MAKING BEVERAGES IN THE NATURE OF FRUIT DRINKS; PASTILLES FOR EFFERVESCING BEVERAGES, NAMELY, PREPARATIONS FOR MAKING SOFT DRINKS; NON-ALCOHOLIC FRUIT EXTRACTS USED IN THE PREPARATION OF BEVERAGES (U.S. CLS. 45, 46 AND 48).

CLASS 33—WINES AND SPIRITS

FOR APERITIFS; BRANDY; WINE; WHISKY; VODKA; GIN; DIGESTERS, NAMELY, LIQUORS; PREPARED ALCOHOLIC COCKTAILS; LIQUEURS; ALCOHOLIC BEVERAGES, NAMELY, LIQUORS; ALCOHOLIC BEVERAGES, CONTAINING FRUIT, NAMELY, ALCOHOLIC BEVERAGES OF FRUIT; HYDROMEL BEING MEAD; ALCOHOLIC BITTERS; HARD CIDER; ALCOHOLIC EXTRACTS (U.S. CLS. 47 AND 49).

CLASS 35—ADVERTISING AND BUSINESS

FOR IMPORT-EXPORT AGENCIES; COMMERCIAL INFORMATION AGENCIES; RENTAL OF ADVERTISING SPACE; EMPLOYMENT AGENCIES; COMPUTERIZED FILE MANAGEMENT; EFFICIENCY EXPERTS; DEMONSTRATION OF GOODS; PUBLIC OPINION POLLING; CONDUCTING MARKETING STUDIES; BUSINESS INFORMATION; BUSINESS INVESTIGATIONS; PERSONNEL RECRUITMENT; BUSINESS MANAGEMENT AND ORGANIZATION CONSULTANCY; UPDATING OF ADVERTISING MATERIAL; ORGANIZATION OF EXHIBITIONS FOR COMMERCIAL OR ADVERTISING PURPOSES; ORGANIZATION OF TRADE FAIRS FOR COMMERCIAL OR ADVERTISING PURPOSES; SHOP WINDOW DRESSING SERVICES; BUSINESS MANAGEMENT ASSISTANCE; SALES PROMOTION FOR OTHERS; RENTAL OF ADVERTISING TIME ON COMMUNICATION MEDIA; PUBLICATION OF PUBLICITY TEXTS; RADIO ADVERTISING; DISTRIBUTION OF SAMPLES; DIRECT MAIL ADVERTISING; ADVERTISING; ADVERTISING AGENCIES; PROCUREMENT SERVICES FOR OTHERS, NAMELY, PURCHASING GOODS AND SERVICES IN THE NATURE OF FOOD STUFF FOR OTHER BUSINESSES; PUBLICITY COLUMNS PREPARATION, NAMELY, WRITING OF PUBLICITY TEXTS; BUSINESS MANAGEMENT OF HOTELS; PSYCHOLOGICAL TESTING FOR THE SELECTION OF PERSONNEL; PUBLIC RELATIONS; MODELING FOR ADVERTISING OR SALES PROMOTION (U.S. CLS. 100, 101 AND 102).

CLASS 43—HOTEL AND RESTAURANT SERVICES

FOR RENTAL FOR TEMPORARY ACCOMMODATION, NAMELY, RENTAL OF BUILDING FOR TEMPORARY OCCUPANCY; RENTAL OF MEETING ROOMS; TOURIST HOMES; MAKING HOTEL RESERVATIONS FOR OTHERS; MAKING BOARDING HOUSE BOOKINGS; MAKING TEMPORARY ACCOMMODATION RESERVATIONS; HOTELS; SNACK-BARS; CAFES; CAFETERIAS; MOTELS; BOARDING HOUSES; BOARDING FOR ANIMALS; RESTAURANTS; SELF-SERVICE RESTAURANTS; CANTEEN SERVICES; HOLIDAY CAMP SERVICES, NAMELY, RESORT LODGING SERVICES; BAR SERVICES; PROVIDING CAMPGROUND FACILITIES; FOOD AND DRINK CATERING (U.S. CLS. 100 AND 101).

KRISTINA MORRIS, EXAMINING ATTORNEY

SN 79-041,989. SCHNEEBERGER HOLDING AG, SWITZERLAND, FILED 6-13-2007.

SCHNEEBERGER

PRIORITY DATE OF 1-9-2007 IS CLAIMED.
OWNER OF INTERNATIONAL REGISTRATION 0933003
DATED 6-13-2007, EXPIRES 6-13-2017.
OWNER OF U.S. REG. NO. 2,816,478.

CLASS 7—MACHINERY

FOR MACHINE PARTS, NAMELY, GUIDEWAYS FOR MACHINES AND THEIR PARTS, IN PARTICULAR, LINEAR GUIDEWAYS, PROFILED RAIL GUIDEWAYS, BEARING TABLES AND CROSS MOVEMENT BEARING TABLES EACH WITH BEARING PARTS; SUPPORT PADS, AS PARTS OF MACHINES, FOR INFINITE MOVEMENTS; MACHINES FOR MANUFACTURING COMPONENTS AND PARTS OF CONSUMER DURABLES, NAMELY COMPLETE MULTI-AXIS POSITIONING DEVICES COMPOSED OF AN UPPER AND LOWER PART, PROFILED RAIL GUIDEWAYS, A BALL SCREW, AN ENGINE COUPLING AND A MEASURING INSTRUMENT (U.S. CLS. 13, 19, 21, 23, 31, 34 AND 35).

CLASS 9—ELECTRICAL AND SCIENTIFIC APPARATUS

FOR MEASURING APPARATUS AND INSTRUMENTS FOR PROFILED RAIL GUIDEWAYS, NAMELY, ABSOLUTE AND INCREMENTAL LINEAR DISPLACEMENT MEASURING DEVICES CONSISTING OF A SCALE INTEGRATED INTO THE RAIL GUIDEWAY AND A READING DEVICE INTEGRATED INTO THE MOVEABLE SLIDER AND THEIR ACCESSORIES, NAMELY, ELECTRONICS FOR SIGNAL-CONDITIONING, SENSORS TO IDENTIFY THE DIRECTION OF MOTION, ELECTRONICS TO REMEMBER CERTAIN POSITION EVEN DURING POWER OUTAGE, ALL COMPRISING AN INTEGRATED MEASURING SYSTEM COMPRISED OF A SCALE INTEGRATED INTO THE RAIL GUIDEWAY AND A READING DEVICE INTEGRATED INTO THE MOVEABLE BEARING SLIDER, FOR LINEAR ROLLER OR BALL GUIDEWAYS WITH ANALOG OR DIGITAL INTERFACE FOR USE WITH MACHINE TOOLS AND AUTOMATION OF MANUFACTURING SEQUENCES (U.S. CLS. 21, 23, 26, 36 AND 38).
ESTHER BELENKER, EXAMINING ATTORNEY

SN 79-042,228. THE TINTOMETER LIMITED, UNITED KINGDOM, FILED 3-8-2007.

LOVIBOND

OWNER OF INTERNATIONAL REGISTRATION 0933559
DATED 3-8-2007, EXPIRES 3-8-2017.
OWNER OF U.S. REG. NOS. 1,027,254 AND 1,600,138.

CLASS 1—CHEMICALS

FOR CHEMICAL REAGENTS FOR NON-MEDICAL TRADE, INDUSTRIAL, COMMERCIAL, SCIENTIFIC, LABORATORY AND FIELD USE; CHEMICAL REAGENTS FOR USE WITH SAMPLE TESTING, LIQUID TESTING, WATER TESTING, EFFLUENT TESTING, ION SPECIFIC TESTING, PH TESTING, TURBIDITY TESTING, WATER CONDITIONING, WATER PURIFICATION, OPTICAL TESTING, COLOR TESTING, ALL FOR NON-MEDICAL PURPOSES; CHEMICAL REAGENTS FOR USE WITH OPTICAL TEST APPARATUS AND TEST CELLS FOR NON-MEDICAL PURPOSES; CHEMICAL REAGENTS FOR NON-MEDICAL PURPOSES IN TABLET, POWDER IN CAPSULE AND LIQUID IN CAPSULE FORM (U.S. CLS. 1, 5, 6, 10, 26 AND 46).

CLASS 9—ELECTRICAL AND SCIENTIFIC APPARATUS

FOR SCIENTIFIC, LABORATORY, TRADE, COMMERCIAL, INDUSTRIAL AND FIELD MEASUREMENT AND TESTING APPARATUS AND INSTRUMENTATION, NAMELY, TITRATION APPARATUS, BIOLOGICAL OXYGEN DEMAND METERS, HEATERS FOR SAMPLE SOFTENING IN OPTICAL AND COLOR MEASUREMENT APPARATUS, TURBIDITY METERS, FLOCCULATION AND SEDIMENTATION METERS, CHEMICAL OXYGEN DEMAND METERS, REDOX METERS, PH-VALUE METERS, THERMOMETERS, OXYGEN SATURATION AND CONCENTRATION METERS, SALINITY METERS, CHLORINE METERS, AND WATER HARDNESS METERS; COLOR COMPARATORS, NAMELY, NESSLERIZERS; SPECTROPHOTOMETERS; COLOR ANALYTICAL INSTRUMENTATION, NAMELY, COLORIMETERS AND SPECTROPHOTOMETERS; COLOR MEASUREMENT APPARATUS IN THE NATURE OF COLORIMETERS, CAMERAS AND IMAGE PROCESSING SOFTWARE SOLD AS A UNIT; COLOR TEST APPARATUS IN THE NATURE OF SPECTROPHOTOMETERS AND COLORIMETERS; COLOR REFERENCE AND COLOR STANDARD TEST APPARATUS IN THE NATURE OF VISUAL AND AUTOMATIC COLORIMETERS; SCIENTIFIC, LABORATORY AND FIELD APPARATUS FOR COMPARING COLORS OF LIQUIDS AND SOLIDS WITH PERMANENT COLOR REFERENCE STANDARDS; COLOR REFERENCE STANDARDS IN THE NATURE OF COLORED GLASSES, TRANSPARENCIES, FILMS, SLIDES AND DISCS, FOR USE IN COLOR MEASUREMENT, COMPARISON AND TESTING; FILTERS FOR OPTICAL DEVICES; COLORIMETERS; COLORIMETRIC ANALYTICAL INSTRUMENTS, NAMELY, OPTICAL TEST APPARATUS FOR COMPARING COLORS TO PERMANENT COLOR STANDARDS; COLOR GRADING INSTRUMENTS IN THE NATURE OF COMPARATORS FOR IDENTIFYING A SAMPLE BY A SPECIFIED COLOR GRADE; COLOR COMPARATORS; COMPARATORS; COLOR TEST CELLS IN THE FORM OF TRANSPARENCIES, FILMS, SLIDES, AND DISCS FOR TESTING USING SPECTROPHOTOMETRY, PHOTOMETRY AND FLUORESCENCE; WATER TEST APPARATUS FOR MONITORING AND DETECTING CONTAMINATION, INORGANIC AND ORGANIC COMPONENTS AND PHYSICAL AND ELECTROCHEMICAL PARAMETERS; WATER QUALITY PARAMETER TEST APPARATUS FOR MONITORING AND DETECTING CONTAMINATION, INORGANIC AND ORGANIC COMPONENTS AND PHYSICAL AND ELECTROCHEMICAL PARAMETERS; PHOTOMETERS; PORTABLE PHOTOMETRIC TEST COMPRISES OF TEST CELLS IN THE FORM OF TRANSPARENCIES, FILMS, SLIDES, AND DISCS AND PHOTOMETRY AND SPECTROPHOTOMETER APPARATUS; ION SPECIFIC PHOTOMETRIC ANALYTICAL INSTRUMENTS; PARAMETRIC CONCENTRATION MEASUREMENT APPARATUS IN THE NATURE OF PHOTOMETERS AND SPECTROPHOTOMETERS; LABORATORY EQUIPMENT IN THE NATURE OF LIGHTING CABINETS AND LAMPS FOR OPTICAL AND COLOR MEASUREMENT, COMPARISON AND TESTING; LABORATORY EQUIPMENT IN THE NATURE OF HEATERS FOR SAMPLE SOFTENING IN OPTICAL AND COLOR MEASUREMENT, COMPARISON AND TESTING; COMPUTER PROGRAMS AND SOFTWARE IN CONNECTION WITH OPTICAL TESTING, COLOR TESTING, COLORIMETRY, COLOR COM-

PARATORS, SPECTROPHOTOMETRY, WATER TESTING AND CONDITIONING (U.S. CLS. 21, 23, 26, 36 AND 38).

DAYNA BROWNE, EXAMINING ATTORNEY

SN 79-042,929. ANDELSMEJERIER SÆDAGER, HOBRO, DENMARK, FILED 8-11-2007.



OWNER OF INTERNATIONAL REGISTRATION 0935269 DATED 8-11-2007, EXPIRES 8-11-2017.

CLASS 29—MEATS AND PROCESSED FOODS

FOR MEAT, FISH, POULTRY AND GAME; MEAT EXTRACTS; PRESERVED, DRIED AND COOKED FRUITS AND VEGETABLES; JELLIES, JAMS, COM-POTES; EGGS; DAIRY PRODUCTS EXCLUDING ICE CREAM, ICE MILK AND FROZEN YOGHURT (U.S. CL. 46).

CLASS 30—STAPLE FOODS

FOR COFFEE, TEA, COCOA, SUGAR, RICE, TAPI-CA, SAGO, ARTIFICIAL COFFEE; FLOUR AND PRE-PARATIONS MADE FROM CEREALS, NAMELY, CEREAL BASED SNACK FOODS; BREAD, PASTRY AND CONFECTIONERY CHIPS FOR BAKING; ICES; HONEY; TREACLE; YEAST, BAKING-POWDER; SALT, MUSTARD; VINEGAR, KETCHUP; SPICES; ICE (U.S. CL. 46).

TEJBIR SINGH, EXAMINING ATTORNEY

SN 79-043,132. MOLL FUNKTIONSMÖBEL GMBH, FED REP GERMANY, FILED 8-8-2007.

moll

THE MARK CONSISTS OF STANDARD CHARACTERS WITHOUT CLAIM TO ANY PARTICULAR FONT, STYLE, SIZE, OR COLOR.

OWNER OF INTERNATIONAL REGISTRATION 0935816 DATED 8-8-2007, EXPIRES 8-8-2017.

OWNER OF U.S. REG. NO. 3,032,524.

CLASS 16—PAPER GOODS AND PRINTED MATTER

FOR STATIONERY; OFFICE REQUISITES, NAMELY, ADHESIVE TAPE DISPENSERS; WRITING IMPLEMENTS; DRAWING RULERS; DESK PADS; OFFICE ORGANIZATION MATERIALS, NAMELY, FILE FOLDERS, RING BINDERS, DESK FILE TRAYS; LETTER FILES; TRANSPARENT SLEEVES FOR PROTECT-ING FILES; TRANSPARENT SLEEVES FOR PROTECT-ING LETTERS AND TRANSPARENT SLEEVES FOR PROTECTING DOCUMENTS; FILE REGISTERS; HANGING LETTER FILES AND HANGING DOCU-MENT FILES; SUSPENSION LETTER FILES; SUS-PENDED LETTER FILES; STORAGE CONTAINERS MADE OF PAPER OR CARDBOARD AND FILING BOXES FOR OFFICE RECORDS; AND DOCUMENT FILE RACKS (U.S. CLS. 2, 5, 22, 23, 29, 37, 38 AND 50).

CLASS 20—FURNITURE AND ARTICLES NOT OTHERWISE CLASSIFIED

FOR FURNITURE; SEATING FURNITURE; OFFICE FURNITURE; FURNITURE FOR CHILDREN AND YOUNG PEOPLE; TABLES; DESKS; CABINETS; NON-METAL OFFICE CONTAINERS FOR THE TRANSPORT AND STORAGE OF STATIONERY AND OFFICE RE-QUISITES; SHELVES; AND CHAIRS (U.S. CLS. 2, 13, 22, 25, 32 AND 50).

CLASS 35—ADVERTISING AND BUSINESS

FOR WHOLESALE AND RETAIL STORE SERVICES FEATURING LIGHTS, OFFICE REQUISITES AND OF-FICE ORGANIZATION MATERIALS, BAGS AND SCHOOL BAGS, FURNITURE, INCLUDING OFFICE FURNITURE AND FURNITURE FOR CHILDREN AND YOUNG PEOPLE, OFFICE EQUIPMENT, TEXTILES AND TEXTILE GOODS, CLOTHING, FOOTWEAR AND HEADGEAR; ARRANGING OF TRADING AND ECO-NOMICAL CONTACTS, ALSO OVER THE INTERNET, NAMELY, THE BRINGING TOGETHER, FOR THE BENEFIT OF OTHERS, OF A VARIETY OF GOODS AND SERVICES, ENABLING CUSTOMERS TO CONVE-NIENTLY VIEW AND PURCHASE THOSE GOODS AND SERVICES FROM AN INTERNET WEBSITE PARTICU-LARLY SPECIALIZING IN THE MARKETING OF THE SALE OF GOODS AND SERVICES OF OTHERS (U.S. CLS. 100, 101 AND 102).

BENJAMIN OKEKE, EXAMINING ATTORNEY

SN 79-043,159. VOLKSWAGEN AG, FED REP GERMANY, FILED 5-10-2007.

Catamount

THE MARK CONSISTS OF STANDARD CHARACTERS WITHOUT CLAIM TO ANY PARTICULAR FONT, STYLE, SIZE, OR COLOR.

PRIORITY DATE OF 11-13-2006 IS CLAIMED.

OWNER OF INTERNATIONAL REGISTRATION 0935908 DATED 5-10-2007, EXPIRES 5-10-2017.

THE WORDING "CATAMOUNT" HAS NO MEANING IN A FOREIGN LANGUAGE.

CLASS 12—VEHICLES

FOR MOTOR VEHICLES AND THEIR PARTS, NAMELY, AUTOMOBILES, TRUCKS, VANS, SPORT UTILITY VEHICLES, MOTOR CARAVANS, LORRIES, BUSES, MOTORCYCLES, SNOW BIKES, NAMELY, SNOW MOBILES AND STRUCTURAL PARTS THEREFOR INCLUDED IN THIS CLASS; ENGINES FOR LAND VEHICLES; TIRES FOR VEHICLE WHEELS, RIMS FOR VEHICLE WHEELS, COMPLETE VEHICLE WHEELS AND THEIR PARTS FOR LAND VEHICLES; VEHICLES FOR CHILDREN, NAMELY, MOTORIZED SCOOTERS; AND MOTORIZED AUTOMOBILES FOR CHILDREN (U.S. CLS. 19, 21, 23, 31, 35 AND 44).

CLASS 28—TOYS AND SPORTING GOODS

FOR SCALE MODEL VEHICLES, NAMELY, SCALE MODEL AUTOMOBILES; PLAYING CARDS; STUFFED TOY ANIMALS AND OTHER STUFFED TOYS; GAMES, NAMELY, VIDEO GAMES, OTHER THAN THOSE ADAPTED FOR USE WITH EXTERNAL SCREENS OR MONITORS (U.S. CLS. 22, 23, 38 AND 50).

CLASS 35—ADVERTISING AND BUSINESS

FOR RETAIL AND WHOLESALE STORE SERVICES FEATURING AUTOMOBILES, TRUCKS, VANS, SPORT UTILITY VEHICLES, MOTOR CARAVANS, LORRIES, BUSES, MOTORCYCLES, SNOW BIKES AND THEIR STRUCTURAL PARTS AND FITTINGS, NAMELY, VIA RETAIL AND WHOLESALE OUTLETS AND VIA MAIL-ORDER BUSINESS; RETAIL STORE SERVICES, WHOLESALE STORE SERVICES, MAIL-ORDER SERVICES AND ONLINE RETAIL AND WHOLESALE STORE SERVICES FEATURING AUTOMOBILES, TRUCKS, VANS, SPORT UTILITY VEHICLES, MOTOR CARAVANS, LORRIES, BUSES, MOTORCYCLES, SNOW BIKES AND THEIR STRUCTURAL PARTS AND FITTINGS; BRINGING TOGETHER, BUT NOT TRANSPORTING, OF A VARIETY OF MOTOR VEHICLES AND THEIR PARTS AND FITTINGS FOR THE BENEFIT OF OTHERS, THEREBY ENABLING CUSTOMERS TO VIEW AND PURCHASE THE GOODS; NEGOTIATION OF COMMERCIAL TRANSACTIONS, NAMELY, CONTRACTS FOR THE BENEFIT OF THIRD PARTIES ABOUT SALE AND PURCHASE OF MOTOR VEHICLES AND THEIR PARTS AND FITTINGS (U.S. CLS. 100, 101 AND 102).

CLASS 37—CONSTRUCTION AND REPAIR

FOR RECONSTRUCTION REBUILDING, REPAIR, SERVICING, DISMANTLING, CLEANING, MAINTENANCE AND VARNISHING OF VEHICLES AND THEIR PARTS AND MOTORS AND THEIR PARTS; VEHICLE REPAIR IN THE COURSE OF VEHICLE BREAKDOWN SERVICE; TUNING OF AUTOMOBILES, AS FAR AS INCLUDED IN THIS CLASS (U.S. CLS. 100, 103 AND 106).

WILLIAM ROSSMAN, EXAMINING ATTORNEY

SN 79-043,356. SOREMARTEC S.A., BELGIUM, FILED 8-3-2007.



The logo for 'naturella' is written in a bold, lowercase, green sans-serif font. To the right of the word, there is a small green icon of a flower or plant with several petals.

PRIORITY DATE OF 2-15-2007 IS CLAIMED.
OWNER OF INTERNATIONAL REGISTRATION 0936308
DATED 8-3-2007, EXPIRES 8-3-2017.

THE COLOR(S) GREEN IS/ARE CLAIMED AS A FEATURE OF THE MARK.

THE MARK CONSISTS OF THE WORD "NATURELLA" APPEARING IN GREEN, WITH A FLOWER FORMING PART OF THE SECOND LETTER "A".

CLASS 5—PHARMACEUTICALS

FOR SUGAR-FREE CONFECTIONERY; SUGAR-FREE CANDY AND CHEWING GUM; ALL THE AFORESAID GOODS INTENDED FOR MEDICAL USE (U.S. CLS. 6, 18, 44, 46, 51 AND 52).

CLASS 30—STAPLE FOODS

FOR CONFECTIONERY; CANDY AND CHEWING GUM; SUGAR-FREE CANDY AND CHEWING GUM; ALL THE AFORESAID GOODS NOT INTENDED FOR MEDICAL USE (U.S. CL. 46).

LINDSEY RUBIN, EXAMINING ATTORNEY

SN 79-043,521. PENSIONDCISIONS LIMITED, BEDFORD, BEDGORDSHIRE, MK40 2SY, UNITED KINGDOM, FILED 5-30-2007.

PensionDCisions

OWNER OF INTERNATIONAL REGISTRATION 0936662
DATED 5-30-2007, EXPIRES 5-30-2017.

CLASS 35—ADVERTISING AND BUSINESS

FOR ADVERTISING; BUSINESS MANAGEMENT; BUSINESS ADMINISTRATION; OFFICE FUNCTIONS; THE ORGANIZATION, OPERATION AND SUPERVISION OF LOYALTY AND INCENTIVE PROGRAMS; ADVERTISING SERVICES PROVIDED VIA THE INTERNET; PRODUCTION OF TELEVISION AND RADIO ADVERTISEMENTS; ACCOUNTANCY; AUCTIONEERING; TRADE FAIRS, NAMELY, PLANNING AND CONDUCTING OF TRADE FAIRS FOR ADVERTISING PURPOSES, CONSULTATION RELATING TO TRADE FAIRS; PUBLIC OPINION POLLING; DATA PROCESSING AND PROVISION OF BUSINESS INFORMATION (U.S. CLS. 100, 101 AND 102).

CLASS 41—EDUCATION AND ENTERTAINMENT

FOR EDUCATION IN THE FIELD OF FINANCE AND INVESTMENT, NAMELY, CLASSES, SEMINARS, WORKSHOPS, AND DISTRIBUTION OF COURSE MATERIALS IN CONNECTION THEREWITH IN THE FORM OF PRINTED REPORTS AND ONLINE ELECTRONIC MATERIALS; PROVIDING OF TRAINING IN THE FIELD OF FINANCE AND INVESTMENT; ELECTRONIC GAMES SERVICES PROVIDED BY MEANS OF THE INTERNET, NAMELY, PROVIDING ONLINE COMPUTER GAMES; PUBLISHING OF ON-LINE ELECTRONIC PUBLICATIONS; NON-DOWNLOADABLE DIGITAL MUSIC FROM THE INTERNET (U.S. CLS. 100, 101 AND 107).

SANDRA MANIOS, EXAMINING ATTORNEY

SN 79-043,594. FINDWORKS TECHNOLOGIES, FRANCE,
FILED 6-11-2007.

OWNER OF INTERNATIONAL REGISTRATION 0936824
DATED 6-11-2007, EXPIRES 6-11-2017.

THE COLOR(S) GREEN (PANTONE 389) IS/ARE
CLAIMED AS A FEATURE OF THE MARK.

THE COLOR GREEN APPEARS IN THE WORDING
LILIGO.

CLASS 35—ADVERTISING AND BUSINESS

FOR ADVERTISING SERVICES, ADVERTISING SERVICES OF A RADIO AND TELEVISION ADVERTISING AGENCY, PUBLISHING OF ADVERTISING TEXTS, NAMELY, PUBLICATION OF ADVERTISING ANNOUNCEMENTS AND MESSAGES, RENTAL OF ADVERTISING SPACE ON WEBSITES; ADVERTISING FLYER DISTRIBUTION, NAMELY, MAILING OF ADVERTISING FLYERS; BUSINESS ADVICE AND INFORMATION, COMMERCIAL INFORMATION AGENCIES; ARRANGING SUBSCRIPTIONS TO TELECOMMUNICATION SERVICES; ARRANGING SUBSCRIPTIONS TO AN INTERNET COMPUTER SERVICE; ARRANGING SUBSCRIPTIONS TO A COMPUTER SERVICE, NAMELY, A COMPUTER DATABASE; SUBSCRIPTIONS TO ELECTRONIC JOURNALS, SUBSCRIPTIONS TO A TELECOMMUNICATION SERVICE IN CONNECTION WITH INFORMATION IN THE FIELD OF TOURISM, ENTERTAINMENT, EDUCATION AND LEISURE; COMPUTER FILE MANAGEMENT (U.S. CLS. 100, 101 AND 102).

CLASS 38—COMMUNICATION

FOR TELECOMMUNICATION SERVICES, NAMELY, PROVIDING ACCESS TO TELECOMMUNICATION NETWORKS, COMMUNICATIONS BETWEEN COMPUTERS VIA BROADBAND, OPTICAL OR WIRELESS COMPUTER NETWORKS, TRANSMISSION OF DATA, SOUNDS AND IMAGES BY MEANS OF TELECOMMUNICATIONS NETWORKS, TRANSMISSION OF DATA, SOUNDS AND IMAGES VIA COMPUTER TERMINALS; TRANSMISSION OF DATABASE INFORMATION VIA TELECOMMUNICATIONS NETWORKS THAT ARE ACCESSIBLE BY ACCESS CODE; PROVIDING ACCESS TO DATABASES; PROVIDING ON-LINE DISCUSSION FORUMS FOR TRANSMISSION OF MESSAGES AMONG COMPUTER USERS CONCERNING TOURISM, ENTERTAINMENT, EDUCATION AND LEISURE; TRANSMISSION OF INFORMATION BY ELECTRONIC COMMUNICATIONS NETWORKS IN CONNECTION WITH THE COMPARISON OF DIFFERENT SERVICES IN THE FIELD OF TOURISM, ENTERTAINMENT, EDUCATION AND LEISURE; ELECTRONIC MAIL SERVICES; ELECTRONIC MAIL TRANSMISSION (U.S. CLS. 100, 101 AND 104).

CLASS 39—TRANSPORTATION AND STORAGE

FOR INFORMATION IN THE FIELD OF TRAVEL AND TOURISM; TRANSPORTATION RESERVATION SERVICES (U.S. CLS. 100 AND 105).

CLASS 41—EDUCATION AND ENTERTAINMENT

FOR PUBLISHING OF BOOKS AND MAGAZINES; PUBLISHING OF ELECTRONIC EDITORIAL AND AUDIOVISUAL PUBLICATIONS (U.S. CLS. 100, 101 AND 107).

CLASS 42—SCIENTIFIC AND COMPUTER SERVICES

FOR DESIGN, DEVELOPMENT, UPDATING, INSTALLATION, AND MAINTENANCE OF COMPUTER SOFTWARE FOR OTHERS, RESEARCH IN THE FIELDS OF SOFTWARE ENGINEERING AND SOFTWARE DEVELOPMENT; DESIGN, DEVELOPMENT, UPDATING, INSTALLATION, AND MAINTENANCE OF SOFTWARE FOR OTHERS FOR DATA PROCESSING AND FOR CREATION, MANAGEMENT, UPDATING AND USE OF DATABASES; DESIGN, DEVELOPMENT, UPDATING, INSTALLATION, AND MAINTENANCE OF SOFTWARE FOR INTERNET PORTAL CREATION FOR OTHERS; COMPUTER PROGRAMMING; CREATING, MAINTAINING, DESIGNING, IMPLEMENTING AND MANAGING WEB SITES FOR OTHERS (U.S. CLS. 100 AND 101).

CLASS 43—HOTEL AND RESTAURANT SERVICES

FOR RESERVATION OF HOTELS FOR OTHERS, MAKING RESERVATIONS AND BOOKINGS FOR INDIVIDUAL OR COLLECTIVE TEMPORARY ACCOMMODATION; RESERVATION OF ROOMS IN BOARDING HOUSES FOR TRAVELERS; PROVISION OF FOOD AND DRINKS (U.S. CLS. 100 AND 101).

ROBIN MITTLER, EXAMINING ATTORNEY

SN 79-043,706. KUHN S.A., FRANCE, FILED 6-5-2007.

MODULINER

THE MARK CONSISTS OF STANDARD CHARACTERS WITHOUT CLAIM TO ANY PARTICULAR FONT, STYLE, SIZE, OR COLOR.

PRIORITY DATE OF 12-7-2006 IS CLAIMED.

OWNER OF INTERNATIONAL REGISTRATION 0937085
DATED 6-5-2007, EXPIRES 6-5-2017.

CLASS 7—MACHINERY

FOR AGRICULTURAL MACHINERY AND MACHINE TOOLS, IMPLEMENTS NOT BEING HAND OPERATED, AND MACHINES ALL FOR USE IN AGRICULTURE, ANIMAL HUSBANDRY, HORTICULTURE, FORESTRY, EARTHMOVING, GARDENING AND PLEASURE GARDENING OR FARMING, NAMELY, TILLING MACHINES, NAMELY, SPRING TOOTH LEVER HARROWS, ROTARY CROSS-HARROWS, POWER OPERATED ROTARY TILLERS, PLOUGHS, CULTIVATORS, PULVERIZERS BEING EARTHMOVING MACHINES, GRINDERS, SOIL MIXERS, SEEDERS, SOIL DECOMPACTORS, AND LAND PACKING ROLLERS; COMBINED TILLING MACHINES; COMBINED TILLING AND SOWING MACHINES; AGRICULTURAL SEED PLANTING MACHINES, NAMELY, SOWERS, PNEUMATIC SOWERS, MECHANICAL SOWERS, PRECISION SOWERS, PRECISION SOWERS AND SOWERS WITH TINES; HAYMAKING MACHINES, NAMELY, MOWING AND REAPING MACHINES, MOWER CONDITIONERS, GRASS-AERATING MOWERS, TEDDING MACHINES, WINDROWERS, COMBINED TEDDER AND WINDROWER MACHINES, GROUPERS AND WINDROW TURNERS; HARVESTING MACHINES, NAMELY, REAPING MACHINES, COMBINE HARVESTERS AND FODDER BALERS; TREATMENT MACHINES, NAMELY, POWER OPERATED SPRAYERS; LAWN MOWERS; POWER OPERATED HEDGE GRASS SHREDDERS; CONVEYORS; ELEVATORS; POWER OPERATED STRAW BLOWERS AND FEEDERS; MACHINES USED TO PREPARE FOOD FOR LIVESTOCK, NAMELY, SILO UNLOADERS, UNLOADER-DISTRIBUTORS AND FODDER MIXER-DISTRIBUTORS; TRACTOR TOWED AGRICULTURAL ELEMENTS, NAMELY, FERTILIZER SPREADERS; MACHINES FOR EARTH MOVING WORK, NAMELY, BULLDOZERS, BACKHOES AND EXCAVATORS; REPLACEMENT PARTS OF THE AFOREMENTIONED GOODS; SELF-PROPELLED LAND APPARATUS, NAMELY, MOWERS, TEDDERS, WINDROWERS AND PRODUCT GROUPERS FOR PLANT MATERIALS; SELF-PROPELLED LAND APPARATUS, NAMELY TILLERS; SELF-PROPELLED LAND DEVICES, NAMELY, SOWERS; SELF-PROPELLED LAND DEVICES, NAMELY COMBINED TILLERS AND SOWERS (U.S. CLS. 13, 19, 21, 23, 31, 34 AND 35).

CLASS 12—VEHICLES

FOR VEHICLES, NAMELY, LAND VEHICLES, NAMELY, DUMP TRUCKS, FREIGHT TRUCKS, CARTS, TRAILERS, AND DISPENSING WAGONS; SELF-PROPELLED LAND VEHICLES; TRACTORS; MOTOR CARS; WAGONS; AND RAILWAY CARS (U.S. CLS. 19, 21, 23, 31, 35 AND 44).

KRISTINA MORRIS, EXAMINING ATTORNEY

SN 79-043,923. GAYE HANDE ZAPSU, SARIYER / ISTANBUL, TURKEY, FILED 6-29-2007.

HANDE ZAPSU

OWNER OF INTERNATIONAL REGISTRATION 0937761 DATED 6-29-2007, EXPIRES 6-29-2017.

THE NAME(S), PORTRAIT(S), AND/OR SIGNATURE(S) SHOWN IN THE MARK IDENTIFIES "HANDE ZAPSU", WHOSE CONSENT(S) TO REGISTER IS SUBMITTED.

CLASS 16—PAPER GOODS AND PRINTED MATTER

FOR PUBLICATIONS, NAMELY, BOOKS, BROCHURES, BOOKLETS, AND TEACHING MATERIALS, STORY BOOKS WHICH ARE PREPARED FOR CHILDREN (U.S. CLS. 2, 5, 22, 23, 29, 37, 38 AND 50).

CLASS 41—EDUCATION AND ENTERTAINMENT

FOR MAGAZINE, BOOKS AND NEWSPAPER PUBLISHING SERVICES (U.S. CLS. 100, 101 AND 107).
DAWN HAN, EXAMINING ATTORNEY

SN 79-044,003. CIRO SANTUCCI, ITALY, AND DOMENICO VANGI, ITALY, FILED 6-22-2007.

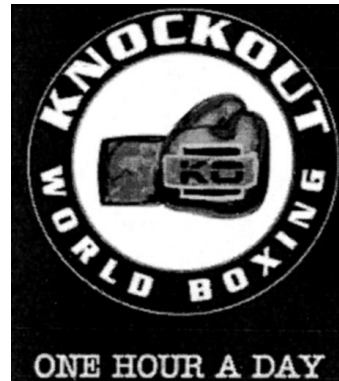

PRIORITY DATE OF 6-5-2007 IS CLAIMED.
OWNER OF INTERNATIONAL REGISTRATION 0938014 DATED 6-22-2007, EXPIRES 6-22-2017.

NO CLAIM IS MADE TO THE EXCLUSIVE RIGHT TO USE "WORLD BOXING", APART FROM THE MARK AS SHOWN.

THE MARK CONSISTS OF A CIRCLE WITH DOUBLE CIRCUMFERENCE IN WHICH THE WORDING "KNOCKOUT WORLD BOXING" IN SPECIAL CHARACTERS IS INCLUDED; IN THE CENTER OF THE CIRCLE, IS REPRESENTED A BOXING GLOVE HAVING THE WORD "KO" ON ITS UPPER SIDE; BELOW THE CIRCLE IS PLACED THE WORDING "ONE HOUR A DAY".

CLASS 3—COSMETICS AND CLEANING PREPARATIONS

FOR COSMETICS, PERFUMERY, SOAPS, ESSENTIAL OILS, HAIR LOTIONS (U.S. CLS. 1, 4, 6, 50, 51 AND 52).

CLASS 25—CLOTHING

FOR CLOTHING, NAMELY, PANTS, SHIRTS, T-SHIRTS, TRACKSUITS, SOCKS, STOCKINGS, SHORTS, SWEATSHIRTS, JACKETS, UNDERSHIRTS, JEANS, UNDERWEAR, BATH ROBES, BOXING JERSEYS, GLOVES, COATS, JOGGING SUITS, BATHING SUITS, BELTS; FOOTWEAR; HEADGEAR, NAMELY, HATS, CAPS, BANDANAS AND VISORS (U.S. CLS. 22 AND 39).

CLASS 28—TOYS AND SPORTING GOODS

FOR GYMNASTIC AND SPORTING ARTICLES NOT INCLUDED IN OTHER CLASSES, NAMELY, EAR AND EYEBROW PROTECTORS FOR BOXERS, BOXING MASKS, TEETH GUARDS, BOXING GLOVES, STRIKING BAGS, FIGHTING GLOVES, TRAINING DUMMIES, STRIKING-BAG PLATFORMS, DUMBBELLS, ROWING MACHINES, CHEST WEIGHTS, SPRING BARS FOR EXERCISING, HAND GRIP DEVELOPERS, PUNCHING BAGS, TRAINING BAGS FOR BOXING, JUMP ROPES, ATHLETIC SUPPORTERS, FOOT GUARDS FOR ATHLETIC USE AND MOUTH GUARDS FOR BOXERS, BOXING AND WRESTLING (U.S. CLS. 22, 23, 38 AND 50).

RENEE SERVANCE, EXAMINING ATTORNEY

SN 79-044,061. MEDIAFRIENDS SRL, ITALY, FILED 8-7-2007.



PRIORITY DATE OF 2-8-2007 IS CLAIMED.
OWNER OF INTERNATIONAL REGISTRATION 0938197
DATED 8-7-2007, EXPIRES 8-7-2017.
NO CLAIM IS MADE TO THE EXCLUSIVE RIGHT TO
USE "TATTOO", APART FROM THE MARK AS SHOWN.

CLASS 16—PAPER GOODS AND PRINTED MATTER

FOR PUBLICATIONS, NAMELY, TRAINING MANUALS IN THE FIELD OF TATTOOING OR BROCHURES, BOOKLETS, AND TEACHING MATERIALS IN THE FIELD OF TATTOOING; PRINTED PRODUCTS, NAMELY, CALENDARS, PRINTED ART REPRODUCTIONS; PAPER, NAMELY, ADHESIVE NOTE PAPER, ART PAPER; CARDBOARD AND PRODUCTS MADE OF THESE MATERIALS, NAMELY, MAGAZINE PAPER, PAPER BAGS, PAPER BOARDS (U.S. CLS. 2, 5, 22, 23, 29, 37, 38 AND 50).

CLASS 41—EDUCATION AND ENTERTAINMENT

FOR TRAINING, NAMELY, TATTOOING TRAINING; LEISURE AND CULTURAL ACTIVITIES, NAMELY, ORGANIZING TATTOOING EVENTS AND EXHIBITIONS FOR ENTERTAINMENT AND CULTURAL PURPOSES (U.S. CLS. 100, 101 AND 107).
CARYN GLASSER, EXAMINING ATTORNEY

SN 79-044,062. MEDIAFRIENDS SRL, I-20135 MILANO, ITALY, FILED 8-7-2007.

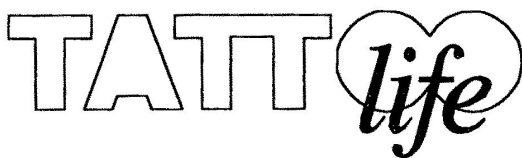

PRIORITY DATE OF 2-8-2007 IS CLAIMED.
OWNER OF INTERNATIONAL REGISTRATION 0938198
DATED 8-7-2007, EXPIRES 8-7-2017.

CLASS 16—PAPER GOODS AND PRINTED MATTER

FOR PUBLICATIONS, NAMELY, TRAINING MANUALS IN THE FIELD OF TATTOOING OR BROCHURES, BOOKLETS, AND PRINTED TEACHING MATERIALS IN THE FIELD OF TATTOOING; PRINTED PRODUCTS, NAMELY, CALENDARS, PRINTED ART REPRODUCTIONS; PAPER, NAMELY, ADHESIVE NOTE PAPER, ART PAPER; CARDBOARD AND PRODUCTS MADE OF THESE MATERIALS, NAMELY, MAGAZINE PAPER, PAPER BAGS, PAPER BOARDS (U.S. CLS. 2, 5, 22, 23, 29, 37, 38 AND 50).

CLASS 41—EDUCATION AND ENTERTAINMENT

FOR TRAINING, NAMELY, TATTOOING TRAINING; LEISURE AND CULTURAL ACTIVITIES, NAMELY, ORGANIZING TATTOOING EVENTS AND EXHIBITIONS FOR ENTERTAINMENT AND CULTURAL PURPOSES (U.S. CLS. 100, 101 AND 107).
CARYN GLASSER, EXAMINING ATTORNEY

SN 79-044,159. DEGRYSE LAURENT, BELGIUM, FILED 8-28-2007.

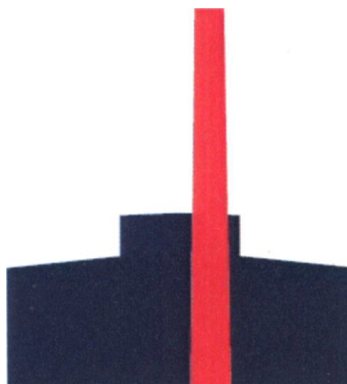

PRIORITY DATE OF 5-16-2007 IS CLAIMED.
OWNER OF INTERNATIONAL REGISTRATION 0938350
DATED 8-28-2007, EXPIRES 8-28-2017.
THE COLOR(S) BLACK AND RED IS/ARE CLAIMED AS
A FEATURE OF THE MARK.
FACTORY: BLACK AND CHIMNEY: RED.

CLASS 14—JEWELRY

FOR PRECIOUS METALS AND THEIR ALLOYS AND GOODS MADE OF OR COATED WITH THESE MATERIALS NOT INCLUDED IN OTHER CLASSES, NAMELY, WATCHES, NECKLACES, EARRINGS, RINGS, AND PINS; JEWELLERY, PRECIOUS STONES; TIMEPIECES AND CHRONOMETRIC INSTRUMENTS (U.S. CLS. 2, 27, 28 AND 50).

CLASS 16—PAPER GOODS AND PRINTED MATTER

FOR PAPER, CARDBOARD AND GOODS MADE FROM THESE MATERIALS, NOT INCLUDED IN OTHER CLASSES, NAMELY, NOTEBOOKS, NOTEPADS, AND PHOTO ALBUMS; PRINTED MATTER, NAMELY, POSTERS, POSTCARDS, BOOKS, LITHOGRAPHS; BOOKBINDING MATERIAL; PHOTOGRAPHS; STATIONERY; ADHESIVES FOR STATIONERY OR HOUSEHOLD PURPOSES; ARTISTS' MATERIALS, NAMELY, WRITING INSTRUMENTS, PENCILS, PENS, AND BOOKMARKS; PAINTBRUSHES; TYPEWRITERS; INSTRUCTIONAL AND TEACHING MATERIAL IN THE FIELDS OF ART, DRAWING, ARCHITECTURE, AND DESIGN; PLASTIC MATERIALS FOR PACKAGING, NAMELY, BUBBLE PACKS, PLASTIC BAGS; PRINTING TYPE; PRINTING BLOCKS (U.S. CLS. 2, 5, 22, 23, 29, 37, 38 AND 50).

CLASS 18—LEATHER GOODS

FOR LEATHER AND IMITATION LEATHER, GOODS MADE OF THESE MATERIALS NOT INCLUDED IN OTHER CLASSES, NAMELY, WALLETS AND CREDIT CARD CASES; ANIMAL SKINS AND HIDES; TRUNKS AND SUITCASES, UMBRELLAS, PARASOLS AND WALKING STICKS; WHIPS, HARNESS AND SADDLERY (U.S. CLS. 1, 2, 3, 22 AND 41).

CLASS 20—FURNITURE AND ARTICLES NOT OTHERWISE CLASSIFIED

FOR FURNITURE, MIRRORS, PICTURE FRAMES (U.S. CLS. 2, 13, 22, 25, 32 AND 50).

CLASS 21—HOUSEWARES AND GLASS

FOR HOUSEHOLD OR KITCHEN UTENSILS AND CONTAINERS, NAMELY, ICE CREAM SCOOPS, CHEESE PLANES, BALL WHISKS, AND SALAD SPINNERS; COMBS AND SPONGES FOR HOUSEHOLD PURPOSES; BRUSHES, NAMELY, BASTING BRUSHES; BRUSH-MAKING MATERIALS, ARTICLES FOR CLEANING PURPOSES, NAMELY, SPONGES; STEEL WOOL; UNWORKED OR SEMI-WORKED GLASS, NOT FOR BUILDING; GLASSWARE, PORCELAIN AND EARTHENWARE, NAMELY, EGG CUPS, WOBBLE COGNAC GLASSES, MARTINI GLASSES, TEA CUPS, COFFEE MUGS, SALT AND PEPPER SHAKERS, OVEN TO TABLE SERVING DISHES (U.S. CLS. 2, 13, 23, 29, 30, 33, 40 AND 50).

CLASS 24—FABRICS

FOR TEXTILES AND TEXTILE GOODS, NAMELY, PLACEMATS; PAPER BED COVERS AND TABLE COVERS NOT OF PAPER (U.S. CLS. 42 AND 50).

CLASS 25—CLOTHING

FOR CLOTHING, NAMELY, TOPS, BOTTOMS, PANTS, SHIRTS, SOCKS, CARDIGANS, PONCHOS, COATS, JACKETS, SCARVES, TIES, BOWTIES, SWEATSHIRTS, AND SWIMSUITS; FOOTWEAR; HEADGEAR, NAMELY, HATS, CAPS, AND WATER-REPELLENT RAIN HATS (U.S. CLS. 22 AND 39).

CLASS 28—TOYS AND SPORTING GOODS

FOR GAMES AND TOYS, NAMELY, PUZZLES, ANIMAL ALPHABET WOODEN PUZZLES, YOYO TOYS, BUILDING CUBES, AND BUILDING BLOCKS; GYMNASIAC AND SPORTING ARTICLES, NAMELY, SPORT BALLS; DECORATIONS FOR CHRISTMAS TREES (U.S. CLS. 22, 23, 38 AND 50).

CLASS 34—SMOKERS' ARTICLES

FOR TOBACCO; SMOKERS' ARTICLES, NAMELY, ASHTRAYS AND LIGHTERS; MATCHES (U.S. CLS. 2, 8, 9 AND 17).

DAVID HOFFMAN, EXAMINING ATTORNEY

SN 79-044,160. DEGRYSE LAURENT, BELGIUM, FILED 8-28-2007.



PRIORITY DATE OF 5-16-2007 IS CLAIMED.
OWNER OF INTERNATIONAL REGISTRATION 0938351 DATED 8-28-2007, EXPIRES 8-28-2017.
THE COLOR(S) BLACK AND RED IS/ARE CLAIMED AS A FEATURE OF THE MARK.
"U": BLACK; "C": RED AND BLACK; "A": RED AND BLACK.

CLASS 14—JEWELRY

FOR PRECIOUS METALS AND THEIR ALLOYS AND GOODS MADE OF OR COATED WITH THESE MATERIALS NOT INCLUDED IN OTHER CLASSES, NAMELY, WATCHES, NECKLACES, EARRINGS, RINGS, AND PINS; JEWELLERY, PRECIOUS STONES; TIMEPIECES AND CHRONOMETRIC INSTRUMENTS (U.S. CLS. 2, 27, 28 AND 50).

CLASS 16—PAPER GOODS AND PRINTED MATTER

FOR PAPER, CARDBOARD AND GOODS MADE FROM THESE MATERIALS, NOT INCLUDED IN OTHER CLASSES, NAMELY, NOTEBOOKS, NOTEPADS, AND PHOTO ALBUMS; PRINTED MATTER, NAMELY, POSTERS, POSTCARDS, BOOKS, LITHOGRAPHS; BOOKBINDING MATERIAL; PHOTOGRAPHS; STATIONERY; ADHESIVES FOR STATIONERY OR HOUSEHOLD PURPOSES; ARTISTS' MATERIALS, NAMELY, WRITING INSTRUMENTS, PENCILS, PENS, AND BOOKMARKS; PAINTBRUSHES; TYPEWRITERS; INSTRUCTIONAL AND TEACHING MATERIAL IN THE FIELDS OF ART, DRAWING, ARCHITECTURE, AND DESIGN; PLASTIC MATERIALS FOR PACKAGING, NAMELY, BUBBLE PACKS, PLASTIC BAGS; PRINTING TYPE; PRINTING BLOCKS (U.S. CLS. 2, 5, 22, 23, 29, 37, 38 AND 50).

CLASS 18—LEATHER GOODS

FOR LEATHER AND IMITATION LEATHER, GOODS MADE OF THESE MATERIALS NOT INCLUDED IN OTHER CLASSES, NAMELY, WALLETS AND CREDIT CARD CASES; ANIMAL SKINS AND HIDES; TRUNKS AND SUITCASES, UMBRELLAS, PARASOLS AND WALKING STICKS; WHIPS, HARNESS AND SADDLERY (U.S. CLS. 1, 2, 3, 22 AND 41).

CLASS 20—FURNITURE AND ARTICLES NOT OTHERWISE CLASSIFIED

FOR FURNITURE, MIRRORS, PICTURE FRAMES (U.S. CLS. 2, 13, 22, 25, 32 AND 50).

CLASS 21—HOUSEWARES AND GLASS

FOR HOUSEHOLD OR KITCHEN UTENSILS AND CONTAINERS, NAMELY, ICE CREAM SCOOPS, CHEESE PLANES, BALL WHISKS, AND SALAD SPINNERS; COMBS AND SPONGES FOR HOUSEHOLD PURPOSES; BRUSHES, NAMELY, BASTING BRUSHES; BRUSH-MAKING MATERIALS, ARTICLES FOR CLEANING PURPOSES, NAMELY, SPONGES; STEEL WOOL; UNWORKED OR SEMI-WORKED GLASS, NOT FOR BUILDING; GLASSWARE, PORCELAIN AND EARTHENWARE, NAMELY, EGG CUPS, WOBBLE COGNAC GLASSES, MARTINI GLASSES, TEA CUPS, COFFEE MUGS, SALT AND PEPPER SHAKERS, OVEN TO TABLE SERVING DISHES (U.S. CLS. 2, 13, 23, 29, 30, 33, 40 AND 50).

CLASS 24—FABRICS

FOR TEXTILES AND TEXTILE GOODS, NAMELY, PLACEMATS; PAPER BED COVERS AND TABLE COVERS NOT OF PAPER (U.S. CLS. 42 AND 50).

CLASS 25—CLOTHING

FOR CLOTHING, NAMELY, TOPS, BOTTOMS, PANTS, SHIRTS, SOCKS, CARDIGANS, PONCHOS, COATS, JACKETS, SCARVES, TIES, BOWTIES, SWEATSHIRTS, AND SWIMSUITS; FOOTWEAR; HEADGEAR, NAMELY, HATS, CAPS, AND WATER-REPELLENT RAIN HATS (U.S. CLS. 22 AND 39).

CLASS 28—TOYS AND SPORTING GOODS

FOR GAMES AND TOYS, NAMELY, PUZZLES, ANIMAL ALPHABET WOODEN PUZZLES, YOYO TOYS, BUILDING CUBES, AND BUILDING BLOCKS; GYMNASIAC AND SPORTING ARTICLES, NAMELY, SPORT BALLS; DECORATIONS FOR CHRISTMAS TREES (U.S. CLS. 22, 23, 38 AND 50).

CLASS 34—SMOKERS' ARTICLES

FOR TOBACCO; SMOKERS' ARTICLES, NAMELY, ASHTRAYS AND LIGHTERS; MATCHES (U.S. CLS. 2, 8, 9 AND 17).

DAVID HOFFMAN, EXAMINING ATTORNEY

SN 79-044,218. LEJEUNE ACADEMY GMBH, FED REP GERMANY, FILED 8-9-2007.



Erich Lejeune

The World of Motivation!

PRIORITY DATE OF 7-12-2007 IS CLAIMED.
OWNER OF INTERNATIONAL REGISTRATION 0938484
DATED 8-9-2007, EXPIRES 8-9-2017.
THE NAME "ERICH LEJEUNE" IDENTIFIES A LIVING
INDIVIDUAL WHOSE CONSENT IS OF RECORD.

CLASS 16—PAPER GOODS AND PRINTED MATTER

FOR PAPER, CARDBOARD AND GOODS MADE FROM THESE MATERIALS, NAMELY, CARDBOARD BOXES; WRITING PAPER, PAPER LABELS AND ADDRESS LABELS OF PAPER; WRITING BOOKS, NAMELY, SCHOOL WRITING BOOKS; WRITING CASES, NAMELY, STATIONERY CASES; DRAWING PADS; PRINTED MATTER, NAMELY, BOOKS, MAGAZINES, CATALOGUES AND BROCHURES IN THE FIELD OF MOTIVATION TRAINING, BIBLIOGRAPHIES OF INDIVIDUALS AND LIFE SCIENCES; PROSPECTUSES, NAMELY, PLANS FOR BUSINESS DEVELOPMENT; COMIC BOOKS, CALENDARS, BOOKMARKERS, BOOK BINDINGS; BOOKENDS; PHOTOGRAPHS; PRINTED INSTRUCTIONAL AND TEACHING MATERIAL IN THE FIELD OF MOTIVATION TRAINING AND SELF-AWARENESS; STATIONERY; DRAWING MATERIALS, NAMELY, PENS AND MARKERS (U.S. CLS. 2, 5, 22, 23, 29, 37, 38 AND 50).

CLASS 35—ADVERTISING AND BUSINESS

FOR BUSINESS MANAGEMENT CONSULTANCY IN PERSONNEL MATTERS AND PERSONNEL MANAGEMENT CONSULTANCY; BUSINESS ORGANIZATION AND MANAGEMENT CONSULTANCY; PUBLIC RELATIONS; PROMOTING THE GOODS AND SERVICES OF OTHERS BY ARRANGING FOR SPONSORS TO AFFILIATE THEIR GOODS AND SERVICES WITH PARTICULAR SPORTS COMPETITIONS AND LIVE PERFORMANCES BY MUSICAL ORCHESTRAS; SALES PROMOTION FOR OTHERS; ADVERTISING SERVICES; ECONOMIC FORECASTING (U.S. CLS. 100, 101 AND 102).

CLASS 41—EDUCATION AND ENTERTAINMENT

FOR EDUCATION SERVICES, NAMELY, PROVIDING CLASSES, SEMINARS, WORKSHOPS IN THE FIELD OF MOTIVATION; CONSULTANCY REGARDING TRAINING AND EDUCATION, NAMELY, CONSULTATION IN THE FIELD OF EDUCATIONAL SYSTEMS, COMPUTER EDUCATION TRAINING CONSULTING; COACHING, NAMELY, PERSONAL COACHING SERVICES IN THE FIELD OF MOTIVATION AND SELF-AWARENESS; ARRANGING AND CONDUCTING SEMINARS AND WORKSHOPS IN THE FIELD OF SELF AWARENESS, MOTIVATION AND ART APPRECIATION; ORGANIZING AND CONDUCTING OF CONGRESSES AND CONFERENCES, NAMELY, ARRANGING AND CONDUCTING EDUCATIONAL CONFERENCES; STAFF DEVELOPMENT THROUGH TRAINING AND CONTINUOUS TRAINING IN THE FIELD OF COMPUTER EDUCATION TRAINING; VOCATIONAL GUIDANCE; PUBLICATION OF BOOKS; TELEVISION ENTERTAINMENT, NAMELY, ENTERTAINMENT IN THE NATURE OF TELEVISION TALK SHOWS AND NEWS SHOWS; PRESENTATION OF LIVE PERFORMANCES, NAMELY, LIVE PERFORMANCES BY MUSICAL BANDS AND MUSICAL ORCHESTRAS; PUBLISHING OF ELECTRONIC PUBLICATIONS; PRODUCTION OF TELEVISION SHOWS (U.S. CLS. 100, 101 AND 107).

JENNIFER MARTIN, EXAMINING ATTORNEY

SN 79-044,268. COLUMBUS TRADING-PARTNERS GMBH, 95326 KULMBACH, FED REP GERMANY, FILED 5-23-2007.

CYBEX

THE MARK CONSISTS OF STANDARD CHARACTERS WITHOUT CLAIM TO ANY PARTICULAR FONT, STYLE, SIZE, OR COLOR.

PRIORITY DATE OF 12-21-2006 IS CLAIMED.
OWNER OF INTERNATIONAL REGISTRATION 0938620
DATED 5-23-2007, EXPIRES 5-23-2017.
OWNER OF U.S. REG. NO. 3,120,947.

CLASS 3—COSMETICS AND CLEANING PREPARATIONS

FOR BLEACHING PREPARATIONS AND OTHER SUBSTANCES FOR LAUNDRY USE, NAMELY, LAUNDRY BLEACH, LAUNDRY BLUEING, AND LAUNDRY DETERGENT; CLEANING, POLISHING, SCOURING AND ABRASIVE PREPARATIONS; SOAPS; PERFUMERY, ESSENTIAL OILS, COSMETIC PREPARATIONS FOR BODY CARE, HAIR, LOTIONS; DENTIFRICES (U.S. CLS. 1, 4, 6, 50, 51 AND 52).

CLASS 8—HAND TOOLS

FOR CUTLERY, NAMELY, KNIVES, FORKS, SPOONS, NAIL CLIPPERS (U.S. CLS. 23, 28 AND 44).

CLASS 9—ELECTRICAL AND SCIENTIFIC APPARATUS

FOR VIDEOTAPE AND DVD PLAYERS FOR INSTALLATION IN AUTOMOBILES AND AUTOMOBILE AND BICYCLE SEATS FOR CHILDREN; BABY PHONES, NAMELY, MOBILE PHONES; SUNGLASSES (U.S. CLS. 21, 23, 26, 36 AND 38).

CLASS 10—MEDICAL APPARATUS

FOR FEVER THERMOMETERS; FEEDING BOTTLES (U.S. CLS. 26, 39 AND 44).

CLASS 11—ENVIRONMENTAL CONTROL APPARATUS

FOR APPARATUS FOR STERILIZING FEEDING BOTTLES, NAMELY, BABY BOTTLE STERILIZERS, ELECTRICALLY HEATED BOTTOM WARMERS, NAMELY, ELECTRIC HEATERS FOR BABY BOTTLES (U.S. CLS. 13, 21, 23, 31 AND 34).

CLASS 12—VEHICLES

FOR APPARATUS FOR LOCOMOTION BY LAND, AIR OR WATER, NAMELY, LAND VEHICLES, AIRPLANES, AND BOATS, VEHICLES, NAMELY, BICYCLE, TRICYCLES, PUSHCHAIRS; ACCESSORIES FOR THE AFORESAID VEHICLES, NAMELY, VEHICLE SEATS FOR CHILDREN, PANNIER BAGS FOR BICYCLES, SHOPPING BASKETS ADAPTED FOR BICYCLES; SAFETY SEATS FOR CHILDREN FOR AUTOMOBILES AND PARTS THEREOF, NAMELY, AUTOMOBILE SEAT CUSHIONS; SAFETY BELTS FOR AUTOMOBILE SEATS; RAIN PROTECTION COVERS FOR PUSHCHAIRS, NAMELY, COVERS FOR BABY STROLLERS (U.S. CLS. 19, 21, 23, 31, 35 AND 44).

CLASS 18—LEATHER GOODS

FOR LEATHER AND LEATHER IMITATIONS AND GOODS MADE OF THESE MATERIALS, NAMELY, LEATHER CASES, LEATHER HANDBAGS, LEATHER PURSES, LEATHER STRAPS; TRUNKS AND TRAVELING BAGS; UMBRELLAS; PARASOLS AND WALKING STICKS; WHIPS, HARNESSES AND SADDLERY; ALL PURPOSE SPORT BAGS; PURSES, WALLETS, BACKPACKS, SCHOOL BAGS; BAGS FOR CARRYING CHILDREN IN THE FORM OF A BACKPACK; CHILD CARRIER FRAMES AND BABY CARRIERS, NAMELY, BACK FRAMES FOR CARRYING CHILDREN AND BABY CARRIERS WORN ON THE BODY; BAGS FOR CARRYING BABY ACCESSORIES; PARASOLS FOR PUSHCHAIRS (U.S. CLS. 1, 2, 3, 22 AND 41).

CLASS 20—FURNITURE AND ARTICLES NOT OTHERWISE CLASSIFIED

FOR CHILDREN'S FURNITURE AND STRUCTURAL PARTS THEREOF; INFANT WALKERS; BABY SWING CHAIRS; HIGH CHAIRS; TABLE SEATS, BABY'S CHANGING TABLES; CRADLES; SLEEPING BAGS FOR BABIES AND TODDLERS, FOR CAMPING PURPOSES (U.S. CLS. 2, 13, 22, 25, 32 AND 50).

CLASS 21—HOUSEWARES AND GLASS

FOR KITCHENWARE NOT OF PRECIOUS METAL, NAMELY, POTS AND PANS FOR HEATING BABY FOOD AND KEEPING SUCH FOOD WARM (U.S. CLS. 2, 13, 23, 29, 30, 33, 40 AND 50).

CLASS 24—FABRICS

FOR BEDDING, NAMELY, PILLOW CASES, SHAMS, DUVETS, COMFORTERS, BED SHEETS AND BED BLANKETS; BABY BLANKETS (U.S. CLS. 42 AND 50).
ROBERT STRUCK, EXAMINING ATTORNEY

SN 79-044,618. LAUTSPRECHER TEUFEL GMBH, FED REP GERMANY, FILED 9-19-2007.

Cinemapaq

PRIORITY DATE OF 4-11-2007 IS CLAIMED.
OWNER OF INTERNATIONAL REGISTRATION 0939606
DATED 9-19-2007, EXPIRES 9-19-2017.

CLASS 9—ELECTRICAL AND SCIENTIFIC APPARATUS

FOR APPARATUS FOR RECORDING, TRANSMISSION OR REPRODUCTION OF SOUND OR IMAGES; LOUDSPEAKERS (U.S. CLS. 21, 23, 26, 36 AND 38).

CLASS 35—ADVERTISING AND BUSINESS

FOR ADVERTISING SERVICES (U.S. CLS. 100, 101 AND 102).

CLASS 41—EDUCATION AND ENTERTAINMENT

FOR ENTERTAINMENT, NAMELY, LIVE PERFORMANCES BY A MUSICAL BAND; ENTERTAINMENT IN THE NATURE OF VISUAL AND AUDIO PERFORMANCES; LIGHT SHOWS; ORGANIZING COMMUNITY EVENTS IN THE NATURE OF VISUAL AND AUDIO PERFORMANCES (U.S. CLS. 100, 101 AND 107).
TRACY CROSS, EXAMINING ATTORNEY

SN 79-044,720. LAUTSPRECHER TEUFEL GMBH, FED REP GERMANY, FILED 9-19-2007.

Cinepaq

PRIORITY DATE OF 4-11-2007 IS CLAIMED.
OWNER OF INTERNATIONAL REGISTRATION 0939816
DATED 9-19-2007, EXPIRES 9-19-2017.

CLASS 9—ELECTRICAL AND SCIENTIFIC APPARATUS

FOR APPARATUS FOR RECORDING, TRANSMISSION OR REPRODUCTION OF SOUND OR IMAGES; LOUDSPEAKERS (U.S. CLS. 21, 23, 26, 36 AND 38).

CLASS 35—ADVERTISING AND BUSINESS

FOR ADVERTISING SERVICES (U.S. CLS. 100, 101 AND 102).

CLASS 41—EDUCATION AND ENTERTAINMENT

FOR ENTERTAINMENT, NAMELY, LIVE PERFORMANCES BY A MUSICAL BAND; ENTERTAINMENT IN THE NATURE OF VISUAL AND AUDIO PERFORMANCES; LIGHT SHOWS; ORGANIZING COMMUNITY EVENTS IN THE NATURE OF VISUAL AND AUDIO PERFORMANCES (U.S. CLS. 100, 101 AND 107).
TRACY CROSS, EXAMINING ATTORNEY

SN 79-044,818. HERMES INTERNATIONAL, FRANCE,
FILED 9-13-2007.

KELLY MANCHON

THE MARK CONSISTS OF STANDARD CHARACTERS WITHOUT CLAIM TO ANY PARTICULAR FONT, STYLE, SIZE, OR COLOR.

PRIORITY DATE OF 3-14-2007 IS CLAIMED.

OWNER OF INTERNATIONAL REGISTRATION 0940146
DATED 9-13-2007, EXPIRES 9-13-2017.

THE NAME "KELLY MANCHON" DOES NOT IDENTIFY A LIVING INDIVIDUAL.

CLASS 18—LEATHER GOODS

FOR LEATHER GOODS OF GENUINE AND IMITATION LEATHER, NAMELY, GLOVES AND BELTS, HANDBAGS, TRAVEL BAGS, RUCKSACKS, SCHOOL BAGS, BEACH BAGS MADE OF LEATHER OR CANVAS, LEATHER AND FABRIC SHOPPING BAGS, GARMENT BAGS FOR TRAVEL, POCKET WALLETS, LEATHER PURSES, CARD HOLDER WALLETS, ATTACHE CASES, LEATHER KEY CASES, TRUNKS AND SUITCASES, TRAVELING CASES SOLD EMPTY, VANITY CASES SOLD EMPTY (U.S. CLS. 1, 2, 3, 22 AND 41).

CLASS 25—CLOTHING

FOR MUFFS (U.S. CLS. 22 AND 39).
DEIRDRE ROBERTSON, EXAMINING ATTORNEY

CLASS 35—ADVERTISING AND BUSINESS

FOR BUSINESS MANAGEMENT; COMMERCIAL ADMINISTRATION, NAMELY, BUSINESS ADMINISTRATION SERVICES; BUSINESS CONSULTING, INFORMATION OR INQUIRIES; COMPUTER FILE MANAGEMENT; COMMERCIAL AND ADMINISTRATIVE ORGANIZATION AND MANAGEMENT OF OPERATIONS FOR OTHERS FOR THE MANUFACTURE OF PERFUMERY, COSMETIC AND BEAUTY CARE PRODUCTS; DIRECT AND BUSINESS MARKETING SERVICES; MARKET RESEARCH, STUDY AND ANALYSIS RELATING TO PERFUMERY, COSMETIC AND BEAUTY CARE PRODUCTS; PROCUREMENT SERVICES, NAMELY, PURCHASING AND SELECTION OF PERFUMERY, COSMETIC AND BEAUTY CARE PRODUCTS FOR COMMERCIAL PURPOSES AND FOR OTHERS; BUSINESS CONSULTING SERVICES, NAMELY, BRINGING BUSINESS PARTNERS TOGETHER IN THE FIELD OF PERFUMES, COSMETICS AND BEAUTY PRODUCTS; ADVERTISING AND PROMOTION OF MANUFACTURERS AND DISTRIBUTORS OF PERFUMES, COSMETICS AND BEAUTY CARE PRODUCTS; COMMUNICATION AND PUBLIC RELATIONS AGENCIES, NAMELY, AGENCIES THAT PROVIDE PUBLIC RELATIONS SERVICES (U.S. CLS. 100, 101 AND 102).

CLASS 38—COMMUNICATION

FOR TELECOMMUNICATION AND COMMUNICATION SERVICES, NAMELY, ELECTRONIC TRANSMISSION OF INFORMATION IN THE FIELD OF PERFUMES, COSMETICS AND BEAUTY PRODUCTS VIA COMPUTER TERMINALS; INFORMATION AGENCY SERVICES, NAMELY, TRANSMISSION OF NEWS IN THE FIELD OF PERFUMES, COSMETICS AND BEAUTY PRODUCTS (U.S. CLS. 100, 101 AND 104).
JENNIFER VASQUEZ, EXAMINING ATTORNEY

SN 79-044,891. SELECTIVE BEAUTY, FRANCE, FILED 8-29-2007.



Selective Beauty

OWNER OF INTERNATIONAL REGISTRATION 0772215
DATED 8-9-2001, EXPIRES 8-9-2011.

NO CLAIM IS MADE TO THE EXCLUSIVE RIGHT TO USE "BEAUTY", APART FROM THE MARK AS SHOWN.

CLASS 3—COSMETICS AND CLEANING PREPARATIONS

FOR PERFUMES, PERFUME WATERS, TOILET WATERS, SOAPS, DEODORANTS FOR PERSONAL USE, COSMETICS, MAINLY CREAMS, MILKS, LOTIONS, GELS AND POWDERS FOR THE FACE, BODY AND HANDS; TANNING AND AFTER-TAN MILKS, GELS AND OILS FOR COSMETIC USE; MAKEUP PREPARATIONS, MAKEUP REMOVERS, SHAMPOOS, HAIR GELS, HAIR FOAMS, BALMS FOR HAIR DRESSING AND HAIR CARE; ESSENTIAL OILS (U.S. CLS. 1, 4, 6, 50, 51 AND 52).

SN 79-045,107. LINET SPOL. S R.O., CZECH REPUBLIC,
FILED 4-30-2007.

Mobi-Lift

THE MARK CONSISTS OF STANDARD CHARACTERS WITHOUT CLAIM TO ANY PARTICULAR FONT, STYLE, SIZE, OR COLOR.

PRIORITY DATE OF 12-28-2006 IS CLAIMED.

OWNER OF INTERNATIONAL REGISTRATION 0940647
DATED 4-30-2007, EXPIRES 4-30-2017.

CLASS 10—MEDICAL APPARATUS

FOR SPECIAL FURNITURE FOR MEDICAL PURPOSES, NAMELY, HOSPITAL AND NURSING CARE BEDS IN THE NATURE OF MECHANICAL BEDS FOR PATIENT TREATMENT AND FOR TRANSPORT FOR EXAMINATION IN HOSPITAL PREMISES; ELECTRICAL BEDS, WHICH ARE ELECTRICALLY ADJUSTABLE FOR PATIENT USE IN HOSPITAL DEPARTMENTS SPECIALIZING IN PATIENT DIAGNOSIS, FOR PATIENTS WITH RESPIRATORY PROBLEMS AND CARDIAC PROBLEMS AND TO PREVENT AND HELP TREATMENT OF PRESSURE SORES; INTENSIVE CARE BEDS FOR PATIENT RESUSCITATION FOR PATIENTS IN CRITICAL CONDITION AND FOR PATIENT TREATMENT; CHILDREN'S AND INFANTS' BEDS FOR PATIENT TREATMENT AND TRANSPORT FOR EXAMINATION IN HOSPITAL PREMISES; MATERNITY BEDS FOR TREATMENT OF MATERNITY PATIENTS AND FACILITATING INFANT DELIVERY; ACCESSORIES FOR USE WITH SUCH BEDS, NAMELY, INFUSION STANDS, LIFTING POLES AND ORTHOPEDIC EXTENSION SYSTEMS FOR PATIENT TREATMENT; OTHER FURNITURE FOR USE IN MEDICAL AND NURSING FACILITIES, NAMELY, ANTI-DECUBITUS SYSTEMS COMPRISED OF AN ACTIVE ANTI-DECUBITUS MATTRESS SYSTEM FOR THE PREVENTION AND TREATMENT OF BED SORES FOR PATIENT'S TREATMENT; PASSIVE ANTI-DECUBITUS MATTRESSES FOR PREVENTION AND TREATMENT OF PRESSURE SORES; COUCHES FOR PATIENT TREATMENT AND FOR TRANSPORT FOR EXAMINATIONS IN HOSPITAL PREMISES; STRETCHERS AND MATTRESSES FOR PATIENT TREATMENT AND TRANSPORT FOR EXAMINATION IN HOSPITAL PREMISES; SEATS FOR PATIENT TREATMENT AND TRANSPORT IN HOSPITAL FORENSIC (U.S. CLS. 26, 39 AND 44).

CLASS 20—FURNITURE AND ARTICLES NOT OTHERWISE CLASSIFIED

FOR FURNITURE, MATTRASSES (U.S. CLS. 2, 13, 22, 25, 32 AND 50).
DAVID I, EXAMINING ATTORNEY

SN 79-045,194. INTERBASIS HOLDING S.A., LUXEMBOURG, FILED 5-15-2007.

SCHIAP

THE MARK CONSISTS OF STANDARD CHARACTERS WITHOUT CLAIM TO ANY PARTICULAR FONT, STYLE, SIZE, OR COLOR.

PRIORITY DATE OF 11-21-2006 IS CLAIMED.
OWNER OF INTERNATIONAL REGISTRATION 0940834 DATED 5-15-2007, EXPIRES 5-15-2017.

CLASS 3—COSMETICS AND CLEANING PREPARATIONS

FOR PERFUMERY AND COSMETICS, NAMELY, PERFUME, COLOGNE, AFTER SHAVE, MAKE-UP, DEODORANTS FOR PERSONAL USE; ANTIPERSPIRANTS; ESSENTIAL OILS FOR PERSONAL USE; SOAPS; SHAVING SOAPS; HAIR CARE PREPARATIONS; DENTIFRICES; LAUNDRY PREPARATIONS, NAMELY, BLEACHING DETERGENTS AND LAUNDRY DETERGENTS (U.S. CLS. 1, 4, 6, 50, 51 AND 52).

CLASS 9—ELECTRICAL AND SCIENTIFIC APPARATUS

FOR SPECTACLES, SUNGLASSES, GLASSES AND FRAMES; CONTACT LENSES, OPTICAL LENSES, MAGNIFYING GLASSES, CELLULAR TELEPHONES, PORTABLE TELEPHONES AND COMPUTERS; LEATHER COVERS ESPECIALLY MADE FOR ELECTRONIC AGENDAS (U.S. CLS. 21, 23, 26, 36 AND 38).

CLASS 14—JEWELRY

FOR WATCHES AND CLOCKS, PENDULUM CLOCKS, CHRONOGRAPHS FOR USE AS WATCHES AND CHRONOMETERS; ROUGH GEMSTONES, NAMELY, PRECIOUS STONES; EARRINGS, RINGS, NECKLACES, BRACELETS, ORNAMENTAL PINS MADE OF PRECIOUS METAL, SHOE ORNAMENTS OF PRECIOUS METAL, PRECIOUS STONES, CHARMS AS JEWELRY; LEATHER KEY RINGS (U.S. CLS. 2, 27, 28 AND 50).

CLASS 16—PAPER GOODS AND PRINTED MATTER

FOR LEATHER COVERS ESPECIALLY MADE FOR AGENDAS; LEATHER COVERS ESPECIALLY MADE FOR ADDRESS BOOKS; CURTAINS OF PAPER (U.S. CLS. 2, 5, 22, 23, 29, 37, 38 AND 50).

CLASS 18—LEATHER GOODS

FOR BAGS, NAMELY, HANDBAGS, TRAVELING BAGS; LEATHER CREDIT CARD CASES, WALLETS, LEATHER KEY CHAINS, LEATHER CASES FOR KEYS, PURSES NOT OF PRECIOUS METAL, TRUNKS, BRIEFCASES, SUITCASES, IMITATION LEATHER BAGS, LEATHER SHOPPING BAGS, LEATHER POUCHES; SPORT AND ATHLETIC BAGS, VANITY CASES SOLD EMPTY, GARMENT BAGS FOR TRAVEL, PURSES OF PRECIOUS METAL (U.S. CLS. 1, 2, 3, 22 AND 41).

CLASS 20—FURNITURE AND ARTICLES NOT OTHERWISE CLASSIFIED

FOR FURNITURE, MIRRORS, PICTURE FRAMES (U.S. CLS. 2, 13, 22, 25, 32 AND 50).

CLASS 21—HOUSEWARES AND GLASS

FOR HOUSEHOLD AND KITCHEN UTENSILS, NAMELY, GRILLS, POT AND PAN SCRAPERS, SPATULAS, WOOD CHOPPING BLOCKS AND HOUSEHOLDS CONTAINER FOR FOOD; COMBS AND CLEANING SPONGES; POT CLEANING BRUSHES, HAIR BRUSHES; ARTICLES FOR CLEANING PURPOSES, NAMELY, POLISHING CLOTHS; STEEL WOOL FOR CLEANING, UNWORKED OR SEMI-WORKED GLASS; BEVERAGE GLASSWARE; DINNERWARE, NAMELY, PLATES AND SAUCERS, PORCELAIN AND EARTHENWARE GOODS, NAMELY, COFFEE CUPS, TEA CUPS AND MUGS OF PORCELAIN, VASES OF PORCELAIN, KNOBS OF PORCELAIN, JARS FOR JAMS AND JELLIES OF EARTHENWARE AND PORCELAIN (U.S. CLS. 2, 13, 23, 29, 30, 33, 40 AND 50).

CLASS 22—CORDAGE AND FIBERS

FOR RAW FIBROUS TEXTILE (U.S. CLS. 1, 2, 7, 19, 22, 42 AND 50).

CLASS 23—YARNS AND THREADS

FOR YARNS AND THREADS FOR TEXTILE USE; WOOLLEN THREAD AND YARN (U.S. CL. 43).

CLASS 24—FABRICS

FOR TEXTILE AND TEXTILE GOODS, NAMELY, FABRICS FOR TEXTILE USE, TEXTILE FABRICS FOR THE MANUFACTURE OF CLOTHING, TEXTILE FABRIC OF ANIMAL SKINS IMITATIONS, TEXTILE FABRICS FOR LINGERIE, TEXTILE SUBSTITUTE MATERIALS MADE FROM SYNTHETIC MATERIALS, TEXTILE USED AS LINING FOR CLOTHING, TOWELS OF TEXTILE; BED BLANKETS, BED-SPREADS, TABLE-CLOTHS NOT MADE OF PAPER; CURTAINS OF TEXTILE; BED AND TEXTILE TABLE COVERS (U.S. CLS. 42 AND 50).

CLASS 25—CLOTHING

FOR CLOTHING MADE FROM LEATHER, NAMELY, LEATHER JACKETS AND LEATHER PANTS, BELTS, LEATHER COATS, SHOES; ATHLETIC SHOES, BOOTS, SLIPPERS, OVERSHOES, SUITS, JACKETS, TROUSERS, JEANS, SKIRTS, DRESSES, COATS, OVERCOATS, RAINCOATS, PARKAS, PADDING JACKETS, PULLOVERS, SHIRTS, T-SHIRTS, BLOUSES, SWEATERS, UNDERWEAR, NEGLIGENCE DRESSING GOWNS, BATHROBES, SWIMMING SUITS, SHAWLS, GLOVES, HATS AND CAPS, VISORS, SCARVES, TIES (U.S. CLS. 22 AND 39).

CLASS 26—FANCY GOODS

FOR RIBBONS, BUTTONS FOR CLOTHING AND CLOTHING HOOKS (U.S. CLS. 37, 39, 40, 42 AND 50).

CLASS 27—FLOOR COVERINGS

FOR CARPETS, RUGS, MATS AND MATTING AS FLOOR COVERINGS (U.S. CLS. 19, 20, 37, 42 AND 50).

CLASS 28—TOYS AND SPORTING GOODS

FOR GAMES AND PLAYTHINGS, NAMELY, DOLLS, BILLIARD TABLES, BOARD GAMES, TOY PISTOLS, DOMINO GAMES; GYMNASTIC AND SPORTING ARTICLES, NAMELY, BASEBALLS, FOOTBALLS, BASKETBALLS, SOCCER BALLS, BILLIARD BALLS, TENNIS RACQUETS, SNOW SKIS, WATER SKIS, BAGS SPECIALLY ADAPTED FOR SPORT EQUIPMENT (U.S. CLS. 22, 23, 38 AND 50).

CLASS 34—SMOKERS' ARTICLES

FOR TOBACCO; SMOKERS' ARTICLES, NAMELY, LIGHTERS FOR CIGARETTES, MATCHES, SMOKING PIPES OF PRECIOUS METAL; CASES FOR CIGARS AND CIGARETTES OF PRECIOUS METAL, CIGARETTE HOLDERS AND CIGAR HOLDERS OF PRECIOUS METAL, ASHTRAYS OF PRECIOUS METAL (U.S. CLS. 2, 8, 9 AND 17).

CLASS 41—EDUCATION AND ENTERTAINMENT

FOR EDUCATIONAL SERVICES, NAMELY, CONDUCTING CLASSES, SEMINARS, CONFERENCES, WORKSHOPS IN THE FIELD OF FASHION AND INTERIOR DESIGN; EDUCATIONAL SERVICES, NAMELY, PROVIDING INTERNSHIPS AND APPRENTICESHIPS IN THE FIELD OF BUSINESS MANAGEMENT AND DEVELOPMENT; TRAINING COURSES IN STRATEGIC PLANNING RELATING TO ADVERTISING, PROMOTION, MARKETING, BUSINESS; ENTERTAINMENT EXHIBITIONS IN THE NATURE OF SPORT GAMES; ORGANIZING AND CONDUCTING ENTERTAINMENT EXHIBITIONS FOR FASHION SHOWS; RADIO AND TELEVISION ENTERTAINMENT PRODUCTION, HEALTH CLUBS, NAMELY, PROVIDING INSTRUCTION AND EQUIPMENT IN THE FIELD OF PHYSICAL EXERCISE; DISCOTHEQUE SERVICES; EDUCATIONAL SERVICES IN THE NATURE OF BEAUTY SCHOOLS; ARRANGING OF BEAUTY CONTESTS; GYMNASIUMS (U.S. CLS. 100, 101 AND 107).

REBECCA POVARCHUK, EXAMINING ATTORNEY

SN 79-045,195. DAIFUKU CO., LTD., JAPAN, FILED 5-18-2007.

Material Handling and Beyond

PRIORITY DATE OF 4-16-2007 IS CLAIMED.

OWNER OF INTERNATIONAL REGISTRATION 0940835 DATED 5-18-2007, EXPIRES 5-18-2017.

NO CLAIM IS MADE TO THE EXCLUSIVE RIGHT TO USE "MATERIAL HANDLING", APART FROM THE MARK AS SHOWN.

CLASS 7—MACHINERY

FOR CONSTRUCTION MACHINES AND APPARATUS, NAMELY, CONCRETE CONSTRUCTION MACHINES, CONCRETE MIXERS, POWER DRILLS, HYDRAULIC EXCAVATORS; AUTOMATIC WAREHOUSING SYSTEMS COMPRISED PRIMARILY OF CRANES AND ALSO RACKS; CONVEYORS; CRANES; SORTING MACHINES; LOADING AND UNLOADING MACHINES; POWER-DRIVEN ROTARY STORAGE AND RETRIEVAL INSTALLATIONS AND APPARATUS, NAMELY, MATERIAL HANDLING MACHINES IN THE NATURE OF PALLETIZERS, CASE ELEVATORS, AUTOMATIC PALLET DISPENSING MACHINES AND AUTOMATIC SLIP SHEET DISPENSING MACHINES; POWER-DRIVEN SLIDING STORAGE AND RETRIEVAL INSTALLATIONS AND APPARATUS, NAMELY, MATERIAL HANDLING MACHINES IN THE NATURE OF PALLETIZERS, CASE ELEVATORS, AUTOMATIC PALLET DISPENSING MACHINES AND AUTOMATIC SLIP SHEET DISPENSING MACHINES; POWER-DRIVEN MOBILE STORAGE AND RETRIEVAL INSTALLATIONS AND APPARATUS, NAMELY, MATERIAL HANDLING MACHINES IN THE NATURE OF PALLETIZERS, CASE ELEVATORS, AUTOMATIC PALLET DISPENSING MACHINES AND AUTOMATIC SLIP SHEET DISPENSING MACHINES; INDUSTRIAL PALLETIZING ROBOTS AND OTHER LOADING-UNLOADING MACHINES AND APPARATUS, NAMELY, MATERIAL HANDLING MACHINES IN THE NATURE OF PALLETIZERS, CASE ELEVATORS, AUTOMATIC PALLET DISPENSING MACHINES AND AUTOMATIC SLIP SHEET DISPENSING MACHINES; SEWING MACHINES; SHOE MAKING MACHINES; LEATHER TANNING MACHINES; TOBACCO PROCESSING MACHINES; PAINTING MACHINES; PAINTING APPARATUS, NAMELY, PAINT SPRAYERS, AIR BRUSHES FOR APPLYING PAINT, TIPS FOR PAINT SPRAY GUNS; PACKAGING AND WRAPPING MACHINES; PACKAGING AND WRAPPING APPARATUS, NAMELY, VACUUM PACKAGING MACHINES; POWER-OPERATED POTTERS' WHEELS; SEMI-CONDUCTOR MANUFACTURING MACHINES; SEMI-CONDUCTOR MANUFACTURING SYSTEMS COMPRISED OF SEMI-CONDUCTOR SUBSTRATES MANUFACTURING MACHINES AND SEMI-CONDUCTOR MANUFACTURING MACHINES; ADHESIVE TAPE DISPENSING MACHINES; AUTOMATIC STAMPING MACHINES; DISH WASHING MACHINES; VACUUM CLEANERS; ELECTRIC FOOD BLENDERS; MECHANICAL PARKING SYSTEMS FOR AUTOMOBILES COMPRISED OF POWER-OPERATED LIFTS FOR PARKING VEHICLES; VEHICLE WASHING INSTALLATIONS; POWER SPRAYERS FOR DISINFECTING, INSECTICIDES AND DEODORANTS, NOT FOR AGRICULTURAL PURPOSES; MACHINE ELEMENTS, NOT FOR LAND VEHICLES, NAMELY, VALVES BEING PARTS OF MACHINES, BLOCK BRAKES; LAWNMOWER; ELECTRICALLY OPERATED CURTAIN DRAWING DEVICES; WASTE COMPACTING MACHINES; WASTE CRUSHING MACHINES; STARTERS FOR MOTORS AND ENGINES; AC MOTORS AND DC MOTORS, NOT FOR LAND VEHICLES; PARTS FOR AC MOTORS AND DC MOTORS, NOT FOR LAND VEHICLES, NAMELY, IGNITION DEVICES, BRUSHES BEING PARTS OF MOTORS; AC GENERATORS; DC GENERATORS; DYNAMO BRUSHES; CAM SHAFTS, CRANK SHAFTS, COUPLING SHAFTS, AXLES AND SPINDLES, FOR MACHINES; BEARINGS AS MACHINE ELEMENTS, NOT FOR LAND VEHICLES, NAMELY, ROLLER BEARINGS, ENGINE BEARINGS; SHAFT COUPLINGS AND CONNECTORS AS MACHINE ELEMENTS, NOT FOR LAND VEHICLES; POWER TRANSMISSIONS AND GEARING FOR MACHINES, NOT FOR LAND VEHICLES; BRAKES AS MACHINE ELEMENTS, NOT FOR LAND VEHICLES;

VALVES AS MACHINE ELEMENTS, NOT FOR LAND VEHICLES; PALLET WASHING MACHINES; CAR WASHING MACHINES; CAR MAT WASHING MACHINES; INTEGRATED CIRCUIT MANUFACTURING MACHINES (U.S. CLS. 13, 19, 21, 23, 31, 34 AND 35).

CLASS 12—VEHICLES

FOR ROPEWAYS FOR CARGO OR FREIGHT HANDLING, NAMELY, CABLE CARS; UNLOADING TIPPLERS FOR TILTING RAILWAY FREIGHT CARS, NAMELY, RAILWAY BOGIES, TRUCKS, FORK LIFT TRUCKS; PUSHER CARTS FOR MINING; PULLER CARTS FOR MINING; LAND VEHICLES, NAMELY, TRACTION ENGINES; NON-ELECTRIC PRIME MOVERS FOR LAND VEHICLES, NOT INCLUDING THEIR PARTS, NAMELY, ENGINES; MACHINE ELEMENTS FOR LAND VEHICLES, NAMELY, DRIVE BELTS, TRANSMISSIONS; PARACHUTES; ANTI-THEFT ALARMS FOR VEHICLES; WHEELCHAIRS; RAILWAY ROLLING STOCK AND THEIR STRUCTURAL PARTS AND FITTINGS; AUTOMOBILES AND THEIR STRUCTURAL PARTS AND FITTINGS; TWO-WHEELED MOTOR VEHICLES, BICYCLES AND THEIR STRUCTURAL PARTS AND FITTINGS; BABY CARRIAGES BEING PRAMS; RICKSHAWS; SLEIGHS AND SLEDS BEING VEHICLES; WHEELBARROWS; CARTS; HORSE DRAWN CARRIAGES; BICYCLE TRAILERS (RIYAKAH); DELIVERY BICYCLES; AUTOMATIC GUIDED VEHICLES; SORTING CARTS; PICKING CARTS; CARGO-HANDLING CARTS (U.S. CLS. 19, 21, 23, 31, 35 AND 44).

REBECCA POVARCHUK, EXAMINING ATTORNEY

CLASS 41—EDUCATION AND ENTERTAINMENT

FOR PUBLICATION AND EDITING OF MAGAZINES AND PRINTED MATTER IN THE FIELD OF EROTICISM; DEVELOPMENT, COMPILATION, PRODUCTION AND EDITING OF FILM AND AUDIOVISUAL PRODUCTIONS; PRODUCTION AND DISTRIBUTION OF FILMS, VIDEO FILMS AND AUDIOVISUAL PRODUCTIONS RECORDED ON DATA CARRIERS; RENTAL OF SOUND AND IMAGE RECORDINGS; RENTAL OF VIDEO SCREENS, AUDIO EQUIPMENT, TELEVISION SETS; ORGANIZATION OF EVENTS FOR ENTERTAINMENT PURPOSES, NAMELY, DANCE PERFORMANCES, LIVE PRESENTATIONS OF PRERECORDED VIDEOS, PERSONAL APPEARANCES BY A MOVIE STAR; PROVIDING A WEBSITE FEATURING EROTIC INFORMATION AND IMAGES FOR ADULT ENTERTAINMENT; AFOREMENTIONED SERVICES ALSO TO BE PROVIDED VIA THE INTERNET (U.S. CLS. 100, 101 AND 107).

REBECCA POVARCHUK, EXAMINING ATTORNEY

SN 79-045,200. CRYOLOG, FRANCE, FILED 5-22-2007.

BREAKPOINT

THE MARK CONSISTS OF STANDARD CHARACTERS WITHOUT CLAIM TO ANY PARTICULAR FONT, STYLE, SIZE, OR COLOR.

PRIORITY DATE OF 11-28-2006 IS CLAIMED.

OWNER OF INTERNATIONAL REGISTRATION 0940842 DATED 5-22-2007, EXPIRES 5-22-2017.

SN 79-045,197. GLOBAL DISTRIBUTORS NETHERLANDS B.V., NETHERLANDS, FILED 5-15-2007.

NEXXT GENERATION

THE MARK CONSISTS OF STANDARD CHARACTERS WITHOUT CLAIM TO ANY PARTICULAR FONT, STYLE, SIZE, OR COLOR.

PRIORITY DATE OF 1-10-2007 IS CLAIMED.

OWNER OF INTERNATIONAL REGISTRATION 0940837 DATED 5-15-2007, EXPIRES 5-15-2017.

CLASS 9—ELECTRICAL AND SCIENTIFIC APPARATUS

FOR PRERECORDED EROTIC CDS, CD-ROMS AND DVDS; EROTIC VIDEO FILMS, PRERECORDED ON DVDS, VIDEOTAPES; BATTERIES (U.S. CLS. 21, 23, 26, 36 AND 38).

CLASS 35—ADVERTISING AND BUSINESS

FOR WHOLESALE STORE AND RETAIL STORE SERVICES IN THE FIELD OF SEX APPLIANCES AND EROTIC VIDEO FILMS, CDS, CD-ROMS AND DVDS, SALES PROMOTION FOR GOODS IN THE FIELD OF EROTICISM; AND BUSINESS INTERMEDIARY SERVICES FOR GOODS IN THE FIELD OF EROTICISM, NAMELY, DISTRIBUTORSHIPS FOR MAGAZINES AND PRINTED MATTER IN THE FIELD OF EROTICISM (U.S. CLS. 100, 101 AND 102).

CLASS 9—ELECTRICAL AND SCIENTIFIC APPARATUS

FOR SCIENTIFIC CONTROL APPARATUS AND INSTRUMENTS, NAMELY, COLD CHAIN FAILURE INDICATORS IN THE FORM OF INDICATOR LAMPS; TEMPERATURE CONTROL DEVICES, NAMELY, TEMPERATURE SENSORS; THERMOSENSITIVE TEMPERATURE INDICATORS IN THE FORM OF STRIPS, INSERT STRIPS AND LABELS, AND HEAT-SENSITIVE DETECTORS; TEMPERATURE INDICATORS FOR DETECTING COLD CHAIN FAILURES AND QUANTIFYING SAME (U.S. CLS. 21, 23, 26, 36 AND 38).

CLASS 16—PAPER GOODS AND PRINTED MATTER

FOR BAGS, NAMELY, PAPER BAGS AND PLASTIC BAGS FOR PACKAGING, PAPER POUCHES, PLASTIC POUCHES FOR PACKAGING, PAPER AND PLASTIC BOXES, ALL THESE GOODS BEING DESIGNED FOR MONITORING COLD CHAIN FAILURES AND VIEWING THE STATE OF FRESHNESS OF A PRODUCT; LABELS, NAMELY, ADHESIVE LABELS FOR MONITORING COLD CHAIN FAILURES AND VIEWING THE STATE OF FRESHNESS OF A PRODUCT (U.S. CLS. 2, 5, 22, 23, 29, 37, 38 AND 50).

CLASS 42—SCIENTIFIC AND COMPUTER SERVICES

FOR TECHNOLOGICAL SERVICES, NAMELY, QUALITY CONTROL OF GOODS IN THE AGRI-FOOD, RESTAURANT AND HEALTH SECTOR FOR THIRD PARTIES (U.S. CLS. 100 AND 101).

REBECCA POVARCHUK, EXAMINING ATTORNEY

SN 79-045,211. CHOCO, COÖPERATIEVE; VENNOOTSCHAP MET BEPERKTE; AANSPRAKELIJKHEID, BELGIUM, FILED 6-11-2007.

CACAO

THE MARK CONSISTS OF STANDARD CHARACTERS WITHOUT CLAIM TO ANY PARTICULAR FONT, STYLE, SIZE, OR COLOR.

PRIORITY DATE OF 12-29-2006 IS CLAIMED.
OWNER OF INTERNATIONAL REGISTRATION 0940869 DATED 6-11-2007, EXPIRES 6-11-2017.
THE ENGLISH TRANSLATION OF THE WORD "CACAO" IN THE MARK IS COCOA.

CLASS 35—ADVERTISING AND BUSINESS

FOR ADVERTISING; PUBLIC RELATIONS; BUSINESS CONSULTING; BUSINESS ORGANISATION AND MANAGEMENT CONSULTING; PERSONNEL CONSULTING; BUSINESS MANAGEMENT OF PERFORMING ARTISTS; PROFESSIONAL BUSINESS CONSULTING; SYSTEMIZATION OF INFORMATION INTO COMPUTER DATABASES; ADVERTISING AND MARKETING CONSULTANCY; SALES PROMOTION (U.S. CLS. 100, 101 AND 102).

CLASS 41—EDUCATION AND ENTERTAINMENT

FOR CAREER COUNSELING; PHOTOGRAPHY AND PHOTOGRAPHIC REPORTING (U.S. CLS. 100, 101 AND 107).

CHARISMA HAMPTON, EXAMINING ATTORNEY

SN 79-045,291. NATFOOD S.R.L., ITALY, FILED 8-27-2007.



PRIORITY DATE OF 6-29-2007 IS CLAIMED.
OWNER OF INTERNATIONAL REGISTRATION 0941167 DATED 8-27-2007, EXPIRES 8-27-2017.

THE MARK CONSISTS OF AN OVAL SHAPE AND THE WORDING "MASCARPONE LATINO" IN TWO HORIZONTAL LINES INSIDE THE OVAL SHAPE; THE WORD "MASCARPONE" APPEARING IN A STYLIZED FORM AND THE LETTER "O" APPEARING IN THE SHAPE OF A CURL WITH AN EMBOSSED LOOK, AND THE WORD "LATINO" IN CAPITAL LETTERS.

THE ENGLISH TRANSLATION OF "MASCARPONE LATINO" IS LATIN MASCARPONE.

CLASS 30—STAPLE FOODS

FOR COFFEE, TEA, COCOA, SUGAR, RICE, TAPIOCA, SAGO, ARTIFICIAL COFFEE; FLOUR; PREPARATIONS MADE FROM CEREALS, NAMELY, CEREAL BASED SNACK FOOD; BREAD, PASTRY AND FROZEN CONFECTIONERY, FROZEN ICES; HONEY, TREACLE; YEAST, BAKING-POWDER; SALT, MUSTARD; VINEGAR, SAUCES; SPICES; ICE (U.S. CL. 46).

CLASS 32—LIGHT BEVERAGES

FOR BEERS; MINERAL AND AERATED WATERS AND OTHER NON-ALCOHOLIC DRINKS, NAMELY, SOFT DRINKS; FRUIT DRINKS AND FRUIT JUICES; SYRUPS, CONCENTRATES AND POWDERS USED IN PREPARATION OF SOFT DRINKS (U.S. CLS. 45, 46 AND 48).

ROBERT STRUCK, EXAMINING ATTORNEY

SN 79-045,295. DEGRYSE LAURENT, BELGIUM, FILED 8-28-2007.



PRIORITY DATE OF 5-16-2007 IS CLAIMED.
OWNER OF INTERNATIONAL REGISTRATION 0941183 DATED 8-28-2007, EXPIRES 8-28-2017.

NO CLAIM IS MADE TO THE EXCLUSIVE RIGHT TO USE "BEIJING, CENTER FOR CONTEMPORARY ART" AND "THE NON-LATIN CHARACTERS THAT MEAN BEIJING" AND "CENTER FOR CONTEMPORARY ART", APART FROM THE MARK AS SHOWN.

THE COLOR(S) BLACK AND RED IS/ARE CLAIMED AS A FEATURE OF THE MARK.

THE MARK CONSISTS OF THE WORDING "CENTER FOR CONTEMPORARY ART" IN BLACK, WITH CHINESE CHARACTERS IN RED AT THE TOP AND THE WORDING "BEIJING 798" IN RED AT THE BOTTOM."

THE NON-LATIN CHARACTER(S) IN THE MARK TRANSLITERATES INTO "ULLENS CENTER FOR CONTEMPORARY ART BEIJING 798", AND THIS MEANS "ULLENS CENTER FOR CONTEMPORARY ART BEIJING 798" IN ENGLISH.

CLASS 14—JEWELRY

FOR PRECIOUS METALS AND THEIR ALLOYS AND GOODS MADE OF OR COATED WITH THESE MATERIALS NOT INCLUDED IN OTHER CLASSES, NAMELY, WATCHES, NECKLACES, EARRINGS, RINGS, AND PINS; JEWELLERY, PRECIOUS STONES; TIMEPIECES AND CHRONOMETRIC INSTRUMENTS (U.S. CLS. 2, 27, 28 AND 50).

CLASS 16—PAPER GOODS AND PRINTED MATTER

FOR PAPER, CARDBOARD AND GOODS MADE FROM THESE MATERIALS, NOT INCLUDED IN OTHER CLASSES, NAMELY, NOTEBOOKS, NOTEPADS, AND PHOTO ALBUMS; PRINTED MATTER, NAMELY, POSTERS, POSTCARDS, BOOKS, LITHOGRAPHS; BOOKBINDING MATERIAL; PHOTOGRAPHS; STATIONERY; ADHESIVES FOR STATIONERY OR HOUSEHOLD PURPOSES; ARTISTS' MATERIALS, NAMELY, WRITING INSTRUMENTS, PENCILS, PENS, AND BOOKMARKS; PAINTBRUSHES; TYPEWRITERS; INSTRUCTIONAL AND TEACHING MATERIAL IN THE FIELDS OF ART, DRAWING, ARCHITECTURE, AND DESIGN; PLASTIC MATERIALS FOR PACKAGING, NAMELY, BUBBLE PACKS, PLASTIC BAGS; PRINTING TYPE; PRINTING BLOCKS (U.S. CLS. 2, 5, 22, 23, 29, 37, 38 AND 50).

CLASS 18—LEATHER GOODS

FOR LEATHER AND IMITATION LEATHER, GOODS MADE OF THESE MATERIALS NOT INCLUDED IN OTHER CLASSES, NAMELY, WALLETS AND CREDIT CARD CASES; ANIMAL SKINS AND HIDES; TRUNKS AND SUITCASES, UMBRELLAS, PARASOLS AND WALKING STICKS; WHIPS, HARNESS AND SADDLERY (U.S. CLS. 1, 2, 3, 22 AND 41).

CLASS 20—FURNITURE AND ARTICLES NOT OTHERWISE CLASSIFIED

FOR FURNITURE, MIRRORS, PICTURE FRAMES (U.S. CLS. 2, 13, 22, 25, 32 AND 50).

SN 79-045,373. ROCCAT GMBH, FED REP GERMANY, FILED 6-15-2007.

CLASS 21—HOUSEWARES AND GLASS

FOR HOUSEHOLD OR KITCHEN UTENSILS AND CONTAINERS, NAMELY, ICE CREAM SCOOPS, CHEESE PLANES, BALL WHISKS, AND SALAD SPINNERS; COMBS AND SPONGES FOR HOUSEHOLD PURPOSES; BRUSHES, NAMELY, BASTING BRUSHES; BRUSH-MAKING MATERIALS, ARTICLES FOR CLEANING PURPOSES, NAMELY, SPONGES; STEEL WOOL; UNWORKED OR SEMI-WORKED GLASS, NOT FOR BUILDING; GLASSWARE, PORCELAIN AND EARTHENWARE, NAMELY, EGG CUPS, WOBBLE COGNAC GLASSES, MARTINI GLASSES, TEA CUPS, COFFEE MUGS, SALT AND PEPPER SHAKERS, OVEN TO TABLE SERVING DISHES (U.S. CLS. 2, 13, 23, 29, 30, 33, 40 AND 50).



PRIORITY DATE OF 1-29-2007 IS CLAIMED. OWNER OF INTERNATIONAL REGISTRATION 0941400 DATED 6-15-2007, EXPIRES 6-15-2017.

THE MARK CONSISTS OF A SILHOUETTE OF A CAT HEAD FACING LEFT WITHIN A CRESCENT-SHAPED BORDER EXTENDING FROM THE NECK OF THE CAT. THREE CLAW MARKS APPEAR ON THE NECK OF THE CAT.

CLASS 24—FABRICS

FOR TEXTILES AND TEXTILE GOODS, NAMELY, PLACEMATS; PAPER BED COVERS AND TABLE COVERS NOT OF PAPER (U.S. CLS. 42 AND 50).

CLASS 9—ELECTRICAL AND SCIENTIFIC APPARATUS

FOR DEVICES FOR THE RECORDING, TRANSMISSION AND PLAYBACK OF SOUND AND IMAGES; LOUDSPEAKER, LOUDSPEAKER ENCLOSURE, HEADPHONES, MICROPHONES; DATA PROCESSING EQUIPMENT, NAMELY, COMPUTERS, NOTEBOOK COMPUTERS AND PERSONAL DIGITAL ASSISTANTS (PDA); AUXILIARY EQUIPMENT FOR COMPUTERS, TELEVISION SETS, AND MULTIMEDIA APPARATUS, NAMELY, COMPUTER GAME PROGRAMS, JOYSTICKS, VIDEO GAME INTERACTIVE CONTROL FLOOR PADS OR MATS, VIDEO GAME MACHINES FOR USE WITH TELEVISIONS, AND DIGITAL INPUT AND OUTPUT SCANNERS; VIDEO GAME INTERACTIVE REMOTE CONTROL UNITS, COMPUTER MOUSE AND MOUSE PADS, COMPUTER GRAPHIC BOARDS, KEYBOARDS, COMPUTER KEYPADS, COMPUTER CURSOR CONTROL DEVICES, NAMELY, LIGHT PENS, COMPUTER STYLUS, AND CONTROL PADS, MULTI-FUNCTION KEYBOARDS, PLAYER-OPERATED ELECTRONIC CONTROLLERS FOR ELECTRONIC VIDEO GAME MACHINES; PLAYER-OPERATED ELECTRONIC CONTROLLERS IN THE FORM OF ACCELERATOR PEDALS, BRAKE PEDALS, STEERING WHEELS AND STEERING WHEEL COLUMNS, AND GUNS FOR ELECTRONIC GAMES AND FOR OPERATING ELECTRONIC APPARATUS; VIDEO OUTPUT GAME MACHINES FOR USE WITH TELEVISIONS; PROGRAMMABLE DIGITAL TELEVISION RECORDERS; MAGNIFYING GLASSES AND HOLDERS FOR HOLDING AND OPERATING ELECTRONIC APPARATUS WITH DISPLAYS; LIGHTING FIXTURES IN THE NATURE OF LCD-PANELS, LIGHT EMITTING DIODES FOR USE IN DISPLAY LIGHTING FOR ELECTRONIC GAMES; COMPUTER INTERFACE BOARDS, UPI (UNIVERSAL PERIPHERAL INTERFACE) HARDWARE, PLUG-IN CONNECTORS, FLASH MEMORY CARDS, COMPUTER MEMORIES, MEMORY CARD READERS, MEMORY CARDS, COMPUTER PARALLEL PORTS AND COMPUTER SERIAL PORTS; EXTERNAL COMPUTER DISC DRIVES, BACK UP DRIVES FOR COMPUTERS, COMPUTER STORAGE DEVICES NAMELY, JUMP DRIVES, FLASH DRIVES AND THUMB DRIVES; REMOTE CONTROL FOR CD PLAYERS, DVD PLAYERS, STEREO RECEIVERS, STEREO TUNERS, AMPLIFIERS, VIDEO RECORDERS, SOUND RECORDERS, TELEVISIONS, VIDEO GAME MACHINES AND AUDIO EQUIPMENT; COMPUTER TERMINALS FOR INTERNET CONNECTIONS, COMPUTER TELEPHONY SOFTWARE, TELEPHONES FOR INTERNET USE; ACTIVE LOUDSPEAKERS; ELECTRICAL CONNECTOR CABLES AND ADAPTERS; MODEMS, BATTERIES, ACCUMULATORS, ELECTRICAL

CLASS 25—CLOTHING

FOR CLOTHING, NAMELY, TOPS, BOTTOMS, PANTS, SHIRTS, SOCKS, CARDIGANS, PONCHOS, COATS, JACKETS, SCARVES, TIES, BOWTIES, SWEATSHIRTS, AND SWIMSUITS; FOOTWEAR; HEADGEAR, NAMELY, HATS, CAPS, AND WATER-REPELLENT RAIN HATS (U.S. CLS. 22 AND 39).

CLASS 28—TOYS AND SPORTING GOODS

FOR GAMES AND TOYS, NAMELY, PUZZLES, ANIMAL ALPHABET WOODEN PUZZLES, YOYO TOYS, BUILDING CUBES, AND BUILDING BLOCKS; GYMNASTIC AND SPORTING ARTICLES, NAMELY, SPORT BALLS; DECORATIONS FOR CHRISTMAS TREES (U.S. CLS. 22, 23, 38 AND 50).

CLASS 34—SMOKERS' ARTICLES

FOR TOBACCO; SMOKERS' ARTICLES, NAMELY, ASHTRAYS AND LIGHTERS; MATCHES (U.S. CLS. 2, 8, 9 AND 17).

DAVID HOFFMAN, EXAMINING ATTORNEY

POWER SUPPLY DISTRIBUTION BOXES, ELECTRICAL POWER SUPPLY CONNECTORS AND ADAPTORS FOR USE WITH PORTABLE ELECTRONIC DEVICES, BATTERY CHARGERS, AC/DC ADAPTERS, COMPUTER NETWORK SWITCHES AND ROUTERS, TELEVISION DECODERS, ELECTRONIC ADAPTER DEVICES FOR THE DISPLAY OF SCREEN CONTENTS, NAMELY ELECTRIC LUMINESCENT DISPLAY PANELS; FLASH CARD ADAPTERS; AND CONNECTORS AND ADAPTERS FOR CONNECTING COMPUTER PERIPHERALS, NAMELY, CABLES, CRADLE CONNECTION UNITS, AND CRADLE RECHARGING UNITS FOR PERSONAL DIGITAL ASSISTANTS (PDA'S) AND CELLULAR TELEPHONES; GOODS OF LEATHER AND PLASTIC, NAMELY, PROTECTIVE BAGS, CARRYING BAGS AND BELT BAGS, PROTECTIVE SLEEVES AND CASES SPECIALLY ADAPTED FOR HOLDING AND STORING DATA PROCESSING EQUIPMENT, NAMELY, COMPUTERS, NOTEBOOK COMPUTERS, PERSONAL DIGITAL ASSISTANTS (PDA), VIDEO GAME MACHINES FOR USE WITH TELEVISIONS, AND MULTIMEDIA PROJECTORS; MOUNTINGS DEVICES, NAMELY, STRAPS AND TRAY MOUNTINGS FOR ELECTRONIC GAME; IMPACT PROTECTION SPECIALTY BOXES AND PROTECTIVE HOLDERS SPECIALLY ADAPTED FOR HOLDING AND STORING ELECTRONIC GAME PROGRAMS, NOTEBOOK COMPUTERS AND PERSONAL DIGITAL ASSISTANTS (PDA'S); ARCHIVING AND STORAGE CONTAINERS SPECIALLY ADAPTED FOR HOLDING ELECTRONIC APPARATUS, NAMELY, COMPUTERS, NOTEBOOK COMPUTERS, PERSONAL DIGITAL ASSISTANTS (PDA), VIDEO GAME MACHINES FOR USE WITH TELEVISIONS, EXTERNAL COMPUTER HARD DRIVES; MULTIMEDIA PROJECTORS, AND BLANK FLOPPY COMPUTER DISCS; BAGS AND BOXES SOLD EMPTY SPECIALLY ADAPTED FOR ELECTRONIC MEMORIES AND MEMORY CARDS; BAGS SPECIALLY ADAPTED FOR ELECTRONIC MEMORIES AND MEMORY CARDS WITH HAND HELD ELECTRONIC DEVICES, NAMELY, PERSONAL DIGITAL ASSISTANTS (PDA) (U.S. CLS. 21, 23, 26, 36 AND 38).

CLASS 20—FURNITURE AND ARTICLES NOT OTHERWISE CLASSIFIED

FOR FURNITURE, NAMELY, FILING AND STORAGE STANDS, NON-METAL BRACKETS, TRAYS AND FRAMES FOR HOLDING ELECTRONIC APPARATUS, ELECTRONIC DATA CARRIERS AND MEMORIES, ELECTRONIC APPARATUS AND APPARATUS MODULES AND FLOPPY DISKS (U.S. CLS. 2, 13, 22, 25, 32 AND 50).

EUGENIA MARTIN, EXAMINING ATTORNEY

SN 79-045,389. AVDEL UK LIMITED, UNITED KINGDOM, FILED 6-28-2007.

HOLDING YOUR WORLD TOGETHER

THE MARK CONSISTS OF STANDARD CHARACTERS WITHOUT CLAIM TO ANY PARTICULAR FONT, STYLE, SIZE, OR COLOR.

PRIORITY DATE OF 5-25-2007 IS CLAIMED.

OWNER OF INTERNATIONAL REGISTRATION 0941473 DATED 6-28-2007, EXPIRES 6-28-2017.

CLASS 6—METAL GOODS

FOR METAL FASTENERS AND METAL BOLTING DEVICES, NAMELY, METAL RIVETS; METAL SCREWS; METAL BOLTS; METAL NUTS; METAL BLIND RIVETS; METAL SWAGED-COLLAR BOLTS; METAL BLIND THREADED INSERTS; METAL BLIND STUDS, METAL SEALING PLUGS; METAL FERRULES; METAL HOLLOW PINS; METAL HOLLOW TERMINAL PINS; METAL BREAK STEM FASTENERS; METAL THREADED RIVETS (U.S. CLS. 2, 12, 13, 14, 23, 25 AND 50).

CLASS 7—MACHINERY

FOR MACHINE TOOLS, NAMELY, TOOLS FOR INSTALLING RIVETS, SCREWS, BOLTS, NUTS, BLIND RIVETS, SWAGED-COLLAR BOLTS, BLIND THREADED INSERTS, BLIND STUDS, SEALING PLUGS, FERRULES, HOLLOW PINS, HOLLOW TERMINAL PINS, THREADED RIVETS, BREAK STEM FASTENERS; MANDRELS FOR EXPANDING RIVETS; MACHINE TOOLS FOR REMOVING RIVETS, SCREWS, BOLTS, NUTS, BLIND RIVETS, SWAGED-COLLAR BOLTS, BLIND THREADED INSERTS, BLIND STUDS, SEALING PLUGS, FERRULES, HOLLOW PINS, HOLLOW TERMINAL PINS, THREADED RIVETS, BREAK STEM FASTENERS; PARTS OF MACHINE TOOLS, NAMELY, BITS, SOCKETS AND DRIVING HEADS FOR INSTALLING RIVETS, SCREWS, BOLTS, NUTS, BLIND RIVETS, SWAGED-COLLAR BOLTS, BLIND THREADED INSERTS, BLIND STUDS, SEALING PLUGS, FERRULES, HOLLOW PINS, HOLLOW TERMINAL PINS, THREADED RIVETS, BREAK STEM FASTENERS; MACHINE TOOLS FOR FABRICATING DRIVE SURFACES AND DRIVE RECESSES ON FASTENERS FOR USE IN THE CONSTRUCTION INDUSTRY; POWER DRILLS AND POWER SCREWDRIVERS FOR DRIVING FASTENERS; MACHINE COUPLINGS; MACHINE BELTING, NOT FOR LAND VEHICLES (U.S. CLS. 13, 19, 21, 23, 31, 34 AND 35).

CLASS 8—HAND TOOLS

FOR HAND TOOLS FOR DRIVING FASTENERS, NAMELY, HAND DRILLS; BITS FOR SCREWDRIVERS AND HAND DRILLS; SCREWDRIVERS, WRENCHES (U.S. CLS. 23, 28 AND 44).

CLASS 16—PAPER GOODS AND PRINTED MATTER

FOR PRINTED MATTER AND PRINTED PUBLICATIONS, NAMELY, MARKETING LITERATURE, DATA SHEETS, CATALOGUES AND BROCHURES IN THE FIELD OF FASTENERS; STATIONARY; PENS; PENCILS; NOTEPADS (U.S. CLS. 2, 5, 22, 23, 29, 37, 38 AND 50).

REGINA DRUMMOND, EXAMINING ATTORNEY

SN 79-045,503. SAINT-ZEBY MARTINE, FRANCE, FILED 6-29-2007.

PHILANTROPIK BY MARTINE SAINT-ZEBY

THE MARK CONSISTS OF STANDARD CHARACTERS WITHOUT CLAIM TO ANY PARTICULAR FONT, STYLE, SIZE, OR COLOR.

PRIORITY DATE OF 2-23-2007 IS CLAIMED.

OWNER OF INTERNATIONAL REGISTRATION 0941806 DATED 6-29-2007, EXPIRES 6-29-2017.

CLASS 3—COSMETICS AND CLEANING PREPARATIONS

FOR SOAPS FOR BODY CARE, BATH SOAPS, MEDICATED SOAPS, DISINFECTANT SOAPS; PERFUMERY, ESSENTIAL OILS, COSMETICS, COSMETIC KITS COMPRISING COSMETIC PENCILS, COSMETIC ROUGES, MASSAGE OILS AND BODY CREAMS; NAIL-CARE PRODUCTS, NAMELY, NAIL VARNISH, NAIL ENAMELS, NAIL CREAMS, MASSAGE OILS FOR NAILS, NAIL CARE PREPARATIONS, LOTIONS FOR STRENGTHENING THE NAILS; TOILETRY PRODUCTS, NOT INCLUDING SANITARY PRODUCTS FOR PERSONAL USE, NAMELY, BODY AND HAND CREAMS, MASSAGE OILS, NON-MEDICATED PREPARATIONS ALL FOR THE CARE OF SKIN, HAIR AND SCALP, MASSAGE OILS FOR BODY, HANDS, AND NAILS FOR USE IN SPECIFIC MASSAGE METHODS, NON-MEDICATED LIP BALM; HAIR-CARE PRODUCTS, NAMELY, HAIR DYES, HAIR GEL, HAIR SPRAYS, NON-MEDICATED HAIR RESTORATION LOTIONS AND CREAMS FOR REPAIR OF THE SCALP, OIL BATHS FOR HAIR CARE, HAIR CARE PREPARATIONS, SHAMPOOS, HAIR CREAMS AND LOTIONS, HAIR MASKS, HAIR SERUMS; BEAUTY MASKS, MAKEUP (U.S. CLS. 1, 4, 6, 50, 51 AND 52).

CLASS 5—PHARMACEUTICALS

FOR DIETETIC FOODS AND SUPPLEMENTS FOR MEDICAL USE; MEDICINAL HERBS; MEDICINAL BATHS, NAMELY, BATH SALTS, BATH PREPARATIONS, MASSAGE OILS, MEDICATED LOTIONS FOR SKIN, HAIR, AND SCALP; MEDICINAL HAIR-GROWTH PREPARATIONS; HERBAL TEAS (U.S. CLS. 6, 18, 44, 46, 51 AND 52).

CLASS 9—ELECTRICAL AND SCIENTIFIC APPARATUS

FOR MAGNETIC DATA CARRIERS, RECORDING DISCS, NAMELY, PRE-RECORDED CD-ROMS AND DVDS IN THE FIELD OF COSMETOLOGY, BEAUTY, HAIR CARE AND MASSAGE METHODS (U.S. CLS. 21, 23, 26, 36 AND 38).

CLASS 10—MEDICAL APPARATUS

FOR MASSAGE APPARATUS, MASSAGE GLOVES (U.S. CLS. 26, 39 AND 44).

CLASS 16—PAPER GOODS AND PRINTED MATTER

FOR TISSUES FOR REMOVING MAKEUP, MADE OF PAPER; PAPER HAND TOWELS; PAPER FACE TOWELS (U.S. CLS. 2, 5, 22, 23, 29, 37, 38 AND 50).

CLASS 18—LEATHER GOODS

FOR LEATHER AND IMITATION LEATHER; HANDBAGS, BACKPACKS, WHEELED BAGS; TRAVEL BAGS, AND BEACH BAGS; CASES FOR HOLDING TOILETRIES (U.S. CLS. 1, 2, 3, 22 AND 41).

CLASS 21—HOUSEWARES AND GLASS

FOR COMBS (U.S. CLS. 2, 13, 23, 29, 30, 33, 40 AND 50).

CLASS 24—FABRICS

FOR BED LINEN; HOUSEHOLD LINEN NOT OF PAPER; BATH LINEN MADE OF TEXTILE; TISSUES FOR REMOVING MAKEUP, MADE OF TEXTILE (U.S. CLS. 42 AND 50).

CLASS 25—CLOTHING

FOR FOOTWEAR, EXCLUDING ORTHOPAEDIC SHOES AND SHOES FOR PROTECTION AGAINST ACCIDENTS, IRRADIATION AND FIRE (U.S. CLS. 22 AND 39).

CLASS 28—TOYS AND SPORTING GOODS

FOR PHYSICAL EXERCISE MACHINES, STATIONARY EXERCISE BICYCLES (U.S. CLS. 22, 23, 38 AND 50).

CLASS 29—MEATS AND PROCESSED FOODS

FOR FOOD SUPPLEMENTS MADE WITH PRESERVED, DRIED AND COOKED FRUITS AND VEGETABLES; BEE POLLEN PROCESSED FOR FOOD PURPOSES (U.S. CL. 46).

CLASS 30—STAPLE FOODS

FOR ROYAL JELLY FOR HUMAN CONSUMPTION AND NOT FOR MEDICAL USE; NON-MEDICINAL HERBAL INFUSIONS; YEAST IN PILL FORM NOT FOR MEDICAL USE; HONEY; PROPOLIS AS IN BEE GLUE FOR HUMAN CONSUMPTION (U.S. CL. 46).

CLASS 31—NATURAL AGRICULTURAL PRODUCTS

FOR PLANT SEEDS; LIVE TREES; SHRUBS; NATURAL FLOWERS; FRESH GARDEN HERBS; LIVE PLANTS; FRESH FRUITS AND VEGETABLES (U.S. CLS. 1 AND 46).

CLASS 41—EDUCATION AND ENTERTAINMENT

FOR PUBLICATION OF BOOKS AND TEXTS NOT FOR ADVERTISING; ELECTRONIC PUBLICATION OF BOOKS AND TEXTS OTHER THAN FOR ADVERTISING; VIDEO TAPE FILM PRODUCTION; PHYSICAL EDUCATION (U.S. CLS. 100, 101 AND 107).

CLASS 42—SCIENTIFIC AND COMPUTER SERVICES

FOR RESEARCH IN THE FIELD OF COSMETOLOGY (U.S. CLS. 100 AND 101).

CLASS 44—MEDICAL, BEAUTY AND AGRICULTURAL SERVICES

FOR HYGIENIC, BEAUTY AND HAIR CARE FOR HUMAN BEINGS, AROMATHERAPY SERVICES, BEAUTY SALONS, HAIR SALONS, MANICURE SERVICES, MASSAGE SERVICES, PHYSICAL THERAPY (U.S. CLS. 100 AND 101).

REGINA DRUMMOND, EXAMINING ATTORNEY

SN 79-045,583. QUATTROCCHIO S.R.L., ITALY, FILED 6-20-2007.

ZERODISEGNO



OWNER OF INTERNATIONAL REGISTRATION 0585504 DATED 4-10-1992, EXPIRES 4-10-2012.

CLASS 6—METAL GOODS

FOR MODULAR METAL FRAMES CONSISTING OF LATTICE ELEMENTS, CONNECTING AND JOINT MEMBERS, COVERING ELEMENTS, SHELVES AND SIMILAR ELEMENTS FOR THE CREATION OF INTERNAL OR EXTERNAL OPEN AND/OR CLOSED AREAS AND PIECES OF FURNITURE (U.S. CLS. 2, 12, 13, 14, 23, 25 AND 50).

CLASS 20—FURNITURE AND ARTICLES NOT OTHERWISE CLASSIFIED

FOR FURNITURE AND PIECES OF FURNITURE, NAMELY, FURNITURE FRAMES, DOORS, SLIDES NOT OF METAL FOR CLOSETS, DRAWERS, SHELVES, TABLES, CHAIRS AND DESKS; DISPLAY STANDS; FURNITURE FRAMES FOR SHOP WINDOWS (U.S. CLS. 2, 13, 22, 25, 32 AND 50).

REGINA DRUMMOND, EXAMINING ATTORNEY

CLASS 1—CHEMICALS

FOR CHEMICAL, BIOCHEMICAL AND BIOTECHNOLOGICAL PRODUCTS FOR INDUSTRIAL AND SCIENTIFIC PURPOSES, IN PARTICULAR NUCLEIC ACIDS, ENZYMES, POLYMERASES, REAGENTS FOR STAINING AND MARKING, MOLECULAR PROBES, BUFFER, AQUEOUS AND NON-AQUEOUS SOLUTIONS OF ALCOHOLS AND SALTS, DISTILLED AND PURIFIED WATER, SILICA IN POWDERED, GRANULATE AND GEL FORM AND MAGNETIC PARTICLES IN FLUID FORM, NONE OF THE FOREGOING FOR MEDICAL OR VETERINARY PURPOSES; MATERIALS FOR COLUMNS AND REAGENTS AND SOLVENTS FOR SAMPLE PREPARATION, ALL OF THE FOREGOING FOR THE PURPOSE OF PURIFICATION, LYSIS, MODIFICATION AND MANIPULATION OF CELLS, AS WELL AS FOR THE PERFORMANCE OF MARKING, SEPARATION, ISOLATION, PURIFICATION, AMPLIFICATION AND ANALYTICAL METHODS FOR BIOPOLYMERS, IN PARTICULAR NUCLEIC ACIDS, ENZYMES, PROTEINS, MACRO MOLECULES AND BIOLOGICALLY ACTIVE SUBSTANCES FOR SEPARATION, ANALYSIS AND PURIFICATION OF BIOLOGICAL AND BIOCHEMICAL COMPOUNDS, NONE OF THE FOREGOING FOR MEDICAL OR VETERINARY PURPOSES; KITS COMPRISING CHEMICAL, BIOCHEMICAL AND BIOTECHNOLOGICAL PRODUCTS FOR SAMPLE PREPARATION, PURIFICATION, LYSIS, MODIFICATION AND MANIPULATION OF CELLS AS WELL AS FOR THE PERFORMANCE OF MARKING, SEPARATION, ISOLATION, PURIFICATION, AMPLIFICATION AND ANALYTICAL METHODS FOR BIOPOLYMERS, IN PARTICULAR NUCLEIC ACIDS, ENZYMES, PROTEINS, MACRO MOLECULES AND BIOLOGICALLY ACTIVE SUBSTANCES FOR SEPARATION, ANALYSIS AND PURIFICATION OF BIOLOGICAL AND BIOCHEMICAL COMPOUNDS, IN PARTICULAR NUCLEIC ACIDS MADE FROM BIOLOGICAL AND BIOCHEMICAL SAMPLE MATERIAL, NONE OF THE FOREGOING FOR MEDICAL OR VETERINARY PURPOSES (U.S. CLS. 1, 5, 6, 10, 26 AND 46).

SN 79-045,657. QIAGEN GMBH, FED REP GERMANY, FILED 2-2-2007.

**CLASS 5—PHARMACEUTICALS**

FOR PRODUCTS FOR MEDICAL AND VETERINARY MEDICAL PURPOSES, IN PARTICULAR DIAGNOSTIC PREPARATIONS, IN PARTICULAR NUCLEIC ACIDS, ENZYMES, POLYMERASES, REAGENTS FOR STAINING AND MARKING, MOLECULAR PROBES, BUFFER CHEMICALS AND AQUEOUS AND NON-AQUEOUS SOLUTIONS OF PRIMARY, SECONDARY AND TERTIARY ALCOHOLS AND SALTS, DISTILLED AND PURIFIED WATER, MAGNETIC PARTICLES IN FLUID FORM, AND MATERIALS FOR COLUMNS FOR THE PURPOSE OF PURIFICATION, LYSIS, MODIFICATION AND MANIPULATION OF CELLS, AS WELL AS FOR THE PERFORMANCE OF MARKING, SEPARATION, ISOLATION, PURIFICATION, AMPLIFICATION AND ANALYTICAL METHODS FOR BIOPOLYMERS, IN PARTICULAR NUCLEIC ACIDS, ENZYMES, PROTEINS, MACRO MOLECULES AND BIOLOGICALLY ACTIVE SUBSTANCES FOR SEPARATION, ANALYSIS AND PURIFICATION OF BIOLOGICAL AND BIOCHEMICAL COMPOUNDS, ALL OF THE FOREGOING FOR MEDICAL AND VETERINARY PURPOSES; PRODUCTS FOR MEDICAL AND VETERINARY MEDICAL PURPOSES, NAMELY, CHEMICAL, BIOCHEMICAL AND BIOTECHNOLOGICAL PRODUCTS AS WELL AS KITS COMPRISING PRODUCTS FOR MEDICAL AND VETERINARY MEDICAL PURPOSES, IN PARTICULAR CHEMICAL, BIOCHEMICAL AND BIOTECHNOLOGICAL PRODUCTS FOR SAMPLE PREPARATION, PURIFICATION, LYSIS, MODIFICATION AND MANIPULATION OF CELLS, AS WELL AS FOR THE PERFORMANCE OF MARKING, SEPARATION, ISOLATION, PURIFICATION, AMPLIFICATION AND ANALYTICAL METHODS FOR BIOPOLYMERS, IN PARTICULAR NUCLEIC ACIDS FOR MEDICAL AND VETERINARY MEDICAL PURPOSES, ENZYMES, NATURAL AND ARTIFICIAL PROTEINS, MACRO MOLECULES, AND BIOLOGICALLY ACTIVE SUBSTANCES FOR DETECTING PATHOGENS, GENETIC INFORMATION AND CONDITIONS OF THE HUMAN BODY (U.S. CLS. 6, 18, 44, 46, 51 AND 52).

PRIORITY DATE OF 10-4-2006 IS CLAIMED.
OWNER OF INTERNATIONAL REGISTRATION 0942109
DATED 2-2-2007, EXPIRES 2-2-2017.
OWNER OF U.S. REG. NOS. 1,630,524 AND 3,181,090.
NO CLAIM IS MADE TO THE EXCLUSIVE RIGHT TO
USE "QUALITY", APART FROM THE MARK AS SHOWN.

CLASS 9—ELECTRICAL AND SCIENTIFIC APPARATUS

FOR SCIENTIFIC APPARATUS, INSTRUMENTS AND EQUIPMENT FOR RESEARCH AND EXAMINATION PURPOSES, NAMELY, LABORATORY EQUIPMENT, NAMELY, CHROMATOGRAPHY COLUMNS; AUTOMATED LABORATORY EQUIPMENT, NAMELY, ROBOTS AND SPARE PARTS AND ADD-ONS THEREFOR, NAMELY, PREPROGRAMMED SMART CARDS FOR DNA PURIFICATION PROTOCOLS; LABORATORY EQUIPMENT, NAMELY, MICROPLATES; LABORATORY EQUIPMENT, NAMELY, PIPETTES, PIPETTE TIPS AND PIPETTE TIP HOLDERS; LABORATORY EQUIPMENT, NAMELY, SAMPLE CONTAINERS, REAGENT HOLDERS, FLASKS, REAGENT TUBE HOLDERS, HOLDERS FOR MICRO CONTAINERS, MAGNETIC SYRINGES, BIOCHIPS FOR THE PURPOSE OF SCREEN LARGE NUMBERS OF BIOLOGICAL ANALYTES, THERMOCYCLERS FOR THE PURPOSE OF PERFORMING POLYMERASE CHAIN REACTIONS, HOMOGENIZERS FOR THE PURPOSE OF BREAKING UP CELL MEMBRANES AND MIXING THE RESULTING LIQUIDS, AND VACUUM VALVES FOR THE PURPOSE OF PERMITTING THE OPERATION OF LABORATORY PROCESSES UNDER SUBATMOSPHERIC PRESSURE, ALL OF THE AFOREMENTIONED BEING INCLUDED IN THIS CLASS AND BEING FOR SCIENTIFIC RESEARCH AND EXAMINATION PURPOSES (U.S. CLS. 21, 23, 26, 36 AND 38).

CLASS 42—SCIENTIFIC AND COMPUTER SERVICES

FOR SCIENTIFIC RESEARCH FOR OTHERS IN THE FIELDS OF CHEMISTRY, GENETICS, BIOLOGY AND BIOCHEMISTRY; SCIENTIFIC DIAGNOSTIC SERVICES FOR OTHERS IN THE FIELDS OF DNA, RNA AND PROTEIN DETECTION AND ANALYSIS; RESEARCH SERVICES IN THE FIELD OF FORENSIC SCIENCE, NAMELY, ANALYSIS, DETECTION AND ISOLATION OF BIOLOGICAL SUBSTANCES IN FORENSIC SAMPLES (U.S. CLS. 100 AND 101).

EUGENIA MARTIN, EXAMINING ATTORNEY

SN 79-045,743. OSRAM GESELLSCHAFT MIT BESCHRÄNKTER HAFTUNG., FED REP GERMANY, FILED 5-22-2007.

CERAMOS

OWNER OF INTERNATIONAL REGISTRATION 0942371 DATED 5-22-2007, EXPIRES 5-22-2017.

THE WORDING "CERAMOS" HAS NO MEANING IN A FOREIGN LANGUAGE.

CLASS 9—ELECTRICAL AND SCIENTIFIC APPARATUS

FOR LIGHT EMITTING DIODES; ELECTRIC CONTROL CIRCUITS FOR DRIVING LIGHT EMITTING DIODES (U.S. CLS. 21, 23, 26, 36 AND 38).

CLASS 11—ENVIRONMENTAL CONTROL APPARATUS

FOR ELECTRIC LAMPS; ELECTRIC LUMINAIRES; ELECTRIC LIGHTING FIXTURES, ADAPTED FOR USE IN FLASHLIGHTS, CAMERA FLASH UNITS, VIDEO CAMERA LIGHT SOURCES, INDOOR COMMERCIAL AND RESIDENTIAL ARCHITECTURAL LIGHTING AND HIGH-LUMINANCE DISPLAY BACK LIGHTS FOR SIGNS, LIQUID CRYSTAL DISPLAYS, AND THE LIKE; LIGHT EMITTING DIODE LAMPS (U.S. CLS. 13, 21, 23, 31 AND 34).

JAMES MACFARLANE, EXAMINING ATTORNEY

SN 79-045,755. PROJECT 9 PTY LTD, AUSTRALIA, FILED 9-20-2007.



PRIORITY DATE OF 4-20-2007 IS CLAIMED.
OWNER OF INTERNATIONAL REGISTRATION 0942406 DATED 9-20-2007, EXPIRES 9-20-2017.

CLASS 24—FABRICS

FOR FABRICS FOR TEXTILE USE; TEXTILE FABRICS FOR THE MANUFACTURE OF CLOTHING (U.S. CLS. 42 AND 50).

CLASS 25—CLOTHING

FOR CLOTHING, NAMELY, JERSEYS, SHIRTS, SHORT-SLEEVED AND LONG-SLEEVED T-SHIRTS, HOODS, TOPS, JACKETS, PANTS, SHORTS, SURF WEAR; SPORTS CLOTHING, NAMELY, JERSEYS, SHIRTS, SHORT-SLEEVED AND LONG-SLEEVED T-SHIRTS, HOODS, TOPS, JACKETS, PANTS, SHORTS (U.S. CLS. 22 AND 39).

JULIE GUTTADAURO, EXAMINING ATTORNEY

SN 79-045,812. HEEREMA GROUP SERVICES S.A., LUXEMBOURG, FILED 7-23-2007.

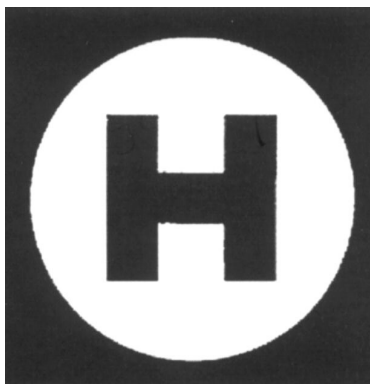

PRIORITY DATE OF 7-5-2007 IS CLAIMED.
OWNER OF INTERNATIONAL REGISTRATION 0942539 DATED 7-23-2007, EXPIRES 7-23-2017.
OWNER OF U.S. REG. NOS. 2,545,577 AND 2,546,015.

CLASS 35—ADVERTISING AND BUSINESS

FOR BUSINESS MANAGEMENT, COMMERCIAL MANAGEMENT, BUSINESS ORGANIZATION CONSULTANCY AND BUSINESS ECONOMICS CONSULTANCY, ALL IN THE FIELD OF DESIGNING, CONSTRUCTING, TRANSPORTING, INSTALLING AND DISMANTLING OF OFFSHORE INSTALLATIONS AND ALSO IN THE FIELD OF EXPLOITATION OF OFFSHORE INSTALLATIONS, THE EXPLOITATION OF OIL AND GAS FIELDS AND OTHER ENERGY PRODUCTS; PROVIDING OFFICE FUNCTIONS RELATED TO INVESTMENTS IN THE FIELD OF OIL, GAS AND OTHER ENERGY PRODUCTS; BUSINESS MANAGEMENT SUPERVISION, NAMELY, PROVIDING ASSISTANCE REGARDING THE OPERATIONAL MANAGEMENT INCLUDING THE SUPERVISION OF COMPANIES (U.S. CLS. 100, 101 AND 102).

CLASS 36—INSURANCE AND FINANCIAL

FOR FINANCE SERVICES, NAMELY, FINANCIAL ADVICE; INSURANCE SERVICES, NAMELY, INSURANCE BROKERAGE; FINANCING SERVICES FOR COMPANIES, ACQUISITIONS AND PARTICIPATIONS IN COMPANIES AND PROJECTS; FINANCIAL CONSULTANCY; INVESTMENT SERVICES, NAMELY, ASSET ACQUISITION, CONSULTATION, DEVELOPMENT AND MANAGEMENT SERVICES; REAL ESTATE PROPERTY MANAGEMENT AND CONSULTANCY IN THIS RESPECT; SERVICES OF A TRUST COMPANY; SERVICES OF HOLDING IN TRUST COMPANIES AND INVESTMENTS TRUSTS; SERVICES OF FINANCE COMPANIES, NAMELY, BUSINESS FINANCE PROCUREMENT SERVICES; FINANCING OF INDUSTRIAL ACTIVITIES; INVESTMENTS; CONSULTATION AND INFORMATION IN THE FIELD OF ALL SERVICES MENTIONED IN THIS CLASS (U.S. CLS. 100, 101 AND 102).

CLASS 37—CONSTRUCTION AND REPAIR

FOR BUILDING, REPAIR, INSTALLATION, AND MAINTENANCE SERVICES OF OFFSHORE HYDRO-CARBON EXPLORATION AND EXPLOITATION PLATFORMS AND FACILITIES, ON AND UNDER WATER, SHIPS AND OTHER VESSELS, DRY DOCKS AND DRY DOCK FACILITIES, DOCKYARDS, WHARFS, PANELING, DAMS, PIERS, BRIDGES, DRAINAGE SYSTEMS, OIL AND GAS PRODUCING FACILITIES, FLOATING OFFSHORE EQUIPMENT, PIPELINES, STEEL CONSTRUCTIONS AND FLOATING PRODUCTION STORAGE AND OFFLOADING VESSELS, CIVIL ENGINEERING CONSTRUCTIONS AND INDUSTRIAL INSTALLATIONS AND MACHINES; DRILLING PILLINGS ON LAND AND AT SEA; MINING EXTRACTION; EXTRACTION OF OIL, GAS AND OTHER ENERGY PRODUCTS, NAMELY, WINDMILLS; DRILLING OF CRUDE OIL AIMED AT EXTRACTING ENERGY PRODUCTS; RENTAL OF APPARATUS FOR THE EXTRACTION OF OIL, GAS AND OTHER ENERGY PRODUCTS, NAMELY, ELECTRICITY; CONSULTATION AND INFORMATION IN THE FIELD OF ALL SERVICES MENTIONED IN THIS CLASS (U.S. CLS. 100, 103 AND 106).

CLASS 39—TRANSPORTATION AND STORAGE

FOR TRANSPORT AND STORAGE OF MATERIALS INCLUDING GAS, OIL AND ELECTRICITY THROUGH PIPELINES AND POWER LINES; TRANSPORT BY BARGE OR HEAVY CARGO VESSELS OF OFFSHORE INSTALLATIONS AND OTHER CIVIL ENGINEERING CONSTRUCTIONS AND INDUSTRIAL INSTALLATIONS AND MACHINERY; CONSULTATION AND INFORMATION IN THE FIELD OF TRANSPORT AND STORAGE OF MATERIALS INCLUDING GASES, LIQUIDS SUCH AS OIL AND OTHER FIXED SUBSTANCES, ALSO THROUGH PIPELINES AND FROM OFFSHORE INSTALLATIONS AND OTHER CIVIL ENGINEERING CONSTRUCTIONS AND INDUSTRIAL INSTALLATIONS; RENTAL OF EQUIPMENT IN THE FIELD OF TRANSPORT AND STORAGE, NAMELY, MOBILE STORAGE TANKS; TRANSPORT OF GOODS OVER WATER AND LAND BY BOATS, TRAINS, AND TRUCKS; SERVICES OF TUG BOATS, NAMELY, BOAT TOWING SERVICES; CONSULTATION AND INFORMATION IN THE FIELD OF ALL SERVICES MENTIONED IN THIS CLASS (U.S. CLS. 100 AND 105).

CLASS 40—MATERIAL TREATMENT

FOR GENERATING, PRODUCING AND CONVERTING ENERGY; SERVICES OF REFINERIES, NAMELY, OIL REFINING; PRESERVING, REFINING AND IMPROVING PETROLEUM, NATURAL GAS, OIL AND OTHER BITUMEN, MINERALS, ELECTRICITY AND HYDROGEN, BOTH IN LIQUID, SOLID AND GAS FORMS; TECHNICAL CONSULTANCY CONCERNING THE TREATMENT OF OIL, PETROLEUM, NATURAL GAS, OTHER BITUMEN AND MINERALS, AND HYDROGEN, BOTH IN LIQUID, SOLID AND GAS FORMS; TREATMENT OF MATERIALS BY GALVANIZATION DURING PRODUCTION OF STEEL AND ALUMINUM COMPONENTS OF PIPELINES, OIL, GAS AND OTHER FACILITIES FOR ENERGY PRODUCTION, DRAINAGE SYSTEMS, INSTRUMENTAL SYSTEMS AND OTHER CIVIL ENGINEERING CONSTRUCTIONS AND INDUSTRIAL INSTALLATIONS AND MACHINERY FOR THE UPSTREAM OIL AND GAS INDUSTRY AND ENERGY INDUSTRY; CONSULTATION AND INFORMATION IN THE FIELD OF ALL SERVICES MENTIONED IN THIS CLASS (U.S. CLS. 100, 103 AND 106).

CLASS 42—SCIENTIFIC AND COMPUTER SERVICES

FOR ENGINEERING; INDUSTRIAL PLANNING AND DESIGN AND RELATED CONSULTATION FOR CONSTRUCTION PURPOSES; DESIGN OF APPARATUS AND INSTALLATIONS FOR OFFSHORE LOCATIONS, ON AND UNDER WATER, SHIPS AND OTHER VESSELS, DRY DOCKS AND DRY DOCK FACILITIES, DOCKYARDS, WHARFS, PANELING, DAMS, PIERS, BRIDGES, DRAINAGE SYSTEMS, OIL AND GAS PRODUCTION FACILITIES, FLOATING OFFSHORE EQUIPMENT FOR PIPELINES, STEEL CONSTRUCTIONS AND OTHER CIVIL ENGINEERING CONSTRUCTIONS AND INDUSTRIAL INSTALLATIONS AND MACHINERY FOR UPSTREAM OIL AND GAS EXPLORATION AND EXPLOITATION PLATFORMS AND FACILITIES; SCIENTIFIC RESEARCH AND INDUSTRIAL RESEARCH IN THE FIELD OF OFFSHORE OIL AND GAS AND TECHNICAL STUDIES, NAMELY, TECHNICAL ANALYSIS OF A PRODUCT OR PROCESS TO DETERMINE HOW TO MAKE IT MORE ENVIRONMENTALLY SOUND; TECHNICAL DESIGN OF SUBSEA AND FLOATING OFFSHORE OIL AND GAS FACILITIES FOR THE OFFSHORE INDUSTRY; SERVICES IN THE FIELD OF GEOLOGICAL AND OCEANOGRAPHIC INSPECTION AND RESEARCH, NAMELY, SEARCH FOR

AND RESEARCH OF NATURAL GAS AND OIL WELLS, BITUMEN, MINERALS AND OTHER ENERGY PRODUCTS; CONSULTANCY IN THE FIELD OF TECHNOLOGIES AND TECHNIQUES FOR THE EXPLOITATION AND EXTRACTION OF RAW MATERIALS; QUALITY CONTROL FOR OTHERS CONCERNING SERVICES IN THE FIELD OF CONSTRUCTION, REPAIR, MAINTENANCE, TRANSPORT, STORAGE, RESEARCH AND EXTRACTION OF OIL, GAS, ELECTRICITY AND HYDROGEN; CONSULTATION AND INFORMATION IN THE FIELD OF ALL SERVICES MENTIONED IN THIS CLASS (U.S. CLS. 100 AND 101).

TASHIA BUNCH, EXAMINING ATTORNEY

SN 79-045,838. SYLVAIN HÚSIPARI KFT., HUNGARY, FILED 10-11-2007.

SYLVAIN
★★★★★

OWNER OF INTERNATIONAL REGISTRATION 0942604 DATED 10-11-2007, EXPIRES 10-11-2017.

THE COLOR(S) RED, BLUE AND BLACK IS/ARE CLAIMED AS A FEATURE OF THE MARK.

THE COLOR RED APPEARS IN THE LETTERS "SYLVA" AND "N" OF THE WORD "SYLVAIN", THE COLOR BLUE APPEARS IN THE LETTER "I", OF THE WORD "SYLVAIN", AND IN THE FIVE STARS CENTERED BELOW, AND THE COLOR BLACK APPEARS IN THE OUTLINE OF THE LETTERS IN THE WORD "SYLVAIN".

CLASS 16—PAPER GOODS AND PRINTED MATTER

FOR PLASTIC PACKAGING, NAMELY, PLASTIC BAGS FOR PACKAGING FISH AND MEAT PRODUCTS, NAMELY, PORK, BEEF, HORSE, AND FOWL (U.S. CLS. 2, 5, 22, 23, 29, 37, 38 AND 50).

CLASS 29—MEATS AND PROCESSED FOODS

FOR MEAT PRODUCTS, NAMELY, UNCOOKED MEAT, AND PROCESSED MEAT, NAMELY, ROASTED MEAT, BOILED MEAT, AND SMOKED MEAT (U.S. CL. 46).

CARYN GLASSER, EXAMINING ATTORNEY

SN 79-045,852. CHRISTINE BUSIN, FRANCE, FILED 9-17-2007.

COCKTAIL WAX

SPECIAL WAX

PRIORITY DATE OF 4-10-2007 IS CLAIMED.
OWNER OF INTERNATIONAL REGISTRATION 0942680 DATED 9-17-2007, EXPIRES 9-17-2017.

NO CLAIM IS MADE TO THE EXCLUSIVE RIGHT TO USE "WAX", APART FROM THE MARK AS SHOWN.

CLASS 3—COSMETICS AND CLEANING PREPARATIONS

FOR SOAPS; PERFUMES, ESSENTIAL OILS, COSMETICS, HAIR LOTIONS; DENTIFRICES; DEPILATORY PREPARATIONS; MAKE-UP REMOVING PREPARATIONS; LIPSTICKS; BEAUTY MASKS; SHAVING PRODUCTS (U.S. CLS. 1, 4, 6, 50, 51 AND 52).

CLASS 44—MEDICAL, BEAUTY AND AGRICULTURAL SERVICES

FOR HYGIENIC AND BEAUTY CARE FOR HUMAN BEINGS; BEAUTY SALONS; HAIRDRESSING SALONS (U.S. CLS. 100 AND 101).

RONALD AIKENS, EXAMINING ATTORNEY

SN 79-045,885. LIDL STIFTUNG & CO. KG, FED REP GERMANY, FILED 10-1-2007.

ALESTO

PRIORITY DATE OF 4-19-2007 IS CLAIMED.

OWNER OF INTERNATIONAL REGISTRATION 0942747 DATED 10-1-2007, EXPIRES 10-1-2017.

OWNER OF U.S. REG. NO. 3,136,025.

THE COLOR(S) BLACK (PANTONE BLACK C), YELLOW (PANTONE YELLOW C), BLUE (PANTONE REFLEX BLUE C), RED (PANTONE 485 C), WHITE IS/ARE CLAIMED AS A FEATURE OF THE MARK.

THE MARK CONSISTS OF THE TERM "ALESTO" WRITTEN IN WHITE CONTAINED ON A RED BANNER WITH YELLOW TRIM. ABOVE THE BANNER ARE SIX WHITE STARS ON A BLUE BANNER ALSO OUTLINED IN YELLOW TRIM.

CLASS 29—MEATS AND PROCESSED FOODS

FOR SNACKS, NAMELY, DRIED, ROASTED, SALTED AND/OR SPICED PEANUT KERNELS; NUTS, NAMELY, BLANCHED NUTS, PROCESSED NUTS, PREPARED NUTS, SEASONED NUTS, AND SHELLED NUTS, ALMONDS AND CASHEW NUT KERNELS, POTATO CRISPS AND POTATO STICKS; SNACKS MADE FROM EXTRUDED POTATO PRODUCTS, NAMELY, POTATO CRISPS AND POTATO STICKS; DEEP-FRIED POTATO SNACKS; DRIED FRUITS; FRUIT CHIPS (U.S. CL. 46).

CLASS 30—STAPLE FOODS

FOR CONFECTIONERY, NAMELY, CHOCOLATE CHIPS, CHOCOLATE TOPPINGS, CARAMEL TOPPINGS, CHOCOLATE CANDY, CHOCOLATE BARS, CHOCOLATE TRUFFLES, MARZIPAN, ALMOND CAKE, ALMOND CANDY, ROASTED ALMONDS COATED IN CHOCOLATE, CRYSTALLIZED SUGAR PIECES, SWEETMEATS, CARAMELS, PASTILLES, CANDY AND SWEETS, PRALINES, TOFFEE, PEANUT BRITTLE, FRUIT JELLIES, GUM SWEETS, SHAVED ICE CONFECTIONS, ICE CREAM, BLANCMANGES, ITALIAN ICE, AND FRUIT ICES; PASTRIES, NAMELY, SHORTCAKE BISCUITS, SPRITZ COOKIES, WAFFLES, SAVOURY PASTRIES, PRETZELS, ONION PASTRIES AND CHEESE PASTRIES, WAFERS, BISCUITS, RUSKS, GINGERBREAD AND HONEY CAKES, CRACKERS, READY-TO-EAT PASTRIES FOR TOASTING, NAMELY, SAVOURY SANDWICH PASTRIES; POP CORN, CORNFLAKES; SNACKS MADE FROM EXTRUDED WHEAT, RICE AND CORN PRODUCTS (U.S. CL. 46).

CLASS 31—NATURAL AGRICULTURAL PRODUCTS

FOR FRESH, RAW, AND UNPROCESSED PEANUTS AND ALMONDS; FRESH FRUITS (U.S. CLS. 1 AND 46).
SHARON MEIER, EXAMINING ATTORNEY

SN 79-045,915. F.LLI CAMPANILE S.P.A., ITALY, FILED 12-29-2006.

CAMPANILE

OWNER OF INTERNATIONAL REGISTRATION 0639725
DATED 6-12-1995, EXPIRES 6-12-2015.
OWNER OF U.S. REG. NO. 1,966,851.

CLASS 18—LEATHER GOODS

FOR LEATHER AND IMITATIONS OF LEATHER, AND GOODS MADE OF THESE MATERIALS, NAMELY, WALLETS, COSMETIC CASES SOLD EMPTY, KEY CHAINS, KEY CASES, BAGS NAMELY, HANDBAGS, SHOULDER BAGS, SHOPPING BAGS, TRAVELLING BAGS, CABIN BAGS, SACKS IN THE NATURE OF HANDBAGS, SHOULDER BAGS AND BACKSIDE BAGS, COIN POUCHES, SUITCASES, BRIEFCASES, BACKPACKS, CLUTCH BAGS, ANTI-THEFT BAGS IN THE NATURE OF TRAVELLING BAGS WITH SECURITY LOCKS, TROLLEY BAGS, CHANGE PURSES, WHIPS, TRUNKS, UMBRELLAS, PARASOLS AND WALKING STICKS, HARNESS AND SADDLERY (U.S. CLS. 1, 2, 3, 22 AND 41).

CLASS 25—CLOTHING

FOR CLOTHING, FOOTWEAR, AND HEADGEAR, NAMELY, UNDERWEAR, LOUNGEWEAR, SWIMWEAR, SANDALS, BOOTS, SHOES, SLIPPERS, NIGHTGOWNS, PAJAMAS, DRESSING GOWNS, PULLOVERS, TUXEDOS, GLOVES, CARDIGANS, HATS, JERSEYS, NECKWEAR, HEAD WEAR, SWEATERS, SOCKS, STOCKINGS, TIGHTS, TROUSERS, LEGGINGS, SKIRTS, JACKETS, JERKINS, SHIRTS, VESTS, WAISTCOATS, JUMPERS, TRACK SUITS, BLOUSES, JEANS, PANTS, BERMUDA SHORTS, T-SHIRTS, SWEATSHIRTS, SUITS AND DRESSES, OVERCOATS, COATS, ANORAKS, RAINCOATS, BELTS, BRACES (U.S. CLS. 22 AND 39).

HEATHER THOMPSON, EXAMINING ATTORNEY

SN 79-045,979. LURGI AG, FED REP GERMANY, FILED 6-21-2007.

Lurgi MegaDME

THE MARK CONSISTS OF STANDARD CHARACTERS WITHOUT CLAIM TO ANY PARTICULAR FONT, STYLE, SIZE, OR COLOR.

PRIORITY DATE OF 12-22-2006 IS CLAIMED.
OWNER OF INTERNATIONAL REGISTRATION 0942877
DATED 6-21-2007, EXPIRES 6-21-2017.
OWNER OF U.S. REG. NOS. 670,186, 2,495,786 AND OTHERS.

NO CLAIM IS MADE TO THE EXCLUSIVE RIGHT TO USE "MEGA DME", APART FROM THE MARK AS SHOWN.

CLASS 1—CHEMICALS

FOR CHEMICAL PRODUCTS FOR COMMERCIAL AND SCIENTIFIC PURPOSES, NAMELY, DIMETHYL ETHER AS FUEL FOR DIESEL ENGINES, AEROSOL PROPELLANT; DIMETHYL ETHER (U.S. CLS. 1, 5, 6, 10, 26 AND 46).

CLASS 4—LUBRICANTS AND FUELS

FOR COMBUSTIBLES, NAMELY, ENGINE FUEL; GASEOUS FUEL (U.S. CLS. 1, 6 AND 15).

CLASS 11—ENVIRONMENTAL CONTROL APPARATUS

FOR APPARATUS, DEVICES AND PLANTS AND THEIR PARTS, FOR GENERATION OF DIMETHYL ETHER OF METHANOL AND TECHNICAL GASSES IN A REACTOR SYSTEM ON INDUSTRIAL SCALE FOR THERMAL PROCESSES (U.S. CLS. 13, 21, 23, 31 AND 34).

CLASS 37—CONSTRUCTION AND REPAIR

FOR BUILDING, INSTALLATION, ASSEMBLY AND MAINTENANCE OF INDUSTRIAL PLANTS (U.S. CLS. 100, 103 AND 106).

CLASS 40—MATERIAL TREATMENT

FOR CHEMICAL PROCESSING OF METHANOL INTO DIMETHYL ETHER AND PRODUCTS OF DIMETHYL ETHER IN INDUSTRIAL PLANTS (U.S. CLS. 100, 103 AND 106).

CLASS 42—SCIENTIFIC AND COMPUTER SERVICES

FOR RESEARCH AND DEVELOPMENT IN THE FIELD OF PROCESS TECHNOLOGY AND CHEMISTRY, IN PARTICULAR THE FIELD OF DIMETHYL ETHER SYNTHESIS AND ITS DERIVATIVES; ENGINEER SERVICES; TECHNICAL DEVELOPMENT, PLANNING, CONSTRUCTION DESIGN, TECHNICAL PROJECTING AND TAKING INTO OPERATION OF PLANTS, DEVICES AND METHODS FOR ANALYSIS AND SYNTHESIS, AND TECHNICAL CONSULTING, IN PARTICULAR IN THE FIELD OF DIMETHYL ETHER SYNTHESIS AND THEIR PRODUCTS; EXECUTION AND EVALUATION OF CHEMICAL ANALYSES; EXECUTION AND EVALUATION OF CHEMICAL SYNTHESSES; ISSUANCE OF TECHNICAL EXPERT OPINIONS IN CONNECTION WITH THE PRODUCTION OF DIMETHYL ETHER (U.S. CLS. 100 AND 101).

DAVID HOFFMAN, EXAMINING ATTORNEY

SN 79-046,017. ELMWOOD DESIGN LIMITED, UNITED KINGDOM, FILED 9-17-2007.

*"Make mine
a Builders"*

OWNER OF INTERNATIONAL REGISTRATION 0942989
DATED 9-17-2007, EXPIRES 9-17-2017.

CLASS 30—STAPLE FOODS

FOR COFFEE; TEA; BEVERAGES MADE FROM TEA; ICED TEA; ICED COFFEE; TEA-BASED BEVERAGES; COFFEE-BASED BEVERAGES; HERBAL TEA OTHER THAN FOR MEDICAL USE; FRUIT FLAVOURED TEA; TEA CONTAINING FRUIT EXTRACTS; AROMATIC TEA; ARTIFICIAL TEA; ARTIFICIAL COFFEE; FLOUR AND PREPARATIONS MADE FROM CEREALS, NAMELY, BISCUITS, COOKIES, CONFECTIONERY, BREAD AND PASTRY; ICES (U.S. CL. 46).

CLASS 32—LIGHT BEVERAGES

FOR BEERS; MINERAL AND AERATED WATERS AND OTHER NON-ALCOHOLIC BEVERAGES, NAMELY, CARBONATED SOFT DRINKS; FRUIT DRINKS AND FRUIT JUICES; SYRUPS AND OTHER PREPARATIONS FOR MAKING BEVERAGES, NAMELY, FRUIT DRINKS, FRUIT CORDIAL DRINKS, FRUIT EXTRACT DRINKS, SYRUPS FOR MAKING CARBONATED SOFT DRINKS (U.S. CLS. 45, 46 AND 48).
RONALD AIKENS, EXAMINING ATTORNEY

SN 79-046.054. WALDHAUSEN GMBH & CO. KG, FED REP GERMANY, FILED 9-21-2007.

AWAtec

SN 79-046.053. WALDHAUSEN GMBH & CO. KG, FED REP GERMANY, FILED 9-24-2007.

PRIORITY DATE OF 4-4-2007 IS CLAIMED.
OWNER OF INTERNATIONAL REGISTRATION 0943080
DATED 9-21-2007, EXPIRES 9-21-2017.



PRIORITY DATE OF 4-4-2007 IS CLAIMED.
OWNER OF INTERNATIONAL REGISTRATION 0943079
DATED 9-24-2007, EXPIRES 9-24-2017.

THE NAME "WALDHAUSEN" DOES NOT IDENTIFY A LIVING INDIVIDUAL.

THE WORDING "WALDHAUSEN" HAS NO MEANING IN A FOREIGN LANGUAGE.

CLASS 3—COSMETICS AND CLEANING PREPARATIONS

FOR COSMETIC PREPARATIONS FOR THE CARE AND WASHING OF HORSES, NAMELY, LOTIONS FOR THE MANE AND THE TAIL, SHAMPOO; LEATHER PRESERVATIVES AS FAR AS INCLUDED IN THIS CLASS, NAMELY, SADDLE SOAP AND PRESERVING OIL (U.S. CLS. 1, 4, 6, 50, 51 AND 52).

CLASS 18—LEATHER GOODS

FOR HORSE BLANKETS; EXERCISE SHEETS FOR HORSES, NAMELY, SHEETS FOR SADDLES; GAITERS, NAMELY, JUMPING BOOTS AS LEGGINGS, LEG WRAPPINGS AND BINDINGS FOR HORSES; JUMPING COVERS FOR HORSES, NAMELY, SADDLE COVERS; SADDLES FOR HORSES, STIRRUPS, STIRRUP STRAPS; HARNESSES, BRIDLES AND BITS FOR BRIDLES; HORSE TACK, NAMELY, GIRTHS AND BRIDDOONS AND CURBS AS PARTS OF HARNESSES AND BRIDLES; HALTERS FOR HORSES; RIDING WHIPS AND HORSE WHIPS (U.S. CLS. 1, 2, 3, 22 AND 41).

WILLIAM ROSSMAN, EXAMINING ATTORNEY

CLASS 6—METAL GOODS

FOR SPURS (U.S. CLS. 2, 12, 13, 14, 23, 25 AND 50).

CLASS 9—ELECTRICAL AND SCIENTIFIC APPARATUS

FOR EQUESTRIAN RIDING HELMETS (U.S. CLS. 21, 23, 26, 36 AND 38).

CLASS 18—LEATHER GOODS

FOR LEATHER AND IMITATIONS OF LEATHER, AND GOODS MADE OF THESE MATERIALS, AS FAR AS INCLUDED IN THIS CLASS, NAMELY, TRUNKS AND TRAVELING BAGS; UMBRELLAS, PARASOLS AND WALKING STICKS; SADDLES FOR HORSES, STIRRUPS, STIRRUP STRAPS, HARNESSES AND BRIDLES; HORSE TACK, NAMELY, GIRTHS AND BRIDDOONS AND CURBS AS PARTS OF HARNESSES AND BRIDLES; BITS FOR BRIDLES; HALTERS FOR HORSES; HORSE BLANKETS; EXERCISE SHEETS FOR HORSES, NAMELY, SHEETS FOR SADDLES; GAITERS, NAMELY, JUMPING BOOTS AS LEGGINGS, LEG WRAPPINGS AND BINDINGS FOR HORSES; JUMPING COVERS FOR HORSES, NAMELY, SADDLE COVERS; RIDING WHIPS AND HORSE WHIPS (U.S. CLS. 1, 2, 3, 22 AND 41).

CLASS 21—HOUSEWARES AND GLASS

FOR BRUSHES, CURRYCOMBS AND COMBS FOR THE MANE OF A HORSE; FABRIC STORING BOXES FOR CLEANING AND GROOMING UTENSILS FOR HORSES (U.S. CLS. 2, 13, 23, 29, 30, 33, 40 AND 50).

CLASS 25—CLOTHING

FOR CLOTHING, ESPECIALLY CLOTHING FOR HORSE RIDING, NAMELY, RIDING BREECHES, RIDING JACKETS, RIDING VESTS, RIDING BLOUSES; RAINCOATS, BAD WEATHER JACKETS AND TROUSERS FOR HORSE RIDING; SHOES AND BOOTS; HEADGEAR, NAMELY, CAPS AND TOP HATS FOR HORSE RIDERS; GLOVES (U.S. CLS. 22 AND 39).

WILLIAM ROSSMAN, EXAMINING ATTORNEY

SN 79-046,073. TECHNOCELL DEKOR GMBH & CO. KG, OSNABRÜCK, 49086, FED REP GERMANY, FILED 10-10-2007.

*my*Dekor.

PRIORITY DATE OF 4-12-2007 IS CLAIMED.
OWNER OF INTERNATIONAL REGISTRATION 0943119 DATED 10-10-2007, EXPIRES 10-10-2017.

NO CLAIM IS MADE TO THE EXCLUSIVE RIGHT TO USE "DEKOR", APART FROM THE MARK AS SHOWN.

THE COLOR(S) RED, BLACK IS/ARE CLAIMED AS A FEATURE OF THE MARK.

THE MARK CONSISTS OF A STYLIZED LITERAL ELEMENT, "MY DEKOR", FOLLOWED BY A PERIOD. THE COLOR BLACK APPEARS IN THE LITERAL PORTION OF THE MARK. THE COLOR RED APPEARS IN THE PERIOD PUNCTUATION.

CLASS 16—PAPER GOODS AND PRINTED MATTER

FOR PAPER FOR THE MANUFACTURE OF DECORATIVE AND INDUSTRIAL LAMINATES, RESIN IMPREGNATED RAW PAPER AND PRE-IMPREGNATED RAW PAPER FOR THE MANUFACTURE OF DECORATIVE AND INDUSTRIAL LAMINATES; PAPER FOR THE FURNITURE INDUSTRY AND DECORATIVE INTERIOR FITTING OF BUILDINGS (U.S. CLS. 2, 5, 22, 23, 29, 37, 38 AND 50).

CLASS 40—MATERIAL TREATMENT

FOR CONSULTANCY FOR THE FURNITURE INDUSTRY IN THE FIELD FURTHER PROCESSING OF PAPER IN THE MANUFACTURE OF DECORATIVE AND INDUSTRIAL LAMINATES (U.S. CLS. 100, 103 AND 106).

LAURIE KAUFMAN, EXAMINING ATTORNEY

SN 79-046,183. SPORTSWEAR COMPANY S.P.A.; (IN SIGLA SPW S.P.A.), ITALY, FILED 5-21-2007.



OWNER OF INTERNATIONAL REGISTRATION 0510222 DATED 2-13-1987, EXPIRES 2-13-2017.

CLASS 3—COSMETICS AND CLEANING PREPARATIONS

FOR PERFUMES; TOILET WATER; PERSONAL DEODORANTS; ESSENTIAL OILS FOR PERSONAL USE; BODY LOTIONS; SHOWER GEL; BUBBLE BATH; BATH OILS; BATH PEARLS; SKIN SOAPS; SHAVING BALMS; SHAVING CREAM; AFTERSHAVE LOTIONS; COSMETIC PENCILS; FOUNDATION MAKE-UP; FACE POWDERS; TALCUM POWDER; ROUGES; LIPSTICKS; MASCARAS; SKIN CLEANSING CREAMS; SKIN CLEANSING LOTIONS; SUN SCREEN PREPARATION; NAIL POLISH; BEAUTY MASKS; FACIAL SCRUBS; FACE CREAMS; BODY CREAMS; HAIR SHAMPOOS; HAIR SPRAYS; HAIR LOTIONS; DENTIFRICES (U.S. CLS. 1, 4, 6, 50, 51 AND 52).

CLASS 9—ELECTRICAL AND SCIENTIFIC APPARATUS

FOR EYEGLASSES; SUNGLASSES; RIM FOR EYEGLASS LENSES, BEING PARTS OF EYEGLASS FRAMES; EYEGLASS LENSES; EYEGLASS FRAMES (U.S. CLS. 21, 23, 26, 36 AND 38).

CLASS 14—JEWELRY

FOR BOXES OF PRECIOUS METAL; PURSES OF PRECIOUS METAL; JEWEL CASES OF PRECIOUS METAL; ORNAMENTAL PINS; JEWELRY ARTICLES, NAMELY, BROOCHES, NECKLACES, BRACELETS, CHAINS, TIE CLIPS, RINGS, MEDALLIONS, EARRINGS, PENDANTS, DIADEMS, CUFF LINKS; WATCHES; CLOCKS; CHRONOMETERS; CLOCK CASES; WRIST-WATCHES; ALARM CLOCKS; WATCH STRAPS; WATCH BANDS; WATCH CHAINS; WATCH GLASSES; WATCH SPRINGS (U.S. CLS. 2, 27, 28 AND 50).

CLASS 18—LEATHER GOODS

FOR HANDBAGS; LUGGAGE; SHOULDER BAGS; BEACH BAGS; CLUTCH BAGS; ALL PURPOSE SPORTS BAGS; ATTACHE CASES; SCHOOL BAGS; TOTE BAGS; TRAVELING BAGS; CASES OF LEATHER OR IMITATION LEATHER; CREDIT CARD CASES OF LEATHER OR IMITATION LEATHER; DOCUMENTS BRIEFCASES OF LEATHER OR IMITATION LEATHER; COSMETIC CASES SOLD EMPTY; KEYCASES; KNAPSACKS; RUCKSACKS; BRIEFCASES; PURSES; WALLETS; TRAVELING TRUNKS; SUITCASES; UMBRELLAS; PARASOLS; WALKING STICKS (U.S. CLS. 1, 2, 3, 22 AND 41).

STEPHANIE ALI, EXAMINING ATTORNEY

SN 79-046,234. FAR RUBINETTERIE S.P.A., ITALY, FILED 6-23-2006.



OWNER OF INTERNATIONAL REGISTRATION 0943453 DATED 6-23-2006, EXPIRES 6-23-2016.

THE MARK CONSISTS OF THE WORD "FAR" IN STYLIZED CAPITAL LETTERS SLIGHTLY INCLINED; EACH LETTER IS ENCLOSED IN A PARALLELOGRAM INCLINED IN THE SAME ANGLE; ALL OF WHICH ARE FRAMED INSIDE A PARALLELOGRAM INCLINED IN THE SAME ANGLE.

CLASS 6—METAL GOODS

FOR MANIFOLDS OF METAL FOR PIPELINES; METAL PLUGS FOR PIPING (U.S. CLS. 2, 12, 13, 14, 23, 25 AND 50).

CLASS 11—ENVIRONMENTAL CONTROL APPARATUS

FOR HEATING AND PLUMBING COMPONENTS, NAMELY, VALVES FOR RADIATORS, PIPE CONNECTORS, STRAINERS FOR HYDRO-SANITARY PLANTS; CONTROL UNIT FOR HYDRO-SANITARY PLANTS WITH MOTORIZED BALL VALVES; PRESSURE REDUCING VALVES FOR PLUMBING AND HYDRO-SANITARY FOR PLUMBING AND HYDRO-SANITARY PLANTS; SAFETY VALVES FOR HEATING PLANTS; AIR VENTING VALVES FOR RADIATORS AND HEATING PLANTS; THERMOSTATIC MIXING VALVES; WATER-FILLING VALVE UNITS FOR HEATING PLANTS (U.S. CLS. 13, 21, 23, 31 AND 34).

FRANK LATTUCA, EXAMINING ATTORNEY

SN 79-046,259, DAIRY AUSTRALIA LIMITED, AUSTRALIA,
FILED 6-5-2007.

DAIRY GOOD FOR LIFE!

THE MARK CONSISTS OF STANDARD CHARACTERS WITHOUT CLAIM TO ANY PARTICULAR FONT, STYLE, SIZE, OR COLOR.

OWNER OF INTERNATIONAL REGISTRATION 0943523
DATED 6-5-2007, EXPIRES 6-5-2017.

CLASS 16—PAPER GOODS AND PRINTED MATTER

FOR PAPER, CARDBOARD AND GOODS MADE FROM THESE MATERIALS, NAMELY, PAPER BAGS AND PAPER BANNERS; PRINTED PUBLICATIONS AND PROMOTIONAL MATERIALS, NAMELY, BROCHURES, LEAFLETS, BOOKLETS, PAMPHLETS, FLIERS, AND GUIDES, ALL IN THE FIELD OF HEALTH ISSUES, NUTRITIONAL ISSUES, THE DAIRY INDUSTRY, FOOD INDUSTRIES, DAIRY, AND DAIRY PRODUCTS; POSTERS; PRINTED CHARTS; PRINTED INSTRUCTIONAL TEACHING AND EDUCATIONAL MATERIALS IN THE FIELD OF HEALTH ISSUES, NUTRITIONAL ISSUES, THE DAIRY INDUSTRY, FOOD INDUSTRIES, DAIRY, AND DAIRY PRODUCTS (U.S. CLS. 2, 5, 22, 23, 29, 37, 38 AND 50).

CLASS 25—CLOTHING

FOR CLOTHING, NAMELY, T-SHIRTS; HEADGEAR, NAMELY, HATS, CAPS, BASEBALL CAPS, BEANIES, VISORS, EARMUFFS, WOOLY HATS, SKULLCAPS, NIGHTCAPS, HEAD SCARVES, SWIM CAPS, HEADBANDS, AND HEAD SWEATBANDS (U.S. CLS. 22 AND 39).

CLASS 29—MEATS AND PROCESSED FOODS

FOR MILK AND MILK PRODUCTS, NAMELY, YOGURT, CHEESE, BUTTER, AND DAIRY DESSERTS, NAMELY, CREAM DESSERTS, NAMELY, CREAM FRAICHE, DAIRY PRODUCTS EXCLUDING ICE CREAM, ICE MILK AND FROZEN YOGURT; DESSERTS MADE FROM MILK, NAMELY, WHIPPED CREAM, DAIRY BASED WHIPPED TOPPING, DAIRY-BASED BEVERAGES, DESSERTS MADE FROM MILK PRODUCTS, NAMELY, WHIPPED CREAM; DAIRY-BASED CHOCOLATE FOOD BEVERAGES; YOGURT-BASED BEVERAGES, MILK-BASED INSTANT DESSERTS, NAMELY, CHOCOLATE MILK AND MILK-BASED PREPARED DESSERTS, NAMELY, WHIPPED CREAM; MILK FORTIFIED WITH IRON; MILK FORTIFIED WITH CALCIUM (U.S. CL. 46).

CLASS 30—STAPLE FOODS

FOR ICE CREAM, YOGURT ICE CREAM; DESSERTS BEING FROZEN DESSERTS, NAMELY, FROZEN CONFECTIONS, FROZEN CUSTARDS, FROZEN YOGURT, ICE CREAM SANDWICHES, ICE CREAM DRINKS, ICE MILK, GELATO; ICE CREAM DESSERTS, NAMELY, FROZEN CONFECTIONS, MILK SHAKES, ICE CREAM DRINKS, ICE CREAM SANDWICHES; DESSERT MOUSSE; AND CHOCOLATE-BASED PREPARED DESSERTS, NAMELY, TRUFFLES, FONDUE, SOUFFLES, PUDDINGS, GELATO, BROWNIES, BONBONS (U.S. CL. 46).

CLASS 35—ADVERTISING AND BUSINESS

FOR ADVERTISING, MARKETING AND PROMOTION SERVICES; PUBLICATION OF PUBLICITY, ADVERTISING, MARKETING AND PROMOTIONAL TEXT; DISSEMINATION OF ADVERTISING MATTER; RENTAL OF ADVERTISING SPACE AND OF PUBLICITY MATERIAL; BILL-POSTING SERVICES; DEMONSTRATION OF PRODUCTS; DISTRIBUTION OF SAMPLES; MARKETING RESEARCH AND STUDIES; ORGANIZATION OF EXHIBITIONS FOR COMMERCIAL OR ADVERTISING PURPOSES; OUTDOOR ADVERTISING, NAMELY, PREPARING AND PLACING OUTDOOR ADVERTISEMENTS FOR OTHERS; ELECTRONIC MEDIA ADVERTISING, NAMELY, PRODUCTION AND DISTRIBUTION OF RADIO AND TELEVISION ADVERTISING AND COMMERCIALS; ONLINE MARKETING AND ADVERTISING SERVICES; ONLINE PUBLICATION OF ADVERTISING MATERIAL (U.S. CLS. 100, 101 AND 102).

CLASS 41—EDUCATION AND ENTERTAINMENT

FOR EDUCATIONAL SERVICES, NAMELY, PROVIDING TRAINING IN THE FIELD OF HEALTH AND NUTRITIONAL ISSUES AND PROVISION OF EDUCATIONAL MATERIALS THEREWITH; EDUCATIONAL SERVICES, NAMELY, PROVIDING TRAINING IN THE FIELD OF DAIRY AND FOOD INDUSTRIES AND PROVISION OF EDUCATIONAL MATERIALS THEREWITH; EDUCATIONAL SERVICES, NAMELY, PROVIDING LECTURES AND PRESENTATIONS TO SCHOOLS, MEDIA, HEALTH AND SPORTING PERSONNEL AND TO SCHOOL, MEDIA, HEALTH, SPORTING AND COMMUNITY ORGANIZATIONS IN THE FIELD OF DAIRY AND DAIRY PRODUCTS AND PROVISION OF EDUCATIONAL MATERIALS THEREWITH; ENTERTAINMENT SERVICES, NAMELY, CONDUCTING PARTIES, CONDUCTING CONTESTS; SPORTING AND CULTURAL ACTIVITIES, NAMELY, ORGANIZING COMMUNITY SPORTING AND CULTURAL EVENTS; ARRANGING AND CONDUCTING SEMINARS AND EXHIBITIONS IN THE FIELD OF HEALTH ISSUES, NUTRITIONAL ISSUES, THE DAIRY INDUSTRY, FOOD INDUSTRIES, DAIRY, AND DAIRY PRODUCTS; ENTERTAINMENT SERVICES, NAMELY, CONDUCTING FAIRS; AND PROVIDING RECOGNITION AND INCENTIVES BY THE WAY OF AWARD CEREMONIES DESIGNED TO DEMONSTRATE EXCELLENCE IN THE FIELD OF HEALTH ISSUES, NUTRITIONAL ISSUES, THE DAIRY INDUSTRY, FOOD INDUSTRIES, DAIRY, AND DAIRY PRODUCTS; PUBLICATION OF BOOKS (U.S. CLS. 100, 101 AND 107).

RICHARD WHITE, EXAMINING ATTORNEY

SN 79-046,314, LIDL STIFTUNG & CO. KG, FED REP GERMANY, FILED 10-23-2007.

PATAYA

PRIORITY DATE OF 4-24-2007 IS CLAIMED.
OWNER OF INTERNATIONAL REGISTRATION 0943677
DATED 10-23-2007, EXPIRES 10-23-2017.

CLASS 29—MEATS AND PROCESSED FOODS

FOR MILK DRINKS CONTAINING FRUITS (U.S. CL. 46).

CLASS 30—STAPLE FOODS

FOR ICED TEA, ICED TEA WITH ADDED FRUITS, ICED TEA DRINKS (U.S. CL. 46).

CLASS 32—LIGHT BEVERAGES

FOR NON-ALCOHOLIC BEVERAGES, NAMELY, FRUIT BASED SOFT DRINKS FLAVORED WITH TEA, FRUIT JUICES, FRUIT CORDIALS, MIXED FRUIT JUICE DRINKS, VEGETABLE JUICES, VEGETABLE JUICE BEVERAGES, MIXED VEGETABLE JUICE DRINKS, LEMONADES, WHEY DRINKS, MINERAL AND AERATED WATERS, SYRUPS FOR MAKING BEVERAGES, PREPARATIONS FOR MAKING BEVERAGES, NAMELY, FRUIT DRINKS (U.S. CLS. 45, 46 AND 48).

SHARON MEIER, EXAMINING ATTORNEY

SN 79-046,372. HUTCHINSON SA, FRANCE, FILED 10-12-2007.

convey)onic

PRIORITY DATE OF 5-3-2007 IS CLAIMED.
OWNER OF INTERNATIONAL REGISTRATION 0943803
DATED 10-12-2007, EXPIRES 10-12-2017.

CLASS 7—MACHINERY

FOR DRIVE BELTS FOR ENGINES OTHER THAN ENGINES FOR LAND VEHICLES (U.S. CLS. 13, 19, 21, 23, 31, 34 AND 35).

CLASS 28—TOYS AND SPORTING GOODS

FOR BELTS USED FOR PHYSICAL TRAINING APPARATUS AND ARTICLES, BODY-BUILDING APPARATUS AND MACHINES FOR PHYSICAL EXERCISES, NAMELY, BELTS FOR FITNESS CYCLES, TREADMILLS, AND ROWING MACHINES (U.S. CLS. 22, 23, 38 AND 50).

MATTHEW MCDOWELL, EXAMINING ATTORNEY

SN 79-046,379. OPED GMBH, FED REP GERMANY, FILED 10-2-2007.

ISURO

THE MARK CONSISTS OF STANDARD CHARACTERS WITHOUT CLAIM TO ANY PARTICULAR FONT, STYLE, SIZE, OR COLOR.

PRIORITY DATE OF 4-3-2007 IS CLAIMED.
OWNER OF INTERNATIONAL REGISTRATION 0943815
DATED 10-2-2007, EXPIRES 10-2-2017.

CLASS 10—MEDICAL APPARATUS

FOR ARTIFICIAL LIMBS, EYES AND TEETH; SUTURE MATERIAL; MATTRESSES FOR MEDICAL PURPOSES AND PARTS THEREOF; BEDS FOR MEDICAL PURPOSES (U.S. CLS. 26, 39 AND 44).

CLASS 20—FURNITURE AND ARTICLES NOT OTHERWISE CLASSIFIED

FOR FURNITURE, MIRRORS, PICTURE FRAMES; MATTRESSES, NOT FOR MEDICAL PURPOSES, AND PARTS THEREOF; BEDS (U.S. CLS. 2, 13, 22, 25, 32 AND 50).

CLASS 44—MEDICAL, BEAUTY AND AGRICULTURAL SERVICES

FOR MEDICAL SERVICES; VETERINARY SERVICES; HYGIENIC AND BEAUTY CARE FOR HUMAN BEINGS OR ANIMALS; SERVICES FOR MEDICAL CARE, NAMELY, NURSING SERVICES; MEDICAL CARE COUNSELING (U.S. CLS. 100 AND 101).

MICHAEL LEWIS, EXAMINING ATTORNEY

SN 79-046,413. SOCIÉTÉ DES PRODUITS NESTLÉ S.A., SWITZERLAND, FILED 10-23-2007.

NESFRAPPE

THE MARK CONSISTS OF STANDARD CHARACTERS WITHOUT CLAIM TO ANY PARTICULAR FONT, STYLE, SIZE, OR COLOR.

PRIORITY DATE OF 6-4-2007 IS CLAIMED.
OWNER OF INTERNATIONAL REGISTRATION 0943932
DATED 10-23-2007, EXPIRES 10-23-2017.

CLASS 29—MEATS AND PROCESSED FOODS

FOR PRESERVED, FROZEN, DRIED AND COOKED VEGETABLES, POTATOES AND FRUITS, PRESERVED, DRIED AND COOKED MUSHROOMS; MEAT, POULTRY, GAME, FISH, AND SEAFOOD; MEAT EXTRACTS; JAMS; EGGS; MILK; CREAM; BUTTER; CHEESE; MILK PRODUCTS, NAMELY, HALF AND HALF, MILK PROTEINS AND MILK BEVERAGES WITH HIGH MILK CONTENT; YOGURT; SOY MILK, PRESERVED SOYBEANS FOR HUMAN CONSUMPTION; EDIBLE OILS AND FATS; NON-DAIRY CREAMER; SAUSAGES; CHARCUTERIE; PEANUT BUTTER; SOUPS, CONCENTRATED SOUPS, THICK SOUPS, BOUILLON CUBES; BOUILLONS; AND CLEAR SOUPS (U.S. CL. 46).

CLASS 30—STAPLE FOODS

FOR COFFEE, COFFEE EXTRACTS, COFFEE-BASED BEVERAGES; ICED COFFEE; ARTIFICIAL COFFEE, ARTIFICIAL COFFEE EXTRACTS, BEVERAGES MADE FROM ARTIFICIAL COFFEE; CHICORY; TEA, TEA EXTRACTS, TEA-BASED BEVERAGES; ICED TEA; MALT FOR FOOD PURPOSES; COCOA; COCOA-BASED BEVERAGES; CHOCOLATE; CHOCOLATE-BASED BEVERAGES; CANDY, NAMELY, CONFECTIONERY, SUGAR CONFECTIONERY, AND SWEETS; SUGAR; CHEWING GUM NOT FOR MEDICAL PURPOSES; NATURAL SWEETENERS; BAKERY PRODUCTS; BREAD; YEAST; PASTRIES; BISCUITS; CAKES; COOKIES; WAFERS; CARAMELS; PUDDINGS; ICES; WATER ICES; SORBETS; ICE CONFECTIONERIES; ICED CAKES; ICE CREAMS; ICE DESSERTS; FROZEN YOGURT; HONEY AND HONEY SUBSTITUTES; BREAKFAST CEREALS; MUESLI; CORN-FLAKES; RICE; PASTA; NOODLES; PIZZAS; SANDWICHES; SAUCES; SOY SAUCE; KETCHUP; PRODUCTS FOR FLAVOURING OR SEASONING FOODSTUFFS; EDIBLE SPICES; SALAD DRESSINGS; MAYONNAISE, MUSTARD AND VINEGAR (U.S. CL. 46).

CLASS 32—LIGHT BEVERAGES

FOR BEER; STILL WATER; SPARKLING AND AERATED WATER; MINERAL WATER; FLAVOURED WATER; FRUIT-FLAVOURED BEVERAGES AND BEVERAGES MADE WITH FRUIT; FRUIT JUICES AND VEGETABLE JUICES; LEMONADES; SOFT DRINKS; CONCENTRATES AND POWDERS FOR MAKING SOFT DRINKS; ISOTONIC BEVERAGES (U.S. CLS. 45, 46 AND 48).

PATRICIA EVANKO, EXAMINING ATTORNEY

SN 79-046,471. GESELLSCHAFT FÜR WOLFRAM INDUSTRIE MBH, FED REP GERMANY, FILED 9-21-2007.



CLASS 35—ADVERTISING AND BUSINESS

FOR ADVERTISING SERVICES; UPDATING OF ADVERTISING MATERIAL; ADVERTISING CONSULTANCY, ADVERTISING SERVICES, NAMELY, PROVIDING ADVERTISING SPACE IN PERIODICALS, BROCHURES AND NEWSPAPERS; PROMOTING THE SALE OF GOODS AND SERVICES OF OTHERS THROUGH DISTRIBUTION OF GOODS, NAMELY, PRINTED MATERIAL AND PROMOTIONAL CONTESTS FOR ADVERTISING PURPOSES; ONLINE ADVERTISING IN A COMPUTER NETWORK; MARKETING SERVICES; ARRANGING, NAMELY, PROCURING OF CONTRACTS FOR OTHERS FOR THE BUYING AND SELLING OF GOODS; BUSINESS MERCHANDISING DISPLAY AND DEMONSTRATION OF GOODS FOR ADVERTISING PURPOSES; SALES PROMOTION FOR OTHERS PROVIDED THROUGH A DISTRIBUTION AND ADMINISTRATION OF PRIVILEGED USER CARDS; CONSULTATION AND ASSISTANCE IN BUSINESS MANAGEMENT, ORGANIZATION AND PROMOTION IN CONNECTION WITH SUPPORT IN THE OPERATION AND MANAGEMENT OF A COMMERCIAL ENTERPRISE; RETAIL STORE SERVICES FEATURING TUNGSTEN AND MOLYBDENUM GOODS; MEDIATION, NEGOTIATION AND CONCLUSION OF COMMERCIAL TRANSACTIONS FOR OTHERS; BUSINESS ORGANIZATION AND MANAGEMENT CONSULTANCY; MARKET RESEARCH; OPINION POLLING; PUBLIC RELATIONS; PRESENTATION OF THE GOODS OF OTHERS VIA A GLOBAL COMPUTER NETWORK AND VIA RADIO, TELEVISION, NEWSPAPERS AND MAGAZINES; ORGANIZATION OF EXHIBITIONS AND TRADE FAIRS FOR COMMERCIAL OR ADVERTISING PURPOSES (U.S. CLS. 100, 101 AND 102).

WILLIAM ROSSMAN, EXAMINING ATTORNEY

PRIORITY DATE OF 8-16-2007 IS CLAIMED.
OWNER OF INTERNATIONAL REGISTRATION 0944093
DATED 9-21-2007, EXPIRES 9-21-2017.

SN 79-046,495. VILLA SAN CARLO BORROMEO S.R.L.,
ITALY, FILED 4-16-2007.

CLASS 6—METAL GOODS

FOR COMMON METALS AND THEIR ALLOYS, NAMELY, IRON, STEEL, ALUMINUM, COPPER AND NICKEL AND ALLOYS THEREOF; TUNGSTEN, MOLYBDENUM, ALLOYS OF TUNGSTEN OR MOLYBDENUM; GOODS OF COMMON METAL, NAMELY, WIRE; GOODS OF TUNGSTEN OR MOLYBDENUM, NAMELY, WIRE AND CRUCIBLES; MOLYBDENUM BONDED WITH OTHER METALS IN THE FORM OF SHEETS, PLATES AND FOILS FOR FURTHER MANUFACTURE; METAL POWDER FOR MAKING ELECTRODES AND HEAT SINKS; RODS OF METAL FOR BRAZING AND WELDING (U.S. CLS. 2, 12, 13, 14, 23, 25 AND 50).

MAKARIA

CLASS 9—ELECTRICAL AND SCIENTIFIC APPARATUS

FOR WELDING ELECTRODES, ARC ELECTRODES, ELECTRODES FOR DISCHARGE LAMPS, LAMP ELECTRODES, ELECTRODES FOR APPLYING COATINGS, ELECTRODES FOR INJECTION PLASMA PROCESSES; HEAT SINKS FOR ELECTRODES; ELECTRODE MATERIAL, NAMELY, ELECTRODES MADE OF TUNGSTEN AND MOLYBDENUM AND ALLOYS THEREOF; PIPE WELDING NOZZLES BEING PARTS OF ELECTRIC WELDING APPARATUS; ELECTRIC WIRES; TUNGSTEN ELECTRIC EVAPORATION COILS AND CRUCIBLES USED FOR ELECTRIC ARC WELDING APPARATUS (U.S. CLS. 21, 23, 26, 36 AND 38).

THE MARK CONSISTS OF STANDARD CHARACTERS WITHOUT CLAIM TO ANY PARTICULAR FONT, STYLE, SIZE, OR COLOR.

OWNER OF INTERNATIONAL REGISTRATION 0944175
DATED 4-16-2007, EXPIRES 4-16-2017.

MAKARIA, FROM THE GREEK, MEANS "HAPPINESS" IN ENGLISH.

CLASS 16—PAPER GOODS AND PRINTED MATTER

FOR BOOKS, NEWSPAPERS, JOURNALS, REVIEWS, MAGAZINES, PERIODICALS, PAMPHLETS, INSTRUCTION HANDBOOKS, REFERENCE GUIDES AND CATALOGUES FEATURING TOPICS OF GENERAL INTEREST AND OF CULTURE, ART, HISTORY, MATHEMATICS, SCIENCE, LITERATURE, LANGUAGES AND GEOGRAPHY; AGENDAS, CALENDARS, POSTERS, BOOKMARKS, PAPER LABELS, BLOTTING PAPER, BOND PAPER, ILLUSTRATION PAPER, GIFT WRAPPING PAPER, WRITING PAPER, ENVELOPES, GIFT CARDS, OCCASION CARDS, POSTCARDS, BLANK CARDS, SCRATCH PADS, PAPER BOXES, PAPER BOARDS, GREETING CARDS, CARDBOARD BOXES, PICTURES, ANNIVERSARY BOOKS, RECIPE BOOKS, PICTURE BOOKS, GUEST BOOKS, DRAWING BOOKS, DICTIONARIES, PHOTOGRAPH ALBUMS, EXERCISE BOOKS, PHOTOGRAPHS, RUBBER ERASERS, MAGNETIC BOARDS, PENCIL SHARPENERS, PENS, PENCILS, PENCIL CASES, PEN CASES, OFFICE REQUISITES, NAMELY PUNCHES, GLUE FOR STATIONERY OR HOUSEHOLD USE, ARTISTS' PASTELS, PAINT BRUSHES, PRINTED AND ENGRAVED PICTURES, BOOKBINDINGS, PAPER CUTTERS, PAPERWEIGHTS, PAPER FASTENERS, HOLE PUNCHERS FOR OFFICE USE, PAPER CLIPS, DRAWING SQUARES, RULERS FOR DRAWING, FILE FOLDERS, DOCUMENT HOLDERS, DESK SETS, DESK TOP ORGANIZERS, PAPER BAGS, PLASTIC BAGS FOR PACKAGING PURPOSES, PAPER RIBBONS AND PAPER BOWS, PAPER CAKE DECORATIONS, DECORATIVE PAPER CENTERPIECES, PAPER DOILIES, PAPER TABLE CLOTH, PAPER NAPKINS, PAPER FILTERS FOR COFFEE MAKERS (U.S. CLS. 2, 5, 22, 23, 29, 37, 38 AND 50).

CLASS 38—COMMUNICATION

FOR ELECTRONIC BULLETIN BOARD SERVICES FEATURING TOPICS OF GENERAL INTEREST TO THE PUBLIC IN THE FIELD OF EDUCATION AND ENTERTAINMENT, TRANSMISSION OF MESSAGES, TEXTS AND IMAGES WITH THE AID OF A COMPUTER, ELECTRONIC MAIL SERVICES, ELECTRONIC TRANSMISSION OF DATA AND DOCUMENTS VIA COMPUTER TERMINALS; TRANSMISSION OF SOUND AND IMAGES VIA SATELLITE OR USING INTERACTIVE MULTIMEDIA EQUIPMENT; ELECTRONIC, ELECTRIC, AND DIGITAL TRANSMISSION OF VOICE, DATA, IMAGES, SIGNALS, AND MESSAGES, INFORMATION TRANSMISSION SERVICES VIA DIGITAL NETWORKS, NETWORK COMMUNICATIONS SERVICES, IN THE FORM OF TRANSMISSION OF STREAMED SOUND AND AUDIO-VISUAL RECORDINGS VIA THE INTERNET, ELECTRONIC TRANSMISSION OF FACSIMILE COMMUNICATIONS AND DATA FEATURING ENCRYPTION AND DECRYPTION, PROVIDING COLLOCATION SERVICES FOR VOICE, VIDEO AND DATA COMMUNICATIONS APPLICATIONS, COMMUNICATIONS VIA COMPUTER TERMINALS, COMMUNICATIONS THROUGH RADIO AND TELEVISION, CABLE AND TERTIARY RADIO/TELEVISION EMITTERS OR BY ONLINE SERVICES VIA TELEMATIC AND DATA PROCESSING NETWORKS, MOBILE RADIOTELEPHONY SERVICES, PROVIDING TELECOMMUNICATIONS CONNECTIONS TO A GLOBAL COMPUTER NETWORK, TELECOMMUNICATIONS CONSULTATION, TELECOMMUNICATIONS GATEWAY SERVICES, PROVIDING LONG DISTANCE TELECOMMUNICATION SERVICES, NAMELY ISDN SERVICES; PERSONAL TELECOMMUNICATION SERVICES, PROVIDING FIBER OPTIC NETWORK SERVICES FOR TELECOMMUNICATIONS; TELEPHONE TELECOMMUNICATIONS SERVICES INVOLVING PAYMENT BY PREPAID TELEPHONE CALLING CARDS; ALL BEING SERVICES FOR THIRD PARTIES (U.S. CLS. 100, 101 AND 104).

CLASS 41—EDUCATION AND ENTERTAINMENT

FOR PUBLICATION OF BOOKS AND MAGAZINES, PUBLICATION OF TEXTS EXCEPT OF ADVERTISING TEXTS, PRESENTATIONS IN MUSEUMS, ARRANGING AND CONDUCTING OF CONVENTIONS, CONGRESSES, CONFERENCES, SEMINARS AND SYMPOSIA ALL FOR EDUCATIONAL AND CULTURAL PURPOSES; ORGANIZATION OF EXHIBITIONS FOR EDUCATIONAL, CULTURAL OR ENTERTAINMENT PURPOSES, ORGANIZATION OF SPORTING AND CULTURAL EVENTS, ORGANIZING AND CONDUCTING TRAINING CLASSES, SEMINARS AND WORKSHOPS IN THE FIELD OF MUSIC, ART AND WRITING, IN COOKERY, IN PERSONAL AWARENESS; EDUCATIONAL SERVICES IN THE NATURE OF FINE ARTS SCHOOLS, OF COURSES AT UNIVERSITY LEVEL, COMPUTER EDUCATION TRAINING, SWIMMING INSTRUCTION, HORSE TRAINING, HORSE RACES, AMUSEMENT PARKS, ORGANIZATION OF FESTIVALS FOR CULTURAL PURPOSES, ORGANIZING COMMUNITY FESTIVALS FEATURING A VARIETY OF ACTIVITIES NAMELY FLEA MARKETS; PHYSICAL EDUCATION, NAMELY STRENGTH AND CONDITIONING TRAINING; ARRANGING FOR TICKET RESERVATIONS FOR SHOWS OR OTHER ENTERTAINMENT EVENTS; CASINOS; ENTERTAINMENT EVENTS IN THE NATURE OF DRAMA, BALLET AND DANCE PERFORMANCES, OF ORCHESTRA PERFORMANCES, OF ATHLETICS, OF LIVE MUSICAL GROUPS, OF MUSICAL BANDS, OF COMEDY SHOWS, OF MUSICAL VARIETY, OF AMUSEMENT PARK RIDES, OF FASHION SHOWS, OF GOLF TOURNAMENTS, OF TENNIS TOURNAMENTS, OF SOCCER AND FOOTBALL GAMES, OF TRACK AND FIELD COMPETITIONS; ENTERTAINMENT SERVICES BEING THE PRODUCTION OF MULTIMEDIA AUDIO-VISUAL COMPONENTS FOR SOFTWARE USED FOR ENTERTAINMENT PURPOSES; COMPUTER GAME SERVICES FOR ENTERTAINMENT PURPOSES, PRODUCTION AND RENTAL OF FILMS, OF BOOKS, OF MOVIES, RENTAL OF COMPUTER GAMES; ALL BEING SERVICES FOR THIRD PARTIES (U.S. CLS. 100, 101 AND 107).

RICHARD A. STRASER, EXAMINING ATTORNEY

SN 79-046,608. MYOTEST SA, SWITZERLAND, FILED 9-28-2007.

 The logo for 'myotest' features the word 'myotest' in a lowercase, sans-serif font. The letter 'o' is replaced by a stylized graphic of a human eye, with a dark iris and a white sclera, looking towards the right.

PRIORITY DATE OF 5-7-2007 IS CLAIMED.
OWNER OF INTERNATIONAL REGISTRATION 0944472
DATED 9-28-2007, EXPIRES 9-28-2017.

CLASS 9—ELECTRICAL AND SCIENTIFIC APPARATUS

FOR MEASURING APPARATUS NOT FOR MEDICAL PURPOSES, NAMELY, APPARATUS FOR MEASURING MUSCLE STRENGTH AND MUSCLE STIFFNESS, APPARATUS FOR MEASURING POWER, STRENGTH, REACTIVITY, AND VELOCITY FOR ATHLETIC MOVEMENTS; TESTING APPARATUS NOT FOR MEDICAL PURPOSES, NAMELY, APPARATUS FOR TESTING MUSCULAR PERFORMANCE; COMPUTER SOFTWARE FOR REPORTING AND ANALYSIS OF ATHLETIC MOVEMENTS AND MEASUREMENTS, FOR THE EVALUATION OF TRAINING INFORMATION FOR ANALYSIS, COMPARISON, STORING AND SHARING OF TEST RESULTS; INSTRUCTIONAL DVDS AND CDS FOR USE WITH THE AFOREMENTIONED APPARATUS AND SOFTWARE (U.S. CLS. 21, 23, 26, 36 AND 38).

CLASS 10—MEDICAL APPARATUS

FOR DIAGNOSTIC APPARTUS FOR MEDICAL PURPOSES FOR TESTING OF MUSCLES AND MUSCULAR PERFORMANCE (U.S. CLS. 26, 39 AND 44).
EMILY CHUO, EXAMINING ATTORNEY

SN 79-046,852. CUDECO LIMITED, AUSTRALIA, FILED 7-30-2007.

CUDECO

THE MARK CONSISTS OF STANDARD CHARACTERS WITHOUT CLAIM TO ANY PARTICULAR FONT, STYLE, SIZE, OR COLOR.

PRIORITY DATE OF 1-30-2007 IS CLAIMED.

OWNER OF INTERNATIONAL REGISTRATION 0945097 DATED 7-30-2007, EXPIRES 7-30-2017.

SN 79-046,670. ZF FRIEDRICHSHAFEN AG, FED REP GERMANY, FILED 5-11-2007.



OWNER OF INTERNATIONAL REGISTRATION 0176386 DATED 4-14-1954, EXPIRES 4-14-2014.

OWNER OF U.S. REG. NOS. 1,161,631, 2,780,982 AND OTHERS.

CLASS 7—MACHINERY

FOR WHEELS BEING PARTS OF MACHINES, NAMELY, TOOTHED WHEELS, OTHER WHEELS AND PARTS OF WHEELS USED IN THE MACHINE BUILDING INDUSTRY AND IN FINE MECHANICS, GEAR SYSTEMS AND DEVICES FOR USE IN TRANSMISSION OF FORCE AND MOTION FROM ONE GEAR SYSTEM TO ANOTHER, AND WITHIN THE SAME GEAR SYSTEM (U.S. CLS. 13, 19, 21, 23, 31, 34 AND 35).

CLASS 9—ELECTRICAL AND SCIENTIFIC APPARATUS

FOR TESTING AND MEASURING APPARATUS DESIGNED FOR VERIFYING THE MANNER AND EXTENT OF THESE TRANSMISSIONS OF FORCE AND MOVEMENT, NAMELY, ANALOG AND DIGITAL FORCE GAUGES, ANALOG AND DIGITAL TORQUE GAUGES, AND MANUAL AND MOTORIZED TEST STANDS USED THEREWITH SOLD AS A UNIT WITH THE GAUGES (U.S. CLS. 21, 23, 26, 36 AND 38).

CLASS 12—VEHICLES

FOR GEARS FOR VEHICLES, NAMELY, TOOTHED WHEELS, GEARS, AND DEVICES FOR USE IN TRANSMISSION OF FORCE AND MOTION FROM ONE GEAR SYSTEM TO ANOTHER, AND WITHIN THE SAME GEAR SYSTEM (U.S. CLS. 19, 21, 23, 31, 35 AND 44).
KRISTINA MORRIS, EXAMINING ATTORNEY

CLASS 6—METAL GOODS

FOR COMMON METALS, NAMELY, INGOTS OF COMMON METAL; COMMON METAL ALLOYS, NAMELY, COPPER ALLOYS, NICKEL ALLOYS, LEAD ALLOYS; ORES OF METAL, NAMELY, COPPER ORES, IRON ORES, LEAD ORES; PROCESSED METAL ORES, NAMELY, SEMI-WORKED COMMON METALS FOR FURTHER MANUFACTURE; COPPER, NAMELY, COPPER ORES, COPPER ALLOYS; COPPER BASED ALLOYS IN WROUGHT FORM, NAMELY, CASTINGS, FOILS, POWDER, AND ROLLED, DRAWN OR EXTRUDED SEMI-FINISHED ARTICLES MADE OF COPPER; COPPER, UNWROUGHT OR SEMI-WROUGHT, NAMELY, CASTINGS, FOILS, POWDER, AND ROLLED, DRAWN OR EXTRUDED SEMI-FINISHED ARTICLES MADE OF COPPER; COPPER SULPHATE PENTAHYDRATE; DISPERSION STRENGTHENED COPPER, NAMELY, SEMI-WORKED COPPER FOR FURTHER MANUFACTURE; SURFACE TREATED COPPER, NAMELY, SEMI-WORKED COPPER FOR FURTHER MANUFACTURE; UNWROUGHT COPPER BASED ALLOYS FOR FURTHER MANUFACTURE (U.S. CLS. 2, 12, 13, 14, 23, 25 AND 50).

CLASS 37—CONSTRUCTION AND REPAIR

FOR MINING, QUARRYING AND EXCAVATION SERVICES; MINING EXTRACTION; BUILDING CONSTRUCTION; REPAIR OF MINES; MAINTENANCE AND INSTALLATION SERVICES OF MINES (U.S. CLS. 100, 103 AND 106).

DOMINIC FATHY, EXAMINING ATTORNEY

SN 79-047,002. V&M DEUTSCHLAND GMBH, 40472 DÜSSELDORF, FED REP GERMANY, FILED 8-14-2007.

TPE

THE MARK CONSISTS OF STANDARD CHARACTERS WITHOUT CLAIM TO ANY PARTICULAR FONT, STYLE, SIZE, OR COLOR.

PRIORITY DATE OF 2-14-2007 IS CLAIMED.

OWNER OF INTERNATIONAL REGISTRATION 0945484 DATED 8-14-2007, EXPIRES 8-14-2017.

THE WORDING "TPE" HAS NO MEANING IN A FOREIGN LANGUAGE.

CLASS 6—METAL GOODS

FOR ROUND AND MOLDED TUBES OF METAL; STRUCTURAL HOLLOWWARE OF METAL FOR USE IN LARGE SPAN CONSTRUCTION (U.S. CLS. 2, 12, 13, 14, 23, 25 AND 50).

CLASS 9—ELECTRICAL AND SCIENTIFIC APPARATUS

FOR COMPUTER PROGRAMS AND COMPUTER SOFTWARE RECORDED ON COMPUTERS FOR USE IN THE MANUFACTURING OF ROUND AND MOLDED TUBES AND STRUCTURAL HOLLOWWARE FOR USE IN CONSTRUCTION (U.S. CLS. 21, 23, 26, 36 AND 38).

CLASS 16—PAPER GOODS AND PRINTED MATTER

FOR PRINTED MATTER, NAMELY, MANUFACTURING MANUALS IN THE FIELD OF MOLDED TUBING AND STRUCTURAL HOLLOWWARE; PRINTED ADVERTISING MATERIAL, NAMELY, POINT OF SALE CARDS IN THE FIELD OF MOLDED TUBING AND STRUCTURAL HOLLOWWARE; BUSINESS INFORMATIONAL BROCHURES RELATING TO MOLDED TUBING AND STRUCTURAL HOLLOWWARE (U.S. CLS. 2, 5, 22, 23, 29, 37, 38 AND 50).

CLASS 40—MATERIAL TREATMENT

FOR CUSTOM STEEL ROLLING AND FABRICATION TO THE ORDER AND SPECIFICATION OF OTHERS, NAMELY, ROLLING MASSIVE METAL BLOCKS AND HOLLOW BLOCKS TO FORM SEAMLESS TUBES (U.S. CLS. 100, 103 AND 106).

CLASS 42—SCIENTIFIC AND COMPUTER SERVICES

FOR DESIGN AND DEVELOPMENT OF COMPUTER SOFTWARE; SCIENTIFIC AND TECHNOLOGICAL SERVICES AND RESEARCH WORK RELATING TO STEEL ROLLING TECHNOLOGY (U.S. CLS. 100 AND 101).
HEATHER SAPP, EXAMINING ATTORNEY

CLASS 9—ELECTRICAL AND SCIENTIFIC APPARATUS

FOR APPARATUS AND INSTRUMENTS FOR CONDUCTING, SWITCHING, CONVERTING, STORING AND CONTROLLING ELECTRICITY, CONVERTERS, NAMELY, FREQUENCY CONVERTERS FOR THE ELECTRONIC SPEED CONTROL OF ELECTRIC MOTORS; CURRENT CONVERTERS; FREQUENCY CONVERTERS; ELECTRONIC CONTROLS FOR MOTORS AND MACHINES; PROGRAMMABLE LOGIC CONTROLLERS (PLCS); ELECTRIC CABLES; AUTOMATIC ELECTRICAL DISTRIBUTION APPARATUS, NAMELY, DISTRIBUTORS FOR ELECTRIC ENERGY; OPERATING TERMINALS FOR CONTROLLING MACHINES; ELECTRONIC AND ELECTRO-TECHNICAL MEASURING INSTRUMENTS, NAMELY, VOLTMETERS, CURRENT METERS, TORQUE METERS; ROTARY SPEED SENSORS; ENCODERS AND INCREMENTAL ENCODERS FOR MEASURING ROTARY SPEED AND POSITION OF DRIVES USED IN MACHINERY; ELECTRIC AND ELECTRONIC CONTROL APPARATUS, NAMELY, ELECTRONIC CONTROLS FOR MOTORS; OIL LEVEL SENSORS; OIL STATUS SENSORS; OIL DETEIORATION SENSORS; TEMPERATURE SENSORS; STRUCTURE-BORNE SOUND SENSORS; DOWNLOADABLE ELECTRONIC PUBLICATIONS IN THE NATURE OF MANUALS AND CATALOGUES IN THE FIELD OF INDUSTRIAL MACHINERY; ELECTROMECHANICAL CONTROLS FOR USE IN POSITIONING ELECTRIC MOTORS; COMPUTER SOFTWARE FOR CONTROLLING MACHINES; COMPUTER SOFTWARE FOR CONTROLLING INDUSTRIAL PROCESSES; COMPUTER SOFTWARE FOR MONITORING INDUSTRIAL PROCESSES; COMPUTER SOFTWARE FOR PLANNING INDUSTRIAL FACILITIES; FIELD BUS CABLES; FIELD BUS SWITCHES; NETWORK DEVICES, NAMELY, MODEMS AND POWER LAN CHIPS; NETWORK DEVICES FOR WIRELESS NETWORKS, NAMELY, RADIO TRANSMITTERS AND ANTENNAS; WIRELESS LAN MODEMS; DEVICES FOR INDUCTIVE SUPPLYING ELECTRIC DRIVES WITH ELECTRIC ENERGY, NAMELY, LINE CONDUCTORS, PICK-UP COILS, CURRENT TRANSFORMERS, DEVICES FOR THE CONTACTLESS SUPPLY OF ELECTRIC DRIVES WITH ELECTRIC ENERGY, NAMELY, LINE CONDUCTORS, PICK-UP COILS, CURRENT TRANSFORMERS; PARTS OF ALL AFORESAID GOODS (U.S. CLS. 21, 23, 26, 36 AND 38).

SN 79-047,025. SEW-EURODRIVE GMBH & CO. KG, 76646 BRUCHSAL, FED REP GERMANY, FILED 8-4-2007.

MAXOLUTION

THE MARK CONSISTS OF STANDARD CHARACTERS WITHOUT CLAIM TO ANY PARTICULAR FONT, STYLE, SIZE, OR COLOR.

PRIORITY DATE OF 2-28-2007 IS CLAIMED.
OWNER OF INTERNATIONAL REGISTRATION 0945558 DATED 8-4-2007, EXPIRES 8-4-2017.

CLASS 7—MACHINERY

FOR ELECTRIC MOTORS, OTHER THAN FOR LAND VEHICLES; GEARED MOTORS; TORQUE CONVERTERS; SERVO GEARS; MECHANICAL VARIABLE SPEED GEARBOXES; HEAVY INDUSTRIAL GEARBOXES; COMPACT DRIVES, NAMELY, DRIVES CONSISTING OF ELECTRIC MOTOR, REDUCTION GEAR AND FREQUENCY CONVERTER IN ONE HOUSING; ELECTRIC DRIVES FOR ELECTRIFIED MONORAILS; ELECTRIFIED MONORAILS; SPEED CONTROLLERS FOR MACHINES AND MOTORS; CONTROLLERS FOR MACHINES AND MOTORS; COUPLINGS, OTHER THAN FOR LAND VEHICLES; BRAKES; MAGNETIC BRAKES (U.S. CLS. 13, 19, 21, 23, 31, 34 AND 35).

CLASS 42—SCIENTIFIC AND COMPUTER SERVICES

FOR ENGINEERING SERVICES; CONSTRUCTION PLANNING SERVICES; DEVELOPMENT SERVICES OF NEW PRODUCTS; CONSULTING IN THE FIELD OF MECHANICAL ENGINEERING; CONSULTING SERVICES IN THE FIELD OF INDUSTRIAL DRIVE TECHNOLOGY; PLANNING AND LAYOUT DESIGN SERVICES OF INDUSTRIAL FACILITIES; ENGINEERING CONSULTING IN THE NATURE OF SELECTING AND DESIGNING THE LAYOUT OF DRIVE COMPONENTS TO BE USED IN MACHINERY; APPLICATION DEVELOPMENT; START UP TECHNICAL SUPPORT IN THE NATURE OF PLANNING, DEVELOPMENT AND TECHNICAL SUPPORT OF INDUSTRIAL MACHINERY; TECHNICAL SUPERVISION IN THE FIELD OF ASSEMBLY OF INDUSTRIAL MACHINERY (U.S. CLS. 100 AND 101).

RENEE SERVANCE, EXAMINING ATTORNEY

SN 79-047,285. EXEL INDUSTRIES, FRANCE, FILED 4-24-2007.

WONDERWEED

THE MARK CONSISTS OF STANDARD CHARACTERS WITHOUT CLAIM TO ANY PARTICULAR FONT, STYLE, SIZE, OR COLOR.

PRIORITY DATE OF 10-25-2006 IS CLAIMED.
OWNER OF INTERNATIONAL REGISTRATION 0946264 DATED 4-24-2007, EXPIRES 4-24-2017.

CLASS 7—MACHINERY

FOR LARGE MACHINERY FOR AGRICULTURAL, VITICULTURAL AND HORTICULTURAL USE, NAMELY, AUTOMOTIVE SPRAYING MACHINES, HARVESTING AND SOIL-ELIMINATING EQUIPMENT FOR BEETS DIGGERS IN THE NATURE OF SOIL ELIMINATORS, LEAF STRIPPERS, SHREDDERS, CUTTING DIVIDERS, AND HOEING MACHINES; MACHINERY FOR PROTECTING VEGETABLES FROM PARASITES IN THE NATURE OF ATOMIZERS, PUMPS BEING PARTS OF MACHINERY, SPRAY NOZZLES BEING PARTS OF MACHINERY, BOOMS FOR SPRAYING MACHINES, MOTORS, OTHER THAN FOR LAND VEHICLES, TRANSMISSION COUPLINGS AND BELTS, NOT BEING FOR LAND VEHICLES; MACHINES FOR DESTROYING RUBBISH AND WASTE, NAMELY, CRUSHERS, SHREDDERS AND APPARATUS USED TO SHEAR ALL PRODUCTS, REFUSE AND MATERIALS; PAINTING MACHINES AND PARTS THEREFORE IN THE NATURE OF SPRAY GUNS AND PUMPS FOR APPLYING PAINT, MASTICS AND OTHER VISCOUS PRODUCTS; INDUSTRIAL MACHINERY FOR PAINTING AND VARNISHING WORKSHOPS; PNEUMATIC TOOLS FOR PAINTING IN THE NATURE OF PNEUMATIC SPRAY GUNS, SANDING MACHINES, FLOOR POLISHING MACHINES AND COMPONENTS OF SUCH TOOLS; AIR COMPRESSORS AND PARTS OF COMPRESSED-AIR INSTALLATIONS, PISTON COMPRESSORS, AND MOBILE AND PORTABLE STATIONARY COMPRESSORS FOR WORKSHOPS; TOOLS FOR PAINTING WORKSHOPS FOR PNEUMATIC, HYDRAULIC PROJECTION OR FOR ELECTROSTATIC APPLICATION OF LIQUID PAINT OR OF POWDER OR SIMILAR PRODUCTS; SURFACE LINING MACHINERY; ACCESSORIES FOR SURFACE LINING MACHINERY; PAINTING MACHINES; LIQUID, POWDERY OR FIBROUS PRODUCT DISPENSING MACHINES; MACHINERY USED FOR PAINTING, POWDER COATING, ENAMELING, AND FLOCKING; AUTOMATIC ELECTROSTATIC PAINT SPRAYERS; AUTOMATIC SPRAYERS FOR PAINT FOR USE IN ELECTROSTATIC ENAMELING AND AUTOMATIC SPRAY HEADS FOR USE THEREWITH; AUTOMATIC SPRAY HEADS FOR ELECTROSTATIC DUSTING; MACHINERY, NAMELY, EXTRACTORS FOR POWDERY AND FIBROUS PRODUCTS; MACHINERY, NAMELY, POWDER DISPENSING TANKS; ELECTROSTATIC GENERATORS; HIGH-VOLTAGE GENERATORS; ACCESSORIES FOR ELECTROSTATIC GENERATORS BEING PARTS OF MACHINERY; ACCESSORIES FOR HIGH-VOLTAGE GENERATORS BEING PARTS OF MACHINERY; AUTOMATION MACHINES USED TO INDUSTRIAL APPLICATION OF SURFACE COATINGS; LIQUID DISPENSING PAINT TANKS; PRODUCT CHANGING MACHINES FOR INDUSTRIAL INSTALLATIONS FOR FLOCKING LIQUID OR POWDERY PAINT (U.S. CLS. 13, 19, 21, 23, 31, 34 AND 35).

CLASS 8—HAND TOOLS

FOR HAND-OPERATED AGRICULTURAL TOOLS AND INSTRUMENTS IN THE NATURE OF INSECTICIDE SPRAYERS, SPRAY GUNS, NOZZLES FOR HAND-HELD SPRAY GUNS, HAND-HELD SPRAY GUNS FOR PAINTING, HAND-OPERATED HAND TOOLS AND INSTRUMENTS FOR TREATING SURFACES BEFORE PAINTING, AND VARIOUS ABRASIVE WHEELS AND SANDERS; HAND-OPERATED AGRICULTURAL TOOLS AND INSTRUMENTS IN THE NATURE OF INSECTICIDE, HERBICIDE AND PESTICIDE SPRAYERS; HAND-HELD SPRAY GUNS FOR ELECTROSTATIC PAINTING; HAND-HELD SPRAY GUNS FOR ELECTROSTATIC ENAMELING; HAND-HELD SPRAY GUNS FOR ELECTROSTATIC DUSTING (U.S. CLS. 23, 28 AND 44).
ANN E. SAPPENFIELD, EXAMINING ATTORNEY

SN 79-047,304. DYNETIC SOLUTIONS GMBH, FED REP GERMANY, FILED 10-1-2007.



PRIORITY DATE OF 7-5-2007 IS CLAIMED.
OWNER OF INTERNATIONAL REGISTRATION 0946317 DATED 10-1-2007, EXPIRES 10-1-2017.
NO CLAIM IS MADE TO THE EXCLUSIVE RIGHT TO USE "NET", APART FROM THE MARK AS SHOWN.

CLASS 9—ELECTRICAL AND SCIENTIFIC APPARATUS

FOR COMPUTER SOFTWARE, NAMELY, WEB-BASED SOFTWARE FOR MOBILE APPLICATION DEVELOPMENT AS WELL AS FOR DIGITAL MEDIA ADAPTATION, FOR RENDERING TEXT, SOUND OR IMAGES-AGES AND FOR DELIVERY OF TEXT, SOUND OR IMAGES FOR MOBILE DEVICES; COMPUTER SOFTWARE FOR TRANSCODING AND DELIVERING OF DIGITAL MEDIA AND PORTALS TO MOBILE DEVICES; COMPUTER SOFTWARE FOR WIRELESS TRANSMISSION OF MULTIMEDIA-DATA, VIDEO, AUDIO, IMAGE AND TEXT-DATA AND FOR DELIVERING OF SOFTWARE APPLICATIONS TO MOBILE DEVICES; COMPUTER SOFTWARE FOR MANAGING AND ENCRYPTING DATA; COMPUTER SOFTWARE FOR WIRELESS MESSAGING, ADVERTISING AND BILLING SYSTEMS FOR USE ON MOBILE DEVICES (U.S. CLS. 21, 23, 26, 36 AND 38).

CLASS 38—COMMUNICATION

FOR BROADCASTING, DISTRIBUTION AND TRANSMISSION OF TELEVISION, RADIO, TELECOMMUNICATIONS AND DATA SIGNALS VIA DIGITAL AND ANALOG WIRELESS AND/OR CABLE NETWORKS AND PORTALS, INCLUDING VIA ONLINE AND OFF-LINE OPERATIONS AND VIA COMPUTER, PARTICULARLY TO MOBILE DEVICES; PROVIDING ACCESS TO TELECOMMUNICATION NETWORKS VIA MOBILE DEVICES (U.S. CLS. 100, 101 AND 104).

CLASS 42—SCIENTIFIC AND COMPUTER SERVICES

FOR COMPUTER SOFTWARE DEVELOPMENT, PROGRAMMING AND DESIGN FOR OTHERS, NAMELY, OF WEB-BASED SOFTWARE FOR MOBILE APPLICATION DEVELOPMENT AS WELL AS FOR DIGITAL MEDIA ADAPTATION, FOR RENDERING TEXT, SOUND OR IMAGES AND FOR DELIVERY OF TEXT, SOUND OR IMAGES FOR MOBILE DEVICES AND OF COMPUTER SOFTWARE FOR TRANSCODING AND DELIVERING OF DIGITAL MEDIA AND PORTALS TO MOBILE DEVICES AND OF COMPUTER SOFTWARE FOR WIRELESS TRANSMISSION OF MULTIMEDIA-DATA, VIDEO, AUDIO, IMAGE AND TEXT-DATA AND FOR DELIVERING OF SOFTWARE APPLICATIONS TO MOBILE DEVICES AND OF COMPUTER SOFTWARE FOR MANAGING AND ENCRYPTING DATA AND OF COMPUTER SOFTWARE FOR WIRELESS MESSAGING, ADVERTISING AND BILLING SYSTEMS FOR USE ON MOBILE DEVICES; COMPUTER SOFTWARE MAINTENANCE AND TECHNICAL SUPPORT SERVICES, NAMELY, SOFTWARE TROUBLESHOOTING; CONDUCTING SOFTWARE TESTS AND SIMULATIONS FOR OTHERS (U.S. CLS. 100 AND 101).
ANTHONY RINKER, EXAMINING ATTORNEY

SN 79-047,305. DYNETIC SOLUTIONS GMBH, FED REP GERMANY, FILED 10-1-2007.

SN 79-047,352. LUNASCAPE CO., LTD., TOKYO 106-0043, JAPAN, FILED 6-1-2007.

NETBISCUITS

THE MARK CONSISTS OF STANDARD CHARACTERS WITHOUT CLAIM TO ANY PARTICULAR FONT, STYLE, SIZE, OR COLOR.

PRIORITY DATE OF 7-5-2007 IS CLAIMED.

OWNER OF INTERNATIONAL REGISTRATION 0946318 DATED 10-1-2007, EXPIRES 10-1-2017.

CLASS 9—ELECTRICAL AND SCIENTIFIC APPARATUS

FOR COMPUTER SOFTWARE, NAMELY, WEB-BASED SOFTWARE FOR MOBILE APPLICATION DEVELOPMENT AS WELL AS FOR DIGITAL MEDIA ADAPTATION, FOR RENDERING TEXT, SOUND OR IMAGES AND FOR DELIVERY OF TEXT, SOUND OR IMAGES FOR MOBILE DEVICES; COMPUTER SOFTWARE FOR TRANSCODING AND DELIVERING OF DIGITAL MEDIA AND PORTALS TO MOBILE DEVICES; COMPUTER SOFTWARE FOR WIRELESS TRANSMISSION OF MULTIMEDIA-DATA, VIDEO, AUDIO, IMAGE AND TEXT-DATA AND FOR DELIVERING OF SOFTWARE APPLICATIONS TO MOBILE DEVICES; COMPUTER SOFTWARE FOR MANAGING AND ENCRYPTING DATA; COMPUTER SOFTWARE FOR WIRELESS MESSAGING, ADVERTISING AND BILLING SYSTEMS FOR USE ON MOBILE DEVICES (U.S. CLS. 21, 23, 26, 36 AND 38).

CLASS 38—COMMUNICATION

FOR BROADCASTING, DISTRIBUTION AND TRANSMISSION OF TELEVISION, RADIO, TELECOMMUNICATIONS AND DATA SIGNALS VIA DIGITAL AND ANALOG WIRELESS AND/OR CABLE NETWORKS AND PORTALS, INCLUDING VIA ONLINE AND OFF-LINE OPERATIONS AND VIA COMPUTER, PARTICULARLY TO MOBILE DEVICES; PROVIDING ACCESS TO TELECOMMUNICATION NETWORKS VIA MOBILE DEVICES (U.S. CLS. 100, 101 AND 104).

CLASS 42—SCIENTIFIC AND COMPUTER SERVICES

FOR COMPUTER SOFTWARE DEVELOPMENT, PROGRAMMING AND DESIGN FOR OTHERS, NAMELY, OF WEB-BASED SOFTWARE FOR MOBILE APPLICATION DEVELOPMENT AS WELL AS FOR DIGITAL MEDIA ADAPTATION, FOR RENDERING TEXT, SOUND OR IMAGES AND FOR DELIVERY OF TEXT, SOUND OR IMAGES FOR MOBILE DEVICES AND OF COMPUTER SOFTWARE FOR TRANSCODING AND DELIVERING OF DIGITAL MEDIA AND PORTALS TO MOBILE DEVICES AND OF COMPUTER SOFTWARE FOR WIRELESS TRANSMISSION OF MULTIMEDIA-DATA, VIDEO, AUDIO, IMAGE AND TEXT-DATA AND FOR DELIVERING OF SOFTWARE APPLICATIONS TO MOBILE DEVICES AND OF COMPUTER SOFTWARE FOR MANAGING AND ENCRYPTING DATA AND OF COMPUTER SOFTWARE FOR WIRELESS MESSAGING, ADVERTISING AND BILLING SYSTEMS FOR USE ON MOBILE DEVICES; COMPUTER SOFTWARE MAINTENANCE AND TECHNICAL SUPPORT SERVICES, NAMELY, SOFTWARE TROUBLESHOOTING; CONDUCTING SOFTWARE TESTS AND SIMULATIONS FOR OTHERS (U.S. CLS. 100 AND 101).
ANTHONY RINKER, EXAMINING ATTORNEY

Lunandscape

OWNER OF INTERNATIONAL REGISTRATION 0946483 DATED 6-1-2007, EXPIRES 6-1-2017.

CLASS 9—ELECTRICAL AND SCIENTIFIC APPARATUS

FOR EAR PLUGS NOT FOR MEDICAL PURPOSE; OPTICAL GLASSES; ELECTRIC ARC WELDING MACHINES; OZONISERS; ELECTROLYSERS; EGG-CANDLERS; CASH REGISTERS; COIN COUNTING OR SORTING MACHINES; ELECTRIC SIGN BOARDS FOR DISPLAYING TARGET FIGURES, CURRENT OUTPUTS OR THE LIKE; PHOTO-COPYING MACHINES; TIME AND DATE STAMPING MACHINES; TIME CLOCKS; PUNCH CLOCKS; VOTING MACHINES; POSTAGE STAMP METERS; VENDING MACHINES; METERED GASOLINE PUMPS FOR SERVICE STATIONS; COIN-OPERATED GATES FOR CAR PARKING FACILITIES; LIFE JACKETS; LIFE NETS; FIRE EXTINGUISHERS; FIRE HYDRANTS; FIRE HOSE NOZZLES; SPRINKLER SYSTEMS FOR FIRE PROTECTION; FIRE ALARMS; ALARMS FOR THE DETECTION OF INFLAMMABLE GASES; THEFT ALARMS; PROTECTIVE HELMETS; RAILWAY SIGNALS; VEHICLE BREAKDOWN WARNING TRIANGLES; LUMINOUS OR MECHANICAL ROAD SIGNS; DIVING HELMETS; DIVING SUITS; APPARATUS FOR ARCADE GAMES ADAPTED FOR USE WITH AN EXTERNAL DISPLAY SCREEN OR MONITOR; ELECTRIC DOOR OPENERS; VEHICLE DRIVE TRAINING SIMULATORS; LABORATORY APPARATUS AND INSTRUMENTS, NAMELY, CENTRIFUGES, INCUBATORS, AND THERMOMETERS; PHOTOGRAPHIC FILTERS; PHOTOGRAPHIC VIEWFINDERS; CINEMATOGRAPHIC MACHINES AND APPARATUS; ELECTRICAL POWER DISTRIBUTION UNITS; ROTARY CONVERTERS; BATTERIES AND ELECTRICAL CELLS; ELECTRIC METERS; CIRCUIT TESTERS; ELECTRIC WIRES AND CABLES; ELECTRIC FLAT IRONS; ELECTRIC HAIR-CURLERS; ELECTRIC BUZZERS; COMPUTER PROGRAMS FOR USING THE INTERNET AND THE WORLD WIDE WEB; MAGNETIC CORES; RESISTANCE WIRES; ELECTRODES; FIRE BOATS; FIRE ENGINES; CIGAR LIGHTERS FOR AUTOMOBILES; GLOVES FOR PROTECTION AGAINST ACCIDENTS; DUST MASKS; GAS MASKS AND WELDING MASKS; FIREPROOF GARMENTS; SPECTACLES; VIDEO GAME MACHINES ADAPTED FOR USE WITH AN EXTERNAL DISPLAY SCREEN OR MONITOR; ELECTRONIC CIRCUITS RECORDING PROGRAMS AND CD-ROMS RECORDED WITH PROGRAMS FOR HAND-HELD GAMES WITH LIQUID CRYSTAL SCREENS; WEIGHT BELTS; PROTECTIVE HELMETS FOR SPORTS; AIR TANKS; SWIMMING FLUTTER BOARDS; REGULATORS; METRONOMES; ELECTRONIC CIRCUITS AND CD-ROMS RECORDED WITH AUTOMATIC PERFORMANCE PROGRAMS FOR ELECTRONIC MUSICAL INSTRUMENTS; EXPOSED CINEMATOGRAPHIC FILMS; EXPOSED SLIDE FILMS; SLIDE FILM MOUNTS (U.S. CLS. 21, 23, 26, 36 AND 38).

CLASS 42—SCIENTIFIC AND COMPUTER SERVICES

FOR PROVIDING METEOROLOGICAL INFORMATION; ARCHITECTURAL DESIGN; SURVEYING; GEOLOGICAL SURVEYS OR RESEARCH; DESIGNING OF MACHINES, APPARATUS, INSTRUMENTS AND THEIR PARTS OR SYSTEMS COMPOSED OF SUCH MACHINES, APPARATUS AND INSTRUMENTS; GRAPHIC ARTS DESIGN; COMPUTER SOFTWARE DESIGN, COMPUTER PROGRAMMING, OR MAINTENANCE OF COMPUTER SOFTWARE; TECHNICAL ADVICE RELATING TO PERFORMANCE AND OPERATION OF COMPUTERS; TESTING, INSPECTION OR RESEARCH OF PHARMACEUTICALS, COSMETICS OR FOODSTUFF; RESEARCH ON BUILDING CONSTRUCTION OR CITY

PLANNING; TESTING OR RESEARCH ON PREVENTION OF POLLUTION; TESTING OR RESEARCH ON ELECTRICITY; TESTING OR RESEARCH ON CIVIL ENGINEERING; TESTING, INSPECTION OR RESEARCH ON AGRICULTURE, LIVESTOCK BREEDING OR FISHERIES; TESTING OR RESEARCH ON MACHINES, APPARATUS AND INSTRUMENTS; RENTAL OF MEASURING APPARATUS; RENTAL OF COMPUTERS; RENTAL OF COMPUTER PROGRAMS; RENTAL OF LABORATORY APPARATUS AND INSTRUMENTS; RENTAL OF DRAFTING INSTRUMENTS (U.S. CLS. 100 AND 101).

G. MAYERSCHOFF, EXAMINING ATTORNEY

SN 79-047,450. ARTWEGER GMBH & CO. KG, FREILASING, FED REP GERMANY, FILED 8-10-2007.

TWINLINE

THE MARK CONSISTS OF STANDARD CHARACTERS WITHOUT CLAIM TO ANY PARTICULAR FONT, STYLE, SIZE, OR COLOR.

OWNER OF INTERNATIONAL REGISTRATION 0946701 DATED 8-10-2007, EXPIRES 8-10-2017.

CLASS 6—METAL GOODS

FOR TRANSPORTABLE BUILDINGS MADE OF METAL (U.S. CLS. 2, 12, 13, 14, 23, 25 AND 50).

CLASS 11—ENVIRONMENTAL CONTROL APPARATUS

FOR SANITARY FACILITIES, NAMELY, BATHS, BATHTUBS, WHIRLPOOL BATHS AND BATH INSTALLATIONS, SHOWER AND BATH CUBICLES, BATH TUBS AND SHOWER TRAYS, SHOWER DOORS, SHOWER ENCLOSURES, SHOWER SURROUNDS, SHOWER TRAYS, SHOWER TUBS, SHOWERS (U.S. CLS. 13, 21, 23, 31 AND 34).

DAYNA BROWNE, EXAMINING ATTORNEY

SN 79-047,720. BOREALIS AG, AUSTRIA, FILED 11-22-2007.

BORECO

OWNER OF INTERNATIONAL REGISTRATION 0947456 DATED 11-22-2007, EXPIRES 11-22-2017.

CLASS 1—CHEMICALS

FOR UNPROCESSED ARTIFICIAL OR SYNTHETIC RESINS; UNPROCESSED PLASTICS; UNPROCESSED PLASTICS IN PELLET FORM; POLYETHYLENE RESINS; POLYPROPYLENE RESINS; POLYOLEFIN RESINS (U.S. CLS. 1, 5, 6, 10, 26 AND 46).

CLASS 17—RUBBER GOODS

FOR SEMI-PROCESSED PLASTIC IN THE FORM OF FILMS, SHEETS, TUBES, BARS, RODS OR FIBERS; PLASTICS IN EXTRUDED FORM USED IN PRODUCTION OF PLASTIC PRODUCTS; SYNTHETIC RESINS IN EXTRUDED FORM, OR IN BARS, BLOCKS, PELLETS, RODS, SHEETS AND TUBES, AS SEMI-FINISHED PRODUCTS ALL FOR GENERAL INDUSTRIAL USE; SEMI-FINISHED PRODUCTS, NAMELY, SEMI-FINISHED ACRYLIC MOLDED PLASTIC SUBSTANCE, FOR USE IN MAKING PLASTIC PRODUCTS (U.S. CLS. 1, 5, 12, 13, 35 AND 50).

CLASS 19—NON-METALLIC BUILDING MATERIALS

FOR PLASTIC PIPES AND FITTINGS THEREFOR FOR CONSTRUCTION AND BUILDING PURPOSES, NAMELY, FOR CONVEYING NATURAL GAS, FOR PLUMBING, WATER PIPES, OR GUTTER PIPES; PLASTIC SEWER PIPES (U.S. CLS. 1, 12, 33 AND 50).

ALYSSA PALADINO, EXAMINING ATTORNEY

SN 79-047,831. METEOBLUE AG, SWITZERLAND, FILED 8-8-2007.

METEOBLUE

THE MARK CONSISTS OF STANDARD CHARACTERS WITHOUT CLAIM TO ANY PARTICULAR FONT, STYLE, SIZE, OR COLOR.

OWNER OF INTERNATIONAL REGISTRATION 0892635 DATED 5-4-2006, EXPIRES 5-4-2016.

THE FOREIGN WORD "METEO" TRANSLATES INTO ENGLISH AS "WEATHER".

CLASS 38—COMMUNICATION

FOR PROVISION OF ACCESS TO DATA STORED ELECTRONICALLY IN CENTRAL FILES FOR REMOTE CONSULTATION; TELETXT SERVICES; DATA TRANSMISSION AND RECEPTION SERVICES VIA TELECOMMUNICATION MEANS; ELECTRONIC TRANSMISSION OF DATA AND DOCUMENTS VIA COMPUTER TERMINALS; ELECTRONIC, ELECTRIC AND DIGITAL TRANSMISSION OF DATA, IMAGES, SIGNALS AND MESSAGES; TRANSMISSION OF DATA, SOUND AND IMAGES BY SATELLITE; PROVIDING USER ACCESS TO A GLOBAL COMPUTER NETWORK; TRANSFER OF DATA BY TELECOMMUNICATIONS (U.S. CLS. 100, 101 AND 104).

CLASS 42—SCIENTIFIC AND COMPUTER SERVICES

FOR RESEARCH AND DEVELOPMENT OF NEW PRODUCTS AND PROVIDING TECHNOLOGY INFORMATION IN THE WEATHER FORECASTING FIELD; SCIENTIFIC RESEARCH; INDUSTRIAL RESEARCH IN THE FIELDS OF COMPUTER PROGRAMS AND WEATHER FORECASTING EQUIPMENT; DESIGN AND DEVELOPMENT OF COMPUTER PROGRAMS; CONVERSION OF DATA OR DOCUMENTS FROM PHYSICAL TO ELECTRONIC MEDIA; RENTAL OF ACCESS TIME TO GLOBAL COMPUTER NETWORKS; COMPUTER VIRUS PROTECTION SERVICES; DEVELOPMENT OF COMPUTER SOFTWARE FOR DATA PROCESSING SERVICES; TECHNOLOGY CONSULTATION IN THE FIELD OF WEATHER FORECASTING AND COMPUTER SOFTWARE DEVELOPMENT; DATA WAREHOUSING FOR COMPUTER DATABANKS (U.S. CLS. 100 AND 101).

IRA J. GOODSaid, EXAMINING ATTORNEY

SN 79-048,032. FFEI LIMITED, UNITED KINGDOM, FILED 4-12-2007.



PRIORITY DATE OF 10-24-2006 IS CLAIMED.
OWNER OF INTERNATIONAL REGISTRATION 0948260
DATED 4-12-2007, EXPIRES 4-12-2017.

CLASS 7—MACHINERY

FOR PRINTING MACHINES FOR COMMERCIAL OR INDUSTRIAL USE; AUTOMATIC PRINTING MACHINES FOR COMMERCIAL OR INDUSTRIAL USE; PRINTING PRESSES; PRINTING PLATES; PLATE SETTING MACHINES FOR PRODUCING IMAGED PRINT PLATES FOR USE IN PRINTING MACHINES; PHOTO SETTING MACHINES, NAMELY, PHOTOTYPESETTING MACHINES; TYPESETTING MACHINES; MACHINE-OPERATED PLATFORMS FOR HANDLING SHEET OUTPUT IN PRINTING PRESSES DURING THE PRINTING PROCESS; MACHINE-OPERATED PLATFORMS FOR HANDLING WEB OUTPUT IN PRINTING PRESSES DURING THE PRINTING PROCESS; MACHINES FOR MAKING PRINTING PLATES; MACHINES FOR PROOFING OF PRINTING PLATES; CONTACT PRINTING MACHINES FOR COMMERCIAL OR INDUSTRIAL USE; MACHINE SUB COMPONENTS OF PRINTING PRESSES FOR PERFORMING OPERATIONAL STEPS IN A PRINTING PRESS; INK JET PRINTING MACHINES FOR COMMERCIAL OR INDUSTRIAL USE; INKING APPARATUS FOR PRINTING MACHINES; OFFSET PRINTING MACHINES FOR COMMERCIAL OR INDUSTRIAL USE; PAPER FEEDERS FOR USE WITH COMMERCIAL OR INDUSTRIAL PRINTING MACHINES; PRINTING MACHINES FOR COMMERCIAL OR INDUSTRIAL ELECTRIC DUPLICATING PROCESSES; PRINTING MACHINES FOR COMMERCIAL OR INDUSTRIAL ELECTRONIC DUPLICATING PROCESSES; REPRODUCTION MACHINES FOR PRINTING IN THE NATURE OF PRINTING MACHINES FOR COMMERCIAL OR INDUSTRIAL USE; THERMAL LABEL PRINTING MACHINES FOR COMMERCIAL OR INDUSTRIAL USE; PARTS AND FITTINGS FOR ALL OF THE AFORESAID GOODS (U.S. CLS. 13, 19, 21, 23, 31, 34 AND 35).

CLASS 9—ELECTRICAL AND SCIENTIFIC APPARATUS

FOR PRINTERS AND SCANNERS; ELECTRONIC AND DIGITAL IMAGING AND PHOTOGRAPHIC APPARATUS, NAMELY, CAMERAS; PHOTOCOPYING MACHINES; COMPUTER HARDWARE AND COMPUTER SOFTWARE FOR PRINTING, SCANNING AND ELECTRONIC IMAGING OF DOCUMENTS, TEXT AND IMAGES, IMAGE PROCESSING, PHOTO SETTING AND TYPESETTING; COMPUTER HARDWARE AND COMPUTER SOFTWARE FOR MANAGING COMPUTER TO PRINTING PLATE WORKFLOW; PRINT COLOR MANAGEMENT SOFTWARE FOR USE IN COMMERCIAL, INDUSTRIAL OR PERSONAL PRINTERS AND PRINTING MACHINES; ELECTROMECHANICAL CONTROLLERS FOR PERFORMING OPERATIONAL STEPS IN A PRINTING PRESS; ELECTRONIC PRINTING APPARATUS FOR USE WITH COMPUTERS, NAMELY, DIGITAL COLOR PRINTERS; PLOTTERS FOR USE IN THE PRINTING OF GRAPHICS; APPARATUS FOR THE TRANSMISSION OF COMMUNICATIONS BETWEEN COMPUTERS, PRINTERS AND PRINTING MACHINES; PRINTING DISSEMINATION APPARATUS, NAMELY, PRINTERS AND FAX MACHINES; PRINTING PLATE SCANNERS; COMPUTER SOFTWARE FOR SIMULATING PRINTING PROCESSES FOR THE PURPOSE OF PRINTING MACHINE CALIBRATION AND THE EXAMINATION OF PRINT QUALITY AND EFFICIENCY; SCANNING APPARATUS FOR USE IN THE PRINTING INDUSTRY (U.S. CLS. 21, 23, 26, 36 AND 38).

CLASS 37—CONSTRUCTION AND REPAIR

FOR INSTALLATION, REPAIR AND MAINTENANCE OF COMPUTERS, COMPUTER HARDWARE, PRINTERS, PRINTING MACHINES, SCANNERS AND COMMERCIAL PRINTING EQUIPMENT FOR THE REPROGRAPHICS AND PRINTING INDUSTRIES (U.S. CLS. 100, 103 AND 106).

STEVEN PEREZ, EXAMINING ATTORNEY

SN 79-048,058. ZHEJIANG TEAMS INTERNATIONAL; ECONOMIC & TECHNICAL; COOPERATION CO., LTD., CHINA, FILED 10-27-2007.



OWNER OF INTERNATIONAL REGISTRATION 0800530
DATED 12-30-2002, EXPIRES 12-30-2012.

CLASS 7—MACHINERY

FOR PUMPS, NAMELY, ELECTRIC PUMPS, PUMPS AS PARTS OF MACHINES, MOTORS AND ENGINES, AQUARIUM PUMPS, BILGE PUMPS, CENTRIFUGAL PUMPS, COMPRESSED AIR PUMPS, FUEL PUMPS FOR LAND VEHICLES, HIGH-PRESSURE PUMPS FOR WASHING APPLIANCES AND INSTALLATIONS, HYDRAULIC PUMPS, LUBRICATING PUMPS, SCREW PUMPS, SUMP PUMPS, VACUUM PUMPS, VERTICAL TURBINE PUMPS, VALVES FOR PUMPS; VALVES, NAMELY, VALVES FOR PUMPS, VALVES BEING PARTS OF MACHINES, PUMP CONTROL VALVES, BALL VALVES BEING PARTS OF MACHINES AND SERVO-VALVES; SPRAYING MACHINES; WATER PUMPS FOR SPRINKLING SYSTEMS; ELECTRIC MOTORS, NAMELY, DIRECT CURRENT MOTORS, ELECTRIC MOTORS FOR MACHINES; ENGINES AND MOTORS FOR THE GENERATION OF ELECTRICITY, LINEAR MOTORS (U.S. CLS. 13, 19, 21, 23, 31, 34 AND 35).

CLASS 9—ELECTRICAL AND SCIENTIFIC APPARATUS

FOR CAPACITORS, VOLTAGE-STABILIZING POWER SUPPLIES, PRESSURE GAUGES; AUTOMOTIVE MEASURING INSTRUMENTS, NAMELY, WATER TEMPERATURE GAUGES, AIR-FUEL-RATIO GAUGES, BOOST GAUGES, VACUUM GAUGES AND EXHAUST GAS TEMPERATURE GAUGES, PRESSURE GAUGES; KILOWATT-HOUR METERS; ELECTRIC CURRENT STABILIZERS, VOLTAGE REGULATORS (U.S. CLS. 21, 23, 26, 36 AND 38).

TINA BROWN, EXAMINING ATTORNEY

SN 79-048,071. KILLTEC SPORT; UND FREIZEIT GMBH, FED REP GERMANY, FILED 10-23-2007.



OWNER OF INTERNATIONAL REGISTRATION 0929439 DATED 9-19-2006, EXPIRES 9-19-2016.

OWNER OF U.S. REG. NO. 1,448,506.

THE COLOR(S) RED AND BLACK IS/ARE CLAIMED AS A FEATURE OF THE MARK.

THE MARK CONSISTS OF THE WORDING "KILLTEC" IN THE COLOR BLACK TO THE RIGHT OF INCOMPLETE QUADRILATERAL DESIGN IN THE COLOR BLACK WITH A RED CIRCLE IN THE UPPER RIGHT OF THE DESIGN.

CLASS 14—JEWELRY

FOR CLOCKS AND CHRONOMETRICAL INSTRUMENTS; JEWELRY ORNAMENTS OF PRECIOUS METAL; WATCH CASES, CLOCK WORKS, NAMELY, CLOCK HOUSINGS, CLOCK CASES, CONTAINERS OF PRECIOUS METAL, NAMELY, BOXES AND JEWELRY CASES (U.S. CLS. 2, 27, 28 AND 50).

CLASS 18—LEATHER GOODS

FOR TRAVELLING BAGS, SPORT BAGS AND SUITCASES, BAGS AND SACS OF LEATHER AND LEATHER IMITATIONS; UMBRELLAS (U.S. CLS. 1, 2, 3, 22 AND 41).

CLASS 25—CLOTHING

FOR CLOTHING, NAMELY, LEISURE CLOTHING, NAMELY, SPORT SHIRTS, SPORT PANTS, SPORT SHORTS, SPORT JACKETS, SPORT SKIRTS, SPORTING ANORAKS, LEATHER JACKETS AND IMITATION LEATHER JACKETS, GLOVES, TIES, BOW-TIES; SPORT SOCKS, SPORT PULLOVER; FOOTWEAR, HEADGEAR, NAMELY, SPORT HATS AND CAPS; POCKET SQUARES FOR CLOTHING; GLOVES; FLEECE-SHIRTS (U.S. CLS. 22 AND 39).

CLASS 28—TOYS AND SPORTING GOODS

FOR GYMNASIAC AND SPORTING ARTICLES, NAMELY, TENNIS RACKETS, RACKET BALLS, RACKETS, BASEBALLS, BATS, BASEBALL BATS, FISHING RODS AND REELS, BASKETBALLS, VOLLEYBALLS, SOCCER BALLS, BASKETBALL NETS, VOLLEYBALL NETS AND HANDHOLD FISHING NETS, SKIS AND SKI POLES, GOLF CLUBS; BAGS ADAPTED FOR SPORTING EQUIPMENT (U.S. CLS. 22, 23, 38 AND 50).

DOMINIC FATHY, EXAMINING ATTORNEY

SN 79-048,130. RITTAL GMBH & CO. KG, FED REP GERMANY, FILED 8-20-2007.



PRIORITY DATE OF 2-21-2007 IS CLAIMED.
OWNER OF INTERNATIONAL REGISTRATION 0948500 DATED 8-20-2007, EXPIRES 8-20-2017.
OWNER OF U.S. REG. NOS. 3,148,959, 3,233,642 AND OTHERS.

CLASS 6—METAL GOODS

FOR COMPONENTS MADE OF METAL FOR SWITCH CABINETS, NAMELY, RACK PANELS, PROFILES, SUPPORT BASES, GUIDE RAILS, SUPPORT RAILS, DEPOSIT BASES, DRAWERS, ACCOMMODATING CONTAINERS; SHEETING MADE OF SHEET METAL, NAMELY, DOORS, WALLS; CLOSURE APPARATUS MADE OF METAL, NAMELY, DOOR LOCKS; CONTROL AND MOVEMENT APPARATUS MADE OF METAL, NAMELY, STATIONARY BASES AND ROLLERS; MOUNTING DEVICES AND MOUNTING AIDS, FIXED OR MOVEABLE, MADE OF METAL, NAMELY, MOUNTING PLATES, PIVOTAL FRAMES, COMPARTMENT BASES; SECURING APPARATUS MADE OF METAL, NAMELY, HOLDING ANGLES (U.S. CLS. 2, 12, 13, 14, 23, 25 AND 50).

CLASS 9—ELECTRICAL AND SCIENTIFIC APPARATUS

FOR SWITCH CABINETS, AND RACKS THEREFORE MADE OF METAL AND/OR PLASTICS MATERIAL; ADAPTED HOUSINGS FOR THE ACCOMMODATION OF ELECTRICAL INSTALLATIONS, IN THE FIELDS OF INDUSTRY, ELECTRONICS, COMPUTERS, INTERACTIVE TERMINAL SYSTEMS AND INFORMATION TRANSFER AND ADAPTED CONSOLES FOR TO PUT UP ELECTRICAL INSTALLATIONS AND WHICH ARE USED PREFERABLY FOR INDUSTRY, INSTALLATION, ELECTRONICS, COMPUTERS, INTERACTIVE TERMINAL SYSTEMS AND DATA TRANSMISSION, ALSO IN CONJUNCTION WITH SUPPORTING ARM SYSTEMS AND/OR EARTHQUAKE-PROOF AND/OR VANDAL-PROOF AND/OR EXPLOSION-PROOF, MODULE CARRIERS FOR PLUGGABLE MODULES WITH ELECTRONIC CIRCUITS; SIGNALING DEVICES THAT EMIT SOUNDS AND LIGHT FOR MONITORING AND SECURITY OF SWITCHGEAR CABINETS; ELECTRIC CURRENT DISTRIBUTION COMPONENTS, NAMELY, ELECTRONIC CONNECTORS AND ELECTRONIC APPARATUS ADAPTERS AND LOAD-BREAKERS; MODULES AND SYSTEM COMPONENTS FOR SECONDARY POWER DISTRIBUTION AND POWER SUPPLIES, NAMELY, POWER PACKS, ELECTRIC ACCUMULATORS, POWER GENERATING DEVICES, NAMELY, ELECTRICAL POWER SUPPLIES, AND NO-BREAK POWER SUPPLYING DEVICES, NAMELY, ELECTRICAL POWER SUPPLIES ALSO CONSTRUCTED IN MODULE FORM; CURRENT CONVERTERS, CURRENT INVERTERS; CABLE BUSHINGS FOR ELECTRIC PURPOSES; OVERLOAD PROTECTION FOR SENSITIVE ELECTRONIC DEVICES AND COMPUTERS, NAMELY, FUSES AND MONITORING UNITS; ELECTRIC AND ELECTRONIC CONTROL DEVICES AND SYSTEMS, NAMELY, ACCESS CONTROL AND ALARM MONITORING SYSTEMS FOR THE SECURITY OF ELECTRICAL SWITCHGEAR CABINETS FOR ELECTRONICS AND COMPUTERS, ELECTRIC AND ELECTRONIC APPARATUS AND INSTRUMENTS, NAMELY, ELECTRICAL CONTROLLERS FOR CONTROL STATIONS, CONTROL OBSERVATION STATIONS, AND CONSOLE WORKPLACES; SOFTWARE FOR USE IN CONFIGURING AND MONITORING SAFE ROOMS IN THE FIELD OF INFORMATION TECHNOLOGY; CABLING AIDS FOR ELECTRIC PURPOSES MADE OF METAL OR PLASTICS MATERIAL, NAMELY, MODULES FOR CABLE MANAGEMENT COMPRISING CABLE ROUTING DUCTS, CABLE BYPASS DUCTS, CABLE SECURING ELEMENTS, NAMELY, CABLE CLAMPING RAILS, CABLE ENTRIES ALL SOLD AS A UNIT; CABLING AIDS FOR ELECTRICAL CABLES, NAMELY, RUBBER CLAMPING PROFILES AND ADAPTED LABELING STRIPS, INSERTS FOR MODULE CARRIERS, NAMELY, PLUG-IN CARDS, BUS BARS, CASSETTES, PLUG CONNECTORS; REPLACEMENT PARTS OF ALL THE ABOVE MENTIONED GOODS (U.S. CLS. 21, 23, 26, 36 AND 38).

CLASS 11—ENVIRONMENTAL CONTROL APPARATUS

FOR DEVICES FOR AIR CONDITIONING, NAMELY, COOLING DEVICES NAMELY, EVAPORATIVE AIR COOLING UNITS, WATER COOLING UNITS, VENTILATORS, HEAT EXCHANGERS, FILTER VENTILATORS, HEATING INSTALLATIONS, LIQUID COOLERS, ALL FOR USE WITH SWITCH CABINETS; AIR CONDITIONING SYSTEMS AND AIR CONDITIONING DEVICES MADE UP FROM EVAPORATIVE AIR COOLING UNITS, WATER COOLING UNITS, VENTILATORS, HEAT EXCHANGERS, FILTER VENTILATORS, HEATING INSTALLATIONS, LIQUID COOLERS, FOR USE IN ROOM AIR CONDITIONING; INSTALLATION ACCESSORIES, NAMELY, SWITCH CABINET LIGHTS (U.S. CLS. 13, 21, 23, 31 AND 34).

CLASS 19—NON-METALLIC BUILDING MATERIALS

FOR CABLE BUSHINGS MADE OF PLASTICS MATERIALS, NAMELY, DOOR AND WALL CLADDINGS; CONTROL AND MOVING APPARATUSSES MADE OF PLASTICS MATERIALS, NAMELY, STATIONARY BASES AND ROLLERS; LININGS MADE OF GLASS OR PLASTICS MATERIAL, NAMELY, DOORS, WALLS (U.S. CLS. 1, 12, 33 AND 50).

CLASS 35—ADVERTISING AND BUSINESS

FOR WHOLESALE ORDERING SERVICES IN THE FIELD OF SERVER RACKS AND ENCLOSURES, SWITCH CABINETS, HOUSINGS, CONSOLES AND ACCESSORIES RELATING TO DATA CENTER POWER MANAGEMENT, COOLING, SECURITY, AND REMOTE MONITORING (U.S. CLS. 100, 101 AND 102).

EUGENIA MARTIN, EXAMINING ATTORNEY

CLASS 25—CLOTHING

FOR CLOTHING, NAMELY, SHIRTS, T-SHIRTS, PANTS, SHORTS, JACKET; FOOTWEAR; HEADGEAR, NAMELY, HATS, CAPS, LEATHER AND IMITATION LEATHER CLOTHING, NAMELY, LEATHER COATS, LEATHER TROUSERS; FUR COATS; BELTS; GLOVES; SCARVES; NECKTIES; HOSIERY; SOCKS; BOOT LINERS; BEACH, SKI AND SPORT FOOTWEAR; BABIES DIAPERS OF TEXTILES; UNDERWEAR (U.S. CLS. 22 AND 39).

CLASS 28—TOYS AND SPORTING GOODS

FOR ACTION SKILL GAMES; TOY ACTION FIGURES, TOY ANIMALS, TOY BALLOONS, TOY BOXES, TOY BUILDING BLOCKS, TOY BUTTERFLY NETS, TOY CARS, TOY CLOCKS AND WATCHES, TOY FIGURES, TOY FILM CARTRIDGES AND VIEWERS, TOY FURNITURE, TOY HOUSES, TOY MOBILES, TOY MODEL CARS, TOY PRISM GLASSES, TOY PUTTY, TOY RECORD PLAYERS, TOY ROBOTS, TOY VEHICLES, TOY WATCHES; DECORATIONS FOR CHRISTMAS TREES EXCLUDING LIGHTING ARTICLES; CHRISTMAS TREES OF SYNTHETIC MATERIAL, BODY TRAINING AND GYMNASTIC APPARATUS; FISHING TACKLE; BALLS FOR GAMES AND PLAY BALLOONS; BILLIARD TABLES, CUES AND BALLS; CARD AND BOARD GAMES; ICE AND ROLLER SKATES; SAIL AND SURF BOARDS; TOY SCOOTERS; RACKETS AND BATS, SNOWSHOES; SKIS; PROTECTIVE PADDING FOR PLAYING ROLLER SKATES (U.S. CLS. 22, 23, 38 AND 50).

RENEE SERVANCE, EXAMINING ATTORNEY

SN 79-048,530. GEIS BENOIT ROCH, FRANCE, FILED 12-5-2007.



PRIORITY DATE OF 6-19-2007 IS CLAIMED.

OWNER OF INTERNATIONAL REGISTRATION 0949612 DATED 12-5-2007, EXPIRES 12-5-2017.

THE COLOR(S) WHITE, BLACK, PURPLE, BLUE, ORANGE, GREEN, YELLOW AND RED IS/ARE CLAIMED AS A FEATURE OF THE MARK.

THE MARK CONSISTS OF A PURPLE STYLIZED LETTER "Q" WITH TWO BLACK AND WHITE EYES AND EYEBROWS, A BLACK, WHITE AND BLUE NOSE, A WHITE MOUTH, ORANGE AND WHITE LEGS AND FEET, AND WHITE HANDS. THE LETTERS "OUIKI" ARE DISPLAYED TO THE RIGHT OF THE LETTER "Q." THE "O" IS BLUE AND WHITE AND PARTIALLY OBSCURED BY THE WHITE HAND ON THE LETTER "Q." THE LETTER "U" IS DISPLAYED IN GREEN. THE LETTER "I" IS DISPLAYED IN YELLOW. THE LETTER "L" IS DISPLAYED IN ORANGE. THE LETTER "I" IS DISPLAYED IN RED.

CLASS 18—LEATHER GOODS

FOR LEATHER AND IMITATION LEATHER; ANIMAL SKINS AND HIDES; TRUNKS AND SUITCASES; UMBRELLAS, PARASOLS AND COMBINED CANES AND WHIPS AND SADDLERY; WALLETS; CHANGE PURSES; HANDBAGS; BACKPACKS; WHEELED BAGS; BAGS FOR CLIMBERS, BAGS FOR CARRYING CAMPING EQUIPMENT, TRAVELING BAGS, BEACH BAGS, SCHOOL BAGS, UNFITTED VANITY CASES, COLLARS AND CLOTHING FOR ANIMALS; SHOPPING BAG; MESH SHOPPING BAGS; LEATHER BAGS FOR MERCHANDISE PACKAGING (U.S. CLS. 1, 2, 3, 22 AND 41).

SN 79-048,859. NITTO KOGYO CORPORATION, JAPAN, FILED 7-24-2007.

NIPAX

THE MARK CONSISTS OF STANDARD CHARACTERS WITHOUT CLAIM TO ANY PARTICULAR FONT, STYLE, SIZE, OR COLOR.

OWNER OF INTERNATIONAL REGISTRATION 0950474 DATED 7-24-2007, EXPIRES 7-24-2017.

THE WORDING IN THE MARK HAS NO MEANING IN A FOREIGN LANGUAGE.

CLASS 9—ELECTRICAL AND SCIENTIFIC APPARATUS

FOR HOUSING CABINETS AND BOXES FOR ELECTRICAL MACHINES, APPARATUS AND ELECTRONIC EQUIPMENT, NAMELY, ELECTRICAL DISTRIBUTION BOARDS, ELECTRICAL DISTRIBUTION CONSOLES, SWITCHBOARDS, ELECTRICAL CONTROL PANELS, MONITORING BOARDS, AND TABLES USED IN MONITORING, ALL FOR MONITORING ELECTRICAL CURRENT, ELECTRICAL ENERGY AND REMOTE CONTROL DEVICES; SWITCH BOXES; JUNCTION BOXES FOR ELECTRICITY; ELECTRICAL BRANCH BOXES; HOUSING CABINETS AND BOXES FOR TELECOMMUNICATION MACHINES AND APPARATUS, NAMELY, FOR TRANSMITTERS, TELEVISIONS, TELEPHONES, JUNCTION BOXES FOR TELECOMMUNICATION; HOUSING CABINETS AND BOXES FOR ELECTRONIC MACHINES AND APPARATUS, NAMELY, FOR COMPUTERS; HOUSING CABINETS AND BOXES FOR MEASURING AND TESTING APPARATUS AND INSTRUMENTS, NAMELY, JUNCTION BOXES FOR OPTICAL FIBERS, ELECTRIC DISTRIBUTION BOARDS, ELECTRIC PANEL BOARDS, ELECTRIC INCOMING BOARDS, ELECTRIC DISTRIBUTION CONSOLES, ELECTRIC SWITCHBOARDS, ELECTRIC LOCAL SWITCHBOARDS, ELECTRIC CONTROL PANELS, ELECTRIC ALARM PANELS, ELECTRICITY MONITORING PANELS, ELECTRIC TERMINAL PANELS, ELECTRIC WIRING BOARDS, ELECTRIC CIRCUIT BREAKERS, ELECTRIC SWITCHES, ELECTRIC DISCONNECTORS, ELECTRIC CIRCUIT CLOSERS, ELECTRIC TERMINAL BLOCKS, ELECTRIC CABLE TROUGHS; PEDESTALS, NAMELY, CABINETS, HOUSING AND STRUCTURAL MOUNTING PARTS FOR ELECTRICAL APPARATUS AND INSTRUMENTS, NAMELY, ELECTRIC POWER METERS THROUGH WHICH ELECTRIC WIRES AND ELECTRIC CABLES LAID UNDERGROUND ARE DRAWN INTO THE BUILDING FROM THE OUTSIDE (U.S. CLS. 21, 23, 26, 36 AND 38).

CLASS 11—ENVIRONMENTAL CONTROL APPARATUS

FOR HEAT EXCHANGERS NOT BEING PARTS OF MACHINES; REFRIGERATORS; AIR CONDITIONERS; DEHUMIDIFIERS; VENTILATORS FOR INDUSTRIAL USE; VENTILATING EXHAUST FANS; AIR FILTERS FOR VENTILATORS; VENTILATING LOUVERS (U.S. CLS. 13, 21, 23, 31 AND 34).
 NAPOLEON SHARMA, EXAMINING ATTORNEY

SN 79-048,934. DIPRITEC AB, SWEDEN, FILED 11-26-2007.



PRIORITY DATE OF 5-29-2007 IS CLAIMED.
 OWNER OF INTERNATIONAL REGISTRATION 0950673 DATED 11-26-2007, EXPIRES 11-26-2017.
 THE MARK CONSISTS OF A FRAME WITH AN OCTOPUS INSIDE OF THE FRAME.

CLASS 9—ELECTRICAL AND SCIENTIFIC APPARATUS

FOR RECORDED COMPUTER PROGRAMS AND RECORDED SOFTWARE FOR USE IN PRINTING; COMPUTERS AND COMPUTER PERIPHERALS (U.S. CLS. 21, 23, 26, 36 AND 38).

CLASS 41—EDUCATION AND ENTERTAINMENT

FOR EDUCATION SERVICES, NAMELY, PROVIDING CLASSES, SEMINARS, CONFERENCES AND WORKSHOPS IN THE FIELD OF COMPUTER PROGRAMS AND SOFTWARE, COMPUTERS, COMPUTER PERIPHERALS, AND INSTALLATION OF COMPUTER PROGRAMS AND SOFTWARE (U.S. CLS. 100, 101 AND 107).

CLASS 42—SCIENTIFIC AND COMPUTER SERVICES

FOR COMPUTER CONSULTANCY SERVICES; DESIGN, DEVELOPMENT, INSTALLATION, MAINTENANCE AND UPDATING COMPUTER PROGRAMS AND SOFTWARE; RENTAL OF COMPUTER PROGRAMS AND SOFTWARE (U.S. CLS. 100 AND 101).
 AMOS T. MATTHEWS, JR., EXAMINING ATTORNEY

SN 79-049,224. SIGLA FASHION S.R.L., I-20010 BOFFALORA S/T (MI), ITALY, FILED 12-12-2007.



PRIORITY DATE OF 11-14-2007 IS CLAIMED.
 OWNER OF INTERNATIONAL REGISTRATION 0951573 DATED 12-12-2007, EXPIRES 12-12-2017.
 NO CLAIM IS MADE TO THE EXCLUSIVE RIGHT TO USE "FASHION", APART FROM THE MARK AS SHOWN.
 THE ENGLISH TRANSLATION OF THE WORD "SIGLA" IN THE MARK IS ABBREVIATION.

CLASS 24—FABRICS

FOR WOVEN FABRICS (U.S. CLS. 42 AND 50).

CLASS 25—CLOTHING

FOR CLOTHING, NAMELY, T-SHIRTS, TROUSERS, SHIRTS, SPORT SHIRTS, DRESS SHIRTS, POLO SHIRTS, SWEATERS, PULLOVERS, BLOUSES, JACKETS, RAINCOATS, OVERCOATS, JEAN PANTS, PANTS, SWEATPANTS, JOGGING SUITS, SHORTS, PAJAMAS, BELTS, AND KNITTED GOODS, NAMELY, PULLOVERS, SWEATERS, SHIRTS (U.S. CLS. 22 AND 39).
 MARILYN IZZI, EXAMINING ATTORNEY

SN 79-049,334. CHOCOLAT FACTORY, S.L., E-08190 SANT CUGAT DEL VALLES (BARCELONA, SPAIN, FILED 10-2-2007.



The expert chocolatier

PRIORITY DATE OF 9-20-2007 IS CLAIMED.
OWNER OF INTERNATIONAL REGISTRATION 0951848 DATED 10-2-2007, EXPIRES 10-2-2017.

NO CLAIM IS MADE TO THE EXCLUSIVE RIGHT TO USE "CHOCOLAT" AND "CHOCOLATIER", APART FROM THE MARK AS SHOWN.

THE NAME "MICHEL LALINE" IDENTIFIES A LIVING INDIVIDUAL WHOSE CONSENT IS OF RECORD.

THE ENGLISH TRANSLATION OF THE WORD "CHOCOLAT" IN THE MARK IS CHOCOLATE.

CLASS 30—STAPLE FOODS

FOR COCOA; CHOCOLATE; CHOCOLATE FOOD BEVERAGES NOT BEING DAIRY-BASED OR VEGETABLE-BASED; CHOCOLATE BEVERAGES WITH MILK; COCOA BEVERAGES WITH MILK; CHOCOLATE BONBONS (U.S. CL. 46).

CLASS 35—ADVERTISING AND BUSINESS

FOR IMPORT-EXPORT AGENCIES; RETAIL STORES AND WHOLESALE STORES FEATURING CHOCOLATE BONBONS AND CHOCOLATES; BUSINESS ORGANIZATION, BUSINESS MANAGEMENT, AND BUSINESS PLANNING SERVICES PROVIDED VIA GLOBAL COMPUTER NETWORK, ALL RELATED TO CHOCOLATE BEVERAGES; ONLINE RETAIL STORES FEATURING CHOCOLATE BEVERAGES WITH MILK BY MEANS OF A GLOBAL COMPUTER NETWORK; PROMOTION AND ADVERTISING OF BONBON AND CHOCOLATE PRODUCTS; COMMERCIAL ADVISORY SERVICES FOR FRANCHISED SHOPS FOR SALE OF BONBONS AND CHOCOLATES (U.S. CLS. 100, 101 AND 102).

Laurie Kaufman, Examining Attorney

SN 79-049,569. SHINZI KATOH DESIGN LIMITED, JAPAN, FILED 10-26-2007.

Shinzi Katoh

PRIORITY DATE OF 9-27-2007 IS CLAIMED.
OWNER OF INTERNATIONAL REGISTRATION 0952554 DATED 10-26-2007, EXPIRES 10-26-2017.

THE NAME(S), PORTRAIT(S), AND/OR SIGNATURE(S) SHOWN IN THE MARK IDENTIFIES "SHINZI KATOH", WHOSE CONSENT(S) TO REGISTER IS OF RECORD.

CLASS 18—LEATHER GOODS

FOR ALL PURPOSE SPORTS BAGS; ALL-PURPOSE ATHLETIC BAGS; ALL PURPOSE CARRYING BAGS; BEACH BAGS; BOOK BAGS; BOSTON BAGS; CANVAS, MESH AND TEXTILE SHOPPING BAGS; COSMETIC BAGS SOLD EMPTY; DIAPER BAGS; DUFFEL BAGS; HIKING BAGS; KEY BAGS; LEATHER AND IMITATION LEATHER BAGS, SUITCASES AND WALLETS; POUCHES AND BAGS SOLD EMPTY FOR ATTACHMENT TO BACKPACKS; SCHOOL BAGS; SHOE BAGS FOR TRAVEL; SHOPPING BAGS WITH WHEELS ATTACHED; SHOULDER BAGS; TOTE BAGS; TRAVEL BAGS; WAIST BAGS; CLOTHING FOR DOMESTIC PETS; VANITY CASES SOLD EMPTY; UMBRELLAS AND THEIR PARTS; WALKING STICKS (U.S. CLS. 1, 2, 3, 22 AND 41).

CLASS 21—HOUSEWARES AND GLASS

FOR STAINLESS STEEL BOTTLES SOLD EMPTY; DRINKING FLASKS FOR TRAVELERS; VACUUM BOTTLES, NAMELY, INSULATED FLASKS; CHOPSTICK CASES; CHOPSTICKS; GLASS BOXES FOR INDUSTRIAL PACKAGING; CONTAINERS OF GLASS FOR HOUSEHOLD USE; JAPANESE NESTS OF FOOD BOXES (JUBAKO); LUNCH BOXES; DRINKING GLASSES; FRUIT BOWLS OF GLASS; GLASS BEVERAGE WARE; GLASS BOWLS; GLASS CARAFES; GLASS DISHES; GLASS MUGS; PILSNER DRINKING GLASSES; SHOT GLASSES; BEER MUGS; COFFEE CUPS; CUPS; DRINKING CUPS; EARTHENWARE MUGS; EGG CUPS; MUGS; PAPER CUPS; PLASTIC CUPS; PORCELAIN MUGS; SAKE CUPS; NON-ELECTRIC PORTABLE COLD BOXES; RICE CHESTS; CHOPSTICK RESTS; ICE PAILS; NON-ELECTRIC WHISKS; COOKING STRAINERS; PEPPER POTS; SUGAR BOWLS; SALT SHAKERS; NAPKIN HOLDERS; NAPKIN RINGS; SERVING TRAYS; TOOTHPICKS HOLDERS; COLANDERS; COCKTAIL SHAKERS; JAPANESE STYLE COOKED RICE SCOOPS (SHAMOJI); HAND-OPERATED COFFEE GRINDERS AND PEPPER MILLS; COOKING FUNNELS; JAPANESE STYLE WOODEN PESTLES (SURIKOGI); JAPANESE STYLE EARTHENWARE MORTARS (SURIBACHI); JAPANESE STYLE PERSONAL DINING TRAYS OR STANDS (ZEN); BOTTLE OPENERS; COOKING GRATERS; TART SCOOPS; LADLES FOR KITCHEN USE; COOKING SIEVES AND SIFTERS; CHOPPING BOARDS FOR KITCHEN USE; ROLLING PINS FOR COOKING PURPOSES; COOKING UTENSILS, NAMELY, GRILLS; TOOTHPICKS; LEMON SQUEEZERS; NON-ELECTRIC WAFFLE IRONS (U.S. CLS. 2, 13, 23, 29, 30, 33, 40 AND 50).

Rebecca Povarchuk, Examining Attorney

SN 79-049,651. LABORATORIOS ALMIRALL, S.A., SPAIN, FILED 12-5-2007.

NUPRESS

PRIORITY DATE OF 6-8-2007 IS CLAIMED.
OWNER OF INTERNATIONAL REGISTRATION 0952729 DATED 12-5-2007, EXPIRES 12-5-2017.

CLASS 5—PHARMACEUTICALS

FOR PHARMACEUTICAL PRODUCTS FOR THE TREATMENT OF RESPIRATORY ILLNESSES (U.S. CLS. 6, 18, 44, 46, 51 AND 52).

CLASS 10—MEDICAL APPARATUS

FOR INHALERS FOR MEDICAL PURPOSES (U.S. CLS. 26, 39 AND 44).

Sara Thomas, Examining Attorney

SN 79-049,698. KABA GILGEN AG, SWITZERLAND, FILED 12-3-2007.

PSD HALF-HEIGHT BIJOU

THE MARK CONSISTS OF STANDARD CHARACTERS WITHOUT CLAIM TO ANY PARTICULAR FONT, STYLE, SIZE, OR COLOR.

PRIORITY DATE OF 6-5-2007 IS CLAIMED.

OWNER OF INTERNATIONAL REGISTRATION 0952872 DATED 12-3-2007, EXPIRES 12-3-2017.

NO CLAIM IS MADE TO THE EXCLUSIVE RIGHT TO USE "HALF-HEIGHT", APART FROM THE MARK AS SHOWN.

THE ENGLISH TRANSLATION OF THE FOREIGN WORD(S) IN THE MARK IS: "JEWELRY".

CLASS 6—METAL GOODS

FOR DOORS OF METAL, NAMELY, PLATFORM DOORS OF METAL, AND COMPONENT PARTS THEREOF (U.S. CLS. 2, 12, 13, 14, 23, 25 AND 50).

CLASS 19—NON-METALLIC BUILDING MATERIALS

FOR NON-METAL DOORS, NAMELY, NON-METAL PLATFORM DOORS AND COMPONENT PARTS THEREOF (U.S. CLS. 1, 12, 33 AND 50).

JIM RINGLE, EXAMINING ATTORNEY

SN 79-049,841. FIMAR S.P.A., I-47827 VERUCCHIO (RN), ITALY, FILED 7-20-2007.



PRIORITY DATE OF 3-22-2007 IS CLAIMED. OWNER OF INTERNATIONAL REGISTRATION 0953149 DATED 7-20-2007, EXPIRES 7-20-2017.

THE WORDING "FIMAR" HAS NO MEANING IN A FOREIGN LANGUAGE.

CLASS 7—MACHINERY

FOR DOMESTIC ELECTRICAL APPLIANCES FOR THE KITCHEN, NAMELY, CUTTING AND MINCING MACHINES, FOOD MIXERS, ELECTRIC FISH PASTE MAKING MACHINES, CENTRIFUGES AND STRUCTURAL PARTS AND FITTINGS FOR THE AFORESAID GOODS (U.S. CLS. 13, 19, 21, 23, 31, 34 AND 35).

CLASS 9—ELECTRICAL AND SCIENTIFIC APPARATUS

FOR ELECTRICAL APPARATUS, NAMELY, ELECTRIC SCALES AND STRUCTURAL PARTS AND FITTINGS FOR THE AFORESAID GOODS (U.S. CLS. 21, 23, 26, 36 AND 38).

CLASS 11—ENVIRONMENTAL CONTROL APPARATUS

FOR APPARATUS FOR HEATING, STEAM GENERATING, COOKING, REFRIGERATING, DRYING, VENTILATING AND WATER SUPPLY, NAMELY, ELECTRIC SPACE HEATERS, STEAM GENERATORS, ELECTRIC SLOW COOKERS, REFRIGERATING MACHINES, CLOTHES DRYERS, VENTILATION HOODS AND FILTERS FOR DRINKING WATER, FREEZERS AND STRUCTURAL PARTS AND FITTINGS FOR THE AFORESAID GOODS (U.S. CLS. 13, 21, 23, 31 AND 34).

CLASS 20—FURNITURE AND ARTICLES NOT OTHERWISE CLASSIFIED

FOR FURNITURE, TEA TROLLEYS, SERVING TROLLEYS, SHOWCASES IN THE NATURE OF CABINETS FOR SHOWCASING BELONGINGS, PACKING CONTAINERS OF PLASTIC MATERIAL, AND STRUCTURAL PARTS AND FITTINGS FOR THE AFORESAID GOODS (U.S. CLS. 2, 13, 22, 25, 32 AND 50).

CLASS 21—HOUSEWARES AND GLASS

FOR KITCHEN UTENSILS, NAMELY, GRATERS, SIEVES, SPATULAS, STRAINERS AND TURNERS, CONTAINERS, NAMELY, CONTAINERS FOR HOUSEHOLD USE; GARBAGE AND DUST BINS, BASINS, CHAFING DISHES (U.S. CLS. 2, 13, 23, 29, 30, 33, 40 AND 50).

COLLEEN KEARNEY, EXAMINING ATTORNEY

SN 79-050,186. JARLTECH EUROPE GMBH, 61250 USINGEN, FED REP GERMANY, FILED 12-20-2007.

JARLTECH

THE MARK CONSISTS OF STANDARD CHARACTERS WITHOUT CLAIM TO ANY PARTICULAR FONT, STYLE, SIZE, OR COLOR.

OWNER OF INTERNATIONAL REGISTRATION 0954000 DATED 12-20-2007, EXPIRES 12-20-2017.

CLASS 9—ELECTRICAL AND SCIENTIFIC APPARATUS

FOR ELECTRONIC OPTICAL INSTRUMENTS, NAMELY, BAR CODE READERS, MAGNETIC RECORDING SUPPORTS IN THE NATURE OF PRE-RECORDED DATA CARRIERS FEATURING MATHEMATIC FORMULAS, MAGNETIC RECORDING SUPPORTS IN THE NATURE OF MAGNETIC CODED CARD READERS, CASH REGISTERS, CALCULATING MACHINES, DATA PROCESSING HARDWARE AND COMPUTERS AS WELL AS COMPUTER ACCESSORIES, NAMELY, BAR CODE SCANNERS, BAR CODE READERS; POINT-OF-SALE COMPUTER HARDWARE, NAMELY, POINT OF SALE PERIPHERALS FOR COMPUTERS, COMPUTER KEYBOARDS, POLE DISPLAYS PRIMARILY COMPRISED OF FLAT PANEL DISPLAY SCREENS WITH POLES ATTACHED, AND COMPUTER TOUCH SCREENS (U.S. CLS. 21, 23, 26, 36 AND 38).

CLASS 35—ADVERTISING AND BUSINESS

FOR ADVERTISING, BUSINESS MANAGEMENT, OFFICE FUNCTIONS, BUSINESS ADMINISTRATION (U.S. CLS. 100, 101 AND 102).

CLASS 42—SCIENTIFIC AND COMPUTER SERVICES

FOR COMPUTER PROGRAMMING (U.S. CLS. 100 AND 101).

MAUREEN DALL, EXAMINING ATTORNEY

SN 79-050,984. HOUSE OF DESIGN STANGL KEG, AUSTRIA, FILED 9-7-2007.

**FIRE
GIRLS**

OWNER OF INTERNATIONAL REGISTRATION 0889958 DATED 3-10-2006, EXPIRES 3-10-2016.

NO CLAIM IS MADE TO THE EXCLUSIVE RIGHT TO USE "GIRLS", APART FROM THE MARK AS SHOWN.

CLASS 16—PAPER GOODS AND PRINTED MATTER

FOR PRINTED MATTER, NAMELY, CALENDARS, PRINTED TIMETABLES, POSTERS (U.S. CLS. 2, 5, 22, 23, 29, 37, 38 AND 50).

CLASS 25—CLOTHING

FOR CLOTHING, NAMELY, SHIRTS, TROUSERS, SHORTS, SWIMWEAR, UNDERWEAR, DRESSES; FOOTWEAR, HEADGEAR, NAMELY, HATS, CAPS (U.S. CLS. 22 AND 39).

DANIEL BRODY, EXAMINING ATTORNEY

SN 79-051,285. ENGADA SWISS AG; C/O DR. HANS DURER, SWITZERLAND, FILED 2-4-2008.

+ ENGADA +

THE MARK CONSISTS OF STANDARD CHARACTERS WITHOUT CLAIM TO ANY PARTICULAR FONT, STYLE, SIZE, OR COLOR.

PRIORITY DATE OF 11-28-2007 IS CLAIMED.

OWNER OF INTERNATIONAL REGISTRATION 0957095 DATED 2-4-2008, EXPIRES 2-4-2018.

CLASS 35—ADVERTISING AND BUSINESS

FOR BUSINESS MANAGEMENT; BUSINESS ADMINISTRATION AND OFFICE FUNCTIONS (U.S. CLS. 100, 101 AND 102).

CLASS 36—INSURANCE AND FINANCIAL

FOR FINANCIAL SERVICES, NAMELY, FINANCIAL ADVICE AND CONSULTANCY SERVICES; MONETARY SERVICES, NAMELY, MONETARY EXCHANGE; REAL ESTATE SERVICES, NAMELY, FINANCIAL INVESTMENT IN REAL ESTATE, LEASING OF REAL ESTATE, AND REAL ESTATE PROPERTY MANAGEMENT (U.S. CLS. 100, 101 AND 102).

CLASS 37—CONSTRUCTION AND REPAIR

FOR BUILDING, NAMELY, CONSTRUCTION OF BUILDINGS (U.S. CLS. 100, 103 AND 106).

CLASS 38—COMMUNICATION

FOR TELECOMMUNICATIONS ROUTING AND JUNCTION SERVICES (GATEWAY SERVICES), VOICE MAIL SERVICES, ELECTRONIC MESSAGE SENDING, PROVIDING ACCESS TO DATABASES, COMPUTER AIDED TRANSMISSION OF MESSAGES AND IMAGES PROVIDING TELECOMMUNICATIONS CONNECTIONS TO A GLOBAL COMPUTER NETWORK, SATELLITE TRANSMISSION, COMMUNICATIONS BY FIBRE-OPTIC NETWORKS (U.S. CLS. 100, 101 AND 104).

CLASS 41—EDUCATION AND ENTERTAINMENT

FOR TRAINING IN THE FIELD OF REAL ESTATE LEASING, BUILDING CONSTRUCTION, FINANCIAL SERVICES AND DEVELOPMENT (U.S. CLS. 100, 101 AND 107).

CLASS 42—SCIENTIFIC AND COMPUTER SERVICES

FOR SCIENTIFIC AND TECHNOLOGICAL SERVICES AND RELATED RESEARCH AND DESIGN SERVICES IN THE FIELD OF THE BUILDING CONSTRUCTION INDUSTRY AND ASSOCIATED INDUSTRIAL ANALYSIS AND RESEARCH SERVICES; DESIGN AND DEVELOPMENT OF COMPUTER HARDWARE AND SOFTWARE (U.S. CLS. 100 AND 101).

KIMBERLY PERRY, EXAMINING ATTORNEY

SN 79-052,552. KEMIRA OYJ, FINLAND, FILED 3-19-2008.

KEMWHITE

THE MARK CONSISTS OF STANDARD CHARACTERS WITHOUT CLAIM TO ANY PARTICULAR FONT, STYLE, SIZE, OR COLOR.

PRIORITY DATE OF 3-10-2008 IS CLAIMED.

OWNER OF INTERNATIONAL REGISTRATION 0960659 DATED 3-19-2008, EXPIRES 3-19-2018.

CLASS 1—CHEMICALS

FOR CHEMICALS FOR USE IN THE MANUFACTURE OF PAPER (U.S. CLS. 1, 5, 6, 10, 26 AND 46).

CLASS 2—PAINTS

FOR COATING PIGMENTS FOR USE IN THE MANUFACTURE OF PAPER (U.S. CLS. 6, 11 AND 16).

MARILYN IZZI, EXAMINING ATTORNEY

SN 79-053,093. BOEHRINGER INGELHEIM INTERNATIONAL GMBH, FED REP GERMANY, FILED 3-20-2008.

COMING

THE MARK CONSISTS OF STANDARD CHARACTERS WITHOUT CLAIM TO ANY PARTICULAR FONT, STYLE, SIZE, OR COLOR.

PRIORITY DATE OF 11-22-2007 IS CLAIMED.

OWNER OF INTERNATIONAL REGISTRATION 0962235 DATED 3-20-2008, EXPIRES 3-20-2018.

CLASS 38—COMMUNICATION

FOR PROVISION OF ACCESS VIA THE INTERNET TO MEDICAL AND PHARMACEUTICAL INFORMATION OF PHARMACEUTICAL PREPARATIONS (U.S. CLS. 100, 101 AND 104).

CLASS 41—EDUCATION AND ENTERTAINMENT

FOR PUBLICATION OF PRINTED MATTER OF THE RESULTS OF CLINICAL TRIALS FOR PHARMACEUTICAL PREPARATIONS, ALSO IN ELECTRONIC FORM (U.S. CLS. 100, 101 AND 107).

CLASS 42—SCIENTIFIC AND COMPUTER SERVICES

FOR CONDUCTING CLINICAL TRIALS FOR PHARMACEUTICAL PRODUCTS (U.S. CLS. 100 AND 101).
JASON BLAIR, EXAMINING ATTORNEY

SN 79-053,774. MADINIT S.R.L., ITALY, FILED 1-24-2008.

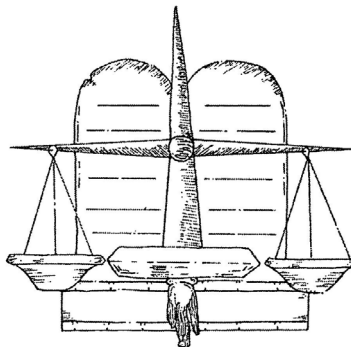

OWNER OF INTERNATIONAL REGISTRATION 0964166
DATED 1-24-2008, EXPIRES 1-24-2018.

CLASS 14—JEWELRY

FOR JEWELLERY AND IMITATION JEWELLERY; KEY HOLDERS OF PRECIOUS METALS; TIE PINS, CUFFLINKS, LAPEL PINS; WATCHES AND CLOCKS (U.S. CLS. 2, 27, 28 AND 50).

SN 79-053,094. BOEHRINGER INGELHEIM INTERNATIONAL GMBH, FED REP GERMANY, FILED 4-2-2008.

VERXVE

CLASS 16—PAPER GOODS AND PRINTED MATTER

FOR BOOKS AND JOURNALS IN THE FIELD OF HISTORY, ARTS, ECONOMICS, ARCHITECTURE; BOOK MARKS; BOXES OF PAPER OR CARDBOARD; CALENDARS AND DIARIES; WRITING INSTRUMENTS, PENS, BALLPOINT PENS, FELT WRITING PENS, FOUNTAIN PENS, PEN NIBS; STANDS FOR PENS AND PENCILS; LETTER PAPER, MEMO PADS, OFFICE STATIONERY, PAPERWEIGHTS; PAPER KNIVES; PEN AND PENCIL CASES; PENHOLDERS; PHOTOGRAPHIC ALBUMS, POSTERS MADE OF PAPER; BUSINESS CARD CASES (U.S. CLS. 2, 5, 22, 23, 29, 37, 38 AND 50).

CLASS 18—LEATHER GOODS

FOR HANDBAGS, SHOULDER BAGS, BRIEFCASES, VANITY CASES SOLD EMPTY, KEY CASES, WALLETS AND PURSES; SUITCASES AND TRAVELLING BAGS; UMBRELLAS (U.S. CLS. 1, 2, 3, 22 AND 41).
JESSICA FATHY, EXAMINING ATTORNEY

THE MARK CONSISTS OF STANDARD CHARACTERS WITHOUT CLAIM TO ANY PARTICULAR FONT, STYLE, SIZE, OR COLOR.
PRIORITY DATE OF 11-22-2007 IS CLAIMED.
OWNER OF INTERNATIONAL REGISTRATION 0962239
DATED 4-2-2008, EXPIRES 4-2-2018.

SN 79-053,775. MADINIT S.R.L., ITALY, FILED 1-24-2008.

CLASS 38—COMMUNICATION

FOR PROVISION OF ACCESS VIA THE INTERNET TO MEDICAL AND PHARMACEUTICAL INFORMATION OF PHARMACEUTICAL PREPARATIONS (U.S. CLS. 100, 101 AND 104).

CLASS 41—EDUCATION AND ENTERTAINMENT

FOR PUBLICATION OF PRINTED MATTER OF THE RESULTS OF CLINICAL TRIALS FOR PHARMACEUTICAL PREPARATIONS, ALSO IN ELECTRONIC FORM AND EXCEPT ADVERTISING TEXTS (U.S. CLS. 100, 101 AND 107).

CLASS 42—SCIENTIFIC AND COMPUTER SERVICES

FOR CONDUCTING CLINICAL TRIALS FOR PHARMACEUTICAL PRODUCTS (U.S. CLS. 100 AND 101).
JASON BLAIR, EXAMINING ATTORNEY



OWNER OF INTERNATIONAL REGISTRATION 0964167
DATED 1-24-2008, EXPIRES 1-24-2018.

CLASS 14—JEWELRY

FOR JEWELLERY AND IMITATION JEWELLERY; KEY HOLDERS OF PRECIOUS METALS; TIE PINS, CUFFLINKS, LAPEL PINS; WATCHES AND CLOCKS (U.S. CLS. 2, 27, 28 AND 50).

CLASS 16—PAPER GOODS AND PRINTED MATTER

FOR BOOKS AND JOURNALS IN THE FIELD OF HISTORY, ARTS, ECONOMICS, ARCHITECTURE; BOOK MARKS; BOXES OF PAPER OR CARDBOARD; CALENDARS AND DIARIES; WRITING INSTRUMENTS, PENS, BALLPOINT PENS, FELT WRITING PENS, FOUNTAIN PENS, PEN NIBS; STANDS FOR PENS AND PENCILS; LETTER PAPER, MEMO PADS, OFFICE STATIONERY, PAPERWEIGHTS; PAPER KNIVES; PEN AND PENCIL CASES; PENHOLDERS; PHOTOGRAPHIC ALBUMS, POSTERS MADE OF PAPER; BUSINESS CARD CASES (U.S. CLS. 2, 5, 22, 23, 29, 37, 38 AND 50).

CLASS 18—LEATHER GOODS

FOR HANDBAGS, SHOULDER BAGS, BRIEFCASES, VANITY CASES SOLD EMPTY, KEY CASES, WALLETS AND PURSES; SUITCASES AND TRAVELLING BAGS; UMBRELLAS (U.S. CLS. 1, 2, 3, 22 AND 41).
JESSICA FATHY, EXAMINING ATTORNEY

CLASS 18—LEATHER GOODS

FOR HANDBAGS, SHOULDER BAGS, BRIEFCASES, VANITY CASES SOLD EMPTY, KEY CASES, WALLETS AND PURSES; SUITCASES AND TRAVELLING BAGS; UMBRELLAS (U.S. CLS. 1, 2, 3, 22 AND 41).
JESSICA FATHY, EXAMINING ATTORNEY

SN 79-053,777. MADINIT S.R.L., ITALY, FILED 1-24-2008.

SN 79-053,776. MADINIT S.R.L., ITALY, FILED 1-24-2008.



OWNER OF INTERNATIONAL REGISTRATION 0964168 DATED 1-24-2008, EXPIRES 1-24-2018.

CLASS 14—JEWELRY

FOR JEWELLERY AND IMITATION JEWELLERY; KEY HOLDERS OF PRECIOUS METALS; TIE PINS, CUFFLINKS, LAPEL PINS; WATCHES AND CLOCKS (U.S. CLS. 2, 27, 28 AND 50).

CLASS 16—PAPER GOODS AND PRINTED MATTER

FOR BOOKS AND JOURNALS IN THE FIELD OF HISTORY, ARTS, ECONOMICS, ARCHITECTURE; BOOK MARKS; BOXES OF PAPER OR CARDBOARD; CALENDARS AND DIARIES; WRITING INSTRUMENTS, PENS, BALLPOINT PENS, FELT WRITING PENS, FOUNTAIN PENS, PEN NIBS; STANDS FOR PEN AND PENCIL; LETTER PAPER, MEMO PADS, OFFICE STATIONERY, PAPERWEIGHTS; PAPER KNIVES; PEN AND PENCIL CASES; PENHOLDERS; PHOTOGRAPHIC ALBUMS, POSTERS MADE OF PAPER; BUSINESS CARD CASES (U.S. CLS. 2, 5, 22, 23, 29, 37, 38 AND 50).



OWNER OF INTERNATIONAL REGISTRATION 0964169 DATED 1-24-2008, EXPIRES 1-24-2018.

CLASS 14—JEWELRY

FOR JEWELLERY AND IMITATION JEWELLERY; KEY HOLDERS OF PRECIOUS METALS; TIE PINS, CUFFLINKS, LAPEL PINS; WATCHES AND CLOCKS (U.S. CLS. 2, 27, 28 AND 50).

CLASS 16—PAPER GOODS AND PRINTED MATTER

FOR BOOKS AND JOURNALS IN THE FIELD OF HISTORY, ARTS, ECONOMICS, ARCHITECTURE; BOOK MARKS; BOXES OF PAPER OR CARDBOARD; CALENDARS AND DIARIES; WRITING INSTRUMENTS, PENS, BALLPOINT PENS, FELT WRITING PENS, FOUNTAIN PENS, PEN NIBS; STANDS FOR PEN AND PENCIL; LETTER PAPER, MEMO PADS, OFFICE STATIONERY, PAPERWEIGHTS; PAPER KNIVES; PEN AND PENCIL CASES; PENHOLDERS; PHOTOGRAPHIC ALBUMS, POSTERS MADE OF PAPER; BUSINESS CARD CASES (U.S. CLS. 2, 5, 22, 23, 29, 37, 38 AND 50).

CLASS 18—LEATHER GOODS

FOR HANDBAGS, SHOULDER BAGS, BRIEFCASES, VANITY CASES SOLD EMPTY, KEY CASES, WALLETS AND PURSES; SUITCASES AND TRAVELLING BAGS; UMBRELLAS (U.S. CLS. 1, 2, 3, 22 AND 41).
JESSICA FATHY, EXAMINING ATTORNEY

SN 79-053,779. BACIO S.R.L., ITALY, FILED 2-6-2008.

SN 79-053,981. QINGDAO HAIER; MARKETING & PLANNING CO., LTD, CHINA, FILED 3-26-2008.

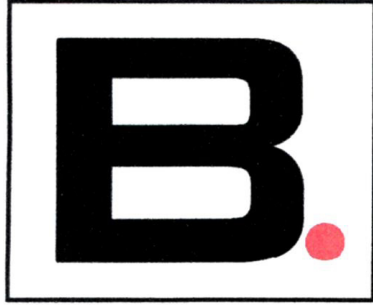

PRIORITY DATE OF 11-14-2007 IS CLAIMED.
OWNER OF INTERNATIONAL REGISTRATION 0964175
DATED 2-6-2008, EXPIRES 2-6-2018.

THE COLOR(S) BLACK, RED AND WHITE IS/ARE CLAIMED AS A FEATURE OF THE MARK.

BLACK APPEARS IN THE LETTER "B" AND IN THE FRAME; RED APPEARS IN THE DOT; WHITE APPEARS IN THE BACKGROUND WITHIN THE FRAME.

THE MARK CONSISTS OF A LARGE BLACK LETTER "B", FOLLOWED BY A RED DOT, ALL ON A WHITE BACKGROUND AND WITHIN A THIN BLACK RECTANGULAR FRAME.

CLASS 14—JEWELRY

FOR SILVER AND GOLD UNWROUGHT; IMITATION JEWELRY; JEWELRY, NAMELY, THREADS AND WIRES OF PRECIOUS METALS; BOXES OF PRECIOUS METAL; JEWEL CASES; WATCH CASES; PRECIOUS METAL TROPHIES; EARRINGS, ORNAMENTAL CHAINS AND PINS, BRACELETS, NECKLACES, RINGS, PENDANTS, BROOCHES, CHAINS, CHARMS, MEDALLIONS, DIADEMS, CUFFLINKS, TIE CLIPS; JEWELRY; KEY RINGS OF PRECIOUS METALS; WORKS OF ART OF PRECIOUS METAL; WATCH BANDS; WRIST WATCHES, CLOCKS, CHRONOMETERS (U.S. CLS. 2, 27, 28 AND 50).

CLASS 18—LEATHER GOODS

FOR UNWORKED OR SEMI-WORKED LEATHER SOLD IN BULK, FUR-SKINS, LUGGAGE, HANDBAGS, SHOULDER BAGS, GARMENT BAGS FOR TRAVEL, TRAVELLING BAGS, BEACH BAGS, CLUTCH BAGS, ALL PURPOSE SPORTS BAGS, ATTACHE CASES, SCHOOL BAGS, TOTE BAGS, SHOPPING BAGS; CARD CASES, NAMELY, NOTE CASES; VANITY CASES NOT FITTED; KEY CASES, KNAPSACKS, RUCKSACKS, BRIEFCASES, PURSES, WALLETS, POUCHES OF LEATHER FOR PACKAGING; TRAVELLING TRUNKS, SUITCASES, UMBRELLAS, PARASOLS, WALKING STICKS; DOG COLLARS, WHIPS (U.S. CLS. 1, 2, 3, 22 AND 41).

DOMINIC FATHY, EXAMINING ATTORNEY

Casarte

OWNER OF INTERNATIONAL REGISTRATION 0964645
DATED 3-26-2008, EXPIRES 3-26-2018.

WORDS IN STYLIZED FORM.

THE WORDING "CASARTE" HAS NO MEANING IN A FOREIGN LANGUAGE.

CLASS 7—MACHINERY

FOR DISHWASHERS; ELECTRIC FOOD BLENDERS FOR HOUSEHOLD PURPOSES; KITCHEN MACHINES, NAMELY, ELECTRIC STANDING MIXERS; ELECTRIC FOOD PROCESSORS; SOYBEAN MILK PREPARATION MACHINES FOR HOUSEHOLD PURPOSES; CLOTHES WASHING MACHINES; LAUNDRY CENTERS, NAMELY, A CLOTHES WASHER COMBINED WITH A CLOTHES DRYER; VACUUM CLEANERS FOR HOUSEHOLD PURPOSES; CARPET CLEANING MACHINES (U.S. CLS. 13, 19, 21, 23, 31, 34 AND 35).

CLASS 9—ELECTRICAL AND SCIENTIFIC APPARATUS

FOR DESKTOP COMPUTERS; COMPUTER ROUTERS; COMPUTER NETWORK ADAPTERS; FACSIMILE MACHINES; NEON SIGNS; MOBILE PHONES; TELEVISION SETS; CAMERAS; PORTABLE LISTENING DEVICES, NAMELY, MP3 PLAYERS; DVD PLAYERS; COMPUTER SOFTWARE FOR APPLICATION AND DATABASE INTEGRATION (U.S. CLS. 21, 23, 26, 36 AND 38).

CLASS 11—ENVIRONMENTAL CONTROL APPARATUS

FOR LIGHTING FIXTURES; ELECTRIC COOKING OVENS FOR HOUSEHOLD PURPOSES; REFRIGERATORS; AIR CONDITIONING UNITS; ELECTRIC HEATING FANS; HEATING INSTALLATIONS; PIPES BEING PARTS OF SANITARY FACILITIES; DISH DISINFECTANT APPARATUS FOR HOUSEHOLD PURPOSES; ELECTRIC RADIATORS; OVEN GAS IGNITERS; GAS WATER HEATERS FOR HOUSEHOLD USE; MICROWAVE OVENS FOR COOKING; EXTRACTOR HOODS FOR HOUSEHOLD PURPOSES; GAS BURNERS; REFRIGERATING APPLIANCES AND INSTALLATIONS; SOLAR WATER HEATERS; REFRIGERATING DISPLAY CABINETS; ELECTRIC COFFEE MAKERS; CLOTHES DRYERS; VENTILATING EXHAUST FANS; ELECTRIC HOT AIR HAND DRYERS; CENTRAL HEATING RADIATORS (U.S. CLS. 13, 21, 23, 31 AND 34).

CHARLES L. JENKINS, EXAMINING ATTORNEY

* * * * *

SECTION 2.— INTERNATIONAL CLASSIFICATION

The short titles associated below with the international class numbers are terms designed merely for quick identification and are not an official part of the international classification. The full names of international classes are given in section 6.1 of the trademark rules of practice.

The designation "U.S. Cl." appearing in this section refers to the U.S. class in effect prior to Sep. 1, 1973 rather than the international class which applies to applications filed on or after that date. For adoption of international classification see notice in the OFFICIAL GAZETTE of Jun. 26, 1973 (911 O.G. TM 210).

Application in one class

CLASS 1—CHEMICALS

SN 76-667,991. MARS FISHCARE NORTH AMERICA, INC.,
CHALFONT, PA. FILED 10-23-2006.



THE COLOR(S) BLUE IS/ARE CLAIMED AS A FEATURE OF THE MARK.

THE MARK CONSISTS OF THE COLOR BLUE AS APPLIED TO THE BOTTLE CAP FOR THE PACKAGING FOR THE OWNER'S GOODS. THE COLOR BLUE APPEARS ON THE CAP OF THE BOTTLE. THE DOTTED OUTLINE OF THE GOODS IS INTENDED TO SHOW THE POSITION OF THE MARK ON THE GOODS AND IS NOT PART OF THE MARK.

SEC. 2(F).

FOR CHEMICAL AND BACTERIA PREPARATIONS FOR THE TREATMENT, CONDITIONING, AND CLEANING OF AQUARIUMS AND AQUARIUM WATER; LIQUID PLANT FOOD FOR USE IN AQUARIUMS; WATER TREATMENT CHEMICALS IN THE NATURE OF RESINS AND MINERALS FOR THE ABSORPTION OF AMMONIA FROM AQUARIUMS (U.S. CLS. 1, 5, 6, 10, 26 AND 46).

FIRST USE 5-0-2005; IN COMMERCE 5-0-2005.

MICHAEL TANNER, EXAMINING ATTORNEY

CLASS 1—(Continued).

SN 76-685,298. INDUSTRIAL SOLUTION SERVICES, INC.,
UPLAND, CA. FILED 12-26-2007.

PUREAIR 32

THE MARK CONSISTS OF STANDARD CHARACTERS WITHOUT CLAIM TO ANY PARTICULAR FONT, STYLE, SIZE, OR COLOR.

NO CLAIM IS MADE TO THE EXCLUSIVE RIGHT TO USE "32", APART FROM THE MARK AS SHOWN.

FOR REAGENT GRADE UREA SOLUTION FOR TREATMENT OF DIESEL EXHAUST EMISSIONS/NOX CONTROL (U.S. CLS. 1, 5, 6, 10, 26 AND 46).

MARK PILARO, EXAMINING ATTORNEY

SN 76-686,739. SMARTPOOL, INC., LAKEWOOD, NJ. FILED
2-11-2008.

BOOST AND MAINTAIN

FOR WATER TREATMENT CHEMICALS FOR USE IN SWIMMING POOLS AND SPAS (U.S. CLS. 1, 5, 6, 10, 26 AND 46).

REGINA DRUMMOND, EXAMINING ATTORNEY

SN 76-686,741. SMARTPOOL, INC., LAKEWOOD, NJ. FILED
2-11-2008.

CHARGE AND RELEASE

FOR WATER TREATMENT CHEMICALS FOR USE IN SWIMMING POOLS AND SPAS (U.S. CLS. 1, 5, 6, 10, 26 AND 46).

REGINA DRUMMOND, EXAMINING ATTORNEY

CLASS 1—(Continued).

SN 76-688,529. H & S CORPORATION., ALMA, AR. FILED 4-11-2008.

DIACTAGEN

THE MARK CONSISTS OF STANDARD CHARACTERS WITHOUT CLAIM TO ANY PARTICULAR FONT, STYLE, SIZE, OR COLOR.

OWNER OF U.S. REG. NO. 2,961,870.
FOR WATER TREATMENT CHEMICALS, NAMELY, ACIDIFIERS FOR USE IN POULTRY AND ANIMAL DRINKING WATER (U.S. CLS. 1, 5, 6, 10, 26 AND 46).
FIRST USE 1-0-1991; IN COMMERCE 1-0-1991.
DORITT L. CARROLL, EXAMINING ATTORNEY

SN 77-101,989. APPLIED BIOTECH INDUSTRIES, INC., BELGUIM, WI. FILED 2-7-2007.

MICROZYME

THE MARK CONSISTS OF STANDARD CHARACTERS WITHOUT CLAIM TO ANY PARTICULAR FONT, STYLE, SIZE, OR COLOR.

FOR BIOTECHNOLOGY FORMED MICROBES AND ENZYMES FOR USE IN THE BREAKDOWN AND CONSUMPTION OF ORGANIC WASTES (U.S. CLS. 1, 5, 6, 10, 26 AND 46).
FIRST USE 1-1-1996; IN COMMERCE 1-1-1996.
BENJAMIN OKEKE, EXAMINING ATTORNEY

SN 77-127,395. SASOL NORTH AMERICA INC., HOUSTON, TX. FILED 3-9-2007.

HF

THE MARK CONSISTS OF STANDARD CHARACTERS WITHOUT CLAIM TO ANY PARTICULAR FONT, STYLE, SIZE, OR COLOR.

FOR NON-AROMATIC AND ECOLOGICALLY SENSITIVE SOLVENTS COMPRISED OF ALKANES, OLEFINS AND OXYGENATES, NAMELY, ESTERS AND ALCOHOLS FOR INDUSTRIAL USE (U.S. CLS. 1, 5, 6, 10, 26 AND 46).

MICHAEL LITZAU, EXAMINING ATTORNEY

CLASS 1—(Continued).

SN 77-195,873. ASTARTE BIOLOGICS, LLC, REDMOND, WA. FILED 6-1-2007.

Rheumera

THE MARK CONSISTS OF STANDARD CHARACTERS WITHOUT CLAIM TO ANY PARTICULAR FONT, STYLE, SIZE, OR COLOR.

THE WORDING "RHEUMERA" HAS NO MEANING IN A FOREIGN LANGUAGE.
FOR REAGENTS FOR RESEARCH PURPOSES (U.S. CLS. 1, 5, 6, 10, 26 AND 46).
FIRST USE 9-21-2006; IN COMMERCE 3-12-2007.
BILL DAWE, EXAMINING ATTORNEY

SN 77-276,848. ELLSWORTH CORPORATION, GERMANTOWN, WI. FILED 9-11-2007.

ECAST

THE MARK CONSISTS OF STANDARD CHARACTERS WITHOUT CLAIM TO ANY PARTICULAR FONT, STYLE, SIZE, OR COLOR.

FOR GLUE AND ADHESIVE PRODUCTS, NAMELY, EPOXY GLUE FOR GENERAL BONDING AND REPAIR PURPOSES; ADHESIVES AND GLUES FOR INDUSTRIAL PURPOSES (U.S. CLS. 1, 5, 6, 10, 26 AND 46).
AISHA SALEM, EXAMINING ATTORNEY

SN 77-284,628. THERMPHOS TRADING GMBH, CH-6300 ZUG, SWITZERLAND, FILED 9-20-2007.



OWNER OF U.S. REG. NO. 3,288,657.
NO CLAIM IS MADE TO THE EXCLUSIVE RIGHT TO USE "ADDITIVES" AS TO CHEMICAL PREPARATIONS FOR USE IN THE MANUFACTURE OF DETERGENT; CHEMICAL PREPARATIONS FOR USE IN WATER PURIFYING; CHEMICAL STABILIZING AGENT FOR USE WITH HYDROGEN PEROXIDE AND OXYGEN BLEACHING SOLUTIONS; COLOR STABILIZER CHEMICALS FOR USE IN INDUSTRIAL PROCESSING; CHEMICAL ANTI-RANCIDITY AGENTS FOR USE IN INDUSTRIAL PROCES-

CLASS 1—(Continued).

SING; CHEMICAL PRESERVATIVES FOR USE IN INDUSTRIAL PROCESSING; CHEMICAL CHELATING AGENTS FOR USE IN STABILIZING METALLIC IONS IN AQUEOUS SOLUTIONS" AND "PERSONAL CARE ADDITIVES" AS TO "CHEMICAL PREPARATIONS FOR USE IN THE MANUFACTURE OF SOAPS, HAIR CARE PREPARATIONS, PERSONAL CARE PREPARATIONS, COSMETICS; CHEMICAL ADDITIVES FOR USE IN THE MANUFACTURE OF PERSONAL CARE PREPARATIONS, APART FROM THE MARK AS SHOWN.

THE MARK CONSISTS OF THE WORDING "TURPINAL PERSONAL CARE ADDITIVES" ON TWO LINES, AND A STYLIZED HUMAN FACE IN PROFILE, ON A DISC, WITH HAIR STREAMING BEHIND.

THE WORDING "TURPINAL" HAS NO MEANING IN ENGLISH.

FOR CHEMICAL PREPARATIONS FOR USE IN THE MANUFACTURE OF SOAPS, HAIR CARE PREPARATIONS, PERSONAL CARE PREPARATIONS, COSMETICS, AND DETERGENT; CHEMICAL PREPARATIONS FOR USE IN WATER PURIFYING; CHEMICAL ADDITIVES FOR USE IN THE MANUFACTURE OF PERSONAL CARE PREPARATIONS; CHEMICAL STABILIZING AGENT FOR USE WITH HYDROGEN PEROXIDE AND OXYGEN BLEACHING SOLUTIONS; COLOR STABILIZER CHEMICALS FOR USE IN INDUSTRIAL PROCESSING; CHEMICAL ANTIRANCIDITY AGENTS FOR USE IN INDUSTRIAL PROCESSING; CHEMICAL PRESERVATIVES FOR USE IN INDUSTRIAL PROCESSING; CHEMICAL CHELATING AGENTS FOR USE IN STABILIZING METALLIC IONS IN AQUEOUS SOLUTIONS (U.S. CLS. 1, 5, 6, 10, 26 AND 46).

MAUREEN DALL, EXAMINING ATTORNEY

CLASS 1—(Continued).

SN 77-289,832. MGS HORTICULTURAL INC., LEAMINGTON, CANADA, FILED 9-26-2007.

MGS SELECT

THE MARK CONSISTS OF STANDARD CHARACTERS WITHOUT CLAIM TO ANY PARTICULAR FONT, STYLE, SIZE, OR COLOR.

PRIORITY CLAIMED UNDER SEC. 44(D) ON CANADA APPLICATION NO. 1345013, FILED 4-26-2007.

NO CLAIM IS MADE TO THE EXCLUSIVE RIGHT TO USE "SELECT", APART FROM THE MARK AS SHOWN.

FOR WATER SOLUBLE FERTILIZERS (U.S. CLS. 1, 5, 6, 10, 26 AND 46).

JANICE KIM, EXAMINING ATTORNEY

SN 77-289,884. MGS HORTICULTURAL INC., LEAMINGTON, CANADA, FILED 9-26-2007.



PRIORITY CLAIMED UNDER SEC. 44(D) ON CANADA APPLICATION NO. 1351063, FILED 6-11-2007.

NO CLAIM IS MADE TO THE EXCLUSIVE RIGHT TO USE "SELECT CUSTOMIZED SOLUBLE NUTRITION", APART FROM THE MARK AS SHOWN.

FOR WATER SOLUBLE FERTILIZERS (U.S. CLS. 1, 5, 6, 10, 26 AND 46).

JANICE KIM, EXAMINING ATTORNEY

SN 77-289,824. MGS HORTICULTURAL INC., LEAMINGTON, CANADA, FILED 9-26-2007.

**MGS SELECT CUSTOMIZED
SOLUBLE NUTRITION**

THE MARK CONSISTS OF STANDARD CHARACTERS WITHOUT CLAIM TO ANY PARTICULAR FONT, STYLE, SIZE, OR COLOR.

PRIORITY CLAIMED UNDER SEC. 44(D) ON CANADA APPLICATION NO. 1345011, FILED 4-26-2007.

NO CLAIM IS MADE TO THE EXCLUSIVE RIGHT TO USE "SELECT CUSTOMIZED SOLUBLE NUTRITION", APART FROM THE MARK AS SHOWN.

FOR WATER SOLUBLE FERTILIZERS (U.S. CLS. 1, 5, 6, 10, 26 AND 46).

JANICE KIM, EXAMINING ATTORNEY

SN 77-296,013. NANODYNAMICS, INC., BUFFALO, NY, FILED 10-4-2007.

CLEARCOL

THE MARK CONSISTS OF STANDARD CHARACTERS WITHOUT CLAIM TO ANY PARTICULAR FONT, STYLE, SIZE, OR COLOR.

FOR CHEMICAL PREPARATIONS, NAMELY, COLLOIDS COMPRISING UNAGGLOMERATED NANOPARTICLES FOR USE IN COATINGS, AS ADDITIVES TO POLYMERIC MATERIALS, AND FOR DEPOSITION ON OR INTO SUBSTRATES (U.S. CLS. 1, 5, 6, 10, 26 AND 46).

FIRST USE 5-1-2006; IN COMMERCE 5-1-2006.

MICHAEL LEWIS, EXAMINING ATTORNEY

CLASS 1—(Continued).

SN 77-301,750. AGRI-WASTE ENERGY, INC., ST. PAUL, MN.
FILED 10-11-2007.

BIO BOOST

THE MARK CONSISTS OF STANDARD CHARACTERS WITHOUT CLAIM TO ANY PARTICULAR FONT, STYLE, SIZE, OR COLOR.

FOR BACTERIAL AND CHEMICAL ADDITIVES TO ENHANCE ANAEROBIC DIGESTION FOR INCREASED PRODUCTION OF METHANE GAS (U.S. CLS. 1, 5, 6, 10, 26 AND 46).

WILLIAM P. SHANAHAN, EXAMINING ATTORNEY

SN 77-303,779. INNOBIO, LLC, DBA INNOBIOACTIVES, INC., GREENSBORO, NC. FILED 10-15-2007.

INNOBIO

THE MARK CONSISTS OF STANDARD CHARACTERS WITHOUT CLAIM TO ANY PARTICULAR FONT, STYLE, SIZE, OR COLOR.

FOR FATTY ACIDS FOR USE IN THE MANUFACTURE OF FOODS, FOOD SUPPLEMENTS, NUTRITIONAL SUPPLEMENTS, COSMETICS, AND PHARMACEUTICALS AND FATTY ACID CONCENTRATES FOR USE IN THE MANUFACTURE OF FOODS, FOOD SUPPLEMENTS, NUTRITIONAL SUPPLEMENTS, COSMETICS, AND PHARMACEUTICALS (U.S. CLS. 1, 5, 6, 10, 26 AND 46).

FIRST USE 6-1-2003; IN COMMERCE 6-1-2003.
JAY FLOWERS, EXAMINING ATTORNEY

SN 77-318,731. BOOST OXYGEN, LLC, BRIDGEPORT, CT.
FILED 11-1-2007.

Oxygenate Like the Pros

THE MARK CONSISTS OF STANDARD CHARACTERS WITHOUT CLAIM TO ANY PARTICULAR FONT, STYLE, SIZE, OR COLOR.

NO CLAIM IS MADE TO THE EXCLUSIVE RIGHT TO USE "OXYGENATE", APART FROM THE MARK AS SHOWN.

FOR OXYGEN, NAMELY, OXYGEN FOR NON-MEDICAL PURPOSES (U.S. CLS. 1, 5, 6, 10, 26 AND 46).

JACQUELINE A. LAVINE, EXAMINING ATTORNEY

CLASS 1—(Continued).

SN 77-327,854. KTK ASSOCIATES, INC., GOLIAD, TX.
FILED 11-13-2007.

SPILL HAND

THE MARK CONSISTS OF STANDARD CHARACTERS WITHOUT CLAIM TO ANY PARTICULAR FONT, STYLE, SIZE, OR COLOR.

FOR A LOOSE ZEOLITE-BASED COMPOSITION SOLD IN BAGS FOR USE ON OIL SPILLS TO ABSORB THE SPILL AND PROVIDE FOR REMEDIATION OF THE SPILLED MATERIAL (U.S. CLS. 1, 5, 6, 10, 26 AND 46).

FIRST USE 11-10-2007; IN COMMERCE 11-10-2007.
PAULA MAHONEY, EXAMINING ATTORNEY

SN 77-329,738. GUIETTE, DEBORAH E, WESTON, WI. FILED 11-14-2007.

Llama Beans

THE MARK CONSISTS OF STANDARD CHARACTERS WITHOUT CLAIM TO ANY PARTICULAR FONT, STYLE, SIZE, OR COLOR.

FOR FERTILIZERS AND MANURES (U.S. CLS. 1, 5, 6, 10, 26 AND 46).

JILL C. ALT, EXAMINING ATTORNEY

SN 77-360,162. FOSTER-GARDNER, INC., COACHELLA, CA.
FILED 12-27-2007.

NATINA

THE MARK CONSISTS OF STANDARD CHARACTERS WITHOUT CLAIM TO ANY PARTICULAR FONT, STYLE, SIZE, OR COLOR.

FOR CHEMICAL COMPOSITION OF MINERALS AND MICRONUTRIENTS FOR APPLICATION TO THE COLOR-ALTERED FACE OF A RECENTLY EXPOSED EARTH OR ROCK SURFACE IN ORDER TO ACCELERATE NATURE'S COLOR CHANGING PROCESS (U.S. CLS. 1, 5, 6, 10, 26 AND 46).

CHRISIE B. KING, EXAMINING ATTORNEY

CLASS 1—(Continued).

SN 77-379,849. PERFORMANCE ROOF SYSTEMS, INC., KANSAS CITY, MO. FILED 1-24-2008.

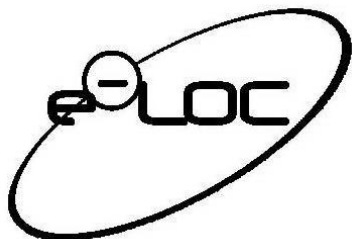

THE MARK CONSISTS OF THE LETTER "E", AN ELECTRON SYMBOL INSIDE A CIRCLE, AND THE LETTERS "LOC" SEMI SURROUNDED BY A SPHERE.

FOR CONSTRUCTION INDUSTRY ADHESIVE, NAMELY, A FOAM AND LIQUID ADHESIVE FOR SEALING THE BUILDING ENVELOPE OF A STRUCTURE, FOR PURPOSES OF ENVIRONMENTAL CONTROL (U.S. CLS. 1, 5, 6, 10, 26 AND 46).

JORDAN BAKER, EXAMINING ATTORNEY

CLASS 1—(Continued).

SN 77-419,821. CALVA PRODUCTS CO., INC., ACAMPO, CA. FILED 3-12-2008.

Calva Lacto-Fresh

NO CLAIM IS MADE TO THE EXCLUSIVE RIGHT TO USE "LACTO-FRESH", APART FROM THE MARK AS SHOWN.

THE COLOR(S) BLACK AND BLUE IS/ARE CLAIMED AS A FEATURE OF THE MARK.

THE MARK CONSISTS OF THE WORDS "CALVA LACTO-FRESH" IN STYLIZED WRITING WITH EACH LETTER BEING THE COLOR BLUE OUTLINED IN THE COLOR BLACK.

THE ENGLISH TRANSLATION OF THE WORD "CALVA" IN THE MARK IS BALD.

FOR PRESERVATIVE COMPOSITION FOR USE IN MILK REPLACEMENT FOR CALVES (U.S. CLS. 1, 5, 6, 10, 26 AND 46).

FIRST USE 1-0-1998; IN COMMERCE 1-0-1998.

APRIL ROACH, EXAMINING ATTORNEY

SN 77-421,123. TRAYLOR CHEMICAL & SUPPLY CO., ORLANDO, FL. FILED 3-13-2008.

T-CHEL

THE MARK CONSISTS OF STANDARD CHARACTERS WITHOUT CLAIM TO ANY PARTICULAR FONT, STYLE, SIZE, OR COLOR.

FOR FERTILIZERS FOR AGRICULTURAL AND DOMESTIC USE (U.S. CLS. 1, 5, 6, 10, 26 AND 46).

MARIA-VICTORIA SUAREZ, EXAMINING ATTORNEY

SN 77-410,905. ELCAT, INC., WARREN, NJ. FILED 3-3-2008.

HAMPOSYL

THE MARK CONSISTS OF STANDARD CHARACTERS WITHOUT CLAIM TO ANY PARTICULAR FONT, STYLE, SIZE, OR COLOR.

FOR CHEMICALLY MODIFIED FATTY ACIDS FOR USE IN PERSONAL CARE PRODUCTS, CLEANING PRODUCTS, MACHINERY AND CHAIN LUBRICANTS, CORROSION INHIBITORS, LEATHER TREATING CHEMICALS, MINING AND MINERAL SEPARATION AIDES, AGRICULTURAL ADJUVANTS AND COMPATIBILIZERS, TEXTILE LUBRICANTS, POLYMER ANTI-STATIC AND ANTIFOGGING ADDITIVES, BIOTECHNOLOGY PRODUCT SEPARATION AND PURIFICATION AIDES, AND DISPERSANTS (U.S. CLS. 1, 5, 6, 10, 26 AND 46).

FIRST USE 1-21-1964; IN COMMERCE 4-22-1964.

BRIAN CALLAGHAN, EXAMINING ATTORNEY

SN 77-422,134. 3D SYSTEMS, INC., ROCK HILL, SC. FILED 3-14-2008.

DURAFORM

THE MARK CONSISTS OF STANDARD CHARACTERS WITHOUT CLAIM TO ANY PARTICULAR FONT, STYLE, SIZE, OR COLOR.

OWNER OF U.S. REG. NO. 2,611,081.

FOR CHEMICAL SUBSTANCE IN THE FORM OF A CONJOINABLE POWDER MATERIAL FOR USE WITH COMPUTER CONTROLLED APPARATUS FOR PROCESSING DESIGN DATA INTO THREE DIMENSIONAL OBJECTS (U.S. CLS. 1, 5, 6, 10, 26 AND 46).

FIRST USE 12-31-1997; IN COMMERCE 12-31-1997.

TINA BROWN, EXAMINING ATTORNEY

CLASS 1—(Continued).

SN 77-423,381. SPEX CERTIPREP, INC., METUCHEN, NJ.
FILED 3-17-2008.

CALIBRATE WITH CONFIDENCE

THE MARK CONSISTS OF STANDARD CHARACTERS
WITHOUT CLAIM TO ANY PARTICULAR FONT, STYLE,
SIZE, OR COLOR.

FOR CHEMICAL REFERENCE STANDARDS FOR
LABORATORY AND INDUSTRIAL USE (U.S. CLS. 1, 5,
6, 10, 26 AND 46).

NORA BUCHANAN WILL, EXAMINING ATTORNEY

SN 77-423,850. CIBA CORPORATION, TARRYTOWN, NY.
FILED 3-17-2008.

CHIMASSORB

THE MARK CONSISTS OF STANDARD CHARACTERS
WITHOUT CLAIM TO ANY PARTICULAR FONT, STYLE,
SIZE, OR COLOR.

FOR CHEMICAL ADDITIVE/STABILIZER FOR PLAS-
TICS, ADHESIVES AND RUBBERS (U.S. CLS. 1, 5, 6, 10,
26 AND 46).

NANCY CLARKE, EXAMINING ATTORNEY

SN 77-424,531. SYNATEK LP, SOUDERTON, PA. FILED 3-18-
2008.

FERTAMINOS

THE MARK CONSISTS OF STANDARD CHARACTERS
WITHOUT CLAIM TO ANY PARTICULAR FONT, STYLE,
SIZE, OR COLOR.

FOR FERTILIZERS (U.S. CLS. 1, 5, 6, 10, 26 AND 46).
FIRST USE 10-6-2006; IN COMMERCE 10-6-2006.
ALYSSA PALADINO, EXAMINING ATTORNEY

CLASS 1—(Continued).

SN 77-425,448. LUBCHEM, INC., SPRING, TX. FILED 3-18-
2008.

FYZEX

THE MARK CONSISTS OF STANDARD CHARACTERS
WITHOUT CLAIM TO ANY PARTICULAR FONT, STYLE,
SIZE, OR COLOR.

FOR CHEMICALS FOR USE IN INDUSTRY AND
SCIENCE (U.S. CLS. 1, 5, 6, 10, 26 AND 46).

JANICE KIM, EXAMINING ATTORNEY

SN 77-425,464. LUBCHEM, INC., SPRING, TX. FILED 3-18-
2008.

FYBA

THE MARK CONSISTS OF STANDARD CHARACTERS
WITHOUT CLAIM TO ANY PARTICULAR FONT, STYLE,
SIZE, OR COLOR.

FOR CHEMICALS FOR USE IN INDUSTRY AND
SCIENCE (U.S. CLS. 1, 5, 6, 10, 26 AND 46).

JANICE KIM, EXAMINING ATTORNEY

SN 77-426,800. PROZYME, INC., SAN LEANDRO, CA. FILED
3-19-2008.

N-GLYCANASE

THE MARK CONSISTS OF STANDARD CHARACTERS
WITHOUT CLAIM TO ANY PARTICULAR FONT, STYLE,
SIZE, OR COLOR.

FOR ENZYME FOR CLIPPING THE SUGAR PORTION
FROM THE PROTEIN PORTION OF GLYCOPROTEINS
FOR IN VITRO LABORATORY USE (U.S. CLS. 1, 5, 6, 10,
26 AND 46).

FIRST USE 1-30-2003; IN COMMERCE 1-30-2003.

JOHN DWYER, EXAMINING ATTORNEY

CLASS 1—(Continued).

SN 77-427,071. PAMAS & COMPANY, INC., EXTON, PA. FILED 3-20-2008.

SILCARB

THE MARK CONSISTS OF STANDARD CHARACTERS WITHOUT CLAIM TO ANY PARTICULAR FONT, STYLE, SIZE, OR COLOR.

FOR NITRIDE-BONDED SILICON CARBIDE COMPOSITE FOR MANUFACTURE OF SIDEWALL BLOCKS FOR USE IN LINING POTS IN ALUMINUM SMELTERS (U.S. CLS. 1, 5, 6, 10, 26 AND 46).

FIRST USE 0-0-1994; IN COMMERCE 0-0-1994.
IRA J. GOODSaid, EXAMINING ATTORNEY

CLASS 1—(Continued).

SN 77-429,288. UNITED SUPPLIERS, INC., ELDORA, IA. FILED 3-24-2008.

DOWNDRAFT

THE MARK CONSISTS OF STANDARD CHARACTERS WITHOUT CLAIM TO ANY PARTICULAR FONT, STYLE, SIZE, OR COLOR.

FOR ADJUVANT FOR DEPOSITION AND DRIFT REDUCTION ADDED TO HERBICIDE TANK MIXTURES (U.S. CLS. 1, 5, 6, 10, 26 AND 46).

FIRST USE 3-20-2008; IN COMMERCE 3-20-2008.
JOHN WILKE, EXAMINING ATTORNEY

SN 77-427,097. PAMAS & COMPANY, INC., EXTON, PA. FILED 3-20-2008.

SILGRAPH

THE MARK CONSISTS OF STANDARD CHARACTERS WITHOUT CLAIM TO ANY PARTICULAR FONT, STYLE, SIZE, OR COLOR.

FOR SILICON CARBIDE AND GRAPHITE COMPOSITE FOR MANUFACTURE OF SIDEWALL BLOCKS FOR USE IN LINING POTS IN ALUMINUM SMELTERS (U.S. CLS. 1, 5, 6, 10, 26 AND 46).

FIRST USE 0-0-1994; IN COMMERCE 0-0-1994.
IRA J. GOODSaid, EXAMINING ATTORNEY

SN 77-429,691. ILLINOIS TOOL WORKS INC., GLENVIEW, IL. FILED 3-24-2008.

TURF GRIP

THE MARK CONSISTS OF STANDARD CHARACTERS WITHOUT CLAIM TO ANY PARTICULAR FONT, STYLE, SIZE, OR COLOR.

FOR CONSTRUCTION INDUSTRY ADHESIVES AND INDUSTRIAL ADHESIVES (U.S. CLS. 1, 5, 6, 10, 26 AND 46).

MARLENE BELL, EXAMINING ATTORNEY

SN 77-428,288. RAHAV, HADAR, PARADISE VALLEY, AZ. FILED 3-21-2008.

SOLID EARTH

THE MARK CONSISTS OF STANDARD CHARACTERS WITHOUT CLAIM TO ANY PARTICULAR FONT, STYLE, SIZE, OR COLOR.

FOR SOIL SOLIDIFIERS, SOIL STABILIZERS, SOIL EROSION CONTROL PREPARATIONS, SOIL DUST CONTROL PREPARATIONS (U.S. CLS. 1, 5, 6, 10, 26 AND 46).

ALICE SUE CARRUTHERS, EXAMINING ATTORNEY

SN 77-429,986. MITSUBISHI TANABE PHARMA CORPORATION, OSAKA-SHI, OSAKA, JAPAN, FILED 3-24-2008.

REHUMALB

THE MARK CONSISTS OF STANDARD CHARACTERS WITHOUT CLAIM TO ANY PARTICULAR FONT, STYLE, SIZE, OR COLOR.

FOR CHEMICALS USED IN INDUSTRY, NAMELY, RECOMBINANT HUMAN ALBUMIN TO BE ADDED AS A RAW MATERIAL FOR MANUFACTURING CELL CULTURE MEDIA, DIAGNOSTIC REAGENTS, AND BIOLOGICAL MEDICINES (U.S. CLS. 1, 5, 6, 10, 26 AND 46).

CHERYL CLAYTON, EXAMINING ATTORNEY

CLASS 1—(Continued).

SN 77-429,994. MITSUBISHI TANABE PHARMA CORPORATION, OSAKA-SHI, OSAKA, JAPAN, FILED 3-24-2008.

ALBUMOL

THE MARK CONSISTS OF STANDARD CHARACTERS WITHOUT CLAIM TO ANY PARTICULAR FONT, STYLE, SIZE, OR COLOR.

FOR CHEMICALS USED IN INDUSTRY, NAMELY, RECOMBINANT HUMAN ALBUMIN TO BE ADDED AS A RAW MATERIAL FOR MANUFACTURING CELL CULTURE MEDIA, DIAGNOSTIC REAGENTS, AND BIOLOGICAL MEDICINES (U.S. CLS. 1, 5, 6, 10, 26 AND 46).

CHERYL CLAYTON, EXAMINING ATTORNEY

SN 77-430,000. MITSUBISHI TANABE PHARMA CORPORATION, OSAKA-SHI, OSAKA, JAPAN, FILED 3-24-2008.

MITABUMIN

THE MARK CONSISTS OF STANDARD CHARACTERS WITHOUT CLAIM TO ANY PARTICULAR FONT, STYLE, SIZE, OR COLOR.

FOR CHEMICALS USED IN INDUSTRY, NAMELY, RECOMBINANT HUMAN ALBUMIN TO BE ADDED AS A RAW MATERIAL FOR MANUFACTURING CELL CULTURE MEDIA, DIAGNOSTIC REAGENTS, AND BIOLOGICAL MEDICINES (U.S. CLS. 1, 5, 6, 10, 26 AND 46).

CHERYL CLAYTON, EXAMINING ATTORNEY

SN 77-431,117. XCEED MOLECULAR CORPORATION, TORONTO, CANADA, FILED 3-25-2008.

ZIPLEX

THE MARK CONSISTS OF STANDARD CHARACTERS WITHOUT CLAIM TO ANY PARTICULAR FONT, STYLE, SIZE, OR COLOR.

OWNER OF U.S. REG. NOS. 3,427,680 AND 3,454,591.
FOR DIAGNOSTIC REAGENTS FOR SCIENTIFIC USE; DIAGNOSTIC TEST KITS FOR SCIENTIFIC USE COMPRISED OF REAGENTS, PROCESSING CHEMICALS, AND POROUS SUBSTRATE MATERIALS, ALONE OR ATTACHED TO A SOLID BODY FOR HANDLING (U.S. CLS. 1, 5, 6, 10, 26 AND 46).

FIRST USE 7-1-2007; IN COMMERCE 7-1-2007.

ALLISON SCHRODY, EXAMINING ATTORNEY

CLASS 1—(Continued).

SN 77-431,141. XCEED MOLECULAR CORPORATION, TORONTO, CANADA, FILED 3-25-2008.

XCEED MOLECULAR

THE MARK CONSISTS OF STANDARD CHARACTERS WITHOUT CLAIM TO ANY PARTICULAR FONT, STYLE, SIZE, OR COLOR.

OWNER OF U.S. REG. NOS. 3,438,921, 3,438,933 AND 3,438,934.

FOR DIAGNOSTIC REAGENTS FOR SCIENTIFIC USE; DIAGNOSTIC TEST KITS FOR SCIENTIFIC USE COMPRISED OF REAGENTS, PROCESSING CHEMICALS, AND POROUS SUBSTRATE MATERIALS, ALONE OR ATTACHED TO A SOLID BODY FOR HANDLING (U.S. CLS. 1, 5, 6, 10, 26 AND 46).

FIRST USE 7-1-2007; IN COMMERCE 7-1-2007.

ALLISON SCHRODY, EXAMINING ATTORNEY

SN 77-433,227. VERICHEM LABORATORIES, INC., PROVIDENCE, RI. FILED 3-27-2008.

VERICHEM

THE MARK CONSISTS OF STANDARD CHARACTERS WITHOUT CLAIM TO ANY PARTICULAR FONT, STYLE, SIZE, OR COLOR.

FOR BILIRUBIN STANDARD KIT COMPRISING OF BILIRUBIN CONJUGATE IN A BASE OF BOVINE SERUM ALBUMIN FOR LABORATORY AND RESEARCH USE IN CALIBRATION OR VERIFICATION OF MEDICAL DIAGNOSTIC TEST EQUIPMENT; FOR CHEMISTRY REFERENCE KIT CONTAINING SODIUM, POTASSIUM, CHLORIDE, CALCIUM, PHOSPHORUS, MAGNESIUM, GLUCOSE, UREA NITROGEN, CREATININE AND TRIGLYCERIDE IN BASE OF BOVINE ALBUMIN FOR CALIBRATION OR VERIFICATION OF MEDICAL DIAGNOSTIC TEST SYSTEMS; FOR TOTAL PROTEIN / ALBUMIN STANDARD KIT CONSISTING OF ALBUMIN AND BOVINE GAMMA GLOBULIN FOR CALIBRATION OR VERIFICATION OF MEDICAL DIAGNOSTIC TEST SYSTEMS; FOR ELECTROLYTE STANDARD KIT CONSISTING OF SODIUM, POTASSIUM, CHLORIDE, LITHIUM AND IONIZED CALCIUM IN A BASE OF BOVINE ALBUMIN FOR CALIBRATION OR VERIFICATION OF MEDICAL DIAGNOSTIC TEST SYSTEMS; FOR CARBON DIOXIDE STANDARD KIT CONSISTING OF CARBON DIOXIDE FOR CALIBRATION OR VERIFICATION OF MEDICAL DIAGNOSTIC TEST SYSTEMS; FOR CHOLESTEROL REFERENCE KIT CONSISTING OF CHOLESTEROL AND URIC ACID FOR CALIBRATION OR VERIFICATION OF MEDICAL DIAGNOSTIC TEST SYSTEMS; FOR MULTI-ENZYME VERIFIER KIT CONSISTING OF ASPARTATE AMINOTRANSFERASE, ALANINE AMINOTRANSFERASE, ALKALINE PHOSPHATASE, LACTATE DEHYDROGENASE, CREATINE PHOSPHOKINASE, GAMMA GLUTAMYLTRANSFERASE, ALPHA-AMYLASE AND LIPASE FOR CALIBRATION OR VERIFICATION OF MEDICAL DIAGNOSTIC TEST SYSTEMS; FOR ENZYME ER VERIFIER KIT CONSISTING OF ASPARTATE AMINOTRANSFERASE, ALANINE AMINOTRANSFERASE, ALKALINE PHOSPHATASE, LACTATE DEHYDROGENASE, CREATINE PHOSPHOKINASE, GAMMA GLUTAMYLTRANSFERASE, ALPHA-AMYLASE, LIPASE AND CHOLINESTERASE FOR CALIBRATION OR VERIFICATION OF MEDICAL DIAGNOSTIC

CLASS 1—(Continued).

TEST SYSTEMS; FOR TRU-ZERO BILIRUBIN STANDARD CONSISTING OF ZERO LEVELS OF BILIRUBIN IN A BASE OF BOVINE SERUM ALBUMIN FOR CALIBRATION OR VERIFICATION OF MEDICAL DIAGNOSTIC TEST SYSTEMS; FOR ELECTROLYTE CONTROL KIT CONSISTING OF NORMAL AND ABNORMAL LEVELS OF SODIUM, POTASSIUM, CHLORIDE, LITHIUM AND IONIZED CALCIUM IN A BASE OF BOVINE ALBUMIN FOR ROUTINE CONTROL OF MEDICAL DIAGNOSTIC TEST SYSTEMS; FOR AMMONIA / IRON STANDARD KIT CONSISTING OF AMMONIA AND IRON FOR CALIBRATION OR VERIFICATION OF MEDICAL DIAGNOSTIC TEST SYSTEMS; FOR MICROPROTEIN STANDARD KIT CONSISTING OF TRACE LEVELS OF ALBUMIN AND GAMMA GLOBULIN FOR CALIBRATION OR VERIFICATION OF MEDICAL DIAGNOSTIC TEST SYSTEMS; FOR HDL CHOLESTEROL VERIFIER KIT CONSISTING OF HIGH AND LOW DENSITY LIPOPROTEIN CHOLESTEROL IN A BASE OF HUMAN ALBUMIN FOR CALIBRATION OR VERIFICATION OF MEDICAL DIAGNOSTIC TEST SYSTEMS; FOR URINE CHEMISTRY STANDARD KIT CONTAINING SODIUM, POTASSIUM, CHLORIDE, CALCIUM, PHOSPHORUS, MAGNESIUM, UREA NITROGEN, AND CREATININE IN DILUTE SULFURIC ACID FOR CALIBRATION OR VERIFICATION OF MEDICAL DIAGNOSTIC TEST SYSTEMS; FOR ETHANOL STANDARD KIT CONSISTING OF ETHANOL, LACTATE, ACETAMINOPHEN AND SALICYLATE IN A BASE OF BOVINE ALBUMIN FOR CALIBRATION OR VERIFICATION OF MEDICAL DIAGNOSTIC TEST SYSTEMS; FOR IRON STANDARD CONSISTING OF IRON FOR CALIBRATION OR VERIFICATION OF MEDICAL DIAGNOSTIC TEST SYSTEMS; FOR LIPASE VERIFIER CONSISTING OF LIPASE FOR CALIBRATION OR VERIFICATION OF MEDICAL DIAGNOSTIC TEST SYSTEMS; FOR LOW LEVEL ENZYME VERIFIER KIT CONSISTING OF ASPARTATE AMINOTRANSFERASE, ALANINE AMINOTRANSFERASE, ALKALINE PHOSPHATASE, LACTATE DEHYDROGENASE, CREATINE PHOSPHOKINASE, GAMMA GLUTAMYLTRANSFERASE, ALPHA-AMYLASE AND LIPASE FOR CALIBRATION OR VERIFICATION OF MEDICAL DIAGNOSTIC TEST SYSTEMS; FOR BILIRUBIN MID-RANGE STANDARD KIT COMPRISING OF BILIRUBIN CONJUGATE IN A BASE OF BOVINE SERUM ALBUMIN FOR LABORATORY AND RESEARCH USE IN CALIBRATION AND LINEARITY EVALUATION OF MEDICAL DIAGNOSTIC TEST EQUIPMENT; FOR TRIGLYCERIDE REFERENCE CONSISTING OF TRIGLYCERIDE FOR CALIBRATION OR VERIFICATION OF MEDICAL DIAGNOSTIC TEST SYSTEMS; LIPOPROTEIN VERIFIER KIT CONSISTING OF HIGH AND LOW DENSITY LIPOPROTEIN CHOLESTEROL IN A BASE OF HUMAN ALBUMIN FOR CALIBRATION OR VERIFICATION OF MEDICAL DIAGNOSTIC TEST SYSTEMS (U.S. CLS. 1, 5, 6, 10, 26 AND 46).

FIRST USE 3-1-1988; IN COMMERCE 9-1-1988.
RONALD AIKENS, EXAMINING ATTORNEY

SN 77-433,368. PACER TECHNOLOGY, INC., TWIN FALLS, ID. FILED 3-27-2008.

AMPLE

THE MARK CONSISTS OF STANDARD CHARACTERS WITHOUT CLAIM TO ANY PARTICULAR FONT, STYLE, SIZE, OR COLOR.

FOR FERTILIZERS (U.S. CLS. 1, 5, 6, 10, 26 AND 46).
FIRST USE 6-0-1990; IN COMMERCE 6-0-1990.
RONALD AIKENS, EXAMINING ATTORNEY

CLASS 1—(Continued).

SN 77-433,488. VERICHEM LABORATORIES, INC., PROVIDENCE, RI. FILED 3-27-2008.



OWNER OF U.S. REG. NO. 2,517,091.

THE MARK CONSISTS OF AN INVERTED TRIANGLE WITH A BLOOD DROP THEREIN.

FOR BILIRUBIN STANDARD KIT COMPRISING OF BILIRUBIN CONJUGATE IN A BASE OF BOVINE SERUM ALBUMIN FOR LABORATORY AND RESEARCH USE IN CALIBRATION OR VERIFICATION OF MEDICAL DIAGNOSTIC TEST EQUIPMENT; FOR CHEMISTRY REFERENCE KIT CONTAINING SODIUM, POTASSIUM, CHLORIDE, CALCIUM, PHOSPHORUS, MAGNESIUM, GLUCOSE, UREA NITROGEN, CREATININE AND TRIGLYCERIDE IN BASE OF BOVINE ALBUMIN FOR CALIBRATION OR VERIFICATION OF MEDICAL DIAGNOSTIC TEST SYSTEMS; FOR TOTAL PROTEIN / ALBUMIN STANDARD KIT CONSISTING OF ALBUMIN AND BOVINE GAMMA GLOBULIN FOR CALIBRATION OR VERIFICATION OF MEDICAL DIAGNOSTIC TEST SYSTEMS; FOR ELECTROLYTE STANDARD KIT CONSISTING OF SODIUM, POTASSIUM, CHLORIDE, LITHIUM AND IONIZED CALCIUM IN A BASE OF BOVINE ALBUMIN FOR CALIBRATION OR VERIFICATION OF MEDICAL DIAGNOSTIC TEST SYSTEMS; FOR CARBON DIOXIDE STANDARD KIT CONSISTING OF CARBON DIOXIDE FOR CALIBRATION OR VERIFICATION OF MEDICAL DIAGNOSTIC TEST SYSTEMS; FOR CHOLESTEROL REFERENCE KIT CONSISTING OF CHOLESTEROL AND URIC ACID FOR CALIBRATION OR VERIFICATION OF MEDICAL DIAGNOSTIC TEST SYSTEMS; FOR MULTI-ENZYME VERIFIER KIT CONSISTING OF ASPARTATE AMINOTRANSFERASE, ALANINE AMINOTRANSFERASE, ALKALINE PHOSPHATASE, LACTATE DEHYDROGENASE, CREATINE PHOSPHOKINASE, GAMMA GLUTAMYLTRANSFERASE, ALPHA-AMYLASE AND LIPASE FOR CALIBRATION OR VERIFICATION OF MEDICAL DIAGNOSTIC TEST SYSTEMS; FOR ENZYME VERIFIER KIT CONSISTING OF ASPARTATE AMINOTRANSFERASE, ALANINE AMINOTRANSFERASE, ALKALINE PHOSPHATASE, LACTATE DEHYDROGENASE, CREATINE PHOSPHOKINASE, GAMMA GLUTAMYLTRANSFERASE, ALPHA-AMYLASE, LIPASE AND CHOLINESTERASE FOR CALIBRATION OR VERIFICATION OF MEDICAL DIAGNOSTIC TEST SYSTEMS; FOR TRU-ZERO BILIRUBIN STANDARD CONSISTING OF ZERO LEVELS OF BILIRUBIN IN A BASE OF BOVINE SERUM ALBUMIN FOR CALIBRATION OR VERIFICATION OF MEDICAL DIAGNOSTIC TEST SYSTEMS; FOR ELECTROLYTE CONTROL KIT CONSISTING OF NORMAL AND ABNORMAL LEVELS OF SODIUM, POTASSIUM, CHLORIDE, LITHIUM AND IONIZED CALCIUM IN A BASE OF BOVINE ALBUMIN FOR ROUTINE CONTROL OF MEDICAL DIAGNOSTIC TEST SYSTEMS; FOR AMMONIA / IRON STANDARD KIT CONSISTING OF AMMONIA AND IRON FOR CALIBRATION OR VERIFICATION OF MEDICAL DIAGNOSTIC TEST SYSTEMS; FOR MICROPROTEIN STANDARD KIT CONSISTING OF TRACE LEVELS OF ALBUMIN AND GAMMA GLOBULIN FOR CALIBRATION OR VERIFICATION OF MEDICAL DIAGNOSTIC TEST SYSTEMS; FOR HDL CHOLESTEROL VERIFIER KIT CONSISTING OF HIGH AND LOW DENSITY LIPOPROTEIN CHOLESTEROL IN A BASE OF HUMAN ALBUMIN FOR CALIBRATION OR VERIFICATION OF MEDICAL DI-

CLASS 1—(Continued).

AGNOSTIC TEST SYSTEMS; FOR URINE CHEMISTRY STANDARD KIT CONTAINING SODIUM, POTASSIUM, CHLORIDE, CALCIUM, PHOSPHORUS, MAGNESIUM, UREA NITROGEN, AND CREATININE IN DILUTE SULFURIC ACID FOR CALIBRATION OR VERIFICATION OF MEDICAL DIAGNOSTIC TEST SYSTEMS; FOR ETHANOL STANDARD KIT CONSISTING OF ETHANOL, LACTATE, ACETAMINOPHEN AND SALICYLATE IN A BASE OF BOVINE ALBUMIN FOR CALIBRATION OR VERIFICATION OF MEDICAL DIAGNOSTIC TEST SYSTEMS; FOR IRON STANDARD CONSISTING OF IRON FOR CALIBRATION OR VERIFICATION OF MEDICAL DIAGNOSTIC TEST SYSTEMS; FOR LIPASE VERIFIER CONSISTING OF LIPASE FOR CALIBRATION OR VERIFICATION OF MEDICAL DIAGNOSTIC TEST SYSTEMS; FOR LOW LEVEL ENZYME VERIFIER KIT CONSISTING OF ASPARTATE AMINOTRANSFERASE, ALANINE AMINOTRANSFERASE, ALKALINE PHOSPHATASE, LACTATE DEHYDROGENASE, CREATINE PHOSPHOKINASE, GAMMA GLUTAMYLTRANSFERASE, ALPHA-AMYLASE AND LIPASE FOR CALIBRATION OR VERIFICATION OF MEDICAL DIAGNOSTIC TEST SYSTEMS; FOR BILIRUBIN MID-RANGE STANDARD KIT COMPRISING OF BILIRUBIN CONJUGATE IN A BASE OF BOVINE SERUM ALBUMIN FOR LABORATORY AND RESEARCH USE IN CALIBRATION AND LINEARITY EVALUATION OF MEDICAL DIAGNOSTIC TEST EQUIPMENT; FOR TRIGLYCERIDE REFERENCE CONSISTING OF TRIGLYCERIDE FOR CALIBRATION OR VERIFICATION OF MEDICAL DIAGNOSTIC TEST SYSTEMS; LIPOPROTEIN VERIFIER KIT CONSISTING OF HIGH AND LOW DENSITY LIPOPROTEIN CHOLESTEROL IN A BASE OF HUMAN ALBUMIN FOR CALIBRATION OR VERIFICATION OF MEDICAL DIAGNOSTIC TEST SYSTEMS (U.S. CLS. 1, 5, 6, 10, 26 AND 46).

FIRST USE 3-1-1988; IN COMMERCE 9-1-1988.
RONALD AIKENS, EXAMINING ATTORNEY

SN 77-434,261. BIO-LAB, INC., LAWRENCEVILLE, GA.
FILED 3-28-2008.

BREAKOUT

THE MARK CONSISTS OF STANDARD CHARACTERS WITHOUT CLAIM TO ANY PARTICULAR FONT, STYLE, SIZE, OR COLOR.

OWNER OF U.S. REG. NO. 1,087,933.

FOR OXIDIZING AGENT FOR USE IN REMOVING OR REDUCING ORGANIC CONTAMINANTS AND INCREASING WATER CLARITY IN SWIMMING POOLS AND OTHER BODIES OF WATER (U.S. CLS. 1, 5, 6, 10, 26 AND 46).

FIRST USE 7-27-1977; IN COMMERCE 7-27-1977.
RICHARD WHITE, EXAMINING ATTORNEY

CLASS 1—(Continued).

SN 77-450,529. CONSTRUCTION RESEARCH & TECHNOLOGY GMBH, TROSTBERG, FED REP GERMANY, FILED 4-17-2008.

RHEOCOLOR

THE MARK CONSISTS OF STANDARD CHARACTERS WITHOUT CLAIM TO ANY PARTICULAR FONT, STYLE, SIZE, OR COLOR.

FOR ADMIXTURES FOR CONCRETE (U.S. CLS. 1, 5, 6, 10, 26 AND 46).

STEVEN PEREZ, EXAMINING ATTORNEY

SN 77-466,773. XCEED MOLECULAR CORPORATION, TORONTO, CANADA, FILED 5-6-2008.



OWNER OF U.S. REG. NOS. 3,438,921, 3,438,933 AND 3,438,934.

THE COLOR(S) BLACK, GRAY, LIGHT BLUE-GRAY AND MEDIUM BLUE-GRAY IS/ARE CLAIMED AS A FEATURE OF THE MARK.

THE MARK CONSISTS OF FOUR THREE-DIMENSIONAL, FOUR-SIDED PARTIAL COLUMNS, SIDEWAYS IN A DIAMOND-LIKE ARRANGEMENT, ALL TO THE LEFT OF THE WORDS "XCEED MOLECULAR" WITH THE WORD "XCEED" APPEARING ABOVE THE WORD "MOLECULAR". COLOR LOCATION STATEMENT: THE MARK CONSISTS OF FOUR THREE-DIMENSIONAL, FOUR-SIDED PARTIAL COLUMNS, SIDEWAYS IN A DIAMOND-LIKE ARRANGEMENT, EACH WITH ITS LOWER LEFT SIDE IN LIGHT BLUE-GREY, AND ITS RIGHT END IN MEDIUM BLUE-GREY ALL TO THE LEFT OF THE WORDS "XCEED" IN BLACK AND "MOLECULAR" IN GRAY.

FOR DIAGNOSTIC REAGENTS FOR SCIENTIFIC USE; DIAGNOSTIC TEST KITS FOR SCIENTIFIC USE COMPRISED OF REAGENTS, PROCESSING CHEMICALS, AND POROUS SUBSTRATE MATERIALS, ALONE OR ATTACHED TO A SOLID BODY FOR HANDLING (U.S. CLS. 1, 5, 6, 10, 26 AND 46).

FIRST USE 7-1-2007; IN COMMERCE 7-1-2007.

ALLISON SCHRODY, EXAMINING ATTORNEY

CLASS 1—(Continued).

SN 77-467,629. ARKEMA INC., PHILADELPHIA, PA. FILED 5-7-2008.

KYNAR RX

THE MARK CONSISTS OF STANDARD CHARACTERS WITHOUT CLAIM TO ANY PARTICULAR FONT, STYLE, SIZE, OR COLOR.

OWNER OF U.S. REG. NOS. 723,719, 1,366,124 AND OTHERS.

FOR FLUORINE CONTAINING SYNTHETIC RESINS (U.S. CLS. 1, 5, 6, 10, 26 AND 46).

ODESSA BIBBINS, EXAMINING ATTORNEY

CLASS 1—(Continued).

SN 78-422,941. FMC CORPORATION, PHILADELPHIA, PA. FILED 5-21-2004.

LIMIT

THE MARK CONSISTS OF STANDARD CHARACTERS WITHOUT CLAIM TO ANY PARTICULAR FONT, STYLE, SIZE, OR COLOR.

FOR DESICCANTS, NAMELY, DRYING AGENTS FOR GENERAL INDUSTRIAL USE (U.S. CLS. 1, 5, 6, 10, 26 AND 46).

FIRST USE 8-16-1994; IN COMMERCE 8-16-1994. CAROLYN CATALDO, EXAMINING ATTORNEY

SN 77-470,341. VALENT BIOSCIENCES CORPORATION, LIBERTYVILLE, IL. FILED 5-9-2008.

CONQUEST

THE MARK CONSISTS OF STANDARD CHARACTERS WITHOUT CLAIM TO ANY PARTICULAR FONT, STYLE, SIZE, OR COLOR.

FOR PLANT GROWTH REGULATOR FOR AGRICULTURAL, HORTICULTURAL, ORNAMENTAL AND HOME AND GARDEN USE (U.S. CLS. 1, 5, 6, 10, 26 AND 46).

KATHERINE STOIDES, EXAMINING ATTORNEY

SN 79-048,586. EVONIK DEGUSSA GMBH, 45128 ESSEN, FED REP GERMANY, FILED 11-10-2007.

VESTASOL

SN 77-470,355. VALENT BIOSCIENCES CORPORATION, LIBERTYVILLE, IL. FILED 5-9-2008.

MARUBA

THE MARK CONSISTS OF STANDARD CHARACTERS WITHOUT CLAIM TO ANY PARTICULAR FONT, STYLE, SIZE, OR COLOR.

FOR PLANT GROWTH REGULATOR FOR AGRICULTURAL, HORTICULTURAL, ORNAMENTAL AND HOME AND GARDEN USE (U.S. CLS. 1, 5, 6, 10, 26 AND 46).

KATHERINE STOIDES, EXAMINING ATTORNEY

THE MARK CONSISTS OF STANDARD CHARACTERS WITHOUT CLAIM TO ANY PARTICULAR FONT, STYLE, SIZE, OR COLOR.

PRIORITY DATE OF 5-12-2007 IS CLAIMED.

OWNER OF INTERNATIONAL REGISTRATION 0949761 DATED 11-10-2007, EXPIRES 11-10-2017.

FOR CHEMICALS USED IN INDUSTRY, SCIENCE AND PHOTOGRAPHY AND SOLVENTS USED IN AGRICULTURE, NAMELY, ISOPHORONE AS SOLVENT FOR HERBICIDES USED IN THE MANUFACTURE OF HERBICIDES; SOLVENTS, NAMELY, ISOPHORONE AS SOLVENT IN COATINGS AND PRINTING INKS USED IN THE MANUFACTURE OF COATINGS AND PRINTING INKS (U.S. CLS. 1, 5, 6, 10, 26 AND 46).

YAT SYE, LEE, EXAMINING ATTORNEY

CLASS 1—(Continued).

SN 79-048,686. POKON & CHRYSAL INTERNATIONAL B.V., NETHERLANDS, FILED 6-12-2007.



OWNER OF INTERNATIONAL REGISTRATION 0877785 DATED 11-9-2005, EXPIRES 11-9-2015.

OWNER OF U.S. REG. NOS. 1,811,742 AND 2,680,107. FOR CHEMICALS USED IN AGRICULTURE, HORTICULTURE, FORESTRY AND FLORICULTURE, NAMELY, CHEMICAL PREPARATIONS FOR THE TREATMENT OF SEEDS, PLANTS AND FLOWERS, INCLUDING CUT FLOWERS; NATURAL AND ARTIFICIAL FERTILIZERS; POTTING SOIL; COMPOST; PRESERVATIVES FOR FLOWERS; NUTRIENTS FOR NATURAL PLANTS, FLOWERS, INCLUDING CUT FLOWERS (U.S. CLS. 1, 5, 6, 10, 26 AND 46).

TARAH HARDY, EXAMINING ATTORNEY

SN 79-050,983. DYSTAR TEXTILFARBEN GMBH & CO. DEUTSCHLAND KG, FED REP GERMANY, FILED 2-15-2008.

LAVA

THE MARK CONSISTS OF STANDARD CHARACTERS WITHOUT CLAIM TO ANY PARTICULAR FONT, STYLE, SIZE, OR COLOR.

OWNER OF INTERNATIONAL REGISTRATION 0888359 DATED 5-23-2006, EXPIRES 5-23-2016.

FOR CHEMICALS USED IN INDUSTRY, NAMELY, FOR FINISHING OF TEXTILES (U.S. CLS. 1, 5, 6, 10, 26 AND 46).

KATHERINE E. HALMEN, EXAMINING ATTORNEY

SN 79-054,168. BASF SE, FED REP GERMANY, FILED 4-24-2008.

AQACell

THE MARK CONSISTS OF STANDARD CHARACTERS WITHOUT CLAIM TO ANY PARTICULAR FONT, STYLE, SIZE, OR COLOR.

PRIORITY DATE OF 10-29-2007 IS CLAIMED.

OWNER OF INTERNATIONAL REGISTRATION 0965145 DATED 4-24-2008, EXPIRES 4-24-2018.

FOR UNPROCESSED PLASTICS, NAMELY, POLYMERS (U.S. CLS. 1, 5, 6, 10, 26 AND 46).

TINA BROWN, EXAMINING ATTORNEY

CLASS 2—PAINTS

SN 77-116,861. IMCO TECHNOLOGIES INC., HAMILTON, CANADA, FILED 2-27-2007.

D-TECH

THE MARK CONSISTS OF STANDARD CHARACTERS WITHOUT CLAIM TO ANY PARTICULAR FONT, STYLE, SIZE, OR COLOR.

FOR COATINGS IN THE NATURE OF INDUSTRIAL SEALANTS FOR SEALING, HARDENING, DUST PROOFING, WATERPROOFING AND WEATHER-PROOFING CONCRETE (U.S. CLS. 6, 11 AND 16).

FIRST USE 8-1-1999; IN COMMERCE 3-1-2003.

SOPHIA S. KIM, EXAMINING ATTORNEY

SN 77-120,009. MICHAEL HUBER MÜNCHEN GMBH, KIRCHHEIM, FED REP GERMANY, FILED 3-1-2007.

INKREDIBLE RAPIDA

THE MARK CONSISTS OF THE WORDS "INKREDIBLE RAPIDA" WITH THE INITIAL LETTER "I" IN THE WORD "INKREDIBLE" INVERTED TO REPRESENT AN EXCLAMATION POINT.

THE FOREIGN WORDING IN THE MARK TRANSLATES INTO ENGLISH AS FAST.

FOR PRINTING INKS, COATINGS, PIGMENTS AND DISPERSIONS FOR USE IN THE GRAPHIC ARTS INDUSTRY (U.S. CLS. 6, 11 AND 16).

AMEETA JORDAN, EXAMINING ATTORNEY

SN 77-312,883. SWIMC, INC., WILMINGTON, DE. FILED 10-25-2007.

PROMAR 200 XP

THE MARK CONSISTS OF STANDARD CHARACTERS WITHOUT CLAIM TO ANY PARTICULAR FONT, STYLE, SIZE, OR COLOR.

FOR PAINTS (U.S. CLS. 6, 11 AND 16).

FIRST USE 11-23-2004; IN COMMERCE 11-23-2004.

MONIQUE MILLER, EXAMINING ATTORNEY

CLASS 2—(Continued).

SN 77-312,885. SWIMC, INC., WILMINGTON, DE. FILED 10-25-2007.

PROCLASSIC XP

THE MARK CONSISTS OF STANDARD CHARACTERS WITHOUT CLAIM TO ANY PARTICULAR FONT, STYLE, SIZE, OR COLOR.

FOR PAINTS (U.S. CLS. 6, 11 AND 16).
FIRST USE 6-22-2005; IN COMMERCE 6-22-2005.
MONIQUE MILLER, EXAMINING ATTORNEY

SN 77-419,997. NU ERA TEC, INC., DAVIE, FL. FILED 3-12-2008.

NU ERA TEC

THE MARK CONSISTS OF STANDARD CHARACTERS WITHOUT CLAIM TO ANY PARTICULAR FONT, STYLE, SIZE, OR COLOR.

NO CLAIM IS MADE TO THE EXCLUSIVE RIGHT TO USE "TEC", APART FROM THE MARK AS SHOWN.

FOR PROTECTIVE COATINGS FOR STAINLESS STEEL, STEEL CABLE, CARBON STEEL, CARBON FIBER, FIBER COMPOSITE, SYNTHETIC FIBERS, SYNTHETIC POLYMERS, FIBERGLASS, ALUMINUM, POLYSTYRENE FOAM, CONCRETE AND WOOD SURFACES FOR USE IN MARINE, OFFSHORE, COMMERCIAL, GOVERNMENT AND INDUSTRIAL APPLICATIONS (U.S. CLS. 6, 11 AND 16).

AISHA SALEM, EXAMINING ATTORNEY

SN 77-421,074. ACE HARDWARE CORPORATION, OAK BROOK, IL. FILED 3-13-2008.

ECHELON

THE MARK CONSISTS OF STANDARD CHARACTERS WITHOUT CLAIM TO ANY PARTICULAR FONT, STYLE, SIZE, OR COLOR.

FOR INDOOR AND OUTDOOR HOUSE AND HOME FURNISHING PAINTS, PRIMERS, COATINGS AND VARNISHES (U.S. CLS. 6, 11 AND 16).

FIRST USE 8-19-2007; IN COMMERCE 8-19-2007.
REGINA DRUMMOND, EXAMINING ATTORNEY

CLASS 2—(Continued).

SN 77-421,114. ACE HARDWARE CORPORATION, OAK BROOK, IL. FILED 3-13-2008.

PAINT SMART, PAINT BETTER.

THE MARK CONSISTS OF STANDARD CHARACTERS WITHOUT CLAIM TO ANY PARTICULAR FONT, STYLE, SIZE, OR COLOR.

FOR INDOOR AND OUTDOOR HOUSE AND HOME FURNISHING PAINTS, PRIMERS, COATINGS AND VARNISHES (U.S. CLS. 6, 11 AND 16).

FIRST USE 8-19-2007; IN COMMERCE 8-19-2007.
REGINA DRUMMOND, EXAMINING ATTORNEY

SN 77-425,420. LUBCHEM, INC., SPRING, TX. FILED 3-18-2008.

FORMASIL

THE MARK CONSISTS OF STANDARD CHARACTERS WITHOUT CLAIM TO ANY PARTICULAR FONT, STYLE, SIZE, OR COLOR.

FOR COATINGS IN THE NATURE OF INDUSTRIAL SEALANTS FOR WATERPROOFING AND SURFACE HARDENING (U.S. CLS. 6, 11 AND 16).

FIRST USE 2-10-1985; IN COMMERCE 2-10-1985.
JANICE KIM, EXAMINING ATTORNEY

SN 77-426,105. BEHR PROCESS CORPORATION, SANTA ANA, CA. FILED 3-19-2008.

PERFORMANCE YOU CAN TRUST

THE MARK CONSISTS OF STANDARD CHARACTERS WITHOUT CLAIM TO ANY PARTICULAR FONT, STYLE, SIZE, OR COLOR.

FOR EXTERIOR PAINT; INTERIOR PAINT (U.S. CLS. 6, 11 AND 16).

ALYSSA PALADINO, EXAMINING ATTORNEY

CLASS 2—(Continued).

SN 77-426,996. HASPEL, ANDY J., NEW PROVIDENCE, NJ. FILED 3-20-2008.

GRAFFITI-PREV

THE MARK CONSISTS OF STANDARD CHARACTERS WITHOUT CLAIM TO ANY PARTICULAR FONT, STYLE, SIZE, OR COLOR.

FOR CHEMICAL FORMULATIONS IN THE NATURE OF COATINGS TO SAFELY PREVENT THE ADHESION OF PAINTS, INKS, AND OTHER WRITING MATERIALS, INCLUDING BUT NOT LIMITED TO SPRAY CAR PAINTS, SPRAY PAINTS, GRAFFITI SHADOW, LEATHER DYE, MARKER PENS, CRAYONS, CHALKS, PENS AND PENCILS, TO ALL SURFACES, SAID SURFACES COMPRISING HARD WOODS, SOFT WOODS, METALS, INCLUDING BUT NOT LIMITED TO ALUMINUM, BRASS, AND COPPER, GLASS, PAINTED SURFACES, STONES, SOFT POROUS STONES, BRICKS, MARBLES, ASPHALTS, CONCRETES, PLASTICS, AND FIBERGLASS (U.S. CLS. 6, 11 AND 16).

MELVIN AXILBUND, EXAMINING ATTORNEY

SN 77-427,395. THE SHERWIN-WILLIAMS COMPANY, CLEVELAND, OH. FILED 3-20-2008.

ECOVISION 20/20

THE MARK CONSISTS OF STANDARD CHARACTERS WITHOUT CLAIM TO ANY PARTICULAR FONT, STYLE, SIZE, OR COLOR.

FOR PAINTS; TINTS FOR ARCHITECTURAL PAINTS AND PIGMENTED COATINGS FOR INTERIOR AND EXTERIOR USE (U.S. CLS. 6, 11 AND 16).

JUDITH HELFMAN, EXAMINING ATTORNEY

SN 77-428,195. SPECIALTY COATINGS, INC., DBA ARMOR-POXY, UNION, NJ. FILED 3-21-2008.

Armorstone

THE MARK CONSISTS OF STANDARD CHARACTERS WITHOUT CLAIM TO ANY PARTICULAR FONT, STYLE, SIZE, OR COLOR.

FOR CLEAR AND PIGMENTED COATINGS USED IN THE NATURE OF PAINT; GLAZES; HOUSE PAINT; INTERIOR PAINT; MIXED PAINTS; PAINT FOR CONCRETE FLOORS; PAINT PRIMERS; PAINT SEALERS; PAINT THINNER; PAINTS; PAINTS AND LACQUERS; PAVEMENT STRIPING PAINT; EPOXY COATING FOR USE ON CONCRETE INDUSTRIAL FLOORS (U.S. CLS. 6, 11 AND 16).

FIRST USE 1-1-2006; IN COMMERCE 1-1-2006.

HOWARD SMIGA, EXAMINING ATTORNEY

CLASS 2—(Continued).

SN 77-428,257. SPECIALTY COATINGS, INC, DBA ARMOR-POXY, UNION, NJ. FILED 3-21-2008.

Armorgranite

THE MARK CONSISTS OF STANDARD CHARACTERS WITHOUT CLAIM TO ANY PARTICULAR FONT, STYLE, SIZE, OR COLOR.

FOR CLEAR AND PIGMENTED COATINGS USED IN THE NATURE OF PAINT; COATINGS IN THE NATURE OF INDUSTRIAL SEALANTS FOR WATERPROOFING AND SURFACE HARDENING; COATINGS USED FOR FURNITURE FINISHING; DECORATIVE SPRAY COATING; EPOXY COATING FOR USE ON CONCRETE INDUSTRIAL FLOORS; EXTERIOR PAINT; HOUSE PAINT; INTERIOR PAINT; MIXED PAINTS; PAINT FOR ARTISTS; PAINT FOR CONCRETE FLOORS; PAINTS, LACQUERS, VARNISHES (U.S. CLS. 6, 11 AND 16).

FIRST USE 1-1-2006; IN COMMERCE 1-1-2006.

WILLIAM P. SHANAHAN, EXAMINING ATTORNEY

SN 77-429,326. TEINNOVATIONS INC., WARRENVILLE, IL. FILED 3-24-2008.

PSM

THE MARK CONSISTS OF STANDARD CHARACTERS WITHOUT CLAIM TO ANY PARTICULAR FONT, STYLE, SIZE, OR COLOR.

FOR BIODEGRADABLE AND COMPOSTABLE RESIN MADE PRIMARILY FROM STARCH (U.S. CLS. 6, 11 AND 16).

FIRST USE 1-18-2006; IN COMMERCE 1-18-2006.

BENJAMIN ALLEN, EXAMINING ATTORNEY

SN 77-432,591. ILLINOIS TOOL WORKS INC., GLENVIEW, IL. FILED 3-26-2008.

ELASTO-POXY

THE MARK CONSISTS OF STANDARD CHARACTERS WITHOUT CLAIM TO ANY PARTICULAR FONT, STYLE, SIZE, OR COLOR.

FOR PRIMERS (U.S. CLS. 6, 11 AND 16).

FIRST USE 0-0-1972; IN COMMERCE 0-0-1972.

MELVIN AXILBUND, EXAMINING ATTORNEY

CLASS 2—(Continued).

SN 77-433,171. PPG ARCHITECTURAL FINISHES, INC., PITTSBURGH, PA. FILED 3-27-2008.

ZONEMARK

THE MARK CONSISTS OF STANDARD CHARACTERS WITHOUT CLAIM TO ANY PARTICULAR FONT, STYLE, SIZE, OR COLOR.
FOR PAINTS (U.S. CLS. 6, 11 AND 16).
CHRISTOPHER BUONGIORNO, EXAMINING ATTORNEY

SN 77-433,180. PPG ARCHITECTURAL FINISHES, INC., PITTSBURGH, PA. FILED 3-27-2008.

ZONELINE

THE MARK CONSISTS OF STANDARD CHARACTERS WITHOUT CLAIM TO ANY PARTICULAR FONT, STYLE, SIZE, OR COLOR.
FOR PAINTS (U.S. CLS. 6, 11 AND 16).
CHRISTOPHER BUONGIORNO, EXAMINING ATTORNEY

SN 77-445,273. COLUMBIA INSURANCE COMPANY, OMAHA, NE. FILED 4-10-2008.

NATURA

THE MARK CONSISTS OF STANDARD CHARACTERS WITHOUT CLAIM TO ANY PARTICULAR FONT, STYLE, SIZE, OR COLOR.
THE FOREIGN WORDING IN THE MARK TRANSLATES INTO ENGLISH AS "NATURE".
FOR INTERIOR AND EXTERIOR PAINTS AND COATINGS IN THE NATURE OF A PAINT (U.S. CLS. 6, 11 AND 16).
JEAN IM, EXAMINING ATTORNEY

CLASS 2—(Continued).

SN 77-461,822. THE SHERWIN-WILLIAMS COMPANY, CLEVELAND, OH. FILED 4-30-2008.

LINE-PLEX

THE MARK CONSISTS OF STANDARD CHARACTERS WITHOUT CLAIM TO ANY PARTICULAR FONT, STYLE, SIZE, OR COLOR.
FOR PAINTS (U.S. CLS. 6, 11 AND 16).
FIRST USE 3-14-2008; IN COMMERCE 3-14-2008.
JUDITH HELFMAN, EXAMINING ATTORNEY

SN 77-461,824. THE SHERWIN-WILLIAMS COMPANY, CLEVELAND, OH. FILED 4-30-2008.

db

THE MARK CONSISTS OF STANDARD CHARACTERS WITHOUT CLAIM TO ANY PARTICULAR FONT, STYLE, SIZE, OR COLOR.
FOR PAINTS (U.S. CLS. 6, 11 AND 16).
FIRST USE 2-21-2008; IN COMMERCE 2-21-2008.
JUDITH HELFMAN, EXAMINING ATTORNEY

SN 77-461,827. THE SHERWIN-WILLIAMS COMPANY, CLEVELAND, OH. FILED 4-30-2008.

db

FOR PAINTS (U.S. CLS. 6, 11 AND 16).
FIRST USE 2-21-2008; IN COMMERCE 2-21-2008.
JUDITH HELFMAN, EXAMINING ATTORNEY

CLASS 2—(Continued).

SN 79-043,754. JOTUN A/S, SANDEFJORD, NORWAY,
FILED 7-23-2007.

JOTUN

THE MARK CONSISTS OF STANDARD CHARACTERS
WITHOUT CLAIM TO ANY PARTICULAR FONT, STYLE,
SIZE, OR COLOR.

OWNER OF INTERNATIONAL REGISTRATION 0937270
DATED 7-23-2007, EXPIRES 7-23-2017.

OWNER OF U.S. REG. NO. 2,673,640.
FOR PAINTS, VARNISHES, LACQUERS, ANTIFOUL-
ING PAINTS FOR BOATS, SHIPS AND OIL RIGS;
COATINGS IN THE NATURE OF PAINTS FOR BOATS,
SHIPS AND OIL RIGS; POWDER VARNISHES FOR
PROTECTION OF METAL PIPELINES, AND FOR PRO-
TECTION OF IRON REINFORCEMENT AND METAL
FRONTAGES (U.S. CLS. 6, 11 AND 16).
SCOTT BIBB, EXAMINING ATTORNEY

**CLASS 3—COSMETICS AND CLEANING PRE-
PARATIONS**

SN 76-687,887. SHIN'S TRADING CO., INC., LOS ANGELES,
CA. FILED 3-19-2008.

LITTLE MISS NAILS

THE MARK CONSISTS OF STANDARD CHARACTERS
WITHOUT CLAIM TO ANY PARTICULAR FONT, STYLE,
SIZE, OR COLOR.

FOR ARTIFICIAL NAILS (U.S. CLS. 1, 4, 6, 50, 51 AND
52).

AMOS T. MATTHEWS, JR., EXAMINING ATTORNEY

SN 77-061,016. L'OREAL, PARIS, FRANCE, FILED 12-11-2006.

FUEL FOR LOVE

THE MARK CONSISTS OF STANDARD CHARACTERS
WITHOUT CLAIM TO ANY PARTICULAR FONT, STYLE,
SIZE, OR COLOR.

PRIORITY CLAIMED UNDER SEC. 44(D) ON FRANCE
APPLICATION NO. 063465246, FILED 11-24-2006, REG. NO.
063465246, DATED 11-24-2006, EXPIRES 11-24-2016.

FOR PERFUMES, EAU DE TOILETTE, BODY MILK,
COLOGNE, AFTER SHAVE LOTION AND BALMS; GELS
AND LOTIONS FOR THE SHOWER AND THE BATH
(U.S. CLS. 1, 4, 6, 50, 51 AND 52).

DAVID MILLER, EXAMINING ATTORNEY

CLASS 3—(Continued).

SN 77-073,660. SPAMEDICA INTERNATIONAL SRL, WAR-
RENS, ST. MICHAEL, BARBADOS, FILED 12-29-2006.

SPAMEDICA SKIN

THE MARK CONSISTS OF STANDARD CHARACTERS
WITHOUT CLAIM TO ANY PARTICULAR FONT, STYLE,
SIZE, OR COLOR.

OWNER OF U.S. REG. NO. 2,408,973.

NO CLAIM IS MADE TO THE EXCLUSIVE RIGHT TO
USE "SKIN", APART FROM THE MARK AS SHOWN.

THE WORDING "SPAMEDICA" HAS NO MEANING IN A
FOREIGN LANGUAGE.

FOR HOUSE MARK FOR A FULL LINE OF NON-
MEDICATED SKIN CARE PREPARATIONS (U.S. CLS. 1,
4, 6, 50, 51 AND 52).

FIRST USE 9-7-2005; IN COMMERCE 9-7-2005.

ELISSA GARBER KON, EXAMINING ATTORNEY

SN 77-084,994. KELLWOOD COMPANY, CHESTERFIELD,
MO. FILED 1-17-2007.

HOLLYWOULD

THE MARK CONSISTS OF STANDARD CHARACTERS
WITHOUT CLAIM TO ANY PARTICULAR FONT, STYLE,
SIZE, OR COLOR.

FOR COSMETICS, NAMELY, COLOGNE, COLOGNE
SPRAY, ROOM FRAGRANCES, PERFUMES, SCENTED
SACHETS AND POTPOURRI, BODY LOTIONS, BODY
CREAMS, BATH AND SHOWER GELS, HAIR LOTIONS,
LIP STICK AND NON-MEDICATED LIP CARE PRE-
PARATIONS, SUN BLOCK AND SUN SCREEN PRE-
PARATIONS, AND SOAPS FOR PERSONAL USE (U.S.
CLS. 1, 4, 6, 50, 51 AND 52).

PAUL MORENO, EXAMINING ATTORNEY

CLASS 3—(Continued).

SN 77-126,058. ALTERNA HOLDINGS CORP., CENTURY CITY, CA. FILED 3-8-2007.

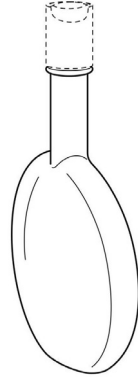

THE MARK CONSISTS OF THE DESIGN OF A 3-DIMENSIONAL BOTTLE WITH A BASE THAT IS SUBSTANTIALLY CIRCULAR IN DIAMETER WITH ITS CROSS SECTION BEING SUBSTANTIALLY OVAL IN SHAPE STRETCHED ALONG ITS VERTICAL AXIS WITH A NARROW, ELONGATED NECK AT THE TOP OF THE BOTTLE, SUCH THAT THE BOTTLE LOOSELY RESEMBLES A PADDLE. THE DOTTED LINES INDICATE PORTIONS OF THE BOTTLE THAT ARE NOT FEATURES OF THE MARK.

FOR (BASED ON USE IN COMMERCE) HAIR CARE PRODUCTS, NAMELY, CONDITIONERS; (BASED ON INTENT TO USE IN COMMERCE) HAIR CARE PRODUCTS, NAMELY, SHAMPOOS AND STYLING PREPARATIONS (U.S. CLS. 1, 4, 6, 50, 51 AND 52).

FIRST USE 7-2-1996; IN COMMERCE 7-2-1996.
AMY ALFIERI, EXAMINING ATTORNEY

SN 77-177,244. ZEN SPA ENTERPRISES, INC., SAN JUAN, PUERTO RICO, FILED 5-10-2007.

Zendera
COLLECTION

NO CLAIM IS MADE TO THE EXCLUSIVE RIGHT TO USE "COLLECTION", APART FROM THE MARK AS SHOWN.

THE MARK CONSISTS OF THE STYLIZED WORD "ZENDERA" CENTERED OVER THE WORD "COLLECTION" IN BLOCK LETTERS.

FOR PERSONAL AND AROMATHERAPY CARE PRODUCTS, NAMELY, STIMULATING MASSAGE OILS AND SKIN CREAMS AND LOTIONS; RELAXING MASSAGE OILS, SKIN CREAMS AND LOTIONS; BATH AND BODY OILS; BATH CRYSTALS; BODY AND FACIAL SCRUBS; BUBBLE BATH; COLOGNE; BODY, FACE, HAND AND FOOT SKIN CREAMS AND LOTIONS; EXFOLIANTS FOR THE FACE, HANDS, FEET AND SKIN; BODY EMULSIONS AND SPRAYS; HAIR SHAMPOO, CONDITIONER, SPRAY, STYLING GEL AND STYLING MOUSSE; PERFUME; BODY POWDER; SHOWER GEL; SKIN SOAPS FOR THE BODY, FACE, HANDS AND FEET (U.S. CLS. 1, 4, 6, 50, 51 AND 52).

IRA J. GOODSaid, EXAMINING ATTORNEY

CLASS 3—(Continued).

SN 77-186,692. AMOREPACIFIC CORPORATION, SEOUL, REPUBLIC OF KOREA, FILED 5-22-2007.

MAMONDE ULTRA SUNBLOCK BALM

THE MARK CONSISTS OF STANDARD CHARACTERS WITHOUT CLAIM TO ANY PARTICULAR FONT, STYLE, SIZE, OR COLOR.

PRIORITY CLAIMED UNDER SEC. 44(D) ON REPUBLIC OF KOREA APPLICATION NO. 40-2007-0004, FILED 1-26-2007, REG. NO. 0728444, DATED 11-16-2007, EXPIRES 11-16-2017.

OWNER OF U.S. REG. NO. 2,514,584.

NO CLAIM IS MADE TO THE EXCLUSIVE RIGHT TO USE "ULTRA SUNBLOCK BALM", APART FROM THE MARK AS SHOWN.

THE WORD "MAMONDE" IN THE MARK HAS NO DICTIONARY MEANING IN ENGLISH.

FOR BODY AND SKIN SUN BLOCK BALM; BODY AND SKIN SUN BLOCK PERFUMED OIL; NON-MEDICATED BODY AND SKIN SUN BLOCK OINTMENT; SUN CREAMS; BODY AND SKIN SUN OIL; BODY AND SKIN SUN BALM (U.S. CLS. 1, 4, 6, 50, 51 AND 52).

LOURDES AYALA, EXAMINING ATTORNEY

SN 77-191,532. BG PRODUCTS LLC, MANALAPAN, NJ. FILED 5-28-2007.

GO COMMANDO

THE MARK CONSISTS OF STANDARD CHARACTERS WITHOUT CLAIM TO ANY PARTICULAR FONT, STYLE, SIZE, OR COLOR.

FOR AFTER-SHAVE LOTION, AFTER-SHAVE CREAM, AFTER-SHAVE GEL, PRE-SHAVE CREAM, PRE-SHAVE LOTION, PRE-SHAVE GEL, SHAVING CREAM, SHAVING FOAM, SHAVING GEL, SHAVING LOTION, SHAVING MOUSSE, SHAVING PREPARATIONS, SHAVING SOAP (U.S. CLS. 1, 4, 6, 50, 51 AND 52).

WILLIAM P. SHANAHAN, EXAMINING ATTORNEY

SN 77-193,210. DENNIS GROSS, NEW YORK, NY. FILED 5-30-2007.

SKIN HAPPENS

THE MARK CONSISTS OF STANDARD CHARACTERS WITHOUT CLAIM TO ANY PARTICULAR FONT, STYLE, SIZE, OR COLOR.

NO CLAIM IS MADE TO THE EXCLUSIVE RIGHT TO USE "SKIN", APART FROM THE MARK AS SHOWN.

FOR A KIT FOR COSMETICS, NAMELY, A KIT COMPRISING FACE AND SKIN CARE LOTIONS, PEELS, CLEANSERS AND CREAMS (U.S. CLS. 1, 4, 6, 50, 51 AND 52).

JILL C. ALT, EXAMINING ATTORNEY

CLASS 3—(Continued).

SN 77-204,124. KAMSUT, INC., THOUSAND OAKS, CA. FILED 6-12-2007.

KAMA SUTRA PETITE PLEASURES

THE MARK CONSISTS OF STANDARD CHARACTERS WITHOUT CLAIM TO ANY PARTICULAR FONT, STYLE, SIZE, OR COLOR.

OWNER OF U.S. REG. NOS. 918,163, 1,284,412 AND OTHERS.

FOR BODY OIL, BODY CREAM, BODY POWDER, BODY MASSAGE CREAM, BODY SOAP, NON-MEDICATED BATH SALTS, MASSAGE OILS; MASSAGE CREAMS; AND COSMETICS (U.S. CLS. 1, 4, 6, 50, 51 AND 52).

TOBY BULLOFF, EXAMINING ATTORNEY

SN 77-251,335. ENVIRONMENTAL BUILDING SCIENCE INC., RICHMOND, CANADA, AND DAUM, GEORGE KEVIN, VANCOUVER, CANADA, FILED 8-9-2007.



OWNER OF CANADA REG. NO. TMA590075, DATED 9-17-2003, EXPIRES 9-17-2018.

NO CLAIM IS MADE TO THE EXCLUSIVE RIGHT TO USE "OIL", APART FROM THE MARK AS SHOWN.

THE COLOR(S) BLACK, YELLOW AND ORANGE IS/ARE CLAIMED AS A FEATURE OF THE MARK.

THE MARK CONSISTS OF THE WORDING "OIL LIFT" THAT APPEARS IN THE COLOR YELLOW WHICH FADES TO THE COLOR ORANGE AND A STYLIZED DESIGN OF AN OIL SPILL APPEARING IN THE COLOR BLACK.

FOR ALL-PURPOSE CLEANERS, NAMELY, ENVIRONMENTAL AND NON-TOXIC INDUSTRIAL STRENGTH CLEANERS FOR USE ON THE MOST SURFACES AND IN MULTIPLE APPLICATION (U.S. CLS. 1, 4, 6, 50, 51 AND 52).

FIRST USE 8-21-2000; IN COMMERCE 8-21-2000.
MICHAEL LEWIS, EXAMINING ATTORNEY

CLASS 3—(Continued).

SN 77-258,618. SAMSON, ALLAN, HOBOKEN, NJ. FILED 8-18-2007.

Mogul

THE MARK CONSISTS OF STANDARD CHARACTERS WITHOUT CLAIM TO ANY PARTICULAR FONT, STYLE, SIZE, OR COLOR.

FOR BABY SHAMPOO; HAIR RINSES; HAIR SHAMPOO; SHAMPOO-CONDITIONERS; SHAMPOOS; SHAMPOOS FOR BABIES; BODY SPRAY USED AS A PERSONAL DEODORANT AND AS FRAGRANCE; DEODORANT FOR PERSONAL USE; DEODORANT SOAP; DEODORANTS AND ANTIPERSPIRANTS; DEODORANTS FOR BODY CARE; FEMININE DEODORANT SPRAYS; FOOT DEODORANT SPRAY; PERSONAL DEODORANTS; ALMOND SOAPS; ANTIBACTERIAL SKIN SOAPS; ANTIBACTERIAL SOAP; BAR SOAP; BATH SOAPS; BATH SOAPS IN LIQUID, SOLID OR GEL FORM; BODY CREAM SOAP; COSMETIC SOAPS; CREAM SOAPS; DETERGENT SOAP; DISINFECTANT SOAPS; DISINFECTING PERFUMED SOAPS; HAND SOAPS; LIQUID BATH SOAPS; LIQUID SOAP; LIQUID SOAP USED IN FOOT BATH; LIQUID SOAPS; LIQUID SOAPS FOR HANDS AND FACE; LIQUID SOAPS FOR HANDS, FACE AND BODY; MEDICATED SOAP; MEDICATED SOAPS; PERFUMED SOAP; PERFUMED SOAPS; SHAVING SOAP; SKIN SOAP; SOAP POWDER; SOAPS FOR BODY CARE; SOAPS FOR PERSONAL USE; SOAPS FOR TOILET PURPOSES; TOILET SOAP; TOILET SOAPS; WATERLESS SOAP; EAU DE PERFUME; LIQUID PERFUMES; PERFUME; PERFUME OILS; PERFUME OILS FOR THE MANUFACTURE OF COSMETIC PREPARATIONS; PERFUMED CREAMS; PERFUMED EXTRACTS FOR TISSUES AND PERFUMES; PERFUMED PASTE; PERFUMED POWDER; PERFUMED POWDERS; PERFUMED TALCUM POWDER; PERFUMES; COLOGNE; COLOGNE WATER; EAU DE COLOGNE; ANTIPERSPIRANTS FOR PERSONAL USE; FRAGRANCES FOR PERSONAL USE; JASMINE OIL FOR PERSONAL USE; BODY CREAM; BODY CREAMS; BODY DEODORANT IN PILL FORM; BODY EMULSIONS; BODY GLITTER; BODY LOTION; BODY LOTIONS; BODY MASK CREAM; BODY MASK LOTION; BODY MASK POWDER; BODY MASKS; BODY MILK; BODY MILKS; BODY OIL; BODY OILS; BODY POWDER; BODY SCRUB; BODY SPRAYS; BODY SPRAYS, NAMELY, WATER IN ATOMIZED CONTAINERS USED TO PRODUCE A COOLING EFFECT; BODY WASHES; COSMETIC PREPARATIONS FOR BODY CARE; FACE AND BODY BEAUTY CREAMS; FACE AND BODY CREAMS; FACE AND BODY GLITTER; FACE AND BODY LOTIONS; FACE AND BODY MILK; FACIAL SCRUBS; LOTIONS FOR FACE AND BODY CARE; MAKE-UP FOR THE FACE AND BODY; NON-MEDICATED BODY SOAKS; SCENTED BODY SPRAY; SKIN AND BODY TOPICAL LOTIONS, CREAMS AND OILS FOR COSMETIC USE; SKIN CARE PREPARATION, NAMELY, BODY POLISH; TONING LOTION, FOR THE FACE, BODY AND HANDS; WAX FOR REMOVING BODY HAIR; WAX STRIPS FOR REMOVING BODY HAIR; ANTI-WRINKLE CREAM; ANTI-WRINKLE CREAMS; EYE MAKE-UP REMOVER; HAIR COLOR REMOVERS; HAIR REMOVING CREAM; MAKE UP REMOVING PREPARATIONS; MAKE-UP REMOVER; MAKE-UP REMOVING LOTIONS; MAKE-UP REMOVING MILK, GEL, LOTIONS AND CREAMS; MAKE-UP REMOVING MILKS; NAIL POLISH REMOVER; NAIL POLISH REMOVERS; WRINKLE REMOVING SKIN CARE PREPARATIONS; WRINKLE RESISTANT CREAM; COSMETIC CREAMS FOR SKIN CARE; COSMETIC PREPARATIONS FOR SKIN RENEWAL; COSMETIC PRODUCTS IN THE FORM OF AEROSOLS FOR SKIN CARE; DISPOSABLE WIPES IMPREGNATED WITH CHEMICALS OR COMPOUNDS FOR PERSONAL USE; NON-MEDICATED SKIN CREAMS; NON-MEDICATED STIMULATING LOTIONS FOR THE SKIN; PATCHES CONTAINING SUN SCREEN AND SUN BLOCK FOR USE ON THE SKIN; SKIN ABRASIVE

CLASS 3—(Continued).

PREPARATIONS; SKIN BRONZER; SKIN BRONZING CREAMS; SKIN CARE PREPARATIONS, NAMELY, CHEMICAL PEELS FOR SKIN; SKIN CARE PREPARATIONS, NAMELY, FRUIT ACID PEELS FOR SKIN; SKIN CARE PRODUCTS, NAMELY, NON-MEDICATED SKIN SERUM; SKIN CLARIFIERS; SKIN CLEANSERS; SKIN CLEANSING CREAM; SKIN CLEANSING LOTION; SKIN CONDITIONERS; SKIN CREAM; SKIN CREAMS; SKIN CREAMS IN LIQUID AND IN SOLID FORM; SKIN CREAMS IN LIQUID AND SOLID; SKIN CREAMS IN LIQUID AND SOLID FORM; SKIN EMOLLIENTS; SKIN GELS FOR ACCELERATING, ENHANCING OR EXTENDING TANS; SKIN LIGHTENERS; SKIN LIGHTENING CREAMS; SKIN LOTION; SKIN LOTIONS; SKIN MASKS; SKIN MOISTURIZER; SKIN MOISTURIZER MASKS; SKIN POLISHING RICE BRAN (ARAI-NUKA); SKIN TEXTURIZERS; SKIN TONERS; SKIN WHITENING CREAMS; SKIN WHITENING PREPARATIONS; TOPICAL SKIN SPRAYS FOR COSMETIC PURPOSES; AFTER-SHAVE GEL; AFTER-SUN GELS; AGE RETARDANT GEL; ALOE VERA GEL FOR COSMETIC PURPOSES; BATH GEL; BATH GELS; BEAUTY GELS; DENTAL BLEACHING GEL; EYE GELS; HAIR GEL; HAIR GELS; HAIR STYLING GEL; MOISTENED TOOTH POWDER; NON-MEDICATED SKIN CARE PREPARATIONS, NAMELY, CREAMS, LOTIONS, GELS, TONERS, CLEANERS AND PEELS; SCULPTING GEL; SHAVING GEL; SHAVING GELS; SHOWER AND BATH GEL; SHOWER GEL; SHOWER GELS; STYLING GELS; SUN TAN GEL; TANNING AND AFTER-SUN MILKS, GELS AND OILS COSMETICS; TANNING GELS; TOOTH CLEANING PREPARATIONS; TOOTH GEL; TOOTH PASTE; TOOTH PASTE IN SOFT CAKE; TOOTH POLISH; TOOTH POWDER; TOOTH POWDERS; TOOTH WHITENING CREAMS; TOOTH WHITENING GELS; TOOTH WHITENING PASTES; TOOTH WHITENING PREPARATIONS; 3-IN-1 HAIR CONDITIONERS; 3-IN-1 HAIR SHAMPOOS; EXFOLIANT CREAMS; COSMETICS, NAMELY, LIP REPAIRERS; LIP BALM; LIP BALM; LIP CREAM; LIP GLOSS; LIP GLOSS PALATTE; LIP LINER; LIP POLISHER; NON-MEDICATED LIP CARE PREPARATIONS; NON-MEDICATED LIP PROTECTOR; SHAVING BALM; NON-MEDICATED SKIN CARE PREPARATIONS; BABY HAIR CONDITIONER; HAIR BALM; HAIR BLEACH; HAIR BLEACHES; HAIR BLEACHING PREPARATIONS; HAIR CARE CREAMS; HAIR CARE LOTIONS; HAIR CARE PREPARATIONS; HAIR CLEANING PREPARATIONS; HAIR COLOR; HAIR COLORANTS; HAIR COLORING PREPARATIONS; HAIR CONDITIONER; HAIR CONDITIONERS; HAIR CONDITIONERS FOR BABIES; HAIR CREAMS; HAIR DECOLORANTS; HAIR DRESSINGS FOR MEN; HAIR DRESSINGS FOR WOMEN; HAIR DYE; HAIR DYES; HAIR EMOLLIENTS; HAIR FIXERS; HAIR FROSTS; HAIR LIGHTENERS; HAIR LOTIONS; HAIR MASCARA; HAIR MOUSSE; HAIR MOUSSES; HAIR NOURISHERS; HAIR OILS; HAIR POMADES; HAIR RELAXERS; HAIR RELAXING PREPARATIONS; HAIR RINSES; HAIR SPRAY; HAIR STRAIGHTENING PREPARATIONS; HAIR STYLING SPRAY; HAIR TONIC; HAIR TONICS; HAIR WAVING LOTION; HAIR-WASHING POWDER; HYDROGEN PEROXIDE FOR USE ON THE HAIR; JAPANESE HAIR FIXING OIL (BINTSUKU-ABURA); OIL BATHS FOR HAIR CARE; OILS FOR HAIR CONDITIONING; MUSTACHE WAX; AFTER-SUN OILS; BATH OILS FOR COSMETIC PURPOSES; BODY AND BEAUTY CARE COSMETICS; CLEANSING CREAMS; COCOA BUTTER FOR COSMETIC PURPOSES; COLORING PREPARATIONS FOR COSMETIC PURPOSES; COSMETIC CREAMS; COSMETIC MILKS; COSMETIC OILS; COSMETIC PREPARATIONS AGAINST SUNBURN; COSMETIC PRODUCTS IN THE FORM OF AEROSOLS FOR SKINCARE; COSMETICS; BABY POWDER; BABY POWDERS; BATH POWDER; CREAMY FACE POWDER; FACE POWDER; FACE POWDER PASTE; FACE-POWDER ON PAPER; FOOT POWDER; BEAUTY CREAMS FOR BODY CARE; AGE SPOT REDUCING CREAMS; COTTON STICKS FOR COSMETIC PURPOSES; AFTER SUN CREAMS; AFTER-SHAVE; AFTER-SHAVE BALMS; AFTER-SHAVE CREAMS; AFTER-SHAVE EMULSIONS; AFTER-SHAVE LOTIONS; AFTER-SUN LOTIONS; AFTER-SUN MILKS; PRE-SHAVE CREAMS; SHAVING CREAM; SHAVING CREAMS; SHAVING FOAM; SHAV-

CLASS 3—(Continued).

ING LOTION; SHAVING LOTIONS; SHAVING MOUSSE; SHAVING PREPARATIONS; AGE RETARDANT LOTION; AROMATHERAPY LOTIONS; BABY LOTION; BATH LOTION; BATHING LOTIONS; BEAUTY LOTIONS; COSMETIC SUNTAN LOTIONS; EYE LOTIONS; FACE MILK AND LOTIONS; FACIAL LOTION; HAND LOTIONS; LOTIONS FOR BEARDS; LOTIONS FOR CELLULITE REDUCTION; LOTIONS FOR STRENGTHENING THE NAILS; NON-MEDICATED DIAPER RASH OINTMENTS AND LOTIONS; STYLING LOTIONS; SUN CARE LOTIONS; SUN TAN LOTION; TEETH CLEANING LOTIONS (U.S. CLS. 1, 4, 6, 50, 51 AND 52).
SAIMA MAKHDOOM, EXAMINING ATTORNEY

SN 77-269,542. MEMPHIS CONTRACT PACKAGING, INC., SOMERVILLE, TN. FILED 8-31-2007.

AFRICAN CROWN

THE MARK CONSISTS OF STANDARD CHARACTERS WITHOUT CLAIM TO ANY PARTICULAR FONT, STYLE, SIZE, OR COLOR.

NO CLAIM IS MADE TO THE EXCLUSIVE RIGHT TO USE "AFRICAN", APART FROM THE MARK AS SHOWN. FOR NON-MEDICATED HAIR CARE PREPARATIONS (U.S. CLS. 1, 4, 6, 50, 51 AND 52).

TRACY CROSS, EXAMINING ATTORNEY

SN 77-271,406. COLOR ME BEAUTY PRODUCTS, LLC., TUSTIN, CA. FILED 9-4-2007.

COLOR ME CM

THE MARK CONSISTS OF STANDARD CHARACTERS WITHOUT CLAIM TO ANY PARTICULAR FONT, STYLE, SIZE, OR COLOR.

OWNER OF U.S. REG. NO. 3,279,005.

FOR NAIL POLISH; NAIL POLISH BASE COAT; NAIL POLISH REMOVER; NAIL POLISH REMOVERS; NAIL POLISH TOP COAT (U.S. CLS. 1, 4, 6, 50, 51 AND 52).

JACQUELINE A. LAVINE, EXAMINING ATTORNEY

CLASS 3—(Continued).

SN 77-271,411. COLOR ME BEAUTY PRODUCTS, LLC., TUSTIN, CA. FILED 9-4-2007.



OWNER OF U.S. REG. NO. 3,279,005.
THE MARK CONSISTS OF THE WORDS "COLOR ME" ABOVE THE STYLIZED LETTERS "CM".
FOR NAIL POLISH; NAIL POLISH BASE COAT; NAIL POLISH REMOVER; NAIL POLISH REMOVERS; NAIL POLISH TOP COAT (U.S. CLS. 1, 4, 6, 50, 51 AND 52).
JACQUELINE A. LAVINE, EXAMINING ATTORNEY

SN 77-282,797. INTELLECTUAL PROPERTY DEVELOPMENT CORPORATION PTY LTD, MELBOURNE, AUSTRALIA, FILED 9-18-2007.

GREEN-RITE

THE MARK CONSISTS OF STANDARD CHARACTERS WITHOUT CLAIM TO ANY PARTICULAR FONT, STYLE, SIZE, OR COLOR.

FOR CLEANING, POLISHING, SCOURING AND ABRASIVE PREPARATIONS; PREPARATIONS FOR GLASS WINDOW CLEANING; GLASS WINDOW CLEANERS; GLASS WINDOW CLEANERS IN SPRAY FORM; GLASS CLEANING PREPARATIONS; GREASE DISSOLVING PREPARATIONS OTHER THAN FOR USE IN INDUSTRIAL PROCESSES; GREASE REMOVING PREPARATIONS FOR USE ON THE SKIN; PREPARATIONS FOR THE REMOVAL OF GREASE FOR HOUSEHOLD USE; DETERGENT RINSE AID FOR USE IN DISHWASHING MACHINES; DETERGENTS FOR DISHWASHING; DISHWASHER POWDER; DISHWASHING AGENTS; DISHWASHING DETERGENTS; DISHWASHING LIQUID DETERGENT; DISHWASHING DETERGENT PREPARATIONS; DISHWASHING PRODUCTS, NAMELY, DETERGENTS, WASHING POWDERS AND LIQUID SOAPS; DETERGENT RINSE ADDITIVES FOR DISHWASHING MACHINES; LIQUID CLEANERS, NAMELY, LIQUID SOAP; POT CLEANING LIQUIDS FOR HOUSEHOLD USE; SOAPS FOR HOUSEHOLD USE; STAIN REMOVERS; ESSENTIAL OILS; HAND WASHING LIQUID SOAPS; HARD SURFACE CLEANING PREPARATIONS FOR HOUSEHOLD USE; FLOOR CLEANING PREPARATIONS FOR HOUSEHOLD USE; PREPARATIONS FOR THE CLEANING OF FLOOR COVERINGS FOR HOUSEHOLD USE; DISINFECTANT SOAP; DISINFECTANT SOAP SOLUTIONS; RUST REMOVING PREPARATIONS AND PRODUCTS, NAMELY, LIQUID SOAP; PREPARATIONS FOR REMOVING LIMESCALE FOR HOUSEHOLD PURPOSES; PREPARATIONS FOR THE REMOVAL OF LIME FOR HOUSEHOLD USE; DRAIN CLEANING PREPARATIONS, NAMELY, DRAIN OPENERS; OVEN CLEANING PREPARATIONS; LAUNDRY DETERGENT; LAUNDRY

CLASS 3—(Continued).

WASHING SOAP PREPARATIONS; SOAPS FOR LAUNDRY USE; CLEANING PREPARATIONS FOR LAUNDRY USE, NAMELY, LAUNDRY BLEACH; DETERGENTS FOR LAUNDRY USE; FABRIC SOFTENERS FOR LAUNDRY USE; STAIN REMOVING PREPARATIONS; TOILET CLEANERS, NAMELY, TOILET BOWL DETERGENTS; STAINLESS STEEL CLEANERS FOR HOUSEHOLD PURPOSES; AUTOMOTIVE CLEANING PREPARATIONS; CLEANING PREPARATIONS FOR WATERCRAFT, PARTS AND FITTINGS THEREFOR; DEGREASING PREPARATIONS FOR WATERCRAFT, PARTS AND FITTINGS THEREFOR; CHROME POLISH; PREPARATIONS FOR CLEANING, PROTECTING AND PRESERVING VEHICLE SURFACES; AUTOMOBILE WAX; WOOD CONDITIONER, BRIGHTENER AND RENEWER; CLEANING PREPARATIONS FOR AUTOMOBILES AND PARTS AND FITTINGS THEREFOR; DETERGENTS FOR AUTOMOBILES; DEGREASING PREPARATIONS FOR AUTOMOBILES AND PARTS AND FITTINGS THEREFOR; TREATMENT PREPARATIONS FOR USE ON VEHICLE WHEELS AND WHEEL COVERS; WINDSHIELD WASHING FLUID; UPHOLSTERY CLEANERS; DEODORIZERS FOR PETS; NON-MEDICATED GROOMING PREPARATIONS, NAMELY, SHAMPOO AND CONDITIONER FOR ANIMALS, NAMELY, DOMESTIC ANIMALS; PET ODOR REMOVERS; PET SHAMPOO; PET STAIN REMOVERS; CLEANER FOR USE ON SWIMMING POOL COVERS; CLEANER FOR USE ON OUTDOOR GLASS; BABY SHAMPOO; BATH SHAMPOO; HAIR SHAMPOO; NON-MEDICATED BODY CARE PREPARATIONS, NAMELY, DEODORANTS; NON-MEDICATED BODY CARE PRODUCTS, NAMELY, DEODORANTS; CLEANING PREPARATIONS FOR USE ON THE BODY, NAMELY, SOAP; COSMETIC PREPARATIONS FOR USE ON THE BODY, NAMELY, SKIN LOTION; SOAP (U.S. CLS. 1, 4, 6, 50, 51 AND 52).

DOMINIC FATHY, EXAMINING ATTORNEY

SN 77-283,596. BEIERSDORF AG, HAMBURG, FED REP GERMANY, FILED 9-19-2007.



OWNER OF U.S. REG. NOS. 93,627, 3,340,402 AND OTHERS.

NO CLAIM IS MADE TO THE EXCLUSIVE RIGHT TO USE "HAND", APART FROM THE MARK AS SHOWN.

THE COLOR(S) BLUE, WHITE AND SILVER IS/ARE CLAIMED AS A FEATURE OF THE MARK.

THE MARK CONSISTS OF THE DESIGNATION "NIVEA" AND THE TERM "HAND" IN THE COLOR WHITE DISPLAYED AGAINST A BLUE PANEL WITH A SILVER BORDER. THE DESIGN OF TWO HANDS IS DISPLAYED IN WHITE WITH A SILVER BORDER.

FOR SOAPS FOR PERSONAL USE, PERFUMERY AND SKIN CARE PREPARATIONS (U.S. CLS. 1, 4, 6, 50, 51 AND 52).

PAUL E. FAHRENKOPF, EXAMINING ATTORNEY

CLASS 3—(Continued).

SN 77-285,053. MAHJOBI, JAMIE, ENCINO, CA. FILED 9-20-2007.

ELASTICIN

THE MARK CONSISTS OF STANDARD CHARACTERS WITHOUT CLAIM TO ANY PARTICULAR FONT, STYLE, SIZE, OR COLOR.

FOR AFTER SUN CREAMS; AFTER-SHAVE CREAMS; AGE SPOT REDUCING CREAMS; ANTI-AGING CREAMS; ANTI-FRECKLE CREAMS; ANTI-WRINKLE CREAMS; ANTIBACTERIAL SKIN SOAPS; AROMATHERAPY CREAMS; BEAUTY CREAMS AND POWDERS; BOOT CREAM; CLEANSING CREAMS; COLD CREAMS; CONCEALERS FOR WRINKLE, AGE SPOTS, BLEMISHES; COSMETIC CREAMS FOR SKIN CARE AND ENHANCEMENT; COSMETIC PREPARATIONS FOR SKIN RENEWAL; COSMETIC PRODUCTS IN THE FORM OF AEROSOLS FOR SKIN CARE; COSMETIC PRODUCTS TAKEN ORALLY, NAMELY, PILLS THAT INDUCE BRONZING OF THE SKIN OR ENHANCE SKIN ELASTICITY; CREAM SOAPS; CREAMS FOR CELLULITE REDUCTION; CREAMS FOR LEATHER; CUTICLE CREAM; DECORATIVE TRANSFERS AND SKIN JEWELS FOR COSMETIC PURPOSES; DEPILATORY CREAMS; EXFOLIANT CREAMS; EYE CREAM; FACE AND BODY BEAUTY CREAMS; FAIR COMPLEXION CREAM; HAIR CARE CREAMS; HAIR CREAMS; HAIR REMOVING CREAM; LOTIONS FOR SKIN, HAND AND LIP CARE; MAKE-UP REMOVING MILK, GEL, LOTIONS AND CREAMS; MOISTURIZING CREAMS; MOUSSE FOR HAIR AND SKIN CARE; NAIL CREAM; NIGHT CREAM; NON-MEDICATED FOOT CREAM; NON-MEDICATED SCALP TREATMENT CREAM; NON-MEDICATED SKIN CARE PREPARATIONS, NAMELY, CREAMS, LOTIONS, GELS, TONERS, CLEANSERS AND PEELS; NON-MEDICATED STIMULATING LOTIONS FOR THE SKIN; PATCHES CONTAINING SUN SCREEN AND SUN BLOCK FOR USE ON THE SKIN; RETINOL CREAM FOR COSMETIC PURPOSES; SCENTED BODY LOTIONS AND CREAMS; SHAVING CREAMS; SKIN ABRASIVE PREPARATIONS; SKIN BRONZING CREAMS; SKIN CARE PREPARATION, NAMELY, BODY POLISH; SKIN CARE PREPARATIONS, NAMELY, CHEMICAL PEELS FOR SKIN, NAMELY, FRUIT ACID PEELS FOR SKIN; SKIN CARE PRODUCTS, NAMELY, NON-MEDICATED SKIN SERUM, CLARIFIERS, CLEANSERS, CONDITIONERS; SKIN CREAMS IN LIQUID AND IN SOLID FORM; SKIN EMOLLIENTS; SKIN GELS FOR ACCELERATING, ENHANCING OR EXTENDING TANS; SKIN LIGHTENERS; SKIN LIGHTENING CREAMS; SKIN LOTIONS; SKIN MASKS; SKIN MOISTURIZER; SKIN MOISTURIZER MASKS; SKIN POLISHING RICE BRAN (ARAI-NUKA); SKIN SOAP; SKIN TEXTURIZERS; SKIN TONERS; SKIN WHITENING CREAMS; SKIN WHITENING PREPARATIONS; SUN CREAMS; SUNSCREEN AND TANNING CREAMS; TOPICAL HERBAL CREAM FOR FIRING AND ENHANCING BREASTS; TOPICAL SKIN SPRAYS FOR COSMETIC PURPOSES; VANISHING CREAM; WRINKLE REMOVING SKIN CARE PREPARATIONS; WRINKLE RESISTANT CREAM (U.S. CLS. 1, 4, 6, 50, 51 AND 52).

FIRST USE 4-20-2008; IN COMMERCE 4-20-2008.
KAPIL BHANOT, EXAMINING ATTORNEY

CLASS 3—(Continued).

SN 77-287,316. VERNAL KABUSHIKI KAISHA, HONOLULU, HI. FILED 9-24-2007.



FOR A HOUSE MARK FOR COSMETIC SKIN CARE AND HAIR CARE PRODUCTS, NAMELY, FACIAL SOAPS, MOISTURIZERS, SKIN CONDITIONERS, MAKEUP, SHAMPOO, HAIR CONDITIONERS, AND STYLING FINISH, NAMELY, STYLING GELS; COSMETICS, HAND SOAPS, PLANT-BASED NATURAL FRAGRANCES FOR PERSONAL USE, SYNTHETIC FRAGRANCES FOR PERSONAL USE, BLENDED FRAGRANCES FOR PERSONAL USE (U.S. CLS. 1, 4, 6, 50, 51 AND 52).

FIRST USE 4-11-1991; IN COMMERCE 12-27-2001.
MARTHA FROMM, EXAMINING ATTORNEY

SN 77-289,034. LANCOME PARFUMS ET BEAUTE & CIE, PARIS, FRANCE, FILED 9-26-2007.

FROM SCIENCE TO GRACE

THE MARK CONSISTS OF STANDARD CHARACTERS WITHOUT CLAIM TO ANY PARTICULAR FONT, STYLE, SIZE, OR COLOR.

PRIORITY CLAIMED UNDER SEC. 44(D) ON FRANCE APPLICATION NO. 073492539, FILED 4-3-2007, REG. NO. 073492539, DATED 4-3-2007, EXPIRES 4-3-2017.

FOR PERFUMERY PRODUCTS, NAMELY, PERFUMES, EAU DE COLOGNE, PERFUMED WATER, SKIN LOTIONS, SOAPS, BATH AND SHOWER FOAMING COMPOSITIONS AND GELS; COSMETICS, NAMELY, CREAMS, GELS, MILKS, POWDERS AND LOTIONS FOR THE FACE, THE BODY AND THE HANDS; MAKEUP PRODUCTS, NAMELY, MASCARA, EYE LINER, EYE SHADOW, EYEBROW PENCIL, LIPSTICKS, NAIL POLISH, BLUSH, FOUNDATION CREAMS AND POWDER, BODY DEODORANTS; SUN CARE PREPARATIONS, NAMELY, TANNING AND AFTER-SUN MILKS, GELS AND OILS; ESSENTIAL OILS FOR PERSONAL USE; GELS, SPRAYS AND BALMS FOR THE HAIR STYLING AND HAIR CARE; HAIR LACQUERS; SHAMPOOS, CONDITIONERS, TREATMENTS, SERUMS, MASQUES AND MOUSSE FOR THE HAIR (U.S. CLS. 1, 4, 6, 50, 51 AND 52).

RUDY R. SINGLETON, EXAMINING ATTORNEY

CLASS 3—(Continued).

SN 77-290,278. THE CLOROX COMPANY, OAKLAND, CA.
FILED 9-27-2007.

RAIN CLEAN

THE MARK CONSISTS OF STANDARD CHARACTERS WITHOUT CLAIM TO ANY PARTICULAR FONT, STYLE, SIZE, OR COLOR.
OWNER OF U.S. REG. NOS. 2,172,943, 2,177,315 AND 2,384,114.

NO CLAIM IS MADE TO THE EXCLUSIVE RIGHT TO USE "CLEAN", APART FROM THE MARK AS SHOWN.

FOR DISPOSABLE WIPES IMPREGNATED WITH CHEMICALS OR COMPOUNDS FOR HOUSEHOLD USE (U.S. CLS. 1, 4, 6, 50, 51 AND 52).

MICHAEL TANNER, EXAMINING ATTORNEY

SN 77-290,305. THE CLOROX COMPANY, OAKLAND, CA.
FILED 9-27-2007.

FRESH MEADOW

THE MARK CONSISTS OF STANDARD CHARACTERS WITHOUT CLAIM TO ANY PARTICULAR FONT, STYLE, SIZE, OR COLOR.

OWNER OF U.S. REG. NO. 2,920,075.

FOR DISPOSABLE WIPES IMPREGNATED WITH CHEMICALS OR COMPOUNDS FOR HOUSEHOLD USE (U.S. CLS. 1, 4, 6, 50, 51 AND 52).

MICHAEL TANNER, EXAMINING ATTORNEY

CLASS 3—(Continued).

SN 77-291,482. PURI COMPANY LIMITED, BANGKOK, THAILAND, FILED 9-28-2007.



THE COLOR(S) GOLD IS/ARE CLAIMED AS A FEATURE OF THE MARK.

THE MARK CONSISTS OF THE WORD "PANPURI" BELOW A LOGO CONSISTING OF A STYLIZED IMAGE OF A PLANT IN THE SHAPE OF CURVED LINES, A PARTIAL CIRCLE, RADII AND SPHERES ALL IN GOLD.

THE FOREIGN WORDING IN THE MARK TRANSLATES INTO ENGLISH AS "PALACE OF WISDOM".

FOR HAIR CARE PREPARATIONS, NAMELY, SHAMPOOS, HAIR CLEANSERS, HAIR WASHES, HAIR DETOXIFIERS, AND HAIR CONDITIONERS, MOISTURIZING SPRAY AND HAIR SCULPTING GELS, HAIR COLORING PREPARATIONS, AND HAIR WAVING LOTIONS; SKIN CARE PREPARATIONS, NAMELY, SOAPS, SKIN MOISTURIZERS, SKIN TONERS, SKIN CLEANSING PREPARATIONS, SKIN LOTIONS, BEAUTY MASQUES AND SKIN ASTRINGENTS FOR COSMETIC PURPOSES, SHAVING CREAMS, SHOWER GELS; PERSONAL HYGIENE PREPARATIONS, NAMELY, TOTAL BODY CLEANING PREPARATION, TOILET WATER, PERFUMES AND COLOGNES, MASSAGE OILS AND LOTIONS; ESSENTIAL OILS AND OIL MISTS FOR PERSONAL USE; SKIN CREAMS, SKIN LOTIONS, SKIN EMOLLIENTS, MOISTURIZING BODY OILS AND LOTIONS, LIP BALMS, FACE AND BODY SCRUBS, BODY WASHES, SKIN DETOXIFIERS AND SKIN POLISHES; HAND LOTIONS, CREAMS AND CLEANSERS; FOOT SCRUBS, CREAMS AND BATHS (U.S. CLS. 1, 4, 6, 50, 51 AND 52).

FIRST USE 10-1-2003; IN COMMERCE 10-1-2003.

LINDA MICKLEBURGH, EXAMINING ATTORNEY

SN 77-294,641. AMANDA GREATENS, WYOMING, OH.
FILED 10-3-2007.

R.B. Hippo

THE MARK CONSISTS OF STANDARD CHARACTERS WITHOUT CLAIM TO ANY PARTICULAR FONT, STYLE, SIZE, OR COLOR.

FOR BODY AND BEAUTY CARE COSMETICS (U.S. CLS. 1, 4, 6, 50, 51 AND 52).

GENE MACIOL, EXAMINING ATTORNEY

CLASS 3—(Continued).

SN 77-296,173. THE PROCTER & GAMBLE COMPANY, CINCINNATI, OH. FILED 10-4-2007.

BREAKAGE DEFENSE

THE MARK CONSISTS OF STANDARD CHARACTERS WITHOUT CLAIM TO ANY PARTICULAR FONT, STYLE, SIZE, OR COLOR.

NO CLAIM IS MADE TO THE EXCLUSIVE RIGHT TO USE "BREAKAGE", APART FROM THE MARK AS SHOWN.

FOR HAIR CARE PREPARATIONS, NAMELY, SHAMPOOS, CONDITIONERS, TREATMENTS AND STYLING AIDS, NAMELY, HAIR CREAMS AND HAIR LOTIONS (U.S. CLS. 1, 4, 6, 50, 51 AND 52).

FIRST USE 1-2-2006; IN COMMERCE 1-2-2006.
BARBARA RUTLAND, EXAMINING ATTORNEY

SN 77-296,713. FREEMAN, GAIL, VALENCIA, CA. FILED 10-4-2007.

Q-TICKLES

THE MARK CONSISTS OF STANDARD CHARACTERS WITHOUT CLAIM TO ANY PARTICULAR FONT, STYLE, SIZE, OR COLOR.

FOR BODY AND BEAUTY CARE COSMETICS (U.S. CLS. 1, 4, 6, 50, 51 AND 52).

FIRST USE 5-21-1998; IN COMMERCE 5-21-1998.
MICHELLE DUBOIS, EXAMINING ATTORNEY

CLASS 3—(Continued).

SN 77-300,488. NIPPON MENARD COSMETIC CO., LTD., NAGOYA-SHI AICHI, JAPAN, FILED 10-10-2007.

MENARDO
EMBE LLIR

THE NAME(S), PORTRAIT(S), AND/OR SIGNATURE(S) SHOWN IN THE MARK DOES NOT IDENTIFY A PARTICULAR LIVING INDIVIDUAL.

THE FOREIGN WORDING IN THE MARK TRANSLATES INTO ENGLISH AS TO BEAUTIFY, TO EMBELLISH.

FOR SOAPS, MEDICATED SOAP, COSMETIC SUN-TANNING PREPARATIONS, COSMETIC PREPARATIONS FOR BATHS, NAMELY, NON-MEDICATED BATH SALTS, BATH LOTION, BUBBLE BATH, AND BATH CRYSTALS; BEAUTY MASKS, HAIR LOTIONS, AFTER SHAVE LOTIONS, LOTIONS FOR COSMETIC PURPOSES, HAIR DYES, COSMETIC PREPARATIONS FOR EYELASHES, DEPILATORY WAX, EAU DE COLOGNE, COSMETIC KITS COMPRISED OF SKIN LOTIONS, CREAMS, WASHING CREAM, AND CLEANSING CREAM; COSMETICS, COSMETIC PENCILS, COSMETIC CREAMS, MAKE-UP REMOVING PREPARATIONS, DENTIFRICES, DEODORANTS FOR PERSONAL USE, TOILET WATER, MAKE-UP, MAKE-UP PREPARATIONS, OIL FOR COSMETIC PURPOSES, ETHEREAL OILS, CLEANSING MILK FOR TOILET PURPOSES, HAIR SPRAY, NAIL VARNISH, NAIL CARE PREPARATIONS, MASCARA, PERFUMERY, PERFUMES, COSMETIC PREPARATIONS FOR SKIN CARE, SHAMPOOS, TOILETRIES, NAMELY, TOOTHPASTE AND NON-MEDICATED MOUTH WASH AND RINSE; SKIN WHITENING CREAMS, EYEBROW COSMETICS, LIPSTICKS, MAKE-UP POWDER, FALSE NAILS, FALSE EYELASHES (U.S. CLS. 1, 4, 6, 50, 51 AND 52).

MARGERY A. TIERNEY, EXAMINING ATTORNEY

SN 77-308,241. L'OREAL, PARIS, FRANCE, FILED 10-19-2007.

DETAILLISTE

THE MARK CONSISTS OF STANDARD CHARACTERS WITHOUT CLAIM TO ANY PARTICULAR FONT, STYLE, SIZE, OR COLOR.

PRIORITY CLAIMED UNDER SEC. 44(D) ON FRANCE APPLICATION NO. 073496926, FILED 4-25-2007, REG. NO. 073496926, DATED 4-25-2007, EXPIRES 4-25-2017.

THE WORD "DETAILLISTE" HAS NO MEANING IN A FOREIGN LANGUAGE.

FOR COSMETICS AND MAKEUP (U.S. CLS. 1, 4, 6, 50, 51 AND 52).

MARK T. MULLEN, EXAMINING ATTORNEY

CLASS 3—(Continued).

SN 77-316,157. COLGATE-PALMOLIVE COMPANY, NEW YORK, NY. FILED 10-29-2007.

HACE FELIZ A TU NARIZ

THE MARK CONSISTS OF STANDARD CHARACTERS WITHOUT CLAIM TO ANY PARTICULAR FONT, STYLE, SIZE, OR COLOR.

THE FOREIGN WORDING IN THE MARK TRANSLATES INTO ENGLISH AS MAKES YOUR NOSE HAPPY.

FOR ALL PURPOSE HOUSEHOLD CLEANING PREPARATION (U.S. CLS. 1, 4, 6, 50, 51 AND 52).

JACQUELINE A. LAVINE, EXAMINING ATTORNEY

CLASS 3—(Continued).

SN 77-372,575. LEONARD ALBERT LEWIS, LONDON, UNITED KINGDOM, FILED 1-15-2008.

**LEONARD**
of Mayfair

OWNER OF ERPN CMNTY TM OFC REG. NO. 4066155, DATED 8-22-2006, EXPIRES 10-5-2014.

THE MARK CONSISTS OF THE TEXT "LEONARD OF MAYFAIR" WITH A SERIES OF SPACED WAVY LINES EXTENDING FROM THE LETTER "L".

FOR SHAMPOOS, HAIR CONDITIONERS AND COLOGNE (U.S. CLS. 1, 4, 6, 50, 51 AND 52).

SALLY SHIH, EXAMINING ATTORNEY

SN 77-322,215. SUN PHARMACEUTICALS CORP., WESTPORT, CT. FILED 11-6-2007.

DRI-BLOK

THE MARK CONSISTS OF STANDARD CHARACTERS WITHOUT CLAIM TO ANY PARTICULAR FONT, STYLE, SIZE, OR COLOR.

FOR NON-MEDICATED SKIN CARE PREPARATIONS; SUNSCREENS IN THE FORM OF LOTIONS, CREAMS, SPRAYS AND GELS (U.S. CLS. 1, 4, 6, 50, 51 AND 52).

FIRST USE 11-0-2006; IN COMMERCE 11-0-2006.

GEOFFREY FOSDICK, EXAMINING ATTORNEY

SN 77-373,705. HEAP, AARON, SALT LAKE CITY, UT. FILED 1-16-2008.

FIZGOLF

THE MARK CONSISTS OF STANDARD CHARACTERS WITHOUT CLAIM TO ANY PARTICULAR FONT, STYLE, SIZE, OR COLOR.

FOR HAND HELD CLEANSER DISPENSER WITH INTEGRAL BRUSH FOR CLEANING GOLF BALLS AND GOLF CLUBS, SOLD WITH CLEANSING SOLUTION (U.S. CLS. 1, 4, 6, 50, 51 AND 52).

SHAUNIA CARLYLE, EXAMINING ATTORNEY

SN 77-344,279. CREATED NATURALS, INC., CLACKAMAS, OR. FILED 12-5-2007.

Created Naturals

THE MARK CONSISTS OF STANDARD CHARACTERS WITHOUT CLAIM TO ANY PARTICULAR FONT, STYLE, SIZE, OR COLOR.

NO CLAIM IS MADE TO THE EXCLUSIVE RIGHT TO USE "NATURALS", APART FROM THE MARK AS SHOWN. FOR COSMETICS (U.S. CLS. 1, 4, 6, 50, 51 AND 52).

DAWN FELDMAN, EXAMINING ATTORNEY

SN 77-374,544. KEVIS REJUVINATION PROGRAMS INC, GLENDALE, CA. FILED 1-17-2008.

MORE HAIR NATURALLY

THE MARK CONSISTS OF STANDARD CHARACTERS WITHOUT CLAIM TO ANY PARTICULAR FONT, STYLE, SIZE, OR COLOR.

NO CLAIM IS MADE TO THE EXCLUSIVE RIGHT TO USE "HAIR", APART FROM THE MARK AS SHOWN.

FOR HAIR CARE PREPARATIONS, HAIR CONDITIONER, HAIR SHAMPOO, HAIR THICKENERS, AND NON-MEDICATED HAIR RESTORATION LOTIONS (U.S. CLS. 1, 4, 6, 50, 51 AND 52).

KIMBERLY PERRY, EXAMINING ATTORNEY

CLASS 3—(Continued).

SN 77-376,629. ZACHARIAH DYLAN, LLC, OKLAHOMA CITY, OK. FILED 1-21-2008.

Zachariah Dylan

THE NAME(S), PORTRAIT(S), AND/OR SIGNATURE(S) SHOWN IN THE MARK DOES NOT IDENTIFY A PARTICULAR LIVING INDIVIDUAL.

THE MARK CONSISTS OF THE STYLIZED NAME "ZACHARIAH DYLAN".

FOR COLOGNE; COLOGNES, PERFUMES AND COSMETICS; PERFUMES, AFTERSHAVES AND COLOGNES (U.S. CLS. 1, 4, 6, 50, 51 AND 52).

FIRST USE 12-1-2007; IN COMMERCE 12-1-2007.
KIMBERLY PERRY, EXAMINING ATTORNEY

SN 77-388,796. CANUS GOAT'S MILK SKIN CARE PRODUCTS INC./PRODUITS DE SOINS POUR LA PEAU AU LAIT DE CHEVRE CANUS INC., ILE-PERROT, CANADA, FILED 2-5-2008.

NATURE BY CANUS

THE MARK CONSISTS OF STANDARD CHARACTERS WITHOUT CLAIM TO ANY PARTICULAR FONT, STYLE, SIZE, OR COLOR.

OWNER OF U.S. REG. NO. 2,932,819.

NO CLAIM IS MADE TO THE EXCLUSIVE RIGHT TO USE "NATURE", APART FROM THE MARK AS SHOWN.

THE NAME(S), PORTRAIT(S), AND/OR SIGNATURE(S) SHOWN IN THE MARK DOES NOT IDENTIFY A PARTICULAR LIVING INDIVIDUAL.

FOR PERSONAL CARE PRODUCTS, NAMELY, FACIAL AND BODY SOAP, BODY WASH, BODY LOTION, BODY BUTTER, FACIAL CREAM, FACIAL SCRUB, BODY SCRUB, FACIAL MASK, LIP BALM, LIP GLOSS, FACIAL SPOT REMOVER (U.S. CLS. 1, 4, 6, 50, 51 AND 52).

ANDREA HACK, EXAMINING ATTORNEY

CLASS 3—(Continued).

SN 77-395,035. PAYLESS SHOESOURCE WORLDWIDE, INC., TOPEKA, KS. FILED 2-12-2008.

I LOVE SHOES

THE MARK CONSISTS OF STANDARD CHARACTERS WITHOUT CLAIM TO ANY PARTICULAR FONT, STYLE, SIZE, OR COLOR.

OWNER OF U.S. REG. NO. 2,646,852.

NO CLAIM IS MADE TO THE EXCLUSIVE RIGHT TO USE "SHOES", APART FROM THE MARK AS SHOWN.

FOR POLISHES AND CREAMS FOR FOOTWEAR AND LEATHER GOODS; CLEANING, POLISHING, PRESERVING, DRESSING, CONDITIONING, AND MOISTURIZING PREPARATIONS FOR LEATHER, IMITATION LEATHER, SUEDE FOOTWEAR, AND ARTICLES MADE OF LEATHER OR IMITATION LEATHER; HEEL AND EDGE DRESSING FOR FOOTWEAR; SHOE SOAPS; SCUFF REMOVING, AND COVERING PREPARATIONS FOR LEATHER AND VINYL FOOTWEAR AND ACCESSORIES; SHOE POLISH KIT CONSISTING OF POLISH, BRUSHES, AND POLISHING CLOTH (U.S. CLS. 1, 4, 6, 50, 51 AND 52).

WANDA KAY PRICE, EXAMINING ATTORNEY

SN 77-396,064. KAO KABUSHIKI KAISHA, TA KAO CORPORATION, TOKYO 103-8210, JAPAN, FILED 2-13-2008.

ALL-OUT HOLD

THE MARK CONSISTS OF STANDARD CHARACTERS WITHOUT CLAIM TO ANY PARTICULAR FONT, STYLE, SIZE, OR COLOR.

NO CLAIM IS MADE TO THE EXCLUSIVE RIGHT TO USE "HOLD", APART FROM THE MARK AS SHOWN.

FOR HAIR CARE PREPARATIONS (U.S. CLS. 1, 4, 6, 50, 51 AND 52).

CHERYL CLAYTON, EXAMINING ATTORNEY

SN 77-396,636. IZER, EVAN, BROOKLYN, NY. FILED 2-14-2008.

CHAMPLEVÉ

THE MARK CONSISTS OF STANDARD CHARACTERS WITHOUT CLAIM TO ANY PARTICULAR FONT, STYLE, SIZE, OR COLOR.

FOR EAU DE PARFUM; EAU DE TOILETTE; EAU-DE-COLOGNE; PERFUME (U.S. CLS. 1, 4, 6, 50, 51 AND 52).

JOHN GARTNER, EXAMINING ATTORNEY

CLASS 3—(Continued).

SN 77-397,870. LEHUA FILMS, INC., ENCINO, CA. FILED 2-15-2008.

élan naturals

THE MARK CONSISTS OF STANDARD CHARACTERS WITHOUT CLAIM TO ANY PARTICULAR FONT, STYLE, SIZE, OR COLOR.

NO CLAIM IS MADE TO THE EXCLUSIVE RIGHT TO USE "NATURALS", APART FROM THE MARK AS SHOWN.

THE ENGLISH TRANSLATION OF THE WORD ELAN IN THE MARK IS "IMPULSE, MOMENTUM, DASH OR RUSH". FOR BODY AND BEAUTY CARE COSMETICS; FACE AND BODY BEAUTY CREAMS; COSMETIC CREAMS; COSMETIC CREAMS FOR SKIN CARE; COSMETICS; COSMETICS IN GENERAL, INCLUDING PERFUMES (U.S. CLS. 1, 4, 6, 50, 51 AND 52).

ZHALEH DELANEY, EXAMINING ATTORNEY

CLASS 3—(Continued).

SN 77-407,890. CONSUMER PRODUCTS DESIGN, LTD, NEW YORK, NY. FILED 2-27-2008.

THE OLIVE MARKET

THE MARK CONSISTS OF STANDARD CHARACTERS WITHOUT CLAIM TO ANY PARTICULAR FONT, STYLE, SIZE, OR COLOR.

NO CLAIM IS MADE TO THE EXCLUSIVE RIGHT TO USE "OLIVE", APART FROM THE MARK AS SHOWN.

FOR NON-MEDICATED SKIN CARE PREPARATIONS; BATH SOAPS IN LIQUID, SOLID OR GEL FORM; FRAGRANCES FOR PERSONAL USE; HOUSEHOLD CLEANING PREPARATIONS; HAIR CARE PREPARATIONS; ROOM FRAGRANCES (U.S. CLS. 1, 4, 6, 50, 51 AND 52).

FIRST USE 2-26-2008; IN COMMERCE 2-26-2008.
TRACY CROSS, EXAMINING ATTORNEY

SN 77-398,105. PAYLESS SHOESOURCE WORLDWIDE, INC., TOPEKA, KS. FILED 2-15-2008.

WE LOVE SHOES

THE MARK CONSISTS OF STANDARD CHARACTERS WITHOUT CLAIM TO ANY PARTICULAR FONT, STYLE, SIZE, OR COLOR.

OWNER OF U.S. REG. NO. 2,646,852.

NO CLAIM IS MADE TO THE EXCLUSIVE RIGHT TO USE "SHOES", APART FROM THE MARK AS SHOWN.

FOR POLISHES AND CREAMS FOR FOOTWEAR AND LEATHER GOODS; CLEANING, POLISHING, PRESERVING, DRESSING, CONDITIONING, AND MOISTURIZING PREPARATIONS FOR LEATHER, IMITATION LEATHER, SUEDE FOOTWEAR, AND ARTICLES MADE OF LEATHER OR IMITATION LEATHER; HEEL AND EDGE DRESSING FOR FOOTWEAR; SHOE SOAPS; SCUFF REMOVING, AND COVERING PREPARATIONS FOR LEATHER AND VINYL FOOTWEAR AND ACCESSORIES; SHOE POLISH KIT CONSISTING OF POLISH, BRUSHES, AND POLISHING CLOTH (U.S. CLS. 1, 4, 6, 50, 51 AND 52).

WANDA KAY PRICE, EXAMINING ATTORNEY

SN 77-410,077. CONSUMER PRODUCTS DESIGN, LTD, NEW YORK, NY. FILED 2-29-2008.

THE OLIVE PRESS

THE MARK CONSISTS OF STANDARD CHARACTERS WITHOUT CLAIM TO ANY PARTICULAR FONT, STYLE, SIZE, OR COLOR.

NO CLAIM IS MADE TO THE EXCLUSIVE RIGHT TO USE "OLIVE", APART FROM THE MARK AS SHOWN.

FOR NON-MEDICATED SKIN CARE PREPARATIONS; BATH SOAPS IN LIQUID, SOLID OR GEL FORM; FRAGRANCES FOR PERSONAL USE; HOUSEHOLD CLEANING PREPARATIONS; HAIR CARE PREPARATIONS; ROOM FRAGRANCES (U.S. CLS. 1, 4, 6, 50, 51 AND 52).

FIRST USE 2-26-2008; IN COMMERCE 2-26-2008.
TRACY CROSS, EXAMINING ATTORNEY

CLASS 3—(Continued).

SN 77-413,061. MCCOY-SIMPSON, LLC, PALM SPRINGS, CA. FILED 3-4-2008.

Skin 2 Skin Care

THE MARK CONSISTS OF STANDARD CHARACTERS WITHOUT CLAIM TO ANY PARTICULAR FONT, STYLE, SIZE, OR COLOR.

FOR SKIN, HAIR, AND BODY CARE PRODUCTS AND FRAGRANCES, NAMELY, FACE AND BODY LOTIONS, FACE AND BODY CLEANSERS, FACE AND BODY MOISTURIZERS, EXFOLIANTS FOR FACE AND BODY, FACE AND BODY SUN SCREENS AND AFTER-SUN LOTIONS, GELS, AND CREAMS, FACE AND BODY LIGHTENERS, NON-MEDICATED ACNE TREATMENT PREPARATIONS, ALL SKIN TYPES FACE AND BODY CREAMS, NAIL AND HAND CREAMS, BODY FRAGRANCE AND PERFUME, NON-MEDICATED FOOT CREAM, SHAVING CREAM, AFTER SHAVE CREAM, NON-MEDICATED AFTER-LASER TREATMENT BODY GELS AND CREAMS, NON-MEDICATED AFTER-BODY WAXING GELS AND CREAMS, NON-MEDICATED HAIR GROWTH INHIBITORS, BABY LOTION, SUN SCREEN FOR BABIES, NON-MEDICATED LIP CARE PREPARATIONS, HAIR CARE PRODUCTS, NAMELY, SHAMPOO, CONDITIONER, AND OTHER HAIR CARE PREPARATIONS, BATH SALTS, MASSAGE AND BODY OILS (U.S. CLS. 1, 4, 6, 50, 51 AND 52).

KRISTIN CARLSON, EXAMINING ATTORNEY

SN 77-413,821. AUSTRALIAN GOLD, INC., INDIANAPOLIS, IN. FILED 3-5-2008.

SWEDISH BEAUTY BOTANICA

THE MARK CONSISTS OF STANDARD CHARACTERS WITHOUT CLAIM TO ANY PARTICULAR FONT, STYLE, SIZE, OR COLOR.

OWNER OF U.S. REG. NOS. 1,928,801, 3,213,892 AND OTHERS.

NO CLAIM IS MADE TO THE EXCLUSIVE RIGHT TO USE "SWEDISH", APART FROM THE MARK AS SHOWN.

FOR SKIN CARE PREPARATIONS, NAMELY, NON-MEDICATED INDOOR SKIN TANNING PREPARATIONS; SKIN MOISTURIZERS (U.S. CLS. 1, 4, 6, 50, 51 AND 52).

BILL DAWE, EXAMINING ATTORNEY

CLASS 3—(Continued).

SN 77-414,034. CONSUMER PRODUCTS DESIGN, LTD, NEW YORK, NY. FILED 3-5-2008.

THE OLIVE HARVEST

THE MARK CONSISTS OF STANDARD CHARACTERS WITHOUT CLAIM TO ANY PARTICULAR FONT, STYLE, SIZE, OR COLOR.

NO CLAIM IS MADE TO THE EXCLUSIVE RIGHT TO USE "OLIVE", APART FROM THE MARK AS SHOWN.

FOR NON-MEDICATED SKIN CARE PREPARATIONS; BATH SOAPS IN LIQUID, SOLID OR GEL FORM; FRAGRANCES FOR PERSONAL USE; HOUSEHOLD CLEANING PREPARATIONS; HAIR CARE PREPARATIONS; ROOM FRAGRANCES (U.S. CLS. 1, 4, 6, 50, 51 AND 52).

FIRST USE 3-3-2008; IN COMMERCE 3-3-2008.

TRACY CROSS, EXAMINING ATTORNEY

SN 77-415,927. BOTICA COMERCIAL FARMACEUTICA S.A., SAO JOSE DOS PINHAIS, PARANA, BRAZIL, FILED 3-7-2008.

ACQUA

B R A S I L I S

NO CLAIM IS MADE TO THE EXCLUSIVE RIGHT TO USE "BRASILIS", APART FROM THE MARK AS SHOWN.

THE MARK CONSISTS OF OF THE STYLIZED WORDS "ACQUA" AND "BRASILIS" BETWEEN A LINE.

THE FOREIGN WORDING IN THE MARK TRANSLATES INTO ENGLISH AS "BRAZILIAN WATER".

FOR EAU DE TOILETTE, DEODORANT FOR PERSONAL USE, SOAP, PRE-SHAVE CREAMS AND AFTER SHAVE CREAMS (U.S. CLS. 1, 4, 6, 50, 51 AND 52).

JULIE WATSON, EXAMINING ATTORNEY

SN 77-418,212. AINSWORTH, PAUL, ENCINITAS, CA. FILED 3-10-2008.

Laundry Door

THE MARK CONSISTS OF STANDARD CHARACTERS WITHOUT CLAIM TO ANY PARTICULAR FONT, STYLE, SIZE, OR COLOR.

NO CLAIM IS MADE TO THE EXCLUSIVE RIGHT TO USE "LAUNDRY", APART FROM THE MARK AS SHOWN.

FOR FILTER BAG FILLED WITH DRIED LAVENDER DESIGNED TO BE PLACED IN A CLOTHING DRYER WITH CLOTHS WITH THE PURPOSE OF SCENTING THEM (U.S. CLS. 1, 4, 6, 50, 51 AND 52).

FIRST USE 6-25-2005; IN COMMERCE 4-21-2006.

ANN E. SAPPENFIELD, EXAMINING ATTORNEY

CLASS 3—(Continued).

SN 77-420,527. MCCOY-SIMPSON, LLC, PALM SPRINGS, CA. FILED 3-12-2008.

Skin 2 Skin

THE MARK CONSISTS OF STANDARD CHARACTERS WITHOUT CLAIM TO ANY PARTICULAR FONT, STYLE, SIZE, OR COLOR.

FOR SKIN, HAIR, AND BODY CARE PRODUCTS AND FRAGRANCES, NAMELY, FACE AND BODY LOTIONS, FACE AND BODY CLEANSERS, FACE AND BODY MOISTURIZERS, EXFOLIANTS FOR FACE AND BODY, FACE AND BODY SUN SCREENS AND AFTER-SUN LOTIONS, GELS, AND CREAMS, FACE AND BODY LIGHTENERS, NON-MEDICATED ACNE TREATMENT PREPARATIONS, ALL SKIN TYPES FACE AND BODY CREAMS, NAIL AND HAND CREAMS, BODY FRAGRANCE AND PERFUME, NON-MEDICATED FOOT CREAM, SHAVING CREAM, AFTER SHAVE CREAM, NON-MEDICATED AFTER-LASER TREATMENT BODY GELS AND CREAMS, NON-MEDICATED AFTER-BODY WAXING GELS AND CREAMS, NON-MEDICATED HAIR GROWTH INHIBITORS, BABY LOTION, SUN SCREEN FOR BABIES, NON-MEDICATED LIP CARE PREPARATIONS, HAIR CARE PRODUCTS, NAMELY, SHAMPOO, CONDITIONER, AND OTHER HAIR CARE PREPARATIONS, BATH SALTS, MASSAGE AND BODY OILS (U.S. CLS. 1, 4, 6, 50, 51 AND 52).

KRISTIN CARLSON, EXAMINING ATTORNEY

SN 77-420,592. VOLA JEAN JACQUES, SAINT TROPEZ, FRANCE, FILED 3-13-2008.

Partagas

THE MARK CONSISTS OF STANDARD CHARACTERS WITHOUT CLAIM TO ANY PARTICULAR FONT, STYLE, SIZE, OR COLOR.

FOR EAU DE COLOGNES; EAU DE PARFUM; EAUX DE TOILETTE (U.S. CLS. 1, 4, 6, 50, 51 AND 52).

CAROL SPILS, EXAMINING ATTORNEY

CLASS 3—(Continued).

SN 77-421,024. ALOE VERA OF AMERICA, INC., DALLAS, TX. FILED 3-13-2008.



OWNER OF U.S. REG. NOS. 2,351,373 AND 2,500,129.
THE MARK CONSISTS OF THE WORD "SONYA" IN STYLIZED SCRIPT FORM WITH A FANCIFUL UPWARD CURVING ARC DESIGN EXTENDING ABOVE AND A FANCIFUL DOWNWARD CURVING ARC DESIGN EXTENDING BELOW THE EXTENSION OF THE LETTER "A".

FOR COSMETIC PRODUCTS, NAMELY, SKIN CLEANSERS, SKIN EXFOLIATORS, SKIN TONERS, SKIN MOISTURIZERS, AND NON-MEDICATED SKIN SERUMS (U.S. CLS. 1, 4, 6, 50, 51 AND 52).

FIRST USE 11-30-2007; IN COMMERCE 11-30-2007.
EDWARD FENNESSY, EXAMINING ATTORNEY

SN 77-421,146. ELSESSER, JACY, SCHAUMBURG, IL. FILED 3-13-2008.

BAD CAT SOLUTIONS

THE MARK CONSISTS OF STANDARD CHARACTERS WITHOUT CLAIM TO ANY PARTICULAR FONT, STYLE, SIZE, OR COLOR.

NO CLAIM IS MADE TO THE EXCLUSIVE RIGHT TO USE "SOLUTIONS", APART FROM THE MARK AS SHOWN.

FOR ALL PURPOSE DRAIN OPENER (U.S. CLS. 1, 4, 6, 50, 51 AND 52).

ODESSA BIBBINS, EXAMINING ATTORNEY

SN 77-421,688. BY THE BROOKE BATH & GIFT SHOPPE, SPRING HILL, TN. FILED 3-13-2008.



NO CLAIM IS MADE TO THE EXCLUSIVE RIGHT TO USE "BATH & GIFT SHOPPE", APART FROM THE MARK AS SHOWN.

THE MARK CONSISTS OF AN OAK LEAF & THE UPPER TRI-LEAF OF A HICKORY TREE OVERLAPPED TO THE LEFT OF THE STYLIZED TEXT "BY THE BROOKE BATH & GIFT SHOPPE".

FOR BODY GLITTER; BODY SPRAYS; BUBBLE BATH; FACIAL CLEANSERS; HAIR CONDITIONER; HAIR GEL; HAIR SHAMPOO; MASSAGE OIL; SHOWER GEL; SKIN LOTION; SKIN TONERS; SOAPS FOR BODY CARE (U.S. CLS. 1, 4, 6, 50, 51 AND 52).

FIRST USE 8-1-2006; IN COMMERCE 10-28-2007.
MARY ROSSMAN, EXAMINING ATTORNEY

CLASS 3—(Continued).

SN 77-423,916. CORINA, L.L.C., ATLANTA, GA. FILED 3-17-2008.



NO CLAIM IS MADE TO THE EXCLUSIVE RIGHT TO USE "DELIVERY SYSTEM", APART FROM THE MARK AS SHOWN.

THE MARK CONSISTS OF THE WORDS "INFUSIDERM DELIVERY SYSTEM" AND A GRAPHICAL REPRESENTATION OF A WATER DROP.

FOR COSMETIC CREAMS FOR SKIN CARE (U.S. CLS. 1, 4, 6, 50, 51 AND 52).

FIRST USE 10-0-2007; IN COMMERCE 10-0-2007.
MICHAEL TANNER, EXAMINING ATTORNEY

SN 77-423,924. THE PROCTER & GAMBLE COMPANY, CINCINNATI, OH. FILED 3-17-2008.



NO CLAIM IS MADE TO THE EXCLUSIVE RIGHT TO USE "ALOE," "JOJOBA," AND "VITAMIN E", APART FROM THE MARK AS SHOWN.

THE COLOR(S) GREEN, YELLOW, ORANGE AND WHITE IS/ARE CLAIMED AS A FEATURE OF THE MARK.

THE MARK CONSISTS OF A TRI-COLORED DROPLET DESIGN. THE WORDING "ALOE", "JOJOBA", AND "VITAMIN E" APPEAR TO THE RIGHT OF THE DROPLET IN THE COLOR WHITE. THE TOP OF THE DROPLET FEATURES THE COLOR GREEN, THE MIDDLE OF THE DROPLET FEATURES THE COLOR YELLOW, AND THE BOTTOM OF THE DROPLET FEATURES THE COLOR ORANGE. THERE IS AN ORANGE "AURA" DESIGN THAT SURROUNDS THE DROPLET.

FOR HAIR COLORANTS (U.S. CLS. 1, 4, 6, 50, 51 AND 52).
MARIA-VICTORIA SUAREZ, EXAMINING ATTORNEY

SN 77-425,139. ROSY GLOW BEAUTY COMPANY, WHITEHOUSE, OH. FILED 3-18-2008.

Get Your Glow Back

THE MARK CONSISTS OF STANDARD CHARACTERS WITHOUT CLAIM TO ANY PARTICULAR FONT, STYLE, SIZE, OR COLOR.

FOR BODY AND BEAUTY CARE COSMETICS (U.S. CLS. 1, 4, 6, 50, 51 AND 52).

FIRST USE 1-17-2008; IN COMMERCE 2-16-2008.
CARRIE GENOVESE, EXAMINING ATTORNEY

CLASS 3—(Continued).

SN 77-426,679. BONSAI INTERNATIONAL, LLC, GREENWOOD VILLAGE, CO. FILED 3-19-2008.



THE STIPPLING IS FOR SHADING PURPOSES ONLY.

THE MARK CONSISTS, IN PART, OF A BONSAI TREE.

FOR BODY AND BATH CARE PRODUCTS, NAMELY, BATH CRYSTALS, BATH OILS, BATH BEADS, BATH FOAM, BATH GELS, BODY SCRUBS, BODY FRAGRANCES, BATH POWDERS, MASSAGE OILS, TALCUM POWDER, ESSENTIAL OILS, FACIAL CREAMS, HAND CREAMS, SKIN AND BODY CREAMS, MOISTURIZERS, LOTIONS, CONDITIONERS AND CLEANSERS, BODY POWDER; RELAXING TEA BAGS FOR PUTTING IN BATHS; NON-MEDICATED SKIN CARE PREPARATIONS; SKIN CARE PREPARATIONS FOR TREATING WRINKLES, FACE LOTIONS, FACIAL WASH, FACIAL MASK, FACE AND BODY CLEANSERS, FACE AND BODY EXFOLIANTS, FACIAL AND BODY MASKS, FACE AND BODY HIGHLIGHTER, FACE AND BODY CONDITIONERS, LIP CREAM, NON-MEDICATED LIP CARE PREPARATIONS, SUNSCREEN PREPARATIONS, SELF-TANNING CREAM AND MILK, SELF-TANNING PREPARATIONS, SELF-TANNING GELS, CREAMS, AND LOTIONS, AFTER-SUN TANNING LOTIONS, NON-MEDICATED SKIN LOTIONS AND CREAMS FOR RELIEVING RAZOR BURNS; PERFUME, EAU DE TOILETTE, COLOGNE, DEODORANT AND ANTIPERSPIRANT COSMETICS; FACIAL MAKEUP, LIPSTICK, LIP GLOSS, LIP LINER PENCIL, COSMETIC COMPACTS, FOUNDATION MAKEUP, COSMETIC EYEBROW PENCILS, EYE PENCILS, EYE COLOR MAKEUP, CONCEALERS, BLUSHERS, FACIAL POWDERS, NAIL POLISH BASE COAT, NAIL POLISH TOP COAT, NAIL STRENGTHENERS AND HARDENERS, NAIL POLISH REMOVERS, NAIL AND HAND CREAMS, NAIL TIPS, CUTICLE REMOVING PREPARATIONS, NAIL BUFFING PREPARATIONS, NON-MEDICATED TOPICAL SKIN CREAMS, TONERS, LOTIONS, GELS, SPRAY, OINTMENT; AROMATHERAPY CREAM LOTIONS AND OILS, HAIR CARE PRODUCTS, NAMELY, SHAMPOO AND CONDITIONERS; CHILDREN'S BODY AND BATH CARE, NAMELY, BODY GEL, BATH AND BODY OILS, BATH AND BODY SOAPS, BODY LOTIONS, SHAMPOO AND CONDITIONERS (U.S. CLS. 1, 4, 6, 50, 51 AND 52).

JEAN IM, EXAMINING ATTORNEY

SN 77-427,201. AUSTIN ROSE, INC., LAS VEGAS, CA. FILED 3-20-2008.

CAROLINE'S

THE MARK CONSISTS OF STANDARD CHARACTERS WITHOUT CLAIM TO ANY PARTICULAR FONT, STYLE, SIZE, OR COLOR.

FOR PET SHAMPOO (U.S. CLS. 1, 4, 6, 50, 51 AND 52).
CHRISTINE COOPER, EXAMINING ATTORNEY

CLASS 3—(Continued).

SN 77-428,408. VICTORIA'S SECRET STORES BRAND MANAGEMENT, INC., REYNOLDSBURG, OH. FILED 3-21-2008.

LOTTA COLADA

THE MARK CONSISTS OF STANDARD CHARACTERS WITHOUT CLAIM TO ANY PARTICULAR FONT, STYLE, SIZE, OR COLOR.

FOR BODY CREAMS; BODY LOTIONS; BODY SPRAYS; BODY WASHES; PERFUMES; FRAGRANCES; LIP GLOSS (U.S. CLS. 1, 4, 6, 50, 51 AND 52).
TEJBIR SINGH, EXAMINING ATTORNEY

SN 77-428,429. LASER CLEANSE LLC, LITTLETON, CO. FILED 3-21-2008.

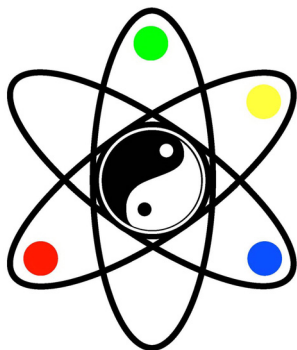

THE COLOR(S) GREEN, YELLOW, BLUE, RED, WHITE AND BLACK IS/ARE CLAIMED AS A FEATURE OF THE MARK.

THE MARK CONSISTS OF THREE OVAL SHAPES THAT INTERSECT EACH OTHER AT THEIR CENTERS. A GREEN DOT EXISTS WITHIN THE TOP OUTSIDE 1/3 OF OVAL; A YELLOW DOT EXISTS WITHIN THE UPPER RIGHT SIDE OF 1/3 OF OVAL; A BLUE DOT EXISTS WITHIN THE LOWER RIGHT SIDE OF 1/3 OF OVAL; A RED DOT EXISTS WITHIN THE LOWER LEFT SIDE OF 1/3 OF OVAL. 1/2 OF THE CENTER OF THE MARK IS SHADED IN BLACK WITH A SMALL WHITE CIRCLE ON THE TOP OF THE BLACK SHADED AREA AND THE REMAINING AREA IS WHITE WITH A SMALL BLACK CIRCLE ON THE BOTTOM OF THE WHITE SHADED AREA.

FOR NON-MEDICATED BATH SALTS (U.S. CLS. 1, 4, 6, 50, 51 AND 52).
JOHN E. MICHOS, EXAMINING ATTORNEY

CLASS 3—(Continued).

SN 77-428,725. ASH, MARIE, LAKE FOREST, CA. FILED 3-21-2008.

OUR NATURAL SOLUTIONS

THE MARK CONSISTS OF STANDARD CHARACTERS WITHOUT CLAIM TO ANY PARTICULAR FONT, STYLE, SIZE, OR COLOR.

FOR SHAMPOO AND SOAPS ALL FOR USE ON HORSES AND DOGS (U.S. CLS. 1, 4, 6, 50, 51 AND 52).
LINDA POWELL, EXAMINING ATTORNEY

SN 77-428,745. CHOPRA ENTERPRISES, LLC, CARLSBAD, CA. FILED 3-21-2008.

AYURNAS

THE MARK CONSISTS OF STANDARD CHARACTERS WITHOUT CLAIM TO ANY PARTICULAR FONT, STYLE, SIZE, OR COLOR.

FOR BODY OIL; COSMETIC OILS; MASSAGE OIL; NATURAL ESSENTIAL OILS; NUTRITIONAL OILS FOR COSMETIC PURPOSES; OILS FOR COSMETIC PURPOSES; PERFUME OILS; SCENTED OILS USED TO PRODUCE AROMAS WHEN HEATED (U.S. CLS. 1, 4, 6, 50, 51 AND 52).

GISELLE AGOSTO, EXAMINING ATTORNEY

SN 77-429,324. ORALABS, INC., PARKER, CO. FILED 3-24-2008.

CLIPPABLES

THE MARK CONSISTS OF STANDARD CHARACTERS WITHOUT CLAIM TO ANY PARTICULAR FONT, STYLE, SIZE, OR COLOR.

FOR HOLDERS FOR LIP BALM (U.S. CLS. 1, 4, 6, 50, 51 AND 52).
WENDY JUN, EXAMINING ATTORNEY

CLASS 3—(Continued).

SN 77-429,515. SEPHORA USA, INC., SAN FRANCISCO, CA.
FILED 3-24-2008.

PAINTED LOVE LIPSTICKS

THE MARK CONSISTS OF STANDARD CHARACTERS WITHOUT CLAIM TO ANY PARTICULAR FONT, STYLE, SIZE, OR COLOR.

NO CLAIM IS MADE TO THE EXCLUSIVE RIGHT TO USE "LIPSTICKS", APART FROM THE MARK AS SHOWN. FOR COSMETICS, NAMELY, LIPSTICK (U.S. CLS. 1, 4, 6, 50, 51 AND 52).

TANYA AMOS, EXAMINING ATTORNEY

SN 77-429,523. JAENICKE, RICHARD A., HOUSTON, TX.
FILED 3-24-2008.

SerityMD

THE MARK CONSISTS OF STANDARD CHARACTERS WITHOUT CLAIM TO ANY PARTICULAR FONT, STYLE, SIZE, OR COLOR.

FOR COSMETICS (U.S. CLS. 1, 4, 6, 50, 51 AND 52).
ZACHARY BELLO, EXAMINING ATTORNEY

SN 77-429,603. SUTHERLAND PRODUCTS, INC., MAYODAN, NC. FILED 3-24-2008.



NO CLAIM IS MADE TO THE EXCLUSIVE RIGHT TO USE "GREEN", "SAFE", "POWERFUL" AND "GREEN", APART FROM THE MARK AS SHOWN.

THE MARK CONSISTS OF THE STYLIZED LETTERS "SP" OVER THE STYLIZED WORD "GREEN" OVER THE STYLIZED WORDS "SAFE - POWERFUL - GREEN".

FOR ALL-PURPOSE CLEANING SOAP FOR INDUSTRIAL USE; ALL-PURPOSE CLEANING SOAP IN THE NATURE OF LIQUID SOAP; ALL-PURPOSE CLEANERS, NAMELY, SOAP (U.S. CLS. 1, 4, 6, 50, 51 AND 52).

FIRST USE 3-10-2008; IN COMMERCE 3-10-2008.

ANDREA HACK, EXAMINING ATTORNEY

CLASS 3—(Continued).

SN 77-429,608. EPIGENETIC ARCHETYPES, LLC, NEW CANAAN, CT. FILED 3-24-2008.

GENOMA SKIN

THE MARK CONSISTS OF STANDARD CHARACTERS WITHOUT CLAIM TO ANY PARTICULAR FONT, STYLE, SIZE, OR COLOR.

NO CLAIM IS MADE TO THE EXCLUSIVE RIGHT TO USE "SKIN", APART FROM THE MARK AS SHOWN.

FOR COSMETIC CREAMS FOR SKIN CARE; COSMETIC PREPARATIONS FOR SKIN RENEWAL; SKIN CREAM; SKIN LOTION; SKIN MOISTURIZER; SKIN TONERS; BEAUTY SERUMS; SKIN CONDITIONERS; FACIAL CLEANSERS; SKIN CLEANSERS; SOAPS FOR PERSONAL USE; HAND CREAMS; LIP CREAM; FACE CREAMS; BODY CREAM (U.S. CLS. 1, 4, 6, 50, 51 AND 52).

FIRST USE 2-1-2008; IN COMMERCE 2-1-2008.

GRETTA YAO, EXAMINING ATTORNEY

SN 77-429,618. CAL TAN LLC, LOS ANGELES, CA. FILED 3-24-2008.

X FORCE

THE MARK CONSISTS OF STANDARD CHARACTERS WITHOUT CLAIM TO ANY PARTICULAR FONT, STYLE, SIZE, OR COLOR.

FOR SUNTANNING PREPARATIONS, SUN TAN LOTION, SUN TAN GEL, SUN TAN CREAMS, ALL FOR USE IN INDOOR TANNING (U.S. CLS. 1, 4, 6, 50, 51 AND 52).

GRETTA YAO, EXAMINING ATTORNEY

SN 77-429,636. MENPER DISTRIBUTORS INC., MIAMI, FL.
FILED 3-24-2008.

VIOLETAS TIERNAS

THE MARK CONSISTS OF STANDARD CHARACTERS WITHOUT CLAIM TO ANY PARTICULAR FONT, STYLE, SIZE, OR COLOR.

NO CLAIM IS MADE TO THE EXCLUSIVE RIGHT TO USE "VIOLETAS", APART FROM THE MARK AS SHOWN. THE FOREIGN WORDING IN THE MARK TRANSLATES INTO ENGLISH AS TENDER VIOLETS.

FOR BABY LOTION (U.S. CLS. 1, 4, 6, 50, 51 AND 52).

FIRST USE 1-15-2004; IN COMMERCE 1-15-2004.

KAELIE KUNG, EXAMINING ATTORNEY

CLASS 3—(Continued).

SN 77-429,750. SEPHORA USA, INC., SAN FRANCISCO, CA. FILED 3-24-2008.

TRUE ROMANCE EYESHADOW
PALETTE

THE MARK CONSISTS OF STANDARD CHARACTERS WITHOUT CLAIM TO ANY PARTICULAR FONT, STYLE, SIZE, OR COLOR.

NO CLAIM IS MADE TO THE EXCLUSIVE RIGHT TO USE "EYESHADOW PALETTE", APART FROM THE MARK AS SHOWN.

FOR COSMETICS, NAMELY, EYESHADOW (U.S. CLS. 1, 4, 6, 50, 51 AND 52).

TANYA AMOS, EXAMINING ATTORNEY

CLASS 3—(Continued).

SN 77-429,945. DNA HEALTH INSTITUTE, CRYOGENIC DIVISION, LLC, VENTURA, CA. FILED 3-24-2008.

ZENVIDA

THE MARK CONSISTS OF STANDARD CHARACTERS WITHOUT CLAIM TO ANY PARTICULAR FONT, STYLE, SIZE, OR COLOR.

FOR NON-MEDICATED SKIN CARE PREPARATIONS, NAMELY, CREAMS, LOTIONS, GELS, TONERS, CLEANSERS AND PEELS; SKIN CARE PREPARATION, NAMELY, BODY POLISH; SKIN CARE PRODUCTS, NAMELY, NON-MEDICATED SKIN SERUM; COSMETIC PREPARATIONS FOR SKIN RENEWAL; SKIN CLEANSERS; SKIN MOISTURIZER; SKIN MOISTURIZER MASKS; SUN BLOCK (U.S. CLS. 1, 4, 6, 50, 51 AND 52). ELLEN PERKINS, EXAMINING ATTORNEY

SN 77-429,786. TED GIBSON & COMPANY, INC., NEW YORK, NY. FILED 3-24-2008.

REINVENTION

THE MARK CONSISTS OF STANDARD CHARACTERS WITHOUT CLAIM TO ANY PARTICULAR FONT, STYLE, SIZE, OR COLOR.

FOR FOAMING PROTEIN SKIN MASK (U.S. CLS. 1, 4, 6, 50, 51 AND 52).

WENDY GOODMAN, EXAMINING ATTORNEY

SN 77-429,962. SOAK WASH INC., MISSISSAUGA, ONTARIO, CANADA, FILED 3-24-2008.



THE MARK CONSISTS OF THE WORD "SOAK" ON A DESIGNED BACKGROUND.

FOR BIODEGRADABLE LAUNDRY PREPARATIONS USED FOR WASHING FINE FIBRES, KNIT ITEMS, LINGERIE, QUILTS AND BABY CLOTHING; LINEN SPRAYS AND LAUNDRY SOAPS (U.S. CLS. 1, 4, 6, 50, 51 AND 52).

WENDY JUN, EXAMINING ATTORNEY

SN 77-429,806. TED GIBSON & COMPANY, INC., NEW YORK, NY. FILED 3-24-2008.

FRIZZENT!

THE MARK CONSISTS OF STANDARD CHARACTERS WITHOUT CLAIM TO ANY PARTICULAR FONT, STYLE, SIZE, OR COLOR.

FOR SHAMPOOS, HAIR CONDITIONERS AND HAIR STYLING PREPARATIONS (U.S. CLS. 1, 4, 6, 50, 51 AND 52).

WENDY GOODMAN, EXAMINING ATTORNEY

SN 77-429,984. SOAK WASH INC., MISSISSAUGA, ONTARIO, CANADA, FILED 3-24-2008.

SOAK WORTHY

THE MARK CONSISTS OF STANDARD CHARACTERS WITHOUT CLAIM TO ANY PARTICULAR FONT, STYLE, SIZE, OR COLOR.

FOR BIODEGRADABLE LAUNDRY PREPARATIONS USED FOR WASHING FINE FIBRES, KNIT ITEMS, LINGERIE, QUILTS AND BABY CLOTHING; LINEN SPRAYS AND LAUNDRY SOAPS (U.S. CLS. 1, 4, 6, 50, 51 AND 52).

WENDY JUN, EXAMINING ATTORNEY

CLASS 3—(Continued).

SN 77-430,269. CHIALTAS, DEBORAH, SAN DIEGO, CA. FILED 3-24-2008.

SOAPSICLE

THE MARK CONSISTS OF STANDARD CHARACTERS WITHOUT CLAIM TO ANY PARTICULAR FONT, STYLE, SIZE, OR COLOR.

FOR BAR SOAP; BATH SOAPS; COSMETIC SOAPS (U.S. CLS. 1, 4, 6, 50, 51 AND 52).
FIRST USE 9-1-2006; IN COMMERCE 9-1-2006.
JAMES LOVELACE, EXAMINING ATTORNEY

CLASS 3—(Continued).

SN 77-431,025. OJON CORPORATION, NEW YORK, NY. FILED 3-25-2008.

RARE HARVEST

THE MARK CONSISTS OF STANDARD CHARACTERS WITHOUT CLAIM TO ANY PARTICULAR FONT, STYLE, SIZE, OR COLOR.

FOR HAIR CARE PREPARATIONS; NON-MEDICATED SKIN CARE PREPARATIONS; BODY AND BEAUTY CARE COSMETICS (U.S. CLS. 1, 4, 6, 50, 51 AND 52).
FIRST USE 10-31-2006; IN COMMERCE 10-31-2006.
BARNEY CHARLON, EXAMINING ATTORNEY

SN 77-430,575. DIAL BRANDS, INC., SCOTTSDALE, AZ. FILED 3-25-2008.

SPRING OASIS

THE MARK CONSISTS OF STANDARD CHARACTERS WITHOUT CLAIM TO ANY PARTICULAR FONT, STYLE, SIZE, OR COLOR.

FOR LAUNDRY DETERGENTS; FABRIC SOFTENERS (U.S. CLS. 1, 4, 6, 50, 51 AND 52).
KAREN SEVERSON, EXAMINING ATTORNEY

SN 77-431,152. PACIFIC WORLD CORPORATION, LAKE FOREST, CA. FILED 3-25-2008.

LIGHT AS AIR

THE MARK CONSISTS OF STANDARD CHARACTERS WITHOUT CLAIM TO ANY PARTICULAR FONT, STYLE, SIZE, OR COLOR.

FOR ARTIFICIAL FINGERNAILS (U.S. CLS. 1, 4, 6, 50, 51 AND 52).
JAMES STEIN, EXAMINING ATTORNEY

SN 77-430,677. WOLFE BROTHERS FACE ART & FX, ORLANDO, FL. FILED 3-25-2008.

WOLFE BROTHERS FACE ART & FX

NO CLAIM IS MADE TO THE EXCLUSIVE RIGHT TO USE "BROTHERS" OR "FACE ART & EFFECTS", APART FROM THE MARK AS SHOWN.

THE MARK CONSISTS OF A STYLIZED EYE SIMILAR TO A WOLF EYE AS THE "O" IN "WOLFE", AND A HORIZONTAL LINE SEPARATING THE TEXT "BROTHERS" AND "FACE ART & FX".

FOR COSMETICS; FACE GLITTER; MAKE-UP (U.S. CLS. 1, 4, 6, 50, 51 AND 52).
FIRST USE 4-1-2004; IN COMMERCE 5-1-2004.
ESTHER BELENKER, EXAMINING ATTORNEY

SN 77-431,313. MORNINGSIDE LLC, GARDEN CITY, ID. FILED 3-25-2008.

SIMPLE ORIGINALS

THE MARK CONSISTS OF STANDARD CHARACTERS WITHOUT CLAIM TO ANY PARTICULAR FONT, STYLE, SIZE, OR COLOR.

FOR BATH SOAPS IN LIQUID, SOLID OR GEL FORM; LIQUID SOAPS FOR HANDS, FACE AND BODY; PERFUMED SOAPS, SKIN CLEANSERS, SKIN SOAP, SOAPS FOR BODY CARE, BODY LOTION, SKIN LOTIONS, HAND CREAMS, PERFUMED CREAMS, HAND SOAPS, BODY SCRUB, EXFOLIANTS FOR SKIN, FRAGRANCES FOR PERSONAL USE AND PERFUMERY (U.S. CLS. 1, 4, 6, 50, 51 AND 52).

FIRST USE 12-15-2007; IN COMMERCE 12-15-2007.
CHRISTOPHER BUONGIORNO, EXAMINING ATTORNEY

CLASS 3—(Continued).

SN 77-431,333. DIAL BRANDS, INC., SCOTTSDALE, AZ.
FILED 3-25-2008.

HEALTHIER SKIN HEALTHIER
YOU

THE MARK CONSISTS OF STANDARD CHARACTERS WITHOUT CLAIM TO ANY PARTICULAR FONT, STYLE, SIZE, OR COLOR.

FOR ANTIBACTERIAL SKIN SOAPS; EXFOLIANTS FOR SKIN; LOTIONS FOR SKIN; NON-MEDICATED SKIN CARE PREPARATIONS; NON-MEDICATED SKIN CREAMS; SKIN CLARIFIERS; SKIN CLEANSERS; SKIN LOTION; SKIN MOISTURIZER; SKIN MOISTURIZER MASKS; SKIN SOAP; SKIN TONERS; ANTIBACTERIAL SOAP; BAR SOAP; BATH SOAPS; DEODORANT SOAP; HAND SOAPS; LIQUID SOAPS; WATERLESS SOAP; BODY DEODORANTS; BODY LOTIONS; BODY MASKS; BODY POWDER; BODY SCRUB; BODY SPRAYS; BODY WASHES; DEODORANTS FOR BODY CARE (U.S. CLS. 1, 4, 6, 50, 51 AND 52).

KAREN SEVERSON, EXAMINING ATTORNEY

SN 77-431,356. WELL-BEING HOUSE, LLC, DBA TEA-LOVE
WELL-BEING HOUSE, LLC, GARDEN GROVE, CA.
FILED 3-25-2008.

NOATO

THE MARK CONSISTS OF STANDARD CHARACTERS WITHOUT CLAIM TO ANY PARTICULAR FONT, STYLE, SIZE, OR COLOR.

FOR MOISTURIZING CREAMS (U.S. CLS. 1, 4, 6, 50, 51 AND 52).

FIRST USE 9-20-2007; IN COMMERCE 11-20-2007.
KEVIN CORWIN, EXAMINING ATTORNEY

SN 77-431,362. INTERNATIONAL DERMAL INSTITUTE,
INC., CARSON, CA. FILED 3-25-2008.

powerfoliant²

THE MARK CONSISTS OF A STYLIZED REPRESENTATION OF "POWERFOLIANT²"

FOR COSMETIC PREPARATIONS FOR SKIN RENEWAL, EXFOLIANTS FOR SKIN, NON-MEDICATED SKIN CARE PREPARATIONS, AND SKIN CREAMS IN LIQUID AND SOLID FORM (U.S. CLS. 1, 4, 6, 50, 51 AND 52).

MONIQUE MILLER, EXAMINING ATTORNEY

CLASS 3—(Continued).

SN 77-431,477. TIENKEN, DAWN MARIE, VENTNOR CITY,
NJ. FILED 3-25-2008.



THE MARK CONSISTS OF THE STYLIZED OUTLINED IMAGE OF A BUTTERFLY.

FOR COSMETICS (U.S. CLS. 1, 4, 6, 50, 51 AND 52).
HENRY S. ZAK, EXAMINING ATTORNEY

SN 77-431,511. MORNINGSIDE LLC, GARDEN CITY, ID.
FILED 3-26-2008.

MORNINGSIDE

THE MARK CONSISTS OF STANDARD CHARACTERS WITHOUT CLAIM TO ANY PARTICULAR FONT, STYLE, SIZE, OR COLOR.

FOR BATH SOAPS IN LIQUID, SOLID OR GEL FORM; LIQUID SOAPS FOR HANDS, FACE AND BODY; PERFUMED SOAPS, SOAPS FOR BODY CARE, BODY LOTION, SKIN LOTIONS, HAND CREAMS, PERFUMED CREAMS, HAND SOAPS, FRAGRANCES FOR PERSONAL USE AND PERFUMERY (U.S. CLS. 1, 4, 6, 50, 51 AND 52).

FIRST USE 6-1-2007; IN COMMERCE 6-1-2007.
CHRISTOPHER BUONGIORNO, EXAMINING ATTORNEY

SN 77-431,738. PIERRE FABRE MEDICAMENT, BOULOGNE, FRANCE, FILED 3-26-2008.

ELGYDIUM

THE MARK CONSISTS OF STANDARD CHARACTERS WITHOUT CLAIM TO ANY PARTICULAR FONT, STYLE, SIZE, OR COLOR.

OWNER OF U.S. REG. NOS. 989,726 AND 1,186,812.
FOR MOUTHWASHES (U.S. CLS. 1, 4, 6, 50, 51 AND 52).

FIRST USE 1-0-1972; IN COMMERCE 1-4-2008.
LANA PHAM, EXAMINING ATTORNEY

CLASS 3—(Continued).

SN 77-431,795. SERGEANT'S PET CARE PRODUCTS, INC., OMAHA, NE. FILED 3-26-2008.

BANSECT

THE MARK CONSISTS OF STANDARD CHARACTERS WITHOUT CLAIM TO ANY PARTICULAR FONT, STYLE, SIZE, OR COLOR.

OWNER OF U.S. REG. NO. 893,965.
FOR PET SHAMPOO (U.S. CLS. 1, 4, 6, 50, 51 AND 52).
FIRST USE 1-0-2005; IN COMMERCE 1-0-2005.
ARETHA SOMERVILLE, EXAMINING ATTORNEY

CLASS 3—(Continued).

SN 77-432,114. STEARN'S PRODUCTS, INC., SIMI VALLEY, CA. FILED 3-26-2008.

SKINBIOTICS

THE MARK CONSISTS OF STANDARD CHARACTERS WITHOUT CLAIM TO ANY PARTICULAR FONT, STYLE, SIZE, OR COLOR.

FOR SKIN CREAM (U.S. CLS. 1, 4, 6, 50, 51 AND 52).
FIRST USE 3-11-2008; IN COMMERCE 3-11-2008.
JERI J. FICKES, EXAMINING ATTORNEY

SN 77-432,046. LTR CAPITAL LLC, HINSDALE, IL. FILED 3-26-2008.

Bike Head

THE MARK CONSISTS OF STANDARD CHARACTERS WITHOUT CLAIM TO ANY PARTICULAR FONT, STYLE, SIZE, OR COLOR.

FOR CONDITIONERS; HAIR CARE CREAMS; HAIR CARE LOTIONS; HAIR CARE PREPARATIONS; HAIR STRAIGHTENING PREPARATIONS; NON-MEDICATED HAIR RESTORATION LOTIONS; OILS FOR HAIR CONDITIONING (U.S. CLS. 1, 4, 6, 50, 51 AND 52).
ROBIN MITTLER, EXAMINING ATTORNEY

SN 77-432,063. MATA BUSINESS SERVICES LLC, HOUSTON, TX. FILED 3-26-2008.

VIRGO

THE MARK CONSISTS OF STANDARD CHARACTERS WITHOUT CLAIM TO ANY PARTICULAR FONT, STYLE, SIZE, OR COLOR.

FOR HAIR CONDITIONERS; HAIR CREAMS; HAIR LOTIONS; HAIR SHAMPOO (U.S. CLS. 1, 4, 6, 50, 51 AND 52).

SANDRA MANIOS, EXAMINING ATTORNEY

SN 77-432,647. MANN, LARRY, AUBURN, ME. FILED 3-26-2008.

Lustershield

THE MARK CONSISTS OF STANDARD CHARACTERS WITHOUT CLAIM TO ANY PARTICULAR FONT, STYLE, SIZE, OR COLOR.

FOR FURNITURE POLISH; A WAX COMPOUND FOR POLISHING INTERIOR WOOD SURFACES (U.S. CLS. 1, 4, 6, 50, 51 AND 52).

BARBARA BROWN, EXAMINING ATTORNEY

SN 77-432,941. THE USHEROFF INSTITUTE, INC., WEST PALM BEACH, FL. FILED 3-27-2008.

THE ART OF WOW

THE MARK CONSISTS OF STANDARD CHARACTERS WITHOUT CLAIM TO ANY PARTICULAR FONT, STYLE, SIZE, OR COLOR.

OWNER OF U.S. REG. NO. 2,727,926.
FOR COSMETICS, NAMELY, LIP GLOSS, LIPSTICK, BLUSH, EYE BROW COLORANTS, EYELINER, CONCEALER, AND FOUNDATION (U.S. CLS. 1, 4, 6, 50, 51 AND 52).

SUNG IN, EXAMINING ATTORNEY

CLASS 3—(Continued).

SN 77-433,189. LULO INC., SYRACUSE, NY. FILED 3-27-2008.

Bark Place

THE MARK CONSISTS OF STANDARD CHARACTERS WITHOUT CLAIM TO ANY PARTICULAR FONT, STYLE, SIZE, OR COLOR.

FOR PET SHAMPOOS, PET FRAGRANCES, AND PET SKIN MOISTURIZERS (U.S. CLS. 1, 4, 6, 50, 51 AND 52).
SUNG IN, EXAMINING ATTORNEY

CLASS 3—(Continued).

SN 77-433,428. URBAN ORGANICS, ROLLING HILLS ESTATES, CA. FILED 3-27-2008.

FOUR TRUFFLES

THE MARK CONSISTS OF STANDARD CHARACTERS WITHOUT CLAIM TO ANY PARTICULAR FONT, STYLE, SIZE, OR COLOR.

FOR BODY AND BEAUTY CARE COSMETICS; BODY LOTIONS; FACE AND BODY CREAMS; FACE AND BODY LOTIONS; BATH GELS; NON-MEDICATED SKIN CARE PREPARATIONS; SKIN CREAMS; HAIR CARE PREPARATIONS; SUNSCREEN CREAMS; SKIN CLEANSERS (U.S. CLS. 1, 4, 6, 50, 51 AND 52).

JESSICA A. POWERS, EXAMINING ATTORNEY

SN 77-433,496. FACEJOY, LLC, RANDOLPH, NJ. FILED 3-27-2008.

facejoy

THE MARK CONSISTS OF STANDARD CHARACTERS WITHOUT CLAIM TO ANY PARTICULAR FONT, STYLE, SIZE, OR COLOR.

FOR NON-MEDICATED SKIN CARE PREPARATIONS; NON-MEDICATED SKIN CARE PREPARATIONS, NAMELY, CREAMS, LOTIONS, GELS, TONERS, CLEANSERS AND PEELS; FACIAL CLEANSERS; FACIAL CREAMS; FACIAL LOTION (U.S. CLS. 1, 4, 6, 50, 51 AND 52).

RONALD AIKENS, EXAMINING ATTORNEY

SN 77-433,258. OD INTERNATIONAL, INC, CHATSWORTH, CA. FILED 3-27-2008.

ONSEN

THE MARK CONSISTS OF STANDARD CHARACTERS WITHOUT CLAIM TO ANY PARTICULAR FONT, STYLE, SIZE, OR COLOR.

THE MEANING OF THE NAME "ONSEN" IS HOT SPRINGS IN JAPANESE.

FOR SKIN CARE PREPARATIONS, FOR THE FACE, AND THE BODY IN THE FORM OF, FACIAL MOISTURIZER, FACIAL CREAM, FACIAL PEELING, FACIAL MASK, FACIAL CLEANSER, NON-MEDICATED FACIAL AND EYE SERUM, EYE GEL, ANTI-AGING EYE CREAM, ANTI-AGING FACE CREAM, NON-MEDICATED INSTANT FACE LIFTING CREAM, NON-MEDICATED INSTANT STRETCHING MASK, HAND CREAM, SALT FACIAL SCRUB, BODY CREAM, NON-MEDICATED COSMETIC PREPARATIONS FOR THE BATH IN THE FORM OF, BATH SALTS, BATH MINERALS, GELS AND OILS, NON-MEDICATED FOOT CREAM AND BODY LOTION, NON-MEDICATED ANTI-AGING PREPARATIONS IN THE FORM OF LOTIONS, MILKS, CREAMS AND GELS, COSMETIC PREPARATION FOR NAIL CARE IN THE FORM OF BUFFERS, FILERS, SHAPERS, HAND AND NAIL CONDITIONER (U.S. CLS. 1, 4, 6, 50, 51 AND 52).

FIRST USE 7-1-2005; IN COMMERCE 7-1-2005.

NORA BUCHANAN WILL, EXAMINING ATTORNEY

SN 77-433,591. SHIPMAN ASSOCIATES, INC., SAN FRANCISCO, CA. FILED 3-27-2008.

mama mia

THE MARK CONSISTS OF STANDARD CHARACTERS WITHOUT CLAIM TO ANY PARTICULAR FONT, STYLE, SIZE, OR COLOR.

THE FOREIGN WORDING IN THE MARK TRANSLATES INTO ENGLISH AS MY MOTHER.

FOR COSMETICS; BLUSH (U.S. CLS. 1, 4, 6, 50, 51 AND 52).

ESTHER BELENKER, EXAMINING ATTORNEY

CLASS 3—(Continued).

SN 77-433,771. THE SWISS COLONY, INC., MONROE, WI.
FILED 3-27-2008.

MIDNIGHT VELVET STYLE

THE MARK CONSISTS OF STANDARD CHARACTERS WITHOUT CLAIM TO ANY PARTICULAR FONT, STYLE, SIZE, OR COLOR.

OWNER OF U.S. REG. NOS. 1,505,336, 3,223,145 AND OTHERS.

FOR PERFUME; FRAGRANCES; COMPACTS CONTAINING MAKE-UP (U.S. CLS. 1, 4, 6, 50, 51 AND 52).

FIRST USE 0-0-2007; IN COMMERCE 0-0-2007.

JILL C. ALT, EXAMINING ATTORNEY

SN 77-433,816. HOWARD BERGER CO., INC., MONROE, NJ.
FILED 3-27-2008.

HOT SHOT

THE MARK CONSISTS OF STANDARD CHARACTERS WITHOUT CLAIM TO ANY PARTICULAR FONT, STYLE, SIZE, OR COLOR.

FOR DRAIN OPENERS (U.S. CLS. 1, 4, 6, 50, 51 AND 52).

BRIAN CALLAGHAN, EXAMINING ATTORNEY

SN 77-433,852. EAST COAST SKIN CARE LLC, NEW YORK, NY. FILED 3-27-2008.

loose lips

THE MARK CONSISTS OF STANDARD CHARACTERS WITHOUT CLAIM TO ANY PARTICULAR FONT, STYLE, SIZE, OR COLOR.

FOR BODY AND BEAUTY CARE COSMETICS; COSMETICS, NAMELY, LIP PRIMER; LIPSTICK; LIPSTICKS (U.S. CLS. 1, 4, 6, 50, 51 AND 52).

FIRST USE 3-1-2008; IN COMMERCE 3-1-2008.

JILL PRATER, EXAMINING ATTORNEY

CLASS 3—(Continued).

SN 77-434,450. REYNOLDS, STEPHANIE A., DBA HOT-HOUSE BOTANICALS, CHANDLER, AZ. FILED 3-28-2008.



NO CLAIM IS MADE TO THE EXCLUSIVE RIGHT TO USE "BOTANICALS", APART FROM THE MARK AS SHOWN.

THE COLOR(S) GREEN AND WHITE IS/ARE CLAIMED AS A FEATURE OF THE MARK.

THE MARK CONSISTS IN PART OF THE DESIGN OF DOUBLE DOORS OVER WHICH IS A FAN-SHAPED WINDOW. THE WORDING AND DESIGNS ARE GREEN, WITH THE WINDOW PANES AND DETAILING OUTLINED IN WHITE.

FOR AROMATHERAPY BODY CARE PRODUCTS, NAMELY, BODY LOTION, SHOWER GEL, CUTICLE CREAM, SHAMPOO, CONDITIONER, NON-MEDICATED LIP BALM, SOAP, BODY POLISH, BODY AND FOOT SCRUB AND NON-MEDICATED FOOT CREAM (U.S. CLS. 1, 4, 6, 50, 51 AND 52).

FIRST USE 11-9-2007; IN COMMERCE 11-9-2007.

IRA J. GOODSaid, EXAMINING ATTORNEY

SN 77-434,494. DESIGNER SKIN, LLC, INDIANAPOLIS, IN.
FILED 3-28-2008.

**DESIGNER SKIN
PHOENICIAN**

OWNER OF U.S. REG. NOS. 2,415,111, 3,362,774 AND OTHERS.

NO CLAIM IS MADE TO THE EXCLUSIVE RIGHT TO USE "SKIN", APART FROM THE MARK AS SHOWN.

THE MARK CONSISTS OF THE WORDS "DESIGNER SKIN PHOENICIAN" IN STYLIZED FONT.

FOR INDOOR TANNING PREPARATIONS (U.S. CLS. 1, 4, 6, 50, 51 AND 52).

NANCY CLARKE, EXAMINING ATTORNEY

CLASS 3—(Continued).

SN 77-434,653. STAINSAFE, INC., PALM BEACH GARDENS, FL. FILED 3-28-2008.

GREENGARD

THE MARK CONSISTS OF STANDARD CHARACTERS WITHOUT CLAIM TO ANY PARTICULAR FONT, STYLE, SIZE, OR COLOR.

FOR CLEANING PREPARATIONS FOR HOUSEHOLD PURPOSES (U.S. CLS. 1, 4, 6, 50, 51 AND 52).

FIRST USE 12-17-2007; IN COMMERCE 2-5-2008.
DANIEL CAPSHAW, EXAMINING ATTORNEY

CLASS 3—(Continued).

SN 77-434,994. MAOLI PERFUMES, LLC, BARRANQUITAS, PUERTO RICO, FILED 3-28-2008.

Maoli Perfumes

THE MARK CONSISTS OF STANDARD CHARACTERS WITHOUT CLAIM TO ANY PARTICULAR FONT, STYLE, SIZE, OR COLOR.

NO CLAIM IS MADE TO THE EXCLUSIVE RIGHT TO USE "PERFUMES", APART FROM THE MARK AS SHOWN.

THE FOREIGN WORDING IN THE MARK TRANSLATES INTO ENGLISH AS "ABORIGINE, INDIGENOUS".

FOR COSMETICS IN GENERAL, INCLUDING PERFUMES (U.S. CLS. 1, 4, 6, 50, 51 AND 52).

FIRST USE 1-16-2000; IN COMMERCE 1-16-2000.
DANIEL CAPSHAW, EXAMINING ATTORNEY

SN 77-434,684. STAINSAFE, INC., PALM BEACH GARDENS, FL. FILED 3-28-2008.

ECO-WISE

THE MARK CONSISTS OF STANDARD CHARACTERS WITHOUT CLAIM TO ANY PARTICULAR FONT, STYLE, SIZE, OR COLOR.

FOR CLEANING PREPARATIONS FOR HOUSEHOLD PURPOSES (U.S. CLS. 1, 4, 6, 50, 51 AND 52).

FIRST USE 12-17-2007; IN COMMERCE 2-5-2008.
DANIEL CAPSHAW, EXAMINING ATTORNEY

SN 77-435,514. VICTORIA'S SECRET STORES BRAND MANAGEMENT, INC., REYNOLDSBURG, OH. FILED 3-31-2008.

BEGUILING

THE MARK CONSISTS OF STANDARD CHARACTERS WITHOUT CLAIM TO ANY PARTICULAR FONT, STYLE, SIZE, OR COLOR.

FOR EAU DE PERFUME; PERFUMED POWDERS; PERFUMES; BODY CREAMS; BODY LOTIONS; BODY WASHES (U.S. CLS. 1, 4, 6, 50, 51 AND 52).

TEJBIR SINGH, EXAMINING ATTORNEY

SN 77-434,770. ZERRAN INTERNATIONAL CORPORATION, PACOIMA, CA. FILED 3-28-2008.

Clari-C

THE MARK CONSISTS OF STANDARD CHARACTERS WITHOUT CLAIM TO ANY PARTICULAR FONT, STYLE, SIZE, OR COLOR.

FOR NON-MEDICATED ACNE TREATMENT PREPARATIONS (U.S. CLS. 1, 4, 6, 50, 51 AND 52).

LOURDES AYALA, EXAMINING ATTORNEY

SN 77-436,594. TIENKEN, DAWN MARIE, VENTNOR CITY, NJ. FILED 4-1-2008.

THE NAME "DAWN MARIE TIENKEN" IDENTIFIES A LIVING INDIVIDUAL WHOSE CONSENT IS OF RECORD.

THE MARK CONSISTS OF THE STYLIZED TERM "DAWN MARIE", WITH THE STYLIZED OUTLINED IMAGE OF A BUTTERFLY.

FOR COSMETICS (U.S. CLS. 1, 4, 6, 50, 51 AND 52).
HENRY S. ZAK, EXAMINING ATTORNEY

CLASS 3—(Continued).

SN 77-439,503. UNILEVER SUPPLY CHAIN, INC., CLINTON, CT. FILED 4-3-2008.

CLASS 3—(Continued).

SN 77-449,521. PALMER FIXTURE COMPANY, GREEN BAY, WI. FILED 4-16-2008.

SaniSuds

FUNKY TO FRESH

THE MARK CONSISTS OF STANDARD CHARACTERS WITHOUT CLAIM TO ANY PARTICULAR FONT, STYLE, SIZE, OR COLOR.
FOR DEODORANT BODY SPRAYS (U.S. CLS. 1, 4, 6, 50, 51 AND 52).
JASON ROTH, EXAMINING ATTORNEY

THE MARK CONSISTS OF STANDARD CHARACTERS WITHOUT CLAIM TO ANY PARTICULAR FONT, STYLE, SIZE, OR COLOR.

FOR ALMOND SOAPS; ANTIBACTERIAL SKIN SOAPS; ANTIBACTERIAL SOAP; AROMATHERAPY BODY CARE PRODUCTS, NAMELY, BODY LOTION, SHOWER GEL, CUTICLE CREAM, SHAMPOO, CONDITIONER, NON-MEDICATED LIP BALM, SOAP, BODY POLISH, BODY AND FOOT SCRUB AND NON-MEDICATED FOOT CREAM; BATH SOAPS; BATH SOAPS IN LIQUID, SOLID OR GEL FORM; BODY CREAM SOAP; CAKES OF TOILET SOAP; COSMETIC SOAPS; CREAM SOAPS; DEODORANT SOAP; DETERGENT SOAP; DISINFECTANT SOAPS; DISINFECTING PERFUMED SOAPS; GRANULATED SOAPS; HAND SOAPS; INDUSTRIAL SOAP; LAUNDRY SOAP; LIQUID BATH SOAPS; LIQUID SOAP; LIQUID SOAP USED IN FOOT BATH; LIQUID SOAPS; LIQUID SOAPS FOR HANDS AND FACE; LIQUID SOAPS FOR HANDS, FACE AND BODY; MEDICATED SOAP; MEDICATED SOAPS; PERFUMED SOAP; PERFUMED SOAPS; SADDLE SOAP; SHAVING SOAP; SHAVING SOAPS; SKIN SOAP; SOAP POWDER; SOAPS; SOAPS AND DETERGENTS; SOAPS FOR BODY CARE; SOAPS FOR HOUSEHOLD USE; SOAPS FOR PERSONAL USE; SOAPS FOR TOILET PURPOSES; TOILET SOAP; TOILET SOAPS; WATERLESS SOAP (U.S. CLS. 1, 4, 6, 50, 51 AND 52).
GISELLE AGOSTO, EXAMINING ATTORNEY

SN 77-446,909. WRIGHT, BRUCE D, SARASOTA, FL. FILED 4-13-2008.

SN 77-450,592. AUSTRALIAN GOLD, INC., INDIANAPOLIS, IN. FILED 4-17-2008.

BioDent

BIOBRONZE

THE MARK CONSISTS OF STANDARD CHARACTERS WITHOUT CLAIM TO ANY PARTICULAR FONT, STYLE, SIZE, OR COLOR.
FOR TOOTHPASTES; TOOTHPASTE AND MOUTHWASHES (U.S. CLS. 1, 4, 6, 50, 51 AND 52).
JOHN WILKE, EXAMINING ATTORNEY

THE MARK CONSISTS OF STANDARD CHARACTERS WITHOUT CLAIM TO ANY PARTICULAR FONT, STYLE, SIZE, OR COLOR.

FOR SKIN CARE PREPARATIONS, NAMELY, NON-MEDICATED INDOOR SKIN TANNING PREPARATIONS (U.S. CLS. 1, 4, 6, 50, 51 AND 52).
INGRID C. EULIN, EXAMINING ATTORNEY

CLASS 3—(Continued).

SN 77-454,383. SCHERER LABS INTERNATIONAL, LLC, HOLLY HILL, FL. FILED 4-22-2008.

NO FADE

THE MARK CONSISTS OF STANDARD CHARACTERS WITHOUT CLAIM TO ANY PARTICULAR FONT, STYLE, SIZE, OR COLOR.

FOR HAIR COLOR, SHAMPOO AND SUN-TANNING PREPARATIONS (U.S. CLS. 1, 4, 6, 50, 51 AND 52).
CHARLES L. JENKINS, EXAMINING ATTORNEY

CLASS 3—(Continued).

SN 77-455,439. AMIR, INC., EAGAN, MN. FILED 4-23-2008.

THAT'S TAN

THE MARK CONSISTS OF STANDARD CHARACTERS WITHOUT CLAIM TO ANY PARTICULAR FONT, STYLE, SIZE, OR COLOR.

NO CLAIM IS MADE TO THE EXCLUSIVE RIGHT TO USE "TAN", APART FROM THE MARK AS SHOWN.

FOR SUN CARE PRODUCTS, NAMELY, SUNTAN LOTIONS, INDOOR TANNING LOTION AND SKIN MOISTURIZERS (U.S. CLS. 1, 4, 6, 50, 51 AND 52).
SUSAN RICHARDS, EXAMINING ATTORNEY

SN 77-454,486. SHIPMAN ASSOCIATES, INC., SAN FRANCISCO, CA. FILED 4-22-2008.

cabana boy

THE MARK CONSISTS OF STANDARD CHARACTERS WITHOUT CLAIM TO ANY PARTICULAR FONT, STYLE, SIZE, OR COLOR.

FOR COSMETICS; EYESHADOW; BLUSH (U.S. CLS. 1, 4, 6, 50, 51 AND 52).
ESTHER BELENKER, EXAMINING ATTORNEY

SN 77-455,445. AMIR, INC., EAGAN, MN. FILED 4-23-2008.

THAT'S BROWN

THE MARK CONSISTS OF STANDARD CHARACTERS WITHOUT CLAIM TO ANY PARTICULAR FONT, STYLE, SIZE, OR COLOR.

NO CLAIM IS MADE TO THE EXCLUSIVE RIGHT TO USE "BROWN", APART FROM THE MARK AS SHOWN.

FOR SUN CARE PRODUCTS, NAMELY, SUNTAN LOTIONS, INDOOR TANNING LOTION AND SKIN MOISTURIZERS (U.S. CLS. 1, 4, 6, 50, 51 AND 52).
SUSAN RICHARDS, EXAMINING ATTORNEY

SN 77-454,523. SHIPMAN ASSOCIATES, INC., SAN FRANCISCO, CA. FILED 4-22-2008.

down boy

THE MARK CONSISTS OF STANDARD CHARACTERS WITHOUT CLAIM TO ANY PARTICULAR FONT, STYLE, SIZE, OR COLOR.

FOR COSMETICS; EYESHADOW; BLUSH (U.S. CLS. 1, 4, 6, 50, 51 AND 52).
ESTHER BELENKER, EXAMINING ATTORNEY

SN 77-456,086. UNILEVER SUPPLY CHAIN, INC., CLINTON, CT. FILED 4-23-2008.

DEGREE CLASSIC ROMANCE

THE MARK CONSISTS OF STANDARD CHARACTERS WITHOUT CLAIM TO ANY PARTICULAR FONT, STYLE, SIZE, OR COLOR.

OWNER OF U.S. REG. NOS. 1,574,203, 2,744,693 AND OTHERS.

FOR ANTI-PERSPIRANTS, DEODORANTS AND BODY MISTS (U.S. CLS. 1, 4, 6, 50, 51 AND 52).
JASON ROTH, EXAMINING ATTORNEY

CLASS 3—(Continued).

SN 77-456,105. UNILEVER SUPPLY CHAIN, INC., CLINTON, CT. FILED 4-23-2008.

FRESHNESS FROM WASH TO WEAR AND BEYOND

THE MARK CONSISTS OF STANDARD CHARACTERS WITHOUT CLAIM TO ANY PARTICULAR FONT, STYLE, SIZE, OR COLOR.
FOR LAUNDRY DETERGENT (U.S. CLS. 1, 4, 6, 50, 51 AND 52).
JASON ROTH, EXAMINING ATTORNEY

SN 77-456,141. UNILEVER SUPPLY CHAIN, INC., CLINTON, CT. FILED 4-23-2008.

DEGREE PERFECT RADIANCE

THE MARK CONSISTS OF STANDARD CHARACTERS WITHOUT CLAIM TO ANY PARTICULAR FONT, STYLE, SIZE, OR COLOR.
OWNER OF U.S. REG. NOS. 1,574,203, 2,744,693 AND OTHERS.
FOR ANTI-PERSPIRANTS AND DEODORANTS (U.S. CLS. 1, 4, 6, 50, 51 AND 52).
JASON ROTH, EXAMINING ATTORNEY

SN 77-456,218. UNILEVER SUPPLY CHAIN, INC., CLINTON, CT. FILED 4-23-2008.

DEGREE SEXY INTRIGUE

THE MARK CONSISTS OF STANDARD CHARACTERS WITHOUT CLAIM TO ANY PARTICULAR FONT, STYLE, SIZE, OR COLOR.
OWNER OF U.S. REG. NOS. 1,574,203, 2,744,693 AND OTHERS.
FOR ANTI-PERSPIRANTS, DEODORANTS AND BODY MISTS (U.S. CLS. 1, 4, 6, 50, 51 AND 52).
JASON ROTH, EXAMINING ATTORNEY

CLASS 3—(Continued).

SN 77-457,260. SHIPMAN ASSOCIATES, INC., SAN FRANCISCO, CA. FILED 4-24-2008.

egoLid

THE MARK CONSISTS OF STANDARD CHARACTERS WITHOUT CLAIM TO ANY PARTICULAR FONT, STYLE, SIZE, OR COLOR.
FOR COSMETICS; EYESHADOW (U.S. CLS. 1, 4, 6, 50, 51 AND 52).
ESTHER BELENKER, EXAMINING ATTORNEY

SN 77-458,216. DESIGNER SKIN, LLC, INDIANAPOLIS, IN. FILED 4-25-2008.

DESIGNER SKIN INTRIGUE

THE MARK CONSISTS OF STANDARD CHARACTERS WITHOUT CLAIM TO ANY PARTICULAR FONT, STYLE, SIZE, OR COLOR.
OWNER OF U.S. REG. NOS. 2,415,111, 2,749,349 AND OTHERS.
NO CLAIM IS MADE TO THE EXCLUSIVE RIGHT TO USE "SKIN", APART FROM THE MARK AS SHOWN.
FOR INDOOR TANNING PREPARATIONS (U.S. CLS. 1, 4, 6, 50, 51 AND 52).
NANCY CLARKE, EXAMINING ATTORNEY

SN 77-459,598. ECO BEAUTY VENTURES, LLC, MAPLE HEIGHTS, OH. FILED 4-28-2008.

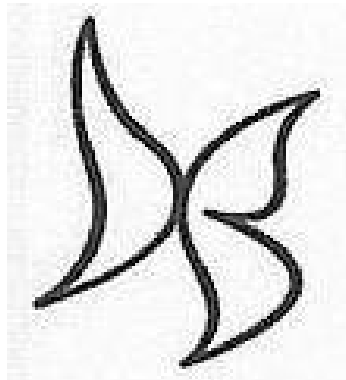

THE MARK CONSISTS OF THE STYLIZED LETTERS "D" AND "B" IN THE FORM OF A BUTTERFLY.
FOR HAIR CONDITIONERS; HAIR SHAMPOO; HAIR CARE PREPARATIONS; HAIR FIXERS (U.S. CLS. 1, 4, 6, 50, 51 AND 52).
CIMMERIAN COLEMAN, EXAMINING ATTORNEY

CLASS 3—(Continued).

SN 77-460,397. LAURA GELLER MAKE-UP STUDIOS LTD.,
NEW YORK, NY. FILED 4-29-2008.

BLUSH -N- BRIGHTEN

THE MARK CONSISTS OF STANDARD CHARACTERS
WITHOUT CLAIM TO ANY PARTICULAR FONT, STYLE,
SIZE, OR COLOR.

OWNER OF U.S. REG. NOS. 2,989,610 AND 3,168,706.
FOR BLUSH (U.S. CLS. 1, 4, 6, 50, 51 AND 52).
FIRST USE 5-1-2006; IN COMMERCE 5-1-2006.
KELLY CHOE, EXAMINING ATTORNEY

SN 77-461,282. GARCEAU, ARTHUR H., HOLLYWOOD, FL.
FILED 4-29-2008.

XI'A XI'ANG

THE MARK CONSISTS OF STANDARD CHARACTERS
WITHOUT CLAIM TO ANY PARTICULAR FONT, STYLE,
SIZE, OR COLOR.

THE FOREIGN WORDING IN THE MARK TRANSLATES
INTO ENGLISH AS "THE FRAGRANCE OF THE IMAGI-
NATION".

FOR COLOGNES, PERFUMES AND COSMETICS (U.S.
CLS. 1, 4, 6, 50, 51 AND 52).
FIRST USE 6-13-2004; IN COMMERCE 6-13-2004.
ANGELA M. MICHELI, EXAMINING ATTORNEY

SN 77-461,356. SHIPMAN ASSOCIATES, INC., SAN FRAN-
CISCO, CA. FILED 4-29-2008.

big boy

THE MARK CONSISTS OF STANDARD CHARACTERS
WITHOUT CLAIM TO ANY PARTICULAR FONT, STYLE,
SIZE, OR COLOR.

FOR COSMETICS; MAKE-UP KITS COMPRISED OF
FACE POWDER, BLUSH, BRONZING POWDER (U.S.
CLS. 1, 4, 6, 50, 51 AND 52).

ESTHER BELENKER, EXAMINING ATTORNEY

CLASS 3—(Continued).

SN 77-461,967. QUANTUM, INC., EUGENE, OR. FILED 4-30-
2008.

BREATH PROTECT

THE MARK CONSISTS OF STANDARD CHARACTERS
WITHOUT CLAIM TO ANY PARTICULAR FONT, STYLE,
SIZE, OR COLOR.

NO CLAIM IS MADE TO THE EXCLUSIVE RIGHT TO
USE "BREATH", APART FROM THE MARK AS SHOWN.

FOR BREATH FRESHENING HERBAL SUPPLE-
MENTS CONTAINING ALL NATURAL INGREDIENTS
THAT ALLEVIATE BAD BREATH; AND NON-MEDI-
CATED DISSOLVABLE SUSTAINED RELEASE PATCH
FOR PLACEMENT IN THE MOUTH CONTAINING
NATURAL INGREDIENTS FOR RELIEF OF HALITOSIS
(U.S. CLS. 1, 4, 6, 50, 51 AND 52).

KATHERINE STOIDES, EXAMINING ATTORNEY

SN 77-462,474. TANNING RESEARCH LABORATORIES,
INC., ORMOND BEACH, FL. FILED 4-30-2008.

ALOHA KISS

THE MARK CONSISTS OF STANDARD CHARACTERS
WITHOUT CLAIM TO ANY PARTICULAR FONT, STYLE,
SIZE, OR COLOR.

FOR NON-MEDICATED LIP BALM, LIP GLOSS, NON-
MEDICATED SUNSCREEN PREPARATIONS (U.S. CLS.
1, 4, 6, 50, 51 AND 52).

ALYSSA PALADINO, EXAMINING ATTORNEY

CLASS 3—(Continued).

SN 77-462,889. SAVE YOUR WORLD, L.L.C., SHORT HILLES, NJ. FILED 5-1-2008.

CLASS 3—(Continued).

SN 77-462,900. SAVE YOUR WORLD, L.L.C., SHORT HILLES, NJ. FILED 5-1-2008.

1 Room for 1 Night = 1
Acre of Rainforest Saved
for 1 Year

One Room for One Night =
One Acre of Rainforest
Saved for One Year

THE MARK CONSISTS OF STANDARD CHARACTERS WITHOUT CLAIM TO ANY PARTICULAR FONT, STYLE, SIZE, OR COLOR.

FOR 3-IN-1 HAIR SHAMPOOS; HAIR CARE KITS COMPRISING NON-MEDICATED HAIR CARE PREPARATIONS, NAMELY, SHAMPOO AND CONDITIONER; HAIR RINSES; HAIR SHAMPOO; HAIR SHAMPOOS AND CONDITIONERS; SHAMPOO-CONDITIONERS; SHAMPOOS; 3-IN-1 HAIR CONDITIONERS; AROMATHERAPY BODY CARE PRODUCTS, NAMELY, BODY LOTION, SHOWER GEL, CUTICLE CREAM, SHAMPOO, CONDITIONER, NON-MEDICATED LIP BALM, SOAP, BODY POLISH, BODY AND FOOT SCRUB AND NON-MEDICATED FOOT CREAM; CONDITIONERS; HAIR CONDITIONER; HAIR CONDITIONERS; SKIN CONDITIONERS; BAR SOAP; BATH SOAPS; BATH SOAPS IN LIQUID, SOLID OR GEL FORM; COSMETIC SOAPS; HAND SOAPS; LIQUID BATH SOAPS; LIQUID SOAP; LIQUID SOAPS; LIQUID SOAPS FOR HANDS, FACE AND BODY; SOAPS; SOAPS FOR BODY CARE; SOAPS FOR PERSONAL USE; BEAUTY LOTIONS; BODY LOTION; BODY LOTIONS; FACE AND BODY LOTIONS; LOTIONS FOR COSMETIC PURPOSES; LOTIONS FOR FACE AND BODY CARE; SCENTED BODY LOTIONS AND CREAMS; SKIN AND BODY TOPICAL LOTIONS, CREAMS AND OILS FOR COSMETIC USE; SKIN LOTION; SKIN LOTIONS; BEAUTY CREAMS FOR BODY CARE; BODY WASHES; CLEANING AND WASHING PREPARATIONS; COSMETIC PREPARATIONS FOR BODY CARE; BODY AND BEAUTY CARE COSMETICS; COSMETICS; COSMETICS AND COSMETIC PREPARATIONS; HAIR CARE PREPARATIONS (U.S. CLS. 1, 4, 6, 50, 51 AND 52).
KAREN M. STRZYZ, EXAMINING ATTORNEY

THE MARK CONSISTS OF STANDARD CHARACTERS WITHOUT CLAIM TO ANY PARTICULAR FONT, STYLE, SIZE, OR COLOR.

FOR 3-IN-1 HAIR SHAMPOOS; HAIR CARE KITS COMPRISING NON-MEDICATED HAIR CARE PREPARATIONS, NAMELY, SHAMPOO AND CONDITIONER; HAIR RINSES; HAIR SHAMPOO; HAIR SHAMPOOS AND CONDITIONERS; SHAMPOO-CONDITIONERS; SHAMPOOS; 3-IN-1 HAIR CONDITIONERS; AROMATHERAPY BODY CARE PRODUCTS, NAMELY, BODY LOTION, SHOWER GEL, CUTICLE CREAM, SHAMPOO, CONDITIONER, NON-MEDICATED LIP BALM, SOAP, BODY POLISH, BODY AND FOOT SCRUB AND NON-MEDICATED FOOT CREAM; CONDITIONERS; HAIR CONDITIONER; HAIR CONDITIONERS; SKIN CONDITIONERS; BAR SOAP; BATH SOAPS; BATH SOAPS IN LIQUID, SOLID OR GEL FORM; COSMETIC SOAPS; HAND SOAPS; LIQUID BATH SOAPS; LIQUID SOAP; LIQUID SOAPS; LIQUID SOAPS FOR HANDS, FACE AND BODY; SOAPS; SOAPS FOR BODY CARE; SOAPS FOR PERSONAL USE; BEAUTY LOTIONS; BODY LOTION; BODY LOTIONS; FACE AND BODY LOTIONS; LOTIONS FOR COSMETIC PURPOSES; LOTIONS FOR FACE AND BODY CARE; SCENTED BODY LOTIONS AND CREAMS; SKIN AND BODY TOPICAL LOTIONS, CREAMS AND OILS FOR COSMETIC USE; SKIN LOTION; SKIN LOTIONS; BEAUTY CREAMS FOR BODY CARE; BODY WASHES; CLEANING AND WASHING PREPARATIONS; COSMETIC PREPARATIONS FOR BODY CARE; BODY AND BEAUTY CARE COSMETICS; COSMETICS; COSMETICS AND COSMETIC PREPARATIONS; HAIR CARE PREPARATIONS (U.S. CLS. 1, 4, 6, 50, 51 AND 52).
KAREN M. STRZYZ, EXAMINING ATTORNEY

SN 77-464,289. ALTICOR INC., ADA, MI. FILED 5-2-2008.

VEIL OF PROTECTION

THE MARK CONSISTS OF STANDARD CHARACTERS WITHOUT CLAIM TO ANY PARTICULAR FONT, STYLE, SIZE, OR COLOR.

FOR SKIN CARE PRODUCTS, NAMELY, CREAMS AND LOTIONS FOR THE FACE AND BODY (U.S. CLS. 1, 4, 6, 50, 51 AND 52).
REGINA DRUMMOND, EXAMINING ATTORNEY

CLASS 3—(Continued).

SN 77-465,414. W STERNOFF LLC, BELLEVUE, WA. FILED 5-5-2008.

CLASS 3—(Continued).

SN 77-500,016. OJON CORPORATION, NEW YORK, NY. FILED 6-16-2008.

BLISTER RESISTER

THE MARK CONSISTS OF STANDARD CHARACTERS WITHOUT CLAIM TO ANY PARTICULAR FONT, STYLE, SIZE, OR COLOR.

FOR NON-MEDICATED SKIN CARE PREPARATIONS (U.S. CLS. 1, 4, 6, 50, 51 AND 52).
SANJEEV VOHRA, EXAMINING ATTORNEY

SN 77-471,647. COLGATE-PALMOLIVE COMPANY, NEW YORK, NY. FILED 5-12-2008.

TRIBAL INDULGENCES

THE MARK CONSISTS OF STANDARD CHARACTERS WITHOUT CLAIM TO ANY PARTICULAR FONT, STYLE, SIZE, OR COLOR.

FOR BODY AND BEAUTY CARE COSMETICS; COSMETICS; DEODORANTS AND ANTIPERSPIRANTS FOR PERSONAL USE; FRAGRANCES FOR PERSONAL USE; HAIR CARE PREPARATIONS; NON-MEDICATED BATH PREPARATIONS; NON-MEDICATED SKIN CARE PREPARATIONS; NON-MEDICATED TOILETRIES; SOAPS FOR PERSONAL USE (U.S. CLS. 1, 4, 6, 50, 51 AND 52).
BARNEY CHARLON, EXAMINING ATTORNEY

FRESHNESS UNLEASHED

THE MARK CONSISTS OF STANDARD CHARACTERS WITHOUT CLAIM TO ANY PARTICULAR FONT, STYLE, SIZE, OR COLOR.

FOR TOOTHPASTE (U.S. CLS. 1, 4, 6, 50, 51 AND 52).
JOHN GARTNER, EXAMINING ATTORNEY

SN 77-472,811. AUSTRALIAN GOLD, INC., INDIANAPOLIS, IN. FILED 5-13-2008.

SN 78-437,981. ANNCO, INC., NEW YORK, NY. FILED 6-18-2004.

ANNTAYLOR LOFT

THE MARK CONSISTS OF STANDARD CHARACTERS WITHOUT CLAIM TO ANY PARTICULAR FONT, STYLE, SIZE, OR COLOR.

OWNER OF U.S. REG. NOS. 2,334,051, 2,825,310 AND OTHERS.

THE NAME(S), PORTRAIT(S), AND/OR SIGNATURE(S) SHOWN IN THE MARK DOES NOT IDENTIFY A PARTICULAR LIVING INDIVIDUAL.

FOR PERFUME; COLOGNE; TOILET WATER; BATH OIL; BATH GEL; BATH SALT; BATH CREAM; SKIN LOTION; MAKEUP FOR LIPS, EYES AND CHEEKS; FACIAL CLEANSER; SKIN MOISTURIZER; MAKEUP REMOVER; PERSONAL SOAPS (U.S. CLS. 1, 4, 6, 50, 51 AND 52).

YONG KIM, EXAMINING ATTORNEY

KISS KISS BRONZE BRONZE

THE MARK CONSISTS OF STANDARD CHARACTERS WITHOUT CLAIM TO ANY PARTICULAR FONT, STYLE, SIZE, OR COLOR.

FOR NON-MEDICATED SKIN TANNING PREPARATIONS (U.S. CLS. 1, 4, 6, 50, 51 AND 52).
INGRID C. EULIN, EXAMINING ATTORNEY

CLASS 3—(Continued).

SN 78-593,649. DEMETER F.L. INC., GREAT NECK, NY.
FILED 3-23-2005.

BIRTHDAY CAKE

THE MARK CONSISTS OF STANDARD CHARACTERS WITHOUT CLAIM TO ANY PARTICULAR FONT, STYLE, SIZE, OR COLOR.

FOR FRAGRANCE FOR PERSONAL USE, ROOM FRAGRANCE, COLOGNE, BATH OIL, BATH GEL AND BODY LOTION (U.S. CLS. 1, 4, 6, 50, 51 AND 52).

FIRST USE 0-0-2000; IN COMMERCE 0-0-2000.
JENNIFER MARTIN, EXAMINING ATTORNEY

SN 78-881,688. EASY LIFE SOLUTIONS, INC., BRADENTON, FL. FILED 5-11-2006.

re:mov

NO CLAIM IS MADE TO THE EXCLUSIVE RIGHT TO USE "REMOVE", APART FROM THE MARK AS SHOWN.

THE MARK CONSISTS OF COINED WORD MARKS "RE" AND "MOV" IN COMBINATION WITH A DESIGN COMPRISING FIVE CIRCLES.

FOR CHEMICAL PREPARATIONS, NAMELY, SILICONE AND ADHESIVE REMOVERS (U.S. CLS. 1, 4, 6, 50, 51 AND 52).

FIRST USE 4-0-2006; IN COMMERCE 4-0-2006.
AMY ALFIERI, EXAMINING ATTORNEY

SN 78-939,595. BOUTEAQUE, LLC, NEW YORK, NY. FILED 7-28-2006.

bouteaque

THE MARK CONSISTS OF STANDARD CHARACTERS WITHOUT CLAIM TO ANY PARTICULAR FONT, STYLE, SIZE, OR COLOR.

FOR NATURAL BATH AND BODY LINE OF PRODUCTS THAT ARE TEA-INSPIRED, NAMELY, LOTIONS, SHAMPOOS AND CONDITIONERS, BATH TEAS AND SALTS, HAND AND BODY SOAPS, SHOWER GELS, AND AROMATHERAPY CREAMS, LOTIONS AND OILS. (U.S. CLS. 1, 4, 6, 50, 51 AND 52).

FIRST USE 5-24-1995; IN COMMERCE 8-23-1995.
ANDREA BUTLER, EXAMINING ATTORNEY

CLASS 3—(Continued).

SN 78-964,310. OPTIDENT LTD, ILKLEY, UNITED KINGDOM, FILED 8-30-2006.

be
white

M a d e e x c l u s i v e l y f o r e v e r y o n e .

PRIORITY CLAIMED UNDER SEC. 44(D) ON ERPN CMNTY TM OFC APPLICATION NO. 5269717, FILED 8-22-2006, REG. NO. 005269717, DATED 11-15-2007, EXPIRES 11-15-2017.

FOR TOOTH CLEANING PREPARATIONS; PREPARATIONS FOR CLEANING TEETH AND DENTURES; TOOTHPASTES; WHITENING PREPARATIONS FOR TEETH AND DENTURES (U.S. CLS. 1, 4, 6, 50, 51 AND 52).

SHANNON TWOHIG, EXAMINING ATTORNEY

SN 79-043,960. YVES SAINT LAURENT PARFUMS, FRANCE, FILED 8-31-2007.



PRIORITY DATE OF 3-15-2007 IS CLAIMED.
OWNER OF INTERNATIONAL REGISTRATION 0937888 DATED 8-31-2007, EXPIRES 8-31-2017.

THE COLOR(S) PURPLE AND GOLD IS/ARE CLAIMED AS A FEATURE OF THE MARK.

THE MARK CONSISTS OF A SPRAY BOTTLE IN THE SHAPE OF A RECTANGULAR PRISM, AND IS THREE-DIMENSIONAL; THE COLOR PURPLE APPEARS IN THE BOTTOM HALF OF THE BOTTLE AND IN THE CAP OF THE BOTTLE; THE COLOR GOLD APPEARS IN THE MIDDLE OF THE BOTTLE.

FOR PERFUMES, EAUX DE TOILETTE; DEODORANTS FOR PERSONAL USE; ESSENTIAL OILS FOR PERSONAL USE; OILS FOR COSMETIC PURPOSES; COSMETIC MILK; CREAMS AND LOTIONS FOR FACE AND BODY CARE PURPOSES; BATH AND SHOWER GELS; HAIR LOTIONS; SHAMPOOS (U.S. CLS. 1, 4, 6, 50, 51 AND 52).

KRISTIN DAHLING, EXAMINING ATTORNEY

CLASS 3—(Continued).

SN 79-045,969. CHOPARD INTERNATIONAL SA, SWITZERLAND, FILED 10-11-2007.

CHOPARD HAPPY SPIRIT

THE MARK CONSISTS OF STANDARD CHARACTERS WITHOUT CLAIM TO ANY PARTICULAR FONT, STYLE, SIZE, OR COLOR.

PRIORITY DATE OF 4-24-2007 IS CLAIMED.

OWNER OF INTERNATIONAL REGISTRATION 0942822 DATED 10-11-2007, EXPIRES 10-11-2017.

OWNER OF U.S. REG. NOS. 1,684,243, 2,687,204 AND 2,995,851.

THE WORDING "CHOPARD" IN THE MARK HAS NO TRANSLATION INTO ENGLISH.

FOR SOAPS FOR PERSONAL USE; PERFUMERY, ESSENTIAL OILS, COSMETICS, LOTIONS FOR THE HAIR; DENTIFRICES (U.S. CLS. 1, 4, 6, 50, 51 AND 52).
MARK PILARO, EXAMINING ATTORNEY

SN 79-046,451. PARFUMS GIVENCHY S.A., LEVALLOIS-PERRET, FRANCE, FILED 10-19-2007.

RADICALLY NO SURGETICS

PRIORITY DATE OF 5-14-2007 IS CLAIMED.

OWNER OF INTERNATIONAL REGISTRATION 0944010 DATED 10-19-2007, EXPIRES 10-19-2017.

OWNER OF U.S. REG. NO. 2,853,424.

THE WORDING IN THE MARK HAS NO MEANING IN A FOREIGN LANGUAGE.

FOR ANTI-WRINKLE COSMETICS (U.S. CLS. 1, 4, 6, 50, 51 AND 52).

JAMES STEIN, EXAMINING ATTORNEY

SN 79-047,655. DUTRAC BEHEER BV, NETHERLANDS, FILED 10-15-2007.

RYZOLIN

THE MARK CONSISTS OF STANDARD CHARACTERS WITHOUT CLAIM TO ANY PARTICULAR FONT, STYLE, SIZE, OR COLOR.

OWNER OF INTERNATIONAL REGISTRATION 0947333 DATED 10-15-2007, EXPIRES 10-15-2017.

FOR CLEANING PREPARATIONS (U.S. CLS. 1, 4, 6, 50, 51 AND 52).

G. MAYERSCHOFF, EXAMINING ATTORNEY

CLASS 3—(Continued).

SN 79-051,489. STRATEGEM, SOCIÉTÉ PAR ACTIONS SIMPLIFIÉE, F-75001 PARIS, FRANCE, FILED 12-3-2007.

GIN FIZZ

OWNER OF INTERNATIONAL REGISTRATION 0320981 DATED 9-19-1966, EXPIRES 9-19-2016.

THE MARK CONSISTS OF THE WORDS "GIN FIZZ" IN STYLIZED FONT.

THE WORD "FIZZ" HAS NO MEANING IN A FOREIGN LANGUAGE.

FOR PERFUME; TOILET WATER; AFTERSHAVE; PERFUME OILS; COLOGNE; EAU DE PERFUME, EAU DE COLOGNE; MAKE-UP; DENTIFRICES; TOILET SOAPS; BEAUTY PRODUCTS, NAMELY, BEAUTY LOTIONS, FACIAL BEAUTY MASKS, MASCARA, BEAUTY CREAMS, BEAUTY GELS, BEAUTY MILKS, BEAUTY SERUMS (U.S. CLS. 1, 4, 6, 50, 51 AND 52).
ALYSSA PALADINO, EXAMINING ATTORNEY

SN 79-052,504. ESCADA AG, FED REP GERMANY, FILED 3-18-2008.

INCREDIBLE ME

THE MARK CONSISTS OF STANDARD CHARACTERS WITHOUT CLAIM TO ANY PARTICULAR FONT, STYLE, SIZE, OR COLOR.

PRIORITY DATE OF 10-5-2007 IS CLAIMED.

OWNER OF INTERNATIONAL REGISTRATION 0960517 DATED 3-18-2008, EXPIRES 3-18-2018.

FOR SOAPS, PERFUMERIES, ESSENTIAL OILS, COSMETICS, HAIR TONIC, DENTIFRICES (U.S. CLS. 1, 4, 6, 50, 51 AND 52).

EDWARD NELSON, EXAMINING ATTORNEY

CLASS 4—LUBRICANTS AND FUELS

SN 77-062,077. PETRO-CANADA, CALGARY, CANADA, FILED 12-12-2006.

KRYSTOL

THE MARK CONSISTS OF STANDARD CHARACTERS WITHOUT CLAIM TO ANY PARTICULAR FONT, STYLE, SIZE, OR COLOR.

PRIORITY CLAIMED UNDER SEC. 44(D) ON CANADA APPLICATION NO. 1327181, FILED 12-7-2006.

OWNER OF CANADA REG. NO. 709647, DATED 3-17-2008, EXPIRES 3-17-2023.

FOR TECHNICAL GRADE WHITE MINERAL OIL (U.S. CLS. 1, 6 AND 15).

FIRST USE 9-0-2006; IN COMMERCE 9-0-2006.

MELVIN AXILBUND, EXAMINING ATTORNEY

CLASS 4—(Continued).

SN 77-104,393. SHANDONG EASTSUN OIL CHEMISTRY COMPANY, JINAN, CHINA, FILED 2-10-2007.

CLASS 4—(Continued).

SN 77-411,295. ISLAND L.P. GAS SERVICES, INC., DBA PROPANE MANE, WAIPAHU, HI. FILED 3-3-2008.



豪润驰凯
HR CHIK

NO CLAIM IS MADE TO THE EXCLUSIVE RIGHT TO USE "PROPANE", APART FROM THE MARK AS SHOWN.

THE COLOR(S) RED, BLUE YELLOW, TAN, GRAY, WHITE, PINK AND BLACK IS/ARE CLAIMED AS A FEATURE OF THE MARK.

THE MARK CONSISTS OF DESIGN OF MALE SUPER HERO WEARING A BLUE TIGHTS WITH A BLACK "P" ON THE CHEST, YELLOW AND BLACK SHOES, YELLOW AND BLACK BELT WITH THE LETTER "M" IN YELLOW, A YELLOW AND BLACK LOIN CLOTH, YELLOW AND BLACK CAPE, YELLOW AND BLACK HAIR, PINK TONGUE, TAN SKIN, WHITE TEETH, BLACK AND WHITE EYES, YELLOW GLOVES, HOLDING A GRAY, BLACK AND RED PROPANE CYLINDER THE WITH TERMS "PROPANE MAN" IN YELLOW ON IT.

FOR PROPANE GAS; AND PROPANE GAS SOLD IN CYLINDERS (U.S. CLS. 1, 6 AND 15).

FIRST USE 1-1-1984; IN COMMERCE 1-1-1984.

ANTHONY RINKER, EXAMINING ATTORNEY

SN 77-422,294. TOTAL S.A., 92400 COURBEVOIE, FRANCE, FILED 3-14-2008.

THE FOREIGN WORDING IN THE MARK TRANSLATES INTO ENGLISH AS HEROIC SLEEK SPEED TRIUMPH.

THE NON-LATIN CHARACTER(S) IN THE MARK TRANSLITERATE INTO "HAU RUN CHI KAI".

FOR ALL PURPOSE LUBRICANTS; AUTOMOBILE LUBRICANTS; AUTOMOTIVE LUBRICANTS; DRILLING LUBRICANTS; GRAPHITE AS A LUBRICANT; GRAPHITE LUBRICANTS; INDUSTRIAL LUBRICANTS; LINSEED OIL FOR USE AS A LUBRICANT; LUBRICANTS FOR AIRCRAFT ENGINES; LUBRICANTS FOR INDUSTRIAL MACHINERY; LUBRICATING GREASES; LUBRICATING OIL FOR MOTOR VEHICLE ENGINES; LUBRICATING OILS; LUBRICATION GREASE FOR VEHICLES; MARINE LUBRICANTS; SOLID FILM LUBRICANTS; VINYL WINDOW LUBRICANT (U.S. CLS. 1, 6 AND 15).

FIRST USE 12-10-2006; IN COMMERCE 12-10-2006.

KHANH LE, EXAMINING ATTORNEY

EXCELLIUM

THE MARK CONSISTS OF STANDARD CHARACTERS WITHOUT CLAIM TO ANY PARTICULAR FONT, STYLE, SIZE, OR COLOR.

THE WORD "EXCELLIUM" HAS NO MEANING IN A FOREIGN LANGUAGE.

FOR MOTOR OILS (U.S. CLS. 1, 6 AND 15).

FIRST USE 3-1-2004; IN COMMERCE 3-1-2004.

TINA BROWN, EXAMINING ATTORNEY

CLASS 4—(Continued).

SN 77-428,327. COST PLUS MANAGEMENT SERVICES, INC., OAKLAND, CA. FILED 3-21-2008.

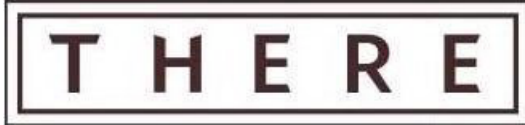

THE MARK CONSISTS OF THE WORD "THERE", SURROUNDED BY TWO RECTANGLES.
FOR CANDLES (U.S. CLS. 1, 6 AND 15).
JAMES STEIN, EXAMINING ATTORNEY

SN 77-429,395. ELM VENTURE FUND LLC, FREEPORT, ME. FILED 3-24-2008.

BIOLOG

THE MARK CONSISTS OF STANDARD CHARACTERS WITHOUT CLAIM TO ANY PARTICULAR FONT, STYLE, SIZE, OR COLOR.

FOR MANUFACTURED SOLID FUEL FOR WOOD STOVES, WOOD FURNACES, AND FIREPLACES (U.S. CLS. 1, 6 AND 15).
LINDSEY RUBIN, EXAMINING ATTORNEY

SN 77-431,364. MALDONADO DISTRIBUTING INC., HOUSTON, TX. FILED 3-25-2008.

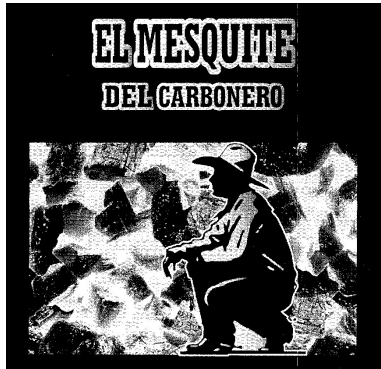

NO CLAIM IS MADE TO THE EXCLUSIVE RIGHT TO USE "EL MESQUITE DEL CARBONERO", APART FROM THE MARK AS SHOWN.

THE STIPPLING IS FOR SHADING PURPOSES ONLY.
THE MARK CONSISTS OF THE STYLIZED TEXT "EL MESQUITE DEL CARBONERO" ABOVE A SQUARE WITH AN IMAGE OF A COWBOY IN A KNEELING POSITION IN FRONT OF BURNING CHARCOAL.

THE ENGLISH TRANSLATION OF "EL MESQUITE DEL CARBONERO" IN THE MARK IS "THE MESQUITE OF THE CHARCOAL MAKER".

FOR HARDWOOD CHARCOAL IN THE FORM OF LUMPS AND/OR BRIQUETTES (U.S. CLS. 1, 6 AND 15).
MONIQUE MILLER, EXAMINING ATTORNEY

CLASS 4—(Continued).

SN 77-434,698. SAFETY-KLEEN SYSTEMS, INC., PLANO, TX. FILED 3-28-2008.

ECOFORCE

THE MARK CONSISTS OF STANDARD CHARACTERS WITHOUT CLAIM TO ANY PARTICULAR FONT, STYLE, SIZE, OR COLOR.

FOR MOTOR OIL (U.S. CLS. 1, 6 AND 15).
HOWARD SMIGA, EXAMINING ATTORNEY

SN 77-450,602. BETA STRATEGY GROUP LTD., CHAGRIN FALLS, OH. FILED 4-17-2008.

BOLT OFF

THE MARK CONSISTS OF STANDARD CHARACTERS WITHOUT CLAIM TO ANY PARTICULAR FONT, STYLE, SIZE, OR COLOR.

FOR MULTI-PURPOSE SPRAY AND DROPPER OR TUBE PACKAGED LUBRICANT FOR GENERAL PURPOSE, SPORTING EQUIPMENT, DOMESTIC, OFFICE AND COMMERCIAL OR INDUSTRIAL USE (U.S. CLS. 1, 6 AND 15).

AMOS T. MATTHEWS, JR., EXAMINING ATTORNEY

SN 77-466,944. WEISENBACH SPECIALTY PRINTING, INC., COLUMBUS, OH. FILED 5-6-2008.

CRAYONDLES

THE MARK CONSISTS OF STANDARD CHARACTERS WITHOUT CLAIM TO ANY PARTICULAR FONT, STYLE, SIZE, OR COLOR.

FOR CANDLES COMPRISED IN PART OF RECYCLED CRAYONS (U.S. CLS. 1, 6 AND 15).

JAMES LOVELACE, EXAMINING ATTORNEY

CLASS 4—(Continued).

SN 77-476,039. DURAFLAME, INC., STOCKTON, CA. FILED 5-15-2008.

ANYFIRE

THE MARK CONSISTS OF STANDARD CHARACTERS WITHOUT CLAIM TO ANY PARTICULAR FONT, STYLE, SIZE, OR COLOR.

FOR ARTIFICIAL FIRELOGS (U.S. CLS. 1, 6 AND 15).
FIRST USE 10-0-2007; IN COMMERCE 10-0-2007.
ALLISON SCHRODY, EXAMINING ATTORNEY

CLASS 5—(Continued).

SN 76-688,107. THETA BIOMED. CONSULT. DEVELOP., CO. INC., BROOKLINE, MA. FILED 3-27-2008.

SkinProtek

THE MARK CONSISTS OF STANDARD CHARACTERS WITHOUT CLAIM TO ANY PARTICULAR FONT, STYLE, SIZE, OR COLOR.

FOR DIETARY NUTRACEUTICAL FOR USE IN TREATING HUMAN SKIN WOUNDS AND BRUISES (U.S. CLS. 6, 18, 44, 46, 51 AND 52).

FIRST USE 8-2-2002; IN COMMERCE 8-2-2002.
JULIE WATSON, EXAMINING ATTORNEY

SN 79-038,827. ZHEJIANG NEEO; HOME DECORATION CO.,LTD, ZHEJIANG, CHINA, FILED 5-21-2007.

neeo

OWNER OF INTERNATIONAL REGISTRATION 0925064 DATED 5-21-2007, EXPIRES 5-21-2017.

THE WORDING "NEEO" HAS NO MEANING IN A FOREIGN LANGUAGE.

FOR CERESINE, NAMELY, OZOCERITE FOR USE IN THE MAKING OF CANDLES; FRAGRANT CANDLE; PARAFFIN; ILLUMINATING WAX FOR USE AS CANDLES; CANDLES; CHRISTMAS TREE CANDLES; TAPERS; CARNAUBA WAX; WICKS FOR CANDLES; BEESWAX FOR USE IN THE MANUFACTURE OF CANDLES (U.S. CLS. 1, 6 AND 15).

MARCIE MILONE, EXAMINING ATTORNEY

SN 76-688,108. THETA BIOMED. CONSULT. DEVELOP., CO. INC., BROOKLINE, MA. FILED 3-27-2008.

BrainGain

THE MARK CONSISTS OF STANDARD CHARACTERS WITHOUT CLAIM TO ANY PARTICULAR FONT, STYLE, SIZE, OR COLOR.

FOR DIETARY NUTRACEUTICAL FOR USE IN TREATING HUMANS WITH A POTENTIAL FOR NEUROLOGICAL DEGENERATIVE DISEASES (U.S. CLS. 6, 18, 44, 46, 51 AND 52).

FIRST USE 1-6-2008; IN COMMERCE 1-6-2008.
JULIE WATSON, EXAMINING ATTORNEY

CLASS 5—PHARMACEUTICALS

SN 76-684,991. INNOVATIVE TECHNOLOGIES, LLC, BRISTOL, VA. FILED 12-17-2007.

Thyromax

THE MARK CONSISTS OF STANDARD CHARACTERS WITHOUT CLAIM TO ANY PARTICULAR FONT, STYLE, SIZE, OR COLOR.

FOR PHARMACEUTICAL FOR THE TREATMENT OF HYPOTHYROIDISM, DEPRESSION AND HYPOMETABOLISM (U.S. CLS. 6, 18, 44, 46, 51 AND 52).

GEORGIA CARTY, EXAMINING ATTORNEY

SN 77-082,999. NANOMED PHARMACEUTICALS, INC., LEXINGTON, KY. FILED 1-15-2007.

Nanotemplate Engineering

THE MARK CONSISTS OF STANDARD CHARACTERS WITHOUT CLAIM TO ANY PARTICULAR FONT, STYLE, SIZE, OR COLOR.

NO CLAIM IS MADE TO THE EXCLUSIVE RIGHT TO USE "ENGINEERING", APART FROM THE MARK AS SHOWN.

FOR SOLID LIPID NANOPARTICLES FOR DRUG DELIVERY SOLD AS AN INTEGRAL COMPONENT OF DRUGS (U.S. CLS. 6, 18, 44, 46, 51 AND 52).

TEJBIR SINGH, EXAMINING ATTORNEY

CLASS 5—(Continued).

SN 77-101,592. PUREPHARM INC., TORONTO, CANADA,
FILED 2-7-2007.



OWNER OF CANADA REG. NO. TMA610822, DATED 5-20-2004, EXPIRES 5-20-2019.

OWNER OF U.S. REG. NOS. 2,974,745 AND 3,005,168.

NO CLAIM IS MADE TO THE EXCLUSIVE RIGHT TO USE "GLUCOSAMINE", APART FROM THE MARK AS SHOWN.

THE MARK CONSISTS OF THE WORDS "ULTIMATE GLUCOSAMINE" IN STYLIZED LETTERS AND A SPHERE DESIGN WITH VORTICES.

SEC. 2(F) AS TO "ULTIMATE GLUCOSAMINE".

FOR NUTRITIONAL AND DIETARY SUPPLEMENT, NAMELY, GLUCOSAMINE (U.S. CLS. 6, 18, 44, 46, 51 AND 52).

FIRST USE 12-12-2003; IN COMMERCE 12-12-2003.

KIMBERLY FRYE, EXAMINING ATTORNEY

SN 77-104,250. SAKURA PROPERTIES, LLC, SALEM, UT.
FILED 2-9-2007.

ABSOLUTE AO

THE MARK CONSISTS OF STANDARD CHARACTERS WITHOUT CLAIM TO ANY PARTICULAR FONT, STYLE, SIZE, OR COLOR.

NO CLAIM IS MADE TO THE EXCLUSIVE RIGHT TO USE "AO", APART FROM THE MARK AS SHOWN.

FOR DIETARY AND NUTRITIONAL SUPPLEMENTS; FOOD SUPPLEMENTS, NAMELY, ANTI-OXIDANTS (U.S. CLS. 6, 18, 44, 46, 51 AND 52).

DAVID TOOLEY, EXAMINING ATTORNEY

CLASS 5—(Continued).

SN 77-128,513. SYLMARK HOLDINGS LIMITED, DUBLIN 2, IRELAND, FILED 3-12-2007.

FLEXHEALTH

THE MARK CONSISTS OF STANDARD CHARACTERS WITHOUT CLAIM TO ANY PARTICULAR FONT, STYLE, SIZE, OR COLOR.

FOR NUTRITIONAL SUPPLEMENTS (U.S. CLS. 6, 18, 44, 46, 51 AND 52).

AMY HELLA, EXAMINING ATTORNEY

SN 77-140,726. CDJ HOLDING, INC., CONCORD, CA. FILED 3-26-2007.

SOOTHING

THE MARK CONSISTS OF STANDARD CHARACTERS WITHOUT CLAIM TO ANY PARTICULAR FONT, STYLE, SIZE, OR COLOR.

FOR DIETARY AND NUTRITIONAL SUPPLEMENTS; HERBAL SUPPLEMENTS (U.S. CLS. 6, 18, 44, 46, 51 AND 52).

FIRST USE 3-2-2007; IN COMMERCE 3-2-2007.

JANET LEE, EXAMINING ATTORNEY

SN 77-140,735. CDJ HOLDING, INC., CONCORD, CA. FILED 3-26-2007.

BODY SPECIFIC

THE MARK CONSISTS OF STANDARD CHARACTERS WITHOUT CLAIM TO ANY PARTICULAR FONT, STYLE, SIZE, OR COLOR.

FOR DIETARY AND NUTRITIONAL SUPPLEMENTS; HERBAL SUPPLEMENTS (U.S. CLS. 6, 18, 44, 46, 51 AND 52).

FIRST USE 3-2-2007; IN COMMERCE 3-2-2007.

JANET LEE, EXAMINING ATTORNEY

CLASS 5—(Continued).

SN 77-145,822. TUNG FUNG TAI GINSENG LTD., HONG KONG, HONG KONG, FILED 4-2-2007.

恒豐泰

OWNER OF HONG KONG REG. NO. 19912552, DATED 9-13-1989, EXPIRES 9-13-2010.

THE FOREIGN WORDING IN THE MARK TRANSLATES INTO ENGLISH AS CONSTANT, ABUNDANT, PROSPEROUS.

THE NON-LATIN CHARACTER(S) IN THE MARK TRANSLITERATE INTO "HANG FUNG TAI", AND THIS MEANS "CONSTANT, ABUNDANT, PROSPEROUS" IN ENGLISH.

FOR GINSENG AS NUTRITIONAL SUPPLEMENTS AND FOR MEDICINAL USE (U.S. CLS. 6, 18, 44, 46, 51 AND 52).

JENNY PARK, EXAMINING ATTORNEY

CLASS 5—(Continued).

SN 77-149,375. N.V. NUTRICIA, ZOETERMEER, NETHERLANDS, FILED 4-5-2007.



OWNER OF BENELUX REG. NO. 0819357, DATED 3-14-2007, EXPIRES 2-19-2017.

OWNER OF U.S. REG. NO. 2,679,490.

FOR DIETETIC SUBSTANCES ADAPTED FOR MEDICAL USE, NAMELY, DIETETIC FOODS; FOOD FOR BABIES, INFANTS AND INVALIDS; FOOD SUPPLEMENTS ADAPTED FOR MEDICAL USE; DIETARY NUTRITIONAL SUPPLEMENTS; EDIBLE PLANT FIBRES FOR MEDICAL USE, NAMELY, DIETARY FIBER AS AN ADDITIVE FOR FOOD PRODUCTS, GROUND FLAXSEED FIBER FOR USE A DIETARY SUPPLEMENT (U.S. CLS. 6, 18, 44, 46, 51 AND 52).

MARY CRAWFORD, EXAMINING ATTORNEY

SN 77-149,357. N.V. NUTRICIA, ZOETERMEER, NETHERLANDS, FILED 4-5-2007.

MF6

THE MARK CONSISTS OF STANDARD CHARACTERS WITHOUT CLAIM TO ANY PARTICULAR FONT, STYLE, SIZE, OR COLOR.

OWNER OF BENELUX REG. NO. 0819350, DATED 3-14-2007, EXPIRES 2-19-2017.

OWNER OF U.S. REG. NO. 2,679,490.

FOR DIETETIC SUBSTANCES ADAPTED FOR MEDICAL USE, NAMELY, DIETETIC FOODS; FOOD FOR BABIES, INFANTS AND INVALIDS; FOOD SUPPLEMENTS ADAPTED FOR MEDICAL USE; DIETARY NUTRITIONAL SUPPLEMENTS; EDIBLE PLANT FIBRES FOR MEDICAL USE, NAMELY, DIETARY FIBER AS AN ADDITIVE FOR FOOD PRODUCTS, GROUND FLAXSEED FIBER FOR USE A DIETARY SUPPLEMENT (U.S. CLS. 6, 18, 44, 46, 51 AND 52).

MARY CRAWFORD, EXAMINING ATTORNEY

SN 77-195,937. LEWIS, SANDERS, JR, LOS ANGELES, CA. AND SANDERS, ANGELICA, D, LOS ANGELES, CA. FILED 6-1-2007.



THE COLOR(S) BROWN, BLUE, WHITE, ORANGE AND GREEN IS/ARE CLAIMED AS A FEATURE OF THE MARK.

THE COLOR BROWN APPEARS IN THE WORDING "WORLD'S HEALTH HUT", AND THE COLORS BROWN, BLUE, WHITE, GREEN AND ORANGE APPEAR IN THE DESIGNS OF A GLOBE, HUT, OVAL AND RECTANGLE.

FOR HERBAL SUPPLEMENTS (U.S. CLS. 6, 18, 44, 46, 51 AND 52).

PAM WILLIS, EXAMINING ATTORNEY

CLASS 5—(Continued).

SN 77-199,059. BONE MEDICAL LIMITED, BENTLEY, WA, AUSTRALIA, FILED 6-6-2007.

CAPSITONIN

THE MARK CONSISTS OF STANDARD CHARACTERS WITHOUT CLAIM TO ANY PARTICULAR FONT, STYLE, SIZE, OR COLOR.

OWNER OF AUSTRALIA REG. NO. 1058336, DATED 6-1-2005, EXPIRES 6-1-2015.

FOR PHARMACEUTICAL PREPARATIONS FOR ALTERING BONE DENSITY; MEDICATIONS FOR THE PREVENTION OR TREATMENT OF BONE DISORDERS; PHARMACEUTICAL PREPARATIONS FOR PREVENTING OR TREATING OF BONE DEGENERATION; PHARMACEUTICAL PREPARATIONS FOR THE TREATMENT OR PREVENTION OF BONE AND RENAL DISEASE; PHARMACEUTICAL PREPARATIONS FOR THE TREATMENT OR PREVENTION OF HYPERCALCEMIA, OSTEOPOROSIS AND PAGET'S DISEASE; CALCITONIN AND HORMONES AND CALCITONIN-BASED AND HORMONE-BASED PREPARATIONS FOR THE TREATMENT OR PREVENTION OF BONE AND RENAL DISEASE, HYPERCALCEMIA, OSTEOPOROSIS AND PAGET'S DISEASE; AND DIETETIC SUBSTANCES, NAMELY, DIETARY AND NUTRITIONALLY FORTIFIED FOOD PRODUCTS, ADAPTED FOR MEDICAL USE (U.S. CLS. 6, 18, 44, 46, 51 AND 52).

LINDA ESTRADA, EXAMINING ATTORNEY

SN 77-209,311. ADVANCED IN VITRO CELL TECHNOLOGIES, S.L., BARCELONA, SPAIN, FILED 6-19-2007.

DERMORBIS

THE MARK CONSISTS OF STANDARD CHARACTERS WITHOUT CLAIM TO ANY PARTICULAR FONT, STYLE, SIZE, OR COLOR.

PRIORITY CLAIMED UNDER SEC. 44(D) ON ERPN CMNTY TM OFC APPLICATION NO. 005970926, FILED 6-5-2007, REG. NO. 005970926, DATED 4-25-2008, EXPIRES 6-5-2017.

FOR MEDICINES FOR THE TREATMENT OF PSORIASIS, ATOPIC DERMATITIS AND OTHER DERMATOLOGIC DISEASES AND DISORDERS (U.S. CLS. 6, 18, 44, 46, 51 AND 52).

KARANENDRA S. CHHINA, EXAMINING ATTORNEY

CLASS 5—(Continued).

SN 77-209,328. ADVANCED IN VITRO CELL TECHNOLOGIES, S.L., BARCELONA, SPAIN, FILED 6-19-2007.

CYCLOSTOPIC

THE MARK CONSISTS OF STANDARD CHARACTERS WITHOUT CLAIM TO ANY PARTICULAR FONT, STYLE, SIZE, OR COLOR.

PRIORITY CLAIMED UNDER SEC. 44(D) ON ERPN CMNTY TM OFC APPLICATION NO. 005971015, FILED 6-5-2007, REG. NO. 005971015, DATED 4-25-2008, EXPIRES 6-5-2017.

FOR MEDICINES FOR THE TREATMENT OF PSORIASIS, ATOPIC DERMATITIS AND OTHER DERMATOLOGIC DISEASES AND DISORDERS (U.S. CLS. 6, 18, 44, 46, 51 AND 52).

KARANENDRA S. CHHINA, EXAMINING ATTORNEY

SN 77-209,337. ADVANCED IN VITRO CELL TECHNOLOGIES, S.L., BARCELONA, SPAIN, FILED 6-19-2007.

SORIFREN

THE MARK CONSISTS OF STANDARD CHARACTERS WITHOUT CLAIM TO ANY PARTICULAR FONT, STYLE, SIZE, OR COLOR.

PRIORITY CLAIMED UNDER SEC. 44(D) ON ERPN CMNTY TM OFC APPLICATION NO. 005970967, FILED 6-5-2007, REG. NO. 005970967, DATED 4-25-2008, EXPIRES 6-5-2017.

FOR MEDICINES FOR THE TREATMENT OF PSORIASIS, ATOPIC DERMATITIS AND OTHER DERMATOLOGIC DISEASES AND DISORDERS (U.S. CLS. 6, 18, 44, 46, 51 AND 52).

KARANENDRA S. CHHINA, EXAMINING ATTORNEY

SN 77-209,987. INDOMITUS ASSET MANAGEMENT LLC, NORTH HUNTINGDON, PA. FILED 6-19-2007.

biossential

THE MARK CONSISTS OF STANDARD CHARACTERS WITHOUT CLAIM TO ANY PARTICULAR FONT, STYLE, SIZE, OR COLOR.

FOR DIETARY AND NUTRITIONAL SUPPLEMENTS (U.S. CLS. 6, 18, 44, 46, 51 AND 52).

FIRST USE 2-2-2007; IN COMMERCE 6-19-2007.

IRA J. GOODSaid, EXAMINING ATTORNEY

CLASS 5—(Continued).

SN 77-256,440. CHRISTINE GREENFIELD, NEW YORK, NY. FILED 8-15-2007.

RESCYOU

THE MARK CONSISTS OF STANDARD CHARACTERS WITHOUT CLAIM TO ANY PARTICULAR FONT, STYLE, SIZE, OR COLOR.

FOR DIETARY SUPPLEMENTS, NAMELY, POWDERS AND LIQUIDS CONTAINING ELECTROLYTES AND VITAMINS TO BE ADDED TO BEVERAGES (U.S. CLS. 6, 18, 44, 46, 51 AND 52).

INGA ERVIN, EXAMINING ATTORNEY

SN 77-268,693. GLORYBEE NATURAL SWEETNERS, Eugene, OR. FILED 8-30-2007.

LIQUID GOLD

THE MARK CONSISTS OF STANDARD CHARACTERS WITHOUT CLAIM TO ANY PARTICULAR FONT, STYLE, SIZE, OR COLOR.

FOR NATURAL SWEETENER-BASED ENERGY GELS FOR HUMAN CONSUMPTION (U.S. CLS. 6, 18, 44, 46, 51 AND 52).

DOMINIC J. FERRAIUOLO, EXAMINING ATTORNEY

CLASS 5—(Continued).

SN 77-271,293. BIONORICA AG, 92318 NEUMARKT, FED REP GERMANY, FILED 9-4-2007.

MENOFEM

THE MARK CONSISTS OF STANDARD CHARACTERS WITHOUT CLAIM TO ANY PARTICULAR FONT, STYLE, SIZE, OR COLOR.

OWNER OF FED REP GERMANY REG. NO. 39548999, DATED 11-30-2005, EXPIRES 11-30-2015.

FOR PHARMACEUTICAL PREPARATIONS FOR THE TREATMENT OF GYNECOLOGICAL DISORDERS, NAMELY, GYNECOLOGICAL DISORDERS AFFECTING MENSTRUATION, MENSTRUAL IRREGULARITIES, POLYCYSTIC OVARIAN SYNDROME, UTERINE BLEEDING, ENDOMETRIOSIS AND PSYCHIC COMPLAINTS, NERVOUSNESS, DEPRESSION, MOOD DISORDERS, MOOD CHANGES, ANXIETY DISORDERS, AFFECTIVE AND COGNITIVE DISORDERS, HOT FLUSHES, PERSPIRATION, WEEPING SPASM, HEADACHE, VERTIGO, PALPITATION, INSOMNIA, PREMENSTRUAL SYNDROME, MENSTRUAL DISORDERS, MASTODYNIA, MASTALGIA, MASTOPATHY, GASTROINTESTINAL DISORDERS, BONE AND JOINT PAINS, BACKACHES, BREAST PAIN, DIZZINESS, NAUSEA, VOMITING, DIARRHEA, TENSENESS, SEXUAL DYSFUNCTION, ACNE, RASHES, HIRSUTISM, OBESITY, FERTILITY DISORDERS, HYPERPROLACTINEMIA; DIETARY SUPPLEMENTS FOR MEDICINAL PURPOSES; HERBAL SUPPLEMENTS FOR MEDICINAL PURPOSES; DIETARY AND NUTRITIONAL SUPPLEMENT FOR HUMAN CONSUMPTION; FOOD SUPPLEMENTS FOR NON-MEDICAL PURPOSES CONTAINING FATTY SUBSTANCES, FATTY ACIDS, ANTI-OXIDANTS, FIBER, VITAMINS, MINERALS AND/OR TRACE ELEMENTS; FOOD SUPPLEMENTS FOR NON-MEDICAL PURPOSES CONTAINING CARBOHYDRATES, ANTI-OXIDANTS, FIBER, VITAMINS, MINERALS AND/OR TRACE ELEMENTS (U.S. CLS. 6, 18, 44, 46, 51 AND 52).

JENNIFER DIXON, EXAMINING ATTORNEY

SN 77-272,377. INTERNATIONAL NUTRITION RESEARCH CENTER, INC., CORAL GABLES, FL. FILED 9-5-2007.

MASTER AMINO ACID PATTERN MAP

THE MARK CONSISTS OF STANDARD CHARACTERS WITHOUT CLAIM TO ANY PARTICULAR FONT, STYLE, SIZE, OR COLOR.

OWNER OF U.S. REG. NO. 2,517,779.

NO CLAIM IS MADE TO THE EXCLUSIVE RIGHT TO USE "AMINO ACID PATTERN", APART FROM THE MARK AS SHOWN.

FOR NUTRITIONAL SUPPLEMENTS, NAMELY, AMINO ACID BASED FORMULATIONS AND NUTRIFIED PROTEIN FOOD SUPPLEMENTS (U.S. CLS. 6, 18, 44, 46, 51 AND 52).

DANIEL CAPSHAW, EXAMINING ATTORNEY

CLASS 5—(Continued).

SN 77-286,122. NUTRI-HEALTH SUPPLEMENTS, LLC, COTTONWOOD, AZ. FILED 9-21-2007.

EMPOWERED CHOICES. BETTER
LIVING.

THE MARK CONSISTS OF STANDARD CHARACTERS WITHOUT CLAIM TO ANY PARTICULAR FONT, STYLE, SIZE, OR COLOR.

FOR DIETARY AND NUTRITIONAL SUPPLEMENTS (U.S. CLS. 6, 18, 44, 46, 51 AND 52).

FIRST USE 8-1-2007; IN COMMERCE 8-1-2007.

CIMMERIAN COLEMAN, EXAMINING ATTORNEY

SN 77-287,153. ATTENDS HEALTHCARE PRODUCTS, INC., GREENVILLE, NC. FILED 9-24-2007.

SECURELY YOURS

THE MARK CONSISTS OF STANDARD CHARACTERS WITHOUT CLAIM TO ANY PARTICULAR FONT, STYLE, SIZE, OR COLOR.

FOR OBSTETRIC INCONTINENCE OR SANITARY NAPKIN PADS AND GARMENT LINERS (U.S. CLS. 6, 18, 44, 46, 51 AND 52).

FIRST USE 11-3-1986; IN COMMERCE 11-3-1986.

MARTHA SANTOMARTINO, EXAMINING ATTORNEY

SN 77-291,656. ARIUS TWO, INC., RALEIGH, NC. FILED 9-28-2007.

BEMA

THE MARK CONSISTS OF STANDARD CHARACTERS WITHOUT CLAIM TO ANY PARTICULAR FONT, STYLE, SIZE, OR COLOR.

FOR PHARMACEUTICAL PREPARATIONS IN THE FORM OF MUCOADHESIVE POLYMER FILMS FOR THE TREATMENT OF PAIN; OPIOID ANALGESIC PREPARATIONS FOR THE TREATMENT OF PAIN (U.S. CLS. 6, 18, 44, 46, 51 AND 52).

ALYSSA PALADINO, EXAMINING ATTORNEY

CLASS 5—(Continued).

SN 77-295,340. VITAL FOOD PROCESSORS LIMITED, AUCKLAND, NEW ZEALAND, FILED 10-3-2007.



PRIORITY CLAIMED UNDER SEC. 44(D) ON NEW ZEALAND APPLICATION NO. 770888, FILED 6-22-2007, REG. NO. 770888, DATED 6-22-2007, EXPIRES 6-22-2017.

FOR PHARMACEUTICAL PREPARATIONS FOR THE TREATMENT OF DIGESTIVE DYSFUNCTION AND RELATED CONDITIONS; VETERINARY PREPARATIONS FOR THE TREATMENT OF DIGESTIVE DYSFUNCTION AND RELATED CONDITIONS; PROCESSED FOODS AND BEVERAGES ADAPTED FOR MEDICAL PURPOSES; DIETARY AND NUTRITIONAL SUPPLEMENTS; DIETARY AND NUTRITIONAL SUPPLEMENTS FOR USE AS A DIGESTIVE AID; PREPARATIONS CONTAINING KIWIFRUIT ENZYMES FOR MEDICAL OR PHARMACEUTICAL PURPOSES, NAMELY, FOR THE TREATMENT OF DIGESTIVE DYSFUNCTION AND RELATED CONDITIONS (U.S. CLS. 6, 18, 44, 46, 51 AND 52).

EDWARD NELSON, EXAMINING ATTORNEY

SN 77-329,180. YOUR VITAMINS INC., DBA PROCAPS LABORATORIES, HENDERSON, NV. FILED 11-14-2007.

TruQ10

THE MARK CONSISTS OF STANDARD CHARACTERS WITHOUT CLAIM TO ANY PARTICULAR FONT, STYLE, SIZE, OR COLOR.

FOR COMPLEX OF MICROORGANISMS SOLD AS AN INTEGRAL COMPONENT OF DIETARY AND NUTRITIONAL SUPPLEMENTS (U.S. CLS. 6, 18, 44, 46, 51 AND 52).

FIRST USE 11-1-2006; IN COMMERCE 11-2-2007.

JIM RINGLE, EXAMINING ATTORNEY

SN 77-358,398. GLAXO GROUP LIMITED, GREENFORD, MIDDLESEX, ENGLAND, FILED 12-21-2007.

ARZERRA

THE MARK CONSISTS OF STANDARD CHARACTERS WITHOUT CLAIM TO ANY PARTICULAR FONT, STYLE, SIZE, OR COLOR.

FOR PHARMACEUTICAL PREPARATIONS FOR THE TREATMENT OF CANCER (U.S. CLS. 6, 18, 44, 46, 51 AND 52).

GEORGE LORENZO, EXAMINING ATTORNEY

CLASS 5—(Continued).

SN 77-358,483. NUVO RESEARCH INC., MARKHAM, CANADA, FILED 12-21-2007.

PENNSAID

THE MARK CONSISTS OF STANDARD CHARACTERS WITHOUT CLAIM TO ANY PARTICULAR FONT, STYLE, SIZE, OR COLOR.

OWNER OF CANADA REG. NO. TMA504587, DATED 11-25-1998, EXPIRES 11-25-2013.

OWNER OF U.S. REG. NO. 2,530,053.

FOR PHARMACEUTICALS, NAMELY, A TOPICAL PRESCRIPTION NON-STEROIDAL ANTI-INFLAMMATORY DRUG (U.S. CLS. 6, 18, 44, 46, 51 AND 52).

LEIGH CAROLINE CASE, EXAMINING ATTORNEY

SN 77-359,615. VETTEC INC., DBA DUX DENTAL / VETTEC, INC., OXNARD, CA. FILED 12-26-2007.

Sole-Guard

THE MARK CONSISTS OF STANDARD CHARACTERS WITHOUT CLAIM TO ANY PARTICULAR FONT, STYLE, SIZE, OR COLOR.

FOR SYNTHETIC CURABLE LIQUID ELASTAMER FOR FORMING PROTECTIVE LAYER ON EQUINE HOOFS FOR CURATIVE AND THERAPEUTIC PURPOSES (U.S. CLS. 6, 18, 44, 46, 51 AND 52).

JOHN SCHUYLER YARD, EXAMINING ATTORNEY

SN 77-360,812. ITALFARMACO, S.A., ALCOBENDAS (MADRID), SPAIN, FILED 12-28-2007.

ZELESSE

THE MARK CONSISTS OF STANDARD CHARACTERS WITHOUT CLAIM TO ANY PARTICULAR FONT, STYLE, SIZE, OR COLOR.

PRIORITY CLAIMED UNDER SEC. 44(D) ON SPAIN APPLICATION NO. 2,798,085, FILED 11-7-2007, REG. NO. 2,798,085, DATED 11-7-2007, EXPIRES 11-7-2017.

FOR PHARMACEUTICAL FORMULATIONS FOR THE TREATMENT OF VULVOVAGINAL ATROPHY (U.S. CLS. 6, 18, 44, 46, 51 AND 52).

CHRISIE B. KING, EXAMINING ATTORNEY

CLASS 5—(Continued).

SN 77-371,916. VAT "FARMAK", KYIV, UKRAINE, FILED 1-15-2008.

Нафтизин

THE MARK CONSISTS OF CYRILLIC LETTERS. THE NON-LATIN CHARACTERS IN THE MARK TRANSLITERATE TO "NAPHTIZIN," AND THIS HAS NO MEANING IN ENGLISH.

FOR DECONGESTANTS (U.S. CLS. 6, 18, 44, 46, 51 AND 52).

FIRST USE 8-31-2006; IN COMMERCE 8-31-2006.

TAMARA FRAZIER, EXAMINING ATTORNEY

SN 77-375,092. NATROL, INC., CHATSWORTH, CA. FILED 1-18-2008.

MILK THISTLE ADVANTAGE

THE MARK CONSISTS OF STANDARD CHARACTERS WITHOUT CLAIM TO ANY PARTICULAR FONT, STYLE, SIZE, OR COLOR.

NO CLAIM IS MADE TO THE EXCLUSIVE RIGHT TO USE "MILK THISTLE", APART FROM THE MARK AS SHOWN.

FOR DIETARY SUPPLEMENTS (U.S. CLS. 6, 18, 44, 46, 51 AND 52).

MARK T. MULLEN, EXAMINING ATTORNEY

SN 77-385,349. MOTHER NATURES MINIATURES, LLC, ROGERSVILLE, MO. FILED 1-31-2008.

Mother Natures

THE MARK CONSISTS OF STANDARD CHARACTERS WITHOUT CLAIM TO ANY PARTICULAR FONT, STYLE, SIZE, OR COLOR.

FOR DIAGNOSTIC TEST KIT TO ASSIST IN DETERMINING THE TIME WHEN A MARE WILL FOAL (U.S. CLS. 6, 18, 44, 46, 51 AND 52).

FIRST USE 1-1-2003; IN COMMERCE 1-1-2003.

SUE LAWRENCE, EXAMINING ATTORNEY

CLASS 5—(Continued).

SN 77-387,685. TAKEDA PHARMACEUTICAL COMPANY LIMITED, CHUO-KU, OSAKA, JAPAN, FILED 2-4-2008.

DAKIBIS

THE MARK CONSISTS OF STANDARD CHARACTERS WITHOUT CLAIM TO ANY PARTICULAR FONT, STYLE, SIZE, OR COLOR.

PRIORITY CLAIMED UNDER SEC. 44(D) ON JAPAN APPLICATION NO. 2007-116143, FILED 11-16-2007, REG. NO. 5132417, DATED 4-25-2008, EXPIRES 4-25-2018.

FOR PHARMACEUTICAL PREPARATIONS FOR THE TREATMENT AND PREVENTION OF DIABETIC DISEASES (U.S. CLS. 6, 18, 44, 46, 51 AND 52).

RONALD DELGIZZI, EXAMINING ATTORNEY

SN 77-389,851. SCIENCE FORMULAS, INC., BALTIMORE, MD. FILED 2-6-2008.

CHEMEXPEL

THE MARK CONSISTS OF STANDARD CHARACTERS WITHOUT CLAIM TO ANY PARTICULAR FONT, STYLE, SIZE, OR COLOR.

THE WORD "CHEMEXPEL" HAS NO MEANING IN A FOREIGN LANGUAGE.

FOR DIETARY AND NUTRITIONAL SUPPLEMENTS (U.S. CLS. 6, 18, 44, 46, 51 AND 52).

DAVID TOOLEY, EXAMINING ATTORNEY

SN 77-395,627. JARROW FORMULAS, INC., LOS ANGELES, CA. FILED 2-13-2008.

JARROSIL

THE MARK CONSISTS OF STANDARD CHARACTERS WITHOUT CLAIM TO ANY PARTICULAR FONT, STYLE, SIZE, OR COLOR.

OWNER OF U.S. REG. NOS. 2,468,898, 3,090,204 AND OTHERS.

FOR DIETARY AND NUTRITIONAL SUPPLEMENTS (U.S. CLS. 6, 18, 44, 46, 51 AND 52).

NATALIE POLZER, EXAMINING ATTORNEY

CLASS 5—(Continued).

SN 77-399,013. HOLLAND, LISA ANN, NAZARETH, PA. AND HOLLAND, VINCENT, NAZARETH, PA. FILED 2-16-2008.

Sexiflex

THE MARK CONSISTS OF STANDARD CHARACTERS WITHOUT CLAIM TO ANY PARTICULAR FONT, STYLE, SIZE, OR COLOR.

FOR DIETARY AND NUTRITIONAL SUPPLEMENTS (U.S. CLS. 6, 18, 44, 46, 51 AND 52).

FIRST USE 2-1-2003; IN COMMERCE 2-1-2003.

JULIE WATSON, EXAMINING ATTORNEY

SN 77-404,316. NATROL, INC., CHATSWORTH, CA. FILED 2-22-2008.

NATROL CLINICAL THERAPY

THE MARK CONSISTS OF STANDARD CHARACTERS WITHOUT CLAIM TO ANY PARTICULAR FONT, STYLE, SIZE, OR COLOR.

OWNER OF U.S. REG. NOS. 1,532,608, 2,252,985 AND 2,906,488.

NO CLAIM IS MADE TO THE EXCLUSIVE RIGHT TO USE "CLINICAL THERAPY", APART FROM THE MARK AS SHOWN.

FOR DIETARY SUPPLEMENTS (U.S. CLS. 6, 18, 44, 46, 51 AND 52).

MARK T. MULLEN, EXAMINING ATTORNEY

SN 77-413,122. ST. HILAIRE, RUSSELL, GLASTONBURY, CT. FILED 3-4-2008.



NO CLAIM IS MADE TO THE EXCLUSIVE RIGHT TO USE "SPORTS BALM", APART FROM THE MARK AS SHOWN.

THE STIPPLING IS FOR SHADING PURPOSES ONLY. THE MARK CONSISTS OF THE STYLIZED WORDS "KATANA SPORTS BALM".

FOR HEATING THERAPEUTIC BALMS FOR MEDICAL PURPOSES, GEL-TYPE HEATING BALMS FOR MEDICAL PURPOSES DISPENSED FROM TWIST-UP TUBE APPLICATORS, TOPICAL ANALGESICS; HEATING ANALGESIC BALMS AND ANTI-INFLAMMATORY SALVES (U.S. CLS. 6, 18, 44, 46, 51 AND 52).

MARK SPARACINO, EXAMINING ATTORNEY

CLASS 5—(Continued).

SN 77-415,392. ADREZIN, BJ, PORTLAND, OR. FILED 3-6-2008.

MACA MIRACLE

THE MARK CONSISTS OF STANDARD CHARACTERS WITHOUT CLAIM TO ANY PARTICULAR FONT, STYLE, SIZE, OR COLOR.

NO CLAIM IS MADE TO THE EXCLUSIVE RIGHT TO USE "MACA", APART FROM THE MARK AS SHOWN.

FOR DIETARY AND NUTRITIONAL SUPPLEMENTS AND FOOD SUPPLEMENTS IN SOLID, CRACKER, POWDER, LIQUID DRINK AND SNACK BAR FORM (U.S. CLS. 6, 18, 44, 46, 51 AND 52).

FIRST USE 1-15-2008; IN COMMERCE 1-15-2008.
KAPIL BHANOT, EXAMINING ATTORNEY

SN 77-415,998. SPECTRUM PHARMACEUTICALS, INC., IRVINE, CA. FILED 3-7-2008.

FUSILEV

THE MARK CONSISTS OF STANDARD CHARACTERS WITHOUT CLAIM TO ANY PARTICULAR FONT, STYLE, SIZE, OR COLOR.

THE WORDING "FUSILEV" HAS NO MEANING IN A FOREIGN LANGUAGE.

FOR PHARMACEUTICAL PREPARATION FOR THE TREATMENT OF FOLIC DEFICIENCY, METHOTREXATE RESCUE, IMPAIRED METHOTREXATE ELIMINATION, INADVERTENT OVERDOSAGE OF FOLIC ACID ANTAGONISTS, OSTEOSARCOMA, AND COLORECTAL INDICATIONS (U.S. CLS. 6, 18, 44, 46, 51 AND 52).

MARK SPARACINO, EXAMINING ATTORNEY

SN 77-417,311. THE PROCTER & GAMBLE COMPANY, CINCINNATI, OH. FILED 3-10-2008.

align

OWNER OF U.S. REG. NOS. 3,172,424 AND 3,321,774. FOR DIETARY AND NUTRITIONAL SUPPLEMENTS (U.S. CLS. 6, 18, 44, 46, 51 AND 52).
TOBY BULLOFF, EXAMINING ATTORNEY

CLASS 5—(Continued).

SN 77-418,022. CANDIDA SURVIVAL KIT, FORT COLLINS, CO. FILED 3-10-2008.

CANDIDA SURVIVAL KIT

THE MARK CONSISTS OF STANDARD CHARACTERS WITHOUT CLAIM TO ANY PARTICULAR FONT, STYLE, SIZE, OR COLOR.

NO CLAIM IS MADE TO THE EXCLUSIVE RIGHT TO USE "CANDIDA" OR "KIT", APART FROM THE MARK AS SHOWN.

FOR NUTRITIONAL SUPPLEMENTS (U.S. CLS. 6, 18, 44, 46, 51 AND 52).

PAULA MAHONEY, EXAMINING ATTORNEY

SN 77-419,568. DR. JOHN'S CANDIES, LLC, GRAND RAPIDS, MI. FILED 3-12-2008.

DR. JOHN'S HERBAL CANDY

THE MARK CONSISTS OF STANDARD CHARACTERS WITHOUT CLAIM TO ANY PARTICULAR FONT, STYLE, SIZE, OR COLOR.

OWNER OF U.S. REG. NO. 3,224,997.

NO CLAIM IS MADE TO THE EXCLUSIVE RIGHT TO USE "HERBAL CANDY", APART FROM THE MARK AS SHOWN.

THE NAME(S), PORTRAIT(S), AND/OR SIGNATURE(S) SHOWN IN THE MARK IDENTIFIES "DR. JOHN BRUINSMA", WHOSE CONSENT(S) TO REGISTER IS SUBMITTED.

FOR HERBAL SUPPLEMENT IN CANDY FORM FOR THE PREVENTION OF DENTAL DECAY AND CAVITIES (U.S. CLS. 6, 18, 44, 46, 51 AND 52).

FIRST USE 7-1-2006; IN COMMERCE 7-1-2006.

KOURTNEE HODGES, EXAMINING ATTORNEY

SN 77-420,470. VALEANT PHARMACEUTICALS NORTH AMERICA, ALISO VIEJO, CA. FILED 3-12-2008.

KOTIGA

THE MARK CONSISTS OF STANDARD CHARACTERS WITHOUT CLAIM TO ANY PARTICULAR FONT, STYLE, SIZE, OR COLOR.

FOR PHARMACEUTICAL PREPARATIONS FOR THE TREATMENT OF EPILEPSY, SEIZURES AND NEUROLOGICAL DISORDERS; POTASSIUM PREPARATIONS FOR PHARMACEUTICALS (U.S. CLS. 6, 18, 44, 46, 51 AND 52).

SANJEEV VOHRA, EXAMINING ATTORNEY

CLASS 5—(Continued).

SN 77-420,484. VALEANT PHARMACEUTICALS NORTH AMERICA, ALISO VIEJO, CA. FILED 3-12-2008.

POTIGA

THE MARK CONSISTS OF STANDARD CHARACTERS WITHOUT CLAIM TO ANY PARTICULAR FONT, STYLE, SIZE, OR COLOR.

FOR PHARMACEUTICAL PREPARATIONS FOR THE TREATMENT OF EPILEPSY, SEIZURES AND NEUROLOGICAL DISORDERS; POTASSIUM PREPARATIONS FOR PHARMACEUTICALS (U.S. CLS. 6, 18, 44, 46, 51 AND 52).

SANJEEV VOHRA, EXAMINING ATTORNEY

SN 77-420,487. VALEANT PHARMACEUTICALS NORTH AMERICA, ALISO VIEJO, CA. FILED 3-12-2008.

KOPTAS

THE MARK CONSISTS OF STANDARD CHARACTERS WITHOUT CLAIM TO ANY PARTICULAR FONT, STYLE, SIZE, OR COLOR.

FOR PHARMACEUTICAL PREPARATIONS FOR THE TREATMENT OF EPILEPSY, SEIZURES AND NEUROLOGICAL DISORDERS; POTASSIUM PREPARATIONS FOR PHARMACEUTICALS (U.S. CLS. 6, 18, 44, 46, 51 AND 52).

SANJEEV VOHRA, EXAMINING ATTORNEY

SN 77-420,494. VALEANT PHARMACEUTICALS NORTH AMERICA, ALISO VIEJO, CA. FILED 3-12-2008.

KALEPSA

THE MARK CONSISTS OF STANDARD CHARACTERS WITHOUT CLAIM TO ANY PARTICULAR FONT, STYLE, SIZE, OR COLOR.

FOR PHARMACEUTICAL PREPARATIONS FOR THE TREATMENT OF EPILEPSY, SEIZURES AND NEUROLOGICAL DISORDERS; POTASSIUM PREPARATIONS FOR PHARMACEUTICALS (U.S. CLS. 6, 18, 44, 46, 51 AND 52).

SANJEEV VOHRA, EXAMINING ATTORNEY

CLASS 5—(Continued).

SN 77-420,747. INDEVUS PHARMACEUTICALS, INC., LEXINGTON, MA. FILED 3-13-2008.

AVEED

THE MARK CONSISTS OF STANDARD CHARACTERS WITHOUT CLAIM TO ANY PARTICULAR FONT, STYLE, SIZE, OR COLOR.

FOR HORMONAL PREPARATIONS (U.S. CLS. 6, 18, 44, 46, 51 AND 52).

JASON ROTH, EXAMINING ATTORNEY

SN 77-421,211. ELI LILLY AND COMPANY, INDIANAPOLIS, IN. FILED 3-13-2008.

PAVENI

THE MARK CONSISTS OF STANDARD CHARACTERS WITHOUT CLAIM TO ANY PARTICULAR FONT, STYLE, SIZE, OR COLOR.

FOR VETERINARY PREPARATIONS FOR COMPANION ANIMALS, NAMELY, WEIGHT LOSS, OBESITY, TOPICAL APPLICATION FOR URINE SPRAY, CHRONIC PAIN, GASTROINTESTINAL DISORDERS, NEURODEGENERATIVE DISORDERS, PARASITIC INFESTATIONS, NEUROLOGICAL DISORDERS, ANXIETY, HYPERTENSION, DERMATITIS, CANCER, ANEMIA ASSOCIATED WITH CHRONIC RENAL FAILURE, FLEA CONTROL, CONTROL OF PAIN ASSOCIATED WITH ORTHOPEDIC AND SOFT TISSUE SURGERY, AND CHRONIC KIDNEY DISEASE; VETERINARY PREPARATIONS, NAMELY, ANTI-EMETIC PRODUCTS; PREPARATIONS FOR DESTROYING VERMIN, INSECTICIDES FOR USE WITH LIVESTOCK AND LIVESTOCK PREMISES; ANTIBIOTICS FOR USE IN LIVESTOCK; VETERINARY PREPARATIONS FOR TREATING CUSHING'S DISEASE IN ANIMALS; DIETARY FOOD SUPPLEMENTS FOR ANIMALS; GROWTH PROMOTERS FOR LIVESTOCK; MEDICATED FEED AND WATER ADDITIVES FOR ANIMALS (U.S. CLS. 6, 18, 44, 46, 51 AND 52).

LINDSEY RUBIN, EXAMINING ATTORNEY

CLASS 5—(Continued).

SN 77-421,215. ELI LILLY AND COMPANY, INDIANAPOLIS, IN. FILED 3-13-2008.

RIAGO

THE MARK CONSISTS OF STANDARD CHARACTERS WITHOUT CLAIM TO ANY PARTICULAR FONT, STYLE, SIZE, OR COLOR.

FOR VETERINARY PREPARATIONS FOR COMPANION ANIMALS, NAMELY, WEIGHT LOSS, OBESITY, TOPICAL APPLICATION FOR URINE SPRAY, CHRONIC PAIN, GASTROINTESTINAL DISORDERS, NEURODEGENERATIVE DISORDERS, PARASITIC INFESTATIONS, NEUROLOGICAL DISORDERS, ANXIETY, HYPERTENSION, DERMATITIS, CANCER, ANEMIA ASSOCIATED WITH CHRONIC RENAL FAILURE, FLEA CONTROL, CONTROL OF PAIN ASSOCIATED WITH ORTHOPEDIC AND SOFT TISSUE SURGERY, AND CHRONIC KIDNEY DISEASE; VETERINARY PREPARATIONS, NAMELY, ANTI-EMETIC PRODUCTS; PREPARATIONS FOR DESTROYING VERMIN, INSECTICIDES FOR USE WITH LIVESTOCK AND LIVESTOCK PREMISES; ANTIBIOTICS FOR USE IN LIVESTOCK; VETERINARY PREPARATIONS FOR TREATING CUSHING'S DISEASE IN ANIMALS; DIETARY FOOD SUPPLEMENTS FOR ANIMALS; GROWTH PROMOTERS FOR LIVESTOCK; MEDICATED FEED AND WATER ADDITIVES FOR ANIMALS (U.S. CLS. 6, 18, 44, 46, 51 AND 52).

LINDSEY RUBIN, EXAMINING ATTORNEY

SN 77-421,339. ELI LILLY AND COMPANY, INDIANAPOLIS, IN. FILED 3-13-2008.

VILLOW

THE MARK CONSISTS OF STANDARD CHARACTERS WITHOUT CLAIM TO ANY PARTICULAR FONT, STYLE, SIZE, OR COLOR.

FOR VETERINARY PREPARATIONS FOR COMPANION ANIMALS, NAMELY, WEIGHT LOSS, OBESITY, TOPICAL APPLICATION FOR URINE SPRAY, CHRONIC PAIN, GASTROINTESTINAL DISORDERS, NEURODEGENERATIVE DISORDERS, PARASITIC INFESTATIONS, NEUROLOGICAL DISORDERS, ANXIETY, HYPERTENSION, DERMATITIS, CANCER, ANEMIA ASSOCIATED WITH CHRONIC RENAL FAILURE, FLEA CONTROL, CONTROL OF PAIN ASSOCIATED WITH ORTHOPEDIC AND SOFT TISSUE SURGERY, AND CHRONIC KIDNEY DISEASE; VETERINARY PREPARATIONS, NAMELY, ANTI-EMETIC PRODUCTS; PREPARATIONS FOR DESTROYING VERMIN, INSECTICIDES FOR USE WITH LIVESTOCK AND LIVESTOCK PREMISES; ANTIBIOTICS FOR USE IN LIVESTOCK; VETERINARY PREPARATIONS FOR TREATING CUSHING'S DISEASE IN ANIMALS; DIETARY FOOD SUPPLEMENTS FOR ANIMALS; GROWTH PROMOTERS FOR LIVESTOCK; MEDICATED FEED AND WATER ADDITIVES FOR ANIMALS (U.S. CLS. 6, 18, 44, 46, 51 AND 52).

LINDSEY RUBIN, EXAMINING ATTORNEY

CLASS 5—(Continued).

SN 77-421,355. DBC, LLC, LEHI, UT. FILED 3-13-2008.

OWNER OF U.S. REG. NOS. 3,104,280, 3,152,299 AND OTHERS.

FOR VITAMIN AND MINERAL SUPPLEMENTS (U.S. CLS. 6, 18, 44, 46, 51 AND 52).

KATHERINE STOIDES, EXAMINING ATTORNEY

SN 77-421,835. TECH STAR MEDICAL, INC., SPRING HILL, FL. FILED 3-14-2008.

JUST 4 HANDS

THE MARK CONSISTS OF STANDARD CHARACTERS WITHOUT CLAIM TO ANY PARTICULAR FONT, STYLE, SIZE, OR COLOR.

NO CLAIM IS MADE TO THE EXCLUSIVE RIGHT TO USE "HANDS", APART FROM THE MARK AS SHOWN.

FOR HAND-SANITIZING PREPARATIONS (U.S. CLS. 6, 18, 44, 46, 51 AND 52).

ELLEN BURNS, EXAMINING ATTORNEY

SN 77-423,370. CALGENEX CORPORATION, TAMPA, FL. FILED 3-17-2008.

Lipideme

THE MARK CONSISTS OF STANDARD CHARACTERS WITHOUT CLAIM TO ANY PARTICULAR FONT, STYLE, SIZE, OR COLOR.

FOR VITAMIN SUPPLEMENTS; VITAMINS; DIETARY AND NUTRITIONAL SUPPLEMENTS; NUTRACEUTICALS FOR USE AS A DIETARY SUPPLEMENT (U.S. CLS. 6, 18, 44, 46, 51 AND 52).

HEATHER SAPP, EXAMINING ATTORNEY

CLASS 5—(Continued).

SN 77-423,396. GERMAINE LABORATORIES, INC., SAN ANTONIO, TX. FILED 3-17-2008.

GERMAINE

THE MARK CONSISTS OF STANDARD CHARACTERS WITHOUT CLAIM TO ANY PARTICULAR FONT, STYLE, SIZE, OR COLOR.

FOR DIAGNOSTIC TEST KITS COMPRISED OF REAGENTS, TEST DEVICES, AND TEST STRIPS FOR IN VITRO USE IN CLINICAL OR MEDICAL LABORATORY, AND HOME USE, MEDICAL DIAGNOSTIC REAGENTS (U.S. CLS. 6, 18, 44, 46, 51 AND 52).

FIRST USE 6-18-1997; IN COMMERCE 6-18-1997.
JILL PRATER, EXAMINING ATTORNEY



SN 77-423,556. HOUSTON NUTRACEUTICALS, INC., SILOAM SPRINGS, AR. FILED 3-17-2008.

HOUSTON ENZYMES

THE MARK CONSISTS OF STANDARD CHARACTERS WITHOUT CLAIM TO ANY PARTICULAR FONT, STYLE, SIZE, OR COLOR.

NO CLAIM IS MADE TO THE EXCLUSIVE RIGHT TO USE "ENZYMES", APART FROM THE MARK AS SHOWN.

FOR DIETARY AND NUTRITIONAL SUPPLEMENTS (U.S. CLS. 6, 18, 44, 46, 51 AND 52).

FIRST USE 4-15-2006; IN COMMERCE 4-15-2006.
MICHAEL KEATING, EXAMINING ATTORNEY



SN 77-423,871. ASTRAZENECA AB, SÖDERTÄLJE, SWEDEN, FILED 3-17-2008.

CERTRIAD

THE MARK CONSISTS OF STANDARD CHARACTERS WITHOUT CLAIM TO ANY PARTICULAR FONT, STYLE, SIZE, OR COLOR.

FOR PHARMACEUTICAL PREPARATIONS AND SUBSTANCES FOR THE TREATMENT OF DISEASES AND DISORDERS OF THE CARDIOVASCULAR SYSTEM (U.S. CLS. 6, 18, 44, 46, 51 AND 52).

STEVEN PEREZ, EXAMINING ATTORNEY

CLASS 5—(Continued).

SN 77-424,594. PLATINUM INTERNET PTY LIMITED, ERINA, AUSTRALIA, FILED 3-18-2008.

Triple Action TrimAndSlim

THE MARK CONSISTS OF STANDARD CHARACTERS WITHOUT CLAIM TO ANY PARTICULAR FONT, STYLE, SIZE, OR COLOR.

FOR DIETARY AND NUTRITIONAL SUPPLEMENTS (U.S. CLS. 6, 18, 44, 46, 51 AND 52).

CHRISTINA SOBRAL, EXAMINING ATTORNEY



SN 77-426,103. NOVARX CORPORATION, SAN DIEGO, CA. FILED 3-19-2008.



NO CLAIM IS MADE TO THE EXCLUSIVE RIGHT TO USE "CANCER", APART FROM THE MARK AS SHOWN.

THE MARK CONSISTS OF SINGLE HELIX DESIGN WITH THE WORD "NOVARX" WRITTEN TO THE RIGHT OF THE DESIGN. THE "A", "R" AND "X" IN "NOVARX" ARE WRITTEN ABOVE THE PHRASE "CANCER STOPS HERE".

FOR PHARMACEUTICAL PREPARATIONS FOR THE TREATMENT OF CANCER (U.S. CLS. 6, 18, 44, 46, 51 AND 52).

ALYSSA PALADINO, EXAMINING ATTORNEY



SN 77-426,249. TRANSPLANT TECHNOLOGIES OF TEXAS LTD., DBA BONE BANK ALLOGRAFTS, SAN ANTONIO, TX. FILED 3-19-2008.

STERIGRAFT

THE MARK CONSISTS OF STANDARD CHARACTERS WITHOUT CLAIM TO ANY PARTICULAR FONT, STYLE, SIZE, OR COLOR.

FOR BIOLOGICAL HUMAN DONOR BONE AND TISSUE INTENDED FOR SUBSEQUENT IMPLANTATION (U.S. CLS. 6, 18, 44, 46, 51 AND 52).

FIRST USE 3-17-2008; IN COMMERCE 3-17-2008.

NANCY CLARKE, EXAMINING ATTORNEY

CLASS 5—(Continued).

SN 77-426,268. TRANSPLANT TECHNOLOGIES OF TEXAS LTD., DBA BONE BANK ALLOGRAFTS, SAN ANTONIO, TX. FILED 3-19-2008.

GRAFTCLEANSE

THE MARK CONSISTS OF STANDARD CHARACTERS WITHOUT CLAIM TO ANY PARTICULAR FONT, STYLE, SIZE, OR COLOR.

FOR PROCESSED HUMAN DONOR BONE AND TISSUE INTENDED FOR SUBSEQUENT IMPLANTATION (U.S. CLS. 6, 18, 44, 46, 51 AND 52).

FIRST USE 3-17-2008; IN COMMERCE 3-17-2008.

NANCY CLARKE, EXAMINING ATTORNEY

SN 77-426,283. TRANSPLANT TECHNOLOGIES OF TEXAS LTD., DBA BONE BANK ALLOGRAFTS, SAN ANTONIO, TX. FILED 3-19-2008.

GRAFTSHIELD

THE MARK CONSISTS OF STANDARD CHARACTERS WITHOUT CLAIM TO ANY PARTICULAR FONT, STYLE, SIZE, OR COLOR.

FOR BIOLOGICAL IMPLANTS, NAMELY, HUMAN BONE AND TISSUE PROTECTED AGAINST CONTAMINATION BY VALIDATED QUALITY CONTROLS AND RECORD KEEPING (U.S. CLS. 6, 18, 44, 46, 51 AND 52).

FIRST USE 3-17-2008; IN COMMERCE 3-17-2008.

NANCY CLARKE, EXAMINING ATTORNEY

SN 77-426,300. TRANSPLANT TECHNOLOGIES OF TEXAS LTD., SAN ANTONIO, TX. FILED 3-19-2008.

STERISPONGE

THE MARK CONSISTS OF STANDARD CHARACTERS WITHOUT CLAIM TO ANY PARTICULAR FONT, STYLE, SIZE, OR COLOR.

FOR SURGICAL IMPLANTS, NAMELY, RESILIENT CANCELLOUS BIOLOGICAL BONE FOR IMPLANTATION INTO HUMANS (U.S. CLS. 6, 18, 44, 46, 51 AND 52).

NANCY CLARKE, EXAMINING ATTORNEY

CLASS 5—(Continued).

SN 77-426,559. AMERICAN COVERS, INC., BLUFFDALE, UT. FILED 3-19-2008.

BAHAMA BAG

THE MARK CONSISTS OF STANDARD CHARACTERS WITHOUT CLAIM TO ANY PARTICULAR FONT, STYLE, SIZE, OR COLOR.

FOR AIR FRESHENER AND AIR DEODORIZER (U.S. CLS. 6, 18, 44, 46, 51 AND 52).

FIRST USE 12-0-2006; IN COMMERCE 12-0-2006.

DOMINICK J. SALEMI, EXAMINING ATTORNEY

SN 77-427,168. ENIVA USA, ANOKA, MN. FILED 3-20-2008.

ovia

THE MARK CONSISTS OF STANDARD CHARACTERS WITHOUT CLAIM TO ANY PARTICULAR FONT, STYLE, SIZE, OR COLOR.

FOR ANIMAL FEED SUPPLEMENTS; BISCUITS, BREAD, BREAD ROLLS, CAKES, CEREAL PRODUCTS, CONFECTIONERY, CRACKERS, NOODLES, FISH SAUCE, RELISH, SAUCES, CEREAL-BASED SNACK-FOODS AND PREPARED DIETARY ITEMS THAT ARE GLUTEN-FREE TO ACCOMMODATE SPECIAL MEDICAL AND HEALTH CONDITIONS; DIETARY AND NUTRITIONAL SUPPLEMENTS; DIETARY AND NUTRITIONALLY FORTIFIED FOOD PRODUCTS ADAPTED FOR MEDICAL USE; DIETARY FOOD SUPPLEMENTS; DIETARY SUPPLEMENTS; DIETARY SUPPLEMENTS FOR ANIMALS; DIETARY SUPPLEMENTS FOR HUMAN CONSUMPTION; DIETARY SUPPLEMENTS FOR PETS; FOOD SUPPLEMENTS; FOOD SUPPLEMENTS, NAMELY, ANTI-OXIDANTS; HERBAL SUPPLEMENTS; HOMEOPATHIC SUPPLEMENTS; MINERAL FOOD SUPPLEMENTS; MINERAL NUTRITIONAL SUPPLEMENTS; MINERAL SUPPLEMENTS; NON-MEDICATED ADDITIVES FOR ANIMAL FEED FOR USE AS NUTRITIONAL SUPPLEMENTS; NUTRACEUTICALS FOR USE AS A DIETARY SUPPLEMENT; NUTRITIONAL ADDITIVES FOR MEDICAL PURPOSES FOR USE IN FOODS AND DIETARY SUPPLEMENTS FOR HUMAN CONSUMPTION; NUTRITIONAL SUPPLEMENTS; VITAMIN AND MINERAL SUPPLEMENTS; VITAMIN SUPPLEMENTS; VITAMINS AND DIETARY FOOD SUPPLEMENTS FOR ANIMALS (U.S. CLS. 6, 18, 44, 46, 51 AND 52).

CYNTHIA TRIPI, EXAMINING ATTORNEY

CLASS 5—(Continued).

SN 77-428,053. CPMC, LLC, PHOENIX, AZ. FILED 3-21-2008.

IDEALDIET

THE MARK CONSISTS OF STANDARD CHARACTERS WITHOUT CLAIM TO ANY PARTICULAR FONT, STYLE, SIZE, OR COLOR.

FOR DIETARY AND NUTRITIONAL SUPPLEMENTS; DIETARY SUPPLEMENTS FOR HUMAN CONSUMPTION (U.S. CLS. 6, 18, 44, 46, 51 AND 52).

BRIAN NEVILLE, EXAMINING ATTORNEY

SN 77-428,119. ARTHRODYNAMIC TECHNOLOGIES, ANIMAL HEALTH DIVISION, INC., LEXINGTON, KY. FILED 3-21-2008.

POLYPOCKETS

THE MARK CONSISTS OF STANDARD CHARACTERS WITHOUT CLAIM TO ANY PARTICULAR FONT, STYLE, SIZE, OR COLOR.

FOR CHEWABLE THERAPEUTIC COMPOSITIONS THAT HOLD ADDITIONAL MEDICATION FOR USE IN THE PREVENTION AND TREATMENT OF OSTEOARTHRITIS, OSTEOCHONDROSIS DESSICANS, SYNOVITIS, INFLAMMATORY ARTHRITIS, SEPTIC ARTHRITIS, DEGENERATIVE JOINT DISEASE, INFLAMMATION AND SURGICAL TRAUMA (U.S. CLS. 6, 18, 44, 46, 51 AND 52).

JOHN WILKE, EXAMINING ATTORNEY

SN 77-428,231. I'M A LITTLE TEA CUP, DBA ANGEL'S EYES, CORAL SPRINGS, FL. FILED 3-21-2008.

GO FROM TEAR TO CLEAR

THE MARK CONSISTS OF STANDARD CHARACTERS WITHOUT CLAIM TO ANY PARTICULAR FONT, STYLE, SIZE, OR COLOR.

FOR EDIBLE DOG TREATS, NAMELY, DOG TREATS INCORPORATING NUTRITIONAL ADDITIVES FOR MEDICAL PURPOSES (U.S. CLS. 6, 18, 44, 46, 51 AND 52).

FIRST USE 6-30-2005; IN COMMERCE 6-30-2005.
ANTHONY RINKER, EXAMINING ATTORNEY

CLASS 5—(Continued).

SN 77-428,273. GENELINK INC., WINTER SPRINGS, FL. FILED 3-21-2008.

LIFEMAP NUTRITION

THE MARK CONSISTS OF STANDARD CHARACTERS WITHOUT CLAIM TO ANY PARTICULAR FONT, STYLE, SIZE, OR COLOR.

NO CLAIM IS MADE TO THE EXCLUSIVE RIGHT TO USE "NUTRITION", APART FROM THE MARK AS SHOWN.

FOR NUTRITIONAL SUPPLEMENTS; VITAMIN AND MINERAL SUPPLEMENTS (U.S. CLS. 6, 18, 44, 46, 51 AND 52).

CYNTHIA SLOAN, EXAMINING ATTORNEY

SN 77-428,428. ARTHRODYNAMIC TECHNOLOGIES, ANIMAL HEALTH DIVISION, INC., DBA ARTHRODYNAMIC TECHNOLOGIES, LLC, LEXINGTON, KY. FILED 3-21-2008.

POLYGLYCAN

THE MARK CONSISTS OF STANDARD CHARACTERS WITHOUT CLAIM TO ANY PARTICULAR FONT, STYLE, SIZE, OR COLOR.

OWNER OF U.S. REG. NO. 3,042,937.

SEC. 2(F).

FOR PHARMACEUTICAL PREPARATIONS FOR USE IN THE PREVENTION AND TREATMENT OF OSTEOARTHRITIS, OSTEOCHONDROSIS DESSICANS, SYNOVITIS, INFLAMMATORY ARTHRITIS, SEPTIC ARTHRITIS, DEGENERATIVE JOINT DISEASE, INFLAMMATION, AND SURGICAL TRAUMA (U.S. CLS. 6, 18, 44, 46, 51 AND 52).

FIRST USE 11-0-2002; IN COMMERCE 11-0-2002.

JOHN WILKE, EXAMINING ATTORNEY

SN 77-428,821. THOMAS SISTERS ORGANICS, DBA THOMAS SISTERS ORGANICS, PORTLAND, OR. FILED 3-21-2008.

Organifiber

THE MARK CONSISTS OF STANDARD CHARACTERS WITHOUT CLAIM TO ANY PARTICULAR FONT, STYLE, SIZE, OR COLOR.

FOR ORGANIC DIETARY FIBER AS AN ADDITIVE FOR FOOD PRODUCTS (U.S. CLS. 6, 18, 44, 46, 51 AND 52).

NICHOLAS COLEMAN, EXAMINING ATTORNEY

CLASS 5—(Continued).

SN 77-429,225. JOHNSON & JOHNSON, NEW BRUNSWICK, NJ. FILED 3-24-2008.

THE HEALING HUG

THE MARK CONSISTS OF STANDARD CHARACTERS WITHOUT CLAIM TO ANY PARTICULAR FONT, STYLE, SIZE, OR COLOR.

FOR WOUND DRESSINGS; ADHESIVE BANDAGES; AND ADHESIVE BANDAGE PADS (U.S. CLS. 6, 18, 44, 46, 51 AND 52).

EDWARD FENNESSY, EXAMINING ATTORNEY

SN 77-429,227. JOHNSON & JOHNSON, NEW BRUNSWICK, NJ. FILED 3-24-2008.

THE HUG WITH HEALING POWER

THE MARK CONSISTS OF STANDARD CHARACTERS WITHOUT CLAIM TO ANY PARTICULAR FONT, STYLE, SIZE, OR COLOR.

FOR WOUND DRESSINGS; ADHESIVE BANDAGES; AND ADHESIVE BANDAGE PADS (U.S. CLS. 6, 18, 44, 46, 51 AND 52).

EDWARD FENNESSY, EXAMINING ATTORNEY

SN 77-429,626. PHARMAVITE LLC, MISSION HILLS, CA. FILED 3-24-2008.



OWNER OF U.S. REG. NOS. 1,963,505 AND 2,451,597. THE MARK CONSISTS OF THE WORDS "NATURE MADE" WITH TWO LEAVES ABOVE, ENCLOSED WITHIN A LINED BORDER.

FOR DIETARY SUPPLEMENTS (U.S. CLS. 6, 18, 44, 46, 51 AND 52).

FIRST USE 11-30-2005; IN COMMERCE 11-30-2005. KIMBERLY FRYE, EXAMINING ATTORNEY

CLASS 5—(Continued).

SN 77-429,781. BIOCRYST PHARMACEUTICALS, INC., BIRMINGHAM, AL. FILED 3-24-2008.

COMPLIS

THE MARK CONSISTS OF STANDARD CHARACTERS WITHOUT CLAIM TO ANY PARTICULAR FONT, STYLE, SIZE, OR COLOR.

FOR PHARMACEUTICALS FOR THE TREATMENT OF HEPATITIS, ACQUIRED IMMUNE DEFICIENCY SYNDROME (AIDS), SARS, AND WEST NILE VIRUS; PHARMACEUTICALS FOR THE TREATMENT OF INFLAMMATORY BOWEL DISEASES, INFLAMMATORY CONNECTIVE TISSUE DISEASES AND INFLAMMATORY SKIN DISEASES; PHARMACEUTICALS FOR THE TREATMENT OF AUTOIMMUNE, CANCER AND CARDIOVASCULAR DISEASES AND DISORDERS; PHARMACEUTICALS FOR THE TREATMENT OF OBESITY; PHARMACEUTICALS FOR THE TREATMENT OF INFLUENZA; AND ANTI-INFECTIVE PHARMACEUTICALS; PHARMACEUTICALS FOR THE TREATMENT OF VIRAL AND INFLAMMATORY DISEASES, INFECTIONS AND DISORDERS (U.S. CLS. 6, 18, 44, 46, 51 AND 52).

RONALD MCMORROW, EXAMINING ATTORNEY

SN 77-429,785. DELTA SPORTS SUPPLEMENTS, LLC, TEMPE, AZ. FILED 3-24-2008.

Supersize

THE MARK CONSISTS OF STANDARD CHARACTERS WITHOUT CLAIM TO ANY PARTICULAR FONT, STYLE, SIZE, OR COLOR.

FOR DIETARY AND NUTRITIONAL SUPPLEMENTS (U.S. CLS. 6, 18, 44, 46, 51 AND 52).

DORITT L. CARROLL, EXAMINING ATTORNEY

SN 77-429,978. PACIFIC STANDARD DISTRIBUTORS, INC., SANDY, OR. FILED 3-24-2008.

GigartinaOne

THE MARK CONSISTS OF STANDARD CHARACTERS WITHOUT CLAIM TO ANY PARTICULAR FONT, STYLE, SIZE, OR COLOR.

FOR NUTRITIONAL SUPPLEMENTS (U.S. CLS. 6, 18, 44, 46, 51 AND 52).

MAUREEN DALL, EXAMINING ATTORNEY

CLASS 5—(Continued).

SN 77-430,049. ADVANCED LIFE SCIENCES, INC., WOODRIDGE, IL. FILED 3-24-2008.

RESTANZA

THE MARK CONSISTS OF STANDARD CHARACTERS WITHOUT CLAIM TO ANY PARTICULAR FONT, STYLE, SIZE, OR COLOR.

FOR PHARMACEUTICAL PREPARATION, NAMELY, AN ANTIBIOTIC (U.S. CLS. 6, 18, 44, 46, 51 AND 52).
ANDREA HACK, EXAMINING ATTORNEY

CLASS 5—(Continued).

SN 77-430,453. J. JIREH HOLDINGS, L.L.C., PAYSON, AZ. FILED 3-25-2008.

REPELLICIDE

THE MARK CONSISTS OF STANDARD CHARACTERS WITHOUT CLAIM TO ANY PARTICULAR FONT, STYLE, SIZE, OR COLOR.

FOR INSECT REPELLENTS; INSECTICIDES (U.S. CLS. 6, 18, 44, 46, 51 AND 52).
SANJEEV VOHRA, EXAMINING ATTORNEY

SN 77-430,073. ADVAXIS, INC., NORTH BRUNSWICK, NJ. FILED 3-24-2008.

LOVAXIN

THE MARK CONSISTS OF STANDARD CHARACTERS WITHOUT CLAIM TO ANY PARTICULAR FONT, STYLE, SIZE, OR COLOR.

FOR PHARMACEUTICAL PREPARATIONS FOR THE TREATMENT OF CANCER, ALLERGIES, AND AUTO-IMMUNE DISEASE; VACCINES FOR HUMAN USE (U.S. CLS. 6, 18, 44, 46, 51 AND 52).

PAULA MAHONEY, EXAMINING ATTORNEY

SN 77-430,488. DESIGNING HEALTH, INC., VALENCIA, CA. FILED 3-25-2008.

THE MISSING LINK FOR LIFE

THE MARK CONSISTS OF STANDARD CHARACTERS WITHOUT CLAIM TO ANY PARTICULAR FONT, STYLE, SIZE, OR COLOR.

OWNER OF U.S. REG. NOS. 1,950,578 AND 2,141,503.
FOR DIETARY SUPPLEMENTS AND FOOD SUPPLEMENTS FOR DOMESTIC ANIMALS (U.S. CLS. 6, 18, 44, 46, 51 AND 52).

DEZMONA MIZELLE, EXAMINING ATTORNEY

SN 77-430,215. LMS HOLDING INC., NEW YORK, NY. FILED 3-24-2008.

SKIP THE HANGOVER!

THE MARK CONSISTS OF STANDARD CHARACTERS WITHOUT CLAIM TO ANY PARTICULAR FONT, STYLE, SIZE, OR COLOR.

FOR DIETARY SUPPLEMENTS; DIETARY AND NUTRITIONAL SUPPLEMENTS; DIETARY SUPPLEMENTAL DRINKS; AMINO ACIDS FOR NUTRITIONAL PURPOSES; DIETARY SUPPLEMENTS FOR HUMAN CONSUMPTION; NUTRACEUTICALS FOR USE AS A DIETARY SUPPLEMENT; NUTRITIONAL SUPPLEMENTS; POWDERED NUTRITIONAL SUPPLEMENT DRINK MIX (U.S. CLS. 6, 18, 44, 46, 51 AND 52).

FIRST USE 1-1-2008; IN COMMERCE 3-20-2008.
SUZANNE BLANE, EXAMINING ATTORNEY

SN 77-430,531. PROCTER & GAMBLE COMPANY, THE, CINCINNATI, OH. FILED 3-25-2008.

HAIR ENDURANCE

THE MARK CONSISTS OF STANDARD CHARACTERS WITHOUT CLAIM TO ANY PARTICULAR FONT, STYLE, SIZE, OR COLOR.

OWNER OF U.S. REG. NOS. 2,032,407, 2,867,936 AND 2,972,892.

NO CLAIM IS MADE TO THE EXCLUSIVE RIGHT TO USE "HAIR", APART FROM THE MARK AS SHOWN.

FOR MEDICATED HAIR CARE PREPARATIONS (U.S. CLS. 6, 18, 44, 46, 51 AND 52).

MARIA-VICTORIA SUAREZ, EXAMINING ATTORNEY

CLASS 5—(Continued).

SN 77-431,109. KHUBANI, CARISHMA, SADDLE RIVER, NJ.
FILED 3-25-2008.

UP DOG

THE MARK CONSISTS OF STANDARD CHARACTERS WITHOUT CLAIM TO ANY PARTICULAR FONT, STYLE, SIZE, OR COLOR.
FOR DIETARY BEVERAGES FOR PETS (U.S. CLS. 6, 18, 44, 46, 51 AND 52).
ATTIYA MALIK, EXAMINING ATTORNEY

SN 77-431,368. DYNAMIC BRIDGE INC., SOUTH EL MONTE, CA. FILED 3-25-2008.

OverSize

THE MARK CONSISTS OF STANDARD CHARACTERS WITHOUT CLAIM TO ANY PARTICULAR FONT, STYLE, SIZE, OR COLOR.
FOR DIETARY SUPPLEMENTS (U.S. CLS. 6, 18, 44, 46, 51 AND 52).
FIRST USE 8-15-2006; IN COMMERCE 8-15-2006.
LINDA ORNDORFF, EXAMINING ATTORNEY

SN 77-431,382. INVITROCARE, INC., FREDERICK, MD.
FILED 3-25-2008.

Spermcare

THE MARK CONSISTS OF STANDARD CHARACTERS WITHOUT CLAIM TO ANY PARTICULAR FONT, STYLE, SIZE, OR COLOR.
FOR SPERM ISOLATING LIQUID SOLUTION MEDIA FOR INTRAUTERINE INSEMINATION (U.S. CLS. 6, 18, 44, 46, 51 AND 52).
FIRST USE 5-0-1998; IN COMMERCE 5-0-1998.
MAYUR VAGHANI, EXAMINING ATTORNEY

CLASS 5—(Continued).

SN 77-431,387. DYNAMIC BRIDGE, SOUTH EL MONTE, CA.
FILED 3-25-2008.

Fertiplex

THE MARK CONSISTS OF STANDARD CHARACTERS WITHOUT CLAIM TO ANY PARTICULAR FONT, STYLE, SIZE, OR COLOR.
FOR HERBAL SUPPLEMENTS (U.S. CLS. 6, 18, 44, 46, 51 AND 52).
FIRST USE 8-15-2006; IN COMMERCE 8-15-2006.
ALEX KEAM, EXAMINING ATTORNEY

SN 77-431,492. MENAGE INNOVATIONS, INC., MEMPHIS, TN. FILED 3-26-2008.

GameOn

THE MARK CONSISTS OF STANDARD CHARACTERS WITHOUT CLAIM TO ANY PARTICULAR FONT, STYLE, SIZE, OR COLOR.
FOR POWDER USED IN THE PREPARATION OF NUTRITIONAL DRINKS ENHANCED WITH VITAMINS, MINERALS, AND PROTEIN (U.S. CLS. 6, 18, 44, 46, 51 AND 52).
FIRST USE 3-7-2008; IN COMMERCE 3-7-2008.
HENRY S. ZAK, EXAMINING ATTORNEY

SN 77-431,547. SERGEANT'S PET CARE PRODUCTS, INC., OMAHA, NE. FILED 3-26-2008.

BANSECT

THE MARK CONSISTS OF STANDARD CHARACTERS WITHOUT CLAIM TO ANY PARTICULAR FONT, STYLE, SIZE, OR COLOR.
OWNER OF U.S. REG. NO. 893,965.
FOR FLEA AND TICK CONTROL PRODUCTS, NAMELY, ANTIPARASITIC COLLARS, SPRAYS, MEDICATED SHAMPOOS, MEDICATED POWDERS AND TOPICAL OINTMENTS FOR PETS; FLEA AND TICK CONTROL SPRAYS, POWDERS AND AEROSOL FOGGERS FOR PREMISE APPLICATIONS; AND CARPET INSECTICIDES AND FRESHENERS (U.S. CLS. 6, 18, 44, 46, 51 AND 52).
FIRST USE 12-0-1998; IN COMMERCE 12-0-1998.
ARETHA SOMERVILLE, EXAMINING ATTORNEY

CLASS 5—(Continued).

SN 77-431,662. MITSUBISHI TANABE PHARMA CORPORATION, OSAKA-SHI, OSAKA, JAPAN, FILED 3-26-2008.

VIMZORPA

THE MARK CONSISTS OF STANDARD CHARACTERS WITHOUT CLAIM TO ANY PARTICULAR FONT, STYLE, SIZE, OR COLOR.

FOR PHARMACEUTICAL PREPARATIONS FOR THE TREATMENT OF KIDNEY DISEASE (U.S. CLS. 6, 18, 44, 46, 51 AND 52).

CHERYL CLAYTON, EXAMINING ATTORNEY

CLASS 5—(Continued).

SN 77-431,683. MITSUBISHI TANABE PHARMA CORPORATION, OSAKA-SHI, OSAKA, JAPAN, FILED 3-26-2008.

LIMZORBA

THE MARK CONSISTS OF STANDARD CHARACTERS WITHOUT CLAIM TO ANY PARTICULAR FONT, STYLE, SIZE, OR COLOR.

FOR PHARMACEUTICAL PREPARATIONS FOR THE TREATMENT OF KIDNEY DISEASE (U.S. CLS. 6, 18, 44, 46, 51 AND 52).

CHERYL CLAYTON, EXAMINING ATTORNEY

SN 77-431,675. MITSUBISHI TANABE PHARMA CORPORATION, OSAKA-SHI, OSAKA, JAPAN, FILED 3-26-2008.

ANEPHLA

THE MARK CONSISTS OF STANDARD CHARACTERS WITHOUT CLAIM TO ANY PARTICULAR FONT, STYLE, SIZE, OR COLOR.

FOR PHARMACEUTICAL PREPARATIONS FOR THE TREATMENT OF KIDNEY DISEASE (U.S. CLS. 6, 18, 44, 46, 51 AND 52).

CHERYL CLAYTON, EXAMINING ATTORNEY

SN 77-431,690. MITSUBISHI TANABE PHARMA CORPORATION, OSAKA-SHI, OSAKA, JAPAN, FILED 3-26-2008.

PALNEPH

THE MARK CONSISTS OF STANDARD CHARACTERS WITHOUT CLAIM TO ANY PARTICULAR FONT, STYLE, SIZE, OR COLOR.

FOR PHARMACEUTICAL PREPARATIONS FOR THE TREATMENT OF KIDNEY DISEASE (U.S. CLS. 6, 18, 44, 46, 51 AND 52).

JOHN SCHUYLER YARD, EXAMINING ATTORNEY

SN 77-431,679. MITSUBISHI TANABE PHARMA CORPORATION, OSAKA-SHI, OSAKA, JAPAN, FILED 3-26-2008.

ENLUMIS

THE MARK CONSISTS OF STANDARD CHARACTERS WITHOUT CLAIM TO ANY PARTICULAR FONT, STYLE, SIZE, OR COLOR.

FOR PHARMACEUTICAL PREPARATIONS FOR THE TREATMENT OF KIDNEY DISEASE (U.S. CLS. 6, 18, 44, 46, 51 AND 52).

CHERYL CLAYTON, EXAMINING ATTORNEY

SN 77-431,699. NICHINO AMERICA, INC., WILMINGTON, DE. FILED 3-26-2008.

TOURISMO

THE MARK CONSISTS OF STANDARD CHARACTERS WITHOUT CLAIM TO ANY PARTICULAR FONT, STYLE, SIZE, OR COLOR.

FOR FUNGICIDES FOR AGRICULTURAL USE; ACARICIDES FOR AGRICULTURAL USE; MITICIDES FOR AGRICULTURAL USE; PESTICIDES FOR AGRICULTURAL USE; INSECTICIDES FOR AGRICULTURAL USE (U.S. CLS. 6, 18, 44, 46, 51 AND 52).

ANTHONY RINKER, EXAMINING ATTORNEY

CLASS 5—(Continued).

SN 77-431,826. IMPRESSIVE EVENTS, LLC, PRINCETON, NJ. FILED 3-26-2008.

CLASS 5—(Continued).

SN 77-432,013. IMPRESSIVE EVENTS, LLC, PRINCETON, NJ. FILED 3-26-2008.

SCENTTONES

DON'T GET CAUGHT TALKIN'
DIRTY

THE MARK CONSISTS OF STANDARD CHARACTERS WITHOUT CLAIM TO ANY PARTICULAR FONT, STYLE, SIZE, OR COLOR.
FOR SCENTED SANITIZING WIPES FOR CELLULAR PHONES (U.S. CLS. 6, 18, 44, 46, 51 AND 52).
ANTHONY RINKER, EXAMINING ATTORNEY

THE MARK CONSISTS OF STANDARD CHARACTERS WITHOUT CLAIM TO ANY PARTICULAR FONT, STYLE, SIZE, OR COLOR.
FOR SCENTED SANITIZING WIPES FOR CELLULAR PHONES (U.S. CLS. 6, 18, 44, 46, 51 AND 52).
ANTHONY RINKER, EXAMINING ATTORNEY

SN 77-431,846. RAMI, ALLEN, LAGUNA NIGUEL, CA. AND FORUHARI, FAIZIN, LAGUNA NIGUEL, CA. FILED 3-26-2008.

Cholestrofix

SN 77-432,171. GLAXO GROUP LIMITED, GREENFORD, MIDDLESEX, UNITED KINGDOM, FILED 3-26-2008.

THE MARK CONSISTS OF STANDARD CHARACTERS WITHOUT CLAIM TO ANY PARTICULAR FONT, STYLE, SIZE, OR COLOR.
FOR HERBAL SUPPLEMENTS (U.S. CLS. 6, 18, 44, 46, 51 AND 52).
JAMES STEIN, EXAMINING ATTORNEY

TANZURA

SN 77-431,919. ONCOLIX, INC., GREENVILLE, SC. FILED 3-26-2008.

PROSMEL

THE MARK CONSISTS OF STANDARD CHARACTERS WITHOUT CLAIM TO ANY PARTICULAR FONT, STYLE, SIZE, OR COLOR.
FOR PHARMACEUTICAL PREPARATIONS AND SUBSTANCES FOR THE TREATMENT OF INFECTIOUS DISEASES, BLOOD DISORDERS, PAIN, INFLAMMATION, SEPSIS, ALOPECIA, OBESITY AND COGNITIVE DISORDERS; PHARMACEUTICAL PREPARATIONS AND SUBSTANCES FOR THE TREATMENT OF VIRAL, METABOLIC, ENDOCRINE, MUSCULOSKELETAL, CARDIOVASCULAR, CARDIOPULMONARY, GENITOURINARY, SEXUAL DYSFUNCTION, ONCOLOGICAL, HEPATOLOGICAL, OPHTHALMIC, RESPIRATORY, NEUROLOGICAL, GASTROINTESTINAL, HORMONAL, DERMATOLOGICAL, PSYCHIATRIC AND IMMUNE SYSTEM RELATED DISEASES AND DISORDERS; PHARMACEUTICAL PREPARATIONS AND SUBSTANCES FOR THE TREATMENT OF DAMAGED SKIN AND TISSUE; AND FOR VACCINES (U.S. CLS. 6, 18, 44, 46, 51 AND 52).
ATTIYA MALIK, EXAMINING ATTORNEY

THE MARK CONSISTS OF STANDARD CHARACTERS WITHOUT CLAIM TO ANY PARTICULAR FONT, STYLE, SIZE, OR COLOR.
FOR PHARMACEUTICAL COMPOSITIONS FOR THE TREATMENT OF CANCER (U.S. CLS. 6, 18, 44, 46, 51 AND 52).
YONG KIM, EXAMINING ATTORNEY

CLASS 5—(Continued).

SN 77-432,176. GLAXO GROUP LIMITED, GREENFORD, MIDDLESEX, UNITED KINGDOM, FILED 3-26-2008.

TERENIQUE

THE MARK CONSISTS OF STANDARD CHARACTERS WITHOUT CLAIM TO ANY PARTICULAR FONT, STYLE, SIZE, OR COLOR.

FOR PHARMACEUTICAL PREPARATIONS AND SUBSTANCES FOR THE TREATMENT OF INFECTIOUS DISEASES, BLOOD DISORDERS, PAIN, INFLAMMATION, SEPSIS, ALOPECIA, OBESITY AND COGNITIVE DISORDERS; PHARMACEUTICAL PREPARATIONS AND SUBSTANCES FOR THE TREATMENT OF VIRAL, METABOLIC, ENDOCRINE, MUSCULOSKELETAL, CARDIOVASCULAR, CARDIOPULMONARY, GENITOURINARY, SEXUAL DYSFUNCTION, ONCOLOGICAL, HEPATOLOGICAL, OPHTHALMIC, RESPIRATORY, NEUROLOGICAL, GASTROINTESTINAL, HORMONAL, DERMATOLOGICAL, PSYCHIATRIC AND IMMUNE SYSTEM RELATED DISEASES AND DISORDERS; PHARMACEUTICAL PREPARATIONS AND SUBSTANCES FOR THE TREATMENT OF DAMAGED SKIN AND TISSUE; AND FOR VACCINES (U.S. CLS. 6, 18, 44, 46, 51 AND 52).
ATTIYA MALIK, EXAMINING ATTORNEY

CLASS 5—(Continued).

SN 77-432,183. GLAXO GROUP LIMITED, GREENFORD, MIDDLESEX, UNITED KINGDOM, FILED 3-26-2008.

ZATURN

THE MARK CONSISTS OF STANDARD CHARACTERS WITHOUT CLAIM TO ANY PARTICULAR FONT, STYLE, SIZE, OR COLOR.

FOR PHARMACEUTICAL PREPARATIONS AND SUBSTANCES FOR THE TREATMENT OF INFECTIOUS DISEASES, BLOOD DISORDERS, PAIN, INFLAMMATION, SEPSIS, ALOPECIA, OBESITY AND COGNITIVE DISORDERS; PHARMACEUTICAL PREPARATIONS AND SUBSTANCES FOR THE TREATMENT OF VIRAL, METABOLIC, ENDOCRINE, MUSCULOSKELETAL, CARDIOVASCULAR, CARDIOPULMONARY, GENITOURINARY, SEXUAL DYSFUNCTION, ONCOLOGICAL, HEPATOLOGICAL, OPHTHALMIC, RESPIRATORY, NEUROLOGICAL, GASTROINTESTINAL, HORMONAL, DERMATOLOGICAL, PSYCHIATRIC AND IMMUNE SYSTEM RELATED DISEASES AND DISORDERS; PHARMACEUTICAL PREPARATIONS AND SUBSTANCES FOR THE TREATMENT OF DAMAGED SKIN AND TISSUE; AND FOR VACCINES (U.S. CLS. 6, 18, 44, 46, 51 AND 52).
ATTIYA MALIK, EXAMINING ATTORNEY

SN 77-432,181. GLAXO GROUP LIMITED, GREENFORD, MIDDLESEX, UNITED KINGDOM, FILED 3-26-2008.

TRAVEK

THE MARK CONSISTS OF STANDARD CHARACTERS WITHOUT CLAIM TO ANY PARTICULAR FONT, STYLE, SIZE, OR COLOR.

FOR PHARMACEUTICAL PREPARATIONS AND SUBSTANCES FOR THE TREATMENT OF INFECTIOUS DISEASES, BLOOD DISORDERS, PAIN, INFLAMMATION, SEPSIS, ALOPECIA, OBESITY AND COGNITIVE DISORDERS; PHARMACEUTICAL PREPARATIONS AND SUBSTANCES FOR THE TREATMENT OF VIRAL, METABOLIC, ENDOCRINE, MUSCULOSKELETAL, CARDIOVASCULAR, CARDIOPULMONARY, GENITOURINARY, SEXUAL DYSFUNCTION, ONCOLOGICAL, HEPATOLOGICAL, OPHTHALMIC, RESPIRATORY, NEUROLOGICAL, GASTROINTESTINAL, HORMONAL, DERMATOLOGICAL, PSYCHIATRIC AND IMMUNE SYSTEM RELATED DISEASES AND DISORDERS; PHARMACEUTICAL PREPARATIONS AND SUBSTANCES FOR THE TREATMENT OF DAMAGED SKIN AND TISSUE; AND FOR VACCINES (U.S. CLS. 6, 18, 44, 46, 51 AND 52).
ATTIYA MALIK, EXAMINING ATTORNEY

SN 77-432,190. GLAXO GROUP LIMITED, GREENFORD, MIDDLESEX, UNITED KINGDOM, FILED 3-26-2008.

KIRVANA

THE MARK CONSISTS OF STANDARD CHARACTERS WITHOUT CLAIM TO ANY PARTICULAR FONT, STYLE, SIZE, OR COLOR.

FOR PHARMACEUTICAL PREPARATIONS AND SUBSTANCES FOR THE TREATMENT OF INFECTIOUS DISEASES, BLOOD DISORDERS, PAIN, INFLAMMATION, SEPSIS, ALOPECIA, OBESITY AND COGNITIVE DISORDERS; PHARMACEUTICAL PREPARATIONS AND SUBSTANCES FOR THE TREATMENT OF VIRAL, METABOLIC, ENDOCRINE, MUSCULOSKELETAL, CARDIOVASCULAR, CARDIOPULMONARY, GENITOURINARY, SEXUAL DYSFUNCTION, ONCOLOGICAL, HEPATOLOGICAL, OPHTHALMIC, RESPIRATORY, NEUROLOGICAL, GASTROINTESTINAL, HORMONAL, DERMATOLOGICAL, PSYCHIATRIC AND IMMUNE SYSTEM RELATED DISEASES AND DISORDERS; PHARMACEUTICAL PREPARATIONS AND SUBSTANCES FOR THE TREATMENT OF DAMAGED SKIN AND TISSUE; AND FOR VACCINES (U.S. CLS. 6, 18, 44, 46, 51 AND 52).
ATTIYA MALIK, EXAMINING ATTORNEY

CLASS 5—(Continued).

SN 77-432,193. GLAXO GROUP LIMITED, GREENFORD, MIDDLESEX, UNITED KINGDOM, FILED 3-26-2008.

OMNEVA

THE MARK CONSISTS OF STANDARD CHARACTERS WITHOUT CLAIM TO ANY PARTICULAR FONT, STYLE, SIZE, OR COLOR.

FOR PHARMACEUTICAL PREPARATIONS AND SUBSTANCES FOR THE TREATMENT OF INFECTIOUS DISEASES, BLOOD DISORDERS, PAIN, INFLAMMATION, SEPSIS, ALOPECIA, OBESITY AND COGNITIVE DISORDERS; PHARMACEUTICAL PREPARATIONS AND SUBSTANCES FOR THE TREATMENT OF VIRAL, METABOLIC, ENDOCRINE, MUSCULOSKELETAL, CARDIOVASCULAR, CARDIOPULMONARY, GENITOURINARY, SEXUAL DYSFUNCTION, ONCOLOGICAL, HEPATOLOGICAL, OPHTHALMIC, RESPIRATORY, NEUROLOGICAL, GASTROINTESTINAL, HORMONAL, DERMATOLOGICAL, PSYCHIATRIC AND IMMUNE SYSTEM RELATED DISEASES AND DISORDERS; PHARMACEUTICAL PREPARATIONS AND SUBSTANCES FOR THE TREATMENT OF DAMAGED SKIN AND TISSUE; AND FOR VACCINES (U.S. CLS. 6, 18, 44, 46, 51 AND 52).

ATTIYA MALIK, EXAMINING ATTORNEY

CLASS 5—(Continued).

SN 77-432,328. GLAXO GROUP LIMITED, GREENFORD, MIDDLESEX, UNITED KINGDOM, FILED 3-26-2008.

TANZEUM

THE MARK CONSISTS OF STANDARD CHARACTERS WITHOUT CLAIM TO ANY PARTICULAR FONT, STYLE, SIZE, OR COLOR.

FOR PHARMACEUTICAL PREPARATIONS AND SUBSTANCES FOR THE TREATMENT OF INFECTIOUS DISEASES, BLOOD DISORDERS, PAIN, INFLAMMATION, SEPSIS, ALOPECIA, OBESITY AND COGNITIVE DISORDERS; PHARMACEUTICAL PREPARATIONS AND SUBSTANCES FOR THE TREATMENT OF VIRAL, METABOLIC, ENDOCRINE, MUSCULOSKELETAL, CARDIOVASCULAR, CARDIOPULMONARY, GENITOURINARY, SEXUAL DYSFUNCTION, ONCOLOGICAL, HEPATOLOGICAL, OPHTHALMIC, RESPIRATORY, NEUROLOGICAL, GASTROINTESTINAL, HORMONAL, DERMATOLOGICAL, PSYCHIATRIC AND IMMUNE SYSTEM RELATED DISEASES AND DISORDERS; PHARMACEUTICAL PREPARATIONS AND SUBSTANCES FOR THE TREATMENT OF DAMAGED SKIN AND TISSUE; AND FOR VACCINES (U.S. CLS. 6, 18, 44, 46, 51 AND 52).

DOMINICK J. SALEMI, EXAMINING ATTORNEY

SN 77-432,336. GLAXO GROUP LIMITED, GREENFORD, MIDDLESEX, UNITED KINGDOM, FILED 3-26-2008.

TAPSODRIN

THE MARK CONSISTS OF STANDARD CHARACTERS WITHOUT CLAIM TO ANY PARTICULAR FONT, STYLE, SIZE, OR COLOR.

FOR PHARMACEUTICAL PREPARATIONS AND SUBSTANCES FOR THE TREATMENT OF INFECTIOUS DISEASES, BLOOD DISORDERS, PAIN, INFLAMMATION, SEPSIS, ALOPECIA, OBESITY AND COGNITIVE DISORDERS; PHARMACEUTICAL PREPARATIONS AND SUBSTANCES FOR THE TREATMENT OF VIRAL, METABOLIC, ENDOCRINE, MUSCULOSKELETAL, CARDIOVASCULAR, CARDIOPULMONARY, GENITOURINARY, SEXUAL DYSFUNCTION, ONCOLOGICAL, HEPATOLOGICAL, OPHTHALMIC, RESPIRATORY, NEUROLOGICAL, GASTROINTESTINAL, HORMONAL, DERMATOLOGICAL, PSYCHIATRIC AND IMMUNE SYSTEM RELATED DISEASES AND DISORDERS; PHARMACEUTICAL PREPARATIONS AND SUBSTANCES FOR THE TREATMENT OF DAMAGED SKIN AND TISSUE; AND FOR VACCINES (U.S. CLS. 6, 18, 44, 46, 51 AND 52).

DOMINICK J. SALEMI, EXAMINING ATTORNEY

SN 77-432,316. CHEMGENEX PHARMACEUTICALS LIMITED, GEELONG, AUSTRALIA, FILED 3-26-2008.

OMAPRO

THE MARK CONSISTS OF STANDARD CHARACTERS WITHOUT CLAIM TO ANY PARTICULAR FONT, STYLE, SIZE, OR COLOR.

FOR PHARMACEUTICAL PREPARATIONS FOR THE TREATMENT OF LEUKEMIA (U.S. CLS. 6, 18, 44, 46, 51 AND 52).

DEZMONA MIZELLE, EXAMINING ATTORNEY

CLASS 5—(Continued).

SN 77-432,344. CHEMGENEX PHARMACEUTICALS LIMITED, GEELONG, AUSTRALIA, FILED 3-26-2008.

TEKINEX

THE MARK CONSISTS OF STANDARD CHARACTERS WITHOUT CLAIM TO ANY PARTICULAR FONT, STYLE, SIZE, OR COLOR.

FOR PHARMACEUTICAL PREPARATIONS FOR THE TREATMENT OF LEUKEMIA (U.S. CLS. 6, 18, 44, 46, 51 AND 52).

DEZMONA MIZELLE, EXAMINING ATTORNEY

CLASS 5—(Continued).

SN 77-432,503. NUFARM AMERICAS, INC., BURR RIDGE, IL. FILED 3-26-2008.

MEDIOCE

THE MARK CONSISTS OF STANDARD CHARACTERS WITHOUT CLAIM TO ANY PARTICULAR FONT, STYLE, SIZE, OR COLOR.

FOR PESTICIDES; HERBICIDES; INSECTICIDES; FUNGICIDES (U.S. CLS. 6, 18, 44, 46, 51 AND 52).

NORA BUCHANAN WILL, EXAMINING ATTORNEY

SN 77-432,360. CHEMGENEX PHARMACEUTICALS LIMITED, GEELONG, AUSTRALIA, FILED 3-26-2008.

ALTEKIA

THE MARK CONSISTS OF STANDARD CHARACTERS WITHOUT CLAIM TO ANY PARTICULAR FONT, STYLE, SIZE, OR COLOR.

FOR PHARMACEUTICAL PREPARATIONS FOR THE TREATMENT OF LEUKEMIA (U.S. CLS. 6, 18, 44, 46, 51 AND 52).

DEZMONA MIZELLE, EXAMINING ATTORNEY

SN 77-432,534. NUFARM AMERICAS, INC., BURR RIDGE, IL. FILED 3-26-2008.

ATTUNEMENT

THE MARK CONSISTS OF STANDARD CHARACTERS WITHOUT CLAIM TO ANY PARTICULAR FONT, STYLE, SIZE, OR COLOR.

FOR PESTICIDES; HERBICIDES; FUNGICIDES; INSECTICIDES (U.S. CLS. 6, 18, 44, 46, 51 AND 52).

NORA BUCHANAN WILL, EXAMINING ATTORNEY

SN 77-432,496. NUFARM AMERICAS, INC., BURR RIDGE, IL. FILED 3-26-2008.

COMET

THE MARK CONSISTS OF STANDARD CHARACTERS WITHOUT CLAIM TO ANY PARTICULAR FONT, STYLE, SIZE, OR COLOR.

FOR HERBICIDES; PESTICIDES; FUNGICIDES; INSECTICIDES (U.S. CLS. 6, 18, 44, 46, 51 AND 52).

NORA BUCHANAN WILL, EXAMINING ATTORNEY

SN 77-432,540. NUFARM AMERICAS, INC., BURR RIDGE, IL. FILED 3-26-2008.

TREATY

THE MARK CONSISTS OF STANDARD CHARACTERS WITHOUT CLAIM TO ANY PARTICULAR FONT, STYLE, SIZE, OR COLOR.

FOR PESTICIDES; INSECTICIDES; FUNGICIDES; HERBICIDES (U.S. CLS. 6, 18, 44, 46, 51 AND 52).

NORA BUCHANAN WILL, EXAMINING ATTORNEY

CLASS 5—(Continued).

SN 77-432,546. NUFARM AMERICAS, INC., BURR RIDGE, IL. FILED 3-26-2008.

TRUSLATE

THE MARK CONSISTS OF STANDARD CHARACTERS WITHOUT CLAIM TO ANY PARTICULAR FONT, STYLE, SIZE, OR COLOR.
FOR PESTICIDES; HERBICIDES; INSECTICIDES; FUNGICIDES (U.S. CLS. 6, 18, 44, 46, 51 AND 52).
NORA BUCHANAN WILL, EXAMINING ATTORNEY

SN 77-432,558. NUFARM AMERICAS, INC., BURR RIDGE, IL. FILED 3-26-2008.

CLEANSWEEP

THE MARK CONSISTS OF STANDARD CHARACTERS WITHOUT CLAIM TO ANY PARTICULAR FONT, STYLE, SIZE, OR COLOR.
FOR PESTICIDES; FUNGICIDES; HERBICIDES; INSECTICIDES (U.S. CLS. 6, 18, 44, 46, 51 AND 52).
NORA BUCHANAN WILL, EXAMINING ATTORNEY

SN 77-432,615. STARR, MICHAEL JAY, CANYON COUNTRY, CA. FILED 3-26-2008.

Dingbats

THE MARK CONSISTS OF STANDARD CHARACTERS WITHOUT CLAIM TO ANY PARTICULAR FONT, STYLE, SIZE, OR COLOR.
FOR ADHESIVE BANDAGES (U.S. CLS. 6, 18, 44, 46, 51 AND 52).
FIRST USE 1-12-2008; IN COMMERCE 2-1-2008.
MATTHEW MCDOWELL, EXAMINING ATTORNEY

CLASS 5—(Continued).

SN 77-433,080. ANIMAL SCIENCE PRODUCTS, INC., NA-COGDOCHES, TX. FILED 3-27-2008.

OrganiGuard

THE MARK CONSISTS OF STANDARD CHARACTERS WITHOUT CLAIM TO ANY PARTICULAR FONT, STYLE, SIZE, OR COLOR.
FOR ANIMAL FEED ADDITIVE FOR USE AS A NUTRITIONAL SUPPLEMENT FOR MEDICAL PURPOSES (U.S. CLS. 6, 18, 44, 46, 51 AND 52).
WENDY JUN, EXAMINING ATTORNEY

SN 77-433,200. FARR LABORATORIES, LLC, LOS ANGELES, CA. FILED 3-27-2008.

Q-UROL

THE MARK CONSISTS OF STANDARD CHARACTERS WITHOUT CLAIM TO ANY PARTICULAR FONT, STYLE, SIZE, OR COLOR.
FOR DIETARY SUPPLEMENTS (U.S. CLS. 6, 18, 44, 46, 51 AND 52).
FIRST USE 4-17-2003; IN COMMERCE 4-17-2003.
SUNG IN, EXAMINING ATTORNEY

SN 77-433,202. URBAN ORGANICS, ROLLING HILLS ESTATES, CA. FILED 3-27-2008.

MINEVITES

THE MARK CONSISTS OF STANDARD CHARACTERS WITHOUT CLAIM TO ANY PARTICULAR FONT, STYLE, SIZE, OR COLOR.
FOR DIETARY SUPPLEMENTS (U.S. CLS. 6, 18, 44, 46, 51 AND 52).
JESSICA A. POWERS, EXAMINING ATTORNEY

CLASS 5—(Continued).

SN 77-433,231. ADIAL PHARMACEUTICALS, CHARLOTTESVILLE, VA. FILED 3-27-2008.

ADial Pharmaceuticals

THE MARK CONSISTS OF STANDARD CHARACTERS WITHOUT CLAIM TO ANY PARTICULAR FONT, STYLE, SIZE, OR COLOR.

NO CLAIM IS MADE TO THE EXCLUSIVE RIGHT TO USE "PHARMACEUTICALS", APART FROM THE MARK AS SHOWN.

FOR PHARMACEUTICAL PREPARATIONS FOR THE TREATMENT OF ADDICTION TO AND ABUSE OF ALCOHOL, NARCOTICS AND OTHER ADDICTIVE OR HABIT FORMING SUBSTANCES (U.S. CLS. 6, 18, 44, 46, 51 AND 52).

GINA FINK, EXAMINING ATTORNEY

CLASS 5—(Continued).

SN 77-433,815. SIMS, MATTHEW, BROOKLYN, NY. FILED 3-27-2008.



THE STIPPLING IS FOR SHADING PURPOSES ONLY. THE MARK CONSISTS OF A CENTER "SWOOSH" WITH AN ORB BELOW AND ABOVE IT, AND THE TEXT "NAYALIFE".

THE FOREIGN WORDING IN THE MARK TRANSLATES INTO ENGLISH AS "WISDOM, BALANCE, HARMONY", "NEW", "LIFE".

FOR LIFESTYLE PRODUCTS, NAMELY, NUTRITIONAL SUPPLEMENTS AND MEDICATED SKIN CARE PREPARATIONS (U.S. CLS. 6, 18, 44, 46, 51 AND 52).

JILL C. ALT, EXAMINING ATTORNEY

SN 77-433,275. CALANDRILLO, NICHOLAS, MOUNTAIN LAKES, NJ. FILED 3-27-2008.

Alibra

THE MARK CONSISTS OF STANDARD CHARACTERS WITHOUT CLAIM TO ANY PARTICULAR FONT, STYLE, SIZE, OR COLOR.

FOR PHARMACEUTICAL PREPARATIONS FOR USE IN UROLOGY (U.S. CLS. 6, 18, 44, 46, 51 AND 52).

BARBARA BROWN, EXAMINING ATTORNEY

SN 77-434,281. ANIMAL SCIENCE PRODUCTS, INC., NA-COGDOCHES, TX. FILED 3-28-2008.

MagnaFerm Supra

THE MARK CONSISTS OF STANDARD CHARACTERS WITHOUT CLAIM TO ANY PARTICULAR FONT, STYLE, SIZE, OR COLOR.

OWNER OF U.S. REG. NO. 3,082,441. NO CLAIM IS MADE TO THE EXCLUSIVE RIGHT TO USE "SUPRA", APART FROM THE MARK AS SHOWN.

FOR ANIMAL FEED SUPPLEMENTS (U.S. CLS. 6, 18, 44, 46, 51 AND 52).

WENDY JUN, EXAMINING ATTORNEY

SN 77-433,732. LAUB BIOCHEMICALS CORPORATION, NEWPORT BEACH, CA. FILED 3-27-2008.

SPT ADVANTAGE

THE MARK CONSISTS OF STANDARD CHARACTERS WITHOUT CLAIM TO ANY PARTICULAR FONT, STYLE, SIZE, OR COLOR.

FOR NUTRITIONAL SUPPLEMENTS, DIETARY SUPPLEMENTS; PHARMACEUTICAL PREPARATION FOR USE IN THE TREATMENT OF HUMAN VIRAL DISEASE (U.S. CLS. 6, 18, 44, 46, 51 AND 52).

FIRST USE 2-22-2008; IN COMMERCE 3-14-2008.

JOHN KELLY, EXAMINING ATTORNEY

SN 77-434,708. ANESTHETIC GAS RECLAMATION, NASHVILLE, TN. FILED 3-28-2008.

C-vo

THE MARK CONSISTS OF STANDARD CHARACTERS WITHOUT CLAIM TO ANY PARTICULAR FONT, STYLE, SIZE, OR COLOR.

FOR GENERAL ANESTHETICS (U.S. CLS. 6, 18, 44, 46, 51 AND 52).

RICHARD A. STRASER, EXAMINING ATTORNEY

CLASS 5—(Continued).

SN 77-434,956. TERRY ANN ABLETT, CONCORD, CA. AND DAVID EUGENE ABLETT, DC, CONCORD, CA. FILED 3-28-2008.

BR Super ENERGY BAR

THE MARK CONSISTS OF STANDARD CHARACTERS WITHOUT CLAIM TO ANY PARTICULAR FONT, STYLE, SIZE, OR COLOR.

NO CLAIM IS MADE TO THE EXCLUSIVE RIGHT TO USE "SUPER ENERGY BAR", APART FROM THE MARK AS SHOWN.

FOR MEAL REPLACEMENT BARS (U.S. CLS. 6, 18, 44, 46, 51 AND 52).

FIRST USE 3-15-2008; IN COMMERCE 3-15-2008.
JOHN WILKE, EXAMINING ATTORNEY

CLASS 5—(Continued).

SN 77-440,262. BAYER AKTIENGESELLSCHAFT, LEVERKUSEN-BAYERWERK, FED REP GERMANY, FILED 4-4-2008.

XARTELO

THE MARK CONSISTS OF STANDARD CHARACTERS WITHOUT CLAIM TO ANY PARTICULAR FONT, STYLE, SIZE, OR COLOR.

FOR PHARMACEUTICAL PREPARATIONS AND SUBSTANCES FOR THE PREVENTION AND TREATMENT OF CARDIOVASCULAR DISEASES, THROMBOSIS, STROKE AND PULMONARY EMBOLISM (U.S. CLS. 6, 18, 44, 46, 51 AND 52).

MARY BOAGNI, EXAMINING ATTORNEY

SN 77-440,006. CALVA PRODUCTS CO. INC, ACAMPO, CA. FILED 4-4-2008.

Calva-Lac

THE COLOR(S) BLACK IS/ARE CLAIMED AS A FEATURE OF THE MARK.

THE MARK CONSISTS OF THE WORDS "CALVA-LAC" IN OFFSET BLACK LETTERING.

THE ENGLISH TRANSLATION OF THE WORD "CALVA" IN THE MARK IS BALD.

FOR MEDICATED DRINK FOR ANIMALS, NAMELY, MEDICATED MILK REPLACEMENT FOR CALVES (U.S. CLS. 6, 18, 44, 46, 51 AND 52).

FIRST USE 1-1-1952; IN COMMERCE 1-1-1952.
APRIL ROACH, EXAMINING ATTORNEY

SN 77-441,201. BAYER AKTIENGESELLSCHAFT, LEVERKUSEN-BAYERWERK, FED REP GERMANY, FILED 4-7-2008.

XAVELTO

THE MARK CONSISTS OF STANDARD CHARACTERS WITHOUT CLAIM TO ANY PARTICULAR FONT, STYLE, SIZE, OR COLOR.

FOR PHARMACEUTICAL PREPARATIONS AND SUBSTANCES FOR THE PREVENTION AND TREATMENT OF CARDIOVASCULAR DISEASES, THROMBOSIS, STROKE AND PULMONARY EMBOLISM (U.S. CLS. 6, 18, 44, 46, 51 AND 52).

MARY BOAGNI, EXAMINING ATTORNEY

SN 77-440,243. BAYER AKTIENGESELLSCHAFT, LEVERKUSEN-BAYERWERK, FED REP GERMANY, FILED 4-4-2008.

XATARGO

THE MARK CONSISTS OF STANDARD CHARACTERS WITHOUT CLAIM TO ANY PARTICULAR FONT, STYLE, SIZE, OR COLOR.

FOR PHARMACEUTICAL PREPARATIONS AND SUBSTANCES FOR THE PREVENTION AND TREATMENT OF CARDIOVASCULAR DISEASES, THROMBOSIS, STROKE AND PULMONARY EMBOLISM (U.S. CLS. 6, 18, 44, 46, 51 AND 52).

MARY BOAGNI, EXAMINING ATTORNEY

SN 77-441,448. JARROW FORMULAS, INC., LOS ANGELES, CA. FILED 4-7-2008.

GENTLE FIBERS

THE MARK CONSISTS OF STANDARD CHARACTERS WITHOUT CLAIM TO ANY PARTICULAR FONT, STYLE, SIZE, OR COLOR.

NO CLAIM IS MADE TO THE EXCLUSIVE RIGHT TO USE "FIBERS", APART FROM THE MARK AS SHOWN.

FOR DIETARY AND NUTRITIONAL SUPPLEMENTS (U.S. CLS. 6, 18, 44, 46, 51 AND 52).

FIRST USE 1-31-1994; IN COMMERCE 1-31-1994.
MATTHEW EINSTEIN, EXAMINING ATTORNEY

CLASS 5—(Continued).

SN 77-441,567. ASKLEPION PHARMACEUTICALS, LLC, BRENTWOOD, TN. FILED 4-7-2008.

CITRUPRESS IV

THE MARK CONSISTS OF STANDARD CHARACTERS WITHOUT CLAIM TO ANY PARTICULAR FONT, STYLE, SIZE, OR COLOR.

NO CLAIM IS MADE TO THE EXCLUSIVE RIGHT TO USE "IV", APART FROM THE MARK AS SHOWN.

FOR PHARMACEUTICALS FOR THE PREVENTION OF PULMONARY HYPERTENSION IN PEDIACRIC PATIENTS UNDERGOING SURGERY FOR THE CORRECTION OF CONGENITAL HEART DEFECTS (U.S. CLS. 6, 18, 44, 46, 51 AND 52).

JILL C. ALT, EXAMINING ATTORNEY

SN 77-445,939. CALVA PRODUCTS CO., INC, ACAMPO, CA. FILED 4-11-2008.



NO CLAIM IS MADE TO THE EXCLUSIVE RIGHT TO USE "PRODUCTS RECOVER ELECTROLYTES", APART FROM THE MARK AS SHOWN.

THE COLOR(S) RED, YELLOW, BLACK AND WHITE IS/ ARE CLAIMED AS A FEATURE OF THE MARK.

THE MARK CONSISTS OF A BLACK AND WHITE COW STANDING ON BLACK GRASS IN A YELLOW CIRCLE OUTLINED IN BLACK, WITH A WHITE INNER BORDER OUTLINED IN BLACK AND A WIDE RED OUTER BORDER OUTLINED IN BLACK WITH THE WORDING "RECOVER" AND "ELECTROLYTES" IN WHITE WITH A BLACK OUTLINE AND TWO WHITE STARS THAT ARE ALSO OUTLINED IN BLACK, A HORIZONTAL YELLOW OVAL OUTLINED IN BLACK WITH THE WORDING "CALVA PRODUCTS" IN BLACK AND TWO BLACK DOTS IN THE YELLOW OVAL WHICH HAS A RED INNER BORDER AND WHITE OUTER BORDER, BOTH WITH A BLACK OUTLINE, AND BLACK AND WHITE HORIZONTAL LINES UNDER THE CIRCLE AND OVAL.

THE ENGLISH TRANSLATION OF THE WORD "CALVA" IN THE MARK IS BALD.

FOR NON-MEDICATED LIQUID SUPPLEMENT FOR ANIMAL FEED FOR USE AS A NUTRITIONAL SUPPLEMENT, NAMELY SALT AND MINERAL PREPARATION FOR NUTRITIONAL SUPPORT AND BODY FLUID REPLENISHMENT FOR USE IN NON-RUMINATING CALVES (U.S. CLS. 6, 18, 44, 46, 51 AND 52).

FIRST USE 4-1-1986; IN COMMERCE 4-1-1986.

APRIL ROACH, EXAMINING ATTORNEY

CLASS 5—(Continued).

SN 77-446,817. WAG'N ENTERPRISES, LLC, HERNDON, VA. FILED 4-12-2008.



OWNER OF U.S. REG. NOS. 3,427,952, 3,442,042 AND OTHERS.

NO CLAIM IS MADE TO THE EXCLUSIVE RIGHT TO USE "ENTERPRISES" AND "LLC.", APART FROM THE MARK AS SHOWN.

THE MARK CONSISTS OF THE WORD "WAG'N" WITH AN ANIMAL TAIL TAKING THE PLACE OF THE APOSTROPHE. THE WORDING "WAG'N ENTERPRISES LLC" IS ABOVE THE WORD "WAG'N" AND THERE ARE TWO SEMI-CIRCULAR LINES ON EACH SIDE OF THE WORD "WAG'N", ALL APPEARING INSIDE AN ELLIPSE.

FOR PET FIRST AID KITS; PERSONAL PET EMERGENCY EVACUATION KITS CONSISTING PRIMARILY OF PET FIRST AID KITS, TOWELS, DEHYDRATED PET FOOD, TRAVEL WATER BOWLS AND FEEDER, PET TOYS, WATER DISPENSERS, WASTE BAGS, AND PET COLLARS AND LEASHES (U.S. CLS. 6, 18, 44, 46, 51 AND 52).

KATHERINE CONNOLLY, EXAMINING ATTORNEY

SN 77-449,461. NICHINO AMERICA, INC., WILMINGTON, DE. FILED 4-16-2008.

RYCAR

THE MARK CONSISTS OF STANDARD CHARACTERS WITHOUT CLAIM TO ANY PARTICULAR FONT, STYLE, SIZE, OR COLOR.

FOR INSECTICIDES FOR AGRICULTURAL USE (U.S. CLS. 6, 18, 44, 46, 51 AND 52).

ANTHONY RINKER, EXAMINING ATTORNEY

SN 77-449,589. SMITHKLINE BEECHAM CORPORATION, PHILADELPHIA, PA. FILED 4-16-2008.

WHENEVER WHATEVER

THE MARK CONSISTS OF STANDARD CHARACTERS WITHOUT CLAIM TO ANY PARTICULAR FONT, STYLE, SIZE, OR COLOR.

FOR PHARMACEUTICAL PREPARATIONS FOR GASTROINTESTINAL DISORDERS (U.S. CLS. 6, 18, 44, 46, 51 AND 52).

SUSAN RICHARDS, EXAMINING ATTORNEY

CLASS 5—(Continued).

SN 77-450,880. NUFARM AMERICAS, INC., BURR RIDGE, IL. FILED 4-17-2008.

CLASS 5—(Continued).

SN 77-451,475. NUFARM AMERICAS, INC., BURR RIDGE, IL. FILED 4-17-2008.

PARABOLIC

CHIME

THE MARK CONSISTS OF STANDARD CHARACTERS WITHOUT CLAIM TO ANY PARTICULAR FONT, STYLE, SIZE, OR COLOR.
FOR PESTICIDES; HERBICIDES; FUNGICIDES; INSECTICIDES (U.S. CLS. 6, 18, 44, 46, 51 AND 52).
NORA BUCHANAN WILL, EXAMINING ATTORNEY

THE MARK CONSISTS OF STANDARD CHARACTERS WITHOUT CLAIM TO ANY PARTICULAR FONT, STYLE, SIZE, OR COLOR.
FOR PESTICIDES; FUNGICIDES AND HERBICIDES; HERBICIDES (U.S. CLS. 6, 18, 44, 46, 51 AND 52).
NORA BUCHANAN WILL, EXAMINING ATTORNEY

SN 77-450,918. NUFARM AMERICAS, INC., BURR RIDGE, IL. FILED 4-17-2008.

SN 77-452,232. ADVANCED LIFE SCIENCES, INC., WOODRIDGE, IL. FILED 4-18-2008.

CHORUS

CETHREO

THE MARK CONSISTS OF STANDARD CHARACTERS WITHOUT CLAIM TO ANY PARTICULAR FONT, STYLE, SIZE, OR COLOR.
FOR PESTICIDES; HERBICIDES; FUNGICIDES; INSECTICIDES (U.S. CLS. 6, 18, 44, 46, 51 AND 52).
NORA BUCHANAN WILL, EXAMINING ATTORNEY

THE MARK CONSISTS OF STANDARD CHARACTERS WITHOUT CLAIM TO ANY PARTICULAR FONT, STYLE, SIZE, OR COLOR.
FOR PHARMACEUTICAL PREPARATIONS, NAMELY, AN ANTIBIOTIC (U.S. CLS. 6, 18, 44, 46, 51 AND 52).
ANDREA HACK, EXAMINING ATTORNEY

SN 77-451,004. NUFARM AMERICAS, INC., BURR RIDGE, IL. FILED 4-17-2008.

SN 77-454,573. AMERICAN COVERS, INC., BLUFFDALE, UT. FILED 4-22-2008.

ELLIPTICAL

CAR.MA

THE MARK CONSISTS OF STANDARD CHARACTERS WITHOUT CLAIM TO ANY PARTICULAR FONT, STYLE, SIZE, OR COLOR.
FOR PESTICIDES; FUNGICIDES AND HERBICIDES; INSECTICIDES (U.S. CLS. 6, 18, 44, 46, 51 AND 52).
NORA BUCHANAN WILL, EXAMINING ATTORNEY

THE MARK CONSISTS OF STANDARD CHARACTERS WITHOUT CLAIM TO ANY PARTICULAR FONT, STYLE, SIZE, OR COLOR.
FOR AIR FRESHENERS AND DEODORIZERS FOR YOUR VEHICLE (U.S. CLS. 6, 18, 44, 46, 51 AND 52).
DOMINICK J. SALEMI, EXAMINING ATTORNEY

CLASS 5—(Continued).

SN 77-461,331. GENESIS TODAY, INC., AUSTIN, TX. FILED 4-29-2008.

GENESIS FUSION

THE MARK CONSISTS OF STANDARD CHARACTERS WITHOUT CLAIM TO ANY PARTICULAR FONT, STYLE, SIZE, OR COLOR.

FOR DIETARY AND NUTRITIONAL SUPPLEMENTS; DIETARY BEVERAGE SUPPLEMENTS FOR HUMAN CONSUMPTION IN LIQUID AND DRY MIX FORM FOR THERAPEUTIC PURPOSES; DIETARY SUPPLEMENTAL DRINKS; DIETARY SUPPLEMENTS; DIETARY SUPPLEMENTS FOR HUMAN CONSUMPTION; HERBAL SUPPLEMENTS; HOMEOPATHIC SUPPLEMENTS; MINERAL NUTRITIONAL SUPPLEMENTS; MINERAL SUPPLEMENTS; NUTRITIONAL SUPPLEMENTS; VITAMIN AND MINERAL SUPPLEMENTS; VITAMIN SUPPLEMENTS (U.S. CLS. 6, 18, 44, 46, 51 AND 52).

KHANH LE, EXAMINING ATTORNEY



SN 77-462,966. HENKEL CONSUMER GOODS INC., SCOTTSDALE, AZ. FILED 5-1-2008.

HIDEAWAY

THE MARK CONSISTS OF STANDARD CHARACTERS WITHOUT CLAIM TO ANY PARTICULAR FONT, STYLE, SIZE, OR COLOR.

FOR INSECTICIDES (U.S. CLS. 6, 18, 44, 46, 51 AND 52).

THEODORE MCBRIDE, EXAMINING ATTORNEY



SN 77-467,082. ALTICOR INC., ADA, MI. FILED 5-6-2008.

FEEL BETTER IN 7 DAYS

THE MARK CONSISTS OF STANDARD CHARACTERS WITHOUT CLAIM TO ANY PARTICULAR FONT, STYLE, SIZE, OR COLOR.

FOR DIETARY AND NUTRITIONAL SUPPLEMENTS (U.S. CLS. 6, 18, 44, 46, 51 AND 52).

REGINA DRUMMOND, EXAMINING ATTORNEY

CLASS 5—(Continued).

SN 77-468,624. HENKEL CONSUMER GOODS INC., SCOTTSDALE, AZ. FILED 5-7-2008.

KILL ONE, DESTROY THEM ALL

THE MARK CONSISTS OF STANDARD CHARACTERS WITHOUT CLAIM TO ANY PARTICULAR FONT, STYLE, SIZE, OR COLOR.

FOR INSECTICIDES (U.S. CLS. 6, 18, 44, 46, 51 AND 52).

THEODORE MCBRIDE, EXAMINING ATTORNEY



SN 77-468,627. HENKEL CONSUMER GOODS INC., SCOTTSDALE, AZ. FILED 5-7-2008.

DESTROY ONE, KILL THEM ALL

THE MARK CONSISTS OF STANDARD CHARACTERS WITHOUT CLAIM TO ANY PARTICULAR FONT, STYLE, SIZE, OR COLOR.

FOR INSECTICIDES (U.S. CLS. 6, 18, 44, 46, 51 AND 52).

THEODORE MCBRIDE, EXAMINING ATTORNEY



SN 77-468,949. SUN PHARMACEUTICAL INDUSTRIES LIMITED, ANDHERI (E), MUMBAI-93, INDIA, FILED 5-8-2008.

Venla XR

THE MARK CONSISTS OF STANDARD CHARACTERS WITHOUT CLAIM TO ANY PARTICULAR FONT, STYLE, SIZE, OR COLOR.

NO CLAIM IS MADE TO THE EXCLUSIVE RIGHT TO USE "XR", APART FROM THE MARK AS SHOWN.

FOR PHARMACEUTICAL PREPARATIONS, NAMELY, ANTIDEPRESSANTS (U.S. CLS. 6, 18, 44, 46, 51 AND 52).

HANNO RITTNER, EXAMINING ATTORNEY

CLASS 5—(Continued).

SN 77-469,258. VALEANT PHARMACEUTICALS NORTH AMERICA, ALISO VIEJO, CA. FILED 5-8-2008.

ZERBILIS

THE MARK CONSISTS OF STANDARD CHARACTERS WITHOUT CLAIM TO ANY PARTICULAR FONT, STYLE, SIZE, OR COLOR.

FOR PHARMACEUTICAL PREPARATIONS FOR THE TREATMENT OF EPILEPSY, SEIZURES AND NEUROLOGICAL DISORDERS; POTASSIUM PREPARATIONS FOR PHARMACEUTICALS (U.S. CLS. 6, 18, 44, 46, 51 AND 52).

SANJEEV VOHRA, EXAMINING ATTORNEY

CLASS 5—(Continued).

SN 77-476,575. WOODSTREAM CORPORATION, LITITZ, PA. FILED 5-16-2008.

MULTI-KILL

THE MARK CONSISTS OF STANDARD CHARACTERS WITHOUT CLAIM TO ANY PARTICULAR FONT, STYLE, SIZE, OR COLOR.

FOR RODENTICIDES (U.S. CLS. 6, 18, 44, 46, 51 AND 52).

GINA HAYES, EXAMINING ATTORNEY

SN 77-470,030. SCHERER LABS INTERNATIONAL, LLC, HOLLY HILL, FL. FILED 5-9-2008.

NASAL FREE

THE MARK CONSISTS OF STANDARD CHARACTERS WITHOUT CLAIM TO ANY PARTICULAR FONT, STYLE, SIZE, OR COLOR.

NO CLAIM IS MADE TO THE EXCLUSIVE RIGHT TO USE "NASAL", APART FROM THE MARK AS SHOWN.

FOR PREPARATION IN THE FORM OF NASAL SPRAY, DROPS OR OINTMENT FOR DECONGESTION OF NASAL PASSAGES AND SINUSES (U.S. CLS. 6, 18, 44, 46, 51 AND 52).

CHARLES L. JENKINS, EXAMINING ATTORNEY

SN 77-477,654. VI-JON, INC., ST. LOUIS, MO. FILED 5-19-2008.

DERMACURE

THE MARK CONSISTS OF STANDARD CHARACTERS WITHOUT CLAIM TO ANY PARTICULAR FONT, STYLE, SIZE, OR COLOR.

FOR MEDICATED SKIN CARE PREPARATIONS (U.S. CLS. 6, 18, 44, 46, 51 AND 52).

LANA PHAM, EXAMINING ATTORNEY

SN 77-473,447. JARROW FORMULAS, INC., LOS ANGELES, CA. FILED 5-13-2008.

SLEEP OPTIMIZER

THE MARK CONSISTS OF STANDARD CHARACTERS WITHOUT CLAIM TO ANY PARTICULAR FONT, STYLE, SIZE, OR COLOR.

OWNER OF U.S. REG. NOS. 3,093,040, 3,349,922 AND OTHERS.

NO CLAIM IS MADE TO THE EXCLUSIVE RIGHT TO USE "SLEEP", APART FROM THE MARK AS SHOWN.

FOR DIETARY AND NUTRITIONAL SUPPLEMENTS (U.S. CLS. 6, 18, 44, 46, 51 AND 52).

MATTHEW EINSTEIN, EXAMINING ATTORNEY

SN 77-479,903. M D SCIENCE LAB, LLC, FT. LAUDERDALE, FL. FILED 5-21-2008.

Dial an O

THE MARK CONSISTS OF STANDARD CHARACTERS WITHOUT CLAIM TO ANY PARTICULAR FONT, STYLE, SIZE, OR COLOR.

FOR ORGASM CREAMS (U.S. CLS. 6, 18, 44, 46, 51 AND 52).

WANDA KAY PRICE, EXAMINING ATTORNEY

CLASS 5—(Continued).

SN 77-481,465. ALTICOR INC., ADA, MI. FILED 5-22-2008.

THE SMART SUPPLEMENT FOR
YOUR KIDS

THE MARK CONSISTS OF STANDARD CHARACTERS
WITHOUT CLAIM TO ANY PARTICULAR FONT, STYLE,
SIZE, OR COLOR.

FOR NUTRITIONAL SUPPLEMENTS (U.S. CLS. 6, 18,
44, 46, 51 AND 52).

REGINA DRUMMOND, EXAMINING ATTORNEY

SN 77-497,581. MAIN STREET DIRECT, LLC, NEW YORK,
NY. FILED 6-12-2008.

NUTRIDAY

THE MARK CONSISTS OF STANDARD CHARACTERS
WITHOUT CLAIM TO ANY PARTICULAR FONT, STYLE,
SIZE, OR COLOR.

FOR HERBAL SUPPLEMENTS; MINERAL NUTRI-
TIONAL SUPPLEMENTS; MINERAL SUPPLEMENTS;
NUTRITIONAL SUPPLEMENTS; VITAMINS (U.S. CLS.
6, 18, 44, 46, 51 AND 52).

FIRST USE 9-1-1998; IN COMMERCE 1-2-1999.

MICHAEL W. BAIRD, EXAMINING ATTORNEY

SN 78-069,045. GALAXY NUTRITION, LAS VEGAS, NV.
FILED 6-14-2001.

GALAXY NUTRITION

NO CLAIM IS MADE TO THE EXCLUSIVE RIGHT TO
USE "NUTRITION", APART FROM THE MARK AS
SHOWN.

FOR NUTRITIONAL AND DIETARY SUPPLEMENTS
(U.S. CLS. 6, 18, 44, 46, 51 AND 52).

REBECCA EISINGER, EXAMINING ATTORNEY

CLASS 5—(Continued).

SN 78-578,351. HEB GROCERY COMPANY, L.P., SAN ANTONIO, TX. FILED 3-2-2005.

**H-E-B TEXAS
BACKYARD**

THE MARK CONSISTS OF STANDARD CHARACTERS
WITHOUT CLAIM TO ANY PARTICULAR FONT, STYLE,
SIZE, OR COLOR.

OWNER OF U.S. REG. NOS. 1,519,398, 1,867,930 AND
OTHERS.

NO CLAIM IS MADE TO THE EXCLUSIVE RIGHT TO
USE "TEXAS", APART FROM THE MARK AS SHOWN.

FOR HERBICIDES, INSECTICIDES, PESTICIDES AND
FUNGICIDES FOR GARDEN AND LAWN USE (U.S.
CLS. 6, 18, 44, 46, 51 AND 52).

DANIEL BRODY, EXAMINING ATTORNEY

SN 78-641,515. MEDICAL RESEARCH INSTITUTE, INC.,
SAN FRANCISCO, CA. FILED 6-1-2005.

Dr. No

THE MARK CONSISTS OF STANDARD CHARACTERS
WITHOUT CLAIM TO ANY PARTICULAR FONT, STYLE,
SIZE, OR COLOR.

FOR NUTRITIONAL AND DIETARY SUPPLEMENTS
(U.S. CLS. 6, 18, 44, 46, 51 AND 52).

LANA PHAM, EXAMINING ATTORNEY

SN 78-726,263. SANDHU, BALDEV, ENGLEWOOD CLIFFS,
NJ. FILED 10-4-2005.

LEANAPLEX

THE MARK CONSISTS OF STANDARD CHARACTERS
WITHOUT CLAIM TO ANY PARTICULAR FONT, STYLE,
SIZE, OR COLOR.

FOR FOOD SUPPLEMENTS; VITAMINS; MINERAL
SUPPLEMENTS; NUTRITIONAL SUPPLEMENTS; DIET-
ARY SUPPLEMENTS; DIETARY DRINK MIX FOR USE
AS A MEAL REPLACEMENT (U.S. CLS. 6, 18, 44, 46, 51
AND 52).

KATHERINE M. DUBRAY, EXAMINING ATTORNEY

CLASS 5—(Continued).

SN 79-044,971. BIOGAIA AB, SWEDEN, FILED 9-15-2007.

Lactobacillus reuteri Prodentis

PRIORITY DATE OF 3-15-2007 IS CLAIMED.
OWNER OF INTERNATIONAL REGISTRATION 0940280
DATED 9-15-2007, EXPIRES 9-15-2017.

NO CLAIM IS MADE TO THE EXCLUSIVE RIGHT TO
USE "LACTOBACILLUS REUTERI", APART FROM THE
MARK AS SHOWN.

FOR MEDICINAL DENTAL CARE PREPARATIONS,
NAMELY, CHEWING GUM, LOZENGES, PASTILLES
AND MOUTHWASH FOR MEDICAL PURPOSES (U.S.
CLS. 6, 18, 44, 46, 51 AND 52).

KATHLEEN LORENZO, EXAMINING ATTORNEY

SN 79-047,227. NEUROPHARMA I SVERIGE AB, SWEDEN,
FILED 9-7-2007.

NEUROVIVE

THE MARK CONSISTS OF STANDARD CHARACTERS
WITHOUT CLAIM TO ANY PARTICULAR FONT, STYLE,
SIZE, OR COLOR.

PRIORITY DATE OF 8-1-2007 IS CLAIMED.
OWNER OF INTERNATIONAL REGISTRATION 0946112
DATED 9-7-2007, EXPIRES 9-7-2017.

FOR PHARMACEUTICAL AND VETERINARY PRE-
PARATIONS, NAMELY, MEDICINES AND PHARMA-
CEUTICAL PREPARATIONS FOR THE TREATMENT
AND PREVENTION OF ACUTE AND CHRONIC NEU-
ROLOGICAL ILLNESSES AND CONDITIONS; MEDI-
CINES AND PHARMACEUTICAL PREPARATIONS
FOR THE TREATMENT OF NEUROSURGICAL CONDI-
TIONS, NAMELY, FOR BRAIN DAMAGE AND FOR USE
IN BRAIN OPERATIONS AND OTHER PHYSICAL AND
NEUROLOGICAL AILMENTS OF THE BRAIN; MEDI-
CINES AND PHARMACEUTICAL PREPARATIONS FOR
USE IN THE AREA OF NEUROLOGICAL INTENSIVE
CARE; MEDICINES AND PHARMACEUTICAL PRE-
PARATIONS FOR USE AS IMMUNOSUPPRESSIVE
AGENTS IN ORGAN TRANSPLANTS OR OTHER MED-
ICAL AND CLINICAL USES OF IMMUNOSUPPRESSIVE
AGENTS AND PREPARATIONS (U.S. CLS. 6, 18, 44, 46,
51 AND 52).

SAIMA MAKHDOOM, EXAMINING ATTORNEY

SN 79-051,446. DECHRA LIMITED, UNITED KINGDOM,
FILED 3-10-2008.

BUPREDALE

THE MARK CONSISTS OF STANDARD CHARACTERS
WITHOUT CLAIM TO ANY PARTICULAR FONT, STYLE,
SIZE, OR COLOR.

PRIORITY DATE OF 9-10-2007 IS CLAIMED.
OWNER OF INTERNATIONAL REGISTRATION 0957583
DATED 3-10-2008, EXPIRES 3-10-2018.

FOR VETERINARY PREPARATIONS FOR ANALGE-
SIA (U.S. CLS. 6, 18, 44, 46, 51 AND 52).

DAVID TOOLEY, EXAMINING ATTORNEY

CLASS 5—(Continued).SN 79-052,602. PIERRE FABRE DERMATOLOGIE, BOU-
LOGNE, FRANCE, FILED 3-14-2008.**ONYSTER**

THE MARK CONSISTS OF STANDARD CHARACTERS
WITHOUT CLAIM TO ANY PARTICULAR FONT, STYLE,
SIZE, OR COLOR.

PRIORITY DATE OF 10-1-2007 IS CLAIMED.
OWNER OF INTERNATIONAL REGISTRATION 0960835
DATED 3-14-2008, EXPIRES 3-14-2018.

FOR DERMATOLOGICAL PRODUCTS FOR THE
TREATMENT OF ONYCHOMYCOSES (U.S. CLS. 6, 18,
44, 46, 51 AND 52).

SEAN CROWLEY, EXAMINING ATTORNEY

CLASS 6—METAL GOODS

SN 77-162,803. CORBIN RUSSWIN, INC., BERLIN, CT.
FILED 4-23-2007.

SECUREBOLT

THE MARK CONSISTS OF STANDARD CHARACTERS
WITHOUT CLAIM TO ANY PARTICULAR FONT, STYLE,
SIZE, OR COLOR.

SEC. 2(F).
FOR EXIT DEVICES COMPRISED OF A METAL
DOOR LATCH OPERATED BY A METAL PUSH BAR
(U.S. CLS. 2, 12, 13, 14, 23, 25 AND 50).

FIRST USE 1-0-1998; IN COMMERCE 1-0-1998.

REBECCA POVARCHUK, EXAMINING ATTORNEY

SN 77-279,398. JAG FLOCOMPONENTS LP, EDMONTON,
ALBERTA, CANADA, FILED 9-14-2007.

MUD LITE

THE MARK CONSISTS OF STANDARD CHARACTERS
WITHOUT CLAIM TO ANY PARTICULAR FONT, STYLE,
SIZE, OR COLOR.

NO CLAIM IS MADE TO THE EXCLUSIVE RIGHT TO
USE "MUD", APART FROM THE MARK AS SHOWN.

FOR MANUALLY OPERATED METAL VALVES FOR
USE IN OIL AND GAS INDUSTRIES (U.S. CLS. 2, 12, 13,
14, 23, 25 AND 50).

ANGELA GAW, EXAMINING ATTORNEY

CLASS 6—(Continued).

SN 77-319,007. WM CASTING INC., LA CANADA, CA. FILED 11-1-2007.



NO CLAIM IS MADE TO THE EXCLUSIVE RIGHT TO USE "CASTING" AND "PRODUCTS", APART FROM THE MARK AS SHOWN.

THE COLOR(S) TURQUOISE AND BLUE IS/ARE CLAIMED AS A FEATURE OF THE MARK.

THE WORD "CASTING" IS PRESENTED IN BLUE AND THE DESIGN AND WORDING "SUPREME WEAR PRODUCTS" APPEAR IN TURQUOISE.

FOR CAST-STEEL PARTS FOR RECYCLING, METALLIC MINING AND AGGREGATE INDUSTRIES, NAMELY, METAL BOLTS, METAL NUTS; MING JAW PLATES, NAMELY, STEEL PLATES; METAL GRATING; SIDE LINERS, NAMELY, SHEET METAL LININGS (U.S. CLS. 2, 12, 13, 14, 23, 25 AND 50).

INGRID C. EULIN, EXAMINING ATTORNEY

SN 77-336,586. LINCOLN GLOBAL, INC., CITY OF INDUSTRY, CA. FILED 11-26-2007.

INFINITY PAK

THE MARK CONSISTS OF STANDARD CHARACTERS WITHOUT CLAIM TO ANY PARTICULAR FONT, STYLE, SIZE, OR COLOR.

NO CLAIM IS MADE TO THE EXCLUSIVE RIGHT TO USE "PAK", APART FROM THE MARK AS SHOWN.

FOR METAL WELDING WIRE (U.S. CLS. 2, 12, 13, 14, 23, 25 AND 50).

RICHARD WHITE, EXAMINING ATTORNEY

CLASS 6—(Continued).

SN 77-341,390. FAIFERLICK, LARRY R., LINCOLN, NE. FILED 11-30-2007.

Crazy Daisies

THE MARK CONSISTS OF STANDARD CHARACTERS WITHOUT CLAIM TO ANY PARTICULAR FONT, STYLE, SIZE, OR COLOR.

FOR WROUGHT IRON DECORATIVE ARTWORK (U.S. CLS. 2, 12, 13, 14, 23, 25 AND 50).

FIRST USE 9-1-2006; IN COMMERCE 9-1-2006.

SOPHIA S. KIM, EXAMINING ATTORNEY

SN 77-375,546. INTEGRATED THEFT SOLUTIONS INC., SAN ANTONIO, TX. FILED 1-18-2008.

THE COLOR(S) WHITE, BLACK, RED IS/ARE CLAIMED AS A FEATURE OF THE MARK.

THE MARK CONSISTS OF WHITE BOX WITH BLACK BORDER AND RED LETTERING.

FOR STEEL HVAC SECURITY CAGE (U.S. CLS. 2, 13, 14, 23, 25 AND 50).

SUNG IN, EXAMINING ATTORNEY

SN 77-377,573. PEX CONNECTION, INC., OKLAHOMA CITY, OK. FILED 1-22-2008.

SPEEDPUSH

THE MARK CONSISTS OF STANDARD CHARACTERS WITHOUT CLAIM TO ANY PARTICULAR FONT, STYLE, SIZE, OR COLOR.

FOR METAL FITTINGS, NAMELY, PIPE COLLARS, COUPLINGS, CONNECTORS, JOINTS, ADAPTORS, RINGS, SWIVELS, TEES, MANIFOLDS, ELBOWS AND PLUGS (U.S. CLS. 2, 12, 13, 14, 23, 25 AND 50).

FIRST USE 12-1-2007; IN COMMERCE 12-1-2007.

WILLIAM VERHOSEK, EXAMINING ATTORNEY

CLASS 6—(Continued).

SN 77-392,625. INTEGRATED THEFT SOLUTIONS INC.,
SAN ANTONIO, TX. FILED 2-8-2008.

Don't be EXPOSED....Get
ENCLOSED

THE MARK CONSISTS OF STANDARD CHARACTERS
WITHOUT CLAIM TO ANY PARTICULAR FONT, STYLE,
SIZE, OR COLOR.

FOR PREFABRICATED METAL ENCLOSURES WITH
INTERLOCKING PANELS TO PROTECT AIR CONDI-
TIONING UNITS FROM THEFT DAMAGE OR VAND-
ALISM (U.S. CLS. 2, 12, 13, 14, 23, 25 AND 50).

SUNG IN, EXAMINING ATTORNEY

SN 77-402,707. CONTINUUM FOOTSPAS, LLC, BROOK-
FIELD, WI. FILED 2-21-2008.

PEDIPROP

THE MARK CONSISTS OF STANDARD CHARACTERS
WITHOUT CLAIM TO ANY PARTICULAR FONT, STYLE,
SIZE, OR COLOR.

FOR PADDED METAL PIVOTAL LEG SUPPORT FOR
FOOTBATHS FOR USE IN PEDICURE SALONS AND
DAY SPAS (U.S. CLS. 2, 12, 13, 14, 23, 25 AND 50).

SHAUNIA CARLYLE, EXAMINING ATTORNEY

SN 77-421,905. SCHNEIDER SADDLERY CO., INC, CHA-
GRIN FALLS, OH. FILED 3-14-2008.

SMART LOCK SYSTEM

THE MARK CONSISTS OF STANDARD CHARACTERS
WITHOUT CLAIM TO ANY PARTICULAR FONT, STYLE,
SIZE, OR COLOR.

NO CLAIM IS MADE TO THE EXCLUSIVE RIGHT TO
USE "LOCK SYSTEM", APART FROM THE MARK AS
SHOWN.

FOR METAL FASTENERS, NAMELY, METAL
THREADLESS FASTENERS FOR SADDLERY (U.S.
CLS. 2, 12, 13, 14, 23, 25 AND 50).

TINA KUAN, EXAMINING ATTORNEY

CLASS 6—(Continued).

SN 77-423,915. HICKORY HARDWARE, INC., NASHVILLE,
TN. FILED 3-17-2008.

BASALTIC

THE MARK CONSISTS OF STANDARD CHARACTERS
WITHOUT CLAIM TO ANY PARTICULAR FONT, STYLE,
SIZE, OR COLOR.

FOR FURNITURE AND CABINET HARDWARE
MADE OF METAL, NAMELY, PULLS, KNOBS, HAN-
DLES, AND LATCHES; METAL HARDWARE FOR
DOORS, NAMELY, LOCKS, HANDLES, LATCHES, ES-
CUTCHEONS, AND DOOR TRIM PLATES (U.S. CLS. 2,
12, 13, 14, 23, 25 AND 50).

MICHELE SWAIN, EXAMINING ATTORNEY

SN 77-425,069. C.J. THEOBALD III, LOUISVILLE, KY. FILED
3-18-2008.

Wind Wobbler

THE MARK CONSISTS OF STANDARD CHARACTERS
WITHOUT CLAIM TO ANY PARTICULAR FONT, STYLE,
SIZE, OR COLOR.

FOR METAL HOLDERS FOR SIGNS (U.S. CLS. 2, 12,
13, 14, 23, 25 AND 50).

ERIN FALK, EXAMINING ATTORNEY

SN 77-426,699. RUSS BASSETT CORPORATION, WHITTIER,
CA. FILED 3-19-2008.

The Beam

THE MARK CONSISTS OF STANDARD CHARACTERS
WITHOUT CLAIM TO ANY PARTICULAR FONT, STYLE,
SIZE, OR COLOR.

FOR METAL CONDUIT (U.S. CLS. 2, 12, 13, 14, 23, 25
AND 50).

FIRST USE 12-31-2004; IN COMMERCE 12-31-2004.

ATTIYA MALIK, EXAMINING ATTORNEY

CLASS 6—(Continued).

SN 77-426,871. INFOSIGHT CORPORATION, CHILLICOTHE, OH. FILED 3-20-2008.

KETTLECODES

THE MARK CONSISTS OF STANDARD CHARACTERS WITHOUT CLAIM TO ANY PARTICULAR FONT, STYLE, SIZE, OR COLOR.

OWNER OF U.S. REG. NO. 2,805,899.
FOR PRE-PRINTED METAL IDENTIFICATION TAGS FOR PARTS SUBJECTED TO ZINC GALVANIZING (U.S. CLS. 2, 12, 13, 14, 23, 25 AND 50).
BARBARA BROWN, EXAMINING ATTORNEY

SN 77-430,540. ILLINOIS TOOL WORKS INC., GLENVIEW, IL. FILED 3-25-2008.

Sinulok

THE MARK CONSISTS OF STANDARD CHARACTERS WITHOUT CLAIM TO ANY PARTICULAR FONT, STYLE, SIZE, OR COLOR.

FOR METAL SCREWS (U.S. CLS. 2, 12, 13, 14, 23, 25 AND 50).
MELVIN AXILBUND, EXAMINING ATTORNEY

SN 77-431,268. GRANT PRIDECO, L.P., HOUSTON, TX. FILED 3-25-2008.

TurboTorque-M

THE MARK CONSISTS OF STANDARD CHARACTERS WITHOUT CLAIM TO ANY PARTICULAR FONT, STYLE, SIZE, OR COLOR.

OWNER OF U.S. REG. NO. 3,399,840.
FOR THREADED METAL DRILL PIPE CONNECTIONS USED ON METAL DRILL PIPE FOR THE DRILLING OF OIL AND GAS WELLS AND OTHER EARTH BOREHOLES (U.S. CLS. 2, 12, 13, 14, 23, 25 AND 50).
TRACY WHITTAKER-BROWN, EXAMINING ATTORNEY

CLASS 6—(Continued).

SN 77-432,405. I.P.H. S.A.I.C.F., SAN MIGUEL, ARGENTINA, FILED 3-26-2008.

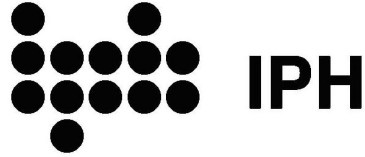

OWNER OF ARGENTINA REG. NO. 1913339, DATED 9-10-2003, EXPIRES 9-10-2013.

FOR NON-ELECTRIC STEEL CABLES (U.S. CLS. 2, 12, 13, 14, 23, 25 AND 50).
CHRISTOPHER BUONGIORNO, EXAMINING ATTORNEY

SN 77-432,959. PHIFER INCORPORATED, TUSCALOOSA, AL. FILED 3-27-2008.

Brite-Kote

THE MARK CONSISTS OF STANDARD CHARACTERS WITHOUT CLAIM TO ANY PARTICULAR FONT, STYLE, SIZE, OR COLOR.

FOR INSECT SCREENS OF METAL; METAL WINDOW SCREENS (U.S. CLS. 2, 12, 13, 14, 23, 25 AND 50).
FIRST USE 5-30-1975; IN COMMERCE 5-30-1975.
LINDA ORNDORFF, EXAMINING ATTORNEY

SN 77-433,711. PLYMOUTH TUBE COMPANY, WARRENVILLE, IL. FILED 3-27-2008.

PROMOLY

THE MARK CONSISTS OF STANDARD CHARACTERS WITHOUT CLAIM TO ANY PARTICULAR FONT, STYLE, SIZE, OR COLOR.

FOR STEEL TUBING (U.S. CLS. 2, 12, 13, 14, 23, 25 AND 50).
RUDY R. SINGLETON, EXAMINING ATTORNEY

CLASS 6—(Continued).

SN 77-459,200. ASCA, INC., PORTSMOUTH, NH. FILED 4-28-2008.

Architectural Sun Control

THE MARK CONSISTS OF STANDARD CHARACTERS WITHOUT CLAIM TO ANY PARTICULAR FONT, STYLE, SIZE, OR COLOR.

SEC. 2(F).
FOR ARCHITECTURAL METALWORK (U.S. CLS. 2, 12, 13, 14, 23, 25 AND 50).
FIRST USE 1-1-1993; IN COMMERCE 1-1-1993.
JILL PRATER, EXAMINING ATTORNEY

CLASS 7—MACHINERY

SN 76-648,949. TRITEK TECHNOLOGIES, INC., HOCKESSIN, PA. FILED 10-21-2005.



FOR MAIL SORTING MACHINES (U.S. CLS. 13, 19, 21, 23, 31, 34 AND 35).
FIRST USE 0-0-1988; IN COMMERCE 0-0-1988.
REBECCA POVARCHUK, EXAMINING ATTORNEY

SN 79-036,406. HIRSCHVOGEL UMFORMTECHNIK GMBH.; GESENKSMIEDE UND PRESSWERK, FED REP GERMANY, FILED 12-13-2006.

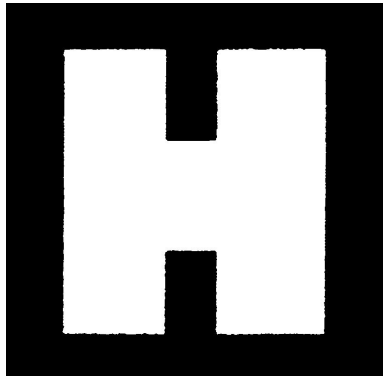

SN 76-687,559. PARK INDUSTRIES, INC., ST. CLOUD, MN. FILED 3-10-2008.

STAMPEDE

PRIORITY DATE OF 6-21-2006 IS CLAIMED.
OWNER OF INTERNATIONAL REGISTRATION 0918514
DATED 12-13-2006, EXPIRES 12-13-2016.
OWNER OF U.S. REG. NO. 2,798,049.
FOR COMMON METALS AND THEIR ALLOYS,
NAMELY, INGOTS OF COMMON METAL; ALL OF
THE AFOREMENTIONED GOODS EXCLUDING
CHAINS AND MARINE ANCHORS (U.S. CLS. 2, 12, 13,
14, 23, 25 AND 50).
ROBERT STRUCK, EXAMINING ATTORNEY

THE MARK CONSISTS OF STANDARD CHARACTERS WITHOUT CLAIM TO ANY PARTICULAR FONT, STYLE, SIZE, OR COLOR.
FOR MULTIPLE BLADE SAWING SYSTEM COMPOSED OF AN INFEED CONVEYOR FOR FEEDING STONE SLABS INTO A PLURALITY OF CIRCULAR SAW BLADES MOUNTED ON A COMMON, MOTOR-DRIVEN ARBOR WITH ADJUSTABLE SPACING BETWEEN ADJACENT BLADES (U.S. CLS. 13, 19, 21, 23, 31, 34 AND 35).
FIRST USE 1-29-2008; IN COMMERCE 1-29-2008.
FRANK LATTUCA, EXAMINING ATTORNEY

CLASS 7—(Continued).

SN 77-113,613. CITIZEN MACHINERY AMERICA, INC., AGAWAM, MA. FILED 2-22-2007.

COOL BLASTER

THE MARK CONSISTS OF STANDARD CHARACTERS WITHOUT CLAIM TO ANY PARTICULAR FONT, STYLE, SIZE, OR COLOR.

OWNER OF U.S. REG. NO. 2,333,188.
 NO CLAIM IS MADE TO THE EXCLUSIVE RIGHT TO USE "COOL", APART FROM THE MARK AS SHOWN.
 FOR HIGH PRESSURE COOLANT PUMP SYSTEM FOR MACHINE TOOLS COMPRISED PRIMARILY OF A HYDRAULIC PUMP, SOLENOIDS, AN ELECTRIC MOTOR, HYDRAULIC FITTINGS AND HOSES, AND A FILTER; AND MIST AND SMOKE CONTROL SYSTEMS COMPRISED OF AIR FILTERS FOR MECHANICAL PURPOSES FOR USE WITH MACHINE TOOLS (U.S. CLS. 13, 19, 21, 23, 31, 34 AND 35).
 FIRST USE 3-11-1997; IN COMMERCE 3-13-1997.
 ALEXANDER L. POWERS, EXAMINING ATTORNEY

SN 77-113,829. CITIZEN MACHINERY AMERICA, INC., AGAWAM, MA. FILED 2-22-2007.



OWNER OF U.S. REG. NO. 2,333,188.
 FOR HIGH PRESSURE COOLANT PUMP SYSTEM FOR MACHINE TOOLS COMPRISED PRIMARILY OF A HYDRAULIC PUMP, SOLENOIDS, AN ELECTRIC MOTOR, HYDRAULIC FITTINGS AND HOSES, AND A FILTER; AND MIST AND SMOKE CONTROL SYSTEMS COMPRISED OF AIR FILTERS FOR MECHANICAL PURPOSES FOR USE WITH MACHINE TOOLS (U.S. CLS. 13, 19, 21, 23, 31, 34 AND 35).
 FIRST USE 5-3-1999; IN COMMERCE 5-3-1999.
 ALEXANDER L. POWERS, EXAMINING ATTORNEY

CLASS 7—(Continued).

SN 77-113,863. CITIZEN MACHINERY AMERICA, INC., AGAWAM, MA. FILED 2-22-2007.



OWNER OF U.S. REG. NO. 2,333,188.
 NO CLAIM IS MADE TO THE EXCLUSIVE RIGHT TO USE "COOL", APART FROM THE MARK AS SHOWN.
 FOR HIGH PRESSURE COOLANT PUMP SYSTEM FOR MACHINE TOOLS COMPRISED PRIMARILY OF A HYDRAULIC PUMP, SOLENOIDS, AN ELECTRIC MOTOR, HYDRAULIC FITTINGS AND HOSES, AND A FILTER; AND MIST AND SMOKE CONTROL SYSTEMS COMPRISED OF AIR FILTERS FOR MECHANICAL PURPOSES FOR USE WITH MACHINE TOOLS (U.S. CLS. 13, 19, 21, 23, 31, 34 AND 35).
 FIRST USE 10-0-2001; IN COMMERCE 10-0-2001.
 ALEXANDER L. POWERS, EXAMINING ATTORNEY

SN 77-239,154. HACKETT PRECISION COMPANY, INC., NASHVILLE, TN. FILED 7-26-2007.



THE COLOR(S) BLUE, GREEN AND ORANGE IS/ARE CLAIMED AS A FEATURE OF THE MARK.
 THE MARK CONSISTS OF THREE SIX SIDED POLYGONS, EACH COMPLETELY SHADED/COLORED IN BLUE, GREEN AND ORANGE.
 FOR CUSTOM DESIGNED MACHINERY FEATURING AUTOMATION AND ROBOTICS FOR USE IN THE ASSEMBLY OR SUBASSEMBLY OF MANUFACTURED GOODS, NAMELY, EQUIPMENT THAT PERMITS CUSTOM INTEGRATION OF MANUFACTURING FACILITIES FOR ASSEMBLY OR SUBASSEMBLY OF GOODS, AUTOMATED ASSEMBLY AND TEST SYSTEMS, AUTOMATED WELDING SYSTEMS, AUTOMATED METAL REMOVAL SYSTEMS, AUTOMATED MATERIAL HANDING MACHINERY, NAMELY, PALLETIZERS, CASE ELEVATORS, AUTOMATIC PALLET DISPENSING MACHINES AND AUTOMATIC SLIP SHEET DISPENSING MACHINES, MACHINERY THAT PERMITS AUTOMATION AND INTEGRATION OF PROCESSES IN MANUFACTURING FACILITIES, ROBOTIC ASSEMBLY AND PACKAGING MACHINERY, TOOLING MACHINERY, AND FIXTURING EQUIPMENT, NAMELY, EQUIPMENT UTILIZING CUSTOM ENGINEERED EQUIPMENT OR ROBOTICS FOR THE ASSEMBLY OR SUBASSEMBLY OF MANUFACTURE GOODS (U.S. CLS. 13, 19, 21, 23, 31, 34 AND 35).
 FIRST USE 7-11-2007; IN COMMERCE 7-11-2007.
 MARY ROSSMAN, EXAMINING ATTORNEY

CLASS 7—(Continued).

SN 77-260,339. ING. JOSEF MUSER, NEU-SEIERSBERG, AUSTRIA, FILED 8-21-2007.



PRIORITY CLAIMED UNDER SEC. 44(D) ON ERPN CMNTY TM OFC APPLICATION NO. 5880869, FILED 4-23-2007, REG. NO. 5880869, DATED 2-27-2008, EXPIRES 4-23-2017.

THE COLOR(S) GRAY, RED AND WHITE IS/ARE CLAIMED AS A FEATURE OF THE MARK.

THE MARK CONSISTS OF THE LETTERS "MAM" AND CHEVRONS FORMING THE DESIGN OF A TRIANGLE. THE LETTERS ARE RED, THE CHEVRON IS GRAY AND THE BACKGROUND OF THE DESIGN IS WHITE.

FOR AUTOMATIC METAL WORKING MACHINES, NAMELY, COMPUTER AIDED MACHINING CENTERS; MACHINE TOOL HOLDERS; MACHINES AND MACHINE TOOLS WHICH IDENTIFY, MONITOR AND RETRIEVE TOOLS (U.S. CLS. 13, 19, 21, 23, 31, 34 AND 35).

IRA J. GOODSaid, EXAMINING ATTORNEY

CLASS 7—(Continued).

SN 77-283,659. DERRICK CORPORATION, BUFFALO, NY, FILED 9-19-2007.

DUAL POOL

THE MARK CONSISTS OF STANDARD CHARACTERS WITHOUT CLAIM TO ANY PARTICULAR FONT, STYLE, SIZE, OR COLOR.

FOR VIBRATORY INDUSTRIAL SCREENING APPARATUS FOR SEPARATING MATERIALS AND PARTS THEREFOR; REPLACEMENT SCREEN CLOTHS FOR VIBRATORY SCREENING MACHINES; DRILL MUD SCREENING MACHINES; SOLIDS SEPARATION EQUIPMENT, NAMELY, MATERIAL DRYER MACHINES; ELECTRIC VIBRATORY MOTORS FOR MACHINES AND PARTS THEREOF (U.S. CLS. 13, 19, 21, 23, 31, 34 AND 35).

FIRST USE 4-30-2007; IN COMMERCE 4-30-2007.
CAROL SPILS, EXAMINING ATTORNEY

SN 77-283,686. DERRICK CORPORATION, BUFFALO, NY, FILED 9-19-2007.



Multi-Gluer

THE MARK CONSISTS OF STANDARD CHARACTERS WITHOUT CLAIM TO ANY PARTICULAR FONT, STYLE, SIZE, OR COLOR.

FOR ENVELOPE-INSERTING MACHINES (U.S. CLS. 13, 19, 21, 23, 31, 34 AND 35).

FIRST USE 7-18-2007; IN COMMERCE 7-18-2007.
AHSEN KHAN, EXAMINING ATTORNEY

NO CLAIM IS MADE TO THE EXCLUSIVE RIGHT TO USE "600 SHAKER", APART FROM THE MARK AS SHOWN.

FOR VIBRATORY INDUSTRIAL SCREENING APPARATUS FOR SEPARATING MATERIALS AND PARTS THEREFOR; REPLACEMENT SCREEN CLOTHS FOR VIBRATORY SCREENING MACHINES; DRILL MUD SCREENING MACHINES; SOLIDS SEPARATION EQUIPMENT, NAMELY, MATERIAL DRYER MACHINES; ELECTRIC VIBRATORY MOTORS FOR MACHINES AND PARTS THEREOF (U.S. CLS. 13, 19, 21, 23, 31, 34 AND 35).

CAROL SPILS, EXAMINING ATTORNEY

CLASS 7—(Continued).

SN 77-291,094. FOXCONN SHENYANG PRECISION INDUSTRY CO., LTD., LIAONING PROVINCE, CHINA, FILED 9-28-2007.

THE NON-LATIN CHARACTER(S) IN THE MARK TRANSLITERATES INTO HONG FU YANG, AND THIS MEANS GREAT, AFFLUENT, SUNNY IN ENGLISH.

FOR MACHINE TOOLS FOR THE CUTTING AND WORKING OF MATERIALS; MACHINE TOOL SPINDLES; TOOL MAGAZINES FOR HOLDING CUTTING TOOLS FOR MACHINING; ALTERNATING CURRENT SERVO MOTORS; DRIVERS FOR ALTERNATING CURRENT SERVO MOTORS; INDUSTRIAL ROBOTS; PUNCH PRESSES; INJECTION MOLDING MACHINES; WIRE CUTTING MACHINES; ELECTRICAL DISCHARGE MACHINES; INDUSTRIAL POLISHING MACHINES FOR USE IN POLISHING METAL; AND METALWORKING MACHINE TOOLS (U.S. CLS. 13, 19, 21, 23, 31, 34 AND 35).

AMY GEARIN, EXAMINING ATTORNEY

CLASS 7—(Continued).

SN 77-291,100. FOXCONN SHENYANG PRECISION INDUSTRY CO., LTD., LIAONING PROVINCE, CHINA, FILED 9-28-2007.

THE MARK CONSISTS OF STANDARD CHARACTERS WITHOUT CLAIM TO ANY PARTICULAR FONT, STYLE, SIZE, OR COLOR.

FOR MACHINE TOOLS FOR THE CUTTING AND WORKING OF MATERIALS; MACHINE TOOL SPINDLES; TOOL MAGAZINES FOR HOLDING CUTTING TOOLS FOR MACHINING; ALTERNATING CURRENT SERVO MOTORS; DRIVERS FOR ALTERNATING CURRENT SERVO MOTORS; INDUSTRIAL ROBOTS; PUNCH PRESSES; INJECTION MOLDING MACHINES; WIRE CUTTING MACHINES; ELECTRICAL DISCHARGE MACHINES; INDUSTRIAL POLISHING MACHINES FOR USE IN POLISHING METAL; AND METALWORKING MACHINE TOOLS (U.S. CLS. 13, 19, 21, 23, 31, 34 AND 35).

AMY GEARIN, EXAMINING ATTORNEY

SN 77-291,098. FOXCONN SHENYANG PRECISION INDUSTRY CO., LTD., LIAONING PROVINCE, CHINA, FILED 9-28-2007.

THE MARK CONSISTS OF STANDARD CHARACTERS WITHOUT CLAIM TO ANY PARTICULAR FONT, STYLE, SIZE, OR COLOR.

FOR MACHINE TOOLS FOR THE CUTTING AND WORKING OF MATERIALS; MACHINE TOOL SPINDLES; TOOL MAGAZINES FOR HOLDING CUTTING TOOLS FOR MACHINING; ALTERNATING CURRENT SERVO MOTORS; DRIVERS FOR ALTERNATING CURRENT SERVO MOTORS; INDUSTRIAL ROBOTS; PUNCH PRESSES; INJECTION MOLDING MACHINES; WIRE CUTTING MACHINES; ELECTRICAL DISCHARGE MACHINES; INDUSTRIAL POLISHING MACHINES FOR USE IN POLISHING METAL; AND METALWORKING MACHINE TOOLS (U.S. CLS. 13, 19, 21, 23, 31, 34 AND 35).

AMY GEARIN, EXAMINING ATTORNEY

SN 77-306,097. ORECK HOLDINGS, LLC, CHEYENNE, WY. FILED 10-17-2007.

OWNER OF U.S. REG. NO. 3,450,711.

THE MARK CONSISTS OF THE WORD "INTELLASHIELD" WITH AN ORBITING BODY.

FOR VACUUM CLEANERS AND PARTS THEREOF SOLD TOGETHER AS A UNIT; EXTRACTING MACHINES FOR USE IN CLEANING CARPETS, FABRICS AND UPHOLSTERY AND PARTS AND FITTINGS SOLD TOGETHER AS A UNIT AND SHAMPOO CARTRIDGES SOLD THEREWITH (U.S. CLS. 13, 19, 21, 23, 31, 34 AND 35).

FIRST USE 9-28-2007; IN COMMERCE 9-28-2007.

MARTHA FROMM, EXAMINING ATTORNEY

CLASS 7—(Continued).

SN 77-322,162. SPACELOGIC, INC., ROCK HILL, SC. FILED 11-6-2007.



THE COLOR(S) BLACK AND TAN IS/ARE CLAIMED AS A FEATURE OF THE MARK.

THE MARK CONSISTS OF 2 BLACK CURVED ARROWS INTERTWINED TO LOOK LIKE A LETTER "S" WITHIN A TAN SQUARE SHADED IN BLACK "SPACELOGIC" IS TO THE RIGHT OF THE BOX. "SPACE" IN COLOR BLACK AND "LOGIC" IN TAN COLOR.

FOR MATERIAL HANDLING MACHINES, NAMELY, PALLETIZERS, CASE ELEVATORS, AUTOMATIC PALLET DISPENSING MACHINES AND AUTOMATIC SLIP SHEET DISPENSING MACHINES (U.S. CLS. 13, 19, 21, 23, 31, 34 AND 35).

REBECCA GILBERT, EXAMINING ATTORNEY

SN 77-325,912. ARROYO PROCESS EQUIPMENT, INC., CLEARWATER, FL. FILED 11-9-2007.



NO CLAIM IS MADE TO THE EXCLUSIVE RIGHT TO USE "SELF PRIMER PUMPS", APART FROM THE MARK AS SHOWN.

THE MARK CONSISTS OF THE STYLIZED WORD "PHANTOM", WHEREIN THE LETTER "A" IN THE WORD "PHANTOM" IS SHAPED LIKE A FIN, AND THE WORDS "SELF PRIMER PUMPS" ARE WRITTEN BELOW THE WORD "PHANTOM".

FOR CENTRIFUGAL PUMPS; COMPRESSED AIR PUMPS; DRIVES FOR VACUUM PUMPS; ELECTRIC PUMPS; ELECTRIC PUMPS FOR DOSIFICATION; ELECTRICAL WATER PUMPS FOR WASTEWATER; HIGH-PRESSURE PUMPS FOR WASHING APPLIANCES AND INSTALLATIONS; HYDRAULIC PUMPS; MULTI-PHASE SCREW PUMPS; PNEUMATIC PUMPS; POSITIVE DISPLACEMENT PUMPS; PUMP DIAPHRAGMS; PUMP IMPELLERS; ROTARY LOBE PUMPS; ROTARY PUMPS; SCREW PUMPS; SHAFTS FOR PUMPS; SLUDGE PUMPS; SUBMERSIBLE PUMPS; SUCTION PUMPS; VACUUM PUMPS; VACUUM PUMPS; VALVES FOR PUMPS; VARIABLE SPEED DRIVES FOR USE WITH FLUID PUMPING SYSTEMS; VERTICAL TURBINE PUMPS; WATER PUMPS FOR LAND VEHICLES; WATER PUMPS FOR USE IN MOTORS AND ENGINES; WATER PUMPS FOR WATER TREATMENT (U.S. CLS. 13, 19, 21, 23, 31, 34 AND 35).

FIRST USE 10-1-2007; IN COMMERCE 1-1-2008.

TIMOTHY FINNEGAN, EXAMINING ATTORNEY

CLASS 7—(Continued).

SN 77-341,825. INNOVATIVE LIFTS, INC. MILLERSVILLE, MD. FILED S.R. 12-1-2007; AM. P.R. 6-30-2008.

Stairs Made Easy

THE MARK CONSISTS OF STANDARD CHARACTERS WITHOUT CLAIM TO ANY PARTICULAR FONT, STYLE, SIZE, OR COLOR.

NO CLAIM IS MADE TO THE EXCLUSIVE RIGHT TO USE "STAIRS", APART FROM THE MARK AS SHOWN.

FOR STAIR LIFTS (U.S. CLS. 13, 19, 21, 23, 31, 34 AND 35).

FIRST USE 1-20-2006; IN COMMERCE 7-10-2006.

ELISSA GARBER KON, EXAMINING ATTORNEY

SN 77-355,644. ZOOPS PRODUCTS INC., BANNING, CA. FILED 12-19-2007.

CORRECT-ALIGN

THE MARK CONSISTS OF STANDARD CHARACTERS WITHOUT CLAIM TO ANY PARTICULAR FONT, STYLE, SIZE, OR COLOR.

FOR AUTOMOTIVE INTAKE MANIFOLDS; AUTOMOTIVE PARTS, NAMELY, ENGINE AND TRANSMISSION SEALS; AIR-INTAKE TUBES AND FILTERS FOR AFTER-MARKET INSTALLATION OF AUTOMOTIVE ENGINES; AUTOMOTIVE ENGINE BLOCKS; ENGINE PARTS, NAMELY, CONTACT POINTS; ENHANCEMENT PARTS FOR INTERNAL COMBUSTION ENGINES, NAMELY, FUEL CATALYSTS; INTERNAL COMBUSTION ENGINES FOR MACHINE OPERATION AND REPLACEMENT PARTS THEREFOR; MECHANICAL ENGINE PARTS FOR LAND VEHICLES; VEHICLE PARTS, NAMELY, ENGINE CASES (U.S. CLS. 13, 19, 21, 23, 31, 34 AND 35).

FIRST USE 7-1-2005; IN COMMERCE 7-1-2005.

PAULA MAHONEY, EXAMINING ATTORNEY

SN 77-379,924. CANYON STREET CROSSING LIMITED LIABILITY COMPANY, BOULDER, CO. FILED 1-24-2008.



OWNER OF U.S. REG. NOS. 726,468 AND 1,289,834. FOR EARTH ENGAGING, EARTH CUTTING AND EARTH PULVERIZING DISCS AND COULTER BLADES FOR PLOWS, HARROWS, AND LIKE AGRICULTURAL IMPLEMENTS (U.S. CLS. 13, 19, 21, 23, 31, 34 AND 35).

FIRST USE 9-0-2007; IN COMMERCE 9-0-2007.

APRIL ROACH, EXAMINING ATTORNEY

CLASS 7—(Continued).

SN 77-379,946. CANYON STREET CROSSING LIMITED LIABILITY COMPANY, BOULDER, CO. FILED 1-24-2008.



OWNER OF U.S. REG. NOS. 726,468 AND 1,289,834. FOR EARTH ENGAGING, EARTH CUTTING AND EARTH PULVERIZING DISCS AND COULTER BLADES FOR PLOWS, HARROWS, AND LIKE AGRICULTURAL IMPLEMENTS (U.S. CLS. 13, 19, 21, 23, 31, 34 AND 35). FIRST USE 7-0-2003; IN COMMERCE 7-0-2003. APRIL ROACH, EXAMINING ATTORNEY

SN 77-389,246. QUICK ATTACH ATTACHMENTS INC., ALEXANDRIA, MN. FILED 2-5-2008.



NO CLAIM IS MADE TO THE EXCLUSIVE RIGHT TO USE "ATTACH" AND "ATTACHMENTS, INC.", APART FROM THE MARK AS SHOWN.

THE COLOR(S) RED, YELLOW, BLACK AND WHITE IS/ARE CLAIMED AS A FEATURE OF THE MARK.

THE MARK CONSISTS OF THE COLORS RED, YELLOW, BLACK AND WHITE, WITH THE COLOR RED APPEARING IN THE WORDING ATTACH, THE COLOR YELLOW APPEARING IN THE WORDING QUICK AND OVAL BORDER, THE COLOR BLACK APPEARING IN THE BACKGROUND OF THE OVAL, AND THE COLOR WHITE APPEARING IN THE WORDING ATTACHMENTS, INC.

SEC. 2(F).

FOR AGRICULTURAL MACHINERY AND ATTACHMENTS THEREFORE, NAMELY, ROTARY MOWERS, BOX SCRAPERS, AND THREE-POINT ATTACHMENTS; ATTACHMENTS FOR VEHICLES, NAMELY, GRAPPLE BUCKETS AND BLADES FOR MOVING EARTH AND LOOSE OBJECTS; POWER OPERATED BLOWERS; SNOW BLOWERS; SNOW PLOWS; SNOW THROWERS (U.S. CLS. 13, 19, 21, 23, 31, 34 AND 35).

FIRST USE 11-1-2002; IN COMMERCE 11-1-2002.

SOPHIA S. KIM, EXAMINING ATTORNEY

CLASS 7—(Continued).

SN 77-389,542. SAINTYU GROUP CO., LTD., TAICHUNG, TAIWAN, FILED 2-5-2008.

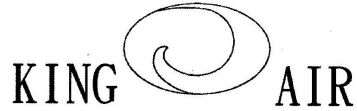

NO CLAIM IS MADE TO THE EXCLUSIVE RIGHT TO USE "AIR", APART FROM THE MARK AS SHOWN.

THE MARK CONSISTS OF WORDING "KING AIR" AND A STYLIZED OVAL.

FOR COMBINATION OIL/WATER SEPARATOR, OIL SEPARATOR, WATER SEPARATOR, CENTRIFUGAL SEPARATOR (U.S. CLS. 13, 19, 21, 23, 31, 34 AND 35).

FIRST USE 3-14-2006; IN COMMERCE 3-14-2006. CHARLES L. JENKINS, EXAMINING ATTORNEY

SN 77-406,555. RED DEVIL EQUIPMENT COMPANY, PLYMOUTH, MN. FILED 2-26-2008.

PROFIVE

THE MARK CONSISTS OF STANDARD CHARACTERS WITHOUT CLAIM TO ANY PARTICULAR FONT, STYLE, SIZE, OR COLOR.

FOR PORTABLE MIXING MACHINE FOR COATING MATERIALS (U.S. CLS. 13, 19, 21, 23, 31, 34 AND 35).

FIRST USE 1-31-2008; IN COMMERCE 1-31-2008.

SIMON TENG, EXAMINING ATTORNEY

SN 77-421,026. SONNY'S ENTERPRISES, INC., TAMARAC, FL. FILED 3-13-2008.

BANANA PEEL RAIL

THE MARK CONSISTS OF STANDARD CHARACTERS WITHOUT CLAIM TO ANY PARTICULAR FONT, STYLE, SIZE, OR COLOR.

NO CLAIM IS MADE TO THE EXCLUSIVE RIGHT TO USE "RAIL", APART FROM THE MARK AS SHOWN.

FOR CAR CONVEYOR FOR AN AUTOMATED CARWASH (U.S. CLS. 13, 19, 21, 23, 31, 34 AND 35).

KAREN SEVERSON, EXAMINING ATTORNEY

CLASS 7—(Continued).

SN 77-423,206. FOSHAN NANHAI DONGFANG CARTON MACHINERY CO., LTD., FOSHAN CITY, CHINA, FILED 3-16-2008.



THE MARK CONSISTS OF AN ITALICIZED AND CAPITALIZED LETTER "D" AND CAPITALIZED LETTERS "VMT.DF" POSITIONED BELOW THE ITALICIZED AND CAPITALIZED LETTER "D".

FOR WRAPPING MACHINES; TYPESETTING MACHINES; PHOTOTYPESETTING OR COMPOSING MACHINES; PACKAGING MACHINES; MACHINE PARTS, NAMELY, CYLINDERS; ELECTRIC PUMPS; SHEAF-BINDING MACHINES; PACKING MACHINES; EMBOSSEMENT MACHINES; MACHINE-OPERATED PLATFORMS FOR STORING PAPER IN PRINTING PRESSES DURING THE PRINTING PROCESS; PAPER BAG MAKING MACHINES; PAPER CALENDERING MACHINES; PAPER COATING MACHINES; PAPER CUTTING MACHINES; PAPER REELING MACHINES; PAPER SHREDDING MACHINES; PRESS FABRIC FOR PAPER MAKING MACHINES; SHREDDING MACHINES; FLEXOGRAPHIC PRINTING MACHINES; INKING APPARATUS FOR PRINTING BLOCKS; INTAGLIO PRINTING MACHINES; PHOTOGRAVURE PRINTING PRESSES; PLANOGRAPHIC PRINTING MACHINES; PRINTING MACHINES FOR COMMERCIAL OR INDUSTRIAL USE; PRINTING PLATES; PRINTING PRESSES; PRINTING PRESSES FOR CERAMIC MATERIAL; ROLLERS FOR ROTARY PRINTING MACHINES; DIE-CUTTING MACHINES; CORRUGATED PAPERBOARD MAKING MACHINES; POWER STAPLERS (U.S. CLS. 13, 19, 21, 23, 31, 34 AND 35).

PATRICIA EVANKO, EXAMINING ATTORNEY

SN 77-423,641. WESTERN SLOPE UTILITIES, INC., BRECKENRIDGE, CO. FILED 3-17-2008.

ROBOTAP

THE MARK CONSISTS OF STANDARD CHARACTERS WITHOUT CLAIM TO ANY PARTICULAR FONT, STYLE, SIZE, OR COLOR.

FOR AUTOMATED PIPELINE INSPECTION AND REPAIR DEVICE, NAMELY, PIPELINE PIGS THAT MARK OPENINGS AND MAKE OPENINGS IN PIPES (U.S. CLS. 13, 19, 21, 23, 31, 34 AND 35).

SIMON TENG, EXAMINING ATTORNEY

CLASS 7—(Continued).

SN 77-425,627. S.O.E. SYSTÈMES D'OPTIMISATION ÉNERGÉTIQUES TECHNOLOGIES INC., STE-JULIE, CANADA, FILED 3-18-2008.

varigen

THE MARK CONSISTS OF STANDARD CHARACTERS WITHOUT CLAIM TO ANY PARTICULAR FONT, STYLE, SIZE, OR COLOR.

FOR TRANSMISSIONS FOR MACHINES, NAMELY, TRANSMISSIONS FOR GENERATORS (U.S. CLS. 13, 19, 21, 23, 31, 34 AND 35).

MARCIE MILONE, EXAMINING ATTORNEY

SN 77-426,606. ELECTRONIC THEATRE CONTROLS, INC., MIDDLETON, WI. FILED 3-19-2008.

PRODIGY

THE MARK CONSISTS OF STANDARD CHARACTERS WITHOUT CLAIM TO ANY PARTICULAR FONT, STYLE, SIZE, OR COLOR.

FOR HOISTS FOR CONTROLLABLE LIFTING IN THEATERS, ARENAS, STAGES AND MANUFACTURING (U.S. CLS. 13, 19, 21, 23, 31, 34 AND 35).

GEORGIA CARTY, EXAMINING ATTORNEY

SN 77-429,215. PROCTER & GAMBLE COMPANY, THE, CINCINNATI, OH. FILED 3-24-2008.

FEBREZE

THE MARK CONSISTS OF STANDARD CHARACTERS WITHOUT CLAIM TO ANY PARTICULAR FONT, STYLE, SIZE, OR COLOR.

OWNER OF U.S. REG. NOS. 2,107,914, 3,152,106 AND OTHERS.

FOR VACUUM CLEANER BAGS, AND VACUUM CLEANER FILTERS (U.S. CLS. 13, 19, 21, 23, 31, 34 AND 35).

MARIA-VICTORIA SUAREZ, EXAMINING ATTORNEY

CLASS 7—(Continued).

SN 77-429,435. MIELE, INC, PRINCETON, NJ. FILED 3-24-2008.

EARTH

THE MARK CONSISTS OF STANDARD CHARACTERS WITHOUT CLAIM TO ANY PARTICULAR FONT, STYLE, SIZE, OR COLOR.
FOR VACUUM CLEANERS (U.S. CLS. 13, 19, 21, 23, 31, 34 AND 35).
PRISCILLA MILTON, EXAMINING ATTORNEY

SN 77-429,439. MIELE, INC, PRINCETON, NJ. FILED 3-24-2008.

CELEBRATION

THE MARK CONSISTS OF STANDARD CHARACTERS WITHOUT CLAIM TO ANY PARTICULAR FONT, STYLE, SIZE, OR COLOR.
FOR VACUUM CLEANERS (U.S. CLS. 13, 19, 21, 23, 31, 34 AND 35).
PRISCILLA MILTON, EXAMINING ATTORNEY

SN 77-429,442. MIELE, INC, PRINCETON, NJ. FILED 3-24-2008.

JUBILEE

THE MARK CONSISTS OF STANDARD CHARACTERS WITHOUT CLAIM TO ANY PARTICULAR FONT, STYLE, SIZE, OR COLOR.
FOR VACUUM CLEANERS (U.S. CLS. 13, 19, 21, 23, 31, 34 AND 35).
PRISCILLA MILTON, EXAMINING ATTORNEY

CLASS 7—(Continued).

SN 77-429,443. MIELE, INC, PRINCETON, NJ. FILED 3-24-2008.

PARK AVE

THE MARK CONSISTS OF STANDARD CHARACTERS WITHOUT CLAIM TO ANY PARTICULAR FONT, STYLE, SIZE, OR COLOR.
FOR VACUUM CLEANERS (U.S. CLS. 13, 19, 21, 23, 31, 34 AND 35).
PRISCILLA MILTON, EXAMINING ATTORNEY

SN 77-430,641. WIDGETEER, INC., OAKWOOD HILLS, IL. FILED 3-25-2008.



THE PHRASE "VAC IT" APPEARS IN THE CENTER OF AN HOUR-GLASS SHAPED BAG THAT IS APPROXIMATELY 2.5 TIMES WIDER THAN IT IS TALL. THE TOP OF THE BAG IS REPRESENTED BY AN ARROW THAT BEGINS AT THE TOP RIGHT CORNER OF THE BAG AND PROCEEDS TO THE TOP LEFT CORNER OF THE BAG WHERE IT OVERLAPS ITSELF AND CHANGES DIRECTION TO POINT TOWARDS THE BOTTOM-CENTER OF THE BAG.

FOR VACUUM PUMP FOR EXTRACTING AIR FROM A PLASTIC STORAGE BAG, OR GLASS STORAGE CONTAINER, OR PLASTIC STORAGE CONTAINER AND RESEALING THE BAG OR CONTAINER FOR DOMESTIC HOUSEHOLD USE (U.S. CLS. 13, 19, 21, 23, 31, 34 AND 35).
COLLEEN KEARNEY, EXAMINING ATTORNEY

SN 77-430,834. EASTMAN KODAK COMPANY, ROCHESTER, NY. FILED 3-25-2008.

GENERATION NEWS

THE MARK CONSISTS OF STANDARD CHARACTERS WITHOUT CLAIM TO ANY PARTICULAR FONT, STYLE, SIZE, OR COLOR.
FOR PLATESETTER FOR PRINTING PLATES FOR USE IN THE PRINTING INDUSTRY; PRINTING PLATES (U.S. CLS. 13, 19, 21, 23, 31, 34 AND 35).
BARBARA BROWN, EXAMINING ATTORNEY

CLASS 7—(Continued).

SN 77-430,897. WIDGETEER, INC., OAKWOOD HILLS, IL. FILED 3-25-2008.

FRESHNESS IN A SNAP

THE MARK CONSISTS OF STANDARD CHARACTERS WITHOUT CLAIM TO ANY PARTICULAR FONT, STYLE, SIZE, OR COLOR.

FOR VACUUM PUMP FOR EXTRACTING AIR FROM A PLASTIC STORAGE BAG, OR GLASS STORAGE CONTAINER, OR PLASTIC STORAGE CONTAINER AND RESEALING THE BAG OR CONTAINER FOR DOMESTIC HOUSEHOLD USE (U.S. CLS. 13, 19, 21, 23, 31, 34 AND 35).

COLLEEN KEARNEY, EXAMINING ATTORNEY

CLASS 7—(Continued).

SN 77-433,649. FUSCI, STEPHEN, OXNARD, CA. FILED 3-27-2008.

IFA SUPERSTOCK

THE MARK CONSISTS OF STANDARD CHARACTERS WITHOUT CLAIM TO ANY PARTICULAR FONT, STYLE, SIZE, OR COLOR.

FOR FILTERS, NAMELY, FUEL OIL AND AIR FILTERS FOR AUTOMOBILES AND TRUCKS (U.S. CLS. 13, 19, 21, 23, 31, 34 AND 35).

JILL PRATER, EXAMINING ATTORNEY

SN 77-433,434. ILLINOIS TOOL WORKS INC., GLENVIEW, IL. FILED 3-27-2008.



OWNER OF U.S. REG. NO. 1.633,722. THE MARK CONSISTS OF "TRANS TECH" AND CIRCLES IN GRID DESIGN.

FOR PRINTING MACHINES AND PARTS THEREOF, NAMELY, CONTROL MECHANISM, DRIVE MECHANISM, PRINTING PADS, PRINTING BLOCKS, PRINTING HEADS, FEED HOPPERS, SORTERS, ELECTRODES, PLATES, DOCTORS, BLADES, SPATULAS, MOLDERS, JIGS, INK PUMPS, INK POTS, STANDS, TABLES, SWITCHES, MOTORS, CONVEYORS, IONIZERS, DRIERS AND WASHERS (U.S. CLS. 13, 19, 21, 23, 31, 34 AND 35).

MELVIN AXILBUND, EXAMINING ATTORNEY

SN 77-433,679. SEIFERD, SCOTT D., WENTZVILLE, MO. FILED 3-27-2008.

EASY-STAY

THE MARK CONSISTS OF STANDARD CHARACTERS WITHOUT CLAIM TO ANY PARTICULAR FONT, STYLE, SIZE, OR COLOR.

FOR PNEUMATIC DOOR CLOSERS (U.S. CLS. 13, 19, 21, 23, 31, 34 AND 35).

ANDREA SAUNDERS, EXAMINING ATTORNEY

SN 77-433,535. GALBREATH INCORPORATED, WINAMAC, IN. FILED 3-27-2008.

SEAL PAK

THE MARK CONSISTS OF STANDARD CHARACTERS WITHOUT CLAIM TO ANY PARTICULAR FONT, STYLE, SIZE, OR COLOR.

FOR WASTE COMPACTORS (U.S. CLS. 13, 19, 21, 23, 31, 34 AND 35).

ANTHONY RINKER, EXAMINING ATTORNEY

SN 77-433,899. CENTRAL ILLINOIS MANUFACTURING COMPANY, BEMENT, IL. FILED 3-27-2008.

CIM-TEK

THE MARK CONSISTS OF STANDARD CHARACTERS WITHOUT CLAIM TO ANY PARTICULAR FONT, STYLE, SIZE, OR COLOR.

FOR FILTERS FOR REMOVING PARTICULATE CONTAMINANTS AND WATER FROM PETROLEUM BASED FLUIDS (U.S. CLS. 13, 19, 21, 23, 31, 34 AND 35).

FIRST USE 0-0-1995; IN COMMERCE 0-0-1995.

JASON TURNER, EXAMINING ATTORNEY

CLASS 7—(Continued).

SN 77-434,572. HEALTHY GAIN INVESTMENTS, LIMITED,
TORTOLA, BR.VIRGIN ISLANDS, FILED 3-28-2008.

LiNX

THE MARK CONSISTS OF STANDARD CHARACTERS
WITHOUT CLAIM TO ANY PARTICULAR FONT, STYLE,
SIZE, OR COLOR.

FOR VACUUM CLEANERS (U.S. CLS. 13, 19, 21, 23, 31,
34 AND 35).

ELLEN B. AWRICH, EXAMINING ATTORNEY

CLASS 7—(Continued).

SN 77-436,726. ILLINOIS TOOL WORKS INC., GLENVIEW,
IL. FILED 4-1-2008.

RINGMASTER

THE MARK CONSISTS OF STANDARD CHARACTERS
WITHOUT CLAIM TO ANY PARTICULAR FONT, STYLE,
SIZE, OR COLOR.

FOR MACHINES FOR USE IN AFFIXING CARRIERS
TO BEVERAGE CONTAINERS (U.S. CLS. 13, 19, 21, 23,
31, 34 AND 35).

MELVIN AXILBUND, EXAMINING ATTORNEY

SN 77-434,602. CP PACKAGING, INC., APPLETON, WI.
FILED 3-28-2008.

RAYMOND

THE MARK CONSISTS OF STANDARD CHARACTERS
WITHOUT CLAIM TO ANY PARTICULAR FONT, STYLE,
SIZE, OR COLOR.

FOR VACUUM PACKAGING MACHINES AND
EQUIPMENT THEREFOR, NAMELY, VACUUM SUPPLY
TANKS AND RESERVOIRS (U.S. CLS. 13, 19, 21, 23, 31,
34 AND 35).

JAMES LOVELACE, EXAMINING ATTORNEY

SN 77-437,548. MIELE, INC, PRINCETON, NJ. FILED 4-2-
2008.

Pure

THE MARK CONSISTS OF STANDARD CHARACTERS
WITHOUT CLAIM TO ANY PARTICULAR FONT, STYLE,
SIZE, OR COLOR.

FOR VACUUM CLEANERS (U.S. CLS. 13, 19, 21, 23, 31,
34 AND 35).

PRISCILLA MILTON, EXAMINING ATTORNEY

SN 77-434,886. MONOSEM, INC., LENEXA, KS. FILED 3-28-
2008.

MONOSHOX

THE MARK CONSISTS OF STANDARD CHARACTERS
WITHOUT CLAIM TO ANY PARTICULAR FONT, STYLE,
SIZE, OR COLOR.

FOR COMPONENT PART OF A SEED PLANTER,
NAMELY, LINKAGE AND A SHOCK ABSORBER FOR
INTERCONNECTING A PLANTING UNIT TO THE
TOOLBAR OF A PLANTER (U.S. CLS. 13, 19, 21, 23, 31,
34 AND 35).

FIRST USE 11-0-2007; IN COMMERCE 11-0-2007.

CORY BOONE, EXAMINING ATTORNEY

SN 77-440,433. CURTIS-TOLEDO, INC., ST. LOUIS, MO.
FILED 4-4-2008.

FSCURTIS

THE MARK CONSISTS OF STANDARD CHARACTERS
WITHOUT CLAIM TO ANY PARTICULAR FONT, STYLE,
SIZE, OR COLOR.

FOR COMPRESSORS AND COMPRESSED AIR TANKS
SOLD AS A UNIT; AIR COMPRESSORS; COMPRESSED
AIR TANKS; COMPRESSED AIR DRYING UNITS; AND,
BLADE TYPE CUT-OFF MACHINES; VACUUM PUMPS;
AIR VACUUM TANKS (U.S. CLS. 13, 19, 21, 23, 31, 34
AND 35).

MARY ROSSMAN, EXAMINING ATTORNEY

CLASS 7—(Continued).

SN 77-442,674. EMERSON ELECTRIC CO., ST. LOUIS, MO.
FILED 4-8-2008.

GRIND MORE. WASTE LESS.

THE MARK CONSISTS OF STANDARD CHARACTERS WITHOUT CLAIM TO ANY PARTICULAR FONT, STYLE, SIZE, OR COLOR.

FOR FOOD WASTE DISPOSERS; GARBAGE DISPOSALS (U.S. CLS. 13, 19, 21, 23, 31, 34 AND 35).
GINA FINK, EXAMINING ATTORNEY

CLASS 7—(Continued).

SN 77-464,891. EMERSON ELECTRIC CO., ST. LOUIS, MO.
FILED 5-2-2008.



THE MARK CONSISTS OF A SILHOUETTE OF A DOG'S HEAD WITH THE WORDS "DIRT HOUND" TO THE RIGHT OF THE HEAD.

FOR VACUUM CLEANERS AND REPLACEMENT PARTS THEREFOR; ACCESSORIES FOR VACUUM CLEANERS, NAMELY, BRUSHES, HOSES AND VACUUM CLEANER BAGS (U.S. CLS. 13, 19, 21, 23, 31, 34 AND 35).

FIRST USE 7-31-2007; IN COMMERCE 7-31-2007.
GINA FINK, EXAMINING ATTORNEY

SN 77-454,839. EMERSON ELECTRIC CO., ST. LOUIS, MO.
FILED 4-22-2008.

VariTough

THE MARK CONSISTS OF STANDARD CHARACTERS WITHOUT CLAIM TO ANY PARTICULAR FONT, STYLE, SIZE, OR COLOR.

FOR ELECTRIC MOTORS FOR MACHINES (U.S. CLS. 13, 19, 21, 23, 31, 34 AND 35).
GINA FINK, EXAMINING ATTORNEY

SN 77-469,880. CENTRAL ILLINOIS MANUFACTURING COMPANY, BEMENT, IL. FILED 5-8-2008.

HYDROSORB

THE MARK CONSISTS OF THE STYLIZED TERM "HYDROSORB" WITH THREE WAVY LINES UNDERNEATH.

FOR FUEL PUMP FILTERS THAT REMOVE AND DETECT WATER IN PETROLEUM FUELS AND BIO-FUELS (U.S. CLS. 13, 19, 21, 23, 31, 34 AND 35).

FIRST USE 0-0-2005; IN COMMERCE 0-0-2005.
JASON TURNER, EXAMINING ATTORNEY

SN 77-463,345. M-I L.L.C., HOUSTON, TX. FILED 5-1-2008.

MEERKAT

THE MARK CONSISTS OF STANDARD CHARACTERS WITHOUT CLAIM TO ANY PARTICULAR FONT, STYLE, SIZE, OR COLOR.

FOR VIBRATORY SCREEN SEPARATORS (U.S. CLS. 13, 19, 21, 23, 31, 34 AND 35).
FIRST USE 1-1-2008; IN COMMERCE 1-1-2008.
CORY BOONE, EXAMINING ATTORNEY

SN 77-474,195. GRANITE CITY TOOL COMPANY, WAITE PARK, MN. FILED 5-14-2008.

DURA-PLUS

THE MARK CONSISTS OF STANDARD CHARACTERS WITHOUT CLAIM TO ANY PARTICULAR FONT, STYLE, SIZE, OR COLOR.

FOR ABRASIVE DISKS FOR POWER-OPERATED GRINDERS; POWER TOOLS, NAMELY, GRINDING PADS AND POLISHING PADS FOR POWER TOOLS (U.S. CLS. 13, 19, 21, 23, 31, 34 AND 35).

FIRST USE 4-30-2007; IN COMMERCE 4-30-2007.
JENNIFER DIXON, EXAMINING ATTORNEY

CLASS 7—(Continued).

SN 77-474,366. GRANITE CITY TOOL COMPANY, WAITE PARK, MN. FILED 5-14-2008.

DX PLUS

THE MARK CONSISTS OF STANDARD CHARACTERS WITHOUT CLAIM TO ANY PARTICULAR FONT, STYLE, SIZE, OR COLOR.

FOR ABRASIVE DISKS FOR POWER-OPERATED GRINDERS; POWER TOOLS, NAMELY, GRINDING PADS, POLISHING PADS, AND DIAMOND BLADES FOR POWER TOOLS; POWER SAW BLADES; CORE DRILLING BITS (U.S. CLS. 13, 19, 21, 23, 31, 34 AND 35).
JENNIFER DIXON, EXAMINING ATTORNEY

SN 78-958,726. CURRENT TO CURRENT CORP., BURLINGTON, MA. FILED 8-23-2006.

CURRENT TO CURRENT

THE MARK CONSISTS OF STANDARD CHARACTERS WITHOUT CLAIM TO ANY PARTICULAR FONT, STYLE, SIZE, OR COLOR.

NO CLAIM IS MADE TO THE EXCLUSIVE RIGHT TO USE "CURRENT", APART FROM THE MARK AS SHOWN.

FOR OCEAN AND WATER CURRENT POWERED ELECTRICITY GENERATORS AND PARTS THEREFOR (U.S. CLS. 13, 19, 21, 23, 31, 34 AND 35).

JULIE WATSON, EXAMINING ATTORNEY

SN 79-006,678. AIXTRON AG, FED REP GERMANY, FILED 8-9-2004.

TriLynx

THE MARK CONSISTS OF STANDARD CHARACTERS WITHOUT CLAIM TO ANY PARTICULAR FONT, STYLE, SIZE, OR COLOR.

PRIORITY DATE OF 6-28-2004 IS CLAIMED.

OWNER OF INTERNATIONAL REGISTRATION 0837033 DATED 8-9-2004, EXPIRES 8-9-2014.

FOR MACHINES FOR MANUFACTURING SEMICONDUCTORS AND STRUCTURAL PARTS THEREFOR (U.S. CLS. 13, 19, 21, 23, 31, 34 AND 35).

LEIGH LOWRY, EXAMINING ATTORNEY

CLASS 7—(Continued).

SN 79-038,689. CANON KABUSHIKI KAISHA, JAPAN, FILED 5-10-2007.

k1 Tune

PRIORITY DATE OF 2-8-2007 IS CLAIMED.
OWNER OF INTERNATIONAL REGISTRATION 0924747 DATED 5-10-2007, EXPIRES 5-10-2017.

NO CLAIM IS MADE TO THE EXCLUSIVE RIGHT TO USE "K1", APART FROM THE MARK AS SHOWN.

FOR SEMICONDUCTOR MANUFACTURING MACHINES (U.S. CLS. 13, 19, 21, 23, 31, 34 AND 35).

GILBERT SWIFT, EXAMINING ATTORNEY

SN 79-042,267. ESM ENNEPETALER SCHNEID- UND MÄHTECHNIK GMBH & CO. KG, FED REP GERMANY, FILED 8-14-2007.

ESM

THE MARK CONSISTS OF STANDARD CHARACTERS WITHOUT CLAIM TO ANY PARTICULAR FONT, STYLE, SIZE, OR COLOR.

OWNER OF INTERNATIONAL REGISTRATION 0933640 DATED 8-14-2007, EXPIRES 8-14-2017.

FOR AGRICULTURAL MACHINES, NAMELY, MOWING MACHINES, MOWERS AND CUTTER BARS FOR CUTTING VEGETATION, PLANTS AND FODDER; PARTS OF SAID AGRICULTURAL MACHINES, NAMELY, KNIVES, BLADES, MOWING FINGER BARS, AND BLADE HOLDERS (U.S. CLS. 13, 19, 21, 23, 31, 34 AND 35).

DEBRA LEE, EXAMINING ATTORNEY

SN 79-044,261. QINGDAO CAPITAL RESOURCE; ELECTRIC CO., LTD., CHINA, FILED 9-21-2007.

Woodfast

OWNER OF INTERNATIONAL REGISTRATION 0938592 DATED 9-21-2007, EXPIRES 9-21-2017.

FOR WOODWORKING MACHINES, NAMELY, WOOD DRILLING MACHINES, WOOD GRINDING MACHINES, WOOD MILLING MACHINES, WOOD PLANING MACHINES, WOOD SAWING MACHINES, WOOD CHIPPING MACHINES, WOOD BEATING MACHINES, WOOD LATHE (U.S. CLS. 13, 19, 21, 23, 31, 34 AND 35).

MONIQUE MILLER, EXAMINING ATTORNEY

CLASS 7—(Continued).

SN 79-046,092. SAMSUNG ELECTRONICS CO., LTD., REPUBLIC OF KOREA, FILED 10-4-2007.

CORE JET

THE MARK CONSISTS OF STANDARD CHARACTERS WITHOUT CLAIM TO ANY PARTICULAR FONT, STYLE, SIZE, OR COLOR.

PRIORITY DATE OF 10-2-2007 IS CLAIMED.

OWNER OF INTERNATIONAL REGISTRATION 0943173 DATED 10-4-2007, EXPIRES 10-4-2017.

NO CLAIM IS MADE TO THE EXCLUSIVE RIGHT TO USE "JET", APART FROM THE MARK AS SHOWN.

FOR ELECTRIC MIXERS FOR HOUSEHOLD PURPOSES; ELECTRIC FOOD GRINDERS FOR HOUSEHOLD PURPOSES; ELECTRIC FOOD BLENDERS FOR HOUSEHOLD PURPOSES; DISHWASHING MACHINES FOR HOUSEHOLD PURPOSES; WASHING MACHINES FOR HOUSEHOLD PURPOSES; VACUUM CLEANERS; VACUUM CLEANER BAGS (U.S. CLS. 13, 19, 21, 23, 31, 34 AND 35).

NAPOLEON SHARMA, EXAMINING ATTORNEY

SN 79-047,034. AKYAPAK MAKINA SANAYI VE TICARET; LIMITED SIRKETI, TURKEY, FILED 9-14-2007.

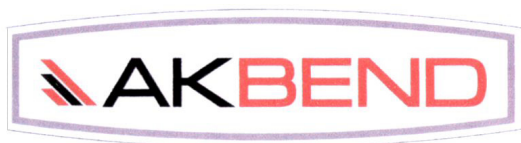

OWNER OF INTERNATIONAL REGISTRATION 0945575 DATED 9-14-2007, EXPIRES 9-14-2017.

THE COLOR(S) BLACK, RED, WHITE, AND PURPLE IS/ARE CLAIMED AS A FEATURE OF THE MARK.

THE MARK CONSISTS OF THE WORDING "AKBEND", WITH "AK" APPEARING IN BLACK, AND "BEND" APPEARING RED. TO THE LEFT OF THE WORDING IS A DESIGN ELEMENT OF THREE PARALLEL BARS EXTENDING ON A DIAGONAL ANGLE, GETTING LONGER FROM LEFT TO RIGHT. THE FIRST AND THIRD BAR ARE RED, AND THE MIDDLE ONE IS BLACK. A PURPLE RECTANGULAR SHAPE WITH CURVED TOP AND BOTTOM LINES APPEARS AROUND THE WORDING AND THE BARS, AND A SECOND THINNER PURPLE LINE OF THE SAME SHAPE SURROUNDS THE ENTIRE MARK. THE MARK IS ON A WHITE BACKGROUND.

FOR METALWORKING MACHINE TOOLS FOR CUTTING, PUNCHING, CROPPING, BENDING, ROLLING AND SHAPING METALS, NAMELY, MECHANICAL PRESSES, BENDING MACHINES, PNEUMATIC CONTROLS FOR MACHINES, ENGINES AND MOTORS, PLASMA ETCHING MACHINES, MACHINES FOR MANUFACTURING METAL STRIPS, NAMELY, CONTINUOUS METAL CASTING MACHINES, METAL SAWING MACHINES, METAL CUTTING MACHINES, METAL WELDING MACHINES, NAMELY, ELECTRIC ARC WELDING MACHINES, GAS WELDING MACHINES, LASER WELDING MACHINES, LATHES BEING MACHINE TOOLS, MACHINE PARTS FOR METALWORKING MACHINES (U.S. CLS. 13, 19, 21, 23, 31, 34 AND 35).

LYDIA BELZER, EXAMINING ATTORNEY

CLASS 7—(Continued).

SN 79-049,000. L'AIR LIQUIDE, SOCIÉTÉ ANONYME; POUR L'ETUDE ET L'EXPLOITATION DES; PROCÉDÉS GEORGES CLAUDE, FRANCE, FILED 7-30-2007.

OXYFLAM

THE MARK CONSISTS OF STANDARD CHARACTERS WITHOUT CLAIM TO ANY PARTICULAR FONT, STYLE, SIZE, OR COLOR.

OWNER OF INTERNATIONAL REGISTRATION 0950869 DATED 7-30-2007, EXPIRES 7-30-2017.

FOR NON-ELECTRIC WELDING SETS, NAMELY, GAS OPERATED WELDING MACHINES (U.S. CLS. 13, 19, 21, 23, 31, 34 AND 35).

DOMINIC FATHY, EXAMINING ATTORNEY

SN 79-050,434. WEIR MINERALS NETHERLANDS B.V., NETHERLANDS, FILED 1-15-2008.

GEHO

THE MARK CONSISTS OF STANDARD CHARACTERS WITHOUT CLAIM TO ANY PARTICULAR FONT, STYLE, SIZE, OR COLOR.

OWNER OF INTERNATIONAL REGISTRATION 0905347 DATED 7-12-2006, EXPIRES 7-12-2016.

OWNER OF U.S. REG. NOS. 2,906,227 AND 2,916,027. SEC. 2(F).

FOR SELF-PRIMING CONTRACTORS' CENTRIFUGAL PUMPS, PISTON PUMPS AND PISTON DIAPHRAGM PUMPS FOR MINERALS, ORES AND SEWAGE/WASTE WATER PUMPING (U.S. CLS. 13, 19, 21, 23, 31, 34 AND 35).

KAREN BRACEY, EXAMINING ATTORNEY

SN 79-050,934. CHAO WANG, CHINA, FILED 1-23-2008.

JUSTMARK

OWNER OF INTERNATIONAL REGISTRATION 0956276 DATED 1-23-2008, EXPIRES 1-23-2018.

FOR LUBRICATING PUMPS; HYDRAULIC PUMPS; VALVES BEING PARTS OF MACHINES; HYDRAULIC CONTROLS FOR MACHINES, MOTORS AND ENGINES; PNEUMATIC CONTROLS FOR MACHINES, MOTORS AND ENGINES; HYDRAULIC VALVES; PRESSURE REGULATING VALVES BEING PARTS OF MACHINES; HYDRAULIC COMPONENTS OTHER THAN FOR VEHICLE HYDRAULIC SYSTEMS, NAMELY, HYDRAULIC PUMPS AND HYDRAULIC VALVE ACTUATORS; HYDRAULIC FILTERS FOR USE IN MOTORS AND ENGINES, FOR USE IN LAND VEHICLES, AND FOR USE IN INDUSTRIAL MACHINES; PNEUMATIC COMPONENTS, NAMELY, PNEUMATIC PUMPS, PNEUMATIC VALVES FOR FLUID CONTROL (U.S. CLS. 13, 19, 21, 23, 31, 34 AND 35).

ESTHER BELENKER, EXAMINING ATTORNEY

CLASS 7—(Continued).

SN 79-052,132. SCREENEX PTY LTD, AUSTRALIA, FILED 2-15-2008.

SCREENEX

THE MARK CONSISTS OF STANDARD CHARACTERS WITHOUT CLAIM TO ANY PARTICULAR FONT, STYLE, SIZE, OR COLOR.

OWNER OF INTERNATIONAL REGISTRATION 0959397 DATED 2-15-2008, EXPIRES 2-15-2018.

FOR REPLACEABLE MODULAR SCREENING SYSTEM CONSISTING OF MODULAR SCREENING PANELS AND FRAMES AND PARTS THEREFOR, USED IN PARTICLE SEPARATION MACHINERY FOR THE MINING AND QUARRYING INDUSTRY (U.S. CLS. 13, 19, 21, 23, 31, 34 AND 35).

SARA THOMAS, EXAMINING ATTORNEY

CLASS 8—HAND TOOLS

SN 77-052,416. GENERAL TOOLS MFG. CO., LLC, NEW YORK, NY. FILED 11-28-2006.

GENERAL TOOLS & INSTRUMENTS

THE MARK CONSISTS OF STANDARD CHARACTERS WITHOUT CLAIM TO ANY PARTICULAR FONT, STYLE, SIZE, OR COLOR.

OWNER OF U.S. REG. NOS. 1,653,464, 2,170,638 AND OTHERS.

NO CLAIM IS MADE TO THE EXCLUSIVE RIGHT TO USE "TOOLS & INSTRUMENTS", APART FROM THE MARK AS SHOWN.

FOR HAND-OPERATED HAND-HELD TOOLS, NAMELY, PUNCHES, CUTTING TOOLS, TUBE CUTTERS, HAMMERS, SCREWDRIVERS, WRENCHES, HAND-OPERATED CIRCLE CUTTERS BEING TOOLS USED TO MAKE CIRCLE-SHAPED CUTS IN MATERIALS, CLAMPS AND POCKET JIGS BEING DRILLS TO MAKE POCKET HOLES; HAND-OPERATED RETRIEVING TOOLS BEING TELESCOPING, PRONGED AND MAGNETIZED RESCUE TOOLS; HAND FILES BEING HAND TOOLS; SCRIBERS BEING HAND TOOLS TO SCRIBE AND ETCH SURFACES; METAL VISES, TWEEZERS, GROMMET TOOLS BEING HAND TOOLS TO REPAIR OR ADD GROMMETS; TUBE BENDERS BEING HAND TOOLS; TAPS BEING HAND TOOLS, TAP WRENCHES BEING HAND TOOLS, REAMERS BEING HAND TOOLS, PLIERS AND UTILITY KNIVES (U.S. CLS. 23, 28 AND 44).

RUDY R. SINGLETON, EXAMINING ATTORNEY

SN 77-197,316. MENARD, INC., EAU CLAIRE, WI. FILED 6-4-2007.

SN 79-052,607. PLUMETTAZ S.A., CH-1880 BEX, SWITZERLAND, FILED 3-20-2008.

ULTIMAZ

THE MARK CONSISTS OF STANDARD CHARACTERS WITHOUT CLAIM TO ANY PARTICULAR FONT, STYLE, SIZE, OR COLOR.

PRIORITY DATE OF 11-8-2007 IS CLAIMED. OWNER OF INTERNATIONAL REGISTRATION 0960861 DATED 3-20-2008, EXPIRES 3-20-2018.

FOR MACHINES FOR INSTALLING, LAYING AND REPLACING CABLES OR OTHER SMALL DIAMETER LONGILINEAL ITEMS (U.S. CLS. 13, 19, 21, 23, 31, 34 AND 35).

CURTIS FRENCH, EXAMINING ATTORNEY



THE COLOR(S) BLACK, GREEN, WHITE AND RED IS/ ARE CLAIMED AS A FEATURE OF THE MARK.

THE MARK CONSISTS OF THE WORD "MASTER" IN BLACK, THE WORD "FORCE" IN THE COLOR GREEN, WITH A RED STAR BETWEEN THE WORDS "MASTER" AND "FORCE". THE MARK IS OUTLINED IN BLACK WITH WHITE SHADING.

FOR HAND OPERATED LAWN AND GARDEN TOOLS, NAMELY, HOES, SPADES, AERATORS, EDGERS, ICE CHOPPERS, CHISELS, WEEDERS, RAKES CULTIVATORS, TILLERS, PRUNERS, SAWS, POLE PRUNERS AND SAWS, TRANSPLANTERS, SHEARS, FRUIT PICKERS, TROWELS, GRASS WHIPS, TILLERS; LONG HANDLED ROUND POINT SHOVELS WITH FIBERGLASS HANDLES, LONG HANDLED ROUND POINT SHOVELS WITH WOOD HANDLES, D-HANDLE ROUND POINT SHOVELS WITH WOOD HANDLES, D-HANDLE SPADE POINT SHOVELS WITH WOOD HANDLES, SPECIALTY SHOVELS IN THE NATURE OF LONG HANDLE TRENCHERS WITH WOOD HANDLES, POST HOLE DIGGERS WITH FIBERGLASS HANDLES, FORKS WITH 5-TINES AND FIBERGLASS HANDLES, AND SOD LIFTERS WITH WOOD HANDLES (U.S. CLS. 23, 28 AND 44).

FIRST USE 4-0-2007; IN COMMERCE 4-0-2007.

KATHERINE CONNOLLY, EXAMINING ATTORNEY

CLASS 8—(Continued).

SN 77-282,069. JORDAN DREW CORPORATION, TARRY-TOWN, NY. FILED 9-18-2007.

HOME SMART SAMURAI SHARK

THE MARK CONSISTS OF STANDARD CHARACTERS WITHOUT CLAIM TO ANY PARTICULAR FONT, STYLE, SIZE, OR COLOR.

FOR HAND-HELD TOOL FOR SHARPENING BLADES, SCISSORS, AND KNIVES (U.S. CLS. 23, 28 AND 44).

KELLY BOULTON, EXAMINING ATTORNEY

SN 77-283,176. WKI HOLDING COMPANY, INC., RESTON, VA. FILED 9-19-2007.

LEGACY FORGED BY CHICAGO
CUTLERY

THE MARK CONSISTS OF STANDARD CHARACTERS WITHOUT CLAIM TO ANY PARTICULAR FONT, STYLE, SIZE, OR COLOR.

OWNER OF U.S. REG. NOS. 2,246,570, 2,919,461 AND OTHERS.

NO CLAIM IS MADE TO THE EXCLUSIVE RIGHT TO USE "FORGED" AND "CHICAGO" AND "CUTLERY", APART FROM THE MARK AS SHOWN.

FOR KITCHEN CUTLERY AND ACCESSORIES THEREFOR, NAMELY, PARING KNIVES FOR USE IN PEELING FOOD, STEAK KNIVES, UTILITY KNIVES, CHEF KNIVES, BREAD KNIVES, CARVING KNIVES FOR USE IN SLICING THIN CUTS OF MEAT, CLEAVERS, FORKS AND SHARPENING STEELS (U.S. CLS. 23, 28 AND 44).

MATTHEW MCDOWELL, EXAMINING ATTORNEY

SN 77-286,014. THE ONTARIO KNIFE COMPANY, FRANKLINVILLE, NY. FILED 9-21-2007.

OLD RELIABLE

THE MARK CONSISTS OF STANDARD CHARACTERS WITHOUT CLAIM TO ANY PARTICULAR FONT, STYLE, SIZE, OR COLOR.

FOR CUTLERY, NAMELY, KNIVES (U.S. CLS. 23, 28 AND 44).

JORDAN BAKER, EXAMINING ATTORNEY

CLASS 8—(Continued).

SN 77-286,524. DEVINE ENTERPRISES INT'L, INC., SARASOTA, FL. FILED 9-22-2007.



THE MARK CONSISTS OF THE WORDING "HANDY BAND WHEN YOU NEED A THIRD HAND!" WITH A HALF-OVAL DESIGN ELEMENT OVER THE WORDING. FOR TOOL HOLDERS (U.S. CLS. 23, 28 AND 44).

TEJBIR SINGH, EXAMINING ATTORNEY

SN 77-286,528. DEVINE ENTERPRISES INT'L, INC., SARASOTA, FL. FILED 9-22-2007.



THE MARK CONSISTS OF THE WORDING "HANDY MAT" WITH A HALF-OVAL DESIGN ELEMENT OVER THE WORDING.

FOR TOOL HOLDERS (U.S. CLS. 23, 28 AND 44).
TEJBIR SINGH, EXAMINING ATTORNEY

SN 77-289,075. C.A.S. IBERIA, INC., SALE CREEK, TN. FILED 9-26-2007.



THE MARK CONSISTS OF A RUNNING HORSE. FOR KNIVES, NAMELY, FIXED-BLADE BOWIE KNIVES (U.S. CLS. 23, 28 AND 44). FIRST USE 9-24-2007; IN COMMERCE 9-24-2007.

MONIQUE MILLER, EXAMINING ATTORNEY

CLASS 8—(Continued).

SN 77-298,639. ROMAR/MEC LLC, HOUSTON, TX. FILED 10-8-2007.

fitupgear

THE MARK CONSISTS OF STANDARD CHARACTERS WITHOUT CLAIM TO ANY PARTICULAR FONT, STYLE, SIZE, OR COLOR.

FOR HAND TOOLS, NAMELY, CLAMPS, KEY PLATES, 90 DEGREE KEY PLATES, HINGED KEY PLATES, BULL PINS, U-BARS, CROWBARS, GOOSE-NECK STYLE CROWBARS, CONNECTING BARS, F-CLAMPS, KEY SHIMS, AND SHIM PINS, FOR STEEL PLATE AND SHEETMETAL ALIGNMENT; MANUALLY OPERATED HAND TOOLS, NAMELY, CLAMPS, KEY PLATES, 90 DEGREE KEY PLATES, HINGED KEY PLATES, BULL PINS, U-BARS, CROWBARS, GOOSE-NECK STYLE CROWBARS, CONNECTING BARS, F-CLAMPS, KEY SHIMS, AND SHIM PINS, FOR STEEL PLATE AND SHEETMETAL ALIGNMENT (U.S. CLS. 23, 28 AND 44).

FIRST USE 9-1-2002; IN COMMERCE 9-1-2002.
LAURIE KAUFMAN, EXAMINING ATTORNEY

SN 77-338,807. SEKERICH, MICHAEL EDWARD, SPRING VALLEY, NY. FILED 11-28-2007.

Sta Sharp

THE MARK CONSISTS OF STANDARD CHARACTERS WITHOUT CLAIM TO ANY PARTICULAR FONT, STYLE, SIZE, OR COLOR.

NO CLAIM IS MADE TO THE EXCLUSIVE RIGHT TO USE "SHARP", APART FROM THE MARK AS SHOWN.

FOR DISPOSABLE RAZORS; NON-ELECTRIC RAZORS; RAZOR BLADES; RAZORS; RAZORS AND RAZOR BLADES; SAFETY RAZORS (U.S. CLS. 23, 28 AND 44).

CHARLOTTE CORWIN, EXAMINING ATTORNEY

SN 77-392,380. HEARTLAND AG PRODUCTS, WATER-TOWN, SD. FILED 2-8-2008.

SUPER-SORT

THE MARK CONSISTS OF STANDARD CHARACTERS WITHOUT CLAIM TO ANY PARTICULAR FONT, STYLE, SIZE, OR COLOR.

FOR LIVESTOCK HERD MANAGING DEVICES, NAMELY, AGRICULTURAL HAND TOOLS IN THE NATURE OF LIVESTOCK HERDING PADDLES INTENDED FOR RANCHERS TO CONTROL THE MOVEMENT OF LIVESTOCK (U.S. CLS. 23, 28 AND 44).

FIRST USE 1-1-2008; IN COMMERCE 1-1-2008.
MARY MUNSON, EXAMINING ATTORNEY

CLASS 8—(Continued).

SN 77-400,811. DEMOLITION TOOLS, INC., CARSON CITY, NV. FILED 2-19-2008.



NO CLAIM IS MADE TO THE EXCLUSIVE RIGHT TO USE "DEMOLITION TOOLS", APART FROM THE MARK AS SHOWN.

THE COLOR(S) BLACK, WHITE, GRAY, SILVER, RED, ORANGE, AND YELLOW ARE IS/ARE CLAIMED AS A FEATURE OF THE MARK.

THE MARK CONSISTS OF THE WORDING "DEMOLITION TOOLS" IN BLACK WITH A RED OUTLINE. A WRECKING BALL IN RED WITH A GRAY AND SILVER CHAIN COMPRISES THE FIRST LETTER "O" IN "DEMOLITION" AND COLLIDES WITH THE LETTER "M". THE WRECKING BALL AND THE LETTER "M" HAS A WHITE FLASH BETWEEN THEM, AND WHITE CRACKS ARE IN THE LETTER "M". RED, ORANGE AND YELLOW FLAMES COME FROM THE WRECKING BALL WHICH FLOW THROUGH THE LETTERS "L", "I", "T", "I", "O", "N", "T", "O", "O", "L", "S".

FOR HAND TOOLS, NAMELY, HAMMERS (U.S. CLS. 23, 28 AND 44).

FIRST USE 9-1-2007; IN COMMERCE 1-2-2008.
TOBY BULLOFF, EXAMINING ATTORNEY

SN 77-413,604. MAYHEW STEEL PRODUCTS, INC, TURNERS FALLS, MA. FILED 3-5-2008.

Dominator

THE MARK CONSISTS OF STANDARD CHARACTERS WITHOUT CLAIM TO ANY PARTICULAR FONT, STYLE, SIZE, OR COLOR.

FOR EXTENSION BARS FOR HAND TOOLS; HAND TOOLS, NAMELY, RIPPING BARS; EXTENSIONS FOR HAND TOOLS; HAND TOOLS, NAMELY, ADZES; HAND TOOLS, NAMELY, AWLS; HAND TOOLS, NAMELY, NAIL SETS; HAND TOOLS, NAMELY, NUT DRIVERS; HAND TOOLS, NAMELY, PICKS; HAND TOOLS, NAMELY, PUNCHES; HAND TOOLS, NAMELY, SCRAPERS; HAND TOOLS, NAMELY, SCREWDRIVERS; HAND-OPERATED CUTTING TOOLS; HAND-OPERATED TOOLS, NAMELY, CHISELS; MANUALLY OPERATED TOOLS, NAMELY, SHEET BENDING BRAKES AND COMPONENTS THEREOF (U.S. CLS. 23, 28 AND 44).

FIRST USE 1-1-2000; IN COMMERCE 1-1-2000.
TASHIA BUNCH, EXAMINING ATTORNEY

CLASS 8—(Continued).

SN 77-416,730. NOAH WHEELER, ISSAQUAH, WA. FILED 3-7-2008.

HANG GUN

THE MARK CONSISTS OF STANDARD CHARACTERS WITHOUT CLAIM TO ANY PARTICULAR FONT, STYLE, SIZE, OR COLOR.

NO CLAIM IS MADE TO THE EXCLUSIVE RIGHT TO USE "GUN", APART FROM THE MARK AS SHOWN.

FOR HAND-OPERATED TOOL, NAMELY, PORTABLE, BODY MOUNTED GREASING TOOL (U.S. CLS. 23, 28 AND 44).

JENNY PARK, EXAMINING ATTORNEY

SN 77-421,221. US EDGEWORKS, DBA WASHI SCISSOR COMPANY, TEQUESTA, FL. FILED 3-13-2008.



NO CLAIM IS MADE TO THE EXCLUSIVE RIGHT TO USE "SCISSOR COMPANY", APART FROM THE MARK AS SHOWN.

THE COLOR(S) RED, ORANGE, YELLOW, GREEN, BLUE, PURPLE AND BLACK IS/ARE CLAIMED AS A FEATURE OF THE MARK.

THE MARK CONSISTS OF THE WORDS "WASHI SCISSOR COMPANY" AND TWO JAPANESE KANJI CHARACTERS. THE COLOR APPEAR IN THE JAPANESE KANJI CHARACTERS AND THE WORD "WASHI" AND A REPEAT OF THE CHARACTER, FADING, IN ORDER, FROM RED INTO ORANGE, YELLOW, GREEN, BLUE AND PURPLE, AND IS OUTLINED IN BLACK. THE WORDS "SCISSOR COMPANY" APPEAR IN BLACK UNDERNEATH THE WORD "WASHI" AND A KANJI CHARACTER.

THE NON-LATIN CHARACTERS IN THE MARK TRANSLITERATE TO "WASHI", AND THIS MEANS "EAGLE" IN ENGLISH.

FOR HAIR CUTTING SCISSORS (U.S. CLS. 23, 28 AND 44).

FIRST USE 4-1-1999; IN COMMERCE 1-1-2000.
EUGENIA MARTIN, EXAMINING ATTORNEY

SN 77-425,454. OMS INVESTMENTS, INC., LOS ANGELES, CA. FILED 3-18-2008.

RAPID FEED

THE MARK CONSISTS OF STANDARD CHARACTERS WITHOUT CLAIM TO ANY PARTICULAR FONT, STYLE, SIZE, OR COLOR.

FOR HAND TOOLS, NAMELY, HOSE-END TRIGGER SPRAYERS FOR SPRAYING LIQUID INSECTICIDES, FUNGICIDES, WEED KILLERS AND FERTILIZERS (U.S. CLS. 23, 28 AND 44).

RONALD AIKENS, EXAMINING ATTORNEY

CLASS 8—(Continued).

SN 77-428,447. B SAFE INDUSTRIES, CUMBERLAND, RI. FILED 3-21-2008.



NO CLAIM IS MADE TO THE EXCLUSIVE RIGHT TO USE "INDUSTRIES", APART FROM THE MARK AS SHOWN.

THE COLOR(S) BLACK, WHITE AND YELLOW IS/ARE CLAIMED AS A FEATURE OF THE MARK.

THE MARK CONSISTS OF BLACK SHIELD TRIMMED IN WHITE WITH A BLACK OUTLINE, CONTAINED IN THE SHIELD IS THE CAPITAL LETTER "B" IN WHITE AND TWO YELLOW CHEVRONS, TO THE RIGHT OF THE SHIELD ARE THE THE WORDS IN CAPITAL LETTERS "SAFE" IN BLACK, UNDER "SAFE" IS THE WORD IN BLACK CAPITALS "INDUSTRIES".

FOR HAND TOOLS, MANUALLY OPERATED TOOLS AND FORCIBLE ENTRY TOOLS, NAMELY, BATTERING RAMS, HALLAGAN TOOLS IN THE NATURE OF HAND TOOLS WITH A CURVED WEDGE-LIKE BLADE AND A POINTED SPIKE AT ONE END OF THE TOOL WITH A CLAW AT THE OTHER END OF THE TOOL TO BE USED FOR DIGGING OR MOVING COMPOSITE MATERIALS OR PIERCING, BENDING, PRYING OR CUTTING HARD SURFACED MATERIALS, BOLT CUTTERS, SLEDGE HAMMERS, HAMMERS, PICKS, RAKES, WEDGES (U.S. CLS. 23, 28 AND 44).

JAMES STEIN, EXAMINING ATTORNEY

SN 77-431,636. BARENTHAL NORTH AMERICA, INC., RUTHERFORD, NJ. FILED 3-26-2008.

GOURMET SELECT

THE MARK CONSISTS OF STANDARD CHARACTERS WITHOUT CLAIM TO ANY PARTICULAR FONT, STYLE, SIZE, OR COLOR.

NO CLAIM IS MADE TO THE EXCLUSIVE RIGHT TO USE "SELECT", APART FROM THE MARK AS SHOWN.

FOR CUTLERY AND FLATWARE (U.S. CLS. 23, 28 AND 44).

KARANENDRA S. CHHINA, EXAMINING ATTORNEY

CLASS 8—(Continued).

SN 77-434,826. LEATHERMAN TOOL GROUP, INC., PORTLAND, OR. FILED 3-28-2008.

CLASS 8—(Continued).

SN 78-578,373. HEB GROCERY COMPANY, L.P., SAN ANTONIO, TX. FILED 3-2-2005.

CRATER

THE MARK CONSISTS OF STANDARD CHARACTERS WITHOUT CLAIM TO ANY PARTICULAR FONT, STYLE, SIZE, OR COLOR.

FOR KNIVES, NAMELY, FOLDING KNIVES, SPORT KNIVES, HUNTING KNIVES, CAMPING KNIVES AND MULTI-FUNCTION KNIVES INCLUDING ONE OR MORE OF THE FOLLOWING TOOLS, FLAT SCREWDRIVER, PHILIPS SCREWDRIVER, CAN OPENER, BOTTLE OPENER, BIT DRIVER, INTERCHANGEABLE SCREWDRIVER BITS, AND CARABINER (U.S. CLS. 23, 28 AND 44).

MARK SPARACINO, EXAMINING ATTORNEY

**H-E-B TEXAS
BACKYARD**

SN 77-434,852. LEATHERMAN TOOL GROUP, INC., PORTLAND, OR. FILED 3-28-2008.

EXPANSE

THE MARK CONSISTS OF STANDARD CHARACTERS WITHOUT CLAIM TO ANY PARTICULAR FONT, STYLE, SIZE, OR COLOR.

FOR KNIVES, NAMELY, FOLDING KNIVES, SPORT KNIVES, HUNTING KNIVES, CAMPING KNIVES AND MULTI-FUNCTION KNIVES INCLUDING ONE OR MORE OF THE FOLLOWING TOOLS, FLAT SCREWDRIVER, PHILIPS SCREWDRIVER, CAN OPENER, BOTTLE OPENER, BIT DRIVER, INTERCHANGEABLE SCREWDRIVER BITS, AND CARABINER (U.S. CLS. 23, 28 AND 44).

MARK SPARACINO, EXAMINING ATTORNEY

THE MARK CONSISTS OF STANDARD CHARACTERS WITHOUT CLAIM TO ANY PARTICULAR FONT, STYLE, SIZE, OR COLOR.

OWNER OF U.S. REG. NOS. 1,519,398, 1,867,930 AND OTHERS.

NO CLAIM IS MADE TO THE EXCLUSIVE RIGHT TO USE "TEXAS", APART FROM THE MARK AS SHOWN.

FOR GARDENING TOOLS, NAMELY, SPADES, SHOVELS, RAKES, HOES, FERTILIZER SCOOPS, TROWELS, CULTIVATORS, PRUNING KNIVES, PRUNING SHEARS, LOPPERS, HAND-OPERATED LAWN EDGERS, WEEDING FORKS, HAND-OPERATED GRASS TRIMMERS, HAND-OPERATED HEDGE TRIMMERS AND HAND-OPERATED LINE TRIMMERS (U.S. CLS. 23, 28 AND 44).

KATHERINE CHANG, EXAMINING ATTORNEY

CLASS 9—ELECTRICAL AND SCIENTIFIC APPARATUS

SN 76-205,634. HUAWEI TECHNOLOGIES CO., LTD., SHENZHEN 518057, CHINA, FILED 2-6-2001.

OPTIXNET

OWNER OF U.S. REG. NO. 2,786,957.

FOR STORED PROGRAM CONTROLLED SWITCHING SYSTEMS, NAMELY, STORED PROGRAM CONTROLLED TELEPHONE SWITCHES, ELECTRIC SWITCHES, GATEWAY COMMUNICATION SERVERS, TRANSPORT DRIVERS; RADIO APPARATUS FOR TELECOMMUNICATION, NAMELY, RADIO PAGERS, CELLULAR BASE STATIONS, HANDSETS, WIRELESS TERMINALS, MOBILE TELEPHONES, MOBILE TELEPHONE SWITCHES, AND RF (RADIO FREQUENCY) POWER TRANSISTORS; DATA COMMUNICATION APPARATUS, NAMELY, TELEPHONES, CELLULAR PHONES, COMMUNICATION SERVERS, ROUTERS, HUBS, MODEMS, ACCESS COMMUNICATION SERVERS, ASYNCHRONOUS TRANSFER MODE (ATM) SWITCHES, ETHERNET SWITCHES, AND LOCAL AREA NETWORK (LAN) SWITCHES; TRANSMISSION APPARATUS FOR COMMUNICATION PURPOSES, NAMELY, TELECOMMUNICATION TRANSCEIVERS, CHANNEL BANKS, NETWORK MULTIPLEXERS, DATA COMMUNICATION MULTIPLEXERS AND CONCENTRATORS, AND ACCESS NETWORKS, NAMELY, LOCAL AREA NETWORKS AND WIDE AREA NETWORKS; COMPUTER HARDWARE, NAMELY, INTELLIGENT NETWORK APPARATUS, NAMELY, SERVICE CREATION ENVIRONMENT POINTS, SERVICE MANAGEMENT POINTS, SERVICE MANAGEMENT ACCESS POINTS, SERVICE CONTROL POINTS, FIXED NETWORK SERVICE SWITCHING POINTS, AND MOBILE NETWORK SERVICE SWITCHING POINTS; INTELLIGENT COMPUTER PERIPHERALS; INTEGRATED CIRCUITS (U.S. CLS. 21, 23, 26, 36 AND 38).

MARY ROSSMAN, EXAMINING ATTORNEY

SN 76-658,148. ECTEL LTD., PETACH TIKVA 49517, ISRAEL, FILED 4-10-2006.

IRM

THE MARK CONSISTS OF STANDARD CHARACTERS WITHOUT CLAIM TO ANY PARTICULAR FONT, STYLE, SIZE, OR COLOR.

PRIORITY CLAIMED UNDER SEC. 44(D) ON ISRAEL APPLICATION NO. 184855, FILED 11-1-2005, REG. NO. 184855, DATED 8-7-2007, EXPIRES 8-7-2017.

FOR COMMUNICATION EQUIPMENT FOR USE IN COMMUNICATION NETWORKS AND DIRECTLY SOLD TO TELECOMMUNICATION SERVICE PROVIDERS, NAMELY, COMPUTER SOFTWARE AND HARDWARE, FOR BILLING VERIFICATION, FRAUD DETECTION, MONITORING, MEASURING, ANALYZING, SECURITY MANAGING, NETWORK SURVEILLANCE, AND REPORTING INFORMATION EXTRACTED FROM COMMUNICATION NETWORKS (U.S. CLS. 21, 23, 26, 36 AND 38).

CHERYL CLAYTON, EXAMINING ATTORNEY

CLASS 9—(Continued).

SN 76-662,311. AVISERE, INC., TUCSON, AZ. FILED 6-29-2006.

Avisere

THE MARK CONSISTS OF STANDARD CHARACTERS WITHOUT CLAIM TO ANY PARTICULAR FONT, STYLE, SIZE, OR COLOR.

FOR COMPUTER HARDWARE, COMPUTER PROGRAMS FOR DATA RETRIEVING DEVICES AND SOFTWARE SYSTEMS, AND PATTERN RECOGNITION THROUGH OPTICAL, ELECTROMAGNETIC, AND TACTILE DEVICES AND SOFTWARE SYSTEMS USED TO DETECT, DIFFERENTIATE, AND INTERPRET BETWEEN OR AMONG OBJECTS AND HUMANS, NON-HUMANS, AND THE OBJECTS WITH WHICH THEY INTERACT; COMPUTER HARDWARE AND SOFTWARE SYSTEMS USED FOR PROCESSING INFORMATION OBTAINED BY PATTERN RECOGNITION DEVICES USED TO DETECT, DIFFERENTIATE, AND INTERPRET BETWEEN OR AMONG OBJECTS AND HUMANS, NON-HUMANS AND THE OBJECTS WITH WHICH THEY INTERACT USED AS MANAGEMENT DECISION TOOLS FOR IDENTIFICATION AND OPTIMIZATION OF THE EFFICIENCY AND PROFITABILITY OF PRODUCT, USER, OR CUSTOMER THROUGHPUT, AS WELL AS THE USE OF SUCH TECHNOLOGIES AND BUSINESS MODELS IN THE DEVELOPMENT OF MARKET STRATEGIES AND BUSINESS PLANS (U.S. CLS. 21, 23, 26, 36 AND 38).

FIRST USE 3-0-2003; IN COMMERCE 3-0-2003.

GRETTA YAO, EXAMINING ATTORNEY

SN 76-673,397. BYON INTERNATIONAL CORP., ROAD TOWN TORTOLA, BR. VIRGIN ISLANDS, FILED 3-1-2007.

B | Y | O | N

FOR NOTEBOOK COMPUTER; LAPTOP COMPUTER; PERSONAL COMPUTER; COMPUTER MONITOR; COMPUTER KEYBOARD; COMPUTER APPARATUS, NAMELY, HARD DISK, BLANK HARD DRIVES, CENTRAL PROCESSING UNIT, MOTHERBOARD, PLOTTERS, DIGITIZERS; PRINTERS; SCANNERS; COMPUTER PERIPHERALS; COMPUTER MOUSE; COMPUTER CASE; MP3 PLAYER; DIGITAL CAMERA; DATA PROCESSING EQUIPMENT, NAMELY, DATA PROCESSORS AND COMPUTERS; SOUND CARDS; VIDEO CARDS; COMPACT DISC READ ONLY MEMORIES; TAPES, NAMELY, BLANK AUDIO TAPES, BLANK MAGNETIC COMPUTER TAPES, BLANK TAPES FOR STORAGE OF COMPUTER DATA, COMPUTER GAME TAPES; COMPUTER HARDWARE; VIDEO CAPTURE CARDS; DATA COMPACT DISC, NAMELY, BLANK DISCS FOR COMPUTERS; READ AND WRITE MEMORY DATA MEDIA STORAGE DEVICE, NAMELY, FLASH MEMORY CARD, EXTERNAL COMPUTER POCKET HARD DRIVES, USB COMPUTER MEMORIES, BLANK CDS AND DVDS; MEMORY EXPANSION MODULES (U.S. CLS. 21, 23, 26, 36 AND 38).

JENNIFER MARTIN, EXAMINING ATTORNEY

CLASS 9—(Continued).

SN 76-675,041. HOYA CORPORATION, TOKYO, JAPAN, FILED 4-4-2007.

NULUX ACTIVE

THE MARK CONSISTS OF STANDARD CHARACTERS WITHOUT CLAIM TO ANY PARTICULAR FONT, STYLE, SIZE, OR COLOR.

OWNER OF U.S. REG. NO. 2,392,743.

NO CLAIM IS MADE TO THE EXCLUSIVE RIGHT TO USE "ACTIVE", APART FROM THE MARK AS SHOWN.

FOR SPECTACLE LENSES; SPECTACLE LENS BLANKS; SPECTACLES; SPECTACLE FRAMES; SPECTACLE CASES; SUNGLASSES; CONTACT LENSES; CONTAINERS FOR CONTACT LENSES; SKI GOGGLES (U.S. CLS. 21, 23, 26, 36 AND 38).

JESSICA A. POWERS, EXAMINING ATTORNEY

SN 76-677,422. JOBY, INC., SAN FRANCISCO, CA. FILED 5-25-2007.

NOMAD

THE MARK CONSISTS OF STANDARD CHARACTERS WITHOUT CLAIM TO ANY PARTICULAR FONT, STYLE, SIZE, OR COLOR.

OWNER OF U.S. REG. NOS. 3,235,624 AND 3,238,686.

FOR CONSUMER ELECTRONICS AND CONSUMER ELECTRONICS ACCESSORIES, NAMELY, A BATTERY CHARGER FOR PERSONAL ELECTRONIC DEVICES AND A BATTERY CHARGER THAT FEATURES A USB CONNECTOR FOR PERSONAL ELECTRONIC DEVICES (U.S. CLS. 21, 23, 26, 36 AND 38).

RENEE SERVANCE, EXAMINING ATTORNEY

CLASS 9—(Continued).

SN 76-678,136. DEEPWATER CORROSION SERVICES, INC., HOUSTON, TX. FILED 6-12-2007.

POLATRAK

THE MARK CONSISTS OF STANDARD CHARACTERS WITHOUT CLAIM TO ANY PARTICULAR FONT, STYLE, SIZE, OR COLOR.

FOR PERMANENT REFERENCE ELECTRODE DESIGNED TO MONITOR LEVELS OF CORROSION ON BURIED OR IMMersed STEEL STRUCTURES; REFERENCE ELECTRODE SYSTEM COMPRISING A PROBE FOR MEASURING LEVELS OF CORROSION ON BURIED STEEL STRUCTURES, AN ELECTRICAL CIRCUIT FOR MEASURING LEVELS OF CORROSION ON BURIED STEEL STRUCTURES, AND A METER FOR MEASURING LEVELS OF CORROSION ON BURIED STEEL STRUCTURES; ELECTRODE BASED PROBE FOR MEASURING LEVELS OF CORROSION ON BURIED STEEL STRUCTURES; ELECTRODE BASED METER FOR MEASURING LEVELS OF CORROSION ON BURIED STEEL STRUCTURES; AND ELECTRODE BASED MONITORING SYSTEM COMPRISING PROBES FOR MEASURING LEVELS OF CORROSION ON BURIED STEEL STRUCTURES, AND METERS FOR MEASURING LEVELS OF CORROSION ON BURIED STEEL STRUCTURES (U.S. CLS. 21, 23, 26, 36 AND 38).

FIRST USE 3-1-1988; IN COMMERCE 3-1-1988.

KRISTINA MORRIS, EXAMINING ATTORNEY

SN 76-681,057. OSIECKI, LORI LYNN, MESA, AZ. FILED 8-23-2007.

ITZ THINK

THE MARK CONSISTS OF STANDARD CHARACTERS WITHOUT CLAIM TO ANY PARTICULAR FONT, STYLE, SIZE, OR COLOR.

FOR DOWNLOADABLE COMPUTER AND TELEPHONE MESSAGE ICONS (U.S. CLS. 21, 23, 26, 36 AND 38).

JAMES GRIFFIN, EXAMINING ATTORNEY

SN 76-681,441. DMTP PINAL HOLDINGS, L.L.C., TUCSON, AZ. FILED 9-4-2007.

DECADES MUSIC THEME PARK

THE MARK CONSISTS OF STANDARD CHARACTERS WITHOUT CLAIM TO ANY PARTICULAR FONT, STYLE, SIZE, OR COLOR.

NO CLAIM IS MADE TO THE EXCLUSIVE RIGHT TO USE "MUSIC", APART FROM THE MARK AS SHOWN.

FOR PRERECORDED AUDIO AND VIDEO DISCS FEATURING MUSIC (U.S. CLS. 21, 23, 26, 36 AND 38).

GEORGIA CARTY, EXAMINING ATTORNEY

CLASS 9—(Continued).

SN 76-681,849. ENDOSOMATIC SYSTEMS, INC, ITHACA, NY. FILED 9-14-2007.

ENDO GEAR

FOR NON MEDICAL INSTRUMENTS AND APPARATUS IN PARTICULAR BIO TELEMETRIC SYSTEMS FOR INTERNAL USE, NAMELY, IMPLANTABLE WIRELESS BATTERY POWERED COMMUNICATION UNITS WITH BLOOD PRESSURE, BLOOD FLOW AND TEMPERATURE SENSORS FOR MEASURING AND MONITORING PHYSIOLOGICAL AND BIOLOGICAL SIGNALS IN ANIMALS (U.S. CLS. 21, 23, 26, 36 AND 38).
DOMINICK J. SALEMI, EXAMINING ATTORNEY

CLASS 9—(Continued).

SN 76-687,687. CONTROLLED AIR SYSTEMS, PERKASIE, PA. FILED 3-13-2008.



SN 76-682,359. RONAN ENGINEERING COMPANY, WOODLAND HILLS, CA. FILED 9-27-2007.

RONAN

THE MARK CONSISTS OF STANDARD CHARACTERS WITHOUT CLAIM TO ANY PARTICULAR FONT, STYLE, SIZE, OR COLOR.

SEC. 2(F).
FOR PROCESS MONITORING APPARATUS, NAMELY, ANNUNCIATORS, TEMPERATURE MONITORS, RADIO TRANSMITTERS AND ALARM TRIPS; SEQUENTIAL EVENTS RECORDERS FOR DATA ACQUISITION; AND NUCLEAR MEASUREMENT INSTRUMENTATION, NAMELY, POINT LEVEL GAUGES, DENSITY GAUGES, CONTINUOUS LEVEL GAUGES, CONTINUOUS WEIGH SCALES AND MASS FLOW APPARATUS (U.S. CLS. 21, 23, 26, 36 AND 38).
FIRST USE 7-6-1959; IN COMMERCE 7-6-1959.
SHANNON TWOHIG, EXAMINING ATTORNEY

FOR TOUCH SCREEN THERMOSTAT (U.S. CLS. 21, 23, 26, 36 AND 38).
FIRST USE 1-1-2008; IN COMMERCE 1-1-2008.
KARANENDRA S. CHHINA, EXAMINING ATTORNEY

SN 76-683,826. BLOMQUIST, GREGORY, PLANO, TX. FILED 11-8-2007.

CODE CLOCK

THE MARK CONSISTS OF STANDARD CHARACTERS WITHOUT CLAIM TO ANY PARTICULAR FONT, STYLE, SIZE, OR COLOR.

THE WORDING "CODE CLOCK" OR "CODE" OR "CLOCK" DOES NOT HAVE ANY MEANING IN THE FOREIGN LANGUAGE.
FOR COMPUTER HARDWARE AND SOFTWARE, FOR USE WITH MEDICAL PATIENT EQUIPMENT, FOR RECEIVING, STORING, PROCESSING, TRANSMITTING AND DISPLAYING DATA, NAMELY, FOR USE IN GUIDING THE NATURE AND TIMING OF APPLYING MEDICAL PROCEDURES AND DRUG DOSAGES TO PATIENTS (U.S. CLS. 21, 23, 26, 36 AND 38).
GEORGIA CARTY, EXAMINING ATTORNEY

SN 76-688,116. MECUL SERVICES CORP., PORTLAND, ME. FILED 3-27-2008.

CU ARCHIVES

THE MARK CONSISTS OF STANDARD CHARACTERS WITHOUT CLAIM TO ANY PARTICULAR FONT, STYLE, SIZE, OR COLOR.

OWNER OF U.S. REG. NO. 2,861,720.
SEC. 2(F).
FOR INTERNET-BASED COMPUTER STORAGE AND RETRIEVAL SOFTWARE APPLICATION USED TO RETRIEVE, REVIEW, RESEARCH AND STORE DOCUMENTS SUCH AS REPORTS AND STATEMENTS (U.S. CLS. 21, 23, 26, 36 AND 38).
FIRST USE 7-1-2001; IN COMMERCE 7-1-2001.
ESTHER BELENKER, EXAMINING ATTORNEY

CLASS 9—(Continued).

SN 77-012,975. MED-EL ELEKTROMEDIZINISCHE GERÄTE GES.M.B.H., 6020 INNSBRUCK, AUSTRIA, FILED 10-3-2006.



PRIORITY CLAIMED UNDER SEC. 44(D) ON AUSTRIA APPLICATION NO. AM63242006, FILED 9-21-2006, REG. NO. 236064, DATED 9-21-2006, EXPIRES 9-21-2016.

NO CLAIM IS MADE TO THE EXCLUSIVE RIGHT TO USE "SYSTEM SOFTWARE BY MED-EL", APART FROM THE MARK AS SHOWN.

THE MARK CONSISTS OF A RECTANGULAR BUTTON WITH THE WORDS MAESTRO "SYSTEM SOFTWARE BY MED-EL" AND A DIAGONAL LINE ON IT.

FOR SOFTWARE FOR PROGRAMMING SPEECH PROCESSORS, NAMELY COCHLEA-IMPLANTS AND IMPLANT SYSTEMS; SOFTWARE FOR IMPEDANCE MEASUREMENTS AND FIELD-TELEMETRIC MEASUREMENTS IN THE FIELD OF IMPLANT AND IMPLANT ELECTRODE FUNCTIONS KNOWN AS IFT IMPEDANCE AND FIELD TELEMETRY; SOFTWARE FOR IMPLANT AND STIMULATION PARAMETER IDENTIFICATION ALSO KNOWN AS TELEMETRY; SOFTWARE FOR DETERMINATION AND ANALYSIS OF INFORMATION ON PHYSIOLOGICAL REACTIONS OF THE STIMULATED HEARING NERVES ALSO KNOWN AS HEARING NERVE-RESPONSE-TELEMETRY OR ART (U.S. CLS. 21, 23, 26, 36 AND 38).

JENNIFER VASQUEZ, EXAMINING ATTORNEY

SN 77-023,679. EL BTEDDINI, MAZEN WAHEEN, DUBAI, UNITED ARAB EMIR., FILED 10-18-2006.

PURUS

THE MARK CONSISTS OF STANDARD CHARACTERS WITHOUT CLAIM TO ANY PARTICULAR FONT, STYLE, SIZE, OR COLOR.

IN LATIN THE WORD "PURUS" MEANS PURE, FREE FROM, SPOTLESS, WITHOUT STAIN.

FOR COMPUTER GAME PROGRAMS; COMPUTER KEYBOARDS; RECORDED COMPUTER OPERATING PROGRAMS; COMPUTER PERIPHERALS; RECORDED COMPUTER PROGRAMS AND COMPUTER SOFTWARE FOR COMMUNICATING WITH USERS OF HAND-HELD COMPUTERS AND PRERECORDED OPTICAL DISCS FEATURING COMPUTER SOFTWARE FOR COMMUNICATING WITH USERS OF HAND-HELD COMPUTERS; COMPUTERS; PRINTERS FOR USE WITH COMPUTERS; BLANK DATA MAGNETIC DATA CARRIERS; DATA PROCESSORS; COMPUTER DISK DRIVES; MICROPROCESSORS; MOUSE PADS; BLANK OPTICAL STORAGE MEDIA, NAMELY, MAGNETIC OPTICAL DISCS, RECORDABLE MINI DISCS, RECORDABLE AND REWRITABLE COMPACT DISCS AND RECORDABLE AND REWRITABLE DIGITAL VERSATILE DISCS, FLOPPY DISKS, CD-ROMS, FLOPPY DISK DRIVES, VIDEO DISKS, SOUND RECORDING DISKS, VIDEO COMPACT DISKS; DATA READER DEVICES, NAMELY, BAR CODE READERS; DATA STORAGE AND READER DEVICES, NAMELY, RFID READERS; COMPUTER MICE; PLAYER-OPERATED ELECTRONIC CONTROLLERS FOR ELECTRONIC VIDEO GAME MACHINES; AUDIO SPEAKERS, MICROPHONES, HEADPHONES; HEADSETS FOR TELEPHONES; DIGITAL

CLASS 9—(Continued).

AND PC CAMERAS; LCD AND CRT COMPUTER MONITORS; OPTICAL DISK DRIVES; BLANK DISKETTES; COMPUTER CASES AND ELECTRICAL POWER SUPPLIES; NOTEBOOK COMPUTERS; PERSONAL DIGITAL ASSISTANTS; SCIENTIFIC, NAUTICAL, SURVEYING, PHOTOGRAPHIC, CINEMATOGRAPHIC, OPTICAL, WEIGHING, MEASURING, SIGNALING, CHECKING, SUPERVISION, LIFE-SAVING AND TEACHING APPARATUS AND INSTRUMENTS, NAMELY, COMPUTERS FOR FACILITATING SUCH DEVICES; APPARATUS AND INSTRUMENTS FOR CONDUCTING, SWITCHING, TRANSFORMING, ACCUMULATING, REGULATING OR CONTROLLING ELECTRICITY, NAMELY, ELECTRICITY CONDUITS, ELECTRICITY ADAPTORS, VOLTAGE REGULATORS FOR ELECTRIC POWER, AND ELECTRIC SWITCHES; APPARATUS FOR RECORDING, TRANSMISSION OR REPRODUCTION OF SOUND OR IMAGES, NAMELY, DVD RECORDERS; AUTOMATIC VENDING MACHINES; MECHANISM FOR COIN-OPERATED APPARATUS, NAMELY, VENDING MACHINES; CASH REGISTERS, CALCULATORS, FIRE EXTINGUISHERS; COVERS FOR MOBILE TELEPHONES; HOLDERS FOR MOBILE TELEPHONES; DOWNLOADABLE ELECTRONIC PUBLICATIONS PROVIDED ON-LINE FROM DATABASE OR THE INTERNET, NAMELY, NEWSLETTERS IN THE FIELD OF COMPUTERS; COMPUTER SOFTWARE TO ENABLE SEARCHING OF DATA; PROTECTIVE CLOTHING, PROTECTED HEADWEAR, NAMELY, SAFETY HELMETS; LIFE JACKETS; SPECTACLES; SPORTS SPECTACLES; SUNGLASSES; RETAINERS FOR SPECTACLES, SPORTS SPECTACLES, AND SUNGLASSES, NAMELY, CHAINS, MOBILE TELEPHONES; LAND LINE TELEPHONES, RECEIVERS AND TRANSMITTERS; ELECTRONIC PERSONAL ORGANIZERS; BLANK SMART CARDS; ENCODED SMART CARDS CONTAINING PROGRAMMING USED TO OPERATE COMPUTERS; ELECTRONIC GAME PROGRAMS; ELECTRONIC ORGANIZERS INCORPORATED WITHIN TELECOMMUNICATIONS APPARATUS AND EQUIPMENT, NAMELY, ELECTRONIC PERSONAL ORGANIZERS SOLD AS A COMPONENT OF MOBILE TELEPHONES; COMPUTER SOFTWARE AND MODEMS FOR ESTABLISHING CONNECTIONS BETWEEN A DATABASE AND THE INTERNET; DOWNLOADABLE DIGITAL MUSIC FILES PROVIDED FROM THE INTERNET; DOWNLOADABLE DIGITAL MP3 MUSIC FILES PROVIDED FROM MP3 INTERNET WEB SITES; MOTORCYCLES HELMETS; MOTHERBOARDS, VIDEO DISPLAY CARDS, MODEMS, INTERNET SET TOP BOXES, STEREO TUNER; STORAGE DEVICES, NAMELY, FLASH DRIVES; ELECTRICAL POWER SUPPLIES IN THE NATURE OF UNINTERRUPTIBLE POWER SUPPLY, SCANNERS, PRINTERS, COMPUTER MONITOR, COMPUTER AUDIO SPEAKERS, HEADSETS FOR USE WITH COMPUTERS, PERSONAL COMPUTERS; TELEPHONES; CALLER ID TELEPHONES; CORDLESS TELEPHONES; DIGITAL TELEPHONES; RECORDING TELEPHONES; AND NORMAL TELEPHONES (U.S. CLS. 21, 23, 26, 36 AND 38).

MARY BOAGNI, EXAMINING ATTORNEY

CLASS 9—(Continued).

SN 77-025,952. 9141-0720 QUEBEC INC., DRUMMONDVILLE - QUEBEC, CANADA, FILED 10-20-2006.

ACCU-CAM

THE MARK CONSISTS OF STANDARD CHARACTERS WITHOUT CLAIM TO ANY PARTICULAR FONT, STYLE, SIZE, OR COLOR.

PRIORITY CLAIMED UNDER SEC. 44(D) ON CANADA APPLICATION NO. 1298652, FILED 4-21-2006, REG. NO. TMA702129, DATED 11-30-2007, EXPIRES 11-30-2022.

FOR ACCESS SYSTEM COMPOSED OF AN ELECTRICALLY POWERED OPERATOR FOR GARAGE DOORS (U.S. CLS. 21, 23, 26, 36 AND 38).

LINDA ESTRADA, EXAMINING ATTORNEY

SN 77-040,223. LIGHTSTONE IP, LLC, RENO, NV. FILED 11-9-2006.



THE MARK CONSISTS OF A LOWERCASE "I" WITH A FLAME ABOVE REPLACING THE DOT.

FOR CD CASES; CD SLEEVES; CHILDREN'S EDUCATIONAL MUSIC CDS AND DVDS; DOWNLOADABLE FILMS AND TV PROGRAMS PROVIDED VIA A VIDEO-ON-DEMAND; DOWNLOADABLE MOTION PICTURES AND TV SHOWS ABOUT RELIGIOUS STORIES; DOWNLOADABLE MUSICAL SOUND RECORDINGS; DOWNLOADABLE RING TONES, GRAPHICS AND MUSIC VIA A GLOBAL COMPUTER NETWORK AND WIRELESS DEVICES; DOWNLOADABLE VIDEO RECORDINGS FEATURING RELIGIOUS STORIES; DVD CASES; DVD SLEEVES; DVDS FEATURING RELIGIOUS STORIES; MOTION PICTURE FILMS ABOUT RELIGIOUS STORIES; MUSICAL SOUND RECORDINGS; MUSICAL VIDEO RECORDINGS; VIDEO RECORDINGS FEATURING RELIGIOUS STORIES (U.S. CLS. 21, 23, 26, 36 AND 38).

FIRST USE 6-7-2002; IN COMMERCE 6-7-2002.

CHARISMA HAMPTON, EXAMINING ATTORNEY

CLASS 9—(Continued).

SN 77-045,409. YOUGHIOGHENY COMMUNICATIONS-IP, LLC, SAN ANTONIO, TX. FILED 11-16-2006.

OWNER OF U.S. REG. NO. 3,098,763.

NO CLAIM IS MADE TO THE EXCLUSIVE RIGHT TO USE "COMMUNICATIONS", APART FROM THE MARK AS SHOWN.

THE MARK CONSISTS OF THE WORD "POCKET" WITH SOUNDWAVES AS THE LETTER "O".

SEC. 2(F).

FOR TELEPHONES, TELEPHONE ACCESSORIES AND EQUIPMENT, NAMELY, WIRELESS TELEPHONES, BATTERIES; CHARGERS; TELEPHONE CARRYING CASES, HANDS-FREE DEVICES, AND CARRYING CLIPS FOR WIRELESS TELEPHONES SOLD AS A UNIT IN COMBINATION WITH WIRELESS TELEPHONES (U.S. CLS. 21, 23, 26, 36 AND 38).

FIRST USE 7-31-2006; IN COMMERCE 7-31-2006.

BENJAMIN OKEKE, EXAMINING ATTORNEY

SN 77-063,492. GINGON SOLUTIONS, INC., DBA MOVE-RMAX, FT. LAUDERDALE, FL. FILED 12-13-2006.

MOVERWORX

THE MARK CONSISTS OF STANDARD CHARACTERS WITHOUT CLAIM TO ANY PARTICULAR FONT, STYLE, SIZE, OR COLOR.

FOR COMPUTER SOFTWARE FOR BUSINESS PROSPECT MANAGEMENT, FOR MANAGING A DATABASE OF INFORMATION PERTAINING TO INVENTORY, MILEAGE CALCULATING, COMPOSING TASKS LISTS AND CREATING REPORT SPREADSHEETS FOR USE BY MEMBERS OF THE MOVING INDUSTRY IN BUSINESS MANAGEMENT (U.S. CLS. 21, 23, 26, 36 AND 38).

FIRST USE 2-1-2003; IN COMMERCE 2-1-2003.

TINA BROWN, EXAMINING ATTORNEY

SN 77-073,318. COMPUSOLVE GOVERNMENT SOLUTIONS, LLC, BOHEMIA, NY. FILED 12-29-2006.

IQM2

THE MARK CONSISTS OF STANDARD CHARACTERS WITHOUT CLAIM TO ANY PARTICULAR FONT, STYLE, SIZE, OR COLOR.

FOR COMPUTER SOFTWARE FOR MANAGEMENT OF MEETINGS (U.S. CLS. 21, 23, 26, 36 AND 38).

STEPHEN AQUILA, EXAMINING ATTORNEY

CLASS 9—(Continued).

SN 77-085,782. VITRONICS SOLTEC CORPORATION, STRATHAM, NH. FILED 1-18-2007.



NO CLAIM IS MADE TO THE EXCLUSIVE RIGHT TO USE "AUTOSET", APART FROM THE MARK AS SHOWN. THE MARK CONSISTS OF THE WORD "AUTOSET" WITH A SWIRL DESIGN.

FOR SOFTWARE FOR REFLOW OVENS; SOFTWARE AS A COMPONENT OF REFLOW OVENS; SOFTWARE FOR SOLDERING EQUIPMENT; SOFTWARE AS A COMPONENT OF SOLDERING EQUIPMENT (U.S. CLS. 21, 23, 26, 36 AND 38).

BENJAMIN OKEKE, EXAMINING ATTORNEY

CLASS 9—(Continued).

SN 77-090,384. GRIMM, IVAN J., WAYZATA, MN. FILED 1-24-2007.



NO CLAIM IS MADE TO THE EXCLUSIVE RIGHT TO USE "STRATEGIC DECEPTION IN DATA", APART FROM THE MARK AS SHOWN.

THE MARK CONSISTS OF THE WORD "FUDJ" IN A HOLLOW FONT WITH THE LEGS OF THE CHARACTER "U" EXTENDED DOWNWARD UNTIL THEY MERGE WITH AN UNDERLINE. THEN BELOW THAT UNDERLINE IS THE CAPTION "STRATEGIC DECEPTION IN DATA" AND ANOTHER UNDERLINE BELOW THAT CAPTION.

FOR COMPUTER SOFTWARE FOR PROVIDING SECURITY THROUGH STRATEGIC DECEPTION WITHIN THE FIELD OF DATA EXCHANGE VIA THE INTERNET (U.S. CLS. 21, 23, 26, 36 AND 38).

MICHELLE DUBOIS, EXAMINING ATTORNEY

SN 77-090,076. CR SOFTWARE, LLC, FAIRFAX, VA. FILED 1-24-2007.

TITANIUM ORE OPEN
RECEIVABLES ENVIRONMENT

THE MARK CONSISTS OF STANDARD CHARACTERS WITHOUT CLAIM TO ANY PARTICULAR FONT, STYLE, SIZE, OR COLOR.

NO CLAIM IS MADE TO THE EXCLUSIVE RIGHT TO USE "OPEN RECEIVABLES ENVIRONMENT", APART FROM THE MARK AS SHOWN.

FOR COMPUTER SOFTWARE, NAMELY, DEBT MANAGEMENT SYSTEMS FOR USE AS A COLLECTIONS RECEIVABLE TOOL (U.S. CLS. 21, 23, 26, 36 AND 38).

FIRST USE 10-16-2006; IN COMMERCE 10-16-2006.

MARILYN IZZI, EXAMINING ATTORNEY

SN 77-094,479. MICROBRIDGE TECHNOLOGIES CANADA, INC., MONTREAL, QUEBEC, CANADA, FILED 1-30-2007.

REJUST-IT

THE MARK CONSISTS OF STANDARD CHARACTERS WITHOUT CLAIM TO ANY PARTICULAR FONT, STYLE, SIZE, OR COLOR.

PRIORITY CLAIMED UNDER SEC. 44(D) ON CANADA APPLICATION NO. 1332091, FILED 1-19-2007, REG. NO. TMA701702, DATED 11-27-2007, EXPIRES 11-27-2022.

FOR COMPUTER SOFTWARE FOR REPEATED, PRECISION ELECTRICAL TRIMMING OF PASSIVE SEMI-CONDUCTOR CHIPS FOR DISCRETE AND INTEGRATED CIRCUITS (U.S. CLS. 21, 23, 26, 36 AND 38).

ELIZABETH KAJUBI, EXAMINING ATTORNEY

CLASS 9—(Continued).

SN 77-094,690. TENNMAN BRANDS, LLC, NEW YORK, NY.
FILED 1-30-2007.

TENNMAN RECORDS

THE MARK CONSISTS OF STANDARD CHARACTERS WITHOUT CLAIM TO ANY PARTICULAR FONT, STYLE, SIZE, OR COLOR.

NO CLAIM IS MADE TO THE EXCLUSIVE RIGHT TO USE "RECORDS", APART FROM THE MARK AS SHOWN.

FOR MUSICAL SOUND RECORDINGS; AUDIO-VISUAL RECORDINGS, NAMELY, PRERECORDED COMPACT DISCS, AUDIO TAPE CASSETTES, AUDIO CASSETTES, AUDIO TAPES, AUDIO DISCS, PHONOGRAPH RECORDS, CD-ROMS, VIDEO TAPES, VIDEO CASSETTES, VIDEO DISCS, DVDS, DATS, MP3S, AND LASER DISCS, ALL FEATURING MUSIC, DANCE, THEATRE, TELEVISION PROGRAMS IN THE FIELDS OF MUSIC, DANCE, NEWS, ANIMATION, COMEDY, DRAMA, DRAMEDY, FASHION, LIFESTYLES, POPULAR CULTURE, SPORTS, POLITICS, AND THE ARTS AND MOTION PICTURE FILMS ABOUT MUSIC, DANCE, NEWS, ANIMATION, COMEDY, DRAMA, DRAMEDY, FASHION, LIFESTYLES, POPULAR CULTURE, PHOTOGRAPHY, SPORTS, POLITICS, AND THE ARTS AND SOUND TRACKS; DOWNLOADABLE MUSICAL SOUND RECORDINGS; DOWNLOADABLE VIDEO RECORDINGS FEATURING MUSIC, DANCE, THEATRE, TELEVISION PROGRAMS IN THE FIELDS OF MUSIC, DANCE, NEWS, ANIMATION, COMEDY, DRAMA, DRAMEDY, FASHION, LIFESTYLES, POPULAR CULTURE, PHOTOGRAPHY, SPORTS, POLITICS AND THE ARTS, FILM ABOUT MUSIC, DANCE, NEWS, ANIMATION, COMEDY, DRAMA, DRAMEDY, FASHION, LIFESTYLES, POPULAR CULTURE, PHOTOGRAPHY, SPORTS, POLITICS AND THE ARTS, ANIMATION, COMEDY, DRAMA, DRAMEDY, FASHION, LIFESTYLES, POPULAR CULTURE, PHOTOGRAPHY, SPORTS, POLITICS AND THE ARTS, ANIMATION, COMEDY, DRAMA, DRAMEDY, FASHION, LIFESTYLES, POPULAR CULTURE, PHOTOGRAPHY, SPORTS, POLITICS AND THE ARTS, ANIMATION, COMEDY, DRAMA, DRAMEDY, FASHION, LIFESTYLES, POPULAR CULTURE, PHOTOGRAPHY, SPORTS, POLITICS AND THE ARTS; DOWNLOADABLE ELECTRONIC PUBLICATIONS IN THE NATURE OF BOOKS, BOOKLETS, MAGAZINES, JOURNALS, MANUALS, BROCHURES, LEAFLETS, PAMPHLETS AND NEWSLETTERS, ALL IN THE FIELD OF MUSIC, ENTERTAINMENT, NAMELY, ENTERTAINMENT NEWS AND REALITY-BASED ENTERTAINMENT, TELEVISION, FILM, ANIMATION, THE ARTS, COMEDY, DRAMA, NEWS, FASHION, LIFESTYLES, CULTURE, SPORTS, POLITICS, ELECTRONICS, TELECOMMUNICATIONS, AND BIOGRAPHIES OF AND NARRATIONS BY MUSICIANS, COMEDIANS, ATHLETES, TELEVISION AND MOVIE STARS, RADIO PERSONALITIES, AND CELEBRITIES; ELECTRONIC PUBLICATIONS, NAMELY, BOOKS, BOOKLETS, MAGAZINES, JOURNALS, MANUALS, BROCHURES, LEAFLETS, PAMPHLETS AND NEWSLETTERS, ALL IN THE FIELD OF MUSIC, ENTERTAINMENT, NAMELY, ENTERTAINMENT NEWS AND REALITY-BASED ENTERTAINMENT, TELEVISION, FILM, ANIMATION, THE ARTS, COMEDY, DRAMA, NEWS, FASHION, LIFESTYLES, CULTURE, SPORTS, POLITICS, ELECTRONICS, TELECOMMUNICATIONS, AND BIOGRAPHIES OF AND NARRATIONS BY MUSICIANS, COMEDIANS, ATHLETES, TELEVISION AND MOVIE STARS, RADIO PERSONALITIES, AND CELEBRITIES, RECORDED ON CD-ROMS, DISKETTES, FLOPPY DISKS, VIDEO CASSETTES, AND MAGNETIC TAPES; DOWNLOADABLE RING TONES, GRAPHICS AND MUSIC VIA A GLOBAL COMPUTER NETWORK AND WIRELESS DEVICES; JACKETS FOR VIDEO CASSETTES, TAPES, AND COMPACT DISCS; COMPUTER GAME CARTRIDGES, DISCS, CASSETTES, TAPES, JOYSTICKS, PROGRAMS AND SOFTWARE; HAND HELD JOY STICK UNITS FOR PLAYING VIDEO GAMES; VIDEO GAME CARTRIDGES, VIDEO GAME DISCS, AND VIDEO GAME TAPE CASSETTES; VIDEO GAME SOFTWARE, VIDEO GAME PROGRAMS, AND, VIDEO GAME JOYSTICKS; VIDEO MAGAZINE RECORDED ON ELECTRONIC MEDIA FEATURING MUSIC, ENTERTAINMENT, NAMELY, ENTERTAINMENT NEWS AND REALITY-BASED ENTERTAINMENT, NEWS, COMPU-

CLASS 9—(Continued).

TER GAMES AND SPORTS; COMPUTER PROGRAMS FOR EDITING IMAGES, SOUND AND VIDEO; COMPUTER PROGRAMS FOR PRE-RECORDED GAMES; ELECTRONIC GAME PROGRAMS; COMPUTERIZED VIDEO TABLE GAMES FOR GAMING PURPOSES; INTERACTIVE MULTIMEDIA COMPUTER GAME PROGRAM; INTERACTIVE VIDEO GAME PROGRAMS; INTERACTIVE AUDIO GAME DISCS CONTAINING ACTION GAMES AND ROLE PLAYING GAMES; INTERACTIVE VIDEO GAMES OF VIRTUAL REALITY COMPRISED OF COMPUTER HARDWARE AND SOFTWARE; VIRTUAL REALITY GAME SOFTWARE; VIDEO GAME MACHINES AND VIDEO OUTPUT GAME MACHINES FOR USE WITH TELEVISIONS; VIDEO TAPES AND VIDEO DISKS RECORDED WITH ANIMATION; GAMING EQUIPMENT, NAMELY, SLOT MACHINES WITH OR WITHOUT VIDEO OUTPUT; COMPUTER SOFTWARE FOR COMMUNICATING WITH USERS OF HAND-HELD COMPUTERS; COMPUTER SOFTWARE TO ENABLE THE TRANSMISSION OF PHOTOGRAPHS TO MOBILE TELEPHONES; COMPUTER SOFTWARE FOR WIRELESS CONTENT DELIVERY; COMPUTER SOFTWARE TO ENHANCE THE AUDIO-VISUAL CAPABILITIES OF MULTIMEDIA APPLICATIONS, NAMELY, FOR THE INTEGRATION OF TEXT, AUDIO, GRAPHICS, STILL IMAGES AND MOVING PICTURES; SOFTWARE FOR PROCESSING IMAGES, GRAPHICS AND TEXT; MULTIMEDIA SOFTWARE RECORDED ON CD-ROM FEATURING MUSIC, ENTERTAINMENT, AND GAMES; MUSIC-COMPOSITION SOFTWARE; HANDHELD COMPUTERS, LAPTOP COMPUTERS, NOTEBOOK COMPUTERS, MAGNETS; DECORATIVE MAGNETS; REFRIGERATOR MAGNETS; NOVELTY MAGNETS; PROTECTIVE EYEWEAR; SUNGLASSES; EYEGLASSES; EYEGLASS FRAMES; OPERA GLASSES; SPECTACLES; EYEGLASS, SUNGLASS AND SPECTACLE CASES; EYEGLASS, SUNGLASS AND SPECTACLE STRAPS; EYEGLASS, SUNGLASS AND SPECTACLE CHAINS; MOUSE PADS; COMPACT DISC CASES; FITTED CASES FOR STORAGE AND TRANSPORTATION, NAMELY, CASES FOR COMPACT DISCS, AUDIO CASSETTES, VIDEO CASSETTES, CD-ROMS, HOME VIDEO GAMES, HOME VIDEO GAME ACCESSORIES, COMPUTERS, COMPUTER ACCESSORIES, CAMERAS, CAMCORDERS, PHONES, PERSONAL DIGITAL ASSISTANTS, TWO-WAY PAGERS, MOBILE DEVICES, AND RADIOS; COMPUTER CARRYING CASES; WRIST RESTS AND SUPPORTS FOR COMPUTER MOUSEUSERS; WRIST RESTS FOR COMPUTERS AND COMPUTER ACCESSORIES; COMPUTER KEYBOARD WRIST PADS; BINOCULARS; EAR PLUGS NOT FOR MEDICAL PURPOSES; TELEPHONES, CELLULAR TELEPHONES, PAGERS, CAR KITS FOR THE ADAPTATION OF PORTABLE COMMUNICATION APPARATUS AND INSTRUMENTS FOR VEHICULAR USE, PRINCIPALLY COMPOSED OF MOUNT, CRADLE, HEADSET, AUDIO SPEAKERS, MICROPHONES, EXTENSION CORDS, POWER CABLES, EXTERNAL ANTENNA CONNECTORS, BATTERY, BATTERY CHARGER AND CARRYING CASE MARKETED AS A UNIT; ELECTRONIC HANDHELD UNITS FOR THE WIRELESS RECEIPT AND TRANSMISSION OF DATA THAT ENABLE THE USER TO KEEP TRACK OF OR MANAGE PERSONAL INFORMATION; SOFTWARE FOR THE REDIRECTION OF MESSAGES, GLOBAL COMPUTER NETWORK E-MAIL, AND OTHER DATA TO ONE OR MORE ELECTRONIC HANDHELD UNITS FROM A DATA STORE ON OR ASSOCIATED WITH A PERSONAL COMPUTER OR A SERVER; SOFTWARE FOR THE SYNCHRONIZATION OF DATA BETWEEN A REMOTE STATION OR UNIT AND A FIXED OR REMOTE STATION OR UNIT; ELECTRONIC ORGANIZERS; PERSONAL DIGITAL ASSISTANTS; HANDHELD COMPUTERS AND ORGANIZERS IN THE NATURE OF A HANDHELD COMPUTING DEVICE AND A CRADLE WHICH ALLOWS THE EXCHANGE OF INFORMATION BETWEEN THE HANDHELD COMPUTING DEVICE AND A DESKTOP COMPUTER; CAR-

CLASS 9—(Continued).

RYING CASES FOR THE FOREGOING GOODS AND REPLACEMENT PARTS FOR THE FOREGOING GOODS; INSTRUCTION MANUALS DISTRIBUTED WITH THE FOREGOING; PREPAID MAGNETICALLY ENCODED TELEPHONE CALLING CARDS; PREPAID CELLULAR TELEPHONES USED IN CONNECTION WITH PREPAID AIRTIME CELLULAR TELEPHONE COMMUNICATION SERVICES; MAGNETICALLY ENCODED CREDIT CARDS; MAGNETICALLY ENCODED DEBIT CARDS; CELLULAR PHONES AND MAGNETICALLY ENCODED DEBIT CARDS SOLD TOGETHER AS A UNIT (U.S. CLS. 21, 23, 26, 36 AND 38).

SETH A. RAPPAPORT, EXAMINING ATTORNEY

CLASS 9—(Continued).

SN 77-100,329. SONY MANUFACTURING SYSTEMS KABUSHIKI KAISHA, DBA SONY MANUFACTURING SYSTEMS CORPORATION, KUKI-SHI, SAITAMA, JAPAN, FILED 2-6-2007.

chicon

SN 77-096,214. DANA INNOVATIONS, SAN CLEMENTE, CA. FILED 1-31-2007.

MODERNO

THE MARK CONSISTS OF STANDARD CHARACTERS WITHOUT CLAIM TO ANY PARTICULAR FONT, STYLE, SIZE, OR COLOR.

THE ENGLISH TRANSLATION OF THE SPANISH WORD "MODERNO" IS MODERN.

FOR AUDIO EQUIPMENT, NAMELY, LOUD SPEAKERS, SUBWOOFERS, IN-WALL AUDIO SPEAKERS, IN-CEILING AUDIO SPEAKERS, VOLUME CONTROLLERS, AUDIO SWITCHES, AUDIO AMPLIFIERS AND CONNECTION CABLES FOR AUDIO (U.S. CLS. 21, 23, 26, 36 AND 38).

BERYL GARDNER, EXAMINING ATTORNEY

THE MARK CONSISTS OF STANDARD CHARACTERS WITHOUT CLAIM TO ANY PARTICULAR FONT, STYLE, SIZE, OR COLOR.

PRIORITY CLAIMED UNDER SEC. 44(D) ON JAPAN APPLICATION NO. 2007-007774, FILED 2-1-2007, REG. NO. 5127821, DATED 4-11-2008, EXPIRES 4-11-2020.

FOR OPTICAL APPARATUS AND INSTRUMENTS NOT FOR MEDICAL USE, NAMELY, LASER-LIGHT GENERATORS (U.S. CLS. 21, 23, 26, 36 AND 38).

GIANCARLO CASTRO, EXAMINING ATTORNEY

SN 77-100,343. SONY MANUFACTURING SYSTEMS KABUSHIKI KAISHA, DBA SONY MANUFACTURING SYSTEMS CORPORATION, KUKI-SHI, SAITAMA, JAPAN, FILED 2-6-2007.

SN 77-098,526. NORDSTROM, DAVID A., SAN CLEMENTE, CA. FILED 2-2-2007.

InsureAudit

chicon

THE MARK CONSISTS OF STANDARD CHARACTERS WITHOUT CLAIM TO ANY PARTICULAR FONT, STYLE, SIZE, OR COLOR.

FOR COMPUTER APPLICATION SOFTWARE FOR PERFORMING PROCESSING, VIEWING, PRINTING, TRANSMITTING, MANAGEMENT, STORAGE AND TRANSFER OF VARIOUS TYPES OF DOCUMENTS, FILES AND DATA, E-MAIL AND TEXT MESSAGES, NAMELY, SPREADSHEETS, TEXT DOCUMENTS, PRESENTATIONS AND GRAPHIC IMAGES FOR USE IN THE FIELD OF PREMIUM AUDITING (U.S. CLS. 21, 23, 26, 36 AND 38).

SARA THOMAS, EXAMINING ATTORNEY

PRIORITY CLAIMED UNDER SEC. 44(D) ON JAPAN APPLICATION NO. 2007-007775, FILED 2-1-2007, REG. NO. 5127822, DATED 4-22-2008, EXPIRES 4-22-2020.

FOR OPTICAL APPARATUS AND INSTRUMENTS NOT FOR MEDICAL USE, NAMELY, LASER-LIGHT GENERATORS (U.S. CLS. 21, 23, 26, 36 AND 38).

GIANCARLO CASTRO, EXAMINING ATTORNEY

CLASS 9—(Continued).

SN 77-102,531. MARY JO SCHULER, OAK PARK, IL. FILED
2-8-2007.

FINAL FINISH FINE PRINT

THE MARK CONSISTS OF STANDARD CHARACTERS WITHOUT CLAIM TO ANY PARTICULAR FONT, STYLE, SIZE, OR COLOR.

FOR ELECTRONIC PUBLICATIONS RECORDED ON COMPUTER MEDIA, NAMELY, MANUALS FEATURING QUICK REFERENCE "HOW TO" INFORMATION ON A WIDE VARIETY OF SUBJECTS, NAMELY, HOME MAINTENANCE, REPAIR AND IMPROVEMENT, FINANCIAL MANAGEMENT, CHARITABLE FOUNDATION START UP PROCEDURES, AND PET CARE; ELECTRONIC PUBLICATIONS RECORDED ON COMPUTER MEDIA, NAMELY, HOME MANUALS AND FORMS FOR ACCOUNTING, BUSINESS, AND BOOK-KEEPING PURPOSES; COMPUTER ACCOUNTING SOFTWARE; COMPUTER SOFTWARE FOR DATABASE MANAGEMENT FOR USE BY HIGH WEALTH INDIVIDUALS AND FAMILIES IN MANAGING THEIR ESTATE, NAMELY PERSONAL AND REAL PROPERTY, FINANCIAL ACCOUNTS, CALENDAR, DOCUMENTS, AND COMMUNICATIONS; COMPUTER PROGRAMS FOR DATABASE MANAGEMENT; COMPUTER PROGRAMS FOR PERSONAL AND REAL ESTATE PROPERTY INFORMATION MANAGEMENT; COMPUTER PROGRAMS FOR CONTACT INFORMATION DATABASE MANAGEMENT; COMPUTER SOFTWARE TO ENABLE PRIVATE AND SECURE REAL TIME ELECTRONIC COMMUNICATION OVER A COMPUTER NETWORK (U.S. CLS. 21, 23, 26, 36 AND 38).

MATTHEW EINSTEIN, EXAMINING ATTORNEY

CLASS 9—(Continued).

SN 77-102,554. MARY JO SCHULER, OAK PARK, IL. FILED
2-8-2007.

FINAL FINISH

THE MARK CONSISTS OF STANDARD CHARACTERS WITHOUT CLAIM TO ANY PARTICULAR FONT, STYLE, SIZE, OR COLOR.

FOR ELECTRONIC PUBLICATIONS RECORDED ON COMPUTER MEDIA, NAMELY, MANUALS FEATURING QUICK REFERENCE "HOW TO" INFORMATION ON A WIDE VARIETY OF SUBJECTS, NAMELY, HOME MAINTENANCE, REPAIR AND IMPROVEMENT, FINANCIAL MANAGEMENT, CHARITABLE FOUNDATION START UP PROCEDURES, AND PET CARE; ELECTRONIC PUBLICATIONS RECORDED ON COMPUTER MEDIA, NAMELY, HOME MANUALS AND FORMS FOR ACCOUNTING, BUSINESS, AND BOOK-KEEPING PURPOSES; COMPUTER ACCOUNTING SOFTWARE; COMPUTER SOFTWARE FOR DATABASE MANAGEMENT FOR USE BY HIGH WEALTH INDIVIDUALS AND FAMILIES IN MANAGING THEIR ESTATE, NAMELY PERSONAL AND REAL PROPERTY, FINANCIAL ACCOUNTS, CALENDAR, DOCUMENTS, AND COMMUNICATIONS; COMPUTER PROGRAMS FOR DATABASE MANAGEMENT; COMPUTER PROGRAMS FOR PERSONAL AND REAL ESTATE PROPERTY INFORMATION MANAGEMENT; COMPUTER PROGRAMS FOR CONTACT INFORMATION DATABASE MANAGEMENT; COMPUTER SOFTWARE TO ENABLE PRIVATE AND SECURE REAL TIME ELECTRONIC COMMUNICATION OVER A COMPUTER NETWORK (U.S. CLS. 21, 23, 26, 36 AND 38).

MATTHEW EINSTEIN, EXAMINING ATTORNEY

SN 77-106,968. ALLURDATA, INC., GREENWOOD VIL-
LAGE, CO. FILED 2-14-2007.

ALLURDATA

THE MARK CONSISTS OF STANDARD CHARACTERS WITHOUT CLAIM TO ANY PARTICULAR FONT, STYLE, SIZE, OR COLOR.

FOR COMPUTER SOFTWARE FOR DATA AND INFORMATION MANAGEMENT; COMPUTER SOFTWARE FOR CUSTOMIZATION OF DATABASES (U.S. CLS. 21, 23, 26, 36 AND 38).

TINA KUAN, EXAMINING ATTORNEY

CLASS 9—(Continued).

SN 77-107,972. ALLEN SYSTEMS GROUP, INC., NAPLES, FL. FILED 2-15-2007.

ASG-Safari.OLAP

THE MARK CONSISTS OF STANDARD CHARACTERS WITHOUT CLAIM TO ANY PARTICULAR FONT, STYLE, SIZE, OR COLOR.

NO CLAIM IS MADE TO THE EXCLUSIVE RIGHT TO USE "OLAP", APART FROM THE MARK AS SHOWN.

FOR COMPUTER SOFTWARE FOR REPORTING AND DRILL-DOWN FOR USERS OF ALL SKILL LEVELS, FOR THE IDENTIFICATION OF RELATIONSHIP PATTERNS, TRENDS, AND CORRELATIONS WITHIN INFORMATION ASSETS VIA EXCEPTION HIGHLIGHTING (U.S. CLS. 21, 23, 26, 36 AND 38).

FIRST USE 1-1-1997; IN COMMERCE 1-1-1997.
ANNE E. GUSTASON, EXAMINING ATTORNEY

SN 77-115,860. ALINEAN, INC., ORLANDO, FL. FILED 2-26-2007.

ROI Analyst

THE MARK CONSISTS OF STANDARD CHARACTERS WITHOUT CLAIM TO ANY PARTICULAR FONT, STYLE, SIZE, OR COLOR.

NO CLAIM IS MADE TO THE EXCLUSIVE RIGHT TO USE "ROI", APART FROM THE MARK AS SHOWN.

SEC. 2(F).

FOR COMPUTER SOFTWARE FOR MEASUREMENT OF RETURN ON INVESTMENT, INTERNAL RATES OF RETURN, NET PRESENT VALUE, AND OTHER COST/BENEFIT ANALYSIS OF THE VALUE OF INFORMATION TECHNOLOGY INVESTMENTS (U.S. CLS. 21, 23, 26, 36 AND 38).

FIRST USE 1-1-2001; IN COMMERCE 1-1-2001.
STEVEN R. FOSTER, EXAMINING ATTORNEY

SN 77-119,453. STABILA MESSGERÄTE GUSTAV ULLRICH GMBH, ANNWEILER AM TRIFELS, FED REP GERMANY, FILED 3-1-2007.

STABILA

THE MARK CONSISTS OF STANDARD CHARACTERS WITHOUT CLAIM TO ANY PARTICULAR FONT, STYLE, SIZE, OR COLOR.

OWNER OF U.S. REG. NOS. 1,817,087 AND 3,124,207.

FOR SPIRIT LEVELS; LASER LEVEL MEASURING MACHINES; LASER LEVEL INDICATORS (U.S. CLS. 21, 23, 26, 36 AND 38).

CAROLYN GRAY, EXAMINING ATTORNEY

CLASS 9—(Continued).

SN 77-121,691. AURORA MEDICAL LLC, LANCASTER, PA. FILED 3-3-2007.



FOR INTERNET PHONES; VIDEO PHONES; WEB CONSOLES (U.S. CLS. 21, 23, 26, 36 AND 38).
DANIEL CAPSHAW, EXAMINING ATTORNEY

SN 77-126,835. CABLE MANUFACTURING & ASSEMBLY, INC., BOLIVAR, OH. FILED 3-9-2007.



THE MARK CONSISTS OF STYLIZED LETTERS "CMA" IN STYLIZED RECTANGULAR BOX.

FOR ELECTRIC CONTROL CABLES MADE PRIMARILY OF METAL FOR USE IN THE AUTOMOTIVE INDUSTRY, NAMELY, CABLES FOR USE WITH TAILGATES, ACCELERATOR CONTROLS, SHIFT CABLES, HOOD RELEASES, FUEL DOOR RELEASES, HEATER AND VENT CONTROLS; FOR USE IN THE HEAVY TRUCK INDUSTRY, NAMELY, HOOD CHECK CABLES, CABLES FOR USE WITH POWER TAKE OFF CONTROLS, CLUTCHES, ACCELERATOR CABLES, REMOTE DOOR AND LATCH RELEASES, TRAILER DOOR CABLES; FOR USE IN THE MEDICAL DEVICE INDUSTRY, NAMELY, CABLES FOR USE WITH STYLETTS, SURGICAL IMPLANTS, REMOTE CONTROLS, HEART MONITOR LEADS, SUTURES, DRIVE CABLES, DISPOSABLE PRODUCTS; FOR USE IN THE FURNITURE INDUSTRY, NAMELY, HOSPITAL BED DRIVE CABLES, CABLES FOR USE WITH GAS SPRING RELEASES, RECLINER RELEASES, CRIB SIDE RELEASES, DESK AND CABINET SECURITY CABLES; FOR USE IN THE RECREATIONAL VEHICLE EQUIPMENT INDUSTRY, NAMELY, CABLES FOR USE WITH PUSH-PULL CONTROLS, HVAC CONTROLS, SAFETY AND RESTRAINT CABLES; FOR USE IN THE BOATING AND MARINE INDUSTRY, NAMELY, CABLES FOR USE WITH PUSH-PULL THROTTLE CONTROLS, GUY, RIGGING, LIFT CABLES, STEERING SYSTEMS; FOR USE IN THE SECURITY PRODUCTS INDUSTRY, NAMELY, CABLES FOR USE WITH RESTRAINTS, TIE-DOWNS, THEFT DETERRENT CABLES; FOR USE IN THE SPORTING GOODS INDUSTRY, NAMELY, WEIGHT LIFTING CABLES, RESTRAINT CABLES, CABLES FOR USE WITH SPEED AND TENSION ADJUSTMENT CONTROLS, SAFETY CABLES, BRAKE AND SHIFT CABLES, CABLES FOR USE WITH DOWN RIGGERS; FOR USE IN THE FARM AND CONSTRUCTION EQUIPMENT INDUSTRY, NAMELY, CABLES FOR USE WITH POWER TAKE OFF CONTROLS, VERNIER THROTTLE CONTROLS, SAFETY RESTRAINT AND LIFT CABLES; FOR USE IN THE APPLIANCE INDUSTRY, NAMELY, CABLES FOR USE WITH DOOR RESTRAINTS, DRUM DRIVES, PUSH-PULL CONTROLS; FOR USE IN THE ELECTRONIC PRODUCTS INDUSTRY, NAMELY, DRIVE CABLES, CABLES FOR USE WITH DOOR RESTRAINTS, PUSH-PULL CONTROLS, LANYARDS, RIBBON DRIVES, AND SOLENOID ACTUATION; AND

CLASS 9—(Continued).

FOR USE IN THE AIRCRAFT AND AEROSPACE INDUSTRY, NAMELY, AIRCRAFT FLIGHT CONTROL CABLES, CABLES FOR USE WITH SEAT BACK RELEASES, SATELLITE PANEL RESTRAINTS, GROUNDING AND ENGINE CONTROL CABLES; ELECTRIC CABLE OPERATORS MADE PRIMARILY OF METAL FOR USE IN THE AUTOMOTIVE INDUSTRY, NAMELY, CABLE OPERATORS FOR USE WITH TAILGATES, ACCELERATOR CONTROLS, SHIFT CABLES, HOOD RELEASES, FUEL DOOR RELEASES, HEATER AND VENT CONTROLS; FOR USE IN THE HEAVY TRUCK INDUSTRY, NAMELY, CABLE OPERATORS FOR USE WITH HOOD CHECK CABLES, POWER TAKE OFF CONTROLS, CLUTCHES, ACCELERATOR CABLES, REMOTE DOOR AND LATCH RELEASES, TRAILER DOOR CABLES; FOR USE IN THE MEDICAL DEVICE INDUSTRY, NAMELY, CABLE OPERATORS FOR USE WITH STYLETS, SURGICAL IMPLANTS, REMOTE CONTROLS, HEART MONITOR LEADS, SUTURES, DRIVE CABLES, DISPOSABLE PRODUCTS; FOR USE IN THE FURNITURE INDUSTRY, NAMELY, CABLE OPERATORS FOR USE WITH HOSPITAL BED DRIVE CABLES, GAS SPRING RELEASES, RECLINER RELEASES, CRIB SIDE RELEASES, DESK AND CABINET SECURITY CABLES; FOR USE IN THE RECREATIONAL VEHICLE EQUIPMENT INDUSTRY, NAMELY, CABLE OPERATORS FOR USE WITH PUSH-PULL CONTROLS, HVAC CONTROLS, SAFETY AND RESTRAINT CABLES; FOR USE IN THE BOATING AND MARINE INDUSTRY, NAMELY, CABLE OPERATORS FOR USE WITH PUSH-PULL THROTTLE CONTROLS, GUY, RIGGING, LIFT CABLES, STEERING SYSTEMS; FOR USE IN THE SECURITY PRODUCTS INDUSTRY, NAMELY, CABLE OPERATORS FOR USE WITH RESTRAINTS, TIE-DOWNS, THEFT DETERRENT CABLES; FOR USE IN THE SPORTING GOODS INDUSTRY, NAMELY, CABLE OPERATORS FOR USE WITH WEIGHT LIFTING CABLES, RESTRAINT CABLES, SPEED AND TENSION ADJUSTMENT CONTROLS, SAFETY CABLES, BRAKE AND SHIFT CABLES, DOWN RIGGERS; FOR USE IN THE FARM AND CONSTRUCTION EQUIPMENT INDUSTRY, NAMELY, CABLE OPERATORS FOR USE WITH POWER TAKE OFF CONTROLS, VERNIER THROTTLE CONTROLS, SAFETY RESTRAINT AND LIFT CABLES; FOR USE IN THE APPLIANCE INDUSTRY, NAMELY, CABLE OPERATORS FOR USE WITH DOOR RESTRAINTS, DRUM DRIVES, PUSH-PULL CONTROLS; FOR USE IN THE ELECTRONIC PRODUCTS INDUSTRY, NAMELY, CABLE OPERATORS FOR USE WITH DRIVE CABLES, DOOR RESTRAINTS, PUSH-PULL CONTROLS, LANYARDS, RIBBON DRIVES, AND SOLENOID ACTUATION; AND FOR USE IN THE AIRCRAFT AND AEROSPACE INDUSTRY, NAMELY, CABLE OPERATORS FOR USE WITH AIRCRAFT FLIGHT CONTROL CABLES, SEAT BACK RELEASES, SATELLITE PANEL RESTRAINTS, GROUNDING AND ENGINE CONTROL CABLES; CABLE OPERATED ELECTRIC ACTUATORS MADE PRIMARILY OF METAL FOR USE IN THE AUTOMOTIVE INDUSTRY, NAMELY, ACTUATORS FOR USE WITH TAILGATES, ACCELERATOR CONTROLS, SHIFT CABLES, HOOD RELEASES, FUEL DOOR RELEASES, HEATER AND VENT CONTROLS; FOR USE IN THE HEAVY TRUCK INDUSTRY, NAMELY, ACTUATORS FOR USE WITH HOOD CHECK CABLES, POWER TAKE OFF CONTROLS, CLUTCHES, ACCELERATOR CABLES, REMOTE DOOR AND LATCH RELEASES, TRAILER DOOR CABLES; FOR USE IN THE MEDICAL DEVICE INDUSTRY, NAMELY, ACTUATORS FOR USE WITH STYLETS, SURGICAL IMPLANTS, REMOTE CONTROLS, HEART MONITOR LEADS, SUTURES, DRIVE CABLES, DISPOSABLE PRODUCTS; FOR USE IN THE FURNITURE INDUSTRY, NAMELY, ACTUATORS FOR USE WITH HOSPITAL BED DRIVE CABLES, GAS SPRING RELEASES, RECLINER RELEASES, CRIB SIDE RELEASES, DESK AND CABINET SECURITY CABLES; FOR USE IN THE RECREATIONAL VEHICLE EQUIPMENT INDUSTRY, NAMELY, ACTUATORS FOR USE WITH PUSH-PULL CONTROLS, HVAC CONTROLS, SAFETY AND RESTRAINT CABLES; FOR USE IN THE BOATING AND MARINE INDUSTRY, NAMELY, ACTUATORS FOR USE WITH PUSH-PULL THROTTLE CONTROLS, GUY, RIGGING, LIFT CABLES, STEERING SYSTEMS; FOR USE IN THE SECURITY PRODUCTS INDUSTRY, NAMELY, ACTUATORS FOR USE WITH RESTRAINTS, TIE-DOWNS, THEFT DETERRENT CABLES; FOR USE IN THE SPORTING GOODS INDU-

CLASS 9—(Continued).

TRY, NAMELY, ACTUATORS FOR USE WITH WEIGHT LIFTING CABLES, RESTRAINT CABLES, SPEED AND TENSION ADJUSTMENT CONTROLS, SAFETY CABLES, BRAKE AND SHIFT CABLES, DOWN RIGGERS; FOR USE IN THE FARM AND CONSTRUCTION EQUIPMENT INDUSTRY, NAMELY, ACTUATORS FOR USE WITH POWER TAKE OFF CONTROLS, VERNIER THROTTLE CONTROLS, SAFETY RESTRAINT AND LIFT CABLES; FOR USE IN THE APPLIANCE INDUSTRY, NAMELY, ACTUATORS FOR USE WITH DOOR RESTRAINTS, DRUM DRIVES, PUSH-PULL CONTROLS; FOR USE IN THE ELECTRONIC PRODUCTS INDUSTRY, NAMELY, ACTUATORS FOR USE WITH DRIVE CABLES, DOOR RESTRAINTS, PUSH-PULL CONTROLS, LANYARDS, RIBBON DRIVES, AND SOLENOID ACTUATION; AND FOR USE IN THE AIRCRAFT AND AEROSPACE INDUSTRY, NAMELY, ACTUATORS FOR USE WITH AIRCRAFT FLIGHT CONTROL CABLES, SEAT BACK RELEASES, SATELLITE PANEL RESTRAINTS, GROUNDING AND ENGINE CONTROL CABLES (U.S. CLS. 21, 23, 26, 36 AND 38).

FIRST USE 12-31-1992; IN COMMERCE 12-31-1992.
MARGARET POWER, EXAMINING ATTORNEY

SN 77-129,218. VARCO I/P, INC., HOUSTON, TX. FILED 3-13-2007.

DRILLINK

THE MARK CONSISTS OF STANDARD CHARACTERS WITHOUT CLAIM TO ANY PARTICULAR FONT, STYLE, SIZE, OR COLOR.

FOR ELECTRONIC INSTRUMENTATION, COMPRISED OF AN ELECTRONIC INTERFACE, COMPUTER HARDWARE, AND COMPUTER SOFTWARE FOR COLLECTING, RECORDING, PROCESSING, ANALYZING, AND DISPLAYING DATA AND INFORMATION ABOUT DRILLING PARAMETERS AND OPERATIONS, AND FOR MONITORING AND CONTROLLING DRILLING EQUIPMENT FUNCTIONS (U.S. CLS. 21, 23, 26, 36 AND 38).

FIRST USE 5-29-2007; IN COMMERCE 5-29-2007.
BILL DAWE, EXAMINING ATTORNEY

SN 77-130,480. BLUE Q CORPORATION, PITTSFIELD, MA. FILED 3-14-2007.

I'M NOT GAY, I JUST REALLY LOVE RAINBOWS

THE MARK CONSISTS OF STANDARD CHARACTERS WITHOUT CLAIM TO ANY PARTICULAR FONT, STYLE, SIZE, OR COLOR.

FOR MAGNETS (U.S. CLS. 21, 23, 26, 36 AND 38).
FIRST USE 1-10-2007; IN COMMERCE 1-10-2007.
KEVON CHISOLM, EXAMINING ATTORNEY

CLASS 9—(Continued).

SN 77-132,337. FLOWLINE, INC., LOS ALAMITOS, CA.
FILED 3-15-2007.

CLASS 9—(Continued).

SN 77-134,760. DE LA RUE INTERNATIONAL LIMITED,
BASINGSTOKE, HAMPSHIRE, ENGLAND, FILED 3-19-
2007.

WEBCAL

THE MARK CONSISTS OF STANDARD CHARACTERS WITHOUT CLAIM TO ANY PARTICULAR FONT, STYLE, SIZE, OR COLOR.

FOR COMPUTER SOFTWARE FOR THE CONFIGURATION OF MEASUREMENT AND MONITORING DEVICES IN THE FIELDS OF LEVEL AND FLOW SENSORS (U.S. CLS. 21, 23, 26, 36 AND 38).

GINA FINK, EXAMINING ATTORNEY



HPF
HIGH PERFORMANCE FEED

SN 77-133,775. CONTROLTHINK LC, OREM, UT. FILED 3-
17-2007.

ThinkPanel

THE MARK CONSISTS OF STANDARD CHARACTERS WITHOUT CLAIM TO ANY PARTICULAR FONT, STYLE, SIZE, OR COLOR.

FOR PORTABLE AND NON-PORTABLE ELECTRONIC LCD AND ORGANIC LIGHT EMITTING DIODE (OLED) DISPLAY SCREENS, WITH TOUCHSCREEN CAPABILITIES AND COMPUTER HARDWARE AND SOFTWARE FOR THE AUTOMATED CONTROL AND MANAGEMENT OF HOUSEHOLD ELECTRICAL AND ELECTRONIC EQUIPMENT IN THE NATURE OF LIGHTING, CLIMATE CONTROL, SECURITY, MUSIC AND RADIO ENTERTAINMENT, AND INTERCOM APPLIANCES AND FIXTURES; PORTABLE AND NON-PORTABLE ELECTRONIC LCD AND ORGANIC LIGHT EMITTING DIODE (OLED) DISPLAY SCREENS, WITH COMPUTER HARDWARE AND SOFTWARE FOR THE AUTOMATED CONTROL AND MANAGEMENT OF HOUSEHOLD ELECTRICAL AND ELECTRONIC EQUIPMENT IN THE NATURE OF LIGHTING, CLIMATE CONTROL, SECURITY, MUSIC AND RADIO ENTERTAINMENT, AND INTERCOM APPLIANCES AND FIXTURES; PORTABLE AND NON-PORTABLE ELECTRONIC LCD AND ORGANIC LIGHT EMITTING DIODE (OLED) DISPLAY SCREENS, WITH TOUCHSCREEN CAPABILITIES; PORTABLE AND NON-PORTABLE ELECTRONIC LCD AND ORGANIC LIGHT EMITTING DIODE (OLED) DISPLAY SCREENS (U.S. CLS. 21, 23, 26, 36 AND 38).

BILL DAWE, EXAMINING ATTORNEY

PRIORITY CLAIMED UNDER SEC. 44(D) ON ERPN CMNTY TM OFC APPLICATION NO. 005764451, FILED 3-16-2007, REG. NO. 005764451, DATED 2-25-2008, EXPIRES 3-16-2017.

NO CLAIM IS MADE TO THE EXCLUSIVE RIGHT TO USE "HIGH PERFORMANCE FEED", APART FROM THE MARK AS SHOWN.

THE MARK CONSISTS OF THE LETTERS "H", "P" AND "F" IN STYLIZED FORM OVER THE WORDS "HIGH PERFORMANCE FEED".

FOR APPARATUS, INSTRUMENTS AND MACHINES FOR HOLDING, SORTING, HANDLING, PROCESSING AND COUNTING MONEY, COINS, BANK NOTES AND CURRENCY, NAMELY, BANK NOTE DISPENSERS, PAPER CURRENCY DISPENSERS, COIN DISPENSERS; NOTE ACCEPTORS, CURRENCY ACCEPTORS AND COIN ACCEPTORS FOR SEPARATING GOOD COINS AND BANK NOTES FROM COUNTERFEITS; CASH CASSETTES AND ATM CASSETTES, NAMELY, BANK NOTE CASSETTES, FEED CASSETTES, CASSETTES FOR CONTAINING MONEY, ELECTRONIC LOCKING CASSETTES FOR CONTAINING MONEY, MECHANICAL LOCKING CASSETTES FOR CONTAINING MONEY, ALL OF WHICH BEING MECHANISMS DESIGNED FOR USE IN CONJUNCTION WITH ATM MACHINES FOR THE PURPOSE OF ACCEPTING, SECURELY STORING AND DISPENSING CURRENCY; AUTOMATED MACHINES FOR DISPENSING VOUCHERS, VOUCHERS OF VALUE AND TICKETS IN RETURN FOR MONEY; CASH COUNTERS, NAMELY, CURRENCY COUNTING MACHINES; COMPUTER SOFTWARE FOR USE IN HANDLING, HOLDING, SORTING, COUNTING OR PROCESSING CURRENCY; MACHINES FOR CURRENCY, COIN AND BANK NOTE HANDLING, HOLDING, SORTING, COUNTING OR PROCESSING; AND STRUCTURAL PARTS FOR ALL OF THE AFORESAID GOODS (U.S. CLS. 21, 23, 26, 36 AND 38).

MICHAEL TANNER, EXAMINING ATTORNEY

CLASS 9—(Continued).

SN 77-134,773. DE LA RUE INTERNATIONAL LIMITED, BASINGSTOKE, HAMPSHIRE, ENGLAND, FILED 3-19-2007.



SCL
SMART CASSETTE LOGIC

PRIORITY CLAIMED UNDER SEC. 44(D) ON ERPNTY TM OFC APPLICATION NO. 005763818, FILED 3-16-2007, REG. NO. 005763818, DATED 2-25-2008, EXPIRES 3-16-2017.

NO CLAIM IS MADE TO THE EXCLUSIVE RIGHT TO USE "SMART CASSETTE LOGIC", APART FROM THE MARK AS SHOWN.

THE MARK CONSISTS OF THE LETTERS "S", "C" AND "L" IN STYLIZED FORM OVER THE WORDS "SMART CASSETTE LOGIC".

FOR APPARATUS, INSTRUMENTS AND MACHINES FOR HOLDING, SORTING, HANDLING, PROCESSING AND COUNTING MONEY, COINS, BANK NOTES AND CURRENCY, NAMELY, BANK NOTE DISPENSERS, PAPER CURRENCY DISPENSERS, COIN DISPENSERS; NOTE ACCEPTORS, CURRENCY ACCEPTORS AND COIN ACCEPTORS FOR SEPARATING GOOD COINS AND BANK NOTES FROM COUNTERFEITS; CASH CASSETTES AND ATM CASSETTES, NAMELY, BANK NOTE CASSETTES, FEED CASSETTES, CASSETTES FOR CONTAINING MONEY, ELECTRONIC LOCKING CASSETTES FOR CONTAINING MONEY, MECHANICAL LOCKING CASSETTES FOR CONTAINING MONEY, ALL OF WHICH BEING MECHANISMS DESIGNED FOR USE IN CONJUNCTION WITH ATM MACHINES FOR THE PURPOSE OF ACCEPTING, SECURELY STORING AND DISPENSING CURRENCY; AUTOMATED MACHINES FOR DISPENSING VOUCHERS, VOUCHERS OF VALUE AND TICKETS IN RETURN FOR MONEY; CASH COUNTERS, NAMELY, CURRENCY COUNTING MACHINES; COMPUTER SOFTWARE FOR USE IN HANDLING, HOLDING, SORTING, COUNTING OR PROCESSING CURRENCY; MACHINES FOR CURRENCY, COIN AND BANK NOTE HANDLING, HOLDING, SORTING, COUNTING OR PROCESSING; AND STRUCTURAL PARTS FOR ALL OF THE AFORESAID GOODS (U.S. CLS. 21, 23, 26, 36 AND 38).

MICHAEL TANNER, EXAMINING ATTORNEY

CLASS 9—(Continued).

SN 77-134,784. DE LA RUE INTERNATIONAL LIMITED, BASINGSTOKE, HAMPSHIRE, ENGLAND, FILED 3-19-2007.



IDP
INTELLIGENT DOUBLE DETECTION

PRIORITY CLAIMED UNDER SEC. 44(D) ON ERPNTY TM OFC APPLICATION NO. 005764188, FILED 3-16-2007, REG. NO. 005764188, DATED 2-25-2008, EXPIRES 3-16-2017.

NO CLAIM IS MADE TO THE EXCLUSIVE RIGHT TO USE "INTELLIGENT DOUBLE DETECTION", APART FROM THE MARK AS SHOWN.

THE MARK CONSISTS OF THE LETTERS "I", "D" AND "D" IN STYLIZED FORM OVER THE WORDS "INTELLIGENT DOUBLE DETECTION".

FOR APPARATUS, INSTRUMENTS AND MACHINES FOR HOLDING, SORTING, HANDLING, PROCESSING AND COUNTING MONEY, COINS, BANK NOTES AND CURRENCY, NAMELY, BANK NOTE DISPENSERS, PAPER CURRENCY DISPENSERS, COIN DISPENSERS; NOTE ACCEPTORS, CURRENCY ACCEPTORS AND COIN ACCEPTORS FOR SEPARATING GOOD COINS AND BANK NOTES FROM COUNTERFEITS; CASH CASSETTES AND ATM CASSETTES, NAMELY, BANK NOTE CASSETTES, FEED CASSETTES, CASSETTES FOR CONTAINING MONEY, ELECTRONIC LOCKING CASSETTES FOR CONTAINING MONEY, MECHANICAL LOCKING CASSETTES FOR CONTAINING MONEY, ALL OF WHICH BEING MECHANISMS DESIGNED FOR USE IN CONJUNCTION WITH ATM MACHINES FOR THE PURPOSE OF ACCEPTING, SECURELY STORING AND DISPENSING CURRENCY; AUTOMATED MACHINES FOR DISPENSING VOUCHERS, VOUCHERS OF VALUE AND TICKETS IN RETURN FOR MONEY; CASH COUNTERS, NAMELY, CURRENCY COUNTING MACHINES; COMPUTER SOFTWARE FOR USE IN HANDLING, HOLDING, SORTING, COUNTING OR PROCESSING CURRENCY; MACHINES FOR CURRENCY, COIN AND BANK NOTE HANDLING, HOLDING, SORTING, COUNTING OR PROCESSING; AND STRUCTURAL PARTS FOR ALL OF THE AFORESAID GOODS (U.S. CLS. 21, 23, 26, 36 AND 38).

MICHAEL TANNER, EXAMINING ATTORNEY

SN 77-137,577. AEGIS PUBLICATIONS, LLC, NEWTOWN, PA. FILED 3-22-2007.

**FUNCTIONAL ESTHETICS &
RESTORATIVE DENTISTRY**

THE MARK CONSISTS OF STANDARD CHARACTERS WITHOUT CLAIM TO ANY PARTICULAR FONT, STYLE, SIZE, OR COLOR.

NO CLAIM IS MADE TO THE EXCLUSIVE RIGHT TO USE "RESTORATIVE DENTISTRY", APART FROM THE MARK AS SHOWN.

FOR DOWNLOADABLE ELECTRONIC PUBLICATIONS IN THE NATURE OF JOURNALS, NEWSLETTERS, SUPPLEMENTS, MONOGRAPHS AND FEATURE REPORTS IN THE FIELD OF DENTISTRY (U.S. CLS. 21, 23, 26, 36 AND 38).

DOMINICK J. SALEMI, EXAMINING ATTORNEY

CLASS 9—(Continued).

SN 77-148,026. LUTWAK, HOWARD P., WESTLAKE VILLAGE, CA. FILED 4-4-2007.

The Relaxing Guitar

THE MARK CONSISTS OF STANDARD CHARACTERS WITHOUT CLAIM TO ANY PARTICULAR FONT, STYLE, SIZE, OR COLOR.

NO CLAIM IS MADE TO THE EXCLUSIVE RIGHT TO USE "GUITAR", APART FROM THE MARK AS SHOWN. FOR MUSICAL SOUND RECORDINGS (U.S. CLS. 21, 23, 26, 36 AND 38).

DOMINICK J. SALEMI, EXAMINING ATTORNEY

SN 77-154,575. CONSCIOUS MEDIA NETWORK INC., LOOMIS, CA. FILED 4-11-2007.



NO CLAIM IS MADE TO THE EXCLUSIVE RIGHT TO USE "CONSCIOUS MEDIA NETWORK", APART FROM THE MARK AS SHOWN.

THE COLOR(S) BLACK, WHITE, GRAY, BLUE, RED, ORANGE AND YELLOW IS/ARE CLAIMED AS A FEATURE OF THE MARK.

THE MARK CONSISTS OF WHITE LETTERING ON A BLACK ROUNDEL WITH A CENTRE SECTION OF BLUE, RED, ORANGE AND YELLOW MERGING INTO THE CENTER. THE LETTERS "C", "M", AND "N" ARE IN BLACK IN THE CENTRE OF THE IMAGE. THE RIM OF THE OUTER CIRCLE IS GRAY.

FOR DOWNLOADABLE FILMS AND TV PROGRAMS FEATURING ENLIGHTENMENT, HUMAN POTENTIAL, SCIENCE AND CONSCIOUSNESS PROVIDED VIA A VIDEO-ON-DEMAND SERVICE; DOWNLOADABLE MULTIMEDIA FILE CONTAINING ARTWORK, TEXT, AUDIO, VIDEO, GAMES, AND INTERNET WEB LINKS RELATING TO ENLIGHTENMENT, HUMAN POTENTIAL, SCIENCE AND CONSCIOUSNESS; DOWNLOADABLE VIDEO RECORDINGS FEATURING ENLIGHTENMENT, HUMAN POTENTIAL, SCIENCE AND CONSCIOUSNESS (U.S. CLS. 21, 23, 26, 36 AND 38).

FIRST USE 4-1-2005; IN COMMERCE 4-1-2005.
MICHAEL WEBSTER, EXAMINING ATTORNEY

CLASS 9—(Continued).

SN 77-162,804. CORBIN RUSSWIN, INC., BERLIN, CT. FILED 4-23-2007.

SECUREBOLT

THE MARK CONSISTS OF STANDARD CHARACTERS WITHOUT CLAIM TO ANY PARTICULAR FONT, STYLE, SIZE, OR COLOR.

SEC. 2(F).

FOR ELECTROMECHANICAL EXIT DEVICES CONSISTING OF AN ELECTROMECHANICAL DOOR LATCH AND PUSHBAR OPERATOR (U.S. CLS. 21, 23, 26, 36 AND 38).

FIRST USE 2-27-2002; IN COMMERCE 2-27-2002.

REBECCA POVARCHUK, EXAMINING ATTORNEY

SN 77-169,154. WISE ON INC., SEOUL, REPUBLIC OF KOREA, FILED 4-30-2007.



OWNER OF REPUBLIC OF KOREA REG. NO. 0733305, DATED 1-7-2008, EXPIRES 1-7-2018.

THE COLOR(S) DARK RED IS/ARE CLAIMED AS A FEATURE OF THE MARK.

THE MARK CONSISTS OF THE WORDS "FREE JACK" APPEARING IN THE COLOR DARK RED.

FOR COMPUTER GAME SOFTWARE (U.S. CLS. 21, 23, 26, 36 AND 38).

DAVID I, EXAMINING ATTORNEY

SN 77-173,666. SUZUKI MOTOR CORPORATION, HAMAMATSU-SHI, JAPAN, FILED 5-4-2007.

TCSS

THE MARK CONSISTS OF STANDARD CHARACTERS WITHOUT CLAIM TO ANY PARTICULAR FONT, STYLE, SIZE, OR COLOR.

PRIORITY CLAIMED UNDER SEC. 44(D) ON JAPAN APPLICATION NO. 2007-011150, FILED 2-13-2007, REG. NO. 5099670, DATED 12-21-2007, EXPIRES 12-21-2017.

FOR TRACTION AND STABILITY CONTROLS FOR AUTOMOTIVE VEHICLES (U.S. CLS. 21, 23, 26, 36 AND 38).

ALEX KEAM, EXAMINING ATTORNEY

CLASS 9—(Continued).

SN 77-178,226. QUEST RELIABILITY, LLC, KENT, WA.
FILED 5-10-2007.

InVista

THE MARK CONSISTS OF STANDARD CHARACTERS WITHOUT CLAIM TO ANY PARTICULAR FONT, STYLE, SIZE, OR COLOR.

FOR ELECTRONIC INLINE INSPECTION DEVICE AND THE EMBEDDED SOFTWARE USED TO PROCESS DATA FOR INSPECTION OF TUBULAR PRODUCTS SUCH AS PIPELINES, PROCESS PIPING, STATION PIPING, FIRED HEATER TUBING INCLUDING PROCESS HEATERS AND REFORMERS, HEAT EXCHANGER TUBING AND OIL COUNTRY TUBULAR GOODS (U.S. CLS. 21, 23, 26, 36 AND 38).

RUDY R. SINGLETON, EXAMINING ATTORNEY

SN 77-178,235. SONOS, INC., SANTA BARBARA, CA. FILED
5-10-2007.

ZONEBRIDGE

THE MARK CONSISTS OF STANDARD CHARACTERS WITHOUT CLAIM TO ANY PARTICULAR FONT, STYLE, SIZE, OR COLOR.

FOR WIRELESS NETWORK DIGITAL MEDIA HUBS; WIRELESS NETWORK DIGITAL MEDIA RECEIVERS; COMPUTER HARDWARE, NAMELY, WIRELESS NETWORK REPEATERS; COMPUTER HARDWARE, NAMELY, WIRELESS NETWORK EXTENDERS; WIRELESS DIGITAL MEDIA PLAYERS, HUBS, RECEIVERS, REPEATERS, AND COMPUTER HARDWARE, NAMELY, WIRELESS NETWORK EXTENDERS FOR USE WITH ENTERTAINMENT AND DIGITAL MEDIA SYSTEMS; WIRELESS DEVICES FOR RECEIVING, TRANSMITTING AND RETRANSMITTING DIGITAL MEDIA, MUSIC, PHOTOS, VIDEO AND DATA; COMPUTER HARDWARE FOR USE IN CONNECTING WIRELESS DIGITAL MEDIA SYSTEMS AND WIRELESS MESH NETWORKS; COMPUTER HARDWARE FOR USE IN EXTENDING WIRELESS DIGITAL MEDIA SYSTEMS AND WIRELESS MESH NETWORKS; WIRELESS NETWORK HARDWARE, NAMELY, BRIDGES AND REPEATERS; COMPUTER AND AUDIO HARDWARE FOR PROCESSING, FACILITATING AND CONTROLLING TRANSMISSION, RECEIPT, AND STREAMING DIGITAL MEDIA, MUSIC, PHOTOS, VIDEO AND DATA; COMPUTER AND AUDIO HARDWARE, NAMELY, DIGITAL MEDIA SYSTEM HARDWARE AND COMPONENTS THEREOF; DIGITAL MEDIA NETWORK CONTROLLERS, ROUTERS, REPEATERS, BRIDGES AND COMPONENTS THEREOF (U.S. CLS. 21, 23, 26, 36 AND 38).

THOMAS MANOR, EXAMINING ATTORNEY

CLASS 9—(Continued).

SN 77-194,012. PITCH COUNT LLC, ANNANDALE, VA.
FILED 5-31-2007.

Coach Dave's Hoop Count

THE MARK CONSISTS OF STANDARD CHARACTERS WITHOUT CLAIM TO ANY PARTICULAR FONT, STYLE, SIZE, OR COLOR.

OWNER OF U.S. REG. NOS. 2,900,397 AND 3,259,332.

NO CLAIM IS MADE TO THE EXCLUSIVE RIGHT TO USE "HOOP COUNT", APART FROM THE MARK AS SHOWN.

FOR HAND HELD ELECTRONIC SPORTS COUNTER TO COUNT TOTAL ATTEMPTS, ATTEMPTS MADE, ATTEMPTS MISSED AND PERCENTAGE OF ATTEMPTS MADE TO MAKE A BASKET IN A BASKETBALL GAME OR PRACTICE AND TRACK PERFORMANCE FOR UP TO TWO BASKETBALL PLAYERS (U.S. CLS. 21, 23, 26, 36 AND 38).

FIRST USE 11-2-2007; IN COMMERCE 11-2-2007.

MARIA-VICTORIA SUAREZ, EXAMINING ATTORNEY

SN 77-197,433. SYNOPSIS, INC., MOUNTAIN VIEW, CA.
FILED 6-5-2007.

MAVERIC

THE MARK CONSISTS OF STANDARD CHARACTERS WITHOUT CLAIM TO ANY PARTICULAR FONT, STYLE, SIZE, OR COLOR.

FOR COMPUTER SOFTWARE FOR USE IN MULTI-VOLTAGE VERIFICATION IN THE DESIGN OF SEMICONDUCTORS DURING ELECTRONIC MEMORY ANALYSIS (U.S. CLS. 21, 23, 26, 36 AND 38).

FIRST USE 5-21-2007; IN COMMERCE 5-21-2007.

HANNO RITTNER, EXAMINING ATTORNEY

CLASS 9—(Continued).

SN 77-200,548. NORTHROP GRUMMAN SPERRY MARINE GMBH, LOS ANGELES, CA. FILED 6-7-2007.

NAVITWIN

THE MARK CONSISTS OF STANDARD CHARACTERS WITHOUT CLAIM TO ANY PARTICULAR FONT, STYLE, SIZE, OR COLOR.

OWNER OF FED REP GERMANY REG. NO. 1011241, DATED 12-4-1980, RENEWED AS REG. NO. 1011241, DATED 5-21-2000, EXPIRES 5-20-2010.

FOR NAUTICAL INSTRUMENTS, NAMELY, FIBER-OPTIC GYROCOMPASSES BEING SPINNING TOP COMPASSES, DIGITAL GYROCOMPASSES BEING SPINNING TOP COMPASSES, SATELLITE COMPASSES, AND MAGNETIC COMPASSES; INERTIAL NAVIGATION EQUIPMENT, NAMELY, SPEED INDICATORS, POSITION INDICATORS, COURSE INDICATORS, SPEED MONITORS, POSITION MONITORS, AND COURSE MONITORS; AND OPERATED NAVIGATION SYSTEMS COMPRISED OF USER INTERFACES, NAMELY, DATA DISPLAYS, CONTROL KEYS AND INPUT KEYS (U.S. CLS. 21, 23, 26, 36 AND 38).

RUDY R. SINGLETON, EXAMINING ATTORNEY

SN 77-200,923. SONOS, INC., SANTA BARBARA, CA. FILED 6-7-2007.

ZONEPLAYER

THE MARK CONSISTS OF STANDARD CHARACTERS WITHOUT CLAIM TO ANY PARTICULAR FONT, STYLE, SIZE, OR COLOR.

FOR COMPUTER HARDWARE; COMPUTER NETWORKING HARDWARE; DIGITAL ELECTRONIC DEVICES FOR RECORDING, ORGANIZING, TRANSMITTING, RECEIVING, MANIPULATING, PLAYING AND REVIEWING TEXT, DATA, IMAGES, DIGITAL MEDIA, AUDIO AND VIDEO FILES; COMPUTER SOFTWARE FOR USE IN ORGANIZING, TRANSMITTING, RECEIVING, MANIPULATING, PLAYING AND REVIEWING TEXT, DATA, IMAGES, DIGITAL MEDIA, AUDIO AND VIDEO FILES; COMPUTER HARDWARE AND COMPUTER SOFTWARE FOR THE REPRODUCTION, PROCESSING, TRANSMISSION AND DELIVERY OF AUDIO, VIDEO AND MULTIMEDIA CONTENT; COMPUTER HARDWARE AND SOFTWARE FOR CONTROLLING THE OPERATION OF DIGITAL AUDIO AND DIGITAL VIDEO PLAYERS AND FOR VIEWING, SEARCHING AND/OR PLAYING AUDIO, VIDEO, TELEVISION, MOVIES, PHOTOGRAPHS AND OTHER DIGITAL IMAGES, AND OTHER MULTIMEDIA CONTENT; STEREOs FOR PERSONAL AND COMMERCIAL USE; WIRELESS STEREOs FOR PERSONAL AND COMMERCIAL USE; MP3 PLAYERS AND DIGITAL AUDIO PLAYERS; DIGITAL MEDIA PLAYERS; AUDIO AMPLIFIERS; AUDIO RECEIVERS; AUDIO SPEAKERS; AMPLIFIERS FOR WIRELESS COMMUNICATIONS; WIRELESS COMPUTER PERIPHERALS; HOME THEATER SYSTEMS COMPRISED OF DIGITAL MEDIA PLAYERS, DIGITAL MEDIA HUBS, DIGITAL MEDIA RECEIVERS, AUDIO SPEAKERS, AMPLIFIERS, COMPUTER HARDWARE, NAMELY, WIRELESS NETWORK REPEATERS AND WIRELESS NETWORK EXTENDERS, AND WIRELESS HANDHELD CONTROLLERS FOR THE CONTROL OF DIGITAL MEDIA, AUDIO AND VIDEO FILES; COMPUTER PERIPHERALS; WIRELESS NET-

CLASS 9—(Continued).

WORK DIGITAL MEDIA HUBS; WIRELESS NETWORK DIGITAL MEDIA RECEIVERS; COMPUTER HARDWARE, NAMELY, WIRELESS NETWORK REPEATERS; COMPUTER HARDWARE, NAMELY, WIRELESS NETWORK EXTENDERS; WIRELESS DIGITAL MEDIA PLAYERS, HUBS, RECEIVERS, REPEATERS, AND COMPUTER HARDWARE, NAMELY, WIRELESS NETWORK EXTENDERS FOR USE WITH ENTERTAINMENT AND DIGITAL MEDIA SYSTEMS; WIRELESS DEVICES FOR RECORDING, ORGANIZING, TRANSMITTING, RECEIVING, MANIPULATING, PLAYING AND REVIEWING TEXT, DATA, IMAGE, DIGITAL MEDIA, AUDIO AND VIDEO FILES; COMPUTER HARDWARE FOR USE IN CONNECTING WIRELESS DIGITAL MEDIA SYSTEMS AND NETWORKS; COMPUTER HARDWARE, NAMELY, WIRELESS DEVICES FOR CONNECTING DIGITAL MEDIA AND MUSIC PLAYERS, AMPLIFIERS, SPEAKERS AND SOUND EQUIPMENT; COMPUTER HARDWARE FOR USE IN EXTENDING WIRELESS DIGITAL MEDIA SYSTEMS AND NETWORKS; COMPUTER HARDWARE FOR PROCESSING, FACILITATING AND CONTROLLING TRANSMISSION, RECEIPT, DELIVERY AND STREAMING OF DIGITAL MEDIA, MUSIC, IMAGES, PHOTOS, VIDEO AND DATA; COMPUTER HARDWARE, NAMELY, DIGITAL MEDIA SYSTEM HARDWARE AND COMPONENTS THEREOF; DIGITAL MEDIA NETWORK CONTROLLERS, ROUTERS, REPEATERS, BRIDGES AND COMPONENTS THEREOF; DVD PLAYERS; PORTABLE VIDEO PLAYERS; DIGITAL MEDIA DISTRIBUTION SYSTEMS COMPRISED OF DIGITAL MEDIA PLAYERS, DIGITAL MEDIA HUBS, DIGITAL MEDIA RECEIVERS, DIGITAL MEDIA PLAYER CONTROLLERS, AUDIO SPEAKERS, AMPLIFIERS, COMPUTER HARDWARE, NAMELY, WIRELESS REPEATERS AND WIRELESS NETWORK EXTENDERS, AND WIRELESS HANDHELD CONTROLLERS FOR HOME AND COMMERCIAL USE; MULTIMEDIA VIDEO DISPLAY SCREENS; VIDEO SCREENS; VIDEO MONITORS; COMPUTER MONITORS (U.S. CLS. 21, 23, 26, 36 AND 38).

THOMAS MANOR, EXAMINING ATTORNEY

SN 77-202,452. YAMATAKE CORPORATION, TOKYO, JAPAN, FILED 6-11-2007.



THE MARK CONSISTS OF A 4X4 DOTTED SQUARE DESIGN WITH THE WORD "GEMKEY" TO THE RIGHT.

FOR DNA CHIPS, NAMELY, DNA MICRO ARRAYS FOR SCIENTIFIC AND MEDICAL RESEARCH, AND CUSTOM DNA MICRO ARRAYS FOR SCIENTIFIC AND MEDICAL RESEARCH (U.S. CLS. 21, 23, 26, 36 AND 38).

MARY ROSSMAN, EXAMINING ATTORNEY

CLASS 9—(Continued).

SN 77-213,389. RECESSED ELECTRICAL DESIGNS, LLC, PESCADERO, CA. FILED 6-22-2007.

RECESSED ELECTRICAL DESIGNS - RED

THE MARK CONSISTS OF STANDARD CHARACTERS WITHOUT CLAIM TO ANY PARTICULAR FONT, STYLE, SIZE, OR COLOR.

NO CLAIM IS MADE TO THE EXCLUSIVE RIGHT TO USE "RECESSED ELECTRICAL DESIGNS", APART FROM THE MARK AS SHOWN.

FOR ELECTRIC CONNECTORS; ELECTRIC JUNCTION BOXES; ELECTRICAL CONNECTION BOXES; ELECTRICAL DISTRIBUTION BOXES; ELECTRICAL OUTLETS; ELECTRICAL RECEPTACLES; MULTI-OUTLET SOCKET BLOCKS; POWER ACCESS PORT FOR USE WITH ELECTRICAL CONTROL PANELS FOR CONNECTING MULTIPLE DATA AND ELECTRICAL DEVICES (U.S. CLS. 21, 23, 26, 36 AND 38).

FIRST USE 4-4-2007; IN COMMERCE 4-4-2007.
SHARON MEIER, EXAMINING ATTORNEY

SN 77-221,313. CREATE YOUR PERFECT LIFE, SAN FRANCISCO, CA. FILED 7-3-2007.

Create Your Perfect Life

THE MARK CONSISTS OF STANDARD CHARACTERS WITHOUT CLAIM TO ANY PARTICULAR FONT, STYLE, SIZE, OR COLOR.

FOR DIGITAL MATERIALS, NAMELY, DOWNLOADABLE AUDIO FILES FEATURING THE SUBJECT OF HYPNOSIS AND GUIDED VISUALIZATION MEDITATION (U.S. CLS. 21, 23, 26, 36 AND 38).

ZHALEH DELANEY, EXAMINING ATTORNEY

SN 77-226,304. ACTIVISION PUBLISHING, INC., SANTA MONICA, CA. FILED 7-10-2007.

VICARIOUS VISIONS ALCHEMY

THE MARK CONSISTS OF STANDARD CHARACTERS WITHOUT CLAIM TO ANY PARTICULAR FONT, STYLE, SIZE, OR COLOR.

OWNER OF U.S. REG. NOS. 2,611,355 AND 2,611,460.

FOR COMPUTER SOFTWARE FOR THE PRODUCTION OF THREE-DIMENSIONAL ANIMATION FOR COMPUTER-GENERATED DISPLAYS SOLD AS A FEATURE OF COMPUTER GAME PROGRAMS; AND COMPUTER OPERATING SYSTEMS (U.S. CLS. 21, 23, 26, 36 AND 38).

FIRST USE 11-0-2003; IN COMMERCE 11-0-2003.
BENJAMIN ALLEN, EXAMINING ATTORNEY

CLASS 9—(Continued).

SN 77-238,384. ARKADIUM, INC., NEW YORK, NY. FILED 7-25-2007.

Great Day Games

THE MARK CONSISTS OF STANDARD CHARACTERS WITHOUT CLAIM TO ANY PARTICULAR FONT, STYLE, SIZE, OR COLOR.

NO CLAIM IS MADE TO THE EXCLUSIVE RIGHT TO USE "GAMES", APART FROM THE MARK AS SHOWN.

FOR DOWNLOADABLE MULTIMEDIA FILE CONTAINING ARTWORK, TEXT, AUDIO, VIDEO, GAMES, AND INTERNET WEB LINKS RELATING TO CASUAL GAMES (U.S. CLS. 21, 23, 26, 36 AND 38).

FIRST USE 2-1-2006; IN COMMERCE 2-1-2006.
JULIE WATSON, EXAMINING ATTORNEY

SN 77-241,179. LENMAR ENTERPRISES, INC., CAMARILLO, CA. FILED 7-27-2007.

BATTERY WIZARD

THE MARK CONSISTS OF STANDARD CHARACTERS WITHOUT CLAIM TO ANY PARTICULAR FONT, STYLE, SIZE, OR COLOR.

NO CLAIM IS MADE TO THE EXCLUSIVE RIGHT TO USE "BATTERY", APART FROM THE MARK AS SHOWN. SEC. 2(F).

FOR COMPUTER PROGRAMS FOR IDENTIFYING AND LINKING ELECTRONIC DEVICES WITH BATTERIES POWERING THOSE DEVICES; COMPUTER PROGRAMS FOR IDENTIFYING AND LINKING ELECTRONIC DEVICES AND BATTERIES WITH APPROPRIATE BATTERY CHARGING DEVICES (U.S. CLS. 21, 23, 26, 36 AND 38).

FIRST USE 6-1-2004; IN COMMERCE 6-1-2004.
JENNIFER VASQUEZ, EXAMINING ATTORNEY

SN 77-252,751. ANIMAL ALLIANCE, BEVERLY HILLS, CA. FILED 8-10-2007.

PET PROJECT

THE MARK CONSISTS OF STANDARD CHARACTERS WITHOUT CLAIM TO ANY PARTICULAR FONT, STYLE, SIZE, OR COLOR.

FOR CASES FOR SPECTACLES AND SUNGLASSES; EYEGLASS CASES; EYEGLASS FRAMES; EYEGLASSES; FRAMES FOR SPECTACLES AND SUNGLASSES; SUNGLASSES (U.S. CLS. 21, 23, 26, 36 AND 38).

BENJAMIN OKEKE, EXAMINING ATTORNEY

CLASS 9—(Continued).

SN 77-253,147. ZHENG JASON GENG, ROCKVILLE, MD.
FILED 8-12-2007.



NO CLAIM IS MADE TO THE EXCLUSIVE RIGHT TO USE "SMART PTZ", APART FROM THE MARK AS SHOWN. THE COLOR(S) WHITE, BLACK, GREEN AND WHITE IS/ ARE CLAIMED AS A FEATURE OF THE MARK.

THE MARK CONSISTS OF A STYLIZED S IN WHITE AT TOP, GREEN IN THE MIDDLE AND BLACK ON THE BOTTOM WITH A WHITE STAR DESIGN AND THE WORD "SMART PTZ" IN GREEN, OUTLINED IN WHITE.

FOR MULTIPLE PURPOSE CAMERAS (U.S. CLS. 21, 23, 26, 36 AND 38).

FIRST USE 4-1-2006; IN COMMERCE 4-1-2006.
BONNIE LUKEN, EXAMINING ATTORNEY

SN 77-253,939. ROSE, CHRISTIAN, TERREBONNE, CANA-
DA, FILED 8-13-2007.

Bullet DVR

THE MARK CONSISTS OF STANDARD CHARACTERS WITHOUT CLAIM TO ANY PARTICULAR FONT, STYLE, SIZE, OR COLOR.

NO CLAIM IS MADE TO THE EXCLUSIVE RIGHT TO USE "DVR", APART FROM THE MARK AS SHOWN.

FOR DIGITAL VIDEO RECORDERS (U.S. CLS. 21, 23, 26, 36 AND 38).

ELISSA GARBER KON, EXAMINING ATTORNEY

SN 77-253,952. S D PRODUCTIONS, INC., SOD, WV. FILED 8-
13-2007.

THE CHILD WHISPERER

THE MARK CONSISTS OF STANDARD CHARACTERS WITHOUT CLAIM TO ANY PARTICULAR FONT, STYLE, SIZE, OR COLOR.

NO CLAIM IS MADE TO THE EXCLUSIVE RIGHT TO USE "CHILD", APART FROM THE MARK AS SHOWN.

FOR CHILDREN'S VIDEO TAPES (U.S. CLS. 21, 23, 26, 36 AND 38).

DAVID H. STINE, EXAMINING ATTORNEY

CLASS 9—(Continued).

SN 77-256,491. CYMBET CORPORATION, ELK RIVER, MN.
FILED 8-15-2007.

ENERCHIP

THE MARK CONSISTS OF STANDARD CHARACTERS WITHOUT CLAIM TO ANY PARTICULAR FONT, STYLE, SIZE, OR COLOR.

FOR SOLID STATE ENERGY PRODUCTS, NAMELY, BATTERIES; SUPERCAPACITORS; CHARGE CONTROL CIRCUITS; AND ENERGY HARVESTING CONVERSION, COLLECTION AND STORAGE CELLS (U.S. CLS. 21, 23, 26, 36 AND 38).

RAMONA ORTIGA, EXAMINING ATTORNEY

SN 77-259,488. BURKE & HERBERT BANK & TRUST
COMPANY, ALEXANDRIA, VA. FILED 8-20-2007.

PARROT CARD

THE MARK CONSISTS OF STANDARD CHARACTERS WITHOUT CLAIM TO ANY PARTICULAR FONT, STYLE, SIZE, OR COLOR.

NO CLAIM IS MADE TO THE EXCLUSIVE RIGHT TO USE "CARD", APART FROM THE MARK AS SHOWN.

FOR MAGNETICALLY ENCODED BANK DEBIT CARDS (U.S. CLS. 21, 23, 26, 36 AND 38).

FIRST USE 7-23-2007; IN COMMERCE 7-23-2007.
SANI KHOURI, EXAMINING ATTORNEY

SN 77-260,997. 21ST CENTURY TECHNOLOGIES, INC.,
AUSTIN, TX. FILED 8-21-2007.

LYNXEON

THE MARK CONSISTS OF STANDARD CHARACTERS WITHOUT CLAIM TO ANY PARTICULAR FONT, STYLE, SIZE, OR COLOR.

"LYNXEON" HAS NO MEANING IN A FOREIGN LANGUAGE.

FOR COMPUTER SOFTWARE, NAMELY, SERVER AND COMPUTER SOFTWARE FOR STORING, MANAGING, QUERYING, SEARCHING, ANALYZING AND REPORTING INTELLIGENCE DATA INCLUDING SOCIAL NETWORK DATA; COMPUTER SOFTWARE FOR PERFORMING INTELLIGENCE ANALYTICS FOR USE BY GOVERNMENT AND BUSINESS INTELLIGENT ANALYSTS, MANAGERS, STAFF, AND TEAM; COMPUTER SOFTWARE PLATFORM AND COMPUTER SOFTWARE DEVELOPMENT TOOLS USED FOR DEVELOPING AND MANAGING INTELLIGENCE ANALYTICS APPLICATIONS (U.S. CLS. 21, 23, 26, 36 AND 38).

SETH A. RAPPAPORT, EXAMINING ATTORNEY

CLASS 9—(Continued).

SN 77-261,497. RIOREY, INC., BETHESDA, MD. FILED 8-22-2007.

RIOREY

THE MARK CONSISTS OF STANDARD CHARACTERS WITHOUT CLAIM TO ANY PARTICULAR FONT, STYLE, SIZE, OR COLOR.

THE FOREIGN WORDING IN THE MARK TRANSLATES INTO ENGLISH AS RIVER KING.

FOR COMPUTER HARDWARE; COMPUTER SOFTWARE, NAMELY, SOFTWARE RESTRICTING ACCESS TO AND BY COMPUTER NETWORKS TO AND OF UNDESIRE WEBSITES, MEDIA, INDIVIDUALS AND FACILITIES TO PREVENT DISTRIBUTED DENIAL (DDOS) ATTACKS ON NETWORKS AND SERVERS; COMPUTER SOFTWARE, NAMELY, SOFTWARE TO CLEANSE NETWORK INFRASTRUCTURE OF VIRUSES, NETWORK TERRORISM, DDOS ATTACKS, WORMS AND EXPLOITS; COMPUTER SOFTWARE, NAMELY, SOFTWARE FOR THE PREVENTION OF AND OR PROTECTION AGAINST BULK E-MAIL, SPAM, DDOS ATTACKS OR OTHER INTENTIONAL MISUSE OR UNAUTHORIZED PENETRATION OF COMPUTER NETWORKS (U.S. CLS. 21, 23, 26, 36 AND 38).

FIRST USE 7-17-2006; IN COMMERCE 7-17-2006.
BRIAN PINO, EXAMINING ATTORNEY

SN 77-261,590. RIOREY, INC., BETHESDA, MD. FILED 8-22-2007.

THE DDOS SPECIALIST

THE MARK CONSISTS OF STANDARD CHARACTERS WITHOUT CLAIM TO ANY PARTICULAR FONT, STYLE, SIZE, OR COLOR.

NO CLAIM IS MADE TO THE EXCLUSIVE RIGHT TO USE "DDOS", APART FROM THE MARK AS SHOWN.

FOR COMPUTER HARDWARE; COMPUTER SOFTWARE, NAMELY, SOFTWARE RESTRICTING ACCESS TO AND BY COMPUTER NETWORKS TO AND OF UNDESIRE WEBSITES, MEDIA, INDIVIDUALS AND FACILITIES TO PREVENT DISTRIBUTED DENIAL (DDOS) ATTACKS ON NETWORKS AND SERVERS; COMPUTER SOFTWARE, NAMELY, SOFTWARE TO CLEANSE NETWORK INFRASTRUCTURE OF VIRUSES, NETWORK TERRORISM, DDOS ATTACKS, WORMS AND EXPLOITS; COMPUTER SOFTWARE, NAMELY, SOFTWARE FOR THE PREVENTION OF AND OR PROTECTION AGAINST BULK E-MAIL, SPAM, DDOS ATTACKS OR OTHER INTENTIONAL MISUSE OR UNAUTHORIZED PENETRATION OF COMPUTER NETWORKS (U.S. CLS. 21, 23, 26, 36 AND 38).

FIRST USE 7-17-2006; IN COMMERCE 7-17-2006.
BRIAN PINO, EXAMINING ATTORNEY

CLASS 9—(Continued).

SN 77-263,466. MDI, INC., SAN ANTONIO, TX. FILED 8-24-2007.

LEARNSAFE INTERNAL FUNDING MODEL

THE MARK CONSISTS OF STANDARD CHARACTERS WITHOUT CLAIM TO ANY PARTICULAR FONT, STYLE, SIZE, OR COLOR.

NO CLAIM IS MADE TO THE EXCLUSIVE RIGHT TO USE "INTERNAL FUNDING MODEL", APART FROM THE MARK AS SHOWN.

FOR AUTHENTICATION AND IDENTIFICATION PRODUCTS, NAMELY, COMPUTER SOFTWARE, BIOMETRIC MATCHING SOFTWARE, BIOMETRIC INDEXING SOFTWARE, AND CRYPTOGRAPHIC PROTECTION SOFTWARE, AND RELATED HARDWARE, NAMELY, FINGERPRINT SENSORS, ELECTRONIC SENSORS, CARD READERS AND ASSOCIATED COMPUTER CHIPS AND ELECTRONIC CIRCUITRY, NAMELY, CONTROLLER BOARDS AND MEMORY BOARDS ALL FOR USE IN DETERMINING THE IDENTITY OF UNKNOWN PERSONS AND TO VERIFY THE CLAIMED IDENTITY OF PERSONS; MAGNETICALLY ENCODED IDENTIFY CARDS; COMPUTER HARDWARE AND COMPUTER SOFTWARE FOR USE IN SECURITY SYSTEMS, MONITORING SYSTEMS AND BACKGROUND INVESTIGATION/PRE-EMPLOYMENT SYSTEMS; COMPUTER MONITORS; TELEVISIONS; TELEVISION CAMERAS, SECURITY CAMERAS, ELECTRIC CABLES; ELECTRONIC DOOR LOCKS; PRERECORDED DIGITAL VIDEO DISCS AND COMPUTER SOFTWARE IN THE SUBJECT OF TRAINING, SECURITY AND BACKGROUND INVESTIGATION (U.S. CLS. 21, 23, 26, 36 AND 38).

JOHN DWYER, EXAMINING ATTORNEY

SN 77-264,971. NEXSAN TECHNOLOGIES, THOUSAND OAKS, CA. FILED 8-27-2007.

Eco-System

THE MARK CONSISTS OF STANDARD CHARACTERS WITHOUT CLAIM TO ANY PARTICULAR FONT, STYLE, SIZE, OR COLOR.

FOR COMPUTER HARDWARE AND SOFTWARE USED FOR DATA STORAGE (U.S. CLS. 21, 23, 26, 36 AND 38).

PAUL MORENO, EXAMINING ATTORNEY

CLASS 9—(Continued).

SN 77-268,492. TYPEHAUS, INC., ENCINITAS, CA. FILED 8-30-2007.

T Y P E H A U S

FOR HARDWARE AND SOFTWARE FOR LASER AND MULTI-FUNCTION PRINTING DEVICES, NAMELY, COMPUTER HARDWARE AND SOFTWARE FOR THE CREATION AND PRINTING OF FORMS, SECURE CHECK WRITING AND BARCODE PRINTING (U.S. CLS. 21, 23, 26, 36 AND 38).

FIRST USE 2-5-1992; IN COMMERCE 2-5-1992.

REGINA DRUMMOND, EXAMINING ATTORNEY

SN 77-270,493. TYPEHAUS, INC., ENCINITAS, CA. FILED 9-3-2007.

**T Y P E
H A U S**

FOR HARDWARE AND SOFTWARE FOR LASER AND MULTI-FUNCTION PRINTING DEVICES, NAMELY, COMPUTER HARDWARE AND SOFTWARE FOR THE CREATION AND PRINTING OF FORMS, SECURE CHECK WRITING AND BARCODE PRINTING (U.S. CLS. 21, 23, 26, 36 AND 38).

FIRST USE 8-23-2007; IN COMMERCE 8-23-2007.

REGINA DRUMMOND, EXAMINING ATTORNEY

SN 77-270,914. BLUE ORB, INC., WINTER PARK, FL. FILED 9-4-2007.

SWITCHBLADE

THE MARK CONSISTS OF STANDARD CHARACTERS WITHOUT CLAIM TO ANY PARTICULAR FONT, STYLE, SIZE, OR COLOR.

FOR COMPUTER GAME SOFTWARE, COMPUTER GAME SOFTWARE THAT MAY BE DOWNLOADED FROM A GLOBAL COMPUTER NETWORK, COMPUTER GAME INTERFACE TO BE USED IN COMPUTER GAME MACHINES (U.S. CLS. 21, 23, 26, 36 AND 38).

WILLIAM ROSSMAN, EXAMINING ATTORNEY

CLASS 9—(Continued).

SN 77-271,487. AINSWORTH GAME TECHNOLOGY LIMITED, NEWINGTON, AUSTRALIA, FILED 9-4-2007.

Inca Reef

THE MARK CONSISTS OF STANDARD CHARACTERS WITHOUT CLAIM TO ANY PARTICULAR FONT, STYLE, SIZE, OR COLOR.

FOR GAMING SOFTWARE THAT GENERATES OR DISPLAYS WAGER OUTCOMES OF GAMING MACHINES; COMPUTER SOFTWARE AND FIRMWARE FOR GAMES OF CHANCE ON ANY COMPUTERIZED PLATFORM, INCLUDING DEDICATED GAMING CONSOLES, VIDEO BASED SLOT MACHINES, REEL BASED SLOT MACHINES, AND VIDEO LOTTERY TERMINALS (U.S. CLS. 21, 23, 26, 36 AND 38).

DORITT L. CARROLL, EXAMINING ATTORNEY

SN 77-273,631. MICROWEST DESIGN LTD., PRINCE GEORGE, CANADA, FILED 9-6-2007.

SMARTALLY

THE MARK CONSISTS OF STANDARD CHARACTERS WITHOUT CLAIM TO ANY PARTICULAR FONT, STYLE, SIZE, OR COLOR.

PRIORITY CLAIMED UNDER SEC. 44(D) ON CANADA APPLICATION NO. 1338890, FILED 3-12-2007, REG. NO. TMA708996, DATED 3-6-2008, EXPIRES 3-6-2023.

FOR COMPUTER SOFTWARE, NAMELY, COMPUTER PROGRAMS FOR MANAGING PRODUCTION INFORMATION AND GENERATING CUSTOMIZABLE PRODUCTION REPORTS; COMPUTER SOFTWARE, NAMELY, COMPUTER PROGRAMS FOR ANALYZING AND REPORTING ON THE MOISTURE CONTENT OF WOOD; COMPUTER SOFTWARE, NAMELY, COMPUTER PROGRAMS FOR REPORTING AND ANALYZING MACHINE PERFORMANCE IN A PLANT; COMPUTER SOFTWARE FOR PRINTING PACKAGE LABELING; COMPUTER SOFTWARE FOR TRACKING QUANTITIES OF SPECIFIC PRODUCT ITEMS OF INVENTORY FOR INVENTORY CONTROL (U.S. CLS. 21, 23, 26, 36 AND 38).

JESSICA A. POWERS, EXAMINING ATTORNEY

CLASS 9—(Continued).

SN 77-273,662. XOPAR LIMITED, QUEEN'S ROAD CENTRAL, HONG KONG, FILED 9-6-2007.



FOR COMPUTER MICE; USB (UNIVERSAL SERIAL BUS) HARDWARE; USB (UNIVERSAL SERIAL BUS) OPERATING SOFTWARE; USB HUBS; ELECTRONIC CARD READERS; WEBCAMS; USB AUDIO SPEAKERS; WIRELESS PRESENTER IN THE NATURE OF A WIRELESS REMOTE POINTER; COMPUTER ACCESSORIES, NAMELY, USB LIGHTS AND USB FANS; COMPUTER STORAGE DEVICES, NAMELY, FLASH DRIVES; BLANK SMART CARDS; INTERNET PHONES; CALCULATORS; MEMORY CARDS; COMPUTER PERIPHERALS; PEDOMETERS; MEDIA PLAYERS; DIGITAL AUDIO PLAYERS; MP4 PLAYERS; MP3 PLAYERS; DIGITAL PHOTO FRAMES FOR DISPLAYING DIGITAL PICTURES, VIDEO CLIPS AND MUSIC (U.S. CLS. 21, 23, 26, 36 AND 38).

PAULA MAHONEY, EXAMINING ATTORNEY

SN 77-276,405. ROSEMOUNT ANALYTICAL INC., SOLON, OH. FILED 9-11-2007.

Xi

THE MARK CONSISTS OF STANDARD CHARACTERS WITHOUT CLAIM TO ANY PARTICULAR FONT, STYLE, SIZE, OR COLOR.

FOR GAS ANALYSER INTERFACE FOR USE WITH GAS ANALYSERS USED IN INDUSTRIAL PROCESSES (U.S. CLS. 21, 23, 26, 36 AND 38).

MARCIE MILONE, EXAMINING ATTORNEY

CLASS 9—(Continued).

SN 77-276,413. JUST WHEELS & TIRE CO., HUNTINGTON BEACH, CA. FILED 9-11-2007.

PETROL

THE MARK CONSISTS OF STANDARD CHARACTERS WITHOUT CLAIM TO ANY PARTICULAR FONT, STYLE, SIZE, OR COLOR.

OWNER OF U.S. REG. NOS. 3,268,827 AND 3,314,265.

FOR EYEGLASSES, SUNGLASSES, GOGGLES FOR SPORTS, SAFETY GOGGLES, DUST MASKS, DUST PROTECTIVE GOGGLES AND MASKS AND CASES THEREFORE; FRAMES FOR SPECTACLES AND SUNGLASSES, CASES FOR EYEGLASSES, CHAINS FOR EYEGLASSES (U.S. CLS. 21, 23, 26, 36 AND 38).

MARCIE MILONE, EXAMINING ATTORNEY

SN 77-278,251. EZSTELLA, LLC, DENVER, CO. FILED 9-12-2007.

EZSTELLA

THE MARK CONSISTS OF STANDARD CHARACTERS WITHOUT CLAIM TO ANY PARTICULAR FONT, STYLE, SIZE, OR COLOR.

FOR POWDERED FORMULA DISPENSERS THAT COUNT OR MEASURE OUTPUT, NAMELY, DISPENSERS USED TO STORE AND DISTRIBUTE UNITS OF POWDERED DRINK MIX (U.S. CLS. 21, 23, 26, 36 AND 38).

JULIE GUTTADAURO, EXAMINING ATTORNEY

SN 77-278,505. TRENCH LIMITED, SCARBOROUGH, CANADA, FILED S.R. 9-13-2007; AM. P.R. 7-2-2008.

PCT

THE MARK CONSISTS OF STANDARD CHARACTERS WITHOUT CLAIM TO ANY PARTICULAR FONT, STYLE, SIZE, OR COLOR.

FOR TELECOMMUNICATION EQUIPMENT, NAMELY, PROGRAMMABLE POWER LINE RELAY TERMINALS FOR USE BY ELECTRIC UTILITIES EMPLOYING COMMUNICATION ASSISTED HIGH VOLTAGE POWER LINE PROTECTION SCHEMES (U.S. CLS. 21, 23, 26, 36 AND 38).

FIRST USE 5-0-2007; IN COMMERCE 5-0-2007.

CHARLES L. JENKINS, EXAMINING ATTORNEY

CLASS 9—(Continued).

SN 77-278,783. DIGITAL JUICE, INC., LAKE MARY, FL. FILED 9-13-2007.

JUICER

THE MARK CONSISTS OF STANDARD CHARACTERS WITHOUT CLAIM TO ANY PARTICULAR FONT, STYLE, SIZE, OR COLOR.

FOR COMPACT DISCS, DIGITAL VERSATILE DISCS, AND DIGITAL MULTIMEDIA FILE DOWNLOADS FEATURING LAYERED AND NON-LAYERED ROYALTY-FREE GRAPHICS AND BACKGROUNDS, ABSTRACT DESIGNS, PEOPLE, PLACES, AND OBJECTS FROM AROUND THE WORLD FOR USE WITH VIDEO EDITING, PRESENTATIONS, WEB, TELEVISION, FILM, GAMES, CELL PHONES, AND ALL MULTIMEDIA APPLICATIONS AND HARDWARE (U.S. CLS. 21, 23, 26, 36 AND 38).

FIRST USE 4-30-2002; IN COMMERCE 4-30-2002.
BENJAMIN OKEKE, EXAMINING ATTORNEY

SN 77-280,246. HIP, INC., WESTMINSTER, MD. FILED 9-14-2007.

HAL

THE MARK CONSISTS OF STANDARD CHARACTERS WITHOUT CLAIM TO ANY PARTICULAR FONT, STYLE, SIZE, OR COLOR.

FOR COMPUTER HARDWARE FOR INTERFACING WITH EXTERNAL ELECTRONIC DEVICES; COMPUTER SOFTWARE TO CONTROL THE COMPUTER HARDWARE INTERFACE AND THE CONNECTED EXTERNAL ELECTRONIC DEVICES (U.S. CLS. 21, 23, 26, 36 AND 38).

FIRST USE 8-1-1997; IN COMMERCE 9-1-1997.
KELLY MCCOY, EXAMINING ATTORNEY

SN 77-281,396. KONICA MINOLTA MEDICAL & GRAPHIC, INC., TOKYO, JAPAN, FILED 9-17-2007.

IMAGEPILOT

THE MARK CONSISTS OF STANDARD CHARACTERS WITHOUT CLAIM TO ANY PARTICULAR FONT, STYLE, SIZE, OR COLOR.

FOR DIAGNOSTIC IMAGING SYSTEM, NAMELY, COMPUTER SERVER, COMPUTER SOFTWARE FOR DISPLAYING, FILING AND TRANSFERRING IMAGES, CONSOLE DEVICE, NAMELY, COMPUTER CONSOLE FOR DATA STORAGE AND USE IN DIAGNOSTIC IMAGING, VIEWER, NAMELY, LIQUID CRYSTAL DISPLAYS, FLAT PANEL DISPLAY SCREENS AND COMPUTER NETWORKING HARDWARE (U.S. CLS. 21, 23, 26, 36 AND 38).

MATTHEW EINSTEIN, EXAMINING ATTORNEY

CLASS 9—(Continued).

SN 77-281,436. MY CHEMICAL ROMANCE, LLC, NEW YORK, NY. FILED 9-17-2007.

MY CHEMICAL ROMANCE

THE MARK CONSISTS OF STANDARD CHARACTERS WITHOUT CLAIM TO ANY PARTICULAR FONT, STYLE, SIZE, OR COLOR.

FOR MUSICAL SOUND RECORDINGS; MUSICAL VIDEO RECORDINGS AND OTHER AUDIO/VISUAL RECORDINGS, NAMELY, COMPACT DISCS FEATURING MUSICAL PERFORMANCES (U.S. CLS. 21, 23, 26, 36 AND 38).

FIRST USE 7-31-2002; IN COMMERCE 7-31-2002.
EUGENIA MARTIN, EXAMINING ATTORNEY

SN 77-282,204. POWERMAND INC., PORTLAND, WA. FILED 9-18-2007.

Enviroelligent

THE MARK CONSISTS OF STANDARD CHARACTERS WITHOUT CLAIM TO ANY PARTICULAR FONT, STYLE, SIZE, OR COLOR.

FOR COMPUTER HARDWARE AND SOFTWARE SYSTEM FOR REMOTELY MONITORING ENVIRONMENTAL CONDITIONS AND CONTROLLING DEVICES WITHIN A BUILDING, FACILITY, GROUNDS, OR DESIGNATED SPATIAL AREA (U.S. CLS. 21, 23, 26, 36 AND 38).

FIRST USE 0-0-2006; IN COMMERCE 0-0-2007.
RENEE SERVANCE, EXAMINING ATTORNEY

CLASS 9—(Continued).

SN 77-284,400. MEDICAL INTERNETICS, INC., TROY, MI. FILED 9-20-2007.



NO CLAIM IS MADE TO THE EXCLUSIVE RIGHT TO USE "MD", APART FROM THE MARK AS SHOWN.

THE COLOR(S) GRAY, BLACK, BLUE AND RED IS/ARE CLAIMED AS A FEATURE OF THE MARK.

THE COLOR BLACK APPEARS IN THE LETTERS "G" AND "P", AND THE COLOR RED APPEARS IN THE LETTER "A" AND IN THE WORK "IT". THE COLOR BLUE APPEARS IN THE WORDING "MD". THE COLOR GRAY APPEARS IN THE TWO HALF OVALS AROUND THE LETTER "G".

FOR MEDICAL SOFTWARE FOR ORGANIZING AND MAINTAINING PATIENT MEDICAL INFORMATION (U.S. CLS. 21, 23, 26, 36 AND 38).

FIRST USE 6-1-2006; IN COMMERCE 8-1-2007.

WENDY JUN, EXAMINING ATTORNEY

CLASS 9—(Continued).

SN 77-286,558. SONES, DENNIS, C., DBA MOBIUS MARKETING CONSULTING GROUP, SAN RAFAEL, CA. FILED 9-23-2007.

SHOMI

THE MARK CONSISTS OF STANDARD CHARACTERS WITHOUT CLAIM TO ANY PARTICULAR FONT, STYLE, SIZE, OR COLOR.

FOR COMPUTER HARDWARE AND SOFTWARE FOR THE INTEGRATION OF TEXT, AUDIO, AND/OR GRAPHICS INTO A STAND-ALONE MULTIMEDIA DEVICE (U.S. CLS. 21, 23, 26, 36 AND 38).

JAY FLOWERS, EXAMINING ATTORNEY

SN 77-284,805. CBL CO., LTD., DAEJEON, REPUBLIC OF KOREA, FILED 9-20-2007.

CBL

THE MARK CONSISTS OF STANDARD CHARACTERS WITHOUT CLAIM TO ANY PARTICULAR FONT, STYLE, SIZE, OR COLOR.

FOR LENSES FOR CAMERA; FLASH-BULBS FOR PHOTOGRAPHY; FLASHLIGHTS WITH LIGHT EMITTING DIODES FOR USE IN PHOTOGRAPHY; PHOTOGRAPHIC PROJECTORS AND MOVIE PROJECTORS (U.S. CLS. 21, 23, 26, 36 AND 38).

ALEXANDER L. POWERS, EXAMINING ATTORNEY

SN 77-287,200. JAIR ELECTRONICS CORPORATION, MIAMI, FL. FILED 9-24-2007.

ISUM

THE MARK CONSISTS OF STANDARD CHARACTERS WITHOUT CLAIM TO ANY PARTICULAR FONT, STYLE, SIZE, OR COLOR.

FOR PORTABLE MEDIA PLAYERS; DIGITAL CAMERAS; CATHODE RAY TUBES; PLASMA DISPLAY PANELS, LCD PANELS, AND PROJECTION TELEVISION SETS; DVD PLAYERS; RADIOS FOR VEHICLES; VIDEO MONITORS; COMPACT DISC PLAYERS AND RECORDERS; BLANK COMPACT DISCS; HOME THEATER SYSTEMS COMPRISED OF SURROUND SPEAKERS, FRONT AND CENTER SPEAKERS, SUBWOOFER, AUDIO AMPLIFIER, DVD AND CD PLAYER, AND AUDIO AND VIDEO RECEIVER; CAR AUDIO SYSTEMS COMPRISED OF AUDIO SPEAKERS, AMPLIFIERS, SUBWOOFERS, TWEETERS, SPEAKER ENCLOSURES, CROSSOVERS, EQUALIZERS, CAPACITORS AND REMOTE CONTROLS; PORTABLE DIGITAL AUDIO PLAYERS INCLUDING BOOM BOXES AND HEADPHONES; AND GPS NAVIGATION SYSTEMS (U.S. CLS. 21, 23, 26, 36 AND 38).

RAMONA ORTIGA, EXAMINING ATTORNEY

SN 77-285,802. NOAB BIODISCOVERIES INC., MISSISSAUGA, CANADA, FILED 9-21-2007.

DTE_x

THE MARK CONSISTS OF STANDARD CHARACTERS WITHOUT CLAIM TO ANY PARTICULAR FONT, STYLE, SIZE, OR COLOR.

FOR MEDICAL APPARATUS AND INSTRUMENTS, NAMELY, DNA MICROARRAY CHIPS FOR SCIENTIFIC, DIAGNOSTIC, SCREENING, TESTING, AND RESEARCH USE (U.S. CLS. 21, 23, 26, 36 AND 38).

SUNG IN, EXAMINING ATTORNEY

CLASS 9—(Continued).

SN 77-287,438. BAKER ELECTRICAL INSTRUMENT COMPANY, FORT COLLINS, CO. FILED 9-24-2007.



OWNER OF U.S. REG. NO. 1,633,013.
THE MARK CONSISTS OF THE WORD "BAKER" AND A DESIGN OF QUADRILATERAL CONTAINING A WAVY LINE.

FOR SCIENTIFIC MEASURING INSTRUMENTS IN THE NATURE OF ELECTRICAL CONDUCTIVITY TESTING METERS FOR USE IN TESTING THE CHARACTERISTICS OF WINDINGS AND PARTS THEREOF (U.S. CLS. 21, 23, 26, 36 AND 38).

FIRST USE 1-1-1966; IN COMMERCE 1-1-1966.
LAURA HAMMEL, EXAMINING ATTORNEY

SN 77-287,611. STARGAMES CORPORATION PTY LTD, MILPERRA NSW 2214, AUSTRALIA, FILED 9-24-2007.

FREE LOOK

THE MARK CONSISTS OF STANDARD CHARACTERS WITHOUT CLAIM TO ANY PARTICULAR FONT, STYLE, SIZE, OR COLOR.

FOR VIDEO GAMING MACHINE WITH MULTIPLE PLAYER TERMINALS AND WITH VIDEO OUTPUT (U.S. CLS. 21, 23, 26, 36 AND 38).

RICHARD A. STRASER, EXAMINING ATTORNEY

SN 77-289,801. THERMOCABLE (FLEXIBLE ELEMENTS) LIMITED, W YORKSHIRE, UNITED KINGDOM, FILED 9-26-2007.

PROH₂O

THE MARK CONSISTS OF THE LETTERS "P" "R" "O" "H", THE NUMERAL "2" LOCATED IN SUBSCRIPT FOLLOWED BY THE NUMERAL "0".

FOR WATER BASED LEAK DETECTION SYSTEM COMPRISED OF ELECTRONIC DETECTION CABLES AND ANCILLARY INTERFACE UNITS FOR USE THEREWITH (U.S. CLS. 21, 23, 26, 36 AND 38).

SAIMA MAKHDOM, EXAMINING ATTORNEY

CLASS 9—(Continued).

SN 77-290,397. SUBTERRACOM WIRELESS SOLUTIONS, LLC, EAST BRUNSWICK, NJ. FILED 9-27-2007.

SUBTERRA-M8

THE MARK CONSISTS OF STANDARD CHARACTERS WITHOUT CLAIM TO ANY PARTICULAR FONT, STYLE, SIZE, OR COLOR.

FOR PORTABLE HANDHELD WIRELESS TRACKING AND TWO-WAY COMMUNICATION APPARATUS CARRIED BY MINERS OR ATTACHED TO EQUIPMENT FOR RECEIVING AND TRANSMITTING SIGNALS, VOICE AND TEXT MESSAGES (U.S. CLS. 21, 23, 26, 36 AND 38).

FIRST USE 7-1-2007; IN COMMERCE 7-1-2007.
JEAN IM, EXAMINING ATTORNEY

SN 77-290,405. SUBTERRACOM WIRELESS SOLUTIONS, LLC, EAST BRUNSWICK, NJ. FILED 9-27-2007.

SUBTERRA-ZAP

THE MARK CONSISTS OF STANDARD CHARACTERS WITHOUT CLAIM TO ANY PARTICULAR FONT, STYLE, SIZE, OR COLOR.

FOR WIRELESS AND WIRE LINE ACCESS POINT COMMUNICATION DEVICE PROVIDING REDUNDANT DATA COMMUNICATION PATHS FROM SOURCE TO DESTINATION FOR TWO-WAY IN-MINE VOICE AND DATA COMMUNICATIONS TO TRACK, MONITOR AND COMMUNICATE WITH MINERS AND EQUIPMENT UNDERGROUND (U.S. CLS. 21, 23, 26, 36 AND 38).

FIRST USE 7-1-2007; IN COMMERCE 7-1-2007.
JEAN IM, EXAMINING ATTORNEY

SN 77-291,536. LEX PRODUCTS CORP., STAMFORD, CT. FILED 9-28-2007.

POWERGATE

THE MARK CONSISTS OF STANDARD CHARACTERS WITHOUT CLAIM TO ANY PARTICULAR FONT, STYLE, SIZE, OR COLOR.

FOR CIRCUIT BREAKERS (U.S. CLS. 21, 23, 26, 36 AND 38).

FIRST USE 11-30-2002; IN COMMERCE 11-30-2002.
LINDA ORNDORFF, EXAMINING ATTORNEY

CLASS 9—(Continued).

SN 77-292,133. CODEREALM CORPORATION, HUNTINGTON BEACH, CA. FILED 9-28-2007.



"THE COLOR(S) BLUE, GREEN, LIGHT BLUE, LIGHT GREEN, AND BLACK, IS/ARE CLAIMED AS A FEATURE OF THE MARK."

THE MARK CONSISTS OF A PYRAMID AND THE WORDING "CODEREALM". THE PYRAMID HAS FOUR QUADRANTS AND FOUR COLORS. THE UPPER LEFT QUADRANT IS THE COLOR BLUE. THE UPPER RIGHT QUADRANT IS THE COLOR GREEN. THE LOWER RIGHT QUADRANT IS THE COLOR LIGHT BLUE. THE LOWER LEFT QUADRANT IS THE COLOR LIGHT GREEN; THE WORDING "CODEREALM" APPEARS IN BLACK.

FOR COMPUTER SOFTWARE USED TO MONITOR ON-DEMAND REAL-TIME DATA FOR THE PURPOSE OF ALLOWING AUTONOMOUS REPORTING, CONTROL, AND HUMAN AND DEVICE INTERACTION, AND WHERE THE DATA MAY BE ACCESSED VIA A GLOBAL COMPUTER NETWORK (U.S. CLS. 21, 23, 26, 36 AND 38).

JORDAN BAKER, EXAMINING ATTORNEY

CLASS 9—(Continued).

SN 77-293,994. MATH MATTERS, LLC, ORLANDO, FL. FILED 10-2-2007.

MATH DRILL EXPRESS

THE MARK CONSISTS OF STANDARD CHARACTERS WITHOUT CLAIM TO ANY PARTICULAR FONT, STYLE, SIZE, OR COLOR.

NO CLAIM IS MADE TO THE EXCLUSIVE RIGHT TO USE "MATH DRILL", APART FROM THE MARK AS SHOWN.

FOR COMPUTER SOFTWARE FOR CHILDREN USED IN DEVELOPING MATHEMATICS SKILLS AND RELATED INSTRUCTIONAL MANUALS, ALL SOLD AS A UNIT (U.S. CLS. 21, 23, 26, 36 AND 38).

FIRST USE 1-4-2006; IN COMMERCE 1-4-2006.

TINA BROWN, EXAMINING ATTORNEY

SN 77-292,338. PROLOGIX INTERNATIONAL CORPORATION, BOCA RATON, FL. FILED 9-29-2007.



OWNER OF U.S. REG. NO. 3,291,472.
THE MARK CONSISTS OF A STYLIZED REPRESENTATION OF A WINE BOTTLE FORMING A PART OF THE WORDING "VINTEMP".

FOR INFRARED THERMOMETERS THAT MEASURE THE TEMPERATURE OF OBJECTS OR FLUIDS BY MEASURING THE INFRARED RADIATION RADIATED BY THE OBJECT OR FLUID (U.S. CLS. 21, 23, 26, 36 AND 38).

FIRST USE 3-1-2005; IN COMMERCE 3-1-2005.
HANNO RITTNER, EXAMINING ATTORNEY

SN 77-294,158. TECHNOMEDIA LLC, GOOSE CREEK, SC. FILED 10-2-2007.

TECHNOMEDIA

THE MARK CONSISTS OF STANDARD CHARACTERS WITHOUT CLAIM TO ANY PARTICULAR FONT, STYLE, SIZE, OR COLOR.

FOR DIGITAL MEDIA, NAMELY, DVDS, CDS, AND DOWNLOADABLE AUDIO/VIDEO/GRAPHIC FILES FEATURING INSTRUCTIONAL LECTURES (U.S. CLS. 21, 23, 26, 36 AND 38).

FIRST USE 11-6-2006; IN COMMERCE 11-6-2006.
JESSICA A. POWERS, EXAMINING ATTORNEY

CLASS 9—(Continued).

SN 77-294,324. DEUTSCHE TELEKOM AG, BONN 53113, FED REP GERMANY, FILED 10-2-2007.



PRIORITY CLAIMED UNDER SEC. 44(D) ON FED REP GERMANY APPLICATION NO. 30722314038, FILED 4-3-2007, REG. NO. 30722314, DATED 12-12-2007, EXPIRES 4-30-2017.

THE MARK CONSISTS OF CIRCLE WITH A STAR INSIDE IT.

FOR ELECTRIC, ELECTRONIC, OPTICAL, MEASURING, SIGNALING, CONTROLLING AND TEACHING APPARATUS AND INSTRUMENTS, ALL FOR USE WITH TELECOMMUNICATIONS, NAMELY, APPARATUS FOR PRODUCING SOUND, IMAGES OR DATA; BLANK MAGNETIC AND OPTICAL DATA CARRIERS; DATA PROCESSORS; COMPUTERS, NAMELY, MICROCOMPUTERS, MINICOMPUTERS, COMPUTER CENTRAL PROCESSORS, COMPUTER MONITORS, COMPUTER KEYBOARDS, COMPUTER TERMINALS, COMPUTER MEMORIES, COMPUTER LASER PRINTERS, COMPUTER IMPACT PRINTERS, COMPUTER DOT MATRIX PRINTERS, COMPUTERS AND INSTRUCTIONAL MANUALS SOLD AS A UNIT; COMPUTER MEMORY HARDWARE; COMPUTER INTERFACE APPARATUS, NAMELY, COMPUTER INTERFACE BOARDS, COMPUTER MOUSE AND MOUSE PAD, COMPUTER PERIPHERALS AND PARTS THEREOF; COMPUTER SOFTWARE PROGRAMS FOR USE IN OPERATING TELECOMMUNICATIONS AND BUSINESS MANAGEMENT SYSTEMS AND RELATED INSTRUCTION MANUALS SOLD AS A UNIT; COMPUTER SOFTWARE FOR FINANCIAL ACCOUNTING, FOR THE PROVISION OF ONLINE INFORMATION SERVICES IN THE FIELD OF NEWS, SPORTS, ENTERTAINMENT, CULTURE, BUSINESS AND FINANCE, WEATHER AND TRAVEL, NETWORK MANAGEMENT, COMPUTER PROXY, FOR CONTROLLING ACCESS AND ALARM MONITORING OF HOMES, APARTMENTS, BUILDINGS AND OTHER PROPERTIES, BILLING ANALYSIS, NETWORK ACCESS CONTROL AND FOR CREATING AND MAINTAINING FIREWALLS; COMPUTER SOFTWARE PROGRAMS FOR ACCESSING A GLOBAL COMPUTER NETWORK AND INTERACTIVE COMPUTER COMMUNICATIONS NETWORKS; OPTICAL FIBERS SOLD AS A COMPONENT OF FIBER OPTICAL CABLES; FIBER OPTIC CABLES; OPTICAL SCANNERS; OPTICAL CHARACTER READERS; OPTICAL BLANK DISCS; OPTICAL GLASS FOR SIGNAL TRANSMISSION; OPTIC TRANSMITTERS FOR RADIO, TELEPHONE; OPTIC RECEIVERS FOR TELEPHONE, AUDIO, VIDEO; OPTICAL SIGNAL PROCESSORS; OPTIC TELECOMMUNICATIONS SWITCHES; OPTICAL ATTENUATORS; OPTICAL AMPLIFIERS; OPTICAL CHARACTER RECOGNITION APPARATUS, FOR USE IN THE TELECOMMUNICATIONS FIELD, AND PARTS THEREOF; TELEPHONE LOCAL AREA NETWORKS; TELECOMMUNICATION AUDIO, VIDEO AND DATA COMMUNICATIONS SYSTEMS, NAMELY, DIGITAL AND ANALOGUE SIGNAL TRANSMITTERS; RECEIVERS AND CONVERTERS FOR USE WITH TELEPHONE, AUDIO, VIDEO; RADIO AND TELEPHONE TRANSMITTERS; COMMUNICATION RECEIVERS AND SERVERS FOR TELEPHONE, AUDIO, VIDEO; TELEPHONE ANSWERING MACHINES; TELEPROMPTERS; TELETYPEWRITERS AND PARTS THEREOF,

CLASS 9—(Continued).

NAMELY, CALLER IDENTIFICATION BOXES, DIALING ASSEMBLIES, TELEPHONE UNITS, AUDIO OPERATED RELAYS, AUDIO/VIDEO SIGNAL AND OPTICAL FILTERS, PROTECTORS AND AUTOMATIC SIGNALING AND CONTROL EQUIPMENT, TELEMETERS, WIRELESS AND CELLULAR TELEPHONES, AND RADIO PAGERS; INTERCOMS; FACSIMILE MACHINE; ELECTRONIC MAIL APPARATUS FOR ELECTRONIC EXCHANGE OF DATA IMAGES AND MESSAGES; ELECTRICAL WIRE; ELECTRICAL WIRE CONNECTORS; INTEGRATED CIRCUITS; PRINTED CIRCUITS; ELECTRIC CIRCUITS; CIRCUIT BREAKERS; PRINTED CIRCUIT BOARDS; CIRCUIT CONNECTORS; ELECTRICAL CONTROLLERS; ELECTRICAL CONVERTERS; ELECTRICAL CONDUCTORS; ELECTRICAL FUSES; ELECTRIC LUMINESCENT DISPLAY PANELS; ELECTRICAL SWITCH PLATES; ELECTRIC PLUGS; ELECTRIC COILS; ANTENNAS; ELECTRICAL CABLES; COMPUTER CABLES; COMPUTER CHIPS; SILICON CHIPS; CHRONOGRAPHS FOR USE AS SPECIALIZED TIME RECORDING APPARATUS; COMPUTER BUFFERS; BLANK COMPUTER DISCS; BLANK COMPUTER FLOPPY DISKS; COMPUTER HARD DISCS; ACOUSTIC CONDUITS; ELECTRICAL CONDUITS; FIBER OPTIC CONDUITS AND PARTS THEREOF; COMPACT DISC PLAYERS; AUDIO AND VIDEO TAPE RECORDERS; AUDIO AND VIDEOTAPE PLAYERS; AUDIO AND VIDEOCASSETTE RECORDERS; AUDIO AND VIDEOCASSETTE PLAYERS; BLANK AUDIO AND VIDEOTAPES, CASSETTES, DISCS AND MICROFICHE; AUDIO AND VIDEO TAPES, CASSETTES, DISCS AND MICROFICHE FEATURING INFORMATION CONCERNING TELECOMMUNICATIONS, AND CONCERNING PERSONAL AND BUSINESS MANAGEMENT SYSTEMS; AUDIO AND VIDEO RECORDINGS IN THE FIELD OF TELECOMMUNICATIONS, INFORMATION TECHNOLOGY AND SAFETY; TELEVISION AND TELEVISION PERIPHERAL EQUIPMENT, NAMELY, CAMERAS, SET TOP BOXES, REMOTE CONTROL UNITS FOR INTERACTIVE AND NON-INTERACTIVE USE; VIDEO MONITORS; AUTOMATIC VENDING MACHINES AND TIMING MECHANISMS THEREFOR AND PARTS THEREOF; MACHINE READABLE, MAGNETICALLY ENCODED CARDS, NAMELY, PREPAID TELEPHONE CALLING CARDS AND CREDIT CARDS; BLANK SMART CARDS; MAGNETIC CODED CARD READERS; DATA PROCESSORS AND READERS; WORD PROCESSORS; MICROPROCESSORS; ELECTRONIC ENCRYPTION UNITS; DEMAGNETIZERS FOR MAGNETIC TAPES AND PARTS THEREOF; LASERS NOT FOR MEDICAL USE; LIGHT EMITTING DIODES; LIGHT EMITTING DIODE DISPLAYS; COMPUTER, DATA AND VIDEO NETWORKING AND CONFERENCING EQUIPMENT, NAMELY, TELECONFERENCING EQUIPMENT AND AUDIOVISUAL TEACHING EQUIPMENT IN THE NATURE OF OVERHEAD FILM, PHOTOGRAPHIC AND SLIDE PROJECTORS; PROJECTION SCREENS; COMPUTER BASED INFORMATION DISPLAY EQUIPMENT, NAMELY, COMPUTERS WHICH DISPLAY INFORMATION ON AN OVERHEAD SCREEN; PORTABLE DEVICES, NAMELY, LAPTOPS, HANDHELD AND POCKET COMPUTERS, WIRELESS FAX MACHINES; PERSONAL COMMUNICATIONS EQUIPMENT, NAMELY, PERSONAL DIGITAL ASSISTANTS; CALCULATORS AND RELATED PERIPHERALS; SATELLITE PROCESSORS, SATELLITE AND SATELLITE COMMUNICATION EARTH STATIONS BOTH STATIONARY AND MOVEABLE; COMPUTER GAME PROGRAMS FOR CHILDREN AND ADULTS; VIDEO AND COMPUTER GAME CARTRIDGES; AUDIO AND VIDEO RECORDINGS IN THE FIELD OF NEWS, SPORTS, ENTERTAINMENT, CULTURE, BUSINESS AND FINANCE, WEATHER AND TRAVEL; PRERECORDED COMPACT DISCS, AUDIOCASSETTE TAPES, VIDEOCASSETTE TAPES, DIGITAL AUDIOTAPES AND DIGI-

CLASS 9—(Continued).

TAL VIDEO DISCS FEATURING MUSICAL, VARIETY, NEWS AND COMEDY SHOWS; CARRYING CASES FOR POCKET CALCULATORS AND CELLPHONES; TELECOMMUNICATIONS SOFTWARE, NAMELY, SOFTWARE FOR WIRELESS CONTENT DELIVERY, SOFTWARE TO ENABLE THE TRANSMISSION OF PHOTOGRAPHS TO MOBILE TELEPHONES, SOFTWARE FOR ACCESSING INFORMATION DIRECTORIES THAT MAY BE DOWNLOADED FROM THE INTERNET, AND COMPUTER APPLICATION SOFTWARE FOR MOBILE PHONES (U.S. CLS. 21, 23, 26, 36 AND 38).

JUDITH HELFMAN, EXAMINING ATTORNEY

SN 77-295,115. BURTON, BRIAN, LOS ANGELES, CA. FILED 10-3-2007.

UNDERGROUND ANIMALS

THE MARK CONSISTS OF STANDARD CHARACTERS WITHOUT CLAIM TO ANY PARTICULAR FONT, STYLE, SIZE, OR COLOR.

FOR AUDIO AND VISUAL RECORDINGS FEATURING MUSIC AND MUSICAL PERFORMANCES; PRE-RECORDED CDS FEATURING MUSIC AND MUSICAL PERFORMANCES; PRE-RECORDED ELECTRONIC MEDIA FEATURING MUSIC AND MUSICAL PERFORMANCES (U.S. CLS. 21, 23, 26, 36 AND 38).

DOMINIC FATHY, EXAMINING ATTORNEY

SN 77-295,576. KOVIO, INC., MILPITAS, CA. FILED 10-3-2007.

RF INTELLIGENT PRODUCT CODE

THE MARK CONSISTS OF STANDARD CHARACTERS WITHOUT CLAIM TO ANY PARTICULAR FONT, STYLE, SIZE, OR COLOR.

NO CLAIM IS MADE TO THE EXCLUSIVE RIGHT TO USE "RF", APART FROM THE MARK AS SHOWN.

FOR ELECTRONIC APPARATUS, NAMELY, TRANSISTORS, CIRCUIT BOARDS, LUMINESCENT DISPLAY PANELS, ORGANIC LIGHT EMITTED DIODE (OLED) DISPLAYS, ELECTROPHORETIC DISPLAYS, ELECTRIC SIGNS, LUMINOUS SIGNS, SENSOR CHIPS FOR SCIENTIFIC USE, LIQUID LEVEL SENSORS, GAS SENSORS FOR MEASURING GAS CONCENTRATION, PROXIMITY SENSORS, PRESSURE SENSORS, TEMPERATURE SENSORS, HUMIDITY SENSORS, BIOSENSORS, PHOTOVOLTAIC CELLS, SOLAR CELLS, RADIO FREQUENCY IDENTIFICATION (RFID) INTEGRATED CIRCUITS; RADIO FREQUENCY IDENTIFICATION (RFID) CARD, TAGS, LABELS, AND TICKETS; SEMICONDUCTOR CHIPS; PRINTED INTEGRATED CIRCUITS; INTEGRATED CIRCUITS; PRINTED CIRCUITS; RADIO FREQUENCY IDENTIFICATION (RFID) CHIPS WITH ATTACHED ANTENNA (U.S. CLS. 21, 23, 26, 36 AND 38).

JOHN WILKE, EXAMINING ATTORNEY

CLASS 9—(Continued).

SN 77-296,566. PORTLAND BIOSCIENCE, INC., PORTLAND, OR. FILED 10-4-2007.

PDXBIO

THE MARK CONSISTS OF STANDARD CHARACTERS WITHOUT CLAIM TO ANY PARTICULAR FONT, STYLE, SIZE, OR COLOR.

FOR COMPUTER HARDWARE FOR RESEARCH AND SCIENTIFIC USE CONCERNING BIOTECHNICS, GENE TECHNOLOGY AND DNA-ANALYSIS; COMPUTER SOFTWARE FOR SCIENTIFIC ANALYSIS OF GENETIC SEQUENCES, GENETIC INFORMATION AND BIOLOGICAL MATERIALS FOR USE IN RESEARCH IN THE FIELDS OF GENOMICS, BIOLOGY, CHEMISTRY AND MEDICINE; DNA CHIPS; BIOSENSORS FOR RESEARCH AND SCIENTIFIC USE CONCERNING BIOTECHNICS, GENE TECHNOLOGY AND DNA-ANALYSIS (U.S. CLS. 21, 23, 26, 36 AND 38).

G. MAYERSCHOFF, EXAMINING ATTORNEY

SN 77-298,621. NORTH BEAR BEAUTY SYSTEM, INC., BARRINGTON, IL. FILED 10-8-2007.

h2prō

THE COLOR(S) BLUE IS/ARE CLAIMED AS A FEATURE OF THE MARK.

THE TERM "H2PRO" APPEARS IN THE BLUE, AS DOES THE HORIZONTAL LINE APPEARING OVER THE LETTER "O".

FOR ELECTRIC HAIR STRAIGHTENING IRONS (U.S. CLS. 21, 23, 26, 36 AND 38).

FIRST USE 10-31-2003; IN COMMERCE 10-31-2003.

JIM RINGLE, EXAMINING ATTORNEY

CLASS 9—(Continued).

SN 77-298,664. CONSUMERPSYCH LABS, INC., DBA BRANDPSYCH LABS, INC., ITHACA, NY. FILED 10-8-2007.

MINDLESS DIETING

THE MARK CONSISTS OF STANDARD CHARACTERS WITHOUT CLAIM TO ANY PARTICULAR FONT, STYLE, SIZE, OR COLOR.

NO CLAIM IS MADE TO THE EXCLUSIVE RIGHT TO USE "DIETING", APART FROM THE MARK AS SHOWN.

FOR PRE-RECORDED ELECTRONIC MEDIA, NAMELY, CDS, DVDS, VIDEO TAPES AND VIDEO RECORDINGS, AND AUDIO BOOKS, ALL IN THE FIELDS OF BEHAVIOR MODIFICATION PSYCHOLOGY, EATING HABITS, DIETING AND WEIGHT MANAGEMENT, FAMILY AND PERSONAL NUTRITION, COMFORT FOODS, FINE DINING AND RESTAURANT DINING; DOWNLOADABLE MP3 FILES, MP3 RECORDINGS, ONLINE DISCUSSION BOARDS, WEBCASTS, AND POD CASTS FEATURING AUDIO BOOKS, NEWS BROADCASTS, AND EMAIL BROADCASTS, ALL IN THE FIELDS OF BEHAVIOR MODIFICATION PSYCHOLOGY, EATING HABITS, DIETING AND WEIGHT MANAGEMENT, FAMILY AND PERSONAL NUTRITION, COMFORT FOODS, FINE DINING AND RESTAURANT DINING; SOFTWARE, MOTION PICTURE FILMS AND DOCUMENTARIES, AUDIO AND VIDEO SOFTWARE DOWNLOADS OF ELECTRONIC PROGRAMS, AND ON-LINE DOWNLOADABLE SOFTWARE FOR USE IN TASK MANAGEMENT, ALL IN THE FIELDS OF BEHAVIOR MODIFICATION PSYCHOLOGY, EATING HABITS, DIETING AND WEIGHT MANAGEMENT, FAMILY AND PERSONAL NUTRITION, COMFORT FOODS, FINE DINING AND RESTAURANT DINING (U.S. CLS. 21, 23, 26, 36 AND 38).

BARBARA RUTLAND, EXAMINING ATTORNEY

SN 77-299,431. CONCRETE TECHNOLOGY WORLDWIDE, INC., GREEN BAY, WI. FILED 10-9-2007.

HYDRAU-THERM

THE MARK CONSISTS OF STANDARD CHARACTERS WITHOUT CLAIM TO ANY PARTICULAR FONT, STYLE, SIZE, OR COLOR.

FOR TEMPERATURE AND MOISTURE CONTROL APPARATUS FOR CURING CONCRETE (U.S. CLS. 21, 23, 26, 36 AND 38).

REBECCA POVARCHUK, EXAMINING ATTORNEY

CLASS 9—(Continued).

SN 77-300,609. PROVIGENT LTD., HERZLIA, ISRAEL, FILED 10-10-2007.

PROVIPACK

THE MARK CONSISTS OF STANDARD CHARACTERS WITHOUT CLAIM TO ANY PARTICULAR FONT, STYLE, SIZE, OR COLOR.

FOR COMMUNICATION SYSTEMS, EQUIPMENT AND DEVICES, NAMELY, ELECTRONIC TRANSMITTERS AND RECEIVERS FOR USE IN WIRELESS COMMUNICATIONS, AND SIGNAL PROCESSORS AND PARTS THEREFOR (U.S. CLS. 21, 23, 26, 36 AND 38).

LOURDES AYALA, EXAMINING ATTORNEY

SN 77-301,712. PREVENT-A-THEFT GROUP NEVADA, LLC, HENDERSON, NV. FILED 10-11-2007.

MAGIC TRAK

THE MARK CONSISTS OF STANDARD CHARACTERS WITHOUT CLAIM TO ANY PARTICULAR FONT, STYLE, SIZE, OR COLOR.

NO CLAIM IS MADE TO THE EXCLUSIVE RIGHT TO USE "TRAK", APART FROM THE MARK AS SHOWN.

FOR GLOBAL POSITIONING SYSTEM (GPS) DEVICE FOR INSTALLATION IN A VEHICLE (U.S. CLS. 21, 23, 26, 36 AND 38).

SALLY SHIH, EXAMINING ATTORNEY

CLASS 9—(Continued).

SN 77-302,894. SONY COMPUTER ENTERTAINMENT EUROPE LIMITED, LONDON, UNITED KINGDOM, FILED 10-12-2007.

CLASS 9—(Continued).

SN 77-303,075. SONY COMPUTER ENTERTAINMENT EUROPE LIMITED, LONDON, UNITED KINGDOM, FILED 10-12-2007.

BLAST FACTOR

SNAKEBALL

THE MARK CONSISTS OF STANDARD CHARACTERS WITHOUT CLAIM TO ANY PARTICULAR FONT, STYLE, SIZE, OR COLOR.

PRIORITY CLAIMED UNDER SEC. 44(D) ON UNITED KINGDOM APPLICATION NO. 2452510, FILED 4-13-2007, REG. NO. 2452510, DATED 10-12-2007, EXPIRES 4-13-2017.

FOR COMPUTER GAME SOFTWARE; VIDEO GAME SOFTWARE; ELECTRONIC GAME PROGRAMS; COMPUTER PERIPHERAL DEVICES FOR PLAYING COMPUTER GAMES; COMPUTER GAMES CONTROLLERS; COMPUTER GAMES CONSOLES ADAPTED FOR USE WITH AN EXTERNAL DISPLAY SCREEN OR MONITOR; COMPUTER SOFTWARE FOR VIDEO GAMES OR FOR GAMES MACHINES; ELECTRONIC DEVICES, NAMELY, WIRELESS ROUTERS FOR THE WIRELESS RECEIPT, STORAGE AND/OR TRANSMISSION OF DATA AND MESSAGES; COMPUTER SOFTWARE FOR PHOTO AND/OR VIDEO MANIPULATION; DOWNLOADABLE ELECTRONIC PUBLICATIONS, NAMELY, MAGAZINES AND NEWSLETTERS ON COMPUTER GAMES; SOUND AND/OR VIDEO RECORDINGS FEATURING MUSIC AND ENTERTAINMENT, TELEVISION PROGRAMS, MOTION PICTURES, NEWS, SPORTS, GAMES, CULTURAL EVENTS, AND ENTERTAINMENT-RELATED PROGRAMS OF ALL KINDS; DOWNLOADABLE DIGITAL SOUND AND/OR VIDEO RECORDINGS FEATURING MUSIC AND ENTERTAINMENT, TELEVISION PROGRAMS, MOTION PICTURES, NEWS, SPORTS, GAMES, CULTURAL EVENTS, AND ENTERTAINMENT-RELATED PROGRAMS OF ALL KINDS; AND COMPUTER SOFTWARE TO ALLOW USERS TO PERFORM ELECTRONIC BUSINESS TRANSACTIONS VIA THE INTERNET (U.S. CLS. 21, 23, 26, 36 AND 38).

JOHN E. MICHOS, EXAMINING ATTORNEY

THE MARK CONSISTS OF STANDARD CHARACTERS WITHOUT CLAIM TO ANY PARTICULAR FONT, STYLE, SIZE, OR COLOR.

PRIORITY CLAIMED UNDER SEC. 44(D) ON UNITED KINGDOM APPLICATION NO. 2452523, FILED 4-13-2007, REG. NO. 2452523, DATED 10-19-2007, EXPIRES 4-13-2017.

FOR COMPUTER GAME SOFTWARE; VIDEO GAME SOFTWARE; ELECTRONIC GAME PROGRAMS; COMPUTER PERIPHERAL DEVICES FOR PLAYING COMPUTER GAMES; COMPUTER GAMES CONTROLLERS; COMPUTER GAMES CONSOLES ADAPTED FOR USE WITH AN EXTERNAL DISPLAY SCREEN OR MONITOR; COMPUTER SOFTWARE FOR VIDEO GAMES OR FOR GAMES MACHINES; ELECTRONIC DEVICES, NAMELY, WIRELESS ROUTERS FOR THE WIRELESS RECEIPT, STORAGE AND/OR TRANSMISSION OF DATA AND MESSAGES; COMPUTER SOFTWARE FOR PHOTO AND/OR VIDEO MANIPULATION; DOWNLOADABLE ELECTRONIC PUBLICATIONS, NAMELY, MAGAZINES AND NEWSLETTERS ON COMPUTER GAMES; SOUND AND/OR VIDEO RECORDINGS FEATURING MUSIC AND ENTERTAINMENT, TELEVISION PROGRAMS, MOTION PICTURES, NEWS, SPORTS, GAMES, CULTURAL EVENTS, AND ENTERTAINMENT-RELATED PROGRAMS OF ALL KINDS; DOWNLOADABLE DIGITAL SOUND AND/OR VIDEO RECORDINGS FEATURING MUSIC AND ENTERTAINMENT, TELEVISION PROGRAMS, MOTION PICTURES, NEWS, SPORTS, GAMES, CULTURAL EVENTS, AND ENTERTAINMENT-RELATED PROGRAMS OF ALL KINDS; AND COMPUTER SOFTWARE TO ALLOW USERS TO PERFORM ELECTRONIC BUSINESS TRANSACTIONS VIA THE INTERNET (U.S. CLS. 21, 23, 26, 36 AND 38).

JOHN E. MICHOS, EXAMINING ATTORNEY

CLASS 9—(Continued).

SN 77-303,090. SONY COMPUTER ENTERTAINMENT EUROPE LIMITED, LONDON, UNITED KINGDOM, FILED 10-12-2007.

STRINGS ATTACHED

THE MARK CONSISTS OF STANDARD CHARACTERS WITHOUT CLAIM TO ANY PARTICULAR FONT, STYLE, SIZE, OR COLOR.

PRIORITY CLAIMED UNDER SEC. 44(D) ON UNITED KINGDOM APPLICATION NO. 2452524, FILED 4-13-2007, REG. NO. 2452524, DATED 10-19-2007, EXPIRES 4-13-2017.

FOR COMPUTER GAME SOFTWARE; VIDEO GAME SOFTWARE; ELECTRONIC GAME PROGRAMS; COMPUTER PERIPHERAL DEVICES FOR PLAYING COMPUTER GAMES; COMPUTER GAMES CONTROLLERS; COMPUTER GAMES CONSOLES ADAPTED FOR USE WITH AN EXTERNAL DISPLAY SCREEN OR MONITOR; COMPUTER SOFTWARE FOR VIDEO GAMES OR FOR GAMES MACHINES; ELECTRONIC DEVICES, NAMELY, WIRELESS ROUTERS FOR THE WIRELESS RECEIPT, STORAGE AND/OR TRANSMISSION OF DATA AND MESSAGES; COMPUTER SOFTWARE FOR PHOTO AND/OR VIDEO MANIPULATION; DOWNLOADABLE ELECTRONIC PUBLICATIONS, NAMELY, MAGAZINES AND NEWSLETTERS ON COMPUTER GAMES; SOUND AND/OR VIDEO RECORDINGS FEATURING MUSIC AND ENTERTAINMENT, TELEVISION PROGRAMS, MOTION PICTURES, NEWS, SPORTS, GAMES, CULTURAL EVENTS, AND ENTERTAINMENT-RELATED PROGRAMS OF ALL KINDS; DOWNLOADABLE DIGITAL SOUND AND/OR VIDEO RECORDINGS FEATURING MUSIC AND ENTERTAINMENT, TELEVISION PROGRAMS, MOTION PICTURES, NEWS, SPORTS, GAMES, CULTURAL EVENTS, AND ENTERTAINMENT-RELATED PROGRAMS OF ALL KINDS; AND COMPUTER SOFTWARE TO ALLOW USERS TO PERFORM ELECTRONIC BUSINESS TRANSACTIONS VIA THE INTERNET (U.S. CLS. 21, 23, 26, 36 AND 38).

JOHN E. MICHOS, EXAMINING ATTORNEY

SN 77-305,630. NORTHCOAST INNOVATIONS, LLC, STRONGSVILLE, OH. FILED 10-16-2007.

GARAGE GUARDIAN

THE MARK CONSISTS OF STANDARD CHARACTERS WITHOUT CLAIM TO ANY PARTICULAR FONT, STYLE, SIZE, OR COLOR.

NO CLAIM IS MADE TO THE EXCLUSIVE RIGHT TO USE "GARAGE!", APART FROM THE MARK AS SHOWN.

FOR SAFETY SENSORS, NAMELY, CARBON MONOXIDE DETECTORS, SMOKE DETECTORS, AND COMBINATION CARBON MONOXIDE AND SMOKE DETECTORS (U.S. CLS. 21, 23, 26, 36 AND 38).

JANICE KIM, EXAMINING ATTORNEY

CLASS 9—(Continued).

SN 77-305,956. CINEGY LLC, WASHINGTON, DC. FILED 10-17-2007.

CINEGY

THE MARK CONSISTS OF STANDARD CHARACTERS WITHOUT CLAIM TO ANY PARTICULAR FONT, STYLE, SIZE, OR COLOR.

FOR COMPUTER SOFTWARE FOR VIDEO AND AUDIO PROCESSING, AUDIO AND VIDEO EDITING, AND AUDIO AND VIDEO ENCODING (U.S. CLS. 21, 23, 26, 36 AND 38).

FIRST USE 6-1-2001; IN COMMERCE 6-1-2002.

TEJBIR SINGH, EXAMINING ATTORNEY

SN 77-307,116. PDS ELECTRONICS, INC., AKRON, OH. FILED 10-18-2007.

EZ-BUILD

THE MARK CONSISTS OF STANDARD CHARACTERS WITHOUT CLAIM TO ANY PARTICULAR FONT, STYLE, SIZE, OR COLOR.

FOR ANTENNA KITS COMPRISING STRUCTURAL ANTENNA PARTS AND RELATED HARDWARE, SOLD AS A UNIT, USED TO BUILD DIFFERENT TYPES OF ANTENNAS, NAMELY, SINGLE BAND, MULTI-BAND, MULTI-FREQUENCY AND FOLDED DIPOLE, DOUBLET AND INVERTED-VEE, OFF-CENTER FED, WINDOM, ZEPP, LONG WIRES, RHOMBIC, VEE BEAM, AND LOOP ANTENNAS FOR AMATEUR RADIO OPERATORS (U.S. CLS. 21, 23, 26, 36 AND 38).

FIRST USE 9-7-2007; IN COMMERCE 9-7-2007.

ELLEN B. AWRICH, EXAMINING ATTORNEY

SN 77-307,480. PDS ELECTRONICS, INC., AKRON, OH. FILED 10-18-2007.

EZ-UP

THE MARK CONSISTS OF STANDARD CHARACTERS WITHOUT CLAIM TO ANY PARTICULAR FONT, STYLE, SIZE, OR COLOR.

FOR HIGH PERFORMANCE SELF-SUPPORTING VERTICAL ANTENNA SYSTEMS FOR AMATEUR RADIO OPERATORS COMPRISING HIGH PERFORMANCE SELF-SUPPORTING VERTICAL ANTENNAS AND ANTENNA SUPPORT STRUCTURES FOR AMATEUR RADIO OPERATORS (U.S. CLS. 21, 23, 26, 36 AND 38).

FIRST USE 9-7-2007; IN COMMERCE 9-7-2007.

ELLEN B. AWRICH, EXAMINING ATTORNEY

CLASS 9—(Continued).

SN 77-307,544. RAI ENTERPRISES, DBA RAIBEAM, GLENDALE, AZ. FILED 10-18-2007.

RAIBEAM

THE MARK CONSISTS OF STANDARD CHARACTERS WITHOUT CLAIM TO ANY PARTICULAR FONT, STYLE, SIZE, OR COLOR.

FOR ANTENNAS FOR RADIO, FOR TELEVISION (U.S. CLS. 21, 23, 26, 36 AND 38).

FIRST USE 2-15-1994; IN COMMERCE 5-1-1995.
MARIA-VICTORIA SUAREZ, EXAMINING ATTORNEY

CLASS 9—(Continued).

SN 77-308,805. SYNAPTICS INCORPORATED, SANTA CLARA, CA. FILED 10-19-2007.



THE MARK IS COMPRISED OF TWO DARKER OUTER CURVES AND TWO LIGHTER INNER CURVES, ALL ARRANGED CONCENTRICALLY.

FOR ELECTRONIC CIRCUITRY; ELECTRONIC INTEGRATED CIRCUITS AND CIRCUIT BOARDS; INPUT DEVICES, NAMELY, TOUCH-SENSITIVE ELECTRONIC CONTROLLERS AND TRANSCEIVERS FOR CONSUMER ELECTRONIC PRODUCTS THAT ALLOW THE USER TO INTERFACE WITH OR CONTROL THE PRODUCTS, AND SOFTWARE THEREFORE; AND COMPUTER SOFTWARE DESIGN TOOLS FOR DESIGNING INPUT DEVICES FOR CONSUMER ELECTRONIC PRODUCTS THAT ALLOW THE USER TO INTERFACE WITH OR CONTROL THE PRODUCTS (U.S. CLS. 21, 23, 26, 36 AND 38).

IRA J. GOODSaid, EXAMINING ATTORNEY

SN 77-308,790. SYNAPTICS INCORPORATED, SANTA CLARA, CA. FILED 10-19-2007.



ChiralMotion

OWNER OF U.S. REG. NO. 3,396,332.

FOR ELECTRONIC CIRCUITRY; ELECTRONIC INTEGRATED CIRCUITS AND CIRCUIT BOARDS; INPUT DEVICES, NAMELY, TOUCH-SENSITIVE INPUT DEVICES FOR CONSUMER ELECTRONIC PRODUCTS THAT ALLOW THE USER TO INTERFACE WITH OR CONTROL THE PRODUCTS, AND SOFTWARE THEREFORE; AND COMPUTER SOFTWARE DESIGN TOOLS FOR DESIGNING INPUT DEVICES FOR CONSUMER ELECTRONIC PRODUCTS THAT ALLOW THE USER TO INTERFACE WITH OR CONTROL THE PRODUCTS (U.S. CLS. 21, 23, 26, 36 AND 38).

ALEXANDER L. POWERS, EXAMINING ATTORNEY

SN 77-312,553. CODEMINION, WARSZAWA, POLAND, FILED 10-24-2007.

CODEMINION

THE MARK CONSISTS OF STANDARD CHARACTERS WITHOUT CLAIM TO ANY PARTICULAR FONT, STYLE, SIZE, OR COLOR.

FOR DOWNLOADABLE ELECTRONIC GAMES VIA THE INTERNET AND WIRELESS DEVICES; COMPUTER SOFTWARE, NAMELY, COMPUTER GAME SOFTWARE (U.S. CLS. 21, 23, 26, 36 AND 38).

FIRST USE 7-0-2002; IN COMMERCE 8-0-2002.
ANDREA K. NADELMAN, EXAMINING ATTORNEY

CLASS 9—(Continued).

SN 77-313,190. MEISTRICH, STEVEN W., HENDERSON, NV.
FILED 10-25-2007.

Genesis Gaming, Inc.

THE MARK CONSISTS OF STANDARD CHARACTERS WITHOUT CLAIM TO ANY PARTICULAR FONT, STYLE, SIZE, OR COLOR.

NO CLAIM IS MADE TO THE EXCLUSIVE RIGHT TO USE "GAMING, INC.", APART FROM THE MARK AS SHOWN.

FOR GAMING SOFTWARE THAT GENERATES OR DISPLAYS WAGER OUTCOMES OF GAMING MACHINES (U.S. CLS. 21, 23, 26, 36 AND 38).

SUSAN LESLIE DUBOIS, EXAMINING ATTORNEY

SN 77-315,981. MEADWESTVACO CORPORATION, GLEN ALLEN, VA. FILED 10-29-2007.

FIVE STAR

THE MARK CONSISTS OF STANDARD CHARACTERS WITHOUT CLAIM TO ANY PARTICULAR FONT, STYLE, SIZE, OR COLOR.

OWNER OF U.S. REG. NOS. 1,336,643, 3,113,881 AND OTHERS.

FOR CAMERAS; SCANNERS; COMPUTER STORAGE DEVICES, NAMELY, USB FLASH DRIVES; COMPUTER CURSOR CONTROL DEVICES, NAMELY, DIGITAL PENS; AUDIO AND VIDEO RECORDING AND TRANSMISSION DEVICES, NAMELY, CAMERAS AND VOICE RECORDERS; DATA RECEIVER DEVICES, NAMELY, MOBILE DATA RECEIVERS; CELL PHONES; PERSONAL DIGITAL ASSISTANTS; ELECTRONIC AND INTERACTIVE WHITEBOARDS; COMPUTER HARDWARE AND SOFTWARE FOR ELECTRONIC AND INTERACTIVE WHITEBOARDS; PROJECTORS FOR ELECTRONIC AND INTERACTIVE WHITEBOARDS; ELECTROMAGNETIC PENS FOR USE WITH ELECTRONIC AND INTERACTIVE WHITEBOARDS; COMPUTER HARDWARE AND SOFTWARE FOR THE COLLECTION, EDITING, ORGANIZING, MODIFYING, BOOK MARKING, TRANSMISSION, STORAGE AND SHARING OF DATA, IMAGES AND INFORMATION; COMPUTER SOFTWARE FOR PROJECT PLANNING, PROJECT ORGANIZATION, PROJECT MANAGEMENT, EVENT PLANNING, EVENT ORGANIZATION, EVENT MANAGEMENT, PERSONAL PLANNING, PERSONAL ORGANIZATION, REPORT PLANNING, REPORT ORGANIZATION, REPORT MANAGEMENT, TIME MANAGEMENT, WORD PROCESSING (U.S. CLS. 21, 23, 26, 36 AND 38).

MONIQUE MILLER, EXAMINING ATTORNEY

CLASS 9—(Continued).

SN 77-316,491. SCENEWISE, INC., EL SEGUNDO, CA. FILED 10-29-2007.

SCENEWISE

THE MARK CONSISTS OF STANDARD CHARACTERS WITHOUT CLAIM TO ANY PARTICULAR FONT, STYLE, SIZE, OR COLOR.

FOR DIGITAL MEDIA PRODUCTS, NAMELY, DVDS, CDS AND DIGITAL AUDIO AND VISUAL TAPES AND DISCS CONTAINING EDUCATIONAL MATERIAL IN THE FIELDS OF THE HUMANITIES, MATHEMATICS, SOCIAL SCIENCES, PHYSICAL SCIENCES, AND HEALTH SCIENCES AT THE PRIMARY, SECONDARY OR COLLEGE LEVEL (U.S. CLS. 21, 23, 26, 36 AND 38).

FIRST USE 8-31-2007; IN COMMERCE 8-31-2007.

GINA FINK, EXAMINING ATTORNEY

SN 77-317,066. HEALTH MANAGEMENT SYSTEMS, INC., NEW YORK, MA. FILED 10-30-2007.



NO CLAIM IS MADE TO THE EXCLUSIVE RIGHT TO USE "CHECK IN", APART FROM THE MARK AS SHOWN.

THE MARK CONSISTS OF FIGURE OF PERSON WALKING IN THE DIRECTION OF AN ARROWHEAD.

FOR INTERACTIVE COMPUTER KIOSKS LOCATED AT A POINT-OF-ENTRY COMPRISING COMPUTERS, COMPUTER HARDWARE, COMPUTER PERIPHERALS, AND COMPUTER OPERATING SOFTWARE, FOR USE IN MEDICAL CENTERS FOR PATIENT REGISTRATION, REAL-TIME COORDINATION OF PATIENT BENEFITS, CAPTURING OF PATIENT INFORMATION, AND PREPARATION OF PATIENT IDENTIFICATION BADGES; AND VERIFICATION SYSTEM COMPRISED OF COMPUTERS AND COMPUTER PERIPHERALS WITH IDENTIFICATION VERIFICATION DEVICES FOR VERIFYING PATIENT IDENTIFICATION AND INSURANCE COVERAGE USING IDENTIFICATION MEANS, SUCH AS PASSWORD SYSTEMS OR MAGNETIC STRIPE IDENTIFICATION CARDS (U.S. CLS. 21, 23, 26, 36 AND 38).

BENJAMIN OKEKE, EXAMINING ATTORNEY

CLASS 9—(Continued).

SN 77-317,169. VULCAN INC., SEATTLE, WA. FILED 10-30-2007.

BACKCHANNEL TV

THE MARK CONSISTS OF STANDARD CHARACTERS WITHOUT CLAIM TO ANY PARTICULAR FONT, STYLE, SIZE, OR COLOR.

NO CLAIM IS MADE TO THE EXCLUSIVE RIGHT TO USE "TV", APART FROM THE MARK AS SHOWN.

FOR COMPUTER HARDWARE; COMPUTER SOFTWARE FOR TRANSMITTING, RECEIVING, MONITORING, VIEWING, TRACKING, STORING, SECURING, CONVERTING AND PROCESSING A COMBINATION OF DIGITAL VIDEO, AUDIO, IMAGES AND TEXT CONTENT AND DATA; ELECTRONIC TRANSMITTERS AND RECEIVERS FOR TRANSMITTING, RECEIVING, MONITORING, VIEWING, TRACKING, STORING, SECURING, CONVERTING AND PROCESSING A COMBINATION OF DIGITAL VIDEO, AUDIO, IMAGES AND TEXT CONTENT AND DATA (U.S. CLS. 21, 23, 26, 36 AND 38).

DANNEAN HETZEL, EXAMINING ATTORNEY

CLASS 9—(Continued).

SN 77-320,184. PDS ELECTRONICS, INC., AKRON, OH. FILED 11-2-2007.

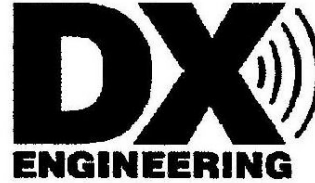

OWNER OF U.S. REG. NOS. 2,618,396 AND 3,071,562.
NO CLAIM IS MADE TO THE EXCLUSIVE RIGHT TO USE "DX ENGINEERING", APART FROM THE MARK AS SHOWN.

THE MARK CONSISTS OF THE LETTERS "DX" WITH CURVILINEAR LINES TO THE RIGHT THEREOF REPRESENTING SOUND WAVES AND THE WORD "ENGINEERING" UNDERNEATH SAID LETTERING.

FOR AMATEUR RADIO ANTENNAS, NAMELY, HIGH PERFORMANCE, LONG DISTANCE ANTENNAS USING HF, VHF OR UHF FREQUENCY BANDS TO OBTAIN OPTIMUM GAIN THROUGH CONTROL OF TAKE-OFF ANGLE, VOLTAGE STANDING WAVE RATIO AND ANTENNA PATTERN; ANTENNA PARTS THEREFOR, NAMELY, PARASITIC AND ALL-DRIVEN ARRAYS, YAGI STACKING SWITCHES AND VERTICAL ANTENNA ARRAY COMBINATIONS WHICH ALLOW INSTANT DIRECTIONAL SWITCHING AND SIMULTANEOUS COVERAGE OF TWO PATHS; AND ANTENNA PERIPHERALS, NAMELY, YAGI PHASE BOXES, VERTICAL PHASE BOXES, SIDE MOUNT PHASE BOXES AND REMOTE COAXIAL ANTENNA SWITCHES; TIME VARIABLE SEQUENCE UNITS; ACTIVE RECEIVE ANTENNAS WITH INTERNAL ANTENNA DISCONNECT RELAYS; CURRENT BALUNS AND FEEDLINE CURRENT CHOKES; REVERSIBLE BEVERAGE ANTENNAS, AND NOISE CANCELING CONTROLLERS (U.S. CLS. 21, 23, 26, 36 AND 38).

FIRST USE 5-4-2004; IN COMMERCE 12-2-2005.
ELLEN B. AWRICH, EXAMINING ATTORNEY

SN 77-319,953. MERS FINANCIAL SOLUTIONS, LLC, WILMINGTON, DE. FILED 11-2-2007.

MERSION

THE MARK CONSISTS OF STANDARD CHARACTERS WITHOUT CLAIM TO ANY PARTICULAR FONT, STYLE, SIZE, OR COLOR.

FOR COMPUTER SOFTWARE PROGRAM IN THE FIELD OF PENSION ADMINISTRATION THAT PERFORMS RECORD KEEPING, REPORT GENERATION, PAYROLL REPORTING, PAYROLL PROCESSING, INVESTMENT MANAGEMENT, BENEFIT AND SERVICE PURCHASE CALCULATIONS, AND MEMBER INFORMATION MANAGEMENT FUNCTIONS (U.S. CLS. 21, 23, 26, 36 AND 38).

SARA THOMAS, EXAMINING ATTORNEY

SN 77-321,858. BRIGHT VIEW TECHNOLOGIES, INC., MORRISVILLE, NC. FILED 11-5-2007.

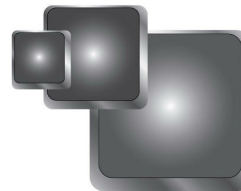

THE MARK CONSISTS OF THREE-PROJECTING SCREENS DESIGN.

FOR OPTICAL FILMS, NAMELY, A MICROLENS-BASED DISPLAY SURFACE (U.S. CLS. 21, 23, 26, 36 AND 38).

FIRST USE 11-0-2003; IN COMMERCE 11-0-2003.
PAULA MAHONEY, EXAMINING ATTORNEY

CLASS 9—(Continued).

SN 77-324,608. KIO YAMATO OPTICS, INC., ENGLEWOOD CLIFFS, NJ. FILED 11-8-2007.

KIO YAMATO

THE MARK CONSISTS OF STANDARD CHARACTERS WITHOUT CLAIM TO ANY PARTICULAR FONT, STYLE, SIZE, OR COLOR.

THE NAME SHOWN IN THE MARK DOES NOT IDENTIFY A PARTICULAR LIVING INDIVIDUAL.

FOR TINTED AND UNTINTED EYEGLASSES, EYEGLASS LENSES, EYEGLASS CASES, CLIP-ON EYEGLASS FRAMES AND EYEGLASS FRAMES (U.S. CLS. 21, 23, 26, 36 AND 38).

FIRST USE 6-15-1999; IN COMMERCE 6-15-1999.
BENJAMIN ALLEN, EXAMINING ATTORNEY

SN 77-325,491. TECHNETIX GROUP LIMITED, WEST SUSSEX, UNITED KINGDOM, FILED 11-9-2007.



NO CLAIM IS MADE TO THE EXCLUSIVE RIGHT TO USE "MODEM SAFE", APART FROM THE MARK AS SHOWN.

FOR APPARATUS FOR PROCESSING SIGNALS FOR DIGITAL TELEVISION, NAMELY, CABLE TELEVISION CONVERTORS; APPARATUS FOR SUPPLYING AND RELAYING SIGNALS FOR DIGITAL TELEVISION, NAMELY, TELEVISION RECEIVERS AND TRANSMITTERS, AERIALS; SYSTEM PROTECTION AND SAFETY APPARATUS, NAMELY, VOLTAGE SURGE PROTECTORS; INTEGRATED CIRCUITS; SIGNAL DISTRIBUTION EQUIPMENT, NAMELY, TRANSMITTERS, RECEIVERS, SPLITTERS, SIGNALS SCRAMBLERS, MODULATORS AND DE-MODULATORS; SIGNAL COMBINERS, NAMELY, ELECTRONIC COMBINERS FOR CONNECTING ANTENNAS AND RECEIVERS; DIGITAL SIGNAL SPLITTERS FOR ELECTRONIC APPARATUS; SURGE PROTECTING GALVANIC ISOLATORS; FILTERS FOR RADIO INTERFERENCE SUPPRESSION; CABLE MODEMS; COAXIAL CABLE TERMINATORS AND ADAPTORS (U.S. CLS. 21, 23, 26, 36 AND 38).

MARY CRAWFORD, EXAMINING ATTORNEY

CLASS 9—(Continued).

SN 77-326,218. OPEN SCAN TECHNOLOGIES, INC., DENVER, CO. FILED 11-9-2007.

Beyond Remote Capture

THE MARK CONSISTS OF STANDARD CHARACTERS WITHOUT CLAIM TO ANY PARTICULAR FONT, STYLE, SIZE, OR COLOR.

NO CLAIM IS MADE TO THE EXCLUSIVE RIGHT TO USE "REMOTE CAPTURE", APART FROM THE MARK AS SHOWN.

FOR COMPUTER SOFTWARE THAT INTEGRATES ELECTRONIC CHECK DEPOSITS, WHOLESALE REMITTANCE PROCESSING, FORMS PROCESSING AND CASH APPLICATION, THAT CAN BE UTILIZED IN DISTRIBUTED AND CENTRALIZED ENVIRONMENTS (U.S. CLS. 21, 23, 26, 36 AND 38).

FIRST USE 8-1-2006; IN COMMERCE 10-20-2006.
TRACY CROSS, EXAMINING ATTORNEY

SN 77-326,273. OPEN SCAN TECHNOLOGIES, INC., DENVER, CO. FILED 11-9-2007.

RedCap

THE MARK CONSISTS OF STANDARD CHARACTERS WITHOUT CLAIM TO ANY PARTICULAR FONT, STYLE, SIZE, OR COLOR.

THE WORDING "REDCAP" HAS NO MEANING IN A FOREIGN LANGUAGE.

FOR COMPUTER SOFTWARE THAT INTEGRATES ELECTRONIC CHECK DEPOSITS, WHOLESALE REMITTANCE PROCESSING, FORMS PROCESSING AND CASH APPLICATION, THAT CAN BE UTILIZED IN DISTRIBUTED AND CENTRALIZED ENVIRONMENTS (U.S. CLS. 21, 23, 26, 36 AND 38).

FIRST USE 4-1-2007; IN COMMERCE 4-1-2007.
TRACY CROSS, EXAMINING ATTORNEY

SN 77-326,445. SCENEWISE, INC., EL SEGUNDO, CA. FILED 11-9-2007.



THE MARK CONSISTS OF THE WORD "SCENEWISE" AND A DEPICTION OF A COMPUTER WITH A GRADUATION CAP.

FOR DIGITAL MEDIA PRODUCTS, NAMELY, DVDS, CDS AND DIGITAL AUDIO AND VISUAL TAPES AND DISCS CONTAINING EDUCATIONAL MATERIAL IN THE FIELDS OF THE HUMANITIES, MATHEMATICS, SOCIAL SCIENCES, PHYSICAL SCIENCES, AND HEALTH SCIENCES AT THE PRIMARY, SECONDARY OR COLLEGE LEVEL (U.S. CLS. 21, 23, 26, 36 AND 38).

FIRST USE 8-31-2007; IN COMMERCE 8-31-2007.
GINA FINK, EXAMINING ATTORNEY

CLASS 9—(Continued).

SN 77-326,459. SHUFFLE MASTER, INC., LAS VEGAS, NV.
FILED 11-9-2007.

ETS

THE MARK CONSISTS OF STANDARD CHARACTERS WITHOUT CLAIM TO ANY PARTICULAR FONT, STYLE, SIZE, OR COLOR.

FOR MULTIPLE PLAYER INTERACTIVE GAMING MACHINE WITH VIDEO OUTPUT (U.S. CLS. 21, 23, 26, 36 AND 38).

RICHARD A. STRASER, EXAMINING ATTORNEY

SN 77-328,964. CAMBRIDGE SILICON RADIO LIMITED,
CAMBRIDGE, ENGLAND, UNITED KINGDOM, FILED
11-14-2007.

ULTRASIRA

THE MARK CONSISTS OF STANDARD CHARACTERS WITHOUT CLAIM TO ANY PARTICULAR FONT, STYLE, SIZE, OR COLOR.

FOR SEMICONDUCTOR COMPONENTS, NAMELY, SEMICONDUCTOR CHIPS, SEMICONDUCTOR DEVICES, AND SEMICONDUCTOR POWER ELEMENTS; INTEGRATED CIRCUITS; SEMICONDUCTOR CHIPS; SEMICONDUCTOR CHIPS SETS COMPRISED PRIMARILY OF SEMICONDUCTOR CHIPS; PRINTED CIRCUIT BOARD ASSEMBLIES; ELECTRONIC CIRCUIT BOARD ASSEMBLIES; ELECTRONIC COMPONENTS FOR COMPUTERS AND FOR TESTING WIRELESS COMMUNICATION INTEGRATED CIRCUIT DEVICES; ALL OF THE AFORESAID GOODS BEING FOR COMMUNICATIONS; CONTROL SOFTWARE FOR MANAGING THE PROTOCOL USED IN CONNECTION WITH RADIO AND WIRELESS COMMUNICATION TRANSMITTERS; INTERFACE SOFTWARE, NAMELY, GRAPHICAL USER INTERFACE SOFTWARE FOR USE IN CONNECTION WITH COMMUNICATION DEVICES; COMMUNICATIONS SOFTWARE FOR CONNECTING RADIO AND WIRELESS COMMUNICATION TRANSMITTERS, RECEIVERS, AND SYNTHESIZERS; SEMICONDUCTOR DEVICES, NAMELY, SEMICONDUCTOR DESIGNS, NAMELY, SEMICONDUCTOR COMPONENT LAYOUTS IN ELECTRONIC FORM (U.S. CLS. 21, 23, 26, 36 AND 38).

JUSTINE D. PARKER, EXAMINING ATTORNEY

CLASS 9—(Continued).

SN 77-333,397. GENESIS DIGITAL IMAGING, INC., LOS ANGELES, CA. FILED 11-19-2007.

OMNI-VUE

THE MARK CONSISTS OF STANDARD CHARACTERS WITHOUT CLAIM TO ANY PARTICULAR FONT, STYLE, SIZE, OR COLOR.

FOR COMPUTER SOFTWARE FOR MEDICAL IMAGING DIAGNOSTICS (U.S. CLS. 21, 23, 26, 36 AND 38).

FIRST USE 9-23-2005; IN COMMERCE 9-23-2005.

HENRY S. ZAK, EXAMINING ATTORNEY

SN 77-334,177. PARETOLOGIC INC., VICTORIA, CANADA,
FILED 11-20-2007.

PGSURFER

THE MARK CONSISTS OF STANDARD CHARACTERS WITHOUT CLAIM TO ANY PARTICULAR FONT, STYLE, SIZE, OR COLOR.

FOR COMPUTER SOFTWARE FOR USE IN BLOCKING USER ACCESS TO CERTAIN INTERNET SITES AND CONTENT THAT MAY BE DOWNLOADED FROM A GLOBAL COMPUTER NETWORK (U.S. CLS. 21, 23, 26, 36 AND 38).

FIRST USE 10-28-2007; IN COMMERCE 10-28-2007.

LINDA ESTRADA, EXAMINING ATTORNEY

CLASS 9—(Continued).

SN 77-346,178. ATP ELECTRONICS, INC., SUNNYVALE, CA. FILED 12-6-2007.



THE COLOR(S) GREEN AND YELLOW IS/ARE CLAIMED AS A FEATURE OF THE MARK.

THE MARK CONSISTS OF A YELLOW LEAF WITH GREEN OUTLINE, SURROUNDED BY A CIRCLE OF GREEN ARROWS. FROM THE CENTER OF THE BOTTOM ARROW EMANATES A GREEN LINE THAT GOES THROUGH THE CENTER OF THE LEAF. THE TERM "EARTHDRIVE" APPEARS IN GREEN UNDER THE CIRCLE.

FOR SEMICONDUCTOR MEMORY DEVICES, NAMELY, FLASH MEMORY CARDS, USB DRIVES, AND COMPUTER PERIPHERALS, PORTABLE AUDIO PLAYERS/RECORDERS WHICH USE SEMICONDUCTOR DEVICES AS RECORDING MEDIA, AND COMPUTER OPERATING PROGRAMS FOR SEMICONDUCTOR MEMORY DEVICES (U.S. CLS. 21, 23, 26, 36 AND 38).
MICHAEL WIENER, EXAMINING ATTORNEY

SN 77-346,258. CONCORD MUSIC GROUP, INC., BEVERLY HILLS, CA. FILED 12-6-2007.



NO CLAIM IS MADE TO THE EXCLUSIVE RIGHT TO USE "CONCORD MUSIC GROUP", APART FROM THE MARK AS SHOWN.

THE COLOR(S) BLUE, BLACK, WHITE, AND GRAY IS/ARE CLAIMED AS A FEATURE OF THE MARK.

THE MARK CONSISTS OF THE BLUE COLOR APPEARS IN THE WORD "CONCORD" AND IN THE BLUE LINE DESIGNS, THE COLOR BLACK APPEARS AS FIVE RECTANGLES, THE COLOR GRAY APPEARS IN THE TERM "MUSIC GROUP", AND THE COLOR WHITE APPEARS IN THE BACKGROUND.

FOR MUSICAL SOUND RECORDINGS (U.S. CLS. 21, 23, 26, 36 AND 38).

TEJBIR SINGH, EXAMINING ATTORNEY

CLASS 9—(Continued).

SN 77-347,097. KARSTEN MANUFACTURING CORPORATION, PHOENIX, AZ. FILED 12-7-2007.

NFLIGHT

THE MARK CONSISTS OF STANDARD CHARACTERS WITHOUT CLAIM TO ANY PARTICULAR FONT, STYLE, SIZE, OR COLOR.

FOR COMPUTERIZED GOLF CLUB FITTING SYSTEM CONSISTING OF A MEASUREMENT DEVICE FOR MEASURING LAUNCH DATA OF A BALL STRUCK BY A GOLF CLUB SWUNG BY AN INDIVIDUAL, COMPUTER SOFTWARE AND HARDWARE FOR SIMULATING THE FLIGHT OF THE BALL BASED ON THE LAUNCH DATA, AND AN OUTPUT DEVICE FOR PROVIDING THE SIMULATED BALL FLIGHT DATA TO ENABLE A USER TO DETERMINE FITTING PARAMETERS IN ORDER TO FIT GOLF CLUBS TO THE INDIVIDUAL (U.S. CLS. 21, 23, 26, 36 AND 38).

LESLEY LAMOTHE, EXAMINING ATTORNEY

SN 77-350,938. JBHM EDUCATION GROUP, LLC, JACKSON, MS. FILED 12-13-2007.



THE COLOR(S) GREEN AND BLACK IS/ARE CLAIMED AS A FEATURE OF THE MARK.

THE MARK CONSISTS OF THE WORDING "ILERT", WITH "E" IN GREEN AND THE REST OF THE LETTERS IN BLACK.

FOR COMPUTER SOFTWARE FOR CREATING SEARCHABLE DATABASES OF INFORMATION AND DATA; COMPUTER SOFTWARE FOR PROVIDING AN ON-LINE DATABASE IN THE FIELD OF TRANSACTION PROCESSING TO UPLOAD TRANSACTIONAL DATA, PROVIDE STATISTICAL ANALYSIS, AND PRODUCE NOTIFICATIONS AND REPORTS; COMPUTER SOFTWARE FOR THE COLLECTION, EDITING, ORGANIZING, MODIFYING, BOOK MARKING, TRANSMISSION, STORAGE AND SHARING OF DATA AND INFORMATION; COMPUTER SOFTWARE FOR USE IN CUSTOMER RELATIONSHIP MANAGEMENT (CRM); COMPUTER SOFTWARE FOR WIRELESS CONTENT DELIVERY; COMPUTER SOFTWARE THAT PROVIDES REAL-TIME, INTEGRATED BUSINESS MANAGEMENT INTELLIGENCE BY COMBINING INFORMATION FROM VARIOUS DATABASES AND PRESENTING IT IN AN EASY-TO-UNDERSTAND USER INTERFACE (U.S. CLS. 21, 23, 26, 36 AND 38).

REBECCA POVARCHUK, EXAMINING ATTORNEY

CLASS 9—(Continued).

SN 77-351,665. PHOTOSPIN, INC., LONG BEACH, CA. FILED 12-13-2007.

PHOTOSPIN

THE MARK CONSISTS OF STANDARD CHARACTERS WITHOUT CLAIM TO ANY PARTICULAR FONT, STYLE, SIZE, OR COLOR.

OWNER OF U.S. REG. NOS. 2,196,128 AND 2,285,790.
FOR DOWNLOADABLE DIGITAL STOCK IMAGES, PHOTOGRAPHS, ILLUSTRATIONS, FONTS, AUDIO AND VIDEO FILES FEATURING A WIDE VARIETY OF SUBJECT MATTERS (U.S. CLS. 21, 23, 26, 36 AND 38).
FIRST USE 3-18-1998; IN COMMERCE 3-18-1998.
ALICIA COLLINS, EXAMINING ATTORNEY

SN 77-352,049. JEWELL INSTRUMENTS, LLC, MANCHESTER, NH. FILED 12-14-2007.

JEWELL INSTRUMENTS

THE MARK CONSISTS OF STANDARD CHARACTERS WITHOUT CLAIM TO ANY PARTICULAR FONT, STYLE, SIZE, OR COLOR.

OWNER OF U.S. REG. NO. 2,506,958.
NO CLAIM IS MADE TO THE EXCLUSIVE RIGHT TO USE "INSTRUMENTS", APART FROM THE MARK AS SHOWN.

SEC. 2(F).
FOR ELECTRICAL AND ELECTRONIC MEASURING AND CONTROL INSTRUMENTS, NAMELY, ANALOG AND DIGITAL PANEL METERS; AND AIRCRAFT NAVIGATIONAL INSTRUMENTS AND INERTIAL SENSORS, NAMELY, ACCELEROMETERS AND INCLINOMETERS (U.S. CLS. 21, 23, 26, 36 AND 38).
FIRST USE 10-1-2000; IN COMMERCE 10-1-2000.
ESTHER BELENKER, EXAMINING ATTORNEY

CLASS 9—(Continued).

SN 77-352,118. JEWELL INSTRUMENTS, LLC, MANCHESTER, NH. FILED 12-14-2007.



OWNER OF U.S. REG. NO. 2,506,958.
NO CLAIM IS MADE TO THE EXCLUSIVE RIGHT TO USE "INSTRUMENTS", APART FROM THE MARK AS SHOWN.

THE COLOR(S) GREEN IS/ARE CLAIMED AS A FEATURE OF THE MARK.

THE COLOR GREEN APPEARS IN THE WORD "JEWELL", AND IN THE BACKGROUND BEHIND THE WORD "INSTRUMENTS". THE WORD "INSTRUMENTS" DOES NOT CONTAIN ANY COLOR (I.E. IT IS CLEAR), NOR DOES THE BACKGROUND BEHIND THE WORD "JEWELL". THEREFORE, THE WORD "INSTRUMENTS" AND THE BACKGROUND BEHIND THE WORD "JEWELL" SHOWS THE COLOR OF THE ITEM ON WHICH IT IS PLACED.

SEC. 2(F).
FOR ELECTRICAL AND ELECTRONIC MEASURING AND CONTROL INSTRUMENTS, NAMELY, ANALOG AND DIGITAL PANEL METERS; AND AIRCRAFT NAVIGATIONAL INSTRUMENTS AND INERTIAL SENSORS, NAMELY, ACCELEROMETERS AND INCLINOMETERS (U.S. CLS. 21, 23, 26, 36 AND 38).

FIRST USE 10-1-2000; IN COMMERCE 10-1-2000.
ESTHER BELENKER, EXAMINING ATTORNEY

SN 77-357,803. GILCHRIST, RANDY, LINCOLN, CA. FILED 12-21-2007.

THE WEIGHT LOSS MINDSET

THE MARK CONSISTS OF STANDARD CHARACTERS WITHOUT CLAIM TO ANY PARTICULAR FONT, STYLE, SIZE, OR COLOR.

NO CLAIM IS MADE TO THE EXCLUSIVE RIGHT TO USE "WEIGHT LOSS", APART FROM THE MARK AS SHOWN.

FOR PRE-RECORDED CD'S FEATURING A THERAPEUTIC WEIGHT CONTROL AND APPETITE SUPPRESSION PROGRAM (U.S. CLS. 21, 23, 26, 36 AND 38).
FIRST USE 11-13-2005; IN COMMERCE 11-13-2006.
MARGARET POWER, EXAMINING ATTORNEY

CLASS 9—(Continued).

SN 77-358,976. INTERPLAY ENTERTAINMENT CORP, BEVERLY HILLS, CA. FILED 12-24-2007.

DESCENT

THE MARK CONSISTS OF STANDARD CHARACTERS WITHOUT CLAIM TO ANY PARTICULAR FONT, STYLE, SIZE, OR COLOR.

OWNER OF U.S. REG. NO. 2,314,929.

FOR COMPUTER PROGRAMS FOR VIDEO GAMES AND COMPUTER GAMES AND INSTRUCTION MANUALS SOLD AS A UNIT WITH THE GAMES, AND COMPUTER PROGRAMS FOR VIDEO GAMES AND COMPUTER GAMES WHICH MAY BE DOWNLOADED FROM A GLOBAL COMPUTER NETWORK (U.S. CLS. 21, 23, 26, 36 AND 38).

FIRST USE 12-22-1994; IN COMMERCE 12-22-1994.
MATTHEW EINSTEIN, EXAMINING ATTORNEY

SN 77-359,901. INTERPLAY ENTERTAINMENT CORP, BEVERLY HILLS, CA. FILED 12-27-2007.

Battle Chess

THE MARK CONSISTS OF STANDARD CHARACTERS WITHOUT CLAIM TO ANY PARTICULAR FONT, STYLE, SIZE, OR COLOR.

NO CLAIM IS MADE TO THE EXCLUSIVE RIGHT TO USE "CHESS", APART FROM THE MARK AS SHOWN.

FOR COMPUTER PROGRAMS FOR VIDEO GAMES AND COMPUTER GAMES AND INSTRUCTION MANUALS SOLD AS A UNIT WITH THE GAMES, AND COMPUTER PROGRAMS FOR VIDEO GAMES AND COMPUTER GAMES WHICH MAY BE DOWNLOADED FROM A GLOBAL COMPUTER NETWORK (U.S. CLS. 21, 23, 26, 36 AND 38).

FIRST USE 9-2-1988; IN COMMERCE 9-2-1988.
MATTHEW EINSTEIN, EXAMINING ATTORNEY

SN 77-360,675. INTERPLAY ENTERTAINMENT CORP, BEVERLY HILLS, CA. FILED 12-28-2007.

DIE BY THE SWORD

THE MARK CONSISTS OF STANDARD CHARACTERS WITHOUT CLAIM TO ANY PARTICULAR FONT, STYLE, SIZE, OR COLOR.

FOR COMPUTER PROGRAMS FOR VIDEO GAMES AND COMPUTER GAMES AND INSTRUCTION MANUALS SOLD AS A UNIT WITH THE GAMES, AND COMPUTER PROGRAMS FOR VIDEO GAMES AND COMPUTER GAMES WHICH MAY BE DOWNLOADED FROM A GLOBAL COMPUTER NETWORK (U.S. CLS. 21, 23, 26, 36 AND 38).

FIRST USE 3-19-1998; IN COMMERCE 3-19-1998.
MATTHEW EINSTEIN, EXAMINING ATTORNEY

CLASS 9—(Continued).

SN 77-367,917. KUBANEY ACQUISITION, LLC, MIAMI, FL. FILED 1-9-2008.

KUBANEY

THE MARK CONSISTS OF STANDARD CHARACTERS WITHOUT CLAIM TO ANY PARTICULAR FONT, STYLE, SIZE, OR COLOR.

FOR MUSICAL SOUND RECORDINGS (U.S. CLS. 21, 23, 26, 36 AND 38).

FIRST USE 0-0-1966; IN COMMERCE 0-0-1966.
KYLE PEETE, EXAMINING ATTORNEY

SN 77-369,394. ARK'S MIND, LLC, BELLMORE, NY. FILED 1-11-2008.

Aristotle's Superheroes

THE MARK CONSISTS OF STANDARD CHARACTERS WITHOUT CLAIM TO ANY PARTICULAR FONT, STYLE, SIZE, OR COLOR.

FOR VIDEO GAME CONSOLE FOR USE WITH AN EXTERNAL DISPLAY SCREEN AND VIDEO GAME SOFTWARE (U.S. CLS. 21, 23, 26, 36 AND 38).

DAVID MILLER, EXAMINING ATTORNEY

SN 77-372,122. PAYLESS SHOESOURCE WORLDWIDE, INC., TOPEKA, KS. FILED 1-15-2008.

I  SHOES

OWNER OF U.S. REG. NO. 2,646,852.
NO CLAIM IS MADE TO THE EXCLUSIVE RIGHT TO USE "SHOES", APART FROM THE MARK AS SHOWN.

THE MARK CONSISTS OF THE WORD "I" FOLLOWED BY THE IMAGE OF A HEART WITH THE WORD "SHOES" PLACED AFTER THE HEART IMAGE; THE WORDS IN THE MARK CONSIST OF STANDARD CHARACTERS, WITHOUT CLAIM TO ANY PARTICULAR FONT, STYLE, SIZE, OR COLOR.

FOR MAGNETIC ENCODED GIFT CARDS (U.S. CLS. 21, 23, 26, 36 AND 38).

WANDA KAY PRICE, EXAMINING ATTORNEY

CLASS 9—(Continued).

SN 77-373,109. BAY BRIDGE DECISION TECHNOLOGIES, INC., ANNAPOLIS, MD. FILED 1-16-2008.

CENTERBRIDGE

THE MARK CONSISTS OF STANDARD CHARACTERS WITHOUT CLAIM TO ANY PARTICULAR FONT, STYLE, SIZE, OR COLOR.

FOR COMPUTER SOFTWARE FOR PLANNING AND ANALYSIS OF THE PERFORMANCE AND OPERATIONS OF CUSTOMER SUPPORT CONTACT CENTERS (U.S. CLS. 21, 23, 26, 36 AND 38).

FIRST USE 4-25-2003; IN COMMERCE 4-25-2003.
GENE MACIOL, EXAMINING ATTORNEY

SN 77-376,231. MOVIE BANK LLC, LYNNWOOD, WA. FILED 1-20-2008.

CINEBANK U.S.

NO CLAIM IS MADE TO THE EXCLUSIVE RIGHT TO USE "U.S.", APART FROM THE MARK AS SHOWN.

THE COLOR(S) ORANGE IS/ARE CLAIMED AS A FEATURE OF THE MARK.

THE MARK CONSISTS OF THE COLOR ORANGE IN THE WORDING "CINEBANK U.S."

FOR COMPUTERIZED, ROBOTIC, VENDING OR RENTING MACHINE FOR DISPENSING ENTERTAINMENT PRODUCTS, NAMELY, DIGITAL VIDEO DISKS, AND OTHER MULTIMEDIA FORMATS, OPERATED BY INTRODUCING A BILL, CARD, OR MAGNETICALLY CODED CARD (U.S. CLS. 21, 23, 26, 36 AND 38).

ANDREA HACK, EXAMINING ATTORNEY

SN 77-376,241. MOVIE BANK LLC, LYNNWOOD, WA. FILED 1-20-2008.

STAR★BOX

THE COLOR(S) ORANGE, WHITE, AND GRAY IS/ARE CLAIMED AS A FEATURE OF THE MARK.

THE COLOR ORANGE APPEARS IN THE WORDING "STAR BOX" AND IN THE DESIGN OF THE STAR. THE COLOR GRAY APPEARS AS THE OUTLINE OF THE BOX AROUND THE STAR DESIGN. THE COLOR WHITE APPEARS AS THE BACKGROUND COLOR IN THE BOX DESIGN.

FOR COMPUTERIZED, ROBOTIC, VENDING OR RENTING MACHINE FOR DISPENSING ENTERTAINMENT PRODUCTS, NAMELY, DIGITAL VIDEO DISKS, AND OTHER MULTIMEDIA FORMATS, OPERATED BY INTRODUCING A BILL, CARD, OR MAGNETICALLY CODED CARD (U.S. CLS. 21, 23, 26, 36 AND 38).

ANDREA HACK, EXAMINING ATTORNEY

CLASS 9—(Continued).

SN 77-376,242. MOVIE BANK LLC, LYNNWOOD, WA. FILED 1-20-2008.

STAR★FLIX

NO CLAIM IS MADE TO THE EXCLUSIVE RIGHT TO USE "FLICKS", APART FROM THE MARK AS SHOWN.

THE COLOR(S) ORANGE IS/ARE CLAIMED AS A FEATURE OF THE MARK.

THE MARK CONSISTS OF THE COLOR ORANGE APPEARS IN THE WORDING "STAR FLIX" AND IN THE DESIGN OF THE STAR.

FOR COMPUTERIZED, ROBOTIC, VENDING OR RENTING MACHINE FOR DISPENSING ENTERTAINMENT PRODUCTS, NAMELY, DIGITAL VIDEO DISKS, AND OTHER MULTIMEDIA FORMATS, OPERATED BY INTRODUCING A BILL, CARD, OR MAGNETICALLY CODED CARD (U.S. CLS. 21, 23, 26, 36 AND 38).

ANDREA HACK, EXAMINING ATTORNEY

SN 77-381,623. MAD MATHEMATICS LABORATORIES, NEW ROCKFORD, ND. FILED 1-27-2008.

Knowledge Arcana

THE MARK CONSISTS OF STANDARD CHARACTERS WITHOUT CLAIM TO ANY PARTICULAR FONT, STYLE, SIZE, OR COLOR.

FOR ELECTRONIC PUBLICATIONS, NAMELY, MAGAZINES FEATURING ROLE-PLAYING GAMES RECORDED ON COMPUTER MEDIA (U.S. CLS. 21, 23, 26, 36 AND 38).

CURTIS FRENCH, EXAMINING ATTORNEY

SN 77-383,005. CARL ZEISS AG, 73447 OBERKOCHEN, FED REP GERMANY, FILED 1-29-2008.

DuraMax

THE MARK CONSISTS OF STANDARD CHARACTERS WITHOUT CLAIM TO ANY PARTICULAR FONT, STYLE, SIZE, OR COLOR.

PRIORITY CLAIMED UNDER SEC. 44(D) ON FED REP GERMANY APPLICATION NO. 30768335.4/0, FILED 10-22-2007, REG. NO. 30768335, DATED 1-14-2008, EXPIRES 10-31-2017.

FOR COORDINATE MEASURING MACHINES AND PARTS THEREOF (U.S. CLS. 21, 23, 26, 36 AND 38).

JORDAN BAKER, EXAMINING ATTORNEY

CLASS 9—(Continued).

SN 77-383,009. CARL ZEISS AG, 73447 OBERKOCHEN, FED REP GERMANY, FILED 1-29-2008.

ShopMax

THE MARK CONSISTS OF STANDARD CHARACTERS WITHOUT CLAIM TO ANY PARTICULAR FONT, STYLE, SIZE, OR COLOR.

PRIORITY CLAIMED UNDER SEC. 44(D) ON FED REP GERMANY APPLICATION NO. 30768334.6/0, FILED 10-22-2007, REG. NO. 30768334, DATED 1-11-2008, EXPIRES 1-11-2018.

FOR COORDINATE MEASURING MACHINES AND PARTS THEREOF (U.S. CLS. 21, 23, 26, 36 AND 38).

JORDAN BAKER, EXAMINING ATTORNEY

CLASS 9—(Continued).

SN 77-384,325. GRACE BIO-LABS., INC., BEND, OR. FILED 1-30-2008.

ProPlate

THE MARK CONSISTS OF STANDARD CHARACTERS WITHOUT CLAIM TO ANY PARTICULAR FONT, STYLE, SIZE, OR COLOR.

FOR MICROSCOPE PARTS FOR USE WITH MICROSCOPE SLIDES, NAMELY, MICROSCOPE SLIDE MODULES COMPRISED OF A NON-METAL WELL PLATE HAVING A WELL ARRAY, A NON-METAL GASKET HAVING A WELL ARRAY, AND METAL AND NON-METAL CLAMPS, THAT ARE SOLD AS INDIVIDUAL MICROSCOPE SLIDE MODULES AND ALSO SOLD AS INTEGRAL PARTS OF A MICROSCOPE TRAY SET COMPRISED OF A TRAY HAVING A MICROTITER PLATE FOOTPRINT AND WELL SPACING AND MICROSCOPE SLIDE MODULES; MICROTITER PLATES (U.S. CLS. 21, 23, 26, 36 AND 38).

FIRST USE 7-31-2001; IN COMMERCE 7-31-2001.

MARY MUNSON, EXAMINING ATTORNEY

SN 77-384,279. ZHANG, DANPENG, CLIFTON, NJ. FILED 1-30-2008.



THE MARK CONSISTS OF THE TERM "BANNA" IN BOLD BLOCK LETTERS, WITH THE "B" APPEARING INSIDE OF A CIRCLE.

FOR ELECTRONIC SENSORS; ELECTRONIC MEASUREMENT AND INSPECTION INSTRUMENTS, NAMELY, PHOTOELECTRIC ENCODERS; ELECTRONIC PROXIMITY SWITCHES FOR DETECTING METAL TARGETS IN INDUSTRIAL POSITION SENSING APPLICATIONS AND FOR DETECTING METAL OR NON-METALLIC TARGETS IN INDUSTRIAL POSITION SENSING APPLICATIONS; PHOTOELECTRIC SENSORS; FLOW SWITCHES FOR MONITORING LIQUID OR GAS FLOW RATE IN PIPES; FLOW METERS FOR MEASURING LIQUID OR GAS FLOW RATE IN PIPES; FLOW SENSORS FOR CONVERTING LIQUID OR GAS FLOW RATE IN PIPES INTO STANDARD INDUSTRIAL ELECTRONIC SIGNAL; PRESSURE SWITCHES FOR MONITORING LIQUID OR GAS PRESSURE IN PIPES OR VESSELS; PRESSURE TRANSMITTERS; PRESSURE METERS FOR MEASURING LIQUID OR GAS PRESSURE VALUE IN PIPES OR VESSELS; LEVEL SWITCHES FOR MONITORING LIQUID OR POWDER LEVEL IN VESSELS; LEVEL TRANSMITTERS FOR CONVERTING LIQUID OR POWDER LEVEL VALUE IN VESSELS INTO STANDARD INDUSTRIAL ELECTRONIC SIGNAL; LEVEL METERS FOR MEASURING LIQUID OR POWDER LEVEL IN VESSELS; TEMPERATURE SWITCHES; TEMPERATURE TRANSMITTERS; TEMPERATURE METERS (U.S. CLS. 21, 23, 26, 36 AND 38).

ESTHER BELENKER, EXAMINING ATTORNEY

SN 77-385,769. VITESSE SEMICONDUCTOR CORPORATION, CAMARILLO, CA. FILED 1-31-2008.

VSCOPE

THE MARK CONSISTS OF STANDARD CHARACTERS WITHOUT CLAIM TO ANY PARTICULAR FONT, STYLE, SIZE, OR COLOR.

FOR INTEGRATED CIRCUITS HAVING AN EMBEDDED SIGNAL INTEGRITY MONITORING FUNCTION FOR SIGNAL INPUTS (U.S. CLS. 21, 23, 26, 36 AND 38).

ESTHER BELENKER, EXAMINING ATTORNEY

SN 77-390,605. WHIRL-I-GIG, INC., GREENPORT, NY. FILED 2-6-2008.

OPENCOLLECTION

THE MARK CONSISTS OF STANDARD CHARACTERS WITHOUT CLAIM TO ANY PARTICULAR FONT, STYLE, SIZE, OR COLOR.

FOR DOWNLOADABLE COMPUTER SOFTWARE FOR THE COLLECTION, EDITING, ORGANIZING, MODIFYING, BOOK MARKING, TRANSMISSION, STORAGE AND SHARING OF DATA AND INFORMATION (U.S. CLS. 21, 23, 26, 36 AND 38).

FIRST USE 7-31-2006; IN COMMERCE 7-31-2006.

CURTIS FRENCH, EXAMINING ATTORNEY

CLASS 9—(Continued).

SN 77-391,901. POLING, KENT E., DBA SUGAR CREEK MUSIC CO., GAHANNA, OH. FILED 2-8-2008.

LIKE A PRO

THE MARK CONSISTS OF STANDARD CHARACTERS WITHOUT CLAIM TO ANY PARTICULAR FONT, STYLE, SIZE, OR COLOR.

FOR AUDIO RECORDINGS FEATURING THE INSTRUCTIONS ON THE USE, MAINTENANCE, AND REPAIR OF MUSICAL INSTRUMENTS; DIGITAL MEDIA, NAMELY, PRE-RECORDED VIDEO CASSETTES, DIGITAL VIDEO DISCS, DIGITAL VERSATILE DISCS, DOWNLOADABLE AUDIO AND VIDEO RECORDINGS, DVDS, AND HIGH DEFINITION DIGITAL DISKS FEATURING THE INSTRUCTIONS ON THE USE, MAINTENANCE, AND REPAIR OF MUSICAL INSTRUMENTS; PRE-RECORDED CDS, VIDEO TAPES, LASER DISKS AND DVDS FEATURING THE INSTRUCTIONS ON THE USE, MAINTENANCE, AND REPAIR OF MUSICAL INSTRUMENTS (U.S. CLS. 21, 23, 26, 36 AND 38).

FIRST USE 7-10-1997; IN COMMERCE 7-11-1997.
JANET LEE, EXAMINING ATTORNEY

SN 77-392,663. INTELLIGENTZ CORPORATION, AUSTIN, TX. FILED 2-8-2008.



NO CLAIM IS MADE TO THE EXCLUSIVE RIGHT TO USE "EVIDENCE", APART FROM THE MARK AS SHOWN. THE COLOR(S) RED, YELLOW AND BLACK IS/ARE CLAIMED AS A FEATURE OF THE MARK.

THE MARK CONSISTS OF THE WORD "CLUES" APPEARING IN RED AND UNDERNEATH THE WORDS "THE EVIDENCE CONNECTION" APPEARING IN BLACK ON TOP OF A YELLOW RECTANGLE.

FOR DATABASE MANAGEMENT SOFTWARE FOR TRACKING AND DISPOSING OF EVIDENCE (U.S. CLS. 21, 23, 26, 36 AND 38).

FIRST USE 10-1-2007; IN COMMERCE 10-1-2007.
APRIL ROACH, EXAMINING ATTORNEY

CLASS 9—(Continued).

SN 77-393,400. GREYSTONE DIGITAL, INC., HUNTERSVILLE, NC. FILED 2-11-2008.

DEXTER MOUSE

THE MARK CONSISTS OF STANDARD CHARACTERS WITHOUT CLAIM TO ANY PARTICULAR FONT, STYLE, SIZE, OR COLOR.

NO CLAIM IS MADE TO THE EXCLUSIVE RIGHT TO USE "MOUSE", APART FROM THE MARK AS SHOWN. FOR COMPUTER CURSOR CONTROL DEVICES, NAMELY, COMPUTER MOUSE (U.S. CLS. 21, 23, 26, 36 AND 38).

KATHERINE STOIDES, EXAMINING ATTORNEY

SN 77-394,100. C AND C DESIGN TECHNOLOGY, LLC, PALM BEACH GARDENS, FL. FILED 2-11-2008.

THE WEDGI

THE MARK CONSISTS OF STANDARD CHARACTERS WITHOUT CLAIM TO ANY PARTICULAR FONT, STYLE, SIZE, OR COLOR.

FOR REMOVABLE STAND FOR PORTABLE ELECTRONIC DEVICES (U.S. CLS. 21, 23, 26, 36 AND 38).
MARK SPARACINO, EXAMINING ATTORNEY

SN 77-395,044. PAYLESS SHOESOURCE WORLDWIDE, INC., TOPEKA, KS. FILED 2-12-2008.

I LOVE SHOES

THE MARK CONSISTS OF STANDARD CHARACTERS WITHOUT CLAIM TO ANY PARTICULAR FONT, STYLE, SIZE, OR COLOR.

OWNER OF U.S. REG. NO. 2,646,852.
NO CLAIM IS MADE TO THE EXCLUSIVE RIGHT TO USE "SHOES", APART FROM THE MARK AS SHOWN.

FOR SUNGLASSES AND SUNGLASS CASES; MAGNETIC ENCODED GIFT CARDS (U.S. CLS. 21, 23, 26, 36 AND 38).

WANDA KAY PRICE, EXAMINING ATTORNEY

CLASS 9—(Continued).

SN 77-395,844. DUNCAN, SCOT M., LAKE FOREST, CA. FILED 2-13-2008.

LOBOS

THE MARK CONSISTS OF STANDARD CHARACTERS WITHOUT CLAIM TO ANY PARTICULAR FONT, STYLE, SIZE, OR COLOR.

THE FOREIGN WORDING IN THE MARK TRANSLATES INTO ENGLISH AS WOLVES.

FOR AIR CONDITIONING MANAGEMENT SOFTWARE (U.S. CLS. 21, 23, 26, 36 AND 38).

TAMARA FRAZIER, EXAMINING ATTORNEY

SN 77-398,123. PAYLESS SHOESOURCE WORLDWIDE, INC., TOPEKA, KS. FILED 2-15-2008.

WE LOVE SHOES

THE MARK CONSISTS OF STANDARD CHARACTERS WITHOUT CLAIM TO ANY PARTICULAR FONT, STYLE, SIZE, OR COLOR.

OWNER OF U.S. REG. NO. 2,646,852.

NO CLAIM IS MADE TO THE EXCLUSIVE RIGHT TO USE "SHOES", APART FROM THE MARK AS SHOWN.

FOR SUNGLASSES AND SUNGLASS CASES; MAGNETIC ENCODED GIFT CARDS (U.S. CLS. 21, 23, 26, 36 AND 38).

WANDA KAY PRICE, EXAMINING ATTORNEY

SN 77-398,224. SAVIO, PHIL, DBA CLIMAX MARKETING GROUP, INC, LAKE WYLIE, SC. FILED 2-15-2008.

River Hills Rock N Music Factory

THE MARK CONSISTS OF STANDARD CHARACTERS WITHOUT CLAIM TO ANY PARTICULAR FONT, STYLE, SIZE, OR COLOR.

NO CLAIM IS MADE TO THE EXCLUSIVE RIGHT TO USE "RIVER HILLS ROCK AND MUSIC", APART FROM THE MARK AS SHOWN.

FOR DOWNLOADABLE MUSICAL SOUND RECORDINGS; MUSICAL SOUND RECORDINGS; MUSICAL VIDEO RECORDINGS (U.S. CLS. 21, 23, 26, 36 AND 38).

ALEX KEAM, EXAMINING ATTORNEY

CLASS 9—(Continued).

SN 77-398,322. PAYLESS SHOESOURCE WORLDWIDE, INC., TOPEKA, KS. FILED 2-15-2008.

I ♥ SHOES

OWNER OF U.S. REG. NO. 2,646,852.

NO CLAIM IS MADE TO THE EXCLUSIVE RIGHT TO USE "SHOES", APART FROM THE MARK AS SHOWN.

THE MARK CONSISTS OF THE WORD "I" IN A STYLIZED FORMAT FOLLOWED BY THE STYLIZED DESIGN OF A HEART FOLLOWED BY THE WORD "SHOES" IN A STYLIZED FORMAT.

FOR SUNGLASSES AND SUNGLASS CASES; MAGNETIC ENCODED GIFT CARDS (U.S. CLS. 21, 23, 26, 36 AND 38).

WANDA KAY PRICE, EXAMINING ATTORNEY

SN 77-398,539. SKY-TRAX INCORPORATED, NEW CASTLE, DE. FILED 2-15-2008.

TOTAL-TRAX

THE MARK CONSISTS OF STANDARD CHARACTERS WITHOUT CLAIM TO ANY PARTICULAR FONT, STYLE, SIZE, OR COLOR.

FOR FACILITY MANAGEMENT- VEHICLE FLEET MANAGEMENT AND INVENTORY CONTROL EQUIPMENT COMPOSED OF VEHICLE MOUNTED OPTICAL COMPONENTS IN THE NATURE OF CAMERAS AND CAMERA ASSEMBLIES, AND RECEIVERS, TRANSMITTERS AND COMPUTER SOFTWARE FOR COLLECTING AND MANAGING INFORMATION ON VEHICLE LOCATIONS, MOVEMENT POSITIONS AND REMOTE MONITORING (U.S. CLS. 21, 23, 26, 36 AND 38).

FIRST USE 12-0-2007; IN COMMERCE 12-0-2007.

HENRY S. ZAK, EXAMINING ATTORNEY

SN 77-403,446. RATNER & PRESTIA, P.C., DBA RATNER-PRESTIA, BERWYN, PA. FILED 2-22-2008.

INSIGHT

THE MARK CONSISTS OF STANDARD CHARACTERS WITHOUT CLAIM TO ANY PARTICULAR FONT, STYLE, SIZE, OR COLOR.

OWNER OF U.S. REG. NO. 1,891,051.

FOR DOWNLOADABLE ELECTRONIC NEWSLETTERS IN THE LEGAL FIELD OF INTELLECTUAL PROPERTY (U.S. CLS. 21, 23, 26, 36 AND 38).

FIRST USE 5-0-2000; IN COMMERCE 5-0-2000.

TANYA AMOS, EXAMINING ATTORNEY

CLASS 9—(Continued).

SN 77-404,986. FIRST MEDICAL SOLUTIONS, LLC, FORT LAUDERDALE, FL. FILED 2-25-2008.

First Medical Office

THE MARK CONSISTS OF STANDARD CHARACTERS WITHOUT CLAIM TO ANY PARTICULAR FONT, STYLE, SIZE, OR COLOR.

NO CLAIM IS MADE TO THE EXCLUSIVE RIGHT TO USE "MEDICAL OFFICE", APART FROM THE MARK AS SHOWN.

FOR COMPUTER SOFTWARE FOR SCHEDULING PATIENT APPOINTMENTS, GENERATING PATIENT REMINDERS, VERIFYING INSURANCE ELIGIBILITY, GENERATING REFERRAL LETTERS, PREPARING PATIENT BILLS, FILING MEDICAL CLAIMS WITH INSURANCE COMPANIES, AND TRACKING PAYMENTS FOR USE IN MEDICAL OFFICE MANAGEMENT (U.S. CLS. 21, 23, 26, 36 AND 38).

MICHAEL KEATING, EXAMINING ATTORNEY

CLASS 9—(Continued).

SN 77-405,962. 6 HEARTS, INC., FT. LAUDERDALE, FL. FILED 2-26-2008.

Iron Pocket

THE MARK CONSISTS OF STANDARD CHARACTERS WITHOUT CLAIM TO ANY PARTICULAR FONT, STYLE, SIZE, OR COLOR.

NO CLAIM IS MADE TO THE EXCLUSIVE RIGHT TO USE "IRON", APART FROM THE MARK AS SHOWN.

FOR HEAT RESISTANT CARRYING CASE FOR ELECTRIC HAIR STRAIGHTENERS, NAMELY, FLAT IRONS, ELECTRIC CURLING IRONS, AND HEATED ELECTRIC HAIR IRONS (U.S. CLS. 21, 23, 26, 36 AND 38).

FIRST USE 6-1-2007; IN COMMERCE 7-18-2007.
BARBARA BROWN, EXAMINING ATTORNEY

SN 77-406,143. ARRIS GROUP, INC., SUWANEE, GA. FILED 2-26-2008.

NGETS

THE MARK CONSISTS OF STANDARD CHARACTERS WITHOUT CLAIM TO ANY PARTICULAR FONT, STYLE, SIZE, OR COLOR.

FOR CABLE BROADCAST TRANSMISSION MACHINES AND APPARATUS (U.S. CLS. 21, 23, 26, 36 AND 38).

EDWARD NELSON, EXAMINING ATTORNEY

SN 77-405,036. SPOUT LLC, GRAND RAPIDS, MI. FILED 2-25-2008.

FILMCOUCH

THE MARK CONSISTS OF STANDARD CHARACTERS WITHOUT CLAIM TO ANY PARTICULAR FONT, STYLE, SIZE, OR COLOR.

FOR DOWNLOADABLE PODCASTS FEATURING REVIEWS OF MOVIES, PRE-RECORDED VIDEOS, MUSICAL RECORDINGS, COMPUTER GAMES AND BOOKS; DOWNLOADABLE PODCASTS FEATURING MOVIES, MUSICAL RECORDINGS, COMPUTER GAMES AND BOOKS; DOWNLOADABLE PODCASTS FEATURING INTERVIEWS OF FAMOUS PERSONS (U.S. CLS. 21, 23, 26, 36 AND 38).

FIRST USE 12-21-2006; IN COMMERCE 1-9-2007.
DAWN FELDMAN, EXAMINING ATTORNEY

SN 77-407,173. THEORY GARDEN LLC, CHAGRIN FALLS, OH. FILED 2-27-2008.

SEED

THE MARK CONSISTS OF STANDARD CHARACTERS WITHOUT CLAIM TO ANY PARTICULAR FONT, STYLE, SIZE, OR COLOR.

FOR COMPUTER SOFTWARE FOR USE IN ORGANIZING ONE'S THOUGHTS AND IDEAS AND FOR SHARING THEM WITH OTHERS (U.S. CLS. 21, 23, 26, 36 AND 38).

FIRST USE 2-15-2008; IN COMMERCE 2-15-2008.
WENDY GOODMAN, EXAMINING ATTORNEY

CLASS 9—(Continued).

SN 77-407,803. SUNRISE TELECOM INCORPORATED, SAN JOSE, CA. FILED 2-27-2008.

GTT

THE MARK CONSISTS OF STANDARD CHARACTERS WITHOUT CLAIM TO ANY PARTICULAR FONT, STYLE, SIZE, OR COLOR.

FOR ELECTRONIC TELECOMMUNICATIONS AND DATA COMMUNICATIONS TESTING EQUIPMENT, NAMELY, HAND-HELD PORTABLE AND RACK MOUNTED TESTING EQUIPMENT, COMPUTER SOFTWARE FOR USE THEREWITH, AND MANUALS SOLD THEREWITH AS A UNIT (U.S. CLS. 21, 23, 26, 36 AND 38).

SAIMA MAKHDOOM, EXAMINING ATTORNEY

SN 77-408,311. THE JEWELLERY STORE DMCC, DEIRA, DUBAI, UNITED ARAB EMIR., FILED 2-28-2008.

TRUE FIDELITY SUPPLY CHAIN

THE MARK CONSISTS OF STANDARD CHARACTERS WITHOUT CLAIM TO ANY PARTICULAR FONT, STYLE, SIZE, OR COLOR.

NO CLAIM IS MADE TO THE EXCLUSIVE RIGHT TO USE "SUPPLY CHAIN", APART FROM THE MARK AS SHOWN.

FOR COMPUTER SOFTWARE RELATING TO PRODUCT DISTRIBUTION, OPERATIONS MANAGEMENT SERVICES, LOGISTICS, REVERSE LOGISTICS, SUPPLY CHAIN AND PRODUCTION SYSTEMS AND DISTRIBUTION SOLUTIONS (U.S. CLS. 21, 23, 26, 36 AND 38).

EDWARD NELSON, EXAMINING ATTORNEY

SN 77-408,313. THE JEWELLERY STORE DMCC, DEIRA, DUBAI, UNITED ARAB EMIR., FILED 2-28-2008.

High Fidelity Supply Chain

THE MARK CONSISTS OF STANDARD CHARACTERS WITHOUT CLAIM TO ANY PARTICULAR FONT, STYLE, SIZE, OR COLOR.

NO CLAIM IS MADE TO THE EXCLUSIVE RIGHT TO USE "SUPPLY CHAIN", APART FROM THE MARK AS SHOWN.

FOR COMPUTER SOFTWARE RELATING TO PRODUCT DISTRIBUTION, OPERATIONS MANAGEMENT SERVICES, LOGISTICS, REVERSE LOGISTICS, SUPPLY CHAIN AND PRODUCTION SYSTEMS AND DISTRIBUTION SOLUTIONS (U.S. CLS. 21, 23, 26, 36 AND 38).

EDWARD NELSON, EXAMINING ATTORNEY

CLASS 9—(Continued).

SN 77-408,321. THE JEWELLERY STORE DMCC, DEIRA, DUBAI, UNITED ARAB EMIR., FILED 2-28-2008.

FULL FIDELITY SUPPLY CHAIN

THE MARK CONSISTS OF STANDARD CHARACTERS WITHOUT CLAIM TO ANY PARTICULAR FONT, STYLE, SIZE, OR COLOR.

NO CLAIM IS MADE TO THE EXCLUSIVE RIGHT TO USE "SUPPLY CHAIN", APART FROM THE MARK AS SHOWN.

FOR COMPUTER SOFTWARE RELATING TO PRODUCT DISTRIBUTION, OPERATIONS MANAGEMENT SERVICES, LOGISTICS, REVERSE LOGISTICS, SUPPLY CHAIN AND PRODUCTION SYSTEMS AND DISTRIBUTION SOLUTIONS (U.S. CLS. 21, 23, 26, 36 AND 38).

EDWARD NELSON, EXAMINING ATTORNEY

SN 77-408,977. KARSTEN MANUFACTURING CORPORATION, PHOENIX, AZ. FILED 2-28-2008.

FOR COMPUTERIZED GOLF CLUB FITTING SYSTEM CONSISTING OF A MEASUREMENT DEVICE FOR MEASURING LAUNCH DATA OF A BALL STRUCK BY A GOLF CLUB SWUNG BY AN INDIVIDUAL, COMPUTER SOFTWARE AND HARDWARE FOR SIMULATING THE FLIGHT OF THE BALL BASED ON THE LAUNCH DATA, AND AN OUTPUT DEVICE FOR PROVIDING THE SIMULATED BALL FLIGHT DATA TO ENABLE A USER TO DETERMINE FITTING PARAMETERS IN ORDER TO FIT GOLF CLUBS TO THE INDIVIDUAL (U.S. CLS. 21, 23, 26, 36 AND 38).

LESLEY LAMOTHE, EXAMINING ATTORNEY

SN 77-409,110. WYNN, SCOTT, MOORES HILL, IN. FILED 2-28-2008.

The Panderers

THE MARK CONSISTS OF STANDARD CHARACTERS WITHOUT CLAIM TO ANY PARTICULAR FONT, STYLE, SIZE, OR COLOR.

FOR DIGITAL MATERIALS, NAMELY, CDS, DVDS, DOWNLOADABLE AUDIO FILES FEATURING MUSIC (U.S. CLS. 21, 23, 26, 36 AND 38).

FIRST USE 10-1-2006; IN COMMERCE 4-25-2007.

DOMINIC J. FERRAIUOLO, EXAMINING ATTORNEY

CLASS 9—(Continued).

SN 77-413,685. KUNZ, BARRY, WEST COVINA, CA. FILED 3-5-2008.

FABULOUS PLACES

THE MARK CONSISTS OF STANDARD CHARACTERS WITHOUT CLAIM TO ANY PARTICULAR FONT, STYLE, SIZE, OR COLOR.
FOR PRERECORDED MUSICAL RECORDINGS (U.S. CLS. 21, 23, 26, 36 AND 38).
ALICE SUE CARRUTHERS, EXAMINING ATTORNEY

SN 77-413,790. FREESON, RICHARD SCOTT, SIMI VALLEY, CA. FILED 3-5-2008.

Tune Toddlers

THE MARK CONSISTS OF STANDARD CHARACTERS WITHOUT CLAIM TO ANY PARTICULAR FONT, STYLE, SIZE, OR COLOR.
NO CLAIM IS MADE TO THE EXCLUSIVE RIGHT TO USE "TUNE", APART FROM THE MARK AS SHOWN.
FOR EDUCATIONAL MUSIC CDS AND DVDS (U.S. CLS. 21, 23, 26, 36 AND 38).
LINDA ESTRADA, EXAMINING ATTORNEY

CLASS 9—(Continued).

SN 77-415,296. SECURE MEDICAL, INC., TEMPE, AZ. FILED 3-6-2008.



NO CLAIM IS MADE TO THE EXCLUSIVE RIGHT TO USE "HEALTHKIOSK", APART FROM THE MARK AS SHOWN.

THE MARK CONSISTS OF A CADUCEUS DESIGN OF TWO INTERTWINING LINES SURROUNDING A GLOBE AT THE TOP WITH FOUR FAN SHAPED PIECES EXTENDING OUT ON EACH SIDE, AND THE WORD HEALTHKIOSK TO THE RIGHT WITH "HEALTH" IN A LARGE FONT AND "KIOSK" IN A SMALL FONT.

FOR INTERACTIVE COMPUTER KIOSKS COMPRISING COMPUTERS, COMPUTER HARDWARE, COMPUTER PERIPHERALS, AND COMPUTER OPERATING SOFTWARE, FOR USE IN THE HEALTHCARE INDUSTRY, NAMELY, HEALTH MONITORING AND COMMUNICATION EQUIPMENT FOR USE IN PROVIDING REMOTE HEALTH CARE SERVICES, ESTABLISHING A DOCTOR PATIENT RELATIONSHIP THROUGH REMOTE EXAMINATION, ESTABLISHING A VIDEO CONFERENCE BETWEEN THE DOCTOR AND PATIENT, ISSUING PRESCRIPTIONS, PROVIDING HEALTH INFORMATION THROUGH THE COMPUTER KIOSK, AND REMOTE REVIEW, AND ANALYSIS AND MONITORING OF HEALTH CONDITIONS OF PATIENTS AT THE COMPUTER KIOSK (U.S. CLS. 21, 23, 26, 36 AND 38).

MAYUR VAGHANI, EXAMINING ATTORNEY

SN 77-416,166. PROCON, INC., KNOXVILLE, TN. FILED 3-7-2008.



NO CLAIM IS MADE TO THE EXCLUSIVE RIGHT TO USE "CONTRACTOR" AND "GPS", APART FROM THE MARK AS SHOWN.

THE COLOR(S) GRAY, ORANGE, CHROME AND WHITE IS/ARE CLAIMED AS A FEATURE OF THE MARK.

THE MARK CONSISTS OF A THREE-DIMENSIONAL CHROME-COLORED RIM ENCIRCLING A THREE-DIMENSIONAL CHROME-COLORED HARDHAT SET AGAINST AN ORANGE BACKGROUND, WITH "CONTRACTOR" IN GRAY BLOCK LETTERS ON A WHITE BACKGROUND DISPOSED TO THE RIGHT OF THE RIM, AND "GPS" IN LARGER ORANGE BLOCK LETTERS ON A WHITE BACKGROUND DISPOSED DIRECTLY BELOW "CONTRACTOR".

FOR PORTABLE ELECTRONIC DEVICES INCORPORATING GLOBAL POSITIONING SYSTEM (GPS) AND WIRELESS COMMUNICATION TECHNOLOGIES CONFIGURED TO BE ATTACHED TO MOBILE CONSTRUCTION-RELATED ASSETS, NAMELY, CONSTRUCTION TOOLS, CONSTRUCTION EQUIPMENT AND CONSTRUCTION VEHICLES, FOR TRACKING THE GEOGRAPHIC LOCATION OF THE MOBILE ASSETS (U.S. CLS. 21, 23, 26, 36 AND 38).

G. MAYERSCHOFF, EXAMINING ATTORNEY

CLASS 9—(Continued).

SN 77-416,494. PLANT EQUIPMENT INC., DBA PLANTCML, TEMECULA, CA. FILED 3-7-2008.

ARIES

THE MARK CONSISTS OF STANDARD CHARACTERS WITHOUT CLAIM TO ANY PARTICULAR FONT, STYLE, SIZE, OR COLOR.

FOR COMPUTER SOFTWARE AND HARDWARE FOR USE IN CRITICAL COMMUNICATION CENTERS TO DISPATCH EMERGENCY PERSONNEL, NAMELY, MAP-CENTRIC, MULTI-USER, MULTI-JURISDICTION MAPPING AND DISPATCHING SOFTWARE AND HARDWARE THAT PROVIDES MAPPING INFORMATION ON DEMAND AND WEB-BASED REPORTING CAPABILITIES FOR USE IN CRITICAL COMMUNICATION CENTERS (U.S. CLS. 21, 23, 26, 36 AND 38).

TINA KUAN, EXAMINING ATTORNEY

CLASS 9—(Continued).

SN 77-417,717. DIVITAS NETWORKS, INC., MOUNTAIN VIEW, CA. FILED 3-10-2008.

ALL-MOBILE-OFFICE

THE MARK CONSISTS OF STANDARD CHARACTERS WITHOUT CLAIM TO ANY PARTICULAR FONT, STYLE, SIZE, OR COLOR.

FOR COMPUTER HARDWARE AND SOFTWARE FOR USE IN MANAGING VOICE AND DATA COMMUNICATIONS (U.S. CLS. 21, 23, 26, 36 AND 38).

BRIAN CALLAGHAN, EXAMINING ATTORNEY

SN 77-417,259. LUSTRA LINE, INC., PITTSBURGH, PA. FILED 3-10-2008.

HEXALON FLEX

THE MARK CONSISTS OF STANDARD CHARACTERS WITHOUT CLAIM TO ANY PARTICULAR FONT, STYLE, SIZE, OR COLOR.

OWNER OF U.S. REG. NO. 1,742,887.

NO CLAIM IS MADE TO THE EXCLUSIVE RIGHT TO USE "FLEX", APART FROM THE MARK AS SHOWN.

FOR RADIOGRAPHIC INTENSIFYING SCREENS FOR USE IN IMAGING EQUIPMENT (U.S. CLS. 21, 23, 26, 36 AND 38).

FIRST USE 10-0-2007; IN COMMERCE 10-0-2007.

JORDAN BAKER, EXAMINING ATTORNEY

SN 77-417,942. ARTUSLABS, INC., DURHAM, NC. FILED 3-10-2008.

Ensemble HR

THE MARK CONSISTS OF STANDARD CHARACTERS WITHOUT CLAIM TO ANY PARTICULAR FONT, STYLE, SIZE, OR COLOR.

NO CLAIM IS MADE TO THE EXCLUSIVE RIGHT TO USE "HR", APART FROM THE MARK AS SHOWN.

FOR COMPUTER SOFTWARE FOR ACCESSING INFORMATION DIRECTORIES THAT MAY BE DOWNLOADED FROM THE GLOBAL COMPUTER NETWORK; COMPUTER SOFTWARE FOR APPLICATION AND DATABASE INTEGRATION; COMPUTER SOFTWARE FOR CREATING SEARCHABLE DATABASES OF INFORMATION AND DATA; COMPUTER SOFTWARE FOR THE COLLECTION, EDITING, ORGANIZING, MODIFYING, BOOK MARKING, TRANSMISSION, STORAGE AND SHARING OF DATA AND INFORMATION; COMPUTER SOFTWARE THAT PROVIDES REAL-TIME, INTEGRATED BUSINESS MANAGEMENT INTELLIGENCE BY COMBINING INFORMATION FROM VARIOUS DATABASES AND PRESENTING IT IN AN EASY-TO-UNDERSTAND USER INTERFACE; COMPUTER SOFTWARE FOR DOCUMENT MANAGEMENT IN THE FIELD OF HUMAN RESOURCES; DATABASE MANAGEMENT SOFTWARE FOR HUMAN RESOURCES; ENTERPRISE SOFTWARE IN THE NATURE OF A DATABASE FOR NON-TRANSACTIONAL DATA AND A SEARCH ENGINE FOR DATABASE CONTENT (U.S. CLS. 21, 23, 26, 36 AND 38).

KATINA MISTER, EXAMINING ATTORNEY

SN 77-417,365. PHACTS, LLC, SEATTLE, WA. FILED 3-10-2008.

PHARMOGISTICS

THE MARK CONSISTS OF STANDARD CHARACTERS WITHOUT CLAIM TO ANY PARTICULAR FONT, STYLE, SIZE, OR COLOR.

FOR INVENTORY MANAGEMENT AND WORKFLOW PROCESS SOFTWARE FOR USE BY PHARMACIES (U.S. CLS. 21, 23, 26, 36 AND 38).

BRIAN CALLAGHAN, EXAMINING ATTORNEY

CLASS 9—(Continued).

SN 77-418,469. STREET KNOWLEDGE ENTERTAINMENT, PHILADELPHIA, PA. FILED 3-11-2008.



NO CLAIM IS MADE TO THE EXCLUSIVE RIGHT TO USE "ENTERTAINMENT", APART FROM THE MARK AS SHOWN.

THE MARK CONSISTS OF THE STYLIZED TEXT "SKE STREET KNOWLEDGE ENTERTAINMENT" WITH STYLIZED BACKGROUND.

FOR MUSICAL SOUND RECORDINGS (U.S. CLS. 21, 23, 26, 36 AND 38).

JENNY PARK, EXAMINING ATTORNEY

SN 77-418,574. SLATER, DAVID A., IRVING, TX. FILED 3-11-2008.

MEDIJANUS

THE MARK CONSISTS OF STANDARD CHARACTERS WITHOUT CLAIM TO ANY PARTICULAR FONT, STYLE, SIZE, OR COLOR.

THE ENGLISH TRANSLATION OF THE CROATIAN WORD "MEDIJANUS" IN THE MARK IS "MEDIAN NERVE."

FOR COMPUTER SOFTWARE FOR PERFORMING TELEPHONE MESSAGE TRANSMISSIONS, NAMELY, FOR PERFORMING SECURE PATIENT-TO-PHYSICIAN MESSAGING FOR DOCTOR-PATIENT TELEMEDICAL CONSULTATIONS (U.S. CLS. 21, 23, 26, 36 AND 38).

JASON LOTT, EXAMINING ATTORNEY

SN 77-419,253. NEXTENGINE, INC., SANTA MONICA, CA. FILED 3-11-2008.

NEXTENGINE

THE MARK CONSISTS OF STANDARD CHARACTERS WITHOUT CLAIM TO ANY PARTICULAR FONT, STYLE, SIZE, OR COLOR.

FOR SCANNERS, COMPUTER CONTROLLED TURN-TABLES FOR ROTATING OBJECTS, IMAGE SCANNING SOFTWARE, COMPUTER SOFTWARE FOR USE IN THE FIELD OF THREE-DIMENSIONAL MODELING, AND COMPUTER AIDED DESIGN SOFTWARE (U.S. CLS. 21, 23, 26, 36 AND 38).

FIRST USE 9-23-2003; IN COMMERCE 9-23-2003.

CIMMERIAN COLEMAN, EXAMINING ATTORNEY

CLASS 9—(Continued).

SN 77-420,549. KUNG, YUEN LING JENNIFER, WESTON, FL. FILED 3-12-2008.

Volcap

THE MARK CONSISTS OF STANDARD CHARACTERS WITHOUT CLAIM TO ANY PARTICULAR FONT, STYLE, SIZE, OR COLOR.

FOR COMMUNICATIONS HEADSETS FOR USE WITH COMMUNICATION RADIOS, INTERCOM SYSTEMS, OR OTHER COMMUNICATIONS NETWORK TRANSCIEVERS; CONSUMER ELECTRONIC PRODUCTS, NAMELY, AUDIO AMPLIFIERS, AUDIO SPEAKERS, AUDIO RECEIVERS, ELECTRICAL AUDIO AND SPEAKER CABLES AND CONNECTORS, HOME THEATER SYSTEMS, AUDIO DECODERS, VIDEO DECODERS, SPEAKERS, POWER CONVERSION DEVICES, POWER CONVERTERS, AND POWER INVERTERS; LOUDSPEAKERS WITH BUILT IN AMPLIFIERS; HARD HATS; APPARATUS FOR BROADCASTING, RECORDING, TRANSMISSION OR REPRODUCTION OF SOUND OR IMAGES; APPARATUS FOR RECORDING, TRANSMISSION OR REPRODUCTION OF SOUND; APPARATUS FOR SPEECH RECORDING AND REPLAYING; APPARATUS FOR TRANSMISSION OF COMMUNICATION; ELECTRONIC SOUND MIXING, PROCESSING AND SYNTHESIZING APPARATUS; MICROPHONES; SOUND FILTERS MADE OF CLOTH, FOR RADIO APPARATUS; SOUND RECORDING AND SOUND REPRODUCING APPARATUS AND INSTRUMENTS; SOUND RECORDING APPARATUS; SOUND RECORDING APPARATUS AND INSTRUMENTS; SOUND REPRODUCING APPARATUS; SOUND REPRODUCTION APPARATUS; SOUND TRANSMITTING APPARATUS; TRANSMITTING AND RECEIVING APPARATUS FOR RADIO AND TELEVISION BROADCASTING AND FOR LONG-DISTANCE TRANSMISSION (U.S. CLS. 21, 23, 26, 36 AND 38).

RAUL CORDOVA, EXAMINING ATTORNEY

SN 77-420,643. WINESTEIN, LLC, WESTERLY, RI. FILED 3-13-2008.

WINESTEIN

THE MARK CONSISTS OF STANDARD CHARACTERS WITHOUT CLAIM TO ANY PARTICULAR FONT, STYLE, SIZE, OR COLOR.

FOR ELECTRONIC DEVICE COMPRISED OF SERVER, ENCRYPTED WIRELESS ROUTER, SOFTWARE AND POINT OF SALE UNIT COMPRISED OF BAR CODE SCANNER AND SPEAKER ALL OF WHICH PROVIDES PRODUCT RELATED INFORMATION ABOUT SCANNED BEVERAGES AND FOODS (U.S. CLS. 21, 23, 26, 36 AND 38).

FIRST USE 6-4-2007; IN COMMERCE 6-4-2007.

MONIQUE MILLER, EXAMINING ATTORNEY

CLASS 9—(Continued).

SN 77-421,007. TRIUMFANT, INC., ROCKVILLE, MD. FILED 3-13-2008.

TRIUMFANT IT INTELLIGENCE

THE MARK CONSISTS OF STANDARD CHARACTERS WITHOUT CLAIM TO ANY PARTICULAR FONT, STYLE, SIZE, OR COLOR.

OWNER OF U.S. REG. NOS. 3,315,665 AND 3,315,666.

NO CLAIM IS MADE TO THE EXCLUSIVE RIGHT TO USE "IT INTELLIGENCE", APART FROM THE MARK AS SHOWN.

FOR COMPUTER SOFTWARE PLATFORMS FOR COLLECTING, PROCESSING, AND ANALYZING DATA FROM IT SYSTEM COMPONENTS' OPERATION, IDENTIFYING AND DIAGNOSING UNDESIRABLE EVENTS IN SYSTEMS' OPERATION AND FUNCTIONING, AND GENERATING REMEDIATION RESPONSES THAT AUTOMATICALLY REPAIR THE IDENTIFIED UNDESIRABLE STATES (U.S. CLS. 21, 23, 26, 36 AND 38).

SUE LAWRENCE, EXAMINING ATTORNEY

CLASS 9—(Continued).

SN 77-421,883. WINESTEIN, LLC, WESTERLY, RI. FILED 3-14-2008.



THE MARK CONSISTS OF THE WORD "WINESTEIN" WITH A FACE IN THE MIDDLE OF THE WORD AND THE WORDS "YOUR WINE ADVICE DEVICE" IN SMALLER FONT UNDER THE WORD "WINESTEIN".

FOR ELECTRONIC DEVICE COMPRISED OF SERVER, ENCRYPTED WIRELESS ROUTER, SOFTWARE AND POINT OF SALE UNIT COMPRISED OF BAR CODE SCANNER AND SPEAKER ALL OF WHICH PROVIDES PRODUCT RELATED INFORMATION ABOUT SCANNED BEVERAGES AND FOODS (U.S. CLS. 21, 23, 26, 36 AND 38).

FIRST USE 6-4-2007; IN COMMERCE 6-4-2007.

MONIQUE MILLER, EXAMINING ATTORNEY

SN 77-422,107. SANDLOT GAMES CORPORATION, BOTHELL, WA. FILED 3-14-2008.

Westward II: Heroes of the
Frontier

THE MARK CONSISTS OF STANDARD CHARACTERS WITHOUT CLAIM TO ANY PARTICULAR FONT, STYLE, SIZE, OR COLOR.

OWNER OF U.S. REG. NO. 3,257,171.

FOR COMPUTER GAME PROGRAMS; ELECTRONIC GAME PROGRAMS; ELECTRONIC GAME SOFTWARE; DOWNLOADABLE ELECTRONIC GAMES VIA THE INTERNET AND WIRELESS DEVICES; INTERACTIVE MULTIMEDIA COMPUTER GAME PROGRAM (U.S. CLS. 21, 23, 26, 36 AND 38).

DAVID YONTEF, EXAMINING ATTORNEY

SN 77-421,824. DIGITAL OCULAR NETWORKS, INC., MEDFORD, NJ. FILED 3-14-2008.

TIMESIGHT SYSTEMS

THE MARK CONSISTS OF STANDARD CHARACTERS WITHOUT CLAIM TO ANY PARTICULAR FONT, STYLE, SIZE, OR COLOR.

NO CLAIM IS MADE TO THE EXCLUSIVE RIGHT TO USE "SYSTEMS", APART FROM THE MARK AS SHOWN.

FOR COMPUTER SOFTWARE AND HARDWARE FOR THE COLLECTION, STORAGE AND MANAGEMENT OF DATA FROM VIDEO AND OTHER ELECTRONIC SURVEILLANCE CAMERAS AND DEVICES (U.S. CLS. 21, 23, 26, 36 AND 38).

FIRST USE 10-1-2007; IN COMMERCE 10-1-2007.

YONG KIM, EXAMINING ATTORNEY

SN 77-422,141. WHITLEY, RODGMAN & WHITLEY, KINSTON, NC. FILED 3-14-2008.

ATTORNEYS ON CALL

THE MARK CONSISTS OF STANDARD CHARACTERS WITHOUT CLAIM TO ANY PARTICULAR FONT, STYLE, SIZE, OR COLOR.

FOR PRE-RECORDED DIGITAL MEDIA FEATURING INFORMATION ON THE LAW, THE JUSTICE SYSTEM, AND LEGAL SERVICES (U.S. CLS. 21, 23, 26, 36 AND 38).

FIRST USE 1-29-2008; IN COMMERCE 1-29-2008.

NANCY CLARKE, EXAMINING ATTORNEY

CLASS 9—(Continued).

SN 77-423,347. NATIONAL GUARD BUREAU (NGB), ARLINGTON, VA. FILED 3-17-2008.

JISCC

THE MARK CONSISTS OF STANDARD CHARACTERS WITHOUT CLAIM TO ANY PARTICULAR FONT, STYLE, SIZE, OR COLOR.

FOR CONTINGENCY RESPONSE COMMUNICATION SYSTEM DESIGNED TO PROVIDE RADIO INTEROPERABILITY, STREAMING VIDEO, WIRELESS INTERNET, AND VOIP PHONE (U.S. CLS. 21, 23, 26, 36 AND 38).

FIRST USE 3-7-2005; IN COMMERCE 8-1-2005.
WILLIAM P. SHANAHAN, EXAMINING ATTORNEY

CLASS 9—(Continued).

SN 77-425,305. SPX CORPORATION, CHARLOTTE, NC. FILED 3-18-2008.

SPEED SCROLL

THE MARK CONSISTS OF STANDARD CHARACTERS WITHOUT CLAIM TO ANY PARTICULAR FONT, STYLE, SIZE, OR COLOR.

FOR LAND VEHICLE ELECTRONIC DIAGNOSTIC TOOLS, NAMELY, COMPUTER HARDWARE (U.S. CLS. 21, 23, 26, 36 AND 38).

LEIGH CAROLINE CASE, EXAMINING ATTORNEY

SN 77-425,266. ACCOMPLISH TECHNOLOGY, LLC, SPRINGFIELD, MO. FILED 3-18-2008.

phpMyDirectory

THE MARK CONSISTS OF STANDARD CHARACTERS WITHOUT CLAIM TO ANY PARTICULAR FONT, STYLE, SIZE, OR COLOR.

FOR COMPUTER SOFTWARE FOR USE IN DATABASE MANAGEMENT THAT MAY BE DOWNLOADED FROM A GLOBAL COMPUTER NETWORK (U.S. CLS. 21, 23, 26, 36 AND 38).

FIRST USE 7-14-2005; IN COMMERCE 7-14-2005.
LYDIA BELZER, EXAMINING ATTORNEY

SN 77-425,843. TEXAS SCENIC COMPANY, INC., SAN ANTONIO, TX. FILED 3-19-2008.

DECK BOSS

THE MARK CONSISTS OF STANDARD CHARACTERS WITHOUT CLAIM TO ANY PARTICULAR FONT, STYLE, SIZE, OR COLOR.

FOR ELECTRIC MOTOR CONTROLLER (U.S. CLS. 21, 23, 26, 36 AND 38).

ALLISON SCHRODY, EXAMINING ATTORNEY

SN 77-425,290. WESTERN DIGITAL TECHNOLOGIES, INC., LAKE FOREST, CA. FILED 3-18-2008.

WD VELOCIRAPTOR

THE MARK CONSISTS OF STANDARD CHARACTERS WITHOUT CLAIM TO ANY PARTICULAR FONT, STYLE, SIZE, OR COLOR.

OWNER OF U.S. REG. NOS. 2,856,017, 3,130,924 AND OTHERS.

FOR COMPUTER PRODUCTS, NAMELY, HARD DRIVES (U.S. CLS. 21, 23, 26, 36 AND 38).

JORDAN BAKER, EXAMINING ATTORNEY

SN 77-425,892. ADVANCED POWER ELECTRONICS CORP., HSINCHU CITY, TAIWAN, FILED 3-19-2008.

PMPAK

THE MARK CONSISTS OF STANDARD CHARACTERS WITHOUT CLAIM TO ANY PARTICULAR FONT, STYLE, SIZE, OR COLOR.

FOR INTEGRATED CIRCUITS; SEMI-CONDUCTOR UNITS (U.S. CLS. 21, 23, 26, 36 AND 38).

G. MAYERSCHOFF, EXAMINING ATTORNEY

CLASS 9—(Continued).

SN 77-426,111. SOUTHERN VISION SYSTEMS, INC., MADISON, AL 35758, AL. FILED 3-19-2008.

LocalPlay

THE MARK CONSISTS OF STANDARD CHARACTERS WITHOUT CLAIM TO ANY PARTICULAR FONT, STYLE, SIZE, OR COLOR.

FOR RECORDING AND PLAYING DEVICES FOR SOUND AND IMAGE CARRIERS (U.S. CLS. 21, 23, 26, 36 AND 38).

DAWN HAN, EXAMINING ATTORNEY

CLASS 9—(Continued).

SN 77-426,265. AMERICAN COVERS, INC., BLUFFDALE, UT. FILED 3-19-2008.

BULLET-PROOF SHIELDS

THE MARK CONSISTS OF STANDARD CHARACTERS WITHOUT CLAIM TO ANY PARTICULAR FONT, STYLE, SIZE, OR COLOR.

FOR PROTECTIVE SHEET FOR COVERING LAPTOP COMPUTERS, MP3 PLAYERS, IPODS, PERSONAL DIGITAL ASSISTANCE, MOBILE PHONES AND OTHER ELECTRONICS (U.S. CLS. 21, 23, 26, 36 AND 38).

DOMINICK J. SALEMI, EXAMINING ATTORNEY

SN 77-426,126. SOUTHERN VISION SYSTEMS, INC., MADISON, AL. FILED 3-19-2008.

HostPlay

THE MARK CONSISTS OF STANDARD CHARACTERS WITHOUT CLAIM TO ANY PARTICULAR FONT, STYLE, SIZE, OR COLOR.

FOR RECORDING AND PLAYING DEVICES FOR SOUND AND IMAGE CARRIERS (U.S. CLS. 21, 23, 26, 36 AND 38).

DAWN HAN, EXAMINING ATTORNEY

SN 77-426,275. JONATHAN MASLIN, DBA ELITE SCENE, BEVERLY HILLS, CA. FILED 3-19-2008.

Elite Scene

THE MARK CONSISTS OF STANDARD CHARACTERS WITHOUT CLAIM TO ANY PARTICULAR FONT, STYLE, SIZE, OR COLOR.

NO CLAIM IS MADE TO THE EXCLUSIVE RIGHT TO USE "SCENE", APART FROM THE MARK AS SHOWN.

FOR DOWNLOADABLE CAPTURED IMAGES AND PHOTOS OF PATRONS AT CLUBS VIA THE INTERNET AND WIRELESS DEVICES (U.S. CLS. 21, 23, 26, 36 AND 38).

JERI J. FICKES, EXAMINING ATTORNEY

SN 77-426,241. GENERAL ELECTRIC COMPANY, SCHENECTADY, NY. FILED 3-19-2008.

OPTICOMP

THE MARK CONSISTS OF STANDARD CHARACTERS WITHOUT CLAIM TO ANY PARTICULAR FONT, STYLE, SIZE, OR COLOR.

FOR ELECTRONIC CONTROL SYSTEMS COMPRISED OF MICRO-PROCESSOR BASED HARDWARE AND SOFTWARE FOR MONITORING MACHINERY AND PROCESS AUTOMATION PRODUCTS FOR USE IN OIL AND GAS PROCESSING, NAMELY, TURBINE, MOTOR-DRIVEN CENTRIFUGAL, AXIAL COMPRESSOR UNITS AND MULTI-UNITS TRAIN (U.S. CLS. 21, 23, 26, 36 AND 38).

JUDITH HELFMAN, EXAMINING ATTORNEY

SN 77-426,609. MIKKEL, NISSEN, OATLEY NSW 2223, AUSTRALIA, FILED 3-19-2008.

TAPNOTES

THE MARK CONSISTS OF STANDARD CHARACTERS WITHOUT CLAIM TO ANY PARTICULAR FONT, STYLE, SIZE, OR COLOR.

FOR APPARATUS FOR RECORDING, TRANSMISSION, PROCESSING AND REPRODUCTION OF SOUND, IMAGES OR DATA; COMPUTER SOFTWARE FOR THE COLLECTION, EDITING, ORGANIZING, MODIFYING, BOOK MARKING, TRANSMISSION, STORAGE AND SHARING OF DATA AND INFORMATION (U.S. CLS. 21, 23, 26, 36 AND 38).

PAUL CROWLEY, EXAMINING ATTORNEY

CLASS 9—(Continued).

SN 77-426,804. AINSWORTH GAME TECHNOLOGY LIMITED, NEWINGTON, AUSTRALIA, FILED 3-19-2008.

CLASS 9—(Continued).

SN 77-426,928. COMPUTERCOP SOFTWARE CORP., BOHEMIA, NY. FILED 3-20-2008.

Triple Crown

COMPUTERCOP

THE MARK CONSISTS OF STANDARD CHARACTERS WITHOUT CLAIM TO ANY PARTICULAR FONT, STYLE, SIZE, OR COLOR.

FOR COMPUTER SOFTWARE AND FIRMWARE FOR GAMES OF CHANCE ON ANY COMPUTERIZED PLATFORM, INCLUDING DEDICATED GAMING CONSOLES, VIDEO BASED SLOT MACHINES, REEL BASED SLOT MACHINES, AND VIDEO LOTTERY TERMINALS; GAMING EQUIPMENT, NAMELY, SLOT MACHINES WITH OR WITHOUT VIDEO OUTPUT (U.S. CLS. 21, 23, 26, 36 AND 38).

STEVEN PEREZ, EXAMINING ATTORNEY

THE MARK CONSISTS OF STANDARD CHARACTERS WITHOUT CLAIM TO ANY PARTICULAR FONT, STYLE, SIZE, OR COLOR.

FOR COMPUTER SOFTWARE PROGRAMS THAT MONITOR ACTIVITY ON A COMPUTER, NAMELY, COMPUTER SOFTWARE THAT MONITORS COMMUNICATIONS BETWEEN COMPUTERS AND/OR THE GLOBAL INFORMATION NETWORK; COMPUTER SOFTWARE FOR MONITORING AND BLOCKING ACCESS TO CERTAIN INFORMATION; COMPUTER SOFTWARE FOR MONITORING DISK AND MEMORY COMPUTER CONTENT; COMPUTER SOFTWARE FOR USE IN ACCESSING AND EVALUATING INFORMATION REGARDING INFORMATION OBTAINED VIA THE GLOBAL INFORMATION NETWORK AND ONLINE COMMUNICATIONS (U.S. CLS. 21, 23, 26, 36 AND 38).

FIRST USE 2-20-2001; IN COMMERCE 2-20-2001.
RON FAIRBANKS, EXAMINING ATTORNEY

SN 77-426,831. AMY SALTZMAN M.D., MENLO PARK, CA. FILED 3-20-2008.

SN 77-426,984. PROVENCHER, SAMUEL D., WALTHAM, MA. FILED 3-20-2008.

STILL QUIET PLACE

SOA in a thimble

THE MARK CONSISTS OF STANDARD CHARACTERS WITHOUT CLAIM TO ANY PARTICULAR FONT, STYLE, SIZE, OR COLOR.

FOR PRERECORDED COMPACT DISCS FEATURING AUDIO PRACTICES IN MINDFULNESS AND MEDITATION FOR CHILDREN AND ADULTS (U.S. CLS. 21, 23, 26, 36 AND 38).

FIRST USE 10-14-2004; IN COMMERCE 1-5-2005.
GIANCARLO CASTRO, EXAMINING ATTORNEY

THE MARK CONSISTS OF STANDARD CHARACTERS WITHOUT CLAIM TO ANY PARTICULAR FONT, STYLE, SIZE, OR COLOR.

NO CLAIM IS MADE TO THE EXCLUSIVE RIGHT TO USE "SOA", APART FROM THE MARK AS SHOWN.

FOR COMPUTER SOFTWARE FOR COMPUTER SYSTEM AND APPLICATION DEVELOPMENT, DEPLOYMENT AND MANAGEMENT (U.S. CLS. 21, 23, 26, 36 AND 38).

KATHERINE STOIDES, EXAMINING ATTORNEY

CLASS 9—(Continued).

SN 77-427,146. XENOSEP TECHNOLOGIES LLC, BOONTON, NJ. FILED 3-20-2008.

XENOFLOW

THE MARK CONSISTS OF STANDARD CHARACTERS WITHOUT CLAIM TO ANY PARTICULAR FONT, STYLE, SIZE, OR COLOR.

FOR SEPARATING EQUIPMENT, APPARATUS AND INSTRUMENTS USED IN CONNECTION WITH A MANUFACTURING PROCESS, NAMELY, CHROMATOGRAPHIC COLUMNS AND CHROMATOGRAPHIC PLATES; EQUIPMENT, APPARATUS AND INSTRUMENTS, NAMELY, CHROMATOGRAPHIC COLUMNS AND CHROMATOGRAPHIC PLATES AND SINGLE USE/DISPOSABLE FILTRATION AND SOLID-PHASE EXTRACTION COLUMNS, CARTRIDGES, SYRINGE-DRIVEN FILTERS, VACUUM FILTERS, PIPETTE FILTERS AND DISK FILTERS, ALL USED IN CONNECTION WITH THE SEPARATION OF CHEMICAL OR MOLECULAR SUBSTANCES OR COMPONENTS FROM ONE ANOTHER, IN LABORATORY AND RESEARCH FACILITIES (U.S. CLS. 21, 23, 26, 36 AND 38).

TEJBIR SINGH, EXAMINING ATTORNEY



SN 77-427,297. JOHN B. STETSON COMPANY, JERSEY CITY, NJ. FILED 3-20-2008.

STETSON OFF ROAD

THE MARK CONSISTS OF STANDARD CHARACTERS WITHOUT CLAIM TO ANY PARTICULAR FONT, STYLE, SIZE, OR COLOR.

OWNER OF U.S. REG. NOS. 51,990, 1,254,420 AND 3,303,995.

FOR EYEGLASS FRAMES; SUNGLASSES (U.S. CLS. 21, 23, 26, 36 AND 38).

MARK RADEMACHER, EXAMINING ATTORNEY



SN 77-427,526. REATEGUI, ARTEMIO, SUN CITY, AZ. FILED 3-20-2008.

ZONELEVEN

THE MARK CONSISTS OF STANDARD CHARACTERS WITHOUT CLAIM TO ANY PARTICULAR FONT, STYLE, SIZE, OR COLOR.

FOR COMPUTER SOFTWARE FOR APPLICATION AND DATABASE INTEGRATION (U.S. CLS. 21, 23, 26, 36 AND 38).

MICHELE SWAIN, EXAMINING ATTORNEY

CLASS 9—(Continued).

SN 77-427,734. DYNAMIC DETAILS, INC., ANAHEIM, CA. FILED 3-20-2008.

SMV

THE MARK CONSISTS OF STANDARD CHARACTERS WITHOUT CLAIM TO ANY PARTICULAR FONT, STYLE, SIZE, OR COLOR.

FOR PRINTED CIRCUIT BOARDS (U.S. CLS. 21, 23, 26, 36 AND 38).

TARA PATE, EXAMINING ATTORNEY



SN 77-427,748. DYNAMIC DETAILS, INC., ANAHEIM, CA. FILED 3-20-2008.

3G-SMV

THE MARK CONSISTS OF STANDARD CHARACTERS WITHOUT CLAIM TO ANY PARTICULAR FONT, STYLE, SIZE, OR COLOR.

FOR PRINTED CIRCUIT BOARDS (U.S. CLS. 21, 23, 26, 36 AND 38).

TARA PATE, EXAMINING ATTORNEY



SN 77-427,847. CLEVERSAFE, INC., CHICAGO, IL. FILED 3-20-2008.

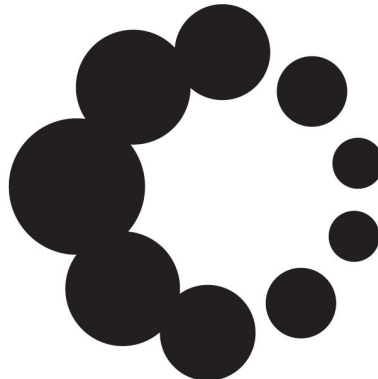

FOR COMPUTER HARDWARE FOR DIVIDING, DISTRIBUTING, STORING AND REASSEMBLING DIGITAL DATA; COMPUTER HARDWARE FOR MONITORING COMPUTER STORAGE DEVICES; COMPUTER SOFTWARE FOR DIVIDING, DISTRIBUTING, STORING AND REASSEMBLING DIGITAL DATA (U.S. CLS. 21, 23, 26, 36 AND 38).

FIRST USE 2-19-2008; IN COMMERCE 2-19-2008.
MICHAEL GAFFAR, EXAMINING ATTORNEY

CLASS 9—(Continued).

SN 77-427,860. ZAP, SANTA ROSA, CA. FILED 3-20-2008.

iZAP

THE MARK CONSISTS OF STANDARD CHARACTERS WITHOUT CLAIM TO ANY PARTICULAR FONT, STYLE, SIZE, OR COLOR.

OWNER OF U.S. REG. NOS. 1,794,866 AND 3,254,373.
FOR RECHARGEABLE ELECTRIC BATTERIES (U.S. CLS. 21, 23, 26, 36 AND 38).
FIRST USE 1-14-2007; IN COMMERCE 1-14-2007.
SHAUNIA CARLYLE, EXAMINING ATTORNEY

SN 77-427,869. CLEVERSAFE, INC., CHICAGO, IL. FILED 3-20-2008.

SLICESTOR

THE MARK CONSISTS OF STANDARD CHARACTERS WITHOUT CLAIM TO ANY PARTICULAR FONT, STYLE, SIZE, OR COLOR.

FOR COMPUTER HARDWARE FOR STORING DIGITAL DATA (U.S. CLS. 21, 23, 26, 36 AND 38).
FIRST USE 11-6-2007; IN COMMERCE 11-6-2007.
MICHAEL GAAFAR, EXAMINING ATTORNEY

SN 77-427,889. REDLINE SOLUTIONS, INC., SANTA CLARA, CA. FILED 3-20-2008.

REDLINEMOBILE

THE MARK CONSISTS OF STANDARD CHARACTERS WITHOUT CLAIM TO ANY PARTICULAR FONT, STYLE, SIZE, OR COLOR.

FOR MOBILITY SOFTWARE APPLICATIONS FOR SUPPLY CHAIN MANAGEMENT (U.S. CLS. 21, 23, 26, 36 AND 38).
FIRST USE 1-1-2005; IN COMMERCE 1-1-2005.
ALEXANDER L. POWERS, EXAMINING ATTORNEY

CLASS 9—(Continued).

SN 77-427,920. LEBEAUX, KELVIN P, JACKSONVILLE, FL. FILED 3-20-2008.

hypercharger

THE MARK CONSISTS OF STANDARD CHARACTERS WITHOUT CLAIM TO ANY PARTICULAR FONT, STYLE, SIZE, OR COLOR.

FOR ELECTRIC AND ELECTRONIC CIRCUITS (U.S. CLS. 21, 23, 26, 36 AND 38).
JOHN KELLY, EXAMINING ATTORNEY

SN 77-427,982. EXCALIBUR ELECTRONICS, INC., MIAMI, FL. FILED 3-21-2008.

SPACE NAVIGATOR

THE MARK CONSISTS OF STANDARD CHARACTERS WITHOUT CLAIM TO ANY PARTICULAR FONT, STYLE, SIZE, OR COLOR.

FOR HAND-HELD ELECTRONIC STAR, PLANET AND CONSTELLATION LOCATOR AND IDENTIFIER (U.S. CLS. 21, 23, 26, 36 AND 38).
FIRST USE 10-31-2006; IN COMMERCE 10-31-2006.
ODESSA BIBBINS, EXAMINING ATTORNEY

SN 77-428,245. WIREFREE CORPORATION, COLUMBUS, OH. FILED 3-21-2008.



NO CLAIM IS MADE TO THE EXCLUSIVE RIGHT TO USE "WIREFREE", APART FROM THE MARK AS SHOWN. THE MARK CONSISTS OF THE WORD "WIREFREE" WITH A SERIES OF HALF ARCS ABOVE THE "E" AND "F".

FOR COMPUTER HARDWARE AND SOFTWARE SYSTEMS FOR MONITORING BUSINESS, ENVIRONMENTAL, MANUFACTURING AND OTHER PROCESSES AND CONDITIONS BY TRANSMITTING DATA AND INFORMATION VIA ELECTRONIC COMMUNICATIONS NETWORKS (U.S. CLS. 21, 23, 26, 36 AND 38).
FIRST USE 9-0-2006; IN COMMERCE 9-0-2006.
CYNTHIA SLOAN, EXAMINING ATTORNEY

CLASS 9—(Continued).

SN 77-428,355. THE INCREDIBLE HEAT MACHINE LLP, MURFREESBORO, TN. FILED 3-21-2008.

The Incredible Heat Machine

THE MARK CONSISTS OF STANDARD CHARACTERS WITHOUT CLAIM TO ANY PARTICULAR FONT, STYLE, SIZE, OR COLOR.

FOR AUDIO RECORDINGS FEATURING MUSIC; DOWNLOADABLE MP3 FILES, MP3 RECORDINGS, ONLINE DISCUSSION BOARDS, WEBCASTS AND PODCASTS FEATURING MUSIC, AUDIO BOOKS AND NEWS BROADCASTS; DOWNLOADABLE MUSICAL SOUND RECORDINGS; DOWNLOADABLE RING TONES, GRAPHICS AND MUSIC VIA A GLOBAL COMPUTER NETWORK AND WIRELESS DEVICES; DOWNLOADABLE VIDEO RECORDINGS FEATURING MUSIC; DOWNLOADABLE MUSIC VIA THE INTERNET AND WIRELESS DEVICES; MUSICAL SOUND RECORDINGS; MUSICAL VIDEO RECORDINGS; SOUND RECORDINGS FEATURING MUSIC; VIDEO RECORDINGS FEATURING MUSIC; VISUAL RECORDINGS AND AUDIO VISUAL RECORDINGS FEATURING MUSIC AND ANIMATION (U.S. CLS. 21, 23, 26, 36 AND 38).

FIRST USE 4-8-2005; IN COMMERCE 4-8-2005.

LEIGH CAROLINE CASE, EXAMINING ATTORNEY

SN 77-428,371. INTERWOVEN, INC., SAN JOSE, CA. FILED 3-21-2008.

ENCONNECT

THE MARK CONSISTS OF STANDARD CHARACTERS WITHOUT CLAIM TO ANY PARTICULAR FONT, STYLE, SIZE, OR COLOR.

FOR COMPUTER SOFTWARE, NAMELY, MESSAGING SOFTWARE FOR USE IN AUTOMATION AND INTEGRATION OF TRANSACTIONAL INFORMATION, NAMELY, PROCESSING TRADES, PAYMENTS, SETTLEMENTS, AND MESSAGES FOR THE AUTOMATED FLOW OF TRANSACTIONAL INFORMATION USED IN DERIVATIVES TRADING (U.S. CLS. 21, 23, 26, 36 AND 38).

DAVID I, EXAMINING ATTORNEY

CLASS 9—(Continued).

SN 77-428,401. SAFECHANNEL, INC, SANTA CLARA, CA. FILED 3-21-2008.

SafeChannel

THE MARK CONSISTS OF STANDARD CHARACTERS WITHOUT CLAIM TO ANY PARTICULAR FONT, STYLE, SIZE, OR COLOR.

FOR COMPUTER ANTI-VIRUS SOFTWARE; COMPUTER APPLICATION SOFTWARE FOR MOBILE PHONES; COMPUTER SOFTWARE FOR USE IN THE SAFEGUARDING OF DIGITAL FILES, INCLUDING AUDIO, VIDEO, TEXT, BINARY, STILL IMAGES, GRAPHICS AND MULTIMEDIA FILES; SOFTWARE FOR ENSURING THE SECURITY OF ELECTRONIC MAIL (U.S. CLS. 21, 23, 26, 36 AND 38).

BARBARA RUTLAND, EXAMINING ATTORNEY

SN 77-428,418. KICKFIRE, INC., SANTA CLARA, CA. FILED 3-21-2008.

KICKFIRE

THE MARK CONSISTS OF STANDARD CHARACTERS WITHOUT CLAIM TO ANY PARTICULAR FONT, STYLE, SIZE, OR COLOR.

FOR COMPUTERS; DESKTOP COMPUTERS; COMPUTER WORKSTATIONS COMPRISING COMPUTERS, COMPUTER SERVERS, COMPUTER PERIPHERAL DEVICES, AND COMPUTER OPERATING SOFTWARE; COMPUTER CHIPS; INTEGRATED CIRCUITS; COMPUTER HARDWARE AND PERIPHERAL DEVICES; DATABASE SOFTWARE; AND COMPUTER SOFTWARE FOR INDEXING, STORAGE, SEARCHING AND RETRIEVAL OF DATA (U.S. CLS. 21, 23, 26, 36 AND 38).

DAVID TAYLOR, EXAMINING ATTORNEY

CLASS 9—(Continued).

SN 77-428,450. LASER CLEANSE LLC, LITTLETON, CO. FILED 3-21-2008.

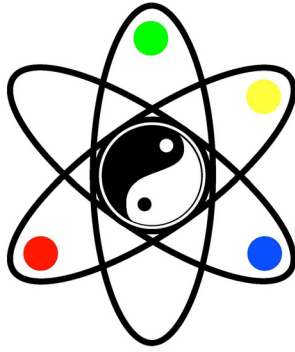

THE COLOR(S) GREEN, YELLOW, BLUE, WHITE, BLACK, AND RED IS/ARE CLAIMED AS A FEATURE OF THE MARK.

THE MARK CONSISTS OF THREE OVAL SHAPES THAT INTERSECT EACH OTHER AT THEIR CENTERS. A GREEN DOT EXISTS WITHIN THE TOP OUTSIDE 1/3 OF OVAL; A YELLOW DOT EXISTS WITHIN THE UPPER RIGHT SIDE OF 1/3 OF OVAL; A BLUE DOT EXISTS WITHIN THE LOWER RIGHT SIDE OF 1/3 OF OVAL; A RED DOT EXISTS WITHIN THE LOWER LEFT SIDE OF 1/3 OF OVAL. 1/2 OF THE CENTER OF THE MARK IS SHADED IN BLACK WITH A SMALL WHITE CIRCLE ON THE TOP OF THE BLACK SHADED AREA AND THE REMAINING AREA IS WHITE WITH A SMALL BLACK CIRCLE ON THE BOTTOM OF THE WHITE SHADED AREA.

FOR LASERS FOR NON-MEDICAL USE (U.S. CLS. 21, 23, 26, 36 AND 38).

JOHN E. MICHOŠ, EXAMINING ATTORNEY

SN 77-428,454. EXAMSOFT WORLDWIDE, INC., DEERFIELD BEACH, FL. FILED 3-21-2008.

THE MARK CONSISTS OF THE STYLIZED TERM "TAKE" WITH A CIRCUMFLEX ACCENT ABOVE THE LETTER "A".

THE WORDING "TAKE" MARK HAS NO MEANING IN A FOREIGN LANGUAGE.

FOR COMPUTER PROGRAMMES FOR DOCUMENT MANAGEMENT (U.S. CLS. 21, 23, 26, 36 AND 38).

AMY ALFIERI, EXAMINING ATTORNEY

CLASS 9—(Continued).

SN 77-428,467. DIGITAL CHECK CORPORATION, WINNETKA, IL. FILED 3-21-2008.

CHEXPRESS

THE MARK CONSISTS OF STANDARD CHARACTERS WITHOUT CLAIM TO ANY PARTICULAR FONT, STYLE, SIZE, OR COLOR.

FOR COUNTERTOP CHECK SCANNERS (U.S. CLS. 21, 23, 26, 36 AND 38).

KATHERINE M. DUBRAY, EXAMINING ATTORNEY

SN 77-428,528. COFFIN, CHARLES, RONALD, POWELL BUTTE, OR. FILED 3-21-2008.

CoDrive

THE MARK CONSISTS OF STANDARD CHARACTERS WITHOUT CLAIM TO ANY PARTICULAR FONT, STYLE, SIZE, OR COLOR.

FOR LOUDSPEAKERS (U.S. CLS. 21, 23, 26, 36 AND 38).

FIRST USE 0-0-1998; IN COMMERCE 0-0-1999.

GEORGIA CARTY, EXAMINING ATTORNEY

SN 77-428,642. ENGEL, JOHN M., OCEANSIDE, CA. FILED 3-21-2008.

A/C Connection

THE MARK CONSISTS OF STANDARD CHARACTERS WITHOUT CLAIM TO ANY PARTICULAR FONT, STYLE, SIZE, OR COLOR.

FOR AUDIO RECORDINGS FEATURING MUSIC; COMPACT DISC PLAYERS; DOWNLOADABLE MP3 FILES, MP3 RECORDINGS, ONLINE DISCUSSION BOARDS, WEBCASTS AND PODCASTS FEATURING MUSIC, AUDIO BOOKS AND NEWS BROADCASTS; DOWNLOADABLE MUSICAL SOUND RECORDINGS; DOWNLOADABLE RING TONES, GRAPHICS AND MUSIC VIA A GLOBAL COMPUTER NETWORK AND WIRELESS DEVICES; DOWNLOADABLE VIDEO RECORDINGS FEATURING MUSIC; DOWNLOADABLE MUSIC VIA THE INTERNET AND WIRELESS DEVICES (U.S. CLS. 21, 23, 26, 36 AND 38).

TINA KUAN, EXAMINING ATTORNEY

CLASS 9—(Continued).

SN 77-428,699. HEMISPHERE GPS LLC, CALGARY, CANADA, FILED 3-21-2008.

Celestia

THE MARK CONSISTS OF THE STYLIZED WORDING "CELESTIA".

FOR SOFTWARE ADAPTED FOR MACHINE CONTROL, POSITIONING AND GUIDANCE FOR PRECISION NAVIGATION DATA PROCESSING, MANAGEMENT AND DISPLAY USING DATA INTEGRATED FROM MULTIPLE SATELLITE, DEAD RECKONING AND INERTIAL NAVIGATION SENSORS, AUTONOMOUS MACHINE CONTROL, AUTOMATIC STEERING, SPATIAL DATA MANAGEMENT, PERCEPTION AWARENESS, SITUATIONAL AWARENESS, AND REMOTE FLEET MANAGEMENT INCLUDING JOB SCHEDULING, MONITORING, ASSET TRACKING AND REMOTE DIAGNOSTICS (U.S. CLS. 21, 23, 26 AND 38).

CHRISTINE BLOMQUIST, EXAMINING ATTORNEY

CLASS 9—(Continued).

SN 77-428,727. READY AT DAWN STUDIOS LLC, IRVINE, CA. FILED 3-21-2008.

SuperNormal

THE MARK CONSISTS OF STANDARD CHARACTERS WITHOUT CLAIM TO ANY PARTICULAR FONT, STYLE, SIZE, OR COLOR.

FOR COMPUTER GAME SOFTWARE; GAME SOFTWARE; VIDEO GAME SOFTWARE (U.S. CLS. 21, 23, 26, 36 AND 38).

LINDA POWELL, EXAMINING ATTORNEY

SN 77-428,847. APEX NETWORKS CORPORATION, MOUNTAIN VIEW, CA. FILED 3-21-2008.

WOW

SN 77-428,702. HEMISPHERE GPS LLC, CALGARY, CANADA, FILED 3-21-2008.



NO CLAIM IS MADE TO THE EXCLUSIVE RIGHT TO USE "CONNECTING TECHNOLOGY", APART FROM THE MARK AS SHOWN.

THE MARK CONSISTS OF THE STYLIZED WORDING "CELESTIA CONNECTING TECHNOLOGY" WITHIN A BLACK LOZENGE-SHAPED BACKGROUND.

FOR SOFTWARE ADAPTED FOR MACHINE CONTROL, POSITIONING AND GUIDANCE FOR PRECISION NAVIGATION DATA PROCESSING, MANAGEMENT AND DISPLAY USING DATA INTEGRATED FROM MULTIPLE SATELLITE, DEAD RECKONING AND INERTIAL NAVIGATION SENSORS, AUTONOMOUS MACHINE CONTROL, AUTOMATIC STEERING, SPATIAL DATA MANAGEMENT, PERCEPTION AWARENESS, SITUATIONAL AWARENESS, AND REMOTE FLEET MANAGEMENT INCLUDING JOB SCHEDULING, MONITORING, ASSET TRACKING AND REMOTE DIAGNOSTICS (U.S. CLS. 21, 23, 26, 36 AND 38).

CHRISTINE BLOMQUIST, EXAMINING ATTORNEY

THE MARK CONSISTS OF STANDARD CHARACTERS WITHOUT CLAIM TO ANY PARTICULAR FONT, STYLE, SIZE, OR COLOR.

FOR COMPUTER APPLICATION SOFTWARE FOR MOBILE PHONES; COMPUTER SOFTWARE AND HARDWARE TO OPTIMIZE AND ACCELERATE THE NETWORK ACCESS AND SPEED UP APPLICATIONS ACROSS WIDE AREA NETWORK AND INTERNET; COMPUTER SOFTWARE FOR USE IN ALL KINDS OF NETWORK DEVICES TO INCREASE THE TRANSMISSION CONTROL PROTOCOL THROUGHPUT AND IMPROVE THE EFFICIENCY OF THE DATA DELIVERY; COMPUTER SOFTWARE FOR USE IN ALL KINDS OF COMPUTERS TO INCREASE THE TRANSMISSION CONTROL PROTOCOL THROUGHPUT AND IMPROVE THE EFFICIENCY OF THE DATA DELIVERY THAT MAY BE DOWNLOADED FROM A GLOBAL COMPUTER NETWORK; DOWNLOADABLE COMPUTER SOFTWARE FOR MORE EFFICIENT UTILIZATION OF THE NETWORK BANDWIDTH TO ACHIEVE HIGHER TRANSMISSION CONTROL PROTOCOL TRAFFIC THROUGHPUT; DOWNLOADABLE SOFTWARE FOR USE IN COMPUTERS OR NETWORK DEVICES TO INCREASE THE TRANSMISSION CONTROL PROTOCOL THROUGHPUT AND IMPROVE THE EFFICIENCY ON USING NETWORK BANDWIDTH; WAN (WIDE AREA NETWORK) OPERATING SOFTWARE (U.S. CLS. 21, 23, 26, 36 AND 38).

CHARLES L. JENKINS, EXAMINING ATTORNEY

CLASS 9—(Continued).

SN 77-428,866. MOBLTZ, LLC, SAN FRANCISCO, CA. FILED 3-22-2008.

MOBLTZ

THE MARK CONSISTS OF STANDARD CHARACTERS WITHOUT CLAIM TO ANY PARTICULAR FONT, STYLE, SIZE, OR COLOR.

FOR COMPUTER PROGRAMS FOR USING THE INTERNET AND THE WORLD WIDE WEB (U.S. CLS. 21, 23, 26, 36 AND 38).

FIRST USE 1-25-2008; IN COMMERCE 1-25-2008.
MICHAEL SOUDERS, EXAMINING ATTORNEY

CLASS 9—(Continued).

SN 77-428,995. OCULI, LLC, MIAMI BEACH, FL. FILED 3-22-2008.

Mapcast

THE MARK CONSISTS OF STANDARD CHARACTERS WITHOUT CLAIM TO ANY PARTICULAR FONT, STYLE, SIZE, OR COLOR.

FOR COMPUTER SOFTWARE FOR THE ACQUISITION AND/OR DISTRIBUTION OF VIDEO, LOCATION AND/OR OTHER DATA VIA A REMOTE CONNECTION TO A CENTRALIZED OR PEER-TO-PEER NETWORK (U.S. CLS. 21, 23, 26, 36 AND 38).

MICHELE SWAIN, EXAMINING ATTORNEY

SN 77-428,989. SEE IT BIGGER LLC, FORT IRWIN, CA. FILED 3-22-2008.

See It Bigger

THE MARK CONSISTS OF STANDARD CHARACTERS WITHOUT CLAIM TO ANY PARTICULAR FONT, STYLE, SIZE, OR COLOR.

FOR MAGNIFYING GLASSES (U.S. CLS. 21, 23, 26, 36 AND 38).

FIRST USE 3-6-2008; IN COMMERCE 3-17-2008.
KATINA MISTER, EXAMINING ATTORNEY

SN 77-428,997. OCULI, LLC, MIAMI BEACH, FL. FILED 3-22-2008.

Newsdock

THE MARK CONSISTS OF STANDARD CHARACTERS WITHOUT CLAIM TO ANY PARTICULAR FONT, STYLE, SIZE, OR COLOR.

FOR COMPUTER SOFTWARE FOR THE ACQUISITION AND/OR DISTRIBUTION OF VIDEO, AUDIO, TEXT, LOCATION AND/OR OTHER DATA VIA A REMOTE CONNECTION TO A CENTRALIZED OR PEER-TO-PEER NETWORK (U.S. CLS. 21, 23, 26, 36 AND 38).

MICHELE SWAIN, EXAMINING ATTORNEY

SN 77-428,994. OCULI, LLC, MIAMI BEACH, FL. FILED 3-22-2008.

Oculi

THE MARK CONSISTS OF STANDARD CHARACTERS WITHOUT CLAIM TO ANY PARTICULAR FONT, STYLE, SIZE, OR COLOR.

FOR COMPUTER SOFTWARE FOR THE ACQUISITION AND/OR DISTRIBUTION OF VIDEO, AUDIO, TEXT, LOCATION AND/OR OTHER DATA VIA A REMOTE CONNECTION TO A CENTRALIZED OR PEER-TO-PEER NETWORK (U.S. CLS. 21, 23, 26, 36 AND 38).

MICHELE SWAIN, EXAMINING ATTORNEY

SN 77-429,138. FROGWARE, LLC, CYPRESS, TX. FILED 3-23-2008.

What's Up?

THE MARK CONSISTS OF STANDARD CHARACTERS WITHOUT CLAIM TO ANY PARTICULAR FONT, STYLE, SIZE, OR COLOR.

FOR COMPUTER SOFTWARE FOR PERSONAL ORGANIZATION AND CONTACT MANAGEMENT, NAMELY, FOR MANAGING PERSONAL CONTACTS, BUSINESS CONTACTS, BIRTHDAYS, ANNIVERSARIES, PARTIES, AND HOLIDAY CARDS (U.S. CLS. 21, 23, 26, 36 AND 38).

FIRST USE 7-1-2007; IN COMMERCE 12-1-2007.
PRISCILLA MILTON, EXAMINING ATTORNEY

CLASS 9—(Continued).

SN 77-429,226. DONOVAN MARINE, INC., HARAHAH, LA.
FILED 3-24-2008.

CLASS 9—(Continued).

SN 77-429,296. SOLIDSCAPE, INC., MERRIMACK, NH.
FILED 3-24-2008.

TIGHTEN UP

THE MARK CONSISTS OF STANDARD CHARACTERS
WITHOUT CLAIM TO ANY PARTICULAR FONT, STYLE,
SIZE, OR COLOR.

FOR LIFE JACKETS (U.S. CLS. 21, 23, 26, 36 AND 38).
FIRST USE 2-14-2004; IN COMMERCE 2-14-2004.
JASON TURNER, EXAMINING ATTORNEY

D76

THE MARK CONSISTS OF STANDARD CHARACTERS
WITHOUT CLAIM TO ANY PARTICULAR FONT, STYLE,
SIZE, OR COLOR.

OWNER OF U.S. REG. NOS. 2,774,050, 2,776,667 AND
3,313,334.

FOR COMPUTER PERIPHERAL APPARATUS (U.S.
CLS. 21, 23, 26, 36 AND 38).

JILL PRATER, EXAMINING ATTORNEY

SN 77-429,279. BOXICOM, INC., COLUMBUS, OH. FILED 3-
24-2008.

3X RBA

THE MARK CONSISTS OF STANDARD CHARACTERS
WITHOUT CLAIM TO ANY PARTICULAR FONT, STYLE,
SIZE, OR COLOR.

FOR HARDWARE AND SOFTWARE FOR COMPUTER
BACKUP AND RECOVERY, NAMELY, FOR POINT-IN-
TIME ARCHIVING OF DATABASES, IMAGES, AND
OTHER ELECTRONIC DATA (U.S. CLS. 21, 23, 26, 36
AND 38).

FIRST USE 9-1-2007; IN COMMERCE 10-14-2007.
JILL PRATER, EXAMINING ATTORNEY

SN 77-429,320. TOUCHTUNES MUSIC CORPORATION,
WILMINGTON, DE. FILED 3-24-2008.

SN 77-429,293. BOXICOM, INC., COLUMBUS, OH. FILED 3-
24-2008.

ALLEGRO MX-1**3X**

THE MARK CONSISTS OF STANDARD CHARACTERS
WITHOUT CLAIM TO ANY PARTICULAR FONT, STYLE,
SIZE, OR COLOR.

FOR HARDWARE AND SOFTWARE FOR COMPUTER
BACKUP AND RECOVERY, NAMELY, FOR POINT-IN-
TIME ARCHIVING OF DATABASES, IMAGES, AND
OTHER ELECTRONIC DATA (U.S. CLS. 21, 23, 26, 36
AND 38).

FIRST USE 9-1-2007; IN COMMERCE 10-14-2007.
JILL PRATER, EXAMINING ATTORNEY

THE MARK CONSISTS OF STANDARD CHARACTERS
WITHOUT CLAIM TO ANY PARTICULAR FONT, STYLE,
SIZE, OR COLOR.

FOR MUSIC SELECTION SYSTEMS COMPRISING
COMPUTER HARDWARE AND SOFTWARE, MUSIC
SERVERS, SPEAKERS, DIGITAL JUKEBOXES AND
TOUCH SCREENS/BUTTONS FOR DISTRIBUTING, SE-
LECTING AND PLAYING AUDIO AND VIDEO MUSI-
CAL INFORMATION; MUSICAL JUKEBOXES; MUSIC
SERVERS; AND JUKEBOX SYSTEMS, NAMELY, ONE
OR MORE MUSICAL JUKEBOXES CONNECTED ELEC-
TRONICALLY TO SELECT, DOWNLOAD AND PLAY
MUSIC CONTENTS AND PARTS THEREOF (U.S. CLS.
21, 23, 26, 36 AND 38).

JILL PRATER, EXAMINING ATTORNEY

CLASS 9—(Continued).

SN 77-429,410. FAUNOS, LLC, GREENWOOD VILLAGE, CO. FILED 3-24-2008.



THE STIPLING IS FOR SHADING PURPOSES ONLY. THE MARK CONSISTS OF THE STYLIZED WORD "FAUNOS". IMAGE OF A MYTHICAL FAUN HOLDING A LAMP TO THE LEFT OF THE WORDS.

FOR COMPUTER SOFTWARE FOR DATABASE MANAGEMENT, FOR USE AS AN OPERATING SYSTEM, FOR WORD PROCESSING, FOR ELECTRONIC DATA PROCESSING, AND FOR NETWORKING, AND USER MANUALS SOLD AS A UNIT; PRERECORDED COMPUTER PROGRAMS FOR USE AS AN OPERATING SYSTEM, FOR WORD PROCESSING, FOR ELECTRONIC DATA PROCESSING, AND FOR NETWORKING, AND USER MANUALS SOLD AS A UNIT (U.S. CLS. 21, 23, 26, 36 AND 38).

FIRST USE 6-3-2007; IN COMMERCE 6-3-2007.
KAPIL BHANOT, EXAMINING ATTORNEY

SN 77-429,513. REMAL IT, DAMMAM, SAUDI ARABIA, FILED 3-24-2008.



THE MARK CONSISTS OF AN EYE WITH DIGITAL THEME, REPRESENTING AUTOMATIC MONITORING OF EMPLOYEES.

FOR COMPUTER SOFTWARE FOR PROJECT MANAGEMENT AND AUTOMATIC SUPERVISION (U.S. CLS. 21, 23, 26, 36 AND 38).

FIRST USE 6-15-2007; IN COMMERCE 6-15-2007.
DORITT L. CARROLL, EXAMINING ATTORNEY

SN 77-429,579. VOXTEC INTERNATIONAL, INC., ANNAPOLIS, MD. FILED 3-24-2008.



FOR COMPUTER SOFTWARE FOR THE PURPOSE OF LANGUAGE TRANSLATION (U.S. CLS. 21, 23, 26, 36 AND 38).

YAT SYE, LEE, EXAMINING ATTORNEY

CLASS 9—(Continued).

SN 77-429,788. CIRRUS HEALTHCARE PRODUCTS, LLC, COLD HARBOR, NY. FILED 3-24-2008.

EARHURTS

THE MARK CONSISTS OF STANDARD CHARACTERS WITHOUT CLAIM TO ANY PARTICULAR FONT, STYLE, SIZE, OR COLOR.

FOR EAR PLUGS NOT FOR MEDICAL PURPOSES (U.S. CLS. 21, 23, 26, 36 AND 38).

FIRST USE 2-28-2008; IN COMMERCE 2-28-2008.
KAREN SEVERSON, EXAMINING ATTORNEY

SN 77-429,811. MIDWAY AMUSEMENT GAMES, LLC, CHICAGO, IL. FILED 3-24-2008.

SINISTAR

THE MARK CONSISTS OF STANDARD CHARACTERS WITHOUT CLAIM TO ANY PARTICULAR FONT, STYLE, SIZE, OR COLOR.

OWNER OF U.S. REG. NO. 1,282,636.

FOR COMPUTER AND VIDEO GAME PROGRAMS RECORDED ON CARTRIDGES, DISCS, CD-ROMS, CASSETTES, TAPES AND MINI DISCS; VIDEO AND COMPUTER GAME SOFTWARE (U.S. CLS. 21, 23, 26, 36 AND 38).

FIRST USE 11-18-2003; IN COMMERCE 11-18-2003.
JASON ROTH, EXAMINING ATTORNEY

SN 77-429,838. TURNASURE LLC, LANGHORNE, PA. FILED 3-24-2008.

TurnAnut

THE MARK CONSISTS OF STANDARD CHARACTERS WITHOUT CLAIM TO ANY PARTICULAR FONT, STYLE, SIZE, OR COLOR.

FOR DIRECT TENSION INDICATORS AND FASTENERS COMBINED WITH DIRECT TENSION INDICATORS FOR MEASURING TENSION IN, AND DETERMINING THE STRENGTH AND INTEGRITY OF, TIGHTENED CONNECTIONS IN STRUCTURES (U.S. CLS. 21, 23, 26, 36 AND 38).

KARANENDRA S. CHHINA, EXAMINING ATTORNEY

CLASS 9—(Continued).

SN 77-429,860. MIDWAY AMUSEMENT GAMES, LLC, CHICAGO, IL. FILED 3-24-2008.

ROBOTRON 2084

THE MARK CONSISTS OF STANDARD CHARACTERS WITHOUT CLAIM TO ANY PARTICULAR FONT, STYLE, SIZE, OR COLOR.

OWNER OF U.S. REG. NO. 1,240,987.
FOR COMPUTER AND VIDEO GAME PROGRAMS RECORDED ON CARTRIDGES, DISCS, CD-ROMS, CASSETTES, TAPES AND MINI DISCS; VIDEO AND COMPUTER GAME SOFTWARE (U.S. CLS. 21, 23, 26, 36 AND 38).

FIRST USE 11-18-2003; IN COMMERCE 11-18-2003.
JASON ROTH, EXAMINING ATTORNEY

CLASS 9—(Continued).

SN 77-429,873. TELEMATRIX, INC., COLORADO SPRINGS, CO. FILED 3-24-2008.

TELECONCEPTS

THE MARK CONSISTS OF STANDARD CHARACTERS WITHOUT CLAIM TO ANY PARTICULAR FONT, STYLE, SIZE, OR COLOR.

FOR TELEPHONES (U.S. CLS. 21, 23, 26, 36 AND 38).
MARTHA SANTOMARTINO, EXAMINING ATTORNEY

SN 77-429,862. JSC "REALORE", KPAIPEDA, LITHUANIA, FILED 3-24-2008.

JANE'S HOTEL

THE MARK CONSISTS OF STANDARD CHARACTERS WITHOUT CLAIM TO ANY PARTICULAR FONT, STYLE, SIZE, OR COLOR.

FOR ELECTRONIC GAME PROGRAMS; DOWNLOADABLE ELECTRONIC GAME PROGRAMS; ELECTRONIC GAME SOFTWARE; COMPUTER GAME PROGRAMS; DOWNLOADABLE COMPUTER GAME PROGRAMS; INTERACTIVE VIDEO AND MULTIMEDIA COMPUTER GAME PROGRAMS; INTERACTIVE GAME SOFTWARE (U.S. CLS. 21, 23, 26, 36 AND 38).

BARBARA BROWN, EXAMINING ATTORNEY

SN 77-429,864. GS YUASA CORPORATION, KYOTO, JAPAN, FILED 3-24-2008.

GYZ

THE MARK CONSISTS OF STANDARD CHARACTERS WITHOUT CLAIM TO ANY PARTICULAR FONT, STYLE, SIZE, OR COLOR.

PRIORITY CLAIMED UNDER SEC. 44(D) ON JAPAN APPLICATION NO. 2007-105183, FILED 10-11-2007, REG. NO. 5132849, DATED 5-2-2008, EXPIRES 5-2-2018.

FOR BATTERIES AND ELECTRICAL CELLS (U.S. CLS. 21, 23, 26, 36 AND 38).

BARBARA BROWN, EXAMINING ATTORNEY

SN 77-429,880. DUB SOFTWARE GROUP, INC., DBA AUTO-FILEPRO, PELHAM, NY. FILED 3-24-2008.

AutoFilePro

THE MARK CONSISTS OF STANDARD CHARACTERS WITHOUT CLAIM TO ANY PARTICULAR FONT, STYLE, SIZE, OR COLOR.

FOR COMPUTER GROUPWARE FOR AUTOMATED FILING AND RETRIEVAL OF DOCUMENTS AND ASSOCIATED DATA CONSISTING OF SCANNED IMAGES, IMPORTED FILES, CAPTURED DATA AND REFERENCE DATA; COMPUTER PROGRAMS FOR AUTOMATED FILING AND RETRIEVAL OF DOCUMENTS AND ASSOCIATED DATA CONSISTING OF SCANNED IMAGES, IMPORTED FILES, CAPTURED DATA AND REFERENCE DATA; COMPUTER SOFTWARE FOR CREATING SEARCHABLE DATABASES OF INFORMATION AND DATA; COMPUTER SOFTWARE FOR THE COLLECTION, EDITING, ORGANIZING, MODIFYING, BOOK MARKING, TRANSMISSION, STORAGE AND SHARING OF DATA AND INFORMATION; COMPUTER SOFTWARE FOR AUTOMATED FILING AND RETRIEVAL OF DOCUMENTS AND ASSOCIATED DATA CONSISTING OF SCANNED IMAGES, IMPORTED FILES, CAPTURED DATA AND REFERENCE DATA; DATABASE MANAGEMENT SOFTWARE FOR AUTOMATED FILING AND RETRIEVAL OF DOCUMENTS AND ASSOCIATED DATA CONSISTING OF SCANNED IMAGES, IMPORTED FILES, CAPTURED DATA AND REFERENCE DATA; ELECTRONIC DATABASE IN THE FIELD OF AUTOMATED FILING AND RETRIEVAL OF DOCUMENTS AND ASSOCIATED DATA CONSISTING OF SCANNED IMAGES, IMPORTED FILES, CAPTURED DATA AND REFERENCE DATA RECORDED ON COMPUTER MEDIA (U.S. CLS. 21, 23, 26, 36 AND 38).

ANNE FARRELL, EXAMINING ATTORNEY

CLASS 9—(Continued).

SN 77-429,918. CALLPOD, INC., CHICAGO, IL. FILED 3-24-2008.



THE COLOR(S) BLACK, RED, YELLOW AND GREEN IS/ ARE CLAIMED AS A FEATURE OF THE MARK.

THE MARK CONSISTS OF THE WORDING "FUEL-TANK" OVERLAYING A RECTANGULAR BOX IN THE COLOR BLACK. THE LETTERS "F" AND "U" ARE RED. THE LETTER "E" FADES FROM RED TO YELLOW. THE LETTER "L" IS YELLOW, AND THE LETTERS "T" "A" "N" "K" ARE ALL GREEN.

FOR DUAL DEVICE BATTERY CHARGERS, NAMELY, BATTERY OPERATED DEVICES THAT CHARGE MULTIPLE ELECTRONIC DEVICES AT ONCE (U.S. CLS. 21, 23, 26, 36 AND 38).

WENDY JUN, EXAMINING ATTORNEY

CLASS 9—(Continued).

SN 77-429,987. ASPEN AVIONICS, INC., ALBUQUERQUE, NM. FILED 3-24-2008.

ASPEN

THE MARK CONSISTS OF STANDARD CHARACTERS WITHOUT CLAIM TO ANY PARTICULAR FONT, STYLE, SIZE, OR COLOR.

FOR AVIONIC SENSOR SYSTEMS, NAMELY, AIRCRAFT AIRSPEED SENSORS; AVIONIC SENSOR SYSTEMS, NAMELY, AIRCRAFT ALTITUDE INDICATORS; AVIONIC SENSOR SYSTEMS, NAMELY, NAVIGATION SYSTEMS; APPARATUS FOR CHECKING FLIGHT PARAMETERS; ELECTRONIC NAVIGATIONAL AND POSITIONING APPARATUS AND INSTRUMENTS (U.S. CLS. 21, 23, 26, 36 AND 38).

FIRST USE 1-31-2005; IN COMMERCE 1-31-2005.

JENNY PARK, EXAMINING ATTORNEY

SN 77-430,070. MIDWAY AMUSEMENT GAMES, LLC, CHICAGO, IL. FILED 3-24-2008.

SN 77-429,971. UNIVERSAL ROBOTICS, INC., NASHVILLE, TN. FILED 3-24-2008.

NEOCORTEX

THE MARK CONSISTS OF STANDARD CHARACTERS WITHOUT CLAIM TO ANY PARTICULAR FONT, STYLE, SIZE, OR COLOR.

FOR COMPUTER SOFTWARE, NAMELY, INTELLIGENT MACHINE SOFTWARE THAT EMPLOYS A SELF-LEARNING ALGORITHM TO ASSESS AND ANALYZE INFORMATION IN ORDER TO ADAPT TO SITUATIONS, FOR USE IN A WIDE VARIETY OF FIELDS (U.S. CLS. 21, 23, 26, 36 AND 38).

ALEXANDER L. POWERS, EXAMINING ATTORNEY

DEFENDER

THE MARK CONSISTS OF STANDARD CHARACTERS WITHOUT CLAIM TO ANY PARTICULAR FONT, STYLE, SIZE, OR COLOR.

OWNER OF U.S. REG. NO. 1,288,008. FOR COMPUTER AND VIDEO GAME PROGRAMS RECORDED ON CARTRIDGES, DISCS, CD-ROMS, CASSETTES, TAPES AND MINI DISCS; VIDEO AND COMPUTER GAME SOFTWARE (U.S. CLS. 21, 23, 26, 36 AND 38).

FIRST USE 11-18-2003; IN COMMERCE 11-18-2003.

JASON ROTH, EXAMINING ATTORNEY

CLASS 9—(Continued).

SN 77-430,101. FARGO ELECTRONICS, INC., EDEN PRAIRIE, MN. FILED 3-24-2008.

ONQUEUE

THE MARK CONSISTS OF STANDARD CHARACTERS WITHOUT CLAIM TO ANY PARTICULAR FONT, STYLE, SIZE, OR COLOR.

FOR COMPUTER SOFTWARE FOR MANAGING CREDENTIAL PRODUCTION DEVICES ON A NETWORK, NAMELY, IDENTIFICATION CARD PRINTERS, IDENTIFICATION CARD LAMINATORS AND IDENTIFICATION CARD DATA ENCODERS; COMPUTER SOFTWARE FOR CONTROLLING ACCESS TO CREDENTIAL PRODUCTION DEVICES ON A NETWORK, NAMELY, IDENTIFICATION CARD PRINTERS, IDENTIFICATION CARD LAMINATORS AND IDENTIFICATION CARD DATA ENCODERS; AND COMPUTER SOFTWARE FOR AUTOMATING CREDENTIAL PRODUCTION DEVICE DRIVER PROGRAM DEPLOYMENT TO CLIENT COMPUTERS ON A NETWORK, NAMELY, AUTOMATING DEPLOYMENT OF IDENTIFICATION CARD PRINTER DRIVER PROGRAMS, IDENTIFICATION CARD LAMINATOR DRIVER PROGRAMS AND IDENTIFICATION CARD DATA ENCODER DRIVER PROGRAMS (U.S. CLS. 21, 23, 26, 36 AND 38).

ARETHA SOMERVILLE, EXAMINING ATTORNEY

SN 77-430,103. GIGAPHOTON USA INC., BEAVERTON, OR. FILED 3-24-2008.

GIGAPHOTON

THE MARK CONSISTS OF STANDARD CHARACTERS WITHOUT CLAIM TO ANY PARTICULAR FONT, STYLE, SIZE, OR COLOR.

FOR EXCIMER LASERS USED FOR LITHOGRAPHY IN THE PRODUCTION OF SEMICONDUCTORS (U.S. CLS. 21, 23, 26, 36 AND 38).

FIRST USE 9-1-2000; IN COMMERCE 9-1-2000.
KYLE PEETE, EXAMINING ATTORNEY

CLASS 9—(Continued).

SN 77-430,113. FINGERSTEPS, INC., EDINA, MN. FILED 3-24-2008.

SONARIO

THE MARK CONSISTS OF STANDARD CHARACTERS WITHOUT CLAIM TO ANY PARTICULAR FONT, STYLE, SIZE, OR COLOR.

OWNER OF U.S. REG. NO. 3,259,351.

FOR COMPUTER HARDWARE AND SOFTWARE SYSTEM FOR PLAYING, COMPOSING, SELECTING AND SEQUENCING VIDEO, VIDEO EFFECTS, VIDEO RECORDINGS, MUSIC, SOUND, SOUND EFFECTS, AND/OR SOUND RECORDINGS; COMPUTER SOFTWARE FOR PLAYING, COMPOSING, SELECTING AND SEQUENCING VIDEO, VIDEO EFFECTS, VIDEO RECORDINGS, MUSIC, SOUND, SOUND EFFECTS, AND/OR SOUND RECORDINGS (U.S. CLS. 21, 23, 26, 36 AND 38).

WENDY GOODMAN, EXAMINING ATTORNEY

SN 77-430,176. COOLIRIS, INC., MENLO PARK, CA. FILED 3-24-2008.

COOLIRIS

THE MARK CONSISTS OF STANDARD CHARACTERS WITHOUT CLAIM TO ANY PARTICULAR FONT, STYLE, SIZE, OR COLOR.

FOR COMPUTER SOFTWARE FOR ENHANCING DISPLAY OF RICH MEDIA AND USER EXPERIENCE IN A WORLD WIDE WEB INTERFACE (U.S. CLS. 21, 23, 26, 36 AND 38).

FIRST USE 1-31-2006; IN COMMERCE 1-31-2006.
ANNE FARRELL, EXAMINING ATTORNEY

SN 77-430,274. CALKINS, MARK ALLEN, SAN JACINTO, CA. FILED 3-24-2008.

Track 'N' Go

THE MARK CONSISTS OF STANDARD CHARACTERS WITHOUT CLAIM TO ANY PARTICULAR FONT, STYLE, SIZE, OR COLOR.

FOR GLOBAL POSITIONING SYSTEMS (GPS); AND ELECTRONIC DEVICES PROGRAMMED TO USE GLOBAL POSITIONING SYSTEMS AND CELLULAR COMMUNICATIONS FOR LOCATING AND TRACKING PEOPLE, OBJECTS AND PETS (U.S. CLS. 21, 23, 26, 36 AND 38).

ALICE SUE CARRUTHERS, EXAMINING ATTORNEY

CLASS 9—(Continued).

SN 77-430,293. AGA IMPORTS LLC, SOUTHFIELD, MI. FILED 3-24-2008.

VIMAX C.T.

THE MARK CONSISTS OF STANDARD CHARACTERS WITHOUT CLAIM TO ANY PARTICULAR FONT, STYLE, SIZE, OR COLOR.

FOR BATTERIES; BATTERIES FOR VEHICLES; BATTERY CABLES; BATTERY CASES; BATTERY CHARGE DEVICES; BATTERY CHARGERS; BATTERY PACKS; BATTERY TERMINAL CONNECTOR CLAMPS (U.S. CLS. 21, 23, 26, 36 AND 38).

AMEETA JORDAN, EXAMINING ATTORNEY

SN 77-430,331. BOOSWEET ENTERPRISES, LLC, RIALTO, CA. FILED 3-25-2008.

G-Fire

THE MARK CONSISTS OF STANDARD CHARACTERS WITHOUT CLAIM TO ANY PARTICULAR FONT, STYLE, SIZE, OR COLOR.

FOR DOWNLOADABLE MUSICAL SOUND RECORDINGS; MUSICAL SOUND RECORDINGS; MUSICAL VIDEO RECORDINGS; SOUND RECORDINGS FEATURING MUSIC; VIDEO RECORDINGS FEATURING MUSIC; PRE-RECORDED CDS, VIDEO TAPES, LASER DISKS AND DVDS FEATURING MUSIC (U.S. CLS. 21, 23, 26, 36 AND 38).

FIRST USE 1-15-2002; IN COMMERCE 1-15-2002.
CARYN GLASSER, EXAMINING ATTORNEY

SN 77-430,359. LI SHERRY HAIXIA, MIAMI, FL. FILED 3-25-2008.

ZIBELINE

THE MARK CONSISTS OF LETTERS "ZIBELINE". THE WORDING "ZIBELINE" HAS NO MEANING IN ENGLISH.

FOR CHAINS FOR SPECTACLES; SPECTACLE CASES; SPECTACLE FRAMES; SPECTACLES; EYEGLASS FRAMES; EYEGLASS CORDS; CONTACT LENSES; CONTAINERS FOR CONTACT LENSES; CORRECTIVE GLASSES; OPTICAL LENSES; SUNGLASSES (U.S. CLS. 21, 23, 26, 36 AND 38).

JULIE GUTTADAURO, EXAMINING ATTORNEY

CLASS 9—(Continued).

SN 77-430,370. HASSING, THOMAS A, SAN JOSE, CA. FILED 3-25-2008.



THE MARK CONSISTS OF A UNIQUE STYLIZED DESIGN OF EYEGLASSES HAVING LENSES SHOWING EAST AND WEST WORLD HEMISPHERES.

FOR ANTIREFLECTION COATED EYEGLASSES; EYEGLASS CASES; EYEGLASS CHAINS; EYEGLASS CORDS; EYEGLASS FRAMES; EYEGLASS LENSES; EYEGLASSES; PROTECTIVE EYEGLASSES; READING EYEGLASSES; SIDE GUARDS FOR EYEGLASSES; SPECTACLES; GOGGLES FOR SPORTS; SAFETY GOGGLES; SUNGLASSES; ANTI-REFLECTIVE LENSES; CONTACT LENSES; CONTAINERS FOR CONTACT LENSES; MAGNIFYING LENSES; OPHTHALMIC LENSES; SUNGLASS LENSES (U.S. CLS. 21, 23, 26, 36 AND 38).

SUNG IN, EXAMINING ATTORNEY

SN 77-430,439. DOUGHERTY, ROBERT D., DBA BODY SPECS EYEWEAR, GRASS VALLEY, CA. FILED 3-25-2008.

SLINGS

THE MARK CONSISTS OF STANDARD CHARACTERS WITHOUT CLAIM TO ANY PARTICULAR FONT, STYLE, SIZE, OR COLOR.

FOR EYEWEAR (U.S. CLS. 21, 23, 26, 36 AND 38).
FIRST USE 1-0-2004; IN COMMERCE 1-0-2004.
HEATHER THOMPSON, EXAMINING ATTORNEY

SN 77-430,457. SEVONE INC, NEWARK, DE. FILED 3-25-2008.

SEVONE

THE MARK CONSISTS OF STANDARD CHARACTERS WITHOUT CLAIM TO ANY PARTICULAR FONT, STYLE, SIZE, OR COLOR.

FOR COMPUTER NETWORKING HARDWARE; SOFTWARE FOR MANAGING COMPUTER NETWORKS (U.S. CLS. 21, 23, 26, 36 AND 38).

FIRST USE 1-0-2005; IN COMMERCE 1-0-2005.
NATALIE POLZER, EXAMINING ATTORNEY

CLASS 9—(Continued).

SN 77-430,537. BEVERAGE METRICS AG, BAAR, SWITZERLAND, FILED 3-25-2008.

Track-The-Apple

THE MARK CONSISTS OF STANDARD CHARACTERS WITHOUT CLAIM TO ANY PARTICULAR FONT, STYLE, SIZE, OR COLOR.

FOR COMPUTER HARDWARE AND COMPUTER SOFTWARE FOR RETAIL INVENTORY MANAGEMENT, SOLD AS A UNIT; DEVICES FOR WIRELESS RADIO TRANSMISSION; ELECTRIC OR ELECTRONIC SENSORS FOR TRACKING INVENTORY AND PEOPLE; ELECTRONIC DATA RELAYS FOR SENSORS (U.S. CLS. 21, 23, 26, 36 AND 38).

MARCIE MILONE, EXAMINING ATTORNEY

SN 77-430,573. COOLIRIS, INC., MENLO PARK, CA. FILED 3-25-2008.

PICLENS

THE MARK CONSISTS OF STANDARD CHARACTERS WITHOUT CLAIM TO ANY PARTICULAR FONT, STYLE, SIZE, OR COLOR.

FOR COMPUTER SOFTWARE FOR ENHANCING DISPLAY OF RICH MEDIA AND USER EXPERIENCE IN A WORLD WIDE WEB INTERFACE (U.S. CLS. 21, 23, 26, 36 AND 38).

FIRST USE 9-30-2006; IN COMMERCE 9-30-2006.
ANNE FARRELL, EXAMINING ATTORNEY

SN 77-430,684. NORTHEAST ELECTRONIC DESIGN CENTER, RONKONKOMA, NY. FILED 3-25-2008.

Switch-Smart

THE MARK CONSISTS OF STANDARD CHARACTERS WITHOUT CLAIM TO ANY PARTICULAR FONT, STYLE, SIZE, OR COLOR.

FOR VEHICLE PARTS, NAMELY, ELECTRONIC SWITCHES (U.S. CLS. 21, 23, 26, 36 AND 38).

FIRST USE 7-1-2007; IN COMMERCE 10-1-2007.
MARIA-VICTORIA SUAREZ, EXAMINING ATTORNEY

CLASS 9—(Continued).

SN 77-430,708. PROPERTYINFO CORPORATION, HOUSTON, TX. FILED 3-25-2008.

FILESTOR

THE MARK CONSISTS OF STANDARD CHARACTERS WITHOUT CLAIM TO ANY PARTICULAR FONT, STYLE, SIZE, OR COLOR.

FOR COMPUTER SOFTWARE FOR USE IN DOCUMENT MANAGEMENT (U.S. CLS. 21, 23, 26, 36 AND 38).

FIRST USE 11-17-1992; IN COMMERCE 11-17-1992.
MARTHA SANTOMARTINO, EXAMINING ATTORNEY

SN 77-430,764. MELISSA DATA CORP., RANCHO SANTA MARGARITA, CA. FILED 3-25-2008.

Right Fielder

THE MARK CONSISTS OF STANDARD CHARACTERS WITHOUT CLAIM TO ANY PARTICULAR FONT, STYLE, SIZE, OR COLOR.

FOR MARKETING AND MAILING SOFTWARE THAT EXAMINES DATA AND MAKES SURE THAT THE DATA IS IN THE CORRECT FIELD BY EXAMINING AND DISTINGUISHING BETWEEN NAMES, TITLES, DEPARTMENTS, COMPANIES, ADDRESSES, CITIES, STATES, ZIP CODES, AND PHONE NUMBERS (U.S. CLS. 21, 23, 26, 36 AND 38).

FIRST USE 10-1-1990; IN COMMERCE 10-1-1990.
H. M. FISHER, EXAMINING ATTORNEY

SN 77-430,965. WPFY, INC., WILMINGTON, DE. FILED 3-25-2008.

AMERICA CABLE SYSTEMS

THE MARK CONSISTS OF STANDARD CHARACTERS WITHOUT CLAIM TO ANY PARTICULAR FONT, STYLE, SIZE, OR COLOR.

OWNER OF U.S. REG. NO. 2,122,562.

NO CLAIM IS MADE TO THE EXCLUSIVE RIGHT TO USE "CABLE SYSTEMS", APART FROM THE MARK AS SHOWN.

SEC. 2(F).

FOR ELECTRICAL WIRING ASSEMBLIES, NAMELY, PREFABRICATED MODULAR WIRING FOR READY INSTALLATION IN BUILDINGS (U.S. CLS. 21, 23, 26, 36 AND 38).

FIRST USE 8-9-1993; IN COMMERCE 8-9-1993.
BARBARA GAYNOR, EXAMINING ATTORNEY

CLASS 9—(Continued).

SN 77-430,986. IBANEZ, RUTH C., NEW YORK, NY. FILED 3-25-2008.

DFRIS

THE MARK CONSISTS OF STANDARD CHARACTERS WITHOUT CLAIM TO ANY PARTICULAR FONT, STYLE, SIZE, OR COLOR.

FOR COMPUTER SOFTWARE SYSTEM DESIGNED TO FACILITATE TELEMEDICINE BY PROVIDING REMOTE ACCESS TO A PATIENT'S MEDICAL RECORDS AND FACILITATING THE PROVISION OF MEDICAL SERVICES BY ENABLING MEDICAL PROFESSIONALS TO COMMUNICATE WITH PATIENTS AND OTHER MEDICAL PROFESSIONALS (U.S. CLS. 21, 23, 26, 36 AND 38).

KATINA MISTER, EXAMINING ATTORNEY

CLASS 9—(Continued).

SN 77-431,061. LASKO, STEPHEN, RESTON, VA. FILED 3-25-2008.



OWNER OF U.S. REG. NO. 2,838,961.

THE MARK CONSISTS OF STYLIZED TEXT CONSISTING OF "JB2" ADJACENT TO "JANGLEBOX".

FOR GUITAR EFFECTS PROCESSORS; GUITAR PEDALS; ELECTRONIC EFFECT PEDALS FOR USE WITH SOUND AMPLIFIERS (U.S. CLS. 21, 23, 26, 36 AND 38).

HENRY S. ZAK, EXAMINING ATTORNEY

SN 77-431,018. IBANEZ, RUTH C., NEW YORK, NY. FILED 3-25-2008.

MDOutpost I

THE MARK CONSISTS OF STANDARD CHARACTERS WITHOUT CLAIM TO ANY PARTICULAR FONT, STYLE, SIZE, OR COLOR.

FOR COMPUTER SOFTWARE SYSTEM DESIGNED TO FACILITATE TELEMEDICINE BY PROVIDING REMOTE ACCESS TO A PATIENT'S MEDICAL RECORDS AND FACILITATING THE PROVISION OF MEDICAL SERVICES BY ENABLING MEDICAL PROFESSIONALS TO COMMUNICATE WITH PATIENTS AND OTHER MEDICAL PROFESSIONALS (U.S. CLS. 21, 23, 26, 36 AND 38).

KATINA MISTER, EXAMINING ATTORNEY

SN 77-431,076. IBANEZ, RUTH C., NEW YORK, NY. FILED 3-25-2008.

MDOutpost X

THE MARK CONSISTS OF STANDARD CHARACTERS WITHOUT CLAIM TO ANY PARTICULAR FONT, STYLE, SIZE, OR COLOR.

FOR COMPUTER SOFTWARE SYSTEM DESIGNED TO FACILITATE TELEMEDICINE BY PROVIDING REMOTE ACCESS TO A PATIENT'S MEDICAL RECORDS AND FACILITATING THE PROVISION OF MEDICAL SERVICES BY ENABLING MEDICAL PROFESSIONALS TO COMMUNICATE WITH PATIENTS AND OTHER MEDICAL PROFESSIONALS (U.S. CLS. 21, 23, 26, 36 AND 38).

KATINA MISTER, EXAMINING ATTORNEY

SN 77-431,031. TATTLE-TRAIL LLC, LARGO, FL. FILED 3-25-2008.

Tattle-Trail

THE MARK CONSISTS OF STANDARD CHARACTERS WITHOUT CLAIM TO ANY PARTICULAR FONT, STYLE, SIZE, OR COLOR.

FOR VEHICLE SAFETY EQUIPMENT, NAMELY, VIBRATION, SHOCK, MOTION, ANGLE, TEMPERATURE AND VOLTAGE MONITOR (U.S. CLS. 21, 23, 26, 36 AND 38).

FIRST USE 6-7-2007; IN COMMERCE 10-18-2007.

AISHA CLARKE, EXAMINING ATTORNEY

SN 77-431,088. IBANEZ, RUTH C., NEW YORK, NY. FILED 3-25-2008.

SPEDRGRAIN

THE MARK CONSISTS OF STANDARD CHARACTERS WITHOUT CLAIM TO ANY PARTICULAR FONT, STYLE, SIZE, OR COLOR.

FOR COMPUTER SOFTWARE SYSTEM DESIGNED TO FACILITATE TELEMEDICINE BY PROVIDING REMOTE ACCESS TO A PATIENT'S MEDICAL RECORDS AND FACILITATING THE PROVISION OF MEDICAL SERVICES BY ENABLING MEDICAL PROFESSIONALS TO COMMUNICATE WITH PATIENTS AND OTHER MEDICAL PROFESSIONALS (U.S. CLS. 21, 23, 26, 36 AND 38).

KATINA MISTER, EXAMINING ATTORNEY

CLASS 9—(Continued).

SN 77-431,226. BREN-TRONICS, INC., COMMACK, NY.
FILED 3-25-2008.

Bren-Tronics

THE MARK CONSISTS OF STANDARD CHARACTERS WITHOUT CLAIM TO ANY PARTICULAR FONT, STYLE, SIZE, OR COLOR.

FOR BATTERIES AND BATTERY CHARGERS (U.S. CLS. 21, 23, 26, 36 AND 38).

FIRST USE 8-31-1973; IN COMMERCE 8-31-1973.
WANDA KAY PRICE, EXAMINING ATTORNEY

SN 77-431,228. ADVANCED MOBIL PRODUCTS, L.L.C.,
PHOENIX, AZ. FILED 3-25-2008.



NO CLAIM IS MADE TO THE EXCLUSIVE RIGHT TO USE "ADVANCED MOBILE PRODUCTS", APART FROM THE MARK AS SHOWN.

THE COLOR(S) RED, WHITE AND BLUE IS/ARE CLAIMED AS A FEATURE OF THE MARK.

THE MARK CONSISTS OF WHITE LETTERS "AMP" INSIDE A RED BOX BLUE LETTERS "ADVANCED MOBIL" ON FIRST LINE BESIDE THE RED BOX BLUE LETTERS "PRODUCTS" ON SECOND LINE BESIDE THE RED BOX.

FOR RADIO-FREQUENCY CONTROLLED LOCKS (U.S. CLS. 21, 23, 26, 36 AND 38).

ANTHONY RINKER, EXAMINING ATTORNEY

SN 77-431,249. ADVANCED MOBIL PRODUCTS, L.L.C.,
PHOENIX, AZ. FILED 3-25-2008.

LocAssist

THE COLOR(S) RED AND BLUE IS/ARE CLAIMED AS A FEATURE OF THE MARK.

THE MARK CONSISTS OF RED HEAVY LETTERS "LOC" BESIDE THE WORD "LOC" IS THE BLUE WORD "ASSIST".

FOR RADIO-FREQUENCY CONTROLLED LOCKS (U.S. CLS. 21, 23, 26, 36 AND 38).

ANTHONY RINKER, EXAMINING ATTORNEY

CLASS 9—(Continued).

SN 77-431,310. NEXTECH INDUSTRIES, LLC, SUNNY ISLES BEACH, FL. FILED 3-25-2008.

STARBOOTH

THE MARK CONSISTS OF STANDARD CHARACTERS WITHOUT CLAIM TO ANY PARTICULAR FONT, STYLE, SIZE, OR COLOR.

FOR BOOTH SIZED VENDING MACHINES THAT ARE CONFIGURED TO ALLOW PERFORMANCE AND RECORDING OF KARAOKE (U.S. CLS. 21, 23, 26, 36 AND 38).

THOMAS MANOR, EXAMINING ATTORNEY

SN 77-431,464. HEIBER, RONALD R., NORTH LAS VEGAS, NV. AND KELLEY, KARL, HENDERSON, NV. FILED 3-25-2008.

INDIBLOCK

THE MARK CONSISTS OF STANDARD CHARACTERS WITHOUT CLAIM TO ANY PARTICULAR FONT, STYLE, SIZE, OR COLOR.

FOR TRAFFIC-LIGHT APPARATUS (U.S. CLS. 21, 23, 26, 36 AND 38).

TASHIA BUNCH, EXAMINING ATTORNEY

SN 77-431,475. CYMBET CORPORATION, ELK RIVER, MN.
FILED 3-25-2008.

EnerChip PS

THE MARK CONSISTS OF STANDARD CHARACTERS WITHOUT CLAIM TO ANY PARTICULAR FONT, STYLE, SIZE, OR COLOR.

FOR BATTERIES AND CHARGE CONTROL CIRCUITRY (U.S. CLS. 21, 23, 26, 36 AND 38).

HENRY S. ZAK, EXAMINING ATTORNEY

CLASS 9—(Continued).

SN 77-431,495. DESTREMP, GERALD, SAUSALITO, CA. FILED 3-26-2008.

Home of the Form

THE MARK CONSISTS OF STANDARD CHARACTERS WITHOUT CLAIM TO ANY PARTICULAR FONT, STYLE, SIZE, OR COLOR.

FOR COMPUTER SOFTWARE FOR THE COLLECTION, EDITING, ORGANIZING, MODIFYING, BOOK MARKING, TRANSMISSION, STORAGE AND SHARING OF DATA AND INFORMATION (U.S. CLS. 21, 23, 26, 36 AND 38).

SUNG IN, EXAMINING ATTORNEY

SN 77-431,539. TRACY, PETER, H., BOCA RATON, FL. FILED 3-26-2008.

Talkeze

THE MARK CONSISTS OF STANDARD CHARACTERS WITHOUT CLAIM TO ANY PARTICULAR FONT, STYLE, SIZE, OR COLOR.

FOR HANDS FREE KITS FOR PHONES (U.S. CLS. 21, 23, 26, 36 AND 38).

MARY CRAWFORD, EXAMINING ATTORNEY

SN 77-431,541. COMMSCOPE, INC. OF NORTH CAROLINA, HICKORY, NC. FILED 3-26-2008.

-IET

THE MARK CONSISTS OF STANDARD CHARACTERS WITHOUT CLAIM TO ANY PARTICULAR FONT, STYLE, SIZE, OR COLOR.

FOR ANTENNAS FOR WIRELESS COMMUNICATIONS, NAMELY, BASE STATION ANTENNAS (U.S. CLS. 21, 23, 26, 36 AND 38).

ANDREA SAUNDERS, EXAMINING ATTORNEY

CLASS 9—(Continued).

SN 77-431,606. NU MONY TECHNOLOGY, INC., POUGH-KEEPSIE, NY. FILED 3-26-2008.



NO CLAIM IS MADE TO THE EXCLUSIVE RIGHT TO USE "HUDSON VALLEY" AND "GIFT CARD", APART FROM THE MARK AS SHOWN.

THE MARK CONSISTS OF THE WORD "NU" INSIDE A SQUARE WITH LINE BREAKS IN THE SQUARE ON THE TOP AND BOTTOM, FOLLOWED BY THE WORD "MONY'S" AND THEN "HUDSON VALLEY" ON THE TOP LINE. ON THE SECOND LINE, THE WORD "GIFT" (IN LARGER FONT THAN THE FIRST LINE) FOLLOWED BY THE IMAGE OF A THREE-PART TALL SHIP SAIL AND MAST WITH A FLAG ATOP THE SAILS, FOLLOWED BY THE WORD "CARD." THE FLAG ATOP THE SAILS EXTENDS UP INTO THE TOP LINE OF THE IMAGE AND IS IN BETWEEN THE WORDS "NUMONY'S" AND THE WORDS "HUDSON VALLEY".

FOR MAGNETICALLY ENCODED DEBIT CARDS (U.S. CLS. 21, 23, 26, 36 AND 38).

FIRST USE 2-1-2008; IN COMMERCE 2-1-2008.

GINA FINK, EXAMINING ATTORNEY

SN 77-431,691. WU, PETER, NEW YORK, NY. FILED 3-26-2008.

D8G

THE MARK CONSISTS OF STANDARD CHARACTERS WITHOUT CLAIM TO ANY PARTICULAR FONT, STYLE, SIZE, OR COLOR.

FOR SUNGLASSES (U.S. CLS. 21, 23, 26, 36 AND 38).

JOHN SCHUYLER YARD, EXAMINING ATTORNEY

SN 77-431,808. SCHOBEL, ANDREAS E, SAN FRANCISCO, CA. FILED 3-26-2008.

3BANANA

THE MARK CONSISTS OF STANDARD CHARACTERS WITHOUT CLAIM TO ANY PARTICULAR FONT, STYLE, SIZE, OR COLOR.

FOR SOFTWARE FOR SENDING, RECEIVING, ORGANIZING, AND SHARING NOTES (U.S. CLS. 21, 23, 26, 36 AND 38).

BARBARA RUTLAND, EXAMINING ATTORNEY

CLASS 9—(Continued).

SN 77-431,865. HOT PEPPER TECHNOLOGY, INC., TAMARAC, FL. FILED 3-26-2008.

eChat Locker

THE MARK CONSISTS OF STANDARD CHARACTERS WITHOUT CLAIM TO ANY PARTICULAR FONT, STYLE, SIZE, OR COLOR.

NO CLAIM IS MADE TO THE EXCLUSIVE RIGHT TO USE "ECHAT", APART FROM THE MARK AS SHOWN.

FOR COMPUTER SOFTWARE FOR THE COLLECTION, EDITING, ORGANIZING, MODIFYING, BOOK MARKING, TRANSMISSION, STORAGE AND SHARING OF DATA AND INFORMATION (U.S. CLS. 21, 23, 26, 36 AND 38).

LAURA HAMMEL, EXAMINING ATTORNEY

SN 77-431,947. SEIKO EPSON KABUSHIKI KAISHA ATA SEIKO EPSON CORPORATION, SHINJUKU-KU, TOKYO, JAPAN, FILED 3-26-2008.

EPSON

THE MARK CONSISTS OF STANDARD CHARACTERS WITHOUT CLAIM TO ANY PARTICULAR FONT, STYLE, SIZE, OR COLOR.

OWNER OF U.S. REG. NOS. 3,092,025 AND 3,385,501.

FOR LIQUID CRYSTAL DISPLAYS; COMPACT LIQUID CRYSTAL DISPLAYS; EYEGLASSES; LENSES FOR EYEGLASSES; EYEGLASS FRAMES; CONTACT LENSES; RARE-EARTH MAGNETS; INTEGRATED CIRCUITS; LARGE SCALE INTEGRATED CIRCUITS; SEMICONDUCTOR MEMORIES; DIODES; CRYSTAL OSCILLATORS; CRYSTAL OSCILLATOR DEVICES, NAMELY, CRYSTAL UNITS COMPRISING CRYSTAL CHIPS AND CRYSTAL OSCILLATOR CIRCUITS, ALL FOR USE IN ELECTRONICS PRODUCTS SUCH AS CELLULAR TELEPHONES, COMPUTERS AND GLOBAL POSITIONING DEVICES (U.S. CLS. 21, 23, 26, 36 AND 38).

FIRST USE 6-30-1975; IN COMMERCE 3-31-1988.

NORA BUCHANAN WILL, EXAMINING ATTORNEY

CLASS 9—(Continued).

SN 77-431,985. BEVERAGE METRICS AG, BAAR, SWITZERLAND, FILED 3-26-2008.

BevMet

THE MARK CONSISTS OF STANDARD CHARACTERS WITHOUT CLAIM TO ANY PARTICULAR FONT, STYLE, SIZE, OR COLOR.

FOR INVENTORY MONITORING SYSTEM FOR MEASURING QUANTITIES OF LIQUIDS AND SEMI-LIQUIDS AND FOR TRACKING USE OF LIQUIDS AND OTHER PRODUCTS COMPRISING OF A MOTION-SENSITIVE DEVICE THAT IS ATTACHED TO BOTTLES, TAPS, FAUCETS, DOORS AND LIDS AND EMITS A WIRELESS SIGNAL TO A COMPUTER WITH INFORMATION ABOUT THE QUANTITY OF LIQUID OR SEMI-LIQUID THAT HAS PASSED OUT OF THE BOTTLE, TAP, FAUCET, DOOR OR LID (U.S. CLS. 21, 23, 26, 36 AND 38).

MARCIE MILONE, EXAMINING ATTORNEY

SN 77-432,135. GE HEALTHCARE BIO-SCIENCES AB, UPSALA, SWEDEN, FILED 3-26-2008.

ÄKTA

THE MARK CONSISTS OF STANDARD CHARACTERS WITHOUT CLAIM TO ANY PARTICULAR FONT, STYLE, SIZE, OR COLOR.

OWNER OF U.S. REG. NOS. 2,124,233, 2,922,171 AND OTHERS.

THE FOREIGN WORDING IN THE MARK TRANSLATES INTO ENGLISH AS GENUINE.

FOR COMPUTER SOFTWARE FOR USE WITH CHROMATOGRAPHY SYSTEMS (U.S. CLS. 21, 23, 26, 36 AND 38).

DOMINIC J. FERRAIUOLO, EXAMINING ATTORNEY

SN 77-432,275. COUNTRY HOME PRODUCTS, INC., VERGENNES, VT. FILED 3-26-2008.

NEUTON

THE MARK CONSISTS OF STANDARD CHARACTERS WITHOUT CLAIM TO ANY PARTICULAR FONT, STYLE, SIZE, OR COLOR.

OWNER OF U.S. REG. NOS. 2,906,108 AND 3,450,114.

FOR BATTERIES (U.S. CLS. 21, 23, 26, 36 AND 38).

FIRST USE 2-0-2003; IN COMMERCE 2-0-2003.

LEIGH CAROLINE CASE, EXAMINING ATTORNEY

CLASS 9—(Continued).

SN 77-432,431. GRACE SAFETY PRODUCTS, L.L.C., FREDERICK, MD. FILED 3-26-2008.

SHOCKENDER

THE MARK CONSISTS OF STANDARD CHARACTERS WITHOUT CLAIM TO ANY PARTICULAR FONT, STYLE, SIZE, OR COLOR.

FOR PROTECTIVE INSULATING FOREARM SLEEVE FOR USE IN PROTECTING USERS FROM ELECTRICAL CURRENT AND SHOCK (U.S. CLS. 21, 23, 26, 36 AND 38).

FIRST USE 10-17-2006; IN COMMERCE 10-17-2006.
MARCIE MILONE, EXAMINING ATTORNEY

CLASS 9—(Continued).

SN 77-432,734. KONAMI AUSTRALIA PTY LTD, BOTANY, NSW, AUSTRALIA, FILED 3-27-2008.

CHINA SHORES

THE MARK CONSISTS OF STANDARD CHARACTERS WITHOUT CLAIM TO ANY PARTICULAR FONT, STYLE, SIZE, OR COLOR.

FOR ELECTRONIC GAME PROGRAMS; GAMING EQUIPMENT, NAMELY, SLOT MACHINES WITH OR WITHOUT VIDEO OUTPUT; GAMING MACHINES; MACHINES FOR PLAYING GAMES OF CHANCE; SLOT MACHINES (U.S. CLS. 21, 23, 26, 36 AND 38).

ALYSSA PALADINO, EXAMINING ATTORNEY

SN 77-432,532. PG MUSIC INC., VICTORIA, CANADA, FILED 3-26-2008.

LiveBand

THE MARK CONSISTS OF STANDARD CHARACTERS WITHOUT CLAIM TO ANY PARTICULAR FONT, STYLE, SIZE, OR COLOR.

FOR COMPUTER SOFTWARE FOR GENERATING AUTOMATIC MUSICAL ACCOMPANIMENTS (U.S. CLS. 21, 23, 26, 36 AND 38).

SANDRA MANIOS, EXAMINING ATTORNEY

SN 77-432,736. KONAMI AUSTRALIA PTY LTD, BOTANY, NSW, AUSTRALIA, FILED 3-27-2008.

MYSTICAL NOMAD

THE MARK CONSISTS OF STANDARD CHARACTERS WITHOUT CLAIM TO ANY PARTICULAR FONT, STYLE, SIZE, OR COLOR.

FOR ELECTRONIC GAME PROGRAMS; GAMING EQUIPMENT, NAMELY, SLOT MACHINES WITH OR WITHOUT VIDEO OUTPUT; GAMING MACHINES; MACHINES FOR PLAYING GAMES OF CHANCE; SLOT MACHINES (U.S. CLS. 21, 23, 26, 36 AND 38).

ALYSSA PALADINO, EXAMINING ATTORNEY

SN 77-432,733. KONAMI AUSTRALIA PTY LTD, BOTANY, NSW, AUSTRALIA, FILED 3-27-2008.

INCA LEGEND

THE MARK CONSISTS OF STANDARD CHARACTERS WITHOUT CLAIM TO ANY PARTICULAR FONT, STYLE, SIZE, OR COLOR.

FOR ELECTRONIC GAME PROGRAMS; GAMING EQUIPMENT, NAMELY, SLOT MACHINES WITH OR WITHOUT VIDEO OUTPUT; GAMING MACHINES; MACHINES FOR PLAYING GAMES OF CHANCE; SLOT MACHINES (U.S. CLS. 21, 23, 26, 36 AND 38).

ALYSSA PALADINO, EXAMINING ATTORNEY

SN 77-432,737. KONAMI AUSTRALIA PTY LTD, BOTANY, NSW, AUSTRALIA, FILED 3-27-2008.

ON GOLDEN WINGS

THE MARK CONSISTS OF STANDARD CHARACTERS WITHOUT CLAIM TO ANY PARTICULAR FONT, STYLE, SIZE, OR COLOR.

FOR ELECTRONIC GAME PROGRAMS; GAMING EQUIPMENT, NAMELY, SLOT MACHINES WITH OR WITHOUT VIDEO OUTPUT; GAMING MACHINES; MACHINES FOR PLAYING GAMES OF CHANCE; SLOT MACHINES (U.S. CLS. 21, 23, 26, 36 AND 38).

ALYSSA PALADINO, EXAMINING ATTORNEY

CLASS 9—(Continued).

SN 77-432,738. KONAMI AUSTRALIA PTY LTD, BOTANY, NSW, AUSTRALIA, FILED 3-27-2008.

NINJA REBELS

THE MARK CONSISTS OF STANDARD CHARACTERS WITHOUT CLAIM TO ANY PARTICULAR FONT, STYLE, SIZE, OR COLOR.

FOR ELECTRONIC GAME PROGRAMS; GAMING EQUIPMENT, NAMELY, SLOT MACHINES WITH OR WITHOUT VIDEO OUTPUT; GAMING MACHINES; MACHINES FOR PLAYING GAMES OF CHANCE; SLOT MACHINES (U.S. CLS. 21, 23, 26, 36 AND 38).

ALYSSA PALADINO, EXAMINING ATTORNEY

CLASS 9—(Continued).

SN 77-432,742. KONAMI AUSTRALIA PTY LTD, BOTANY, NSW, AUSTRALIA, FILED 3-27-2008.

THALASSICA

THE MARK CONSISTS OF STANDARD CHARACTERS WITHOUT CLAIM TO ANY PARTICULAR FONT, STYLE, SIZE, OR COLOR.

FOR ELECTRONIC GAME PROGRAMS; GAMING EQUIPMENT, NAMELY, SLOT MACHINES WITH OR WITHOUT VIDEO OUTPUT; GAMING MACHINES; MACHINES FOR PLAYING GAMES OF CHANCE; SLOT MACHINES (U.S. CLS. 21, 23, 26, 36 AND 38).

ALYSSA PALADINO, EXAMINING ATTORNEY

SN 77-432,739. KONAMI AUSTRALIA PTY LTD, BOTANY, NSW, AUSTRALIA, FILED 3-27-2008.

GOLDEN STAKES

THE MARK CONSISTS OF STANDARD CHARACTERS WITHOUT CLAIM TO ANY PARTICULAR FONT, STYLE, SIZE, OR COLOR.

FOR ELECTRONIC GAME PROGRAMS; GAMING EQUIPMENT, NAMELY, SLOT MACHINES WITH OR WITHOUT VIDEO OUTPUT; GAMING MACHINES; MACHINES FOR PLAYING GAMES OF CHANCE; SLOT MACHINES (U.S. CLS. 21, 23, 26, 36 AND 38).

ALYSSA PALADINO, EXAMINING ATTORNEY

SN 77-432,743. KONAMI AUSTRALIA PTY LTD, BOTANY, NSW, AUSTRALIA, FILED 3-27-2008.

RAPA NUI RICHES

THE MARK CONSISTS OF STANDARD CHARACTERS WITHOUT CLAIM TO ANY PARTICULAR FONT, STYLE, SIZE, OR COLOR.

FOR ELECTRONIC GAME PROGRAMS; GAMING EQUIPMENT, NAMELY, SLOT MACHINES WITH OR WITHOUT VIDEO OUTPUT; GAMING MACHINES; MACHINES FOR PLAYING GAMES OF CHANCE; SLOT MACHINES (U.S. CLS. 21, 23, 26, 36 AND 38).

ALYSSA PALADINO, EXAMINING ATTORNEY

SN 77-432,741. KONAMI AUSTRALIA PTY LTD, BOTANY, AUSTRALIA, FILED 3-27-2008.

COOK'S CATCH

THE MARK CONSISTS OF STANDARD CHARACTERS WITHOUT CLAIM TO ANY PARTICULAR FONT, STYLE, SIZE, OR COLOR.

FOR ELECTRONIC GAME PROGRAMS; GAMING EQUIPMENT, NAMELY, SLOT MACHINES WITH OR WITHOUT VIDEO OUTPUT; GAMING MACHINES; MACHINES FOR PLAYING GAMES OF CHANCE; SLOT MACHINES (U.S. CLS. 21, 23, 26, 36 AND 38).

ALYSSA PALADINO, EXAMINING ATTORNEY

SN 77-432,744. KONAMI AUSTRALIA PTY LTD, BOTANY, AUSTRALIA, FILED 3-27-2008.

GENERALS OF THE EAST

THE MARK CONSISTS OF STANDARD CHARACTERS WITHOUT CLAIM TO ANY PARTICULAR FONT, STYLE, SIZE, OR COLOR.

FOR ELECTRONIC GAME PROGRAMS; GAMING EQUIPMENT, NAMELY, SLOT MACHINES WITH OR WITHOUT VIDEO OUTPUT; GAMING MACHINES; MACHINES FOR PLAYING GAMES OF CHANCE; SLOT MACHINES (U.S. CLS. 21, 23, 26, 36 AND 38).

JOHN WILKE, EXAMINING ATTORNEY

CLASS 9—(Continued).

SN 77-432,747. KONAMI AUSTRALIA PTY LTD, BOTANY, AUSTRALIA, FILED 3-27-2008.

VIKING LEGEND

THE MARK CONSISTS OF STANDARD CHARACTERS WITHOUT CLAIM TO ANY PARTICULAR FONT, STYLE, SIZE, OR COLOR.
FOR ELECTRONIC GAME PROGRAMS; GAMING EQUIPMENT, NAMELY, SLOT MACHINES WITH OR WITHOUT VIDEO OUTPUT; GAMING MACHINES; MACHINES FOR PLAYING GAMES OF CHANCE; SLOT MACHINES (U.S. CLS. 21, 23, 26, 36 AND 38).
JOHN WILKE, EXAMINING ATTORNEY

SN 77-432,752. SENTRIGO INC., WOBURN, MA. FILED 3-27-2008.

HEDGEHOG

THE MARK CONSISTS OF STANDARD CHARACTERS WITHOUT CLAIM TO ANY PARTICULAR FONT, STYLE, SIZE, OR COLOR.
FOR COMPUTER SOFTWARE FOR PROTECTING AND SECURING DATABASES (U.S. CLS. 21, 23, 26, 36 AND 38).
FIRST USE 6-18-2007; IN COMMERCE 6-18-2007.
IRA J. GOODSaid, EXAMINING ATTORNEY

SN 77-432,753. SENTRIGO INC., WOBURN, MA. FILED 3-27-2008.

SENTRIGO

THE MARK CONSISTS OF STANDARD CHARACTERS WITHOUT CLAIM TO ANY PARTICULAR FONT, STYLE, SIZE, OR COLOR.
THE WORDING "SENTRIGO" HAS NO MEANING IN A FOREIGN LANGUAGE.
FOR COMPUTER SOFTWARE FOR PROTECTING AND SECURING DATABASES (U.S. CLS. 21, 23, 26, 36 AND 38).
FIRST USE 6-18-2007; IN COMMERCE 6-18-2007.
IRA J. GOODSaid, EXAMINING ATTORNEY

CLASS 9—(Continued).

SN 77-432,755. SENTRIGO INC., WOBURN, MA. FILED 3-27-2008.



THE MARK CONSISTS OF PICTURE OF A HEDGEHOG WITH WORDING.
FOR COMPUTER SOFTWARE FOR PROTECTING AND SECURING DATABASES (U.S. CLS. 21, 23, 26, 36 AND 38).
FIRST USE 6-18-2007; IN COMMERCE 6-18-2007.
IRA J. GOODSaid, EXAMINING ATTORNEY

SN 77-432,756. SENTRIGO INC., WOBURN, MA. FILED 3-27-2008.

SENTRIGO HEDGEHOG

THE MARK CONSISTS OF STANDARD CHARACTERS WITHOUT CLAIM TO ANY PARTICULAR FONT, STYLE, SIZE, OR COLOR.
FOR COMPUTER SOFTWARE FOR PROTECTING AND SECURING DATABASES (U.S. CLS. 21, 23, 26, 36 AND 38).
IRA J. GOODSaid, EXAMINING ATTORNEY

SN 77-432,794. WMS GAMING INC., WAUKEGAN, IL. FILED 3-27-2008.

CORONADO GOLD

THE MARK CONSISTS OF STANDARD CHARACTERS WITHOUT CLAIM TO ANY PARTICULAR FONT, STYLE, SIZE, OR COLOR.
FOR GAMING MACHINES THAT GENERATE OR DISPLAY WAGER OUTCOMES; GAMING SOFTWARE THAT GENERATES OR DISPLAYS WAGER OUTCOMES OF GAMING MACHINES (U.S. CLS. 21, 23, 26, 36 AND 38).
REGINA DRUMMOND, EXAMINING ATTORNEY

CLASS 9—(Continued).

SN 77-432,890. RIVERS, REBECCA, POLLOCK PINES, CA.
FILED 3-27-2008.

GEMERATIONS

THE MARK CONSISTS OF STANDARD CHARACTERS
WITHOUT CLAIM TO ANY PARTICULAR FONT, STYLE,
SIZE, OR COLOR.

FOR DIGITAL MATERIALS, NAMELY, DVDS FEATURING
COOKING WITH BOOKLET SOLD AS A UNIT (U.S. CLS. 21, 23, 26, 36 AND 38).

CURTIS FRENCH, EXAMINING ATTORNEY

SN 77-433,068. MELAMED, MICHAEL, RIVERSIDE, CA.
FILED 3-27-2008.

SALVADOR AND THE DOLLIES

THE MARK CONSISTS OF STANDARD CHARACTERS
WITHOUT CLAIM TO ANY PARTICULAR FONT, STYLE,
SIZE, OR COLOR.

FOR DOWNLOADABLE MUSICAL SOUND RECORDINGS ;
COMPACT DISCS FEATURING MUSIC (U.S. CLS. 21, 23, 26, 36 AND 38).

FIRST USE 2-29-2008; IN COMMERCE 2-29-2008.
PETER B. BROMAGHIM, EXAMINING ATTORNEY

SN 77-433,073. PIPPEN, PATTI LEE, BRONX, NY. FILED 3-27-2008.



THE STIPLING IS FOR SHADING PURPOSES ONLY.
FOR MOTION PICTURE FILMS ABOUT THE ENVIRONMENT (U.S. CLS. 21, 23, 26, 36 AND 38).

ANTHONY RINKER, EXAMINING ATTORNEY

CLASS 9—(Continued).

SN 77-433,296. WAI, LUI KA, KWUN TONG, HONG KONG,
FILED 3-27-2008.

CASEPAR

THE MARK CONSISTS OF STANDARD CHARACTERS
WITHOUT CLAIM TO ANY PARTICULAR FONT, STYLE,
SIZE, OR COLOR.

FOR PROTECTIVE CARRYING CASES FOR PORTABLE
MUSIC PLAYERS, NAMELY, MP3 PLAYERS; PROTECTIVE
CARRYING CASES SPECIALLY ADAPTED FOR PERSONAL
DIGITAL ASSISTANTS (PDA); PLASTIC CASE USED AS A
SECURITY DEVICE FOR PROTECTING AND SECURING
DVDS AND OTHER MAGNETIC AND ELECTRONIC MEDIA
FROM THEFT; SPECIALTY HOLSTER FOR CARRYING
IPODS, MP3 PLAYERS, MP4 PLAYERS AND PERSONAL
DIGITAL ASSISTANTS; LAPTOP CARRYING CASES;
COMPUTER CARRYING CASES; PROTECTIVE SLEEVES
FOR LAPTOP COMPUTERS; BAGS AND CASES SPECIALLY
ADAPTED FOR HOLDING OR CARRYING PORTABLE
TELEPHONES AND TELEPHONE EQUIPMENT AND
ACCESSORIES; CARRYING CASES FOR CELL PHONES;
CASES FOR MOBILE PHONES; CASES FOR DISKETTES
AND COMPACT DISKS; CASES FOR ELECTRONIC
DIARIES; COMPACT DISC CASES; DVD CASES;
SHIELD CASES FOR MAGNETIC DISKS; CAMERA CASES;
CASES FOR PHOTOGRAPHIC APPARATUS (U.S. CLS.
21, 23, 26, 36 AND 38).

REGINA DRUMMOND, EXAMINING ATTORNEY

SN 77-433,307. JONES EVOLUTIONS, LLC, WAIPAHU, HI.
FILED 3-27-2008.

It's a Keeper!

THE MARK CONSISTS OF STANDARD CHARACTERS
WITHOUT CLAIM TO ANY PARTICULAR FONT, STYLE,
SIZE, OR COLOR.

FOR DISTANCE MEASURING APPARATUS; INSTRUMENTS
FOR MEASURING LENGTH; MEASURING TAPES;
TAPE MEASURES; TAPE RULERS; TOOL MEASURING
INSTRUMENTS (U.S. CLS. 21, 23, 26, 36 AND 38).

LINDA LAVACHE, EXAMINING ATTORNEY

CLASS 9—(Continued).

SN 77-433,407. SAVE THE PLANET AND WIN LLC., WILMINGTON, DE. FILED 3-27-2008.

Click Green and Win

THE MARK CONSISTS OF STANDARD CHARACTERS WITHOUT CLAIM TO ANY PARTICULAR FONT, STYLE, SIZE, OR COLOR.

FOR COMPUTER SOFTWARE THAT ADMINISTERS AND SELLS POLLUTANT EMISSION REDUCTION CREDITS (U.S. CLS. 21, 23, 26, 36 AND 38).

MELVIN AXILBUND, EXAMINING ATTORNEY

SN 77-433,540. SHOREGROUP, INC., NEW YORK, NY. FILED 3-27-2008.

SEXTANT

THE MARK CONSISTS OF STANDARD CHARACTERS WITHOUT CLAIM TO ANY PARTICULAR FONT, STYLE, SIZE, OR COLOR.

FOR COMPUTER HARDWARE AND SOFTWARE FOR MANAGING NETWORKED APPLICATIONS, NAMELY, FOR ACQUISITION AND ANALYTICAL PROCESSING OF EXISTING APPLICATION DATA TO DERIVE ENHANCED RELATIONSHIPS, AND FOR PRESENTING ENHANCED RELATIONSHIPS AMONGST THE APPLICATION DATA (U.S. CLS. 21, 23, 26, 36 AND 38).

ANDREA SAUNDERS, EXAMINING ATTORNEY

SN 77-433,560. WMS GAMING INC., WAUKEGAN, IL. FILED 3-27-2008.

THE EYE OF HORUS

THE MARK CONSISTS OF STANDARD CHARACTERS WITHOUT CLAIM TO ANY PARTICULAR FONT, STYLE, SIZE, OR COLOR.

FOR GAMING MACHINES THAT GENERATE OR DISPLAY WAGER OUTCOMES; GAMING SOFTWARE THAT GENERATES OR DISPLAYS WAGER OUTCOMES OF GAMING MACHINES (U.S. CLS. 21, 23, 26, 36 AND 38).

REGINA DRUMMOND, EXAMINING ATTORNEY

CLASS 9—(Continued).

SN 77-433,574. SHOREGROUP, INC., NEW YORK, NY. FILED 3-27-2008.

EMERALD

THE MARK CONSISTS OF STANDARD CHARACTERS WITHOUT CLAIM TO ANY PARTICULAR FONT, STYLE, SIZE, OR COLOR.

FOR COMPUTER HARDWARE AND SOFTWARE FOR MANAGING NETWORKED APPLICATIONS, NAMELY, FOR ACQUISITION AND ANALYTICAL PROCESSING OF EXISTING APPLICATION DATA TO DERIVE ENHANCED RELATIONSHIPS, AND FOR PRESENTING ENHANCED RELATIONSHIPS AMONGST THE APPLICATION DATA (U.S. CLS. 21, 23, 26, 36 AND 38).

ANDREA SAUNDERS, EXAMINING ATTORNEY

SN 77-433,598. SHOREGROUP, INC., NEW YORK, NY. FILED 3-27-2008.

MARINER

THE MARK CONSISTS OF STANDARD CHARACTERS WITHOUT CLAIM TO ANY PARTICULAR FONT, STYLE, SIZE, OR COLOR.

FOR COMPUTER HARDWARE AND SOFTWARE FOR MANAGING NETWORKED APPLICATIONS, NAMELY, FOR ACQUISITION AND ANALYTICAL PROCESSING OF EXISTING APPLICATION DATA TO DERIVE ENHANCED RELATIONSHIPS, AND FOR PRESENTING ENHANCED RELATIONSHIPS AMONGST THE APPLICATION DATA (U.S. CLS. 21, 23, 26, 36 AND 38).

ANDREA SAUNDERS, EXAMINING ATTORNEY

SN 77-433,632. AKM ENTERPRISE, INC., HOUSTON, TX. FILED 3-27-2008.

DARP

THE MARK CONSISTS OF STANDARD CHARACTERS WITHOUT CLAIM TO ANY PARTICULAR FONT, STYLE, SIZE, OR COLOR.

FOR COMPUTER SOFTWARE FOR RETREIVAL, TRANSLATION AND DISTRIBUTION OF DATA ACROSS MULTIPLE FORMATS, OPTIMIZED FOR MANAGEMENT OF GEOGRAPHICALLY SEPARATE SOURCES AND USERS (U.S. CLS. 21, 23, 26, 36 AND 38). FIRST USE 2-1-2008; IN COMMERCE 2-1-2008.

CHARLOTTE CORWIN, EXAMINING ATTORNEY

CLASS 9—(Continued).

SN 77-433,638. PML WIRELESS, LLC, ATLANTA, GA. FILED 3-27-2008.

HAVE YOUR SAY

THE MARK CONSISTS OF STANDARD CHARACTERS WITHOUT CLAIM TO ANY PARTICULAR FONT, STYLE, SIZE, OR COLOR.

FOR MOBILE TELEPHONES; WIRELESS TELEPHONES; CELL PHONES; MOBILE/WIRELESS/CELL PHONE PRODUCTS, NAMELY, MOBILE TELEPHONE BATTERIES, MOBILE PHONE STRAPS, KEYBOARDS FOR MOBILE PHONES, WIRELESS TELEPHONY APPARATUS, CELL PHONE COVERS, CELL PHONE BATTERY CHARGERS, CELL PHONE BATTERY CHARGERS FOR USE IN VEHICLES (U.S. CLS. 21, 23, 26, 36 AND 38).

ELISSA GARBER KON, EXAMINING ATTORNEY

SN 77-433,712. PML WIRELESS, LLC, ATLANTA, GA. FILED 3-27-2008.

YOUR TERMS. YOUR WAY.

THE MARK CONSISTS OF STANDARD CHARACTERS WITHOUT CLAIM TO ANY PARTICULAR FONT, STYLE, SIZE, OR COLOR.

FOR MOBILE TELEPHONES; WIRELESS TELEPHONES; CELL PHONES; MOBILE/WIRELESS/CELL PHONE PRODUCTS, NAMELY, MOBILE TELEPHONE BATTERIES, MOBILE PHONE STRAPS, KEYBOARDS FOR MOBILE PHONES, WIRELESS TELEPHONY APPARATUS, CELL PHONE COVERS, CELL PHONE BATTERY CHARGERS, CELL PHONE BATTERY CHARGERS FOR USE IN VEHICLES (U.S. CLS. 21, 23, 26, 36 AND 38).

ELISSA GARBER KON, EXAMINING ATTORNEY

SN 77-433,790. ER ASSETS, LP, FT. LAUDERDALE, FL. FILED 3-27-2008.

BACKFIRE

THE MARK CONSISTS OF STANDARD CHARACTERS WITHOUT CLAIM TO ANY PARTICULAR FONT, STYLE, SIZE, OR COLOR.

FOR ELECTRONIC PUBLICATIONS, NAMELY, MAGAZINE DIRECTED TO READERS AND VIEWERS INTERESTED IN AUTOMOBILE RESTORATION AND AUTOMOBILE CUSTOMIZATION, RECORDED ON COMPUTER MEDIA (U.S. CLS. 21, 23, 26, 36 AND 38).

STEVEN R. FINE, EXAMINING ATTORNEY

CLASS 9—(Continued).

SN 77-433,897. FANROCKET, LLC, WEST HOLLYWOOD, CA. FILED 3-27-2008.

VOOZOO

THE MARK CONSISTS OF STANDARD CHARACTERS WITHOUT CLAIM TO ANY PARTICULAR FONT, STYLE, SIZE, OR COLOR.

FOR COMPUTER SOFTWARE, NAMELY, APPLICATIONS ENABLING UPLOADING, POSTING, SHOWING, DISPLAYING, TAGGING, BLOGGING, MANAGING, SHARING OR OTHERWISE PROVIDING ELECTRONIC MEDIA OR INFORMATION OVER THE INTERNET OR OTHER COMMUNICATIONS NETWORK, INCLUDING VIA MOBILE DEVICES; SOFTWARE DEVELOPMENT TOOLS FOR THE CREATION OF MOBILE AND INTERNET APPLICATIONS AND CLIENT INTERFACES (U.S. CLS. 21, 23, 26, 36 AND 38).

ALICE SUE CARRUTHERS, EXAMINING ATTORNEY

SN 77-434,103. PACIFIC LINK TRADE USA, INC., DALTON, GA. FILED 3-28-2008.



OWNER OF U.S. REG. NOS. 3,042,689, 3,392,413 AND OTHERS.

THE MARK CONSISTS OF THE STYLIZED NUMBER "8", WHEREIN "E" SHAPED ELEMENTS EXTEND OUTWARDLY AND UPWARDLY FROM THE "8" ON EITHER SIDE.

FOR SUNGLASSES (U.S. CLS. 21, 23, 26, 36 AND 38). FIRST USE 1-0-2008; IN COMMERCE 1-0-2008.

GEOFFREY FOSDICK, EXAMINING ATTORNEY

SN 77-434,131. ECONOMIC ANALYSIS GROUP, LTD., WASHINGTON, DC. FILED 3-28-2008.

CounselDirect

THE MARK CONSISTS OF STANDARD CHARACTERS WITHOUT CLAIM TO ANY PARTICULAR FONT, STYLE, SIZE, OR COLOR.

FOR COMPUTER SOFTWARE FOR TRACKING LEGAL FEES AND LEGAL SERVICES FEES AND COSTS, MONITORING BUDGETS, AND ELECTRONIC BILLING OF LEGAL SERVICES AND SERVICES PROVIDED IN CONNECTION WITH LEGAL MATTERS (U.S. CLS. 21, 23, 26, 36 AND 38).

FIRST USE 3-28-2007; IN COMMERCE 4-6-2007.

KATHY DE JONGE, EXAMINING ATTORNEY

CLASS 9—(Continued).

SN 77-434,256. ALPAQUA ENGINEERING, LLC, MAGNOLIA, MA. FILED 3-28-2008.

ALPAQUA

THE MARK CONSISTS OF STANDARD CHARACTERS WITHOUT CLAIM TO ANY PARTICULAR FONT, STYLE, SIZE, OR COLOR.

FOR LABORATORY EQUIPMENT AND SUPPLIES, NAMELY, APPARATUS HOLDING OR MANIPULATING SAMPLE CONTAINERS, AND CONSUMABLES, NAMELY, REAGENT RESERVOIRS (U.S. CLS. 21, 23, 26, 36 AND 38).

DAVID MURRAY, EXAMINING ATTORNEY

SN 77-434,324. EDWARDS, JUDITH, SELMA, AL. AND GIFFORD, CHRISTOPHER D, CHELSEA, AL. AND LAYCOCK, WILLIAM, BIRMINGHAM, AL. FILED 3-28-2008.

Bunko Bucks

THE MARK CONSISTS OF STANDARD CHARACTERS WITHOUT CLAIM TO ANY PARTICULAR FONT, STYLE, SIZE, OR COLOR.

NO CLAIM IS MADE TO THE EXCLUSIVE RIGHT TO USE "BUNKO", APART FROM THE MARK AS SHOWN.

FOR MACHINES FOR PLAYING GAMES OF CHANCE (U.S. CLS. 21, 23, 26, 36 AND 38).

PAUL F. GAST, EXAMINING ATTORNEY

SN 77-434,326. ROADCOMM, INC., DBA LIFEINPOCKET, CUPERTINO, CA. FILED 3-28-2008.

LifeInPocket

THE MARK CONSISTS OF STANDARD CHARACTERS WITHOUT CLAIM TO ANY PARTICULAR FONT, STYLE, SIZE, OR COLOR.

FOR CELL PHONES; CELLULAR PHONES; COMPUTER APPLICATION SOFTWARE FOR MOBILE PHONES; COMPUTER SOFTWARE TO ENABLE THE TRANSMISSION OF PHOTOGRAPHS TO MOBILE TELEPHONES; COMPUTER SOFTWARE, NAMELY, AN APPLICATION ALLOWING SALES AND FIELD SERVICE EMPLOYEES TO UPDATE AND RECEIVE DATA STORED IN AN ENTERPRISE'S COMPUTER DATABASES IN REAL TIME, USING A MOBILE DEVICE, WITH FULL TELEPHONY INTEGRATION WITH THE TELEPHONE AND/OR SOFTWARE FEATURES OF THE MOBILE DEVICE; COMPUTER SOFTWARE, NAMELY, SOFTWARE DEVELOPMENT TOOLS FOR THE CREATION OF MOBILE INTERNET APPLICATIONS AND CLIENT INTERFACES; MOBILE COMPUTERS; MOBILE PHONES; INTERNET PHONES; INTERNET SERVERS; COMPUTER PROGRAMS FOR USING THE INTERNET AND THE WORLD WIDE WEB; WIRELESS TELEPHONES; COM-

CLASS 9—(Continued).

PUTER HARDWARE, NAMELY, WIRELESS ACCESS POINT (WAP) DEVICES; COMPUTER PROGRAMS FOR USING THE INTERNET AND THE WORLDWIDE WEB; COMPUTER SOFTWARE FOR WIRELESS CONTENT DELIVERY; CONTINGENCY RESPONSE COMMUNICATION SYSTEM DESIGNED TO PROVIDE RADIO INTEROPERABILITY, STREAMING VIDEO, WIRELESS INTERNET, AND VOIP PHONE; PERSONAL DIGITAL ASSISTANTS (PDA); PROTECTIVE CARRYING CASES SPECIALLY ADAPTED FOR PERSONAL DIGITAL ASSISTANTS (PDA); COMMUNICATIONS SERVERS; INTRANET SERVERS; NETWORK ACCESS SERVER OPERATING SOFTWARE; SOFTWARE UTILIZING BIDIRECTIONAL COMMUNICATION VIA ETHERNET AND INTERNET TO MONITOR AND/OR CONFIGURE PROGRAMMABLE LOGIC CONTROLS FOR WINE CELLARS; AVIONIC SENSOR SYSTEMS, NAMELY, NAVIGATION SYSTEMS; CAR NAVIGATION COMPUTERS; ELECTRIC NAVIGATIONAL INSTRUMENTS; ELECTRONIC NAVIGATIONAL AND POSITIONING APPARATUS AND INSTRUMENTS; NAVIGATION APPARATUS FOR VEHICLES; NAVIGATION APPARATUS FOR VEHICLES IN THE NATURE OF ON-BOARD COMPUTERS; NAVIGATIONAL BUOYS; SATELLITE NAVIGATIONAL SYSTEM, NAMELY, A GLOBAL POSITIONING SYSTEM (GPS); PORTABLE TELECOMMUNICATION INSTANT MESSAGING DEVICES (U.S. CLS. 21, 23, 26, 36 AND 38).

FIRST USE 10-1-2006; IN COMMERCE 10-7-2007.
RENEE MCCRAY, EXAMINING ATTORNEY

SN 77-434,329. FANROCKET, LLC, WEST HOLLYWOOD, CA. FILED 3-28-2008.

VOOHOO

THE MARK CONSISTS OF STANDARD CHARACTERS WITHOUT CLAIM TO ANY PARTICULAR FONT, STYLE, SIZE, OR COLOR.

FOR COMPUTER SOFTWARE, NAMELY, APPLICATIONS ENABLING UPLOADING, POSTING, SHOWING, DISPLAYING, TAGGING, BLOGGING, MANAGING, SHARING OR OTHERWISE PROVIDING ELECTRONIC MEDIA OR INFORMATION OVER THE INTERNET OR OTHER COMMUNICATIONS NETWORK, INCLUDING VIA MOBILE DEVICES; SOFTWARE DEVELOPMENT TOOLS FOR THE CREATION OF MOBILE AND INTERNET APPLICATIONS AND CLIENT INTERFACES (U.S. CLS. 21, 23, 26, 36 AND 38).

ALICE SUE CARRUTHERS, EXAMINING ATTORNEY

SN 77-434,574. DYNETICS, INC., HUNTSVILLE, AL. FILED 3-28-2008.

INTELLIWRIter

THE MARK CONSISTS OF STANDARD CHARACTERS WITHOUT CLAIM TO ANY PARTICULAR FONT, STYLE, SIZE, OR COLOR.

FOR COMPUTER SOFTWARE PROGRAM, NAMELY, A WORD PROCESSING PROGRAM FOR THE GENERATION OF CLASSIFIED DOCUMENTS AND INTELLIGENCE REPORTS (U.S. CLS. 21, 23, 26, 36 AND 38).

KRISTIN CARLSON, EXAMINING ATTORNEY

CLASS 9—(Continued).

SN 77-434,620. ABB AB, VÄSTERÅS, SWEDEN, FILED 3-28-2008.

ROBOTCOACH

THE MARK CONSISTS OF STANDARD CHARACTERS WITHOUT CLAIM TO ANY PARTICULAR FONT, STYLE, SIZE, OR COLOR.

FOR COMPUTER SOFTWARE FOR THE PROGRAMMING AND OPERATION OF AUTOMATED MACHINES (U.S. CLS. 21, 23, 26, 36 AND 38).

JAMES LOVELACE, EXAMINING ATTORNEY

SN 77-434,803. SILVERLINX CORPORATION, WYLIE, TX. FILED 3-28-2008.

SILVERLINX

THE MARK CONSISTS OF STANDARD CHARACTERS WITHOUT CLAIM TO ANY PARTICULAR FONT, STYLE, SIZE, OR COLOR.

FOR COMPUTER SOFTWARE FOR PROVIDING DIGITAL/ELECTRONIC SIGNATURES; COMPUTER SOFTWARE IN THE FIELD OF FINANCIAL DATA PROCESSING AND TRANSACTIONS (U.S. CLS. 21, 23, 26, 36 AND 38).

JOHN GARTNER, EXAMINING ATTORNEY

SN 77-434,917. COULL, THOMAS B, MORAGA, CA. FILED 3-28-2008.

FENCENOTES

THE MARK CONSISTS OF STANDARD CHARACTERS WITHOUT CLAIM TO ANY PARTICULAR FONT, STYLE, SIZE, OR COLOR.

FOR COMPUTER PROGRAMS FOR USING THE INTERNET AND THE WORLD WIDE WEB (U.S. CLS. 21, 23, 26, 36 AND 38).

KAELIE KUNG, EXAMINING ATTORNEY

CLASS 9—(Continued).

SN 77-436,485. LIBERTY HARDWARE MFG. CORP., WINSTON-SALEM, NC. FILED 4-1-2008.

SENSITIVE LIVING SYSTEMS

THE MARK CONSISTS OF STANDARD CHARACTERS WITHOUT CLAIM TO ANY PARTICULAR FONT, STYLE, SIZE, OR COLOR.

NO CLAIM IS MADE TO THE EXCLUSIVE RIGHT TO USE "SYSTEMS", APART FROM THE MARK AS SHOWN.

FOR ELECTROTECHNICAL AND ELECTRONIC APPARATUS, DEVICES AND INSTRUMENTS, NAMELY, SENSOR TRANSMITTING MODULES, TRANSCEIVER MODULES FOR RADIO SYSTEMS, REPEATER MODULES FOR RADIO SYSTEMS, RECEIVER MODULES FOR RADIO SYSTEMS, RADIO TRANSMITTERS, EVALUATION BOARDS FOR RECEIVER MODULES AND TRANSMITTER MODULES; RADIO CONTROLLED SWITCHES, LIGHTING TRANSCEIVER CONSOLES, PROGRAMMABLE LIGHTING TRANSCEIVER CONSOLES, UTILITY UTILIZATION MONITORS, SECURITY CONTACT TRANSMITTERS, SECURITY ALARM TRANSCEIVERS, OCCUPANCY SENSORS, MOTION SENSORS, KEY CARD OCCUPANCY SENSORS, REMOTE LIQUID FLOW SENSORS, REMOTE GAS FLOW SENSORS, REMOTE TEMPERATURE SENSORS, AND REMOTE ELECTRIC WATT USAGE SENSORS, RADIO STATUS TRANSCEIVERS, APPLIANCE CONTROLS, LIGHTING CONTROLS, BUILDING SYSTEM MONITORS, LIGHT DIMMERS, HVAC SENSORS AND CONTROLS (U.S. CLS. 21, 23, 26, 36 AND 38).

HELENE LIWINSKI, EXAMINING ATTORNEY

SN 77-437,112. SANDLOT GAMES CORPORATION, BOTHELL, WA. FILED 4-1-2008.

Cake Mania: Batter Up!

THE MARK CONSISTS OF STANDARD CHARACTERS WITHOUT CLAIM TO ANY PARTICULAR FONT, STYLE, SIZE, OR COLOR.

OWNER OF U.S. REG. NO. 3,263,179.

FOR COMPUTER GAME PROGRAMS; COMPUTER GAME SOFTWARE; ELECTRONIC GAME PROGRAMS; ELECTRONIC GAME SOFTWARE; INTERACTIVE MULTIMEDIA COMPUTER GAME PROGRAM; INTERACTIVE VIDEO GAME PROGRAMS; VIDEO AND COMPUTER GAME PROGRAMS; VIDEO GAME SOFTWARE (U.S. CLS. 21, 23, 26, 36 AND 38).

DAVID YONTEF, EXAMINING ATTORNEY

CLASS 9—(Continued).

SN 77-437,300. EARHUGGER, INC., LINDON, UT. FILED 4-1-2008.

WICKED AUDIO

THE MARK CONSISTS OF STANDARD CHARACTERS WITHOUT CLAIM TO ANY PARTICULAR FONT, STYLE, SIZE, OR COLOR.

NO CLAIM IS MADE TO THE EXCLUSIVE RIGHT TO USE "AUDIO", APART FROM THE MARK AS SHOWN.

FOR HEADPHONES; EARPHONES; PORTABLE DVD PLAYERS; PORTABLE LISTENING DEVICES; NAMELY, MP3 PLAYERS; PORTABLE MEDIA PLAYERS; PORTABLE RADIOS; PORTABLE TELECOMMUNICATION INSTANT MESSAGING DEVICES; PORTABLE TELEPHONES (U.S. CLS. 21, 23, 26, 36 AND 38).

RONALD MCMORROW, EXAMINING ATTORNEY

CLASS 9—(Continued).

SN 77-438,888. WMS GAMING INC., WAUKEGAN, IL. FILED 4-3-2008.

XERXES

THE MARK CONSISTS OF STANDARD CHARACTERS WITHOUT CLAIM TO ANY PARTICULAR FONT, STYLE, SIZE, OR COLOR.

FOR GAMING MACHINES THAT GENERATE OR DISPLAY WAGER OUTCOMES; GAMING SOFTWARE THAT GENERATES OR DISPLAYS WAGER OUTCOMES OF GAMING MACHINES (U.S. CLS. 21, 23, 26, 36 AND 38).

REGINA DRUMMOND, EXAMINING ATTORNEY

SN 77-437,488. WMS GAMING INC., WAUKEGAN, IL. FILED 4-2-2008.

RETURN TO PLANET LOOT

THE MARK CONSISTS OF STANDARD CHARACTERS WITHOUT CLAIM TO ANY PARTICULAR FONT, STYLE, SIZE, OR COLOR.

FOR GAMING MACHINES THAT GENERATE OR DISPLAY WAGER OUTCOMES; GAMING SOFTWARE THAT GENERATES OR DISPLAYS WAGER OUTCOMES OF GAMING MACHINES (U.S. CLS. 21, 23, 26, 36 AND 38).

REGINA DRUMMOND, EXAMINING ATTORNEY



SN 77-438,975. IOLO TECHNOLOGIES, LLC, LOS ANGELES, CA. FILED 4-3-2008.

SN 77-438,876. WMS GAMING INC., WAUKEGAN, IL. FILED 4-3-2008.

MAORI RICHES

THE MARK CONSISTS OF STANDARD CHARACTERS WITHOUT CLAIM TO ANY PARTICULAR FONT, STYLE, SIZE, OR COLOR.

FOR GAMING MACHINES THAT GENERATE OR DISPLAY WAGER OUTCOMES; GAMING SOFTWARE THAT GENERATES OR DISPLAYS WAGER OUTCOMES OF GAMING MACHINES (U.S. CLS. 21, 23, 26, 36 AND 38).

REGINA DRUMMOND, EXAMINING ATTORNEY

THE COLOR(S) BLACK, WHITE, GRAY, RED, AND GREEN IS/ARE CLAIMED AS A FEATURE OF THE MARK.

THE MARK CONSISTS OF A CIRCULAR GAUGE DESIGN OUTLINED IN GRAY WITH AN INNER RING OF WHITE. WITHIN THE GRAY AND WHITE CIRCLES, THERE ARE THREE INDIVIDUAL GAUGES, ONE LARGE AND TWO SMALL, ALL OF WHICH ARE IDENTICAL IN STYLE AND COLOR. THE BACKGROUND OF THE GAUGES IS BLACK. THE INDICATOR NEEDLES ARE RED, EXTENDING FROM A GRAY CIRCLE WITH WHITE SHADING. THE ARCHED INDICATOR PORTION OF THE GAUGES IS DIVIDED INTO FOUR SECTIONS WITH THE LEFT-MOST SECTION BEING RED AND FADING TO GREEN IN THE RIGHT-MOST SECTION. THE INTERIM SECTIONS ARE A COMBINATION OF RED COMBINED WITH GREEN, WITH RED BEING THE PREDOMINANT SHADE IN THE LEFT INNER PORTION AND GREEN BEING THE PREDOMINANT SHADE IN THE RIGHT INNER PORTION.

FOR COMPUTER SOFTWARE, NAMELY, COMPUTER SOFTWARE PROVIDING UTILITY PROGRAMS FOR ASSURING THE EFFICIENT MAINTENANCE AND OPERATION OF OPERATING SYSTEMS (U.S. CLS. 21, 23, 26, 36 AND 38).

FIRST USE 3-7-2008; IN COMMERCE 3-7-2008.

KAREN SEVERSON, EXAMINING ATTORNEY

CLASS 9—(Continued).

SN 77-439,216. GENERAL ELECTRIC COMPANY, SCHE-
NECTADY, NY. FILED 4-3-2008.

TRACKPANEL

THE MARK CONSISTS OF STANDARD CHARACTERS
WITHOUT CLAIM TO ANY PARTICULAR FONT, STYLE,
SIZE, OR COLOR.

FOR CIRCUIT BREAKER PANEL BOARDS (U.S. CLS.
21, 23, 26, 36 AND 38).

JUDITH HELFMAN, EXAMINING ATTORNEY

CLASS 9—(Continued).

SN 77-439,981. PG MUSIC INC., VICTORIA, CANADA,
FILED 4-4-2008.

GuitarTouch

THE MARK CONSISTS OF STANDARD CHARACTERS
WITHOUT CLAIM TO ANY PARTICULAR FONT, STYLE,
SIZE, OR COLOR.

FOR COMPUTER SOFTWARE FOR INTERACTIVE
MULTIMEDIA GUITAR INSTRUCTION AND MUSICAL
GAMES (U.S. CLS. 21, 23, 26, 36 AND 38).

SANDRA MANIOS, EXAMINING ATTORNEY

SN 77-439,321. ARROW PRODUCTIONS, LTD., LAS VEGAS,
NV. FILED 4-3-2008.

CANDY STRIPERS

THE MARK CONSISTS OF STANDARD CHARACTERS
WITHOUT CLAIM TO ANY PARTICULAR FONT, STYLE,
SIZE, OR COLOR.

FOR PRERECORDED VIDEO CASSETTES AND DIGI-
TAL VIDEO DISCS FEATURING ADULT ENTERTAIN-
MENT (U.S. CLS. 21, 23, 26, 36 AND 38).

FIRST USE 12-26-1978; IN COMMERCE 12-26-1978.

WILLIAM P. SHANAHAN, EXAMINING ATTORNEY

SN 77-441,944. WMS GAMING INC., WAUKEGAN, IL.
FILED 4-7-2008.

EYE OF THE DRAGON

THE MARK CONSISTS OF STANDARD CHARACTERS
WITHOUT CLAIM TO ANY PARTICULAR FONT, STYLE,
SIZE, OR COLOR.

FOR GAMING MACHINES THAT GENERATE OR
DISPLAY WAGER OUTCOMES; GAMING SOFTWARE
THAT GENERATES OR DISPLAYS WAGER OUTCOMES
OF GAMING MACHINES (U.S. CLS. 21, 23, 26, 36 AND
38).

REGINA DRUMMOND, EXAMINING ATTORNEY

SN 77-439,891. EMERSON ELECTRIC CO., ST. LOUIS, MO.
FILED 4-4-2008.

GreenDrive

THE MARK CONSISTS OF STANDARD CHARACTERS
WITHOUT CLAIM TO ANY PARTICULAR FONT, STYLE,
SIZE, OR COLOR.

FOR ELECTRONIC CONTROLS FOR MOTORS (U.S.
CLS. 21, 23, 26, 36 AND 38).

GINA FINK, EXAMINING ATTORNEY

SN 77-441,955. WMS GAMING INC., WAUKEGAN, IL.
FILED 4-7-2008.

WILD WILD SAFARI

THE MARK CONSISTS OF STANDARD CHARACTERS
WITHOUT CLAIM TO ANY PARTICULAR FONT, STYLE,
SIZE, OR COLOR.

FOR GAMING MACHINES THAT GENERATE OR
DISPLAY WAGER OUTCOMES; GAMING SOFTWARE
THAT GENERATES OR DISPLAYS WAGER OUTCOMES
OF GAMING MACHINES (U.S. CLS. 21, 23, 26, 36 AND
38).

REGINA DRUMMOND, EXAMINING ATTORNEY

CLASS 9—(Continued).

SN 77-443,471. LI SHERRY HAIXIA, MIAMI, FL. FILED 4-9-2008.



THE MARK CONSISTS OF LETTERS "BOOGALOO". FOR EYEGLOSS CHAINS; EYEGLOSS CORDS; EYEGLOSS FRAMES; EYEGASSES; CORRECTIVE GLASSES; CONTACT LENSES; CONTAINERS FOR CONTACT LENSES; SPECTACLE CASES; SPECTACLE LENSES; OPTICAL LENSES; SUNGLASSES (U.S. CLS. 21, 23, 26, 36 AND 38).

JULIE GUTTADAURO, EXAMINING ATTORNEY

CLASS 9—(Continued).

SN 77-444,755. TRIUMFANT, INC., ROCKVILLE, MD. FILED 4-10-2008.



OWNER OF U.S. REG. NOS. 3,315,665 AND 3,315,666. NO CLAIM IS MADE TO THE EXCLUSIVE RIGHT TO USE "IT INTELLIGENCE", APART FROM THE MARK AS SHOWN.

THE COLOR(S) YELLOW, GREEN, BLUE, AND BLACK IS/ARE CLAIMED AS A FEATURE OF THE MARK.

THE MARK CONSISTS OF THE WORD "TRIUMFANT", APPEARING IN BLACK, AND BENEATH IT, THE WORDS "IT INTELLIGENCE" IN BLUE, PLUS A DESIGN OF FIVE BARS APPEARING TO THE LEFT OF "TRIUMFANT", INCREASING IN SIZE FROM LEFT TO RIGHT, THE FIRST, YELLOW, THE SECOND, DARK GREEN, THE THIRD, LIGHTER GREEN, THE FOURTH, LIGHT BLUE, AND THE FIFTH, DARK BLUE.

FOR COMPUTER SOFTWARE PLATFORMS FOR COLLECTING, PROCESSING, AND ANALYZING DATA FROM IT SYSTEM COMPONENTS' OPERATION, IDENTIFYING AND DIAGNOSING UNDESIRABLE EVENTS IN SYSTEMS' OPERATION AND FUNCTIONING, AND GENERATING REMEDIATION RESPONSES THAT AUTOMATICALLY REPAIR THE IDENTIFIED UNDESIRABLE STATES (U.S. CLS. 21, 23, 26, 36 AND 38).

SUE LAWRENCE, EXAMINING ATTORNEY

SN 77-444,214. U.S. VISION, INC., GLENDORA, NJ. FILED 4-9-2008.



THE COLOR(S) BLACK AND RED IS/ARE CLAIMED AS A FEATURE OF THE MARK.

THE MARK CONSISTS OF A BLACK UPPER CASE LETTER "I", A BLACK DOT, AN UPPER CASE BLACK "S", A LOWER CASE RED "O" IN A SLANTED POSITION, AND A LOWER CASE BLACK "O" IN A SLANTED POSITION.

FOR SUNGLASSES; EYEWEAR; EYEWEAR ACCESSORIES, NAMELY, STRAPS, NECK CORDS AND HEAD STRAPS WHICH RESTRAIN EYEWEAR FROM MOVEMENT ON A WEARER; EYEWEAR CASES; EYEGLASSES (U.S. CLS. 21, 23, 26, 36 AND 38).

LINDA POWELL, EXAMINING ATTORNEY

SN 77-444,943. TWO TECHNOLOGIES, INC., HORSHAM, PA. FILED 4-10-2008.



THE MARK CONSISTS OF STANDARD CHARACTERS WITHOUT CLAIM TO ANY PARTICULAR FONT, STYLE, SIZE, OR COLOR.

FOR COMPUTER HARDWARE, NAMELY, A HANDHELD OPERATOR INTERFACE WITH BUILT-IN CAMERA; COMPUTER HARDWARE, NAMELY, A HANDHELD DATA PROCESSOR WITH BUILT-IN CAMERA (U.S. CLS. 21, 23, 26, 36 AND 38).

KRISTINA MORRIS, EXAMINING ATTORNEY

CLASS 9—(Continued).

SN 77-446,283. SONY ERICSSON MOBILE COMMUNICATIONS AB, LUND, SWEDEN, FILED 4-11-2008.

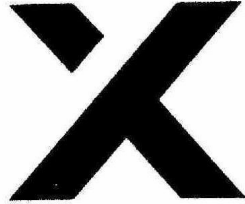

FOR A FEATURE FOUND ON CELLULAR OR MOBILE PHONES THAT ENABLES USERS TO ACCESS COMMONLY USED APPLICATIONS ON THE PHONES (U.S. CLS. 21, 23, 26, 36 AND 38).

HOWARD FRIEDMAN, EXAMINING ATTORNEY

SN 77-447,024. KONAMI AUSTRALIA PTY LTD, BOTANY, AUSTRALIA, FILED 4-14-2008.

SAMURAI PRINCESS

THE MARK CONSISTS OF STANDARD CHARACTERS WITHOUT CLAIM TO ANY PARTICULAR FONT, STYLE, SIZE, OR COLOR.

FOR ELECTRONIC GAME PROGRAMS; GAMING EQUIPMENT, NAMELY, SLOT MACHINES WITH OR WITHOUT VIDEO OUTPUT; GAMING MACHINES; MACHINES FOR PLAYING GAMES OF CHANCE; SLOT MACHINES (U.S. CLS. 21, 23, 26, 36 AND 38).

JOHN WILKE, EXAMINING ATTORNEY

SN 77-447,596. NOVINT TECHNOLOGIES, INC., ALBUQUERQUE, NM. FILED 4-14-2008.

NOVINT FALCON

THE MARK CONSISTS OF STANDARD CHARACTERS WITHOUT CLAIM TO ANY PARTICULAR FONT, STYLE, SIZE, OR COLOR.

OWNER OF U.S. REG. NO. 2,512,087.

FOR COMPUTER SYSTEMS AND PERIPHERALS, NAMELY, COMPUTER GAMING MACHINES ADAPTED FOR USE WITH AN EXTERNAL DISPLAY SCREEN OR MONITOR, COMPUTER GAME CONSOLES ADAPTED FOR USE WITH AN EXTERNAL DISPLAY SCREEN OR MONITOR, AND COMPUTER SOFTWARE FOR OPERATING ANY OF THE FOREGOING (U.S. CLS. 21, 23, 26, 36 AND 38).

AMEETA JORDAN, EXAMINING ATTORNEY

CLASS 9—(Continued).

SN 77-448,795. DUB SOFTWARE GROUP, INC., DBA AUTO-FILEPRO, PELHAM, NY. FILED 4-15-2008.

Documents that file themselves

THE MARK CONSISTS OF STANDARD CHARACTERS WITHOUT CLAIM TO ANY PARTICULAR FONT, STYLE, SIZE, OR COLOR.

FOR COMPUTER PROGRAMMES FOR DOCUMENT MANAGEMENT; COMPUTER PROGRAMS FOR AUTOMATED FILING AND RETRIEVAL OF DOCUMENTS AND ASSOCIATED DATA CONSISTING OF SCANNED IMAGES, IMPORTED FILES, CAPTURED DATA AND REFERENCE DATA; COMPUTER SOFTWARE FOR CREATING SEARCHABLE DATABASES OF INFORMATION AND DATA; COMPUTER SOFTWARE FOR THE COLLECTION, EDITING, ORGANIZING, MODIFYING, BOOK MARKING, TRANSMISSION, STORAGE AND SHARING OF DATA AND INFORMATION; COMPUTER SOFTWARE FOR AUTOMATED FILING AND RETRIEVAL OF DOCUMENTS AND ASSOCIATED DATA CONSISTING OF SCANNED IMAGES, IMPORTED FILES, CAPTURED DATA AND REFERENCE DATA; DATABASE MANAGEMENT SOFTWARE FOR AUTOMATED FILING AND RETRIEVAL OF DOCUMENTS AND ASSOCIATED DATA CONSISTING OF SCANNED IMAGES, IMPORTED FILES, CAPTURED DATA AND REFERENCE DATA; COMPUTER SOFTWARE TO AUTOMATE DATA WAREHOUSING; COMPUTER GROUPWARE FOR AUTOMATED FILING AND RETRIEVAL OF DOCUMENTS AND ASSOCIATED DATA CONSISTING OF SCANNED IMAGES, IMPORTED FILES, CAPTURED DATA AND REFERENCE DATA; ELECTRONIC DATABASE IN THE FIELD OF AUTOMATED FILING AND RETRIEVAL OF DOCUMENTS AND ASSOCIATED DATA CONSISTING OF SCANNED IMAGES, IMPORTED FILES, CAPTURED DATA AND REFERENCE DATA RECORDED ON COMPUTER MEDIA (U.S. CLS. 21, 23, 26, 36 AND 38).

ANNE FARRELL, EXAMINING ATTORNEY

SN 77-451,140. WMS GAMING INC., WAUKEGAN, IL. FILED 4-17-2008.

MAGIC TIME

THE MARK CONSISTS OF STANDARD CHARACTERS WITHOUT CLAIM TO ANY PARTICULAR FONT, STYLE, SIZE, OR COLOR.

FOR GAMING MACHINES THAT GENERATE OR DISPLAY WAGER OUTCOMES; GAMING SOFTWARE THAT GENERATES OR DISPLAYS WAGER OUTCOMES OF GAMING MACHINES (U.S. CLS. 21, 23, 26, 36 AND 38).

REGINA DRUMMOND, EXAMINING ATTORNEY

CLASS 9—(Continued).

SN 77-452,120. GENERAL MOTORS CORPORATION, DETROIT, MI. FILED 4-18-2008.



THE MARK CONSISTS OF THE DESIGN OF A HOUSE WITH THE GARAGE DOOR HALF WAY OPENED.

FOR WIRELESS CONTROL DEVICES, INTEGRATED INTO VEHICLES, FOR ACTIVATION OF GARAGE DOOR OPENERS, GATES, ENTRY DOOR LOCKS, INTERIOR AND EXTERIOR LIGHTING, SECURITY SYSTEMS, HEATING AND COOLING SYSTEMS AND ELECTRICAL APPLIANCES (U.S. CLS. 21, 23, 26, 36 AND 38).

NANCY CLARKE, EXAMINING ATTORNEY

SN 77-453,245. MICRON TECHNOLOGY, INC., BOISE, ID. FILED 4-21-2008.

CellularRAM

OWNER OF U.S. REG. NOS. 3,266,728 AND 3,266,741. THE MARK CONSISTS OF THE WORD "CELLULARRAM" IN STYLIZED FONT WITH A SERIES OF DOTS ABOVE THE WORD.

SEC. 2(F) AS TO "CELLULARRAM" FOR SEMICONDUCTOR DEVICES (U.S. CLS. 21, 23, 26, 36 AND 38).

FIRST USE 3-4-2003; IN COMMERCE 3-4-2003. KEVIN DINALLO, EXAMINING ATTORNEY

SN 77-454,260. OCLC ONLINE COMPUTER LIBRARY CENTER, INC., DUBLIN, OH. FILED 4-22-2008.

WORLDCAT NAVIGATOR

THE MARK CONSISTS OF STANDARD CHARACTERS WITHOUT CLAIM TO ANY PARTICULAR FONT, STYLE, SIZE, OR COLOR.

OWNER OF U.S. REG. NO. 2,194,670. FOR INTERLIBRARY LOAN COMPUTER SOFTWARE (U.S. CLS. 21, 23, 26, 36 AND 38).

DAYNA BROWNE, EXAMINING ATTORNEY

CLASS 9—(Continued).

SN 77-454,870. PLAYFIRST, INC., SAN FRANCISCO, CA. FILED 4-22-2008.

Dash

THE MARK CONSISTS OF STANDARD CHARACTERS WITHOUT CLAIM TO ANY PARTICULAR FONT, STYLE, SIZE, OR COLOR.

FOR COMPUTER GAME SOFTWARE; ELECTRONIC GAME SOFTWARE; GAME SOFTWARE; VIDEO GAME SOFTWARE (U.S. CLS. 21, 23, 26, 36 AND 38).

MATTHEW PAPPAS, EXAMINING ATTORNEY

SN 77-455,343. AINSWORTH GAME TECHNOLOGY LIMITED, NEWINGTON, AUSTRALIA, FILED 4-23-2008.

Empress and Warrior

THE MARK CONSISTS OF STANDARD CHARACTERS WITHOUT CLAIM TO ANY PARTICULAR FONT, STYLE, SIZE, OR COLOR.

FOR COMPUTER SOFTWARE AND FIRMWARE FOR GAMES OF CHANCE ON ANY COMPUTERIZED PLATFORM, INCLUDING DEDICATED GAMING CONSOLES, VIDEO BASED SLOT MACHINES, REEL BASED SLOT MACHINES, AND VIDEO LOTTERY TERMINALS; GAMING EQUIPMENT, NAMELY, SLOT MACHINES WITH OR WITHOUT VIDEO OUTPUT (U.S. CLS. 21, 23, 26, 36 AND 38).

STEVEN PEREZ, EXAMINING ATTORNEY

SN 77-455,931. MANAGING EDITOR INC., DBA MEI, JENKINTOWN, PA. FILED 4-23-2008.

JumpStory

THE MARK CONSISTS OF STANDARD CHARACTERS WITHOUT CLAIM TO ANY PARTICULAR FONT, STYLE, SIZE, OR COLOR.

FOR COMPUTER SOFTWARE FOR APPLICATION AND DATABASE INTEGRATION; COMPUTER SOFTWARE FOR CREATING SEARCHABLE DATABASES OF INFORMATION AND DATA; COMPUTER SOFTWARE FOR USE IN THE SAFEGUARDING OF DIGITAL FILES, INCLUDING AUDIO, VIDEO, TEXT, BINARY, STILL IMAGES, GRAPHICS AND MULTIMEDIA FILES; COMPUTER SOFTWARE FOR MANAGING CONTENT ACROSS ONE OR MANY DOCUMENTS AND/OR DATABASES; DESKTOP PUBLISHING SOFTWARE; ENTERPRISE SOFTWARE IN THE NATURE OF A DATABASE FOR NON-TRANSACTIONAL DATA AND A SEARCH ENGINE FOR DATABASE CONTENT; SOFTWARE FOR PROCESSING IMAGES, GRAPHICS AND TEXT (U.S. CLS. 21, 23, 26, 36 AND 38).

EMILY CARLSEN, EXAMINING ATTORNEY

CLASS 9—(Continued).

SN 77-457,633. NOVINT TECHNOLOGIES, INC., ALBUQUERQUO, NM. FILED 4-24-2008.

N TOUCH

THE MARK CONSISTS OF STANDARD CHARACTERS WITHOUT CLAIM TO ANY PARTICULAR FONT, STYLE, SIZE, OR COLOR.

NO CLAIM IS MADE TO THE EXCLUSIVE RIGHT TO USE "TOUCH", APART FROM THE MARK AS SHOWN.

FOR COMPUTER SOFTWARE IN THE NATURE OF AN APPLICATION PROGRAMMING INTERFACE THAT PROVIDES SUPPORT FOR HAPTIC INTERACTION, FORCE SENSING AND FORCE FEEDBACK, THREE DIMENSIONAL INTERACTION, OR A COMBINATION THEREOF; AND COMPUTER SOFTWARE IN THE NATURE OF COMPUTER PROGRAMMING TOOLS AND SOFTWARE LIBRARIES THAT ALLOW USERS TO CREATE COMPUTER GAMES AND COMPUTER PROGRAMS THAT PROVIDE HAPTIC INTERACTION, FORCE SENSING AND FORCE FEEDBACK, THREE DIMENSIONAL INTERACTION, OR A COMBINATION THEREOF (U.S. CLS. 21, 23, 26, 36 AND 38).

AMEETA JORDAN, EXAMINING ATTORNEY

SN 77-458,144. KABUSHIKI KAISHA SEGA, DBA D/B/A SEGA CORPORATION, OHTA-KU, TOKYO, JAPAN, FILED 4-25-2008.

COSMIC SMASH

THE MARK CONSISTS OF STANDARD CHARACTERS WITHOUT CLAIM TO ANY PARTICULAR FONT, STYLE, SIZE, OR COLOR.

OWNER OF JAPAN REG. NO. 4402366, DATED 7-21-2000, EXPIRES 7-21-2010.

OWNER OF U.S. REG. NO. 2,606,363.

FOR HOME VIDEO GAME MACHINES FOR USE WITH TELEVISION; PLAYER-OPERATED ELECTRONIC CONTROLLERS FOR ELECTRONIC VIDEO GAME MACHINES; VIDEO GAME INTERACTIVE CONTROLLERS, NAMELY, HAND HELD PADS, AND FLOOR PADS OR MATS; JOYSTICKS FOR VIDEO GAMES; COMPUTER CURSOR CONTROL DEVICES, NAMELY, COMPUTER MOUSE; FLASH MEMORY CARDS; VIDEO GAME SOFTWARE, COMPUTER GAME PROGRAMS (U.S. CLS. 21, 23, 26, 36 AND 38).

JANICE L. MCMORROW, EXAMINING ATTORNEY

CLASS 9—(Continued).

SN 77-459,716. WORLD WRESTLING ENTERTAINMENT, INC., STAMFORD, CT. FILED 4-28-2008.

NIGHT OF CHAMPIONS

THE MARK CONSISTS OF STANDARD CHARACTERS WITHOUT CLAIM TO ANY PARTICULAR FONT, STYLE, SIZE, OR COLOR.

FOR DOWNLOADABLE RING TONES, GRAPHICS AND MUSIC VIA A GLOBAL COMPUTER NETWORK AND WIRELESS DEVICES; DECORATIVE REFRIGERATOR MAGNETS; VIDEO AND COMPUTER GAME TAPES, VIDEO AND COMPUTER GAME DISCS, VIDEO AND COMPUTER GAME CASSETTES, VIDEO AND COMPUTER GAME CARTRIDGES, VIDEO AND COMPUTER GAME CD-ROMS, VIDEO OUTPUT GAME MACHINES FOR USE WITH TELEVISIONS; VIDEO AND COMPUTER GAME SOFTWARE; CINEMATOGRAPHIC AND TELEVISION FILMS, NAMELY, MOTION PICTURE FILMS IN THE NATURE OF SPORTS ENTERTAINMENT; PRE-RECORDED PHONOGRAPH RECORDS, PRE-RECORDED COMPACT DISCS, PRE-RECORDED VIDEO TAPES, PRE-RECORDED VIDEO CASSETTE TAPES, PRE-RECORDED DVDS AND PRE-RECORDED AUDIO CASSETTES, ALL FEATURING SPORTS ENTERTAINMENT; COIN-FED AMUSEMENT GAMING MACHINES; INTERACTIVE VIDEO GAME PROGRAMS AND COMPUTER GAME CARTRIDGES; MOUSE PADS; DISPOSABLE CAMERAS; SUNGLASSES; SUNGLASS CASES; PRESCRIPTION GLASSES; AND OPTICAL CASES, NAMELY, CASES FOR SPECTACLES AND SUNGLASSES; WALKIE TALKIES, PROTECTIVE HELMETS; SPORTS HELMETS (U.S. CLS. 21, 23, 26, 36 AND 38).

SUZANNE BLANE, EXAMINING ATTORNEY

SN 77-459,978. JACK HENRY SOFTWARE/COMMLINK, L.P., MONETT, MO. FILED 4-28-2008.

GODOUGH

THE MARK CONSISTS OF STANDARD CHARACTERS WITHOUT CLAIM TO ANY PARTICULAR FONT, STYLE, SIZE, OR COLOR.

FOR COMPUTER SOFTWARE LICENSED TO BANKS, CREDIT UNIONS AND THRIFT FINANCIAL INSTITUTIONS TO ENABLE THEIR CUSTOMERS TO USE CELL PHONES, PDAS AND OTHER ELECTRONIC MOBILE COMMUNICATION DEVICES TO INITIATE TRANSACTIONS AND VIEW ACCOUNT RECORDS (U.S. CLS. 21, 23, 26, 36 AND 38).

FIRST USE 7-17-2007; IN COMMERCE 7-17-2007.

KATHERINE M. DUBRAY, EXAMINING ATTORNEY

CLASS 9—(Continued).

SN 77-461,809. KICKFIRE, INC., SANTA CLARA, CA. FILED 4-30-2008.



THE MARK CONSISTS OF A STYLIZED FIRE WITH FOUR FLAMES.

FOR COMPUTERS; DESKTOP COMPUTERS; COMPUTER WORKSTATIONS COMPRISING COMPUTERS, COMPUTER SERVERS, COMPUTER PERIPHERAL DEVICES, AND COMPUTER OPERATING SOFTWARE; COMPUTER CHIPS; INTEGRATED CIRCUITS; COMPUTER HARDWARE AND PERIPHERAL DEVICES; DATABASE SOFTWARE; AND COMPUTER SOFTWARE FOR INDEXING, STORAGE, SEARCHING AND RETRIEVAL OF DATA (U.S. CLS. 21, 23, 26, 36 AND 38).
DAVID TAYLOR, EXAMINING ATTORNEY

SN 77-461,878. MATTEL, INC., EL SEGUNDO, CA. FILED 4-30-2008.

MY BARBIE PHOTOS

THE MARK CONSISTS OF STANDARD CHARACTERS WITHOUT CLAIM TO ANY PARTICULAR FONT, STYLE, SIZE, OR COLOR.

OWNER OF U.S. REG. NOS. 741,208, 3,287,023 AND OTHERS.

NO CLAIM IS MADE TO THE EXCLUSIVE RIGHT TO USE "PHOTOS", APART FROM THE MARK AS SHOWN.

FOR DIGITAL CAMERAS; DIGITAL CAMERA SOFTWARE (U.S. CLS. 21, 23, 26, 36 AND 38).
JOHN KELLY, EXAMINING ATTORNEY

SN 77-462,132. QWEST COMMUNICATIONS INTERNATIONAL INC., DENVER, CO. FILED 4-30-2008.

ENTRA EN ONDA

THE MARK CONSISTS OF STANDARD CHARACTERS WITHOUT CLAIM TO ANY PARTICULAR FONT, STYLE, SIZE, OR COLOR.

THE FOREIGN WORDING IN THE MARK TRANSLATES INTO ENGLISH AS "GET IN THE LOOP".

FOR MOBILE PHONES; SMARTPHONES; MODEMS; TELEPHONE HEADSETS; CARRYING CASES FOR CELL PHONES; CELL PHONE BATTERY CHARGERS; CELL PHONE BATTERY CHARGERS FOR USE IN VEHICLES; USB (UNIVERSAL SERIAL BUS) HARDWARE; RAM (RANDOM ACCESS MEMORY) CARD; DOWNLOADABLE RING TONES, GRAPHICS AND MUSIC VIA A GLOBAL COMPUTER NETWORK AND WIRELESS DEVICES (U.S. CLS. 21, 23, 26, 36 AND 38).
DAVID TAYLOR, EXAMINING ATTORNEY

CLASS 9—(Continued).

SN 77-465,343. ONE LAPTOP PER CHILD ASSOCIATION, INC., CAMBRIDGE, MA. FILED 5-5-2008.

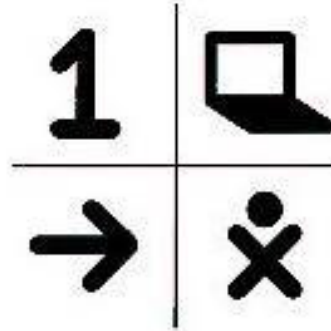

THE MARK CONSISTS OF FOUR IMAGES, THE NUMERAL ONE, A STYLIZED LAPTOP COMPUTER, AN ARROW POINTING TO THE RIGHT AND A STYLIZED CHILD FIGURE, WITH THE IMAGES SEPARATED BY SOLID LINES AND ARRANGED IN A 2 X 2 GRID.

FOR COMPUTERS; COMPUTER HARDWARE; COMPUTER PERIPHERALS; COMPUTER NETWORKING HARDWARE; SOFTWARE DRIVERS FOR COMPUTER PERIPHERALS (U.S. CLS. 21, 23, 26, 36 AND 38).

FIRST USE 11-0-2007; IN COMMERCE 11-0-2007.

LEIGH CAROLINE CASE, EXAMINING ATTORNEY

SN 77-466,180. SANDLOT GAMES CORPORATION, BOTHELL, WA. FILED 5-5-2008.

Tradewinds Caravans

THE MARK CONSISTS OF STANDARD CHARACTERS WITHOUT CLAIM TO ANY PARTICULAR FONT, STYLE, SIZE, OR COLOR.

OWNER OF U.S. REG. NO. 3,101,783.

FOR COMPUTER GAME PROGRAMS; COMPUTER GAME SOFTWARE; COMPUTER PROGRAMS FOR VIDEO AND COMPUTER GAMES; DOWNLOADABLE MULTIMEDIA GAME PROGRAMS VIA THE INTERNET AND WIRELESS DEVICES; GAME SOFTWARE; INTERACTIVE VIDEO GAME PROGRAMS; ELECTRONIC GAME PROGRAMS; ELECTRONIC GAME SOFTWARE (U.S. CLS. 21, 23, 26, 36 AND 38).
DAVID YONTEF, EXAMINING ATTORNEY

CLASS 9—(Continued).

SN 77-470,058. PG MUSIC INC., VICTORIA, CANADA,
FILED 5-9-2008.

RealStyle

THE MARK CONSISTS OF STANDARD CHARACTERS WITHOUT CLAIM TO ANY PARTICULAR FONT, STYLE, SIZE, OR COLOR.

FOR COMPUTER SOFTWARE FOR GENERATING STYLIZED MUSICAL ACCOMPANIMENTS FROM AUDIO RECORDINGS OF LIVE MUSICAL PERFORMANCES (U.S. CLS. 21, 23, 26, 36 AND 38).

SANDRA MANIOS, EXAMINING ATTORNEY

CLASS 9—(Continued).

SN 77-475,789. PLAYFIRST, INC., SAN FRANCISCO, CA.
FILED 5-15-2008.

Cooking Dash

THE MARK CONSISTS OF STANDARD CHARACTERS WITHOUT CLAIM TO ANY PARTICULAR FONT, STYLE, SIZE, OR COLOR.

FOR COMPUTER GAME SOFTWARE; ELECTRONIC GAME SOFTWARE; GAME SOFTWARE; VIDEO GAME SOFTWARE (U.S. CLS. 21, 23, 26, 36 AND 38).

MATTHEW PAPPAS, EXAMINING ATTORNEY

SN 77-470,090. PLAYFIRST, INC., SAN FRANCISCO, CA.
FILED 5-9-2008.

Diner Dash Flo on the Go

THE MARK CONSISTS OF STANDARD CHARACTERS WITHOUT CLAIM TO ANY PARTICULAR FONT, STYLE, SIZE, OR COLOR.

OWNER OF U.S. REG. NO. 3,127,997.
FOR COMPUTER GAME SOFTWARE; ELECTRONIC GAME SOFTWARE; GAME SOFTWARE; VIDEO GAME SOFTWARE (U.S. CLS. 21, 23, 26, 36 AND 38).

FIRST USE 8-25-2006; IN COMMERCE 8-25-2006.
MATTHEW PAPPAS, EXAMINING ATTORNEY

SN 77-478,401. GANNETT SATELLITE INFORMATION NETWORK, INC., MCLEAN, VA. FILED 5-19-2008.

CAPTIVATE CONCIERGE

THE MARK CONSISTS OF STANDARD CHARACTERS WITHOUT CLAIM TO ANY PARTICULAR FONT, STYLE, SIZE, OR COLOR.

FOR COMPUTER SOFTWARE, NAMELY, SCHEDULING APPLICATION SOFTWARE FOR USE IN CREATING AND MANIPULATING MESSAGE CONTENT ON DISPLAY MONITORS (U.S. CLS. 21, 23, 26, 36 AND 38).

MONIQUE MILLER, EXAMINING ATTORNEY

SN 77-470,161. CBS STUDIOS INC., STUDIO CITY, CA.
FILED 5-9-2008.

THE MEANT TO BE'S

THE MARK CONSISTS OF STANDARD CHARACTERS WITHOUT CLAIM TO ANY PARTICULAR FONT, STYLE, SIZE, OR COLOR.

FOR PRE-RECORDED DVDS AND VIDEO TAPES FEATURING ENTERTAINMENT IN THE NATURE OF A DRAMATIC TELEVISION PROGRAM SERIES (U.S. CLS. 21, 23, 26, 36 AND 38).

MARTHA FROMM, EXAMINING ATTORNEY

SN 77-479,321. MANTECH INTERNATIONAL CORPORATION, FAIRFAX, VA. FILED 5-20-2008.

CROWBAR

THE MARK CONSISTS OF STANDARD CHARACTERS WITHOUT CLAIM TO ANY PARTICULAR FONT, STYLE, SIZE, OR COLOR.

FOR ENCODED INTEGRATED CIRCUIT CARDS CONTAINING PROGRAMMING USED TO GENERATE PASSWORDS FOR THE PURPOSE OF EVALUATING COMPUTER NETWORK SECURITY; SOFTWARE FOR GENERATING PASSWORDS FOR THE PURPOSE OF EVALUATING COMPUTER NETWORK SECURITY (U.S. CLS. 21, 23, 26, 36 AND 38).

DEZMONA MIZELLE, EXAMINING ATTORNEY

CLASS 9—(Continued).

SN 77-485,713. SENTRIGO INC., WOBURN, MA. FILED 5-29-2008.

HEDGEHOG VPATCH

THE MARK CONSISTS OF STANDARD CHARACTERS WITHOUT CLAIM TO ANY PARTICULAR FONT, STYLE, SIZE, OR COLOR.

FOR COMPUTER SOFTWARE FOR PROTECTING AND SECURING DATABASES (U.S. CLS. 21, 23, 26, 36 AND 38).

IRA J. GOODSAD, EXAMINING ATTORNEY

SN 77-500,944. WRIGHT, BRUCE D, SARASOTA, FL. FILED 6-17-2008.

Tennis Rocks

THE MARK CONSISTS OF STANDARD CHARACTERS WITHOUT CLAIM TO ANY PARTICULAR FONT, STYLE, SIZE, OR COLOR.

FOR MUSICAL SOUND RECORDINGS; MUSICAL VIDEO RECORDINGS (U.S. CLS. 21, 23, 26, 36 AND 38).

FIRST USE 6-17-2008; IN COMMERCE 6-17-2008.

JOHN WILKE, EXAMINING ATTORNEY

SN 77-975,143. NISSAN JIDOSHA KABUSHIKI KAISHA, TA NISSAN MOTOR CO., LTD., YOKOHAMA-SHI, JAPAN, FILED 3-27-2007.

NISSAN GT-R

THE MARK CONSISTS OF STANDARD CHARACTERS WITHOUT CLAIM TO ANY PARTICULAR FONT, STYLE, SIZE, OR COLOR.

OWNER OF U.S. REG. NOS. 686,587, 2,055,075 AND OTHERS.

FOR COMPUTER SOFTWARE GAMES, COMPUTER PERIPHERALS, NAMELY MOUSE PADS, COMPUTER STORAGE DEVICES, NAMELY, FLASH DRIVES; VIDEO GAME SOFTWARE AND VIDEO GAME TAPE CASSETTES (U.S. CLS. 21, 23, 26, 36 AND 38).

ANDREA K. NADELMAN, EXAMINING ATTORNEY

CLASS 9—(Continued).

SN 78-308,426. DRS DATA & IMAGING SYSTEMS, INC., OAKLAND, NJ. FILED 10-2-2003.

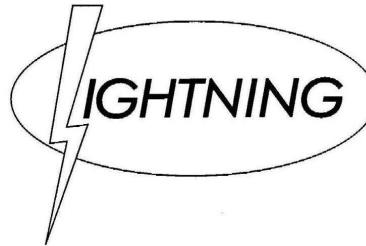

FOR HIGH SPEED DIGITAL CAMERAS (U.S. CLS. 21, 23, 26, 36 AND 38).

LOURDES AYALA, EXAMINING ATTORNEY

SN 78-308,434. DRS DATA & IMAGING SYSTEMS, INC., OAKLAND, NJ. FILED 10-2-2003.



FOR HIGH SPEED DIGITAL CAMERAS (U.S. CLS. 21, 23, 26, 36 AND 38).

LOURDES AYALA, EXAMINING ATTORNEY

SN 78-308,437. DRS DATA & IMAGING SYSTEMS, INC., OAKLAND, NJ. FILED 10-2-2003.

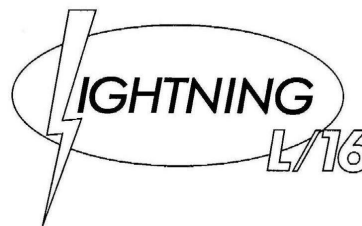

NO CLAIM IS MADE TO THE EXCLUSIVE RIGHT TO USE "L/16", APART FROM THE MARK AS SHOWN.

FOR HIGH SPEED DIGITAL CAMERAS (U.S. CLS. 21, 23, 26, 36 AND 38).

LOURDES AYALA, EXAMINING ATTORNEY

CLASS 9—(Continued).

SN 78-365,711. STEARMAN DAVE ADVENTURES, INC., POTTSBORO, TX. FILED 2-10-2004.

Stearman Dave Adventures

THE MARK CONSISTS OF STANDARD CHARACTERS WITHOUT CLAIM TO ANY PARTICULAR FONT, STYLE, SIZE, OR COLOR.

FOR COMPUTER GAME PROGRAMS (U.S. CLS. 21, 23, 26, 36 AND 38).

MAYUR VAGHANI, EXAMINING ATTORNEY

SN 78-382,337. SHELL TRADEMARK MANAGEMENT BV, THE HAGUE, NETHERLANDS, FILED 3-11-2004.

RADDICAL

THE MARK CONSISTS OF STANDARD CHARACTERS WITHOUT CLAIM TO ANY PARTICULAR FONT, STYLE, SIZE, OR COLOR.

OWNER OF BENELUX REG. NO. 0736939, DATED 9-12-2003, EXPIRES 9-12-2013.

FOR COMPUTER SOFTWARE FOR DATA RETRIEVAL (U.S. CLS. 21, 23, 26, 36 AND 38).

PRISCILLA MILTON, EXAMINING ATTORNEY

SN 78-402,741. DK SUNGLASSES CORP., LOS ANGELES, CA. FILED 4-15-2004.

WESTERN CHOPPERS

THE MARK CONSISTS OF STANDARD CHARACTERS WITHOUT CLAIM TO ANY PARTICULAR FONT, STYLE, SIZE, OR COLOR.

FOR EYEWEAR, NAMELY, SUNGLASSES, OPTICAL FRAMES, READING GLASSES, AND STORAGE CONTAINERS THEREFOR (U.S. CLS. 21, 23, 26, 36 AND 38).

SUSAN LESLIE DUBOIS, EXAMINING ATTORNEY

CLASS 9—(Continued).

SN 78-406,851. VACCARO, HENRY S., BRADENTON, FL. FILED 4-23-2004.

Retail Heartbeat

THE MARK CONSISTS OF STANDARD CHARACTERS WITHOUT CLAIM TO ANY PARTICULAR FONT, STYLE, SIZE, OR COLOR.

NO CLAIM IS MADE TO THE EXCLUSIVE RIGHT TO USE "RETAIL", APART FROM THE MARK AS SHOWN.

FOR COMPUTER SOFTWARE FOR ANALYZING RETAIL TRANSACTION DATA AND DETECTING OUT OF STOCK CONDITIONS AND IMPACTS ON CUSTOMERS (U.S. CLS. 21, 23, 26, 36 AND 38).

C. DIONNE CLYBURN, EXAMINING ATTORNEY

SN 78-664,955. IRIS RECORDS, LLC, EVERGREEN, CO. FILED 7-6-2005.

Iris Records

THE MARK CONSISTS OF STANDARD CHARACTERS WITHOUT CLAIM TO ANY PARTICULAR FONT, STYLE, SIZE, OR COLOR.

NO CLAIM IS MADE TO THE EXCLUSIVE RIGHT TO USE "RECORDS", APART FROM THE MARK AS SHOWN.

FOR COMPACT DISCS, AUDIO CASSETTES, PHOTOGRAPH RECORDS, AND PRERECORDED VIDEO TAPES FEATURING MUSICAL AND VOCAL PERFORMANCES. (U.S. CLS. 21, 23, 26, 36 AND 38).

FIRST USE 5-1-2002; IN COMMERCE 5-1-2002.

DAWN HAN, EXAMINING ATTORNEY

SN 78-747,658. MTEKVISION CO., LTD., SEOUL, REPUBLIC OF KOREA, FILED 11-4-2005.



FOR INTEGRATED CIRCUITS; SEMICONDUCTOR CHIPS; SIGNAL PROCESSORS; AND COMPUTER MEMORIES (U.S. CLS. 21, 23, 26, 36 AND 38).

JILL PRATER, EXAMINING ATTORNEY

CLASS 9—(Continued).

SN 78-747,669. MTEKVISION CO., LTD., SEOUL, REPUBLIC OF KOREA, FILED 11-4-2005.

CLASS 9—(Continued).

SN 78-794,386. SAMSUNG ELECTRONICS CO., LTD., GYEONGGI-DO, REPUBLIC OF KOREA, FILED 1-18-2006.

MTEKVISION

SAMSUNG SLIC

THE MARK CONSISTS OF STANDARD CHARACTERS WITHOUT CLAIM TO ANY PARTICULAR FONT, STYLE, SIZE, OR COLOR.

FOR INTEGRATED CIRCUITS; SEMICONDUCTOR CHIPS; SIGNAL PROCESSORS; AND COMPUTER MEMORIES (U.S. CLS. 21, 23, 26, 36 AND 38).

JILL PRATER, EXAMINING ATTORNEY

PRIORITY CLAIMED UNDER SEC. 44(D) ON REPUBLIC OF KOREA APPLICATION NO. 40-2006-0001, FILED 1-10-2006, REG. NO. 0691538, DATED 12-28-2006, EXPIRES 12-28-2016.

OWNER OF U.S. REG. NOS. 2,882,774 AND 2,929,523. THE MARK CONSISTS OF THE LETTERS "SAMSUNG SLIC".

FOR MULTI-LAYER CERAMIC CAPACITORS (U.S. CLS. 21, 23, 26, 36 AND 38).

SUSAN LESLIE DUBOIS, EXAMINING ATTORNEY

SN 78-753,915. OPTOSEcurity INC., SAINTE-FOY (QUEBEC), CANADA, FILED 11-15-2005.

SN 78-820,420. CELSIA TECHNOLOGIES, INC., MIAMI, FL. FILED 2-22-2006.

OptoScreeener

CELSIA TECHNOLOGIES

THE MARK CONSISTS OF STANDARD CHARACTERS WITHOUT CLAIM TO ANY PARTICULAR FONT, STYLE, SIZE, OR COLOR.

PRIORITY CLAIMED UNDER SEC. 44(D) ON CANADA APPLICATION NO. 1279281, FILED 11-10-2005, REG. NO. TMA708693, DATED 3-3-2008, EXPIRES 3-3-2023.

FOR IMAGE RECOGNITION DEVICES, NAMELY, OPTICAL CORRELATORS THAT PROVIDE REAL-TIME IMAGE PROCESSING THROUGH OPTICAL COMPUTER HARDWARE AND COMPUTER SOFTWARE PROGRAMS (U.S. CLS. 21, 23, 26, 36 AND 38).

RICHARD A. STRASER, EXAMINING ATTORNEY

THE MARK CONSISTS OF STANDARD CHARACTERS WITHOUT CLAIM TO ANY PARTICULAR FONT, STYLE, SIZE, OR COLOR.

NO CLAIM IS MADE TO THE EXCLUSIVE RIGHT TO USE "TECHNOLOGIES", APART FROM THE MARK AS SHOWN.

FOR ELECTRONIC COMPONENTS, NAMELY, MICROFLUIDIC AND NANOFUIDIC COOLING PLATES FOR USE IN ELECTRONIC DEVICES; MICROFLUIDIC AND NANOFUIDIC COOLING FLUIDS AND VAPORS FOR USE IN ELECTRONIC DEVICES (U.S. CLS. 21, 23, 26, 36 AND 38).

ALLISON HOLTZ, EXAMINING ATTORNEY

CLASS 9—(Continued).

SN 78-912,391. O'NEIL PROPERTY MANAGEMENT, INC., LAFAYETTE, IN. FILED 6-20-2006.

MAKE READY MANAGER

THE MARK CONSISTS OF STANDARD CHARACTERS WITHOUT CLAIM TO ANY PARTICULAR FONT, STYLE, SIZE, OR COLOR.

NO CLAIM IS MADE TO THE EXCLUSIVE RIGHT TO USE "MANAGER", APART FROM THE MARK AS SHOWN.

FOR COMPUTER SOFTWARE SPECIFIC TO THE RESIDENTIAL PROPERTY MANAGEMENT INDUSTRY USED TO ASSIST RESIDENTIAL PROPERTY OWNERS OR MANAGERS IN THE OPERATION AND TURNOVER OF RENTAL UNITS (U.S. CLS. 21, 23, 26, 36 AND 38).

MICHAEL LITZAU, EXAMINING ATTORNEY

SN 78-917,689. SEPAND RIAHI, LANCASTER, PA. FILED 6-27-2006.

TV-TAC-TOE

THE MARK CONSISTS OF STANDARD CHARACTERS WITHOUT CLAIM TO ANY PARTICULAR FONT, STYLE, SIZE, OR COLOR.

FOR DVDS FEATURING AN INTERACTIVE MULTIMEDIA COMPUTER GAME PROGRAM (U.S. CLS. 21, 23, 26, 36 AND 38).

FIRST USE 6-1-2006; IN COMMERCE 6-26-2006.

ROBIN CHOSID, EXAMINING ATTORNEY

SN 79-036,644. TOKYO ELECTRON LIMITED, TOKYO, JAPAN, FILED 9-12-2006.

TELPADS

THE MARK CONSISTS OF STANDARD CHARACTERS WITHOUT CLAIM TO ANY PARTICULAR FONT, STYLE, SIZE, OR COLOR.

PRIORITY DATE OF 8-23-2006 IS CLAIMED.

OWNER OF INTERNATIONAL REGISTRATION 0919235 DATED 9-12-2006, EXPIRES 9-12-2016.

THE WORDING "TELPADS" HAS NO MEANING IN A FOREIGN LANGUAGE.

FOR OPTICAL INSPECTION APPARATUS FOR INDUSTRIAL USE, NAMELY, FOR SEMICONDUCTOR WAFER INSPECTION MACHINES FOR THE PURPOSES OF DETECTING MARKS CAUSED BY WAFER PROBING; AND COMPUTERS (U.S. CLS. 21, 23, 26, 36 AND 38).

WILLIAM ROSSMAN, EXAMINING ATTORNEY

CLASS 9—(Continued).

SN 79-038,760. CANON KABUSHIKI KAISHA, JAPAN, FILED 5-10-2007.

k1 Tune

PRIORITY DATE OF 2-8-2007 IS CLAIMED.

OWNER OF INTERNATIONAL REGISTRATION 0924916 DATED 5-10-2007, EXPIRES 5-10-2017.

NO CLAIM IS MADE TO THE EXCLUSIVE RIGHT TO USE "K1", APART FROM THE MARK AS SHOWN.

FOR COMPUTER APPLICATION SOFTWARE FOR OPTIMIZING EXPOSURE CONDITIONS AND MASK CONDITIONS IN THE OPERATION OF SEMICONDUCTOR MANUFACTURING MACHINES (STEPPERS) BY USING PRACTICAL DATA OF SUCH MACHINES (U.S. CLS. 21, 23, 26, 36 AND 38).

GILBERT SWIFT, EXAMINING ATTORNEY

SN 79-043,098. H. STOLL GMBH & CO. KG, FED REP GERMANY, FILED 7-23-2007.

M1plus

THE MARK CONSISTS OF STANDARD CHARACTERS WITHOUT CLAIM TO ANY PARTICULAR FONT, STYLE, SIZE, OR COLOR.

PRIORITY DATE OF 4-13-2007 IS CLAIMED.

OWNER OF INTERNATIONAL REGISTRATION 0935698 DATED 7-23-2007, EXPIRES 7-23-2017.

FOR COMPUTERS AND COMPUTER PROGRAMS FOR USE IN CONNECTION WITH KNITTING MACHINES, NAMELY, FOR CREATING DIFFERENT STITCH PATTERNS AND DESIGNS (U.S. CLS. 21, 23, 26, 36 AND 38).

CARYN GLASSER, EXAMINING ATTORNEY

CLASS 9—(Continued).

SN 79-043,243. AKAPP-STEMMANN B.V., NETHERLANDS, FILED 10-23-2006.

AKAPP

THE MARK CONSISTS OF STANDARD CHARACTERS WITHOUT CLAIM TO ANY PARTICULAR FONT, STYLE, SIZE, OR COLOR.

OWNER OF INTERNATIONAL REGISTRATION 0860378 DATED 5-4-2005, EXPIRES 5-4-2015.

FOR ELECTRIC CABLES; ELECTRIC WIRES; ELECTRIC CONNECTORS FOR WIRES AND ELECTRIC CABLES; COAXIAL CABLES; APPARATUS, INSTRUMENTS AND APPLIANCES FOR MEASURING CABLES, YARN, STEEL WIRE, ROPES AND PIPES, NAMELY, TAPE MEASURES; ELECTRICAL CONTROLLERS FOR ALL OF THE FOLLOWING GOODS, NAMELY, CONVEYOR BELTS, CONDUCTOR BAR SYSTEMS, ELECTRIC CABLE REELS, ELECTRIC HOSE REELS, ELECTRIC DRAG CHAINS, ELECTRIC FESTOON SYSTEMS AND MOBILE POWER FEEDS SYSTEMS; ELECTRIC CONNECTION BOXES; COMPUTER TERMINALS; PROTECTIVE SHEATHS FOR FIBER OPTICAL CABLES; ELECTRIC SOCKETS (U.S. CLS. 21, 23, 26, 36 AND 38).
REBECCA SMITH, EXAMINING ATTORNEY

SN 79-043,921. TEMIS SA, FRANCE, FILED 4-24-2007.

LUXID

THE MARK CONSISTS OF STANDARD CHARACTERS WITHOUT CLAIM TO ANY PARTICULAR FONT, STYLE, SIZE, OR COLOR.

OWNER OF INTERNATIONAL REGISTRATION 0937753 DATED 4-24-2007, EXPIRES 4-24-2017.

FOR COMPUTER SOFTWARE FOR TEXT MINING AND TEXT PROCESSING, NAMELY, FOR INDEXING AND ORGANIZING COLLECTIONS OF DOCUMENTS AND EXTRACTING INFORMATION FROM THEM; COMPUTER SOFTWARE FOR AUTOMATED INFORMATION EXTRACTION AND RETRIEVAL METHODS; COMPUTER SOFTWARE FOR ANALYSIS AND FILTERING OF TECHNOLOGICAL AND ECONOMIC DATA IN THE FIELD OF LIFE SCIENCES, PUBLISHING, AUTOMOTIVE INDUSTRY AND HOMELAND SECURITY; COMPUTER SOFTWARE FOR GATHERING AND STRUCTURING INFORMATION AND DATA IN THE FIELD OF HUMAN RESOURCES, IN THE FIELD OF DATABASES CONTAINING INFORMATION ABOUT CLIENTS AND ABOUT CLIENTS' FEEDBACK ON PRODUCTS AS CONSUMERS, AND IN THE FIELD OF ECONOMIC INTELLIGENCE; DATA PROCESSING APPARATUS, NAMELY, COMPUTERS, SERVERS, COMPUTER MEMORIES, DATA PROCESSORS, CHIPS, NAMELY, INTEGRATED CIRCUITS; PRINTED CIRCUITS (U.S. CLS. 21, 23, 26, 36 AND 38).
LAURIE KAUFMAN, EXAMINING ATTORNEY

CLASS 9—(Continued).

SN 79-045,318. AB VOLVO, SWEDEN, FILED 10-3-2007.

DYNAFLEET

THE MARK CONSISTS OF STANDARD CHARACTERS WITHOUT CLAIM TO ANY PARTICULAR FONT, STYLE, SIZE, OR COLOR.

OWNER OF INTERNATIONAL REGISTRATION 0941332 DATED 10-3-2007, EXPIRES 10-3-2017.

FOR COMPUTERS; RECORDED DOWNLOADABLE COMPUTER SOFTWARE FOR MODULAR SYSTEMS FOR COMMUNICATION BETWEEN HIGHWAY TRUCKS AND TRACTORS AND CENTRAL STATIONS; COMPUTER PERIPHERAL DEVICES (U.S. CLS. 21, 23, 26, 36 AND 38).
DAVID YONTEF, EXAMINING ATTORNEY

SN 79-046,292. OPTION, NAAMLOZE VENNOOTSCHAP, BELGIUM, FILED 9-12-2007.



PRIORITY DATE OF 3-20-2007 IS CLAIMED.
OWNER OF INTERNATIONAL REGISTRATION 0943622 DATED 9-12-2007, EXPIRES 9-12-2017.

OWNER OF U.S. REG. NO. 2,452,286.
FOR TELECOMMUNICATION INSTRUMENTS AND APPARATUS, PERIPHERAL APPARATUS AND PARTS THEREFOR, NAMELY, ELECTRONIC CARDS FOR RECORDAL, PROCESSING AND TRANSMITTING DATA AND IMAGES; COMPUTERS, DATA PROCESSING EQUIPMENT, NAMELY, PERSONAL COMPUTER MEMORY CARDS SUCH AS PCMCIA AND PCI EXPRESS CARDS WHICH CAN BE USED FOR WIRELESS CONNECTIVITY, MODEM AND OTHER FUNCTIONS IN LAPTOPS AND NOTEBOOK PERSONAL COMPUTERS, PERSONAL DIGITAL ASSISTANTS (PDA'S), MOBILE INTERNET DEVICES (MID), ULTRA-MOBILE PERSONAL COMPUTERS (UMPC'S), SMART PHONES, SEMICONDUCTOR COMPONENTS, COMPUTER PERIPHERAL APPARATUS AND PARTS THEREFOR; COMPUTER PROGRAMS IN PARTICULAR AN INTERFACE WHICH ENABLES THE INTEGRATION OF MOBILE TELEPHONE SERVICES WITH OTHER SYSTEMS SUCH AS LAPTOPS, MOBILE TELEPHONES AND THE LIKE AND TELEPHONES AND FAX MACHINES; APPARATUS FOR REPRODUCTION, TRANSMISSION OR RECORDING OF SOUND, IMAGES AND DATA; TELEPHONE AND FAX APPARATUS AND MACHINES AND PARTS THEREFOR; INSTRUMENTS AND APPARATUS FOR DATA COMMUNICATION, PERIPHERAL APPARATUS, AND PARTS THEREFOR, NAMELY, HEADPHONES, ANTENNAS, MEASURING AND TESTING EQUIPMENT, EXTENSION CRADLES (U.S. CLS. 21, 23, 26, 36 AND 38).
PAM WILLIS, EXAMINING ATTORNEY

CLASS 9—(Continued).

SN 79-046,488. AUTOFORM ENGINEERING GMBH, SWITZERLAND, FILED 10-26-2007.

EASYBLANK

THE MARK CONSISTS OF STANDARD CHARACTERS WITHOUT CLAIM TO ANY PARTICULAR FONT, STYLE, SIZE, OR COLOR.

PRIORITY DATE OF 5-8-2007 IS CLAIMED.

OWNER OF INTERNATIONAL REGISTRATION 0944154 DATED 10-26-2007, EXPIRES 10-26-2017.

OWNER OF U.S. REG. NOS. 3,057,945 AND 3,378,876.

FOR COMPUTER SOFTWARE FOR USE IN THE FIELD OF FORMING TECHNOLOGIES AND IN THE FIELD OF GEOMETRY MODELING, NAMELY, SOFTWARE USED FOR COMPUTER AIDED ENGINEERING (CAE), DATABASE MANAGEMENT, COMPUTER AIDED DESIGN (CAD), COST ESTIMATION AND PLANNING (U.S. CLS. 21, 23, 26, 36 AND 38).

MELISSA VALLILLO, EXAMINING ATTORNEY

SN 79-050,745. WIBRAIN INC., REPUBLIC OF KOREA, FILED 11-23-2007.



PRIORITY DATE OF 5-25-2007 IS CLAIMED.

OWNER OF INTERNATIONAL REGISTRATION 0955694 DATED 11-23-2007, EXPIRES 11-23-2017.

"THE COLOR(S) BLUE, LIGHT BLUE, GREEN, YELLOW, ORANGE AND RED IS/ARE CLAIMED AS A FEATURE OF THE MARK."

THE MARK CONSISTS OF THE COLOR BLUE APPEARS IN THE LETTERS "W" AND "BRAIN" AND IN THE TOP BAND RADIATING FROM THE LETTER "I", THE COLOR LIGHT BLUE APPEARS IN THE LOWER TWO BANDS RADIATING FROM THE LETTER "I" AND THE TOP OF THE DOT OVER THE LETTER "I", THE COLOR GREEN APPEARS IN THE DOT OVER THE LETTER "I", THE COLOR YELLOW APPEARS AT THE TOP OF THE LETTER "I", THE COLOR ORANGE APPEARS IN THE MIDDLE OF THE LETTER "I", AND THE COLOR RED APPEARS AT THE BOTTOM OF THE LETTER "I".

FOR ULTRA MOBILE PERSONAL COMPUTERS (UMPC); DISPLAYING DEVICES FOR ULTRA MOBILE PERSONAL COMPUTERS, NAMELY, LIQUID CRYSTAL DISPLAYS; PORTABLE MULTIMEDIA PLAYERS (PMP); PORTABLE MULTIMEDIA PLAYER COMPUTERS (PMPC); ULTRA PORTABLE PERSONAL COMPUTERS (UPPC); NAVIGATION APPARATUS, NAMELY, GLOBAL POSITIONING SYSTEM (GPS); PERSONAL DIGITAL ASSISTANTS (PDA); MPEG AUDIO LAYER-3 (MP3) PLAYERS; COMPACT DISC PLAYERS (CDP); PORTABLE MOBILE COMMUNICATORS, NAMELY, MOBILE TELEPHONES (U.S. CLS. 21, 23, 26, 36 AND 38).

KRISTINA MORRIS, EXAMINING ATTORNEY

CLASS 9—(Continued).

SN 79-052,625. MICRONICS LIMITED, UNITED KINGDOM, FILED 3-12-2008.

PORTAFLOW

THE MARK CONSISTS OF STANDARD CHARACTERS WITHOUT CLAIM TO ANY PARTICULAR FONT, STYLE, SIZE, OR COLOR.

OWNER OF INTERNATIONAL REGISTRATION 0960946 DATED 3-12-2008, EXPIRES 3-12-2018.

FOR APPARATUS AND INSTRUMENTS FOR USE IN FLOW MEASUREMENT, AND PARTS AND FITTINGS THEREFOR INCLUDED IN THIS CLASS (U.S. CLS. 21, 23, 26, 36 AND 38).

WARREN L. OLANDRIA, EXAMINING ATTORNEY

CLASS 10—MEDICAL APPARATUS

SN 76-329,153. NEUROSTREAM TECHNOLOGIES, INC., PORT COQUITLAM, BRITISH COLUMBIA V3B 1A8, CANADA, FILED 10-24-2001.

NEUROSTEP

PRIORITY CLAIMED UNDER SEC. 44(D) ON CANADA APPLICATION NO. 1101669, FILED 5-1-2001, REG. NO. TMA704558, DATED 1-11-2008, EXPIRES 1-11-2023.

FOR BIOMEDICAL DEVICES, NAMELY, NERVE CUFFS FOR STIMULATING NERVES, RECORDING NERVE ACTIVITY, MODULATING NERVE ACTIVITY, AND/OR FLUID INFUSION, IMPLANTABLE ELECTRONIC DEVICES INCLUDING BIOELECTRICAL SIGNAL PROCESSORS AND BIOELECTRIC STIMULATORS; AND SURGICAL TOOLS FOR IMPLANTING NERVE CUFFS AND ASSOCIATED BIOMEDICAL DEVICES (U.S. CLS. 26, 39 AND 44).

ALEXANDER L. POWERS, EXAMINING ATTORNEY

SN 76-599,178. GALDERMA S.A., CHAM, SWITZERLAND, FILED 6-24-2004.

SILKIDOSE

THE MARK CONSISTS OF STANDARD CHARACTERS WITHOUT CLAIM TO ANY PARTICULAR FONT, STYLE, SIZE, OR COLOR.

OWNER OF SWITZERLAND REG. NO. 521219, DATED 5-4-2004, EXPIRES 2-27-2014.

FOR RECEPTACLE IN THE NATURE OF A DRUG DELIVERY DEVICE, NAMELY, A HANDHELD APPLICATOR FOR DELIVERING MEASURED AMOUNTS OF MEDICATION TO THE SKIN FOR THE TREATMENT OF DERMATOLOGICAL DISORDERS (U.S. CLS. 26, 39 AND 44).

BRENDAN REGAN, EXAMINING ATTORNEY

CLASS 10—(Continued).

SN 76-687,637. ARES TRADING S.A., CH-1170 AUBONNE, SWITZERLAND, FILED 3-12-2008.



OWNER OF U.S. REG. NO. 3,150,806.
ANY GRAY IN THE MARK IS INTENDED TO SHOW SHADING OR CONTRAST ONLY.
FOR MEDICAL APPARATUS AND INSTRUMENTS, NAMELY, INJECTOR FOR GROWTH HORMONE (U.S. CLS. 26, 39 AND 44).
FIRST USE 0-0-2007; IN COMMERCE 0-0-2007.
BRIAN CALLAGHAN, EXAMINING ATTORNEY

SN 76-688,074. BULLARD, BRIAN, ELK GROVE, CA. FILED 3-26-2008.

QUICKMIX

THE MARK CONSISTS OF STANDARD CHARACTERS WITHOUT CLAIM TO ANY PARTICULAR FONT, STYLE, SIZE, OR COLOR.
FOR BABY FEEDING, NAMELY, BABY FEEDING BOTTLES (U.S. CLS. 26, 39 AND 44).
SANI KHOURI, EXAMINING ATTORNEY

SN 76-688,085. BULLARD, BRIAN, ELK GROVE, CA. FILED 3-26-2008.

BETTERBABY

THE MARK CONSISTS OF STANDARD CHARACTERS WITHOUT CLAIM TO ANY PARTICULAR FONT, STYLE, SIZE, OR COLOR.
FOR BABY CARE PRODUCTS, NAMELY, BOTTLES AND PACIFIERS (U.S. CLS. 26, 39 AND 44).
SANI KHOURI, EXAMINING ATTORNEY

CLASS 10—(Continued).

SN 77-116,097. DIXTAL MEDICAL, INC., CHESHIRE, CT. FILED 2-26-2007.

ENLIGHT

THE MARK CONSISTS OF STANDARD CHARACTERS WITHOUT CLAIM TO ANY PARTICULAR FONT, STYLE, SIZE, OR COLOR.

FOR MEDICAL APPARATUS AND DEVICES, NAMELY, APPARATUS AND DEVICES UTILIZING THE TECHNOLOGY OF ELECTRICAL IMPEDANCE TOMOGRAPHY FOR MEASURING AND MONITORING OF CARDIAC PERFORMANCE, BRAIN AND PULMONARY VENTILATION AND PERFUSION AND PROVIDING VISUAL REPRESENTATION AND IMAGING THEREOF (U.S. CLS. 26, 39 AND 44).
REBECCA SMITH, EXAMINING ATTORNEY

SN 77-129,467. OTICON A/S, SMORUM 2765, DENMARK, FILED 3-13-2007.

MICRO MOULD

THE MARK CONSISTS OF STANDARD CHARACTERS WITHOUT CLAIM TO ANY PARTICULAR FONT, STYLE, SIZE, OR COLOR.

PRIORITY CLAIMED UNDER SEC. 44(D) ON DENMARK APPLICATION NO. DKVA20060, FILED 9-14-2006, REG. NO. VR200700541, DATED 3-1-2007, EXPIRES 3-1-2017.

NO CLAIM IS MADE TO THE EXCLUSIVE RIGHT TO USE "MOULD", APART FROM THE MARK AS SHOWN.

FOR PARTS FOR HEARING AIDS, NAMELY, EAR-PLUGS FOR MEDICAL PURPOSES (U.S. CLS. 26, 39 AND 44).

SARA THOMAS, EXAMINING ATTORNEY

SN 77-206,119. ASTRA TECH INC., WALTHAM, MA. FILED 6-14-2007.

CaseSafe

THE MARK CONSISTS OF STANDARD CHARACTERS WITHOUT CLAIM TO ANY PARTICULAR FONT, STYLE, SIZE, OR COLOR.

FOR CASES FITTED FOR DENTAL IMPLANT ABUTMENTS (U.S. CLS. 26, 39 AND 44).

DAVID YONTEF, EXAMINING ATTORNEY

CLASS 10—(Continued).

SN 77-223,408. SENTRA MEDICAL DEVICES LLC, CANTON, MI. FILED 7-6-2007.

TRUEPULSE

THE MARK CONSISTS OF STANDARD CHARACTERS WITHOUT CLAIM TO ANY PARTICULAR FONT, STYLE, SIZE, OR COLOR.

FOR MEDICAL DIAGNOSTIC APPARATUS, ANALYTICAL APPARATUS FOR MEDICAL PURPOSES AND BLOOD PRESSURE MEASURING APPARATUS (U.S. CLS. 26, 39 AND 44).

TEJBIR SINGH, EXAMINING ATTORNEY

SN 77-245,563. SPINEVISION, SOCIÉTÉ ANONYME, PARIS, FRANCE, FILED 8-2-2007.

FLEXPLUS

THE MARK CONSISTS OF STANDARD CHARACTERS WITHOUT CLAIM TO ANY PARTICULAR FONT, STYLE, SIZE, OR COLOR.

PRIORITY CLAIMED UNDER SEC. 44(D) ON ERPN CMNTY TM OFC APPLICATION NO. 005743539, FILED 2-26-2007, REG. NO. 005743539, DATED 3-12-2008, EXPIRES 2-26-2017.

FOR SURGICAL IMPLANTS COMPRISING ARTIFICIAL MATERIALS (U.S. CLS. 26, 39 AND 44).

JENNIFER VASQUEZ, EXAMINING ATTORNEY

SN 77-257,028. PATHWAY MEDICAL TECHNOLOGIES, INC., KIRKLAND, WA. FILED 8-16-2007.



OWNER OF U.S. REG. NOS. 2,964,442, 3,023,979 AND OTHERS.

NO CLAIM IS MADE TO THE EXCLUSIVE RIGHT TO USE "MEDICAL TECHNOLOGIES", APART FROM THE MARK AS SHOWN.

THE MARK CONSISTS OF THE WORDS "PATHWAY MEDICAL TECHNOLOGIES" AND A MOUNTAIN-LIKE LOGO.

SEC. 2(F) AS TO "PATHWAY MEDICAL TECHNOLOGIES".

FOR MEDICAL DEVICES, NAMELY, INTERVENTIONAL CATHETERS FOR USE IN TREATING PERIPHERAL ARTERIAL DISEASES AND PARTS AND FITTINGS THEREFOR, NAMELY, CONSOLE AND CONTROL POD IN CONNECTION WITH THE OPERATION OF THE INTERVENTIONAL CATHETERS (U.S. CLS. 26, 39 AND 44).

KATHERINE M. DUBRAY, EXAMINING ATTORNEY

CLASS 10—(Continued).

SN 77-260,533. THE MAGSTIM COMPANY LIMITED, CARMARTHENSHIRE, UNITED KINGDOM, FILED 8-21-2007.

AIR FILM

THE MARK CONSISTS OF STANDARD CHARACTERS WITHOUT CLAIM TO ANY PARTICULAR FONT, STYLE, SIZE, OR COLOR.

OWNER OF UNITED KINGDOM REG. NO. 2445404, DATED 1-31-2007, EXPIRES 1-31-2017.

NO CLAIM IS MADE TO THE EXCLUSIVE RIGHT TO USE "AIR", APART FROM THE MARK AS SHOWN.

FOR MEDICAL APPARATUS, NAMELY, MAGNETIC STIMULATORS FOR NON-INVASIVE STIMULATION OF NERVES FOR USE IN PSYCHIATRY, COGNITIVE NEUROSCIENCE, NEUROLOGY, NEUROPHYSIOLOGY AND REHABILITATION; DIAGNOSTIC APPARATUS FOR MEDICAL PURPOSES, NAMELY, MAGNETIC STIMULATORS FOR NON-INVASIVE STIMULATION OF THE NERVES; THERAPEUTIC APPARATUS, NAMELY, MAGNETIC STIMULATORS FOR NON-INVASIVE STIMULATION OF NERVES; APPARATUS AND INSTRUMENTS FOR THE MONITORING OR TREATMENT OF THE NERVOUS SYSTEM OF PATIENTS, NAMELY, MAGNETIC STIMULATORS FOR NON-INVASIVE STIMULATION OF THE NERVES; ELECTRODES FOR USE WITH MEDICAL APPARATUS; ELECTRONIC APPARATUS FOR MEDICAL PURPOSES, NAMELY, ACCESSORY COILS FOR USE WITH MAGNETIC STIMULATORS FOR NON-INVASIVE STIMULATION OF NERVES IN PSYCHIATRY, COGNITIVE NEUROSCIENCES, NEUROLOGY, NEUROPHYSIOLOGY AND REHABILITATION; APPARATUS FOR MEDICAL USE, NAMELY, ACCESSORY COILS FOR USE WITH A MAGNETIC STIMULATOR FOR NON-INVASIVE STIMULATION OF NERVES; MAGNETIC NERVE STIMULATION FOR MEDICAL USE, NAMELY, NERVE STIMULATOR APPARATUS; TRANSCRANIAL MAGNETIC STIMULATOR COILS FOR MEDICAL USE FOR STIMULATION OF THE FACE AND SCALP NERVES; MEDICAL PARTS, NAMELY, ACCESSORY COILS FOR USE WITH MAGNETIC STIMULATORS FOR NON-INVASIVE STIMULATION OF NERVES; PROBES FOR THE AFORESAID GOODS, NAMELY, PROBES FOR MEDICAL PURPOSES; AND FITTINGS FOR THE AFORESAID GOODS (U.S. CLS. 26, 39 AND 44).

JOHN DWYER, EXAMINING ATTORNEY

SN 77-274,560. SAN DIEGO SWISS MACHINING, INC., SAN DIEGO, CA. FILED 9-7-2007.

THE OUTPOST

THE MARK CONSISTS OF STANDARD CHARACTERS WITHOUT CLAIM TO ANY PARTICULAR FONT, STYLE, SIZE, OR COLOR.

FOR DENTAL INSTRUMENTS, NAMELY, OBSTRUCTION REMOVAL KIT COMPOSED OF EXTRACTORS FOR REMOVAL OF OBSTRUCTIONS WITHIN DENTAL STRUCTURES, DENTAL BURRS, DENTAL DRILL BITS, DENTAL EXCAVATORS, DENTAL PICK TIPS, FORCEPS FOR DENTAL TECHNICAL PURPOSES (U.S. CLS. 26, 39 AND 44).

FIRST USE 6-28-2007; IN COMMERCE 6-28-2007.

ROBIN MITTLER, EXAMINING ATTORNEY

CLASS 10—(Continued).

SN 77-274,623. MICROCHIPS, INC., BEDFORD, MA. FILED 9-7-2007.

CCW

THE MARK CONSISTS OF STANDARD CHARACTERS WITHOUT CLAIM TO ANY PARTICULAR FONT, STYLE, SIZE, OR COLOR.

FOR MEDICAL IMPLANTS, NAMELY, MICROCHIPS CONTAINING RESERVOIRS THAT STORE DRUGS, CHEMICALS, CHEMICAL SENSORS OR BIOSENSORS, AND WHICH EXPOSE OR RELEASE SAME, FOR USE BY MEDICAL PROFESSIONALS AND PATIENTS (U.S. CLS. 26, 39 AND 44).

LINDA POWELL, EXAMINING ATTORNEY

SN 77-280,817. THE BOC GROUP, INC., MURRAY HILL, NJ. FILED 9-17-2007.

HELI-FLO

THE MARK CONSISTS OF STANDARD CHARACTERS WITHOUT CLAIM TO ANY PARTICULAR FONT, STYLE, SIZE, OR COLOR.

FOR RESPIRATORY MEDICAL EQUIPMENT, NAMELY, GAS INHALATION REGULATOR DEVICES FOR INHALING IN THE NATURE OF A GAS CYLINDER AND GAS FLOW METER (U.S. CLS. 26, 39 AND 44).

RAMONA ORTIGA, EXAMINING ATTORNEY

SN 77-282,403. PREVENT PRODUCTS, INC., MENDOTA HEIGHTS, MN. FILED 9-18-2007.

GERILINE

THE MARK CONSISTS OF STANDARD CHARACTERS WITHOUT CLAIM TO ANY PARTICULAR FONT, STYLE, SIZE, OR COLOR.

FOR GERIATRIC HAND AND ARM PROTECTORS USED TO PROTECT SKIN; GERIATRIC LEG PROTECTORS USED TO PROTECT SKIN; ORTHOPEDIC ARM AND WRIST PROTECTORS USED TO PROTECT SKIN AND ENHANCE FUNCTION RECOVERY FOLLOWING SURGERY OR REMOVAL OF A CAST; ICEPACK-CONTAINING SUPPORTIVE BANDAGES USED TO RELIEVE PAIN, REDUCE SWELLING AND PROMOTE HEALING; PADDED ELBOW PROTECTORS USED TO PREVENT PRESSURE WOUNDS; PADDED HEEL PROTECTORS USED TO PREVENT PRESSURE WOUNDS; HIP PROTECTORS USED TO HELP PROTECT THE HIP AND GREATER TROCHANTER FROM IMPACT; AND SACROCCYGEAL PROTECTORS USED TO HELP PREVENT PRESSURE ULCERS ON THE SACRAL AREA (U.S. CLS. 26, 39 AND 44).

FIRST USE 7-20-2006; IN COMMERCE 7-20-2006.
JIM RINGLE, EXAMINING ATTORNEY

CLASS 10—(Continued).

SN 77-285,217. MAX ENDOSCOPY INC., ANNAPOLIS, MD. FILED 9-20-2007.

Precision

ENDOSCOPIC INFRARED COAGULATOR

NO CLAIM IS MADE TO THE EXCLUSIVE RIGHT TO USE "ENDOSCOPIC INFRARED COAGULATOR", APART FROM THE MARK AS SHOWN.

THE COLOR(S) ORANGE IS/ARE CLAIMED AS A FEATURE OF THE MARK.

THE MARK CONSISTS OF PRECISION IS IN TIMES NEW ROMAN FONT AND UNDERLINED. "ENDOSCOPIC INFRARED COAGULATOR" IS IN TIMES NEW ROMAN FONT, ITALIC AND SMALL CAPS. THE COLOR ORANGE APPEARS IN THE WORDING "PRECISION INFRARED COAGULATOR".

FOR ENDOSCOPIC EQUIPMENT (U.S. CLS. 26, 39 AND 44).

CAROL SPILS, EXAMINING ATTORNEY

SN 77-285,876. BACOUSTICS, LLC, MINNETONKA, MN. FILED 9-21-2007.

BACOUSTICS, LLC

THE MARK CONSISTS OF STANDARD CHARACTERS WITHOUT CLAIM TO ANY PARTICULAR FONT, STYLE, SIZE, OR COLOR.

NO CLAIM IS MADE TO THE EXCLUSIVE RIGHT TO USE "LLC", APART FROM THE MARK AS SHOWN.

FOR MEDICAL ULTRASOUND APPARATUS (U.S. CLS. 26, 39 AND 44).

CAROLYN CATALDO, EXAMINING ATTORNEY

SN 77-288,757. HERMAN M.D., WESLEY K., DALLAS, TX. FILED 9-25-2007.

SANITEYES

THE MARK CONSISTS OF STANDARD CHARACTERS WITHOUT CLAIM TO ANY PARTICULAR FONT, STYLE, SIZE, OR COLOR.

FOR SURGICAL ASSISTANCE DEVICE, NAMELY, A SANITARY NAPKIN FOR THE EYE FOR USE IN SURGERY; SURGICAL NAPKINS FOR USE IN OPHTHALMIC SURGERY; SURGICAL NAPKINS (U.S. CLS. 26, 39 AND 44).

PAUL CROWLEY, EXAMINING ATTORNEY

CLASS 10—(Continued).

SN 77-290,635. MAX ENDOSCOPY INC., ANNAPOLIS, MD. FILED 9-27-2007.

Dr. Clean
CLEANING BRUSHES FOR ENDOSCOPES

NO CLAIM IS MADE TO THE EXCLUSIVE RIGHT TO USE "CLEANING BRUSHES FOR ENDOSCOPES", APART FROM THE MARK AS SHOWN.

THE COLOR(S) BLUE IS/ARE CLAIMED AS A FEATURE OF THE MARK.

THE MARK CONSISTS OF "DR. CLEAN" IS IN TIMES NEW ROMAN FONT UNDERLINED. "CLEANING BRUSHES FOR ENDOSCOPES" IS IN TIMES NEW ROMAN FONT, ITALIC AND SMALL CAPS. THE COLOR BLUE APPEARS IN THE WORDING "DR. CLEAN CLEANING BRUSHES FOR ENDOSCOPES".

FOR ENDOSCOPIC EQUIPMENT (U.S. CLS. 26, 39 AND 44).

CAROL SPILS, EXAMINING ATTORNEY

SN 77-321,446. SS WHITE BURS, INC., LAKEWOOD, NJ. FILED 11-5-2007.

**SS WHITE
JAZZ
POLISHERS**

OWNER OF U.S. REG. NO. 1,658,139.

NO CLAIM IS MADE TO THE EXCLUSIVE RIGHT TO USE "POLISHERS", APART FROM THE MARK AS SHOWN.

THE NAME(S), PORTRAIT(S), AND/OR SIGNATURE(S) SHOWN IN THE MARK DOES NOT IDENTIFY A PARTICULAR LIVING INDIVIDUAL.

THE MARK CONSISTS OF THE LETTERS "SS" FOLLOWED BY "WHITE" AND "JAZZ POLISHERS" ONE ABOVE THE OTHER.

FOR DENTAL POLISHING, NAMELY, DENTAL INSTRUMENTS FOR POLISHING TEETH (U.S. CLS. 26, 39 AND 44).

RON FAIRBANKS, EXAMINING ATTORNEY

CLASS 10—(Continued).

SN 77-384,561. MANI, INC., UTSUNOMIYA, JAPAN, FILED 1-30-2008.

DIAMOND TOMITA-SAW

THE MARK CONSISTS OF STANDARD CHARACTERS WITHOUT CLAIM TO ANY PARTICULAR FONT, STYLE, SIZE, OR COLOR.

NO CLAIM IS MADE TO THE EXCLUSIVE RIGHT TO USE "DIAMOND", APART FROM THE MARK AS SHOWN.

FOR (BASED ON USE) SURGICAL AND MEDICAL APPARATUS AND INSTRUMENTS COATED WITH DIAMOND PARTICLES FOR USE IN GENERAL SURGERY; SURGICAL SAWS COATED WITH DIAMOND PARTICLES; (BASED ON INTENT TO USE) DENTAL APPARATUS, NAMELY, SAWS COATED WITH DIAMOND PARTICLES FOR DENTAL PURPOSES (U.S. CLS. 26, 39 AND 44).

FIRST USE 11-22-2006; IN COMMERCE 11-22-2006.

YAT SYE, LEE, EXAMINING ATTORNEY

SN 77-402,318. VERILUX, INC., WAITSFIELD, VT. FILED 2-21-2008.

CUREWAVE

THE MARK CONSISTS OF STANDARD CHARACTERS WITHOUT CLAIM TO ANY PARTICULAR FONT, STYLE, SIZE, OR COLOR.

OWNER OF U.S. REG. NO. 3,231,366.

FOR THERAPEUTIC LIGHTING SYSTEM CONSISTING OF LAMPS AND AN ELECTRICALLY-POWERED LIGHTING APPARATUS FOR TREATING SKIN BY APPLYING LOW LEVEL LIGHT (U.S. CLS. 26, 39 AND 44).

CYNTHIA TRIPI, EXAMINING ATTORNEY

SN 77-411,806. DIALOM DIAMOND TOOLS LIMITED, RAMAT GAN, ISRAEL, FILED 3-3-2008.

GALIL DIAMOND BURS

THE MARK CONSISTS OF STANDARD CHARACTERS WITHOUT CLAIM TO ANY PARTICULAR FONT, STYLE, SIZE, OR COLOR.

NO CLAIM IS MADE TO THE EXCLUSIVE RIGHT TO USE "DIAMOND BURS", APART FROM THE MARK AS SHOWN.

FOR DENTAL BURRS (U.S. CLS. 26, 39 AND 44).

FIRST USE 3-1-1985; IN COMMERCE 3-1-1985.

BARNEY CHARLON, EXAMINING ATTORNEY

CLASS 10—(Continued).

SN 77-416,707. ROONEY, BRYAN, LOS ANGELES, CA.
FILED 3-7-2008.

Fit~Skin

THE MARK CONSISTS OF STANDARD CHARACTERS WITHOUT CLAIM TO ANY PARTICULAR FONT, STYLE, SIZE, OR COLOR.

FOR FACIAL TONING MACHINES FOR COSMETIC USE; MOUTH EXERCISER FOR USE IN EXERCISING AND STRENGTHENING MOUTH AND FACIAL MUSCLES FOR MEDICAL AND BEAUTY BENEFITS (U.S. CLS. 26, 39 AND 44).

SONYA STEPHENS, EXAMINING ATTORNEY

SN 77-417,110. ULTRALIGHT OPTIX INC., AKA ULTRALIGHT, FOUNTAIN VALLEY, CA. FILED 3-9-2008.

Feather Light

THE MARK CONSISTS OF STANDARD CHARACTERS WITHOUT CLAIM TO ANY PARTICULAR FONT, STYLE, SIZE, OR COLOR.

NO CLAIM IS MADE TO THE EXCLUSIVE RIGHT TO USE "LIGHT", APART FROM THE MARK AS SHOWN. FOR DENTAL INSTRUMENTS, NAMELY, LIGHT-WEIGHT LOUPE LIGHTING SYSTEMS (U.S. CLS. 26, 39 AND 44).

FIRST USE 9-1-2007; IN COMMERCE 9-1-2007.

MARK PILARO, EXAMINING ATTORNEY

SN 77-419,020. FUNNELL, DAVID MARTIN, MEDFORD, MA. FILED 3-11-2008.

C-KURATOME

THE MARK CONSISTS OF STANDARD CHARACTERS WITHOUT CLAIM TO ANY PARTICULAR FONT, STYLE, SIZE, OR COLOR.

THE WORDING IN THE MARK HAS NO MEANING IN A FOREIGN LANGUAGE.

FOR CASES FITTED FOR MEDICAL INSTRUMENTS AND/OR FOR USE BY DOCTORS (U.S. CLS. 26, 39 AND 44).

REBECCA POVARCHUK, EXAMINING ATTORNEY

CLASS 10—(Continued).

SN 77-419,805. SMITHKLINE BEECHAM CORPORATION, PHILADELPHIA, PA. FILED 3-12-2008.

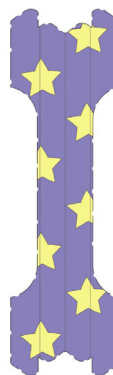

THE COLOR(S) PURPLE AND YELLOW IS/ARE CLAIMED AS A FEATURE OF THE MARK.

THE MARK CONSISTS OF YELLOW STARS WITHIN A PURPLE BACKGROUND. THE DOTTED LINES ARE NOT A FEATURE OF THE MARK, BUT TO SHOW PLACEMENT. FOR EXTERNAL NASAL DILATORS (U.S. CLS. 26, 39 AND 44).

ANNE MADDEN, EXAMINING ATTORNEY

SN 77-419,809. SMITHKLINE BEECHAM CORPORATION, PHILADELPHIA, PA. FILED 3-12-2008.

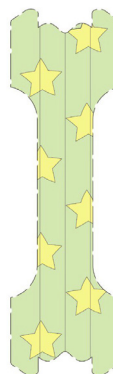

THE COLOR(S) GREEN AND YELLOW IS/ARE CLAIMED AS A FEATURE OF THE MARK.

THE MARK CONSISTS OF YELLOW STARS WITHIN A GREEN BACKGROUND. THE DOTTED LINES ARE NOT A FEATURE OF THE MARK, BUT TO SHOW PLACEMENT.

FOR EXTERNAL NASAL DILATORS (U.S. CLS. 26, 39 AND 44).

ANNE MADDEN, EXAMINING ATTORNEY

CLASS 10—(Continued).

SN 77-419,811. SMITHKLINE BEECHAM CORPORATION, PHILADELPHIA, PA. FILED 3-12-2008.

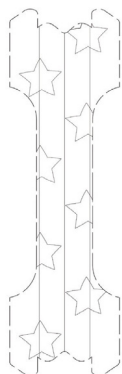

THE MARK CONSISTS OF STARS WITHIN A BACKGROUND. THE DOTTED LINES ARE NOT A FEATURE OF THE MARK, BUT TO SHOW PLACEMENT.
FOR EXTERNAL NASAL DILATORS (U.S. CLS. 26, 39 AND 44).
ANNE MADDEN, EXAMINING ATTORNEY

SN 77-419,816. SMITHKLINE BEECHAM CORPORATION, PHILADELPHIA, PA. FILED 3-12-2008.

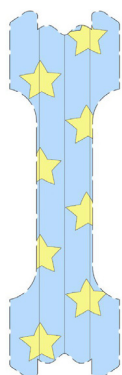

THE COLOR(S) BLUE AND YELLOW IS/ARE CLAIMED AS A FEATURE OF THE MARK.
THE MARK CONSISTS OF YELLOW STARS WITHIN A BLUE BACKGROUND. THE DOTTED LINES ARE NOT A FEATURE OF THE MARK, BUT TO SHOW PLACEMENT.
FOR EXTERNAL NASAL DILATORS (U.S. CLS. 26, 39 AND 44).
ANNE MADDEN, EXAMINING ATTORNEY

CLASS 10—(Continued).

SN 77-421,762. HONEYCUTT, JAMES DAVID, VANCOUVER, WA. AND HONEYCUTT, VICTORIA LYNN, PALM DESERT, CA. FILED 3-14-2008.

Rhythmedics

THE MARK CONSISTS OF STANDARD CHARACTERS WITHOUT CLAIM TO ANY PARTICULAR FONT, STYLE, SIZE, OR COLOR.
FOR CIRCADIAN RHYTHMIC ELECTROMAGNETIC THERAPY APPARATUS (U.S. CLS. 26, 39 AND 44).
FIRST USE 8-30-2006; IN COMMERCE 1-4-2007.
AMY MCMENAMIN, EXAMINING ATTORNEY

SN 77-422,640. SYNAPSE BIOMEDICAL, INC., OBERLIN, OH. FILED 3-14-2008.

NEURX DPS

THE MARK CONSISTS OF STANDARD CHARACTERS WITHOUT CLAIM TO ANY PARTICULAR FONT, STYLE, SIZE, OR COLOR.
NO CLAIM IS MADE TO THE EXCLUSIVE RIGHT TO USE "DPS", APART FROM THE MARK AS SHOWN.
FOR ELECTRONIC STIMULATOR FOR DIAPHRAGM (U.S. CLS. 26, 39 AND 44).
NICHOLAS ALTREE, EXAMINING ATTORNEY

SN 77-423,339. AGUILAR, JR., HUMBERTO J., ALVIN, TX. FILED 3-17-2008.



NO CLAIM IS MADE TO THE EXCLUSIVE RIGHT TO USE "INTUBATING AIRWAY", APART FROM THE MARK AS SHOWN.
THE COLOR(S) BLACK AND LIGHT GREEN IS/ARE CLAIMED AS A FEATURE OF THE MARK.
THE MARK CONSISTS OF THE TERMS "HUM" AND "LAR" IN BLACK DISPLAYED ABOVE THE WORDS "INTUBATING AIRWAY" IN BLACK. BOTH SETS OF WORDS ARE DISPLAYED ON THE CENTER OF A LIGHT GREEN CADUCEUS.
FOR MEDICAL INTUBATION EQUIPMENT (U.S. CLS. 26, 39 AND 44).
YAT SYE, LEE, EXAMINING ATTORNEY

CLASS 10—(Continued).

SN 77-423,394. BERMAN, JEREMY, FINDLAY, OH. AND REED, TRENA C., FINDLAY, OH. FILED 3-17-2008.

The Jeco Brace

THE MARK CONSISTS OF STANDARD CHARACTERS WITHOUT CLAIM TO ANY PARTICULAR FONT, STYLE, SIZE, OR COLOR.

NO CLAIM IS MADE TO THE EXCLUSIVE RIGHT TO USE "BRACE", APART FROM THE MARK AS SHOWN.

FOR CUSTOM FOOT/ANKLE BRACE USED AS A CONSERVATIVE TREATMENT FOR FOOT/ANKLE PAIN (U.S. CLS. 26, 39 AND 44).

JILL PRATER, EXAMINING ATTORNEY

CLASS 10—(Continued).

SN 77-426,723. BOUNCING BRAIN PRODUCTIONS, LLC, DBA EVERYDAY EDISONS, LLC, CHARLOTTE, NC. FILED 3-19-2008.

EDISON NATION

THE MARK CONSISTS OF STANDARD CHARACTERS WITHOUT CLAIM TO ANY PARTICULAR FONT, STYLE, SIZE, OR COLOR.

FOR CONSUMER PRODUCTS IN THE FIELD OF BABY PRODUCTS, NAMELY, ATTACHMENTS TO BABY BOTTLES ENABLING GRASPING THEREOF BY BABIES (U.S. CLS. 26, 39 AND 44).

JOHN DWYER, EXAMINING ATTORNEY

SN 77-424,592. LEARNING CURVE BRANDS, INC., DYERSVILLE, IA. FILED 3-18-2008.

FLOW RIGHT

THE MARK CONSISTS OF STANDARD CHARACTERS WITHOUT CLAIM TO ANY PARTICULAR FONT, STYLE, SIZE, OR COLOR.

FOR BABY BOTTLE NIPPLES; BABY BOTTLES (U.S. CLS. 26, 39 AND 44).

JAY FLOWERS, EXAMINING ATTORNEY

SN 77-426,935. ACULUX, INC., NAPLES, FL. FILED 3-20-2008.

TRILUX

THE MARK CONSISTS OF STANDARD CHARACTERS WITHOUT CLAIM TO ANY PARTICULAR FONT, STYLE, SIZE, OR COLOR.

OWNER OF U.S. REG. NOS. 2,744,141, 3,343,675 AND OTHERS.

FOR HEADLIGHT LENS MODULES FOR MEDICAL AND SURGICAL USE (U.S. CLS. 26, 39 AND 44).

SANDRA MANIOS, EXAMINING ATTORNEY

SN 77-426,051. WALLACE, CHARLES, HOUSTON, MN. FILED 3-19-2008.

These Two

THE MARK CONSISTS OF STANDARD CHARACTERS WITHOUT CLAIM TO ANY PARTICULAR FONT, STYLE, SIZE, OR COLOR.

FOR NIPPLE BREAST COVERS FOR PROTECTION WHILE SUN TANNING (U.S. CLS. 26, 39 AND 44).

STEVEN R. FOSTER, EXAMINING ATTORNEY

SN 77-427,651. IN THE GROOVE, L.L.C., SAGINAW, MI. FILED 3-20-2008.

IN THE GROOVE

THE MARK CONSISTS OF STANDARD CHARACTERS WITHOUT CLAIM TO ANY PARTICULAR FONT, STYLE, SIZE, OR COLOR.

FOR ORTHOPEDIC BRACES; BRACES FOR LIMBS AND JOINTS, FOR MEDICAL USE; MEDICAL BRACES FOR KNEES (U.S. CLS. 26, 39 AND 44).

FIRST USE 2-0-2006; IN COMMERCE 2-0-2006.

FRANK LATTUCA, EXAMINING ATTORNEY

CLASS 10—(Continued).

SN 77-428,135. NATIONAL DENTEX CORPORATION, DBA MALLOW-TRU DENTAL STUDIO, WAYLAND, MA. FILED 3-21-2008.

MTZ

THE MARK CONSISTS OF STANDARD CHARACTERS WITHOUT CLAIM TO ANY PARTICULAR FONT, STYLE, SIZE, OR COLOR.

FOR DENTAL BRIDGES; DENTAL CROWNS; PROSTHETIC INSTRUMENTS FOR DENTAL PURPOSES (U.S. CLS. 26, 39 AND 44).

CHRISTINA SOBRAL, EXAMINING ATTORNEY

SN 77-429,228. JOHNSON & JOHNSON, NEW BRUNSWICK, NJ. FILED 3-24-2008.

INTELLIGARD

THE MARK CONSISTS OF STANDARD CHARACTERS WITHOUT CLAIM TO ANY PARTICULAR FONT, STYLE, SIZE, OR COLOR.

FOR MEDICAL INSTRUMENT, NAMELY, COMPUTER SOFTWARE SOLD AS AN INTEGRAL COMPONENT OF A MEDICAL DEVICE THAT DRIVES THE MEDICAL PUMP THAT ADMINISTERS DRUGS IN SURGICAL SEDATION PROCEDURES (U.S. CLS. 26, 39 AND 44).

JERI J. FICKES, EXAMINING ATTORNEY

SN 77-430,394. MEDICAL SPECIALTIES, INC., CHARLOTTE, NC. FILED 3-25-2008.

EVO

THE MARK CONSISTS OF STANDARD CHARACTERS WITHOUT CLAIM TO ANY PARTICULAR FONT, STYLE, SIZE, OR COLOR.

FOR ATHLETIC ANKLE BRACES FOR MEDICAL USE; BRACES FOR LIMBS AND JOINTS, FOR MEDICAL USE; MEDICAL BRACES FOR ANKLES; ORTHOPEDIC BRACES (U.S. CLS. 26, 39 AND 44).

FIRST USE 2-6-2008; IN COMMERCE 2-6-2008.
SUNG IN, EXAMINING ATTORNEY

CLASS 10—(Continued).

SN 77-430,945. TRU TOUCH TECHNOLOGIES, INC., ALBUQUERQUE, NM. FILED 3-25-2008.

TRU TOUCH GUARDIAN

THE MARK CONSISTS OF STANDARD CHARACTERS WITHOUT CLAIM TO ANY PARTICULAR FONT, STYLE, SIZE, OR COLOR.

OWNER OF U.S. REG. NO. 3,412,727.

FOR DEVICES THAT MEASURE THE CONCENTRATION OF, OR DETECT THE PRESENCE OF, OR BOTH, ALCOHOL, DRUGS, OR BYPRODUCTS THEREOF IN BIOLOGICAL TISSUE, HUMAN BREATH, OR SAMPLES TAKEN THEREFROM; AND REPLACEABLE PARTS FOR SUCH DEVICES (U.S. CLS. 26, 39 AND 44).

DANNEAN HETZEL, EXAMINING ATTORNEY

SN 77-431,013. GALIL MEDICAL LTD., YOKNEAM, ISRAEL, FILED 3-25-2008.

ICESPHERE

THE MARK CONSISTS OF STANDARD CHARACTERS WITHOUT CLAIM TO ANY PARTICULAR FONT, STYLE, SIZE, OR COLOR.

FOR MEDICAL DEVICES FOR PERFORMING CRYOTHERAPY, NAMELY, CRYOABLATION NEEDLES USED FOR THE MINIMALLY INVASIVE CRYOABLATION OF CANCEROUS AND BENIGN TISSUES (U.S. CLS. 26, 39 AND 44).

AISHA CLARKE, EXAMINING ATTORNEY

SN 77-431,388. MY CASE MANAGER, WEATHERBY LAKE, MO. FILED 3-25-2008.

S&S SOULEAR

THE MARK CONSISTS OF THE STYLIZED TEXT "SOULEAR".

FOR CARRYING CASES SPECIALLY ADAPTED FOR HOLDING HEARING AIDS (U.S. CLS. 26, 39 AND 44).
B. PARADEWELAI, EXAMINING ATTORNEY

CLASS 10—(Continued).

SN 77-431,528. MERCURY ENTERPRISES, INC., CLEARWATER, FL. FILED 3-26-2008.

AIR-VU PLUS

THE MARK CONSISTS OF STANDARD CHARACTERS WITHOUT CLAIM TO ANY PARTICULAR FONT, STYLE, SIZE, OR COLOR.

OWNER OF U.S. REG. NO. 3,420,651.
FOR MEDICAL DEVICE, NAMELY, A LIGHTED SEETHROUGH SCOPE FOR EXAMINING THE TRACHEA (U.S. CLS. 26, 39 AND 44).
MATTHEW EINSTEIN, EXAMINING ATTORNEY

CLASS 10—(Continued).

SN 77-433,114. NAVOTEK MEDICAL LTD., YOKNEAM, ISRAEL, FILED 3-27-2008.

REALEYE

THE MARK CONSISTS OF STANDARD CHARACTERS WITHOUT CLAIM TO ANY PARTICULAR FONT, STYLE, SIZE, OR COLOR.

FOR PATIENT POSITIONING AND MONITORING SYSTEM FOR RADIATION THERAPY (U.S. CLS. 26, 39 AND 44).
MARK RADEMACHER, EXAMINING ATTORNEY

SN 77-431,564. ASPEN DENTAL MANAGEMENT, INC., EAST SYRACUSE, NY. FILED 3-26-2008.

confidents
FIT FOR LIFE



OWNER OF U.S. REG. NO. 2,545,075.
THE MARK CONSISTS OF THE WORD "CONFIDENTS" WITH A CURVED LINE REPRESENTATIVE OF A SMILE POSITIONED BELOW AND THE WORDS "FIT FOR LIFE" THAT ARE, IN TURN, POSITIONED WITHIN THE CONFINES OF THE CURVED LINE.
FOR DENTURES (U.S. CLS. 26, 39 AND 44).
AMY HELLA, EXAMINING ATTORNEY

SN 77-433,799. COOLTOUCH INCORPORATED, ROSEVILLE, CA. FILED 3-27-2008.

COOLBLUE

OWNER OF U.S. REG. NOS. 2,153,205, 3,374,858 AND OTHERS.

THE MARK CONSISTS OF THE WORD "COOLBLUE" ALL IN CAPITAL LETTER AND THE OVAL LOGO OF COOLTOUCH INCORPORATED APPEARS IN THE UPPER LEFT CORNER.

FOR MEDICAL LASERS, DERMATOLOGICAL DEVICES AND ASSOCIATED SYSTEMS, NAMELY, LASER ENERGY DELIVERY HANDPIECES (U.S. CLS. 26, 39 AND 44).
KARANENDRA S. CHHINA, EXAMINING ATTORNEY

SN 77-432,157. INVACARE AQUATEC GMBH, ISNY, FED REP GERMANY, FILED 3-26-2008.

AQUATEC

THE MARK CONSISTS OF STANDARD CHARACTERS WITHOUT CLAIM TO ANY PARTICULAR FONT, STYLE, SIZE, OR COLOR.

OWNER OF U.S. REG. NO. 1,477,529.
FOR INVALID LIFTS (U.S. CLS. 26, 39 AND 44).
FIRST USE 5-12-1987; IN COMMERCE 5-12-1987.
MICHAEL TANNER, EXAMINING ATTORNEY

SN 77-434,028. ARTHREX, INC., NAPLES, FL. FILED 3-28-2008.

D.A.S.H.

THE MARK CONSISTS OF STANDARD CHARACTERS WITHOUT CLAIM TO ANY PARTICULAR FONT, STYLE, SIZE, OR COLOR.

FOR MEDICAL DEVICES, NAMELY, A DRILL ADAPTER (U.S. CLS. 26, 39 AND 44).
SUSAN LESLIE DUBOIS, EXAMINING ATTORNEY

CLASS 10—(Continued).

SN 77-434,509. PROSSER HOLDINGS, LLC, CORAL GABLES, FL. FILED 3-28-2008.



NO CLAIM IS MADE TO THE EXCLUSIVE RIGHT TO USE "CONDOM", APART FROM THE MARK AS SHOWN.

THE MARK CONSISTS OF THE CAPITALIZED WORD "CONDOM" APPEARING ABOVE THE CAPITALIZED WORD "CUBBY". THE "COND" IN "CONDOM" IS BOLDLY OUTLINED, WHILE THE "M" IN "CONDOM" AND THE WORD "CUBBY" ARE SHADED BLOCK LETTERS AND "CUBBY" SLIGHTLY OVERLAPS THE BOTTOM OF "CONDOM". THE SECOND "O" IN "CONDOM" IS STYLIZED TO LOOK LIKE A RING AND SLIGHTLY OVERLAPS THE TOP OF THE SECOND "B" IN "CUBBY". TO THE LEFT OF THE "C" IN "CONDOM" IS A DESIGN MADE TO LOOK LIKE THE RESERVOIR TIP OF A CONDOM. THE ENTIRE DESIGN IS OUTLINED IN ONE BOLD LINE.

FOR CONDOM HOLDER (U.S. CLS. 26, 39 AND 44).
TOBY BULLOFF, EXAMINING ATTORNEY

SN 77-439,863. APOLLO ENDOSURGERY, INC., AUSTIN, TX. FILED 4-4-2008.

SUMO

THE MARK CONSISTS OF STANDARD CHARACTERS WITHOUT CLAIM TO ANY PARTICULAR FONT, STYLE, SIZE, OR COLOR.

FOR MEDICAL DEVICES AND SURGICAL INSTRUMENTS FOR USE IN DIAGNOSIS AND SURGERY OF THE GASTROINTESTINAL TRACT (U.S. CLS. 26, 39 AND 44).

RUDY R. SINGLETON, EXAMINING ATTORNEY

SN 77-449,387. ARTHREX, INC., NAPLES, FL. FILED 4-16-2008.

PEAK POWERPLATE

THE MARK CONSISTS OF STANDARD CHARACTERS WITHOUT CLAIM TO ANY PARTICULAR FONT, STYLE, SIZE, OR COLOR.

FOR MEDICAL DEVICES, NAMELY, A SURGICAL PLATE (U.S. CLS. 26, 39 AND 44).

SUSAN LESLIE DUBOIS, EXAMINING ATTORNEY

CLASS 10—(Continued).

SN 77-454,753. TRUTOUCH TECHNOLOGIES, INC., ALBUQUERQUE, NM. FILED 4-22-2008.

BOUNCER

THE MARK CONSISTS OF STANDARD CHARACTERS WITHOUT CLAIM TO ANY PARTICULAR FONT, STYLE, SIZE, OR COLOR.

FOR DEVICES THAT MEASURE THE CONCENTRATION OF, OR DETECT THE PRESENCE OF, OR BOTH, ALCOHOL, DRUGS, OR BYPRODUCTS THEREOF IN BIOLOGICAL TISSUE, HUMAN BREATH, OR SAMPLES TAKEN THEREFROM; AND REPLACEABLE PARTS FOR SUCH DEVICES (U.S. CLS. 26, 39 AND 44).

DANNEAN HETZEL, EXAMINING ATTORNEY

SN 77-454,791. TRUTOUCH TECHNOLOGIES, INC., ALBUQUERQUE, NM. FILED 4-22-2008.

TEST DON'T GUESS

THE MARK CONSISTS OF STANDARD CHARACTERS WITHOUT CLAIM TO ANY PARTICULAR FONT, STYLE, SIZE, OR COLOR.

FOR DEVICES THAT MEASURE THE CONCENTRATION OF, OR DETECT THE PRESENCE OF, OR BOTH, ALCOHOL, DRUGS, OR BYPRODUCTS THEREOF IN BIOLOGICAL TISSUE, HUMAN BREATH, OR SAMPLES TAKEN THEREFROM; AND REPLACEABLE PARTS FOR SUCH DEVICES (U.S. CLS. 26, 39 AND 44).

DANNEAN HETZEL, EXAMINING ATTORNEY

SN 77-454,806. TRUTOUCH TECHNOLOGIES, INC., ALBUQUERQUE, NM. FILED 4-22-2008.

INSPECT WHAT YOU EXPECT

THE MARK CONSISTS OF STANDARD CHARACTERS WITHOUT CLAIM TO ANY PARTICULAR FONT, STYLE, SIZE, OR COLOR.

FOR DEVICES THAT MEASURE THE CONCENTRATION OF, OR DETECT THE PRESENCE OF, OR BOTH, ALCOHOL, DRUGS, OR BYPRODUCTS THEREOF IN BIOLOGICAL TISSUE, HUMAN BREATH, OR SAMPLES TAKEN THEREFROM; AND REPLACEABLE PARTS FOR SUCH DEVICES (U.S. CLS. 26, 39 AND 44).

DANNEAN HETZEL, EXAMINING ATTORNEY

CLASS 10—(Continued).

SN 77-454,813. TRUTOUCH TECHNOLOGIES, INC., ALBUQUERQUE, NM. FILED 4-22-2008.

WELCOME TO A SAFER WORLD

THE MARK CONSISTS OF STANDARD CHARACTERS WITHOUT CLAIM TO ANY PARTICULAR FONT, STYLE, SIZE, OR COLOR.

FOR DEVICES THAT MEASURE THE CONCENTRATION OF, OR DETECT THE PRESENCE OF, OR BOTH, ALCOHOL, DRUGS, OR BYPRODUCTS THEREOF IN BIOLOGICAL TISSUE, HUMAN BREATH, OR SAMPLES TAKEN THEREFROM; AND REPLACEABLE PARTS FOR SUCH DEVICES (U.S. CLS. 26, 39 AND 44).
DANNEAN HETZEL, EXAMINING ATTORNEY

SN 77-461,685. IDEXX LABORATORIES, INC., WESTBROOK, ME. FILED 4-30-2008.

OPTIRHYTHM

THE MARK CONSISTS OF STANDARD CHARACTERS WITHOUT CLAIM TO ANY PARTICULAR FONT, STYLE, SIZE, OR COLOR.

FOR FINGER PULSE OXIMETERS (U.S. CLS. 26, 39 AND 44).
DAVID TAYLOR, EXAMINING ATTORNEY

SN 77-461,700. IDEXX LABORATORIES, INC., WESTBROOK, ME. FILED 4-30-2008.

OPTIRhythm

FOR FINGER PULSE OXIMETERS (U.S. CLS. 26, 39 AND 44).
DAVID TAYLOR, EXAMINING ATTORNEY

CLASS 10—(Continued).

SN 77-467,337. ZHEN DISTRIBUTION, INC., DBA ZHEN GLOBAL CORPORATION, SEATTLE, WA. FILED 5-6-2008.

Nanovibe

THE MARK CONSISTS OF STANDARD CHARACTERS WITHOUT CLAIM TO ANY PARTICULAR FONT, STYLE, SIZE, OR COLOR.

FOR ADULT SEXUAL AIDS, NAMELY, FINGER VIBRATORS AND MINI MASSAGERS, NAMELY, ELECTRIC MASSAGING APPARATUS FOR PERSONAL USE; ELECTRIC MASSAGE APPARATUS FOR HOUSEHOLD USE; ELECTRIC MASSAGE APPLIANCES, NAMELY, ELECTRIC VIBRATING MASSAGER; MASSAGE APPARATUS; MASSAGE APPARATUS AND INSTRUMENTS; MASSAGING APPARATUS FOR PERSONAL USE (U.S. CLS. 26, 39 AND 44).
WILLIAM ROSSMAN, EXAMINING ATTORNEY

SN 77-480,338. NORTH AMERICAN RESCUE PRODUCTS, INC., DBA NORTH AMERICAN RESCUE, GREER, SC. FILED 5-21-2008.

CYCLONE

THE MARK CONSISTS OF STANDARD CHARACTERS WITHOUT CLAIM TO ANY PARTICULAR FONT, STYLE, SIZE, OR COLOR.

FOR BAG-VALVE-MASK RESUSCITATOR (U.S. CLS. 26, 39 AND 44).
RENEE SERVANCE, EXAMINING ATTORNEY

SN 77-481,039. NORTH AMERICAN RESCUE PRODUCTS, INC., DBA NORTH AMERICAN RESCUE, GREER, SC. FILED 5-22-2008.

BOBSLED

THE MARK CONSISTS OF STANDARD CHARACTERS WITHOUT CLAIM TO ANY PARTICULAR FONT, STYLE, SIZE, OR COLOR.

FOR MEDICAL STRETCHERS (U.S. CLS. 26, 39 AND 44).
RENEE SERVANCE, EXAMINING ATTORNEY

CLASS 10—(Continued).

SN 77-482,092. NORTH AMERICAN RESCUE PRODUCTS, INC., DBA NORTH AMERICAN RESCUE, GREER, SC. FILED 5-23-2008.

ARS

THE MARK CONSISTS OF STANDARD CHARACTERS WITHOUT CLAIM TO ANY PARTICULAR FONT, STYLE, SIZE, OR COLOR.
FOR NEEDLES FOR MEDICAL PURPOSES (U.S. CLS. 26, 39 AND 44).
RENEE SERVANCE, EXAMINING ATTORNEY

CLASS 10—(Continued).

SN 78-885,784. TERUMO KABUSHIKI KAISHA A/K/A TERUMO CORPORATION, SHIBUYA-KU, JAPAN, FILED 5-17-2006.

MEDISAFE

THE MARK CONSISTS OF STANDARD CHARACTERS WITHOUT CLAIM TO ANY PARTICULAR FONT, STYLE, SIZE, OR COLOR.
OWNER OF JAPAN REG. NO. 4403348, DATED 7-28-2000, EXPIRES 7-28-2010.
FOR BLOOD GLUCOSE MONITORS, BLOOD TESTING TIPS, LANCETS, AND LANCET DEVICES (U.S. CLS. 26, 39 AND 44).
DORITT L. CARROLL, EXAMINING ATTORNEY

SN 77-488,119. ARTHREX, INC., NAPLES, FL. FILED 6-1-2008.

BIOWIRE

THE MARK CONSISTS OF STANDARD CHARACTERS WITHOUT CLAIM TO ANY PARTICULAR FONT, STYLE, SIZE, OR COLOR.
FOR MEDICAL DEVICES, NAMELY, A SUTURE (U.S. CLS. 26, 39 AND 44).
SUSAN LESLIE DUBOIS, EXAMINING ATTORNEY

SN 78-972,821. HESHMAT MAJLESSI, RYE, NY. FILED 9-12-2006.

MAJLESSI HARVESTER

SN 78-593,715. OXYBAND TECHNOLOGIES INC, MILL VALLEY, CA. FILED 3-23-2005.

Oxy-Band

THE MARK CONSISTS OF STANDARD CHARACTERS WITHOUT CLAIM TO ANY PARTICULAR FONT, STYLE, SIZE, OR COLOR.
FOR WOUND DRESSINGS, NAMELY, AN OXYGEN DIFFUSION WOUND DRESSING WHICH ACCELERATES HEALING AND REDUCES INFECTION BY DELIVERING A CONTINUOUS SUPPLY OF OXYGEN DIRECTLY TO THE WOUND TO IMPROVE HEALING (U.S. CLS. 26, 39 AND 44).
EUGENIA MARTIN, EXAMINING ATTORNEY

THE MARK CONSISTS OF STANDARD CHARACTERS WITHOUT CLAIM TO ANY PARTICULAR FONT, STYLE, SIZE, OR COLOR.
NO CLAIM IS MADE TO THE EXCLUSIVE RIGHT TO USE "HARVESTER", APART FROM THE MARK AS SHOWN.
SEC. 2(F).
FOR VEIN HARVESTING MEDICAL INSTRUMENT (U.S. CLS. 26, 39 AND 44).
DEZMONA MIZELLE, EXAMINING ATTORNEY

CLASS 10—(Continued).

SN 79-039,309. DIRECTA AB, SWEDEN, FILED 6-4-2007.



PRIORITY DATE OF 1-22-2007 IS CLAIMED.
 OWNER OF INTERNATIONAL REGISTRATION 0926178
 DATED 6-4-2007, EXPIRES 6-4-2017.
 OWNER OF U.S. REG. NO. 849,514.
 NO CLAIM IS MADE TO THE EXCLUSIVE RIGHT TO
 USE "DESIGN BY DENTISTS", APART FROM THE MARK
 AS SHOWN.

FOR DENTAL APPARATUS, INSTRUMENTS AND
 CONSUMABLES FOR HUMAN AND VETERINARY
 PURPOSES, ALL IN THE FORM OF AN INCLUSIVE
 RANGE OF DEVICES FOR DENTAL APPLICATIONS
 AND FOR DENTAL PURPOSES, NAMELY, DENTAL
 WEDGES, DENTAL MATRIX SYSTEMS COMPRISED
 OF MATRIX BANDS AND MATRIX BAND RETAINERS,
 TEMPORARY DENTAL CROWNS, ELEVATORS,
 NAMELY, PERIOSTEAL ELEVATORS, DENTAL APPLI-
 CATION BRUSHES AND STICKS FOR USE BY DEN-
 TISTS DURING OFFICE PROCEDURES, DENTAL PICS,
 TRAYS AND CONTAINERS SPECIALLY DESIGNED TO
 HOLD, SECURE, MAKE ACCESSIBLE FOR USE, AND
 STORE DENTAL INSTRUMENTS DURING CLINICAL
 PROCEDURES FOR MEDICAL AND VETERINARY
 PURPOSES (U.S. CLS. 26, 39 AND 44).

SUZANNE BLANE, EXAMINING ATTORNEY

SN 79-045,619. LABORATOIRES INNOTHERA, FRANCE,
 FILED 1-25-2007.

INNOTHERA

OWNER OF INTERNATIONAL REGISTRATION 0900353
 DATED 9-28-2006, EXPIRES 9-28-2016.
 OWNER OF U.S. REG. NOS. 2,438,007 AND 2,611,084.
 FOR MEDICAL APPARATUS AND INSTRUMENTS
 FOR DIAGNOSING OR TREATING VENOUS PATHOL-
 OGY; ORTHOPAEDIC ARTICLES, NAMELY, ORTHO-
 PAEDIC BANDAGES, ORTHOPAEDIC SOLES;
 COMPRESSIONS ORTHOSES, NAMELY, ORTHOTIC IN-
 SERTS FOR FOOTWEAR; MEDICAL COMPRESSION
 STRIPS AND BANDAGES, MEDICAL COMPRESSION
 SOCKS; MEDICAL COMPRESSION STOCKINGS AND
 TIGHTS; MEDICAL COMPRESSION STOCKINGS AND
 TIGHTS FOR VARICOSE VEINS; STOCKING AND
 TIGHTS FOR MEDICAL USE (U.S. CLS. 26, 39 AND 44).
 NAPOLEON SHARMA, EXAMINING ATTORNEY

CLASS 10—(Continued).SN 79-045,620. LABORATOIRES INNOTHERA, FRANCE,
FILED 1-25-2007.OWNER OF INTERNATIONAL REGISTRATION 0900354
DATED 9-28-2006, EXPIRES 9-28-2016.

OWNER OF U.S. REG. NOS. 2,438,007 AND 2,611,084.
 FOR MEDICAL APPARATUS AND INSTRUMENTS
 FOR DIAGNOSING OR TREATING VENOUS PATHOL-
 OGY; ORTHOPAEDIC ARTICLES, NAMELY, ORTHO-
 PAEDIC BANDAGES, ORTHOPAEDIC SOLES;
 COMPRESSIONS ORTHOSES, NAMELY, ORTHOTIC IN-
 SERTS FOR FOOTWEAR; MEDICAL COMPRESSION
 STRIPS AND BANDAGES, MEDICAL COMPRESSION
 SOCKS; MEDICAL COMPRESSION STOCKINGS AND
 TIGHTS; MEDICAL COMPRESSION STOCKINGS AND
 TIGHTS FOR VARICOSE VEINS; STOCKING AND
 TIGHTS FOR MEDICAL USE (U.S. CLS. 26, 39 AND 44).
 NAPOLEON SHARMA, EXAMINING ATTORNEY

SN 79-051,415. GN RESOUND A/S, DENMARK, FILED 2-15-
 2008.

RESOUND ESSENCE

THE MARK CONSISTS OF STANDARD CHARACTERS
 WITHOUT CLAIM TO ANY PARTICULAR FONT, STYLE,
 SIZE, OR COLOR.

PRIORITY DATE OF 11-12-2007 IS CLAIMED.
 OWNER OF INTERNATIONAL REGISTRATION 0957511
 DATED 2-15-2008, EXPIRES 2-15-2018.
 OWNER OF U.S. REG. NOS. 1,488,398, 3,427,171 AND
 OTHERS.
 FOR HEARING AIDS (U.S. CLS. 26, 39 AND 44).
 PATRICIA EVANKO, EXAMINING ATTORNEY

SN 79-053,146. GIPHARMA SRL, ITALY, FILED 3-21-2008.

LEUKOKIT

THE MARK CONSISTS OF STANDARD CHARACTERS
 WITHOUT CLAIM TO ANY PARTICULAR FONT, STYLE,
 SIZE, OR COLOR.

PRIORITY DATE OF 3-17-2008 IS CLAIMED.
 OWNER OF INTERNATIONAL REGISTRATION 0962381
 DATED 3-21-2008, EXPIRES 3-21-2018.
 FOR MEDICAL DEVICES FOR DIAGNOSTIC ACTIV-
 ITY BY MEANS OF SCINTIGRAPHY (U.S. CLS. 26, 39
 AND 44).
 MATTHEW EINSTEIN, EXAMINING ATTORNEY

CLASS 11—ENVIRONMENTAL CONTROL APPARATUS

SN 76-686,722. HOME INVENTIONS, INC., ORLANDO, FL. FILED 2-11-2008.



NO CLAIM IS MADE TO THE EXCLUSIVE RIGHT TO USE "FRIDGERACK", APART FROM THE MARK AS SHOWN.

THE MARK CONSISTS OF THE WORD "FRIDGERACK" AND A DESIGN OF PARALLEL BARS ADJACENT TO THE WORD IN BLACK TYPE FONT.

FOR REFRIGERATOR STORAGE RACKS (U.S. CLS. 13, 21, 23, 31 AND 34).

MICHELE SWAIN, EXAMINING ATTORNEY

SN 76-687,418. ROSSMAN ENTERPRISES, INCORPORATED, CINCINNATI, OH. FILED 3-6-2008.

AIRHAWK

THE MARK CONSISTS OF STANDARD CHARACTERS WITHOUT CLAIM TO ANY PARTICULAR FONT, STYLE, SIZE, OR COLOR.

FOR AIR PURIFICATION UNITS (U.S. CLS. 13, 21, 23, 31 AND 34).

FIRST USE 9-15-2003; IN COMMERCE 2-15-2004.
RAMONA ORTIGA, EXAMINING ATTORNEY

CLASS 11—(Continued).

SN 77-047,707. METHVEN LIMITED, AVONDALE AUCKLAND, NEW ZEALAND, FILED 11-20-2006.

MAIA

THE MARK CONSISTS OF STANDARD CHARACTERS WITHOUT CLAIM TO ANY PARTICULAR FONT, STYLE, SIZE, OR COLOR.

THE ENGLISH TRANSLATION OF THE MAORI WORD "MAIA" IN THE MARK IS COURAGEOUS.

FOR SHOWERS; PLUMBING FITTINGS, NAMELY, SHOWER UNITS AND ENCLOSURES, SHOWER ENCLOSURES, SHOWER ROSES, SHOWER HEADS, NAMELY, SHOWER ROSES, HAND SETS, HAND SETS COMPRISING HAND HELD SHOWER HEADS, HAND SHOWERS AND HAND-HELD SHOWERS, HOSES AND MOUNTINGS, SHOWER HOSES AND MOUNTINGS, SHOWER TAPS, FAUCETS, BEAUTY SHOWERS, MIXERS AND CONTROLLERS, SHOWER MIXERS AND CONTROLLERS; HEATING EQUIPMENT, NAMELY, PIPES FOR HEATING BOILERS, THERMOSTATIC VALVES; STEAM GENERATION EQUIPMENT, NAMELY, STEAM GENERATORS, SHAM SHOWER CONTROL VALVES; SANITARY EQUIPMENT, NAMELY, PIPES BEING PARTS OF SANITARY FACILITIES; WATER SUPPLY EQUIPMENT, NAMELY, WATER FAUCET AND SHOWER SPOUTS, WATER COOLERS; PLUMBING FITTINGS, NAMELY, VALVES, MANUALLY OPERATED PLUMBING VALVES, TUB CONTROL VALVES AND STOP COCKS; WATER SUPPLY EQUIPMENT FOR USE IN THE BEAUTY INDUSTRY, NAMELY, FACIAL SHOWER HAND SETS COMPRISING HAND HELD SHOWER HEADS, HAND SHOWERS AND HAND-HELD SHOWERS; SHOWER HAND SETS FOR MASSAGE PURPOSES COMPRISING HAND HELD SHOWER HEADS, HAND SHOWERS AND HAND-HELD SHOWERS; SHOWER INFUSION APPARATUS AND INSTRUMENTS, NAMELY, APPARATUS AND INSTRUMENTS FOR INFUSING ADDITIVES INTO WATER; SHOWER HEADS FOR INFUSING ADDITIVES INTO WATER (U.S. CLS. 13, 21, 23, 31 AND 34).

SOPHIA S. KIM, EXAMINING ATTORNEY

SN 77-124,873. GLJ, LLC, CHICAGO, IL. FILED 3-7-2007.

Job Site

THE MARK CONSISTS OF STANDARD CHARACTERS WITHOUT CLAIM TO ANY PARTICULAR FONT, STYLE, SIZE, OR COLOR.

FOR PORTABLE ELECTRIC FANS (U.S. CLS. 13, 21, 23, 31 AND 34).

FIRST USE 12-6-2006; IN COMMERCE 12-6-2006.
KEVIN DINALLO, EXAMINING ATTORNEY

CLASS 11—(Continued).

SN 77-147,494. HENNY PENNY CORPORATION, EATON, OH. FILED 4-3-2007.

ClassicCombi

THE MARK CONSISTS OF THE WORDS "CLASSIC" AND "COMBI" APPEARING IN ITALICIZED VERDANA FONT WITH NO SPACE BETWEEN THEM, WITH THE WORD "COMBI" APPEARING IN BOLD ITALICIZED VERDANA FONT.

FOR COMMERCIAL FOOD PREPARATION EQUIPMENT, NAMELY, COMBINATION STEAMERS AND OVENS (U.S. CLS. 13, 21, 23, 31 AND 34).

JENNIFER VASQUEZ, EXAMINING ATTORNEY

SN 77-154,053. AQUASTAR POOL PRODUCTS, INC., SAN DIEGO, CA. FILED 4-11-2007.

FLOW MAX

THE MARK CONSISTS OF STANDARD CHARACTERS WITHOUT CLAIM TO ANY PARTICULAR FONT, STYLE, SIZE, OR COLOR.

FOR SWIMMING POOL DRAIN COVERS (U.S. CLS. 13, 21, 23, 31 AND 34).

FIRST USE 2-1-2006; IN COMMERCE 2-1-2006.

COLLEEN DOMBROW, EXAMINING ATTORNEY

CLASS 11—(Continued).

SN 77-157,258. AQUA-WIN WATERTEC CO., LTD., KAOHSIUNG CITY, TAIWAN, FILED 4-16-2007.

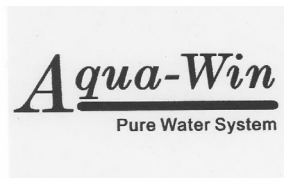

NO CLAIM IS MADE TO THE EXCLUSIVE RIGHT TO USE "PURE WATER SYSTEM", APART FROM THE MARK AS SHOWN.

FOR WATER FILTERS; WATER PURIFIERS; FILTER CARTRIDGES FOR WATER FILTERS; WATER IONIZERS; OZONE GENERATORS THAT KILL MOLD AND MILDEW; WATER TREATMENT EQUIPMENT, NAMELY, REVERSE OSMOSIS FILTRATION UNITS; WATER FILTERING UNITS FOR HOUSEHOLD USE; DRINKING FOUNTAINS; DRINKING FOUNTAIN PEDESTALS; ULTRAVIOLET LAMPS NOT FOR MEDICAL PURPOSES; HOUSINGS FOR WATER FILTERS; OZONE ULTRASONIC ANION GENERATORS; WATER AND SOFT-WATER TREATMENT EQUIPMENT, NAMELY, CARTRIDGE FILTRATION, CHEMICAL STERILIZATION, ULTRAVIOLET STERILIZATION AND REVERSE OSMOSIS FILTRATION UNITS; WATER FILTERING UNITS FOR DOMESTIC, COMMERCIAL AND INDUSTRIAL USE; REFRIGERATED WATER DISPENSING UNITS; WATER SOFTENING UNITS; DRINKING WATER DISPENSERS, NAMELY, WATER COOLERS; WATER DISPENSERS, NAMELY, WATER COOLERS WITH REVERSE OSMOSIS FILTRATION UNITS; FILTER CARTRIDGES FOR DRINKING FOUNTAINS; WATER IONIZERS; FILTER CARTRIDGES FOR WATER IONIZERS; WATER COOLERS; WATER TREATMENT EQUIPMENT, NAMELY, ULTRAVIOLET STERILIZATION UNITS; WATER TREATMENT EQUIPMENT, NAMELY, MEMBRANE FILTRATION UNITS; ALKALINE IONIC WATER GENERATORS (U.S. CLS. 13, 21, 23, 31 AND 34).

FIRST USE 7-31-2006; IN COMMERCE 7-31-2006.

STEVEN R. FINE, EXAMINING ATTORNEY

SN 77-173,659. VENTAMATIC, LTD., MINERAL WELLS, TX. FILED 5-4-2007.

VENTAMATIC

THE MARK CONSISTS OF STANDARD CHARACTERS WITHOUT CLAIM TO ANY PARTICULAR FONT, STYLE, SIZE, OR COLOR.

FOR POWER VENTILATORS TO EXHAUST HOT AIR FROM ATTICS; STATIC VENTILATORS TO EXHAUST HOT AIR FROM ATTICS; HIGH-VELOCITY ELECTRIC FLOOR FANS (U.S. CLS. 13, 21, 23, 31 AND 34).

FIRST USE 2-26-1949; IN COMMERCE 2-26-1949.

KATHERINE E. HALMEN, EXAMINING ATTORNEY

CLASS 11—(Continued).

SN 77-224,728. NUDE-LIGHT S.R.L., FIRENZE, ITALY, FILED 7-9-2007.

NUDELIGHT

THE MARK CONSISTS OF STANDARD CHARACTERS WITHOUT CLAIM TO ANY PARTICULAR FONT, STYLE, SIZE, OR COLOR.

PRIORITY CLAIMED UNDER SEC. 44(D) ON ERPN CMNTY TM OFC APPLICATION NO. 5724893, FILED 3-1-2007, REG. NO. 005724893, DATED 2-11-2008, EXPIRES 3-1-2017.

PRIORITY CLAIMED UNDER SEC. 44(D) ON ERPN CMNTY TM OFC APPLICATION NO. 5724893, FILED 3-1-2007, REG. NO. 005724893, DATED 2-11-2008, EXPIRES 1-3-2017.

FOR LIGHTING FIXTURES, ELECTRIC LIGHTING FIXTURES FOR STAGE LIGHTING, LIGHTS FOR VEHICLES, ELECTRIC LIGHT BULBS, FLUORESCENT TUBES FOR LIGHTING, FLUORESCENT LAMP TUBES, LAMPS, LAMP BASES, LAMP SHADES, ARC LAMPS, LAMPS FOR OUTDOOR USE, SOLDERING LAMPS, GAS LAMPS, ELECTRIC LANTERNS, OIL LAMPS, CHANDELIERS (U.S. CLS. 13, 21, 23, 31 AND 34).
FRED CARL, EXAMINING ATTORNEY

SN 77-254,014. TRUE MANUFACTURING CO., INC., O'FALON, MO. FILED 8-13-2007.

COLD INNOVATIONS

THE MARK CONSISTS OF STANDARD CHARACTERS WITHOUT CLAIM TO ANY PARTICULAR FONT, STYLE, SIZE, OR COLOR.

NO CLAIM IS MADE TO THE EXCLUSIVE RIGHT TO USE "COLD", APART FROM THE MARK AS SHOWN.

FOR REFRIGERATORS AND REFRIGERATED COOLERS (U.S. CLS. 13, 21, 23, 31 AND 34).

DAVID H. STINE, EXAMINING ATTORNEY

SN 77-265,334. HUNTAIR INC., TUALATIN, OR. FILED 8-27-2007.

FANWALL TECHNOLOGY

THE MARK CONSISTS OF STANDARD CHARACTERS WITHOUT CLAIM TO ANY PARTICULAR FONT, STYLE, SIZE, OR COLOR.

OWNER OF U.S. REG. NOS. 3,236,486 AND 3,321,029.

NO CLAIM IS MADE TO THE EXCLUSIVE RIGHT TO USE "TECHNOLOGY", APART FROM THE MARK AS SHOWN.

FOR AIR HANDLING UNITS (U.S. CLS. 13, 21, 23, 31 AND 34).

FIRST USE 9-29-2006; IN COMMERCE 9-29-2006.

JULIE GUTTADAURO, EXAMINING ATTORNEY

CLASS 11—(Continued).

SN 77-305,011. KOHLER CO., KOHLER, WI. FILED 10-16-2007.

PRO FORCE

THE MARK CONSISTS OF STANDARD CHARACTERS WITHOUT CLAIM TO ANY PARTICULAR FONT, STYLE, SIZE, OR COLOR.

FOR TOILETS; TOILET TANKS; TOILET BOWLS; TOILET FLUSH LEVERS; AND FLUSHING TECHNOLOGY, NAMELY, TOILET FLUSHING SYSTEMS COMPRISED OF TOILET TRIP LEVERS, TOILET TRIP ARMS, PLUNGERS, GASKETS, TOILET TANKS, TOILET FLUSH ACTUATORS, TOILET TRAPWAYS, FLUSH VALVE CANISTERS, FLUSH VALVES, FLUSH VALVE SEALS, FLUSH VALVE GASKETS, FILL VALVES, AND FILL VALVE PISTONS (U.S. CLS. 13, 21, 23, 31 AND 34).
NAPOLEON SHARMA, EXAMINING ATTORNEY

SN 77-306,433. LULLA BEDS, L.L.C., ORLANDO, FL. FILED 10-17-2007.

BED EFFECTS

THE MARK CONSISTS OF STANDARD CHARACTERS WITHOUT CLAIM TO ANY PARTICULAR FONT, STYLE, SIZE, OR COLOR.

NO CLAIM IS MADE TO THE EXCLUSIVE RIGHT TO USE "BED", APART FROM THE MARK AS SHOWN.

FOR DECORATIVE ELECTRIC LIGHTS FOR BEDS, LED LIGHTS AND ELECTRIC LIGHT STRIPS (U.S. CLS. 13, 21, 23, 31 AND 34).

FIRST USE 6-0-2007; IN COMMERCE 6-0-2007.

MICHELE SWAIN, EXAMINING ATTORNEY

SN 77-313,630. HOMER TLC, INC., CLAYMONT, DE. FILED 10-25-2007.

Altura

THE MARK CONSISTS OF STANDARD CHARACTERS WITHOUT CLAIM TO ANY PARTICULAR FONT, STYLE, SIZE, OR COLOR.

THE FOREIGN WORDING IN THE MARK TRANSLATES INTO ENGLISH AS HEIGHT.

FOR CEILING FANS; ELECTRIC LIGHTING FIXTURES (U.S. CLS. 13, 21, 23, 31 AND 34).

DANIEL BRODY, EXAMINING ATTORNEY

CLASS 11—(Continued).

SN 77-334,850. HESHAN LIDE ELECTRONIC ENTERPRISE COMPANY LIMITED, GONGHE TOWN, HESHAN, CHINA, FILED 11-21-2007.



THE MARK CONSISTS OF A HOUSE WITH THE SUN AT BACKGROUND AND THE WORD "HOME AND BEYOND". FOR LIGHT BULBS; LANTERNS FOR LIGHTING; STANDARD LAMPS; POCKET SEARCHLIGHTS; ELECTRIC CHINESE LANTERNS; ELECTRIC LIGHTS FOR CHRISTMAS TREES; LAMPS FOR OUTDOOR USE; LIGHTING FIXTURES FOR USE ON STAGE; ELECTRIC LAMPS; AQUARIUM LIGHTS (U.S. CLS. 13, 21, 23, 31 AND 34).

WANDA KAY PRICE, EXAMINING ATTORNEY

SN 77-339,383. SHOE CARE INNOVATIONS, INC., REDWOOD CITY, CA. FILED 11-28-2007.



NO CLAIM IS MADE TO THE EXCLUSIVE RIGHT TO USE "SHOE CARE", APART FROM THE MARK AS SHOWN. THE MARK CONSISTS OF A MAN'S SHOE NEXT TO A WOMAN'S SHOE WITH A PLUS SYMBOL IN THE MIDDLE, WITH AN UNDERLINE DIRECTLY BELOW AND THE WORDS "SHOECARE INNOVATIONS" BELOW THE UNDERLINE.

FOR ELECTRIC UNITS FOR DEODORIZING AND SANITIZING SHOES (U.S. CLS. 13, 21, 23, 31 AND 34).

WENDY JUN, EXAMINING ATTORNEY

SN 77-339,395. SHOE CARE INNOVATIONS, INC., REDWOOD CITY, CA. FILED 11-28-2007.



THE MARK CONSISTS OF THE WORD "STERISHOE" WITH A LIGHT BULB IN PLACE OF THE DOT FOR THE LETTER "I" WITH TWO SEMICIRCLES ABOVE THE LIGHT BULB.

FOR ELECTRIC UNITS FOR DEODORIZING AND SANITIZING SHOES (U.S. CLS. 13, 21, 23, 31 AND 34).

WENDY JUN, EXAMINING ATTORNEY

CLASS 11—(Continued).

SN 77-366,650. OPTO-ELECTRONIC DESIGN, INC., EDEN PRAIRIE, MN. FILED 1-8-2008.

FakeTV

THE MARK CONSISTS OF STANDARD CHARACTERS WITHOUT CLAIM TO ANY PARTICULAR FONT, STYLE, SIZE, OR COLOR.

FOR BURGLAR DETERRENT DEVICES FOR PROVIDING HOME OCCUPANCY SIMULATION, NAMELY, DEVICES FOR PRODUCING A LIGHT OUTPUT THAT SIMULATES THE EFFECT OF AN OPERATING TELEVISION RECEIVER (U.S. CLS. 13, 21, 23, 31 AND 34).

FIRST USE 2-11-2008; IN COMMERCE 2-11-2008.

SARA THOMAS, EXAMINING ATTORNEY

SN 77-387,864. INNOVATIVE LIGHTING, INC., ROLAND, IA. FILED 2-4-2008.

ECOBRITE

THE MARK CONSISTS OF STANDARD CHARACTERS WITHOUT CLAIM TO ANY PARTICULAR FONT, STYLE, SIZE, OR COLOR.

FOR CEILING LIGHTS; LIGHTING PRODUCTS, NAMELY, LIGHTING FIXTURES; LED LIGHTING FIXTURES; HOME LIGHTING, NAMELY, LED LAMPS, LED LIGHT BULBS, AND LED UNDER CABINET LIGHTING (U.S. CLS. 13, 21, 23, 31 AND 34).

SUE LAWRENCE, EXAMINING ATTORNEY

CLASS 11—(Continued).

SN 77-389,212. TABLETOP STUDIO LLC, CARPINTERIA, CA. FILED 2-5-2008.



NO CLAIM IS MADE TO THE EXCLUSIVE RIGHT TO USE "LITE", APART FROM THE MARK AS SHOWN.

THE MARK CONSISTS OF A SQUARE DESIGN INCORPORATING FOUR INTERSECTING LINES ABOVE THE WORD "KÜHL LITE".

FOR ELECTRIC LIGHTING FIXTURES FOR PHOTOGRAPHIC AND VIDEO USE (U.S. CLS. 13, 21, 23, 31 AND 34).

FIRST USE 1-29-2008; IN COMMERCE 1-29-2008.
TEJBIR SINGH, EXAMINING ATTORNEY

SN 77-401,208. LINDSAY CORPORATION, OMAHA, NE. FILED 2-20-2008.

Z-TRAX

THE MARK CONSISTS OF STANDARD CHARACTERS WITHOUT CLAIM TO ANY PARTICULAR FONT, STYLE, SIZE, OR COLOR.

OWNER OF U.S. REG. NO. 2,955,739.

FOR TRACK MANAGEMENT SYSTEM FOR MECHANICAL MOVE IRRIGATION (U.S. CLS. 13, 21, 23, 31 AND 34).

FIRST USE 8-15-2007; IN COMMERCE 8-15-2007.
HEATHER SAPP, EXAMINING ATTORNEY

CLASS 11—(Continued).

SN 77-409,416. JARRETT, EUGENE, WINTER PARK, FL. FILED 2-29-2008.



NO CLAIM IS MADE TO THE EXCLUSIVE RIGHT TO USE "CAB" AND "HEAT MONITOR", APART FROM THE MARK AS SHOWN.

THE COLOR(S) RED AND BLACK IS/ARE CLAIMED AS A FEATURE OF THE MARK.

THE MARK CONSISTS OF THE WORDS "CAB EXTREME HEAT MONITOR" IN RED DISPOSED ON A IMAGE OF A HALF SUN IN BLACK, AND THE TERM "EUG-J" IN BLACK ABOVE THE TERM "CAB EXTREME HEAT MONITOR".

FOR VEHICLE SAFETY EQUIPMENT, NAMELY, ELECTRONIC HEAT SENSOR MONITORS (U.S. CLS. 13, 21, 23, 31 AND 34).

THOMAS MANOR, EXAMINING ATTORNEY

SN 77-412,122. MERIDIAN LIFEFORCE INC., SCARBOROUGH, CANADA, FILED 3-4-2008.



NO CLAIM IS MADE TO THE EXCLUSIVE RIGHT TO USE "HEALTH IONIZER", APART FROM THE MARK AS SHOWN.

THE MARK CONSISTS OF THE "Z" IN THE WORD "IONIZER" IS A STYLIZED LETTER "Z" OF A LIGHTNING BOLT DESIGN..

FOR PORTABLE FOOT BATHS FOR USE IN PEDICURE SALONS AND DAY SPAS (U.S. CLS. 13, 21, 23, 31 AND 34).

BERYL GARDNER, EXAMINING ATTORNEY

CLASS 11—(Continued).

SN 77-418,204. LEE, DAVID, GARDENA, CA. FILED 3-10-2008.



THE MARK CONSISTS OF A STYLIZED SHIELD BEARING A TRIANGULAR ELEMENT TO THE LEFT OF THE STYLIZED TEXT "RIKENSPORT" AND "THE SPIRIT OF PERFORMANCE" THAT APPEARS ON TWO LINES OF TEXT SEPARATED BY A LINE.

FOR LIGHTS FOR VEHICLES (U.S. CLS. 13, 21, 23, 31 AND 34).

FIRST USE 8-16-2005; IN COMMERCE 8-16-2005.
LINDA POWELL, EXAMINING ATTORNEY

CLASS 11—(Continued).

SN 77-421,481. SCHUNK GRAPHITE TECHNOLOGY, LLC, MENOMONEE FALLS, WI. FILED 3-13-2008.

BASKIT

THE MARK CONSISTS OF STANDARD CHARACTERS WITHOUT CLAIM TO ANY PARTICULAR FONT, STYLE, SIZE, OR COLOR.

FOR HEAT TREATING FURNACE ACCESSORIES, NAMELY, KIT OF NON-METAL, CARBON-BASED COMPONENTS AND PARTS, WHICH, WHEN CONNECTED TO GRIDS, FORMS A CONTAINER FOR HOLDING OBJECTS TO BE HEAT TREATED (U.S. CLS. 13, 21, 23, 31 AND 34).

ROBERT LAVACHE, EXAMINING ATTORNEY

SN 77-420,897. Q MARKETING GROUP, LTD., GREAT NECK, NY. FILED 3-13-2008.

NEWRAY

THE MARK CONSISTS OF STANDARD CHARACTERS WITHOUT CLAIM TO ANY PARTICULAR FONT, STYLE, SIZE, OR COLOR.

FOR OUTDOOR LIGHTS, NAMELY, OUTDOOR SOLAR POWERED LIGHTING UNITS AND FIXTURES (U.S. CLS. 13, 21, 23, 31 AND 34).

DAVID COLLIER, EXAMINING ATTORNEY

SN 77-423,300. ACORN ENGINEERING COMPANY, CITY OF INDUSTRY, CA. FILED 3-17-2008.

SAFETYWARE

THE MARK CONSISTS OF STANDARD CHARACTERS WITHOUT CLAIM TO ANY PARTICULAR FONT, STYLE, SIZE, OR COLOR.

FOR INDUSTRIAL EYE WASH FOUNTAINS AND EMERGENCY SHOWERS (U.S. CLS. 13, 21, 23, 31 AND 34).

RONALD AIKENS, EXAMINING ATTORNEY

SN 77-421,013. SONNY'S ENTERPRISES, INC., TAMARAC, FL. FILED 3-13-2008.

GATOR

THE MARK CONSISTS OF STANDARD CHARACTERS WITHOUT CLAIM TO ANY PARTICULAR FONT, STYLE, SIZE, OR COLOR.

FOR BLOW DRYERS FOR CARWASHES (U.S. CLS. 13, 21, 23, 31 AND 34).

KAREN SEVERSON, EXAMINING ATTORNEY

SN 77-423,538. CURTIS-TOLEDO, INC., ST. LOUIS, MO. FILED 3-17-2008.

DEMANDSMART

THE MARK CONSISTS OF STANDARD CHARACTERS WITHOUT CLAIM TO ANY PARTICULAR FONT, STYLE, SIZE, OR COLOR.

FOR AIR DRYERS (U.S. CLS. 13, 21, 23, 31 AND 34).

MARY ROSSMAN, EXAMINING ATTORNEY

CLASS 11—(Continued).

SN 77-424,962. FIBER-FAB LLC, GERVAIS, OR. FILED 3-18-2008.

FIBER-FAB

THE MARK CONSISTS OF STANDARD CHARACTERS WITHOUT CLAIM TO ANY PARTICULAR FONT, STYLE, SIZE, OR COLOR.
FOR SHOWERS, BATHTUBS, SHOWER TUBS, SPAS AND SHOWER BASES (U.S. CLS. 13, 21, 23, 31 AND 34).
FIRST USE 0-0-1957; IN COMMERCE 0-0-1957.
LEIGH CAROLINE CASE, EXAMINING ATTORNEY

SN 77-425,739. GOODHAIR LLC, NORTH CANTON, OH. FILED 3-19-2008.

GOODHAIR

THE MARK CONSISTS OF STANDARD CHARACTERS WITHOUT CLAIM TO ANY PARTICULAR FONT, STYLE, SIZE, OR COLOR.
FOR HAND-HELD ELECTRIC HAIR DRYERS (U.S. CLS. 13, 21, 23, 31 AND 34).
B. PARADEWELAI, EXAMINING ATTORNEY

CLASS 11—(Continued).

SN 77-426,611. WIRELESS LIGHTING TECHNOLOGIES, LLC, PEPPER PIKE, OH. FILED 3-19-2008.



THE NAME(S), PORTRAIT(S), AND/OR SIGNATURE(S) SHOWN IN THE MARK DOES NOT IDENTIFY A PARTICULAR LIVING INDIVIDUAL.

THE COLOR(S) BLACK, WHITE, GRAY AND YELLOW IS/ARE CLAIMED AS A FEATURE OF THE MARK.

THE MARK CONSISTS OF A BUTLER LINED IN BLACK WITH WHITE AND GRAY FILLING IN A TUXEDO WITH BOW TIE HOLDS A BLACK TRAY IN HIS HAND. THE WORDS "MR. BEAMS" APPEAR IN BLACK ABOVE THE BUTLER. A BEAM OF YELLOW LIGHT EMITS FROM THE WORDS "MR. BEAMS" AND SHINES DOWN ON TO THE TRAY HELD BY THE BUTLER.

FOR (BASED ON USE IN COMMERCE) LED (LIGHT EMITTING DIODES) LIGHTING FIXTURES FOR USE IN DISPLAY, COMMERCIAL, INDUSTRIAL, RESIDENTIAL, AND ARCHITECTURAL ACCENT LIGHTING APPLICATIONS; LED AND HID LIGHT FIXTURES; LED LIGHTING FIXTURES FOR INDOOR AND OUTDOOR LIGHTING APPLICATIONS(BASED ON INTENT TO USE) LED LIGHT BULBS (U.S. CLS. 13, 21, 23, 31 AND 34).

FIRST USE 5-15-2007; IN COMMERCE 10-19-2007.
CHRISTINA SOBRAL, EXAMINING ATTORNEY

SN 77-426,897. RETTIG USA INC., COLCHESTER, VT. FILED 3-20-2008.



OWNER OF U.S. REG. NOS. 1,801,995, 1,803,173 AND 2,494,192.

THE MARK CONSISTS OF THE WORD "MYSON" TOGETHER WITH A STYLIZED REPRESENTATION OF A FIREBALL.

FOR ENVIRONMENTAL CONTROL APPARATUS FOR RESIDENTIAL USE; NAMELY, RADIATORS, ELECTRIC TOWEL WARMERS, AND FAN CONVECTION HEATERS (U.S. CLS. 13, 21, 23, 31 AND 34).

FIRST USE 1-1-2008; IN COMMERCE 1-1-2008.
JOHN KELLY, EXAMINING ATTORNEY

CLASS 11—(Continued).

SN 77-427,029. FIRST LINE TECHNOLOGY, LLC, CHANTILLY, VA. FILED 3-20-2008.

PhaseCore

THE MARK CONSISTS OF STANDARD CHARACTERS WITHOUT CLAIM TO ANY PARTICULAR FONT, STYLE, SIZE, OR COLOR.

FOR HEATING AND COOLING PACKS FILLED WITH CHEMICAL SUBSTANCES THAT REACT WHEN REQUIRED TO WARM OR COOL THE BODY (U.S. CLS. 13, 21, 23, 31 AND 34).

FIRST USE 6-1-2006; IN COMMERCE 6-1-2006.
MARY ROSSMAN, EXAMINING ATTORNEY

SN 77-427,382. NORDIC PLUS, INC., DBA NORDICPURE, CELINA, TX. FILED 3-20-2008.

NORDICPURE

THE MARK CONSISTS OF STANDARD CHARACTERS WITHOUT CLAIM TO ANY PARTICULAR FONT, STYLE, SIZE, OR COLOR.

FOR AIR FILTERS FOR DOMESTIC USE (U.S. CLS. 13, 21, 23, 31 AND 34).

FIRST USE 1-0-2004; IN COMMERCE 1-0-2004.
WENDY GOODMAN, EXAMINING ATTORNEY

SN 77-427,426. SCHUMAN'S CLEANING SERVICE, INC., TRAPPE, MD. FILED 3-20-2008.

Nautic Air

THE MARK CONSISTS OF STANDARD CHARACTERS WITHOUT CLAIM TO ANY PARTICULAR FONT, STYLE, SIZE, OR COLOR.

NO CLAIM IS MADE TO THE EXCLUSIVE RIGHT TO USE "AIR", APART FROM THE MARK AS SHOWN.

FOR AIR PURIFICATION UNITS (U.S. CLS. 13, 21, 23, 31 AND 34).

CHARLES L. JENKINS, EXAMINING ATTORNEY

CLASS 11—(Continued).

SN 77-428,936. WCM INDUSTRIES, INC., COLORADO SPRINGS, CO. FILED 3-22-2008.

QUICKTRIM

THE MARK CONSISTS OF STANDARD CHARACTERS WITHOUT CLAIM TO ANY PARTICULAR FONT, STYLE, SIZE, OR COLOR.

FOR TUB PARTS, NAMELY, TUB WASTE COVERS (U.S. CLS. 13, 21, 23, 31 AND 34).

FIRST USE 9-0-2007; IN COMMERCE 9-0-2007.
INGA ERVIN, EXAMINING ATTORNEY

SN 77-428,939. WCM INDUSTRIES, INC., COLORADO SPRINGS, CO. FILED 3-22-2008.

PRESFLO

THE MARK CONSISTS OF STANDARD CHARACTERS WITHOUT CLAIM TO ANY PARTICULAR FONT, STYLE, SIZE, OR COLOR.

FOR DRAINS (U.S. CLS. 13, 21, 23, 31 AND 34).

FIRST USE 1-0-1998; IN COMMERCE 1-0-1998.
INGA ERVIN, EXAMINING ATTORNEY

SN 77-429,076. GALPA INVESTMENT LTD., CHRIST CHURCH, BARBADOS, FILED 3-23-2008.

THE COLOR(S) WHITE, BLACK, GREY AND BLUE IS/ ARE CLAIMED AS A FEATURE OF THE MARK.

THE MARK CONSISTS OF THE WORD "ECOX" IN STYLIZED BLACK LETTERS. A BLUE ARCH LIKE FIGURE APPEARS OVER THE DRAWING, INTERSECTING PORTIONS OF THE LETTERS "E", "C" AND "O". THE COLOR WHITE APPEARS IN THE AREAS OF THE LETTER "E" THE ARCH LIKE FIGURE CROSSES. THE COLOR GREY APPEARS IN THE AREAS OF THE LETTERS "C" AND "O" THE ARCH LIKE FIGURE CROSSES.

FOR AIR CONDITIONERS; AIR CONDITIONING UNITS; APPLIANCES FOR DOMESTIC USE, NAMELY, TEMPERATURE CONTROLLED WINE CELLARS; WINE COOLERS, NAMELY, REFRIGERATED CABINETS CONTAINING RACKS FOR WINE BOTTLES AND STORAGE SHELVES; DEHUMIDIFIERS (U.S. CLS. 13, 21, 23, 31 AND 34).

FIRST USE 12-31-2003; IN COMMERCE 12-31-2003.
MARLENE BELL, EXAMINING ATTORNEY

CLASS 11—(Continued).

SN 77-429,740. VITAL SAUNAS INC., SAN DIEGO, CA.
FILED 3-24-2008.



NO CLAIM IS MADE TO THE EXCLUSIVE RIGHT TO USE "SAUNAS", APART FROM THE MARK AS SHOWN. THE MARK CONSISTS OF THE WORDING "VITAL SAUNAS" IN STYLIZED FONT WITH TWO CURVED LINES SEPARATING THE TWO TERMS.

FOR SAUNAS (U.S. CLS. 13, 21, 23, 31 AND 34).
FIRST USE 3-24-2008; IN COMMERCE 3-24-2008.
MARCIE MILONE, EXAMINING ATTORNEY

SN 77-429,910. EVAPCO, INC., WESTMINSTER, MD. FILED
3-24-2008.

SENSI-COIL

THE MARK CONSISTS OF STANDARD CHARACTERS WITHOUT CLAIM TO ANY PARTICULAR FONT, STYLE, SIZE, OR COLOR.

FOR COMPONENTS FOR AIR CONDITIONING AND COOLING SYSTEMS, NAMELY, EVAPORATIVE AIR COOLERS (U.S. CLS. 13, 21, 23, 31 AND 34).
FIRST USE 7-1-2006; IN COMMERCE 7-1-2006.
ATTIYA MALIK, EXAMINING ATTORNEY

SN 77-430,665. JEW IT UP, LLC, HOLMDEL, NJ. FILED 3-25-
2008.

JEW IT UP

THE MARK CONSISTS OF STANDARD CHARACTERS WITHOUT CLAIM TO ANY PARTICULAR FONT, STYLE, SIZE, OR COLOR.

FOR INDOOR AND OUTDOOR JEWISH HOLIDAY LIGHTS (U.S. CLS. 13, 21, 23, 31 AND 34).
SUZANNE BLANE, EXAMINING ATTORNEY

CLASS 11—(Continued).

SN 77-431,733. TECH LIGHTING, L.L.C., SKOKIE, IL. FILED
3-26-2008.

LBL LIGHTING

THE MARK CONSISTS OF STANDARD CHARACTERS WITHOUT CLAIM TO ANY PARTICULAR FONT, STYLE, SIZE, OR COLOR.

NO CLAIM IS MADE TO THE EXCLUSIVE RIGHT TO USE "LIGHTING", APART FROM THE MARK AS SHOWN. FOR ELECTRIC LIGHTING FIXTURES (U.S. CLS. 13, 21, 23, 31 AND 34).

FIRST USE 0-0-1991; IN COMMERCE 0-0-1991.
H. M. FISHER, EXAMINING ATTORNEY

SN 77-431,812. TECH LIGHTING, L.L.C., SKOKIE, IL. FILED
3-26-2008.



FOR ELECTRIC LIGHTING FIXTURES (U.S. CLS. 13, 21, 23, 31 AND 34).

FIRST USE 0-0-1987; IN COMMERCE 0-0-1987.
H. M. FISHER, EXAMINING ATTORNEY

SN 77-432,480. GULFSTREAM PLASTICS LTD., CAM-
BRIDGE, CANADA, FILED 3-26-2008.

CAMELIA

THE MARK CONSISTS OF STANDARD CHARACTERS WITHOUT CLAIM TO ANY PARTICULAR FONT, STYLE, SIZE, OR COLOR.

FOR HYDROTHERAPY TUBS; WHIRLPOOLS AND WHIRLPOOL JETS; HOT TUBS AND HOT TUB JETS; BATH TUBS AND BATH TUB JETS; PERSONAL CARE FOOT SPAS, NAMELY, PEDICURE STATIONS; WATER/AIR JETS FOR PRODUCING BUBBLES FOR USE IN WHIRLPOOLS, HOT TUBS, BATH TUBS, FOOT SPAS; FAUCETS; FITTED LINERS FOR HOT TUBS OR SPAS (U.S. CLS. 13, 21, 23, 31 AND 34).

BARNEY CHARLON, EXAMINING ATTORNEY

CLASS 11—(Continued).

SN 77-433,416. PALMER FIXTURE COMPANY, GREEN BAY, WI. FILED 3-27-2008.



THE MARK CONSISTS OF A TORNADO AT THE END OF THE WORD "BLUSTORM".
FOR ELECTRIC HOT AIR HAND DRYERS (U.S. CLS. 13, 21, 23, 31 AND 34).
GISELLE AGOSTO, EXAMINING ATTORNEY

SN 77-433,887. TROY-CSL LIGHTING, INC., CITY OF INDUSTRY, CA. FILED 3-27-2008.

CSL

THE MARK CONSISTS OF STANDARD CHARACTERS WITHOUT CLAIM TO ANY PARTICULAR FONT, STYLE, SIZE, OR COLOR.
OWNER OF U.S. REG. NO. 2,831,438.
FOR ELECTRICAL LIGHTING APPARATUS, NAMELY, FIXTURES, SPOT LIGHTS, DOWNLIGHTS AND LIGHTING STRIPS (U.S. CLS. 13, 21, 23, 31 AND 34).
FIRST USE 0-0-1958; IN COMMERCE 0-0-1958.
NORA BUCHANAN WILL, EXAMINING ATTORNEY

SN 77-434,203. ALEN CORPORATION, AUSTIN, TX. FILED 3-28-2008.

Paralda

THE MARK CONSISTS OF STANDARD CHARACTERS WITHOUT CLAIM TO ANY PARTICULAR FONT, STYLE, SIZE, OR COLOR.
FOR AIR PURIFIERS (U.S. CLS. 13, 21, 23, 31 AND 34).
FIRST USE 3-24-2008; IN COMMERCE 3-24-2008.
TARA PATE, EXAMINING ATTORNEY

CLASS 11—(Continued).

SN 77-434,680. TRUE MANUFACTURING CO., INC., O'FAL-LON, MO. FILED 3-28-2008.

MAKING THE WORLD COOLER

THE MARK CONSISTS OF STANDARD CHARACTERS WITHOUT CLAIM TO ANY PARTICULAR FONT, STYLE, SIZE, OR COLOR.
FOR REFRIGERATED COOLERS (U.S. CLS. 13, 21, 23, 31 AND 34).
RICHARD A. STRASER, EXAMINING ATTORNEY

SN 77-434,755. K-RAIN MANUFACTURING CORP., RIV-IERA BEACH, FL. FILED 3-28-2008.

K5

THE MARK CONSISTS OF STANDARD CHARACTERS WITHOUT CLAIM TO ANY PARTICULAR FONT, STYLE, SIZE, OR COLOR.
FOR IRRIGATION SPRINKLERS (U.S. CLS. 13, 21, 23, 31 AND 34).
JULIE WATSON, EXAMINING ATTORNEY

SN 77-435,580. GUNLER, INC., THE WOODLANDS, TX. FILED 3-31-2008.

The logo for Healthy source Elite features the word "Healthy" in a large, black, sans-serif font. Below it, the word "source" is written in a smaller, black, sans-serif font with wide letter spacing. Below "source" is the word "Elite" in a very large, bold, black, sans-serif font.

THE MARK CONSISTS OF THE WORD "HEALTHY" IN LARGE LETTERS, UNDERNEATH IT THE WORD "SOURCE" IN SMALL LETTERS, UNDERNEATH IT THE WORD "ELITE" IN LARGE LETTERS.
FOR HUMIDIFIERS (U.S. CLS. 13, 21, 23, 31 AND 34).
AMOS T. MATTHEWS, JR., EXAMINING ATTORNEY

CLASS 11—(Continued).

SN 77-436,311. VITAL SAUNAS INC., SAN DIEGO, CA.
FILED 3-31-2008.

Vital Rays

THE MARK CONSISTS OF STANDARD CHARACTERS WITHOUT CLAIM TO ANY PARTICULAR FONT, STYLE, SIZE, OR COLOR.

FOR HEATING ELEMENTS SOLD AS A COMPONENT PART OF SAUNAS (U.S. CLS. 13, 21, 23, 31 AND 34).

FIRST USE 3-25-2008; IN COMMERCE 3-25-2008.

MARCIE MILONE, EXAMINING ATTORNEY

SN 77-443,733. MJSI, INC., SHOREWOOD, IL. FILED 4-9-2008.

HYDROFORCE

THE MARK CONSISTS OF STANDARD CHARACTERS WITHOUT CLAIM TO ANY PARTICULAR FONT, STYLE, SIZE, OR COLOR.

FOR PARTS FOR TOILETS, NAMELY, TOILET TANK FLAPPERS (U.S. CLS. 13, 21, 23, 31 AND 34).

FIRST USE 4-20-2007; IN COMMERCE 4-20-2007.

KATHLEEN M. VANSTON, EXAMINING ATTORNEY

SN 77-461,883. EVERDRY MARKETING & MANAGEMENT, INC., MACEDONIA, OH. FILED 4-30-2008.

EZ BREATHE

THE MARK CONSISTS OF STANDARD CHARACTERS WITHOUT CLAIM TO ANY PARTICULAR FONT, STYLE, SIZE, OR COLOR.

OWNER OF U.S. REG. NO. 2,787,212.

FOR VENTILATION SYSTEMS COMPRISED OF VENTILATION EXHAUST FANS, ELECTRONIC FAN CONTROLS, DUCTING FOR ELECTRIC CABLES, VENTILATION LOUVERS AND RELATIVE HUMIDITY SENSORS (U.S. CLS. 13, 21, 23, 31 AND 34).

FIRST USE 6-30-2006; IN COMMERCE 6-30-2006.

SUE LAWRENCE, EXAMINING ATTORNEY

CLASS 11—(Continued).

SN 77-464,640. MJSI, INC., SHOREWOOD, IL. FILED 5-2-2008.

HYDROWORKS

THE MARK CONSISTS OF STANDARD CHARACTERS WITHOUT CLAIM TO ANY PARTICULAR FONT, STYLE, SIZE, OR COLOR.

FOR PLUMBING SUPPLIES AND PARTS, NAMELY, TOILET FILL VALVES, TOILET FLAPPERS AND KITS FOR TOILET REPAIR COMPRISED PRIMARILY OF A TOILET FILL VALVE, TOILET FLAPPER, AND TANK CLEANING TUBE (U.S. CLS. 13, 21, 23, 31 AND 34).

FIRST USE 6-1-2007; IN COMMERCE 6-1-2007.

KATHLEEN M. VANSTON, EXAMINING ATTORNEY

SN 77-476,000. LEATHERMAN TOOL GROUP, INC., PORTLAND, OR. FILED 5-15-2008.

HEADWALL

THE MARK CONSISTS OF STANDARD CHARACTERS WITHOUT CLAIM TO ANY PARTICULAR FONT, STYLE, SIZE, OR COLOR.

FOR PERSONAL HEADLAMPS AND HEADBAND MOUNTED FLASHLIGHTS (U.S. CLS. 13, 21, 23, 31 AND 34).

MARK SPARACINO, EXAMINING ATTORNEY

SN 77-476,015. LEATHERMAN TOOL GROUP, INC., PORTLAND, OR. FILED 5-15-2008.

MORAINÉ

THE MARK CONSISTS OF STANDARD CHARACTERS WITHOUT CLAIM TO ANY PARTICULAR FONT, STYLE, SIZE, OR COLOR.

FOR MULTIPURPOSE FLASHLIGHT FEATURING ONE OR MORE OF THE FOLLOWING TOOL ELEMENTS, KNIFE, SCREWDRIVER, WRENCH, PLIERS, AWL, FILE, SAW, SCISSORS, SHEARS AND CAN OPENER (U.S. CLS. 13, 21, 23, 31 AND 34).

MARK SPARACINO, EXAMINING ATTORNEY

CLASS 11—(Continued).

SN 77-480,971. ALTICOR INC., ADA, MI. FILED 5-22-2008.

CLASS 11—(Continued).

SN 78-812,002. GESTION M.J.P.A. INC., RICHMOND, CANADA, FILED 2-10-2006.

PEAK POWER

THE MARK CONSISTS OF STANDARD CHARACTERS WITHOUT CLAIM TO ANY PARTICULAR FONT, STYLE, SIZE, OR COLOR.

OWNER OF U.S. REG. NO. 2,516,038.
FOR LIGHT BULBS (U.S. CLS. 13, 21, 23, 31 AND 34).
REGINA DRUMMOND, EXAMINING ATTORNEY

COMBOMAX

THE MARK CONSISTS OF STANDARD CHARACTERS WITHOUT CLAIM TO ANY PARTICULAR FONT, STYLE, SIZE, OR COLOR.

PRIORITY CLAIMED UNDER SEC. 44(D) ON CANADA APPLICATION NO. 1267962, FILED 8-10-2005, REG. NO. TMA711003, DATED 4-4-2008, EXPIRES 4-4-2023.

FOR HOT WATER HEATER, NAMELY, AN ELECTRIC MACHINE WHICH PRODUCES DOMESTIC HOT WATER INSTANTANEOUSLY AND HOT WATER FOR HYDRONIC SYSTEMS, SUCH AS HEATED FLOORS, RADIATORS, INDEPENDENT HOT AIR GENERATORS AND FAN COIL UNITS (U.S. CLS. 13, 21, 23, 31 AND 34).
JAMES LOVELACE, EXAMINING ATTORNEY

SN 77-481,503. PARAMOUNT LEISURE INDUSTRIES, INC., CHANDLER, AZ. FILED 5-22-2008.

PARASCOPE

THE MARK CONSISTS OF STANDARD CHARACTERS WITHOUT CLAIM TO ANY PARTICULAR FONT, STYLE, SIZE, OR COLOR.

FOR SWIMMING POOL FOUNTAINS (U.S. CLS. 13, 21, 23, 31 AND 34).

FIRST USE 4-28-2008; IN COMMERCE 4-28-2008.
STEPHEN AQUILA, EXAMINING ATTORNEY

SN 78-854,176. TROJAN TECHNOLOGIES INC., LONDON, ONTARIO, CANADA, FILED 4-5-2006.

TROJANUV3000PLUS

THE MARK CONSISTS OF STANDARD CHARACTERS WITHOUT CLAIM TO ANY PARTICULAR FONT, STYLE, SIZE, OR COLOR.

PRIORITY CLAIMED UNDER SEC. 44(D) ON CANADA APPLICATION NO. 1,295,819, FILED 3-29-2006, REG. NO. TMA692,106, DATED 7-16-2007, EXPIRES 7-16-2022.

OWNER OF U.S. REG. NOS. 1,916,336, 3,052,154 AND OTHERS.

FOR WATER AND FLUID TREATMENT EQUIPMENT, NAMELY, MECHANICAL EQUIPMENT WHICH UTILIZES ULTRA-VIOLET TECHNOLOGY FOR THE TREATMENT, DISINFECTION, PURIFICATION, AND STERILIZATION OF WATER AND OTHER FLUIDS FOR INDUSTRIAL, COMMERCIAL, MUNICIPAL, AND RESIDENTIAL USE (U.S. CLS. 13, 21, 23, 31 AND 34).
PETER B. BROMAGHIM, EXAMINING ATTORNEY

SN 77-510,308. TRUE MANUFACTURING CO., INC., O'FALLON, MO. FILED 6-27-2008.

MAKING YOUR WORLD COOLER

THE MARK CONSISTS OF STANDARD CHARACTERS WITHOUT CLAIM TO ANY PARTICULAR FONT, STYLE, SIZE, OR COLOR.

FOR REFRIGERATED COOLERS (U.S. CLS. 13, 21, 23, 31 AND 34).

RICHARD A. STRASER, EXAMINING ATTORNEY

CLASS 11—(Continued).

SN 78-936,553. KYUNG DONG AMERICA, INC., IRVINE, CA.
FILED 7-24-2006.

KD HEISS

THE MARK CONSISTS OF STANDARD CHARACTERS WITHOUT CLAIM TO ANY PARTICULAR FONT, STYLE, SIZE, OR COLOR.

THE ENGLISH TRANSLATION OF THE WORD "HEISS" IN THE MARK IS HOT.

FOR GAS BOILERS, GAS STOVES, BOILERS FOR HOUSEHOLD PURPOSES, NAMELY, FURNACE BOILER, HEARTHS, INDUSTRIAL BOILERS, DAMPERS FOR HEATING, VENTILATING AND AIR CONDITIONING SYSTEMS, WARMING PANS FOR BEDS, STEAM RADIATORS FOR HEATING BUILDINGS, HOT WATER HEATER, HOT-AIR SPACE HEATING APPARATUS, AIR HEATING FURNACES, WATER HEATERS, HOT-WATER SPACE HEATING APPARATUS, STEAM HEATING APPARATUS, GAS REFRIGERATORS, AIR CONDITIONERS, VENTILATORS FOR DOMESTIC AND INDUSTRIAL USE, WASTE WATER TREATMENT TANKS FOR HOUSEHOLD PURPOSES, AIR STERILIZERS, BEVERAGES COOLERS, AIR PURIFIERS, GAS SCRUBBERS, GERMICIDAL LAMPS, FAIRY LIGHTS FOR FESTIVE DECORATION, GERMICIDAL LAMPS FOR PURIFYING AIR, ROOM COOLERS FOR HOUSEHOLD PURPOSES, ELECTRIC REFRIGERATORS, ELECTRIC STOVES, ELECTRIC BLANKET NOT FOR MEDICAL PURPOSES, MICROWAVE RANGES, ELECTRIC BED WARMERS, ELECTRIC REFRIGERATING SHOWCASES (U.S. CLS. 13, 21, 23, 31 AND 34).

DAVID I, EXAMINING ATTORNEY

SN 78-936,555. KYUNG DONG AMERICA, INC., IRVINE, CA.
FILED 7-24-2006.

HEISS

THE MARK CONSISTS OF STANDARD CHARACTERS WITHOUT CLAIM TO ANY PARTICULAR FONT, STYLE, SIZE, OR COLOR.

THE ENGLISH TRANSLATION OF THE WORD "HEISS" IN THE MARK IS HOT.

FOR GAS BOILERS, GAS STOVES, BOILERS FOR HOUSEHOLD PURPOSES NAMELY, FURNACE BOILER, HEARTHS, INDUSTRIAL BOILERS, DAMPERS FOR HEATING, VENTILATING AND AIR CONDITIONING SYSTEMS, WARMING PANS FOR BEDS, STEAM RADIATORS FOR HEATING BUILDINGS, HOT WATER HEATER, HOT-AIR SPACE HEATING APPARATUS, AIR HEATING FURNACES, WATER HEATERS, HOT-WATER SPACE HEATING APPARATUS, STEAM HEATING APPARATUS, GAS REFRIGERATORS, AIR CONDITIONERS, VENTILATORS FOR DOMESTIC AND INDUSTRIAL USE, WASTE WATER TREATMENT TANKS FOR HOUSEHOLD PURPOSES, AIR STERILIZERS, BEVERAGES COOLERS, AIR PURIFIERS, GAS SCRUBBERS, GERMICIDAL LAMPS, FAIRY LIGHTS FOR FESTIVE DECORATION, GERMICIDAL LAMPS FOR PURIFYING AIR, ROOM COOLERS FOR HOUSEHOLD PURPOSES, ELECTRIC REFRIGERATORS, ELECTRIC STOVES, ELECTRIC BLANKET NOT FOR MEDICAL PURPOSES, MICROWAVE RANGES, ELECTRIC BED WARMERS, ELECTRIC REFRIGERATING SHOWCASES (U.S. CLS. 13, 21, 23, 31 AND 34).

DAVID I, EXAMINING ATTORNEY

CLASS 11—(Continued).

SN 78-973,438. ELFBLEND PTY LTD, ASHMORE CITY, AUSTRALIA, FILED 9-13-2006.



PRIORITY CLAIMED UNDER SEC. 44(D) ON AUSTRALIA APPLICATION NO. 1104156, FILED 3-17-2006, REG. NO. 1104156, DATED 3-17-2006, EXPIRES 3-17-2016.

THE MARK CONSISTS OF AN ABSTRACT ARTISTIC REPRESENTATION OF A DRAIN IN WHICH THE DRAIN OPENING IS IN THE FORM OF A STYLIZED LETTER "W" WITH TWO OVAL SHAPES ON EITHER SIDE OF THE STYLIZED LETTER "W", ALL ON TOP OF A CIRCULAR BACKGROUND.

FOR PLUMBING FITTINGS, NAMELY, BIBS AND DRAINS, WATER DRAINAGE APPARATUS, NAMELY, PLUMBING DRAINS, PLUMBING FITTINGS FOR WATER CLOSETS, BATHROOMS AND OTHER SANITARY AND ABLUTION AREAS, NAMELY, BIBS, COCKS, TRAPS, VALVES, DRAINS (U.S. CLS. 13, 21, 23, 31 AND 34).

COLLEEN DOMBROW, EXAMINING ATTORNEY

SN 79-045,441. FLUROSOLAR SYSTEMS LIMITED, PARAMATTA, AUSTRALIA, FILED 7-31-2007.

DAYRAY

THE MARK CONSISTS OF STANDARD CHARACTERS WITHOUT CLAIM TO ANY PARTICULAR FONT, STYLE, SIZE, OR COLOR.

PRIORITY DATE OF 5-1-2007 IS CLAIMED.

OWNER OF INTERNATIONAL REGISTRATION 0941635 DATED 7-31-2007, EXPIRES 7-31-2017.

FOR APPARATUS FOR BUILDING LIGHTING, NAMELY, SOLAR LIGHT COLLECTORS FOR CHANNELING SUNLIGHT IN BUILDINGS (U.S. CLS. 13, 21, 23, 31 AND 34).

DAVID YONTEF, EXAMINING ATTORNEY

CLASS 11—(Continued).

SN 79-046,962. ATELIER SEDAP, SOCIÉTÉ ANONYME, FRANCE, FILED 7-16-2007.

SEDAP

OWNER OF INTERNATIONAL REGISTRATION 0555650 DATED 6-12-1990, EXPIRES 6-12-2010.

FOR LIGHTING APPARATUS, NAMELY, LAMP SHADES; WALL LIGHTS; STANDARD LAMPS; LAMPS; LAMP BASES; CEILING LIGHTS; PILLAR LAMPS (U.S. CLS. 13, 21, 23, 31 AND 34).

LAURIE KAUFMAN, EXAMINING ATTORNEY

CLASS 12—(Continued).

SN 76-687,921. SUCKERPUNCH SALLYS, LLC, SCOTTSDALE, AZ. FILED 3-20-2008.

SuckerPunch Sallys

THE MARK CONSISTS OF STANDARD CHARACTERS WITHOUT CLAIM TO ANY PARTICULAR FONT, STYLE, SIZE, OR COLOR.

OWNER OF U.S. REG. NO. 3,058,678.
FOR MOTORCYCLES AND STRUCTURAL PARTS THEREFOR (U.S. CLS. 19, 21, 23, 31, 35 AND 44).
FIRST USE 10-1-2003; IN COMMERCE 10-1-2003.
MARTHA FROMM, EXAMINING ATTORNEY

CLASS 12—VEHICLES

SN 76-658,399. SUOMEN RENGASTEHDAS OY, 37100 NO-KIA, FINLAND, FILED 4-13-2006.

GAZZA

PRIORITY CLAIMED UNDER SEC. 44(D) ON ERPNCMNTY TM OFC APPLICATION NO. 4699971, FILED 11-3-2005, REG. NO. 004599971, DATED 10-23-2006, EXPIRES 11-3-2015.

OWNER OF U.S. REG. NO. 2,309,195.
FOR TIRES FOR VEHICLES AND BICYCLES (U.S. CLS. 19, 21, 23, 31, 35 AND 44).
DAVID HOFFMAN, EXAMINING ATTORNEY

SN 76-688,103. RICHEY LLC, TAMPA, FL. FILED 3-27-2008.

Gator Blades

THE MARK CONSISTS OF STANDARD CHARACTERS WITHOUT CLAIM TO ANY PARTICULAR FONT, STYLE, SIZE, OR COLOR.

NO CLAIM IS MADE TO THE EXCLUSIVE RIGHT TO USE "BLADES", APART FROM THE MARK AS SHOWN.
FOR MOTOR VEHICLES, NAMELY, WINDSHIELD WIPER BLADES (U.S. CLS. 19, 21, 23, 31, 35 AND 44).
BRENDAN MCCAULEY, EXAMINING ATTORNEY

SN 77-054,200. JTEKT CORPORATION, OSAKA, JAPAN, FILED 11-30-2006.

SILENT EPS

THE MARK CONSISTS OF STANDARD CHARACTERS WITHOUT CLAIM TO ANY PARTICULAR FONT, STYLE, SIZE, OR COLOR.

PRIORITY CLAIMED UNDER SEC. 44(D) ON JAPAN APPLICATION NO. 2006-78999, FILED 8-24-2006, REG. NO. 5050857, DATED 6-1-2007, EXPIRES 6-1-2017.

NO CLAIM IS MADE TO THE EXCLUSIVE RIGHT TO USE "EPS", APART FROM THE MARK AS SHOWN.

FOR CABLE CARS; CAR DAMPERS; MINE-CAR PUSHERS; MINE-CAR PULLERS; TRACTION ENGINE; POWER MACHINERIES AND TOOLS FOR LAND VEHICLES, NAMELY, INTERNAL COMBUSTION ENGINES FOR LAND VEHICLES, STEAM ENGINES FOR LAND VEHICLES, JET ENGINES FOR LAND VEHICLES, TURBINES FOR LAND VEHICLES; POWER STEERING GEARS FOR AUTOMOBILES AND STRUCTURAL PARTS THEREFOR; STEERING GEARS FOR AUTOMOBILES AND STRUCTURAL PARTS THEREFOR; POWER TRAIN PARTS FOR LAND VEHICLES, NAMELY AXLES FOR LAND VEHICLES, SPINDLES, SHAFT COUPLINGS AND CONNECTORS FOR LAND VEHICLES, IDLING PULLEYS FOR LAND VEHICLES, REVERSING GEARS, REDUCTION GEARS FOR LAND VEHICLES, BELT PULLEYS FOR LAND VEHICLES, POWER TRANSMIS-

SN 76-685,993. QA1 PRECISION PRODUCTS, INC., LAKEVILLE, MN. FILED 1-22-2008.

ROCK ENDS

THE MARK CONSISTS OF STANDARD CHARACTERS WITHOUT CLAIM TO ANY PARTICULAR FONT, STYLE, SIZE, OR COLOR.

FOR BEARINGS FOR AUTOMOTIVE USE, NAMELY, STEERING LINKAGE AND SUSPENSION BEARINGS FOR LAND VEHICLES (U.S. CLS. 19, 21, 23, 31, 35 AND 44).

ERIN FALK, EXAMINING ATTORNEY

CLASS 12—(Continued).

SION BELTS FOR LAND VEHICLES, TOOTHED WHEELS AND GEARS FOR LAND VEHICLES, SPEED CHANGE GEARS FOR LAND VEHICLES, FLUID COUPLINGS FOR LAND VEHICLES, HYDRAULIC TORQUE CONVERTERS FOR LAND VEHICLES, LINKS FOR LAND VEHICLES, ROLLER CHAINS FOR LAND VEHICLES, SHOCK ABSORBERS FOR LAND VEHICLES, SPRINGS FOR LAND VEHICLES, BRAKES FOR LAND VEHICLES; PARACHUTES; BURGLAR ALARMS FOR VEHICLES; WHEELCHAIRS; ELECTRIC MOTORS FOR LAND VEHICLES; VESSELS AND STRUCTURAL PARTS THEREFOR; AIRCRAFT AND STRUCTURAL PARTS THEREFOR; RAILCARS AND STRUCTURAL PARTS THEREFOR; AUTOMOBILES AND STRUCTURAL PARTS THEREFOR; TWO-WHEELED MOTOR VEHICLES, BICYCLES AND STRUCTURAL PARTS THEREFOR; BABY CARRIAGES; RICKSHAWS; SLEIGHS; HAND CARTS FOR HANDLING GOODS; CARTS; HORSE DRAWN CARRIAGES; BICYCLE TRAILERS; ADHESIVE RUBBER PATCHES FOR REPAIRING TIRES AND TUBES (U.S. CLS. 19, 21, 23, 31, 35 AND 44).
CAROLYN CATALDO, EXAMINING ATTORNEY

CLASS 12—(Continued).

SN 77-281,848. DAIMLER AG, STUTTGART, FED REP GERMANY, FILED 9-18-2007.

TRIDION

SN 77-055,739. RUPP MARINE, INC., PORT SALERNO, FL. FILED 12-1-2006.

Z-30

THE MARK CONSISTS OF STANDARD CHARACTERS WITHOUT CLAIM TO ANY PARTICULAR FONT, STYLE, SIZE, OR COLOR.

OWNER OF FED REP GERMANY REG. NO. 39640780, DATED 12-11-1996, EXPIRES 9-30-2016.

FOR BODIES FOR PASSENGER CARS (U.S. CLS. 19, 21, 23, 31, 35 AND 44).

RON FAIRBANKS, EXAMINING ATTORNEY

THE MARK CONSISTS OF STANDARD CHARACTERS WITHOUT CLAIM TO ANY PARTICULAR FONT, STYLE, SIZE, OR COLOR.

FOR STRUCTURAL PARTS AND ACCESSORIES FOR FISHING BOATS, NAMELY, ANTENNA MOUNTINGS, ROD AND REEL HANGERS; OUTRIGGERS AND PARTS THEREOF; ACCESSORIES FOR FISHING BOAT OUTRIGGERS, NAMELY, RELEASE CLIPS, LAY DOWN HOOKS, SPACER BLOCKS, HOLD-IN ARMS, AND CLAMP-ON FITTINGS; STRUCTURAL PARTS FOR FISHING BOATS, NAMELY, OUTRIGGER POLES, POLE BASES, POLE MOUNTINGS, TOWER MOUNTS, ROD HOLDERS, POLE SETTERS; STRUCTURAL PARTS FOR BOATS, NAMELY, COLLAPSIBLE BACK BARS; HULL FITTINGS, NAMELY, CLEATS AND BAILERS (U.S. CLS. 19, 21, 23, 31, 35 AND 44).

FIRST USE 1-1-2002; IN COMMERCE 1-1-2003.

SETH A. RAPPAPORT, EXAMINING ATTORNEY

SN 77-289,607. COMPANION TRAILERS, INC., HURST, TX. FILED 9-26-2007.



SN 77-280,429. JAIME PUJOL, MIAMI, FL. FILED 9-15-2007.

UNSINKABLE STAR-SPANGLED BANNER

THE MARK CONSISTS OF STANDARD CHARACTERS WITHOUT CLAIM TO ANY PARTICULAR FONT, STYLE, SIZE, OR COLOR.

FOR RAFTS (U.S. CLS. 19, 21, 23, 31, 35 AND 44).

DAVID MILLER, EXAMINING ATTORNEY

NO CLAIM IS MADE TO THE EXCLUSIVE RIGHT TO USE "TRAILERS", APART FROM THE MARK AS SHOWN. THE MARK CONSISTS OF BANNER INCLUDING BARS OR LINES.

FOR CARGO CARRIER FOR VEHICLES (U.S. CLS. 19, 21, 23, 31, 35 AND 44).

FIRST USE 11-29-2006; IN COMMERCE 11-29-2006.

DARRYL SPRUILL, EXAMINING ATTORNEY

CLASS 12—(Continued).

SN 77-313,178. MDSA, LLC, NORCROSS, GA. FILED 10-25-2007.

MIGHTY

THE MARK CONSISTS OF STANDARD CHARACTERS WITHOUT CLAIM TO ANY PARTICULAR FONT, STYLE, SIZE, OR COLOR.

OWNER OF U.S. REG. NOS. 2,823,994, 3,212,026 AND OTHERS.

FOR AUTOMOTIVE REPAIR, REPLACEMENT AND MAINTENANCE PARTS, NAMELY, AUTOMOTIVE BRAKE SYSTEMS AND PARTS THEREFOR, NAMELY, BRAKE DRUMS, BRAKE HOSES, BRAKE LINES, BRAKE LINE ADAPTER/UNION FITTINGS, BRAKE PAD SHIMS, BRAKE PADS, BRAKE ROTORS, BRAKE SHOES, BRAKE CALIPERS AND CALIPER PISTONS, BRAKE DRUM BACKING PLATES, BRAKE MASTER CYLINDERS, WHEEL CYLINDERS, AND ELECTRONIC BRAKE WEAR CYLINDERS; AUTOMOTIVE SUSPENSION, CHASSIS AND FRONT END PARTS, NAMELY, SHOCK ABSORBERS, SUSPENSION STRUTS AND ASSAYS, SUSPENSION BRACES, LIFT SUPPORTS, SUSPENSION MOUNTS, SUSPENSION SYSTEM TOOLS, WHEEL SUSPENSION AND STEERING COMPONENTS, NAMELY, ADJUSTING SLEEVES, CENTER LINKS, DRAG LINKS, AND TRACK BARS, AND CHASSIS BUSHINGS; AUTOMOTIVE ALIGNMENT PARTS, NAMELY, WHEEL WEIGHTS, ALIGNMENT BUSHINGS, ALIGNMENT SHIMS AND SPACERS, IDLER ARM ASSEMBLIES, TIE RODS AND TIE ROD ENDS, CONTROL ARM BUSHINGS, RACK AND PINION STEERING GEAR, IDLER ARMS AND PITMAN ARMS, TORSION BARS, ADJUSTING SLEEVES, BALL JOINTS, CONTROL ARMS, SEALS AND BEARINGS; AUTOMOTIVE TRANSMISSION AND DRIVELINE PARTS, NAMELY, WHEEL BEARINGS, DRIVE SHAFTS, CV BOOTS, OIL AND GREASE SEALS, U-JOINTS, TRANSMISSION COOLER HOSES; WINDSHIELD WIPER BLADES AND REFILLS (U.S. CLS. 19, 21, 23, 31, 35 AND 44).

FIRST USE 6-0-1973; IN COMMERCE 6-0-1973.
HEATHER THOMPSON, EXAMINING ATTORNEY

SN 77-319,644. IMPACT JACKETS, LLC, SILVER SPRING, MD. FILED 11-2-2007.

IPJ IMPACT JACKETS

THE MARK CONSISTS OF STANDARD CHARACTERS WITHOUT CLAIM TO ANY PARTICULAR FONT, STYLE, SIZE, OR COLOR.

NO CLAIM IS MADE TO THE EXCLUSIVE RIGHT TO USE "JACKETS", APART FROM THE MARK AS SHOWN.

FOR SAFETY APPAREL, NAMELY, AUTOMATICALLY INFLATABLE JACKETS AND VESTS TO ABSORB THE IMPACT CAUSED BY FALLS (U.S. CLS. 19, 21, 23, 31, 35 AND 44).

FIRST USE 10-12-2005; IN COMMERCE 10-12-2005.
JULIE GUTTADAURO, EXAMINING ATTORNEY

CLASS 12—(Continued).

SN 77-378,957. KUAT INNOVATIONS, LLC, SPRINGFIELD, MO. FILED 1-23-2008.

..küat..

THE MARK CONSISTS OF TWO DOTS FOLLOWED BY THE LETTERS "KÜAT" FOLLOWED BY TWO DOTS, AND WHEREIN THE LETTER "Ü" INCLUDES AN UMLAUT TO REFLECT PRONUNCIATION.

FOR BICYCLE RACKS FOR VEHICLES (U.S. CLS. 19, 21, 23, 31, 35 AND 44).

FIRST USE 1-30-2007; IN COMMERCE 1-30-2007.
JANET LEE, EXAMINING ATTORNEY

SN 77-411,568. JASON D. MALCOLM, TOLEDO, OH. FILED 3-3-2008.

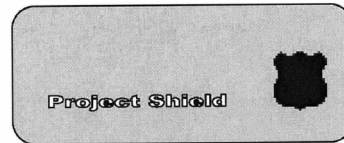

THE MARK CONSISTS OF A RECTANGULAR SHAPE WITH THE WORDS "PROJECT SHIELD" AND A SHIELD APPEARING WITHIN IT.

FOR AUTOMOBILE BODIES; TRUCKS (U.S. CLS. 19, 21, 23, 31, 35 AND 44).

APRIL HESIK, EXAMINING ATTORNEY

SN 77-413,064. KRESS, ALISA, LINCOLN, CA. FILED 3-4-2008.

SNUGGLE ME'Z

THE MARK CONSISTS OF STANDARD CHARACTERS WITHOUT CLAIM TO ANY PARTICULAR FONT, STYLE, SIZE, OR COLOR.

FOR FITTED COVERS FOR CAR SEATS FOR INFANTS (U.S. CLS. 19, 21, 23, 31, 35 AND 44).

STEPHEN AQUILA, EXAMINING ATTORNEY

CLASS 12—(Continued).

SN 77-415,695. PORTER, TIMOTHY, HORSHAM, UNITED KINGDOM, FILED 3-7-2008.



THE MARK CONSISTS OF A CIRCULAR SHAPE CONTAINING THE LETTERS "UBB".
 FOR CARS; RACING CARS; RACING MOTOR CARS (U.S. CLS. 19, 21, 23, 31, 35 AND 44).
 FIRST USE 1-10-2008; IN COMMERCE 1-10-2008.
 AHSEN KHAN, EXAMINING ATTORNEY

SN 77-417,211. ADRIAN STEEL COMPANY, ADRIAN, MI. FILED 3-10-2008.



THE MARK CONSISTS OF THE LETTERS "AS" IN A STYLIZED MANNER.
 FOR STEEL ACCESSORIES SPECIFICALLY FITTED FOR USE IN SERVICE VEHICLES, NAMELY, BINS, CABINETS, DRAWER UNITS, SHELVING, CAB/CARGO PARTITIONS, ROOF RACKS FOR LADDERS, AND FILE CABINETS FOR CATALOGS AND BOOKS (U.S. CLS. 19, 21, 23, 31, 35 AND 44).
 FIRST USE 0-0-1963; IN COMMERCE 0-0-1963.
 NATALIE POLZER, EXAMINING ATTORNEY

SN 77-419,233. K-2 CORPORATION, SEATTLE, WA. FILED 3-11-2008.



OWNER OF U.S. REG. NO. 2,022,859.
 THE MARK CONSISTS OF THE LETTER "M".
 FOR BICYCLES AND PARTS THEREFORE SOLD AS A UNIT (U.S. CLS. 19, 21, 23, 31, 35 AND 44).
 CAROLINE WOOD, EXAMINING ATTORNEY

CLASS 12—(Continued).

SN 77-419,258. BULLZYE PTY. LTD, DBA BULLZYE DESIGN, BRISBANE, AUSTRALIA, FILED 3-11-2008.



NO CLAIM IS MADE TO THE EXCLUSIVE RIGHT TO USE "AUSTRALIA", APART FROM THE MARK AS SHOWN.
 THE MARK CONSISTS OF A STYLIZED BULL'S HEAD SURROUNDED BY AN INCOMPLETE CIRCLE WITH THE WORDING "BULLZYE AUSTRALIA" BELOW THE DESIGN.
 FOR FITTED COVERS FOR VEHICLE STEERING WHEELS; FITTED AUTOMOTIVE SEAT COVERS; SEAT COVERS FOR VEHICLES; STEERING WHEEL COVERS; SUN SHIELDS AND VISORS FOR MOTOR CARS; VEHICLE SEAT COVERS (U.S. CLS. 19, 21, 23, 31, 35 AND 44).
 FIRST USE 12-10-2004; IN COMMERCE 12-10-2004.
 CIMMERIAN COLEMAN, EXAMINING ATTORNEY

SN 77-420,708. AERO INDUSTRIES, INC., INDIANAPOLIS, IN. FILED 3-13-2008.

AEROTAIL

THE MARK CONSISTS OF STANDARD CHARACTERS WITHOUT CLAIM TO ANY PARTICULAR FONT, STYLE, SIZE, OR COLOR.
 FOR AERO-DYNAMIC FAIRINGS FOR VEHICLES (U.S. CLS. 19, 21, 23, 31, 35 AND 44).
 CURTIS FRENCH, EXAMINING ATTORNEY

SN 77-425,624. DOWN ETC, SAN FRANCISCO, CA. FILED 3-18-2008.

Pillow Butler

THE MARK CONSISTS OF STANDARD CHARACTERS WITHOUT CLAIM TO ANY PARTICULAR FONT, STYLE, SIZE, OR COLOR.
 NO CLAIM IS MADE TO THE EXCLUSIVE RIGHT TO USE "PILLOW", APART FROM THE MARK AS SHOWN.
 FOR CARTS (U.S. CLS. 19, 21, 23, 31, 35 AND 44).
 MARCIE MILONE, EXAMINING ATTORNEY

CLASS 12—(Continued).

SN 77-426,900. AUTOMATIC EQUIPMENT MANUFACTURING COMPANY, PENDER, NE. FILED 3-20-2008.

AMBASSADOR

THE MARK CONSISTS OF STANDARD CHARACTERS WITHOUT CLAIM TO ANY PARTICULAR FONT, STYLE, SIZE, OR COLOR.
FOR TOW BARS FOR VEHICLES (U.S. CLS. 19, 21, 23, 31, 35 AND 44).
FIRST USE 3-0-1998; IN COMMERCE 3-0-1998.
RENEE SERVANCE, EXAMINING ATTORNEY

CLASS 12—(Continued).

SN 77-427,707. WAVELET, HOT SPRINGS, AR. FILED 3-20-2008.

wavelet

THE MARK CONSISTS OF STANDARD CHARACTERS WITHOUT CLAIM TO ANY PARTICULAR FONT, STYLE, SIZE, OR COLOR.
FOR HORNS FOR MOTOR CARS (U.S. CLS. 19, 21, 23, 31, 35 AND 44).
NORA BUCHANAN WILL, EXAMINING ATTORNEY

SN 77-426,960. AUTOMATIC EQUIPMENT MANUFACTURING COMPANY, PENDER, NE. FILED 3-20-2008.

ADVENTURER

THE MARK CONSISTS OF STANDARD CHARACTERS WITHOUT CLAIM TO ANY PARTICULAR FONT, STYLE, SIZE, OR COLOR.
FOR TOW BARS FOR VEHICLES (U.S. CLS. 19, 21, 23, 31, 35 AND 44).
FIRST USE 2-0-2004; IN COMMERCE 2-0-2004.
RENEE SERVANCE, EXAMINING ATTORNEY

SN 77-427,823. ZAP, SANTA ROSA, CA. FILED 3-20-2008.

ZAP X

THE MARK CONSISTS OF STANDARD CHARACTERS WITHOUT CLAIM TO ANY PARTICULAR FONT, STYLE, SIZE, OR COLOR.
OWNER OF U.S. REG. NOS. 1,794,866 AND 2,912,329.
FOR ELECTRIC VEHICLES, NAMELY, PASSENGER SEDANS (U.S. CLS. 19, 21, 23, 31, 35 AND 44).
SHAUNIA CARLYLE, EXAMINING ATTORNEY

SN 77-426,968. AUTOMATIC EQUIPMENT MANUFACTURING COMPANY, PENDER, NE. FILED 3-20-2008.

ACCLAIM

THE MARK CONSISTS OF STANDARD CHARACTERS WITHOUT CLAIM TO ANY PARTICULAR FONT, STYLE, SIZE, OR COLOR.
FOR TOW BARS FOR VEHICLES (U.S. CLS. 19, 21, 23, 31, 35 AND 44).
FIRST USE 9-0-1997; IN COMMERCE 9-0-1997.
RENEE SERVANCE, EXAMINING ATTORNEY

SN 77-427,838. ZAP, SANTA ROSA, CA. FILED 3-20-2008.

ZAPTRUCK

THE MARK CONSISTS OF STANDARD CHARACTERS WITHOUT CLAIM TO ANY PARTICULAR FONT, STYLE, SIZE, OR COLOR.
OWNER OF U.S. REG. NOS. 1,794,866 AND 2,912,329.
FOR ELECTRIC VEHICLES, NAMELY, PASSENGER TRUCKS (U.S. CLS. 19, 21, 23, 31, 35 AND 44).
FIRST USE 2-3-2007; IN COMMERCE 2-3-2007.
SHAUNIA CARLYLE, EXAMINING ATTORNEY

CLASS 12—(Continued).

SN 77-428,048. HYUNDAI MOTOR AMERICA, FOUNTAIN VALLEY, CA. FILED 3-21-2008.

TELLURIDE

THE MARK CONSISTS OF STANDARD CHARACTERS WITHOUT CLAIM TO ANY PARTICULAR FONT, STYLE, SIZE, OR COLOR.
FOR AUTOMOBILES AND STRUCTURAL PARTS THEREFOR (U.S. CLS. 19, 21, 23, 31, 35 AND 44).
JORDAN BAKER, EXAMINING ATTORNEY

SN 77-428,517. DOUGHERTY, PATRICK S., BOISE, ID. FILED 3-21-2008.

FreeWheel

THE MARK CONSISTS OF STANDARD CHARACTERS WITHOUT CLAIM TO ANY PARTICULAR FONT, STYLE, SIZE, OR COLOR.
FOR WHEELCHAIRS (U.S. CLS. 19, 21, 23, 31, 35 AND 44).
TASNEEM HUSSAIN, EXAMINING ATTORNEY

SN 77-429,196. AUTOMATIC EQUIPMENT MANUFACTURING COMPANY, PENDER, NE. FILED 3-24-2008.

PATRIOT

THE MARK CONSISTS OF STANDARD CHARACTERS WITHOUT CLAIM TO ANY PARTICULAR FONT, STYLE, SIZE, OR COLOR.
OWNER OF U.S. REG. NO. 2,143,143.
FOR BRAKING SYSTEMS FOR TOWED VEHICLES (U.S. CLS. 19, 21, 23, 31, 35 AND 44).
RENEE SERVANCE, EXAMINING ATTORNEY

CLASS 12—(Continued).

SN 77-429,645. CHUNG, SUNY, BREA, CA. FILED 3-24-2008.

Marcello

THE MARK CONSISTS OF STANDARD CHARACTERS WITHOUT CLAIM TO ANY PARTICULAR FONT, STYLE, SIZE, OR COLOR.
FOR VEHICLE WHEELS; WHEEL COVERS; WHEEL RIMS; WHEELS (U.S. CLS. 19, 21, 23, 31, 35 AND 44).
STEVEN R. FOSTER, EXAMINING ATTORNEY

SN 77-429,944. ARVANITES, MARGHERITA, FOUNTAIN HILLS, AZ. FILED 3-24-2008.

KCP STEPS

THE MARK CONSISTS OF STANDARD CHARACTERS WITHOUT CLAIM TO ANY PARTICULAR FONT, STYLE, SIZE, OR COLOR.
NO CLAIM IS MADE TO THE EXCLUSIVE RIGHT TO USE "STEPS", APART FROM THE MARK AS SHOWN.
FOR FOLDABLE STEP ASSEMBLY REMOVABLY ATTACHABLE TO THE TRAILER HITCH OF A VEHICLE TO FACILITATE ENTRY THEREOF AND EXITING THEREFROM (U.S. CLS. 19, 21, 23, 31, 35 AND 44).
WENDY JUN, EXAMINING ATTORNEY

SN 77-429,979. KINSEY, STANLEY, LOS ANGELES, CA. FILED 3-24-2008.

ASS TANK

THE MARK CONSISTS OF STANDARD CHARACTERS WITHOUT CLAIM TO ANY PARTICULAR FONT, STYLE, SIZE, OR COLOR.
NO CLAIM IS MADE TO THE EXCLUSIVE RIGHT TO USE "TANK", APART FROM THE MARK AS SHOWN.
FOR GAS TANKS FOR LAND VEHICLES; GAS TANKS FOR MOTORCYCLES (U.S. CLS. 19, 21, 23, 31, 35 AND 44).
ATTIYA MALIK, EXAMINING ATTORNEY

CLASS 12—(Continued).

SN 77-430,025. FARR, SANDRA L., ORWIGSBURG, PA. AND FARR, DAVID E., ORWIGSBURG, PA. FILED 3-24-2008.

Y-LUGG-IT

THE MARK CONSISTS OF STANDARD CHARACTERS WITHOUT CLAIM TO ANY PARTICULAR FONT, STYLE, SIZE, OR COLOR.

FOR CONVERTIBLE CHILD STROLLER PACKAGE CARRIER; A DEVICE WHICH ATTACHES TO A BABY STROLLER TO ASSIST IN CARRYING PACKAGES AND BAGS (U.S. CLS. 19, 21, 23, 31, 35 AND 44).

CHERYL CLAYTON, EXAMINING ATTORNEY

SN 77-431,030. COX, BRIAN, C, ROCHESTER, NH. FILED 3-25-2008.

Little Drivers

THE COLOR(S) BLUE IS/ARE CLAIMED AS A FEATURE OF THE MARK.

THE MARK CONSISTS OF LETTERS AND THE COLOR BLUE. THE FONT FOR THE LETTERS ARE PORKYS FONT AND ALL LETTERS ARE BLUE IN COLOR. THE LETTERS SPELL OUT "LITTLE DRIVERS".

FOR STROLLERS (U.S. CLS. 19, 21, 23, 31, 35 AND 44).
AISHA CLARKE, EXAMINING ATTORNEY

SN 77-432,084. LIFE STYLE METAL CO., LTD., CHANGHUA, TAIWAN, FILED 3-26-2008.



THE MARK CONSISTS OF THE WORDING "APROVE" AND A SHIELD DESIGN CONTAINING A DESIGN.

FOR AUTOMOBILES AND STRUCTURAL PARTS THEREFOR; ALL-TERRAIN VEHICLES AND STRUCTURAL PARTS THEREFOR; MOTORCYCLES AND STRUCTURAL PARTS THEREFOR (U.S. CLS. 19, 21, 23, 31, 35 AND 44).

EUGENIA MARTIN, EXAMINING ATTORNEY

CLASS 12—(Continued).

SN 77-432,812. VOLCANIC MANUFACTURING LLC, OLYMPIA, WA. FILED 3-27-2008.

Volcanic

THE MARK CONSISTS OF STANDARD CHARACTERS WITHOUT CLAIM TO ANY PARTICULAR FONT, STYLE, SIZE, OR COLOR.

FOR BICYCLES (U.S. CLS. 19, 21, 23, 31, 35 AND 44).
FIRST USE 12-31-2003; IN COMMERCE 12-31-2003.
ANNE E. GUSTASON, EXAMINING ATTORNEY

SN 77-432,903. EXTREME METAL PRODUCTS, LLC, CLEVELAND, OH. FILED 3-27-2008.

EMP

THE MARK CONSISTS OF STANDARD CHARACTERS WITHOUT CLAIM TO ANY PARTICULAR FONT, STYLE, SIZE, OR COLOR.

FOR LAND VEHICLE PARTS, NAMELY, WINDSHIELDS; RECREATIONAL VEHICLES, NAMELY, CAMPERS; METAL PARTS FOR VEHICLES, NAMELY, AUTOMOTIVE EXTERIOR AND INTERIOR METAL DECORATIVE AND PROTECTIVE TRIM (U.S. CLS. 19, 21, 23, 31, 35 AND 44).

FIRST USE 8-21-2005; IN COMMERCE 8-21-2005.
GEOFFREY FOSDICK, EXAMINING ATTORNEY

SN 77-433,220. JAEGER, JASON, YPSILANTI, MI. FILED 3-27-2008.

JFLAP

THE MARK CONSISTS OF STANDARD CHARACTERS WITHOUT CLAIM TO ANY PARTICULAR FONT, STYLE, SIZE, OR COLOR.

FOR MUD FLAPS FOR VEHICLES (U.S. CLS. 19, 21, 23, 31, 35 AND 44).

FIRST USE 11-9-2005; IN COMMERCE 11-9-2005.
WANDA KAY PRICE, EXAMINING ATTORNEY

CLASS 12—(Continued).

SN 77-433,520. SCOTT USA, INC, KETCHUM, ID. FILED 3-27-2008.



OWNER OF U.S. REG. NOS. 1,837,348, 2,632,715 AND OTHERS.

THE MARK CONSISTS OF A STYLIZED "S" AND THE WORD "SCOTT".

FOR BICYCLES AND BICYCLE HANDLEBARS AND PARTS THEREOF; GRIPS FOR HANDLEBARS FOR MOTORCYCLES AND BICYCLES (U.S. CLS. 19, 21, 23, 31, 35 AND 44).

FIRST USE 0-0-2000; IN COMMERCE 0-0-2000.
MARK T. MULLEN, EXAMINING ATTORNEY

CLASS 12—(Continued).

SN 77-447,126. JAGUAR CARS LIMITED, COVENTRY, UNITED KINGDOM, FILED 4-14-2008.

C-XJ

THE MARK CONSISTS OF STANDARD CHARACTERS WITHOUT CLAIM TO ANY PARTICULAR FONT, STYLE, SIZE, OR COLOR.

FOR MOTOR LAND VEHICLES (U.S. CLS. 19, 21, 23, 31, 35 AND 44).

VERNA BETH RIRIE, EXAMINING ATTORNEY

SN 77-433,614. GENERAL ELECTRIC COMPANY, SCHE-
NECTADY, NY. FILED 3-27-2008.

POWERHAUL

THE MARK CONSISTS OF STANDARD CHARACTERS WITHOUT CLAIM TO ANY PARTICULAR FONT, STYLE, SIZE, OR COLOR.

FOR LOCOMOTIVES (U.S. CLS. 19, 21, 23, 31, 35 AND 44).

JUDITH HELFMAN, EXAMINING ATTORNEY

SN 77-450,105. ZAP, SANTA ROSA, CA. FILED 4-16-2008.

ZAPINA

THE MARK CONSISTS OF STANDARD CHARACTERS WITHOUT CLAIM TO ANY PARTICULAR FONT, STYLE, SIZE, OR COLOR.

OWNER OF U.S. REG. NO. 3,297,140.
FOR ELECTRIC VEHICLES, NAMELY, MOTORCYCLES (U.S. CLS. 19, 21, 23, 31, 35 AND 44).

FIRST USE 2-12-2008; IN COMMERCE 2-12-2008.
SHAUNIA CARLYLE, EXAMINING ATTORNEY

SN 77-434,686. COULTER ROD, BLAINE, MN. FILED 3-28-2008.

ANACONDA

THE MARK CONSISTS OF STANDARD CHARACTERS WITHOUT CLAIM TO ANY PARTICULAR FONT, STYLE, SIZE, OR COLOR.

FOR AUTOMOBILES (U.S. CLS. 19, 21, 23, 31, 35 AND 44).

TEJBIR SINGH, EXAMINING ATTORNEY

SN 77-451,531. JAGUAR CARS LIMITED, COVENTRY, UNITED KINGDOM, FILED 4-18-2008.

C-XE

THE MARK CONSISTS OF STANDARD CHARACTERS WITHOUT CLAIM TO ANY PARTICULAR FONT, STYLE, SIZE, OR COLOR.

FOR MOTOR LAND VEHICLES (U.S. CLS. 19, 21, 23, 31, 35 AND 44).

VERNA BETH RIRIE, EXAMINING ATTORNEY

CLASS 12—(Continued).

SN 77-459,238. COACHMEN RECREATIONAL VEHICLE COMPANY, MIDDLEBURY, IN. FILED 4-28-2008.

Y2GEN

THE MARK CONSISTS OF STANDARD CHARACTERS WITHOUT CLAIM TO ANY PARTICULAR FONT, STYLE, SIZE, OR COLOR.

FOR RECREATIONAL VEHICLES, NAMELY, MOTOR HOMES, MINI MOTOR HOMES, TRAILERS, FIFTH WHEELS, FOLDING TRAILERS, TRAVEL TRAILERS, TRUCK CAMPERS, COMBINATION TRAILERS AND ENCLOSED TRAILER STORAGE AREA FOR HAULING MOTORCYCLES, ATVS, BICYCLES AND OTHER RECREATIONAL ITEMS AND EQUIPMENT, AND COMBINATION FIFTH WHEELS AND ENCLOSED TRAILER STORAGE AREA FOR HAULING MOTORCYCLES, ATVS, BICYCLES AND OTHER RECREATIONAL ITEMS AND EQUIPMENT (U.S. CLS. 19, 21, 23, 31, 35 AND 44).
MONIQUE MILLER, EXAMINING ATTORNEY

SN 77-459,252. COACHMEN RECREATIONAL VEHICLE COMPANY, MIDDLEBURY, IN. FILED 4-28-2008.

X2GEN

THE MARK CONSISTS OF STANDARD CHARACTERS WITHOUT CLAIM TO ANY PARTICULAR FONT, STYLE, SIZE, OR COLOR.

FOR RECREATIONAL VEHICLES, NAMELY, MOTOR HOMES, MINI MOTOR HOMES, TRAILERS, FIFTH WHEELS, FOLDING TRAILERS, TRAVEL TRAILERS, TRUCK CAMPERS, COMBINATION TRAILERS AND ENCLOSED TRAILER STORAGE AREA FOR HAULING MOTORCYCLES, ATVS, BICYCLES AND OTHER RECREATIONAL ITEMS AND EQUIPMENT, AND COMBINATION FIFTH WHEELS AND ENCLOSED TRAILER STORAGE AREA FOR HAULING MOTORCYCLES, ATVS, BICYCLES AND OTHER RECREATIONAL ITEMS AND EQUIPMENT (U.S. CLS. 19, 21, 23, 31, 35 AND 44).
MONIQUE MILLER, EXAMINING ATTORNEY

SN 77-466,225. ZAP, SANTA ROSA, CA. FILED 5-5-2008.

ZAP ZIP

THE MARK CONSISTS OF STANDARD CHARACTERS WITHOUT CLAIM TO ANY PARTICULAR FONT, STYLE, SIZE, OR COLOR.

OWNER OF U.S. REG. NO. 1,794,866.
FOR ELECTRIC VEHICLES, NAMELY, BICYCLES (U.S. CLS. 19, 21, 23, 31, 35 AND 44).
SHAUNIA CARLYLE, EXAMINING ATTORNEY

CLASS 12—(Continued).

SN 77-470,227. JUICY COUTURE, INC., PACOIMA, CA. FILED 5-9-2008.

JUICY COUTURE

THE MARK CONSISTS OF STANDARD CHARACTERS WITHOUT CLAIM TO ANY PARTICULAR FONT, STYLE, SIZE, OR COLOR.

FOR STROLLERS (U.S. CLS. 19, 21, 23, 31, 35 AND 44).
STEPHANIE ALI, EXAMINING ATTORNEY

SN 78-897,159. DUAL-TECH, INC., BEAN STATION, TN. FILED 5-31-2006.

INVADER

THE MARK CONSISTS OF STANDARD CHARACTERS WITHOUT CLAIM TO ANY PARTICULAR FONT, STYLE, SIZE, OR COLOR.

FOR TILT BED TRAILERS MOUNTED ON TOWING AND WRECKER TRUCKS (U.S. CLS. 19, 21, 23, 31, 35 AND 44).

FIRST USE 0-0-1996; IN COMMERCE 0-0-1996.
TRACY WHITTAKER-BROWN, EXAMINING ATTORNEY

SN 79-042,587. SAAB AUTOMOBILE AB, SE-461 80 TROLLHÄTTAN, SWEDEN, FILED 7-10-2007.

TTiD

THE MARK CONSISTS OF STANDARD CHARACTERS WITHOUT CLAIM TO ANY PARTICULAR FONT, STYLE, SIZE, OR COLOR.

PRIORITY DATE OF 1-29-2007 IS CLAIMED.
OWNER OF INTERNATIONAL REGISTRATION 0934398 DATED 7-10-2007, EXPIRES 7-10-2017.

THE WORDING "TTiD" HAS NO MEANING IN A FOREIGN LANGUAGE.

FOR MOTOR LAND VEHICLES, NAMELY, AUTOMOBILES, SPORT UTILITY VEHICLES, TRUCKS, VANS, ENGINES THEREFOR AND STRUCTURAL PARTS THEREOF (U.S. CLS. 19, 21, 23, 31, 35 AND 44).
MATTHEW MCDOWELL, EXAMINING ATTORNEY

CLASS 12—(Continued).

SN 79-051,498. TIANJIN UNITED TIRE & RUBBER INTERNATIONAL CO. LTD., CHINA, FILED 1-28-2008.



OWNER OF INTERNATIONAL REGISTRATION 0669237 DATED 1-30-1997, EXPIRES 1-30-2017.

THE FOREIGN WORDING IN THE MARK TRANSLATES INTO ENGLISH AS "POWER FROM HEAVEN".

THE NON-LATIN CHARACTER(S) IN THE MARK TRANSLITERATES INTO "TIAN LI", AND THIS MEANS "POWER FROM HEAVEN" IN ENGLISH.

FOR TIRES (U.S. CLS. 19, 21, 23, 31, 35 AND 44).
RONALD DELGIZZI, EXAMINING ATTORNEY

SN 79-052,384. CHANGZHOU; YAMASAKI MOTORCYCLE CO., LTD, 213022 JIANGSU, CHINA, FILED 3-20-2008.



OWNER OF INTERNATIONAL REGISTRATION 0960148 DATED 3-20-2008, EXPIRES 3-20-2018.

THE ENGLISH TRANSLATION OF THE FOREIGN WORD(S) IN THE MARK IS: THE FIRST CHINESE CHARACTER WHOSE TRANSLITERATION IS "SHAN" MEANS "HILL"; THE SECOND CHINESE CHARACTER WHOSE TRANSLITERATION IS "QI" MEANS "CRAGGED"; THE COMBINATION OF THE TWO CHINESE CHARACTERS AND THE ENGLISH WORD "YAMASAKI" HAVE NO SIGNIFICANCE IN THE RELEVANT TRADE OR INDUSTRY, AND HAVE NO GEOGRAPHICAL SIGNIFICANCE, AND HAVE NO MEANING IN A FOREIGN LANGUAGE, AND HAVE NO SIGNIFICANCE AS APPLIED TO THE GOODS.

THE TRANSLITERATION OF THE NON-LATIN CHARACTERS IN THE MARK IS: SHAN QI.

FOR MOTORCYCLES; BICYCLES; CYCLE CARS; AUTOMOBILES (U.S. CLS. 19, 21, 23, 31, 35 AND 44).
CURTIS FRENCH, EXAMINING ATTORNEY

CLASS 13—FIREARMS

SN 76-687,958. WINCO FIREWORKS INTERNATIONAL, L.L.C., PRAIRIE VILLAGE, KS. FILED 3-21-2008.

PYRO HEROES

THE MARK CONSISTS OF STANDARD CHARACTERS WITHOUT CLAIM TO ANY PARTICULAR FONT, STYLE, SIZE, OR COLOR.

NO CLAIM IS MADE TO THE EXCLUSIVE RIGHT TO USE "PYRO", APART FROM THE MARK AS SHOWN.

FOR FIREWORKS (U.S. CLS. 2 AND 9).
WENDY GOODMAN, EXAMINING ATTORNEY

CLASS 13—(Continued).

SN 77-282,451. ELECTRONICS LLC, NORMAN, OK. FILED 9-18-2007.

ELECTRONICS LLC

THE MARK CONSISTS OF STANDARD CHARACTERS WITHOUT CLAIM TO ANY PARTICULAR FONT, STYLE, SIZE, OR COLOR.

NO CLAIM IS MADE TO THE EXCLUSIVE RIGHT TO USE "LLC", APART FROM THE MARK AS SHOWN.

FOR EXPLOSIVE DETONATORS (U.S. CLS. 2 AND 9).
FIRST USE 4-10-2007; IN COMMERCE 4-10-2007.
DAWN FELDMAN, EXAMINING ATTORNEY

SN 77-400,102. PHALANX CORPORATION, BOCA RATON, FL. FILED 2-19-2008.

STRAPLESS LOCKING ACTION SHOULDER HOLSTER

THE MARK CONSISTS OF STANDARD CHARACTERS WITHOUT CLAIM TO ANY PARTICULAR FONT, STYLE, SIZE, OR COLOR.

OWNER OF U.S. REG. NO. 2,548,564.

NO CLAIM IS MADE TO THE EXCLUSIVE RIGHT TO USE "SHOULDER HOLSTER", APART FROM THE MARK AS SHOWN.

SEC. 2(F).

FOR HOLSTERS (U.S. CLS. 2 AND 9).

FIRST USE 10-4-2000; IN COMMERCE 10-4-2000.
JULIE GUTTADAURO, EXAMINING ATTORNEY

SN 77-409,018. CTD, INC., FT. WORTH, TX. FILED 2-28-2008.

CowTown Shooters

THE MARK CONSISTS OF STANDARD CHARACTERS WITHOUT CLAIM TO ANY PARTICULAR FONT, STYLE, SIZE, OR COLOR.

NO CLAIM IS MADE TO THE EXCLUSIVE RIGHT TO USE "SHOOTERS", APART FROM THE MARK AS SHOWN.

FOR FIREARMS AND SHOOTING ACCESSORIES, NAMELY, GOLF BALL LAUNCHERS FOR ATTACHMENT TO FIREARMS, BRASS CATCHER MESH BAGS FOR CATCHING EJECTED CARTRIDGES FROM FIREARMS, RIFLE SLINGS, SNIPER FIREARM SLINGS, SHOOTING SUPPORT BAGS FOR FIREARMS AND HOLSTERS (U.S. CLS. 2 AND 9).

FIRST USE 2-14-2008; IN COMMERCE 2-14-2008.

DOMINIC J. FERRAIUOLO, EXAMINING ATTORNEY

CLASS 13—(Continued).

SN 77-409,122. CTD, INC., FT. WORTH, TX. FILED 2-28-2008.



NO CLAIM IS MADE TO THE EXCLUSIVE RIGHT TO USE "SHOOTERS", APART FROM THE MARK AS SHOWN. THE MARK CONSISTS OF A "LONGHORN SKULL" SUPERIMPOSED OVER TWO CROSSED RIFLES OVER A HALF-CIRCLE ATOP A BANNER WITH THE NAME "COW-TOWN SHOOTERS".

FOR FIREARMS AND SHOOTING ACCESSORIES, NAMELY, GOLF BALL LAUNCHERS FOR ATTACHMENT TO FIREARMS, BRASS CATCHER MESH BAGS FOR CATCHING EJECTED CARTRIDGES FROM FIREARMS, RIFLE SLINGS, SNIPER FIREARM SLINGS, SHOOTING SUPPORT BAGS FOR FIREARMS AND HOLSTERS (U.S. CLS. 2 AND 9).

FIRST USE 2-14-2008; IN COMMERCE 2-14-2008.
DOMINIC J. FERRAIUOLO, EXAMINING ATTORNEY

SN 77-410,543. AWATER LTD, RENO, NV. FILED 3-1-2008.

THE ALTERNATIVE

THE MARK CONSISTS OF STANDARD CHARACTERS WITHOUT CLAIM TO ANY PARTICULAR FONT, STYLE, SIZE, OR COLOR.

FOR LESS-LETHAL PROJECTILE, NAMELY, A ROUNDED METAL BLOCK ENCAPSULATED IN RUBBER, DISCHARGED FROM A PISTOL TO TEMPORARILY INCAPACITATE A PERSON (U.S. CLS. 2 AND 9).

FIRST USE 9-30-2005; IN COMMERCE 10-30-2007.
LEIGH CAROLINE CASE, EXAMINING ATTORNEY

SN 77-410,979. XTREME MACHINING, LLC, DBA XTREME MACHINING, GRASSFLAT, PA. FILED 3-3-2008.



NO CLAIM IS MADE TO THE EXCLUSIVE RIGHT TO USE ".338", APART FROM THE MARK AS SHOWN.

THE COLOR(S) RED, PINK, GRAY, AND BLACK IS/ARE CLAIMED AS A FEATURE OF THE MARK.

THE MARK CONSISTS OF A GRAPHICAL FAN DESIGN APPEARING ON THE LEFT-HAND SIDE OF THE MARK. THE GRAPHICAL FAN DESIGN CONSISTING OF THE COLORS RED, PINK, AND DIFFERENT SHADES OF GRAY. THE WORDS ".338 XTREME" APPEAR IN BLACK AT THE BOTTOM OF THE MARK..

FOR FIREARMS (U.S. CLS. 2 AND 9).
EDWARD NELSON, EXAMINING ATTORNEY

CLASS 13—(Continued).

SN 77-430,170. LASER ENERGETICS, INC., MERCERVILLE, NJ. FILED 3-24-2008.

Dazer-Laser

THE MARK CONSISTS OF STANDARD CHARACTERS WITHOUT CLAIM TO ANY PARTICULAR FONT, STYLE, SIZE, OR COLOR.

FOR NON-LETHAL WEAPONS WHICH FLASH LASER LIGHT TO TEMPORARILY IMPAIR THE VISION OF THE TARGET (U.S. CLS. 2 AND 9).

ANDREA HACK, EXAMINING ATTORNEY

SN 77-430,196. MCNEAL, WILLIAM S., SR., DBA DBA/ KEYSTONE SPORTING ARMS, INC., MILTON, PA. FILED 3-24-2008.

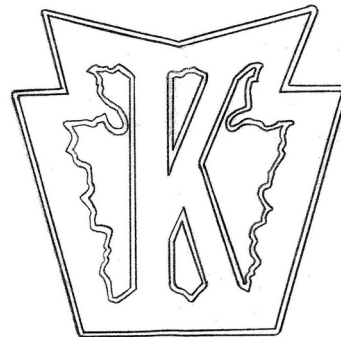

THE MARK CONSISTS OF KEYSTONE WITH A "K". FOR RIFLES AND RIFLE CASES (U.S. CLS. 2 AND 9).
CHERYL CLAYTON, EXAMINING ATTORNEY

SN 77-430,423. FRANCHI S.P.A., BRESCIA, ITALY, FILED 3-25-2008.



THE MARK CONSISTS OF THE WORDS "I-MAG" IN A STYLIZED FORMAT.

FOR FIREARMS (U.S. CLS. 2 AND 9).
ANTHONY RINKER, EXAMINING ATTORNEY

CLASS 13—(Continued).

SN 77-430,451. ARMATAC INDUSTRIES, INC., CHARLOTTEVILLE, VA. FILED 3-25-2008.

ARMATAC

THE MARK CONSISTS OF STANDARD CHARACTERS WITHOUT CLAIM TO ANY PARTICULAR FONT, STYLE, SIZE, OR COLOR.

FOR MAGAZINES FOR WEAPONS (U.S. CLS. 2 AND 9).

FIRST USE 4-1-2005; IN COMMERCE 4-1-2005.
NICHOLAS ALTREE, EXAMINING ATTORNEY

CLASS 13—(Continued).

SN 77-432,622. TIGER CORPORATION, HONOLULU, HI. FILED 3-26-2008.

KING THUNDER

THE MARK CONSISTS OF STANDARD CHARACTERS WITHOUT CLAIM TO ANY PARTICULAR FONT, STYLE, SIZE, OR COLOR.

FOR FIREWORKS (U.S. CLS. 2 AND 9).
FIRST USE 12-26-2007; IN COMMERCE 12-26-2007.
JASON TURNER, EXAMINING ATTORNEY

SN 77-432,613. TIGER CORPORATION, HONOLULU, HI. FILED 3-26-2008.

SN 77-432,629. TIGER CORPORATION, HONOLULU, HI. FILED 3-26-2008.



NO CLAIM IS MADE TO THE EXCLUSIVE RIGHT TO USE "FIREWORKS", APART FROM THE MARK AS SHOWN.

THE COLOR(S) BLACK, RED, ORANGE, YELLOW, BEIGE, AND BLUE IS/ARE CLAIMED AS A FEATURE OF THE MARK.

THE MARK CONSISTS OF THE BUST OF AN EMPEROR WITH BEARD AND HEADWEAR IN THE COLORS BLACK, BEIGE, ORANGE, YELLOW AND BLUE, OVER THE CHINESE SYMBOL WANG OR WONG FOR KING OR EMPEROR, ALL ON A BLACK BACKGROUND AND ABOVE THE WORDS "EMPEROR" IN BOLD BLACK LETTERS ABOVE THE WORD "FIREWORKS" IN SMALLER STYLIZED LETTERS, THE WORD PORTION OF THE MARK BEING SUPERIMPOSED OVER A YELLOW, ORANGE AND RED BACKGROUND.

THE NON-LATIN CHARACTER(S) IN THE MARK TRANSLITERATE INTO WANG OR WONG, AND THIS MEANS KING OR EMPEROR IN ENGLISH.

FOR FIREWORKS (U.S. CLS. 2 AND 9).
FIRST USE 6-27-2005; IN COMMERCE 6-7-2005.
JASON TURNER, EXAMINING ATTORNEY



NO CLAIM IS MADE TO THE EXCLUSIVE RIGHT TO USE "FIREWORKS", APART FROM THE MARK AS SHOWN.

THE COLOR(S) RED, YELLOW, ORANGE, BLUE, WHITE, AND BLACK IS/ARE CLAIMED AS A FEATURE OF THE MARK.

THE MARK CONSISTS OF A STYLIZED DRAWING OF A DRAGON HAVING A FACE COLORED RED, YELLOW, ORANGE AND WHITE AND A BODY OF BLUE, ORANGE AND WHITE, WITH THE WORD "DESTRUCTION" IN BOLD BLACK LETTERS ABOVE, AND THE WORD "FIREWORKS" IN NARROWER BLACK LETTERS BELOW, ALL ENCLOSED WITHIN A NARROW CIRCLE COLORED RED, ORANGE AND YELLOW.

FOR FIREWORKS (U.S. CLS. 2 AND 9).
FIRST USE 12-26-2007; IN COMMERCE 12-26-2007.
JASON TURNER, EXAMINING ATTORNEY

CLASS 14—JEWELRY

SN 75-455,657. RICHMAN ASSOCIATES INC., NEW YORK, NY. FILED S.R. 3-24-1998; AM. P.R. 5-17-2007.

REPLICA COLLECTION ITALY

NO CLAIM IS MADE TO THE EXCLUSIVE RIGHT TO USE "COLLECTION", APART FROM THE MARK AS SHOWN.

SEC. 2(F).
FOR COSTUME JEWELRY MADE IN ITALY (U.S. CLS. 2, 27, 28 AND 50).

FIRST USE 12-1-1995; IN COMMERCE 12-1-1995.
BONNIE LUKEN, EXAMINING ATTORNEY

CLASS 14—(Continued).

SN 77-268,429. YAKIRA, LLC, NEW YORK, NY. FILED 8-30-2007.

MADE TO MEASURE

THE MARK CONSISTS OF STANDARD CHARACTERS WITHOUT CLAIM TO ANY PARTICULAR FONT, STYLE, SIZE, OR COLOR.

FOR WATCHES (U.S. CLS. 2, 27, 28 AND 50).
ALICE BENMAMAN, EXAMINING ATTORNEY

SN 77-229,673. KIMORA LEE SIMMONS LICENSING, INC., NEW YORK, NY. FILED 7-13-2007.

KIMORA

THE MARK CONSISTS OF STANDARD CHARACTERS WITHOUT CLAIM TO ANY PARTICULAR FONT, STYLE, SIZE, OR COLOR.

OWNER OF U.S. REG. NO. 2,926,512.
THE NAME "KIMORA" IDENTIFIES A LIVING INDIVIDUAL WHOSE CONSENT IS OF RECORD.

FOR PRECIOUS METALS AND THEIR ALLOYS AND GOODS IN PRECIOUS METALS OR COATED THEREWITH IN THE NATURE OF KEY RINGS OF PRECIOUS METALS, NOT INCLUDED IN OTHER CLASSES; JEWELRY, PRECIOUS STONES; HOROLOGICAL AND CHRONOMETRIC INSTRUMENTS (U.S. CLS. 2, 27, 28 AND 50).

KAELIE KUNG, EXAMINING ATTORNEY

SN 77-268,467. YAKIRA, LLC, NEW YORK, NY. FILED 8-30-2007.

MARC ECKO MADE TO MEASURE

THE MARK CONSISTS OF STANDARD CHARACTERS WITHOUT CLAIM TO ANY PARTICULAR FONT, STYLE, SIZE, OR COLOR.

THE NAME(S), PORTRAIT(S), AND/OR SIGNATURE(S) SHOWN IN THE MARK IDENTIFIES "MARC ECKO", WHOSE CONSENT(S) TO REGISTER IS SUBMITTED.

FOR WATCHES (U.S. CLS. 2, 27, 28 AND 50).
ALICE BENMAMAN, EXAMINING ATTORNEY

SN 77-245,918. HUPP, ALISON L., TUCSON, AZ. FILED 8-2-2007.



NO CLAIM IS MADE TO THE EXCLUSIVE RIGHT TO USE "JEWELRY", APART FROM THE MARK AS SHOWN.

THE MARK CONSISTS OF STYLIZED LETTERS SPELLING OUT AMBROSIA JEWELRY.

FOR JEWELRY (U.S. CLS. 2, 27, 28 AND 50).
FIRST USE 4-25-2007; IN COMMERCE 5-1-2007.
KAREN BRACEY, EXAMINING ATTORNEY

Dream
Star

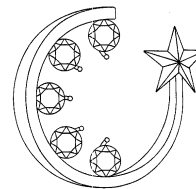

NO CLAIM IS MADE TO THE EXCLUSIVE RIGHT TO USE "THE CONFIGURATION OF THE JEWELRY", APART FROM THE MARK AS SHOWN.

THE WORDING "DREAM STAR" APPEARS TO THE LEFT OF THE JEWELRY DESIGN, WHICH IS COMPOSED OF A PENANNULAR CIRCLE WITH A STAR AT ONE END AND FIVE SMALL CIRCLES IN A ROW WITHIN THE PENANNULAR CIRCLE.

FOR JEWELRY (U.S. CLS. 2, 27, 28 AND 50).
ELI HELLMAN, EXAMINING ATTORNEY

CLASS 14—(Continued).

SN 77-280,842. SILMAR S.P.A., ROMANO D'EZZELINO (VI), ITALY, FILED 9-17-2007.

ECOSILMAR

THE MARK CONSISTS OF STANDARD CHARACTERS WITHOUT CLAIM TO ANY PARTICULAR FONT, STYLE, SIZE, OR COLOR.

OWNER OF U.S. REG. NOS. 1,250,274 AND 1,648,100.
FOR PRECIOUS METALS AND THEIR ALLOYS; GOODS IN PRECIOUS METALS OR COATED THEREWITH, NOT INCLUDED IN OTHER CLASSES, NAMELY, JEWELRY; PRECIOUS STONES; JEWELRY, NAMELY, BRACELETS, CHAINS, EARRINGS, NECKLACES, BROOCHES, AND RINGS, IN GOLD, SILVER OR OTHER PRECIOUS METALS (U.S. CLS. 2, 27, 28 AND 50).

KARANENDRA S. CHHINA, EXAMINING ATTORNEY

SN 77-280,873. SILMAR S.P.A., ROMANO D'EZZELINO (VI), ITALY, FILED 9-17-2007.



THE COLOR(S) BLACK AND GOLD IS/ARE CLAIMED AS A FEATURE OF THE MARK.

THE MARK CONSISTS OF THE WORDS "EASY 2 WEAR THE ORIGINAL SYSTEM" IN BLACK, WITH A GOLD CURVED LINE TO THE LEFT OF THE LITERAL PORTION.

FOR PRECIOUS METALS AND THEIR ALLOYS; GOODS IN PRECIOUS METALS OR COATED THEREWITH, NOT INCLUDED IN OTHER CLASSES, NAMELY, JEWELRY; PRECIOUS STONES; JEWELRY, NAMELY, BRACELETS, CHAINS, EARRINGS, NECKLACES, BROOCHES, AND RINGS, IN GOLD, SILVER OR OTHER PRECIOUS METALS (U.S. CLS. 2, 27, 28 AND 50).

KARANENDRA S. CHHINA, EXAMINING ATTORNEY

SN 77-281,326. RETAIL ROYALTY COMPANY, LAS VEGAS, NV. FILED 9-17-2007.

AEO

THE MARK CONSISTS OF STANDARD CHARACTERS WITHOUT CLAIM TO ANY PARTICULAR FONT, STYLE, SIZE, OR COLOR.

OWNER OF U.S. REG. NOS. 1,877,686 AND 1,974,494.
FOR JEWELRY (U.S. CLS. 2, 27, 28 AND 50).
MATTHEW MCDOWELL, EXAMINING ATTORNEY

CLASS 14—(Continued).

SN 77-284,848. HANONICK, DICKRAN, WILMETTE, IL. FILED 9-20-2007.



FOR JEWELRY (U.S. CLS. 2, 27, 28 AND 50).
MARK RADEMACHER, EXAMINING ATTORNEY

SN 77-290,030. NGUYEN, DO CAO, WESTMINSTER, CA. FILED 9-27-2007.

CAODO

THE MARK CONSISTS OF STANDARD CHARACTERS WITHOUT CLAIM TO ANY PARTICULAR FONT, STYLE, SIZE, OR COLOR.

THE ENGLISH TRANSLATION OF THE WORD CAODO IN THE MARK IS "VERY HIGH".

FOR COSTUME JEWELRY (U.S. CLS. 2, 27, 28 AND 50).

FIRST USE 1-1-2007; IN COMMERCE 1-1-2007.
EVELYN BRADLEY, EXAMINING ATTORNEY

SN 77-293,109. M M A LTDA, COTIA, SAO PAULO, BRAZIL, FILED 10-1-2007.

ROMMANEL

THE MARK CONSISTS OF STANDARD CHARACTERS WITHOUT CLAIM TO ANY PARTICULAR FONT, STYLE, SIZE, OR COLOR.

"ROMMANEL" HAS NO MEANING IN A FOREIGN LANGUAGE.

FOR JEWELRY (U.S. CLS. 2, 27, 28 AND 50).
BARBARA GAYNOR, EXAMINING ATTORNEY

CLASS 14—(Continued).

SN 77-299,482. HILL, LARA NOEL, SHERMAN OAKS, CA. FILED 10-9-2007.



DESIGNS BY
LARA NOEL HILL

NO CLAIM IS MADE TO THE EXCLUSIVE RIGHT TO USE "DESIGNS BY", APART FROM THE MARK AS SHOWN.

THE STIPPLING IS A FEATURE OF THE MARK. THE MARK CONSISTS IN PART OF A THUMB PRINT ON THE BELLY OF THE ANIMATED DESIGN.

FOR NECKLACES, BRACELETS, EARRINGS, RINGS, BROOCHES AS JEWELRY (U.S. CLS. 2, 27, 28 AND 50).

FIRST USE 1-30-2002; IN COMMERCE 8-11-2002.

ALEX KEAM, EXAMINING ATTORNEY

SN 77-304,064. ADVANCE WATCH COMPANY LTD., CANTON, MI. FILED 10-15-2007.



FOR TIMEPIECES AND CHRONOMETRIC INSTRUMENTS, NAMELY, ALARM CLOCKS, WALL CLOCKS AND PARTS THEREFORE; CLOCK ACCESSORIES, NAMELY, CLOCK CABINETS, HOUSINGS, CASES, GEARS, PENDULUMS, HANDS, FACE INSERTS AND DIALS (U.S. CLS. 2, 27, 28 AND 50).

FIRST USE 2-0-2007; IN COMMERCE 6-0-2007.

JUSTINE D. PARKER, EXAMINING ATTORNEY

CLASS 14—(Continued).

SN 77-377,695. BLUE MARTINI RED MARTINI, PRINCETON, NJ. FILED 1-22-2008.



• Don't Fall For It Girlfriend •

THE MARK CONSISTS OF A STYLIZED HEART MADE UP OF THE STYLIZED TEXT "DFFIGF". THE STYLIZED WORDS "DONT FALL FOR IT GIRLFRIEND" ARE BELOW THE HEART.

FOR JEWELRY (U.S. CLS. 2, 27, 28 AND 50).

PAUL CROWLEY, EXAMINING ATTORNEY

SN 77-378,363. DIACOM CORP., BOCA RATON, FL. FILED 1-23-2008.

LineaBolde

THE MARK CONSISTS OF STANDARD CHARACTERS WITHOUT CLAIM TO ANY PARTICULAR FONT, STYLE, SIZE, OR COLOR.

FOR DIAMOND JEWELRY; JEWELLERY AND WATCHES (U.S. CLS. 2, 27, 28 AND 50).

FIRST USE 11-6-2007; IN COMMERCE 11-6-2007.

ALEX KEAM, EXAMINING ATTORNEY

SN 77-393,758. AMERICLOCK, INC., ST. LOUIS, MO. FILED 2-11-2008.

AMERICLOCK

THE MARK CONSISTS OF STANDARD CHARACTERS WITHOUT CLAIM TO ANY PARTICULAR FONT, STYLE, SIZE, OR COLOR.

FOR CLOCKS, NAMELY, TOWER CLOCKS, CUPOLA CLOCKS, PROJECTING CLOCKS, DRUM CLOCKS, WALL CLOCKS AND FLORAL CLOCKS (U.S. CLS. 2, 27, 28 AND 50).

DANIEL BRODY, EXAMINING ATTORNEY

CLASS 14—(Continued).

SN 77-402,335. BIJOU JEWELERS, INC., POWAY, CA. FILED 2-21-2008.

MARY THEADORA COLLECTION

THE MARK CONSISTS OF STANDARD CHARACTERS WITHOUT CLAIM TO ANY PARTICULAR FONT, STYLE, SIZE, OR COLOR.

NO CLAIM IS MADE TO THE EXCLUSIVE RIGHT TO USE "COLLECTION", APART FROM THE MARK AS SHOWN.

THE NAME(S), PORTRAIT(S), AND/OR SIGNATURE(S) SHOWN IN THE MARK IDENTIFIES A PARTICULAR LIVING INDIVIDUAL, WHOSE CONSENT(S) TO REGISTER IS SUBMITTED.

FOR JEWELRY (U.S. CLS. 2, 27, 28 AND 50).
TRACY WHITTAKER-BROWN, EXAMINING ATTORNEY

SN 77-406,192. JENNIFER FISHER, NEW YORK, NY. FILED 2-26-2008.

JENNIFER FISHER

THE MARK CONSISTS OF STANDARD CHARACTERS WITHOUT CLAIM TO ANY PARTICULAR FONT, STYLE, SIZE, OR COLOR.

THE NAME "JENNIFER FISHER" IDENTIFIES A LIVING INDIVIDUAL WHOSE CONSENT IS OF RECORD.

FOR JEWELRY (U.S. CLS. 2, 27, 28 AND 50).
FIRST USE 4-30-2006; IN COMMERCE 4-30-2006.
MATTHEW EINSTEIN, EXAMINING ATTORNEY

CLASS 14—(Continued).

SN 77-408,365. PHYLLIS G. PESSOLANO, SCARSDALE, NY. FILED 2-28-2008.

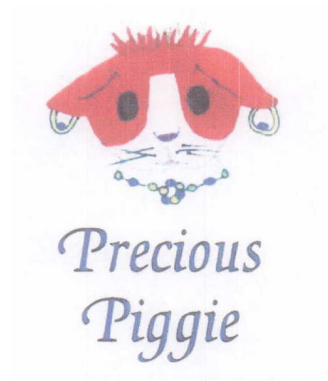

THE COLOR(S) BROWN, WHITE, BLACK, YELLOW, BLUE AND PINK IS/ARE CLAIMED AS A FEATURE OF THE MARK.

THE MARK CONSISTS OF THE WORDING "PRECIOUS PIGGIE" IN BLUE AND A GUINEA PIG WITH BROWN AND WHITE FUR, BLACK EYES, PINK NOSE, MOUTH AND WHISKERS AND BLACK DETAILING. THE GUINEA PIG IS WEARING YELLOW AND BLUE EARRINGS AND YELLOW AND BLUE NECKLACE, ALL OF WHICH ARE OUTLINED IN BLACK.

FOR JEWELRY, NAMELY, NECKLACES, BRACELETS AND EARRINGS (U.S. CLS. 2, 27, 28 AND 50).
FIRST USE 3-12-2008; IN COMMERCE 3-12-2008.
MARTHA FROMM, EXAMINING ATTORNEY

SN 77-410,215. EVADE, LLC, CAMARILLO, CA. FILED 2-29-2008.

Evade

THE MARK CONSISTS OF STANDARD CHARACTERS WITHOUT CLAIM TO ANY PARTICULAR FONT, STYLE, SIZE, OR COLOR.

FOR JEWELRY, NAMELY, NECKLACES IN THE NATURE OF DOG TAGS (U.S. CLS. 2, 27, 28 AND 50).
ALEX KEAM, EXAMINING ATTORNEY

CLASS 14—(Continued).

SN 77-410,997. A.B.C. HOME FURNISHINGS, INC., NEW YORK, NY. FILED 3-3-2008.

CHARMS FOR CHANGE

THE MARK CONSISTS OF STANDARD CHARACTERS WITHOUT CLAIM TO ANY PARTICULAR FONT, STYLE, SIZE, OR COLOR.

NO CLAIM IS MADE TO THE EXCLUSIVE RIGHT TO USE "CHARMS", APART FROM THE MARK AS SHOWN.

FOR JEWELRY (U.S. CLS. 2, 27, 28 AND 50).

FIRST USE 11-1-2007; IN COMMERCE 11-1-2007.

ROBERT LAVACHE, EXAMINING ATTORNEY

SN 77-415,346. HELMICH, SUSAN, MONUMENT, CO. FILED 3-6-2008.

SUSAN HELMICH

THE MARK CONSISTS OF STANDARD CHARACTERS WITHOUT CLAIM TO ANY PARTICULAR FONT, STYLE, SIZE, OR COLOR.

THE NAME(S), PORTRAIT(S), AND/OR SIGNATURE(S) SHOWN IN THE MARK IDENTIFIES "SUSAN HELMICH", WHOSE CONSENT(S) TO REGISTER IS SUBMITTED.

FOR JEWELRY, NAMELY, PENDANTS, BROOCHES, NAMELY, BROOCHES FOR WOMEN AND TIE TACKS FOR MEN, EARRINGS, NECKLACES, RINGS, CHARMS, LAPEL PINS, BRACELETS AND CUFFLINKS (U.S. CLS. 2, 27, 28 AND 50).

FIRST USE 9-1-1974; IN COMMERCE 9-1-1974.

MARY MUNSON, EXAMINING ATTORNEY

SN 77-417,449. SKELETAL METAL, LLC, HENDERSON, NV. FILED 3-10-2008.

SKELETAL METAL

THE MARK CONSISTS OF STANDARD CHARACTERS WITHOUT CLAIM TO ANY PARTICULAR FONT, STYLE, SIZE, OR COLOR.

NO CLAIM IS MADE TO THE EXCLUSIVE RIGHT TO USE "METAL", APART FROM THE MARK AS SHOWN.

FOR JEWELRY (U.S. CLS. 2, 27, 28 AND 50).

DAWN FELDMAN, EXAMINING ATTORNEY

CLASS 14—(Continued).

SN 77-421,548. GLENN MILLER ASSOCIATES, LAKEWOOD, CA. FILED 3-13-2008.



THE MARK CONSISTS OF THE LETTERS "J" AND "A" STYLIZED.

FOR JEWELRY (U.S. CLS. 2, 27, 28 AND 50).

FIRST USE 3-0-2007; IN COMMERCE 3-0-2007.

LIEF MARTIN, EXAMINING ATTORNEY

SN 77-421,773. WATCH FACTORY INC., LOS ANGELES, CA. FILED 3-14-2008.

TECHNO SOURCE

THE MARK CONSISTS OF STANDARD CHARACTERS WITHOUT CLAIM TO ANY PARTICULAR FONT, STYLE, SIZE, OR COLOR.

FOR WATCHES (U.S. CLS. 2, 27, 28 AND 50).

RUDY R. SINGLETON, EXAMINING ATTORNEY

SN 77-423,653. SNUGZ/USA INCORPORATED, SALT LAKE CITY, UT. FILED 3-17-2008.

PAY IT FORWARD

THE MARK CONSISTS OF STANDARD CHARACTERS WITHOUT CLAIM TO ANY PARTICULAR FONT, STYLE, SIZE, OR COLOR.

FOR BRACELETS; RUBBER OR SILICON WRIST-BANDS IN THE NATURE OF A BRACELET (U.S. CLS. 2, 27, 28 AND 50).

FIRST USE 7-31-2007; IN COMMERCE 7-31-2007.

CHRISIE B. KING, EXAMINING ATTORNEY

CLASS 14—(Continued).

SN 77-426,891. THE BAZAR GROUP, INC., EAST PROVIDENCE, RI. FILED 3-20-2008.

IMPERIAL CROWN CULTURED
PEARLS

THE MARK CONSISTS OF STANDARD CHARACTERS WITHOUT CLAIM TO ANY PARTICULAR FONT, STYLE, SIZE, OR COLOR.

OWNER OF U.S. REG. NOS. 500,280 AND 2,656,515.

NO CLAIM IS MADE TO THE EXCLUSIVE RIGHT TO USE "CULTURED PEARLS", APART FROM THE MARK AS SHOWN.

FOR PEARLS, NAMELY, CULTURED PEARLS; NECKLACES FEATURING CULTURED PEARLS; RINGS FEATURING CULTURED PEARLS; JEWELRY FEATURING CULTURED PEARLS (U.S. CLS. 2, 27, 28 AND 50).

FIRST USE 2-1-2002; IN COMMERCE 2-1-2002.

JOHN KELLY, EXAMINING ATTORNEY

SN 77-427,019. CROTON WATCH CO., INC., MOONACHIE, NJ. FILED 3-20-2008.

CROTON BALLROOM COLLECTION

THE MARK CONSISTS OF STANDARD CHARACTERS WITHOUT CLAIM TO ANY PARTICULAR FONT, STYLE, SIZE, OR COLOR.

OWNER OF U.S. REG. NOS. 648,249, 3,133,953 AND OTHERS.

NO CLAIM IS MADE TO THE EXCLUSIVE RIGHT TO USE "COLLECTION", APART FROM THE MARK AS SHOWN.

FOR WATCHES AND JEWELRY (U.S. CLS. 2, 27, 28 AND 50).

KATHERINE STOIDES, EXAMINING ATTORNEY

SN 77-427,978. DOXA WATCHES LTD, BIENNE, SWITZERLAND, FILED 3-21-2008.

ULTRASPEED

THE MARK CONSISTS OF STANDARD CHARACTERS WITHOUT CLAIM TO ANY PARTICULAR FONT, STYLE, SIZE, OR COLOR.

FOR DIVING WATCHES; JEWELRY WATCHES; MECHANICAL AND AUTOMATIC WATCHES; STOP WATCHES; WATCH PARTS; WATCHES AND CLOCKS; WATCHES FOR OUTDOOR USE; WATCHES, CLOCKS; WRIST WATCHES; WATCHES AND JEWELRY; CHRONOGRAPHS FOR USE AS TIMEPIECES; CHRONOGRAPHS FOR USE AS WATCHES (U.S. CLS. 2, 27, 28 AND 50).

FIRST USE 1-2-1972; IN COMMERCE 1-2-1973.

JOHN WILKE, EXAMINING ATTORNEY

CLASS 14—(Continued).

SN 77-428,150. TOBB ENTERPRISES, BEAVERTON, OR. FILED 3-21-2008.

Faith Inspire Love Live
(FILL)

THE MARK CONSISTS OF STANDARD CHARACTERS WITHOUT CLAIM TO ANY PARTICULAR FONT, STYLE, SIZE, OR COLOR.

FOR JEWELRY; IMITATION JEWELRY (U.S. CLS. 2, 27, 28 AND 50).

SANI KHOURI, EXAMINING ATTORNEY

SN 77-428,752. TAYLOR, STEPHANIE, HOUSTON, TX. FILED 3-21-2008.

Aubrey Ellen

THE MARK CONSISTS OF STANDARD CHARACTERS WITHOUT CLAIM TO ANY PARTICULAR FONT, STYLE, SIZE, OR COLOR.

THE NAME "AUBREY ELLEN" DOES NOT IDENTIFY A LIVING INDIVIDUAL.

FOR JEWELRY, NAMELY, NECKLACES, EARRINGS, PENDANTS, BRACELETS, AND RINGS (U.S. CLS. 2, 27, 28 AND 50).

FIRST USE 10-13-2007; IN COMMERCE 10-13-2007.

CYNTHIA SLOAN, EXAMINING ATTORNEY

SN 77-428,808. BARNEY'S BLING, SANTA MONICA, CA. FILED 3-21-2008.



barney's bling

NO CLAIM IS MADE TO THE EXCLUSIVE RIGHT TO USE "BLING", APART FROM THE MARK AS SHOWN.

THE MARK CONSISTS OF THE TEXT "BARNEY'S BLING" IN SMALL CASE LETTERS, SIMPLE TYPE FONT; A DIAMOND SYMBOL OVER THE "I" IN "BLING"; A DOG LOGO (SILHOUETTE OF A YORKSHIRE TERRIER STANDING WITH DIAMOND AROUND NECK).

FOR JEWELRY; PET JEWELRY (U.S. CLS. 2, 27, 28 AND 50).

PAM WILLIS, EXAMINING ATTORNEY

CLASS 14—(Continued).

SN 77-428,968. CONTINENTAL JEWELRY (USA), INC., NEW YORK, NY. FILED 3-22-2008.

FRESCO

THE MARK CONSISTS OF STANDARD CHARACTERS WITHOUT CLAIM TO ANY PARTICULAR FONT, STYLE, SIZE, OR COLOR.

FOR JEWELRY (U.S. CLS. 2, 27, 28 AND 50).
KEVIN CORWIN, EXAMINING ATTORNEY

CLASS 14—(Continued).

SN 77-430,452. KATHRYN ROBBINS-SULLIVAN, SAN MARRINO, CA. FILED 3-25-2008.

Scentsations

THE MARK CONSISTS OF STANDARD CHARACTERS WITHOUT CLAIM TO ANY PARTICULAR FONT, STYLE, SIZE, OR COLOR.

FOR PERFUME RETAINING JEWELRY (U.S. CLS. 2, 27, 28 AND 50).
SANI KHOURI, EXAMINING ATTORNEY

SN 77-430,065. ELIZABETH FLOWER, CARLSBAD, CA. AND TYRONE FLOWER, CARLSBAD, CA. FILED 3-24-2008.

HIDDEN CRYSTALS

THE MARK CONSISTS OF STANDARD CHARACTERS WITHOUT CLAIM TO ANY PARTICULAR FONT, STYLE, SIZE, OR COLOR.

NO CLAIM IS MADE TO THE EXCLUSIVE RIGHT TO USE "CRYSTALS", APART FROM THE MARK AS SHOWN.
FOR JEWELRY FOR ATTACHMENT TO CLOTHING; JEWELRY TO BE AFFIXED TO BIKINIS (U.S. CLS. 2, 27, 28 AND 50).

TAMARA FRAZIER, EXAMINING ATTORNEY

SN 77-430,675. DEAXIS LLC, CAMPBELL, CA. FILED 3-25-2008.

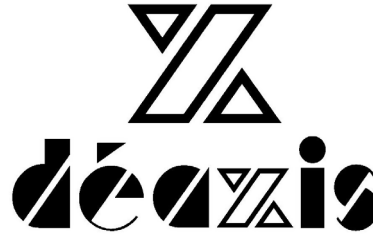

THE MARK CONSISTS OF THE TEXT "DEAXIS" WHICH APPEARS UNDER A BIG LETTER "X"; THERE IS AN ACCENT ON THE "E" IN "DEAXIS" ("DÉAXIS").

THE WORDING "DÉAXIS" HAS NO MEANING IN A FOREIGN LANGUAGE.

FOR ANKLE BRACELETS; BRACELETS; BROOCHES; COSTUME JEWELRY; EARRINGS; JEWELRY; NECK CHAINS; RINGS (U.S. CLS. 2, 27, 28 AND 50).

FIRST USE 1-10-2006; IN COMMERCE 1-10-2006.
ESTHER BELENKER, EXAMINING ATTORNEY

SN 77-430,084. ELIZABETH FLOWER, CARLSBAD, CA. AND TYRONE FLOWER, CARLSBAD, CA. FILED 3-24-2008.



THE MARK CONSISTS OF A STYLIZED "H" ON A DIAMOND SHAPED BACKGROUND WITH BORDER, ALL OVER A BACKGROUND OF RADIANS NARROWING TO A HORIZONTALLY-ORIENTED OVAL.

FOR JEWELRY FOR ATTACHMENT TO CLOTHING; JEWELRY TO BE AFFIXED TO BIKINIS (U.S. CLS. 2, 27, 28 AND 50).

TAMARA FRAZIER, EXAMINING ATTORNEY

SN 77-431,107. MIMI SO INTERNATIONAL LLC, NEW YORK, NY. FILED 3-25-2008.

JACKSON

THE MARK CONSISTS OF STANDARD CHARACTERS WITHOUT CLAIM TO ANY PARTICULAR FONT, STYLE, SIZE, OR COLOR.

THE NAME "JACKSON" DOES NOT IDENTIFY A LIVING INDIVIDUAL.

FOR JEWELRY (U.S. CLS. 2, 27, 28 AND 50).
ATTIYA MALIK, EXAMINING ATTORNEY

CLASS 14—(Continued).

SN 77-431,284. JOHNSON, STEPHEN D., DBA GREEN-SOURCE TECHNOLOGIES, SAN JOSE, CA. FILED 3-25-2008.

Stephen D.

THE MARK CONSISTS OF STANDARD CHARACTERS WITHOUT CLAIM TO ANY PARTICULAR FONT, STYLE, SIZE, OR COLOR.

THE NAME "STEPHEN D." IDENTIFIES A LIVING INDIVIDUAL WHOSE CONSENT IS OF RECORD. FOR WATCHES AND JEWELRY (U.S. CLS. 2, 27, AND 50).

BARNEY CHARLON, EXAMINING ATTORNEY

SN 77-432,429. EMBY JEWELRY LLC, NEW YORK, NY. FILED 3-26-2008.

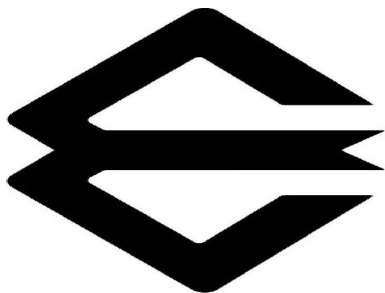

THE MARK CONSISTS OF THE LETTER "E" IN THE STYLIZED LETTERING AS SHOWN IN THE DRAWING. FOR JEWELRY (U.S. CLS. 2, 27, 28 AND 50). MARCIE MILONE, EXAMINING ATTORNEY

SN 77-433,173. MONTESINO INTERNATIONAL CORP., FORT LAUDERDALE, FL. FILED 3-27-2008.

PIT CREW

THE MARK CONSISTS OF STANDARD CHARACTERS WITHOUT CLAIM TO ANY PARTICULAR FONT, STYLE, SIZE, OR COLOR.

FOR JEWELRY (U.S. CLS. 2, 27, 28 AND 50). SONG IN, EXAMINING ATTORNEY

CLASS 14—(Continued).

SN 77-434,192. CARLINO, CRISTINA M., PARADISE VALLEY, AZ. FILED 3-28-2008.

YOU COLOR MY DAY

THE MARK CONSISTS OF STANDARD CHARACTERS WITHOUT CLAIM TO ANY PARTICULAR FONT, STYLE, SIZE, OR COLOR.

FOR JEWELRY (U.S. CLS. 2, 27, 28 AND 50). REBECCA SMITH, EXAMINING ATTORNEY

SN 77-434,588. WELLALARM LLC, NEW YORK, NY. FILED 3-28-2008.

WELLCHARMS

THE MARK CONSISTS OF STANDARD CHARACTERS WITHOUT CLAIM TO ANY PARTICULAR FONT, STYLE, SIZE, OR COLOR.

FOR JEWELRY (U.S. CLS. 2, 27, 28 AND 50). ANDREA BUTLER, EXAMINING ATTORNEY

SN 77-434,640. WELLALARM LLC, NEW YORK, NY. FILED 3-28-2008.

WELLTAGS

THE MARK CONSISTS OF STANDARD CHARACTERS WITHOUT CLAIM TO ANY PARTICULAR FONT, STYLE, SIZE, OR COLOR.

FOR JEWELRY (U.S. CLS. 2, 27, 28 AND 50). ANDREA BUTLER, EXAMINING ATTORNEY

SN 77-434,858. MAURICE KRAIEM & COMPANY, DBA M.K. DIAMONDS & JEWELRY, LOS ANGELES, CA. FILED 3-28-2008.

STARDESIRE

THE MARK CONSISTS OF STANDARD CHARACTERS WITHOUT CLAIM TO ANY PARTICULAR FONT, STYLE, SIZE, OR COLOR.

FOR JEWELRY AND LOOSE DIAMONDS (U.S. CLS. 2, 27, 28 AND 50). BILL DAWE, EXAMINING ATTORNEY

CLASS 14—(Continued).

SN 77-434,862. MAURICE KRAIEM & COMPANY, DBA M.K. DIAMONDS & JEWELRY, LOS ANGELES, CA. FILED 3-28-2008.

ROYALSTAR

THE MARK CONSISTS OF STANDARD CHARACTERS WITHOUT CLAIM TO ANY PARTICULAR FONT, STYLE, SIZE, OR COLOR.
FOR JEWELRY AND LOOSE DIAMONDS (U.S. CLS. 2, 27, 28 AND 50).
BILL DAWE, EXAMINING ATTORNEY

CLASS 14—(Continued).

SN 77-440,565. GLENN MILLER ASSOCIATES, LAKEWOOD, CA. FILED 4-4-2008.

dura tungsten

NO CLAIM IS MADE TO THE EXCLUSIVE RIGHT TO USE "TUNGSTEN", APART FROM THE MARK AS SHOWN.
THE MARK CONSISTS OF THE WORD DURA TUNGSTEN.
FOR JEWELRY MADE IN WHOLE OR SUBSTANTIAL PART OF TUNGSTEN (U.S. CLS. 2, 27, 28 AND 50).
LIEF MARTIN, EXAMINING ATTORNEY

SN 77-434,868. MAURICE KRAIEM & COMPANY, DBA M.K. DIAMONDS & JEWELRY, LOS ANGELES, CA. FILED 3-28-2008.

PRINCESTAR

THE MARK CONSISTS OF STANDARD CHARACTERS WITHOUT CLAIM TO ANY PARTICULAR FONT, STYLE, SIZE, OR COLOR.
FOR JEWELRY AND LOOSE DIAMONDS (U.S. CLS. 2, 27, 28 AND 50).
BILL DAWE, EXAMINING ATTORNEY

SN 77-451,822. MIMI SO INTERNATIONAL LLC, NEW YORK, NY. FILED 4-18-2008.

GATE B9

THE MARK CONSISTS OF STANDARD CHARACTERS WITHOUT CLAIM TO ANY PARTICULAR FONT, STYLE, SIZE, OR COLOR.
FOR JEWELRY (U.S. CLS. 2, 27, 28 AND 50).
FIRST USE 10-1-2005; IN COMMERCE 6-3-2006.
ATTIYA MALIK, EXAMINING ATTORNEY

SN 77-434,873. MAURICE KRAIEM & COMPANY, DBA M.K. DIAMONDS & JEWELRY, LOS ANGELES, CA. FILED 3-28-2008.

FIRELIGHT

THE MARK CONSISTS OF STANDARD CHARACTERS WITHOUT CLAIM TO ANY PARTICULAR FONT, STYLE, SIZE, OR COLOR.
FOR JEWELRY AND LOOSE DIAMONDS (U.S. CLS. 2, 27, 28 AND 50).
BILL DAWE, EXAMINING ATTORNEY

SN 77-463,965. SANJOY INC., NEW YORK, NY. FILED 5-2-2008.

GO-G

THE MARK CONSISTS OF STANDARD CHARACTERS WITHOUT CLAIM TO ANY PARTICULAR FONT, STYLE, SIZE, OR COLOR.
FOR JEWELRY (U.S. CLS. 2, 27, 28 AND 50).
TEJBIR SINGH, EXAMINING ATTORNEY

CLASS 14—(Continued).

SN 77-463,979. SANJOY INC., NEW YORK, NY. FILED 5-2-2008.



THE MARK CONSISTS OF THE WORD "RACHEL" IN STYLIZED LETTERS WITH A STAR DEVICE UNDERNEATH.

FOR JEWELRY (U.S. CLS. 2, 27, 28 AND 50).
FIRST USE 9-25-1997; IN COMMERCE 9-25-1997.
TEJBIR SINGH, EXAMINING ATTORNEY

SN 77-466,712. WONDER JEWELRY LIMITED, TSUEN WAN, N.T., HONG KONG, FILED 5-6-2008.

ANTONIUS WATCH COMPANY

THE MARK CONSISTS OF STANDARD CHARACTERS WITHOUT CLAIM TO ANY PARTICULAR FONT, STYLE, SIZE, OR COLOR.

NO CLAIM IS MADE TO THE EXCLUSIVE RIGHT TO USE "WATCH COMPANY", APART FROM THE MARK AS SHOWN.

FOR BRACELETS; BROOCHES; CHARMS; CHOKERS; DIAMONDS; EARRINGS; JEWELRY; NECKLACES; PEARLS; PENDANTS; PRECIOUS GEMSTONES; PRECIOUS METALS AND THEIR ALLOYS; RINGS; SEMI-PRECIOUS GEMSTONES; WATCH BANDS AND STRAPS; WATCHES (U.S. CLS. 2, 27, 28 AND 50).
EDWARD NELSON, EXAMINING ATTORNEY

SN 77-478,378. MULTI MEDIA EXPOSURE, INC., BERNARDSVILLE, NJ. FILED 5-19-2008.

PAB

THE MARK CONSISTS OF STANDARD CHARACTERS WITHOUT CLAIM TO ANY PARTICULAR FONT, STYLE, SIZE, OR COLOR.

FOR JEWELRY (U.S. CLS. 2, 27, 28 AND 50).
PRISCILLA MILTON, EXAMINING ATTORNEY

CLASS 14—(Continued).

SN 78-770,115. FABRIKANT-LEER INTERNATIONAL LTD., NEW YORK, NY. FILED 12-9-2005.

LOVE AND BELOVED

THE MARK CONSISTS OF STANDARD CHARACTERS WITHOUT CLAIM TO ANY PARTICULAR FONT, STYLE, SIZE, OR COLOR.

FOR JEWELRY (U.S. CLS. 2, 27, 28 AND 50).
DAVID HOFFMAN, EXAMINING ATTORNEY

SN 79-044,776. CHOPARD INTERNATIONAL SA, SWITZERLAND, FILED 9-24-2007.

HAPPY TWELVE

THE MARK CONSISTS OF STANDARD CHARACTERS WITHOUT CLAIM TO ANY PARTICULAR FONT, STYLE, SIZE, OR COLOR.

PRIORITY DATE OF 5-8-2007 IS CLAIMED.

OWNER OF INTERNATIONAL REGISTRATION 0939981 DATED 9-24-2007, EXPIRES 9-24-2017.

OWNER OF U.S. REG. NOS. 1,180,074, 3,014,862 AND OTHERS.

FOR PRECIOUS METALS AND THEIR ALLOYS; FANCY KEY RINGS OF PRECIOUS METAL, ALLOYED OR PLATED WITH PRECIOUS METALS; CUFF LINKS, TIE PINS; JEWELLERY; CUT DIAMONDS; HOROLOGICAL AND CHRONOMETRIC INSTRUMENTS AND PARTS THEREOF (U.S. CLS. 2, 27, 28 AND 50).

MARK PILARO, EXAMINING ATTORNEY

SN 79-046,143. CARRERA Y CARRERA, S.A., SPAIN, FILED 9-3-2007.



PRIORITY DATE OF 4-27-2007 IS CLAIMED.

OWNER OF INTERNATIONAL REGISTRATION 0943315 DATED 9-3-2007, EXPIRES 9-3-2017.

OWNER OF U.S. REG. NO. 1,247,018.

THE ENGLISH TRANSLATION OF THE WORD "CARRERA Y CARRERA" IN THE MARK IS RACE AND RACE.

FOR JEWELRY WRISTWATCHES AND OTHER WATCHES MADE WITH PRECIOUS METALS (GOLD, PLATINUM AND STERLING SILVER) AND MOUNTED WITH OR WITHOUT PRECIOUS OR NATURAL STONES (U.S. CLS. 2, 27, 28 AND 50).

STEPHEN AQUILA, EXAMINING ATTORNEY

CLASS 14—(Continued).

SN 79-051,541. BJB LTD, UNITED KINGDOM, FILED 1-14-2008.

Satin Ice

THE MARK CONSISTS OF STANDARD CHARACTERS WITHOUT CLAIM TO ANY PARTICULAR FONT, STYLE, SIZE, OR COLOR.

OWNER OF INTERNATIONAL REGISTRATION 0957776 DATED 1-14-2008, EXPIRES 1-14-2018.

FOR JEWELRY AND FASHION JEWELRY OF PRECIOUS AND NON-PRECIOUS MATERIALS, WATCHES AND CLOCKS (U.S. CLS. 2, 27, 28 AND 50).

REGINA DRUMMOND, EXAMINING ATTORNEY

CLASS 14—(Continued).

SN 79-053,988. FLASH & PARTNERS S.P.A., ITALY, FILED 3-26-2008.



OWNER OF INTERNATIONAL REGISTRATION 0964657 DATED 3-26-2008, EXPIRES 3-26-2018.

FOR PRECIOUS METAL, NAMELY, GOLD, SILVER, PLATINUM AND PRECIOUS METAL ALLOYS; JEWELRY; PRECIOUS STONES; DIVING WATCHES, POCKET WATCHES, WRISTWATCHES, SMALL CLOCKS, HOROLOGICAL AND CHRONOMETRIC INSTRUMENTS AND CASES THEREFOR; GOODS MADE OF PRECIOUS METALS, NAMELY, BRACELETS, NECKLACES, EARRINGS, PENDANTS, RINGS BEING JEWELRY, TIE CLIPS, KEY RINGS, CASES FOR CLOCKS AND WATCHES (U.S. CLS. 2, 27, 28 AND 50).

CHARLES L. JENKINS, EXAMINING ATTORNEY

SN 79-052,212. BULGARI S.P.A., ITALY, FILED 2-12-2008.

DIAGONO

THE MARK CONSISTS OF STANDARD CHARACTERS WITHOUT CLAIM TO ANY PARTICULAR FONT, STYLE, SIZE, OR COLOR.

PRIORITY DATE OF 1-17-2008 IS CLAIMED.

OWNER OF INTERNATIONAL REGISTRATION 0959603 DATED 2-12-2008, EXPIRES 2-12-2018.

FOR PRECIOUS METALS AND THEIR ALLOYS; GOODS IN PRECIOUS METALS OR COATED THEREWITH, NOT INCLUDED IN OTHER CLASSES, NAMELY, JEWELRY; PRECIOUS STONES; HOROLOGICAL AND CHRONOMETRIC INSTRUMENTS (U.S. CLS. 2, 27, 28 AND 50).

JASON TURNER, EXAMINING ATTORNEY

CLASS 15—MUSICAL INSTRUMENTS

SN 76-683,993. ALLEN, RHEUBEN A., HOLLYWOOD, CA, FILED 11-13-2007.

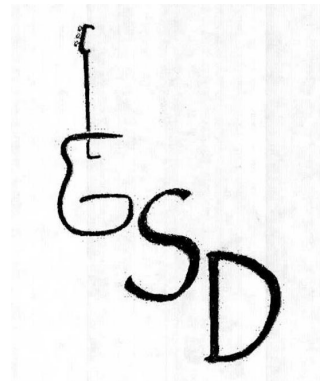

THE MARK IS A STYLIZED REPRESENTATION OF THE LETTERS "GSD".

FOR MUSICAL INSTRUMENTS, NAMELY, SAXOPHONES, CLARINETS, FLUTES, OBOES AND ENGLISH HORNS (U.S. CLS. 2, 21 AND 36).

AMOS T. MATTHEWS, JR., EXAMINING ATTORNEY

SN 79-053,905. SALVATORE FERRAGAMO ITALIA S.P.A., I-50123 FIRENZE (FI), ITALY, FILED 3-27-2008.

F-80

THE MARK CONSISTS OF STANDARD CHARACTERS WITHOUT CLAIM TO ANY PARTICULAR FONT, STYLE, SIZE, OR COLOR.

PRIORITY DATE OF 3-5-2008 IS CLAIMED.

OWNER OF INTERNATIONAL REGISTRATION 0964490 DATED 3-27-2008, EXPIRES 3-27-2018.

FOR CLOCKS, WATCHES, WRISTWATCHES, DIVING WATCHES, POCKET WATCHES, WATCH BANDS AND STRAPS, WATCH CHAINS, WATCH CASES, CHRONOGRAPHS FOR USE AS TIMEPIECES AND FOR USE AS WATCHES, CHRONOMETERS (U.S. CLS. 2, 27, 28 AND 50).

AISHA SALEM, EXAMINING ATTORNEY

CLASS 15—(Continued).

SN 76-687,018. YAMAHA CORPORATION, HAMAMATSU-SHI, SHIZUOKA, JAPAN, FILED 2-21-2008.

A·R·E·)))

THE MARK CONSISTS OF THE LETTERS "A", "R", AND "E" WITH DIAMONDS TO THE RIGHT OF THE LETTERS. SOUND WAVES APPEAR TO THE RIGHT OF THE LETTER "E."

FOR MUSICAL INSTRUMENTS, NAMELY, PIANOS, GUITARS, DRUMS AND VIOLINS; STRINGED MUSICAL INSTRUMENTS; WIND MUSICAL INSTRUMENTS (U.S. CLS. 2, 21 AND 36).

SETH A. RAPPAPORT, EXAMINING ATTORNEY

CLASS 15—(Continued).

SN 78-938,566. JOBES, DALE A., DBA MIRRORACULOUS OF LAS VEGAS UNLIMITED, LAS VEGAS, NV. FILED 7-27-2006.

MIRRORACULOUS

THE MARK CONSISTS OF STANDARD CHARACTERS WITHOUT CLAIM TO ANY PARTICULAR FONT, STYLE, SIZE, OR COLOR.

FOR A VERSATILE CONFIGURATION TYPE OF PICK GUARD FOR MUSICAL INSTRUMENTS THAT FITS TOGETHER FLUSH BETWEEN PIECES OR CAN BE SEPARATED FOR PERSONAL ARTISTIC OR FUNCTIONAL TASTE (U.S. CLS. 2, 21 AND 36).

FIRST USE 1-8-2006; IN COMMERCE 1-8-2006.
INGRID C. EULIN, EXAMINING ATTORNEY

SN 77-343,054. GREGORIAN, ARNOLD J., GLYNDON, MD. AND GREGORIAN, JULIE A., GLYNDON, MD. FILED 12-3-2007.

**Gaston Brohan's
OAK BASS ROSIN**

THE MARK CONSISTS OF STANDARD CHARACTERS WITHOUT CLAIM TO ANY PARTICULAR FONT, STYLE, SIZE, OR COLOR.

NO CLAIM IS MADE TO THE EXCLUSIVE RIGHT TO USE "OAK BASS ROSIN", APART FROM THE MARK AS SHOWN.

THE NAME(S), PORTRAIT(S), AND/OR SIGNATURE(S) SHOWN IN THE MARK DOES NOT IDENTIFY A PARTICULAR LIVING INDIVIDUAL.

FOR ROSIN FOR STRINGED MUSICAL INSTRUMENTS (U.S. CLS. 2, 21 AND 36).

FIRST USE 4-1-2004; IN COMMERCE 5-1-2004.
KATHLEEN LORENZO, EXAMINING ATTORNEY

CLASS 16—PAPER GOODS AND PRINTED MATTER

SN 76-681,445. DMTP PINAL HOLDINGS, L.L.C., TUCSON, AZ. FILED 9-4-2007.

DECADES MUSIC THEME PARK

THE MARK CONSISTS OF STANDARD CHARACTERS WITHOUT CLAIM TO ANY PARTICULAR FONT, STYLE, SIZE, OR COLOR.

NO CLAIM IS MADE TO THE EXCLUSIVE RIGHT TO USE "MUSIC", APART FROM THE MARK AS SHOWN.

FOR PAPER AND PRINTED MATTER, NAMELY, SOUVENIR STATIONERY AND BOOKS IN THE FIELD OF MUSIC (U.S. CLS. 2, 5, 22, 23, 29, 37, 38 AND 50).

GEORGIA CARTY, EXAMINING ATTORNEY

SN 77-430,749. MUSIC IS ELEMENTARY, DBA MOTTER'S MUSIC HOUSE, INC., CLEVELAND, OH. FILED 3-25-2008.

Rhythm Works

THE MARK CONSISTS OF STANDARD CHARACTERS WITHOUT CLAIM TO ANY PARTICULAR FONT, STYLE, SIZE, OR COLOR.

FOR MUSICAL INSTRUMENTS (U.S. CLS. 2, 21 AND 36).

MARY CRAWFORD, EXAMINING ATTORNEY

SN 76-684,747. SAFETYTAT, LLC, PHOENIX, MD. FILED 12-10-2007.



THE MARK IS IN LOWERCASE SHOWING A DESIGN ELEMENT APPEARING ON THE LEFT OF THE MARK. THE DESIGN COMPRISES A CIRCLE INSIDE A BIGGER CIRCLE WITH A CHILD SHOWING HIS ARM WITH A TATTOO.

FOR TEMPORARY TATTOOS, NAMELY, CHILDREN'S AND ADULT'S IDENTIFICATION TATTOOS (U.S. CLS. 2, 5, 22, 23, 29, 37, 38 AND 50).

FIRST USE 10-30-2007; IN COMMERCE 10-30-2007.
ANNE E. GUSTASON, EXAMINING ATTORNEY

CLASS 16—(Continued).

SN 76-687,575. PLAID ENTERPRISES, INC., NORCROSS, GA.
FILED 3-10-2008.

BABY STITCHES

THE MARK CONSISTS OF STANDARD CHARACTERS WITHOUT CLAIM TO ANY PARTICULAR FONT, STYLE, SIZE, OR COLOR.

NO CLAIM IS MADE TO THE EXCLUSIVE RIGHT TO USE "STITCHES", APART FROM THE MARK AS SHOWN. FOR IRON-ON TRANSFER SHEETS (U.S. CLS. 2, 5, 22, 23, 29, 37, 38 AND 50).

BRIAN NEVILLE, EXAMINING ATTORNEY

CLASS 16—(Continued).

SN 77-079,219. FLYPAPER, LLC, CAPE GIRARDEAU, MO.
FILED 1-9-2007.

TAKE FLIGHT

THE MARK CONSISTS OF STANDARD CHARACTERS WITHOUT CLAIM TO ANY PARTICULAR FONT, STYLE, SIZE, OR COLOR.

FOR STATIONARY, NOTE CARDS, BLANK NOTE CARDS, PICTURE ALBUMS, PHOTOGRAPHIC ALBUMS; POSTERS; MOUNTED POSTERS; DECORATIVE PICTURES; ART PICTURES, ART PRINTS, GRAPHIC ART REPRODUCTIONS (U.S. CLS. 2, 5, 22, 23, 29, 37, 38 AND 50).

TANYA AMOS, EXAMINING ATTORNEY

SN 76-688,083. MILLER, STEPHANIE, BALTIMORE, MD.
FILED 3-26-2008.

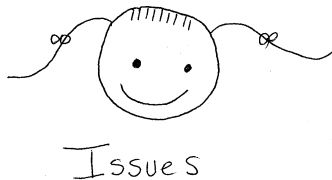

FOR GREETING CARDS (U.S. CLS. 2, 5, 22, 23, 29, 37, 38 AND 50).

CHARLOTTE CORWIN, EXAMINING ATTORNEY

SN 77-096,459. CONNING ASSET MANAGEMENT, HARTFORD, CT. FILED 2-1-2007.

AFFIRM

THE MARK CONSISTS OF STANDARD CHARACTERS WITHOUT CLAIM TO ANY PARTICULAR FONT, STYLE, SIZE, OR COLOR.

FOR PRINTED MATTER AND PAPER GOODS, NAMELY, NEWSLETTERS, PAMPHLETS, BROCHURES, AND MANUALS FEATURING INFORMATION PERTAINING TO THE INSURANCE INDUSTRY AND RISK MANAGEMENT CONSULTING (U.S. CLS. 2, 5, 22, 23, 29, 37, 38 AND 50).

GRETTA YAO, EXAMINING ATTORNEY

SN 77-029,906. GANNETT CO., INC., MCLEAN, VA. FILED 10-26-2006.

YOURSTYLE

THE MARK CONSISTS OF STANDARD CHARACTERS WITHOUT CLAIM TO ANY PARTICULAR FONT, STYLE, SIZE, OR COLOR.

FOR MAGAZINES FEATURING INFORMATION REGARDING LIFESTYLES, ENTERTAINMENT, DINING, COMMUNITY EVENTS, FASHION, HEALTH AND FAMILY (U.S. CLS. 2, 5, 22, 23, 29, 37, 38 AND 50).

CAROLINE WOOD, EXAMINING ATTORNEY

SN 77-116,661. VAN WINKLE, ERIC P., WOODINVILLE, WA.
FILED 2-26-2007.

Eternal Psychology

THE MARK CONSISTS OF STANDARD CHARACTERS WITHOUT CLAIM TO ANY PARTICULAR FONT, STYLE, SIZE, OR COLOR.

NO CLAIM IS MADE TO THE EXCLUSIVE RIGHT TO USE "PSYCHOLOGY", APART FROM THE MARK AS SHOWN.

FOR PRINTED INSTRUCTIONAL, EDUCATIONAL, AND TEACHING MATERIALS IN THE FIELD OF HEALING PSYCHOLOGY (U.S. CLS. 2, 5, 22, 23, 29, 37, 38 AND 50).

FIRST USE 1-6-2006; IN COMMERCE 11-25-2006.

EDWARD NELSON, EXAMINING ATTORNEY

CLASS 16—(Continued).

SN 77-133,407. PT. PURINUSA EKAPERSADA, JAKARTA, INDONESIA, FILED 3-16-2007.



THE MARK CONSISTS OF THE WORD "EXCEEDO" IN STYLIZED LETTERING WITH A LEAF AS THE TOP OF A LOWER CASE D.

FOR PAPER, CARDBOARD AND GOODS MADE FROM THESE MATERIALS, NAMELY, FINE PAPER, NAMELY, WOODFREE PAPER, OFFSET PAPER, RECYCLED PAPER, OFFICE PHOTOCOPY PAPER, PRINTING PAPER, PHOTOCOPY PAPER AND WRITING PAPER (U.S. CLS. 2, 5, 22, 23, 29, 37, 38 AND 50).

KATHRYN COWARD, EXAMINING ATTORNEY

CLASS 16—(Continued).

SN 77-138,776. WALKER, SUSANNE F., ISSAQUAH, WA. FILED 3-23-2007.

LINT LICK

THE MARK CONSISTS OF STANDARD CHARACTERS WITHOUT CLAIM TO ANY PARTICULAR FONT, STYLE, SIZE, OR COLOR.

NO CLAIM IS MADE TO THE EXCLUSIVE RIGHT TO USE "LINT", APART FROM THE MARK AS SHOWN.

FOR ADHESIVE PAPER SHEETS FOR USE IN THE REMOVAL OF LINT, DUST AND OTHER PARTICLES FROM SURFACES (U.S. CLS. 2, 5, 22, 23, 29, 37, 38 AND 50).

ELISSA GARBER KON, EXAMINING ATTORNEY

SN 77-173,612. KITTRICH CORPORATION, LA MIRADA, CA. FILED 5-4-2007.

CON-TACT

SN 77-137,589. AEGIS PUBLICATIONS, LLC, NEWTOWN, PA. FILED 3-22-2007.

FUNCTIONAL ESTHETICS & RESTORATIVE DENTISTRY

THE MARK CONSISTS OF STANDARD CHARACTERS WITHOUT CLAIM TO ANY PARTICULAR FONT, STYLE, SIZE, OR COLOR.

NO CLAIM IS MADE TO THE EXCLUSIVE RIGHT TO USE "RESTORATIVE DENTISTRY", APART FROM THE MARK AS SHOWN.

FOR TRADE JOURNALS IN THE FIELD OF DENTISTRY (U.S. CLS. 2, 5, 22, 23, 29, 37, 38 AND 50).

DOMINICK J. SALEMI, EXAMINING ATTORNEY

THE MARK CONSISTS OF STANDARD CHARACTERS WITHOUT CLAIM TO ANY PARTICULAR FONT, STYLE, SIZE, OR COLOR.

OWNER OF U.S. REG. NOS. 630,599, 998,439 AND OTHERS.

FOR CALENDARS, PRINTED CHARTS; PAPER MEMO TABS FOR PORTABLE ELECTRONIC DEVICES, NAMELY, MOBILE PHONES, MP3 PLAYERS, PDA'S AND CELLPHONES; LABELS, ENVELOPES, NOTE TABS, NOTE CUBES, PAGE MARKING TABS, SIGN HERE MARKING TABS, STICKERS ALL OF PAPER; TRANSPARENT AND INVISIBLE ADHESIVE TAPE FOR USE WITH PAPER; PRINTED SIGNS OF CARDBOARD, PAPER BOARD, OR POSTER BOARD (U.S. CLS. 2, 5, 22, 23, 29, 37, 38 AND 50).

G. MAYERSCHOFF, EXAMINING ATTORNEY

CLASS 16—(Continued).

SN 77-186,238. KRISTY VALSHAN, INC., ELMHURST, IL.
FILED 5-21-2007.



THE NAME SHOWN IN THE MARK DOES NOT IDENTIFY A PARTICULAR LIVING INDIVIDUAL.

THE MARK CONSISTS OF THE NAME "KRISTY VALSHAN" WITH LARGE LETTERS FOR THE "K" AND THE "V" WITH SCROLLED EMBELLISHMENTS.

FOR ADHESIVE NOTE PAPER; BOXES OF PAPER OR CARDBOARD; CARRYING CASES MADE OF PAPER; COASTERS MADE OF PAPER; GIFT WRAP PAPER; NOTE PAPERS; PAPER BAGS; PAPER BOXES FOR STORING GREETING CARDS; PAPER FOR USE IN THE MANUFACTURE OF WALLPAPER; PAPER GIFT BAGS; PAPER GIFT TAGS; PAPER HANG TAGS; PAPER STATIONERY; STATIONERY WRITING PAPER AND ENVELOPES; SCRAPBOOK ALBUMS; SCRAPBOOK PAGES; BRAG BOOKS; MEMORY BOOKS; BLANK JOURNAL BOOKS (U.S. CLS. 2, 5, 22, 23, 29, 37, 38 AND 50).

BARBARA RUTLAND, EXAMINING ATTORNEY

SN 77-205,634. ALLERGIK-ID, LLC, MERION STATION, PA.
FILED 6-13-2007.

STATKIDS

THE MARK CONSISTS OF STANDARD CHARACTERS WITHOUT CLAIM TO ANY PARTICULAR FONT, STYLE, SIZE, OR COLOR.

FOR LUNCH BAGS; STICKERS; POSTERS; PAPER SNACK BOXES SOLD EMPTY; PRINTED CARDS CONTAINING EMERGENCY INFORMATION REGARDING THE CARD CARRIER; STICKER AND PAPER IDENTIFICATION TAGS FOR USE ON BAGS (U.S. CLS. 2, 5, 22, 23, 29, 37, 38 AND 50).

AMY HELLA, EXAMINING ATTORNEY

CLASS 16—(Continued).

SN 77-205,748. CRUMPTON-YOUNG, LESIA L., ORLANDO, FL. FILED 6-14-2007.

You've Got The Power

THE MARK CONSISTS OF STANDARD CHARACTERS WITHOUT CLAIM TO ANY PARTICULAR FONT, STYLE, SIZE, OR COLOR.

FOR A SERIES OF BOOKS, WRITTEN ARTICLES, HANDOUTS AND WORKSHEETS IN THE FIELD OF SELF-IMPROVEMENT (U.S. CLS. 2, 5, 22, 23, 29, 37, 38 AND 50).

FIRST USE 4-0-2004; IN COMMERCE 5-0-2004.

MARK SPARACINO, EXAMINING ATTORNEY

SN 77-219,596. FUCHS, JODI, SANTA MONICA, CA. FILED 6-29-2007.

THE COLOR(S) PINK AND BROWN IS/ARE CLAIMED AS A FEATURE OF THE MARK.

THE COLOR PINK APPEARS IN THE WORDING "PEACE IN THE HOME / PEACE IN THE WORLD" AND IN THE ACCENT MARK LOCATED OVER THE WORD "HOME". THE COLOR BROWN APPEARS IN THE WORDING "HOME SHANTI".

THE ENGLISH TRANSLATION OF THE WORD "SHANTI" IN THE MARK IS "PEACE".

FOR PAINTINGS AND THEIR REPRODUCTIONS (U.S. CLS. 2, 5, 22, 23, 29, 37, 38 AND 50).

FIRST USE 12-0-2003; IN COMMERCE 1-0-2006.

JENNIFER VASQUEZ, EXAMINING ATTORNEY

SN 77-220,392. NATURAL COUTURE, INC., LAS VEGAS, NV. FILED 7-2-2007.

XTREME COUTURE TRAINING MANUAL

THE MARK CONSISTS OF STANDARD CHARACTERS WITHOUT CLAIM TO ANY PARTICULAR FONT, STYLE, SIZE, OR COLOR.

NO CLAIM IS MADE TO THE EXCLUSIVE RIGHT TO USE "TRAINING MANUAL", APART FROM THE MARK AS SHOWN.

FOR EDUCATIONAL PUBLICATIONS, NAMELY, TRAINING MANUALS IN THE FIELD OF MIXED MARTIAL ARTS (U.S. CLS. 2, 5, 22, 23, 29, 37, 38 AND 50).

AMY GEARIN, EXAMINING ATTORNEY

CLASS 16—(Continued).

SN 77-235,454. PACE, KIMBERLIE A., DBA KIMBERLIE A. PETERSON, DELRAY BEACH, FL. FILED 7-21-2007.



Efitte

THE MARK CONSISTS OF KOREAN SCRIPT THAT MEANS "MOVEMENT" ON EITHER SIDE OF A CAPITAL BLOCK "E", THE WORD EFITTE IS DIRECTLY UNDER THE KOREAN SCRIPT AND THE LETTER "E", AND "FITTE" IS ITALICIZED..

THE NON-LATIN CHARACTERS IN THE MARK TRANSLITERATE TO OON DOHNG AND THIS MEANS MOVEMENT IN ENGLISH.

FOR EDUCATIONAL PUBLICATIONS, NAMELY, TRAINING MANUALS IN THE FIELD OF HEALTH, FITNESS, WELLNESS AND NUTRITION (U.S. CLS. 2, 5, 22, 23, 29, 37, 38 AND 50).

FIRST USE 9-15-2006; IN COMMERCE 5-10-2007.

REGINA DRUMMOND, EXAMINING ATTORNEY

SN 77-236,045. EGMONT UK LIMITED, LONDON, UNITED KINGDOM, FILED 7-23-2007.

2HEADS

THE MARK CONSISTS OF STANDARD CHARACTERS WITHOUT CLAIM TO ANY PARTICULAR FONT, STYLE, SIZE, OR COLOR.

OWNER OF UNITED KINGDOM REG. NO. 2441816, DATED 7-20-2007, EXPIRES 12-19-2016.

FOR PAPER; CARDBOARD; PRINTED MATTER, NAMELY, BOOKS IN THE FIELD OF CHILDREN'S FICTION; ANNUALS IN THE FIELD OF CHILDREN'S FICTION; PUBLICATIONS, NAMELY, COMIC BOOKS; SONG BOOKS; MAGAZINES FEATURING CHILDREN'S FICTION; NEWSLETTERS IN THE FIELD OF CHILDREN'S FICTION; NEWSPAPERS; ALBUMS FOR STICKERS; PRINTED PERIODICALS IN THE FIELD OF CHILDREN'S FICTION; JOURNALS CONCERNING CHILDREN'S FICTION; CATALOGUES IN THE FIELD OF CHILDREN'S FICTION; MANUALS IN THE FIELD OF CHILDREN'S FICTION; MAPS; PAMPHLETS AND LEAFLETS IN THE FIELD OF CHILDREN'S FICTION; POSTERS; STATIONERY; PAPER LABELS; DRAWING AND PAINTING MATERIALS, NAMELY, PAINT BOXES, PAINT BRUSHES AND PENCILS; DRAWING RULERS; WRITING INSTRUMENTS; INSTRUCTIONAL AND TEACHING MATERIALS, NAMELY, EDUCATIONAL CARD GAMES; BOOK BINDING MATERIALS; BOOK COVERS; BOOK MARKS; PRINTING SETS, NAMELY, PRINTING PAPER AND LABEL PRINTING MACHINES; DRAWINGS; PAINTINGS; PHOTOGRAPHS; PRINTS; PICTURES; CALENDARS; DIARIES; PENS; PENCILS; PENCIL BOXES; PENCIL CASES; PAPER TAGS; GIFT WRAP CARDS; WRAPPING PAPERS; NOTE PADS; DECALCOMANIAS; ERASERS; GREETING CARDS; STICKERS; TEACHING CLOCKS MADE OF PAPER; TABLE CLOTHS OF PAPER; PAPER NAPKINS; SERVIETTES MADE OF PAPER; AND TISSUE PAPER (U.S. CLS. 2, 5, 22, 23, 29, 37, 38 AND 50).

KAPIL BHANOT, EXAMINING ATTORNEY

CLASS 16—(Continued).

SN 77-253,359. THE MODERN GROUP, LTD., BEAUMONT, TX. FILED 8-13-2007.

GO GALVANIZED

THE MARK CONSISTS OF STANDARD CHARACTERS WITHOUT CLAIM TO ANY PARTICULAR FONT, STYLE, SIZE, OR COLOR.

NO CLAIM IS MADE TO THE EXCLUSIVE RIGHT TO USE "GALVANIZED", APART FROM THE MARK AS SHOWN.

FOR PRINTED PRODUCTS, NAMELY, PRODUCT GUIDES FEATURING AGRICULTURAL MACHINES, NAMELY, MOWERS, HYDRAULIC SKID MOWERS, AND HAY EQUIPMENT, AGRICULTURAL MACHINERY AND ATTACHMENTS THEREFORE, NAMELY, ROTARY MOWERS, BOX SCRAPERS, AND THREE POINT ATTACHMENTS, AND TRACTOR TOWED AGRICULTURAL IMPLEMENTS, NAMELY, MOWERS; PRINTED VISUALS IN THE NATURE OF PROMOTIONAL MATERIALS FEATURING AGRICULTURAL MACHINES, AGRICULTURAL MACHINERY AND ATTACHMENTS THEREFORE, AND TRACTOR TOWED AGRICULTURAL IMPLEMENTS (U.S. CLS. 2, 5, 22, 23, 29, 37, 38 AND 50).

FIRST USE 9-30-2006; IN COMMERCE 9-30-2006.

KATHERINE CHANG, EXAMINING ATTORNEY

SN 77-257,257. NEW LINE PRODUCTIONS, INC., NEW YORK, NY. FILED 8-16-2007.

SILVERTONGUE

THE MARK CONSISTS OF STANDARD CHARACTERS WITHOUT CLAIM TO ANY PARTICULAR FONT, STYLE, SIZE, OR COLOR.

FOR ACTIVITY KITS CONSISTING OF MODELING COMPOUNDS AND ACCESSORIES FOR USE THEREWITH PACKAGED AS A UNIT, ACTIVITY KITS CONTAINING STAMPER MARKERS, RUBBER STAMPERS, INK PAD, COLORED PENCILS AND STAMPER HOLDER PACKAGED AS A UNIT, ADDRESS BOOKS, ART PRINTS, PRINTED ART REPRODUCTIONS, ARTIST'S MATERIALS, NAMELY, PENCILS, PENS, BRUSHES, ARTS AND CRAFT DRAWING KITS COMPRISED OF PAPER, PENCILS, PENS, CRAYONS, MARKERS AND STENCILS, ARTS AND CRAFT MODEL-MAKING KITS COMPRISED PRIMARILY OF PLASTIC FIGURES FOR USE AS TOYS, ARTS AND CRAFT PAINT AND DRAWING KITS, BANK CHECKS, BLANK NOTE CARDS, BOOK MARKS, BOOK PLATES, BOOKS CONTAINING PUZZLES AND GAMES, BOOKS FEATURING ADVENTURE AND DRAMATIC STORIES, BOOKS FEATURING PHOTOGRAPHIC PRINTS, BOOKS FOR ROLE-PLAYING, BOOKS ON FANTASY, BOOKS ON MYTHS, CALENDARS, CARDBOARD FIGURES, CHILDREN'S ACTIVITY BOOKS, CHILDREN'S ACTIVITY SETS COMPRISED OF PUZZLE AND MAZE BOOKS, COIN ALBUMS, COLLECTOR ALBUMS FOR STAMPS, COINS, STICKERS AND PHOTOGRAPHS, COLORING BOOKS, COMIC BOOKS, COMIC MAGAZINES, NEWSLETTERS, JOURNALS, MAGAZINES IN THE FIELD OF COMEDY, ACTION, ADVENTURE AND/OR ANIMATION, COMPOSITION BOOKS, COOKBOOKS, COPY BOOKS, CORRESPONDENCE NOTE PAPER, CRAYON AND COLOR BY NUMBER KITS, DECORATIVE RUBBER STAMPS, DESK ACCESSORIES, NAMELY, DESK

CLASS 16—(Continued).

BASKETS, DESK PADS AND STATIONERY SETS COMPRISED OF PAPER, ENVELOPES, SEALS AND NOTEPADS, DESK STANDS, DESK HOLDERS FOR PENS, PENCILS, TAPE, AND PAPER CLIPS, DESK TOP ORGANIZERS, DIARIES, FANTASY MAGAZINES, GIFT BOOKS, GREETING CARDS, GUEST BOOKS, PRINTED HOLOGRAMS, INSTRUCTIONAL MANUALS AND STRATEGY GUIDES FOR GAMES, PRINTED INVITATIONS, PAPER IRON-ON PATCHES, LITHOGRAPHIC PRINTS, LITHOGRAPHS, NON-MAGNETIC CARDS FOR USE AS CREDIT CARDS, MEMORANDUM BOARDS, MODELING MATERIALS AND COMPOUNDS FOR USE BY CHILDREN, NON-ELECTRONIC PERSONAL PLANNERS AND ORGANIZERS, NON-MAGNETICALLY CODED TELEPHONE CALLING CARDS, NON-MAGNETICALLY CODED TRANSPORTATION FARE CARDS, NOTEBOOKS, NOTEPAD AND PENCIL SETS, NOTEPADS, ORGANIZERS FOR STATIONERY USE, ORIGINAL ARTWORK PRINTS, PAINTING SETS FOR CHILDREN; PAPER ACTIVITY KITS CONSISTING OF WRITING AND DRAWING IMPLEMENTS, PAPER MACHE FIGURES, PAPER NAPKINS, PAPER PARTY DECORATIONS, PAPER PARTY HATS, PAPER RIBBONS, PAPER TABLE CLOTHS, PATTERNS FOR MAKING COSTUMES, PENCIL CASES, PENCIL SHARPENERS, PERSONAL ORGANIZERS, PHOTOGRAPH ALBUMS, PHOTOGRAPHIC PRINTS, PICTURE BOOKS, POP-UP BOOKS, POSTCARDS, POSTER BOOKS, POSTERS, PRINTED PAPER PATTERNS, RUB DOWN TRANSFERS, SCHOOL AND OFFICE SUPPLIES, NAMELY, ERASERS, PENCILS, PENS, MARKERS, AND GLUE FOR STATIONERY OR HOUSEHOLD USE, SCRAPBOOK ALBUMS, SKETCHBOOKS, STAMP ALBUMS, STATIONERY, STATIONERY PORTFOLIOS, STENCILS, STICKER BOOKS, STICKERS, TEMPORARY TATTOOS, TRADING CARD MILK BOTTLE CAPS, TRADING CARDS, AND WRITING PADS (U.S. CLS. 2, 5, 22, 23, 29, 37, 38 AND 50).

RONALD MCMORROW, EXAMINING ATTORNEY

SN 77-258,539. HAUSER'S COIN COMPANY OF CLEARWATER, INC., CLEARWATER, FL. FILED 8-17-2007.

Currency Portfolio

THE MARK CONSISTS OF STANDARD CHARACTERS WITHOUT CLAIM TO ANY PARTICULAR FONT, STYLE, SIZE, OR COLOR.

FOR ALBUMS FOR CURRENCY (U.S. CLS. 2, 5, 22, 23, 29, 37, 38 AND 50).

FIRST USE 3-19-2007; IN COMMERCE 3-19-2007.

JOHN GARTNER, EXAMINING ATTORNEY

CLASS 16—(Continued).

SN 77-260,591. BERKSHIRE CORPORATION, GREAT BARRINGTON, MA. FILED 8-21-2007.

ECO BOND

THE MARK CONSISTS OF STANDARD CHARACTERS WITHOUT CLAIM TO ANY PARTICULAR FONT, STYLE, SIZE, OR COLOR.

FOR PAPER, NAMELY, BOND, STATIONERY, BUSINESS FORMS, COPYING, PRINTING, NOT CHEMICALLY IMPREGNATED FOR USE IN CLEANROOMS AND CONTROLLED ENVIRONMENTS (U.S. CLS. 2, 5, 22, 23, 29, 37, 38 AND 50).

GIANCARLO CASTRO, EXAMINING ATTORNEY

SN 77-260,669. BERKSHIRE CORPORATION, GREAT BARRINGTON, MA. FILED 8-21-2007.

ECOBOND

THE MARK CONSISTS OF STANDARD CHARACTERS WITHOUT CLAIM TO ANY PARTICULAR FONT, STYLE, SIZE, OR COLOR.

FOR PAPER, NAMELY BOND, STATIONERY, BUSINESS FORMS, COPYING, PRINTING, NOT CHEMICALLY IMPREGNATED FOR USE IN CLEANROOMS AND CONTROLLED ENVIRONMENTS (U.S. CLS. 2, 5, 22, 23, 29, 37, 38 AND 50).

GIANCARLO CASTRO, EXAMINING ATTORNEY

SN 77-263,557. LIFE/LEADERSHIP DEVELOPMENT, INC., DBA RUTH LILLY HEALTH EDUCATION CENTER, INDIANAPOLIS, IN. FILED 8-24-2007.

HEALTHY YOUTH AMERICA

THE MARK CONSISTS OF STANDARD CHARACTERS WITHOUT CLAIM TO ANY PARTICULAR FONT, STYLE, SIZE, OR COLOR.

NO CLAIM IS MADE TO THE EXCLUSIVE RIGHT TO USE "AMERICA", APART FROM THE MARK AS SHOWN.

FOR PRINTED EDUCATIONAL MATERIAL, NAMELY, TEACHER CURRICULUM GUIDES IN THE FIELDS OF NUTRITION AND FITNESS (U.S. CLS. 2, 5, 22, 23, 29, 37, 38 AND 50).

HEATHER SAPP, EXAMINING ATTORNEY

CLASS 16—(Continued).

SN 77-267,620. DISNEY ENTERPRISES, INC., BURBANK, CA. FILED 8-29-2007.

THE FIRST

THE MARK CONSISTS OF STANDARD CHARACTERS WITHOUT CLAIM TO ANY PARTICULAR FONT, STYLE, SIZE, OR COLOR.

FOR PRINTED MATERIALS AND PUBLICATIONS, NAMELY, COMIC BOOKS, COMIC MAGAZINES AND PRINTED STORIES IN ILLUSTRATED FORM FEATURED IN BOOKS AND MAGAZINES (U.S. CLS. 2, 5, 22, 23, 29, 37, 38 AND 50).

LEIGH CAROLINE CASE, EXAMINING ATTORNEY

CLASS 16—(Continued).

SN 77-277,203. DPE LABEL HOLDING CORP., BROOKLYN, NY. FILED 9-12-2007.

MI CHANGARRITO

THE MARK CONSISTS OF STANDARD CHARACTERS WITHOUT CLAIM TO ANY PARTICULAR FONT, STYLE, SIZE, OR COLOR.

THE FOREIGN WORDING IN THE MARK TRANSLATES INTO ENGLISH AS MY STALL.

FOR PRE-PAID TELEPHONE CALLING CARDS, NOT MAGNETICALLY ENCODED (U.S. CLS. 2, 5, 22, 23, 29, 37, 38 AND 50).

FIRST USE 7-1-2007; IN COMMERCE 7-1-2007.
STEVEN R. FOSTER, EXAMINING ATTORNEY

SN 77-269,667. BRYAN ZARDENETA, SAN PEDRO, CA. FILED 8-31-2007.



THE LINING AND STIPPLING ARE FEATURES OF THE MARK.

THE MARK CONSISTS OF THE STYLIZED LETTERS "GH" AND WORDS "GET YOUR HARD ON" ALONG WITH CRACKS AND DOTS SHOWN THROUGHOUT THE MARK.

FOR PAPER PRODUCTS, NAMELY, BUMPER STICKERS (U.S. CLS. 2, 5, 22, 23, 29, 37, 38 AND 50).

DAVID YONTEF, EXAMINING ATTORNEY

SN 77-280,605. PROMO PRINT SOLUTIONS, INC., OSHKOSH, WI. FILED 9-16-2007.

Snap Mobile

THE MARK CONSISTS OF STANDARD CHARACTERS WITHOUT CLAIM TO ANY PARTICULAR FONT, STYLE, SIZE, OR COLOR.

FOR AN ADVERTISING SIGN OF PAPER OR CARDBOARD (U.S. CLS. 2, 5, 22, 23, 29, 37, 38 AND 50).

FIRST USE 9-15-2007; IN COMMERCE 9-15-2007.
CHARLES L. JENKINS, EXAMINING ATTORNEY

SN 77-276,642. SANDOW MEDIA, LLC, BOCA RATON, FL. FILED 9-11-2007.

LUXE THE SOUTH FLORIDA HOME REDEFINED

THE MARK CONSISTS OF STANDARD CHARACTERS WITHOUT CLAIM TO ANY PARTICULAR FONT, STYLE, SIZE, OR COLOR.

FOR MAGAZINES FEATURING LUXURY HOME ARCHITECTURE, DESIGN, AND FURNISHINGS, AND INCLUDING ART, CULINARY, AND HOMEMAKING ARTICLES (U.S. CLS. 2, 5, 22, 23, 29, 37, 38 AND 50).

FIRST USE 10-1-2007; IN COMMERCE 10-1-2007.
EUGENIA MARTIN, EXAMINING ATTORNEY

SN 77-280,614. PROMO PRINT SOLUTIONS, INC., OSHKOSH, WI. FILED 9-16-2007.

Snap Stacker

THE MARK CONSISTS OF STANDARD CHARACTERS WITHOUT CLAIM TO ANY PARTICULAR FONT, STYLE, SIZE, OR COLOR.

NO CLAIM IS MADE TO THE EXCLUSIVE RIGHT TO USE "STACKER", APART FROM THE MARK AS SHOWN.

FOR A CARDBOARD FLOOR DISPLAY UNIT FOR MERCHANDISING PRODUCTS (U.S. CLS. 2, 5, 22, 23, 29, 37, 38 AND 50).

FIRST USE 9-15-2007; IN COMMERCE 9-15-2007.
CHARLES L. JENKINS, EXAMINING ATTORNEY

CLASS 16—(Continued).

SN 77-280,617. PROMO PRINT SOLUTIONS, INC., OSH-KOSH, WI. FILED 9-16-2007.

Snap Sampler Bin

THE MARK CONSISTS OF STANDARD CHARACTERS WITHOUT CLAIM TO ANY PARTICULAR FONT, STYLE, SIZE, OR COLOR.

NO CLAIM IS MADE TO THE EXCLUSIVE RIGHT TO USE "SAMPLER BIN", APART FROM THE MARK AS SHOWN.

FOR A CARDBOARD FLOOR DISPLAY UNIT FOR MERCHANDISING PRODUCTS (U.S. CLS. 2, 5, 22, 23, 29, 37, 38 AND 50).

FIRST USE 9-15-2007; IN COMMERCE 9-15-2007.
CHARLES L. JENKINS, EXAMINING ATTORNEY

SN 77-280,621. PROMO PRINT SOLUTIONS, INC., OSH-KOSH, WI. FILED 9-16-2007.

Promo Print Solutions

THE MARK CONSISTS OF STANDARD CHARACTERS WITHOUT CLAIM TO ANY PARTICULAR FONT, STYLE, SIZE, OR COLOR.

NO CLAIM IS MADE TO THE EXCLUSIVE RIGHT TO USE "PROMO PRINT", APART FROM THE MARK AS SHOWN.

FOR PRINTED VISUALS IN THE NATURE OF PROMOTIONAL MATERIALS AND COMMERCIAL PRINTS (U.S. CLS. 2, 5, 22, 23, 29, 37, 38 AND 50).

FIRST USE 9-15-2007; IN COMMERCE 9-15-2007.
CHARLES L. JENKINS, EXAMINING ATTORNEY

SN 77-282,209. DONNE DAVIS, MENLO PARK, CA. FILED 9-18-2007.

GaGa

THE MARK CONSISTS OF STANDARD CHARACTERS WITHOUT CLAIM TO ANY PARTICULAR FONT, STYLE, SIZE, OR COLOR.

FOR EDUCATIONAL BOOKS AND BROCHURES IN THE FIELD OF GRAND PARENTING AND USEFUL GOODS FOR GRANDCHILDREN TO SERVE GRANDMOTHERS AND THEIR INTERESTS (U.S. CLS. 2, 5, 22, 23, 29, 37, 38 AND 50).

CAROL SPILS, EXAMINING ATTORNEY

CLASS 16—(Continued).

SN 77-285,595. CANSON, ANNONAY, FRANCE, FILED 9-21-2007.

MONTVAL

THE MARK CONSISTS OF STANDARD CHARACTERS WITHOUT CLAIM TO ANY PARTICULAR FONT, STYLE, SIZE, OR COLOR.

OWNER OF FRANCE REG. NO. 1596330, DATED 6-8-1990, EXPIRES 6-8-2010.

FOR PAPER; STATIONERY; ART PAPER; BLOTTING PAPER; BOND PAPER; CALLIGRAPHY PAPER; CONSTRUCTION PAPER; CRAFT PAPER; DRAWING PAPER; PAPER FOR USE IN THE GRAPHIC ARTS INDUSTRY; PAPER FOR DRAWING, SKETCHING, WATERCOLOR, OIL AND ACRYLIC PAINTING AND PRINTMAKING; WRITING PAPER PADS; SKETCH PADS; PAPER NOTEBOOKS; PAPER ALBUMS FOR WRITING, ART, OR COLLECTIONS; AND ROLLS OF PAPER FOR WRITING AND ART (U.S. CLS. 2, 5, 22, 23, 29, 37, 38 AND 50).

ESTHER BELENKER, EXAMINING ATTORNEY

SN 77-287,215. ROGERS, JAN MORGAN, COCONUT CREEK, FL. AND TURNER, LAUREN, COCONUT CREEK, FL. FILED 9-24-2007.



THE COLOR(S) YELLOW, RED, ORANGE, WHITE AND BROWN IS/ARE CLAIMED AS A FEATURE OF THE MARK.

"THE MARK CONSISTS OF A YELLOW SMILING STAR WITH A RED MOUTH, ORANGE CHEEKS AND WHITE AND BROWN EYES."

FOR STORY BOOKS, ACTIVITY BOOKS, COLORING BOOKS, JOURNALS, DIARIES, NOTEBOOKS, NOTE-PADS, PAPERWEIGHTS, PENCILS, PENS, POSTERS, STICKERS (U.S. CLS. 2, 5, 22, 23, 29, 37, 38 AND 50).

DOMINIC J. FERRAIUOLO, EXAMINING ATTORNEY

CLASS 16—(Continued).

SN 77-289,143. KABUSHIKI KAISHA KURETAKE, DBA KURETAKE CO., LTD, NARA-SHI, NARA-KEN, JAPAN, FILED 9-26-2007.

CLASS 16—(Continued).

SN 77-298,678. CONSUMERPSYCH LABS, INC., DBA BRANDPSYCH LABS, INC., ITHACA, NY. FILED 10-8-2007.

KOLOURBORATION

THE MARK CONSISTS OF STANDARD CHARACTERS WITHOUT CLAIM TO ANY PARTICULAR FONT, STYLE, SIZE, OR COLOR.

FOR PAPER; PAPER RIBBONS; TRACING PAPER; WAXED PAPER; POLISHED PAPER; DRAWING PAPER; PAPER FOR PAINTING; JAPANESE ART PAPER; CARDBOARD ; WHITE CARDBOARD; CRAFT CARDBOARD; PHOTOGRAPH ALBUMS; ALBUMS FOR SCRAPBOOKING; SCRAPBOOKS; NOTE CARDS; POSTCARDS; GREETING CARDS; BUSINESS CARDS; PICTURE POSTCARDS; CATALOGUES IN THE FIELD OF STATIONARY, ARTS AND CRAFTS AND SCRAPBOOKING; MAGAZINES FEATURING STATIONARY, ARTS AND CRAFTS AND SCRAPBOOKING; BOOKS IN THE FIELD OF STATIONARY, ARTS AND CRAFTS AND SCRAPBOOKING; NEWSPAPERS IN THE FIELD OF STATIONARY, ARTS AND CRAFTS AND SCRAPBOOKING; PAMPHLETS IN THE FIELD OF STATIONARY, ARTS AND CRAFTS AND SCRAPBOOKING; WRITING PAPER; PICTURES; WATERCOLOR PICTURES; PHOTOGRAPHS; PHOTOGRAPH MOUNTS; GLUE FOR MOUNTING PHOTOGRAPHS; PHOTOGRAPH STANDS; WRAPPING PAPER; CRAFT PAPER; PAPER KNIVES; PUNCHES FOR CRAFT PAPER FOR SCRAPBOOKING; STATIONARY; WRITING INK; WRITING INSTRUMENTS; STICKERS (U.S. CLS. 2, 5, 22, 23, 29, 37, 38 AND 50).

FIRST USE 9-1-2005; IN COMMERCE 8-1-2006.
ARETHA SOMERVILLE, EXAMINING ATTORNEY

MINDLESS DIETING

THE MARK CONSISTS OF STANDARD CHARACTERS WITHOUT CLAIM TO ANY PARTICULAR FONT, STYLE, SIZE, OR COLOR.

NO CLAIM IS MADE TO THE EXCLUSIVE RIGHT TO USE "DIETING", APART FROM THE MARK AS SHOWN.

FOR PUBLICATIONS, NAMELY, BOOKS , MANUALS, NEWSLETTERS, CALENDARS, EDUCATIONAL LEARNING CARDS, POSTERS, STICKERS, OVERHEAD DISPLAYS IN THE NATURE OF PLASTIC AND PAPER TRANSPARENCIES FEATURING POWER POINT PRESENTATIONS, ALL IN THE FIELDS OF BEHAVIOR MODIFICATION PSYCHOLOGY, EATING HABITS, DIETING AND WEIGHT MANAGEMENT, FAMILY AND PERSONAL NUTRITION, COMFORT FOODS, FINE DINING AND RESTAURANT DINING (U.S. CLS. 2, 5, 22, 23, 29, 37, 38 AND 50).

BARBARA RUTLAND, EXAMINING ATTORNEY

SN 77-299,287. THE PROCTER & GAMBLE COMPANY, CINCINNATI, OH. FILED 10-9-2007.

SN 77-295,151. SAM GLENN INC., NAPERVILLE, IL. FILED 10-3-2007.

P&GBRANDSAMPLER**A KICK IN THE ATTITUDE**

THE MARK CONSISTS OF STANDARD CHARACTERS WITHOUT CLAIM TO ANY PARTICULAR FONT, STYLE, SIZE, OR COLOR.

FOR SERIES OF NON-FICTION BOOKS IN THE FIELD OF MOTIVATION AND INSPIRATION (U.S. CLS. 2, 5, 22, 23, 29, 37, 38 AND 50).

TEJBIR SINGH, EXAMINING ATTORNEY

THE MARK CONSISTS OF STANDARD CHARACTERS WITHOUT CLAIM TO ANY PARTICULAR FONT, STYLE, SIZE, OR COLOR.

OWNER OF U.S. REG. NOS. 2,744,900, 3,165,266 AND OTHERS.

FOR COUPONS AND FREE-STANDING COUPON INSERTS USED IN NEWSPAPER (U.S. CLS. 2, 5, 22, 23, 29, 37, 38 AND 50).

BARBARA RUTLAND, EXAMINING ATTORNEY

CLASS 16—(Continued).

SN 77-299,626. CAMPBELL, JR., ALFONSO L., HYATTSVILLE, MD. FILED 10-9-2007.

The BE BLESSED Health Model

THE MARK CONSISTS OF STANDARD CHARACTERS WITHOUT CLAIM TO ANY PARTICULAR FONT, STYLE, SIZE, OR COLOR.

NO CLAIM IS MADE TO THE EXCLUSIVE RIGHT TO USE "HEALTH MODEL", APART FROM THE MARK AS SHOWN.

FOR A SERIES OF BOOKS AND WRITTEN ARTICLES IN THE FIELD OF PSYCHOLOGY, MEDICINE, HEALTH, AND THEOLOGY; A SERIES OF BOOKS, WRITTEN ARTICLES, HANDOUTS AND WORKSHEETS IN THE FIELD OF PSYCHOLOGY, MEDICINE, HEALTH, AND THEOLOGY; BOOKS IN THE FIELD OF PSYCHOLOGY, MEDICINE, HEALTH, AND THEOLOGY; EDUCATIONAL BOOKS FEATURING PSYCHOLOGY, MEDICINE, HEALTH, AND THEOLOGY; EDUCATIONAL PUBLICATIONS, NAMELY, EDUCATIONAL LEARNING CARDS, FLASH CARDS, ACTIVITY CARDS, WORKBOOKS, TEXTBOOKS, ACTIVITY BOOKS, STORY BOOKS, PUZZLE BOOKS, PUZZLES, TEACHER GUIDES, MANUALS, POSTERS, EDUCATIONAL CARD GAMES AND EDUCATIONAL BOOKLETS IN THE FIELD OF PSYCHOLOGY, MEDICINE, HEALTH, AND THEOLOGY; NEWSLETTERS IN THE FIELD OF PSYCHOLOGY, MEDICINE, HEALTH, AND THEOLOGY; PAMPHLETS IN THE FIELD OF PSYCHOLOGY, MEDICINE, HEALTH, AND THEOLOGY; PRAYER BOOKS; PRINTED INFORMATIONAL CARDS IN THE FIELD OF PSYCHOLOGY, MEDICINE, HEALTH, AND THEOLOGY; RELIGIOUS BOOKS; SCHOLARLY BOOKS ON VARIOUS TOPICS, NAMELY, PSYCHOLOGY, MEDICINE, HEALTH, AND THEOLOGY; SERIES OF NON-FICTION BOOKS IN THE FIELD OF PSYCHOLOGY, MEDICINE, HEALTH, AND THEOLOGY (U.S. CLS. 2, 5, 22, 23, 29, 37, 38 AND 50).

JENNIFER VASQUEZ, EXAMINING ATTORNEY

SN 77-300,337. SHERYL KURLAND, LONGWOOD, FL. FILED 10-10-2007.

Everlasting Matrimony

THE MARK CONSISTS OF STANDARD CHARACTERS WITHOUT CLAIM TO ANY PARTICULAR FONT, STYLE, SIZE, OR COLOR.

NO CLAIM IS MADE TO THE EXCLUSIVE RIGHT TO USE "MATRIMONY", APART FROM THE MARK AS SHOWN.

FOR A SERIES OF BOOKS AND WRITTEN ARTICLES IN THE FIELD OF MARRIAGE, RELATIONSHIPS, ANNIVERSARIES, WEDDINGS, AND ENGAGEMENTS; ANNIVERSARY BOOKS; ENGAGEMENT BOOKS; WEDDING BOOKS; GIFT BOOKS FEATURING MARRIAGE, RELATIONSHIPS, ANNIVERSARIES, WEDDINGS, AND ENGAGEMENTS; COFFEE TABLE BOOKS FEATURING MARRIAGE, RELATIONSHIPS, ANNIVERSARIES, WEDDINGS, AND ENGAGEMENTS (U.S. CLS. 2, 5, 22, 23, 29, 37, 38 AND 50).

KAELIE KUNG, EXAMINING ATTORNEY

CLASS 16—(Continued).

SN 77-301,208. PREMISE MEDIA CORPORATION, L.P., SANTA FE, NM. FILED 10-10-2007.

NO CLAIM IS MADE TO THE EXCLUSIVE RIGHT TO USE "MEDIA CORPORATION", APART FROM THE MARK AS SHOWN.

THE MARK CONSISTS OF AN IMAGE DEPICTING A PLANE DISSECTING THE WORD "PREMISE" OVER THE WORDS "MEDIA CORPORATION".

FOR BOOKS IN THE FIELDS OF SCIENCE, HISTORY, EDUCATION, PUBLIC AFFAIRS, GOVERNMENT POLICY, LAW AND JUDICIAL DECISIONS, POLITICS, MORAL AND ETHICAL CONCERNS, RELIGION, CULTURE, CURRENT EVENTS AND NATIONAL AND INTERNATIONAL ISSUES (U.S. CLS. 2, 5, 22, 23, 29, 37, 38 AND 50).

CURTIS FRENCH, EXAMINING ATTORNEY

SN 77-302,172. TELMEX USA, L.L.C., MIRAMAR, FL. FILED 10-11-2007.

CHECALA

THE MARK CONSISTS OF STANDARD CHARACTERS WITHOUT CLAIM TO ANY PARTICULAR FONT, STYLE, SIZE, OR COLOR.

THE FOREIGN WORDING IN THE MARK TRANSLATES INTO ENGLISH AS CHECK IT OUT.

FOR PRE-PAID TELEPHONE CALLING CARDS, NOT MAGNETICALLY ENCODED (U.S. CLS. 2, 5, 22, 23, 29, 37, 38 AND 50).

LINDA POWELL, EXAMINING ATTORNEY

CLASS 16—(Continued).

SN 77-303,416. PACIFIC GROUP USA, INC., S. EL MONTE, CA. FILED 10-12-2007.



NO CLAIM IS MADE TO THE EXCLUSIVE RIGHT TO USE "BRAND", APART FROM THE MARK AS SHOWN. THE COLOR(S) BLUE AND GREEN IS/ARE CLAIMED AS A FEATURE OF THE MARK.

THE MARK CONSISTS OF THE BLUE WORDING "EVER BRAND" SUPERIMPOSED ON A RECTANGULAR GREEN DESIGN ELEMENT.

FOR GENERAL PURPOSE PLASTIC BAGS; GROCERY BAGS, LAW AND LEAF DISPOSAL BAGS; LEAF DISPOSAL BAGS; LUNCH BAGS; LUNCH BAGS MADE OF TEXTILE; MERCHANDISE BAGS; MICROWAVE COOKING BAGS; PLASTIC BAGS FOR PACKAGING; PLASTIC BAGS FOR PACKING; PLASTIC FOOD STORAGE BAGS FOR HOUSEHOLD USE; PLASTIC GARBAGE BAGS; PLASTIC OR PAPER BAGS FOR HOUSEHOLD USE; PLASTIC OVEN COOKING BAGS; PLASTIC SANDWICH BAGS; PLASTIC SHOPPING BAGS; PLASTIC TRASH BAGS; RUBBISH BAGS MADE OF PAPER OR PLASTIC MATERIALS; SANDWICH BAGS; TRASH BAGS; TRASH CAN LINERS (U.S. CLS. 2, 5, 22, 23, 29, 37, 38 AND 50). FIRST USE 5-10-2007; IN COMMERCE 5-10-2007.

DAWN HAN, EXAMINING ATTORNEY

SN 77-316,267. FREMANTLEMEDIA OPERATIONS B.V., HILVERSUM, NETHERLANDS, FILED 10-29-2007.

TATTLETALES

THE MARK CONSISTS OF STANDARD CHARACTERS WITHOUT CLAIM TO ANY PARTICULAR FONT, STYLE, SIZE, OR COLOR.

FOR PRINTED MATTER, NAMELY, POSTERS, CALENDARS, NOTEBOOKS, BINDERS, DAILY PERSONAL ORGANIZERS, MEMO PADS, STICKERS, COMIC BOOKS, WRITING PAPER, ENVELOPES, GREETING CARDS, PAPER COASTERS, PAPER MATS, NEWSPAPERS FOR GENERAL CIRCULATION, BOOKS AND MAGAZINES IN THE FIELD OF GAME SHOWS, NEWSLETTERS IN THE FIELD OF GAME SHOWS, PHOTOGRAPHS, POSTCARDS, TRADING CARDS, CARDBOARD STAND-UP FLOOR DISPLAY UNITS FOR MERCHANDISING PRODUCTS FEATURING PHOTOGRAPHS OR ARTWORK, PREPAID PHONE DEBIT CARDS WITHOUT MAGNETIC CODING, TRADING CARD MILK BOTTLE CAPS, PERSONAL BANK CHECKS (U.S. CLS. 2, 5, 22, 23, 29, 37, 38 AND 50).

MARGARET POWER, EXAMINING ATTORNEY

CLASS 16—(Continued).

SN 77-324,798. AGC, LLC, CLEVELAND, OH. FILED 11-8-2007.

WOO SHOUT GIRLS

THE MARK CONSISTS OF STANDARD CHARACTERS WITHOUT CLAIM TO ANY PARTICULAR FONT, STYLE, SIZE, OR COLOR.

NO CLAIM IS MADE TO THE EXCLUSIVE RIGHT TO USE "GIRLS", APART FROM THE MARK AS SHOWN.

FOR PAPER GIFT BAGS; PAPER NAPKINS; PENS; PENCILS; ERASERS; STATIONERY; BINDERS; BOOKMARKS; CALENDARS; DIARIES; ADDRESS BOOKS; GREETING CARDS; BLANK JOURNAL BOOKS; SKETCH PADS; NOTE CARDS; WRAPPING PAPER (U.S. CLS. 2, 5, 22, 23, 29, 37, 38 AND 50).

ALEX KEAM, EXAMINING ATTORNEY

SN 77-325,247. MISSLER, NANCY, COEUR D' ALENE, ID. FILED 11-8-2007.

THE KINGDOM, POWER AND GLORY THE OVERCOMER'S HANDBOOK

THE MARK CONSISTS OF STANDARD CHARACTERS WITHOUT CLAIM TO ANY PARTICULAR FONT, STYLE, SIZE, OR COLOR.

NO CLAIM IS MADE TO THE EXCLUSIVE RIGHT TO USE "HANDBOOK", APART FROM THE MARK AS SHOWN.

FOR SERIES OF FICTION BOOKS; SERIES OF NON-FICTION BOOKS IN THE FIELD OF RELIGION AND BIBLE INTERPRETATION; SERIES OF NON-FICTION BOOKS AND PRINTED PERIODICALS, NAMELY, PAMPHLETS, NEWSLETTERS, JOURNALS, MAGAZINES AND TEACHING AIDES ON RELIGION AND BIBLE INTERPRETATION; PAPER GOODS AND PRINTED MATTER, NAMELY, PAMPHLETS, NEWSLETTERS, TEXTBOOKS, WORKBOOKS, TEACHING AIDES AND BOOKS ON THE SUBJECT OF RELIGION AND BIBLE INTERPRETATION (U.S. CLS. 2, 5, 22, 23, 29, 37, 38 AND 50).

CHRISTINE COOPER, EXAMINING ATTORNEY

CLASS 16—(Continued).

SN 77-341,031. INKTREE, INC., CHARLOTTESVILLE, VA.
FILED 11-30-2007.

NO MORE FLIPPIN' PAGES

THE MARK CONSISTS OF STANDARD CHARACTERS WITHOUT CLAIM TO ANY PARTICULAR FONT, STYLE, SIZE, OR COLOR.

FOR PRESENTATION BOARDS; PRESENTATION FOLDERS; DRY ERASE WRITING BOARDS AND WRITING SURFACES; FOLDERS; FOLDABLE POSTER BOARDS FOR DISPLAY OF PRINTED INSTRUCTIONAL, EDUCATIONAL, AND TEACHING MATERIALS; PRINTED PRODUCTS, NAMELY, INSTRUCTIONAL, EDUCATIONAL, AND TEACHING MATERIALS IN THE FIELDS OF MUSIC, COOKING, EXERCISE, AUTO-MECHANIC, HOME-REPAIR, HOME IMPROVEMENT, SMALL CRAFT PROJECTS, SMALL HOME AND OFFICE PROJECTS, CONSUMER ELECTRONICS ASSEMBLY AND INSTALLATION, FURNITURE ASSEMBLY, CORPORATE AND EMPLOYEE TRAINING MATERIAL, MARKETING COLLATERAL SUCH AS TRADE SHOW DISPLAY OR GENERAL COLLATERAL, QUICK REFERENCE GUIDE, COMPUTER SOFTWARE QUICK REFERENCE GUIDE, VIDEO GAME QUICK REFERENCE GUIDE, CALL CENTER EMPLOYEE QUICK REFERENCE GUIDE, TEACHING MATERIALS IN THE FIELDS OF TEXTBOOK SUPPLEMENT ON THE SUBJECTS OF MATH, SCIENCE, LITERACY, SOCIAL STUDIES, LAW, MEDICINE, ECONOMICS, HOME ECONOMICS, HISTORY, RELIGION, ENGINEERING, ART, MUSIC, COMPUTERS AND COMPUTER SCIENCE, ARCHITECTURE, CULTURE, FINANCE, ACCOUNTING, POLITICS, BUSINESS, MARKETING, ADVERTISING, AND ELECTRONICS, MAPS, GEOGRAPHICAL MAPS, TOPOGRAPHICAL MAPS, KEY CONCEPTS IN TEACHING CURRICULUMS, HOBBY MODELING, COURTROOM EVIDENCE AND VISUAL AID PRESENTATION, COACHING AID, ANY HOBBY GAME AND ACTIVITY, PRESENTED ON FOLDABLE DISPLAY BOARDS; PRINTED PRODUCTS, NAMELY INSTRUCTIONAL, EDUCATIONAL, AND TEACHING MATERIALS IN THE FIELDS OF PRE-KINDERGARTEN, PRIMARY, SECONDARY, COLLEGE, GRADUATE, PROFESSIONAL AND TRADE SCHOOL TEXTBOOK SUPPLEMENTS, PRESENTED ON FOLDABLE DISPLAY BOARDS; PRINTED PRODUCTS, NAMELY, INSTRUCTION SHEETS, PRINTED CHARTS, AND STUDY GUIDES PRESENTED ON FOLDABLE DISPLAY BOARDS (U.S. CLS. 2, 5, 22, 23, 29, 37, 38 AND 50).

RAMONA ORTIGA, EXAMINING ATTORNEY

CLASS 16—(Continued).

SN 77-343,591. CPP INTERNATIONAL, LLC, CHARLOTTE, NC. FILED 12-4-2007.

Fashion Office

THE MARK CONSISTS OF STANDARD CHARACTERS WITHOUT CLAIM TO ANY PARTICULAR FONT, STYLE, SIZE, OR COLOR.

NO CLAIM IS MADE TO THE EXCLUSIVE RIGHT TO USE "OFFICE", APART FROM THE MARK AS SHOWN.

FOR NOTEBOOKS; ADDRESS BOOKS; BALL POINT PENS; PENCIL CASES; PENCILS; ADHESIVE NOTE PAPER; APPOINTMENT BOOKS; ART PADS; BINDERS; BLANK JOURNALS; CALENDARS; DAILY PLANNERS; DESK CALENDARS; CONSTRUCTION PAPER; INK PENS; FOLDERS; DRAWING PADS; TIME PLANNERS; RULED PAPER; POSTER BOARD; POCKET CALENDARS; NOTEBOOK DIVIDERS; LEGAL PADS; BLANK NOTE CARDS; INDEX CARDS; FILE CARDS; FILE FOLDERS (U.S. CLS. 2, 5, 22, 23, 29, 37, 38 AND 50).

ELLEN B. AWRICH, EXAMINING ATTORNEY

SN 77-352,369. RAYNOLDS, EDWARD, PORTSMOUTH, NH.
FILED 12-14-2007.

SENTIMENT SAVOR

THE MARK CONSISTS OF STANDARD CHARACTERS WITHOUT CLAIM TO ANY PARTICULAR FONT, STYLE, SIZE, OR COLOR.

FOR GREETING CARD HOLDER THAT IS USED TO CONVENIENTLY DISPLAY MULTIPLE PERSONAL GREETING CARDS IN A HOME, OFFICE, OR BUSINESS SETTING (U.S. CLS. 2, 5, 22, 23, 29, 37, 38 AND 50).

GINA HAYES, EXAMINING ATTORNEY

SN 77-362,170. FINLEY, JIMMY D, DBA FINLEY GALLERY LLC, HONOLULU, HI. FILED 12-31-2007.

WoodPenPro

THE MARK CONSISTS OF STANDARD CHARACTERS WITHOUT CLAIM TO ANY PARTICULAR FONT, STYLE, SIZE, OR COLOR.

FOR BALLPOINT PENS; FOUNTAIN PEN INK CARTRIDGES; FOUNTAIN PENS; GEL ROLLER PENS; INK PENS; MARKING PENS; PEN AND PENCIL CASES AND BOXES; PEN AND PENCIL HOLDERS; PEN AND PENCIL TRAYS; PEN CLIPS; PEN HOLDERS; PEN INK CARTRIDGES; PEN INK REFILLS; PENS; REFILLS FOR BALLPOINT PENS; ROLLER BALL PENS; TIPS FOR BALLPOINT PENS; WRITING PEN KITS COMPRISING PARTS FOR MAKING WRITING PENS (U.S. CLS. 2, 5, 22, 23, 29, 37, 38 AND 50).

FIRST USE 10-12-2001; IN COMMERCE 7-15-2002.

EDWARD NELSON, EXAMINING ATTORNEY

CLASS 16—(Continued).

SN 77-373,692. KIDD, ROBERT, SAN DIEGO, CA. FILED 1-16-2008.

LONGBOARD COWBOYS

THE MARK CONSISTS OF STANDARD CHARACTERS WITHOUT CLAIM TO ANY PARTICULAR FONT, STYLE, SIZE, OR COLOR.

FOR ART ETCHINGS; ART PRINTS; ART PRINTS ON CANVAS; LITHOGRAPHIC WORKS OF ART (U.S. CLS. 2, 5, 22, 23, 29, 37, 38 AND 50).

FIRST USE 10-5-1967; IN COMMERCE 10-5-1987.

DAVID YONTEF, EXAMINING ATTORNEY

SN 77-375,473. CMD MAGAZINE LLC, ORLANDO, FL. FILED 1-18-2008.



NO CLAIM IS MADE TO THE EXCLUSIVE RIGHT TO USE "MAGAZINE" AND "CASA MODA DINERO", APART FROM THE MARK AS SHOWN.

THE MARK CONSISTS OF THREE LETTERS "C" "M" AND "D". THEY COME ALL TOGETHER TO FORM THIS MARK. INSIDE OF THE MARK THERE IS WRITTEN "CMD MAGAZINE CASA MODA DINERO".

THE ENGLISH TRANSLATION OF "CASA MODA DINERO" IN THE MARK IS HOUSE FASHION MONEY.

FOR MAGAZINES AND NEWSPAPERS IN THE FIELD OF HOME FURNISHINGS, FASHION AND FINANCE (U.S. CLS. 2, 5, 22, 23, 29, 37, 38 AND 50).

JENNIFER VASQUEZ, EXAMINING ATTORNEY

SN 77-382,566. NCE, NEWCASTLE ENTERTAINMENT, INC, DEL MAR, CA. FILED 1-28-2008.

THE GINI METHOD

THE MARK CONSISTS OF STANDARD CHARACTERS WITHOUT CLAIM TO ANY PARTICULAR FONT, STYLE, SIZE, OR COLOR.

NO CLAIM IS MADE TO THE EXCLUSIVE RIGHT TO USE "METHOD", APART FROM THE MARK AS SHOWN.

FOR PRINTED INSTRUCTIONAL MANUAL FOR LEARNING HOW TO PLAY THE PIANO (U.S. CLS. 2, 5, 22, 23, 29, 37, 38 AND 50).

FIRST USE 6-10-2007; IN COMMERCE 6-10-2007.

BRENDAN REGAN, EXAMINING ATTORNEY

CLASS 16—(Continued).

SN 77-393,632. ANGELICA IRENE, RIALTO, CA. FILED 2-11-2008.

Angelica Irene

THE MARK CONSISTS OF STANDARD CHARACTERS WITHOUT CLAIM TO ANY PARTICULAR FONT, STYLE, SIZE, OR COLOR.

THE NAME "ANGELICA IRENE" IDENTIFIES A LIVING INDIVIDUAL WHOSE CONSENT IS OF RECORD.

FOR SCRAPBOOK PAGES; SCRAPBOOK ALBUMS; SCRAPBOOKS (U.S. CLS. 2, 5, 22, 23, 29, 37, 38 AND 50).

ROBIN MITTLER, EXAMINING ATTORNEY

SN 77-393,652. ANGELICA IRENE, RIALTO, CA. FILED 2-11-2008.

Lil' Miss Gelica

THE MARK CONSISTS OF STANDARD CHARACTERS WITHOUT CLAIM TO ANY PARTICULAR FONT, STYLE, SIZE, OR COLOR.

FOR SCRAPBOOK ALBUMS; SCRAPBOOK PAGES; SCRAPBOOKS (U.S. CLS. 2, 5, 22, 23, 29, 37, 38 AND 50).

ROBIN MITTLER, EXAMINING ATTORNEY

SN 77-397,098. BREDENBERG, JEFFREY E., ORELAND, PA. FILED 2-14-2008.

HOW TO CHEAT

THE MARK CONSISTS OF STANDARD CHARACTERS WITHOUT CLAIM TO ANY PARTICULAR FONT, STYLE, SIZE, OR COLOR.

FOR SERIES OF GUIDE BOOKS FEATURING TIPS AND SHORTCUTS ON LIFESTYLE AND CONSUMER SUBJECTS (U.S. CLS. 2, 5, 22, 23, 29, 37, 38 AND 50).

FIRST USE 10-31-2006; IN COMMERCE 10-31-2006.

ALICE SUE CARRUTHERS, EXAMINING ATTORNEY

CLASS 16—(Continued).

SN 77-397,686. BKH MEDIA, LLC, AUBURN, WA. FILED 2-14-2008.

— d e s i g n i n g —
WEALTH

NO CLAIM IS MADE TO THE EXCLUSIVE RIGHT TO USE "WEALTH", APART FROM THE MARK AS SHOWN.

THE MARK CONSISTS OF THE WORD "DESIGNING" IN LOWERCASE CENTERED ABOVE THE WORD "WEALTH" IN UPPERCASE WITH A FEW STYLIZED LINES AND SPACING BETWEEN LETTERS.

FOR MAGAZINES FEATURING LIFESTYLE AND FINANCE (U.S. CLS. 2, 5, 22, 23, 29, 37, 38 AND 50).

FIRST USE 1-28-2008; IN COMMERCE 1-28-2008.
MICHELLE DUBOIS, EXAMINING ATTORNEY

CLASS 16—(Continued).

SN 77-404,961. PEARL, ERIC, HOLLYWOOD, CA. FILED 2-25-2008.

THE RECONNECTION

THE MARK CONSISTS OF STANDARD CHARACTERS WITHOUT CLAIM TO ANY PARTICULAR FONT, STYLE, SIZE, OR COLOR.

OWNER OF U.S. REG. NOS. 2,757,926 AND 2,967,837.

FOR PRINTED MATTER AND PAPER GOODS, NAMELY, PENCILS; BINDERS; PAPER PRODUCTS, NAMELY, STATIONERY, NOTE PADS AND POST-CARDS; NOTE CARDS; POSTERS; ADDRESS BOOKS, BLANK JOURNAL BOOKS, PENS, PRINTED EDUCATIONAL CARDS FEATURING INFORMATION REGARDING PHYSICAL, EMOTIONAL, SPIRITUAL AND ENERGETIC HEALING; PRINTED NEWSLETTERS, BROCHURES, SEMINARS, PAMPHLETS, FLYERS, AND PRINTED INSTRUCTIONAL AND TEACHING MATERIALS ON THE SUBJECT OF PHYSICAL, EMOTIONAL, SPIRITUAL AND ENERGETIC HEALING (U.S. CLS. 2, 5, 22, 23, 29, 37, 38 AND 50).

FIRST USE 12-1-1997; IN COMMERCE 12-1-1997.

TINA KUAN, EXAMINING ATTORNEY

SN 77-407,643. TEARE, ANNA, DBA SEE. BE. DRAW., ANN ARBOR, MI. FILED 2-27-2008.

See. Be. Draw.

SN 77-401,326. ACCELLART, LLC, JOPLIN, MO. FILED 2-20-2008.

Beverly's
Just for You
Coloring Calendar

NO CLAIM IS MADE TO THE EXCLUSIVE RIGHT TO USE "COLORING CALENDAR", APART FROM THE MARK AS SHOWN.

THE MARK CONSISTS OF THE WORDS "BEVERLY'S JUST FOR YOU" IN STYLIZED FORM ABOVE THE ARTISTIC DRAWING OF THE WORDS "COLOR CALENDAR" WHEREIN THE "L'S ARE DRAWN TO REPRESENT CRAYONS.

FOR CALENDARS (U.S. CLS. 2, 5, 22, 23, 29, 37, 38 AND 50).

FIRST USE 12-31-2006; IN COMMERCE 12-31-2006.
TRACY CROSS, EXAMINING ATTORNEY

THE MARK CONSISTS OF STANDARD CHARACTERS WITHOUT CLAIM TO ANY PARTICULAR FONT, STYLE, SIZE, OR COLOR.

FOR MEMO PADS; PAPER; CARDS, NAMELY, GREETING CARDS; ART PADS; ART PICTURES; ART PRINTS; STATIONERY WRITING PAPER AND ENVELOPES (U.S. CLS. 2, 5, 22, 23, 29, 37, 38 AND 50).

TAMARA FRAZIER, EXAMINING ATTORNEY

SN 77-408,359. MCGRIMLEY, WILLIAM, SENECA FALLS, NY. FILED 2-28-2008.

HAPPY HOLY DAYS

THE MARK CONSISTS OF STANDARD CHARACTERS WITHOUT CLAIM TO ANY PARTICULAR FONT, STYLE, SIZE, OR COLOR.

NO CLAIM IS MADE TO THE EXCLUSIVE RIGHT TO USE "HOLY DAYS", APART FROM THE MARK AS SHOWN.

FOR HOLIDAY CARDS; GREETING CARDS; CARDS BEARING UNIVERSAL GREETINGS; CHRISTMAS CARDS (U.S. CLS. 2, 5, 22, 23, 29, 37, 38 AND 50).

MARTHA FROMM, EXAMINING ATTORNEY

CLASS 16—(Continued).

SN 77-408,590. MEDICAL OUTCOMES TRUST, INC., WALTHAM, MA. FILED 2-28-2008.

SF-12

THE MARK CONSISTS OF STANDARD CHARACTERS WITHOUT CLAIM TO ANY PARTICULAR FONT, STYLE, SIZE, OR COLOR.

OWNER OF U.S. REG. NOS. 1,837,851, 3,289,836 AND 3,289,838.

FOR PRINTED HEALTH STATUS QUESTIONNAIRES AND USER MANUAL RELATING TO ADMINISTERING, SCORING AND ANALYZING HEALTH STATUS SURVEY RESULTS; PRINTED INDIVIDUAL AND GROUP HEALTH SURVEY REPORTS AND DOCUMENTATION AND USER MANUALS FOR COMPUTERIZED ANALYSIS OF HEALTH STATUS SURVEYS (U.S. CLS. 2, 5, 22, 23, 29, 37, 38 AND 50).

FIRST USE 5-31-1994; IN COMMERCE 7-31-1995.
BARBARA RUTLAND, EXAMINING ATTORNEY

SN 77-409,156. WILSON, GLENN V., ZELIENOPLE, PA. FILED 2-28-2008.

REIA Report

THE MARK CONSISTS OF STANDARD CHARACTERS WITHOUT CLAIM TO ANY PARTICULAR FONT, STYLE, SIZE, OR COLOR.

NO CLAIM IS MADE TO THE EXCLUSIVE RIGHT TO USE "REPORT", APART FROM THE MARK AS SHOWN.

FOR PRINTED REPORTS FEATURING A PERSONAL PROFILE AND FINANCIAL ANALYSIS OF INCOME PRODUCING PROPERTY (U.S. CLS. 2, 5, 22, 23, 29, 37, 38 AND 50).

KHANH LE, EXAMINING ATTORNEY

SN 77-410,013. ARBOGAST PROPERTY MANAGEMENT, LLC, GENOA, NV. FILED 2-29-2008.

BULLETPROOF

THE MARK CONSISTS OF STANDARD CHARACTERS WITHOUT CLAIM TO ANY PARTICULAR FONT, STYLE, SIZE, OR COLOR.

OWNER OF U.S. REG. NO. 1,808,859.

FOR NEWSLETTERS IN THE FIELD OF LAW, PATENTS, TRADEMARKS, PERSONAL FINANCE, LEGAL SELF-HELP, ASSET PROTECTION, BUSINESS STRUCTURING, INCORPORATION, POLITICS, MARKETING, BUSINESS (U.S. CLS. 2, 5, 22, 23, 29, 37, 38 AND 50).

FIRST USE 2-29-2008; IN COMMERCE 2-29-2008.
MARY ROSSMAN, EXAMINING ATTORNEY

CLASS 16—(Continued).

SN 77-412,836. PARK, GLENNA SANDRA, DBA SUPER STAR PARK, FT. PIERCE, FL. FILED 3-4-2008.



THE COLOR(S) PINK AND BLUE IS/ARE CLAIMED AS A FEATURE OF THE MARK.

THE MARK CONSISTS OF A FIVE-POINTED STAR WITH PINK COLOR THROUGHOUT AND, WITH FOUR DIFFERENT LEVELS AND SIZES OF BLUE STAR-SHAPED OUTLINES TO DEPICT DEPTH, CHARACTER AND OPTICAL ILLUSION. THE WORDING "SUPER STAR PARK" IS THE COLOR PINK WITH A BLUE SHADOW THAT IS OFFSET SLIGHTLY TO THE LEFT AND BOTTOM OF "SUPER STAR PARK" WHILE STILL MAINTAINING CONTACT WITH THAT WORDING. THE WORDING "PROMOTING LOVE, CIVILITY AND PEACE" IS THE COLOR BLUE, AND "WWW.SUPERSTARPARK.COM" IS THE COLOR PINK.

FOR POSTERS MADE OF PAPER; BUMPER STICKERS (U.S. CLS. 2, 5, 22, 23, 29, 37, 38 AND 50).

FIRST USE 12-31-2007; IN COMMERCE 12-31-2007.
DANIEL BRODY, EXAMINING ATTORNEY

SN 77-414,188. ARBOGAST PROPERTY MANAGEMENT, LLC, GENOA, NV. FILED 3-5-2008.

BULLETPROOF

THE MARK CONSISTS OF STANDARD CHARACTERS WITHOUT CLAIM TO ANY PARTICULAR FONT, STYLE, SIZE, OR COLOR.

OWNER OF U.S. REG. NO. 1,808,859.

FOR BOOKS IN THE FIELD OF LAW, ASSET PROTECTION, FORMATION OF BUSINESS STRUCTURES INCLUDING INCORPORATING CORPORATIONS, LIMITED LIABILITY COMPANIES, LIMITED PARTNERSHIPS AND OTHER BUSINESS ENTITIES, PATENTS, TRADEMARKS, PERSONAL FINANCE, LEGAL SELF-HELP, BRAND SELECTION, MARKETING, BUSINESS (U.S. CLS. 2, 5, 22, 23, 29, 37, 38 AND 50).

FIRST USE 9-14-2007; IN COMMERCE 9-14-2007.
MARY ROSSMAN, EXAMINING ATTORNEY

CLASS 16—(Continued).

SN 77-414,396. SCHILLER CARD & GIFT LLC, SAN MATEO, CA. FILED 3-6-2008.



THE MARK CONSISTS OF A PICTURE OF A CAT SITTING ON A MANTLE WITH THE WORDS "I LOVE MEOWMEOW" WRITTEN ABOVE THE CAT, WITH THE WORD "MEOW" WRITTEN ON EITHER SIDE OF THE CAT. FOR GREETING CARDS, STATIONERY, NOTE CARDS, POSTCARDS, INVITATION CARDS, PRINTED FOLDERS, PRINTED BINDERS, FOLDERS, EVENT ALBUMS, PHOTO ALBUMS, STAMP ALBUMS, SCRAPBOOK ALBUMS, NOTEBOOKS, ADDRESS BOOKS, GUEST BOOKS, DESK PADS, DOCUMENT HOLDERS OF PAPER OR CARDBOARD, PAPER BOXES, PAPER STORAGE BOXES, CARDBOARD STORAGE BOXES, COLLECTIBLE BOXES OF PAPER OR CARDBOARD, STICKERS, GIFT WRAPPING PAPER, PAPER GIFT BAGS, AND PAPER GIFT TAGS (U.S. CLS. 2, 5, 22, 23, 29, 37, 38 AND 50).
FRANK LATTUCA, EXAMINING ATTORNEY

SN 77-415,623. NEW CREATIONS CUSTOM DESIGNS FOR KINGDOM LIVING, LLP, CATONSVILLE, MD. FILED 3-6-2008.



NO CLAIM IS MADE TO THE EXCLUSIVE RIGHT TO USE "SCRIPTURE" "PRAYER" AND "FOR THE SHOWER, HOME, OFFICE & CAR", APART FROM THE MARK AS SHOWN. THE COLOR(S) GOLD, NAVY BLUE, ORANGE-RED, BURGUNDY, BLACK AND OLIVE GREEN IS/ARE CLAIMED AS A FEATURE OF THE MARK. THE MARK CONSISTS OF LETTERS IN "SCRIPTURE YOUR SPACE" IN NAVY BLUE IN KOZUKA GOTHIC PRO "L" FONT, LETTERS IN "INSPIRATIONAL PRAYER TOOLS" IN ORANGE-RED IN THE NUEVA STD CON-

CLASS 16—(Continued).

DENSED FONT, A CURVED RIBBON-LIKE LINE IN GOLD CURVING LIKE THE LETTER "C", COMING TO A PEAK THEN GOING STRAIGHT DOWN WITH A SLIGHT CURVE UP, THIS CURVED RIBBON-LIKE GOLD LINE IS NEXT TO THE LETTER "Y" IN "YOUR", A BUTTERFLY WITH A BLACK DOT FOR THE HEAD, 2 OLIVE GREEN ANTENNAE, ONE BURGUNDY WING AND ONE ORANGE-RED WING ON TOP OF THIS RIBBON-LIKE GOLD LINE, LETTERS IN "FOR THE SHOWER, HOME, OFFICE & CAR" IN BLACK IN THE KOZUKA GOTHIC PRO EL FONT. FOR EDUCATIONAL PUBLICATIONS, NAMELY, EDUCATIONAL LEARNING CARDS, FLASH CARDS, ACTIVITY CARDS, WORKBOOKS, TEXTBOOKS, ACTIVITY BOOKS, STORY BOOKS, PUZZLE BOOKS, PRINTED PUZZLES, TEACHER GUIDES, MANUALS, POSTERS, EDUCATIONAL CARD GAMES AND EDUCATIONAL BOOKLETS IN THE FIELD OF CHRISTIAN BIBLICAL STUDY (U.S. CLS. 2, 5, 22, 23, 29, 37, 38 AND 50).
FIRST USE 0-0-2002; IN COMMERCE 3-1-2008.
SKYE YOUNG, EXAMINING ATTORNEY

SN 77-416,720. COMMAND PACKAGING, LOS ANGELES, CA. FILED 3-7-2008.

Your restaurant has an image...
Your bags should too.

NO CLAIM IS MADE TO THE EXCLUSIVE RIGHT TO USE "BAGS", APART FROM THE MARK AS SHOWN. FOR MERCHANDISE BAGS (U.S. CLS. 2, 5, 22, 23, 29, 37, 38 AND 50).
FIRST USE 4-1-2007; IN COMMERCE 4-1-2007.
KATHERINE STOIDES, EXAMINING ATTORNEY

SN 77-418,646. REDKNAPP, TERENCE E, SAN LUIS OBISPO, CA. FILED 3-11-2008.



"THE COLOR(S) BLACK, RED AND WHITE IS/ARE CLAIMED AS A FEATURE OF THE MARK." THE MARK CONSISTS OF A LARGE STYLIZED LETTER "C" IN BLACK WITH THE TERM "SCAPES" APPEARING IN STYLIZED RED TYPE THEREIN, AGAINST A WHITE BACKGROUND. FOR GREETING CARDS (U.S. CLS. 2, 5, 22, 23, 29, 37, 38 AND 50).
JERI J. FICKES, EXAMINING ATTORNEY

CLASS 16—(Continued).

SN 77-419,450. CARLSON, LYNN M., SALT LAKE CITY, UT.
FILED 3-12-2008.

JJ IN FLAMES

THE MARK CONSISTS OF STANDARD CHARACTERS WITHOUT CLAIM TO ANY PARTICULAR FONT, STYLE, SIZE, OR COLOR.

FOR PHOTOGRAPHIC PRINTS; PHOTOGRAPHS THAT HAVE BEEN COMPUTER MANIPULATED AND ENHANCED TO LOOK LIKE PAINTINGS (U.S. CLS. 2, 5, 22, 23, 29, 37, 38 AND 50).

ZACHARY BELLO, EXAMINING ATTORNEY

SN 77-420,681. EXCELSIOR COLLEGE, ALBANY, NY. FILED
3-13-2008.

UEXCEL

THE MARK CONSISTS OF STANDARD CHARACTERS WITHOUT CLAIM TO ANY PARTICULAR FONT, STYLE, SIZE, OR COLOR.

OWNER OF U.S. REG. NOS. 2,500,388, 2,661,665 AND OTHERS.

FOR PRINTED TESTS, TEST BOOKLETS, BOOKS AND BROCHURES PROVIDING INFORMATION AND GUIDANCE FOR SCHOOLS, UNIVERSITIES, TEACHERS AND STUDENTS REGARDING COLLEGE LEVEL CREDIT EXAMINATIONS; TEST PREPARATION GUIDES IN THE FIELD OF COLLEGE LEVEL COURSE CREDIT EXAMINATIONS; PRINTED INSTRUCTIONAL EDUCATIONAL AND TEACHING MATERIALS IN THE FIELD OF COLLEGE LEVEL COURSE PREPARATION AND EXAMINATIONS (U.S. CLS. 2, 5, 22, 23, 29, 37, 38 AND 50).

DAYNA BROWNE, EXAMINING ATTORNEY

SN 77-420,872. INTEGRATED MANAGEMENT ASSOCIATES, INC., HENDERSON, NV. FILED 3-13-2008.

NEOTHINK

THE MARK CONSISTS OF STANDARD CHARACTERS WITHOUT CLAIM TO ANY PARTICULAR FONT, STYLE, SIZE, OR COLOR.

FOR A SERIES OF BOOKS AND WRITTEN ARTICLES IN THE FIELD OF SELF-HELP, PHILOSOPHY AND POLITICS (U.S. CLS. 2, 5, 22, 23, 29, 37, 38 AND 50).

FIRST USE 8-0-1989; IN COMMERCE 8-0-1989.
DAYNA BROWNE, EXAMINING ATTORNEY

CLASS 16—(Continued).

SN 77-421,158. JAM CREATIVE, LLC, CINCINNATI, OH.
FILED 3-13-2008.

POSITIVE

THE MARK CONSISTS OF STANDARD CHARACTERS WITHOUT CLAIM TO ANY PARTICULAR FONT, STYLE, SIZE, OR COLOR.

FOR MAGAZINES FEATURING MUSIC LYRICS, POPULAR CULTURE, ARCHITECTURE, LITERATURE, POETRY, LITERATURE REVIEW, GENERAL COMMENTARY ABOUT LIFESTYLES, HISTORICAL COMMENTARY, PHILOSOPHICAL COMMENTARY; MAGAZINE COLUMNS ABOUT MUSIC, POPULAR CULTURE, ARCHITECTURE, LITERATURE, POETRY, LITERATURE REVIEW, GENERAL COMMENTARY ABOUT LIFESTYLES, HISTORICAL COMMENTARY, PHILOSOPHICAL COMMENTARY; MAGAZINE SECTIONS IN THE FIELD OF MUSIC, POPULAR CULTURE, ARCHITECTURE, LITERATURE, POETRY, LITERATURE REVIEW, GENERAL COMMENTARY ABOUT LIFESTYLE ISSUES, HISTORICAL COMMENTARY, PHILOSOPHICAL COMMENTARY (U.S. CLS. 2, 5, 22, 23, 29, 37, 38 AND 50).

JUSTINE D. PARKER, EXAMINING ATTORNEY

SN 77-421,531. VISION IMPORT GROUP LLC, RIVER EDGE, NJ. FILED 3-13-2008.



THE STIPPLING IS FOR SHADING PURPOSES ONLY. THE MARK CONSISTS OF THE STYLIZED WORDS "MOJITO LIMES". BETWEEN THE WORD "MOJITO" AND "LIMES" IS AN IMAGE OF CUT AND SLICED LIMES AND MINT LEAVES.

FOR CARDBOARD PACKAGING (U.S. CLS. 2, 5, 22, 23, 29, 37, 38 AND 50).
KHANH LE, EXAMINING ATTORNEY

CLASS 16—(Continued).

SN 77-424,254. LUXE PET PRODUCTS, LLC, SAN DIEGO, CA. FILED 3-17-2008.

FUR FACE

THE MARK CONSISTS OF STANDARD CHARACTERS WITHOUT CLAIM TO ANY PARTICULAR FONT, STYLE, SIZE, OR COLOR.

FOR PRINTED MATERIALS, NAMELY, A SERIES OF CHILDREN'S BOOKS, WORKBOOKS, ACTIVITY BOOKS, COLORING BOOKS, NOTEBOOKS, STICKERS, STATIONARY, NOTE CARDS, POSTERS (U.S. CLS. 2, 5, 22, 23, 29, 37, 38 AND 50).

KEVON CHISOLM, EXAMINING ATTORNEY

CLASS 16—(Continued).

SN 77-424,939. YASSIN, SOFIA, ARLINGTON, VA. FILED 3-18-2008.

PRISTINE POUCH

THE MARK CONSISTS OF STANDARD CHARACTERS WITHOUT CLAIM TO ANY PARTICULAR FONT, STYLE, SIZE, OR COLOR.

NO CLAIM IS MADE TO THE EXCLUSIVE RIGHT TO USE "POUCH", APART FROM THE MARK AS SHOWN.

FOR PLASTIC BAGS FOR PACKAGING (U.S. CLS. 2, 5, 22, 23, 29, 37, 38 AND 50).

VERNA BETH RIRIE, EXAMINING ATTORNEY

SN 77-424,654. EVERT-FRESH CORPORATION, KATY, TX. FILED 3-18-2008.

BIOGREEN

THE MARK CONSISTS OF STANDARD CHARACTERS WITHOUT CLAIM TO ANY PARTICULAR FONT, STYLE, SIZE, OR COLOR.

FOR BIO-DEGRADABLE SEMI-TRANSPARENT PLASTIC FILM PRESERVING STORAGE BAGS FOR FRUIT, VEGETABLES, AND FLOWERS, FOR HOUSEHOLD USE; BIO-DEGRADABLE PLASTIC GARBAGE BAGS (U.S. CLS. 2, 5, 22, 23, 29, 37, 38 AND 50).

JAY FLOWERS, EXAMINING ATTORNEY

SN 77-425,079. NICHE PUBLISHING, LLC, APEX, NC. FILED 3-18-2008.

SLOW GUIDES

THE MARK CONSISTS OF STANDARD CHARACTERS WITHOUT CLAIM TO ANY PARTICULAR FONT, STYLE, SIZE, OR COLOR.

NO CLAIM IS MADE TO THE EXCLUSIVE RIGHT TO USE "GUIDES", APART FROM THE MARK AS SHOWN.

FOR GUIDE BOOKS FEATURING TRAVEL (U.S. CLS. 2, 5, 22, 23, 29, 37, 38 AND 50).

JANICE L. MCMORROW, EXAMINING ATTORNEY

SN 77-424,862. AMERICAN GLASS TOP COMPANY, BENSINVILLE, IL. FILED 3-18-2008.

**"Foreverwhite" Glass
Whiteboard**

THE MARK CONSISTS OF STANDARD CHARACTERS WITHOUT CLAIM TO ANY PARTICULAR FONT, STYLE, SIZE, OR COLOR.

NO CLAIM IS MADE TO THE EXCLUSIVE RIGHT TO USE "GLASS WHITEBOARD", APART FROM THE MARK AS SHOWN.

FOR DRY ERASE WHITEBOARD MADE OF STEEL BACKED WHITE TEMPERED GLASS (U.S. CLS. 2, 5, 22, 23, 29, 37, 38 AND 50).

KATHERINE CONNOLLY, EXAMINING ATTORNEY

SN 77-425,289. CKMEDIA LLC, NEW YORK, NY. FILED 3-18-2008.

creating
Keepsakes

OWNER OF U.S. REG. NOS. 2,765,973 AND 2,778,816. SEC. 2(F).

FOR PRINTED MATTER, NAMELY, MAGAZINES FEATURING INFORMATION ON SCRAPBOOKS (U.S. CLS. 2, 5, 22, 23, 29, 37, 38 AND 50).

FIRST USE 11-30-2007; IN COMMERCE 11-30-2007.

PATRICIA EVANKO, EXAMINING ATTORNEY

CLASS 16—(Continued).

SN 77-425,758. VIRGO PUBLISHING, LLC, PHOENIX, AZ.
FILED 3-19-2008.

CORPORATE LOGO

THE MARK CONSISTS OF STANDARD CHARACTERS WITHOUT CLAIM TO ANY PARTICULAR FONT, STYLE, SIZE, OR COLOR.

OWNER OF U.S. REG. NO. 2,132,838.
FOR TRADE MAGAZINE PROVIDING NEWS, FEATURE STORIES, AND ARTICLES TO THE APPAREL AND ACCESSORY PROMOTIONAL-PRODUCTS INDUSTRY (U.S. CLS. 2, 5, 22, 23, 29, 37, 38 AND 50).
FIRST USE 12-27-2000; IN COMMERCE 12-27-2000.
YONG KIM, EXAMINING ATTORNEY

SN 77-425,920. JOSEPH S. FABIAN, JR., KALAMAZOO, MI.
FILED 3-19-2008.

FOOD FUEL AND AMMUNITION

THE MARK CONSISTS OF STANDARD CHARACTERS WITHOUT CLAIM TO ANY PARTICULAR FONT, STYLE, SIZE, OR COLOR.

FOR A SERIES OF BOOKS AND WRITTEN ARTICLES IN THE FIELD OF INVESTMENTS, TAXES AND ESTATE PLANNING; ACCOUNT BOOKS (U.S. CLS. 2, 5, 22, 23, 29, 37, 38 AND 50).
ALYSSA PALADINO, EXAMINING ATTORNEY

SN 77-426,041. JOSEPH S. FABIAN, JR., KALAMAZOO, MI.
FILED 3-19-2008.

SURVIVE AND PROSPER

THE MARK CONSISTS OF STANDARD CHARACTERS WITHOUT CLAIM TO ANY PARTICULAR FONT, STYLE, SIZE, OR COLOR.

FOR A SERIES OF BOOKS AND WRITTEN ARTICLES IN THE FIELD OF INVESTMENTS, TAXES AND ESTATE PLANNING; ACCOUNT BOOKS (U.S. CLS. 2, 5, 22, 23, 29, 37, 38 AND 50).
ALYSSA PALADINO, EXAMINING ATTORNEY

CLASS 16—(Continued).

SN 77-426,104. WARREN, CYNTHIA, LAGUNA HILLS, CA.
FILED 3-19-2008.

Not Me

THE MARK CONSISTS OF STANDARD CHARACTERS WITHOUT CLAIM TO ANY PARTICULAR FONT, STYLE, SIZE, OR COLOR.

FOR CHILDREN'S BOOKS (U.S. CLS. 2, 5, 22, 23, 29, 37, 38 AND 50).
ALYSSA PALADINO, EXAMINING ATTORNEY

SN 77-426,863. WOLFE, IRA S., LANCASTER, PA. FILED 3-20-2008.

THE PERFECT LABOR STORM

THE MARK CONSISTS OF STANDARD CHARACTERS WITHOUT CLAIM TO ANY PARTICULAR FONT, STYLE, SIZE, OR COLOR.

FOR A SERIES OF BOOKS, WRITTEN ARTICLES, HANDOUTS AND WORKSHEETS IN THE FIELD OF HUMAN RESOURCES CONSULTING (U.S. CLS. 2, 5, 22, 23, 29, 37, 38 AND 50).
FIRST USE 5-1-2004; IN COMMERCE 5-1-2004.
NORA BUCHANAN WILL, EXAMINING ATTORNEY

SN 77-426,989. J. SOIF, INC., CHESTER SPRINGS, PA. FILED 3-20-2008.



THE COLOR(S) YELLOW, BLUE AND WHITE IS/ARE CLAIMED AS A FEATURE OF THE MARK.

THE MARK CONSISTS OF A YELLOW RECTANGLE WITH THE WORD "YELLOW" WRITTEN IN BLUE CHARACTERS ACROSS THE CENTER OF THE RECTANGLE. ADJACENT TO THE EAST (RIGHT SIDE) IS A SECOND RECTANGLE IN BLUE, CONTAINING A WHITE PLUS SYMBOL FOLLOWED (TO THE EAST/RIGHT) BY THE WORD "BLUE" WRITTEN IN YELLOW CHARACTERS. BOTH THE PLUS SYMBOL AND THE WORD "BLUE" APPEAR ACROSS THE CENTER OF THE SECOND RECTANGLE.

FOR PRINTED NOVELTY WINE LABELS (U.S. CLS. 2, 5, 22, 23, 29, 37, 38 AND 50).
FIRST USE 3-1-2008; IN COMMERCE 3-1-2008.
LEIGH CAROLINE CASE, EXAMINING ATTORNEY

CLASS 16—(Continued).

SN 77-427,092. NATIONAL ASSOCIATION OF INDEPENDENT SCHOOLS, WASHINGTON, DC. FILED 3-20-2008.

INDEPENDENT SCHOOL

THE MARK CONSISTS OF STANDARD CHARACTERS WITHOUT CLAIM TO ANY PARTICULAR FONT, STYLE, SIZE, OR COLOR.

SEC. 2(F).
FOR MAGAZINES FEATURING INFORMATION IN THE FIELD OF ELEMENTARY AND SECONDARY EDUCATION (U.S. CLS. 2, 5, 22, 23, 29, 37, 38 AND 50).
FIRST USE 10-0-1976; IN COMMERCE 10-0-1976.
KAELIE KUNG, EXAMINING ATTORNEY

SN 77-427,229. PAPPAS, DIANE H., SAN MARINO, CA. FILED 3-20-2008.

ALPHABAK YAKS

THE MARK CONSISTS OF STANDARD CHARACTERS WITHOUT CLAIM TO ANY PARTICULAR FONT, STYLE, SIZE, OR COLOR.

FOR EDUCATIONAL PUBLICATIONS, NAMELY, EDUCATIONAL LEARNING CARDS, FLASH CARDS, ACTIVITY CARDS, WORKBOOKS, TEXTBOOKS, ACTIVITY BOOKS, STORY BOOKS, PUZZLE BOOKS, PRINTED PUZZLES, TEACHER GUIDES, MANUALS, POSTERS, EDUCATIONAL CARD GAMES AND EDUCATIONAL BOOKLETS IN THE FIELD OF BASIC LITERACY EDUCATION (U.S. CLS. 2, 5, 22, 23, 29, 37, 38 AND 50).

FRANK LATTUCA, EXAMINING ATTORNEY

SN 77-427,393. THE SHERWIN-WILLIAMS COMPANY, CLEVELAND, OH. FILED 3-20-2008.

ECOVISION 20/20

THE MARK CONSISTS OF STANDARD CHARACTERS WITHOUT CLAIM TO ANY PARTICULAR FONT, STYLE, SIZE, OR COLOR.

FOR PUBLICATIONS, NAMELY, BROCHURES, BOOKLETS, AND TEACHING MATERIALS IN THE FIELD OF ECOLOGY (U.S. CLS. 2, 5, 22, 23, 29, 37, 38 AND 50).

JUDITH HELFMAN, EXAMINING ATTORNEY

CLASS 16—(Continued).

SN 77-428,068. WAG'N ENTERPRISES, LLC, HERNDON, VA. FILED 3-21-2008.

WAG 'N PET PASSPORT

THE MARK CONSISTS OF STANDARD CHARACTERS WITHOUT CLAIM TO ANY PARTICULAR FONT, STYLE, SIZE, OR COLOR.

OWNER OF U.S. REG. NOS. 3,427,952, 3,442,042 AND OTHERS.

NO CLAIM IS MADE TO THE EXCLUSIVE RIGHT TO USE "PET PASSPORT", APART FROM THE MARK AS SHOWN.

FOR BOOKLET STYLED AS A PASSPORT FOR MAINTAINING VETERINARY RECORDS (U.S. CLS. 2, 5, 22, 23, 29, 37, 38 AND 50).

KATHERINE CONNOLLY, EXAMINING ATTORNEY

SN 77-428,304. MOUNTAINEERS, THE, SEATTLE, WA. FILED 3-21-2008.

BRAIDED RIVER

THE MARK CONSISTS OF STANDARD CHARACTERS WITHOUT CLAIM TO ANY PARTICULAR FONT, STYLE, SIZE, OR COLOR.

FOR BOOKS IN THE FIELD OF A WIDE VARIETY OF GENERAL ENVIRONMENTAL, CONSERVATION AND NATURAL HISTORY TOPICS (U.S. CLS. 2, 5, 22, 23, 29, 37, 38 AND 50).

FIRST USE 12-4-2007; IN COMMERCE 12-19-2007.

ELLEN B. AWRICH, EXAMINING ATTORNEY

SN 77-428,330. TPC OPERATIONS, LLC, MOORPARK, CA. FILED 3-21-2008.

THE PLAYERS CLUB

THE MARK CONSISTS OF STANDARD CHARACTERS WITHOUT CLAIM TO ANY PARTICULAR FONT, STYLE, SIZE, OR COLOR.

FOR MAGAZINE IN THE FIELD OF FINANCE, FINANCIAL PLANNING, SPORTS AND LIFESTYLE (U.S. CLS. 2, 5, 22, 23, 29, 37, 38 AND 50).

MARK RADEMACHER, EXAMINING ATTORNEY

CLASS 16—(Continued).

SN 77-428,345. THE MOUNTAINEERS, SEATTLE, WA.
FILED 3-21-2008.

SKIPSTONE

THE MARK CONSISTS OF STANDARD CHARACTERS WITHOUT CLAIM TO ANY PARTICULAR FONT, STYLE, SIZE, OR COLOR.

FOR BOOKS IN THE FIELDS OF SUSTAINABLE LIFESTYLES, FOOD AND COOKING, GARDENING, CRAFTS, HOME, HEALTH, WELLNESS, FITNESS, PETS, OUTDOORS, THE ENVIRONMENT AND CONSERVATION (U.S. CLS. 2, 5, 22, 23, 29, 37, 38 AND 50).

FIRST USE 10-10-2007; IN COMMERCE 10-16-2007.
ELLEN B. AWRICH, EXAMINING ATTORNEY

CLASS 16—(Continued).

SN 77-428,871. GREGG APPLIANCES, INC., INDIANAPOLIS, IN. FILED 3-22-2008.

FINE POINTS

THE MARK CONSISTS OF STANDARD CHARACTERS WITHOUT CLAIM TO ANY PARTICULAR FONT, STYLE, SIZE, OR COLOR.

FOR MAGAZINES FEATURING INFORMATION REGARDING CONSUMER APPLIANCES, ELECTRONICS, COOKING, FOODS, DRINKS, AND PERSONAL LIFESTYLE, RECIPES AND PROMOTIONAL MATERIALS (U.S. CLS. 2, 5, 22, 23, 29, 37, 38 AND 50).

FIRST USE 8-0-2006; IN COMMERCE 8-0-2006.
DAVID TAYLOR, EXAMINING ATTORNEY

SN 77-428,713. MICHELE MORRIS, LITTLETON, CO. FILED
3-21-2008.

COOKING WITH MICHELE

THE MARK CONSISTS OF STANDARD CHARACTERS WITHOUT CLAIM TO ANY PARTICULAR FONT, STYLE, SIZE, OR COLOR.

FOR COLUMNS ON THE SUBJECT OF COOKING, FOOD, AND CUISINE; NEWSLETTERS IN THE FIELD OF COOKING, FOOD, AND CUISINE (U.S. CLS. 2, 5, 22, 23, 29, 37, 38 AND 50).

LINDA POWELL, EXAMINING ATTORNEY

SN 77-429,094. WALKER, SUZANNE P., SPOKANE, WA.
FILED 3-23-2008.

SUNSHINE MEADOWS

THE MARK CONSISTS OF STANDARD CHARACTERS WITHOUT CLAIM TO ANY PARTICULAR FONT, STYLE, SIZE, OR COLOR.

FOR CHILDREN'S BOOKS (U.S. CLS. 2, 5, 22, 23, 29, 37, 38 AND 50).

HEATHER THOMPSON, EXAMINING ATTORNEY

SN 77-428,765. ALEXANDER, ALAINA R., CULVER CITY, CA. FILED 3-21-2008.

Divatosity

THE MARK CONSISTS OF STANDARD CHARACTERS WITHOUT CLAIM TO ANY PARTICULAR FONT, STYLE, SIZE, OR COLOR.

FOR COOK BOOKS (U.S. CLS. 2, 5, 22, 23, 29, 37, 38 AND 50).

NATALIE POLZER, EXAMINING ATTORNEY

SN 77-429,117. KAUFMAN, ROBERT, NEWTON, MA. FILED
3-23-2008.

SILVER VISIONS

THE MARK CONSISTS OF STANDARD CHARACTERS WITHOUT CLAIM TO ANY PARTICULAR FONT, STYLE, SIZE, OR COLOR.

OWNER OF U.S. REG. NO. 1,247,684.
FOR CALENDAR-FINISHED PAPER; CALENDARS; CALENDARS AND DIARIES; PRINTED CALENDARS; WALL CALENDARS (U.S. CLS. 2, 5, 22, 23, 29, 37, 38 AND 50).

FIRST USE 6-1-1977; IN COMMERCE 8-1-1977.
PAM WILLIS, EXAMINING ATTORNEY

CLASS 16—(Continued).

SN 77-429,368. CERTIFIED PLUMBING COMPANY, LITTLETON, CO. FILED 3-24-2008.

RETAEH

THE MARK CONSISTS OF STANDARD CHARACTERS WITHOUT CLAIM TO ANY PARTICULAR FONT, STYLE, SIZE, OR COLOR.

THE MARK "RETEAH" IS A COINED TERM WITHOUT SIGNIFICANCE IN A FOREIGN LANGUAGE.

FOR GENERAL PURPOSE PLASTIC BAGS (U.S. CLS. 2, 5, 22, 23, 29, 37, 38 AND 50).

JERI J. FICKES, EXAMINING ATTORNEY

CLASS 16—(Continued).

SN 77-429,493. FEWELL, LINDA, WINDERMERE, FL. FILED 3-24-2008.

INKSNAPS

THE MARK CONSISTS OF STANDARD CHARACTERS WITHOUT CLAIM TO ANY PARTICULAR FONT, STYLE, SIZE, OR COLOR.

FOR NOTE CARDS; STATIONERY (U.S. CLS. 2, 5, 22, 23, 29, 37, 38 AND 50).

EUGENIA MARTIN, EXAMINING ATTORNEY

SN 77-429,398. ANDREWS, ADELAIDE, ENCINITAS, CA. FILED 3-24-2008.

No, Thanks... I've got a
bag

THE MARK CONSISTS OF STANDARD CHARACTERS WITHOUT CLAIM TO ANY PARTICULAR FONT, STYLE, SIZE, OR COLOR.

FOR REUSABLE POLYPROPYLENE GROCERY AND SHOPPING BAGS (U.S. CLS. 2, 5, 22, 23, 29, 37, 38 AND 50).

FIRST USE 11-1-2007; IN COMMERCE 11-1-2007.
WENDY GOODMAN, EXAMINING ATTORNEY

SN 77-429,592. AGUILAR, VANESSA, LAKE VIEW TERRACE, CA. FILED 3-24-2008.

AESTHETIQUE

THE MARK CONSISTS OF THE STYLIZED WORD "AESTHETIQUE".

FOR BOOKS IN THE FIELD OF MAKEUP AND HAIR (U.S. CLS. 2, 5, 22, 23, 29, 37, 38 AND 50).

ZHALEH DELANEY, EXAMINING ATTORNEY

SN 77-429,462. HAGAN, JENNIFER, SAVANNAH, GA. FILED 3-24-2008.

BIKINI NATION

THE MARK CONSISTS OF STANDARD CHARACTERS WITHOUT CLAIM TO ANY PARTICULAR FONT, STYLE, SIZE, OR COLOR.

NO CLAIM IS MADE TO THE EXCLUSIVE RIGHT TO USE "BIKINI", APART FROM THE MARK AS SHOWN.

FOR CALENDARS; POSTERS (U.S. CLS. 2, 5, 22, 23, 29, 37, 38 AND 50).

FIRST USE 6-1-2006; IN COMMERCE 10-1-2007.
CAROL SPILS, EXAMINING ATTORNEY

SN 77-429,831. TPC OPERATIONS, LLC, MOORPARK, CA. FILED 3-24-2008.

KEEP LIVING THE DREAM

THE MARK CONSISTS OF STANDARD CHARACTERS WITHOUT CLAIM TO ANY PARTICULAR FONT, STYLE, SIZE, OR COLOR.

FOR MAGAZINE IN THE FIELD OF FINANCE, FINANCIAL PLANNING, SPORTS AND LIFESTYLE (U.S. CLS. 2, 5, 22, 23, 29, 37, 38 AND 50).

MARK RADEMACHER, EXAMINING ATTORNEY

CLASS 16—(Continued).

SN 77-429,872. UP WITH PAPER, MASON, OH. FILED 3-24-2008.

TURNING POINTS

THE MARK CONSISTS OF STANDARD CHARACTERS WITHOUT CLAIM TO ANY PARTICULAR FONT, STYLE, SIZE, OR COLOR.
FOR BLANK JOURNALS (U.S. CLS. 2, 5, 22, 23, 29, 37, 38 AND 50).
MARTHA SANTOMARTINO, EXAMINING ATTORNEY

SN 77-429,943. CARSTENS & CAHOON, LLP, DALLAS, TX. FILED 3-24-2008.

THE UMBRELLA

THE MARK CONSISTS OF STANDARD CHARACTERS WITHOUT CLAIM TO ANY PARTICULAR FONT, STYLE, SIZE, OR COLOR.
FOR NEWSLETTERS IN THE FIELD OF INTELLECTUAL PROPERTY LAW (U.S. CLS. 2, 5, 22, 23, 29, 37, 38 AND 50).
FIRST USE 9-1-2007; IN COMMERCE 9-1-2007.
JOHN KELLY, EXAMINING ATTORNEY

SN 77-430,127. NEW MILFORD HOSPITAL, NEW MILFORD, CT. FILED 3-24-2008.

FARM BUCKS

THE MARK CONSISTS OF STANDARD CHARACTERS WITHOUT CLAIM TO ANY PARTICULAR FONT, STYLE, SIZE, OR COLOR.
FOR PRINTED MATERIALS, NAMELY, COUPONS (U.S. CLS. 2, 5, 22, 23, 29, 37, 38 AND 50).
CHERYL CLAYTON, EXAMINING ATTORNEY

CLASS 16—(Continued).

SN 77-430,163. BEYOND TWILIGHT, LLC, JACKSON, TN. FILED 3-24-2008.

MARVELOUS ME

THE MARK CONSISTS OF STANDARD CHARACTERS WITHOUT CLAIM TO ANY PARTICULAR FONT, STYLE, SIZE, OR COLOR.
FOR CHILDREN'S BOOKS (U.S. CLS. 2, 5, 22, 23, 29, 37, 38 AND 50).
GISELLE AGOSTO, EXAMINING ATTORNEY

SN 77-430,603. MUTTNATION, LLC, LOS ANGELES, CA. FILED 3-25-2008.

Mutt-ificate

THE MARK CONSISTS OF STANDARD CHARACTERS WITHOUT CLAIM TO ANY PARTICULAR FONT, STYLE, SIZE, OR COLOR.
FOR PRINTED CERTIFICATE FANCIFULLY IDENTIFYING THE BREED AND TRACING THE ANCESTRY OF MULTI-BREED DOGS (U.S. CLS. 2, 5, 22, 23, 29, 37, 38 AND 50).
JOHN DWYER, EXAMINING ATTORNEY

SN 77-430,613. KARE DISTRIBUTION, INC., NEW YORK, NY. FILED 3-25-2008.

ASTRAL

THE MARK CONSISTS OF STANDARD CHARACTERS WITHOUT CLAIM TO ANY PARTICULAR FONT, STYLE, SIZE, OR COLOR.
FOR PRE-PAID TELEPHONE CALLING CARDS, NOT MAGNETICALLY ENCODED (U.S. CLS. 2, 5, 22, 23, 29, 37, 38 AND 50).
FIRST USE 3-25-2008; IN COMMERCE 3-25-2008.
JOHN SCHUYLER YARD, EXAMINING ATTORNEY

CLASS 16—(Continued).

SN 77-430,782. WHIMSY HILL STUDIO, DBA WHIMSY HILL PUBLISHING, WEST ALEXANDRIA, OH. FILED 3-25-2008.



NO CLAIM IS MADE TO THE EXCLUSIVE RIGHT TO USE "PUBLISHING" AND "EST. 2001", APART FROM THE MARK AS SHOWN.

THE MARK CONSISTS OF A WINGED HORSE INSIDE AN OVAL THAT'S THICKER ON THE TOP AND BOTTOM, NARROWER ON THE SIDES. THE WORDS "WHIMSY HILL PUBLISHING" LINE THE INSIDE EDGES OF THE OVAL. "EST. 2001" IS PLACED ON EITHER SIDE OF THE HORSE ("EST." ON THE LEFT, "2001" ON THE RIGHT).

FOR SERIES OF FICTION AND NON-FICTION BOOKS ON A VARIETY OF TOPICS (U.S. CLS. 2, 5, 22, 23, 29, 37, 38 AND 50).

FIRST USE 1-7-2008; IN COMMERCE 1-7-2008.
GINA FINK, EXAMINING ATTORNEY

SN 77-430,932. AVILA, EDWARD D, DBA CASTING CALL, FRESNO, CA. FILED 3-25-2008.

CASTING CALL

THE MARK CONSISTS OF STANDARD CHARACTERS WITHOUT CLAIM TO ANY PARTICULAR FONT, STYLE, SIZE, OR COLOR.

FOR MAGAZINE DEPARTMENTS IN THE FIELD OF ENTERTAINMENT FEATURING INSPIRATIONAL, EDUCATIONAL AND INSTRUCTIONAL ARTICLES IN THE FIELD OF THE ENTERTAINMENT INDUSTRY (U.S. CLS. 2, 5, 22, 23, 29, 37, 38 AND 50).

BILL DAWE, EXAMINING ATTORNEY

CLASS 16—(Continued).

SN 77-431,337. TURTLETECH DESIGN, INC., CARDIFF-BY-THE-SEA, CA. FILED 3-25-2008.



OWNER OF U.S. REG. NOS. 3,200,628 AND 3,384,785.
THE MARK CONSISTS OF THE WORD "MOVA" WHERE A HORIZONTAL LINE APPEARS OVER THE "O" WHICH IS A STYLIZED FILLED CIRCLE CONTAINING A NEGATIVE CURVED ARROW IMPLYING A ROTATING SPHERE, AND THE WORDS "MOTION WITHIN" WRITTEN BELOW.

THE FOREIGN WORDING IN THE MARK TRANSLATES INTO ENGLISH AS IT MOVES.

FOR GLOBES (U.S. CLS. 2, 5, 22, 23, 29, 37, 38 AND 50).
SANDRA MANIOS, EXAMINING ATTORNEY

SN 77-431,363. POTOMAC CORPORATION, WHEELING, IL. FILED 3-25-2008.

ALPHASELECT

THE MARK CONSISTS OF STANDARD CHARACTERS WITHOUT CLAIM TO ANY PARTICULAR FONT, STYLE, SIZE, OR COLOR.

FOR MAT BOARDS; PICTURE FRAMING MAT BOARDS (U.S. CLS. 2, 5, 22, 23, 29, 37, 38 AND 50).

MONIQUE MILLER, EXAMINING ATTORNEY

SN 77-431,366. GRIFFITH, ROBERT G, REDDING, CT. FILED 3-25-2008.

Topstone Photo

THE MARK CONSISTS OF STANDARD CHARACTERS WITHOUT CLAIM TO ANY PARTICULAR FONT, STYLE, SIZE, OR COLOR.

NO CLAIM IS MADE TO THE EXCLUSIVE RIGHT TO USE "PHOTO", APART FROM THE MARK AS SHOWN.

FOR PHOTOGRAPHIC PRINTS; PHOTOGRAPHS THAT HAVE BEEN COMPUTER MANIPULATED AND ENHANCED TO LOOK LIKE PAINTINGS; UNMOUNTED AND MOUNTED PHOTOGRAPHS (U.S. CLS. 2, 5, 22, 23, 29, 37, 38 AND 50).

MONIQUE MILLER, EXAMINING ATTORNEY

CLASS 16—(Continued).

SN 77-431,479. NURSE ATTORNEY INSTITUTE, LLC, NEW ORLEANS, LA. FILED 3-25-2008.

PYA Series - Protect Your Assets

THE MARK CONSISTS OF STANDARD CHARACTERS WITHOUT CLAIM TO ANY PARTICULAR FONT, STYLE, SIZE, OR COLOR.

FOR EDUCATIONAL BOOKS FEATURING NURSING LAW AND ETHICS; EDUCATIONAL PUBLICATIONS, NAMELY, EDUCATIONAL LEARNING CARDS, FLASH CARDS, ACTIVITY CARDS, WORKBOOKS, TEXTBOOKS, ACTIVITY BOOKS, STORY BOOKS, PUZZLE BOOKS, PRINTED PUZZLES, TEACHER GUIDES, MANUALS, POSTERS, EDUCATIONAL CARD GAMES AND EDUCATIONAL BOOKLETS IN THE FIELD OF NURSING LAW AND ETHICS; EDUCATIONAL PUBLICATIONS, NAMELY, TRAINING MANUALS IN THE FIELD OF NURSING LAW AND ETHICS; EDUCATIONAL PUBLICATIONS, NAMELY, BROCHURES, LAMINATED INSTRUCTIONAL CARDS IN THE FIELDS OF NURSING LAW AND ETHICS; PRINTED EDUCATIONAL MATERIAL, NAMELY, TEACHING TILES; PRINTED INSTRUCTIONAL, EDUCATIONAL, AND TEACHING MATERIALS IN THE FIELD OF NURSING LAW AND ETHICS (U.S. CLS. 2, 5, 22, 23, 29, 37, 38 AND 50).

FIRST USE 3-21-2008; IN COMMERCE 3-24-2008.
HENRY S. ZAK, EXAMINING ATTORNEY

SN 77-431,695. GENEVA CUBS BASEBALL, INC, WILLIAMSPORT, PA. FILED 3-26-2008.



OWNER OF U.S. REG. NO. 2,345,664.
NO CLAIM IS MADE TO THE EXCLUSIVE RIGHT TO USE "WILLIAMSPORT", APART FROM THE MARK AS SHOWN.

THE MARK CONSISTS OF A LUMBERJACK IN FRONT OF A LOG WITH "CROSSCUTTERS" IN FRONT AND "WILLIAMSPORT" ARCHED ABOVE.

FOR PAPER GOODS AND PRINTED MATTER, NAMELY, AUTOGRAPH BOOKS, BINDERS, BOOKMARKS, BUMPER STICKERS, CALENDARS, CATALOGS OF INTEREST TO BASEBALL FANS, DECALS, MERCHANDISE BAGS, NEWSLETTERS OF INTEREST TO BASEBALL FANS, NOTE PADS, PAPER CONTAINERS, PAPER PENNANTS, PAPER SCHEDULES, PENS, PENCILS, POSTCARDS, POSTERS, PRINTED AWARDS, PRINTED GAME TICKETS, PRINTED GUIDES OF INTEREST TO BASEBALL FANS, REFERENCE BOOKS OF INTEREST TO BASEBALL FANS, SCORE BOOKS, SCORE CARDS, SCORE SHEETS, STATIONERY, STICKERS, STICKER ALBUMS AND TRADING CARDS (U.S. CLS. 2, 5, 22, 23, 29, 37, 38 AND 50).

FIRST USE 1-17-2008; IN COMMERCE 1-17-2008.
REGINA DRUMMOND, EXAMINING ATTORNEY

CLASS 16—(Continued).

SN 77-431,814. TOUGHQUIP LLC, JACKSONVILLE, TX. FILED 3-26-2008.

Toughquip

THE MARK CONSISTS OF STANDARD CHARACTERS WITHOUT CLAIM TO ANY PARTICULAR FONT, STYLE, SIZE, OR COLOR.

FOR PRINTED GUIDES FOR BUYING CONSTRUCTION EQUIPMENT (U.S. CLS. 2, 5, 22, 23, 29, 37, 38 AND 50).

FIRST USE 1-22-2004; IN COMMERCE 6-5-2004.
REGINA DRUMMOND, EXAMINING ATTORNEY

SN 77-431,885. DUNCAN ENTERPRISES, FRESNO, CA. FILED 3-26-2008.

COLLAGE PAUGE

THE MARK CONSISTS OF STANDARD CHARACTERS WITHOUT CLAIM TO ANY PARTICULAR FONT, STYLE, SIZE, OR COLOR.

FOR GLUE FOR STATIONERY OR HOUSEHOLD USE (U.S. CLS. 2, 5, 22, 23, 29, 37, 38 AND 50).

JULIE GUTTADAURO, EXAMINING ATTORNEY

SN 77-431,977. GAYLORD PROGRAM SERVICES, INC., NASHVILLE, TN. FILED 3-26-2008.



OWNER OF U.S. REG. NO. 2,979,192.
THE MARK CONSISTS OF THE WORD "HEE" LOCATED SLIGHTLY TO THE LEFT OF AND ABOVE THE WORD "HAW" BOTH IN A STYLIZED FORMAT.

FOR PENS (U.S. CLS. 2, 5, 22, 23, 29, 37, 38 AND 50).
KARANENDRA S. CHHINA, EXAMINING ATTORNEY

CLASS 16—(Continued).

SN 77-431,984. GAYLORD PROGRAM SERVICES, INC., NASHVILLE, TN. FILED 3-26-2008.

HEE HAW

THE MARK CONSISTS OF STANDARD CHARACTERS WITHOUT CLAIM TO ANY PARTICULAR FONT, STYLE, SIZE, OR COLOR.

OWNER OF U.S. REG. NO. 2,979,192.
FOR PENS (U.S. CLS. 2, 5, 22, 23, 29, 37, 38 AND 50).
KARANENDRA S. CHHINA, EXAMINING ATTORNEY

CLASS 16—(Continued).

SN 77-432,196. STEVENS, ROGER L., MANHATTAN, KS. FILED 3-26-2008.

NOTHING BUT THE TOOTH

THE MARK CONSISTS OF STANDARD CHARACTERS WITHOUT CLAIM TO ANY PARTICULAR FONT, STYLE, SIZE, OR COLOR.

FOR COLUMNS ON THE SUBJECT OF DENTISTRY; NEWSLETTERS IN THE FIELD OF DENTISTRY (U.S. CLS. 2, 5, 22, 23, 29, 37, 38 AND 50).
STEPHEN AQUILA, EXAMINING ATTORNEY

SN 77-432,006. TECHLINE TECHNOLOGIES, INC., DBA MPS TECHLINE OF PENNSYLVANIA, INC., WILLOW GROVE, PA. FILED 3-26-2008.

SOFTTECH

THE MARK CONSISTS OF STANDARD CHARACTERS WITHOUT CLAIM TO ANY PARTICULAR FONT, STYLE, SIZE, OR COLOR.

FOR REPLICAS SIMULATING WOUNDS FOR USE IN FIRST AID TRAINING (U.S. CLS. 2, 5, 22, 23, 29, 37, 38 AND 50).
SCOTT BIBB, EXAMINING ATTORNEY

SN 77-432,323. CAMPANA, MICHAEL, FORT COLLINS, CO. FILED 3-26-2008.

DESTINATION STATION

THE MARK CONSISTS OF STANDARD CHARACTERS WITHOUT CLAIM TO ANY PARTICULAR FONT, STYLE, SIZE, OR COLOR.

FOR CHILDREN'S BOOKS (U.S. CLS. 2, 5, 22, 23, 29, 37, 38 AND 50).
SONYA STEPHENS, EXAMINING ATTORNEY

SN 77-432,040. NEW MILFORD HOSPITAL, NEW MILFORD, CT. FILED 3-26-2008.

IN FARMS WE TRUST

THE MARK CONSISTS OF STANDARD CHARACTERS WITHOUT CLAIM TO ANY PARTICULAR FONT, STYLE, SIZE, OR COLOR.

FOR PRINTED MATERIALS, NAMELY, COUPONS (U.S. CLS. 2, 5, 22, 23, 29, 37, 38 AND 50).
CHERYL CLAYTON, EXAMINING ATTORNEY

SN 77-432,644. KING, ERIC HANS, MINNEAPOLIS, MN. FILED 3-26-2008.



THE MARK CONSISTS OF STANDARD CHARACTERS WITHOUT CLAIM TO ANY PARTICULAR FONT, STYLE, SIZE, OR COLOR.

FOR COMIC BOOKS; STORIES IN ILLUSTRATED FORM (U.S. CLS. 2, 5, 22, 23, 29, 37, 38 AND 50).
BARBARA BROWN, EXAMINING ATTORNEY

CLASS 16—(Continued).

SN 77-432,862. TECHLINE TECHNOLOGIES, INC., DBA MPS
TECHLINE OF PENNSYLVANIA, INC., WILLOW GROVE,
PA. FILED 3-27-2008.

SOFTTECH

THE MARK CONSISTS OF STANDARD CHARACTERS
WITHOUT CLAIM TO ANY PARTICULAR FONT, STYLE,
SIZE, OR COLOR.

FOR THREE DIMENSIONAL MODELS FOR IN-
STRUCTIONAL AND EDUCATIONAL PURPOSES (U.S.
CLS. 2, 5, 22, 23, 29, 37, 38 AND 50).

SCOTT BIBB, EXAMINING ATTORNEY

SN 77-433,120. THE PROCTER & GAMBLE COMPANY,
CINCINNATI, OH. FILED 3-27-2008.

ABSORBENT CUSHIONS

THE MARK CONSISTS OF STANDARD CHARACTERS
WITHOUT CLAIM TO ANY PARTICULAR FONT, STYLE,
SIZE, OR COLOR.

NO CLAIM IS MADE TO THE EXCLUSIVE RIGHT TO
USE "ABSORBENT", APART FROM THE MARK AS
SHOWN.

FOR BATHROOM TISSUE (U.S. CLS. 2, 5, 22, 23, 29, 37,
38 AND 50).

MARIA-VICTORIA SUAREZ, EXAMINING ATTORNEY

SN 77-433,151. KING MIDAS WORLD ENTERTAINMENT,
INC., LAS VEGAS, NE. FILED 3-27-2008.

TO DREAM TO DARE TO WIN

THE MARK CONSISTS OF STANDARD CHARACTERS
WITHOUT CLAIM TO ANY PARTICULAR FONT, STYLE,
SIZE, OR COLOR.

FOR SERIES OF FICTION BOOKS (U.S. CLS. 2, 5, 22,
23, 29, 37, 38 AND 50).

FIRST USE 3-27-2008; IN COMMERCE 3-27-2008.

JOHN DWYER, EXAMINING ATTORNEY

CLASS 16—(Continued).

SN 77-433,773. ER ASSETS, LP, FT. LAUDERDALE, FL.
FILED 3-27-2008.

BACKFIRE

THE MARK CONSISTS OF STANDARD CHARACTERS
WITHOUT CLAIM TO ANY PARTICULAR FONT, STYLE,
SIZE, OR COLOR.

FOR MAGAZINES FEATURING PHOTOGRAPHS
CONCERNING AUTOMOBILE RESTORATION AND
CUSTOMIZING AND MAGAZINE SECTION FEATUR-
ING PHOTOGRAPHS CONCERNING AUTOMOBILE RE-
STORATION AND CUSTOMIZING (U.S. CLS. 2, 5, 22, 23,
29, 37, 38 AND 50).

STEVEN R. FINE, EXAMINING ATTORNEY

SN 77-433,785. BUCKNER, SCOTT A., LANSING, IL. FILED
3-27-2008.

PERFECTHOUGHT

THE MARK CONSISTS OF STANDARD CHARACTERS
WITHOUT CLAIM TO ANY PARTICULAR FONT, STYLE,
SIZE, OR COLOR.

FOR GREETING CARDS (U.S. CLS. 2, 5, 22, 23, 29, 37,
38 AND 50).

SCOTT BIBB, EXAMINING ATTORNEY

SN 77-433,865. SALAZAR PACKAGING, INC., PLAINFIELD,
IL. FILED 3-27-2008.

Globe Guard

THE MARK CONSISTS OF STANDARD CHARACTERS
WITHOUT CLAIM TO ANY PARTICULAR FONT, STYLE,
SIZE, OR COLOR.

FOR CARDBOARD PACKAGING (U.S. CLS. 2, 5, 22,
23, 29, 37, 38 AND 50).

FIRST USE 3-1-2008; IN COMMERCE 3-1-2008.

JILL PRATER, EXAMINING ATTORNEY

CLASS 16—(Continued).

SN 77-434,088. ROCKWELL SOLUTIONS LIMITED, DUNDEE, SCOTLAND, FILED 3-28-2008.

 The logo for "Vent Sys" features the word "Vent" in a blue, stylized script font with a grey shadow effect. The word "Sys" is in a red, stylized script font. A small grey zigzag line is positioned above the "V" in "Vent".

THE COLOR(S) BLUE, RED, GREY IS/ARE CLAIMED AS A FEATURE OF THE MARK.

THE MARK CONSISTS OF THE WORD "VENT" IN STYLIZED BLUE LETTERS AND THE WORD "SYS" IN STYLIZED RED LETTERS WITH A GREY SHADOW AND A WIGLY LINE ON TOP OF THE "V" IN "VENT".

FOR PLASTIC OVEN COOKING BAGS (U.S. CLS. 2, 5, 22, 23, 29, 37, 38 AND 50).

ELISSA GARBER KON, EXAMINING ATTORNEY

SN 77-434,209. TEMPLE, FRANCINA L., ATLANTA, GA. FILED 3-28-2008.

Where actions do not speak
louder than words, they
co-exist.

THE MARK CONSISTS OF STANDARD CHARACTERS WITHOUT CLAIM TO ANY PARTICULAR FONT, STYLE, SIZE, OR COLOR.

FOR CARDS, NAMELY, GREETING CARDS & POSTCARDS; GREETING CARDS; GREETING CARDS HAVING A CHRISTIAN MESSAGE; GREETINGS CARDS AND POSTCARDS; HOLIDAY CARDS; INVITATION CARDS; MOTIVATIONAL CARDS; OCCASION CARDS; POST CARDS; POSTCARDS AND GREETING CARDS; SOCIAL NOTE CARDS (U.S. CLS. 2, 5, 22, 23, 29, 37, 38 AND 50).

SETH A. RAPPAPORT, EXAMINING ATTORNEY

SN 77-434,231. PREVENTION RESEARCH INSTITUTE, INC., LEXINGTON, KY. FILED 3-28-2008.

PRIME TIMES

THE MARK CONSISTS OF STANDARD CHARACTERS WITHOUT CLAIM TO ANY PARTICULAR FONT, STYLE, SIZE, OR COLOR.

FOR NEWSLETTERS IN THE FIELD OF PREVENTION OF DRUG AND ALCOHOL RELATED PROBLEMS (U.S. CLS. 2, 5, 22, 23, 29, 37, 38 AND 50).

FIRST USE 10-1-1999; IN COMMERCE 10-1-1999.

ELISSA GARBER KON, EXAMINING ATTORNEY

CLASS 16—(Continued).

SN 77-434,264. THEURER, JR., HAROLD, BROOKLYN, NY. FILED 3-28-2008.

Hey Dad, Let's...

THE MARK CONSISTS OF STANDARD CHARACTERS WITHOUT CLAIM TO ANY PARTICULAR FONT, STYLE, SIZE, OR COLOR.

FOR CHILDREN'S BOOKS (U.S. CLS. 2, 5, 22, 23, 29, 37, 38 AND 50).

DAVID MURRAY, EXAMINING ATTORNEY

SN 77-434,345. THE MOUNTAINEERS, SEATTLE, WA. FILED 3-28-2008.



FOR BOOKS IN THE FIELDS OF SUSTAINABLE LIFESTYLES, FOOD AND COOKING, GARDENING, CRAFTS, HOME, HEALTH, WELLNESS, FITNESS, PETS, OUTDOORS, THE ENVIRONMENT AND CONSERVATION (U.S. CLS. 2, 5, 22, 23, 29, 37, 38 AND 50).

FIRST USE 10-10-2007; IN COMMERCE 10-16-2007.

ELLEN B. AWRICH, EXAMINING ATTORNEY

SN 77-435,637. ANDREWS, CATHERINE, PACIFIC PALISADES, CA. FILED 3-31-2008.

CATHERINE ANDREWS

THE MARK CONSISTS OF STANDARD CHARACTERS WITHOUT CLAIM TO ANY PARTICULAR FONT, STYLE, SIZE, OR COLOR.

THE NAME "CATHERINE ANDREWS" IDENTIFIES A LIVING INDIVIDUAL WHOSE CONSENT IS OF RECORD.

FOR ART PRINTS; GRAPHIC ART REPRODUCTIONS; GREETING CARDS; GICLEE PRINTS (U.S. CLS. 2, 5, 22, 23, 29, 37, 38 AND 50).

FIRST USE 1-1-1973; IN COMMERCE 1-1-1973.

JENNIFER DIXON, EXAMINING ATTORNEY

CLASS 16—(Continued).

SN 77-437,921. ADVANCE MAGAZINE PUBLISHERS INC., DBA PARADE PUBLICATIONS, NEW YORK, NY. FILED 4-2-2008.

PARADE'S HEALTHY STYLE

THE MARK CONSISTS OF STANDARD CHARACTERS WITHOUT CLAIM TO ANY PARTICULAR FONT, STYLE, SIZE, OR COLOR.

OWNER OF U.S. REG. NOS. 740,934, 3,035,859 AND OTHERS.

FOR GENERAL INTEREST MAGAZINE (U.S. CLS. 2, 5, 22, 23, 29, 37, 38 AND 50).

STEVEN R. FINE, EXAMINING ATTORNEY

SN 77-438,231. TECHLINE TECHNOLOGIES, INC., DBA MPS TECHLINE OF PENNSYLVANIA, INC., WILLOW GROVE, PA. FILED 4-2-2008.

ROCKTECH

THE MARK CONSISTS OF STANDARD CHARACTERS WITHOUT CLAIM TO ANY PARTICULAR FONT, STYLE, SIZE, OR COLOR.

FOR REPLICAS SIMULATING WOUNDS FOR USE IN FIRST AID TRAINING (U.S. CLS. 2, 5, 22, 23, 29, 37, 38 AND 50).

SCOTT BIBB, EXAMINING ATTORNEY

SN 77-438,674. TECHLINE TECHNOLOGIES, INC., DBA MPS TECHLINE OF PENNSYLVANIA, INC., WILLOW GROVE, PA. FILED 4-3-2008.

ROCKTECH

THE MARK CONSISTS OF STANDARD CHARACTERS WITHOUT CLAIM TO ANY PARTICULAR FONT, STYLE, SIZE, OR COLOR.

FOR THREE DIMENSIONAL MODELS FOR INSTRUCTIONAL AND EDUCATIONAL PURPOSES (U.S. CLS. 2, 5, 22, 23, 29, 37, 38 AND 50).

SCOTT BIBB, EXAMINING ATTORNEY

CLASS 16—(Continued).

SN 77-446,819. WAG'N ENTERPRISES, LLC, HERNDON, VA. FILED 4-12-2008.



OWNER OF U.S. REG. NOS. 3,427,952, 3,442,042 AND OTHERS.

NO CLAIM IS MADE TO THE EXCLUSIVE RIGHT TO USE "ENTERPRISES" AND "LLC.", APART FROM THE MARK AS SHOWN.

THE MARK CONSISTS OF THE WORD "WAG 'N" WITH AN ANIMAL TAIL TAKING THE PLACE OF THE APOSTROPHE. THE WORDING "WAG 'N ENTERPRISES LLC" IS ABOVE THE WORD "WAG 'N", AND THERE ARE TWO SEMI-CIRCULAR LINES ON EACH SIDE OF THE WORD "WAG 'N", ALL APPEARING INSIDE AN ELLIPSE.

FOR BOOKLETS IN THE FIELD OF PET SAFETY AND PET MEDICAL RECORDKEEPING; PRINTED INFORMATIONAL CARDS IN THE FIELD OF PET SAFETY AND PET MEDICAL RECORDKEEPING; BROCHURES ABOUT PET SAFETY AND PET MEDICAL RECORDKEEPING; STICKERS; PLASTIC BAGS FOR DISPOSING OF PET WASTE (U.S. CLS. 2, 5, 22, 23, 29, 37, 38 AND 50).

KATHERINE CONNOLLY, EXAMINING ATTORNEY

SN 77-451,798. UP WITH PAPER, MASON, OH. FILED 4-18-2008.

TURNING POINTS

THE MARK CONSISTS OF STANDARD CHARACTERS WITHOUT CLAIM TO ANY PARTICULAR FONT, STYLE, SIZE, OR COLOR.

FOR BLANK JOURNALS AND GREETING CARDS (U.S. CLS. 2, 5, 22, 23, 29, 37, 38 AND 50).

MARTHA SANTOMARTINO, EXAMINING ATTORNEY

SN 77-455,388. ACCESS INTELLIGENCE, LLC, ROCKVILLE, MD. FILED 4-23-2008.

COMMUNICATIONS TECHNOLOGY

THE MARK CONSISTS OF STANDARD CHARACTERS WITHOUT CLAIM TO ANY PARTICULAR FONT, STYLE, SIZE, OR COLOR.

SEC. 2(F).

FOR PUBLICATIONS, NAMELY, MAGAZINES IN THE FIELDS OF CABLE TELECOMMUNICATIONS AND TECHNOLOGIES (U.S. CLS. 2, 5, 22, 23, 29, 37, 38 AND 50).

FIRST USE 7-0-1993; IN COMMERCE 7-0-1993.

RON FAIRBANKS, EXAMINING ATTORNEY

CLASS 16—(Continued).

SN 77-458,818. A-TRADITIONAL ADVERTISING CONCEPTS, LLC, DBA CITYPHONE, DALLAS, TX. FILED 4-26-2008.

FASTT CODE

THE MARK CONSISTS OF STANDARD CHARACTERS WITHOUT CLAIM TO ANY PARTICULAR FONT, STYLE, SIZE, OR COLOR.

NO CLAIM IS MADE TO THE EXCLUSIVE RIGHT TO USE "CODE", APART FROM THE MARK AS SHOWN, FOR BAR CODE LABELS (U.S. CLS. 2, 5, 22, 23, 29, 37, 38 AND 50).

DOMINIC J. FERRAIUOLO, EXAMINING ATTORNEY

CLASS 16—(Continued).

SN 77-459,792. WORLD WRESTLING ENTERTAINMENT, INC., STAMFORD, CT. FILED 4-28-2008.

NIGHT OF CHAMPIONS

SN 77-459,635. NH TRIPLE PLAY, LLC, MANCHESTER, NH. FILED 4-28-2008.



OWNER OF U.S. REG. NO. 2,936,249.

NO CLAIM IS MADE TO THE EXCLUSIVE RIGHT TO USE "NEW HAMPSHIRE", APART FROM THE MARK AS SHOWN.

THE MARK CONSISTS OF A SCRIPT "FISHER CATS" WITH CAT PEEKING OVER LETTERS FROM BEHIND. "NEW HAMPSHIRE" IN ARC ABOVE CAT.

FOR PAPER GOODS AND PRINTED MATTER, NAMELY, AUTOGRAPH BOOKS, BINDERS, BOOKMARKS, BUMPER STICKERS, CALENDARS, CATALOGS OF INTEREST TO BASEBALL FANS, CHILDREN'S ACTIVITY BOOKS, CHILDREN'S BOOKS, DECALS, GAME PROGRAMS, MERCHANDISE BAGS, NEWSLETTERS OF INTEREST TO BASEBALL FANS, NOTE PADS, PAPER CONTAINERS, PAPER PENNANTS, PAPER SCHEDULES, PENS, PENCILS, POSTCARDS, POSTERS, PRINTED AWARDS, PRINTED GAME TICKETS, PRINTED GUIDES OF INTEREST TO BASEBALL FANS, REFERENCE BOOKS OF INTEREST TO BASEBALL FANS, SCORE BOOKS, SCORE CARDS, SCORE SHEETS, STATIONERY, STICKERS, STICKER ALBUMS AND TRADING CARDS (U.S. CLS. 2, 5, 22, 23, 29, 37, 38 AND 50).

FIRST USE 11-28-2007; IN COMMERCE 11-28-2007.

ELLEN PERKINS, EXAMINING ATTORNEY

THE MARK CONSISTS OF STANDARD CHARACTERS WITHOUT CLAIM TO ANY PARTICULAR FONT, STYLE, SIZE, OR COLOR.

FOR PAPER HANGTAGS, CARDBOARD HANGTAGS; PACKAGING, NAMELY BLISTER CARDS, PAPER FOR WRAPPING AND PACKAGING, PAPER POUCHES FOR PACKAGING, PLASTIC BAGS FOR PACKAGING, PLASTIC BUBBLE PACKS FOR WRAPPING OR PACKAGING; COLLECTOR ALBUMS, NAMELY, FOR STICKER COLLECTABLE CARDS, PHOTO COLLECTABLES; LABELS, NAMELY, PRINTED PAPER LABELS, PRINTED SHIPPING LABELS; RETURN ADDRESS LABELS NOT OF TEXTILE; FOLDERS; PLASTIC BAGS FOR GENERAL USE; PAPER TABLEWARE, NAMELY, PAPER PLACE MATS, PAPER TABLE MATS, PAPER NAPKINS, PAPER TABLE LINENS, PAPER TABLECLOTHS; PAPER LUNCH BAGS; STICKERS; BUMPER STICKERS; WINDOW DECALS; PENS; PENCILS; PENCIL SHARPENERS; PENCIL CASES; CHALK; ERASERS, NAMELY, RUBBER ERASERS, CHALK ERASERS, BLACKBOARD ERASERS; POSTERS; NOTEBOOKS; TRADING CARDS; CALENDARS; PHOTOGRAPHS; FRAMED PICTURES; PHOTOGRAPHIC PRINTS; PICTURES; PHOTO ALBUMS; BROCHURES, NEWSLETTERS, MAGAZINES, AND NEWSPAPERS CONCERNING SPORTS ENTERTAINMENT; POSTCARDS; GREETING CARDS; DECALS; TEMPORARY TATTOO TRANSFERS; COLORING BOOKS; CHILDREN'S ACTIVITY BOOKS; SOUVENIR PROGRAMS CONCERNING SPORTS ENTERTAINMENT; BOOKS FEATURING PICTORIAL BIOGRAPHIES; AUTOGRAPH BOOKS; COMIC BOOKS; PICTURE BOOKS; STICKER ALBUMS; BOOK COVERS; PAPER BOOK MARKERS; BOOKPLATES; MEMO PADS; SCRIBBLE PADS; DATE BOOKS; ADDRESS BOOKS; AGENDA BOOKS; RUBBER STAMPS; STAMP PADS; COLLECTIBLE PREPAID TELEPHONE CARDS NOT MAGNETICALLY ENCODED; COLLECTOR STAMPS, NAMELY, COMMEMORATIVE STAMP SHEETS; CUSTOMIZED PERSONAL CHECKS; CHECKBOOK COVERS; PAPER BANNERS; PRINTED PAPER SIGNS FOR DOORS; DRAWING RULERS; LITHOGRAPHS; PAPER PARTY BAGS; PAPER PARTY FAVORS, NAMELY, PAPER HATS; STENCILS FOR TRACING DESIGNS ONTO PAPER; PAPER GIFT WRAP; PAPER CAKE DECORATIONS (U.S. CLS. 2, 5, 22, 23, 29, 37, 38 AND 50).

SUZANNE BLANE, EXAMINING ATTORNEY

CLASS 16—(Continued).

SN 77-459,908. SECURING AMERICA'S FUTURE ENERGY ALLIANCE, INC., WASHINGTON, DC. AND SECURING AMERICA'S FUTURE ENERGY FOUNDATION, WASHINGTON, DC. FILED 4-28-2008.

SECURING AMERICA'S FUTURE
ENERGY

THE MARK CONSISTS OF STANDARD CHARACTERS WITHOUT CLAIM TO ANY PARTICULAR FONT, STYLE, SIZE, OR COLOR.

FOR PROVIDING NEWSLETTERS, PRINTED REPORTS, AND PRINTED INSTRUCTIONAL, EDUCATIONAL, AND TEACHING MATERIALS IN THE FIELDS OF FUEL AND ENERGY RESOURCES, POLICY, SECURITY, MANAGEMENT AND CONSERVATION, AND ALTERNATIVE FUEL SOURCES, ALTERNATIVE ENERGY SOURCES, AND ENVIRONMENTAL MATTERS CONCERNING FUEL AND ENERGY; EDUCATIONAL PUBLICATIONS, NAMELY, EDUCATIONAL CARDS, WORKBOOKS, TEXTBOOKS, ACTIVITY BOOKS, TEACHER GUIDES, MANUALS, AND BOOKLETS IN THE FIELDS OF FUEL AND ENERGY RESOURCES, POLICY, SECURITY, MANAGEMENT, AND CONSERVATION, AND ALTERNATIVE FUEL SOURCES, ALTERNATIVE ENERGY SOURCES, AND ENVIRONMENTAL MATTERS CONCERNING FUEL AND ENERGY (U.S. CLS. 2, 5, 22, 23, 29, 37, 38 AND 50).
CHERYL CLAYTON, EXAMINING ATTORNEY

SN 77-466,929. WEISENBACH SPECIALTY PRINTING, INC., COLUMBUS, OH. FILED 5-6-2008.

SNAPTIGHT

THE MARK CONSISTS OF STANDARD CHARACTERS WITHOUT CLAIM TO ANY PARTICULAR FONT, STYLE, SIZE, OR COLOR.

FOR BINDERS FOR OFFICE AND EDUCATIONAL USE, LOOSE LEAF BINDERS, THREE-RING BINDERS, MECHANICAL BINDER SETS COMPRISING RINGS, DIVIDERS, AND FOLDERS (U.S. CLS. 2, 5, 22, 23, 29, 37, 38 AND 50).

JAMES LOVELACE, EXAMINING ATTORNEY

CLASS 16—(Continued).

SN 77-469,047. WEISENBACH SPECIALTY PRINTING, INC., COLUMBUS, OH. FILED 5-8-2008.

GREEN PUMPKIN

THE MARK CONSISTS OF STANDARD CHARACTERS WITHOUT CLAIM TO ANY PARTICULAR FONT, STYLE, SIZE, OR COLOR.

FOR WRITING INSTRUMENTS, PENS, PENCILS, MECHANICAL PENCILS, ERASERS, MARKERS, CRAYONS, HIGHLIGHTER PENS, HIGHLIGHTER MARKERS, FOLDERS, NOTEBOOKS, NOTEBOOK DIVIDERS, BINDERS, PAPER, PENCIL SHARPENERS, CRAYON SHARPENERS, STICKERS, STICKER ALBUMS, COLORING BOOKS, AND HALLOWEEN GOODIE BAGS OF PAPER OR PLASTIC (U.S. CLS. 2, 5, 22, 23, 29, 37, 38 AND 50).

JAMES LOVELACE, EXAMINING ATTORNEY

SN 77-476,774. MOORECO, INC., TEMPLE, TX. FILED 5-16-2008.

GREEN-RITE

THE MARK CONSISTS OF STANDARD CHARACTERS WITHOUT CLAIM TO ANY PARTICULAR FONT, STYLE, SIZE, OR COLOR.

FOR TACK BOARDS; FELT BOARDS; DIRECTORY BOARDS; CHALK AND ERASABLE MARKER BOARDS FOR WRITING; WALL MOUNTED CHALK AND BLACKBOARDS; EASELS; CORK BOARDS; PROJECTION SURFACES, NAMELY LOW-GLARE PORCELAIN MARKER BOARDS; ADJUSTABLE WALL MOUNTED CHALK AND BLACKBOARDS; MARKERS; ERASERS; ROLLS OF VINYL SURFACE SHEETING FOR RESURFACING DRY ERASE WRITING BOARDS AND OTHER WRITING SURFACES, PORCELAIN STEEL SKINS AND PORCELAIN STEEL PANELS FOR RESURFACING DRY ERASE WRITING BOARDS AND OTHER WRITING SURFACES; ACCESSORIES FOR MARKER BOARDS AND CHALK BOARDS, NAMELY MAP RAILS, PAPER HOLDERS, CORK STRIPS, AND DISPLAY RAILS (U.S. CLS. 2, 5, 22, 23, 29, 37, 38 AND 50).

WILLIAM VERHOSEK, EXAMINING ATTORNEY

SN 78-727,017. SIERRASTYLE PUBLISHING, INC., FOLSOM, CA. FILED 10-5-2005.

FOLSOM ELDORADOHILLS STYLE

THE MARK CONSISTS OF STANDARD CHARACTERS WITHOUT CLAIM TO ANY PARTICULAR FONT, STYLE, SIZE, OR COLOR.

OWNER OF U.S. REG. NO. 2,943,027.
NO CLAIM IS MADE TO THE EXCLUSIVE RIGHT TO USE "FOLSOM EL DORADO HILLS", APART FROM THE MARK AS SHOWN.

FOR GENERAL FEATURE MAGAZINES; MAGAZINES FEATURING LUXURY BUSINESSES, ITEMS AND SERVICES (U.S. CLS. 2, 5, 22, 23, 29, 37, 38 AND 50).
FIRST USE 4-10-2005; IN COMMERCE 4-15-2005.

BARBARA GAYNOR, EXAMINING ATTORNEY

CLASS 16—(Continued).

SN 78-845,774. BENEDETTO ARTS GMBH, SOLINGEN, FED REP GERMANY, FILED 3-24-2006.

TONY BENNETT

THE MARK CONSISTS OF STANDARD CHARACTERS WITHOUT CLAIM TO ANY PARTICULAR FONT, STYLE, SIZE, OR COLOR.

PRIORITY CLAIMED UNDER SEC. 44(D) ON FED REP GERMANY APPLICATION NO. 305569139, FILED 9-27-2005, REG. NO. 30556913, DATED 12-1-2005, EXPIRES 9-30-2015.

THE NAME(S), PORTRAIT(S), AND/OR SIGNATURE(S) SHOWN IN THE MARK IDENTIFIES "TONY BENNETT", WHOSE CONSENT(S) TO REGISTER IS SUBMITTED.

FOR ALBUMS FOR PHOTOGRAPHS AND KEEP SAKES; APPOINTMENT BOOKS; WRITING BOOKS; BOOKS FOR SKETCHING AND DRAWING; ART ETCHINGS; MOUNTS, NAMELY, ART MOUNTS, PAPER PICTURE MOUNTS AND PHOTOGRAPH MOUNTS; PADS, NAMELY, NOTE, MEMO AND DESK PADS, PAPER, ART PRINTS, POSTERS AND GRAPHIC ART REPRODUCTIONS; CALENDARS; CANVAS FOR PAINTING; CHILDREN'S BOOKS; COOKBOOKS; DESK SETS AND ORGANIZERS; PAINTING SETS FOR ARTISTS AND CHILDREN; PAINTINGS; SHEET MUSIC; SONG BOOKS; STATIONERY; WRITING AND DRAWING MATERIALS AND APPARATUS, NAMELY, PAINT-BRUSHES, PASTELS, PENCILS, PENS, MARKERS, INK, NAMELY, WRITING INK AND STAMPING INK, FOUNTAIN PENS, FELT TIP MARKERS, FELT TIP PENS (U.S. CLS. 2, 5, 22, 23, 29, 37, 38 AND 50).

MARY MUNSON, EXAMINING ATTORNEY

CLASS 16—(Continued).

SN 78-932,653. AL AMAL INDUSTRIES COMPANY SAOC, RUSAYL POSTAL CODE 124, OMAN, FILED 7-19-2006.



NO CLAIM IS MADE TO THE EXCLUSIVE RIGHT TO USE "BABY-SOFT DIAPERS", APART FROM THE MARK AS SHOWN.

THE COLOR(S) GREEN, BLACK, WHITE, PINK, RED, LIGHT AND DARK BLUE IS/ARE CLAIMED AS A FEATURE OF THE MARK.

THE MARK CONSISTS OF THE WORD "BUNNIES", THE BACKGROUND OF THE RIBBON, AND THE CENTER OF ALL FLOWERS ARE YELLOW AND OUTLINED IN BLACK, BACKGROUND OF INNER CIRCLE IS GREEN AND OUTLINED IN BLACK, OUTER IS WHITE TRIMMED IN BLACK, THREE FLOWERS ARE PINK AND THREE ARE LIGHT BLUE AND OUTLINED IN BLACK, THE RABBIT HAS LIGHT BLUE, WHITE, PINK, RED AND BLACK, AND THE WORDS "BABY-SOFT DIAPERS" ARE DARK BLUE.

FOR DISPOSABLE DIAPERS (U.S. CLS. 2, 5, 22, 23, 29, 37, 38 AND 50).

DEIRDRE ROBERTSON, EXAMINING ATTORNEY

SN 79-033,594. DICOTA GESELLSCHAFT ZUR; ENTWICKLUNG VON TRAGESYSTEMEN; FÜR ELEKTRISCHE GERÄTE MBH, 74321 BIETIGHEIM-BISSINGEN, FED REP GERMANY, FILED 12-13-2006.

base xx

THE MARK CONSISTS OF STANDARD CHARACTERS WITHOUT CLAIM TO ANY PARTICULAR FONT, STYLE, SIZE, OR COLOR.

OWNER OF INTERNATIONAL REGISTRATION 0890057 DATED 4-25-2005, EXPIRES 4-25-2015.

FOR ELASTIC BANDS FOR OFFICES; COVERS, NAMELY, BOOK COVERS, DOCUMENT COVERS; FILES, NAMELY, CARD FILES, DOCUMENT FILES, FILE FOLDERS, LETTER FILES; OFFICE REQUISITES, NAMELY, OFFICE BINDERS, GLUE FOR THE OFFICE, ELECTRIC STAPLERS FOR OFFICES, COLLATORS FOR OFFICE USE; WRITING INSTRUMENTS, NOTEPADS, BUSINESS CARDS (U.S. CLS. 2, 5, 22, 23, 29, 37, 38 AND 50).

EMILY CARLSEN, EXAMINING ATTORNEY

CLASS 16—(Continued).

SN 79-047,950. KING JIM CO., LTD., JAPAN, FILED 9-14-2007.

KING JIM

PRIORITY DATE OF 7-12-2007 IS CLAIMED.
OWNER OF INTERNATIONAL REGISTRATION 0948019
DATED 9-14-2007, EXPIRES 9-14-2017.

OWNER OF U.S. REG. NOS. 2,183,479 AND 3,326,929.
THE NAME(S), PORTRAIT(S), AND/OR SIGNATURE(S)
SHOWN IN THE MARK DOES NOT IDENTIFY A PARTICULAR
LIVING INDIVIDUAL.

FOR LETTER FILES, CARD FILES, DOCUMENT FILES; CLEAR LETTER FILES, CLEAR CARD FILES, CLEAR DOCUMENT FILES; BOOK COVERS, DOCUMENT COVERS, PAPER REPORT COVERS; FOLDERS FOR PAPERS; CARD HOLDERS; PHOTOGRAPH ALBUMS, STAMP ALBUMS; LOOSE-LEAF BINDERS; LOOSE-LEAF PAPERS; DOCUMENT FILING BOXES OF CARDBOARD OR PAPER; DOCUMENT FILING BOXES OF PLASTIC; DESKTOP STATIONERY CABINETS; CLIPS FOR OFFICES, NAMELY, LETTER CLIPS, PAPER CLIPS, PEN CLIPS; DOCUMENT FILES; INDEX CARDS; INDEXES, NAMELY, INDEX BOOKS, INDEX DIVIDERS, PAPER LABELS, ADHESIVE LABELS, ADDRESS LABELS, SHIPPING LABELS; LETTER TRAYS; NOTE BOOKS; PAPER CLASPS; PAPER-CLIPS; PUNCHES; TAGS FOR INDEX CARDS; HOLDERS FOR PAPERS, NAMELY, WRITING PAPER HOLDERS; CASES FOR DRAWINGS; FOLDERS FOR HOLDING PAPER PADS; ADDRESS STAMPS; ANNOUNCEMENT CARDS; BOOK BINDINGS; CASES FOR STAMPS; HOLDERS FOR STAMPS; INKING PADS; PAPER JACKETS FOR PAPERS, CARDBOARD JACKETS FOR PAPERS; SCRAPBOOKS; STAMP PADS; STAMP STANDS; RUBBER STAMPS, IMPRESSION STAMPS, DATE STAMPS, ADDRESS STAMPS; STAPLING PRESSES AS OFFICE REQUISITES; STAPLES FOR OFFICES; STATIONERY; FILE POCKETS, PENCIL ORNAMENTS, SEALS; CATALOGS IN THE FIELD OF OFFICE SUPPLIES; PERIODICALS AND JOURNALS ON THE SUBJECT MATTER OF OFFICE SUPPLIES; INDUSTRIAL PACKAGING CONTAINERS OF PAPER; INKING RIBBONS; TYPEWRITERS; TAPE PRINTING MACHINES AS OFFICE REQUISITES; TAPE CARTRIDGE AND INK RIBBON CASSETTES FOR TAPE PRINTING MACHINES; PHOTOGRAPH STANDS (U.S. CLS. 2, 5, 22, 23, 29, 37, 38 AND 50).

REBECCA POVARCHUK, EXAMINING ATTORNEY

CLASS 17—RUBBER GOODS

SN 77-155,485. KITTRICH CORPORATION, LA MIRADA, CA. FILED 4-12-2007.

CON-TACT

THE MARK CONSISTS OF STANDARD CHARACTERS WITHOUT CLAIM TO ANY PARTICULAR FONT, STYLE, SIZE, OR COLOR.

OWNER OF U.S. REG. NOS. 630,599, 998,439 AND OTHERS.

FOR ADHESIVE PACKING TAPE FOR INDUSTRIAL AND COMMERCIAL USE; DUCT TAPE; ELECTRICAL TAPE; MASKING TAPE; PAVEMENT MARKING TAPE (U.S. CLS. 1, 5, 12, 13, 35 AND 50).

G. MAYERSCHOFF, EXAMINING ATTORNEY

SN 77-244,781. INTERNATIONAL CELLULOSE CORPORATION, HOUSTON, TX. FILED 8-1-2007.

International Cellulose Corporation

THE MARK CONSISTS OF STANDARD CHARACTERS WITHOUT CLAIM TO ANY PARTICULAR FONT, STYLE, SIZE, OR COLOR.

NO CLAIM IS MADE TO THE EXCLUSIVE RIGHT TO USE "CELLULOSE CORPORATION", APART FROM THE MARK AS SHOWN.

FOR BUILDING INSULATION, ACOUSTICAL AND THERMAL INSULATION FOR USE IN BUILDINGS, SPRAY-TYPE CELLULOSE FIBER INSULATION FOR BUILDINGS, ADHESIVE FOR USE WITH CELLULOSE INSULATION (U.S. CLS. 1, 5, 12, 13, 35 AND 50).

FIRST USE 3-1-1987; IN COMMERCE 3-1-1987.

MARY BOAGNI, EXAMINING ATTORNEY

SN 77-277,639. SELENA USA, INC., ELKHART, IN. FILED 9-12-2007.

TYTAN

THE MARK CONSISTS OF STANDARD CHARACTERS WITHOUT CLAIM TO ANY PARTICULAR FONT, STYLE, SIZE, OR COLOR.

FOR SEALANTS, EXPANDING FOAM POLYURETHANE SEALANTS, CAULKING, AND EXPANDING FOAM INSULATION, ALL FOR USE IN BUILDING AND CONSTRUCTION (U.S. CLS. 1, 5, 12, 13, 35 AND 50).

FIRST USE 9-0-2001; IN COMMERCE 9-0-2001.

NATALIE POLZER, EXAMINING ATTORNEY

CLASS 17—(Continued).

SN 77-283,094. WEST PHARMACEUTICAL SERVICES, INC., LIONVILLE, PA. FILED 9-19-2007.

VERISURE

THE MARK CONSISTS OF STANDARD CHARACTERS WITHOUT CLAIM TO ANY PARTICULAR FONT, STYLE, SIZE, OR COLOR.
FOR RUBBER VIAL STOPPERS (U.S. CLS. 1, 5, 12, 13, 35 AND 50).
FIRST USE 11-6-2007; IN COMMERCE 11-21-2007.
MARK PILARO, EXAMINING ATTORNEY

SN 77-362,719. TURNER, TOMMY L. GRANBURY, TX. FILED 1-2-2008.



THE COLOR(S) RED, WHITE, BLACK, BLUE IS/ARE CLAIMED AS A FEATURE OF THE MARK.
THE MARK CONSISTS OF WORDING THAT IS RED AND WHITE, A HOSE ON EACH END THAT IS BLACK WITH BLUE ENDS, AND A BACKGROUND IN ROYAL BLUE. ALL CHARACTERS OUTLINED IN BLACK.
FOR AIR HOSES, NAMELY A HOSE USED TO TRANSFER AIR FROM ONE TIRE TO ANOTHER (U.S. CLS. 1, 5, 12, 13, 35 AND 50).
MARTHA SANTOMARTINO, EXAMINING ATTORNEY

SN 77-383,121. COMPAC CORPORATION, HACKETTS-TOWN, NJ. FILED 1-29-2008.

COMPAC

THE MARK CONSISTS OF STANDARD CHARACTERS WITHOUT CLAIM TO ANY PARTICULAR FONT, STYLE, SIZE, OR COLOR.
FOR PRESSURE SENSITIVE TAPES FOR USE IN THE CONSTRUCTION, INDUSTRIAL, ELECTRONICS, AND MEDICAL INDUSTRIES; VAPOR RETARDERS, NAMELY, INSULATION FACING FOR IMPEDING WATER VAPOR (U.S. CLS. 1, 5, 12, 13, 35 AND 50).
FIRST USE 1-1-1969; IN COMMERCE 1-1-1969.
JAY FLOWERS, EXAMINING ATTORNEY

CLASS 17—(Continued).

SN 77-383,220. COMPAC CORPORATION, HACKETTS-TOWN, NJ. FILED 1-29-2008.

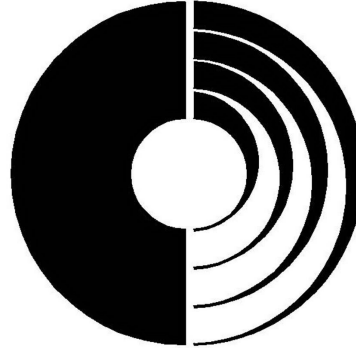

THE MARK CONSISTS OF THE BLOCK LETTER "C" ON THE LEFT SIDE WITH FOUR SPACED-APART SEMICIRCULAR ARCS ON THE RIGHT SIDE.
FOR PRESSURE SENSITIVE TAPES FOR USE IN THE CONSTRUCTION, INDUSTRIAL, ELECTRONICS, AND MEDICAL INDUSTRIES; VAPOR RETARDERS, NAMELY, INSULATION FACING FOR IMPEDING WATER VAPOR (U.S. CLS. 1, 5, 12, 13, 35 AND 50).
FIRST USE 1-1-2006; IN COMMERCE 1-1-2006.
JAY FLOWERS, EXAMINING ATTORNEY

SN 77-402,502. ELASTOMERIC ROOFING SYSTEMS, INC., ROCKFORD, MN. FILED 2-21-2008.



ELASTOMERIC ROOFING

NO CLAIM IS MADE TO THE EXCLUSIVE RIGHT TO USE "SYSTEMS" AND "ELASTOMERIC ROOFING", APART FROM THE MARK AS SHOWN.
THE MARK CONSISTS OF "ER" OVER THE WORD "SYSTEMS". THE "ER" PORTION OF THE MARK HAS A THIN LINE ABOVE IT AND BELOW IT, WITH ANOTHER THIN LINE BELOW THE WORD "SYSTEMS". THE WORDS "ELASTOMERIC ROOFING" ARE BELOW THE THIRD LINE.
FOR RESIN-BASED SEALANTS FOR USE ON ROOFS, WALLS AND PAVEMENTS; SEALANTS FOR BUILDINGS; WATERPROOF SEALANTS (U.S. CLS. 1, 5, 12, 13, 35 AND 50).
FIRST USE 6-30-2005; IN COMMERCE 6-30-2005.
MICHELE SWAIN, EXAMINING ATTORNEY

CLASS 17—(Continued).

SN 77-406,003. INTERFACE SOLUTIONS INC., LANCASTER, PA. FILED 2-26-2008.

EXIGENT

THE MARK CONSISTS OF STANDARD CHARACTERS WITHOUT CLAIM TO ANY PARTICULAR FONT, STYLE, SIZE, OR COLOR.

FOR METAL REINFORCED ADHESIVE, NAMELY, DIE-CUTTABLE ADHESIVE SHEET MATERIAL REINFORCED WITH METAL FOR USE IN INDUSTRY (U.S. CLS. 1, 5, 12, 13, 35 AND 50).

CYNTHIA TRIPI, EXAMINING ATTORNEY

CLASS 17—(Continued).

SN 77-422,617. ILLINOIS TOOL WORKS INC., GLENVIEW, IL. FILED 3-14-2008.

ULTRASEAL

THE MARK CONSISTS OF STANDARD CHARACTERS WITHOUT CLAIM TO ANY PARTICULAR FONT, STYLE, SIZE, OR COLOR.

FOR DUCT SEALANTS, NAMELY, SEALANTS FOR USE IN HEATING, VENTILATION AND AIR CONDITIONING SYSTEMS IN BUILDINGS (U.S. CLS. 1, 5, 12, 13, 35 AND 50).

FIRST USE 10-0-2005; IN COMMERCE 10-0-2005.

MARLENE BELL, EXAMINING ATTORNEY

SN 77-422,249. JAMES DIEFENTHAL, MANDEVILLE, LA. FILED 3-14-2008.



NO CLAIM IS MADE TO THE EXCLUSIVE RIGHT TO USE "PREMIUM LIQUID RUBBER", APART FROM THE MARK AS SHOWN.

THE COLOR(S) BLACK AND GOLD IS/ARE CLAIMED AS A FEATURE OF THE MARK.

THE MARK CONSISTS OF THE WORD "PREMIUM" IN BLACK AND THE WORDS "LIQUID RUBBER" IN GOLD ALONG WITH A GOLD RIBBON ELEMENT.

FOR LIQUID RUBBER MEMBRANES APPLIED BY SPRAY, ROLLER, BRUSH, OR TROWEL, AND USED FOR WATERPROOFING AND CORROSION PROTECTION (U.S. CLS. 1, 5, 12, 13, 35 AND 50).

JENNIFER VASQUEZ, EXAMINING ATTORNEY

SN 77-428,031. PRIMEX PLASTICS CORP., RICHMOND, IN. FILED 3-21-2008.

PRIME BIOGREEN

THE MARK CONSISTS OF STANDARD CHARACTERS WITHOUT CLAIM TO ANY PARTICULAR FONT, STYLE, SIZE, OR COLOR.

OWNER OF U.S. REG. NOS. 974,743, 1,098,784 AND OTHERS.

FOR BIODEGRADABLE SMOOTH PRINT-GRADE PLASTIC IN SHEETS AND ROLLS FOR GENERAL INDUSTRIAL AND COMMERCIAL USE; BIODEGRADABLE FORMING-GRADE PLASTIC IN SHEETS AND ROLLS FOR GENERAL INDUSTRIAL AND COMMERCIAL USE (U.S. CLS. 1, 5, 12, 13, 35 AND 50).

CHARLES L. JENKINS, EXAMINING ATTORNEY

SN 77-422,392. SURFACE AMERICA, INC., CHEEKTOWA-GA, NY. FILED 3-14-2008.

ECOTRAIL

THE MARK CONSISTS OF STANDARD CHARACTERS WITHOUT CLAIM TO ANY PARTICULAR FONT, STYLE, SIZE, OR COLOR.

FOR RUBBER SURFACING USED ON TRAILS (U.S. CLS. 1, 5, 12, 13, 35 AND 50).

SHAUNIA CARLYLE, EXAMINING ATTORNEY

SN 77-430,121. WILLIAMS PRODUCTS, INC., TROY, MI. FILED 3-24-2008.

2ND SEAL

THE MARK CONSISTS OF STANDARD CHARACTERS WITHOUT CLAIM TO ANY PARTICULAR FONT, STYLE, SIZE, OR COLOR.

NO CLAIM IS MADE TO THE EXCLUSIVE RIGHT TO USE "SEAL", APART FROM THE MARK AS SHOWN.

FOR ELASTOMERIC EXPANSION AND CONTRACTION JOINT SEALS FOR USE IN BUILDING, BRIDGES, ROADWAYS, PARKING STRUCTURES AND OPEN-AIR STRUCTURES (U.S. CLS. 1, 5, 12, 13, 35 AND 50).

DORITT L. CARROLL, EXAMINING ATTORNEY

CLASS 17—(Continued).

SN 77-430,541. KOVICS, STANLEY, NEW YORK, NY. FILED 3-25-2008.

TOUCH AND BE TOUCHED

THE MARK CONSISTS OF STANDARD CHARACTERS WITHOUT CLAIM TO ANY PARTICULAR FONT, STYLE, SIZE, OR COLOR.

FOR SCULPTURES OF RUBBER AND RELATED COMPOUNDS, NAMELY, SILICONE RUBBER, ACRYLIC RUBBER, URETHANE RUBBER, AND FOAM RUBBER (U.S. CLS. 1, 5, 12, 13, 35 AND 50).

MARCIE MILONE, EXAMINING ATTORNEY

SN 77-432,281. LENDELL MANUFACTURING, INC., SAINT CHARLES, MI. FILED 3-26-2008.

Micro-Len

THE MARK CONSISTS OF STANDARD CHARACTERS WITHOUT CLAIM TO ANY PARTICULAR FONT, STYLE, SIZE, OR COLOR.

FOR OPEN CELL FOAM IN ROLL FORM (U.S. CLS. 1, 5, 12, 13, 35 AND 50).

FIRST USE 3-26-2008; IN COMMERCE 3-26-2008.
KIMBERLY FRYE, EXAMINING ATTORNEY

SN 77-434,147. ROCKWELL SOLUTIONS LIMITED, DUNDEE, SCOTLAND, FILED 3-28-2008.



THE COLOR(S) GREEN AND BLUE IS/ARE CLAIMED AS A FEATURE OF THE MARK.

THE MARK CONSISTS OF A LOWER CASE "I" IN GREEN FOLLOWED BY THE WORD "PEEL" IN BLUE, A BLUE RECTANGLE PARTIALLY OUTLINING THE GREEN LETTER "I".

FOR PLASTIC FILMS USED AS PACKAGING FOR FOOD (U.S. CLS. 1, 5, 12, 13, 35 AND 50).

ELISSA GARBER KON, EXAMINING ATTORNEY

CLASS 17—(Continued).

SN 77-434,798. VYSTAR CORPORATION, DULUTH, GA. FILED 3-28-2008.



THE MARK CONSISTS OF A BIFURCATED OVAL; ONE PORTION OF THE BIFURCATED OVAL CONTAINS THE LETTERS "VY" AND THE OTHER PORTION OF THE BIFURCATED OVAL CONTAINS THE LETTERS "TEX".

FOR LATEX FOR INDUSTRIAL USE, NAMELY, A CHEMICALLY TREATED, LOW PROTEIN NATURAL RUBBER LATEX FOR USE IN THE MANUFACTURE OF RUBBER PRODUCTS (U.S. CLS. 1, 5, 12, 13, 35 AND 50).
JOHN GARTNER, EXAMINING ATTORNEY

SN 77-434,799. VYSTAR CORPORATION, DULUTH, GA. FILED 3-28-2008.

**CREATED BY NATURE.
RECREATED BY SCIENCE.**

THE MARK CONSISTS OF STANDARD CHARACTERS WITHOUT CLAIM TO ANY PARTICULAR FONT, STYLE, SIZE, OR COLOR.

FOR LATEX FOR INDUSTRIAL USE, NAMELY, A CHEMICALLY TREATED, LOW PROTEIN NATURAL RUBBER LATEX FOR USE IN THE MANUFACTURE OF RUBBER PRODUCTS (U.S. CLS. 1, 5, 12, 13, 35 AND 50).
JOHN GARTNER, EXAMINING ATTORNEY

SN 77-451,562. LENDELL MANUFACTURING, INC., SAINT CHARLES, MI. FILED 4-18-2008.

Novalux

THE MARK CONSISTS OF STANDARD CHARACTERS WITHOUT CLAIM TO ANY PARTICULAR FONT, STYLE, SIZE, OR COLOR.

FOR OPEN CELL FOAM IN ROLL FORM (U.S. CLS. 1, 5, 12, 13, 35 AND 50).

FIRST USE 2-22-2000; IN COMMERCE 2-22-2000.
KIMBERLY FRYE, EXAMINING ATTORNEY

CLASS 17—(Continued).

SN 77-451,580. LENDELL MANUFACTURING, INC., SAINT CHARLES, MI. FILED 4-18-2008.

HSS X-7

THE MARK CONSISTS OF STANDARD CHARACTERS WITHOUT CLAIM TO ANY PARTICULAR FONT, STYLE, SIZE, OR COLOR.
FOR OPEN CELL FOAM IN ROLL FORM (U.S. CLS. 1, 5, 12, 13, 35 AND 50).
FIRST USE 1-24-2005; IN COMMERCE 1-24-2008.
KIMBERLY FRYE, EXAMINING ATTORNEY

SN 77-455,458. TEKNOR APEX COMPANY, PAWTUCKET, RI. FILED 4-23-2008.

EcoSmart

THE MARK CONSISTS OF STANDARD CHARACTERS WITHOUT CLAIM TO ANY PARTICULAR FONT, STYLE, SIZE, OR COLOR.
FOR GARDEN HOSES; WATERING HOSES (U.S. CLS. 1, 5, 12, 13, 35 AND 50).
STEVEN JACKSON, EXAMINING ATTORNEY

SN 77-455,466. TEKNOR APEX COMPANY, PAWTUCKET, RI. FILED 4-23-2008.

Eco-Smart

THE MARK CONSISTS OF STANDARD CHARACTERS WITHOUT CLAIM TO ANY PARTICULAR FONT, STYLE, SIZE, OR COLOR.
FOR GARDEN HOSES; WATERING HOSES (U.S. CLS. 1, 5, 12, 13, 35 AND 50).
STEVEN JACKSON, EXAMINING ATTORNEY

CLASS 17—(Continued).

SN 77-455,733. TEKNOR APEX COMPANY, PAWTUCKET, RI. FILED 4-23-2008.

Greener Living

THE MARK CONSISTS OF STANDARD CHARACTERS WITHOUT CLAIM TO ANY PARTICULAR FONT, STYLE, SIZE, OR COLOR.
FOR GARDEN HOSES; WATERING HOSES (U.S. CLS. 1, 5, 12, 13, 35 AND 50).
STEVEN JACKSON, EXAMINING ATTORNEY

SN 78-701,412. AGRI-COVER, INC., JAMESTOWN, ND. FILED 8-26-2005.

ACI

THE MARK CONSISTS OF STANDARD CHARACTERS WITHOUT CLAIM TO ANY PARTICULAR FONT, STYLE, SIZE, OR COLOR.
FOR NON-METAL SEALING GASKETS FOR PICK-UP TRUCK BED COVERS (U.S. CLS. 1, 5, 12, 13, 35 AND 50).
KYLE PEETE, EXAMINING ATTORNEY

SN 79-045,082. CORCOS INDUSTRIALE DI FREUDENBERG & COSSO S.R.L., S.A.S., ITALY, FILED 8-27-2007.

CASCO

THE MARK CONSISTS OF STANDARD CHARACTERS WITHOUT CLAIM TO ANY PARTICULAR FONT, STYLE, SIZE, OR COLOR.
PRIORITY DATE OF 6-5-2007 IS CLAIMED.
OWNER OF INTERNATIONAL REGISTRATION 0940590 DATED 8-27-2007, EXPIRES 8-27-2017.
THE FOREIGN WORDING IN THE MARK TRANSLATES INTO ENGLISH AS HELMET.
FOR SEALING ELEMENTS FOR ROTATING SHAFTS, NAMELY, NON-METAL GASKETS FOR SEALING ROTATING SHAFTS IN MACHINES (U.S. CLS. 1, 5, 12, 13, 35 AND 50).
KATHERINE E. HALMEN, EXAMINING ATTORNEY

CLASS 17—(Continued).

SN 79-046,939. NIPPON VALQUA INDUSTRIES, LTD., JAPAN, FILED 7-18-2007.

VICTRA

THE MARK CONSISTS OF STANDARD CHARACTERS WITHOUT CLAIM TO ANY PARTICULAR FONT, STYLE, SIZE, OR COLOR.

OWNER OF INTERNATIONAL REGISTRATION 0945359 DATED 7-18-2007, EXPIRES 7-18-2017.

FOR JOINT PACKINGS FOR USE WITH PIPES FOR LIQUIDS; PACKING MATERIAL FOR FORMING SEALS FOR INDUSTRIAL, RESIDENTIAL AND ORIGINAL MANUFACTURER USES; NON-METAL GASKETS FOR INDUSTRIAL, RESIDENTIAL AND ORIGINAL MANUFACTURER USES EXCEPT FOR USE IN MOTORS AND ENGINE (U.S. CLS. 1, 5, 12, 13, 35 AND 50).

Laurie Kaufman, Examining Attorney

CLASS 18—LEATHER GOODS

SN 76-272,557. VERSATILE ENTERTAINMENT, INC., COMMERCE, CA. FILED 6-18-2001.

DW

FOR BAGS, NAMELY, ALL PURPOSE SPORT BAGS, ALL PURPOSE ATHLETIC BAGS, ATHLETIC BAGS, BARREL BAGS, BEACH BAGS, BOOK BAGS, BOSTON BAGS, CARRY-ON BAGS, CLUTCH BAGS, COSMETIC BAGS SOLD EMPTY, DIAPER BAGS, DUFFEL BAGS, GARMENT BAGS FOR TRAVEL, GYM BAGS, LEATHER BAGS FOR MERCHANDISE PACKAGING, LEATHER SHOPPING BAGS, MESH SHOPPING BAGS, OVER-NIGHT BAGS, ROLL BAGS, SCHOOL BAGS, SCHOOL BOOKS BAGS, SHAVING BAGS SOLD EMPTY, SHOE BAGS FOR TRAVEL, SHOPPING BAGS WITH WHEELS ATTACHED, SHOULDER BAGS, SOUVENIR BAGS, SUIT BAGS, TEXTILE SHOPPING BAGS, TOTE BAGS, TRAVEL BAGS, TRAVELING BAGS, AND WRIST MOUNTED CARRYALL BAGS (U.S. CLS. 1, 2, 3, 22 AND 41).

Michael W. Baird, Examining Attorney

SN 76-687,986. RIZIK, TRACY R., SCOTTSDALE, AZ. FILED 3-24-2008.

O-Count

THE MARK CONSISTS OF STANDARD CHARACTERS WITHOUT CLAIM TO ANY PARTICULAR FONT, STYLE, SIZE, OR COLOR.

FOR PURSES, HANDBAGS AND WALLETS (U.S. CLS. 1, 2, 3, 22 AND 41).

Henry S. Zak, Examining Attorney

CLASS 18—(Continued).

SN 77-229,689. KIMORA LEE SIMMONS LICENSING, INC., NEW YORK, NY. FILED 7-13-2007.

KIMORA

THE MARK CONSISTS OF STANDARD CHARACTERS WITHOUT CLAIM TO ANY PARTICULAR FONT, STYLE, SIZE, OR COLOR.

OWNER OF U.S. REG. NO. 2,926,512.

THE NAME "KIMORA" IDENTIFIES A LIVING INDIVIDUAL WHOSE CONSENT IS OF RECORD.

FOR LEATHER AND IMITATIONS OF LEATHER, AND GOODS MADE OF THESE MATERIALS IN THE NATURE OF LEATHER AND IMITATION LEATHER BAGS, BRIEFCASES, HANDBAGS AND SHOPPING BAGS; TRUNKS AND TRAVELLING BAGS; UMBRELLAS, PARASOLS AND WALKING STICKS (U.S. CLS. 1, 2, 3, 22 AND 41).

Kaelie Kung, Examining Attorney

SN 77-259,479. YAP DESIGNS, INC., SAN FRANCISCO, CA. FILED 8-20-2007.

YAP SAK

THE MARK CONSISTS OF STANDARD CHARACTERS WITHOUT CLAIM TO ANY PARTICULAR FONT, STYLE, SIZE, OR COLOR.

OWNER OF U.S. REG. NO. 3,274,562.

NO CLAIM IS MADE TO THE EXCLUSIVE RIGHT TO USE "SAK", APART FROM THE MARK AS SHOWN.

FOR ANIMAL CARRIERS; ANIMAL LEASHES; PET CLOTHING (U.S. CLS. 1, 2, 3, 22 AND 41).

Mary Rossman, Examining Attorney

SN 77-265,917. IVY TRADING INC., ORLANDO, FL. FILED S.R. 8-28-2007; AM. P.R. 6-13-2008.

ARGO SPORT

THE MARK CONSISTS OF STANDARD CHARACTERS WITHOUT CLAIM TO ANY PARTICULAR FONT, STYLE, SIZE, OR COLOR.

NO CLAIM IS MADE TO THE EXCLUSIVE RIGHT TO USE "SPORT", APART FROM THE MARK AS SHOWN.

FOR BACKPACKS; DUFFLE BAGS; GARMENT BAGS FOR TRAVEL; LEATHER AND IMITATION LEATHER BAGS; LEATHER BAGS, SUITCASES AND WALLETS; TOTE BAGS; WHEELED DUFFLE BAGS; WHEELED TOTE BAGS; LUGGAGE; ANIMAL CARRIERS; LEATHER HANDBAGS; LEATHER PURSES; POUCHES OF LEATHER (U.S. CLS. 1, 2, 3, 22 AND 41).

Paula Mahoney, Examining Attorney

CLASS 18—(Continued).

SN 77-282,704. SUNJEEN, INC., FULLERTON, CA. FILED 9-18-2007.

B L V D

OWNER OF U.S. REG. NO. 2,656,917.
 THE MARK CONSISTS OF THE LETTERS "B", "L", "V",
 AND "D" SEPARATED BY SPACES.
 FOR HANDBAGS; LEATHER BAGS, SUITCASES AND
 WALLETS (U.S. CLS. 1, 2, 3, 22 AND 41).
 MARK T. MULLEN, EXAMINING ATTORNEY

SN 77-283,256. ROBINSON, STEVEN, GRANTS PASS, OR.
 FILED 9-19-2007.



NO CLAIM IS MADE TO THE EXCLUSIVE RIGHT TO
 USE "PACK", APART FROM THE MARK AS SHOWN.
 THE MARK CONSISTS OF AN "S" INSIDE OF A
 RECTANGLE SHAPED AS A BACKPACK SITTING ON
 THE BACK OF A DRAWN CHARACTER IN THE SHAPE
 OF A HUMAN. THE LETTERS WITCH FOLLOW THE "S"
 IN THE BACKPACK SO WHEN COMBINED IT READS
 SWITCH. BELOW THAT A LARGER SQUARE CONTAIN-
 ING THE WORDS PACK. ALSO IN THAT SQUARE THE
 WORDS "THE ULTIMATE SPECTATOR PROTECTION" IS
 WRITER UNDERNEATH THE WORD PACK. ALL THE
 LETTERING IN THIS MARK ARE CAPITALIZED BUT NOT
 SPECIFIC TO A PARTICULAR LETTERING FONT STYLE.
 ON THE OTHER SIDE OF THIS MARK A DRAWN
 CHARACTER SHAPED LIKE A HUMAN IN THE SITTING
 POSITION BUT CHEERING MOTION IS POSITIONED ON
 THE RIGHT SIDE OF THE SQUARE, THE SAME SQUARE
 DESCRIBED ABOVE. UNDERNEATH THE "S" DESCRIBED
 ABOVE, 6 SMALLER SQUARE CONTINUE IN A STRAIGHT
 LINE WITH A SMALL SPACE BETWEEN EACH. ALSO 6
 MORE OF THE SAME SHAPES CONTINUE ALONG THE
 BOTTOM OF THE MARK SO THAT ALL 6 DOWN AND 6
 ACROSS MAKE THE SHAPE OF AN "L".
 FOR BACKPACK WHICH CAN BE CONVERTED INTO
 A SEAT CUSHION, BLANKET OR JACKET (U.S. CLS. 1,
 2, 3, 22 AND 41).
 ELLEN PERKINS, EXAMINING ATTORNEY

CLASS 18—(Continued).

SN 77-304,286. FNC KOLON CORPORATION, SEOUL, RE-
 PUBLIC OF KOREA, FILED 10-15-2007.



FOR VANITY CASES SOLD EMPTY; LEATHER KEY
 CASES; SCHOOL CHILDREN'S BACKPACKS; BUSINESS
 CARD CASES; BACKPACKS; BOSTON BAGS; PURSES
 NOT OF PRECIOUS METAL; BEACH BAGS; BRIEF-
 CASES; SUITCASES; CASES FOR CREDIT CARDS;
 TRAVELING BAGS; TRAVELING TRUNKS; LEATHER
 PACKING BAGS; SCHOOL BAGS; HAND BAGS; BEACH
 UMBRELLAS; BEACH PARASOLS; PARASOLS; SUN
 UMBRELLAS; UMBRELLAS FOR GOLF; SHOULDER
 BAGS; AND SHOPPING BAGS MADE OF CANVAS,
 LEATHER, MESH, SKIN, OR TEXTILE (U.S. CLS. 1, 2,
 3, 22 AND 41).
 SANDRA MANIOS, EXAMINING ATTORNEY

SN 77-304,344. FNC KOLON CORPORATION, SEOUL, RE-
 PUBLIC OF KOREA, FILED 10-15-2007.

series;
 urban generation

NO CLAIM IS MADE TO THE EXCLUSIVE RIGHT TO
 USE "SERIES", APART FROM THE MARK AS SHOWN.
 THE MARK CONSISTS OF A STYLIZED REPRESENTA-
 TION OF THE WORDS "SERIES; URBAN GENERATION".
 FOR VANITY CASES SOLD EMPTY; LEATHER KEY
 CASES; SCHOOL CHILDREN'S BACKPACKS; BUSINESS
 CARD CASES; BACKPACKS; BOSTON BAGS; PURSES
 NOT OF PRECIOUS METAL; BEACH BAGS; BRIEF-
 CASES; SUITCASES; CASES FOR CREDIT CARDS;
 TRAVELING BAGS; LEATHER PACKING BAGS;
 SCHOOL BAGS; HAND BAGS; BEACH UMBRELLAS;
 BEACH PARASOLS; PARASOLS; SUN UMBRELLAS;
 UMBRELLAS FOR GOLF; MOUNTAINEERING BAGS;
 AND SHOULDER BAGS (U.S. CLS. 1, 2, 3, 22 AND 41).
 SANDRA MANIOS, EXAMINING ATTORNEY

CLASS 18—(Continued).

SN 77-304,592. CHUN, DAVID, SOUTH SAN FRANCISCO, CA. FILED 10-15-2007.

Volare

"THE MARK CONSISTS OF THE WORD "VOLARE" WITH THE LETTER O CONTAINING AN ASTERISK.

"THE FOREIGN WORDING IN THE MARK TRANSLATES INTO ENGLISH AS "TO FLY"."

FOR BRIEFCASES; LEATHER BAGS, SUITCASES AND WALLETS; LEATHER HANDBAGS; LEATHER PURSES; LEATHER KEY CHAINS; SADDLES; WHIPS; LUGGAGE (U.S. CLS. 1, 2, 3, 22 AND 41).

FIRST USE 9-1-2007; IN COMMERCE 9-1-2007.
ODESSA BIBBINS, EXAMINING ATTORNEY

SN 77-304,932. FNC KOLON CORPORATION, SEOUL, REPUBLIC OF KOREA, FILED 10-16-2007.

1492 MILES

THE MARK CONSISTS OF STANDARD CHARACTERS WITHOUT CLAIM TO ANY PARTICULAR FONT, STYLE, SIZE, OR COLOR.

FOR VANITY CASES SOLD EMPTY; LEATHER KEY CASES; SCHOOL CHILDREN'S BACKPACKS; BUSINESS CARD CASES; BACKPACKS; BOSTON BAGS; PURSES NOT OF PRECIOUS METAL; BEACH BAGS; BRIEFCASES; SUITCASES; CASES FOR CREDIT CARDS; TRAVELING BAGS; TRAVELING TRUNKS; LEATHER PACKING BAGS; SCHOOL BAGS; HAND BAGS; BEACH UMBRELLAS; BEACH PARASOLS; PARASOLS; SUN UMBRELLAS; UMBRELLAS FOR GOLF; MOUNTAINNEERING BAGS; AND SHOULDER BAGS (U.S. CLS. 1, 2, 3, 22 AND 41).

SANDRA MANIOS, EXAMINING ATTORNEY

CLASS 18—(Continued).

SN 77-305,181. KOLON FASHION CORPORATION, KWACHEON-CITY, REPUBLIC OF KOREA, FILED 10-16-2007.



THE MARK CONSISTS OF A STYLIZED LETTER "M" AND THE WORD "MANSTAR".

FOR VANITY CASES SOLD EMPTY; LEATHER KEY CASES; SCHOOL CHILDREN'S BACKPACKS; BUSINESS CARD CASES; BACKPACKS; BOSTON BAGS; PURSES NOT OF PRECIOUS METAL; BEACH BAGS; BRIEFCASES; SUITCASES; CASES FOR CREDIT CARDS; TRAVELING BAGS; TRAVELING TRUNKS; LEATHER PACKING BAGS; SCHOOL BAGS; HAND BAGS; BEACH UMBRELLAS; BEACH PARASOLS; PARASOLS; SUN UMBRELLAS; UMBRELLAS FOR GOLF; MOUNTAINNEERING BAGS; AND SHOULDER BAGS (U.S. CLS. 1, 2, 3, 22 AND 41).

PATRICIA EVANKO, EXAMINING ATTORNEY

SN 77-306,039. KOLON FASHION CORPORATION, KWACHEON-CITY, REPUBLIC OF KOREA, FILED 10-17-2007.



THE NAME "ARTHUR DIXON" DOES NOT IDENTIFY A LIVING INDIVIDUAL.

THE MARK CONSISTS OF A STYLIZED REPRESENTATION OF THE LETTERS "AD" AND THE WORDS "ARTHUR DIXON".

FOR VANITY CASES SOLD EMPTY; LEATHER KEY CASES; SCHOOL CHILDREN'S BACKPACKS; BUSINESS CARD CASES; BACKPACKS; BOSTON BAGS; PURSES NOT OF PRECIOUS METAL; BEACH BAGS; BRIEFCASES; SUITCASES; CASES FOR CREDIT CARDS; TRAVELING BAGS; TRAVELING TRUNKS; LEATHER PACKING BAGS; SCHOOL BAGS; HAND BAGS; BEACH UMBRELLAS; BEACH PARASOLS; PARASOLS; SUN UMBRELLAS; UMBRELLAS FOR GOLF; MOUNTAINNEERING BAGS; AND SHOULDER BAGS (U.S. CLS. 1, 2, 3, 22 AND 41).

PATRICIA EVANKO, EXAMINING ATTORNEY

SN 77-374,124. COAST TO COAST LEATHER & VINYL, INC., SAYREVILLE, NJ. FILED 1-17-2008.

LEATHERTREASURES

THE MARK CONSISTS OF STANDARD CHARACTERS WITHOUT CLAIM TO ANY PARTICULAR FONT, STYLE, SIZE, OR COLOR.

FOR TANNED LEATHER (U.S. CLS. 1, 2, 3, 22 AND 41).

TEJBIR SINGH, EXAMINING ATTORNEY

CLASS 18—(Continued).

SN 77-389,953. OKEKE, NKEMDILIM, HOUSTON, TX.
FILED 2-6-2008.

imjuky

THE MARK CONSISTS OF STANDARD CHARACTERS WITHOUT CLAIM TO ANY PARTICULAR FONT, STYLE, SIZE, OR COLOR.

FOR DIAPER BAGS (U.S. CLS. 1, 2, 3, 22 AND 41).
FIRST USE 1-3-2008; IN COMMERCE 1-3-2008.
MICHAEL TANNER, EXAMINING ATTORNEY

SN 77-393,056. NICHOLS, LEE JAMES, DBA NICHOLS, LEE JAMES, IMMOKALEE, FL. FILED 2-9-2008.

L-L Leathers

THE MARK CONSISTS OF STANDARD CHARACTERS WITHOUT CLAIM TO ANY PARTICULAR FONT, STYLE, SIZE, OR COLOR.

NO CLAIM IS MADE TO THE EXCLUSIVE RIGHT TO USE "LEATHERS", APART FROM THE MARK AS SHOWN.

FOR LEATHER EVENING HANDBAGS; LEATHER HANDBAGS, LEATHER PURSES AND LEATHER WALLETS (U.S. CLS. 1, 2, 3, 22 AND 41).

GIANCARLO CASTRO, EXAMINING ATTORNEY

SN 77-416,370. INTERNATIONAL DESIGN ASSOCIATES LTD, NEW YORK, NY. FILED 3-7-2008.

AVION EXPRESS

THE MARK CONSISTS OF STANDARD CHARACTERS WITHOUT CLAIM TO ANY PARTICULAR FONT, STYLE, SIZE, OR COLOR.

THE FOREIGN WORDING IN THE MARK TRANSLATES INTO ENGLISH AS "AIRPLANE EXPRESS".

FOR ALL PURPOSE SPORT BAGS; ALL-PURPOSE CARRYING BAGS; BABY CARRYING BAGS; BAGS FOR CARRYING BABIES' ACCESSORIES; BACKPACKS, BOOK BAGS, SPORTS BAGS, BUM BAGS, WALLETS AND HANDBAGS; BEACH BAGS; BELT BAGS AND HIP BAGS; CANVAS SHOPPING BAGS; COSMETIC BAGS SOLD EMPTY; TOILETRY BAGS SOLD EMPTY; DIAPER BAGS; DUFFEL BAGS; SHOPPING BAGS WITH WHEELS ATTACHED; BILLFOLDS; BRIEFCASES AND ATTACHE CASES; LUGGAGE; LUGGAGE TAGS; STRAPS FOR LUGGAGE; UMBRELLAS (U.S. CLS. 1, 2, 3, 22 AND 41).

FIRST USE 3-3-2008; IN COMMERCE 3-3-2008.
NELSON SNYDER, EXAMINING ATTORNEY

CLASS 18—(Continued).

SN 77-418,008. TU WEN HSIANG CO., LTD., TAIPEI COUNTY 235, TAIWAN, FILED 3-10-2008.

PEILIN

THE MARK CONSISTS OF STANDARD CHARACTERS WITHOUT CLAIM TO ANY PARTICULAR FONT, STYLE, SIZE, OR COLOR.

FOR WALLETS; PURSES; BACKPACKS; HAVERSACKS; SCHOOL BAGS; SCHOOL KNAPSACKS; LUGGAGE TRUNKS; LEATHER CASES; TRAVELING CASES OF LEATHER; COSMETIC CASES SOLD EMPTY; COSMETIC BAGS SOLD EMPTY; VANITY CASES SOLD EMPTY; OVERNIGHT CASES; ATTACHE CASES; BRIEFCASES; SUITCASES; RUCKSACKS FOR MOUNTAINEERS; GARMENT BAGS FOR TRAVEL; BELT BAGS; CARRY-ON BAGS; HANDBAGS; STRAPS FOR HANDBAGS; SHOE BAGS FOR TRAVEL (U.S. CLS. 1, 2, 3, 22 AND 41).

FIRST USE 2-1-2008; IN COMMERCE 2-1-2008.
DAVID HOFFMAN, EXAMINING ATTORNEY

SN 77-421,051. MASCOT METROPOLITAN INC., SOUTH SAN FRANCISCO, CA. FILED 3-13-2008.

ELECTION ON WHEELS

THE MARK CONSISTS OF STANDARD CHARACTERS WITHOUT CLAIM TO ANY PARTICULAR FONT, STYLE, SIZE, OR COLOR.

OWNER OF U.S. REG. NOS. 2,802,228, 3,261,162 AND OTHERS.

FOR LUGGAGE PRIMARILY FOR VOTING EQUIPMENT AND SUPPLIES (U.S. CLS. 1, 2, 3, 22 AND 41).

FIRST USE 11-30-2005; IN COMMERCE 11-30-2005.
AMY ALFIERI, EXAMINING ATTORNEY

CLASS 18—(Continued).

SN 77-426,144. SHAW, JILLIAN MICHELLE, LITTLETON, MA. FILED 3-19-2008.

CHEEK & CO.

THE MARK CONSISTS OF STANDARD CHARACTERS WITHOUT CLAIM TO ANY PARTICULAR FONT, STYLE, SIZE, OR COLOR.

NO CLAIM IS MADE TO THE EXCLUSIVE RIGHT TO USE "& CO.", APART FROM THE MARK AS SHOWN.

FOR ALL PURPOSE SPORT BAGS; ALL-PURPOSE ATHLETIC BAGS; ALL-PURPOSE CARRYING BAGS; ATHLETIC BAGS; BABY BACKPACKS; BABY CARRIERS WORN ON THE BODY; BABY CARRYING BAGS; BACK PACKS; BACKPACKS; BACKPACKS; BACKPACKS, BOOK BAGS, SPORTS BAGS, BUM BAGS, WALLETS AND HANDBAGS; BAGS AND HOLDALLS FOR SPORTS CLOTHING; BAGS FOR CARRYING BABIES' ACCESSORIES; BAGS FOR SPORTS; BARREL BAGS; BEACH BAGS; BEACHBAGS; BOOK BAGS; BOSTON BAGS; BUM BAGS; BUMBAGS; CANVAS SHOPPING BAGS; CARRY-ALL BAGS; CARRY-ON BAGS; CARRYALLS; CARRYING CASES; CHANGE PURSES; CLUTCH BAGS; CLUTCH PURSES; CLUTCHES; COIN PURSES; COSMETIC BAGS SOLD EMPTY; COSMETIC CARRYING CASES SOLD EMPTY; COSMETIC CASES SOLD EMPTY; DAYPACKS; DIAPER BAGS; DRAWSTRING POUCHES; DUFFEL BAGS; DUFFEL BAGS FOR TRAVEL; DUFFLE BAGS; FANNY PACKS; FELT POUCHES; GENERAL PURPOSE BAGS FOR CARRYING YOGA EQUIPMENT; GYM BAGS; HANDBAGS; HANDBAGS, PURSES AND WALLETS; INFANT CARRIERS WORN ON THE BODY; KEY BAGS; KEY CASE; KEY CASES; KEY WALLETS; KEYCASES; KIT BAGS; KNAP SACKS; KNAPSACKS; MAKE-UP BAGS SOLD EMPTY; OVERNIGHT BAGS; OVERNIGHT CASES; OVERNIGHT SUITCASES; POCKET WALLETS; POCKETBOOKS; POMMEL BAGS; POUCHES AND BAGS SOLD EMPTY FOR ATTACHMENT TO BACKPACKS; POUCHES FOR HOLDING SCHOOL SUPPLIES THAT FITS OVER THE BACK OF A CHAIR; PURSES; PURSES; PURSES AND WALLETS; SATCHELS; SCHOOL BAGS; SCHOOL BOOK BAGS; SCHOOL KNAPSACKS; SCHOOL SATCHELS; SCHOOLBAGS; SCHOOLCHILDREN'S BACKPACKS; SHOULDER BAGS; SLING BAGS; SLING BAGS FOR CARRYING INFANTS; SLINGS FOR CARRYING INFANTS; SMALL BACKPACKS; SMALL BAGS FOR MEN; SMALL CLUTCH PURSES; SMALL PURSES; SMALL RUCKSACKS; SOUVENIR BAGS; SPORT BAGS; SPORTS BAGS; SPORTS PACKS; TOILETRY BAGS SOLD EMPTY; TOILETRY CASES SOLD EMPTY; TOTE BAGS; TRAVEL BAGS; TRAVEL CASES; TRAVELING BAGS; WAIST BAGS; WAIST PACKS; WALLETS; WASH BAGS FOR CARRYING TOILETRIES; WEARABLE STRAP-ON POUCH; WRIST MOUNTED CARRYALL BAGS; WRIST MOUNTED PURSES; WRISTLET BAGS (U.S. CLS. 1, 2, 3, 22 AND 41).

NORA BUCHANAN WILL, EXAMINING ATTORNEY

CLASS 18—(Continued).

SN 77-426,269. ACHILLES CORPORATION, TOKYO, JAPAN, FILED 3-19-2008.



OWNER OF U.S. REG. NO. 1,289,972.
FOR SYNTHETIC LEATHER SOLD IN BULK (U.S. CLS. 1, 2, 3, 22 AND 41).
FIRST USE 1-0-1997; IN COMMERCE 1-0-1997.
MATTHEW MCDOWELL, EXAMINING ATTORNEY

SN 77-426,663. KIM, HYUNG JONG, LOS ANGELES, CA. FILED 3-19-2008.

Jupiter & Juno

THE MARK CONSISTS OF STANDARD CHARACTERS WITHOUT CLAIM TO ANY PARTICULAR FONT, STYLE, SIZE, OR COLOR.

FOR ATHLETIC BAGS; BEACH BAGS; BOSTON BAGS; DUFFEL BAGS; SHOULDER BAGS; SLING BAGS; SPORTS BAGS; TOTE BAGS; HANDBAGS; PURSES; WALLETS; BACKPACKS; LEATHER POUCHES; SUITCASES; BRIEFCASES; LUGGAGE (U.S. CLS. 1, 2, 3, 22 AND 41).

FRANK LATTUCA, EXAMINING ATTORNEY

SN 77-427,157. PEGGY LEEVE UMBRELLAS, INC., NEW YORK, NY. FILED 3-20-2008.

RAIN OR SHINE

THE MARK CONSISTS OF STANDARD CHARACTERS WITHOUT CLAIM TO ANY PARTICULAR FONT, STYLE, SIZE, OR COLOR.

OWNER OF U.S. REG. NO. 3,067,488.
FOR UMBRELLAS; PARASOLS (U.S. CLS. 1, 2, 3, 22 AND 41).
FIRST USE 1-2-2001; IN COMMERCE 5-3-2004.
TEJBIR SINGH, EXAMINING ATTORNEY

CLASS 18—(Continued).

SN 77-427,458. KOKOPAX, LLC., HENDERSON, NV. FILED 3-20-2008.

EVERY DAY. EVERYWHERE.

THE MARK CONSISTS OF STANDARD CHARACTERS WITHOUT CLAIM TO ANY PARTICULAR FONT, STYLE, SIZE, OR COLOR.

FOR INFANT CARRIERS WORN ON THE BODY (U.S. CLS. 1, 2, 3, 22 AND 41).

BRIAN NEVILLE, EXAMINING ATTORNEY

SN 77-427,985. SIMPLY THE BEST, INC., GREENWOOD, IN. FILED 3-21-2008.

BARK SKARF

THE MARK CONSISTS OF STANDARD CHARACTERS WITHOUT CLAIM TO ANY PARTICULAR FONT, STYLE, SIZE, OR COLOR.

NO CLAIM IS MADE TO THE EXCLUSIVE RIGHT TO USE "SCARF", APART FROM THE MARK AS SHOWN.

FOR BANDANAS FOR PETS (U.S. CLS. 1, 2, 3, 22 AND 41).

SUSAN STIGLITZ, EXAMINING ATTORNEY

SN 77-428,142. GLOBAL DESIGN CONCEPTS, INC., NEW YORK, NY. FILED 3-21-2008.



THE MARK CONSISTS OF DISTINCTIVE "BOTTLE SHAPE" OF A HANG TAG.

FOR LUGGAGE, HANDBAGS, BACKPACKS, DIAPER BAGS, TOTE BAGS AND COORDINATED ACCESSORIES (U.S. CLS. 1, 2, 3, 22 AND 41).

FIRST USE 1-0-2008; IN COMMERCE 1-0-2008.

RAUL CORDOVA, EXAMINING ATTORNEY

CLASS 18—(Continued).

SN 77-428,322. MCKENNA LUXURY GOODS LTD., NEW YORK, NY. FILED 3-21-2008.

PERIPATETIC

THE MARK CONSISTS OF STANDARD CHARACTERS WITHOUT CLAIM TO ANY PARTICULAR FONT, STYLE, SIZE, OR COLOR.

FOR ALL PURPOSE SPORT BAGS; ALL-PURPOSE CARRYING BAGS; BABY CARRYING BAGS; BAGS FOR CARRYING BABIES' ACCESSORIES; BACKPACKS, BOOK BAGS, SPORTS BAGS, BUM BAGS, WALLETS AND HANDBAGS; BEACH BAGS; BELT BAGS AND HIP BAGS; CANVAS SHOPPING BAGS; COSMETIC BAGS SOLD EMPTY; TOILETRY BAGS SOLD EMPTY; DIAPER BAGS; DUFFEL BAGS; SHOPPING BAGS WITH WHEELS ATTACHED; BILLFOLDS; BRIEFCASES AND ATTACHE CASES; LUGGAGE; LUGGAGE TAGS; STRAPS FOR LUGGAGE; UMBRELLAS (U.S. CLS. 1, 2, 3, 22 AND 41).

FIRST USE 3-17-2008; IN COMMERCE 3-17-2008.

CHRISTOPHER BUONGIORNO, EXAMINING ATTORNEY

SN 77-428,367. CONSUMER PRODUCTS DESIGN, LTD, NEW YORK, NY. FILED 3-21-2008.

AVENTURA

THE MARK CONSISTS OF STANDARD CHARACTERS WITHOUT CLAIM TO ANY PARTICULAR FONT, STYLE, SIZE, OR COLOR.

THE FOREIGN WORDING IN THE MARK TRANSLATES INTO ENGLISH AS ADVENTURE.

FOR ALL PURPOSE SPORT BAGS; ALL-PURPOSE CARRYING BAGS; BABY CARRYING BAGS; BAGS FOR CARRYING BABIES' ACCESSORIES; BACKPACKS, BOOK BAGS, SPORTS BAGS, BUM BAGS, WALLETS AND HANDBAGS; BEACH BAGS; BELT BAGS AND HIP BAGS; CANVAS SHOPPING BAGS; COSMETIC BAGS SOLD EMPTY; TOILETRY BAGS SOLD EMPTY; DIAPER BAGS; DUFFEL BAGS; SHOPPING BAGS WITH WHEELS ATTACHED; BILLFOLDS; BRIEFCASES AND ATTACHE CASES; LUGGAGE; LUGGAGE TAGS; STRAPS FOR LUGGAGE; UMBRELLAS (U.S. CLS. 1, 2, 3, 22 AND 41).

FIRST USE 3-17-2008; IN COMMERCE 3-17-2008.

REBECCA GILBERT, EXAMINING ATTORNEY

CLASS 18—(Continued).

SN 77-429,129. MACALUSO, JOHN, PHOENIX, AZ. FILED 3-23-2008.

GIO GIOVANNI

THE MARK CONSISTS OF STANDARD CHARACTERS WITHOUT CLAIM TO ANY PARTICULAR FONT, STYLE, SIZE, OR COLOR.

THE NAME(S), PORTRAIT(S), AND/OR SIGNATURE(S) SHOWN IN THE MARK DOES NOT IDENTIFY A PARTICULAR LIVING INDIVIDUAL.

FOR HANDBAGS; ANIMAL CARRIERS (U.S. CLS. 1, 2, 3, 22 AND 41).

MARY MUNSON, EXAMINING ATTORNEY



SN 77-429,394. LI JIANGUO, LU CHENG DISTRICT, CHINA, FILED 3-24-2008.



THE MARK CONSISTS OF THE STYLIZED LETTER "E". FOR PURSES; VALISES; FUR; TEXTILE SHOPPING BAGS; MESH SHOPPING BAGS; CANVAS SHOPPING BAGS; LEATHER SHOPPING BAGS; SHOPPING BAGS WITH WHEELS ATTACHED; ATTACHE CASES; TRAVELING TRUNKS; HANDBAGS; GARMENT BAGS FOR TRAVEL; BAGS FOR SPORTS; LEATHER FOR FURNITURE (U.S. CLS. 1, 2, 3, 22 AND 41).

FIRST USE 6-0-2006; IN COMMERCE 1-0-2007. MICHAEL SOUDERS, EXAMINING ATTORNEY

CLASS 18—(Continued).

SN 77-429,815. CONSUMER PRODUCTS DESIGN, LTD, NEW YORK, NY. FILED 3-24-2008.

NATURAL WONDERS

THE MARK CONSISTS OF STANDARD CHARACTERS WITHOUT CLAIM TO ANY PARTICULAR FONT, STYLE, SIZE, OR COLOR.

FOR ALL PURPOSE SPORT BAGS; ALL-PURPOSE CARRYING BAGS; BABY CARRYING BAGS; BAGS FOR CARRYING BABIES' ACCESSORIES; BACKPACKS, BOOK BAGS, SPORTS BAGS, BUM BAGS, WALLETS AND HANDBAGS; BEACH BAGS; BELT BAGS AND HIP BAGS; CANVAS SHOPPING BAGS; COSMETIC BAGS SOLD EMPTY; TOILETRY BAGS SOLD EMPTY; DIAPER BAGS; DUFFEL BAGS; SHOPPING BAGS WITH WHEELS ATTACHED; BILLFOLDS; BRIEFCASES AND ATTACHE CASES; LUGGAGE; LUGGAGE TAGS; STRAPS FOR LUGGAGE; UMBRELLAS (U.S. CLS. 1, 2, 3, 22 AND 41).

FIRST USE 3-24-2008; IN COMMERCE 3-24-2008. REBECCA GILBERT, EXAMINING ATTORNEY

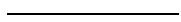

SN 77-429,846. CONSUMER PRODUCTS DESIGN, LTD, NEW YORK, NY. FILED 3-24-2008.

LAND, AIR & SEA

THE MARK CONSISTS OF STANDARD CHARACTERS WITHOUT CLAIM TO ANY PARTICULAR FONT, STYLE, SIZE, OR COLOR.

FOR ALL PURPOSE SPORT BAGS; ALL-PURPOSE CARRYING BAGS; BABY CARRYING BAGS; BAGS FOR CARRYING BABIES' ACCESSORIES; BACKPACKS, BOOK BAGS, SPORTS BAGS, BUM BAGS, WALLETS AND HANDBAGS; BEACH BAGS; BELT BAGS AND HIP BAGS; CANVAS SHOPPING BAGS; COSMETIC BAGS SOLD EMPTY; TOILETRY BAGS SOLD EMPTY; DIAPER BAGS; DUFFEL BAGS; SHOPPING BAGS WITH WHEELS ATTACHED; BILLFOLDS; BRIEFCASES AND ATTACHE CASES; LUGGAGE; LUGGAGE TAGS; STRAPS FOR LUGGAGE; UMBRELLAS (U.S. CLS. 1, 2, 3, 22 AND 41).

FIRST USE 3-24-2008; IN COMMERCE 3-24-2008. REBECCA GILBERT, EXAMINING ATTORNEY

CLASS 18—(Continued).

SN 77-429,914. CONSUMER PRODUCTS DESIGN, LTD., NEW YORK, NY. FILED 3-24-2008.

BOARDING PASS

THE MARK CONSISTS OF STANDARD CHARACTERS WITHOUT CLAIM TO ANY PARTICULAR FONT, STYLE, SIZE, OR COLOR.

FOR ALL PURPOSE SPORT BAGS; ALL-PURPOSE CARRYING BAGS; BABY CARRYING BAGS; BAGS FOR CARRYING BABIES' ACCESSORIES; BACKPACKS, BOOK BAGS, SPORTS BAGS, BUM BAGS, WALLETS AND HANDBAGS; BEACH BAGS; BELT BAGS AND HIP BAGS; CANVAS SHOPPING BAGS; COSMETIC BAGS SOLD EMPTY; TOILETRY BAGS SOLD EMPTY; DIAPER BAGS; DUFFEL BAGS; SHOPPING BAGS WITH WHEELS ATTACHED; BILLFOLDS; BRIEFCASES AND ATTACHE CASES; LUGGAGE; LUGGAGE TAGS; STRAPS FOR LUGGAGE; UMBRELLAS (U.S. CLS. 1, 2, 3, 22 AND 41).

FIRST USE 3-24-2008; IN COMMERCE 3-24-2008.
REBECCA GILBERT, EXAMINING ATTORNEY

SN 77-430,524. SCOTT USA, INC., KETCHUM, ID. FILED 3-25-2008.



OWNER OF U.S. REG. NOS. 1,837,348, 2,643,873 AND OTHERS.

FOR ALL PURPOSE SPORTS BAGS; BACKPACKS (U.S. CLS. 1, 2, 3, 22 AND 41).

FIRST USE 0-0-2000; IN COMMERCE 0-0-2000.
JENNY PARK, EXAMINING ATTORNEY

SN 77-430,632. PAK IT 4 LIFE, LLC, OLD GREENWICH, CT. FILED 3-25-2008.

PAK it 4life

THE MARK CONSISTS OF THE WORDS "PAK IT 4 LIFE" IN STYLIZED FONTS. THE ARMS OF THE LETTER "K" IN THE "PAK" ELEMENT OF THE MARK ARE EXTENDED TO COMPLETELY ENVELOP THE "IT" ELEMENT OF THE MARK.

FOR REUSABLE SHOPPING BAGS MADE OF CLOTH, COTTON, AND SILK (U.S. CLS. 1, 2, 3, 22 AND 41).

LINDA ESTRADA, EXAMINING ATTORNEY

CLASS 18—(Continued).

SN 77-430,802. JANSPOUT APPAREL CORP., WILMINGTON, DE. FILED 3-25-2008.

SOLE VERT

THE MARK CONSISTS OF STANDARD CHARACTERS WITHOUT CLAIM TO ANY PARTICULAR FONT, STYLE, SIZE, OR COLOR.

FOR ALL PURPOSE SPORTING BAGS, ALL PURPOSE CARRYING BAGS, SOFT LUGGAGE, LUGGAGE CASES, ATTACHE CASES, BRIEFCASES, BACKPACKS, DAYPACKS, FANNY PACKS, FRAME BACKPACKS, KNAPSACKS, BOOK BAGS FOR TRAVELING, TOTE BAGS, DUFFEL BAGS, HANDBAGS, CLUTCHES, GARMENT BAGS FOR TRAVELING, TOILETRY CASES SOLD EMPTY, WALLETS, CLOTHING BAGS FOR TRAVELING (U.S. CLS. 1, 2, 3, 22 AND 41).

TOBY BULLOFF, EXAMINING ATTORNEY

SN 77-431,763. TENNESSEE NATIONAL, LLC, LOUDEN, TN. FILED 3-26-2008.



THE COLOR(S) BLUE, GREEN AND WHITE IS/ARE CLAIMED AS A FEATURE OF THE MARK.

THE MARK CONSISTS OF TWO STYLIZED DEPICTIONS OF GREEN MOUNTAINS AND A STYLIZED DEPICTION OF A BLUE RIVER RUNNING UNDERNEATH AND WHITE IN THE SPACES BETWEEN THE DEPICTIONS.

FOR TOTE BAGS; LUGGAGE; TRAVEL BAGS (U.S. CLS. 1, 2, 3, 22 AND 41).

LAURIE KAUFMAN, EXAMINING ATTORNEY

SN 77-431,905. SERGEANT'S PET CARE PRODUCTS, INC., OMAHA, NE. FILED 3-26-2008.

TUG N' CHEW

THE MARK CONSISTS OF STANDARD CHARACTERS WITHOUT CLAIM TO ANY PARTICULAR FONT, STYLE, SIZE, OR COLOR.

OWNER OF U.S. REG. NO. 2,565,582.
FOR RAWHIDE CHEWS FOR DOGS (U.S. CLS. 1, 2, 3, 22 AND 41).

ARETHA SOMERVILLE, EXAMINING ATTORNEY

CLASS 18—(Continued).

SN 77-433,297. CONSUMER PRODUCTS DESIGN, LTD.,
NEW YORK, NY. FILED 3-27-2008.

OPEN ROAD

THE MARK CONSISTS OF STANDARD CHARACTERS
WITHOUT CLAIM TO ANY PARTICULAR FONT, STYLE,
SIZE, OR COLOR.

FOR ALL PURPOSE SPORT BAGS; ALL-PURPOSE
CARRYING BAGS; BABY CARRYING BAGS; BACK-
PACKS, BOOK BAGS, SPORTS BAGS, BUM BAGS,
WALLETS AND HANDBAGS; BAGS FOR CARRYING
BABIES' ACCESSORIES; BEACH BAGS; BELT BAGS
AND HIP BAGS; BILLFOLDS; BRIEFCASES AND AT-
TACHE CASES; CANVAS SHOPPING BAGS; COSMETIC
BAGS SOLD EMPTY; DIAPER BAGS; DUFFEL BAGS;
LUGGAGE; LUGGAGE TAGS; STRAPS FOR LUGGAGE;
SHOPPING BAGS WITH WHEELS ATTACHED; TOILET-
RY BAGS SOLD EMPTY; UMBRELLAS (U.S. CLS. 1, 2, 3,
22 AND 41).

FIRST USE 3-24-2008; IN COMMERCE 3-24-2008.
JASON TURNER, EXAMINING ATTORNEY

CLASS 18—(Continued).

SN 77-433,697. INTERNATIONAL DESIGN ASSOCIATES
LTD, NEW YORK, NY. FILED 3-27-2008.

URBAN LEGEND

THE MARK CONSISTS OF STANDARD CHARACTERS
WITHOUT CLAIM TO ANY PARTICULAR FONT, STYLE,
SIZE, OR COLOR.

FOR ALL PURPOSE SPORT BAGS; ALL-PURPOSE
CARRYING BAGS; BABY CARRYING BAGS; BAGS
FOR CARRYING BABIES' ACCESSORIES; BACKPACKS,
BOOK BAGS, SPORTS BAGS, BUM BAGS, WALLETS
AND HANDBAGS; BEACH BAGS; BELT BAGS AND HIP
BAGS; CANVAS SHOPPING BAGS; COSMETIC BAGS
SOLD EMPTY; TOILETRY BAGS SOLD EMPTY; DIAPER
BAGS; DUFFEL BAGS; SHOPPING BAGS WITH
WHEELS ATTACHED; BILLFOLDS; BRIEFCASES AND
ATTACHE CASES; LUGGAGE; LUGGAGE TAGS;
STRAPS FOR LUGGAGE; UMBRELLAS (U.S. CLS. 1, 2,
3, 22 AND 41).

FIRST USE 3-24-2008; IN COMMERCE 3-24-2008.
ANTHONY RINKER, EXAMINING ATTORNEY

SN 77-433,813. JACKSON, JULIA, DALLAS, TX. FILED 3-27-
2008.

SO.BOO

THE MARK CONSISTS OF STANDARD CHARACTERS
WITHOUT CLAIM TO ANY PARTICULAR FONT, STYLE,
SIZE, OR COLOR.

FOR HANDBAGS (U.S. CLS. 1, 2, 3, 22 AND 41).
FIRST USE 1-0-2007; IN COMMERCE 11-0-2007.
JILL C. ALT, EXAMINING ATTORNEY

SN 77-433,310. CONSUMER PRODUCTS DESIGN, LTD.,
NEW YORK, NY. FILED 3-27-2008.

RAMBLER

THE MARK CONSISTS OF STANDARD CHARACTERS
WITHOUT CLAIM TO ANY PARTICULAR FONT, STYLE,
SIZE, OR COLOR.

FOR ALL PURPOSE SPORT BAGS; ALL-PURPOSE
CARRYING BAGS; BABY CARRYING BAGS; BACK-
PACKS, BOOK BAGS, SPORTS BAGS, BUM BAGS,
WALLETS AND HANDBAGS; BAGS FOR CARRYING
BABIES' ACCESSORIES; BEACH BAGS; BELT BAGS
AND HIP BAGS; BILLFOLDS; BRIEFCASES AND AT-
TACHE CASES; CANVAS SHOPPING BAGS; COSMETIC
BAGS SOLD EMPTY; DIAPER BAGS; DUFFEL BAGS;
LUGGAGE; LUGGAGE TAGS; STRAPS FOR LUGGAGE;
SHOPPING BAGS WITH WHEELS ATTACHED; TOILET-
RY BAGS SOLD EMPTY; UMBRELLAS (U.S. CLS. 1, 2, 3,
22 AND 41).

FIRST USE 3-24-2008; IN COMMERCE 3-24-2008.
JASON TURNER, EXAMINING ATTORNEY

SN 77-434,248. CARLINO, CRISTINA M., PARADISE VAL-
LEY, AZ. FILED 3-28-2008.

YOU COLOR MY DAY

THE MARK CONSISTS OF STANDARD CHARACTERS
WITHOUT CLAIM TO ANY PARTICULAR FONT, STYLE,
SIZE, OR COLOR.

FOR BACK PACKS; ALL-PURPOSE CARRYING BAGS;
HANDBAGS; LUGGAGE; COSMETIC BAGS SOLD
EMPTY; WALLETS (U.S. CLS. 1, 2, 3, 22 AND 41).
REBECCA SMITH, EXAMINING ATTORNEY

CLASS 18—(Continued).

SN 77-440,423. CONSUMER PRODUCTS DESIGN, LTD.,
NEW YORK, NY. FILED 4-4-2008.

SUMMER OF LOVE

THE MARK CONSISTS OF STANDARD CHARACTERS WITHOUT CLAIM TO ANY PARTICULAR FONT, STYLE, SIZE, OR COLOR.

FOR ALL PURPOSE SPORT BAGS; ALL-PURPOSE CARRYING BAGS; BABY CARRYING BAGS; BAGS FOR CARRYING BABIES' ACCESSORIES; BACKPACKS, BOOK BAGS, SPORTS BAGS, BUM BAGS, WALLETS AND HANDBAGS; BEACH BAGS; BELT BAGS AND HIP BAGS; CANVAS SHOPPING BAGS; COSMETIC BAGS SOLD EMPTY; TOILETRY BAGS SOLD EMPTY; DIAPER BAGS; DUFFEL BAGS; SHOPPING BAGS WITH WHEELS ATTACHED; BILLFOLDS; BRIEFCASES AND ATTACHE CASES; LUGGAGE; LUGGAGE TAGS; STRAPS FOR LUGGAGE; UMBRELLAS (U.S. CLS. 1, 2, 3, 22 AND 41).

FIRST USE 4-1-2008; IN COMMERCE 4-1-2008.
REBECCA GILBERT, EXAMINING ATTORNEY

SN 77-446,820. WAG'N ENTERPRISES, LLC, HERNDON, VA.
FILED 4-12-2008.



OWNER OF U.S. REG. NOS. 3,427,952, 3,442,042 AND OTHERS.

NO CLAIM IS MADE TO THE EXCLUSIVE RIGHT TO USE "ENTERPRISES" AND "LLC.", APART FROM THE MARK AS SHOWN.

THE MARK CONSISTS OF THE WORD "WAG'N" WITH AN ANIMAL TAIL TAKING THE PLACE OF THE APOSTROPHE. THE WORDING "WAG'N ENTERPRISES LLC" IS ABOVE THE WORD "WAG'N" AND THERE ARE TWO SEMI-CIRCULAR LINES ON EACH SIDE OF THE WORD "WAG'N", ALL APPEARING INSIDE AN ELLIPSE.

FOR BACKPACKS; COLLARS FOR PETS; LEASHES FOR ANIMALS (U.S. CLS. 1, 2, 3, 22 AND 41).

KATHERINE CONNOLLY, EXAMINING ATTORNEY

CLASS 18—(Continued).

SN 77-469,942. CONSUMER PRODUCTS DESIGN, LTD.,
NEW YORK, NY. FILED 5-9-2008.

PORTOFINO

THE MARK CONSISTS OF STANDARD CHARACTERS WITHOUT CLAIM TO ANY PARTICULAR FONT, STYLE, SIZE, OR COLOR.

THE FOREIGN WORDING IN THE MARK TRANSLATES INTO ENGLISH AS "FINE PORT".

FOR ALL PURPOSE SPORT BAGS; ALL-PURPOSE CARRYING BAGS; BABY CARRYING BAGS; BACKPACKS, BOOK BAGS, SPORTS BAGS, BUM BAGS, WALLETS AND HANDBAGS; BAGS FOR CARRYING BABIES' ACCESSORIES; BEACH BAGS; BELT BAGS AND HIP BAGS; BRIEFCASES AND ATTACHE CASES; COSMETIC BAGS SOLD EMPTY; DIAPER BAGS; DUFFEL BAGS; LUGGAGE; LUGGAGE TAGS; STRAPS FOR LUGGAGE; SHOPPING BAGS WITH WHEELS ATTACHED; TOILETRY BAGS SOLD EMPTY; UMBRELLAS (U.S. CLS. 1, 2, 3, 22 AND 41).

FIRST USE 4-7-2008; IN COMMERCE 4-7-2008.
JASON TURNER, EXAMINING ATTORNEY

SN 77-474,459. INTERNATIONAL DESIGN ASSOCIATES LTD, NEW YORK, NY. FILED 5-14-2008.

ARRIVEDERCI

THE MARK CONSISTS OF STANDARD CHARACTERS WITHOUT CLAIM TO ANY PARTICULAR FONT, STYLE, SIZE, OR COLOR.

THE FOREIGN WORDING IN THE MARK TRANSLATES INTO ENGLISH AS FAREWELL; GOODBYE.

FOR TOTE BAGS; LUGGAGE; LUGGAGE TAGS; UMBRELLAS; TOILETRY BAGS SOLD EMPTY (U.S. CLS. 1, 2, 3, 22 AND 41).

FIRST USE 4-7-2008; IN COMMERCE 4-7-2008.
ANTHONY RINKER, EXAMINING ATTORNEY

SN 77-480,149. INTERNATIONAL DESIGN ASSOCIATES LTD, NEW YORK, NY. FILED 5-21-2008.

GLITTERATI

THE MARK CONSISTS OF STANDARD CHARACTERS WITHOUT CLAIM TO ANY PARTICULAR FONT, STYLE, SIZE, OR COLOR.

FOR TOTE BAGS; LUGGAGE; LUGGAGE TAGS; UMBRELLAS; TOILETRY BAGS SOLD EMPTY (U.S. CLS. 1, 2, 3, 22 AND 41).

FIRST USE 5-21-2008; IN COMMERCE 5-21-2008.
ANTHONY RINKER, EXAMINING ATTORNEY

CLASS 18—(Continued).

SN 77-480,190. INTERNATIONAL DESIGN ASSOCIATES LTD, NEW YORK, NY. FILED 5-21-2008.

CLASS 18—(Continued).

SN 78-336,878. CHUMS, INC., DBA CHUMS-CHISCO, SALT LAKE CITY, UT. FILED 12-5-2003.

TEAM PLAYER

THE MARK CONSISTS OF STANDARD CHARACTERS WITHOUT CLAIM TO ANY PARTICULAR FONT, STYLE, SIZE, OR COLOR.

FOR LUGGAGE; LUGGAGE TAGS; TOILETRY BAGS SOLD EMPTY; TOTE BAGS; DUFFEL BAGS (U.S. CLS. 1, 2, 3, 22 AND 41).

FIRST USE 5-21-2008; IN COMMERCE 5-21-2008.
ANTHONY RINKER, EXAMINING ATTORNEY

STARPUPS

THE MARK CONSISTS OF STANDARD CHARACTERS WITHOUT CLAIM TO ANY PARTICULAR FONT, STYLE, SIZE, OR COLOR.

FOR PACKAGES FOR DOGS PRIMARILY CONTAINING DOG COLLARS, DOG LEASHES, FABRIC DOG BOWLS AND ALSO DOG TOYS (U.S. CLS. 1, 2, 3, 22 AND 41).

CAROL SPILS, EXAMINING ATTORNEY

SN 78-137,152. KEMISTRE 8 LLC, NEW YORK, NY. FILED 6-19-2002.

SN 79-046,549. ZUEKOO LTD, UNITED KINGDOM, FILED 8-9-2007.

JEANIUS LEVEL PRODUCTS

NO CLAIM IS MADE TO THE EXCLUSIVE RIGHT TO USE "PRODUCTS", APART FROM THE MARK AS SHOWN.

FOR ALL-PURPOSE SPORT BAGS; ALL-PURPOSE ATHLETIC BAGS; TOTE BAGS; SHOULDER BAGS; TRAVEL ACCESSORY BAGS; CREDIT CARD HOLDERS; CREDIT CARD CASES; HANDBAGS; BEACH BAGS; BRIEFCASES; COSMETIC BAGS SOLD EMPTY; RUCKSACKS; TRAVELING BAGS; SUITCASES; PURSES; CHANGE PURSES; WALLETS; ZIPPED WALLETS; BILLFOLD WALLETS; BOOK BAGS; BACKPACKS; DUFFEL BAGS; KEY CASES; UMBRELLAS; BACKPACKS; BILLFOLDS; BRIEFCASE-TYPE PORTFOLIOS; ATTACHE CASES; BUSINESS CARD CASES; FANNY PACKS; GYM BAGS; KNAPSACKS; LUGGAGE; POCKETBOOKS; SCHOOL BAGS; STRAPS FOR HANDBAGS AND LUGGAGE AND ACCESSORIES USED THEREWITH, NAMELY, SHOULDER STRAP PADS, HOLDERS, AND POUCHES; GOODS MADE OF LEATHER AND IMITATIONS OF LEATHER, NAMELY, KEY CHAINS, HANDBAGS, WALLETS, CASES, BILLFOLDS, COSMETIC BAGS SOLD EMPTY, BRIEFCASES, BRIEFCASE-TYPE PORTFOLIOS, ATTACHES, TOTES, TRUNKS AND TRAVELING BAGS; GARMENT BAGS FOR TRAVEL; SHOE BAGS FOR TRAVEL (U.S. CLS. 1, 2, 3, 22 AND 41).

FIRST USE 8-1-1999; IN COMMERCE 1-1-2000.
GIANCARLO CASTRO, EXAMINING ATTORNEY

Charlotte Reid

OWNER OF INTERNATIONAL REGISTRATION 0944293 DATED 8-9-2007, EXPIRES 8-9-2017.

THE NAME "CHARLOTTE REID" DOES NOT IDENTIFY A LIVING INDIVIDUAL.

FOR LEATHER AND IMITATION LEATHER AND GOODS MADE OF THE AFORESAID MATERIAL, NAMELY, LUGGAGE, HAND-BAGS, BAGS, TRAVELING BAGS, HOLD-ALLS AND CASES; LUGGAGE; TRUNKS AND SUITCASES; HOLDALLS, RUCKSACKS, BACKPACKS, SHOULDER BAGS, HANDBAGS, SPORT BAGS, BUMBAGS, TOILET BAGS AND VANITY CASES SOLD EMPTY; BRIEFCASES, CARRY-ALL AND CARRY-ON BAGS; ATTACHE CASE; SATCHELS, BRIEFCASE-TYPE PORTFOLIO CASES, BELTS; PURSES, WALLETS AND COIN CASES; AND CALLING CARD, BUSINESS CARD AND CREDIT CARD CASES (U.S. CLS. 1, 2, 3, 22 AND 41).

EMILY CARLSEN, EXAMINING ATTORNEY

CLASS 18—(Continued).

SN 79-049,725. WENZHOU CONCH GROUP CO., LTD,
ZHEJIANG 325028, CHINA, FILED 2-14-2008.



OWNER OF INTERNATIONAL REGISTRATION 0952938
DATED 2-14-2008, EXPIRES 2-14-2018.

"HAILUO" HAS NO MEANING IN FOREIGN LANGUAGE.

FOR UMBRELLAS; TRAVELING BAGS; TRAVELING SETS MADE OF LEATHER COMPRISED OF CARRY-ON BAGS, GARMENT BAGS FOR TRAVEL, SUITCASES; ATTACHE CASES; HANDBAGS; SCHOOL BAGS; IMITATION LEATHER; WALKING STICKS; HARNESES (U.S. CLS. 1, 2, 3, 22 AND 41).

JORDAN BAKER, EXAMINING ATTORNEY

CLASS 19—NON-METALLIC BUILDING MATERIALS

SN 77-096,694. CONKLIN COMPANY, INC., SHAKOPEE,
MN. FILED 2-1-2007.

MR SYSTEM

THE MARK CONSISTS OF STANDARD CHARACTERS WITHOUT CLAIM TO ANY PARTICULAR FONT, STYLE, SIZE, OR COLOR.

NO CLAIM IS MADE TO THE EXCLUSIVE RIGHT TO USE "SYSTEM", APART FROM THE MARK AS SHOWN, FOR THERMOPLASTIC ROOFING MEMBRANE (U.S. CLS. 1, 12, 33 AND 50).

BENJAMIN OKEKE, EXAMINING ATTORNEY

SN 79-050,964. WEILL PRODUCTIONS, FRANCE, FILED 9-7-2007.

ATIKA

OWNER OF INTERNATIONAL REGISTRATION 0594561
DATED 12-7-1992, EXPIRES 12-7-2012.

OWNER OF U.S. REG. NO. 2,941,747.

THE WORDING "ATIKA" HAS NO MEANING OTHER THAN TRADEMARK SIGNIFICANCE.

FOR LEATHER AND IMITATION LEATHER, NAMELY, CALLING CARDS CASES, DOCUMENT CASES, ATTACHE CASES, HANDBAGS, BACKPACKS, BEACH BAGS, TRAVELING BAGS, SPORTS BAGS, TRAVEL BAGS, UNFITTED VANITY CASES, POUCHES, KEY CASES; WALLETS, PURSES, SATCHELS, TRUNKS, SUITCASES, UMBRELLAS, WALKING STICKS (U.S. CLS. 1, 2, 3, 22 AND 41).

CYNTHIA SLOAN, EXAMINING ATTORNEY

SN 77-173,615. KITTRICH CORPORATION, LA MIRADA,
CA. FILED 5-4-2007.

CON-TACT

THE MARK CONSISTS OF STANDARD CHARACTERS WITHOUT CLAIM TO ANY PARTICULAR FONT, STYLE, SIZE, OR COLOR.

OWNER OF U.S. REG. NOS. 630,599, 998,439 AND OTHERS.

FOR SELF-ADHESIVE PLASTIC OR VINYL INDICIA TAB; NON-LUMINOUS, NON-MECHANICAL SIGNS NOT OF METAL (U.S. CLS. 1, 12, 33 AND 50).

G. MAYERSCHOFF, EXAMINING ATTORNEY

CLASS 19—(Continued).

SN 77-188,186. DUTCH QUALITY STONE, INC., MOUNT EATON, OH. FILED 5-23-2007.



OWNER OF U.S. REG. NO. 3,001,611.

NO CLAIM IS MADE TO THE EXCLUSIVE RIGHT TO USE "STONE", APART FROM THE MARK AS SHOWN.

THE MARK CONSISTS OF A SMALL LETTER "D" INSIDE A CAPITAL LETTER "Q" ABOVE THE WORD "STONE" IN SMALL LETTERS ABOVE A LINE AND THE WORDS "DUTCH QUALITY" BELOW THE LINE, ALL IN STYLIZED LETTERING.

FOR BUILDING MATERIALS, NAMELY, MANUFACTURED STONE VENEERS FOR EXTERIOR AND INTERIOR SURFACES OF WALLS AND BUILDINGS AND SYNTHETIC, ARTIFICIAL, MANUFACTURED AND REFORMED STONES (U.S. CLS. 1, 12, 33 AND 50).

FIRST USE 6-1-1996; IN COMMERCE 1-1-1997.

JOHN GARTNER, EXAMINING ATTORNEY

SN 77-258,065. CARTHAGE MILLS EROSION CONTROL COMPANY, CINCINNATI, OH. FILED 8-17-2007.

GX

THE MARK CONSISTS OF STANDARD CHARACTERS WITHOUT CLAIM TO ANY PARTICULAR FONT, STYLE, SIZE, OR COLOR.

FOR GEOSYNTHETICS, NAMELY, NON-METALLIC GEOGRIDS WITH OPEN APERTURES DESIGNED TO PROVIDE REINFORCEMENT AND STABILIZATION OF SOIL, ROCK, GRAVEL, EARTH AND OTHER SURROUNDING EARTHEN AGGREGATES (U.S. CLS. 1, 12, 33 AND 50).

FIRST USE 11-9-2006; IN COMMERCE 11-9-2006.

DAWN FELDMAN, EXAMINING ATTORNEY

SN 77-267,459. EASTERN WHOLESALE FENCE CO., INC., MEDFORD, NY. FILED 8-29-2007.

JUST BUILT BETTER

THE MARK CONSISTS OF STANDARD CHARACTERS WITHOUT CLAIM TO ANY PARTICULAR FONT, STYLE, SIZE, OR COLOR.

FOR NON-METAL FENCING PANELS, POSTS, GATES (U.S. CLS. 1, 12, 33 AND 50).

FIRST USE 0-0-2003; IN COMMERCE 0-0-2003.

DANIEL CAPSHAW, EXAMINING ATTORNEY

CLASS 19—(Continued).

SN 77-274,610. ANCHOR WALL SYSTEMS, INC., MINNETONKA, MN. FILED 9-7-2007.

VERTICA STONE CUT

THE MARK CONSISTS OF STANDARD CHARACTERS WITHOUT CLAIM TO ANY PARTICULAR FONT, STYLE, SIZE, OR COLOR.

OWNER OF U.S. REG. NOS. 1,897,522 AND 1,901,751.

NO CLAIM IS MADE TO THE EXCLUSIVE RIGHT TO USE "STONE", APART FROM THE MARK AS SHOWN.

FOR MODULAR CONCRETE UNITS, NAMELY, RETAINING WALL UNITS CONSISTING OF CONCRETE BLOCKS AND LANDSCAPING UNITS CONSISTING OF CONCRETE BLOCKS (U.S. CLS. 1, 12, 33 AND 50).

ANDREA HACK, EXAMINING ATTORNEY

SN 77-274,612. ANCHOR WALL SYSTEMS, INC., MINNETONKA, MN. FILED 9-7-2007.

WINDSOR STONE CUT

THE MARK CONSISTS OF STANDARD CHARACTERS WITHOUT CLAIM TO ANY PARTICULAR FONT, STYLE, SIZE, OR COLOR.

OWNER OF U.S. REG. NO. 2,473,901.

NO CLAIM IS MADE TO THE EXCLUSIVE RIGHT TO USE "STONE", APART FROM THE MARK AS SHOWN.

FOR MODULAR CONCRETE UNITS, NAMELY, RETAINING WALL UNITS CONSISTING OF CONCRETE BLOCKS AND LANDSCAPING UNITS CONSISTING OF CONCRETE BLOCKS (U.S. CLS. 1, 12, 33 AND 50).

ANDREA HACK, EXAMINING ATTORNEY

SN 77-274,613. ANCHOR WALL SYSTEMS, INC., MINNETONKA, MN. FILED 9-7-2007.

DIAMOND STONE CUT

THE MARK CONSISTS OF STANDARD CHARACTERS WITHOUT CLAIM TO ANY PARTICULAR FONT, STYLE, SIZE, OR COLOR.

OWNER OF U.S. REG. NOS. 1,715,776 AND 3,035,251.

NO CLAIM IS MADE TO THE EXCLUSIVE RIGHT TO USE "STONE", APART FROM THE MARK AS SHOWN.

FOR MODULAR CONCRETE UNITS, NAMELY, RETAINING WALL UNITS CONSISTING OF CONCRETE BLOCKS AND LANDSCAPING UNITS CONSISTING OF CONCRETE BLOCKS (U.S. CLS. 1, 12, 33 AND 50).

ANDREA HACK, EXAMINING ATTORNEY

CLASS 19—(Continued).

SN 77-288,197. NORTHFIELD BLOCK COMPANY, MUNDELEIN, IL. FILED 9-25-2007.

HARVARD PAVER

THE MARK CONSISTS OF STANDARD CHARACTERS WITHOUT CLAIM TO ANY PARTICULAR FONT, STYLE, SIZE, OR COLOR.

OWNER OF U.S. REG. NO. 2,525,639.
NO CLAIM IS MADE TO THE EXCLUSIVE RIGHT TO USE "PAVER", APART FROM THE MARK AS SHOWN.
FOR PAVERS (U.S. CLS. 1, 12, 33 AND 50).
ALEXANDER L. POWERS, EXAMINING ATTORNEY

SN 77-296,379. PANELES ARAUCO S.A., SANTIAGO, CHILE, FILED 10-4-2007.



PRIORITY CLAIMED UNDER SEC. 44(D) ON CHILE APPLICATION NO. 786.282, FILED 8-27-2007, REG. NO. 806.972, DATED 1-25-2008, EXPIRES 1-25-2018.

THE MARK CONSISTS OF THE WORD "TRUPAN" WITH STYLIZED LINES THROUGH THE LETTERS "A" AND "N". THE WORDING "TRUPAN" IN THE MARK HAS NO MEANING IN A FOREIGN LANGUAGE.

FOR NON-METAL BUILDING CONSTRUCTION MATERIALS, NAMELY, WOOD PANELS, HARDBOARD, WOOD MOLDINGS AND WOOD MATERIALS IN THE NATURE OF WOOD BEAMS, WOOD WINDOW FRAMES, WOOD DOOR FRAMES, WOOD TRIMS, WOOD POSTS, WOOD JOISTS, WOOD JOINTS (U.S. CLS. 1, 12, 33 AND 50).

TRACY WHITTAKER-BROWN, EXAMINING ATTORNEY

SN 77-298,702. NORTHFIELD BLOCK COMPANY, MUNDELEIN, IL. FILED 10-8-2007.

HARVARD STONE

THE MARK CONSISTS OF STANDARD CHARACTERS WITHOUT CLAIM TO ANY PARTICULAR FONT, STYLE, SIZE, OR COLOR.

OWNER OF U.S. REG. NO. 2,525,639.
NO CLAIM IS MADE TO THE EXCLUSIVE RIGHT TO USE "STONE", APART FROM THE MARK AS SHOWN.
FOR PAVERS (U.S. CLS. 1, 12, 33 AND 50).
ALEXANDER L. POWERS, EXAMINING ATTORNEY

CLASS 19—(Continued).

SN 77-318,566. CALERA CORPORATION, LOS GATOS, CA. FILED 10-31-2007.

GREEN-AGE CEMENT FOR A BLUE PLANET

THE MARK CONSISTS OF STANDARD CHARACTERS WITHOUT CLAIM TO ANY PARTICULAR FONT, STYLE, SIZE, OR COLOR.

NO CLAIM IS MADE TO THE EXCLUSIVE RIGHT TO USE "CEMENT", APART FROM THE MARK AS SHOWN.

FOR NON-METALLIC CONSTRUCTION MATERIALS, NAMELY, MINERAL-BASED CEMENTITIOUS MATERIALS IN THE NATURE OF PORTLAND, HYDRAULIC, WHITE, MASONRY, PLASTIC, STUCCO, AND OIL WELL CEMENT, OTHER MINERAL-BASED CEMENTITIOUS MATERIALS; SUPPLEMENTARY CEMENTITIOUS MATERIALS, NAMELY, POZZOLANIC MATERIALS, BLAST FURNACE SLAG, COAL CLINKER AND FLY ASH; NON-METALLIC CONSTRUCTION MATERIALS, NAMELY, CEMENT MIXES AND PATCHES, CONCRETE, MORTAR, STONE, AGGREGATE, SAND, NON-METALLIC MOSAIC, NON-METALLIC FLOOR AND ROOFING TILES, NON-AGRICULTURAL LIME, NON-RUBBER PLASTER, GYPSUM, GRAVEL, BRICK; ASPHALT; BUILDING MATERIALS MADE FROM CONCRETE, NAMELY, BLOCKS, BRICKS, STONES, WALLS, CONDUITS, DUCTS, PAVERS, POSTS, PEDESTALS FOR USE AS A BUILDING MATERIAL, BEAMS, PARTITIONS FOR USE AS WALLS, BARRIERS OF CONCRETE FOR USE AS A BUILDING MATERIAL, PIPES, PANELS, ARCHITECTURAL COLUMNS, MONUMENTS, CONCRETE CONTAINERS FOR HOLDING A LIQUID, CONCRETE STREET CURBS, CONCRETE FENCES, CONCRETE BEAMS, AND CONCRETE PLANKS (U.S. CLS. 1, 12, 33 AND 50).

RICHARD A. STRASER, EXAMINING ATTORNEY

SN 77-324,284. THE SHERWIN-WILLIAMS COMPANY, CLEVELAND, OH. FILED 11-8-2007.

COLORCUE

THE MARK CONSISTS OF STANDARD CHARACTERS WITHOUT CLAIM TO ANY PARTICULAR FONT, STYLE, SIZE, OR COLOR.

FOR SPACKLING COMPOUND (U.S. CLS. 1, 12, 33 AND 50).
MONIQUE MILLER, EXAMINING ATTORNEY

CLASS 19—(Continued).

SN 77-383,228. ADVANTAGE TRIM & LUMBER COMPANY, INC., BUFFALO, NY. FILED 1-29-2008.



NO CLAIM IS MADE TO THE EXCLUSIVE RIGHT TO USE "TRIM AND LUMBER", APART FROM THE MARK AS SHOWN.

THE MARK CONSISTS OF A RING IN WHICH THE WORD "ADVANTAGE" IS WRITTEN AT THE TOP AND "TRIM & LUMBER" ARE WRITTEN AT THE BOTTOM, SURROUNDING A CIRCLE CONTAINING A DRAWING OF A TREE WITH ROOTS.

FOR LUMBER; BUILDING MATERIALS, NAMELY, DECKING BOARDS; WOODEN FLOORING (U.S. CLS. 1, 12, 33 AND 50).

FIRST USE 8-31-2007; IN COMMERCE 8-31-2007.
ANTHONY RINKER, EXAMINING ATTORNEY

SN 77-397,892. BONSAI AMERICAN, INC., CHARLOTTE, NC. FILED 2-15-2008.

RUBCRETE

THE MARK CONSISTS OF STANDARD CHARACTERS WITHOUT CLAIM TO ANY PARTICULAR FONT, STYLE, SIZE, OR COLOR.

FOR CEMENT MIXES FOR PATCHING AND FINISHING (U.S. CLS. 1, 12, 33 AND 50).

DAWN HAN, EXAMINING ATTORNEY

CLASS 19—(Continued).

SN 77-413,935. CENTURY-BOARD USA, LLC, MOORESVILLE, NC. FILED 3-5-2008.

CENTURY-BOARD

THE MARK CONSISTS OF STANDARD CHARACTERS WITHOUT CLAIM TO ANY PARTICULAR FONT, STYLE, SIZE, OR COLOR.

FOR NON-METALLIC BUILDING PRODUCTS, NAMELY, LUMBER, ROOFING, SIDING, FENCING, HIGHWAY LUMBER, BUILDING PANELS, MARINE LUMBER, FLOOR TILES, HOUSING TRIM, MOLDING, WINDOW FRAMES, AND STAIR TREADS (U.S. CLS. 1, 12, 33 AND 50).

JENNIFER HETU, EXAMINING ATTORNEY

SN 77-414,416. PROTON, LLC, DBA DOWN TO EARTH GEOTHERMAL, CLARKSVILLE, MD. FILED 3-6-2008.

Down To Earth Geothermal

THE MARK CONSISTS OF STANDARD CHARACTERS WITHOUT CLAIM TO ANY PARTICULAR FONT, STYLE, SIZE, OR COLOR.

NO CLAIM IS MADE TO THE EXCLUSIVE RIGHT TO USE "GEOTHERMAL", APART FROM THE MARK AS SHOWN.

FOR POLYETHYLENE PIPE USED IN GEOTHERMAL HEATING AND COOLING SYSTEMS (U.S. CLS. 1, 12, 33 AND 50).

LIEF MARTIN, EXAMINING ATTORNEY

SN 77-417,562. APPLIED FELTS, INC., MARTINSVILLE, VA. FILED 3-10-2008.

AQUACURE RP

THE MARK CONSISTS OF STANDARD CHARACTERS WITHOUT CLAIM TO ANY PARTICULAR FONT, STYLE, SIZE, OR COLOR.

NO CLAIM IS MADE TO THE EXCLUSIVE RIGHT TO USE "RP", APART FROM THE MARK AS SHOWN.

FOR COATED FELT INVERSION LINER FOR REINFORCED GRAVITY SEWER LINERS USED IN THE REHABILITATION OF SEWER PIPES USING THE CURED-IN-PLACE-PIPE PROCESS (U.S. CLS. 1, 12, 33 AND 50).

KATHERINE STOIDES, EXAMINING ATTORNEY

CLASS 19—(Continued).

SN 77-422,274. SEAMAN CORPORATION, WOOSTER, OH. FILED 3-14-2008.

PORTOMOD

THE MARK CONSISTS OF STANDARD CHARACTERS WITHOUT CLAIM TO ANY PARTICULAR FONT, STYLE, SIZE, OR COLOR.

FOR PREFABRICATED PRIMARILY NON-METAL BUILDINGS MADE FROM FABRIC, NAMELY, PREFABRICATED RIGID FRAME AND STRESSED FABRIC MEMBRANE BUILDINGS (U.S. CLS. 1, 12, 33 AND 50).
WENDY JUN, EXAMINING ATTORNEY

SN 77-424,674. ESSEX CEMENT COMPANY LLC, PORT NEWARK, NJ. FILED 3-18-2008.



OWNER OF U.S. REG. NOS. 2,914,407 AND 2,951,253.
NO CLAIM IS MADE TO THE EXCLUSIVE RIGHT TO USE "CEMENT" AND "AMERICA BUSINESS", APART FROM THE MARK AS SHOWN.

THE COLOR(S) BLUE AND GRAY IS/ARE CLAIMED AS A FEATURE OF THE MARK.

THE MARK CONSISTS OF THE WORDS "ESSEX" IN ALL LOWER CASE ABOVE THE WORD "CEMENT" IN ALL LOWER CASE. THERE IS A RECTANGLE TO THE LEFT OF THE WORD CEMENT THAT "FADES IN" TO THE COLOR OF THE WORD "CEMENT." THE WORDS "A TITAN AMERICA BUSINESS" ARE BELOW THE WORD "CEMENT". THE WORDS "ESSEX" AND "A TITAN AMERICA BUSINESS" ARE IN BLUE, PMS 288. THE WORD "CEMENT" AND DESIGN TO THE LEFT OF THE WORD CEMENT ARE IN GRAY, PMS 430.

FOR PORTLAND CEMENT (U.S. CLS. 1, 12, 33 AND 50).

RAMONA ORTIGA, EXAMINING ATTORNEY

SN 77-429,184. PILKINGTON NORTH AMERICA, INC., TOLEDO, OH. FILED 3-24-2008.

DATA STOP

THE MARK CONSISTS OF STANDARD CHARACTERS WITHOUT CLAIM TO ANY PARTICULAR FONT, STYLE, SIZE, OR COLOR.

FOR SHEETS OR PANELS OF GLASS PROVIDED WITH AN ELECTRICALLY CONDUCTIVE COATING FOR BUILDING AND CONSTRUCTION (U.S. CLS. 1, 12, 33 AND 50).

LEIGH CAROLINE CASE, EXAMINING ATTORNEY

CLASS 19—(Continued).

SN 77-429,459. SHULER, THOMAS, MEMPHIS, TN. FILED 3-24-2008.

oakleigh hardwood

THE MARK CONSISTS OF STANDARD CHARACTERS WITHOUT CLAIM TO ANY PARTICULAR FONT, STYLE, SIZE, OR COLOR.

NO CLAIM IS MADE TO THE EXCLUSIVE RIGHT TO USE "HARDWOOD", APART FROM THE MARK AS SHOWN.

FOR WOODEN FLOORING (U.S. CLS. 1, 12, 33 AND 50).

EUGENIA MARTIN, EXAMINING ATTORNEY

SN 77-429,521. CARIELLO, BART, FREEPORT, NY. FILED 3-24-2008.

RockGrout

THE MARK CONSISTS OF STANDARD CHARACTERS WITHOUT CLAIM TO ANY PARTICULAR FONT, STYLE, SIZE, OR COLOR.

FOR UNDERWATER CEMENT GROUT FOR REPAIRING MARINE STRUCTURES (U.S. CLS. 1, 12, 33 AND 50).

FIRST USE 10-1-1993; IN COMMERCE 10-1-1993.
HOWARD B. LEVINE, EXAMINING ATTORNEY

SN 77-430,114. JANYLYN MARKS, UPPER LAKE, CA. FILED 3-24-2008.

HonestWood

THE MARK CONSISTS OF STANDARD CHARACTERS WITHOUT CLAIM TO ANY PARTICULAR FONT, STYLE, SIZE, OR COLOR.

FOR WOOD SIDING; WOOD PANNELLING; WOOD BOARDS; WOOD MOLDINGS; WOOD POLES; WOOD POSTS; WOOD RAFTERS; WOOD TRIM; WOOD VENEER; WOOD BEAMS; NON-METAL BUILDING PRODUCTS, NAMELY, SHUTTERS, SHINGLES, SIDING, AND TRIM; NON-METAL CLADDING FOR CONSTRUCTION AND BUILDING (U.S. CLS. 1, 12, 33 AND 50).

WENDY GOODMAN, EXAMINING ATTORNEY

CLASS 19—(Continued).

SN 77-430,343. NEWMAN BROTHERS OF CALIFORNIA, INC., DBA A-1 GRIT COMPANY, RIVERSIDE, CA. FILED 3-25-2008.

SNOW WHITE

THE MARK CONSISTS OF STANDARD CHARACTERS WITHOUT CLAIM TO ANY PARTICULAR FONT, STYLE, SIZE, OR COLOR.

FOR AGGREGATE MATERIAL COMPOSED OF MARBLE FOR ROOFING (U.S. CLS. 1, 12, 33 AND 50). FIRST USE 1-1-2008; IN COMMERCE 1-1-2008. ESTHER BELENKER, EXAMINING ATTORNEY

CLASS 19—(Continued).

SN 77-434,368. KRONOSPAN SCHWEIZ AG, MENZNAU, SWITZERLAND, FILED 3-28-2008.

Zero-F

THE MARK CONSISTS OF STANDARD CHARACTERS WITHOUT CLAIM TO ANY PARTICULAR FONT, STYLE, SIZE, OR COLOR.

OWNER OF SWITZERLAND REG. NO. 563588, DATED 7-19-2007, EXPIRES 7-19-2017. FOR PARTICLE BOARDS AND MEDIUM DENSITY FIBREBOARDS (U.S. CLS. 1, 12, 33 AND 50). ANDREA SAUNDERS, EXAMINING ATTORNEY

SN 77-430,553. KRONOPOL LTD., POLSKA, POLAND, FILED 3-25-2008.

FLOOR-ENCIA

THE MARK CONSISTS OF STANDARD CHARACTERS WITHOUT CLAIM TO ANY PARTICULAR FONT, STYLE, SIZE, OR COLOR.

FOR LAMINATE FLOORING (U.S. CLS. 1, 12, 33 AND 50). RUDY R. SINGLETON, EXAMINING ATTORNEY

SN 77-434,456. KALEI INC, LOS ANGELES, CA. FILED 3-28-2008.

Kaléi

THE MARK CONSISTS OF STANDARD CHARACTERS WITHOUT CLAIM TO ANY PARTICULAR FONT, STYLE, SIZE, OR COLOR.

FOR GLASS TILES (U.S. CLS. 1, 12, 33 AND 50). FIRST USE 4-20-2007; IN COMMERCE 4-20-2007. GRETTA YAO, EXAMINING ATTORNEY

SN 77-433,285. FLORIDA TILE, INC., LAKELAND, FL. FILED 3-27-2008.

FT

THE MARK CONSISTS OF STANDARD CHARACTERS WITHOUT CLAIM TO ANY PARTICULAR FONT, STYLE, SIZE, OR COLOR.

OWNER OF U.S. REG. NO. 660,002. FOR CERAMIC TILES (U.S. CLS. 1, 12, 33 AND 50). FIRST USE 5-15-1954; IN COMMERCE 5-15-1954. WANDA KAY PRICE, EXAMINING ATTORNEY

SN 77-434,864. QUOTES ON BOARD, LLC, LAKEWOOD, CO. FILED 3-28-2008.

quotesonboard.com

THE MARK CONSISTS OF STANDARD CHARACTERS WITHOUT CLAIM TO ANY PARTICULAR FONT, STYLE, SIZE, OR COLOR.

FOR WOOD BOARDS, NAMELY, 2X4S, HAVING PHRASES DISPLAYED THEREON (U.S. CLS. 1, 12, 33 AND 50). TEJBIR SINGH, EXAMINING ATTORNEY

CLASS 19—(Continued).

SN 77-445,251. MILLIKEN & COMPANY, SPARTANBURG, SC. FILED 4-10-2008.

TRANSCEND

THE MARK CONSISTS OF STANDARD CHARACTERS WITHOUT CLAIM TO ANY PARTICULAR FONT, STYLE, SIZE, OR COLOR.

FOR CEILING PANELS, NOT OF METAL (U.S. CLS. 1, 12, 33 AND 50).

KELLY MCCOY, EXAMINING ATTORNEY

SN 77-461,589. PENTAIR FILTRATION, INC., SHEBOYGAN, WI. FILED 4-30-2008.

PENTEK

THE MARK CONSISTS OF STANDARD CHARACTERS WITHOUT CLAIM TO ANY PARTICULAR FONT, STYLE, SIZE, OR COLOR.

OWNER OF U.S. REG. NO. 2,949,145.

FOR UNDERGROUND UTILITY ACCESS BOXES MADE OF NON-METAL MATERIALS (U.S. CLS. 1, 12, 33 AND 50).

MARIA-VICTORIA SUAREZ, EXAMINING ATTORNEY

SN 78-815,145. COMMONWEALTH PLYWOOD CO. LTD., STE. THERESE, QUEBEC, CANADA, FILED 2-15-2006.

HUSKY STAIN

THE MARK CONSISTS OF STANDARD CHARACTERS WITHOUT CLAIM TO ANY PARTICULAR FONT, STYLE, SIZE, OR COLOR.

PRIORITY CLAIMED UNDER SEC. 44(D) ON CANADA APPLICATION NO. 1288707, FILED 2-6-2006, REG. NO. TMA696651, DATED 9-18-2007, EXPIRES 9-18-2022.

OWNER OF U.S. REG. NO. 1,177,236.

FOR BUILDING MATERIALS, NAMELY, ROUGH OR PRE-FINISHED SOLID WOOD FLOORING BOARDS (U.S. CLS. 1, 12, 33 AND 50).

WENDY JUN, EXAMINING ATTORNEY

CLASS 19—(Continued).

SN 78-816,416. COMMONWEALTH PLYWOOD CO. LTD., STE. THERESE, QUEBEC, CANADA, FILED 2-16-2006.

HUSKY FINISH

THE MARK CONSISTS OF STANDARD CHARACTERS WITHOUT CLAIM TO ANY PARTICULAR FONT, STYLE, SIZE, OR COLOR.

OWNER OF CANADA REG. NO. 1288713, DATED 9-18-2007, EXPIRES 9-18-2022.

OWNER OF U.S. REG. NO. 1,177,236.

FOR BUILDING MATERIALS, NAMELY, ROUGH OR PRE-FINISHED SOLID WOOD FLOORING BOARDS (U.S. CLS. 1, 12, 33 AND 50).

WENDY JUN, EXAMINING ATTORNEY

SN 79-047,138. MOMO DESIGN S.R.L., ITALY, FILED 10-19-2007.

MOMODESIGN

OWNER OF INTERNATIONAL REGISTRATION 0945886 DATED 10-19-2007, EXPIRES 10-19-2017.

OWNER OF U.S. REG. NOS. 2,652,011, 3,041,899 AND OTHERS.

NO CLAIM IS MADE TO THE EXCLUSIVE RIGHT TO USE "DESIGN", APART FROM THE MARK AS SHOWN.

WRITING "MOMODESIGN" IN SPECIAL CHARACTERS.

FOR NON METALLIC BUILDING MATERIALS, NAMELY, NON-METAL TILES, CERAMIC FLOOR AND WALL TILES, FLOOR AND WALL NATURAL STONES, GLASS AND WOOD MATERIALS COMBINED WITH FLOOR AND WALL TILES FOR USE IN BUILDING (U.S. CLS. 1, 12, 33 AND 50).

ANN E. SAPPENFIELD, EXAMINING ATTORNEY

CLASS 20—FURNITURE AND ARTICLES NOT OTHERWISE CLASSIFIED

SN 76-650,606. THE PENCIL GRIP, INC., BRIGHTWATERS, NY. FILED 11-14-2005.

CHAIR SOX

THE MARK CONSISTS OF STANDARD CHARACTERS WITHOUT CLAIM TO ANY PARTICULAR FONT, STYLE, SIZE, OR COLOR.

NO CLAIM IS MADE TO THE EXCLUSIVE RIGHT TO USE "CHAIR", APART FROM THE MARK AS SHOWN.

FOR CHAIR LEG END COVERS AND DESK LEG END COVERS (U.S. CLS. 2, 13, 22, 25, 32 AND 50).

FIRST USE 1-1-2005; IN COMMERCE 1-1-2005.

CHARLOTTE CORWIN, EXAMINING ATTORNEY

CLASS 20—(Continued).

SN 76-666,239. SCHOTT AG, D-55122 MAINZ, FED REP GERMANY, FILED 9-18-2006.

Schott PI Coating

THE MARK CONSISTS OF STANDARD CHARACTERS WITHOUT CLAIM TO ANY PARTICULAR FONT, STYLE, SIZE, OR COLOR.

NO CLAIM IS MADE TO THE EXCLUSIVE RIGHT TO USE "COATING", APART FROM THE MARK AS SHOWN, FOR FITTED PRIMARY PACKAGING MADE OF SPECIAL GLASS AND PLASTICS FOR PHARMACEUTICAL PREPARATIONS, NAMELY, PHARMACEUTICAL VIALS, CARTRIDGES, AMPOULES, INJECTION AMPOULES, FINE TIP AND DRINKING AMPOULES, AND AEROSOL CONTAINERS, ALL SOLD EMPTY (U.S. CLS. 2, 13, 22, 25, 32 AND 50).

FIRST USE 9-0-2005; IN COMMERCE 9-0-2005.
ALICE BENMAMAN, EXAMINING ATTORNEY

SN 76-679,898. KABUSHIKI KAISHA SATO CHISHIKI ZAI-SAN KENKYUSHO, SHIBUYA-KU, TOKYO 150-0013, JAPAN, FILED 7-25-2007.

SLIP-ON

THE MARK CONSISTS OF STANDARD CHARACTERS WITHOUT CLAIM TO ANY PARTICULAR FONT, STYLE, SIZE, OR COLOR.

SEC. 2(F).
FOR BLANK OR PARTIALLY PRINTED PLASTIC LABELS AND PLASTIC TAGS FOR USE IN THE DESIGNATION OF PLANTS AND HORTICULTURAL PRODUCTS (U.S. CLS. 2, 13, 22, 25, 32 AND 50).
FIRST USE 4-0-1954; IN COMMERCE 5-26-1954.
ESTHER BELENKER, EXAMINING ATTORNEY

SN 76-683,388. L&P PROPERTY MANAGEMENT COMPANY, SOUTH GATE, CA. FILED 10-29-2007.

ACTIVE SUPPORT

THE MARK CONSISTS OF STANDARD CHARACTERS WITHOUT CLAIM TO ANY PARTICULAR FONT, STYLE, SIZE, OR COLOR.

NO CLAIM IS MADE TO THE EXCLUSIVE RIGHT TO USE "SUPPORT", APART FROM THE MARK AS SHOWN.
FOR BEDDING PRODUCTS, NAMELY, MATTRESSES AND MATTRESS FOUNDATIONS (U.S. CLS. 2, 13, 22, 25, 32 AND 50).

CHRISTOPHER BUONGIORNO, EXAMINING ATTORNEY

CLASS 20—(Continued).

SN 77-070,409. WELLBORN HOLDINGS, INC., ASHLAND, AL. FILED S.R. 12-22-2006; AM. P.R. 6-20-2008.

ZONA Cucina

NO CLAIM IS MADE TO THE EXCLUSIVE RIGHT TO USE "ZONA CUCINA", APART FROM THE MARK AS SHOWN.

THE FOREIGN WORDING IN THE MARK TRANSLATES INTO ENGLISH AS "KITCHEN SPACE".

FOR FURNITURE, NAMELY, CABINETS, DRAWERS, CUPBOARDS AND SHELVES; ORGANIZATIONAL DIVIDERS AND ACCESSORIES, NAMELY, PLATE RACKS, BOTTLE STORAGE RACKS, DRAWER ORGANIZERS FOR UTENSILS AND CUTLERY, DEEP DRAWER DIVIDERS, PULL OUT SWING PANTRY UNITS, AND INTERIOR ROLL OUT DRAWERS, EACH SOLD AS A UNIT WITH CABINETS, DRAWERS, CUPBOARDS OR SHELVES; AND KITCHEN CABINETS, NAMELY, APPLIANCE END PANELS, AND APPLIANCE FRONT PANELS; AND CABINET UNITS FOR APPLIANCES, NAMELY, COOKTOPS, OVENS, REFRIGERATORS, COFFEE SYSTEMS, AND MICROWAVES (U.S. CLS. 2, 13, 22, 25, 32 AND 50).

JIM RINGLE, EXAMINING ATTORNEY

SN 77-241,529. KIRKENDALL, ALLAN R. ROSEBURG, OR. AND KIRKENDALL, SHERYL L. ROSEBURG, OR. AND DOWNING, ANDREA L. MESA, AZ. AND KIRKENDALL, GEOFFREY A. ROSEBURG, OR. FILED 7-29-2007.

WineStem

THE MARK CONSISTS OF STANDARD CHARACTERS WITHOUT CLAIM TO ANY PARTICULAR FONT, STYLE, SIZE, OR COLOR.

FOR WINE RACKS (U.S. CLS. 2, 13, 22, 25, 32 AND 50).
FIRST USE 3-1-2006; IN COMMERCE 3-20-2006.
PAUL MORENO, EXAMINING ATTORNEY

CLASS 20—(Continued).

SN 77-246,427. LEHMANN, TAMELA, CUMBERLAND, MD.
FILED 8-3-2007.

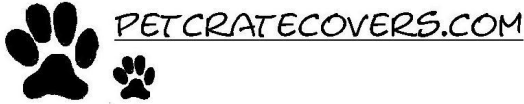

NO CLAIM IS MADE TO THE EXCLUSIVE RIGHT TO USE "PETCRATECOVERS.COM", APART FROM THE MARK AS SHOWN.

THE MARK CONSISTS OF THE WORDS "PETCRATECOVERS.COM" IN A STYLIZED TEXT WITH TWO PAW PRINTS.

FOR FITTED FABRIC PET CRATES AND KENNEL COVERS THAT ARE FIVE-SIDED, MACHINE-WASHABLE, AND ARE UNIVERSAL TO FIT OVER ALL STANDARD-SIZED WIRE PET CRATES AND KENNELS REGARDLESS OF DOOR PLACEMENT (U.S. CLS. 2, 13, 22, 25, 32 AND 50).

FIRST USE 8-13-2007; IN COMMERCE 8-13-2007.
DANIEL BRODY, EXAMINING ATTORNEY

SN 77-252,139. FREEDOM CONCEPTS INC., WINNIPEG,
MANITOBA, CANADA, FILED 8-10-2007.

CHILL-OUT CHAIR

THE MARK CONSISTS OF STANDARD CHARACTERS WITHOUT CLAIM TO ANY PARTICULAR FONT, STYLE, SIZE, OR COLOR.

PRIORITY CLAIMED UNDER SEC. 44(D) ON CANADA APPLICATION NO. 1337458, FILED 2-21-2007.

NO CLAIM IS MADE TO THE EXCLUSIVE RIGHT TO USE "CHAIR", APART FROM THE MARK AS SHOWN.

FOR FURNITURE, NAMELY, LIVING AND FAMILY ROOM FURNITURE; CHAIR FOR INDOOR USE, NAMELY, CHAIR WITH OTTOMAN, ARM CHAIR; CHAIR PADS; OTTOMAN (U.S. CLS. 2, 13, 22, 25, 32 AND 50).

FIRST USE 6-5-2005; IN COMMERCE 6-5-2005.
STEVEN R. FINE, EXAMINING ATTORNEY

SN 77-258,840. HUBER, LISA T, DBA HUBER MARKETING
GROUP, CHANHASSEN, MN. FILED 8-19-2007.

LightStone Edging

THE MARK CONSISTS OF STANDARD CHARACTERS WITHOUT CLAIM TO ANY PARTICULAR FONT, STYLE, SIZE, OR COLOR.

NO CLAIM IS MADE TO THE EXCLUSIVE RIGHT TO USE "EDGING", APART FROM THE MARK AS SHOWN.

FOR FAUX STONE GARDEN/LANDSCAPE EDGING THAT IS NON METAL OR PLASTIC (U.S. CLS. 2, 13, 22, 25, 32 AND 50).

SUNG IN, EXAMINING ATTORNEY

CLASS 20—(Continued).

SN 77-260,931. O'WEL PRODUCTIONS, MACOMB, MI.
FILED 8-21-2007.



THE MARK CONSISTS OF THE WORD "MOMMYHOOD" IN STYLIZED FORM OVERLAYING THE INFINITY SIGN, FOR FURNITURE (U.S. CLS. 2, 13, 22, 25, 32 AND 50).
GISELLE AGOSTO, EXAMINING ATTORNEY

SN 77-280,012. USM HOLDING AG, GUMLIGEN, SWITZERLAND,
FILED 9-14-2007.

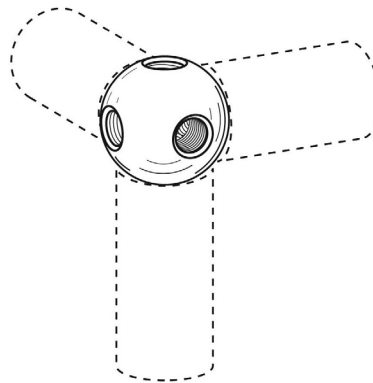

PRIORITY CLAIMED UNDER SEC. 44(D) ON AUSTRALIA APPLICATION NO. 1166221, FILED 3-15-2007.

THE MARK CONSISTS OF THE DESIGN OF A CONNECTING BALL PORTION OF THE FURNITURE. THE BALL IS ROUND WITH SIX OPENINGS FOR USE IN ATTACHMENT TO THE FURNITURE. THE DOTTED LINES ARE NOT PART OF THE MARK, BUT ARE INTENDED TO SHOW THE POSITION OF THE MARK ON THE GOODS AND NO CLAIM IS MADE TO THEM.

SEC. 2(F).

FOR FURNITURE, METAL FURNITURE, OFFICE FURNITURE, STORAGE CABINETS, METAL CUPBOARDS, DISPLAY CASES, SHELVING, AND PARTS FOR FURNITURE (U.S. CLS. 2, 13, 22, 25, 32 AND 50).

FIRST USE 8-31-1971; IN COMMERCE 8-31-1971.

G. MAYERSCHOFF, EXAMINING ATTORNEY

CLASS 20—(Continued).

SN 77-289,680. SMART BOX LLC, MIAMI, FL. FILED 9-26-2007.

Smart Box

THE MARK CONSISTS OF STANDARD CHARACTERS WITHOUT CLAIM TO ANY PARTICULAR FONT, STYLE, SIZE, OR COLOR.

NO CLAIM IS MADE TO THE EXCLUSIVE RIGHT TO USE "BOX", APART FROM THE MARK AS SHOWN.

FOR PACKAGING MATERIALS, NAMELY, PLASTIC SHIPPING AND STORAGE BOXES; CONTAINERS, NOT OF METAL FOR COMMERCIAL USE; PLASTIC STORAGE CONTAINERS FOR COMMERCIAL OR INDUSTRIAL USE (U.S. CLS. 2, 13, 22, 25, 32 AND 50).

RONALD AIKENS, EXAMINING ATTORNEY

CLASS 20—(Continued).

SN 77-313,349. SERTA, INC., HOFFMAN ESTATES, IL. FILED 10-25-2007.

ACTIVE RESPONSE

THE MARK CONSISTS OF STANDARD CHARACTERS WITHOUT CLAIM TO ANY PARTICULAR FONT, STYLE, SIZE, OR COLOR.

OWNER OF U.S. REG. NOS. 3,325,483 AND 3,330,315. FOR MATTRESS COMPONENT, NAMELY, THE INNERSPRING UNIT, WHICH IS SOLD AS PART OF THE MATTRESS (U.S. CLS. 2, 13, 22, 25, 32 AND 50).

PAUL CROWLEY, EXAMINING ATTORNEY

SN 77-303,839. KRAFTMAID CABINETRY, INC., MIDDLEFIELD, OH. FILED 10-15-2007.

MASCO RETAIL CABINET GROUP

THE MARK CONSISTS OF STANDARD CHARACTERS WITHOUT CLAIM TO ANY PARTICULAR FONT, STYLE, SIZE, OR COLOR.

NO CLAIM IS MADE TO THE EXCLUSIVE RIGHT TO USE "RETAIL CABINET GROUP", APART FROM THE MARK AS SHOWN.

FOR KITCHEN AND BATH CABINETRY (U.S. CLS. 2, 13, 22, 25, 32 AND 50).

DOMINIC J. FERRAIUOLO, EXAMINING ATTORNEY

SN 77-334,133. DOREL JUVENILE GROUP, INC., CANTON, MA. FILED 11-20-2007.

FEAST N FOLD

THE MARK CONSISTS OF STANDARD CHARACTERS WITHOUT CLAIM TO ANY PARTICULAR FONT, STYLE, SIZE, OR COLOR.

NO CLAIM IS MADE TO THE EXCLUSIVE RIGHT TO USE "FOLD", APART FROM THE MARK AS SHOWN.

FOR HIGH CHAIRS; BOOSTER SEATS (U.S. CLS. 2, 13, 22, 25, 32 AND 50).

ASMAT KHAN, EXAMINING ATTORNEY

SN 77-305,801. WINE FATHER, LLC, CHICAGO, IL. FILED 10-17-2007.

GEO-CORK

THE MARK CONSISTS OF STANDARD CHARACTERS WITHOUT CLAIM TO ANY PARTICULAR FONT, STYLE, SIZE, OR COLOR.

FOR CORKS AND STOPPERS FOR SEALING WINE BOTTLES AND OTHER BOTTLES (U.S. CLS. 2, 13, 22, 25, 32 AND 50).

DOMINIC J. FERRAIUOLO, EXAMINING ATTORNEY

SN 77-346,086. 6860966 CANADA INC., LAVAL, CANADA, FILED 12-6-2007.

essentia 

PRIORITY CLAIMED UNDER SEC. 44(D) ON CANADA APPLICATION NO. 1350490, FILED 6-6-2007, REG. NO. TMA715589, DATED 5-30-2008, EXPIRES 5-30-2023.

FOR BED MATTRESSES, BED PILLOWS (U.S. CLS. 2, 13, 22, 25, 32 AND 50).

DOMINIC J. FERRAIUOLO, EXAMINING ATTORNEY

CLASS 20—(Continued).

SN 77-355,030. ENDICK, MITCHELL, ATHENS, OH. FILED 12-18-2007.

Sleep Smith

THE MARK CONSISTS OF STANDARD CHARACTERS WITHOUT CLAIM TO ANY PARTICULAR FONT, STYLE, SIZE, OR COLOR.

OWNER OF U.S. REG. NO. 3,045,829.
FOR BOX SPRINGS; MATTRESSES (U.S. CLS. 2, 13, 22, 25, 32 AND 50).
FIRST USE 3-10-2006; IN COMMERCE 10-10-2007.
GRETTA YAO, EXAMINING ATTORNEY

SN 77-408,978. BERKSHIRE CABINETRY, INC., NAPPANEE, IN. FILED 2-28-2008.

BERKSHIRE CABINETS

THE MARK CONSISTS OF STANDARD CHARACTERS WITHOUT CLAIM TO ANY PARTICULAR FONT, STYLE, SIZE, OR COLOR.

NO CLAIM IS MADE TO THE EXCLUSIVE RIGHT TO USE "CABINETS", APART FROM THE MARK AS SHOWN.
FOR CABINETRY, NAMELY, KITCHEN AND BATHROOM CABINETS, UTILITY CABINETS, WALL CABINETS, BASE CABINETS, BATHROOM VANITIES AND RELATED STRUCTURAL COMPONENTS THEREOF SOLD AS A UNIT, NAMELY, WOOD MOLDING AND LAZY SUSANS (U.S. CLS. 2, 13, 22, 25, 32 AND 50).
GEORGIA CARTY, EXAMINING ATTORNEY

SN 77-409,609. ELEVATION STUDIOS INC., WAUKEGAN, IL. FILED 2-29-2008.



NO CLAIM IS MADE TO THE EXCLUSIVE RIGHT TO USE "STUDIOS INC.", APART FROM THE MARK AS SHOWN.

THE COLOR(S) WHITE GREEN BLUE IS/ARE CLAIMED AS A FEATURE OF THE MARK.

THE MARK CONSISTS OF GREEN SQUARE WITH 4 WHITE ARROW SHAPED FORMS INSIDE SQUARE 1 BLUE ARROW SHAPED FORM IN UPPER RIGHT CORNER OF SQUARE. TEXT LOCATED TO THE RIGHT OF SQUARE GRAPHIC.

FOR FURNITURE FOR DISPLAYING GOODS; POINT OF PURCHASE DISPLAYS (U.S. CLS. 2, 13, 22, 25, 32 AND 50).

FIRST USE 11-1-2006; IN COMMERCE 11-1-2006.
RONALD AIKENS, EXAMINING ATTORNEY

CLASS 20—(Continued).

SN 77-409,989. FOAMORDER.COM, INC., SAN FRANCISCO, CA. FILED 2-29-2008.



NO CLAIM IS MADE TO THE EXCLUSIVE RIGHT TO USE "ALL NATURAL FOAM MADE FROM TREE SAP", APART FROM THE MARK AS SHOWN.

THE MARK CONSISTS OF THE LITERAL ELEMENT "NATURAL SENSE" WITH A SOLID TRIANGLE ABOVE IT CONFORMING TO THE SHAPE OF THE LETTERS AND A SOLID TRIANGLE BELOW IT CONTAINING THE LITERAL ELEMENT "ALL NATURAL FOAM MADE FROM TREE SAP."

FOR MATTRESSES AND PILLOWS (U.S. CLS. 2, 13, 22, 25, 32 AND 50).

FIRST USE 6-4-2007; IN COMMERCE 9-3-2007.
MELISSA VALLILLO, EXAMINING ATTORNEY

SN 77-416,082. NEWELL OPERATING COMPANY, ATLANTA, GA. FILED 3-7-2008.

LEVOLOR

THE MARK CONSISTS OF STANDARD CHARACTERS WITHOUT CLAIM TO ANY PARTICULAR FONT, STYLE, SIZE, OR COLOR.

FOR VENETIAN AND VERTICAL WINDOW BLINDS; ROLL UP AND BEAD CHAIN WINDOW SHADES; SAMPLERS IN THE NATURE OF DISPLAYS CONSISTING OF SMALL SIZE WINDOW BLINDS OF ALL TYPES AND OPERATING HARDWARE FOR SUCH BLINDS SOLD AS A UNIT THEREWITH, USED FOR ILLUSTRATIVE AND DEMONSTRATION PURPOSES; DECKS OF WINDOW BLIND SLAT SEGMENTS FOR COLOR ILLUSTRATION PURPOSES (U.S. CLS. 2, 13, 22, 25, 32 AND 50).

FIRST USE 1-21-1941; IN COMMERCE 1-21-1941.
MELISSA VALLILLO, EXAMINING ATTORNEY

CLASS 20—(Continued).

SN 77-416,287. NEWELL OPERATING COMPANY, ATLANTA, GA. FILED 3-7-2008.

LEVOLOR

THE MARK CONSISTS OF STANDARD CHARACTERS WITHOUT CLAIM TO ANY PARTICULAR FONT, STYLE, SIZE, OR COLOR.
FOR PLEATED, SPRING ROLLER, AND ROLL-UP WINDOW SHADES ALL MADE OF FABRIC (U.S. CLS. 2, 13, 22, 25, 32 AND 50).
FIRST USE 5-11-1954; IN COMMERCE 5-11-1954.
MELISSA VALLILLO, EXAMINING ATTORNEY

CLASS 20—(Continued).

SN 77-419,424. NINGBO HONGDU MODEL PLASTICS CO., LTD, NINGBO, CHINA, FILED 3-11-2008.



THE COLOR(S) MAUVE, CREAM, BROWN, WHITE, PINK AND BLACK IS/ARE CLAIMED AS A FEATURE OF THE MARK.
THE MARK CONSISTS OF A MAUVE COLORED RECTANGLE WITH ROUNDED CORNERS ON A CREAM BACKGROUND CONTAINING THE MAUVE "PETMODE" LOGO AT THE TOP AND A PHOTO OF THE HEAD AND NECK OF A LABRADOR DOG WITH BROWN AND WHITE FUR, A PINK TONGUE AND BLACK NOSE AND EYES, IN THE BOTTOM RIGHT HAND CORNER.
FOR DOG BEDS; DOG KENNELS (U.S. CLS. 2, 13, 22, 25, 32 AND 50).
RUDY R. SINGLETON, EXAMINING ATTORNEY

SN 77-416,412. SPIRIT SPECIALTY SOLUTIONS, INC., LANSDOWNE, PA. FILED 3-7-2008.

PAN MINDER

THE MARK CONSISTS OF STANDARD CHARACTERS WITHOUT CLAIM TO ANY PARTICULAR FONT, STYLE, SIZE, OR COLOR.
OWNER OF U.S. REG. NO. 2,502,708.
NO CLAIM IS MADE TO THE EXCLUSIVE RIGHT TO USE "PAN", APART FROM THE MARK AS SHOWN.
FOR PLASTIC MERCHANDISING LABELS FEATURING PRODUCT INFORMATION FOR FOOD ITEMS (U.S. CLS. 2, 13, 22, 25, 32 AND 50).
FIRST USE 11-0-2006; IN COMMERCE 11-0-2006.
NATALIE POLZER, EXAMINING ATTORNEY

SN 77-420,951. LA-Z-BOY INCORPORATED, MONROE, MI. FILED 3-13-2008.

AMERICAN JOURNAL

THE MARK CONSISTS OF STANDARD CHARACTERS WITHOUT CLAIM TO ANY PARTICULAR FONT, STYLE, SIZE, OR COLOR.
NO CLAIM IS MADE TO THE EXCLUSIVE RIGHT TO USE "AMERICAN", APART FROM THE MARK AS SHOWN.
FOR FURNITURE (U.S. CLS. 2, 13, 22, 25, 32 AND 50).
MARY CRAWFORD, EXAMINING ATTORNEY

SN 77-421,292. MILTON ADLER CO., PLEASANTVILLE, NJ. FILED 3-13-2008.

DAVEE

THE MARK CONSISTS OF STANDARD CHARACTERS WITHOUT CLAIM TO ANY PARTICULAR FONT, STYLE, SIZE, OR COLOR.
FOR FLORISTS' ACCESSORIES, NAMELY, ADHESIVE BACKED CLOTH TAPE (U.S. CLS. 2, 13, 22, 25, 32 AND 50).
BENJAMIN ALLEN, EXAMINING ATTORNEY

CLASS 20—(Continued).

SN 77-423,392. MUMOOOCIE, INC., SANFORD, FL. FILED 3-17-2008.



THE MARK CONSISTS OF THE WORD "MUMOOOCIE" WITH THE LETTERING RESEMBLING STITCHING WITH A CAPITAL M, A BACKWARDS C, BOTH O'S FILLED IN AND THE DOT OVER THE I AS A FILLED IN CIRCLE. FOR PILLOWS (U.S. CLS. 2, 13, 22, 25, 32 AND 50). FIRST USE 2-19-2008; IN COMMERCE 2-19-2008. JILL PRATER, EXAMINING ATTORNEY

SN 77-425,753. PANDUIT CORP., TINLEY PARK, IL. FILED 3-19-2008.

TURN-TELL

THE MARK CONSISTS OF STANDARD CHARACTERS WITHOUT CLAIM TO ANY PARTICULAR FONT, STYLE, SIZE, OR COLOR. FOR PLASTIC LABELS FOR IDENTIFICATION OF CABLES AND WIRES (U.S. CLS. 2, 13, 22, 25, 32 AND 50). TASHIA BUNCH, EXAMINING ATTORNEY

SN 77-426,451. HIGHLAND PLASTICS, INC., PASADENA, CA. FILED 3-19-2008.

HI-PLAS

THE MARK CONSISTS OF STANDARD CHARACTERS WITHOUT CLAIM TO ANY PARTICULAR FONT, STYLE, SIZE, OR COLOR. FOR MOLDED PLASTIC CONTAINERS FOR CONSUMER PACKAGING (U.S. CLS. 2, 13, 22, 25, 32 AND 50). FIRST USE 12-31-1958; IN COMMERCE 12-31-1958. ROBIN CHOSID, EXAMINING ATTORNEY

CLASS 20—(Continued).

SN 77-428,604. HARD ROCK CAFE INTERNATIONAL (USA), INC., ORLANDO, FL. FILED 3-21-2008.

HARD ROCK HOTEL

THE MARK CONSISTS OF STANDARD CHARACTERS WITHOUT CLAIM TO ANY PARTICULAR FONT, STYLE, SIZE, OR COLOR. OWNER OF U.S. REG. NOS. 1,909,483, 3,272,459 AND OTHERS. FOR MATTRESS FOUNDATIONS; MATTRESSES (U.S. CLS. 2, 13, 22, 25, 32 AND 50). JIM RINGLE, EXAMINING ATTORNEY

SN 77-429,082. VJJ ENTERPRISES, INC., LAKE TAPPS, WA. FILED 3-23-2008.

Va j-j Visor

THE MARK CONSISTS OF STANDARD CHARACTERS WITHOUT CLAIM TO ANY PARTICULAR FONT, STYLE, SIZE, OR COLOR. FOR FEMALE VAGINAL INNER VULVA AND ANAL COVER, NAMELY, A PLASTIC PROTECTIVE SHIELD FOR A WOMAN'S GENITAL AREA, FOR USE WHEN REMOVING PUBIC HAIR, DYING AND BLEACHING PUBIC HAIR, TANNING, TATTOOING, PIERCING, AND TRYING ON INTIMATE APPAREL AND BATHING SUITS (U.S. CLS. 2, 13, 22, 25, 32 AND 50). HEATHER THOMPSON, EXAMINING ATTORNEY

SN 77-429,188. OTIS BED MANUFACTURING COMPANY, INC., BUFFALO, NY. FILED 3-24-2008.



THE MARK CONSISTS OF THE STYLIZED WORD "IFORM" WHEREIN THE LETTER "I" IS IN LOWERCASE FORM AND INCORPORATES A COIL SPRING DESIGN. FOR MATTRESSES AND MATTRESS FOUNDATIONS (U.S. CLS. 2, 13, 22, 25, 32 AND 50). TINA BROWN, EXAMINING ATTORNEY

CLASS 20—(Continued).

SN 77-429,192. OTIS BED MANUFACTURING COMPANY, INC., BUFFALO, NY. FILED 3-24-2008.



THE MARK CONSISTS OF THE STYLIZED WORD "IMOD" WHEREIN THE LETTER "I" IS IN LOWERCASE FORM AND INCORPORATES A COIL SPRING DESIGN. FOR MATTRESSES AND MATTRESS FOUNDATIONS (U.S. CLS. 2, 13, 22, 25, 32 AND 50).
TINA BROWN, EXAMINING ATTORNEY

SN 77-429,216. OTIS BED MANUFACTURING COMPANY, INC., BUFFALO, NY. FILED 3-24-2008.

IFORM

THE MARK CONSISTS OF STANDARD CHARACTERS WITHOUT CLAIM TO ANY PARTICULAR FONT, STYLE, SIZE, OR COLOR. FOR MATTRESSES AND MATTRESS FOUNDATIONS (U.S. CLS. 2, 13, 22, 25, 32 AND 50).
TINA BROWN, EXAMINING ATTORNEY

SN 77-429,269. ZORCH INTERNATIONAL, INC., CHICAGO, IL. FILED 3-24-2008.

ZORCH

THE MARK CONSISTS OF STANDARD CHARACTERS WITHOUT CLAIM TO ANY PARTICULAR FONT, STYLE, SIZE, OR COLOR. OWNER OF U.S. REG. NO. 2,993,947. FOR OFFICE FURNITURE (U.S. CLS. 2, 13, 22, 25, 32 AND 50).
EMILY CARLSEN, EXAMINING ATTORNEY

CLASS 20—(Continued).

SN 77-429,560. LI JIANGUO, LU CHENG DISTRICT, CHINA. FILED 3-24-2008.



THE MARK CONSISTS OF THE STYLIZED LETTER "E". FOR FURNITURE; SIDEBARDS; BEDS; MIRRORS AS FURNITURE; PILLOWS; SLEEPING BAGS FOR CAMPING; COSTUME DISPLAY STANDS; CHAIRS; SOFAS (U.S. CLS. 2, 13, 22, 25, 32 AND 50).
FIRST USE 8-0-2006; IN COMMERCE 3-0-2007.
MICHAEL SOUDERS, EXAMINING ATTORNEY

SN 77-429,923. TECHNIMARK, INC., ASHEBORO, NC. FILED 3-24-2008.

HOME SELECTS

THE MARK CONSISTS OF STANDARD CHARACTERS WITHOUT CLAIM TO ANY PARTICULAR FONT, STYLE, SIZE, OR COLOR. FOR CLOTHES HANGERS (U.S. CLS. 2, 13, 22, 25, 32 AND 50).
FIRST USE 5-31-2007; IN COMMERCE 5-31-2007.
NORA BUCHANAN WILL, EXAMINING ATTORNEY

CLASS 20—(Continued).

SN 77-429,925. PROMENS USA, INC., SOUTH BEND, IN.
FILED 3-24-2008.

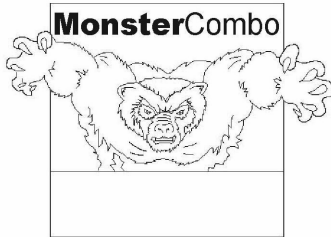

OWNER OF U.S. REG. NO. 3,332,635.
THE MARK CONSISTS OF THE WORD "MONSTERCOMBO" APPEARING ABOVE A STYLIZED DESIGN OF A MONSTER WITH OUTSTRETCHED ARMS, ALL WITHIN A RECTANGULAR OUTLINE DESIGN.
FOR PLASTIC CONTAINERS FOR MATERIAL HANDLING AND SHIPPING FOR INDUSTRIAL USE (U.S. CLS. 2, 13, 22, 25, 32 AND 50).
RUDY R. SINGLETON, EXAMINING ATTORNEY

SN 77-429,932. TECHNIMARK, INC., ASHEBORO, NC.
FILED 3-24-2008.

RENEW

THE MARK CONSISTS OF STANDARD CHARACTERS WITHOUT CLAIM TO ANY PARTICULAR FONT, STYLE, SIZE, OR COLOR.
FOR CLOTHES HANGERS (U.S. CLS. 2, 13, 22, 25, 32 AND 50).
FIRST USE 6-30-2007; IN COMMERCE 6-30-2007.
NORA BUCHANAN WILL, EXAMINING ATTORNEY

SN 77-430,337. IMPERIAL BEDDING COMPANY, SAN ANTONIO, TX. FILED 3-25-2008.



THE MARK CONSISTS OF A STYLIZED IMAGE OF A HUMAN-LIKE FIGURE IN RECLINING POSITION.
FOR BEDS, MATTRESSES, PILLOWS AND BOLSTERS; BEDSPRINGS; BOLSTERS; BOX SPRINGS; BEDS; MATTRESS TOPPERS; MATTRESSES; MATTRESSES AND PILLOWS; MATTRESS CUSHIONS; MATTRESS FOUNDATIONS (U.S. CLS. 2, 13, 22, 25, 32 AND 50).
ESTHER BELENKER, EXAMINING ATTORNEY

CLASS 20—(Continued).

SN 77-430,341. IMPERIAL BEDDING COMPANY, SAN ANTONIO, TX. FILED 3-25-2008.

DESIGNS FOR THE SLEEP OF YOUR LIFE

THE MARK CONSISTS OF STANDARD CHARACTERS WITHOUT CLAIM TO ANY PARTICULAR FONT, STYLE, SIZE, OR COLOR.
FOR BEDS; BEDS, MATTRESSES, PILLOWS AND BOLSTERS; BEDSPRINGS; BOLSTERS; BOX SPRINGS; MATTRESS CUSHIONS; MATTRESS FOUNDATIONS; MATTRESS TOPPERS; MATTRESSES; MATTRESSES AND PILLOWS (U.S. CLS. 2, 13, 22, 25, 32 AND 50).
ESTHER BELENKER, EXAMINING ATTORNEY

SN 77-431,185. HABIMANA, YOLONDA P, FRISCO, TX.
FILED 3-25-2008.

Living Exploring Dreaming, One pad at a time

THE MARK CONSISTS OF STANDARD CHARACTERS WITHOUT CLAIM TO ANY PARTICULAR FONT, STYLE, SIZE, OR COLOR.
FOR BABY CHANGING PADS IN THE NATURE OF MATS (U.S. CLS. 2, 13, 22, 25, 32 AND 50).
LAURA HAMMEL, EXAMINING ATTORNEY

SN 77-432,378. FIGUREPRINTS, LLC, KIRKLAND, WA.
FILED 3-26-2008.

FIGURE PRINTS

THE MARK CONSISTS OF STANDARD CHARACTERS WITHOUT CLAIM TO ANY PARTICULAR FONT, STYLE, SIZE, OR COLOR.
NO CLAIM IS MADE TO THE EXCLUSIVE RIGHT TO USE "FIGURE", APART FROM THE MARK AS SHOWN.
FOR FIGURINES OF PLASTER (U.S. CLS. 2, 13, 22, 25, 32 AND 50).
FIRST USE 8-17-2007; IN COMMERCE 8-17-2007.
ESTHER BELENKER, EXAMINING ATTORNEY

CLASS 20—(Continued).

SN 77-432,865. HADISONCOLE, INC., MINNETONKA, MN.
FILED 3-27-2008.

MyPillSafe

THE MARK CONSISTS OF STANDARD CHARACTERS WITHOUT CLAIM TO ANY PARTICULAR FONT, STYLE, SIZE, OR COLOR.
FOR MEDICINE CABINETS (U.S. CLS. 2, 13, 22, 25, 32 AND 50).

TOBY BULLOFF, EXAMINING ATTORNEY

SN 77-434,246. BORROR, REGINA, SUNNYVALE, CA.
FILED 3-28-2008.

O'SO SNUGLY

THE MARK CONSISTS OF STANDARD CHARACTERS WITHOUT CLAIM TO ANY PARTICULAR FONT, STYLE, SIZE, OR COLOR.

FOR MATS FOR INFANT PLAYPENS; NAP MATS; SLEEPING MATS; CUSHIONS; PET CUSHIONS; SEAT CUSHIONS; STADIUM CUSHIONS; CHAIR PADS; BEDS FOR HOUSEHOLD PETS; DOG BEDS (U.S. CLS. 2, 13, 22, 25, 32 AND 50).

JULIE WATSON, EXAMINING ATTORNEY

SN 77-434,827. BORLAND, JOHN, WINNIPEG, CANADA,
FILED 3-28-2008.



THE COLOR(S) GREEN, WHITE, YELLOW IS/ARE CLAIMED AS A FEATURE OF THE MARK.

THE MARK CONSISTS OF SIDE VIEW OF A GREEN, STYLIZED ALIGATOR'S HEAD WITH A YELLOWISH GREEN SINGLE EYE, BUT EXCLUDING THE LOWER JAW. STYLIZED SWAMP GRASS LEAVES ARE CUTOUT TO GIVE A STYLIZED APPEARANCE.

FOR PLASTIC FRAME TO SUPPORT AND ACCOMMODATE USE OF PLASTIC GARBAGE BAGS (U.S. CLS. 2, 13, 22, 25, 32 AND 50).

THOMAS MANOR, EXAMINING ATTORNEY

CLASS 20—(Continued).

SN 77-435,495. HATHAWAY-DOUGLAS SHADES D'ART LLC, BAR HARBOR, ME. FILED 3-31-2008.

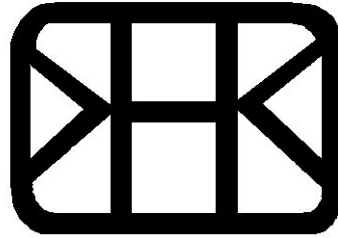

THE MARK CONSISTS OF A RECTANGULAR BORDER WITH ROUNDED CORNERS ENCLOSED THE LETTER "H" BRACKETED BY LINES DESCRIBING ANGLES WHEREIN THE APICES OF THE ANGLES IMPINGE AGAINST THE SIDES OF THE "H" AND THE ANGLES OPEN LATERALLY AWAY.

FOR WINDOW SHADES (U.S. CLS. 2, 13, 22, 25, 32 AND 50).

TASNEEM HUSSAIN, EXAMINING ATTORNEY

SN 77-436,811. PRECIOUS MOMENTS, INC., ROLLING MEADOWS, IL. FILED 4-1-2008.

Katie Bennett

THE MARK CONSISTS OF STANDARD CHARACTERS WITHOUT CLAIM TO ANY PARTICULAR FONT, STYLE, SIZE, OR COLOR.

THE NAME "KATIE BENNETT" DOES NOT IDENTIFY A LIVING INDIVIDUAL.

FOR COLD CAST RESIN FIGURINES (U.S. CLS. 2, 13, 22, 25, 32 AND 50).

RON FAIRBANKS, EXAMINING ATTORNEY

SN 77-436,952. PRECIOUS MOMENTS, INC., ROLLING MEADOWS, IL. FILED 4-1-2008.

Anna Bennett

THE MARK CONSISTS OF STANDARD CHARACTERS WITHOUT CLAIM TO ANY PARTICULAR FONT, STYLE, SIZE, OR COLOR.

THE NAME "ANNA BENNETT" DOES NOT IDENTIFY A LIVING INDIVIDUAL.

FOR COLD CAST RESIN FIGURINES (U.S. CLS. 2, 13, 22, 25, 32 AND 50).

RON FAIRBANKS, EXAMINING ATTORNEY

CLASS 20—(Continued).

SN 77-438,028. PRECIOUS MOMENTS, INC., ROLLING MEADOWS, IL. FILED 4-2-2008.

Aunt Ella

THE MARK CONSISTS OF STANDARD CHARACTERS WITHOUT CLAIM TO ANY PARTICULAR FONT, STYLE, SIZE, OR COLOR.

THE NAME "AUNT ELLA" DOES NOT IDENTIFY A LIVING INDIVIDUAL.

FOR COLD CAST RESIN FIGURINES (U.S. CLS. 2, 13, 22, 25, 32 AND 50).

RON FAIRBANKS, EXAMINING ATTORNEY

SN 77-439,686. TOFASCO OF AMERICA, INC., LA VERNE, CA. FILED 4-3-2008.

Maccabee Sports

THE MARK CONSISTS OF STANDARD CHARACTERS WITHOUT CLAIM TO ANY PARTICULAR FONT, STYLE, SIZE, OR COLOR.

FOR FURNITURE, NAMELY, INDOOR AND OUTDOOR FURNITURE AND CHILDREN'S FURNITURE (U.S. CLS. 2, 13, 22, 25, 32 AND 50).

FIRST USE 6-11-1993; IN COMMERCE 6-11-1993.

RAMONA ORTIGA, EXAMINING ATTORNEY

SN 77-441,212. AMERICAN TEXTILE COMPANY, DUQUESNE, PA. FILED 4-7-2008.

ETERNALOFT

THE MARK CONSISTS OF STANDARD CHARACTERS WITHOUT CLAIM TO ANY PARTICULAR FONT, STYLE, SIZE, OR COLOR.

FOR SYNTHETIC FIBER FILL FOR PILLOWS SOLD AS AN INTEGRAL COMPONENT OF THE PILLOW (U.S. CLS. 2, 13, 22, 25, 32 AND 50).

JUDITH HELFMAN, EXAMINING ATTORNEY

CLASS 20—(Continued).

SN 77-448,587. HUHTAMAKI COMPANY MANUFACTURING, DE SOTO, KS. FILED 4-15-2008.

OWNER OF U.S. REG. NOS. 3,327,924, 3,350,378 AND 3,358,034.

THE MARK CONSISTS OF THE WORDS "COMFORT-CUP", SLANTED TO THE RIGHT, THE LETTERS BEING PARTIALLY BLOCK AND PARTIALLY CURSIVE; WITH THE LETTER "C" BEING CAPITALIZED IN EACH INSTANCE; THE LINE OF THE "T" EXTENDING TO THE LEFT ABOVE THE "O" AND "R"; THE BOTTOM OF THE FIRST "C" EXTENDING AS A LINE TO THE RIGHT UNDER THE "O" AND "M", AND UNDER THE "O" AND "R"; THE BOTTOM OF THE SECOND "C" EXTENDING AS A LINE BELOW THE "U".

FOR PLASTIC LIDS (U.S. CLS. 2, 13, 22, 25, 32 AND 50).

TOBY BULLOFF, EXAMINING ATTORNEY

SN 77-466,211. ZAP, SANTA ROSA, CA. FILED 5-5-2008.

PLUGGY

THE MARK CONSISTS OF STANDARD CHARACTERS WITHOUT CLAIM TO ANY PARTICULAR FONT, STYLE, SIZE, OR COLOR.

FOR PROMOTIONAL FIGURINES, NAMELY, PLASTIC CARICATURES OF PERSONS WITH THEIR HEAD IN THE SHAPE OF AN ELECTRIC PLUG AND FEET IN THE SHAPE OF A VEHICLE TIRE (U.S. CLS. 2, 13, 22, 25, 32 AND 50).

FIRST USE 2-29-2008; IN COMMERCE 2-29-2008.

SHAUNIA CARLYLE, EXAMINING ATTORNEY

CLASS 20—(Continued).

SN 77-472,950. LEE, GARY L., CHICAGO, IL. AND MCWALTERS, THOMAS J., CHICAGO, IL. FILED 5-13-2008.



COUTURE

NO CLAIM IS MADE TO THE EXCLUSIVE RIGHT TO USE "COUTURE", APART FROM THE MARK AS SHOWN. THE MARK CONSISTS OF THE LETTER "T" ON TOP OF THE LETTER "G" OVER THE WORD "COUTURE". FOR FURNITURE (U.S. CLS. 2, 13, 22, 25, 32 AND 50). ALEX KEAM, EXAMINING ATTORNEY

SN 77-474,845. SERTA, INC., HOFFMAN ESTATES, IL. FILED 5-15-2008.

POSTURESSMART

THE MARK CONSISTS OF STANDARD CHARACTERS WITHOUT CLAIM TO ANY PARTICULAR FONT, STYLE, SIZE, OR COLOR. FOR MATTRESSES AND MATTRESS FOUNDATIONS (U.S. CLS. 2, 13, 22, 25, 32 AND 50). KATINA MISTER, EXAMINING ATTORNEY

SN 78-837,308. CHUN-CHIEH HUANG, AUBURN, WA. FILED 3-15-2006.

Take It Pocket

THE MARK CONSISTS OF STANDARD CHARACTERS WITHOUT CLAIM TO ANY PARTICULAR FONT, STYLE, SIZE, OR COLOR. FOR NON-METAL HOLDER FOR SIGNS (U.S. CLS. 2, 13, 22, 25, 32 AND 50). FIRST USE 2-16-2006; IN COMMERCE 2-16-2006. PATRICIA EVANKO, EXAMINING ATTORNEY

CLASS 21—HOUSEWARES AND GLASS

SN 77-083,634. FLORIDA COOL RING COMPANY, LAKE-LAND, FL. FILED 1-16-2007.

COOL RING

THE MARK CONSISTS OF STANDARD CHARACTERS WITHOUT CLAIM TO ANY PARTICULAR FONT, STYLE, SIZE, OR COLOR. FOR HOLDERS FOR PLANTS, NAMELY, PLASTIC CONTAINERS FOR TREES (U.S. CLS. 2, 13, 23, 29, 30, 33, 40 AND 50). FIRST USE 12-30-2005; IN COMMERCE 1-13-2006. MATTHEW EINSTEIN, EXAMINING ATTORNEY

SN 77-083,667. FLORIDA COOL RING COMPANY, LAKE-LAND, FL. FILED 1-16-2007.

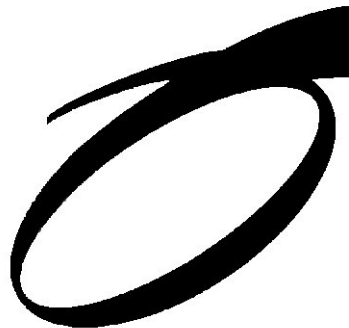

THE MARK CONSISTS OF A FANCIFUL DESIGN. FOR HOLDERS FOR PLANTS, NAMELY, PLASTIC CONTAINERS FOR TREES (U.S. CLS. 2, 13, 23, 29, 30, 33, 40 AND 50). FIRST USE 12-30-2005; IN COMMERCE 1-13-2006. MATTHEW EINSTEIN, EXAMINING ATTORNEY

CLASS 21—(Continued).

SN 77-088,435. DD TRADERS, INC., STILLWELL, KS. FILED 1-22-2007.

SILVESTRI

THE MARK CONSISTS OF STANDARD CHARACTERS WITHOUT CLAIM TO ANY PARTICULAR FONT, STYLE, SIZE, OR COLOR.

SEC. 2(F).

FOR SMALL ORNAMENTAL DISPLAY BOXES MADE PRIMARILY OF GLASS, NAMELY, KEEPSAKE BOXES; CANDLEHOLDERS; DINNERWARE; GLASS BEVERAGE WARE; GLASS ORNAMENTS AND DECORATIONS, NAMELY, VASES, SCULPTURES, CERAMIC FIGURINES; SERVING PIECES MADE OF GLASS, NAMELY, TRAYS, PLATTERS, AND BOWLS; STEMWARE AND SERVING PIECES, NAMELY, TRAYS, BOWLS, AND PLATTERS; DECORATIVE CERAMIC KEEPSAKE BOXES, SOLD EMPTY; FIGURINES OF PORCELAIN AND CERAMIC (U.S. CLS. 2, 13, 23, 29, 30, 33, 40 AND 50).

FIRST USE 11-21-1984; IN COMMERCE 11-21-1984.
TASHIA BUNCH, EXAMINING ATTORNEY

SN 77-189,659. BIALETTI INDUSTRIE S.P.A., COCCAGLIO (BS), ITALY, FILED 5-24-2007.

ALLUMINIA FUSION

THE MARK CONSISTS OF STANDARD CHARACTERS WITHOUT CLAIM TO ANY PARTICULAR FONT, STYLE, SIZE, OR COLOR.

PRIORITY CLAIMED UNDER SEC. 44(D) ON ERP CMNTY TM OFC APPLICATION NO. 5934294, FILED 5-15-2007, REG. NO. 5934294, DATED 4-16-2008, EXPIRES 5-15-2017.

NO CLAIM IS MADE TO THE EXCLUSIVE RIGHT TO USE "ALLUMINIA", APART FROM THE MARK AS SHOWN.

THE FOREIGN WORDING IN THE MARK TRANSLATES INTO ENGLISH AS ALUMINUM.

FOR KITCHEN UTENSILS AND CONTAINERS NOT OF PRECIOUS METALS OR COATED THEREWITH, AND NOT OF CERAMIC OR PORCELAIN, NAMELY, LADLES AND DIPPERS, PANS, COOKING PANS, KETTLES, NON-ELECTRIC KETTLES, POTS, SAUCEPANS, NON-ELECTRIC PRESSURE COOKERS, BAKING PANS, FRYING PANS, NON ELECTRIC COFFEE MAKERS AND COMPONENT PARTS THEREOF, LIDS AND HANDLES FOR POTS AND PANS, COLANDERS, STRAINERS (U.S. CLS. 2, 13, 23, 29, 30, 33, 40 AND 50).

EMILY CHUO, EXAMINING ATTORNEY

CLASS 21—(Continued).

SN 77-226,313. MATSUMOTO, SUSAN M., LANTANA, FL. AND CHININIS, STEPHEN, NORCROSS, GA. AND KENNEDY, MELVIN R., LANTANA, FL. AND LEVY, RICHARD C., BOCA RATON, FL. AND LONGORIA, JOSE, MIAMI, FL. FILED 7-10-2007.

CUPCAKE FACTORY

THE MARK CONSISTS OF STANDARD CHARACTERS WITHOUT CLAIM TO ANY PARTICULAR FONT, STYLE, SIZE, OR COLOR.

NO CLAIM IS MADE TO THE EXCLUSIVE RIGHT TO USE "CUPCAKE", APART FROM THE MARK AS SHOWN.

FOR PASTRY DECORATION APPLICATOR WITH ATTACHMENT TIPS, SOLD EMPTY, FOR APPLYING FROSTING TO BAKED GOODS (U.S. CLS. 2, 13, 23, 29, 30, 33, 40 AND 50).

BENJAMIN ALLEN, EXAMINING ATTORNEY

SN 77-270,667. ARMALY SPONGE CO., WALLED LAKE, MI. FILED 9-4-2007.

CLAWTH

THE MARK CONSISTS OF STANDARD CHARACTERS WITHOUT CLAIM TO ANY PARTICULAR FONT, STYLE, SIZE, OR COLOR.

FOR CLEANING SPONGES; SPONGES FOR HOUSEHOLD PURPOSES (U.S. CLS. 2, 13, 23, 29, 30, 33, 40 AND 50).

SARA THOMAS, EXAMINING ATTORNEY

CLASS 21—(Continued).

SN 77-282,267. PORT CLYDE LOBSTER PRODUCTS, LLC,
PORT CLDYE, ME. FILED 9-18-2007.



NO CLAIM IS MADE TO THE EXCLUSIVE RIGHT TO USE "PORT CLYDE", APART FROM THE MARK AS SHOWN.

THE MARK CONSISTS OF A FANCIFUL DEPICTION OF A LOBSTER WITHIN A FANCIFUL DESIGN CIRCLE WITHIN TWO CIRCLES BETWEEN WHICH ARE THE WORDS "PORT CLYDE LOBSTER".

FOR MUGS, DISHES, TRIVETS (U.S. CLS. 2, 13, 23, 29, 30, 33, 40 AND 50).

CAROL SPILS, EXAMINING ATTORNEY

SN 77-286,254. OVERSTOCK.COM, INC., SALT LAKE CITY,
UT. FILED 9-21-2007.

O.COM

THE MARK CONSISTS OF STANDARD CHARACTERS WITHOUT CLAIM TO ANY PARTICULAR FONT, STYLE, SIZE, OR COLOR.

FOR HOUSEWARES, NAMELY, BOTTLE OPENERS; GARDEN HOSE SPRAYERS; HAND-OPERATED COFFEE GRINDERS; NON-ELECTRIC KETTLES; COOKWARE, NAMELY, SAUCE PANS, SAUCE POTS, STOCK POTS, DOUBLE BOILERS, SKILLETS, DUTCH OVENS, OMELET PANS, CASSEROLES, NON-ELECTRIC WOKS AND GRIDDLES, FONDUE PANS, BAKING PANS, EGG POACHERS, STEAMERS, STRAINERS, KETTLES, COOKERY MOLDS, MIXING BOWLS AND COVERS THEREFORE; KITCHEN UTENSILS, NAMELY, SERVING SPOONS, SERVING FORKS, LADLES, BOTTLE OPENERS, HAND-HELD GRATERS, MELON BALLERS, WHISKS, PASTRY BRUSHES, PASTRY SERVERS, STEAMER BASKETS, GARLIC PRESSES, ICE CREAM SCOOPS, BASTING BRUSHES, KITCHEN TONGS, MANUALLY OPERATED MEAT TENDERIZERS, POTATO RICERS, POTATO MASHERS, CORK SCREWS, SPOON RESTS, COLANDERS, STRAINERS, POT AND PAN SCRAPERS, SPATULAS, ROLLING PINS, TURNERS, FLOUR SIFTERS, COOKIE STAMPS, COOKIE CUTTERS, AND COOKIE PRESSES; KITCHEN SOAP DISHES; KITCHEN SOAP DISPENSERS; FOOD BRUSHES FOR CLEANING FRUITS AND VEGETABLES; DISH RACKS; PAPER TOWEL HOLDERS; BREAD BOXES; CANISTERS; SPICE RACKS; NAPKIN HOLDERS; RECIPE BOXES; CRUETS NOT OF PRECIOUS METAL; WINE COOLERS FOR WINES; PITCHERS; ICE BUCKETS; SALAD SPINNERS; BED SERVING TRAYS NOT OF PRECIOUS METAL FOR SERVING FOOD; NON-ELECTRIC JUICERS; PEPPER MILLS; PEPPER SHAKERS; SALT MILLS; SALT SHAKERS; NON-ELECTRIC COOKING OIL SPRAYERS, CHEESE CUT-

CLASS 21—(Continued).

TING BOARDS; PLASTIC COASTERS; DINNERWARE; CUT CRYSTAL GLASSWARE; GLASSWARE, NAMELY, STEMWARE, TUMBLERS, ICED TEA GLASSES, HIBALL GLASSES, GOBLETS, CHAMPAGNE GLASSES, LIQUEUR GLASSES, BRANDY GLASSES, CARAFES, DECANTERS, AND BOWLS; TABLEWARE, NAMELY, CAKE SERVERS, SALAD BOWLS, SALAD SERVING SPOONS AND FORKS; BATHROOM ACCESSORIES, NAMELY, TISSUE BOXES, WASTEBASKETS, TOOTHBRUSH AND TUMBLER HOLDERS, TUMBLERS, COTTON BALL AND SWAB HOLDERS, VANITY TRAYS, SOAP DISHES, AND SOAP DISPENSERS, LOTION DISPENSERS, DECORATIVE CHINA BOXES, TISSUE PAPER DISPENSERS, AND POTPOURRI JARS; HOUSEWARES AND ACCESSORIES, NAMELY, CANDLE HOLDERS NOT OF PRECIOUS METAL, CANDLE TRAYS NOT OF PRECIOUS METAL, FIGURINES AND STATUES MADE OF CHINA, CRYSTAL, EARTHENWARE, GLASS, PORCELAIN AND TERRA COTTA; PILLAR CANDLE HOLDERS NOT OF METAL, ORNAMENTS MADE OF CHINA, CRYSTAL, GLASS, PORCELAIN AND TERRACOTTA; VASES, BOWLS, NON-METAL JARS MADE OF EARTHENWARE, GLASS, PORCELAIN, PLASTIC; VOTIVE CANDLE HOLDERS NOT OF PRECIOUS METAL, MEAL AND SERVING TRAYS NOT OF PRECIOUS METAL, TRIVETS, DECORATIVE BASKETS AND BOXES ALL MADE OF CERAMIC, CHINA, PORCELAIN, GLASS, LEAD CRYSTAL, EARTHENWARE, NON-PRECIOUS METAL, WICKER, BAMBOO, STRAW, WOOD, BARK OR CLOTH; BIRD BATHS; BIRD FEEDERS; BIRDHOUSES; FLOWER BASKETS; PLANT HOLDERS; AND PLANT POTS; ORNAMENTAL GLASS SPHERES SOLD SOLELY THROUGH AN ONLINE WEBSITE (U.S. CLS. 2, 13, 23, 29, 30, 33, 40 AND 50).

MICHAEL LEWIS, EXAMINING ATTORNEY

SN 77-288,429. FAKTORIE CORPORATION, TORONTO,
ONTARIO, CANADA, FILED 9-25-2007.

MABU

THE MARK CONSISTS OF STANDARD CHARACTERS WITHOUT CLAIM TO ANY PARTICULAR FONT, STYLE, SIZE, OR COLOR.

OWNER OF CANADA REG. NO. TMA521008, DATED 1-5-2000, EXPIRES 1-5-2015.

THE TERM "MABU" HAS NO MEANING IN A FOREIGN LANGUAGE.

FOR CLEANING CLOTHS USED FOR CLEANING, WIPING, POLISHING AND DUSTING SURFACES IN WORK PLACES, HOMES, WORKSHOPS, GARAGES AND BOATS (U.S. CLS. 2, 13, 23, 29, 30, 33, 40 AND 50).

KEVIN DINALLO, EXAMINING ATTORNEY

CLASS 21—(Continued).

SN 77-365,941. HOLSTER, INC., LOS ANGELES, CA. FILED 1-7-2008.



THE MARK CONSISTS OF THE WORDS "BLO", AND "GO", CONTAINING WAVES THROUGH THE "O", WITH AN AMPERSAND IN BETWEEN INCORPORATING A DEPICTION OF A HAIR DRYER.

FOR CADDIES FOR HOLDING HAIR ACCESSORIES FOR HOUSEHOLD AND DOMESTIC USE, NAMELY, A PORTABLE HOLDER FOR HANDS FREE OPERATION OF THE HAIR ACCESSORIES (U.S. CLS. 2, 13, 23, 29, 30, 33, 40 AND 50).

FIRST USE 1-4-2008; IN COMMERCE 1-4-2008.
WILLIAM ROSSMAN, EXAMINING ATTORNEY

CLASS 21—(Continued).

SN 77-372,145. JPH DESIGNS INC, PALM BAY, FL. FILED 1-15-2008.

THE FIRST TEXT MESSAGE WAS SENT BY GOD

THE MARK CONSISTS OF STANDARD CHARACTERS WITHOUT CLAIM TO ANY PARTICULAR FONT, STYLE, SIZE, OR COLOR.

FOR ALL PURPOSE PORTABLE HOUSEHOLD CONTAINERS, BABY BATHTUBS, BEER MUGS, INSULATING SLEEVE BEVERAGE CAN HOLDERS, BEVERAGE GLASSWARE, BEVERAGE WARE, BOTTLE OPENERS, BOWLS, BOXES FOR DISPENSING PAPER TOWELS, BREAD BOXES, BUCKETS, CANDLETICKS NOT OF PRECIOUS METAL, GLASS CANDY JARS, CANTEENS, CHAMPAGNE BUCKETS, CHINA ORNAMENTS, COCKTAIL SHAKERS, COFFEE CUPS, COFFEE STIRRERS, COMB CASES, COMMEMORATIVE PLATES, COOKERY MOLDS, COOKIE CUTTERS, COOLERS FOR WINE, STAINED GLASS, DECORATIVE CRYSTAL PRISMS, DECORATIVE PLATES, DISH COVERS, DRINKING FLASKS, DRINKING VESSELS, EARTHENWARE MUGS, ELECTRIC OR NON ELECTRIC TOOTHBRUSHES, GARBAGE CANS, GLASS BEVERAGE WARE, GLASS BOWLS, GLASS BOXES, GLASS MUGS, HAIR BRUSHES, HAIR COMBS, HOUSEHOLD BEVERAGE GLASSWARE, PORTABLE ICE CHESTS FOR FOOD, ICE CUBE MOLDS, DINNERWARE, DISHES, INSULATED WATER BOTTLES, NAMELY, VACUUM BOTTLES, GLASS STORAGE JARS, JUGS, LUNCH BOXES, LUNCH PAILS, MEAL TRAYS, MIXING SPOONS, MUG TREES, NAPKIN HOLDERS, NAPKIN RINGS NOT OF PRECIOUS METAL, NON METAL DECORATIVE BOXES FOR STORING RECIPES, CARDS OR JEWELRY, NON METAL PIGGY BANKS, OVEN TO TABLE RACKS, PAPER CUPS, PAPER PLATES, PEPPER GRINDERS, PET FEEDING DISHES, PICNIC COOLERS, PITCHERS, PLASTIC BUCKETS, PLASTIC COASTERS, PLASTIC CUPS, PORCELAIN MUGS, PORCELAIN TEA KETTLE KNOBS OF GLASS OR CERAMIC, PORTABLE BEVERAGE COOLERS, PORTABLE BEVERAGE DISPENSERS, PORTABLE COOLERS, PORTABLE ICE BUCKET, POT LIDS, PUDDING MOLDS, RECIPE BOXES, RUBBER HOUSEHOLD GLOVES, SALAD BOWLS, SAUCERS, SERVING PLATTERS, SERVING PLATTERS NOT OF PRECIOUS METAL, SERVING TRAYS NOT OF PRECIOUS METAL, SHAPED COVERS FOR IRONING BOARDS, SHAPED INSULATED PLASTIC WATER BOTTLES SOLD EMPTY, SHOT GLASSES, SOAP BOXES, SOAP DISHES, SOAP DISPENSERS, SPONGES FOR HOUSEHOLD PURPOSES, SUN CATCHERS, SUN TEA GLASS JARS SOLD EMPTY, SWIZZLE STICKS, SYRUP JUGS, TANKARDS NOT OF PRECIOUS METAL, TEA KETTLES, TEA POTS NOT OF PRECIOUS METAL, TEA SETS, TRASH CANS, TRIVETS, VASES, WASH BASINS, WASTEPAPER BASKETS (U.S. CLS. 2, 13, 23, 29, 30, 33, 40 AND 50).

JESSICA A. POWERS, EXAMINING ATTORNEY

SN 77-371,252. KAYHAN COYNE, SELDA, MAPLEWOOD, NJ. FILED 1-14-2008.



NO CLAIM IS MADE TO THE EXCLUSIVE RIGHT TO USE "DESIGN STUDIO", APART FROM THE MARK AS SHOWN.

THE NAME SHOWN IN THE MARK IDENTIFIES "VERDA KAYHAN" A LIVING INDIVIDUAL, WHOSE CONSENT IS OF RECORD.

THE MARK CONSISTS OF A STYLIZED "V" AND "VERDA KAYHAN" IS WRITTEN AT AN ANGLE. ALL LETTERS IN BLACK HAVE AN ANTIQUE FINISH AS IF AGED BY TIME.

FOR NAPKIN RINGS (U.S. CLS. 2, 13, 23, 29, 30, 33, 40 AND 50).

FIRST USE 12-18-2007; IN COMMERCE 12-18-2007.
KIMBERLY PERRY, EXAMINING ATTORNEY

CLASS 21—(Continued).

SN 77-376,528. HARPER BRUSH WORKS, INC., FAIRFIELD, IA. FILED 1-21-2008.

MICROWOOL

THE MARK CONSISTS OF STANDARD CHARACTERS WITHOUT CLAIM TO ANY PARTICULAR FONT, STYLE, SIZE, OR COLOR.

FOR DUSTERS (U.S. CLS. 2, 13, 23, 29, 30, 33, 40 AND 50).

ARETHA SOMERVILLE, EXAMINING ATTORNEY

SN 77-409,744. THE HARTZ MOUNTAIN CORPORATION, SECAUCUS, NJ. FILED 2-29-2008.

HARTZ FRESHENING BRUSH

THE MARK CONSISTS OF STANDARD CHARACTERS WITHOUT CLAIM TO ANY PARTICULAR FONT, STYLE, SIZE, OR COLOR.

OWNER OF U.S. REG. NOS. 2,524,782, 3,222,910 AND OTHERS.

NO CLAIM IS MADE TO THE EXCLUSIVE RIGHT TO USE "FRESHENING BRUSH", APART FROM THE MARK AS SHOWN.

FOR BRUSHES WITH PRE-MOISTENED CLOTH FOR PETS (U.S. CLS. 2, 13, 23, 29, 30, 33, 40 AND 50).

MAYUR VAGHANI, EXAMINING ATTORNEY

SN 77-410,637. NOWAK, JACQUE', DBA SQUID PRODUCTS, AUSTIN, TX. FILED 3-1-2008.

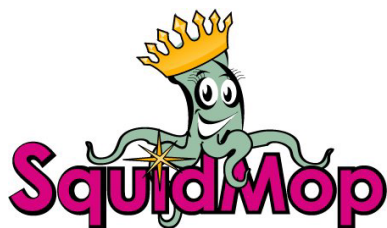

THE COLOR(S) GOLD, GREEN, PINK, BLACK, WHITE IS/ARE CLAIMED AS A FEATURE OF THE MARK.

THE MARK CONSISTS OF THE COLORS GOLD, GREEN, PINK, BLACK, AND WHITE. WITH THE COLOR GOLD APPEARING IN THE CROWN DESIGN, THE COLOR GREEN APPEARING IN THE SQUID DESIGN, THE COLOR PINK APPEARING IN THE LETTERING OF THE WORDING "SQUIDMOP", THE COLOR BLACK APPEARING IN THE OUTLINE OF THE MARK AND THE EYELASHES, EYEBROWS, EYEBALLS, LIPS, AND BACKS OF THE EYES OF THE SQUID DESIGN, AND THE COLOR WHITE APPEARING IN THE MOUTH AND EYES OF THE SQUID DESIGN.

FOR MOPS (U.S. CLS. 2, 13, 23, 29, 30, 33, 40 AND 50). FIRST USE 11-1-2007; IN COMMERCE 1-15-2008.

TINA KUAN, EXAMINING ATTORNEY

CLASS 21—(Continued).

SN 77-411,002. JAMES J. CORBETT, HIRD, LLC, VERONA, NJ. FILED 3-3-2008.

BUBBA'S TUBBA TOOLS!

THE MARK CONSISTS OF STANDARD CHARACTERS WITHOUT CLAIM TO ANY PARTICULAR FONT, STYLE, SIZE, OR COLOR.

NO CLAIM IS MADE TO THE EXCLUSIVE RIGHT TO USE "TOOLS", APART FROM THE MARK AS SHOWN.

FOR PLASTIC BUCKETS (U.S. CLS. 2, 13, 23, 29, 30, 33, 40 AND 50).

EDWARD NELSON, EXAMINING ATTORNEY

SN 77-414,526. LIBERTY HARDWARE MFG. CORP., WINSTON-SALEM, NC. FILED 3-6-2008.

PIROUETTE

THE MARK CONSISTS OF STANDARD CHARACTERS WITHOUT CLAIM TO ANY PARTICULAR FONT, STYLE, SIZE, OR COLOR.

FOR BATHROOM ACCESSORIES, NAMELY, TOWEL BARS, TOWEL RINGS, TISSUE HOLDERS AND TUMBLER-TOOTHBRUSH HOLDERS (U.S. CLS. 2, 13, 23, 29, 30, 33, 40 AND 50).

HELENE LIWINSKI, EXAMINING ATTORNEY

SN 77-416,137. PROCTER & GAMBLE BUSINESS SERVICES CANADA COMPANY, HALIFAX, CANADA, FILED 3-7-2008.

PRECISION TIP

THE MARK CONSISTS OF STANDARD CHARACTERS WITHOUT CLAIM TO ANY PARTICULAR FONT, STYLE, SIZE, OR COLOR.

FOR TOOTHBRUSHES AND TOOTHBRUSH BRISTLES (U.S. CLS. 2, 13, 23, 29, 30, 33, 40 AND 50).

TINA KUAN, EXAMINING ATTORNEY

CLASS 21—(Continued).

SN 77-418,480. SCOOPPEEZE BRANDS, LLC, OMAHA, NE. FILED 3-11-2008.

SCOOPPEEZE

THE MARK CONSISTS OF STANDARD CHARACTERS WITHOUT CLAIM TO ANY PARTICULAR FONT, STYLE, SIZE, OR COLOR.

FOR PET WASTE PICK-UP DEVICES, NAMELY, SCOOPS FOR THE DISPOSAL OF PET WASTE AND LINERS FOR SCOOPS FOR THE DISPOSAL OF PET WASTE (U.S. CLS. 2, 13, 23, 29, 30, 33, 40 AND 50).

CHARLES L. JENKINS, EXAMINING ATTORNEY

SN 77-419,839. THE PROCTER & GAMBLE COMPANY, CINCINNATI, OH. FILED 3-12-2008.

MAGIC ERASER

THE MARK CONSISTS OF STANDARD CHARACTERS WITHOUT CLAIM TO ANY PARTICULAR FONT, STYLE, SIZE, OR COLOR.

OWNER OF U.S. REG. NOS. 2,926,903, 3,160,306 AND OTHERS.

FOR HOUSEHOLD CLEANING TOOLS, NAMELY, MOPS AND REPLACEMENT MOP HEADS (U.S. CLS. 2, 13, 23, 29, 30, 33, 40 AND 50).

FIRST USE 12-31-2005; IN COMMERCE 12-31-2005.

TOBY BULLOFF, EXAMINING ATTORNEY

SN 77-420,055. GARY MONACO, HAWTHORNE WOODS, IL. AND MATTHEW MENGES, NORTH BARRINGTON, IL. FILED 3-12-2008.

TRAYSTATION

THE MARK CONSISTS OF STANDARD CHARACTERS WITHOUT CLAIM TO ANY PARTICULAR FONT, STYLE, SIZE, OR COLOR.

FOR A SYNTHETIC PLASTIC TRAY FOR SUPPORTING VARIOUS PRODUCTS ON INCLINED OR LEVEL SURFACES SUCH AS PAINTS, PAINT CONTAINERS, TOOLS, NUTS, BOLTS, AND SCREWS (U.S. CLS. 2, 13, 23, 29, 30, 33, 40 AND 50).

SOPHIA S. KIM, EXAMINING ATTORNEY

CLASS 21—(Continued).

SN 77-423,135. TERRY, GENISH B., OAKLAND, CA. FILED 3-16-2008.



THE MARK CONSISTS OF THE LETTER "I"; A HEART DESIGN; THE LETTER "C"; THE LETTER "A"; A DOLLAR "\$" SYMBOL; AND THE LETTER "H". THE MARK CONSISTS OF A HEART DESIGN AND WORDS "I CASH".

FOR MUGS (U.S. CLS. 2, 13, 23, 29, 30, 33, 40 AND 50).

COURTNEY MCCORMICK, EXAMINING ATTORNEY

SN 77-428,349. COPIER, FLORIS CHAD, HIGHLAND, UT. AND COPIER, DUSTI, HIGHLAND, UT. FILED 3-21-2008.

Knifelock

THE MARK CONSISTS OF STANDARD CHARACTERS WITHOUT CLAIM TO ANY PARTICULAR FONT, STYLE, SIZE, OR COLOR.

FOR KNIFE BLOCKS (U.S. CLS. 2, 13, 23, 29, 30, 33, 40 AND 50).

MARK RADEMACHER, EXAMINING ATTORNEY

SN 77-428,606. PAMELA MOROVATI, LOS ANGELES, CA. AND BEN MOROVATI, LOS ANGELES, CA. FILED 3-21-2008.

P.P.GOGO

THE MARK CONSISTS OF STANDARD CHARACTERS WITHOUT CLAIM TO ANY PARTICULAR FONT, STYLE, SIZE, OR COLOR.

FOR URINE RECEPTACLE TO ENABLE CHILDREN TO URINATE WHEN NO TOILET IS AVAILABLE (U.S. CLS. 2, 13, 23, 29, 30, 33, 40 AND 50).

TINA BROWN, EXAMINING ATTORNEY

CLASS 21—(Continued).

SN 77-428,983. CAPT. GABRIELA DÍAZ, SPENCER, OH. FILED 3-22-2008.

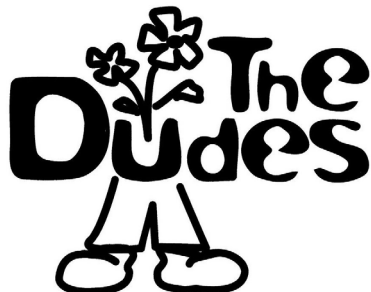

THE MARK CONSISTS OF THE WORDS "THE DUDES" WITH TWO FLOWERS COMING OUT OF THE TOP OF THE "U" AND LEGS WITH PANTS AND SHOES COMING OUT OF THE BOTTOM OF THE "U".

FOR PLANTERS FOR FLOWERS AND PLANTS (U.S. CLS. 2, 13, 23, 29, 30, 33, 40 AND 50).

FIRST USE 5-1-2004; IN COMMERCE 12-24-2006.
FRED MANDIR, EXAMINING ATTORNEY

SN 77-429,505. SEPHORA USA, INC., SAN FRANCISCO, CA. FILED 3-24-2008.

KAT EYE BRUSH SET

THE MARK CONSISTS OF STANDARD CHARACTERS WITHOUT CLAIM TO ANY PARTICULAR FONT, STYLE, SIZE, OR COLOR.

NO CLAIM IS MADE TO THE EXCLUSIVE RIGHT TO USE "BRUSH SET", APART FROM THE MARK AS SHOWN. FOR COSMETIC BRUSHES (U.S. CLS. 2, 13, 23, 29, 30, 33, 40 AND 50).

TANYA AMOS, EXAMINING ATTORNEY

SN 77-429,536. ANDWIN CORPORATION, THE, WOODLAND HILLS, CA. FILED 3-24-2008.

SEALSAFE

THE MARK CONSISTS OF STANDARD CHARACTERS WITHOUT CLAIM TO ANY PARTICULAR FONT, STYLE, SIZE, OR COLOR.

FOR PLASTIC SAFETY CAPS FOR MEDICINE CONTAINERS (U.S. CLS. 2, 13, 23, 29, 30, 33, 40 AND 50).

KAPIL BHANOT, EXAMINING ATTORNEY

CLASS 21—(Continued).

SN 77-430,278. THE BOO BIRDS, POCONO PINES, PA. FILED 3-24-2008.

The Boo Birds

THE MARK CONSISTS OF STANDARD CHARACTERS WITHOUT CLAIM TO ANY PARTICULAR FONT, STYLE, SIZE, OR COLOR.

OWNER OF U.S. REG. NO. 3,281,784.

SEC. 2(F).

FOR BEER MUGS; COFFEE CUPS, TEA CUPS AND MUGS; BEVERAGE GLASSWARE (U.S. CLS. 2, 13, 23, 29, 30, 33, 40 AND 50).

FIRST USE 9-1-2006; IN COMMERCE 9-1-2006.

CHERYL CLAYTON, EXAMINING ATTORNEY

SN 77-431,049. THE ORIGINAL HONEY BAKED HAM CO. OF GEORGIA, INC., NORCROSS, GA. FILED 3-25-2008.

Bonfetti

THE MARK CONSISTS OF STANDARD CHARACTERS WITHOUT CLAIM TO ANY PARTICULAR FONT, STYLE, SIZE, OR COLOR.

FOR DINNERWARE, NAMELY, DISHES, PLATTERS, PLATES, BOWLS, CUPS, SAUCERS, AND MUGS; GLASSWARE, NAMELY, STEMWARE, BEVERAGE GLASSES, CANDLEHOLDERS, AND VASES (U.S. CLS. 2, 13, 23, 29, 30, 33, 40 AND 50).

HENRY S. ZAK, EXAMINING ATTORNEY

SN 77-431,090. BRAVOS, ZACHARY M., WHEATON, IL. FILED 3-25-2008.

KITTY KAN

THE MARK CONSISTS OF STANDARD CHARACTERS WITHOUT CLAIM TO ANY PARTICULAR FONT, STYLE, SIZE, OR COLOR.

THE NAME(S), PORTRAIT(S), AND/OR SIGNATURE(S) SHOWN IN THE MARK DOES NOT IDENTIFY A PARTICULAR LIVING INDIVIDUAL.

FOR PET LITTER BOXES (U.S. CLS. 2, 13, 23, 29, 30, 33, 40 AND 50).

FIRST USE 9-24-1989; IN COMMERCE 9-24-1989.

MAUREEN DALL, EXAMINING ATTORNEY

CLASS 21—(Continued).

SN 77-431,620. QUICKIE MANUFACTURING CORPORATION, CINNAMINSON, NJ. FILED 3-26-2008.



THE MARK CONSISTS OF A GECKO. FOR MOPS, BUCKETS, BROOMS, DUST PANS, SQUEEGEES, CLEANING SPONGES, SCRUBBING SPONGES, DUSTERS, DUST CLOTHS, POT SCOURERS, SOAP DISPENSERS, TOILET PLUNGERS AND HOLDERS FOR TOILET PLUNGERS; BRUSHES FOR HOUSEHOLD USE, NAMELY, SCRUB BRUSHES, BOTTLE AND SPOUT BRUSHES, TOILET BRUSHES, DISH BRUSHES, POT CLEANING BRUSHES, GRILL BRUSHES, DUST BRUSHES, BATH AND SHOWER BRUSHES, VEGETABLE BRUSHES, AND LINT BRUSHES (U.S. CLS. 2, 13, 23, 29, 30, 33, 40 AND 50).
KARANENDRA S. CHHINA, EXAMINING ATTORNEY

SN 77-431,633. BARENTHAL NORTH AMERICA, INC., RUTHERFORD, NJ. FILED 3-26-2008.

GOURMET SELECT

THE MARK CONSISTS OF STANDARD CHARACTERS WITHOUT CLAIM TO ANY PARTICULAR FONT, STYLE, SIZE, OR COLOR.

NO CLAIM IS MADE TO THE EXCLUSIVE RIGHT TO USE "SELECT", APART FROM THE MARK AS SHOWN.

FOR COOKWARE AND KITCHEN EQUIPMENT, NAMELY, POTS, PANS, HOLLOWARE, NAMELY, SALT AND PEPPER SHAKERS, SERVING TRAYS NOT MADE OF PRECIOUS METAL AND BAKING DISHES (U.S. CLS. 2, 13, 23, 29, 30, 33, 40 AND 50).

KARANENDRA S. CHHINA, EXAMINING ATTORNEY

CLASS 21—(Continued).

SN 77-431,634. QUICKIE MANUFACTURING CORPORATION, CINNAMINSON, NJ. FILED 3-26-2008.

TELE-FLEX

THE MARK CONSISTS OF STANDARD CHARACTERS WITHOUT CLAIM TO ANY PARTICULAR FONT, STYLE, SIZE, OR COLOR.

OWNER OF U.S. REG. NO. 1,484,307.

FOR MOPS, BUCKETS, BROOMS, DUST PANS, SQUEEGEES, CLEANING SPONGES, SCRUBBING SPONGES, DUSTERS, DUST CLOTHS, POT SCOURERS, SOAP DISPENSERS, TOILET PLUNGERS AND HOLDERS FOR TOILET PLUNGERS; BRUSHES FOR HOUSEHOLD USE, NAMELY, SCRUB BRUSHES, BOTTLE AND SPOUT BRUSHES, TOILET BRUSHES, DISH BRUSHES, POT CLEANING BRUSHES, GRILL BRUSHES, DUST BRUSHES, BATH AND SHOWER BRUSHES, VEGETABLE BRUSHES, AND LINT BRUSHES (U.S. CLS. 2, 13, 23, 29, 30, 33, 40 AND 50).

KARANENDRA S. CHHINA, EXAMINING ATTORNEY

SN 77-431,989. ZEROEDGE AQUARIUM CORPORATION, DBA A SPLASH OF LIFE, INC., ELGIN, IL. FILED 3-26-2008.



OWNER OF U.S. REG. NO. 3,257,312.

THE MARK CONSISTS OF THE TERM "ZEROEDGE" WHEREIN THE "O" CONTAINS A STYLIZED WAVE.

FOR AQUARIUMS (U.S. CLS. 2, 13, 23, 29, 30, 33, 40 AND 50).

FIRST USE 3-1-2007; IN COMMERCE 3-1-2007.

KARANENDRA S. CHHINA, EXAMINING ATTORNEY

SN 77-433,020. HOME ESSENTIALS & BEYOND INC, EDISON, NJ. FILED 3-27-2008.

MARKET SQUARE

THE MARK CONSISTS OF STANDARD CHARACTERS WITHOUT CLAIM TO ANY PARTICULAR FONT, STYLE, SIZE, OR COLOR.

FOR DRINKING CUPS (U.S. CLS. 2, 13, 23, 29, 30, 33, 40 AND 50).

HEATHER THOMPSON, EXAMINING ATTORNEY

CLASS 21—(Continued).

SN 77-433,809. KELERIN CORP., ELMHURST, IL. FILED 3-27-2008.

Dust Defender

THE MARK CONSISTS OF STANDARD CHARACTERS WITHOUT CLAIM TO ANY PARTICULAR FONT, STYLE, SIZE, OR COLOR.

NO CLAIM IS MADE TO THE EXCLUSIVE RIGHT TO USE "DUST", APART FROM THE MARK AS SHOWN.

FOR CLEANING SUPPLIES, NAMELY, MICRO FIBER DUST MOPS, DUST CLOTHS AND CLEANING MOPS THAT CAN BE MOISTENED (U.S. CLS. 2, 13, 23, 29, 30, 33, 40 AND 50).

FIRST USE 7-1-2005; IN COMMERCE 7-1-2005.
ANDREA SAUNDERS, EXAMINING ATTORNEY

SN 77-438,144. THE ORIGINAL HONEY BAKED HAM CO. OF GEORGIA, INC., NORCROSS, GA. FILED 4-2-2008.

THE MARK CONSISTS OF THE WORD "BONFETTI" IN STYLIZED SCRIPT, WITH DESIGN REPRESENTING SPLOTCHES OF PAINT.

FOR DINNERWARE, NAMELY, DISHES, PLATTERS, PLATES, BOWLS, CUPS, SAUCERS, AND MUGS; GLASSWARE, NAMELY, STEMWARE, BEVERAGE GLASSES, CANDLEHOLDERS, AND VASES (U.S. CLS. 2, 13, 23, 29, 30, 33, 40 AND 50).

HENRY S. ZAK, EXAMINING ATTORNEY

SN 77-442,491. PROCTER & GAMBLE BUSINESS SERVICES CANADA COMPANY, HALIFAX, CANADA, FILED 4-8-2008.

BRISTLE SHIELD

THE MARK CONSISTS OF STANDARD CHARACTERS WITHOUT CLAIM TO ANY PARTICULAR FONT, STYLE, SIZE, OR COLOR.

NO CLAIM IS MADE TO THE EXCLUSIVE RIGHT TO USE "BRISTLE", APART FROM THE MARK AS SHOWN.

FOR TOOTHBRUSH BRISTLES (U.S. CLS. 2, 13, 23, 29, 30, 33, 40 AND 50).

TINA KUAN, EXAMINING ATTORNEY

CLASS 21—(Continued).

SN 77-445,550. SAID, MARIA GRUNER, WINDERMERE, FL. FILED 4-10-2008.

NO CLAIM IS MADE TO THE EXCLUSIVE RIGHT TO USE "THE LINT & FUR REMOVER THAT WORKS IN YOUR DRYER", APART FROM THE MARK AS SHOWN.

THE STIPPLING IS FOR SHADING PURPOSES ONLY.

THE MARK CONSISTS OF THE STYLIZED TEXT "LINTIGATOR THE LINT AND FUR REMOVER THAT WORKS IN YOUR DRYER". THE DOT IN THE LETTER "I" IN THE TEXT "LINTIGATOR" IS A PAW PRINT AND THE LETTER "O" IN "LINTIGATOR" IS AN IMAGE OF A DRYER AND THE DRYER WINDOW IS USED AS THE LETTER "O".

FOR CYLINDER WITH STICKY ADHESIVE THAT REMOVES FUR AND LINT FROM CLOTHES WHEN THEY ARE BEING DRIED IN A CLOTHES DRYER (U.S. CLS. 2, 13, 23, 29, 30, 33, 40 AND 50).

KARANENDRA S. CHHINA, EXAMINING ATTORNEY

SN 77-452,148. ECOLAB INC., ST. PAUL, MN. FILED 4-18-2008.

POLIFIX

THE MARK CONSISTS OF STANDARD CHARACTERS WITHOUT CLAIM TO ANY PARTICULAR FONT, STYLE, SIZE, OR COLOR.

FOR MOPS (U.S. CLS. 2, 13, 23, 29, 30, 33, 40 AND 50).

FIRST USE 8-3-2006; IN COMMERCE 8-3-2006.

MONIQUE MILLER, EXAMINING ATTORNEY

SN 77-455,817. INDUSTRIES FOR THE BLIND, INC., WEST ALLIS, WI. FILED 4-23-2008.

Mr. BIG

FOR SCRUBBING BRUSHES FOR USE IN CLEANING POTS (U.S. CLS. 2, 13, 23, 29, 30, 33, 40 AND 50).

JENNY PARK, EXAMINING ATTORNEY

CLASS 21—(Continued).

SN 77-461,038. REYNOLDS PACKAGING LLC, RICHMOND, VA. FILED 4-29-2008.

INVERTIBLES

THE MARK CONSISTS OF STANDARD CHARACTERS WITHOUT CLAIM TO ANY PARTICULAR FONT, STYLE, SIZE, OR COLOR.

FOR PLASTIC FOOD CONTAINERS (U.S. CLS. 2, 13, 23, 29, 30, 33, 40 AND 50).
TAMARA FRAZIER, EXAMINING ATTORNEY

SN 77-469,043. WEISENBACH SPECIALTY PRINTING, INC., COLUMBUS, OH. FILED 5-8-2008.

ADAPT-A-JUG

THE MARK CONSISTS OF STANDARD CHARACTERS WITHOUT CLAIM TO ANY PARTICULAR FONT, STYLE, SIZE, OR COLOR.

FOR GOODS MADE OF RECYCLED PLASTIC, NAMELY, FUNNELS, AUTOMOBILE OIL FUNNELS, COOKING FUNNELS, POURING SPOUTS FOR HOUSEHOLD USE, AND POURING SPOUTS FOR HOUSEHOLD AUTOMOBILE USE (U.S. CLS. 2, 13, 23, 29, 30, 33, 40 AND 50).

FIRST USE 3-13-1990; IN COMMERCE 3-13-1990.
JAMES LOVELACE, EXAMINING ATTORNEY

SN 77-480,383. QUICKIE MANUFACTURING CORPORATION, CINNAMINSON, NJ. FILED 5-21-2008.

CLEAN DESIGNS

THE MARK CONSISTS OF STANDARD CHARACTERS WITHOUT CLAIM TO ANY PARTICULAR FONT, STYLE, SIZE, OR COLOR.

FOR MOPS, BUCKETS, BROOMS, DUST PANS, SQUEEGEES, CLEANING SPONGES, SCRUBBING SPONGES, DUSTERS, DUST CLOTHS, POT SCOURERS, SOAP DISPENSERS, TOILET PLUNGERS AND HOLDERS FOR TOILET PLUNGERS; BRUSHES FOR HOUSEHOLD USE, NAMELY, SCRUB BRUSHES, BOTTLE AND SPOUT BRUSHES, TOILET BRUSHES, DISH BRUSHES, POT CLEANING BRUSHES, GRILL BRUSHES, DUST BRUSHES, BATH AND SHOWER BRUSHES, VEGETABLE BRUSHES AND LINT BRUSHES (U.S. CLS. 2, 13, 23, 29, 30, 33, 40 AND 50).

KARANENDRA S. CHHINA, EXAMINING ATTORNEY

CLASS 21—(Continued).

SN 77-498,160. COLGATE-PALMOLIVE COMPANY, NEW YORK, NY. FILED 6-13-2008.

FRESHNESS UNLEASHED

THE MARK CONSISTS OF STANDARD CHARACTERS WITHOUT CLAIM TO ANY PARTICULAR FONT, STYLE, SIZE, OR COLOR.

FOR TOOTHBRUSHES (U.S. CLS. 2, 13, 23, 29, 30, 33, 40 AND 50).

JOHN GARTNER, EXAMINING ATTORNEY

SN 78-764,932. AMOROSO, SHARYN, WALNUT CREEK, CA. FILED 12-1-2005.

ETI-KITS

THE MARK CONSISTS OF STANDARD CHARACTERS WITHOUT CLAIM TO ANY PARTICULAR FONT, STYLE, SIZE, OR COLOR.

FOR MANUALS, PAMPHLETS, BOOKS, NOTE CARDS, REMINDER CARDS AND BOOKLETS FOR TEACHING MANNERS AND/OR ETIQUETTE, SOLD AS A COMPONENT OF PLASTIC NAPKIN HOLDERS (U.S. CLS. 2, 13, 23, 29, 30, 33, 40 AND 50).

FIRST USE 3-1-2005; IN COMMERCE 1-9-2006.

JOHN GARTNER, EXAMINING ATTORNEY

SN 79-043,802. ÖZLEM KRISTAL; SANAYI VE TICARET ANONIM SİRKETİ, TURKEY, FILED 4-5-2007.

Monna Glass

by ^{**}
**ÖZLEM
KRISTAL**

OWNER OF INTERNATIONAL REGISTRATION 0808956 DATED 6-10-2003, EXPIRES 6-10-2013.

NO CLAIM IS MADE TO THE EXCLUSIVE RIGHT TO USE "KRISTAL", APART FROM THE MARK AS SHOWN.

THE ENGLISH TRANSLATION OF "ÖZLEM" IS LONGING OR YEARNING; "KRISTAL" IS CRYSTAL.

FOR GLASSWARE, PORCELAIN AND EARTHENWARE FOR HOUSEHOLD AND KITCHEN, NAMELY, VESSELS AND POTS, BUCKETS, WASTE BINS, PANS, PLATES, BASINS; CUPS; MUGS; SAUCERS; DISHES; CANDY DISHES; DECANTERS; BAKING DISHES; ROASTING DISHES; CASSEROLE DISHES; GLASS DISHES; DISH COVERS; BEVERAGE WARE; BAKEWARE; OVENWARE; DINNERWARE; PLASTIC PLATES, GLASSES, CUPS AND TRAYS; DISPOSABLE SERVING SPOONS, DISPOSABLE PAPERBOARD BAKEWARE; PLASTIC STORAGE CONTAINERS FOR HOUSEHOLD OR DOMESTIC USE; BUTTER DISHES; CHEESE COVERS; PIE SERVERS; CAKE DOMES; CAKE SERVERS; CAKE STANDS; CANDLE HOLDERS; CANDLE RINGS; CANDLESTICKS; CARAFES; CHAMPAGNE BUCKETS;

CLASS 21—(Continued).

COFFEE SERVERS; CREAMER PITCHERS; CRUET STANDS; CRUETS; CRUMB TRAYS; NAPKIN HOLDERS; NAPKIN RINGS; PILLAR CANDLE PLATES; PITCHERS; SALT AND PEPPER SHAKERS; SERVING DISHES; SERVING FORKS; SERVING PLATTERS; SERVING TRAYS; SERVING WARE FOR SERVING FOOD; SPOON RESTS; SAUCEBOATS; GRAVY BOATS; TEA SERVICES; TEA SETS; WINE JUGS; CARVING BOARDS; CHOPPING BOARDS FOR KITCHEN USE; KNIFE BLOCKS; KNIFE BOARDS; KNIFE RESTS; RECIPE BOXES; WOOD COOKING PLANKS FOR USE IN GRILLING; CHOCOLATE MOLDS; PUDDING MOLDS; NON-ELECTRIC GRIDDLES; NON-ELECTRIC DEEP FRYERS; NON-ELECTRIC RICE COOKING POTS; NON-ELECTRIC WOKS; DOUBLE BOILERS; EGG POACHERS; GLASS PANS; MUFFIN TINS; PIE PANS; POT LIDS; SAUCEPANS; SKILLETS; SWEDISH PANCAKE PANS; PASTRY MOLDS; BOTTLE STANDS; CAKE PANS; CAKE RINGS; CAKE TINS; CARVER RESTS; COFFEE SERVICE; COOKERY MOLDS; COOKIE SHEETS; NON-ELECTRIC COOKING PANS; COOKING POTS; NON-ELECTRIC COOKING STEAMERS; COOLING RACKS FOR BAKED GOODS; DISH DRYING RACKS; DISH STANDS; DUTCH OVENS; FRYING PANS; NOT ELECTRICALLY HEATED HOT POTS; NON-ELECTRIC KETTLES; MENU CARD HOLDERS; POT STANDS; SPICE RACKS; STANDS FOR DISHES; TABLE PLACE CARD HOLDERS; TEA CADDIES; TEA INFUSERS; TEA KETTLES; NON-ELECTRIC TEA POTS; TRAYS FOR DOMESTIC PURPOSES; TRIVETS; NON-ELECTRIC WAFFLE IRONS; WATERING CANS; CUP HOLDERS FOR BATH AND HOUSEHOLD USE; GLASS HOLDERS FOR BATH AND HOUSEHOLD USE; BUCKETS; CANDY BOXES; CANISTER SETS; CERAMIC TISSUE BOX COVERS; CONTAINERS FOR HOUSEHOLD OR KITCHEN USE; FLOWER POT HOLDERS; JUGS; TEA CANISTERS; VASES; WALL SOAP DISHES; PAPER PLATES, GLASSES, CUPS AND TRAYS; NON-ELECTRIC COFFEE POTS; COOKING STRAINERS; TEA STRAINERS; WINE STRAINERS; STRAINERS FOR HOUSEHOLD PURPOSES; SCOOPS, SPATULAS, BOWLS, EGG CUPS, CAKE MOULDS, WATER BOWLS, FOOD PRESERVING BOWLS; COASTERS, NOT OF PAPER AND OTHER THAN TABLE LINEN FOR GLASS AND PANS; FLOWER POTS, SOAP BOXES, SOAP DISPENSERS, METAL BOXES FOR DISPENSING PAPER TOWELS, PORTABLE BABY BATHS, ICE CUBE MOULDS AND ICE BUCKETS; HEAT-INSULATED VESSELS; VACUUM BOTTLES, FLASKS, FITTED PICNIC BASKETS; DRINKING CUPS GIVEN AT SPORTS MATCHES, BREAD BOXES, BREAD BASKETS, BREAD CUTTING BOARDS; KNICK-KNACKS OF PORCELAIN, TERRA-COTTA AND GLASS, NAMELY, FIGURES, BUSTS, COMMEMORATIVE PLATES, DECORATIVE CRYSTAL PRISMS, DECORATIVE PLATES, DESKTOP STATUARY, FIGURINES, GLASS ETCHED BY ACID, ORNAMENTS NOT FOR TREES, ORNAMENTAL GLASS SPHERES, PLAQUES, PORCELAIN EGGS, SCULPTURES, SOUVENIR PLATES, STAINED GLASS, AND STATUETTES; STATUES AND WORKS OF ART OF PORCELAIN, TERRA-COTTA AND GLASS; BOTTLES, SOLD EMPTY; JARS, NAMELY, GLASS JARS, COOKIE JARS, INSULATING JARS; DEMIJOHNS, DOOR-HANDLES OF PORCELAIN AND CERAMIC; PERFUME BURNERS, PERFUME SPRAYERS, PERFUME VAPORIZERS SOLD EMPTY; NON-ELECTRIC APPLIANCES FOR REMOVING MAKE-UP, NAMELY, SPONGES, SCRUBBING PUFFS, NON-WOVEN FABRIC COSMETIC WIPES, AND CLEANSING PUFFS, NOT BEING IMPREGNATED WITH PREPARATIONS; POWDER PUFFS; TOILET CASES, NAMELY, PLASTIC STORAGE CONTAINERS FOR HOUSEHOLD PURPOSES SOLD EMPTY; CONTAINERS OF PLASTIC FOR STORAGE OF FEMININE PRODUCTS FOR HOUSEHOLD OR DOMESTIC USE; UNWORKED OR SEMI-WORKED GLASS; POWDERED GLASS AND MOSAICS OF GLASS FOR DECORATION, NOT FOR BUILDING, GLASS WOOL OTHER THAN FOR INSULATION (U.S. CLS. 2, 13, 23, 29, 30, 33, 40 AND 50).

REBECCA POVARCHUK, EXAMINING ATTORNEY

CLASS 21—(Continued).

SN 79-044,091. CRISAL - CRISTALARIA AUTOMÁTICA, S.A., PORTUGAL, FILED 8-20-2007.



OWNER OF INTERNATIONAL REGISTRATION 0657308 DATED 7-12-1996, EXPIRES 7-12-2016.

OWNER OF U.S. REG. NO. 2,585,550.

NO CLAIM IS MADE TO THE EXCLUSIVE RIGHT TO USE "GLASS", APART FROM THE MARK AS SHOWN.

FOR GLASSWARE AND CRYSTAL, NAMELY, BEVERAGE GLASSES AND GOBLET, DINNERWARE, PLATES, SCULPTURES, FIGURINES, VASES, NAPKIN HOLDERS; EARTHENWARE AND FAIENCE, NAMELY, MUGS, DINNERWARE, PLATES, SCULPTURES, FIGURINES, VASES, NAPKIN HOLDERS; PORCELAIN, NAMELY, DINNERWARE, PLATES, SCULPTURES, FIGURINES, VASES, NAPKIN HOLDERS (U.S. CLS. 2, 13, 23, 29, 30, 33, 40 AND 50).

INGA ERVIN, EXAMINING ATTORNEY

SN 79-047,832. YONG FENG YUAN INDUSTRY CO., LTD, CHINA, FILED 12-11-2007.

cip

OWNER OF INTERNATIONAL REGISTRATION 0910166 DATED 9-26-2006, EXPIRES 9-26-2016.

THE WORDING "CIP" HAS NO MEANING IN A FOREIGN LANGUAGE.

FOR CERAMICS FOR HOUSEHOLD PURPOSES, NAMELY, CERAMIC FIGURINES, CERAMIC SCULPTURES, CERAMIC VASES, CERAMIC PLATES, CERAMIC POTS; POTTERY FOR EVERYDAY USE, NAMELY, BASINS, BOWLS, PLATES, INSULATING JARS, PET TREAT JARS, JUGS, POTS, MARMITES, KETTLES; PORCELAIN FOR EVERYDAY USE, NAMELY, BASINS, BOWLS, PLATES, KETTLES, INSULATING JARS, PET TREAT JARS, JUGS AND POTS; GLASSWARE FOR EVERYDAY USE, NAMELY, CUPS, PLATES, KETTLES AND JARS; WORKS OF ART, OF PORCELAIN, TERRA-COTTA OR GLASS; DRINKING VESSELS; COFFEE SERVICES, NOT OF PRECIOUS METAL; TEA SERVICES, NOT OF PRECIOUS METAL; PORCELAIN COPY, NAMELY, PLATES, BOWLS, FIGURINES MADE OF IMITATION PORCELAIN; POTTERY COPY, NAMELY, POTS, PLATES, BOWLS MADE OF IMITATION POTTERY (U.S. CLS. 2, 13, 23, 29, 30, 33, 40 AND 50).

TINA BROWN, EXAMINING ATTORNEY

CLASS 21—(Continued).

SN 79-049,324. BARBERI, S.L., SPAIN, FILED 11-29-2007.

FUNDIX

OWNER OF INTERNATIONAL REGISTRATION 0951827 DATED 11-29-2007, EXPIRES 11-29-2017.

FOR NON-ELECTRIC STEW-PANS, POTS, FRYING PANS, WOKS, OVEN TO TABLE TRAYS; KITCHEN UTENSILS, NAMELY, SPATULAS, GRATERS, SIEVES; HOUSEHOLD CONTAINERS FOR FOOD NOT OF PRECIOUS METALS OR COATED THEREWITH (U.S. CLS. 2, 13, 23, 29, 30, 33, 40 AND 50).

DAYNA BROWNE, EXAMINING ATTORNEY

CLASS 22—(Continued).

SN 77-416,368. NEWELL OPERATING COMPANY, ATLANTA, GA. FILED 3-7-2008.

LEVOLOR

THE MARK CONSISTS OF STANDARD CHARACTERS WITHOUT CLAIM TO ANY PARTICULAR FONT, STYLE, SIZE, OR COLOR.

FOR VENETIAN BLIND LADDER TAPES (U.S. CLS. 1, 2, 7, 19, 22, 42 AND 50).

FIRST USE 1-21-1941; IN COMMERCE 1-21-1941.
MELISSA VALLILLO, EXAMINING ATTORNEY**CLASS 22—CORDAGE AND FIBERS**

SN 77-374,176. CARRILLO, ROBERT G, ANAHEIM, CA. FILED 1-17-2008.

POWERTYE

THE MARK CONSISTS OF STANDARD CHARACTERS WITHOUT CLAIM TO ANY PARTICULAR FONT, STYLE, SIZE, OR COLOR.

SEC. 2(F).
FOR TIE DOWN STRAPS (U.S. CLS. 1, 2, 7, 19, 22, 42 AND 50).FIRST USE 10-18-1993; IN COMMERCE 10-18-1993.
ALEX KEAM, EXAMINING ATTORNEY

SN 77-428,296. GARWARE-WALL ROPES LTD., PUNE, INDIA, FILED 3-21-2008.

SAPPHIRE

THE MARK CONSISTS OF STANDARD CHARACTERS WITHOUT CLAIM TO ANY PARTICULAR FONT, STYLE, SIZE, OR COLOR.

FOR FISHING NETS; TWINE (U.S. CLS. 1, 2, 7, 19, 22, 42 AND 50).

FIRST USE 2-26-2004; IN COMMERCE 2-26-2004.
AMOS T. MATTHEWS, JR., EXAMINING ATTORNEY

SN 77-381,139. MASTER-PULL, LLC, BELLINGHAM, WA. FILED 1-25-2008.

MASTER-PULL

THE MARK CONSISTS OF STANDARD CHARACTERS WITHOUT CLAIM TO ANY PARTICULAR FONT, STYLE, SIZE, OR COLOR.

FOR ANCHORING ROPES; CAR TOWING ROPES; ROPES; ROPES AND SYNTHETIC ROPES; TOW ROPES FOR AUTOMOBILES; STRAPS FOR HANDLING LOADS; TOWING STRAPS (U.S. CLS. 1, 2, 7, 19, 22, 42 AND 50).

FIRST USE 12-6-2000; IN COMMERCE 12-19-2000.
GENE MACIOL, EXAMINING ATTORNEY

SN 77-432,043. INTERNATIONAL E-Z UP, INC., RIVERSIDE, CA. FILED 3-26-2008.

JAMBOREE

THE MARK CONSISTS OF STANDARD CHARACTERS WITHOUT CLAIM TO ANY PARTICULAR FONT, STYLE, SIZE, OR COLOR.

FOR COLLAPSIBLE CANVAS CANOPIES (U.S. CLS. 1, 2, 7, 19, 22, 42 AND 50).

ROBIN MITTLER, EXAMINING ATTORNEY

CLASS 22—(Continued).

SN 77-433,175. BAEJIN CORPORATION, SEOUL, REPUBLIC OF KOREA, FILED 3-27-2008.

CAMPTOWN

THE MARK CONSISTS OF STANDARD CHARACTERS WITHOUT CLAIM TO ANY PARTICULAR FONT, STYLE, SIZE, OR COLOR.

OWNER OF U.S. REG. NO. 1,466,368.
FOR TENTS (U.S. CLS. 1, 2, 7, 19, 22, 42 AND 50).
FIRST USE 12-31-2002; IN COMMERCE 12-31-2002.
SUNG IN, EXAMINING ATTORNEY

CLASS 24—(Continued).

SN 77-112,030. SAGE II, ROBERT G., POST FALLS, ID. FILED 2-21-2007.

**BUTT
HEAD**

THE MARK CONSISTS OF STANDARD CHARACTERS WITHOUT CLAIM TO ANY PARTICULAR FONT, STYLE, SIZE, OR COLOR.

FOR TOWELS (U.S. CLS. 42 AND 50).
DOMINIC J. FERRAIUOLO, EXAMINING ATTORNEY

SN 77-442,655. GARWARE-WALL ROPES LTD., PUNE, INDIA, FILED 4-8-2008.



THE COLOR(S) BLUE AND YELLOW IS/ARE CLAIMED AS A FEATURE OF THE MARK.

THE MARK CONSISTS OF NUMEROUS BLUE SHAPES PLACED IN THE SHAPE OF A TRIANGLE, DIVIDED BY WHITE AND YELLOW LINES, FOLLOWED BY THE WORD "SAPHIRE", WITH A YELLOW CRESCENT SHAPE ACROSS THE "E" AT THE END OF "SAPHIRE".

FOR FISHING NETS; TWINE (U.S. CLS. 1, 2, 7, 19, 22, 42 AND 50).

AMOS T. MATTHEWS, JR., EXAMINING ATTORNEY

SN 77-155,000. DOWN LITE INTERNATIONAL, MASON, OH. FILED 4-12-2007.

SUREGRIP

THE MARK CONSISTS OF STANDARD CHARACTERS WITHOUT CLAIM TO ANY PARTICULAR FONT, STYLE, SIZE, OR COLOR.

FOR MATTRESS PADS; BED-SKIRTING MATERIAL USED AS A COMPONENT OF MATTRESS PADS (U.S. CLS. 42 AND 50).

FRANK LATTUCA, EXAMINING ATTORNEY

CLASS 24—FABRICS

SN 76-548,328. SPERIAN PROTECTIVE APPAREL INC./ SPERIAN VETEMENTS DE PROTECTION LTEE, MONTREAL, QUEBEC, CANADA, FILED 10-1-2003.

2F3FABRIC

FOR FABRICS FOR THE MANUFACTURE OF PROTECTIVE CLOTHING AND ACCESSORIES, NAMELY, FABRIC RESISTANT TO FIRE, HEAT, WATER, PERFORATION, CHEMICALS, GASES, GERMS, BACTERIA, BLOOD AND BODY FLUIDS FOR THE MANUFACTURE OF COATS, HATS, HELMETS, JACKETS, VESTS, PANTS, BOOTS, SHIRTS, SOCKS, STOCKINGS, UNDERTOPS, UNDER BOTTOMS, WETSUITS AND BODY SUITS (U.S. CLS. 42 AND 50).

SHARON MEIER, EXAMINING ATTORNEY

SN 77-190,818. MASA S.P.A., BOLLADELLO DI CAIRATE, ITALY, FILED 5-25-2007.

MASA

THE MARK CONSISTS OF STANDARD CHARACTERS WITHOUT CLAIM TO ANY PARTICULAR FONT, STYLE, SIZE, OR COLOR.

OWNER OF U.S. REG. NO. 2,369,213.

THE TERM "MASA" HAS NO MEANING IN A FOREIGN LANGUAGE.

FOR TABLE TEXTILES, LINENS AND TEXTILE GOODS, NOT INCLUDED IN OTHER CLASSES, NAMELY, TEXTILE TABLECLOTHS, TEXTILE NAPKINS, FABRIC TABLE TOPPERS; KITCHEN TEXTILES AND LINENS, NAMELY, DISH TOWELS, TEXTILE PLACE MATS; BATH TEXTILES AND LINENS, NAMELY, FACE TOWELS, HAND TOWELS, BATH TOWELS, BED TEXTILES AND LINENS, NAMELY, BED SHEETS; PILLOWCASES; TEXTILE BED COVERS, DUVET COVERS (U.S. CLS. 42 AND 50).

FIRST USE 4-28-1997; IN COMMERCE 4-28-1997.

MICHAEL LITZAU, EXAMINING ATTORNEY

CLASS 24—(Continued).

SN 77-191,148. ROBERT KAUFMAN CO., INC., LOS ANGELES, CA. FILED 5-25-2007.

FUSIONS

THE MARK CONSISTS OF STANDARD CHARACTERS WITHOUT CLAIM TO ANY PARTICULAR FONT, STYLE, SIZE, OR COLOR.

FOR FABRICS FOR USE IN THE MANUFACTURE OF QUILTING AND CRAFTS; TEXTILE FABRICS FOR USE IN THE MANUFACTURE OF QUILTING AND CRAFTS (U.S. CLS. 42 AND 50).

FIRST USE 4-11-2001; IN COMMERCE 4-11-2001.
JOHN KELLY, EXAMINING ATTORNEY

SN 77-206,131. WELSPUN INDIA LIMITED, MUMBAI, INDIA, FILED 6-14-2007.

SMART IDEAS FOR BED AND BATH

THE MARK CONSISTS OF STANDARD CHARACTERS WITHOUT CLAIM TO ANY PARTICULAR FONT, STYLE, SIZE, OR COLOR.

NO CLAIM IS MADE TO THE EXCLUSIVE RIGHT TO USE "BED" AND "BATH", APART FROM THE MARK AS SHOWN.

FOR BED SHEETS AND TOWELS (U.S. CLS. 42 AND 50).
KATHY DE JONGE, EXAMINING ATTORNEY

SN 77-248,386. LES LAINAGES VICTOR LTÉE, SAINT-VICTOR, CANADA, FILED 8-6-2007.



PRIORITY CLAIMED UNDER SEC. 44(D) ON CANADA APPLICATION NO. 1348693, FILED 5-24-2007.

THE MARK CONSISTS OF A FANCIFUL DESIGN OF A BILLIARD BALL FOLLOWED BY THE WORDING "FORSTMANN".

FOR BILLIARD CLOTH (U.S. CLS. 42 AND 50).
FIRST USE 6-30-1986; IN COMMERCE 6-30-1986.
JAMES LOVELACE, EXAMINING ATTORNEY

CLASS 24—(Continued).

SN 77-280,557. JAIME PUJOL, MIAMI, FL. FILED 9-16-2007.

UNSINKABLE SPIRIT OF AMERICA

THE MARK CONSISTS OF STANDARD CHARACTERS WITHOUT CLAIM TO ANY PARTICULAR FONT, STYLE, SIZE, OR COLOR.

FOR CLOTH BANNERS (U.S. CLS. 42 AND 50).
DAVID MILLER, EXAMINING ATTORNEY

SN 77-313,451. FORTI-PLAST, L.L.C., GRAND PRAIRIE, TX. FILED 10-25-2007.

FORTI-BANNER

THE MARK CONSISTS OF STANDARD CHARACTERS WITHOUT CLAIM TO ANY PARTICULAR FONT, STYLE, SIZE, OR COLOR.

FOR SYNTHETIC FIBER FABRIC WITH PRINTABLE COATING (U.S. CLS. 42 AND 50).

FIRST USE 10-24-2007; IN COMMERCE 10-24-2007.
VIVIAN MICZNIK FIRST, EXAMINING ATTORNEY

SN 77-323,036. WARNER BROS. ENTERTAINMENT INC., BURBANK, CA. FILED 11-6-2007.

MUGGLES

THE MARK CONSISTS OF STANDARD CHARACTERS WITHOUT CLAIM TO ANY PARTICULAR FONT, STYLE, SIZE, OR COLOR.

OWNER OF U.S. REG. NO. 2,769,531.

FOR BATH LINENS, NAMELY, BATH TOWELS AND WASH CLOTHS; BED LINENS, NAMELY, BED BLANKETS, BED CANOPIES, BED PADS, BED SHEETS, BED SPREADS, PILLOW CASES, COMFORTERS, DUVET COVERS, MATTRESS COVERS, DUST RUFFLES, CRIB BUMPERS, PILLOW SHAMS AND BED SPREADS; TEXTILE WALL HANGINGS; CURTAINS; DRAPERIES; COTTON, POLYESTER AND/OR NYLON FABRIC; LINEN; KITCHEN LINENS, NAMELY, BARBECUE MITTS, CLOTH NAPKINS, DISH CLOTHS, FABRIC TABLE CLOTHS, KITCHEN TOWELS, FABRIC PLACE MATS, OVEN MITTS, WASHING MITTS, FABRIC TABLE RUNNERS, POT HOLDERS AND CLOTH COASTERS; HANDKERCHIEFS, QUILTS, AND GOLF TOWELS (U.S. CLS. 42 AND 50).

CAROLINE WOOD, EXAMINING ATTORNEY

CLASS 24—(Continued).

SN 77-364,402. EPOCH TRADE, LLC, HILLSBOROUGH, CA. FILED 1-4-2008.

Alternative Naturals

THE MARK CONSISTS OF STANDARD CHARACTERS WITHOUT CLAIM TO ANY PARTICULAR FONT, STYLE, SIZE, OR COLOR.

NO CLAIM IS MADE TO THE EXCLUSIVE RIGHT TO USE "NATURALS", APART FROM THE MARK AS SHOWN. FOR HOME TEXTILE PRODUCTS, NAMELY, COMFORTERS, BED BLANKETS, FABRIC WINDOW COVERINGS, NAMELY, CURTAINS AND DRAPERIES (U.S. CLS. 42 AND 50).

FIRST USE 8-28-2007; IN COMMERCE 8-28-2007.
TRICIA SONNEBORN, EXAMINING ATTORNEY

SN 77-423,281. EASTERN EXCEL, INC., DBA BED HOG, SAN CARLOS, CA. FILED 3-17-2008.

Bed Hog

THE MARK CONSISTS OF STANDARD CHARACTERS WITHOUT CLAIM TO ANY PARTICULAR FONT, STYLE, SIZE, OR COLOR.

NO CLAIM IS MADE TO THE EXCLUSIVE RIGHT TO USE "BED", APART FROM THE MARK AS SHOWN.

FOR BED AND TABLE LINEN; BED AND TABLE LINEN, WALL HANGINGS OF TEXTILE; BED BLANKETS; BED CANOPIES; BED LINEN; BED LINEN AND TABLE LINEN; BED PADS; BED SHEETS; BED SHEETS, FITTED BED SHEET COVERS, BED FLAT SHEETS, AND PILLOW CASES USED IN THE BEDDING, HEALTH CARE, HOME-HEALTH CARE AND NURSING HOME INDUSTRIES MADE OF BIODEGRADABLE FILM CREATED FROM RENEWABLE BIO-POLYMER RESOURCES; BED SKIRTS; BED SPREADS; FEATHER BEDS; SILK BED BLANKETS; TABLE AND BED LINEN (U.S. CLS. 42 AND 50).

FIRST USE 3-1-2008; IN COMMERCE 5-30-2008.
YAT SYE, LEE, EXAMINING ATTORNEY

SN 77-425,175. A.B.C. HOME FURNISHINGS, INC., NEW YORK, NY. FILED 3-18-2008.

CONSCIOUS COUTURE

THE MARK CONSISTS OF STANDARD CHARACTERS WITHOUT CLAIM TO ANY PARTICULAR FONT, STYLE, SIZE, OR COLOR.

NO CLAIM IS MADE TO THE EXCLUSIVE RIGHT TO USE "COUTURE", APART FROM THE MARK AS SHOWN. FOR UPHOLSTERY FABRICS COMPRISED OF SUSTAINABLE MATERIALS (U.S. CLS. 42 AND 50).

FIRST USE 10-1-2007; IN COMMERCE 10-1-2007.
ROBERT LAVACHE, EXAMINING ATTORNEY

CLASS 24—(Continued).

SN 77-430,010. XYMID, L.L.C., MIDLOTHIAN, VA. FILED 3-24-2008.

Tywik

THE MARK CONSISTS OF STANDARD CHARACTERS WITHOUT CLAIM TO ANY PARTICULAR FONT, STYLE, SIZE, OR COLOR.

FOR ABSORBENT TEXTILE FABRIC OF SYNTHETIC FIBERS (U.S. CLS. 42 AND 50).

FIRST USE 9-30-1998; IN COMMERCE 9-30-1998.
JOHN SCHUYLER YARD, EXAMINING ATTORNEY

SN 77-431,058. THE ORIGINAL HONEY BAKED HAM CO. OF GEORGIA, INC., NORCROSS, GA. FILED 3-25-2008.

Bonfetti

THE MARK CONSISTS OF STANDARD CHARACTERS WITHOUT CLAIM TO ANY PARTICULAR FONT, STYLE, SIZE, OR COLOR.

FOR TABLE LINENS, NAMELY, TABLE CLOTHS, PLACEMATS, AND NAPKINS (U.S. CLS. 42 AND 50).

HENRY S. ZAK, EXAMINING ATTORNEY

SN 77-431,983. STUDIO Z TEXTILES, LLC, GRAND RAPIDS, MI. FILED 3-26-2008.

JACQFORM

THE MARK CONSISTS OF STANDARD CHARACTERS WITHOUT CLAIM TO ANY PARTICULAR FONT, STYLE, SIZE, OR COLOR.

FOR FABRICS FOR TEXTILE USE (U.S. CLS. 42 AND 50).

JENNIFER MARTIN, EXAMINING ATTORNEY

CLASS 24—(Continued).

SN 77-433,657. UCHINO CO., LTD., TOKYO, JAPAN, FILED 3-27-2008.

ECOLIVE

THE MARK CONSISTS OF STANDARD CHARACTERS WITHOUT CLAIM TO ANY PARTICULAR FONT, STYLE, SIZE, OR COLOR.
FOR TOWELS (U.S. CLS. 42 AND 50).
WANDA KAY PRICE, EXAMINING ATTORNEY

SN 77-434,720. GIATI DESIGNS, INC., SANTA BARBARA, CA. FILED 3-28-2008.

GIATI ELEMENTS

THE MARK CONSISTS OF STANDARD CHARACTERS WITHOUT CLAIM TO ANY PARTICULAR FONT, STYLE, SIZE, OR COLOR.
OWNER OF U.S. REG. NO. 3,358,474.
FOR TEXTILES FOR FURNITURE AND HOME AND OUTDOOR FURNISHINGS (U.S. CLS. 42 AND 50).
FIRST USE 5-23-2007; IN COMMERCE 5-23-2007.
CURTIS FRENCH, EXAMINING ATTORNEY

SN 77-438,124. THE ORIGINAL HONEY BAKED HAM CO. OF GEORGIA, INC., NORCROSS, GA. FILED 4-2-2008.



THE MARK CONSISTS OF THE WORD "BONFETTI" IN STYLIZED SCRIPT, WITH DESIGN REPRESENTING PLOTCHES OF PAINT.
FOR TABLE LINENS, NAMELY, TABLE CLOTHS, PLACEMATS, AND NAPKINS (U.S. CLS. 42 AND 50).
HENRY S. ZAK, EXAMINING ATTORNEY

CLASS 24—(Continued).

SN 78-719,114. ROUTE 66, L.P., NEW YORK, NY. FILED 9-23-2005.

ROUTE 66

THE MARK CONSISTS OF STANDARD CHARACTERS WITHOUT CLAIM TO ANY PARTICULAR FONT, STYLE, SIZE, OR COLOR.

OWNER OF U.S. REG. NOS. 2,550,930 AND 2,948,285.
FOR BED SHEETS, PILLOWCASES, BED BLANKETS, COMFORTERS, COMFORTER COVERS, DUVETS, DUVET COVERS, QUILTS, TOWELS, WASHCLOTHS, TABLECLOTHS AND NAPKINS NOT OF PAPER, HANDKERCHIEFS, CURTAINS, DRAPERIES, CLOTH FLAGS AND CLOTH BANNERS (U.S. CLS. 42 AND 50).
ANNE FARRELL, EXAMINING ATTORNEY

SN 79-045,355. SVENSKT TENN AKTIEBOLAG, SWEDEN, FILED 5-30-2007.



PRIORITY DATE OF 11-30-2006 IS CLAIMED.
OWNER OF INTERNATIONAL REGISTRATION 0929651 DATED 12-1-2006, EXPIRES 12-1-2016.

NO CLAIM IS MADE TO THE EXCLUSIVE RIGHT TO USE "SVENSKT" AND "STOCKHOLM", APART FROM THE MARK AS SHOWN.

THE NAME(S), PORTRAIT(S), AND/OR SIGNATURE(S) SHOWN IN THE MARK DOES NOT IDENTIFY A PARTICULAR LIVING INDIVIDUAL.

THE MARK CONSISTS OF TWO CONCENTRIC CIRCLES CREATING THE WORDING "SVENSKT TENN STOCKHOLM" AROUND IT WITH TOW ANGLES PRAYING INSIDE THE CIRCLES WITH A CREST FEATURING THE STYLIZED LETTERS "ST".

"THE FOREIGN WORDING IN THE MARK TRANSLATES INTO ENGLISH AS SWEDISH TIN."

FOR TEXTILES AND TEXTILE GOODS, NAMELY, TABLE CLOTHS NOT OF PAPER, OIL CLOTHS, TABLE LINEN, TABLE MATS NOT OF PAPER, PLACE MATS OF TEXTILE MATERIAL, TOWELS OF TEXTILE, HOUSEHOLD LINEN, HANDKERCHIEFS OF TEXTILE, PILLOW SHAMS, BED SHEETS, BED LINEN, BED BLANKETS, BED COVERS, NAMELY, DUVET COVERS AND PAPER BED COVERS; MATTRESS COVERS, UPHOLSTERY FABRICS, UNFITTED FURNITURE COVERING OF TEXTILE OR PLASTIC, WALL HANGING OF TEXTILE, DOOR CURTAINS, CURTAINS OF TEXTILE OF PLASTIC (U.S. CLS. 42 AND 50).

WARREN L. OLANDRIA, EXAMINING ATTORNEY

CLASS 24—(Continued).

SN 79-049,230. HANGZHOU HONGFENG; TEXTILE GROUP CO., LTD., CHINA, FILED 1-10-2008.



OWNER OF INTERNATIONAL REGISTRATION 0951584 DATED 1-10-2008, EXPIRES 1-10-2018.

THE ENGLISH TRANSLATION OF THE FOREIGN WORD(S) IN THE MARK IS: "GREAT PEAK".

THE TRANSLITERATION OF THE NON-LATIN CHARACTERS IN THE MARK IS: "HONG FENG".

FOR KNITTED FABRIC; CLOTH, NAMELY, LINEN, SILK, DISH CLOTHS; ELASTIC WOVEN MATERIAL, NAMELY, ELASTIC FABRICS FOR CLOTHING; COTTON FABRICS; JERSEY AS FABRIC; RAYON FABRIC; LINEN CLOTH; FABRIC, NAMELY, JEANS, JUTE; UPHOLSTERY FABRICS; FABRICS FOR TEXTILE USE (U.S. CLS. 42 AND 50).

SAIMA MAKHDOOM, EXAMINING ATTORNEY

CLASS 25—CLOTHING

SN 76-331,234. FOX HEAD, INC., MORGAN HILL, CA. FILED 10-29-2001.

FOX RACING

OWNER OF U.S. REG. NO. 2,181,243. FOR CLOTHING, NAMELY, JACKETS, RAINCOATS, SWEATSHIRTS, JERSEYS, SHIRTS, BLOUSES, PANTS, UNITARDS, TIGHTS, HATS, CAPS, SWEATBANDS, GLOVES, BELTS, SHOES, SOCKS, APRONS, POLO SHIRTS, OUTRIDER JACKETS (U.S. CLS. 22 AND 39).

HENRY S. ZAK, EXAMINING ATTORNEY

SN 76-628,627. SVENGIRLY MUSIC, INC., PASADENA, CA. FILED 1-20-2005.

T.REX

THE MARK CONSISTS OF STANDARD CHARACTERS WITHOUT CLAIM TO ANY PARTICULAR FONT, STYLE, SIZE, OR COLOR.

FOR APPAREL, NAMELY, T-SHIRTS, SHIRTS, SWEATSHIRTS, JACKETS, WRIST BANDS, AND CAPS (U.S. CLS. 22 AND 39).

FIRST USE 6-1-1971; IN COMMERCE 6-1-1971.

JOHN DWYER, EXAMINING ATTORNEY

CLASS 25—(Continued).

SN 76-633,115. MOOCOW LIMITED, LONDON W1T 4EF, UNITED KINGDOM, FILED 3-11-2005.



PRIORITY CLAIMED UNDER SEC. 44(D) ON UNITED KINGDOM APPLICATION NO. 2376368, FILED 10-22-2004, REG. NO. 2376368, DATED 4-1-2005, EXPIRES 10-22-2014.

FOR CLOTHING, NAMELY, WOMEN'S T-SHIRTS, BLOUSES, VESTS, TOPS, CROP TOPS, SHORTS, SKIRTS, JACKETS, GLOVES, SOCKS; FOOTWEAR; HEADGEAR, NAMELY, CAPS, CAPS WITH VISORS, BERETS, HATS, WOOLLY HATS; LADIES LINGERIE AND UNDERWEAR; TIGHTS, STOCKINGS; SPORTSWEAR, NAMELY, WOMEN'S SHORTS, SHIRTS, POLO SHIRTS, TRACK SUITS, JACKETS, SWEATSHIRTS; LEISURE WEAR, NAMELY, WOMEN'S SHORTS, SHIRTS, TOPS, T-SHIRTS, POLO SHIRTS, TRACK SUITS, JACKETS, SWEATSHIRTS; SCARVES; NIGHTWEAR; NIGHT DRESSES; PAJAMAS; NEGLIGEEES; CAPS (U.S. CLS. 22 AND 39).

YONG KIM, EXAMINING ATTORNEY

SN 76-638,707. COMPONENTS BY JOHN MCCOY, INC, NEW YORK, NY. FILED 5-16-2005.

THE DEFENDER

THE MARK CONSISTS OF STANDARD CHARACTERS WITHOUT CLAIM TO ANY PARTICULAR FONT, STYLE, SIZE, OR COLOR.

FOR CLOTHING, NAMELY, SUITS, AND SPORT JACKETS (U.S. CLS. 22 AND 39).

MARY BOAGNI, EXAMINING ATTORNEY

SN 76-681,490. CLARK, ANTHONY, GLENDALE, AZ. FILED 9-4-2007.



FOR APPAREL, NAMELY, SPORTSWEAR AND ATHLETIC APPAREL, NAMELY, HATS, VISORS, SWEAT SHIRTS, SWEAT SUITS, PANTS, SHIRTS, SOCKS, WRISTBANDS, AND HEADBANDS (U.S. CLS. 22 AND 39).

GRETTA YAO, EXAMINING ATTORNEY

CLASS 25—(Continued).

SN 76-682,583. FINIS, INC., LIVERMORE, CA. FILED 10-4-2007.

FINIS

THE MARK CONSISTS OF STANDARD CHARACTERS WITHOUT CLAIM TO ANY PARTICULAR FONT, STYLE, SIZE, OR COLOR.

THE ENGLISH TRANSLATION OF THE FRENCH WORD "FINIS" IS COMPLETE OR CONCLUDED.

FOR SWIM WEAR; SWIM CAPS (U.S. CLS. 22 AND 39).

FIRST USE 9-0-2001; IN COMMERCE 9-0-2001.

SETH A. RAPPAPORT, EXAMINING ATTORNEY

SN 76-682,759. SCRUNCH-ITZ, LLC, SAYREVILLE, NJ. FILED 10-10-2007.

ITZ KIDZ

THE MARK CONSISTS OF STANDARD CHARACTERS WITHOUT CLAIM TO ANY PARTICULAR FONT, STYLE, SIZE, OR COLOR.

FOR APPAREL FOR CHILDREN AND ADOLESCENTS, NAMELY, SHIRTS, PANTS, DRESSES, JACKETS, COATS, ONE-PIECE GARMENTS, AND ACCESSORIES ASSOCIATED THEREWITH, NAMELY, BELTS, SCARVES, HATS AND CAPS (U.S. CLS. 22 AND 39).

KARANENDRA S. CHHINA, EXAMINING ATTORNEY

SN 76-682,762. SCRUNCH-ITZ, LLC, SAYREVILLE, NJ. FILED 10-10-2007.

BABY ITZ

THE MARK CONSISTS OF STANDARD CHARACTERS WITHOUT CLAIM TO ANY PARTICULAR FONT, STYLE, SIZE, OR COLOR.

NO CLAIM IS MADE TO THE EXCLUSIVE RIGHT TO USE "BABY", APART FROM THE MARK AS SHOWN.

FOR CLOTHING FOR INFANTS AND TODDLERS, NAMELY, SHIRTS, PANTS, DRESSES, ONE-PIECE GARMENTS, AND ACCESSORIES ASSOCIATED THEREWITH, NAMELY, CAPS AND BIBS NOT OF PAPER (U.S. CLS. 22 AND 39).

KARANENDRA S. CHHINA, EXAMINING ATTORNEY

CLASS 25—(Continued).

SN 76-683,849. JR286, INC., REDONDO BEACH, CA. FILED 11-8-2007.

PRO STRETCH

THE MARK CONSISTS OF STANDARD CHARACTERS WITHOUT CLAIM TO ANY PARTICULAR FONT, STYLE, SIZE, OR COLOR.

NO CLAIM IS MADE TO THE EXCLUSIVE RIGHT TO USE "STRETCH", APART FROM THE MARK AS SHOWN.

FOR A HAT WITH A SWEATBAND INCORPORATED THEREIN (U.S. CLS. 22 AND 39).

GIANCARLO CASTRO, EXAMINING ATTORNEY

SN 76-685,526. CLYMER, BRETT T., MURRIETA, CA. FILED 1-4-2008.

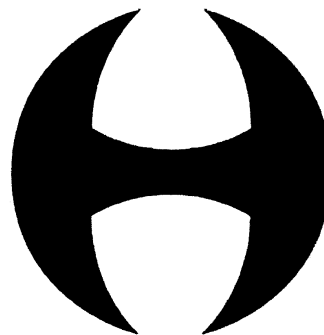

FOR CLOTHING, NAMELY, SURFING HATS, SURFING JACKETS, SURFING SHIRTS, SURFING BUTTON-UPS, SURFING PANTS, SURFING SHORTS, SURFING BOARD SHORTS, SURFING SOCKS, SURFING SHOES, AND SURFING SANDALS, FOR SURFING ENTHUSIASTS; SKATEBOARDING HATS, SKATEBOARDING JACKETS, SKATEBOARDING SHIRTS, SKATEBOARDING BUTTON-UPS, SKATEBOARDING PANTS, SKATEBOARDING SHORTS, SKATEBOARDING BOARD SHORTS, SKATEBOARDING SOCKS, SKATEBOARDING SHOES, AND SKATEBOARDING SANDALS, FOR SKATEBOARDING ENTHUSIASTS; AND SNOWBOARDING HATS, SNOWBOARDING JACKETS, SNOWBOARDING SHIRTS, SNOWBOARDING BUTTON-UPS, SNOWBOARDING PANTS, SNOWBOARDING SHORTS, SNOWBOARDING BOARD SHORTS, SNOWBOARDING SOCKS, SNOWBOARDING SHOES, AND SNOWBOARDING SANDALS, FOR SNOWBOARDING ENTHUSIASTS (U.S. CLS. 22 AND 39).

JANET LEE, EXAMINING ATTORNEY

CLASS 25—(Continued).

SN 76-686,533. ENCHANTED ENFANT, LLC, FALLSING-
TON, PA. FILED 2-4-2008.

ENCHANTED ENFANT

THE MARK CONSISTS OF STANDARD CHARACTERS WITHOUT CLAIM TO ANY PARTICULAR FONT, STYLE, SIZE, OR COLOR.

NO CLAIM IS MADE TO THE EXCLUSIVE RIGHT TO USE "ENFANT", APART FROM THE MARK AS SHOWN.

THE WORD "ENFANT" TRANSLATES FROM THE FRENCH AS "CHILD".

FOR CHILDREN'S CLOTHING, NAMELY, DRESSES, TOPS, PANTS, COATS, JACKETS, SWEATERS, BATHING SUITS, SOCKS, BELTS AND SUSPENDERS (U.S. CLS. 22 AND 39).

FIRST USE 7-29-2007; IN COMMERCE 7-29-2007.
KIMBERLY PERRY, EXAMINING ATTORNEY

CLASS 25—(Continued).

SN 76-687,911. DND FASHION, INC., SOUTH EL MONTE, CA. FILED 3-20-2008.

LOVMARK

THE MARK CONSISTS OF STANDARD CHARACTERS WITHOUT CLAIM TO ANY PARTICULAR FONT, STYLE, SIZE, OR COLOR.

FOR WOMEN'S AND CHILDREN'S SHOES (U.S. CLS. 22 AND 39).

LINDA M. KING, EXAMINING ATTORNEY

SN 76-687,143. HAMILTON, THOMAS, BERLIN, MD. FILED 2-27-2008.

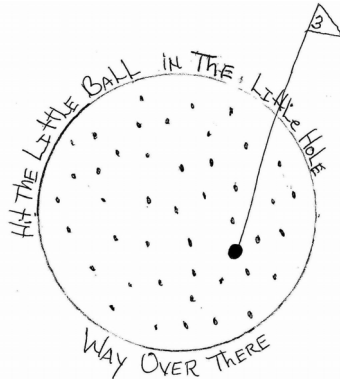

FOR CLOTHING, NAMELY, GOLF SHIRTS, SHIRTS, JACKETS, HATS, SOCKS, AND SHORTS (U.S. CLS. 22 AND 39).

ALEX KEAM, EXAMINING ATTORNEY

SN 76-688,015. COOGI PARTNERS, LLC, LAKE SUCCESS, NY. FILED 3-24-2008.

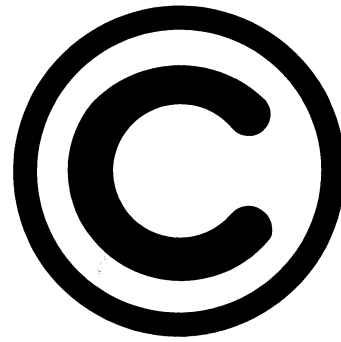

FOR CLOTHING, NAMELY, PANTS, SHIRTS AND FOOTWEAR (U.S. CLS. 22 AND 39).

FIRST USE 8-0-2006; IN COMMERCE 11-0-2006.
DORITT L. CARROLL, EXAMINING ATTORNEY

SN 76-687,689. ARMSTEAD, ERIC, TROY, NY. FILED 3-13-2008.

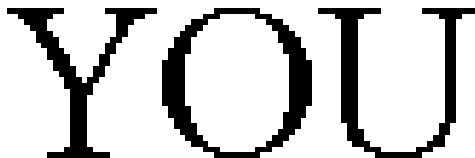

THE MARK CONSISTS OF STANDARD CHARACTERS WITHOUT CLAIM TO ANY PARTICULAR FONT, STYLE, SIZE, OR COLOR.

FOR CLOTHING, NAMELY, BASEBALL CAPS, T-SHIRTS, FOOTWEAR, HEADWEAR, AND HOODED PULLOVERS (U.S. CLS. 22 AND 39).

KARANENDRA S. CHHINA, EXAMINING ATTORNEY

SN 76-688,087. EAGLES, LTD., LOS ANGELES, CA. FILED 3-27-2008.

EAGLES LIFE IN THE FAST LANE

THE MARK CONSISTS OF STANDARD CHARACTERS WITHOUT CLAIM TO ANY PARTICULAR FONT, STYLE, SIZE, OR COLOR.

OWNER OF U.S. REG. NO. 2,161,179.

FOR CLOTHING, NAMELY, T-SHIRTS, POLO SHIRTS, SWEATSHIRTS, SWEATPANTS, SHIRTS AND HEADWEAR (U.S. CLS. 22 AND 39).

ELIZABETH BEYER, EXAMINING ATTORNEY

CLASS 25—(Continued).

SN 77-007,403. GORDINI U.S.A. INC., ESSEX JUNCTION, VT.
FILED 9-26-2006.

EAR TOASTERS

THE MARK CONSISTS OF STANDARD CHARACTERS WITHOUT CLAIM TO ANY PARTICULAR FONT, STYLE, SIZE, OR COLOR.

FOR EARMUFFS, EAR WRAPS AND EAR BANDS (U.S. CLS. 22 AND 39).
SUZANNE BLANE, EXAMINING ATTORNEY

SN 77-007,411. GORDINI U.S.A. INC., ESSEX JUNCTION, VT.
FILED 9-26-2006.

STEREO TOASTERS

THE MARK CONSISTS OF STANDARD CHARACTERS WITHOUT CLAIM TO ANY PARTICULAR FONT, STYLE, SIZE, OR COLOR.

FOR EARMUFFS, EAR WRAPS AND EAR BANDS (U.S. CLS. 22 AND 39).
SUZANNE BLANE, EXAMINING ATTORNEY

SN 77-015,992. ICECO LIMITED, QUARRY BAY, HONG KONG, FILED 10-6-2006.



PRIORITY CLAIMED UNDER SEC. 44(D) ON HONG KONG APPLICATION NO. 300671887, FILED 7-3-2006, REG. NO. 300671887, DATED 7-3-2006, EXPIRES 7-3-2016.

THE ENGLISH TRANSLATION OF "CREAZIONE ARTISTICA DEL BALLO" IS ARTISTIC CREATION THROUGH DANCE.

FOR APRONS, CLOTHING BELTS, COATS, TOP-COATS, DRESSING GOWNS, FROCKS, GOWNS, JACKETS, JERSEYS, JUMPERS, KNITWEAR, NAMELY, TOPS, SWEATERS, VESTS, HATS AND SCARVES, LEATHER AND IMITATION LEATHER CLOTHING, NAMELY, BELTS, COATS, JACKETS AND PANTS, OUTERWEAR, NAMELY, COATS AND JACKETS, OVERALLS, PANTS, DRESS SHIELDS, SHIRTS, SKIRTS, SWEATERS, T-SHIRTS, TIGHTS, TROUSERS, SOCKS; HEADGEAR, NAMELY, HATS, CAPS AND HEADBANDS (U.S. CLS. 22 AND 39).

FIRST USE 5-0-2005; IN COMMERCE 5-0-2006.
ODESSA BIBBINS, EXAMINING ATTORNEY

CLASS 25—(Continued).

SN 77-034,882. ANTONIO OJEDA MERCADO, LEON, MEXICO, FILED 11-2-2006.

INNIU

THE MARK CONSISTS OF STANDARD CHARACTERS WITHOUT CLAIM TO ANY PARTICULAR FONT, STYLE, SIZE, OR COLOR.

THE ENGLISH TRANSLATION OF THE GAELIC TERM "INNIU" IS TODAY.

FOR CLOTHING, NAMELY, SHIRTS, PANTS, SHOES, HEADWEAR, AND BELTS (U.S. CLS. 22 AND 39).
STEPHEN AQUILA, EXAMINING ATTORNEY

SN 77-038,254. FINE LINE IMPORTS INC., TORONTO, CANADA, FILED 11-7-2006.

Uptown Girl by Sheri

THE MARK CONSISTS OF STANDARD CHARACTERS WITHOUT CLAIM TO ANY PARTICULAR FONT, STYLE, SIZE, OR COLOR.

THE NAME "SHERI" IDENTIFIES A LIVING INDIVIDUAL WHOSE CONSENT IS OF RECORD.

FOR LADIES' CLOTHING, NAMELY, JACKETS, PANTS, BLAZERS, SUITS, SWEATERS, BLOUSES AND SKIRTS (U.S. CLS. 22 AND 39).

LAURA HAMMEL, EXAMINING ATTORNEY

SN 77-066,882. SCOTT SHOE CO., LTD., HONOLULU, HI. FILED 12-18-2006.

SCOTT HAWAIIAN SLIPPAHS

THE MARK CONSISTS OF STANDARD CHARACTERS WITHOUT CLAIM TO ANY PARTICULAR FONT, STYLE, SIZE, OR COLOR.

NO CLAIM IS MADE TO THE EXCLUSIVE RIGHT TO USE "HAWAIIAN SLIPPERS", APART FROM THE MARK AS SHOWN.

THE NAME SHOWN IN THE MARK DOES NOT IDENTIFY A PARTICULAR LIVING INDIVIDUAL.

FOR SANDALS (U.S. CLS. 22 AND 39).
INGA ERVIN, EXAMINING ATTORNEY

CLASS 25—(Continued).

SN 77-086,210. JIMENEZ, VIRGINIA, FOUNTAIN HILLS, AZ.
FILED S.R. 1-19-2007; AM. P.R. 12-11-2007.



THE MARK CONSISTS OF A CHILI PEPPER IN THE SHAPE OF A WOMAN JUXTAPOSED BETWEEN THE LITERAL TERMS OF THE MARK; THE LETTER "I" APPEARS AS THE STEM OF THE CHILI PEPPER AND/OR THE HEAD AND NECK OF THE WOMAN.

THE FOREIGN WORDING IN THE MARK TRANSLATES INTO ENGLISH AS PRETTY WOMAN OR PRETTY MOM-MA.

FOR WOMEN'S APPAREL, NAMELY, T-SHIRTS AND HATS (U.S. CLS. 22 AND 39).

FIRST USE 9-15-2006; IN COMMERCE 9-15-2006.
SAIMA MAKHDOOM, EXAMINING ATTORNEY

CLASS 25—(Continued).

SN 77-098,217. CANINE COMBAT ENTERTAINMENT, INC.,
BROOKLYN, NY. FILED 2-2-2007.

CANINE COMBAT

THE MARK CONSISTS OF STANDARD CHARACTERS WITHOUT CLAIM TO ANY PARTICULAR FONT, STYLE, SIZE, OR COLOR.

OWNER OF U.S. REG. NO. 2,512,679.

FOR ADULT AND CHILDREN'S CLOTHING, NAMELY, SHIRTS, UNDERWEAR, BOXER SHORTS, PULLOVERS, SHORTS, UNDERSHIRTS, SWEATSHIRTS, VESTS, JEANS, LEATHER COATS, HEADWEAR, T-SHIRTS, TANK TOPS, COATS, JACKETS, UNDERPANTS AND PANTS; ADULT AND CHILDREN'S FOOTWEAR (U.S. CLS. 22 AND 39).

JAMES STEIN, EXAMINING ATTORNEY

SN 77-116,696. BLUE PAINT, LLC, LOS ANGELES, CA.
FILED 2-26-2007.

BLUE PAINT

THE MARK CONSISTS OF STANDARD CHARACTERS WITHOUT CLAIM TO ANY PARTICULAR FONT, STYLE, SIZE, OR COLOR.

FOR JEANS (U.S. CLS. 22 AND 39).

FIRST USE 11-2-2006; IN COMMERCE 11-2-2006.

RUDY R. SINGLETON, EXAMINING ATTORNEY

SN 77-088,795. CUFFS, AN IDAHO PARTNERSHIP, IDAHO
FALLS, ID. FILED 1-23-2007.

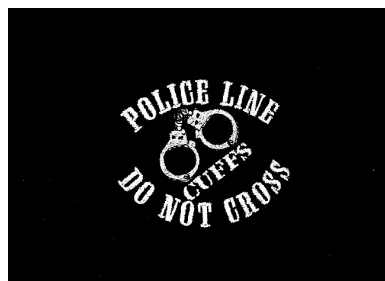

OWNER OF U.S. REG. NO. 3,216,602.

THE MARK CONSISTS OF THE WORDS "POLICE LINE" "DO NOT CROSS" AND "CUFFS," AND A DESIGN OF HANDCUFFS.

FOR CLOTHING, NAMELY, T-SHIRTS, HATS, UNDERWEAR, PAJAMAS, JACKETS, AND SWEATSHIRTS (U.S. CLS. 22 AND 39).

FIRST USE 9-9-2003; IN COMMERCE 6-10-2005.
EVELYN BRADLEY, EXAMINING ATTORNEY

SN 77-119,498. PANTHERS FOOTBALL LLC, CHARLOTTE,
NC. FILED 3-1-2007.

PANTHERS

THE MARK CONSISTS OF STANDARD CHARACTERS WITHOUT CLAIM TO ANY PARTICULAR FONT, STYLE, SIZE, OR COLOR.

OWNER OF U.S. REG. NO. 2,120,117.

FOR MEN'S, WOMEN'S AND CHILDREN'S CLOTHING, NAMELY, FLEECE TOPS AND BOTTOMS, HEADWEAR, CAPS, KNIT HATS, T-SHIRTS, SWEATSHIRTS, SHORTS, TANK TOPS, SWEATERS, PANTS, JACKETS, GOLF SHIRTS, WOMEN'S SHIRTS, KNIT SHIRTS, JERSEYS AND WRISTBANDS, ALL RELATING TO PROFESSIONAL FOOTBALL (U.S. CLS. 22 AND 39).

FIRST USE 9-30-1995; IN COMMERCE 9-30-1995.
MAUREEN DALL, EXAMINING ATTORNEY

CLASS 25—(Continued).

SN 77-129,819. MARC SOREL, RUMFORD, RI. AND RACHEL NOAH, RUMFORD, RI. FILED 3-13-2007.



THE MARK CONSISTS OF A SMILEY FACE WITH THE WORD "HAPPILY" ABOVE THE SMILEY FACE, AND THE WORD "DIVORCED" WITH AN EXCLAMATION POINT BELOW THE SMILEY FACE.

FOR CLOTHING, NAMELY, T-SHIRTS, TANK TOPS, SPORT SHIRTS, SWEATSHIRTS, SWEAT SHORTS, SWEAT PANTS, SWEAT SOCKS, JACKETS, SWEATERS, SCARVES, NIGHT SHIRTS, PAJAMAS, UNDERWEAR, AND BASEBALL CAPS (U.S. CLS. 22 AND 39).
JULIE GUTTADAURO, EXAMINING ATTORNEY

SN 77-135,254. MICHAEL T. WHITE, INC., TAMPA, FL. FILED 3-20-2007.

CULTIVATE YOUR IMAGE

THE MARK CONSISTS OF STANDARD CHARACTERS WITHOUT CLAIM TO ANY PARTICULAR FONT, STYLE, SIZE, OR COLOR.

FOR FOOTWEAR; CLOTHING, NAMELY, SHIRTS, T-SHIRTS, TANK TOPS, SWEATSHIRTS, PANTS, SWEAT-PANTS, SHORTS, WARM-UP SUITS, JACKETS, HATS AND SOCKS (U.S. CLS. 22 AND 39).
MAUREEN DALL, EXAMINING ATTORNEY

SN 77-178,802. BITZ LLC, WILMINGTON, DE. FILED 5-11-2007.

SKAAMZ

THE MARK CONSISTS OF STANDARD CHARACTERS WITHOUT CLAIM TO ANY PARTICULAR FONT, STYLE, SIZE, OR COLOR.

FOR CLOTHING, NAMELY, TROUSERS, SHORT TROUSERS, SHORTS, SWEAT TROUSERS, LEGGINGS, JEANS, T-SHIRTS, SHIRTS, SWEATSHIRTS, BELTS FOR CLOTHING (U.S. CLS. 22 AND 39).
RICHARD A. STRASER, EXAMINING ATTORNEY

CLASS 25—(Continued).

SN 77-180,875. NDREU, ALMIR, STATEN ISLAND, NY. FILED 5-15-2007.

Bald Brothers

THE COLOR(S) RED, CREAM, GREEN, AND BLACK IS/ARE CLAIMED AS A FEATURE OF THE MARK.

THE MARK CONSISTS OF THE COLOR RED APPEARS IN THE DESIGN AS SHADING FOR THE TONGUES OF THE SMILEY FACES THAT FORM THE LETTERS "A" AND "O". THE COLOR CREAM APPEARS IN THE WORDING AS SHADING OF THE LETTERS "A" AND "O" AND IN THE DESIGN AS SHADING FOR THE SMILEY FACES THAT FORM THE SAME LETTERS "A" AND "O". THE COLOR GREEN APPEARS IN THE WORDING AS SHADING FOR THE LETTERS "B", "LD", "BR" AND "THERS" THAT FORM THE WORDING "BALD BROTHERS". THE COLOR BLACK APPEARS AS OUTLINING FOR THE WORDING "BALD BROTHERS" AND IN THE DESIGN AS SHADING FOR THE EYES, NOSE AND MOUTH OF THE SMILEY FACES THAT FORM THE LETTERS "A" AND "O".

FOR SHIRTS; SPORTS SHIRTS; SPORTS SHIRTS WITH SHORT SLEEVES; SWEAT SHIRTS; T-SHIRTS; WIND SHIRTS; YOGA SHIRTS; A-SHIRTS; BUTTON-FRONT ALOHA SHIRTS; CAMP SHIRTS; DRESS SHIRTS; GOLF SHIRTS; KNIT SHIRTS; NIGHT SHIRTS; OPEN-NECKED SHIRTS; PIQUE SHIRTS; POLO SHIRTS; SHIRT FRONTS; SHIRT YOKES; SHIRTS FOR SUITS; SHORT-SLEEVED OR LONG-SLEEVED T-SHIRTS; SHORT-SLEEVED SHIRTS; SLEEP SHIRTS; SPORT SHIRTS (U.S. CLS. 22 AND 39).
BRIAN CALLAGHAN, EXAMINING ATTORNEY

SN 77-186,280. BITZ LLC, WILMINGTON, DE. FILED 5-21-2007.

THE MARK CONSISTS OF THE WORD "SKAAMZ" IN STYLIZED LETTERS WITH A THE LETTER "S" IN STYLIZED FORM AND A CIRCLE APPEARING AROUND THE LETTER.

FOR CLOTHING, NAMELY, TROUSERS, SHORT TROUSERS, SHORTS, SWEAT TROUSERS, LEGGINGS, JEANS, T-SHIRTS, SHIRTS, SWEATSHIRTS, BELTS FOR CLOTHING (U.S. CLS. 22 AND 39).
RICHARD A. STRASER, EXAMINING ATTORNEY

CLASS 25—(Continued).

SN 77-186,389. TARANTELLI, PAULA, HORSEHEADS, NY.
FILED 5-21-2007.



THE MARK CONSISTS OF THE WORD "ELEBINI" IN A
STYLIZED TEXT.

"ELEBINI" HAS NO MEANING IN A FOREIGN LAN-
GUAGE.

FOR CAPES; COATS; DRESSES; HATS; MUFFS;
PANTS; ROBES; SHIRTS; STOCKINGS; SWEATERS;
TIES; VESTS (U.S. CLS. 22 AND 39).

REBECCA EISINGER, EXAMINING ATTORNEY

CLASS 25—(Continued).

SN 77-207,562. LA COKA NOSTRA INC., LOS ANGELES, CA.
FILED 6-15-2007.

LA COKA NOSTRA

THE MARK CONSISTS OF STANDARD CHARACTERS
WITHOUT CLAIM TO ANY PARTICULAR FONT, STYLE,
SIZE, OR COLOR.

OWNER OF U.S. REG. NO. 3,388,200.

THE WORDING LA COKA NOSTRA HAS NO MEANING
OTHER THAN TRADEMARK SIGNIFICANCE.

FOR CLOTHING, TO BE SOLD AS PROMOTIONAL
MERCHANDISE FOR A MUSICAL GROUP, NAMELY,
HATS, HOODED SWEATSHIRTS, JACKETS, AND T-
SHIRTS (U.S. CLS. 22 AND 39).

FIRST USE 10-0-2006; IN COMMERCE 10-0-2006.

SHARON MEIER, EXAMINING ATTORNEY

SN 77-197,053. BLUE LINE PRODUCTIONS, INC., SUWAN-
NEE, GA. FILED 6-4-2007.



SN 77-215,564. JACOBSON, ANITA, SANTA MONICA, CA.
FILED 6-26-2007.

ALITTA

THE COLOR(S) BLACK, BLUE, YELLOW, WHITE, AND
GOLD IS/ARE CLAIMED AS A FEATURE OF THE MARK.

THE MARK CONSISTS OF A GOLD BIRD WITH A
WHITE HEAD, AND WITH OPEN WINGS CLUTCHING
TWO BLACK BARS, WITH A BLUE BAR DISPOSED
BETWEEN THE TWO BLACK BARS, A YELLOW BANNER
LOCATED IN FRONT OF THE BIRD'S WINGS, AND A
YELLOW BANNER LOCATED BEHIND THE BIRD'S
WINGS.

SEC. 2(F).

FOR SHIRTS, T-SHIRTS, CAPS (U.S. CLS. 22 AND 39).

FIRST USE 10-0-1994; IN COMMERCE 10-0-1994.

JAMES GRIFFIN, EXAMINING ATTORNEY

THE MARK CONSISTS OF STANDARD CHARACTERS
WITHOUT CLAIM TO ANY PARTICULAR FONT, STYLE,
SIZE, OR COLOR.

FOR JACKETS, PANTS, SHIRTS, AND SHORTS USED
FOR BICYCLING (U.S. CLS. 22 AND 39).

FIRST USE 6-29-1983; IN COMMERCE 8-15-1983.

BARBARA GAYNOR, EXAMINING ATTORNEY

CLASS 25—(Continued).

SN 77-217,410. MATTHEW E. OLSEN, NEWPORT BEACH, CA. FILED 6-27-2007.



THE MARK CONSISTS OF A HUMAN SKULL WITH THE SKULL'S RIGHT EYE IN THE SHAPE OF A GEAR.

FOR CLOTHING, NAMELY, TOPS, BOTTOMS, SHIRTS, PANTS, SHORTS, UNDERGARMENTS, LINGERIE, JERSEYS, GLOVES, SWEATSHIRTS, T-SHIRTS, TANK TOPS, AND CYCLING PANTS, SHIRTS, JERSEYS, SHORTS AND GLOVES; OUTERWEAR, NAMELY, COATS, JACKETS AND SWEATSUITS; HATS, CAPS AND BEANIES; AND BELTS (U.S. CLS. 22 AND 39).
NICHOLAS ALTREE, EXAMINING ATTORNEY

CLASS 25—(Continued).

SN 77-225,972. UNDER ARMOUR, INC., BALTIMORE, MD. FILED 7-10-2007.

ONE TEAM. ONE VOICE. ONE RHYTHM.

THE MARK CONSISTS OF STANDARD CHARACTERS WITHOUT CLAIM TO ANY PARTICULAR FONT, STYLE, SIZE, OR COLOR.

FOR FOOTWEAR; CLOTHING, NAMELY, UNDERWEAR, BRAS, SHORTS, TIGHTS, LEGGINGS, TANK TOPS, SHIRTS, POLO SHIRTS, RAIN SUITS, BIB OVERALLS, PANTS, JACKETS, VESTS, SKIRTS, SKORTS, MOCK TURTLENECKS, GLOVES, SLIDING SHORTS, ARM SLEEVES, SOCKS, HOODS, SWEAT SHIRTS, PULL OVERS, WRISTBANDS AND HEADWEAR (U.S. CLS. 22 AND 39).

BILL DAWE, EXAMINING ATTORNEY

SN 77-232,802. CI PRODUCTIONS, INC., GUILDERLAND, NY. FILED 7-18-2007.

SN 77-223,394. FOR THE RELENTLESS APPAREL, LLC, COLORADO SPRINGS, CO. FILED 7-6-2007.



THE MARK CONSISTS OF THE DESIGN OF A STAR AND THE LETTERS "R," "T," AND A BACKWARDS "F".

FOR CLOTHING, NAMELY, T-SHIRTS, SWEATSHIRTS, SHIRTS, BANDANAS, TANK TOPS, SHORTS, PANTS, JACKETS, SOCKS, BELTS, FOOTWEAR AND HEADWEAR (U.S. CLS. 22 AND 39).

MARGARET POWER, EXAMINING ATTORNEY

FLAMMABLE

THE MARK CONSISTS OF STANDARD CHARACTERS WITHOUT CLAIM TO ANY PARTICULAR FONT, STYLE, SIZE, OR COLOR.

FOR CLOTHING, NAMELY, JACKETS, COATS, PULL-OVERS, JERSEYS, SWEATSHIRTS, SHIRTS, T-SHIRTS, TANK TOPS, VESTS, SWEATERS, SHORTS, BIKER SHORTS, JEANS, PANTS, SLACKS, SUITS, SWEATPANTS, JUMP SUITS, WARM-UP SUITS, SWIMWEAR, SURFWEAR, LOUNGEWEAR, BEACHWEAR, DRESSES, SKIRTS, GOWNS, HEAD WEAR, HATS, CAPS, VISORS, BANDANNAS, HEADBANDS, SOCKS, SLIPPERS, GLOVES, SCARVES, WRISTBANDS, BELTS, ROBES, LINGERIE, UNDERGARMENTS, UNDERPANTS, BRAS, CROPTOPS, CAMISOLES, BODYSUITS, COVER UPS, SLIPS, PANTYHOSE, STOCKINGS, TEDDIES, MERRY WIDOWS, APRONS, BOXER SHORTS, BRIEFS, BOOTS, SNEAKERS, SHOES, SANDALS, GAITERS (U.S. CLS. 22 AND 39).

MARGARET POWER, EXAMINING ATTORNEY

CLASS 25—(Continued).

SN 77-239,734. LOCALS HAVE MORE FUN, LLC, PARK CITY, UT. FILED 7-26-2007.

LOCALS ARE GREENER

THE MARK CONSISTS OF STANDARD CHARACTERS WITHOUT CLAIM TO ANY PARTICULAR FONT, STYLE, SIZE, OR COLOR.

FOR CLOTHING, NAMELY, SKIWEAR, SHIRTS, T-SHIRTS, SPORTS SHIRTS, POLO SHIRTS, TANK TOPS, SWEATPANTS, SWEATSHIRTS, HOODED SWEATSHIRTS, COATS, JACKETS, SWEATERS, SHORTS, BOARD SHORTS FOR SURFING, SWIMSUITS, PANTS, HEADWEAR, HATS, BUCKET HATS, CAPS, VISORS AND SOCKS (U.S. CLS. 22 AND 39).

DANIEL CAPSHAW, EXAMINING ATTORNEY

CLASS 25—(Continued).

SN 77-255,964. CRISP, TONY, COSTA MESA, CA. FILED 8-15-2007.

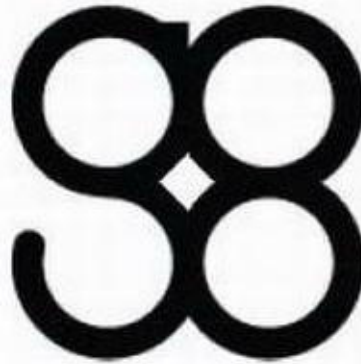

THE MARK CONSISTS OF A LOWER CASE "G" AND THE NUMBER "8" SIDE BY SIDE.

FOR APPAREL, NAMELY, T-SHIRTS, SWEATSHIRTS; AND ACCESSORIES, NAMELY, HATS, KNIT CAPS, AND WRISTBANDS (U.S. CLS. 22 AND 39).

LAURA HAMMEL, EXAMINING ATTORNEY

SN 77-244,772. DINA BAR-EL, LOS ANGELES, CA. FILED 8-1-2007.

DINA BAR-EL

THE MARK CONSISTS OF THE WORDS "DINA BAR-EL", IN STYLIZED FORM.

FOR DRESSES (U.S. CLS. 22 AND 39).
FIRST USE 1-25-1994; IN COMMERCE 1-25-1994.
BONNIE LUKEN, EXAMINING ATTORNEY

SN 77-250,482. MERE, MALIBU, CA. FILED 8-8-2007.

MERE

THE MARK CONSISTS OF STANDARD CHARACTERS WITHOUT CLAIM TO ANY PARTICULAR FONT, STYLE, SIZE, OR COLOR.

THE ENGLISH TRANSLATION OF THE WORD "MERE" IN THE MARK IS MOTHER.
FOR SHOES (U.S. CLS. 22 AND 39).
RICHARD A. STRASER, EXAMINING ATTORNEY

SN 77-256,992. WEAR ME APPAREL LLC, NEW YORK, NY. FILED 8-16-2007.

ENTERTAINMENT APPAREL GROUP

THE MARK CONSISTS OF STANDARD CHARACTERS WITHOUT CLAIM TO ANY PARTICULAR FONT, STYLE, SIZE, OR COLOR.

NO CLAIM IS MADE TO THE EXCLUSIVE RIGHT TO USE "APPAREL GROUP", APART FROM THE MARK AS SHOWN.

FOR CLOTHING, NAMELY, PANTS, OVERALLS, SHORTS, SHIRTS, T-SHIRTS, TANK TOPS, TOPS, SWEATERS, JACKETS, VESTS, SWEATSHIRTS, SWEATPANTS, SLEEPWEAR, SWIMWEAR, HATS, CAPS, SWEATERS, SHORT SETS, DENIM JEANS, COORDINATED TWO AND THREE PIECE PLAYSUITS (U.S. CLS. 22 AND 39).
MICHELE SWAIN, EXAMINING ATTORNEY

SN 77-258,624. CISCO TECHNOLOGY, INC., SAN JOSE, CA. FILED 8-18-2007.

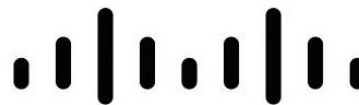

THE MARK CONSISTS OF VERICAL BARS THAT CREATE THE APPEARANCE OF A BRIDGE.

FOR NECKTIES (U.S. CLS. 22 AND 39).
FIRST USE 10-0-2007; IN COMMERCE 10-0-2007.
JAMES GRIFFIN, EXAMINING ATTORNEY

CLASS 25—(Continued).

SN 77-261,576. THE MANNA KO GROUP, INC., RANCHO SANTA FE, CA. FILED 8-22-2007.

MANNA FOR LIFE

THE MARK CONSISTS OF STANDARD CHARACTERS WITHOUT CLAIM TO ANY PARTICULAR FONT, STYLE, SIZE, OR COLOR.

FOR CLOTHING, NAMELY, T-SHIRTS, CAPS (U.S. CLS. 22 AND 39).

BILL DAWE, EXAMINING ATTORNEY

SN 77-261,950. LOCALS HAVE MORE FUN, LLC, PARK CITY, UT. FILED 8-22-2007.

LOCALS TRANSPORTATION

THE MARK CONSISTS OF STANDARD CHARACTERS WITHOUT CLAIM TO ANY PARTICULAR FONT, STYLE, SIZE, OR COLOR.

FOR CLOTHING, NAMELY, SKIWEAR, SHIRTS, T-SHIRTS, SPORTS SHIRTS, POLO SHIRTS, BICYCLE SHIRTS, TANK TOPS, SWEATPANTS, SWEATSHIRTS, HOODED SWEATSHIRTS, COATS, JACKETS, SWEATERS, SHORTS, BOARD SHORTS FOR SURFING, SWIMSUITS, PANTS, HEADWEAR, HATS, BUCKET HATS, CAPS, VISORS AND SOCKS (U.S. CLS. 22 AND 39).

DANIEL CAPSHAW, EXAMINING ATTORNEY

SN 77-262,256. KAHTOOLA INC., FLAGSTAFF, AZ. FILED 8-22-2007.

MICROSPIKES

THE MARK CONSISTS OF STANDARD CHARACTERS WITHOUT CLAIM TO ANY PARTICULAR FONT, STYLE, SIZE, OR COLOR.

FOR ADAPTABLE FLEXIBLE FOOTWEAR TRACTION SYSTEM, NAMELY, SLIP-ON TRACTION DEVICES CONTAINING CHAINS FOR ATTACHMENT TO FOOTWEAR (U.S. CLS. 22 AND 39).

FIRST USE 8-9-2007; IN COMMERCE 8-9-2007.

AHSEN KHAN, EXAMINING ATTORNEY

CLASS 25—(Continued).

SN 77-267,420. JE VEUX DESIGNS, LLC, LARKSPUR, CA. FILED 8-29-2007.

JE VEUX

THE MARK CONSISTS OF STANDARD CHARACTERS WITHOUT CLAIM TO ANY PARTICULAR FONT, STYLE, SIZE, OR COLOR.

THE FOREIGN WORDING IN THE MARK TRANSLATES INTO ENGLISH AS "I WOULD LIKE".

FOR DESIGNER CLOTHING FOR MEN AND WOMEN, NAMELY, T-SHIRTS (U.S. CLS. 22 AND 39).

AMY HELLA, EXAMINING ATTORNEY

SN 77-269,682. BRYAN ZARDENETA, SAN PEDRO, CA. FILED 8-31-2007.

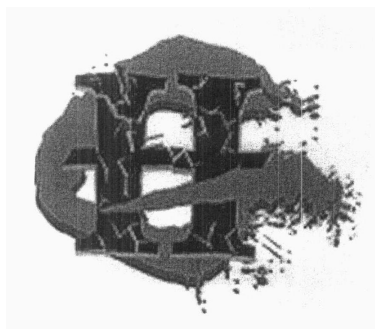

THE LINING AND STIPPLING ARE FEATURES OF THE MARK.

THE MARK CONSISTS OF THE STYLIZED LETTERS "H" AND "G" WITH CRACKS AND DOTS SHOWN THROUGHOUT THE MARK.

FOR CLOTHING, NAMELY, T-SHIRTS, HATS, BEANIES, SHORTS, PANTS, BANDANAS, SWEATERS, SWIMMING TRUNKS, BIKINIS, AND JACKETS (U.S. CLS. 22 AND 39).

DAVID YONTEF, EXAMINING ATTORNEY

CLASS 25—(Continued).

SN 77-270,207. HOODOO, LLC, LITTLETON, CO. FILED 9-2-2007.

HOODOONATION

THE MARK CONSISTS OF STANDARD CHARACTERS WITHOUT CLAIM TO ANY PARTICULAR FONT, STYLE, SIZE, OR COLOR.

FOR (BASED ON USE IN COMMERCE) HOODS; SHORT-SLEEVED OR LONG-SLEEVED T-SHIRTS; T-SHIRTS; A-SHIRTS; CAMP SHIRTS; DRESS SHIRTS; LONG-SLEEVED SHIRTS; OPEN-NECKED SHIRTS; SHIRT FRONTS; SHIRTS; SHIRTS FOR SUITS; SHORT-SLEEVED SHIRTS; SPORT SHIRTS; SPORTS SHIRTS WITH SHORT SLEEVES; SWEAT SHIRTS; SWEAT SUITS; BASEBALL CAPS; CAPS; KNITTED CAPS; SKULL CAPS; HEAD WEAR; BEANIES; COATS; COATS FOR MEN AND WOMEN; COATS MADE OF COTTON; FUR COATS AND JACKETS; LEATHER COATS; MEN AND WOMEN JACKETS, TROUSERS, VESTS; HEAVY JACKETS; LEATHER JACKETS; SUEDE JACKETS; DRESSES; HATS; TANK TOPS; TUBE TOPS(BASED ON INTENT TO USE) BUTTON-FRONT ALOHA SHIRTS; HEADBANDS AGAINST SWEATING; KNIT SHIRTS; SLEEP SHIRTS; STOCKINGS; SWEAT BANDS; SWEAT PANTS; SWEAT SHORTS; TROUSERS FOR SWEATING; WIND SHIRTS; YOGA SHIRTS; GOLF SHIRTS; NIGHT SHIRTS; PIQUE SHIRTS; POLO SHIRTS; SHIRT YOKES; CAP VISORS; CAPS WITH VISORS; BEACH FOOTWEAR; BEACH SHOES; INFANT WEAR; SKI WEAR; SURF WEAR; SWIM WEAR; SWIM WEAR FOR GENTLEMEN AND LADIES; ATHLETIC SHOES; CANVAS SHOES; LEATHER SHOES; RUNNING SHOES; SHOES; SKI AND SNOWBOARD SHOES AND PARTS THEREOF; SKIING SHOES; TONGUE OR PULLSTRAP FOR SHOES AND BOOTS; TRAINING SHOES; WOMEN'S SHOES; WORK SHOES AND BOOTS; BELTS; BELTS MADE OF LEATHER; BELTS OF TEXTILE; FABRIC BELTS; MONEY BELTS; SUSPENDER BELTS FOR MEN; SUSPENDER BELTS FOR WOMEN; WAIST BELTS; BICYCLE GLOVES; CROSS-COUNTRY GLOVES; GLOVES; GLOVES FOR PERSONAL HAND CONDITIONING USE; GLOVES INCLUDING THOSE MADE OF SKIN, HIDE OR FUR; MOTORCYCLE GLOVES; OUTDOOR GLOVES; RIDING GLOVES; SKI GLOVES; SNOWBOARD GLOVES; WET SUIT GLOVES; BERMUDA SHORTS; BOARD SHORTS; BOXER SHORTS; FLEECE SHORTS; GYM SHORTS; PANTIES, SHORTS AND BRIEFS; RUGBY SHORTS; SHORT OVERCOAT FOR KIMONO (HAORI); SHORT PETTICOATS; SHORT SETS; SHORT TROUSERS; SHORTS; SLIDING SHORTS; UNDERWEAR, NAMELY, BOY SHORTS; WALKING SHORTS; AFTER SKI BOOTS; ANKLE BOOTS; BOOTS; FOOTWEAR, NAMELY WORK BOOTS; HIKING BOOTS; LACE BOOTS; MOTORCYCLIST BOOTS; SKI BOOT BAGS; SKI BOOTS; SNOWBOARD BOOTS; WINTER BOOTS; BOXER BRIEFS; BRIEFS; COATS OF DENIM; DUST COATS; FUR COATS; LIGHT-REFLECTING COATS; MORNING COATS; OVER COATS; RAIN COATS; RIDING COATS; SPORT COATS; SUIT COATS; TOP COATS; TRENCH COATS; WIND COATS; BED JACKETS; DENIM JACKETS; DOWN JACKETS; FISHERMEN'S JACKETS; JACKET LINERS; JACKETS; LIGHT-REFLECTING JACKETS; LONG JACKETS; RAIN JACKETS; RAINPROOF JACKETS; SKI JACKETS; SLEEVED OR SLEEVELESS JACKETS; SMOKING JACKETS; SPORTS JACKETS; STUFF JACKETS; WATERPROOF JACKETS AND PANTS; WIND RESISTANT JACKETS; WIND-JACKETS; DRESS SUITS; DRESSES MADE FROM SKINS; DRESSING GOWNS; EVENING DRESSES; NURSE DRESSES; SKIRTS AND DRESSES; WOMEN'S CEREMONIAL DRESSES; FUR HATS; HAT BANDS; SEDGE HATS (SUGE-GASA); SMALL HATS; TOBOGGAN HATS, PANTS AND CAPS; WOOLLY HATS; FLIP FLOPS; FOOTWEAR; FOOTWEAR FOR MEN; FOOTWEAR FOR MEN AND WOMEN; FOOTWEAR FOR TRACK AND FIELD ATHLETICS; FOOTWEAR FOR WOMEN; FOOTWEAR MADE OF WOOD; FOOTWEAR NOT FOR SPORTS; FOOTWEAR, NAMELY,

CLASS 25—(Continued).

RUBBERS; JAPANESE FOOTWEAR OF RICE STRAW (WARAJI); JAPANESE SPLIT-TOED WORK FOOTWEAR (JIKATABI); PUMPS; THONGS; TIPS FOR FOOTWEAR; CHILDREN'S HEADWEAR; LEATHER HEADWEAR; NOVELTY HEADWEAR WITH ATTACHED WIGS; SKULLIES; HEAD SWEATBANDS; SWEATBANDS; BALLOON PANTS; CAPRI PANTS; CARGO PANTS; DENIMS; JOGGING PANTS; LEATHER PANTS; LOUNGE PANTS; NON-DISPOSABLE CLOTH TRAINING PANTS; NURSE PANTS; PANTS; PETTI-PANTS; SKI PANTS; SNOW PANTS; SNOWBOARD PANTS; TRACK PANTS; WIND PANTS; YOGA PANTS; TAP PANTS; FISHING VESTS; HUNTING VESTS; LONG SLEEVED VESTS; QUILTED VESTS; VEST EXTENDERS; VESTED SUITS; VESTS; WIND VESTS; GOLF TROUSERS; INFANTS' TROUSERS; OVER-TROUSERS; RAIN TROUSERS; TROUSERS; TROUSERS OF LEATHER; CROSS-COUNTRY MITTENS; MITTENS; OUTDOOR MITTENS; SNOWBOARD MITTENS; ANORAKS; PARKAS; FUR MUFFS; HEAD SCARVES; SCARVES; SHOULDER SCARVES; SILK SCARVES; BANDANAS; SKATING OUTFITS; SKIBIBS; SKI MASKS; SKI SUITS; SKI SUITS FOR COMPETITION; WET SUITS FOR WATER-SKIING AND SUBAQUA; SLACKS; HUNTING BOOT BAGS; BATH SLIPPERS; FOAM PEDICURE SLIPPERS; LEATHER SLIPPERS; SLIPPER SOLES; SLIPPERS; ANKLE SOCKS; ANKLETS; ANTI-PERSPIRANT SOCKS; JAPANESE STYLE SOCKS (TABI COVERS); JAPANESE STYLE SOCKS (TABI); MEN'S SOCKS; PAPER SHOES USED WHEN GOING THROUGH METAL DETECTORS TO KEEP FEET AND SOCKS CLEAN; SOCK SUSPENDERS; SOCKS; THERMAL SOCKS; WATER SOCKS; WOOLLEN SOCKS; KNEE-HIGH STOCKINGS; STOCKINGS; SPORTS BRA; SPORTS JERSEYS; SPORTS OVERUNIFORMS; CYCLISTS' JERSEYS; JERSEYS; SLEEVELESS JERSEYS; SUN SLEEVES; CLOTHING, NAMELY, HAND-WARMERS; CLOTHING, NAMELY, KNEE WARMERS; CLOTHING, NAMELY, NECK TUBES; CLOTHING, NAMELY, WRAP-AROUNDS; CORSETS; DUSTERS; SHOULDER WRAPS; SWADDLING CLOTHES; TOPS; UNDERARM CLOTHING SHIELDS; WRAPS; HALTER TOPS; MUSCLE TOPS; RUGBY TOPS; CROP TOPS; BATHING SUITS; BATHING SUITS FOR MEN; BODY SUITS; DRY SUITS; FLIGHT SUITS; GYM SUITS; JOGGING SUITS; JUDO SUITS; KARATE SUITS; LADIES' SUITS; MEN'S SUITS; MEN'S SUITS, WOMEN'S SUITS; ONE-PIECE PLAY SUITS; PARTS OF CLOTHING, NAMELY, GUSSETS FOR TIGHTS, GUSSETS FOR STOCKINGS, GUSSETS FOR BATHING SUITS, GUSSETS FOR UNDERWEAR, GUSSETS FOR LEOTARDS AND GUSSETS FOR FOOTLETS; PLAY SUITS; RAIN SUITS; SKIRT SUITS; SNOW BOARDING SUITS; SNOW SUITS; SUITS; SUITS OF LEATHER; TRACK SUITS; TRAINING SUITS; WARM UP SUITS; WET SUITS; ZOOT SUITS; KNITTED UNDERWEAR; LADIES' UNDERWEAR; PERSPIRATION ABSORBENT UNDERWEAR CLOTHING; THERMAL UNDERWEAR; THONGS; UNDERWEAR; WOMEN'S UNDERWEAR; WOVEN OR KNITTED UNDERWEAR; SNEAKERS; GOLF CAPS; ATHLETIC UNIFORMS; MARTIAL ARTS UNIFORMS; SCHOOL UNIFORMS; UNIFORMS; DRIVERS; GOLF SHOES; GYMNASIAC SHOES; HANDBALL SHOES; HEEL PIECES FOR SHOES; RUBBER SHOES; RUGBY SHOES; SOCCER SHOES; TAP SHOES; TENNIS SHOES; TRACK AND FIELD SHOES; VOLLEYBALL SHOES; SUSPENDERS; UNDER GARMENTS; SLEEPING GARMENTS; FOOTWEAR; JAPANESE STYLE SANDALS OF LEATHER; CLIMBING BOOTS; MOUNTAINEERING BOOTS (U.S. CLS. 22 AND 39).

FIRST USE 5-1-2004; IN COMMERCE 6-21-2005.

KAELIE KUNG, EXAMINING ATTORNEY

CLASS 25—(Continued).

SN 77-273,200. INFINITY SPORTS, LLC, CHANHASSEN, MN. FILED 9-6-2007.

INSOCK

THE MARK CONSISTS OF STANDARD CHARACTERS WITHOUT CLAIM TO ANY PARTICULAR FONT, STYLE, SIZE, OR COLOR.

FOR ATHLETIC SOCKS (U.S. CLS. 22 AND 39).
FIRST USE 1-1-2007; IN COMMERCE 1-1-2007.
BRIAN PINO, EXAMINING ATTORNEY

SN 77-273,440. GOTRYBE, LLC, JOHNSTON CITY, TN.
FILED 9-6-2007.

NEXTRYBE

THE MARK CONSISTS OF STANDARD CHARACTERS WITHOUT CLAIM TO ANY PARTICULAR FONT, STYLE, SIZE, OR COLOR.

FOR CLOTHING, NAMELY, SHIRTS AND HEADWEAR (U.S. CLS. 22 AND 39).
JANET LEE, EXAMINING ATTORNEY

SN 77-273,520. GOTRYBE, LLC, JOHNSTON CITY, TN.
FILED 9-6-2007.

GOTRYBE

THE MARK CONSISTS OF STANDARD CHARACTERS WITHOUT CLAIM TO ANY PARTICULAR FONT, STYLE, SIZE, OR COLOR.

FOR CLOTHING, NAMELY, SHIRTS AND HEADWEAR (U.S. CLS. 22 AND 39).
JANET LEE, EXAMINING ATTORNEY

CLASS 25—(Continued).

SN 77-274,146. RYAN, CHELSEA, LOS ANGELES, CA. FILED 9-7-2007.

lovedove

THE MARK CONSISTS OF STANDARD CHARACTERS WITHOUT CLAIM TO ANY PARTICULAR FONT, STYLE, SIZE, OR COLOR.

FOR BABY AND WOMEN'S CLOTHING, NAMELY, TOPS, BOTTOMS, PANTS, DRESSES, T-SHIRTS, JACKETS, SWEAT PANTS, SWEAT SHIRTS, TRACK SUITS, GLOVES, HATS, BOOTIES, UNDERGARMENTS, BLOOMERS, SOCKS, AND INFANT AND TODDLER ONE PIECE CLOTHING (U.S. CLS. 22 AND 39).
SALLY SHIH, EXAMINING ATTORNEY

SN 77-276,104. LYNCH, BRENDAN T., CULVER CITY, CA.
FILED 9-11-2007.

NVOHK

THE MARK CONSISTS OF STANDARD CHARACTERS WITHOUT CLAIM TO ANY PARTICULAR FONT, STYLE, SIZE, OR COLOR.

FOR CLOTHING, NAMELY, SHIRTS; FOOTWEAR; HEADWEAR (U.S. CLS. 22 AND 39).
TIMOTHY FINNEGAN, EXAMINING ATTORNEY

SN 77-276,838. ESSENCE COMMUNICATIONS INC., NEW YORK, NY. FILED 9-11-2007.

ESSENCE

THE MARK CONSISTS OF STANDARD CHARACTERS WITHOUT CLAIM TO ANY PARTICULAR FONT, STYLE, SIZE, OR COLOR.

FOR PANTYHOSE (U.S. CLS. 22 AND 39).
FIRST USE 8-2-1993; IN COMMERCE 8-2-1993.
KIMBERLY FRYE, EXAMINING ATTORNEY

CLASS 25—(Continued).

SN 77-277,773. IDEMA, JOSHUA D., MURRIETA, CA. AND IDEMA, CORRINE T., MURRIETA, CA. FILED 9-12-2007.

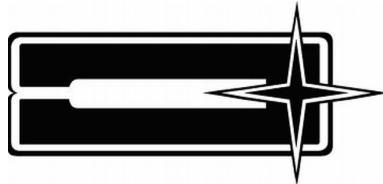

THE MARK CONSISTS OF A BACKWARDS LETTER "C" WITH A FINE OUTLINE AND AN OUTLINE STAR, OR CROSS, VERTICALLY CENTERED ON THE RIGHT SIDE OF THE LETTER "C".

SEC. 2(F).
FOR MEN'S SOCKS; SOCKS; T-SHIRTS; WRIST-BANDS; ANKLE SOCKS; BANDANAS; HATS; SWEAT-SHIRTS (U.S. CLS. 22 AND 39).
FIRST USE 1-1-2001; IN COMMERCE 1-1-2001.
DARRYL SPRUILL, EXAMINING ATTORNEY

SN 77-277,826. IDEMA, JOSHUA D., MURRIETA, CA. AND IDEMA, CORRINE T., MURRIETA, CA. FILED 9-12-2007.

COMMISSIONED

THE MARK CONSISTS OF STANDARD CHARACTERS WITHOUT CLAIM TO ANY PARTICULAR FONT, STYLE, SIZE, OR COLOR.

SEC. 2(F).
FOR MEN'S SOCKS; SOCKS; T-SHIRTS; WRIST-BANDS; ANKLE SOCKS; BANDANAS; HATS; SWEAT-SHIRTS (U.S. CLS. 22 AND 39).
FIRST USE 1-1-2001; IN COMMERCE 1-1-2001.
DARRYL SPRUILL, EXAMINING ATTORNEY

CLASS 25—(Continued).

SN 77-282,668. KELLY, JAMES MICHAEL, HAMILTON, MA. FILED 9-18-2007.

Jimbo's Surf Co.

THE MARK CONSISTS OF STANDARD CHARACTERS WITHOUT CLAIM TO ANY PARTICULAR FONT, STYLE, SIZE, OR COLOR.

NO CLAIM IS MADE TO THE EXCLUSIVE RIGHT TO USE "SURF CO.", APART FROM THE MARK AS SHOWN.
FOR A-SHIRTS; BUTTON-FRONT ALOHA SHIRTS; CAMP SHIRTS; DRESS SHIRTS; GOLF SHIRTS; KNIT SHIRTS; LONG-SLEEVED SHIRTS; OPEN-NECKED SHIRTS; PIQUE SHIRTS; POLO SHIRTS; RUGBY SHIRTS; SHORT-SLEEVED OR LONG-SLEEVED T-SHIRTS; SHORT-SLEEVED SHIRTS; SPORT SHIRTS; SPORTS SHIRTS; SPORTS SHIRTS WITH SHORT SLEEVES; SWEAT SHIRTS; T-SHIRTS; TEE SHIRTS; WIND SHIRTS; BERMUDA SHORTS; BOARD SHORTS; BOXER SHORTS; GYM SHORTS; RUGBY SHORTS; SHORT TROUSERS; SHORTS; UNDERWEAR, NAMELY, BOY SHORTS; BATHING SUITS; BATHING SUITS FOR MEN; BATHING TRUNKS; DRY SUITS; GYM SUITS; SNOW SUITS; SWEAT SUITS; TRACK SUITS; WARM UP SUITS; WET SUIT GLOVES; WET SUITS; WET SUITS FOR WATER-SKIING AND SUB-AQUA; FOOTWEAR FOR MEN AND WOMEN; PARTS OF CLOTHING, NAMELY, GUSSETS FOR TIGHTS, GUSSETS FOR STOCKINGS, GUSSETS FOR BATHING SUITS, GUSSETS FOR UNDERWEAR, GUSSETS FOR LEOTARDS AND GUSSETS FOR FOOTLETS; SNEAKERS; SANDAL-CLOGS; SANDALS; FLIP FLOPS; BASEBALL CAPS; WOOLLY HATS; CARGO PANTS; DENIMS; JOGGING PANTS; PANTS; SWEAT PANTS; WATERPROOF JACKETS AND PANTS; JACKETS; WIND COATS; WIND RESISTANT JACKETS; WIND-JACKETS (U.S. CLS. 22 AND 39).

TIMOTHY FINNEGAN, EXAMINING ATTORNEY

SN 77-283,153. FREDDIE L. MURPHY, JR., FLORISSANT, MO. FILED 9-19-2007.

DYJH

THE MARK CONSISTS OF STANDARD CHARACTERS WITHOUT CLAIM TO ANY PARTICULAR FONT, STYLE, SIZE, OR COLOR.

FOR CLOTHING, NAMELY, SHIRTS, T-SHIRTS, PANTS, HATS (U.S. CLS. 22 AND 39).
CHERYL CLAYTON, EXAMINING ATTORNEY

CLASS 25—(Continued).

SN 77-283,910. CHERRYDALE MANUFACTURING, L.L.C., ALLENTOWN, PA. FILED 9-19-2007.



THE STIPPLING IS A FEATURE OF THE MARK. FOR CLOTHING, NAMELY, T-SHIRTS, SHIRTS, TANK TOPS, SWEATSHIRTS, SHORTS, UNDERWEAR AND JACKETS; FOOTWEAR; AND HEADWEAR (U.S. CLS. 22 AND 39).

JOHN E. MICHS, EXAMINING ATTORNEY

CLASS 25—(Continued).

SN 77-285,530. FROSCHAUER JOHNNA J., SUMMIT, NJ, AND GELINAS-COFFEY, NADINE M., CHATHAM, NJ, NJ. FILED 9-21-2007.

J & N Beach Rose

THE MARK CONSISTS OF STANDARD CHARACTERS WITHOUT CLAIM TO ANY PARTICULAR FONT, STYLE, SIZE, OR COLOR.

FOR BEACH COVER-UPS; BEACH COVERUPS; BEACH FOOTWEAR; BEACH SHOES; CLOTHING, NAMELY, ARM WARMERS; CLOTHING, NAMELY, NECK TUBES; CLOTHING, NAMELY, WRAP-AROUNDS; HOODS; JERSEYS; SHIRTS; SHORT SETS; SHOULDER WRAPS; TIES; TOPS; WRAPS (U.S. CLS. 22 AND 39).

RAMONA ORTIGA, EXAMINING ATTORNEY

SN 77-284,603. MILLER DESIGN INC., DBA ISLAND IMAGE, KEY WEST, FL. FILED 9-20-2007.



OWNER OF U.S. REG. NO. 3,295,435. THE COLOR(S) RED, YELLOW, BLUE AND GREEN IS/ARE CLAIMED AS A FEATURE OF THE MARK.

THE MACAW DESIGN IS IN THE COLORS RED, YELLOW AND BLUE; THE WORDING "ISLAND" IS IN SHADES OF GREEN, YELLOW AND BLUE; AND THE WORDING "IMAGE" IS IN RED.

FOR SHIRTS (U.S. CLS. 22 AND 39). FIRST USE 8-20-2003; IN COMMERCE 8-20-2003. DAWN HAN, EXAMINING ATTORNEY

SN 77-285,706. HIGH IMPACT MERCHANDISING LLC, MILWAUKEE, WI. FILED 9-21-2007.

ONE OF GEAR

THE MARK CONSISTS OF STANDARD CHARACTERS WITHOUT CLAIM TO ANY PARTICULAR FONT, STYLE, SIZE, OR COLOR.

NO CLAIM IS MADE TO THE EXCLUSIVE RIGHT TO USE "GEAR", APART FROM THE MARK AS SHOWN.

FOR CLOTHING, NAMELY, SHIRTS, SWEATSHIRTS, WARM UP SHIRTS, T-SHIRTS, FOOTBALL AND BASKETBALL JERSEYS, COATS, PULLOVERS, PANTS, SWEATPANTS, WARM UP PANTS, SHORTS, MESH SHORTS, SLIDING SHORTS, SOCKS, CAPS, HATS, BASEBALL CAPS, SKULL CAPS, GLOVES, FOOTBALL GLOVES, SINGLETs FOR WRESTLING, WRIST BANDS, HEAD BANDS, MINI WRIST BANDS, VESTS, TURTLE NECKS, SPORTS BRAS, TRACK UNIFORMS (U.S. CLS. 22 AND 39).

ELLEN BURNS, EXAMINING ATTORNEY

CLASS 25—(Continued).

SN 77-286,252. OVERSTOCK.COM, INC., SALT LAKE CITY, UT. FILED 9-21-2007.

O.COM

THE MARK CONSISTS OF STANDARD CHARACTERS WITHOUT CLAIM TO ANY PARTICULAR FONT, STYLE, SIZE, OR COLOR.

FOR MEN'S, WOMEN'S, AND CHILDREN'S APPAREL, NAMELY, BOOTS, SHOES, SLIPPERS, HIKING BOOTS, HUNTING BOOTS, SNOW BOOTS, GARDEN SHOES, MOCCASINS, CLOGS, SANDALS, HOSIERY, TIGHTS, LEGGINGS, SWEATERS, CARDIGANS, TURTLENECKS, UNDERWEAR, PANTIES, BRAS, BUS-TIERS, CAMISOLES, SLIPS, TAP PANTS, TEDDIES, BRIEFS, UNDER SHIRTS, SPORTS BRAS, BLOUSES, SKIRTS, DRESSES, GOWNS, SWIMSUITS, JACKETS, BLAZERS, COATS, BICYCLE SHORTS, LEOTARDS, UNITARDS, PARKAS, JERSEYS, ANORAKS, SKI BIBS, SKI SUITS, GAITERS, ROBES, PAJAMAS, NIGHT SHIRTS, NIGHT GOWNS, SHIRTS, TROUSERS, SOCKS, BELTS, NECKTIES, AND SUITS SOLD SOLELY THROUGH AN ONLINE WEBSITE (U.S. CLS. 22 AND 39).

FIRST USE 9-24-2007; IN COMMERCE 9-24-2007.
MICHAEL LEWIS, EXAMINING ATTORNEY

CLASS 25—(Continued).

SN 77-286,718. MINNEAPOLIS SAINT PAUL 2008 HOST COMMITTEE, INC., SAINT PAUL, MN. FILED 9-24-2007.



NO CLAIM IS MADE TO THE EXCLUSIVE RIGHT TO USE "MSP," "MINNEAPOLIS," "SAINT PAUL," AND THE REPRESENTATION OF THE MAP OF MINNESOTA, APART FROM THE MARK AS SHOWN.

THE MARK CONSISTS OF A CITY SCAPE DESIGN SHOWING BUILDINGS LOCATED IN MINNEAPOLIS ON THE LEFT AND BUILDINGS LOCATED IN SAINT PAUL ON THE RIGHT, WITH AN IMAGE OF THE STATE OF MINNESOTA LOCATED BETWEEN THE WORDS "MSP" AND "2008", AND BELOW THIS ARE THE WORDS "MINNEAPOLIS" AND "SAINT PAUL".

FOR CLOTHING, NAMELY, SHIRTS, JACKETS, SWEATSHIRTS, AND PANTS; HEADWEAR (U.S. CLS. 22 AND 39).

LEIGH CAROLINE CASE, EXAMINING ATTORNEY

SN 77-286,415. HOGY LURE COMPANY, LLC, FALMOUTH, MA. FILED 9-22-2007.

FISH BIG

THE MARK CONSISTS OF STANDARD CHARACTERS WITHOUT CLAIM TO ANY PARTICULAR FONT, STYLE, SIZE, OR COLOR.

FOR FISHING VESTS; FISHING WADERS; HEADWEAR; SLEEPWEAR; RAINWEAR; BEACHWEAR; FOOTWEAR; SURF WEAR; SWIM WEAR; FISHERMEN'S JACKETS; JACKETS; COATS; SHIRTS; SWEAT SHIRTS; TEE SHIRTS; PANTS; SWEAT PANTS (U.S. CLS. 22 AND 39).

ALEXANDER L. POWERS, EXAMINING ATTORNEY

SN 77-286,727. MINNEAPOLIS SAINT PAUL 2008 HOST COMMITTEE, INC., SAINT PAUL, MN. FILED 9-24-2007.

MSP 2008

THE MARK CONSISTS OF STANDARD CHARACTERS WITHOUT CLAIM TO ANY PARTICULAR FONT, STYLE, SIZE, OR COLOR.

NO CLAIM IS MADE TO THE EXCLUSIVE RIGHT TO USE "MSP", APART FROM THE MARK AS SHOWN.

FOR CLOTHING, NAMELY, SHIRTS, JACKETS, SWEATSHIRTS AND PANTS; HEADWEAR (U.S. CLS. 22 AND 39).

LEIGH CAROLINE CASE, EXAMINING ATTORNEY

CLASS 25—(Continued).

SN 77-287,148. COLORTEX INTERNATIONAL, INC., TINTON FALLS, NJ. FILED 9-24-2007.

ORGANIC PLANET

THE MARK CONSISTS OF STANDARD CHARACTERS WITHOUT CLAIM TO ANY PARTICULAR FONT, STYLE, SIZE, OR COLOR.

NO CLAIM IS MADE TO THE EXCLUSIVE RIGHT TO USE "ORGANIC", APART FROM THE MARK AS SHOWN.

FOR ORGANIC CLOTHING, ORGANIC OUTERWEAR, ORGANIC UNDERWEAR, AND ORGANIC ACCESSORIES, NAMELY, KNIT AND WOVEN TOPS AND BOTTOMS, PANTS, JEANS, SHORTS, SKIRTS, SHIRTS, T-SHIRTS, BLOUSES, VESTS, JACKETS, COATS, SPORTCOATS, SWEATERS, SWEATSHIRTS, SWEATPANTS, HATS, GLOVES, TIES, BELTS AND SOCKS (U.S. CLS. 22 AND 39).

RONALD AIKENS, EXAMINING ATTORNEY

SN 77-288,817. DOTSON, JR., ROBERT E., ORANGE, CA. FILED 9-25-2007.

CHOPPERS ARE A LIFE SENTENCE

THE MARK CONSISTS OF STANDARD CHARACTERS WITHOUT CLAIM TO ANY PARTICULAR FONT, STYLE, SIZE, OR COLOR.

FOR FOOTWEAR; HATS; HEADWEAR; PANTS; SHIRTS; SHOES; SHORTS; T-SHIRTS (U.S. CLS. 22 AND 39).

FIRST USE 9-13-2000; IN COMMERCE 9-13-2000.
AHSEN KHAN, EXAMINING ATTORNEY

SN 77-289,956. J'AIME PRODUCTIONS, INC., LOS ANGELES, CA. FILED 9-26-2007.

VINTAGE PARK

THE MARK CONSISTS OF STANDARD CHARACTERS WITHOUT CLAIM TO ANY PARTICULAR FONT, STYLE, SIZE, OR COLOR.

FOR CLOTHING, NAMELY, PANTS, SHIRTS, TOPS, DRESSES, MINI-DRESSES, SKIRTS, SHORTS, JACKETS, AND LINGERIE (U.S. CLS. 22 AND 39).

INGRID C. EULIN, EXAMINING ATTORNEY

CLASS 25—(Continued).

SN 77-289,957. J'AIME PRODUCTIONS, INC., LOS ANGELES, CA. FILED 9-26-2007.

J'AIME PRODUCTIONS

THE MARK CONSISTS OF STANDARD CHARACTERS WITHOUT CLAIM TO ANY PARTICULAR FONT, STYLE, SIZE, OR COLOR.

NO CLAIM IS MADE TO THE EXCLUSIVE RIGHT TO USE "PRODUCTIONS", APART FROM THE MARK AS SHOWN.

THE FOREIGN WORDING IN THE MARK TRANSLATES INTO ENGLISH AS I LOVE.

FOR CLOTHING, NAMELY, PANTS, SHIRTS, TOPS, DRESSES, MINI-DRESSES, SKIRTS, SHORTS, JACKETS, AND LINGERIE (U.S. CLS. 22 AND 39).

INGRID C. EULIN, EXAMINING ATTORNEY

SN 77-291,159. THE DUCK COMPANY, ARVADA, CO. FILED 9-28-2007.



NO CLAIM IS MADE TO THE EXCLUSIVE RIGHT TO USE "CO" AND "800.355.3565", APART FROM THE MARK AS SHOWN.

THE MARK CONSISTS OF THE NUMBERS AND WORDS "800.255.3565 DUCK CO CREATIVE REVOLUTION" IN STYLIZED FORM AND DESIGN OF DUCK CARTOON CHARACTER IN SUNGLASSES HOLDING ITS THUMB UP.

FOR CLOTHING, NAMELY, SHIRTS, T-SHIRTS, TANK TOPS, BOXER SHORTS, SWEATSHIRTS, CASUAL AND LEISURE JACKETS, OUTERWEAR, NAMELY, VESTS, PULLOVERS, AND COATS, AND HEADWEAR (U.S. CLS. 22 AND 39).

FIRST USE 11-30-2006; IN COMMERCE 11-30-2006.
DOMINICK J. SALEMI, EXAMINING ATTORNEY

SN 77-291,800. NUOVA SCHONTESS S.R.L., 20144 MILANO, ITALY, FILED 9-28-2007.

UBALDO RANZI

THE MARK CONSISTS OF STANDARD CHARACTERS WITHOUT CLAIM TO ANY PARTICULAR FONT, STYLE, SIZE, OR COLOR.

THE NAME(S), PORTRAIT(S), AND/OR SIGNATURE(S) SHOWN IN THE MARK IDENTIFIES "UBALDO RANZI", WHOSE CONSENT(S) TO REGISTER IS SUBMITTED.

FOR CLOTHING ARTICLES, NAMELY, TIES, POCKET SQUARES, FOULARDS, BOW TIES, SCARVES (U.S. CLS. 22 AND 39).

TRICIA SONNEBORN, EXAMINING ATTORNEY

CLASS 25—(Continued).

SN 77-294,291. INTERNATIONAL STORES CORP., PANAMA CITY, PANAMA, FILED 10-2-2007.



THE MARK CONSISTS OF FIVE SHOPPING BAGS ARRANGED TO BE A FIVE-POINTED STAR.
FOR CLOTHING, NAMELY, SHIRTS AND PANTS; FOOTWEAR; HEADGEAR, NAMELY, HATS AND CAPS (U.S. CLS. 22 AND 39).

WARREN L. OLANDRIA, EXAMINING ATTORNEY

SN 77-294,321. DEUTSCHE TELEKOM AG, BONN 53113, FED REP GERMANY, FILED 10-2-2007.



PRIORITY CLAIMED UNDER SEC. 44(D) ON FED REP GERMANY APPLICATION NO. 30722314038, FILED 4-3-2007.

OWNER OF FED REP GERMANY REG. NO. 30722314, DATED 12-12-2007, EXPIRES 4-30-2017.

THE MARK CONSISTS OF AN INCOMPLETE CIRCLE AND AN INCOMPLETE STAR WITHIN THE CIRCLE.

FOR CLOTHING, NAMELY, SHIRTS, DRESSES, PANTS, JACKETS, COATS, T-SHIRTS, SHORTS; HEADWEAR, NAMELY, CAPS AND HATS (U.S. CLS. 22 AND 39).

MARLENE BELL, EXAMINING ATTORNEY

CLASS 25—(Continued).

SN 77-294,338. INTERNATIONAL STORES CORP., PANAMA CITY, PANAMA, FILED 10-2-2007.



NO CLAIM IS MADE TO THE EXCLUSIVE RIGHT TO USE "DUTY FREE", APART FROM THE MARK AS SHOWN.

THE MARK CONSISTS OF FIVE SHOPPING BAGS ARRANGED TO BE A FIVE-POINTED STAR.

FOR CLOTHING, NAMELY, SHIRTS AND PANTS; FOOTWEAR; HEADGEAR, NAMELY, HATS AND CAPS (U.S. CLS. 22 AND 39).

WARREN L. OLANDRIA, EXAMINING ATTORNEY

SN 77-294,381. INTERNATIONAL STORES CORP., PANAMA CITY, PANAMA, FILED 10-2-2007.



NO CLAIM IS MADE TO THE EXCLUSIVE RIGHT TO USE "LA MEJOR ATENCION", APART FROM THE MARK AS SHOWN.

THE MARK CONSISTS OF FIVE SHOPPING BAGS ARRANGED TO BE A FIVE-POINTED STAR.

THE FOREIGN WORDING IN THE MARK TRANSLATES INTO ENGLISH AS "BEST CARE".

FOR CLOTHING, NAMELY, SHIRTS AND PANTS; FOOTWEAR; HEADGEAR, NAMELY, HATS AND CAPS (U.S. CLS. 22 AND 39).

WARREN L. OLANDRIA, EXAMINING ATTORNEY

CLASS 25—(Continued).

SN 77-294,476. DEUTSCHE TELEKOM AG, BONN 53113, FED REP GERMANY, FILED 10-2-2007.



PRIORITY CLAIMED UNDER SEC. 44(D) ON FED REP GERMANY APPLICATION NO. 30722313.2/3, FILED 4-3-2007, REG. NO. 30722313, DATED 12-14-2007, EXPIRES 4-30-2017.

OWNER OF U.S. REG. NOS. 3,312,794, 3,348,739 AND 3,348,740.

THE MARK CONSISTS OF THE TERM "CONGSTAR" BELOW A DESIGN OF AN INCOMPLETE CIRCLE AND AN INCOMPLETE STAR WITHIN THE CIRCLE.

THE TERM IN THE MARK DOES NOT HAVE ANY MEANING IN A FOREIGN LANGUAGE.

FOR CLOTHING, NAMELY, SHIRTS, DRESSES, PANTS, JACKETS, COATS, T-SHIRTS, SHORTS; HEADWEAR, NAMELY, CAPS AND HATS (U.S. CLS. 22 AND 39).

MARLENE BELL, EXAMINING ATTORNEY

CLASS 25—(Continued).

SN 77-306,189. CHIERIGHINI, JOSE, DBA 07/20/72, LONG ISLAND CITY, NY. FILED 10-17-2007.

Ikaika

THE MARK CONSISTS OF STANDARD CHARACTERS WITHOUT CLAIM TO ANY PARTICULAR FONT, STYLE, SIZE, OR COLOR.

THE FOREIGN WORDING IN THE MARK TRANSLATES INTO ENGLISH AS "STRONG".

FOR CLOTHING FOR MEN, WOMEN AND CHILDREN, NAMELY, COATS, RAINCOATS, ANORAKS, PARKAS, BLAZERS, JACKETS, CARDIGANS, BOLEROS, SPORT COATS, WIND RESISTANT JACKETS, SUITS, DRESSES, GOWNS, JUMPERS, SKIRTS, PANTS, SLACKS, TROUSERS, JEANS, DUNGAREES, JUMPSUITS, OVERALLS, COVERALLS, FLIGHT SUITS, GYM SUITS, JOGGING SUITS, SWEAT PANTS, THERMAL UNDERWEAR, SHORTS, SKORTS, ROMPERS, CULOTTES, SHORTALLS, SHIRTS, SWEATERS, JERSEYS, BLOUSES, TUNICS, SWEATSHIRTS, T-SHIRTS, HALTER TOPS, TANK TOPS, BODYSUITS, UNITARDS, CAMISOLES, CHEMISES, UNDERSHIRTS, SLIPS, FOUNDATION GARMENTS, BODYSHAPERS, BRASSIERES, BUSTIERS, GARTER BELTS, BRIEFS, BOXER SHORTS, BLOOMERS, UNDERPANTS, PANTIES, LINGERIE, LOUNGEWEAR, NIGHTGOWNS, NIGHT SHIRTS, NEGLIGENCEES, ROBES, PAJAMAS, HOSIERY, PANTYHOSE, TIGHTS, KNEE HIGHS, LEG WARMERS, LEGGINGS, SOCKS, HEAD WEAR, HATS, CAPS, HOODS, HEAD BANDS, NECKTIES, GLOVES, MITTENS, BELTS, SASHES, SHOES, FOOTWEAR, BOOTS, ATHLETIC SHOES, ATHLETIC FOOTWEAR, GALOSHES, SWIMWEAR, BATHING SUITS, BATHING TRUNKS, BEACHWEAR, BEACH COVERUPS, SARONGS, SKI WEAR, SKI SUITS, SKI PANTS, SKI GLOVES, THERMAL SOCKS, AND PLAYSUITS (U.S. CLS. 22 AND 39).

JENNY PARK, EXAMINING ATTORNEY

SN 77-307,836. SCOTT J. MACKNEY, BILLINGS, MT. FILED 10-18-2007.

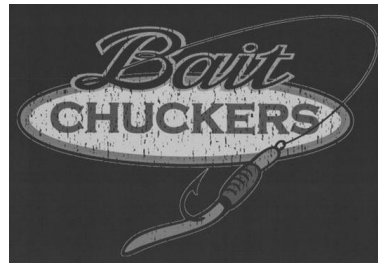

THE MARK CONSISTS OF THE WORD "BAIT" OVER THE WORD "CHUCKERS" WHICH IS ENCLOSED IN AN OVAL DIRECTLY ABOVE A WORM ON A HOOK.

FOR CAPS; TOPS; KNIT SHIRTS; LONG-SLEEVED SHIRTS; OPEN-NECKED SHIRTS; POLO SHIRTS; SHIRTS; SHORT-SLEEVED OR LONG-SLEEVED T-SHIRTS; SPORT SHIRTS; SWEAT SHIRTS; TEE SHIRTS; DENIM JACKETS; DOWN JACKETS; FISHERMEN'S JACKETS; HEAVY JACKETS; JACKETS; LEATHER JACKETS; MEN AND WOMEN JACKETS, COATS, TROUSERS, VESTS; RAIN JACKETS; WATERPROOF JACKETS AND PANTS; WIND RESISTANT JACKETS; CARGO PANTS; DENIMS; LOUNGE PANTS; PANTS; SWEAT PANTS (U.S. CLS. 22 AND 39).

FIRST USE 1-1-2006; IN COMMERCE 1-1-2006.

REBECCA EISINGER, EXAMINING ATTORNEY

CLASS 25—(Continued).

SN 77-312,037. ARCTIC GUARD, LLC, HOUSTON, TX. FILED 10-24-2007.

ECO GUARD

THE MARK CONSISTS OF STANDARD CHARACTERS WITHOUT CLAIM TO ANY PARTICULAR FONT, STYLE, SIZE, OR COLOR.

FOR SPORTS APPAREL MADE OF RECYCLED OR ORGANIC MATERIAL, NAMELY, SHIRTS, SHORTS, SWEATSHIRTS, HEADWEAR, JACKETS, PANTS, WARM-UP SUITS, UNDERWEAR AND SOCKS (U.S. CLS. 22 AND 39).

PAULA MAHONEY, EXAMINING ATTORNEY

SN 77-315,265. LANNER, AMY, KINGSHILL, VI, US VIRGIN ISLANDS, FILED 10-27-2007.



FOR MEN'S AND WOMEN'S APPAREL ACCESSORY, NAMELY, A MULTI-FUNCTIONAL OUTERWEAR ACCESSORY IN THE NATURE OF EAR MUFFS, HEADBANDS, FACE COVERINGS, NECK COVERINGS, HEAD COVERINGS, NECK GAITERS, SCARVES, AND VISORLESS AND BRIMLESS HATS (U.S. CLS. 22 AND 39).

FIRST USE 6-1-2007; IN COMMERCE 7-12-2007.
KAREN SEVERSON, EXAMINING ATTORNEY

SN 77-326,761. WINKLER, ERICH, NEW YORK, NY. FILED 11-11-2007.

Keymono

THE MARK CONSISTS OF STANDARD CHARACTERS WITHOUT CLAIM TO ANY PARTICULAR FONT, STYLE, SIZE, OR COLOR.

FOR HOODS; BELTS; CAPS; COATS FOR MEN AND WOMEN; FOOTWEAR FOR MEN AND WOMEN; JERSEYS; MEN AND WOMEN JACKETS, COATS, TROUSERS, VESTS; TOPS (U.S. CLS. 22 AND 39).

FIRST USE 11-1-2007; IN COMMERCE 11-1-2007.
NAPOLEON SHARMA, EXAMINING ATTORNEY

CLASS 25—(Continued).

SN 77-327,658. ZEAL AND COMPANY INC., DANA POINT, CA. FILED 11-12-2007.



NO CLAIM IS MADE TO THE EXCLUSIVE RIGHT TO USE "WEAR", APART FROM THE MARK AS SHOWN.

THE MARK CONSISTS OF THE STYLIZED TEXT "ZEAL WEAR" THAT APPEARS ON A BACKGROUND, IN TWO LINES, IN THE FIRST LINE "ZEAL" IS WRITTEN, AND "WEAR" IS WRITTEN IN THE SECOND LINE.

FOR MEN'S BUSINESS AND BUSINESS-CASUAL CLOTHING, NAMELY, SUITS, SPORT JACKETS, DRESS PANTS, DRESS SHIRTS, COLLARED POLO SHIRTS, TIES, SOCKS, AND BELTS (U.S. CLS. 22 AND 39).

DAVID H. STINE, EXAMINING ATTORNEY

SN 77-331,839. ADAMS, KIMBERLY M., NORTH WALES, PA. FILED 11-16-2007.

empowRment panties

THE MARK CONSISTS OF STANDARD CHARACTERS WITHOUT CLAIM TO ANY PARTICULAR FONT, STYLE, SIZE, OR COLOR.

NO CLAIM IS MADE TO THE EXCLUSIVE RIGHT TO USE "PANTIES", APART FROM THE MARK AS SHOWN.

FOR PANTIES; SHAPEWEAR, NAMELY, GIRDLES, BRAS; HOSIERY; LINGERIE; UNDERWEAR (U.S. CLS. 22 AND 39).

FIRST USE 8-0-2007; IN COMMERCE 8-0-2007.

PETER B. BROMAGHIM, EXAMINING ATTORNEY

SN 77-332,183. SCHROEDER, SHERRI, SAN DIEGO, CA. FILED 11-16-2007.

HOTTROT

THE MARK CONSISTS OF STANDARD CHARACTERS WITHOUT CLAIM TO ANY PARTICULAR FONT, STYLE, SIZE, OR COLOR.

FOR HATS; PANTS; SHORTS; SPORTS BRAS; SWEAT PANTS; SWEAT SHIRTS; T-SHIRTS; TANK TOPS; THERMAL UNDERWEAR (U.S. CLS. 22 AND 39).

FIRST USE 8-10-2007; IN COMMERCE 9-9-2007.

COLLEEN DOMBROW, EXAMINING ATTORNEY

CLASS 25—(Continued).

SN 77-337,437. HIGH IMPACT MERCHANDISING LLC, MILWAUKEE, WI. FILED 11-27-2007.

WHAT ARE YOU ONE OF?

THE MARK CONSISTS OF STANDARD CHARACTERS WITHOUT CLAIM TO ANY PARTICULAR FONT, STYLE, SIZE, OR COLOR.

FOR CLOTHING, NAMELY, SHIRTS, SWEATSHIRTS, WARM UP SHIRTS, T-SHIRTS, FOOTBALL AND BASKETBALL JERSEYS, COATS, PULLOVERS, PANTS, SWEATPANTS, WARM UP PANTS, SHORTS, MESH SHORTS, SLIDING SHORTS, SOCKS, CAPS, HATS, BASEBALL CAPS, SKULL CAPS, GLOVES, FOOTBALL GLOVES, SINGLETS FOR WRESTLING, WRIST BANDS, HEAD BANDS, MINI WRIST BANDS, VESTS, TURTLE NECKS, SPORTS BRAS, TRACK UNIFORMS (U.S. CLS. 22 AND 39).

ELLEN BURNS, EXAMINING ATTORNEY

SN 77-338,039. PERFECTION UNIFORMS, LLC, BRENTWOOD, TN. FILED 11-27-2007.

PERFECTION EGC SYSTEM

THE MARK CONSISTS OF STANDARD CHARACTERS WITHOUT CLAIM TO ANY PARTICULAR FONT, STYLE, SIZE, OR COLOR.

OWNER OF U.S. REG. NO. 3,382,994.
NO CLAIM IS MADE TO THE EXCLUSIVE RIGHT TO USE "SYSTEM", APART FROM THE MARK AS SHOWN, FOR UNIFORMS (U.S. CLS. 22 AND 39).
FIRST USE 10-20-2005; IN COMMERCE 10-20-2005.
LINDA POWELL, EXAMINING ATTORNEY

SN 77-345,262. CHANEY, TRACIE L., EL CAJON, CA. AND CHANEY, DELTON G., EL CAJON, CA. FILED 12-5-2007.

Jesus Junkie

THE MARK CONSISTS OF STANDARD CHARACTERS WITHOUT CLAIM TO ANY PARTICULAR FONT, STYLE, SIZE, OR COLOR.

FOR CLOTHING ITEMS, NAMELY, T-SHIRTS, HATS, TIES, SHORTS, POLO SHIRTS, AND DRESS SHIRTS (U.S. CLS. 22 AND 39).

HEATHER SAPP, EXAMINING ATTORNEY

CLASS 25—(Continued).

SN 77-348,057. SHO SUM, INC., MABLETON, GA. FILED 12-10-2007.



THE MARK CONSISTS OF A STYLIZED LETTER "S". FOR T-SHIRTS AND LONG-SLEEVE T-SHIRTS (U.S. CLS. 22 AND 39).

FIRST USE 1-0-2008; IN COMMERCE 1-0-2008.
FRANK LATTUCA, EXAMINING ATTORNEY

SN 77-353,660. RAFAELLA APPAREL GROUP, INC., NEW YORK, NY. FILED 12-17-2007.

2W 2 WAY STRETCH

THE MARK CONSISTS OF STANDARD CHARACTERS WITHOUT CLAIM TO ANY PARTICULAR FONT, STYLE, SIZE, OR COLOR.

NO CLAIM IS MADE TO THE EXCLUSIVE RIGHT TO USE "2 WAY STRETCH", APART FROM THE MARK AS SHOWN.

FOR WOMEN'S SPORTSWEAR AND OUTERWEAR CLOTHING, NAMELY, JEANS, PANTS, SHIRTS, JACKETS, BLAZERS, BLOUSES, T-SHIRTS, SWEATERS, SKIRTS, DRESSES, SUITS, VESTS AND SHORTS (U.S. CLS. 22 AND 39).

CHRISIE B. KING, EXAMINING ATTORNEY

SN 77-353,677. RAFAELLA APPAREL GROUP, INC., NEW YORK, NY. FILED 12-17-2007.

ERGOFIT

THE MARK CONSISTS OF STANDARD CHARACTERS WITHOUT CLAIM TO ANY PARTICULAR FONT, STYLE, SIZE, OR COLOR.

FOR WOMEN'S SPORTSWEAR AND OUTERWEAR CLOTHING, NAMELY, JEANS, PANTS, SHIRTS, JACKETS, BLAZERS, BLOUSES, T-SHIRTS, SWEATERS, SKIRTS, DRESSES, SUITS, VESTS AND SHORTS (U.S. CLS. 22 AND 39).

CHRISIE B. KING, EXAMINING ATTORNEY

CLASS 25—(Continued).

SN 77-358,782. HAMPTON ISLAND, LLC, ATLANTA, GA.
FILED 12-22-2007.

HAMPTON ISLAND PRESERVE

THE MARK CONSISTS OF STANDARD CHARACTERS WITHOUT CLAIM TO ANY PARTICULAR FONT, STYLE, SIZE, OR COLOR.

FOR CLOTHING, NAMELY, SHIRTS, GOLF SHIRTS, T-SHIRTS, POLO SHIRTS, KNIT SHIRTS, TANK TOPS, SWEATSHIRTS, SWEATERS, HUNTING VESTS, COATS, JACKETS, PANTS, GOLF TROUSERS, SHORTS, SKIRTS, DRESSES, RAIN WEAR, SWIMWEAR, SLEEPWEAR, UNDERWEAR, BOXER SHORTS, SOCKS, NECKTIES, BELTS, APRONS AND BANDANAS; FOOTWEAR; HEADWEAR (U.S. CLS. 22 AND 39).

GEORGIA CARTY, EXAMINING ATTORNEY

SN 77-358,785. HAMPTON ISLAND, LLC, ATLANTA, GA.
FILED 12-22-2007.



NO CLAIM IS MADE TO THE EXCLUSIVE RIGHT TO USE "EST. 1769", APART FROM THE MARK AS SHOWN.

THE MARK CONSISTS OF THE WORDS "HAMPTON ISLAND PRESERVE" ON THE PERIMETER CREATING A CIRCULAR SHAPE. WITHIN THE CIRCULAR SHAPE CREATED BY THE WORDING ARE THE SHAPES OF A RADIATING SUN RISING OVER A PYRAMID, REPRESENTING A PALM FRAWN, WITH THE WORD "EST." AND THE NUMBERS "1769" AT THE BASE OF THE PYRAMID AND CENTERED OVER THE WORD "PRESERVE" AT THE BOTTOM OF THE PERIMETER OF THE CIRCULAR SHAPE.

FOR CLOTHING, NAMELY, SHIRTS, GOLF SHIRTS, T-SHIRTS, POLO SHIRTS, KNIT SHIRTS, TANK TOPS, SWEATSHIRTS, SWEATERS, HUNTING VESTS, COATS, JACKETS, PANTS, GOLF TROUSERS, SHORTS, SKIRTS, DRESSES, RAIN WEAR, SWIMWEAR, SLEEPWEAR, UNDERWEAR, BOXER SHORTS, SOCKS, NECKTIES, BELTS, APRONS AND BANDANAS; FOOTWEAR; HEADWEAR (U.S. CLS. 22 AND 39).

GEORGIA CARTY, EXAMINING ATTORNEY

CLASS 25—(Continued).

SN 77-371,143. ZEIGEL, JOSEPH WADE, DUBLIN, OH.
FILED 1-14-2008.

SCREWBLUE

THE MARK CONSISTS OF STANDARD CHARACTERS WITHOUT CLAIM TO ANY PARTICULAR FONT, STYLE, SIZE, OR COLOR.

FOR SHORT-SLEEVED OR LONG-SLEEVED T-SHIRTS; SHORT-SLEEVED SHIRTS; SLEEP SHIRTS; SPORT SHIRTS; SPORTS SHIRTS; SPORTS SHIRTS WITH SHORT SLEEVES; SWEAT SHIRTS; T-SHIRTS; TEE SHIRTS; TRIATHLON CLOTHING, NAMELY, TRIATHLON TIGHTS, TRIATHLON SHORTS, TRIATHLON SINGLET, TRIATHLON SHIRTS, TRIATHLON SUITS; WIND SHIRTS; YOGA SHIRTS; A-SHIRTS; BUTTON-FRONT ALOHA SHIRTS; CAMP SHIRTS; DRESS SHIRTS; GOLF SHIRTS; KNIT SHIRTS; LONG-SLEEVED SHIRTS; NIGHT SHIRTS; OPEN-NECKED SHIRTS; PIQUE SHIRTS; POLO SHIRTS; RUGBY SHIRTS; SHIRT FRONTS; SHIRT YOKES; SHIRTS; SHIRTS FOR SUITS (U.S. CLS. 22 AND 39).

FIRST USE 9-8-2007; IN COMMERCE 6-25-2008.

DOMINICK J. SALEMI, EXAMINING ATTORNEY

SN 77-374,178. LIFE IS WICKED COM LLC, WILTON, CT.
FILED 1-17-2008.

LIFE IS WICKED

THE MARK CONSISTS OF STANDARD CHARACTERS WITHOUT CLAIM TO ANY PARTICULAR FONT, STYLE, SIZE, OR COLOR.

FOR SHIRTS, T-SHIRTS (U.S. CLS. 22 AND 39).

FIRST USE 3-26-2008; IN COMMERCE 3-26-2008.

ALEX KEAM, EXAMINING ATTORNEY

SN 77-381,142. JIANLIANG LIN, CITY OF INDUSTRY, CA.
FILED 1-25-2008.



NO CLAIM IS MADE TO THE EXCLUSIVE RIGHT TO USE "ATHLETIC", APART FROM THE MARK AS SHOWN.

THE MARK CONSISTS OF A DESIGN OF LETTER "A" AND WORD "ATHLETIC" IN A SHAPED BOX.

FOR FOOTWEAR; SHOES; BOOTS; SLIPPERS; SUITS; COATS; JEANS; JACKETS; SHIRTS; SKIRTS; SHORTS; SOCKS; HATS; BELTS (U.S. CLS. 22 AND 39).

FIRST USE 7-1-2007; IN COMMERCE 7-1-2007.

RONALD DELGIZZI, EXAMINING ATTORNEY

CLASS 25—(Continued).

SN 77-381,182. JIANLIANG LIN, CITY OF INDUSTRY, CA.
FILED 1-25-2008.



NO CLAIM IS MADE TO THE EXCLUSIVE RIGHT TO USE "ATHLETIC", APART FROM THE MARK AS SHOWN.

THE MARK CONSISTS OF A DESIGN OF LETTER "A" AND WORD "ATHLETIC" WITH "A" ABOVE "ATHLETIC".

FOR FOOTWEAR; SHOES; BOOTS; SLIPPERS; SUITS; COATS; JEANS; JACKETS; SHIRTS; SKIRTS; SHORTS; SOCKS; HATS; BELTS (U.S. CLS. 22 AND 39).

FIRST USE 7-1-2007; IN COMMERCE 7-1-2007.

RONALD DELGIZZI, EXAMINING ATTORNEY

CLASS 25—(Continued).

SN 77-387,067. THE 17/21 GROUP, LLC, LOS ANGELES, CA.
FILED 2-1-2008.

FRAGILE BLUE JEANS

THE MARK CONSISTS OF STANDARD CHARACTERS WITHOUT CLAIM TO ANY PARTICULAR FONT, STYLE, SIZE, OR COLOR.

NO CLAIM IS MADE TO THE EXCLUSIVE RIGHT TO USE "BLUE JEANS", APART FROM THE MARK AS SHOWN.

FOR APPAREL, NAMELY, JEANS, PANTS, SHORTS, SKIRTS, JACKETS, SHIRTS, T-SHIRTS, VESTS, OVERALLS, COVERALLS, BOTTOMS, SHORTALLS, SKORTS, SWEAT PANTS, SWEAT SHIRTS, TOPS, TANK TOPS, TROUSERS, BATHING SUITS, BATHING TRUNKS, BATH ROBES, BEACHWEAR, BIKINIS, BLAZERS, BLOUSES, CAPS, COATS, COVER-UPS, DRESSES, GLOVES, HATS, HEAD WEAR, LINGERIE, PAJAMAS, RAINWEAR, SCARVES, SKIWEAR, SLEEPWEAR, SOCKS, SURF WEAR, SWEATERS, SWIM WEAR, UNDERWEAR, BELTS AND FOOTWEAR (U.S. CLS. 22 AND 39).

HEATHER THOMPSON, EXAMINING ATTORNEY

SN 77-382,392. RANK, GREGORY, SONOMA, CA. FILED 1-28-2008.

TWENTY 2 ONE GOLF

THE MARK CONSISTS OF STANDARD CHARACTERS WITHOUT CLAIM TO ANY PARTICULAR FONT, STYLE, SIZE, OR COLOR.

NO CLAIM IS MADE TO THE EXCLUSIVE RIGHT TO USE "GOLF", APART FROM THE MARK AS SHOWN.

FOR T-SHIRTS; SPORT SHIRTS; DRESS SHIRTS; CAMP SHIRTS; KNIT SHIRTS; POLO SHIRTS; SWEAT SHIRTS; SWEATERS; TANK TOPS; BLOUSES; CAMI-SOLES; BELTS; BLAZERS; GLOVES; MITTENS; SPORT COATS; COATS; VESTS; DRESSES; JACKETS; PANTS; SWEAT PANTS; PULLOVERS; TIES; SCARVES; JEANS; SHORTS; SKIRTS; SKORTS; SLACKS; SOCKS; HOSIERY; SWIMWEAR; UNDERWEAR; CAPS; VISORS; HATS; BEANIES; WARM UP SUITS; WINDSHIRTS; RAINWEAR; SHOES; BOOTS; GOLF CAPS; GOLF SHIRTS; GOLF TROUSERS (U.S. CLS. 22 AND 39).

FIRST USE 12-7-2007; IN COMMERCE 12-7-2007.

TEJBIR SINGH, EXAMINING ATTORNEY

SN 77-388,149. RAU CORPORATION, WEST LOS ANGELES, CA. FILED 2-4-2008.



OWNER OF U.S. REG. NO. 3,372,079.

THE NAME "WILLIAM RAU" IDENTIFIES A LIVING INDIVIDUAL WHOSE CONSENT IS OF RECORD.

THE MARK CONSISTS OF THE WORDS "WILLIAM" ABOVE "RAU" IN WHITE ON A BLACK, RECTANGULAR BACKGROUND, OVER THE WORDS "AUTOMOTIVE WOODWORK" IN BLACK ON A WHITE RECTANGLE WITH A BLACK BORDER.

FOR APPAREL, NAMELY, HEADWEAR, SHIRTS, SHORTS, PANTS, SWEATSHIRTS, JACKETS (U.S. CLS. 22 AND 39).

CHRISTINE BLOMQUIST, EXAMINING ATTORNEY

CLASS 25—(Continued).

SN 77-390,183. AGUIAR, GRACE, CLAREMONT, CA. FILED 2-6-2008.

CUTE CLOZE

THE MARK CONSISTS OF STANDARD CHARACTERS WITHOUT CLAIM TO ANY PARTICULAR FONT, STYLE, SIZE, OR COLOR.

NO CLAIM IS MADE TO THE EXCLUSIVE RIGHT TO USE "CLOTHES", APART FROM THE MARK AS SHOWN. FOR LINGERIE (U.S. CLS. 22 AND 39).
AMY ALFIERI, EXAMINING ATTORNEY

CLASS 25—(Continued).

SN 77-393,919. OSCAR THE THIRD PTY LTD., SOUTH AUSTRALIA, AUSTRALIA, FILED 2-11-2008.

OSCAR THE THIRD

THE MARK CONSISTS OF STANDARD CHARACTERS WITHOUT CLAIM TO ANY PARTICULAR FONT, STYLE, SIZE, OR COLOR.

THE NAME(S), PORTRAIT(S), AND/OR SIGNATURE(S) SHOWN IN THE MARK IDENTIFIES OSCAR BOYLE POLK, III, WHOSE CONSENT(S) TO REGISTER IS SUBMITTED.

FOR BATHING COSTUMES FOR WOMEN; COATS FOR MEN AND WOMEN; FOOTWEAR FOR MEN AND WOMEN; FOOTWEAR FOR WOMEN; LEOTARDS AND TIGHTS FOR WOMEN, MEN AND CHILDREN OF NYLON, COTTON OR OTHER TEXTILE FIBERS; MEN AND WOMEN JACKETS, COATS, TROUSERS, VESTS; MEN'S SUITS, WOMEN'S SUITS; SUSPENDER BELTS FOR WOMEN; WOMEN'S CEREMONIAL DRESSES; WOMEN'S SHOES; WOMEN'S UNDERWEAR; BELTS; BIBS NOT OF CLOTH OR PAPER; CAPS; CHILDREN'S AND INFANTS' CLOTH BIBS; CHILDREN'S CLOTH EATING BIBS; CLOTH BIBS; CLOTH BIBS FOR ADULT DINERS; CLOTH BIBS FOR USE BY SENIOR CITIZENS OR PHYSICALLY- OR MENTALLY-CHALLENGED PERSONS; CLOTH DIAPERS; CLOTHING FOR WEAR IN JUDO PRACTICES; CLOTHING FOR WEAR IN WRESTLING GAMES; CLOTHING, NAMELY, ARM WARMERS; CLOTHING, NAMELY, FOLK COSTUMES; CLOTHING, NAMELY, HAND-WARMERS; CLOTHING, NAMELY, KNEE WARMERS; CLOTHING, NAMELY, NECK TUBES; CLOTHING, NAMELY, THOBES; CLOTHING, NAMELY, WRAP-AROUNDS; CORSETS; DUSTERS; FOULARDS; HOODS; INFANT AND TODDLER ONE PIECE CLOTHING; INFANT CLOTH DIAPERS; JERSEYS; LEATHER BELTS; MANTLES; MUFFLERS; NON-DISPOSABLE CLOTH TRAINING PANTS; PAPER HATS FOR USE AS CLOTHING ITEMS; PARTS OF CLOTHING, NAMELY, GUSSETS FOR TIGHTS, GUSSETS FOR STOCKINGS, GUSSETS FOR BATHING SUITS, GUSSETS FOR UNDERWEAR, GUSSETS FOR LEOTARDS AND GUSSETS FOR FOOTLETS; PERSPIRATION ABSORBENT UNDERWEAR CLOTHING; SHIRTS; SHORT SETS; SHOULDER WRAPS; SWADDLING CLOTHES; TIES; TOPS; TRIATHLON CLOTHING, NAMELY, TRIATHLON TIGHTS, TRIATHLON SHORTS, TRIATHLON SINGLET, TRIATHLON SHIRTS, TRIATHLON SUITS; UNDERARM CLOTHING SHIELDS; WRAPS; LADIES' BOOTS; LADIES' SUITS; LADIES' UNDERWEAR; SWIM WEAR FOR GENTLEMEN AND LADIES; LINGERIE ACCESSORIES, NAMELY, REMOVABLE SILICONE BREAST ENHANCER PADS USED IN A BRA; UNDERGARMENT ACCESSORIES, NAMELY, REMOVABLE SILICONE BUTTOCK ENHANCER PADS; HEAD WEAR; INFANT WEAR; SKI WEAR; SURF WEAR; SWIM WEAR; TENNIS WEAR; BATHING SUITS FOR MEN; FOOTWEAR FOR MEN; MEN'S SOCKS; MEN'S SUITS; SUSPENDER BELTS FOR MEN; BRIDESMAID DRESSES; DRESS SHIELDS; DRESS SHIRTS; DRESS SUITS; DRESSES; DRESSES MADE FROM SKINS; DRESSING GOWNS; EVENING DRESSES; NURSE DRESSES; SKIRTS AND DRESSES; WEDDING DRESSES (U.S. CLS. 22 AND 39).

FIRST USE 10-25-2005; IN COMMERCE 10-25-2005.

ALICE SUE CARRUTHERS, EXAMINING ATTORNEY

FIRST USE 1-16-2008; IN COMMERCE 1-16-2008.

ROBIN CHOSID, EXAMINING ATTORNEY

SN 77-392,056. EAGLE CREST, INC., JACKSONVILLE, FL. FILED 2-8-2008.

GOT FREEDOM?

THE MARK CONSISTS OF STANDARD CHARACTERS WITHOUT CLAIM TO ANY PARTICULAR FONT, STYLE, SIZE, OR COLOR.

OWNER OF U.S. REG. NOS. 3,421,508, 3,421,512 AND OTHERS.

FOR CLOTHING, NAMELY, HATS, SHIRTS, UNDERGARMENTS, SWIMSUITS, SWEATSHIRTS, SWEATERS, JACKETS, COATS, GLOVES, SCARVES, BELTS, HEADBANDS, WRISTBANDS, PANTS, SHORTS, SKIRTS, DRESSES, OVERALLS, SOCKS, STOCKINGS, AND LEGGINGS (U.S. CLS. 22 AND 39).

FIRST USE 10-25-2005; IN COMMERCE 10-25-2005.

ALICE SUE CARRUTHERS, EXAMINING ATTORNEY

SN 77-393,364. DANIEL BROWN, STATEN ISLAND, NY. AND NANCY MARRIOTT, STATEN ISLAND, NY. FILED 2-11-2008.

B&M CLOTHING, AIYANA SYDNEY

THE MARK CONSISTS OF STANDARD CHARACTERS WITHOUT CLAIM TO ANY PARTICULAR FONT, STYLE, SIZE, OR COLOR.

NO CLAIM IS MADE TO THE EXCLUSIVE RIGHT TO USE "CLOTHING", APART FROM THE MARK AS SHOWN. THE NAME "AIYANA SYDNEY" IDENTIFIES A LIVING INDIVIDUAL WHOSE CONSENT IS OF RECORD.

FOR SHIRTS, PANTS, SHOES, DRESSES, JEANS, BOOTS (U.S. CLS. 22 AND 39).

KATHERINE STOIDES, EXAMINING ATTORNEY

CLASS 25—(Continued).

SN 77-394,088. ANTHONY JOHNICAN, DBA STRUOC STANDARD LLC, HOUSTON, TX. FILED 2-11-2008.

Power by Nino Antonello

THE MARK CONSISTS OF STANDARD CHARACTERS WITHOUT CLAIM TO ANY PARTICULAR FONT, STYLE, SIZE, OR COLOR.

THE NAME(S), PORTRAIT(S), AND/OR SIGNATURE(S) SHOWN IN THE MARK DOES NOT IDENTIFY A PARTICULAR LIVING INDIVIDUAL.

FOR SHIRTS (U.S. CLS. 22 AND 39).
SUSAN LESLIE DUBOIS, EXAMINING ATTORNEY

SN 77-397,580. SAVAGE, ROBERT, NEW YORK, NY. AND LEPORE, NANETTE, NEW YORK, NY. FILED 2-14-2008.

NANETTE LEPORE

THE MARK CONSISTS OF STANDARD CHARACTERS WITHOUT CLAIM TO ANY PARTICULAR FONT, STYLE, SIZE, OR COLOR.

OWNER OF U.S. REG. NOS. 2,270,261 AND 2,679,668. THE NAME "NANETTE LEPORE" IDENTIFIES A LIVING INDIVIDUAL WHOSE CONSENT IS OF RECORD.

FOR INTIMATE APPAREL, NAMELY UNDERWEAR, BRAS, PANTIES, CAMISOLES, SLIPS, CHEMISES, BODY SUITS, TEDDIES, BUSTIERS, CORSETS, AND SLEEPWEAR, NAMELY, NIGHT GOWNS, PYJAMAS, ROBES, LOUNGE PANTS, TOPS; SWIMWEAR (U.S. CLS. 22 AND 39).

ALYSSA PALADINO, EXAMINING ATTORNEY

SN 77-397,614. ZAPF, CAROLINA, NEW YORK, NY. FILED 2-14-2008.

CZ

THE MARK CONSISTS OF STANDARD CHARACTERS WITHOUT CLAIM TO ANY PARTICULAR FONT, STYLE, SIZE, OR COLOR.

OWNER OF U.S. REG. NOS. 2,680,837 AND 3,094,798. FOR CLOTHING FOR INFANTS, CHILDREN AND ADULTS, NAMELY, SWEATERS, SHIRTS, BLOUSES, JACKETS, CARDIGANS, COATS, VESTS, SKIRTS, PANTS, SHORTS, DRESSES, SCARVES, WRAPS AND HEADWEAR; KNITWEAR, NAMELY, DRESSES, SWEATERS, CARDIGANS, PANTS, SCARVES, HATS, MITTENS, SHIRTS, BATHROBES, SKIRTS AND OVERALLS; AND OUTERWEAR, NAMELY, JACKETS, PARKAS, COATS, VESTS, PANTS, SCARVES, WRAPS AND HEADWEAR, MITTENS (U.S. CLS. 22 AND 39).
FIRST USE 1-31-2005; IN COMMERCE 1-31-2005.

KATHERINE CONNOLLY, EXAMINING ATTORNEY

CLASS 25—(Continued).

SN 77-399,633. CAPKOVIC, MICHAEL, ROGERS, AR. FILED 2-18-2008.

since feudalism

THE MARK CONSISTS OF THE STYLIZED TEXT "SINCE FEUDALISM" WITH TWO CIRCLES ATTACHED TO THE LETTER "S" IN THE WORD "SINCE" AND TWO CIRCLES ATTACHED TO THE LETTER "S" IN THE WORD "FEUDALISM". IN ADDITION, THE LETTER "S" IN THE TERM "FEUDALISM" APPEARS BACKWARDS.

FOR CAPS; HATS; HEADWEAR (U.S. CLS. 22 AND 39).
FIRST USE 9-1-2007; IN COMMERCE 9-1-2007.

MICHAEL TANNER, EXAMINING ATTORNEY

SN 77-399,692. HAIR SPACE GEAR, SUNRISE, FL. FILED S.R. 2-18-2008; AM. P.R. 6-30-2008.



NO CLAIM IS MADE TO THE EXCLUSIVE RIGHT TO USE "GEAR", APART FROM THE MARK AS SHOWN.

THE MARK CONSISTS OF THE "STYLIZED, STACKED" WORDS "HAIR SPACE GEAR" INCLUDING A CURVED LINE EXTENDING FROM TOP OF LOGO TO THE BOTTOM.

FOR HATS; HEADGEAR, NAMELY, HATS, CAPS, SCARVES; HOODED SWEATSHIRTS; LONG-SLEEVED SHIRTS; SHIRTS; SPORT SHIRTS; T-SHIRTS; HAT BANDS; SPORTS SHIRTS WITH SHORT SLEEVES; SWEAT SHIRTS; TEE SHIRTS (U.S. CLS. 22 AND 39).

LINDA M. KING, EXAMINING ATTORNEY

CLASS 25—(Continued).

SN 77-402,114. BETTER THAN CHOCOLATE BOUTIQUE, LLC, DBA BTC BOUTIQUE, LLC, RICHMOND, VA. FILED 2-20-2008.



NO CLAIM IS MADE TO THE EXCLUSIVE RIGHT TO USE "BOUTIQUE", APART FROM THE MARK AS SHOWN. THE COLOR(S) BROWN, PINK AND WHITE IS/ARE CLAIMED AS A FEATURE OF THE MARK.

THE COLOR PINK APPEARS IN THE TRUFFLE WRAPPER AND IN THE WORD "BOUTIQUE". THE COLOR BROWN APPEARS IN THE CHOCOLATE CANDY AND IN THE WORDING "BETTER THAN CHOCOLATE". THE COLOR WHITE APPEARS IN THE GLAZE ON TOP OF THE CHOCOLATE.

FOR LINGERIE; PAJAMAS; SHORT-SLEEVED OR LONG-SLEEVED T-SHIRTS; HATS; LOUNGEWEAR (U.S. CLS. 22 AND 39).

RAMONA ORTIGA, EXAMINING ATTORNEY

SN 77-402,527. THORNE, CHRISTAN, ATLANTA, GA. FILED 2-21-2008.



THE MARK CONSISTS OF TWO STYLIZED LETTER "KS" BACK TO BACK WITH A WOMAN'S SILHOUETTE IN THE MIDDLE.

FOR HATS; JACKETS; PANTS; SHIRTS; SUITS; T-SHIRTS (U.S. CLS. 22 AND 39).

TOBY BULLOFF, EXAMINING ATTORNEY

CLASS 25—(Continued).

SN 77-408,887. BERNARD CHAUS, INC., NEW YORK, NY. FILED 2-28-2008.

JO CHAUS

THE MARK CONSISTS OF STANDARD CHARACTERS WITHOUT CLAIM TO ANY PARTICULAR FONT, STYLE, SIZE, OR COLOR.

OWNER OF U.S. REG. NO. 2,418,302.

THE NAME "JO CHAUS" IDENTIFIES A LIVING INDIVIDUAL WHOSE CONSENT IS OF RECORD.

FOR CLOTHING, NAMELY, LADIES' BLOUSES, SWEATERS, SHIRTS, JACKETS, PANTS, SLACKS, SKIRTS, T SHIRTS, JEANS, AND FOOTWEAR (U.S. CLS. 22 AND 39).

THEODORE MCBRIDE, EXAMINING ATTORNEY

SN 77-410,446. NATURAL COLLECTION, CORP., LOS ANGELES, CA. FILED 2-29-2008.

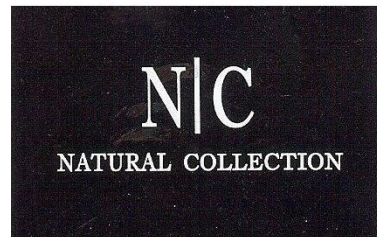

NO CLAIM IS MADE TO THE EXCLUSIVE RIGHT TO USE "NATURAL COLLECTION", APART FROM THE MARK AS SHOWN.

FOR A-SHIRTS; BALLOON PANTS; BED JACKETS; BUTTON-FRONT ALOHA SHIRTS; CAMP SHIRTS; CAPRI PANTS; CARGO PANTS; DENIM JACKETS; DENIMS; DOWN JACKETS; DRESS SHIRTS; FISHERMEN'S JACKETS; FUR COATS AND JACKETS; FUR JACKETS; GOLF SHIRTS; HEAVY JACKETS; HOODED SWEAT SHIRTS; JACKET LINERS; JACKETS; JOGGING PANTS; KNIT SHIRTS; LEATHER JACKETS; LEATHER PANTS; LIGHT-REFLECTING JACKETS; LONG JACKETS; LONG-SLEEVED SHIRTS; LOUNGE PANTS; MEN AND WOMEN JACKETS, COATS, TROUSERS, VESTS; NIGHT SHIRTS; NON-DISPOSABLE CLOTH TRAINING PANTS; NURSE PANTS; OPEN-NECKED SHIRTS; PANTS; PETTI-PANTS; PIQUE SHIRTS; POLO SHIRTS; RAIN JACKETS; RAINPROOF JACKETS; REVERSIBLE JACKETS; RUGBY SHIRTS; SHELL JACKETS; SHIRT FRONTS; SHIRT YOKES; SHIRTS; SHIRTS FOR SUITS; ALL OF THE FOREGOING ITEMS ARE COMPOSED IN WHOLE OR IN PART OF NATURAL FIBERS OR FABRICS (U.S. CLS. 22 AND 39).

FIRST USE 4-1-2000; IN COMMERCE 4-1-2000.

TOBY BULLOFF, EXAMINING ATTORNEY

CLASS 25—(Continued).

SN 77-410,972. CLINTON BASEBALL CLUB, INC., CLINTON, IA. FILED 3-3-2008.



OWNER OF U.S. REG. NO. 2,087,382.
 THE MARK CONSISTS OF A LUMBERJACK WEARING A CROWN SWINGING A BASEBALL BAT.
 FOR CLOTHING, NAMELY, APRONS, ATHLETIC UNIFORMS, BANDANAS, BOXER SHORTS, CAPS, CLOTH BABY BIBS, COATS, GOLF SHIRTS, GYM SHORTS, GYM SUITS, HATS, JACKETS, JERSEYS, JOGGING SUITS, KNIT SHIRTS, PAJAMAS, POLO SHIRTS, PONCHOS, PULLOVERS, RAIN COATS, RAINWEAR, SWEATERS, SWEAT PANTS, SWEAT SHIRTS, SWEAT SUITS, SOCKS, SPORT SHIRTS, T-SHIRTS, TANK TOPS, TIES, VISORS, WIND RESISTANT JACKETS AND WRISTBANDS (U.S. CLS. 22 AND 39).
 FIRST USE 12-1-2007; IN COMMERCE 12-1-2007.
 CHRISTINA SOBRAL, EXAMINING ATTORNEY

SN 77-412,030. ANJOO GOVAN, DBA GOOD SHEPHERD GEAR, SAN CLEMENTE, CA. FILED 3-4-2008.

Good Shepherd Gear

THE MARK CONSISTS OF STANDARD CHARACTERS WITHOUT CLAIM TO ANY PARTICULAR FONT, STYLE, SIZE, OR COLOR.
 NO CLAIM IS MADE TO THE EXCLUSIVE RIGHT TO USE "GEAR", APART FROM THE MARK AS SHOWN.
 FOR T-SHIRTS; SWEAT JACKETS; BEANIES (U.S. CLS. 22 AND 39).
 TAMARA FRAZIER, EXAMINING ATTORNEY

CLASS 25—(Continued).

SN 77-412,505. PEDERSON, WILLIAM, ST PAUL, MN. FILED 3-4-2008.



NO CLAIM IS MADE TO THE EXCLUSIVE RIGHT TO USE "COLLECTION", APART FROM THE MARK AS SHOWN.
 THE COLOR(S) BLACK, BLUE ORANGE, YELLOW AND WHITE IS/ARE CLAIMED AS A FEATURE OF THE MARK.
 THE MARK CONSISTS OF THE WORD "CONASAUR" IN BLUE WITH BLACK OUTLINES ABOVE A DINOSAUR IN ORANGE WITH BLUE TRIM, WHITE TEETH AND OUTLINES IN BLACK AND THE WORD "COLLECTION" UNDERNEATH IT IN BLUE WITH BLACK OULINES ENCLOSED WITH A BLACK CIRCLE AROUND THE ENTIRE DESIGN THE BACKGROUND IS WHITE THE EYE IS YELLOW.
 FOR FOOTWEAR (U.S. CLS. 22 AND 39).
 MARK SPARACINO, EXAMINING ATTORNEY

SN 77-412,511. PEDERSON, WILLIAM, ST PAUL, MN. FILED 3-4-2008.



NO CLAIM IS MADE TO THE EXCLUSIVE RIGHT TO USE "COLLECTION", APART FROM THE MARK AS SHOWN.
 THE COLOR(S) BLACK YELLOW RED AND WHITE IS/ARE CLAIMED AS A FEATURE OF THE MARK.
 THE MARK CONSISTS OF THE WORD "TARGASAURUS" IN RED AND SHADOW OUTLINED IN BLACK ABOVE A DINOSAUR IN RED AND WHITE AND THE WORD "COLLECTION" IN RED AND SHADOW OUTLINED IN BLACK UNDERNEATH AT THE BOTTOM OF THE CIRCLE AND 2 BULLSEYES ON EITHER SIDE OF THE DINOSAUR AND THE WHOLE DESIGN ENCLOSED WITH A BLACK CIRCLE THE EYE IS YELLOW AND THE BACKGROUND IN WHITE.
 FOR FOOTWEAR (U.S. CLS. 22 AND 39).
 MARK SPARACINO, EXAMINING ATTORNEY

CLASS 25—(Continued).

SN 77-412,802. EDUCATION PAYS INC, ALPHARETTA, GA.
FILED 3-4-2008.



NO CLAIM IS MADE TO THE EXCLUSIVE RIGHT TO USE "INC.", APART FROM THE MARK AS SHOWN.

THE MARK CONSISTS OF A STYLIZED DEPICTION OF THE LETTER "A" WEARING A GRADUATION CAP, HOLDING A REPORT CARD IN ONE HAND AND MONEY IN THE OTHER.

FOR T-SHIRTS (U.S. CLS. 22 AND 39).
FIRST USE 2-1-2008; IN COMMERCE 2-1-2008.
TOBY BULLOFF, EXAMINING ATTORNEY

CLASS 25—(Continued).

SN 77-413,834. PERMISSIONDIRECT.COM, INC, MOUNTAIN-
SIDE, NJ. FILED 3-5-2008.

Jonny Kink

THE MARK CONSISTS OF STANDARD CHARACTERS WITHOUT CLAIM TO ANY PARTICULAR FONT, STYLE, SIZE, OR COLOR.

THE NAME(S), PORTRAIT(S), AND/OR SIGNATURE(S) SHOWN IN THE MARK DOES NOT IDENTIFY A PARTICULAR LIVING INDIVIDUAL.

FOR MEN'S, WOMEN'S AND CHILDRENS CLOTHING, NAMELY, SCARVES, BELTS, SHIRTS, SWEATERS, COATS, SUITS, HATS, BEANIES, CAP VISORS, SOCKS, CAPS, DRESSES, BATHING SUITS, SKIRTS, JACKETS, JOGGING SUITS, SWEATSHIRTS, SWEATPANTS, SHORTS, JEANS, PANTS, SHIRTS, UNDERWEAR, LINGERIE, SWIMWEAR, VESTS, BLOUSES, TEE SHIRTS, STOCKINGS, TIGHTS, ROBES, PAJAMAS, KNIT TOPS, CAMISOLES, TANK TOPS, GLOVES, UNDERSHIRTS, TROUSERS, BLAZERS, LEGGINGS, PANTIES, BRAS, BUSTIERS, TEDDIES, FOOTWEAR, NAMELY, FLIP FLOPS, SANDALS, SLIPPERS, BOOTS, SNEAKERS, PUMPS, LOAFERS, AND CLOGS (U.S. CLS. 22 AND 39).
KATHERINE E. HALMEN, EXAMINING ATTORNEY

SN 77-412,917. CALLUM MACSWEEN, OAKVIEW, CA.
FILED 3-4-2008.

PROFESSIONAL BEER DRINKERS ASSOCIATION

THE MARK CONSISTS OF STANDARD CHARACTERS WITHOUT CLAIM TO ANY PARTICULAR FONT, STYLE, SIZE, OR COLOR.

NO CLAIM IS MADE TO THE EXCLUSIVE RIGHT TO USE "ASSOCIATION", APART FROM THE MARK AS SHOWN.

FOR SHORT-SLEEVED OR LONG-SLEEVED T-SHIRTS; TANK TOPS (U.S. CLS. 22 AND 39).
FIRST USE 6-30-2005; IN COMMERCE 6-30-2005.
VERNA BETH RIRIE, EXAMINING ATTORNEY

SN 77-414,689. RAGGATT CORPORATION, DANA POINT, CA. FILED 3-6-2008.

Runway Cushion Footbed

THE MARK CONSISTS OF STANDARD CHARACTERS WITHOUT CLAIM TO ANY PARTICULAR FONT, STYLE, SIZE, OR COLOR.

NO CLAIM IS MADE TO THE EXCLUSIVE RIGHT TO USE "CUSHION FOOTBED", APART FROM THE MARK AS SHOWN.

FOR FOOTWEAR FOR WOMEN (U.S. CLS. 22 AND 39).
LIEF MARTIN, EXAMINING ATTORNEY

CLASS 25—(Continued).

SN 77-415,503. SPYDER ACTIVE SPORTS, INC., BOULDER, CO. FILED 3-6-2008.



OWNER OF U.S. REG. NO. 2,278,756.
THE MARK CONSISTS OF STYLIZED "C" ENCIRCLING AN ABSTRACT "M" AND "W".

FOR FOOTWEAR; HEADWEAR; CLOTHING, NAMELY, JACKETS, WIND-RESISTANT JACKETS, WATERPROOF JACKETS, WATERPROOF PANTS, SHORTS, PANTS, HATS, VESTS, WIND-RESISTANT VESTS, SHIRTS, SHELL JACKETS, PULLOVERS, BUTTON SHIRTS, SWEATERS, FLEECE JACKETS, MITTENS, GLOVES, SWEATSHIRTS, HOODED SWEATSHIRTS, INSULATED PANTS, WATERPROOF PANTS, UNDERWEAR, TIGHTS, KNICKERS, T-SHIRTS, TANK TOPS, BALACLAVAS, NECK GAITER, CAPS, FISHING WADERS, BUTTON SHIRTS, GAITERS, VISORS; BOOTS; WADER BOOTS (U.S. CLS. 22 AND 39).
FIRST USE 7-1-1997; IN COMMERCE 7-1-1997.
PAULA MAHONEY, EXAMINING ATTORNEY

SN 77-416,893. ALLI, JEFFREY, BROOKLYN, NY. FILED 3-8-2008.

kondumb denim

THE MARK CONSISTS OF STANDARD CHARACTERS WITHOUT CLAIM TO ANY PARTICULAR FONT, STYLE, SIZE, OR COLOR.

NO CLAIM IS MADE TO THE EXCLUSIVE RIGHT TO USE "DENIM", APART FROM THE MARK AS SHOWN.

FOR CLOTHING AND HEADGEAR, NAMELY, SHIRTS, TROUSERS, TIES, T-SHIRTS, SHORTS, BLOUSES, SKIRTS, DRESSES, JUMPERS, PANTS, TANK SHIRTS, VESTS, SWEATERS, COATS, JACKETS, GLOVES, SCARVES, HATS, CAPS, BERETS; FOOTWEAR (U.S. CLS. 22 AND 39).
CAROLINE WOOD, EXAMINING ATTORNEY

CLASS 25—(Continued).

SN 77-417,241. LAUREN NICOLE LLC, DBA PURPLE KISS COUTURE, WALDORF, MD. AND DAVIDSON, LAUREN N, WALDORF, MD. FILED 3-10-2008.

Purple Kiss Couture

THE MARK CONSISTS OF STANDARD CHARACTERS WITHOUT CLAIM TO ANY PARTICULAR FONT, STYLE, SIZE, OR COLOR.

NO CLAIM IS MADE TO THE EXCLUSIVE RIGHT TO USE "COUTURE", APART FROM THE MARK AS SHOWN.

FOR DRESS SHIRTS; HOODED SWEAT SHIRTS; KNIT SHIRTS; LONG-SLEEVED SHIRTS; OPEN-NECKED SHIRTS; POLO SHIRTS; RUGBY SHIRTS; SHIRTS; SHORT-SLEEVED OR LONG-SLEEVED T-SHIRTS; SHORT-SLEEVED SHIRTS; SWEAT SHIRTS; T-SHIRTS; TEE SHIRTS; BLOUSES; DENIM JACKETS; JACKETS; LONG JACKETS; RAIN JACKETS; CARGO PANTS; DENIMS; LOUNGE PANTS; STRETCH PANTS; TRACK PANTS; DRESSING GOWNS; EVENING DRESSES; SKIRTS AND DRESSES; SKIRTS; JEANS; COATS; COATS MADE OF COTTON; COATS OF DENIM; FUR COATS; FUR COATS AND JACKETS; HEAVY COATS; LEATHER COATS; MEN AND WOMEN JACKETS, COATS, TROUSERS, VESTS; OVER COATS; RAIN COATS; RIDING COATS; SPORT COATS; SUIT COATS; TRENCH COATS; HATS (U.S. CLS. 22 AND 39).
SUSAN RICHARDS, EXAMINING ATTORNEY

SN 77-417,563. HUDSON, CHERYL E., SAN DIEGO, CA. FILED 3-10-2008.

UNDERSLIMS FOR MEN

THE MARK CONSISTS OF STANDARD CHARACTERS WITHOUT CLAIM TO ANY PARTICULAR FONT, STYLE, SIZE, OR COLOR.

NO CLAIM IS MADE TO THE EXCLUSIVE RIGHT TO USE "FOR MEN", APART FROM THE MARK AS SHOWN.

FOR LEOTARDS AND TIGHTS FOR MEN OF NYLON, COTTON OR OTHER TEXTILE FIBERS; CORSETS FOR MEN (U.S. CLS. 22 AND 39).

FIRST USE 1-1-2004; IN COMMERCE 1-1-2004.
WENDY JUN, EXAMINING ATTORNEY

CLASS 25—(Continued).

SN 77-418,394. CLARK, THOMAS, NEW BERN, NC. FILED 3-11-2008.



THE MARK CONSISTS OF STYLIZED "ONE LIFE LIVE IT !, OLLI!" LOGO; STYLIZED EXCLAMATION POINT.

FOR HATS; JACKETS; PANTS; SANDALS; SHIRTS; SHOES (U.S. CLS. 22 AND 39).

KATHERINE E. HALMEN, EXAMINING ATTORNEY

SN 77-419,414. MARK D. HANSEN, CHICAGO, IL. AND LAUREN J. HANSEN, CHICAGO, IL. FILED 3-11-2008.

What Can Lou Do For You...

THE MARK CONSISTS OF STANDARD CHARACTERS WITHOUT CLAIM TO ANY PARTICULAR FONT, STYLE, SIZE, OR COLOR.

FOR A-SHIRTS; BUTTON-FRONT ALOHA SHIRTS; CAMP SHIRTS; DRESS SHIRTS; GOLF SHIRTS; HOODED SWEAT SHIRTS; KNIT SHIRTS; LONG-SLEEVED SHIRTS; NIGHT SHIRTS; OPEN-NECKED SHIRTS; PIQUE SHIRTS; POLO SHIRTS; RUGBY SHIRTS; SHIRT FRONTS; SHIRT YOKES; SHIRTS; SHIRTS FOR SUITS; SHORT-SLEEVED OR LONG-SLEEVED T-SHIRTS; SHORT-SLEEVED SHIRTS; SLEEP SHIRTS; SPORT SHIRTS; SPORTS SHIRTS; SPORTS SHIRTS WITH SHORT SLEEVES; SWEAT SHIRTS; T-SHIRTS; TEE SHIRTS; TRIATHLON CLOTHING, NAMELY, TRIATHLON TIGHTS, TRIATHLON SHORTS, TRIATHLON SINGLETS, TRIATHLON SHIRTS, TRIATHLON SUITS; WIND SHIRTS; YOGA SHIRTS; CHEF'S HATS; FUR HATS; HAT BANDS; HATS; HEADGEAR, NAMELY, BASEBALL HATS; PAPER HATS FOR USE AS CLOTHING ITEMS; SEDGE HATS (SUGE-GASA); SMALL HATS; TOBOGGAN HATS, PANTS AND CAPS; WOOLLY HATS; BALLOON PANTS; CAPRI PANTS; CARGO PANTS; DENIMS; JOGGING PANTS; LEATHER PANTS; LOUNGE PANTS; NON-DISPOSABLE CLOTH TRAINING PANTS; NURSE PANTS; PANTS; PETTI-PANTS; SKI PANTS; SNOW PANTS; SNOWBOARD PANTS; STRETCH PANTS; SWEAT PANTS; TAP PANTS; TRACK PANTS; WATERPROOF JACKETS AND PANTS; WIND PANTS; YOGA PANTS (U.S. CLS. 22 AND 39).

KIM MONINGHOFF, EXAMINING ATTORNEY

CLASS 25—(Continued).

SN 77-419,674. CHRISTOPHER E. SMITH, EAST CLEVELAND, OH. FILED 3-12-2008.

Roads Less Traveled

THE MARK CONSISTS OF STANDARD CHARACTERS WITHOUT CLAIM TO ANY PARTICULAR FONT, STYLE, SIZE, OR COLOR.

FOR BELTS; CAPS; HOODS; LEATHER BELTS; SHORT SETS; BUTTON-FRONT ALOHA SHIRTS; CAMP SHIRTS; DRESS SHIRTS; GOLF SHIRTS; HOODED SWEAT SHIRTS; KNIT SHIRTS; LONG-SLEEVED SHIRTS; NIGHT SHIRTS; OPEN-NECKED SHIRTS; PIQUE SHIRTS; POLO SHIRTS; RUGBY SHIRTS; SHIRTS; SHIRTS FOR SUITS; SHORT-SLEEVED OR LONG-SLEEVED T-SHIRTS; SHORT-SLEEVED SHIRTS; SLEEP SHIRTS; SPORT SHIRTS; SPORTS SHIRTS; SPORTS SHIRTS WITH SHORT SLEEVES; SWEAT SHIRTS; T-SHIRTS; TEE SHIRTS; TRIATHLON CLOTHING, NAMELY, TRIATHLON TIGHTS, TRIATHLON SHORTS, TRIATHLON SINGLETS, TRIATHLON SHIRTS, TRIATHLON SUITS; WIND SHIRTS; YOGA SHIRTS; BALLOON PANTS; CAPRI PANTS; CARGO PANTS; DENIMS; JOGGING PANTS; LEATHER PANTS; LOUNGE PANTS; NON-DISPOSABLE CLOTH TRAINING PANTS; NURSE PANTS; PANTS; PETTI-PANTS; SKI PANTS; SNOW PANTS; SNOWBOARD PANTS; STRETCH PANTS; SWEAT PANTS; TAP PANTS; TOBOGGAN HATS, PANTS AND CAPS; TRACK PANTS; WATERPROOF JACKETS AND PANTS; WIND PANTS; YOGA PANTS; CHEF'S HATS; FUR HATS; HAT BANDS; HATS; PAPER HATS FOR USE AS CLOTHING ITEMS; SEDGE HATS (SUGE-GASA); SMALL HATS; WOOLLY HATS; ANKLE SOCKS; ANKLETS; ANTI-PERSPIRANT SOCKS; JAPANESE STYLE SOCKS (TABI COVERS); JAPANESE STYLE SOCKS (TABI); MEN'S SOCKS; PAPER SHOES USED WHEN GOING THROUGH METAL DETECTORS TO KEEP FEET AND SOCKS CLEAN; SOCK SUSPENDERS; SOCKS; SOCKS AND STOCKINGS; THERMAL SOCKS; WATER SOCKS; WOOLLEN SOCKS; BRIEFS; DISPOSABLE UNDERWEAR; KNITTED UNDERWEAR; LADIES' UNDERWEAR; LONG UNDERWEAR; PERSPIRATION ABSORBENT UNDERWEAR CLOTHING; THERMAL UNDERWEAR; THONGS; UNDERWEAR; UNDERWEAR, NAMELY, BOY SHORTS; WOMEN'S UNDERWEAR; WOVEN OR KNITTED UNDERWEAR; ANGLERS' SHOES; APRES-SKI SHOES; ATHLETIC SHOES; BALLET SHOES; BALLROOM DANCING SHOES; BASEBALL SHOES; BEACH SHOES; BOWLING SHOES; BOXING SHOES; CANVAS SHOES; CLEATS FOR ATTACHMENT TO SPORTS SHOES; CYCLING SHOES; DANCE SHOES; DECK-SHOES; DRIVERS; FOOTBALL SHOES; GOLF SHOES; GYMNASIATIC SHOES; HANDBALL SHOES; HEEL PIECES FOR SHOES; HOCKEY SHOES; INFANTS' SHOES AND BOOTS; INSOLES; LEATHER SHOES; PROTECTIVE METAL MEMBERS FOR SHOES AND BOOTS; RUBBER SHOES; RUGBY SHOES; RUNNING SHOES; SHOE DOWELS; SHOE INSERTS FOR PRIMARILY NON-ORTHOPEDIC PURPOSES; SHOE PEGS; SHOE SOLES; SHOES; SHOES SOLES FOR REPAIR; SKI AND SNOWBOARD SHOES AND PARTS THEREOF; SKIING SHOES; SOCCER SHOES; TAP SHOES; TENNIS SHOES; TONGUE OR PULL STRAP FOR SHOES AND BOOTS; TRACK AND FIELD SHOES; TRAINING SHOES; VOLLEYBALL SHOES; WOMEN'S SHOES; WORK SHOES AND BOOTS; BICYCLE GLOVES; BICYCLING GLOVES; CROSS-COUNTRY GLOVES; GLOVES; GLOVES FOR PERSONAL HAND CONDITIONING USE; GLOVES INCLUDING THOSE MADE OF SKIN, HIDE OR FUR; MOTORCYCLE GLOVES; OUTDOOR GLOVES; RIDING GLOVES; SKI GLOVES; SNOWBOARD GLOVES; WET SUIT GLOVES (U.S. CLS. 22 AND 39).

ARETHA SOMERVILLE, EXAMINING ATTORNEY

CLASS 25—(Continued).

SN 77-420,149. STEELE, MARIANNE I, FLOWER MOUND, TX. FILED 3-12-2008.



THE MARK CONSISTS OF THE BOTTOM OF A PAIR OF SHOES OR FLIP FLOPS WITH THE WORD "BLESS" WRITTEN/EMBOSSSED ON ONE AND "MY SOLE" WRITTEN/EMBOSSSED ON THE OTHER.

FOR BALLET SHOES; BEACH FOOTWEAR; BEACH SHOES; CANVAS SHOES; DANCE SHOES; FLIP FLOPS; FOOTWEAR; GYMNASTIC SHOES; INFANTS' SHOES AND BOOTS; INSOLES; LEATHER SHOES; SANDAL-CLOGS; SANDALS; SHOE SOLES; SHOES; TAP SHOES; TENNIS SHOES; THONGS; VOLLEYBALL SHOES; WOMEN'S SHOES; BASEBALL SHOES; DECK-SHOES; GOLF SHOES (U.S. CLS. 22 AND 39).

CAROLYN CATALDO, EXAMINING ATTORNEY

SN 77-420,361. EQUALS 4 INC, NEW YORK, NY. FILED 3-12-2008.

Absolute Silk

THE MARK CONSISTS OF STANDARD CHARACTERS WITHOUT CLAIM TO ANY PARTICULAR FONT, STYLE, SIZE, OR COLOR.

NO CLAIM IS MADE TO THE EXCLUSIVE RIGHT TO USE "SILK", APART FROM THE MARK AS SHOWN.

FOR CLOTHING, NAMELY, SILK TOPS, PANTS, SKIRTS, DRESSES, SHORTS AND BLOUSES (U.S. CLS. 22 AND 39).

KIM MONINGHOFF, EXAMINING ATTORNEY

CLASS 25—(Continued).

SN 77-420,610. JEAN WYCLEF, NEW YORK, NY. AND JERRY DUPLESSIS, NY, UNITED STATES, FILED 3-13-2008.

Nel Ust

THE MARK CONSISTS OF STANDARD CHARACTERS WITHOUT CLAIM TO ANY PARTICULAR FONT, STYLE, SIZE, OR COLOR.

THE NAME "NEL UST" DOES NOT IDENTIFY A LIVING INDIVIDUAL.

FOR CLOTHING, NAMELY, WRAP-AROUNDS; SHIRTS; SHORT SETS; SHOULDER WRAPS; TIES; TOPS; WRAPS; PANTS; SKIRTS AND DRESSES; SWEAT PANTS; TAP PANTS; SHIRTS; BATHING SUITS FOR MEN; DRESS SUITS; GYM SUITS; JOGGING SUITS; SWIMWEAR; SHORTS; SWEAT SHORTS (U.S. CLS. 22 AND 39).

CHRISTOPHER BUONGIORNO, EXAMINING ATTORNEY

SN 77-420,838. PANG, MAY, POMONA, NY. FILED 3-13-2008.

MAY PANG INSTAMATIC KARMA

THE MARK CONSISTS OF STANDARD CHARACTERS WITHOUT CLAIM TO ANY PARTICULAR FONT, STYLE, SIZE, OR COLOR.

OWNER OF U.S. REG. NOS. 3,022,610 AND 3,289,123.

FOR A-SHIRTS; BUTTON-FRONT ALOHA SHIRTS; CAMP SHIRTS; DRESS SHIRTS; GOLF SHIRTS; HOODED SWEAT SHIRTS; KNIT SHIRTS; LONG-SLEEVED SHIRTS; NIGHT SHIRTS; OPEN-NECKED SHIRTS; PIQUE SHIRTS; POLO SHIRTS; RUGBY SHIRTS; SHIRT FRONTS; SHIRT YOKES; SHIRTS; SHIRTS FOR SUITS; SHORT-SLEEVED OR LONG-SLEEVED T-SHIRTS; SHORT-SLEEVED SHIRTS; SLEEP SHIRTS; SPORT SHIRTS; SPORTS SHIRTS; SPORTS SHIRTS WITH SHORT SLEEVES; SWEAT SHIRTS; T-SHIRTS; TEE SHIRTS; TRIATHLON CLOTHING, NAMELY, TRIATHLON TIGHTS, TRIATHLON SHORTS, TRIATHLON SINGLETS, TRIATHLON SHIRTS, TRIATHLON SUITS; WIND SHIRTS; YOGA SHIRTS; HEAD SCARVES; SCARVES; SHOULDER SCARVES; SILK SCARVES; BICYCLE GLOVES; BICYCLING GLOVES; CROSS-COUNTRY GLOVES; GLOVES; GLOVES FOR PERSONAL HAND CONDITIONING USE; GLOVES INCLUDING THOSE MADE OF SKIN, HIDE OR FUR; MOTORCYCLE GLOVES; OUTDOOR GLOVES; RIDING GLOVES; SKI GLOVES; SNOWBOARD GLOVES; WET SUIT GLOVES; CHEF'S HATS; FUR HATS; HAT BANDS; HATS; PAPER HATS FOR USE AS CLOTHING ITEMS; SEDGE HATS OR SUGE-GASA; SMALL HATS; TOBOGGAN HATS, PANTS AND CAPS; WOOLLY HATS; BALLOON PANTS; CAPRI PANTS; CARGO PANTS; DENIMS; JOGGING PANTS; LEATHER PANTS; LOUNGE PANTS; NON-DISPOSABLE CLOTH TRAINING PANTS; NURSE PANTS; PANTS; PETTI-PANTS; SKI PANTS; SNOW PANTS; SNOWBOARD

CLASS 25—(Continued).

PANTS; STRETCH PANTS; SWEAT PANTS; TAP PANTS; TRACK PANTS; WATERPROOF JACKETS AND PANTS; WIND PANTS; YOGA PANTS; BED JACKETS; DENIM JACKETS; DOWN JACKETS; FISHERMEN'S JACKETS; FUR COATS AND JACKETS; FUR JACKETS; HEAVY JACKETS; JACKET LINERS; JACKETS; LEATHER JACKETS; LIGHT-REFLECTING JACKETS; LONG JACKETS; MEN AND WOMEN JACKETS, COATS, TROUSERS, VESTS; PADDED JACKETS; PADDING JACKETS; RAIN JACKETS; RAINPROOF JACKETS; REVERSIBLE JACKETS; SHELL JACKETS; SKI JACKETS; SLEEVED OR SLEEVELESS JACKETS; SMOKING JACKETS; SPORTS JACKETS; STUFF JACKETS; SUEDE JACKETS; SWEAT JACKETS; TRACK JACKETS; WIND RESISTANT JACKETS; WIND-JACKETS; PLEATED SKIRTS FOR FORMAL KIMONOS OR HAKAMA; SKIRT SUITS; SKIRTS; SKIRTS AND DRESSES; FISHING VESTS; FLEECE VESTS; HUNTING VESTS; LONG SLEEVED VESTS; QUILTED VESTS; VEST EXTENDERS; VESTED SUITS; VESTS; WIND VESTS (U.S. CLS. 22 AND 39).

FIRST USE 3-4-2008; IN COMMERCE 3-4-2008.
ZACHARY BELLO, EXAMINING ATTORNEY

CLASS 25—(Continued).

SN 77-421,903. EUBER, CHARLES W, POULTNEY, VT. FILED 3-14-2008.



THE COLOR(S) RED IS/ARE CLAIMED AS A FEATURE OF THE MARK.

THE MARK CONSISTS OF THE COLOR RED APPEARING IN THE LETTERING OF THE WORDING "REDNECK POSSE".

FOR INFANT AND TODDLER ONE PIECE CLOTHING; CAPS; SHORT-SLEEVED OR LONG-SLEEVED T-SHIRTS; JERSEYS; LEATHER BELTS; SHORT SETS; TIES; TOPS (U.S. CLS. 22 AND 39).

TINA KUAN, EXAMINING ATTORNEY

SN 77-421,258. Z-TECH, INC., ALBUQUERQUE, NM. FILED 3-13-2008.



THE MARK CONSISTS OF A SILHOUETTE OF FOOTWEAR HAVING A COILED SPRING ADJACENT THE HEEL.

FOR FOOTWEAR (U.S. CLS. 22 AND 39).
FIRST USE 1-1-2005; IN COMMERCE 1-1-2005.
EUGENIA MARTIN, EXAMINING ATTORNEY

SN 77-422,227. PONCHO & GOLDSTEIN, INC, LAGUNA NIGUEL, CA. FILED 3-14-2008.



NO CLAIM IS MADE TO THE EXCLUSIVE RIGHT TO USE "HAWAIIAN", APART FROM THE MARK AS SHOWN.

FOR MEN'S, WOMEN'S, BOYS', GIRLS CLOTHING, NAMELY, KNIT AND WOVEN SHIRTS; KNIT AND WOVEN PANTS, SHORTS AND JEANS; SWEATERS, JACKETS, VESTS, COATS, RAINWEAR, BELTS, SOCKS AND HATS (U.S. CLS. 22 AND 39).

FIRST USE 1-4-2008; IN COMMERCE 3-13-2008.
CHERYL CLAYTON, EXAMINING ATTORNEY

CLASS 25—(Continued).

SN 77-423,400. COLOR IMAGE APPAREL, INC., COMMERCE, CA. FILED 3-17-2008.

BELLA

THE MARK CONSISTS OF STANDARD CHARACTERS WITHOUT CLAIM TO ANY PARTICULAR FONT, STYLE, SIZE, OR COLOR.

OWNER OF U.S. REG. NOS. 3,158,111, 3,293,659 AND OTHERS.

THE ENGLISH TRANSLATION OF THE WORD "BELLA" IN THE MARK IS "BEAUTIFUL".

FOR WOMEN'S CLOTHING, NAMELY, TEE SHIRTS, SHORT SLEEVE SHIRTS, LONG SLEEVE SHIRTS, TANK TOPS, FLEECE TOPS, FLEECE PANTS, SHIRTS, PANTS, YOGA PANTS, CAPRI PANTS, SHORTS, BRAS, UNDERWEAR, CAMISOLES, SWEATSHIRTS, POLO SHIRTS, AND JACKETS (U.S. CLS. 22 AND 39).

FIRST USE 1-1-2000; IN COMMERCE 1-1-2000.
LYDIA BELZER, EXAMINING ATTORNEY

SN 77-423,609. FASHION AVENUE KNITS, INC., NEW YORK, NY. FILED 3-17-2008.

LOVE ALWAYS

THE MARK CONSISTS OF STANDARD CHARACTERS WITHOUT CLAIM TO ANY PARTICULAR FONT, STYLE, SIZE, OR COLOR.

FOR CLOTHING, NAMELY, SWEATERS AND TOPS (U.S. CLS. 22 AND 39).

TINA BROWN, EXAMINING ATTORNEY

SN 77-424,330. RODRIGUEZ, ALICIA, HAYWARD, CA. FILED 3-17-2008.

THE FOREIGN WORDING IN THE MARK TRANSLATES INTO ENGLISH AS "BOND/FRIENDSHIP OF YOUNG GIRLS".

FOR APRONS; HATS; SHIRTS (U.S. CLS. 22 AND 39).
ELIZABETH KAJUBI, EXAMINING ATTORNEY

CLASS 25—(Continued).

SN 77-424,978. LAPRISE, SHERRY L., FARMINGTON, CT. AND LAPRISE, DEREK J., FARMINGTON, CT. FILED 3-18-2008.



THE MARK CONSISTS OF THE OUTLINE OF A FIGURE THAT IS RUNNING, WITH TWO LINES ON THE LEFT SIDE TO INDICATE MOTION.

FOR HEADGEAR, NAMELY, HATS AND VISORS; SHIRTS; T-SHIRTS; SWEATSHIRTS (U.S. CLS. 22 AND 39).

FIRST USE 11-1-2007; IN COMMERCE 11-1-2007.
CIMMERIAN COLEMAN, EXAMINING ATTORNEY

SN 77-425,149. U.S. TOP IMPORTERS, INC., LOS ANGELES, CA. FILED 3-18-2008.

Fleur De Lis

THE MARK CONSISTS OF STANDARD CHARACTERS WITHOUT CLAIM TO ANY PARTICULAR FONT, STYLE, SIZE, OR COLOR.

FOR CLOTHING, NAMELY, WOMENS BLOUSES, TANK TOPS, T-SHIRTS, SWEATERS, DRESSES, SKIRTS, AND PANTS (U.S. CLS. 22 AND 39).

FIRST USE 2-22-2008; IN COMMERCE 2-22-2008.
DORITT L. CARROLL, EXAMINING ATTORNEY

SN 77-425,231. THOMPSON, SCOTT L, SAN DIEGO, CA. FILED 3-18-2008.

THE SAINT'S SINPHONY

THE MARK CONSISTS OF STANDARD CHARACTERS WITHOUT CLAIM TO ANY PARTICULAR FONT, STYLE, SIZE, OR COLOR.

FOR CAMP SHIRTS; DRESS SHIRTS; GOLF SHIRTS; HOODED SWEAT SHIRTS; KNIT SHIRTS; LONG-SLEEVED SHIRTS; NIGHT SHIRTS; OPEN-NECKED SHIRTS; PIQUE SHIRTS; POLO SHIRTS; RUGBY SHIRTS; SHIRT FRONTS; SHIRTS; SHIRTS FOR SUITS; SHORT-SLEEVED OR LONG-SLEEVED T-SHIRTS; SHORT-SLEEVED SHIRTS; SLEEP SHIRTS; SPORT SHIRTS; SPORTS SHIRTS; T-SHIRTS; TEE SHIRTS; CARGO PANTS; LEATHER PANTS; LOUNGE PANTS; STRETCH PANTS; SHORTS; FUR JACKETS; HEAVY JACKETS; JACKETS; BELTS; CAPS; BRIEFS; SWEAT JACKETS; SWEAT SHIRTS; SWEAT SHORTS (U.S. CLS. 22 AND 39).

FIRST USE 2-1-2008; IN COMMERCE 2-1-2008.
KEVON CHISOLM, EXAMINING ATTORNEY

CLASS 25—(Continued).

SN 77-425,344. O'BRYAN BROS., INC., CHICAGO, IL. FILED 3-18-2008.

SKINSATIONS

THE MARK CONSISTS OF STANDARD CHARACTERS WITHOUT CLAIM TO ANY PARTICULAR FONT, STYLE, SIZE, OR COLOR.

FOR UNDERWEAR (U.S. CLS. 22 AND 39).
FIRST USE 9-30-2006; IN COMMERCE 9-30-2006.
HANNO RITTNER, EXAMINING ATTORNEY

SN 77-425,579. FLOSSY CHIC APPAREL, SCOTTSDALE, AZ. FILED 3-18-2008.



THE MARK CONSISTS OF A FREE FORM BUTTERFLY WITH THE TEXT "FLOSSY" ATTACHED TO THE BODY OF THE BUTTERFLY.

FOR JACKETS; PANTS; SHIRTS (U.S. CLS. 22 AND 39).
KARANENDRA S. CHHINA, EXAMINING ATTORNEY

SN 77-425,583. EDWARDS, JON SCOTT, VENICE, CA. FILED 3-18-2008.

VAMPIRA

THE MARK CONSISTS OF STANDARD CHARACTERS WITHOUT CLAIM TO ANY PARTICULAR FONT, STYLE, SIZE, OR COLOR.

THE NAME(S), PORTRAIT(S), AND/OR SIGNATURE(S) SHOWN IN THE MARK DOES NOT IDENTIFY A PARTICULAR LIVING INDIVIDUAL.

FOR CLOTHING, NAMELY, JACKETS, RAINCOATS, PANTS, SHORTS, SWEATERS, SWEAT PANTS, SWEAT-SHIRTS, T-SHIRTS, SHIRTS, SOCKS, UNDERWEAR, OVERALLS, DRESSES, SKIRTS, TANK TOPS, POLO SHIRTS, VESTS, PAJAMAS, JUMP SUITS, GLOVES, NECK TIES, BANDANNAS, BELTS AND SUSPENDERS; HEADGEAR, NAMELY, HATS, CAPS AND SUN VISORS; FOOTWEAR, NAMELY, SHOES, SLIPPERS AND SANDALS (U.S. CLS. 22 AND 39).

MARCIE MILONE, EXAMINING ATTORNEY

CLASS 25—(Continued).

SN 77-425,748. GONZALEZ, TAHTEBAH A., BEKLEVILLE, NJ. FILED 3-19-2008.

GWOP

THE MARK CONSISTS OF STANDARD CHARACTERS WITHOUT CLAIM TO ANY PARTICULAR FONT, STYLE, SIZE, OR COLOR.

FOR SHIRTS; T-SHIRTS; HOODED SWEAT SHIRTS; SWEAT BANDS; SWEAT PANTS; SWEAT SHIRTS; SWEAT SUITS; PANTS; JEANS; HATS; HEAD SWEAT-BANDS (U.S. CLS. 22 AND 39).

B. PARADEWELAI, EXAMINING ATTORNEY

SN 77-425,759. P DEVOS DESIGNS, INC., GRAND RAPIDS, MI. FILED 3-19-2008.

PAMELLA BY PAMELLA ROLAND

THE MARK CONSISTS OF STANDARD CHARACTERS WITHOUT CLAIM TO ANY PARTICULAR FONT, STYLE, SIZE, OR COLOR.

OWNER OF U.S. REG. NOS. 2,740,479 AND 2,750,449.

THE NAME(S), PORTRAIT(S), AND/OR SIGNATURE(S) SHOWN IN THE MARK DOES NOT IDENTIFY A PARTICULAR LIVING INDIVIDUAL.

FOR JACKETS; PANTS; BELTS; BLOUSES; DRESSES; GOWNS; SKIRTS (U.S. CLS. 22 AND 39).

B. PARADEWELAI, EXAMINING ATTORNEY

SN 77-425,973. COTTON DENIM, LLC, LOS ANGELES, CA. FILED 3-19-2008.

M Blue Not For All

THE MARK CONSISTS OF STANDARD CHARACTERS WITHOUT CLAIM TO ANY PARTICULAR FONT, STYLE, SIZE, OR COLOR.

NO CLAIM IS MADE TO THE EXCLUSIVE RIGHT TO USE "BLUE", APART FROM THE MARK AS SHOWN.

FOR SHORTS, PANTS, SHIRTS, JEANS, KNIT TOPS, SWEATERS, SWEAT SHIRTS, T-SHIRTS, JACKETS, COATS, BELTS, SCARVES, HEAD WEAR, HATS, FOOTWEAR, SHOES (U.S. CLS. 22 AND 39).

FIRST USE 11-1-2003; IN COMMERCE 11-1-2003.

CHARLES L. JENKINS, EXAMINING ATTORNEY

CLASS 25—(Continued).

SN 77-426,092. SAGAMORE HILL APPAREL, LLC, OXNARD, CA. FILED 3-19-2008.

SAVAGE ART

THE MARK CONSISTS OF STANDARD CHARACTERS WITHOUT CLAIM TO ANY PARTICULAR FONT, STYLE, SIZE, OR COLOR.

FOR CLOTHING, NAMELY, JEANS, PANTS, SHORTS, SHIRTS, T-SHIRTS, SWEATSHIRTS, SWEATPANTS, SWEATSUITS, OVERALLS, SKIRTS, DRESSES, BLOUSES, JACKETS, SWEATERS, VESTS, OUTERWEAR, NAMELY, COATS, OVERCOATS AND RAINCOATS, SLEEPWEAR, UNDERWEAR, HATS, CAPS, SOCKS AND FOOTWEAR (U.S. CLS. 22 AND 39).
SAMUEL E. SHARPER JR., EXAMINING ATTORNEY

SN 77-426,129. SHOPKO STORES OPERATING CO., LLC, GREEN BAY, WI. FILED 3-19-2008.

peanut & ollie

FOR PANTS; SHIRTS; BABY BOTTOMS; BOTTOMS; BABY TOPS; SLEEPWEAR; SHORTS; COVERALLS; CREEPERS; JUMPERS; DRESSES; SWIMWEAR; SHORT SETS; SWEATERS; JACKETS; COATS; SNOW PANTS; SNOW SUITS; VESTS; SKORTS; CAPRIS; HATS; CAPS; SHOES; MITTENS; CLOTH BIBS; SOCKS (U.S. CLS. 22 AND 39).

DAWN HAN, EXAMINING ATTORNEY

SN 77-426,134. SHOPKO STORES OPERATING CO., LLC, GREEN BAY, WI. FILED 3-19-2008.

Peanut & Ollie

THE MARK CONSISTS OF STANDARD CHARACTERS WITHOUT CLAIM TO ANY PARTICULAR FONT, STYLE, SIZE, OR COLOR.

FOR PANTS; SHIRTS; BABY BOTTOMS; BOTTOMS; BABY TOPS; SLEEPWEAR; SHORTS; COVERALLS; CREEPERS; JUMPERS; DRESSES; SWIMWEAR; SHORT SETS; SWEATERS; JACKETS; COATS; SNOW PANTS; SNOW SUITS; VESTS; SKORTS; CAPRIS; HATS; CAPS; SHOES; MITTENS; CLOTH BIBS; SOCKS (U.S. CLS. 22 AND 39).

DAWN HAN, EXAMINING ATTORNEY

CLASS 25—(Continued).

SN 77-426,165. M & R SUPPLIES IMPORT EXPORT, INC., DBA M & R SUPPLIES, FLUSHING, NY. FILED 3-19-2008.

DOLCE & B

THE MARK CONSISTS OF STANDARD CHARACTERS WITHOUT CLAIM TO ANY PARTICULAR FONT, STYLE, SIZE, OR COLOR.

THE ENGLISH TRANSLATION OF "DOLCE" IS SWEET. FOR JEANS; SHORT-SLEEVED OR LONG-SLEEVED T-SHIRTS; T-SHIRTS; DENIM JACKETS; DENIMS; PANTS (U.S. CLS. 22 AND 39).

FIRST USE 3-1-2006; IN COMMERCE 3-1-2006.
MARY ROSSMAN, EXAMINING ATTORNEY

SN 77-426,189. ATKINSON III, THOMAS T., MCKENNEY, VA. FILED 3-19-2008.

ONE COUNTRY

THE MARK CONSISTS OF STANDARD CHARACTERS WITHOUT CLAIM TO ANY PARTICULAR FONT, STYLE, SIZE, OR COLOR.

FOR CAPS; PANTS; SHIRTS; DRESSES; JACKETS; BABY BODYSUITS; SOCKS AND STOCKINGS; SHOES; UNDERWEAR; GLOVES; LEATHER BELTS; MONEY BELTS; SUSPENDER BELTS FOR MEN; SUSPENDER BELTS FOR WOMEN; WAIST BELTS; JEANS; FLEECE PULLOVERS; FLEECE SHORTS; FLEECE VESTS; BANDANAS; CREWNECK SWEATERS; MOCK TURTLENECK SWEATERS; SWEATERS; TURTLENECK SWEATERS; V-NECK SWEATERS; BLOUSES; BERMUDA SHORTS; BOARD SHORTS; BOXER SHORTS; GYM SHORTS; PANTIES, SHORTS AND BRIEFS; RUGBY SHORTS; SHORT SETS; SHORT TROUSERS; SHORT-SLEEVED OR LONG-SLEEVED T-SHIRTS; SHORT-SLEEVED SHIRTS; SHORTS; SLIDING SHORTS; SPORTS SHIRTS WITH SHORT SLEEVES; SWEAT SHORTS; LONG SLEEVED VESTS; LONG-SLEEVED SHIRTS; SLEEVED OR SLEEVELESS JACKETS; SKIRT SUITS; SKIRTS; SKIRTS AND DRESSES; HATS; SMALL HATS; TOBOGGAN HATS, PANTS AND CAPS (U.S. CLS. 22 AND 39).

RONALD AIKENS, EXAMINING ATTORNEY

SN 77-426,536. TRUE INDEPENDENT STUDIOS, LLC, LAS VEGAS, NV. FILED 3-19-2008.

TRUE INDEPENDENT

THE MARK CONSISTS OF STANDARD CHARACTERS WITHOUT CLAIM TO ANY PARTICULAR FONT, STYLE, SIZE, OR COLOR.

FOR T-SHIRTS; LONG-SLEEVED SHIRTS; SWEAT SHIRTS; HATS (U.S. CLS. 22 AND 39).

THOMAS MANOR, EXAMINING ATTORNEY

CLASS 25—(Continued).

SN 77-426,545. TRUE INDEPENDENT STUDIOS, LLC, LAS VEGAS, NV. FILED 3-19-2008.



TRUE INDEPENDENT

THE MARK CONSISTS OF A STYLIZED T IN THE FORM OF A WATERMARK CROSS FOLLOWED WITH STYLIZED LETTERS RUE INDEPENDENT, ENDING WITH A STYLIZED T IN THE FORM OF A WATERMARK CROSS..

FOR T-SHIRTS; LONG-SLEEVED SHIRTS; SWEAT SHIRTS; HATS (U.S. CLS. 22 AND 39).

THOMAS MANOR, EXAMINING ATTORNEY

CLASS 25—(Continued).

SN 77-426,634. TROPICAL TUX, LLC., CARLSBAD, CA. FILED 3-19-2008.



Tropical Tux

NO CLAIM IS MADE TO THE EXCLUSIVE RIGHT TO USE "TUX", APART FROM THE MARK AS SHOWN.

THE COLOR(S) GREEN AND BLACK IS/ARE CLAIMED AS A FEATURE OF THE MARK.

THE MARK CONSISTS OF THE WORDS "TROPICAL TUX" AND A DESIGN ELEMENT COMPRISING TWO PALM TREES. THE COLOR BLACK APPEARS IN THE WORDING "TROPICAL TUX" AND THE COLOR GREEN APPEARS IN THE PALM TREES.

FOR DRESS SHIRTS; SHIRTS FOR SUITS (U.S. CLS. 22 AND 39).

FIRST USE 3-1-2007; IN COMMERCE 3-1-2007.

LAURIE KAUFMAN, EXAMINING ATTORNEY

SN 77-426,841. ALVIN JOHN BARRERA, CERRITOS, CA. FILED 3-20-2008.

PEOPLE WITH AGENDAS

SN 77-426,622. HOMER, JOHN TRAVIS, LOS ANGELES, CA. FILED 3-19-2008.

Estate Clothing

THE MARK CONSISTS OF STANDARD CHARACTERS WITHOUT CLAIM TO ANY PARTICULAR FONT, STYLE, SIZE, OR COLOR.

FOR CLOTHING, NAMELY, PANTS, SOCKS, BELTS, BLAZERS, BLOUSES, COATS, DRESSES, FOOTWEAR, HALTER TOPS, HATS, JACKETS, JEANS, JERSEYS, JUMPERS, JUMPSUITS, OVERALLS, PULLOVERS, SHIRTS, SHORTS, SKIRTS, SLACKS, SPORT COATS, SWEATSHIRTS, T-SHIRTS AND TANK TOPS (U.S. CLS. 22 AND 39).

FIRST USE 2-1-2006; IN COMMERCE 2-1-2006.

ASMAT KHAN, EXAMINING ATTORNEY

SN 77-426,843. LAUREN NICOLE BLACKWELDER, BEND, OR. FILED 3-20-2008.

Frank & Me

THE MARK CONSISTS OF STANDARD CHARACTERS WITHOUT CLAIM TO ANY PARTICULAR FONT, STYLE, SIZE, OR COLOR.

NO CLAIM IS MADE TO THE EXCLUSIVE RIGHT TO USE "CLOTHING", APART FROM THE MARK AS SHOWN.

FOR DENIMS; CAMP SHIRTS; DRESS SHIRTS; GOLF SHIRTS; HOODED SWEAT SHIRTS; KNIT SHIRTS; LONG-SLEEVED SHIRTS; NIGHT SHIRTS; PIQUE SHIRTS; POLO SHIRTS; SHIRTS; SHORT-SLEEVED OR LONG-SLEEVED T-SHIRTS; HATS; JACKETS; HEADGEAR, NAMELY, BASEBALL CAPS (U.S. CLS. 22 AND 39).

ALYSSA PALADINO, EXAMINING ATTORNEY

THE MARK CONSISTS OF STANDARD CHARACTERS WITHOUT CLAIM TO ANY PARTICULAR FONT, STYLE, SIZE, OR COLOR.

FOR BABY BOTTOMS; CAPES (U.S. CLS. 22 AND 39).

ASMAT KHAN, EXAMINING ATTORNEY

CLASS 25—(Continued).

SN 77-426,849. MCNAIR STUDIO AND PRODUCTION COMPANY, L.L.C., SILVER SPRING, MD. FILED 3-20-2008.

The International Singers' Circle

THE MARK CONSISTS OF STANDARD CHARACTERS WITHOUT CLAIM TO ANY PARTICULAR FONT, STYLE, SIZE, OR COLOR.

FOR TEE SHIRTS (U.S. CLS. 22 AND 39).
H. M. FISHER, EXAMINING ATTORNEY

SN 77-427,070. KANTROWICH, ALISON, LOS ANGELES, CA. FILED 3-20-2008.

RIOUXLETTE

THE MARK CONSISTS OF STANDARD CHARACTERS WITHOUT CLAIM TO ANY PARTICULAR FONT, STYLE, SIZE, OR COLOR.

FOR GLOVES; HATS; HOODED PULLOVERS; JACKETS; SCARVES; SHIRTS; UNDERWEAR (U.S. CLS. 22 AND 39).

FIRST USE 2-28-2008; IN COMMERCE 3-1-2008.
DAVID YONTEF, EXAMINING ATTORNEY

SN 77-427,380. KIM, STEVE J, LOS ANGELES, CA. FILED 3-20-2008.



THE MARK CONSISTS OF THE WORDING ESKAY IN STYLIZED LETTERING.

FOR A-SHIRTS; CAMP SHIRTS; DRESS SHIRTS; GOLF SHIRTS; HOODED SWEAT SHIRTS; KNIT SHIRTS; LONG-SLEEVED SHIRTS; OPEN-NECKED SHIRTS; PIQUE SHIRTS; POLO SHIRTS; RUGBY SHIRTS; SHIRT FRONTS; SHIRT YOKES; SHIRTS; SHIRTS FOR SUITS; SHORT-SLEEVED OR LONG-SLEEVED T-SHIRTS; SHORT-SLEEVED SHIRTS; SPORT SHIRTS; SPORTS SHIRTS; SPORTS SHIRTS WITH SHORT SLEEVES; SWEAT SHIRTS; T-SHIRTS; TEE SHIRTS; TRIATHLON CLOTHING, NAMELY, TRIATHLON TIGHTS, TRIATHLON SHORTS, TRIATHLON SINGLET, TRIATHLON SHIRTS, TRIATHLON SUITS; WIND SHIRTS; YOGA SHIRTS; JEANS; DENIM JACKETS; DENIMS; DOWN JACKETS; FUR COATS AND JACKETS; HEAVY JACKETS; JACKET LINERS; JACKETS; LEATHER JACKETS; LIGHT-REFLECTING JACKETS; LONG JACKETS; MEN AND WOMEN JACKETS,

CLASS 25—(Continued).

COATS, TROUSERS, VESTS; PADDED JACKETS; PADDING JACKETS; RAIN JACKETS; RAINPROOF JACKETS; REVERSIBLE JACKETS; SHELL JACKETS; SKI JACKETS; SLEEVED OR SLEEVELESS JACKETS; SMOKING JACKETS; SPORTS JACKETS; STUFF JACKETS; SWEAT JACKETS; TRACK JACKETS; WATERPROOF JACKETS AND PANTS; WIND RESISTANT JACKETS; WIND-JACKETS; HAT BANDS; HATS; HEADGEAR, NAMELY, BASEBALL HATS; PAPER HATS FOR USE AS CLOTHING ITEMS; SPORT COATS; FOOTWEAR NOT FOR SPORTS; HEAD WEAR; INFANT WEAR; SPORTS JERSEYS; SPORTS JERSEYS AND BREECHES FOR SPORTS; SPORTS OVERUNIFORMS; SURF WEAR; SWIM WEAR; SWIM WEAR FOR GENTLEMEN AND LADIES; TENNIS WEAR; SKI AND SNOWBOARD SHOES AND PARTS THEREOF; SNOWBOARD BOOTS; SNOWBOARD GLOVES; SNOWBOARD MITTENS; SNOWBOARD PANTS; CREWNECK SWEATERS; SWEATERS; TURTLENECK SWEATERS; V-NECK SWEATERS; HOODED PULLOVERS; HOODS; BRIEFS; DISPOSABLE UNDERWEAR; LADIES' UNDERWEAR; LONG UNDERWEAR; THERMAL UNDERWEAR; THONGS; UNDERWEAR; UNDERWEAR, NAMELY, BOY SHORTS; WOMEN'S UNDERWEAR; WOVEN OR KNITTED UNDERWEAR (U.S. CLS. 22 AND 39).
WENDY GOODMAN, EXAMINING ATTORNEY

SN 77-427,427. HUDSON, KATHLEEN MARY, NEWBURYPORT, MA. FILED 3-20-2008.

WEAR AND CARE

THE MARK CONSISTS OF STANDARD CHARACTERS WITHOUT CLAIM TO ANY PARTICULAR FONT, STYLE, SIZE, OR COLOR.

FOR GOLF SHIRTS; HOODED SWEAT SHIRTS; LONG-SLEEVED SHIRTS; POLO SHIRTS; SHIRTS; SHORT-SLEEVED OR LONG-SLEEVED T-SHIRTS; SHORT-SLEEVED SHIRTS; SWEAT SHIRTS; T-SHIRTS; TEE SHIRTS; JACKETS; JOGGING PANTS; PANTS; SWEAT PANTS; BASEBALL CAPS; CAP VISORS; CAPS; CAPS WITH VISORS (U.S. CLS. 22 AND 39).

LINDSEY RUBIN, EXAMINING ATTORNEY

CLASS 25—(Continued).

SN 77-427,562. GLAMOUR CAMPAIGN, INC., LOS ANGELES, CA. FILED 3-20-2008.



THE MARK CONSISTS OF A STYLIZED SKULL. FOR HOODED SWEAT SHIRTS; BLAZERS; PANTS; COATS; HATS; DRESSES; LINGERIE; SHORTS (U.S. CLS. 22 AND 39).
FIRST USE 6-1-2006; IN COMMERCE 6-1-2006.
ARETHA SOMERVILLE, EXAMINING ATTORNEY

CLASS 25—(Continued).

SN 77-427,845. KNUDSON, THOMAS, MERRITT ISLAND, FL. FILED 3-20-2008.

Mountain Dude

THE MARK CONSISTS OF STANDARD CHARACTERS WITHOUT CLAIM TO ANY PARTICULAR FONT, STYLE, SIZE, OR COLOR.
FOR BELTS; COATS; FOOTWEAR; FOUL WEATHER GEAR; GLOVES; HEADWEAR; JACKETS; MITTENS; PANTS; SHIRTS; SOCKS; UNDERWEAR; VESTS (U.S. CLS. 22 AND 39).
ELI HELLMAN, EXAMINING ATTORNEY

SN 77-427,655. LYNCH-ROUNTREE, JENNIFER, AUSTIN, TX. FILED 3-20-2008.



THE MARK CONSISTS OF THE STYLIZED SPACED WORDS "YOU ARE GOOD". EACH WORD IS DIVIDED BY A THIN LINE. ABOVE THE WORDS IS AN IMAGE OF ANGEL WINGS.
FOR BOTTOMS; T-SHIRTS; TANK TOPS; TOPS (U.S. CLS. 22 AND 39).
FIRST USE 12-10-2007; IN COMMERCE 12-10-2007.
JIM RINGLE, EXAMINING ATTORNEY

SN 77-427,963. SCHWARTZBURG, CHELSEA, SAN DIEGO, CA. FILED 3-21-2008.

Upicka

THE MARK CONSISTS OF STANDARD CHARACTERS WITHOUT CLAIM TO ANY PARTICULAR FONT, STYLE, SIZE, OR COLOR.
FOR BABY BODYSUITS; BABY BOTTOMS; BABY TOPS; INFANT AND TODDLER ONE PIECE CLOTHING; CLOTH DIAPERS; ONE PIECE GARMENT FOR INFANTS AND TODDLERS; INFANT WEAR; INFANTS' TROUSERS (U.S. CLS. 22 AND 39).
FIRST USE 3-1-2008; IN COMMERCE 3-1-2008.
SUSAN STIGLITZ, EXAMINING ATTORNEY

CLASS 25—(Continued).

SN 77-428,049. NBA PROPERTIES, INC., NEW YORK, NY. FILED 3-21-2008.

THERE CAN ONLY BE ONE

THE MARK CONSISTS OF STANDARD CHARACTERS WITHOUT CLAIM TO ANY PARTICULAR FONT, STYLE, SIZE, OR COLOR.

FOR CLOTHING, NAMELY, HOSIERY, FOOTWEAR, BASKETBALL SHOES, BASKETBALL SNEAKERS, T-SHIRTS, SHIRTS, POLO SHIRTS, SWEATSHIRTS, SWEATPANTS, PANTS, TANK TOPS, JERSEYS, SHORTS, PAJAMAS, SPORT SHIRTS, RUGBY SHIRTS, SWEATERS, BELTS, TIES, NIGHTSHIRTS, HATS, CAPS, VISORS, WARM-UP SUITS, WARM-UP PANTS, WARM-UP TOPS/SHOOTING SHIRTS, JACKETS, WIND RESISTANT JACKETS, PARKAS, COATS, BABY BIBS NOT OF PAPER, HEAD BANDS, WRIST BANDS, APRONS, UNDERGARMENTS, BOXER SHORTS, SLACKS, EAR MUFFS, GLOVES, MITTENS, SCARVES, WOVEN AND KNIT SHIRTS, JERSEY DRESSES, DRESSES, CHEERLEADING DRESSES AND UNIFORMS, SWIM WEAR, BATHING SUITS, SWIMSUITS, BIKINIS, TANKINIS, SWIM TRUNKS, BATHING TRUNKS, BOARD SHORTS, WET SUITS, BEACH COVER-UPS, BATHING SUIT COVER-UPS, BATHING SUIT WRAPS, SANDALS, BEACH SANDALS, BEACH HATS, SUN VISORS, SWIM CAPS, BATHING CAPS, NOVELTY HEADWEAR WITH ATTACHED WIGS (U.S. CLS. 22 AND 39).

ANNE E. GUSTASON, EXAMINING ATTORNEY

SN 77-428,138. SHARON YOUNG INC, DALLAS, TX. FILED 3-21-2008.

FOR CLOTHING, NAMELY, SKIRTS, JACKETS, BLOUSES, SWEATERS, PANTS, VESTS, SKORTS, DRESSES, SHIRTS (U.S. CLS. 22 AND 39).

FIRST USE 1-1-2008; IN COMMERCE 1-1-2008.

DEZMONA MIZELLE, EXAMINING ATTORNEY

CLASS 25—(Continued).

SN 77-428,191. STEPHEN M. ALLEN, TELLURIDE, CO. FILED 3-21-2008.

Seize The World

THE MARK CONSISTS OF STANDARD CHARACTERS WITHOUT CLAIM TO ANY PARTICULAR FONT, STYLE, SIZE, OR COLOR.

FOR A-SHIRTS; BUTTON-FRONT ALOHA SHIRTS; CAMP SHIRTS; DRESS SHIRTS; GOLF SHIRTS; HOODED SWEAT SHIRTS; KNIT SHIRTS; LONG-SLEEVED SHIRTS; NIGHT SHIRTS; OPEN-NECKED SHIRTS; PIQUE SHIRTS; POLO SHIRTS; RUGBY SHIRTS; SHIRT FRONTS; SHIRT YOKES; SHIRTS; SHIRTS FOR SUITS; SHORT-SLEEVED OR LONG-SLEEVED T-SHIRTS (U.S. CLS. 22 AND 39).

HOWARD SMIGA, EXAMINING ATTORNEY

SN 77-428,270. MMK BRANDS, LLC, HOUSTON, TX. FILED 3-21-2008.

DOUBLE FEATURE

THE MARK CONSISTS OF STANDARD CHARACTERS WITHOUT CLAIM TO ANY PARTICULAR FONT, STYLE, SIZE, OR COLOR.

FOR LINGERIE; LOUNGEWEAR; CAMISOLES; SLIPS; TANK TOPS (U.S. CLS. 22 AND 39).

TINA L. SNAPP, EXAMINING ATTORNEY

SN 77-428,275. SOLANGE INC., RANCHO SANTA MARGARITA, CA. FILED 3-21-2008.

THE MARK CONSISTS OF STANDARD CHARACTERS WITHOUT CLAIM TO ANY PARTICULAR FONT, STYLE, SIZE, OR COLOR.

FOR WOMEN'S CLOTHING, NAMELY, DRESSES, SUITS, PANTS, SKIRTS AND TOPS (U.S. CLS. 22 AND 39).

FIRST USE 1-6-2003; IN COMMERCE 1-6-2003.

CHRISTOPHER BUONGIORNO, EXAMINING ATTORNEY

CLASS 25—(Continued).

SN 77-428,498. SATENSTEIN JOSHUA, MONTREAL, CANADA, FILED 3-21-2008.

EcoUniform

THE MARK CONSISTS OF STANDARD CHARACTERS WITHOUT CLAIM TO ANY PARTICULAR FONT, STYLE, SIZE, OR COLOR.

FOR ATHLETIC UNIFORMS; MARTIAL ARTS UNIFORMS; SCHOOL UNIFORMS; UNIFORMS; TRACK PANTS; WATERPROOF JACKETS AND PANTS; WIND PANTS; YOGA PANTS; CAPRI PANTS; CARGO PANTS; DENIMS; JOGGING PANTS; LOUNGE PANTS; NURSE PANTS; PANTS; SKI PANTS; SNOW PANTS; SNOWBOARD PANTS; STRETCH PANTS; SWEAT PANTS; CAMP SHIRTS; DRESS SHIRTS; GOLF SHIRTS; HOODED SWEAT SHIRTS; KNIT SHIRTS; LONG-SLEEVED SHIRTS; NIGHT SHIRTS; OPEN-NECKED SHIRTS; POLO SHIRTS; RUGBY SHIRTS; SHIRTS; SHIRTS FOR SUITS; SHORT-SLEEVED OR LONG-SLEEVED T-SHIRTS; SHORT-SLEEVED SHIRTS; SLEEP SHIRTS; SPORTS SHIRTS; SPORTS SHIRTS WITH SHORT SLEEVES; SWEAT SHIRTS; T-SHIRTS; TEE SHIRTS; TRIATHLON CLOTHING, NAMELY, TRIATHLON TIGHTS, TRIATHLON SHORTS, TRIATHLON SINGLET, TRIATHLON SHIRTS, TRIATHLON SUITS; WIND SHIRTS; YOGA SHIRTS; JEANS; DRESS SUITS; DRESSES; DRESSING GOWNS; EVENING DRESSES; NURSE DRESSES; SKIRTS AND DRESSES; WOMEN'S CEREMONIAL DRESSES; BASEBALL CAPS; CAPS; SWIM CAPS; BOW TIES; TIES; BELTS; BELTS OF TEXTILE; FABRIC BELTS; SKIRT SUITS; SKIRTS; SKORTS; FLEECE VESTS; HUNTING VESTS; LONG SLEEVED VESTS; MEN AND WOMEN JACKETS, COATS, TROUSERS, VESTS; VESTS; WIND VESTS; CARDIGANS; COATS; COATS FOR MEN AND WOMEN; COATS MADE OF COTTON; COATS OF DENIM; LAB COATS; RAIN COATS; SPORT COATS; SUIT COATS; TRENCH COATS; WIND COATS; DENIM JACKETS; DOWN JACKETS; JACKETS; RAIN JACKETS; REVERSIBLE JACKETS; SKI JACKETS; SPORTS JACKETS; SWEAT JACKETS; TRACK JACKETS; WIND RESISTANT JACKETS; WIND-JACKETS; BATHING SUITS; GYM SUITS; JOGGING SUITS; JUDO SUITS; KARATE SUITS; LADIES' SUITS; MEN'S SUITS; MEN'S SUITS, WOMEN'S SUITS; SKI SUITS; SNOW BOARDING SUITS; SUITS; SWEAT SUITS; TRACK SUITS; TRAINING SUITS; UNION SUITS; VESTED SUITS; ANKLE SOCKS; ANKLETS; MEN'S SOCKS; SOCKS; SOCKS AND STOCKINGS; THERMAL SOCKS; CHEF'S HATS; HATS; CREW-NECK SWEATERS; MOCK TURTLE-NECK SWEATERS; SWEATERS; TURTLENECK SWEATERS; V-NECK SWEATERS; FLEECE PULLOVERS; FLEECE SHORTS; LEOTARDS AND TIGHTS FOR WOMEN, MEN AND CHILDREN OF NYLON, COTTON OR OTHER TEXTILE FIBERS; FINISHED TEXTILE LININGS FOR GARMENTS; TEXTILE DIAPERS; ATHLETIC FOOTWEAR; FOOTWEAR; FOOTWEAR, NAMELY, WORK BOOTS; GLOVES; GYM SHORTS; JOGGING OUTFITS; INFANT AND TODDLER ONE PIECE CLOTHING; INFANT WEAR; ONE PIECE GARMENT FOR INFANTS AND TODDLERS; BABY BOTTOMS; BABY TOPS; WORK SHOES AND BOOTS; WORKING OVERALLS; NURSE OVERALLS; SCRUBS NOT FOR MEDICAL PURPOSES; CHOIR ROBES; ROBES (U.S. CLS. 22 AND 39).

KIMBERLY FRYE, EXAMINING ATTORNEY

CLASS 25—(Continued).

SN 77-428,576. ONE AKER HARVEST, INC., HUMBLE, TX, FILED 3-21-2008.

yormi

THE MARK CONSISTS OF STANDARD CHARACTERS WITHOUT CLAIM TO ANY PARTICULAR FONT, STYLE, SIZE, OR COLOR.

FOR CAMP SHIRTS; SHIRTS; SLEEP SHIRTS; SWEAT SHIRTS; T-SHIRTS; TEE SHIRTS; CARDIGANS; CREW-NECK SWEATERS; CREWNECKS; HOODED SWEAT SHIRTS; KNIT SHIRTS; LONG-SLEEVED SHIRTS; NIGHT SHIRTS; POLO SHIRTS; SHORT-SLEEVED OR LONG-SLEEVED T-SHIRTS; SHORT-SLEEVED SHIRTS; PANTS; SWEAT JACKETS; SWEAT PANTS; SWEAT SHORTS; TRACK PANTS; SKIRTS; SKIRTS AND DRESSES; SOCKS; PANTIES (U.S. CLS. 22 AND 39).

MICHAEL ENGEL, EXAMINING ATTORNEY

SN 77-428,624. VOLUMECCOMO APPAREL, INC., LOS ANGELES, CA. FILED 3-21-2008.

Upload

THE MARK CONSISTS OF STANDARD CHARACTERS WITHOUT CLAIM TO ANY PARTICULAR FONT, STYLE, SIZE, OR COLOR.

FOR CLOTHING AND APPAREL, NAMELY, TOPS, KNIT SHIRTS, SHIRTS, PANTS, BLOUSES, SWEATERS, SPORTS SHIRTS, T-SHIRTS, DRESSES, COATS, BLAZERS, JACKETS, SHORTS, SKIRTS, JEANS, SLACKS, SPORTS JACKETS, SWEAT PANTS, SWEAT SHIRTS, TANK TOPS, JERSEY TOPS, CAMISOLES, WOVEN TOPS, DENIM SHIRTS, DENIM JACKETS AND SLEEPWEAR (U.S. CLS. 22 AND 39).

APRIL HESIK, EXAMINING ATTORNEY

SN 77-428,703. SMART-TEK, LLC, ORANGE, CA. FILED 3-21-2008.

Boogawolfcookie

THE MARK CONSISTS OF STANDARD CHARACTERS WITHOUT CLAIM TO ANY PARTICULAR FONT, STYLE, SIZE, OR COLOR.

FOR CLOTHING, NAMELY, T-SHIRTS, HATS, AND SWEATSHIRTS (U.S. CLS. 22 AND 39).

CHARLES L. JENKINS, EXAMINING ATTORNEY

CLASS 25—(Continued).

SN 77-428,805. WALTON, JAMES, SYLMAR, CA. FILED 3-21-2008.



THE STIPPLING IS FOR SHADING PURPOSES ONLY.
THE MARK CONSISTS OF BLOCKED LETTERS THAT SAY "HOLLYWOOD" WITH SMALL STARS ON TOP OF LETTERING. THE MARK IS SUPPORTED BY A LINE AROUND IT. THERE IS A BASKETBALL IN THE CENTER OF THE MARK WITH A SHADOW OF A PERSON IN THE CENTER OF THE BALL. ON THE UPPER EDGES OF THE WORDING, THERE ARE FOUR OTHER SHADOW FIGURES STANDING. THERE IS A DIM LIGHT SHINING FROM THE "H" AND THE "D" IN "HOLLYWOOD". UNDERNEATH THE WORD "HOLLYWOOD" IS THE WORD "HOOPZ" IN BLOCKED LETTERING WITH A STRAIGHT LINE IN FRONT AND IN BACK OF IT.

FOR GLOVES; HATS; JACKETS; PANTS; SHIRTS; SHOES; SOCKS; UNDERWEAR (U.S. CLS. 22 AND 39).
PAM WILLIS, EXAMINING ATTORNEY

SN 77-429,057. LORDEN, CHARLES W, PEPPERELL, MA. FILED 3-23-2008.

Poor Bastard

THE MARK CONSISTS OF STANDARD CHARACTERS WITHOUT CLAIM TO ANY PARTICULAR FONT, STYLE, SIZE, OR COLOR.

FOR SHORT-SLEEVED OR LONG-SLEEVED T-SHIRTS; T-SHIRTS; HATS (U.S. CLS. 22 AND 39).
SETH A. RAPPAPORT, EXAMINING ATTORNEY

SN 77-429,079. CDC MARKETING, INC., NEW YORK, NY. FILED 3-23-2008.

IRON FREAK

THE MARK CONSISTS OF STANDARD CHARACTERS WITHOUT CLAIM TO ANY PARTICULAR FONT, STYLE, SIZE, OR COLOR.

FOR SHIRTS; HOODED SWEAT SHIRTS; SWEAT SHIRTS; TANK-TOPS; SHORT-SLEEVED OR LONG-SLEEVED T-SHIRTS; T-SHIRTS; HATS; SHORTS; SWEAT PANTS; JACKETS; DRESS SHIRTS; POLO SHIRTS (U.S. CLS. 22 AND 39).
HEATHER THOMPSON, EXAMINING ATTORNEY

CLASS 25—(Continued).

SN 77-429,153. POINT OF INTEREST, LLC, HONOLULU, HI. FILED 3-23-2008.

Point of Interest

THE MARK CONSISTS OF STANDARD CHARACTERS WITHOUT CLAIM TO ANY PARTICULAR FONT, STYLE, SIZE, OR COLOR.

FOR BUTTON-FRONT ALOHA SHIRTS; DRESS SHIRTS; GOLF SHIRTS; HOODED SWEAT SHIRTS; KNIT SHIRTS; LONG-SLEEVED SHIRTS; NIGHT SHIRTS; OPEN-NECKED SHIRTS; PIQUE SHIRTS; POLO SHIRTS; SHIRTS; SHIRTS FOR SUITS; SHORT-SLEEVED OR LONG-SLEEVED T-SHIRTS; SHORT-SLEEVED SHIRTS; SLEEP SHIRTS; SPORT SHIRTS; SPORTS SHIRTS; SPORTS SHIRTS WITH SHORT SLEEVES; SWEAT SHIRTS; T-SHIRTS; TEE SHIRTS; WIND SHIRTS; YOGA SHIRTS (U.S. CLS. 22 AND 39).

GEORGIA CARTY, EXAMINING ATTORNEY

SN 77-429,170. HIEB, DAVID, NEW YORK, NY. FILED 3-24-2008.

KiwiTangerine

THE MARK CONSISTS OF STANDARD CHARACTERS WITHOUT CLAIM TO ANY PARTICULAR FONT, STYLE, SIZE, OR COLOR.

FOR DRESSES; JACKETS; SHIRTS; SKIRTS (U.S. CLS. 22 AND 39).
TARA PATE, EXAMINING ATTORNEY

SN 77-429,290. POLSTON, JEREMY DAVID, LANTANA, FL. FILED 3-24-2008.

Fat Baby Fabulous

THE MARK CONSISTS OF STANDARD CHARACTERS WITHOUT CLAIM TO ANY PARTICULAR FONT, STYLE, SIZE, OR COLOR.

FOR SHORT-SLEEVED OR LONG-SLEEVED T-SHIRTS; BASEBALL CAPS (U.S. CLS. 22 AND 39).
ELISSA GARBER KON, EXAMINING ATTORNEY

CLASS 25—(Continued).

SN 77-429,369. HOUSTON JR., STANLEY C., ELBA, AL.
FILED 3-24-2008.

I DON'T RECALL

THE MARK CONSISTS OF STANDARD CHARACTERS
WITHOUT CLAIM TO ANY PARTICULAR FONT, STYLE,
SIZE, OR COLOR.

FOR HATS; SHIRTS; SHORTS (U.S. CLS. 22 AND 39).
JERI J. FICKES, EXAMINING ATTORNEY

SN 77-429,404. VILLAFLO, DEL, UNION CITY, CA. FILED
3-24-2008.

PIMPNERD

THE MARK CONSISTS OF STANDARD CHARACTERS
WITHOUT CLAIM TO ANY PARTICULAR FONT, STYLE,
SIZE, OR COLOR.

FOR CAPS; HATS; HEADWEAR; JACKETS; PANTS;
SHIRTS; SHORTS; T-SHIRTS; TANK TOPS; WIND RE-
SISTANT JACKETS; SWEAT SUITS; SWEAT SHIRTS
(U.S. CLS. 22 AND 39).

FIRST USE 9-1-2003; IN COMMERCE 7-20-2004.
EUGENIA MARTIN, EXAMINING ATTORNEY

SN 77-429,541. ADAMS, MICHAEL, SURFSIDE, SC. FILED 3-
24-2008.

Down To Ride

THE MARK CONSISTS OF STANDARD CHARACTERS
WITHOUT CLAIM TO ANY PARTICULAR FONT, STYLE,
SIZE, OR COLOR.

FOR HOODED SWEAT SHIRTS; SHORT-SLEEVED OR
LONG-SLEEVED T-SHIRTS; SWEATERS (U.S. CLS. 22
AND 39).

KHANH LE, EXAMINING ATTORNEY

CLASS 25—(Continued).

SN 77-429,597. BRENNAN, MATTHEW LEO, WEST ROX-
BURY, MA. FILED 3-24-2008.

RALLY-SOCK

THE MARK CONSISTS OF STANDARD CHARACTERS
WITHOUT CLAIM TO ANY PARTICULAR FONT, STYLE,
SIZE, OR COLOR.

FOR MEN'S SOCKS (U.S. CLS. 22 AND 39).
CAROL SPILS, EXAMINING ATTORNEY

SN 77-429,600. LI JIANGUO, LU CHENG DISTRICT, CHINA,
FILED 3-24-2008.



THE MARK CONSISTS OF THE STYLIZED LETTER "E".
FOR CLOTHING, NAMELY, SHIRTS, SKIRTS, TROU-
SERS, JACKETS, COATS, T-SHIRTS; SWIMSUITS; MAS-
QUERADE COSTUMES; SHOES; CAPS AS CLOTHING;
HOSIERY; SHAWLS; GIRDLES AS FOUNDATION GAR-
MENTS; LAYETTES (U.S. CLS. 22 AND 39).

FIRST USE 5-0-2006; IN COMMERCE 2-0-2007.
MICHAEL SOUDERS, EXAMINING ATTORNEY

SN 77-429,650. MCCLOSKEY, DAVID P, PITTSBURGH, PA.
FILED 3-24-2008.

One Shall Rise

THE MARK CONSISTS OF STANDARD CHARACTERS
WITHOUT CLAIM TO ANY PARTICULAR FONT, STYLE,
SIZE, OR COLOR.

FOR CLOTHING, NAMELY, SHIRTS, T-SHIRTS,
SWEATSHIRTS, HATS, CAPS, PANTS, SWEATPANTS,
SHOES, JACKETS, COATS, SHORTS AND TRUNKS (U.S.
CLS. 22 AND 39).

KAREN SEVERSON, EXAMINING ATTORNEY

CLASS 25—(Continued).

SN 77-429,696. CHURCHILL DOWNS INCORPORATED,
LOUISVILLE, KY. FILED 3-24-2008.

CPO

THE MARK CONSISTS OF STANDARD CHARACTERS
WITHOUT CLAIM TO ANY PARTICULAR FONT, STYLE,
SIZE, OR COLOR.

FOR CLOTHING, NAMELY, HATS AND SHIRTS (U.S.
CLS. 22 AND 39).

KIM MONINGHOFF, EXAMINING ATTORNEY

SN 77-429,704. CHURCHILL DOWNS INCORPORATED,
LOUISVILLE, KY. FILED 3-24-2008.

CHIEF PARTY OFFICER

THE MARK CONSISTS OF STANDARD CHARACTERS
WITHOUT CLAIM TO ANY PARTICULAR FONT, STYLE,
SIZE, OR COLOR.

FOR CLOTHING, NAMELY, HATS AND SHIRTS (U.S.
CLS. 22 AND 39).

KIM MONINGHOFF, EXAMINING ATTORNEY

SN 77-429,770. MOUNTAIN HARDWEAR, INC., PORT-
LAND, OR. FILED 3-24-2008.

ZWELD

THE MARK CONSISTS OF STANDARD CHARACTERS
WITHOUT CLAIM TO ANY PARTICULAR FONT, STYLE,
SIZE, OR COLOR.

FOR JACKETS; PANTS; SHIRTS (U.S. CLS. 22 AND 39).
FIRST USE 7-0-2005; IN COMMERCE 7-0-2005.

BRENDAN REGAN, EXAMINING ATTORNEY

CLASS 25—(Continued).

SN 77-429,774. SOUTHWEST SEPTIC LOO, INC., ELGIN, TX,
AND WITTA, GEORGE H., ELGIN, TX. AND WITTA,
JERI M., ELGIN, TX. AND DOLEZAL, WAYNE, SPICE-
WOOD SPRINGS, TX. AND MCCRELESS, DAYLON L.,
AUSTIN, TX. AND MCCRELESS, BEVERLY, AUSTIN, TX.
FILED 3-24-2008.

Save the Water, Save the World!

THE MARK CONSISTS OF STANDARD CHARACTERS
WITHOUT CLAIM TO ANY PARTICULAR FONT, STYLE,
SIZE, OR COLOR.

FOR SHORT-SLEEVED SHIRTS; SLEEP SHIRTS;
SPORT SHIRTS; SPORTS SHIRTS; SWEAT SHIRTS; T-
SHIRTS; TEE SHIRTS; TRIATHLON CLOTHING,
NAMELY, TRIATHLON TIGHTS, TRIATHLON SHORTS,
TRIATHLON SINGLET, TRIATHLON SHIRTS,
TRIATHLON SUITS; WIND SHIRTS; YOGA SHIRTS; A-
SHIRTS; BUTTON-FRONT ALOHA SHIRTS; DRESS
SHIRTS; GOLF SHIRTS; HOODED SWEAT SHIRTS;
KNIT SHIRTS; LONG-SLEEVED SHIRTS; NIGHT
SHIRTS; OPEN-NECKED SHIRTS; PIQUE SHIRTS; POLO
SHIRTS; RUGBY SHIRTS; SHIRT FRONTS; SHIRT
YOKES; SHIRTS; SHIRTS FOR SUITS; SHORT-SLEEVED
OR LONG-SLEEVED T-SHIRTS; CHEF'S HATS; FUR
HATS; HAT BANDS; HATS; HEADGEAR, NAMELY,
BASEBALL CAPS; PAPER HATS FOR USE AS CLOTH-
ING ITEMS; SEDGE HATS (SUGE-GASA); SMALL HATS;
TOBOGGAN HATS, PANTS AND CAPS (U.S. CLS. 22
AND 39).

ELLEN PERKINS, EXAMINING ATTORNEY

SN 77-430,225. COLE, TIMOTHY, HENDERSON, NV. FILED
3-24-2008.

RACIN' DIRTY

THE MARK CONSISTS OF STANDARD CHARACTERS
WITHOUT CLAIM TO ANY PARTICULAR FONT, STYLE,
SIZE, OR COLOR.

FOR T-SHIRTS; BATHING SUITS FOR MEN; CAMP
SHIRTS; A-SHIRTS; GOLF SHIRTS; HOODED SWEAT
SHIRTS; KNIT SHIRTS; LONG-SLEEVED SHIRTS;
NIGHT SHIRTS; OPEN-NECKED SHIRTS; PIQUE
SHIRTS; POLO SHIRTS; RUGBY SHIRTS; SHIRTS;
SHORT-SLEEVED OR LONG-SLEEVED T-SHIRTS;
SHORT-SLEEVED SHIRTS; SPORT SHIRTS; SPORTS
SHIRTS WITH SHORT SLEEVES; SWEAT SHIRTS; WIND
SHIRTS; SWIMWEAR; BERMUDA SHORTS; BOARD
SHORTS; BOXER SHORTS; FLEECE SHORTS; GYM
SHORTS; PANTIES, SHORTS AND BRIEFS; SHORTS;
HEADGEAR, NAMELY, CAPS, HATS, BEANIES (U.S.
CLS. 22 AND 39).

FIRST USE 1-1-2008; IN COMMERCE 1-2-2008.

MICHELE SWAIN, EXAMINING ATTORNEY

CLASS 25—(Continued).

SN 77-430,280. HAMMID FIROOZEH, MELVILLE, NY. AND CHRIS GUBNITSKY, NORTH BABYLON, NY. AND CHARLES KOUVEL, DEER PARK, NY. FILED 3-24-2008.

EFFECTIVE AGGRESSION

THE MARK CONSISTS OF STANDARD CHARACTERS WITHOUT CLAIM TO ANY PARTICULAR FONT, STYLE, SIZE, OR COLOR.

FOR ATHLETIC AND SPORTING APPAREL, NAMELY, SHIRTS, SHORTS, PANTS, RASH GUARDS AND HATS (U.S. CLS. 22 AND 39).

ANN E. SAPPENFIELD, EXAMINING ATTORNEY

CLASS 25—(Continued).

SN 77-430,355. GUEVARA, ROEL B., LOS ANGELES, CA. FILED 3-25-2008.



NO CLAIM IS MADE TO THE EXCLUSIVE RIGHT TO USE "FIGHT GEAR", APART FROM THE MARK AS SHOWN.

THE MARK CONSISTS OF DESIGN PLUS WORDS, LETTERS, AND/OR NUMBERS.

FOR T-SHIRTS; HOODED SWEAT SHIRTS; LONG-SLEEVED SHIRTS; SHORT-SLEEVED OR LONG-SLEEVED T-SHIRTS; SHORTS; SPORTS JERSEYS; BRIEFS; LADIES' UNDERWEAR; HATS; BEANIES; JACKETS; WIND-JACKETS; SWEAT SHIRTS; BOARD SHORTS; BOXER SHORTS; BERMUDA SHORTS (U.S. CLS. 22 AND 39).

ANTHONY RINKER, EXAMINING ATTORNEY

SN 77-430,586. R.PHILIP GRIZZARD, TUCSON, AZ. FILED 3-25-2008.

CACTASTIC

THE MARK CONSISTS OF STANDARD CHARACTERS WITHOUT CLAIM TO ANY PARTICULAR FONT, STYLE, SIZE, OR COLOR.

FOR BELTS; HATS; PANTS; SHIRTS (U.S. CLS. 22 AND 39).

ANNE FARRELL, EXAMINING ATTORNEY

SN 77-430,593. CHUN, DAVID H., SANTA FE SPRINGS, CA. FILED 3-25-2008.

EVERTAN

THE MARK CONSISTS OF STANDARD CHARACTERS WITHOUT CLAIM TO ANY PARTICULAR FONT, STYLE, SIZE, OR COLOR.

FOR GOLF APPAREL, NAMELY, VISORS, SOCKS AND GLOVES (U.S. CLS. 22 AND 39).

FIRST USE 1-24-1996; IN COMMERCE 1-24-1996.

ANNE FARRELL, EXAMINING ATTORNEY

SN 77-430,285. WALKER, AMY J, DBA FUZZY BUNNY, BOULDER, CO. FILED 3-24-2008.

Fuzzy Bunny

THE MARK CONSISTS OF STANDARD CHARACTERS WITHOUT CLAIM TO ANY PARTICULAR FONT, STYLE, SIZE, OR COLOR.

FOR BLOUSES; CARDIGANS; CLOTHING, NAMELY, ARM WARMERS; CLOTHING, NAMELY, HAND-WARMERS; CLOTHING, NAMELY, KNEE WARMERS; CLOTHING, NAMELY, NECK TUBES; CLOTHING, NAMELY, WRAP-AROUNDS; COATS; CREWNECK SWEATERS; DRESSES; EAR MUFFS; EARBANDS; FABRIC BELTS; FLEECE PULLOVERS; FOOTWEAR; G-STRINGS; HATS; INFANT WEAR; KNIT SHIRTS; LADIES' UNDERWEAR; LEATHER BELTS; LONG-SLEEVED SHIRTS; LOUNGEWEAR; NIGHT GOWNS; SCARVES; SHIRTS; SHORT-SLEEVED OR LONG-SLEEVED T-SHIRTS; SHORT-SLEEVED SHIRTS; SINGLET; SKIRTS AND DRESSES; SLEEPWEAR; SLIPPERS; SWEAT SUITS; SWEATERS; SWIM WEAR; T-SHIRTS; TANK TOPS; TUBE TOPS (U.S. CLS. 22 AND 39).

SETH A. RAPPAPORT, EXAMINING ATTORNEY

CLASS 25—(Continued).

SN 77-430,614. GENERAL MOTORS CORPORATION, DETROIT, MI. FILED 3-25-2008.

ESCALADE

THE MARK CONSISTS OF STANDARD CHARACTERS WITHOUT CLAIM TO ANY PARTICULAR FONT, STYLE, SIZE, OR COLOR.

OWNER OF U.S. REG. NOS. 2,269,827, 2,931,763 AND 3,435,186.

FOR CLOTHING, NAMELY, T-SHIRTS (U.S. CLS. 22 AND 39).

FIRST USE 1-14-2002; IN COMMERCE 1-14-2002.
NANCY CLARKE, EXAMINING ATTORNEY

CLASS 25—(Continued).

SN 77-430,678. SARAMAX APPAREL GROUP INC., NEW YORK, NY. FILED 3-25-2008.

Nut House

THE MARK CONSISTS OF STANDARD CHARACTERS WITHOUT CLAIM TO ANY PARTICULAR FONT, STYLE, SIZE, OR COLOR.

FOR BRIEFS; UNDERWEAR; TRUNKS; BOXER BRIEFS; TANK TOPS; LOUNGEWEAR; SLEEPING GARMENTS; LOUNGE PANTS; PAJAMA BOTTOMS; PAJAMAS (U.S. CLS. 22 AND 39).

MARIA-VICTORIA SUAREZ, EXAMINING ATTORNEY

SN 77-430,717. SARAMAX APPAREL GROUP INC., NEW YORK, NY. FILED 3-25-2008.

SN 77-430,625. LANIADO, MOSHE, OAKHURST, NJ. FILED 3-25-2008.

Chiquou

THE MARK CONSISTS OF STANDARD CHARACTERS WITHOUT CLAIM TO ANY PARTICULAR FONT, STYLE, SIZE, OR COLOR.

FOR CLOTHING, NAMELY, BATHING SUITS, SWIM SUITS, SHIRTS, T-SHIRTS, SWEATSHIRTS, JACKETS, SHORTS, CAPS, HATS (U.S. CLS. 22 AND 39).

ANNE FARRELL, EXAMINING ATTORNEY

THE MARK CONSISTS OF STANDARD CHARACTERS WITHOUT CLAIM TO ANY PARTICULAR FONT, STYLE, SIZE, OR COLOR.

FOR BRIEFS; UNDERWEAR; TRUNKS; BOXER BRIEFS; TANK TOPS; LOUNGEWEAR; SLEEPING GARMENTS; LOUNGE PANTS; PAJAMA BOTTOMS; PAJAMAS; UNDERWEAR, NAMELY, BOY SHORTS; CHILDREN'S AND INFANTS' CLOTH BIBS; INFANT AND TODDLER ONE PIECE CLOTHING; INFANT WEAR; GLOVES; PANTS; SCARVES; HATS; SHORT-SLEEVED OR LONG-SLEEVED T-SHIRTS; T-SHIRTS; JACKETS (U.S. CLS. 22 AND 39).

MARIA-VICTORIA SUAREZ, EXAMINING ATTORNEY

SN 77-430,656. GUIDO, JULIE, HOPEDALE, MA. AND HOWARD, CHRISTINE, HOPEDALE, MA. FILED 3-25-2008.



THE MARK CONSISTS OF THE STYLIZED TEXT "ONLY IN TOWN!".

FOR SWEAT SHIRTS; T-SHIRTS (U.S. CLS. 22 AND 39).

COLLEEN KEARNEY, EXAMINING ATTORNEY

SN 77-430,751. GENERAL MOTORS CORPORATION, DETROIT, MI. FILED 3-25-2008.

ESCALADE

THE MARK CONSISTS OF STANDARD CHARACTERS WITHOUT CLAIM TO ANY PARTICULAR FONT, STYLE, SIZE, OR COLOR.

OWNER OF U.S. REG. NOS. 2,269,827, 2,931,763 AND 3,435,186.

FOR CLOTHING, NAMELY, JACKETS (U.S. CLS. 22 AND 39).

FIRST USE 11-10-2006; IN COMMERCE 11-10-2006.

NANCY CLARKE, EXAMINING ATTORNEY

CLASS 25—(Continued).

SN 77-430,770. UTILIKILTS COMPANY, LLC, SEATTLE, WA. FILED 3-25-2008.

better caught with the kilt
up than the pants down

THE MARK CONSISTS OF STANDARD CHARACTERS WITHOUT CLAIM TO ANY PARTICULAR FONT, STYLE, SIZE, OR COLOR.
FOR KILTS; SKIRTS (U.S. CLS. 22 AND 39).
GINA FINK, EXAMINING ATTORNEY

SN 77-430,772. GENERAL MOTORS CORPORATION, DETROIT, MI. FILED 3-25-2008.

ESCALADE

THE MARK CONSISTS OF STANDARD CHARACTERS WITHOUT CLAIM TO ANY PARTICULAR FONT, STYLE, SIZE, OR COLOR.
OWNER OF U.S. REG. NOS. 2,269,827, 2,931,763 AND 3,435,186.
FOR CLOTHING, NAMELY, HATS (U.S. CLS. 22 AND 39).
FIRST USE 5-9-2005; IN COMMERCE 5-9-2005.
NANCY CLARKE, EXAMINING ATTORNEY

SN 77-430,807. GENERAL MOTORS CORPORATION, DETROIT, MI. FILED 3-25-2008.

ESCALADE

THE MARK CONSISTS OF STANDARD CHARACTERS WITHOUT CLAIM TO ANY PARTICULAR FONT, STYLE, SIZE, OR COLOR.
OWNER OF U.S. REG. NOS. 2,269,827, 2,931,763 AND 3,435,186.
FOR SHOES (U.S. CLS. 22 AND 39).
NANCY CLARKE, EXAMINING ATTORNEY

CLASS 25—(Continued).

SN 77-430,893. TWO STAR DOG, INC., BERKELEY, CA. FILED 3-25-2008.

STELLA CARAKASI

THE MARK CONSISTS OF STANDARD CHARACTERS WITHOUT CLAIM TO ANY PARTICULAR FONT, STYLE, SIZE, OR COLOR.

THE NAME(S), PORTRAIT(S), AND/OR SIGNATURE(S) SHOWN IN THE MARK IDENTIFIES "STELLA CARAKASI", WHOSE CONSENT(S) TO REGISTER IS MADE OF RECORD.

FOR BATHROBES; BELTS; BLAZERS; BLOUSES; BRASSIERES; CAMISOLES; CHEMISES; COATS; DRESSES; HATS; HOSIERY; JACKETS; JEANS; LINGERIE; LOUNGEWEAR; NEGLIGEEES; NIGHT GOWNS; NIGHT SHIRTS; PAJAMAS; PANTIES; PANTS; SANDALS; SARONGS; SCARVES; SHIRTS; SHOES; SHORTS; SKIRTS; SOCKS; STOCKINGS; SWEAT SHIRTS; SWEATERS; SWIMSUITS; T-SHIRTS; UNDERWEAR; VISORS (U.S. CLS. 22 AND 39).
LINDA MICKLEBURGH, EXAMINING ATTORNEY

SN 77-430,993. GENE THERAPY GROUP INC, NORTH HALEDON, NJ. FILED 3-25-2008.

uber luxe

THE MARK CONSISTS OF STANDARD CHARACTERS WITHOUT CLAIM TO ANY PARTICULAR FONT, STYLE, SIZE, OR COLOR.

FOR CLOTHING, NAMELY, ARM WARMERS; CLOTHING, NAMELY, FOLK COSTUMES; CLOTHING, NAMELY, HAND-WARMERS; CLOTHING, NAMELY, KNEE WARMERS; CLOTHING, NAMELY, NECK TUBES; CLOTHING, NAMELY, THOBES; CLOTHING, NAMELY, WRAP-AROUNDS; CORSETS; DUSTERS; FOULARDS; HOODS; INFANT AND TODDLER ONE PIECE CLOTHING; INFANT CLOTH DIAPERS; JERSEYS; LEATHER BELTS; MANTLES; MUFFLERS; NON-DISPOSABLE CLOTH TRAINING PANTS; PAPER HATS FOR USE AS CLOTHING ITEMS; PARTS OF CLOTHING, NAMELY, GUSSETS FOR TIGHTS, GUSSETS FOR STOCKINGS, GUSSETS FOR BATHING SUITS, GUSSETS FOR UNDERWEAR, GUSSETS FOR LEOTARDS AND GUSSETS FOR FOOTLETS; PERSPIRATION ABSORBENT UNDERWEAR CLOTHING; SHIRTS; SHORT SETS; SHOULDER WRAPS; SWADDLING CLOTHES; TIES; TOPS; TRIATHLON CLOTHING, NAMELY, TRIATHLON TIGHTS, TRIATHLON SHORTS, TRIATHLON SINGLET, TRIATHLON SHIRTS, TRIATHLON SUITS; UNDERARM CLOTHING SHIELDS; WRAPS (U.S. CLS. 22 AND 39).
PATRICIA EVANKO, EXAMINING ATTORNEY

CLASS 25—(Continued).

SN 77-431,158. TENA, SARAH V., EL PASO, TX. FILED 3-25-2008.



FOR SHIRTS (U.S. CLS. 22 AND 39).
BARNEY CHARLON, EXAMINING ATTORNEY

SN 77-431,184. CW INDUSTRIES, DBA UNFIT GEAR,
ENUMCLAW, WA. FILED 3-25-2008.

Unfit Gear

THE MARK CONSISTS OF STANDARD CHARACTERS
WITHOUT CLAIM TO ANY PARTICULAR FONT, STYLE,
SIZE, OR COLOR.

NO CLAIM IS MADE TO THE EXCLUSIVE RIGHT TO
USE "GEAR", APART FROM THE MARK AS SHOWN.

FOR PANTS; SPORTS JERSEYS; SHIRTS; SOCKS;
FITTED SHOE OR BOOT COVERING TO PROTECT
THE SHOES OR BOOT FROM WATER OR OTHER
DAMAGE (U.S. CLS. 22 AND 39).

CYNTHIA TRIPI, EXAMINING ATTORNEY

SN 77-431,217. O'BRIEN, ANNE, BALTIMORE, MD. FILED 3-25-2008.

BREASTFEST

THE MARK CONSISTS OF STANDARD CHARACTERS
WITHOUT CLAIM TO ANY PARTICULAR FONT, STYLE,
SIZE, OR COLOR.

OWNER OF U.S. REG. NO. 2,612,210.

FOR SHIRTS (U.S. CLS. 22 AND 39).

FIRST USE 10-11-2007; IN COMMERCE 10-11-2007.

CYNTHIA SLOAN, EXAMINING ATTORNEY

CLASS 25—(Continued).

SN 77-431,242. TURNCOAT APPAREL, LLC, LEXINGTON,
KY. FILED 3-25-2008.

ATTUS PREP

THE MARK CONSISTS OF STANDARD CHARACTERS
WITHOUT CLAIM TO ANY PARTICULAR FONT, STYLE,
SIZE, OR COLOR.

FOR SHIRTS, T-SHIRTS, SWEAT SHIRTS, PANTS,
SHORTS, BOXER SHORTS, SOCKS, TIES (U.S. CLS. 22
AND 39).

FRED MANDIR, EXAMINING ATTORNEY

SN 77-431,247. GONZALES, ALBERT, NORTH VERSAILLES,
PA. FILED 3-25-2008.

G I God's Imitator

THE MARK CONSISTS OF STANDARD CHARACTERS
WITHOUT CLAIM TO ANY PARTICULAR FONT, STYLE,
SIZE, OR COLOR.

FOR CLOTHING, NAMELY, T-SHIRTS, HATS, HEAD-
WEAR, SWEAT SHIRTS, SWEAT PANTS, BEANIES,
HATS AND CAPS (U.S. CLS. 22 AND 39).

ANTHONY RINKER, EXAMINING ATTORNEY

SN 77-431,269. BYP AMERICAS, INC., MIAMI, FL. FILED 3-25-2008.

domus

THE MARK CONSISTS OF THE STYLIZED WORD
"DOMUS".

FOR PANTS; POLO SHIRTS; SHIRTS; SOCKS; T-
SHIRTS (U.S. CLS. 22 AND 39).

JOHN KELLY, EXAMINING ATTORNEY

CLASS 25—(Continued).

SN 77-431,287. ARTHURS, JONI L., MILWAUKEE, WI.
FILED 3-25-2008.

SIMPLY PUT

THE MARK CONSISTS OF STANDARD CHARACTERS WITHOUT CLAIM TO ANY PARTICULAR FONT, STYLE, SIZE, OR COLOR.

FOR T-SHIRTS (U.S. CLS. 22 AND 39),
LAURIE KAUFMAN, EXAMINING ATTORNEY

SN 77-431,318. DEPRIEST, DEVIN, STATEN ISLAND, NY.
FILED 3-25-2008.



THE MARK CONSISTS OF A ROUND FACE WITH ARCHED EYEBROWS, AN X FOR EACH EYE AND TONGUE STICKING OUT OF MOUTH.

FOR A-SHIRTS; BUTTON-FRONT ALOHA SHIRTS; CAMP SHIRTS; DRESS SHIRTS; GOLF SHIRTS; HOODED SWEAT SHIRTS; KNIT SHIRTS; LONG-SLEEVED SHIRTS; NIGHT SHIRTS; OPEN-NECKED SHIRTS; PIQUE SHIRTS; POLO SHIRTS; RUGBY SHIRTS; SHIRT FRONTS; SHIRTS; SHIRTS FOR SUITS; SHORT-SLEEVED OR LONG-SLEEVED T-SHIRTS; SHORT-SLEEVED SHIRTS; SLEEP SHIRTS; SPORT SHIRTS; SPORTS SHIRTS; SPORTS SHIRTS WITH SHORT SLEEVES; SWEAT SHIRTS; T-SHIRTS; TEE SHIRTS; WIND SHIRTS; BERMUDA SHORTS; BOARD SHORTS; BOXER SHORTS; FLEECE SHORTS; GYM SHORTS; RUGBY SHORTS; SHORT TROUSERS; SHORTS; SWEAT SHORTS; UNDERWEAR, NAMELY, BOY SHORTS; WALKING SHORTS; BALLOON PANTS; CAPRI PANTS; CARGO PANTS; DENIMS; JOGGING PANTS; LEATHER PANTS; LOUNGE PANTS; PANTS; PETTI-PANTS; SKI PANTS; SNOW PANTS; SNOWBOARD PANTS; STRETCH PANTS; SWEAT PANTS; TAP PANTS; TOBOGGAN HATS, PANTS AND CAPS; TRACK PANTS; WATERPROOF JACKETS AND PANTS; WIND PANTS; YOGA PANTS; BED JACKETS; DENIM JACKETS; DOWN JACKETS; FISHERMEN'S JACKETS; FUR COATS AND JACKETS; FUR JACKETS; HEAVY JACKETS; JACKET LINERS; JACKETS; LEATHER JACKETS; LIGHT-REFLECTING JACKETS; LONG JACKETS; MEN AND WOMEN JACKETS, COATS, TROUSERS, VESTS; PADDED JACKETS; PADDING JACKETS; RAIN JACKETS; RAINPROOF JACKETS;

CLASS 25—(Continued).

REVERSIBLE JACKETS; SHELL JACKETS; SKI JACKETS; SLEEVED OR SLEEVELESS JACKETS; SMOKING JACKETS; SPORTS JACKETS; STUFF JACKETS; SUEDE JACKETS; SWEAT JACKETS; TRACK JACKETS; WIND RESISTANT JACKETS; WIND-JACKETS; SNEAKERS; BASKETBALL SNEAKERS; MEN'S SOCKS; FISHING VESTS; FLEECE VESTS; HUNTING VESTS; VESTS; WIND VESTS; BATHING SUITS; BATHING SUITS FOR MEN; BODY SUITS; DRESS SUITS; DRY SUITS; FLIGHT SUITS; GYM SUITS; JOGGING SUITS; LADIES' SUITS; MEN'S SUITS; MEN'S SUITS, WOMEN'S SUITS; ONE-PIECE PLAY SUITS; SKI SUITS; SKIRT SUITS; SNOW BOARDING SUITS; SNOW SUITS; SUIT COATS; SWEAT SUITS; TRACK SUITS; TRAINING SUITS; WARM UP SUITS; BATHING COSTUMES; BATHING COSTUMES FOR WOMEN; BATHING TRUNKS; BRIEFS; DISPOSABLE UNDERWEAR; KNITTED UNDERWEAR; LADIES' UNDERWEAR; LONG UNDERWEAR; THERMAL UNDERWEAR; THONGS; UNDERWEAR; WOMEN'S UNDERWEAR; WOVEN OR KNITTED UNDERWEAR; JEANS (U.S. CLS. 22 AND 39).
CHRISTINE BLOMQUIST, EXAMINING ATTORNEY

SN 77-431,346. DEPRIEST, DEVIN, STATEN ISLAND, NY.
FILED 3-25-2008.

ILLEGIT

THE MARK CONSISTS OF STANDARD CHARACTERS WITHOUT CLAIM TO ANY PARTICULAR FONT, STYLE, SIZE, OR COLOR.

FOR A-SHIRTS; BUTTON-FRONT ALOHA SHIRTS; CAMP SHIRTS; DRESS SHIRTS; GOLF SHIRTS; HOODED SWEAT SHIRTS; KNIT SHIRTS; LONG-SLEEVED SHIRTS; NIGHT SHIRTS; OPEN-NECKED SHIRTS; PIQUE SHIRTS; POLO SHIRTS; RUGBY SHIRTS; SHIRT FRONTS; SHIRTS; SHIRTS FOR SUITS; SHORT-SLEEVED OR LONG-SLEEVED T-SHIRTS; SHORT-SLEEVED SHIRTS; SLEEP SHIRTS; SPORT SHIRTS; SPORTS SHIRTS; SPORTS SHIRTS WITH SHORT SLEEVES; SWEAT SHIRTS; T-SHIRTS; TEE SHIRTS; WIND SHIRTS; BERMUDA SHORTS; BOARD SHORTS; BOXER SHORTS; FLEECE SHORTS; GYM SHORTS; RUGBY SHORTS; SHORT TROUSERS; SHORTS; SWEAT SHORTS; UNDERWEAR, NAMELY, BOY SHORTS; WALKING SHORTS; BALLOON PANTS; CAPRI PANTS; CARGO PANTS; DENIMS; JOGGING PANTS; LEATHER PANTS; LOUNGE PANTS; PANTS; PETTI-PANTS; SKI PANTS; SNOW PANTS; SNOWBOARD PANTS; STRETCH PANTS; SWEAT PANTS; TAP PANTS; TOBOGGAN HATS, PANTS AND CAPS; TRACK PANTS; WATERPROOF JACKETS AND PANTS; WIND PANTS; YOGA PANTS; BED JACKETS; DENIM JACKETS; DOWN JACKETS; FISHERMEN'S JACKETS; FUR COATS AND JACKETS; FUR JACKETS; HEAVY JACKETS; JACKET LINERS; JACKETS; LEATHER JACKETS; LIGHT-REFLECTING JACKETS; LONG JACKETS; MEN AND WOMEN JACKETS, COATS, TROUSERS, VESTS; PADDED JACKETS; PADDING JACKETS; RAIN JACKETS; RAINPROOF JACKETS;

CLASS 25—(Continued).

REVERSIBLE JACKETS; SHELL JACKETS; SKI JACKETS; SLEEVED OR SLEEVELESS JACKETS; SMOKING JACKETS; SPORTS JACKETS; STUFF JACKETS; SUEDE JACKETS; SWEAT JACKETS; TRACK JACKETS; WIND RESISTANT JACKETS; WIND-JACKETS; SNEAKERS; BASKETBALL SNEAKERS; MEN'S SOCKS; FISHING VESTS; FLEECE VESTS; HUNTING VESTS; VESTS; WIND VESTS; BATHING SUITS; BATHING SUITS FOR MEN; BODY SUITS; DRESS SUITS; DRY SUITS; FLIGHT SUITS; GYM SUITS; JOGGING SUITS; LADIES' SUITS; MEN'S SUITS; MEN'S SUITS, WOMEN'S SUITS; ONE-PIECE PLAY SUITS; SKI SUITS; SKIRT SUITS; SNOW BOARDING SUITS; SNOW SUITS; SUIT COATS; SWEAT SUITS; TRACK SUITS; TRAINING SUITS; WARM UP SUITS; BATHING COSTUMES; BATHING COSTUMES FOR WOMEN; BATHING TRUNKS; BRIEFS; DISPOSABLE UNDERWEAR; KNITTED UNDERWEAR; LADIES' UNDERWEAR; LONG UNDERWEAR; THERMAL UNDERWEAR; THONGS; UNDERWEAR; WOMEN'S UNDERWEAR; WOVEN OR KNITTED UNDERWEAR; JEANS (U.S. CLS. 22 AND 39).

CHRISTINE BLOMQUIST, EXAMINING ATTORNEY

SN 77-431,348. JACKSONS VIP HOLDINGS INC., DBA HIP HOP VS AMERICA, RIDGELAND, MS. FILED 3-25-2008.

Hip Hop vs America

THE MARK CONSISTS OF STANDARD CHARACTERS WITHOUT CLAIM TO ANY PARTICULAR FONT, STYLE, SIZE, OR COLOR.

FOR MEN'S, WOMEN'S AND CHILDREN'S CLOTHING AND FASHION ACCESSORIES, NAMELY, DRESSES, COATS, SHORTS, SHIRTS, DRESS SHIRTS, PANTS, DRESS PANTS, JEANS, SWEATERS, JACKETS, SUITS, TUXEDOS, DINNER JACKETS, T-SHIRTS, BLOUSES, KNIT TOPS, HALTER TOPS, SMOCK TOPS, VESTS, WIND RESISTANT JACKETS, JOGGING SUITS, SWEATSHIRTS, SWEATPANTS, SKI JACKETS, SKI PANTS, MUFFLERS, HEAD BANDS, BELTS, GLOVES, SHAWLS, SCARVES, PONCHOS, SHOULDER WRAPS, NECKERCHIEFS, STOCKINGS, HOSIERY, SOCKS, TIGHTS, LEGGINGS, LEOTARDS, PAJAMAS, ROBES, NIGHTGOWNS, PANTIES, BRAS, UNDERWEAR, UNDERSHIRTS, RAINWEAR, RAINCOATS, SWIMWEAR, BATHING SUITS, COVER-UPS, AND WOMEN'S LINGERIE; FOOTWEAR, HEADWEAR, TIES, CAPS, AND HATS (U.S. CLS. 22 AND 39).

FIRST USE 1-20-2006; IN COMMERCE 1-20-2006.
MARK RADEMACHER, EXAMINING ATTORNEY

SN 77-431,402. SANNER, ADAM, FRANKLIN, TN. FILED 3-25-2008.

13ANK

THE MARK CONSISTS OF STANDARD CHARACTERS WITHOUT CLAIM TO ANY PARTICULAR FONT, STYLE, SIZE, OR COLOR.

FOR HATS; SWEAT SHIRTS; T-SHIRTS (U.S. CLS. 22 AND 39).

FIRST USE 2-3-2008; IN COMMERCE 2-3-2008.
WILLIAM P. SHANAHAN, EXAMINING ATTORNEY

CLASS 25—(Continued).

SN 77-431,455. JAMISE FISHER, DALLAS, TX. FILED 3-25-2008.

COWGIRL JUSTICE

THE MARK CONSISTS OF STANDARD CHARACTERS WITHOUT CLAIM TO ANY PARTICULAR FONT, STYLE, SIZE, OR COLOR.

FOR WOMEN'S WESTERN APPAREL, NAMELY, SHIRTS, JEANS, SWEATPANTS AND CAPS (U.S. CLS. 22 AND 39).

HAI-LY LAM, EXAMINING ATTORNEY

SN 77-431,476. PARAS, MICHAEL N., NEW YORK, NY. FILED 3-25-2008.

PHOTOGRAPHER WORKING!

THE MARK CONSISTS OF STANDARD CHARACTERS WITHOUT CLAIM TO ANY PARTICULAR FONT, STYLE, SIZE, OR COLOR.

FOR SHIRTS; SWEAT SHIRTS; COATS; WIND COATS; OVER COATS; RAIN COATS; HATS (U.S. CLS. 22 AND 39).

FIRST USE 3-25-2008; IN COMMERCE 3-25-2008.
HENRY S. ZAK, EXAMINING ATTORNEY

SN 77-431,478. TIENKEN, DAWN MARIE, VENTNOR CITY, NJ. FILED 3-25-2008.



THE MARK CONSISTS OF THE STYLIZED OUTLINED IMAGE OF A BUTTERFLY.

FOR SHIRTS; BASEBALL CAPS; CAPS; HEADWEAR; TOPS (U.S. CLS. 22 AND 39).

HENRY S. ZAK, EXAMINING ATTORNEY

CLASS 25—(Continued).

SN 77-431,481. LIFE MISHAPS, LLC, SAN ANTONIO, TX. FILED 3-25-2008.

Life Mishaps

THE MARK CONSISTS OF STANDARD CHARACTERS WITHOUT CLAIM TO ANY PARTICULAR FONT, STYLE, SIZE, OR COLOR.

FOR T-SHIRTS; SWEAT PANTS; SWEAT SHIRTS; HATS; CAPS; SPORTS SHIRTS; SHORTS; PANTS; FOOTWEAR; SLEEPWEAR; BANDANAS; UNDERWEAR (U.S. CLS. 22 AND 39).

HENRY S. ZAK, EXAMINING ATTORNEY

SN 77-431,489. DOLPHIN GLOBE INTERNATIONAL, FREMONT, CA. FILED 3-25-2008.

Kimbro's

THE MARK CONSISTS OF STANDARD CHARACTERS WITHOUT CLAIM TO ANY PARTICULAR FONT, STYLE, SIZE, OR COLOR.

FOR BASEBALL CAPS; BERMUDA SHORTS; BLOUSES; BOARD SHORTS; CAP VISORS; CAPRI PANTS; CAPS; CARGO PANTS; DENIMS; FLEECE SHORTS; GOLF CAPS; GYM SHORTS; HATS; JEANS; JOGGING PANTS; KNITTED CAPS; LOUNGE PANTS; PANTIES, SHORTS AND BRIEFS; PANTS; POLO SHIRTS; SHORT TROUSERS; SHORT-SLEEVED OR LONG-SLEEVED T-SHIRTS; SHORT-SLEEVED SHIRTS; SHORTS; SKULL CAPS; SWEAT PANTS; SWEAT SHORTS; T-SHIRTS; WALKING SHORTS; WIND PANTS (U.S. CLS. 22 AND 39).

FIRST USE 8-28-2007; IN COMMERCE 8-28-2007.
HENRY S. ZAK, EXAMINING ATTORNEY

CLASS 25—(Continued).

SN 77-431,497. BRIAN J PETERS, DBA PURPLE-REIGN, INC, HUNTINGTON BEACH, CA. FILED 3-26-2008.

Ride for Freedom Freedom to Ride

THE MARK CONSISTS OF STANDARD CHARACTERS WITHOUT CLAIM TO ANY PARTICULAR FONT, STYLE, SIZE, OR COLOR.

FOR HOODED SWEAT SHIRTS; LONG-SLEEVED SHIRTS; POLO SHIRTS; SHORT-SLEEVED OR LONG-SLEEVED T-SHIRTS; SHORT-SLEEVED SHIRTS; SLEEP SHIRTS; SPORT SHIRTS; SWEAT SHIRTS; T-SHIRTS; TEE SHIRTS; DENIM JACKETS; DOWN JACKETS; HEAVY JACKETS; JACKET LINERS; JACKETS; LEATHER JACKETS; LIGHT-REFLECTING JACKETS; LONG JACKETS; MEN AND WOMEN JACKETS, COATS, TROUSERS, VESTS; PADDED JACKETS; PADDING JACKETS; RAIN JACKETS; RAINPROOF JACKETS; REVERSIBLE JACKETS; SHELL JACKETS; SKI JACKETS; SLEEVED OR SLEEVELESS JACKETS; SMOKING JACKETS; SPORTS JACKETS; STUFF JACKETS; SUEDE JACKETS; SWEAT JACKETS; TRACK JACKETS; WATERPROOF JACKETS AND PANTS; WIND RESISTANT JACKETS; WIND-JACKETS; BALLOON PANTS; CAPRI PANTS; CARGO PANTS; DENIMS; JOGGING PANTS; LEATHER PANTS; LOUNGE PANTS; NON-DISPOSABLE CLOTH TRAINING PANTS; NURSE PANTS; PANTS; PETTI-PANTS; SKI PANTS; SNOW PANTS; SNOWBOARD PANTS; STRETCH PANTS; SWEAT PANTS; TRACK PANTS; WIND PANTS; YOGA PANTS (U.S. CLS. 22 AND 39).

SUNG IN, EXAMINING ATTORNEY

SN 77-431,622. SCHINELLA JR., ANTHONY J., DBA INNOVATIVE PRODUCT SOURCE LLC, SOMERSET, NJ. FILED 3-26-2008.

MY tiny REMINDER

THE MARK CONSISTS OF STANDARD CHARACTERS WITHOUT CLAIM TO ANY PARTICULAR FONT, STYLE, SIZE, OR COLOR.

FOR WRISTBANDS (U.S. CLS. 22 AND 39).
TRACY CROSS, EXAMINING ATTORNEY

CLASS 25—(Continued).

SN 77-431,844. HOUSTON, STANLEY C., JR., ELBA, AL.
FILED 3-26-2008.



THE MARK CONSISTS OF AN ANIMATED SHADOWED MAN SITTING ON THE LETTER "R" WITH HIS HANDS IN THE AIR, LOOKING CONFUSED FOLLOWED BY THE WORDS "I DON'T RECALL".

FOR CLOTHING, NAMELY, T-SHIRTS, SHIRTS, SHORTS, HATS (U.S. CLS. 22 AND 39).
LANA PHAM, EXAMINING ATTORNEY

CLASS 25—(Continued).

SN 77-431,988. PHANNY SILK GROUP INC., NEW YORK, NY. FILED 3-26-2008.

VINTAGE ROYALTY

THE MARK CONSISTS OF STANDARD CHARACTERS WITHOUT CLAIM TO ANY PARTICULAR FONT, STYLE, SIZE, OR COLOR.

FOR MEN'S AND WOMEN'S CLOTHING, NAMELY, SHIRTS, T-SHIRTS, BLOUSES, PANTS, SKIRTS, PANTSUITS, SUITS, SLACKS, SHORTS, DRESSES, TOPS, SWEATERS, SWEAT SUITS, SOCKS, JACKETS, COATS, UNDERWEAR, SLIPS, PAJAMAS, SLEEPWEAR, CAPS, HATS, GLOVES (U.S. CLS. 22 AND 39).

KARANENDRA S. CHHINA, EXAMINING ATTORNEY

SN 77-431,990. SAVAGE DESIGNS, INC., TOPANGA, CA.
FILED 3-26-2008.

SN 77-431,860. PRATT, ERIC, BOISE, ID. FILED 3-26-2008.

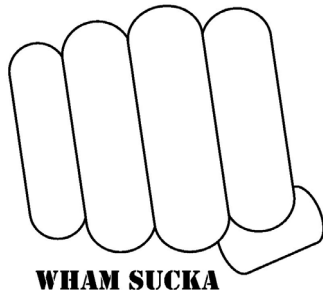

THE MARK CONSISTS OF A FIST AND THE WORDS "WHAM SUCKA" UNDER THE FIST.

FOR CLOTHING, NAMELY, BEANIES, T-SHIRTS, HATS, CAPS, SWEAT SHIRTS (U.S. CLS. 22 AND 39).
MARIA-VICTORIA SUAREZ, EXAMINING ATTORNEY

SUNNY SAVAGE DESIGNS

THE MARK CONSISTS OF STANDARD CHARACTERS WITHOUT CLAIM TO ANY PARTICULAR FONT, STYLE, SIZE, OR COLOR.

NO CLAIM IS MADE TO THE EXCLUSIVE RIGHT TO USE "DESIGNS", APART FROM THE MARK AS SHOWN.

THE NAME "SUNNY SAVAGE" IDENTIFIES A LIVING INDIVIDUAL WHOSE CONSENT IS OF RECORD.

FOR CLOTHING, NAMELY, PANTS, JEANS, COTTON PANTS, SHORTS, SHIRTS, T-SHIRTS, LONG SLEEVED SHIRTS, TANK TOPS, HOODED SWEATSHIRTS, SWEATSHIRTS, SWEATERS, VESTS, DRESSES, SKIRTS, JACKETS, COATS, ZIPPED HOODED SWEATSHIRTS, WRAPS THAT CAN BE USED AS SKIRTS; SCARVES, SHAWLS AND WRAPS; HEADWEAR, NAMELY, HATS, BEANIES AND CAPS; HOODS; SOCKS; UNDERGARMENTS, NAMELY, UNDERWEAR; BELTS; ARM WARMERS AND CUFFS; HEADBANDS (U.S. CLS. 22 AND 39).

TANYA AMOS, EXAMINING ATTORNEY

CLASS 25—(Continued).

SN 77-432,031. GENEVA CUBS BASEBALL, INC, WILLIAMSPORT, PA. FILED 3-26-2008.

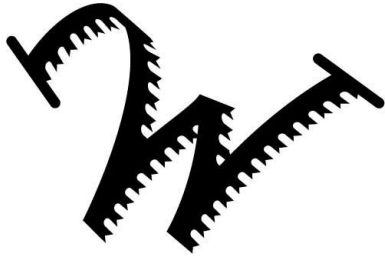

OWNER OF U.S. REG. NO. 3,264,322.
THE MARK CONSISTS OF A STYLIZED "W" TO LOOK LIKE SAW BLADES.

FOR CLOTHING, NAMELY, APRONS, ATHLETIC UNIFORMS, BANDANAS, BOXER SHORTS, CAPS, CLOTH BABY BIBS, COATS, GOLF SHIRTS, GYM SHORTS, GYM SUITS, HATS, JACKETS, JERSEYS, KNIT SHIRTS, POLO SHIRTS, PONCHOS, PULLOVERS, RAIN COATS, RAINWEAR, SWEATERS, SWEAT PANTS, SWEAT SHIRTS, SWEAT SUITS, SOCKS, SPORT SHIRTS, T-SHIRTS, TANK TOPS, TIES, VISORS, WIND RESISTANT JACKETS AND WRISTBANDS (U.S. CLS. 22 AND 39).

FIRST USE 1-17-2008; IN COMMERCE 1-17-2008.
REGINA DRUMMOND, EXAMINING ATTORNEY

SN 77-432,284. RANPRO INC., SIMCOE, CANADA, FILED 3-26-2008.

RANPRO SELECT

THE MARK CONSISTS OF STANDARD CHARACTERS WITHOUT CLAIM TO ANY PARTICULAR FONT, STYLE, SIZE, OR COLOR.

OWNER OF U.S. REG. NO. 2,603,648.
FOR CLOTHING, NAMELY, SHIRTS, JACKETS, PANTS, COATS, VESTS, SUITS, LEGGINGS, SLEEVES, COVERALLS AND OVERALLS, APRONS, HOODS, CAPS, HATS (U.S. CLS. 22 AND 39).

MAUREEN DALL, EXAMINING ATTORNEY

CLASS 25—(Continued).

SN 77-432,299. SPITZER, ELLIOT, BROOKLYN, NY. FILED 3-26-2008.



THE NAME(S), PORTRAIT(S), AND/OR SIGNATURE(S) SHOWN IN THE MARK DOES NOT IDENTIFY A PARTICULAR LIVING INDIVIDUAL.

THE MARK CONSISTS OF THE WORDS "E.J. SAMUEL" IN A STYLIZED SCRIPT FORMAT, BELOW THE DEPICTION OF A STYLIZED CROWN.

FOR COATS; JACKETS; MEN'S SUITS; NECKWEAR; PANTS; SPORT COATS; SPORTS JACKETS; SUITS; TIES; TROUSERS; VESTED SUITS; VESTS (U.S. CLS. 22 AND 39).

FIRST USE 1-1-2008; IN COMMERCE 1-1-2008.
DEZMONA MIZELLE, EXAMINING ATTORNEY

SN 77-432,458. KJM ENTERPRISES, SAN DIEGO, CA. FILED 3-26-2008.



THE MARK CONSISTS OF THE STYLIZED WORD "GLORIFIED".

FOR TOPS, SHIRTS, SWEATSHIRTS, AND HATS (U.S. CLS. 22 AND 39).

FIRST USE 9-26-2007; IN COMMERCE 9-26-2007.
EUGENIA MARTIN, EXAMINING ATTORNEY

SN 77-432,499. JOHNSON, LAURA B., SOUTH ORANGE, NJ. FILED 3-26-2008.

HUGGUMS

THE MARK CONSISTS OF STANDARD CHARACTERS WITHOUT CLAIM TO ANY PARTICULAR FONT, STYLE, SIZE, OR COLOR.

FOR BELTS, BANDS, STRAPS FOR USE IN ASSOCIATION WITH SHOES AND BOOTS (U.S. CLS. 22 AND 39).

DARRYL SPRUILL, EXAMINING ATTORNEY

CLASS 25—(Continued).

SN 77-432,506. YANGZHOU YAXIYA HEADWEAR & GARMENT CO. LTD, YANGZHOU CITY, CHINA, FILED 3-26-2008.



THE MARK CONSISTS OF A COMBINATION OF A MODIFIED OVAL DESIGN AND A MEANINGLESS WORD. FOR SHIRTS; TROUSERS; KNIT SHIRTS; KNITTED CAPS; KNITTED UNDERWEAR; JACKETS; BODY LINEN; SHOES; HOSIERY; NECKTIES; SUSPENDER BELTS FOR MEN; SUSPENDER BELTS FOR WOMEN; HATS; GLOVES; SCARVES; TURBANS; WEDDING DRESSES; CHILDREN'S HEADWEAR; CHILDREN'S AND INFANTS' CLOTH BIBS; INFANTS' TROUSERS; BATHING SUITS; WATERPROOF JACKETS AND PANTS; DANCE COSTUMES (U.S. CLS. 22 AND 39).
EUGENIA MARTIN, EXAMINING ATTORNEY

SN 77-432,576. BLAIR, TIMOTHY, SAN LUIS OBISPO, CA. FILED 3-26-2008.

GOD >

THE MARK CONSISTS OF STANDARD CHARACTERS WITHOUT CLAIM TO ANY PARTICULAR FONT, STYLE, SIZE, OR COLOR.
FOR HATS; JACKETS; SHIRTS; SWEAT SHIRTS (U.S. CLS. 22 AND 39).
GINA FINK, EXAMINING ATTORNEY

SN 77-432,606. COURTWRIGHT, BRENDAN, NYACK, NY. FILED 3-26-2008.

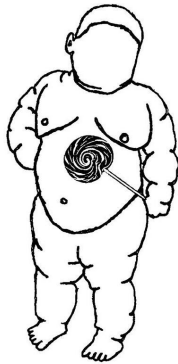

THE MARK CONSISTS OF AN OUTLINED FAT KID HOLDING A LOLLI POP.
FOR CLOTHING, NAMELY, T-SHIRTS, HOODED SWEAT SHIRTS, JACKETS, SWEATERS, HATS, PANTS, SHOES (U.S. CLS. 22 AND 39).
KATHY DE JONGE, EXAMINING ATTORNEY

CLASS 25—(Continued).

SN 77-432,697. BE THE ALPHA, INC., NEW YORK, NY. FILED 3-26-2008.

BE THE ALPHA

THE MARK CONSISTS OF STANDARD CHARACTERS WITHOUT CLAIM TO ANY PARTICULAR FONT, STYLE, SIZE, OR COLOR.
FOR SHIRTS; SWEAT SHIRTS; JACKETS; HATS; SWEAT PANTS (U.S. CLS. 22 AND 39).
GISELLE AGOSTO, EXAMINING ATTORNEY

SN 77-432,722. VENOM ENTERPRISES, LLC, LAS VEGAS, NV. FILED 3-27-2008.

lipsplitter

THE MARK CONSISTS OF STANDARD CHARACTERS WITHOUT CLAIM TO ANY PARTICULAR FONT, STYLE, SIZE, OR COLOR.
FOR CLOTHING, NAMELY, TRUNKS, TANK TOPS, BELTS, CAPS, BASEBALL CAPS, COATS, GLOVES, HATS, HEADBANDS, JACKETS, SKULL CAPS, THONG UNDERWEAR, WRISTBANDS, G-STRINGS, SWEAT-PANTS, JERSEYS, BRIEFS, PULLOVERS, SHIRTS, SWEATSHIRTS, T-SHIRTS, SOCKS, SWEATERS, SWIM-SUITS, TROUSERS (U.S. CLS. 22 AND 39).
FIRST USE 9-25-2005; IN COMMERCE 9-1-2007.
JULIE WATSON, EXAMINING ATTORNEY

SN 77-432,841. MUNOZ, RENE GALVAN, CHULA VISTA, CA. FILED 3-27-2008.

FEAR THE FRIARS

THE MARK CONSISTS OF STANDARD CHARACTERS WITHOUT CLAIM TO ANY PARTICULAR FONT, STYLE, SIZE, OR COLOR.
FOR GOLF SHIRTS; POLO SHIRTS; T-SHIRTS; HOODED SWEAT SHIRTS; SWEAT JACKETS; SWEAT PANTS; SWEAT SHIRTS; HATS; BEANIES; SPORTS JERSEYS (U.S. CLS. 22 AND 39).
REBECCA EISINGER, EXAMINING ATTORNEY

CLASS 25—(Continued).

SN 77-432,853. BARBARA HODES, LTD., NEW YORK, NY. FILED 3-27-2008.

BIBELOT

THE MARK CONSISTS OF STANDARD CHARACTERS WITHOUT CLAIM TO ANY PARTICULAR FONT, STYLE, SIZE, OR COLOR.
FOR SWEATERS, DRESSES, T-SHIRTS (U.S. CLS. 22 AND 39).
FIRST USE 6-5-1999; IN COMMERCE 6-5-1999.
REBECCA EISINGER, EXAMINING ATTORNEY

SN 77-432,864. RUSNAK, JOEL, NEWBURYPORT, MA. FILED 3-27-2008.

TAIL-LITES

THE MARK CONSISTS OF STANDARD CHARACTERS WITHOUT CLAIM TO ANY PARTICULAR FONT, STYLE, SIZE, OR COLOR.
FOR SHOE STRAPS; FOOTWEAR (U.S. CLS. 22 AND 39).
JESSICA A. POWERS, EXAMINING ATTORNEY

SN 77-432,943. MANDARIN, LLC, MIAMI BEACH, FL. FILED 3-27-2008.

STAR ISLAND

THE MARK CONSISTS OF STANDARD CHARACTERS WITHOUT CLAIM TO ANY PARTICULAR FONT, STYLE, SIZE, OR COLOR.
FOR JEANS; JACKETS; PANTS; SHIRTS; SWEATERS; T-SHIRTS; HATS; BASEBALL CAPS; TRACK PANTS; SWEAT PANTS; VESTS; TOPS (U.S. CLS. 22 AND 39).
KIMBERLY PERRY, EXAMINING ATTORNEY

CLASS 25—(Continued).

SN 77-433,012. PRIMARY WAVE MUSIC PUBLISHING LLC, NEW YORK, NY. FILED 3-27-2008.

J. STACHE

THE MARK CONSISTS OF STANDARD CHARACTERS WITHOUT CLAIM TO ANY PARTICULAR FONT, STYLE, SIZE, OR COLOR.
THE NAME "J. STACHE" DOES NOT IDENTIFY A LIVING INDIVIDUAL.
FOR SHIRTS; HATS; JACKETS; TIES; SWEAT SHIRTS; PANTS; UNDERWEAR; SOCKS; SHOES; CAPES (U.S. CLS. 22 AND 39).
ANTHONY RINKER, EXAMINING ATTORNEY

SN 77-433,026. PRIMARY WAVE MUSIC PUBLISHING LLC, NEW YORK, NY. FILED 3-27-2008.

THE J. STACHE SHOW

THE MARK CONSISTS OF STANDARD CHARACTERS WITHOUT CLAIM TO ANY PARTICULAR FONT, STYLE, SIZE, OR COLOR.
THE NAME "J. STACHE" DOES NOT IDENTIFY A LIVING INDIVIDUAL.
FOR SHIRTS; HATS; JACKETS; TIES; SWEAT SHIRTS; PANTS; UNDERWEAR; SOCKS; SHOES; CAPES (U.S. CLS. 22 AND 39).
ANTHONY RINKER, EXAMINING ATTORNEY

SN 77-433,113. JESUS CHRIST MY SAVIOR, INC., DBA JCMS, LONGWOOD, FL. FILED 3-27-2008.

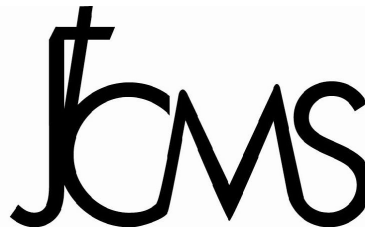

THE MARK CONSISTS OF THE LETTERS JCMS WITH A CROSS BETWEEN THE J AND C.
FOR A-SHIRTS; ANGLERS' SHOES; ANKLE SOCKS; ANKLETS; ANTI-PERSPIRANT SOCKS; APRES-SKI SHOES; ATHLETIC SHOES; BALLET SHOES; BALLOON PANTS; BALLROOM DANCING SHOES; BASEBALL CAPS; BASEBALL SHOES; BASKETBALL SNEAKERS; BATHING CAPS; BATHING SUITS; BATHING SUITS FOR MEN; BEACH SHOES; BERMUDA SHORTS; BLOUSES; BOARD SHORTS; BODY SUITS; BUTTON-FRONT ALOHA SHIRTS; CAMP SHIRTS; CANVAS SHOES; CAP VISORS; CAPS; CAPS WITH VISORS; CARGO PANTS; DANCE SHOES; DECK-SHOES; DENIMS; DRESS SHIRTS; DRESS SUITS; DRIVERS; FUR HATS; GOLF CAPS; GOLF SHIRTS; GOLF SHOES; GYM SHORTS; GYM SUITS; GYMNASTIC SHOES; HAT BANDS; HATS; HOODED SWEAT SHIRTS; INFANTS'

CLASS 25—(Continued).

SHOES AND BOOTS; INSOLES; JAPANESE STYLE SOCKS (TABI COVERS); JAPANESE STYLE SOCKS (TABI); JEANS; JOGGING PANTS; JOGGING SUITS; JUDO SUITS; KARATE SUITS; KNIT SHIRTS; KNITTED CAPS; LADIES' SUITS; LEATHER PANTS; LEATHER SHOES; LONG-SLEEVED SHIRTS; LOUNGE PANTS; MEN'S SOCKS; MEN'S SUITS; MEN'S SUITS, WOMEN'S SUITS; NIGHT SHIRTS; NON-DISPOSABLE CLOTH TRAINING PANTS; NURSE PANTS; ONE-PIECE PLAY SUITS; OPEN-NECKED SHIRTS; PANTIES, SHORTS AND BRIEFS; PANTS; PAPER HATS FOR USE AS CLOTHING ITEMS; PAPER SHOES USED WHEN GOING THROUGH METAL DETECTORS TO KEEP FEET AND SOCKS CLEAN; PARTS OF CLOTHING, NAMELY, GUSSETS FOR TIGHTS, GUSSETS FOR STOCKINGS, GUSSETS FOR BATHING SUITS, GUSSETS FOR UNDERWEAR, GUSSETS FOR LEOTARDS AND GUSSETS FOR FOOTLETS; PETTI-PANTS; PIQUE SHIRTS; PLAY SUITS; PLEATED SKIRTS FOR FORMAL KIMONOS (HAKAMA); POLO SHIRTS; PROTECTIVE METAL MEMBERS FOR SHOES AND BOOTS; RAIN SUITS; RUBBER SHOES; RUGBY SHIRTS; RUGBY SHOES; RUNNING SHOES; SEDGE HATS (SUGE-GASA); SHIRT FRONTS; SHIRT YOKES; SHIRTS; SHIRTS FOR SUITS; SHOE DOWELS; SHOE INSERTS FOR PRIMARILY NON-ORTHOPEDIC PURPOSES; SHOE PEGS; SHOE SOLES; SHOE STRAPS; SHOES; SHOES SOLES FOR REPAIR; SHORT OVERCOAT FOR KIMONO (HAORI); SHORT PETTICOATS; SHORT SETS; SHORT TROUSERS; SHORT-SLEEVED OR LONG-SLEEVED T-SHIRTS; SHORT-SLEEVED SHIRTS; SHORTS; SHOWER CAPS; SKI AND SNOWBOARD SHOES AND PARTS THEREOF; SKIRT SUITS; SKIRTS; SKIRTS AND DRESSES; SKULL CAPS; SLEEP SHIRTS; SLIDING SHORTS; SMALL HATS; SNEAKERS; SOCCER SHOES; SOCKS; SOCKS AND STOCKINGS; SPORT SHIRTS; SPORTS SHIRTS; SPORTS SHIRTS WITH SHORT SLEEVES; STRETCH PANTS; SUIT COATS; SUITS; SUITS OF LEATHER; SWEAT PANTS; SWEAT SHIRTS; SWEAT SHORTS; SWEAT SUITS; SWIM CAPS; SWIMMING CAPS; T-SHIRTS; TAP PANTS; TAP SHOES; TEE SHIRTS; TENNIS SHOES; THERMAL SOCKS; TOBOGGAN HATS, PANTS AND CAPS; TOE CAPS; TONGUE OR PULLSTRAP FOR SHOES AND BOOTS; TRACK AND FIELD SHOES; TRACK PANTS; TRACK SUITS; TRAINING SHOES; TRAINING SUITS; TRIATHLON CLOTHING, NAMELY, TRIATHLON TIGHTS, TRIATHLON SHORTS, TRIATHLON SINGLET, TRIATHLON SHIRTS, TRIATHLON SUITS; UNDERWEAR, NAMELY, BOY SHORTS; UNION SUITS; VESTED SUITS; VOLLEYBALL SHOES; WALKING SHORTS; WARM UP SUITS; WATER SOCKS; WATERPROOF JACKETS AND PANTS; WIND PANTS; WIND SHIRTS; WOMEN'S SHOES; WOOLLEN SOCKS; WOOLLY HATS; WORK SHOES AND BOOTS; YOGA PANTS; YOGA SHIRTS; ZOOT SUITS (U.S. CLS. 22 AND 39).

SUNG IN, EXAMINING ATTORNEY

SN 77-433,144. FUNKYKUFFS INC., HOMER GLEN, IL. FILED 3-27-2008.

FUNKYKUFFS

THE MARK CONSISTS OF STANDARD CHARACTERS WITHOUT CLAIM TO ANY PARTICULAR FONT, STYLE, SIZE, OR COLOR.

FOR CUFFS (U.S. CLS. 22 AND 39).
FIRST USE 3-31-2007; IN COMMERCE 3-31-2007.
SUNG IN, EXAMINING ATTORNEY

CLASS 25—(Continued).

SN 77-433,178. WATSON JR., JAMES H., LITTLETON, CO. FILED 3-27-2008.

WHOOOP-DE-DOO

THE MARK CONSISTS OF STANDARD CHARACTERS WITHOUT CLAIM TO ANY PARTICULAR FONT, STYLE, SIZE, OR COLOR.

FOR SHIRTS; POLO SHIRTS; SWEAT SHIRTS; T-SHIRTS; WIND SHIRTS; JERSEYS; TANK TOPS; SHORTS; JACKETS; COATS; BELTS; CAPS; HATS; VISORS; BEANIES; FLEECE PULLOVERS; SWEATERS; JEANS; PANTS; OVERALLS; BATHING SUITS; SWIM TRUNKS; BANDANAS; SHOES; SANDALS; SOCKS; PAJAMAS; SWEAT PANTS; UNDERWEAR; BRIEFS; THERMAL UNDERWEAR (U.S. CLS. 22 AND 39).
SUNG IN, EXAMINING ATTORNEY

SN 77-433,529. PROJECT ROUTE 66.COM INC., HURRICANE MILLS, TN. FILED 3-27-2008.

Take A Trip On 66

THE MARK CONSISTS OF STANDARD CHARACTERS WITHOUT CLAIM TO ANY PARTICULAR FONT, STYLE, SIZE, OR COLOR.

FOR BASEBALL CAPS; HOODED SWEAT SHIRTS; POLO SHIRTS; SHORT-SLEEVED OR LONG-SLEEVED T-SHIRTS; LEATHER JACKETS; JACKETS (U.S. CLS. 22 AND 39).
RENEE SERVANCE, EXAMINING ATTORNEY

SN 77-433,555. SYNCHRONICITY LIVE, LLC, JACKSONVILLE BEACH, FL. FILED 3-27-2008.

synclive.com

THE MARK CONSISTS OF STANDARD CHARACTERS WITHOUT CLAIM TO ANY PARTICULAR FONT, STYLE, SIZE, OR COLOR.

FOR CLOTHING, NAMELY, SHIRTS AND OTHER TOPS, PANTS AND OTHER BOTTOMS, BELTS, HATS AND OTHER HEADWEAR, UNDERGARMENTS, SWIMWEAR AND SLEEPWEAR (U.S. CLS. 22 AND 39).
TASNEEM HUSSAIN, EXAMINING ATTORNEY

CLASS 25—(Continued).

SN 77-433,643. THE SWISS COLONY, INC., MONROE, WI. FILED 3-27-2008.

MONROE & MAIN

THE MARK CONSISTS OF STANDARD CHARACTERS WITHOUT CLAIM TO ANY PARTICULAR FONT, STYLE, SIZE, OR COLOR.

OWNER OF U.S. REG. NO. 2,619,056.
FOR DRESSES; PANTS; PANTSUITS; SKIRT SUITS; SKIRTS; TOPS; JACKETS; SWIMWEAR; SWEATERS; ROBES; SLEEPWEAR; LOUNGEWEAR; SHOES (U.S. CLS. 22 AND 39).

FIRST USE 0-0-2000; IN COMMERCE 0-0-2000.
JILL C. ALT, EXAMINING ATTORNEY

SN 77-433,699. THE SWISS COLONY, INC., MONROE, WI. FILED 3-27-2008.

MIDNIGHT VELVET

THE MARK CONSISTS OF STANDARD CHARACTERS WITHOUT CLAIM TO ANY PARTICULAR FONT, STYLE, SIZE, OR COLOR.

OWNER OF U.S. REG. NOS. 1,505,336, 3,223,144 AND OTHERS.

FOR DRESSES; PANTS; PANTSUITS; SKIRT SUITS; SKIRTS; TOPS; JACKETS; ROBES; SLEEPWEAR; LOUNGEWEAR; SWIMWEAR; SWEATERS (U.S. CLS. 22 AND 39).

FIRST USE 0-0-2000; IN COMMERCE 0-0-2000.
JILL C. ALT, EXAMINING ATTORNEY

SN 77-433,730. THE SWISS COLONY, INC., MONROE, WI. FILED 3-27-2008.

MIDNIGHT VELVET STYLE

THE MARK CONSISTS OF STANDARD CHARACTERS WITHOUT CLAIM TO ANY PARTICULAR FONT, STYLE, SIZE, OR COLOR.

OWNER OF U.S. REG. NOS. 1,505,336, 3,223,145 AND OTHERS.

FOR DRESSES; PANTS; PANTSUITS; SKIRTS; SKIRT SUITS; TOPS; JACKETS; ROBES; SLEEPWEAR; LOUNGEWEAR; SWIMWEAR; SWEATERS (U.S. CLS. 22 AND 39).

FIRST USE 0-0-2000; IN COMMERCE 0-0-2000.
JILL C. ALT, EXAMINING ATTORNEY

CLASS 25—(Continued).

SN 77-433,751. JONQUIL, INC., SANTA MONICA, CA. FILED 3-27-2008.

IN BLOOM

THE MARK CONSISTS OF STANDARD CHARACTERS WITHOUT CLAIM TO ANY PARTICULAR FONT, STYLE, SIZE, OR COLOR.

FOR LINGERIE; SLEEPWEAR; PAJAMAS; GOWNS; NIGHT GOWNS; ROBES; CHEMISES; BABY DOLL PAJAMAS; PEIGNOIRS; NIGHT SHIRTS; SLEEP SHIRTS; LOUNGEWEAR; WRAPS; COVERUPS (U.S. CLS. 22 AND 39).

ANGELA GAW, EXAMINING ATTORNEY

SN 77-433,840. CM BUSINESS GROUP, LLC, TEMPE, AZ. FILED 3-27-2008.

PATIENTLY WAITING

THE MARK CONSISTS OF STANDARD CHARACTERS WITHOUT CLAIM TO ANY PARTICULAR FONT, STYLE, SIZE, OR COLOR.

FOR ANKLE BOOTS; ANKLE SOCKS; ATHLETIC FOOTWEAR; ATHLETIC SHOES; ATHLETIC UNIFORMS; BANDANAS; BASEBALL CAPS; BASELAYER BOTTOMS; BASELAYER TOPS; BATHING SUITS; BATHING TRUNKS; BATHROBES; BEACH COVER-UPS; BEACH FOOTWEAR; BEACHWEAR; BEANIES; BELTS; BERETS; BIKINIS; BODY SUITS; BOOTS; BOXER BRIEFS; BOXER SHORTS; BOXING SHOES; BRAS; BRIEFS; CAPRIS; CAPS; COATS; COVERALLS; CREWNECKS; CROP TOPS; DRESS SHIRTS; DRESSES; FOOTWEAR; FULL-LENGTH KIMONOS (NAGAGI); GLOVES; GYM SHORTS; GYM SUITS; HATS; HEAD WEAR; HOODED PULLOVERS; HOODED SWEAT SHIRTS; HOODS; JACKETS; JEANS; JERSEYS; JUDO SUITS; JUMPSUITS; KARATE SUITS; KIMONOS; KNIT SHIRTS; LONG-SLEEVED SHIRTS; MARTIAL ARTS UNIFORMS; NECKWEAR; NIGHTWEAR; PANTIES, SHORTS AND BRIEFS; PANTS; PARKAS; POLO SHIRTS; PONCHOS; PULLOVERS; RAINWEAR; ROBES; SANDALS; SASHES; SHIRTS; SHOES; SKIRTS; SLACKS; SLEEPWEAR; SOCKS; SUITS; SWEAT BANDS; SWEAT JACKETS; SWEAT PANTS; SWEAT SHIRTS; SWEAT SHORTS; SWEAT SUITS; SWEATBANDS; SWEATERS; SWEAT-SOCKS; SWIMSUITS; SWIMWEAR; T-SHIRTS; TANK TOPS; UNDERCLOTHES; UNDERGARMENTS; UNIFORMS; WAIST BELTS; WARM UP OUTFITS; WARM UP SUITS (U.S. CLS. 22 AND 39).

JASON TURNER, EXAMINING ATTORNEY

CLASS 25—(Continued).

SN 77-433,895. SMITH, SHARON LOUISE, RANCHO BELA-GO, CA. FILED 3-27-2008.

DIVA'S 4 GOD

THE MARK CONSISTS OF STANDARD CHARACTERS WITHOUT CLAIM TO ANY PARTICULAR FONT, STYLE, SIZE, OR COLOR.

FOR TOPS; PULLOVERS; JACKETS; SUITS (U.S. CLS. 22 AND 39).

STEVEN R. FOSTER, EXAMINING ATTORNEY

SN 77-434,133. VILLANOVA UNIVERSITY, VILLANOVA, PA. FILED 3-28-2008.

**VILLANOVA UNIVERSITY
ALUMNI ASSOCIATION**

THE MARK CONSISTS OF STANDARD CHARACTERS WITHOUT CLAIM TO ANY PARTICULAR FONT, STYLE, SIZE, OR COLOR.

OWNER OF U.S. REG. NOS. 1,353,326, 2,603,598 AND OTHERS.

NO CLAIM IS MADE TO THE EXCLUSIVE RIGHT TO USE "UNIVERSITY ALUMNI ASSOCIATION", APART FROM THE MARK AS SHOWN.

FOR CLOTHING, NAMELY, SHIRTS, HATS, SWEATERS, SWEATSHIRTS (U.S. CLS. 22 AND 39).

FIRST USE 6-0-1995; IN COMMERCE 6-0-1995.

PAUL F. GAST, EXAMINING ATTORNEY

SN 77-434,220. LEAVE ZERO, WARWICK, RI. FILED 3-28-2008.

LEAVE ZERO

THE MARK CONSISTS OF STANDARD CHARACTERS WITHOUT CLAIM TO ANY PARTICULAR FONT, STYLE, SIZE, OR COLOR.

FOR SHIRTS, TOPS, SWEAT SHIRTS (U.S. CLS. 22 AND 39).

FIRST USE 1-0-2008; IN COMMERCE 3-13-2008.

KIMBERLY FRYE, EXAMINING ATTORNEY

CLASS 25—(Continued).

SN 77-434,265. DAVID LOREN CORPORATION, BEVERLY HILLS, CA. FILED 3-28-2008.

DAVID & LILI

THE MARK CONSISTS OF STANDARD CHARACTERS WITHOUT CLAIM TO ANY PARTICULAR FONT, STYLE, SIZE, OR COLOR.

FOR CLOTHING FOR MEN, WOMEN AND CHILDREN, NAMELY, SWIMWEAR, LINGERIE, FOOTWEAR, COATS, JACKETS, UNDERWEAR, SUITS, DRESSES, TROUSERS, JEANS, SKIRTS, BLOUSES, COATS, OVERCOATS, RAINCOATS, PARKAS, JACKETS, VESTS; KNITWEAR, NAMELY, PULLOVERS, JERSEYS, JUMPERS, SWEATERS, OVERALLS, PANTS, HOSIERY, SOCKS AND STOCKINGS; DRESSING GOWNS; PAJAMAS; BATHING SUITS, BATHING CAPS; ROBES; CLOTHING ACCESSORIES, NAMELY, NECKTIES, SUSPENDERS, BELTS, HATS AND CAPS, SCARVES, SHAWLS, GLOVES, MUFFS; FOOTWEAR, NAMELY, SHOES, BOOTS, SANDALS, AND SLIPPERS AND SNEAKERS (U.S. CLS. 22 AND 39).

MELISSA VALLILLO, EXAMINING ATTORNEY

SN 77-434,273. DAVID LOREN CORPORATION, BEVERLY HILLS, CA. FILED 3-28-2008.

LILI & DAVID

THE MARK CONSISTS OF STANDARD CHARACTERS WITHOUT CLAIM TO ANY PARTICULAR FONT, STYLE, SIZE, OR COLOR.

FOR CLOTHING FOR MEN, WOMEN AND CHILDREN, NAMELY, SWIMWEAR, LINGERIE, FOOTWEAR, COATS, JACKETS, UNDERWEAR, SUITS, DRESSES, TROUSERS, JEANS, SKIRTS, BLOUSES, COATS, OVERCOATS, RAINCOATS, PARKAS, JACKETS, VESTS; KNITWEAR, NAMELY, PULLOVERS, JERSEYS, JUMPERS, SWEATERS, OVERALLS, PANTS, HOSIERY, SOCKS AND STOCKINGS; DRESSING GOWNS; PAJAMAS; BATHING SUITS, BATHING CAPS; ROBES; CLOTHING ACCESSORIES, NAMELY, NECKTIES, SUSPENDERS, BELTS, HATS AND CAPS, SCARVES, SHAWLS, GLOVES, MUFFS; FOOTWEAR, NAMELY, SHOES, BOOTS, SANDALS, AND SLIPPERS AND SNEAKERS (U.S. CLS. 22 AND 39).

MELISSA VALLILLO, EXAMINING ATTORNEY

CLASS 25—(Continued).

SN 77-434,296. CARLINO, CRISTINA M., PARADISE VALLEY, AZ. FILED 3-28-2008.

YOU COLOR MY DAY

THE MARK CONSISTS OF STANDARD CHARACTERS WITHOUT CLAIM TO ANY PARTICULAR FONT, STYLE, SIZE, OR COLOR.

FOR BABY BIBS NOT OF PAPER; BATHROBES; BEACHWEAR; CHILDREN'S HEADWEAR; COATS; DRESSES; FOOTWEAR; GLOVES; HEADWEAR; INFANT WEAR; INFANTS' SHOES AND BOOTS; LINGERIE; NECKWEAR; PAJAMAS; ROBES; SHIRTS; SHOES; SHORTS; SLACKS; SLEEPWEAR; SOCKS; SWEAT PANTS; SWEAT SHIRTS; SWEATERS; SWIM WEAR; T-SHIRTS; UNDER GARMENTS (U.S. CLS. 22 AND 39).

REBECCA SMITH, EXAMINING ATTORNEY

SN 77-434,352. CM BUSINESS GROUP, LLC, TEMPE, AZ. FILED 3-28-2008.



THE MARK CONSISTS OF A PERSON IN A CIRCLE.
FOR ANKLE BOOTS; ANKLE SOCKS; ATHLETIC FOOTWEAR; ATHLETIC SHOES; ATHLETIC UNIFORMS; BANDANAS; BASEBALL CAPS; BASELAYER BOTTOMS; BASELAYER TOPS; BATHING SUITS; BATHING TRUNKS; BATHROBES; BEACH COVER-UPS; BEACH FOOTWEAR; BEACHWEAR; BEANIES; BELTS; BERETS; BIKINIS; BODY SUITS; BOOTS; BOXER BRIEFS; BOXER SHORTS; BOXING SHOES; BRAS; BRIEFS; CAPRIS; CAPS; COATS; COVERALLS; CREWNECKS; CROP TOPS; DRESS SHIRTS; DRESSES; FOOTWEAR; FULL-LENGTH KIMONOS (NAGAGI); GLOVES; GYM SHORTS; GYM SUITS; HATS; HEAD WEAR; HOODED PULLOVERS; HOODED SWEAT SHIRTS; HOODS; JACKETS; JEANS; JERSEYS; JUDO SUITS; JUMPSUITS; KARATE SUITS; KIMONOS; KNIT SHIRTS; LONG-SLEEVED SHIRTS; MARTIAL ARTS UNIFORMS; NECKWEAR; NIGHTWEAR; PANTIES, SHORTS AND BRIEFS; PANTS; PARKAS; POLO SHIRTS; PONCHOS; PULLOVERS; RAINWEAR; ROBES; SANDALS; SASHES; SHIRTS; SHOES; SKIRTS; SLACKS; SLEEPWEAR; SOCKS; SUITS; SWEAT BANDS; SWEAT JACKETS; SWEAT PANTS; SWEAT SHIRTS; SWEAT SHORTS; SWEAT SUITS; SWEATBANDS; SWEATERS; SWEAT-SOCKS; SWIMSUITS; SWIMWEAR; T-SHIRTS; TANK TOPS; UNDERCLOTHES; UNDERGARMENTS; UNIFORMS; WAIST BELTS; WARM UP OUTFITS; WARM UP SUITS (U.S. CLS. 22 AND 39).

JASON TURNER, EXAMINING ATTORNEY

CLASS 25—(Continued).

SN 77-434,581. ZENO PRODUCTIONS INCORPORATED, PORTAGE, IN. FILED 3-28-2008.



THE MARK CONSISTS OF A DESIGN OF DEVIL HORNS. FOR FULL LINE OF CLOTHING INCLUDING OUTERWEAR AND UNDERWEAR, SHIRTS, HATS, PANTS (U.S. CLS. 22 AND 39).

DANNEAN HETZEL, EXAMINING ATTORNEY

SN 77-434,651. GRUBMAN, PATTY, BEVERLY HILLS, CA. FILED 3-28-2008.



THE MARK CONSISTS OF THE WORDS "THE CITY FARM" WITH THE "I" IN CITY SUBSTITUTED WITH A SKYSCRAPER DRAWING AND THE "A" IN FARM SUBSTITUTED WITH A BARN DRAWING.

FOR BATHROBES; BELTS; BLAZERS; BLOUSES; BOOTS; BRASSIERES; CAMISOLES; CHEMISES; COATS; DRESSES; HATS; HOSIERY; JACKETS; JEANS; LINGERIE; LOUNGEWEAR; NEGLIGENCES; NIGHT GOWNS; NIGHT SHIRTS; PAJAMAS; PANTIES; PANTS; SANDALS; SARONGS; SCARVES; SHIRTS; SHOES; SHORTS; SKIRTS; SOCKS; STOCKINGS; SWEAT SHIRTS; SWEATERS; SWIMSUITS; T-SHIRTS; UNDERWEAR; VESTS; VISORS (U.S. CLS. 22 AND 39).

TARA PATE, EXAMINING ATTORNEY

CLASS 25—(Continued).

SN 77-434,666. GRUBMAN, PATTY, BEVERLY HILLS, CA. FILED 3-28-2008.

THE CITY FARM

THE MARK CONSISTS OF STANDARD CHARACTERS WITHOUT CLAIM TO ANY PARTICULAR FONT, STYLE, SIZE, OR COLOR.

FOR BATHROBES; BELTS; BLAZERS; BLOUSES; BOOTS; BRASSIERES; CAMISOLES; CHEMISES; COATS; DRESSES; HATS; HOSIERY; JACKETS; JEANS; LINGERIE; LOUNGEWEAR; PANTIES; PANTS; SANDALS; SARONGS; SCARVES; SHIRTS; SHOES; SHORTS; SKIRTS; SOCKS; STOCKINGS; SWEAT SHIRTS; SWEATERS; SWIMSUITS; T-SHIRTS; UNDERWEAR; VESTS; VISORS (U.S. CLS. 22 AND 39).

TARA PATE, EXAMINING ATTORNEY

SN 77-434,915. RUNWAY CHICK, LLC, LOS ANGELES, CA. FILED 3-28-2008.

Runway Chick

THE MARK CONSISTS OF STANDARD CHARACTERS WITHOUT CLAIM TO ANY PARTICULAR FONT, STYLE, SIZE, OR COLOR.

FOR INSOLES FOR SHOES AND BOOTS AND SHOE INSERTS FOR PRIMARILY NON-ORTHOPEDIC PURPOSES (U.S. CLS. 22 AND 39).

JAMES STEIN, EXAMINING ATTORNEY

SN 77-434,953. RBR, LLC, VERNON, CA. FILED 3-28-2008.

Petit Joie

THE MARK CONSISTS OF STANDARD CHARACTERS WITHOUT CLAIM TO ANY PARTICULAR FONT, STYLE, SIZE, OR COLOR.

THE FOREIGN WORDING IN THE MARK TRANSLATES INTO ENGLISH AS "LITTLE JOY".

FOR CLOTHING, NAMELY, PANTS, SHIRTS, JACKETS, T-SHIRTS, DRESSES AND SKIRTS (U.S. CLS. 22 AND 39).

DAVID H. STINE, EXAMINING ATTORNEY

CLASS 25—(Continued).

SN 77-434,997. NIKE, INC., BEAVERTON, OR. FILED 3-28-2008.

MY BETTER IS BETTER THAN YOUR BETTER

THE MARK CONSISTS OF STANDARD CHARACTERS WITHOUT CLAIM TO ANY PARTICULAR FONT, STYLE, SIZE, OR COLOR.

FOR FOOTWEAR; APPAREL, NAMELY, PANTS, SHORTS, SHIRTS, T-SHIRTS, PULLOVERS, SWEAT SHIRTS, SWEAT PANTS, UNDERWEAR, SPORTS BRAS, DRESSES, SKIRTS, SWEATERS, JACKETS, SOCKS, HEADWEAR, SWEATBANDS, GLOVES, BELTS, HOSIERY, ARMBANDS, COATS, VESTS (U.S. CLS. 22 AND 39).

MATTHEW MCDOWELL, EXAMINING ATTORNEY

SN 77-436,087. JUICY COUTURE, INC., PACOIMA, CA. FILED 3-31-2008.



Dirty English

THE MARK CONSISTS OF TWO HERALDIC LIONS HOLDING A SHIELD WITH A CROWN ABOVE IT. BELOW THE SHIELD ARE THE WORDS "DIRTY ENGLISH".

FOR BELTS; COATS; DENIM JACKETS; DENIMS; DRESS SHIRTS; DRESS SUITS; DRESSES; FOOTWEAR; HEADWEAR; JACKETS; JEANS; KNIT SHIRTS; MEN'S SOCKS; MEN'S SUITS; PANTS; SHIRTS; SHORT-SLEEVED OR LONG-SLEEVED T-SHIRTS; SHORT-SLEEVED SHIRTS; SHORTS; SLEEPWEAR; SOCKS; SPORT COATS; SPORT SHIRTS; SPORTS JACKETS; SPORTS SHIRTS; SUITS; SWEAT JACKETS; SWEAT PANTS; SWEAT SHIRTS; SWEATERS; SWIMWEAR; T-SHIRTS; TANK TOPS; TIES; TOP COATS; TOPS; UNDERWEAR (U.S. CLS. 22 AND 39).

STEPHANIE ALI, EXAMINING ATTORNEY

CLASS 25—(Continued).

SN 77-437,804. PEI LICENSING, INC., MIAMI, FL. FILED 4-2-2008.

ECO-FOCUS

THE MARK CONSISTS OF STANDARD CHARACTERS WITHOUT CLAIM TO ANY PARTICULAR FONT, STYLE, SIZE, OR COLOR.

FOR CLOTHING, NAMELY, PANTS, SLACKS, TROUSERS, SHORTS, SUITS AND SHIRTS (U.S. CLS. 22 AND 39).

JOHN GARTNER, EXAMINING ATTORNEY

SN 77-437,835. CPR BRANDS, L.L.C., DBA CPR GEAR, LOS ANGELES, CA. FILED 4-2-2008.

IT'S IN OUR DNA

THE MARK CONSISTS OF STANDARD CHARACTERS WITHOUT CLAIM TO ANY PARTICULAR FONT, STYLE, SIZE, OR COLOR.

FOR BASEBALL CAPS; BOXER SHORTS; CHILDREN'S AND INFANTS' CLOTH BIBS; CHILDREN'S CLOTH EATING BIBS; CHILDREN'S HEADWEAR; COATS; COATS FOR MEN AND WOMEN; COATS MADE OF COTTON; EAR MUFFS; FLEECE PULL-OVERS; GLOVES; GOLF CAPS; GYM SHORTS; GYM SUITS; HATS; HEAD SCARVES; HEAD SWEATBANDS; HEAD WEAR; HEADBANDS; HOODED PULLOVERS; HOODED SWEAT SHIRTS; INFANT SLEEPERS; INFANT WEAR; INFANT AND TODDLER ONE PIECE CLOTHING; JOGGING OUTFITS; JOGGING PANTS; JOGGING SUITS; JUMPERS; JUMPSUITS; KNITTED CAPS; LONG JACKETS; DOWN JACKETS; MEN AND WOMEN JACKETS; COATS, TROUSERS, VESTS; NIGHT SHIRTS; NIGHTGOWNS; PAJAMA BOTTOMS; PAJAMAS; PARKAS; POLO SHIRTS; PULLOVERS; RAIN COATS; RAIN JACKETS; RUGBY SHIRTS; RUGBY TOPS; SHIRTS; SHORTS; SKULL CAPS; SLEEPWEAR; SPORTS JACKETS; SPORTS JERSEYS; SPORTS JERSEYS AND BREECHES FOR SPORTS; SPORTS OVERUNIFORMS; SPORTS SHIRTS; SPORTS SHIRTS WITH SHORT SLEEVES; SWEAT BANDS; SWEAT PANTS; SWEAT SHIRTS; SWEAT SHORTS; SWEAT SUITS; SWEATBANDS; SWEATERS; T-SHIRTS; TANK TOPS; TANK-TOPS; TRACK PANTS; TRACK SUITS; TRACKSUITS; TURTLENECKS; WIND-JACKETS; WOMEN'S UNDERWEAR (U.S. CLS. 22 AND 39).

JAMES LOVELACE, EXAMINING ATTORNEY

CLASS 25—(Continued).

SN 77-442,233. JADE APPAREL, INC., VERNON, CA. FILED 4-7-2008.



THE MARK CONSISTS OF A FROG WEARING A HAT, SHIRT, PANTS AND SHOES LEANING ON A GOLF IRON. FOR SHIRTS, GOLF SHIRTS, SWEATERS, VEST, PANTS, SOCKS, SHOES, CAPS, HATS, JACKETS, SWEAT SHIRTS (U.S. CLS. 22 AND 39).

FIRST USE 2-1-2008; IN COMMERCE 2-1-2008.

BILL DAWE, EXAMINING ATTORNEY

SN 77-443,326. NIKE, INC., BEAVERTON, OR. FILED 4-8-2008.

AIR FORCE I

THE MARK CONSISTS OF STANDARD CHARACTERS WITHOUT CLAIM TO ANY PARTICULAR FONT, STYLE, SIZE, OR COLOR.

FOR FOOTWEAR (U.S. CLS. 22 AND 39).

FIRST USE 10-28-1982; IN COMMERCE 10-28-1982.

MATTHEW MCDOWELL, EXAMINING ATTORNEY

SN 77-447,203. LACZAI, CHRISTINE, SANDPOINT, ID. FILED 4-14-2008.

SLIMMING ESSENTIALS

THE MARK CONSISTS OF STANDARD CHARACTERS WITHOUT CLAIM TO ANY PARTICULAR FONT, STYLE, SIZE, OR COLOR.

FOR CLOTHING, NAMELY, PANTS, JEANS, TOPS, SHIRTS, DRESSES AND SKIRTS (U.S. CLS. 22 AND 39).

DOMINICK J. SALEMI, EXAMINING ATTORNEY

CLASS 25—(Continued).

SN 77-447,471. VOLCANIC MANUFACTURING LLC, OLYMPIA, WA. FILED 4-14-2008.

Volcanic

THE MARK CONSISTS OF STANDARD CHARACTERS WITHOUT CLAIM TO ANY PARTICULAR FONT, STYLE, SIZE, OR COLOR.

FOR SHIRTS; CAPS (U.S. CLS. 22 AND 39).
FIRST USE 12-31-2003; IN COMMERCE 12-31-2003.
ANNE E. GUSTASON, EXAMINING ATTORNEY



SN 77-447,489. VOLCANIC MANUFACTURING LLC, OLYMPIA, WA. FILED 4-14-2008.



THE MARK CONSISTS OF AN IMAGE OF A VOLCANO . FOR SHIRTS; CAPS (U.S. CLS. 22 AND 39).
FIRST USE 12-31-2003; IN COMMERCE 12-31-2003.
ANNE E. GUSTASON, EXAMINING ATTORNEY



SN 77-448,642. ACHILLES CORPORATION, TOKYO, JAPAN, FILED 4-15-2008.



THE MARK CONSISTS OF THE LETTERS "IC" IN A STYLIZED FONT.

THE WORDING "IC" HAS NO MEANING OTHER THAN TRADEMARK SIGNIFICANCE.

FOR FOOTWEAR (U.S. CLS. 22 AND 39).
FIRST USE 1-0-1987; IN COMMERCE 6-1-2004.
MATTHEW MCDOWELL, EXAMINING ATTORNEY

CLASS 25—(Continued).

SN 77-452,418. BASS PRO INTELLECTUAL PROPERTY, L.L.C., SPRINGFIELD, MO. FILED 4-18-2008.

ECOLITE

THE MARK CONSISTS OF STANDARD CHARACTERS WITHOUT CLAIM TO ANY PARTICULAR FONT, STYLE, SIZE, OR COLOR.

FOR FOOTWEAR (U.S. CLS. 22 AND 39).
THOMAS MANOR, EXAMINING ATTORNEY



SN 77-459,752. NH TRIPLE PLAY, LLC, MANCHESTER, NH. FILED 4-28-2008.



OWNER OF U.S. REG. NO. 2,936,249.
NO CLAIM IS MADE TO THE EXCLUSIVE RIGHT TO USE "NEW HAMPSHIRE", APART FROM THE MARK AS SHOWN.

THE MARK CONSISTS OF A SCRIPT "FISHER CATS" WITH CAT PEEKING OVER LETTERS FROM BEHIND AND THE WORDS "NEW HAMPSHIRE" IN THE ARC ABOVE CAT.

FOR CLOTHING, NAMELY, ATHLETIC UNIFORMS, CAPS, CLOTH BABY BIBS, GOLF SHIRTS, GYM SHORTS, GYM SUITS, HATS, JACKETS, JERSEYS, JOGGING SUITS, KNIT SHIRTS, PAJAMAS, POLO SHIRTS, PONCHOS, PULLOVERS, RAIN COATS, RAINWEAR, SWEATERS, SWEAT PANTS, SWEAT SHIRTS, SWEAT SUITS, SOCKS, SPORT SHIRTS, T- SHIRTS, TANK TOPS, TIES, VISORS, WIND RESISTANT JACKETS AND WRISTBANDS (U.S. CLS. 22 AND 39).
FIRST USE 11-28-2007; IN COMMERCE 11-28-2007.

ELLEN PERKINS, EXAMINING ATTORNEY

CLASS 25—(Continued).

SN 77-459,779. WORLD WRESTLING ENTERTAINMENT, INC., STAMFORD, CT. FILED 4-28-2008.

NIGHT OF CHAMPIONS

THE MARK CONSISTS OF STANDARD CHARACTERS WITHOUT CLAIM TO ANY PARTICULAR FONT, STYLE, SIZE, OR COLOR.

FOR CLOTHING, NAMELY, TANK TOPS, T-SHIRTS, SHIRTS, SPORT SHIRTS, DRESS SHIRTS, POLO SHIRTS, UNDERSHIRTS, SWEATSHIRTS, SWEATERS, PULL-OVERS, BLOUSES, JACKETS, RAINCOATS, OVERCOATS, TOPCOATS, TROUSERS, PANTS, JEAN PANTS, JOGGING SUITS, EXERCISE PANTS, EXERCISE SUITS, SWEATPANTS, SHORTS, UNDERWEAR, BOXER SHORTS, SOCKS, CLOTHING TIES, PAJAMAS, BELTS, GLOVES, HALLOWEEN AND MASQUERADE COSTUMES, WRIST BANDS, BANDANNAS; FOOTWEAR, NAMELY, SHOES, SNEAKERS, BOOTS, SLIPPERS; HEADWEAR, NAMELY, HATS, CAPS (U.S. CLS. 22 AND 39).

SUZANNE BLANE, EXAMINING ATTORNEY

CLASS 25—(Continued).

SN 77-469,908. KBT DIRECT, INC., DALLAS, TX. FILED 5-9-2008.



THE MARK CONSISTS OF COAT OF ARMS WITH LION ON LEFT SIDE, UNICORN ON RIGHT SIDE, SHIELD IN CENTER WITH STYLIZED "H" AND "W", BANNERS BELOW COAT OF ARMS WITH STYLIZED "HARD" AND "WEAR" WORDS WITHIN BANNER.

FOR T-SHIRTS; TOPS; CARGO PANTS; PANTS; JEANS; HATS; CAPS; BELTS; LEATHER BELTS (U.S. CLS. 22 AND 39).

FIRST USE 6-25-2004; IN COMMERCE 6-25-2004.

RUDY R. SINGLETON, EXAMINING ATTORNEY

SN 77-469,794. LAZY MAN, INC., LOS ANGELES, CA. FILED 5-8-2008.

LazyMan

THE MARK CONSISTS OF STANDARD CHARACTERS WITHOUT CLAIM TO ANY PARTICULAR FONT, STYLE, SIZE, OR COLOR.

FOR SHORT-SLEEVED OR LONG-SLEEVED T-SHIRTS; T-SHIRTS; DRESS SHIRTS; GOLF SHIRTS; HOODED SWEAT SHIRTS; POLO SHIRTS; HATS; BELTS; BOARD SHORTS; SHORTS; CARGO PANTS; JOGGING PANTS; LOUNGE PANTS; PANTS; SKI PANTS; SNOW PANTS; SNOWBOARD PANTS; SPORTS PANTS; JACKETS; SANDALS; SHOES; BEACH SHOES; ROBES; SLIPPERS; TANK TOPS; SWEAT PANTS; SWEAT SHIRTS (U.S. CLS. 22 AND 39).

JOHN DWYER, EXAMINING ATTORNEY

SN 77-474,664. RED WING SHOE COMPANY, INC., RED WING, MN. FILED 5-15-2008.

STEP BEYOND

THE MARK CONSISTS OF STANDARD CHARACTERS WITHOUT CLAIM TO ANY PARTICULAR FONT, STYLE, SIZE, OR COLOR.

FOR FOOTWEAR (U.S. CLS. 22 AND 39).

REBECCA GILBERT, EXAMINING ATTORNEY

CLASS 25—(Continued).

SN 77-478,286. DISNEY ENTERPRISES, INC., BURBANK, CA. FILED 5-19-2008.

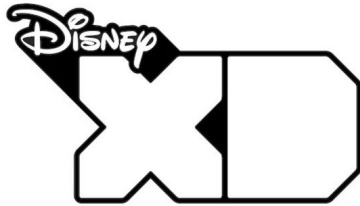

OWNER OF U.S. REG. NOS. 2,759,132, 3,340,426 AND OTHERS.

FOR ATHLETIC SHOES; BANDANAS; BASEBALL CAPS; BEACH COVER-UPS; BEACHWEAR; BELTS; BIKINIS; BLAZERS; BOOTS; BOW TIES; BRAS; CAPS; CHAPS; CLOTH BIBS; COATS; DRESSES; EAR MUFFS; FOOTWEAR; GLOVES; GOLF SHIRTS; HALLOWEEN COSTUMES; HATS; HEAD BANDS; HEAD WEAR; HOSIERY; INFANT WEAR; JACKETS; JEANS; JERSEYS; KERCHIEFS; LEOTARDS; LEG WARMERS; MITTENS; NECKTIES; NIGHT SHIRTS; NIGHT GOWNS; OVERALLS; PAJAMAS; PANTS; PANTY HOSE; POLO SHIRTS; PONCHOS; RAINWEAR; ROBES; SANDALS; SCARVES; SHIRTS; SHOES; SKIRTS; SHORTS; SLACKS; SLIPPERS; SLEEP WEAR; SOCKS; STOCKINGS; SWEATERS; SWEAT PANTS; SWEAT SHIRTS; SWIMSUITS; TANK TOPS; TIGHTS; T-SHIRTS; UNDERWEAR; VESTS; WRIST BANDS (U.S. CLS. 22 AND 39).

BRIDGETT SMITH, EXAMINING ATTORNEY

SN 77-479,447. SILK THREADS, INC., IRVING, TX. FILED 5-20-2008.

Nikki and Sebastian

THE MARK CONSISTS OF STANDARD CHARACTERS WITHOUT CLAIM TO ANY PARTICULAR FONT, STYLE, SIZE, OR COLOR.

THE NAMES "NIKKI" AND "SEBASTIAN" DO NOT IDENTIFY LIVING INDIVIDUALS.

FOR COATS FOR MEN AND WOMEN; DRESS SHIRTS; DRESS SUITS; DRESSES; DRESSING GOWNS; EVENING DRESSES; MEN'S SUITS, WOMEN'S SUITS; SKIRTS AND DRESSES; TUNICS; WEDDING DRESSES; WOMEN'S CEREMONIAL DRESSES (U.S. CLS. 22 AND 39).

JAMES MACFARLANE, EXAMINING ATTORNEY

CLASS 25—(Continued).

SN 77-487,357. NEW YORK YACHT CLUB, NEW YORK, NY. FILED 5-30-2008.



OWNER OF U.S. REG. NOS. 822,593, 2,287,370 AND OTHERS.

THE MARK CONSISTS OF A FLAG DESIGN WITH A FIVE-POINTED STAR-POINT-UP IN THE CENTER OF TWO CROSSED STRIPES.

SEC. 2(F).

FOR CLOTHING, NAMELY, SHIRTS, PANTS, SHORTS, SWEATERS, JACKETS, VESTS, CAPS, HATS, TIES AND SCARVES (U.S. CLS. 22 AND 39).

FIRST USE 0-0-1960; IN COMMERCE 0-0-1960.

COLLEEN DOMBROW, EXAMINING ATTORNEY

SN 78-272,258. SOCCADELIC CORPORATION, LOS ANGELES, CA. FILED 7-9-2003.

SOCCADELIC

THE MARK CONSISTS OF STANDARD CHARACTERS WITHOUT CLAIM TO ANY PARTICULAR FONT, STYLE, SIZE, OR COLOR.

FOR SOCCER THEMED CLOTHING, NAMELY, SOCCER JACKETS, PULLOVERS, JERSEYS, SWEATSHIRTS, SHORTS AND SWEAT PANTS AND THE FOLLOWING WITH SOCCER THEMES OR DESIGNS— SWEATERS, SWEATSHIRTS, SHORTS, PANTS, JEANS, JOGGING SUITS, SWEAT PANTS, SWEAT SHORTS, PONCHOS, CAPS AND VISORS (U.S. CLS. 22 AND 39).

JANICE L. MCMORROW, EXAMINING ATTORNEY

SN 78-484,882. J & N SALES, LLC, WEST HARTFORD, CT. FILED 9-16-2004.

the myth of.. **Jade**

FOR WOMEN'S AND CHILDREN'S APPAREL AND ACCESSORIES, NAMELY, JEANS, PANTS, SKIRTS, SHORTS, T-SHIRTS, SWEATSHIRTS, KNIT TOPS, SHIRTS, SWEATERS (U.S. CLS. 22 AND 39).

FIRST USE 8-18-2004; IN COMMERCE 8-18-2004.

DANIEL BRODY, EXAMINING ATTORNEY

CLASS 25—(Continued).

SN 78-486,191. WARRIOR SPORTS, INC., WARREN, MI. FILED 9-20-2004.



THE MARK CONSISTS OF THE LETTER "W" AND THE WORD "WARRIOR" IN STYLIZED FORM.

FOR CLOTHING, NAMELY, TEE SHIRTS, SWEATSHIRTS, SHORTS, COLLARED SHIRTS, JERSEYS, HATS AND FOOTWEAR; MOISTURE MANAGEMENT GARMENTS, NAMELY, TEE SHIRTS, SWEATSHIRTS, SHORTS, COLLARED SHIRTS, JERSEYS, HATS AND FOOTWEAR (U.S. CLS. 22 AND 39).

FIRST USE 6-1-1996; IN COMMERCE 6-1-1996.
ALLISON HOLTZ, EXAMINING ATTORNEY

CLASS 25—(Continued).

SN 78-637,745. CHRISTINA AMERICA INC., MONTREAL, QUEBEC, CANADA, FILED 5-26-2005.

BEACH FRONT AVENUE SWIMWEAR

THE MARK CONSISTS OF STANDARD CHARACTERS WITHOUT CLAIM TO ANY PARTICULAR FONT, STYLE, SIZE, OR COLOR.

PRIORITY CLAIMED UNDER SEC. 44(D) ON CANADA APPLICATION NO. 1,258,603, FILED 5-24-2005, REG. NO. TMA688927, DATED 6-1-2007, EXPIRES 6-1-2022.

NO CLAIM IS MADE TO THE EXCLUSIVE RIGHT TO USE "SWIMWEAR", APART FROM THE MARK AS SHOWN.

FOR SWIMWEAR AND BEACHWEAR, NAMELY, SWIMSUITS WITH MIX AND MATCH TOPS AND BOTTOMS, SWIMSUITS, SURF TRUNKS, BEACH COATS, PANTS, SHORTS, SKIRTS, DRESSES, PAREOS, T-SHIRTS, COVER-UPS, JACKETS AND HOODED JACKETS (U.S. CLS. 22 AND 39).

TRACY CROSS, EXAMINING ATTORNEY

SN 78-661,308. LIVE AWEAR INC., NEW YORK, NY. FILED 6-29-2005.

NOT A WIFEBEATER

THE MARK CONSISTS OF STANDARD CHARACTERS WITHOUT CLAIM TO ANY PARTICULAR FONT, STYLE, SIZE, OR COLOR.

FOR CLOTHING, NAMELY, TANK TOPS (U.S. CLS. 22 AND 39).

LESLEY LAMOTHE, EXAMINING ATTORNEY

SN 78-536,250. GLOBAL ONE HEADWEAR LIMITED, FOTAN, SHANTIN, HONG KONG, FILED 12-21-2004.



THE COLOR(S) BLUE, BLACK AND GREEN IS/ARE CLAIMED AS A FEATURE OF THE MARK.

THE WORDING IS IN BLACK, THE CURVED BAND ON TOP IS GREEN. THE CURVED BANDS AT THE BOTTOM ARE BLUE.

FOR HEADGEAR, NAMELY, HATS, CAPS, HEADBANDS, BEACH HATS, RAINPROOF HATS, BOBBLE HATS, SUN HATS, BOWLER HATS, WOOLLY HATS, STRAW HATS, SPORTS CAPS, BASEBALL CAPS, SKULL CAPS, RIDING CAPS, SWIMMING CAPS, BERETS, BOATERS AND DEERSTALKERS (U.S. CLS. 22 AND 39).

AMY HELLA, EXAMINING ATTORNEY

SN 78-767,936. TRIFIT, LLC, SANTA MONICA, CA. FILED 12-6-2005.



THE COLOR(S) ORANGE, BLACK AND WHITE IS/ARE CLAIMED AS A FEATURE OF THE MARK.

THE MARK CONSISTS OF FIGURE ATTACHED WITH WORD "TRYOGA" NEXT TO IT WITH THE "Y" IN RED. THE CIRCLE AND LETTER "Y" ARE ORANGE, THE LETTERS "T" "R" "O" "G", AND A ARE BLACK, AND THE FIGURE IN THE CIRCLE IS WHITE.

FOR EXERCISE CLOTHING FOR YOGA, NAMELY, SWEATPANTS, SWEATSHIRTS, T-SHIRTS, AND SOCKS (U.S. CLS. 22 AND 39).

JOHN WILKE, EXAMINING ATTORNEY

CLASS 25—(Continued).

SN 78-773,604. WARNER BROS. ENTERTAINMENT INC., BURBANK, CA. FILED 12-14-2005.

DAISY DUKE

THE MARK CONSISTS OF STANDARD CHARACTERS WITHOUT CLAIM TO ANY PARTICULAR FONT, STYLE, SIZE, OR COLOR.

THE NAME "DAISY DUKE" DOES NOT IDENTIFY A LIVING INDIVIDUAL.

FOR CLOTHING FOR MEN, WOMEN AND CHILDREN, NAMELY, SHIRTS, T-SHIRTS, SWEATSHIRTS, JOGGING SUITS, TROUSERS, PANTS, TANK TOPS, RAINWEAR, CLOTH BABY BIBS, SKIRTS, BLOUSES, DRESSES, SUSPENDERS, SWEATERS, JACKETS, COATS, RAINCOATS, SNOW SUITS, TIES, ROBES, HATS, CAPS, SUNVISORS, BELTS, SCARVES, SLEEPWEAR, PAJAMAS, LINGERIE, UNDERWEAR, BOOTS, SHOES, SNEAKERS, SANDALS, BOOTIES, SLIPPER SOCKS, SWIMWEAR AND MASQUERADE AND HALLOWEEN COSTUMES AND MASKS SOLD IN CONNECTION THEREWITH (U.S. CLS. 22 AND 39).

LAURA HAMMEL, EXAMINING ATTORNEY

SN 78-833,726. NORDSTROM, INC., SEATTLE, WA. FILED 3-9-2006.

BP.

THE MARK CONSISTS OF STANDARD CHARACTERS WITHOUT CLAIM TO ANY PARTICULAR FONT, STYLE, SIZE, OR COLOR.

OWNER OF U.S. REG. NO. 3,027,963.

FOR GIRL'S AND YOUNG WOMEN'S FASHION CLOTHING, NAMELY, JACKETS, TURTLENECKS, TANK TOPS, DRESSES, SHORTS, OVERALLS, BLAZERS, SWEATERS, CARDIGANS, COATS, SWEATSHIRTS, VESTS, SKIRTS, SWEATPANTS, SHIRTS, LINGERIE, MOCK TURTLENECKS, SOCKS, PANTS AND SKORTS; AND WOMEN'S FOOTWEAR (U.S. CLS. 22 AND 39).

FIRST USE 0-0-1985; IN COMMERCE 0-0-1985.

STEPHEN AQUILA, EXAMINING ATTORNEY

SN 78-853,631. POOLE, GLORIA DEAN, UPPER MARLBORO, MD. FILED 4-4-2006.

DYNKE

THE MARK CONSISTS OF STANDARD CHARACTERS WITHOUT CLAIM TO ANY PARTICULAR FONT, STYLE, SIZE, OR COLOR.

FOR TOPS (U.S. CLS. 22 AND 39).

RICHARD A. STRASER, EXAMINING ATTORNEY

CLASS 25—(Continued).

SN 78-856,937. LESLIE ALESSANDRO, LOS ANGELES, CA. FILED 4-7-2006.

BLACK GIRLS RULE

THE MARK CONSISTS OF STANDARD CHARACTERS WITHOUT CLAIM TO ANY PARTICULAR FONT, STYLE, SIZE, OR COLOR.

FOR DENIMS; DRESSES; GYM SUITS; HATS; HEADGEAR, NAMELY, HEADBANDS, SCARVES, CAPS; HOODS; JACKETS; JERSEYS; JOGGING SUITS; KNIT SHIRTS; NIGHT SHIRTS; PANTS; SHIRTS; SHORT-SLEEVED OR LONG-SLEEVED T-SHIRTS; SKIRTS; SLEEP SHIRTS; SLEEPWEAR; SPORT SHIRTS; SPORTS SHIRTS WITH SHORT SLEEVES; SWEAT PANTS; SWEAT SHIRTS; SWEAT SUITS; T-SHIRTS; TANK TOPS; TOPS (U.S. CLS. 22 AND 39).

CAROL SPILS, EXAMINING ATTORNEY

SN 78-869,640. D.L.S. OUTFITTERS, INC., NEW YORK, NY. FILED 4-26-2006.



NO CLAIM IS MADE TO THE EXCLUSIVE RIGHT TO USE "COLLECTION", APART FROM THE MARK AS SHOWN.

THE COLOR(S) RED, GREEN AND YELLOW IS/ARE CLAIMED AS A FEATURE OF THE MARK.

THE COLOR RED APPEARS IN THE LETTERING "JUDSON", THE COLOR GREEN APPEARS IN THE LETTERING "WADE" AND "COLLECTION". THE COLOR YELLOW APPEARS IN THE BACKGROUND OF THE RECTANGLE DESIGN ELEMENT IN THE MARK.

FOR CLOTHING, NAMELY, SLACKS, PANTS, JEANS, JACKETS, BLAZERS, SPORT COATS, SUITS, SHIRTS, TIES, OUTERWEAR, NAMELY OVERCOATS, RAINCOATS, AND WIND RESISTANT JACKETS, FOOTWEAR, SKIRTS, BLOUSES, BELTS, HATS, SCARVES AND SOCKS (U.S. CLS. 22 AND 39).

FIRST USE 7-3-2006; IN COMMERCE 8-7-2006.

GEORGIA CARTY, EXAMINING ATTORNEY

CLASS 25—(Continued).

SN 78-918,399. ZHUJI TAIRONG KNITTING CO., LTD, ZHEJIANG, CHINA, FILED 6-28-2006.

FootForward

THE MARK CONSISTS OF STANDARD CHARACTERS WITHOUT CLAIM TO ANY PARTICULAR FONT, STYLE, SIZE, OR COLOR.

FOR ANKLE SOCKS, ANKLETS SOCKS, ANTI-PERSPIRANT SOCKS, ATHLETIC FOOTWEAR, BODY STOCKINGS, HOSIERY, JAPANESE STYLE SOCKS (TABI COVERS), JAPANESE STYLE SOCKS (TABI), MEN'S SOCKS, SOCK SUSPENDERS, SOCKS, SOCKS AND STOCKINGS, STOCKINGS, STOCKINGS SWEAT-ABSORBENT, SWEATSOCKS, THERMAL SOCKS, TIGHTS, WATER SOCKS, WOOLLEN SOCKS (U.S. CLS. 22 AND 39).

GEORGE LORENZO, EXAMINING ATTORNEY

CLASS 25—(Continued).

SN 79-014,430. ZELAL GIYIM SANAYI VE TICARET LIMITED SIRKETI, BOMONTI-SISLI/ISTANBUL, TURKEY, FILED 12-31-2004.



OWNER OF INTERNATIONAL REGISTRATION 0859895 DATED 12-31-2004, EXPIRES 12-31-2014.

THE FOREIGN WORDING IN THE MARK TRANSLATES INTO ENGLISH AS APPLE JUICE.

FOR CARDIGANS, JEANS, CLOTHING OF LEATHER, NAMELY, LEATHER COATS, LEATHER JACKETS; TRACK SUITS; BATHING SUITS, BEACHWEAR, UNDERWEAR, GLOVES, NAMELY, BICYCLE GLOVES, RIDING GLOVES; SOCKS; SHOES, BOOTS, SLIPPERS, SPORTS SHOES, NAMELY, FOOTBALL SHOES, GYMNASIIC SHOES, STOCKINGS, OVERSHOES; HEADGEAR, NAMELY, HATS, CAPS; BIBS NOT OF PAPER FOR CHILDREN; NECKTIES, BOW-TIES, FOULARDS, SHAWLS, SCARVES, CLOTHING, NAMELY, COLLARS, MUFFS, BANDANAS IN THE NATURE OF NECKERCHIEFS, WRISTBANDS, AND BELTS; SUSPENDERS, AND ANKLE GARTERS (U.S. CLS. 22 AND 39).

JULIE WATSON, EXAMINING ATTORNEY

SN 79-038,632. LES GANTS ELEGANTS, F-92100 BOULOGNE BILLANCOURT, FRANCE, FILED 3-8-2007.

Saona®

OWNER OF INTERNATIONAL REGISTRATION 0924613 DATED 3-8-2007, EXPIRES 3-8-2017.

THE WORDING "SAONA" HAS NO MEANING IN A FOREIGN LANGUAGE.

FOR CLOTHING, NAMELY, SKIRTS, DRESSES, COATS, SHIRTS, PANTS, BUSTIERS, AND JACKETS (U.S. CLS. 22 AND 39).

DEZMONA MIZELLE, EXAMINING ATTORNEY

SN 78-932,718. MY BODY ROCKS, LLC., LARGO, FL. FILED 7-19-2006.

THE COLOR(S) PINK IS/ARE CLAIMED AS A FEATURE OF THE MARK.

THE MARK CONSISTS OF THE LETTER "M" WITH A SYLIZED "Y" THIS IS A REPRESENTATION OF A PERSON, THE WORDS "BODY ROCKS!" WITH THE COLOR PINK APPEARING IN THE WORDING "MY BODY ROCKS!" AND IN THE STYLIZED FIGURE DESIGN.

FOR SPORT SHIRTS; SPORTS BRA; SPORTS JACKETS; SPORTS JERSEYS; SPORTS JERSEYS AND BREECHES FOR SPORTS; SPORTS OVERUNIFORMS; SPORTS SHIRTS; SPORTS SHIRTS WITH SHORT SLEEVES (U.S. CLS. 22 AND 39).

SETH A. RAPPAPORT, EXAMINING ATTORNEY

SN 79-043,720. RIPSTOP LLP, LURGAN, CRAIGAVON, UNITED KINGDOM, FILED 8-28-2007.



PRIORITY DATE OF 3-22-2007 IS CLAIMED. OWNER OF INTERNATIONAL REGISTRATION 0937138 DATED 8-28-2007, EXPIRES 8-28-2017.

FOR FOOTWEAR (U.S. CLS. 22 AND 39).

DANIEL BRODY, EXAMINING ATTORNEY

CLASS 25—(Continued).

SN 79-043,723. RIPSTOP LLP, LURGAN, CRAIGAVON,
UNITED KINGDOM, FILED 8-28-2007.

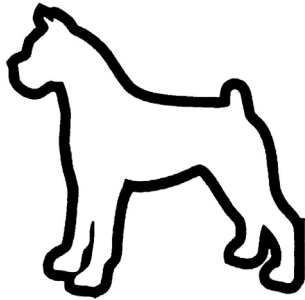

PRIORITY DATE OF 3-22-2007 IS CLAIMED.
OWNER OF INTERNATIONAL REGISTRATION 0937142
DATED 8-28-2007, EXPIRES 8-28-2017.
FOR FOOTWEAR (U.S. CLS. 22 AND 39).
DANIEL BRODY, EXAMINING ATTORNEY

SN 79-045,187. BALDOVI GIL, ROBERTO, SPAIN, FILED 4-
23-2007.



PRIORITY DATE OF 11-2-2006 IS CLAIMED.
OWNER OF INTERNATIONAL REGISTRATION 0940825
DATED 4-23-2007, EXPIRES 4-23-2017.
FOR CLOTHING, NAMELY, SHIRTS, TROUSERS,
SKIRTS, JACKETS, CAPS, BONNETS, SHOES, SPORTS
FOOTWEAR, BELTS, HANDKERCHIEVES, SCARVES,
AND GLOVES (U.S. CLS. 22 AND 39).
REGINA DRUMMOND, EXAMINING ATTORNEY

CLASS 25—(Continued).

SN 79-045,294. VIDORRETA, S.L., SPAIN, FILED 9-28-2007.



OWNER OF INTERNATIONAL REGISTRATION 0941173
DATED 9-28-2007, EXPIRES 9-28-2017.
THE COLOR(S) BROWN AND YELLOW IS/ARE
CLAIMED AS A FEATURE OF THE MARK.
THE MARK CONSISTS OF THE WORD "VIDORRETA"
SUPERIMPOSED ON TOPE OF A CIRCLE OF SWIRLY
LINES. THE COLOR BROWN APPEARS IN THE WORDING
"VIDORRETA", WHILE THE COLOR YELLOW APPEARS
IN THE SWIRLS THAT SURROUND THE WORD "VIDOR-
RETA".
FOR SUITS, SOLES FOR FOOTWEAR (U.S. CLS. 22
AND 39).
INGA ERVIN, EXAMINING ATTORNEY

SN 79-047,760. ALBY SRL, ITALY, FILED 11-21-2007.

PAOLO ALBIZZATI

OWNER OF INTERNATIONAL REGISTRATION 0947573
DATED 11-21-2007, EXPIRES 11-21-2017.
THE NAME "PAOLO ALBIZZATI" IDENTIFIES A LIVING
INDIVIDUAL WHOSE CONSENT IS OF RECORD.
FOR CLOTHING, NAMELY, NECKWEAR, SHIRTS
(U.S. CLS. 22 AND 39).
PAULA MAHONEY, EXAMINING ATTORNEY

CLASS 26—FANCY GOODS

SN 77-235,478. NEARY, LYNN L., COTATI, CA. FILED 7-22-2007.



NO CLAIM IS MADE TO THE EXCLUSIVE RIGHT TO USE "ACCESSORIES", APART FROM THE MARK AS SHOWN.

THE COLOR(S) GOLD IS/ARE CLAIMED AS A FEATURE OF THE MARK.

THE MARK CONSISTS OF THE WORDING "KIKIBEE" FEATURED AGAINST A RIBBON BACKGROUND TOGETHER WITH A BEE DESIGN SURROUNDED BY OLIVE BRANCHES ALL INSIDE A LEOPARD PATTERN CREST AND FEATURING A CROWN WITH FIVE BEES ABOVE THE CREST DESIGN. THE WORDING "ACCESSORIES" IS BELOW THE RIBBON DESIGN. ALL ELEMENTS OF THE MARK ARE IN THE COLOR GOLD. THE COLOR WHITE IS FEATURED AS BACKGROUND OR TRANSPARENT AND IS NOT A FEATURE OF THE MARK.

FOR HAIR RIBBONS; HAIR SCRUNCHIES; HAIR ACCESSORIES, NAMELY, CLAW CLIPS; HAIR ACCESSORIES, NAMELY, SNAP CLIPS; HAIR ACCESSORIES, NAMELY, TWISTERS; HAIR BANDS; HAIR BARRETTES; HAIR BOWS; HAIR CLIPS (U.S. CLS. 37, 39, 40, 42 AND 50).

LINDA ESTRADA, EXAMINING ATTORNEY

SN 77-347,476. BROWN-LAWSON, EGYPT P., NEW YORK, NY. FILED 12-9-2007.

Hairline Illusions

THE MARK CONSISTS OF STANDARD CHARACTERS WITHOUT CLAIM TO ANY PARTICULAR FONT, STYLE, SIZE, OR COLOR.

NO CLAIM IS MADE TO THE EXCLUSIVE RIGHT TO USE "HAIRLINE". APART FROM THE MARK AS SHOWN. FOR HAIR PIECES AND WIGS (U.S. CLS. 37, 39, 40, 42 AND 50).

FIRST USE 6-30-2004; IN COMMERCE 12-1-2007.
STEPHEN AQUILA, EXAMINING ATTORNEY

CLASS 26—(Continued).

SN 77-395,089. PAYLESS SHOESOURCE WORLDWIDE, INC., TOPEKA, KS. FILED 2-12-2008.

I LOVE SHOES

THE MARK CONSISTS OF STANDARD CHARACTERS WITHOUT CLAIM TO ANY PARTICULAR FONT, STYLE, SIZE, OR COLOR.

OWNER OF U.S. REG. NO. 2,646,852.

NO CLAIM IS MADE TO THE EXCLUSIVE RIGHT TO USE "SHOES", APART FROM THE MARK AS SHOWN.

FOR SHOE LACES AND SHOE ORNAMENTS NOT OF PRECIOUS METAL, AND HAIR ACCESSORIES, NAMELY, BARRETTES, HAIR BOWS, HAIR CLIPS, HAIR RIBBONS, HAIR ORNAMENTS IN THE NATURE OF HAIR WRAPS, HAIR BANDS, HAIRPINS, PONYTAIL HOLDERS, CONTOUR CLIPS, CLAW CLIPS, AND MINI CLAW CLIPS; LACE AND EMBROIDERY, RIBBONS AND BRAID; BUTTONS, HOOKS AND EYES, PINS AND NEEDLES; ARTIFICIAL FLOWERS (U.S. CLS. 37, 39, 40, 42 AND 50).

WANDA KAY PRICE, EXAMINING ATTORNEY

SN 77-398,291. PAYLESS SHOESOURCE WORLDWIDE, INC., TOPEKA, KS. FILED 2-15-2008.

WE LOVE SHOES

THE MARK CONSISTS OF STANDARD CHARACTERS WITHOUT CLAIM TO ANY PARTICULAR FONT, STYLE, SIZE, OR COLOR.

OWNER OF U.S. REG. NO. 2,646,852.

NO CLAIM IS MADE TO THE EXCLUSIVE RIGHT TO USE "SHOES", APART FROM THE MARK AS SHOWN.

FOR SHOE LACES AND SHOE ORNAMENTS NOT OF PRECIOUS METAL, AND HAIR ACCESSORIES, NAMELY, BARRETTES, HAIR BOWS, HAIR CLIPS, HAIR RIBBONS, HAIR ORNAMENTS IN THE NATURE OF HAIR WRAPS, HAIR BANDS, HAIRPINS, PONYTAIL HOLDERS, CONTOUR CLIPS, CLAW CLIPS, AND MINI CLAW CLIPS; LACE AND EMBROIDERY, RIBBONS AND BRAID; BUTTONS, HOOKS AND EYES, PINS AND NEEDLES; ARTIFICIAL FLOWERS (U.S. CLS. 37, 39, 40, 42 AND 50).

WANDA KAY PRICE, EXAMINING ATTORNEY

CLASS 26—(Continued).

SN 77-398,376. PAYLESS SHOESOURCE WORLDWIDE, INC., TOPEKA, KS. FILED 2-15-2008.



OWNER OF U.S. REG. NO. 2,646,852.

NO CLAIM IS MADE TO THE EXCLUSIVE RIGHT TO USE "SHOES", APART FROM THE MARK AS SHOWN.

THE MARK CONSISTS OF THE WORD "I" IN A STYLIZED FORMAT FOLLOWED BY THE STYLIZED DESIGN OF A HEART FOLLOWED BY THE WORD "SHOES" IN A STYLIZED FORMAT.

FOR SHOE LACES AND SHOE ORNAMENTS NOT OF PRECIOUS METAL, AND HAIR ACCESSORIES, NAMELY, BARRETTES, HAIR BOWS, HAIR CLIPS, HAIR RIBBONS, HAIR ORNAMENTS IN THE NATURE OF HAIR WRAPS, HAIR BANDS, HAIRPINS, PONYTAIL HOLDERS, CONTOUR CLIPS, CLAW CLIPS, AND MINI CLAW CLIPS; LACE AND EMBROIDERY, RIBBONS AND BRAID; BUTTONS, HOOKS AND EYES, PINS AND NEEDLES; ARTIFICIAL FLOWERS (U.S. CLS. 37, 39, 40, 42 AND 50).

WANDA KAY PRICE, EXAMINING ATTORNEY

SN 77-424,010. GREEN, SHAWONIKA S, HOUSTON, TX. FILED 3-17-2008.

Divas Wear Lace

THE MARK CONSISTS OF STANDARD CHARACTERS WITHOUT CLAIM TO ANY PARTICULAR FONT, STYLE, SIZE, OR COLOR.

FOR HAIR PIECES AND WIGS (U.S. CLS. 37, 39, 40, 42 AND 50).

RENEE SERVANACE, EXAMINING ATTORNEY

SN 77-425,756. PANDUIT CORP., TINLEY PARK, IL. FILED 3-19-2008.

GECK-TAPE

THE MARK CONSISTS OF STANDARD CHARACTERS WITHOUT CLAIM TO ANY PARTICULAR FONT, STYLE, SIZE, OR COLOR.

FOR HOOK AND LOOP TAPE FOR FASTENING ELECTRICAL CONDUCTORS (U.S. CLS. 37, 39, 40, 42 AND 50).

TASHIA BUNCH, EXAMINING ATTORNEY

CLASS 26—(Continued).

SN 77-427,848. SAVAGE DESIGNS, INC., TOPANGA, CA. FILED 3-20-2008.

JUNGALI DREADS

THE MARK CONSISTS OF STANDARD CHARACTERS WITHOUT CLAIM TO ANY PARTICULAR FONT, STYLE, SIZE, OR COLOR.

NO CLAIM IS MADE TO THE EXCLUSIVE RIGHT TO USE "DREADS", APART FROM THE MARK AS SHOWN.

THE FOREIGN WORDING IN THE MARK TRANSLATES INTO ENGLISH AS WILD.

FOR HAIR EXTENSIONS (U.S. CLS. 37, 39, 40, 42 AND 50).

TANYA AMOS, EXAMINING ATTORNEY

SN 77-430,682. SHAINSWARE, LOS ANGELES, CA. FILED 3-25-2008.

SHAINS

THE MARK CONSISTS OF STANDARD CHARACTERS WITHOUT CLAIM TO ANY PARTICULAR FONT, STYLE, SIZE, OR COLOR.

FOR SMALL DECORATIVE OBJECTS MADE OF RUBBER, PLASTIC, PASTE, GLASS, NON-PRECIOUS STONES OR NON-PRECIOUS METAL, NAMELY, SHOE ORNAMENTS, BUTTONS FOR CLOTHING, BROOCHES AS CLOTHING ACCESSORIES AND NOT AS IMITATION JEWELRY, SNAP FASTENERS, SLIDE FASTENERS, AND ZIPPER FASTENERS (U.S. CLS. 37, 39, 40, 42 AND 50).

FIRST USE 7-30-2007; IN COMMERCE 7-30-2007.

MARIA-VICTORIA SUAREZ, EXAMINING ATTORNEY

SN 77-431,764. TURNER, PAMELA S., DBA PST INNOVATIONS, BLAINE, MN. FILED 3-26-2008.

Spiral Eye

THE MARK CONSISTS OF STANDARD CHARACTERS WITHOUT CLAIM TO ANY PARTICULAR FONT, STYLE, SIZE, OR COLOR.

NO CLAIM IS MADE TO THE EXCLUSIVE RIGHT TO USE "EYE", APART FROM THE MARK AS SHOWN.

FOR NEEDLES; SEWING NEEDLES; (BASED ON INTENT TO USE) SEWING MACHINE NEEDLES (U.S. CLS. 37, 39, 40, 42 AND 50).

FIRST USE 10-1-2006; IN COMMERCE 10-1-2007.

H. M. FISHER, EXAMINING ATTORNEY

CLASS 26—(Continued).

SN 77-432,671. WING SUN METAL PRODUCTS LIMITED, NEW TERRITORIES, HONG KONG, FILED 3-26-2008.

WING SUN

THE MARK CONSISTS OF STANDARD CHARACTERS WITHOUT CLAIM TO ANY PARTICULAR FONT, STYLE, SIZE, OR COLOR.

FOR LACE AND EMBROIDERY; RIBBONS AND BRAID; BUTTONS, HOOKS AND EYES; SEWING PINS; NEEDLES; ARTIFICIAL FLOWERS; BEADS OTHER THAN FOR MAKING JEWELRY; ORNAMENTAL NOVELTY BADGES; HAT ORNAMENTS NOT OF PRECIOUS METAL; SHOE ORNAMENTS NOT OF PRECIOUS METAL; BUCKLES FOR CLOTHING; ZIPPERS; HAIR ORNAMENTS; ARTIFICIAL FRUIT; COLLAR STAYS; ORNAMENTAL CLOTH PATCHES; COMPETITORS' NUMBERS NOT OF TEXTILE; TEA COSIES (U.S. CLS. 37, 39, 40, 42 AND 50).

FIRST USE 6-15-1976; IN COMMERCE 1-1-1980. SANDRA MANIOS, EXAMINING ATTORNEY

CLASS 27—FLOOR COVERINGS

SN 77-094,443. COLUMBIA INSURANCE COMPANY, OMAHA, NE. FILED 1-30-2007.

BUILDER SELECT

THE MARK CONSISTS OF STANDARD CHARACTERS WITHOUT CLAIM TO ANY PARTICULAR FONT, STYLE, SIZE, OR COLOR.

SEC. 2(F) AS TO "BUILDER". FOR CARPETING (U.S. CLS. 19, 20, 37, 42 AND 50). FIRST USE 7-31-2000; IN COMMERCE 7-31-2000. SETH A. RAPPAPORT, EXAMINING ATTORNEY

SN 77-258,109. MILLIKEN & COMPANY, SPARTANBURG, SC. FILED 8-17-2007.

MEGAHOLD

THE MARK CONSISTS OF STANDARD CHARACTERS WITHOUT CLAIM TO ANY PARTICULAR FONT, STYLE, SIZE, OR COLOR.

FOR DOOR MATS, FLOOR MATS, AND ANTI-FATIGUE FLOOR MATS (U.S. CLS. 19, 20, 37, 42 AND 50). MICHAEL LEWIS, EXAMINING ATTORNEY

SN 79-044,718. YKK CORPORATION, JAPAN, FILED 9-4-2007.

QUICKLOOP

PRIORITY DATE OF 8-7-2007 IS CLAIMED. OWNER OF INTERNATIONAL REGISTRATION 0939807 DATED 9-4-2007, EXPIRES 9-4-2017.

OWNER OF U.S. REG. NOS. 2,691,908 AND 3,202,371. FOR SLIDE FASTENERS; SNAP BUTTONS BEING SNAP FASTENERS; BUTTONS; HOOK AND LOOP FASTENERS FOR USE IN FASTENING AUTOMOBILE SEAT COVERS; HOOK FASTENING TAPES BEING FASTENERS FOR CLOTHING AND FOOTWEAR; PILE FASTENING TAPES BEING FASTENERS FOR CLOTHING AND FOOTWEAR; HOOK AND EYES; ELASTIC RIBBONS; BUCKLES FOR CLOTHING; BUCKLES FOR SHOES; EYELETS FOR CLOTHES; EYELETS FOR SHOES; SWIVEL HOOKS BEING CLOTHING HOOKS (U.S. CLS. 37, 39, 40, 42 AND 50).

RUDY R. SINGLETON, EXAMINING ATTORNEY

SN 77-427,522. MILLIKEN & COMPANY, SPARTANBURG, SC. FILED 3-20-2008.

ECOUNTABILITY

THE MARK CONSISTS OF STANDARD CHARACTERS WITHOUT CLAIM TO ANY PARTICULAR FONT, STYLE, SIZE, OR COLOR.

FOR CARPETS, CARPET TILES, RUGS AND FLOOR MATS FOR USE IN RESIDENTIAL AND COMMERCIAL ESTABLISHMENTS (U.S. CLS. 19, 20, 37, 42 AND 50).

KELLY MCCOY, EXAMINING ATTORNEY

CLASS 27—(Continued).

SN 77-430,110. SAXONY DISTRIBUTORS, INC., DELRAY BEACH, FL. FILED 3-24-2008.



THE COLOR(S) BLACK AND RED IS/ARE CLAIMED AS A FEATURE OF THE MARK.

THE MARK CONSISTS OF THE WORD "SAXONY" WITH THE CAPITAL LETTER "S" IN RED AND SHADOWED WITH A BLACK/GRAY "S" UNDERNEATH IT AND THE LETTERS "AXONY" IN BLACK.

FOR FLOOR COVERINGS (U.S. CLS. 19, 20, 37, 42 AND 50).

FIRST USE 1-1-2006; IN COMMERCE 1-1-2006.
HOWARD SMIGA, EXAMINING ATTORNEY

SN 77-430,588. HELLAS CONSTRUCTION, INC., AUSTIN, TX. FILED 3-25-2008.

AXIS

THE MARK CONSISTS OF STANDARD CHARACTERS WITHOUT CLAIM TO ANY PARTICULAR FONT, STYLE, SIZE, OR COLOR.

FOR SYNTHETIC TURF (U.S. CLS. 19, 20, 37, 42 AND 50).

SUZANNE BLANE, EXAMINING ATTORNEY

SN 77-430,599. HELLAS CONSTRUCTION, INC., AUSTIN, TX. FILED 3-25-2008.

SOLO

THE MARK CONSISTS OF STANDARD CHARACTERS WITHOUT CLAIM TO ANY PARTICULAR FONT, STYLE, SIZE, OR COLOR.

FOR SYNTHETIC TURF (U.S. CLS. 19, 20, 37, 42 AND 50).

SUZANNE BLANE, EXAMINING ATTORNEY

CLASS 27—(Continued).

SN 77-431,191. MANNINGTON MILLS, INC., SALEM, NJ. FILED 3-25-2008.

V2TECH

THE MARK CONSISTS OF STANDARD CHARACTERS WITHOUT CLAIM TO ANY PARTICULAR FONT, STYLE, SIZE, OR COLOR.

FOR RESILIENT HARD SURFACE COVERING FOR FLOORS, WALLS AND OTHER SURFACES (U.S. CLS. 19, 20, 37, 42 AND 50).

KEVIN DINALLO, EXAMINING ATTORNEY

SN 77-436,938. MILLIKEN & COMPANY, SPARTANBURG, SC. FILED 4-1-2008.



MILLIKEN

THE MARK CONSISTS OF ROUND CIRCLE SEPARATED IN THE MIDDLE CONTAINING THE WORD "ECO" ABOVE THE NUMBER "360", AND THE WORD "MILLIKEN" IS SHOWN UNDERNEATH.

FOR CARPETS, CARPET TILES, RUGS AND FLOOR MATS FOR USE IN RESIDENTIAL AND COMMERCIAL ESTABLISHMENTS (U.S. CLS. 19, 20, 37, 42 AND 50).

KELLY MCCOY, EXAMINING ATTORNEY

SN 77-455,431. MANNINGTON MILLS, INC., SALEM, NJ. FILED 4-23-2008.

CHOICES THAT WORK

THE MARK CONSISTS OF STANDARD CHARACTERS WITHOUT CLAIM TO ANY PARTICULAR FONT, STYLE, SIZE, OR COLOR.

FOR CARPET BACKING; CARPET TILES; CARPETING; RESILIENT HARD SURFACE COVERING FOR FLOORS, WALLS AND OTHER SURFACES (U.S. CLS. 19, 20, 37, 42 AND 50).

FIRST USE 11-1-2007; IN COMMERCE 11-1-2007.

KEVIN DINALLO, EXAMINING ATTORNEY

CLASS 28—TOYS AND SPORTING GOODS

SN 76-681,050. ALLEN, SHAWN E., HAUGHTON, LA. FILED 8-23-2007.



NO CLAIM IS MADE TO THE EXCLUSIVE RIGHT TO USE "SKIRT TOOL", APART FROM THE MARK AS SHOWN.

FOR DEVICE FOR APPLYING RESILIENT RINGS TO FISHING LURE SKIRTS (U.S. CLS. 22, 23, 38 AND 50).
TRACY CROSS, EXAMINING ATTORNEY

SN 76-681,541. YONEX KABUSHIKI KAISHA, TOKYO, JAPAN, FILED 9-6-2007.

IMPACT SPEED

THE MARK CONSISTS OF STANDARD CHARACTERS WITHOUT CLAIM TO ANY PARTICULAR FONT, STYLE, SIZE, OR COLOR.

FOR GOLF CLUBS (U.S. CLS. 22, 23, 38 AND 50).
ALICE SUE CARRUTHERS, EXAMINING ATTORNEY

SN 76-682,626. FINIS, INC., LIVERMORE, CA. FILED 10-2-2007.

FINIS

THE MARK CONSISTS OF STANDARD CHARACTERS WITHOUT CLAIM TO ANY PARTICULAR FONT, STYLE, SIZE, OR COLOR.

THE ENGLISH TRANSLATION OF THE FRENCH WORD "FINIS" IS "COMPLETE" OR "CONCLUDED."

FOR SWIM FINS AND SWIM PADDLES (U.S. CLS. 22, 23, 38 AND 50).

FIRST USE 1-8-1995; IN COMMERCE 1-8-1995.
SETH A. RAPPAPORT, EXAMINING ATTORNEY

CLASS 28—(Continued).

SN 76-685,325. TECH ART, INC., LAS VEGAS, NV. FILED 12-27-2007.

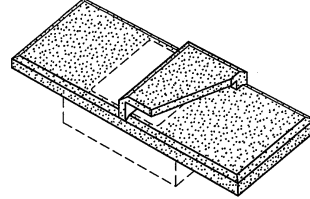

OWNER OF U.S. REG. NOS. 1,762,122 AND 1,798,804.
THE STIPPLING IS FOR SHADING PURPOSES ONLY AND DOES NOT INDICATE COLOR.

THE MARK CONSISTS OF THE PRODUCT CONFIGURATION OF AN OPTICAL PLAYING CARD CHARACTER READER. THE PRODUCT CONFIGURATION INCLUDES A FLAT MEMBER TO WHICH IS ATTACHED A HOOD. THE BOTTOM HOUSING AND THE OPENING IN THE FLAT MEMBER ARE SHOWN IN PHANTOM, ARE NOT PART OF THE MARK, AND SERVE ONLY TO INDICATE THE POSITION OF THE MARK.

SEC. 2(F).

FOR NON-METAL, NON-ELECTRONIC PLAYING CARD HOUSING THAT ALLOWS THE USER TO READ PLAYING CARDS (U.S. CLS. 22, 23, 38 AND 50).

FIRST USE 4-0-1990; IN COMMERCE 4-0-1992.

TRACY CROSS, EXAMINING ATTORNEY

SN 76-687,299. QUAGLIA, BRIAN, WARWICK, RI. FILED 3-3-2008.

JIU LING

THE MARK CONSISTS OF STANDARD CHARACTERS WITHOUT CLAIM TO ANY PARTICULAR FONT, STYLE, SIZE, OR COLOR.

THE NAME "JIU LING" DOES NOT IDENTIFY A LIVING INDIVIDUAL.

THE ENGLISH TRANSLATION OF THE WORD "JIU LING" IN THE MARK IS "ONLY KING."

FOR A GAME, NAMELY, A BOARD AND DICE DRINKING GAME INVOLVING TRICKERY, DECEPTION AND BLUFF (U.S. CLS. 22, 23, 38 AND 50).

FIRST USE 2-16-2008; IN COMMERCE 2-16-2008.

CARYN GLASSER, EXAMINING ATTORNEY

SN 76-688,000. NATURE VISION, INC., BRAINERD, MN. FILED 3-24-2008.

JERKY J

THE MARK CONSISTS OF STANDARD CHARACTERS WITHOUT CLAIM TO ANY PARTICULAR FONT, STYLE, SIZE, OR COLOR.

FOR ARTIFICIAL FISHING LURES (U.S. CLS. 22, 23, 38 AND 50).

FIRST USE 6-1-2007; IN COMMERCE 9-1-2007.

LINDSEY RUBIN, EXAMINING ATTORNEY

CLASS 28—(Continued).

SN 77-093,523. SPIN MASTER LTD., TORONTO, ONTARIO, CANADA, FILED 1-29-2007.

FUR BERRIES

THE MARK CONSISTS OF STANDARD CHARACTERS WITHOUT CLAIM TO ANY PARTICULAR FONT, STYLE, SIZE, OR COLOR.

PRIORITY CLAIMED UNDER SEC. 44(D) ON CANADA APPLICATION NO. 1324870, FILED 11-20-2006, REG. NO. TMA710475, DATED 3-31-2008, EXPIRES 3-31-2023.

NO CLAIM IS MADE TO THE EXCLUSIVE RIGHT TO USE "FUR", APART FROM THE MARK AS SHOWN.

FOR PLUSH TOYS, NAMELY, PLUSH BALLS THAT CAN BE TRANSFORMED INTO PLUSH ANIMALS (U.S. CLS. 22, 23, 38 AND 50).

AHSEN KHAN, EXAMINING ATTORNEY

SN 77-093,528. SPIN MASTER LTD., TORONTO, ONTARIO, CANADA, FILED 1-29-2007.

HAVOC HELI

THE MARK CONSISTS OF STANDARD CHARACTERS WITHOUT CLAIM TO ANY PARTICULAR FONT, STYLE, SIZE, OR COLOR.

PRIORITY CLAIMED UNDER SEC. 44(D) ON CANADA APPLICATION NO. 1328211, FILED 12-14-2006, REG. NO. TMA713633, DATED 5-6-2008, EXPIRES 5-6-2023.

NO CLAIM IS MADE TO THE EXCLUSIVE RIGHT TO USE "HELI", APART FROM THE MARK AS SHOWN.

FOR FLYING TOYS, NAMELY, TOY AIRCRAFT AND TOY HELICOPTERS (U.S. CLS. 22, 23, 38 AND 50).

AHSEN KHAN, EXAMINING ATTORNEY

SN 77-106,850. WEBB, QUENTIN, NEW YORK, NY. FILED 2-13-2007.

SOCK ORPHANS

THE MARK CONSISTS OF STANDARD CHARACTERS WITHOUT CLAIM TO ANY PARTICULAR FONT, STYLE, SIZE, OR COLOR.

NO CLAIM IS MADE TO THE EXCLUSIVE RIGHT TO USE "SOCK", APART FROM THE MARK AS SHOWN.

FOR PLUSH TOYS; SOFT SCULPTURE PLUSH TOYS; SOFT SCULPTURE TOYS; STUFFED TOYS (U.S. CLS. 22, 23, 38 AND 50).

FIRST USE 11-15-2005; IN COMMERCE 5-1-2006.
ANNE E. GUSTASON, EXAMINING ATTORNEY

CLASS 28—(Continued).

SN 77-114,109. WONDERWORX LLC, ASPEN, CO. FILED 2-22-2007.



THE MARK CONSISTS OF A MUSICAL NOTE WITH A PERSON SHAPED AS ANOTHER MUSICAL NOTE SWINGING FROM THE LARGER MUSICAL NOTE.

FOR PLAYGROUND EQUIPMENT, NAMELY, SEESAWS; SWINGS; TEETER-TOTTERS; AND SPINNING, BOUNCING AND ROTATING CHAIRS AND PLATFORMS, NAMELY, MERRY GO ROUNDS, CAROUSELS, AND RIDERS, NAMELY RIDE-ON TOYS, ROCKING HORSES, AND SPRING RIDERS (U.S. CLS. 22, 23, 38 AND 50).

FIRST USE 6-29-2006; IN COMMERCE 8-29-2006.
JENNIFER VASQUEZ, EXAMINING ATTORNEY

SN 77-114,113. WONDERWORX LLC, ASPEN, CO. FILED 2-22-2007.

WonderWorx

OWNER OF U.S. REG. NO. 3,112,594.

THE MARK CONSISTS OF THE WORD "WONDERWORX" WITH MUSICAL NOTES IN THE PLACE OF THE "N" AND THE SECOND "O".

FOR PLAYGROUND EQUIPMENT, NAMELY, SEESAWS; SWINGS; TEETER-TOTTERS; AND SPINNING, BOUNCING AND ROTATING CHAIRS AND PLATFORMS, NAMELY, MERRY GO ROUNDS, CAROUSELS, AND RIDERS, NAMELY, RIDE-ON TOYS, ROCKING HORSES, AND SPRING RIDERS (U.S. CLS. 22, 23, 38 AND 50).

FIRST USE 6-29-2006; IN COMMERCE 8-29-2006.
AHSEN KHAN, EXAMINING ATTORNEY

CLASS 28—(Continued).

SN 77-164,492. HILDA JANSSEN, ZWIJNDRECHT, NETHERLANDS, FILED 4-24-2007.

FitPads

THE MARK CONSISTS OF STANDARD CHARACTERS WITHOUT CLAIM TO ANY PARTICULAR FONT, STYLE, SIZE, OR COLOR.

PRIORITY CLAIMED UNDER SEC. 44(D) ON BENELUX APPLICATION NO. 1121941, FILED 10-27-2006, REG. NO. 0812054, DATED 2-7-2007, EXPIRES 10-27-2016.

FOR STRUCTURAL PARTS FOR EXERCISE MACHINES, NAMELY, INLAYS FOR PEDALS OF SPORTING AND FITNESS APPARATUS, FLEXIBLE PEDAL INLAYS, ANTI-NUMBNESS PEDAL INLAYS, AND MATS FOR PEDALS OF SPORTING AND FITNESS APPARATUS (U.S. CLS. 22, 23, 38 AND 50).

ELISSA GARBER KON, EXAMINING ATTORNEY



SN 77-166,954. MARUMAN GLOBAL, LA HABRA, CA. FILED 4-26-2007.

NIXXON GOLF

THE MARK CONSISTS OF STANDARD CHARACTERS WITHOUT CLAIM TO ANY PARTICULAR FONT, STYLE, SIZE, OR COLOR.

NO CLAIM IS MADE TO THE EXCLUSIVE RIGHT TO USE "GOLF", APART FROM THE MARK AS SHOWN.

FOR GOLF CLUBS, GOLF IRONS, GOLF DRIVERS, GOLF PUTTERS, GOLF WEDGES, GOLF CLUB BAGS, GOLF BALLS, GOLF CLUB GRIPS, GOLF CLUB HEADS, GOLF CLUB COVERS, AND GOLF GLOVES (U.S. CLS. 22, 23, 38 AND 50).

INGA ERVIN, EXAMINING ATTORNEY

CLASS 28—(Continued).

SN 77-172,629. FOUNTAIN PARTNERS, LLC, PEN ARGYL, PA. FILED 5-4-2007.

HIP CHICAS

THE MARK CONSISTS OF STANDARD CHARACTERS WITHOUT CLAIM TO ANY PARTICULAR FONT, STYLE, SIZE, OR COLOR.

NO CLAIM IS MADE TO THE EXCLUSIVE RIGHT TO USE "CHICAS", APART FROM THE MARK AS SHOWN.

THE FOREIGN WORDING IN THE MARK TRANSLATES INTO ENGLISH AS GIRLS.

FOR DOLLS AND ACCESSORIES THEREFOR; ACTION FIGURES AND ACCESSORIES THEREFOR; BOARD GAMES; RUBBER ACTION BALLS; SOCCER BALLS; SPORT BALLS; TENNIS BALLS; STAND ALONE VIDEO GAME MACHINES; PLUSH TOYS; BABY MULTIPLE ACTIVITY TOYS; BALLOONS; TOY BANKS; BATH TOYS; CARD GAMES; DOLL CLOTHING; DOLL HOUSES; TOY MOBILES; CRIB TOYS; PARTY FAVORS IN THE NATURE OF CRACKERS AND NOISEMAKERS; PARTY FAVORS IN THE NATURE OF SMALL TOYS; DART BOARDS; PUZZLES; KITES; COSTUME MASKS; WATER SQUIRTING TOYS; PAPER DOLLS; IN-LINE SKATES; ROLLER SKATES; TARGET GAMES; CHRISTMAS STOCKINGS; CHRISTMAS TREE DECORATIONS (U.S. CLS. 22, 23, 38 AND 50).

REBECCA GILBERT, EXAMINING ATTORNEY



SN 77-179,704. ELLERBECK, RONALD L., HOUSTON, TX. FILED 5-13-2007.

YIP BUSTER

THE MARK CONSISTS OF STANDARD CHARACTERS WITHOUT CLAIM TO ANY PARTICULAR FONT, STYLE, SIZE, OR COLOR.

NO CLAIM IS MADE TO THE EXCLUSIVE RIGHT TO USE "YIP", APART FROM THE MARK AS SHOWN.

FOR GOLF CHIPPING AND PUTTING TRAINING DEVICES, NAMELY, AN ATTACHMENT TO A GOLF CLUB SHAFT USED TO GUIDE THE HANDS DURING SWING FOR IMPROVING CHIPPING AND PUTTING (U.S. CLS. 22, 23, 38 AND 50).

MARGARET POWER, EXAMINING ATTORNEY

CLASS 28—(Continued).

SN 77-195,789. 3 IN 1 WASHER TOSS, LOS ALAMITOS, CA. FILED 6-1-2007.

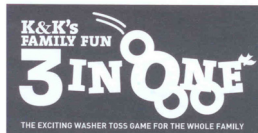

NO CLAIM IS MADE TO THE EXCLUSIVE RIGHT TO USE "THE EXCITING WASHER TOSS GAME FOR THE WHOLE FAMILY", APART FROM THE MARK AS SHOWN. THE MARK CONSISTS OF THE WORDS "K & K'S FAMILY FUN", "3 IN ONE, THE EXCITING WASHER TOSS GAME FOR THE WHOLE FAMILY" IN WHITE ON A DARK RECTANGULAR BACKGROUND; THREE WHITE WASHERS APPEARING TO PASS THROUGH THE "O" IN THE WORD "ONE"; AND A WHITE SYMBOL OF A BIRD ADJACENT THE "E" IN THE WORD "ONE".

FOR GAMES, NAMELY, RING OR WASHER TOSS GAMES (U.S. CLS. 22, 23, 38 AND 50).
INGA ERVIN, EXAMINING ATTORNEY

SN 77-203,706. PRO HITTER CORPORATION, NEW CITY, NY. FILED 6-12-2007.

PROHITTER

THE MARK CONSISTS OF STANDARD CHARACTERS WITHOUT CLAIM TO ANY PARTICULAR FONT, STYLE, SIZE, OR COLOR.

FOR ATHLETIC SPORTING GOODS, NAMELY, BASEBALL AND SOFTBALL BATTING AIDS IN THE NATURE OF A HAND POSITIONING DEVICE WHICH FITS OVER A BATTER'S THUMB SPECIFICALLY FOR DEVELOPING GRIP TECHNIQUE, BAT POSITIONING AND FOR THUMB PROTECTION (U.S. CLS. 22, 23, 38 AND 50).

FIRST USE 3-10-2008; IN COMMERCE 3-10-2008.
TINA BROWN, EXAMINING ATTORNEY

CLASS 28—(Continued).

SN 77-219,182. ONTEL PRODUCTS CORPORATION, FAIRFIELD, NJ. FILED 6-29-2007.

PUSHUP PRO

THE MARK CONSISTS OF STANDARD CHARACTERS WITHOUT CLAIM TO ANY PARTICULAR FONT, STYLE, SIZE, OR COLOR.

NO CLAIM IS MADE TO THE EXCLUSIVE RIGHT TO USE "PUSHUP", APART FROM THE MARK AS SHOWN. FOR MANUALLY-OPERATED EXERCISE EQUIPMENT FOR DOING PUSHUPS (U.S. CLS. 22, 23, 38 AND 50).

FIRST USE 7-21-2007; IN COMMERCE 7-21-2007.
TANYA AMOS, EXAMINING ATTORNEY

SN 77-219,201. ONTEL PRODUCTS CORPORATION, FAIRFIELD, NJ. FILED 6-29-2007.

NO CLAIM IS MADE TO THE EXCLUSIVE RIGHT TO USE "PUSHUP", APART FROM THE MARK AS SHOWN.

THE MARK CONSISTS OF STYLIZED WORDING OF "PUSHUP PRO".

FOR MANUALLY-OPERATED EXERCISE EQUIPMENT FOR DOING PUSHUPS (U.S. CLS. 22, 23, 38 AND 50).

FIRST USE 7-21-2007; IN COMMERCE 7-21-2007.
TANYA AMOS, EXAMINING ATTORNEY

SN 77-220,548. LAS VEGAS SANDS CORP., LAS VEGAS, NV. FILED 7-2-2007.

THE VENETIAN LAS VEGAS

THE MARK CONSISTS OF STANDARD CHARACTERS WITHOUT CLAIM TO ANY PARTICULAR FONT, STYLE, SIZE, OR COLOR.

NO CLAIM IS MADE TO THE EXCLUSIVE RIGHT TO USE "LAS VEGAS", APART FROM THE MARK AS SHOWN.

FOR PLUSH TOYS; PLUSH ANIMALS; STUFFED TOYS; STUFFED ANIMALS; PLAY FIGURES; PLASTIC TOY FIGURINES; SNOW GLOBES; TOY MUSIC BOXES (U.S. CLS. 22, 23, 38 AND 50).

FIRST USE 3-29-2007; IN COMMERCE 3-29-2007.
MELISSA VALLILLO, EXAMINING ATTORNEY

CLASS 28—(Continued).

SN 77-242,646. FANG HANXIANG, WUHAN, HUBEI., CHINA, AND TIAN MING, WUHAN, HUBEI., CHINA, AND TIAN YAN, WUHAN, HUBEI., CHINA, AND ZHOUPENG, WUHAN, HUBEI., CHINA, FILED 7-31-2007.



FOR ARTIFICIAL FISHING LURES, FISHING EQUIPMENT, NAMELY, WINGING MATERIAL FOR FISHING JIGS AND STREAMERS, FISHING FLOATS, FISHING HOOKS, FISHING LINES, FISHING LURES, FISHING REELS, FISHING RODS, FISHING TACKLE (U.S. CLS. 22, 23, 38 AND 50).

DAWN FELDMAN, EXAMINING ATTORNEY

SN 77-253,451. BIOCAM ENTERPRISES LLC, BARRINGTON HILLS, IL. FILED 8-13-2007.

MUTANT MUSCLE CARS

THE MARK CONSISTS OF STANDARD CHARACTERS WITHOUT CLAIM TO ANY PARTICULAR FONT, STYLE, SIZE, OR COLOR.

NO CLAIM IS MADE TO THE EXCLUSIVE RIGHT TO USE "MUSCLE CAR", APART FROM THE MARK AS SHOWN.

FOR TOY MODEL VEHICLES AND RELATED ACCESSORIES SOLD AS UNITS (U.S. CLS. 22, 23, 38 AND 50).

JENNIFER MARTIN, EXAMINING ATTORNEY

SN 77-254,060. CITY OF NEW YORK BY AND THROUGH THE NEW YORK CITY TAXI AND LIMOUSINE COMMISSION, NEW YORK, NY. FILED 8-13-2007.



NYC TAXI

NO CLAIM IS MADE TO THE EXCLUSIVE RIGHT TO USE "NYC TAXI", APART FROM THE MARK AS SHOWN.

THE MARK CONSISTS OF A STYLIZED CHECKER DESIGN TO THE LEFT OF "7C43", OF A RECTANGLE CONTAINING A STYLIZED DEPICTION OF A MAN HAILING A CAB NEXT TO THE WORDING "\$2.50 INITIAL FARE" AND ILLEGIBLE TAXI FARE INFORMATION, AND OF THE WORDING "NYC TAXI" IN STYLIZED FORMAT WHEREIN THE "T" IS ENCASED IN A CIRCLE.

FOR TOY VEHICLES (U.S. CLS. 22, 23, 38 AND 50).

FIRST USE 8-13-2007; IN COMMERCE 8-13-2007.

JASON LOTT, EXAMINING ATTORNEY

CLASS 28—(Continued).

SN 77-256,053. HOTEL FITNESS CLUB, INC., ROSWELL, GA. FILED 8-15-2007.

HOTEL FITNESS

THE MARK CONSISTS OF STANDARD CHARACTERS WITHOUT CLAIM TO ANY PARTICULAR FONT, STYLE, SIZE, OR COLOR.

OWNER OF U.S. REG. NOS. 2,369,604 AND 3,259,877. SEC. 2(F).

FOR EXERCISE EQUIPMENT, NAMELY, BENCHES, WEIGHT RACKS, EXERCISE MACHINES WITH SINGLE OR MULTIPLE STATIONS AND WEIGHT LIFTING MACHINES WITH MULTI-STATIONS AND SINGLE STATIONS; EXERCISE EQUIPMENT, NAMELY, TREADMILLS, STATIONARY CYCLES, ELLIPTICAL EXERCISE MACHINES (U.S. CLS. 22, 23, 38 AND 50).

FIRST USE 5-0-2007; IN COMMERCE 5-0-2007.

H. M. FISHER, EXAMINING ATTORNEY

SN 77-266,780. FISH NATURE INC, PLEASANTON, CA. FILED 8-29-2007.



NO CLAIM IS MADE TO THE EXCLUSIVE RIGHT TO USE "FISH" AND "INC", APART FROM THE MARK AS SHOWN.

THE COLOR(S) GREEN, WHITE, BLACK, YELLOW, BLUE, ORANGE AND RED IS/ARE CLAIMED AS A FEATURE OF THE MARK.

THE MARK CONSISTS OF A GREEN, WHITE, RED AND BLACK FISH, A YELLOW SUN, BLUE WATER AND THE WORDING "FISH NATURE" IN ORANGE OUTLINED IN BLACK AND THE TERM "INC" IN BLACK.

FOR ARTIFICIAL FISHING LURES (U.S. CLS. 22, 23, 38 AND 50).

JENNIFER VASQUEZ, EXAMINING ATTORNEY

CLASS 28—(Continued).

SN 77-271,974. CITY OF NEW YORK BY AND THROUGH THE NEW YORK CITY TAXI AND LIMOUSINE COMMISSION, NEW YORK, NY. FILED 9-5-2007.

7C43



NYC TAXI

NO CLAIM IS MADE TO THE EXCLUSIVE RIGHT TO USE "NYC TAXI", APART FROM THE MARK AS SHOWN.

THE MARK CONSISTS OF A STYLIZED CHECKER DESIGN TO THE RIGHT OF "7C43", OF A RECTANGLE CONTAINING A STYLIZED DEPICTION OF A MAN HAILING A CAB NEXT TO THE WORDING "\$2.50 INITIAL FARE" AND ILLEGIBLE TAXI FARE INFORMATION, AND OF THE WORDING "NYC TAXI" IN STYLIZED FORMAT WHEREIN THE "T" IS ENCASED IN A CIRCLE.

FOR TOY VEHICLES (U.S. CLS. 22, 23, 38 AND 50).
JASON LOTT, EXAMINING ATTORNEY

SN 77-273,107. KERZNER INTERNATIONAL LIMITED, NASSAU, BAHAMAS, FILED 9-6-2007.

BLUE COLLECTION

THE MARK CONSISTS OF STANDARD CHARACTERS WITHOUT CLAIM TO ANY PARTICULAR FONT, STYLE, SIZE, OR COLOR.

NO CLAIM IS MADE TO THE EXCLUSIVE RIGHT TO USE "COLLECTION", APART FROM THE MARK AS SHOWN.

FOR TOYS AND GAMES, NAMELY, JIG SAW PUZZLES, TRADING CARD GAMES, PLASTIC TOY FIGURINES, BOUNCING BALLS, NAMELY, RUBBER BALLS, BEACH BALLS, BASKET BALLS, FOOTBALLS, HAND BALLS, SOCCER BALLS AND VOLLEY BALLS, ELECTRONIC FLOATING AND SWIMMING TOYS, SWIM FLOATS FOR RECREATIONAL USE, TOY AQUARIUMS, TOY WATER GLOBES, DOLLS AND CHRISTMAS TREE ORNAMENTS (U.S. CLS. 22, 23, 38 AND 50).
MATTHEW EINSTEIN, EXAMINING ATTORNEY

SN 77-279,735. TRUE FITNESS TECHNOLOGY, INC., O'FAL-
LON, MO. FILED 9-14-2007.

HRC CRUISE CONTROL

THE MARK CONSISTS OF STANDARD CHARACTERS WITHOUT CLAIM TO ANY PARTICULAR FONT, STYLE, SIZE, OR COLOR.

FOR EXERCISE EQUIPMENT COMPONENT SOLD AS PART OF THE FINAL PRODUCT IN THE NATURE OF AN AUTOMATIC VARIABLE SPEED AND GRADE CONTROL (U.S. CLS. 22, 23, 38 AND 50).

FIRST USE 2-1-2007; IN COMMERCE 2-1-2007.
HEATHER SAPP, EXAMINING ATTORNEY

CLASS 28—(Continued).

SN 77-281,099. MCPHERSON, MATHEW A., NORWALK, WI.
FILED 9-17-2007.

CLASSIC

THE MARK CONSISTS OF STANDARD CHARACTERS WITHOUT CLAIM TO ANY PARTICULAR FONT, STYLE, SIZE, OR COLOR.

FOR ARCHERY BOWS (U.S. CLS. 22, 23, 38 AND 50).
FIRST USE 11-4-2005; IN COMMERCE 11-4-2005.
BARBARA BROWN, EXAMINING ATTORNEY

SN 77-286,418. HOGY LURE COMPANY, LLC, FALMOUTH,
MA. FILED 9-22-2007.

FISH BIG

THE MARK CONSISTS OF STANDARD CHARACTERS WITHOUT CLAIM TO ANY PARTICULAR FONT, STYLE, SIZE, OR COLOR.

NO CLAIM IS MADE TO THE EXCLUSIVE RIGHT TO USE "FISH", APART FROM THE MARK AS SHOWN.

FOR ARTIFICIAL FISHING LURES; FISHING LURE BOXES; FISHING LURE PARTS; FISHING LURES; FISHING HOOKS; ARTIFICIAL FISHING BAIT; FISHING RODS; FISHING TACKLE; FISHING TACKLE BOXES; FISHING WEIGHTS; HAND-HELD FISHING NETS; FISH ATTRACTANTS; FISHING SINKERS; FISHING SPINNERS; FISHING TACKLE CONTAINERS; FISHING LINES (U.S. CLS. 22, 23, 38 AND 50).

ALEXANDER L. POWERS, EXAMINING ATTORNEY

CLASS 28—(Continued).

SN 77-287,235. ROGERS, JAN MORGAN, COCONUT CREEK, FL. AND TURNER, LAUREN, COCONUT CREEK, FL. FILED 9-24-2007.



THE COLOR(S) YELLOW, RED, ORANGE, WHITE AND BROWN IS/ARE CLAIMED AS A FEATURE OF THE MARK.

"THE MARK CONSISTS OF A YELLOW SMILING STAR WITH A RED MOUTH, ORANGE CHEEKS AND WHITE AND BROWN EYES."

FOR PLUSH TOYS, STUFFED TOYS, BEAN FILLED TOYS, HAND PUPPETS, PLAY BALLOONS (U.S. CLS. 22, 23, 38 AND 50).

DOMINIC J. FERRAIUOLO, EXAMINING ATTORNEY

SN 77-290,825. OK-1 MANUFACTURING, ALTUS, OK. FILED 9-27-2007.



OWNER OF U.S. REG. NOS. 1,529,851, 3,212,340 AND 3,232,496.

FOR ATHLETIC EQUIPMENT, NAMELY, PORTABLE EXERCISE KITS COMPRISED OF MANUALLY OPERATED EXERCISE EQUIPMENT SOLD WITH PRINTED EXERCISE INSTRUCTION MANUALS, MANUALLY OPERATED EXERCISE EQUIPMENT, WEIGHTLIFTING GLOVES, WRIST WRAPS, AEROBIC EXERCISE GLOVES, WEIGHTLIFTING BELTS, ADJUSTABLE WRIST AND ANKLE WEIGHTS, FIXED WRIST AND ANKLE WEIGHTS, WEIGHTED VEST FOR ATHLETIC USE AS WEIGHT LIFTING ACCESSORIES, ELASTIC RESISTANCE EXERCISE DEVICES, FOREARM AND HAND STRENGTH DEVICES CONSISTING OF STEEL OR LATEX RESISTANCE DEVICES, JUMP ROPES, EXERCISE BALLS, PERSONAL EXERCISE MATS, ABDOMINAL EXERCISE DEVICES CONSISTING OF ELASTIC RESISTANCE BANDS AND EXERCISE BALLS, WEIGHTLIFTING ACCESSORIES IN THE NATURE OF WEIGHTLIFTING GLOVES AND WEIGHTLIFTING BELTS, WEIGHTLIFTING BENCHES, DUMBBELLS,

CLASS 28—(Continued).

WEIGHTLIFTING MACHINES, BALANCE BOARD FOR EXERCISE, AEROBIC STEP EQUIPMENT IN THE NATURE OF AEROBIC STEPS, DUMBBELLS, FIXED WRIST AND ANKLE WEIGHTS, ADJUSTABLE WRIST AND ANKLE WEIGHTS, STRESS RELIEF DEVICES FOR EXERCISE IN THE NATURE OF GEL SQUEEZE BALLS, YOGA EQUIPMENT IN THE NATURE OF YOGA MATS, YOGA BLOCKS AND YOGA STRAPS, PILATES EQUIPMENT IN THE NATURE OF PERSONAL EXERCISE MATS AND ELASTIC RESISTANCE BANDS, BOXING AEROBICS EQUIPMENT IN THE NATURE OF WEIGHTED GLOVES AND JUMP ROPES, BOXING GLOVES, AQUATIC FITNESS EQUIPMENT IN THE NATURE OF KICK BOARD FLOATATION DEVICES, FOAM DUMBBELLS, FOAM WRIST WEIGHTS, SPEED AND AGILITY AIDS IN THE NATURE OF HURDLES, SPEED LADDERS, CONES, RINGS, AND FITNESS WALKING EQUIPMENT AND AIDS IN THE NATURE OF WALKING POLES, FIXED WRIST AND ANKLE WEIGHTS, AND ADJUSTABLE WRIST AND ANKLE WEIGHTS (U.S. CLS. 22, 23, 38 AND 50).

ANDREA HACK, EXAMINING ATTORNEY

SN 77-295,722. READY SET GOAL LTD., SURREY GU9 7LL, UNITED KINGDOM, FILED 10-4-2007.

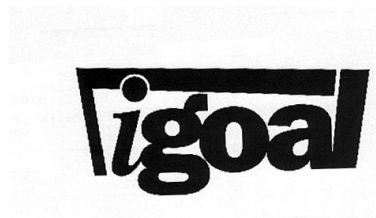

PRIORITY CLAIMED UNDER SEC. 44(D) ON ERPN CMNTY TM OFC APPLICATION NO. 005825096, FILED 4-11-2007, REG. NO. 005825096, DATED 4-24-2008, EXPIRES 4-11-2017.

THE MARK CONSISTS OF IN PART OF STYLIZED GOAL FORMED BY A HORIZONTAL LINE, A VERTICAL LINE AND THE LETTER "L".

FOR SPORTS GOALS, NAMELY, SOCCER GOALS, HOCKEY GOALS AND LACROSSE GOALS (U.S. CLS. 22, 23, 38 AND 50).

EDWARD NELSON, EXAMINING ATTORNEY

CLASS 28—(Continued).

SN 77-304,326. FNC KOLON CORPORATION, SEOUL, REPUBLIC OF KOREA, FILED 10-15-2007.



FOR GOLF BAGS; BALLS FOR GOLF; DIVOT REPAIR TOOLS USED AS GOLF ACCESSORIES; GOLF TEE MARKERS; GOLF GLOVES; GOLF CLUBS; GRIPS FOR GOLF CLUBS; SHAFTS FOR GOLF CLUBS; HEADS FOR GOLF CLUBS; BAGS FOR GOLF CLUBS; COVERS FOR GOLF CLUBS; GOLF TEES; KNEE GUARDS FOR ATHLETIC USE; MASCOT DOLLS; PLAYING BALLS; TARGETS; BALL BASES FOR BASEBALL; RACKETS; FITTED GRIPS FOR RACKETS; STRINGS FOR RACKETS; CADDIE BAGS FOR GOLF CLUBS; CRICKET BAGS; RODS FOR FISHING; FISHING SINKERS; FISHING TACKLE BOXES; CHEST PROTECTORS; SKIS; EDGES OF SKIS; SKI BAGS; SKI STICKS; BAGS ESPECIALLY DESIGNED FOR SKIS; BOWLING BAGS; BARBELLS; BADUK STONES, NAMELY, STONES USED FOR KOREAN CHECKERS; BADUK BOARDS FOR KOREAN CHECKERS; AND BAGS ESPECIALLY DESIGNED FOR SURF BOARDS (U.S. CLS. 22, 23, 38 AND 50).

SANDRA MANIOS, EXAMINING ATTORNEY

SN 77-304,475. MATTEL, INC., EL SEGUNDO, CA. FILED 10-15-2007.

BAD MUDDER

THE MARK CONSISTS OF STANDARD CHARACTERS WITHOUT CLAIM TO ANY PARTICULAR FONT, STYLE, SIZE, OR COLOR.

FOR TOYS, GAMES AND PLAYTHINGS, NAMELY, TOY VEHICLES AND ACCESSORIES THEREFOR (U.S. CLS. 22, 23, 38 AND 50).

FIRST USE 6-17-2008; IN COMMERCE 6-17-2008.
MELISSA VALLILLO, EXAMINING ATTORNEY

CLASS 28—(Continued).

SN 77-305,062. JAKKS PACIFIC, INC., MALIBU, CA. FILED 10-16-2007.

GIRL GOURMET

THE MARK CONSISTS OF STANDARD CHARACTERS WITHOUT CLAIM TO ANY PARTICULAR FONT, STYLE, SIZE, OR COLOR.

NO CLAIM IS MADE TO THE EXCLUSIVE RIGHT TO USE "GIRL", APART FROM THE MARK AS SHOWN.

FOR TOYS, GAMES AND PLAYTHINGS, NAMELY, TOY BAKEWARE AND ACCESSORIES THEREFOR, TOY COOKWARE AND ACCESSORIES THEREFOR, TOY FOOD DECORATING KITS, TOY FROSTING DISPENSERS, TOY ICING DISPENSERS, TOY SPRINKLES DISPENSERS, AND RELATED GOODS, NAMELY, TOY BAKING UTENSILS AND BAKERY MIXES FOR USE BY CHILDREN IN PLAYING WITH SAID TOY BAKING UTENSILS, SOLD AS A UNIT (U.S. CLS. 22, 23, 38 AND 50).

LESLIE RICHARDS, EXAMINING ATTORNEY

SN 77-305,171. JAKKS PACIFIC, INC., MALIBU, CA. FILED 10-16-2007.



NO CLAIM IS MADE TO THE EXCLUSIVE RIGHT TO USE "GIRL", APART FROM THE MARK AS SHOWN.

THE MARK CONSISTS OF THE WORDS "GIRL" IN CURSIVE SCRIPT WITH A STYLIZED DOT OF THE LETTER "I"; THE WORD "GOURMET" IN CAPITAL LETTERS APPEARS DIRECTLY BELOW THE WORD "GIRL"; THERE IS A SQUIGGLY LINE DIRECTLY BENEATH THE WORD "GOURMET"; THE ENTIRE WORD MARK AND LINE ARE ENCLOSED IN AN OVAL WITH A THIN LINE ON THE INNER SIDE OF THE OVAL.

FOR TOYS, GAMES AND PLAYTHINGS, NAMELY, TOY BAKEWARE AND ACCESSORIES THEREFOR, TOY COOKWARE AND ACCESSORIES THEREFOR, TOY FOOD DECORATING KITS, TOY FROSTING DISPENSERS, TOY ICING DISPENSERS, TOY SPRINKLES DISPENSERS, AND RELATED GOODS, NAMELY, TOY BAKING UTENSILS AND BAKERY MIXES FOR USE BY CHILDREN IN PLAYING WITH SAID TOY BAKING UTENSILS, SOLD AS A UNIT (U.S. CLS. 22, 23, 38 AND 50).

LESLIE RICHARDS, EXAMINING ATTORNEY

CLASS 28—(Continued).

SN 77-306,700. JAKKS PACIFIC, INC., MALIBU, CA. FILED 10-17-2007.

SPA FACTORY

THE MARK CONSISTS OF STANDARD CHARACTERS WITHOUT CLAIM TO ANY PARTICULAR FONT, STYLE, SIZE, OR COLOR.

FOR TOYS, GAMES AND PLAYTHINGS, NAMELY, CHILDREN'S PLAY COSMETICS, TOY COSMETIC MAKING KITS, TOY TOILETRY SETS, TOY JEWELRY (U.S. CLS. 22, 23, 38 AND 50).

LESLIE RICHARDS, EXAMINING ATTORNEY

SN 77-307,737. KEE ACTION SPORTS I LLC, SEWELL, NJ. FILED 10-18-2007.

MINI

THE MARK CONSISTS OF STANDARD CHARACTERS WITHOUT CLAIM TO ANY PARTICULAR FONT, STYLE, SIZE, OR COLOR.

FOR PAINTBALL MARKERS (U.S. CLS. 22, 23, 38 AND 50).

FIRST USE 12-0-2006; IN COMMERCE 12-0-2006.
JENNIFER VASQUEZ, EXAMINING ATTORNEY

SN 77-334,425. OLSON, KEVIN J., NEWPORT BEACH, CA. FILED S.R. 11-20-2007; AM. P.R. 6-17-2008.

Romulus Extreme Gear

THE MARK CONSISTS OF STANDARD CHARACTERS WITHOUT CLAIM TO ANY PARTICULAR FONT, STYLE, SIZE, OR COLOR.

OWNER OF U.S. REG. NO. 3,321,530.

NO CLAIM IS MADE TO THE EXCLUSIVE RIGHT TO USE "EXTREME GEAR", APART FROM THE MARK AS SHOWN.

FOR SKATEBOARD DECKS (U.S. CLS. 22, 23, 38 AND 50).

FIRST USE 4-13-2005; IN COMMERCE 5-13-2007.
TEJBIR SINGH, EXAMINING ATTORNEY

CLASS 28—(Continued).

SN 77-339,840. KINESIFIT INC., SAN CLEMETE, CA. FILED 11-29-2007.



THE STIPPLING IS FOR SHADING PURPOSES ONLY. THE MARK CONSISTS OF THREE RINGS WITH THE STYLIZED WORDS "KINESIFIT IN EVERY STEP I FIT". FOR EXERCISE WEIGHTS FOR THIGHS, FOREARMS, CALVES, AND BICEPS (U.S. CLS. 22, 23, 38 AND 50).
MICHAEL WIENER, EXAMINING ATTORNEY

SN 77-345,362. PRECIOUS MOMENTS, INC., ROLLING MEADOWS, IL. FILED 12-6-2007.



OWNER OF U.S. REG. NOS. 1,802,187, 3,168,312 AND OTHERS.

THE MARK CONSISTS OF A DESIGN MARK WITH THE WORDS PRECIOUS MOMENTS INSERTED INTO A SCRIPT STYLE HEART SHAPE WITH SCROLLED ACCENT LINE(S) BENEATH THE WORD MOMENTS.

FOR ARTIFICIAL CHRISTMAS GARLAND; ARTIFICIAL CHRISTMAS TREES; BABY MULTIPLE ACTIVITY TOYS; BABY RATTLES; BABY RATTLES INCORPORATING TEETHING RINGS; BABY SWINGS; BALLOONS; BALLS FOR GAMES; BATH TOYS; BATHTUB TOYS; BEACH BALLS; BOARD GAMES; BOWLING BAGS; BOWLING BALLS; CAT TOYS; CHESS SETS; CHILDREN'S MULTIPLE ACTIVITY TOYS; CHILDREN'S PLAY COSMETICS; CHRISTMAS STOCKINGS; CHRISTMAS TREE DECORATIONS; CHRISTMAS TREE ORNAMENTS, NAMELY BELLS; CHRISTMAS TREE ORNAMENTS; CHRISTMAS TREE ORNAMENTS WITH A MUSIC FEATURE; CHRISTMAS TREE SKIRTS; CHRISTMAS TREE TOPPERS; CONFETTI; COVERS FOR GOLF CLUBS; CRIB MOBILES; CRIB TOYS; DOG TOYS; DOLL ACCESSORIES; DOLL CASES; DOLL CLOTHING; DOLL COSTUMES; DOLLS AND DOLL

CLASS 28—(Continued).

ACCESSORIES THEREFORE; ICE SKATES; INFANT ACTION CRIB TOYS; INFANT RATTLES; INFANT TOYS; IN-LINE SKATES; JIGSAW PUZZLES; KITES; MUSIC BOX TOYS; MUSICAL TOYS; PIÑATAS; PLAY HOUSES AND TENTS; PLUSH TOYS; PORCELAIN DOLLS; PUZZLES; RAG DOLLS; ROLLER SKATES, SAND TOYS; SNOW GLOBES; STUFFED DOLLS AND ANIMALS; STUFFED TOY BEARS; STUFFED ANIMALS; STUFFED TOYS; CRAFTS, NAMELY PAPER DOLLS; ARTS AND CRAFT KITS FOR MAKING DECORATIVE ITEMS, ALL BEING IN THE NATURE OF CHILDREN ACTIVITY KITS; AND CRAFT KITS COMPRISING BASE, CHARACTERS, PROPS AND GLUE; GAMES, NAMELY BOARD GAMES, CARD GAMES, PARTY GAMES, ROLE PLAYING GAMES, PADDLEBALL GAMES, AND BALLS FOR GAMES, WATER GLOBES, WATER GLOBE CHRISTMAS TREE ORNAMENTS, SOFT SCULPTURED TOYS, CLIP ON SOFT SCULPTURED TOYS, BEAN BAG TOYS, AND PLUSH TOY GIFT CARD HOLDERS (U.S. CLS. 22, 23, 38 AND 50).

ANNE E. GUSTASON, EXAMINING ATTORNEY

SN 77-348,709. JASMAN ASIA LTD., TSIMSHATSUI E. KOWLOON, HONG KONG, FILED 12-11-2007.

FASTDRAW

THE MARK CONSISTS OF STANDARD CHARACTERS WITHOUT CLAIM TO ANY PARTICULAR FONT, STYLE, SIZE, OR COLOR.

FOR TOYS AND GAMES, NAMELY, TOY GUNS, TOY GUN SHOOTING GAMES, AND TOY GUN TARGETS; AND ACCESSORIES THEREFOR, NAMELY, TOY GUN AMMUNITION AND TOY GUN HOLSTERS (U.S. CLS. 22, 23, 38 AND 50).

JACQUELINE A. LAVINE, EXAMINING ATTORNEY

SN 77-350,821. HEALTHCORE, INC., BEDFORD, TX. FILED 12-13-2007.

COREGYM

THE MARK CONSISTS OF STANDARD CHARACTERS WITHOUT CLAIM TO ANY PARTICULAR FONT, STYLE, SIZE, OR COLOR.

FOR MANUALLY OPERATED EXERCISE EQUIPMENT, NAMELY, EXERCISE BALLS, YOGA BRICKS, AND EXERCISE STRAPS (U.S. CLS. 22, 23, 38 AND 50).

BRIAN PINO, EXAMINING ATTORNEY

CLASS 28—(Continued).

SN 77-356,262. SUNNYWOOD, INC., SPRING GROVE, IL. FILED 12-19-2007.

STERLING

THE MARK CONSISTS OF STANDARD CHARACTERS WITHOUT CLAIM TO ANY PARTICULAR FONT, STYLE, SIZE, OR COLOR.

OWNER OF U.S. REG. NO. 2,371,224.

FOR DART GAMES; ELECTRONIC DART GAMES; GAME TABLES; GAMING TABLES; BACKGAMMON GAME SETS; ACTION SKILL GAMES; ACTION TARGET GAMES; ACTION-TYPE TARGET GAMES; AERO-DYNAMIC DISK FOR USE IN PLAYING CATCHING GAMES; AMUSEMENT GAME MACHINES; APPARATUS FOR ELECTRONIC GAMES OTHER THAN THOSE ADAPTED FOR USE WITH AN EXTERNAL DISPLAY SCREEN OR MONITOR; ARCADE GAMES; ARCADE-TYPE ELECTRONIC EDUCATION VIDEO GAMES; ARCADE-TYPE ELECTRONIC VIDEO GAMES; BACKGAMMON GAMES; BADMINTON GAME PLAYING EQUIPMENT; BALLS FOR GAMES; BASKETBALL TABLE TOP GAMES; BATS FOR GAMES; BINGO GAME PLAYING EQUIPMENT; BOARD GAMES; BUILDING GAMES; CARD GAME FOR BUSINESS TRAINING; CARD GAMES; CHESS GAMES; COIN-OPERATED VIDEO GAMES; COUNTERS AND MARBLES FOR GAMES; CRAPS GAME PLAYING EQUIPMENT; DICE GAMES; DISPOSABLE TICKET SETS FOR PLAYING GAMES OF CHANCE; ELECTRONIC EDUCATIONAL GAME MACHINES FOR CHILDREN; ELECTRONIC GAME EQUIPMENT WITH A WATCH FUNCTION; ELECTRONIC GAMES OTHER THAN THOSE ADAPTED FOR USE WITH TELEVISION RECEIVERS ONLY; ELECTRONIC HUNTING GAME CALL WITH INTERCHANGEABLE SOUND CARTRIDGES; ELECTRONIC TARGETS FOR GAMES AND SPORTS; EQUIPMENT FOR PLAYING A VERTICAL HOOP TARGET GAME; EQUIPMENT SOLD AS A UNIT FOR PLAYING A MEMORY GAME; EQUIPMENT SOLD AS A UNIT FOR PLAYING ACTION TYPE TARGET GAMES; EQUIPMENT SOLD AS A UNIT FOR PLAYING BOARD GAMES; EQUIPMENT SOLD AS A UNIT FOR PLAYING CARD GAMES; EQUIPMENT SOLD AS A UNIT FOR PLAYING CRAPS GAMES; EXERCISE MACHINES INCORPORATING ELECTRONIC AND VIDEO GAME CONTROLLERS; FLOOR-STANDING UNITS FOR PLAYING ELECTRONIC GAMES OTHER THAN IN CONJUNCTION WITH A TELEVISION OR COMPUTER; GAME EQUIPMENT, NAMELY, CHIPS; GAME RANDOMIZER FOR RANDOMLY DETERMINING GAME PLAY IN A PARLOR GAME, SOLD AS A COMPONENT PART THEREOF; GAMING EQUIPMENT, NAMELY, CRAPS TABLES; GAMING EQUIPMENT, NAMELY, CHIPS; GAMING EQUIPMENT, NAMELY, GAME WHEELS; GAMING EQUIPMENT, NAMELY, POKER CHIPS; GAMING TABLES, NAMELY, CRAPS TABLES; GO GAMES; HAND HELD UNIT FOR PLAYING ELECTRONIC GAMES; HAND HELD UNIT FOR PLAYING VIDEO GAMES; HAND-HELD GAMES WITH LIQUID CRYSTAL DISPLAYS; HORIZONTAL PINBALL MACHINE, NAMELY, KORINTO-GAME MACHINES; HORSESHOE GAMES; HUNTING GAME CALLS; JAPANESE CHESS, NAMELY, SHOGI GAMES; JAPANESE DICE GAMES, NAMELY, SUGOROKU; KARUTA PLAYING CARDS, NAMELY, JAPANESE CARD GAME; KITS FOR BUILDING OUTDOOR PLAY EQUIPMENT; LCD GAME MACHINES; MAH JONG GAMES; MANIPULATIVE GAMES; MARBLES FOR GAMES; MEMORY GAMES; NETS FOR BALL GAMES; OUTDOOR ACTIVITY GAMES IN THE NATURE OF, NAMELY, CROQUET, BOCCIE BALL, LADDER GOLF, LAWN BOWLING, KICKBALL, DISC GOLF; PADDLE BALL GAMES; PADDLES FOR USE IN PADDLE BALL GAMES; PARLOR GAMES; PARLOUR GAMES; PARTY GAMES; PINBALL GAMES; PINBALL-TYPE GAMES; PLAY YARDS IN THE NATURE OF OUTDOOR PLAY STRUCTURES; PLAYING CARDS AND CARD GAMES; POSITIONABLE PRINTED TOY FIGURES FOR USE IN GAMES; POSITIONABLE THREE

CLASS 28—(Continued).

DIMENSIONAL TOYS FOR USE IN GAMES; POSITIONABLE TWO DIMENSIONAL TOYS FOR USE IN GAMES; PRINTED POSITIONABLE TOYS FOR USE IN CHILDREN'S BOARD GAMES; PROMOTIONAL GAME CARDS; PROMOTIONAL GAME MATERIALS; PROTECTIVE CARRYING CASES SPECIALLY ADAPTED FOR HANDHELD VIDEO GAMES; QUOITS; RING GAMES; ROLE PLAYING GAMES; STAND ALONE VIDEO GAME MACHINES; STAND ALONE VIDEO OUTPUT GAME MACHINES; STONE-PIECES POTS FOR GO GAME, NAMELY, GOKE POTS; TABLETOP UNITS FOR PLAYING ELECTRONIC GAMES OTHER THAN IN CONJUNCTION WITH A TELEVISION OR COMPUTER; TARGET GAMES; TIBETAN DICE GAME; TOY, NAMELY, BATTERY-POWERED COMPUTER GAME WITH LCD SCREEN WHICH FEATURES ANIMATION AND SOUND EFFECTS; TOYS, NAMELY, A DISK TO TOSS IN PLAYING A GAME WHEREIN OTHER DISKS ARE FLIPPED AND COLLECTED; TRADING CARD GAMES; TWO AND THREE DIMENSIONAL POSITIONABLE GAME FIGURES THAT MAY BE AFFIXED TO CLOTHING; VOLLEYBALL GAME PLAYING EQUIPMENT; WOODEN PIECES FOR SHOGI GAME, NAMELY, KOMA (U.S. CLS. 22, 23, 38 AND 50).

FIRST USE 12-15-1997; IN COMMERCE 7-25-2000.

LOURDES AYALA, EXAMINING ATTORNEY

CLASS 28—(Continued).

SN 77-358,527. INTERQUANTUM, LLC, ENCINO, CA. FILED 12-21-2007.



NO CLAIM IS MADE TO THE EXCLUSIVE RIGHT TO USE "TRAINER", APART FROM THE MARK AS SHOWN.

THE COLOR(S) YELLOW, RED AND BLACK IS/ARE CLAIMED AS A FEATURE OF THE MARK.

THE MARK CONSISTS OF THE COLOR YELLOW APPEARS IN THE BACKGROUND OF THE MARK; THE COLOR RED APPEARS IN THE DESIGN OF THE FLAME, AND THE COLOR BLACK APPEARS IN THE OUTLINE OF THE LETTERS IN THE MARK AND THE OUTLINE OF THE DESIGN OF THE FLAME, AND IN THE SHADOWING FOR THE LETTERS.

FOR EQUIPMENT FOR PHYSICAL AND GYMNAS TIC AND SPORTS EXERCISES, FOR MUSCLE TRAINING AND FOR AEROBIC AND CARDIOVASCULAR EXERCISE, NAMELY, MANUALLY-OPERATED EXERCISE MACHINES, AND MANUALLY-OPERATED AEROBIC EXERCISE MACHINES (U.S. CLS. 22, 23, 38 AND 50).

FIRST USE 1-14-2008; IN COMMERCE 1-14-2008.

SUSAN RICHARDS, EXAMINING ATTORNEY

SN 77-358,515. INTERQUANTUM, LLC, ENCINO, CA. FILED 12-21-2007.

SN 77-358,783. HAMPTON ISLAND, LLC, ATLANTA, GA. FILED 12-22-2007.

HAMPTON ISLAND PRESERVE

STRIKE TRAINER

THE MARK CONSISTS OF STANDARD CHARACTERS WITHOUT CLAIM TO ANY PARTICULAR FONT, STYLE, SIZE, OR COLOR.

NO CLAIM IS MADE TO THE EXCLUSIVE RIGHT TO USE "TRAINER", APART FROM THE MARK AS SHOWN.

FOR EQUIPMENT FOR PHYSICAL AND GYMNAS TIC AND SPORTS EXERCISES, FOR MUSCLE TRAINING AND FOR AEROBIC AND CARDIOVASCULAR EXERCISE, NAMELY, MANUALLY-OPERATED EXERCISE MACHINES, AND MANUALLY-OPERATED AEROBIC EXERCISE MACHINES (U.S. CLS. 22, 23, 38 AND 50).

FIRST USE 1-14-2008; IN COMMERCE 1-14-2008.

SUSAN RICHARDS, EXAMINING ATTORNEY

THE MARK CONSISTS OF STANDARD CHARACTERS WITHOUT CLAIM TO ANY PARTICULAR FONT, STYLE, SIZE, OR COLOR.

FOR GOLF CLUBS, GOLF BALLS, GOLF TEES, DIVOT REPAIR TOOLS; GOLF ACCESSORY POUCHES; GOLF BAGS; GOLF BALL MARKERS; GOLF BALL RETRIEVERS; GOLF BALL SLEEVES; GOLF CLUB COVERS; GOLF CLUB GRIPS; GOLF CLUB HEADS; GOLF GLOVES; GOLF IRONS; GOLF PUTTERS; GRIP TAPES FOR GOLF CLUBS; HUNTING LURES; CAMOUFLAGE SCREENS FOR HUNTING PURPOSES; HUNTING ARROW POINTS; HUNTING BLINDS; HUNTING BOWS; HUNTING DECOY BAGS; HUNTING EQUIPMENT, NAMELY, SCENT DISPENSER FOR ATTRACTING OR REPELLING ANIMALS; HUNTING GAME CALLS; HUNTING STANDS; FISHING HOOKS; FISHING LURES; FISHING NETS; FISHING POLE HOLDERS WORN ON THE BODY; FISHING REELS; FISHING ROD CASES; FISHING RODS; FISHING TACKLE; FISHING TACKLE BOXES; SPEARS FOR USE IN FISHING; SPORTSMAN'S FISHING BAGS; TENNIS RACKETS, TENNIS RACKET COVERS, TENNIS NETS, TENNIS BALLS; CASES FOR TENNIS BALLS; TENNIS BALL RETRIEVERS; SWIM FLOATS FOR RECREATIONAL USE (U.S. CLS. 22, 23, 38 AND 50).

GEORGIA CARTY, EXAMINING ATTORNEY

CLASS 28—(Continued).

SN 77-358,786. HAMPTON ISLAND, LLC, ATLANTA, GA.
FILED 12-22-2007.



NO CLAIM IS MADE TO THE EXCLUSIVE RIGHT TO USE "EST. 1769", APART FROM THE MARK AS SHOWN.

THE MARK CONSISTS OF THE WORDS "HAMPTON ISLAND PRESERVE" ON THE PERIMETER CREATING A CIRCULAR SHAPE, WITHIN THE CIRCULAR SHAPE CREATED BY THE WORDING ARE THE SHAPES OF A RADIATING SUN RISING OVER A PYRAMID, REPRESENTING A PALM FRAWN, WITH THE WORD "EST." AND THE NUMBERS "1769" AT THE BASE OF THE PYRAMID AND CENTERED OVER THE WORD "PRESERVE" AT THE BOTTOM OF THE PERIMETER OF THE CIRCULAR SHAPE.

FOR GOLF CLUBS; GOLF BALLS; GOLF TEES; DIVOT REPAIR TOOLS; GOLF ACCESSORY POUCHES; GOLF BAGS; GOLF BALL MARKERS; GOLF BALL RETRIEVERS; GOLF BALL SLEEVES; GOLF CLUB COVERS; GOLF CLUB GRIPS; GOLF CLUB HEADS; GOLF GLOVES; GOLF IRONS; GOLF PUTTERS; GRIP TAPES FOR GOLF CLUBS; HUNTING LURES; CAMOUFLAGE SCREENS FOR HUNTING PURPOSES; HUNTING ARROW POINTS; HUNTING BLINDS; HUNTING BOWS; HUNTING DECOY BAGS; HUNTING EQUIPMENT, NAMELY, SCENT DISPENSER FOR ATTRACTING OR REPELLING ANIMALS; HUNTING GAME CALLS; HUNTING STANDS; FISHING HOOKS; FISHING LURES; FISHING NETS; FISHING POLE HOLDERS WORN ON THE BODY; FISHING REELS; FISHING ROD CASES; FISHING RODS; FISHING TACKLE; FISHING TACKLE BOXES; SPEARS FOR USE IN FISHING; SPORTSMAN'S FISHING BAGS; TENNIS RACKETS, TENNIS RACKET COVERS, TENNIS NETS, TENNIS BALLS; CASES FOR TENNIS BALLS; TENNIS BALL RETRIEVERS; SWIM FLOATS FOR RECREATIONAL USE (U.S. CLS. 22, 23, 38 AND 50).

GEORGIA CARTY, EXAMINING ATTORNEY

SN 77-359,194. GREENE, JULIE A., DBA MISPHIT TOYZ,
BELLA VISTA, AR. FILED 12-25-2007.

NO CLAIM IS MADE TO THE EXCLUSIVE RIGHT TO USE "TOYS", APART FROM THE MARK AS SHOWN.

THE MARK CONSISTS OF FLATING TO DEFLATED

CLASS 28—(Continued).

LETTERS IN THE CENTER OF THE FULL NAME SWOOPING BACK TO FLATED AT THE END OF THE FULL NAME. SHADOWED 3-D IMPACT FONT LETTERING CAPITALIZING ONLY THE LETTERS "M", "P", AND "T" WITH A GRADUAL COLOR FADING BEGINNING AT THE TOP OF EACH LETTER FROM GREY INTO WHITE, THEN INTO BLACK IN THE CENTER OF EACH LETTER AND FADING OUT AGAIN TO GREY AS MOVING TOWARDS THE BOTTOM OF EACH LETTER DEMONSTRATING A STAINLESS STEEL REFLECTIVE EFFECT.

FOR ARROWS; BABY MULTIPLE ACTIVITY TOYS; BATH TOYS; BATHTUB TOYS; BATTERY OPERATED ACTION TOYS; BENDABLE TOYS; CAPS FOR TOY PISTOLS; CASES FOR TOY STRUCTURES; CASES FOR TOY VEHICLES; CAT TOYS; CHILDREN'S ACTIVITY TABLES CONTAINING MANIPULATIVE TOYS WHICH CONVERT TO EASELS; CHILDREN'S MULTIPLE ACTIVITY TOYS; CHILDREN'S MULTIPLE ACTIVITY TOYS SOLD AS A UNIT WITH PRINTED BOOKS; CHILDREN'S WIRE CONSTRUCTION AND ART ACTIVITY TOYS; CLOCKWORK TOYS; COLLECTABLE TOY FIGURES; CONSTRUCTION TOYS; CRIB TOYS; DISC TOSS TOYS; DOG TOYS; DRAWING TOYS; EDUCATIONAL TOY FOR THE PURPOSE OF THE DEMONSTRATION OF ALTERNATIVE ENERGY SOURCES; ELECTRIC ACTION TOYS; ELECTRIC EDUCATIONAL TOY USED TO DEMONSTRATE ALTERNATIVE ENERGY SOURCES; ELECTRIC TOY TRAIN TRANSFORMERS; ELECTRONIC ACTION TOYS; ELECTRONIC LEARNING TOYS; ELECTRONIC TOY BUILDING BLOCKS THAT LIGHT UP AS A NIGHT LIGHT; ELECTRONIC TOY VEHICLES; ELECTRONICALLY OPERATED TOY MOTOR VEHICLES; FANTASY CHARACTER TOYS; FLYING SAUCERS; INFANT ACTION CRIB TOYS; INFANT DEVELOPMENT TOYS; INFANT TOYS; INFLATABLE BATH TOYS; INFLATABLE RIDE-ON TOYS; INFLATABLE THIN RUBBER TOYS; INFLATABLE TOYS; INFLATABLE TOYS SHOWING DECORATIVE PICTURES; LEVER ACTION TOYS; MECHANICAL ACTION TOYS; MECHANICAL TOYS; MINIATURE TOY HELMETS; MODEL TOY STEAM ENGINES; MODEL TOY STEAM OPERATED TRACTION ENGINES; MOLDDED PLASTIC TOY FIGURINES; MOLDED TOY FIGURES; MUSIC BOX TOYS; MUSICAL TOYS; NON-ELECTRONIC TOY VEHICLES; NON-RIDING TRANSPORTATION TOYS; PARTY FAVORS IN THE NATURE OF SMALL TOYS; PET TOYS; PET TOYS CONTAINING CATNIP; PET TOYS MADE OF ROPE; PLASTIC CHARACTER TOYS; PLASTIC TOY HOOPS; PLAY MATS CONTAINING INFANT TOYS; PLAY MATS FOR USE WITH TOY VEHICLES; PLUSH TOYS; POP UP TOYS; POSITIONABLE PRINTED TOY FIGURES FOR USE IN GAMES; POSITIONABLE PRINTED TOY FIGURES FOR USE IN PUZZLES; POSITIONABLE THREE DIMENSIONAL TOYS FOR USE IN GAMES; POSITIONABLE TOY FIGURES; POSITIONABLE TWO DIMENSIONAL TOYS FOR USE IN GAMES; PRINTED POSITIONABLE TOYS FOR USE IN CHILDREN'S BOARD GAMES; PRINTING TOYS; PULL TOYS; PUNCHING TOYS; PUSH TOYS; RADIO CONTROLLED TOY VEHICLES; RADIO TRANSMITTERS FOR USE WITH RADIO-CONTROLLED TOYS; REMOTE CONTROL TOYS, NAMELY, HELICOPTERS, AIRPLANES, FLYING CONTRAPTIONS; RIDE-ON TOYS; RUBBER CHARACTER TOYS; SAND TOYS; SANDBOX TOYS; SKETCHING TOYS; SOFT SCULPTURE PLUSH TOYS; SOFT SCULPTURE TOYS; SQUEEZABLE SQUEAKING TOYS; SQUEEZE TOYS; STACKING TOYS; STUFFED AND PLUSH TOYS; STUFFED TOY ANIMALS; STUFFED TOY BEARS; STUFFED TOYS; TALKING ELECTRONIC PRESS-DOWN TOY; TALKING TOYS; TESSELLATION TOYS; TOSSING DISC TOYS; TOY CHRISTMAS TREES; TOY ACTION FIGURES; TOY ACTION FIGURES AND ACCESSORIES THEREFOR; TOY AIRPLANES; TOY AND NOVELTY FACE MASKS; TOY ANIMALS; TOY ANIMALS AND ACCESSORIES THEREFOR; TOY ARMOR; TOY ARTIFICIAL FINGERNAILS; TOY BAKEWARE AND COOKWARE; TOY BALLOONS; TOY BANKS; TOY BOWS AND ARROWS; TOY BOXES; TOY BUILDING BLOCKS; TOY BUILDING BLOCKS CAPABLE OF INTERCONNECTION; TOY BUILDING STRUCTURES AND TOY VEHICLE TRACKS; TOY BUILDINGS AND ACCESSORIES THEREFOR; TOY BUTTERFLY NETS; TOY CAP PISTOLS; TOY CARS; TOY CLOCKS AND WATCHES; TOY CONSTRUCTION BLOCKS; TOY CONSTRUCTION SETS; TOY FIGURES; TOY FILM CARTRIDGES AND VIEWERS; TOY FURNITURE; TOY

CLASS 28—(Continued).

GLIDERS; TOY GLOCKENSPIELS; TOY GUNS; TOY HARMONICAS; TOY HOLSTERS; TOY HOOP SETS; TOY HOUSES; TOY MAIL BOXES; TOY MASKS; TOY MOBILES; TOY MODEL CARS; TOY MODEL HOBBY CRAFT KITS; TOY MODEL KIT CARS; TOY MODEL TRAIN SETS; TOY MODEL VEHICLES AND RELATED ACCESSORIES SOLD AS UNITS; TOY MODELING DOUGH; TOY MUSIC BOXES; TOY NOISEMAKERS; TOY PIANOS; TOY PIANOS, SOLD AS A UNIT WITH PRINTED BOOKS IN THE FIELD OF MUSIC EDUCATION; TOY PISTOLS; TOY PRISM GLASSES; TOY PUTTY; TOY RECORD PLAYERS; TOY ROBOTS; TOY ROCKETS; TOY SCOOTERS; TOY SETS OF CARPENTERS' TOOLS; TOY SNOW GLOBES; TOY STAMPS; TOY SWORDS; TOY TRAINS AND PARTS AND ACCESSORIES THEREFOR; TOY VEHICLE TRACK SETS AND ROADWAYS AND ACCESSORIES THEREFOR; TOY VEHICLES; TOY VEHICLES AND ACCESSORIES THEREFOR; TOY VEHICLES WITH TRANSFORMING PARTS; TOY WATCHES; TOY WATER GLOBES; TOY WEAPONS; TOY WHISTLES; TOY WIND SOCKS; TOY XYLOPHONES; TOY ZIP GUNS; TOY, NAMELY, BATTERY-POWERED COMPUTER GAME WITH LCD SCREEN WHICH FEATURES ANIMATION AND SOUND EFFECTS; TOYS DESIGNED TO BE ATTACHED TO VEHICLES, BIKES, CAR SEATS, HOUSEHOLD AND OFFICE FURNITURE; TOYS FOR DOMESTIC PETS; TOYS, NAMELY, CHILDREN'S DRESS-UP ACCESSORIES; TOYS, NAMELY, A DISK TO TOSS IN PLAYING A GAME WHEREIN OTHER DISKS ARE FLIPPED AND COLLECTED; TRANSFORMING ROBOTIC TOY VEHICLES; TRANSFORMING ROBOTIC TOYS; TWO AND THREE DIMENSIONAL POSITIONABLE FIGURES SOLD AS AN INTEGRAL COMPONENT OF TOYS; TWO AND THREE DIMENSIONAL POSITIONABLE TOY FIGURES SOLD AS A UNIT WITH EDUCATIONAL BOOKS; TWO AND THREE DIMENSIONAL POSITIONABLE TOY FIGURES SOLD AS A UNIT WITH MEMORY TRAINING EQUIPMENT.; TWO AND THREE DIMENSIONAL POSITIONABLE TOY FIGURES SOLD AS A UNIT WITH OTHER TOYS; WATER SQUIRTING TOYS; WIND-UP TOYS; WIND-UP WALKING TOYS (U.S. CLS. 22, 23, 38 AND 50).

FIRST USE 11-0-2007; IN COMMERCE 12-23-2007.
LINDA MICKLEBURGH, EXAMINING ATTORNEY

SN 77-359,454. BRIDGESTONE SPORTS CO., LTD., SHINAGAWA-KU, TOKYO, JAPAN, FILED 12-26-2007.



OWNER OF U.S. REG. NO. 3,231,512.
THE MARK CONSISTS OF THE LETTER "E" INSIDE A CIRCLE WITH THE NUMBER "5" AND A PLUS SIGN.
FOR GOLF EQUIPMENT, NAMELY, GOLF BALLS (U.S. CLS. 22, 23, 38 AND 50).
FIRST USE 12-26-2007; IN COMMERCE 12-26-2007.
NELSON SNYDER, EXAMINING ATTORNEY

CLASS 28—(Continued).

SN 77-359,460. BRIDGESTONE SPORTS CO., LTD., SHINAGAWA-KU, TOKYO, JAPAN, FILED 12-26-2007.



OWNER OF U.S. REG. NO. 3,235,252.
THE MARK CONSISTS OF THE LETTER "E" INSIDE A CIRCLE WITH THE NUMBER "6" AND A PLUS SIGN.
FOR GOLF EQUIPMENT, NAMELY, GOLF BALLS (U.S. CLS. 22, 23, 38 AND 50).
FIRST USE 12-26-2007; IN COMMERCE 12-26-2007.
NELSON SNYDER, EXAMINING ATTORNEY

SN 77-379,033. MOOSE ENTERPRISE (AUST) PTY LTD, MELBOURNE, AUSTRALIA, FILED 1-23-2008.

Beados

THE MARK CONSISTS OF STANDARD CHARACTERS WITHOUT CLAIM TO ANY PARTICULAR FONT, STYLE, SIZE, OR COLOR.
FOR HOBBY CRAFT KITS COMPRISING BONDING BEADS, TRAYS, DESIGNS, TEMPLATES, BEAD DISPENSERS, AND WATER SPRAYERS; HOBBY CRAFT ACCESSORIES SOLD INDIVIDUALLY, NAMELY, BONDING BEADS, TEMPLATES, TRAYS, AND DESIGNS (U.S. CLS. 22, 23, 38 AND 50).
CHARISMA HAMPTON, EXAMINING ATTORNEY

SN 77-386,257. GOLDSTEIN COLUMBIA, LLC, RIDGEFIELD, CT. FILED 2-1-2008.

ACCUDRIVE

THE MARK CONSISTS OF STANDARD CHARACTERS WITHOUT CLAIM TO ANY PARTICULAR FONT, STYLE, SIZE, OR COLOR.
OWNER OF U.S. REG. NO. 2,540,710.
FOR FABRIC OR PLASTIC STRIPES FOR ATTACHMENT TO GOLF SHOES FOR ALIGNING PROPER FOOT PLACEMENT (U.S. CLS. 22, 23, 38 AND 50).
GENE MACIOL, EXAMINING ATTORNEY

CLASS 28—(Continued).

SN 77-408,764. CHARLES A. VIOLA, FAIRFIELD, IA. FILED 2-28-2008.

K-9 KICKER

THE MARK CONSISTS OF STANDARD CHARACTERS WITHOUT CLAIM TO ANY PARTICULAR FONT, STYLE, SIZE, OR COLOR.

NO CLAIM IS MADE TO THE EXCLUSIVE RIGHT TO USE "K-9", APART FROM THE MARK AS SHOWN. FOR DOG TOYS (U.S. CLS. 22, 23, 38 AND 50). FIRST USE 2-18-2002; IN COMMERCE 2-18-2002. MATTHEW EINSTEIN, EXAMINING ATTORNEY

CLASS 28—(Continued).

SN 77-416,144. RICHIE, LINTON LOWELL, UPPER MARLBORO, MD. FILED 3-7-2008.

SPANKIN STRIPERS

THE MARK CONSISTS OF STANDARD CHARACTERS WITHOUT CLAIM TO ANY PARTICULAR FONT, STYLE, SIZE, OR COLOR.

NO CLAIM IS MADE TO THE EXCLUSIVE RIGHT TO USE "STRIPERS", APART FROM THE MARK AS SHOWN. FOR FISHING LURES (U.S. CLS. 22, 23, 38 AND 50). KRISTIN CARLSON, EXAMINING ATTORNEY

SN 77-415,172. THE HARTZ MOUNTAIN CORPORATION, SECAUCUS, NJ. FILED 3-6-2008.

HARTZ ROUND ABOUT ANIMALS

THE MARK CONSISTS OF STANDARD CHARACTERS WITHOUT CLAIM TO ANY PARTICULAR FONT, STYLE, SIZE, OR COLOR.

OWNER OF U.S. REG. NOS. 2,524,782, 3,222,910 AND OTHERS. FOR PET TOYS (U.S. CLS. 22, 23, 38 AND 50). MAYUR VAGHANI, EXAMINING ATTORNEY

SN 77-419,294. HUGHES, JOHN, DBA BOW FITNESS PRODUCTS, PHOENIX, AZ. FILED 3-11-2008.

Bow Classic

THE MARK CONSISTS OF STANDARD CHARACTERS WITHOUT CLAIM TO ANY PARTICULAR FONT, STYLE, SIZE, OR COLOR.

NO CLAIM IS MADE TO THE EXCLUSIVE RIGHT TO USE "BOW", APART FROM THE MARK AS SHOWN. FOR MANUALLY-OPERATED EXERCISE EQUIPMENT (U.S. CLS. 22, 23, 38 AND 50). EMILY CARLSEN, EXAMINING ATTORNEY

SN 77-415,809. GOUVEIA, JUSTINA J.P., HONOLULU, HI. FILED 3-7-2008.

MY MAN... MY WOMAN

THE MARK CONSISTS OF STANDARD CHARACTERS WITHOUT CLAIM TO ANY PARTICULAR FONT, STYLE, SIZE, OR COLOR.

FOR BOARD GAMES (U.S. CLS. 22, 23, 38 AND 50). B. PARADEWELAI, EXAMINING ATTORNEY

SN 77-420,370. HUGE FACTORY, LLC, PORTLAND, OR. FILED 3-12-2008.

Bunk Bot

THE MARK CONSISTS OF STANDARD CHARACTERS WITHOUT CLAIM TO ANY PARTICULAR FONT, STYLE, SIZE, OR COLOR.

FOR PLUSH TOYS (U.S. CLS. 22, 23, 38 AND 50). LIEF MARTIN, EXAMINING ATTORNEY

CLASS 28—(Continued).

SN 77-424,537. INTELLIGENT AUTOMATION, INC., ROCKVILLE, MD. FILED 3-18-2008.

TALKTILES

THE MARK CONSISTS OF STANDARD CHARACTERS WITHOUT CLAIM TO ANY PARTICULAR FONT, STYLE, SIZE, OR COLOR.

FOR EQUIPMENT SOLD AS A UNIT FOR PLAYING EDUCATIONAL PARLOR GAMES IN THE NATURE OF PLAYER-MANIPULATED TILES TO BE PLACED IN RECESSES IN A CRADLE (U.S. CLS. 22, 23, 38 AND 50). FIRST USE 3-1-2004; IN COMMERCE 3-1-2004.

VERNA BETH RIRIE, EXAMINING ATTORNEY

SN 77-426,069. CURTISS, WAYNE, LUTZ, FL. FILED 3-19-2008.

ZARLIES

THE MARK CONSISTS OF STANDARD CHARACTERS WITHOUT CLAIM TO ANY PARTICULAR FONT, STYLE, SIZE, OR COLOR.

FOR TOYS, NAMELY, SOFT MOVABLE CREATURES FOR CONNECTION TO SNOWBOARDS (U.S. CLS. 22, 23, 38 AND 50).

NAAKWAMA ANKRAH, EXAMINING ATTORNEY

SN 77-426,441. GOLF GEOMETRICS, LLC, MATTHEWS, NC. FILED 3-19-2008.

THEGRIDLOCK

THE MARK CONSISTS OF STANDARD CHARACTERS WITHOUT CLAIM TO ANY PARTICULAR FONT, STYLE, SIZE, OR COLOR.

FOR GOLF CLUB SWING AIDS, NAMELY, GOLF TRAINING DEVICES USED TO AID GOLFERS IN MAKING A PROPER SWING; GOLF PUTTING AIDS, NAMELY, GOLF TRAINING DEVICES USED TO AID GOLFERS IN MAKING A PROPER PUTT (U.S. CLS. 22, 23, 38 AND 50).

JORDAN BAKER, EXAMINING ATTORNEY

CLASS 28—(Continued).

SN 77-426,455. GOLF GEOMETRICS, LLC, MATTHEWS, NC. FILED 3-19-2008.

THEGRIDPRO

THE MARK CONSISTS OF STANDARD CHARACTERS WITHOUT CLAIM TO ANY PARTICULAR FONT, STYLE, SIZE, OR COLOR.

FOR GOLF CLUB SWING AIDS, NAMELY, GOLF TRAINING DEVICES USED TO AID GOLFERS IN MAKING A PROPER SWING; GOLF PUTTING AIDS, NAMELY, GOLF TRAINING DEVICES USED TO AID GOLFERS IN MAKING A PROPER GOLF PUTT (U.S. CLS. 22, 23, 38 AND 50).

JORDAN BAKER, EXAMINING ATTORNEY

SN 77-426,816. 2SPOT COMMUNICATIONS, BANGKOK, THAILAND, FILED 3-19-2008.

Unsleep Sheep

THE MARK CONSISTS OF STANDARD CHARACTERS WITHOUT CLAIM TO ANY PARTICULAR FONT, STYLE, SIZE, OR COLOR.

NO CLAIM IS MADE TO THE EXCLUSIVE RIGHT TO USE "SHEEP", APART FROM THE MARK AS SHOWN.

FOR PLUSH TOYS; STUFFED AND PLUSH TOYS; DOLL ACCESSORIES; DOLLS (U.S. CLS. 22, 23, 38 AND 50).

INGA ERVIN, EXAMINING ATTORNEY

SN 77-427,080. WILLIAMS, BRANT, JUPITER, FL. FILED 3-20-2008.

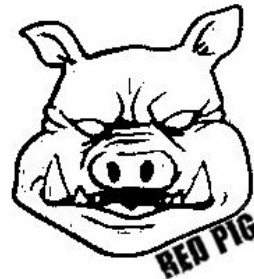

THE MARK CONSISTS OF A PIG'S FACE WITH THE WORDS "RED PIG" UNDER THE LOWER LEFT PORTION OF THE PIG'S FACE.

FOR FISHING RODS; FISHING REELS (U.S. CLS. 22, 23, 38 AND 50).

FIRST USE 11-1-2007; IN COMMERCE 11-1-2007.

MATTHEW PAPPAS, EXAMINING ATTORNEY

CLASS 28—(Continued).

SN 77-428,290. INNOVATIVE REEL TECHNOLOGIES, LTD., MYERSTOWN, PA. FILED 3-21-2008.

IRT

THE MARK CONSISTS OF STANDARD CHARACTERS WITHOUT CLAIM TO ANY PARTICULAR FONT, STYLE, SIZE, OR COLOR.

FOR FISHING TACKLE, NAMELY, FISHING REELS (U.S. CLS. 22, 23, 38 AND 50).
SUZANNE BLANE, EXAMINING ATTORNEY

CLASS 28—(Continued).

SN 77-428,651. KRUMBOLTZ, DAVID R., DANVILLE, CA. FILED 3-21-2008.

Mobopoly

THE MARK CONSISTS OF STANDARD CHARACTERS WITHOUT CLAIM TO ANY PARTICULAR FONT, STYLE, SIZE, OR COLOR.

FOR BOARD GAMES (U.S. CLS. 22, 23, 38 AND 50).
LINDSEY RUBIN, EXAMINING ATTORNEY

SN 77-428,328. INNOVATIVE REEL TECHNOLOGIES, LTD., MYERSTOWN, PA. FILED 3-21-2008.

INNOVATIVE REEL TECHNOLOGIES

THE MARK CONSISTS OF STANDARD CHARACTERS WITHOUT CLAIM TO ANY PARTICULAR FONT, STYLE, SIZE, OR COLOR.

NO CLAIM IS MADE TO THE EXCLUSIVE RIGHT TO USE "REEL TECHNOLOGIES", APART FROM THE MARK AS SHOWN.

FOR FISHING TACKLE, NAMELY, FISHING REELS (U.S. CLS. 22, 23, 38 AND 50).
SUZANNE BLANE, EXAMINING ATTORNEY

SN 77-428,878. ROCK CREEK MOLDING INC., GLENWOOD, AR. FILED 3-22-2008.

Fantastic Fingertip Flyer

THE MARK CONSISTS OF STANDARD CHARACTERS WITHOUT CLAIM TO ANY PARTICULAR FONT, STYLE, SIZE, OR COLOR.

NO CLAIM IS MADE TO THE EXCLUSIVE RIGHT TO USE "FLYER", APART FROM THE MARK AS SHOWN.

FOR HAND-POWERED NON-MECHANICAL FLYING TOY (U.S. CLS. 22, 23, 38 AND 50).
FRANK LATTUCA, EXAMINING ATTORNEY

SN 77-428,347. INNOVATIVE REEL TECHNOLOGIES, LTD., MYERSTOWN, PA. FILED 3-21-2008.

INNOVATION BEYOND DESCRIPTION: PERFORMANCE BEYOND COMPARE

THE MARK CONSISTS OF STANDARD CHARACTERS WITHOUT CLAIM TO ANY PARTICULAR FONT, STYLE, SIZE, OR COLOR.

FOR FISHING TACKLE, NAMELY, FISHING REELS (U.S. CLS. 22, 23, 38 AND 50).
SUZANNE BLANE, EXAMINING ATTORNEY

SN 77-429,182. EXCALIBUR ELECTRONICS, INC., MIAMI, FL. FILED 3-24-2008.

PHANTOM FORCE

THE MARK CONSISTS OF STANDARD CHARACTERS WITHOUT CLAIM TO ANY PARTICULAR FONT, STYLE, SIZE, OR COLOR.

FOR ELECTRONIC CHESS GAME (U.S. CLS. 22, 23, 38 AND 50).

FIRST USE 10-31-2007; IN COMMERCE 10-31-2007.
ODESSA BIBBINS, EXAMINING ATTORNEY

CLASS 28—(Continued).

SN 77-429,338. MURPHY, BRUNO P., CINCINNATI, OH.
FILED 3-24-2008.

Endango

THE MARK CONSISTS OF STANDARD CHARACTERS
WITHOUT CLAIM TO ANY PARTICULAR FONT, STYLE,
SIZE, OR COLOR.
FOR BOARD GAMES (U.S. CLS. 22, 23, 38 AND 50).
CAROL SPILS, EXAMINING ATTORNEY

SN 77-429,492. BOBBLE NATION LLC, SAN JOSE, CA. FILED
3-24-2008.

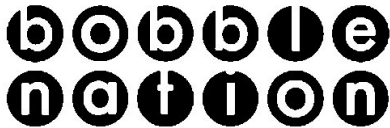

NO CLAIM IS MADE TO THE EXCLUSIVE RIGHT TO
USE "BOBBLE", APART FROM THE MARK AS SHOWN.
THE MARK CONSISTS OF THE WORDING "BOBBLE
NATION"; EACH LETTER IS INSIDE A SHADED CIRCLE.
FOR BOBBLEHEAD DOLLS (U.S. CLS. 22, 23, 38 AND
50).
FIRST USE 12-19-2007; IN COMMERCE 3-1-2008.
ALICE SUE CARRUTHERS, EXAMINING ATTORNEY

SN 77-429,497. HOFSTEDT, THOMAS, TACOMA, WA. FILED
3-24-2008.

hufstroke

THE MARK CONSISTS OF STANDARD CHARACTERS
WITHOUT CLAIM TO ANY PARTICULAR FONT, STYLE,
SIZE, OR COLOR.
FOR BILLIARD CUES; GOLF CLUBS (U.S. CLS. 22, 23,
38 AND 50).
ALICIA COLLINS, EXAMINING ATTORNEY

CLASS 28—(Continued).

SN 77-430,026. SCHULTZ, BRUCE A., DBA BODYLINES,
WOODLAND HILLS, CA. FILED 3-24-2008.

Ground Pounders

THE MARK CONSISTS OF STANDARD CHARACTERS
WITHOUT CLAIM TO ANY PARTICULAR FONT, STYLE,
SIZE, OR COLOR.
FOR TOY VEHICLES (U.S. CLS. 22, 23, 38 AND 50).
JENNY PARK, EXAMINING ATTORNEY

SN 77-430,711. U-HAUL INTERNATIONAL, INC., PHOENIX,
AZ. FILED 3-25-2008.

U-HAUL

THE MARK CONSISTS OF STANDARD CHARACTERS
WITHOUT CLAIM TO ANY PARTICULAR FONT, STYLE,
SIZE, OR COLOR.
OWNER OF U.S. REG. NOS. 746,034, 893,891 AND
OTHERS.
FOR STUFFED TOYS AND PLUSH TOYS (U.S. CLS.
22, 23, 38 AND 50).
FIRST USE 10-10-2006; IN COMMERCE 10-10-2006.
LEIGH CAROLINE CASE, EXAMINING ATTORNEY

SN 77-430,743. FZ MEDIA DESIGN, INC., YARDLEY, PA.
FILED 3-25-2008.



THE COLOR(S) BLACK AND GRAY IS/ARE CLAIMED
AS A FEATURE OF THE MARK.
THE MARK CONSISTS OF IN BLACK, THE MARK
"RAYSKIN" IN THE SHAPE OF A STINGRAY, ABOVE
FOUR SMALLER BLACK AND GRAY STINGRAYS.
FOR SURFBOARDS (U.S. CLS. 22, 23, 38 AND 50).
VERNA BETH RIRIE, EXAMINING ATTORNEY

CLASS 28—(Continued).

SN 77-431,073. ICON HEALTH & FITNESS, INC., LOGAN, UT. FILED 3-25-2008.

ACTIVATOR

THE MARK CONSISTS OF STANDARD CHARACTERS WITHOUT CLAIM TO ANY PARTICULAR FONT, STYLE, SIZE, OR COLOR.

FOR EXERCISE MACHINES (U.S. CLS. 22, 23, 38 AND 50).

THOMAS MANOR, EXAMINING ATTORNEY

CLASS 28—(Continued).

EXTERIOR BORDER CIRCLE; THE COLOR YELLOW APPEARING IN THE HYPHEN CHARACTER AND THE DESIGN OF THE UNDER SHELL; THE COLOR BLACK APPEARING IN THE OUTLINE OF THE WORDING AND THE TURTLE DESIGN AND IN DETAILS OF THE WINGS, SHELL AND HEAD; THE COLOR GRAY APPEARING IN THE DESIGN OF THE WINGS; THE COLOR BLUE APPEARING IN THE DESIGN OF THE INTERIOR BORDER CIRCLE; THE COLOR WHITE APPEARING IN THE DESIGN OF THE TURTLE'S EYES AND TEETH.

FOR ACTION FIGURES; PLUSH TOYS; TOY WATER GLOBES; TOY SNOW GLOBES; CHILDREN'S MULTIPLE ACTIVITY TOYS; CHILDREN'S WIRE CONSTRUCTION AND ART ACTIVITY TOYS; ARCADE-TYPE ELECTRONIC EDUCATION VIDEO GAMES; ELECTRONIC EDUCATIONAL GAME MACHINES FOR CHILDREN; STAND ALONE VIDEO GAME MACHINES; ARCADE-TYPE ELECTRONIC VIDEO GAMES; BABY MULTIPLE ACTIVITY TOYS; BATH TOYS; BENDABLE TOYS; CHILDREN'S MULTIPLE ACTIVITY TOYS SOLD AS A UNIT WITH PRINTED BOOKS; COLLECTABLE TOY FIGURES; DRAWING TOYS; ELECTRONIC LEARNING TOYS; FANTASY CHARACTER TOYS; INFANT ACTION CRIB TOYS; INFANT DEVELOPMENT TOYS; INFANT TOYS; MOLDED TOY FIGURES; MUSIC BOX TOYS; MUSICAL TOYS; PARTY FAVORS IN THE NATURE OF SMALL TOYS; PLAY MATS CONTAINING INFANT TOYS; POP UP TOYS; POSITIONABLE TOY FIGURES; PULL TOYS; PUSH TOYS; RUBBER CHARACTER TOYS; STUFFED AND PLUSH TOYS; TALKING TOYS (U.S. CLS. 22, 23, 38 AND 50).

JOHN SCHUYLER YARD, EXAMINING ATTORNEY

SN 77-431,685. DAVID ISAACS, BROOKLYN, NY. FILED 3-26-2008.



THE COLOR(S) GREEN, RED, YELLOW, BLACK, GRAY, BLUE AND WHITE IS/ARE CLAIMED AS A FEATURE OF THE MARK.

THE MARK CONSISTS OF THE COLORS GREEN, RED, YELLOW, BLACK, GRAY, BLUE AND WHITE, WITH THE COLOR GREEN APPEARING IN THE WORDING "THE FLYING TURTLE" AND THE DESIGN OF THE TURTLE'S HEAD, ARMS, LEGS AND INTERIOR EYES; THE COLOR RED APPEARING IN THE WORDING "HI HELLO" AND THE DESIGN OF THE TURTLE'S OUTER SHELL AND THE

SN 77-431,757. WINFIELD SOLUTIONS, LLC., SHOREVIEW, MN. FILED 3-26-2008.

JACK PLOT!

THE MARK CONSISTS OF STANDARD CHARACTERS WITHOUT CLAIM TO ANY PARTICULAR FONT, STYLE, SIZE, OR COLOR.

FOR BOARD GAMES (U.S. CLS. 22, 23, 38 AND 50).
ANTHONY RINKER, EXAMINING ATTORNEY

CLASS 28—(Continued).

SN 77-431,774. TENNESSEE NATIONAL, LLC, LOUDEN, TN. FILED 3-26-2008.



THE COLOR(S) BLUE, GREEN AND WHITE IS/ARE CLAIMED AS A FEATURE OF THE MARK.

THE MARK CONSISTS OF TWO STYLIZED DEPICTIONS OF GREEN MOUNTAINS AND A STYLIZED DEPICTION OF A BLUE RIVER RUNNING UNDERNEATH AND WHITE IN THE SPACES BETWEEN THE DEPICTIONS.

FOR GOLF ACCESSORY POUCHES; GOLF BAG TAGS; GOLF BAGS; GOLF BALL MARKERS; GOLF BALLS; GOLF GLOVES; HEAD COVERS FOR GOLF CLUBS; DIVOT REPAIR TOOLS (U.S. CLS. 22, 23, 38 AND 50).

LAURIE KAUFMAN, EXAMINING ATTORNEY

SN 77-432,134. PET LOGIC, L.L.C., OMAHA, NE. FILED 3-26-2008.

SLED HEDZ

THE MARK CONSISTS OF STANDARD CHARACTERS WITHOUT CLAIM TO ANY PARTICULAR FONT, STYLE, SIZE, OR COLOR.

FOR PET TOYS (U.S. CLS. 22, 23, 38 AND 50). ANTHONY RINKER, EXAMINING ATTORNEY

SN 77-432,473. MINER, STEPHEN C., HAILEY, ID. FILED 3-26-2008.

The Kedge

THE MARK CONSISTS OF STANDARD CHARACTERS WITHOUT CLAIM TO ANY PARTICULAR FONT, STYLE, SIZE, OR COLOR.

FOR GOLF CLUBS (U.S. CLS. 22, 23, 38 AND 50). JOHN KELLY, EXAMINING ATTORNEY

CLASS 28—(Continued).

SN 77-432,505. DYNAFLEX INTERNATIONAL, INC., ANAHEIM, CA. FILED 3-26-2008.

ACU-STRENGTH

THE MARK CONSISTS OF STANDARD CHARACTERS WITHOUT CLAIM TO ANY PARTICULAR FONT, STYLE, SIZE, OR COLOR.

FOR HAND EXERCISING DEVICE, NAMELY, STRESS RELIEF EXERCISERS FOR HAND EXERCISE (U.S. CLS. 22, 23, 38 AND 50).

FIRST USE 3-26-2008; IN COMMERCE 3-26-2008. SONYA STEPHENS, EXAMINING ATTORNEY

SN 77-432,618. KATON, JARROD, STRONGSVILLE, OH. FILED 3-26-2008.

**Cleveland...Where Football
is Religion!**

THE MARK CONSISTS OF STANDARD CHARACTERS WITHOUT CLAIM TO ANY PARTICULAR FONT, STYLE, SIZE, OR COLOR.

FOR MODELED PLASTIC TOY FIGURINES (U.S. CLS. 22, 23, 38 AND 50).

MARTHA SANTOMARTINO, EXAMINING ATTORNEY

SN 77-432,666. S&N MARKETING, INC., ENCINO, CA. FILED 3-26-2008.

Fit it in.

THE MARK CONSISTS OF STANDARD CHARACTERS WITHOUT CLAIM TO ANY PARTICULAR FONT, STYLE, SIZE, OR COLOR.

FOR ROLLER SKATES (U.S. CLS. 22, 23, 38 AND 50). CHARLES L. JENKINS, EXAMINING ATTORNEY

CLASS 28—(Continued).

SN 77-433,024. C & G SYNERGISTICS, INC., LEE'S SUMMIT, MO. FILED 3-27-2008.

ANTAGONISTIC SUPERSET REPS

THE MARK CONSISTS OF STANDARD CHARACTERS WITHOUT CLAIM TO ANY PARTICULAR FONT, STYLE, SIZE, OR COLOR.

FOR EXERCISE MACHINES (U.S. CLS. 22, 23, 38 AND 50).

WANDA KAY PRICE, EXAMINING ATTORNEY

SN 77-433,316. PARADOXY PRODUCTS LLC, NEW YORK, NY. FILED 3-27-2008.

HOLDUP

THE MARK CONSISTS OF STANDARD CHARACTERS WITHOUT CLAIM TO ANY PARTICULAR FONT, STYLE, SIZE, OR COLOR.

FOR BOARD GAMES (U.S. CLS. 22, 23, 38 AND 50).

GISELLE AGOSTO, EXAMINING ATTORNEY

SN 77-433,341. CLAFFEY, DANIEL F., STEVENSON RANCH, CA. FILED 3-27-2008.

PUZZLE'OPOLY

THE MARK CONSISTS OF STANDARD CHARACTERS WITHOUT CLAIM TO ANY PARTICULAR FONT, STYLE, SIZE, OR COLOR.

FOR PUZZLES; BOARD GAMES (U.S. CLS. 22, 23, 38 AND 50).

KATINA MISTER, EXAMINING ATTORNEY

CLASS 28—(Continued).

SN 77-433,351. MIRACLE RECREATION EQUIPMENT COMPANY, MONETT, MO. FILED 3-27-2008.

JET SKI

THE MARK CONSISTS OF STANDARD CHARACTERS WITHOUT CLAIM TO ANY PARTICULAR FONT, STYLE, SIZE, OR COLOR.

FOR PLAYGROUND EQUIPMENT, NAMELY, TEE-TER TOTTERS (U.S. CLS. 22, 23, 38 AND 50).

KATINA MISTER, EXAMINING ATTORNEY

SN 77-433,758. MINDPIX, INC., OREM, UT. FILED 3-27-2008.

THERAFLEX

THE MARK CONSISTS OF STANDARD CHARACTERS WITHOUT CLAIM TO ANY PARTICULAR FONT, STYLE, SIZE, OR COLOR.

FOR EXERCISE EQUIPMENT, NAMELY, MANUALLY OPERATED RESISTANCE TRAINING DEVICE (U.S. CLS. 22, 23, 38 AND 50).

BRIAN NEVILLE, EXAMINING ATTORNEY

SN 77-439,044. KARSTEN MANUFACTURING CORPORATION, PHOENIX, AZ. FILED 4-3-2008.

HOOFER C-1

THE MARK CONSISTS OF STANDARD CHARACTERS WITHOUT CLAIM TO ANY PARTICULAR FONT, STYLE, SIZE, OR COLOR.

FOR GOLF BAGS (U.S. CLS. 22, 23, 38 AND 50).

ROBIN CHOSID, EXAMINING ATTORNEY

SN 77-451,165. MASTERGRIP, INC., IRVING, TX. FILED 4-17-2008.

OUTRIGGER

THE MARK CONSISTS OF STANDARD CHARACTERS WITHOUT CLAIM TO ANY PARTICULAR FONT, STYLE, SIZE, OR COLOR.

FOR GOLF CLUBS (U.S. CLS. 22, 23, 38 AND 50).

ANDREA HACK, EXAMINING ATTORNEY

CLASS 28—(Continued).

SN 77-452,183. DYNAFLEX INTERNATIONAL, INC., ANAHEIM, CA. FILED 4-18-2008.

ACU-GRIP

THE MARK CONSISTS OF STANDARD CHARACTERS WITHOUT CLAIM TO ANY PARTICULAR FONT, STYLE, SIZE, OR COLOR.

FOR MANUALLY-OPERATED EXERCISE EQUIPMENT; STRESS RELIEF BALLS FOR HAND EXERCISE (U.S. CLS. 22, 23, 38 AND 50).

FIRST USE 3-26-2008; IN COMMERCE 3-26-2008.
SONYA STEPHENS, EXAMINING ATTORNEY

CLASS 28—(Continued).

SN 77-457,579. NIKE, INC., BEAVERTON, OR. FILED 4-24-2008.

GURU

THE MARK CONSISTS OF STANDARD CHARACTERS WITHOUT CLAIM TO ANY PARTICULAR FONT, STYLE, SIZE, OR COLOR.

FOR GOLF BALLS (U.S. CLS. 22, 23, 38 AND 50).
MATTHEW MCDOWELL, EXAMINING ATTORNEY

SN 77-452,355. DAN-DEE INTERNATIONAL, LTD., JERSEY CITY, NJ. FILED 4-18-2008.

BOING BOING BUNNY

THE MARK CONSISTS OF STANDARD CHARACTERS WITHOUT CLAIM TO ANY PARTICULAR FONT, STYLE, SIZE, OR COLOR.

NO CLAIM IS MADE TO THE EXCLUSIVE RIGHT TO USE "BUNNY", APART FROM THE MARK AS SHOWN.

FOR STUFFED TOYS AND ANIMATED STUFFED TOYS (U.S. CLS. 22, 23, 38 AND 50).

FIRST USE 6-10-1994; IN COMMERCE 6-10-1994.
DANNEAN HETZEL, EXAMINING ATTORNEY

SN 77-459,731. WORLD WRESTLING ENTERTAINMENT, INC., STAMFORD, CT. FILED 4-28-2008.

NIGHT OF CHAMPIONS

THE MARK CONSISTS OF STANDARD CHARACTERS WITHOUT CLAIM TO ANY PARTICULAR FONT, STYLE, SIZE, OR COLOR.

FOR TOY ACTION FIGURES AND ACCESSORIES THEREFOR; CASES FOR ACTION FIGURES; TOY VEHICLES; BOARD GAMES; PLAYING CARDS; TOY SPINNING TOPS; STAND ALONE VIDEO OUTPUT GAME MACHINES FEATURING WRESTLING; ARCADE GAMES RELATED TO WRESTLING; PINBALL GAMES RELATED TO WRESTLING; HAND-HELD UNITS FOR PLAYING ELECTRONIC GAME; TABLETOP ACTION SKILL GAMES RELATED TO WRESTLING; JIGSAW PUZZLES; KITES; TOY WRESTLING RINGS; DOLLS; BOBBLE-HEAD DOLLS; PUPPETS; STUFFED TOY ANIMALS; CARD GAMES; TOY GUITARS; WATER GUNS; VINYL PRODUCTS FOR PLAYING IN A POOL, NAMELY, FLOATING PILLOW BACK LOUNGE CHAIR, INFLATABLE TOY RAFTS FOR AQUATIC RECREATIONAL USE; CHRISTMAS TREE DECORATIONS; COSTUME MASKS; TOY BELTS, DOLL FURNITURE; PARTY FAVORS IN THE NATURE OF CRACKERS AND NOISEMAKERS; SKATEBOARDS; BOWLING BALLS AND ACCESSORIES, NAMELY, BOWLING GLOVES, WRIST SUPPORTS, BOWLING BALL BAGS; WINDUP TOYS; TOY SCOOTERS; BOWLING PINS; KNEE AND ELBOW PADS FOR ATHLETIC USE; YO-YO'S; PLASTIC MODEL KITS FOR MAKING TOY VEHICLES; POOL CUES; NOVELTY TOYS, NAMELY, TOY BANKS MADE OF TIN; TOY GUM MACHINES; TOY CANDY BOWL MECHANICAL DISPENSERS; TOY STICK GUM DISPENSERS; TOY GUM FIGURE MAKERS; TOY FOAM HANDS; CONFETTI (U.S. CLS. 22, 23, 38 AND 50).

SUZANNE BLANE, EXAMINING ATTORNEY

SN 77-453,765. SHURE PRODUCTS, INC., CHICAGO, IL. FILED 4-21-2008.

EngineerQuest

THE MARK CONSISTS OF STANDARD CHARACTERS WITHOUT CLAIM TO ANY PARTICULAR FONT, STYLE, SIZE, OR COLOR.

FOR CHILDREN'S MULTIPLE ACTIVITY TOYS; CHILDREN'S MULTIPLE ACTIVITY TOYS SOLD AS A UNIT WITH PRINTED BOOKS (U.S. CLS. 22, 23, 38 AND 50).

RON FAIRBANKS, EXAMINING ATTORNEY

CLASS 28—(Continued).

SN 77-459,913. SECURING AMERICA'S FUTURE ENERGY ALLIANCE, INC., WASHINGTON, DC. AND SECURING AMERICA'S FUTURE ENERGY FOUNDATION, WASHINGTON, DC. FILED 4-28-2008.

SECURING AMERICA'S FUTURE
ENERGY

THE MARK CONSISTS OF STANDARD CHARACTERS WITHOUT CLAIM TO ANY PARTICULAR FONT, STYLE, SIZE, OR COLOR.

FOR ROLE PLAYING GAMES; ROLE PLAYING GAMES IN THE FIELDS OF FUEL AND ENERGY RESOURCES, POLICY, SECURITY, MANAGEMENT AND CONSERVATION, AND ALTERNATIVE FUEL SOURCES, ALTERNATIVE ENERGY SOURCES, AND ENVIRONMENTAL MATTERS CONCERNING FUEL AND ENERGY (U.S. CLS. 22, 23, 38 AND 50).

CHERYL CLAYTON, EXAMINING ATTORNEY

SN 77-463,381. VIRTUE PAINTBALL LLC, HAUPPAUGE, NY. FILED 5-1-2008.

CROWN

THE MARK CONSISTS OF STANDARD CHARACTERS WITHOUT CLAIM TO ANY PARTICULAR FONT, STYLE, SIZE, OR COLOR.

FOR PAINTBALL PELLET HOPPER LIDS FOR USE WITH PAINTBALL GUNS (U.S. CLS. 22, 23, 38 AND 50).

ATTIYA MALIK, EXAMINING ATTORNEY

SN 77-470,708. ZHEN DISTRIBUTION, INC., DBA ZHEN GLOBAL CORPORATION, SEATTLE, WA. FILED 5-9-2008.

Bumble Mouse

THE MARK CONSISTS OF STANDARD CHARACTERS WITHOUT CLAIM TO ANY PARTICULAR FONT, STYLE, SIZE, OR COLOR.

NO CLAIM IS MADE TO THE EXCLUSIVE RIGHT TO USE "MOUSE", APART FROM THE MARK AS SHOWN.

FOR CAT TOYS; PET TOYS; PET TOYS CONTAINING CATNIP; TOYS FOR DOMESTIC PETS (U.S. CLS. 22, 23, 38 AND 50).

WILLIAM ROSSMAN, EXAMINING ATTORNEY

CLASS 28—(Continued).

SN 77-472,733. DAN-DEE INTERNATIONAL, LTD., JERSEY CITY, NJ. FILED 5-13-2008.

FEELS SO REAL

THE MARK CONSISTS OF STANDARD CHARACTERS WITHOUT CLAIM TO ANY PARTICULAR FONT, STYLE, SIZE, OR COLOR.

FOR PLUSH TOYS, SOUND-GENERATING PLUSH TOYS, AND ANIMATED PLUSH TOYS (U.S. CLS. 22, 23, 38 AND 50).

FIRST USE 5-15-2003; IN COMMERCE 5-15-2003.
DANNEAN HETZEL, EXAMINING ATTORNEY

SN 77-482,032. INNOVATIVE REEL TECHNOLOGIES, LTD., MYERSTOWN, PA. FILED 5-23-2008.

STRIKE SAVER

THE MARK CONSISTS OF STANDARD CHARACTERS WITHOUT CLAIM TO ANY PARTICULAR FONT, STYLE, SIZE, OR COLOR.

FOR DRAG MECHANISM FOR A FISHING REEL (U.S. CLS. 22, 23, 38 AND 50).

SUZANNE BLANE, EXAMINING ATTORNEY

SN 77-501,817. MATHEW A. MCPHERSON, NORWALK, WI. FILED 6-18-2008.

DXT

THE MARK CONSISTS OF STANDARD CHARACTERS WITHOUT CLAIM TO ANY PARTICULAR FONT, STYLE, SIZE, OR COLOR.

FOR ARCHERY BOWS (U.S. CLS. 22, 23, 38 AND 50).

FIRST USE 12-31-2007; IN COMMERCE 12-31-2007.
SUSAN RICHARDS, EXAMINING ATTORNEY

CLASS 28—(Continued).

SN 78-370,967. FRANKLIN SPORTS, INC., STOUGHTON, MA. FILED 2-19-2004.

AIR TECH

THE MARK CONSISTS OF STANDARD CHARACTERS WITHOUT CLAIM TO ANY PARTICULAR FONT, STYLE, SIZE, OR COLOR.

OWNER OF U.S. REG. NO. 2,735,440.

NO CLAIM IS MADE TO THE EXCLUSIVE RIGHT TO USE "AIR", APART FROM THE MARK AS SHOWN.

FOR INFLATABLE TOYS; INFLATABLE SPORTS EQUIPMENT, NAMELY, SPORTS BALLS, PLAYGROUND BALLS, BASKETBALLS, FOOTBALLS, SOCCER BALLS, AND VOLLEYBALLS; TABLETOP SPORTS GAMES, NAMELY, HOCKEY, SOCCER, AND BASEBALL; AND HOCKEY STICKS (U.S. CLS. 22, 23, 38 AND 50).

FIRST USE 7-1-1998; IN COMMERCE 7-1-1998.
BRIAN PINO, EXAMINING ATTORNEY

SN 78-474,554. ACHILLES, PETER M., KAISERSLAUTERN, FED REP GERMANY, FILED 8-27-2004.

Lunatic

THE MARK CONSISTS OF STANDARD CHARACTERS WITHOUT CLAIM TO ANY PARTICULAR FONT, STYLE, SIZE, OR COLOR.

PRIORITY CLAIMED UNDER SEC. 44(D) ON FED REP GERMANY APPLICATION NO. 30418494, FILED 4-2-2004.

FOR KITES, KITEBOARDS IN THE NATURE OF BOARDS FOR RIDING WHEN BEING PROPELLED BY A KITE, AND KITE HARNESSSES, ALL FOR USE IN KITESURFING (U.S. CLS. 22, 23, 38 AND 50).

DANIEL BRODY, EXAMINING ATTORNEY

CLASS 28—(Continued).

SN 78-656,356. MATTEL, INC., EL SEGUNDO, CA. FILED 6-22-2005.

SPARKLE THE SECRET STARFISH

THE MARK CONSISTS OF STANDARD CHARACTERS WITHOUT CLAIM TO ANY PARTICULAR FONT, STYLE, SIZE, OR COLOR.

OWNER OF U.S. REG. NOS. 2,666,737, 2,718,115 AND 2,738,973.

NO CLAIM IS MADE TO THE EXCLUSIVE RIGHT TO USE "STARFISH", APART FROM THE MARK AS SHOWN. FOR TOYS, GAMES AND PLAYTHINGS, NAMELY, DOLL PLAYSETS AND ACCESSORIES THEREFOR (U.S. CLS. 22, 23, 38 AND 50).

FIRST USE 1-23-2006; IN COMMERCE 1-23-2006.
ALEXANDER L. POWERS, EXAMINING ATTORNEY

SN 78-747,893. KATHERINE F. WESTBROOK, UNITED STATES CITIZEN, JOINT APPLICANTS, STEVEN D. PEO, UNITED STATES CITIZEN, JOINT APPLICANTS AND MARU C. FOLEY, UNITED STATES CITIZEN, JOINT APPLICANTS, LEXINGTON, MI. AND PEO, STEVEN, D. LEXINGTON, MI. AND FOLEY, MARY C., LEXINGTON, MI. FILED 11-5-2005.

Fandanglers

THE MARK CONSISTS OF STANDARD CHARACTERS WITHOUT CLAIM TO ANY PARTICULAR FONT, STYLE, SIZE, OR COLOR.

FOR FANTASY CHARACTER TOYS (U.S. CLS. 22, 23, 38 AND 50).

FIRST USE 12-1-2003; IN COMMERCE 12-1-2003.
AMOS T. MATTHEWS, JR., EXAMINING ATTORNEY

SN 78-842,491. SPIN MASTER LTD., TORONTO, ONTARIO, CANADA, FILED 3-21-2006.

I-TATTOO

THE MARK CONSISTS OF STANDARD CHARACTERS WITHOUT CLAIM TO ANY PARTICULAR FONT, STYLE, SIZE, OR COLOR.

PRIORITY CLAIMED UNDER SEC. 44(D) ON CANADA APPLICATION NO. 1290566, FILED 2-20-2006, REG. NO. TMA695468, DATED 9-4-2007, EXPIRES 9-4-2022.

FOR TOYS, GAMES AND PLAYTHINGS, NAMELY, TOY PENS FOR APPLYING TATTOOS, AND ACCESSORIES THEREFOR. (U.S. CLS. 22, 23, 38 AND 50).

MARY CRAWFORD, EXAMINING ATTORNEY

CLASS 28—(Continued).

SN 78-904,510. COTRAN, RALPH, FAYETTEVILLE, NY.
AND WRIGHT, KARI, JAMESVILLE, NY. FILED 6-9-2006.

YOGAMATE

THE MARK CONSISTS OF STANDARD CHARACTERS WITHOUT CLAIM TO ANY PARTICULAR FONT, STYLE, SIZE, OR COLOR.

FOR YOGA MATS WITH INDICIA SHOWING EXERCISE POSITIONS. (U.S. CLS. 22, 23, 38 AND 50).

PAUL MORENO, EXAMINING ATTORNEY

SN 78-915,545. VOIT CORPORATION, SAN ANTONIO, TX.
FILED 6-23-2006.

ENDURO

THE MARK CONSISTS OF STANDARD CHARACTERS WITHOUT CLAIM TO ANY PARTICULAR FONT, STYLE, SIZE, OR COLOR.

OWNER OF U.S. REG. NO. 420,389.

FOR SPORTING GOODS, NAMELY, SPORTS BALLS OF ALL TYPES, TOY RUBBER BALLS, GOLF BALLS, BASKETBALLS, FOOTBALLS, SOCCER BALLS, VOLLEYBALLS, HANDBALLS, BASEBALLS AND SOFTBALLS; BASEBALL, CRICKET, SOFTBALL AND TABLE TENNIS BATS; CUE, FIELD HOCKEY, ICE HOCKEY, STREET HOCKEY, LACROSSE AND SKI STICKS AND REPLACEMENT PARTS THEREOF FOR SPORTS AND FITNESS ACTIVITIES; GOLF CLUBS; BASEBALL AND SOFTBALL PITCHING MACHINES, GRIP TAPE FOR BASEBALL, CRICKET, SOFTBALL AND TABLE TENNIS BATS, GOLF CLUBS AND CUE, FIELD HOCKEY, ICE HOCKEY, STREET HOCKEY, LACROSSE AND SKI STICKS; BASKETBALL BACKBOARDS, SNOWBOARDS AND SNOWBOARD BINDINGS; SKATEBOARDS; EXERCISE WEIGHTS, ANKLE WEIGHTS FOR EXERCISE, HAND WEIGHTS FOR EXERCISE, WEIGHT LIFTING BELTS, AEROBIC BOXING GLOVES; GOLF CLUB HEAD COVERS, GOLF BAGS, GOLF BAG TAGS, GOLF TEES, GOLF BALLS, GOLF BALL MARKERS, SHOULDER STRAPS FOR GOLF BAGS, DIVOT REPAIR TOOLS; IN-LINE, ROLLER AND ICE SKATES AND REPLACEMENT PARTS THEREOF FOR SPORTS AND FITNESS ACTIVITIES; HAND GRIPS FOR GOLF CLUBS, BASEBALL, SOFTBALL AND CRICKET BATS, FIELD HOCKEY STICKS, ICE HOCKEY STICKS, LACROSSE STICKS, NAMELY, MITTS AND GLOVES FOR THE PRACTICE OF ALL TYPES OF SPORTS, NAMELY, FOR, BASEBALL, SOFTBALL, GOLF, SOCCER, FOOTBALL, SKIING, LACROSSE, STREET HOCKEY, FIELD HOCKEY, ICE HOCKEY; SAFETY PADDING AND SAFETY CUSHIONING USED IN SPORTS FACILITIES AND ON EQUIPMENT FOR BASKETBALL, BASEBALL, FOOTBALL, SOCCER, HOCKEY, LACROSSE, ICE SKATING, INLINE SKATING, CRICKET, VOLLEYBALL, AND IN GYMNASIUMS AND PLAYGROUNDS; KICKBOARDS, AND RING BUOYS FOR RECREATIONAL AND SPORT TRAINING USE; BAGS SPECIFICALLY ADAPTED TO SPORTS EQUIPMENT, NAMELY, BAT BAGS; ICE AND ROLLER SKATES, SKIS AND SKI EQUIPMENT, NAMELY, SKIS AND SKI STICKS; FACE MASKS FOR SPORTS AND FITNESS ACTIVITIES, NAMELY, FIELD HOCKEY, STREET HOCKEY, ICE HOCKEY, BASEBALL, FOOTBALL AND LACROSSE; PROTECTIVE PADDING, MOUTH AND SHIN GUARDS, SUPPORTERS AND

CLASS 28—(Continued).

BODY PROTECTORS FOR SPORTS AND FITNESS ACTIVITIES, NAMELY, ICE HOCKEY, STREET HOCKEY, FIELD HOCKEY, BASEBALL, FOOTBALL, SOCCER, BASKETBALL, SQUASH, RACQUETBALL, LACROSSE AND SKIING; LACROSSE STICK HEADS AND REPLACEMENT PARTS THEREOF, LACROSSE GLOVES, LACROSSE ARM PADS, LACROSSE SHOULDER PADS, LACROSSE RIB PADS, LACROSSE CHEST PROTECTORS, LACROSSE GOALS, LACROSSE NETS; SOCCER GOALKEEPER GLOVES, SOCCER SHIN GUARDS, SOCCER GOALS, SOCCER NETS; FIELD HOCKEY GLOVES, FIELD HOCKEY SHIN GUARDS, FIELD HOCKEY GOALS, FIELD HOCKEY NETS; VOLLEYBALL NETS; SPORTS PROTECTIVE PADS FOR VARIOUS PARTS OF THE BODY, NAMELY, SHOULDER PADS, CHEST PADS, AND THIGH PADS; WATER SPORTS EQUIPMENT, NAMELY, PLASTIC OR METAL DIVING PLANES FOR USE BY SNORKELERS AND SCUBA DIVERS, SCUBA AND SWIM FINS AND FLIPPERS; FINS FOR BODY BOARDS, SURF FINS, SURFBOARD FINS, WATER SKIS, TRICK SKIS, SLALOM WATER SKIS, JUMP SKIS, SKI WAX; BOARDS USED IN THE PRACTICE OF WATER SPORTS, NAMELY, WAKE BOARDS, SURFBOARDS, KICK BOARDS, PADDLE BOARDS, SAIL BOARDS, KNEE BOARDS; WATER SKI BINDINGS AND PARTS THEREOF, WAKEBOARD BINDINGS, AND WATER SKI ROPES, ROPE HANDLES AND BRIDLES, WATER SPORTS TOW HARNESSSES, WATER SKI COVERS AND WATER SKI CARRYING BAGS; INFLATABLE TUBES FOR WATER SPORTS AND RECREATION, INFLATABLE RIDE-ON TOYS, INFLATABLE POOLS FOR RECREATIONAL USE, INFLATABLE MATTRESSES FOR RECREATIONAL USE (U.S. CLS. 22, 23, 38 AND 50).

LINDA ORNDORFF, EXAMINING ATTORNEY

SN 79-041,834. MARKER VÖLKL (INTERNATIONAL)
GMBH, SWITZERLAND, FILED 5-7-2007.

BARON

THE MARK CONSISTS OF STANDARD CHARACTERS WITHOUT CLAIM TO ANY PARTICULAR FONT, STYLE, SIZE, OR COLOR.

PRIORITY DATE OF 11-9-2006 IS CLAIMED.

OWNER OF INTERNATIONAL REGISTRATION 0932558 DATED 5-7-2007, EXPIRES 5-7-2017.

FOR SPORTING ARTICLES AND SPORTING APPARATUS, NAMELY, SKIS, SNOWBOARDS, SKI BINDINGS, SNOWBOARD BINDINGS, SKI STICKS AND BAGS ESPECIALLY DESIGNED FOR SKIS AND SNOWBOARDS, EXCLUDING ICE-HOCKEY PRODUCTS (U.S. CLS. 22, 23, 38 AND 50).

REBECCA POVARCHUK, EXAMINING ATTORNEY

CLASS 29—MEATS AND PROCESSED FOODS

SN 76-684,093. HEB GROCERY COMPANY, LP, SAN ANTONIO, TX. FILED 11-16-2007.

TEXAS HERITAGE

THE MARK CONSISTS OF STANDARD CHARACTERS WITHOUT CLAIM TO ANY PARTICULAR FONT, STYLE, SIZE, OR COLOR.

OWNER OF U.S. REG. NO. 2,919,358.

NO CLAIM IS MADE TO THE EXCLUSIVE RIGHT TO USE "TEXAS", APART FROM THE MARK AS SHOWN.

FOR MEAT PRODUCTS, NAMELY, HOT DOGS, JERKY (U.S. CL. 46).

FIRST USE 3-26-2003; IN COMMERCE 3-26-2003.

G. MAYERSCHOFF, EXAMINING ATTORNEY

SN 77-086,005. COUNTRY FRESH AUSTRALIA PTY LTD, ARMIDALE, AUSTRALIA, FILED 1-18-2007.

COUNTRY FRESH AUSTRALASIA

THE MARK CONSISTS OF STANDARD CHARACTERS WITHOUT CLAIM TO ANY PARTICULAR FONT, STYLE, SIZE, OR COLOR.

NO CLAIM IS MADE TO THE EXCLUSIVE RIGHT TO USE "FRESH", APART FROM THE MARK AS SHOWN.

FOR MEAT AND MEAT PRODUCTS, NAMELY, LAMB, MUTTON AND GOAT MEAT (U.S. CL. 46).

STEVEN JACKSON, EXAMINING ATTORNEY

SN 77-101,668. FRESH EXPRESS INCORPORATED, SALINAS, CA. FILED 2-7-2007.

FRESH EXPRESS TAKEOUTS

THE MARK CONSISTS OF STANDARD CHARACTERS WITHOUT CLAIM TO ANY PARTICULAR FONT, STYLE, SIZE, OR COLOR.

OWNER OF U.S. REG. NOS. 2,569,875, 3,028,912 AND OTHERS.

NO CLAIM IS MADE TO THE EXCLUSIVE RIGHT TO USE "FRESH", APART FROM THE MARK AS SHOWN.

FOR PRE-PACKAGED SALAD KITS FOR MAKING GARDEN AND VEGETABLE SALADS CONSISTING PRIMARILY OF PRECUT VEGETABLES, SALAD MIX, SALAD DRESSING, AND ALSO INCLUDING SALAD ACCOUTREMENTS, NAMELY, BACON BITS, CROUTONS, CHOPPED PROCESSED NUTS, PROCESSED EDIBLE SEEDS, AND PREPARED MEATS (U.S. CL. 46).

HEATHER SAPP, EXAMINING ATTORNEY

CLASS 29—(Continued).

SN 77-122,034. COUNTRY FRESH AUSTRALIA PTY LTD, ARMIDALE, AUSTRALIA, FILED 3-5-2007.



NO CLAIM IS MADE TO THE EXCLUSIVE RIGHT TO USE "FRESH", APART FROM THE MARK AS SHOWN.

THE MARK CONSISTS OF THE WORDS "COUNTRY FRESH AUSTRALASIA" AND THE LETTERS "CFA" WITHIN A STYLIZED "C".

FOR MEAT AND MEAT PRODUCTS, NAMELY, LAMB, MUTTON AND GOAT MEAT (U.S. CL. 46).

STEVEN JACKSON, EXAMINING ATTORNEY

SN 77-122,037. COUNTRY FRESH AUSTRALIA PTY LTD, ARMIDALE, AUSTRALIA, FILED 3-5-2007.



NO CLAIM IS MADE TO THE EXCLUSIVE RIGHT TO USE "FRESH" AND "AMERICA", APART FROM THE MARK AS SHOWN.

THE MARK CONSISTS OF THE WORDS "COUNTRY FRESH AMERICA" AND THE LETTERS "CFA" WITHIN A STYLIZED "C".

FOR MEAT AND MEAT PRODUCTS, NAMELY, LAMB, MUTTON AND GOAT MEAT (U.S. CL. 46).

STEVEN JACKSON, EXAMINING ATTORNEY

CLASS 29—(Continued).

SN 77-157,925. PETERS, DANIEL R., PITTSBURGH, PA. AND ARRINGTON, KATHRENE A., PITTSBURGH, PA. FILED 4-16-2007.

CLASS 29—(Continued).

SN 77-168,074. BBI, INC., WILMINGTON, DE. FILED 4-27-2007.

Dr. Dan's "The Spread Of Life"

THE MARK CONSISTS OF STANDARD CHARACTERS WITHOUT CLAIM TO ANY PARTICULAR FONT, STYLE, SIZE, OR COLOR.

"DR. DAN" IDENTIFIES A LIVING INDIVIDUAL WHOSE CONSENT IS OF RECORD.

FOR DAIRY PRODUCTS EXCLUDING ICE CREAM, ICE MILK AND FROZEN YOGURT (U.S. CL. 46).

MICHAEL ENGEL, EXAMINING ATTORNEY



SN 77-168,059. BBI, INC., WILMINGTON, DE. FILED 4-27-2007.

BEAN MAN

THE MARK CONSISTS OF STANDARD CHARACTERS WITHOUT CLAIM TO ANY PARTICULAR FONT, STYLE, SIZE, OR COLOR.

NO CLAIM IS MADE TO THE EXCLUSIVE RIGHT TO USE "BEAN", APART FROM THE MARK AS SHOWN.

FOR PROCESSED BEANS, NAMELY, BAKED BEANS, WHITE BEANS, RED BEANS, BLACK BEANS, GREEN BEANS, KIDNEY BEANS, LIMA BEANS, BLACK-EYED PEAS, COWPEAS, CROWDER BEANS, CHICKPEAS, CANNELLINI BEANS, GREAT NORTHERN BEANS, NAVY BEANS, PURPLE HULL BEANS, PINK BEANS, AND PINTO BEANS (U.S. CL. 46).

MICHAEL WEBSTER, EXAMINING ATTORNEY

OWNER OF U.S. REG. NOS. 2,991,252, 2,999,845 AND OTHERS.

NO CLAIM IS MADE TO THE EXCLUSIVE RIGHT TO USE "SINCE 1908", APART FROM THE MARK AS SHOWN.

THE COLOR(S) YELLOW, BLUE, BROWN, BLACK, GRAY AND WHITE IS/ARE CLAIMED AS A FEATURE OF THE MARK.

THE WORDING "BUSH'S BEST" APPEARS IN BLUE WITH THE WORDING "SINCE 1908" IN THE COLOR BLUE ABOVE IT. THE WORDING IS INSIDE A YELLOW POLYGON ON A WHITE APRON WORN BY THE BEAN MAN CHARACTER. THE SKIN OF THE BEAN MAN CHARACTER IS BROWN, THE EYE PUPILS ARE BLACK, AND HE IS WEARING WHITE GLOVES, SHORTS AND SHOES WHICH ALSO CONTAIN GRAY SHADING. THE CHARACTER IS HOLDING A BROWN SPATULA. THE WORDING "SECRET FAMILY RECIPE" APPEARS IN BROWN AT THE BOTTOM OF THE APRON.

SEC. 2(F) AS TO "BEST".

FOR PROCESSED BEANS, NAMELY, BAKED BEANS, WHITE BEANS, RED BEANS, BLACK BEANS, GREEN BEANS, KIDNEY BEANS, LIMA BEANS, BLACK-EYED PEAS, COWPEAS, CROWDER BEANS, CHICKPEAS, CANNELLINI BEANS, GREAT NORTHERN BEANS, NAVY BEANS, PURPLE HULL BEANS, PINK BEANS, AND PINTO BEANS (U.S. CL. 46).

MICHAEL WEBSTER, EXAMINING ATTORNEY

CLASS 29—(Continued).

SN 77-198,803. VELAZQUEZ PRODUCTOS MARINOS SA DE CV, ZAPOPAN, MEXICO, FILED 6-6-2007.



NO CLAIM IS MADE TO THE EXCLUSIVE RIGHT TO USE "CAMARON", APART FROM THE MARK AS SHOWN. THE COLOR(S) RED, YELLOW, GREEN, ORANGE, GRAY, BLACK AND WHITE IS/ARE CLAIMED AS A FEATURE OF THE MARK.

THE MARK CONSISTS OF RED BACKGROUND WITH GREEN AND WHITE CIRCLES CONTAINING AN ORANGE SHRIMP WITH BLACK SUNGLASSES WITH GRAY LENSES, BLACK EYEBROWS, WHITE TEETH AND BLACK DEFINITION LINES. THE WORDING "CAMARON PELAO" IS IN YELLOW OUTLINED BY BLACK. THE BOX AROUND THE WORD "PELAO" IS IN BLACK FILLED IN WITH RED.

THE FOREIGN WORDING IN THE MARK TRANSLATES INTO ENGLISH AS "PELAO SHRIMP".

FOR SHRIMP; SHRIMPS, PRAWNS AND LOBSTERS (U.S. CL. 46).

DAWN FELDMAN, EXAMINING ATTORNEY

SN 77-250,952. PROMARK BRANDS INC., MERIDIAN, ID. FILED 8-9-2007.

JUNGLE ANIMAL TATER TOTS

THE MARK CONSISTS OF STANDARD CHARACTERS WITHOUT CLAIM TO ANY PARTICULAR FONT, STYLE, SIZE, OR COLOR.

OWNER OF U.S. REG. NO. 668,762.
NO CLAIM IS MADE TO THE EXCLUSIVE RIGHT TO USE "ANIMAL", APART FROM THE MARK AS SHOWN.
FOR PROCESSED POTATOES (U.S. CL. 46).
INGA ERVIN, EXAMINING ATTORNEY

CLASS 29—(Continued).

SN 77-251,871. STANISLAUS PARTNERS, MODESTO, CA. FILED 8-9-2007.

Tomate del Verano

THE MARK CONSISTS OF STANDARD CHARACTERS WITHOUT CLAIM TO ANY PARTICULAR FONT, STYLE, SIZE, OR COLOR.

OWNER OF U.S. REG. NO. 2,914,991.

NO CLAIM IS MADE TO THE EXCLUSIVE RIGHT TO USE "TOMATE", APART FROM THE MARK AS SHOWN.

THE FOREIGN WORDING IN THE MARK TRANSLATES INTO ENGLISH AS "TOMATO OF THE SUMMER".

FOR PROCESSED VEGETABLES; CANNED VEGETABLES; CANNED TOMATOES; VEGETABLE PASTE; VEGETABLE PUREE; TOMATO PASTE; TOMATO PUREE (U.S. CL. 46).

FIRST USE 8-25-2004; IN COMMERCE 8-25-2004.

CHRISTINA SOBRAL, EXAMINING ATTORNEY

SN 77-275,270. ST. ANDREWS OF SCOTLAND INTERNATIONAL LTD, HOLLAND, MI. FILED 9-10-2007.

St.Andrews Golf

THE MARK CONSISTS OF STANDARD CHARACTERS WITHOUT CLAIM TO ANY PARTICULAR FONT, STYLE, SIZE, OR COLOR.

FOR FISH, MEAT (U.S. CL. 46).

TOBY BULLOFF, EXAMINING ATTORNEY

SN 77-276,546. ST. ANDREWS OF SCOTLAND INTERNATIONAL LTD, HOLLAND, MI. FILED 9-11-2007.

St.Andrews of Scotland

THE MARK CONSISTS OF STANDARD CHARACTERS WITHOUT CLAIM TO ANY PARTICULAR FONT, STYLE, SIZE, OR COLOR.

FOR FISH, MEAT (U.S. CL. 46).

TOBY BULLOFF, EXAMINING ATTORNEY

CLASS 29—(Continued).

SN 77-289,408. J&B WHOLESALE DISTRIBUTING, INC., ST. MICHAEL, MN. FILED 9-26-2007.



OWNER OF U.S. REG. NOS. 1,601,126, 2,164,808 AND 2,869,731.

NO CLAIM IS MADE TO THE EXCLUSIVE RIGHT TO USE "FULLY GUARANTEED BUTCHER QUALITY MEATS", APART FROM THE MARK AS SHOWN.

THE COLOR(S) WHITE, BLACK AND RED IS/ARE CLAIMED AS A FEATURE OF THE MARK.

THE MARK CONSISTS OF A BLACK RECTANGULAR DESIGN THAT WIDENS TO A CIRCLE IN THE CENTER. THE WORDS "NO NAME" APPEAR IN LARGE WHITE LETTERS IN THE MIDDLE OF THE DESIGN, OUTLINED IN RED. THE WORDS "FULLY GUARANTEED" APPEAR IN SMALLER RED LETTERING AROUND THE TOP OF THE CIRCLE AND THE WORDS "BUTCHER QUALITY MEATS" APPEAR IN SMALLER RED LETTERING AROUND THE BOTTOM OF THE CIRCLE. A STRAIGHT RED LINE APPEARS ABOVE AND BELOW THE WORDS "NO NAME".

FOR MEAT; FISH; POULTRY; BEEF; PORK; PREPARED AND/OR PACKAGED ENTREES CONSISTING PRIMARILY OF MEAT, SEAFOOD, POULTRY OR VEGETABLES; FROZEN ENTREES CONSISTING OF SEASONED, MARINATED, BREADED, WRAPPED OR STUFFED MEAT, FISH, POULTRY OR SEAFOOD; MARINATED BEEF, PORK AND POULTRY (U.S. CL. 46).

FIRST USE 2-0-2005; IN COMMERCE 2-0-2005.

MARTHA SANTOMARTINO, EXAMINING ATTORNEY

SN 77-290,154. LEIDY'S INC., SOUDERTON, PA. FILED 9-27-2007.

NATURE'S TRADITION

THE MARK CONSISTS OF STANDARD CHARACTERS WITHOUT CLAIM TO ANY PARTICULAR FONT, STYLE, SIZE, OR COLOR.

OWNER OF U.S. REG. NO. 3,279,091.

FOR PORK; PORK, NAMELY, TENDERLOIN, PORK CHOPS, RIBS, PORK ROAST (U.S. CL. 46).

FIRST USE 10-18-2006; IN COMMERCE 10-18-2006.

STEPHEN AQUILA, EXAMINING ATTORNEY

CLASS 29—(Continued).

SN 77-291,337. KABUSHIKI KAISHA MITSUKAN GROUP HONSHA, AICHI-KEN, JAPAN, FILED 9-28-2007.



THE COLOR(S) BLACK, WHITE AND RED IS/ARE CLAIMED AS A FEATURE OF THE MARK.

THE MARK CONSISTS OF JAPANESE CHARCTERS IN WHITE WITH RED SHADOWING ON A BLACK BACKGROUND.

THE TRANSLITERATED WORDING NIOWANATTO HAS NO MEANING OTHER THAN TRADEMARK SIGNIFICANCE AND NO MEANING IN A FOREIGN LANGUAGE. THE NON-LATIN CHARACTERS IN THE MARK TRANSLITERATE TO NIOWANATTO.

FOR FERMENTED SOY BEANS (U.S. CL. 46).

MARK T. MULLEN, EXAMINING ATTORNEY

SN 77-294,068. HEB GROCERY COMPANY, LP, SAN ANTONIO, TX. FILED 10-2-2007.

TASTY TRIO

THE MARK CONSISTS OF STANDARD CHARACTERS WITHOUT CLAIM TO ANY PARTICULAR FONT, STYLE, SIZE, OR COLOR.

NO CLAIM IS MADE TO THE EXCLUSIVE RIGHT TO USE "TASTY", APART FROM THE MARK AS SHOWN.

FOR SNACK MIX CONSISTING PRIMARILY OF PROCESSED NUTS AND PROCESSED FRUIT (U.S. CL. 46).

G. MAYERSCHOFF, EXAMINING ATTORNEY

SN 77-301,041. PFCCB ADMINISTRATION, INC., SCOTTSDALE, AZ. FILED 10-10-2007.

PEI WEI

THE MARK CONSISTS OF STANDARD CHARACTERS WITHOUT CLAIM TO ANY PARTICULAR FONT, STYLE, SIZE, OR COLOR.

OWNER OF U.S. REG. NOS. 2,598,916, 3,005,828 AND OTHERS.

"PEI WEI" DOES NOT IDENTIFY A LIVING INDIVIDUAL.

FOR FROZEN ENTREES CONSISTING PRIMARILY OF MEAT, SEAFOOD, POULTRY OR VEGETABLES; FROZEN MEALS CONSISTING PRIMARILY OF MEAT, SEAFOOD, POULTRY OR VEGETABLES; FROZEN APPETIZERS CONSISTING PRIMARILY OF POULTRY, MEAT, VEGETABLES OR SEAFOOD; FROZEN VEGETABLES; INSTANT OR PRE-COOKED SOUP (U.S. CL. 46).

MICHAEL LEWIS, EXAMINING ATTORNEY

CLASS 29—(Continued).

SN 77-301,088. PFCCB ADMINISTRATION, INC., SCOTTS-DALE, AZ. FILED 10-10-2007.



OWNER OF U.S. REG. NO. 1,847,107.
"P.F. CHANG'S" DOES NOT IDENTIFY A LIVING INDIVIDUAL.

THE MARK CONSISTS OF THE WORDS "P.F. CHANG'S" FLANKED ON EITHER SIDE BY A TREE DESIGN.

FOR FROZEN MEALS CONSISTING PRIMARILY OF MEAT, SEAFOOD, POULTRY OR VEGETABLES; FROZEN APPETIZERS CONSISTING PRIMARILY OF POULTRY, MEAT, VEGETABLES OR SEAFOOD; FROZEN VEGETABLES; INSTANT OR PRE-COOKED SOUP (U.S. CL. 46).

MICHAEL LEWIS, EXAMINING ATTORNEY

SN 77-301,105. PFCCB ADMINISTRATION, INC., SCOTTS-DALE, AZ. FILED 10-10-2007.

P.F. CHANG'S

THE MARK CONSISTS OF STANDARD CHARACTERS WITHOUT CLAIM TO ANY PARTICULAR FONT, STYLE, SIZE, OR COLOR.

OWNER OF U.S. REG. NOS. 1,847,107 AND 3,334,674.
THE NAME "P.F." CHANG'S DOES NOT IDENTIFY A LIVING INDIVIDUAL.

SEC. 2(F).
FOR FROZEN MEALS CONSISTING PRIMARILY OF MEAT, SEAFOOD, POULTRY OR VEGETABLES; FROZEN APPETIZERS CONSISTING PRIMARILY OF POULTRY, MEAT, VEGETABLES OR SEAFOOD; FROZEN VEGETABLES; INSTANT OR PRE-COOKED SOUP (U.S. CL. 46).

MICHAEL LEWIS, EXAMINING ATTORNEY

SN 77-308,915. INSTITUTIONAL JOBBERS COMOPANY, DBA THE IJ COMPANY, LOUISVILLE, TN. FILED 10-19-2007.



NO CLAIM IS MADE TO THE EXCLUSIVE RIGHT TO USE "PREMIUM MEATS", APART FROM THE MARK AS SHOWN.

THE MARK CONSISTS OF A PLAQUE CONTAINING THE WORDS "HAWTHORN PREMIUM MEATS".

FOR FROZEN AND FRESH PORTION CONTROL BEEF, PORK, AND VEAL STEAKS (U.S. CL. 46).

DANIEL CAPSHAW, EXAMINING ATTORNEY

CLASS 29—(Continued).

SN 77-310,184. PETALUMA ACQUISITION, LLC, PETALUMA, CA. FILED 10-22-2007.

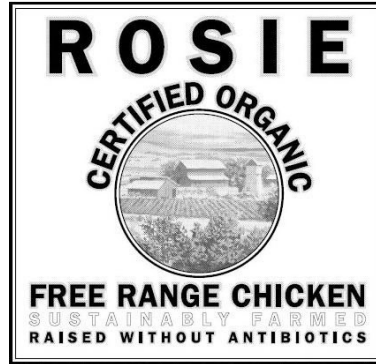

OWNER OF U.S. REG. NOS. 2,314,594, 2,536,026 AND 2,919,072.

NO CLAIM IS MADE TO THE EXCLUSIVE RIGHT TO USE "CERTIFIED ORGANIC" AND "FREE RANGE CHICKEN SUSTAINABLY FARMED RAISED WITHOUT ANTIBIOTICS", APART FROM THE MARK AS SHOWN.

FOR ORGANIC CHICKEN AND CHICKEN PARTS (U.S. CL. 46).

FIRST USE 12-31-2002; IN COMMERCE 12-31-2002.
BRENDAN MCCAULEY, EXAMINING ATTORNEY

SN 77-310,201. PETALUMA ACQUISITION, LLC, PETALUMA, CA. FILED 10-22-2007.



OWNER OF U.S. REG. NOS. 1,493,346, 2,883,480 AND OTHERS.

NO CLAIM IS MADE TO THE EXCLUSIVE RIGHT TO USE "CHICKEN", APART FROM THE MARK AS SHOWN. SEC. 2(F) AS TO "THE RANGE CHICKEN".

FOR CHICKEN AND CHICKEN PARTS (U.S. CL. 46).
FIRST USE 12-31-2002; IN COMMERCE 12-31-2002.

BRENDAN MCCAULEY, EXAMINING ATTORNEY

CLASS 29—(Continued).

SN 77-311,380. BUNGE OILS, INC., ST. LOUIS, MO. FILED 10-23-2007.



OWNER OF U.S. REG. NOS. 1,506,176, 2,942,147 AND 3,004,135.

THE MARK CONSISTS OF THE WORDS "NUTRA-CLEAR NT" WITH THE "NT" IN AN OVAL.
FOR EDIBLE OILS; VEGETABLE BASED SHORTENINGS (U.S. CL. 46).
FIRST USE 6-22-2006; IN COMMERCE 6-22-2006.
LYDIA BELZER, EXAMINING ATTORNEY

SN 77-340,975. D.R. SEAFOOD, MONTCLAIR, NJ. FILED 11-30-2007.



NO CLAIM IS MADE TO THE EXCLUSIVE RIGHT TO USE "CARIBBEAN", APART FROM THE MARK AS SHOWN.
THE MARK CONSISTS OF A BOAT WITH AN OCEAN AS A BACKGROUND AND THE STYLIZED TEXT "D.R. CARIBBEAN SEAS".
FOR SEAFOOD (U.S. CL. 46).
MARK SPARACINO, EXAMINING ATTORNEY

CLASS 29—(Continued).

SN 77-342,974. FPL FOOD LLC, AUGUSTA, GA. FILED 12-3-2007.



NO CLAIM IS MADE TO THE EXCLUSIVE RIGHT TO USE "FARMS", APART FROM THE MARK AS SHOWN.
THE MARK CONSISTS OF AN OVAL BACKGROUND WITH THE WORDS "CHÂTEL FARMS" ARCHED ABOVE THE DESIGN OF A LEFT-FACING COW IN THE MIDDLE OF A FARM FIELD, WITH TREES TO ITS LEFT AND RIGHT.
FOR MEAT, PROCESSED MEAT, MARINATED AND PREPARED MEAT, POULTRY (U.S. CL. 46).
ELISSA GARBER KON, EXAMINING ATTORNEY

SN 77-354,774. OBERTO SAUSAGE COMPANY, KENT, WA. FILED 12-18-2007.

OH BOY! OBERTO TURKEY JERKY

THE MARK CONSISTS OF STANDARD CHARACTERS WITHOUT CLAIM TO ANY PARTICULAR FONT, STYLE, SIZE, OR COLOR.
OWNER OF U.S. REG. NOS. 2,905,251, 3,069,238 AND OTHERS.
NO CLAIM IS MADE TO THE EXCLUSIVE RIGHT TO USE "TURKEY JERKY", APART FROM THE MARK AS SHOWN.
FOR MEAT; JERKY (U.S. CL. 46).
FIRST USE 12-31-1999; IN COMMERCE 12-31-1999.
STEVEN R. FOSTER, EXAMINING ATTORNEY

CLASS 29—(Continued).

SN 77-359,633. A&P GROWERS COOPERATIVE, TULARE, CA. FILED 12-26-2007.

SAN JOAQUIN VALLEY FARMS
CALIFORNIA PISTACHIOS

THE MARK CONSISTS OF STANDARD CHARACTERS WITHOUT CLAIM TO ANY PARTICULAR FONT, STYLE, SIZE, OR COLOR.

OWNER OF U.S. REG. NO. 2,424,978.

NO CLAIM IS MADE TO THE EXCLUSIVE RIGHT TO USE "CALIFORNIA PISTACHIOS", APART FROM THE MARK AS SHOWN.

SEC. 2(F).

FOR DRIED FRUITS; PROCESSED NUTS (U.S. CL. 46).

FIRST USE 11-19-1984; IN COMMERCE 11-19-1984.

LINDSEY RUBIN, EXAMINING ATTORNEY

SN 77-365,175. FIGO FOODS SENDIRIAN BERHAD, SKUDAI, JOHOR, MALAYSIA, FILED 1-7-2008.



THE MARK CONSISTS OF THE WORD "FIGO" APPEARING WITHIN A CIRCLE WHICH HAS A SHADED LOWER PORTION AND AN UPPER PORTION WHICH INCLUDES AN ABSTRACT DESIGN.

FOR FISH, CRAYFISH, FISH FILLETS, PRAWNS, TUNAFISH, SHRIMP, AND SHELLFISH ALL SOLD FROZEN; FROZEN FOOD PRODUCTS MADE FROM FISH, NAMELY, FISH CHIPS; FISHBALLS AND CUTLEFISH BALLS (U.S. CL. 46).

DAVID MURRAY, EXAMINING ATTORNEY

SN 77-391,089. JAYE, ROBERT C., INDIAN WELLS, CA. FILED 2-7-2008.

Malibu Olive Company

THE MARK CONSISTS OF STANDARD CHARACTERS WITHOUT CLAIM TO ANY PARTICULAR FONT, STYLE, SIZE, OR COLOR.

NO CLAIM IS MADE TO THE EXCLUSIVE RIGHT TO USE "OLIVE COMPANY", APART FROM THE MARK AS SHOWN.

FOR PROCESSED OLIVES, NAMELY, OLIVE OIL (U.S. CL. 46).

FIRST USE 1-1-2008; IN COMMERCE 1-1-2008.

BRIAN PINO, EXAMINING ATTORNEY

CLASS 29—(Continued).

SN 77-392,328. NATIONAL BAKERY, INC., LANCASTER, PA. FILED 2-8-2008.

SOMERSAULTS

THE MARK CONSISTS OF STANDARD CHARACTERS WITHOUT CLAIM TO ANY PARTICULAR FONT, STYLE, SIZE, OR COLOR.

FOR SNACK FOODS, NAMELY, SEED-BASED SNACK FOODS AND NUT-BASED SNACK FOODS (U.S. CL. 46).

KATHLEEN LORENZO, EXAMINING ATTORNEY

SN 77-401,572. ONEG FOODS, INC., SCHILLER PARK, IL. FILED 2-20-2008.

ONEG

THE MARK CONSISTS OF STANDARD CHARACTERS WITHOUT CLAIM TO ANY PARTICULAR FONT, STYLE, SIZE, OR COLOR.

THE ENGLISH TRANSLATION OF THE WORD "ONEG" IN THE MARK IS "ENJOYMENT".

FOR CHEESE (U.S. CL. 46).

FIRST USE 3-28-2006; IN COMMERCE 3-28-2006.

APRIL HESIK, EXAMINING ATTORNEY

SN 77-417,709. THOMAS SISTERS ORGANICS, DBA THOMAS SISTERS ORGANICS, PORTLAND, OR. FILED 3-10-2008.

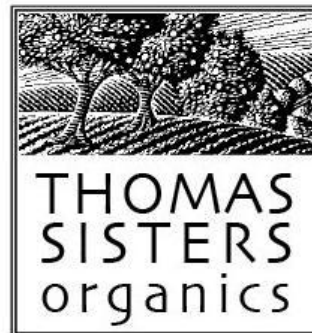

NO CLAIM IS MADE TO THE EXCLUSIVE RIGHT TO USE "SISTERS ORGANICS", APART FROM THE MARK AS SHOWN.

THE MARK CONSISTS OF ORCHARD SCENE WITH "THOMAS SISTERS ORGANICS" WORDING, FOR ORGANIC NUT MEATS; ORGANIC DEHYDRATED FRUIT SNACKS (U.S. CL. 46).

FIRST USE 3-15-2004; IN COMMERCE 3-15-2004.

NICHOLAS COLEMAN, EXAMINING ATTORNEY

CLASS 29—(Continued).

SN 77-417,838. THOMAS SISTERS ORGANICS, DBA THOMAS SISTERS ORGANICS, PORTLAND, OR. FILED 3-10-2008.

Organiccream

THE MARK CONSISTS OF STANDARD CHARACTERS WITHOUT CLAIM TO ANY PARTICULAR FONT, STYLE, SIZE, OR COLOR.

FOR ORGANIC DAIRY PRODUCTS EXCLUDING ICE CREAM, ICE MILK AND FROZEN YOGURT (U.S. CL. 46).

NICHOLAS COLEMAN, EXAMINING ATTORNEY

SN 77-419,178. LESSLIE, JAMES, HOWARD BEACH, NY. FILED 3-11-2008.

FINISH LINE

THE MARK CONSISTS OF STANDARD CHARACTERS WITHOUT CLAIM TO ANY PARTICULAR FONT, STYLE, SIZE, OR COLOR.

FOR MEAT-BASED SNACK FOODS (U.S. CL. 46).
LESLEY LAMOTHE, EXAMINING ATTORNEY

SN 77-421,293. CARR VALLEY CHEESE COMPANY, INC., LA VALLE, WI. FILED 3-13-2008.

Black Sheep Truffle

THE MARK CONSISTS OF STANDARD CHARACTERS WITHOUT CLAIM TO ANY PARTICULAR FONT, STYLE, SIZE, OR COLOR.

NO CLAIM IS MADE TO THE EXCLUSIVE RIGHT TO USE "SHEEP TRUFFLE", APART FROM THE MARK AS SHOWN.

FOR CHEESE (U.S. CL. 46).
FIRST USE 0-0-2005; IN COMMERCE 0-0-2005.
FRANK LATTUCA, EXAMINING ATTORNEY

CLASS 29—(Continued).

SN 77-422,282. PALACE INDUSTRIES, LLC, CENTRAL POINT, OR. FILED 3-14-2008.

TOUVELLE

THE MARK CONSISTS OF STANDARD CHARACTERS WITHOUT CLAIM TO ANY PARTICULAR FONT, STYLE, SIZE, OR COLOR.

FOR CHEESE (U.S. CL. 46).
JANET LEE, EXAMINING ATTORNEY

SN 77-422,398. AVOMEX, INC., FORT WORTH, TX. FILED 3-14-2008.

WHOLLY HIP DIPS

THE MARK CONSISTS OF STANDARD CHARACTERS WITHOUT CLAIM TO ANY PARTICULAR FONT, STYLE, SIZE, OR COLOR.

NO CLAIM IS MADE TO THE EXCLUSIVE RIGHT TO USE "DIPS", APART FROM THE MARK AS SHOWN.
FOR REFRIGERATED DIPS (U.S. CL. 46).
EDWARD FENNESSY, EXAMINING ATTORNEY

SN 77-422,744. YOPLAIT MARQUES INTERNATIONALES, 75014 PARIS, FRANCE. FILED 3-14-2008.



THE MARK CONSISTS OF A FLOWER.
FOR DAIRY PRODUCTS EXCLUDING ICE CREAM, ICE MILK AND FROZEN YOGURT (U.S. CL. 46).
FIRST USE 9-0-1974; IN COMMERCE 9-0-1974.
NATALIE POLZER, EXAMINING ATTORNEY

CLASS 29—(Continued).

SN 77-423,291. LESSLIE, JAMES, HOWARD BEACH, NY.
FILED 3-17-2008.

SLAPSHOT

THE MARK CONSISTS OF STANDARD CHARACTERS
WITHOUT CLAIM TO ANY PARTICULAR FONT, STYLE,
SIZE, OR COLOR.

OWNER OF U.S. REG. NO. 2,097,182.
FOR MEAT-BASED SNACK FOODS (U.S. CL. 46).
FIRST USE 6-10-1995; IN COMMERCE 6-10-1995.
LESLEY LAMOTHE, EXAMINING ATTORNEY

CLASS 29—(Continued).

SN 77-426,964. SENECA FOODS CORPORATION, MARION,
NY. FILED 3-20-2008.

WE FEED THE WORLD

THE MARK CONSISTS OF STANDARD CHARACTERS
WITHOUT CLAIM TO ANY PARTICULAR FONT, STYLE,
SIZE, OR COLOR.

FOR CANNED FRUITS; CANNED VEGETABLES (U.S.
CL. 46).
LINDA ESTRADA, EXAMINING ATTORNEY

SN 77-425,188. BIRDS EYE FOODS, INC., DBA LINDEN
OAKS CORPORATION, ROCHESTER, NY. FILED 3-18-
2008.

**THE ULTIMATE SOUTHWEST
BLEND**

THE MARK CONSISTS OF STANDARD CHARACTERS
WITHOUT CLAIM TO ANY PARTICULAR FONT, STYLE,
SIZE, OR COLOR.

OWNER OF U.S. REG. NO. 2,554,312.
SEC. 2(F).
FOR FROZEN VEGETABLES (U.S. CL. 46).
FIRST USE 2-0-2001; IN COMMERCE 2-0-2001.
CHRISTINA SOBRAL, EXAMINING ATTORNEY

SN 77-428,173. SEABOARD CORPORATION, SHAWNEE
MISSION, KS. FILED 3-21-2008.

SEABOARD FOODS

THE MARK CONSISTS OF STANDARD CHARACTERS
WITHOUT CLAIM TO ANY PARTICULAR FONT, STYLE,
SIZE, OR COLOR.

OWNER OF U.S. REG. NOS. 2,246,196, 3,000,193 AND
OTHERS.

NO CLAIM IS MADE TO THE EXCLUSIVE RIGHT TO
USE "FOODS", APART FROM THE MARK AS SHOWN.

FOR MEAT; PROCESSED MEAT, NAMELY, BACON,
HAM AND SAUSAGE (U.S. CL. 46).
FIRST USE 5-11-2005; IN COMMERCE 2-29-2008.
BARBARA RUTLAND, EXAMINING ATTORNEY

SN 77-425,734. SHERMAN, JASON, PHILADELPHIA, PA.
FILED 3-19-2008.



NO CLAIM IS MADE TO THE EXCLUSIVE RIGHT TO
USE "CHICKEN BITS", APART FROM THE MARK AS
SHOWN.

THE COLOR(S) YELLOW, RED, BROWN, AND BLACK IS/
ARE CLAIMED AS A FEATURE OF THE MARK.

THE MARK CONSISTS OF THE LETTERS "CHICK N
BITS" ARE IN A LIGHT YELLOW FONT WITH BLACK
OUTLINE AND RED SHADOW. THE APOSTROPHE IS A
CHICKEN LEG WITH LIGHT BROWN CHICKEN FLESH
COLOR AND WHITE BONE.

FOR CHICKEN-FLAVORED SOY BASED SNACK
FOODS (U.S. CL. 46).

ALICE BENMAMAN, EXAMINING ATTORNEY

SN 77-428,217. KHAYAT-TOUBIA, RITA, SAN JOSE, CA.
FILED 3-21-2008.

FLEUR DE LUXE

THE MARK CONSISTS OF STANDARD CHARACTERS
WITHOUT CLAIM TO ANY PARTICULAR FONT, STYLE,
SIZE, OR COLOR.

OWNER OF U.S. REG. NO. 3,405,406.
THE ENGLISH TRANSLATION OF "FLEUR DE LUXE IS
FLOWER OF LUXURY"

FOR BLENDED OIL; EDIBLE OIL; OLIVE OIL;
SALAD OIL (U.S. CL. 46).

FIRST USE 2-23-2005; IN COMMERCE 4-1-2005.

MONIQUE MILLER, EXAMINING ATTORNEY

CLASS 29—(Continued).

SN 77-429,105. MARIEL'S KITCHEN, INC., WOODLAND HILLS, CA. FILED 3-23-2008.

BLISSCUIT

THE MARK CONSISTS OF STANDARD CHARACTERS WITHOUT CLAIM TO ANY PARTICULAR FONT, STYLE, SIZE, OR COLOR.
FOR NUT-BASED FOOD BAR (U.S. CL. 46).
MARLENE BELL, EXAMINING ATTORNEY

SN 77-429,107. MARIEL'S KITCHEN, INC., WOODLAND HILLS, CA. FILED 3-23-2008.

ONE'S A SNACK, TWO'S A MEAL

THE MARK CONSISTS OF STANDARD CHARACTERS WITHOUT CLAIM TO ANY PARTICULAR FONT, STYLE, SIZE, OR COLOR.
FOR NUT-BASED FOOD BAR (U.S. CL. 46).
MARLENE BELL, EXAMINING ATTORNEY

SN 77-430,005. SOYLINK, LLC, SIOUX FALLS, SD. FILED 3-24-2008.

Gold 300

THE MARK CONSISTS OF STANDARD CHARACTERS WITHOUT CLAIM TO ANY PARTICULAR FONT, STYLE, SIZE, OR COLOR.
FOR SOY POWDER FOR USE AS A FOOD ADDITIVE (U.S. CL. 46).
FIRST USE 9-1-2000; IN COMMERCE 9-1-2000.
AMY MCMENAMIN, EXAMINING ATTORNEY

CLASS 29—(Continued).

SN 77-430,017. SOYLINK, LLC, SIOUX FALLS, SD. FILED 3-24-2008.

Gold 1000

THE MARK CONSISTS OF STANDARD CHARACTERS WITHOUT CLAIM TO ANY PARTICULAR FONT, STYLE, SIZE, OR COLOR.
FOR SOY POWDER FOR USE AS A FOOD ADDITIVE (U.S. CL. 46).
FIRST USE 9-1-2000; IN COMMERCE 9-1-2000.
AMY MCMENAMIN, EXAMINING ATTORNEY

SN 77-430,020. SOYLINK, LLC, SIOUX FALLS, SD. FILED 3-24-2008.

Silver 300

THE MARK CONSISTS OF STANDARD CHARACTERS WITHOUT CLAIM TO ANY PARTICULAR FONT, STYLE, SIZE, OR COLOR.
FOR SOY POWDER FOR USE AS A FOOD ADDITIVE (U.S. CL. 46).
FIRST USE 9-1-2000; IN COMMERCE 9-1-2000.
AMY MCMENAMIN, EXAMINING ATTORNEY

SN 77-430,029. SOYLINK, LLC, SIOUX FALLS, SD. FILED 3-24-2008.

Silver 1000

THE MARK CONSISTS OF STANDARD CHARACTERS WITHOUT CLAIM TO ANY PARTICULAR FONT, STYLE, SIZE, OR COLOR.
FOR SOY POWDER FOR USE AS A FOOD ADDITIVE (U.S. CL. 46).
FIRST USE 9-1-2000; IN COMMERCE 9-1-2000.
AMY MCMENAMIN, EXAMINING ATTORNEY

CLASS 29—(Continued).

SN 77-430,034. SOYLINK, LLC, SIOUX FALLS, SD. FILED 3-24-2008.

Jade 300

THE MARK CONSISTS OF STANDARD CHARACTERS WITHOUT CLAIM TO ANY PARTICULAR FONT, STYLE, SIZE, OR COLOR.

FOR SOY POWDER FOR USE AS A FOOD ADDITIVE (U.S. CL. 46).

FIRST USE 1-1-2004; IN COMMERCE 1-1-2004.

AMY MCMENAMIN, EXAMINING ATTORNEY

SN 77-430,039. SOYLINK, LLC, SIOUX FALLS, SD. FILED 3-24-2008.

Jade 1000

THE MARK CONSISTS OF STANDARD CHARACTERS WITHOUT CLAIM TO ANY PARTICULAR FONT, STYLE, SIZE, OR COLOR.

FOR SOY POWDER FOR USE AS A FOOD ADDITIVE (U.S. CL. 46).

FIRST USE 6-1-2003; IN COMMERCE 6-1-2003.

AMY MCMENAMIN, EXAMINING ATTORNEY

SN 77-430,856. CARR VALLEY CHEESE COMPANY, INC., LA VALLE, WI. FILED 3-25-2008.

Black Goat Truffle

THE MARK CONSISTS OF STANDARD CHARACTERS WITHOUT CLAIM TO ANY PARTICULAR FONT, STYLE, SIZE, OR COLOR.

NO CLAIM IS MADE TO THE EXCLUSIVE RIGHT TO USE "GOAT TRUFFLE", APART FROM THE MARK AS SHOWN.

FOR CHEESE FOOD (U.S. CL. 46).

FIRST USE 0-0-2007; IN COMMERCE 0-0-2007.

FRANK LATTUCA, EXAMINING ATTORNEY

CLASS 29—(Continued).

SN 77-431,042. KENOSHA BEEF INTERNATIONAL LTD., KENOSHA, WI. FILED 3-25-2008.



THE MARK CONSISTS OF A CHEF GRILLING WITH WORDS "CHEF'S GRILL".

FOR GROUND BEEF, GROUND PORK AND OTHER GROUND BEEF AND PORK PRODUCTS, NAMELY, PROCESSED, COOKED OR SEASONED BEEF AND PORK (U.S. CL. 46).

FIRST USE 4-30-2008; IN COMMERCE 4-30-2008.

AISHA CLARKE, EXAMINING ATTORNEY

SN 77-431,150. YOGAVIVE LLC, SACRAMENTO, CA. FILED 3-25-2008.



THE COLOR(S) LIGHT GREEN; DARK GREEN IS/ARE CLAIMED AS A FEATURE OF THE MARK.

THE MARK CONSISTS OF TWO LEAVES, AND THE WORD "YOGAVIVE"; THE LEAVES ARE IN VARYING SHADES OF GREEN; THE SMALLER LEAF IS POINTING TO THE LEFT, AND THE LARGER LEAF IS POINTING TO THE RIGHT. BELOW THE LEAVES IS THE WORD "YOGAVIVE" IN LOWERCASE LETTERS. THE "Y", "O", "G", AND "A" ARE IN DARK GREEN, AND THE "V", "I", "V", AND "E" ARE IN LIGHT GREEN.

FOR FRUIT AND SOY BASED SNACK FOOD (U.S. CL. 46).

KIMBERLY FRYE, EXAMINING ATTORNEY

SN 77-431,173. YOGAVIVE LLC, SACRAMENTO, CA. FILED 3-25-2008.

Yogavive

THE MARK CONSISTS OF STANDARD CHARACTERS WITHOUT CLAIM TO ANY PARTICULAR FONT, STYLE, SIZE, OR COLOR.

FOR FRUIT AND SOY BASED SNACK FOOD (U.S. CL. 46).

KIMBERLY FRYE, EXAMINING ATTORNEY

CLASS 29—(Continued).

SN 77-431,180. HERRERA ALE, CARLOS MANUEL, DURANGO, MEXICO, AND HERRERA ALE, ERNESTO, DURANGO, MEXICO, FILED 3-25-2008.



NO CLAIM IS MADE TO THE EXCLUSIVE RIGHT TO USE "DURANGUENO", APART FROM THE MARK AS SHOWN.

THE MARK CONSISTS OF THE WORD "DURANGUENO" WITH COLUMNS BELOW THE WORD, A MOUNTAIN RANGE IN THE BACKGROUND AND A MAN SADDLED ON A HORSE.

THE FOREIGN WORDING IN THE MARK TRANSLATES INTO ENGLISH AS AN OBJECT OR PERSON FROM DURANGO, MEXICO.

FOR CHEESE (U.S. CL. 46).

WENDY JUN, EXAMINING ATTORNEY

SN 77-431,222. YOGAVIVE LLC, SACRAMENTO, CA. FILED 3-25-2008.

Yogasmooth

THE MARK CONSISTS OF STANDARD CHARACTERS WITHOUT CLAIM TO ANY PARTICULAR FONT, STYLE, SIZE, OR COLOR.

FOR FRUIT AND SOY BASED SNACK FOOD (U.S. CL. 46).

KIMBERLY FRYE, EXAMINING ATTORNEY

SN 77-432,335. MRS. SIPPS LLC, GLENVIEW, IL. FILED 3-26-2008.

MRS. SIPPS

THE MARK CONSISTS OF STANDARD CHARACTERS WITHOUT CLAIM TO ANY PARTICULAR FONT, STYLE, SIZE, OR COLOR.

THE NAME(S), PORTRAIT(S), AND/OR SIGNATURE(S) SHOWN IN THE MARK DOES NOT IDENTIFY A PARTICULAR LIVING INDIVIDUAL.

FOR CONFECTIONARY PRODUCTS, NAMELY, ROASTED, SALTED, SUGARED, SPICED, CANDIED, OR SEASONED NUTS (U.S. CL. 46).

FIRST USE 4-20-2007; IN COMMERCE 4-20-2007.

RENEE MCCRAY, EXAMINING ATTORNEY

CLASS 29—(Continued).

SN 77-432,354. MRS. SIPPS LLC, GLENVIEW, IL. FILED 3-26-2008.



NO CLAIM IS MADE TO THE EXCLUSIVE RIGHT TO USE "PURVEYOR OF SPICED NUTS", APART FROM THE MARK AS SHOWN.

THE NAME(S), PORTRAIT(S), AND/OR SIGNATURE(S) SHOWN IN THE MARK DOES NOT IDENTIFY A PARTICULAR LIVING INDIVIDUAL.

THE MARK CONSISTS OF A RIVER BETWEEN TWO MASSES OF LAND, A FLYING BIRD, A FULL MOON AND THE STYLIZED WORDS "MRS. SIPPS" CONTAINED WITHIN A SQUARE-SHAPED CARRIER ABOVE THE STYLIZED WORDS "PURVEYOR OF SPICED NUTS" WHICH ARE CONTAINED WITHIN A RIBBON DESIGN BELOW THE RIVER.

FOR CONFECTIONARY PRODUCTS, NAMELY, ROASTED, SALTED, SUGARED, SPICED, CANDIED, OR SEASONED NUTS (U.S. CL. 46).

FIRST USE 4-20-2007; IN COMMERCE 4-20-2007.

RENEE MCCRAY, EXAMINING ATTORNEY

SN 77-432,463. BBF & L, INC., MUNDELEIN, IL. FILED 3-26-2008.

BETTER HARVEST

THE MARK CONSISTS OF STANDARD CHARACTERS WITHOUT CLAIM TO ANY PARTICULAR FONT, STYLE, SIZE, OR COLOR.

FOR NUT BUTTER (U.S. CL. 46).

KARANENDRA S. CHHINA, EXAMINING ATTORNEY

SN 77-432,468. BBF & L, INC., MUNDELEIN, IL. FILED 3-26-2008.

HARVEST BETTER

THE MARK CONSISTS OF STANDARD CHARACTERS WITHOUT CLAIM TO ANY PARTICULAR FONT, STYLE, SIZE, OR COLOR.

FOR NUT BUTTERS (U.S. CL. 46).

KARANENDRA S. CHHINA, EXAMINING ATTORNEY

CLASS 29—(Continued).

SN 77-432,675. SEGOVIA LLC, PLYMOUTH, MN. FILED 3-26-2008.

ANTI-UP

THE MARK CONSISTS OF STANDARD CHARACTERS WITHOUT CLAIM TO ANY PARTICULAR FONT, STYLE, SIZE, OR COLOR.

FOR SNACK MIX CONSISTING PRIMARILY OF PROCESSED FRUITS, PROCESSED NUTS AND/OR RAISINS (U.S. CL. 46).

GISELLE AGOSTO, EXAMINING ATTORNEY

CLASS 29—(Continued).

SN 77-433,138. XANADEUX BRANDS, INC., GENEVA, NY. FILED 3-27-2008.

Where the Good Stuff Comes From

THE MARK CONSISTS OF STANDARD CHARACTERS WITHOUT CLAIM TO ANY PARTICULAR FONT, STYLE, SIZE, OR COLOR.

FOR DRIED FRUIT AND VEGETABLES (U.S. CL. 46).

SUNG IN, EXAMINING ATTORNEY

SN 77-432,980. HICKORY NUT GAP FARM, LLC, FAIRVIEW, NC. FILED 3-27-2008.

Hickory Nut Gap

THE MARK CONSISTS OF STANDARD CHARACTERS WITHOUT CLAIM TO ANY PARTICULAR FONT, STYLE, SIZE, OR COLOR.

NO CLAIM IS MADE TO THE EXCLUSIVE RIGHT TO USE "HICKORY", APART FROM THE MARK AS SHOWN.

FOR MEAT; MEAT, FROZEN; MEAT, POULTRY AND GAME; PREPARED MEAT; PRESERVED MEATS AND SAUSAGES; PROCESSED MEAT (U.S. CL. 46).

FIRST USE 10-31-2000; IN COMMERCE 3-13-2008.

REGINA DRUMMOND, EXAMINING ATTORNEY

SN 77-434,424. LOBEL, STANLEY, PURCHASE, NY. FILED 3-28-2008.

SHOULDER IRON

THE MARK CONSISTS OF STANDARD CHARACTERS WITHOUT CLAIM TO ANY PARTICULAR FONT, STYLE, SIZE, OR COLOR.

FOR BEEF (U.S. CL. 46).

MAYUR VAGHANI, EXAMINING ATTORNEY

SN 77-433,019. KEYSTONE BRAND MEATS, INC., DBA KEYSTONE CANNING COMPANY, LIMA, OH. FILED 3-27-2008.

Ma Collis

THE MARK CONSISTS OF STANDARD CHARACTERS WITHOUT CLAIM TO ANY PARTICULAR FONT, STYLE, SIZE, OR COLOR.

FOR CANNED COOKED MEAT (U.S. CL. 46).

HEATHER THOMPSON, EXAMINING ATTORNEY

SN 77-437,088. WAYMOUTH FARMS, INC., NEW HOPE, MN. FILED 4-1-2008.

Lemon Landslide

THE MARK CONSISTS OF STANDARD CHARACTERS WITHOUT CLAIM TO ANY PARTICULAR FONT, STYLE, SIZE, OR COLOR.

NO CLAIM IS MADE TO THE EXCLUSIVE RIGHT TO USE "LEMON", APART FROM THE MARK AS SHOWN.

FOR DRIED FRUIT (U.S. CL. 46).

AMY HELLA, EXAMINING ATTORNEY

CLASS 29—(Continued).

SN 77-447,476. NBA PROPERTIES, INC., NEW YORK, NY.
FILED 4-14-2008.

NBA FIT

THE MARK CONSISTS OF STANDARD CHARACTERS WITHOUT CLAIM TO ANY PARTICULAR FONT, STYLE, SIZE, OR COLOR.

OWNER OF U.S. REG. NOS. 1,859,871, 3,076,695 AND OTHERS.

FOR FRUIT BASED SNACK FOOD (U.S. CL. 46).

ANNE E. GUSTASON, EXAMINING ATTORNEY

SN 77-447,644. NBA PROPERTIES, INC., NEW YORK, NY.
FILED 4-14-2008.



OWNER OF U.S. REG. NOS. 1,859,871, 3,076,695 AND OTHERS.

NO CLAIM IS MADE TO THE EXCLUSIVE RIGHT TO USE "STICKS", APART FROM THE MARK AS SHOWN.

THE MARK CONSISTS OF FOUR SILHOUETTES OF BASKETBALL PLAYERS IN ACTION WITH THE WORDS "NBA FIT STIX"

FOR FRUIT BASED SNACK FOOD (U.S. CL. 46).

ANNE E. GUSTASON, EXAMINING ATTORNEY

SN 77-447,722. NBA PROPERTIES, INC., NEW YORK, NY.
FILED 4-14-2008.



OWNER OF U.S. REG. NOS. 938,213, 1,859,871 AND OTHERS.

THE MARK CONSISTS OF THE SILHOUETTE OF FOUR BASKETBALL PLAYERS WITH THE WORDS "NBA FIT".

FOR FRUIT BASED SNACK FOOD (U.S. CL. 46).

ANNE E. GUSTASON, EXAMINING ATTORNEY

CLASS 29—(Continued).

SN 77-452,713. GOLDMARKS COMPANY, ROSEMONT, IL.
FILED 4-19-2008.

Restaurant Requests

THE MARK CONSISTS OF STANDARD CHARACTERS WITHOUT CLAIM TO ANY PARTICULAR FONT, STYLE, SIZE, OR COLOR.

NO CLAIM IS MADE TO THE EXCLUSIVE RIGHT TO USE "RESTAURANT", APART FROM THE MARK AS SHOWN.

FOR FROZEN APPETIZERS CONSISTING PRIMARILY OF CHICKEN OR SEAFOOD (U.S. CL. 46).

CHARLES L. JENKINS, EXAMINING ATTORNEY

SN 77-460,977. WAYMOUTH FARMS, INC., NEW HOPE, MN.
FILED 4-29-2008.

Earth Sense

THE MARK CONSISTS OF STANDARD CHARACTERS WITHOUT CLAIM TO ANY PARTICULAR FONT, STYLE, SIZE, OR COLOR.

FOR SNACK MIXES CONSISTING PRIMARILY OF DRIED FRUIT, PROCESSED NUTS AND PROCESSED EDIBLE SEEDS (U.S. CL. 46).

DANIEL CAPSHAW, EXAMINING ATTORNEY

SN 77-460,992. WAYMOUTH FARMS, INC., NEW HOPE, MN.
FILED 4-29-2008.

Frunchies

THE MARK CONSISTS OF STANDARD CHARACTERS WITHOUT CLAIM TO ANY PARTICULAR FONT, STYLE, SIZE, OR COLOR.

OWNER OF U.S. REG. NO. 2,704,871.

FOR SNACK MIX CONSISTING OF DRIED FRUIT (U.S. CL. 46).

AMY HELLA, EXAMINING ATTORNEY

CLASS 29—(Continued).

SN 77-462,989. PALACE INDUSTRIES, LLC, CENTRAL POINT, OR. FILED 5-1-2008.

NOT JUST A STATE OF MIND

THE MARK CONSISTS OF STANDARD CHARACTERS WITHOUT CLAIM TO ANY PARTICULAR FONT, STYLE, SIZE, OR COLOR.
FOR CHEESE (U.S. CL. 46).
JANET LEE, EXAMINING ATTORNEY

SN 77-463,007. PALACE INDUSTRIES, LLC, CENTRAL POINT, OR. FILED 5-1-2008.

DOMINO

THE MARK CONSISTS OF STANDARD CHARACTERS WITHOUT CLAIM TO ANY PARTICULAR FONT, STYLE, SIZE, OR COLOR.
FOR CHEESE (U.S. CL. 46).
JANET LEE, EXAMINING ATTORNEY

SN 77-466,585. YOPLAIT MARQUES INTERNATIONALES, PARIS, FRANCE, FILED 5-6-2008.

DELIGHTS

THE MARK CONSISTS OF STANDARD CHARACTERS WITHOUT CLAIM TO ANY PARTICULAR FONT, STYLE, SIZE, OR COLOR.
FOR YOGURTS (U.S. CL. 46).
NATALIE POLZER, EXAMINING ATTORNEY

CLASS 29—(Continued).

SN 77-469,380. HQM, LTD., WILMINGTON, DE. FILED 5-8-2008.



OWNER OF U.S. REG. NO. 3,242,259.
NO CLAIM IS MADE TO THE EXCLUSIVE RIGHT TO USE "SINCE 1895", APART FROM THE MARK AS SHOWN.
THE PORTRAIT IN THE MARK DOES NOT IDENTIFY A LIVING INDIVIDUAL.
THE COLOR(S) LIGHT BLUE, DARK BLUE, RED, YELLOW, BLACK, WHITE IS/ARE CLAIMED AS A FEATURE OF THE MARK.

THE MARK CONSISTS OF THE STYLIZED WORDS "RED'S LEGENDARY" APPEARING ON A KEYSTONE-SHAPED BACKGROUND, WHICH IS BORDERED IN BLACK. THE BACKGROUND SHADING OF THE KEYSTONE CONSISTS OF LIGHT BLUE AND DARK BLUE VERTICAL STRIPES. AT THE TOP OF THE KEYSTONE, THERE IS AN OVAL-SHAPED PROTRUSION CONTAINING THE PORTRAIT OF A BEARDED GENTLEMAN WEARING A HAT, RENDERED IN RED AND WHITE. UNDER THE PORTRAIT IS A YELLOW BANNER OUTLINED IN BLACK, BEARING THE WORDS "SINCE 1895" RENDERED IN RED. UNDER THE PORTRAIT AND BANNER IS THE WORD "RED'S" IN LARGE RED LETTERS, HIGHLIGHTED IN YELLOW AND OUTLINED IN BLACK. UNDER THE WORD "RED'S" IS THE WORD "LEGENDARY", RENDERED IN YELLOW AND OUTLINED IN BLACK.

FOR PROCESSED MEAT, PROCESSED PORK, FROZEN APPETIZERS CONSISTING PRIMARILY OF PORK, PORK SPARE RIBS (U.S. CL. 46).
EDWARD NELSON, EXAMINING ATTORNEY

SN 77-476,698. MCCAIN FOODS USA, INC., LISLE, IL. FILED 5-16-2008.



OWNER OF U.S. REG. NO. 3,010,598.
THE MARK CONSISTS OF THE WORDING "HARVEST SPLENDOR" AND A DEPICTION OF A BUSHEL OF POTATOES.
FOR FROZEN PROCESSED POTATOES (U.S. CL. 46).
RONALD AIKENS, EXAMINING ATTORNEY

CLASS 29—(Continued).

SN 77-495,119. ACH FOOD COMPANIES, INC., CORDOVA, TN. FILED 6-10-2008.

DURKEE

THE MARK CONSISTS OF STANDARD CHARACTERS WITHOUT CLAIM TO ANY PARTICULAR FONT, STYLE, SIZE, OR COLOR.

OWNER OF U.S. REG. NOS. 866,908, 2,698,852 AND OTHERS.

SEC. 2(F).

FOR DRIED AND COOKED VEGETABLES; BUTTER SUBSTITUTES; PROCESSED COCONUT; FRENCH FRIED ONIONS; PROCESSED OLIVES (U.S. CL. 46).

FIRST USE 4-24-1967; IN COMMERCE 4-24-1967.
SUSAN RICHARDS, EXAMINING ATTORNEY

SN 78-580,501. ATALANTA CORPORATION, ELIZABETH, NJ. FILED 3-4-2005.

CHEVRELAIT BRAND

THE MARK CONSISTS OF STANDARD CHARACTERS WITHOUT CLAIM TO ANY PARTICULAR FONT, STYLE, SIZE, OR COLOR.

NO CLAIM IS MADE TO THE EXCLUSIVE RIGHT TO USE "BRAND", APART FROM THE MARK AS SHOWN.

THE ENGLISH TRANSLATION OF "CHEVRE" IS "GOAT," THE ENGLISH TRANSLATION OF "LAIT" IS MILK; BUT THE COMBINED WORD "CHEVRELAIT" HAS NO MEANING IN ENGLISH.

FOR GOAT CHEESE (U.S. CL. 46).

FIRST USE 3-1-1997; IN COMMERCE 3-1-1997.
DANIEL BRODY, EXAMINING ATTORNEY

SN 79-044,301. EKOLIVE GIDA TURIZM VE SU; ÜRÜNLERİ İTHALAT İHRACAT; SANAYİ VE TİCARET LIMITED SİRKETİ, TURKEY, FILED 7-23-2007.

meytin

OWNER OF INTERNATIONAL REGISTRATION 0938725 DATED 7-23-2007, EXPIRES 7-23-2017.

FOR CANNED PROCESSED OLIVES, PRESERVED DRIED AND COOKED OLIVES, PICKLES, EDIBLE OILS, REFINED OLIVE OIL, COTTON OIL, SUNFLOWER OIL; MARGARINES, BUTTERS (U.S. CL. 46).

GEORGIA CARTY, EXAMINING ATTORNEY

CLASS 29—(Continued).

SN 79-044,576. OLEIFICIO FABBRI S.P.A., ITALY, FILED 9-4-2007.



PRIORITY DATE OF 5-21-2007 IS CLAIMED.
OWNER OF INTERNATIONAL REGISTRATION 0939458 DATED 9-4-2007, EXPIRES 9-4-2017.

THE COLOR(S) GOLD, BLUE, BLACK, WHITE AND BROWN IS/ARE CLAIMED AS A FEATURE OF THE MARK.

THE MARK CONSISTS OF A CLOVER LEAF DESIGN WITH FOUR POINTS AT EACH CORNER WITH A BORDER DESIGN AND A STAR WITHIN A FANCIFUL SHAPE INSIDE THE MIDDLE OF THE CLOVER DESIGN. CENTERED UNDERNEATH IS THE WORD "SIGNUM" WITHIN A RECTANGLE WITH A BORDER DESIGN. THE COLORS BLACK, BROWN AND WHITE APPEARS IN THE BORDER AROUND THE CLOVER DESIGN, THE COLOR BLUE APPEARS IN THE FANCIFUL DESIGN WITHIN THE CLOVER DESIGN AND AS THE BACKGROUND WITHIN THE RECTANGLE, THE COLOR GOLD APPEARS AS THE BACKGROUND COLOR OF THE CLOVER DESIGN AND AS THE BORDER DESIGN OF THE RECTANGLE, AND THE COLOR WHITE APPEARS IN PART OF THE BORDER OF THE CLOVER DESIGN, AS THE STAR WITHIN THE CLOVER, AND IN THE WORD "SIGNUM" WITHIN THE RECTANGLE.

FOR EDIBLE OILS AND FATS; OLIVE OIL; PRESERVED, FROZEN, DRY OR COOKED FRUIT AND VEGETABLES (U.S. CL. 46).

CARYN GLASSER, EXAMINING ATTORNEY

CLASS 29—(Continued).

SN 79-045,176. VILLANI S.P.A., ITALY, FILED 5-14-2007.



PRIORITY DATE OF 2-22-2007 IS CLAIMED.
OWNER OF INTERNATIONAL REGISTRATION 0940806
DATED 5-14-2007, EXPIRES 5-14-2017.
OWNER OF U.S. REG. NO. 2,623,164.

NO CLAIM IS MADE TO THE EXCLUSIVE RIGHT TO USE "SALUMI" AND "DAL 1886", APART FROM THE MARK AS SHOWN.

THE ENGLISH TRANSLATION OF "SALUMI" IS COLD CUTS AND "ARTE DI FAMIGLIA DAL 1886" IS "FAMILY ART SINCE 1886".

FOR MEAT AND MEAT PRODUCTS, NAMELY, COOKED, CURED AND SMOKED SAUSAGE AND HAM; SALAMI AND MORTADELLA, WHOLE LEG HAMS, BONED OR PACKAGED HAMS, WHOLE AND PACKAGED SPECK (SMOKED HAM); HAMS AND PRESERVED MEATS, SALTED MEATS, SAUSAGES, SPECIALTY HAM, NAMELY, CULATELLO; SPECIALTY SALAMI, NAMELY, COPPA, BACON (U.S. CL. 46).
REBECCA POVARCHUK, EXAMINING ATTORNEY

SN 79-045,380. LIDL STIFTUNG & CO. KG, FED REP GERMANY, FILED 10-1-2007.

GLENFELL

PRIORITY DATE OF 5-3-2007 IS CLAIMED.
OWNER OF INTERNATIONAL REGISTRATION 0941429
DATED 10-1-2007, EXPIRES 10-1-2017.
OWNER OF U.S. REG. NO. 2,690,326.

THE MARK CONSISTS OF THE WORD "GLENFELL".
FOR FROZEN AND PRESERVED MEAT AND MEAT PRODUCTS, NAMELY, MEAT AND SAUSAGE, MEAT PRESERVES, SAUSAGE PRESERVES, SMALL SAUSAGE PRESERVES, MEAT JELLIES; MEAT PASTE, MEAT JUICES, SAUSAGES, SMALL SAUSAGES, BLOOD SAUSAGES, RING BOLOGNA, BRAUNSCHWEIGER, SMOKED SAUSAGE, BRATWURST, POLISH SAUSAGE, ITALIAN SAUSAGE, SUMMER SAUSAGE, BOLOGNA AND SMOKED BEEF, FRANKFURTERS, HAMBURGER MEAT, HOT DOGS, MEAT-BASED MOUSSE, MEAT-BASED SPREADS, HAM, BACON, SALAMI, MORTADELLA, BACON RINDS, ROAST BEEF, BEEF PATTIES; VEAL; BEEF MEAT EXTRACTS, CANNED COOKED MEAT; FROZEN AND PRESERVED POULTRY AND POULTRY PRODUCTS, NAMELY, CHICKEN, TURKEY, DUCK, TURKEY SAUSAGE, CHICKEN SAUSAGE, AND DUCK SAUSAGE; CANNED COOKED CHICKEN, DUCK, OR TURKEY; CHICKEN MOUSSE, CHICKEN STOCK; TURKEY BURGER PATTIES (U.S. CL. 46).
SHARON MEIER, EXAMINING ATTORNEY

CLASS 29—(Continued).

SN 79-047,347. LIDL STIFTUNG & CO. KG, FED REP GERMANY, FILED 11-29-2007.

CASCINA SERENA

PRIORITY DATE OF 7-2-2007 IS CLAIMED.
OWNER OF INTERNATIONAL REGISTRATION 0946452
DATED 11-29-2007, EXPIRES 11-29-2017.

OWNER OF U.S. REG. NO. 2,708,558.
THE FOREIGN WORDING IN THE MARK TRANSLATES INTO ENGLISH AS "SERENE FARM".

FOR MEAT AND SAUSAGE, MEAT PRODUCTS AND CHARCUTERIE, NAMELY, MEAT PASTE, MEAT JUICES, SAUSAGES, SMALL SAUSAGES, BLOOD SAUSAGES, FRANKFURTERS, HAMBURGERS, HOT DOGS, MEAT-BASED MOUSSE, MEAT-BASED SPREADS, HAM, BACON, SALAMI, MORTADELLA, BACON RINDS, ROAST BEEF, CORNED BEEF, BEEF PATTIES, MEAT AND SAUSAGE PRESERVES, MEAT JELLIES, MEAT EXTRACTS; PREPARED MEALS, MAINLY COMPRISING MEAT AND/OR CHARCUTERIE AND/OR VEGETABLES (U.S. CL. 46).

SHARON MEIER, EXAMINING ATTORNEY

CLASS 30—STAPLE FOODS

SN 76-335,975. GERTRUDE HAWK CHOCOLATES, INC., DUNMORE, PA. FILED 11-8-2001.

POLAR BITS

NO CLAIM IS MADE TO THE EXCLUSIVE RIGHT TO USE "BITS", APART FROM THE MARK AS SHOWN.
FOR CHOCOLATE AND CANDY ICE CREAM INCLUSIONS SOLD BUSINESS TO BUSINESS (U.S. CL. 46).
KAREN M. STRYZ, EXAMINING ATTORNEY

SN 76-659,681. WAGNER, PAUL, FOGELSVILLE, PA. FILED 5-8-2006.

THE POWER OF FRUIT

THE MARK CONSISTS OF STANDARD CHARACTERS WITHOUT CLAIM TO ANY PARTICULAR FONT, STYLE, SIZE, OR COLOR.

OWNER OF U.S. REG. NO. 3,325,347.
NO CLAIM IS MADE TO THE EXCLUSIVE RIGHT TO USE "FRUIT", APART FROM THE MARK AS SHOWN.
FOR FROZEN FRUIT BARS CONSISTING OF WHOLE, GROUND OR PUREED FRUIT AND NATURAL JUICES THEREFROM (U.S. CL. 46).

FIRST USE 3-23-2006; IN COMMERCE 12-18-2006.
ANNE E. GUSTASON, EXAMINING ATTORNEY

CLASS 30—(Continued).

SN 76-670,928. MARUKYO SEIKA KABUSHIKI KAISHA, TOTTORI 683-0845, JAPAN, FILED 12-29-2006.

菓子庵丸京

NO CLAIM IS MADE TO THE EXCLUSIVE RIGHT TO USE THE NON-LATIN CHARACTERS THAT TRANSLATE TO "CONFECTIONERY", APART FROM THE MARK AS SHOWN.

THE NAME "MARUKYO" DOES NOT IDENTIFY A LIVING INDIVIDUAL.

THE FIRST CIRCULAR COMPONENT WITH THE DOT IN THE MIDDLE IS MERELY A DESIGN WITH NO MEANING. THE FIRST THREE NON-LATIN CHARACTERS ON THE MARK TRANSLITERATES INTO "KASHIAN" AND THIS MEANS CONFECTIONERY IN ENGLISH, AND THE LAST TWO NON-LATIN CHARACTERS TRANSLITERATES INTO "MARUKYO," WHICH IS PART OF OWNER'S NAME AND HAS NO ENGLISH TRANSLATION.

FOR PASTRIES (U.S. CL. 46).

FIRST USE 10-31-2002; IN COMMERCE 10-31-2002.

ANTHONY RINKER, EXAMINING ATTORNEY

SN 76-687,924. SUCKERPUNCH SALLYS, LLC, SCOTTSDALE, AZ. FILED 3-20-2008.

SuckerPunch Sallys

THE MARK CONSISTS OF STANDARD CHARACTERS WITHOUT CLAIM TO ANY PARTICULAR FONT, STYLE, SIZE, OR COLOR.

OWNER OF U.S. REG. NO. 3,058,678.

FOR ICED TEAS AND TEA-BASED BEVERAGES WITH FRUIT FLAVORING (U.S. CL. 46).

MARTHA FROMM, EXAMINING ATTORNEY

CLASS 30—(Continued).

SN 77-040,142. VANEGAS, RAFAEL ANTONIO NIETO, MANIZALES, CALDAS, COLOMBIA, FILED 11-9-2006.

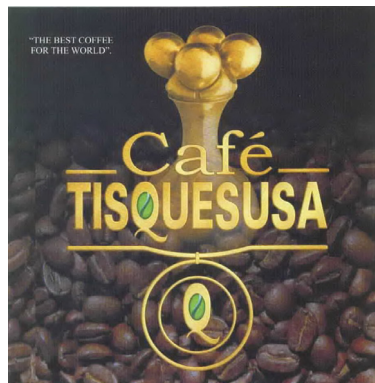

NO CLAIM IS MADE TO THE EXCLUSIVE RIGHT TO USE "THE BEST COFFEE FOR THE WORLD", "CAFÉ" AND THE DESIGN OF THE COFFEE BEANS, APART FROM THE MARK AS SHOWN.

THE COLOR(S) BROWN, BLACK, WHITE, YELLOW AND GREEN IS/ARE CLAIMED AS A FEATURE OF THE MARK.

THE MARK CONSISTS OF A REPRESENTATION OF BROWN COFFEE BEANS, THE WORDS "CAFÉ TISQUESUSA" IN YELLOW WITH A GREEN COFFEE BEAN IN THE "Q", A YELLOW CIRCLE SURROUNDING A YELLOW "Q" WITH A GREEN CENTER, AND THE WORDS "THE BEST COFFEE FOR THE WORLD" IN WHITE, ALL AGAINST A BLACK BACKGROUND.

THE ENGLISH TRANSLATION OF "CAFÉ" IN THE MARK IS COFFEE. THE WORDING "TISQUESUSA" HAS NO MEANING IN A FOREIGN LANGUAGE.

FOR COFFEE AND AROMATIC FOOD ADDITIVES FOR NON-NUTRITIONAL PURPOSES FOR USE AS A FLAVORING (U.S. CL. 46).

TINA BROWN, EXAMINING ATTORNEY

SN 77-041,972. THE GOOD EARTH CORPORATION, SANTA CRUZ, CA. FILED 11-11-2006.

GOOD EARTH CHAICINO

THE MARK CONSISTS OF STANDARD CHARACTERS WITHOUT CLAIM TO ANY PARTICULAR FONT, STYLE, SIZE, OR COLOR.

OWNER OF U.S. REG. NOS. 2,165,571, 2,172,587 AND OTHERS.

FOR TEA; READY-TO-DRINK TEA BASED BEVERAGES; TEA BASED POWDERED BEVERAGE MIXES; TEA BASED LIQUID BEVERAGE MIXES (U.S. CL. 46).

DEBRA LEE, EXAMINING ATTORNEY

CLASS 30—(Continued).

SN 77-072,658. NANTUCKET HARVEST CO., INC., FALL RIVER, MA. FILED 12-28-2006.

COCKTAIL CENTRAL

THE MARK CONSISTS OF STANDARD CHARACTERS WITHOUT CLAIM TO ANY PARTICULAR FONT, STYLE, SIZE, OR COLOR.

NO CLAIM IS MADE TO THE EXCLUSIVE RIGHT TO USE "COCKTAIL", APART FROM THE MARK AS SHOWN. FOR SALT; SPICE BLENDS; SUGAR (U.S. CL. 46). FIRST USE 10-23-2006; IN COMMERCE 10-23-2006. BONNIE LUKEN, EXAMINING ATTORNEY

SN 77-158,187. KLN ENTERPRISES, INC., PERHAM, MN. FILED 4-17-2007.

NATURAL PLANET

THE MARK CONSISTS OF STANDARD CHARACTERS WITHOUT CLAIM TO ANY PARTICULAR FONT, STYLE, SIZE, OR COLOR.

NO CLAIM IS MADE TO THE EXCLUSIVE RIGHT TO USE "NATURAL", APART FROM THE MARK AS SHOWN. FOR CANDY (U.S. CL. 46). FRANK LATTUCA, EXAMINING ATTORNEY

SN 77-158,208. KLN ENTERPRISES, INC., PERHAM, MN. FILED 4-17-2007.

NATURAL PLANET

THE MARK CONSISTS OF STANDARD CHARACTERS WITHOUT CLAIM TO ANY PARTICULAR FONT, STYLE, SIZE, OR COLOR.

OWNER OF U.S. REG. NO. 2,468,143. NO CLAIM IS MADE TO THE EXCLUSIVE RIGHT TO USE "NATURAL", APART FROM THE MARK AS SHOWN. FOR CEREAL-BASED SNACK FOODS (U.S. CL. 46). FIRST USE 4-19-1999; IN COMMERCE 4-19-1999. FRANK LATTUCA, EXAMINING ATTORNEY

CLASS 30—(Continued).

SN 77-197,624. PIZZERIA UNO CORPORATION, WILMINGTON, DE. FILED 6-5-2007.

MUNCH BOX

THE MARK CONSISTS OF STANDARD CHARACTERS WITHOUT CLAIM TO ANY PARTICULAR FONT, STYLE, SIZE, OR COLOR.

FOR PREPARED ENTREES CONSISTING PRIMARILY OF PIZZA AND/OR A SANDWICH, WITH A SIDE SALAD, FOR CONSUMPTION ON OR OFF THE PREMISES (U.S. CL. 46).

WILLIAM P. SHANAHAN, EXAMINING ATTORNEY

SN 77-201,784. SHIROHATO FOOD INDUSTRY CORPORATION, OSAKA 570-0083, JAPAN, FILED 6-8-2007.



NO CLAIM IS MADE TO THE EXCLUSIVE RIGHT TO USE "TAKO YA" AND "DOTONBORI", APART FROM THE MARK AS SHOWN.

THE THREE CHARACTERS ON THE FAR LEFT SIDE ARE TRANSLITERATED AS "DOUTONBORI", WHICH IS THE NAME OF A RESTAURANT DISTRICT IN OSAKA. THE MIDDLE CHARACTERS ARE TRANSLITERATED AS "KUKURU", WHICH IS BIRD CALL. THE FAR RIGHT THREE CHARACTERS ARE TRANSLITERATED AS "TAKO YA". "TAKO" MEANS OCTOPUS AND "YA" MEANS SHOPS INCLUDING RESTAURANTS, CLOTH SHOP, AND ANY KIND OF STORE.

FOR PASTRY, BREAD, CAKES, AND TAKOYAKI, NAMELY, ROUND DUMPLINGS MADE FROM FLOUR, WATER, EGG AND OTHER INGREDIENTS WITH CHOPPED OCTOPUS (U.S. CL. 46).

FIRST USE 4-30-2004; IN COMMERCE 4-30-2004. HOWARD SMIGA, EXAMINING ATTORNEY

SN 77-210,735. ÉTABLISSEMENTS MORINA PÂTISSIER, CONTRES, FRANCE, FILED 6-20-2007.

CHÂTEAU DE FOUGÈRES

THE MARK CONSISTS OF STANDARD CHARACTERS WITHOUT CLAIM TO ANY PARTICULAR FONT, STYLE, SIZE, OR COLOR.

THE ENGLISH TRANSLATION OF THE WORD "CHATEAU DE FOUGERES" IN THE MARK IS CASTLE OF FOUGERES.

FOR CAKES, PASTRIES AND BISCUITS (U.S. CL. 46). ELLEN PERKINS, EXAMINING ATTORNEY

CLASS 30—(Continued).

SN 77-217,029. G.E.I. GRUPPO ESSENZIERO ITALIANO SOCIETA' IN ACCOMANDITA SEMPLICE DI FERRERO E C., TORINO, ITALY, FILED 6-27-2007.

AROMITALIA

THE MARK CONSISTS OF STANDARD CHARACTERS WITHOUT CLAIM TO ANY PARTICULAR FONT, STYLE, SIZE, OR COLOR.

OWNER OF ITALY REG. NO. 944539, DATED 11-11-2001, EXPIRES 11-11-2021.

OWNER OF U.S. REG. NOS. 2,384,544 AND 2,544,099.

FOR BASES, CONSISTING OF MILK POWDER, VEGETABLE FAT, FRUIT, DEXTROSE STABILIZER, EMULSIFIER, FLAVOR, MILK OR VEGETABLE PROTEIN AND COLOR FOR MAKING, OR FLAVOURING OR GARNISHING OR MARBLEIZING PASTRY, ICE CREAMS, FLAVORED ICES, FRUIT ICE, ITALIAN STYLE ICE CREAMS AND ITALIAN GELATO, FROZEN CONFECTIONS, FROZEN CUSTARDS, FROZEN YOGURT, ICE MILK, PARFAITS, SHERBET AND SORBET, FLAVORING SYRUP AND TOPPING SYRUP, ALL FOR COMMERCIAL OR INDUSTRIAL USE (U.S. CL. 46).

JESSICA FATHY, EXAMINING ATTORNEY

SN 77-233,261. TEAVANA CORPORATION, ATLANTA, GA. FILED 7-19-2007.

HAUTE CHOCOLATE

THE MARK CONSISTS OF STANDARD CHARACTERS WITHOUT CLAIM TO ANY PARTICULAR FONT, STYLE, SIZE, OR COLOR.

NO CLAIM IS MADE TO THE EXCLUSIVE RIGHT TO USE "CHOCOLATE", APART FROM THE MARK AS SHOWN.

FOR TEA (U.S. CL. 46).

FIRST USE 6-0-2005; IN COMMERCE 6-0-2005.

DEBRA LEE, EXAMINING ATTORNEY

SN 77-244,374. J.T. RONNEFELDT KG, FRANFURT, FED REP GERMANY, FILED 8-1-2007.

WINTERMÄRCHEN

THE MARK CONSISTS OF STANDARD CHARACTERS WITHOUT CLAIM TO ANY PARTICULAR FONT, STYLE, SIZE, OR COLOR.

OWNER OF FED REP GERMANY REG. NO. 1032226, DATED 4-20-1982, EXPIRES 4-30-2012.

THE FOREIGN WORDING IN THE MARK TRANSLATES INTO ENGLISH AS WINTER FAIRY TALE.

FOR TEA (U.S. CL. 46).

DANIEL BRODY, EXAMINING ATTORNEY

CLASS 30—(Continued).

SN 77-262,456. CONSOLIDATED TEA COMPANY, INC., LYNBROOK, NY. FILED 8-23-2007.



OWNER OF U.S. REG. NO. 2,862,785.

THE COLOR(S) RED, YELLOW-GOLD AND BLACK IS/ ARE CLAIMED AS A FEATURE OF THE MARK.

THE MARK CONSISTS OF A BOX REPRESENTING A STEAMER STYLE TRUNK WITH CORNER PLATES, TOP AND SIDE VERTICAL STRAPS, EDGE BANDING AND THE WORD "SWEE-TOUCH-NEE" WITHIN A RIBBON BANNER APPEARING ON THE TOP AND SIDES OF THE TRUNK. NO CLAIM IS MADE TO THE SHAPE OF THE BOX. THE OWNER IS NOT CLAIMING THE BOX CONFIGURATION AS A FEATURE OF ITS MARK. THE BACKGROUND OF THE STEAMER TRUNK CONFIGURATION THAT IS THE MARK IS RED IN COLOR WITH THE CORNER PLATES, STRAPS, EDGE BANDING AND BANNERS IN YELLOW-GOLD, AND THE WORDS "SWEE-TOUCH-NEE" IN BLACK.

SEC. 2(F).

FOR TEA (U.S. CL. 46).

FIRST USE 12-31-1950; IN COMMERCE 12-31-1950.

ANGELA GAW, EXAMINING ATTORNEY

SN 77-262,526. BROWN, DAN, MEDFORD, MA. FILED 8-23-2007.

BOOTSYY

THE MARK CONSISTS OF STANDARD CHARACTERS WITHOUT CLAIM TO ANY PARTICULAR FONT, STYLE, SIZE, OR COLOR.

FOR CONDIMENTS, NAMELY, BARBECUE SAUCE (U.S. CL. 46).

KATHERINE CHANG, EXAMINING ATTORNEY

CLASS 30—(Continued).

SN 77-268,305. THE ALLAN CANDY COMPANY LIMITED, MISSISSAUGA, ONTARIO, FILED 8-30-2007.

JUNGLE RUMBLE LAVA FLOW

THE MARK CONSISTS OF STANDARD CHARACTERS WITHOUT CLAIM TO ANY PARTICULAR FONT, STYLE, SIZE, OR COLOR.

OWNER OF CANADA REG. NO. TMA706473, DATED 2-4-2008, EXPIRES 2-4-2023.

FOR CONFECTIONERY, NAMELY, CANDY (U.S. CL. 46).

SANJEEV VOHRA, EXAMINING ATTORNEY

SN 77-268,316. THE ALLAN CANDY COMPANY LIMITED, MISSISSAUGA, ONTARIO, FILED 8-30-2007.

ALLAN PEACH SLICES

THE MARK CONSISTS OF STANDARD CHARACTERS WITHOUT CLAIM TO ANY PARTICULAR FONT, STYLE, SIZE, OR COLOR.

OWNER OF CANADA REG. NO. TMA673299, DATED 9-25-2006, EXPIRES 9-25-2021.

OWNER OF U.S. REG. NOS. 1,708,471 AND 1,718,452.

NO CLAIM IS MADE TO THE EXCLUSIVE RIGHT TO USE "PEACH SLICES", APART FROM THE MARK AS SHOWN.

FOR CONFECTIONERY, NAMELY, CANDY (U.S. CL. 46).

G. MAYERSCHOFF, EXAMINING ATTORNEY

SN 77-270,517. COFCO LE CONTE FOOD (SHENZHEN)CO., LTD., GUANGDONG PROVINCE, CHINA, FILED 9-4-2007.

Le conté

THE ENGLISH TRANSLATION OF "LE CONTÉ" IS "THE TALE".

FOR COCOA-BASED INGREDIENT IN CONFECTIONERY PRODUCTS; BEVERAGES MADE OF TEA; SWEETMEATS; CHOCOLATE; FUDGE; FRUIT JELLIES; HONEY; BISCUITS; PROCESSED CEREALS; POPCORN; ICE CREAM (U.S. CL. 46).

KATHERINE STOIDES, EXAMINING ATTORNEY

CLASS 30—(Continued).

SN 77-271,515. CARRILLO HOLDINGS, INC., DBA CARRILLO'S FIRE-ROASTED SALSA, RYE, NY. FILED 9-5-2007.

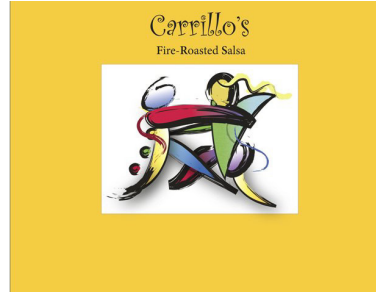

NO CLAIM IS MADE TO THE EXCLUSIVE RIGHT TO USE "FIRE-ROASTED SALSA", APART FROM THE MARK AS SHOWN.

THE COLOR(S) BLACK, RED, BLUE, YELLOW, GREEN, PURPLE, WHITE IS/ARE CLAIMED AS A FEATURE OF THE MARK.

THE MARK CONSISTS OF AN ABSTRACT REPRESENTATION OF TWO SALSA DANCERS DANCING TOGETHER. THE WORDING "CARRILLO'S FIRE-ROASTED SALSA" IS IN BLACK CENTERED AT THE TOP OF THE MARK. THE ART STYLE IS A PAINTBRUSH EFFECT. BLACK IS USED AS AN OUTLINE FOR MOST OF THE TWO FIGURES. BLUE IS SEEN IN THE HEAD AND LEFT LEG OF THE FIGURE ON THE LEFT, AS WELL AS LEFT PORTION OF THE UPPER TORSO AND ARM OF THE FIGURE ON THE RIGHT. THERE IS A BLUE CURVED VERTICAL LINE EXTENDING DOWNWARD FROM THE MID-TORSO OF THE FIGURE ON THE RIGHT. THE RIGHT ARM OF THE FIGURE ON THE LEFT APPEARS IN RED AND PURPLE, OUTLINED IN BLACK. THERE IS A RED CURVED VERTICAL LINE EXTENDING DOWNWARD FROM THE FIGURE ON THE LEFT'S NECK. THERE ARE THREE DOTS EXTENDING DOWNWARD FROM THE SHOULDER OF THE FIGURE ON THE LEFT. THE FIRST DOT IS YELLOW, OUTLINED IN BLACK. THE SECOND DOT IS GREEN, OUTLINED IN BLACK AND THE THIRD DOT IS RED, OUTLINED IN BLACK. THE HEAD OF THE FIGURE ON THE RIGHT IS YELLOW WITH A YELLOW STREAM EXTENDING FROM THE HEAD, ALL OUTLINED IN BLACK. THE LEFT LEG OF THE FIGURE ON THE RIGHT IS YELLOW AND PURPLE, OUTLINED IN BLACK. THE RIGHT LEG OF THE FIGURE ON THE RIGHT IS RED AND PURPLE, OUTLINED IN BLACK. THE TORSO AND RIGHT ARM FOR THE FIGURE ON THE RIGHT IS GREEN. WHITE IS USED FOR THE RECTANGULAR FIELD BEHIND THE FIGURES. THERE IS ALSO A SUBTLE SHADOW EFFECT FOR THE FIGURES. THE BACKGROUND OF THE MARK IS A YELLOW SQUARE.

FOR SALSA; CONDIMENT, NAMELY, PEPPER SAUCE; SAUCES FOR BARBECUED MEAT (U.S. CL. 46).

FIRST USE 8-30-2007; IN COMMERCE 8-30-2007.

PAULA MAHONEY, EXAMINING ATTORNEY

SN 77-275,297. ST. ANDREWS OF SCOTLAND INTERNATIONAL LTD, HOLLAND, MI. FILED 9-10-2007.

St. Andrews Golf

THE MARK CONSISTS OF STANDARD CHARACTERS WITHOUT CLAIM TO ANY PARTICULAR FONT, STYLE, SIZE, OR COLOR.

FOR COFFEE, TEA, CHOCOLATE (U.S. CL. 46).

TOBY BULLOFF, EXAMINING ATTORNEY

CLASS 30—(Continued).

SN 77-276,572. ST. ANDREWS OF SCOTLAND INTERNATIONAL LTD, HOLLAND, MI. FILED 9-11-2007.

St.Andrews of Scotland

THE MARK CONSISTS OF STANDARD CHARACTERS WITHOUT CLAIM TO ANY PARTICULAR FONT, STYLE, SIZE, OR COLOR.

FOR COFFEE, TEA, CHOCOLATE (U.S. CL. 46).
TOBY BULLOFF, EXAMINING ATTORNEY

SN 77-279,325. CAFÉ CULTIVO, INC., YONKERS, NY. FILED 9-13-2007.

Cafe CULTIVO

THE MARK CONSISTS OF STANDARD CHARACTERS WITHOUT CLAIM TO ANY PARTICULAR FONT, STYLE, SIZE, OR COLOR.

NO CLAIM IS MADE TO THE EXCLUSIVE RIGHT TO USE "CAFE", APART FROM THE MARK AS SHOWN.

THE FOREIGN WORDING IN THE MARK TRANSLATES INTO "CULTIVATION" (MASCULINE), "CROP" (USED FOR PLANTS) AND "CULTURE" (USED IN BIOLOGY).

FOR COFFEE; COFFEE; COFFEE BEANS; GROUND COFFEE BEANS; PREPARED COFFEE AND COFFEE-BASED BEVERAGES; ROASTED COFFEE BEANS (U.S. CL. 46).

SIMÓN TENG, EXAMINING ATTORNEY

SN 77-281,302. BRANCH, CHARLES S., HASTINGS ON HUDSON, NY. AND LEHNER, CHRISTINE R., HASTINGS ON HUDSON, NY. FILED 9-17-2007.

LET IT BEE HONEY

THE MARK CONSISTS OF STANDARD CHARACTERS WITHOUT CLAIM TO ANY PARTICULAR FONT, STYLE, SIZE, OR COLOR.

NO CLAIM IS MADE TO THE EXCLUSIVE RIGHT TO USE "HONEY", APART FROM THE MARK AS SHOWN.

FOR HONEY (U.S. CL. 46).
DAWN FELDMAN, EXAMINING ATTORNEY

CLASS 30—(Continued).

SN 77-283,111. MO ROCKIN FOODS LLC, WEST BLOOMFIELD, MI. FILED 9-19-2007.

MO ROCKIN

THE MARK CONSISTS OF STANDARD CHARACTERS WITHOUT CLAIM TO ANY PARTICULAR FONT, STYLE, SIZE, OR COLOR.

FOR CONDIMENT, NAMELY, PEPPER SAUCE; HOT SAUCE; READY-MADE SAUCES; SALAD DRESSINGS; SALAD SAUCES; SALSA; SAUCES (U.S. CL. 46).

MARGARET POWER, EXAMINING ATTORNEY

SN 77-286,979. NEW YASMEEN DETROIT, INC., DEARBORN, MI. FILED 9-24-2007.



NO CLAIM IS MADE TO THE EXCLUSIVE RIGHT TO USE "BAKERY" AND THE NON-LATIN CHARACTERS THAT MEAN BAKERIES, APART FROM THE MARK AS SHOWN.

THE COLOR(S) GREEN, WHITE IS/ARE CLAIMED AS A FEATURE OF THE MARK.

THE MARK CONSISTS OF THE COLOR GREEN APPEARS IN THE NON-LATIN CHARACTERS, IN "YASMEEN BAKERY", IN THE FLOWER DESIGNS, AS LINING TO THE RECTANGULAR LABEL BOXES, AND AS CIRCULAR BANDS TO THE OVERALL DESIGN. THE COLOR WHITE APPEARS IN THE FLOWER DESIGNS, IN THE RECTANGULAR LABEL BOXES, AND AS A CIRCULAR BAND. THE COLOR WHITE THAT APPEARS AS BACKGROUND OF THE ENTIRE MARK REPRESENTS TRANSPARENT AREAS AND IS NOT PART OF THE MARK.

THE FOREIGN WORDING IN THE MARK TRANSLATES INTO ENGLISH AS NEW YASMEEN BAKERIES.

THE NON-LATIN CHARACTER(S) IN THE MARK TRANSLITERATES INTO AH-FRAHN EL YAS-MEEN EL JE-DE-DA. AND THIS MEANS NEW YASMEEN BAKERIES IN ENGLISH.

FOR BAKERY PRODUCTS, NAMELY, PITA BREAD (U.S. CL. 46).

FIRST USE 11-9-1985; IN COMMERCE 11-9-1985.

TIMOTHY FINNEGAN, EXAMINING ATTORNEY

CLASS 30—(Continued).

SN 77-287,942. WILLIE HARMON, DBA HOT TAMALES HEAVEN, GREENVILLE, MS. FILED 9-25-2007.

HOT TAMALES HEAVEN

THE MARK CONSISTS OF STANDARD CHARACTERS WITHOUT CLAIM TO ANY PARTICULAR FONT, STYLE, SIZE, OR COLOR.

NO CLAIM IS MADE TO THE EXCLUSIVE RIGHT TO USE "HOT TAMALES", APART FROM THE MARK AS SHOWN.

FOR TAMALES (U.S. CL. 46).
FIRST USE 9-19-1985; IN COMMERCE 0-0-1986.
PAM WILLIS, EXAMINING ATTORNEY

SN 77-296,164. SOCIETE DES PRODUITS NESTLE S.A., 1800 VEVEY, SWITZERLAND, FILED 10-4-2007.

TINGLERZ

THE MARK CONSISTS OF STANDARD CHARACTERS WITHOUT CLAIM TO ANY PARTICULAR FONT, STYLE, SIZE, OR COLOR.

FOR CANDY (U.S. CL. 46).
KATHERINE E. HALMEN, EXAMINING ATTORNEY

SN 77-300,726. UNION SQUARE HOSPITALITY GROUP, LLC, NEW YORK, NY. FILED 10-10-2007.

POPPIN' SPICE

THE MARK CONSISTS OF STANDARD CHARACTERS WITHOUT CLAIM TO ANY PARTICULAR FONT, STYLE, SIZE, OR COLOR.

NO CLAIM IS MADE TO THE EXCLUSIVE RIGHT TO USE "SPICE", APART FROM THE MARK AS SHOWN.

FOR BREADS; SPICES; POPPED POPCORN (U.S. CL. 46).
MICHAEL LEWIS, EXAMINING ATTORNEY

CLASS 30—(Continued).

SN 77-301,048. PFCCB ADMINISTRATION, INC., SCOTTSDALE, AZ. FILED 10-10-2007.

PEI WEI

THE MARK CONSISTS OF STANDARD CHARACTERS WITHOUT CLAIM TO ANY PARTICULAR FONT, STYLE, SIZE, OR COLOR.

OWNER OF U.S. REG. NOS. 2,598,916, 3,005,828 AND OTHERS.

"PEI WEI" DOES NOT IDENTIFY A LIVING INDIVIDUAL.

FOR SPRING ROLLS; SAUCES; SAUCE MIXES; FROZEN ENTREES CONSISTING PRIMARILY OF PASTA OR RICE; FROZEN MEALS CONSISTING PRIMARILY OF PASTA OR RICE; NOODLES, SAUCE, AND TOPPING COMBINED IN UNITARY PACKAGES; RICE AND SEASONING MIX COMBINED IN UNITARY PACKAGES; TEA (U.S. CL. 46).
MICHAEL LEWIS, EXAMINING ATTORNEY

SN 77-301,090. PFCCB ADMINISTRATION, INC., SCOTTSDALE, AZ. FILED 10-10-2007.



OWNER OF U.S. REG. NO. 1,847,107.

"P.F. CHANG'S" DOES NOT IDENTIFY A LIVING INDIVIDUAL.

THE MARK CONSISTS OF THE WORDS "P.F. CHANG'S" FLANKED ON EITHER SIDE BY A TREE DESIGN.

FOR SAUCES; SAUCE MIXES; FROZEN ENTREES CONSISTING PRIMARILY OF PASTA OR RICE; FROZEN MEALS CONSISTING PRIMARILY OF PASTA OR RICE; NOODLES, SAUCE, AND TOPPING COMBINED IN UNITARY PACKAGES; RICE AND SEASONING MIX COMBINED IN UNITARY PACKAGES; TEA (U.S. CL. 46).

MICHAEL LEWIS, EXAMINING ATTORNEY

CLASS 30—(Continued).

SN 77-301,107. PFCCB ADMINISTRATION, INC., SCOTTS-DALE, AZ. FILED 10-10-2007.

P.F. CHANG'S

THE MARK CONSISTS OF STANDARD CHARACTERS WITHOUT CLAIM TO ANY PARTICULAR FONT, STYLE, SIZE, OR COLOR.

OWNER OF U.S. REG. NOS. 1,847,107 AND 3,334,674.

THE NAME "P.F." CHANG'S DOES NOT IDENTIFY A LIVING INDIVIDUAL.

SEC. 2(F).

FOR SAUCES; SAUCE MIXES; FROZEN ENTREES CONSISTING PRIMARILY OF PASTA OR RICE; FROZEN MEALS CONSISTING PRIMARILY OF PASTA OR RICE; NOODLES, SAUCE, AND TOPPING COMBINED IN UNITARY PACKAGES; RICE AND SEASONING MIX COMBINED IN UNITARY PACKAGES; TEA (U.S. CL. 46).

MICHAEL LEWIS, EXAMINING ATTORNEY

SN 77-301,114. PFCCB ADMINISTRATION, INC., SCOTTS-DALE, AZ. FILED 10-10-2007.

P.F. CHANG'S

THE MARK CONSISTS OF STANDARD CHARACTERS WITHOUT CLAIM TO ANY PARTICULAR FONT, STYLE, SIZE, OR COLOR.

OWNER OF U.S. REG. NO. 1,847,107.

THE NAME "P.F. CHANG'S" DOES NOT IDENTIFY A LIVING INDIVIDUAL.

SEC. 2(F).

FOR SPRING ROLLS (U.S. CL. 46).

FIRST USE 1-26-2007; IN COMMERCE 1-26-2007.

MICHAEL LEWIS, EXAMINING ATTORNEY

SN 77-302,585. PROMARK BRANDS INC., MERIDIAN, ID. FILED 10-12-2007.



NO CLAIM IS MADE TO THE EXCLUSIVE RIGHT TO USE "BAGEL", APART FROM THE MARK AS SHOWN.

THE MARK CONSISTS OF THE WORDS "BAGEL BISTROT" WITH LEAVES, CHEESE, A SLICED BAGEL AND A BOWL OF SPREAD ENCASED IN AN OVAL SHAPE.

FOR FROZEN BAGELS WITH VARIOUS TOPPINGS (U.S. CL. 46).

GEOFFREY FOSDICK, EXAMINING ATTORNEY

CLASS 30—(Continued).

SN 77-305,785. THE ENLIGHTENED GOURMET, INC., WEST HARTFORD, CT. FILED 10-17-2007.

ABSOLUTELY COOL

THE MARK CONSISTS OF STANDARD CHARACTERS WITHOUT CLAIM TO ANY PARTICULAR FONT, STYLE, SIZE, OR COLOR.

OWNER OF U.S. REG. NO. 3,289,142.

FOR FROZEN AND REFRIGERATED DESSERTS, NAMELY, ICE CREAM AND CHEESE CAKES (U.S. CL. 46).

CHRISTINA SOBRAL, EXAMINING ATTORNEY

SN 77-321,854. SARA LEE BAKERY GROUP, INC., DOWNERS GROVE, IL. FILED 11-5-2007.

SIMPLE MEAL SOLUTIONS

THE MARK CONSISTS OF STANDARD CHARACTERS WITHOUT CLAIM TO ANY PARTICULAR FONT, STYLE, SIZE, OR COLOR.

NO CLAIM IS MADE TO THE EXCLUSIVE RIGHT TO USE "MEAL", APART FROM THE MARK AS SHOWN.

FOR BREAD AND BUNS; ROLLS (U.S. CL. 46).

CIMMERIAN COLEMAN, EXAMINING ATTORNEY

SN 77-337,463. NASH-FINCH COMPANY, MINNEAPOLIS, MN. FILED 11-27-2007.

FROSTED HOOLA FRUITS

THE MARK CONSISTS OF STANDARD CHARACTERS WITHOUT CLAIM TO ANY PARTICULAR FONT, STYLE, SIZE, OR COLOR.

NO CLAIM IS MADE TO THE EXCLUSIVE RIGHT TO USE "FROSTED" AND "FRUITS", APART FROM THE MARK AS SHOWN.

FOR BREAKFAST CEREAL, CEREAL BASED SNACK FOOD, AND PROCESSED CEREAL-BASED FOODS USED AS AN INGREDIENT FOR MAKING OTHER FOODS (U.S. CL. 46).

JENNIFER MARTIN, EXAMINING ATTORNEY

CLASS 30—(Continued).

SN 77-368,624. PARTNERS IN MARKETING, IRWIN, PA. FILED 1-10-2008.



NO CLAIM IS MADE TO THE EXCLUSIVE RIGHT TO USE "FUDGE", APART FROM THE MARK AS SHOWN.

THE NAME "CLAUDIA LAYNE" DOES NOT IDENTIFY A LIVING INDIVIDUAL.

THE COLOR(S) BLUE, WHITE IS/ARE CLAIMED AS A FEATURE OF THE MARK.

THE MARK CONSISTS OF THE WORDING "CLAUDIA LAYNE" AND "CL" AND THE OVAL DESIGN IN THE MARK ARE BLUE; THE WORDING "FUDGE" IS WHITE.

FOR FUDGE (U.S. CL. 46).

FIRST USE 1-1-2002; IN COMMERCE 1-1-2002.

DANIEL CAPSHAW, EXAMINING ATTORNEY

SN 77-368,945. VITALICIOUS, INC., NEW YORK, NY. FILED 1-10-2008.

VITA PITA

THE MARK CONSISTS OF STANDARD CHARACTERS WITHOUT CLAIM TO ANY PARTICULAR FONT, STYLE, SIZE, OR COLOR.

OWNER OF U.S. REG. NOS. 2,292,363 AND 3,243,451.

NO CLAIM IS MADE TO THE EXCLUSIVE RIGHT TO USE "PITA", APART FROM THE MARK AS SHOWN.

FOR PITA BREAD (U.S. CL. 46).

KEVIN CORWIN, EXAMINING ATTORNEY

SN 77-375,768. FULLY LOADED TEA (USA) INC., CARSON CITY, NV. FILED 1-18-2008.

overloadedtea

NO CLAIM IS MADE TO THE EXCLUSIVE RIGHT TO USE "TEA", APART FROM THE MARK AS SHOWN.

THE MARK CONSISTS OF THE WORDING "OVERLOADED" IN BOLD TO THE LEFT OF THE WORDING "TEA" WHICH IS IN STANDARD TYPE. THE LETTER "A" IN "TEA" IS REPLACED BY A TEA LEAF.

FOR (BASED ON USE IN COMMERCE) BLACK TEA; FRUIT TEAS; GREEN TEA; JAPANESE GREEN TEA; TEA; TEA BAGS; TEA FOR INFUSIONS; TEA PODS; TEA-BASED BEVERAGES WITH FRUIT FLAVORING-(BASED ON INTENT TO USE) BEVERAGES MADE OF TEA; HERB TEA; HERBAL TEA; ICED TEA; INSTANT TEA; LIME TEA; OOLONG TEA; TEA EXTRACTS; TEA SUBSTITUTES (U.S. CL. 46).

FIRST USE 4-20-2007; IN COMMERCE 9-4-2007.

SETH A. RAPPAPORT, EXAMINING ATTORNEY

CLASS 30—(Continued).

SN 77-387,005. DOBIAGIO, BOCA RATON, FL. FILED 2-1-2008.

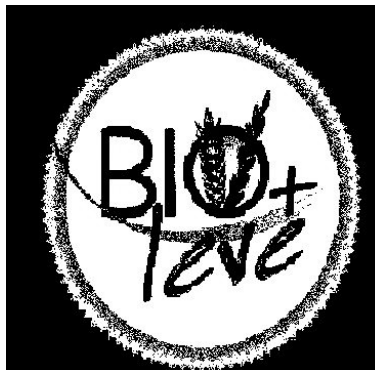

NO CLAIM IS MADE TO THE EXCLUSIVE RIGHT TO USE "LEVE", APART FROM THE MARK AS SHOWN.

THE STIPPLING IS FOR SHADING PURPOSES ONLY.

THE MARK CONSISTS OF A STYLIZED DEPICTION OF THE SUN CONTAINING THE WORDING "BIO +" ABOVE THE WORDING "LEVE". THERE ARE TWO WHEAT SPROUTS COMING OUT OF THE "O" IN THE WORD "BIO" AND THERE IS A CURVED LINE UNDER THE WORD "BIO".

THE ENGLISH TRANSLATION OF THE WORD "LEVE" IN THE MARK IS "LIGHT".

FOR RICE FLOUR; WHEAT FLOUR (U.S. CL. 46).

FIRST USE 12-1-2007; IN COMMERCE 1-1-2008.

TINA BROWN, EXAMINING ATTORNEY

SN 77-392,162. AMERICAN BLUE MILLS, INC, HAYWARD, CA. FILED S.R. 2-8-2008; AM. P.R. 6-25-2008.



THE COLOR(S) DARK GREEN, WHITE, AND YELLOW IS/ARE CLAIMED AS A FEATURE OF THE MARK.

THE COLOR DARK GREEN APPEARS IN THE DESIGN OF THE OVAL AND THE RECTANGLE; THE COLOR WHITE APPEARS IN THE ARABIC CHARACTERS AND THE WORDING "KHUDARI"; AND THE COLOR YELLOW APPEARS IN THE OUTLINE OF THE OVAL AND RECTANGLE.

THE ENGLISH TRANSLATION OF THE WORD KHUDARI IN THE MARK IS LAST NAME.

THE NON-LATIN CHARACTER(S) IN THE MARK TRANSLITERATE INTO KHUDARI.

FOR FLAVORINGS OF LEMON; SPICE BLENDS; SPICES; SWEETS; BAKING SPICES (U.S. CL. 46).

FIRST USE 1-0-2008; IN COMMERCE 1-0-2008.

YAT SYE, LEE, EXAMINING ATTORNEY

CLASS 30—(Continued).

SN 77-395,818. KOUMETZ, GERARD, BEVERLY HILLS, CA. AND KOUMETZ, PAULE, BEVERLY HILLS, CA. FILED 2-13-2008.

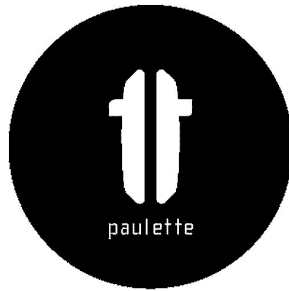

THE MARK CONSISTS OF THE WORD "PAULETTE" IN LOWERCASE STYLIZED LETTERING BELOW A DOUBLE "T" APPEARING AS TWO SIDES OF A MACARON. FOR BAKERY GOODS (U.S. CL. 46). FIRST USE 9-5-2007; IN COMMERCE 9-5-2007. TAMARA FRAZIER, EXAMINING ATTORNEY

SN 77-398,916. ULTIMATE START, LLC, PHOENIX, AZ. FILED 2-16-2008.



NO CLAIM IS MADE TO THE EXCLUSIVE RIGHT TO USE "ULTIMATE", APART FROM THE MARK AS SHOWN. THE COLOR(S) BLUE, GREEN, BROWN IS/ARE CLAIMED AS A FEATURE OF THE MARK. THE MARK CONSISTS OF "ULTIMATE" IN BLUE, "START" IN GREEN, "THE TASTY MUFFIN THAT'S GOOD FOR YOU" IN BROWN, AND A WHEAT GRAIN WITH ALL THREE COLORS. FOR MUFFINS (U.S. CL. 46). FIRST USE 5-1-2007; IN COMMERCE 6-1-2007. TARA PATE, EXAMINING ATTORNEY

CLASS 30—(Continued).

SN 77-403,647. BERRY CHILL, LLC, CHICAGO, IL. FILED 2-22-2008.

CRU D' CHILL

THE MARK CONSISTS OF STANDARD CHARACTERS WITHOUT CLAIM TO ANY PARTICULAR FONT, STYLE, SIZE, OR COLOR. FOR FROZEN YOGURT WITH A SIDE OF RAW VEGETABLES (U.S. CL. 46). WENDY JUN, EXAMINING ATTORNEY

SN 77-409,426. CONAGRA FOODS RDM, INC., OMAHA, NE. FILED 2-29-2008.

HEALTHY CHOICE FRESH MIXERS

THE MARK CONSISTS OF STANDARD CHARACTERS WITHOUT CLAIM TO ANY PARTICULAR FONT, STYLE, SIZE, OR COLOR. OWNER OF U.S. REG. NOS. 1,724,726, 1,885,162 AND OTHERS. NO CLAIM IS MADE TO THE EXCLUSIVE RIGHT TO USE "FRESH", APART FROM THE MARK AS SHOWN. FOR PREPARED OR PACKAGED ENTREES CONSISTING PRIMARILY OF PASTA OR RICE (U.S. CL. 46). THOMAS MANOR, EXAMINING ATTORNEY

SN 77-410,632. DE LOS SANTOS, LISA, ANN, DBA LISA ANN'S, TORRANCE, CA. FILED 3-1-2008.

Lisa Ann's Cookies To Go

THE MARK CONSISTS OF STANDARD CHARACTERS WITHOUT CLAIM TO ANY PARTICULAR FONT, STYLE, SIZE, OR COLOR. NO CLAIM IS MADE TO THE EXCLUSIVE RIGHT TO USE "COOKIES TO GO", APART FROM THE MARK AS SHOWN. FOR FOOD PACKAGE COMBINATIONS CONSISTING PRIMARILY OF BREAD, CRACKERS AND/OR COOKIES (U.S. CL. 46). FIRST USE 2-4-2008; IN COMMERCE 2-4-2008. WENDY GOODMAN, EXAMINING ATTORNEY

CLASS 30—(Continued).

SN 77-415,338. HAMMOND'S CANDIES SINCE 1920 II, LLC,
DENVER, CO. FILED 3-6-2008.

PANTRY CANDIES

THE MARK CONSISTS OF STANDARD CHARACTERS WITHOUT CLAIM TO ANY PARTICULAR FONT, STYLE, SIZE, OR COLOR.

NO CLAIM IS MADE TO THE EXCLUSIVE RIGHT TO USE "CANDIES", APART FROM THE MARK AS SHOWN.
FOR CANDY (U.S. CL. 46).
FIRST USE 1-31-2006; IN COMMERCE 1-31-2006.
KATHLEEN LORENZO, EXAMINING ATTORNEY

SN 77-416,104. SANSONE, GLENN, OLD TAPPAN, NJ. FILED
3-7-2008.

VITAMIN BILL'S ENERGY ICE

THE MARK CONSISTS OF STANDARD CHARACTERS WITHOUT CLAIM TO ANY PARTICULAR FONT, STYLE, SIZE, OR COLOR.

NO CLAIM IS MADE TO THE EXCLUSIVE RIGHT TO USE "ENERGY ICE", APART FROM THE MARK AS SHOWN.

THE NAME "VITAMIN BILL" DOES NOT IDENTIFY A LIVING INDIVIDUAL.

FOR FLAVORED ICES CONTAINING VITAMINS (U.S. CL. 46).
EMILY CHUO, EXAMINING ATTORNEY

SN 77-420,377. WILLAMETTE APEX INDUSTRIES, LLC,
VENETA, OR. FILED 3-12-2008.



NO CLAIM IS MADE TO THE EXCLUSIVE RIGHT TO USE "WESTERN BBQ SAUCE", APART FROM THE MARK AS SHOWN.

THE COLOR(S) BURGUNDY, TAN IS/ARE CLAIMED AS A FEATURE OF THE MARK.

THE MARK CONSISTS OF OVAL WITH BURGUNDY COLORED FILL AND TAN LINE AROUND EDGE, TAN HAT IN CENTER, TAN COLORED WORD "ROOSTERS" ON TOP OF HAT AND TAN COLORED WORDS "WESTERN BBQ SAUCE" ON BOTTOM OF HAT, TAN COLORED BANNER ACROSS CENTER OF OVAL WITH BURGUNDY WORDS "THE SAUCE" ON LEFT SIDE OF HAT AND BURGUNDY WORDS "WITH GRIT" ON RIGHT SIDE OF HAT.

FOR BARBEQUE SAUCE (U.S. CL. 46).
REBECCA POVARCHUK, EXAMINING ATTORNEY

CLASS 30—(Continued).

SN 77-422,278. HIGHTECH MANUFACTURING, INC.,
WYOMING, MI. FILED 3-14-2008.

My Sweet Lord Candy & Confections

THE MARK CONSISTS OF STANDARD CHARACTERS WITHOUT CLAIM TO ANY PARTICULAR FONT, STYLE, SIZE, OR COLOR.

NO CLAIM IS MADE TO THE EXCLUSIVE RIGHT TO USE "CANDY & CONFECTIONS", APART FROM THE MARK AS SHOWN.

FOR CANDIES; FROZEN CONFECTIONS (U.S. CL. 46).
ARETHA SOMERVILLE, EXAMINING ATTORNEY

SN 77-422,878. HOLM, DONNA J., ROSEBURG, OR. FILED 3-
14-2008.

DONA~DULCE

THE MARK CONSISTS OF STANDARD CHARACTERS WITHOUT CLAIM TO ANY PARTICULAR FONT, STYLE, SIZE, OR COLOR.

THE FOREIGN WORDING IN THE MARK TRANSLATES INTO ENGLISH AS SWEET DONNA.

FOR CANDY, NAMELY, OREGON HAZELNUT TOFFEE (U.S. CL. 46).

FIRST USE 10-0-2007; IN COMMERCE 10-0-2007.
YONG KIM, EXAMINING ATTORNEY

SN 77-423,589. DIVERSIFIED PRODUCTS GROUP, INC.,
RENO, NV. FILED 3-17-2008.

Decadent Classics

THE MARK CONSISTS OF STANDARD CHARACTERS WITHOUT CLAIM TO ANY PARTICULAR FONT, STYLE, SIZE, OR COLOR.

FOR BAKERY PRODUCTS (U.S. CL. 46).
KYLE PEETE, EXAMINING ATTORNEY

CLASS 30—(Continued).

SN 77-424,096. SANTA BARBARA COFFEE, LLC, DBA GREEN STAR COFFEE, GOLETA, CA. FILED 3-17-2008.



NO CLAIM IS MADE TO THE EXCLUSIVE RIGHT TO USE "COFFEE", APART FROM THE MARK AS SHOWN.

THE COLOR(S) WHITE, BROWN, BEIGE AND GREEN IS/ARE CLAIMED AS A FEATURE OF THE MARK.

THE MARK CONSISTS OF A GREEN FIVE POINT STAR SUPERIMPOSED ON A LIGHT GREEN SHADED CIRCLE WITH AN OUTER GREEN RING OUTSIDE OF THE SHADED CIRCLE ALL DESIGNS CENTERED INSIDE A WREATH MADE OF BEIGE AND WHITE COFFEE BEANS WITH GREEN LEAFS UNDERNEATH AND CENTERED BETWEEN THE WREATH; THE WORDING "GREEN STAR" IS BROWN AND CENTERED BELOW THE WREATH WITH THE TERM "COFFEE" IN THE COLOR BROWN IMMEDIATELY UNDERNEATH THE WORDING.

FOR COFFEE AND TEA; ROASTED COFFEE BEANS (U.S. CL. 46).

CHRISTOPHER BUONGIORNO, EXAMINING ATTORNEY

CLASS 30—(Continued).

SN 77-425,024. TITIAN ENTERPRISES INC., NEW YORK, NY. FILED 3-18-2008.

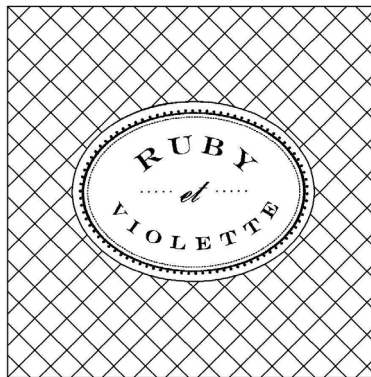

OWNER OF U.S. REG. NO. 2,842,847.

THE MARK CONSISTS OF THE WORDS "RUBY ET VIOLETTE" ENCLOSED IN AN OVAL SURROUNDED BY LITTLE DOTS. THE OVAL IS WITHIN A CRISS CROSS DESIGN.

THE ENGLISH TRANSLATION OF THE WORD "VIOLETTE" IN THE MARK IS VIOLET.

FOR BAKERY GOODS, NAMELY, COOKIES, CAKES, TARTS, AND BROWNIES; FROZEN CONFECTIONS, NAMELY, ICE CREAM (U.S. CL. 46).

KHANH LE, EXAMINING ATTORNEY

SN 77-424,611. CJ CHEILJEDANG CORPORATION, SEOUL, REPUBLIC OF KOREA, FILED 3-18-2008.

FRESHIAN

THE MARK CONSISTS OF STANDARD CHARACTERS WITHOUT CLAIM TO ANY PARTICULAR FONT, STYLE, SIZE, OR COLOR.

FOR NOODLES, PACKED BOILED RICE, DUMPLINGS, RICE PORRIDGE, NON-MEDICATED CONFECTIONERY IN JELLY FORM, CAKES, BREAD CRUMBS, SUGAR, SOYA SAUCE, FERMENTED HOT PEPPER PASTE, FERMENTED SOYBEAN PASTE, BLACK BEAN PASTE, SEASONINGS, VINEGAR, SAUCES, SALT, TEA, COFFEE, FLAVORING FOR ANIMAL FEED (U.S. CL. 46).

PAULA MAHONEY, EXAMINING ATTORNEY

SN 77-425,103. BRIGATI, ROBERT, MELVILLE, NY. FILED 3-18-2008.

LOAFFIN

THE MARK CONSISTS OF STANDARD CHARACTERS WITHOUT CLAIM TO ANY PARTICULAR FONT, STYLE, SIZE, OR COLOR.

FOR BAKERY PRODUCTS, NAMELY, MUFFIN VARIETIES BAKED IN THE SHAPE OF A LOAF (U.S. CL. 46). FIRST USE 11-15-2006; IN COMMERCE 11-15-2006.

HEATHER SAPP, EXAMINING ATTORNEY

CLASS 30—(Continued).

SN 77-425,669. SONA SPICES U.S.A. INC., SAUGUS, CA. FILED 3-19-2008.

Nirapara

THE MARK CONSISTS OF STANDARD CHARACTERS WITHOUT CLAIM TO ANY PARTICULAR FONT, STYLE, SIZE, OR COLOR.

THE FOREIGN WORDING "NIRAPARA" IN THE MARK TRANSLATES INTO ENGLISH AS "MEASURING CUP".

FOR RICE; RICE FLOUR; RICE NOODLES; FLOUR; SOYA FLOUR; WHEAT FLOUR; WHEAT STARCH FLOUR; EDIBLE FLOUR; FLOUR FOR FOOD (U.S. CL. 46).

JAY BESCH, EXAMINING ATTORNEY

CLASS 30—(Continued).

SN 77-426,288. JANIE'S CAKES, LP, TYLER, TX. FILED 3-19-2008.



NO CLAIM IS MADE TO THE EXCLUSIVE RIGHT TO USE "CAKES", APART FROM THE MARK AS SHOWN.

THE COLOR(S) BLACK, WHITE, BLUE, TEAL, BROWN, RED, GREY, FLESH TONE, PINK AND YELLOW IS/ARE CLAIMED AS A FEATURE OF THE MARK.

THE MARK CONSISTS OF A YELLOW CIRCLE IN FRONT OF WHICH A WOMAN STANDS WEARING A TEAL AND BLUE DRESS WITH A WHITE AND GREY APRON. THE WOMAN IS WEARING BLACK SHOES AND HER SILHOUETTE IS OUTLINED IN BLACK. THE WOMAN'S ARMS AND LEGS ARE FLESH TONE AND THE WOMAN'S LEFT HAND HAS A RED RING ON HER FINGER AND THE LEFT HAND IS DOWN NEAR HER SIDE. THE WOMAN'S RIGHT ARM IS HOLDING A LIGHT BROWN POUND CAKE THAT IS SLIGHTLY TIPPED FORWARD AND ON A WHITE BASE OUTLINED IN BLACK. THE WOMAN IS WEARING A NECKLACE WITH FOUR WHITE AND GREY PEARLS AND WHITE AND GREY PEARL EARRINGS. THE WOMAN'S FACE IS FLESH COLOR WITH PINK CHEEKS AND LIPS. THE WOMAN HAS LIGHT BROWN, WHITE AND BLACK HAIR, AND IS WEARING A WHITE, GREY AND BLACK CHEF'S HAT WITH THE BLACK WORDS "PLAIN JANE" WRITTEN ON THE FRONT OF THE HAT. ABOVE THE WOMAN AND TO THE LEFT APPEARS THE DARK BLUE, AND OUTLINED IN TEAL WORDS "JANIE'S CAKES".

FOR CAKES (U.S. CL. 46).

FIRST USE 10-1-2003; IN COMMERCE 11-1-2003.

STEPHANIE ALI, EXAMINING ATTORNEY

SN 77-425,939. PEPSICO, INC., PURCHASE, NY. FILED 3-19-2008.

BOMBIUX SUPER

THE MARK CONSISTS OF STANDARD CHARACTERS WITHOUT CLAIM TO ANY PARTICULAR FONT, STYLE, SIZE, OR COLOR.

OWNER OF U.S. REG. NO. 3,051,309.

NO CLAIM IS MADE TO THE EXCLUSIVE RIGHT TO USE "SUPER", APART FROM THE MARK AS SHOWN.

FOR CHEWING GUM; CANDY (U.S. CL. 46).

TRACY CROSS, EXAMINING ATTORNEY

SN 77-426,286. MONCHIPS, INC., NEW YORK, NY. FILED 3-19-2008.

MONCHIPS

THE MARK CONSISTS OF STANDARD CHARACTERS WITHOUT CLAIM TO ANY PARTICULAR FONT, STYLE, SIZE, OR COLOR.

FOR COOKIES (U.S. CL. 46).

JOHN KELLY, EXAMINING ATTORNEY

SN 77-427,121. J.B.R., INC., SAN LEANDRO, CA. FILED 3-20-2008.

CHAI@HOME

THE MARK CONSISTS OF STANDARD CHARACTERS WITHOUT CLAIM TO ANY PARTICULAR FONT, STYLE, SIZE, OR COLOR.

FOR TEA (U.S. CL. 46).

B. PARADEWELAI, EXAMINING ATTORNEY

CLASS 30—(Continued).

SN 77-427,122. J.B.R., INC., SAN LEANDRO, CA. FILED 3-20-2008.

LATTE@HOME

THE MARK CONSISTS OF STANDARD CHARACTERS WITHOUT CLAIM TO ANY PARTICULAR FONT, STYLE, SIZE, OR COLOR.
FOR COFFEE (U.S. CL. 46).
B. PARADEWELAI, EXAMINING ATTORNEY

CLASS 30—(Continued).

SN 77-428,221. THE CHA DAO TEA COMPANY, INC., SEATTLE, WA. FILED 3-21-2008.

FALLING LEAF TEA

THE MARK CONSISTS OF STANDARD CHARACTERS WITHOUT CLAIM TO ANY PARTICULAR FONT, STYLE, SIZE, OR COLOR.
NO CLAIM IS MADE TO THE EXCLUSIVE RIGHT TO USE "TEA", APART FROM THE MARK AS SHOWN.
FOR TEA (U.S. CL. 46).
MONIQUE MILLER, EXAMINING ATTORNEY

SN 77-427,732. COPELAND, AL C, METAIRIE, LA. FILED 3-20-2008.

CHEESECAKE MARTINI

THE MARK CONSISTS OF STANDARD CHARACTERS WITHOUT CLAIM TO ANY PARTICULAR FONT, STYLE, SIZE, OR COLOR.
NO CLAIM IS MADE TO THE EXCLUSIVE RIGHT TO USE "CHEESECAKE", APART FROM THE MARK AS SHOWN.
FOR PREPARED DESSERT IN THE NATURE OF CHEESECAKE SERVED IN A GLASS (U.S. CL. 46).
MICHAEL TANNER, EXAMINING ATTORNEY

SN 77-428,234. REDBONE, INC., FLORENCE, SC. FILED 3-21-2008.

**RIDICULOUSLY EASY
SERIOUSLY GOOD**

THE MARK CONSISTS OF STANDARD CHARACTERS WITHOUT CLAIM TO ANY PARTICULAR FONT, STYLE, SIZE, OR COLOR.
FOR CONDIMENTS, NAMELY, AIOLI AND FLAVORED MAYONNAISE (U.S. CL. 46).
FIRST USE 2-14-2007; IN COMMERCE 8-1-2007.
JAY FLOWERS, EXAMINING ATTORNEY

SN 77-427,752. VERVE, LLC, CAPITOLA, CA. FILED 3-20-2008.

VERVE

THE MARK CONSISTS OF STANDARD CHARACTERS WITHOUT CLAIM TO ANY PARTICULAR FONT, STYLE, SIZE, OR COLOR.
FOR COFFEE (U.S. CL. 46).
JENNIFER HETU, EXAMINING ATTORNEY

SN 77-428,476. DINAPOLI-TIETZ, KAREN, SAN JOSE, CA. FILED 3-21-2008.

Bad Girl Chocolates

THE MARK CONSISTS OF STANDARD CHARACTERS WITHOUT CLAIM TO ANY PARTICULAR FONT, STYLE, SIZE, OR COLOR.
NO CLAIM IS MADE TO THE EXCLUSIVE RIGHT TO USE "CHOCOLATES", APART FROM THE MARK AS SHOWN.
FOR CHOCOLATES, COOKIES, AND CANDY (U.S. CL. 46).
FIRST USE 12-1-2007; IN COMMERCE 12-1-2007.
KAREN BRACEY, EXAMINING ATTORNEY

CLASS 30—(Continued).

SN 77-428,581. EMPTY NEST IDEAS LLC, BENTON, KY. FILED 3-21-2008.



NO CLAIM IS MADE TO THE EXCLUSIVE RIGHT TO USE "JOE", APART FROM THE MARK AS SHOWN.

THE MARK CONSISTS OF THE WORDS "CUPLESS JOE" IN AN OVAL WITH AN INVERTED CUP ABOVE A SAUCER UNDER THE WORD "JOE".

FOR INSTANT COFFEE CONTAINED IN A GELATIN CAPSULE (U.S. CL. 46).

CYNTHIA SLOAN, EXAMINING ATTORNEY

SN 77-428,826. THOMAS SISTERS ORGANICS, DBA THOMAS SISTERS ORGANICS, PORTLAND, OR. FILED 3-21-2008.

Organisweet

THE MARK CONSISTS OF STANDARD CHARACTERS WITHOUT CLAIM TO ANY PARTICULAR FONT, STYLE, SIZE, OR COLOR.

FOR ORGANIC NATURAL SWEETENER (U.S. CL. 46).
NICHOLAS COLEMAN, EXAMINING ATTORNEY

SN 77-429,101. MARIEL'S KITCHEN, INC., WOODLAND HILLS, CA. FILED 3-23-2008.

Blisscream

THE MARK CONSISTS OF STANDARD CHARACTERS WITHOUT CLAIM TO ANY PARTICULAR FONT, STYLE, SIZE, OR COLOR.

FOR MUSTARD (U.S. CL. 46).

MARLENE BELL, EXAMINING ATTORNEY

CLASS 30—(Continued).

SN 77-429,104. MARIEL'S KITCHEN, INC., WOODLAND HILLS, CA. FILED 3-23-2008.

MARIEL'S MUSTARD

THE MARK CONSISTS OF STANDARD CHARACTERS WITHOUT CLAIM TO ANY PARTICULAR FONT, STYLE, SIZE, OR COLOR.

NO CLAIM IS MADE TO THE EXCLUSIVE RIGHT TO USE "MUSTARD", APART FROM THE MARK AS SHOWN. FOR MUSTARD (U.S. CL. 46).

MARLENE BELL, EXAMINING ATTORNEY

SN 77-429,130. MACALUSO, JOHN F., PHOENIX, AZ. FILED 3-23-2008.

GIO GIOVANNI

THE MARK CONSISTS OF STANDARD CHARACTERS WITHOUT CLAIM TO ANY PARTICULAR FONT, STYLE, SIZE, OR COLOR.

THE NAME(S), PORTRAIT(S), AND/OR SIGNATURE(S) SHOWN IN THE MARK DOES NOT IDENTIFY A PARTICULAR LIVING INDIVIDUAL.

FOR ICE-CREAM; GELATO; COOKIES; COFFEE (U.S. CL. 46).

MARY MUNSON, EXAMINING ATTORNEY

SN 77-429,194. JANIE'S CAKES, LP, TYLER, TX. FILED 3-24-2008.



NO CLAIM IS MADE TO THE EXCLUSIVE RIGHT TO USE "CAKES TYLER TEXAS", APART FROM THE MARK AS SHOWN.

THE COLOR(S) YELLOW, WHITE AND BLUE IS/ARE CLAIMED AS A FEATURE OF THE MARK.

THE MARK CONSISTS OF A THREE-DIMENSIONAL WHITE BOX WITH AN OVERLAPPING YELLOW AND WHITE VERTICALLY STRIPED LID. ON THE LID APPEARS AN OVAL OUTLINED IN BLUE THAT CONTAINS THE BLUE WORDS "JANIE'S CAKES" ABOVE THE BLUE WORDS "TYLER, TEXAS". A BLUE RIBBON WRAPS AROUND THE BOX AND TIES IN THE MIDDLE.

FOR CAKES (U.S. CL. 46).

FIRST USE 10-1-2003; IN COMMERCE 11-1-2003.

STEPHANIE ALI, EXAMINING ATTORNEY

CLASS 30—(Continued).

SN 77-429,496. THRIVE FOODS, INC., LA MESA, CA. FILED 3-24-2008.



THE MARK CONSISTS OF THE STYLIZED TERM "THRIVE" WITH AN IMAGE OF A LEAF LOCATED DIRECTLY ABOVE IT.

FOR VEGAN CAKES; VEGAN CHEESECAKE; VEGAN COOKIES; VEGAN CUP CAKES; VEGAN PIES; BARBECUE SAUCE; HOT SAUCE; READY-MADE SAUCES; SALAD SAUCES; SAUCES; STEAK SAUCE; TERIYAKI SAUCE; BAKERY DESSERTS; SALAD DRESSINGS; CANDIES; CANDY; COOKIES; PIES; CAKES; CUP CAKES; CHEESECAKE (U.S. CL. 46).

FIRST USE 10-4-2004; IN COMMERCE 10-4-2004.
CHRISTINA SOBRAL, EXAMINING ATTORNEY

SN 77-429,855. THE NEW WORLD BAKERY, INC., KYLE, TX. FILED 3-24-2008.

THE NEW WORLD BAKERY

THE MARK CONSISTS OF STANDARD CHARACTERS WITHOUT CLAIM TO ANY PARTICULAR FONT, STYLE, SIZE, OR COLOR.

NO CLAIM IS MADE TO THE EXCLUSIVE RIGHT TO USE "BAKERY", APART FROM THE MARK AS SHOWN.

FOR BREAD AND BREAD ROLLS (U.S. CL. 46).

FIRST USE 5-0-1995; IN COMMERCE 5-0-1996.
BARBARA BROWN, EXAMINING ATTORNEY

SN 77-430,015. BEDIKIAN, ARAM, GLENDALE, CA. FILED 3-24-2008.

MINTIROSA

THE MARK CONSISTS OF STANDARD CHARACTERS WITHOUT CLAIM TO ANY PARTICULAR FONT, STYLE, SIZE, OR COLOR.

FOR CANDY AND MINTS (U.S. CL. 46).

JOHN SCHUYLER YARD, EXAMINING ATTORNEY

CLASS 30—(Continued).

SN 77-430,219. LOPEZ, BRENDA E., WOODLAND PARK, CO. FILED 3-24-2008.

MOUNTAIN LIGHTNING SALSA

THE MARK CONSISTS OF STANDARD CHARACTERS WITHOUT CLAIM TO ANY PARTICULAR FONT, STYLE, SIZE, OR COLOR.

NO CLAIM IS MADE TO THE EXCLUSIVE RIGHT TO USE "SALSA", APART FROM THE MARK AS SHOWN.

FOR NATURAL SALSA (U.S. CL. 46).

FIRST USE 2-1-2008; IN COMMERCE 2-1-2008.

GISELLE AGOSTO, EXAMINING ATTORNEY

SN 77-430,895. SKS FLOWERS S.C.C., DBA ECUADORIAN ORGANICS, QUITO, ECUADOR, FILED 3-25-2008.

PACARI

THE MARK CONSISTS OF STANDARD CHARACTERS WITHOUT CLAIM TO ANY PARTICULAR FONT, STYLE, SIZE, OR COLOR.

THE FOREIGN WORDING IN THE MARK TRANSLATES INTO ENGLISH AS "NATURE".

FOR CHOCOLATE, CHOCOLATE BARS, CHOCOLATE CANDIES, CHOCOLATE COVERED DRIED FRUITS, CHOCOLATE COVERED COFFEE BEANS (U.S. CL. 46).

FIRST USE 1-1-2008; IN COMMERCE 1-1-2008.

KRISTINA MORRIS, EXAMINING ATTORNEY

SN 77-431,021. LYON CREATIVE SERVICES, LTD, MESA, AZ. FILED 3-25-2008.

RATTLE STEAK

THE MARK CONSISTS OF STANDARD CHARACTERS WITHOUT CLAIM TO ANY PARTICULAR FONT, STYLE, SIZE, OR COLOR.

FOR STEAK SEASONING (U.S. CL. 46).

AISHA CLARKE, EXAMINING ATTORNEY

CLASS 30—(Continued).

SN 77-431,482. YOGURT CITY, INC, TENAFLY, NJ. FILED 3-25-2008.

16 Handles

THE MARK CONSISTS OF STANDARD CHARACTERS WITHOUT CLAIM TO ANY PARTICULAR FONT, STYLE, SIZE, OR COLOR.

FOR FROZEN YOGURT (U.S. CL. 46).
HENRY S. ZAK, EXAMINING ATTORNEY

SN 77-431,519. WOLRD OF DIFFERENCE FOODS, WHISLER, CANADA, FILED 3-26-2008.

GOOD HAPPENS

THE MARK CONSISTS OF STANDARD CHARACTERS WITHOUT CLAIM TO ANY PARTICULAR FONT, STYLE, SIZE, OR COLOR.

FOR GRANOLA-BASED SNACK BARS (U.S. CL. 46).
KELLY MCCOY, EXAMINING ATTORNEY

SN 77-431,701. YOSWIRL, FREMONT, CA. FILED 3-26-2008.

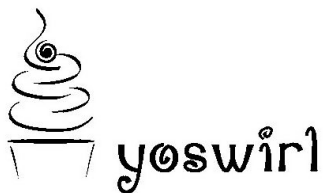

THE MARK CONSISTS OF THE STYLIZED WORD "YOSWIRL". TO THE LEFT OF THE STYLIZED WORDS IS A IMAGE OF OUTLINED CUP WITH OUTLINED FROZEN YOGURT ABOVE THE CUP WITH SWIRL TOPPING.

FOR FROZEN YOGURT WITH TOPPING, NAMELY, FRUITS, CEREALS, CANDIES, AND NUTS (U.S. CL. 46).
ANTHONY RINKER, EXAMINING ATTORNEY

CLASS 30—(Continued).

SN 77-431,924. CAROLINA FOOD INGREDIENTS, LLC, NORTH CHARLESTON, SC. FILED 3-26-2008.

CAROPERM

THE MARK CONSISTS OF STANDARD CHARACTERS WITHOUT CLAIM TO ANY PARTICULAR FONT, STYLE, SIZE, OR COLOR.

FOR FOOD GRADE TAPIOCA STARCH (U.S. CL. 46).
LEIGH CAROLINE CASE, EXAMINING ATTORNEY

SN 77-432,545. HIGH BRASS COFFEE COMPANY, LLC, TROY, VA. FILED 3-26-2008.

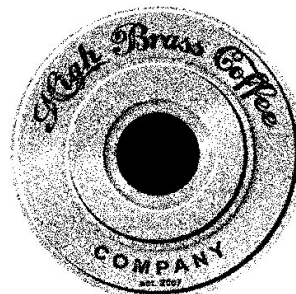

NO CLAIM IS MADE TO THE EXCLUSIVE RIGHT TO USE "COFFEE COMPANY EST. 2007", APART FROM THE MARK AS SHOWN.

THE STIPPLING IS FOR SHADING PURPOSES ONLY.
THE MARK CONSISTS OF THE END OF A SHOTGUN SHELL WITH THE STYLIZED TEXT "HIGH BRASS COFFEE" ON THE TOP PART OF THE SHOTGUN SHELL AND THE STYLIZED TEXT "COMPANY EST. 2007" ON THE BOTTOM OF THE SHOTGUN SHELL.

FOR COFFEE (U.S. CL. 46).
ALEXANDER L. POWERS, EXAMINING ATTORNEY

CLASS 30—(Continued).

SN 77-432,608. BEST OF TROPICS, EDGEWATER, NJ. FILED 3-26-2008.

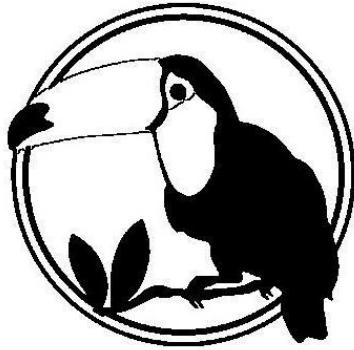

THE MARK CONSISTS OF A TROPICAL TUCAN BIRD SITTING ON THE TREE BRANCH.
FOR COCOA; COCOA-BASED BEVERAGES; COFFEE (U.S. CL. 46).
FIRST USE 12-31-2007; IN COMMERCE 12-31-2007.
SUZANNE BLANE, EXAMINING ATTORNEY

SN 77-432,689. ELINA NUBARYAN, ORLANDO, FL. FILED 3-26-2008.

GURTZBERRY

THE MARK CONSISTS OF STANDARD CHARACTERS WITHOUT CLAIM TO ANY PARTICULAR FONT, STYLE, SIZE, OR COLOR.

FOR FROZEN YOGHURT; FROZEN YOGURT; FROZEN YOGURT MIXES; FROZEN CONFECTIONERY; FROZEN CONFECTIONS; FROZEN CONFECTIONS, NAMELY, FREEZER POPS; FROZEN CUSTARDS; FROZEN DESSERT CONSISTING OF FRUIT AND CREAM OR CREAM SUBSTITUTES; FROZEN FLAVOURED WATERS; CONES FOR ICE CREAM; EDIBLE FRUIT ICES; EDIBLE ICES; FLAVORED ICES; FRUIT ICE; FRUIT ICE BAR; FRUIT ICES; ICE; ICE BLOCKS; ICE CANDIES; ICE CREAM; ICE CREAM DRINKS; ICE CREAM MIXES; ICE CREAM POWDER; ICE CREAM SANDWICHES; ICE CREAM SUBSTITUTE; ICE CREAMS; ICE MILK; ICE MILK BARS; ICE-CREAM; ICE-CREAM CAKES; ICED CAKES; ICED COFFEE; ICED TEA; ICES AND ICE CREAMS; ITALIAN ICE; SHAVED ICE CONFECTIONS; SOY-BASED ICE CREAM SUBSTITUTE; FRUIT JELLIES; FRUIT PIES; FRUIT SAUCES EXCLUDING CRANBERRY SAUCE AND APLESAUCE; FRUIT TEAS; FRUIT TURNOVERS; TEA-BASED BEVERAGES WITH FRUIT FLAVORING; MILK SHAKES; SHAKES; CREAM BUNS; CREAM PUFFS; APPLE TURNOVERS; CANDY COATED APPLES (U.S. CL. 46).

Laurie Kaufman, Examining Attorney

CLASS 30—(Continued).

SN 77-433,182. NUBARYAN, ELINA, ORLANDO, FL. FILED 3-27-2008.

GURTZ

THE MARK CONSISTS OF STANDARD CHARACTERS WITHOUT CLAIM TO ANY PARTICULAR FONT, STYLE, SIZE, OR COLOR.

FOR FROZEN CONFECTIONERY; FROZEN CONFECTIONS; FROZEN CONFECTIONS, NAMELY, FREEZER POPS; FROZEN YOGHURT; FROZEN YOGURT; FROZEN YOGURT MIXES; EDIBLE FRUIT ICES; FLAVORED ICES; FROZEN DESSERT CONSISTING OF FRUIT AND CREAM OR CREAM SUBSTITUTES; FRUIT ICE; FRUIT ICES; ICE CREAM; ICE CREAM DRINKS; ICE CREAM MIXES; ICE CREAMS; ICE-CREAM; ICE-CREAM CAKES (U.S. CL. 46).

Laurie Kaufman, Examining Attorney

SN 77-433,594. VILLAGE TART LLC, NEW YORK, NY. FILED 3-27-2008.

The Village Tart

THE MARK CONSISTS OF STANDARD CHARACTERS WITHOUT CLAIM TO ANY PARTICULAR FONT, STYLE, SIZE, OR COLOR.

FOR FROZEN YOGURT (U.S. CL. 46).

Barbara Rutland, Examining Attorney

SN 77-433,871. FAIRYTALE BROWNIES, INC., PHOENIX, AZ. FILED 3-27-2008.

FAIRYTALE TRUFFLES

THE MARK CONSISTS OF STANDARD CHARACTERS WITHOUT CLAIM TO ANY PARTICULAR FONT, STYLE, SIZE, OR COLOR.

OWNER OF U.S. REG. NOS. 2,555,642, 3,212,350 AND OTHERS.

NO CLAIM IS MADE TO THE EXCLUSIVE RIGHT TO USE "TRUFFLES", APART FROM THE MARK AS SHOWN. FOR BAKERY DESSERTS, NAMELY, BROWNIES COATED IN CHOCOLATE (U.S. CL. 46).

Linda Lavache, Examining Attorney

CLASS 30—(Continued).

SN 77-434,431. NUTRITIONAL GENETICS & HEALTH, LLC,
COLUMBUS, OH. FILED 3-28-2008.

FOUNTAIN OF YOUTH PIE

THE MARK CONSISTS OF STANDARD CHARACTERS
WITHOUT CLAIM TO ANY PARTICULAR FONT, STYLE,
SIZE, OR COLOR.

NO CLAIM IS MADE TO THE EXCLUSIVE RIGHT TO
USE "PIE", APART FROM THE MARK AS SHOWN.
FOR PIES (U.S. CL. 46).

MARK PILARO, EXAMINING ATTORNEY

CLASS 30—(Continued).

SN 77-441,685. MORRIS NATIONAL, INC., AZUSA, CA.
FILED 4-7-2008.

Apropos

THE MARK CONSISTS OF STANDARD CHARACTERS
WITHOUT CLAIM TO ANY PARTICULAR FONT, STYLE,
SIZE, OR COLOR.

FOR TEA (U.S. CL. 46).

B. PARADEWELAI, EXAMINING ATTORNEY

SN 77-434,647. PETITT, ROBERT, COLUMBUS, GA. FILED 3-
28-2008.



THE COLOR(S) RED, BLACK AND WHITE IS/ARE
CLAIMED AS A FEATURE OF THE MARK.

THE WORD "SWINEHEARTS" IS RED AND FEATURES
A THICK WHITE OUTLINE AND THIN BLACK OUTLINE.
THE LETTER "A" APPEARS AS AN UPSIDE-DOWN RED
HEART, ALSO FEATURING A THICK WHITE OUTLINE
AND THIN BLACK OUTLINE. THE GRAY IN THE MARK
REPRESENTS SHADING AND IS NOT PART OF THE
MARK. THE MARK APPEARS ON A TRANSPARENT
BACKGROUND, AND NO OTHER COLOR IS CLAIMED
AS A FEATURE OF THE MARK.

FOR BARBEQUE SAUCE (U.S. CL. 46).

FIRST USE 12-1-2007; IN COMMERCE 12-1-2007.

DAVID MILLER, EXAMINING ATTORNEY

SN 77-445,477. WRIGHT, BRUCE D, SARASOTA, FL. FILED
4-10-2008.

BioCrunch

THE MARK CONSISTS OF STANDARD CHARACTERS
WITHOUT CLAIM TO ANY PARTICULAR FONT, STYLE,
SIZE, OR COLOR.

FOR BREAKFAST CEREALS; PROCESSED CEREAL-
BASED FOOD TO BE USED AS A BREAKFAST FOOD,
SNACK FOOD OR INGREDIENT FOR MAKING OTHER
FOODS (U.S. CL. 46).

JOHN WILKE, EXAMINING ATTORNEY

SN 77-437,799. LESAFFRE ET COMPAGNIE, PARIS,
FRANCE, FILED 4-2-2008.

VIVA

THE MARK CONSISTS OF STANDARD CHARACTERS
WITHOUT CLAIM TO ANY PARTICULAR FONT, STYLE,
SIZE, OR COLOR.

OWNER OF ERPN CMNTY TM OFC REG. NO. 3798485,
DATED 9-14-2005, EXPIRES 4-27-2014.

FOR YEAST (U.S. CL. 46).

PAM WILLIS, EXAMINING ATTORNEY

SN 77-448,931. MATE REVOLUTION INC., DBA ECOTEAS,
ASHLAND, OR. FILED 4-15-2008.



NO CLAIM IS MADE TO THE EXCLUSIVE RIGHT TO
USE "TEAS", APART FROM THE MARK AS SHOWN.

THE MARK CONSISTS OF THE WORD "ECOTEAS",
SPLIT BETWEEN "ECO" AND "TEAS" BY A STYLIZED
IMAGE OF A BUTTERFLY STANDING ON A BOMBILLA
(TEA FILTER STRAW) THAT IS INSERTED INTO A
SPIRAL-EMBELLISHED GOURD VESSEL FILLED WITH
THE HERB YERBA MATE.

FOR HERBAL TEA (U.S. CL. 46).

FIRST USE 1-1-2007; IN COMMERCE 6-1-2007.

ALICE SUE CARRUTHERS, EXAMINING ATTORNEY

CLASS 30—(Continued).

SN 77-454,332. UNILEVER SUPPLY CHAIN, INC., CLINTON, CT. FILED 4-22-2008.

1-2-TEA

THE MARK CONSISTS OF STANDARD CHARACTERS WITHOUT CLAIM TO ANY PARTICULAR FONT, STYLE, SIZE, OR COLOR.
FOR TEA AND TEA BASED BEVERAGES (U.S. CL. 46).
JASON ROTH, EXAMINING ATTORNEY

CLASS 30—(Continued).

SN 77-477,651. WELLS' DAIRY, INC., LE MARS, IA. FILED 5-19-2008.

SOUR WOWER

THE MARK CONSISTS OF STANDARD CHARACTERS WITHOUT CLAIM TO ANY PARTICULAR FONT, STYLE, SIZE, OR COLOR.
NO CLAIM IS MADE TO THE EXCLUSIVE RIGHT TO USE "SOUR", APART FROM THE MARK AS SHOWN.
FOR FROZEN CONFECTIONS (U.S. CL. 46).
FIRST USE 2-11-2008; IN COMMERCE 2-11-2008.
BRENDAN MCCAULEY, EXAMINING ATTORNEY

SN 77-462,659. OCEAN SPRAY CRANBERRIES, INC., LAKEVILLE-MIDDLEBORO, MA. FILED 5-1-2008.

OCEAN SPRAY

THE MARK CONSISTS OF STANDARD CHARACTERS WITHOUT CLAIM TO ANY PARTICULAR FONT, STYLE, SIZE, OR COLOR.
FOR OATMEAL (U.S. CL. 46).
JOHN DWYER, EXAMINING ATTORNEY

SN 77-479,828. REDBONE, INC., FLORENCE, SC. FILED 5-21-2008.

Bermuda Triangles

THE MARK CONSISTS OF STANDARD CHARACTERS WITHOUT CLAIM TO ANY PARTICULAR FONT, STYLE, SIZE, OR COLOR.
FOR APPETIZERS IN THE FORM OF FRESH OR FROZEN PASTRY PUFFS STUFFED WITH CHICKEN, CREAM CHEESE, AND BACON (U.S. CL. 46).
JAY FLOWERS, EXAMINING ATTORNEY

SN 77-468,236. MCDONALD'S CORPORATION, OAK BROOK, IL. FILED 5-7-2008.

BAKERY MELTS

THE MARK CONSISTS OF STANDARD CHARACTERS WITHOUT CLAIM TO ANY PARTICULAR FONT, STYLE, SIZE, OR COLOR.
NO CLAIM IS MADE TO THE EXCLUSIVE RIGHT TO USE "BAKERY", APART FROM THE MARK AS SHOWN.
FOR DESSERTS, NAMELY, PASTRIES, BISCUITS, BREAD, CAKES (U.S. CL. 46).
ANTHONY RINKER, EXAMINING ATTORNEY

SN 77-486,923. FRITO-LAY NORTH AMERICA, INC., PLANO, TX. FILED 5-30-2008.

SANTITAS

THE MARK CONSISTS OF STANDARD CHARACTERS WITHOUT CLAIM TO ANY PARTICULAR FONT, STYLE, SIZE, OR COLOR.
OWNER OF U.S. REG. NOS. 1,408,752 AND 3,077,510.
THE ENGLISH TRANSLATION OF THE WORD "SANTITAS" IN THE MARK IS "LITTLE FEMALE SAINTS".
FOR HOT SAUCE; SALSA (U.S. CL. 46).
FIRST USE 5-19-2007; IN COMMERCE 5-19-2007.
JILL PRATER, EXAMINING ATTORNEY

CLASS 30—(Continued).

SN 78-124,765. CANADA BREAD FROZEN BAKERY LTD., LAVAL, QUEBEC, CANADA, FILED 4-29-2002.

CLASS 30—(Continued).

SN 78-337,672. MCWHORTER, HOLLY SUZANNE, BROOKLYN, NY. FILED 12-8-2003.



Mobile Foodie Survival Kit

THE MARK CONSISTS OF STANDARD CHARACTERS WITHOUT CLAIM TO ANY PARTICULAR FONT, STYLE, SIZE, OR COLOR.

NO CLAIM IS MADE TO THE EXCLUSIVE RIGHT TO USE "MOBILE FOODIE" OR "KIT", APART FROM THE MARK AS SHOWN.

FOR MOBILE KIT CONSISTING PRIMARILY OF SPICES (U.S. CL. 46).

FIRST USE 10-23-2003; IN COMMERCE 10-23-2003.

JOHN KELLY, EXAMINING ATTORNEY

PRIORITY CLAIMED UNDER SEC. 44(D) ON CANADA APPLICATION NO. 1137039, FILED 4-16-2002.

OWNER OF U.S. REG. NO. 1,925,662.

NO CLAIM IS MADE TO THE EXCLUSIVE RIGHT TO USE "SINCE 1921", APART FROM THE MARK AS SHOWN. COLOR IS NOT CLAIMED AS A FEATURE OF THE MARK.

FOR BREADS AND UNCOOKED FROZEN BREAD; CAKES; VIENNESE PASTRIES; CROISSANTS; DRY PETIT FOURS; PIES; BRIOCHES; DANISH PASTRIES; BISCUITS AND COOKIES; ROUND FLAT BISCUITS; MUFFINS (U.S. CL. 46).

FIRST USE 6-30-2001; IN COMMERCE 6-30-2001.

MARCIE MILONE, EXAMINING ATTORNEY

SN 78-340,506. BARRY CALLEBAUT FRANCE, 78250 HARDICOURT, FRANCE, FILED 12-13-2003.

SN 78-237,965. UNGAR'S FOOD PRODUCTS, INC., ELMWOOD PARK, NJ. FILED 4-15-2003.

AMBRE JAVA

SOYBET

THE MARK CONSISTS OF STANDARD CHARACTERS WITHOUT CLAIM TO ANY PARTICULAR FONT, STYLE, SIZE, OR COLOR.

OWNER OF FRANCE REG. NO. 1638349, DATED 7-28-2000, EXPIRES 7-28-2010.

THE WORDS AMBRE JAVA MAY BE TRANSLATED AS "JAVA AMBER".

FOR CHOCOLATE COUVERTURES (U.S. CL. 46).

CAROLYN CATALDO, EXAMINING ATTORNEY

FOR NON-DAIRY FROZEN CONFECTIONS (U.S. CL. 46).

KARANENDRA S. CHHINA, EXAMINING ATTORNEY

CLASS 30—(Continued).

SN 78-660,619. CALIP HOLDINGS INC., BRONX, NY. FILED 6-29-2005.

SLENDER TREAT

THE MARK CONSISTS OF STANDARD CHARACTERS WITHOUT CLAIM TO ANY PARTICULAR FONT, STYLE, SIZE, OR COLOR.

NO CLAIM IS MADE TO THE EXCLUSIVE RIGHT TO USE "TREAT", APART FROM THE MARK AS SHOWN.

FOR FROZEN CONFECTIONS; ICE CREAM, FROZEN YOGURT, BAKERY GOODS (U.S. CL. 46).

LINDA ESTRADA, EXAMINING ATTORNEY

SN 78-688,495. BEN & JERRY'S HOMEMADE, INC., BURLINGTON, VT. FILED 8-9-2005.

LEGENDAIRY

THE MARK CONSISTS OF STANDARD CHARACTERS WITHOUT CLAIM TO ANY PARTICULAR FONT, STYLE, SIZE, OR COLOR.

FOR FROZEN YOGURT; ICE CREAM (U.S. CL. 46).

INGA ERVIN, EXAMINING ATTORNEY

SN 78-700,789. ATHENA PARTNERS, SEATTLE, WA. FILED 8-25-2005.

ATHENA

THE MARK CONSISTS OF STANDARD CHARACTERS WITHOUT CLAIM TO ANY PARTICULAR FONT, STYLE, SIZE, OR COLOR.

OWNER OF U.S. REG. NO. 2,903,885.

FOR FOOD FLAVORINGS BEING NON-ESSENTIAL OILS; NON COFFEE RELATED FLAVORING SYRUPS; CEREAL-BASED PRODUCTS, NAMELY, BREAKFAST CEREALS, CEREAL-BASED SNACK FOOD, CEREAL-BASED SNACK BARS; GRANOLA, GRANOLA-BASED SNACK BARS; CANDIES; CANDY BARS; CARAMELS; CHOCOLATE; MILK CHOCOLATE; CHOCOLATE-BASED PRODUCTS, NAMELY, CHOCOLATE BARS, CHOCOLATE CANDIES, CHOCOLATE TRUFFLES, CHOCOLATE CHIPS, CHOCOLATE-COVERED NUTS, CHOCOLATE SYRUP, CHOCOLATE TOPPING, CHOCOLATE FLAVORING; ROASTED, POWDERED, GRANULATED COCOA NOT FOR BEVERAGE USE; COCOA EXTRACTS FOR HUMAN CONSUMPTION NOT FOR BEVERAGE USE; COCOA MIXES NOT FOR BEVERAGE USE; PASTA; PROCESSED GRAINS, NAMELY, COUS-COUS, RICE, RISOTTO, TABOULI, AND TAHINI (U.S. CL. 46).

CURTIS FRENCH, EXAMINING ATTORNEY

CLASS 30—(Continued).

SN 78-745,234. SOUTHLINGTON RECORDS, INC., SOUTHLINGTON, OH. FILED 11-2-2005.

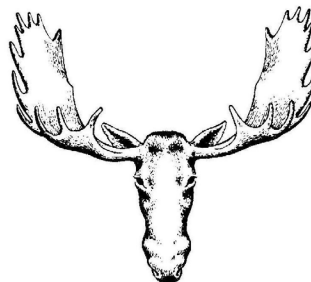
Moose Muffins

NO CLAIM IS MADE TO THE EXCLUSIVE RIGHT TO USE "MUFFINS", APART FROM THE MARK AS SHOWN.

THE STIPPLING IS FOR SHADING PURPOSES ONLY.

THE MARK CONSISTS OF A LINE DRAWING OF A MOOSE'S HEAD, AND THE STYLIZED WORDS "MOOSE MUFFINS".

FOR BAKERY DESSERTS; BAKERY GOODS; BAKERY PRODUCTS; BAKERY PRODUCTS, NAMELY, SWEET BAKERY GOODS; MIXES FOR BAKERY GOODS (U.S. CL. 46).

FIRST USE 10-1-2005; IN COMMERCE 10-1-2005.

STEPHEN AQUILA, EXAMINING ATTORNEY

SN 78-860,723. FABRICA DE ESPECIAS Y PRODUCTOS EL REY S.A., 7700500 BOGOTA, COLOMBIA, FILED 4-13-2006.

EL REY

THE MARK CONSISTS OF STANDARD CHARACTERS WITHOUT CLAIM TO ANY PARTICULAR FONT, STYLE, SIZE, OR COLOR.

OWNER OF COLOMBIA REG. NO. 94250, DATED 6-26-1978, EXPIRES 6-26-2013.

THE FOREIGN WORDING IN THE MARK TRANSLATES INTO ENGLISH AS THE KING.

FOR SPICES; PROCESSED HERBS; ROASTED AND GROUND SESAME SEEDS, MINCED, POWDERED AND PROCESSED SPICES; SEASONINGS AND SEASONING PASTES; CONDIMENTS, NAMELY, GARLIC SAUCE, HOT CHILI SAUCE, SOY SAUCE, WORCESTERSHIRE SAUCE, ONION SAUCE AND BASIL SAUCE (U.S. CL. 46).

FIRST USE 6-30-1940; IN COMMERCE 5-11-2000.

YONG KIM, EXAMINING ATTORNEY

CLASS 30—(Continued).

SN 78-925,986. SPECIALTY CONCEPTS PTY LIMITED, MT KURING-GAI, AUSTRALIA, FILED 7-10-2006.

CLUSTER CUPS

THE MARK CONSISTS OF STANDARD CHARACTERS WITHOUT CLAIM TO ANY PARTICULAR FONT, STYLE, SIZE, OR COLOR.

PRIORITY CLAIMED UNDER SEC. 44(D) ON AUSTRALIA APPLICATION NO. 1095266, FILED 1-19-2006, REG. NO. 1095266, DATED 3-31-2008, EXPIRES 1-19-2016.

FOR CEREAL-BASED BAKERY PRODUCTS; BREADS; CAKES; COOKIES; SWEET AND SAVORY CEREAL-BASED SNACK FOOD; READY-TO-EAT CEREAL DERIVED FOOD BARS AND BREAKFAST CEREALS (U.S. CL. 46).

JORDAN BAKER, EXAMINING ATTORNEY

CLASS 30—(Continued).

SN 79-041,285. RELANGHE S.R.L., ITALY, FILED 6-26-2007.

RECIT

THE MARK CONSISTS OF STANDARD CHARACTERS WITHOUT CLAIM TO ANY PARTICULAR FONT, STYLE, SIZE, OR COLOR.

OWNER OF INTERNATIONAL REGISTRATION 0931362 DATED 6-26-2007, EXPIRES 6-26-2017.

THE FOREIGN WORDING IN THE MARK TRANSLATES INTO ENGLISH AS "TALE", "STORY" OR "NARRATIVE".

FOR COFFEE, TEA, COCOA, SUGAR, RICE, TAPIOCA, SAGO, ARTIFICIAL COFFEE; FLOUR, BREAD, PASTRY, CONFECTIONERY, NAMELY, CHOCOLATES, CHOCOLATE COVERED NUTS, CHOCOLATE BARS, CHOCOLATE TRUFFLES, MILK CHOCOLATE, DARK CHOCOLATE, CANDY, PASTILLES, CRYSTAL SUGAR PIECES, FONDANTS, FROZEN CONFECTIONERY, FROZEN YOGURT, FRUIT JELLIES, PEPPERMINT FOR CONFECTIONERY, FLAVORED ICES; HONEY, TREACLE; YEAST, BAKING-POWDER; SALT, MUSTARD; VINEGAR, SAUCES, SPICES, ICE (U.S. CL. 46).

MELISSA VALLILLO, EXAMINING ATTORNEY

SN 79-047,375. LIDL STIFTUNG & CO. KG, FED REP GERMANY, FILED 11-6-2007.

Knights Bridge

THE MARK CONSISTS OF STANDARD CHARACTERS WITHOUT CLAIM TO ANY PARTICULAR FONT, STYLE, SIZE, OR COLOR.

OWNER OF INTERNATIONAL REGISTRATION 0710193 DATED 3-10-1999, EXPIRES 3-10-2009.

OWNER OF U.S. REG. NOS. 2,529,868 AND 2,850,968. FOR TEA IMPORTED FROM ENGLAND OR INTENDED FOR ENGLISH-SPEAKING REGIONS (U.S. CL. 46).

SHARON MEIER, EXAMINING ATTORNEY

SN 78-968,964. CARLOS SALVADOR REYNOSO GUTIERREZ, ZAPOPAN, MEXICO, FILED 9-7-2006.



NO CLAIM IS MADE TO THE EXCLUSIVE RIGHT TO USE "SABOR Y CALIDAD", APART FROM THE MARK AS SHOWN.

THE ENGLISH TRANSLATION FOR "SABOR Y CALIDAD" IS FLAVOR AND QUALITY.

FOR MEXICAN-STYLE SALSA (U.S. CL. 46). SARA THOMAS, EXAMINING ATTORNEY

CLASS 31—NATURAL AGRICULTURAL PRODUCTS

SN 76-684,094. HEB GROCERY COMPANY, LP, SAN ANTONIO, TX. FILED 11-16-2007.

JUST FOR YOU!

THE MARK CONSISTS OF STANDARD CHARACTERS WITHOUT CLAIM TO ANY PARTICULAR FONT, STYLE, SIZE, OR COLOR.

FOR LIVE FLOWERS; LIVE FLOWER ARRANGEMENTS (U.S. CLS. 1 AND 46).

FIRST USE 7-30-2004; IN COMMERCE 7-30-2007. G. MAYERSCHOFF, EXAMINING ATTORNEY

CLASS 31—(Continued).

SN 77-147,247. MAHAN, RICHARD E., CHANNELVIEW, TX. FILED 4-3-2007.

TERMISOIL

THE MARK CONSISTS OF STANDARD CHARACTERS WITHOUT CLAIM TO ANY PARTICULAR FONT, STYLE, SIZE, OR COLOR.

"TERMISOIL" APPEARING IN THE MARK HAS NO MEANING IN A FOREIGN LANGUAGE.

FOR TOPSOIL TREATED WITH TERMITE PREVENTING AND/OR ELIMINATING AGENTS (U.S. CLS. 1 AND 46).

MICHAEL GAAFAR, EXAMINING ATTORNEY

SN 77-261,415. DISCOV-TREE PARTNERS, LLC, CHAMPAIGN, IL. FILED 8-22-2007.



OWNER OF U.S. REG. NO. 3,161,537.
NO CLAIM IS MADE TO THE EXCLUSIVE RIGHT TO USE "AUTUMN BRILLIANCE", APART FROM THE MARK AS SHOWN.

THE MARK CONSISTS OF SILHOUETTE OF A TREE, SILHOUETTE OF A BRANCH WITH LEAVES, WORDS "DISCOVTREE" AND "AUTUMN BRILLIANCE" SURROUNDED BY A THIN BORDER.

FOR LIVE TREES (U.S. CLS. 1 AND 46).
ALLISON SCHRODY, EXAMINING ATTORNEY

SN 77-261,688. DISCOV-TREE PARTNERS, LLC, CHAMPAIGN, IL. FILED 8-22-2007.



OWNER OF U.S. REG. NO. 1,313,741.
NO CLAIM IS MADE TO THE EXCLUSIVE RIGHT TO USE "SHANGRI-LA", APART FROM THE MARK AS SHOWN.

THE MARK CONSISTS OF SILHOUETTE OF A TREE, SILHOUETTE OF A LEAF, WORDS "DISCOVTREE" AND "SHANGRI-LA" SURROUNDED BY A THIN BORDER.

FOR LIVE TREES (U.S. CLS. 1 AND 46).
ALLISON SCHRODY, EXAMINING ATTORNEY

CLASS 31—(Continued).

SN 77-261,694. DISCOV-TREE PARTNERS, LLC, CHAMPAIGN, IL. FILED 8-22-2007.



NO CLAIM IS MADE TO THE EXCLUSIVE RIGHT TO USE "STERLING", APART FROM THE MARK AS SHOWN.

THE MARK CONSISTS OF SILHOUETTE OF A TREE, SILHOUETTE OF A LEAF, WORDS "DISCOVTREE" AND "STERLING" SURROUNDED BY A THIN BORDER.

FOR LIVE TREES (U.S. CLS. 1 AND 46).
ALLISON SCHRODY, EXAMINING ATTORNEY

SN 77-261,707. DISCOV-TREE PARTNERS, LLC, CHAMPAIGN, IL. FILED 8-22-2007.



OWNER OF U.S. REG. NO. 1,313,742.
NO CLAIM IS MADE TO THE EXCLUSIVE RIGHT TO USE "URBANITE", APART FROM THE MARK AS SHOWN.

THE MARK CONSISTS OF SILHOUETTE OF A TREE, SILHOUETTE OF A LEAF, WORDS "DISCOVTREE" AND "URBANITE" SURROUNDED BY A THIN BORDER.

FOR LIVE TREES (U.S. CLS. 1 AND 46).
ALLISON SCHRODY, EXAMINING ATTORNEY

SN 77-261,720. DISCOV-TREE PARTNERS, LLC, CHAMPAIGN, IL. FILED 8-22-2007.



NO CLAIM IS MADE TO THE EXCLUSIVE RIGHT TO USE "ALL SEASONS", APART FROM THE MARK AS SHOWN.

THE MARK CONSISTS OF SILHOUETTE OF A TREE, SILHOUETTE OF A LEAF, WORDS "DISCOVTREE" AND "ALL SEASONS" SURROUNDED BY A THIN BORDER.

FOR LIVE TREES (U.S. CLS. 1 AND 46).
ANDREA K. NADELMAN, EXAMINING ATTORNEY

SN 77-309,576. MARS, INCORPORATED, MCLEAN, VA. FILED 10-22-2007.

WINERGY

THE MARK CONSISTS OF STANDARD CHARACTERS WITHOUT CLAIM TO ANY PARTICULAR FONT, STYLE, SIZE, OR COLOR.

FOR FEED FOR HORSES (U.S. CLS. 1 AND 46).
DOMINIC FATHY, EXAMINING ATTORNEY

CLASS 31—(Continued).

SN 77-323,047. OMS INVESTMENTS, INC., LOS ANGELES, CA. FILED 11-6-2007.

WATER SMART

THE MARK CONSISTS OF STANDARD CHARACTERS WITHOUT CLAIM TO ANY PARTICULAR FONT, STYLE, SIZE, OR COLOR.

FOR GRASS SEED; GRASS PRODUCTS, NAMELY, GRASS SOD AND GRASS PLUGS; TOP SOIL; MULCH; RAW BARK; PEAT MOSS; GRASS SEED COMBINED WITH FERTILIZER AND MULCH FOR THE PURPOSE OF LAWN REPAIR; TOP SOIL CONTAINING FERTILIZER (U.S. CLS. 1 AND 46).

THOMAS MANOR, EXAMINING ATTORNEY

SN 77-337,646. MARS, INCORPORATED, MCLEAN, VA. FILED 11-27-2007.

M.P.S.

THE MARK CONSISTS OF STANDARD CHARACTERS WITHOUT CLAIM TO ANY PARTICULAR FONT, STYLE, SIZE, OR COLOR.

FOR PET FOOD (U.S. CLS. 1 AND 46).
DOMINIC FATHY, EXAMINING ATTORNEY

SN 77-358,784. HAMPTON ISLAND, LLC, ATLANTA, GA. FILED 12-22-2007.

HAMPTON ISLAND PRESERVE

THE MARK CONSISTS OF STANDARD CHARACTERS WITHOUT CLAIM TO ANY PARTICULAR FONT, STYLE, SIZE, OR COLOR.

FOR FRESH FRUIT AND VEGETABLES (U.S. CLS. 1 AND 46).
GEORGIA CARTY, EXAMINING ATTORNEY

CLASS 31—(Continued).

SN 77-358,787. HAMPTON ISLAND, LLC, ATLANTA, GA. FILED 12-22-2007.



NO CLAIM IS MADE TO THE EXCLUSIVE RIGHT TO USE "EST. 1769", APART FROM THE MARK AS SHOWN.

THE MARK CONSISTS OF THE WORDS "HAMPTON ISLAND PRESERVE" ON THE PERIMETER CREATING A CIRCULAR SHAPE. WITHIN THE CIRCULAR SHAPE CREATED BY THE WORDING ARE THE SHAPES OF A RADIATING SUN RISING OVER A PYRAMID, REPRESENTING A PALM FRAWN, WITH THE WORD "EST." AND THE NUMBERS "1769" AT THE BASE OF THE PYRAMID AND CENTERED OVER THE WORD "PRESERVE" AT THE BOTTOM OF THE PERIMETER OF THE CIRCULAR SHAPE.

FOR FRESH FRUIT AND VEGETABLES (U.S. CLS. 1 AND 46).

GEORGIA CARTY, EXAMINING ATTORNEY

SN 77-395,424. COLOUR REPUBLIC HOLDINGS, LLC, MIAMI, FL. FILED 2-12-2008.



THE COLOR(S) ORANGE, GREEN, BLACK AND WHITE IS/ARE CLAIMED AS A FEATURE OF THE MARK.

THE MARK CONSISTS OF THE LITERAL ELEMENT "COLOUREPUBLIC" APPEARING AT THE TOP OF THE DESIGN WITH THE FIRST LETTER CAPITALIZED AND THE REST OF THE TEXT IN LOWER CASE LETTERS. THE TEXT "REPUBLIC" IS ORANGE AND THE TEXT "COLOU" IS BLACK. BELOW THIS HEADING, ALIGNED TO THE RIGHT, IS THE FACE OF A DAISY-LIKE FLOWER. THE FLOWER IS SPLIT IN HALF BY A RING THAT PROTRUDES ON BOTH SIDES. THE RING AND THE LOWER HALF OF THE FLOWER ARE GREEN. THE UPPER HALF OF THE FLOWER IS OUTLINED BY AN ORANGE HALF CIRCLE, AND THE CENTER OF THE UPPER HALF OF THE FLOWER IS ORANGE.

FOR CUT FLOWERS (U.S. CLS. 1 AND 46).
SANJEEV VOHRA, EXAMINING ATTORNEY

CLASS 31—(Continued).

SN 77-401,153. THE DEER CANDY COMPANY, LLC, WINFIELD, MO. FILED 2-20-2008.

Buck Brittle

THE MARK CONSISTS OF STANDARD CHARACTERS WITHOUT CLAIM TO ANY PARTICULAR FONT, STYLE, SIZE, OR COLOR.

NO CLAIM IS MADE TO THE EXCLUSIVE RIGHT TO USE "BUCK", APART FROM THE MARK AS SHOWN.
FOR ANIMAL FEED (U.S. CLS. 1 AND 46).
THOMAS MANOR, EXAMINING ATTORNEY

SN 77-406,353. THE BIG BAD WOOF, INC., WASHINGTON, DC. FILED 2-26-2008.

CALL OF THE RAW

THE MARK CONSISTS OF STANDARD CHARACTERS WITHOUT CLAIM TO ANY PARTICULAR FONT, STYLE, SIZE, OR COLOR.

FOR PET FOOD AND EDIBLE PET TREATS (U.S. CLS. 1 AND 46).
KATHERINE CHANG, EXAMINING ATTORNEY

SN 77-419,136. NUTRO PRODUCTS, INC., CITY OF INDUSTRY, CA. FILED 3-11-2008.

NATURAL NUTRITION MAXIMUM HEALTH

THE MARK CONSISTS OF STANDARD CHARACTERS WITHOUT CLAIM TO ANY PARTICULAR FONT, STYLE, SIZE, OR COLOR.

NO CLAIM IS MADE TO THE EXCLUSIVE RIGHT TO USE "NATURAL NUTRITION", APART FROM THE MARK AS SHOWN.
FOR PET FOOD (U.S. CLS. 1 AND 46).
KRISTIN CARLSON, EXAMINING ATTORNEY

CLASS 31—(Continued).

SN 77-419,748. BOYETT, GARY QUIN, KENTON, TN. FILED 3-12-2008.



NO CLAIM IS MADE TO THE EXCLUSIVE RIGHT TO USE "NUTRITION", APART FROM THE MARK AS SHOWN.

THE STIPPLING IS FOR SHADING PURPOSES ONLY.
THE MARK CONSISTS OF A TORCH WITH A FLAME CENTERED IN FRONT OF A CIRCLE WITH THE NAME "PRIME LINE NUTRITION" CENTERED BELOW AND IN FRONT OF THE FLAME.

FOR ANIMAL FEED (U.S. CLS. 1 AND 46).
FIRST USE 1-0-2007; IN COMMERCE 2-1-2007.
BARBARA BROWN, EXAMINING ATTORNEY

SN 77-424,616. CJ CHEILJEDANG CORPORATION, SEOUL, REPUBLIC OF KOREA, FILED 3-18-2008.

FRESHIAN

THE MARK CONSISTS OF STANDARD CHARACTERS WITHOUT CLAIM TO ANY PARTICULAR FONT, STYLE, SIZE, OR COLOR.

FOR SUGAR CANE; FOOD FOR ANIMALS; NON-MEDICATED ADDITIVES FOR ANIMAL FEED; NUTRITIONAL ADDITIVES FOR ANIMAL FOODSTUFFS, NOT FOR MEDICAL PURPOSES; ALGAE FOR HUMAN CONSUMPTION (U.S. CLS. 1 AND 46).
PAULA MAHONEY, EXAMINING ATTORNEY

SN 77-424,656. MILK PRODUCTS, LLC, CHILTON, WI. FILED 3-18-2008.

THERACAF

THE MARK CONSISTS OF STANDARD CHARACTERS WITHOUT CLAIM TO ANY PARTICULAR FONT, STYLE, SIZE, OR COLOR.

FOR ANIMAL FEED (U.S. CLS. 1 AND 46).
STEVEN R. FOSTER, EXAMINING ATTORNEY

CLASS 31—(Continued).

SN 77-425,196. INTERTRADE SALES OF STRATAM, LLC, STRATHAM, NH. FILED 3-18-2008.

FUN TO EAT FRUIT

THE MARK CONSISTS OF STANDARD CHARACTERS WITHOUT CLAIM TO ANY PARTICULAR FONT, STYLE, SIZE, OR COLOR.

NO CLAIM IS MADE TO THE EXCLUSIVE RIGHT TO USE "FRUIT", APART FROM THE MARK AS SHOWN, FOR FRESH FRUITS, NAMELY, APPLES, PEARS, TOMATOES, CITRUS FRUITS, BANANAS, OLIVES, GRAPES AND PLUMS, ALL MARKED WITH TEXT AND/OR GRAPHICS IN EDIBLE INK (U.S. CLS. 1 AND 46).

KATHERINE CONNOLLY, EXAMINING ATTORNEY

SN 77-428,156. VISION IMPORT GROUP LLC, RIVER EDGE, NJ. FILED 3-21-2008.



NO CLAIM IS MADE TO THE EXCLUSIVE RIGHT TO USE "MANGO", APART FROM THE MARK AS SHOWN.

THE STIPPLING IS FOR SHADING PURPOSES ONLY.

THE MARK CONSISTS OF A CARICATURE OF A MANGO WITH A SMILING SINISTER FACE ON THE MANGO AND A SILHOUETTE OF THE SUN AROUND THE MANGO. TO THE RIGHT OF THE DESIGN IS THE STYLIZED TEXT "MANGO MANIAC".

FOR FRESH MANGOS (U.S. CLS. 1 AND 46).

KHANH LE, EXAMINING ATTORNEY

SN 77-428,346. RBI PACKING LLC, MECCA, CA. FILED 3-21-2008.

BLUE MAX

THE MARK CONSISTS OF STANDARD CHARACTERS WITHOUT CLAIM TO ANY PARTICULAR FONT, STYLE, SIZE, OR COLOR.

NO CLAIM IS MADE TO THE EXCLUSIVE RIGHT TO USE "BLUE", APART FROM THE MARK AS SHOWN.

FOR FRESH FRUITS (U.S. CLS. 1 AND 46).

TEJBIR SINGH, EXAMINING ATTORNEY

CLASS 31—(Continued).

SN 77-428,518. BOW WOW GIFTS, LLC, MANTUA, OH. FILED 3-21-2008.

PAWSITIVELY GOURMET

THE MARK CONSISTS OF STANDARD CHARACTERS WITHOUT CLAIM TO ANY PARTICULAR FONT, STYLE, SIZE, OR COLOR.

NO CLAIM IS MADE TO THE EXCLUSIVE RIGHT TO USE "GOURMET", APART FROM THE MARK AS SHOWN, FOR PET TREATS (U.S. CLS. 1 AND 46).

RUDY R. SINGLETON, EXAMINING ATTORNEY

SN 77-429,457. JAMES, ELLEN, RONDA, NC. FILED 3-24-2008.



THE MARK CONSISTS OF A DOG WITH A BOWTIE ON HIS NECK AND A HEART SHAPE ON HIS CHEST, ALONG WITH THE STYLIZED WORDS "THE FINICKY HOUND", THIS IS ENCLOSED BY A WOODEN SIGN FRAME.

FOR GOURMET DOG TREATS (U.S. CLS. 1 AND 46).

FIRST USE 9-22-2007; IN COMMERCE 9-22-2007.

CAROL SPILS, EXAMINING ATTORNEY

SN 77-429,660. PEAK MINERALS-AZOMITE, INC., WARRENSBURG, MO. FILED 3-24-2008.

AZO-FEED

THE MARK CONSISTS OF STANDARD CHARACTERS WITHOUT CLAIM TO ANY PARTICULAR FONT, STYLE, SIZE, OR COLOR.

FOR ANIMAL FEED ADDITIVES FOR NONNUTRITIONAL PURPOSES FOR USE AS INGREDIENT OR FILLER (U.S. CLS. 1 AND 46).

NATALIE POLZER, EXAMINING ATTORNEY

CLASS 31—(Continued).

SN 77-429,674. LESAFFRE ET COMPAGNIE, PARIS, FRANCE, FILED 3-24-2008.

MAXI-PELL

THE MARK CONSISTS OF STANDARD CHARACTERS WITHOUT CLAIM TO ANY PARTICULAR FONT, STYLE, SIZE, OR COLOR.

OWNER OF U.S. REG. NO. 2,556,501.
 FOR ANIMAL FEED ADDITIVES FOR NONNUTRITIONAL PURPOSES FOR USE AS INGREDIENT OR FILLER; PELLET BINDER USED IN THE PRODUCTION OF AGRICULTURAL FEED (U.S. CLS. 1 AND 46).
 PAM WILLIS, EXAMINING ATTORNEY

SN 77-430,009. TRIPLE B CORPORATION, SEATTLE, WA. FILED 3-24-2008.

HUSKY

THE MARK CONSISTS OF STANDARD CHARACTERS WITHOUT CLAIM TO ANY PARTICULAR FONT, STYLE, SIZE, OR COLOR.

OWNER OF U.S. REG. NO. 2,098,580.
 FOR FRESH FRUITS AND VEGETABLES; UNPROCESSED NUTS, AND CUT FLOWERS (U.S. CLS. 1 AND 46).
 FIRST USE 12-31-1958; IN COMMERCE 12-31-1958.
 JASON ROTH, EXAMINING ATTORNEY

SN 77-430,045. TRIPLE B CORPORATION, SEATTLE, WA. FILED 3-24-2008.



OWNER OF U.S. REG. NO. 2,098,580.
 FOR FRESH FRUITS AND VEGETABLES; UNPROCESSED NUTS, AND CUT FLOWERS (U.S. CLS. 1 AND 46).
 FIRST USE 12-31-1958; IN COMMERCE 12-31-1958.
 JASON ROTH, EXAMINING ATTORNEY

CLASS 31—(Continued).

SN 77-430,774. MCRAE, JOANNE, WILMINGTON, NC. FILED 3-25-2008.



NO CLAIM IS MADE TO THE EXCLUSIVE RIGHT TO USE "PET BAKERY", APART FROM THE MARK AS SHOWN.

THE MARK CONSISTS OF A DOG WITH PAW PRINTS ON IT BODY WITH A BACKGROUND CONTAINING BONES.
 FOR PET FOODS (U.S. CLS. 1 AND 46).
 FIRST USE 7-1-2003; IN COMMERCE 7-1-2003.
 GINA FINK, EXAMINING ATTORNEY

SN 77-430,783. MCCORKLE NURSERIES, INC., DEARING, GA. FILED 3-25-2008.

BLUE SUEDE

THE MARK CONSISTS OF STANDARD CHARACTERS WITHOUT CLAIM TO ANY PARTICULAR FONT, STYLE, SIZE, OR COLOR.

NO CLAIM IS MADE TO THE EXCLUSIVE RIGHT TO USE "BLUE", APART FROM THE MARK AS SHOWN.
 FOR LIVE PLANTS (U.S. CLS. 1 AND 46).
 TAMARA FRAZIER, EXAMINING ATTORNEY

SN 77-431,749. IMS TRADING CORPORATION, WOODRIDGE, NJ. FILED 3-26-2008.

ABACUS

THE MARK CONSISTS OF STANDARD CHARACTERS WITHOUT CLAIM TO ANY PARTICULAR FONT, STYLE, SIZE, OR COLOR.

FOR PET TREATS (U.S. CLS. 1 AND 46).
 ATTIYA MALIK, EXAMINING ATTORNEY

CLASS 31—(Continued).

SN 77-431,881. SERGEANT'S PET CARE PRODUCTS, INC., OMAHA, NE. FILED 3-26-2008.

DENTA PLAY

THE MARK CONSISTS OF STANDARD CHARACTERS WITHOUT CLAIM TO ANY PARTICULAR FONT, STYLE, SIZE, OR COLOR.
FOR PET TREATS (U.S. CLS. 1 AND 46).
ARETHA SOMERVILLE, EXAMINING ATTORNEY

SN 77-432,876. OLD MOTHER HUBBARD, INC., TEWKSBURY, MA. FILED 3-27-2008.

PURE DELIGHTS

THE MARK CONSISTS OF STANDARD CHARACTERS WITHOUT CLAIM TO ANY PARTICULAR FONT, STYLE, SIZE, OR COLOR.
FOR PET FOOD AND PET TREATS (U.S. CLS. 1 AND 46).
JESSICA A. POWERS, EXAMINING ATTORNEY

SN 77-433,185. METROLINA GREENHOUSES, INC., HUNTERSVILLE, NC. FILED 3-27-2008.

Water Sense

THE MARK CONSISTS OF STANDARD CHARACTERS WITHOUT CLAIM TO ANY PARTICULAR FONT, STYLE, SIZE, OR COLOR.
FOR LIVE FLOWERING PLANTS; LIVE FLOWERS; LIVE PLANTS (U.S. CLS. 1 AND 46).
GINA FINK, EXAMINING ATTORNEY

CLASS 31—(Continued).

SN 77-433,324. NATURAL PACK, INC., SANTA BARBARA, CA. FILED 3-27-2008.

MOSSVINE

THE MARK CONSISTS OF STANDARD CHARACTERS WITHOUT CLAIM TO ANY PARTICULAR FONT, STYLE, SIZE, OR COLOR.
OWNER OF U.S. REG. NOS. 2,839,305 AND 3,036,981.
FOR NATURAL MOSS AND OTHER MOSSES SOLD DRIED, DYED AND PRESERVED FOR USE WITH FLORAL ARRANGEMENTS, ARTS, CRAFTS, HOBBIES, PETS, AND FOR USE IN THE GARDEN (U.S. CLS. 1 AND 46).
FIRST USE 10-26-2007; IN COMMERCE 10-26-2007.
GISELLE AGOSTO, EXAMINING ATTORNEY

SN 77-433,627. A-G SOD FARMS, INC., RIVERSIDE, CA. FILED 3-27-2008.

ECOLOTURF

THE MARK CONSISTS OF STANDARD CHARACTERS WITHOUT CLAIM TO ANY PARTICULAR FONT, STYLE, SIZE, OR COLOR.
FOR GRASS PRODUCTS, NAMELY, NON-ARTIFICIAL TURF AND GRASS SEEDS AND SOD (U.S. CLS. 1 AND 46).
FIRST USE 1-1-2005; IN COMMERCE 1-1-2005.
JOHN DWYER, EXAMINING ATTORNEY

SN 77-434,893. ADAPTIVE ACTIVITIES NONPROFIT CORPORATION, BOTHELL, WA. FILED 3-28-2008.

Better Bites

THE MARK CONSISTS OF STANDARD CHARACTERS WITHOUT CLAIM TO ANY PARTICULAR FONT, STYLE, SIZE, OR COLOR.
FOR PET TREATS (U.S. CLS. 1 AND 46).
FIRST USE 3-1-2008; IN COMMERCE 3-15-2008.
CORY BOONE, EXAMINING ATTORNEY

CLASS 31—(Continued).

SN 77-442,737. MONROVIA NURSERY COMPANY, AZUSA, CA. FILED 4-8-2008.

EMERALD WAVE

THE MARK CONSISTS OF STANDARD CHARACTERS WITHOUT CLAIM TO ANY PARTICULAR FONT, STYLE, SIZE, OR COLOR.

FOR LIVE PLANTS (U.S. CLS. 1 AND 46).
FIRST USE 10-21-1996; IN COMMERCE 10-21-1996.
RENEE SERVANCE, EXAMINING ATTORNEY

SN 77-442,794. PACER TECHNOLOGY, INC., TWIN FALLS, ID. FILED 4-8-2008.

CFP

THE MARK CONSISTS OF STANDARD CHARACTERS WITHOUT CLAIM TO ANY PARTICULAR FONT, STYLE, SIZE, OR COLOR.

FOR ANIMAL FEED (U.S. CLS. 1 AND 46).
FIRST USE 1-0-1996; IN COMMERCE 1-0-1996.
RONALD AIKENS, EXAMINING ATTORNEY

SN 77-445,421. WRIGHT, BRUCE D, SARASOTA, FL. FILED 4-10-2008.

BioDog

THE MARK CONSISTS OF STANDARD CHARACTERS WITHOUT CLAIM TO ANY PARTICULAR FONT, STYLE, SIZE, OR COLOR.

FOR DOG FOOD (U.S. CLS. 1 AND 46).
JOHN WILKE, EXAMINING ATTORNEY

SN 77-445,471. WRIGHT, BRUCE D, SARASOTA, FL. FILED 4-10-2008.

BioCat

THE MARK CONSISTS OF STANDARD CHARACTERS WITHOUT CLAIM TO ANY PARTICULAR FONT, STYLE, SIZE, OR COLOR.

FOR CAT FOOD; CAT TREATS (U.S. CLS. 1 AND 46).
JOHN WILKE, EXAMINING ATTORNEY

CLASS 31—(Continued).

SN 77-452,709. WRIGHT, BRUCE D, SARASOTA, FL. FILED 4-19-2008.

BioGrains

THE MARK CONSISTS OF STANDARD CHARACTERS WITHOUT CLAIM TO ANY PARTICULAR FONT, STYLE, SIZE, OR COLOR.

FOR UNPROCESSED GRAINS FOR EATING (U.S. CLS. 1 AND 46).
JOHN WILKE, EXAMINING ATTORNEY

SN 77-466,920. WEISENBACH SPECIALTY PRINTING, INC., COLUMBUS, OH. FILED 5-6-2008.

RESTORECO

THE MARK CONSISTS OF STANDARD CHARACTERS WITHOUT CLAIM TO ANY PARTICULAR FONT, STYLE, SIZE, OR COLOR.

FOR SEEDS FOR GROWING FLOWERS, FRUITS, VEGETABLES, TREES, AND PLANTS (U.S. CLS. 1 AND 46).

JAMES LOVELACE, EXAMINING ATTORNEY

SN 77-472,198. SERGEANT'S PET CARE PRODUCTS, INC., OMAHA, NE. FILED 5-12-2008.

SIRLOINS

THE MARK CONSISTS OF STANDARD CHARACTERS WITHOUT CLAIM TO ANY PARTICULAR FONT, STYLE, SIZE, OR COLOR.

OWNER OF U.S. REG. NO. 2,610,844.
SEC. 2(F).

FOR PET TREATS (U.S. CLS. 1 AND 46).
FIRST USE 6-1-2001; IN COMMERCE 6-1-2001.

ARETHA SOMERVILLE, EXAMINING ATTORNEY

CLASS 31—(Continued).

SN 78-288,228. POHLMANS NURSERY PTY LTD., GATTON, AUSTRALIA, FILED 8-15-2003.



OWNER OF AUSTRALIA REG. NO. 1160743, DATED 2-9-2007, EXPIRES 2-9-2017.

NO CLAIM IS MADE TO THE EXCLUSIVE RIGHT TO USE "10 POTS", APART FROM THE MARK AS SHOWN. FOR LIVE PLANTS, PLANT SEEDS, SEEDLINGS AND LIVE FLOWERS (U.S. CLS. 1 AND 46).
KATHERINE CHANG, EXAMINING ATTORNEY

SN 78-407,003. 804935 ONTARIO LTD., JORDAN STATION, ONTARIO, CANADA, FILED 4-23-2004.

CONNECT DESIGNS

THE MARK CONSISTS OF STANDARD CHARACTERS WITHOUT CLAIM TO ANY PARTICULAR FONT, STYLE, SIZE, OR COLOR.

PRIORITY CLAIMED UNDER SEC. 44(D) ON CANADA APPLICATION NO. 1213816, FILED 4-19-2004, REG. NO. TMA710,230, DATED 3-26-2008, EXPIRES 3-26-2023.

NO CLAIM IS MADE TO THE EXCLUSIVE RIGHT TO USE "DESIGNS", APART FROM THE MARK AS SHOWN. FOR LIVE FLORAL ARRANGEMENTS WITH LIVE OR CUT FLOWERS; CUT FLOWERS; LIVE POTTED BLOOMING PLANTS (U.S. CLS. 1 AND 46).
DANIEL BRODY, EXAMINING ATTORNEY

CLASS 31—(Continued).

SN 78-906,556. WAGGERS PET PRODUCTS INC., CALGARY, CANADA, FILED 6-13-2006.

BUG TUB

THE MARK CONSISTS OF STANDARD CHARACTERS WITHOUT CLAIM TO ANY PARTICULAR FONT, STYLE, SIZE, OR COLOR.

PRIORITY CLAIMED UNDER SEC. 44(D) ON CANADA APPLICATION NO. 1304305, FILED 6-6-2006, REG. NO. TMA710,504, DATED 3-31-2008, EXPIRES 3-31-2023.

NO CLAIM IS MADE TO THE EXCLUSIVE RIGHT TO USE "BUG", APART FROM THE MARK AS SHOWN. FOR LIVE INSECTS (U.S. CLS. 1 AND 46).
LINDA ORNDORFF, EXAMINING ATTORNEY

SN 79-053,904. JUNGPFANZEN GRÜNEWALD GMBH, FED REP GERMANY, FILED 3-17-2008.

Checkies

THE MARK CONSISTS OF STANDARD CHARACTERS WITHOUT CLAIM TO ANY PARTICULAR FONT, STYLE, SIZE, OR COLOR.

PRIORITY DATE OF 9-19-2007 IS CLAIMED.

OWNER OF INTERNATIONAL REGISTRATION 0964487 DATED 3-17-2008, EXPIRES 3-17-2018.

FOR AGRICULTURAL, HORTICULTURAL AND FORESTRY PRODUCTS, NAMELY, SEEDS AND BULBS FOR AGRICULTURAL PURPOSES, AGRICULTURAL SEEDS, SPORES AND SPAWN FOR AGRICULTURAL PURPOSES, AGRICULTURAL GRAINS FOR PLANTING, SEEDS AND BULBS FOR HORTICULTURAL PURPOSES, LIVING TREES, NON-DEBARKED TIMBER, UNSAWN TIMBER, RAW TIMBER, UNPROCESSED TIMBER; GRAINS, NAMELY, UNPROCESSED GRAINS, AGRICULTURAL AND HORTICULTURAL GRAINS FOR PLANTING; FRESH FRUITS AND VEGETABLES; AGRICULTURAL AND HORTICULTURAL SEEDS, NAMELY, CROP SEEDS, GRASS SEEDS, PLANT SEEDS; NATURAL PLANTS AND FLOWERS, NAMELY, LIVE ORNAMENTAL PLANTS, LIVE YOUNG ORNAMENTAL PLANTS, LIVE ROOTED AND UNROOTED CUTTINGS OF ORNAMENTAL PLANTS AND HERBS FOR PROPAGATION, FRESH HERBS, LIVE FLOWERING PLANTS, LIVING PLANTS, LIVING FRUIT PLANTS, LIVE FLOWERS; FOODSTUFFS FOR ANIMALS, MALT FOR BREWING AND DISTILLING, INCLUDED IN THIS CLASS (U.S. CLS. 1 AND 46).
SUE LAWRENCE, EXAMINING ATTORNEY

CLASS 31—(Continued).

SN 79-053,982. FINSIPO S.R.L., ITALY, FILED 2-13-2008.



PRIORITY DATE OF 1-22-2008 IS CLAIMED.
OWNER OF INTERNATIONAL REGISTRATION 0964646
DATED 2-13-2008, EXPIRES 2-13-2018.

THE COLOR(S) GREEN, RED, WHITE IS/ARE CLAIMED
AS A FEATURE OF THE MARK.

THE MARK CONSISTS OF THE FOLLOWING, THE MAN:
GREEN, APPLE: RED, LETTER "S": WHITE, WORD "SALVI":
WHITE ON A GREEN BACKGROUND.

THE MARK CONSISTS OF A STYLIZED SILHOUETTE
OF A MAN BRINGING BEFORE THE MOUTH AN APPLE;
ON THE CHEST OF THAT MAN IS PRINTED THE LETTER
"S"; ALL IS SIGNED BY THE WORD "SALVI".

FOR FRESH FRUIT AND VEGETABLES SEEDS, NATURAL
PLANTS (U.S. CLS. 1 AND 46).

HELENE LIWINSKI, EXAMINING ATTORNEY

CLASS 32—(Continued).SN 77-128,853. GOLDDILOCKS BAKE SHOP, INC., METRO,
MANILA, PHILIPPINES, FILED 3-12-2007.

goldilocks

THE MARK CONSISTS OF STANDARD CHARACTERS
WITHOUT CLAIM TO ANY PARTICULAR FONT, STYLE,
SIZE, OR COLOR.

OWNER OF U.S. REG. NOS. 1,358,272, 2,784,683 AND
OTHERS.

FOR FRUIT JUICES (U.S. CLS. 45, 46 AND 48).

FRANK LATTUCA, EXAMINING ATTORNEY

SN 77-268,989. RED TORPEDO LIMITED, GLASGOW, UNITED
KINGDOM, FILED 8-31-2007.

RED TORPEDO

THE MARK CONSISTS OF STANDARD CHARACTERS
WITHOUT CLAIM TO ANY PARTICULAR FONT, STYLE,
SIZE, OR COLOR.

OWNER OF U.S. REG. NO. 3,000,660.

FOR BEERS, LAGERS (U.S. CLS. 45, 46 AND 48).

TRACY CROSS, EXAMINING ATTORNEY

SN 77-269,028. RED TORPEDO LIMITED, GLASGOW, UNITED
KINGDOM, FILED 8-31-2007.**CLASS 32—LIGHT BEVERAGES**SN 76-687,920. SUCKERPUNCH SALLYS, LLC, SCOTTS-
DALE, AZ. FILED 3-20-2008.

SuckerPunch Sallys

THE MARK CONSISTS OF STANDARD CHARACTERS
WITHOUT CLAIM TO ANY PARTICULAR FONT, STYLE,
SIZE, OR COLOR.

OWNER OF U.S. REG. NO. 3,058,678.

FOR NON-ALCOHOLIC BEVERAGES, NAMELY, FLA-
VORED WATERS, FRUIT DRINKS, FRUIT JUICES,
LEMONADES, SPORTS DRINKS, SOFT DRINKS AND
ENERGY DRINKS (U.S. CLS. 45, 46 AND 48).

MARTHA FROMM, EXAMINING ATTORNEY



OWNER OF U.S. REG. NO. 3,000,660.

THE MARK CONSISTS OF A REPRESENTATION OF A
ROOSTER ON A TORPEDO BELOW THE WORDS "RED
TORPEDO" AND ABOVE THE WORDS "KING OF THE
UNDERWORLD".

FOR BEERS, LAGERS (U.S. CLS. 45, 46 AND 48).

TRACY CROSS, EXAMINING ATTORNEY

CLASS 32—(Continued).

SN 77-272,017. FOSSIL FUELS BREWING COMPANY, OAKLAND, CA. FILED 9-5-2007.

CLASS 32—(Continued).

SN 77-290,198. ACCESS BEVERAGE, INC., IRVINE, CA. FILED 9-27-2007.

FOSSIL FUELS

MARDI GRAS

THE MARK CONSISTS OF STANDARD CHARACTERS WITHOUT CLAIM TO ANY PARTICULAR FONT, STYLE, SIZE, OR COLOR.

FOR BEER (U.S. CLS. 45, 46 AND 48).
MATTHEW PAPPAS, EXAMINING ATTORNEY

THE MARK CONSISTS OF STANDARD CHARACTERS WITHOUT CLAIM TO ANY PARTICULAR FONT, STYLE, SIZE, OR COLOR.

FOR BEERS; MINERAL AND AERATED WATERS AND OTHER NON-ALCOHOLIC DRINKS; FRUIT DRINKS AND FRUIT JUICES (U.S. CLS. 45, 46 AND 48).
REGINA DRUMMOND, EXAMINING ATTORNEY

SN 77-275,307. ST. ANDREWS OF SCOTLAND INTERNATIONAL LTD, HOLLAND, MI. FILED 9-10-2007.

SN 77-335,893. GLOJI, INC., ALHAMBRA, CA. FILED 11-23-2007.

St.Andrews Golf

THE JUICE THAT MAKES YOU GLOW

THE MARK CONSISTS OF STANDARD CHARACTERS WITHOUT CLAIM TO ANY PARTICULAR FONT, STYLE, SIZE, OR COLOR.

FOR MINERAL WATERS; ISOTONIC AND FRUIT BEVERAGES, BEERS (U.S. CLS. 45, 46 AND 48).
TOBY BULLOFF, EXAMINING ATTORNEY

THE MARK CONSISTS OF STANDARD CHARACTERS WITHOUT CLAIM TO ANY PARTICULAR FONT, STYLE, SIZE, OR COLOR.

FOR FRUIT JUICES AND FRUIT DRINKS (U.S. CLS. 45, 46 AND 48).
FIRST USE 12-6-2006; IN COMMERCE 3-8-2007.
JAMES A. RAUEN, EXAMINING ATTORNEY

SN 77-276,615. ST. ANDREWS OF SCOTLAND INTERNATIONAL LTD, HOLLAND, MI. FILED 9-11-2007.

SN 77-338,892. NUTRI/SYSTEM IPHC, INC., WILMINGTON, DE. FILED 11-28-2007.

St.Andrews of Scotland

NUTRISYSTEM

THE MARK CONSISTS OF STANDARD CHARACTERS WITHOUT CLAIM TO ANY PARTICULAR FONT, STYLE, SIZE, OR COLOR.

FOR MINERAL WATERS; ISOTONIC AND FRUIT BEVERAGES, BEERS (U.S. CLS. 45, 46 AND 48).
TOBY BULLOFF, EXAMINING ATTORNEY

THE MARK CONSISTS OF STANDARD CHARACTERS WITHOUT CLAIM TO ANY PARTICULAR FONT, STYLE, SIZE, OR COLOR.

FOR FRUIT DRINKS, FRUIT JUICES, AND OTHER PREPARATIONS, NAMELY, POWDER MIXES FOR MAKING LEMONADE AND CITRUS FLAVORED DRINKS, AND ORANGEADE (U.S. CLS. 45, 46 AND 48).
FIRST USE 5-0-1986; IN COMMERCE 5-0-1986.
BRIAN NEVILLE, EXAMINING ATTORNEY

CLASS 32—(Continued).

SN 77-373,125. PATEL, ROBERT B., NEW BRUNSWICK, NJ. FILED 1-16-2008.

Sakthi

THE MARK CONSISTS OF STANDARD CHARACTERS WITHOUT CLAIM TO ANY PARTICULAR FONT, STYLE, SIZE, OR COLOR.

FOR ENERGY DRINK (U.S. CLS. 45, 46 AND 48).
GENE MACIOL, EXAMINING ATTORNEY

SN 77-387,350. ALL SURFACE ENTERTAINMENT, INC., NEW YORK, NY. FILED 2-3-2008.

ALA CRATE

THE MARK CONSISTS OF STANDARD CHARACTERS WITHOUT CLAIM TO ANY PARTICULAR FONT, STYLE, SIZE, OR COLOR.

OWNER OF U.S. REG. NO. 3,079,347.
FOR BREWED MALT-BASED ALCOHOLIC BEVERAGE IN THE NATURE OF A BEER (U.S. CLS. 45, 46 AND 48).
BRENDAN REGAN, EXAMINING ATTORNEY

SN 77-398,136. THE AGAVE MARKETING COMPANY, CHICAGO, IL. FILED 2-15-2008.

SUGAR LAND FARMS

THE MARK CONSISTS OF STANDARD CHARACTERS WITHOUT CLAIM TO ANY PARTICULAR FONT, STYLE, SIZE, OR COLOR.

NO CLAIM IS MADE TO THE EXCLUSIVE RIGHT TO USE "SUGAR" AND "FARMS", APART FROM THE MARK AS SHOWN.

FOR SYRUPS FOR MAKING BEVERAGES (U.S. CLS. 45, 46 AND 48).
ALEX KEAM, EXAMINING ATTORNEY

CLASS 32—(Continued).

SN 77-420,912. SPORT ENERGY, LAS VEGAS, NV. FILED 3-13-2008.

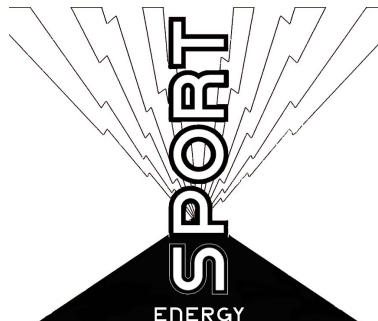

NO CLAIM IS MADE TO THE EXCLUSIVE RIGHT TO USE "SPORT" AND "ENERGY", APART FROM THE MARK AS SHOWN.

FOR ENERGY DRINKS (U.S. CLS. 45, 46 AND 48).
FIRST USE 8-15-2007; IN COMMERCE 8-15-2007.
TASHIA BUNCH, EXAMINING ATTORNEY

SN 77-421,319. MAR-KEY FOODS, INC., VIDALIA, GA. FILED 3-13-2008.

COOL TWISTED

THE MARK CONSISTS OF STANDARD CHARACTERS WITHOUT CLAIM TO ANY PARTICULAR FONT, STYLE, SIZE, OR COLOR.

FOR NON-CARBONATED, NON-ALCOHOLIC FLAVORED BEVERAGES (U.S. CLS. 45, 46 AND 48).
BENJAMIN ALLEN, EXAMINING ATTORNEY

SN 77-423,266. FUNCTIONAL BRANDS, DETROIT, MI. FILED 3-16-2008.

LIFE 2 GO

THE MARK CONSISTS OF STANDARD CHARACTERS WITHOUT CLAIM TO ANY PARTICULAR FONT, STYLE, SIZE, OR COLOR.

FOR ENERGY DRINKS; FRUIT BEVERAGES; FRUIT DRINKS; FRUIT FLAVORED DRINKS; FRUIT-FLAVORED BEVERAGES; NON-ALCOHOLIC BEVERAGES CONTAINING FRUIT JUICES; NON-ALCOHOLIC COCKTAIL MIXES; SPORTS DRINKS; WHEY BEVERAGES (U.S. CLS. 45, 46 AND 48).

FIRST USE 3-14-2008; IN COMMERCE 3-14-2008.
CHRISTINA SOBRAL, EXAMINING ATTORNEY

CLASS 32—(Continued).

SN 77-427,106. SANPELLEGRINO S.P.A., 20143 MILANO, ITALY, FILED 3-20-2008.



OWNER OF U.S. REG. NOS. 692,142, 2,232,355 AND OTHERS.

THE COLOR(S) BLUE, WHITE AND RED IS/ARE CLAIMED AS A FEATURE OF THE MARK.

THE MARK CONSISTS OF A ROUNDED SHAPE EDGED IN DARK BLUE AND WHITE WITH SAN PELLEGRINO IN DARK BLUE AND A RED STAR ABOVE THE WORDS ON A BLUE AND WHITE PATTERNED BACKGROUND.

FOR SPARKLING FRUIT BEVERAGES (U.S. CLS. 45, 46 AND 48).

FIRST USE 10-30-2007; IN COMMERCE 10-30-2007.

PATRICIA EVANKO, EXAMINING ATTORNEY

SN 77-427,650. PEPSICO, INC., PURCHASE, NY. FILED 3-20-2008.

H2OH!

THE MARK CONSISTS OF STANDARD CHARACTERS WITHOUT CLAIM TO ANY PARTICULAR FONT, STYLE, SIZE, OR COLOR.

OWNER OF U.S. REG. NOS. 1,560,082, 1,778,465 AND 2,924,369.

FOR CARBONATED WATER; SOFT DRINKS (U.S. CLS. 45, 46 AND 48).

TRACY CROSS, EXAMINING ATTORNEY

SN 77-427,874. ROCKS NO SALT, INC., SAN FRANCISCO, CA. FILED 3-20-2008.

TRES AGAVES

THE MARK CONSISTS OF STANDARD CHARACTERS WITHOUT CLAIM TO ANY PARTICULAR FONT, STYLE, SIZE, OR COLOR.

NO CLAIM IS MADE TO THE EXCLUSIVE RIGHT TO USE "AGAVES", APART FROM THE MARK AS SHOWN.

THE ENGLISH TRANSLATION OF THE WORD "TRES" IN THE MARK IS "THREE".

FOR NON-ALCOHOLIC BEVERAGES INTENDED TO BE MIXED WITH ALCOHOL, NAMELY, AGAVE NECTAR; SYRUP PREPARED FROM AGAVE NECTAR USED AS A BEVERAGE INGREDIENT (U.S. CLS. 45, 46 AND 48).

FIRST USE 1-28-2008; IN COMMERCE 1-28-2008.

JAMES MACFARLANE, EXAMINING ATTORNEY

CLASS 32—(Continued).

SN 77-428,609. BARD'S TALE BEER COMPANY, LLC, EDINA, MN. FILED 3-21-2008.



OWNER OF U.S. REG. NO. 3,211,334.
THE MARK CONSIST OF AN UPRAISED HUMAN HAND HOLDING A BOTTLE OF "BARD'S BEER".
FOR BEER (U.S. CLS. 45, 46 AND 48).
NICHOLAS ALTREE, EXAMINING ATTORNEY

SN 77-428,858. HOFFMAN HOSPITALITY LLC, RAINIER, WA. FILED 3-22-2008.

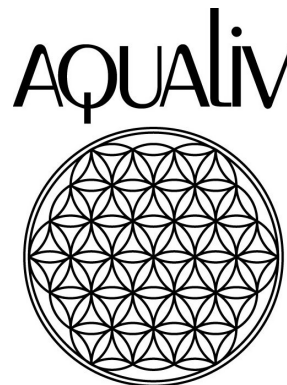

THE MARK CONSISTS OF THE WORD "AQUALIV" IN CONJUNCTION WITH 19 OVERLAPPING CIRCLES, ALL CONTAINED IN A 20TH CIRCLE, FURTHER CONTAINED IN A 21ST CIRCLE.

FOR BOTTLED WATER (U.S. CLS. 45, 46 AND 48).

FIRST USE 12-1-2006; IN COMMERCE 1-1-2007.

INGA ERVIN, EXAMINING ATTORNEY

CLASS 32—(Continued).

SN 77-429,305. LUBINGER BREWING COMPANY, INC., TRINITY, FL. FILED 3-24-2008.

LUBINGER

THE MARK CONSISTS OF STANDARD CHARACTERS WITHOUT CLAIM TO ANY PARTICULAR FONT, STYLE, SIZE, OR COLOR.

FOR BEER, ALE, LAGER, STOUT, PORTER, SHANDY; NON-ALCOHOLIC BEER; MINERAL AND CARBONATED WATERS; AND NON-ALCOHOLIC BEVERAGES, NAMELY, CARBONATED BEVERAGES (U.S. CLS. 45, 46 AND 48).

JILL PRATER, EXAMINING ATTORNEY

SN 77-429,812. KUNG KING, LLC, LYNDHURST, NJ. FILED 3-24-2008.

KUNG KING

THE MARK CONSISTS OF STANDARD CHARACTERS WITHOUT CLAIM TO ANY PARTICULAR FONT, STYLE, SIZE, OR COLOR.

FOR SOFT DRINKS; ENERGY DRINKS; DRINKING WATER; ISOTONIC DRINKS (U.S. CLS. 45, 46 AND 48).

RONALD MCMORROW, EXAMINING ATTORNEY

SN 77-430,408. AMERICAN INSTANTS, INC., FLANDERS, NJ. FILED 3-25-2008.

VAZOOM

THE MARK CONSISTS OF STANDARD CHARACTERS WITHOUT CLAIM TO ANY PARTICULAR FONT, STYLE, SIZE, OR COLOR.

FOR NON-ALCOHOLIC BEVERAGES, NAMELY, VITAMIN DRINKS AND SPORTS DRINKS (U.S. CLS. 45, 46 AND 48).

LEIGH CAROLINE CASE, EXAMINING ATTORNEY

CLASS 32—(Continued).

SN 77-431,325. WHITE, DANNY J, COUNTRY CLUB HILLS, IL. FILED 3-25-2008.



THE MARK CONSISTS OF A SEMI-TRUCK AND TRAILER WITH EYES AND A MOUTH, WEARING A HAT THAT READS "BIG OL' TRUCKER". THERE IS SMOKE COMING OUT OF THE EXHAUST STACKS AND THE WHEELS ARE SPINNING IN A CARTOON LIKE MANNER. THE TRUCK IS ENCLOSED WITHIN A CIRCULAR BORDER. THE INTERIOR OF THE CIRCLE HAS STRIPES RADIATING FROM THE CENTER. THERE IS A RING AROUND THE CIRCLE, CONTAINING THE WORDING "BIG OL' TRUCKER HEALTHY FUEL TO KEEP YOUR MOTOR RUNNIN'".

FOR BOTTLED DRINKING WATER; COFFEE-FLAVORED SOFT DRINK; ENERGY DRINKS; FRUIT DRINKS; FRUIT DRINKS AND JUICES; FRUIT FLAVORED DRINKS; FRUIT FLAVOURED DRINKS; FRUIT JUICES AND FRUIT DRINKS; FRUIT-BASED SOFT DRINKS FLAVORED WITH TEA; GUARANA DRINKS; ISOTONIC DRINKS; POP; POWDERS USED IN THE PREPARATION OF ISOTONIC SPORTS DRINKS AND SPORTS BEVERAGES; SPORTS DRINKS; SYRUPS FOR MAKING SOFT DRINKS; SOFT DRINKS; SOFT DRINKS FLAVORED WITH TEA (U.S. CLS. 45, 46 AND 48).

AMEETA JORDAN, EXAMINING ATTORNEY

SN 77-431,573. TAPPED, INC., SAN FRANCISCO, CA. FILED 3-26-2008.

tap'dla

THE MARK CONSISTS OF STANDARD CHARACTERS WITHOUT CLAIM TO ANY PARTICULAR FONT, STYLE, SIZE, OR COLOR.

FOR BOTTLED WATER; BOTTLED DRINKING WATER (U.S. CLS. 45, 46 AND 48).

SUNG IN, EXAMINING ATTORNEY

CLASS 32—(Continued).

SN 77-431,756. MOORE, KENT D., WELLINGTON, CO.
FILED 3-26-2008.

STARFIRE

THE MARK CONSISTS OF STANDARD CHARACTERS
WITHOUT CLAIM TO ANY PARTICULAR FONT, STYLE,
SIZE, OR COLOR.
FOR ENERGY DRINKS (U.S. CLS. 45, 46 AND 48).
ANTHONY RINKER, EXAMINING ATTORNEY

CLASS 32—(Continued).

SN 77-432,254. DEL BARRIO, JON, LOS ANGELES, CA.
FILED 3-26-2008.

TRANSPHUSION

THE MARK CONSISTS OF STANDARD CHARACTERS
WITHOUT CLAIM TO ANY PARTICULAR FONT, STYLE,
SIZE, OR COLOR.
FOR SOFT DRINKS (U.S. CLS. 45, 46 AND 48).
EMILY CARLSEN, EXAMINING ATTORNEY

SN 77-432,069. THIRSTY DOG BREWING COMPANY, AK-
RON, OH. FILED 3-26-2008.

THIRSTY DOG BREWING COMPANY

THE MARK CONSISTS OF STANDARD CHARACTERS
WITHOUT CLAIM TO ANY PARTICULAR FONT, STYLE,
SIZE, OR COLOR.
OWNER OF U.S. REG. NOS. 2,182,857 AND 2,186,602.
NO CLAIM IS MADE TO THE EXCLUSIVE RIGHT TO
USE "BREWING COMPANY", APART FROM THE MARK
AS SHOWN.
FOR MALT LIQUOR (U.S. CLS. 45, 46 AND 48).
FIRST USE 2-4-1997; IN COMMERCE 2-4-1997.
BARNEY CHARLON, EXAMINING ATTORNEY

SN 77-432,214. LOPERA, FRANK, BEVERLY HILLS, CA.
FILED 3-26-2008.

SPEEDY

THE MARK CONSISTS OF STANDARD CHARACTERS
WITHOUT CLAIM TO ANY PARTICULAR FONT, STYLE,
SIZE, OR COLOR.
FOR ENERGY DRINKS (U.S. CLS. 45, 46 AND 48).
BARBARA RUTLAND, EXAMINING ATTORNEY

SN 77-432,817. TAPPED, INC., SAN FRANCISCO, CA. FILED
3-27-2008.

tap'dchi

THE MARK CONSISTS OF STANDARD CHARACTERS
WITHOUT CLAIM TO ANY PARTICULAR FONT, STYLE,
SIZE, OR COLOR.
FOR BOTTLED WATER; BOTTLED DRINKING
WATER (U.S. CLS. 45, 46 AND 48).
SUNG IN, EXAMINING ATTORNEY

SN 77-433,298. KARMA 4 U, INC., ATLANTA, GA. FILED 3-
27-2008.

The Power of Good

THE MARK CONSISTS OF STANDARD CHARACTERS
WITHOUT CLAIM TO ANY PARTICULAR FONT, STYLE,
SIZE, OR COLOR.
FOR ENERGY DRINKS, DRINKING WATER, FLA-
VORED WATERS, SODA POPS, FRUIT JUICES (U.S.
CLS. 45, 46 AND 48).
REGINA DRUMMOND, EXAMINING ATTORNEY

CLASS 32—(Continued).

SN 77-433,314. HAN, MICHAEL, ARLINGTON, VA. FILED 3-27-2008.

EROS

THE MARK CONSISTS OF STANDARD CHARACTERS WITHOUT CLAIM TO ANY PARTICULAR FONT, STYLE, SIZE, OR COLOR.

FOR ENERGY DRINKS (U.S. CLS. 45, 46 AND 48).
GISELLE AGOSTO, EXAMINING ATTORNEY

SN 77-434,169. TAPPED, INC., SAN FRANCISCO, CA. FILED 3-28-2008.

tap'd

THE MARK CONSISTS OF STANDARD CHARACTERS WITHOUT CLAIM TO ANY PARTICULAR FONT, STYLE, SIZE, OR COLOR.

FOR BOTTLED WATER; BOTTLED DRINKING WATER (U.S. CLS. 45, 46 AND 48).
SUNG IN, EXAMINING ATTORNEY

SN 77-434,559. DONG-A PHARMACEUTICAL CO., LTD., SEOUL, REPUBLIC OF KOREA, FILED 3-28-2008.

Morning Care

THE MARK CONSISTS OF THE LITERAL WORD ELEMENTS "MORNING CARE", WITH THE "M" IN "MORNING" AND THE "C" IN "CARE" IN UPPERCASE, AND THE REMAINING LETTERS OF THE MARK IN LOWER CASE.

FOR NON-ALCOHOLIC BEVERAGES FOR HANG-OVER RECOVERY, NAMELY, SOFT DRINKS AND FRUIT JUICES WITH ANTI-HANGOVER HEALTH SUPPLEMENTS; FRUIT DRINKS AND FRUIT JUICES; SYRUPS AND OTHER PREPARATIONS FOR MAKING SOFT DRINKS, FRUIT JUICES AND ENERGY DRINKS; NON-ALCOHOLIC FLAVORED WATERS (U.S. CLS. 45, 46 AND 48).
REBECCA SMITH, EXAMINING ATTORNEY

CLASS 32—(Continued).

SN 77-441,419. CCM IP, S.A., LAUSANNE, SWITZERLAND, FILED 4-7-2008.



OWNER OF U.S. REG. NOS. 1,551,192 AND 1,702,032.
THE MARK CONSISTS OF STYLIZED LETTERS WITH SUN BURST IMAGE IN BACKGROUND.
THE ENGLISH TRANSLATION OF THE WORD "SOL" IN THE MARK IS "SUN".
FOR BEER (U.S. CLS. 45, 46 AND 48).
REGINA DRUMMOND, EXAMINING ATTORNEY

SN 77-441,643. NUTRILAB CORPORATION, ST. PETERSBURG, FL. FILED 4-7-2008.

THIRST MATRIX

THE MARK CONSISTS OF STANDARD CHARACTERS WITHOUT CLAIM TO ANY PARTICULAR FONT, STYLE, SIZE, OR COLOR.

FOR SPORTS DRINKS FOR ATHLETES, SPORTS-SPECIFIC DRINKS, LOW GLYCEMIC SPORTS DRINKS (U.S. CLS. 45, 46 AND 48).
TERESA M. RUPP, EXAMINING ATTORNEY

SN 77-449,253. PHOENIX INTANGIBLES HOLDING COMPANY, GREENVILLE, DE. FILED 4-16-2008.

CHESTNUT RIDGE

THE MARK CONSISTS OF STANDARD CHARACTERS WITHOUT CLAIM TO ANY PARTICULAR FONT, STYLE, SIZE, OR COLOR.

FOR PURIFIED BOTTLED WATER (U.S. CLS. 45, 46 AND 48).
KATHRYN COWARD, EXAMINING ATTORNEY

CLASS 32—(Continued).

SN 77-450,640. PACIFIC WATER COMPANY LIMITED, MATAFELE, APIA, SAMOA, FILED 4-17-2008.

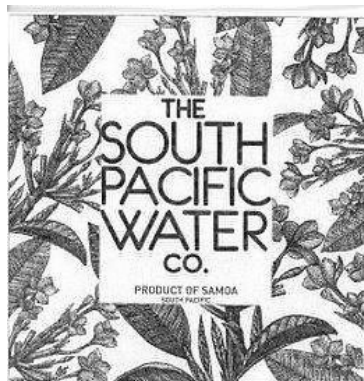

NO CLAIM IS MADE TO THE EXCLUSIVE RIGHT TO USE "WATER CO. PRODUCT OF SAMOA", APART FROM THE MARK AS SHOWN.

THE MARK CONSISTS OF THE WORDING "THE SOUTH PACIFIC WATER CO. PRODUCT OF SAMOA SOUTH PACIFIC" SURROUNDED BY STYLIZED FLOWERS AND PLANTS.

FOR BEVERAGES, NAMELY, DRINKING WATER, MINERAL AND AERATED WATER, SPRING WATER, FRUIT DRINKS AND FRUIT JUICES AND OTHER NON-ALCOHOLIC DRINKS, NAMELY, FLAVORED WATERS (U.S. CLS. 45, 46 AND 48).

KEVON CHISOLM, EXAMINING ATTORNEY

SN 77-457,424. TAPPED, INC., SAN FRANCISCO, CA. FILED 4-24-2008.

tap'dsf

THE MARK CONSISTS OF STANDARD CHARACTERS WITHOUT CLAIM TO ANY PARTICULAR FONT, STYLE, SIZE, OR COLOR.

FOR BOTTLED WATER; BOTTLED DRINKING WATER (U.S. CLS. 45, 46 AND 48).

SUNG IN, EXAMINING ATTORNEY

SN 77-469,186. WRIGHT, BRUCE D, SARASOTA, FL. FILED 5-8-2008.

BioJuice

THE MARK CONSISTS OF STANDARD CHARACTERS WITHOUT CLAIM TO ANY PARTICULAR FONT, STYLE, SIZE, OR COLOR.

FOR FRUIT JUICES; HERBAL JUICES; VEGETABLE JUICES (U.S. CLS. 45, 46 AND 48).

JOHN WILKE, EXAMINING ATTORNEY

CLASS 32—(Continued).

SN 77-470,137. MARRIOTT INTERNATIONAL, INC., BETHESDA, MD. FILED 5-9-2008.

VASA

THE MARK CONSISTS OF STANDARD CHARACTERS WITHOUT CLAIM TO ANY PARTICULAR FONT, STYLE, SIZE, OR COLOR.

OWNER OF U.S. REG. NO. 2,258,142.

FOR DRINKING WATER (U.S. CLS. 45, 46 AND 48).

FIRST USE 7-1-1998; IN COMMERCE 7-1-1998.

MARTHA SANTOMARTINO, EXAMINING ATTORNEY

SN 78-704,777. CHAMPION PERFORMANCE PRODUCTS, INC., DBA CHAMPION NUTRITION, CONCORD, CA. FILED 8-31-2005.

CHAMPION NUTRITION

THE MARK CONSISTS OF STANDARD CHARACTERS WITHOUT CLAIM TO ANY PARTICULAR FONT, STYLE, SIZE, OR COLOR.

OWNER OF U.S. REG. NOS. 1,963,221 AND 2,647,807.

NO CLAIM IS MADE TO THE EXCLUSIVE RIGHT TO USE "NUTRITION", APART FROM THE MARK AS SHOWN.

FOR POWDER DRINK MIXES FOR THE PREPARATION OF SPORTS DRINKS (U.S. CLS. 45, 46 AND 48).

FIRST USE 12-31-1992; IN COMMERCE 12-31-1992.

JOHN GARTNER, EXAMINING ATTORNEY

SN 79-051,760. ISKLAR AS, NORWAY, FILED 2-15-2008.

ISKLAR

OWNER OF INTERNATIONAL REGISTRATION 0958365 DATED 2-15-2008, EXPIRES 2-15-2018.

THE ENGLISH TRANSLATION OF THE WORD "ISKLAR" IN THE MARK IS ICE CLEAR.

FOR MINERAL AND AERATED WATERS AND OTHER NONALCOHOLIC BEVERAGES, NAMELY, SOFT DRINKS, FRUIT JUICES, AND FRUIT DRINKS, SYRUPS FOR MAKING BEVERAGES AND OTHER PREPARATIONS FOR MAKING BEVERAGES, NAMELY, FRUIT DRINKS (U.S. CLS. 45, 46 AND 48).

PATRICIA EVANKO, EXAMINING ATTORNEY

CLASS 32—(Continued).

SN 79-051,812. ISKLAR AS, NORWAY, FILED 2-15-2008.



PRIORITY DATE OF 10-25-2007 IS CLAIMED.
OWNER OF INTERNATIONAL REGISTRATION 0958490
DATED 2-15-2008, EXPIRES 2-15-2018.
"THE COLOR(S) BLUE IS/ARE CLAIMED AS A FEATURE
OF THE MARK."

"THE MARK CONSISTS OF TWO SHADES OF THE
COLOR BLUE, WITH THE LIGHT AND DARK SHADES
APPEARING IN AN ALTERNATING PATTERN COMPRIS-
ING DIAMONDS THAT FORM A SNOWFLAKE DESIGN."
FOR MINERAL AND AERATED WATERS AND
OTHER NONALCOHOLIC BEVERAGES, NAMELY,
SOFT DRINKS, FRUIT JUICES, AND FRUIT DRINKS,
SYRUPS FOR MAKING BEVERAGES AND OTHER
PREPARATIONS FOR MAKING BEVERAGES,
NAMELY, FRUIT DRINKS (U.S. CLS. 45, 46 AND 48).
PATRICIA EVANKO, EXAMINING ATTORNEY

CLASS 33—WINES AND SPIRITSSN 76-504,061. PIZZA WINE NOMINEES PTY LTD, MILA-
WA, VICTORIA, AUSTRALIA, FILED 4-3-2003.**PIZZA**

PRIORITY CLAIMED UNDER SEC. 44(D) ON AUSTRA-
LIA APPLICATION NO. 935567, FILED 11-26-2002.
FOR ALCOHOLIC BEVERAGES, NAMELY, WINE
AND WINE BASED BEVERAGES, DISTILLED SPIRIT
BASED PRE-MIXED ALCOHOLIC COCKTAILS (U.S.
CLS. 47 AND 49).
FIRST USE 8-0-2004; IN COMMERCE 8-0-2004.
MARY CRAWFORD, EXAMINING ATTORNEY

CLASS 33—(Continued).SN 76-679,831. CANTINA LA VIS E VALLE DI CEMBRA
SOCIETA COOPERATIVA, 7 LAVIS (TN), ITALY, FILED 7-
23-2007.**DIPINTI**

THE MARK CONSISTS OF STANDARD CHARACTERS
WITHOUT CLAIM TO ANY PARTICULAR FONT, STYLE,
SIZE, OR COLOR.

PRIORITY CLAIMED UNDER SEC. 44(D) ON ITALY
APPLICATION NO. RM2007C00041, FILED 1-23-2007, REG.
NO. 0001107308, DATED 4-17-2008, EXPIRES 1-21-2017.

THE FOREIGN WORDING IN THE MARK TRANSLATES
INTO ENGLISH AS PAINTINGS.

FOR WINES, SPARKLING WINES, DISTILLED SPIR-
ITS AND LIQUORS (U.S. CLS. 47 AND 49).
BERYL GARDNER, EXAMINING ATTORNEY

SN 76-687,869. MILLER, RICK, LOVELAND, CO. FILED 3-19-
2008.**RIZER**

THE MARK CONSISTS OF STANDARD CHARACTERS
WITHOUT CLAIM TO ANY PARTICULAR FONT, STYLE,
SIZE, OR COLOR.

FOR ALCOHOLIC BEVERAGES EXCEPT BEERS (U.S.
CLS. 47 AND 49).

BARBARA RUTLAND, EXAMINING ATTORNEY

SN 77-102,205. THE WINE ANGEL, INC., NEW YORK, NY.
FILED 2-8-2007.**Mirrabooka**

THE MARK CONSISTS OF STANDARD CHARACTERS
WITHOUT CLAIM TO ANY PARTICULAR FONT, STYLE,
SIZE, OR COLOR.

FOR WINE; WINES (U.S. CLS. 47 AND 49).

FIRST USE 12-28-2005; IN COMMERCE 5-1-2006.

TIMOTHY FINNEGAN, EXAMINING ATTORNEY

CLASS 33—(Continued).

SN 77-108,341. NORINA S.R.L., VICENZA (VI), ITALY,
FILED 2-15-2007.



THE MARK CONSISTS OF THE THREE DIMENSIONAL CONFIGURATION OF A BOTTLE AND THE CAP THERE-OF USED FOR WINES, DISTILLED SPIRITS AND LIQUEURS, BOTH HAVING A SQUARE SHAPE AS VIEWED FROM ABOVE AND BOTH HAVING A RECTANGULAR SHAPE WHEN VIEWED FROM THE SIDE.

FOR WINES, DISTILLED SPIRITS AND LIQUEURS (U.S. CLS. 47 AND 49).

MELVIN AXILBUND, EXAMINING ATTORNEY

CLASS 33—(Continued).

SN 77-206,646. NOVATNY, GLENN, WALNUT CREEK, CA.
FILED 6-14-2007.

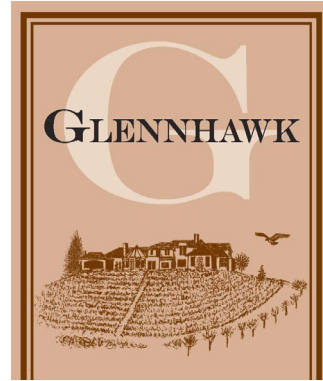

THE COLOR(S) BLACK, BEIGE AND BROWN IS/ARE CLAIMED AS A FEATURE OF THE MARK.

THE MARK CONSISTS OF THE WORD "GLENNHAWK" IN THE COLOR BLACK IN STYLIZED LETTERING AGAINST A LARGE STYLIZED LETTER "G" IN THE COLOR LIGHT BEIGE IN THE UPPER HALF, A DRAWING IN THE COLOR BROWN OF A LARGE HOME ON TOP OF A HILL COVERED WITH VINEYARDS WITH A HAWK FLYING TO THE RIGHT OF THE HOME IN THE BOTTOM HALF, TWO BORDERS IN THE COLOR BROWN, WITH THE REMAINDER BEING IN THE COLOR MEDIUM BEIGE.

FOR WINE (U.S. CLS. 47 AND 49).

ALEXANDER L. POWERS, EXAMINING ATTORNEY

SN 77-164,484. IN THE BLACK BEVERAGE CORPORATION,
NEW YORK, NY. FILED 4-24-2007.

INOCENTE

THE MARK CONSISTS OF STANDARD CHARACTERS WITHOUT CLAIM TO ANY PARTICULAR FONT, STYLE, SIZE, OR COLOR.

THE ENGLISH TRANSLATION OF "INOCENTE" IS INNOCENT.

FOR DISTILLED SPIRITS, NAMELY, TEQUILA (U.S. CLS. 47 AND 49).

ANTHONY RINKER, EXAMINING ATTORNEY

SN 77-209,958. VIETRI, ANTHONY, AVONDALE, PA. FILED
6-19-2007.

Mahogany Va La

THE MARK CONSISTS OF STANDARD CHARACTERS WITHOUT CLAIM TO ANY PARTICULAR FONT, STYLE, SIZE, OR COLOR.

NO CLAIM IS MADE TO THE EXCLUSIVE RIGHT TO USE "MAHOGANY", APART FROM THE MARK AS SHOWN.

THE ENGLISH TRANSLATION OF THE WORD "VA LA" IN THE MARK IS GO THERE.

FOR WINES (U.S. CLS. 47 AND 49).

FIRST USE 0-0-2005; IN COMMERCE 4-0-2007.

H. M. FISHER, EXAMINING ATTORNEY

CLASS 33—(Continued).

SN 77-211,984. JINRO BALLANTINES CO., INC., (ICHEON-SI)GYEONGGI-DO, REPUBLIC OF KOREA, FILED 6-21-2007.

IP CLASSIC

THE MARK CONSISTS OF STANDARD CHARACTERS WITHOUT CLAIM TO ANY PARTICULAR FONT, STYLE, SIZE, OR COLOR.

NO CLAIM IS MADE TO THE EXCLUSIVE RIGHT TO USE "CLASSIC", APART FROM THE MARK AS SHOWN. FOR SPIRITS, NAMELY, WHISKY (U.S. CLS. 47 AND 49).

CIMMERIAN COLEMAN, EXAMINING ATTORNEY

SN 77-257,709. BACALHÔA - VINHOS DE PORTUGAL, S.A., SAO LOURENÇO, PORTUGAL, FILED 8-17-2007.

CATHEDRAL OF NECTAR

THE MARK CONSISTS OF STANDARD CHARACTERS WITHOUT CLAIM TO ANY PARTICULAR FONT, STYLE, SIZE, OR COLOR.

FOR WINES (U.S. CLS. 47 AND 49).
HENRY S. ZAK, EXAMINING ATTORNEY

SN 77-266,705. POSTERNAK-SILOV, KARINA NATASHA, CALABASAS, CA. FILED 8-28-2007.

SOLE LUNA

THE MARK CONSISTS OF STANDARD CHARACTERS WITHOUT CLAIM TO ANY PARTICULAR FONT, STYLE, SIZE, OR COLOR.

THE FOREIGN WORDING IN THE MARK TRANSLATES INTO ENGLISH AS "SUN MOON".

FOR TEQUILA (U.S. CLS. 47 AND 49).
REGINA DRUMMOND, EXAMINING ATTORNEY

CLASS 33—(Continued).

SN 77-275,317. ST. ANDREWS OF SCOTLAND INTERNATIONAL LTD, HOLLAND, MI. FILED 9-10-2007.

St.Andrews Golf

THE MARK CONSISTS OF STANDARD CHARACTERS WITHOUT CLAIM TO ANY PARTICULAR FONT, STYLE, SIZE, OR COLOR.

FOR ALCOHOLIC BEVERAGES EXCEPT BEERS (U.S. CLS. 47 AND 49).

TOBY BULLOFF, EXAMINING ATTORNEY

SN 77-276,622. ST. ANDREWS OF SCOTLAND INTERNATIONAL LTD, HOLLAND, MI. FILED 9-11-2007.

St.Andrews of Scotland

THE MARK CONSISTS OF STANDARD CHARACTERS WITHOUT CLAIM TO ANY PARTICULAR FONT, STYLE, SIZE, OR COLOR.

FOR ALCOHOLIC BEVERAGES EXCEPT BEERS (U.S. CLS. 47 AND 49).

TOBY BULLOFF, EXAMINING ATTORNEY

SN 77-280,313. DELICATO VINEYARDS, MANTECA, CA. FILED 9-14-2007.

BOTA BOX

THE MARK CONSISTS OF STANDARD CHARACTERS WITHOUT CLAIM TO ANY PARTICULAR FONT, STYLE, SIZE, OR COLOR.

NO CLAIM IS MADE TO THE EXCLUSIVE RIGHT TO USE "BOX", APART FROM THE MARK AS SHOWN.

THE FOREIGN WORDING IN THE MARK TRANSLATES INTO ENGLISH AS "BOOT".

FOR COOKING WINE; FRUIT WINE; GRAPE WINE; KITS FOR MAKING WINE; NATURAL SPARKLING WINES; PORT WINES; RED WINE; SPARKLING FRUIT WINE; SPARKLING GRAPE WINE; SPARKLING WINES; STRAWBERRY WINE; SWEET WINES; TABLE WINES; WHITE WINE; WINE; WINE COOLERS; WINE PUNCH; WINE PUNCHES; WINES (U.S. CLS. 47 AND 49).

FIRST USE 7-18-2003; IN COMMERCE 9-15-2003.
MATTHEW MCDOWELL, EXAMINING ATTORNEY

CLASS 33—(Continued).

SN 77-292,436. STEINSSON, JON, ENCINO, CA. FILED 9-30-2007.

GREEN ICE

THE MARK CONSISTS OF STANDARD CHARACTERS WITHOUT CLAIM TO ANY PARTICULAR FONT, STYLE, SIZE, OR COLOR.

NO CLAIM IS MADE TO THE EXCLUSIVE RIGHT TO USE "GREEN", APART FROM THE MARK AS SHOWN. FOR DISTILLED SPIRITS (U.S. CLS. 47 AND 49).
MICHELE SWAIN, EXAMINING ATTORNEY

SN 77-296,002. DESTILERIA LIMTUACO & CO., INC., QUEZON CITY, PHILIPPINES, FILED 10-4-2007.

PARADISE MANGO RUM LIQUEUR

THE MARK CONSISTS OF STANDARD CHARACTERS WITHOUT CLAIM TO ANY PARTICULAR FONT, STYLE, SIZE, OR COLOR.

NO CLAIM IS MADE TO THE EXCLUSIVE RIGHT TO USE "MANGO RUM LIQUEUR", APART FROM THE MARK AS SHOWN. FOR DISTILLED SPIRITS; LIQUEURS; WINES (U.S. CLS. 47 AND 49).
FIRST USE 11-19-1998; IN COMMERCE 1-15-2000.
ANNE E. GUSTASON, EXAMINING ATTORNEY

SN 77-297,731. TSUJIMOTO, KENZO, OSAKA, JAPAN, FILED 10-5-2007.

KENZO

THE MARK CONSISTS OF STANDARD CHARACTERS WITHOUT CLAIM TO ANY PARTICULAR FONT, STYLE, SIZE, OR COLOR.

PRIORITY CLAIMED UNDER SEC. 44(D) ON JAPAN APPLICATION NO. 2007-034706, FILED 4-9-2007, REG. NO. 2098315, DATED 12-14-2007, EXPIRES 12-14-2017. FOR WINE; ALCOHOLIC BEVERAGES OF FRUIT; LIQUOR (U.S. CLS. 47 AND 49).
SAIMA MAKHDOOM, EXAMINING ATTORNEY

CLASS 33—(Continued).

SN 77-300,260. HESHE AND SHULEM MANAGEMENT, INC., BROOKLYN, NY. FILED 10-10-2007.

RUSSIA ON ICE

THE MARK CONSISTS OF STANDARD CHARACTERS WITHOUT CLAIM TO ANY PARTICULAR FONT, STYLE, SIZE, OR COLOR.

NO CLAIM IS MADE TO THE EXCLUSIVE RIGHT TO USE "RUSSIA", APART FROM THE MARK AS SHOWN. FOR ALCOHOLIC BEVERAGES, NAMELY, VODKA AND WHISKEY (U.S. CLS. 47 AND 49).
SANJEEV VOHRA, EXAMINING ATTORNEY

SN 77-305,868. TEQUILA CUERVO LA ROJENA, S.A. DE C.V., CODIGO, MEXICO, FILED 10-17-2007.

EVERY FAMILY HAS ITS SECRETS

THE MARK CONSISTS OF STANDARD CHARACTERS WITHOUT CLAIM TO ANY PARTICULAR FONT, STYLE, SIZE, OR COLOR.

FOR TEQUILA LIQUEUR (U.S. CLS. 47 AND 49).
PAUL CROWLEY, EXAMINING ATTORNEY

SN 77-319,364. BENSON FERRY LLC, LODI, CA. FILED 11-1-2007.

Around the Horn

THE MARK CONSISTS OF STANDARD CHARACTERS WITHOUT CLAIM TO ANY PARTICULAR FONT, STYLE, SIZE, OR COLOR.

FOR WINES (U.S. CLS. 47 AND 49).
BILL DAWE, EXAMINING ATTORNEY

CLASS 33—(Continued).

SN 77-341,683. TEQUILA CUERVO LA ROJENA, S.A. DE C.V., CODIGO, MEXICO, FILED 11-30-2007.

RAYA NEGRA

THE MARK CONSISTS OF STANDARD CHARACTERS WITHOUT CLAIM TO ANY PARTICULAR FONT, STYLE, SIZE, OR COLOR.

THE FOREIGN WORDING IN THE MARK TRANSLATES INTO ENGLISH AS "BLACK LINE".

FOR TEQUILA AND TEQUILA LIQUEUR (U.S. CLS. 47 AND 49).

JOHN GARTNER, EXAMINING ATTORNEY

SN 77-343,903. BARR ENTERPRISES, INC., PASO ROBLES, CA. FILED 12-4-2007.

Jubilado Cellars

THE MARK CONSISTS OF STANDARD CHARACTERS WITHOUT CLAIM TO ANY PARTICULAR FONT, STYLE, SIZE, OR COLOR.

NO CLAIM IS MADE TO THE EXCLUSIVE RIGHT TO USE "CELLARS", APART FROM THE MARK AS SHOWN.

THE FOREIGN WORDING IN THE MARK TRANSLATES INTO ENGLISH AS "RETIRED PERSON".

FOR WINE (U.S. CLS. 47 AND 49).

TINA KUAN, EXAMINING ATTORNEY

SN 77-350,362. DIAGEO NORTH AMERICA, INC., NORWALK, CT. FILED 12-12-2007.



NO CLAIM IS MADE TO THE EXCLUSIVE RIGHT TO USE "COCKTAILS OF THE WORLD", APART FROM THE MARK AS SHOWN.

THE MARK CONSISTS OF A DESIGN OF A GLOBE AND THE WORDS "COCKTAILS OF THE WORLD" IN STYLIZED LETTERS.

FOR ALCOHOLIC BEVERAGES, NAMELY, DISTILLED SPIRITS AND PREPARED COCKTAILS (U.S. CLS. 47 AND 49).

KATHERINE STOIDES, EXAMINING ATTORNEY

CLASS 33—(Continued).

SN 77-354,775. VERDUZCO ESPINOZA, RAQUEL, MONTEBELLO, CA. FILED 12-18-2007.

BUEN PAIS COFFEE LIQUEUR

THE MARK CONSISTS OF STANDARD CHARACTERS WITHOUT CLAIM TO ANY PARTICULAR FONT, STYLE, SIZE, OR COLOR.

NO CLAIM IS MADE TO THE EXCLUSIVE RIGHT TO USE "COFFEE LIQUEUR", APART FROM THE MARK AS SHOWN.

THE ENGLISH TRANSLATION OF "BUEN PAIS" IN THE MARK IS GOOD COUNTRY.

FOR COFFEE-BASED LIQUEURS (U.S. CLS. 47 AND 49).

STEVEN R. FOSTER, EXAMINING ATTORNEY

SN 77-354,839. CARIBBEAN CONNECTION, INC., TEMECULA, CA. FILED 12-18-2007.

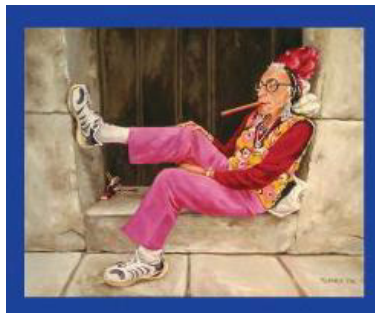

OWNER OF U.S. REG. NO. 3,396,284.

THE LIKENESS IN THE MARK IDENTIFIES A LIVING INDIVIDUAL WHOSE CONSENT IS OF RECORD.

THE COLOR(S) TAN, BROWN, WHITE, PINK, RED, ORANGE, YELLOW, BLACK AND BLUE IS/ARE CLAIMED AS A FEATURE OF THE MARK.

THE MARK CONSISTS OF THE COLORS TAN AND BROWN THAT APPEAR IN THE STEPS, GROUND, AND WOODEN DOOR IN THE BACKGROUND; THE COLOR BROWN APPEARS ON THE CIGAR AND THE RIM IN THE WOMAN'S EYEGLASSES; THE COLOR WHITE APPEARS IN THE WOMAN'S SNEAKERS, SOCKS AND HAIR; THE COLOR PINK APPEARS IN THE WOMAN'S PANTS; THE COLOR RED APPEARS IN THE WOMAN'S SHIRT AND HAT; THE COLORS ORANGE AND YELLOW APPEAR IN THE WOMAN'S VEST; THE COLOR BLACK APPEARS AS STRIPES AND LINES IN THE WOMAN'S SNEAKERS; THE COLOR BLUE APPEARS IN THE RECTANGULAR BORDER SURROUNDING THE DRAWING OF THE WOMAN.

FOR GRAPE WINE (U.S. CLS. 47 AND 49).

FIRST USE 8-1-2006; IN COMMERCE 8-1-2006.

JOHN GARTNER, EXAMINING ATTORNEY

CLASS 33—(Continued).

SN 77-357,280. O'SHAUGHNESSY DEL OSO, LLC, ANGWIN, CA. FILED 12-20-2007.

FOOTLOOSE VINEYARD

THE MARK CONSISTS OF STANDARD CHARACTERS WITHOUT CLAIM TO ANY PARTICULAR FONT, STYLE, SIZE, OR COLOR.

NO CLAIM IS MADE TO THE EXCLUSIVE RIGHT TO USE "VINEYARD", APART FROM THE MARK AS SHOWN. FOR WINE (U.S. CLS. 47 AND 49).

MARK RADEMACHER, EXAMINING ATTORNEY

SN 77-379,181. COGNAC ONE, LLC, NEW YORK, NY. FILED 1-24-2008.

LA PILAR

THE MARK CONSISTS OF STANDARD CHARACTERS WITHOUT CLAIM TO ANY PARTICULAR FONT, STYLE, SIZE, OR COLOR.

FOR WINE; APERITIF WINES; COOKING WINE; FRUIT WINE; GRAPE WINE; NATURAL SPARKLING WINES (U.S. CLS. 47 AND 49).

ZACHARY BELLO, EXAMINING ATTORNEY

SN 77-379,462. DIEGO ZAMORA S.A., CARTAGENA, SPAIN, FILED 1-24-2008.

THE HEART AND SOUL OF SPAIN

THE MARK CONSISTS OF STANDARD CHARACTERS WITHOUT CLAIM TO ANY PARTICULAR FONT, STYLE, SIZE, OR COLOR.

NO CLAIM IS MADE TO THE EXCLUSIVE RIGHT TO USE "SPAIN", APART FROM THE MARK AS SHOWN. FOR LIQUEURS (U.S. CLS. 47 AND 49).

DANIEL BRODY, EXAMINING ATTORNEY

CLASS 33—(Continued).

SN 77-381,670. HAKUNA MATATA WINES (PTY) LTD, DENNESIG, SOUTH AFRICA, FILED 1-28-2008.

BONNE NOUVELLE

THE MARK CONSISTS OF STANDARD CHARACTERS WITHOUT CLAIM TO ANY PARTICULAR FONT, STYLE, SIZE, OR COLOR.

THE FOREIGN WORDING IN THE MARK TRANSLATES INTO ENGLISH AS "GOOD NEWS".

FOR ALCOHOLIC BEVERAGES, NAMELY, WINES (U.S. CLS. 47 AND 49).

STEVEN R. FOSTER, EXAMINING ATTORNEY

SN 77-384,932. JORDAN, SCOTT, DBA SIPS OF SONOMA, SANTA ROSA, CA. FILED 1-31-2008.



NO CLAIM IS MADE TO THE EXCLUSIVE RIGHT TO USE "SONOMA", APART FROM THE MARK AS SHOWN.

THE MARK CONSISTS OF THE STYLIZED WORDING "SIPS OF SONOMA" AND A WINE GLASS WITH LIPSTICK MARK.

FOR NATURAL SPARKLING WINES; PORT WINES; PREPARED WINE COCKTAILS; RED WINE; SPARKLING FRUIT WINE; SPARKLING GRAPE WINE; SPARKLING WINES; SWEET WINES; TABLE WINES; WHITE WINE; WINE; WINES; WINES AND LIQUEURS; WINES AND SPARKLING WINES; APERITIF WINES; APERITIFS WITH A WINE BASE; COOKING WINE; GRAPE WINE (U.S. CLS. 47 AND 49).

PRISCILLA MILTON, EXAMINING ATTORNEY

SN 77-392,333. SCENIC ROOT WINEGROWERS, LLC, SAN ANSELMO, CA. FILED 2-8-2008.

PEY-LUCIA VINEYARDS

THE MARK CONSISTS OF STANDARD CHARACTERS WITHOUT CLAIM TO ANY PARTICULAR FONT, STYLE, SIZE, OR COLOR.

OWNER OF U.S. REG. NO. 2,896,981.

NO CLAIM IS MADE TO THE EXCLUSIVE RIGHT TO USE "VINEYARDS", APART FROM THE MARK AS SHOWN.

FOR GRAPE WINE (U.S. CLS. 47 AND 49).

FIRST USE 1-24-2008; IN COMMERCE 1-24-2008.

KATHLEEN LORENZO, EXAMINING ATTORNEY

CLASS 33—(Continued).

SN 77-398,323. COGNAC ONE, LLC, NEW YORK, NY. FILED 2-15-2008.

FLACA

THE MARK CONSISTS OF STANDARD CHARACTERS WITHOUT CLAIM TO ANY PARTICULAR FONT, STYLE, SIZE, OR COLOR.

THE FOREIGN WORDING IN THE MARK TRANSLATES INTO ENGLISH AS ELEGANT.

FOR WINE (U.S. CLS. 47 AND 49).

ZACHARY BELLO, EXAMINING ATTORNEY

SN 77-404,437. THE GRANDE DALLES LLC, PORTLAND, OR. FILED 2-22-2008.

INDIVIDUAL BY NATURE

THE MARK CONSISTS OF STANDARD CHARACTERS WITHOUT CLAIM TO ANY PARTICULAR FONT, STYLE, SIZE, OR COLOR.

FOR ALCOHOLIC BEVERAGES, NAMELY, WINES, SPIRITS, AND LIQUEURS (U.S. CLS. 47 AND 49).

RAMONA ORTIGA, EXAMINING ATTORNEY

SN 77-409,603. ROTHCHILD, ERIC, RUTHERFORD, CA. FILED 2-29-2008.

TAYSON PIERCE

THE MARK CONSISTS OF STANDARD CHARACTERS WITHOUT CLAIM TO ANY PARTICULAR FONT, STYLE, SIZE, OR COLOR.

THE NAME(S), PORTRAIT(S), AND/OR SIGNATURE(S) SHOWN IN THE MARK DOES NOT IDENTIFY A PARTICULAR LIVING INDIVIDUAL.

FOR WINES (U.S. CLS. 47 AND 49).

RONALD AIKENS, EXAMINING ATTORNEY

CLASS 33—(Continued).

SN 77-413,110. SUGARLOAF FARMING CORPORATION, CALISTOGA, CA. FILED 3-4-2008.



'MA DANSEUSE'

OWNER OF U.S. REG. NOS. 2,087,515 AND 2,087,516.
NO CLAIM IS MADE TO THE EXCLUSIVE RIGHT TO USE "WINERY", APART FROM THE MARK AS SHOWN.

THE NAME(S), PORTRAIT(S), AND/OR SIGNATURE(S) SHOWN IN THE MARK IDENTIFIES PETER MICHAEL, WHOSE CONSENT(S) TO REGISTER IS MADE OF RECORD.

"THE FOREIGN WORDING IN THE MARK TRANSLATES INTO ENGLISH AS MY DANCER (FEMALE)."

FOR WINE (U.S. CLS. 47 AND 49).

MARK SPARACINO, EXAMINING ATTORNEY

SN 77-413,116. SUGARLOAF FARMING CORPORATION, CALISTOGA, CA. FILED 3-4-2008.



'LA SOLUTION'

OWNER OF U.S. REG. NOS. 2,087,515 AND 2,087,516.
NO CLAIM IS MADE TO THE EXCLUSIVE RIGHT TO USE "WINERY", APART FROM THE MARK AS SHOWN.

THE NAME(S), PORTRAIT(S), AND/OR SIGNATURE(S) SHOWN IN THE MARK IDENTIFIES PETER MICHAEL, WHOSE CONSENT(S) TO REGISTER IS MADE OF RECORD.

FOR WINE (U.S. CLS. 47 AND 49).

MARK SPARACINO, EXAMINING ATTORNEY

CLASS 33—(Continued).

SN 77-414,602. MAGIC SPIRITS CORP., KIRKLAND, WA. FILED 3-6-2008.

MAGIC SPIRITS CELEBRATION

THE MARK CONSISTS OF STANDARD CHARACTERS WITHOUT CLAIM TO ANY PARTICULAR FONT, STYLE, SIZE, OR COLOR.

NO CLAIM IS MADE TO THE EXCLUSIVE RIGHT TO USE "SPIRITS", APART FROM THE MARK AS SHOWN.

FOR LIQUEURS, COGNAC, BRANDY, VODKA, WINE (U.S. CLS. 47 AND 49).

SHAUNIA CARLYLE, EXAMINING ATTORNEY

CLASS 33—(Continued).

SN 77-419,631. COLORADO PURE DISTILLING, LLC, DENVER, CO. FILED 3-12-2008.

NEVE

THE MARK CONSISTS OF STANDARD CHARACTERS WITHOUT CLAIM TO ANY PARTICULAR FONT, STYLE, SIZE, OR COLOR.

FOR DISTILLED SPIRITS, NAMELY, VODKA (U.S. CLS. 47 AND 49).

TINA KUAN, EXAMINING ATTORNEY

SN 77-420,188. DONNA DECUNZO TADDEO, LIGHTHOUSE POINT, FL. FILED 3-12-2008.

SN 77-417,934. DIAGEO BRANDS B.V., AMSTERDAM 1014 BG, NETHERLANDS, FILED 3-10-2008.

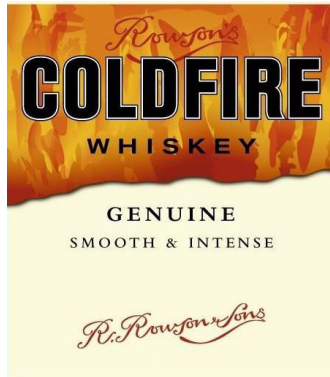

NO CLAIM IS MADE TO THE EXCLUSIVE RIGHT TO USE "WHISKEY GENUINE" AND "SMOOTH", APART FROM THE MARK AS SHOWN.

THE NAME(S), PORTRAIT(S), AND/OR SIGNATURE(S) SHOWN IN THE MARK DOES NOT IDENTIFY A PARTICULAR LIVING INDIVIDUAL.

THE COLOR(S) RED, ORANGE, WHITE, BLACK AND CREAM IS/ARE CLAIMED AS A FEATURE OF THE MARK.

THE MARK CONSISTS OF THE WORDS "ROWSON'S GOLDFIRE WHISKEY" ACROSS AN ORANGE AND RED BACKGROUND ABOVE THE WORDS "GENUINE SMOOTH & INTENSE R. ROWSON & SONS" WHICH APPEAR ACROSS A LIGHT BACKGROUND. THE COLOR RED APPEARS IN THE WORDS "ROWSON'S" AND "R. ROWSON & SONS" AND IN THE BACKGROUND OF THE UPPER PORTION OF THE MARK; THE COLOR ORANGE APPEARS IN THE BACKGROUND OF THE UPPER PORTION OF THE MARK; THE COLOR BLACK APPEARS IN THE WORDS "GOLDFIRE, WHISKEY, GENUINE, SMOOTH & INTENSE"; THE COLOR WHITE APPEARS IN THE OUTLINE OF THE WORD "GOLDFIRE"; AND THE COLOR CREAM APPEARS IN THE BACKGROUND OF THE LOWER PORTION OF THE MARK.

FOR ALCOHOLIC BEVERAGES, NAMELY, A WHISKEY-BASED ALCOHOLIC BEVERAGE (U.S. CLS. 47 AND 49).

JORDAN BAKER, EXAMINING ATTORNEY

MarTiki

THE MARK CONSISTS OF STANDARD CHARACTERS WITHOUT CLAIM TO ANY PARTICULAR FONT, STYLE, SIZE, OR COLOR.

FOR PREPARED ALCOHOLIC COCKTAIL (U.S. CLS. 47 AND 49).

FIRST USE 4-2-2002; IN COMMERCE 10-26-2002.

ANDREA SAUNDERS, EXAMINING ATTORNEY

SN 77-420,541. CRISTALL U.S.A., INC., BOCA RATON, FL. FILED 3-12-2008.



OWNER OF U.S. REG. NOS. 2,301,166, 2,770,506 AND OTHERS.

NO CLAIM IS MADE TO THE EXCLUSIVE RIGHT TO USE "ULTRA PREMIUM RUSSIAN VODKA" AND "SIGNATURE SERIES", APART FROM THE MARK AS SHOWN.

THE COLOR(S) BLACK, GOLD AND RED IS/ARE CLAIMED AS A FEATURE OF THE MARK.

THE MARK CONSISTS OF THE WORD "CRISTALL" IS GOLD IN COLOR AND VERTICALLY DISPLAYED WITH-

CLASS 33—(Continued).

IN A RECTANGULAR DOMED FRAME. THE OVERALL BACKGROUND COLOR OF THE WHOLE FRAME IS BLACK. THE LETTER "I" IN THE VERTICAL WORD "CRISTALL" IS DOTTED WITH A RED CROWN. THE RED CROWN IS OUTLINED IN THE COLOR GOLD. CENTERED INSIDE THE DOMED FRAME TOWARDS THE TOP OF THE FRAME IS A RED COLORED CROWN OUTLINED IN THE COLOR GOLD. THE COLORS BLACK, GOLD AND RED ARE AN INTEGRAL PART OF THE MARK.

FOR ALCOHOLIC BEVERAGE, NAMELY, VODKA (U.S. CLS. 47 AND 49).

FIRST USE 2-1-2007; IN COMMERCE 2-1-2007.
SANJEEV VOHRA, EXAMINING ATTORNEY

CLASS 33—(Continued).

SN 77-425,123. W.J. DEUTSCH & SONS, LTD., WHITE PLAINS, NY. FILED 3-18-2008.

ALWAYS SPARKLE

THE MARK CONSISTS OF STANDARD CHARACTERS WITHOUT CLAIM TO ANY PARTICULAR FONT, STYLE, SIZE, OR COLOR.

NO CLAIM IS MADE TO THE EXCLUSIVE RIGHT TO USE "SPARKLE", APART FROM THE MARK AS SHOWN.

FOR WINE (U.S. CLS. 47 AND 49).
CHARLES L. JENKINS, EXAMINING ATTORNEY

SN 77-423,892. RIVERAERIE CELLARS LLC, PROSSER, WA.
FILED 3-17-2008.

Bunnell Family Cellar

THE MARK CONSISTS OF STANDARD CHARACTERS WITHOUT CLAIM TO ANY PARTICULAR FONT, STYLE, SIZE, OR COLOR.

NO CLAIM IS MADE TO THE EXCLUSIVE RIGHT TO USE "FAMILY CELLAR", APART FROM THE MARK AS SHOWN.

FOR GRAPE WINE (U.S. CLS. 47 AND 49).
FIRST USE 3-1-2006; IN COMMERCE 5-1-2006.
LYDIA BELZER, EXAMINING ATTORNEY

SN 77-425,972. VAL D'OCA S.R.L., VALDOBBIADENE, TREVISO, ITALY, FILED 3-19-2008.

LA VELA

SN 77-424,147. CONWAY VINEYARDS, INC., ARROYO GRANDE, CA. FILED 3-17-2008.

RANCHO ARROYO GRANDE

THE MARK CONSISTS OF STANDARD CHARACTERS WITHOUT CLAIM TO ANY PARTICULAR FONT, STYLE, SIZE, OR COLOR.

OWNER OF U.S. REG. NO. 2,977,466.
THE ENGLISH TRANSLATION OF "RANCHO ARROYO GRANDE" IS "BIG RIVER RANCH".
FOR WINES (U.S. CLS. 47 AND 49).
KATHERINE CONNOLLY, EXAMINING ATTORNEY

THE MARK CONSISTS OF STANDARD CHARACTERS WITHOUT CLAIM TO ANY PARTICULAR FONT, STYLE, SIZE, OR COLOR.

THE FOREIGN WORDING IN THE MARK TRANSLATES INTO ENGLISH AS THE SAIL.

FOR WINES, STILL WINES, SEMI-SPARKLING WINES, SPARKLING WINES, FRUIT WINE, GRAPE WINES, SWEET WINES, STRAWBERRY WINES, TABLE WINES, COOKING WINES, PORT WINES, WINE PUNCHES, APERITIF WINES, APERITIF WITH A WINE BASE, WINE-BASED AROMATIC BEVERAGES, PREPARED WINE COCKTAILS, ALCOHOLIC APERITIF BITTERS, PREPARED ALCOHOLIC COCKTAILS, ALCOHOLIC APERITIFS, GRAPPA, VERMOUTH, ALCOHOLIC BITTERS, COGNAC, VODKA, BRANDIES, WHISKEYS, DISTILLED SPIRITS, LIQUEURS, DISTILLED LIQUORS (U.S. CLS. 47 AND 49).

G. MAYERSCHOFF, EXAMINING ATTORNEY

CLASS 33—(Continued).

SN 77-426,027. VAL D'OCA S.R.L., VALDOBBIADENE, TRE-
VISO, ITALY, FILED 3-19-2008.

BELLUVA

THE MARK CONSISTS OF STANDARD CHARACTERS WITHOUT CLAIM TO ANY PARTICULAR FONT, STYLE, SIZE, OR COLOR.

THE WORDING "BELLUVA" HAS NO MEANING IN A FOREIGN LANGUAGE.

FOR WINES, STILL WINES, SEMI-SPARKLING WINES, SPARKLING WINES, FRUIT WINE, GRAPE WINES, SWEET WINES, STRAWBERRY WINES, TABLE WINES, COOKING WINES, PORT WINES, WINE PUNCHES, APERITIF WINES, APERITIF WITH A WINE BASE, WINE-BASED AROMATIC BEVERAGES, PREPARED WINE COCKTAILS, ALCOHOLIC APERITIF BITTERS, PREPARED ALCOHOLIC COCKTAILS, ALCOHOLIC APERITIFS, GRAPPA, VERMOUTH, ALCOHOLIC BITTERS, COGNAC, VODKA, BRANDIES, WHISKEYS, DISTILLED SPIRITS, LIQUEURS, DISTILLED LIQUORS (U.S. CLS. 47 AND 49).

G. MAYERSCHOFF, EXAMINING ATTORNEY

CLASS 33—(Continued).

SN 77-427,356. J. WRAY & NEPHEW LIMITED, KINGSTON
11, JAMAICA, FILED 3-20-2008.



NO CLAIM IS MADE TO THE EXCLUSIVE RIGHT TO USE "PRODUCT OF JAMAICA," "WINE," AND "RED WINE", APART FROM THE MARK AS SHOWN.

THE STIPPLING IS FOR SHADING PURPOSES ONLY.

THE NAME "J. WRAY" DOES NOT IDENTIFY A LIVING INDIVIDUAL.

FOR ALCOHOLIC BEVERAGES EXCLUDING BEER (U.S. CLS. 47 AND 49).

FIRST USE 0-0-1967; IN COMMERCE 4-0-2007.

DANNEAN HETZEL, EXAMINING ATTORNEY

SN 77-427,285. BARTON & GUESTIER, BLANQUEFORT,
FRANCE, FILED 3-20-2008.

B&G

THE MARK CONSISTS OF STANDARD CHARACTERS WITHOUT CLAIM TO ANY PARTICULAR FONT, STYLE, SIZE, OR COLOR.

OWNER OF U.S. REG. NOS. 1,697,913, 1,977,965 AND OTHERS.

FOR ALCOHOLIC BEVERAGES, NAMELY, WINES (U.S. CLS. 47 AND 49).

FIRST USE 0-0-1932; IN COMMERCE 0-0-1932.

JAMES LOVELACE, EXAMINING ATTORNEY

SN 77-427,418. ATLAS DRINKS, LLC, REDMOND, WA,
FILED 3-20-2008.

ZERO ONE

THE MARK CONSISTS OF STANDARD CHARACTERS WITHOUT CLAIM TO ANY PARTICULAR FONT, STYLE, SIZE, OR COLOR.

FOR ALCOHOLIC BEVERAGES EXCEPT BEERS (U.S. CLS. 47 AND 49).

JAY BESCH, EXAMINING ATTORNEY

CLASS 33—(Continued).

SN 77-427,471. J. WRAY & NEPHEW LIMITED, KINGSTON 11, JAMAICA, FILED 3-20-2008.

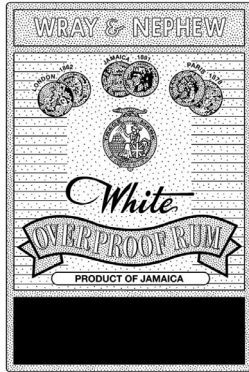

OWNER OF U.S. REG. NO. 771,648.
NO CLAIM IS MADE TO THE EXCLUSIVE RIGHT TO USE "WHITE OVERPROOF RUM", "PRODUCT OF JAMAICA", "LONDON, 1862", "JAMAICA, 1891", "PARIS, 1878", AND "TRADE MARK", APART FROM THE MARK AS SHOWN.

THE STIPPLING IS FOR SHADING PURPOSES ONLY.
FOR ALCOHOLIC BEVERAGES EXCLUDING BEER (U.S. CLS. 47 AND 49).

FIRST USE 9-7-1962; IN COMMERCE 10-10-1962.
DANNEAN HETZEL, EXAMINING ATTORNEY

SN 77-427,509. GOLDEN HILL DISTILLERY LLC, DARIEN, CT. FILED 3-20-2008.

GOLDEN HILL VODKA

THE MARK CONSISTS OF STANDARD CHARACTERS WITHOUT CLAIM TO ANY PARTICULAR FONT, STYLE, SIZE, OR COLOR.

NO CLAIM IS MADE TO THE EXCLUSIVE RIGHT TO USE "VODKA", APART FROM THE MARK AS SHOWN.

FOR VODKA (U.S. CLS. 47 AND 49).
MICHELE SWAIN, EXAMINING ATTORNEY

SN 77-427,515. IRISH THUNDER, LLC, PEARL RIVER, NY. FILED 3-20-2008.

F317

THE MARK CONSISTS OF STANDARD CHARACTERS WITHOUT CLAIM TO ANY PARTICULAR FONT, STYLE, SIZE, OR COLOR.

FOR ALCOHOLIC BEVERAGES, NAMELY, CORDIALS AND LIQUEURS (U.S. CLS. 47 AND 49).

JORDAN BAKER, EXAMINING ATTORNEY

CLASS 33—(Continued).

SN 77-427,527. IRISH THUNDER, LLC, PEARL RIVER, NY. FILED 3-20-2008.

f317

THE COLOR(S) GREEN AND BLACK IS/ARE CLAIMED AS A FEATURE OF THE MARK.

THE MARK CONSISTS OF "F317" IN GREEN WITH BLACK SHADOW.

FOR ALCOHOLIC BEVERAGES, NAMELY, CORDIALS AND LIQUEURS (U.S. CLS. 47 AND 49).

JORDAN BAKER, EXAMINING ATTORNEY

SN 77-427,876. PHUSION PROJECTS, CHICAGO, IL. FILED 3-20-2008.

four
Maxed

THE STIPPLING IS FOR SHADING PURPOSES ONLY.
THE MARK CONSISTS OF THE STYLIZED TEXT "FOUR MAXED".

FOR FLAVORED BREWED MALT BEVERAGE (U.S. CLS. 47 AND 49).

FIRST USE 10-1-2007; IN COMMERCE 11-1-2007.
TAMARA FRAZIER, EXAMINING ATTORNEY

SN 77-428,132. FIGLEAF CELLAR, LLC, ALPHARETTA, GA. FILED 3-21-2008.

FIGLEAF CELLAR

THE MARK CONSISTS OF STANDARD CHARACTERS WITHOUT CLAIM TO ANY PARTICULAR FONT, STYLE, SIZE, OR COLOR.

NO CLAIM IS MADE TO THE EXCLUSIVE RIGHT TO USE "CELLAR", APART FROM THE MARK AS SHOWN.

FOR WINE (U.S. CLS. 47 AND 49).
INGA ERVIN, EXAMINING ATTORNEY

CLASS 33—(Continued).

SN 77-428,274. L & L JORDAN, INC., HEALDSBURG, CA.
FILED 3-21-2008.

TYMPANY FIVE

THE MARK CONSISTS OF STANDARD CHARACTERS
WITHOUT CLAIM TO ANY PARTICULAR FONT, STYLE,
SIZE, OR COLOR.

FOR WINES (U.S. CLS. 47 AND 49).
HOWARD B. LEVINE, EXAMINING ATTORNEY

SN 77-428,390. LAWER FAMILY WINERY, INC., ANCHO-
RAGE, AK. FILED 3-21-2008.

THREE COINS

THE MARK CONSISTS OF STANDARD CHARACTERS
WITHOUT CLAIM TO ANY PARTICULAR FONT, STYLE,
SIZE, OR COLOR.

FOR WINES (U.S. CLS. 47 AND 49).
SANJEEV VOHRA, EXAMINING ATTORNEY

SN 77-428,446. SCHINDLER, STEPHAN, FAIRFAX, CA. AND
TSCHEPPE, STEFAN, FAIRFAX, CA. FILED 3-21-2008.

The Original Zin

THE MARK CONSISTS OF STANDARD CHARACTERS
WITHOUT CLAIM TO ANY PARTICULAR FONT, STYLE,
SIZE, OR COLOR.

FOR WINE (U.S. CLS. 47 AND 49).
FIRST USE 3-19-2008; IN COMMERCE 3-20-2008.
APRIL HESIK, EXAMINING ATTORNEY

SN 77-428,830. HIGH SPIRITS USA LLC, NAPA, CA. FILED 3-
21-2008.

CALL THE SHOTS

THE MARK CONSISTS OF STANDARD CHARACTERS
WITHOUT CLAIM TO ANY PARTICULAR FONT, STYLE,
SIZE, OR COLOR.

FOR DISTILLED SPIRITS (U.S. CLS. 47 AND 49).
ANNE FARRELL, EXAMINING ATTORNEY

CLASS 33—(Continued).

SN 77-428,882. IRB L.L.C., TROY, MI. FILED 3-22-2008.

**Tequila's Passion
The Heart of the Blue Agave**

THE MARK CONSISTS OF STANDARD CHARACTERS
WITHOUT CLAIM TO ANY PARTICULAR FONT, STYLE,
SIZE, OR COLOR.

NO CLAIM IS MADE TO THE EXCLUSIVE RIGHT TO
USE "TEQUILA'S" AND "BLUE AGAVE", APART FROM
THE MARK AS SHOWN.

FOR DISTILLED SPIRITS (U.S. CLS. 47 AND 49).
ALICE SUE CARRUTHERS, EXAMINING ATTORNEY

SN 77-429,407. CONRAD, THOMAS J., NORTHBROOK, IL.
FILED 3-24-2008.

PORTERHOUSE

THE MARK CONSISTS OF STANDARD CHARACTERS
WITHOUT CLAIM TO ANY PARTICULAR FONT, STYLE,
SIZE, OR COLOR.

FOR WINE (U.S. CLS. 47 AND 49).
CHRISTINA SOBRAL, EXAMINING ATTORNEY

SN 77-429,845. FLAT CREEK ESTATE, LLC, DBA FLAT
CREEK ESTATE, MARBLE FALLS, TX. FILED 3-24-2008.



THE MARK CONSISTS OF THE WORDS FLAT AND
CREEK ON EITHER SIDE OF AN IMAGE OF AN OUT-
LINED GRAPE CLUSTER OVERLAYED ON AN OUTLINE
OF THE STATE OF TEXAS, SURROUNDED BY A DOUBLE-
LINE BORDER.

FOR WINE (U.S. CLS. 47 AND 49).
FIRST USE 1-3-2000; IN COMMERCE 1-5-2000.
KARANENDRA S. CHHINA, EXAMINING ATTORNEY

CLASS 33—(Continued).

SN 77-430,409. GLOBAL CUSTOM WINE CO., LLC, NAPA, CA. FILED 3-25-2008.

DEVIL TOAD

THE MARK CONSISTS OF STANDARD CHARACTERS WITHOUT CLAIM TO ANY PARTICULAR FONT, STYLE, SIZE, OR COLOR.

FOR WINE (U.S. CLS. 47 AND 49).
JASON BLAIR, EXAMINING ATTORNEY

SN 77-430,416. GLOBAL CUSTOM WINE CO., LLC, NAPA, CA. FILED 3-25-2008.

DEVIL FROG

THE MARK CONSISTS OF STANDARD CHARACTERS WITHOUT CLAIM TO ANY PARTICULAR FONT, STYLE, SIZE, OR COLOR.

FOR WINE (U.S. CLS. 47 AND 49).
JASON BLAIR, EXAMINING ATTORNEY

SN 77-430,693. CARIBBEAN CONNECTION, INC., DBA DBA/ LA CEREZA WINERY, TEMECULA, CA. FILED 3-25-2008.

**GIRLFRIENDS
"GET SOME!"**

THE MARK CONSISTS OF STANDARD CHARACTERS WITHOUT CLAIM TO ANY PARTICULAR FONT, STYLE, SIZE, OR COLOR.

FOR GRAPE WINE (U.S. CLS. 47 AND 49).
FIRST USE 1-26-2008; IN COMMERCE 1-26-2008.
CHERYL CLAYTON, EXAMINING ATTORNEY

SN 77-431,064. REPERTOIRE WINES, LLC, CALISTOGA, CA. FILED 3-25-2008.

PERCEPTION

THE MARK CONSISTS OF STANDARD CHARACTERS WITHOUT CLAIM TO ANY PARTICULAR FONT, STYLE, SIZE, OR COLOR.

FOR WINE (U.S. CLS. 47 AND 49).
HENRY S. ZAK, EXAMINING ATTORNEY

CLASS 33—(Continued).

SN 77-431,132. VAZQUEZ OLIVAS ALFONSO, LA PAZ, MEXICO, FILED 3-25-2008.



THE MARK CONSISTS OF THE DESIGN OF AN OVAL IN THE CENTER OF THE LOGO WHERE APPEARS THE MARK "LAS VARTAS" (THE WANDS), IN THE UPPER PART HAS A DESIGN SIMULATING AN AGAVE PLANT, IN BOTH SIDES LEFT AND RIGHT OF THE UPPER PART IT HAS AN OLIVE LEAVES PAIR, IN THE LOWER PART THERE IS A RIBBON AND CONTAINS THREE DESIGNS THAT DO NOT REPRESENT ANYTHING PARTICULARLY, THEY ARE ONLY GRAPHIC ELEMENTS OF THE DESIGN.

THE FOREIGN WORDING IN THE MARK TRANSLATES INTO ENGLISH AS "THE WANDS".

FOR DISTILLED SPIRITS; TEQUILA (U.S. CLS. 47 AND 49).

FIRST USE 5-25-2007; IN COMMERCE 5-25-2007.
BRIAN NEVILLE, EXAMINING ATTORNEY

SN 77-431,224. BABCOCK ENTERPRISES, INC., LOMPOC, CA. FILED 3-25-2008.

Ψ CLONE

THE MARK CONSISTS OF THE GREEK LETTER PSI AND THE WORD "CLONE".

FOR WINES (U.S. CLS. 47 AND 49).
FIRST USE 8-31-2007; IN COMMERCE 8-31-2007.
WANDA KAY PRICE, EXAMINING ATTORNEY

SN 77-431,800. UNEK WINES, INC., OLYMPIA FIELDS, IL. FILED 3-26-2008.

U·NēK'

THE MARK CONSISTS OF A CAPITAL "U", THEN A DOT, AND THEN A CAPITAL "N", LOWERCASE "E" WITH LINE OVER IT, A CAPITAL "K" AND A PRIME MARK.

FOR ALCOHOLIC BEVERAGES EXCEPT BEERS (U.S. CLS. 47 AND 49).

LAURIE KAUFMAN, EXAMINING ATTORNEY

CLASS 33—(Continued).

SN 77-431,803. MEINHARDT, KATHY, RUTHERFORD, CA. FILED 3-26-2008.

CLASS 33—(Continued).

SN 77-432,475. HIGH WEST DISTILLERY, LLC, PARK CITY, UT. FILED 3-26-2008.

TRUNK UP MAMMOTH

Valley Tan

THE MARK CONSISTS OF STANDARD CHARACTERS WITHOUT CLAIM TO ANY PARTICULAR FONT, STYLE, SIZE, OR COLOR.
FOR WINE (U.S. CLS. 47 AND 49).
SONYA STEPHENS, EXAMINING ATTORNEY

THE MARK CONSISTS OF STANDARD CHARACTERS WITHOUT CLAIM TO ANY PARTICULAR FONT, STYLE, SIZE, OR COLOR.
NO CLAIM IS MADE TO THE EXCLUSIVE RIGHT TO USE "TAN", APART FROM THE MARK AS SHOWN.
FOR DISTILLED SPIRITS (U.S. CLS. 47 AND 49).
STEPHANIE ALI, EXAMINING ATTORNEY

SN 77-431,845. STANDLEY, CLAUDE THOMAS, HEALDSBURG, CA. FILED 3-26-2008.

SN 77-432,487. EDDINS, JUAN EDUARDO NÚÑEZ, ZAPO-PAN, JALISCO, MEXICO, FILED 3-26-2008.

Claude Thomas

IMPROVING ON PERFECTION

THE MARK CONSISTS OF STANDARD CHARACTERS WITHOUT CLAIM TO ANY PARTICULAR FONT, STYLE, SIZE, OR COLOR.
FOR WINE (U.S. CLS. 47 AND 49).
YONG KIM, EXAMINING ATTORNEY

THE MARK CONSISTS OF STANDARD CHARACTERS WITHOUT CLAIM TO ANY PARTICULAR FONT, STYLE, SIZE, OR COLOR.
FOR TEQUILA (U.S. CLS. 47 AND 49).
SONYA STEPHENS, EXAMINING ATTORNEY

SN 77-432,461. HIGH WEST DISTILLERY, LLC, DBA QUAKING ASPEN DISTILLERS, LLC, PARK CITY, UT. FILED 3-26-2008.

SN 77-432,539. PJH VINES & WINES, LLC, SCOTTSDALE, AZ. FILED 3-26-2008.

Snow Fall Vodka

Impact

THE MARK CONSISTS OF STANDARD CHARACTERS WITHOUT CLAIM TO ANY PARTICULAR FONT, STYLE, SIZE, OR COLOR.
NO CLAIM IS MADE TO THE EXCLUSIVE RIGHT TO USE "VODKA", APART FROM THE MARK AS SHOWN.
FOR VODKA (U.S. CLS. 47 AND 49).
STEPHANIE ALI, EXAMINING ATTORNEY

THE MARK CONSISTS OF STANDARD CHARACTERS WITHOUT CLAIM TO ANY PARTICULAR FONT, STYLE, SIZE, OR COLOR.
FOR ALCOHOLIC BEVERAGES, NAMELY, WINE, COOKING WINE, LIQUOR, POTABLE SPIRITS, BRANDY, CHAMPAGNE, GIN, HARD CIDER, LIQUEURS, RUM, SCHNAPPS, TEQUILA, VODKA, WHISKEY (U.S. CLS. 47 AND 49).
MAUREEN DALL, EXAMINING ATTORNEY

CLASS 33—(Continued).

SN 77-432,757. BEBIDAS INTELIGENTES, S.A. DE C.V., ATIZAPAN DE ZARAGOSA, MEXICO, FILED 3-27-2008.

CLAUSTRO

THE MARK CONSISTS OF STANDARD CHARACTERS WITHOUT CLAIM TO ANY PARTICULAR FONT, STYLE, SIZE, OR COLOR.

THE FOREIGN WORDING IN THE MARK TRANSLATES INTO ENGLISH AS "CLOISTER" AS WELL AS "STAFF MEETING".

FOR ALCOHOLIC BEVERAGES, NAMELY, EGGNOG, TEQUILA AND AGAVE-BASED ALCOHOLIC BEVERAGES (U.S. CLS. 47 AND 49).

IRA J. GOODSARD, EXAMINING ATTORNEY

SN 77-432,936. SAZERAC COMPANY, INC., NEW ORLEANS, LA. FILED 3-27-2008.

CABOT TRAIL

THE MARK CONSISTS OF STANDARD CHARACTERS WITHOUT CLAIM TO ANY PARTICULAR FONT, STYLE, SIZE, OR COLOR.

FOR WHISKY (U.S. CLS. 47 AND 49).
AMY HELLA, EXAMINING ATTORNEY

SN 77-433,131. CONWAY VINEYARDS, INC., ARROYO GRANDE, CA. FILED 3-27-2008.

COQUINA

THE MARK CONSISTS OF STANDARD CHARACTERS WITHOUT CLAIM TO ANY PARTICULAR FONT, STYLE, SIZE, OR COLOR.

THE FOREIGN WORDING IN THE MARK TRANSLATES INTO ENGLISH AS SHELLFISH.

FOR WINES (U.S. CLS. 47 AND 49).

KATHERINE CONNOLLY, EXAMINING ATTORNEY

CLASS 33—(Continued).

SN 77-433,244. CHATAM INTERNATIONAL INCORPORATED, WILMINGTON, DE. FILED 3-27-2008.

STRANOV

THE MARK CONSISTS OF STANDARD CHARACTERS WITHOUT CLAIM TO ANY PARTICULAR FONT, STYLE, SIZE, OR COLOR.

FOR DISTILLED SPIRITS (U.S. CLS. 47 AND 49).
JILL C. ALT, EXAMINING ATTORNEY

SN 77-433,501. LITTLE VINEYARDS, GLEN ELLEN, CA. FILED 3-27-2008.

CENTER STAGE

THE MARK CONSISTS OF STANDARD CHARACTERS WITHOUT CLAIM TO ANY PARTICULAR FONT, STYLE, SIZE, OR COLOR.

FOR WINES (U.S. CLS. 47 AND 49).
RONALD AIKENS, EXAMINING ATTORNEY

SN 77-433,518. LION NATHAN WINE GROUP AUSTRALIA LIMITED, SYDNEY NSW 2000, AUSTRALIA, FILED 3-27-2008.

TWO TRACKS

THE MARK CONSISTS OF STANDARD CHARACTERS WITHOUT CLAIM TO ANY PARTICULAR FONT, STYLE, SIZE, OR COLOR.

FOR WINES (U.S. CLS. 47 AND 49).
WANDA KAY PRICE, EXAMINING ATTORNEY

SN 77-434,599. MERCOSPIRITS INC., TEANECK, NJ. FILED 3-28-2008.

MYTHE

THE MARK CONSISTS OF STANDARD CHARACTERS WITHOUT CLAIM TO ANY PARTICULAR FONT, STYLE, SIZE, OR COLOR.

FOR DISTILLED SPIRITS (U.S. CLS. 47 AND 49).
FIRST USE 3-24-2008; IN COMMERCE 3-24-2008.
DAVID MILLER, EXAMINING ATTORNEY

CLASS 33—(Continued).

SN 77-435,535. SAZERAC COMPANY, INC., NEW ORLEANS, LA. FILED 3-31-2008.

STROIKA

THE MARK CONSISTS OF STANDARD CHARACTERS WITHOUT CLAIM TO ANY PARTICULAR FONT, STYLE, SIZE, OR COLOR.

THE ENGLISH TRANSLATION OF THE WORD "STROIKA" IN THE MARK IS DEVELOPMENT. FOR VODKA (U.S. CLS. 47 AND 49). AMY HELLA, EXAMINING ATTORNEY

SN 77-435,545. SAZERAC COMPANY, INC., NEW ORLEANS, LA. FILED 3-31-2008.

ZACKARIAH HARRIS

THE MARK CONSISTS OF STANDARD CHARACTERS WITHOUT CLAIM TO ANY PARTICULAR FONT, STYLE, SIZE, OR COLOR.

THE NAME "ZACKARIAH HARRIS" DOES NOT IDENTIFY A LIVING INDIVIDUAL. FOR WHISKEY (U.S. CLS. 47 AND 49). AMY HELLA, EXAMINING ATTORNEY

SN 77-435,554. SAZERAC COMPANY, INC., NEW ORLEANS, LA. FILED 3-31-2008.

ZACKARIAH

THE MARK CONSISTS OF STANDARD CHARACTERS WITHOUT CLAIM TO ANY PARTICULAR FONT, STYLE, SIZE, OR COLOR.

FOR WHISKEY (U.S. CLS. 47 AND 49). AMY HELLA, EXAMINING ATTORNEY

CLASS 33—(Continued).

SN 77-435,558. SAZERAC COMPANY, INC., NEW ORLEANS, LA. FILED 3-31-2008.

CROWN HARRIS

THE MARK CONSISTS OF STANDARD CHARACTERS WITHOUT CLAIM TO ANY PARTICULAR FONT, STYLE, SIZE, OR COLOR.

FOR WHISKEY (U.S. CLS. 47 AND 49). AMY HELLA, EXAMINING ATTORNEY

SN 77-435,562. SAZERAC COMPANY, INC., NEW ORLEANS, LA. FILED 3-31-2008.

HOBBLE CREEK

THE MARK CONSISTS OF STANDARD CHARACTERS WITHOUT CLAIM TO ANY PARTICULAR FONT, STYLE, SIZE, OR COLOR.

FOR WHISKEY (U.S. CLS. 47 AND 49). AMY HELLA, EXAMINING ATTORNEY

SN 77-445,753. CHATAM INTERNATIONAL INCORPORATED, WILMINGTON, DE. FILED 4-11-2008.

STRAVOSKI

THE MARK CONSISTS OF STANDARD CHARACTERS WITHOUT CLAIM TO ANY PARTICULAR FONT, STYLE, SIZE, OR COLOR.

FOR DISTILLED SPIRITS (U.S. CLS. 47 AND 49). JILL C. ALT, EXAMINING ATTORNEY

SN 77-446,455. SANCHEZ, JOSEPH, SAN DIEGO, CA. FILED 4-11-2008.

GRAN MARQUIS

THE MARK CONSISTS OF STANDARD CHARACTERS WITHOUT CLAIM TO ANY PARTICULAR FONT, STYLE, SIZE, OR COLOR.

THE FOREIGN WORDING IN THE MARK TRANSLATES INTO ENGLISH AS "GRAND NOBLEMAN". FOR TEQUILA (U.S. CLS. 47 AND 49). KEVIN CORWIN, EXAMINING ATTORNEY

CLASS 33—(Continued).

SN 77-451,944. SAZERAC COMPANY, INC., NEW ORLEANS, LA. FILED 4-18-2008.

HOUSE OF HARRIS DISTILLED
LONDON DRY GIN

THE MARK CONSISTS OF STANDARD CHARACTERS WITHOUT CLAIM TO ANY PARTICULAR FONT, STYLE, SIZE, OR COLOR.

NO CLAIM IS MADE TO THE EXCLUSIVE RIGHT TO USE "DISTILLED LONDON DRY GIN", APART FROM THE MARK AS SHOWN.

FOR GIN (U.S. CLS. 47 AND 49).
AMY HELLA, EXAMINING ATTORNEY



SN 77-451,957. SAZERAC COMPANY, INC., NEW ORLEANS, LA. FILED 4-18-2008.



THE MARK CONSISTS OF A MAN WEARING A SOMBRERO.

FOR TEQUILA (U.S. CLS. 47 AND 49).
AMY HELLA, EXAMINING ATTORNEY



SN 77-453,823. DRINKS AMERICAS, WILTON, CT. FILED 4-21-2008.

TOPLESS

THE MARK CONSISTS OF STANDARD CHARACTERS WITHOUT CLAIM TO ANY PARTICULAR FONT, STYLE, SIZE, OR COLOR.

FOR SPIRITS (U.S. CLS. 47 AND 49).
MAUREEN DALL, EXAMINING ATTORNEY

CLASS 33—(Continued).

SN 77-462,825. DRINKS AMERICAS, WILTON, CT. FILED 5-1-2008.

AFTERMATH

THE MARK CONSISTS OF STANDARD CHARACTERS WITHOUT CLAIM TO ANY PARTICULAR FONT, STYLE, SIZE, OR COLOR.

FOR SPIRITS (U.S. CLS. 47 AND 49).
MAUREEN DALL, EXAMINING ATTORNEY



SN 77-479,136. QUENCH LLC, MALIBU, CA. FILED 5-20-2008.



THE MARK CONSISTS OF THE LETTER "D" IN A STYLIZED FONT.

FOR TEQUILA (U.S. CLS. 47 AND 49).
CHRISTINE BLOMQUIST, EXAMINING ATTORNEY

CLASS 33—(Continued).

SN 78-492,081. TRANSCONTINENTAL BEVERAGE GROUP, INC., NEW YORK, NY. FILED 9-30-2004.

Bonzai Saké

THE MARK CONSISTS OF STANDARD CHARACTERS WITHOUT CLAIM TO ANY PARTICULAR FONT, STYLE, SIZE, OR COLOR.

NO CLAIM IS MADE TO THE EXCLUSIVE RIGHT TO USE "SAKE", APART FROM THE MARK AS SHOWN.

FOR ALCOHOLIC BEVERAGES, NAMELY, SAKÉ (U.S. CLS. 47 AND 49).

GISELLE AGOSTO, EXAMINING ATTORNEY

SN 78-874,677. STRATUS VINEYARDS LIMITED, DOWNSVIEW, CANADA, FILED 5-2-2006.

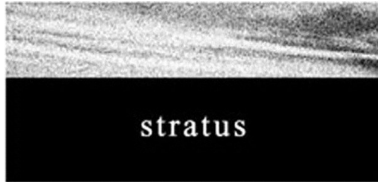

PRIORITY CLAIMED UNDER SEC. 44(D) ON CANADA APPLICATION NO. 1278901, FILED 11-8-2005, REG. NO. TMA677110, DATED 11-16-2006, EXPIRES 11-16-2021.

OWNER OF U.S. REG. NO. 3,081,133.

FOR WINE (U.S. CLS. 47 AND 49).

FIRST USE 2-28-2005; IN COMMERCE 12-1-2005.

BENJAMIN OKEKE, EXAMINING ATTORNEY

SN 79-024,755. DOMAINE DU GRAND CROS (EARL), FRANCE, FILED 4-18-2006.

jules

THE MARK CONSISTS OF STANDARD CHARACTERS WITHOUT CLAIM TO ANY PARTICULAR FONT, STYLE, SIZE, OR COLOR.

OWNER OF INTERNATIONAL REGISTRATION 0887302 DATED 4-18-2006, EXPIRES 4-18-2016.

THE ENGLISH TRANSLATION OF "JULES" IS BOY-FRIEND OR LOVER.

FOR WINES (U.S. CLS. 47 AND 49).

TRACY WHITTAKER-BROWN, EXAMINING ATTORNEY

CLASS 33—(Continued).

SN 79-040,187. DOUBLE EAGLE BRANDS N.V., NETHERLANDS, FILED 5-23-2007.



PRIORITY DATE OF 5-4-2007 IS CLAIMED. OWNER OF INTERNATIONAL REGISTRATION 0928631 DATED 5-23-2007, EXPIRES 5-23-2017.

THE COLOR(S) BLACK, WHITE, RED AND GOLD IS/ARE CLAIMED AS A FEATURE OF THE MARK.

THE COLOR BLACK APPEARS IN THE LETTER "K", OUTLINED IN WHITE. THE COLOR RED APPEARS IN THE RECTANGULAR BACKGROUND, WITH DARKER RED GRADUATING TO LIGHTER RED FROM TOP TO BOTTOM OF THE RECTANGLE. THE COLOR GOLD APPEARS IN THE BARS ATTACHED TO THE TOP AND BOTTOM OF THE RED RECTANGLE.

FOR ALCOHOLIC BEVERAGES, NAMELY, VODKA, GIN, DUTCH GIN, DISTILLED SPIRITS, LIQUORS, RUM, WHISKEY AND BRANDY (U.S. CLS. 47 AND 49).
DAWN HAN, EXAMINING ATTORNEY

SN 79-045,797. ZENATO AZIENDA VITIVINICOLA S.R.L., ITALY, FILED 9-7-2007.

ZENATO RIPASSA

THE MARK CONSISTS OF STANDARD CHARACTERS WITHOUT CLAIM TO ANY PARTICULAR FONT, STYLE, SIZE, OR COLOR.

PRIORITY DATE OF 4-20-2007 IS CLAIMED.

OWNER OF INTERNATIONAL REGISTRATION 0942513 DATED 9-7-2007, EXPIRES 9-7-2017.

THE WORDING "ZENATO" AND "RIPASSA" HAVE NO MEANING IN A FOREIGN LANGUAGE.

FOR WINES (U.S. CLS. 47 AND 49).

LINDA E. BLOHM, EXAMINING ATTORNEY

SN 79-046,482. JEREMY MULLER; AS TRUSTEE FOR THE MULLER FAMILY TRUST, SINGAPORE 276957, SINGAPORE, FILED 10-23-2007.

NO REGRETS

THE MARK CONSISTS OF STANDARD CHARACTERS WITHOUT CLAIM TO ANY PARTICULAR FONT, STYLE, SIZE, OR COLOR.

PRIORITY DATE OF 4-24-2007 IS CLAIMED.

OWNER OF INTERNATIONAL REGISTRATION 0944136 DATED 10-23-2007, EXPIRES 10-23-2017.

FOR WINES; RED WINES; WHITE WINES; ESTATE PRODUCED WINES; LIQUEURS AND FORTIFIED WINES (U.S. CLS. 47 AND 49).

MICHAEL TANNER, EXAMINING ATTORNEY

CLASS 33—(Continued).

SN 79-049,493. GIANFRANCO SOLDERA, ITALY, FILED 12-20-2007.

SOLDERA

THE MARK CONSISTS OF STANDARD CHARACTERS WITHOUT CLAIM TO ANY PARTICULAR FONT, STYLE, SIZE, OR COLOR.

OWNER OF INTERNATIONAL REGISTRATION 0952343 DATED 12-20-2007, EXPIRES 12-20-2017.

THE NAME "SOLDERA" IDENTIFIES A LIVING INDIVIDUAL WHOSE CONSENT IS OF RECORD.

SEC. 2(F).
FOR WINES, SPIRITS AND LIQUEURS (U.S. CLS. 47 AND 49).

JENNIFER VASQUEZ, EXAMINING ATTORNEY



SN 79-051,511. DORIS WÄLTI, SWITZERLAND, AND ROBERT WÄLTI, SWITZERLAND, FILED 2-6-2008.

AIONE

THE MARK CONSISTS OF STANDARD CHARACTERS WITHOUT CLAIM TO ANY PARTICULAR FONT, STYLE, SIZE, OR COLOR.

OWNER OF INTERNATIONAL REGISTRATION 0923091 DATED 4-17-2007, EXPIRES 4-17-2017.

THE WORDING "AIONE" REFERS TO A FARM IN TUSCANY, ITALY AND HAS NO MEANING IN A FOREIGN LANGUAGE.

FOR ALCOHOLIC BEVERAGES, NAMELY, WINE (U.S. CLS. 47 AND 49).

MATTHEW MCDOWELL, EXAMINING ATTORNEY



SN 79-051,716. DORIS WÄLTI, CH-1789 LUGNORRE FR, SWITZERLAND, AND ROBERT WÄLTI, CH-1789 LUGNORRE FR, SWITZERLAND, FILED 2-6-2008.

ETICO

THE MARK CONSISTS OF STANDARD CHARACTERS WITHOUT CLAIM TO ANY PARTICULAR FONT, STYLE, SIZE, OR COLOR.

OWNER OF INTERNATIONAL REGISTRATION 0932911 DATED 7-26-2007, EXPIRES 7-26-2017.

THE ENGLISH TRANSLATION OF THE WORD "ETICO" IN THE MARK IS ETHICS.

FOR ALCOHOLIC BEVERAGES, NAMELY, WINE (U.S. CLS. 47 AND 49).

MATTHEW MCDOWELL, EXAMINING ATTORNEY

CLASS 33—(Continued).

SN 79-052,677. GIANNI GAGLIARDO SRL, ITALY, FILED 2-26-2008.

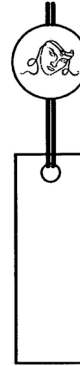

PRIORITY DATE OF 2-5-2008 IS CLAIMED.
OWNER OF INTERNATIONAL REGISTRATION 0961070 DATED 2-26-2008, EXPIRES 2-26-2018.
FOR WINES (U.S. CLS. 47 AND 49).
JULIE GUTTADAURO, EXAMINING ATTORNEY



SN 79-052,678. GIANNI GAGLIARDO SRL, ITALY, FILED 2-26-2008.

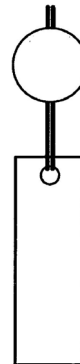

PRIORITY DATE OF 2-5-2008 IS CLAIMED.
OWNER OF INTERNATIONAL REGISTRATION 0961071 DATED 2-26-2008, EXPIRES 2-26-2018.
FOR WINES (U.S. CLS. 47 AND 49).
JULIE GUTTADAURO, EXAMINING ATTORNEY

CLASS 33—(Continued).

SN 79-053,126. YAEGAKI SHUZO KABUSHIKI KAISHA; (DOING INTERNATIONAL BUSINESS AS; YAEGAKI SAKE & SPIRITS, INC.), JAPAN, FILED 3-21-2008.

麗
子

OWNER OF INTERNATIONAL REGISTRATION 0962325 DATED 3-21-2008, EXPIRES 3-21-2018.

THE ENGLISH TRANSLATION OF THE WORD REIKO IN THE MARK IS A WOMAN'S FIRST NAME OR A LOVELY GIRL.

THE NON-LATIN CHARACTERS IN THE MARK TRANSLITERATE TO "REIKO" AND THIS MEANS A WOMAN'S FIRST NAME OR A LOVELY GIRL IN ENGLISH.

FOR JAPANESE LIQUORS, CHINESE LIQUORS, FLAVORED TONIC LIQUORS (U.S. CLS. 47 AND 49).

MATTHEW EINSTEIN, EXAMINING ATTORNEY

CLASS 34—(Continued).

SN 76-656,591. EL HABANERO CIGARS, INC., MIAMI, FL. FILED 3-14-2006.



THE MARK CONSISTS OF THE WORDING "MANICATO," A DESIGN OF A MAN SITTING OUTSIDE A HUT SMOKING A CIGAR, AND LEAVES FORMING A CIRCLE AROUND ALL THE OTHER FEATURES OF THE MARK.

FOR CIGAR BANDS, CIGAR BOXES NOT OF PRECIOUS METAL, CIGAR CUTTERS, CIGAR HUMIDIFIERS, CIGAR TUBES, CIGARS AND NON-ELECTRIC CIGAR LIGHTERS NOT OF PRECIOUS METAL (U.S. CLS. 2, 8, 9 AND 17).

EVELYN BRADLEY, EXAMINING ATTORNEY

CLASS 34—SMOKERS' ARTICLES

SN 76-501,581. IMPOREXPOR BALBOA, S.A., MADRID, SPAIN, FILED 3-10-2003.

BALBOA

OWNER OF ERPN CMNTY TM OFC REG. NO. 2468658, DATED 1-11-2008, EXPIRES 4-11-2012.

THE MARK CONSISTS OF THE WORD "BALBOA" IN CAPITALIZED LETTERS IN WHICH THE BORDERING LINES ARE IN THE COLOR WHITE, AND THE BULK OF THE LETTERS IS IN THE COLOR GOLD. THE MARK ALSO COMPRISES A DESIGN ELEMENT, I.E., THE BLACK BACKGROUND ON WHICH THE WORD "BALBOA" IS PLACED.

FOR TOBACCO, SMOKING ARTICLES, NAMELY, CIGARETTES, CIGARS, HERBS FOR SMOKING, SMOKING TOBACCO; MATCHES (U.S. CLS. 2, 8, 9 AND 17).

GEORGIA CARTY, EXAMINING ATTORNEY

SN 76-688,122. VINTAGE ENTERPRISES, INC., EAST STROUDSBURG, PA. FILED 3-27-2008.

JOSE DOMINGUEZ

THE MARK CONSISTS OF STANDARD CHARACTERS WITHOUT CLAIM TO ANY PARTICULAR FONT, STYLE, SIZE, OR COLOR.

THE NAME "JOSE DOMINGUEZ" IDENTIFIES A LIVING INDIVIDUAL WHOSE CONSENT IS OF RECORD.

FOR CIGARS (U.S. CLS. 2, 8, 9 AND 17).

LINDA ORNDORFF, EXAMINING ATTORNEY

CLASS 34—(Continued).

SN 77-075,278. IP, LLC, RUSSELL SPRINGS, KY. FILED 1-3-2007.

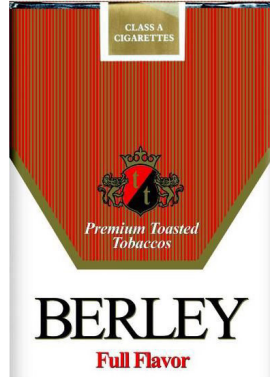

NO CLAIM IS MADE TO THE EXCLUSIVE RIGHT TO USE "CLASS A CIGARETTES," "PREMIUM TOASTED TOBACCOS," "FULL FLAVOR," AND "BURLEY", APART FROM THE MARK AS SHOWN.

THE COLOR(S) RED, GOLD, BLACK AND WHITE IS/ARE CLAIMED AS A FEATURE OF THE MARK.

THE MARK CONSISTS OF THE WORD "BERLEY" IN BLACK ABOVE THE WORDING "FULL FLAVOR" IN RED ALL SET AGAINST A WHITE BACKGROUND. ABOVE THE WORD "BERLEY" IS A SIX SIDED POLYGON WITH THE BOTTOM THREE SIDES OUTLINED IN GOLD AND FEATURING A SERIES OF RED AND GOLD VERTICAL LINES ACROSS THE DESIGN. AT THE BOTTOM OF THE RED AND GOLD IS THE WORDING "PREMIUM TOASTED TOBACCOS" IN WHITE WITH BLACK HIGHLIGHTS ABOVE WHICH IS A DESIGN OF GOLD LIONS OUTLINED IN BLACK ON EITHER SIDE OF A RED AND BLACK SHIELD FEATURING THE LETTERS "T T" IN GOLD AND BEARING A GOLD CROWN OUTLINED IN BLACK. AT THE TOP CENTER OF THE RED AND GOLD BACKGROUND IS A WHITE RECTANGLE WITHIN WHICH SITS A GOLD RECTANGLE AGAINST WHICH IS THE WORDING "CLASS A CIGARETTES" IN WHITE.

FOR CIGARETTES (U.S. CLS. 2, 8, 9 AND 17).

FIRST USE 8-31-2005; IN COMMERCE 8-31-2005.

MARCIE MILONE, EXAMINING ATTORNEY

SN 77-174,744. TIERNEY LOGISTICS LLC, KING OF PRUSSIA, PA. FILED 5-7-2007.

BUKA

THE MARK CONSISTS OF STANDARD CHARACTERS WITHOUT CLAIM TO ANY PARTICULAR FONT, STYLE, SIZE, OR COLOR.

THE FOREIGN WORDING IN THE MARK TRANSLATES INTO ENGLISH AS "NOISE."

FOR CIGARS, TOBACCO AND RELATED PRODUCTS, NAMELY, CIGAR BOXES, LIGHTERS, HOLDERS, ASHTRAYS, CIGAR BANDS, CIGAR CUTTERS, HUMIDORS, AND CIGAR TUBES (U.S. CLS. 2, 8, 9 AND 17).

ROBERT LAVACHE, EXAMINING ATTORNEY

CLASS 34—(Continued).

SN 77-275,335. ST. ANDREWS OF SCOTLAND INTERNATIONAL LTD, HOLLAND, MI. FILED 9-10-2007.

St.Andrews Golf

THE MARK CONSISTS OF STANDARD CHARACTERS WITHOUT CLAIM TO ANY PARTICULAR FONT, STYLE, SIZE, OR COLOR.

FOR TOBACCO; CIGAR LIGHTERS, CIGARETTE CASES, CIGARETTE LIGHTERS, MATCHES (U.S. CLS. 2, 8, 9 AND 17).

TOBY BULLOFF, EXAMINING ATTORNEY

SN 77-276,635. ST. ANDREWS OF SCOTLAND INTERNATIONAL LTD, HOLLAND, MI. FILED 9-11-2007.

St.Andrews of Scotland

THE MARK CONSISTS OF STANDARD CHARACTERS WITHOUT CLAIM TO ANY PARTICULAR FONT, STYLE, SIZE, OR COLOR.

FOR TOBACCO; CIGAR LIGHTERS, CIGARETTE CASES, CIGARETTE LIGHTERS; MATCHES (U.S. CLS. 2, 8, 9 AND 17).

TOBY BULLOFF, EXAMINING ATTORNEY

SN 77-283,244. BRECO INTERNATIONAL LIMITED, WICKHAM CAY, ROAD TOWN, BR.VIRGIN ISLANDS, FILED 9-19-2007.

ROXTON JADE

THE MARK CONSISTS OF STANDARD CHARACTERS WITHOUT CLAIM TO ANY PARTICULAR FONT, STYLE, SIZE, OR COLOR.

FOR CIGARETTES (U.S. CLS. 2, 8, 9 AND 17).

KATHERINE CONNOLLY, EXAMINING ATTORNEY

CLASS 34—(Continued).

SN 77-367,395. COMPANIA INDUSTRIAL DE TABACOS MONTE PAZ, MONTEVIDEO, URUGUAY, FILED 1-9-2008.

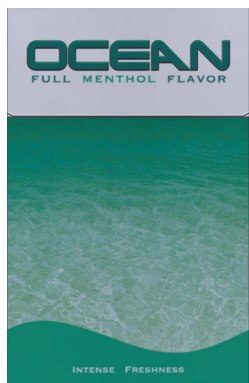

NO CLAIM IS MADE TO THE EXCLUSIVE RIGHT TO USE "FULL MENTHOL FLAVOR" AND "FRESHNESS", APART FROM THE MARK AS SHOWN.

THE COLOR(S) BLUE, GREEN, GRAY, WHITE AND BLACK IS/ARE CLAIMED AS A FEATURE OF THE MARK.

THE MARK CONSISTS OF A RECTANGLE WHICH INCLUDES A DESIGN OF OCEAN WAVES APPEARING IN GRADIENT GREEN TO WHITE. ABOVE THE OCEAN WAVE DESIGN IS A GRAY RECTANGLE WITH THE WORDING "OCEAN" IN GREEN AND OUTLINED IN BLACK, APPEARING ABOVE THE LETTERING "FULL MENTHOL FLAVOR", IN GREEN, BORDERING THE BOTTOM OF THE MARK IS A SOLID GREEN WAVE DESIGN WITH THE WORDING "INTENSE FRESHNESS" IN WHITE.

FOR CIGARETTES (U.S. CLS. 2, 8, 9 AND 17).
PAULA MAHONEY, EXAMINING ATTORNEY

SN 77-395,067. CUBAN IMPORTS, INC., MIAMI LAKES, FL. FILED 2-12-2008.

ARGENTI S.A.

THE MARK CONSISTS OF STANDARD CHARACTERS WITHOUT CLAIM TO ANY PARTICULAR FONT, STYLE, SIZE, OR COLOR.

NO CLAIM IS MADE TO THE EXCLUSIVE RIGHT TO USE "S.A.", APART FROM THE MARK AS SHOWN.

THE ENGLISH TRANSLATION OF THE WORD "ARGENTI" IN THE MARK IS SILVER ITEMS.

FOR CIGARS; TOBACCO (U.S. CLS. 2, 8, 9 AND 17).
BRIAN NEVILLE, EXAMINING ATTORNEY

CLASS 34—(Continued).

SN 77-422,880. BBK TOBACCO & FOODS, LLP, DBA HBI INTERNATIONAL, PHOENIX, AZ. FILED 3-14-2008.

VANILLA ICE

THE MARK CONSISTS OF STANDARD CHARACTERS WITHOUT CLAIM TO ANY PARTICULAR FONT, STYLE, SIZE, OR COLOR.

NO CLAIM IS MADE TO THE EXCLUSIVE RIGHT TO USE "VANILLA", APART FROM THE MARK AS SHOWN.

FOR CIGARETTE PAPERS; CIGARETTE ROLLING PAPERS (U.S. CLS. 2, 8, 9 AND 17).

FIRST USE 1-27-2008; IN COMMERCE 3-12-2008.
ELLEN PERKINS, EXAMINING ATTORNEY

SN 77-427,138. KT&G CORPORATION, DAEJEON CITY, REPUBLIC OF KOREA, FILED 3-20-2008.



OWNER OF U.S. REG. NO. 2,295,951.
FOR ASHTRAYS, CHEWING TOBACCO, PIPE TOBACCO, ROLLING TOBACCO, CIGARETTES, CIGARS, CIGARETTES CONTAINING TOBACCO SUBSTITUTES NOT FOR MEDICAL PURPOSES, HAND-ROLLING TOBACCO, FILTER-TIPPED CIGARETTES, SMOKELESS TOBACCO, SNUFF, TOBACCO, TOBACCO POWDER, NAMELY, SNUFF, CIGAR AND CIGARETTE BOXES, HOLDERS FOR CIGARS AND CIGARETTES, CIGAR CASES, CIGAR BANDS, CIGAR CUTTERS, CIGAR HUMIDIFIERS, CIGAR LIGHTERS, CIGAR TUBES, CIGARETTE CASES, CIGARETTE LIGHTERS NOT OF PRECIOUS METAL, NOT FOR AUTOMOBILES, CIGARETTE ROLLING MACHINES, CIGARETTE ROLLING PAPERS, CIGARETTE TUBES, FLINTS FOR LIGHTERS, MATCH BOXES, LIGHTERS NOT OF PRECIOUS METAL, NOT FOR AUTOMOBILES, MATCHES, PIPE POUCHES, MENTHOLATED PIPES, SMOKING PIPE CLEANERS, SMOKING PIPES, SNUFF BOXES, SNUFF DISPENSERS, TOBACCO FILTERS, TOBACCO GRINDERS, TOBACCO PIPES NOT OF PRECIOUS METAL, TOBACCO POUCHES, TOBACCO SUBSTITUTE, TOBACCO TINS (U.S. CLS. 2, 8, 9 AND 17).
B. PARADEWELAI, EXAMINING ATTORNEY

CLASS 34—(Continued).

SN 77-428,145. THOMPSON & CO. OF TAMPA, INC., TAMPA, FL. FILED 3-21-2008.

CLASS 34—(Continued).

SN 77-430,139. INTERNATIONAL PIPES & ACCESSORIES LLC, SPARTA, NC. FILED 3-24-2008.

BATTLE OF THE BRANDS

THE MARK CONSISTS OF STANDARD CHARACTERS WITHOUT CLAIM TO ANY PARTICULAR FONT, STYLE, SIZE, OR COLOR.

NO CLAIM IS MADE TO THE EXCLUSIVE RIGHT TO USE "BRANDS", APART FROM THE MARK AS SHOWN, FOR CIGARS, NAMELY, A BUNDLED SELECTION OF DIFFERENT VARIETIES OF CIGARS (U.S. CLS. 2, 8, 9 AND 17).

FIRST USE 2-18-2008; IN COMMERCE 2-18-2008.
RAUL CORDOVA, EXAMINING ATTORNEY

SN 77-429,307. NATIVE WHOLESALE SUPPLY COMPANY, GOWANDA, NY. FILED 3-24-2008.

DR. GRABOW

THE MARK CONSISTS OF STANDARD CHARACTERS WITHOUT CLAIM TO ANY PARTICULAR FONT, STYLE, SIZE, OR COLOR.

OWNER OF U.S. REG. NO. 500,710.
SEC. 2(F).

FOR SMOKING PIPES, TOBACCO PIPE FILTERS, PIPE TOBACCO, ROLL YOUR OWN TOBACCO, SMOKELESS TOBACCO, TOBACCO POWDER, NAMELY SNUS, AND TOBACCO PIPE CLEANERS (U.S. CLS. 2, 8, 9 AND 17).
KRISTINA MORRIS, EXAMINING ATTORNEY

ALLEGANY

THE MARK CONSISTS OF STANDARD CHARACTERS WITHOUT CLAIM TO ANY PARTICULAR FONT, STYLE, SIZE, OR COLOR.

FOR CIGARETTES (U.S. CLS. 2, 8, 9 AND 17).
JILL PRATER, EXAMINING ATTORNEY

SN 77-429,591. CIGARS INTERNATIONAL, INC., BATH, PA. FILED 3-24-2008.

SN 77-430,323. TABACALERA EL ARTISTA, S.A., SANTIAGO, DOMINICAN REP. FILED 3-25-2008.

DON ELÍAS**JOHN BULL**

THE MARK CONSISTS OF STANDARD CHARACTERS WITHOUT CLAIM TO ANY PARTICULAR FONT, STYLE, SIZE, OR COLOR.

FOR CIGARS; CIGAR HUMIDORS; CIGAR ASH-TRAYS (U.S. CLS. 2, 8, 9 AND 17).
JAY BESCH, EXAMINING ATTORNEY

THE MARK CONSISTS OF STANDARD CHARACTERS WITHOUT CLAIM TO ANY PARTICULAR FONT, STYLE, SIZE, OR COLOR.

THE ENGLISH TRANSLATION OF THE WORD "DON" IN THE MARK IS MR.

FOR CIGARS (U.S. CLS. 2, 8, 9 AND 17).
FIRST USE 10-0-1997; IN COMMERCE 7-0-1998.
ZHALEH DELANEY, EXAMINING ATTORNEY

CLASS 34—(Continued).

SN 77-430,471. TRADEMARKS LLC, RICHMOND, VA. FILED 3-25-2008.

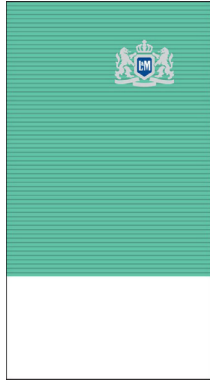

OWNER OF U.S. REG. NOS. 594,798, 1,062,895 AND OTHERS.

THE COLOR(S) LIGHT GREEN, DARK GREEN, SILVER, BLUE AND WHITE IS/ARE CLAIMED AS A FEATURE OF THE MARK.

THE MARK CONSISTS OF A RECTANGLE DESIGN WITH A LIGHT GREEN AND DARK GREEN HORIZONTAL STRIPE PATTERN COVERING THE TOP THREE-QUARTERS OF THE RECTANGLE AND WHITE COVERING THE BOTTOM QUARTER, AND A SILVER CREST DESIGN WITH THE LETTERS "L&M" IN WHITE IN THE CENTER OF A BLUE BACKGROUND.

FOR CIGARETTES (U.S. CLS. 2, 8, 9 AND 17).

KATHERINE M. DUBRAY, EXAMINING ATTORNEY

CLASS 34—(Continued).

SN 77-434,520. SMOKER FRIENDLY INTERNATIONAL LLC, BOULDER, CO. FILED 3-28-2008.

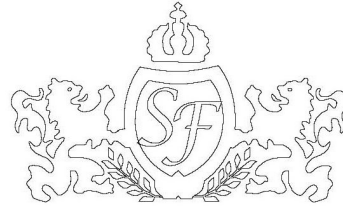

OWNER OF U.S. REG. NOS. 2,134,804, 3,028,215 AND OTHERS.

THE MARK CONSISTS OF A COAT OF ARMS WITH THE LETTERING "SF".

FOR CIGARETTES, CIGARS, ASHTRAYS NOT OF PRECIOUS METAL, CIGARETTE CASES NOT OF PRECIOUS METAL, CHEWING TOBACCO, CIGAR CUTTERS, CIGARETTE HOLDERS NOT OF PRECIOUS METAL, CIGARETTE LIGHTERS NOT OF PRECIOUS METAL, CIGARETTE PAPERS, CIGARILLOS, FLINTS FOR LIGHTERS, HERBS FOR SMOKING, POCKET MACHINES FOR ROLLING CIGARETTES, MATCHES, SMOKING PIPE CLEANERS, PIPES, TOBACCO POUCHES, SMOKELESS TOBACCO, SMOKING TOBACCO, SNUFF, SNUFF BOXES, AND SMOKING SPITTOONS (U.S. CLS. 2, 8, 9 AND 17).

MELVIN AXILBUND, EXAMINING ATTORNEY

SN 77-434,529. SMOKER FRIENDLY INTERNATIONAL LLC, BOULDER, CO. FILED 3-28-2008.

SN 77-430,651. THE CIGAR AGENCY, NASHUA, NH. FILED 3-25-2008.



THE MARK CONSISTS OF THE STYLIZED TEXT "TWENTY" WITH A STYLIZED BACKGROUND.

FOR CIGARS ; CIGAR ASHTRAYS; CIGAR LIGHTERS; CIGAR CUTTERS; CIGAR HUMIDORS; CIGAR AGING CABINETS; CIGAR CASES; CIGAR HOLDERS (U.S. CLS. 2, 8, 9 AND 17).

FIRST USE 9-30-2007; IN COMMERCE 9-30-2007.

JOHN DWYER, EXAMINING ATTORNEY

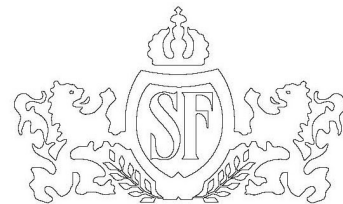

OWNER OF U.S. REG. NOS. 2,134,804, 3,028,215 AND OTHERS.

THE MARK CONSISTS OF A COAT OF ARMS WITH THE LETTERING "SF".

FOR CIGARETTES, CIGARS, ASHTRAYS NOT OF PRECIOUS METAL, CIGARETTE CASES NOT OF PRECIOUS METAL, CHEWING TOBACCO, CIGAR CUTTERS, CIGARETTE HOLDERS NOT OF PRECIOUS METAL, CIGARETTE LIGHTERS NOT OF PRECIOUS METAL, CIGARETTE PAPERS, CIGARILLOS, FLINTS FOR LIGHTERS, HERBS FOR SMOKING, POCKET MACHINES FOR ROLLING CIGARETTES, MATCHES, SMOKING PIPE CLEANERS, PIPES, TOBACCO POUCHES, SMOKELESS TOBACCO, SMOKING TOBACCO, SNUFF, SNUFF BOXES, AND SMOKING SPITTOONS (U.S. CLS. 2, 8, 9 AND 17).

MELVIN AXILBUND, EXAMINING ATTORNEY

CLASS 34—(Continued).

SN 77-442,664. MANUFACTURA DE TABACOS (MATASA), SANTIAGO, DOMINICAN REP. FILED 4-8-2008.

CASA MAGNA

THE MARK CONSISTS OF STANDARD CHARACTERS WITHOUT CLAIM TO ANY PARTICULAR FONT, STYLE, SIZE, OR COLOR.

THE FOREIGN WORDING IN THE MARK TRANSLATES INTO ENGLISH AS "GREAT HOUSE."

FOR CIGARS (U.S. CLS. 2, 8, 9 AND 17).

ZACHARY BELLO, EXAMINING ATTORNEY

CLASS 34—(Continued).

SN 77-464,440. NHA, INC., DBA NATIONAL HONEY ALMOND, BRISTOL, PA. FILED 5-2-2008.

Sweet Seduction

THE MARK CONSISTS OF STANDARD CHARACTERS WITHOUT CLAIM TO ANY PARTICULAR FONT, STYLE, SIZE, OR COLOR.

FOR HAND-ROLLING TOBACCO; ROLL YOUR OWN TOBACCO; ROLLING TOBACCO; SMOKING TOBACCO; TOBACCO; TOBACCO, CIGARS AND CIGARETTES; CIGAR BANDS; CIGAR BOXES; CIGAR CASES; CIGAR TUBES; CIGARS; CIGARILLOS (U.S. CLS. 2, 8, 9 AND 17).

ESTHER BELENKER, EXAMINING ATTORNEY

SN 77-449,874. LORILLARD LICENSING COMPANY, LLC, GREENSBORO, NC. FILED 4-16-2008.

NO SMOKING NO PROBLEM.

THE MARK CONSISTS OF STANDARD CHARACTERS WITHOUT CLAIM TO ANY PARTICULAR FONT, STYLE, SIZE, OR COLOR.

FOR SMOKELESS TOBACCO; TOBACCO POWDER, NAMELY, SNUS; SNUFF (U.S. CLS. 2, 8, 9 AND 17).

FIRST USE 1-28-2008; IN COMMERCE 1-28-2008.

KELLY MCCOY, EXAMINING ATTORNEY

SN 77-468,474. G & R BRANDS, LLC, LAS VEGAS, NV. FILED 5-7-2008.

NICO FREE

THE MARK CONSISTS OF STANDARD CHARACTERS WITHOUT CLAIM TO ANY PARTICULAR FONT, STYLE, SIZE, OR COLOR.

FOR ABSORBENT PAPER FOR TOBACCO PIPES; ASIAN LONG TOBACCO PIPE SHEATHS; ASIAN LONG TOBACCO PIPES (KISERU); CIGARETTES CONTAINING TOBACCO SUBSTITUTES NOT FOR MEDICAL PURPOSES; HAND-ROLLING TOBACCO; PIPE TOBACCO; ROLL YOUR OWN TOBACCO; ROLLING TOBACCO; SMOKELESS TOBACCO; SMOKING TOBACCO; TOBACCO; TOBACCO FILTERS; TOBACCO GRINDERS; TOBACCO JARS; TOBACCO PIPE CLEANERS; TOBACCO PIPES; TOBACCO SUBSTITUTE; TOBACCO TINS; TOBACCO, CIGARS AND CIGARETTES; CIGAR BANDS; CIGAR BOXES; CIGAR CASES; CIGAR CUTTERS; CIGAR HUMIDIFIERS; CIGAR TUBES; CIGARS; CIGARETTE ASH RECEPTACLES; CIGARETTE CASES; CIGARETTE CASES MADE OF PRECIOUS METAL; CIGARETTE CASES, NOT OF PRECIOUS METAL; CIGARETTE FILTERS; CIGARETTE HOLDERS, NOT OF PRECIOUS METAL; CIGARETTE LIGHTERS NOT FOR LAND VEHICLES; CIGARETTE LIGHTERS NOT OF PRECIOUS METAL; CIGARETTE LIGHTERS OF PRECIOUS METAL; CIGARETTE PAPER; CIGARETTE PAPERS; CIGARETTE ROLLING MACHINES; CIGARETTE ROLLING PAPERS; CIGARETTE TUBES; CIGARETTE-ROLLING MACHINES; CIGARETTES; FILTER-TIPPED CIGARETTES; MACHINES ALLOWING SMOKERS TO MAKE CIGARETTES BY THEMSELVES; POCKET APPARATUS FOR ROLLING CIGARETTES; POCKET APPARATUS FOR SELF-ROLLING CIGARETTES; POCKET APPLIANCES FOR ROLLING ONE'S OWN CIGARETTES; POCKET DEVICES FOR SELF-ROLLING OF CIGARETTES; POCKET MACHINES FOR ROLLING CIGARETTES; POCKET-SIZE CIGARETTE ROLLING MACHINES; HOOKAHS; SMOKING PIPE CLEANERS; SMOKING PIPES (U.S. CLS. 2, 8, 9 AND 17).

LINDSEY RUBIN, EXAMINING ATTORNEY

SN 77-451,555. THOMPSON & CO. OF TAMPA, INC., TAMPA, FL. FILED 4-18-2008.

LILLIPUT

THE MARK CONSISTS OF STANDARD CHARACTERS WITHOUT CLAIM TO ANY PARTICULAR FONT, STYLE, SIZE, OR COLOR.

FOR CIGARS (U.S. CLS. 2, 8, 9 AND 17).

RAUL CORDOVA, EXAMINING ATTORNEY

CLASS 34—(Continued).

SN 77-472,757. LORILLARD LICENSING COMPANY, LLC, GREENSBORO, NC. FILED 5-13-2008.

Menthol Gold

THE MARK CONSISTS OF STANDARD CHARACTERS WITHOUT CLAIM TO ANY PARTICULAR FONT, STYLE, SIZE, OR COLOR.
NO CLAIM IS MADE TO THE EXCLUSIVE RIGHT TO USE "MENTHOL", APART FROM THE MARK AS SHOWN. FOR CIGARETTES (U.S. CLS. 2, 8, 9 AND 17).
FIRST USE 5-0-2007; IN COMMERCE 5-0-2007.
KELLY MCCOY, EXAMINING ATTORNEY

SN 77-472,770. LORILLARD LICENSING COMPANY, LLC, GREENSBORO, NC. FILED 5-13-2008.

Menthol Blue

THE MARK CONSISTS OF STANDARD CHARACTERS WITHOUT CLAIM TO ANY PARTICULAR FONT, STYLE, SIZE, OR COLOR.
NO CLAIM IS MADE TO THE EXCLUSIVE RIGHT TO USE "MENTHOL", APART FROM THE MARK AS SHOWN. FOR CIGARETTES (U.S. CLS. 2, 8, 9 AND 17).
FIRST USE 5-0-2006; IN COMMERCE 5-0-2006.
KELLY MCCOY, EXAMINING ATTORNEY

SN 77-473,292. LORILLARD LICENSING COMPANY, LLC, GREENSBORO, NC. FILED 5-13-2008.



OWNER OF U.S. REG. NO. 1,178,413.
THE COLOR(S) GREEN, GOLD AND WHITE IS/ARE CLAIMED AS A FEATURE OF THE MARK.
THE MARK CONSISTS OF A GOLD SPINNAKER OUTLINED IN WHITE ON A GREEN BACKGROUND.
FOR CIGARETTES (U.S. CLS. 2, 8, 9 AND 17).
FIRST USE 5-0-2007; IN COMMERCE 5-0-2007.
KELLY MCCOY, EXAMINING ATTORNEY

CLASS 34—(Continued).

SN 77-473,635. BBK TOBACCO & FOODS, LLP, PHOENIX, AZ. FILED 5-13-2008.

GRAPES GONE WILD

THE MARK CONSISTS OF STANDARD CHARACTERS WITHOUT CLAIM TO ANY PARTICULAR FONT, STYLE, SIZE, OR COLOR.
NO CLAIM IS MADE TO THE EXCLUSIVE RIGHT TO USE "GRAPES", APART FROM THE MARK AS SHOWN.
FOR CIGARETTE PAPER; CIGARETTE PAPERS; CIGARETTE ROLLING PAPERS; CIGARS (U.S. CLS. 2, 8, 9 AND 17).
FIRST USE 4-29-2008; IN COMMERCE 5-9-2008.
ELLEN PERKINS, EXAMINING ATTORNEY

SN 77-474,343. LORILLARD LICENSING COMPANY, GREENSBORO, NC. FILED 5-14-2008.

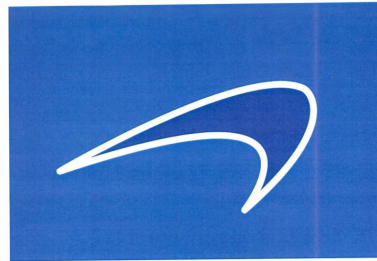

OWNER OF U.S. REG. NO. 1,178,413.
THE COLOR(S) BLUE AND WHITE IS/ARE CLAIMED AS A FEATURE OF THE MARK.
THE MARK CONSISTS OF A BLUE SPINNAKER OUTLINED IN WHITE ON A BLUE BACKGROUND.
FOR CIGARETTES (U.S. CLS. 2, 8, 9 AND 17).
FIRST USE 5-0-2006; IN COMMERCE 5-0-2006.
KELLY MCCOY, EXAMINING ATTORNEY

SN 77-479,851. PHILIP MORRIS USA INC., RICHMOND, VA. FILED 5-21-2008.



OWNER OF U.S. REG. NOS. 68,502, 938,510 AND OTHERS.
THE MARK CONSISTS OF A STRIATED RECTANGLE WITH ONE HORIZONTAL LINE ALONG THE TOP EDGE

CLASS 34—(Continued).

AND TWO HORIZONTAL LINES ALONG THE BOTTOM EDGE. THERE IS A RECTANGLE LOCATED IN THE UPPER RIGHT HAND CORNER OF THE STRIATED RECTANGLE WITH A BORDER ON THREE SIDES AND A CIRCULAR PATTERN AND A LEAF DESIGN LOCATED WITHIN THE BORDER. NEAR THE CENTER OF THE STRIATED RECTANGLE IS A CREST CONSISTING OF A HORSE ON EITHER SIDE OF AN OVAL, ON TOP OF WHICH IS A CROWN, BELOW WHICH IS A BANNER DESIGN.

FOR TOBACCO PRODUCTS, NAMELY, CIGARETTES (U.S. CLS. 2, 8, 9 AND 17).

FIRST USE 9-10-2007; IN COMMERCE 9-10-2007.
ELI HELLMAN, EXAMINING ATTORNEY

CLASS 34—(Continued).

SN 79-048,822. ROYAL DISTRIBUTION TABAC DISTRI
NORD, FRANCE, FILED 11-26-2007.

SN 77-487,715. G & R BRANDS, LLC, LAS VEGAS, NV.
FILED 5-30-2008.

NICO-FREE

THE MARK CONSISTS OF STANDARD CHARACTERS WITHOUT CLAIM TO ANY PARTICULAR FONT, STYLE, SIZE, OR COLOR.

FOR TOBACCO FILTERS (U.S. CLS. 2, 8, 9 AND 17).
LINDSEY RUBIN, EXAMINING ATTORNEY



SN 79-021,310. PETROS L. KOLOKAS & CO O.E.; EISAGO-
GIKI EXAGOGIKI ETAIREIA EIDON; KAPNISTOU KAI
DORON, GREECE, FILED 11-30-2005.

ROLLING INTERNATIONAL

OWNER OF INTERNATIONAL REGISTRATION 0878010
DATED 11-30-2005, EXPIRES 11-30-2015.

NO CLAIM IS MADE TO THE EXCLUSIVE RIGHT TO USE "ROLLING INTERNATIONAL", APART FROM THE MARK AS SHOWN.

THE MARK CONSISTS OF THE WORDS "ROLLING INTERNATIONAL" IN WHICH A SMALL FLAME DESIGN APPEARS OVER THE FIRST "I" IN THE WORD "INTERNATIONAL".

FOR ABSORBENT PAPER FOR TOBACCO PIPES; HAND-ROLLING TOBACCO; PIPE TOBACCO; ROLL-YOUR-OWN TOBACCO; ROLLING TOBACCO; SMOKING TOBACCO; TOBACCO; TOBACCO FILTERS; TOBACCO GRINDERS; TOBACCO PIPE CLEANERS; TOBACCO POUCHES; LIGHTERS FOR SMOKERS; MACHINES ALLOWING SMOKERS TO MAKE CIGARETTES BY THEMSELVES (U.S. CLS. 2, 8, 9 AND 17).

MICHAEL WIENER, EXAMINING ATTORNEY

PRIORITY DATE OF 6-12-2007 IS CLAIMED.

OWNER OF INTERNATIONAL REGISTRATION 0950344
DATED 11-26-2007, EXPIRES 11-26-2017.

NO CLAIM IS MADE TO THE EXCLUSIVE RIGHT TO USE "BLUNT" AND "ORIGINAL FLAVOR", APART FROM THE MARK AS SHOWN.

"THE COLOR(S) RED, YELLOW, ORANGE, BLACK AND WHITE IS/ARE CLAIMED AS A FEATURE OF THE MARK."

THE MARK CONSISTS OF THE COLORS RED, BLACK AND YELLOW APPEAR IN THE STAR DESIGN, THE COLOR ORANGE APPEARS IN THE BANNER DESIGN, THE COLORS BLACK AND WHITE APPEAR IN THE WORDING "REDGIES BLUNT" AND "ORIGINAL FLAVORS".

FOR SMOKERS' ARTICLES, NAMELY, MATCHES, CIGARETTE PAPER, PIPES, SMOKERS' LIGHTERS, CIGAR BOXES AND CASES, CIGARETTE BOXES AND CASES, SMOKERS' ASHTRAYS, CIGARETTE FILTERS, POCKET MACHINES FOR ROLLING CIGARETTES, SMOKING PIPES (U.S. CLS. 2, 8, 9 AND 17).

AMOS T. MATTHEWS, JR., EXAMINING ATTORNEY

CLASS 35—(Continued).

SERVICE MARKS

CLASS 35—ADVERTISING AND BUSINESS

SN 76-673,948. VEGE USA, LLC, ARCADIA, CA. FILED 3-12-2007.



FOR WHOLESALE DISTRIBUTORSHIPS IN THE FIELD OF FROZEN FOODS AND IMPORT AGENCIES IN THE FIELD OF FROZEN FOOD (U.S. CLS. 100, 101 AND 102).

FIRST USE 6-2-2000; IN COMMERCE 6-2-2000.
MARY CRAWFORD, EXAMINING ATTORNEY

SN 76-676,231. DAWSON COUNTY CHAMBER OF COMMERCE, DAWSONVILLE, GA. FILED 4-30-2007.



NO CLAIM IS MADE TO THE EXCLUSIVE RIGHT TO USE "DAWSON" AND THE PICTORIAL REPRESENTATION OF DAWSON COUNTY, APART FROM THE MARK AS SHOWN.

THE COLOR(S) BLACK, RED, GREEN AND WHITE IS/ARE CLAIMED AS A FEATURE OF THE MARK.

THE MARK CONSISTS OF THE COLORS BLACK, RED, GREEN, AND WHITE. THE COLOR BLACK APPEAR INSIDE THE SCOTTY DOG DESIGN AND IN THE OUTLINE OF THE PICTORIAL REPRESENTATION OF DAWSON COUNTY, THE COLOR RED APPEARS IN THE DOG'S BOWTIE AND THE LETTERING FOR THE WORDING "DAWSON SAYS...". THE COLOR GREEN APPEARS IN THE DESIGN OF THE MOUNTAINS, AND THE COLOR WHITE APPEARS IN THE DESIGN OF THE MOUNTAINS, IN THE DOG DESIGN, AND INSIDE THE PICTORIAL REPRESENTATION OF DAWSON COUNTY.

FOR BUSINESS INFORMATION SERVICES (U.S. CLS. 100, 101 AND 102).

FIRST USE 2-27-2007; IN COMMERCE 2-27-2007.
SETH A. RAPPAPORT, EXAMINING ATTORNEY

CLASS 35—(Continued).

SN 76-678,334. SCOTT SOUTHARD TALENT, INC., GLOUCESTER, MA. FILED 6-18-2007.



NO CLAIM IS MADE TO THE EXCLUSIVE RIGHT TO USE "INTERNATIONAL MUSIC NETWORK", APART FROM THE MARK AS SHOWN.

THE COLOR(S) BLUE, WHITE, BROWN, BLACK AND GREY IS/ARE CLAIMED AS A FEATURE OF THE MARK.

THE COLOR BLUE APPEARS ON THE LETTERS "IMN". THE COLOR WHITE APPEARS IN CLOUD LIKE SMATTERINGS ON THE BLUE BACKGROUND OF THE LETTERS "IMN". THE COLOR BROWN APPEARS ON THE PLANKS AND THE COLOR BLACK APPEARS ON THE TIES IN THE DESIGN COMPONENT OF THE MARK. THE WORDING "INTERNATIONAL MUSIC NETWORK" APPEARS IN GREY.

FOR TALENT AGENCY AND ARTISTS MANAGEMENT SERVICES (U.S. CLS. 100, 101 AND 102).

FIRST USE 7-1-2004; IN COMMERCE 7-1-2004.
KATHRYN COWARD, EXAMINING ATTORNEY

SN 76-681,239. COMFORT24-7.COM, LLC, MELROSE PARK, IL. FILED 8-28-2007.

COMFORT24-7

THE MARK CONSISTS OF STANDARD CHARACTERS WITHOUT CLAIM TO ANY PARTICULAR FONT, STYLE, SIZE, OR COLOR.

FOR BUSINESS SERVICES, NAMELY, REGISTERING, SCREENING, CREDENTIALING, AND ORGANIZING COMPANIES AND SKILLED LABORERS AND INFORMATION CONCERNING HEATING, AIR CONDITIONING, INDOOR AIR QUALITY AND SAFETY PRODUCTS AND SERVICES FOR POTENTIAL CONSUMERS ALL PROVIDED VIA THE INTERNET (U.S. CLS. 100, 101 AND 102).

FIRST USE 4-26-2007; IN COMMERCE 4-26-2007.
BENJAMIN OKEKE, EXAMINING ATTORNEY

CLASS 35—(Continued).

SN 76-682,012. TAP PUBLISHING CO., CROSSVILLE, TN. FILED 9-18-2007.



OWNER OF U.S. REG. NO. 2,456,583.
NO CLAIM IS MADE TO THE EXCLUSIVE RIGHT TO USE "PUBLISHING", APART FROM THE MARK AS SHOWN.

FOR CLASSIFIED ADVERTISING SERVICES RENDERED VIA PRINTED PUBLICATIONS AND ELECTRONIC MEDIA ACCESSIBLE THROUGH THE INTERNET IN THE FIELDS OF AVIATION, HEAVY EQUIPMENT, COMMUNICATIONS EQUIPMENT AND OIL FIELD EQUIPMENT (U.S. CLS. 100, 101 AND 102).

FIRST USE 8-29-2003; IN COMMERCE 8-29-2003.
TINA L. SNAPP, EXAMINING ATTORNEY

CLASS 35—(Continued).

SN 76-685,422. CREATIVE CHRISTIANS INCORPORATED, MAGNOLIA, TX. FILED 12-31-2007.

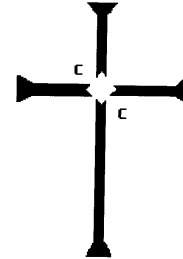

CC - Creative Christians

SN 76-682,437. A SOFTER PLACE, LLC, CARROLLTON, TX. FILED 10-1-2007.



THE MARK CONSISTS OF STANDARD CHARACTERS WITHOUT CLAIM TO ANY PARTICULAR FONT, STYLE, SIZE, OR COLOR.

FOR PROMOTING THE GOODS AND SERVICES OF OTHERS BY PROVIDING A WEB SITE AT WHICH USERS CAN LINK TO SERVICES TO ADVANCE THE QUALITY OF LIFE FOR AGING INDIVIDUALS AND THEIR FAMILIES (U.S. CLS. 100, 101 AND 102).

MELVIN AXILBUND, EXAMINING ATTORNEY

NO CLAIM IS MADE TO THE EXCLUSIVE RIGHT TO USE "CHRISTIANS", APART FROM THE MARK AS SHOWN.

THE MARK CONSISTS OF THE LETTERS AND WORDING "CC CREATIVE CHRISTIANS" AND A DESIGN ABOVE THE LETTER AND WORDING, NAMELY, A CROSS WITH A DIAMOND IN THE MIDDLE OF THE CROSS. THE LETTER "C" APPEARS ON THE LEFT TOP CENTER AND THE LETTER "C" APPEARS ON THE RIGHT BOTTOM CENTER.

FOR RETAIL STORE SERVICES FEATURING CHRISTIAN BOOKS, CLOTHING, JEWELRY, PURSES, GENERAL GIFTS, AND LABELS (U.S. CLS. 100, 101 AND 102).

WANDA KAY PRICE, EXAMINING ATTORNEY

SN 76-684,533. A SOFTER PLACE, LLC, CARROLLTON, TX. FILED 12-3-2007.



FOR PROMOTING THE GOODS AND SERVICES OF OTHERS BY PROVIDING A WEB SITE AT WHICH USERS CAN LINK TO SERVICES TO ADVANCE THE QUALITY OF LIFE FOR AGING INDIVIDUALS AND THEIR FAMILIES (U.S. CLS. 100, 101 AND 102).

MELVIN AXILBUND, EXAMINING ATTORNEY

SN 76-685,520. BILCARE, INC., PHOENIXVILLE, PA. FILED 1-4-2008.

SERVICE AND QUALITY BEYOND COMPLIANCE

THE MARK CONSISTS OF STANDARD CHARACTERS WITHOUT CLAIM TO ANY PARTICULAR FONT, STYLE, SIZE, OR COLOR.

NO CLAIM IS MADE TO THE EXCLUSIVE RIGHT TO USE "SERVICE AND QUALITY" AND "COMPLIANCE", APART FROM THE MARK AS SHOWN.

FOR PROFESSIONAL BUSINESS CONSULTING SERVICES IN THE FIELD OF PHARMACEUTICAL PACKAGING; BUSINESS ADVISORY SERVICES RELATING TO PRODUCT DEVELOPMENT AND MANUFACTURING; BUSINESS RESEARCH; AND COMPILATION OF STATISTICAL DATA FOR BUSINESS PURPOSES RELATING TO MEDICAL RESEARCH (U.S. CLS. 100, 101 AND 102).

JIM RINGLE, EXAMINING ATTORNEY

CLASS 35—(Continued).

SN 76-685,720. BILCARE, INC., PHOENIXVILLE, PA. FILED 1-11-2008.

CLIENT DELIGHT

THE MARK CONSISTS OF STANDARD CHARACTERS WITHOUT CLAIM TO ANY PARTICULAR FONT, STYLE, SIZE, OR COLOR.

NO CLAIM IS MADE TO THE EXCLUSIVE RIGHT TO USE "CLIENT", APART FROM THE MARK AS SHOWN.

FOR PROFESSIONAL BUSINESS CONSULTING SERVICES IN THE FIELD OF PHARMACEUTICAL PACKAGING; BUSINESS ADVISORY SERVICES RELATING TO PRODUCT DEVELOPMENT AND MANUFACTURING; BUSINESS RESEARCH; AND COMPILATION OF STATISTICAL DATA FOR BUSINESS PURPOSES RELATING TO MEDICAL RESEARCH (U.S. CLS. 100, 101 AND 102).
JIM RINGLE, EXAMINING ATTORNEY

SN 76-686,133. DTC HEALTHCOM, LLC, WHITE PLAINS, NY. FILED 1-25-2008.

Orthoogle

THE COLOR(S) BLACK, RED, YELLOW, BLUE, AND GREEN IS/ARE CLAIMED AS A FEATURE OF THE MARK.

THE MARK CONSISTS OF THE WORD "ORTHOOGLE" IN STYLIZED LETTERS. THE COLOR BLACK APPEARS IN THE FIRST FOUR LETTERS, "ORTH". THE COLOR RED APPEARS IN THE FIFTH LETTER, "O", AND THE NINTH LETTER, "E". THE COLOR YELLOW APPEARS IN THE SIXTH LETTER, "O", THE COLOR BLUE APPEARS IN THE SEVENTH LETTER, "G", AND THE COLOR GREEN APPEARS IN THE EIGHTH LETTER, "L".

FOR CONSULTANT TO ORTHOPEDIC PRACTICES AS TO EFFICIENCY RELATED TO INTERNET ADVERTISING (U.S. CLS. 100, 101 AND 102).

FIRST USE 11-28-2006; IN COMMERCE 11-28-2006.
LIEF MARTIN, EXAMINING ATTORNEY

SN 76-686,313. KLEIN, DYANN, EASTHAMPTON, NY. FILED 1-30-2008.

PROPS FOR TOMORROW

THE MARK CONSISTS OF STANDARD CHARACTERS WITHOUT CLAIM TO ANY PARTICULAR FONT, STYLE, SIZE, OR COLOR.

NO CLAIM IS MADE TO THE EXCLUSIVE RIGHT TO USE "PROPS", APART FROM THE MARK AS SHOWN.

FOR RETAIL STORE SERVICES FOR THE FURNITURE OF CELEBRITIES AND THE PROPS FROM ENTERTAINMENT PRODUCTIONS (U.S. CLS. 100, 101 AND 102).

DANNEAN HETZEL, EXAMINING ATTORNEY

CLASS 35—(Continued).

SN 76-686,314. KLEIN, DYANN, EASTHAMPTON, NY. FILED 1-30-2008.

PROPS FROM YESTERDAY

THE MARK CONSISTS OF STANDARD CHARACTERS WITHOUT CLAIM TO ANY PARTICULAR FONT, STYLE, SIZE, OR COLOR.

NO CLAIM IS MADE TO THE EXCLUSIVE RIGHT TO USE "PROPS", APART FROM THE MARK AS SHOWN.

FOR RETAIL STORE SERVICES FOR THE FURNITURE OF CELEBRITIES AND THE PROPS FROM ENTERTAINMENT PRODUCTIONS (U.S. CLS. 100, 101 AND 102).

DANNEAN HETZEL, EXAMINING ATTORNEY

SN 76-687,043. FRESCOS & COMPANY INC., LONDON, ONTARIO, CANADA. FILED 2-22-2008.



NO CLAIM IS MADE TO THE EXCLUSIVE RIGHT TO USE "FRESH MEALS", APART FROM THE MARK AS SHOWN.

FOR RETAIL STORE AND OUTLET SERVICES FEATURING PACKAGED FOODS AND PACKAGED MEALS THAT ARE READY TO COOK OR READY TO HEAT (U.S. CLS. 100, 101 AND 102).

G. MAYERSCHOFF, EXAMINING ATTORNEY

SN 76-687,710. WALGREEN CO., DEERFIELD, IL. FILED 3-14-2008.

READYDOSE.COM

THE MARK CONSISTS OF STANDARD CHARACTERS WITHOUT CLAIM TO ANY PARTICULAR FONT, STYLE, SIZE, OR COLOR.

FOR INTERNET ADVERTISING SERVICES PROMOTING THE SALE OF MULTI DOSE MEDICATION PACKAGING (U.S. CLS. 100, 101 AND 102).

KRISTINA MORRIS, EXAMINING ATTORNEY

SN 76-687,806. MISKELLY FURNITURE, JACKSON, MS. FILED 3-17-2008.

BEYOND FURNITURE

THE MARK CONSISTS OF STANDARD CHARACTERS WITHOUT CLAIM TO ANY PARTICULAR FONT, STYLE, SIZE, OR COLOR.

NO CLAIM IS MADE TO THE EXCLUSIVE RIGHT TO USE "FURNITURE", APART FROM THE MARK AS SHOWN.

FOR RETAIL FURNITURE STORE (U.S. CLS. 100, 101 AND 102).

FIRST USE 2-24-2005; IN COMMERCE 2-24-2005.
ANGELA M. MICHELI, EXAMINING ATTORNEY

CLASS 35—(Continued).

SN 76-687,866. WELCH, DESAREE J, NASHVILLE, TN. FILED 3-19-2008.



NO CLAIM IS MADE TO THE EXCLUSIVE RIGHT TO USE "CELEBRITY", APART FROM THE MARK AS SHOWN. FOR ON-LINE AUCTION SERVICES FOR ITEMS DONATED BY CELEBRITIES; ON-LINE CONSIGNMENT SERVICES WHEREBY GOODS ARE RECEIVED ON CONSIGNMENT FOR AUCTION ON AN ON-LINE AUCTION SITE; ON-LINE CONSIGNMENT SERVICES WHEREBY GOODS ARE RECEIVED ON CONSIGNMENT FOR SELLING ON AN ON-LINE SITE; AND ON-LINE RETAIL CONSIGNMENT STORES FEATURING GOODS DONATED BY CELEBRITIES FOR SALE (U.S. CLS. 100, 101 AND 102).

BARBARA RUTLAND, EXAMINING ATTORNEY

SN 76-687,874. TWINHOUSE, L.L.C, ATLANTA, GA. FILED 3-17-2008.



twinhouse

THE MARK CONSISTS OF THE DESIGN REPRESENTATION OF TWO CHAIRS FACING BACK TO BACK ON A LINE INSIDE A CIRCLE WITH THE WORD "TWINHOUSE" BELOW.

FOR ART GALLERY SERVICES (U.S. CLS. 100, 101 AND 102).

FIRST USE 9-1-1996; IN COMMERCE 9-1-1996.
WENDY JUN, EXAMINING ATTORNEY

CLASS 35—(Continued).

SN 76-687,885. AVA, INC., UNIVERSAL CITY, TX. FILED 3-19-2008.



OWNER OF U.S. REG. NOS. 1,461,433 AND 1,491,683. THE MARK CONTAINS A TWO-DIMENSIONAL DESIGN CONSISTING OF THE LETTERS AVA. THE GRAY IS USED FOR SHADING ONLY AND IS NOT AN INDICATION OF COLOR.

FOR ASSOCIATION SERVICES, NAMELY, PROMOTING THE INTERESTS OF PERSONS INTERESTED IN PROMOTING HEALTH AND PERSONAL WELLNESS THROUGH WALKING, SWIMMING, BIKING, AND CROSS-COUNTRY SKIING (U.S. CLS. 100, 101 AND 102). FIRST USE 9-0-1994; IN COMMERCE 9-0-1994.

AMOS T. MATTHEWS, JR., EXAMINING ATTORNEY

SN 76-687,905. STRATEGIC MOMENTUM, INC., SAN DIEGO, CA. FILED 3-20-2008.

BREAKAWAY INNOVATION

THE MARK CONSISTS OF STANDARD CHARACTERS WITHOUT CLAIM TO ANY PARTICULAR FONT, STYLE, SIZE, OR COLOR.

FOR CONSULTING SERVICES IN THE FIELD OF HUMAN AND BUSINESS RESOURCE DEVELOPMENT, NAMELY, IMPLEMENTING PROCESSES TO ENHANCE COMMUNICATION AND INCREASE PRODUCTIVITY FOR EMPLOYEES AND EMPLOYERS, AND ENHANCE GROWTH, PROFITABILITY AND COMPETITIVENESS FOR THE BUSINESS (U.S. CLS. 100, 101 AND 102).

FIRST USE 6-24-2007; IN COMMERCE 6-24-2007.
DORITT L. CARROLL, EXAMINING ATTORNEY

SN 76-687,922. SUCKERPUNCH SALLYS, LLC, SCOTTSDALE, AZ. FILED 3-20-2008.

SuckerPunch Sallys

THE MARK CONSISTS OF STANDARD CHARACTERS WITHOUT CLAIM TO ANY PARTICULAR FONT, STYLE, SIZE, OR COLOR.

OWNER OF U.S. REG. NO. 3,058,678.

FOR RETAIL STORE SERVICES AND ON-LINE RETAIL STORE SERVICES FEATURING MOTORCYCLES, MOTORCYCLE KITS, MOTORCYCLE PARTS, MOTORCYCLE ACCESSORIES, APPAREL, HEADWEAR, KEY CHAINS AND BELT BUCKLES (U.S. CLS. 100, 101 AND 102).

FIRST USE 3-23-2006; IN COMMERCE 3-23-2006.
MARTHA FROMM, EXAMINING ATTORNEY

CLASS 35—(Continued).

SN 76-687,944. CRESCENT PROCESSING COMPANY, LP, DALLAS, TX. FILED 3-21-2008.

CRESCENT

THE MARK CONSISTS OF STANDARD CHARACTERS WITHOUT CLAIM TO ANY PARTICULAR FONT, STYLE, SIZE, OR COLOR.

FOR PREPARING ONLINE BUSINESS REPORTS FOR MERCHANTS FEATURING TRANSACTION DATA (U.S. CLS. 100, 101 AND 102).

WANDA KAY PRICE, EXAMINING ATTORNEY

SN 76-688,010. KABLE MEDIA SERVICES, INC., NEW YORK, NY. FILED 3-24-2008.

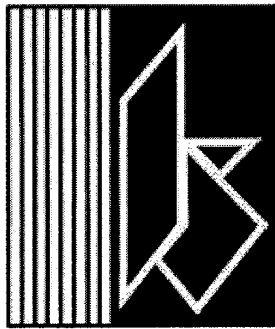

OWNER OF U.S. REG. NO. 2,600,264.

THE MARK CONSISTS OF QUADRILATERALS IN A RECTANGULAR BOX WITH VERTICAL LINES ON LEFT.

FOR ORDER FULFILLMENT SERVICES; DISTRIBUTORSHIP SERVICES FOR PUBLICATIONS OF OTHERS; RETAIL SERVICES BY DIRECT SOLICITATION BY SALES AGENTS IN THE FIELDS OF MAGAZINES, PUBLICATIONS, VIDEOS, PRE-RECORDED MUSIC AND MOVIES, COMPUTER SOFTWARE, CATALOGS, COMPACT DISCS, DVDS, BOOK CLUBS, CRAFT SUPPLIES AND CRAFT MATERIALS, BOOKS, NEWSLETTERS, NOVELTIES, CLOTHING, JEWELRY, AND TOYS; MAIL SORTING; MAIL HANDLING AND RECEIVING, MAIL LIST PREPARATION AND ENHANCING; PICKING; SORTING, PREPARING PACKING ARTICLES TO THE ORDER AND SPECIFICATION OF OTHERS; ORDER FULFILLMENT SERVICES, NAMELY, ORDER PROCESSING; CALL CENTER SERVICES, NAMELY, PROVIDING TELEPHONE ANSWERING SERVICES FOR OTHERS; MERCHANDISE PACKAGING; COMPUTERIZED TRACKING AND TRACING OF PACKAGES IN TRANSIT; PROMOTING THE GOODS AND SERVICES OF OTHERS THROUGH ELECTRONIC AND PRINT ADVERTISING; ARRANGING FOR PICKUP, DELIVERY, STORAGE AND TRANSPORTATION OF DOCUMENTS, PACKAGES, FREIGHT AND PARCELS VIA GROUND AND AIR CARRIERS; MANAGEMENT OF COMPUTERIZED AND NON-COMPUTERIZED MARKETING DATABASES FOR OTHERS (U.S. CLS. 100, 101 AND 102).

FIRST USE 5-1-2003; IN COMMERCE 5-1-2003.

LINDA ESTRADA, EXAMINING ATTORNEY

CLASS 35—(Continued).

SN 77-017,253. ONCOLOGY THERAPEUTICS NETWORK CORPORATION, SOUTH SAN FRANCISCO, CA. FILED 10-9-2006.

PHARMATEC

THE MARK CONSISTS OF STANDARD CHARACTERS WITHOUT CLAIM TO ANY PARTICULAR FONT, STYLE, SIZE, OR COLOR.

FOR ADMINISTERING PHARMACY REIMBURSEMENT PROGRAMS AND SERVICES; MANAGEMENT SERVICES PROVIDED TO PHARMACIES FOR CONTROLLING DRUG INVENTORIES (U.S. CLS. 100, 101 AND 102).

MARY BOAGNI, EXAMINING ATTORNEY

SN 77-045,609. SOUTHDALE LIMITED PARTNERSHIP, CHEVY CHASE, MD. FILED 11-16-2006.

SOUTHDALE

FOR SHOPPING CENTER SERVICES, NAMELY, BUSINESS MANAGEMENT SERVICES FOR SHOPPING MALLS AND PROMOTING THE GOODS AND SERVICES OF OTHERS BY MEANS OF OPERATING A SHOPPING MALL (U.S. CLS. 100, 101 AND 102).

FIRST USE 11-0-2000; IN COMMERCE 11-0-2000.

CHARLOTTE CORWIN, EXAMINING ATTORNEY

SN 77-045,749. SCHOEN, RONALD E., SANFORD, NC. FILED 11-16-2006.

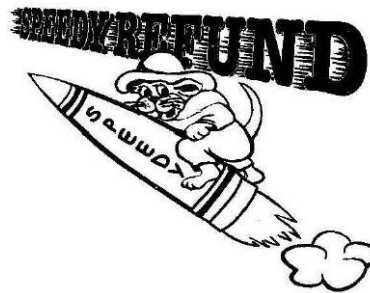

NO CLAIM IS MADE TO THE EXCLUSIVE RIGHT TO USE "SPEEDY REFUND", APART FROM THE MARK AS SHOWN.

THE MARK CONSISTS OF A CAT IN A HAT RIDING A ROCKET BEARING THE WORD "SPEEDY" WITH THE STYLIZED WORDS "SPEEDY REFUND" APPEARING ABOVE.

FOR INCOME TAX CONSULTATION; INCOME TAX PREPARATION; TAX FILING SERVICES (U.S. CLS. 100, 101 AND 102).

BARBARA GAYNOR, EXAMINING ATTORNEY

CLASS 35—(Continued).

SN 77-064,883. THE ETHICAL TEA PARTNERSHIP, LONDON, UNITED KINGDOM, FILED 12-15-2006.



NO CLAIM IS MADE TO THE EXCLUSIVE RIGHT TO USE "ETHICAL TEA PARTNERSHIP", APART FROM THE MARK AS SHOWN.

THE MARK CONSISTS OF A TEA CUP WITH A SPOT OF STEAM COMING OUT WITH THE WORDS UNDERNEATH IT.

FOR ASSOCIATION SERVICES, NAMELY, PROMOTING THE INTERESTS OF THE TEA INDUSTRY, NAMELY, TO PROMOTE RESPONSIBILITY AND AWARENESS OF THE SOCIAL, ETHICAL AND POLITICAL CONDITIONS INVOLVED IN THE SOURCING OF TEA AND TO ALIGN WITH OTHERS TO DO THE SAME; LOBBYING SERVICES, NAMELY, PROMOTING THE INTERESTS OF THE TEA INDUSTRY IN THE FIELDS OF LEGISLATION AND REGULATION; POLITICAL ACTION COMMITTEE SERVICES, NAMELY, PROMOTING THE INTERESTS OF THE TEA INDUSTRY IN THE FIELD OF POLITICS; PROMOTING THE ECONOMIC DEVELOPMENT IN THE COUNTRIES AND TERRITORIES WHICH PRODUCE AND SELL TEA; PROVIDING INFORMATION ABOUT THE TRADING OF TEA; PROVIDING STATISTICAL INFORMATION; PROVIDING TRADE INFORMATION; PUBLIC POLICY RESEARCH SERVICES; PUBLIC RELATIONS; PUBLICITY CONSULTATION; SERVICES FOR PROVISION OF FOREIGN TRADE INFORMATION; TRADE INFORMATION (U.S. CLS. 100, 101 AND 102).

PETER B. BROMAGHIM, EXAMINING ATTORNEY

SN 77-066,785. DILLON COMPANIES, INC., HUTCHISON, KS. FILED 12-18-2006.



NO CLAIM IS MADE TO THE EXCLUSIVE RIGHT TO USE "CAFE", APART FROM THE MARK AS SHOWN.

THE MARK CONSISTS OF THE WORDS "REAL TIME" ABOVE THE WORD "CAFE" AND ABOVE A BORDERED DESIGN.

FOR CONVENIENCE STORE SERVICES FEATURING COFFEE (U.S. CLS. 100, 101 AND 102).

LINDA ESTRADA, EXAMINING ATTORNEY

CLASS 35—(Continued).

SN 77-073,329. COMPUSOLVE GOVERNMENT SOLUTIONS, LLC, BOHEMIA, NY. FILED 12-29-2006.

"WHERE DO YOU STORE YOUR DECISIONS"

THE MARK CONSISTS OF STANDARD CHARACTERS WITHOUT CLAIM TO ANY PARTICULAR FONT, STYLE, SIZE, OR COLOR.

FOR DISTRIBUTORSHIP SERVICES IN THE FIELD OF COMPUTER SOFTWARE FOR MANAGEMENT OF MEETINGS (U.S. CLS. 100, 101 AND 102).

STEPHEN AQUILA, EXAMINING ATTORNEY

SN 77-073,876. FORD, MICHAEL, CAMARILLO, CA. FILED 12-31-2006.

Secret Headquarters

THE MARK CONSISTS OF STANDARD CHARACTERS WITHOUT CLAIM TO ANY PARTICULAR FONT, STYLE, SIZE, OR COLOR.

FOR PRODUCING VIDEO COMMERCIALS AND INFOMERCIALS (U.S. CLS. 100, 101 AND 102).

MICHELLE DUBOIS, EXAMINING ATTORNEY

SN 77-083,326. GABLE, TOM P., DEL MAR, CA. FILED 1-15-2007.

Guru Program

THE MARK CONSISTS OF STANDARD CHARACTERS WITHOUT CLAIM TO ANY PARTICULAR FONT, STYLE, SIZE, OR COLOR.

NO CLAIM IS MADE TO THE EXCLUSIVE RIGHT TO USE "PROGRAM", APART FROM THE MARK AS SHOWN.

FOR CONSULTING SERVICES RELATING TO PUBLICITY; PROMOTING PUBLIC AWARENESS OF PROFESSIONAL LEGAL AND ACCOUNTING SERVICES, HEALTH CARE, FINANCIAL SERVICES, REAL ESTATE, LODGING, HOSPITALITY, LIFE SCIENCES, GOLF EQUIPMENT, GOLF EVENT, INFORMATION TECHNOLOGY, WIRELESS, BIOTECHNOLOGY, EDUCATIONAL, AND NOT-FOR-PROFIT ORGANIZATIONS AND INSTITUTIONS; PUBLIC RELATIONS (U.S. CLS. 100, 101 AND 102).

FIRST USE 8-13-1998; IN COMMERCE 8-13-1998.

JASON BLAIR, EXAMINING ATTORNEY

CLASS 35—(Continued).

SN 77-090,419. R.C. RASMUSSEN CORPORATION, SEATTLE, WA. FILED 1-24-2007.

RASMUSSEN

THE MARK CONSISTS OF STANDARD CHARACTERS WITHOUT CLAIM TO ANY PARTICULAR FONT, STYLE, SIZE, OR COLOR.

SEC. 2(F).

FOR RETAIL STORE SERVICES AND WHOLESALE DISTRIBUTORSHIP FEATURING MARINE VESSELS, BARGES, MARINE CONSTRUCTION EQUIPMENT, WINCHES, FAIRLEADS, SHEAVES, MARINE HARDWARE, SHACKLES AND TOW LINES, AND PARTS FOR ALL OF THE ABOVE (U.S. CLS. 100, 101 AND 102).

FIRST USE 0-0-1981; IN COMMERCE 0-0-1981.

DAVID I, EXAMINING ATTORNEY

CLASS 35—(Continued).

SN 77-104,812. FLUM, PAUL L., ST. LOUIS, MO. FILED 2-12-2007.

ALL AMERICAN PARTY

THE MARK CONSISTS OF STANDARD CHARACTERS WITHOUT CLAIM TO ANY PARTICULAR FONT, STYLE, SIZE, OR COLOR.

NO CLAIM IS MADE TO THE EXCLUSIVE RIGHT TO USE "PARTY", APART FROM THE MARK AS SHOWN.

FOR PROMOTING AND ADVOCATING A POLITICAL PHILOSOPHY AND PUBLIC AWARENESS FOR WORLD PEACE, NATIONAL SECURITY, EDUCATION, ECOLOGY, MILITARY AFFAIRS, HUMAN RIGHTS, HEALTH AND NUTRITION, COMMERCE, NATURE AND THE ENVIRONMENT, HUMAN SERVICES, ECONOMICS, POLITICS, BUSINESS, AND JUSTICE FOR ALL (U.S. CLS. 100, 101 AND 102).

JOHN KELLY, EXAMINING ATTORNEY

SN 77-111,992. ORCHARD SUPPLY HARDWARE LLC, SAN JOSE, CA. FILED 2-20-2007.

SN 77-102,031. GOMEX, CHOYO, POMONA, CA. FILED 2-7-2007.

LONUESTRO.COM

THE MARK CONSISTS OF STANDARD CHARACTERS WITHOUT CLAIM TO ANY PARTICULAR FONT, STYLE, SIZE, OR COLOR.

THE FOREIGN WORDING IN THE MARK TRANSLATES INTO ENGLISH AS OUR OWN.

FOR ADVERTISING, MARKETING AND PROMOTION SERVICES; PROMOTING THE GOODS AND SERVICES OF OTHERS BY PROVIDING HYPERTEXT LINKS TO THE WEB SITES OF OTHERS; PROVIDING AN ONLINE DIRECTORY INFORMATION SERVICE FEATURING INFORMATION REGARDING IMMIGRATION AND CITIZENSHIP ASSISTANCE, INCOME TAX ASSISTANCE CENTERS AND IRS OFFICES AND SERVICES (U.S. CLS. 100, 101 AND 102).

DAVID MILLER, EXAMINING ATTORNEY



NO CLAIM IS MADE TO THE EXCLUSIVE RIGHT TO USE "EARTH FRIENDLY", APART FROM THE MARK AS SHOWN.

THE MARK CONSISTS OF AN OUTSIDE CIRCLE WITH THE WORDS "EARTH FRIENDLY EARTH FRIENDLY" SURROUNDING AN INSIDE CIRCLE WITH A DESIGN OF A PORTION OF A WORLD MAP.

FOR RETAIL STORE SERVICES FEATURING ITEMS SOLD IN A HARDWARE STORE, NAMELY, GARDEN, NURSERY, ELECTRICAL, HARDWARE, PLUMBING, OUTDOOR POWER, PAINT, APPLIANCE AND HOUSEWARE PRODUCTS (U.S. CLS. 100, 101 AND 102).

MARK SPACINO, EXAMINING ATTORNEY

CLASS 35—(Continued).

SN 77-120,369. PAPA MURPHY'S INTERNATIONAL, INC., VANCOUVER, WA. FILED 3-1-2007.

We can do that

THE MARK CONSISTS OF STANDARD CHARACTERS WITHOUT CLAIM TO ANY PARTICULAR FONT, STYLE, SIZE, OR COLOR.

FOR RETAIL STORE SERVICES FEATURING PIZZA (U.S. CLS. 100, 101 AND 102).

FIRST USE 9-1-2007; IN COMMERCE 9-1-2007.
ELIZABETH BEYER, EXAMINING ATTORNEY

SN 77-128,261. SCOTTJOE, LLC, DBA RED NUMBAT, HACKETTSTOWN, NJ. FILED 3-12-2007.



THE MARK CONSISTS OF A CARTOON NUMBAT AND STYLIZED TEXT.

FOR GOODS OR SERVICES PRICE QUOTATIONS (U.S. CLS. 100, 101 AND 102).

FIRST USE 11-12-2006; IN COMMERCE 12-1-2006.
MARILYN IZZI, EXAMINING ATTORNEY

SN 77-132,391. UNDEFEATED, INC., LOS ANGELES, CA. FILED 3-15-2007.



THE MARK CONSISTS OF ONE DIAGONAL SLASH MARK CROSSING OVER FOUR VERTICAL SLASH MARKS.

FOR ONLINE RETAIL SERVICES AND RETAIL STORE SERVICES IN THE FIELDS OF FOOTWEAR, CLOTHING, HEADWEAR, SCARVES, GLOVES, JEWELRY, WATCHES, SUNGLASSES, TOTE BAGS, BACKPACKS, DUFFLE BAGS, AND PURSES; TOYS AND COLLECTIBLES (U.S. CLS. 100, 101 AND 102).

JOHN SCHUYLER YARD, EXAMINING ATTORNEY

CLASS 35—(Continued).

SN 77-133,028. R & D ENTERPRISES, INC., VINEMONT, AL. FILED 3-16-2007.

MOTORHEAD

THE MARK CONSISTS OF STANDARD CHARACTERS WITHOUT CLAIM TO ANY PARTICULAR FONT, STYLE, SIZE, OR COLOR.

FOR MARKETING OF PRODUCTS, NAMELY, MARKETING OF TRADEMARK LICENSED PRODUCTS IN THE FIELD OF NOVELTIES (U.S. CLS. 100, 101 AND 102).

FIRST USE 8-1-1999; IN COMMERCE 8-1-1999.
KATHERINE CHANG, EXAMINING ATTORNEY

SN 77-136,451. MACHLEIT, CHRISTINE, BALDWIN PARK, CA. AND BEELER, MATILDA, BALDWIN PARK, CA. FILED 3-21-2007.



TIME FOR A CURE

NO CLAIM IS MADE TO THE EXCLUSIVE RIGHT TO USE THE RIBBON DESIGN, APART FROM THE MARK AS SHOWN.

THE MARK CONSISTS OF CIRCLE WITH RIBBON IN MIDDLE OF THAT CIRCLE WITH THE NUMBERS "12," "3," "6" AND "9" WITH THE WORDS "TIME FOR A CURE".

FOR PROMOTING PUBLIC AWARENESS OF BREAST CANCER (U.S. CLS. 100, 101 AND 102).

FIRST USE 10-1-1999; IN COMMERCE 10-1-1999.
SARA THOMAS, EXAMINING ATTORNEY

SN 77-137,594. AEGIS PUBLICATIONS, LLC, NEWTOWN, PA. FILED 3-22-2007.

FUNCTIONAL ESTHETICS & RESTORATIVE DENTISTRY

THE MARK CONSISTS OF STANDARD CHARACTERS WITHOUT CLAIM TO ANY PARTICULAR FONT, STYLE, SIZE, OR COLOR.

NO CLAIM IS MADE TO THE EXCLUSIVE RIGHT TO USE "RESTORATIVE DENTISTRY", APART FROM THE MARK AS SHOWN.

FOR ADVERTISING SERVICES, NAMELY, PROVIDING ADVERTISING SPACE IN A PERIODICAL; ADVERTISING VIA ELECTRONIC MEDIA AND SPECIFICALLY THE INTERNET (U.S. CLS. 100, 101 AND 102).

DOMINICK J. SALEMI, EXAMINING ATTORNEY

CLASS 35—(Continued).

SN 77-138,310. UPTOWN HOUSE AND GARDEN, ELMHURST, IL. FILED 3-22-2007.

The Uptown Shop

THE MARK CONSISTS OF STANDARD CHARACTERS WITHOUT CLAIM TO ANY PARTICULAR FONT, STYLE, SIZE, OR COLOR.

NO CLAIM IS MADE TO THE EXCLUSIVE RIGHT TO USE "SHOP", APART FROM THE MARK AS SHOWN.

FOR RETAIL STORE SERVICES FOR WOMEN AND TEENAGE GIRLS FEATURING LADIES CLOTHING ACCESSORIES AND HOME DECOR (U.S. CLS. 100, 101 AND 102).

FIRST USE 4-1-2004; IN COMMERCE 6-1-2004.
EMILY CARLSEN, EXAMINING ATTORNEY

SN 77-158,074. MUSTARD SEED COMMUNICATIONS, LLC, BOWIE, MD. FILED 4-16-2007.



NO CLAIM IS MADE TO THE EXCLUSIVE RIGHT TO USE "COMMUNICATIONS", APART FROM THE MARK AS SHOWN.

THE MARK CONSISTS OF STYLIZED TEXT WITH GRAPHIC REPRESENTATION OF A TREE WITH ROOTS EMBEDDED IN THE LETTER "D" OF THE WORD "MUSTARD".

FOR ADVERTISING BY TRANSMISSION OF ON-LINE PUBLICITY FOR THIRD PARTIES THROUGH ELECTRONIC COMMUNICATIONS NETWORKS; ADVERTISING SERVICES, NAMELY, PROMOTING AND MARKETING THE GOODS AND SERVICES OF OTHERS THROUGH ALL PUBLIC COMMUNICATION MEANS; ADVERTISING THROUGH ALL PUBLIC COMMUNICATION MEANS; DISSEMINATION OF ADVERTISING FOR OTHERS VIA AN ON-LINE COMMUNICATIONS NETWORK ON THE INTERNET (U.S. CLS. 100, 101 AND 102).

FIRST USE 2-8-2006; IN COMMERCE 2-8-2006.
G. MAYERSCHOFF, EXAMINING ATTORNEY

CLASS 35—(Continued).

SN 77-180,722. AMERICA'S HEALTH INSURANCE PLANS, INC., WASHINGTON, DC. FILED 5-14-2007.

AGENTS ACTION NETWORK

THE MARK CONSISTS OF STANDARD CHARACTERS WITHOUT CLAIM TO ANY PARTICULAR FONT, STYLE, SIZE, OR COLOR.

NO CLAIM IS MADE TO THE EXCLUSIVE RIGHT TO USE "AGENTS" AND "NETWORK", APART FROM THE MARK AS SHOWN.

FOR COORDINATION OF LOBBYING AND GRASS ROOTS EFFORTS TO BUILD SUPPORT FOR, AND AWARENESS OF, HEALTH-RELATED ISSUES OF INTEREST TO INSURANCE AGENTS AND BROKERS (U.S. CLS. 100, 101 AND 102).

GEORGIA CARTY, EXAMINING ATTORNEY

SN 77-185,417. LIGHTNER, DEREK D., DENVER, CO. FILED 5-19-2007.



NO CLAIM IS MADE TO THE EXCLUSIVE RIGHT TO USE "COLORADO", APART FROM THE MARK AS SHOWN.

THE COLOR(S) ORANGE, WHITE, BLACK, GREY IS/ARE CLAIMED AS A FEATURE OF THE MARK.

THE COLOR BLACK APPEARS IN THE WORDING "I S", THE COLORS ORANGE AND WHITE APPEARING IN THE WORDING "COLORADO". THE COLORS BLACK, GRAY AND WHITE APPEAR IN THE OVAL DESIGN, THE ARROWS ARE BLACK SURROUNDED BY ORANGE SHADING.

FOR RETAIL MUSIC AND RECORD STORES; RETAIL STORE SERVICES FEATURING A WIDE VARIETY OF CONSUMER GOODS OF OTHERS (U.S. CLS. 100, 101 AND 102).

MATTHEW EINSTEIN, EXAMINING ATTORNEY

CLASS 35—(Continued).

SN 77-188,431. BIG BIKE RIDERS ASSOCIATION OF FLORIDA, INC., CORAL SPRINGS, FL. FILED 5-23-2007.

BBRA

THE MARK CONSISTS OF STANDARD CHARACTERS WITHOUT CLAIM TO ANY PARTICULAR FONT, STYLE, SIZE, OR COLOR.

FOR ASSOCIATION SERVICES, NAMELY, PROMOTING THE INTERESTS OF MOTORCYCLE RIDERS, CHILDREN AND CHILDREN'S CHARITIES; CLUB SERVICES, NAMELY, PROMOTING THE INTERESTS OF MOTORCYCLE ENTHUSIASTS (U.S. CLS. 100, 101 AND 102).

FIRST USE 2-0-2004; IN COMMERCE 5-0-2004.
RENEE SERVANCE, EXAMINING ATTORNEY

CLASS 35—(Continued).

SN 77-197,834. DELTA SOLUTIONS AND TECHNOLOGIES, INC., RESTON, VA. FILED 6-5-2007.

FinMart

THE MARK CONSISTS OF STANDARD CHARACTERS WITHOUT CLAIM TO ANY PARTICULAR FONT, STYLE, SIZE, OR COLOR.

FOR MANAGEMENT AND BUSINESS CONSULTING SERVICES IN THE FIELD OF ENTERPRISE PERFORMANCE (U.S. CLS. 100, 101 AND 102).

NELSON SNYDER, EXAMINING ATTORNEY

SN 77-209,269. BASSMAN, THOMAS A., HALLANDALE BEACH, FL. FILED 6-19-2007.

Manny Poppins

THE MARK CONSISTS OF STANDARD CHARACTERS WITHOUT CLAIM TO ANY PARTICULAR FONT, STYLE, SIZE, OR COLOR.

THE NAME "MANNY POPPINS" DOES NOT IDENTIFY A LIVING INDIVIDUAL.

FOR EMPLOYMENT HIRING, RECRUITING, PLACEMENT, STAFFING AND CAREER NETWORKING SERVICES (U.S. CLS. 100, 101 AND 102).

FIRST USE 6-1-2007; IN COMMERCE 6-1-2007.

ARETHA SOMERVILLE, EXAMINING ATTORNEY

SN 77-192,971. HEALTH CARE POLICY ROUNDTABLE, L.L.C., WASHINGTON, DC. FILED 5-30-2007.



OWNER OF U.S. REG. NO. 3,440,614.
SEC. 2(F) AS TO "RETIREE HEALTH ACCESS".
FOR PROVIDING CONSUMERS WITH REFERRALS IN THE FIELD OF HEALTH INSURANCE; BUSINESS INTERMEDIARY SERVICES, NAMELY, PROMOTING THE BROKERAGE SERVICES OF OTHERS IN THE FIELD OF HEALTH INSURANCE; BUSINESS MANAGEMENT CONSULTING SERVICES, NAMELY, PROVIDING STRATEGIES FOR MAKING HEALTH INSURANCE BENEFITS AVAILABLE TO RETIRED EMPLOYEES AND THEIR FAMILIES (U.S. CLS. 100, 101 AND 102).

FIRST USE 10-0-2005; IN COMMERCE 10-0-2005.
MARCIE MILONE, EXAMINING ATTORNEY

SN 77-215,449. EDGEWOOD CONSULTING GROUP, INC., PARSIPPANY, NJ. FILED 6-26-2007.

BRAND POWER INDEX

THE MARK CONSISTS OF STANDARD CHARACTERS WITHOUT CLAIM TO ANY PARTICULAR FONT, STYLE, SIZE, OR COLOR.

SEC. 2(F).

FOR MARKET RESEARCH CONSULTATION; MARKET RESEARCH SERVICES; MARKET RESEARCH STUDIES (U.S. CLS. 100, 101 AND 102).

FIRST USE 4-1-1999; IN COMMERCE 4-1-1999.

JILL C. ALT, EXAMINING ATTORNEY

CLASS 35—(Continued).

SN 77-217,387. CERTIFIED CUSTOM WOODWORKERS ASSOCIATION, WASHINGTON, DC. FILED 6-27-2007.

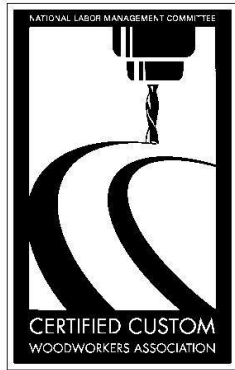

NO CLAIM IS MADE TO THE EXCLUSIVE RIGHT TO USE "NATIONAL LABOR MANAGEMENT COMMITTEE" AND "CERTIFIED CUSTOM WOODWORKERS ASSOCIATION", APART FROM THE MARK AS SHOWN.

THE MARK CONSISTS OF A VERTICAL LOGO THAT DEPICTS A "CNC" ROUTER BIT CARVING A ROUNDED DESIGN, WITH THE STYLIZED TEXT "NATIONAL LABOR MANAGEMENT COMMITTEE CERTIFIED CUSTOM WOODWORKERS ASSOCIATION".

FOR ASSOCIATION SERVICES, NAMELY, PROMOTING THE INTERESTS OF ARCHITECTURAL MILLWORK CONTRACTORS (U.S. CLS. 100, 101 AND 102).

FIRST USE 10-15-2006; IN COMMERCE 10-15-2006.
SALLY SHIH, EXAMINING ATTORNEY

SN 77-224,916. MIRYAZDI, ALLEN, LAGUNA BEACH, CA. FILED 7-9-2007.

DIAORO BY GIORDANO ZANON

THE MARK CONSISTS OF STANDARD CHARACTERS WITHOUT CLAIM TO ANY PARTICULAR FONT, STYLE, SIZE, OR COLOR.

OWNER OF U.S. REG. NO. 3,295,707.

"GIORDANO ZANON" IDENTIFIES A LIVING INDIVIDUAL WHOSE CONSENT IS OF RECORD.

"DIAORO" HAS NO MEANING IN A FOREIGN LANGUAGE.

FOR ON-LINE RETAIL STORE SERVICES FEATURING WALLETS, BRIEFCASES, PURSES, BACKPACKS, SUNGLASSES, PERFUME, COLOGNE, FOUNTAIN PENS, WRITING PENS, PENCILS, ALARM CLOCKS, BRACELETS, BRACELETS OF PRECIOUS METAL, CHARMS, CHOKERS, CIGARETTE HOLDERS OF PRECIOUS METAL, CLIP EARRINGS, CLOCK AND WATCH HANDS, CLOCKS, CUFF-LINKS, CUT DIAMONDS, DIAMONDS, DIVING WATCHES, EAR STUDS, EARRINGS, JEWEL PENDANTS, JEWELRY CASES OF PRECIOUS METAL, JEWELRY PINS FOR USE ON HATS, JEWELRY WATCHES, LAPEL PINS, NECKLACES, OPAL, ORNAMENTAL LAPEL PINS, PENDANTS, PINS BEING JEWELRY, PRECIOUS METAL MONEY CLIPS, PRECIOUS METALS, PRECIOUS METALS AND THEIR ALLOYS, NAMELY, GOLD, SILVER AND PLATINUM, PRECIOUS STONES, RINGS, RINGS BEING JEWELRY, RUBY, SAPPHIRE, SEMI-PRECIOUS GEMSTONES, SEMI-WROUGHT PRECIOUS STONES AND THEIR IMITATIONS, STOP WATCHES, SYNTHETIC DIAMONDS, TABLE CLOCKS, TIE CLIPS, TIE PINS, UNWROUGHT AND SEMI-WROUGHT PRECIOUS STONES AND THEIR IMITATIONS, WATCH BANDS, WATCH BRACELETS,

CLASS 35—(Continued).

WATCHES, WRIST WATCHES; WHOLESALE DISTRIBUTORSHIPS FEATURING WALLETS, BRIEFCASES, PURSES, BACKPACKS, SUNGLASSES, PERFUME, COLOGNE, FOUNTAIN PENS, WRITING PENS, PENCILS, ALARM CLOCKS, BRACELETS, BRACELETS OF PRECIOUS METAL, CHARMS, CHOKERS, CIGARETTE HOLDERS OF PRECIOUS METAL, CLIP EARRINGS, CLOCK AND WATCH HANDS, CLOCKS, CUFF-LINKS, CUT DIAMONDS, DIAMONDS, DIVING WATCHES, EAR STUDS, EARRINGS, JEWEL PENDANTS, JEWELRY CASES OF PRECIOUS METAL, JEWELRY PINS FOR USE ON HATS, JEWELRY WATCHES, LAPEL PINS, NECKLACES, OPAL, ORNAMENTAL LAPEL PINS, PENDANTS, PINS BEING JEWELRY, PRECIOUS METAL MONEY CLIPS, PRECIOUS METALS, PRECIOUS METALS AND THEIR ALLOYS, NAMELY, GOLD, SILVER AND PLATINUM, PRECIOUS STONES, RINGS, RINGS BEING JEWELRY, RUBY, SAPPHIRE, SEMI-PRECIOUS GEMSTONES, SEMI-WROUGHT PRECIOUS STONES AND THEIR IMITATIONS, STOP WATCHES, SYNTHETIC DIAMONDS, TABLE CLOCKS, TIE CLIPS, TIE PINS, UNWROUGHT AND SEMI-WROUGHT PRECIOUS STONES AND THEIR IMITATIONS, WATCH BANDS, WATCH BRACELETS, WATCHES, WRIST WATCHES; MAIL ORDER CATALOG SERVICES FEATURING WALLETS, BRIEFCASES, PURSES, BACKPACKS, SUNGLASSES, PERFUME, COLOGNE, FOUNTAIN PENS, WRITING PENS, PENCILS, ALARM CLOCKS, BRACELETS, BRACELETS OF PRECIOUS METAL, CHARMS, CHOKERS, CIGARETTE HOLDERS OF PRECIOUS METAL, CLIP EARRINGS, CLOCK AND WATCH HANDS, CLOCKS, CUFF-LINKS, CUT DIAMONDS, DIAMONDS, DIVING WATCHES, EAR STUDS, EARRINGS, JEWEL PENDANTS, JEWELRY CASES OF PRECIOUS METAL, JEWELRY PINS FOR USE ON HATS, JEWELRY WATCHES, LAPEL PINS, NECKLACES, OPAL, ORNAMENTAL LAPEL PINS, PENDANTS, PINS BEING JEWELRY, PRECIOUS METAL MONEY CLIPS, PRECIOUS METALS, PRECIOUS METALS AND THEIR ALLOYS, NAMELY, GOLD, SILVER AND PLATINUM, PRECIOUS STONES, RINGS, RINGS BEING JEWELRY, RUBY, SAPPHIRE, SEMI-PRECIOUS GEMSTONES, SEMI-WROUGHT PRECIOUS STONES AND THEIR IMITATIONS, STOP WATCHES, SYNTHETIC DIAMONDS, TABLE CLOCKS, TIE CLIPS, TIE PINS, UNWROUGHT AND SEMI-WROUGHT PRECIOUS STONES AND THEIR IMITATIONS, WATCH BANDS, WATCH BRACELETS, WATCHES, WRIST WATCHES (U.S. CLS. 100, 101 AND 102).

FIRST USE 1-0-2007; IN COMMERCE 1-0-2007.
MELISSA VALLILLO, EXAMINING ATTORNEY

CLASS 35—(Continued).

SN 77-230,427. B. WILLIAMS ENTERPRISE, LLC, BOWIE, MD. FILED 7-16-2007.



NO CLAIM IS MADE TO THE EXCLUSIVE RIGHT TO USE "ENTERPRISE", APART FROM THE MARK AS SHOWN.

THE COLOR(S) DARK BLUE IS/ARE CLAIMED AS A FEATURE OF THE MARK.

THE MARK CONSISTS OF THE COLOR DARK BLUE APPEARS IN THE STYLIZED LETTERS "B" AND "W" AND IN THE WORD "ENTERPRISE".

FOR BUSINESS CONSULTATION SERVICES (U.S. CLS. 100, 101 AND 102).

FIRST USE 11-1-2006; IN COMMERCE 11-1-2006.
B. PARADEWELAI, EXAMINING ATTORNEY

SN 77-246,571. UNCLE LEFTY, INC., YONKERS, NY. FILED 8-3-2007.

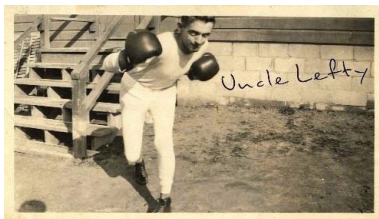

OWNER OF U.S. REG. NO. 3,425,884.
THE NAME(S), PORTRAIT(S), AND/OR SIGNATURE(S) SHOWN IN THE MARK DOES NOT IDENTIFY A PARTICULAR LIVING INDIVIDUAL.

THE MARK CONSISTS OF A PHOTO DEPICTION OF A FIGHTER IN UNDERSHIRT TOP, WITH THE WORDS "UNCLE LEFTY" IMPOSED IN SCRIPT ON THE PHOTO. FOR TALENT AGENCIES IN THE FILM AND MUSIC INDUSTRY (U.S. CLS. 100, 101 AND 102).

FIRST USE 8-1-2005; IN COMMERCE 8-1-2005.
STEVEN JACKSON, EXAMINING ATTORNEY

CLASS 35—(Continued).

SN 77-251,544. SAN DIEGO ONLINE AUCTION, INC., SAN DIEGO, CA. FILED 8-9-2007.



OWNER OF U.S. REG. NO. 7,724,832.
NO CLAIM IS MADE TO THE EXCLUSIVE RIGHT TO USE "SAN DIEGO ONLINEAUCTION", APART FROM THE MARK AS SHOWN.

THE COLOR(S) BLUE, RED AND WHITE IS/ARE CLAIMED AS A FEATURE OF THE MARK.

THE MARK CONSISTS OF THE LETTERS "SANDIEGO" AND "NLINEACTION" ARE IN A LOWERCASE BLUE VERANDA FONT. THE "O" OF THE WORD ONLINE IS CAPITALIZED IN A RED BOX WITH A WHITE CAPITALIZED LETTER "O" INSIDE, WHICH IS COMMONLY KNOWN AS THE EARWIG FACTORY FONT.

FOR PROVIDING A WEB SITE THAT ENABLES USERS TO POST ITEMS FOR SALE THROUGH ON-LINE CLASSIFIED ADVERTISEMENTS; PROVIDING AN ON-LINE SEARCHABLE DATABASE FEATURING CLASSIFIED AD LISTINGS AND EMPLOYMENT OPPORTUNITIES; AUCTION MANAGEMENT SERVICES PROVIDED TO OTHERS OVER AN ON-LINE WEB SITE ACCESSED THROUGH A GLOBAL COMPUTER NETWORK; ON-LINE TRADING SERVICES IN WHICH SELLER POSTS PRODUCTS TO BE AUCTIONED AND BIDDING IS DONE VIA THE INTERNET; ONLINE AUCTION BIDDING FOR OTHERS; ONLINE AUCTION SERVICES (U.S. CLS. 100, 101 AND 102).

NORA BUCHANAN WILL, EXAMINING ATTORNEY

SN 77-254,876. FEDERATION OF STATE MEDICAL BOARDS OF THE UNITED STATES, INC., EULESS, TX. AND NATIONAL BOARD OF MEDICAL EXAMINERS, PHILADELPHIA, PA. FILED 8-14-2007.



TRUSTED AGENT

THE MARK CONSISTS OF THE WORDING "TRUSTED AGENT" SITUATED TO THE RIGHT OF A KEYHOLE DESIGN.

FOR WEBSITE SERVICES IN THE NATURE OF CONFIDENTIAL AND SECURE REAL-TIME DATA COMPILATION FOR MEDICAL PROFESSIONALS FOR THE PURPOSE OF COLLECTING AND REPORTING DATA USEFUL FOR MEASUREMENT AND IMPROVEMENT OF PHYSICIAN PERFORMANCE AND HEALTHCARE DELIVERY (U.S. CLS. 100, 101 AND 102).

FIRST USE 9-20-2006; IN COMMERCE 9-20-2006.
RICHARD A. STRASER, EXAMINING ATTORNEY

CLASS 35—(Continued).

SN 77-255,507. THE HOME SERVICE STORE, INC., RUTLAND, VT. FILED 8-15-2007.

HOMEVENTS

THE MARK CONSISTS OF STANDARD CHARACTERS WITHOUT CLAIM TO ANY PARTICULAR FONT, STYLE, SIZE, OR COLOR.

FOR REFERRAL OF HOMEOWNERS, BUSINESSES AND INSTITUTIONS TO CONTRACTORS, NAMELY, MATCHING CONTRACTORS WITH PARTIES THAT DESIRE TO ACQUIRE GOODS AND SERVICES FOR THE IMPROVEMENT OF HOMES, BUSINESSES AND INSTITUTIONS; REFERRAL OF HOMEOWNERS, BUSINESSES AND INSTITUTIONS TO CONTRACTORS, NAMELY, MATCHING CONTRACTORS THAT PERFORM MAINTENANCE, IMPROVEMENT AND/OR REPAIR SERVICES IN HOMES, BUSINESSES AND INSTITUTIONS WITH PARTIES THAT DESIRE SUCH MAINTENANCE, IMPROVEMENT AND/OR REPAIR SERVICES; OFFERING A REFERRAL SERVICE FOR CONTRACTORS, NAMELY INTRODUCING CONTRACTORS TO HOMEOWNERS, BUSINESSES AND INSTITUTIONS DESIRING MAINTENANCE, IMPROVEMENT OR REPAIR SERVICES (U.S. CLS. 100, 101 AND 102).

DANIEL BRODY, EXAMINING ATTORNEY

SN 77-255,531. THE HOME SERVICE STORE, INC., RUTLAND, VT. FILED 8-15-2007.

HOMEEvents

THE MARK CONSISTS OF THE WORD "HOMEVENTS" IN STYLIZED FORM.

FOR REFERRAL OF HOMEOWNERS, BUSINESSES AND INSTITUTIONS TO CONTRACTORS, NAMELY, MATCHING CONTRACTORS WITH PARTIES THAT DESIRE TO ACQUIRE GOODS AND SERVICES FOR THE IMPROVEMENT OF HOMES, BUSINESSES AND INSTITUTIONS; REFERRAL OF HOMEOWNERS, BUSINESSES AND INSTITUTIONS TO CONTRACTORS, NAMELY, MATCHING CONTRACTORS THAT PERFORM MAINTENANCE, IMPROVEMENT AND/OR REPAIR SERVICES IN HOMES, BUSINESSES AND INSTITUTIONS WITH PARTIES THAT DESIRE SUCH MAINTENANCE, IMPROVEMENT AND/OR REPAIR SERVICES; OFFERING A REFERRAL SERVICE FOR CONTRACTORS, NAMELY INTRODUCING CONTRACTORS TO HOMEOWNERS, BUSINESSES AND INSTITUTIONS DESIRING MAINTENANCE, IMPROVEMENT OR REPAIR SERVICES (U.S. CLS. 100, 101 AND 102).

DANIEL BRODY, EXAMINING ATTORNEY

CLASS 35—(Continued).

SN 77-256,625. MOBILE DISCOVERY, INC., RESTON, VA. FILED 8-16-2007.

NO CLAIM IS MADE TO THE EXCLUSIVE RIGHT TO USE "MOBILE", APART FROM THE MARK AS SHOWN.

THE MARK CONSISTS OF THE WORD "MOBILE" AND AN OUTLINE OF THE WORD "DISCOVERY" WITH A SOLID "L" SHAPE IN THE BOTTOM LEFT-HAND CORNER AND AN OUTLINED "L" SHAPE IN THE TOP RIGHT-HAND CORNER.

FOR ADVERTISING SERVICES (U.S. CLS. 100, 101 AND 102).

MATTHEW MCDOWELL, EXAMINING ATTORNEY

SN 77-257,810. HELPING THOSE LEFT BEHIND CORPORATION, BROOKLYN, NY. FILED 8-17-2007.

HELPING THOSE LEFT BEHIND

THE MARK CONSISTS OF STANDARD CHARACTERS WITHOUT CLAIM TO ANY PARTICULAR FONT, STYLE, SIZE, OR COLOR.

FOR CHARITABLE SERVICES, NAMELY, PROMOTING PUBLIC AWARENESS ABOUT THOSE IN NEED OR WHO HAVE SUFFERED AN INJURY OR OTHER HARDSHIP (U.S. CLS. 100, 101 AND 102).

ESTHER A. BORSUK, EXAMINING ATTORNEY

SN 77-258,945. STRONGWOOD INSURANCE HOLDINGS CORPORATION, MONTEREY, CA. FILED 8-20-2007.

STRONGWOOD

THE MARK CONSISTS OF STANDARD CHARACTERS WITHOUT CLAIM TO ANY PARTICULAR FONT, STYLE, SIZE, OR COLOR.

FOR ADVERTISING, MARKETING AND PROMOTION SERVICES (U.S. CLS. 100, 101 AND 102).

CHRISTINE COOPER, EXAMINING ATTORNEY

CLASS 35—(Continued).

SN 77-260,481. NIELSEN MEDIA RESEARCH, INC., NEW YORK, NY. FILED 8-21-2007.

CLASS 35—(Continued).

SN 77-260,501. NIELSEN MEDIA RESEARCH, INC., NEW YORK, NY. FILED 8-21-2007.

FDMS

AUTOMATED DISCOVERY MARKETS

THE MARK CONSISTS OF STANDARD CHARACTERS WITHOUT CLAIM TO ANY PARTICULAR FONT, STYLE, SIZE, OR COLOR.

FOR MARKET RESEARCH SERVICES; MARKET RESEARCH SERVICES, NAMELY, COMMERCIAL SPOT TRACKING AND ANALYSIS SERVICES; MEDIA VIEWER DEMOGRAPHIC AND MARKET RESEARCH AND ANALYSIS SERVICES; CONDUCTING MARKET AND MEDIA RESEARCH STUDIES FOR OTHERS (U.S. CLS. 100, 101 AND 102).

FIRST USE 9-25-2000; IN COMMERCE 9-25-2000.
SOPHIA S. KIM, EXAMINING ATTORNEY

THE MARK CONSISTS OF STANDARD CHARACTERS WITHOUT CLAIM TO ANY PARTICULAR FONT, STYLE, SIZE, OR COLOR.

NO CLAIM IS MADE TO THE EXCLUSIVE RIGHT TO USE "MARKETS", APART FROM THE MARK AS SHOWN. FOR MARKET RESEARCH SERVICES; MARKET RESEARCH SERVICES, NAMELY, COMMERCIAL SPOT TRACKING AND ANALYSIS SERVICES; MEDIA VIEWER DEMOGRAPHIC AND MARKET RESEARCH AND ANALYSIS SERVICES; CONDUCTING MARKET AND MEDIA RESEARCH STUDIES FOR OTHERS (U.S. CLS. 100, 101 AND 102).

FIRST USE 9-25-2000; IN COMMERCE 9-25-2000.
SOPHIA S. KIM, EXAMINING ATTORNEY

SN 77-260,498. NIELSEN MEDIA RESEARCH, INC., NEW YORK, NY. FILED 8-21-2007.

SN 77-260,720. BETTER BUSINESS BUREAU OF THE SOUTHLAND, INC., COLTON, CA. FILED 8-21-2007.

FULL DISCOVERY MARKETS

TRUSTLINK

THE MARK CONSISTS OF STANDARD CHARACTERS WITHOUT CLAIM TO ANY PARTICULAR FONT, STYLE, SIZE, OR COLOR.

NO CLAIM IS MADE TO THE EXCLUSIVE RIGHT TO USE "MARKETS", APART FROM THE MARK AS SHOWN. FOR MARKET RESEARCH SERVICES; MARKET RESEARCH SERVICES, NAMELY, COMMERCIAL SPOT TRACKING AND ANALYSIS SERVICES; MEDIA VIEWER DEMOGRAPHIC AND MARKET RESEARCH AND ANALYSIS SERVICES; CONDUCTING MARKET AND MEDIA RESEARCH STUDIES FOR OTHERS (U.S. CLS. 100, 101 AND 102).

FIRST USE 9-25-2000; IN COMMERCE 9-25-2000.
SOPHIA S. KIM, EXAMINING ATTORNEY

THE MARK CONSISTS OF STANDARD CHARACTERS WITHOUT CLAIM TO ANY PARTICULAR FONT, STYLE, SIZE, OR COLOR.

FOR PROVIDING INFORMATION, EVALUATION AND FEEDBACK OF BUSINESSES, PRODUCTS AND SERVICES, NAMELY, PROVIDING BUSINESS AND CONSUMER PRODUCTS AND SERVICES INFORMATION, DESCRIPTIONS, ASSESSMENTS, EVALUATIONS AND RANKINGS OF CONSUMER GOODS AND SERVICES AND BUSINESSES VIA THE INTERNET; PROVIDING A WEBSITE WHERE USERS CAN POST RATINGS, REVIEWS AND RECOMMENDATIONS ON PRODUCTS, SERVICES AND BUSINESSES; PROVIDING A WEBSITE FEATURING PRODUCT RATINGS OF THE CONSUMER GOODS AND SERVICES OF OTHERS IN A WIDE VARIETY OF FIELDS (U.S. CLS. 100, 101 AND 102).

MYRIAH HABEEB, EXAMINING ATTORNEY

CLASS 35—(Continued).

SN 77-261,391. SEQUOIA SUPPLY, WARRINGTON, PA. FILED 8-22-2007.

SEQUOIA

THE MARK CONSISTS OF STANDARD CHARACTERS WITHOUT CLAIM TO ANY PARTICULAR FONT, STYLE, SIZE, OR COLOR.

FOR DISTRIBUTORSHIP SERVICES IN THE FIELD OF OUTDOOR DECK PRODUCTS, NAMELY, DECKBOARDS, RAILINGS, AND FRAMING HARDWARE, NAMELY, SCREWS, FASTENER, BOLTS AND HANGERS (U.S. CLS. 100, 101 AND 102).

FIRST USE 7-21-2004; IN COMMERCE 7-21-2004.
JOHN DWYER, EXAMINING ATTORNEY

SN 77-261,856. AMERICAN PLANNING ASSOCIATION, WASHINGTON, DC. FILED 8-22-2007.



The American Planning Association's
Professional Institute
**American Institute
of Certified Planners**

Making Great Communities Happen

NO CLAIM IS MADE TO THE EXCLUSIVE RIGHT TO USE "AMERICAN PLANNING ASSOCIATION'S PROFESSIONAL INSTITUTE" OR "AMERICAN INSTITUTE OF CERTIFIED PLANNERS", APART FROM THE MARK AS SHOWN.

THE MARK CONSISTS OF A BLOCK CONTAINING THE LETTERS "AICP", TO THE RIGHT OF THE BLOCK THE WORDS "THE AMERICAN PLANNING ASSOCIATION'S PROFESSIONAL INSTITUTE" AND "AMERICAN INSTITUTE OF CERTIFIED PLANNERS" IN A BOLD TEXT, BELOW WHICH THE WORDS "MAKING GREAT COMMUNITIES HAPPEN" ARE PLACED IN ITALIC TEXT.

FOR ASSOCIATION SERVICES, NAMELY, PROMOTING THE INTERESTS OF URBAN PLANNERS (U.S. CLS. 100, 101 AND 102).

JAMES GRIFFIN, EXAMINING ATTORNEY

SN 77-263,142. MARK SIPE, GOLD CANYON, AZ. FILED 8-23-2007.

OUT OF SIGHT BUT NOT OUT OF REACH

THE MARK CONSISTS OF STANDARD CHARACTERS WITHOUT CLAIM TO ANY PARTICULAR FONT, STYLE, SIZE, OR COLOR.

FOR RETAIL STORES AND WHOLESALE ORDERING SERVICES TO DISTRIBUTORS IN THE FIELD OF NEW AND RETROFIT BUILDING CONSTRUCTION PRODUCTS (U.S. CLS. 100, 101 AND 102).

MARY BOAGNI, EXAMINING ATTORNEY

CLASS 35—(Continued).

SN 77-264,549. MY NEXT BIG THING, INC., BOSTON, MA. FILED 8-26-2007.

I'M NOT DONE YET

THE MARK CONSISTS OF STANDARD CHARACTERS WITHOUT CLAIM TO ANY PARTICULAR FONT, STYLE, SIZE, OR COLOR.

FOR PROVIDING ONLINE SEARCHABLE DATABASE OF EMPLOYMENT BIOGRAPHIES, RESUMES, CURRICULA VITAE AND CAREER DESCRIPTIONS (U.S. CLS. 100, 101 AND 102).

DORITT L. CARROLL, EXAMINING ATTORNEY

SN 77-264,612. MY NEXT BIG THING, INC., BOSTON, MA. FILED 8-27-2007.

WE'RE NOT DONE YET

THE MARK CONSISTS OF STANDARD CHARACTERS WITHOUT CLAIM TO ANY PARTICULAR FONT, STYLE, SIZE, OR COLOR.

FOR PROVIDING ONLINE SEARCHABLE DATABASE OF EMPLOYMENT BIOGRAPHIES, RESUMES, CURRICULA VITAE AND CAREER DESCRIPTIONS (U.S. CLS. 100, 101 AND 102).

DORITT L. CARROLL, EXAMINING ATTORNEY

SN 77-266,249. INFOUSA INC., OMAHA, NE. FILED 8-28-2007.

THE MARK CONSISTS OF A CHECK MARK ABOVE THE LETTER "I" IN THE WORD "CREDIT".

FOR PROVIDING AN ONLINE COMPUTER DATABASE IN THE FIELD OF BUSINESS INFORMATION (U.S. CLS. 100, 101 AND 102).

FIRST USE 7-0-2004; IN COMMERCE 7-0-2004.
LINDA ORNDORFF, EXAMINING ATTORNEY

CLASS 35—(Continued).

SN 77-267,021. CBS PERSONNEL HOLDINGS, INC., CINCINNATI, OH. FILED 8-29-2007.

EXPERT

THE MARK CONSISTS OF STANDARD CHARACTERS WITHOUT CLAIM TO ANY PARTICULAR FONT, STYLE, SIZE, OR COLOR.

FOR PROVIDING RECRUITING AND CAREER PLACEMENT SERVICES TO BUSINESSES TO RECRUIT AND PLACE RETIRED OR RETIRING WORKERS BACK INTO THE WORK FORCE (U.S. CLS. 100, 101 AND 102).
FIRST USE 10-0-2006; IN COMMERCE 10-0-2006.
MELISSA VALLILLO, EXAMINING ATTORNEY

SN 77-269,308. PENA, GLORIA V, LONG BEACH, CA. FILED 8-31-2007.

APOSTOLIC BUSINESS CONNECTIONS

THE MARK CONSISTS OF STANDARD CHARACTERS WITHOUT CLAIM TO ANY PARTICULAR FONT, STYLE, SIZE, OR COLOR.

NO CLAIM IS MADE TO THE EXCLUSIVE RIGHT TO USE "BUSINESS CONNECTIONS", APART FROM THE MARK AS SHOWN.

FOR ONLINE BUSINESS NETWORKING SERVICES (U.S. CLS. 100, 101 AND 102).
SANJEEV VOHRA, EXAMINING ATTORNEY

SN 77-269,400. FUTURE CARE, INC., NEW YORK, NY. FILED 8-31-2007.

FUTURE CARE

THE MARK CONSISTS OF STANDARD CHARACTERS WITHOUT CLAIM TO ANY PARTICULAR FONT, STYLE, SIZE, OR COLOR.

NO CLAIM IS MADE TO THE EXCLUSIVE RIGHT TO USE "CARE", APART FROM THE MARK AS SHOWN.

FOR MEDICAL COST CONTAINMENT SERVICES TO AVOID FRAUD AND ERRONEOUS BILLING IN MEDICAL TREATMENT SITUATIONS (U.S. CLS. 100, 101 AND 102).

FIRST USE 0-0-1986; IN COMMERCE 0-0-1986.
MARY ROSSMAN, EXAMINING ATTORNEY

CLASS 35—(Continued).

SN 77-269,452. MOTO-DIRECT USA, WARREN, IN. FILED 8-31-2007.

Moto Direct

THE MARK CONSISTS OF STANDARD CHARACTERS WITHOUT CLAIM TO ANY PARTICULAR FONT, STYLE, SIZE, OR COLOR.

NO CLAIM IS MADE TO THE EXCLUSIVE RIGHT TO USE "DIRECT", APART FROM THE MARK AS SHOWN.

FOR ON-LINE RETAIL STORE SERVICES FEATURING MOTORCYCLE APPAREL, FOOTWEAR AND ACCESSORIES (U.S. CLS. 100, 101 AND 102).

KRISTINA MORRIS, EXAMINING ATTORNEY

SN 77-272,619. S.A.A.Z. CORPORATION, KISSIMMEE, FL. FILED 9-6-2007.

MAX PROPERTY DEALERS

THE MARK CONSISTS OF STANDARD CHARACTERS WITHOUT CLAIM TO ANY PARTICULAR FONT, STYLE, SIZE, OR COLOR.

NO CLAIM IS MADE TO THE EXCLUSIVE RIGHT TO USE "PROPERTY DEALERS", APART FROM THE MARK AS SHOWN.

FOR ADVERTISING AND PUBLICITY SERVICES, NAMELY, PROMOTING THE GOODS, SERVICES, BRAND IDENTITY AND COMMERCIAL INFORMATION AND NEWS OF OTHERS AND THIRD PARTIES THROUGH PRINT, AUDIO, VIDEO, DIGITAL AND ON-LINE MEDIUM FOR PURCHASE, SALES AND LISTINGS OF PROPERTIES AND BUSINESSES (U.S. CLS. 100, 101 AND 102).

JAY BESCH, EXAMINING ATTORNEY

SN 77-272,643. S.A.A.Z. CORPORATION, KISSIMMEE, FL. FILED 9-6-2007.

MAX DEALERS

THE MARK CONSISTS OF STANDARD CHARACTERS WITHOUT CLAIM TO ANY PARTICULAR FONT, STYLE, SIZE, OR COLOR.

NO CLAIM IS MADE TO THE EXCLUSIVE RIGHT TO USE "DEALERS", APART FROM THE MARK AS SHOWN.

FOR ADVERTISING AND PUBLICITY SERVICES, NAMELY, PROMOTING THE GOODS, SERVICES, BRAND IDENTITY AND COMMERCIAL INFORMATION AND NEWS OF OTHERS AND THIRD PARTIES THROUGH PRINT, AUDIO, VIDEO, DIGITAL AND ON-LINE MEDIUM (U.S. CLS. 100, 101 AND 102).

JAY BESCH, EXAMINING ATTORNEY

CLASS 35—(Continued).

SN 77-273,375. RECENTER CONSULTING, LLC, SAN DIEGO, CA. FILED 9-6-2007.

ReCenter

THE MARK CONSISTS OF STANDARD CHARACTERS WITHOUT CLAIM TO ANY PARTICULAR FONT, STYLE, SIZE, OR COLOR.

FOR BUSINESS CONSULTATION; BUSINESS MANAGEMENT CONSULTATION IN THE FIELD OF EXECUTIVE AND LEADERSHIP DEVELOPMENT; BUSINESS MANAGEMENT CONSULTING WITH RELATION TO STRATEGY, MARKETING, PRODUCTION, PERSONNEL AND RETAIL SALE MATTERS; BUSINESS ORGANIZATION AND MANAGEMENT CONSULTING; CONSULTING SERVICES IN BUSINESS ORGANIZATION AND MANAGEMENT; CONSULTING SERVICES IN THE FIELD OF HIGHER EDUCATION ADMINISTRATION; CONSULTING SERVICES IN THE FIELD OF HUMAN RESOURCES DEVELOPMENT, NAMELY, FOR THE PROMOTION OF EMPLOYEE RETENTION, CAREER GROWTH, AND INCREASED PRODUCTIVITY FOR EMPLOYEES AND EMPLOYERS; PERSONNEL MANAGEMENT CONSULTATION; PROVIDING BUSINESS MANAGEMENT INFORMATION IN CONNECTION WITH CONSULTING AND ADVISORY SERVICES IN THE FIELD OF STRATEGIC PLANNING (U.S. CLS. 100, 101 AND 102).

FIRST USE 5-21-1999; IN COMMERCE 5-21-1999.
TRACY CROSS, EXAMINING ATTORNEY

CLASS 35—(Continued).

PUBLIC OPINION POLLING; CONDUCTING OF PUBLIC OPINION POLLS; PROVIDING BUSINESS MARKET INFORMATION, NAMELY, MARKET DYNAMICS INFORMATION USING STATISTICAL MODELS; COMMERCIAL INFORMATION SERVICES PROVIDED BY ACCESS TO A COMPUTER DATABASE OR ONLINE VIA THE INTERNET; MARKET RESEARCH BY MEANS OF A COMPUTER DATABASE; PROVIDING BUSINESS INFORMATION, NAMELY, BUSINESS STATISTICAL DATA; BUSINESS MARKETING SERVICES, NAMELY, MARKETING SERVICES FOR BUYER LOYALTY MANAGEMENT, MARKETING SERVICES FOR CUSTOMER SERVICE MANAGEMENT, MARKETING SERVICES FOR PERMISSION-MARKETING AND MOBILE MANAGEMENT; PROVIDING CONSUMER PRODUCT INFORMATION; INVESTIGATIONS OF MARKETING STRATEGY; AUTOMATED DATA PROCESSING; COMPUTERIZED DATABASE MANAGEMENT; SYSTEMIZATION OF INFORMATION IN COMPUTER DATABASES; MARKET RESEARCH SERVICES (U.S. CLS. 100, 101 AND 102).

DANNEAN HETZEL, EXAMINING ATTORNEY

SN 77-274,199. SAN FRANCISCO PUBLIC GOLF ALLIANCE, SAN FRANCISCO, CA. FILED 9-7-2007.

SN 77-273,962. THE FOURNAISE MARKETING GROUP PTE LTD, SINGAPORE, SINGAPORE, FILED 9-7-2007.

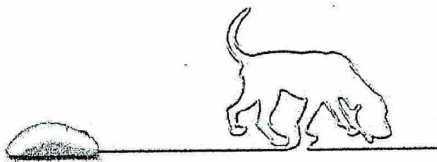

THE MARK CONSISTS OF A DESIGN OF A DOG AND A COMPUTER MOUSE.

FOR MARKET ANALYSIS SERVICES; MARKET CAMPAIGNS, NAMELY, DEVELOPMENT OF ADVERTISING CAMPAIGNS FOR THE INTERNET; MARKETING STRATEGIES RESULTS ANALYSIS; MARKET RESEARCH STUDIES; BUSINESS MARKETING SERVICES, NAMELY, MARKETING CONSULTANCY, STRATEGIES, RESEARCH, PROGRAM CAMPAIGN MANAGEMENT AND RESULTS ANALYSIS PROVIDED ONLINE VIA A COMPUTER DATABASE OR THE INTERNET; MARKET RESEARCH SERVICES, NAMELY, RETRIEVAL OF MARKETING RESEARCH DATA VIA A COMPUTER DATABASE OR THE INTERNET; CONSULTANCY RELATING TO THE ORGANIZATION OF PROMOTIONAL CAMPAIGNS FOR BUSINESS; MARKET RESEARCH FOR ADVERTISING; ONLINE ADVERTISING ON A COMPUTER NETWORK; CONDUCTING MARKET RESEARCH SURVEYS; CONDUCTING OF MARKET AND BUSINESS RESEARCH; ANALYSIS OF MARKET RESEARCH DATA AND STATISTICS; COMPUTERIZED BUSINESS AND MARKET RESEARCH; ONLINE DATA PROCESSING SERVICES;



NO CLAIM IS MADE TO THE EXCLUSIVE RIGHT TO USE "SAN FRANCISCO PUBLIC GOLF ALLIANCE", APART FROM THE MARK AS SHOWN.

FOR PROMOTING PUBLIC AWARENESS OF THE NEED FOR PUBLIC GOLF COURSES (U.S. CLS. 100, 101 AND 102).

FIRST USE 8-9-2007; IN COMMERCE 8-9-2007.
DANIEL CAPSHAW, EXAMINING ATTORNEY

CLASS 35—(Continued).

SN 77-275,057. WHOLESACRAFTS.COM, INC., MOORESVILLE, NC. FILED 9-9-2007.

ACRE

THE MARK CONSISTS OF STANDARD CHARACTERS WITHOUT CLAIM TO ANY PARTICULAR FONT, STYLE, SIZE, OR COLOR.

FOR INFOMEDIARY SERVICES, NAMELY, FACILITATING TRANSACTIONS BETWEEN BUYERS AND SELLERS THROUGH PROVIDING BUYERS WITH INFORMATION ABOUT SELLERS, GOODS, AND/OR SERVICES; ONLINE BUSINESS NETWORKING SERVICES; OPERATING ON-LINE MARKETPLACES FOR SELLERS OF GOODS AND/OR SERVICES; PROMOTING THE GOODS AND SERVICES OF OTHERS BY PROVIDING A WEB SITE AT WHICH USERS CAN LINK TO ARTISTS AND RETAILERS; PROMOTING THE GOODS AND SERVICES OF OTHERS BY PROVIDING HYPERTEXT LINKS TO THE WEB SITES OF OTHERS; PROMOTING THE GOODS AND SERVICES OF OTHERS THROUGH ON-LINE ORDERING AND CATALOGING OF THOSE GOODS AND SERVICES; PROVIDING A WEB SITE WHICH FEATURES ADVERTISEMENTS FOR THE GOODS AND SERVICES OF OTHERS ON A GLOBAL COMPUTER NETWORK; COMPUTERIZED ON-LINE ORDERING SERVICES IN THE FIELD OF ART; INTERNET ADVERTISING SERVICES; ON-LINE ORDERING SERVICES FEATURING ART (U.S. CLS. 100, 101 AND 102).

FIRST USE 12-15-1997; IN COMMERCE 12-15-1997.
DAVID MURRAY, EXAMINING ATTORNEY

SN 77-276,067. VULCAN INC., SEATTLE, WA. FILED 9-10-2007.

BACKCHANNEL

THE MARK CONSISTS OF STANDARD CHARACTERS WITHOUT CLAIM TO ANY PARTICULAR FONT, STYLE, SIZE, OR COLOR.

FOR ADVERTISING AND MARKETING SERVICES; ADVERTISING CONSULTATION; MARKET RESEARCH SERVICES, NAMELY, COLLECTING AND MEASURING DATA RELATED TO TELEVISION AUDIENCE VIEWING (U.S. CLS. 100, 101 AND 102).

DANNEAN HETZEL, EXAMINING ATTORNEY

CLASS 35—(Continued).

SN 77-278,460. BEATYOUTHERE.COM LLP, STAMFORD, CT. FILED 9-13-2007.



THE COLOR(S) BLUE IS/ARE CLAIMED AS A FEATURE OF THE MARK.

THE WORDING AND THE DESIGN OF THE MARK ARE IN BLUE.

FOR MATCHING CONSUMERS WITH REAL ESTATE PROFESSIONALS IN THE FIELD OF REAL ESTATE SERVICES VIA COMPUTER NETWORK; PROMOTING THE GOODS AND SERVICES OF OTHERS BY PROVIDING A WEBSITE FEATURING COUPONS, REBATES, PRICE-COMPARISON INFORMATION, PRODUCT REVIEWS, LINKS TO THE RETAIL WEBSITES OF OTHERS, AND DISCOUNT INFORMATION (U.S. CLS. 100, 101 AND 102).

FIRST USE 8-1-2007; IN COMMERCE 8-1-2007.
DAWN FELDMAN, EXAMINING ATTORNEY

SN 77-278,499. ADVERTISING SPECIALTY INSTITUTE, INC., TREVOSE, PA. FILED 9-13-2007.

ESP Online

THE MARK CONSISTS OF STANDARD CHARACTERS WITHOUT CLAIM TO ANY PARTICULAR FONT, STYLE, SIZE, OR COLOR.

OWNER OF U.S. REG. NOS. 1,595,034, 2,489,865 AND OTHERS.

NO CLAIM IS MADE TO THE EXCLUSIVE RIGHT TO USE "ONLINE", APART FROM THE MARK AS SHOWN.

FOR PROVIDING AN ONLINE COMPUTER DATABASE FEATURING BUSINESS INFORMATION FOR PROMOTIONAL PRODUCTS/SPECIALTY ADVERTISING INDUSTRY (U.S. CLS. 100, 101 AND 102).

FIRST USE 2-18-2004; IN COMMERCE 2-18-2004.
STEVEN JACKSON, EXAMINING ATTORNEY

SN 77-279,293. AHOLD LICENSING SA, GENEVA, SWITZERLAND, FILED 9-13-2007.

HEALTHY IDEAS

THE MARK CONSISTS OF STANDARD CHARACTERS WITHOUT CLAIM TO ANY PARTICULAR FONT, STYLE, SIZE, OR COLOR.

FOR PROMOTING PUBLIC AWARENESS OF THE NEED FOR FITNESS, WELLNESS AND NUTRITION (U.S. CLS. 100, 101 AND 102).

COLLEEN DOMBROW, EXAMINING ATTORNEY

CLASS 35—(Continued).

SN 77-280,227. WELLBORN CABINET, INC., ASHLAND, AL.
FILED 9-14-2007.

DIRECT CONNECT

THE MARK CONSISTS OF STANDARD CHARACTERS WITHOUT CLAIM TO ANY PARTICULAR FONT, STYLE, SIZE, OR COLOR.

FOR PROVIDING AN ON-LINE INTERNET-BASED INTERACTIVE WEBSITE FOR CABINET RETAILERS TO USE FOR ORDERING, QUOTING, PRICING, ISSUING CHANGE ORDERS, CONFIRMING ORDERS, CONFIRMING SHIPPING, AND RECEIVING INVOICES FOR CUSTOM CABINETRY (U.S. CLS. 100, 101 AND 102).

FIRST USE 9-1-2005; IN COMMERCE 9-1-2005.
JANICE KIM, EXAMINING ATTORNEY

SN 77-282,230. DONNE DAVIS, MENLO PARK, CA. FILED 9-18-2007.

GaGa

THE MARK CONSISTS OF STANDARD CHARACTERS WITHOUT CLAIM TO ANY PARTICULAR FONT, STYLE, SIZE, OR COLOR.

FOR ADVERTISING SERVICES; PROVIDING A WEBSITE WITH BUSINESS INFORMATION FEATURING PRODUCT INFORMATION, PRODUCT REVIEWS OF GOODS AND SERVICES FOR GRANDMOTHERS (U.S. CLS. 100, 101 AND 102).

CAROL SPILS, EXAMINING ATTORNEY

SN 77-286,373. EXPRESS INNOVATIONS, INC., TIVERTON, RI. FILED 9-21-2007.

SurveySearch.net

THE MARK CONSISTS OF STANDARD CHARACTERS WITHOUT CLAIM TO ANY PARTICULAR FONT, STYLE, SIZE, OR COLOR.

FOR PROVIDING AN ON-LINE COMPUTER DATABASE FEATURING CONTACT INFORMATION FOR LAND SURVEYORS FOR HIRE (U.S. CLS. 100, 101 AND 102).

FIRST USE 7-23-2007; IN COMMERCE 7-23-2007.
BILL DAWE, EXAMINING ATTORNEY

CLASS 35—(Continued).

SN 77-286,922. SHEARDIGITAL INC., DBA GRAVITANT, INC., AUSTIN, TX. FILED 9-24-2007.

 The logo for Gravitant features the word "Gravitant" in a sans-serif font. The letter "i" is stylized with a blue semi-circle above it, resembling a planet or a celestial body. The rest of the letters are in orange.

THE COLOR(S) ORANGE AND BLUE IS/ARE CLAIMED AS A FEATURE OF THE MARK.

THE MARK CONSISTS OF THE "GRAVITANT" WORD IN ORANGE WITH A STYLIZED LETTER "I". THE LETTER "I" HAS A SEMI-CIRCLE FACING UPWARDS IN BLUE.

THE FOREIGN WORDING IN THE MARK TRANSLATES INTO ENGLISH AS "GRAVITATING" OR "REVOLVING".

FOR BUSINESS MANAGEMENT INTELLIGENCE CONSULTANCY SERVICES (U.S. CLS. 100, 101 AND 102).

FIRST USE 3-1-2004; IN COMMERCE 3-15-2004.
LINDA ORNDORFF, EXAMINING ATTORNEY

SN 77-288,324. AMERICAN DAIRY GOAT ASSOCIATION, SPINDALE, NC. FILED 9-25-2007.



THE MARK CONSISTS OF THREE GOAT HEADS. FOR MAINTAINING A REGISTRY OF BREEDS IN THE FIELD OF DAIRY GOATS; ASSOCIATION SERVICES, NAMELY, PROMOTING THE INTERESTS OF DAIRY GOAT HERD OWNERS (U.S. CLS. 100, 101 AND 102).

FIRST USE 10-18-2006; IN COMMERCE 10-18-2006.
CHARISMA HAMPTON, EXAMINING ATTORNEY

CLASS 35—(Continued).

SN 77-288,366. FONDA SAMULAK, JACKSON, MI. FILED 9-25-2007.



THE MARK CONSISTS OF A PICTURE OF A CAT IN CLOTHES WITH THE LETTER "S" ON THE CAT'S SWEATER.

FOR CONDUCTING EMPLOYEE INCENTIVE AWARD PROGRAMS TO PROMOTE EMPLOYEE PRODUCTIVITY, PERFORMANCE, RECOGNITION, AND MORALE (U.S. CLS. 100, 101 AND 102).

WANDA KAY PRICE, EXAMINING ATTORNEY

SN 77-288,597. ODYSSEY, L.P., SAN FRANCISCO, CA. FILED 9-25-2007.

SLEDGEHAMMER

THE MARK CONSISTS OF STANDARD CHARACTERS WITHOUT CLAIM TO ANY PARTICULAR FONT, STYLE, SIZE, OR COLOR.

FOR MARKET RESEARCH; CONDUCTING MARKET RESEARCH STUDIES; MARKET RESEARCH CONSULTATION; MARKETING CONSULTING; STATISTICAL EVALUATIONS OF MARKETING DATA; MARKET REPORTS AND STUDIES; MARKET STUDY AND ANALYSIS OF MARKET STUDIES; MARKET ANALYSIS (U.S. CLS. 100, 101 AND 102).

AHSEN KHAN, EXAMINING ATTORNEY

SN 77-288,628. E'STEPHENIE, INC., CARMEL, IN. FILED 9-25-2007.

takeouttees.com

THE MARK CONSISTS OF STANDARD CHARACTERS WITHOUT CLAIM TO ANY PARTICULAR FONT, STYLE, SIZE, OR COLOR.

FOR RETAIL INTERNET STORE SERVICES FEATURING CLOTHING, APPAREL AND ACCESSORIES (U.S. CLS. 100, 101 AND 102).

FIRST USE 10-9-2006; IN COMMERCE 10-9-2006.
DEZMONA MIZELLE, EXAMINING ATTORNEY

CLASS 35—(Continued).

SN 77-291,384. EXCENTUS CORPORATION, IRVING, TX. FILED 9-28-2007.

PERXPAY

THE MARK CONSISTS OF STANDARD CHARACTERS WITHOUT CLAIM TO ANY PARTICULAR FONT, STYLE, SIZE, OR COLOR.

FOR ADVERTISING, MARKETING AND PROMOTIONS SERVICES, NAMELY, PROVIDING AWARD PROGRAMS TO PROMOTE THE GROCERY AND RETAIL SERVICES OF OTHERS; ADVERTISING AGENCY SERVICES, NAMELY, PROMOTING THE SERVICES OF GROCERY AND RETAIL STORES THROUGH THE DISTRIBUTION OF POINT OF SALE MATERIALS (U.S. CLS. 100, 101 AND 102).

MICHAEL SOUDERS, EXAMINING ATTORNEY

SN 77-291,442. EXCENTUS CORPORATION, IRVING, TX. FILED 9-28-2007.

PAYPERX

THE MARK CONSISTS OF STANDARD CHARACTERS WITHOUT CLAIM TO ANY PARTICULAR FONT, STYLE, SIZE, OR COLOR.

FOR ADVERTISING, MARKETING AND PROMOTIONS SERVICES, NAMELY, PROVIDING AWARD PROGRAMS TO PROMOTE THE GROCERY AND RETAIL SERVICES OF OTHERS; ADVERTISING AGENCY SERVICES, NAMELY, PROMOTING THE SERVICES OF GROCERY AND RETAIL STORES THROUGH THE DISTRIBUTION OF POINT OF SALE MATERIALS (U.S. CLS. 100, 101 AND 102).

MICHAEL SOUDERS, EXAMINING ATTORNEY

CLASS 35—(Continued).

SN 77-293,647. HERSHEY CHOCOLATE & CONFECTIONERY CORPORATION, WHEAT RIDGE, CO. FILED 10-2-2007.



OWNER OF U.S. REG. NOS. 54,041, 3,102,017 AND OTHERS.

THE STIPPLING IS FOR SHADING PURPOSES ONLY. THE MARK CONSISTS OF THE WORD "HERSHEY'S" WITHIN A DOUBLE BORDER RECTANGLE; TO THE RIGHT OF THE WORD "HERSHEY'S" IS A LIGHTBULB DESIGN. THE LIGHTBULB IS POSITIONED ON ITS SIDE. DIRECTLY BELOW THE WORD "HERSHEY'S" AND THE LIGHTBULB DESIGN IS THE WORD "IDEAWORKS".

FOR CUSTOMER SERVICES IN THE NATURE OF AN IDEA SUBMISSION WEBSITE PROGRAM ADMINISTERED ONLINE TO ENCOURAGE CONSUMER SUBMISSIONS OF PRODUCT IDEAS IN THE FIELD OF CHOCOLATE, CANDY AND SNACK FOODS FOR THE PURPOSE OF RETAINING CUSTOMER LOYALTY AND GOOD WILL (U.S. CLS. 100, 101 AND 102).

LYDIA BELZER, EXAMINING ATTORNEY

CLASS 35—(Continued).

SN 77-294,348. INTERNATIONAL STORES CORP., PANAMA CITY, PANAMA, FILED 10-2-2007.



NO CLAIM IS MADE TO THE EXCLUSIVE RIGHT TO USE "DUTY FREE", APART FROM THE MARK AS SHOWN.

THE MARK CONSISTS OF FIVE SHOPPING BAGS ARRANGED TO BE A FIVE-POINTED STAR.

FOR ADVERTISING CONSULTATION; BUSINESS MANAGEMENT; BUSINESS ADMINISTRATION CONSULTANCY; OFFICE FUNCTIONS (U.S. CLS. 100, 101 AND 102).

WARREN L. OLANDRIA, EXAMINING ATTORNEY

SN 77-294,295. INTERNATIONAL STORES CORP., PANAMA CITY, PANAMA, FILED 10-2-2007.



THE MARK CONSISTS OF FIVE SHOPPING BAGS ARRANGED TO BE A FIVE-POINTED STAR.

FOR ADVERTISING CONSULTATION; BUSINESS MANAGEMENT; BUSINESS ADMINISTRATION CONSULTANCY; OFFICE FUNCTIONS (U.S. CLS. 100, 101 AND 102).

WARREN L. OLANDRIA, EXAMINING ATTORNEY

SN 77-294,384. INTERNATIONAL STORES CORP., PANAMA CITY, PANAMA, FILED 10-2-2007.



NO CLAIM IS MADE TO THE EXCLUSIVE RIGHT TO USE "LA MEJOR ATENCION", APART FROM THE MARK AS SHOWN.

THE MARK CONSISTS OF FIVE SHOPPING BAGS ARRANGED TO BE A FIVE-POINTED STAR.

THE FOREIGN WORDING IN THE MARK TRANSLATES INTO ENGLISH AS "BEST CARE".

FOR ADVERTISING CONSULTATION; BUSINESS MANAGEMENT; BUSINESS ADMINISTRATION CONSULTANCY; OFFICE FUNCTIONS (U.S. CLS. 100, 101 AND 102).

WARREN L. OLANDRIA, EXAMINING ATTORNEY

CLASS 35—(Continued).

SN 77-294,595. BUSINESS IS LIFE LLC, SANTA CLARA, CA. FILED 10-2-2007.

Business is Life

THE MARK CONSISTS OF STANDARD CHARACTERS WITHOUT CLAIM TO ANY PARTICULAR FONT, STYLE, SIZE, OR COLOR.

NO CLAIM IS MADE TO THE EXCLUSIVE RIGHT TO USE "BUSINESS", APART FROM THE MARK AS SHOWN.

FOR BUSINESS CONSULTANCY TOWARDS STRATEGIC IDENTIFICATION, ARCHITECTURE, AND INTEGRATION, OF BUSINESSES, MARKETS AND PHILOSOPHY (U.S. CLS. 100, 101 AND 102).

MARIAM MAHMOUDI, EXAMINING ATTORNEY

CLASS 35—(Continued).

SN 77-301,362. GARY KING, BURLINGTON, NC. FILED 10-11-2007.



NO CLAIM IS MADE TO THE EXCLUSIVE RIGHT TO USE "FRAGRANCES", APART FROM THE MARK AS SHOWN.

FOR RETAIL/WHOLESALE OUTLET STORE SPECIALIZING IN EXOTIC BODY OILS, PERFUMES, INCENSES, LOTIONS AND SOAPS (U.S. CLS. 100, 101 AND 102).

FIRST USE 4-1-1997; IN COMMERCE 4-1-1997.

KIMBERLY PERRY, EXAMINING ATTORNEY

SN 77-299,485. REED TECHNOLOGY AND INFORMATION SERVICES INC., HORSHAM, PA. FILED 10-9-2007.

TRANSFORMING DATA, DELIVERING INFORMATION

THE MARK CONSISTS OF STANDARD CHARACTERS WITHOUT CLAIM TO ANY PARTICULAR FONT, STYLE, SIZE, OR COLOR.

FOR PROVIDING BUSINESS INFORMATION IN THE FIELD OF MANAGING PHARMACEUTICAL LABELING (U.S. CLS. 100, 101 AND 102).

FIRST USE 1-15-2003; IN COMMERCE 1-15-2003.

REBECCA GILBERT, EXAMINING ATTORNEY

SN 77-301,786. RAK IT UP, LISLE, ONTARIO, CANADA, FILED 10-11-2007.

DOING OUR PART

THE MARK CONSISTS OF STANDARD CHARACTERS WITHOUT CLAIM TO ANY PARTICULAR FONT, STYLE, SIZE, OR COLOR.

FOR ORGANIZING AND CONDUCTING VOLUNTEER AND COMMUNITY SERVICE CAMPAIGNS TO CLEAN-UP THE ENVIRONMENT; PROMOTING PUBLIC AWARENESS REGARDING THE NECESSITY FOR MAINTAINING A CLEAN ENVIRONMENT (U.S. CLS. 100, 101 AND 102).

JULIE GUTTADAURO, EXAMINING ATTORNEY

SN 77-299,536. REED TECHNOLOGY AND INFORMATION SERVICES INC., HORSHAM, PA. FILED 10-9-2007.

TRANSFORMING DATA, DELIVERING INFORMATION

THE MARK CONSISTS OF STANDARD CHARACTERS WITHOUT CLAIM TO ANY PARTICULAR FONT, STYLE, SIZE, OR COLOR.

FOR PROVIDING BUSINESS INFORMATION REGARDING MANAGING INTELLECTUAL PROPERTIES VIA THE INTERNET (U.S. CLS. 100, 101 AND 102).

FIRST USE 1-15-2003; IN COMMERCE 1-15-2003.

REBECCA GILBERT, EXAMINING ATTORNEY

SN 77-301,814. RAK IT UP, LISLE, ONTARIO, CANADA, FILED 10-11-2007.

DOING MY PART

THE MARK CONSISTS OF STANDARD CHARACTERS WITHOUT CLAIM TO ANY PARTICULAR FONT, STYLE, SIZE, OR COLOR.

FOR ORGANIZING AND CONDUCTING VOLUNTEER AND COMMUNITY SERVICE CAMPAIGNS TO CLEAN-UP THE ENVIRONMENT; PROMOTING PUBLIC AWARENESS REGARDING THE NECESSITY FOR MAINTAINING A CLEAN ENVIRONMENT (U.S. CLS. 100, 101 AND 102).

JULIE GUTTADAURO, EXAMINING ATTORNEY

CLASS 35—(Continued).

SN 77-301,824. RAK IT UP, LISLE, ONTARIO, CANADA,
FILED 10-11-2007.

LEADING THE WAY

THE MARK CONSISTS OF STANDARD CHARACTERS WITHOUT CLAIM TO ANY PARTICULAR FONT, STYLE, SIZE, OR COLOR.

FOR ORGANIZING AND CONDUCTING VOLUNTEER AND COMMUNITY SERVICE CAMPAIGNS TO CLEAN-UP THE ENVIRONMENT; PROMOTING PUBLIC AWARENESS REGARDING THE NECESSITY FOR MAINTAINING A CLEAN ENVIRONMENT (U.S. CLS. 100, 101 AND 102).

JULIE GUTTADAURO, EXAMINING ATTORNEY

SN 77-303,596. SNAXILLA, INC., PELHAM, AL. FILED 10-14-2007.



THE MARK CONSISTS OF A DINOSAUR DRAWING WITHIN A CIRCULAR BORDER.

FOR ADVERTISING BY TRANSMISSION OF ON-LINE PUBLICITY FOR THIRD PARTIES THROUGH ELECTRONIC COMMUNICATIONS NETWORKS; ADVERTISING, PROMOTION AND MARKETING SERVICES IN THE NATURE OF E-MAIL BLAST CAMPAIGNS FOR OTHERS; ADVERTISING, INCLUDING PROMOTION RELATING TO THE SALE OF ARTICLES AND SERVICES FOR THIRD PARTIES BY THE TRANSMISSION OF ADVERTISING MATERIAL AND THE DISSEMINATION OF ADVERTISING MESSAGES ON COMPUTER NETWORKS (U.S. CLS. 100, 101 AND 102).

FIRST USE 4-1-2007; IN COMMERCE 4-1-2007.
STEPHANIE ALI, EXAMINING ATTORNEY

CLASS 35—(Continued).

SN 77-303,676. MARIANO FERNANDEZ, SAN YSIDRO, CA.
FILED 10-14-2007.



NO CLAIM IS MADE TO THE EXCLUSIVE RIGHT TO USE "SUPERMARKET", APART FROM THE MARK AS SHOWN.

THE MARK CONSISTS OF LOGO OF "N" WITH LEAVES ON TOP OF "N" WITH NAME "NEIGHBORS SUPERMARKET" UNDER LETTER.

FOR SUPERMARKETS (U.S. CLS. 100, 101 AND 102).
FIRST USE 9-1-2007; IN COMMERCE 9-1-2007.
NAPOLEON SHARMA, EXAMINING ATTORNEY

SN 77-307,106. DOLAN MEDIA COMPANY, MINNEAPOLIS, MN. FILED 10-18-2007.

CALENDARWATCH

THE MARK CONSISTS OF STANDARD CHARACTERS WITHOUT CLAIM TO ANY PARTICULAR FONT, STYLE, SIZE, OR COLOR.

FOR PROVIDING LEGAL DOCKET MANAGEMENT SERVICES FOR OTHERS, NAMELY, REMINDER SERVICES IN THE AREA OF MONITORING COURT DOCKETS AND PROVIDING NOTICE OF UPCOMING DATES (U.S. CLS. 100, 101 AND 102).

DAWN FELDMAN, EXAMINING ATTORNEY

CLASS 35—(Continued).

SN 77-312,927. USBA USA, INC., TAMPA, FL. FILED 10-25-2007.

PAVEON

THE MARK CONSISTS OF STANDARD CHARACTERS WITHOUT CLAIM TO ANY PARTICULAR FONT, STYLE, SIZE, OR COLOR.

FOR BUSINESS MARKETING SERVICES; ON-LINE ADVERTISING AND MARKETING SERVICES; PROMOTION, ADVERTISING AND MARKETING OF ON-LINE WEBSITES; MARKETING CONSULTATION IN THE FIELD OF WEB SITE DESIGN, WEB SITE HOSTING, ISP SERVICES, VOIP, E-MAIL, DOMAIN NAME MANAGEMENT, AND IT CONSULTING (U.S. CLS. 100, 101 AND 102).

PAUL CROWLEY, EXAMINING ATTORNEY

SN 77-314,794. NICKEY CHICAGO, INC., ST. CHARLES, IL. FILED 10-26-2007.



OWNER OF U.S. REG. NOS. 2,502,627, 2,889,108 AND OTHERS.

NO CLAIM IS MADE TO THE EXCLUSIVE RIGHT TO USE "CHICAGO", APART FROM THE MARK AS SHOWN.

THE MARK CONSISTS OF STYLIZED LETTERS SPELLING "NICKEY", IN WHICH THE LETTER "K" IS BACKWARDS; THE WORD "NICKEY" IS INSIDE A RECTANGLE DESIGN WHICH IS LONGER ON THE TOP IN RELATION TO THE BOTTOM WITH INDENTED SIDES; THE WORD "CHICAGO" IS SITUATED BELOW THE WORD "NICKEY".

FOR RETAIL STORE SERVICES FEATURING CUSTOM AND RESTORED AUTOMOBILES AND AUTOMOBILE PARTS (U.S. CLS. 100, 101 AND 102).

MELISSA VALLILLO, EXAMINING ATTORNEY

SN 77-317,191. VULCAN INC., SEATTLE, WA. FILED 10-30-2007.

BACKCHANNEL TV

THE MARK CONSISTS OF STANDARD CHARACTERS WITHOUT CLAIM TO ANY PARTICULAR FONT, STYLE, SIZE, OR COLOR.

NO CLAIM IS MADE TO THE EXCLUSIVE RIGHT TO USE "TV", APART FROM THE MARK AS SHOWN.

FOR ADVERTISING AND MARKETING SERVICES; ADVERTISING CONSULTATION; MARKET RESEARCH SERVICES, NAMELY, COLLECTING AND MEASURING DATA RELATED TO TELEVISION AUDIENCE VIEWING (U.S. CLS. 100, 101 AND 102).

DANNEAN HETZEL, EXAMINING ATTORNEY

CLASS 35—(Continued).

SN 77-319,845. NUMERIC ANALYTICS, LLC, CHADDS FORD, PA. FILED 11-2-2007.

analyticsLife

THE MARK CONSISTS OF STANDARD CHARACTERS WITHOUT CLAIM TO ANY PARTICULAR FONT, STYLE, SIZE, OR COLOR.

FOR PROVIDING A BUSINESS NETWORKING WEBSITE FOR PROFESSIONALS AND ENTHUSIASTS IN THE FIELD OF ANALYTICS; PROVIDING BUSINESS INFORMATION VIA A WEBSITE IN THE FIELD OF WEB AND INTERNET ANALYTICS; PROVIDING COMMERCIAL INFORMATION VIA A WEBSITE IN THE FIELD OF WEB AND INTERNET ANALYTICS COMPANIES (U.S. CLS. 100, 101 AND 102).

FIRST USE 1-10-2008; IN COMMERCE 1-10-2008.

DANIEL CAPSHAW, EXAMINING ATTORNEY

SN 77-322,296. SAVAGE DESIGN GROUP, INC., HOUSTON, TX. FILED 11-6-2007.

BPS BRAND POSITIONING SYSTEM

THE MARK CONSISTS OF STANDARD CHARACTERS WITHOUT CLAIM TO ANY PARTICULAR FONT, STYLE, SIZE, OR COLOR.

NO CLAIM IS MADE TO THE EXCLUSIVE RIGHT TO USE "BRAND POSITIONING SYSTEM", APART FROM THE MARK AS SHOWN.

FOR ADVERTISING AND MARKETING SERVICES (U.S. CLS. 100, 101 AND 102).

JAY FLOWERS, EXAMINING ATTORNEY

SN 77-329,346. MIZE, BRENDA J., PFLUGERVILLE, TX. FILED 11-14-2007.



NO CLAIM IS MADE TO THE EXCLUSIVE RIGHT TO USE "TOY", APART FROM THE MARK AS SHOWN.

THE COLOR(S) WHITE, BLACK, GREEN, ORANGE, GREY, PINK, BROWN, LIGHT BROWN, TAN, YELLOW, PURPLE, BLUE, LIGHT BLUE AND RED IS/ARE CLAIMED AS A FEATURE OF THE MARK.

THE MARK CONSISTS OF THE COLOR GREEN THAT APPEARS IN THE WORDS "THE TOY BENCH," IN PART OF THE ONE OF THE ALPHABET BLOCKS ON THE BENCH, AND IN PART OF THE WAVY LINE UNDERLINING THE WORD "TOY"; THE COLOR WHITE APPEARS AS PART OF THE SHADOWING IN THE WORDING "THE TOY BENCH", AS THE REFLECTION OF LIGHT ON THE SQUEAKER ON THE TOY HORN, IN PART OF THE WAVY

CLASS 35—(Continued).

LINE UNDERLINING THE WORD "TOY"; IN THE SEAT PORTION OF THE BENCH, IN PART OF THE ALPHABET BLOCKS ON THE BENCH, AS PART OF THE TOY BALL ON THE BENCH; THE COLOR BLACK APPEARS AS PART OF THE INSIDE OF THE BENCH, IN THE LETTERS "A" AND "B" AND "C" IN THE ALPHABET BLOCKS, AS THE OUTLINE OF THE TOY HORN AND THE TOY BALL; THE COLOR ORANGE APPEARS AS PART OF THE BABY DOLL'S HAIR AND AS ONE OF THE WAVY LINES UNDERLINING THE WORD "BENCH"; THE COLOR GREY APPEARS AS THE SIDES OF THE BENCH, AND AS PART OF THE TOY HORN; THE COLOR PINK APPEARS AS THE BACK OF THE BENCH AND AS PART OF THE WAVY LINE UNDERLINING THE WORDS "TOY" AND "BENCH"; THE COLORS BROWN AND LIGHT BROWN APPEARS AS THE COLORS OF THE TOY BEAR ON THE BENCH; THE COLOR TAN APPEARS AS THE FACE AND HANDS OF THE BABY DOLLS AND AS THE FRONT OF THE BENCH; THE COLOR YELLOW APPEARS AS PART OF THE ONE OF THE ALPHABET BLOCKS ON THE BENCH; THE COLOR PURPLE APPEARS AS THE CLOTHING ON THE BABY DOLL AND AS PART OF THE ONE OF THE ALPHABET BLOCKS; THE COLOR BLUE APPEARS AS THE SQUEAKER ON THE TOY HORN; THE COLOR LIGHT BLUE APPEARS ON PART OF THE TOY BALL, AND THE COLOR RED APPEARS AS PART OF THE TOY BALL AND IN PART OF THE WAVY LINE UNDERLINING THE WORDS "TOY" AND "BENCH".

FOR ON-LINE RETAIL STORE SERVICES FEATURING BABY TOYS AND GIFTS (U.S. CLS. 100, 101 AND 102).

FIRST USE 2-7-2007; IN COMMERCE 2-7-2007.
SALLY SHIH, EXAMINING ATTORNEY

SN 77-331,892. MY LIFE DESIGNS, LLC, LITTLETON, CO.
FILED 11-16-2007.

KIMBRA

THE MARK CONSISTS OF STANDARD CHARACTERS WITHOUT CLAIM TO ANY PARTICULAR FONT, STYLE, SIZE, OR COLOR.

FOR ON-LINE RETAIL STORES FEATURING JEWELRY AND GIFTS (U.S. CLS. 100, 101 AND 102).

FIRST USE 6-0-2007; IN COMMERCE 6-0-2007.
LEIGH CAROLINE CASE, EXAMINING ATTORNEY

SN 77-331,918. MY LIFE DESIGNS, LLC, LITTLETON, CO.
FILED 11-16-2007.

KIMBRA STUDIOS

THE MARK CONSISTS OF STANDARD CHARACTERS WITHOUT CLAIM TO ANY PARTICULAR FONT, STYLE, SIZE, OR COLOR.

NO CLAIM IS MADE TO THE EXCLUSIVE RIGHT TO USE "STUDIOS", APART FROM THE MARK AS SHOWN.

FOR ON-LINE RETAIL STORES FEATURING JEWELRY AND GIFTS (U.S. CLS. 100, 101 AND 102).

FIRST USE 6-0-2007; IN COMMERCE 6-0-2007.
LEIGH CAROLINE CASE, EXAMINING ATTORNEY

CLASS 35—(Continued).

SN 77-332,659. CANDY HEAVEN, INC., PORT CHARLOTTE, FL. FILED 11-19-2007.

CANDY HEAVEN

THE MARK CONSISTS OF STANDARD CHARACTERS WITHOUT CLAIM TO ANY PARTICULAR FONT, STYLE, SIZE, OR COLOR.

NO CLAIM IS MADE TO THE EXCLUSIVE RIGHT TO USE "CANDY", APART FROM THE MARK AS SHOWN.

FOR RETAIL CANDY STORES (U.S. CLS. 100, 101 AND 102).

FIRST USE 1-31-2005; IN COMMERCE 1-31-2005.
JENNIFER VASQUEZ, EXAMINING ATTORNEY

SN 77-332,867. J. MICHAELS CLOTHIER, LLC, SMITH-TOWN, NY. FILED 11-19-2007.

J. Michaels

THE MARK CONSISTS OF STANDARD CHARACTERS WITHOUT CLAIM TO ANY PARTICULAR FONT, STYLE, SIZE, OR COLOR.

"J. MICHAELS" DOES IDENTIFY A LIVING INDIVIDUAL WHOSE CONSENT IS OF RECORD.

FOR RETAIL STORES FEATURING CLOTHING, NAMELY, SHIRTS, DRESS SHIRTS, TIES, PANTS, JACKETS, SUITS, UNDERWEAR, BELTS, SWEATERS, SHOES (U.S. CLS. 100, 101 AND 102).

FIRST USE 1-1-2006; IN COMMERCE 5-1-2007.
MICHELE SWAIN, EXAMINING ATTORNEY

SN 77-333,830. ABBOTT DIABETES CARE INC., ALAMEDA, CA. FILED 11-20-2007.

FREESTYLE PROMISE

THE MARK CONSISTS OF STANDARD CHARACTERS WITHOUT CLAIM TO ANY PARTICULAR FONT, STYLE, SIZE, OR COLOR.

OWNER OF U.S. REG. NOS. 2,670,744, 3,169,832 AND OTHERS.

FOR CUSTOMER LOYALTY SERVICES AND CUSTOMER CLUB SERVICES FOR COMMERCIAL, PROMOTIONAL, AND/OR ADVERTISING PURPOSES (U.S. CLS. 100, 101 AND 102).

SANJEEV VOHRA, EXAMINING ATTORNEY

CLASS 35—(Continued).

SN 77-339,238. SAVORY CHEF, LLC, TULSA, OK. FILED 11-28-2007.



NO CLAIM IS MADE TO THE EXCLUSIVE RIGHT TO USE "CHEF" "COOKING SOLUTIONS" AND "FOOD", APART FROM THE MARK AS SHOWN.

THE MARK CONSISTS OF TWO CONCENTRIC CIRCLES; THE INNER CIRCLE CONTAINING A SHAKER, LADLE, STOCK PAN WITH STEAM ABOVE IT, TOMATO AND MUSHROOM; A HORIZONTAL BANNER BETWEEN THE CONCENTRIC CIRCLES WITH THE WORDING "FOOD" ON ONE SIDE OF THE CIRCLE AND "ARTS" ON THE OTHER; AND THE WORDING "COOKING SOLUTIONS" CONTOURED WITHIN THE TOP PORTION OF THE CONCENTRIC CIRCLES, AND THE WORDING "SAVORY CHEF" ON THE BOTTOM PORTION.

FOR RETAIL AND ON-LINE STORE SERVICES FEATURING CULINARY EQUIPMENT, COOKWARE, BAKEWARE, CUTLERY, KITCHEN GADGETS, UTENSILS, DINNERWARE, TABLEWARE, GLASSWARE, FLATWARE, SERVING TRAYS, CERAMIC ELECTRIC KITCHEN APPLIANCES, COOKBOOKS, RECIPES, GOURMET FOODS, MEAT, SAUCES, PREPARED FOOD MIXES, MIXES FOR BAKING GOODS, SOUP MIXES, SEASONING MIXES, DRINK MIXES, SAUCE MIXES, HOUSEWARES, INDOOR AND OUTDOOR FURNITURE, RUGS, LAMPS AND LIGHTING FIXTURES, CLOCKS, CANDLES AND CANDLE HOLDERS, CURTAINS, TABLE LINENS, KITCHEN TOWELS, BASKETS, BROOMS, BRUSHES AND DUSTERS FOR CLEANING, BARBECUES AND BARBECUE ACCESSORIES, PICNIC ACCESSORIES, SOAPS AND HAND CREAMS (U.S. CLS. 100, 101 AND 102).

FIRST USE 7-21-2004; IN COMMERCE 7-21-2004.
PAULA MAHONEY, EXAMINING ATTORNEY

CLASS 35—(Continued).

SN 77-339,739. TANDUS US INC., DALTON, GA. FILED 11-29-2007.

CONNEXION FROM TANDUS

THE MARK CONSISTS OF STANDARD CHARACTERS WITHOUT CLAIM TO ANY PARTICULAR FONT, STYLE, SIZE, OR COLOR.

OWNER OF U.S. REG. NOS. 2,672,859, 2,832,384 AND OTHERS.

FOR BUSINESS CONSULTING SERVICES, NAMELY, PROVIDING INFORMATION, ADVICE AND ASSISTANCE TO CUSTOMERS IN THE CARPET AND FLOOR COVERING INDUSTRIES RELATED TO PRODUCT DISTRIBUTION, OPERATIONS MANAGEMENT SERVICES, LOGISTICS, REVERSE LOGISTICS, SUPPLY CHAIN, AND PRODUCTION SYSTEMS AND DISTRIBUTION SOLUTIONS (U.S. CLS. 100, 101 AND 102).

FIRST USE 3-9-2006; IN COMMERCE 3-9-2006.

DOMINICK J. SALEMI, EXAMINING ATTORNEY

SN 77-340,072. CIRELLI FOODS, INC., MIDDLEBOROUGH, MA. FILED 11-29-2007.

MARKETPLACE AT CIRELLI FOODS

THE MARK CONSISTS OF STANDARD CHARACTERS WITHOUT CLAIM TO ANY PARTICULAR FONT, STYLE, SIZE, OR COLOR.

OWNER OF U.S. REG. NOS. 2,164,909 AND 2,315,813.

NO CLAIM IS MADE TO THE EXCLUSIVE RIGHT TO USE "MARKETPLACE" AND "FOODS", APART FROM THE MARK AS SHOWN.

SEC. 2(F) AS TO "CIRELLI".

FOR WHOLESALE DISTRIBUTORSHIP AND SUPERMARKETS FEATURING FOODSERVICE AND GROCERY PRODUCTS (U.S. CLS. 100, 101 AND 102).

DAWN FELDMAN, EXAMINING ATTORNEY

SN 77-340,501. WHOLE PET CENTRAL, INC., ODENTON, MD. FILED 11-29-2007.



NO CLAIM IS MADE TO THE EXCLUSIVE RIGHT TO USE "PET", APART FROM THE MARK AS SHOWN.

FOR RETAIL STORE SERVICES FEATURING PET FOOD, PET SUPPLEMENTS AND PET PRODUCTS (U.S. CLS. 100, 101 AND 102).

FIRST USE 4-4-2007; IN COMMERCE 5-15-2007.

PAULA MAHONEY, EXAMINING ATTORNEY

CLASS 35—(Continued).

SN 77-340,851. HEALTHSCREENDIRECT, LLC, FORT LAUDERDALE, FL. FILED 11-30-2007.

HEALTHPAK

THE MARK CONSISTS OF STANDARD CHARACTERS WITHOUT CLAIM TO ANY PARTICULAR FONT, STYLE, SIZE, OR COLOR.

FOR ADVERTISING, NAMELY, PROMOTING THE GOODS AND SERVICES OF HEALTH RELATED PROVIDERS AND SERVICES THROUGH DIRECT MARKETING (U.S. CLS. 100, 101 AND 102).

BARBARA GAYNOR, EXAMINING ATTORNEY

SN 77-341,588. IMPACT MARKETING & PROMOTIONS, TARZANA, CA. FILED 11-30-2007.

DJ Ambassador

THE MARK CONSISTS OF STANDARD CHARACTERS WITHOUT CLAIM TO ANY PARTICULAR FONT, STYLE, SIZE, OR COLOR.

NO CLAIM IS MADE TO THE EXCLUSIVE RIGHT TO USE "DJ", APART FROM THE MARK AS SHOWN.

FOR ADVERTISING SERVICES, NAMELY, PROMOTING AND MARKETING THE GOODS AND SERVICES OF OTHERS THROUGH ALL PUBLIC COMMUNICATION MEANS (U.S. CLS. 100, 101 AND 102).

FIRST USE 6-1-2005; IN COMMERCE 6-1-2005.

PAUL MORENO, EXAMINING ATTORNEY

SN 77-344,042. MARTINS, SYLVIO JR., PHOENIX, AZ. FILED 12-4-2007.

Sweet
VENEZIA

THE MARK CONSISTS OF THE WORD "SWEET" HAVING A SQUIGGLY LINE OFF THE "S" AND THE "T". THE WORD "VENEZIA" IS BOLD.

THE FOREIGN WORDING IN THE MARK TRANSLATES INTO ENGLISH AS "VENICE".

FOR RETAIL ICE CREAM STORE SERVICES FEATURING ICE CREAM, GELATO, AND DESSERTS (U.S. CLS. 100, 101 AND 102).

PAULA MAHONEY, EXAMINING ATTORNEY

CLASS 35—(Continued).

SN 77-347,622. JOB OTTER LLC, LEBANON, IN. FILED 12-9-2007.

JOB OTTER

THE MARK CONSISTS OF STANDARD CHARACTERS WITHOUT CLAIM TO ANY PARTICULAR FONT, STYLE, SIZE, OR COLOR.

NO CLAIM IS MADE TO THE EXCLUSIVE RIGHT TO USE "JOB", APART FROM THE MARK AS SHOWN.

FOR PROVIDING ON-LINE INFORMATION IN THE FIELDS OF EMPLOYMENT, RECRUITMENT, CAREERS, PERSONAL ISSUES RELATED TO CAREERS AND WORKLIFE, JOB RESOURCES, JOB LISTINGS AND RESUMES; PROVIDING ON-LINE INTERACTIVE EMPLOYMENT COUNSELING AND RECRUITMENT SERVICES; PROVIDING ON-LINE EMPLOYMENT PLACEMENT SERVICES; PROVIDING INTERACTIVE COMPUTER DATABASE FEATURING RECRUITMENT AND EMPLOYMENT INFORMATION, EMPLOYMENT ADVERTISING, CAREER INFORMATION AND RESOURCES, RESUME CREATION AND POSTING, RESUME TRANSMITTAL AND COMMUNICATION OF RESPONSES THERETO VIA A GLOBAL COMPUTER NETWORK (U.S. CLS. 100, 101 AND 102).

SETH A. RAPPAPORT, EXAMINING ATTORNEY

SN 77-353,318. BATES, ANDREE, LONDON, ENGLAND, FILED 12-17-2007.

94.8 ANALYTICS

THE MARK CONSISTS OF STANDARD CHARACTERS WITHOUT CLAIM TO ANY PARTICULAR FONT, STYLE, SIZE, OR COLOR.

NO CLAIM IS MADE TO THE EXCLUSIVE RIGHT TO USE "ANALYTICS", APART FROM THE MARK AS SHOWN.

FOR ADVERTISING AND ADVERTISEMENT SERVICES; ADVERTISING, MARKETING AND PROMOTION SERVICES; ADVERTISING AND PROMOTION SERVICES AND RELATED CONSULTING; ADVERTISING CONSULTATION; CONDUCTING MARKETING STUDIES; MARKET ANALYSIS; MARKET RESEARCH CONSULTATION; MARKET RESEARCH SERVICES; MARKET RESEARCH STUDIES; PROMOTION AND MARKETING SERVICES AND RELATED CONSULTING; PROVIDING ADVERTISING, MARKETING AND PROMOTIONAL SERVICES FOR THE PHARMACEUTICAL AND MEDICAL INDUSTRY (U.S. CLS. 100, 101 AND 102).

FIRST USE 9-1-2007; IN COMMERCE 9-1-2007.

CARYN GLASSER, EXAMINING ATTORNEY

CLASS 35—(Continued).

SN 77-355,931. LEAD HOTLINE, INC., JACKSONVILLE, FL. FILED 12-19-2007.

**Lead
Hotline.com**

NO CLAIM IS MADE TO THE EXCLUSIVE RIGHT TO USE "LEAD", APART FROM THE MARK AS SHOWN.

THE MARK CONSISTS OF THE WORDS "LEAD" AND "HOTLINE.COM" WITH CIRCLES WITHIN CERTAIN LETTERS. GRAY IS NOT A FEATURE OF THE MARK.

FOR ADVERTISING AND MARKETING (U.S. CLS. 100, 101 AND 102).

FIRST USE 8-13-2007; IN COMMERCE 10-1-2007.
TOBY BULLOFF, EXAMINING ATTORNEY

SN 77-357,040. FIRSTBORN MULTIMEDIA CORPORATION, NEW YORK, NY. FILED 12-20-2007.

FIRSTBORN

THE MARK CONSISTS OF STANDARD CHARACTERS WITHOUT CLAIM TO ANY PARTICULAR FONT, STYLE, SIZE, OR COLOR.

FOR DESIGN OF DIGITAL MARKETING MATERIAL FOR OTHERS; DESIGN OF INTERNET ADVERTISING; MARKETING SERVICES, NAMELY, INFORMATIONAL WEB PAGES DESIGNED TO GENERATE SALES TRAFFIC VIA HYPERLINKS TO OTHER WEBSITES; ADVERTISING SERVICES, NAMELY, PROMOTING AND MARKETING THE GOODS AND SERVICES OF OTHERS THROUGH ALL PUBLIC COMMUNICATIONS MEANS; PROVISION OF SPACE ON WEBSITES FOR ADVERTISING GOODS AND SERVICES (U.S. CLS. 100, 101 AND 102).

FIRST USE 0-0-1997; IN COMMERCE 0-0-1997.
HENRY S. ZAK, EXAMINING ATTORNEY

SN 77-361,773. I-COMMERCE PARTNERS, CEDAR RAPIDS, IA. FILED 12-31-2007.

**iCOMMERCE
PARTNERS**
Delivering Quality of Life

NO CLAIM IS MADE TO THE EXCLUSIVE RIGHT TO USE "COMMERCE PARTNERS", APART FROM THE MARK AS SHOWN.

THE MARK CONSISTS OF THE LETTER "I" THE WORDING "COMMERCE PARTNERS" AND "DELIVERING QUALITY OF LIFE".

FOR BUSINESS DEVELOPMENT SERVICES, NAMELY, PROVIDING RECRUITMENT SERVICES, TRAINING, AND ONGOING SUPPORT FOR BUSINESSES OF OTHERS (U.S. CLS. 100, 101 AND 102).

FIRST USE 4-0-2007; IN COMMERCE 4-0-2007.
REGINA DRUMMOND, EXAMINING ATTORNEY

CLASS 35—(Continued).

SN 77-362,508. CHRISTOPHER DEAN MAJER, SPOKANE, WA. FILED 1-2-2008.



"THE COLOR(S) WHITE, BLACK, ORANGE AND GRAY IS/ARE CLAIMED AS A FEATURE OF THE MARK."

THE MARK CONSISTS OF A BLACK FIGURE STANDING ASTRIDE A GLOBE WITH THE FIGURE'S HANDS RAISED ABOVE ITS HEAD, WITH A HALO SUN DESIGN BEHIND THE PERSON AND ABOVE THE GLOBE. THE HALO SUN BEHIND THE PERSON IS ORANGE, AND THE GLOBE IS GRAY WITH WHITE MERIDIANS AND PARALLELS.

FOR BUSINESS MANAGEMENT CONSULTANCY AS WELL AS DEVELOPMENT OF PROCESSES FOR THE ANALYSIS AND THE IMPLEMENTATION OF STRATEGY PLANS AND MANAGEMENT PROJECTS; BUSINESS MANAGEMENT CONSULTATION IN THE FIELD OF EXECUTIVE AND LEADERSHIP DEVELOPMENT (U.S. CLS. 100, 101 AND 102).

FIRST USE 2-1-2002; IN COMMERCE 2-1-2002.
RUDY R. SINGLETON, EXAMINING ATTORNEY

SN 77-364,179. ALLIANCE HR NETWORK, INC., ARLINGTON HEIGHTS, IL. FILED 1-4-2008.

**KEEN HIRE HIRE WITH CLARITY
& INSIGHT.**

THE MARK CONSISTS OF STANDARD CHARACTERS WITHOUT CLAIM TO ANY PARTICULAR FONT, STYLE, SIZE, OR COLOR.

NO CLAIM IS MADE TO THE EXCLUSIVE RIGHT TO USE "HIRE", APART FROM THE MARK AS SHOWN.

FOR EMPLOYMENT HIRING, RECRUITING, PLACEMENT, STAFFING AND CAREER NETWORKING SERVICES; EMPLOYMENT RECRUITING CONSULTATION; TESTING TO DETERMINE EMPLOYMENT SKILLS (U.S. CLS. 100, 101 AND 102).

FIRST USE 1-1-2007; IN COMMERCE 1-1-2007.
LINDA ESTRADA, EXAMINING ATTORNEY

CLASS 35—(Continued).

SN 77-364,469. CREATIVE TRUST, INC., NASHVILLE, TN. FILED 1-4-2008.

CREATIVE TRUST

THE MARK CONSISTS OF STANDARD CHARACTERS WITHOUT CLAIM TO ANY PARTICULAR FONT, STYLE, SIZE, OR COLOR.

FOR PERSONAL MANAGEMENT SERVICES FOR LITERARY AUTHORS, SONGWRITERS, RECORDING ARTISTS, PRODUCERS, AND FILM PRODUCERS; MARKETING SERVICES, NAMELY, MARKETING, PROMOTION AND ADVERTISING FOR LITERARY AUTHORS, SONGWRITERS, RECORDING ARTISTS, PRODUCERS, AND FILM PRODUCERS (U.S. CLS. 100, 101 AND 102).

FIRST USE 1-1-1989; IN COMMERCE 1-1-1989.
JASON ROTH, EXAMINING ATTORNEY

SN 77-365,251. GLOWAC, HARRIS, MADISON, INC., MADISON, WI. FILED 1-7-2008.

Brand SMART

NO CLAIM IS MADE TO THE EXCLUSIVE RIGHT TO USE "BRAND", APART FROM THE MARK AS SHOWN.

THE COLOR(S) BLACK, WHITE AND GREEN IS/ARE CLAIMED AS A FEATURE OF THE MARK.

THE MARK CONSISTS OF THE WORD "BRAND" IN THE COLOR WHITE AND THE WORD "SMART" IN THE COLOR BLACK. A RECTANGULAR DESIGN APPEARS BEHIND THE WORD "BRAND" IN THE COLOR GREEN.

FOR ADVERTISING SERVICES (U.S. CLS. 100, 101 AND 102).

FIRST USE 3-1-2007; IN COMMERCE 3-1-2007.
MARK T. MULLEN, EXAMINING ATTORNEY

CLASS 35—(Continued).

SN 77-366,244. AMERICAN FEDERATION OF LABOR CONGRESS OF INDUSTRIAL ORGANIZATIONS, WASHINGTON, DC. FILED 1-8-2008.

WORKING FAMILIES TOOLKIT

THE MARK CONSISTS OF STANDARD CHARACTERS WITHOUT CLAIM TO ANY PARTICULAR FONT, STYLE, SIZE, OR COLOR.

OWNER OF U.S. REG. NO. 2,576,803.

NO CLAIM IS MADE TO THE EXCLUSIVE RIGHT TO USE "TOOLKIT", APART FROM THE MARK AS SHOWN. SEC. 2(F).

FOR PREPARATION OF CUSTOMIZABLE MATERIALS, NAMELY, WORKPLACE FLYERS, SAMPLE ARTICLES FOR LOCAL UNION AND CENTRAL LABOR COUNCIL NEWSLETTERS, SAMPLE LETTERS FROM LOCAL UNION PRESIDENTS TO MEMBERS, DVDS AND POWER POINT PRESENTATIONS, REGARDING POLITICAL CAMPAIGNS AND OTHER ISSUES OF IMPORTANCE TO WORKERS FOR LABOR UNIONS TO DOWNLOAD AND DISSEMINATE TO THEIR MEMBERS (U.S. CLS. 100, 101 AND 102).

FIRST USE 9-0-2000; IN COMMERCE 9-0-2000.
CHRISTINA SOBRAL, EXAMINING ATTORNEY

SN 77-367,346. HOUSTON, NORMAN, HOUSTON, TX. FILED 1-9-2008.

RICH TEXAN

THE MARK CONSISTS OF STANDARD CHARACTERS WITHOUT CLAIM TO ANY PARTICULAR FONT, STYLE, SIZE, OR COLOR.

NO CLAIM IS MADE TO THE EXCLUSIVE RIGHT TO USE "TEXAN", APART FROM THE MARK AS SHOWN.

FOR ADVERTISING AND PROMOTIONAL SERVICES (U.S. CLS. 100, 101 AND 102).

FIRST USE 5-1-2008; IN COMMERCE 5-1-2008.
TINA BROWN, EXAMINING ATTORNEY

SN 77-370,372. INTERGEO S.A., MONTEVIDEO, URUGUAY. FILED 1-13-2008.

ALINA

THE MARK CONSISTS OF STANDARD CHARACTERS WITHOUT CLAIM TO ANY PARTICULAR FONT, STYLE, SIZE, OR COLOR.

FOR ASSOCIATION SERVICES, NAMELY, PROMOTING THE MANUFACTURING AND DISTRIBUTION OF MEMBERS' AGROCHEMICAL PRODUCTS (U.S. CLS. 100, 101 AND 102).

EMILY CARLSEN, EXAMINING ATTORNEY

CLASS 35—(Continued).

SN 77-374,889. BLOCK IMAGING INTERNATIONAL, INC., LANSING, MI. FILED 1-18-2008.

BLOCK IMAGING

THE MARK CONSISTS OF STANDARD CHARACTERS WITHOUT CLAIM TO ANY PARTICULAR FONT, STYLE, SIZE, OR COLOR.

NO CLAIM IS MADE TO THE EXCLUSIVE RIGHT TO USE "IMAGING", APART FROM THE MARK AS SHOWN, FOR WHOLESALE DISTRIBUTORSHIP SERVICES IN THE FIELD OF MEDICAL DIAGNOSTIC IMAGING SYSTEMS (U.S. CLS. 100, 101 AND 102).

FIRST USE 10-0-1997; IN COMMERCE 10-0-1997.
DAWN FELDMAN, EXAMINING ATTORNEY

SN 77-375,679. HAGGEN, INC., BELLINGHAM, WA. FILED 1-18-2008.

**QUALITY IN THE BAG.
SAVINGS IN THE BILL.**

THE MARK CONSISTS OF STANDARD CHARACTERS WITHOUT CLAIM TO ANY PARTICULAR FONT, STYLE, SIZE, OR COLOR.

FOR RETAIL GROCERY STORE SERVICES; RETAIL PHARMACY AND DRUG STORE SERVICES; RETAIL BAKERY; RETAIL DELICATESSEN; RETAIL SHOP FEATURING FLOWERS; RETAIL STORE SERVICES FEATURING A WIDE VARIETY OF PACKAGED, PREPARED AND FRESH FOOD AND BEVERAGES; ONLINE RETAIL SHOP FEATURING UMBRELLAS, COMPUTER BAGS, COFFEE CUPS, LUNCH BOXES, CALCULATORS, PENS AND PENCILS, CLOTHING (U.S. CLS. 100, 101 AND 102).

FIRST USE 7-28-1998; IN COMMERCE 7-28-1998.
MARGARET POWER, EXAMINING ATTORNEY

CLASS 35—(Continued).

SN 77-375,751. HAGGEN, INC., BELLINGHAM, WA. FILED 1-18-2008.



OWNER OF U.S. REG. NO. 2,478,119.

NO CLAIM IS MADE TO THE EXCLUSIVE RIGHT TO USE "SINCE 1933", APART FROM THE MARK AS SHOWN.

THE COLOR(S) GREEN, MAROON, WHITE AND GOLD IS/ARE CLAIMED AS A FEATURE OF THE MARK.

THE MARK CONSISTS OF A SUBSTANTIALLY OVAL SHAPE WITH THE WORD "HAGGEN" SUPERIMPOSED OVER CONCENTRIC CIRCLES WITH THE TERMS "SINCE" AND "1933". THE COLOR GREEN APPEARS IN THE SUBSTANTIALLY OVAL SHAPE AND THE INNER AND OUTER CIRCLES. THE COLOR MAROON APPEARS IN THE MIDDLE CIRCLE. THE COLOR GOLD OUTLINES THE CIRCLES AND SHAPE. THE COLOR WHITE APPEARS IN THE WORDING "HAGGEN" AND "SINCE 1933".

FOR RETAIL GROCERY STORE SERVICES; RETAIL PHARMACY AND DRUG STORE SERVICES; RETAIL BAKERY; RETAIL DELICATESSEN; RETAIL SHOP FEATURING FLOWERS; RETAIL STORE SERVICES FEATURING A WIDE VARIETY OF PACKAGED, PREPARED AND FRESH FOOD AND BEVERAGES; ONLINE RETAIL SHOP FEATURING UMBRELLAS, COMPUTER BAGS, COFFEE CUPS, LUNCH BOXES, CALCULATORS, PENS, PENCILS AND CLOTHING (U.S. CLS. 100, 101 AND 102).

FIRST USE 10-1-1997; IN COMMERCE 10-1-1997.
MARGARET POWER, EXAMINING ATTORNEY

SN 77-378,742. VSR FINANCIAL SERVICES, INC., OVERLAND PARK, KS. FILED 1-23-2008.

ROADMAP TO MILLIONS

THE MARK CONSISTS OF STANDARD CHARACTERS WITHOUT CLAIM TO ANY PARTICULAR FONT, STYLE, SIZE, OR COLOR.

FOR BUSINESS DEVELOPMENT SERVICES, NAMELY, PROVIDING BUSINESS ADVICE AND START UP SUPPORT FOR FINANCIAL PLANNING REPRESENTATIVES (U.S. CLS. 100, 101 AND 102).

DANIEL CAPSHAW, EXAMINING ATTORNEY

CLASS 35—(Continued).

SN 77-378,773. PRECURSOR LLC, MC LEAN, VA. FILED 1-23-2008.

SAFE INTERNET ALLIANCE

THE MARK CONSISTS OF STANDARD CHARACTERS WITHOUT CLAIM TO ANY PARTICULAR FONT, STYLE, SIZE, OR COLOR.

NO CLAIM IS MADE TO THE EXCLUSIVE RIGHT TO USE "SAFE INTERNET", APART FROM THE MARK AS SHOWN.

FOR PUBLIC ADVOCACY TO PROMOTE AWARENESS OF THE NEED TO HALT ILLEGAL PRACTICES ON THE INTERNET INCLUDING ILLEGAL INTERNET USAGE AND AGGRESSIVE OR EVASIVE BUSINESS PRACTICES (U.S. CLS. 100, 101 AND 102).

SALLY SHIH, EXAMINING ATTORNEY

CLASS 35—(Continued).

SN 77-384,492. SPEAK, KARL D., MINNETONKA, MN. FILED 1-30-2008.



OWNER OF U.S. REG. NO. 2,684,744.

NO CLAIM IS MADE TO THE EXCLUSIVE RIGHT TO USE "BRAND TOOLS", APART FROM THE MARK AS SHOWN.

THE COLOR(S) BLUE AND WHITE IS/ARE CLAIMED AS A FEATURE OF THE MARK.

THE MARK CONSISTS OF A RECTANGLE WITH THE WORDING, "BRAND TOOLS IN A BOX" AND A HORIZONTAL LINE SEPARATING THE WORDING, "BRAND TOOLS" AND "IN A BOX". THE COLOR BLUE APPEARS IN THE RECTANGLE AND THE COLOR WHITE APPEARS IN THE WORDING "BRAND TOOLS IN A BOX" AND IN THE HORIZONTAL LINE.

FOR CONCEPT AND BRAND DEVELOPMENT IN THE PROFESSIONAL SERVICES FIELD (U.S. CLS. 100, 101 AND 102).

PAUL CROWLEY, EXAMINING ATTORNEY

SN 77-384,180. FITZENZ, JOHN A., DBA HUMAN CAPITAL SOURCE, INC., SAN JOSE, CA. FILED 1-30-2008.

HCM: 21

THE MARK CONSISTS OF STANDARD CHARACTERS WITHOUT CLAIM TO ANY PARTICULAR FONT, STYLE, SIZE, OR COLOR.

NO CLAIM IS MADE TO THE EXCLUSIVE RIGHT TO USE "HCM", APART FROM THE MARK AS SHOWN.

FOR MANAGEMENT AND BUSINESS CONSULTING SERVICES IN THE FIELD OF TRAINING AND RECRUITMENT (U.S. CLS. 100, 101 AND 102).

FIRST USE 9-1-2007; IN COMMERCE 9-1-2007.

JULIE WATSON, EXAMINING ATTORNEY

SN 77-389,347. COALITION BMX, LLC, ROCHESTER, NY. FILED 2-5-2008.



THE MEPHISTO GROUP

THE MARK CONSISTS OF THE STYLIZED LETTERS "MG", AND THE STYLIZED WORDS "THE MEPHISTO GROUP".

FOR DISTRIBUTORSHIP SERVICES IN THE FIELD OF BICYCLE PARTS AND ACCESSORIES, CLOTHING, SKATEBOARDS, WATCHES (U.S. CLS. 100, 101 AND 102).

FIRST USE 9-1-2007; IN COMMERCE 9-1-2007.

TEJBIR SINGH, EXAMINING ATTORNEY

CLASS 35—(Continued).

SN 77-389,671. CAD, LLC, ALCOA, TN. FILED 2-6-2008.

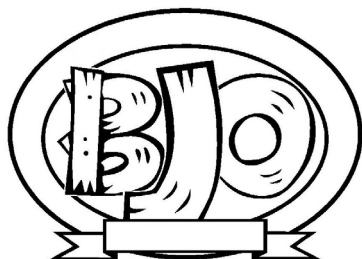

THE MARK CONSISTS OF STYLIZED LETTERS "BJO" APPEARING WITHIN AN OVAL FRAME AND A RIBBON APPEARING BENEATH THE STYLIZED LETTERS. FOR DISTRIBUTORSHIP SERVICES FEATURING MEAT PRODUCTS (U.S. CLS. 100, 101 AND 102). FIRST USE 10-13-2007; IN COMMERCE 10-13-2007. STEPHANIE ALI, EXAMINING ATTORNEY

CLASS 35—(Continued).

SN 77-392,109. BEST WESTERN INTERNATIONAL, INC., PHOENIX, AZ. FILED 2-8-2008.

BEST WESTERN REWARDS

THE MARK CONSISTS OF STANDARD CHARACTERS WITHOUT CLAIM TO ANY PARTICULAR FONT, STYLE, SIZE, OR COLOR.

OWNER OF U.S. REG. NOS. 1,072,360, 3,236,561 AND OTHERS.

NO CLAIM IS MADE TO THE EXCLUSIVE RIGHT TO USE "REWARDS", APART FROM THE MARK AS SHOWN. FOR CUSTOMER LOYALTY SERVICES AND CUSTOMER CLUB SERVICES, FOR COMMERCIAL, PROMOTIONAL AND/OR ADVERTISING PURPOSES (U.S. CLS. 100, 101 AND 102).

GRETTA YAO, EXAMINING ATTORNEY

SN 77-391,618. KATY AREA ECONOMIC DEVELOPMENT COUNCIL, INC., KATY, TX. FILED 2-7-2008.



NO CLAIM IS MADE TO THE EXCLUSIVE RIGHT TO USE "KATY AREA ECONOMIC DEVELOPMENT COUNCIL", APART FROM THE MARK AS SHOWN.

THE COLOR(S) RED AND BLACK AND WHITE IS/ARE CLAIMED AS A FEATURE OF THE MARK.

THE MARK CONSISTS OF A RED GEOMETRIC REPRESENTATION OF A SPINNING GLOBE. THE WORD "KATY" AND THE WORDING "TEAMING WITH TALENT. ENERGIZING THE WORLD" APPEAR IN RED. THE WORD "AREA" AND THE WORDING "ECONOMIC DEVELOPMENT COUNCIL" APPEAR IN BLACK.

FOR PROMOTING THE ECONOMIC DEVELOPMENT IN THE GREATER KATY, TEXAS AREA AND THE STATE OF TEXAS (U.S. CLS. 100, 101 AND 102).

FIRST USE 1-1-2007; IN COMMERCE 1-1-2007. REBECCA SMITH, EXAMINING ATTORNEY

SN 77-392,251. CANADIAN TOURISM COMMISSION, VANCOUVER, CANADA, FILED 2-8-2008.



NO CLAIM IS MADE TO THE EXCLUSIVE RIGHT TO USE "CANADA", APART FROM THE MARK AS SHOWN.

THE MARK CONSISTS OF THE WORDS "CANADA" AND "KEEP EXPLORING" AND A DESIGN OF A MAPLE LEAF.

FOR PROMOTION OF TOURISM IN CANADA; PROMOTION AND ADVERTISEMENT OF CANADA AS AN INTERNATIONAL TOURISM DESTINATION; PROVISION OF A WEBSITE FEATURING PROMOTIONAL AND ADVERTISING INFORMATIONAL INFORMATION RELATED TO TOURISM IN CANADA; BUSINESS RESEARCH, ADVERTISING, MARKETING, MARKET STUDY AND ANALYSIS SERVICES IN THE NATURE OF COMPILATION, EVALUATION, ANALYSIS, RESEARCH, STUDIES, PROVISION AND DISSEMINATION OF INFORMATION AND DATA ON THE TOURISM INDUSTRY, TOURISM MARKET AND TOURISM TRENDS; MARKETING RESEARCH AND STUDIES IN THE FIELD OF TOURISM; PUBLIC RELATIONS AND PUBLICITY SERVICES; PUBLICATION OF PUBLICITY TEXTS; ARRANGING, ORGANIZING AND CONDUCTING TRADE SHOWS, TRADE FAIRS, EXHIBITIONS

CLASS 35—(Continued).

AND PRESENTATIONS FOR ADVERTISING AND PROMOTION OF TOURISM IN CANADA; ADVERTISING AGENCIES, NAMELY, PROMOTING TOURISM AND TRAVEL THROUGH THE DISTRIBUTION AND DISSEMINATION OF PRINTED AND AUDIO PROMOTIONAL MATERIALS, RADIO ADVERTISING AND COMMERCIALS, TELEVISION ADVERTISING AND COMMERCIALS, TRADE SHOWS, TRADE FAIRS, EXHIBITIONS, PRESENTATIONS, BY RENDERING SALES PROMOTION ADVICE, DISTRIBUTION OF SAMPLES OF PRODUCTS AND BANNER ADVERTISING; DIRECT MAIL AND ADVERTISING FOR PROMOTING AND FOSTERING TOURISM; CONTESTS AND INCENTIVE AWARD PROGRAMS TO PROMOTE THE SALE OF PRODUCTS AND SERVICES OF OTHERS IN THE FIELDS OF TOURISM AND PROMOTION OF TOURISM AND TRAVEL; RENTAL OF ADVERTISING SPACE; BUSINESS ADVISORY, MANAGEMENT AND CONSULTATION SERVICES IN THE FIELD OF TOURISM AND PROMOTION OF TOURISM AND TRAVEL (U.S. CLS. 100, 101 AND 102).

FIRST USE 1-15-2007; IN COMMERCE 1-15-2007.
REBECCA GILBERT, EXAMINING ATTORNEY

SN 77-392,259. CANADIAN TOURISM COMMISSION, VANCOUVER, CANADA, FILED 2-8-2008.



NO CLAIM IS MADE TO THE EXCLUSIVE RIGHT TO USE "CANADA", APART FROM THE MARK AS SHOWN.

THE MARK CONSISTS OF THE WORD "CANADA" AND A DESIGN OF A MAPLE LEAF.

FOR PROMOTION OF TOURISM IN CANADA; PROMOTION AND ADVERTISEMENT OF CANADA AS AN INTERNATIONAL TOURISM DESTINATION; PROVISION OF A WEBSITE FEATURING PROMOTIONAL AND ADVERTISING INFORMATIONAL INFORMATION RELATED TO TOURISM IN CANADA; BUSINESS RESEARCH, ADVERTISING, MARKETING, MARKET STUDY AND ANALYSIS SERVICES IN THE NATURE OF COMPILATION, EVALUATION, ANALYSIS, RESEARCH, STUDIES, PROVISION AND DISSEMINATION OF INFORMATION AND DATA ON THE TOURISM INDUSTRY, TOURISM MARKET AND TOURISM TRENDS; MARKETING RESEARCH AND STUDIES IN THE FIELD OF TOURISM; PUBLIC RELATIONS AND PUBLICITY SERVICES; PUBLICATION OF PUBLICITY TEXTS; ARRANGING, ORGANIZING AND CONDUCTING TRADE SHOWS, TRADE FAIRS, EXHIBITIONS AND PRESENTATIONS FOR ADVERTISING AND PROMOTION OF TOURISM IN CANADA; ADVERTISING AGENCIES, NAMELY, PROMOTING TOURISM AND TRAVEL THROUGH THE DISTRIBUTION AND DISSEMINATION OF PRINTED AND AUDIO PROMOTIONAL MATERIALS, RADIO ADVERTISING AND COMMERCIALS, TELEVISION ADVERTISING AND COMMERCIALS, TRADE SHOWS, TRADE FAIRS, EXHIBITIONS, PRESENTATIONS, BY RENDERING SALES PROMOTION ADVICE, DISTRIBUTION OF SAMPLES OF PRODUCTS AND BANNER ADVERTISING; DIRECT MAIL AND ADVERTISING FOR PROMOTING AND FOSTERING TOURISM; CONTESTS AND INCENTIVE AWARD PROGRAMS TO PROMOTE THE SALE OF PRODUCTS AND SERVICES OF OTHERS IN THE FIELDS OF TOURISM AND PROMOTION OF TOURISM AND TRAVEL; RENTAL OF ADVERTISING SPACE; BUSINESS ADVISORY, MANAGEMENT AND CONSULTATION SERVICES IN THE FIELD OF TOURISM AND PROMOTION OF TOURISM AND TRAVEL (U.S. CLS. 100, 101 AND 102).

FIRST USE 1-15-2007; IN COMMERCE 1-15-2007.
REBECCA GILBERT, EXAMINING ATTORNEY

CLASS 35—(Continued).

SN 77-392,261. CANADIAN TOURISM COMMISSION, VANCOUVER, CANADA, FILED 2-8-2008.

KEEP EXPLORING

THE MARK CONSISTS OF STANDARD CHARACTERS WITHOUT CLAIM TO ANY PARTICULAR FONT, STYLE, SIZE, OR COLOR.

FOR PROMOTION OF TOURISM IN CANADA; PROMOTION AND ADVERTISEMENT OF CANADA AS AN INTERNATIONAL TOURISM DESTINATION; PROVISION OF A WEBSITE FEATURING PROMOTIONAL AND ADVERTISING INFORMATIONAL INFORMATION RELATED TO TOURISM IN CANADA; BUSINESS RESEARCH, ADVERTISING, MARKETING, MARKET STUDY AND ANALYSIS SERVICES IN THE NATURE OF COMPILATION, EVALUATION, ANALYSIS, RESEARCH, STUDIES, PROVISION AND DISSEMINATION OF INFORMATION AND DATA ON THE TOURISM INDUSTRY, TOURISM MARKET AND TOURISM TRENDS; MARKETING RESEARCH AND STUDIES IN THE FIELD OF TOURISM; PUBLIC RELATIONS AND PUBLICITY SERVICES; PUBLICATION OF PUBLICITY TEXTS; ARRANGING, ORGANIZING AND CONDUCTING TRADE SHOWS, TRADE FAIRS, EXHIBITIONS AND PRESENTATIONS FOR ADVERTISING AND PROMOTION OF TOURISM IN CANADA; ADVERTISING AGENCIES, NAMELY, PROMOTING TOURISM AND TRAVEL THROUGH THE DISTRIBUTION AND DISSEMINATION OF PRINTED AND AUDIO PROMOTIONAL MATERIALS, RADIO ADVERTISING AND COMMERCIALS, TELEVISION ADVERTISING AND COMMERCIALS, TRADE SHOWS, TRADE FAIRS, EXHIBITIONS, PRESENTATIONS, BY RENDERING SALES PROMOTION ADVICE, DISTRIBUTION OF SAMPLES OF PRODUCTS AND BANNER ADVERTISING; DIRECT MAIL AND ADVERTISING FOR PROMOTING AND FOSTERING TOURISM; CONTESTS AND INCENTIVE AWARD PROGRAMS TO PROMOTE THE SALE OF PRODUCTS AND SERVICES OF OTHERS IN THE FIELDS OF TOURISM AND PROMOTION OF TOURISM AND TRAVEL; RENTAL OF ADVERTISING SPACE; BUSINESS ADVISORY, MANAGEMENT AND CONSULTATION SERVICES IN THE FIELD OF TOURISM AND PROMOTION OF TOURISM AND TRAVEL (U.S. CLS. 100, 101 AND 102).

FIRST USE 1-15-2007; IN COMMERCE 1-15-2007.
REBECCA GILBERT, EXAMINING ATTORNEY

CLASS 35—(Continued).

SN 77-392,272. CANADIAN TOURISM COMMISSION, VANCOUVER, CANADA, FILED 2-8-2008.



NO CLAIM IS MADE TO THE EXCLUSIVE RIGHT TO USE "CANADA", APART FROM THE MARK AS SHOWN.

THE MARK CONSISTS OF THE WORDS "CANADA" AND "KEEP EXPLORING" AND A DESIGN OF A MAPLE LEAF.

FOR PROMOTION OF TOURISM IN CANADA; PROMOTION AND ADVERTISEMENT OF CANADA AS AN INTERNATIONAL TOURISM DESTINATION; PROVISION OF A WEBSITE FEATURING PROMOTIONAL AND ADVERTISING INFORMATIONAL INFORMATION RELATED TO TOURISM IN CANADA; BUSINESS RESEARCH, ADVERTISING, MARKETING, MARKET STUDY AND ANALYSIS SERVICES IN THE NATURE OF COMPILATION, EVALUATION, ANALYSIS, RESEARCH, STUDIES, PROVISION AND DISSEMINATION OF INFORMATION AND DATA ON THE TOURISM INDUSTRY, TOURISM MARKET AND TOURISM TRENDS; MARKETING RESEARCH AND STUDIES IN THE FIELD OF TOURISM; PUBLIC RELATIONS AND PUBLICITY SERVICES; PUBLICATION OF PUBLICITY TEXTS; ARRANGING, ORGANIZING AND CONDUCTING TRADE SHOWS, TRADE FAIRS, EXHIBITIONS AND PRESENTATIONS FOR ADVERTISING AND PROMOTION OF TOURISM IN CANADA; ADVERTISING AGENCIES, NAMELY, PROMOTING TOURISM AND TRAVEL THROUGH THE DISTRIBUTION AND DISSEMINATION OF PRINTED AND AUDIO PROMOTIONAL MATERIALS, RADIO ADVERTISING AND COMMERCIALS, TELEVISION ADVERTISING AND COMMERCIALS, TRADE SHOWS, TRADE FAIRS, EXHIBITIONS, PRESENTATIONS, BY RENDERING SALES PROMOTION ADVICE, DISTRIBUTION OF SAMPLES OF PRODUCTS AND BANNER ADVERTISING; DIRECT MAIL AND ADVERTISING FOR PROMOTING AND FOSTERING TOURISM; CONTESTS AND INCENTIVE AWARD PROGRAMS TO PROMOTE THE SALE OF PRODUCTS AND SERVICES OF OTHERS IN THE FIELDS OF TOURISM AND PROMOTION OF TOURISM AND TRAVEL; RENTAL OF ADVERTISING SPACE; BUSINESS ADVISORY, MANAGEMENT AND CONSULTATION SERVICES IN THE FIELD OF TOURISM AND PROMOTION OF TOURISM AND TRAVEL (U.S. CLS. 100, 101 AND 102).

REBECCA GILBERT, EXAMINING ATTORNEY

CLASS 35—(Continued).

SN 77-392,278. CANADIAN TOURISM COMMISSION, VANCOUVER, CANADA, FILED 2-8-2008.



NO CLAIM IS MADE TO THE EXCLUSIVE RIGHT TO USE "CANADA", APART FROM THE MARK AS SHOWN.

THE MARK CONSISTS OF THE WORD "CANADA" AND A DESIGN OF A MAPLE LEAF.

FOR PROMOTION OF TOURISM IN CANADA; PROMOTION AND ADVERTISEMENT OF CANADA AS AN INTERNATIONAL TOURISM DESTINATION; PROVISION OF A WEBSITE FEATURING PROMOTIONAL AND ADVERTISING INFORMATIONAL INFORMATION RELATED TO TOURISM IN CANADA; BUSINESS RESEARCH, ADVERTISING, MARKETING, MARKET STUDY AND ANALYSIS SERVICES IN THE NATURE OF COMPILATION, EVALUATION, ANALYSIS, RESEARCH, STUDIES, PROVISION AND DISSEMINATION OF INFORMATION AND DATA ON THE TOURISM INDUSTRY, TOURISM MARKET AND TOURISM TRENDS; MARKETING RESEARCH AND STUDIES IN THE FIELD OF TOURISM; PUBLIC RELATIONS AND PUBLICITY SERVICES; PUBLICATION OF PUBLICITY TEXTS; ARRANGING, ORGANIZING AND CONDUCTING TRADE SHOWS, TRADE FAIRS, EXHIBITIONS AND PRESENTATIONS FOR ADVERTISING AND PROMOTION OF TOURISM IN CANADA; ADVERTISING AGENCIES, NAMELY, PROMOTING TOURISM AND TRAVEL THROUGH THE DISTRIBUTION AND DISSEMINATION OF PRINTED AND AUDIO PROMOTIONAL MATERIALS, RADIO ADVERTISING AND COMMERCIALS, TELEVISION ADVERTISING AND COMMERCIALS, TRADE SHOWS, TRADE FAIRS, EXHIBITIONS, PRESENTATIONS, BY RENDERING SALES PROMOTION ADVICE, DISTRIBUTION OF SAMPLES OF PRODUCTS AND BANNER ADVERTISING; DIRECT MAIL AND ADVERTISING FOR PROMOTING AND FOSTERING TOURISM; CONTESTS AND INCENTIVE AWARD PROGRAMS TO PROMOTE THE SALE OF PRODUCTS AND SERVICES OF OTHERS IN THE FIELDS OF TOURISM AND PROMOTION OF TOURISM AND TRAVEL; RENTAL OF ADVERTISING SPACE; BUSINESS ADVISORY, MANAGEMENT AND CONSULTATION SERVICES IN THE FIELD OF TOURISM AND PROMOTION OF TOURISM AND TRAVEL (U.S. CLS. 100, 101 AND 102).

REBECCA GILBERT, EXAMINING ATTORNEY

CLASS 35—(Continued).

SN 77-397,108. ENGBERS CORPORATION, MARTINSVILLE, IN. FILED 2-14-2008.

Equiclaim

THE MARK CONSISTS OF STANDARD CHARACTERS WITHOUT CLAIM TO ANY PARTICULAR FONT, STYLE, SIZE, OR COLOR.

FOR NEWS REPORTING SERVICES, NAMELY, PROVIDING REAL-TIME INFORMATION RELATED TO THE TRACKING OF SALES OF THOROUGHBRED HORSES (U.S. CLS. 100, 101 AND 102).

FIRST USE 1-15-2008; IN COMMERCE 1-15-2008.
MELISSA VALLILLO, EXAMINING ATTORNEY

CLASS 35—(Continued).

SN 77-398,389. PAYLESS SHOESOURCE WORLDWIDE, INC., TOPEKA, KS. FILED 2-15-2008.

I ♥ SHOES

OWNER OF U.S. REG. NO. 2,646,852.

NO CLAIM IS MADE TO THE EXCLUSIVE RIGHT TO USE "SHOES", APART FROM THE MARK AS SHOWN.

THE MARK CONSISTS OF THE WORD "I" IN A STYLIZED FORMAT FOLLOWED BY THE STYLIZED DESIGN OF A HEART FOLLOWED BY THE WORD "SHOES" IN A STYLIZED FORMAT.

FOR RETAIL SHOE AND FASHION ACCESSORIES STORE SERVICES; COMPUTERIZED ON-LINE RETAIL STORE SERVICES IN THE FIELD OF FOOTWEAR, APPAREL, PURSES, HANDBAGS, AND BACKPACKS, ACCESSIBLE VIA GLOBAL COMPUTER NETWORKS (U.S. CLS. 100, 101 AND 102).

WANDA KAY PRICE, EXAMINING ATTORNEY

SN 77-397,940. GASOLINE ALLEY CLASSICS, INC., BROKEN ARROW, OK. FILED 2-15-2008.



OWNER OF U.S. REG. NO. 3,203,733.

THE MARK CONSISTS OF A WOMAN STANDING BETWEEN TWO CHECKERED FLAGS WITH A RIBBON BANNER READING "LADY LUCK" UNDERNEATH. THE WOMAN IS DRESSED IN A TOP COMPRISING THE IMAGES OF TWO POOL BALLS WITH THE NUMBER "8" ON EACH, AND A SARONG SKIRT WITH A HEART DESIGN, AND IS HOLDING A WRENCH IN ONE HAND AND A FOUR-LEAF CLOVER IN THE OTHER. THERE IS A HORSESHOE ADORNING HER HAIR AND SHE IS WEARING DICE AS EARRINGS.

FOR RETAIL STORES FEATURING GOODS WITH AN AUTOMOTIVE THEME, NAMELY, NOVELTY ITEMS, AUTOMOTIVE MEMORABILIA, DISPLAY CASES, CLOCKS AND AUTOMOTIVE ACCESSORIES; ONLINE RETAIL STORE SERVICES FEATURING GOODS WITH AN AUTOMOTIVE THEME, NAMELY, NOVELTY ITEMS, AUTOMOTIVE MEMORABILIA, DISPLAY CASES, CLOCKS AND AUTOMOTIVE ACCESSORIES (U.S. CLS. 100, 101 AND 102).

FIRST USE 1-1-2003; IN COMMERCE 1-1-2003.
ELLEN BURNS, EXAMINING ATTORNEY

SN 77-399,096. EMARKETLINE, INC., DBA FAUCETLINE.COM, FOREST HILLS, NY. FILED 2-17-2008.

FAUCETLINE.COM

THE MARK CONSISTS OF STANDARD CHARACTERS WITHOUT CLAIM TO ANY PARTICULAR FONT, STYLE, SIZE, OR COLOR.

FOR OPERATING AN ONLINE SHOPPING SITE IN THE FIELD OF KITCHEN AND BATH PRODUCTS (U.S. CLS. 100, 101 AND 102).

FIRST USE 6-21-2004; IN COMMERCE 6-21-2004.
KATHRYN COWARD, EXAMINING ATTORNEY

SN 77-399,158. THOMAS J NESTER, CRYSTAL LAKE, IL. FILED 2-17-2008.

Neats and Sweets

THE MARK CONSISTS OF STANDARD CHARACTERS WITHOUT CLAIM TO ANY PARTICULAR FONT, STYLE, SIZE, OR COLOR.

NO CLAIM IS MADE TO THE EXCLUSIVE RIGHT TO USE "SWEETS", APART FROM THE MARK AS SHOWN.

FOR ON-LINE RETAIL STORE SERVICES FEATURING TOYS, NOVELTIES AND CANDY; RETAIL SHOPS FEATURING TOYS, NOVELTIES AND CANDY (U.S. CLS. 100, 101 AND 102).

FIRST USE 5-13-2008; IN COMMERCE 6-20-2008.
JESSICA FATHY, EXAMINING ATTORNEY

CLASS 35—(Continued).

SN 77-399,433. LIVEPORT CORPORATION, WESTBANK, CANADA, FILED 2-18-2008.

LIVEPORT

THE MARK CONSISTS OF STANDARD CHARACTERS WITHOUT CLAIM TO ANY PARTICULAR FONT, STYLE, SIZE, OR COLOR.

FOR CUSTOMER SERVICE IN THE FIELD OF LIVE TELEPHONE SUPPORT SERVICES FOR WIRELESS INTERNET USERS AT HOTELS AND PUBLIC VENUES (U.S. CLS. 100, 101 AND 102).

FIRST USE 1-1-2008; IN COMMERCE 1-1-2008.
KRISTIN CARLSON, EXAMINING ATTORNEY

SN 77-399,809. CHO, BYUNG DUCK, LOS ANGELES, CA. FILED 2-18-2008.

Palace Beauty

THE MARK CONSISTS OF STANDARD CHARACTERS WITHOUT CLAIM TO ANY PARTICULAR FONT, STYLE, SIZE, OR COLOR.

NO CLAIM IS MADE TO THE EXCLUSIVE RIGHT TO USE "BEAUTY", APART FROM THE MARK AS SHOWN.

FOR RETAIL STORES FEATURING BEAUTY SUPPLIES, BEAUTY CREAMS, BEAUTY CREAMS FOR BODY CARE, BEAUTY GELS, BEAUTY LOTIONS, BEAUTY MASKS, BEAUTY MILKS, BEAUTY SERUMS, BODY AND BEAUTY CARE COSMETICS, FACE AND BODY BEAUTY CREAMS, FACIAL BEAUTY MASKS (U.S. CLS. 100, 101 AND 102).

FIRST USE 2-1-1996; IN COMMERCE 2-1-1996.
ZACHARY BELLO, EXAMINING ATTORNEY

SN 77-400,877. MAR-VEL INTERNATIONAL, INC., PENNSAUKEN, NJ. FILED 2-19-2008.

MAR-VEL International

THE MARK CONSISTS OF STANDARD CHARACTERS WITHOUT CLAIM TO ANY PARTICULAR FONT, STYLE, SIZE, OR COLOR.

NO CLAIM IS MADE TO THE EXCLUSIVE RIGHT TO USE "INTERNATIONAL", APART FROM THE MARK AS SHOWN.

FOR OPERATING AN ONLINE SHOPPING SITE IN THE FIELD OF EQUIPMENT AND CLOTHING FOR EXTREME ENVIRONMENTS CONSISTING OF DIVING, MILITARY AND RESCUE (U.S. CLS. 100, 101 AND 102).

FIRST USE 1-1-2003; IN COMMERCE 1-1-2003.
DORITT L. CARROLL, EXAMINING ATTORNEY

CLASS 35—(Continued).

SN 77-401,607. DUCHESS MEDIA CORPORATION, NEW YORK, NY. FILED 2-20-2008.

STARTISTE

THE MARK CONSISTS OF STANDARD CHARACTERS WITHOUT CLAIM TO ANY PARTICULAR FONT, STYLE, SIZE, OR COLOR.

THE WORDING "STARTISTE" HAS NO MEANING IN A FOREIGN LANGUAGE.

FOR RETAIL STORE SERVICES AND ONLINE RETAIL STORE SERVICES FEATURING FASHION SUPPLIES, NAMELY, SNAPS, PINS, CLASPS, CHAINS, BEADS, FASHION COMPONENTS, NAMELY, RIBBONS, BOWS, MATERIAL, FASHION ACCESSORIES, SHOES, COSTUME JEWELRY, JEWELRY, BELTS, HATS, GLOVES, SCARVES, BAGS, LUGGAGE, WALLETS, KEY CHAINS, UMBRELLAS, JEWELRY BOXES, BEADS, CHARMS, HANDLES, BUCKLES, SKIN CARE PRODUCTS, PERSONAL CARE PRODUCTS IN THE NATURE OF BODY LOTION, SHAMPOO, SHOWER GEL, PERFUME, PERSONAL CARE ACCESSORIES IN THE NATURE OF MIRROR COMPACTS, COSMETIC CASES, LIPSTICK CASES, PERFUME BOTTLES, COSMETICS, CASES, MIRROR, FRAGRANCE, CONTAINERS, HAIR CARE PRODUCTS, HAIR-RELATED PRODUCTS, TRAVEL ACCESSORIES, HOME ACCESSORIES, HOME DECORATING PRODUCTS, HOME FURNISHINGS, STATIONERY, NOTEBOOKS, PHOTO ALBUMS, PAPER, STICKERS, GOODS FOR TRAVEL, NAMELY, TRAVEL CASES, TRAVEL BAGS, LAUNDRY CASES, SHOE BAGS, SWIMWEAR, SWIM APPAREL, BOOKS, BOARD GAMES, VIDEOS, CANDY, JUICE, SOFT DRINKS, SODA, PRE-RECORDED CDS FEATURING MUSIC, BOOKS AND MAGAZINES IN THE FIELD OF PUBLISHING, MAGAZINES, NOVELS, COMPUTER ACCESSORIES, VIDEO GAMES, COMPUTER GAMES, PRE-RECORDED CDS FEATURING MUSIC, COMPUTER AND DESK ACCESSORIES, AND CRAFTING SUPPLIES (U.S. CLS. 100, 101 AND 102).

SETH A. RAPPAPORT, EXAMINING ATTORNEY

SN 77-402,306. CUTTER AND COMPANY BROKERAGE, INC., DBA CUTTER & COMPANY, INC., BALLWIN, MO. FILED 2-21-2008.



"Go Independent, But Don't Go It Alone."

NO CLAIM IS MADE TO THE EXCLUSIVE RIGHT TO USE "COMPANY, INC." OR "PARTNERSHIP", APART FROM THE MARK AS SHOWN.

THE MARK CONSISTS OF A SHIP WITH WAVES DEPICTED UNDER "CUTTER & COMPANY INC. PARTNERSHIP PLUS". UNDER THE WAVES THE LITERAL TERM "GO INDEPENDENT BUT DON'T GO IT ALONE".

FOR PLANNING CONCERNING BUSINESS MANAGEMENT, NAMELY, SEARCHING FOR PARTNERS FOR AMALGAMATIONS AND BUSINESS TAKE-OVERS AS WELL AS FOR BUSINESS ESTABLISHMENTS (U.S. CLS. 100, 101 AND 102).

BRIAN PINO, EXAMINING ATTORNEY

CLASS 35—(Continued).

SN 77-403,932. JAMES MILLER & COMPANY, INC., NEW ULM, TX. FILED 2-22-2008.

SuckerNation

THE MARK CONSISTS OF STANDARD CHARACTERS WITHOUT CLAIM TO ANY PARTICULAR FONT, STYLE, SIZE, OR COLOR.

FOR PROVIDING A WEB SITE FEATURING POLITICAL IDEAS, ISSUES, INFORMATION, AND PERSPECTIVES (U.S. CLS. 100, 101 AND 102).

STEVEN R. FOSTER, EXAMINING ATTORNEY

SN 77-405,363. EUQUANT, INC., ATLANTA, GA. FILED 2-25-2008.

FALCON INDEX

THE MARK CONSISTS OF STANDARD CHARACTERS WITHOUT CLAIM TO ANY PARTICULAR FONT, STYLE, SIZE, OR COLOR.

NO CLAIM IS MADE TO THE EXCLUSIVE RIGHT TO USE "INDEX", APART FROM THE MARK AS SHOWN.

FOR CONDUCTING BUSINESS SURVEYS; COLLECTING BUSINESS DATA FROM INDIVIDUALS AND ANALYZING COLLECTED INFORMATION; PROVIDING A WEBSITE DETAILING SURVEY QUESTIONS TO BUSINESSES THAT ARE OWNED BY MINORITIES AND SHOWING AN ANALYSIS OF THE COLLECTED INFORMATION (U.S. CLS. 100, 101 AND 102).

JOHN E. MICHOS, EXAMINING ATTORNEY

SN 77-405,368. EUQUANT, INC., ATLANTA, GA. FILED 2-25-2008.

DRAGON INDEX

THE MARK CONSISTS OF STANDARD CHARACTERS WITHOUT CLAIM TO ANY PARTICULAR FONT, STYLE, SIZE, OR COLOR.

NO CLAIM IS MADE TO THE EXCLUSIVE RIGHT TO USE "INDEX", APART FROM THE MARK AS SHOWN.

FOR CONDUCTING BUSINESS SURVEYS; COLLECTING BUSINESS DATA FROM INDIVIDUALS AND ANALYZING COLLECTED INFORMATION; PROVIDING A WEBSITE DETAILING SURVEY QUESTIONS TO BUSINESSES THAT ARE OWNED BY MINORITIES AND SHOWING AN ANALYSIS OF THE COLLECTED INFORMATION (U.S. CLS. 100, 101 AND 102).

JOHN E. MICHOS, EXAMINING ATTORNEY

CLASS 35—(Continued).

SN 77-405,404. EUQUANT, INC., ATLANTA, GA. FILED 2-25-2008.

TORO INDEX

THE MARK CONSISTS OF STANDARD CHARACTERS WITHOUT CLAIM TO ANY PARTICULAR FONT, STYLE, SIZE, OR COLOR.

NO CLAIM IS MADE TO THE EXCLUSIVE RIGHT TO USE "INDEX", APART FROM THE MARK AS SHOWN.

FOR CONDUCTING BUSINESS SURVEYS; COLLECTING BUSINESS DATA FROM INDIVIDUALS AND ANALYZING COLLECTED INFORMATION; PROVIDING A WEBSITE DETAILING SURVEY QUESTIONS TO BUSINESSES THAT ARE OWNED BY MINORITIES AND SHOWING AN ANALYSIS OF THE COLLECTED INFORMATION (U.S. CLS. 100, 101 AND 102).

JOHN E. MICHOS, EXAMINING ATTORNEY

SN 77-405,630. NYPSA, INC., REDMOND, WA. FILED 2-25-2008.

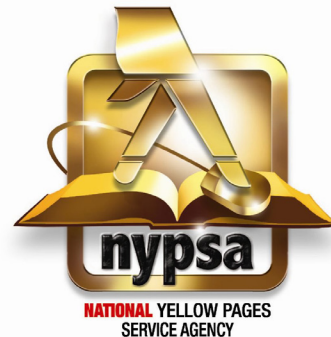

OWNER OF U.S. REG. NO. 3,391,143.

NO CLAIM IS MADE TO THE EXCLUSIVE RIGHT TO USE "NATIONAL YELLOW PAGES SERVICE AGENCY" AND THE WALKING FINGERS DESIGN, APART FROM THE MARK AS SHOWN.

THE COLOR(S) GOLD, BLACK, RED, AND WHITE IS/ARE CLAIMED AS A FEATURE OF THE MARK.

THE MARK CONSISTS OF GOLD FINGERS, COMPUTER MOUSE, AND COMPUTER MOUSE CORD IN GOLD HIGHLIGHTED WITH WHITE, A GOLD RECTANGLE FILLED IN WITH GOLD ABOVE AN OPEN GOLD BOOK AND FILLED IN WITH WHITE BELOW THE GOLD BOOK, THE LETTERS "NYPSA" IN BLACK LETTERING, "NATIONAL" IN RED LETTERING, AND "YELLOW PAGES SERVICE AGENCY" IN BLACK LETTERING.

FOR MARKETING SERVICES, NAMELY, PREPARATION OF AUDIO-VISUAL MARKETING PRESENTATIONS FEATURING ADVERTISING LAYOUTS FOR YELLOW PAGES, PRINT AND INTERNET ADVERTISING AND SEARCH ENGINE MARKETING (U.S. CLS. 100, 101 AND 102).

FIRST USE 6-30-2007; IN COMMERCE 6-30-2007.

SARA THOMAS, EXAMINING ATTORNEY

CLASS 35—(Continued).

SN 77-405,904. TEXAS BUILDING SUPPLY, L.P., CROSS ROADS, TX. FILED 2-26-2008.



NO CLAIM IS MADE TO THE EXCLUSIVE RIGHT TO USE "BUILDING SUPPLY, L.P.", APART FROM THE MARK AS SHOWN.

THE MARK CONSISTS OF THE LETTERS "TBS" INSIDE A MAP OF THE STATE OF TEXAS FOLLOWED BY THE WORDS "TEXAS BUILDING SUPPLY, L.P." THAT ARE BRACKETED ABOVE AND BELOW BY SINGLE HORIZONTAL LINES EXTENDING TO THE RIGHT FROM THE TEXAS MAP.

SEC. 2(F) AS TO "TEXAS" AND THE OUTLINE OF THE STATE OF TEXAS.

FOR WHOLESALE DISTRIBUTORSHIP SERVICES FEATURING BUILDING MATERIALS AND BUILDING SUPPLIES (U.S. CLS. 100, 101 AND 102).

FIRST USE 3-1-2001; IN COMMERCE 3-1-2001.
BARBARA GAYNOR, EXAMINING ATTORNEY

SN 77-407,722. BRANDJUICE CONSULTING INC, DENVER, CO. FILED 2-27-2008.

IDEAS PEOPLE BUY

THE MARK CONSISTS OF STANDARD CHARACTERS WITHOUT CLAIM TO ANY PARTICULAR FONT, STYLE, SIZE, OR COLOR.

FOR ADVERTISING SERVICES; MARKETING SERVICES; BRAND MERCHANDISING CONSULTATION; PUBLICITY SERVICES; CREATING BRAND IDENTITY FOR OTHERS (U.S. CLS. 100, 101 AND 102).

JANET LEE, EXAMINING ATTORNEY

SN 77-407,736. BRANDJUICE CONSULTING INC, DENVER, CO. FILED 2-27-2008.

360° PLATFORM

THE MARK CONSISTS OF STANDARD CHARACTERS WITHOUT CLAIM TO ANY PARTICULAR FONT, STYLE, SIZE, OR COLOR.

FOR ADVERTISING SERVICES; MARKETING SERVICES; BRAND MERCHANDISING CONSULTATION; PUBLICITY SERVICES; CREATING BRAND IDENTITY FOR OTHERS (U.S. CLS. 100, 101 AND 102).

JANET LEE, EXAMINING ATTORNEY

CLASS 35—(Continued).

SN 77-407,750. CHAMBERLAIN, PAUL, LA CANADA FLINTRIDGE, CA. FILED 2-27-2008.



Picture Their Imagination

THE MARK CONSISTS OF THREE ANIMATED CARTOON CHARACTERS. FROM LEFT TO RIGHT, A SKATEBOARDER, WIZARD, AND BALLERINA. ABOVE THE CHARACTERS IS THE STYLIZED WORDS "FREE TO BE ME", AND BELOW THE CHARACTERS IS THE STYLIZED WORDS "PICTURE THEIR IMAGINATION".

FOR ON-LINE RETAIL STORE SERVICES FEATURING PORTRAIT, EVENT AND SPORTS PHOTOGRAPHS; RETAIL STORE SERVICES FEATURING PORTRAIT, EVENT AND SPORTS PHOTOGRAPHS (U.S. CLS. 100, 101 AND 102).

FIRST USE 1-1-2001; IN COMMERCE 6-6-2001.
CARYN GLASSER, EXAMINING ATTORNEY

SN 77-407,751. BRANDJUICE CONSULTING INC, DENVER, CO. FILED 2-27-2008.



THE MARK CONSISTS OF THE WORD "BRANDJUICE" ABOVE A DESIGN OF A BAR CODE WITH LIGHTNING ROD GOING THROUGH IT, WITH THE WORDS "IDEAS PEOPLE BUY" BENEATH THE DESIGN.

FOR ADVERTISING SERVICES; MARKETING SERVICES; BRAND MERCHANDISING CONSULTATION; PUBLICITY SERVICES; CREATING BRAND IDENTITY FOR OTHERS (U.S. CLS. 100, 101 AND 102).

JANET LEE, EXAMINING ATTORNEY

CLASS 35—(Continued).

SN 77-408,274. SEIDMAN, DANIEL P., BARRINGTON, IL.
FILED 2-28-2008.

SALES AUTOPSY

THE MARK CONSISTS OF STANDARD CHARACTERS WITHOUT CLAIM TO ANY PARTICULAR FONT, STYLE, SIZE, OR COLOR.

SEC. 2(F).
FOR BUSINESS MARKETING CONSULTING SERVICES (U.S. CLS. 100, 101 AND 102).
FIRST USE 11-30-1992; IN COMMERCE 11-30-1992.
BARBARA RUTLAND, EXAMINING ATTORNEY

SN 77-408,312. THE JEWELLERY STORE DMCC, DEIRA,
DUBAI, UNITED ARAB EMIR., FILED 2-28-2008.

TRUE FIDELITY SUPPLY CHAIN

THE MARK CONSISTS OF STANDARD CHARACTERS WITHOUT CLAIM TO ANY PARTICULAR FONT, STYLE, SIZE, OR COLOR.

NO CLAIM IS MADE TO THE EXCLUSIVE RIGHT TO USE "SUPPLY CHAIN", APART FROM THE MARK AS SHOWN.

FOR BUSINESS CONSULTING SERVICES RELATING TO PRODUCT DISTRIBUTION, OPERATIONS MANAGEMENT SERVICES, LOGISTICS, REVERSE LOGISTICS, SUPPLY CHAIN AND PRODUCTION SYSTEMS AND DISTRIBUTION SOLUTIONS (U.S. CLS. 100, 101 AND 102).

EDWARD NELSON, EXAMINING ATTORNEY

SN 77-408,315. THE JEWELLERY STORE DMCC, DEIRA,
DUBAI, UNITED ARAB EMIR., FILED 2-28-2008.

HIGH FIDELITY SUPPLY CHAIN

THE MARK CONSISTS OF STANDARD CHARACTERS WITHOUT CLAIM TO ANY PARTICULAR FONT, STYLE, SIZE, OR COLOR.

NO CLAIM IS MADE TO THE EXCLUSIVE RIGHT TO USE "SUPPLY CHAIN", APART FROM THE MARK AS SHOWN.

FOR BUSINESS CONSULTING SERVICES RELATING TO PRODUCT DISTRIBUTION, OPERATIONS MANAGEMENT SERVICES, LOGISTICS, REVERSE LOGISTICS, SUPPLY CHAIN AND PRODUCTION SYSTEMS AND DISTRIBUTION SOLUTIONS (U.S. CLS. 100, 101 AND 102).

EDWARD NELSON, EXAMINING ATTORNEY

CLASS 35—(Continued).

SN 77-408,324. THE JEWELLERY STORE DMCC, DEIRA,
DUBAI, UNITED ARAB EMIR., FILED 2-28-2008.

FULL FIDELITY SUPPLY CHAIN

THE MARK CONSISTS OF STANDARD CHARACTERS WITHOUT CLAIM TO ANY PARTICULAR FONT, STYLE, SIZE, OR COLOR.

NO CLAIM IS MADE TO THE EXCLUSIVE RIGHT TO USE "SUPPLY CHAIN", APART FROM THE MARK AS SHOWN.

FOR BUSINESS CONSULTING SERVICES RELATING TO PRODUCT DISTRIBUTION, OPERATIONS MANAGEMENT SERVICES, LOGISTICS, REVERSE LOGISTICS, SUPPLY CHAIN AND PRODUCTION SYSTEMS AND DISTRIBUTION SOLUTIONS (U.S. CLS. 100, 101 AND 102).

EDWARD NELSON, EXAMINING ATTORNEY

SN 77-408,544. KIERNAN, BRIAN W, CHIEFLAND, FL. AND
PARISE, JAMES T., CHIEFLAND, FL. FILED 2-28-2008.

BUY MARINE

THE MARK CONSISTS OF STANDARD CHARACTERS WITHOUT CLAIM TO ANY PARTICULAR FONT, STYLE, SIZE, OR COLOR.

FOR PROVIDING A WEB SITE THAT FEATURES AN ONLINE MARKET FOR USERS TO LIST OFFERED OR WANTED PERSONAL AND BUSINESS ASSETS AND SKILLS FOR HIRE, RENT, SALE OR AUCTION TRANSACTED ON THE BASIS OF PREDEFINED PERFORMANCE AND CLOSING TERMS AND CONDITIONS (U.S. CLS. 100, 101 AND 102).

TEJBIR SINGH, EXAMINING ATTORNEY

SN 77-409,796. BOTELHO, ROBERT D. JR., CANTON, MA.
FILED 2-29-2008.

terrene

THE MARK CONSISTS OF STANDARD CHARACTERS WITHOUT CLAIM TO ANY PARTICULAR FONT, STYLE, SIZE, OR COLOR.

FOR WHOLESALE AND RETAIL STORE SERVICES FEATURING ENVIRONMENTALLY FRIENDLY BUILDING PRODUCTS; BUSINESS MANAGEMENT SERVICES, NAMELY, CONSULTATION RELATING TO ENVIRONMENTALLY FRIENDLY SERVICES AND PRACTICES (U.S. CLS. 100, 101 AND 102).

LINDSEY RUBIN, EXAMINING ATTORNEY

CLASS 35—(Continued).

SN 77-410,451. EMERALD BABY, ROCHESTER, NY. FILED 2-29-2008.

Emerald Baby

THE MARK CONSISTS OF STANDARD CHARACTERS WITHOUT CLAIM TO ANY PARTICULAR FONT, STYLE, SIZE, OR COLOR.

NO CLAIM IS MADE TO THE EXCLUSIVE RIGHT TO USE "BABY", APART FROM THE MARK AS SHOWN.

FOR RETAIL MUSIC AND RECORD STORES; ON-LINE RETAIL STORE SERVICES FEATURING MUSIC COMPACT DISCS, BABY ITEMS OF BLANKETS, BIBS, RATTLES, CRIB BUMPERS, ONESIES, TOWELS, AND GIFT BASKETS; ON-LINE RETAIL STORE SERVICES FEATURING DOWNLOADABLE PRE-RECORDED MUSIC AND VIDEO; ON-LINE RETAIL STORE SERVICES FEATURING DOWNLOADABLE RING TONES; OPERATING AN ONLINE SHOPPING SITE IN THE FIELD OF MUSIC COMPACT DISCS, BABY ITEMS OF BLANKETS, BIBS, RATTLES, CRIB BUMPERS, ONESIES, TOWELS, AND GIFT BASKETS; PROMOTING THE GOODS AND SERVICES OF OTHERS BY PROVIDING A WEB SITE FEATURING COUPONS, REBATES, PRICE-COMPARISON INFORMATION, PRODUCT REVIEWS, LINKS TO THE RETAIL WEB SITES OF OTHERS, AND DISCOUNT INFORMATION (U.S. CLS. 100, 101 AND 102).

JUSTINE D. PARKER, EXAMINING ATTORNEY

SN 77-411,635. HANAPIN MARKETING LLC, BLOOMINGTON, IN. FILED 3-3-2008.

PPC HERO

THE MARK CONSISTS OF STANDARD CHARACTERS WITHOUT CLAIM TO ANY PARTICULAR FONT, STYLE, SIZE, OR COLOR.

NO CLAIM IS MADE TO THE EXCLUSIVE RIGHT TO USE "PPC", APART FROM THE MARK AS SHOWN.

FOR PROVIDING INFORMATION IN THE FIELD OF ONLINE MARKETING, SPECIFICALLY PAY PER CLICK ADVERTISING (U.S. CLS. 100, 101 AND 102).

FIRST USE 3-31-2007; IN COMMERCE 3-31-2007.
CHRISIE B. KING, EXAMINING ATTORNEY

CLASS 35—(Continued).

SN 77-413,645. FIRST NATIONAL OF NEBRASKA, INC., OMAHA, NE. FILED 3-5-2008.

DRIVING SUCCESS.

THE MARK CONSISTS OF STANDARD CHARACTERS WITHOUT CLAIM TO ANY PARTICULAR FONT, STYLE, SIZE, OR COLOR.

FOR ACQUISITION AND MERGER CONSULTATION (U.S. CLS. 100, 101 AND 102).

FIRST USE 3-1-2007; IN COMMERCE 3-1-2007.
IRA J. GOODSAD, EXAMINING ATTORNEY

SN 77-415,371. CHEMSOURCE TECHNOLOGIES, LLC, SEAL BEACH, CA. FILED 3-6-2008.

CHEMSOURCE TECHNOLOGIES

THE MARK CONSISTS OF STANDARD CHARACTERS WITHOUT CLAIM TO ANY PARTICULAR FONT, STYLE, SIZE, OR COLOR.

NO CLAIM IS MADE TO THE EXCLUSIVE RIGHT TO USE "TECHNOLOGIES", APART FROM THE MARK AS SHOWN.

FOR DISTRIBUTORSHIPS FEATURING BUILDING CONSTRUCTION MATERIALS, CEMENT AND CONCRETE-BASED PRODUCTS, ADHESIVES AND COATINGS (U.S. CLS. 100, 101 AND 102).

FIRST USE 1-26-2007; IN COMMERCE 1-26-2007.
EVELYN BRADLEY, EXAMINING ATTORNEY

SN 77-415,454. BARKIS, MARTIN, TUMWATER, WA. FILED 3-6-2008.



NO CLAIM IS MADE TO THE EXCLUSIVE RIGHT TO USE "GOODS", APART FROM THE MARK AS SHOWN.

THE STIPPLING IS FOR SHADING PURPOSES ONLY.

THE MARK CONSISTS OF THE STYLIZED WORDS "FRIENDLY GOODS" INSIDE A CIRCLE. THE LETTER "F" STRETCHES DOWN TO THE WORD "GOODS". SMILING THEATRICAL FACE ON THE BOTTOM OF THE LETTER "F".

FOR ON-LINE RETAIL STORE SERVICES FEATURING ARTS AND CRAFTS, COFFEE, CHOCOLATES, ENVIRONMENTALLY FRIENDLY PRODUCTS, CLOTHING, JEWELRY, AND HOUSEWARES (U.S. CLS. 100, 101 AND 102).

SUSAN LESLIE DUBOIS, EXAMINING ATTORNEY

CLASS 35—(Continued).

SN 77-415,764. FIRST NATIONAL OF NEBRASKA, INC., OMAHA, NE. FILED 3-7-2008.

**WORLD CLASS EXPERIENCE -
MIDWESTERN VALUES**

THE MARK CONSISTS OF STANDARD CHARACTERS WITHOUT CLAIM TO ANY PARTICULAR FONT, STYLE, SIZE, OR COLOR.

FOR ACQUISITION AND MERGER CONSULTATION (U.S. CLS. 100, 101 AND 102).

IRA J. GOODSaid, EXAMINING ATTORNEY

SN 77-416,076. EXCELLENCE IN BUSINESS, INC., AURORA, OR. FILED 3-7-2008.

The Excellent Leader

THE MARK CONSISTS OF STANDARD CHARACTERS WITHOUT CLAIM TO ANY PARTICULAR FONT, STYLE, SIZE, OR COLOR.

FOR BUSINESS MANAGEMENT CONSULTATION IN THE FIELD OF EXECUTIVE AND LEADERSHIP DEVELOPMENT; BUSINESS MANAGEMENT CONSULTING IN THE FIELD OF TEAM DEVELOPMENT (U.S. CLS. 100, 101 AND 102).

FIRST USE 11-11-2006; IN COMMERCE 7-30-2007.
MARK PILARO, EXAMINING ATTORNEY

SN 77-416,172. EXCELLENCE IN BUSINESS, INC., DBA FAMILY BUSINESS ADVISERS, AURORA, OR. FILED 3-7-2008.

Certified Successor

THE MARK CONSISTS OF STANDARD CHARACTERS WITHOUT CLAIM TO ANY PARTICULAR FONT, STYLE, SIZE, OR COLOR.

FOR ASSISTANCE, ADVISORY SERVICES AND CONSULTANCY WITH REGARD TO BUSINESS PLANNING, BUSINESS ANALYSIS, BUSINESS MANAGEMENT, AND BUSINESS ORGANIZATION (U.S. CLS. 100, 101 AND 102).

MARK PILARO, EXAMINING ATTORNEY

CLASS 35—(Continued).

SN 77-416,193. PROCON, INC., KNOXVILLE, TN. FILED 3-7-2008.



NO CLAIM IS MADE TO THE EXCLUSIVE RIGHT TO USE "CONTRACTOR" AND "GPS", APART FROM THE MARK AS SHOWN.

THE COLOR(S) GRAY, ORANGE, CHROME AND WHITE IS/ARE CLAIMED AS A FEATURE OF THE MARK.

THE MARK CONSISTS OF A THREE-DIMENSIONAL CHROME-COLORED RIM ENCIRCLING A THREE-DIMENSIONAL CHROME-COLORED HARDHAT SET AGAINST AN ORANGE BACKGROUND, WITH "CONTRACTOR" IN GRAY BLOCK LETTERS ON A WHITE BACKGROUND DISPOSED TO THE RIGHT OF THE RIM, AND "GPS" IN LARGER ORANGE BLOCK LETTERS ON A WHITE BACKGROUND DISPOSED DIRECTLY BELOW "CONTRACTOR".

FOR WEB-BASED TRACKING AND ALERT SERVICES FOR TRACKING THE GEOGRAPHIC LOCATION OF MOBILE ASSETS, NAMELY, CONSTRUCTION TOOLS, CONSTRUCTION EQUIPMENT AND CONSTRUCTION VEHICLES FOR COMMERCIAL PURPOSES, AND PROVIDING ALERTS WHEN THE MOBILE ASSETS GO OUTSIDE A PREDETERMINED GEOGRAPHIC BOUNDARY (U.S. CLS. 100, 101 AND 102).

G. MAYERSCHOFF, EXAMINING ATTORNEY

SN 77-416,938. ROCKIN' BABY, INC., LOS ANGELES, CA. FILED 3-8-2008.

ROCKIN' KID SHOP

THE MARK CONSISTS OF STANDARD CHARACTERS WITHOUT CLAIM TO ANY PARTICULAR FONT, STYLE, SIZE, OR COLOR.

NO CLAIM IS MADE TO THE EXCLUSIVE RIGHT TO USE "KID SHOP", APART FROM THE MARK AS SHOWN.

FOR RETAIL STORES FEATURING INFANT AND CHILDREN'S CARRIERS, BEDDING, LINENS, PILLOWS, CAR SEAT COVERS, BOOKS, TOYS, INFANT AND CHILDREN'S APPAREL, CLOTHING, DIAPER BAGS, BAGS, HOUSEHOLD ITEMS, GIFTS, CAR SEAT COVERS AND SHOPPING CART COVERS (U.S. CLS. 100, 101 AND 102).

FIRST USE 4-24-2006; IN COMMERCE 4-24-2006.

AHSEN KHAN, EXAMINING ATTORNEY

CLASS 35—(Continued).

SN 77-417,324. NEXIDIOM, INC., WEST MIFFLIN, PA.
FILED 3-10-2008.

NEXIDIOM NETWORK

THE MARK CONSISTS OF STANDARD CHARACTERS WITHOUT CLAIM TO ANY PARTICULAR FONT, STYLE, SIZE, OR COLOR.

NO CLAIM IS MADE TO THE EXCLUSIVE RIGHT TO USE "NETWORK", APART FROM THE MARK AS SHOWN. FOR ADVERTISING VIA ELECTRONIC MEDIA AND SPECIFICALLY THE INTERNET (U.S. CLS. 100, 101 AND 102).

FIRST USE 11-15-2007; IN COMMERCE 2-26-2008.
GEORGIA CARTY, EXAMINING ATTORNEY

SN 77-417,458. EDL TECHNOLOGY, LLC, FREDERICK, MD.
FILED 3-10-2008.

Neighborhood Outlet

THE MARK CONSISTS OF STANDARD CHARACTERS WITHOUT CLAIM TO ANY PARTICULAR FONT, STYLE, SIZE, OR COLOR.

NO CLAIM IS MADE TO THE EXCLUSIVE RIGHT TO USE "OUTLET", APART FROM THE MARK AS SHOWN.

FOR PROVIDING A WEB SITE THAT ENABLES USERS TO POST ITEMS FOR SALE THROUGH ON-LINE CLASSIFIED ADVERTISEMENTS (U.S. CLS. 100, 101 AND 102).

BARNEY CHARLON, EXAMINING ATTORNEY

SN 77-417,468. HEALTH CARE WE CARE, HIGHLAND PARK, IL. FILED 3-10-2008.

**Health Care We Care
Helping You Navigate the
Health Care Maze**

THE MARK CONSISTS OF STANDARD CHARACTERS WITHOUT CLAIM TO ANY PARTICULAR FONT, STYLE, SIZE, OR COLOR.

NO CLAIM IS MADE TO THE EXCLUSIVE RIGHT TO USE "HEALTH CARE", APART FROM THE MARK AS SHOWN.

FOR MANAGEMENT AND BUSINESS CONSULTING SERVICES IN THE FIELD OF HEALTH CARE (U.S. CLS. 100, 101 AND 102).

ALICIA COLLINS, EXAMINING ATTORNEY

CLASS 35—(Continued).

SN 77-417,575. TICKETVOID, LLC, DENVER, CO. FILED 3-10-2008.



THE MARK CONSISTS OF THE CAPITAL LETTER "T" INSIDE THE CAPITAL LETTER "V" FORMING AN UPSIDE DOWN BISECTED TRIANGAL. TO THE RIGHT OF THE STYLIZED MARK IS THE WORD "TICKETVOID" EACH LETTER IS CAPITALIZED. THE LETTERS "VOID" ARE IN BOLD.

FOR ATTORNEY REFERRALS, NAMELY, AN ELECTRONIC MATCHING SYSTEM BETWEEN TRAFFIC OFFENDERS AND ATTORNEYS REGARDING TICKET INFORMATION (U.S. CLS. 100, 101 AND 102).

COURTNEY MCCORMICK, EXAMINING ATTORNEY

SN 77-417,731. HERVOCHON, DEAN P., CHICAGO, IL.
FILED 3-10-2008.

WHAT WOULD A GAY GUY DO?

THE MARK CONSISTS OF STANDARD CHARACTERS WITHOUT CLAIM TO ANY PARTICULAR FONT, STYLE, SIZE, OR COLOR.

FOR PROVIDING A WEBSITE IN THE FIELD OF LOCATING PRODUCTS, DESCRIBING PRODUCTS, RATING PRODUCTS, PRICING PRODUCTS AND COMPARING PRICES OF PRODUCTS; PROVIDING CONSUMER INFORMATION SERVICES AND MAKING REFERRALS IN THE FIELD OF ENTERTAINMENT SERVICES FOR PRODUCTS, SERVICES, EVENTS, ACTIVITIES, FACILITIES AND LOCATIONS (U.S. CLS. 100, 101 AND 102).

KATHERINE STOIDES, EXAMINING ATTORNEY

SN 77-418,211. CONSUMERTRACK, INC., EL SEGUNDO, CA. FILED 3-10-2008.

The logo for Go Free Credit.com features the words 'Go Free Credit.com' in a sans-serif font. The word 'Go' is in a smaller font size and is positioned to the left of 'Free'. The word 'Credit.com' is in a larger font size. The word 'Free' is enclosed within a light-colored oval shape.

THE MARK CONSISTS OF LETTERS CONSISTING OF "GO"; THE LETTERS "FREE" INSIDE AN OVAL; AND "CREDIT.COM".

FOR MONITORING CONSUMER CREDIT REPORTS AND PROVIDING AN ALERT AS TO ANY CHANGES THEREIN; ADVERTISING, PROMOTION AND MARKETING SERVICES IN THE NATURE OF CONSUMER CREDIT REPORTS FOR OTHERS (U.S. CLS. 100, 101 AND 102).

FIRST USE 10-21-2006; IN COMMERCE 10-21-2006.
WILLIAM ROSSMAN, EXAMINING ATTORNEY

CLASS 35—(Continued).

SN 77-418,327. BRIGHTHOUSE, LLC, ATLANTA, GA. FILED 3-11-2008.

SOULFUL EXCELLENCE

THE MARK CONSISTS OF STANDARD CHARACTERS WITHOUT CLAIM TO ANY PARTICULAR FONT, STYLE, SIZE, OR COLOR.

FOR BUSINESS CONSULTING SERVICES (U.S. CLS. 100, 101 AND 102).

ELIZABETH KAJUBI, EXAMINING ATTORNEY

SN 77-418,749. STARFISHPEOPLE, LLC., MEQUON, WI. FILED 3-11-2008.



THE COLOR(S) ORANGE AND GRAY IS/ARE CLAIMED AS A FEATURE OF THE MARK.

THE MARK CONSISTS OF AN ABSTRACT STARFISH IMAGE IN ORANGE TO THE LEFT OF "STARFISHPEOPLE.COM", WITH "YOUR CONSULTING CONNECTION" IN GRAY UNDERNEATH. "STARFISH" AND ".COM" ARE GRAY AND PEOPLE IS ORANGE.

FOR THE BRINGING TOGETHER, FOR THE BENEFIT OF OTHERS, OF A VARIETY OF GOODS AND SERVICES, ENABLING CUSTOMERS TO CONVENIENTLY VIEW AND PURCHASE THOSE GOODS AND SERVICES FROM AN INTERNET WEBSITE PARTICULARLY SPECIALIZING IN THE MARKETING OF THE SALE OF GOODS AND SERVICES OF OTHERS (U.S. CLS. 100, 101 AND 102).

FIRST USE 3-1-2008; IN COMMERCE 3-10-2008.

KARANENDRA S. CHHINA, EXAMINING ATTORNEY

SN 77-419,042. UNITED CONSUMER BENEFITS NETWORK, INC., SAN FRANCISCO, CA. FILED 3-11-2008.

LeAlta Media

THE MARK CONSISTS OF STANDARD CHARACTERS WITHOUT CLAIM TO ANY PARTICULAR FONT, STYLE, SIZE, OR COLOR.

NO CLAIM IS MADE TO THE EXCLUSIVE RIGHT TO USE "MEDIA", APART FROM THE MARK AS SHOWN.

THE ENGLISH TRANSLATION OF THE WORD "LEALTA" IN THE MARK IS "ALLEGIANCE".

FOR PROVIDING A LOYALTY REWARDS PROGRAM VIA THE PROMOTION OF OTHER'S PRODUCTS AND SERVICES FOR THE PURPOSES OF PROVIDING A SAVINGS PLAN TO ENROLLED MEMBERS; ADVERTISING AND MARKETING VIA ELECTRONIC MEDIA SPECIFICALLY THE INTERNET; ADVERTISING, NAMELY, PROMOTING THE GOODS AND SERVICES, BRAND IDENTITY, AND COMMERCIAL INFORMATION AND NEWS OF THIRD PARTIES VIA THE INTERNET (U.S. CLS. 100, 101 AND 102).

REBECCA POVARCHUK, EXAMINING ATTORNEY

CLASS 35—(Continued).

SN 77-419,297. SEAWOOD PHOTO, INC., SAN ANSELMO, CA. FILED 3-11-2008.

SEAWOOD PHOTO

THE MARK CONSISTS OF STANDARD CHARACTERS WITHOUT CLAIM TO ANY PARTICULAR FONT, STYLE, SIZE, OR COLOR.

NO CLAIM IS MADE TO THE EXCLUSIVE RIGHT TO USE "PHOTO", APART FROM THE MARK AS SHOWN.

FOR RETAIL STORES FEATURING NEW AND USED CAMERAS, PHOTO ACCESSORIES AND SUPPLIES (U.S. CLS. 100, 101 AND 102).

FIRST USE 8-0-1961; IN COMMERCE 8-0-1961.

EMILY CARLSEN, EXAMINING ATTORNEY

SN 77-419,329. SHOP BILLBOARD, SARATOGA SPRINGS, NY. FILED 3-11-2008.

SHOP BILLBOARD, INC.

THE MARK CONSISTS OF STANDARD CHARACTERS WITHOUT CLAIM TO ANY PARTICULAR FONT, STYLE, SIZE, OR COLOR.

NO CLAIM IS MADE TO THE EXCLUSIVE RIGHT TO USE "SHOP" OR "INC.", APART FROM THE MARK AS SHOWN.

FOR ELECTRONIC COMMERCE SERVICES, NAMELY, PROVIDING INFORMATION NETWORKS FOR ADVERTISING AND SALES PURPOSES (U.S. CLS. 100, 101 AND 102).

JAMES A. RAUEN, EXAMINING ATTORNEY

CLASS 35—(Continued).

SN 77-419,390. SWEENEY, KATHRYN MARION, DBA RESUME WRITERS RESOURCE, QUEEN CREEK, AZ. FILED 3-11-2008.



NO CLAIM IS MADE TO THE EXCLUSIVE RIGHT TO USE "RESUME WRITERS RESOURCE", APART FROM THE MARK AS SHOWN.

THE COLOR(S) BLACK, BROWN, TAN, AND RUST IS/ARE CLAIMED AS A FEATURE OF THE MARK.

THE MARK CONSISTS OF THE WORDS "RESUME" IN BROWN, "WRITERS" IN RUST, AND "RESOURCE" IN BLACK, WITH A BLACK ARROW CURVING UPWARD TO THE LEFT OF THE WORDS, AND FOUR TAN RECTANGULAR SHAPES GRADUATING UPWARD TO THE LEFT OF THE ARROW.

FOR BUSINESS MANAGEMENT CONSULTING AND ADVISORY SERVICES (U.S. CLS. 100, 101 AND 102).

FIRST USE 1-1-2008; IN COMMERCE 1-1-2008.

KRISTIN CARLSON, EXAMINING ATTORNEY

SN 77-419,412. CARBON12, LLC, MONTEREY, CA. FILED 3-11-2008.

Carbon12

THE MARK CONSISTS OF STANDARD CHARACTERS WITHOUT CLAIM TO ANY PARTICULAR FONT, STYLE, SIZE, OR COLOR.

FOR ADVERTISING AND INFORMATION DISTRIBUTION SERVICES, NAMELY, PROVIDING CLASSIFIED ADVERTISING SPACE VIA THE GLOBAL COMPUTER NETWORK; PROMOTING THE GOODS AND SERVICES OF OTHERS OVER THE INTERNET; PROVIDING ON-LINE COMPUTER DATABASES AND ON-LINE SEARCHABLE DATABASES FEATURING CLASSIFIED LISTINGS (U.S. CLS. 100, 101 AND 102).

JORDAN BAKER, EXAMINING ATTORNEY

CLASS 35—(Continued).

SN 77-420,018. LUXE & PRODUCT LLC, DBA MATTER, BROOKLYN, NY. FILED 3-12-2008.

THE MARK CONSISTS OF UPPER-CASE BLOCK LETTERS ALL ATTACHED.

FOR RETAIL SHOPS FEATURING FURNITURE AND LIGHTING AND DECORATIVE ACCESSORIES FOR HOME AND OFFICE (U.S. CLS. 100, 101 AND 102).

FIRST USE 7-1-2003; IN COMMERCE 9-1-2003.

RONALD AIKENS, EXAMINING ATTORNEY

SN 77-420,540. PROMINENT CEASE ENTERTAINMENT, INC, LANHAM, MD. FILED 3-12-2008.

Discover Imagitainment

THE MARK CONSISTS OF STANDARD CHARACTERS WITHOUT CLAIM TO ANY PARTICULAR FONT, STYLE, SIZE, OR COLOR.

FOR ADVERTISING AND MARKETING; ADVERTISING AND PROMOTIONAL SERVICES; ADVERTISING AND PUBLICITY SERVICES; ADVERTISING BY TRANSMISSION OF ON-LINE PUBLICITY FOR THIRD PARTIES THROUGH ELECTRONIC COMMUNICATIONS NETWORKS; ADVERTISING CONSULTATION; ADVERTISING PARTICULARLY SERVICES FOR THE PROMOTION OF GOODS; ADVERTISING SERVICES; ORGANIZATION OF PROMOTIONS USING AUDIOVISUAL MEDIA; ADVERTISING FLYER DISTRIBUTION; ADVERTISING THROUGH ALL PUBLIC COMMUNICATION MEANS; ADVERTISING VIA ELECTRONIC MEDIA AND SPECIFICALLY THE INTERNET; CINEMA ADVERTISING; DESIGN OF ADVERTISING FLYERS FOR OTHERS; DESIGN OF ADVERTISING MATERIALS FOR OTHERS; PROVIDING ADVERTISING SERVICES USING 3D AND ANIMATION DESIGNS; PROVIDING ADVERTISING, MARKETING AND PROMOTIONAL SERVICES, NAMELY, DEVELOPMENT OF ADVERTISING CAMPAIGNS FOR TELEVISION (U.S. CLS. 100, 101 AND 102).

DEZMONA MIZELLE, EXAMINING ATTORNEY

CLASS 35—(Continued).

SN 77-420,706. DIEBOLD, INCORPORATED, NORTH CANTON, OH. FILED 3-13-2008.

IDENX.COM

THE MARK CONSISTS OF STANDARD CHARACTERS WITHOUT CLAIM TO ANY PARTICULAR FONT, STYLE, SIZE, OR COLOR.

FOR COMPUTERIZED ON-LINE RETAIL STORE SERVICES IN THE FIELD OF SECURITY IDENTIFICATION CARDS (U.S. CLS. 100, 101 AND 102).

FIRST USE 3-12-2008; IN COMMERCE 3-12-2008.
CURTIS FRENCH, EXAMINING ATTORNEY

CLASS 35—(Continued).

SN 77-421,836. CIVIX-M-R, LLC, SARASOTA, FL. FILED 3-14-2008.

MEDEPLEX

THE MARK CONSISTS OF STANDARD CHARACTERS WITHOUT CLAIM TO ANY PARTICULAR FONT, STYLE, SIZE, OR COLOR.

FOR BUSINESS MANAGEMENT AND CONSULTATION IN THE FIELD OF MEDICAL OFFICES COMPLEXES AND FACILITIES (U.S. CLS. 100, 101 AND 102).
ELLEN BURNS, EXAMINING ATTORNEY

SN 77-420,746. WILLIAMS, SHERRY, CHAPIN, SC. FILED 3-13-2008.



when losing your baggage is a good thing

THE STIPPLING IS FOR SHADING PURPOSES ONLY.
THE MARK CONSISTS OF THE STYLIZED WORDS "WHEN LOSING YOUR BAGGAGE IS A GOOD THING". TO THE LEFT OF THE STYLIZED WORDS IS AN IMAGE OF TWO HANDBAGS OF DIFFERENT STYLES.

FOR BUSINESS ADVISORY SERVICES, CONSULTANCY AND INFORMATION (U.S. CLS. 100, 101 AND 102).

LESLIE RICHARDS, EXAMINING ATTORNEY

SN 77-422,286. XENITH, LLC, BOSTON, MA. FILED 3-14-2008.

USE YOUR BRAIN, NOT YOUR
HEAD

THE MARK CONSISTS OF STANDARD CHARACTERS WITHOUT CLAIM TO ANY PARTICULAR FONT, STYLE, SIZE, OR COLOR.

FOR PROMOTING PUBLIC INTEREST IN SAFETY IN SPORTS AND OTHER POTENTIALLY HAZARDOUS ACTIVITIES BY THE PROVISION OF NEW PRODUCT TECHNOLOGIES AND INFORMATION TO MINIMIZE INJURIES (U.S. CLS. 100, 101 AND 102).
AMY GEARIN, EXAMINING ATTORNEY

SN 77-421,369. IN-STORE BROADCASTING NETWORK, LLC, SALT LAKE CITY, UT. FILED 3-13-2008.



NO CLAIM IS MADE TO THE EXCLUSIVE RIGHT TO USE "BROADCASTING NETWORK", APART FROM THE MARK AS SHOWN.

THE MARK CONSISTS OF THE WORDS IN STORE BROADCASTING NETWORK WITH A DESIGN AROUND THE WORD IN.

FOR ADVERTISING SERVICES, NAMELY, DELIVERY AND RENDERING OF CUSTOMIZED DIGITAL AUDIO-VISUAL CONTENT AND ADVERTISING TO RETAIL ENVIRONMENT (U.S. CLS. 100, 101 AND 102).
STEPHANIE ALI, EXAMINING ATTORNEY

SN 77-422,403. PERFORMANCE MEDIA, LLC, SALISBURY, MA. FILED 3-14-2008.



NO CLAIM IS MADE TO THE EXCLUSIVE RIGHT TO USE "EXPO", APART FROM THE MARK AS SHOWN.

THE COLOR(S) RED, YELLOW, BLACK AND WHITE IS/ARE CLAIMED AS A FEATURE OF THE MARK.

THE MARK CONSISTS OF THE WORD SPEEDWAY IN RED LETTERS OUTLINED IN BLACK AND WHITE IMMEDIATELY FOLLOWED BY THE WORD "EXPO" IN YELLOW LETTERS OUTLINED IN BLACK WITH A BLACK AND WHITE CHECKERED FLAG BETWEEN THE WORD SPEEDWAY AND "EXPO".

FOR MOTORSPORTS CONSUMER TRADE SHOW FOR RACERS AND FANS OF RACING (U.S. CLS. 100, 101 AND 102).

FIRST USE 12-1-2006; IN COMMERCE 12-1-2006.
MARIA-VICTORIA SUAREZ, EXAMINING ATTORNEY

CLASS 35—(Continued).

SN 77-423,062. GLOBALNOW INC., GARLAND, TX. FILED 3-15-2008.

Business Class Software Solutions

THE MARK CONSISTS OF STANDARD CHARACTERS WITHOUT CLAIM TO ANY PARTICULAR FONT, STYLE, SIZE, OR COLOR.

NO CLAIM IS MADE TO THE EXCLUSIVE RIGHT TO USE "BUSINESS" AND "SOFTWARE SOLUTIONS", APART FROM THE MARK AS SHOWN.

FOR VALUE-ADDED RESELLER SERVICES, NAMELY, DISTRIBUTORSHIP SERVICES FEATURING COMPUTER SOFTWARE (U.S. CLS. 100, 101 AND 102).

FIRST USE 11-15-2007; IN COMMERCE 3-3-2008.
ROBIN CHOSID, EXAMINING ATTORNEY

CLASS 35—(Continued).

SN 77-423,251. HELLMAN, ANDREA, DENVER, CO. FILED 3-16-2008.

OmPass

THE MARK CONSISTS OF STANDARD CHARACTERS WITHOUT CLAIM TO ANY PARTICULAR FONT, STYLE, SIZE, OR COLOR.

FOR ADMINISTRATION OF A DISCOUNT PROGRAM FOR ENABLING PARTICIPANTS TO OBTAIN DISCOUNTS ON GOODS AND SERVICES THROUGH USE OF A DISCOUNT MEMBERSHIP CARD (U.S. CLS. 100, 101 AND 102).

FIRST USE 10-1-2005; IN COMMERCE 1-3-2006.
NATALIE POLZER, EXAMINING ATTORNEY

SN 77-423,446. FERRIN, ABIGAIL, DALLAS, TX. FILED 3-17-2008.

SN 77-423,250. EVENT PRODUCERS, LLC, DBA ENLIGHTENED PROFESSIONALS, WEST HARTFORD, CT. FILED 3-16-2008.



THE REVOLVING DOOR

THE MARK CONSISTS OF STANDARD CHARACTERS WITHOUT CLAIM TO ANY PARTICULAR FONT, STYLE, SIZE, OR COLOR.

FOR RETAIL CLOTHING BOUTIQUES; RETAIL CLOTHING STORES (U.S. CLS. 100, 101 AND 102).

FIRST USE 11-30-2004; IN COMMERCE 11-30-2004.
JAMES LOVELACE, EXAMINING ATTORNEY

SN 77-423,648. GRUPO GALLEGOS, LONG BEACH, CA. FILED 3-17-2008.

THE COLOR(S) BLUE, ORANGE, GREY, RED, CREAM, AND BLACK IS/ARE CLAIMED AS A FEATURE OF THE MARK.

THE MARK CONSISTS OF A CIRCLE CONTAINING GREY, BLACK, BLUE AND RED CIRCLES, STARS, SQUARES AND OTHER FOUR-SIDED SHAPES, WITH GREY, BLACK AND ORANGE BORDERLINES, AND CREAM AND ORANGE LETTERS "E" AND "P" IN THE CENTER OF THE DESIGN AND REPEATING IN A ROTATIONAL MANNER SO AS TO GIVE THE APPEARANCE OF A CROSS-SHAPED DESIGN USING THE LETTERS "E" AND "P" SUPERIMPOSED ON A SIX-POINTED STAR-SHAPED DESIGN SURROUNDED BY A CIRCULAR ORANGE BORDERLINE WHICH IS IN TURN ENCIRCLED BY A RING OF BLUE FOUR-SIDED SHAPES WHICH IS IN TURN ENCIRCLED BY A RING OF RED CIRCLES ON A BLACK CIRCULAR BACKGROUND.

FOR PROMOTING PUBLIC AWARENESS OF WAYS TO ENHANCE WELLNESS AND SPIRITUAL GROWTH FOR INDIVIDUALS, ORGANIZATIONS AND BUSINESSES (U.S. CLS. 100, 101 AND 102).

FIRST USE 5-20-2007; IN COMMERCE 5-20-2007.

KATHERINE M. DUBRAY, EXAMINING ATTORNEY

LSN CONSUMER MODEL

THE MARK CONSISTS OF STANDARD CHARACTERS WITHOUT CLAIM TO ANY PARTICULAR FONT, STYLE, SIZE, OR COLOR.

NO CLAIM IS MADE TO THE EXCLUSIVE RIGHT TO USE "CONSUMER MODEL", APART FROM THE MARK AS SHOWN.

FOR MARKETING SERVICES, NAMELY, CONSUMER MARKETING RESEARCH (U.S. CLS. 100, 101 AND 102).
ANGELA M. MICHELI, EXAMINING ATTORNEY

CLASS 35—(Continued).

SN 77-423,662. GRUPO GALLEGOS, LONG BEACH, CA. FILED 3-17-2008.

LSN MODEL

THE MARK CONSISTS OF STANDARD CHARACTERS WITHOUT CLAIM TO ANY PARTICULAR FONT, STYLE, SIZE, OR COLOR.

NO CLAIM IS MADE TO THE EXCLUSIVE RIGHT TO USE "MODEL", APART FROM THE MARK AS SHOWN.

FOR MARKETING SERVICES, NAMELY, CONSUMER MARKETING RESEARCH (U.S. CLS. 100, 101 AND 102). ANGELA M. MICHELI, EXAMINING ATTORNEY

SN 77-423,673. GRUPO GALLEGOS, LONG BEACH, CA. FILED 3-17-2008.

LSN SEGMENTATION MODEL

THE MARK CONSISTS OF STANDARD CHARACTERS WITHOUT CLAIM TO ANY PARTICULAR FONT, STYLE, SIZE, OR COLOR.

NO CLAIM IS MADE TO THE EXCLUSIVE RIGHT TO USE "SEGMENTATION MODEL", APART FROM THE MARK AS SHOWN.

FOR MARKETING SERVICES, NAMELY, CONSUMER MARKETING RESEARCH (U.S. CLS. 100, 101 AND 102). ANGELA M. MICHELI, EXAMINING ATTORNEY

SN 77-424,134. ELAYNE M. DUDLEY, DBA INSIDE SALES GROUP, EXETER, NH. FILED 3-17-2008.



NO CLAIM IS MADE TO THE EXCLUSIVE RIGHT TO USE "INSIDE SALES" AND "GROUP", APART FROM THE MARK AS SHOWN.

THE MARK CONSISTS OF A SOLID HORIZONTAL RECTANGLE CARRYING A LOWER CASE "I" AND A STYLIZED LETTER "S" EXTENDING FROM THE TOP TO THE BOTTOM OF THE RECTANGLE. THE WORD "INSIDE" APPEARS ABOVE THE WORD "SALES" ON THE RIGHT SIDE OF THE RECTANGLE. THE WORD "GROUP" APPEARS VERTICALLY ALONG THE RIGHT OF THE RECTANGLE.

FOR ADVERTISING AND MARKETING SERVICES, NAMELY, PROMOTING THE GOODS AND SERVICES OF OTHERS BY DEVELOPING BUSINESS LEADS, GENERATING, CONFIRMING AND QUALIFYING PROSPECTS OR EXISTING CLIENTS VIA TELEMARKETING AND ELECTRONIC MAIL (U.S. CLS. 100, 101 AND 102).

FIRST USE 8-1-2004; IN COMMERCE 12-15-2004. SANDRA MANIOS, EXAMINING ATTORNEY

CLASS 35—(Continued).

SN 77-424,253. REYNOLDS, ROBERT L., BIRMINGHAM, AL. FILED 3-17-2008.

Planet Thrift

THE MARK CONSISTS OF STANDARD CHARACTERS WITHOUT CLAIM TO ANY PARTICULAR FONT, STYLE, SIZE, OR COLOR.

NO CLAIM IS MADE TO THE EXCLUSIVE RIGHT TO USE "THRIFT", APART FROM THE MARK AS SHOWN.

FOR RETAIL AND WHOLESALE STORE SERVICES IN THE FIELD OF NEW AND USED CLOTHING AND NEW AND USED GENERAL CONSUMER MERCHANDISE (U.S. CLS. 100, 101 AND 102).

CHARLES L. JENKINS, EXAMINING ATTORNEY

SN 77-424,268. REYNOLDS, ROBERT L., BIRMINGHAM, AL. FILED 3-17-2008.



NO CLAIM IS MADE TO THE EXCLUSIVE RIGHT TO USE "THRIFT", APART FROM THE MARK AS SHOWN.

THE MARK CONSISTS OF THE WORDS "PLANET THRIFT", ALONG WITH A CIRCULAR OBJECT AND AN ADDITIONAL STYLIZED DESIGN.

FOR RETAIL AND WHOLESALE STORE SERVICES IN THE FIELD OF NEW AND USED CLOTHING AND NEW AND USED GENERAL CONSUMER MERCHANDISE (U.S. CLS. 100, 101 AND 102).

CHARLES L. JENKINS, EXAMINING ATTORNEY

CLASS 35—(Continued).

SN 77-424,270. THE ENKEBOLL CO., DBA ENKEBOLL DESIGNS, CARSON, CA. FILED 3-17-2008.



OWNER OF U.S. REG. NOS. 2,344,663, 2,450,561 AND OTHERS.

THE MARK CONSISTS OF A KEY, A FEATHER, AND THE WORD "ENKEBOLL" INSIDE A CIRCLE.

FOR CATALOG ORDERING SERVICE FEATURING ARCHITECTURAL WOOD CARVINGS, ONLINE RETAIL STORE SERVICES FEATURING ARCHITECTURAL WOOD CARVINGS (U.S. CLS. 100, 101 AND 102).

JIM RINGLE, EXAMINING ATTORNEY

CLASS 35—(Continued).

SN 77-424,624. LORILLARD LICENSING COMPANY, LLC, GREENSBORO, NC. FILED 3-18-2008.

Newport Pleasure Draw

THE MARK CONSISTS OF STANDARD CHARACTERS WITHOUT CLAIM TO ANY PARTICULAR FONT, STYLE, SIZE, OR COLOR.

OWNER OF U.S. REG. NOS. 3,164,986, 3,292,908 AND OTHERS.

NO CLAIM IS MADE TO THE EXCLUSIVE RIGHT TO USE "DRAW", APART FROM THE MARK AS SHOWN.

FOR CUSTOMER LOYALTY SERVICES FOR COMMERCIAL, PROMOTIONAL AND/OR ADVERTISING PURPOSES, NAMELY, SWEEPSTAKES FOR CIGARETTES (U.S. CLS. 100, 101 AND 102).

FIRST USE 6-18-2007; IN COMMERCE 6-18-2007.

KELLY MCCOY, EXAMINING ATTORNEY

SN 77-424,619. BASS, RYAN LEE, BLOOMINGTON, IN. FILED 3-18-2008.

Kaplaa

THE MARK CONSISTS OF STANDARD CHARACTERS WITHOUT CLAIM TO ANY PARTICULAR FONT, STYLE, SIZE, OR COLOR.

THE TERM "KAPLAA" HAS NO MEANING IN A FOREIGN LANGUAGE.

FOR THE BRINGING TOGETHER, FOR THE BENEFIT OF OTHERS, OF A VARIETY OF GOODS AND SERVICES, ENABLING CUSTOMERS TO CONVENIENTLY VIEW AND PURCHASE THOSE GOODS AND SERVICES FROM AN INTERNET WEBSITE PARTICULARLY SPECIALIZING IN THE MARKETING OF THE SALE OF GOODS AND SERVICES OF OTHERS (U.S. CLS. 100, 101 AND 102).

ALYSSA PALADINO, EXAMINING ATTORNEY

SN 77-424,664. LK MIX, LLC, LAKE WORTH, FL. FILED 3-18-2008.

WE RESCUE TREASURES & LOCATE HOMES FOR THEM

THE MARK CONSISTS OF STANDARD CHARACTERS WITHOUT CLAIM TO ANY PARTICULAR FONT, STYLE, SIZE, OR COLOR.

FOR RETAIL STORE SERVICES FEATURING FURNITURE, DECORATIVE HOME FURNISHINGS, DINING AND KITCHEN GOODS, TEXTILES, LAMPS, BATHROOM ACCESSORIES, NOVELTY ITEMS AND PICTURE FRAMES (U.S. CLS. 100, 101 AND 102).

FIRST USE 10-26-2007; IN COMMERCE 10-26-2007.

CHERYL CLAYTON, EXAMINING ATTORNEY

CLASS 35—(Continued).

SN 77-424,784. WHYPARK, LLC, WILLOUGHBY, OH. FILED 3-18-2008.

WhyPark

THE MARK CONSISTS OF STANDARD CHARACTERS WITHOUT CLAIM TO ANY PARTICULAR FONT, STYLE, SIZE, OR COLOR.

FOR ONLINE MARKETING AND ADVERTISING SERVICES; MARKETING SERVICES, NAMELY, PROVIDING INFORMATIONAL WEB PAGES DESIGNED TO GENERATE SALES TRAFFIC VIA HYPERLINKS TO OTHER WEB SITES; SERVICES RELATING TO THE ANALYSIS, EVALUATION, CREATION AND BRAND ESTABLISHMENT OF TRADEMARKS, TRADE NAMES AND DOMAIN NAMES; ADVERTISING AND BUSINESS MANAGEMENT CONSULTANCY; PROMOTING THE GOODS AND SERVICES OF OTHERS THROUGH SEARCH ENGINE REFERRAL TRAFFIC ANALYSIS AND REPORTING (U.S. CLS. 100, 101 AND 102).

FIRST USE 4-17-2006; IN COMMERCE 4-17-2006.
INGA ERVIN, EXAMINING ATTORNEY

SN 77-424,948. NEWS AMERICA MARKETING PROPERTIES LLC, CHICAGO, IL. FILED 3-18-2008.

SMARTSOURCE FLOORTALK

THE MARK CONSISTS OF STANDARD CHARACTERS WITHOUT CLAIM TO ANY PARTICULAR FONT, STYLE, SIZE, OR COLOR.

OWNER OF U.S. REG. NO. 2,874,691.
FOR ADVERTISING AND PROMOTION SERVICES, NAMELY, PROVIDING ADVERTISING SPACE ON STORE FLOORS FOR THE MARKETING OF THE GOODS AND SERVICE OF OTHERS TO CONSUMERS (U.S. CLS. 100, 101 AND 102).

FIRST USE 8-30-1999; IN COMMERCE 8-30-1999.
PRISCILLA MILTON, EXAMINING ATTORNEY

CLASS 35—(Continued).

SN 77-425,107. MMKS, LLC, DBA MID-TOWN DIRECT REALTY, MAPLEWOOD, NJ. FILED 3-18-2008.



NO CLAIM IS MADE TO THE EXCLUSIVE RIGHT TO USE "REALTY", APART FROM THE MARK AS SHOWN.

THE COLOR(S) BLACK, RED, WHITE IS/ARE CLAIMED AS A FEATURE OF THE MARK.

THE MARK CONSISTS OF THE IMAGE OF A BLACK TRAIN WITH RED TRIM UNDER A RED TRAIN TUNNEL/HOUSE. THE HOUSE IS BISECTED BY THE TERM "REALTY" WHICH APPEARS IN BLACK. THE WHOLE IMAGE IS ENCLOSED WITHIN THE OUTLINE OF A CIRCLE WHICH APPEARS IN RED AND WHICH CONTAINS THE TERMS "MID-TOWN DIRECT" IN RED OUTLINED IN BLACK. THE OUTLINED WHITE CIRCLE IS BISECTED ON THE RIGHT AND LEFT BY LINES IN BLACK REPRESENTING TRAIN TRACKS.

FOR REAL ESTATE SALES MANAGEMENT; LOBBYING SERVICES, NAMELY, PROMOTING THE INTERESTS OF INTERNATIONAL, REAL ESTATE AND NONPROFIT COMPANIES IN THE FIELDS OF POLITICS, LEGISLATION, AND REGULATION; MATCHING CONSUMERS WITH REAL ESTATE PROFESSIONALS IN THE FIELD OF REAL ESTATE SERVICES VIA COMPUTER NETWORK; MATCHING POTENTIAL BUYERS TO FACILITATE CO-OWNERSHIP OF RESIDENTIAL REAL PROPERTY; NEWS REPORTING SERVICES, NAMELY, PROVIDING REAL-TIME INFORMATION RELATED TO THE TRACKING OF SALES OF THOROUGHBRED HORSES; PROMOTING THE GOODS OF OTHERS BY MEANS OF ON-LINE REAL TIME PRESENTATION FOR INSPECTION, VIEWING OR SHOWING OF REAL ESTATE; PROVIDING A DATABASE FEATURING REAL PROPERTY TAX INFORMATION; PROVIDING INTERACTIVE SALES ASSESSMENT SERVICES VIA THE TELEPHONE FOR MEASURING THE SKILLS AND KNOWLEDGE OF FIELD SALES FORCES IN REAL WORLD SELLING SITUATIONS; PROVIDING REAL ESTATE LEADS FOR PROSPECTIVE PURCHASERS; REAL ESTATE ADVERTISING SERVICES; REAL ESTATE AUCTIONS; REAL ESTATE MARKETING SERVICES IN THE FIELD OF SALES; REAL ESTATE MARKETING SERVICES, NAMELY, ON-LINE SERVICES FEATURING TOURS OF RESIDENTIAL AND COMMERCIAL REAL ESTATE; REAL ESTATE MARKETING SERVICES, NAMELY, ON-LINE SERVICES FEATURING THE PROMOTION OF RESIDENTIAL NEW CONSTRUCTION, WHICH ALSO CONTAINS BACK OFFICE SOLUTIONS FOR BUILDERS (U.S. CLS. 100, 101 AND 102).

FIRST USE 12-1-2007; IN COMMERCE 1-2-2008.
JILL PRATER, EXAMINING ATTORNEY

CLASS 35—(Continued).

SN 77-425,285. NUWAVE MEDIA INC., RENO, NV. FILED 3-18-2008.



NO CLAIM IS MADE TO THE EXCLUSIVE RIGHT TO USE "MEDIA INC", APART FROM THE MARK AS SHOWN. THE STIPPLING IS FOR SHADING PURPOSES ONLY.

THE MARK CONSISTS OF THE STYLIZED WORDS "NUWAVE MEDIA INC WWW.NUWAVEMEDIAINC.COM". IN THE BACKGROUND IS AN IMAGE OF A WAVE.

FOR ADVERTISING SERVICES, NAMELY, ADVERTISING ON LCD MONITORS WHERE CONTENT IS TRANSMITTED FROM COMPUTER SERVERS TO DIGITAL MEDIA PLAYERS BEHIND THE MONITORS; FRANCHISE SERVICES, NAMELY, OFFERING BUSINESS MANAGEMENT ASSISTANCE IN THE ESTABLISHMENT AND OPERATION OF ADVERTISING (U.S. CLS. 100, 101 AND 102).

PATRICIA EVANKO, EXAMINING ATTORNEY

SN 77-425,637. JOHNSTON, PHILIP W, DBA JOHNSTON ASSOCIATES, BOSTON, MA. AND BERGAN, MICHAEL A, BOSTON, MA. FILED 3-18-2008.

When Relationships Matter.

THE MARK CONSISTS OF STANDARD CHARACTERS WITHOUT CLAIM TO ANY PARTICULAR FONT, STYLE, SIZE, OR COLOR.

FOR ADVERTISING SERVICES, PUBLIC RELATIONS AND MARKETING SERVICES, NAMELY, PROMOTING AND MARKETING THE GOODS AND SERVICES OF OTHERS THROUGH ALL PUBLIC COMMUNICATION MEANS (U.S. CLS. 100, 101 AND 102).

ANDREA SAUNDERS, EXAMINING ATTORNEY

CLASS 35—(Continued).

SN 77-425,653. ABI SARKIS, TEDDY, DBA PREPBOOKS, LLC, ATLANTA, GA. FILED 3-18-2008.



THE COLOR(S) RED, BLACK, WHITE, GREY, DARK GREY, OLIVE GREEN, LIGHT YELLOW IS/ARE CLAIMED AS A FEATURE OF THE MARK.

THE MARK CONSISTS OF A MALE FICTIONAL CHARACTER READING A BOOK, DRAWN WITH BLACK LINES. THE CHARACTER HAIR COLOR IS BLACK AND IS COMBED BACKWARDS. CHARACTER HAS LIGHT YELLOW SKIN COLOR ON ITS FACE, NECK AND HANDS. CHARACTER IS WEARING A LONG SLEEVE GREY SHIRT AND A RED TIE. CHARACTER IS WEARING DARK GREY PANTS AND BLACK SHOES. CHARACTER IS HOLDING AN OLIVE GREEN BOOK WITH ONE HAND AND APPEARS TO BE READING. THE EDGES OF THE PAGES OF THE BOOK ARE WHITE. THE OTHER HAND IS IN THE RIGHT POCKET OF DARK GREY PANTS. CHARACTER APPROXIMATE AGE IS OF A TEENAGER OR YOUNG GUY.

FOR THE BRINGING TOGETHER, FOR THE BENEFIT OF OTHERS, OF A VARIETY OF GOODS AND SERVICES, ENABLING CUSTOMERS TO CONVENIENTLY VIEW AND PURCHASE THOSE GOODS AND SERVICES FROM AN INTERNET WEBSITE PARTICULARLY SPECIALIZING IN THE MARKETING OF THE SALE OF GOODS AND SERVICES OF OTHERS (U.S. CLS. 100, 101 AND 102).

FIRST USE 3-18-2008; IN COMMERCE 3-18-2008.
JAMES MACFARLANE, EXAMINING ATTORNEY

SN 77-425,860. ELECTRONIC ENTERTAINMENT DESIGN AND RESEARCH, SAN DIEGO, CA. FILED 3-19-2008.

GamePulse

THE MARK CONSISTS OF STANDARD CHARACTERS WITHOUT CLAIM TO ANY PARTICULAR FONT, STYLE, SIZE, OR COLOR.

FOR COMMERCIAL INFORMATION IN THE FIELD OF VIDEO GAMES AND ELECTRONIC ENTERTAINMENT (U.S. CLS. 100, 101 AND 102).

TIMOTHY FINNEGAN, EXAMINING ATTORNEY

CLASS 35—(Continued).

SN 77-425,889. AUXANO CONSULTING, LLC, HOUSTON, TX. FILED 3-19-2008.

auxano

THE MARK CONSISTS OF THE STYLZIED TEXT "AUXANO" WITH A STRAIGHT HORIZONTAL LINE ABOVE THE "O".

FOR BUSINESS CONSULTATION SERVICES; BUSINESS LEADERSHIP DEVELOPMENT (U.S. CLS. 100, 101 AND 102).

FIRST USE 3-1-2004; IN COMMERCE 5-1-2004.
JORDAN BAKER, EXAMINING ATTORNEY

SN 77-425,923. MARTORANO, DONIELLE, BLACKWOOD, NJ. FILED 3-19-2008.

Donielle Martorano

THE MARK CONSISTS OF STANDARD CHARACTERS WITHOUT CLAIM TO ANY PARTICULAR FONT, STYLE, SIZE, OR COLOR.

FOR WHOLESALE STORE SERVICES AND RETAIL STORE SERVICES IN THE FIELD OF CLOTHING (U.S. CLS. 100, 101 AND 102).

CHRISTINE COOPER, EXAMINING ATTORNEY

SN 77-426,125. CITY PUBLIC SERVICE OF SAN ANTONIO, TEXAS, SAN ANTONIO, TX. FILED 3-19-2008.

FIRST CONNECTIONS

THE COLOR(S) RED, BLACK, ORANGE AND YELLOW IS/ARE CLAIMED AS A FEATURE OF THE MARK.

THE MARK CONSISTS OF THE WORD "FIRST" IN RED SPELLED VERTICALLY UPWARDS WITH THE WORD "CONNECTIONS" IN BLACK TO THE RIGHT OF THE WORD "FIRST"; A MULTI-COLOR HORIZONTAL LINE THROUGH THE WORD "CONNECTIONS" TRANSITIONING FROM RED TO ORANGE TO YELLOW TO ORANGE TO RED WHICH FORMS THE MIDDLE LINE OF THE LETTER "E" IN "CONNECTIONS".

FOR BUSINESS SERVICES, NAMELY, COORDINATING ADDRESS CHANGES IN RELATION TO UTILITIES, SECURITY SYSTEMS, CABLE TELEVISION SERVICE, NEWSPAPER DELIVERY, UNITED STATES MAIL DELIVERY, AND OTHER SERVICES FOR OTHERS (U.S. CLS. 100, 101 AND 102).

FIRST USE 11-30-2007; IN COMMERCE 11-30-2007.
DAWN HAN, EXAMINING ATTORNEY

CLASS 35—(Continued).

SN 77-426,145. UMANSYS, INC., DALLAS, TX. FILED 3-19-2008.

UMANSYS

THE MARK CONSISTS OF STANDARD CHARACTERS WITHOUT CLAIM TO ANY PARTICULAR FONT, STYLE, SIZE, OR COLOR.

FOR BUSINESS MANAGEMENT CONSULTING AND ADVISORY SERVICES (U.S. CLS. 100, 101 AND 102).

FIRST USE 1-15-2000; IN COMMERCE 9-5-2000.
ANDREA SAUNDERS, EXAMINING ATTORNEY

SN 77-426,150. PREPARED2PAY LIMITED, SEVENOAKS, ENGLAND, FILED 3-19-2008.

PREPARED2PAY

THE MARK CONSISTS OF STANDARD CHARACTERS WITHOUT CLAIM TO ANY PARTICULAR FONT, STYLE, SIZE, OR COLOR.

FOR ADVERTISING AGENCIES; ADVERTISING AGENCIES, NAMELY, PROMOTING THE GOODS AND SERVICES OF OTHERS; ADVERTISING AGENCY SPECIALIZING IN THE DESIGN AND EXECUTION OF WORD OF MOUTH, VIRAL, BUZZ AND EXPERIENTIAL MARKETING PROGRAMS; ADVERTISING AND ADVERTISEMENT SERVICES; ADVERTISING AND BUSINESS ADVICE RELATING TO TELEMATICS SERVICES; ADVERTISING AND BUSINESS MANAGEMENT CONSULTANCY; ADVERTISING AND BUSINESS SERVICES, NAMELY, SECURING AIRTIME ON ALL FORMS OF MEDIA COMMUNICATIONS STATIONS, SYSTEMS, NETWORKS, AND SERVICES FOR THE PURPOSE OF PROMOTING THE GOODS AND SERVICES OF OTHERS; ADVERTISING AND COMMERCIAL INFORMATION SERVICES, VIA THE INTERNET; ADVERTISING AND MARKETING; ADVERTISING AND PROMOTION SERVICES AND RELATED CONSULTING; ADVERTISING AND PROMOTIONAL SERVICES; ADVERTISING AND PUBLICITY SERVICES; ADVERTISING AND PUBLICITY SERVICES, NAMELY, PROMOTING THE GOODS, SERVICES, BRAND IDENTITY AND COMMERCIAL INFORMATION AND NEWS OF THIRD PARTIES THROUGH PRINT, AUDIO, VIDEO, DIGITAL AND ON-LINE MEDIUM; ADVERTISING BUSINESS ESPECIALLY IN THE FIELD OF TELEMATIC AND TELEPHONE NETWORKS; ADVERTISING BY TRANSMISSION OF ON-LINE PUBLICITY FOR THIRD PARTIES THROUGH ELECTRONIC COMMUNICATIONS NETWORKS; ADVERTISING CONSULTATION; ADVERTISING FLYER DISTRIBUTION; ADVERTISING PARTICULARLY SERVICES FOR THE PROMOTION OF GOODS; ADVERTISING SERVICES; ADVERTISING SERVICES OF A RADIO AND TELEVISION ADVERTISING AGENCY; ADVERTISING SERVICES, NAMELY, PROMOTING AND MARKETING THE GOODS AND SERVICES OF OTHERS THROUGH ALL PUBLIC COMMUNICATION MEANS; ADVERTISING SERVICES, NAMELY, PROMOTING PROPERTIES FOR SALE BY OWNER VIA THE INTERNET; ADVERTISING SERVICES, PUBLIC RELATIONS AND MARKETING SERVICES, NAMELY, PROMOTING AND MARKETING THE GOODS AND SERVICES OF OTHERS THROUGH ALL PUBLIC COMMUNICATION MEANS; ADVERTISING THROUGH ALL PUBLIC COMMUNICATION MEANS; ADVERTISING VIA ELECTRONIC MED-

CLASS 35—(Continued).

IA AND SPECIFICALLY THE INTERNET; ADVERTISING, INCLUDING PROMOTION OF PRODUCTS AND SERVICES OF THIRD PARTIES THROUGH SPONSORING ARRANGEMENTS AND LICENCE AGREEMENTS RELATING TO INTERNATIONAL SPORTS' EVENTS; ADVERTISING, INCLUDING PROMOTION RELATING TO THE SALE OF ARTICLES AND SERVICES FOR THIRD PARTIES BY THE TRANSMISSION OF ADVERTISING MATERIAL AND THE DISSEMINATION OF ADVERTISING MESSAGES ON COMPUTER NETWORKS; ADVERTISING, MARKETING AND PROMOTION SERVICES; ADVERTISING, PROMOTION AND MARKETING SERVICES IN THE NATURE OF E-MAIL BLAST CAMPAIGNS FOR OTHERS; ADVICE AND INFORMATION ABOUT CUSTOMER SERVICES AND PRODUCT MANAGEMENT AND PRICES ON INTERNET SITES IN CONNECTION WITH PURCHASES MADE OVER THE INTERNET; ADVICE RELATING TO THE ORGANISATION AND MANAGEMENT OF BUSINESS; ADVISORY SERVICE FOR ORGANIZATIONAL ISSUES AND BUSINESS ADMINISTRATION, WITH AND WITHOUT THE HELP OF ELECTRONIC DATA BASES; ADVISORY SERVICES RELATING TO BUSINESS MANAGEMENT AND BUSINESS OPERATIONS; AGENCIES FOR ADVERTISING TIME AND SPACE; ARRANGING AND CONDUCTING BUSINESS CONFERENCES; ARRANGING AND CONDUCTING MARKETING PROMOTIONAL EVENTS FOR OTHERS; ARRANGING AND CONDUCTING OF FAIRS AND EXHIBITIONS FOR BUSINESS AND ADVERTISING PURPOSES; ARRANGING AND CONDUCTION OF AUCTION SALES; ASSISTANCE IN MANAGEMENT OF BUSINESS ACTIVITIES; ASSISTANCE WITH BUSINESS MANAGEMENT AND PLANNING; ASSISTANCE, ADVISORY SERVICES AND CONSULTANCY WITH REGARD TO BUSINESS PLANNING, BUSINESS ANALYSIS, BUSINESS MANAGEMENT, AND BUSINESS ORGANIZATION; AUCTION MANAGEMENT SERVICES PROVIDED TO OTHERS OVER AN ON-LINE WEB SITE ACCESSED THROUGH A GLOBAL COMPUTER NETWORK; AUCTIONEERING; AUCTIONING VIA TELECOMMUNICATION NETWORKS; BUSINESS ADMINISTRATION AND MANAGEMENT; BUSINESS ADVICE AND ANALYSIS OF MARKETS; BUSINESS ADVICE AND COMMERCIAL INFORMATION; BUSINESS ADVICE AND INFORMATION; BUSINESS ADVICE, INQUIRIES OR INFORMATION; BUSINESS ADVISORY SERVICES, CONSULTANCY AND INFORMATION; BUSINESS CONSULTATION; BUSINESS CONSULTATION AND MANAGEMENT REGARDING MARKETING ACTIVITIES AND LAUNCHING OF NEW PRODUCTS; BUSINESS CONSULTATION SERVICES; BUSINESS CONSULTING AND INFORMATION SERVICES; BUSINESS CONSULTING SERVICES, NAMELY, PROVIDING ASSISTANCE IN DEVELOPMENT BUSINESS STRATEGIES AND CREATIVE IDEATION; BUSINESS CONSULTING, INQUIRIES OR INFORMATION; BUSINESS CONSULTING, MANAGEMENT, PLANNING AND SUPERVISION; BUSINESS ENQUIRIES AND INVESTIGATIONS; BUSINESS INFORMATION AND INQUIRIES; BUSINESS INFORMATION MANAGEMENT; BUSINESS INVESTIGATIONS; BUSINESS MANAGEMENT; BUSINESS MANAGEMENT AND ADVICE; BUSINESS MANAGEMENT AND CONSULTATION; BUSINESS MANAGEMENT CONSULTANCY AND ADVISORY SERVICES; BUSINESS MANAGEMENT CONSULTANCY SERVICES; BUSINESS MANAGEMENT CONSULTATION; BUSINESS MANAGEMENT CONSULTING; BUSINESS MANAGEMENT CONSULTING AND ADVISORY SERVICES; BUSINESS MARKETING CONSULTING SERVICES; BUSINESS MARKETING SERVICES; BUSINESS ORGANISATION CONSULTING; BUSINESS ORGANIZATION ADVICE; BUSINESS ORGANIZATION CONSULTING; BUSINESS ORGANIZATIONAL CONSULTATION; COMMERCIAL AND INDUSTRIAL MANAGEMENT ASSISTANCE; COMMERCIAL ASSISTANCE IN BUSINESS MANAGEMENT; COMMERCIAL BUSINESS MANAGEMENT; COMMERCIAL CONSULTANCY; CONSULTANCY SERVICES REGARDING BUSINESS STRATEGIES; CONSULTING SERVICES IN BUSINESS ORGANIZATION AND MANAGEMENT; CONSULTING SERVICES RELATING TO PUBLICITY; COOPERATIVE ADVERTISING AND MARKETING; CREATING AND UPDATING ADVERTISING MATERIAL; DESIGN OF INTERNET ADVERTISING; DEVELOPING PROMOTIONAL CAMPAIGNS FOR BUSINESS; DISSEMINATION OF ADVERTISING FOR

CLASS 35—(Continued).

OTHERS VIA AN ON-LINE COMMUNICATIONS NETWORK ON THE INTERNET; DISSEMINATION OF ADVERTISING FOR OTHERS VIA THE INTERNET; DISSEMINATION OF ADVERTISING MATERIAL; DISSEMINATION OF ADVERTISING MATTER; DISTRIBUTION AND DISSEMINATION OF ADVERTISING MATERIALS; ELECTRONIC BILLBOARD ADVERTISING; ELECTRONIC COMMERCE SERVICES, NAMELY, PROVIDING INFORMATION ABOUT PRODUCTS VIA TELECOMMUNICATION NETWORKS FOR ADVERTISING AND SALES PURPOSES; INFORMATION IN BUSINESS MATTERS; INFORMATION OR ENQUIRIES ON BUSINESS AND MARKETING; INFORMATION SERVICES RELATING TO BUSINESS MATTERS; INFORMATION, ADVISORY AND CONSULTANCY SERVICES RELATING TO BUSINESS AND MANAGEMENT OR BUSINESS ADMINISTRATION, INCLUDING SUCH SERVICES PROVIDED ON LINE OR VIA THE INTERNET; INTERNET ADVERTISING SERVICES; MARKETING CONSULTING; ON-LINE ADVERTISING AND MARKETING SERVICES; ON-LINE ADVERTISING ON COMPUTER COMMUNICATION NETWORKS; ON-LINE TRADING SERVICES IN WHICH SELLER POSTS PRODUCTS TO BE AUCTIONED AND BIDDING IS DONE VIA THE INTERNET; ONLINE AUCTION BIDDING FOR OTHERS; ONLINE AUCTION SERVICES; ONLINE BUSINESS NETWORKING SERVICES; OPERATING ON-LINE MARKETPLACES FOR SELLERS OF GOODS AND/OR SERVICES; PREPARATION OF CUSTOM ADVERTISEMENTS FOR OTHERS; PREPARATION OF CUSTOM OR NON-CUSTOM ADVERTISING FOR BUSINESSES FOR DISSEMINATION VIA THE WEB, CD OR DVD FOR OPTIONAL UPLOAD OR DOWNLOAD TO A COMPUTER; PREPARING ADVERTISEMENTS FOR OTHERS; PREPARING AND PLACING ADVERTISEMENTS FOR OTHERS; PREPARING AND PLACING OF ADVERTISEMENTS; PROMOTING THE GOODS AND SERVICES OF OTHERS BY MEANS OF OPERATING AN ON-LINE SHOPPING MALL WITH LINKS TO THE RETAIL WEB SITES OF OTHERS; PROMOTING THE GOODS AND SERVICES OF OTHERS BY PREPARING AND PLACING ADVERTISEMENTS IN AN ELECTRONIC MAGAZINE ACCESSED THROUGH A GLOBAL COMPUTER NETWORK; PROMOTING THE GOODS AND SERVICES OF OTHERS BY PROVIDING A COMMUNITY-DRIVEN WEB SITE FEATURING USER-SUBMITTED CONTENT IN THE NATURE OF COUPONS, REBATES, PRICE-COMPARISON INFORMATION, PRODUCT REVIEWS, LINKS TO THE RETAIL WEB SITES OF OTHERS, AND DISCOUNT INFORMATION; PROMOTING THE GOODS AND SERVICES OF OTHERS BY PROVIDING A WEB SITE FEATURING COUPONS, REBATES, PRICE-COMPARISON INFORMATION, PRODUCT REVIEWS, LINKS TO THE RETAIL WEB SITES OF OTHERS, AND DISCOUNT INFORMATION; PROMOTING THE GOODS AND SERVICES OF OTHERS BY PROVIDING HYPERTEXT LINKS TO THE WEB SITES OF OTHERS; PROMOTING THE GOODS AND SERVICES OF OTHERS THROUGH ON-LINE ORDERING AND CATALOGING OF THOSE GOODS AND SERVICES; PROMOTING THE GOODS AND SERVICES OF OTHERS THROUGH SEARCH ENGINE REFERRAL TRAFFIC ANALYSIS AND REPORTING; PROMOTING THE GOODS AND SERVICES OF OTHERS VIA A GLOBAL COMPUTER NETWORK; PROMOTING, ADVERTISING AND MARKETING OF THE ON-LINE WEB SITES OF OTHERS; PROMOTION, ADVERTISING AND MARKETING OF ON-LINE WEB SITES; PROVIDING A SEARCHABLE ONLINE ADVERTISING GUIDE FEATURING THE GOODS AND SERVICES OF OTHER ON-LINE VENDORS ON THE INTERNET; PROVIDING A WEB SITE AT WHICH USERS CAN OFFER GOODS FOR SALE AND BUY GOODS OFFERED BY OTHERS; PROVIDING A WEB SITE THAT ENABLES USERS TO POST ITEMS FOR SALE THROUGH ON-LINE CLASSIFIED ADVERTISEMENTS; PROVIDING A WEB SITE WHEREBY BUYERS OF GOODS OR SERVICES LOCATE AND RECEIVE QUOTATIONS FROM MULTIPLE COMPETITIVE SOURCES AND SELLERS OF GOODS OR SERVICES IDENTIFY AND BID ON MULTIPLE NEW SALES OPPORTUNITIES; PROVIDING A WEB SITE WHICH FEATURES ADVERTISEMENTS FOR THE GOODS AND SERVICES OF OTHERS ON A GLOBAL COMPUTER NETWORK; PROVIDING BUSINESS MARKETING INFORMATION; PROVIDING INFORMATION IN THE FIELD OF MARKETING AND ON-LINE MARKETING MEDIA VIA THE INTERNET; PROVIDING MARKET-

CLASS 35—(Continued).

ING AND PROMOTION OF SPECIAL EVENTS; PROVISION OF A WEB SITE FEATURING INFORMATION ON SHOPPING; PROVISION OF ADVERTISING SPACE BY ELECTRONIC MEANS AND GLOBAL INFORMATION NETWORKS; PROVISION OF SPACE ON WEBSITES FOR ADVERTISING GOODS AND SERVICES; PUBLICITY AND SALES PROMOTION RELATING TO GOODS AND SERVICES, OFFERED AND ORDERED BY TELECOMMUNICATION OR THE ELECTRONIC WAY; THE BRINGING TOGETHER, FOR THE BENEFIT OF OTHERS, OF A VARIETY OF GOODS AND SERVICES, ENABLING CUSTOMERS TO CONVENIENTLY VIEW AND PURCHASE THOSE GOODS AND SERVICES FROM AN INTERNET WEBSITE PARTICULARLY SPECIALIZING IN THE MARKETING OF THE SALE OF GOODS AND SERVICES OF OTHERS (U.S. CLS. 100, 101 AND 102).

STEPHANIE ALI, EXAMINING ATTORNEY

SN 77-426,324. DIA CENTER FOR THE ARTS, INC., NEW YORK, NY. FILED 3-19-2008.

DIA:BEACON

THE MARK CONSISTS OF STANDARD CHARACTERS WITHOUT CLAIM TO ANY PARTICULAR FONT, STYLE, SIZE, OR COLOR.

NO CLAIM IS MADE TO THE EXCLUSIVE RIGHT TO USE "BEACON", APART FROM THE MARK AS SHOWN.

THE ENGLISH TRANSLATION OF THE GERMAN WORD "DIA" IN THE MARK IS "SLIDE".

FOR ART GALLERIES (U.S. CLS. 100, 101 AND 102).

FIRST USE 12-0-1999; IN COMMERCE 12-0-1999.

ELLEN BURNS, EXAMINING ATTORNEY

SN 77-426,332. BARKLEY EVERGREEN & PARTNERS, INC., KANSAS CITY, MO. FILED 3-19-2008.

BARKLEYREI

THE MARK CONSISTS OF STANDARD CHARACTERS WITHOUT CLAIM TO ANY PARTICULAR FONT, STYLE, SIZE, OR COLOR.

OWNER OF U.S. REG. NO. 3,420,823.

FOR ADVERTISING AND MARKETING (U.S. CLS. 100, 101 AND 102).

FIRST USE 3-7-2008; IN COMMERCE 3-7-2008.

REGINA DRUMMOND, EXAMINING ATTORNEY

CLASS 35—(Continued).

SN 77-426,510. LILLEY, RODNEY, DBA TRAIN TIME HOBBY, LAVISTA, NE. FILED 3-19-2008.

TRAIN TIME HOBBY

THE MARK CONSISTS OF STANDARD CHARACTERS WITHOUT CLAIM TO ANY PARTICULAR FONT, STYLE, SIZE, OR COLOR.

NO CLAIM IS MADE TO THE EXCLUSIVE RIGHT TO USE "TRAIN" AND "HOBBY", APART FROM THE MARK AS SHOWN.

FOR ON-LINE RETAIL STORE SERVICES FEATURING MODEL TRAINS AND ACCESSORIES THEREFOR; RETAIL STORE SERVICES FEATURING MODEL TRAINS AND ACCESSORIES THEREFOR (U.S. CLS. 100, 101 AND 102).

FIRST USE 7-30-2004; IN COMMERCE 7-30-2004.

SUSAN RICHARDS, EXAMINING ATTORNEY

SN 77-426,582. BROWN, DAJUAN, JERSEY CITY, NJ. AND BROWN, JASMIN, JERSEY CITY, NJ. FILED 3-19-2008.



NO CLAIM IS MADE TO THE EXCLUSIVE RIGHT TO USE "CRISIS INTERVENTION SERVICES", APART FROM THE MARK AS SHOWN.

THE MARK CONSISTS OF AN ABSTRACT DESIGN WITH THE STYLIZED WORDS "CRISIS INTERVENTION SERVICES".

FOR CHARITABLE SERVICES, NAMELY, ORGANIZING AND CONDUCTING VOLUNTEER PROGRAMS AND COMMUNITY SERVICE PROJECTS; CHARITABLE SERVICES, NAMELY, ORGANIZING YOUTH GROUPS TO UNDERTAKE PROJECTS TO BENEFIT THE NEEDY AND THE COMMUNITY TO ENCOURAGE LEADERSHIP, CHARACTER, COMPASSION, AND GOOD CITIZENSHIP (U.S. CLS. 100, 101 AND 102).

ATTIYA MALIK, EXAMINING ATTORNEY

SN 77-426,825. ABC - AGENCIES BRANDING AND CONTENT GROUP LLC, SAN FRANCISCO, CA. FILED 3-20-2008.

Pereira & O'Dell

THE MARK CONSISTS OF STANDARD CHARACTERS WITHOUT CLAIM TO ANY PARTICULAR FONT, STYLE, SIZE, OR COLOR.

FOR ADVERTISING AND MARKETING (U.S. CLS. 100, 101 AND 102).

MARCIE MILONE, EXAMINING ATTORNEY

CLASS 35—(Continued).

SN 77-426,869. NATIONAL ASSOCIATION OF BLACK ACCOUNTANTS, INC., GREENBELT, MD. FILED 3-20-2008.

LIFTING AS WE CLIMB

THE MARK CONSISTS OF STANDARD CHARACTERS WITHOUT CLAIM TO ANY PARTICULAR FONT, STYLE, SIZE, OR COLOR.

FOR ASSOCIATION SERVICES, NAMELY, PROMOTING THE INTERESTS OF MINORITIES IN THE FIELD OF ACCOUNTING (U.S. CLS. 100, 101 AND 102).

FIRST USE 3-31-1994; IN COMMERCE 3-31-1994.
BARBARA BROWN, EXAMINING ATTORNEY

CLASS 35—(Continued).

SN 77-427,030. MYHOUSEAD.COM LLC, PANAMA CITY BEACH, FL. FILED 3-20-2008.

MyHouseAd

THE MARK CONSISTS OF STANDARD CHARACTERS WITHOUT CLAIM TO ANY PARTICULAR FONT, STYLE, SIZE, OR COLOR.

FOR REAL ESTATE ADVERTISING SERVICES (U.S. CLS. 100, 101 AND 102).

NICHOLAS ALTREE, EXAMINING ATTORNEY

SN 77-426,924. FRY'S ELECTRONICS, INC., SAN JOSE, CA. FILED 3-20-2008.



OWNER OF U.S. REG. NOS. 2,031,351 AND 2,102,637.
NO CLAIM IS MADE TO THE EXCLUSIVE RIGHT TO USE "ELECTRONICS", APART FROM THE MARK AS SHOWN.

SEC. 2(F).
FOR RETAIL STORE SERVICES AND WHOLESALE STORES FEATURING PERSONAL COMPUTERS, COMPUTER HARDWARE, COMPONENTS AND ACCESSORIES, AND RELATED MERCHANDISE, PHOTOCOPY MACHINES AND SCANNERS, HOME OFFICE PRODUCTS AND FURNISHINGS, TELECOMMUNICATION EQUIPMENT, DEVICES AND ACCESSORIES, NETWORKING EQUIPMENT, DEVICES AND ACCESSORIES, PHOTOGRAPHIC EQUIPMENT, DEVICES AND ACCESSORIES, VIDEO EQUIPMENT, DEVICES, ACCESSORIES AND RECORDINGS, VIDEO GAMES, TELEVISIONS, PROJECTORS, MONITORS AND DISPLAYS, IMAGING EQUIPMENT, AUDIO EQUIPMENT, DEVICES, ACCESSORIES AND RECORDINGS, MULTIMEDIA EQUIPMENT, DEVICES, ACCESSORIES AND RECORDINGS, CONSUMER ELECTRONICS, ELECTRONIC EQUIPMENT, DEVICES AND ACCESSORIES, DIGITAL EQUIPMENT, DEVICES AND ACCESSORIES, STORAGE MEDIA, MUSICAL INSTRUMENTS, AUTOMOTIVE AUDIO EQUIPMENT, DEVICES AND ACCESSORIES, HOUSEHOLD APPLIANCES, BOOKS AND MAGAZINES, TOYS, HEALTH CARE, SKIN CARE, PERSONAL CARE, PERSONAL SAFETY, PERSONAL HOME COMFORT AND THERAPY PRODUCTS, SPA PRODUCTS, CLOTHING AND FOOD AND BEVERAGES (U.S. CLS. 100, 101 AND 102).

FIRST USE 5-17-1985; IN COMMERCE 5-17-1985.
LEIGH CAROLINE CASE, EXAMINING ATTORNEY

SN 77-427,057. SCARDANA CORPORATION CANADA LTD., GREENFIELD PARK, CANADA, FILED 3-20-2008.

SCARDANA

THE MARK CONSISTS OF STANDARD CHARACTERS WITHOUT CLAIM TO ANY PARTICULAR FONT, STYLE, SIZE, OR COLOR.

FOR PROCUREMENT SERVICES, NAMELY, PURCHASING MACHINERY, EQUIPMENT, ELECTRICAL UTILITIES AND SPARE PARTS FOR SHIPS (U.S. CLS. 100, 101 AND 102).

FIRST USE 12-31-1974; IN COMMERCE 6-30-1984.
LINDA ESTRADA, EXAMINING ATTORNEY

SN 77-427,077. HETRICK COMMUNICATIONS, INC., INDIANAPOLIS, IN. FILED 3-20-2008.

TELL HETRICK

THE MARK CONSISTS OF STANDARD CHARACTERS WITHOUT CLAIM TO ANY PARTICULAR FONT, STYLE, SIZE, OR COLOR.

FOR PUBLIC RELATIONS AND MARKETING CONSULTING SERVICES FOR OTHERS (U.S. CLS. 100, 101 AND 102).

MATTHEW PAPPAS, EXAMINING ATTORNEY

CLASS 35—(Continued).

SN 77-427,344. MICROVU, LLC, SCOTTSDALE, AZ. FILED 3-20-2008.



NO CLAIM IS MADE TO THE EXCLUSIVE RIGHT TO USE "EMPLOYEE DIRECT DISCOUNT MEDICAL CARD", APART FROM THE MARK AS SHOWN.

THE COLOR(S) DARK BLUE, LIGHT BLUE, TEAL, AND GREY IS/ARE CLAIMED AS A FEATURE OF THE MARK.

THE MARK CONSISTS OF THE WORDS EMPLOYEE DIRECT IN LARGE, BOLD LETTERING COLORED DARK BLUE. THE WORDS DISCOUNT MEDICAL CARD IN MEDIUM BLUE BELOW THE WORDS EMPLOYEE DIRECT. TWO HALF CIRCLES WITH ARROWS ON ONE END WRAPPING AROUND THE FIRST THREE LETTERS OF EMPLOYEE, COLORED TEAL WITH A GREY SHADOW.

FOR ADMINISTRATION OF A DISCOUNT PROGRAM FOR ENABLING PARTICIPANTS TO OBTAIN DISCOUNTS ON GOODS AND SERVICES THROUGH USE OF A DISCOUNT MEMBERSHIP CARD (U.S. CLS. 100, 101 AND 102).

FIRST USE 3-12-2008; IN COMMERCE 3-17-2008.
GINA FINK, EXAMINING ATTORNEY

SN 77-427,500. MIDWEST MOBILITY SOLUTIONS, INC., DES MOINES, IA. FILED 3-20-2008.

medicallyours

THE MARK CONSISTS OF STANDARD CHARACTERS WITHOUT CLAIM TO ANY PARTICULAR FONT, STYLE, SIZE, OR COLOR.

OWNER OF U.S. REG. NO. 2,317,830.
FOR RETAIL STORE SERVICES FEATURING MEDICAL EQUIPMENT (U.S. CLS. 100, 101 AND 102).
FIRST USE 12-21-2007; IN COMMERCE 12-21-2007.
HOWARD FRIEDMAN, EXAMINING ATTORNEY

SN 77-427,678. FRIES FRAME PRODUCTIONS, INC., CHICAGO, IL. FILED 3-20-2008.

REELDIGS.COM

THE MARK CONSISTS OF STANDARD CHARACTERS WITHOUT CLAIM TO ANY PARTICULAR FONT, STYLE, SIZE, OR COLOR.

FOR REAL ESTATE MARKETING SERVICES, NAMELY, PRODUCTION OF VIDEO HOME TOURS FOR ACTIVE REAL ESTATE LISTINGS FOR VIEWING VIA TELEVISION, INTERNET AND MOBILE PHONES (U.S. CLS. 100, 101 AND 102).

FIRST USE 5-17-2007; IN COMMERCE 5-17-2007.
SAIMA MAKHDOOM, EXAMINING ATTORNEY

CLASS 35—(Continued).

SN 77-427,828. METRO TAX INC., DBA METRO INCOME TAX SERVICES, MILWAUKEE, WI. FILED 3-20-2008.



NO CLAIM IS MADE TO THE EXCLUSIVE RIGHT TO USE "INCOME TAX SERVICES", APART FROM THE MARK AS SHOWN.

THE COLOR(S) GREEN AND BLACK IS/ARE CLAIMED AS A FEATURE OF THE MARK.

THE MARK CONSISTS OF GREEN ARCH ON TOP, BLACK ARCH ON THE BOTTOM, THE WORD "METRO" IN BLACK IN THE MIDDLE, "INCOME TAX SERVICES" IN BLACK UNDER THE WORD "METRO".

FOR INCOME TAX PREPARATION (U.S. CLS. 100, 101 AND 102).

FIRST USE 9-1-2007; IN COMMERCE 9-1-2007.
CHRISTINE BLOMQUIST, EXAMINING ATTORNEY

SN 77-427,858. CHICK LLC, PITTSBURGH, PA. FILED 3-20-2008.

CHICKDOWNTOWN.COM

THE MARK CONSISTS OF STANDARD CHARACTERS WITHOUT CLAIM TO ANY PARTICULAR FONT, STYLE, SIZE, OR COLOR.

FOR ON-LINE RETAIL STORE SERVICES FEATURING CLOTHING; RETAIL STORES FEATURING CLOTHING (U.S. CLS. 100, 101 AND 102).

FIRST USE 5-15-2007; IN COMMERCE 5-15-2007.
CHERYL CLAYTON, EXAMINING ATTORNEY

SN 77-428,114. FUTURITY GROUP, INC, DBA FUTURITY GROUP, LLC, PAHRUMP, NV. FILED 3-21-2008.

Futurity CPI

THE MARK CONSISTS OF STANDARD CHARACTERS WITHOUT CLAIM TO ANY PARTICULAR FONT, STYLE, SIZE, OR COLOR.

FOR PROVIDING STATISTICAL EVALUATION OF INSURANCE CLAIMS PERFORMANCE MEASURES FOR OTHERS (U.S. CLS. 100, 101 AND 102).

NICHOLAS ALTREE, EXAMINING ATTORNEY

CLASS 35—(Continued).

SN 77-428,131. EAR PHONE CONNECTION, INC., VALENCIA, CA. FILED 3-21-2008.

AUDIO ARMOR

THE MARK CONSISTS OF STANDARD CHARACTERS WITHOUT CLAIM TO ANY PARTICULAR FONT, STYLE, SIZE, OR COLOR.

NO CLAIM IS MADE TO THE EXCLUSIVE RIGHT TO USE "AUDIO", APART FROM THE MARK AS SHOWN.

FOR RETAIL STORE SERVICES FEATURING AUDIO ACCESSORIES FOR TWO-WAY RADIOS, NAMELY, MICROPHONES, EARPIECES, HEADSETS (U.S. CLS. 100, 101 AND 102).

BRENDAN MCCAULEY, EXAMINING ATTORNEY

SN 77-428,204. SELBY, BRIAN, DBA SELBY ENERGY GROUP, SONORA, CA. FILED 3-21-2008.

EnergyPros

THE MARK CONSISTS OF STANDARD CHARACTERS WITHOUT CLAIM TO ANY PARTICULAR FONT, STYLE, SIZE, OR COLOR.

FOR CONSULTATION IN THE FIELD OF ENERGY EFFICIENCY (U.S. CLS. 100, 101 AND 102).

NATALIE POLZER, EXAMINING ATTORNEY

SN 77-428,254. BOWEY, VINCENT, WOODLAND, CA. AND ALBRIGHT, HUNTER, WOODLAND, CA. FILED 3-21-2008.



**KNOWLEDGE
NETWORK
INTERNATIONAL**

NO CLAIM IS MADE TO THE EXCLUSIVE RIGHT TO USE "NETWORK" AND "INTERNATIONAL", APART FROM THE MARK AS SHOWN.

THE MARK CONSISTS OF A GLOBE WITH THREE PEOPLE WITH THEIR ARMS OUTSTRETCHED AROUND THE GLOBE. THE WORDS "KNOWLEDGE NETWORK INTERNATIONAL" ARE TO THE RIGHT OF THE LOGO. THE WORDS "KNOWLEDGE" AND "NETWORK" ARE ALL CAPITALS. THE WORD "INTERNATIONAL" IS ALL CAPITALS AND IT IS SMALLER THAN THE WORDS "KNOWLEDGE" AND "NETWORK". "KNOWLEDGE" IS ABOVE "NETWORK", "NETWORK" IS ABOVE "INTERNATIONAL".

FOR BUSINESS MANAGEMENT CONSULTING (U.S. CLS. 100, 101 AND 102).

FIRST USE 1-0-2007; IN COMMERCE 1-0-2007.

WILLIAM P. SHANAHAN, EXAMINING ATTORNEY

CLASS 35—(Continued).

SN 77-428,265. ANF LLC, BURNSVILLE, MN. FILED 3-21-2008.



THE MARK CONSISTS OF THE STYLIZED TEXT "ZIDA". FOR RETAIL STORE SERVICES FEATURING FASHION AND HOME ACCESSORIES (U.S. CLS. 100, 101 AND 102).

FIRST USE 8-17-2007; IN COMMERCE 8-17-2007.
SEAN CROWLEY, EXAMINING ATTORNEY

SN 77-428,280. SNYDER, CATHY, GREENWOOD, IN. FILED 3-21-2008.

Pupster Kisses

THE MARK CONSISTS OF STANDARD CHARACTERS WITHOUT CLAIM TO ANY PARTICULAR FONT, STYLE, SIZE, OR COLOR.

FOR ON-LINE RETAIL STORE SERVICES FEATURING DOG COOKIES TREATS, DOG BISCUITS TREATS AND DOG CUPCAKE TREATS (U.S. CLS. 100, 101 AND 102).

FRANK LATTUCA, EXAMINING ATTORNEY

SN 77-428,286. ARMORY GARAGE, ALBANY, NY. FILED 3-21-2008.

ARMORY GARAGE

THE MARK CONSISTS OF STANDARD CHARACTERS WITHOUT CLAIM TO ANY PARTICULAR FONT, STYLE, SIZE, OR COLOR.

NO CLAIM IS MADE TO THE EXCLUSIVE RIGHT TO USE "GARAGE", APART FROM THE MARK AS SHOWN.

FOR AUTOMOBILE DEALERSHIPS; ON-LINE RETAIL STORE SERVICES FEATURING NEW AND PREOWNED AUTOMOBILES, PARTS AND ACCESSORIES (U.S. CLS. 100, 101 AND 102).

FIRST USE 12-0-1918; IN COMMERCE 12-0-1918.

ANNE E. GUSTASON, EXAMINING ATTORNEY

CLASS 35—(Continued).

SN 77-428,343. MAZDA MOTOR OF AMERICA, INC.,
IRVINE, CA. FILED 3-21-2008.

5 TO DRIVE

THE MARK CONSISTS OF STANDARD CHARACTERS
WITHOUT CLAIM TO ANY PARTICULAR FONT, STYLE,
SIZE, OR COLOR.

FOR AUTOMOBILE DEALERSHIPS (U.S. CLS. 100, 101
AND 102).

FIRST USE 3-12-2008; IN COMMERCE 3-12-2008.
MELVIN AXILBUND, EXAMINING ATTORNEY

SN 77-428,364. MAZDA MOTOR OF AMERICA, INC.,
IRVINE, CA. FILED 3-21-2008.



NO CLAIM IS MADE TO THE EXCLUSIVE RIGHT TO
USE "SALES EVENT", APART FROM THE MARK AS
SHOWN.

THE MARK CONSISTS OF THE NUMBER 5 SHOWN ON
A CIRCULAR BACKGROUND, WITH THE WORDS TO
DRIVE SHOWN TO THE RIGHT, AND THE WORDS SALES
EVENT BENEATH THE WORD DRIVE.

FOR AUTOMOBILE DEALERSHIPS (U.S. CLS. 100, 101
AND 102).

FIRST USE 3-12-2008; IN COMMERCE 3-12-2008.
MELVIN AXILBUND, EXAMINING ATTORNEY

SN 77-428,369. SGI, INC., CINCINNATI, OH. FILED 3-21-2008.

SHEAKLEY IT'S DONE

THE MARK CONSISTS OF STANDARD CHARACTERS
WITHOUT CLAIM TO ANY PARTICULAR FONT, STYLE,
SIZE, OR COLOR.

FOR OUTSOURCING IN THE FIELD OF HUMAN
RESOURCES, PAYROLL, WORKERS COMPENSATION,
UNEMPLOYMENT SERVICES, INSURANCE, RETIRE-
MENT PLANS, AND HEALTHCARE (U.S. CLS. 100, 101
AND 102).

KIM MONINGHOFF, EXAMINING ATTORNEY

CLASS 35—(Continued).

SN 77-428,453. REPLY! INC., ALAMO, CA. FILED 3-21-2008.

GO BEYOND THE CLICK

THE MARK CONSISTS OF STANDARD CHARACTERS
WITHOUT CLAIM TO ANY PARTICULAR FONT, STYLE,
SIZE, OR COLOR.

FOR ADVERTISING SERVICES (U.S. CLS. 100, 101
AND 102).

TEJBIR SINGH, EXAMINING ATTORNEY

SN 77-428,477. BUSLER, BARRY J., MOUNT JULIET, TN.
FILED 3-21-2008.

Business SuperStar

THE MARK CONSISTS OF STANDARD CHARACTERS
WITHOUT CLAIM TO ANY PARTICULAR FONT, STYLE,
SIZE, OR COLOR.

NO CLAIM IS MADE TO THE EXCLUSIVE RIGHT TO
USE "BUSINESS", APART FROM THE MARK AS SHOWN.

FOR BUSINESS CONSULTING AND INFORMATION
SERVICES (U.S. CLS. 100, 101 AND 102).

JUDITH HELFMAN, EXAMINING ATTORNEY

SN 77-428,487. FANCY FOODS SOUTH ORANGE, LLC,
BRONX, NY. FILED 3-21-2008.

TEMPTATION IN EVERY AISLE

THE MARK CONSISTS OF STANDARD CHARACTERS
WITHOUT CLAIM TO ANY PARTICULAR FONT, STYLE,
SIZE, OR COLOR.

FOR RETAIL STORE SERVICES FEATURING A WIDE
VARIETY OF CONSUMER GOODS OF OTHERS (U.S.
CLS. 100, 101 AND 102).

FIRST USE 1-1-2007; IN COMMERCE 1-1-2007.
JUDITH HELFMAN, EXAMINING ATTORNEY

SN 77-428,559. SHAW'S SUPERMARKETS, INC., BOISE, ID.
FILED 3-21-2008.

FAST. FRESH. FOOLPROOF.

THE MARK CONSISTS OF STANDARD CHARACTERS
WITHOUT CLAIM TO ANY PARTICULAR FONT, STYLE,
SIZE, OR COLOR.

FOR RETAIL GROCERY STORE SERVICES (U.S. CLS.
100, 101 AND 102).

FIRST USE 4-25-2008; IN COMMERCE 4-25-2008.
PATRICIA EVANKO, EXAMINING ATTORNEY

CLASS 35—(Continued).

SN 77-428,595. CAMPBELL AUTOMOTIVE MARKETING, INC., CLOVER, SC. FILED 3-21-2008.

MARKETING SOLUTIONS THAT
PUT ACCOUNTABILITY FIRST

THE MARK CONSISTS OF STANDARD CHARACTERS WITHOUT CLAIM TO ANY PARTICULAR FONT, STYLE, SIZE, OR COLOR.

FOR MARKETING AND PROMOTION SERVICES FOR TARGETING PROSPECTIVE CUSTOMERS FOR AUTOMOBILE DEALERS (U.S. CLS. 100, 101 AND 102).

FIRST USE 1-21-2008; IN COMMERCE 1-21-2008.
G. MAYERSCHOFF, EXAMINING ATTORNEY

SN 77-428,685. BILLINGS, DAWN L., MABLETON, GA. FILED 3-21-2008.

The Heart Link Network

THE MARK CONSISTS OF STANDARD CHARACTERS WITHOUT CLAIM TO ANY PARTICULAR FONT, STYLE, SIZE, OR COLOR.

NO CLAIM IS MADE TO THE EXCLUSIVE RIGHT TO USE "LINK NETWORK", APART FROM THE MARK AS SHOWN.

FOR ADVERTISING AND COMMERCIAL INFORMATION SERVICES, VIA THE INTERNET (U.S. CLS. 100, 101 AND 102).

FIRST USE 3-14-2008; IN COMMERCE 3-14-2008.
MICHAEL GAAFAR, EXAMINING ATTORNEY

CLASS 35—(Continued).

SN 77-428,715. DON'T FORGET YOUR CHILD, LLC, FLORA, MS. FILED 3-21-2008.

DON'T FORGET YOUR CHILD

THE MARK CONSISTS OF STANDARD CHARACTERS WITHOUT CLAIM TO ANY PARTICULAR FONT, STYLE, SIZE, OR COLOR.

FOR PUBLIC ADVOCACY TO PROMOTE AWARENESS OF THE DANGERS OF LEAVING YOUR CHILD IN THE BACK SEAT OF A VEHICLE, RESULTING IN DEATH BY HYPOTHERMIA, HEAT STROKE, OR NEGLIGENCE; PROMOTIONAL SERVICES, NAMELY, PROMOTING THE CHARITIES OF OTHERS; PROMOTING PUBLIC AWARENESS OF THE NEED FOR ATTENTION TO THE DANGERS OF LEAVING YOUR CHILD IN THE BACK SEAT OF A VEHICLE, RESULTING IN DEATH BY HYPOTHERMIA, HEAT STROKE, OR NEGLIGENCE; PROMOTING PUBLIC AWARENESS OF THE DANGERS OF LEAVING YOUR CHILD IN THE BACK SEAT OF A VEHICLE, RESULTING IN DEATH BY HYPOTHERMIA, HEAT STROKE, OR NEGLIGENCE; ORGANIZING AND CONDUCTING CHARITY AUCTIONS FOR CHARITABLE FUNDRAISING PURPOSES; CHARITABLE SERVICES, NAMELY, ORGANIZING AND CONDUCTING VOLUNTEER PROGRAMS AND COMMUNITY SERVICE PROJECTS; DEVELOPING AND COORDINATING VOLUNTEER PROJECTS FOR CHARITABLE ORGANIZATIONS (U.S. CLS. 100, 101 AND 102).

FIRST USE 9-5-2007; IN COMMERCE 9-10-2007.
DANIEL BRODY, EXAMINING ATTORNEY

SN 77-428,740. AGELESS AESTHETICS, INC, GREENWOOD VILLAGE, CO. FILED 3-21-2008.

agelessaesthetics

THE MARK CONSISTS OF STANDARD CHARACTERS WITHOUT CLAIM TO ANY PARTICULAR FONT, STYLE, SIZE, OR COLOR.

FOR DISTRIBUTORSHIP SERVICES IN THE FIELD OF SKIN CARE PRODUCTS AND EQUIPMENT (U.S. CLS. 100, 101 AND 102).

FIRST USE 6-1-2001; IN COMMERCE 6-1-2001.
KATHERINE M. DUBRAY, EXAMINING ATTORNEY

CLASS 35—(Continued).

SN 77-428,756. LOCAL.COM CORPORATION, IRVINE, CA. FILED 3-21-2008.

LOCAL PROMOTE

THE MARK CONSISTS OF STANDARD CHARACTERS WITHOUT CLAIM TO ANY PARTICULAR FONT, STYLE, SIZE, OR COLOR.

FOR DISSEMINATION OF ADVERTISING FOR OTHERS VIA THE INTERNET; ONLINE ADVERTISING SERVICES FOR OTHERS, NAMELY, PROVIDING ADVERTISING SPACE ON INTERNET WEB SITES; ADVERTISING SERVICES, INCLUDING, PROVIDING ONLINE MARKETING SERVICES IN THE NATURE OF BANNER ADVERTISING, DISPLAY ADVERTISING, LINK EXCHANGES AND SEARCH ENGINE PLACEMENT AND KEYWORD SELECTION SERVICES; BUSINESS MARKETING AND ADVERTISING CONSULTATION IN THE FIELD OF SEARCH ENGINE OPTIMIZATION AND WEBSITE MARKETING (U.S. CLS. 100, 101 AND 102).

FIRST USE 10-0-2006; IN COMMERCE 10-0-2006.
ANNE MADDEN, EXAMINING ATTORNEY

SN 77-428,757. ASLINGER, ED, ROSSVILLE, GA. FILED 3-21-2008.



NO CLAIM IS MADE TO THE EXCLUSIVE RIGHT TO USE "CHATTANOOGA", APART FROM THE MARK AS SHOWN.

THE STIPPLING IS FOR SHADING PURPOSES ONLY. THE MARK CONSISTS OF THE STYLIZED TEXT "WWW.SEE CHATTANOOGA NOW.COM". THERE IS A CIRCLE WITH AN IMAGE OF THE SUN BEHIND A PEAKED-ROOF BUILDING.

FOR ON-LINE ADVERTISING AND MARKETING SERVICES (U.S. CLS. 100, 101 AND 102).

FIRST USE 3-7-2008; IN COMMERCE 3-7-2008.
CYNTHIA SLOAN, EXAMINING ATTORNEY

CLASS 35—(Continued).

SN 77-428,787. MINDOPIA HOLDINGS, LLC, LOS ANGELES, CA. FILED 3-21-2008.

MINDOPIA

THE MARK CONSISTS OF STANDARD CHARACTERS WITHOUT CLAIM TO ANY PARTICULAR FONT, STYLE, SIZE, OR COLOR.

FOR EMPLOYMENT HIRING, RECRUITING, PLACEMENT, STAFFING AND CAREER NETWORKING SERVICES (U.S. CLS. 100, 101 AND 102).

LINDA M. KING, EXAMINING ATTORNEY

SN 77-428,789. THE FABULOUS STORE LLC, BEL AIR, MD. FILED 3-21-2008.



NO CLAIM IS MADE TO THE EXCLUSIVE RIGHT TO USE "SCRAPBOOK STORE", APART FROM THE MARK AS SHOWN.

THE MARK CONSISTS OF THE WORDING "THE FABULOUS SCRAPBOOK STORE WWW.FABULOUSSCRAPBOOK.COM", ALONG WITH FOUR DIAMONDS - TWO IN THE TOP LEFT CORNER AND TWO IN THE BOTTOM RIGHT CORNER.

FOR ON-LINE RETAIL STORE SERVICES FEATURING SCRAPBOOK-RELATED PRODUCTS (U.S. CLS. 100, 101 AND 102).

FIRST USE 11-0-2006; IN COMMERCE 11-0-2006.
ALICE SUE CARRUTHERS, EXAMINING ATTORNEY

CLASS 35—(Continued).

SN 77-428,792. MINDOPIA HOLDINGS, LLC, LOS ANGELES, CA. FILED 3-21-2008.



THE COLOR(S) ORANGE, YELLOW, GREEN, BLUE, PURPLE, RED, GRAY AND BLACK IS/ARE CLAIMED AS A FEATURE OF THE MARK.

THE MARK CONSISTS OF A FANCIFUL RENDITION OF THE LITERAL ELEMENT WITH THE FIRST LETTER "I" DOTTED BY A MULTI-COLORED WHEEL, AND THE SECOND LETTER "I" REPRESENTED UPSIDE DOWN. THE COLORS ORANGE, YELLOW, GREEN, BLUE, PURPLE, RED AND GRAY APPEAR IN THE CIRCLE DESIGN ABOVE THE LETTER "I", AND THE COLOR BLACK APPEARS IN THE WORDING.

FOR EMPLOYMENT HIRING, RECRUITING, PLACEMENT, STAFFING AND CAREER NETWORKING SERVICES (U.S. CLS. 100, 101 AND 102).

LINDA M. KING, EXAMINING ATTORNEY

CLASS 35—(Continued).

SN 77-428,812. CODET VISION, INC., CHULA VISTA, CA. FILED 3-21-2008.

CODET LASIK System

THE MARK CONSISTS OF STANDARD CHARACTERS WITHOUT CLAIM TO ANY PARTICULAR FONT, STYLE, SIZE, OR COLOR.

NO CLAIM IS MADE TO THE EXCLUSIVE RIGHT TO USE "LASIK SYSTEM", APART FROM THE MARK AS SHOWN.

FOR ADVERTISING, MARKETING AND PROMOTION SERVICES; BUSINESS MARKETING SERVICES; BUSINESS MARKETING CONSULTING SERVICES; BUSINESS MANAGEMENT (U.S. CLS. 100, 101 AND 102).
MELVIN AXILBUND, EXAMINING ATTORNEY

SN 77-428,796. MINDOPIA HOLDINGS, LLC, LOS ANGELES, CA. FILED 3-21-2008.



THE COLOR(S) ORANGE, YELLOW, GREEN, BLUE, PURPLE, RED, AND GREY IS/ARE CLAIMED AS A FEATURE OF THE MARK.

THE MARK CONSISTS OF A COLOR WHEEL COMPRISED OF INDIVIDUAL COLORED CIRCLES. THE COLORS ORANGE, YELLOW, GREEN, BLUE, PURPLE, RED AND GRAY APPEAR IN THE CIRCLES WITHIN THE DESIGN.

FOR EMPLOYMENT HIRING, RECRUITING, PLACEMENT, STAFFING AND CAREER NETWORKING SERVICES (U.S. CLS. 100, 101 AND 102).

LINDA M. KING, EXAMINING ATTORNEY

SN 77-428,873. GREGG APPLIANCES, INC., INDIANAPOLIS, IN. FILED 3-22-2008.

WEBSTOCK

THE MARK CONSISTS OF STANDARD CHARACTERS WITHOUT CLAIM TO ANY PARTICULAR FONT, STYLE, SIZE, OR COLOR.

FOR ON-LINE RETAIL STORE SERVICES FEATURING CONSUMER APPLIANCES, ELECTRONICS, PHOTOGRAPHIC EQUIPMENT, TELECOMMUNICATION EQUIPMENT, VIDEO EQUIPMENT, AUDIO EQUIPMENT, SATELLITE RECEIVING EQUIPMENT, HOME OFFICE EQUIPMENT, CAR EQUIPMENT, COMPUTER HARDWARE, COMPUTER SOFTWARE, ENTERTAINMENT SOFTWARE, AND RELATED EQUIPMENT AND MERCHANDISE (U.S. CLS. 100, 101 AND 102).

FIRST USE 10-10-2006; IN COMMERCE 10-10-2006.

DAVID TAYLOR, EXAMINING ATTORNEY

CLASS 35—(Continued).

SN 77-428,985. LANDERS, JAMES B., SILVER SPRING, MD.
FILED 3-22-2008.



NO CLAIM IS MADE TO THE EXCLUSIVE RIGHT TO USE "INTERACTIVE", APART FROM THE MARK AS SHOWN.

THE COLOR(S) BLUE/PURPLE/WHITE/BLACK IS/ARE CLAIMED AS A FEATURE OF THE MARK.

THE MARK CONSISTS OF A CIRCLE WITH BLUE/PURPLE UPPER HALF AND BLACK LOWER HALF PARTIALLY SURROUNDED BY A BLUE STYLIZED "C". THE WORDS "BLUE" AND "CORONA" WITH THE FIRST "O" IN THE WORD "CORONA" IN PURPLE AND THE WORD "INTERACTIVE" BELOW IN PURPLE. THE BACKGROUND IS WHITE.

FOR ADVERTISING AND MARKETING; BUSINESS MARKETING SERVICES (U.S. CLS. 100, 101 AND 102).

FIRST USE 0-0-2008; IN COMMERCE 0-0-2008.

ANDREA SAUNDERS, EXAMINING ATTORNEY

CLASS 35—(Continued).

SN 77-429,134. SHOEBUY.COM, INC., BOSTON, MA. FILED
3-23-2008.

SHOEBUY.COM

THE MARK CONSISTS OF STANDARD CHARACTERS WITHOUT CLAIM TO ANY PARTICULAR FONT, STYLE, SIZE, OR COLOR.

OWNER OF U.S. REG. NOS. 2,518,099 AND 2,871,916.

FOR ON-LINE RETAIL STORE SERVICES FEATURING BAGS, NAMELY, BACKPACKS, HANDBAGS, COMPUTER BAGS, AND LUGGAGE; ON-LINE RETAIL STORE SERVICES FEATURING APPAREL, NAMELY, PANTS, SHORTS, SKIRTS, TOPS, JACKETS, ACTIVE WEAR, UNDERWEAR AND OUTERWEAR; ON-LINE RETAIL STORE SERVICES FEATURING ACCESSORIES, NAMELY, BELTS, GLOVES, HEADBANDS, SCARVES, SUNGLASSES, INSOLES, SOCKS, WALLETS, WATCHES, AND SHOE CARE PRODUCTS (U.S. CLS. 100, 101 AND 102).

FIRST USE 12-31-2002; IN COMMERCE 12-31-2002.

INGA ERVIN, EXAMINING ATTORNEY

SN 77-429,148. HIATT, CURTIS SHANNON, CASTLE DALE, UT. FILED 3-23-2008.

**WAHOONBOX... WELCOME TO MY
WORLD**

THE MARK CONSISTS OF STANDARD CHARACTERS WITHOUT CLAIM TO ANY PARTICULAR FONT, STYLE, SIZE, OR COLOR.

FOR COMPUTER SERVICES, NAMELY, ADDRESS CHANGE NOTIFICATION SERVICES IN THE NATURE OF POSTING NOTIFICATIONS OF CHANGES OF ADDRESSES FOR BUSINESSES VIA THE INTERNET; DESIGN OF INTERNET ADVERTISING; DISSEMINATION OF ADVERTISING FOR OTHERS VIA AN ON-LINE COMMUNICATIONS NETWORK ON THE INTERNET; DISSEMINATION OF ADVERTISING FOR OTHERS VIA THE INTERNET; FACILITATING THE EXCHANGE OF NEEDED INFORMATION FOR FINANCIAL COMPENSATION VIA THE INTERNET; INFORMATION MANAGEMENT SERVICES, NAMELY, SHIPMENT PROCESSING, PREPARING SHIPPING DOCUMENTS AND INVOICES, TRACKING DOCUMENTS, PACKAGES AND FREIGHT OVER COMPUTER NETWORKS, INTRANETS AND INTERNETS; INFORMATION, ADVISORY AND CONSULTANCY SERVICES RELATING TO BUSINESS AND MANAGEMENT OR BUSINESS ADMINISTRATION, INCLUDING SUCH SERVICES PROVIDED ON LINE OR VIA THE INTERNET; INSURANCE LEAD COLLECTION AND MATCHING SERVICES, NAMELY, MATCHING CONSUMER REQUESTS FOR INSURANCE POLICY QUOTES COLLECTED OVER THE INTERNET TO PRE-QUALIFIED INSURANCE BROKERS, AGENTS AND AGENCIES INTERESTED IN THOSE REQUESTS; INTERNET ADVERTISING SERVICES; MARKET MANIPULATION, RESEARCH AND ANALYSIS, WHETHER OR NOT VIA THE INTERNET; ON-LINE TRADING SERVICES IN WHICH SELLER POSTS PRODUCTS TO BE AUCTIONED AND BIDDING IS DONE VIA THE INTERNET; ONLINE BUSINESS RESEARCH SERVICE THAT ALLOWS THE USER TO ANALYZE OPINION TRENDS CONTAINED IN DOCUMENTS ON THE INTERNET; ORGANISATION OF INTERNET AUCTIONS; PROVIDING A SEARCHABLE ONLINE ADVERTISING GUIDE FEATURING THE

SN 77-429,100. GALPA INVESTMENT LTD., CHRIST CHURCH, BARBADOS, FILED 3-23-2008.



NO CLAIM IS MADE TO THE EXCLUSIVE RIGHT TO USE "PARTS", APART FROM THE MARK AS SHOWN.

THE MARK CONSISTS OF THE DRAWING OF A WALKING MAN HOLDING A TOOL BOX FOLLOWED BY THE WORDS "TOTAL PARTS" IN STYLIZED CAPITAL LETTERS.

FOR ON-LINE RETAIL STORE SERVICES FEATURING REFRIGERATORS, AIR CONDITIONERS, AIR CONDITIONING UNITS, TEMPERATURE CONTROLLED WINE CELLARS, DEHUMIDIFIERS AND THEIR PARTS AND ACCESSORIES; RETAIL STORE SERVICES FEATURING REFRIGERATORS, AIR CONDITIONERS, AIR CONDITIONING UNITS, TEMPERATURE CONTROLLED WINE CELLARS, DEHUMIDIFIERS AND THEIR PARTS AND ACCESSORIES (U.S. CLS. 100, 101 AND 102).

MARLENE BELL, EXAMINING ATTORNEY

CLASS 35—(Continued).

GOODS AND SERVICES OF OTHER ON-LINE VENDORS ON THE INTERNET; PROVIDING A SECURED ACCESS DATABASE VIA THE INTERNET THROUGH WHICH DOCUMENTS AND IMAGES CAN BE VIEWED, COPIED, AND PRINTED FOR PURPOSES OF CONDUCTING CORPORATE TRANSACTIONS; PROVIDING AN INTERNET-BASED DATABASE OF PATIENT MEDICAL INFORMATION DESIGNED TO FACILITATE PATIENT-AUTHORIZED, HIPAA-COMPLIANT SHARING AND MAINTENANCE OF PATIENT MEDICAL INFORMATION AMONGST A PATIENT'S DOCTORS SUCH THAT THIS INFORMATION CAN BE DIRECTLY INSERTED INTO THE DOCTOR'S MEDICAL REPORTS AS A MEANS OF INCREASING MEDICAL RECORD GENERATION EFFICIENCY AND ACCURACY; PROVIDING AN ON-LINE COMMERCIAL INFORMATION DIRECTORY ON THE INTERNET; PROVIDING AND RENTAL OF ADVERTISING SPACE ON THE INTERNET; PROVIDING BUSINESS INFORMATION, ALSO VIA INTERNET, THE CABLE NETWORK OR OTHER FORMS OF DATA TRANSFER; PROVIDING CONSUMER PRODUCT INFORMATION VIA THE INTERNET; SUBSCRIPTION TO A TELEMATICS, TELEPHONE OR COMPUTER SERVICE; THE BRINGING TOGETHER, FOR THE BENEFIT OF OTHERS, OF A VARIETY OF GOODS AND SERVICES, ENABLING CUSTOMERS TO CONVENIENTLY VIEW AND PURCHASE THOSE GOODS AND SERVICES FROM AN INTERNET WEBSITE PARTICULARLY SPECIALIZING IN THE MARKETING OF THE SALE OF GOODS AND SERVICES OF OTHERS; ADVERTISING AND COMMERCIAL INFORMATION SERVICES, VIA THE INTERNET; ADVERTISING SERVICES, NAMELY, PROMOTING PROPERTIES FOR SALE BY OWNER VIA THE INTERNET; ADVERTISING VIA ELECTRONIC MEDIA AND SPECIFICALLY THE INTERNET; ADVICE AND INFORMATION ABOUT CUSTOMER SERVICES AND PRODUCT MANAGEMENT AND PRICES ON INTERNET SITES IN CONNECTION WITH PURCHASES MADE OVER THE INTERNET; AN INTERACTIVE WEB SITE FOR USERS TO REVIEW AND RATE INTERNET CONTENT, PEOPLE, COMPANIES, PRODUCTS AND/OR SERVICES UTILIZING A SOFTWARE APPLICATION TO AWARD POINTS WHEREBY WEB SITE USERS ARE ELIGIBLE TO EXCHANGE POINTS EARNED FOR PROMOTIONAL ITEMS CONSISTING; OF COUPONS, REBATES, DISCOUNTS OR SPECIAL OFFERINGS ON GOODS AND/OR SERVICE PROVIDED BY WEB SITE SPONSORS (U.S. CLS. 100, 101 AND 102).

DORITT L. CARROLL, EXAMINING ATTORNEY

SN 77-429,175. BEAUCOUP WEDDINGFAVORS, INC., MOUNTAIN VIEW, CA. FILED 3-24-2008.



THE MARK CONSISTS OF THE WORD "BEAUCOUP" IN STYLIZED LETTERING, WITH A DRAWING OF A FLOWER BEHIND THE WORD. THE FIRST HALF OF THE MARK, "BEAU" IS IN THIN LETTERING AND THE SECOND HALF, "COUP" IS IN THICK LETTERING.

THE FOREIGN WORDING IN THE MARK TRANSLATES INTO ENGLISH AS "MUCH".

FOR ON-LINE RETAIL STORE SERVICES FEATURING SPECIAL OCCASION FAVORS AND GIFTS (U.S. CLS. 100, 101 AND 102).

FIRST USE 1-1-2002; IN COMMERCE 1-1-2002.
MYRIAH HABEEB, EXAMINING ATTORNEY

CLASS 35—(Continued).

SN 77-429,346. ISLAND ADVANTAGE REALTY, LLC, HUNTINGTON, NY. FILED 3-24-2008.

ISLAND ADVANTAGE

THE MARK CONSISTS OF STANDARD CHARACTERS WITHOUT CLAIM TO ANY PARTICULAR FONT, STYLE, SIZE, OR COLOR.

FOR REAL ESTATE ADVERTISING SERVICES; REAL ESTATE AUCTIONS; REAL ESTATE MARKETING SERVICES IN THE FIELD OF REAL ESTATE OWNED (REO) PROPERTIES; REAL ESTATE SALES MANAGEMENT (U.S. CLS. 100, 101 AND 102).

FIRST USE 10-6-1998; IN COMMERCE 10-6-1998.
WENDY GOODMAN, EXAMINING ATTORNEY

SN 77-429,355. ISLAND ADVANTAGE REALTY, LLC, HUNTINGTON, NY. FILED 3-24-2008.



NO CLAIM IS MADE TO THE EXCLUSIVE RIGHT TO USE "REALTY, LLC", APART FROM THE MARK AS SHOWN.

THE MARK CONSISTS OF TWO SAILS WITHIN A CIRCLE, WHICH IS ENCLOSED IN A SQUARE, NEXT TO THE LITERAL ELEMENT "ISLAND", WHICH IS ON TOP OF THE LITERAL ELEMENT "ADVANTAGE", WHICH IS ON TOP OF THE LITERAL ELEMENT "REALTY, LLC", WHICH IS ENCLOSED IN A RECTANGLE.

FOR REAL ESTATE ADVERTISING SERVICES; REAL ESTATE AUCTIONS; REAL ESTATE MARKETING SERVICES IN THE FIELD OF REAL ESTATE OWNED (REO) PROPERTIES; REAL ESTATE SALES MANAGEMENT (U.S. CLS. 100, 101 AND 102).

FIRST USE 10-6-1998; IN COMMERCE 10-6-1998.
WENDY GOODMAN, EXAMINING ATTORNEY

CLASS 35—(Continued).

SN 77-429,370. MYJAMBI, INC., DBA MYJAMBI, LLC, NEW YORK, NY. FILED 3-24-2008.

Friend+1

THE MARK CONSISTS OF STANDARD CHARACTERS WITHOUT CLAIM TO ANY PARTICULAR FONT, STYLE, SIZE, OR COLOR.

FOR PROVIDING A WEB SITE THAT FEATURES AN ONLINE MARKET FOR USERS TO LIST OFFERED OR WANTED PERSONAL AND BUSINESS ASSETS AND SKILLS FOR HIRE, OFFERING ADVERTISING AND INFORMATION DISTRIBUTION SERVICES, NAMELY, PROVIDING CLASSIFIED ADVERTISING SPACE VIA THE GLOBAL COMPUTER NETWORK (U.S. CLS. 100, 101 AND 102).

FIRST USE 2-26-2008; IN COMMERCE 2-26-2008.
ANNE E. GUSTASON, EXAMINING ATTORNEY

SN 77-429,420. INTERIM HEALTHCARE MANAGERS, INC., ST. LOUIS, MO. FILED 3-24-2008.

NIELSEN HEALTHCARE GROUP

THE MARK CONSISTS OF STANDARD CHARACTERS WITHOUT CLAIM TO ANY PARTICULAR FONT, STYLE, SIZE, OR COLOR.

NO CLAIM IS MADE TO THE EXCLUSIVE RIGHT TO USE "HEALTHCARE GROUP", APART FROM THE MARK AS SHOWN.

SEC. 2(F) AS TO "NIELSEN".
FOR EMPLOYEE STAFFING AND PLACEMENT SERVICES (U.S. CLS. 100, 101 AND 102).
FIRST USE 12-0-1992; IN COMMERCE 12-0-1992.
STEVEN R. FINE, EXAMINING ATTORNEY

SN 77-429,448. CUPMERCIAL, LLC, RICHMOND HILL, GA. FILED 3-24-2008.

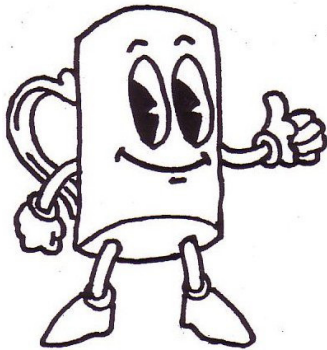

THE MARK CONSISTS OF CARICATURE OF A MUG WITH A HANDLE ATTACHED TO THE MUG IN THE

CLASS 35—(Continued).

USUAL POSITION AND TWO ARMS WITH GLOVED HANDS ON THE SIDES OF THE MUG, BOTH GLOVED HANDS ARE IN THE SHAPE OF A FIST WITH THE THUMBS UP POSITION OF THE LEFT FIST, AND TWO LEGS WITH BOOTED FEET ATTACHED TO THE BOTTOM OF THE MUG, AND ON THE FRONT OF THE MUG IS A SMILING FACE WHICH CONSISTS OF TWO EYE BROWS OVER TWO OPEN EYES AND A SHORT ACCENT LINE UNDER THE SMILE GIVING THE APPEARANCE OF A CHIN.

FOR ADVERTISING AND PROMOTIONAL SERVICES; PREPARATION OF CUSTOM ADVERTISEMENTS FOR OTHERS (U.S. CLS. 100, 101 AND 102).

FIRST USE 5-0-2007; IN COMMERCE 5-0-2007.
JAY FLOWERS, EXAMINING ATTORNEY

SN 77-429,518. RANKER, LLC, LOS ANGELES, CA. FILED 3-24-2008.

RANKER

THE MARK CONSISTS OF STANDARD CHARACTERS WITHOUT CLAIM TO ANY PARTICULAR FONT, STYLE, SIZE, OR COLOR.

FOR PROVIDING AN INTERACTIVE WEBSITE FOR USERS TO LIST, RATE, AND REVIEW PRODUCTS, SERVICES, BUSINESSES, EXPERIENCES, PEOPLE, PLACES, CONTENT, AND THINGS; PROVIDING INFORMATION IN THE FIELD OF PUBLIC OPINIONS VIA THE INTERNET; PROVIDING AN ONLINE COMPUTER DATABASE IN THE FIELD OF CONSUMER PRODUCT REVIEWS (U.S. CLS. 100, 101 AND 102).

ZACHARY BELLO, EXAMINING ATTORNEY

SN 77-429,613. DIGITAL BUSINESS SOLUTIONS, INC., LOUISVILLE, KY. FILED 3-24-2008.

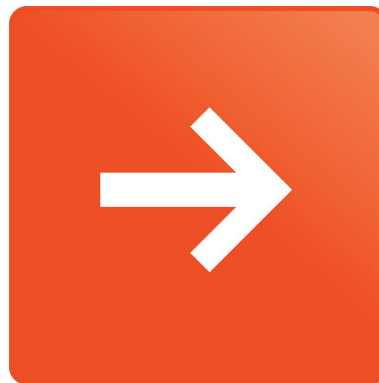

THE COLOR(S) ORANGE AND WHITE IS/ARE CLAIMED AS A FEATURE OF THE MARK.

THE MARK CONSISTS OF AN ORANGE COLOR FILLED SQUARE HAVING ROUNDED CORNERS; IN THE CENTER OF THE SQUARE IS WHITE-COLORED ARROW POINTING TO THE RIGHT.

FOR CREATIVE MARKETING DESIGN SERVICES; BUSINESS MARKETING CONSULTING SERVICES; ON-LINE ADVERTISING AND MARKETING SERVICES (U.S. CLS. 100, 101 AND 102).

FIRST USE 4-1-2007; IN COMMERCE 5-1-2007.
CHARLES L. JENKINS, EXAMINING ATTORNEY

CLASS 35—(Continued).

SN 77-429,644. DIGITAL BUSINESS SOLUTIONS, INC., LOUISVILLE, KY. FILED 3-24-2008.

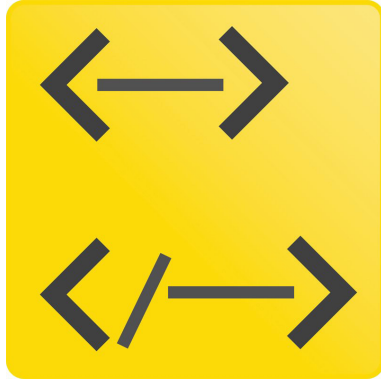

THE COLOR(S) YELLOW AND BLACK IS/ARE CLAIMED AS A FEATURE OF THE MARK.

THE MARK CONSISTS OF A YELLOW COLOR-FILLED SQUARE HAVING ROUNDED CORNERS; AT THE TOP CENTER OF THE SQUARE ARE BLACK-COLORED CHARACTERS "<->", WITH THE CHARACTER "-" BEING ELONGATED; AND AT THE BOTTOM CENTER OF THE SQUARE ARE BLACK-COLORED CHARACTERS "</->", WITH THE CHARACTER "/" BEING ELONGATED.

FOR CREATIVE MARKETING DESIGN SERVICES; BUSINESS MARKETING CONSULTING SERVICES; ON-LINE ADVERTISING AND MARKETING SERVICES (U.S. CLS. 100, 101 AND 102).

FIRST USE 4-1-2007; IN COMMERCE 5-1-2007.
CHARLES L. JENKINS, EXAMINING ATTORNEY

SN 77-429,664. DIGITAL BUSINESS SOLUTIONS, INC., LOUISVILLE, KY. FILED 3-24-2008.



THE COLOR(S) ORANGE AND WHITE IS/ARE CLAIMED AS A FEATURE OF THE MARK.

THE MARK CONSISTS OF AN ORANGE COLOR-FILLED SQUARE HAVING ROUNDED CORNERS; AT THE CENTER OF THE SQUARE IS A WHITE-COLORED "X" CHARACTER GEOMETRICALLY SURROUNDED ON BOTH SIDES BY A PAIR OF STYLIZED, WHITE-COLORED CHEVRONS.

FOR CREATIVE MARKETING DESIGN SERVICES; BUSINESS MARKETING CONSULTING SERVICES; ON-LINE ADVERTISING AND MARKETING SERVICES (U.S. CLS. 100, 101 AND 102).

FIRST USE 4-1-2007; IN COMMERCE 5-1-2007.
CHARLES L. JENKINS, EXAMINING ATTORNEY

CLASS 35—(Continued).

SN 77-429,720. HDA, INC., HAZELWOOD, MO. FILED 3-24-2008.

HDA MERCHANDISING

THE MARK CONSISTS OF STANDARD CHARACTERS WITHOUT CLAIM TO ANY PARTICULAR FONT, STYLE, SIZE, OR COLOR.

NO CLAIM IS MADE TO THE EXCLUSIVE RIGHT TO USE "MERCHANDISING", APART FROM THE MARK AS SHOWN.

FOR PRODUCT MERCHANDISING; MERCHANDISING OF BOOKS AND MAGAZINES (U.S. CLS. 100, 101 AND 102).

MARCIE MILONE, EXAMINING ATTORNEY

SN 77-429,763. ROBERT A. MCNEIL, HOUSTON, TX. FILED 3-24-2008.

VOTE WITH YOUR DOLLARS

THE MARK CONSISTS OF STANDARD CHARACTERS WITHOUT CLAIM TO ANY PARTICULAR FONT, STYLE, SIZE, OR COLOR.

FOR TAX ADVISORY AND CONSULTATION SERVICES (U.S. CLS. 100, 101 AND 102).

ELLEN PERKINS, EXAMINING ATTORNEY

SN 77-429,827. LEAN JOURNEY LLC, FENTON, MI. FILED 3-24-2008.



NO CLAIM IS MADE TO THE EXCLUSIVE RIGHT TO USE "LLC", APART FROM THE MARK AS SHOWN.

THE MARK CONSISTS OF ASCENDING STEPS. FOR BUSINESS CONSULTING AND BUSINESS INFORMATION FOR ENTERPRISES (U.S. CLS. 100, 101 AND 102).

FIRST USE 3-1-2008; IN COMMERCE 3-1-2008.
ROBIN CHOSID, EXAMINING ATTORNEY

CLASS 35—(Continued).

SN 77-429,833. WOODHAVEN PHARMACY SERVICES, LLC, BALTIMORE, MD. FILED 3-24-2008.

REMEMDI HEALTHCARE

THE MARK CONSISTS OF STANDARD CHARACTERS WITHOUT CLAIM TO ANY PARTICULAR FONT, STYLE, SIZE, OR COLOR.

NO CLAIM IS MADE TO THE EXCLUSIVE RIGHT TO USE "HEALTHCARE", APART FROM THE MARK AS SHOWN.

FOR WHOLESALE INSTITUTIONAL PHARMACY SERVICES, NAMELY, PROVIDING PHARMACEUTICAL PRODUCTS, MEDICATIONS AND PRESCRIPTION DRUGS TO NURSING HOMES, ASSISTED LIVING FACILITIES AND OTHER INSTITUTIONS (U.S. CLS. 100, 101 AND 102).

ELLEN BURNS, EXAMINING ATTORNEY

CLASS 35—(Continued).

SN 77-429,885. EMERGENCE CONSULTING LLC, WOODINVILLE, WA. FILED 3-24-2008.



NO CLAIM IS MADE TO THE EXCLUSIVE RIGHT TO USE "CONSULTING", APART FROM THE MARK AS SHOWN.

THE COLOR(S) PURPLE AND BLACK IS/ARE CLAIMED AS A FEATURE OF THE MARK.

THE MARK CONSISTS OF THE WORDS "EMERGENCE CONSULTING" WITH THE INITIAL "E" TWICE THE SIZE OF THE REST OF THE WORD "EMERGENCE" IN A CURSIVE FONT IN THE COLOR PURPLE. THE WORD "CONSULTING" IS POSITIONED BELOW THE WORD "EMERGENCE" WITH THE INITIAL "C" POSITIONED IN BETWEEN THE "E" AND "R" OF "EMERGENCE". THE COLOR BLACK APPEARS IN THE REMAINING LETTERS OF "EMERGENCE" AND IN THE TERM "CONSULTING".

FOR PROVIDING ORGANIZATIONAL DEVELOPMENT CONSULTING SERVICES (U.S. CLS. 100, 101 AND 102).

FIRST USE 3-29-2006; IN COMMERCE 3-29-2006.

ANNE FARRELL, EXAMINING ATTORNEY

SN 77-429,924. SERTA, INC., HOFFMAN ESTATES, IL. FILED 3-24-2008.

CHOOSE YOUR PRICE, CHOOSE YOUR COMFORT

THE MARK CONSISTS OF STANDARD CHARACTERS WITHOUT CLAIM TO ANY PARTICULAR FONT, STYLE, SIZE, OR COLOR.

FOR RETAIL STORE SERVICES FEATURING MATTRESSES (U.S. CLS. 100, 101 AND 102).

KATINA MISTER, EXAMINING ATTORNEY

SN 77-429,854. WOODHAVEN PHARMACY SERVICES, LLC, BALTIMORE, MD. FILED 3-24-2008.

REMEMDI SENIORCARE

THE MARK CONSISTS OF STANDARD CHARACTERS WITHOUT CLAIM TO ANY PARTICULAR FONT, STYLE, SIZE, OR COLOR.

NO CLAIM IS MADE TO THE EXCLUSIVE RIGHT TO USE "SENIORCARE", APART FROM THE MARK AS SHOWN.

FOR WHOLESALE INSTITUTIONAL PHARMACY SERVICES, NAMELY, PROVIDING PHARMACEUTICAL PRODUCTS, MEDICATIONS AND PRESCRIPTION DRUGS TO NURSING HOMES, ASSISTED LIVING FACILITIES AND OTHER INSTITUTIONS (U.S. CLS. 100, 101 AND 102).

ELLEN BURNS, EXAMINING ATTORNEY

SN 77-429,939. SERTA, INC., HOFFMAN ESTATES, IL. FILED 3-24-2008.

PICK YOUR PRICE, PICK YOUR COMFORT

THE MARK CONSISTS OF STANDARD CHARACTERS WITHOUT CLAIM TO ANY PARTICULAR FONT, STYLE, SIZE, OR COLOR.

FOR RETAIL STORE SERVICES FEATURING MATTRESSES (U.S. CLS. 100, 101 AND 102).

FIRST USE 2-21-2008; IN COMMERCE 2-21-2008.

KATINA MISTER, EXAMINING ATTORNEY

CLASS 35—(Continued).

SN 77-429,952. DONG-WOOK LEE, GWANGMYEONG-SI, REPUBLIC OF KOREA, FILED 3-24-2008.

ECONET

THE MARK CONSISTS OF STANDARD CHARACTERS WITHOUT CLAIM TO ANY PARTICULAR FONT, STYLE, SIZE, OR COLOR.

FOR INDEPENDENT SALES REPRESENTATIVES IN THE FIELD OF MEDICAL EQUIPMENT; EXPORT AND IMPORT AGENCIES (U.S. CLS. 100, 101 AND 102).
NICHOLAS ALTREE, EXAMINING ATTORNEY

SN 77-430,109. INDIAN HANDICRAFTS & TEXTILES SYNDICATE, NEW DELHI, INDIA, FILED 3-24-2008.



THE MARK CONSISTS OF A FLYING PHOENIX.
FOR DISTRIBUTORSHIP SERVICES IN THE FIELD OF FINE BLADEWARE, CUTLERY AND REPRODUCTION WEAPONRY, NAMELY, KNIVES, SWORDS, DAGGERS, REPLICA ARMOUR, HELMETS, SHIELDS, AXES, POLE ARMS AND OTHER HISTORICAL ARTIFACTS OF WEAPONRY AND RELATED COLLECTIBLES AND ACCESSORIES; RETAIL STORE SERVICES FEATURING FINE BLADEWARE, CUTLERY AND REPRODUCTION WEAPONRY, NAMELY, KNIVES, SWORDS, DAGGERS, REPLICA ARMOUR, HELMETS, SHIELDS, AXES, POLE ARMS AND OTHER HISTORICAL ARTIFACTS OF WEAPONRY AND RELATED COLLECTIBLES AND ACCESSORIES; ON-LINE ORDERING SERVICES FEATURING FINE BLADEWARE, CUTLERY AND REPRODUCTION WEAPONRY, NAMELY, KNIVES, SWORDS, DAGGERS, REPLICA ARMOUR, HELMETS, SHIELDS, AXES, POLE ARMS AND OTHER HISTORICAL ARTIFACTS OF WEAPONRY AND RELATED COLLECTIBLES AND ACCESSORIES (U.S. CLS. 100, 101 AND 102).
FIRST USE 1-18-2008; IN COMMERCE 1-18-2008.
JASON ROTH, EXAMINING ATTORNEY

CLASS 35—(Continued).

SN 77-430,124. INDIAN HANDICRAFTS & TEXTILES SYNDICATE, NEW DELHI, INDIA, FILED 3-24-2008.



THE MARK CONSISTS OF THE CAPITALIZED LETTERS "GDFB" ENCLOSED IN AN OVAL.

FOR DISTRIBUTORSHIP SERVICES IN THE FIELD OF FINE BLADEWARE, CUTLERY AND REPRODUCTION WEAPONRY, NAMELY, KNIVES, SWORDS, DAGGERS, ARMOUR, HELMETS, SHIELDS, AXES, POLE ARMS AND OTHER HISTORICAL ARTIFACTS OF WEAPONRY AND RELATED COLLECTIBLES AND ACCESSORIES; ON-LINE ORDERING SERVICES FEATURING FINE BLADEWARE, CUTLERY AND REPRODUCTION WEAPONRY, NAMELY, KNIVES, SWORDS, DAGGERS, ARMOUR, HELMETS, SHIELDS, AXES, POLE ARMS AND OTHER HISTORICAL ARTIFACTS OF WEAPONRY AND RELATED COLLECTIBLES AND ACCESSORIES; RETAIL STORE SERVICES FEATURING FINE BLADEWARE, CUTLERY AND REPRODUCTION WEAPONRY, NAMELY, KNIVES, SWORDS, DAGGERS, ARMOUR, HELMETS, SHIELDS, AXES, POLE ARMS AND OTHER HISTORICAL ARTIFACTS OF WEAPONRY AND RELATED COLLECTIBLES AND ACCESSORIES (U.S. CLS. 100, 101 AND 102).

FIRST USE 1-18-2008; IN COMMERCE 1-18-2008.
JASON ROTH, EXAMINING ATTORNEY

SN 77-430,197. SEACOLOGY CORPORATION, BERKELEY, CA. FILED 3-24-2008.

SEACOLOGY

THE MARK CONSISTS OF STANDARD CHARACTERS WITHOUT CLAIM TO ANY PARTICULAR FONT, STYLE, SIZE, OR COLOR.

FOR PROMOTING PUBLIC AWARENESS OF THE NEED FOR PRESERVING AND PROTECTING THE ENVIRONMENTS AND CULTURES OF ISLANDS THROUGHOUT THE WORLD (U.S. CLS. 100, 101 AND 102).

FIRST USE 5-1-1991; IN COMMERCE 5-1-1991.
SHAUNIA CARLYLE, EXAMINING ATTORNEY

CLASS 35—(Continued).

SN 77-430,199. TRAFFIC MANAGEMENT SERVICES, INC., THORNHILL, CANADA, FILED 3-24-2008.

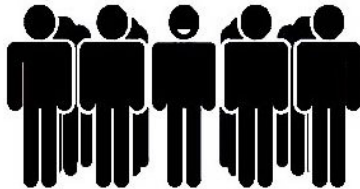

THE MARK CONSISTS OF FIVE ROWS OF STYLIZED HUMAN FIGURES.

FOR CONSULTING, NAMELY, CONSULTING TO THE AUTOMOTIVE INDUSTRY RELATING TO BEST PRACTICES IN OPERATING OF AUTO DEALERSHIPS AND SALES TECHNIQUES (U.S. CLS. 100, 101 AND 102).
ANN E. SAPPENFIELD, EXAMINING ATTORNEY

SN 77-430,207. MONUMENT LUMBER CO., INC., FREEDOM, CA. FILED 3-24-2008.



NO CLAIM IS MADE TO THE EXCLUSIVE RIGHT TO USE "LUMBER", APART FROM THE MARK AS SHOWN.

THE MARK CONSISTS OF THE PROFILE OF A MAN WALKING AND CARRYING A 2X4 OVER HIS SHOULDER TO THE LEFT OF THE STYLIZED WORDS "MONUMENT LUMBER".

FOR DISTRIBUTORSHIPS IN THE FIELD OF LUMBER AND BUILDING MATERIALS, HARDWARE, PLYWOOD, DRYWALL AND ROOFING PRODUCTS (U.S. CLS. 100, 101 AND 102).

FIRST USE 9-1-2007; IN COMMERCE 9-1-2007.
GISELLE AGOSTO, EXAMINING ATTORNEY

SN 77-430,436. DANCONIA MEDIA, WEARE, NH. FILED 3-25-2008.

METROINFO

THE MARK CONSISTS OF STANDARD CHARACTERS WITHOUT CLAIM TO ANY PARTICULAR FONT, STYLE, SIZE, OR COLOR.

FOR ADVERTISING THROUGH ALL PUBLIC COMMUNICATION MEANS (U.S. CLS. 100, 101 AND 102).

FIRST USE 4-18-2008; IN COMMERCE 4-18-2008.
HEATHER THOMPSON, EXAMINING ATTORNEY

CLASS 35—(Continued).

SN 77-430,589. EGENCIE, INC., DBA EGENCIE, MIDDLETON, WI. FILED 3-25-2008.

Egency

THE MARK CONSISTS OF STANDARD CHARACTERS WITHOUT CLAIM TO ANY PARTICULAR FONT, STYLE, SIZE, OR COLOR.

FOR ADVERTISING AND PUBLICITY SERVICES, NAMELY, PROMOTING THE GOODS, SERVICES, BRAND IDENTITY AND COMMERCIAL INFORMATION AND NEWS OF THIRD PARTIES THROUGH PRINT, AUDIO, VIDEO, DIGITAL AND ON-LINE MEDIUM; ADVERTISING VIA ELECTRONIC MEDIA AND SPECIFICALLY THE INTERNET; DESIGN OF INTERNET ADVERTISING; ON-LINE ADVERTISING AND MARKETING SERVICES; PROMOTION, ADVERTISING AND MARKETING OF ON-LINE WEB SITES; PROVIDING ADVERTISING, MARKETING AND PROMOTIONAL SERVICES, NAMELY, DEVELOPMENT OF ADVERTISING CAMPAIGNS FOR DIGITAL AND ON-LINE MEDIUMS (U.S. CLS. 100, 101 AND 102).
ANNE FARRELL, EXAMINING ATTORNEY

SN 77-430,679. SOUTHEASTERN GOLF CARS, MARTINSVILLE, VA. FILED 3-25-2008.



THE STIPPLING IS FOR SHADING PURPOSES ONLY.
THE MARK CONSISTS OF A CIRCLE WITH THE LETTERS "E" AND "C" INSIDE WITH THE "E" FACING FORWARD AND THE "C" BEING BACKWARDS, AND THE STYLIZED TEXT "EVERYTHING CARTS".

FOR CATALOG ORDERING SERVICE FEATURING GOLF CART PARTS, AND ACCESSORIES, GOLF CART TIRES AND WHEELS, GOLF CART SEAT COVERS, GOLF CART STAINLESS BUMPERS, GOLF CART LIFT KITS, GOLF CART LIGHTS, GOLF CART DIAMOND PLATE, ANY PARTS AND ACCESSORIES FOR A GOLF CART; ON-LINE RETAIL STORE SERVICES FEATURING GOLF CART PARTS, AND ACCESSORIES, GOLF CART TIRES AND WHEELS, GOLF CART SEAT COVERS, GOLF CART STAINLESS BUMPERS, GOLF CART LIFT KITS, GOLF CART LIGHTS, GOLF CART DIAMOND PLATE, ANY PARTS AND ACCESSORIES FOR A GOLF CART (U.S. CLS. 100, 101 AND 102).

FIRST USE 6-30-2007; IN COMMERCE 6-30-2007.
WENDY JUN, EXAMINING ATTORNEY

CLASS 35—(Continued).

SN 77-430,710. SELECT STAFFING SOLUTIONS, INC., FRAMINGHAM, MA. FILED 3-25-2008.

SELECTSTAFF

THE MARK CONSISTS OF STANDARD CHARACTERS WITHOUT CLAIM TO ANY PARTICULAR FONT, STYLE, SIZE, OR COLOR.

FOR EMPLOYMENT STAFFING SERVICES (U.S. CLS. 100, 101 AND 102).

FIRST USE 5-31-2000; IN COMMERCE 5-31-2000.
H. M. FISHER, EXAMINING ATTORNEY

CLASS 35—(Continued).

SN 77-430,940. SPARTAN INTERNATIONAL, LLC, HARRISON, AR. FILED 3-25-2008.

UNDERGROUND

THE MARK CONSISTS OF STANDARD CHARACTERS WITHOUT CLAIM TO ANY PARTICULAR FONT, STYLE, SIZE, OR COLOR.

FOR ON-LINE BUSINESS NETWORKING SERVICES (U.S. CLS. 100, 101 AND 102).

ANTHONY RINKER, EXAMINING ATTORNEY

SN 77-430,746. PANKAJ AND YEN CORP., REDMOND, WA. FILED 3-25-2008.

Subconscious Segmentation

THE MARK CONSISTS OF STANDARD CHARACTERS WITHOUT CLAIM TO ANY PARTICULAR FONT, STYLE, SIZE, OR COLOR.

NO CLAIM IS MADE TO THE EXCLUSIVE RIGHT TO USE "SEGMENTATION", APART FROM THE MARK AS SHOWN.

FOR MARKETING SEGMENTATION (U.S. CLS. 100, 101 AND 102).

H. M. FISHER, EXAMINING ATTORNEY

SN 77-430,944. DIGITALMAILER, INC., HERNDON, VA. FILED 3-25-2008.

Connect. Communicate. Grow.

THE MARK CONSISTS OF STANDARD CHARACTERS WITHOUT CLAIM TO ANY PARTICULAR FONT, STYLE, SIZE, OR COLOR.

FOR MARKETING SERVICES, NAMELY, PROVIDING INFORMATIONAL WEB PAGES DESIGNED TO GENERATE SALES TRAFFIC VIA HYPERLINKS TO OTHER WEB SITES (U.S. CLS. 100, 101 AND 102).

CYNTHIA SLOAN, EXAMINING ATTORNEY

SN 77-430,811. HERNANDEZ, JOSEPH, RIDGEWOOD, NY. FILED 3-25-2008.

LYRICARIO

THE MARK CONSISTS OF STANDARD CHARACTERS WITHOUT CLAIM TO ANY PARTICULAR FONT, STYLE, SIZE, OR COLOR.

FOR ENTERTAINMENT MARKETING SERVICES, NAMELY, MARKETING, PROMOTION AND ADVERTISING FOR INDEPENDENT RECORDING ARTISTS (U.S. CLS. 100, 101 AND 102).

FIRST USE 7-1-1998; IN COMMERCE 7-8-2006.
CHERYL CLAYTON, EXAMINING ATTORNEY

SN 77-431,038. GREENFISH ADVENTURE SPORTS, ANDES, NY. FILED 3-25-2008.

Greenfish Adventure Sports

THE MARK CONSISTS OF STANDARD CHARACTERS WITHOUT CLAIM TO ANY PARTICULAR FONT, STYLE, SIZE, OR COLOR.

NO CLAIM IS MADE TO THE EXCLUSIVE RIGHT TO USE "ADVENTURE SPORTS", APART FROM THE MARK AS SHOWN.

FOR COMPUTERIZED ON-LINE RETAIL STORE SERVICES IN THE FIELD OF SPORTING GOODS (U.S. CLS. 100, 101 AND 102).

FIRST USE 7-22-2001; IN COMMERCE 7-22-2001.
ARETHA SOMERVILLE, EXAMINING ATTORNEY

CLASS 35—(Continued).

SN 77-431,059. LANCE ARMSTRONG FOUNDATION, AUSTIN, TX. FILED 3-25-2008.

LIVESTRONG

THE MARK CONSISTS OF STANDARD CHARACTERS WITHOUT CLAIM TO ANY PARTICULAR FONT, STYLE, SIZE, OR COLOR.

OWNER OF U.S. REG. NOS. 3,052,284, 3,363,666 AND OTHERS.

FOR PROVIDING DOCTOR AND MEDICAL FACILITY REFERRALS SERVICES; MEDICAL REFERRALS; PHYSICIAN REFERRALS; PROVIDING REFERRALS TO MENTAL HEALTH AND PSYCHOTHERAPY PROFESSIONALS; AND REFERRALS IN THE FIELD OF MATCHING PATIENTS WITH CLINICAL TRIALS FOR NEW TREATMENTS IN THE FIELD OF CANCER (U.S. CLS. 100, 101 AND 102).

Laura Hammel, Examining Attorney



SN 77-431,072. PROVIDER MEDS, LP, SUNNYVALE, TX. FILED 3-25-2008.

PROVIDERX

THE MARK CONSISTS OF STANDARD CHARACTERS WITHOUT CLAIM TO ANY PARTICULAR FONT, STYLE, SIZE, OR COLOR.

FOR RETAIL PHARMACY SERVICES (U.S. CLS. 100, 101 AND 102).

Caryn Glasser, Examining Attorney



SN 77-431,085. GREENFISH ADVENTURE SPORTS, INC., ANDES, NY. FILED 3-25-2008.

Greenfish Sports

THE MARK CONSISTS OF STANDARD CHARACTERS WITHOUT CLAIM TO ANY PARTICULAR FONT, STYLE, SIZE, OR COLOR.

NO CLAIM IS MADE TO THE EXCLUSIVE RIGHT TO USE "SPORTS", APART FROM THE MARK AS SHOWN.

FOR COMPUTERIZED ON-LINE RETAIL STORE SERVICES IN THE FIELD OF SPORTING GOODS (U.S. CLS. 100, 101 AND 102).

First Use 7-22-2001; In Commerce 7-22-2001.

Aretha Somerville, Examining Attorney

CLASS 35—(Continued).

SN 77-431,097. RESEARCH HORIZONS LLC, DBA PHOENIX MARKETING INTERNATIONAL, RHINEBECK, NY. FILED 3-25-2008.

VIRTUAL MAILBOX

THE MARK CONSISTS OF STANDARD CHARACTERS WITHOUT CLAIM TO ANY PARTICULAR FONT, STYLE, SIZE, OR COLOR.

FOR CONSULTING SERVICES RELATING TO BUSINESS AND MARKET RESEARCH; CONDUCTING ON-LINE BUSINESS AND MARKET RESEARCH SURVEYS (U.S. CLS. 100, 101 AND 102).

First Use 4-23-2007; In Commerce 4-23-2007.

Dominick J. Salemi, Examining Attorney



SN 77-431,176. VARTANIAN, JACK, SAO PAULO, BRAZIL, FILED 3-25-2008.

JACK VARTANIAN

THE MARK CONSISTS OF STANDARD CHARACTERS WITHOUT CLAIM TO ANY PARTICULAR FONT, STYLE, SIZE, OR COLOR.

OWNER OF U.S. REG. NO. 2,812,730. THE NAME(S), PORTRAIT(S), AND/OR SIGNATURE(S) SHOWN IN THE MARK IDENTIFIES JACK VARTANIAN, WHOSE CONSENT(S) TO REGISTER IS MADE OF RECORD.

FOR RETAIL STORE SERVICES IN THE FIELD OF GENERAL MERCHANDISE, NAMELY, JEWELRY (U.S. CLS. 100, 101 AND 102).

Gilbert Swift, Examining Attorney



SN 77-431,241. RUEDAS, JAVIER, WALNUT, CA. FILED 3-25-2008.

unzip...the possibilities

THE MARK CONSISTS OF STANDARD CHARACTERS WITHOUT CLAIM TO ANY PARTICULAR FONT, STYLE, SIZE, OR COLOR.

FOR ADVERTISING AND MARKETING (U.S. CLS. 100, 101 AND 102).

Giselle Agosto, Examining Attorney

CLASS 35—(Continued).

SN 77-431,301. NEXXION SOLUTIONS, INC., BELLEVUE, WA. FILED 3-25-2008.

NEXXION SOLUTIONS

THE MARK CONSISTS OF STANDARD CHARACTERS WITHOUT CLAIM TO ANY PARTICULAR FONT, STYLE, SIZE, OR COLOR.

NO CLAIM IS MADE TO THE EXCLUSIVE RIGHT TO USE "SOLUTIONS", APART FROM THE MARK AS SHOWN.

FOR VALUE-ADDED RESELLER SERVICES, NAMELY, DISTRIBUTORSHIP SERVICES FEATURING COMPUTER SOFTWARE AND COMPUTER HARDWARE (U.S. CLS. 100, 101 AND 102).

AMEETA JORDAN, EXAMINING ATTORNEY

SN 77-431,305. MARICOPA PARTNERSHIP FOR ARTS AND CULTURE, PHOENIX, AZ. FILED 3-25-2008.

MEETGREATERPHOENIX.COM

THE MARK CONSISTS OF STANDARD CHARACTERS WITHOUT CLAIM TO ANY PARTICULAR FONT, STYLE, SIZE, OR COLOR.

FOR PROMOTING REGIONAL ARTS AND CULTURE; PROMOTING ECONOMIC DEVELOPMENT, EMPLOYEE RECRUITMENT AND EMPLOYEE RETENTION THROUGH REGIONAL ARTS AND CULTURAL RESOURCES IN THE GREATER PHOENIX AREA (U.S. CLS. 100, 101 AND 102).

RUDY R. SINGLETON, EXAMINING ATTORNEY

SN 77-431,367. BANANATOYS.COM, INC., GLENDORA, CA. FILED 3-25-2008.

BANANATOYS.COM

THE MARK CONSISTS OF STANDARD CHARACTERS WITHOUT CLAIM TO ANY PARTICULAR FONT, STYLE, SIZE, OR COLOR.

FOR ON-LINE RETAIL STORE SERVICES FEATURING TOYS, ACTION FIGURES, AND GAMES (U.S. CLS. 100, 101 AND 102).

FIRST USE 8-1-2003; IN COMMERCE 10-1-2003.

MONIQUE MILLER, EXAMINING ATTORNEY

CLASS 35—(Continued).

SN 77-431,414. CHIROPRACTIC LEADERSHIP EDUCATIONAL ADVANCEMENT AND RESEARCH INSTITUTE, PA, ST. CLOUD, MN. FILED 3-25-2008.

CLEAR Scoliosis Center

THE MARK CONSISTS OF STANDARD CHARACTERS WITHOUT CLAIM TO ANY PARTICULAR FONT, STYLE, SIZE, OR COLOR.

NO CLAIM IS MADE TO THE EXCLUSIVE RIGHT TO USE "SCOLIOSIS CENTER", APART FROM THE MARK AS SHOWN.

FOR BUSINESS MANAGEMENT AND CONSULTING SERVICES FOR THE HEALTH CARE INDUSTRY, NAMELY, CUSTOMER SERVICE, ACCOUNTING SERVICES, AND WEB-BASED ADVERTISING AND MARKETING SERVICES (U.S. CLS. 100, 101 AND 102).

LINDSEY RUBIN, EXAMINING ATTORNEY

SN 77-431,506. GUILLAUME, MICHAEL J, TUCSON, AZ. FILED 3-26-2008.



THE COLOR(S) RED, WHITE, BLUE, SILVER AND GREEN IS/ARE CLAIMED AS A FEATURE OF THE MARK.

THE MARK CONSISTS OF THE GLOBE OF THE EARTH WITH METALLIC SILVER LAND MASSES (N. & S. AMERICA) AND METALLIC BLUE OCEANS (ATLANTIC AND PACIFIC). A WHITE DOVE WITH A GREEN OLIVE LEAF IN ITS BEAK. THE LETTERS "EARTHENDOVE" ARE SURROUNDING THE GLOBE. THE UPPER HALF OF THE "E" BETWEEN THE "V" AND "A" IS RED AND THE LOWER HALF IS BLUE. THE "ARTHEN" LETTERS ARE RED AND THE "DOV" LETTERS ARE BLUE.

FOR PROMOTING PUBLIC AWARENESS IN THE FIELD OF SOCIAL WELFARE; ADVERTISING THROUGH ALL PUBLIC COMMUNICATION MEANS (U.S. CLS. 100, 101 AND 102).

KELLY MCCOY, EXAMINING ATTORNEY

CLASS 35—(Continued).

SN 77-431,510. KELLY RENEE INTERNATIONAL, INC., SIMI VALLEY, CA. FILED 3-26-2008.

PEEP-SHOW

THE MARK CONSISTS OF STANDARD CHARACTERS WITHOUT CLAIM TO ANY PARTICULAR FONT, STYLE, SIZE, OR COLOR.

FOR WHOLESALE DISTRIBUTORSHIP AND RETAIL STORE SERVICES FEATURING COSMETICS AND APPLICATORS (U.S. CLS. 100, 101 AND 102).

EMILY CARLSEN, EXAMINING ATTORNEY

SN 77-431,515. GUILLAUME, MICHAEL J, TUCSON, AZ. FILED 3-26-2008.



THE COLOR(S) RED, BLACK AND WHITE IS/ARE CLAIMED AS A FEATURE OF THE MARK.

THE MARK CONSISTS OF THE GLOBE OF THE EARTH WITH LIGHT BLACK LAND MASSES (N. & S. AMERICA). AN UPSIDE DOWN DARK BLACK DOVE IS SUPERIMPOSED ONTO THE GLOBE. THE DOVE HAS AN X FOR IT'S EYE. THE OCEANS ARE RED EXCEPT FOR A WHITE FADED AREA NEAR THE PACIFIC COASTLINE. THE BLACK LETTERS "EARTHENDOF" ARE SURROUNDING THE GLOBE.

FOR PROMOTING PUBLIC AWARENESS IN THE FIELD OF SOCIAL WELFARE; ADVERTISING THROUGH ALL PUBLIC COMMUNICATION MEANS (U.S. CLS. 100, 101 AND 102).

KELLY MCCOY, EXAMINING ATTORNEY

CLASS 35—(Continued).

SN 77-431,527. VIABLE VENTURES LLC, DBA NAYMZ, CHICAGO, IL. FILED 3-26-2008.

Naymz

THE MARK CONSISTS OF STANDARD CHARACTERS WITHOUT CLAIM TO ANY PARTICULAR FONT, STYLE, SIZE, OR COLOR.

FOR ONLINE BUSINESS NETWORKING SERVICES (U.S. CLS. 100, 101 AND 102).

FIRST USE 11-1-2005; IN COMMERCE 5-1-2006.

ELISSA GARBER KON, EXAMINING ATTORNEY

SN 77-431,570. GREENFISH ADVENTURE SPORTS, INC., ANDES, NY. FILED 3-26-2008.

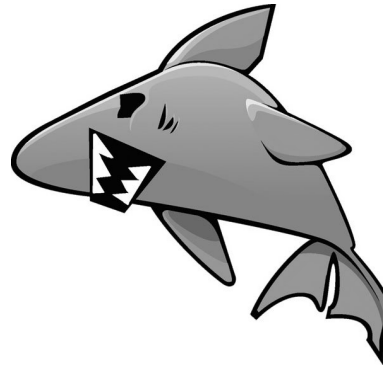

THE MARK CONSISTS OF A FISH WITH WHITE TEETH, BLACK OUTLINE AND SHADES OF GRAY FILL. FOR COMPUTERIZED ON-LINE RETAIL STORE SERVICES IN THE FIELD OF SPORTING GOODS (U.S. CLS. 100, 101 AND 102).

FIRST USE 7-22-2001; IN COMMERCE 7-22-2001.

ARETHA SOMERVILLE, EXAMINING ATTORNEY

SN 77-431,591. GREENFISH ADVENTURE SPORTS, INC., ANDES, NY. FILED 3-26-2008.

greenfish

THE MARK CONSISTS OF STANDARD CHARACTERS WITHOUT CLAIM TO ANY PARTICULAR FONT, STYLE, SIZE, OR COLOR.

FOR ON-LINE RETAIL STORE SERVICES FEATURING SPORTING GOODS (U.S. CLS. 100, 101 AND 102).

FIRST USE 7-22-2001; IN COMMERCE 7-22-2001.

ARETHA SOMERVILLE, EXAMINING ATTORNEY

CLASS 35—(Continued).

SN 77-431,641. THE MOM CORPS, INC, MARIETTA, GA.
FILED 3-26-2008.

Mom Corps

THE MARK CONSISTS OF STANDARD CHARACTERS WITHOUT CLAIM TO ANY PARTICULAR FONT, STYLE, SIZE, OR COLOR.

FOR PROVIDING AN ON-LINE SEARCHABLE DATABASE FEATURING CLASSIFIED AD LISTINGS AND EMPLOYMENT OPPORTUNITIES; JOB AND PERSONNEL PLACEMENT (U.S. CLS. 100, 101 AND 102).

FIRST USE 1-1-2006; IN COMMERCE 1-1-2006.

KARANENDRA S. CHHINA, EXAMINING ATTORNEY

CLASS 35—(Continued).

SN 77-431,722. DABESTANI, PENNY, INDIAN TRAIL, NC.
FILED 3-26-2008.

A LASTING ROMANCE

THE MARK CONSISTS OF STANDARD CHARACTERS WITHOUT CLAIM TO ANY PARTICULAR FONT, STYLE, SIZE, OR COLOR.

FOR ON-LINE RETAIL STORE SERVICES FEATURING ROBES, PAJAMAS, JEWELRY, LINGERIE, BATH AND BODY OILS, LOTIONS, CANDLES, BEDDING, CLOTHING, AND GIFTS; RETAIL STORE SERVICES FEATURING ROBES, PAJAMAS, JEWELRY, LINGERIE, BATH AND BODY OILS, LOTIONS, CANDLES, BEDDING, CLOTHING, AND GIFTS (U.S. CLS. 100, 101 AND 102).

JOHN DWYER, EXAMINING ATTORNEY

SN 77-431,746. PPF SYRACUSE, INC., SYRACUSE, NY.
FILED 3-26-2008.

STREETGAME

THE MARK CONSISTS OF STANDARD CHARACTERS WITHOUT CLAIM TO ANY PARTICULAR FONT, STYLE, SIZE, OR COLOR.

FOR RETAIL STORE SERVICES FEATURING FOOTWEAR, SPORTSWEAR, SHIRTS, SWEATSHIRTS, PANTS, SWEAT PANTS, JACKETS, HATS, AND SOCKS (U.S. CLS. 100, 101 AND 102).

FIRST USE 7-1-2004; IN COMMERCE 7-1-2004.

CHARLES L. JENKINS, EXAMINING ATTORNEY

SN 77-431,817. WILSON-FRICKS, GAIL, CHAPIN, SC. FILED
3-26-2008.

"LET SOMEONE FIND THE POUNDS YOU LOSE!"

THE COLOR(S) BLUE IS/ARE CLAIMED AS A FEATURE OF THE MARK.

THE MARK CONSISTS OF THE STYLIZED LETTER "U" IN BLUE.

FOR RETAIL STORE SERVICES FEATURING CONVENIENCE STORE ITEMS AND GASOLINE (U.S. CLS. 100, 101 AND 102).

ANDREA SAUNDERS, EXAMINING ATTORNEY

THE MARK CONSISTS OF STANDARD CHARACTERS WITHOUT CLAIM TO ANY PARTICULAR FONT, STYLE, SIZE, OR COLOR.

FOR PROMOTIONAL SERVICES, NAMELY, PROMOTING THE CHARITIES OF OTHERS (U.S. CLS. 100, 101 AND 102).

SONYA STEPHENS, EXAMINING ATTORNEY

CLASS 35—(Continued).

SN 77-431,864. SMARTBASE SOLUTIONS, LLC, DEEPHAVEN, MN. FILED 3-26-2008.

SmartBaseSuite

THE MARK CONSISTS OF STANDARD CHARACTERS WITHOUT CLAIM TO ANY PARTICULAR FONT, STYLE, SIZE, OR COLOR.

FOR ADVERTISING AND MARKETING; BUSINESS ADVICE AND ANALYSIS OF MARKETS; BUSINESS MANAGEMENT CONSULTING WITH RELATION TO STRATEGY, MARKETING, PRODUCTION, PERSONNEL AND RETAIL SALE MATTERS; BUSINESS MARKETING AND DIRECT MAIL CONSULTING SERVICES; BUSINESS MARKETING SERVICES; BUSINESS SERVICES, NAMELY, PROVIDING COMPUTER DATABASES REGARDING THE PURCHASE AND SALE OF A WIDE VARIETY OF PRODUCTS AND SERVICES OF OTHERS; CREATION OF MARKETING TOOLS DESIGNED TO INCREASE A CLIENT COMPANY'S KNOWLEDGE OF CUSTOMER NEEDS, AND ITS COMPETITORS' PRODUCTS AND SERVICES, PRICING, ADVERTISING STRATEGY AND SALES STRATEGY; DIRECT MARKETING SERVICES; MANAGEMENT AND COMPILATION OF COMPUTERISED DATABASES (U.S. CLS. 100, 101 AND 102).

LAURA HAMMEL, EXAMINING ATTORNEY

SN 77-431,936. QNICOM INC., PLAINVIEW, NY. FILED 3-26-2008.



THE COLOR(S) RED AND WHITE IS/ARE CLAIMED AS A FEATURE OF THE MARK.

THE COLOR RED APPEARS IN THE CIRCULAR DESIGN, WHITE APPEARS FOR THE FILL COLOR OF THE CIRCULAR DESIGN ELEMENTS AND BACKGROUND COLOR.

FOR RETAIL STORE SERVICES FEATURING WIRELESS SERVICE PLANS AND WIRELESS SERVICE ACTIVATION; RETAIL AND WHOLESALE STORE SERVICES FEATURING CELL PHONES, CELL PHONE ACCESSORIES AND PROMOTIONAL ITEMS (U.S. CLS. 100, 101 AND 102).

FIRST USE 12-21-2007; IN COMMERCE 1-0-2008.
ANTHONY RINKER, EXAMINING ATTORNEY

CLASS 35—(Continued).

SN 77-431,949. QNICOM INC., PLAINVIEW, NY. FILED 3-26-2008.



THE COLOR(S) RED, WHITE AND BLACK IS/ARE CLAIMED AS A FEATURE OF THE MARK.

THE COLOR BLACK APPEARS AS THE LETTERING QNICOM, RED APPEARS IN THE CIRCULAR DESIGN AND THE DOT OVER THE LETTER I, WHITE APPEARS FOR THE FILL COLOR OF THE CIRCULAR DESIGN ELEMENTS AND BACKGROUND COLOR.

FOR RETAIL STORE SERVICES FEATURING WIRELESS SERVICE PLANS AND WIRELESS SERVICE ACTIVATION; RETAIL AND WHOLESALE STORE SERVICES FEATURING CELL PHONES, CELL PHONE ACCESSORIES AND PROMOTIONAL ITEMS (U.S. CLS. 100, 101 AND 102).

FIRST USE 12-21-2007; IN COMMERCE 1-0-2008.
ANTHONY RINKER, EXAMINING ATTORNEY

SN 77-431,955. QNICOM INC., PLAINVIEW, NY. FILED 3-26-2008.

QNICOM

THE MARK CONSISTS OF STANDARD CHARACTERS WITHOUT CLAIM TO ANY PARTICULAR FONT, STYLE, SIZE, OR COLOR.

FOR RETAIL STORE SERVICES FEATURING WIRELESS SERVICE PLANS AND WIRELESS SERVICE ACTIVATION; RETAIL AND WHOLESALE STORE SERVICES FEATURING CELL PHONES, CELL PHONE ACCESSORIES AND PROMOTIONAL ITEMS (U.S. CLS. 100, 101 AND 102).

FIRST USE 12-21-2007; IN COMMERCE 1-0-2008.
ANTHONY RINKER, EXAMINING ATTORNEY

SN 77-431,956. ARAMIAN, JOHN, RIDGEWOOD, NJ. FILED 3-26-2008.

H2O Promise

THE MARK CONSISTS OF STANDARD CHARACTERS WITHOUT CLAIM TO ANY PARTICULAR FONT, STYLE, SIZE, OR COLOR.

FOR ADVERTISING, MARKETING AND PROMOTION SERVICES (U.S. CLS. 100, 101 AND 102).

TIMOTHY FINNEGAN, EXAMINING ATTORNEY

CLASS 35—(Continued).

SN 77-431,981. PARTS DISTRIBUTION XPRESS INC., ES-
SINGTON, PA. FILED 3-26-2008.

PDX

THE MARK CONSISTS OF STANDARD CHARACTERS WITHOUT CLAIM TO ANY PARTICULAR FONT, STYLE, SIZE, OR COLOR.

FOR TRANSPORTATION LOGISTICS SERVICES, NAMELY, PROVIDING DRIVERS FOR COMPANIES IN THE AUTOMOBILE INDUSTRY (U.S. CLS. 100, 101 AND 102).

FIRST USE 0-0-1998; IN COMMERCE 0-0-1998.
ROBIN CHOSID, EXAMINING ATTORNEY

SN 77-432,005. GENOCIDE INTERVENTION NETWORK,
WASHINGTON, DC. FILED 3-26-2008.



GENOCIDE INTERVENTION

NETWORK

Have a hand in stopping genocide

NO CLAIM IS MADE TO THE EXCLUSIVE RIGHT TO USE "GENOCIDE INTERVENTION NETWORK", APART FROM THE MARK AS SHOWN.

THE MARK CONSISTS OF AN OUTFACED HAND IN A CIRCLE NEXT TO THE WORDS GENOCIDE INTERVENTION OVER THE WORD NETWORK WITH LINES ON BOTH SIDES OF THE WORD. OVER THE WORDS HAVE A HAND IN STOPPING GENOCIDE.

FOR CHARITABLE SERVICES, NAMELY, PROMOTING PUBLIC AWARENESS OF GENOCIDE, DEVELOPING AND COORDINATING VOLUNTEER PROJECTS; ORGANIZING ADVOCATE GROUPS TO UNDERTAKE CHARITABLE PROJECTS IN THE FIELD OF GENOCIDE INTERVENTION; PUBLIC ADVOCACY TO PROMOTE THE AWARENESS AND PREVENTION OF GENOCIDE (U.S. CLS. 100, 101 AND 102).

FIRST USE 11-0-2004; IN COMMERCE 11-0-2004.
EUGENIA MARTIN, EXAMINING ATTORNEY

SN 77-432,011. GENOCIDE INTERVENTION NETWORK,
WASHINGTON, DC. FILED 3-26-2008.

GI-NET

THE MARK CONSISTS OF STANDARD CHARACTERS WITHOUT CLAIM TO ANY PARTICULAR FONT, STYLE, SIZE, OR COLOR.

FOR CHARITABLE SERVICES, NAMELY, PROMOTING PUBLIC AWARENESS OF GENOCIDE, DEVELOPING AND COORDINATING VOLUNTEER PROJECTS; ORGANIZING ADVOCATE GROUPS TO UNDERTAKE CHARITABLE PROJECTS IN THE FIELD OF GENOCIDE INTERVENTION; PUBLIC ADVOCACY TO PROMOTE THE AWARENESS AND PREVENTION OF GENOCIDE (U.S. CLS. 100, 101 AND 102).

EUGENIA MARTIN, EXAMINING ATTORNEY

CLASS 35—(Continued).

SN 77-432,015. GENOCIDE INTERVENTION NETWORK,
WASHINGTON, DC. FILED 3-26-2008.



STAND

A Student Anti-Genocide Coalition

NO CLAIM IS MADE TO THE EXCLUSIVE RIGHT TO USE "A STUDENT ANTI-GENOCIDE COALITION", APART FROM THE MARK AS SHOWN.

THE MARK CONSISTS OF THE OUTLINES OF FOUR PEOPLE STANDING IN FRONT OF THE EARTH WITH THE WORD "STAND" NEXT TO THE IMAGE AND OVER THE WORDS "A STUDENT ANTI-GENOCIDE COALITION".

FOR CHARITABLE SERVICES, NAMELY, PROMOTING PUBLIC AWARENESS OF GENOCIDE, DEVELOPING AND COORDINATING VOLUNTEER PROJECTS; ORGANIZING ADVOCATE GROUPS TO UNDERTAKE CHARITABLE PROJECTS IN THE FIELD OF GENOCIDE INTERVENTION; PUBLIC ADVOCACY TO PROMOTE THE AWARENESS AND PREVENTION OF GENOCIDE (U.S. CLS. 100, 101 AND 102).

FIRST USE 8-0-2006; IN COMMERCE 8-0-2006.
EUGENIA MARTIN, EXAMINING ATTORNEY

SN 77-432,037. PARTS DISTRIBUTION XPRESS INC., ES-
SINGTON, PA. FILED 3-26-2008.



THE MARK CONSISTS OF LETTERS "PDX" WITH ARCHING ARROW.

FOR TRANSPORTATION LOGISTICS SERVICES, NAMELY, PROVIDING DRIVERS FOR COMPANIES IN THE AUTOMOBILE INDUSTRY (U.S. CLS. 100, 101 AND 102).

FIRST USE 3-0-2002; IN COMMERCE 3-0-2002.
ROBIN CHOSID, EXAMINING ATTORNEY

CLASS 35—(Continued).

SN 77-432,056. EZ OFFICE PRODUCTS, L.L.C., MADISON, WI. FILED 3-26-2008.

You Got It!

THE MARK CONSISTS OF STANDARD CHARACTERS WITHOUT CLAIM TO ANY PARTICULAR FONT, STYLE, SIZE, OR COLOR.

FOR RETAIL STORE SERVICES IN THE FIELD OF OFFICE SUPPLIES, STATIONERY, OFFICE EQUIPMENT, AND RELATED OFFICE ACCESSORIES (U.S. CLS. 100, 101 AND 102).

FIRST USE 1-1-2006; IN COMMERCE 1-1-2006.
BARBARA GAYNOR, EXAMINING ATTORNEY

SN 77-432,116. A-TRADITIONAL ADVERTISING CONCEPTS, LLC, DALLAS, TX. FILED 3-26-2008.

Pocketstop

THE MARK CONSISTS OF STANDARD CHARACTERS WITHOUT CLAIM TO ANY PARTICULAR FONT, STYLE, SIZE, OR COLOR.

FOR ADVERTISING SERVICES, NAMELY, PROMOTING AND MARKETING THE GOODS AND SERVICES OF OTHERS THROUGH ALL PUBLIC COMMUNICATION MEANS (U.S. CLS. 100, 101 AND 102).

FIRST USE 7-1-2007; IN COMMERCE 10-1-2007.
DOMINIC J. FERRAIUOLO, EXAMINING ATTORNEY

SN 77-432,151. TEVA PHARMACEUTICALS USA, INC., NORTH WALES, PA. FILED 3-26-2008.

OWNER OF U.S. REG. NO. 2,962,577.
THE MARK CONSISTS OF THE WORDS "GROWTH SOLUTIONS" IN FANCIFUL SCRIPT WITH A FLOWER ATTACHED TO THE "L" IN THE WORD "SOLUTIONS" THAT STANDS FOR THE "O" IN THE WORD "GROWTH".

FOR ADMINISTERING PHARMACY REIMBURSEMENT PROGRAMS AND SERVICES; ADMINISTRATION OF PATIENT REIMBURSEMENT PROGRAMS; MEDICAL BILLING SUPPORT SERVICES; PROVIDING OFFICE SUPPORT STAFF SERVICES (U.S. CLS. 100, 101 AND 102).

FIRST USE 4-28-2008; IN COMMERCE 4-28-2008.
SUNG IN, EXAMINING ATTORNEY

CLASS 35—(Continued).

SN 77-432,158. MULTIPLEX PROPERTIES, INC., WILMINGTON, DE. FILED 3-26-2008.

RELAX. REFRESH. ENJOY.

THE MARK CONSISTS OF STANDARD CHARACTERS WITHOUT CLAIM TO ANY PARTICULAR FONT, STYLE, SIZE, OR COLOR.

FOR CONCESSION STANDS FEATURING FOOD AND DRINK (U.S. CLS. 100, 101 AND 102).

FIRST USE 10-17-2007; IN COMMERCE 10-17-2007.
ARETHA SOMERVILLE, EXAMINING ATTORNEY

SN 77-432,160. TEVA PHARMACEUTICALS USA, INC., NORTH WALES, PA. FILED 3-26-2008.

OWNER OF U.S. REG. NO. 2,962,577.

THE COLOR(S) RED AND BLUE IS/ARE CLAIMED AS A FEATURE OF THE MARK.

THE MARK CONSISTS OF THE WORDS "GROWTH SOLUTIONS" IN FANCIFUL SCRIPT WITH A FLOWER ATTACHED TO THE "L" IN THE WORD "SOLUTIONS" THAT FORMS THE "O" IN THE WORD "GROWTH". THE WORD "GROWTH", ALONG WITH THE OUTSIDE OF THE FLOWER DESIGN, APPEARS IN RED AND THE WORD "SOLUTIONS", ALONG WITH THE INSIDE OF THE FLOWER DESIGN, APPEARS IN BLUE. THE CURVED LINE UNDERNEATH THE TERMS APPEARS IN RED.

FOR ADMINISTERING PHARMACY REIMBURSEMENT PROGRAMS AND SERVICES; ADMINISTRATION OF PATIENT REIMBURSEMENT PROGRAMS; MEDICAL BILLING SUPPORT SERVICES; PROVIDING OFFICE SUPPORT STAFF SERVICES (U.S. CLS. 100, 101 AND 102).

FIRST USE 4-28-2008; IN COMMERCE 4-28-2008.
SUNG IN, EXAMINING ATTORNEY

SN 77-432,161. SZPR, INC., CARLSBAD, CA. FILED 3-26-2008.

ZENZI

THE MARK CONSISTS OF STANDARD CHARACTERS WITHOUT CLAIM TO ANY PARTICULAR FONT, STYLE, SIZE, OR COLOR.

FOR ADVERTISING, MARKETING AND PUBLIC RELATIONS SERVICES (U.S. CLS. 100, 101 AND 102).

RENEE MCCRAY, EXAMINING ATTORNEY

CLASS 35—(Continued).

SN 77-432,180. TEVA PHARMACEUTICALS USA, INC., NORTH WALES, PA. FILED 3-26-2008.

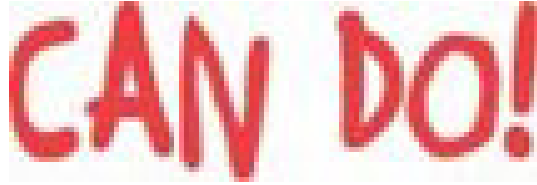

THE COLOR(S) RED IS/ARE CLAIMED AS A FEATURE OF THE MARK.

THE MARK CONSISTS OF THE WORDS "CAN DO" IN A FANCIFUL FONT WITH AN EXCLAMATION POINT IN RED.

FOR ADMINISTRATION OF PATIENT REIMBURSEMENT PROGRAMS; ADMINISTERING PHARMACY REIMBURSEMENT PROGRAMS AND SERVICES; MEDICAL BILLING SUPPORT SERVICES; PROVIDING OFFICE SUPPORT STAFF SERVICES (U.S. CLS. 100, 101 AND 102).

FIRST USE 4-28-2008; IN COMMERCE 4-28-2008.
SUNG IN, EXAMINING ATTORNEY

SN 77-432,187. TEVA PHARMACEUTICALS USA, INC., NORTH WALES, DE. FILED 3-26-2008.

CAN DO!

THE MARK CONSISTS OF STANDARD CHARACTERS WITHOUT CLAIM TO ANY PARTICULAR FONT, STYLE, SIZE, OR COLOR.

FOR ADMINISTRATION OF PATIENT REIMBURSEMENT PROGRAMS; ADMINISTERING PHARMACY REIMBURSEMENT PROGRAMS AND SERVICES; MEDICAL BILLING SUPPORT SERVICES; PROVIDING OFFICE SUPPORT STAFF SERVICES (U.S. CLS. 100, 101 AND 102).

FIRST USE 4-28-2008; IN COMMERCE 4-28-2008.
SUNG IN, EXAMINING ATTORNEY

SN 77-432,266. CARSTAR FRANCHISE SYSTEMS, INC., OVERLAND PARK, KS. FILED 3-26-2008.

TAKE BACK YOUR LIFE

THE MARK CONSISTS OF STANDARD CHARACTERS WITHOUT CLAIM TO ANY PARTICULAR FONT, STYLE, SIZE, OR COLOR.

FOR FRANCHISING SERVICES, NAMELY, OFFERING TECHNICAL ASSISTANCE IN THE ESTABLISHMENT AND/OR OPERATION OF AUTOMOBILE BODY REPAIR SHOPS (U.S. CLS. 100, 101 AND 102).

FIRST USE 2-13-2007; IN COMMERCE 2-13-2007.
ALICE SUE CARRUTHERS, EXAMINING ATTORNEY

CLASS 35—(Continued).

SN 77-432,369. KANSAS BIOSCIENCE AUTHORITY, OLATHE, KS. FILED 3-26-2008.

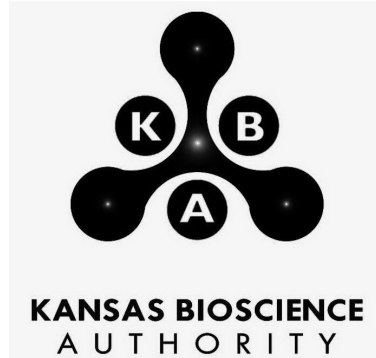

NO CLAIM IS MADE TO THE EXCLUSIVE RIGHT TO USE "KANSAS BIOSCIENCE AUTHORITY", APART FROM THE MARK AS SHOWN.

THE MARK CONSISTS OF THE LETTERS "K", "B" AND "A" WITHIN A MOLECULE STRUCTURE WITH "KANSAS BIOSCIENCE AUTHORITY" REFERENCED BELOW.

FOR PROMOTING THE ECONOMIC DEVELOPMENT OF KANSAS IN THE FIELD OF BIOSCIENCE RESEARCH AND INDUSTRY (U.S. CLS. 100, 101 AND 102).

FIRST USE 4-19-2004; IN COMMERCE 4-19-2004.
ESTHER BELENKER, EXAMINING ATTORNEY

SN 77-432,386. NEWMARK KNIGHT FRANK, KENNESAW, GA. FILED 3-26-2008.

NKF Consulting

THE MARK CONSISTS OF STANDARD CHARACTERS WITHOUT CLAIM TO ANY PARTICULAR FONT, STYLE, SIZE, OR COLOR.

NO CLAIM IS MADE TO THE EXCLUSIVE RIGHT TO USE "CONSULTING", APART FROM THE MARK AS SHOWN.

FOR BUSINESS CONSULTING AND BUSINESS INFORMATION FOR ENTERPRISES; BUSINESS CONSULTING AND INFORMATION SERVICES; BUSINESS CONSULTING SERVICES RELATING TO PRODUCT DISTRIBUTION, OPERATIONS MANAGEMENT SERVICES, LOGISTICS, REVERSE LOGISTICS, SUPPLY CHAIN, AND PRODUCTION SYSTEMS AND DISTRIBUTION SOLUTIONS; BUSINESS CONSULTING, MANAGEMENT, PLANNING AND SUPERVISION; BUSINESS MANAGEMENT CONSULTING AND ADVISORY SERVICES; BUSINESS ORGANIZATION CONSULTING; PROFESSIONAL BUSINESS CONSULTING; PROVIDING BUSINESS MANAGEMENT INFORMATION IN CONNECTION WITH CONSULTING AND ADVISORY SERVICES IN THE FIELD OF STRATEGIC PLANNING (U.S. CLS. 100, 101 AND 102).

FIRST USE 1-1-2008; IN COMMERCE 1-1-2008.
DOMINICK J. SALEMI, EXAMINING ATTORNEY

CLASS 35—(Continued).

SN 77-432,472. HOLLOWAY, CYNTHIA, CULVER CITY, CA.
FILED 3-26-2008.

THE WITCHY WOMAN

THE MARK CONSISTS OF STANDARD CHARACTERS WITHOUT CLAIM TO ANY PARTICULAR FONT, STYLE, SIZE, OR COLOR.

FOR ON-LINE RETAIL STORE SERVICES FEATURING METAPHYSICAL RETAIL ITEMS SUCH AS BOOKS, CANDLES, AND CLOTHING; AND RETAIL STORE SERVICES FEATURING METAPHYSICAL RETAIL ITEMS SUCH AS BOOKS, CANDLES, AND CLOTHING (U.S. CLS. 100, 101 AND 102).

KARANENDRA S. CHHINA, EXAMINING ATTORNEY

SN 77-432,488. CONNOLLY, JEANNE, DENVER, CO. FILED
3-26-2008.

VINTAGE RENEWAL

THE MARK CONSISTS OF STANDARD CHARACTERS WITHOUT CLAIM TO ANY PARTICULAR FONT, STYLE, SIZE, OR COLOR.

NO CLAIM IS MADE TO THE EXCLUSIVE RIGHT TO USE "VINTAGE", APART FROM THE MARK AS SHOWN.

FOR ON-LINE RETAIL STORE SERVICES FEATURING FURNITURE, CHAIRS, STOOLS, CLOTHING, BAGS, LINENS, SLIPCOVERS, TABLE CLOTHS, WINDOW TREATMENTS, BABY CLOTHES, DOG CLOTHES, HEADBOARDS, PILLOWS, BEDDING (U.S. CLS. 100, 101 AND 102).

FIRST USE 8-1-2007; IN COMMERCE 8-1-2007.

EUGENIA MARTIN, EXAMINING ATTORNEY

SN 77-432,494. REDUCED EFFORT, INC., LAS VEGAS, NV.
FILED 3-26-2008.

ReducedEffort

THE MARK CONSISTS OF THE STYLIZED WORD "REDUCEDEFFORT".

FOR BUSINESS CONSULTING SERVICES IN THE FIELD OF ORGANIZATIONAL CHANGE MANAGEMENT (U.S. CLS. 100, 101 AND 102).

FIRST USE 3-7-2008; IN COMMERCE 3-7-2008.

RUDY R. SINGLETON, EXAMINING ATTORNEY

CLASS 35—(Continued).

SN 77-432,536. CALIFORNIA ASSOCIATION OF ALCOHOLISM AND DRUG ABUSE COUNSELORS, SACRAMENTO, CA. FILED 3-26-2008.

CAADAC

THE MARK CONSISTS OF STANDARD CHARACTERS WITHOUT CLAIM TO ANY PARTICULAR FONT, STYLE, SIZE, OR COLOR.

FOR ASSOCIATION SERVICES, NAMELY, PROMOTING THE INTERESTS OF CALIFORNIA ALCOHOLISM AND DRUG ABUSE COUNSELORS (U.S. CLS. 100, 101 AND 102).

FIRST USE 4-0-1985; IN COMMERCE 10-15-1985.

ESTHER BELENKER, EXAMINING ATTORNEY

SN 77-432,560. ROBERTS, COREY, FOREST LAKE, MN.
FILED 3-26-2008.

**MYSTERY PHONE CUSTOMER
OPTIMIZE YOUR PHONE
BUSINESS**

THE MARK CONSISTS OF STANDARD CHARACTERS WITHOUT CLAIM TO ANY PARTICULAR FONT, STYLE, SIZE, OR COLOR.

FOR BUSINESS CONSULTING SERVICES RELATED TO MONITORING, CONTROLLING, AND MANAGING TELEPRESENCE ENVIRONMENTS OF OTHERS (U.S. CLS. 100, 101 AND 102).

NORA BUCHANAN WILL, EXAMINING ATTORNEY

SN 77-432,580. DISNEY ENTERPRISES, INC., BURBANK, CA. FILED 3-26-2008.

CREATE WHAT'S NEXT

THE MARK CONSISTS OF STANDARD CHARACTERS WITHOUT CLAIM TO ANY PARTICULAR FONT, STYLE, SIZE, OR COLOR.

FOR HUMAN RESOURCES, NAMELY, HUMAN RESOURCES MANAGEMENT SERVICES AND EMPLOYMENT HIRING AND RECRUITING, PLACEMENT, STAFFING AND CAREER NETWORKING SERVICES (U.S. CLS. 100, 101 AND 102).

FIRST USE 10-0-2007; IN COMMERCE 10-0-2007.

DANNEAN HETZEL, EXAMINING ATTORNEY

CLASS 35—(Continued).

SN 77-432,838. ORTHOPAEDIC NURSES CERTIFICATION BOARD, COLUMBIA, SC. FILED 3-27-2008.

ONCB

THE MARK CONSISTS OF STANDARD CHARACTERS WITHOUT CLAIM TO ANY PARTICULAR FONT, STYLE, SIZE, OR COLOR.

FOR PROVIDING OCCUPATIONAL TESTING SERVICES TO DETERMINE THE PROFESSIONAL COMPETENCE OF NURSES IN THE FIELD OF ORTHOPEDICS (U.S. CLS. 100, 101 AND 102).

FIRST USE 12-11-1986; IN COMMERCE 12-11-1986.
CHRISTINA SOBRAL, EXAMINING ATTORNEY

SN 77-432,869. TOWN & COUNTRY RESOURCES, INC., PALO ALTO, CA. FILED 3-27-2008.

TOWN & COUNTRY RESOURCES

THE MARK CONSISTS OF STANDARD CHARACTERS WITHOUT CLAIM TO ANY PARTICULAR FONT, STYLE, SIZE, OR COLOR.

OWNER OF U.S. REG. NOS. 2,418,392 AND 2,530,653.

NO CLAIM IS MADE TO THE EXCLUSIVE RIGHT TO USE "RESOURCES", APART FROM THE MARK AS SHOWN.

FOR EMPLOYMENT AGENCY SERVICES IN THE FIELD OF EXECUTIVE ASSISTANTS, FAMILY ASSISTANTS, DOMESTIC COUPLES, DRIVERS, HOUSEMEN, LAUNDRESSES, PROFESSIONAL CAREGIVERS, AND PARTY HELPERS TO ASSIST IN PARTY SETUP, FOOD AND BEVERAGE SERVICE, AND CLEAN UP (U.S. CLS. 100, 101 AND 102).

FIRST USE 9-0-2005; IN COMMERCE 9-0-2005.
CHRISTINA SOBRAL, EXAMINING ATTORNEY

SN 77-432,905. J. JOU INC., DBA BIJOU BRIDAL & SPECIAL OCCASION, ALPINE, NJ. FILED 3-27-2008.

BIJOU BRIDAL & SPECIAL OCCASION

THE MARK CONSISTS OF STANDARD CHARACTERS WITHOUT CLAIM TO ANY PARTICULAR FONT, STYLE, SIZE, OR COLOR.

NO CLAIM IS MADE TO THE EXCLUSIVE RIGHT TO USE "BRIDAL & SPECIAL OCCASION", APART FROM THE MARK AS SHOWN.

FOR RETAIL STORE SERVICES FEATURING WEDDING GOWNS, BRIDAL GOWNS, BRIDESMAID DRESSES, PROM DRESSES, SPECIAL OCCASION DRESSES AND COORDINATING ACCESSORIES (U.S. CLS. 100, 101 AND 102).

FIRST USE 12-16-2005; IN COMMERCE 12-14-2006.
GEOFFREY FOSDICK, EXAMINING ATTORNEY

CLASS 35—(Continued).

SN 77-432,928. DIGICOMM INTERNATIONAL, INC., ENGLEWOOD, CO. FILED 3-27-2008.

DIGICOMM INTERNATIONAL

THE MARK CONSISTS OF STANDARD CHARACTERS WITHOUT CLAIM TO ANY PARTICULAR FONT, STYLE, SIZE, OR COLOR.

NO CLAIM IS MADE TO THE EXCLUSIVE RIGHT TO USE "INTERNATIONAL", APART FROM THE MARK AS SHOWN.

FOR WORLDWIDE RETAIL AND WHOLESALE DISTRIBUTORSHIP SERVICES FEATURING BROADBAND PRODUCTS FOR THE CABLE TELEVISION INDUSTRY, NAMELY, COAXIAL AND FIBEROPTIC CABLE, AMPLIFIERS, SWITCHES, AND SIGNAL CONVERTERS (U.S. CLS. 100, 101 AND 102).

FIRST USE 9-1-1993; IN COMMERCE 2-1-1994.
REBECCA GILBERT, EXAMINING ATTORNEY

SN 77-432,935. UNITEDHEALTH GROUP INCORPORATED, MINNETONKA, MN. FILED 3-27-2008.

CARROT

THE MARK CONSISTS OF STANDARD CHARACTERS WITHOUT CLAIM TO ANY PARTICULAR FONT, STYLE, SIZE, OR COLOR.

FOR PROVIDING ADVERTISING, MARKETING, AND CONSUMER RESEARCH SERVICES IN THE FIELDS OF HEALTH AND WELL-BEING (U.S. CLS. 100, 101 AND 102).

JUDITH HELFMAN, EXAMINING ATTORNEY

CLASS 35—(Continued).

SN 77-432,985. DISH NETWORK L.L.C., ENGLEWOOD, CO. FILED 3-27-2008.



**AUTO RECORD
SERIES**

NO CLAIM IS MADE TO THE EXCLUSIVE RIGHT TO USE "AUTO RECORD SERIES", APART FROM THE MARK AS SHOWN.

THE COLOR(S) BLACK, GREY AND RED IS/ARE CLAIMED AS A FEATURE OF THE MARK.

THE MARK CONSISTS OF A BUTTON THAT HAS AN INNER RED CIRCLE AND A BLACK AND GREY OUTER CIRCLE WITH THE STYLIZED BLACK WORDS "AUTO RECORD" UNDER THE CIRCLES. UNDER "AUTO RECORD" IS THE STYLIZED BLACK WORD "SERIES".

FOR ADVERTISING AND MARKETING; ADVERTISING PARTICULARLY SERVICES FOR THE PROMOTION OF GOODS; ADVERTISING VIA ELECTRONIC MEDIA AND SPECIFICALLY THE INTERNET; ADVERTISING, MARKETING AND PROMOTION SERVICES; DIRECT MAIL ADVERTISING; ADVERTISING AND COMMERCIAL INFORMATION SERVICES, VIA THE INTERNET; ADVERTISING SERVICES, NAMELY, PROMOTING AND MARKETING THE GOODS AND SERVICES OF OTHERS THROUGH ALL PUBLIC COMMUNICATION MEANS; ADVERTISING THROUGH ALL PUBLIC COMMUNICATION MEANS; ADVERTISING, PROMOTION AND MARKETING SERVICES IN THE NATURE OF E-MAIL BLAST CAMPAIGNS FOR OTHERS; DISTRIBUTION OF ADVERTISEMENTS AND COMMERCIAL ANNOUNCEMENTS; PLACING ADVERTISEMENTS FOR OTHERS; PROVIDING SPACE AT A WEB SITE FOR THE ADVERTISEMENT OF THE GOODS AND SERVICES OF OTHERS; PRESENTATION OF GOODS ON COMMUNICATION MEDIA FOR RETAIL PURPOSES; PROMOTION USING AUDIOVISUAL MEDIA; RETAIL SERVICES BY DIRECT SOLICITATION BY SALES AGENTS IN THE FIELD OF SATELLITE TELEVISION; ADVERTISING AND PUBLICITY SERVICES, NAMELY, PROMOTING THE GOODS, SERVICES, BRAND IDENTITY AND COMMERCIAL INFORMATION AND NEWS OF THIRD PARTIES THROUGH PRINT, AUDIO, VIDEO, DIGITAL AND ON-LINE MEDIUM; PROMOTING AND CONDUCTING TRADE SHOWS IN THE FIELD OF SATELLITE TELEVISION; PROVIDING MARKETING AND PROMOTION OF SPECIAL EVENTS (U.S. CLS. 100, 101 AND 102).

KOURTNEE HODGES, EXAMINING ATTORNEY

CLASS 35—(Continued).

SN 77-433,067. BUSCH, BARRY L., DBA BUSCH ENTERPRISES, BERRYTON, KS. FILED 3-27-2008.

THE COLOR(S) BLUE, RED, BLACK AND TWO SHADES OF GREEN IS/ARE CLAIMED AS A FEATURE OF THE MARK.

THE MARK CONSISTS OF THE WORD "ICE" IN BLUE CONNECTED BY A RED AMPERSAND TO THE WORD "OLIVES" IN GREEN. THE CENTER OF THE "O" IS FILLED WITH A SECOND SHADE OF GREEN TO CREATE THE IMAGE OF AN OLIVE, INCLUDING A RED MARK TO REPRESENT A PIMENTO AND A TWO BLACK MARKS TO HIGHLIGHT THE PIMENTO AND CREATE THE IMAGE OF A TOOTHPICK.

FOR RETAIL DELICATESSEN SERVICES; RETAIL GROCERY STORES (U.S. CLS. 100, 101 AND 102).

FIRST USE 7-1-2007; IN COMMERCE 11-1-2007.

REGINA DRUMMOND, EXAMINING ATTORNEY

SN 77-433,071. SALES ADVANCEMENT SOLUTIONS, PASADENA, CA. FILED 3-27-2008.

TrainTrac

THE MARK CONSISTS OF STANDARD CHARACTERS WITHOUT CLAIM TO ANY PARTICULAR FONT, STYLE, SIZE, OR COLOR.

FOR DISSEMINATION OF ADVERTISING, SCHEDULING AND MANAGING OF TRAINING COURSES AND PROGRAMS FOR OTHERS VIA A GLOBAL COMPUTER NETWORK (U.S. CLS. 100, 101 AND 102).

ANTHONY RINKER, EXAMINING ATTORNEY

SN 77-433,217. IMAGEWORKS, LLC, VERNON, CT. FILED 3-27-2008.

FOR COMPANIES ON THE MOVE

THE MARK CONSISTS OF STANDARD CHARACTERS WITHOUT CLAIM TO ANY PARTICULAR FONT, STYLE, SIZE, OR COLOR.

FOR ADVERTISING AND PUBLICITY SERVICES, NAMELY, PROMOTING THE GOODS, SERVICES, BRAND IDENTITY AND COMMERCIAL INFORMATION AND NEWS OF THIRD PARTIES THROUGH PRINT, AUDIO, VIDEO, DIGITAL AND ON-LINE MEDIUM (U.S. CLS. 100, 101 AND 102).

FIRST USE 3-5-2008; IN COMMERCE 3-5-2008.

WANDA KAY PRICE, EXAMINING ATTORNEY

CLASS 35—(Continued).

SN 77-433,367. CH2M HILL ENGINEERS, INC., ENGLEWOOD, CO. FILED 3-27-2008.



THE MARK CONSISTS OF FOUR THICK LINES, ONE ABOVE THE OTHER, WITH DARK SQUARES ON THE RIGHT SIDE OF EACH LINE AND A DIAGONAL SLASH FROM THE LOWER LEFT SIDE TO THE UPPER RIGHT SIDE.

FOR PROCUREMENT SERVICES, NAMELY, PURCHASING MECHANICAL, ELECTRICAL AND HVAC SYSTEMS FOR HIGH TECHNOLOGY INDUSTRIES SUCH AS ELECTRONICS AND FOOD PROCESSING (U.S. CLS. 100, 101 AND 102).

JENNIFER HETU, EXAMINING ATTORNEY

CLASS 35—(Continued).

SN 77-433,523. BLACKHEART INTERNATIONAL, LLC, PHILIPPI, WV. FILED 3-27-2008.

BLACKHEART INTERNATIONAL

THE MARK CONSISTS OF STANDARD CHARACTERS WITHOUT CLAIM TO ANY PARTICULAR FONT, STYLE, SIZE, OR COLOR.

NO CLAIM IS MADE TO THE EXCLUSIVE RIGHT TO USE "INTERNATIONAL", APART FROM THE MARK AS SHOWN.

FOR COMPUTERIZED ON-LINE RETAIL STORE SERVICES IN THE FIELD OF TACTICAL GEAR, INSTRUCTIONAL MATERIALS, EMERGENCY AND LOGISTICS MATERIALS AND EQUIPMENT, FOR MILITARY, PARA-MILITARY, LAW ENFORCEMENT AND PRIVATE SECURITY SERVICES; ON-LINE RETAIL STORE SERVICES FEATURING TACTICAL GEAR, INSTRUCTIONAL MATERIALS, EMERGENCY AND LOGISTICS MATERIALS AND EQUIPMENT, FOR MILITARY, PARA-MILITARY, LAW ENFORCEMENT AND PRIVATE SECURITY SERVICES; RETAIL STORE SERVICES FEATURING TACTICAL GEAR, INSTRUCTIONAL MATERIALS, EMERGENCY AND LOGISTICS MATERIALS AND EQUIPMENT, FOR MILITARY, PARA-MILITARY, LAW ENFORCEMENT AND PRIVATE SECURITY SERVICES (U.S. CLS. 100, 101 AND 102).

FIRST USE 12-31-1999; IN COMMERCE 12-31-1999; CHARLOTTE CORWIN, EXAMINING ATTORNEY

SN 77-433,438. BOOKS ARE FUN, LTD., FAIRFIELD, IA. FILED 3-27-2008.

ONE CLEAR CHOICE

THE MARK CONSISTS OF STANDARD CHARACTERS WITHOUT CLAIM TO ANY PARTICULAR FONT, STYLE, SIZE, OR COLOR.

FOR DISTRIBUTORSHIP SERVICES IN THE FIELD OF GENERAL INTEREST BOOKS, CHILDREN'S BOOKS, REFERENCE BOOKS, COOKBOOKS, PRE-RECORDED VIDEOTAPES, PRE-RECORDED DVDS, PRE-RECORDED MUSIC COMPILATIONS, COMPUTER SOFTWARE, TOYS AND DECORATIVE HOME FURNISHINGS (U.S. CLS. 100, 101 AND 102).

FIRST USE 1-31-2006; IN COMMERCE 1-31-2006; CHARLOTTE CORWIN, EXAMINING ATTORNEY

SN 77-433,537. JULIE WILLIAMS, PEACHTREE CITY, GA. FILED 3-27-2008.

Redneckistan

THE MARK CONSISTS OF STANDARD CHARACTERS WITHOUT CLAIM TO ANY PARTICULAR FONT, STYLE, SIZE, OR COLOR.

FOR PROVISION OF SPACE ON WEBSITES FOR ADVERTISING GOODS AND SERVICES; THE BRINGING TOGETHER, FOR THE BENEFIT OF OTHERS, OF A VARIETY OF GOODS AND SERVICES, ENABLING CUSTOMERS TO CONVENIENTLY VIEW AND PURCHASE THOSE GOODS AND SERVICES FROM AN INTERNET WEBSITE PARTICULARLY SPECIALIZING IN THE MARKETING OF THE SALE OF GOODS AND SERVICES OF OTHERS (U.S. CLS. 100, 101 AND 102).

ANTHONY RINKER, EXAMINING ATTORNEY

CLASS 35—(Continued).

SN 77-433,610. A & E STORES, INC., TETERBORO, NJ. FILED 3-27-2008.

ARCADE AMERICA

THE MARK CONSISTS OF STANDARD CHARACTERS WITHOUT CLAIM TO ANY PARTICULAR FONT, STYLE, SIZE, OR COLOR.

NO CLAIM IS MADE TO THE EXCLUSIVE RIGHT TO USE "AMERICA", APART FROM THE MARK AS SHOWN.

FOR RETAIL STORE SERVICES IN THE FIELD OF CLOTHING AND LEATHER BAGS, BACKPACKS, JEWELRY, SUNGLASSES, HAIR ACCESSORIES AND CLOTHING ACCESSORIES (U.S. CLS. 100, 101 AND 102).

FIRST USE 11-23-1999; IN COMMERCE 11-23-1999.
LINDA LAVACHE, EXAMINING ATTORNEY

CLASS 35—(Continued).

SN 77-433,660. KAKOULLIS, STEVEN S., MISSISSAUGA, CANADA, FILED 3-27-2008.

Pajama King

THE MARK CONSISTS OF STANDARD CHARACTERS WITHOUT CLAIM TO ANY PARTICULAR FONT, STYLE, SIZE, OR COLOR.

NO CLAIM IS MADE TO THE EXCLUSIVE RIGHT TO USE "PAJAMA", APART FROM THE MARK AS SHOWN.

FOR RETAIL STORE SERVICES AND ONLINE RETAIL STORE SERVICES FEATURING BATH AND BODY PRODUCTS, BATH TOWELS, BED SHEETS, BEDDING, LINENS, APPAREL FOR BABIES, PREEMIES, INFANTS, CHILDREN, BOYS, GIRLS, TEENAGERS, MEN, WOMEN AND SENIORS, TOYS AND GENERAL MERCHANDISE (U.S. CLS. 100, 101 AND 102).

DEZMONA MIZELLE, EXAMINING ATTORNEY

SN 77-433,630. IT'S ALL HERE, INC., GREEN BAY, WI. FILED 3-27-2008.

BETTER BY THE BAY

THE MARK CONSISTS OF STANDARD CHARACTERS WITHOUT CLAIM TO ANY PARTICULAR FONT, STYLE, SIZE, OR COLOR.

FOR PROMOTING THE ECONOMIC DEVELOPMENT IN THE CITY OF GREEN BAY; PROMOTING TOURISM IN THE CITY OF GREEN BAY AREA (U.S. CLS. 100, 101 AND 102).

JOHN DWYER, EXAMINING ATTORNEY

SN 77-433,703. SOLARTECH POWER, INC., CERRITOS, CA. FILED 3-27-2008.



NO CLAIM IS MADE TO THE EXCLUSIVE RIGHT TO USE "POWER, INC.", APART FROM THE MARK AS SHOWN.

THE MARK CONSISTS OF A STYLIZED SUN DESIGN WITH TWO LINES THROUGH THE SUN WITH THE STYLIZED WORDING "SOLARTECH" BELOW THE DESIGN AND THE WORDING "POWER, INC." AT THE BOTTOM OF THE MARK.

FOR WHOLESALE DISTRIBUTORSHIPS FEATURING SOLAR PANELS (U.S. CLS. 100, 101 AND 102).
CHARLOTTE CORWIN, EXAMINING ATTORNEY

SN 77-433,636. FUSCI, STEPHEN, OXNARD, CA. FILED 3-27-2008.

IFA METROSTREET

THE MARK CONSISTS OF STANDARD CHARACTERS WITHOUT CLAIM TO ANY PARTICULAR FONT, STYLE, SIZE, OR COLOR.

FOR WHOLESALE ORDERING SERVICES IN THE FIELD OF AUTOMOTIVE PARTS AND EQUIPMENT AND CAR CARE PRODUCTS FOR SERVICING AND REPAIRING AUTOMOBILES AND TRUCKS (U.S. CLS. 100, 101 AND 102).

JILL PRATER, EXAMINING ATTORNEY

SN 77-433,916. SILVA, DENISE L., CRANSTON, RI. FILED 3-27-2008.

Polka Dot Panda

THE MARK CONSISTS OF STANDARD CHARACTERS WITHOUT CLAIM TO ANY PARTICULAR FONT, STYLE, SIZE, OR COLOR.

FOR RETAIL APPAREL STORES (U.S. CLS. 100, 101 AND 102).

FIRST USE 9-26-2004; IN COMMERCE 7-25-2006.
DEZMONA MIZELLE, EXAMINING ATTORNEY

CLASS 35—(Continued).

SN 77-434,111. COLORADO RESORT REFERRALS, LLC, ENGLEWOOD, CO. FILED 3-28-2008.



NO CLAIM IS MADE TO THE EXCLUSIVE RIGHT TO USE "COLORADO RESORT REFERRALS", APART FROM THE MARK AS SHOWN.

THE COLOR(S) BLUE AND BLACK IS/ARE CLAIMED AS A FEATURE OF THE MARK.

THE MARK CONSISTS OF A STYLIZED MOUNTAIN RANGE IN BLUE OVER THE WORD "COLORADO" WHICH APPEARS IN BLACK. UNDER THE WORD "COLORADO" A THIN BLACK HORIZONTAL LINE IS PROVIDED AND UNDER THE LINE IN A SLIGHTLY SMALLER FONT SIZE THAN THE WORD "COLORADO" IS WRITTEN "RESORT REFERRALS" IN BLACK.

FOR REFERRALS IN THE FIELD OF REAL ESTATE AGENTS (U.S. CLS. 100, 101 AND 102).

FIRST USE 5-25-2007; IN COMMERCE 5-25-2007.
ODESSA BIBBINS, EXAMINING ATTORNEY

SN 77-434,124. PACIFIC SUNWEAR OF CALIFORNIA, INC., ANAHEIM, CA. FILED 3-28-2008.

PACLOOT

THE MARK CONSISTS OF STANDARD CHARACTERS WITHOUT CLAIM TO ANY PARTICULAR FONT, STYLE, SIZE, OR COLOR.

FOR RETAIL CLOTHING STORE SERVICES FEATURING A BUYER REWARD PROGRAM IN WHICH PURCHASES OVER A SET AMOUNT ARE REWARDED WITH A COUPON FOR DISCOUNTS ON FUTURE PURCHASES (U.S. CLS. 100, 101 AND 102).

FIRST USE 3-8-2006; IN COMMERCE 3-8-2006.
JENNIFER VASQUEZ, EXAMINING ATTORNEY

CLASS 35—(Continued).

SN 77-434,163. BENTON, ADAM, SPRINGFIELD, MO. FILED 3-28-2008.

MIDISCOUNTS

THE MARK CONSISTS OF STANDARD CHARACTERS WITHOUT CLAIM TO ANY PARTICULAR FONT, STYLE, SIZE, OR COLOR.

FOR PROMOTING THE GOODS AND SERVICES OF OTHERS THROUGH THE ADMINISTRATION OF DISCOUNT, REBATE, INCENTIVE AWARDS, AND CUSTOMER LOYALTY PROGRAMS; PROVIDING PROGRAMS TO PROMOTE THE SALE OF PRODUCTS AND SERVICES OF OTHERS; PROMOTING FINANCIAL SERVICES, ON BEHALF OF THIRD PARTIES; THE BRINGING TOGETHER, FOR THE BENEFIT OF OTHERS, OF A VARIETY OF GOODS AND SERVICES, ENABLING CUSTOMERS TO CONVENIENTLY VIEW AND PURCHASE THOSE GOODS AND SERVICES FROM AN INTERNET WEBSITE AND/OR A RETAIL STORE PARTICULARLY SPECIALIZING IN THE MARKETING OF THE SALE OF GOODS AND SERVICES OF OTHERS (U.S. CLS. 100, 101 AND 102).

FIRST USE 6-12-2007; IN COMMERCE 6-12-2007.
JORDAN BAKER, EXAMINING ATTORNEY

SN 77-434,193. INFLUENCE INTERNATIONAL, INC., PROVO, UT. FILED 3-28-2008.

DOWNTOWN

THE MARK CONSISTS OF STANDARD CHARACTERS WITHOUT CLAIM TO ANY PARTICULAR FONT, STYLE, SIZE, OR COLOR.

FOR BUSINESS NETWORKING; ONLINE BUSINESS NETWORKING SERVICES (U.S. CLS. 100, 101 AND 102).

JAMES STEIN, EXAMINING ATTORNEY

SN 77-434,344. TRESPLAN GROUP INC., MIAMI, FL. FILED 3-28-2008.

Dnewmedia

THE MARK CONSISTS OF STANDARD CHARACTERS WITHOUT CLAIM TO ANY PARTICULAR FONT, STYLE, SIZE, OR COLOR.

FOR ADVERTISING AND MARKETING (U.S. CLS. 100, 101 AND 102).

FIRST USE 7-25-2006; IN COMMERCE 7-25-2006.
JOHN GARTNER, EXAMINING ATTORNEY

CLASS 35—(Continued).

SN 77-434,396. AVIDAMED, INC., ANDOVER, MA. FILED 3-28-2008.

AVIDAMED

THE MARK CONSISTS OF STANDARD CHARACTERS WITHOUT CLAIM TO ANY PARTICULAR FONT, STYLE, SIZE, OR COLOR.

FOR STRATEGIC BUSINESS CONSULTING SERVICES, BUSINESS NETWORKING SERVICES AND BUSINESS ADMINISTRATION SERVICES, NAMELY, PATIENT REGISTRATION, SCHEDULING, BILL GENERATION AND TRACKING, ACCOUNTS RECEIVABLE AND ACCOUNTS PAYABLE ADMINISTRATION, PURCHASING ADMINISTRATION AND FINANCIAL REPORTING SERVICES FOR HEALTHCARE PROVIDERS (U.S. CLS. 100, 101 AND 102).

SETH A. RAPPAPORT, EXAMINING ATTORNEY

CLASS 35—(Continued).

SN 77-434,624. SAFARI SHIRT CO., STAYTON, OR. FILED 3-28-2008.

Munition

THE MARK CONSISTS OF STANDARD CHARACTERS WITHOUT CLAIM TO ANY PARTICULAR FONT, STYLE, SIZE, OR COLOR.

FOR RETAIL STORES FEATURING SURFING, SKATEBOARDING, SNOWBOARDING AND MOTORCROSS CLOTHING, ACTIVE-WEAR AND SPORTING GOODS (U.S. CLS. 100, 101 AND 102).

TASNEEM HUSSAIN, EXAMINING ATTORNEY

SN 77-434,614. MEDIA MAYHEM CORPORATION, LOS ANGELES, CA. FILED 3-28-2008.

Media Mayhem

THE MARK CONSISTS OF STANDARD CHARACTERS WITHOUT CLAIM TO ANY PARTICULAR FONT, STYLE, SIZE, OR COLOR.

NO CLAIM IS MADE TO THE EXCLUSIVE RIGHT TO USE "MEDIA", APART FROM THE MARK AS SHOWN.

FOR ADVERTISING AND MARKETING; ADVERTISING SERVICES, NAMELY, PROMOTING AND MARKETING THE GOODS AND SERVICES OF OTHERS THROUGH ALL PUBLIC COMMUNICATION MEANS; ADVERTISING, MARKETING AND PROMOTION SERVICES; BUSINESS MARKETING SERVICES; DEVELOPMENT OF MARKETING STRATEGIES AND CONCEPTS; DIRECT MARKETING ADVERTISING FOR OTHERS; DIRECT MARKETING SERVICES; PROVIDING INFORMATION IN THE FIELD OF MARKETING AND ON-LINE MARKETING MEDIA VIA THE INTERNET; ON-LINE ADVERTISING AND MARKETING SERVICES; PROMOTING, ADVERTISING AND MARKETING OF THE ON-LINE WEB SITES OF OTHERS; PROMOTION, ADVERTISING AND MARKETING OF ON-LINE WEB SITES; ADVERTISING SERVICES, PUBLIC RELATIONS AND MARKETING SERVICES, NAMELY, PROMOTING AND MARKETING THE GOODS AND SERVICES OF OTHERS THROUGH ALL PUBLIC COMMUNICATION MEANS (U.S. CLS. 100, 101 AND 102).

FIRST USE 8-7-2006; IN COMMERCE 8-7-2006.
JAMES LOVELACE, EXAMINING ATTORNEY

SN 77-434,723. BENTON, ADAM, SPRINGFIELD, MO. FILED 3-28-2008.

MISTUDENT

THE MARK CONSISTS OF STANDARD CHARACTERS WITHOUT CLAIM TO ANY PARTICULAR FONT, STYLE, SIZE, OR COLOR.

FOR PROMOTING THE GOODS AND SERVICES OF OTHERS THROUGH THE ADMINISTRATION OF DISCOUNT, REBATE, INCENTIVE AWARDS, AND CUSTOMER LOYALTY PROGRAMS; PROVIDING PROGRAMS TO PROMOTE THE SALE OF PRODUCTS AND SERVICES OF OTHERS; PROMOTING FINANCIAL SERVICES, ON BEHALF OF THIRD PARTIES; THE BRINGING TOGETHER, FOR THE BENEFIT OF OTHERS, OF A VARIETY OF GOODS AND SERVICES, ENABLING CUSTOMERS TO CONVENIENTLY VIEW AND PURCHASE THOSE GOODS AND SERVICES FROM AN INTERNET WEBSITE OR RETAIL STORE PARTICULARLY SPECIALIZING IN THE MARKETING OF THE SALE OF GOODS AND SERVICES OF OTHERS (U.S. CLS. 100, 101 AND 102).

FIRST USE 3-28-2008; IN COMMERCE 3-28-2008.
JORDAN BAKER, EXAMINING ATTORNEY

CLASS 35—(Continued).

SN 77-434,752. LEADERSINSPIRE, LLC, HIGHLANDS RANCH, CO. FILED 3-28-2008.



THE COLOR(S) BLACK, RED AND YELLOW IS/ARE CLAIMED AS A FEATURE OF THE MARK.

THE MARK CONSISTS OF THE WORD "LEADERS" IN BLACK CAPITAL LETTERS; THE WORD "INSPIRE" APPEARS IN RED LOWERCASE LETTERS UNDERNEATH THE WORD "LEADERS" WITH A STYLIZED FLAME ABOVE THE SECOND "I"; THE FLAME IS RED ON THE OUTSIDE WITH A YELLOW INNER CORE.

FOR BUSINESS MANAGEMENT CONSULTATION IN THE FIELD OF EXECUTIVE AND LEADERSHIP DEVELOPMENT (U.S. CLS. 100, 101 AND 102).
 LOURDES AYALA, EXAMINING ATTORNEY

CLASS 35—(Continued).

SN 77-434,908. SALES RESULT INC., BELLEVUE, WA. FILED 3-28-2008.

Paint-the-Picture

THE MARK CONSISTS OF STANDARD CHARACTERS WITHOUT CLAIM TO ANY PARTICULAR FONT, STYLE, SIZE, OR COLOR.

FOR BUSINESS CONSULTATION IN THE FIELD OF BUSINESS MARKETING AND STRATEGIC BUSINESS PLANNING WITH RESPECT TO SALES AND MARKETING ANALYSIS, SALES OPERATIONS, SALES PRESENTATIONS, PROJECT MANAGEMENT AND TARGETED BUSINESS ASSESSMENTS (U.S. CLS. 100, 101 AND 102).

FIRST USE 4-10-2004; IN COMMERCE 4-10-2004.
 JAMES STEIN, EXAMINING ATTORNEY

SN 77-434,758. METROPOLITAN LIFE INSURANCE COMPANY, LONG ISLAND CITY, NY. FILED 3-28-2008.

METLIFE PENSION RESOURCE CENTER

THE MARK CONSISTS OF STANDARD CHARACTERS WITHOUT CLAIM TO ANY PARTICULAR FONT, STYLE, SIZE, OR COLOR.

OWNER OF U.S. REG. NOS. 1,541,862, 2,724,666 AND 3,119,644.

NO CLAIM IS MADE TO THE EXCLUSIVE RIGHT TO USE "PENSION RESOURCE CENTER", APART FROM THE MARK AS SHOWN.

FOR PROVIDING A RESOURCE FOR ADMINISTRATION OF RETIREMENT SERVICES, NAMELY, PROVIDING PROVIDER SEARCHES, INVESTMENT AND FIDUCIARY REVIEW, ADMINISTRATION AND PLAN DESIGN ILLUSTRATIONS, REGULATORY UPDATES, PROSPECTING TOOLS, QUALIFIED PLAN TECHNICAL ASSISTANCE, PRODUCT SOLUTIONS, AND SALES MARKETING (U.S. CLS. 100, 101 AND 102).

FIRST USE 3-3-2008; IN COMMERCE 3-3-2008.
 JULIE GUTTADAURO, EXAMINING ATTORNEY

SN 77-437,097. UNITEDHEALTH GROUP INCORPORATED, MINNETONKA, MN. FILED 4-1-2008.



THE COLOR(S) BLUE, GREEN, ORANGE AND GRAY IS/ARE CLAIMED AS A FEATURE OF THE MARK.

THE MARK CONSISTS OF THE LITERAL ELEMENT "CARROT." IN STYLIZED LETTERING APPEARING IN THE COLOR BLUE AND ASSOCIATED DESIGN. THE DESIGN IS OF A CARROT, WITH THE TAPROOT APPEARING IN ORANGE AND THE LEAFY PORTION APPEARING IN GREEN, WHICH IS DANGLING FROM A GRAY ROPE THAT HANGS FROM THE LETTER "T" IN "CARROT".

FOR PROVIDING ADVERTISING, MARKETING, AND CONSUMER RESEARCH SERVICES IN THE FIELDS OF HEALTH AND WELL-BEING (U.S. CLS. 100, 101 AND 102).

JUDITH HELFMAN, EXAMINING ATTORNEY

CLASS 35—(Continued).

SN 77-437,757. DISH NETWORK L.L.C., ENGLEWOOD, CO. FILED 4-2-2008.



**AUTO RECORD
SERIES**

NO CLAIM IS MADE TO THE EXCLUSIVE RIGHT TO USE "AUTO RECORD SERIES", APART FROM THE MARK AS SHOWN.

THE COLOR(S) BLACK, GREY AND RED IS/ARE CLAIMED AS A FEATURE OF THE MARK.

THE MARK CONSISTS OF A BUTTON THAT HAS AN INNER RED CIRCLE AND A BLACK AND GREY OUTER CIRCLE WITH THE STYLIZED BLACK WORDS "AUTO RECORD" TO THE RIGHT OF THE CIRCLES. UNDER "AUTO RECORD" IS THE STYLIZED BLACK WORD "SERIES".

FOR ADVERTISING AND MARKETING; ADVERTISING PARTICULARLY SERVICES FOR THE PROMOTION OF GOODS; ADVERTISING VIA ELECTRONIC MEDIA AND SPECIFICALLY THE INTERNET; ADVERTISING, MARKETING AND PROMOTION SERVICES; DIRECT MAIL ADVERTISING; ADVERTISING AND COMMERCIAL INFORMATION SERVICES, VIA THE INTERNET; ADVERTISING SERVICES, NAMELY, PROMOTING AND MARKETING THE GOODS AND SERVICES OF OTHERS THROUGH ALL PUBLIC COMMUNICATION MEANS; ADVERTISING THROUGH ALL PUBLIC COMMUNICATION MEANS; ADVERTISING, PROMOTION AND MARKETING SERVICES IN THE NATURE OF E-MAIL BLAST CAMPAIGNS FOR OTHERS; DISTRIBUTION OF ADVERTISEMENTS AND COMMERCIAL ANNOUNCEMENTS; PLACING ADVERTISEMENTS FOR OTHERS; PROVIDING SPACE AT A WEB SITE FOR THE ADVERTISEMENT OF THE GOODS AND SERVICES OF OTHERS; PRESENTATION OF GOODS ON COMMUNICATION MEDIA FOR RETAIL PURPOSES; PROMOTION USING AUDIOVISUAL MEDIA; RETAIL SERVICES BY DIRECT SOLICITATION BY SALES AGENTS IN THE FIELD OF SATELLITE TELEVISION; ADVERTISING AND PUBLICITY SERVICES, NAMELY, PROMOTING THE GOODS, SERVICES, BRAND IDENTITY AND COMMERCIAL INFORMATION AND NEWS OF THIRD PARTIES THROUGH PRINT, AUDIO, VIDEO, DIGITAL AND ON-LINE MEDIUM; PROMOTING AND CONDUCTING TRADE SHOWS IN THE FIELD OF SATELLITE TELEVISION; PROVIDING MARKETING AND PROMOTION OF SPECIAL EVENTS (U.S. CLS. 100, 101 AND 102).

KOURTNEE HODGES, EXAMINING ATTORNEY

CLASS 35—(Continued).

SN 77-439,095. TICKETMASTER CORPORATION, HOLLYWOOD, CA. FILED 4-3-2008.

HELLO. HELLO.

THE MARK CONSISTS OF STANDARD CHARACTERS WITHOUT CLAIM TO ANY PARTICULAR FONT, STYLE, SIZE, OR COLOR.

FOR MARKETING SERVICES, NAMELY, PROMOTING THE GOODS, SERVICES, BRAND IDENTITY, COMMERCIAL INFORMATION AND NEWS OF THIRD PARTIES THROUGH PRINT, AUDIO, VIDEO, DIGITAL AND ON-LINE MEDIA, ALL IN THE FIELDS OF SPORTS AND ENTERTAINMENT (U.S. CLS. 100, 101 AND 102).

CIMMERIAN COLEMAN, EXAMINING ATTORNEY

SN 77-440,519. GAS SOUTH, LLC, ATLANTA, GA. FILED 4-4-2008.

PAY-AS-YOU-GO

THE MARK CONSISTS OF STANDARD CHARACTERS WITHOUT CLAIM TO ANY PARTICULAR FONT, STYLE, SIZE, OR COLOR.

FOR UTILITY BILL MANAGEMENT SERVICES, NAMELY, TRACKING, REPORTING, ANALYZING AND DELIVERING ENERGY INFORMATION IN THE FORM OF UTILITY BILLS AND UTILITY METER DATA RATE SCHEDULES, APPOINTMENT SCHEDULING FOR DELIVERY OF ENERGY FOR OTHERS, PROMOTION AND MARKETING SERVICES AND PROVIDING CONSUMER INFORMATION ALL IN THE FIELD OF ENERGY (U.S. CLS. 100, 101 AND 102).

KYLE PEETE, EXAMINING ATTORNEY

SN 77-441,942. CALIFORNIA ACADEMY OF SCIENCES, SAN FRANCISCO, CA. FILED 4-7-2008.

Academy Store

THE MARK CONSISTS OF STANDARD CHARACTERS WITHOUT CLAIM TO ANY PARTICULAR FONT, STYLE, SIZE, OR COLOR.

OWNER OF U.S. REG. NO. 1,510,473.

NO CLAIM IS MADE TO THE EXCLUSIVE RIGHT TO USE "STORE", APART FROM THE MARK AS SHOWN. FOR RETAIL STORE SERVICES IN THE FIELD OF SOUVENIRS AND GIFT ITEMS (U.S. CLS. 100, 101 AND 102).

SETH A. RAPPAPORT, EXAMINING ATTORNEY

CLASS 35—(Continued).

SN 77-443,602. RESEARCH HORIZONS LLC, DBA PHOENIX MARKETING INTERNATIONAL, RHINEBECK, NY. FILED 4-9-2008.

MD TouchPoint

THE MARK CONSISTS OF STANDARD CHARACTERS WITHOUT CLAIM TO ANY PARTICULAR FONT, STYLE, SIZE, OR COLOR.

NO CLAIM IS MADE TO THE EXCLUSIVE RIGHT TO USE "MD", APART FROM THE MARK AS SHOWN.

FOR MARKET RESEARCH SERVICES; CREATION OF MARKETING TOOLS DESIGNED TO INCREASE A CLIENT COMPANY'S KNOWLEDGE OF CUSTOMER NEEDS, AND ITS COMPETITORS' PRODUCTS AND SERVICES, PRICING, ADVERTISING STRATEGY AND SALES STRATEGY; BUSINESS MANAGEMENT CONSULTING WITH RELATION TO STRATEGY, MARKETING, SALES, OPERATION, PRODUCT DESIGN PARTICULARLY SPECIALIZING IN THE USE OF ANALYTIC AND STATISTIC MODELS FOR THE UNDERSTANDING AND PREDICTING OF CONSUMERS, BUSINESSES, AND MARKET TRENDS AND ACTIONS (U.S. CLS. 100, 101 AND 102).

FIRST USE 2-1-2008; IN COMMERCE 2-1-2008.

DOMINICK J. SALEMI, EXAMINING ATTORNEY

SN 77-448,402. CUPMERCIAL, LLC, RICHMOND HILL, GA. FILED 4-15-2008.

CUPMERCIAL

THE MARK CONSISTS OF STANDARD CHARACTERS WITHOUT CLAIM TO ANY PARTICULAR FONT, STYLE, SIZE, OR COLOR.

FOR ADVERTISING AND PROMOTIONAL SERVICES; PREPARATION OF CUSTOM ADVERTISEMENTS FOR OTHERS (U.S. CLS. 100, 101 AND 102).

FIRST USE 5-0-2007; IN COMMERCE 5-0-2007.

JAY FLOWERS, EXAMINING ATTORNEY

CLASS 35—(Continued).

SN 77-450,212. ICON BURGER DEVELOPMENT COMPANY, LLC, DENVER, CO. FILED 4-16-2008.



THE COLOR(S) RED AND WHITE IS/ARE CLAIMED AS A FEATURE OF THE MARK.

THE MARK CONSISTS OF A WHITE OVAL CONTAINING THE WORD "CASH" IN RED WITHIN A RED OVAL CONTAINING THE WORD "SMASH" IN WHITE.

FOR PROMOTING THE SALE OF RESTAURANT SERVICES, THROUGH THE ADMINISTRATION OF A GIFT CARD PROGRAM; GIFT CARD SERVICES, NAMELY, ISSUING GIFT CARD CERTIFICATES WHICH MAY BE REDEEMED FOR PREPARED FOOD AND RESTAURANT SERVICES (U.S. CLS. 100, 101 AND 102).

HANNO RITTNER, EXAMINING ATTORNEY

SN 77-450,219. ICON BURGER DEVELOPMENT COMPANY, LLC, DENVER, CO. FILED 4-16-2008.

SMASHCASH

THE MARK CONSISTS OF STANDARD CHARACTERS WITHOUT CLAIM TO ANY PARTICULAR FONT, STYLE, SIZE, OR COLOR.

FOR PROMOTING THE SALE OF RESTAURANT SERVICES, THROUGH THE ADMINISTRATION OF A GIFT CARD PROGRAM; GIFT CARD SERVICES, NAMELY, ISSUING GIFT CARD CERTIFICATES WHICH MAY BE REDEEMED FOR PREPARED FOOD AND RESTAURANT SERVICES (U.S. CLS. 100, 101 AND 102).

HANNO RITTNER, EXAMINING ATTORNEY

SN 77-451,198. DISNEY ENTERPRISES, INC., BURBANK, CA. FILED 4-17-2008.

PHOTOTALES

THE MARK CONSISTS OF STANDARD CHARACTERS WITHOUT CLAIM TO ANY PARTICULAR FONT, STYLE, SIZE, OR COLOR.

FOR RETAIL STORE SERVICES IN THE FIELD OF PHOTOGRAPHS; ON-LINE RETAIL STORE SERVICES IN THE FIELD OF PHOTOGRAPHS VIA THE INTERNET (U.S. CLS. 100, 101 AND 102).

DANNEAN HETZEL, EXAMINING ATTORNEY

CLASS 35—(Continued).

SN 77-455,374. RESEARCH HORIZONS LLC, DBA PHOENIX MARKETING INTERNATIONAL, RHINEBECK, NY. FILED 4-23-2008.

AdPi

THE MARK CONSISTS OF STANDARD CHARACTERS WITHOUT CLAIM TO ANY PARTICULAR FONT, STYLE, SIZE, OR COLOR.

FOR MARKET RESEARCH CONSULTATION; MARKET RESEARCH SERVICES; CREATION OF MARKETING TOOLS DESIGNED TO INCREASE A CLIENT COMPANY'S KNOWLEDGE OF CUSTOMER NEEDS, AND ITS COMPETITORS' PRODUCTS AND SERVICES, PRICING, ADVERTISING STRATEGY AND SALES STRATEGY; BUSINESS MANAGEMENT CONSULTING WITH RELATION TO STRATEGY, MARKETING, SALES, OPERATION, PRODUCT DESIGN PARTICULARLY SPECIALIZING IN THE USE OF ANALYTIC AND STATISTIC MODELS FOR THE UNDERSTANDING AND PREDICTING OF CONSUMERS, BUSINESSES, AND MARKET TRENDS AND ACTIONS; MARKET OPINION POLLING STUDIES (U.S. CLS. 100, 101 AND 102).

FIRST USE 1-1-2001; IN COMMERCE 8-13-2003.
DOMINICK J. SALEMI, EXAMINING ATTORNEY

SN 77-455,377. RESEARCH HORIZONS LLC, DBA PHOENIX MARKETING INTERNATIONAL, RHINEBECK, NY. FILED 4-23-2008.

BrandPi

THE MARK CONSISTS OF STANDARD CHARACTERS WITHOUT CLAIM TO ANY PARTICULAR FONT, STYLE, SIZE, OR COLOR.

FOR BUSINESS MANAGEMENT CONSULTING WITH RELATION TO STRATEGY, MARKETING, SALES, OPERATION, PRODUCT DESIGN PARTICULARLY SPECIALIZING IN THE USE OF ANALYTIC AND STATISTIC MODELS FOR THE UNDERSTANDING AND PREDICTING OF CONSUMERS, BUSINESSES, AND MARKET TRENDS AND ACTIONS; CREATION OF MARKETING TOOLS DESIGNED TO INCREASE A CLIENT COMPANY'S KNOWLEDGE OF CUSTOMER NEEDS, AND ITS COMPETITORS' PRODUCTS AND SERVICES, PRICING, ADVERTISING STRATEGY AND SALES STRATEGY; MARKET OPINION POLLING STUDIES; MARKET RESEARCH; MARKET RESEARCH SERVICES; MARKET RESEARCH STUDIES; MARKETING SERVICES, NAMELY, CONSUMER MARKETING RESEARCH (U.S. CLS. 100, 101 AND 102).

FIRST USE 1-1-2001; IN COMMERCE 8-13-2003.
DOMINICK J. SALEMI, EXAMINING ATTORNEY

CLASS 35—(Continued).

SN 77-455,557. ALTICOR INC., ADA, MI. FILED 4-23-2008.

GREAT PEOPLE HAPPEN HERE

THE MARK CONSISTS OF STANDARD CHARACTERS WITHOUT CLAIM TO ANY PARTICULAR FONT, STYLE, SIZE, OR COLOR.

FOR EMPLOYMENT HIRING, RECRUITING, PLACEMENT, STAFFING AND CAREER NETWORKING SERVICES (U.S. CLS. 100, 101 AND 102).

REGINA DRUMMOND, EXAMINING ATTORNEY

SN 77-458,100. IVY VENTURES, LLC, RICHMOND, VA. FILED 4-25-2008.

IVY VENTURES

THE MARK CONSISTS OF STANDARD CHARACTERS WITHOUT CLAIM TO ANY PARTICULAR FONT, STYLE, SIZE, OR COLOR.

NO CLAIM IS MADE TO THE EXCLUSIVE RIGHT TO USE "VENTURES", APART FROM THE MARK AS SHOWN. FOR BUSINESS CONSULTING SERVICES FOR THE HEALTHCARE INDUSTRY; BUSINESS MANAGEMENT AND CONSULTING SERVICES IN THE FIELD OF HEALTHCARE SERVICES AND THE HEALTHCARE INDUSTRY (U.S. CLS. 100, 101 AND 102).

FIRST USE 6-0-2003; IN COMMERCE 6-0-2003.

PAUL E. FAHRENKOPF, EXAMINING ATTORNEY

SN 77-459,215. AMERICAN CHEMICAL SOCIETY, DBA ACS, WASHINGTON, DC. FILED 4-28-2008.

THE MARK CONSISTS OF THE WORD "TECHCATALYST" WITH AN ARROW BELOW THE TECH PORTION OF THE WORD.

FOR CONSULTING SERVICES RELATED TO THE COMMERCIAL ADMINISTRATION OF DEVELOPING, ADVANCING, ACQUIRING OR LICENSING OF NEW TECHNOLOGY IN THE FIELDS OF CHEMICAL AND APPLIED SCIENCES OF OTHERS (U.S. CLS. 100, 101 AND 102).

FIRST USE 2-1-2008; IN COMMERCE 2-1-2008.
MONIQUE MILLER, EXAMINING ATTORNEY

CLASS 35—(Continued).

SN 77-459,804. SEVEN CORNERS, INC., CARMEL, IN. FILED 4-28-2008.

Wellabroad

THE MARK CONSISTS OF STANDARD CHARACTERS WITHOUT CLAIM TO ANY PARTICULAR FONT, STYLE, SIZE, OR COLOR.

FOR PROVIDING AN ONLINE DIRECTORY INFORMATION SERVICE FEATURING INFORMATION REGARDING HEALTH CARE, INSURANCE, SECURITY, AND CULTURE FOR PEOPLE TRAVELING AROUND THE WORLD (U.S. CLS. 100, 101 AND 102).

BENJAMIN ALLEN, EXAMINING ATTORNEY

SN 77-460,842. TIMESHARING TODAY, INC., TENAFLY, NJ. FILED 4-29-2008.

RESORT REPORT CARDS

THE MARK CONSISTS OF STANDARD CHARACTERS WITHOUT CLAIM TO ANY PARTICULAR FONT, STYLE, SIZE, OR COLOR.

OWNER OF U.S. REG. NO. 2,017,926.

NO CLAIM IS MADE TO THE EXCLUSIVE RIGHT TO USE "RESORT", APART FROM THE MARK AS SHOWN.

FOR RATING OF ACCOMMODATIONS (U.S. CLS. 100, 101 AND 102).

FIRST USE 5-1-1993; IN COMMERCE 5-1-1993.

JENNIFER MARTIN, EXAMINING ATTORNEY

SN 77-469,312. ADSCOPE MEDIA, LLC, TROY, MI. FILED 5-8-2008.

KNOW IT NOW

THE MARK CONSISTS OF STANDARD CHARACTERS WITHOUT CLAIM TO ANY PARTICULAR FONT, STYLE, SIZE, OR COLOR.

FOR MOBILE ADVERTISING; ADVERTISING PROMOTIONS AND PROMOTIONAL EVENTS (U.S. CLS. 100, 101 AND 102).

WANDA KAY PRICE, EXAMINING ATTORNEY

CLASS 35—(Continued).

SN 77-470,391. CALLSOURCE, INC., WESTLAKE VILLAGE, CA. FILED 5-9-2008.

LEADPOP

THE MARK CONSISTS OF STANDARD CHARACTERS WITHOUT CLAIM TO ANY PARTICULAR FONT, STYLE, SIZE, OR COLOR.

OWNER OF U.S. REG. NO. 3,423,350.

FOR BUSINESS SERVICE THAT RECEIVES INBOUND TELEPHONE CALLS AND AUTOMATICALLY PROVIDES TO A CONSUMER RESPONSE MARKETING DATABASE OR ELECTRONIC CALL LOG INFORMATION CONCERNING THE TIME, CONCERNING THE DATE, THE CALLER'S TELEPHONE NUMBER, CALLER'S NAME AND ADDRESS, AND THEN ALLOWS AN AGENT RECEIVING THE CALL TO INPUT FROM A PERSONAL COMPUTER OR WORKSTATION ADDITIONAL DATA SUCH AS THE PRODUCTS OR SERVICES OF INTEREST TO THE CALLER AND WHEN THE CALLER INTENDS TO BUY; THE SYSTEM THEN ASSIGNS THE LEAD TO A SPECIFIC AGENT FOR FOLLOW-UP AND GENERATES REMINDS AND/OR AUTOMATICALLY DIALS OUT WHEN A FOLLOW-UP CALL IS SCHEDULED (U.S. CLS. 100, 101 AND 102).

ALICE SUE CARRUTHERS, EXAMINING ATTORNEY

SN 77-471,365. USA TAX & INSURANCE SERVICES, INC., PALM HARBOR, FL. FILED 5-11-2008.

TOTAL SERVICE PLANNING

THE MARK CONSISTS OF STANDARD CHARACTERS WITHOUT CLAIM TO ANY PARTICULAR FONT, STYLE, SIZE, OR COLOR.

NO CLAIM IS MADE TO THE EXCLUSIVE RIGHT TO USE "SERVICE PLANNING", APART FROM THE MARK AS SHOWN.

FOR BUSINESS ADMINISTRATION CONSULTANCY; BUSINESS ADVICE AND INFORMATION; BUSINESS CONSULTATION SERVICES; BUSINESS CONSULTING AND INFORMATION SERVICES; BUSINESS MANAGEMENT CONSULTING; BUSINESS MANAGEMENT PLANNING (U.S. CLS. 100, 101 AND 102).

DORITT L. CARROLL, EXAMINING ATTORNEY

CLASS 35—(Continued).

SN 77-471,368. USA TAX & INSURANCE SERVICES, INC., PALM HARBOR, FL. FILED 5-11-2008.

TOTAL SUPPORT PLANNING

THE MARK CONSISTS OF STANDARD CHARACTERS WITHOUT CLAIM TO ANY PARTICULAR FONT, STYLE, SIZE, OR COLOR.

NO CLAIM IS MADE TO THE EXCLUSIVE RIGHT TO USE "SUPPORT PLANNING", APART FROM THE MARK AS SHOWN.

FOR BUSINESS ADMINISTRATION CONSULTANCY; BUSINESS ADVICE AND INFORMATION; BUSINESS CONSULTATION SERVICES; BUSINESS CONSULTING AND INFORMATION SERVICES; BUSINESS MANAGEMENT CONSULTING; BUSINESS MANAGEMENT PLANNING (U.S. CLS. 100, 101 AND 102).

DORITT L. CARROLL, EXAMINING ATTORNEY

SN 77-471,376. VERMA, ANIL, SYLMAR, CA. FILED 5-12-2008.

FilipinoRide

THE MARK CONSISTS OF STANDARD CHARACTERS WITHOUT CLAIM TO ANY PARTICULAR FONT, STYLE, SIZE, OR COLOR.

FOR ADVERTISING, MARKETING AND PROMOTION SERVICES FOR PROVIDING ELECTRONIC MEDIA AND INFORMATION TO AUTOMOTIVE AND MOTORCYCLE ENTHUSIASTS OF FILIPINO DESCENT, THROUGH THE INTERNET AND ALL OTHER FORMS OF COMMUNICATION (U.S. CLS. 100, 101 AND 102).

LINDA M. KING, EXAMINING ATTORNEY

SN 77-471,383. VERMA, ANIL, SYLMAR, CA. FILED 5-12-2008.

WorldRideNetwork

THE MARK CONSISTS OF STANDARD CHARACTERS WITHOUT CLAIM TO ANY PARTICULAR FONT, STYLE, SIZE, OR COLOR.

FOR ADVERTISING, MARKETING AND PROMOTION SERVICES FOR PROVIDING ELECTRONIC MEDIA AND INFORMATION TO AUTOMOTIVE, BOAT, AIRPLANE AND MOTORCYCLE ENTHUSIASTS ALL OVER THE WORLD, THROUGH THE INTERNET AND ALL OTHER FORMS OF COMMUNICATION (U.S. CLS. 100, 101 AND 102).

LINDA M. KING, EXAMINING ATTORNEY

CLASS 35—(Continued).

SN 77-472,246. SERTA, INC., HOFFMAN ESTATES, IL. FILED 5-12-2008.

SELECT YOUR PRICE. SELECT YOUR COMFORT.

THE MARK CONSISTS OF STANDARD CHARACTERS WITHOUT CLAIM TO ANY PARTICULAR FONT, STYLE, SIZE, OR COLOR.

FOR RETAIL STORE SERVICES FEATURING MATTRESSES (U.S. CLS. 100, 101 AND 102).

KATINA MISTER, EXAMINING ATTORNEY

SN 77-472,252. SERTA, INC., HOFFMAN ESTATES, IL. FILED 5-12-2008.

FIND YOUR PRICE. FIND YOUR COMFORT.

THE MARK CONSISTS OF STANDARD CHARACTERS WITHOUT CLAIM TO ANY PARTICULAR FONT, STYLE, SIZE, OR COLOR.

FOR RETAIL STORE SERVICES FEATURING MATTRESSES (U.S. CLS. 100, 101 AND 102).

KATINA MISTER, EXAMINING ATTORNEY

SN 77-472,486. VISION IMPORT GROUP LLC, RIVER EDGE, NJ. FILED 5-12-2008.



Miss E.Z. Peel

THE MARK CONSISTS OF A STYLIZED IMAGE OF A CLEMENTINE PEEL WITH A SILHOUETTE OF A LADY HOLDING A CLEMENTINE. BELOW THE CLEMENTINE PEEL IS THE STYLIZED TEXT "MISS E.Z. PEEL".

FOR EXPORT AND IMPORT AGENCIES (U.S. CLS. 100, 101 AND 102).

KHANH LE, EXAMINING ATTORNEY

CLASS 35—(Continued).

SN 77-472,954. LEE GARY L., CHICAGO, IL. AND MCWALTERS, THOMAS J., CHICAGO, IL. FILED 5-13-2008.



NO CLAIM IS MADE TO THE EXCLUSIVE RIGHT TO USE "COUTURE", APART FROM THE MARK AS SHOWN. THE MARK CONSISTS OF THE LETTER "T" ON TOP OF THE LETTER "G" OVER THE WORD "COUTURE". FOR FURNITURE STORE SERVICES FOR THOSE IN THE INTERIOR DESIGN INDUSTRY (U.S. CLS. 100, 101 AND 102).
ALEX KEAM, EXAMINING ATTORNEY

CLASS 35—(Continued).

SN 77-475,997. HETRICK COMMUNICATIONS, INC., SUITE 800, IN. FILED 5-15-2008.



THE MARK CONSISTS OF THE LETTER "H" WITH A DOOR AT THE BOTTOM OF THE "H". FOR PUBLIC RELATIONS AND MARKETING CONSULTING SERVICES FOR OTHERS (U.S. CLS. 100, 101 AND 102).
MATTHEW PAPPAS, EXAMINING ATTORNEY

SN 77-477,794. UNIT 7, NEW YORK, NY. FILED 5-19-2008.

SN 77-473,904. AMERICAN MULTI-CINEMA, INC., KANSAS CITY, MO. FILED 5-14-2008.

CORNISTA

THE MARK CONSISTS OF STANDARD CHARACTERS WITHOUT CLAIM TO ANY PARTICULAR FONT, STYLE, SIZE, OR COLOR. FOR CONCESSION STANDS FEATURING POPCORN AND CANDY (U.S. CLS. 100, 101 AND 102).
KATHERINE M. DUBRAY, EXAMINING ATTORNEY

**TRUST RELATIONSHIP
MANAGEMENT**

THE MARK CONSISTS OF STANDARD CHARACTERS WITHOUT CLAIM TO ANY PARTICULAR FONT, STYLE, SIZE, OR COLOR. NO CLAIM IS MADE TO THE EXCLUSIVE RIGHT TO USE "RELATIONSHIP MANAGEMENT", APART FROM THE MARK AS SHOWN. FOR ADVERTISING AGENCY SERVICES; CUSTOMER RELATIONSHIP MARKETING; DIRECT MARKETING ADVERTISING; BUSINESS MARKETING CONSULTING IN THE FIELDS OF BRAND DEVELOPMENT AND BRAND MARKETING; SALES PROMOTION SERVICES; PUBLIC RELATIONS; RELATIONSHIP MARKETING AND CUSTOMER LOYALTY SERVICES FOR BUSINESS PURPOSES; AND MARKET RESEARCH (U.S. CLS. 100, 101 AND 102).
SIMON TENG, EXAMINING ATTORNEY

CLASS 35—(Continued).

SN 77-477,989. THE GOODWILL GROUP, INC., TOKYO, JAPAN, FILED 5-19-2008.

CLASS 35—(Continued).

SN 77-485,506. NATIONAL CINEMEDIA, LLC, CENTENNIAL, CO. FILED 5-28-2008.

**TECHNOPRO
ENGINEERING**

HYPERPREVIEW

THE MARK CONSISTS OF THE WORDING "TECHNOPRO ENGINEERING" WITH A HORIZONTAL LINE BETWEEN "TECHNOPRO" AND "ENGINEERING".

FOR TALENT AGENCY, NAMELY, ARRANGING AND DISPATCHING TALENTS (U.S. CLS. 100, 101 AND 102).

HOWARD FRIEDMAN, EXAMINING ATTORNEY

THE MARK CONSISTS OF STANDARD CHARACTERS WITHOUT CLAIM TO ANY PARTICULAR FONT, STYLE, SIZE, OR COLOR.

FOR PROMOTING THE GOODS AND SERVICES OF OTHERS BY PROVIDING A WEBSITE FEATURING FACTS AND INFORMATION ABOUT AND RELATED TO MOTION PICTURES (U.S. CLS. 100, 101 AND 102).

ESTHER BELENKER, EXAMINING ATTORNEY

SN 77-478,115. KERR DRUG, INC., RALEIGH, NC. FILED 5-19-2008.

HEALTH CARE YOU CAN COUNT
ON

THE MARK CONSISTS OF STANDARD CHARACTERS WITHOUT CLAIM TO ANY PARTICULAR FONT, STYLE, SIZE, OR COLOR.

FOR RETAIL DRUG STORE SERVICES AND RETAIL PHARMACY SERVICES (U.S. CLS. 100, 101 AND 102).

COLLEEN KEARNEY, EXAMINING ATTORNEY

SN 77-485,694. KELLY RENEE INTERNATIONAL, INC., SIMI VALLEY, CA. FILED 5-29-2008.

SN 77-481,687. JAYNE HANCOCK GROUP, INC., SAN DIEGO, CA. FILED 5-22-2008.

JHG

SKIN ON SKIN

THE MARK CONSISTS OF STANDARD CHARACTERS WITHOUT CLAIM TO ANY PARTICULAR FONT, STYLE, SIZE, OR COLOR.

FOR ADVERTISING SERVICES, PUBLIC RELATIONS AND MARKETING SERVICES, NAMELY, PROMOTING AND MARKETING THE GOODS AND SERVICES OF OTHERS THROUGH ALL PUBLIC COMMUNICATION MEANS (U.S. CLS. 100, 101 AND 102).

FIRST USE 7-1-2005; IN COMMERCE 7-1-2005.
BRIAN CALLAGHAN, EXAMINING ATTORNEY

THE MARK CONSISTS OF STANDARD CHARACTERS WITHOUT CLAIM TO ANY PARTICULAR FONT, STYLE, SIZE, OR COLOR.

FOR WHOLESALE DISTRIBUTORSHIP AND RETAIL STORE SERVICES FEATURING COSMETICS AND APPLICATORS (U.S. CLS. 100, 101 AND 102).

EMILY CARLSEN, EXAMINING ATTORNEY

CLASS 35—(Continued).

SN 77-486,092. BUILDING FOR HEALTH CORPORATION, CARBONDALE, CO. FILED 5-29-2008.

BUILDING FOR HEALTH

THE MARK CONSISTS OF STANDARD CHARACTERS WITHOUT CLAIM TO ANY PARTICULAR FONT, STYLE, SIZE, OR COLOR.

FOR RETAIL AND WHOLESALE STORE SERVICES FEATURING HEALTHY, GREEN, ENVIRONMENTALLY-FRIENDLY AND/OR SUSTAINABLE BUILDING MATERIALS, HOME IMPROVEMENT ITEMS, HOME DECOR, AND PERSONAL CARE PRODUCTS; ROOFING, PAINTS, STAINS, FINISHES, PLASTER, SEALERS, CAULK, INSULATION, CABINETS, FLOORING, CARPET AND RUGS, LUMBER, GLUES, ADHESIVES, FURNITURE, APPLIANCES, HOME DECORATIONS AND INTERIOR DESIGN PRODUCTS, MATTRESSES AND BEDDING, LINENS AND TOWELS, FABRICS, NAPKINS, KITCHENWARE, HOUSE WARES, COOKING TOOLS, KNIVES, CUTTING BOARDS, CLEANING PRODUCTS, LIGHTING, PERSONAL CARE PRODUCTS, CLOTHING, BABY CLOTHES, BABY PRODUCTS, TOYS, ALTERNATIVE ENERGY SYSTEMS, GARDENING AND LANDSCAPING PRODUCTS, TOOLS, GARDENING, WOODWORKING TOOLS, CANDLES, LIGHTING, BAGS, HANDBAGS, BACKPACKS, COTTON BAGS, HEMP BAGS, DUFFEL BAGS, BOOKS AND VIDEOS, HOME SAFETY EQUIPMENT (U.S. CLS. 100, 101 AND 102).

FIRST USE 6-1-1988; IN COMMERCE 12-1-1988.
ALLISON SCHRODY, EXAMINING ATTORNEY

SN 77-487,137. LAVALIFE INC., WILMINGTON, DE. FILED 5-30-2008.

PRIME
Where singles 45+ click!

OWNER OF U.S. REG. NOS. 2,633,091, 2,737,935 AND OTHERS.

THE MARK CONSISTS OF TWO CURSIVE LINES FOLLOWED BY THE WORDS "LAVALIFE PRIME WHERE SINGLES 45+ CLICK!"

FOR DISSEMINATION OF ADVERTISING MATTER FOR OTHERS IN THE NATURE OF PERSONAL ADVERTISEMENTS VIA AN INTERACTIVE ELECTRONIC TELECOMMUNICATIONS NETWORK LINKED WITH AN INTERACTIVE ON-LINE GLOBAL COMPUTER NETWORK (U.S. CLS. 100, 101 AND 102).

EMILY CARLSEN, EXAMINING ATTORNEY

CLASS 35—(Continued).

SN 77-502,407. HARD ROCK CAFE INTERNATIONAL (USA), INC., ORLANDO, FL. FILED 6-18-2008.

HARD ROCK HOTEL

THE MARK CONSISTS OF STANDARD CHARACTERS WITHOUT CLAIM TO ANY PARTICULAR FONT, STYLE, SIZE, OR COLOR.

OWNER OF U.S. REG. NOS. 1,909,483, 3,422,550 AND OTHERS.

NO CLAIM IS MADE TO THE EXCLUSIVE RIGHT TO USE "HOTEL", APART FROM THE MARK AS SHOWN.

FOR REAL ESTATE MARKETING SERVICES IN THE FIELD OF CONDOMINIUM HOTELS (U.S. CLS. 100, 101 AND 102).

FIRST USE 12-10-2007; IN COMMERCE 12-10-2007.
JIM RINGLE, EXAMINING ATTORNEY

SN 77-975,591. BIO-LAB, INC., LAWRENCEVILLE, GA. FILED 7-6-2007.

WKND.

THE MARK CONSISTS OF STANDARD CHARACTERS WITHOUT CLAIM TO ANY PARTICULAR FONT, STYLE, SIZE, OR COLOR.

FOR RETAIL STORES FEATURING LAWN SPORTING GOODS, LAWN EQUIPMENT, AND DECORATIVE LAWN ORNAMENTS, SUCH AS, LAWN SCULPTURES, GAZING BALLS, WATER FOUNTAINS AND GAZEBO (U.S. CLS. 100, 101 AND 102).

JOHN KELLY, EXAMINING ATTORNEY

SN 77-975,671. AMIN, TARIQ, HAWTHORNE, CA. FILED 7-9-2007.

KING KEG

THE MARK CONSISTS OF STANDARD CHARACTERS WITHOUT CLAIM TO ANY PARTICULAR FONT, STYLE, SIZE, OR COLOR.

FOR RETAIL STORE SERVICES IN THE FIELDS OF ICE (U.S. CLS. 100, 101 AND 102).

FIRST USE 0-0-2004; IN COMMERCE 0-0-2004.
BERYL GARDNER, EXAMINING ATTORNEY

CLASS 35—(Continued).

SN 78-229,326. RX WEST, INC., CENTENNIAL, CO. FILED 3-24-2003.



NO CLAIM IS MADE TO THE EXCLUSIVE RIGHT TO USE "SYSTEMS", APART FROM THE MARK AS SHOWN.
FOR MANAGED CARE SERVICES, NAMELY, ELECTRONIC PROCESSING OF PRESCRIPTION DRUG BENEFIT PLAN INFORMATION AND BENEFITS (U.S. CLS. 100, 101 AND 102).

FIRST USE 10-25-2002; IN COMMERCE 10-25-2002.
GIANCARLO CASTRO, EXAMINING ATTORNEY

SN 78-643,787. LYNDBURST CONSULTANCY LTD., NORTH VANCOUVER, CANADA, FILED 6-4-2005.

Lyndhurst Naturals

THE MARK CONSISTS OF STANDARD CHARACTERS WITHOUT CLAIM TO ANY PARTICULAR FONT, STYLE, SIZE, OR COLOR.

PRIORITY CLAIMED UNDER SEC. 44(D) ON CANADA APPLICATION NO. 1259811, FILED 5-2-2005, REG. NO. TMA710423, DATED 3-28-2008, EXPIRES 3-28-2023.

NO CLAIM IS MADE TO THE EXCLUSIVE RIGHT TO USE "NATURALS", APART FROM THE MARK AS SHOWN.

FOR IMPORT OF COSMETIC AND CLEANING PRODUCTS, DISTRIBUTORSHIPS FEATURING COSMETIC AND CLEANING PRODUCTS, AND RETAIL AND WHOLESALE STORES FEATURING COSMETIC AND CLEANING PRODUCTS (U.S. CLS. 100, 101 AND 102).
MICHELLE DUBOIS, EXAMINING ATTORNEY

SN 78-746,756. EXPRESS, LLC, COLUMBUS, OH. FILED 11-3-2005.

GET THE SKINNY

THE MARK CONSISTS OF STANDARD CHARACTERS WITHOUT CLAIM TO ANY PARTICULAR FONT, STYLE, SIZE, OR COLOR.

FOR RETAIL STORE SERVICES, MAIL ORDER CATALOG SERVICES, AND ON-LINE RETAIL STORE SERVICES FEATURING CLOTHING (U.S. CLS. 100, 101 AND 102).

FIRST USE 2-28-2006; IN COMMERCE 2-28-2006.
DARRYL SPRUILL, EXAMINING ATTORNEY

CLASS 35—(Continued).

SN 78-788,752. BRANCH, CAHLEB, JEREMIAH, PHOENIX, AZ. FILED 1-10-2006.

Money Power Respect Entertainment

THE MARK CONSISTS OF STANDARD CHARACTERS WITHOUT CLAIM TO ANY PARTICULAR FONT, STYLE, SIZE, OR COLOR.

NO CLAIM IS MADE TO THE EXCLUSIVE RIGHT TO USE "ENTERTAINMENT", APART FROM THE MARK AS SHOWN.

FOR MANAGEMENT OF PERFORMING ARTISTS AND ENTERTAINERS; ADVERTISING, MARKETING AND PROMOTION SERVICES; ONLINE RETAIL STORE SERVICES IN THE FIELD OF CLOTHING (U.S. CLS. 100, 101 AND 102).

KATHY DE JONGE, EXAMINING ATTORNEY

SN 78-804,686. JACOBSON ACQUISITION CO., DES MOINES, IA. FILED 2-1-2006.



OWNER OF U.S. REG. NO. 1,857,946.

FOR SUPPLY CHAIN MANAGEMENT SERVICES, NAMELY, INVENTORY MANAGEMENT, WAREHOUSE ORDER PROCESSING, TRANSPORTATION ROUTING AND TRACKING, AND SHIPMENT TRACING (U.S. CLS. 100, 101 AND 102).

FIRST USE 1-11-2005; IN COMMERCE 1-11-2005.

STEVEN R. FINE, EXAMINING ATTORNEY

SN 78-817,389. THANX GIFTS, INC., GLEN ELLYN, IL. FILED 2-17-2006.

Thanx Gifts, Inc.

THE MARK CONSISTS OF STANDARD CHARACTERS WITHOUT CLAIM TO ANY PARTICULAR FONT, STYLE, SIZE, OR COLOR.

NO CLAIM IS MADE TO THE EXCLUSIVE RIGHT TO USE "GIFTS" AND "INC.", APART FROM THE MARK AS SHOWN.

FOR ON-LINE RETAIL STORE SERVICES FEATURING GENERAL MERCHANDISE (U.S. CLS. 100, 101 AND 102).

SAIMA MAKHDOOM, EXAMINING ATTORNEY

CLASS 35—(Continued).

SN 78-874,147. POROUS MEDIA CORPORATION, ST. PAUL, MN. FILED 5-2-2006.

Global Advantage Program

THE MARK CONSISTS OF STANDARD CHARACTERS WITHOUT CLAIM TO ANY PARTICULAR FONT, STYLE, SIZE, OR COLOR.

NO CLAIM IS MADE TO THE EXCLUSIVE RIGHT TO USE "GLOBAL" AND "PROGRAM", APART FROM THE MARK AS SHOWN.

FOR CONSULTING SERVICES IN THE FIELD OF PURCHASE OF FILTER MEDIA, NAMELY, RECOMMENDING WHICH FILTER SEPARATION PRODUCTS RELATING TO AIR, WATER, HYDROCARBON, AND CHEMICAL PROCESSING AND TREATMENT A CLIENT SHOULD PURCHASE BASED UPON THE CLIENT'S INDIVIDUAL NEEDS (U.S. CLS. 100, 101 AND 102).

FIRST USE 1-1-1998; IN COMMERCE 1-1-1998.
LINDA LAVACHE, EXAMINING ATTORNEY

SN 78-950,855. LA MICHOCANA MEAT MARKET, INC., HOUSTON, TX. FILED 8-12-2006.

LA MICHOCANA MEAT MARKET

THE MARK CONSISTS OF STANDARD CHARACTERS WITHOUT CLAIM TO ANY PARTICULAR FONT, STYLE, SIZE, OR COLOR.

NO CLAIM IS MADE TO THE EXCLUSIVE RIGHT TO USE "MEAT MARKET", APART FROM THE MARK AS SHOWN.

THE FOREIGN WORDING IN THE MARK TRANSLATES INTO ENGLISH AS "THE WOMAN FROM MICHOCANA".

FOR RETAIL MEAT MARKET STORES (U.S. CLS. 100, 101 AND 102).

FIRST USE 1-1-1986; IN COMMERCE 1-1-1986.
SANI KHOURI, EXAMINING ATTORNEY

SN 78-958,166. IMACRON, INC., QUEZON CITY, PHILIPPINES, FILED 8-23-2006.

imacron

THE MARK CONSISTS OF "IMACRON" WORD IN LOWERCASE, WITH FONT TYPE: IMPACT.

FOR POST-PRODUCTION EDITING SERVICES FOR VIDEO AND AUDIO COMMERCIALS (U.S. CLS. 100, 101 AND 102).

FIRST USE 7-3-1993; IN COMMERCE 11-12-2005.
SUNG IN, EXAMINING ATTORNEY

CLASS 35—(Continued).

SN 78-964,964. BULLSEYE TELECOM, INC., OAK PARK, MI. FILED 8-31-2006.

MOBILEADVANTAGE

THE MARK CONSISTS OF STANDARD CHARACTERS WITHOUT CLAIM TO ANY PARTICULAR FONT, STYLE, SIZE, OR COLOR.

FOR BUSINESS CONSULTING SERVICES IN THE FIELD OF WIRELESS TELECOMMUNICATIONS CONCERNING ASSET AND COST MANAGEMENT AND PROVIDING BILLING INFORMATION (U.S. CLS. 100, 101 AND 102).

KATHERINE CONNOLLY, EXAMINING ATTORNEY

SN 79-046,117. LIDL STIFTUNG & CO. KG, FED REP GERMANY, FILED 10-22-2007.



PRIORITY DATE OF 4-24-2007 IS CLAIMED.
OWNER OF INTERNATIONAL REGISTRATION 0943240 DATED 10-22-2007, EXPIRES 10-22-2017.

OWNER OF U.S. REG. NOS. 3,006,706 AND 3,302,791.
THE COLOR(S) BLUE (PANTONE 286 C), RED (PANTONE 199 C), YELLOW (PANTONE 3955) IS/ARE CLAIMED AS A FEATURE OF THE MARK.

THE TRADEMARK CONSISTS OF THE COLOURS BLUE (PANTONE 286C), RED (PANTONE 199C), YELLOW (PANTONE 3955); THE COLOURS ARE ARRANGED NEXT TO ONE ANOTHER IN THE SEQUENCE BLUE, RED, YELLOW; THE RATIO BETWEEN THE COLOURS IS 32.7%:7.7%:59.6% (BLUE: RED: YELLOW).

FOR RETAIL STORE SERVICES, ONLINE RETAIL STORE SERVICES, AND MAIL ORDER RETAIL SERVICES FEATURING FOODSTUFFS, ALCOHOLIC BEVERAGES AND TOBACCO GOODS, SANITARY ARTICLES, WASHING AND CLEANING PREPARATIONS, COSMETICS, MEDICINES, HOUSEHOLD OR KITCHEN ARTICLES AND UTENSILS, CROCKERY AND CUTLERY, OFFICE REQUISITES, CRAFT SUPPLIES, DECORATIVE ARTICLES, STATIONERY REQUISITES AND SCHOOL SUPPLIES, CLOTHING, FOOTWEAR, TEXTILE GOODS, IN PARTICULAR HOUSEHOLD TEXTILES, HABERDASHERY, LEATHERWARE, TRAVEL ARTICLES, ELECTRONIC CONSUMER EQUIPMENT AND APPARATUS, COMPUTERS, TELECOMMUNICATIONS APPARATUS, SPORTING ARTICLES AND TOYS, CONSTRUCTION, DO IT YOURSELF AND GARDENING REQUISITES, MACHINES, IN PARTICULAR HOUSEHOLD MACHINES AND UTENSILS, FOODSTUFFS FOR ANIMALS AND PET ACCESSORIES (U.S. CLS. 100, 101 AND 102).

SHARON MEIER, EXAMINING ATTORNEY

CLASS 36—INSURANCE AND FINANCIAL

SN 75-709,738. CENTURY BANCORP, INC., MEDFORD, MA. FILED 5-19-1999.

CENTURY FINANCIAL SERVICES

NO CLAIM IS MADE TO THE EXCLUSIVE RIGHT TO USE "FINANCIAL SERVICES", APART FROM THE MARK AS SHOWN.

FOR INVESTMENT SERVICES, NAMELY, BROKERAGE AND INVESTMENT SERVICES TO INDIVIDUAL AND COMMERCIAL CUSTOMERS (U.S. CLS. 100, 101 AND 102).

FIRST USE 9-0-1991; IN COMMERCE 9-0-1991.
INGA ERVIN, EXAMINING ATTORNEY

CLASS 36—(Continued).

SN 76-681,589. OUTSOURCEONE, INC., MINNEAPOLIS, MN. FILED 9-6-2007.



OWNER OF U.S. REG. NO. 3,232,250.
NO CLAIM IS MADE TO THE EXCLUSIVE RIGHT TO USE "BENEFIT", APART FROM THE MARK AS SHOWN.

THE COLOR(S) TEAL AND GRAY IS/ARE CLAIMED AS A FEATURE OF THE MARK.

THE COLOR GRAY APPEARS IN THE WORDING "BENEFIT" AND IN THE DESIGN OF THE UMBRELLA AND THE CIRCLES, AND THE COLOR TEAL APPEARS IN THE WORDING "READY" AND THE DESIGN OF THE UMBRELLA AND THE CIRCLES.

FOR BENEFIT ADMINISTRATION SERVICES, NAMELY, ADMINISTRATION OF EMPLOYEE BENEFIT PLANS (U.S. CLS. 100, 101 AND 102).

SHANNON TWOHIG, EXAMINING ATTORNEY

SN 75-709,833. CENTURY BANCORP, INC., MEDFORD, MA. FILED 5-19-1999.

CENTURY BANK

NO CLAIM IS MADE TO THE EXCLUSIVE RIGHT TO USE "BANK", APART FROM THE MARK AS SHOWN.

FOR BANKING SERVICES (U.S. CLS. 100, 101 AND 102).

FIRST USE 5-0-1969; IN COMMERCE 5-0-1969.
INGA ERVIN, EXAMINING ATTORNEY

SN 76-682,068. AMERICA'S INFOMART, INC., ALLEN, TX. FILED 9-19-2007.

AMERICA'S INFOMART, INC.

SN 76-587,806. BERNO, GAMBAL & BARBEE, INC., ARLINGTON, VA. FILED 4-21-2004.

AEGIS VALUE FUND

THE MARK CONSISTS OF STANDARD CHARACTERS WITHOUT CLAIM TO ANY PARTICULAR FONT, STYLE, SIZE, OR COLOR.

NO CLAIM IS MADE TO THE EXCLUSIVE RIGHT TO USE "VALUE FUND", APART FROM THE MARK AS SHOWN.

FOR INVESTMENT SERVICES, NAMELY, FINANCIAL SERVICES IN THE NATURE OF AN INVESTMENT SECURITY (U.S. CLS. 100, 101 AND 102).

FIRST USE 10-22-1997; IN COMMERCE 10-22-1997.
PAULA MAHONEY, EXAMINING ATTORNEY

THE MARK CONSISTS OF STANDARD CHARACTERS WITHOUT CLAIM TO ANY PARTICULAR FONT, STYLE, SIZE, OR COLOR.

NO CLAIM IS MADE TO THE EXCLUSIVE RIGHT TO USE "AMERICA'S" AND "INC.", APART FROM THE MARK AS SHOWN.

FOR BUILDING MANAGEMENT SERVICES FOR RESIDENTIAL AND COMMERCIAL PROPERTIES (U.S. CLS. 100, 101 AND 102).

FIRST USE 7-1-1993; IN COMMERCE 7-1-1993.
ESTHER BELENKER, EXAMINING ATTORNEY

CLASS 36—(Continued).

SN 76-682,088. AMERICA'S INFOMART, INC., ALLEN, TX. FILED 9-19-2007.

**AMERICA'S
INFOMART**

THE MARK CONSISTS OF STANDARD CHARACTERS WITHOUT CLAIM TO ANY PARTICULAR FONT, STYLE, SIZE, OR COLOR.

NO CLAIM IS MADE TO THE EXCLUSIVE RIGHT TO USE "AMERICA'S", APART FROM THE MARK AS SHOWN. FOR BUILDING MANAGEMENT SERVICES FOR RESIDENTIAL AND COMMERCIAL PROPERTIES (U.S. CLS. 100, 101 AND 102).

FIRST USE 7-1-1993; IN COMMERCE 7-1-1993.
ESTHER BELENKER, EXAMINING ATTORNEY

SN 76-684,097. REVERSINATE, LLC, OXFORD, CT. FILED 11-16-2007.

REVERSINATE

THE MARK CONSISTS OF STANDARD CHARACTERS WITHOUT CLAIM TO ANY PARTICULAR FONT, STYLE, SIZE, OR COLOR.

FOR FINANCIAL SERVICES, NAMELY, FINANCIAL RISK MANAGEMENT (U.S. CLS. 100, 101 AND 102).

TEJBIR SINGH, EXAMINING ATTORNEY

CLASS 36—(Continued).

SN 76-687,040. STERLING WEALTH MANAGEMENT, INC., CHAMPAIGN, IL. FILED 2-22-2008.

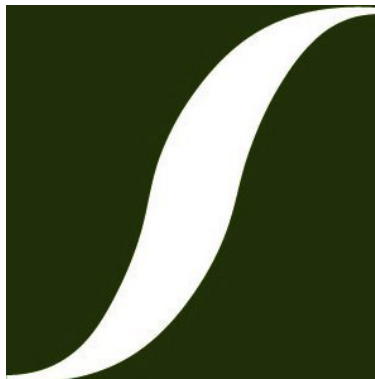

THE COLOR(S) DARK GREEN AND WHITE IS/ARE CLAIMED AS A FEATURE OF THE MARK.

THE MARK CONSISTS OF DARK GREEN SQUARE WITH WHITE STYLIZED "S" FROM UPPER RIGHT CORNER TO LOWER LEFT CORNER.

FOR FINANCIAL ADMINISTRATION OF RETIREMENT PLANS; FINANCIAL ANALYSIS AND CONSULTATION; FINANCIAL CONSULTATION; FINANCIAL INVESTMENT IN THE FIELD OF SECURITIES; FINANCIAL MANAGEMENT; FINANCIAL PLANNING; FINANCIAL PLANNING CONSULTATION; FINANCIAL PLANNING FOR RETIREMENT; FINANCIAL PLANNING, NAMELY, THE CREATION OF PERSONALIZED STRATEGIES TO ACHIEVE FINANCIAL INDEPENDENCE; FINANCIAL PORTFOLIO MANAGEMENT; FINANCIAL RESEARCH; FINANCIAL SERVICES IN THE NATURE OF AN INVESTMENT SECURITY; FINANCIAL SERVICES, NAMELY, ASSISTING OTHERS WITH THE COMPLETION OF FINANCIAL TRANSACTIONS FOR STOCKS, BONDS, SECURITIES AND EQUITIES (U.S. CLS. 100, 101 AND 102).

FIRST USE 9-1-2004; IN COMMERCE 9-1-2004.
PETER B. BROMAGHIM, EXAMINING ATTORNEY

SN 76-687,070. SAVITR CAPITAL, LLC, SAN FRANCISCO, CA. FILED 2-25-2008.

SAVITR

THE MARK CONSISTS OF STANDARD CHARACTERS WITHOUT CLAIM TO ANY PARTICULAR FONT, STYLE, SIZE, OR COLOR.

FOR PROVIDING INVESTMENT ADVISORY SERVICES, INVESTMENT ASSET MANAGEMENT SERVICES AND ADVISING PRIVATE EQUITY FUND INVESTMENT FUND SERVICES (U.S. CLS. 100, 101 AND 102).

DANNEAN HETZEL, EXAMINING ATTORNEY

CLASS 36—(Continued).

SN 76-687,875. DRALUCK, RON, ATLANTA, GA. FILED 3-17-2008.

PUSH BUTTON INVESTING

THE MARK CONSISTS OF STANDARD CHARACTERS WITHOUT CLAIM TO ANY PARTICULAR FONT, STYLE, SIZE, OR COLOR.

NO CLAIM IS MADE TO THE EXCLUSIVE RIGHT TO USE "INVESTING", APART FROM THE MARK AS SHOWN.

FOR REAL ESTATE INVESTMENT SERVICES, NAMELY, REAL ESTATE ACQUISITION SERVICES, REAL ESTATE SALES BROKERAGE, AND REAL ESTATE FINANCING SERVICES (U.S. CLS. 100, 101 AND 102).

FIRST USE 3-1-2005; IN COMMERCE 5-12-2005.
WENDY JUN, EXAMINING ATTORNEY

SN 76-688,021. CANNON & MASSARSKY, INC., HOBOKEN, NJ. FILED 3-24-2008.



THE MARK CONSISTS OF STANDARD CHARACTERS WITHOUT CLAIM TO ANY PARTICULAR FONT, STYLE, SIZE, OR COLOR.

FOR FINANCIAL SERVICES IN THE NATURE OF HYBRID INVESTMENT SECURITIES THAT CONSIST OF A YIELD AND A TRANSFERABLE CARBON CREDIT (U.S. CLS. 100, 101 AND 102).

CARYN GLASSER, EXAMINING ATTORNEY

SN 76-688,062. TIB THE INDEPENDENT BANKERSBANK, IRVING, TX. FILED 3-26-2008.

SERVICE THAT MAKES CENTS

THE MARK CONSISTS OF STANDARD CHARACTERS WITHOUT CLAIM TO ANY PARTICULAR FONT, STYLE, SIZE, OR COLOR.

FOR FINANCIAL SERVICES, NAMELY, BANKING SERVICES, MORTGAGE LENDING SERVICES, STOCK FINANCING SERVICES, CREDIT CARD SERVICES, CREDIT AND DEBIT CARD TRANSACTION PROCESSING SERVICES, ASSET/LIABILITY MANAGEMENT SERVICES, INVESTMENT SERVICES, ELECTRONIC BANKING SERVICES, CHECK PROCESSING AND ELECTRONIC WIRE TRANSFER SERVICES (U.S. CLS. 100, 101 AND 102).

FIRST USE 7-1-2004; IN COMMERCE 7-1-2004.
ANNE E. GUSTASON, EXAMINING ATTORNEY

CLASS 36—(Continued).

SN 77-061,552. MILLENNIUM PARK REALTY, LLC, CHICAGO, IL. FILED 12-11-2006.

MILLENNIUM PARK REALTY

THE MARK CONSISTS OF STANDARD CHARACTERS WITHOUT CLAIM TO ANY PARTICULAR FONT, STYLE, SIZE, OR COLOR.

NO CLAIM IS MADE TO THE EXCLUSIVE RIGHT TO USE "REALTY", APART FROM THE MARK AS SHOWN.

FOR REAL ESTATE BROKERAGE; REAL ESTATE CONSULTATION; REAL ESTATE AGENCIES; LEASING OF REAL ESTATE; REAL ESTATE INVESTMENT; REAL ESTATE MANAGEMENT SERVICES; REAL ESTATE ACQUISITION; REAL ESTATE FINANCING AND FINANCIAL ANALYSIS (U.S. CLS. 100, 101 AND 102).
KATHY DE JONGE, EXAMINING ATTORNEY

SN 77-067,174. HAGERTY INSURANCE AGENCY, INC., TRAVERSE CITY, MI. FILED 12-19-2006.

Hagerty International Limited

THE MARK CONSISTS OF STANDARD CHARACTERS WITHOUT CLAIM TO ANY PARTICULAR FONT, STYLE, SIZE, OR COLOR.

OWNER OF U.S. REG. NOS. 2,414,043, 3,125,672 AND OTHERS.

NO CLAIM IS MADE TO THE EXCLUSIVE RIGHT TO USE "INTERNATIONAL LIMITED", APART FROM THE MARK AS SHOWN.

FOR INSURANCE AGENCIES, NAMELY, AUTOMOBILE INSURANCE UNDERWRITING FOR CLASSIC AUTOMOBILES (U.S. CLS. 100, 101 AND 102).
STEVEN PEREZ, EXAMINING ATTORNEY

SN 77-070,677. SECURITY FEDERAL CREDIT UNION, FLINT, MI. FILED 12-22-2006.

THE PEOPLE WHO KNOW

THE MARK CONSISTS OF STANDARD CHARACTERS WITHOUT CLAIM TO ANY PARTICULAR FONT, STYLE, SIZE, OR COLOR.

FOR CREDIT UNION AND BANKING SERVICES (U.S. CLS. 100, 101 AND 102).

FIRST USE 0-0-2001; IN COMMERCE 0-0-2001.
MICHELE SWAIN, EXAMINING ATTORNEY

CLASS 36—(Continued).

SN 77-123,430. FIRST MONTAUK SECURITIES CORPORATION, RED BANK, NJ. FILED 3-6-2007.



NO CLAIM IS MADE TO THE EXCLUSIVE RIGHT TO USE "ADVISORY STRATEGIES PLATFORM", APART FROM THE MARK AS SHOWN.

THE MARK CONSISTS OF GRAPHIC, TEXT AND CHARTS.

FOR INVESTMENT ADVISORY SERVICES AND FINANCIAL CONSULTATION (U.S. CLS. 100, 101 AND 102).

INGA ERVIN, EXAMINING ATTORNEY

SN 77-150,290. SPECTRUM PROPERTIES GROUP, INC., CHICAGO, IL. FILED 4-5-2007.

JEWELERS CENTER

THE MARK CONSISTS OF STANDARD CHARACTERS WITHOUT CLAIM TO ANY PARTICULAR FONT, STYLE, SIZE, OR COLOR.

SEC. 2(F).

FOR REAL ESTATE SERVICES, NAMELY, LEASING SHOWROOMS TO TENANTS (U.S. CLS. 100, 101 AND 102).

FIRST USE 1-1-1992; IN COMMERCE 1-1-1992.

LEIGH CAROLINE CASE, EXAMINING ATTORNEY

SN 77-157,708. AMERICAN INTERNATIONAL GROUP, INC., NEW YORK, NY. FILED 4-16-2007.

AIG AMBASSADOR

THE MARK CONSISTS OF STANDARD CHARACTERS WITHOUT CLAIM TO ANY PARTICULAR FONT, STYLE, SIZE, OR COLOR.

OWNER OF U.S. REG. NOS. 1,151,229, 1,273,845 AND OTHERS.

FOR INSURANCE UNDERWRITING SERVICES IN THE FIELD OF ACCIDENT AND HEALTH INSURANCE FOR BUSINESS TRAVELERS (U.S. CLS. 100, 101 AND 102).

FIRST USE 2-1-2007; IN COMMERCE 2-1-2007.

KELLY MCCOY, EXAMINING ATTORNEY

CLASS 36—(Continued).

SN 77-174,521. EVOLUTION MARKETS, INC., WHITE PLAINS, NY. FILED 5-7-2007.

GREEN EXCHANGE

THE MARK CONSISTS OF STANDARD CHARACTERS WITHOUT CLAIM TO ANY PARTICULAR FONT, STYLE, SIZE, OR COLOR.

NO CLAIM IS MADE TO THE EXCLUSIVE RIGHT TO USE "EXCHANGE", APART FROM THE MARK AS SHOWN.

FOR FINANCIAL SERVICES IN THE NATURE OF TRADING COMMODITIES (U.S. CLS. 100, 101 AND 102).

CHERYL CLAYTON, EXAMINING ATTORNEY

SN 77-190,905. TRANSLIBERTY, INC., LAS VEGAS, NV. FILED 5-25-2007.

THE CURRENCY OF THE AMERICAN DREAM

THE MARK CONSISTS OF STANDARD CHARACTERS WITHOUT CLAIM TO ANY PARTICULAR FONT, STYLE, SIZE, OR COLOR.

FOR FINANCING SERVICES AND INSURANCE CONSULTATION RELATED TO PURCHASES OF VEHICLES AND CONSUMER GOODS, NAMELY, COMPUTERS, COMPUTER PERIPHERALS, TV'S, AND OTHER ELECTRONIC DEVICES (U.S. CLS. 100, 101 AND 102).

ANDREA SAUNDERS, EXAMINING ATTORNEY

SN 77-213,685. SADDLE RIVER VALLEY BANK, SADDLE RIVER, NJ. FILED 6-22-2007.

ScanCap

THE MARK CONSISTS OF STANDARD CHARACTERS WITHOUT CLAIM TO ANY PARTICULAR FONT, STYLE, SIZE, OR COLOR.

FOR REMOTE DEPOSIT SERVICES, NAMELY, ELECTRONIC CHECK ACCEPTANCE AND ELECTRONIC DEPOSITING OF CHECKS (U.S. CLS. 100, 101 AND 102).

JAMES GRIFFIN, EXAMINING ATTORNEY

CLASS 36—(Continued).

SN 77-232,562. CASSIDAY, DARRIN, FLINT, MI. FILED 7-18-2007.

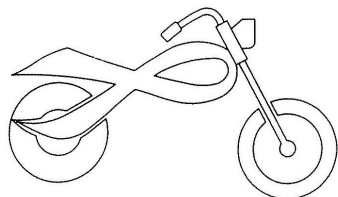

THE MARK CONSISTS OF MOTORCYCLE WITH RIBBON AS SEAT.

FOR CHARITABLE FUND RAISING SERVICES, NAMELY, ORGANIZING AND PROMOTING MOTORCYCLE RIDES TO RAISE FUNDS FOR CHARITABLE ORGANIZATIONS (U.S. CLS. 100, 101 AND 102).

FIRST USE 7-0-2004; IN COMMERCE 7-0-2004.
WILLIAM P. SHANAHAN, EXAMINING ATTORNEY

SN 77-248,648. ENDURANCE SPECIALTY HOLDINGS LTD., PEMBROKE, BERMUDA, FILED 8-7-2007.

ENDURANCE SPECIALTY HOLDINGS LTD.

THE MARK CONSISTS OF STANDARD CHARACTERS WITHOUT CLAIM TO ANY PARTICULAR FONT, STYLE, SIZE, OR COLOR.

NO CLAIM IS MADE TO THE EXCLUSIVE RIGHT TO USE "SPECIALTY HOLDINGS LTD.", APART FROM THE MARK AS SHOWN.

FOR REINSURANCE UNDERWRITING FOR ALL TYPES OF REINSURANCE, NAMELY, PROPERTY, CASUALTY, PROPERTY CATASTROPHE, AGRICULTURE, MARINE, AEROSPACE, SURETY AND SPECIALTY REINSURANCE; REINSURANCE UNDERWRITING ADMINISTRATION; REINSURANCE ACTUARIAL SERVICES; REINSURANCE CLAIMS ADMINISTRATION; PROCESSING OF REINSURANCE CLAIMS AND PAYMENT DATA; FINANCIAL EVALUATION FOR REINSURANCE PURPOSES; REINSURANCE CONSULTATION SERVICES; ACCIDENT INSURANCE UNDERWRITING; APPRAISALS FOR INSURANCE CLAIMS OF REAL ESTATE; CLAIMS ADJUSTMENT IN THE FIELD OF INSURANCE; ELECTRONIC PROCESSING OF INSURANCE CLAIMS AND PAYMENT DATA; FINANCIAL EVALUATION FOR INSURANCE PURPOSES; FIRE INSURANCE UNDERWRITING; INSURANCE ACTUARIAL SERVICES; INSURANCE ADMINISTRATION; INSURANCE AGENCY AND BROKERAGE; INSURANCE BROKERAGE IN THE FIELD OF PROPERTY AND CASUALTY INSURANCE; INSURANCE CARRIER SERVICES; INSURANCE CLAIMS ADMINISTRATION; INSURANCE CLAIMS PROCESSING; INSURANCE CONSULTATION; INSURANCE PREMIUM RATE COMPUTING; INSURANCE SERVICES, NAMELY, WRITING PROPERTY AND CASUALTY INSURANCE; INSURANCE SUBROGATION AND SALVAGE; INSURANCE UNDERWRITING IN THE FIELD OF PROPERTY, CASUALTY, HEALTHCARE LIABILITY, WORKER'S COMPENSATION, AND PROFESSIONAL LIABILITY INSURANCE; INSURANCE UNDERWRITING CONSULTATION; PROVIDING INFORMATION IN INSURANCE MATTERS (U.S. CLS. 100, 101 AND 102).

FIRST USE 12-0-2001; IN COMMERCE 12-0-2001.
DEBRA LEE, EXAMINING ATTORNEY

CLASS 36—(Continued).

SN 77-248,649. ENDURANCE SPECIALTY HOLDINGS LTD., PEMBROKE, BERMUDA, FILED 8-7-2007.

ENDURANCE REINSURANCE CORPORATION OF AMERICA

THE MARK CONSISTS OF STANDARD CHARACTERS WITHOUT CLAIM TO ANY PARTICULAR FONT, STYLE, SIZE, OR COLOR.

NO CLAIM IS MADE TO THE EXCLUSIVE RIGHT TO USE "REINSURANCE CORPORATION OF AMERICA", APART FROM THE MARK AS SHOWN.

FOR REINSURANCE UNDERWRITING FOR ALL TYPES OF REINSURANCE, NAMELY, PROPERTY, CASUALTY, PROPERTY CATASTROPHE, AGRICULTURE, MARINE, AEROSPACE, SURETY AND SPECIALTY REINSURANCE; REINSURANCE UNDERWRITING ADMINISTRATION; REINSURANCE ACTUARIAL SERVICES; REINSURANCE CLAIMS ADMINISTRATION; PROCESSING OF REINSURANCE CLAIMS AND PAYMENT DATA; FINANCIAL EVALUATION FOR REINSURANCE PURPOSES; REINSURANCE CONSULTATION SERVICES (U.S. CLS. 100, 101 AND 102).

FIRST USE 12-0-2002; IN COMMERCE 12-0-2002.
DEBRA LEE, EXAMINING ATTORNEY

SN 77-250,262. MILLIKEN & COMPANY, SPARTANBURG, SC. FILED 8-8-2007.

PACOLET

THE MARK CONSISTS OF STANDARD CHARACTERS WITHOUT CLAIM TO ANY PARTICULAR FONT, STYLE, SIZE, OR COLOR.

FOR REAL ESTATE BROKERAGE, REAL ESTATE INVESTMENT, REAL ESTATE MANAGEMENT, LEASING OF REAL ESTATE, BUILDING LEASING, LAND LEASING, LEASING OR RENTING OF BUILDINGS (U.S. CLS. 100, 101 AND 102).

MICHAEL LEWIS, EXAMINING ATTORNEY

CLASS 36—(Continued).

SN 77-255,879. MORGAN STANLEY, NEW YORK, NY.
FILED 8-15-2007.



THE MARK CONSISTS OF TWO STYLIZED GEARS, WITH STYLIZED LETTERS "ALT", THE GREEK LETTER ALPHA BEING SUBSTITUTED FOR THE LETTER "A", APPEARING IN THE LEFT GEAR AND THE STYLIZED LETTERS "ERA" APPEARING IN THE RIGHT GEAR.

FOR FINANCIAL SERVICES IN THE NATURE OF TRADING, BROKERING, AND STRUCTURING INVESTMENT SECURITIES (U.S. CLS. 100, 101 AND 102).
GEORGIA CARTY, EXAMINING ATTORNEY

CLASS 36—(Continued).

SN 77-260,238. VIRGIN MONEY USA, INC., WALTHAM, MA.
FILED 8-21-2007.

FAMILY ADVANTAGE

THE MARK CONSISTS OF STANDARD CHARACTERS WITHOUT CLAIM TO ANY PARTICULAR FONT, STYLE, SIZE, OR COLOR.

NO CLAIM IS MADE TO THE EXCLUSIVE RIGHT TO USE "FAMILY", APART FROM THE MARK AS SHOWN.

FOR FINANCIAL SERVICES, NAMELY, ARRANGING OF LOANS, FINANCIAL LOAN CONSULTATION, FINANCIAL LOAN PLANNING, PROVIDING LOANS SECURED BY COMMERCIAL PAPER; ELECTRONIC FUNDS TRANSFER SERVICES VIA THE INTERNET TO ENABLE INDIVIDUALS TO ENGAGE IN LENDING AND BORROWING TRANSACTIONS WITH OTHER INDIVIDUALS (U.S. CLS. 100, 101 AND 102).

FIRST USE 2-1-2007; IN COMMERCE 2-1-2007.
SHARON MEIER, EXAMINING ATTORNEY

SN 77-256,864. EMIGRANT BANCORP, INC., NEW YORK, NY. FILED 8-16-2007.

GSP FINANCE

THE MARK CONSISTS OF STANDARD CHARACTERS WITHOUT CLAIM TO ANY PARTICULAR FONT, STYLE, SIZE, OR COLOR.

NO CLAIM IS MADE TO THE EXCLUSIVE RIGHT TO USE "FINANCE", APART FROM THE MARK AS SHOWN.

FOR FINANCIAL SERVICES, NAMELY, PROVIDING FINANCIAL ADVICE AND FINANCIAL CONSULTING SERVICES TO SPORTS TEAM OWNERS AND POTENTIAL PURCHASERS OF SPORTS TEAMS; AND PROVIDING LOANS AND SERVICING LOANS FOR PURCHASERS OF SPORTS TEAMS (U.S. CLS. 100, 101 AND 102).
EDWARD NELSON, EXAMINING ATTORNEY

SN 77-261,685. EAST WEST BANK, PASADENA, CA. FILED 8-22-2007.

DESERT COMMUNITY BANK

THE MARK CONSISTS OF STANDARD CHARACTERS WITHOUT CLAIM TO ANY PARTICULAR FONT, STYLE, SIZE, OR COLOR.

OWNER OF U.S. REG. NO. 1,804,747.

NO CLAIM IS MADE TO THE EXCLUSIVE RIGHT TO USE "COMMUNITY BANK", APART FROM THE MARK AS SHOWN.

FOR BANKING SERVICES (U.S. CLS. 100, 101 AND 102).

FIRST USE 12-16-1991; IN COMMERCE 12-16-1991.
CHRISIE B. KING, EXAMINING ATTORNEY

CLASS 36—(Continued).

SN 77-261,898. TRIBUL CASH, LLC, NEW YORK, NY. FILED 8-22-2007.



OWNER OF U.S. REG. NO. 3,336,372.
NO CLAIM IS MADE TO THE EXCLUSIVE RIGHT TO USE "CASH", APART FROM THE MARK AS SHOWN.

THE MARK CONSISTS OF THE WORD "TRIBUL" WRITTEN IN STYLIZED CAPITAL LETTERS WITH A DIAMOND DOTTING THE LETTER "I", FOLLOWED BY THE WORD "CASH" WRITTEN IN STYLIZED LETTERS WHICH APPEARS JUST UNDER AND IN FRONT OF THE LETTER "U" IN "TRIBUL".

FOR PAYMENT PROCESSING SERVICES, NAMELY, CREDIT CARD AND DEBIT CARD TRANSACTION PROCESSING SERVICES, NAMELY, FINANCIAL, ELECTRONIC PAYMENT, CREDIT AND DEBIT CARD TRANSACTION PROCESSING SERVICES, NAMELY, CREDIT AND DEBIT CARD PROCESSING; CHECK VERIFICATION, CHECK GUARANTEE, AND CHECK CONVERSION, NAMELY, CHECK CASHING; ELECTRONIC FUNDS TRANSFER SERVICES; ISSUING GIFT, STORED VALUE, AND PRE-PAID CREDIT CARDS AND CREDIT CARD TRANSACTION OF GIFT, STORED VALUE, AND PRE-PAID CREDIT CARDS; PROVIDING ELECTRONIC PROCESSING OF CREDIT CARD TRANSACTIONS AND ELECTRONIC PAYMENTS VIA A GLOBAL COMPUTER NETWORK; ACCOUNTS RECEIVABLES FINANCING; CONSUMER LENDING SERVICES; FINANCIAL SERVICES IN THE FIELD OF MONEY LENDING; FINANCIAL SERVICES IN THE FIELD OF MONEY LENDING, NAMELY, MONEY LENDING; CREDIT AND CASH CARD SERVICES; ELECTRONIC CREDIT CARD TRANSACTIONS; LOAN FINANCING; LOAN FINANCING AND DISCOUNT OF BILLS; PROVIDING TEMPORARY LOANS; PROVIDING LOANS SECURED BY COMMERCIAL PAPER; BUSINESS FINANCING PROCUREMENT SERVICES (U.S. CLS. 100, 101 AND 102).

FIRST USE 5-1-2007; IN COMMERCE 5-1-2007.
CHRISTINA SOBRAL, EXAMINING ATTORNEY

CLASS 36—(Continued).

SN 77-266,222. INTER NATIONAL BANK, MCALLEN, TX. FILED 8-28-2007.

INTER NATIONAL BANK

THE MARK CONSISTS OF STANDARD CHARACTERS WITHOUT CLAIM TO ANY PARTICULAR FONT, STYLE, SIZE, OR COLOR.

NO CLAIM IS MADE TO THE EXCLUSIVE RIGHT TO USE "BANK", APART FROM THE MARK AS SHOWN. SEC. 2(F).

FOR BANKING SERVICES; FINANCIAL MANAGEMENT AND CONSULTATION SERVICES; CASH MANAGEMENT SERVICES; TRUST SERVICES, NAMELY, INVESTMENT AND TRUST COMPANY SERVICES; FINANCIAL ASSET MANAGEMENT SERVICES; INVESTMENT MANAGEMENT AND CONSULTATION SERVICES; SECURITIES MANAGEMENT, NAMELY, MANAGEMENT OF PORTFOLIOS COMPRISING SECURITIES AND CONSULTATION SERVICES IN THE FIELD OF MANAGING PORTFOLIOS OF SECURITIES; INSURANCE AGENCY FOR ALL TYPES OF INSURANCE; MONEY LENDING SERVICES; COMMERCIAL LENDING SERVICES; MORTGAGE LENDING SERVICES; PERSONAL LENDING SERVICES, NAMELY, CONSUMER LENDING SERVICES; COMMERCIAL REAL ESTATE LENDING SERVICES; AND CAPITAL FUNDING INVESTMENT ASSISTANCE IN THE NATURE OF VENTURE CAPITAL FUNDING SERVICES TO EMERGING AND START-UP COMPANIES AND CONSULTATION SERVICES REGARDING VENTURE CAPITAL FUNDING (U.S. CLS. 100, 101 AND 102).

FIRST USE 3-20-1990; IN COMMERCE 3-20-1990.
ALICE BENMAMAN, EXAMINING ATTORNEY

SN 77-263,604. VIRGIN MONEY USA, INC., WALTHAM, MA. FILED 8-24-2007.

SMART SELLER

THE MARK CONSISTS OF STANDARD CHARACTERS WITHOUT CLAIM TO ANY PARTICULAR FONT, STYLE, SIZE, OR COLOR.

NO CLAIM IS MADE TO THE EXCLUSIVE RIGHT TO USE "SELLER", APART FROM THE MARK AS SHOWN.

FOR PROVIDING FINANCIAL SERVICES, NAMELY, FINANCIAL ADVICE AND CONSULTANCY, FINANCIAL LOAN PLANNING; PROVIDING LOAN SERVICES, NAMELY, LOAN ORIGATION, FINANCIAL LOAN CONSULTATION, PROVIDING LOANS SECURED BY COMMERCIAL PAPER; ARRANGING OF LOANS (U.S. CLS. 100, 101 AND 102).

SHARON MEIER, EXAMINING ATTORNEY

CLASS 36—(Continued).

SN 77-266,260. INTER NATIONAL BANK, MCALLEN, TX. FILED 8-28-2007.



NO CLAIM IS MADE TO THE EXCLUSIVE RIGHT TO USE "BANK", APART FROM THE MARK AS SHOWN.

THE MARK CONSISTS OF A LINE ABOVE EACH WORD OF THE MARK WITH AN ANGLED POINTER TO THE LEFT OF THE WORDS.

SEC. 2(F).

FOR BANKING SERVICES; FINANCIAL MANAGEMENT AND CONSULTATION SERVICES; CASH MANAGEMENT SERVICES; TRUST SERVICES, NAMELY, INVESTMENT AND TRUST COMPANY SERVICES; FINANCIAL ASSET MANAGEMENT SERVICES; INVESTMENT MANAGEMENT AND CONSULTATION SERVICES; SECURITIES MANAGEMENT, NAMELY, MANAGEMENT OF PORTFOLIOS COMPRISING SECURITIES AND CONSULTATION SERVICES IN THE FIELD OF MANAGING PORTFOLIOS OF SECURITIES; INSURANCE AGENCY FOR ALL TYPES OF INSURANCE; MONEY LENDING SERVICES; COMMERCIAL LENDING SERVICES; MORTGAGE LENDING SERVICES; PERSONAL LENDING SERVICES, NAMELY, CONSUMER LENDING SERVICES; COMMERCIAL REAL ESTATE LENDING SERVICES; AND CAPITAL FUNDING INVESTMENT ASSISTANCE IN THE NATURE OF VENTURE CAPITAL FUNDING SERVICES TO EMERGING AND START-UP COMPANIES AND CONSULTATION SERVICES REGARDING VENTURE CAPITAL FUNDING (U.S. CLS. 100, 101 AND 102).

FIRST USE 8-25-2000; IN COMMERCE 8-25-2000.
ALICE BENMAMAN, EXAMINING ATTORNEY

SN 77-273,384. LODESTONE BANKING CONSULTANCY, INC., JAMESVILLE, NY. FILED 9-6-2007.

SHAHIN YIELD CALC.

THE MARK CONSISTS OF STANDARD CHARACTERS WITHOUT CLAIM TO ANY PARTICULAR FONT, STYLE, SIZE, OR COLOR.

NO CLAIM IS MADE TO THE EXCLUSIVE RIGHT TO USE "YIELD CALC", APART FROM THE MARK AS SHOWN.

FOR BANKING CONSULTATION SERVICES IN THE FIELD OF ANALYZING PROFITABILITY OF LOAN AND CUSTOMER CRITERIA (U.S. CLS. 100, 101 AND 102).

FIRST USE 8-0-2007; IN COMMERCE 8-0-2007.
TRACY CROSS, EXAMINING ATTORNEY

CLASS 36—(Continued).

SN 77-273,524. DINORAH, INC., COSTA MESA, CA. FILED 9-6-2007.



THE MARK CONSISTS OF THE LETTERS "PD" IN STYLIZED FONT OVERLAYING A DESIGN OF THE EARTH DISPLAYING NORTH AND SOUTH AMERICA.

FOR REAL ESTATE SERVICES, NAMELY, PROVIDING INFORMATION IN THE FIELD OF REAL ESTATE BY MEANS OF LINKING THE WEB SITE TO OTHER WEB SITES FEATURING REAL ESTATE INFORMATION; PROVIDING REAL ESTATE LISTINGS AND REAL ESTATE INFORMATION VIA THE INTERNET; REAL ESTATE CONSULTATION; REAL ESTATE INVESTMENT; REAL ESTATE VALUATION SERVICES; REAL ESTATE LISTING (U.S. CLS. 100, 101 AND 102).

JOHN DWYER, EXAMINING ATTORNEY

SN 77-275,376. ST. ANDREWS OF SCOTLAND INTERNATIONAL LTD, HOLLAND, MI. FILED 9-10-2007.

St.Andrews Golf

THE MARK CONSISTS OF STANDARD CHARACTERS WITHOUT CLAIM TO ANY PARTICULAR FONT, STYLE, SIZE, OR COLOR.

FOR FINANCIAL AFFAIRS, NAMELY, FINANCIAL CONSULTATION AND FINANCIAL MANAGEMENT (U.S. CLS. 100, 101 AND 102).

TOBY BULLOFF, EXAMINING ATTORNEY

SN 77-276,663. ST. ANDREWS OF SCOTLAND INTERNATIONAL LTD, HOLLAND, MI. FILED 9-11-2007.

St.Andrews of Scotland

THE MARK CONSISTS OF STANDARD CHARACTERS WITHOUT CLAIM TO ANY PARTICULAR FONT, STYLE, SIZE, OR COLOR.

FOR FINANCIAL AFFAIRS, NAMELY, FINANCIAL CONSULTATION, FINANCIAL MANAGEMENT (U.S. CLS. 100, 101 AND 102).

TOBY BULLOFF, EXAMINING ATTORNEY

CLASS 36—(Continued).

SN 77-278,079. HOPE UNLIMITED FOR CHILDREN, INC.,
LOS ALAMITOS, CA. FILED 9-12-2007.

HOPE UNLIMITED

THE MARK CONSISTS OF STANDARD CHARACTERS
WITHOUT CLAIM TO ANY PARTICULAR FONT, STYLE,
SIZE, OR COLOR.

FOR CHARITABLE SERVICES, NAMELY, PROMOT-
ING ASSISTANCE FOR THE LIVES OF CHILDREN AT
MORTAL RISK BY CHARITABLE FUNDRAISING (U.S.
CLS. 100, 101 AND 102).

FIRST USE 1-0-1991; IN COMMERCE 1-0-1991.
MICHAEL LEWIS, EXAMINING ATTORNEY

SN 77-278,093. HOPE UNLIMITED FOR CHILDREN, INC.,
LOS ALAMITOS, CA. FILED 9-12-2007.

HOPE UNLIMITED FOR CHILDREN

THE MARK CONSISTS OF STANDARD CHARACTERS
WITHOUT CLAIM TO ANY PARTICULAR FONT, STYLE,
SIZE, OR COLOR.

NO CLAIM IS MADE TO THE EXCLUSIVE RIGHT TO
USE "CHILDREN", APART FROM THE MARK AS SHOWN.
FOR CHARITABLE SERVICES, NAMELY, PROMOT-
ING ASSISTANCE FOR THE LIVES OF CHILDREN AT
MORTAL RISK BY CHARITABLE FUNDRAISING (U.S.
CLS. 100, 101 AND 102).

FIRST USE 4-29-2003; IN COMMERCE 4-29-2003.
MICHAEL LEWIS, EXAMINING ATTORNEY

SN 77-279,102. RENEWABLE FUEL TECHNOLOGY, LLC,
KEARNEY, NE. FILED 9-13-2007.



THE COLOR(S) ORANGE, GREEN AND BLUE IS/ARE
CLAIMED AS A FEATURE OF THE MARK.

THE MARK CONSISTS OF ORANGE SUNRAYS OVER A
GREEN CULTIVATED FIELD. THE COLOR GREEN ALSO
APPEARS IN THE WORDING "AG" AND THE COLOR
BLUE APPEARS IN THE WORD "NAVIGATOR".

FOR FINANCIAL RISK MANAGEMENT, NAMELY,
AGRICULTURE RISK MANAGEMENT SERVICES UTIL-
IZING FEDERAL CROP INSURANCE, ADD-ON YIELD
CONTRACT PROTECTION, GRAIN HEDGING
THROUGH FUTURES AND OPTIONS, GRAIN POOL-
ING AND INPUT SAVINGS AND HEDGES, NAMELY,
INPUT FINANCING AND ENERGY HEDGES (U.S. CLS.
100, 101 AND 102).

FIRST USE 2-0-2007; IN COMMERCE 2-0-2007.
YAT SYE, LEE, EXAMINING ATTORNEY

CLASS 36—(Continued).

SN 77-279,111. THE BUCKEYE STATE MUTUAL INSUR-
ANCE COMPANY, DBA BUCKEYE INSURANCE GROUP,
PIQUA, OH. FILED 9-13-2007.

INSURING THE HEARTLAND

THE MARK CONSISTS OF STANDARD CHARACTERS
WITHOUT CLAIM TO ANY PARTICULAR FONT, STYLE,
SIZE, OR COLOR.

FOR INSURANCE AGENCY AND BROKERAGE SER-
VICES; INSURANCE UNDERWRITING IN THE FIELDS
OF HOME, AUTO AND FARM (U.S. CLS. 100, 101 AND
102).

FIRST USE 6-0-2007; IN COMMERCE 6-0-2007.
MARIA-VICTORIA SUAREZ, EXAMINING ATTORNEY

SN 77-279,742. TAL CASH LLC, MIAMI, FL. FILED 9-14-2007.



NO CLAIM IS MADE TO THE EXCLUSIVE RIGHT TO
USE "CARD", APART FROM THE MARK AS SHOWN.

THE MARK CONSISTS OF THE WORD "TAL", WITH
THREE PETAL SHAPES DRAWN AT THE BASE OF THE
"T", ABOVE THE WORD "CARD".

FOR DEBIT CARD SERVICES; DEBIT CARD ADMIN-
ISTRATION AND PAYMENT PROCESSING SERVICES,
NAMELY, CREDIT CARD AND DEBIT CARD TRANS-
ACTION PROCESSING SERVICES (U.S. CLS. 100, 101
AND 102).

SANJEEV VOHRA, EXAMINING ATTORNEY

CLASS 36—(Continued).

SN 77-280,811. MARCELLA GONZALEZ, CAMARILLO, CA.
FILED 9-17-2007.

REAL ESTATE WITH KNOWLEDGE
AND CARE

THE MARK CONSISTS OF STANDARD CHARACTERS WITHOUT CLAIM TO ANY PARTICULAR FONT, STYLE, SIZE, OR COLOR.

FOR REAL ESTATE SERVICES, NAMELY, REAL ESTATE BROKERAGE, MORTGAGE LENDING, INVESTMENT ASSET ACQUISITION MANAGEMENT AND ESCROW SERVICES, AND ARRANGING FOR TITLE INSURANCE AND REAL ESTATE FINANCING FOR OTHERS; REAL ESTATE MANAGEMENT SERVICES ; FINANCIAL SERVICES, NAMELY, REAL ESTATE INVESTMENT BANKING, MORTGAGE BANKING AND LENDING, MANAGEMENT OF FINANCIAL AND REAL-ESTATE PORTFOLIOS; VENTURE CAPITAL FUNDING SERVICES TO EMERGING AND START-UP COMPANIES; REAL ESTATE EVALUATIONS, AND APPRAISALS AGENCIES OR BROKERAGE FOR LEASING OR RENTING OF LAND; AGENCIES OR BROKERAGE FOR RENTING LAND; AGENCIES OR BROKERAGE FOR RENTING OF BUILDINGS; APPRAISAL OF REAL ESTATE; ASSESSMENT AND MANAGEMENT OF REAL ESTATE; BUSINESS BROKERAGE; EVALUATION OF REAL PROPERTY; FINANCIAL INVESTMENT IN THE FIELD OF REAL ESTATE; FINANCIAL VALUATION OF PERSONAL PROPERTY AND REAL ESTATE; INVESTMENT BROKERAGE; LAND ACQUISITION, NAMELY, REAL ESTATE BROKERAGE; LEASING OF REAL ESTATE; LEASING OF REAL PROPERTY; MORTGAGE BANKING SERVICES, NAMELY, ORIGINATION, ACQUISITION, SERVICING, SECURITIZATION AND BROKERAGE OF MORTGAGE LOANS; MORTGAGE BROKERAGE; OPERATING MARKETPLACES FOR SELLERS OF GOODS AND/OR SERVICES; PROVIDING INFORMATION IN THE FIELD OF REAL ESTATE BY MEANS OF LINKING THE WEB SITE TO OTHER WEB SITES FEATURING REAL ESTATE INFORMATION; REAL ESTATE ACQUISITION SERVICES; REAL ESTATE AGENCIES; REAL ESTATE APPRAISAL; REAL ESTATE BROKERAGE; REAL ESTATE CONSULTANCY; REAL ESTATE CONSULTATION; REAL ESTATE EQUITY SHARING, NAMELY, MANAGING AND ARRANGING FOR CO-OWNERSHIP OF REAL ESTATE; REAL ESTATE ESCROW SERVICES; REAL ESTATE INVESTMENT; REAL ESTATE LISTING; REAL ESTATE MANAGEMENT; REAL ESTATE MANAGEMENT CONSULTATION; REAL ESTATE MULTIPLE LISTING SERVICES; REAL ESTATE PROCUREMENT FOR OTHERS; REAL ESTATE SERVICES, NAMELY, RENTAL OF VACATION HOMES, CONDOMINIUMS, CABINS, AND VILLAS USING PAY PER CLICK ADVERTISING ON A GLOBAL COMPUTER NETWORK; REAL ESTATE SYNDICATION; REAL ESTATE TIME-SHARING; REAL ESTATE TRUSTEE SERVICES; REAL ESTATE VALUATION SERVICES; REAL ESTATE VALUATIONS; VACATION REAL ESTATE TIME SHARE EXCHANGE SERVICES; VACATION REAL ESTATE TIME-SHARING (U.S. CLS. 100, 101 AND 102).

FIRST USE 5-31-2007; IN COMMERCE 5-31-2007.
RAMONA ORTIGA, EXAMINING ATTORNEY

CLASS 36—(Continued).

SN 77-285,918. EAGLE CREDIT UNION, STOCKTON, CA.
FILED 9-21-2007.

Eagle Credit Union

THE MARK CONSISTS OF STANDARD CHARACTERS WITHOUT CLAIM TO ANY PARTICULAR FONT, STYLE, SIZE, OR COLOR.

NO CLAIM IS MADE TO THE EXCLUSIVE RIGHT TO USE "CREDIT UNION", APART FROM THE MARK AS SHOWN.

FOR CREDIT UNION SERVICES (U.S. CLS. 100, 101 AND 102).

FIRST USE 9-1-2007; IN COMMERCE 9-1-2007.
BARBARA GAYNOR, EXAMINING ATTORNEY

SN 77-287,076. ROGERS, JAN MORGAN, COCONUT CREEK, FL. AND TURNER, LAUREN, COCONUT CREEK, FL. FILED 9-24-2007.



THE COLOR(S) YELLOW, RED, ORANGE, WHITE AND BROWN IS/ARE CLAIMED AS A FEATURE OF THE MARK.

"THE MARK CONSISTS OF A YELLOW SMILING STAR WITH A RED MOUTH, ORANGE CHEEKS AND WHITE AND BROWN EYES."

FOR CHARITABLE FUNDRAISING SERVICES (U.S. CLS. 100, 101 AND 102).

DOMINIC J. FERRAIUOLO, EXAMINING ATTORNEY

CLASS 36—(Continued).

SN 77-287,662. SCOUT MORTGAGE, INC., SCOTTSDALE, AZ. FILED 9-24-2007.

MORTGAGE MANIAC

THE MARK CONSISTS OF STANDARD CHARACTERS WITHOUT CLAIM TO ANY PARTICULAR FONT, STYLE, SIZE, OR COLOR.

NO CLAIM IS MADE TO THE EXCLUSIVE RIGHT TO USE "MORTGAGE", APART FROM THE MARK AS SHOWN.

FOR FINANCIAL SERVICES, NAMELY, FINANCIAL CONSULTING SERVICES IN THE FIELDS OF MORTGAGE BROKERING, SERVICING, AND REGULATION; MORTGAGE PLANNING, NAMELY, ORIGATION, ACQUISITION, SERVICING, SECURITIZATION AND BROKERAGE OF MORTGAGE LOANS, MORTGAGE PROCUREMENT FOR OTHERS, AND BUYER PRE-QUALIFICATION OF MORTGAGES FOR MORTGAGE BROKERS AND BANKS (U.S. CLS. 100, 101 AND 102).

B. PARADEWELAI, EXAMINING ATTORNEY

CLASS 36—(Continued).

SN 77-288,713. GOLDMAN, SACHS & CO., NEW YORK, NY. FILED 9-25-2007.

 The logo for Rothesay life features a stylized, dark grey swoosh on the left that curves upwards and then downwards, resembling a partial circle or a wave. To the right of this swoosh, the word "Rothesay" is written in a clean, sans-serif font, followed by the word "life" in a smaller, lowercase, sans-serif font.

SN 77-288,672. GOLDMAN, SACHS & CO., NEW YORK, NY. FILED 9-25-2007.

**ROTHESAY PENSIONS
MANAGEMENT**

THE MARK CONSISTS OF STANDARD CHARACTERS WITHOUT CLAIM TO ANY PARTICULAR FONT, STYLE, SIZE, OR COLOR.

NO CLAIM IS MADE TO THE EXCLUSIVE RIGHT TO USE "PENSIONS MANAGEMENT", APART FROM THE MARK AS SHOWN.

FOR INSURANCE SERVICES, NAMELY, LIFE INSURANCE BROKERAGE; LIFE INSURANCE UNDERWRITING SERVICES; CLAIMS MANAGEMENT AND ADJUSTMENT SERVICES FOR LIFE INSURANCE; INSURANCE ACTUARIAL SERVICES; INSURANCE CLAIMS ADMINISTRATION AND PROCESSING SERVICES; INSURANCE CONSULTING SERVICES; REINSURANCE SERVICES, NAMELY, REINSURANCE IN THE FIELD OF LIFE INSURANCE; REINSURANCE BROKERAGE SERVICES; REINSURANCE UNDERWRITING SERVICES; REINSURANCE CLAIMS ADMINISTRATION AND PROCESSING SERVICES; REINSURANCE CONSULTING SERVICES; REINSURANCE CLAIMS MANAGEMENT AND ADJUSTMENT SERVICES; FINANCIAL SERVICES, NAMELY, INVESTMENT AND ASSET MANAGEMENT SERVICES; COMPREHENSIVE FINANCIAL RISK MANAGEMENT SERVICES FOCUSING ON ASSETS AND LIABILITIES INCLUDING COMBINING INSURANCE AND REINSURANCE SERVICES WITH DERIVATIVE FINANCIAL INSTRUMENTS; FINANCIAL CONSULTING SERVICES; FINANCIAL PLANNING SERVICES; ASSET MANAGEMENT SERVICES, NAMELY, FINANCIAL AND INVESTMENT MANAGEMENT; FINANCIAL RESEARCH SERVICES; ANNUITY UNDERWRITING SERVICES; ANNUITY CLAIMS ADMINISTRATION AND PROCESSING; CONSULTING SERVICES IN THE FIELD OF ANNUITIES AND PENSIONS; MANAGEMENT AND ADMINISTRATION OF ANNUITY AND PENSION PLANS (U.S. CLS. 100, 101 AND 102).

SHANNON TWOHIG, EXAMINING ATTORNEY

NO CLAIM IS MADE TO THE EXCLUSIVE RIGHT TO USE "LIFE", APART FROM THE MARK AS SHOWN.

THE MARK CONSISTS OF THE DESIGNATION "ROTHESAY LIFE" COMBINED WITH A BOX WITH THE TOP RIGHT CORNER ROUNDED AND A SWOOSH DESIGN THROUGH IT.

FOR INSURANCE SERVICES, NAMELY, LIFE INSURANCE BROKERAGE; LIFE INSURANCE UNDERWRITING SERVICES; CLAIMS MANAGEMENT AND ADJUSTMENT SERVICES FOR LIFE INSURANCE; INSURANCE ACTUARIAL SERVICES; INSURANCE CLAIMS ADMINISTRATION AND PROCESSING SERVICES; INSURANCE CONSULTING SERVICES; REINSURANCE SERVICES, NAMELY, REINSURANCE IN THE FIELD OF LIFE INSURANCE; REINSURANCE BROKERAGE SERVICES; REINSURANCE UNDERWRITING SERVICES; REINSURANCE CLAIMS ADMINISTRATION AND PROCESSING SERVICES; REINSURANCE CONSULTING SERVICES; REINSURANCE CLAIMS MANAGEMENT AND ADJUSTMENT SERVICES; FINANCIAL SERVICES, NAMELY, INVESTMENT AND ASSET MANAGEMENT SERVICES; COMPREHENSIVE FINANCIAL RISK MANAGEMENT SERVICES FOCUSING ON ASSETS AND LIABILITIES INCLUDING COMBINING INSURANCE AND REINSURANCE SERVICES WITH DERIVATIVE FINANCIAL INSTRUMENTS; FINANCIAL CONSULTING SERVICES; FINANCIAL PLANNING SERVICES; ASSET MANAGEMENT SERVICES, NAMELY, FINANCIAL AND INVESTMENT MANAGEMENT; FINANCIAL RESEARCH SERVICES; ANNUITY UNDERWRITING SERVICES; ANNUITY CLAIMS ADMINISTRATION AND PROCESSING; CONSULTING SERVICES IN THE FIELD OF ANNUITIES AND PENSIONS; MANAGEMENT AND ADMINISTRATION OF ANNUITY AND PENSION PLANS (U.S. CLS. 100, 101 AND 102).

SHANNON TWOHIG, EXAMINING ATTORNEY

CLASS 36—(Continued).

SN 77-288,882. GOLDMAN, SACHS & CO., NEW YORK, NY.
FILED 9-25-2007.



NO CLAIM IS MADE TO THE EXCLUSIVE RIGHT TO USE "LIFE", APART FROM THE MARK AS SHOWN.

THE MARK CONSISTS OF THE DESIGNATION "ROTHERSAY LIFE" WITH A SQUARE DESIGN.

FOR INSURANCE SERVICES, NAMELY, LIFE INSURANCE BROKERAGE; LIFE INSURANCE UNDERWRITING SERVICES; CLAIMS MANAGEMENT AND ADJUSTMENT SERVICES FOR LIFE INSURANCE; INSURANCE ACTUARIAL SERVICES; INSURANCE CLAIMS ADMINISTRATION AND PROCESSING SERVICES; INSURANCE CONSULTING SERVICES; REINSURANCE SERVICES, NAMELY, REINSURANCE IN THE FIELD OF LIFE INSURANCE; REINSURANCE BROKERAGE SERVICES; REINSURANCE UNDERWRITING SERVICES; REINSURANCE CLAIMS ADMINISTRATION AND PROCESSING SERVICES; REINSURANCE CONSULTING SERVICES; REINSURANCE CLAIMS MANAGEMENT AND ADJUSTMENT SERVICES; FINANCIAL SERVICES, NAMELY, INVESTMENT AND ASSET MANAGEMENT SERVICES; COMPREHENSIVE FINANCIAL RISK MANAGEMENT SERVICES FOCUSING ON ASSETS AND LIABILITIES INCLUDING COMBINING INSURANCE AND REINSURANCE SERVICES WITH DERIVATIVE FINANCIAL INSTRUMENTS; FINANCIAL CONSULTING SERVICES; FINANCIAL PLANNING SERVICES; ASSET MANAGEMENT SERVICES, NAMELY, FINANCIAL AND INVESTMENT MANAGEMENT; FINANCIAL RESEARCH SERVICES; ANNUITY UNDERWRITING SERVICES; ANNUITY CLAIMS ADMINISTRATION AND PROCESSING; CONSULTING SERVICES IN THE FIELD OF ANNUITIES AND PENSIONS; MANAGEMENT AND ADMINISTRATION OF ANNUITY AND PENSION PLANS (U.S. CLS. 100, 101 AND 102).
SHANNON TWOHIG, EXAMINING ATTORNEY

SN 77-288,950. SNOWBIRD MEDI-QUOTE INC., CALGARY, AB, CANADA, FILED 9-26-2007.

Snowbird Medi-Quote

THE MARK CONSISTS OF STANDARD CHARACTERS WITHOUT CLAIM TO ANY PARTICULAR FONT, STYLE, SIZE, OR COLOR.

PRIORITY CLAIMED UNDER SEC. 44(D) ON CANADA APPLICATION NO. 1341178, FILED 3-28-2007, REG. NO. TMA717184, DATED 6-23-2008, EXPIRES 6-23-2023.

FOR (BASED ON INTENT TO USE) INSURANCE BROKERAGE IN THE FIELD OF HEALTH INSURANCE (BASED ON 44(D) PRIORITY APPLICATION) INSURANCE BROKERAGE IN THE FIELD OF HEALTH INSURANCE (U.S. CLS. 100, 101 AND 102).

BARNEY CHARLON, EXAMINING ATTORNEY

CLASS 36—(Continued).

SN 77-291,314. EAGLE CREDIT UNION, STOCKTON, CA.
FILED 9-28-2007.



NO CLAIM IS MADE TO THE EXCLUSIVE RIGHT TO USE "CREDIT UNION", APART FROM THE MARK AS SHOWN.

THE COLOR(S) ORANGE AND NAVY BLUE IS/ARE CLAIMED AS A FEATURE OF THE MARK.

THE MARK CONSISTS OF AN OUTLINE DRAWING OF AN EAGLE HEAD AND WINGS IN PROFILE, ABOVE THE WORDS "EAGLE CREDIT UNION". THE OUTSTRETCHED WINGS EXTEND OVER AND THEN DOWN ALONG THE SIDES OF THE WORDS. THERE IS A BREAK IN THE LINE AT THE BOTTOM OF THE EAGLE'S BEAK. THE OUTLINE DRAWING IS IN ORANGE EXCEPT FOR THE TIPS OF THE WINGS, WHICH ARE IN NAVY BLUE. THE WORDS "EAGLE CREDIT UNION" ARE IN NAVY BLUE.

FOR CREDIT UNION SERVICES, NAMELY, PROVIDING BANKING SERVICES, SAVINGS AND CHECKING ACCOUNTS, MONEY MARKET ACCOUNTS, CERTIFICATES OF DEPOSIT, INDIVIDUAL RETIREMENT ACCOUNTS, CONSUMER AND MORTGAGE LENDING, CREDIT CARD SERVICES, DEBIT CARD SERVICES, AND ONLINE BANKING FEATURING BILL PAYMENT SERVICES (U.S. CLS. 100, 101 AND 102).

FIRST USE 9-1-2007; IN COMMERCE 9-1-2007.

BARBARA GAYNOR, EXAMINING ATTORNEY

SN 77-294,297. INTERNATIONAL STORES CORP., PANAMA CITY, PANAMA, FILED 10-2-2007.



attenza

THE MARK CONSISTS OF FIVE SHOPPING BAGS ARRANGED TO BE A FIVE-POINTED STAR.

FOR INSURANCE AGENCIES; FINANCIAL ADVICE AND CONSULTANCY; MONETARY EXCHANGE; AND REAL ESTATE CONSULTANCY (U.S. CLS. 100, 101 AND 102).

WARREN L. OLANDRIA, EXAMINING ATTORNEY

CLASS 36—(Continued).

SN 77-294,354. INTERNATIONAL STORES CORP., PANAMA CITY, PANAMA, FILED 10-2-2007.



NO CLAIM IS MADE TO THE EXCLUSIVE RIGHT TO USE "DUTY FREE", APART FROM THE MARK AS SHOWN.

THE MARK CONSISTS OF FIVE SHOPPING BAGS ARRANGED TO BE A FIVE-POINTED STAR.

FOR INSURANCE AGENCIES; FINANCIAL ADVICE AND CONSULTANCY; MONETARY EXCHANGE; AND REAL ESTATE CONSULTANCY (U.S. CLS. 100, 101 AND 102).

WARREN L. OLANDRIA, EXAMINING ATTORNEY

CLASS 36—(Continued).

SN 77-297,062. MISSOURI CREDIT UNION, COLUMBIA, MO. FILED 10-5-2007.

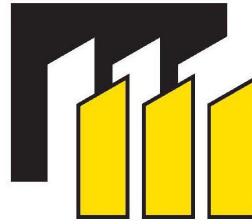

THE COLOR(S) BLACK, WHITE AND GOLD IS/ARE CLAIMED AS A FEATURE OF THE MARK.

THE MARK CONSISTS OF A GRAPHIC ELEMENT OF A BLACK POLYGON WITH SUPERIMPOSED WHITE QUADRILATERALS AND GOLD QUADRILATERALS WHICH FORMS A STYLIZED LETTER "M". THE GOLD QUADRILATERALS ARE OUTLINED IN BLACK.

FOR BANKING AND CREDIT UNION SERVICES (U.S. CLS. 100, 101 AND 102).

FIRST USE 3-0-1987; IN COMMERCE 3-0-1987.
JUSTINE D. PARKER, EXAMINING ATTORNEY

SN 77-294,388. INTERNATIONAL STORES CORP., PANAMA CITY, PANAMA, FILED 10-2-2007.



LA MEJOR ATENCION

NO CLAIM IS MADE TO THE EXCLUSIVE RIGHT TO USE "LA MEJOR ATENCION", APART FROM THE MARK AS SHOWN.

THE MARK CONSISTS OF FIVE SHOPPING BAGS ARRANGED TO BE A FIVE-POINTED STAR.

THE FOREIGN WORDING IN THE MARK TRANSLATES INTO ENGLISH AS "BEST CARE".

FOR INSURANCE AGENCIES; FINANCIAL ADVICE AND CONSULTANCY; MONETARY EXCHANGE; AND REAL ESTATE CONSULTANCY (U.S. CLS. 100, 101 AND 102).

WARREN L. OLANDRIA, EXAMINING ATTORNEY

SN 77-298,092. BAYVIEW LENDING GROUP L.L.C., CORAL GABLES, FL. FILED 10-7-2007.

DIRECT RESULTS

THE MARK CONSISTS OF STANDARD CHARACTERS WITHOUT CLAIM TO ANY PARTICULAR FONT, STYLE, SIZE, OR COLOR.

OWNER OF U.S. REG. NOS. 2,974,760, 3,207,059 AND 3,300,655.

NO CLAIM IS MADE TO THE EXCLUSIVE RIGHT TO USE "DIRECT", APART FROM THE MARK AS SHOWN.

FOR FINANCIAL INFORMATION PROVIDED BY ELECTRONIC MEANS REGARDING LOANS AND LENDING; FINANCIAL SERVICES, NAMELY, MONEY LENDING; FINANCIAL SERVICES, NAMELY, COMMERCIAL MORTGAGE LENDING; AND FINANCIAL SERVICES, NAMELY, ORIGINATING REAL ESTATE AND ASSET BACKED LOANS (U.S. CLS. 100, 101 AND 102).

TRACY WHITTAKER-BROWN, EXAMINING ATTORNEY

CLASS 36—(Continued).

SN 77-299,199. BAYAT FOUNDATION, FORT LEE, NJ. FILED 10-9-2007.



NO CLAIM IS MADE TO THE EXCLUSIVE RIGHT TO USE "FOUNDATION", APART FROM THE MARK AS SHOWN.

THE COLOR(S) BLACK AND GOLD IS/ARE CLAIMED AS A FEATURE OF THE MARK.

THE MARK CONSISTS OF "BAYAT FOUNDATION" AND A DESIGN ALL IN GOLD AND OUTLINED IN BLACK.

THE FOREIGN WORDING IN THE MARK TRANSLATES INTO ENGLISH AS "BAYAT FOUNDATION".

THE NON-LATIN CHARACTER(S) IN THE MARK TRANSLITERATES INTO "BAYAT BUNYAT", AND THIS MEANS "BAYAT FOUNDATION" IN ENGLISH.

FOR CHARITABLE FUND RAISING SERVICES; CHARITABLE FUND RAISING BY SPONSORSHIP OF SPORTING EVENTS (U.S. CLS. 100, 101 AND 102).

FIRST USE 2-0-2004; IN COMMERCE 9-10-2005.
TRACY CROSS, EXAMINING ATTORNEY

SN 77-302,640. FINANCIAL CONSORTIUM INTERNATIONAL ASSET MANAGEMENT L.L.C., CHICAGO, IL. FILED 10-12-2007.

AFFILIATED ADVISORS

THE MARK CONSISTS OF STANDARD CHARACTERS WITHOUT CLAIM TO ANY PARTICULAR FONT, STYLE, SIZE, OR COLOR.

NO CLAIM IS MADE TO THE EXCLUSIVE RIGHT TO USE "ADVISORS", APART FROM THE MARK AS SHOWN. FOR FINANCIAL PLANNING AND INVESTMENT ADVISORY SERVICES (U.S. CLS. 100, 101 AND 102).

DAWN FELDMAN, EXAMINING ATTORNEY

SN 77-302,646. FINANCIAL CONSORTIUM INTERNATIONAL ASSET MANAGEMENT L.L.C., CHICAGO, IL. FILED 10-12-2007.

SNC CAPITAL MANAGEMENT

THE MARK CONSISTS OF STANDARD CHARACTERS WITHOUT CLAIM TO ANY PARTICULAR FONT, STYLE, SIZE, OR COLOR.

NO CLAIM IS MADE TO THE EXCLUSIVE RIGHT TO USE CAPITAL MANAGEMENT, APART FROM THE MARK AS SHOWN.

FOR FINANCIAL SERVICES, NAMELY, SECURITIES BROKERAGE SERVICES RELATING TO STOCKS, STOCK OPTIONS, BONDS, MUTUAL FUNDS AND INSURANCE ANNUITIES; FINANCIAL CONSULTATION SERVICES (U.S. CLS. 100, 101 AND 102).

DAWN FELDMAN, EXAMINING ATTORNEY

CLASS 36—(Continued).

SN 77-307,312. MACQUARIE BANK LIMITED, SYDNEY, NSW, AUSTRALIA, FILED 10-18-2007.

MQ PRIME

THE MARK CONSISTS OF STANDARD CHARACTERS WITHOUT CLAIM TO ANY PARTICULAR FONT, STYLE, SIZE, OR COLOR.

NO CLAIM IS MADE TO THE EXCLUSIVE RIGHT TO USE "PRIME", APART FROM THE MARK AS SHOWN.

FOR FINANCIAL SERVICES, NAMELY, CORPORATE FINANCE SERVICES CONSISTING OF CONSULTATION AND MANAGEMENT, FINANCIAL DUE DILIGENCE IN THE NATURE OF CONDUCTING SUFFICIENT ANALYSIS BEFORE MAKING LOAN OR INVESTMENT RECOMMENDATIONS, FINANCIAL DECISION MAKING FOR CORPORATIONS, PROJECT FINANCE SERVICES, NAMELY, PROVIDING WORKING CAPITAL THROUGH LISTED AND UNLISTED EQUITY, HYBRID INSTRUMENTS AND DEBT, INVESTING FUNDS IN UNLISTED EQUITY FOR OTHERS, INVESTING FUNDS IN LISTED EQUITY FOR OTHERS, NAMELY, FLOATING PRIVATE COMPANIES, RAISING NEW EQUITY FOR LISTED COMPANIES AND BROKERAGE FEATURING EXISTING EQUITY, NAMELY, STOCKS AND OTHER SECURITIES IN LISTED COMPANIES, INVESTING FUNDS IN HYBRID INSTRUMENTS FOR OTHERS, NAMELY, CONVERTIBLE BONDS AND PREFERENCE SHARES; BROKERAGE OF INCOME SECURITIES, RESET PREFERENCE SHARES AND EXCHANGEABLE BONDS; FINANCIAL ADVISORY SERVICES IN RELATION TO THE STRUCTURING AND THE RAISING OF EQUITY CAPITAL; FINANCIAL MARKET SERVICES, NAMELY, COMMODITIES TRADING FOR OTHERS, TRADING OF EQUITIES, DERIVATIVES TRADING, TREASURIES TRADING, NAMELY, TRADING IN FIXED INCOME SECURITIES, BONDS, FOREIGN EXCHANGE, DERIVATIVES AND MONEY MARKET DEPOSITS, DEBT TRADING AND FUTURES TRADING; DEBT TRADING AND FUTURES TRADING; TRADING, STRUCTURING AND FINANCING ALL IN RELATION TO COMMODITIES, NAMELY, FINANCING, HEDGING, NAMELY, PROVIDING INVESTMENT STRATEGIES, RESEARCH AND ANALYSIS RELATING TO HEDGING AGAINST VARIOUS MARKET RISKS, COMMODITIES TRADING AND MARKET MAKING AND TAILORED RISK MANAGEMENT SERVICES FOR COMMODITIES, THE AGRICULTURAL SECTOR AND THE ENERGY SECTOR; INVESTMENT SERVICES, NAMELY, CAPITAL INVESTMENT SERVICES CONSISTING OF INVESTMENT OF FUNDS FOR OTHERS; INVESTMENT BANKING SERVICES; INVESTMENT MANAGEMENT SERVICES TO CORPORATIONS, BUSINESSES AND INDIVIDUALS; FINANCIAL RISK MANAGEMENT SERVICES TO CORPORATIONS, BUSINESSES AND INDIVIDUALS; FINANCIAL RISK AND CAPITAL INVESTMENT FUND MANAGEMENT SERVICES FOR FINANCING LEASED ASSETS, PROPERTY INVESTMENT BANKING; FINANCIAL ADVISORY AND FINANCIAL MANAGEMENT SERVICES; COMMODITIES TRADING; FUTURES TRADING; WHOLESALE INVESTMENT MANAGEMENT SERVICES; FINANCIAL ADVICE IN RELATION TO MERGERS AND ACQUISITIONS; DEBT RESTRUCTURING AND TRANSACTION RESTRUCTURING, NAMELY, FINANCING THROUGH CAPITAL MARKETS, BRIDGING ARRANGEMENTS, LONG AND SHORT TERM UNDERWRITINGS, BANK SYNDICATIONS, AND SUBORDINATED DEBT PLACEMENTS; INSTITUTIONAL STOCKBROKERAGE, NAMELY, ASSISTING OTHERS IN FACILITATING AND EXECUTING BROKERAGE OF CASH EQUITY, FINANCIAL ADVISORY SERVICES IN RELATION TO THE STRUCTURING OF EQUITY CAPITAL RAISINGS; STRUCTURING AND FINANCING IN RELATION TO COMMODITIES TRADING, NAMELY, FINANCING, HEDGING, NAMELY, PROVIDING INVESTMENT STRATEGIES, RESEARCH AND ANALYSIS RELATING TO HEDGING AGAINST VARIOUS MARKET RISKS, TRADING AND MARKET MAKING, TAILORED FI-

CLASS 36—(Continued).

NANCIAL RISK MANAGEMENT SERVICES; FOREIGN EXCHANGE SERVICES, NAMELY, PROVIDED IN RELATION TO STRUCTURED DERIVATIVE PRODUCTS, DEBT MARKETS, NAMELY, PROVIDING FINANCIAL RISK MANAGEMENT VIA STRUCTURED SECURITIES AND DERIVATIVES RELATING TO CREDIT AND INTEREST RATE RISK; RESEARCH SERVICES, NAMELY, FINANCIAL RESEARCH SERVICES, ECONOMIC COMMODITY AND FINANCIAL TREND REVIEW, COMMENTARY, ANALYSIS AND FORECASTING; ASSET AND WEALTH MANAGEMENT SERVICES, NAMELY, RETAIL FINANCIAL SERVICES, NAMELY, CASH MANAGEMENT TRUST ADMINISTRATION SERVICES, RETAIL SUPERANNUATION SERVICES, NAMELY, PROVIDING PENSION PLANS FOR NON-CORPORATE ENTITIES, ANNUITY UNDERWRITING AND ADMINISTRATION OF ANNUITY AND EMPLOYEE PENSION PLANS ADMINISTRATION, ALTERNATIVE ASSET FUND FINANCIAL MANAGEMENT SERVICES, THIRD PARTY MANAGED FUND DISTRIBUTION SERVICES, STRATEGIC FINANCIAL PLANNING SERVICES, EXECUTIVE WEALTH MANAGEMENT SERVICES, PRIVATE FINANCIAL PORTFOLIO MANAGEMENT SERVICES, FINANCIAL ADVISORY SERVICES AND BROKERAGE SERVICES PROVIDED IN RELATION TO CURRENCIES, COMMODITIES, DERIVATIVES, BONDS AND CASH SECURITIES; PRIVATE AND TRADITIONAL FUNDS FINANCIAL MANAGEMENT, SECURITIES FUNDS FINANCIAL MANAGEMENT, NAMELY, PROVIDING A RANGE OF MANAGED FUNDS IN EQUITIES, ALTERNATIVE INVESTMENTS, CURRENCY, CASH, BALANCED FUNDS, FIXED INTEREST AND SMALL CAP EQUITIES, SPECIALIST FUNDS FINANCIAL MANAGEMENT SERVICES, PROPERTY FUNDS FINANCIAL MANAGEMENT SERVICES AND PRIVATE EQUITY FUNDS FINANCIAL MANAGEMENT SERVICES; BROKERAGE SERVICES, NAMELY, STOCK BROKERAGE SERVICES, PRIVATE CLIENT BROKERAGE SERVICES IN THE FIELD OF STOCK AND COMMODITIES; LEASE-PURCHASE FINANCING SERVICES PROVIDED IN RELATION TO REAL ESTATE, INFRASTRUCTURE ASSETS BEING AIRPORTS, TOLL ROADS, PUBLIC UTILITIES, NAMELY, WATER, SEWERAGE, ELECTRICITY AND GAS, INFORMATION TECHNOLOGY EQUIPMENT, NAMELY, DESKTOPS, MONITORS, LAPTOPS, SERVERS, PRINTERS, COPIERS, COMPUTER NETWORK HUBS, SWITCHES, ROUTERS, AUDIO-VISUAL EQUIPMENT, MEDICAL EQUIPMENT, SCIENTIFIC EQUIPMENT, ELECTRONICS MANUFACTURING, MOTOR VEHICLE FLEETS, COMMERCIAL VEHICLES, EARTH MOVING EQUIPMENT, PLANT AND MACHINERY, TELECOMMUNICATIONS, JET AIRCRAFT ENGINES, VENDOR FINANCING, CAR PARKS; FINANCIAL ADVISORY SERVICES; FINANCIAL MANAGEMENT SERVICES; RISK MANAGEMENT SERVICES; UNDERWRITING SERVICES, NAMELY, PROCURING SUBSCRIBERS OR PURCHASERS FOR DEBT, EQUITY OR OTHER SECURITIES OFFERED FOR ISSUE OR SUBSCRIPTION (U.S. CLS. 100, 101 AND 102).

ANDREA K. NADELMAN, EXAMINING ATTORNEY

CLASS 36—(Continued).

SN 77-320,397. CONSOLIDATED RESORTS, INC., LAS VEGAS, NV. FILED 11-2-2007.

CONSOLIDATED RESORTS

THE MARK CONSISTS OF STANDARD CHARACTERS WITHOUT CLAIM TO ANY PARTICULAR FONT, STYLE, SIZE, OR COLOR.

SEC. 2(F).

FOR REAL ESTATE BROKERAGE AND LEASING; FORMATION, BROKERAGE AND MANAGEMENT OF TIME SHARE INTEREST IN VACATION PROPERTY (U.S. CLS. 100, 101 AND 102).

FIRST USE 4-1-1982; IN COMMERCE 4-1-1982.
RAMONA ORTIGA, EXAMINING ATTORNEY

SN 77-321,616. HARTFORD FIRE INSURANCE COMPANY, HARTFORD, CT. FILED 11-5-2007.

**Hartford ExtraOrdinary
Whole Life**

THE MARK CONSISTS OF STANDARD CHARACTERS WITHOUT CLAIM TO ANY PARTICULAR FONT, STYLE, SIZE, OR COLOR.

OWNER OF U.S. REG. NOS. 1,155,051 AND 2,249,001.

NO CLAIM IS MADE TO THE EXCLUSIVE RIGHT TO USE "WHOLE LIFE", APART FROM THE MARK AS SHOWN.

SEC. 2(F) AS TO "HARTFORD".

FOR LIFE INSURANCE UNDERWRITING AND ADMINISTRATION SERVICES (U.S. CLS. 100, 101 AND 102).
BRENDAN REGAN, EXAMINING ATTORNEY

SN 77-338,215. MADISON & PARK, INC., DENVER, CO. FILED 11-27-2007.

Madison & Park

THE MARK CONSISTS OF STANDARD CHARACTERS WITHOUT CLAIM TO ANY PARTICULAR FONT, STYLE, SIZE, OR COLOR.

FOR REAL ESTATE BROKERAGE (U.S. CLS. 100, 101 AND 102).

FIRST USE 11-1-2007; IN COMMERCE 11-1-2007.
KATINA MISTER, EXAMINING ATTORNEY

CLASS 36—(Continued).

SN 77-345,585. GLK STRATEGIC ADVISORS, INC., BOCA RATON, FL. FILED 12-6-2007.

Simplifying the complicated

THE MARK CONSISTS OF STANDARD CHARACTERS WITHOUT CLAIM TO ANY PARTICULAR FONT, STYLE, SIZE, OR COLOR.

FOR HEDGE FUND INVESTMENT SERVICES; FINANCIAL CONSULTANCY AND INSURANCE CONSULTANCY (U.S. CLS. 100, 101 AND 102).
LINDA LAVACHE, EXAMINING ATTORNEY

SN 77-349,204. BROCKWAY MORAN & PARTNERS, INC., BOCA RATON, FL. FILED 12-11-2007.

BROCKWAY MORAN & PARTNERS

THE MARK CONSISTS OF STANDARD CHARACTERS WITHOUT CLAIM TO ANY PARTICULAR FONT, STYLE, SIZE, OR COLOR.

OWNER OF U.S. REG. NO. 2,417,699.
NO CLAIM IS MADE TO THE EXCLUSIVE RIGHT TO USE "PARTNERS", APART FROM THE MARK AS SHOWN.
FOR INVESTMENT BANKING SERVICES AND INVESTMENT MANAGEMENT SERVICES (U.S. CLS. 100, 101 AND 102).
FIRST USE 5-0-1998; IN COMMERCE 5-0-1998.
YAT SYE, LEE, EXAMINING ATTORNEY

SN 77-351,309. CLSA B.V., AMSTERDAM, NETHERLANDS, FILED 12-13-2007.



NO CLAIM IS MADE TO THE EXCLUSIVE RIGHT TO USE "LIQUIDITY", APART FROM THE MARK AS SHOWN.

THE COLOR(S) BLUE (PANTONE 299) BLUE (PANTONE 294) AND GRAY (PANTONE 423) IS/ARE CLAIMED AS A FEATURE OF THE MARK.

THE MARK CONSISTS OF TWO SHADED OVALS INSIDE OF A CIRCLE FOLLOWED BY THE PHRASE "BLOCSEC INFINITE LIQUIDITY". THE WORD "BLOCSEC" IN STYLIZED BLUE CHARACTERS WITH GRAY TRIM AROUND EACH LETTER IS ABOVE THE PHRASE "INFINITE LIQUIDITY". THE PHRASE "INFINITE LIQUIDITY" IS IN STYLIZED CHARACTERS. "INFINITE" IS IN GRAY AND "LIQUIDITY" IS IN BLUE.

FOR FINANCIAL SERVICES, NAMELY, ELECTRONIC TRADING IN EQUITY SECURITIES AND OTHER FINANCIAL INSTRUMENTS (U.S. CLS. 100, 101 AND 102).

AMOS T. MATTHEWS, JR., EXAMINING ATTORNEY

CLASS 36—(Continued).

SN 77-356,430. ARGO GROUP INTERNATIONAL HOLDINGS, LTD., PEMBROKE, BERMUDA, FILED 12-20-2007.

ARGO SELECT

THE MARK CONSISTS OF STANDARD CHARACTERS WITHOUT CLAIM TO ANY PARTICULAR FONT, STYLE, SIZE, OR COLOR.

NO CLAIM IS MADE TO THE EXCLUSIVE RIGHT TO USE "SELECT", APART FROM THE MARK AS SHOWN.

FOR REINSURANCE UNDERWRITING; INSURANCE BROKERAGE; INSURANCE UNDERWRITING SERVICES FOR ALL TYPES OF INSURANCE (U.S. CLS. 100, 101 AND 102).

CHRISIE B. KING, EXAMINING ATTORNEY

SN 77-356,432. ARGO GROUP INTERNATIONAL HOLDINGS, LTD., PEMBROKE, BERMUDA, FILED 12-20-2007.

ARGO RE

THE MARK CONSISTS OF STANDARD CHARACTERS WITHOUT CLAIM TO ANY PARTICULAR FONT, STYLE, SIZE, OR COLOR.

NO CLAIM IS MADE TO THE EXCLUSIVE RIGHT TO USE "RE", APART FROM THE MARK AS SHOWN.

FOR REINSURANCE UNDERWRITING (U.S. CLS. 100, 101 AND 102).

FIRST USE 4-7-2008; IN COMMERCE 4-7-2008.

CHRISIE B. KING, EXAMINING ATTORNEY

SN 77-365,374. SUNFLOWER CHILDREN, NEW YORK, NY. FILED 1-7-2008.



NO CLAIM IS MADE TO THE EXCLUSIVE RIGHT TO USE "CHILDREN", APART FROM THE MARK AS SHOWN.

THE MARK CONSISTS OF THE WORDS "SUNFLOWER CHILDREN" AND A DESIGN OF THE SUN COMPRISED OF STYLIZED HUMAN FIGURES.

FOR CHARITABLE FUND RAISING SERVICES FOR THE MEDICAL, NUTRITIONAL, PSYCHOLOGICAL, EDUCATIONAL, AND HUMANITARIAN SUPPORT FOR THE ORPHANED, DISABLED, ABANDONED, REFUGEE AND IMPOVERISHED CHILDREN OF THE WORLD (U.S. CLS. 100, 101 AND 102).

FIRST USE 5-21-2008; IN COMMERCE 5-21-2008.

TEJBIR SINGH, EXAMINING ATTORNEY

CLASS 36—(Continued).

SN 77-365,763. RADLOVIC, MICHAEL M., LOS ANGELES, CA. FILED S.R. 1-7-2008; AM. P.R. 6-5-2008.

SmartFed

THE MARK CONSISTS OF STANDARD CHARACTERS WITHOUT CLAIM TO ANY PARTICULAR FONT, STYLE, SIZE, OR COLOR.

OWNER OF U.S. REG. NO. 3,289,188.

FOR BANKING SERVICES; AUTOMATED TELLER MACHINE SERVICES; SAVINGS, CHECKING AND CERTIFICATE OF DEPOSIT ACCOUNT SERVICES; CHECK CARD SERVICES; CREDIT CARD SERVICES; DEBIT CARD SERVICES; CASH CARD SERVICES; STORED VALUE CARD SERVICES; DEPOSIT CARD SERVICES; ONLINE BANKING SERVICES; ELECTRONIC PAYMENT SERVICES, NAMELY ELECTRONIC PROCESSING AND TRANSMISSION OF BILL PAYMENT DATA, MORTGAGE LENDING SERVICES; HOME EQUITY LENDING SERVICES; CONSUMER LENDING SERVICES; COMMERCIAL LENDING SERVICES; MORTGAGE BANKING SERVICES; NAMELY, ORIGINATION, ACQUISITION, SERVICING, SPECIALTY FINANCE LENDING SERVICES, NAMELY LENDING TO UNDERSERVED BORROWERS (U.S. CLS. 100, 101 AND 102).

FIRST USE 1-31-2007; IN COMMERCE 1-31-2007.
ODESSA BIBBINS, EXAMINING ATTORNEY

SN 77-374,467. LATIGO PARTNERS, L.P., NEW YORK, NY. FILED 1-17-2008.

LATIGO

THE MARK CONSISTS OF STANDARD CHARACTERS WITHOUT CLAIM TO ANY PARTICULAR FONT, STYLE, SIZE, OR COLOR.

OWNER OF U.S. REG. NO. 3,146,895.

THE ENGLISH TRANSLATION OF THE SPANISH WORD "LATIGO" IS "WHIP".

FOR FINANCIAL SERVICES, NAMELY, INVESTMENT ADVISORY SERVICES, MANAGEMENT OF INVESTMENT FUNDS, AND FUND MANAGEMENT SERVICES; HEDGE FUND INVESTMENT, MANAGEMENT, AND ADVISORY SERVICES (U.S. CLS. 100, 101 AND 102).

FIRST USE 6-0-2005; IN COMMERCE 6-0-2005.
DAVID H. STINE, EXAMINING ATTORNEY

CLASS 36—(Continued).

SN 77-380,437. SUTTON BOCA ONE DEVELOPERS LLC, BOCA RATON, FL. FILED 1-25-2008.

THE RESERVE SHOPPING CENTER

THE MARK CONSISTS OF STANDARD CHARACTERS WITHOUT CLAIM TO ANY PARTICULAR FONT, STYLE, SIZE, OR COLOR.

NO CLAIM IS MADE TO THE EXCLUSIVE RIGHT TO USE "SHOPPING CENTER", APART FROM THE MARK AS SHOWN.

FOR LEASING OF SHOPPING MALL SPACE (U.S. CLS. 100, 101 AND 102).

FIRST USE 1-0-2004; IN COMMERCE 1-0-2004.

DOMINIC J. FERRAIUOLO, EXAMINING ATTORNEY

SN 77-385,818. NUNEZ LAW GROUP, SAN DIEGO, CA. FILED 1-31-2008.

AIMSKYHI

THE MARK CONSISTS OF STANDARD CHARACTERS WITHOUT CLAIM TO ANY PARTICULAR FONT, STYLE, SIZE, OR COLOR.

FOR CONSULTING SERVICES TO HELP CLIENTS SET AND ACHIEVE GLOBAL PHILANTHROPY OBJECTIVES AND GOALS THROUGH DONATING MONEY TO SUPPORT A CHARITABLE CAUSE OVER AN EXTENDED PERIOD OF TIME (U.S. CLS. 100, 101 AND 102).

STEPHEN AQUILA, EXAMINING ATTORNEY

SN 77-385,906. TAUNTON FEDERAL CREDIT UNION, TAUNTON, MA. FILED 1-31-2008.

IWIZARDONLINE

THE MARK CONSISTS OF STANDARD CHARACTERS WITHOUT CLAIM TO ANY PARTICULAR FONT, STYLE, SIZE, OR COLOR.

FOR BANKING SERVICES (U.S. CLS. 100, 101 AND 102).

FIRST USE 1-1-2003; IN COMMERCE 1-1-2003.

JENNY PARK, EXAMINING ATTORNEY

CLASS 36—(Continued).

SN 77-387,580. THE KYLIE JANE LONG FOUNDATION, BATH, OH. FILED 2-4-2008.

HOPE ON THE SLOPES

THE MARK CONSISTS OF STANDARD CHARACTERS WITHOUT CLAIM TO ANY PARTICULAR FONT, STYLE, SIZE, OR COLOR.

FOR CHARITABLE FUNDRAISING SERVICES BY MEANS OF ENTERTAINMENT AND SPORTING EVENTS TO PROVIDE FINANCIAL AND EMOTIONAL SUPPORT TO CHILDREN AND THEIR FAMILIES FACING SERIOUS PEDIATRIC ILLNESSES (U.S. CLS. 100, 101 AND 102).

FIRST USE 12-1-2007; IN COMMERCE 12-1-2007. LIEF MARTIN, EXAMINING ATTORNEY

SN 77-388,472. SPC FINANCIAL, INC., ROCKVILLE, MD. FILED 2-5-2008.

Financial Advocate

THE MARK CONSISTS OF STANDARD CHARACTERS WITHOUT CLAIM TO ANY PARTICULAR FONT, STYLE, SIZE, OR COLOR.

NO CLAIM IS MADE TO THE EXCLUSIVE RIGHT TO USE "FINANCIAL", APART FROM THE MARK AS SHOWN.

FOR FINANCIAL PLANNING AND INVESTMENT ADVISORY SERVICES (U.S. CLS. 100, 101 AND 102).

FIRST USE 9-12-2007; IN COMMERCE 9-12-2007. DAWN FELDMAN, EXAMINING ATTORNEY

SN 77-391,380. B&B REALTY, INC., PLAINFIELD, IL. FILED 2-7-2008.



B&B Realty, Inc.
...working hard for you

NO CLAIM IS MADE TO THE EXCLUSIVE RIGHT TO USE "REALTY, INC.", APART FROM THE MARK AS SHOWN.

THE MARK CONSISTS OF A BUMBLEBEE WITH THREE POLYGONS.

FOR REAL ESTATE AGENCIES; REAL ESTATE BROKERAGE AND MANAGEMENT (U.S. CLS. 100, 101 AND 102).

FIRST USE 2-0-2007; IN COMMERCE 2-0-2007. MICHELE SWAIN, EXAMINING ATTORNEY

CLASS 36—(Continued).

SN 77-391,473. B&B REALTY, INC., PLAINFIELD, IL. FILED 2-7-2008.

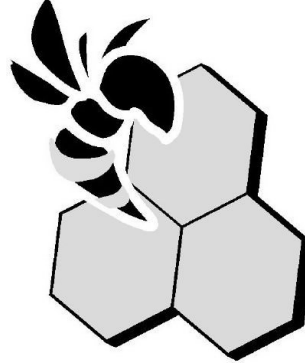

THE MARK CONSISTS OF A BUMBLEBEE WITH THREE POLYGONS.

FOR REAL ESTATE AGENCIES; REAL ESTATE BROKERAGE AND MANAGEMENT (U.S. CLS. 100, 101 AND 102).

FIRST USE 2-0-2007; IN COMMERCE 2-0-2007. MICHELE SWAIN, EXAMINING ATTORNEY

SN 77-396,023. OSPRAIE MANAGEMENT, LLC, NEW YORK, NY. FILED 2-13-2008.

THE OSPRAIE FOUNDATION

THE MARK CONSISTS OF STANDARD CHARACTERS WITHOUT CLAIM TO ANY PARTICULAR FONT, STYLE, SIZE, OR COLOR.

NO CLAIM IS MADE TO THE EXCLUSIVE RIGHT TO USE "FOUNDATION", APART FROM THE MARK AS SHOWN.

FOR ACCEPTING AND ADMINISTERING MONETARY CHARITABLE CONTRIBUTIONS (U.S. CLS. 100, 101 AND 102).

MICHAEL WIENER, EXAMINING ATTORNEY

SN 77-400,981. VANWEELDEN, JOHN D., WEST CHESTER, OH. FILED 2-19-2008.

The Real Deal on Money

THE MARK CONSISTS OF STANDARD CHARACTERS WITHOUT CLAIM TO ANY PARTICULAR FONT, STYLE, SIZE, OR COLOR.

FOR FINANCIAL ADVICE (U.S. CLS. 100, 101 AND 102).

FIRST USE 7-7-2007; IN COMMERCE 7-7-2007. ANDREA BUTLER, EXAMINING ATTORNEY

CLASS 36—(Continued).

SN 77-401,875. AXIS SPECIALTY U.S. SERVICES, INC., ALPHARETTA, GA. FILED 2-20-2008.

AXIS

THE MARK CONSISTS OF STANDARD CHARACTERS WITHOUT CLAIM TO ANY PARTICULAR FONT, STYLE, SIZE, OR COLOR.

FOR SPECIALTY PROPERTY AND CASUALTY INSURANCE UNDERWRITING AND SPECIALTY PROPERTY AND CASUALTY REINSURANCE UNDERWRITING PRIMARILY FOR COMMERCIAL CUSTOMERS, EXCLUDING SERVICES IN THE FIELDS OF HEALTH AND DISABILITY INCOME INSURANCE (U.S. CLS. 100, 101 AND 102).

FIRST USE 1-0-2002; IN COMMERCE 1-0-2002.
REBECCA SMITH, EXAMINING ATTORNEY

SN 77-401,898. AXIS SPECIALTY U.S. SERVICES, INC., ALPHARETTA, GA. FILED 2-20-2008.

THE MARK CONSISTS OF THE WORD "AXIS" IN AN OVAL.

FOR SPECIALTY PROPERTY AND CASUALTY INSURANCE UNDERWRITING AND SPECIALTY PROPERTY AND CASUALTY REINSURANCE UNDERWRITING PRIMARILY FOR COMMERCIAL CUSTOMERS, EXCLUDING SERVICES IN THE FIELDS OF HEALTH AND DISABILITY INCOME INSURANCE (U.S. CLS. 100, 101 AND 102).

FIRST USE 1-0-2002; IN COMMERCE 1-0-2002.
REBECCA SMITH, EXAMINING ATTORNEY

SN 77-407,599. EMPLOYERS MUTUAL CASUALTY COMPANY, DES MOINES, IA. FILED 2-27-2008.



OWNER OF U.S. REG. NO. 2,654,582.
FOR CREDIT UNION SERVICES (U.S. CLS. 100, 101 AND 102).
FIRST USE 10-30-2001; IN COMMERCE 10-30-2001.
SHAUNIA CARLYLE, EXAMINING ATTORNEY

CLASS 36—(Continued).

SN 77-409,461. NEWTEK BUSINESS SERVICES, INC., NEW YORK, NY. FILED 2-29-2008.

NEWTEK RECEIVABLES FINANCING

THE MARK CONSISTS OF STANDARD CHARACTERS WITHOUT CLAIM TO ANY PARTICULAR FONT, STYLE, SIZE, OR COLOR.

NO CLAIM IS MADE TO THE EXCLUSIVE RIGHT TO USE "RECEIVABLES FINANCING", APART FROM THE MARK AS SHOWN.

FOR FINANCING SERVICES; ACCOUNTS RECEIVABLES FINANCING SERVICES (U.S. CLS. 100, 101 AND 102).

CHERYL CLAYTON, EXAMINING ATTORNEY

SN 77-409,949. MIDDLESEX MUTUAL ASSURANCE COMPANY, MIDDLETOWN, CT. FILED 2-29-2008.

OWNER OF U.S. REG. NOS. 3,344,826, 3,346,091 AND 3,346,310.

NO CLAIM IS MADE TO THE EXCLUSIVE RIGHT TO USE "SPECIALTY", APART FROM THE MARK AS SHOWN.

THE MARK CONSISTS OF THE WORD "MIDDLE OAK" WITH THE WORD "SPECIALTY" UNDERNEATH WITH SIX CURVED LINES FORMING A TREE NEXT TO THE WORDS.

FOR UNDERWRITING PROPERTY AND CAUSALTY INSURANCE (U.S. CLS. 100, 101 AND 102).

FIRST USE 9-25-2006; IN COMMERCE 9-25-2006.
FRANK LATTUCA, EXAMINING ATTORNEY

SN 77-410,891. UNITED WAY OF GREATER ROCHESTER, INC., ROCHESTER, NY. FILED 3-3-2008.

CHILDREN'S SUCCESS FUND

THE MARK CONSISTS OF STANDARD CHARACTERS WITHOUT CLAIM TO ANY PARTICULAR FONT, STYLE, SIZE, OR COLOR.

NO CLAIM IS MADE TO THE EXCLUSIVE RIGHT TO USE "CHILDREN'S" AND "FUND", APART FROM THE MARK AS SHOWN.

FOR CHARITABLE FUND RAISING (U.S. CLS. 100, 101 AND 102).

STEVEN R. FINE, EXAMINING ATTORNEY

CLASS 36—(Continued).

SN 77-413,358. T.A.G. INSURANCE AND FINANCIAL SERVICES INC., GLENDALE, CA. FILED 3-5-2008.



NO CLAIM IS MADE TO THE EXCLUSIVE RIGHT TO USE "FIRM" AND "INSURANCE AGENCY" AND "HOME AUTO LIFE WORK", APART FROM THE MARK AS SHOWN.

THE MARK CONSISTS OF A CIRCLE WITH TWO COIL DESIGNS IN IT WITH THE LARGER SPINNING CLOCKWISE, AND A SMALLER ONE INSIDE OF BIG COIL SPINNING COUNTER CLOCK WISE. OUTSIDE OF THE OVERALL CIRCULAR DESIGN ARE THE STYLIZED WORDS "SAFE FIRM" AROUND THE TOP HALF, AND "INSURANCE AGENCY" AROUND THE LOWER PORTION. INSIDE THE CIRCLE BETWEEN THE SPIRAL COILS ARE THE STYLIZED WORDS "HOME", "AUTO", "LIFE", AND "WORK". SEPARATING THE WORDS "SAFE FIRM" AND "INSURANCE AGENCY" ON BOTH SIDES OF THE OVERALL CIRCULAR DESIGN ARE TWO SMALL CIRCLES, EACH CONTAINING THE LETTERS "SF".

FOR INSURANCE BROKERAGE; LIFE INSURANCE BROKERAGE; MUTUAL FUND BROKERAGE (U.S. CLS. 100, 101 AND 102).

FIRST USE 4-5-2007; IN COMMERCE 4-5-2007.
LINDA POWELL, EXAMINING ATTORNEY

SN 77-413,776. ACTS 1:8 MINISTRY, INCORPORATED, GREEN BAY, WI. FILED 3-5-2008.

ACTS 1:8 FOUNDATION

THE MARK CONSISTS OF STANDARD CHARACTERS WITHOUT CLAIM TO ANY PARTICULAR FONT, STYLE, SIZE, OR COLOR.

OWNER OF U.S. REG. NO. 3,224,164.
NO CLAIM IS MADE TO THE EXCLUSIVE RIGHT TO USE "FOUNDATION", APART FROM THE MARK AS SHOWN.

FOR CHARITABLE FOUNDATION SERVICES, NAMELY, FUND RAISING AND PHILANTHROPIC SERVICES CONCERNING MONETARY DONATIONS (U.S. CLS. 100, 101 AND 102).

FIRST USE 12-30-2005; IN COMMERCE 12-30-2005.
AISHA CLARKE, EXAMINING ATTORNEY

CLASS 36—(Continued).

SN 77-415,798. METROPOLITAN NATIONAL BANK, LITTLE ROCK, AR. FILED 3-7-2008.



OWNER OF U.S. REG. NO. 3,135,874.
NO CLAIM IS MADE TO THE EXCLUSIVE RIGHT TO USE "CAPITAL MANAGEMENT REGISTERED INVESTMENT ADVISERS", APART FROM THE MARK AS SHOWN.

THE MARK CONSISTS OF AN EAGLE SILHOUETTE IN A BOX WITH SIX STARS WITH THE WORDS "METROPOLITAN CAPITAL MANAGEMENT" TO THE RIGHT AND THE WORDS "REGISTERED INVESTMENT ADVISERS" UNDERNEATH SUCH WORDS.

FOR INVESTMENT ADVISORY SERVICES (U.S. CLS. 100, 101 AND 102).

B. PARADEWELAI, EXAMINING ATTORNEY

SN 77-417,568. BUYERS NATION, LLC, BROOKFIELD, WI. FILED 3-10-2008.



NO CLAIM IS MADE TO THE EXCLUSIVE RIGHT TO USE "REAL ESTATE", APART FROM THE MARK AS SHOWN.

THE MARK CONSISTS OF A COMPUTER WITH A ROOF TO THE LEFT OF THE STYLIZED TEXT "BUYERS NATION REAL ESTATE EVOLVED".

FOR REAL ESTATE BROKERAGE; REAL ESTATE CONSULTANCY; REAL ESTATE CONSULTATION; REAL ESTATE LENDING SERVICES; REAL ESTATE MULTIPLE LISTING SERVICES (U.S. CLS. 100, 101 AND 102).

FIRST USE 7-6-2007; IN COMMERCE 7-6-2007.
KATHERINE STOIDES, EXAMINING ATTORNEY

SN 77-417,868. WELLS FARGO & COMPANY, MINNEAPOLIS, MN. FILED 3-10-2008.

WELLS FARGO PAYMENT PROTECTOR

THE MARK CONSISTS OF STANDARD CHARACTERS WITHOUT CLAIM TO ANY PARTICULAR FONT, STYLE, SIZE, OR COLOR.

OWNER OF U.S. REG. NOS. 779,187, 3,396,296 AND OTHERS.

NO CLAIM IS MADE TO THE EXCLUSIVE RIGHT TO USE "PAYMENT" AND "PROTECTOR", APART FROM THE MARK AS SHOWN.

FOR FINANCIAL SERVICES, NAMELY, PROVIDING DEBT CANCELLATION SERVICES IN ASSOCIATION WITH CREDIT AND DEBIT CARD ACCOUNTS (U.S. CLS. 100, 101 AND 102).

PAULA MAHONEY, EXAMINING ATTORNEY

CLASS 36—(Continued).

SN 77-418,482. TRADEWINDS COMMERCE PARK - CENTRAL, LLC, TRAVERSE CITY, MI. FILED 3-11-2008.

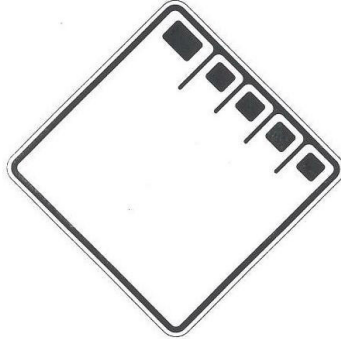

THE MARK CONSISTS OF A STYLIZED TOP VIEW OF A FOOT, HAVING A SQUARE, DOUBLE-EDGED OUTLINE AND SHOWING A STYLIZED VERSION OF A LARGE TWO AND FOUR SMALLER TOES.

FOR COMMERCIAL REAL ESTATE AGENCIES (U.S. CLS. 100, 101 AND 102).
CHARLES L. JENKINS, EXAMINING ATTORNEY

SN 77-418,809. MERK INVESTMENTS, LLC, PALO ALTO, CA. FILED 3-11-2008.

MERK ASIAN CURRENCY FUND

THE MARK CONSISTS OF STANDARD CHARACTERS WITHOUT CLAIM TO ANY PARTICULAR FONT, STYLE, SIZE, OR COLOR.

OWNER OF U.S. REG. NOS. 3,050,409, 3,050,410 AND 3,090,238.

NO CLAIM IS MADE TO THE EXCLUSIVE RIGHT TO USE "ASIAN CURRENCY FUND", APART FROM THE MARK AS SHOWN.

FOR INVESTMENT MANAGEMENT (U.S. CLS. 100, 101 AND 102).
RON FAIRBANKS, EXAMINING ATTORNEY

SN 77-419,251. NOVAPRO RISK SOLUTIONS, LP, SAN DIEGO, CA, CA. FILED 3-11-2008.

NOVAPRO RISK SOLUTIONS

THE MARK CONSISTS OF STANDARD CHARACTERS WITHOUT CLAIM TO ANY PARTICULAR FONT, STYLE, SIZE, OR COLOR.

NO CLAIM IS MADE TO THE EXCLUSIVE RIGHT TO USE "RISK SOLUTIONS", APART FROM THE MARK AS SHOWN.

FOR INSURANCE CLAIMS ADMINISTRATION (U.S. CLS. 100, 101 AND 102).

FIRST USE 2-0-2008; IN COMMERCE 2-0-2008.

CIMMERIAN COLEMAN, EXAMINING ATTORNEY

CLASS 36—(Continued).

SN 77-419,886. THE NATIONAL CHURCH SUPPLY COMPANY, INC., CHESTER, WV. FILED 3-12-2008.



NO CLAIM IS MADE TO THE EXCLUSIVE RIGHT TO USE "E-GIVING", APART FROM THE MARK AS SHOWN. THE COLOR(S) LIGHT BLUE, DARK BLUE AND WHITE IS/ARE CLAIMED AS A FEATURE OF THE MARK.

THE MARK CONSISTS OF A BLUE STARBURST THAT FADES TO A WHITE STAR IN THE CENTER. THE WORDS "E-GIVING" ARE IN DARK BLUE AND ARE BORDERED IN WHITE AND SHADOWED IN LIGHT BLUE.

FOR PROVIDING ELECTRONIC PROCESSING OF ACH AND CREDIT CARD TRANSACTIONS AND ELECTRONIC PAYMENTS VIA A GLOBAL COMPUTER NETWORK; CHARITABLE FUND RAISING; CHARITABLE FUND RAISING SERVICES (U.S. CLS. 100, 101 AND 102).

FIRST USE 1-31-2008; IN COMMERCE 1-31-2008.

MARY CRAWFORD, EXAMINING ATTORNEY

SN 77-420,016. EQUESTRIAN AID FOUNDATION, INC., WELLINGTON, FL. FILED 3-12-2008.



NO CLAIM IS MADE TO THE EXCLUSIVE RIGHT TO USE "EQUESTRIAN AID FOUNDATION", APART FROM THE MARK AS SHOWN.

THE MARK CONSISTS OF THE PROFILE OF A HORSE, IN WHITE, ON A BLACK BACKGROUND, WITH THE WORDS "EQUESTRIAN AID FOUNDATION" ABOVE THE HORSE, AND THE WORDS "THE RIDE FOR HOPE" BELOW THE HORSE. THE HORSE AND LETTERING ARE WHITE.

FOR MEMBERSHIP BASED ORGANIZATION FEATURING SERVICES TO ASSIST INDIVIDUALS IN THE EQUESTRIAN WORLD THAT HAVE SUFFERED A LIFE-THREATENING ILLNESS, CATASTROPHIC ACCIDENT OR INJURY BY PROVIDING DIRECT FINANCIAL SUPPORT FOR THEIR MEDICAL OR OTHER BASIC NEEDS (U.S. CLS. 100, 101 AND 102).

FIRST USE 10-1-2006; IN COMMERCE 10-1-2006.

RONALD AIKENS, EXAMINING ATTORNEY

CLASS 36—(Continued).

SN 77-421,834. PROSPERITY CAPITAL MANAGEMENT LIMITED, GEORGE TOWN, CAYMAN ISLANDS, FILED 3-14-2008.

**PROSPERITY CAPITAL
MANAGEMENT**

THE MARK CONSISTS OF STANDARD CHARACTERS WITHOUT CLAIM TO ANY PARTICULAR FONT, STYLE, SIZE, OR COLOR.

NO CLAIM IS MADE TO THE EXCLUSIVE RIGHT TO USE "CAPITAL MANAGEMENT", APART FROM THE MARK AS SHOWN.

FOR FINANCIAL SERVICES, NAMELY, INVESTMENT ADVISORY SERVICES, INVESTMENT MANAGEMENT SERVICES, ASSET MANAGEMENT SERVICES, AND FINANCIAL CONSULTANCY SERVICES, ALL RELATING TO INVESTMENTS IN EMERGING MARKETS (U.S. CLS. 100, 101 AND 102).

FIRST USE 9-19-1996; IN COMMERCE 5-6-2003.
ELLEN BURNS, EXAMINING ATTORNEY

SN 77-421,837. PROSPERITY CAPITAL MANAGEMENT LIMITED, GEORGE TOWN, CAYMAN ISLANDS, FILED 3-14-2008.



Prosperity Capital Management

NO CLAIM IS MADE TO THE EXCLUSIVE RIGHT TO USE "CAPITAL MANAGEMENT", APART FROM THE MARK AS SHOWN.

THE MARK CONSISTS OF SLIGHTLY OVERLAPPING UPPER CASE LETTERS "P", "C" AND "M" PLACED IN THE CENTER OF A SHADED OVAL WITH THE WORDS PROSPERITY CAPITAL MANAGEMENT, INITIAL CAPS, PRINTED DIRECTLY BENEATH THE SHADED OVAL.

FOR FINANCIAL SERVICES, NAMELY, INVESTMENT ADVISORY SERVICES, INVESTMENT MANAGEMENT SERVICES, ASSET MANAGEMENT SERVICES, AND FINANCIAL CONSULTANCY SERVICES, ALL RELATING TO INVESTMENTS IN EMERGING MARKETS (U.S. CLS. 100, 101 AND 102).

FIRST USE 9-19-1996; IN COMMERCE 5-6-2003.
ELLEN BURNS, EXAMINING ATTORNEY

CLASS 36—(Continued).

SN 77-422,028. COMMUNITY BANCORP, LAS VEGAS, NV. FILED 3-14-2008.



THE MARK CONSISTS OF A SOLID OVAL BIASECTED BY A VERTICAL LINE AND A HORIZONTAL LINE CENTERED WITHIN THE RIGHT SIDE OF THE BIASECTED OVAL.

FOR BANKING SERVICES; CREDIT CARD AND DEBIT CARD SERVICES; ELECTRONIC PAYMENT, NAMELY, ELECTRONIC PROCESSING AND TRANSMISSION OF BILL PAYMENT DATA; FINANCIAL MANAGEMENT; FINANCIAL CONSULTATION; FINANCIAL INVESTMENT IN THE FIELD OF INVESTMENT SECURITIES AND CERTIFICATES OF DEPOSIT (U.S. CLS. 100, 101 AND 102).

FIRST USE 7-14-1995; IN COMMERCE 7-14-1995.
KATHRYN COWARD, EXAMINING ATTORNEY

SN 77-422,325. OLD MUTUAL (US) HOLDINGS INC., BOSTON, MA. FILED 3-14-2008.

TARGET PLUS

THE MARK CONSISTS OF STANDARD CHARACTERS WITHOUT CLAIM TO ANY PARTICULAR FONT, STYLE, SIZE, OR COLOR.

NO CLAIM IS MADE TO THE EXCLUSIVE RIGHT TO USE "TARGET", APART FROM THE MARK AS SHOWN.

FOR MUTUAL FUND BROKERAGE SERVICES; MUTUAL FUND INVESTMENT SERVICES (U.S. CLS. 100, 101 AND 102).

AMY ALFIERI, EXAMINING ATTORNEY

SN 77-423,654. COMMUNITY BANK, NA, DEWITT, NY. FILED 3-17-2008.

TURBO CHECKING

THE MARK CONSISTS OF STANDARD CHARACTERS WITHOUT CLAIM TO ANY PARTICULAR FONT, STYLE, SIZE, OR COLOR.

NO CLAIM IS MADE TO THE EXCLUSIVE RIGHT TO USE "CHECKING", APART FROM THE MARK AS SHOWN.

FOR CHECKING ACCOUNT SERVICES (U.S. CLS. 100, 101 AND 102).

CHRISIE B. KING, EXAMINING ATTORNEY

CLASS 36—(Continued).

SN 77-424,911. GREAT AMERICAN LIFE INSURANCE COMPANY, CINCINNATI, OH. FILED 3-18-2008.

IncomeSustainer

THE MARK CONSISTS OF STANDARD CHARACTERS WITHOUT CLAIM TO ANY PARTICULAR FONT, STYLE, SIZE, OR COLOR.

FOR ANNUITY UNDERWRITING (U.S. CLS. 100, 101 AND 102).

JASON TURNER, EXAMINING ATTORNEY

SN 77-425,034. MAXN SYSTEMS, INC., SUNNYVALE, CA. FILED 3-18-2008.



NO CLAIM IS MADE TO THE EXCLUSIVE RIGHT TO USE "VISITORS COVERAGE", APART FROM THE MARK AS SHOWN.

THE MARK CONSISTS OF A STYLIZED REPRESENTATION OF A HUMAN FIGURE COMPOSED OF GEOMETRIC SHAPES, HOLDING A SUITCASE, WITH A CRESCENT SHAPE EXTENDING FROM THE SUITCASE AND CONTINUING ABOVE THE STYLIZED FIGURE, FOLLOWED BY THE WORDS "VISITORS COVERAGE".

FOR INSURANCE AGENCIES IN THE FIELD OF INTERNATIONAL TRAVEL INSURANCE AND TRAVEL HEALTH INSURANCE (U.S. CLS. 100, 101 AND 102).

FIRST USE 3-12-2006; IN COMMERCE 3-12-2006.
JESSICA A. POWERS, EXAMINING ATTORNEY

CLASS 36—(Continued).

SN 77-425,793. CAPITOL BANCORP LTD, DBA CAPITOL BANCORP LIMITED, LANSING, MI. FILED 3-19-2008.



OWNER OF U.S. REG. NO. 3,015,245.
NO CLAIM IS MADE TO THE EXCLUSIVE RIGHT TO USE "5K" OR "BANCORP", APART FROM THE MARK AS SHOWN.

THE COLOR(S) WHITE, BROWN, BLACK AND RED IS/ ARE CLAIMED AS A FEATURE OF THE MARK.

THE MARK CONSISTS OF A BLACK CHALKBOARD WITH A BROWN WOOD FRAME. A PAIR OF RED SHOES WITH BLACK AND WHITE STRIPES, WHITE SHOELACES AND BLACK CLEATS IS HUNG OVER THE UPPER RIGHT HAND CORNER OF THE CHALKBOARD. A RED APPLE IS SUPERIMPOSED ON THE RIGHT EDGE OF THE CHALKBOARD. THE WORDING "CAPITOL BANCORP 5K FOR JA" APPEARS IN WHITE LETTERING ON THE BLACK CHALKBOARD.

FOR CHARITABLE FUND RAISING (U.S. CLS. 100, 101 AND 102).

FIRST USE 5-1-2004; IN COMMERCE 5-1-2005.
DAVID H. STINE, EXAMINING ATTORNEY

SN 77-425,831. POPULAR, INC., SAN JUAN, PUERTO RICO, FILED 3-19-2008.

u-design

THE MARK CONSISTS OF STANDARD CHARACTERS WITHOUT CLAIM TO ANY PARTICULAR FONT, STYLE, SIZE, OR COLOR.

FOR CREDIT CARD SERVICES (U.S. CLS. 100, 101 AND 102).

STEVEN PEREZ, EXAMINING ATTORNEY

CLASS 36—(Continued).

SN 77-426,639. OXYGEN FINANCIAL, INC., MILTON, GA. FILED 3-19-2008.



NO CLAIM IS MADE TO THE EXCLUSIVE RIGHT TO USE "FINANCIAL", APART FROM THE MARK AS SHOWN.

THE COLOR(S) BLUE, LIGHT BLUE AND WHITE IS/ARE CLAIMED AS A FEATURE OF THE MARK.

THE MARK CONSISTS OF THE WORD "OXYGEN" WITH THE "XYG" CAPITALIZED. THE OTHER LETTERS IN THE WORD ARE IN LOWER CASE. THE UPPER HALF OF THE LETTERS ARE IN DARK BLUE, AND THE BLUE LIGHTENS TOWARDS THE LOWER HALF OF THE LETTERS SO THAT THE LOWER HALF OF THE LETTERS IS WHITE. THE WORD "FINANCIAL" IS UNDER "OXYGEN" IN OUTLINED WHITE CAPITAL LETTERS, AND IS IN A DIFFERENT FONT FROM THE ONE USED FOR "OXYGEN"; UNDER THE WORD "FINANCIAL" IS A THIN WHITE LINE, AND BENEATH THIS LINE APPEAR THE WORDS "BREATHE EASIER" IN SMALL WHITE CAPITAL LETTERS. THE BACKGROUND COLOR OF THE MARK IS SKY BLUE, AND WHITE CLOUDS APPEAR IN THE UPPER RIGHT PART OF THE MARK, DIRECTLY ABOVE THE "GEN" IN "OXYGEN".

FOR FINANCIAL SERVICES, NAMELY, FINANCIAL CONSULTATION IN THE FIELDS OF ASSET MANAGEMENT, PROPERTY, CASUALTY INSURANCE AND MORTGAGES (U.S. CLS. 100, 101 AND 102).

MARGERY A. TIERNEY, EXAMINING ATTORNEY

SN 77-427,174. FRIENDLY FINANCE CORPORATION, BALTIMORE, MD. FILED 3-20-2008.

Turning Problems into Solutions

THE MARK CONSISTS OF STANDARD CHARACTERS WITHOUT CLAIM TO ANY PARTICULAR FONT, STYLE, SIZE, OR COLOR.

FOR FINANCIAL SERVICES IN THE FIELD OF MONEY LENDING (U.S. CLS. 100, 101 AND 102).

PAM WILLIS, EXAMINING ATTORNEY

CLASS 36—(Continued).

SN 77-427,266. SALLIE MAE, INC., RESTON, VA. FILED 3-20-2008.

Sallie Mae Dental School Loans

THE MARK CONSISTS OF STANDARD CHARACTERS WITHOUT CLAIM TO ANY PARTICULAR FONT, STYLE, SIZE, OR COLOR.

OWNER OF U.S. REG. NOS. 1,337,128, 3,271,420 AND OTHERS.

NO CLAIM IS MADE TO THE EXCLUSIVE RIGHT TO USE "DENTAL SCHOOL LOANS", APART FROM THE MARK AS SHOWN.

FOR STUDENT LOAN SERVICES (U.S. CLS. 100, 101 AND 102).

FIRST USE 3-20-2008; IN COMMERCE 3-20-2008.

EUGENIA MARTIN, EXAMINING ATTORNEY

SN 77-427,313. SALLIE MAE, INC., RESTON, VA. FILED 3-20-2008.

Sallie Mae Law School Loans

THE MARK CONSISTS OF STANDARD CHARACTERS WITHOUT CLAIM TO ANY PARTICULAR FONT, STYLE, SIZE, OR COLOR.

OWNER OF U.S. REG. NOS. 1,337,128, 3,271,420 AND OTHERS.

NO CLAIM IS MADE TO THE EXCLUSIVE RIGHT TO USE "LAW SCHOOL LOANS", APART FROM THE MARK AS SHOWN.

FOR STUDENT LOAN SERVICES (U.S. CLS. 100, 101 AND 102).

FIRST USE 3-20-2008; IN COMMERCE 3-20-2008.

EUGENIA MARTIN, EXAMINING ATTORNEY

SN 77-427,331. SALLIE MAE, INC., RESTON, VA. FILED 3-20-2008.

SALLIE MAE MEDICAL SCHOOL LOANS

THE MARK CONSISTS OF STANDARD CHARACTERS WITHOUT CLAIM TO ANY PARTICULAR FONT, STYLE, SIZE, OR COLOR.

OWNER OF U.S. REG. NOS. 1,337,128, 3,271,420 AND OTHERS.

NO CLAIM IS MADE TO THE EXCLUSIVE RIGHT TO USE "MEDICAL SCHOOL LOANS", APART FROM THE MARK AS SHOWN.

FOR STUDENT LOAN SERVICES (U.S. CLS. 100, 101 AND 102).

FIRST USE 3-20-2008; IN COMMERCE 3-20-2008.

EUGENIA MARTIN, EXAMINING ATTORNEY

CLASS 36—(Continued).

SN 77-427,351. NEWTEK BUSINESS SERVICES, INC., NEW YORK, NY. FILED 3-20-2008.

NEWTEK BUSINESS CREDIT

THE MARK CONSISTS OF STANDARD CHARACTERS WITHOUT CLAIM TO ANY PARTICULAR FONT, STYLE, SIZE, OR COLOR.

NO CLAIM IS MADE TO THE EXCLUSIVE RIGHT TO USE "BUSINESS CREDIT", APART FROM THE MARK AS SHOWN.

FOR FINANCING SERVICES; ACCOUNTS RECEIVABLES FINANCING SERVICES (U.S. CLS. 100, 101 AND 102).

CHERYL CLAYTON, EXAMINING ATTORNEY

SN 77-427,670. RENOAK MORTGAGE, MCKINNEY, TX. FILED 3-20-2008.

WHERE DREAMS GROW

THE MARK CONSISTS OF STANDARD CHARACTERS WITHOUT CLAIM TO ANY PARTICULAR FONT, STYLE, SIZE, OR COLOR.

FOR INSURANCE BROKERAGE; MORTGAGE BROKERAGE (U.S. CLS. 100, 101 AND 102).

SAIMA MAKHDOOM, EXAMINING ATTORNEY

SN 77-427,881. THE QUERCUS TRUST, COSTA MESA, CA. FILED 3-20-2008.



quercustrust

THE MARK CONSISTS OF A TREE ABOVE THE WORD "QUERCUSTRUST".

FOR CAPITAL INVESTMENT IN THE FIELD OF DEBT AND EQUITY; FINANCIAL INVESTMENT IN THE FIELDS OF REAL ESTATE, DEBT AND EQUITY SECURITIES, DERIVATIVE SECURITIES AND OTHER INVESTMENT VEHICLES, SUCH AS PARTNERSHIP AND LIMITED LIABILITY COMPANY INTERESTS AND TRUSTS; MUTUAL FUNDS INVESTMENT (U.S. CLS. 100, 101 AND 102).

FIRST USE 3-19-2008; IN COMMERCE 3-19-2008.
TAMARA FRAZIER, EXAMINING ATTORNEY

CLASS 36—(Continued).

SN 77-427,986. BELRON HUNGARY KFT. ZUG BRANCH, CH 6304 ZUG, SWITZERLAND, FILED 3-21-2008.

PREFERRED CARE

THE MARK CONSISTS OF STANDARD CHARACTERS WITHOUT CLAIM TO ANY PARTICULAR FONT, STYLE, SIZE, OR COLOR.

FOR ADMINISTRATION OF INSURANCE PAYMENT SYSTEMS FOR MOTOR VEHICLE GLASS REPAIR AND GLASS REPLACEMENT PROGRAMS (U.S. CLS. 100, 101 AND 102).

DANNEAN HETZEL, EXAMINING ATTORNEY

SN 77-428,026. STATEWIDE INSURANCE, LLC, DADE CITY, FL. FILED 3-21-2008.

way2insure

THE MARK CONSISTS OF STANDARD CHARACTERS WITHOUT CLAIM TO ANY PARTICULAR FONT, STYLE, SIZE, OR COLOR.

FOR INSURANCE AGENCIES; INSURANCE AGENCY AND BROKERAGE; INSURANCE CONSULTANCY; INSURANCE CONSULTANCY SERVICES, NAMELY, PROVIDING ADVICE IN THE FIELD OF PROPERTY AND CASUALTY INSURANCE; INSURANCE CONSULTATION; INSURANCE INFORMATION; INSURANCE INFORMATION AND CONSULTANCY (U.S. CLS. 100, 101 AND 102).

BERYL GARDNER, EXAMINING ATTORNEY

SN 77-428,309. MOUNTAINEERS, THE, SEATTLE, WA. FILED 3-21-2008.

BRAIDED RIVER

THE MARK CONSISTS OF STANDARD CHARACTERS WITHOUT CLAIM TO ANY PARTICULAR FONT, STYLE, SIZE, OR COLOR.

FOR CHARITABLE FUNDRAISING SERVICE THAT SUPPORTS CAUSES RELATING TO A WIDE VARIETY OF GENERAL ENVIRONMENTAL, CONSERVATION AND NATURAL HISTORY TOPICS (U.S. CLS. 100, 101 AND 102).

FIRST USE 3-0-2007; IN COMMERCE 12-0-2007.
ELLEN B. AWRICH, EXAMINING ATTORNEY

CLASS 36—(Continued).

SN 77-428,331. TPC OPERATIONS, LLC, MOORPARK, CA.
FILED 3-21-2008.

THE PLAYERS CLUB

THE MARK CONSISTS OF STANDARD CHARACTERS WITHOUT CLAIM TO ANY PARTICULAR FONT, STYLE, SIZE, OR COLOR.

FOR PROVIDING INFORMATION IN THE FIELD OF FINANCE THROUGH THE INTERNET; PROVIDING INFORMATION AND ASSISTANCE IN CONNECTION WITH ANNUITIES (U.S. CLS. 100, 101 AND 102).
MARK RADEMACHER, EXAMINING ATTORNEY

SN 77-428,449. WOMEN THAT SOAR, LLC, MESQUITE, TX.
FILED 3-21-2008.

BRILLIANTLY YOU

THE MARK CONSISTS OF STANDARD CHARACTERS WITHOUT CLAIM TO ANY PARTICULAR FONT, STYLE, SIZE, OR COLOR.

FOR CHARITABLE FUND RAISING SERVICES BY MEANS OF ACHIEVEMENT AWARD EVENTS, SOCIAL EVENTS AND BUSINESS NETWORKING EVENTS (U.S. CLS. 100, 101 AND 102).
CHRISTINE BLOMQUIST, EXAMINING ATTORNEY

SN 77-428,563. WEINSTEIN MANAGEMENT CO., INC.,
GLEN ALLEN, VA. FILED 3-21-2008.

BEXLEY AT BRIER CREEK

THE MARK CONSISTS OF STANDARD CHARACTERS WITHOUT CLAIM TO ANY PARTICULAR FONT, STYLE, SIZE, OR COLOR.

OWNER OF U.S. REG. NOS. 2,889,355, 3,222,386 AND OTHERS.

FOR REAL ESTATE SERVICES, NAMELY, LEASING AND MANAGEMENT OF REAL PROPERTY (U.S. CLS. 100, 101 AND 102).

FIRST USE 1-25-2008; IN COMMERCE 1-25-2008.
LAURA HAMMEL, EXAMINING ATTORNEY

CLASS 36—(Continued).

SN 77-428,721. MERRILL LYNCH BANK & TRUST CO., FSB,
DBA FIRST REPUBLIC BANK, NEW YORK, NY. FILED 3-21-2008.

**IT'S A PRIVILEGE TO SERVE
YOU**

THE MARK CONSISTS OF STANDARD CHARACTERS WITHOUT CLAIM TO ANY PARTICULAR FONT, STYLE, SIZE, OR COLOR.

OWNER OF U.S. REG. NO. 2,209,636.
FOR SAFETY DEPOSIT BOX SERVICES (U.S. CLS. 100, 101 AND 102).
ALEXANDER L. POWERS, EXAMINING ATTORNEY

SN 77-428,724. MERRILL LYNCH BANK & TRUST CO., FSB,
DBA FIRST REPUBLIC BANK, NEW YORK, NY. FILED 3-21-2008.

**IT'S A PRIVILEGE TO SERVE
YOU**

THE MARK CONSISTS OF STANDARD CHARACTERS WITHOUT CLAIM TO ANY PARTICULAR FONT, STYLE, SIZE, OR COLOR.

OWNER OF U.S. REG. NO. 2,209,636.

FOR CREDIT CARD SERVICES; DEBIT CARD SERVICES; COMMERCIAL AND CONSUMER LENDING, LEASING, AND FINANCING; TRUST, ESTATE, AND FIDUCIARY MANAGEMENT, PLANNING, AND CONSULTING; INVESTMENT SERVICES, NAMELY, PROVIDING INVESTMENT ANALYSIS, CONSULTATION, PLANNING, MANAGEMENT, ADVISORY, BROKERAGE, BANKING, AND RESEARCH SERVICES WITH RESPECT TO STOCKS, MUTUAL FUNDS, SECURITIES, BONDS, COMMODITIES, REAL ESTATE AND OTHER INSTRUMENTS OF INVESTMENT; PROVIDING SECURE FINANCIAL TRANSACTIONS IN THE NATURE OF ELECTRONIC CASH TRANSACTIONS, ELECTRONIC CREDIT CARD TRANSACTIONS, ELECTRONIC DEBIT TRANSACTIONS, ELECTRONIC CHECK PROCESSING TRANSACTIONS AND ELECTRONIC TRANSMISSION OF BILL PAYMENT DATA VIA A GLOBAL COMPUTER NETWORK; FINANCIAL PLANNING AND INVESTMENT ADVISORY SERVICES; FINANCIAL PLANNING CONSULTATION; AUTOMATED TELLER MACHINE SERVICES (U.S. CLS. 100, 101 AND 102).

FIRST USE 9-1-1997; IN COMMERCE 9-1-1997.
ALEXANDER L. POWERS, EXAMINING ATTORNEY

CLASS 36—(Continued).

SN 77-429,254. SEVEN CORNERS, INC., CARMEL, IN. FILED 3-24-2008.

Wander

THE MARK CONSISTS OF STANDARD CHARACTERS WITHOUT CLAIM TO ANY PARTICULAR FONT, STYLE, SIZE, OR COLOR.

FOR INSURANCE UNDERWRITING IN THE FIELD OF MEDICAL, LIFE, ACCIDENT AND DISABILITY (U.S. CLS. 100, 101 AND 102).

BENJAMIN ALLEN, EXAMINING ATTORNEY

SN 77-429,768. ROBERT A. MCNEIL, HOUSTON, TX. FILED 3-24-2008.

VOTE WITH YOUR DOLLARS

THE MARK CONSISTS OF STANDARD CHARACTERS WITHOUT CLAIM TO ANY PARTICULAR FONT, STYLE, SIZE, OR COLOR.

FOR TAX PAYMENT PROCESSING SERVICES (U.S. CLS. 100, 101 AND 102).

ELLEN PERKINS, EXAMINING ATTORNEY

SN 77-429,784. CATHY PARETO AND ASSOCIATES, INC., MIAMI, FL. FILED 3-24-2008.

The 360° Financial Review

THE MARK CONSISTS OF STANDARD CHARACTERS WITHOUT CLAIM TO ANY PARTICULAR FONT, STYLE, SIZE, OR COLOR.

NO CLAIM IS MADE TO THE EXCLUSIVE RIGHT TO USE "FINANCIAL REVIEW", APART FROM THE MARK AS SHOWN.

FOR FINANCIAL ADVICE; FINANCIAL ADVICE AND CONSULTANCY SERVICES; FINANCIAL ADVISORY AND CONSULTANCY SERVICES; FINANCIAL ADVISORY AND CONSULTANCY SERVICES RELATING TO MICRO CREDITS, MICRO FINANCE AND ENERGY PRODUCTS; FINANCIAL ANALYSIS AND CONSULTATION; FINANCIAL ANALYSIS AND RESEARCH SERVICES; FINANCIAL AND INVESTMENT SERVICES, NAMELY, MANAGEMENT AND BROKERAGE IN THE FIELDS OF STOCKS, BONDS, OPTIONS, COMMODITIES, FUTURES AND OTHER SECURITIES, AND THE INVESTMENT OF FUNDS OF OTHERS; FINANCIAL CONSULTANCY; FINANCIAL CONSULTANCY AND INSURANCE CONSULTANCY; FINANCIAL EVALUATION FOR INSURANCE PURPOSES; FINANCIAL INFORMATION AND ADVISORY SERVICES; FINANCIAL PLANNING; FINANCIAL PLANNING AND INVESTMENT ADVISORY SERVICES; FINANCIAL PLANNING

CLASS 36—(Continued).

CONSULTATION; FINANCIAL PLANNING FOR RETIREMENT; FINANCIAL PLANNING, NAMELY, THE CREATION OF PERSONALIZED STRATEGIES TO ACHIEVE FINANCIAL INDEPENDENCE; FINANCIAL PORTFOLIO ANALYSIS SERVICES; FINANCIAL PORTFOLIO MANAGEMENT; FINANCIAL RESEARCH; FINANCIAL RESEARCH AND INFORMATION SERVICES; FINANCIAL RISK MANAGEMENT; FINANCIAL RISK MANAGEMENT CONSULTATION; FINANCIAL SERVICES IN THE NATURE OF AN INVESTMENT SECURITY; FINANCIAL SERVICES, NAMELY, A TOTAL PORTFOLIO OFFERING FOR HIGH NET WORTH CLIENTS CONSISTING OF BOTH SEPARATE ACCOUNTS AND MUTUAL FUNDS FOR EQUITY AND FIXED INCOME INVESTMENTS; INSURANCE AND FINANCIAL INFORMATION AND CONSULTANCY SERVICES; PROVIDING INFORMATION AND ADVICE IN THE FIELD OF FINANCE, FINANCIAL INVESTMENTS, FINANCIAL VALUATIONS, AND THE FINANCIAL ASPECTS OF RETIREMENT (U.S. CLS. 100, 101 AND 102).

RONALD MCMORROW, EXAMINING ATTORNEY

SN 77-429,895. ENTERGY CORPORATION, NEW ORLEANS, LA. FILED 3-24-2008.

THE POWER TO CARE

THE MARK CONSISTS OF STANDARD CHARACTERS WITHOUT CLAIM TO ANY PARTICULAR FONT, STYLE, SIZE, OR COLOR.

FOR CHARITABLE FUNDRAISING SERVICES IN THE NATURE OF RAISING FUNDS TO ASSIST LOW-INCOME ELDERLY AND DISABLED UTILITY SERVICES CUSTOMERS WITH UTILITY PAYMENTS (U.S. CLS. 100, 101 AND 102).

RAMONA ORTIGA, EXAMINING ATTORNEY

SN 77-430,141. CREDILIFE, INC., MIAMI, FL. FILED 3-24-2008.

CREDILIFE

THE MARK CONSISTS OF STANDARD CHARACTERS WITHOUT CLAIM TO ANY PARTICULAR FONT, STYLE, SIZE, OR COLOR.

FOR FINANCIAL INFORMATION AND ADVISORY SERVICES (U.S. CLS. 100, 101 AND 102).

FIRST USE 1-15-2005; IN COMMERCE 1-15-2005.
AMEETA JORDAN, EXAMINING ATTORNEY

CLASS 36—(Continued).

SN 77-430,152. PREMIER SERVICER SOLUTIONS, INC., DBA ALOHA REAL ESTATE GROUP, HOUSTON, TX. FILED 3-24-2008.

We say Hello & Goodbye

THE MARK CONSISTS OF STANDARD CHARACTERS WITHOUT CLAIM TO ANY PARTICULAR FONT, STYLE, SIZE, OR COLOR.

FOR APPRAISAL OF REAL ESTATE; APPRAISALS FOR INSURANCE CLAIMS OF REAL ESTATE; ASSESSMENT AND MANAGEMENT OF REAL ESTATE; EVALUATION OF REAL PROPERTY; FINANCIAL INVESTMENT IN THE FIELD OF REAL ESTATE; FINANCIAL VALUATION OF PERSONAL PROPERTY AND REAL ESTATE; HOUSING SERVICES, NAMELY, REAL PROPERTY ACQUISITION AND CONSUMER FINANCING TO FACILITATE HOME OWNERSHIP; LAND ACQUISITION, NAMELY, REAL ESTATE BROKERAGE; LEASING OF REAL ESTATE; PROVIDING INFORMATION IN THE FIELD OF REAL ESTATE BY MEANS OF LINKING THE WEB SITE TO OTHER WEB SITES FEATURING REAL ESTATE INFORMATION; PROVIDING INFORMATION IN THE FIELD OF REAL ESTATE VIA THE INTERNET; PROVIDING REAL ESTATE LISTINGS AND REAL ESTATE INFORMATION VIA THE INTERNET; REAL ESTATE ACQUISITION SERVICES; REAL ESTATE AGENCIES; REAL ESTATE APPRAISAL; REAL ESTATE APPRAISAL AND VALUATION; REAL ESTATE BROKERAGE; REAL ESTATE CONSULTANCY; REAL ESTATE CONSULTATION; REAL ESTATE EQUITY SHARING, NAMELY, MANAGING AND ARRANGING FOR CO-OWNERSHIP OF REAL ESTATE; REAL ESTATE ESCROW SERVICES; REAL ESTATE INVESTMENT; REAL ESTATE INVESTMENT SERVICES IN THE NATURE OF PURCHASING AND SELLING OF REAL ESTATE FOR OTHERS; REAL ESTATE LENDING SERVICES; REAL ESTATE LISTING; REAL ESTATE MANAGEMENT; REAL ESTATE MANAGEMENT CONSULTATION; REAL ESTATE MULTIPLE LISTING SERVICES; REAL ESTATE PROCUREMENT FOR OTHERS; REAL ESTATE RENTAL SERVICES, NAMELY, RENTAL OF RESIDENTIAL HOUSING; REAL ESTATE SERVICES IN THE FORM OF PROVIDING PHYSICAL ACCESS TO AVAILABLE PROPERTIES VIA A REMOTE CALL-IN LOCKING DEVICE; REAL ESTATE SERVICES, NAMELY, RENTAL OF SHORT-TERM FURNISHED APARTMENTS; REAL ESTATE SERVICES, NAMELY, RENTAL OF VACATION HOMES, CONDOMINIUMS, CABINS, AND VILLAS USING PAY PER CLICK ADVERTISING ON A GLOBAL COMPUTER NETWORK; REAL ESTATE SYNDICATION; REAL ESTATE TRUSTEE SERVICES; REAL ESTATE VALUATION SERVICES; REAL ESTATE VALUATIONS; VACATION REAL ESTATE TIME SHARE EXCHANGE SERVICES; VACATION REAL ESTATE TIME-SHARING; VACATION REAL ESTATE TIME-SHARE SERVICES (U.S. CLS. 100, 101 AND 102).

ANN E. SAPPENFIELD, EXAMINING ATTORNEY

CLASS 36—(Continued).

SN 77-430,286. SIMPSON, TROY, DESOTO, TX. FILED 3-24-2008.

TRAFFICARE

THE MARK CONSISTS OF STANDARD CHARACTERS WITHOUT CLAIM TO ANY PARTICULAR FONT, STYLE, SIZE, OR COLOR.

FOR BILL PAYMENT SERVICES FOR THE PAYMENT OF FINES, DEFENSIVE DRIVING COURSE COSTS, DRIVER SAFETY COURSE COSTS, ATTORNEY FEES, COURT COSTS, AND INCREASES IN INSURANCE PREMIUMS THAT RESULT FROM RECEIVING ONE OR MORE TRAFFIC TICKETS (U.S. CLS. 100, 101 AND 102).

EDWARD FENNESSY, EXAMINING ATTORNEY

SN 77-430,419. PEARCE, ROBERT W., WICHITA, KS. AND PEARCE, ERMA STARLENE, WICHITA, KS. FILED 3-25-2008.



THE MARK CONSISTS OF MAN IN A COAT AND TOP HAT WITH A HAND ON A "CENTS" SYMBOL.

FOR BANKING SERVICES, CREDIT CARD SERVICES, DEBIT CARD SERVICES, FINANCIAL PLANNING (U.S. CLS. 100, 101 AND 102).

JASON BLAIR, EXAMINING ATTORNEY

SN 77-430,506. AMPHOR CAPITAL MANAGEMENT, LLC, NEW YORK, NY. FILED 3-25-2008.

AMPHOR

THE MARK CONSISTS OF STANDARD CHARACTERS WITHOUT CLAIM TO ANY PARTICULAR FONT, STYLE, SIZE, OR COLOR.

FOR FINANCIAL SERVICES, NAMELY, INVESTMENT MANAGEMENT AND ADVISORY SERVICES AND HEDGE FUND INVESTMENT SERVICES (U.S. CLS. 100, 101 AND 102).

JOHN DWYER, EXAMINING ATTORNEY

CLASS 36—(Continued).

SN 77-430,515. AMPHOR CAPITAL MANAGEMENT, LLC, NEW YORK, NY. FILED 3-25-2008.

AMPHOR CAPITAL

THE MARK CONSISTS OF STANDARD CHARACTERS WITHOUT CLAIM TO ANY PARTICULAR FONT, STYLE, SIZE, OR COLOR.

NO CLAIM IS MADE TO THE EXCLUSIVE RIGHT TO USE "CAPITAL", APART FROM THE MARK AS SHOWN.

FOR FINANCIAL SERVICES, NAMELY, INVESTMENT MANAGEMENT AND ADVISORY SERVICES AND HEDGE FUND INVESTMENT SERVICES (U.S. CLS. 100, 101 AND 102).

JOHN DWYER, EXAMINING ATTORNEY

CLASS 36—(Continued).

SN 77-430,634. OVVO FINANCIAL SYSTEMS, LLC, SPRING LAKE, NJ. FILED 3-25-2008.

OVVO

THE MARK CONSISTS OF STANDARD CHARACTERS WITHOUT CLAIM TO ANY PARTICULAR FONT, STYLE, SIZE, OR COLOR.

FOR FINANCIAL ADVISORY AND CONSULTANCY SERVICES; FINANCIAL ANALYSIS AND RESEARCH SERVICES (U.S. CLS. 100, 101 AND 102).

LINDA ESTRADA, EXAMINING ATTORNEY

SN 77-430,518. PRESPOINT CAPITAL LLC, SAN FRANCISCO, CA. FILED 3-25-2008.

PresPoint Capital

THE MARK CONSISTS OF STANDARD CHARACTERS WITHOUT CLAIM TO ANY PARTICULAR FONT, STYLE, SIZE, OR COLOR.

NO CLAIM IS MADE TO THE EXCLUSIVE RIGHT TO USE "CAPITAL", APART FROM THE MARK AS SHOWN.

FOR HEDGE FUND INVESTMENT SERVICES; INVESTMENT MANAGEMENT (U.S. CLS. 100, 101 AND 102).

FIRST USE 3-7-2008; IN COMMERCE 3-14-2008.
RENEE MCCRAY, EXAMINING ATTORNEY

SN 77-430,848. PLANNED ADMINISTRATORS, INC., COLUMBIA, SC. FILED 3-25-2008.

SIMPLY MED/RX

THE MARK CONSISTS OF STANDARD CHARACTERS WITHOUT CLAIM TO ANY PARTICULAR FONT, STYLE, SIZE, OR COLOR.

FOR HEALTH INSURANCE UNDERWRITING (U.S. CLS. 100, 101 AND 102).

AISHA CLARKE, EXAMINING ATTORNEY

SN 77-430,602. ENTERGY CORPORATION, NEW ORLEANS, LA. FILED 3-25-2008.



THE COLOR(S) RED, WHITE, BLUE, AND GRAY IS/ARE CLAIMED AS A FEATURE OF THE MARK.

THE MARK CONSISTS OF THE WORDS "THE POWER TO" IN THE COLOR GRAY ABOVE THE WORD "CARE" IN THE COLOR WHITE, ALL SET ON A BLUE RECTANGULAR BACKGROUND WITH A RED LINE BENEATH THE RECTANGLE, AND A RED HEART SUPERIMPOSED OVER THE "A" IN "CARE".

FOR CHARITABLE FUNDRAISING SERVICES IN THE NATURE OF RAISING FUNDS TO ASSIST LOW-INCOME ELDERLY AND DISABLED UTILITY SERVICES CUSTOMERS WITH UTILITY PAYMENTS (U.S. CLS. 100, 101 AND 102).

RAMONA ORTIGA, EXAMINING ATTORNEY

SN 77-430,872. PLANNED ADMINISTRATORS, INC., COLUMBIA, SC. FILED 3-25-2008.

SIMPLY VISION

THE MARK CONSISTS OF STANDARD CHARACTERS WITHOUT CLAIM TO ANY PARTICULAR FONT, STYLE, SIZE, OR COLOR.

NO CLAIM IS MADE TO THE EXCLUSIVE RIGHT TO USE "VISION", APART FROM THE MARK AS SHOWN.

FOR HEALTH INSURANCE UNDERWRITING (U.S. CLS. 100, 101 AND 102).

AISHA CLARKE, EXAMINING ATTORNEY

CLASS 36—(Continued).

SN 77-430,889. PLANNED ADMINISTRATORS, INC., COLUMBIA, SC. FILED 3-25-2008.

SIMPLY DENTAL

THE MARK CONSISTS OF STANDARD CHARACTERS WITHOUT CLAIM TO ANY PARTICULAR FONT, STYLE, SIZE, OR COLOR.

NO CLAIM IS MADE TO THE EXCLUSIVE RIGHT TO USE "DENTAL", APART FROM THE MARK AS SHOWN.

FOR HEALTH INSURANCE UNDERWRITING (U.S. CLS. 100, 101 AND 102).

AISHA CLARKE, EXAMINING ATTORNEY

SN 77-430,941. U.S. BANK N.A., MINNEAPOLIS, MN. FILED 3-25-2008.

U.S. BANK FIVE STAR PLATINUM

THE MARK CONSISTS OF STANDARD CHARACTERS WITHOUT CLAIM TO ANY PARTICULAR FONT, STYLE, SIZE, OR COLOR.

OWNER OF U.S. REG. NOS. 2,662,840, 2,736,040 AND OTHERS.

NO CLAIM IS MADE TO THE EXCLUSIVE RIGHT TO USE "BANK", APART FROM THE MARK AS SHOWN.

SEC. 2(F) AS TO "U.S."
FOR BANKING SERVICES (U.S. CLS. 100, 101 AND 102).

DANNEAN HETZEL, EXAMINING ATTORNEY

SN 77-430,946. U.S. BANK N.A., MINNEAPOLIS, MN. FILED 3-25-2008.

U.S. BANK FIVE STAR GOLD

THE MARK CONSISTS OF STANDARD CHARACTERS WITHOUT CLAIM TO ANY PARTICULAR FONT, STYLE, SIZE, OR COLOR.

OWNER OF U.S. REG. NOS. 2,662,840, 2,736,040 AND OTHERS.

NO CLAIM IS MADE TO THE EXCLUSIVE RIGHT TO USE "BANK", APART FROM THE MARK AS SHOWN.

SEC. 2(F) AS TO "U.S."
FOR BANKING SERVICES (U.S. CLS. 100, 101 AND 102).

DANNEAN HETZEL, EXAMINING ATTORNEY

CLASS 36—(Continued).

SN 77-430,950. U.S. BANK N.A., MINNEAPOLIS, MN. FILED 3-25-2008.

U.S. BANK FIVE STAR SILVER

THE MARK CONSISTS OF STANDARD CHARACTERS WITHOUT CLAIM TO ANY PARTICULAR FONT, STYLE, SIZE, OR COLOR.

OWNER OF U.S. REG. NOS. 2,662,840, 2,736,040 AND OTHERS.

NO CLAIM IS MADE TO THE EXCLUSIVE RIGHT TO USE "BANK", APART FROM THE MARK AS SHOWN.

SEC. 2(F) AS TO "U.S."
FOR BANKING SERVICES (U.S. CLS. 100, 101 AND 102).

DANNEAN HETZEL, EXAMINING ATTORNEY

SN 77-430,977. PLANNED ADMINISTRATORS, INC., COLUMBIA, SC. FILED 3-25-2008.

SIMPLY LIFE

THE MARK CONSISTS OF STANDARD CHARACTERS WITHOUT CLAIM TO ANY PARTICULAR FONT, STYLE, SIZE, OR COLOR.

NO CLAIM IS MADE TO THE EXCLUSIVE RIGHT TO USE "LIFE", APART FROM THE MARK AS SHOWN.

FOR LIFE INSURANCE UNDERWRITING (U.S. CLS. 100, 101 AND 102).

AISHA CLARKE, EXAMINING ATTORNEY

SN 77-431,002. PLANNED ADMINISTRATORS, INC., COLUMBIA, SC. FILED 3-25-2008.

SIMPLY SHORT TERM DISABILITY

THE MARK CONSISTS OF STANDARD CHARACTERS WITHOUT CLAIM TO ANY PARTICULAR FONT, STYLE, SIZE, OR COLOR.

NO CLAIM IS MADE TO THE EXCLUSIVE RIGHT TO USE "SHORT TERM DISABILITY", APART FROM THE MARK AS SHOWN.

FOR HEALTH INSURANCE UNDERWRITING (U.S. CLS. 100, 101 AND 102).

AISHA CLARKE, EXAMINING ATTORNEY

CLASS 36—(Continued).

SN 77-431,086. LANCE ARMSTRONG FOUNDATION, AUSTIN, TX. FILED 3-25-2008.

LIVESTRONG

THE MARK CONSISTS OF STANDARD CHARACTERS WITHOUT CLAIM TO ANY PARTICULAR FONT, STYLE, SIZE, OR COLOR.

OWNER OF U.S. REG. NOS. 3,052,284, 3,296,017 AND OTHERS.

FOR PROVIDING A WEBSITE FEATURING HEALTH CARE INSURANCE AND SHORT TERM MEDICAL INSURANCE INFORMATION; PROVIDING A WEBSITE FEATURING INFORMATION IN THE FIELD OF HEALTH INSURANCE, SHORT TERM MEDICAL INSURANCE, HEALTH SAVINGS ACCOUNTS, AND FINANCE IN THE FIELD OF HEALTH CARE (U.S. CLS. 100, 101 AND 102).

FIRST USE 4-0-2004; IN COMMERCE 4-0-2004.
LAURA HAMMEL, EXAMINING ATTORNEY

SN 77-431,115. GEMEX SYSTEMS, INC., MEQUON, WI. FILED 3-25-2008.

GEMEXCELLENCE

THE MARK CONSISTS OF STANDARD CHARACTERS WITHOUT CLAIM TO ANY PARTICULAR FONT, STYLE, SIZE, OR COLOR.

FOR JEWELRY APPRAISAL SERVICES (U.S. CLS. 100, 101 AND 102).

TIMOTHY FINNEGAN, EXAMINING ATTORNEY

SN 77-431,203. METROPOLITAN LIFELONG LEARNING CENTER, LLC, WAYZATA, MN. FILED 3-25-2008.

LEARNING FORWARD

THE MARK CONSISTS OF STANDARD CHARACTERS WITHOUT CLAIM TO ANY PARTICULAR FONT, STYLE, SIZE, OR COLOR.

FOR REAL ESTATE LEASING AND MANAGEMENT SERVICES FOR EDUCATIONAL INSTITUTIONS (U.S. CLS. 100, 101 AND 102).

WANDA KAY PRICE, EXAMINING ATTORNEY

CLASS 36—(Continued).

SN 77-431,524. BOWSER, TODD A., CUMMING, GA. FILED 3-26-2008.

BETTER ALLIANCE

THE MARK CONSISTS OF STANDARD CHARACTERS WITHOUT CLAIM TO ANY PARTICULAR FONT, STYLE, SIZE, OR COLOR.

NO CLAIM IS MADE TO THE EXCLUSIVE RIGHT TO USE "ALLIANCE", APART FROM THE MARK AS SHOWN.

FOR REAL ESTATE AGENCIES; REAL ESTATE BROKERAGE; REAL ESTATE CONSULTANCY (U.S. CLS. 100, 101 AND 102).

FIRST USE 12-1-2007; IN COMMERCE 12-1-2007.

ELISSA GARBER KON, EXAMINING ATTORNEY

SN 77-431,551. OMNICARDS LLC, PITTSBURGH, PA. FILED 3-26-2008.

OmniProcess

THE MARK CONSISTS OF STANDARD CHARACTERS WITHOUT CLAIM TO ANY PARTICULAR FONT, STYLE, SIZE, OR COLOR.

FOR CREDIT CARD PAYMENT PROCESSING SERVICES; CREDIT CARD TRANSACTION PROCESSING SERVICES; FINANCIAL INFORMATION PROCESSING; PAYMENT PROCESSING SERVICES, NAMELY, CREDIT CARD AND DEBIT CARD TRANSACTION PROCESSING SERVICES; PRE-PAID PURCHASE CARD SERVICES, NAMELY, PROCESSING ELECTRONIC PAYMENTS MADE THROUGH PREPAID CARDS; PRE-PAID PURCHASE CARD SERVICES, NAMELY, PROCESSING ELECTRONIC PAYMENTS THROUGH PRE-PAID CARDS; PROVIDING ELECTRONIC PROCESSING OF CREDIT CARD TRANSACTIONS AND ELECTRONIC PAYMENTS VIA A GLOBAL COMPUTER NETWORK; PROVIDING ELECTRONIC PROCESSING OF ELECTRONIC FUNDS TRANSFER, ACH, CREDIT CARD, DEBIT CARD, ELECTRONIC CHECK AND ELECTRONIC PAYMENTS (U.S. CLS. 100, 101 AND 102).

GISELLE AGOSTO, EXAMINING ATTORNEY

SN 77-431,562. HILLSTAR INSURANCE COMPANY, BIRMINGHAM, AL. FILED 3-26-2008.

YOUR TRUSTED FRIEND ON THE ROAD

THE MARK CONSISTS OF STANDARD CHARACTERS WITHOUT CLAIM TO ANY PARTICULAR FONT, STYLE, SIZE, OR COLOR.

FOR INSURANCE UNDERWRITING IN THE FIELD OF PROPERTY AND CASUALTY INSURANCE (U.S. CLS. 100, 101 AND 102).

AMY HELLA, EXAMINING ATTORNEY

CLASS 36—(Continued).

SN 77-431,684. NATIONAL CHECK TRUST, INC., MIRAMAR, FL. FILED 3-26-2008.

Built on Trust. Powered
by Service.

THE MARK CONSISTS OF STANDARD CHARACTERS WITHOUT CLAIM TO ANY PARTICULAR FONT, STYLE, SIZE, OR COLOR.
FOR CHECK GUARANTEE SERVICE (U.S. CLS. 100, 101 AND 102).
JOHN SCHUYLER YARD, EXAMINING ATTORNEY

SN 77-431,703. LAWERY, ROBERT, NORTH ATTLEBORO, MA. FILED 3-26-2008.

TripleNet Performance

THE MARK CONSISTS OF STANDARD CHARACTERS WITHOUT CLAIM TO ANY PARTICULAR FONT, STYLE, SIZE, OR COLOR.
FOR MUTUAL FUND INVESTMENT SERVICES; RETIREMENT FUND INVESTMENT SERVICES; FINANCIAL INFORMATION PROVIDED BY ELECTRONIC MEANS, PROVIDING PERSONALIZED INVESTMENT INFORMATION, ALL BY MEANS OF A GLOBAL COMPUTER NETWORK (U.S. CLS. 100, 101 AND 102).
ANTHONY RINKER, EXAMINING ATTORNEY

SN 77-431,705. OMNICARDS LLC, PITTSBURGH, PA. FILED 3-26-2008.

OmniPrint

THE MARK CONSISTS OF STANDARD CHARACTERS WITHOUT CLAIM TO ANY PARTICULAR FONT, STYLE, SIZE, OR COLOR.
FOR CREDIT AND DEBIT CARD SERVICES; CREDIT CARD AND DEBIT CARD SERVICES; DEBIT CARD SERVICES (U.S. CLS. 100, 101 AND 102).
GISELLE AGOSTO, EXAMINING ATTORNEY

CLASS 36—(Continued).

SN 77-431,794. GLOBAL 1 ENTERPRISES, INC., HOUSTON, TX. FILED 3-26-2008.

C\$

THE MARK CONSISTS OF STANDARD CHARACTERS WITHOUT CLAIM TO ANY PARTICULAR FONT, STYLE, SIZE, OR COLOR.
FOR ELECTRONIC CASH TRANSACTIONS (U.S. CLS. 100, 101 AND 102).
BARBARA BROWN, EXAMINING ATTORNEY

SN 77-431,973. APARTMENT BROKERAGE TEAM, LLC, STILLWATER, OK. FILED 3-26-2008.



A P A R T M E N T
B R O K E R A G E T E A M

NO CLAIM IS MADE TO THE EXCLUSIVE RIGHT TO USE "APARTMENT BROKERAGE TEAM", APART FROM THE MARK AS SHOWN.
THE MARK CONSISTS OF CONCENTRIC CIRCLES WITH A CHEVRON MARK IN THE CENTER OF THE CIRCLES USED WITH THE WORDS APARTMENT BROKERAGE TEAM IN BLOCK LETTERS.
FOR APARTMENT AND COMMERCIAL REAL ESTATE BROKERAGE SERVICES (U.S. CLS. 100, 101 AND 102).
FIRST USE 11-27-2007; IN COMMERCE 11-27-2007.
ESTHER BELENKER, EXAMINING ATTORNEY

SN 77-432,446. CHALGIAN, DOUGLAS G., EAST LANSING, MI. FILED 3-26-2008.

PET FRIENDLY

THE MARK CONSISTS OF STANDARD CHARACTERS WITHOUT CLAIM TO ANY PARTICULAR FONT, STYLE, SIZE, OR COLOR.
FOR ESTATE PLANNING (U.S. CLS. 100, 101 AND 102).
KATHERINE STOIDES, EXAMINING ATTORNEY

CLASS 36—(Continued).

SN 77-432,735. STARS US, INC., HILTON HEAD ISLAND, SC. FILED 3-27-2008.

YACHT HOP

THE MARK CONSISTS OF STANDARD CHARACTERS WITHOUT CLAIM TO ANY PARTICULAR FONT, STYLE, SIZE, OR COLOR.

NO CLAIM IS MADE TO THE EXCLUSIVE RIGHT TO USE "YACHT", APART FROM THE MARK AS SHOWN. FOR CHARITABLE FUND RAISING (U.S. CLS. 100, 101 AND 102).

FIRST USE 10-1-2007; IN COMMERCE 10-1-2007. RONALD DELGIZZI, EXAMINING ATTORNEY

SN 77-432,868. WOMEN FOR WOMEN INTERNATIONAL, WASHINGTON, DC. FILED 3-27-2008.

STRONGER WOMEN, STRONGER NATIONS

THE MARK CONSISTS OF STANDARD CHARACTERS WITHOUT CLAIM TO ANY PARTICULAR FONT, STYLE, SIZE, OR COLOR.

FOR CHARITABLE FUND RAISING SERVICES TO ASSIST WOMEN VICTIMS OF WAR AND CIVIL STRIFE; ESTABLISHING AND ADMINISTERING MONETARY CHARITABLE PROGRAMS TO PROVIDE INCOME-GENERATING SUPPORT AND MICRO CREDIT LOANS TO BENEFIT WOMEN VICTIMS OF WAR AND CIVIL STRIFE (U.S. CLS. 100, 101 AND 102).

FIRST USE 6-1-2007; IN COMMERCE 6-1-2007. REBECCA SMITH, EXAMINING ATTORNEY

SN 77-432,870. WOMEN FOR WOMEN INTERNATIONAL, WASHINGTON, DC. FILED 3-27-2008.

ONE WOMAN CAN DO ANYTHING, MANY WOMEN CAN DO EVERYTHING

THE MARK CONSISTS OF STANDARD CHARACTERS WITHOUT CLAIM TO ANY PARTICULAR FONT, STYLE, SIZE, OR COLOR.

FOR CHARITABLE FUND RAISING SERVICES TO ASSIST WOMEN VICTIMS OF WAR AND CIVIL STRIFE; ESTABLISHING AND ADMINISTERING MONETARY CHARITABLE PROGRAMS TO PROVIDE INCOME-GENERATING SUPPORT AND MICRO CREDIT LOANS TO BENEFIT WOMEN VICTIMS OF WAR AND CIVIL STRIFE (U.S. CLS. 100, 101 AND 102).

REBECCA SMITH, EXAMINING ATTORNEY

CLASS 36—(Continued).

SN 77-432,879. 39REALTY.COM,LLC, AUSTIN, TX. FILED 3-27-2008.

39REALTY

THE MARK CONSISTS OF STANDARD CHARACTERS WITHOUT CLAIM TO ANY PARTICULAR FONT, STYLE, SIZE, OR COLOR.

FOR REAL ESTATE BROKERAGE (U.S. CLS. 100, 101 AND 102).

CHRISTINA SOBRAL, EXAMINING ATTORNEY

SN 77-433,125. INTERBANK FX, LLC, SALT LAKE CITY, UT. FILED 3-27-2008.



THE MARK CONSISTS OF INSIDE A CIRCLE IS A LARGE U WITH THE LETTERS IBFXU GOING THROUGH THE MIDDLE, ON TOP OF THE U IS A HALF CIRCLE AND ON BOTTOM IS A SMALLER HALF CIRCLE.

FOR FINANCIAL SERVICES, NAMELY, FOREIGN CURRENCY TRADING AND EXCHANGE SERVICES (U.S. CLS. 100, 101 AND 102).

DEZMONA MIZELLE, EXAMINING ATTORNEY

SN 77-433,283. CAPITAL GROWTH MANAGEMENT LIMITED PARTNERSHIP, BOSTON, MA. FILED 3-27-2008.

WAYFARER

THE MARK CONSISTS OF STANDARD CHARACTERS WITHOUT CLAIM TO ANY PARTICULAR FONT, STYLE, SIZE, OR COLOR.

FOR HEDGE FUND INVESTMENT SERVICES (U.S. CLS. 100, 101 AND 102).

ANTHONY RINKER, EXAMINING ATTORNEY

CLASS 36—(Continued).

SN 77-433,459. ACTS HIV/AIDS MINISTRY, SAN ANTONIO, TX. FILED 3-27-2008.

CLASS 36—(Continued).

SN 77-433,746. PML WIRELESS, LLC, ATLANTA, GA. FILED 3-27-2008.

ACTS-travaganza

THE MARK CONSISTS OF STANDARD CHARACTERS WITHOUT CLAIM TO ANY PARTICULAR FONT, STYLE, SIZE, OR COLOR.

FOR CHARITABLE FUNDRAISING SERVICES FOR PERSONS INFECTED WITH AND AFFECTED BY HIV AND AIDS (U.S. CLS. 100, 101 AND 102).

FIRST USE 7-1-2005; IN COMMERCE 7-1-2005.
NANCY CLARKE, EXAMINING ATTORNEY

YOUR TERMS. YOUR WAY.

THE MARK CONSISTS OF STANDARD CHARACTERS WITHOUT CLAIM TO ANY PARTICULAR FONT, STYLE, SIZE, OR COLOR.

FOR FINANCIAL SERVICES, NAMELY, SHORT TERM LOANS, INSTALLMENT LOANS, AND CREDIT CARD SERVICES (U.S. CLS. 100, 101 AND 102).

ELISSA GARBER KON, EXAMINING ATTORNEY

SN 77-433,653. PML WIRELESS, LLC, ATLANTA, GA. FILED 3-27-2008.

SN 77-433,749. INTERBANK FX, LLC, SALT LAKE CITY, UT. FILED 3-27-2008.

HAVE YOUR SAY

THE MARK CONSISTS OF STANDARD CHARACTERS WITHOUT CLAIM TO ANY PARTICULAR FONT, STYLE, SIZE, OR COLOR.

FOR FINANCIAL SERVICES, NAMELY, SHORT TERM LOANS, INSTALLMENT LOANS, AND CREDIT CARD SERVICES (U.S. CLS. 100, 101 AND 102).

ELISSA GARBER KON, EXAMINING ATTORNEY

IBFX.COM

THE MARK CONSISTS OF STANDARD CHARACTERS WITHOUT CLAIM TO ANY PARTICULAR FONT, STYLE, SIZE, OR COLOR.

FOR FINANCIAL SERVICES, NAMELY, FOREIGN CURRENCY TRADING AND EXCHANGE SERVICES (U.S. CLS. 100, 101 AND 102).

DEZMONA MIZELLE, EXAMINING ATTORNEY

SN 77-433,677. THE REESE GROUP LLC, NEW YORK, NY. FILED 3-27-2008.

SN 77-433,818. STONEWALL REAL ESTATE, LLC, INDIANAPOLIS, IN. FILED 3-27-2008.

OFFICE DRAGON

THE MARK CONSISTS OF STANDARD CHARACTERS WITHOUT CLAIM TO ANY PARTICULAR FONT, STYLE, SIZE, OR COLOR.

FOR REAL ESTATE LISTING (U.S. CLS. 100, 101 AND 102).

JASON TURNER, EXAMINING ATTORNEY

BUYERWATCH

THE MARK CONSISTS OF STANDARD CHARACTERS WITHOUT CLAIM TO ANY PARTICULAR FONT, STYLE, SIZE, OR COLOR.

FOR REAL ESTATE BROKERAGE; REAL ESTATE LISTING (U.S. CLS. 100, 101 AND 102).

JOHN KELLY, EXAMINING ATTORNEY

CLASS 36—(Continued).

SN 77-435,670. GLOBAL 1 ENTERPRISES, INC., HOUSTON, TX. FILED 3-31-2008.

CMONEY

THE MARK CONSISTS OF STANDARD CHARACTERS WITHOUT CLAIM TO ANY PARTICULAR FONT, STYLE, SIZE, OR COLOR.

FOR ELECTRONIC CASH TRANSACTIONS (U.S. CLS. 100, 101 AND 102).

BARBARA BROWN, EXAMINING ATTORNEY

SN 77-437,284. RIZZI, RON, BALL GROUND, GA. FILED 4-1-2008.

CARS & COFFEE

THE COLOR(S) DARK BROWN, BLACK AND WHITE, LIGHT BROWN (TAN) IS/ARE CLAIMED AS A FEATURE OF THE MARK.

THE MARK CONSISTS OF THE WORDS "CARS & COFFEE" TOGETHER WITH A STEERING WHEEL IN THE CENTER OF THE LETTER "C" AND A COFFEE CUP IN THE LETTER "O". THE STEERING WHEEL, THE WORD "&" (AMPERSAND) AND THE COFFEE CUP ARE BLACK AND WHITE. THE WORD "CARS" IS DARK BROWN AND THE WORD "COFFEE" IS LIGHT BROWN (TAN).

FOR CHARITABLE FUNDRAISING SERVICES, NAMELY, RAISING MONEY FOR CHARITY BY CONDUCTING CAR SHOWS (U.S. CLS. 100, 101 AND 102).

FIRST USE 3-1-2008; IN COMMERCE 3-1-2008.

STEPHANIE ALI, EXAMINING ATTORNEY

SN 77-437,895. AGSTAR FINANCIAL SERVICES, ACA, MANKATO, MN. FILED 4-2-2008.

AgriSpan

THE MARK CONSISTS OF THE WORDING "AGRISPAN" ABOVE A FIELD DESIGN

FOR FINANCIAL SERVICES, NAMELY, AGRICULTURAL LOANS AND LEASES; AGRICULTURAL LOAN FINANCING; FINANCIAL RISK MANAGEMENT FOR FARMS; AGRICULTURAL LEASING-PURCHASE FINANCING; AND FINANCIAL ANALYSIS (U.S. CLS. 100, 101 AND 102).

JORDAN BAKER, EXAMINING ATTORNEY

CLASS 36—(Continued).

SN 77-443,831. SALLIE MAE, INC., RESTON, VA. FILED 4-9-2008.

SallieMae | Business School Loans

OWNER OF U.S. REG. NOS. 1,337,128, 3,271,420 AND OTHERS.

NO CLAIM IS MADE TO THE EXCLUSIVE RIGHT TO USE "BUSINESS SCHOOL LOANS", APART FROM THE MARK AS SHOWN.

THE MARK CONSISTS OF THE WORD "SALLIE MAE BUSINESS SCHOOL LOANS" WITH A HASH MARK BETWEEN THE WORDS "MAE" AND "BUSINESS".

FOR STUDENT LOAN SERVICES (U.S. CLS. 100, 101 AND 102).

FIRST USE 4-7-2008; IN COMMERCE 4-7-2008.

EUGENIA MARTIN, EXAMINING ATTORNEY

SN 77-446,966. WAG'N ENTERPRISES, LLC, HERNDON, VA. FILED 4-13-2008.

O2 FUR LIFE

THE MARK CONSISTS OF STANDARD CHARACTERS WITHOUT CLAIM TO ANY PARTICULAR FONT, STYLE, SIZE, OR COLOR.

FOR CHARITABLE FUND RAISING; PROVIDING FUND RAISING SERVICES FOR OTHERS VIA A GLOBAL COMPUTER NETWORK (U.S. CLS. 100, 101 AND 102).

FIRST USE 12-6-2007; IN COMMERCE 12-6-2007.

KATHERINE CONNOLLY, EXAMINING ATTORNEY

SN 77-450,721. ALLSTATE INSURANCE COMPANY, CHICAGO, IL. FILED 4-17-2008.

COVERAGE TOUR

THE MARK CONSISTS OF STANDARD CHARACTERS WITHOUT CLAIM TO ANY PARTICULAR FONT, STYLE, SIZE, OR COLOR.

NO CLAIM IS MADE TO THE EXCLUSIVE RIGHT TO USE "COVERAGE", APART FROM THE MARK AS SHOWN.

FOR PROVIDING ON-LINE INFORMATION IN THE FIELD OF AUTO INSURANCE (U.S. CLS. 100, 101 AND 102).

NATALIE POLZER, EXAMINING ATTORNEY

CLASS 36—(Continued).

SN 77-450,731. ALLSTATE INSURANCE COMPANY,
NORTHBROOK, IL. FILED 4-17-2008.

COBERTOUR

THE MARK CONSISTS OF STANDARD CHARACTERS
WITHOUT CLAIM TO ANY PARTICULAR FONT, STYLE,
SIZE, OR COLOR.

FOR PROVIDING ON-LINE INFORMATION IN THE
FIELD OF AUTO INSURANCE (U.S. CLS. 100, 101 AND
102).

NATALIE POLZER, EXAMINING ATTORNEY

SN 77-456,026. THE MORTGAGE STORE, INC., KIHEI, HI.
FILED 4-23-2008.



THE COLOR(S) GREEN, WHITE, AND GRAY IS/ARE
CLAIMED AS A FEATURE OF THE MARK.

THE MARK CONSISTS OF A DESIGN OF A GREEN
HOUSE WITH THE FOLLOWING LETTERS AND WORDS
ON IT: "H.E.L.P." IS ON THE FIRST LINE, UNDERLINED.
"UNIVERSITY" IS UNDERNEATH THIS. "HARNESS EQUITY
FOR LIFE PLANNING" ARE ALL ON THE THIRD LINE.
ALL WORDS AND LETTERS ARE IN WHITE, TO THE LEFT
OF THE GREEN HOUSE ARE GRAY LEAVES WHICH
APPEAR TO BE EXTENDING FROM A NEARBY TREE
THAT IS NOT SHOWN IN THE DRAWING.

FOR FINANCIAL PLANNING AND INVESTMENT
ADVISORY SERVICES (U.S. CLS. 100, 101 AND 102).

REGINA DRUMMOND, EXAMINING ATTORNEY

SN 77-456,597. METRO CREDIT UNION, WARREN, MI.
FILED 4-24-2008.

**A GREATER INTEREST IN
SCHOOLS**

THE MARK CONSISTS OF STANDARD CHARACTERS
WITHOUT CLAIM TO ANY PARTICULAR FONT, STYLE,
SIZE, OR COLOR.

FOR CREDIT UNION SERVICES (U.S. CLS. 100, 101
AND 102).

TARA PATE, EXAMINING ATTORNEY

CLASS 36—(Continued).

SN 77-457,277. METRO CREDIT UNION, WARREN, MI.
FILED 4-24-2008.



THE COLOR(S) GOLD AND WHITE IS/ARE CLAIMED AS
A FEATURE OF THE MARK.

THE MARK CONSISTS OF A GOLD STAR WITH A
WHITE HUMAN FIGURE INSIDE.

FOR CREDIT UNION SERVICES (U.S. CLS. 100, 101
AND 102).

TARA PATE, EXAMINING ATTORNEY

SN 77-460,445. POPULAR, INC., SAN JUAN, PUERTO RICO,
FILED 4-29-2008.

Mystique

THE MARK CONSISTS OF STANDARD CHARACTERS
WITHOUT CLAIM TO ANY PARTICULAR FONT, STYLE,
SIZE, OR COLOR.

FOR CREDIT CARD SERVICES (U.S. CLS. 100, 101
AND 102).

FIRST USE 10-26-2007; IN COMMERCE 10-26-2007.

STEVEN PEREZ, EXAMINING ATTORNEY

SN 77-466,776. WEINSTEIN MANAGEMENT CO., INC.,
GLEN ALLEN, VA. FILED 5-6-2008.

BEXLEY AT HERITAGE

THE MARK CONSISTS OF STANDARD CHARACTERS
WITHOUT CLAIM TO ANY PARTICULAR FONT, STYLE,
SIZE, OR COLOR.

OWNER OF U.S. REG. NOS. 2,889,355, 3,222,386 AND
OTHERS.

FOR REAL ESTATE SERVICES, NAMELY, LEASING
AND MANAGEMENT OF REAL PROPERTY (U.S. CLS.
100, 101 AND 102).

FIRST USE 4-29-2008; IN COMMERCE 4-29-2008.

LAURA HAMMEL, EXAMINING ATTORNEY

CLASS 36—(Continued).

SN 77-466,857. THE TICKET RESERVE, INC., CHICAGO, IL. FILED 5-6-2008.

DIBZ

THE MARK CONSISTS OF STANDARD CHARACTERS WITHOUT CLAIM TO ANY PARTICULAR FONT, STYLE, SIZE, OR COLOR.

FOR COMMODITY TRADING SERVICES FOR OTHERS IN CONNECTION WITH EVENT TICKETS AND CONSUMER PRODUCTS AND SERVICES AND FORWARD CONTRACTS ON EVENT TICKETS AND OTHER CONSUMER SERVICES (U.S. CLS. 100, 101 AND 102).

AMY MCMENAMIN, EXAMINING ATTORNEY

SN 77-474,424. OVVO FINANCIAL SYSTEMS, LLC, SPRING LAKE, NJ. FILED 5-14-2008.



THE COLOR(S) RED AND GREEN IS/ARE CLAIMED AS A FEATURE OF THE MARK.

THE MARK CONSISTS OF A RED ARROW AND A GREEN ARROW.

FOR FINANCIAL ADVISORY AND CONSULTANCY SERVICES; FINANCIAL ANALYSIS AND RESEARCH SERVICES (U.S. CLS. 100, 101 AND 102).

LINDA ESTRADA, EXAMINING ATTORNEY

SN 77-476,688. CHALGIAN, DOUGLAS G., LANSING, MI. FILED 5-16-2008.

FUREVER

THE MARK CONSISTS OF STANDARD CHARACTERS WITHOUT CLAIM TO ANY PARTICULAR FONT, STYLE, SIZE, OR COLOR.

FOR ESTATE PLANNING (U.S. CLS. 100, 101 AND 102).

KATHERINE STOIDES, EXAMINING ATTORNEY

CLASS 36—(Continued).

SN 77-478,449. AMGEN INC., THOUSAND OAKS, CA. FILED 5-19-2008.



THE MARK CONSISTS OF A STYLIZED HUMAN FIGURE WITH UPRAISED ARMS ON A BICYCLE.

FOR CHARITABLE FUNDRAISING, NAMELY, RAISING FUNDS FOR CANCER RESEARCH, CANCER TREATMENT AND CANCER AWARENESS (U.S. CLS. 100, 101 AND 102).

FIRST USE 1-31-2005; IN COMMERCE 1-31-2005. ASMAT KHAN, EXAMINING ATTORNEY

SN 77-480,990. MIRACLE RECREATION EQUIPMENT COMPANY, MONETT, MO. FILED 5-22-2008.

GET GIVE GO

THE MARK CONSISTS OF STANDARD CHARACTERS WITHOUT CLAIM TO ANY PARTICULAR FONT, STYLE, SIZE, OR COLOR.

FOR PROVIDING GRANTS FOR THE PURCHASE OF PLAYGROUND EQUIPMENT (U.S. CLS. 100, 101 AND 102).

KATINA MISTER, EXAMINING ATTORNEY

SN 77-482,485. ALLSTATE INSURANCE COMPANY, NORTHBROOK, IL. FILED 5-23-2008.

GENBUILDER

THE MARK CONSISTS OF STANDARD CHARACTERS WITHOUT CLAIM TO ANY PARTICULAR FONT, STYLE, SIZE, OR COLOR.

FOR INSURANCE SERVICES, NAMELY, UNDERWRITING, ISSUING AND ADMINISTRATION OF LIFE INSURANCE (U.S. CLS. 100, 101 AND 102).

NATALIE POLZER, EXAMINING ATTORNEY

CLASS 36—(Continued).

SN 77-975,626. CONSUMERINFO.COM, INC., IRVINE, CA. FILED 10-31-2006.

TRIPLE ADVANTAGE

THE MARK CONSISTS OF STANDARD CHARACTERS WITHOUT CLAIM TO ANY PARTICULAR FONT, STYLE, SIZE, OR COLOR.

FOR CREDIT REPORTING SERVICES, NAMELY, PROVIDING AN ON-LINE INTERACTIVE CONSUMER CREDIT SCORE SIMULATOR WHICH PERMITS AN INDIVIDUAL TO SIMULATE HIS OR HER CREDIT SCORE BY SELECTING DATA VARIABLES TO SHOW THE EFFECT OF THE DIFFERENT VARIABLES UPON THE INDIVIDUAL'S CREDIT SCORE (U.S. CLS. 100, 101 AND 102).

ELIZABETH BEYER, EXAMINING ATTORNEY

SN 77-975,666. STRONGWOOD INSURANCE HOLDINGS CORPORATION, MONTEREY, CA. FILED 8-20-2007.

STRONGWOOD

THE MARK CONSISTS OF STANDARD CHARACTERS WITHOUT CLAIM TO ANY PARTICULAR FONT, STYLE, SIZE, OR COLOR.

FOR PROPERTY AND CASUALTY INSURANCE UNDERWRITING SERVICES (U.S. CLS. 100, 101 AND 102). FIRST USE 11-30-2006; IN COMMERCE 11-30-2006. CHRISTINE COOPER, EXAMINING ATTORNEY

SN 78-695,249. MERCURY INVESTMENT PROPERTIES, LP, MEMPHIS, TN. FILED 8-18-2005.



MERCURY
INVESTMENT PROPERTIES

NO CLAIM IS MADE TO THE EXCLUSIVE RIGHT TO USE "INVESTMENT PROPERTIES", APART FROM THE MARK AS SHOWN.

THE GRAY TONES IN THE DRAWING ARE NOT INTENDED TO INDICATE THE COLOR GRAY, RATHER ARE ONLY USED FOR SHADING PURPOSES.

THE MARK CONSISTS OF A LIKENESS OF THE ROMAN GOD OF COMMERCE, "MERCURY", WEARING A WINGED HAT KNOWN AS A PETASUS.

FOR FINANCIAL INVESTMENT IN THE FIELD OF COMMERCIAL REAL ESTATE (U.S. CLS. 100, 101 AND 102).

BARBARA RUTLAND, EXAMINING ATTORNEY

CLASS 36—(Continued).

SN 78-726,120. LIFE INSURANCE COMPANY OF THE SOUTHWEST, DALLAS, TX. FILED 10-4-2005.

LIFETIME INCOME ADVANTAGE

THE MARK CONSISTS OF STANDARD CHARACTERS WITHOUT CLAIM TO ANY PARTICULAR FONT, STYLE, SIZE, OR COLOR.

NO CLAIM IS MADE TO THE EXCLUSIVE RIGHT TO USE "LIFETIME INCOME", APART FROM THE MARK AS SHOWN.

FOR FINANCIAL SERVICES, NAMELY, FINANCIAL PLANNING FOR RETIREMENT; PROVIDING FINANCIAL INFORMATION IN THE FIELD OF RETIREMENT PLANNING; INVESTMENT MANAGEMENT IN THE FIELD OF ANNUITIES (U.S. CLS. 100, 101 AND 102).

FIRST USE 6-5-2005; IN COMMERCE 6-5-2005.

KATHERINE CONNOLLY, EXAMINING ATTORNEY

SN 78-896,972. INFORMA USA, INC., WESTBOROUGH, MA. FILED 5-31-2006.

INFORMA

THE MARK CONSISTS OF STANDARD CHARACTERS WITHOUT CLAIM TO ANY PARTICULAR FONT, STYLE, SIZE, OR COLOR.

FOR PROVIDING INFORMATION, ANALYSIS AND COMMENTARY IN THE FIELDS OF FINANCE AND INSURANCE; PROVIDING INFORMATION, ANALYSIS, AND COMMENTARY IN THE FIELDS OF FINANCE AND INSURANCE BY MEANS OF THE INTERNET; PROVIDING ON-LINE COMPUTER DATABASES IN THE FIELD OF FINANCE; FINANCIAL PLANNING; FINANCIAL PLANNING CONSULTATION AND FINANCIAL RESEARCH (U.S. CLS. 100, 101 AND 102).

FIRST USE 1-1-2000; IN COMMERCE 1-1-2000.

GEOFFREY FOSDICK, EXAMINING ATTORNEY

SN 78-929,936. BYRON UDELL AND ASSOCIATES, INC., WHEELING, IL. FILED 7-14-2006.



ACQUQUOTE

OWNER OF U.S. REG. NO. 2,405,370.
"THE COLOR(S) BLUE IS/ARE CLAIMED AS A FEATURE OF THE MARK."

"THE MARK CONSISTS OF THE COLOR BLUE IN THE TERM "ACQUQUOTE" AND IN THE STYLIZED LETTER "Q"."

FOR LIFE INSURANCE BROKERAGE (U.S. CLS. 100, 101 AND 102).

FIRST USE 1-1-1996; IN COMMERCE 1-1-1996.

TASHIA BUNCH, EXAMINING ATTORNEY

CLASS 36—(Continued).

SN 78-974,451. FIGHT FOREVER FOUNDATION, CHICAGO, IL. FILED 9-14-2006.

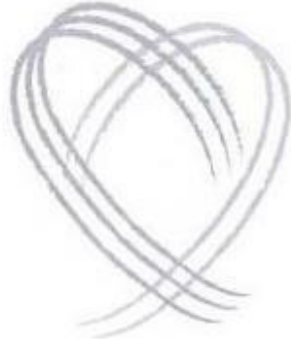

THE MARK CONSISTS OF HEART DESIGN.
FOR CHARITABLE FUND RAISING (U.S. CLS. 100,
101 AND 102).
FIRST USE 12-15-2006; IN COMMERCE 12-15-2006.
CHRISTINA SOBRAL, EXAMINING ATTORNEY

SN 79-033,645. AVRIL FINANCE SAS, FRANCE, FILED 12-1-2006.

STAYING ROOTED IN REALITY

THE MARK CONSISTS OF STANDARD CHARACTERS WITHOUT CLAIM TO ANY PARTICULAR FONT, STYLE, SIZE, OR COLOR.

OWNER OF INTERNATIONAL REGISTRATION 0910977 DATED 12-1-2006, EXPIRES 12-1-2016.

FOR FINANCIAL SERVICES, NAMELY, BANKING SERVICES, MUTUAL FUND AND ELECTRONIC FUNDS TRANSFER, FINANCIAL PORTFOLIO MANAGEMENT IN STOCKS, BONDS, SECURITIES, MONETARY INVESTMENT AND EQUITIES, INVESTMENT OF FUNDS FOR OTHERS, FUND MANAGEMENT SERVICES, MUTUAL FUND BROKERAGE AND MUTUAL FUND INVESTMENT SERVICES, CREATION, MANAGEMENT AND BROKERAGE OF MUTUAL FUNDS FOR THIRD PARTIES, SERVICES FOR THE ESTABLISHMENT OF PORTFOLIOS OF SECURITIES FOR OTHERS AND MANAGEMENT OF SECURITIES PORTFOLIOS; BANKING; INSURANCE BROKERAGE SERVICES; LIFE INSURANCE BROKERAGE AND CONSULTING; INSURANCE CONSULTING; FINANCIAL CONSULTING; FUNDS INVESTMENT; MONETARY INVESTMENT AND CONSULTATION SERVICES, NAMELY, CAPITAL INVESTMENT SERVICES AND CONSULTATION IN THE FIELD OF SECURITIES; FINANCIAL ANALYSIS; FINANCIAL PORTFOLIO MANAGEMENT SERVICES; FINANCIAL TRANSACTIONS SERVICES, NAMELY ASSISTING OTHERS WITH THE COMPLETION OF FINANCIAL TRANSACTIONS FOR STOCKS, BONDS, SECURITIES, EQUITIES; STOCK BROKERAGE; FINANCIAL EVALUATIONS FOR INSURANCE AND BANKING PURPOSES; CAPITAL INVESTMENT CONSULTATION; INVESTMENT SERVICES, NAMELY, ASSET MANAGEMENT SERVICES; SAFE DEPOSIT BOX SERVICES; FINANCIAL MANAGEMENT; SAVINGS AND LOAN SERVICES; ACTUARIAL SERVICES (U.S. CLS. 100, 101 AND 102).

EDWARD FENNESSY, EXAMINING ATTORNEY

CLASS 36—(Continued).

SN 79-043,944. GILDO LUNGARELLA, SWITZERLAND, FILED 8-17-2007.

SwissWay Asset Management

THE MARK CONSISTS OF STANDARD CHARACTERS WITHOUT CLAIM TO ANY PARTICULAR FONT, STYLE, SIZE, OR COLOR.

PRIORITY DATE OF 2-28-2007 IS CLAIMED.

OWNER OF INTERNATIONAL REGISTRATION 0937852 DATED 8-17-2007, EXPIRES 8-17-2017.

NO CLAIM IS MADE TO THE EXCLUSIVE RIGHT TO USE "ASSET MANAGEMENT", APART FROM THE MARK AS SHOWN.

FOR FINANCIAL AFFAIRS, NAMELY, FINANCIAL MANAGEMENT, FINANCIAL CONSULTING, FINANCIAL PORTFOLIO MANAGEMENT AND ASSET MANAGEMENT; MONETARY AFFAIRS, NAMELY, CAPITAL INVESTMENTS, VENTURE CAPITAL INVESTMENTS AND PRIVATE EQUITY INVESTMENTS; REAL ESTATE AFFAIRS, NAMELY, ASSESSMENT AND MANAGEMENT OF REAL ESTATE, REAL ESTATE INVESTMENT (U.S. CLS. 100, 101 AND 102).
PRISCILLA MILTON, EXAMINING ATTORNEY

SN 79-043,964. GILDO LUNGARELLA, SWITZERLAND, FILED 8-23-2007.

SwissWay Group

THE MARK CONSISTS OF STANDARD CHARACTERS WITHOUT CLAIM TO ANY PARTICULAR FONT, STYLE, SIZE, OR COLOR.

PRIORITY DATE OF 2-28-2007 IS CLAIMED.

OWNER OF INTERNATIONAL REGISTRATION 0937907 DATED 8-23-2007, EXPIRES 8-23-2017.

NO CLAIM IS MADE TO THE EXCLUSIVE RIGHT TO USE "GROUP", APART FROM THE MARK AS SHOWN.

FOR FINANCIAL AFFAIRS, NAMELY, FINANCIAL MANAGEMENT, FINANCIAL CONSULTING, FINANCIAL PORTFOLIO MANAGEMENT AND ASSET MANAGEMENT; MONETARY AFFAIRS, NAMELY, CAPITAL INVESTMENTS, VENTURE CAPITAL INVESTMENTS AND PRIVATE EQUITY INVESTMENTS; REAL ESTATE AFFAIRS, NAMELY, ASSESSMENT AND MANAGEMENT OF REAL ESTATE, REAL ESTATE INVESTMENT (U.S. CLS. 100, 101 AND 102).

PRISCILLA MILTON, EXAMINING ATTORNEY

CLASS 36—(Continued).

SN 79-046,254. MEZHREGIONALNY KOMMERCHESKY BANK; RAZVITIA SVYAZI I INFORMATIKI; (OTKRITOE AKTSIONERNOE OBSHCHESTVO); (OAO AKB "SVYAZ-BANK", RUSSIAN FED., FILED 1-12-2007.



PRIORITY DATE OF 7-13-2006 IS CLAIMED.
OWNER OF INTERNATIONAL REGISTRATION 0943517
DATED 1-12-2007, EXPIRES 1-12-2017.

THE ENGLISH TRANSLATION OF THE FOREIGN WORD(S) IN THE MARK IS: "NEAR BY".

FOR CREDIT BUREAUS; FINANCIAL ANALYSIS; HIRE-PURCHASE FINANCING; SAVINGS BANKS; ISSUANCE OF CREDIT CARDS; ISSUE OF TOKENS OF VALUE; CAPITAL INVESTMENTS; PROVIDING BANK ACCOUNT INSURANCE INFORMATION; PROVIDING FINANCIAL INFORMATION; FINANCIAL CLEARING HOUSES; FINANCIAL CONSULTANCY; STOCK EXCHANGE QUOTATIONS; FINANCIAL BUSINESS LIQUIDATION SERVICES; FINANCIAL MANAGEMENT; EXCHANGING MONEY; DEBIT CARD SERVICES; CREDIT CARD SERVICES; HOME BANKING; FACTORING AGENCIES; ORGANIZATION OF COLLECTIONS OF DEBT; FINANCIAL EVALUATION FOR BANKING PURPOSES; ELECTRONIC FUNDS TRANSFER; FINANCIAL GUARANTEE AND SURETY; FINANCING LOANS; MONEY, CONSUMER, REAL ESTATE, COMMERCIAL LENDING AGAINST SECURITY; CHECK VERIFICATION; FINANCIAL SPONSORSHIP OF SHOW-BUSINESS EVENTS, SPORTING EVENTS, CONFERENCES AND CONGRESSES IN THE BANKING INDUSTRY; MORTGAGE BANKING; INSTALLMENT LOANS; BANKING; RETIREMENT PAYMENT SERVICES; BROKERAGE, DISTRIBUTION AND INVESTMENT IN MUTUAL FUNDS; FINANCING SERVICES; SAFE DEPOSIT BOX SERVICES; FISCAL ASSESSMENTS (U.S. CLS. 100, 101 AND 102).

FRANK LATTUCA, EXAMINING ATTORNEY

CLASS 36—(Continued).

SN 79-046,390. THE DAI-ICHI MUTUAL LIFE INSURANCE COMPANY, TOKYO, JAPAN, FILED 4-19-2007.



PRIORITY DATE OF 2-7-2007 IS CLAIMED.
OWNER OF INTERNATIONAL REGISTRATION 0943857
DATED 4-19-2007, EXPIRES 4-19-2017.

OWNER OF U.S. REG. NO. 1,740,165.

NO CLAIM IS MADE TO THE EXCLUSIVE RIGHT TO USE "LIFE", APART FROM THE MARK AS SHOWN.

THE COLOR(S) RED AND WHITE IS/ARE CLAIMED AS A FEATURE OF THE MARK.

THE COLOR WHITE APPEARS IN THE WORDING "DAI-ICHI LIFE" AND THE COLOR RED APPEARS IN THE CURVED POLYGON DESIGN.

THE ENGLISH TRANSLATION OF THE WORD "DAI-ICHI" IN THE MARK IS FIRST.

FOR LOANS; DISCOUNT OF BILLS; ACQUISITION AND TRANSFER OF MONETARY CLAIMS; FOREIGN EXCHANGE TRANSACTIONS; PROVIDING STOCK MARKET INFORMATION; EVALUATION OF THE CREDIT WORTHINESS OF COMPANIES; PROVIDING INFORMATION ON PERSONAL PENSION INSURANCE; PROVIDING INFORMATION ON LIFE INSURANCE; PROVIDING INFORMATION IN INSURANCE MATTERS, OTHER THAN LIFE INSURANCE; REINSURANCE UNDERWRITING; FINANCIAL RESEARCH AND PROVIDING INFORMATION ON FINANCE AND SECURITIES MARKET (U.S. CLS. 100, 101 AND 102).

LAURA HAMMEL, EXAMINING ATTORNEY

SN 79-047,215. ACTION CONTRE LA FAIM, FRANCE, FILED 6-13-2007.



PRIORITY DATE OF 12-15-2006 IS CLAIMED.
OWNER OF INTERNATIONAL REGISTRATION 0946078
DATED 6-13-2007, EXPIRES 6-13-2017.

NO CLAIM IS MADE TO THE EXCLUSIVE RIGHT TO USE "INTERNATIONAL NETWORK", APART FROM THE MARK AS SHOWN.

FROM LEFT TO RIGHT AND FROM TOP TO BOTTOM: STYLIZED YOUNG SHOOT OF A PLANT, REPRESENTED HEAD UP AND HEAD DOWN, FOLLOWED ON ITS RIGHT BY THE LETTERS "ACF", THE WHOLE UNDERLINED BY A BANNER INSCRIBED WITH THE LETTERS "ACF INTERNATIONAL NETWORK".

FOR CHARITABLE FUND RAISING ; FINANCIAL SPONSORSHIP OF INTERNATIONAL AID AND DEVELOPMENT PROJECTS (U.S. CLS. 100, 101 AND 102).

G. MAYERSCHOFF, EXAMINING ATTORNEY

CLASS 36—(Continued).

SN 79-050,146. EURIBOR; FÉDÉRATION BANCAIRE EUROPÉENNE.; ORGANISATION SCIENTIFIQUE INTERNATIONALE; DE DROIT BELGE, BELGIUM, FILED 1-23-2008.

EONIA

THE MARK CONSISTS OF STANDARD CHARACTERS WITHOUT CLAIM TO ANY PARTICULAR FONT, STYLE, SIZE, OR COLOR.

OWNER OF INTERNATIONAL REGISTRATION 0932443 DATED 5-30-2007, EXPIRES 5-30-2017.

FOR FINANCIAL AFFAIRS, NAMELY, FINANCIAL TRUST OPERATIONS; GRANTING OF CREDIT, NAMELY, OFFERING CREDIT CONTRACTS WITH DELAYED REIMBURSEMENT; GRANTING ADVANCES AGAINST SALES PAID BY INSTALLMENTS, SETTLING AND DISTRIBUTION OF CURRENT BASIC INTEREST RATES FOR CREDIT CONTRACTS; GRANTING OF CREDIT; FINANCIAL ANALYSIS; FINANCING SERVICES; AND FINANCIAL INFORMATION AND EVALUATIONS (U.S. CLS. 100, 101 AND 102).

FRANK LATTUCA, EXAMINING ATTORNEY

CLASS 37—(Continued).

SN 76-687,796. GREENWAVE ELECTRIC, INC., TOPEKA, KS. FILED 3-17-2008.



THE COLOR(S) DARK GREEN, LIGHT GREEN AND WHITE IS/ARE CLAIMED AS A FEATURE OF THE MARK.

THE MARK CONSISTS OF THREE CONCENTRIC CIRCLES WITH THE LETTER "W" IN THE CENTER. "W" IS ASYMMETRICAL AND HAS HORIZONTAL LINES RUNNING FROM THE TOP LEFT AND RIGHT ENDS OF THE "W" AND TAPERS OFF TO THE LEFT AND TO THE RIGHT RESPECTIVELY. THE COLOR DARK GREEN APPEARS IN THE BACKGROUND OF THE INTERIOR CIRCLE; THE COLOR LIGHT GREEN APPEARS IN THE OUTER CIRCLE AND IN THE "W"; AND THE COLOR WHITE APPEARS IN THE MIDDLE THIN CIRCLE BETWEEN THE DARK GREEN AND LIGHT GREEN.

FOR ELECTRICAL CONTRACTING SERVICES (U.S. CLS. 100, 103 AND 106).

FIRST USE 11-1-2007; IN COMMERCE 11-6-2007.

KARANENDRA S. CHHINA, EXAMINING ATTORNEY

CLASS 37—CONSTRUCTION AND REPAIR

SN 76-686,074. JEK ARCHITECTURAL & ENGINEERING SERVICES, INC., DBA JEK OWNER'S ADVOCATE, INC., ROLLING MEADOW, IL. FILED 1-24-2008.

OAP OWNER'S ADVOCATE PROGRAM

THE MARK CONSISTS OF STANDARD CHARACTERS WITHOUT CLAIM TO ANY PARTICULAR FONT, STYLE, SIZE, OR COLOR.

NO CLAIM IS MADE TO THE EXCLUSIVE RIGHT TO USE "OWNER'S ADVOCATE PROGRAM", APART FROM THE MARK AS SHOWN.

FOR CONSTRUCTION CONSULTATION (U.S. CLS. 100, 103 AND 106).

FIRST USE 11-0-2005; IN COMMERCE 11-0-2005.

TINA KUAN, EXAMINING ATTORNEY

SN 77-111,767. ONE HOUR AIR CONDITIONING FRANCHISING, LLC, SARASOTA, FL. FILED 2-20-2007.

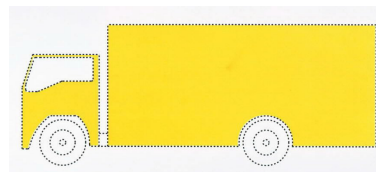

THE COLOR(S) YELLOW IS/ARE CLAIMED AS A FEATURE OF THE MARK.

THE MARK CONSISTS OF THE COLOR YELLOW (PMS 109) USED OVER THE ENTIRE TRUCK. THE MATTER SHOWN IN THE DRAWING IN BROKEN LINES SERVES TO SHOW POSITIONING OF THE MARK AND IS NOT A FEATURE OF THE MARK.

SEC. 2(F).

FOR REPAIR, MAINTENANCE, AND INSTALLATION SERVICES IN THE FIELD OF HEATING, VENTILATION, AND AIR CONDITIONING (U.S. CLS. 100, 103 AND 106).

FIRST USE 12-31-2001; IN COMMERCE 12-31-2001.

TERESA M. RUPP, EXAMINING ATTORNEY

CLASS 37—(Continued).

SN 77-111,793. MISTER SPARKY FRANCHISING, LLC, SARASOTA, FL. FILED 2-20-2007.

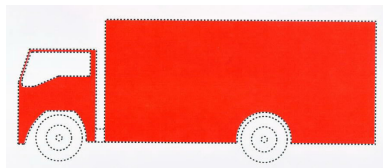

THE COLOR(S) RED (PMS 485) IS/ARE CLAIMED AS A FEATURE OF THE MARK.

THE MARK CONSISTS OF THE COLOR RED (PMS 485) USED OVER THE ENTIRE TRUCK. THE MATTER SHOWN IN THE DRAWING IN BROKEN LINES SERVES TO SHOW POSITIONING OF THE MARK AND IS NOT A FEATURE OF THE MARK.

SEC. 2(F).

FOR REPAIR, MAINTENANCE, AND INSTALLATION OF ELECTRICAL WIRING, OUTLETS, LIGHT FIXTURES, SWITCHES, AND ELECTRICAL PANELS (U.S. CLS. 100, 103 AND 106).

FIRST USE 0-0-1996; IN COMMERCE 0-0-1996.
TERESA M. RUPP, EXAMINING ATTORNEY

SN 77-128,414. GILLECE HEATING AND COOLING, INC., BETHEL PARK, PA. FILED 3-12-2007.

ROOTER-MEDIC

THE MARK CONSISTS OF STANDARD CHARACTERS WITHOUT CLAIM TO ANY PARTICULAR FONT, STYLE, SIZE, OR COLOR.

FOR PLUMBING SERVICES (U.S. CLS. 100, 103 AND 106).

FIRST USE 3-9-2007; IN COMMERCE 3-9-2007.
AMEETA JORDAN, EXAMINING ATTORNEY

SN 77-152,593. CLEGG, DENNIS NAKURU, SEDONA, AZ. FILED 4-10-2007.

Fix-it Man

THE MARK CONSISTS OF STANDARD CHARACTERS WITHOUT CLAIM TO ANY PARTICULAR FONT, STYLE, SIZE, OR COLOR.

FOR REPAIR OF STRUCTURES, NAMELY, ELECTRICAL AND PLUMBING FIXTURES IN COMMERCIAL FOOD SERVICE BUILDINGS AND RESIDENTIAL HOMES, FOOD SERVICE PROCESSING EQUIPMENT, EQUIPMENT FOR COLD STORAGE OF FOOD SERVICE PERISHABLES, HEATING EQUIPMENT FOR FOOD SERVICE PREPARATIONS, HEATING AND COOLING EQUIPMENT FOR BOTH COMMERCIAL AND RESIDENTIAL (U.S. CLS. 100, 103 AND 106).

FIRST USE 4-1-2006; IN COMMERCE 4-1-2006.
JUSTINE D. PARKER, EXAMINING ATTORNEY

CLASS 37—(Continued).

SN 77-190,251. CONCEPTS SERGETTI INC., VAUDREUIL-DORION, (QC), CANADA, FILED 5-25-2007.



PRIORITY CLAIMED UNDER SEC. 44(D) ON CANADA APPLICATION NO. 1341661, FILED 3-30-2007, REG. NO. TMA711251, DATED 4-8-2008, EXPIRES 4-8-2023.

NO CLAIM IS MADE TO THE EXCLUSIVE RIGHT TO USE "SWEETSPOT OPTIMIZER PROCESS", APART FROM THE MARK AS SHOWN.

FOR STRINGING AND RE-STRINGING OF RACKETS FOR RACKET SPORTS (U.S. CLS. 100, 103 AND 106).
SIMON TENG, EXAMINING ATTORNEY

SN 77-214,244. PETROLEUM HEAT & POWER CO., INC., STAMFORD, CT. FILED 6-25-2007.

PETRO PROTECTION SERVICES

THE MARK CONSISTS OF STANDARD CHARACTERS WITHOUT CLAIM TO ANY PARTICULAR FONT, STYLE, SIZE, OR COLOR.

OWNER OF U.S. REG. NOS. 538,181 AND 2,171,734.

NO CLAIM IS MADE TO THE EXCLUSIVE RIGHT TO USE "PROTECTION SERVICES", APART FROM THE MARK AS SHOWN.

FOR INSTALLATION, MAINTENANCE AND REPAIR OF SECURITY ALARM SYSTEMS FOR POLICE, FIRE AND MEDICAL EMERGENCIES FOR RESIDENTIAL AND COMMERCIAL USE (U.S. CLS. 100, 103 AND 106).
CHARLOTTE CORWIN, EXAMINING ATTORNEY

SN 77-214,260. PETROLEUM HEAT & POWER CO., INC., STAMFORD, CT. FILED 6-25-2007.

PETRO SECURITY SERVICES

THE MARK CONSISTS OF STANDARD CHARACTERS WITHOUT CLAIM TO ANY PARTICULAR FONT, STYLE, SIZE, OR COLOR.

OWNER OF U.S. REG. NOS. 538,181 AND 2,171,734.

NO CLAIM IS MADE TO THE EXCLUSIVE RIGHT TO USE "SECURITY SERVICES", APART FROM THE MARK AS SHOWN.

FOR INSTALLATION, MAINTENANCE AND REPAIR OF SECURITY ALARM SYSTEMS FOR POLICE, FIRE AND MEDICAL EMERGENCIES FOR RESIDENTIAL AND COMMERCIAL USE (U.S. CLS. 100, 103 AND 106).
CHARLOTTE CORWIN, EXAMINING ATTORNEY

CLASS 37—(Continued).

SN 77-214,886. PETROLEUM HEAT & POWER CO., INC., STAMFORD, CT. FILED 6-25-2007.



OWNER OF U.S. REG. NOS. 538,181, 2,171,734 AND 2,423,595.

THE MARK CONSISTS OF THE WORD "PETRO" SANDWICHED BETWEEN IMAGES OF A ROOF ABOVE AND A HAND BELOW.

FOR INSTALLATION, MAINTENANCE AND REPAIR OF SECURITY ALARM SYSTEMS FOR POLICE, FIRE AND MEDICAL EMERGENCIES FOR RESIDENTIAL AND COMMERCIAL USE (U.S. CLS. 100, 103 AND 106).
CHARLOTTE CORWIN, EXAMINING ATTORNEY

CLASS 37—(Continued).

SN 77-262,773. CARMA PASO ROBLES LLC, AUSTIN, TX. FILED 8-23-2007.

PASO ROBLES

THE MARK CONSISTS OF STANDARD CHARACTERS WITHOUT CLAIM TO ANY PARTICULAR FONT, STYLE, SIZE, OR COLOR.

THE FOREIGN WORDING IN THE MARK TRANSLATES INTO ENGLISH AS PASS IN THE OAKS.

FOR REAL ESTATE DEVELOPMENT SERVICES AND DEVELOPMENT OF MASTER PLANNED COMMERCIAL AND RESIDENTIAL COMMUNITIES (U.S. CLS. 100, 103 AND 106).

SARA THOMAS, EXAMINING ATTORNEY

SN 77-238,877. BATHREBUILDERS, LLC, CROFTON, MD. FILED 7-25-2007.



NO CLAIM IS MADE TO THE EXCLUSIVE RIGHT TO USE "BATHREBUILDERS", APART FROM THE MARK AS SHOWN.

FOR HOME REMODELING SERVICES (U.S. CLS. 100, 103 AND 106).

FIRST USE 3-1-2005; IN COMMERCE 3-1-2005.
GEORGIA CARTY, EXAMINING ATTORNEY

SN 77-270,680. THE SEWER HOUND, BRANDY STATION, VA. FILED 9-4-2007.

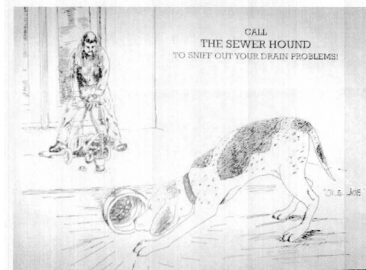

SN 77-250,226. MILLIKEN & COMPANY, SPARTANBURG, SC. FILED 8-8-2007.

PACOLET

THE MARK CONSISTS OF STANDARD CHARACTERS WITHOUT CLAIM TO ANY PARTICULAR FONT, STYLE, SIZE, OR COLOR.

FOR REAL ESTATE DEVELOPMENT (U.S. CLS. 100, 103 AND 106).

MICHAEL LEWIS, EXAMINING ATTORNEY

THE LIKENESS (OR, "PORTRAIT") IN THE MARK IDENTIFIES A LIVING INDIVIDUAL WHOSE CONSENT IS OF RECORD.

THE MARK CONSISTS IN PART OF THE WORDS "OLE JOE" TO THE RIGHT OF THE DOG.

FOR PLUMBING CONTRACTOR SERVICES; PLUMBING SERVICES (U.S. CLS. 100, 103 AND 106).

MARY BOAGNI, EXAMINING ATTORNEY

CLASS 37—(Continued).

SN 77-288,012. MOHAMMAD MALAKOUTI-ZAMIR, HOUSTON, TX. FILED 9-25-2007.



NO CLAIM IS MADE TO THE EXCLUSIVE RIGHT TO USE "AUTO", APART FROM THE MARK AS SHOWN.

THE COLOR(S) RED, BLUE, BLACK, WHITE AND GRAY IS/ARE CLAIMED AS A FEATURE OF THE MARK.

THE MARK CONSISTS OF FIVE RED STARS ABOVE A BLACK AND GRAY STEERING WHEEL PARTIALLY ENCIRCLED BY BLUE CIRCLES AND THE WORDS "AUTO CHAMP" ATOP THREE LINES WRITTEN IN WHITE ON A BLUE BACKGROUND, AND THE REMAINDER OF THE WHITE IN THE MARK IS INTENDED TO INDICATE TRANSPARENCY.

FOR VEHICLE REPAIR AND MAINTENANCE SERVICES (U.S. CLS. 100, 103 AND 106).

MICHAEL KAZAZIAN, EXAMINING ATTORNEY

SN 77-290,908. LEWIS OPERATING CORPORATION, UPLAND, CA. FILED 9-27-2007.



NO CLAIM IS MADE TO THE EXCLUSIVE RIGHT TO USE "LAKVIEW NUEVO", APART FROM THE MARK AS SHOWN.

THE MARK CONSISTS OF AN OVAL SHAPE; WITHIN THE SHAPE ARE A HOUSE, A TREE NEXT TO THE HOUSE, A MOUNTAIN RANGE IN THE BACKGROUND, OPEN FIELD IN FRONT OF THE HOUSE, FENCING AROUND THE FIELD, BOULDERS OUTSIDE OF THE FENCING AND THE WORDS "LAKEVIEW NUEVO".

THE FOREIGN WORDING IN THE MARK TRANSLATES INTO ENGLISH AS NEW.

FOR LAND DEVELOPMENT AND CONSTRUCTION SERVICES, NAMELY, PLANNING, DEVELOPMENT AND CUSTOM CONSTRUCTION OF RESIDENTIAL AND COMMERCIAL COMMUNITIES (U.S. CLS. 100, 103 AND 106).

DAVID MURRAY, EXAMINING ATTORNEY

CLASS 37—(Continued).

SN 77-296,852. J.G. ELEVATOR, LLC, BRANCBURG, NJ. FILED 10-5-2007.

#1 VERTICAL TRANSPORTATION

THE MARK CONSISTS OF STANDARD CHARACTERS WITHOUT CLAIM TO ANY PARTICULAR FONT, STYLE, SIZE, OR COLOR.

SEC. 2(F).

FOR INSTALLATION, MAINTENANCE AND REPAIR OF ELEVATORS AND ASSOCIATED EQUIPMENT (U.S. CLS. 100, 103 AND 106).

FIRST USE 1-1-1997; IN COMMERCE 1-1-1997.

SALLY SHIH, EXAMINING ATTORNEY

SN 77-299,195. SUGAR LAND RANCH DEVELOPMENT, L.L.C., HOUSTON, TX. FILED 10-9-2007.

RIVERSTONE

THE MARK CONSISTS OF STANDARD CHARACTERS WITHOUT CLAIM TO ANY PARTICULAR FONT, STYLE, SIZE, OR COLOR.

FOR REAL ESTATE DEVELOPMENT (U.S. CLS. 100, 103 AND 106).

FIRST USE 3-1-2001; IN COMMERCE 3-1-2001.

HENRY S. ZAK, EXAMINING ATTORNEY

SN 77-312,592. ULTRACLEAN ELECTROPOLISH, INC., HOUSTON, TX. FILED 10-24-2007.

ElectroChemical Cleaning (ECC)

THE MARK CONSISTS OF STANDARD CHARACTERS WITHOUT CLAIM TO ANY PARTICULAR FONT, STYLE, SIZE, OR COLOR.

NO CLAIM IS MADE TO THE EXCLUSIVE RIGHT TO USE "ELECTROCHEMICAL CLEANING", APART FROM THE MARK AS SHOWN.

FOR CLEANING OF INDUSTRIAL PREMISES UTILIZING A CHEMICAL CLEANING PROCESS WHICH UTILIZES VARIOUS ACIDS AND ELECTRICAL CURRENT TO REMOVE DISCOLORATION DUE TO WELDING PROCESSES AND CORROSION MECHANISMS PRIMARILY ON STAINLESS STEELS, NICKEL ALLOYS, AS WELL AS OTHER VARIOUS MATERIALS OF CONSTRUCTION (U.S. CLS. 100, 103 AND 106).

FIRST USE 10-1-2007; IN COMMERCE 10-1-2007.

ANDREA K. NADELMAN, EXAMINING ATTORNEY

CLASS 37—(Continued).

SN 77-315,742. GOLF CART DOCTOR INC., AURORA, CO.
FILED 10-29-2007.



NO CLAIM IS MADE TO THE EXCLUSIVE RIGHT TO USE "GOLF CART", APART FROM THE MARK AS SHOWN.

THE STIPPLING IS FOR SHADING PURPOSES ONLY.

THE MARK CONSISTS OF THE STYLIZED WORDS "GOLF CART DOCTOR GOLF CART DOCTOR". THERE IS AN IMAGE OF A GOLF CART THAT CONTAINS THE WORDS "GOLF CART DOCTOR" ON THE FRONT OF THE CART AND THE WORDS "GOLF CART DOCTOR" NEXT TO THE IMAGE OF THE GOLF CART. TO THE RIGHT OF THE CART AND UNDER THE WORD "DOCTOR" IS AN IMAGE OF VITAL SIGN.

FOR MAINTENANCE AND REPAIR OF ALL TYPES OF GOLF CARTS AND GOLF CARS, BOTH GAS AND ELECTRIC (U.S. CLS. 100, 103 AND 106).

FIRST USE 8-0-2000; IN COMMERCE 8-0-2000.

ELLEN PERKINS, EXAMINING ATTORNEY

SN 77-316,233. L&P PROPERTY MANAGEMENT COMPANY, SOUTHGATE, CA. FILED 10-29-2007.

CROWN NORTH AMERICA

THE MARK CONSISTS OF STANDARD CHARACTERS WITHOUT CLAIM TO ANY PARTICULAR FONT, STYLE, SIZE, OR COLOR.

NO CLAIM IS MADE TO THE EXCLUSIVE RIGHT TO USE "NORTH AMERICA", APART FROM THE MARK AS SHOWN.

FOR MOTOR VEHICLE UP-FITTING AND CUSTOMIZATION SERVICES, NAMELY, INSTALLING EQUIPMENT AND FIXTURES AND CUSTOMIZING VEHICLES TO ADAPT THE VEHICLES FOR USE IN DIFFERENT VOCATIONAL FIELDS (U.S. CLS. 100, 103 AND 106).

FIRST USE 0-0-2000; IN COMMERCE 0-0-2000.

CHRISTOPHER BUONGIORNO, EXAMINING ATTORNEY

CLASS 37—(Continued).

SN 77-322,310. SEMBLER BELL BROOKHAVEN, LLC, ST. PETERSBURG, FL. FILED 11-6-2007.

TOWN BROOKHAVEN

THE MARK CONSISTS OF STANDARD CHARACTERS WITHOUT CLAIM TO ANY PARTICULAR FONT, STYLE, SIZE, OR COLOR.

NO CLAIM IS MADE TO THE EXCLUSIVE RIGHT TO USE "TOWN", APART FROM THE MARK AS SHOWN.

FOR REAL ESTATE DEVELOPMENT (U.S. CLS. 100, 103 AND 106).

LYDIA BELZER, EXAMINING ATTORNEY

SN 77-325,001. SPORTS IMPORTS, INC., COLUMBUS, OH. FILED 11-8-2007.

UPRIGHT REJUVENATION

THE MARK CONSISTS OF STANDARD CHARACTERS WITHOUT CLAIM TO ANY PARTICULAR FONT, STYLE, SIZE, OR COLOR.

OWNER OF U.S. REG. NO. 2,637,784.

NO CLAIM IS MADE TO THE EXCLUSIVE RIGHT TO USE "UPRIGHT", APART FROM THE MARK AS SHOWN.

SEC. 2(F).

FOR RENOVATION IN THE FIELD OF SPORTS EQUIPMENT, NAMELY, VOLLEYBALL UPRIGHTS (U.S. CLS. 100, 103 AND 106).

FIRST USE 2-23-2000; IN COMMERCE 2-23-2000.

FRANK LATTUCA, EXAMINING ATTORNEY

SN 77-351,542. QUALITY STAIR BUILDERS, INC., FARMINGDALE, NY. FILED 12-13-2007.

QUALITY STAIR BUILDERS

THE MARK CONSISTS OF STANDARD CHARACTERS WITHOUT CLAIM TO ANY PARTICULAR FONT, STYLE, SIZE, OR COLOR.

NO CLAIM IS MADE TO THE EXCLUSIVE RIGHT TO USE "STAIR BUILDERS", APART FROM THE MARK AS SHOWN.

SEC. 2(F).

FOR CONSTRUCTION AND REPAIR OF STAIRS AND RAILINGS (U.S. CLS. 100, 103 AND 106).

FIRST USE 0-0-1955; IN COMMERCE 0-0-1955.

KAREN SEVERSON, EXAMINING ATTORNEY

CLASS 37—(Continued).

SN 77-358,788. HAMPTON ISLAND, LLC, ATLANTA, GA. FILED 12-22-2007.

HAMPTON ISLAND PRESERVE

THE MARK CONSISTS OF STANDARD CHARACTERS WITHOUT CLAIM TO ANY PARTICULAR FONT, STYLE, SIZE, OR COLOR.

FOR PLANNING AND LAYING OUT OF RESIDENTIAL COMMUNITIES; HOUSING SERVICES, NAMELY, DEVELOPMENT OF REAL PROPERTY, NAMELY, REPAIR, IMPROVEMENT, AND NEW CONSTRUCTION (U.S. CLS. 100, 103 AND 106).

FIRST USE 1-0-2004; IN COMMERCE 1-0-2004.
 GEORGIA CARTY, EXAMINING ATTORNEY

SN 77-365,320. NORTH AMERICAN INSURANCE SERVICES INC., SAN JOSE, CA. FILED 1-7-2008.

GATP

THE MARK CONSISTS OF STANDARD CHARACTERS WITHOUT CLAIM TO ANY PARTICULAR FONT, STYLE, SIZE, OR COLOR.

FOR PROVIDING INFORMATION RELATED TO AVIATION MAINTENANCE AND RESOURCE PLANNING WITH REGARD TO AVIATION MAINTENANCE VIA THE INTERNET (U.S. CLS. 100, 103 AND 106).

KAREN BRACEY, EXAMINING ATTORNEY

SN 77-367,687. US EXTERIOR MAINTENANCE & REPAIR, PLAINFIELD, IL. FILED 1-9-2008.



NO CLAIM IS MADE TO THE EXCLUSIVE RIGHT TO USE "EXTERIOR" AND "MAINTENANCE & REPAIR", APART FROM THE MARK AS SHOWN.

THE MARK CONSISTS OF AN OVAL WITH THE STYLIZED WORDS "U.S. EXTERIOR MAINTENANCE & REPAIR" INSIDE OF THE OVAL.

SEC. 2(F).

FOR MAINTENANCE AND/OR REPAIR OF SYNTHETIC STUCCO ; INSTALLATION, MAINTENANCE AND REPAIR OF WINDOWS AND DOORS; BUILDING SEALING AND CAULKING SERVICES ; RECOATING, NAMELY, PAINTING OF EXTERIOR SIDING; BUILDING CONSTRUCTION SERVICES (U.S. CLS. 100, 103 AND 106).

FIRST USE 1-1-2000; IN COMMERCE 1-1-2000.
 TARA PATE, EXAMINING ATTORNEY

CLASS 37—(Continued).

SN 77-375,981. THE TERMINIX INTERNATIONAL COMPANY LIMITED PARTNERSHIP, MEMPHIS, TN. FILED 1-19-2008.



THE COLOR(S) GREEN AND GRAY IS/ARE CLAIMED AS A FEATURE OF THE MARK.

THE MARK CONSISTS OF A SHIELD IN THE COLOR GREEN OUTLINED IN THE COLOR GRAY AND LETTER "T" IN THE COLOR GRAY, IN WHICH THE BASE OF THE "T" EXTENDS AT AN ANGLE TOWARD THE UPPER RIGHT PORTION OF THE SHIELD, AND THE CROSS MEMBER OF THE "T" IS HORIZONTALLY LOCATED IN THE UPPER RIGHT PORTION OF THE SHIELD.

FOR TERMITE AND PEST CONTROL (U.S. CLS. 100, 103 AND 106).

FIRST USE 12-29-2007; IN COMMERCE 12-29-2007.
 WILLIAM ROSSMAN, EXAMINING ATTORNEY

SN 77-375,996. THE TERMINIX INTERNATIONAL COMPANY LIMITED PARTNERSHIP, MEMPHIS, TN. FILED 1-19-2008.



THE COLOR(S) GREEN AND GRAY IS/ARE CLAIMED AS A FEATURE OF THE MARK.

THE MARK CONSISTS OF A 3-DIMENSIONAL SHIELD IN THE COLOR GREEN OUTLINED IN THE COLOR GRAY AND LETTER "T" IN THE COLOR GRAY, IN WHICH THE BASE OF THE "T" EXTENDS AT AN ANGLE TOWARD THE UPPER RIGHT PORTION OF THE SHIELD, AND THE CROSS MEMBER OF THE "T" IS HORIZONTALLY LOCATED IN THE UPPER RIGHT PORTION OF THE SHIELD. "A" GRAY COIN APPEARS AT THE TOP OF THE SHIELD AS THOUGH IT IS BEING DEPOSITED WITHIN THE SHIELD.

FOR TERMITE AND PEST CONTROL (U.S. CLS. 100, 103 AND 106).

WILLIAM ROSSMAN, EXAMINING ATTORNEY

CLASS 37—(Continued).

SN 77-376,009. THE TERMINIX INTERNATIONAL COMPANY LIMITED PARTNERSHIP, MEMPHIS, TN. FILED 1-19-2008.



THE COLOR(S) GREEN AND GRAY IS/ARE CLAIMED AS A FEATURE OF THE MARK.

THE MARK CONSISTS OF A SHIELD IN THE COLOR GREEN OUTLINED IN THE COLOR GRAY AND LETTER "T" IN THE COLOR GRAY, IN WHICH THE BASE OF THE "T" EXTENDS AT AN ANGLE TOWARD THE UPPER RIGHT PORTION OF THE SHIELD, AND THE CROSS MEMBER OF THE "T" IS HORIZONTALLY LOCATED IN THE UPPER RIGHT PORTION OF THE SHIELD. THE SHIELD IS IN THE SHAPE OF A LOCK WITH A KEY HOLE IN THE CENTER OF THE "T" AND A U-SHAPED BAR ON TOP OF THE SHIELD.

FOR TERMITE AND PEST CONTROL (U.S. CLS. 100, 103 AND 106).

FIRST USE 12-29-2007; IN COMMERCE 12-29-2007.
WILLIAM ROSSMAN, EXAMINING ATTORNEY

CLASS 37—(Continued).

SN 77-387,187. FITZGERALD'S HEAVY TIMBER CONSTRUCTION, INC., THURMONT, MD. FILED 2-2-2008.



NO CLAIM IS MADE TO THE EXCLUSIVE RIGHT TO USE "STANDING SEAM METAL ROOFING," "A DIVISION OF," AND "HEAVY TIMBER CONSTRUCTION, INC.," APART FROM THE MARK AS SHOWN.

THE COLOR(S) RED AND BLACK IS/ARE CLAIMED AS A FEATURE OF THE MARK.

THE MARK CONSISTS OF THE WORDS "FITZGERALD'S STANDING SEAM METAL ROOFING A DIVISION OF FITZGERALD'S HEAVY TIMBER CONSTRUCTION, INC." IN BLACK SURMOUNTED BY THE OUTLINE OF A STYLIZED BUILDING IN RED.

FOR INSTALLATION OF STANDING SEAM METAL ROOFING (U.S. CLS. 100, 103 AND 106).

FIRST USE 0-0-2007; IN COMMERCE 0-0-2007.
GEOFFREY FOSDICK, EXAMINING ATTORNEY

SN 77-384,089. OJALA, LLC, COVINGTON, LA. FILED 1-30-2008.

5 MINUTE OIL CHANGE

THE MARK CONSISTS OF STANDARD CHARACTERS WITHOUT CLAIM TO ANY PARTICULAR FONT, STYLE, SIZE, OR COLOR.

NO CLAIM IS MADE TO THE EXCLUSIVE RIGHT TO USE "OIL CHANGE", APART FROM THE MARK AS SHOWN.

SEC. 2(F).

FOR AUTOMOTIVE LUBRICATION MAINTENANCE SERVICES, NAMELY, CHANGING MOTOR OIL, REFILLING FLUID RESERVOIRS, FLUSHING AND FILLING COOLANT SYSTEMS AND REPLACING OIL, FUEL AND AIR FILTERS (U.S. CLS. 100, 103 AND 106).

FIRST USE 11-20-1996; IN COMMERCE 11-20-1996.
CYNTHIA TRIPI, EXAMINING ATTORNEY

SN 77-408,262. ARKEMA INC., PHILADELPHIA, PA. FILED 2-28-2008.

GO ABOUT YOUR BUSINESS

THE MARK CONSISTS OF STANDARD CHARACTERS WITHOUT CLAIM TO ANY PARTICULAR FONT, STYLE, SIZE, OR COLOR.

FOR CONSTRUCTION, REPAIR AND INSTALLATION OF PIPES, VALVES, FITTINGS, VESSELS, CONTAINERS, HOUSINGS, MEMBRANES AND PUMPS MADE FROM FLUORINE CONTAINING SYNTHETIC RESINS (U.S. CLS. 100, 103 AND 106).

ODESSA BIBBINS, EXAMINING ATTORNEY

CLASS 37—(Continued).

SN 77-414,445. CONCRETE TECHNOLOGY, INC., LARGO, FL. FILED 3-6-2008.

THE EURO BOND SYSTEM

THE MARK CONSISTS OF STANDARD CHARACTERS WITHOUT CLAIM TO ANY PARTICULAR FONT, STYLE, SIZE, OR COLOR.

NO CLAIM IS MADE TO THE EXCLUSIVE RIGHT TO USE "BOND SYSTEM", APART FROM THE MARK AS SHOWN.

FOR REMODELING OF KITCHEN COUNTERTOPS; RENOVATION IN THE FIELD OF KITCHEN COUNTERTOPS (U.S. CLS. 100, 103 AND 106).

FIRST USE 2-22-2008; IN COMMERCE 2-22-2008.
ESTHER BELENKER, EXAMINING ATTORNEY

CLASS 37—(Continued).

SN 77-417,511. ALL FURNITURE SERVICES, LLC, FOREST HILLS, NY. FILED 3-10-2008.

All Furniture Services

THE MARK CONSISTS OF STANDARD CHARACTERS WITHOUT CLAIM TO ANY PARTICULAR FONT, STYLE, SIZE, OR COLOR.

NO CLAIM IS MADE TO THE EXCLUSIVE RIGHT TO USE "FURNITURE SERVICES", APART FROM THE MARK AS SHOWN.

FOR (BASED ON USE IN COMMERCE) FURNITURE RESTORATION CONSULTATION; FURNITURE RESTORATION, REPAIR AND MAINTENANCE (BASED ON INTENT TO USE) FURNITURE UPHOLSTERING; FURNITURE VARNISHING (U.S. CLS. 100, 103 AND 106).

FIRST USE 4-1-2007; IN COMMERCE 4-1-2007.
HANNO RITTNER, EXAMINING ATTORNEY

SN 77-420,098. PRO TAPPING, INC., MEDFORD, NJ. FILED 3-12-2008.

PRO TAPPING

THE MARK CONSISTS OF STANDARD CHARACTERS WITHOUT CLAIM TO ANY PARTICULAR FONT, STYLE, SIZE, OR COLOR.

OWNER OF U.S. REG. NO. 1,705,436.
NO CLAIM IS MADE TO THE EXCLUSIVE RIGHT TO USE "TAPPING", APART FROM THE MARK AS SHOWN.

SEC. 2(F).
FOR PIPELINE MAINTENANCE AND REPAIR SERVICES; NAMELY, PRESSURE TAPPING, VALVE INSERTIONS, PIPE FREEZING AND LINE STOPS (U.S. CLS. 100, 103 AND 106).

FIRST USE 4-30-1984; IN COMMERCE 4-30-1994.
KATHY DE JONGE, EXAMINING ATTORNEY

SN 77-415,460. DETECTION LOGIC FIRE PROTECTION, INC., BURBANK, CA. FILED 3-6-2008.



OWNER OF U.S. REG. NO. 3,388,088.
NO CLAIM IS MADE TO THE EXCLUSIVE RIGHT TO USE "DETECTION" AND "FIRE PROTECTION INC.", APART FROM THE MARK AS SHOWN.

THE COLOR(S) BLUE AND RED IS/ARE CLAIMED AS A FEATURE OF THE MARK.

THE COLOR BLUE APPEARS IN THE WORDING "DETECTION LOGIC" AND "FIRE PROTECTION, INC.", WITH A RED SQUIGGLE DESIGN RUNNING UNDERNEATH AND IN BETWEEN THE WORDS "DETECTION" AND "LOGIC" AND THE WORDS "FIRE PROTECTION, INC." ARE BENEATH THAT.

FOR INSTALLATION AND MAINTENANCE OF BURGALAR AND/OR FIRE ALARMS; INSTALLATION AND MAINTENANCE OF FIRE ALARM, DETECTION AND SUPPRESSION SYSTEMS; REPAIR OR MAINTENANCE OF FIRE ALARMS (U.S. CLS. 100, 103 AND 106).

FIRST USE 3-1-2006; IN COMMERCE 3-1-2006.
ASMAT KHAN, EXAMINING ATTORNEY

SN 77-420,351. THE IBS SERVICES GROUP, INC., NEW YORK, NY. FILED 3-12-2008.

**WELCOME
HEALTHY HOUSEKEEPING
WE CARE ABOUT YOUR HEALTH**

THE MARK CONSISTS OF STANDARD CHARACTERS WITHOUT CLAIM TO ANY PARTICULAR FONT, STYLE, SIZE, OR COLOR.

OWNER OF U.S. REG. NOS. 2,425,597, 3,038,227 AND OTHERS.

NO CLAIM IS MADE TO THE EXCLUSIVE RIGHT TO USE "HEALTHY HOUSEKEEPING", APART FROM THE MARK AS SHOWN.

FOR CLEANING OF BUILDINGS (U.S. CLS. 100, 103 AND 106).

FIRST USE 1-1-2007; IN COMMERCE 1-1-2007.
HELENE LIWINSKI, EXAMINING ATTORNEY

CLASS 37—(Continued).

SN 77-420,586. SHIELD AND ASSOCIATES, EL DORADO HILLS, CA. FILED 3-13-2008.

Sun Solutions

THE MARK CONSISTS OF STANDARD CHARACTERS WITHOUT CLAIM TO ANY PARTICULAR FONT, STYLE, SIZE, OR COLOR.

FOR INSTALLATION AND MAINTENANCE OF PHOTOVOLTAIC/SOLAR THERMAL HYBRID INSTALLATIONS; INSTALLATION AND MAINTENANCE OF SOLAR ENERGY BASED POWER PLANTS; INSTALLATION AND MAINTENANCE OF SOLAR THERMAL INSTALLATIONS; REPAIR AND INSTALLATION SERVICES, NAMELY, THE INSTALLATION OF HEATING, COOLING AND ENVIRONMENTAL CONTROL SYSTEMS PRIMARILY USING SOLAR ENERGY, RENEWABLE ENERGY RESOURCES AND RAINWATER (U.S. CLS. 100, 103 AND 106).

KAELIE KUNG, EXAMINING ATTORNEY



SN 77-421,396. KIMMEL, KEVIN GRANT, WICHITA, KS. FILED 3-13-2008.

SLUG BUG AND RUG

THE MARK CONSISTS OF STANDARD CHARACTERS WITHOUT CLAIM TO ANY PARTICULAR FONT, STYLE, SIZE, OR COLOR.

FOR PLUMBING SERVICES, NAMELY, CLEANING OBSTRUCTED DRAINS AND PIPES; EXTERMINATION SERVICES, NAMELY, PEST CONTROL AND EXTERMINATION; AND CARPET AND RUG CLEANING SERVICES (U.S. CLS. 100, 103 AND 106).

CHRISTINA SOBRAL, EXAMINING ATTORNEY



SN 77-421,669. RS LINING SYSTEMS, CARY, NC. FILED 3-13-2008.

AGUAPURA

THE MARK CONSISTS OF STANDARD CHARACTERS WITHOUT CLAIM TO ANY PARTICULAR FONT, STYLE, SIZE, OR COLOR.

THE FOREIGN WORDING IN THE MARK TRANSLATES INTO ENGLISH AS PURE WATER.

FOR INSTALLATION, MAINTENANCE AND REPAIR OF SEWER LINES (U.S. CLS. 100, 103 AND 106).

MICHAEL LITZAU, EXAMINING ATTORNEY

CLASS 37—(Continued).

SN 77-421,675. LEGACY PEST CONTROL, MESA, AZ. FILED 3-13-2008.



NO CLAIM IS MADE TO THE EXCLUSIVE RIGHT TO USE "PEST CONTROL", APART FROM THE MARK AS SHOWN.

THE MARK CONSISTS OF A SHIELD WITH THE STYLIZED LETTER "L". TO THE RIGHT OF THE SHIELD IS THE STYLIZED TEXT "LEGACY PEST CONTROL". BELOW THE TEXT IS AN IMAGE OF A SPIDER, CRICKET, ANT AND SCORPION WALKING ON A LINE.

FOR PEST CONTROL (U.S. CLS. 100, 103 AND 106).

FIRST USE 9-1-2007; IN COMMERCE 9-14-2007.

GEORGE LORENZO, EXAMINING ATTORNEY



SN 77-422,834. VT CONSTRUCTION, INC., NORTH LAS VEGAS, NV. FILED 3-14-2008.

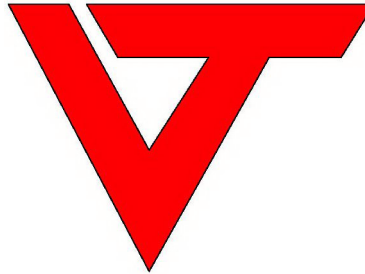

THE COLOR(S) RED AND BLACK IS/ARE CLAIMED AS A FEATURE OF THE MARK.

THE MARK CONSISTS OF A CAPITAL "V" WITH THE RIGHT LEG OF THE "V" CROSSED TO MAKE A CAPITAL "T" IN THE COLOR RED OUTLINED IN BLACK.

FOR CONSTRUCTION GRADING SERVICES (U.S. CLS. 100, 103 AND 106).

FIRST USE 2-0-2000; IN COMMERCE 2-0-2000.

PRISCILLA MILTON, EXAMINING ATTORNEY

CLASS 37—(Continued).

SN 77-424,453. FACILITIES ELECTRIC, INC., HOUSTON, TX. FILED 3-18-2008.



NO CLAIM IS MADE TO THE EXCLUSIVE RIGHT TO USE "FACILITIES" AND "ELECTRIC", APART FROM THE MARK AS SHOWN.

THE COLOR(S) YELLOW AND BLACK IS/ARE CLAIMED AS A FEATURE OF THE MARK.

THE MARK CONSISTS OF LETTERS "FE" WITH A YELLOW THUNDERBOLT BETWEEN THE LETTERS BETWEEN THE WORDS "FACILITIES" AND "ELECTRIC"; THE LETTERS "FE" AND THE WORDS "FACILITIES" AND "ELECTRIC" ARE BLACK.

FOR ELECTRICAL CONTRACTOR SERVICES; ELECTRICAL CONTRACTING; ELECTRICAL REPAIRS AND INSTALLATION OF ELECTRICAL SYSTEMS; INSTALLATION OF ELECTRICAL AND GENERATING MACHINERY; REPAIR OR MAINTENANCE OF ELECTRIC LIGHTING APPARATUS; INSTALLATION OF ELECTRICAL SYSTEMS; INSTALLATION OF ELECTRONIC AND DIGITAL CONNECTION TO A CALL CENTRE (U.S. CLS. 100, 103 AND 106).

FIRST USE 8-1-1998; IN COMMERCE 8-1-1998.
G. MAYERSCHOFF, EXAMINING ATTORNEY

SN 77-425,902. JET, INC., CLEVELAND, OH. FILED 3-19-2008.

SIMPLY BETTER

THE MARK CONSISTS OF STANDARD CHARACTERS WITHOUT CLAIM TO ANY PARTICULAR FONT, STYLE, SIZE, OR COLOR.

FOR INSTALLATION, REPAIR, AND MAINTENANCE OF WASTEWATER TREATMENT AND DISPOSAL PLANTS FOR RESIDENTIAL AND COMMERCIAL USE (U.S. CLS. 100, 103 AND 106).

FIRST USE 1-17-2007; IN COMMERCE 1-17-2007.
CURTIS FRENCH, EXAMINING ATTORNEY

CLASS 37—(Continued).

SN 77-426,065. AMERICAN MULTI-CINEMA, INC., KANSAS CITY, MO. FILED 3-19-2008.

CENTERTAINMENT

THE MARK CONSISTS OF STANDARD CHARACTERS WITHOUT CLAIM TO ANY PARTICULAR FONT, STYLE, SIZE, OR COLOR.

FOR REAL ESTATE DEVELOPMENT SERVICES, NAMELY, THE DEVELOPMENT OF MOTION PICTURE THEATERS AND RESTAURANTS (U.S. CLS. 100, 103 AND 106).

KATHERINE M. DUBRAY, EXAMINING ATTORNEY

SN 77-426,674. WILLS, INC., TWIN FALLS, ID. FILED 3-19-2008.



Green Building

NO CLAIM IS MADE TO THE EXCLUSIVE RIGHT TO USE "GREEN BUILDING", APART FROM THE MARK AS SHOWN.

THE MARK CONSISTS OF AN OUTLINE OF A PLANT WITH A LEAF ON EACH SIDE WITH AN OUTLINE OF A SMALL HOUSE WITH TWO WINDOWS EMERGING OUT THE TOP OF THE PLANT. BELOW THE TWO LEAFS IS THE STYLIZED TEXT "GREEN BUILDING".

FOR CONSTRUCTION OF BUILDINGS; LAND DEVELOPMENT SERVICES, NAMELY, PLANNING AND LAYING OUT OF RESIDENTIAL AND/OR COMMERCIAL COMMUNITIES (U.S. CLS. 100, 103 AND 106).

FIRST USE 2-25-2008; IN COMMERCE 2-25-2008.
GISELLE AGOSTO, EXAMINING ATTORNEY

SN 77-427,100. COVERALL NORTH AMERICA, INC., BOCA RATON, FL. FILED 3-20-2008.

FOCUS 180

THE MARK CONSISTS OF STANDARD CHARACTERS WITHOUT CLAIM TO ANY PARTICULAR FONT, STYLE, SIZE, OR COLOR.

FOR MAINTENANCE AND CLEANING OF OFFICES AND OTHER COMMERCIAL BUILDINGS (U.S. CLS. 100, 103 AND 106).

FIRST USE 0-0-2001; IN COMMERCE 0-0-2001.
BENJAMIN OKEKE, EXAMINING ATTORNEY

CLASS 37—(Continued).

SN 77-427,113. COVERALL NORTH AMERICA, INC., BOCA RATON, FL. FILED 3-20-2008.

C.A.R.E.

THE MARK CONSISTS OF STANDARD CHARACTERS WITHOUT CLAIM TO ANY PARTICULAR FONT, STYLE, SIZE, OR COLOR.

FOR MAINTENANCE AND CLEANING OF OFFICES AND COMMERCIAL BUILDINGS (U.S. CLS. 100, 103 AND 106).

FIRST USE 0-0-2001; IN COMMERCE 0-0-2001. BENJAMIN OKEKE, EXAMINING ATTORNEY

SN 77-427,214. H.O.M.E., INC (EXECUTIVE HOME SERVICES), CARMEL, IN. FILED 3-20-2008.

EXHS

THE MARK CONSISTS OF STANDARD CHARACTERS WITHOUT CLAIM TO ANY PARTICULAR FONT, STYLE, SIZE, OR COLOR.

FOR CLEANING OF RESIDENTIAL HOUSES, CARPET CLEANING AND WINDOW CLEANING (U.S. CLS. 100, 103 AND 106).

FIRST USE 1-1-2002; IN COMMERCE 1-1-2002. MAYUR VAGHANI, EXAMINING ATTORNEY

SN 77-427,384. SEARS BRANDS, LLC, HOFFMAN ESTATES, IL. FILED 3-20-2008.

SEARS EXPRESS

THE MARK CONSISTS OF STANDARD CHARACTERS WITHOUT CLAIM TO ANY PARTICULAR FONT, STYLE, SIZE, OR COLOR.

OWNER OF U.S. REG. NOS. 1,563,683, 2,922,885 AND OTHERS.

NO CLAIM IS MADE TO THE EXCLUSIVE RIGHT TO USE "EXPRESS", APART FROM THE MARK AS SHOWN.

FOR AUTOMOTIVE LUBRICATION AND OIL CHANGE SERVICES (U.S. CLS. 100, 103 AND 106).

HANNO RITTNER, EXAMINING ATTORNEY

CLASS 37—(Continued).

SN 77-427,870. FRATFIX INC., BELLEFONTE, PA. FILED 3-20-2008.



NO CLAIM IS MADE TO THE EXCLUSIVE RIGHT TO USE "INC", APART FROM THE MARK AS SHOWN.

THE MARK CONSISTS OF THE STYLIZED TEXT "FRATFIX INC". THE LETTER "X" IS AN IMAGE OF A MAN HOLDING WRENCH AND HAMMER.

FOR BUILDING MAINTENANCE AND REPAIR SERVICES (U.S. CLS. 100, 103 AND 106).

AMY ALFIERI, EXAMINING ATTORNEY

SN 77-428,842. METALOCK CORPORATION, WILLOW SPRINGS, IL. FILED 3-21-2008.

METALOCK

THE MARK CONSISTS OF STANDARD CHARACTERS WITHOUT CLAIM TO ANY PARTICULAR FONT, STYLE, SIZE, OR COLOR.

FOR MACHINERY REPAIR SERVICES (U.S. CLS. 100, 103 AND 106).

FIRST USE 9-1-1937; IN COMMERCE 9-1-1937.

LINDA M. KING, EXAMINING ATTORNEY

SN 77-429,092. GALPA INVESTMENT LTD., CHRIST CHURCH, BARBADOS, FILED 3-23-2008.



NO CLAIM IS MADE TO THE EXCLUSIVE RIGHT TO USE "PARTS", APART FROM THE MARK AS SHOWN.

THE MARK CONSISTS OF THE DRAWING OF A WALKING MAN HOLDING A TOOL BOX FOLLOWED BY THE WORDS "TOTAL PARTS" IN STYLIZED CAPITAL LETTERS.

FOR REFRIGERATOR REPAIR; INSTALLATION, MAINTENANCE AND REPAIR OF AIR CONDITIONERS, AIR CONDITIONING UNITS, TEMPERATURE CONTROLLED WINE CELLARS AND DEHUMIDIFIERS (U.S. CLS. 100, 103 AND 106).

MARLENE BELL, EXAMINING ATTORNEY

CLASS 37—(Continued).

SN 77-429,351. ISLAND ADVANTAGE REALTY, LLC, HUNTINGTON, NY. FILED 3-24-2008.

ISLAND ADVANTAGE

THE MARK CONSISTS OF STANDARD CHARACTERS WITHOUT CLAIM TO ANY PARTICULAR FONT, STYLE, SIZE, OR COLOR.

FOR CONSTRUCTION CONSULTATION; CONSTRUCTION PLANNING; CONSTRUCTION SUPERVISION; CONSTRUCTION AND RENOVATION OF BUILDINGS (U.S. CLS. 100, 103 AND 106).

FIRST USE 10-6-1998; IN COMMERCE 10-6-1998.
WENDY GOODMAN, EXAMINING ATTORNEY

CLASS 37—(Continued).

SN 77-429,540. STEWARD'S PLUMBING, INC, ALBUQUERQUE, NM. FILED 3-24-2008.



THE MARK CONSISTS OF A IMAGE OF AN ANIMATED PLUMBER RUNNING WITH A TOOL BOX HOLDING A WRENCH WEARING A CAP.

FOR PLUMBING SERVICES; INSTALLATION, MAINTENANCE AND REPAIR OF GAS, HEATING, COOLING, AND DRAINING SYSTEMS (U.S. CLS. 100, 103 AND 106).

FIRST USE 3-1-1985; IN COMMERCE 3-1-1985.
LAURA HAMMEL, EXAMINING ATTORNEY

SN 77-429,359. ISLAND ADVANTAGE REALTY, LLC, HUNTINGTON, NY. FILED 3-24-2008.



NO CLAIM IS MADE TO THE EXCLUSIVE RIGHT TO USE "REALTY, LLC", APART FROM THE MARK AS SHOWN.

THE MARK CONSISTS OF TWO SAILS WITHIN A CIRCLE, WHICH IS ENCLOSED IN A SQUARE, NEXT TO THE LITERAL ELEMENT "ISLAND", WHICH IS ON TOP OF THE LITERAL ELEMENT "ADVANTAGE", WHICH IS ON TOP OF THE LITERAL ELEMENT "REALTY, LLC", WHICH IS ENCLOSED IN A RECTANGLE.

FOR CONSTRUCTION CONSULTATION; CONSTRUCTION PLANNING; CONSTRUCTION SUPERVISION; CONSTRUCTION AND RENOVATION OF BUILDINGS (U.S. CLS. 100, 103 AND 106).

FIRST USE 10-6-1998; IN COMMERCE 10-6-1998.
WENDY GOODMAN, EXAMINING ATTORNEY

SN 77-430,179. ECOSHINE, LLC, DBA ECOSHINE AUTO SPA, PHOENIX, AZ. FILED 3-24-2008.

Ecoshine Auto Spa

SN 77-429,483. ROLWES CO., ST. LOUIS, MO. FILED 3-24-2008.

**THE LIFESTYLE YOU WANT
FROM THE BUILDER YOU TRUST**

THE MARK CONSISTS OF STANDARD CHARACTERS WITHOUT CLAIM TO ANY PARTICULAR FONT, STYLE, SIZE, OR COLOR.

FOR RESIDENTIAL HOME CONSTRUCTION SERVICES (U.S. CLS. 100, 103 AND 106).

FIRST USE 2-0-2008; IN COMMERCE 2-0-2008.
AMOS T. MATTHEWS, JR., EXAMINING ATTORNEY

THE MARK CONSISTS OF STANDARD CHARACTERS WITHOUT CLAIM TO ANY PARTICULAR FONT, STYLE, SIZE, OR COLOR.

NO CLAIM IS MADE TO THE EXCLUSIVE RIGHT TO USE "AUTO SPA", APART FROM THE MARK AS SHOWN.

FOR AUTOMOBILE CLEANING; AUTOMOBILE CLEANING AND CAR WASHING; CAR CLEANING; CAR WASHING; CLEANING OF CARS, RECREATIONAL VEHICLES, AND AUTOMOBILES USING WATERLESS/LOW-WATER SYSTEM; AUTOMOBILE WASHING; WASHING OF CARS, RECREATIONAL VEHICLES, AND AUTOMOBILES USING WATERLESS/LOW-WATER SYSTEM; VEHICLE CLEANING; VEHICLE WASHING (U.S. CLS. 100, 103 AND 106).

FIRST USE 6-0-2007; IN COMMERCE 6-0-2007.
GISELLE AGOSTO, EXAMINING ATTORNEY

CLASS 37—(Continued).

SN 77-430,198. ECOSHINE, LLC, DBA ECOSHINE AUTO SPA, PHOENIX, AZ. FILED 3-24-2008.

Where Conservation Meets Innovation

THE MARK CONSISTS OF STANDARD CHARACTERS WITHOUT CLAIM TO ANY PARTICULAR FONT, STYLE, SIZE, OR COLOR.

FOR AUTOMOBILE CLEANING; AUTOMOBILE CLEANING AND CAR WASHING; CAR CLEANING; CAR WASHING; CLEANING OF CARS, RECREATIONAL VEHICLES, AND AUTOMOBILES USING WATERLESS/LOW-WATER SYSTEM; AUTOMOBILE WASHING; WASHING OF CARS, RECREATIONAL VEHICLES, AND AUTOMOBILES USING WATERLESS/LOW-WATER SYSTEM; VEHICLE CLEANING; VEHICLE WASHING (U.S. CLS. 100, 103 AND 106).

FIRST USE 6-0-2007; IN COMMERCE 6-0-2007.
GISELLE AGOSTO, EXAMINING ATTORNEY

CLASS 37—(Continued).

SN 77-431,175. GLOBAL GARAGE FLOORING, LLC, DENVER, CO. FILED 3-25-2008.

GLOBAL GARAGE FLOORING

THE MARK CONSISTS OF STANDARD CHARACTERS WITHOUT CLAIM TO ANY PARTICULAR FONT, STYLE, SIZE, OR COLOR.

NO CLAIM IS MADE TO THE EXCLUSIVE RIGHT TO USE "GARAGE FLOORING", APART FROM THE MARK AS SHOWN.

FOR RENOVATION AND RESTORATION OF BUILDINGS, NAMELY, RENOVATION OF GARAGES (U.S. CLS. 100, 103 AND 106).

FIRST USE 12-6-2005; IN COMMERCE 12-6-2005.
JENNIFER MARTIN, EXAMINING ATTORNEY

SN 77-431,659. MASONRY TECHNOLOGY, INC., CRESCO, IA. FILED 3-26-2008.

HYPERSPECS

THE MARK CONSISTS OF STANDARD CHARACTERS WITHOUT CLAIM TO ANY PARTICULAR FONT, STYLE, SIZE, OR COLOR.

FOR PROVIDING ON-LINE INFORMATION FOR CONSTRUCTION PROFESSIONALS (U.S. CLS. 100, 103 AND 106).

FIRST USE 3-26-2008; IN COMMERCE 3-26-2008.
H. M. FISHER, EXAMINING ATTORNEY

SN 77-430,486. PEARL SERVICES, INC., SALEM, SC. FILED 3-25-2008.



NO CLAIM IS MADE TO THE EXCLUSIVE RIGHT TO USE "SERVICES, INC", APART FROM THE MARK AS SHOWN.

THE COLOR(S) IVORY, VIOLET, AND BLACK IS/ARE CLAIMED AS A FEATURE OF THE MARK.

THE MARK CONSISTS OF THE LITERAL ELEMENT "PEARL" IN VIOLET, AND "SERVICES, INC" IN BLACK LOCATED BENEATH A DESIGN OF A IVORY COLORED PEARL CASTING A SHADOW.

FOR JANITORIAL SERVICES; CLEANING OF INDUSTRIAL PREMISES; CLEANING OF RESIDENTIAL HOUSES (U.S. CLS. 100, 103 AND 106).

FIRST USE 11-1-2005; IN COMMERCE 11-1-2005.
SANJEEV VOHRA, EXAMINING ATTORNEY

SN 77-431,784. TENNESSEE NATIONAL, LLC, LOUDEN, TN. FILED 3-26-2008.



THE COLOR(S) BLUE, GREEN AND WHITE IS/ARE CLAIMED AS A FEATURE OF THE MARK.

THE MARK CONSISTS OF TWO STYLIZED DEPICTIONS OF GREEN MOUNTAINS AND A STYLIZED DEPICTION OF A BLUE RIVER RUNNING UNDERNEATH AND WHITE IN THE SPACES BETWEEN THE DEPICTIONS.

FOR REAL ESTATE DEVELOPMENT (U.S. CLS. 100, 103 AND 106).

FIRST USE 3-2-2008; IN COMMERCE 3-2-2008.
LAURIE KAUFMAN, EXAMINING ATTORNEY

CLASS 37—(Continued).

SN 77-431,790. AROUND THE HOUSE HOME REPAIR, OLATHE, KS. FILED 3-26-2008.



NO CLAIM IS MADE TO THE EXCLUSIVE RIGHT TO USE "HOME REPAIR, LLC", APART FROM THE MARK AS SHOWN.

THE STIPPLING IS FOR SHADING PURPOSES ONLY. THE MARK CONSISTS OF THE WORDS "AROUND THE HOUSE" IN A CURVED FORMAT ABOVE AN ART WORK OF A HANDYMAN. THE WORD "HOME" APPEARS TO THE LEFT OF THE ART WORK IN A STRAIGHT FORMAT. THE WORD AND LETTERS "REPAIR, LLC" APPEAR TO THE RIGHT OF THE ART WORK IN A STRAIGHT FORMAT.

FOR CARPENTRY; ELECTRICAL CONTRACTING; PAINTING; REPAIR WORK ON BUILDINGS; PLUMBING (U.S. CLS. 100, 103 AND 106).

FIRST USE 9-18-2003; IN COMMERCE 9-18-2003.
BARBARA BROWN, EXAMINING ATTORNEY

SN 77-432,208. CARSTAR FRANCHISE SYSTEMS, INC., OVERLAND PARK, KS. FILED 3-26-2008.

BE SAFE AMERICA

THE MARK CONSISTS OF STANDARD CHARACTERS WITHOUT CLAIM TO ANY PARTICULAR FONT, STYLE, SIZE, OR COLOR.

NO CLAIM IS MADE TO THE EXCLUSIVE RIGHT TO USE "AMERICA", APART FROM THE MARK AS SHOWN. FOR AUTOMOBILE COLLISION REPAIR SERVICES (U.S. CLS. 100, 103 AND 106).

FIRST USE 8-22-2005; IN COMMERCE 8-22-2005.
ALICE SUE CARRUTHERS, EXAMINING ATTORNEY

SN 77-432,398. CASELLA WASTE SYSTEMS, INC., RUTLAND, VT. FILED 3-26-2008.

THINK SMART

THE MARK CONSISTS OF STANDARD CHARACTERS WITHOUT CLAIM TO ANY PARTICULAR FONT, STYLE, SIZE, OR COLOR.

FOR WASTE COLLECTION, TRANSFER AND DISPOSAL SERVICES FOR OTHERS (U.S. CLS. 100, 103 AND 106).

KATHERINE STOIDES, EXAMINING ATTORNEY

CLASS 37—(Continued).

SN 77-432,578. ULTIMATE CONCEPTS, COLUMBUS, OH. FILED 3-26-2008.

YOUR NEIGHBORS KNOW !!!

THE MARK CONSISTS OF STANDARD CHARACTERS WITHOUT CLAIM TO ANY PARTICULAR FONT, STYLE, SIZE, OR COLOR.

FOR INSTALLATION OF DECKING, FENCING, SIDING, WINDOWS, PATIO ROOMS, FINISHED BASEMENTS (U.S. CLS. 100, 103 AND 106).

FIRST USE 6-1-1997; IN COMMERCE 6-1-1997.
GINA FINK, EXAMINING ATTORNEY

SN 77-432,683. REGAL REGALIA CORPORATION, OCEAN, NJ. FILED 3-26-2008.

Regal Regalia

THE MARK CONSISTS OF STANDARD CHARACTERS WITHOUT CLAIM TO ANY PARTICULAR FONT, STYLE, SIZE, OR COLOR.

FOR DRY CLEANING (U.S. CLS. 100, 103 AND 106).
ALEXANDER L. POWERS, EXAMINING ATTORNEY

SN 77-432,843. AIROOM, INC., LINCOLNWOOD, IL. FILED 3-27-2008.

HOMEISTIC

THE MARK CONSISTS OF STANDARD CHARACTERS WITHOUT CLAIM TO ANY PARTICULAR FONT, STYLE, SIZE, OR COLOR.

FOR REPAIR OF HOMES; RESIDENTIAL AND COMMERCIAL BUILDING CONSTRUCTION AND REMODELING; CUSTOM CONSTRUCTION AND BUILDING RENOVATION (U.S. CLS. 100, 103 AND 106).

REBECCA EISINGER, EXAMINING ATTORNEY

CLASS 37—(Continued).

SN 77-432,927. DIESEL DIRECT, INC., STOUGHTON, MA. FILED 3-27-2008.

DIESEL DIRECT

THE MARK CONSISTS OF STANDARD CHARACTERS WITHOUT CLAIM TO ANY PARTICULAR FONT, STYLE, SIZE, OR COLOR.

NO CLAIM IS MADE TO THE EXCLUSIVE RIGHT TO USE "DIESEL", APART FROM THE MARK AS SHOWN.

FOR RE-FUELING SERVICES FOR DIESEL OPERATED VEHICLES AT CUSTOMER ON-SITE LOCATIONS AND ON-SITE SERVICES FOR FUELING VEHICLE FLEETS AND FUELING SKID TANKS AT CONSTRUCTION SITES (U.S. CLS. 100, 103 AND 106).

FIRST USE 5-1-1998; IN COMMERCE 5-1-1998.
REBECCA GILBERT, EXAMINING ATTORNEY

SN 77-433,508. SLAB MASTERS, INC., BELLEVILLE, IL. FILED 3-27-2008.

**HEAL YOUR HOME WITH
HELITECH**

THE MARK CONSISTS OF STANDARD CHARACTERS WITHOUT CLAIM TO ANY PARTICULAR FONT, STYLE, SIZE, OR COLOR.

OWNER OF U.S. REG. NOS. 2,301,603 AND 3,242,451.
FOR STRUCTURAL REPAIR, NAMELY, PIERING AND FOUNDATION REPAIR, CONCRETE REPAIR AND WATERPROOFING (U.S. CLS. 100, 103 AND 106).

FIRST USE 1-0-2005; IN COMMERCE 1-0-2005.
PETER B. BROMAGHIM, EXAMINING ATTORNEY

SN 77-434,944. STRIZER CONSTRUCTION, INC., SAN FRANCISCO, CA. FILED 3-28-2008.



NO CLAIM IS MADE TO THE EXCLUSIVE RIGHT TO USE "CONSTRUCTION", APART FROM THE MARK AS SHOWN.

THE MARK CONSISTS OF THE STYLIZED WORDS "STRIZER CONSTRUCTION" AND A PENTAGON DESIGN. FOR RESIDENTIAL AND COMMERCIAL BUILDING CONSTRUCTION (U.S. CLS. 100, 103 AND 106).

FIRST USE 0-0-1999; IN COMMERCE 0-0-1999.
TOBY BULLOFF, EXAMINING ATTORNEY

CLASS 37—(Continued).

SN 77-447,057. GALPA INVESTMENT LTD., CHRIST CHURCH, BARBADOS, FILED 4-14-2008.



THE COLOR(S) WHITE, BLACK, GREY AND BLUE IS/ ARE CLAIMED AS A FEATURE OF THE MARK.

THE MARK CONSISTS OF THE WORD "ECOX" IN STYLIZED BLACK LETTERS. A BLUE ARCH LIKE FIGURE APPEARS OVER THE DRAWING, INTERSECTING PORTIONS OF THE LETTERS "E," "C" AND "O". THE COLOR WHITE APPEARS IN THE AREAS OF THE LETTER "E" THE ARCH LIKE FIGURE CROSSES. THE COLOR GREY APPEARS IN THE AREAS OF THE LETTERS "C" AND "O" THE ARCH LIKE FIGURE CROSSES.

FOR REFRIGERATOR REPAIR; INSTALLATION, MAINTENANCE AND REPAIR OF AIR CONDITIONERS, AIR CONDITIONING UNITS, TEMPERATURE CONTROLLED WINE CELLARS AND DEHUMIDIFIERS (U.S. CLS. 100, 103 AND 106).

MARLENE BELL, EXAMINING ATTORNEY

SN 77-449,839. PALMER FIXTURE COMPANY, GREEN BAY, WI. FILED 4-16-2008.

Restroom Automation

THE MARK CONSISTS OF STANDARD CHARACTERS WITHOUT CLAIM TO ANY PARTICULAR FONT, STYLE, SIZE, OR COLOR.

NO CLAIM IS MADE TO THE EXCLUSIVE RIGHT TO USE "RESTROOM", APART FROM THE MARK AS SHOWN.

FOR JANITORIAL SERVICES (U.S. CLS. 100, 103 AND 106).

GISELLE AGOSTO, EXAMINING ATTORNEY

SN 77-459,730. SLAB MASTERS, INC., BELLEVILLE, IL. FILED 4-28-2008.

**PROTECT YOUR GREATEST
ASSET.... YOUR HOME**

THE MARK CONSISTS OF STANDARD CHARACTERS WITHOUT CLAIM TO ANY PARTICULAR FONT, STYLE, SIZE, OR COLOR.

FOR STRUCTURAL REPAIR, NAMELY, PIERING AND FOUNDATION REPAIR, CONCRETE REPAIR AND WATERPROOFING (U.S. CLS. 100, 103 AND 106).

FIRST USE 1-0-2000; IN COMMERCE 1-0-2000.

PETER B. BROMAGHIM, EXAMINING ATTORNEY

CLASS 37—(Continued).

SN 77-459,922. GROMAN, ELLIOT, BROOKLYN, NY. FILED 4-28-2008.

SAVING THE PLANET, ONE GALLON AT THE TIME!

THE MARK CONSISTS OF STANDARD CHARACTERS WITHOUT CLAIM TO ANY PARTICULAR FONT, STYLE, SIZE, OR COLOR.

FOR WASTE OIL COLLECTION FOR RECYCLING (U.S. CLS. 100, 103 AND 106).

FIRST USE 2-15-2008; IN COMMERCE 2-15-2008.
SANI KHOURI, EXAMINING ATTORNEY

SN 77-479,983. CASELLA WASTE SYSTEMS, INC., RUTLAND, VT. FILED 5-21-2008.

ZERO-SORT

THE MARK CONSISTS OF STANDARD CHARACTERS WITHOUT CLAIM TO ANY PARTICULAR FONT, STYLE, SIZE, OR COLOR.

FOR WASTE COLLECTION, TRANSFER AND DISPOSAL SERVICES FOR OTHERS (U.S. CLS. 100, 103 AND 106).

KATHERINE STOIDES, EXAMINING ATTORNEY

SN 78-851,249. STANLEY MARTIN COMPANIES, INC., RESTON, VA. FILED 3-31-2006.

STANLEY  MARTIN
FEEL RIGHT AT HOME

OWNER OF U.S. REG. NOS. 3,045,367 AND 3,067,662.
THE NAME "STANLEY MARTIN" DOES NOT IDENTIFY A LIVING INDIVIDUAL.

FOR CONSTRUCTION AND LAND DEVELOPMENT SERVICES, NAMELY, PLANNING, LAYING OUT, AND CONSTRUCTION OF RESIDENTIAL COMMUNITIES; CUSTOM CONSTRUCTION OF HOMES; CONSTRUCTION OF SINGLE FAMILY AND MULTIPLE FAMILY DWELLING UNITS; REAL ESTATE DEVELOPMENT (U.S. CLS. 100, 103 AND 106).

FIRST USE 1-6-2006; IN COMMERCE 1-6-2006.
ASMAT KHAN, EXAMINING ATTORNEY

CLASS 37—(Continued).

SN 78-855,344. STANLEY MARTIN COMPANIES, INC., RESTON, VA. FILED 4-6-2006.

FEEL RIGHT AT HOME

THE MARK CONSISTS OF STANDARD CHARACTERS WITHOUT CLAIM TO ANY PARTICULAR FONT, STYLE, SIZE, OR COLOR.

FOR CONSTRUCTION AND LAND DEVELOPMENT SERVICES, NAMELY, PLANNING, LAYING OUT, AND CONSTRUCTION OF RESIDENTIAL COMMUNITIES; CUSTOM CONSTRUCTION OF HOMES; CONSTRUCTION OF SINGLE FAMILY AND MULTIPLE FAMILY DWELLING UNITS; REAL ESTATE DEVELOPMENT (U.S. CLS. 100, 103 AND 106).

FIRST USE 1-6-2006; IN COMMERCE 1-6-2006.
ASMAT KHAN, EXAMINING ATTORNEY

CLASS 38—COMMUNICATION

SN 76-671,734. CALIFORNIA CATALOG & TECHNOLOGY, LODI, CA. FILED 1-24-2007.



NO CLAIM IS MADE TO THE EXCLUSIVE RIGHT TO USE "TELECOMM VOICE DATA INTERNET", APART FROM THE MARK AS SHOWN.

THE COLOR(S) DARK BLUE, LIGHT BLUE AND WHITE IS/ARE CLAIMED AS A FEATURE OF THE MARK.

THE DARK BLUE APPEARS IN THE UPPER BARS AND LOWER PART OF THE CIRCLE OF THE DESIGN AND IN THE LETTERING FOR "CCT" AND "VOICE DATA INTERNET", LIGHT BLUE IN THE LETTERING FOR "TELECOMM" AND THE LOWER BARS OF THE DESIGN AND WHITE IN THE MIDDLE PORTION OF THE DESIGN CIRCLE.

FOR TELECOMMUNICATIONS SERVICES INCLUDING VOICE, DATA AND INTERNET, NAMELY, TELEPHONE COMMUNICATIONS, CELLULAR PHONE SERVICES, CELLULAR TELEPHONE SERVICES, PAGING SERVICES, TELECOMMUNICATION CONNECTIONS TO A GLOBAL COMPUTER NETWORK (U.S. CLS. 100, 101 AND 104).

BENJAMIN OKEKE, EXAMINING ATTORNEY

CLASS 38—(Continued).

SN 76-680,954. TUNETOAD.COM, LLC, ROCKPORT, TX.
FILED 8-21-2007.

TUNETOAD

THE MARK CONSISTS OF STANDARD CHARACTERS WITHOUT CLAIM TO ANY PARTICULAR FONT, STYLE, SIZE, OR COLOR.

FOR AUDIO AND VIDEO BROADCASTING SERVICES OVER THE INTERNET OR OTHER COMMUNICATIONS NETWORK, NAMELY, UPLOADING, POSTING, SHOWING, DISPLAYING, TAGGING AND ELECTRONICALLY TRANSMITTING INFORMATION, AUDIO, AND VIDEO CLIPS; PROVIDING ACCESS TO INFORMATION, AUDIO, AND VIDEO VIA WEBSITES, ONLINE FORUMS, CHAT ROOMS, LISTSERVS AND BLOGS OVER THE INTERNET; PROVIDING ON-LINE CHAT ROOMS AND ELECTRONIC BULLETIN BOARDS FOR TRANSMISSION OF MESSAGES AMONG USERS IN THE FIELD OF GENERAL INTEREST (U.S. CLS. 100, 101 AND 104).

JANICE L. MCMORROW, EXAMINING ATTORNEY

SN 76-682,756. NOWACEK, DAVID, SAN ANTONIO, TX.
FILED 10-10-2007.

SIMJAM

THE MARK CONSISTS OF STANDARD CHARACTERS WITHOUT CLAIM TO ANY PARTICULAR FONT, STYLE, SIZE, OR COLOR.

FOR DIGITAL MEDIA ORDERING FROM A CELL PHONE, NAMELY, TRANSMISSION OF DATA, IMAGES, AND MESSAGES (U.S. CLS. 100, 101 AND 104).

ELIZABETH KAJUBI, EXAMINING ATTORNEY

SN 76-687,992. SELAH DEVELOPMENT S.A., MONTRÉAL (QUÉBEC), H3B 4W5, CANADA, FILED 3-24-2008.



The logo for 'Honesty Box' features the word 'Honesty' in a bold, sans-serif font with a stylized 'o' that has a horizontal line through it. Below 'Honesty' is the word 'Box' in a similar font, with the 'o' also stylized with a horizontal line.

FOR PROVIDING TRANSMISSION OF ELECTRONIC MESSAGES AMONG ONLINE USERS IN THE FIELD OF SOCIAL NETWORKING AND RELATIONSHIPS (U.S. CLS. 100, 101 AND 104).

FIRST USE 3-2-2008; IN COMMERCE 3-2-2008.
FRED MANDIR, EXAMINING ATTORNEY

CLASS 38—(Continued).

SN 77-143,051. UNITED FOOTBALL LEAGUE, LLC, NEW YORK, NY. FILED 3-28-2007.

UNITED FOOTBALL LEAGUE

THE MARK CONSISTS OF STANDARD CHARACTERS WITHOUT CLAIM TO ANY PARTICULAR FONT, STYLE, SIZE, OR COLOR.

NO CLAIM IS MADE TO THE EXCLUSIVE RIGHT TO USE "FOOTBALL LEAGUE", APART FROM THE MARK AS SHOWN.

FOR AUDIO BROADCASTING; BROADCAST OF CABLE TELEVISION PROGRAMMES; BROADCASTING PROGRAMS VIA A GLOBAL COMPUTER NETWORK; BROADCASTING SERVICES AND PROVISION OF TELECOMMUNICATION ACCESS TO FILMS AND TV PROGRAMMES PROVIDED VIA A VIDEO-ON-DEMAND SERVICE; BROADCASTING SERVICES AND PROVISION OF TELECOMMUNICATION ACCESS TO VIDEO AND AUDIO CONTENT PROVIDED VIA A VIDEO-ON-DEMAND SERVICE VIA THE INTERNET; CABLE CASTING SERVICES; CABLE RADIO BROADCASTING; CABLE RADIO TRANSMISSION; CABLE TELEVISION BROADCASTING; CABLE TELEVISION TRANSMISSION; COMPUTER AIDED TRANSMISSION OF INFORMATION AND IMAGES; ELECTRONIC EXCHANGE OF DATA STORED IN DATABASES ACCESSIBLE VIA TELECOMMUNICATION NETWORKS; MOBILE MEDIA AND ENTERTAINMENT SERVICES IN THE NATURE OF ELECTRONIC TRANSMISSION OF ENTERTAINMENT MEDIA CONTENT; NEWS AGENCIES, NAMELY, THE TRANSMISSION OF NEWS ITEMS TO NEWS REPORTING ORGANIZATIONS; PAY-PER-VIEW TELEVISION TRANSMISSION SERVICES; PODCASTING SERVICES; PROVIDING INTERNET CHATROOMS; PROVIDING ON-LINE CHAT ROOMS AND ELECTRONIC BULLETIN BOARDS FOR TRANSMISSION OF MESSAGES AMONG USERS IN THE FIELD OF GENERAL INTEREST; PROVIDING ON-LINE CHAT ROOMS FOR TRANSMISSION OF MESSAGES AMONG COMPUTER USERS CONCERNING SPORTS; PROVIDING ON-LINE COMMUNICATIONS LINKS WHICH TRANSFER THE WEBSITE USER TO OTHER LOCAL AND GLOBAL WEB PAGES; PROVIDING ON-LINE ELECTRONIC BULLETIN BOARDS FOR TRANSMISSION OF MESSAGES AMONG COMPUTER USERS CONCERNING SPORTS; RADIO BROADCASTING; RADIO BROADCASTING CONSULTATION; RADIO BROADCASTING INFORMATION; RADIO BROADCASTING OF INFORMATION AND OTHER PROGRAMS; RADIO COMMUNICATION; RADIO PROGRAM BROADCASTING; RADIO PROGRAMME BROADCASTING; SATELLITE TELEVISION BROADCASTING; SATELLITE TRANSMISSION OF MESSAGES AND DATA FOR NAVIGATION BY AIR; STREAMING OF AUDIO MATERIAL ON THE INTERNET; STREAMING OF VIDEO MATERIAL ON THE INTERNET; SUBSCRIPTION TELEVISION BROADCASTING; VIDEO-ON-DEMAND TRANSMISSION SERVICES (U.S. CLS. 100, 101 AND 104).

JORDAN BAKER, EXAMINING ATTORNEY

CLASS 38—(Continued).

SN 77-243,859. IMPORTS & EMPORIUM, INC, COLUMBUS, OH. FILED S.R. 8-1-2007; AM. P.R. 3-12-2008.



THE COLOR(S) BLACK, WHITE, RED & GRAY IS/ARE CLAIMED AS A FEATURE OF THE MARK. THE MARK CONSISTS OF A WOMAN'S WHITE FACE WITH GRAY AND BLACK SHADING, HER WHITE INDEX FINGER UP TO HER RED LIP, WITH THE LITERAL ELEMENT "2TABOO4U" IN RED UNDERNEATH HER FINGER.

FOR DOMESTIC ARTICLES FOR PROFIT, FEATURING ADULT VIDEO ON DEMAND, NAMELY, STREAMING OF VIDEO MATERIAL ON DEMAND; WEBCASTING SERVICES, NAMELY, ADULT LIVE VIDEO ON DEMAND (U.S. CLS. 100, 101 AND 104). FIRST USE 1-1-2006; IN COMMERCE 1-1-2006. FRANK LATTUCA, EXAMINING ATTORNEY

SN 77-263,462. INNER CITY BROADCASTING CORPORATION OF BERKELEY, SAN FRANCISCO, CA. FILED 8-24-2007.

ALL REQUEST CLASSIC SOUL LUNCH HOUR

THE MARK CONSISTS OF STANDARD CHARACTERS WITHOUT CLAIM TO ANY PARTICULAR FONT, STYLE, SIZE, OR COLOR. OWNER OF U.S. REG. NOS. 2,481,813, 2,570,720 AND 2,644,722.

NO CLAIM IS MADE TO THE EXCLUSIVE RIGHT TO USE "SOUL", APART FROM THE MARK AS SHOWN. SEC. 2(F). FOR RADIO PROGRAM BROADCASTING (U.S. CLS. 100, 101 AND 104). FIRST USE 1-6-1997; IN COMMERCE 1-6-1997. KELLY CHOE, EXAMINING ATTORNEY

SN 77-275,848. TNT EXPENSE MANAGEMENT, SANDY HOOK, CT. FILED 9-10-2007.



NO CLAIM IS MADE TO THE EXCLUSIVE RIGHT TO USE "SOURCING/CONTRACT NEGOTIATIONS AUDIT & BILL PROCESSING INVENTORY MANAGEMENT WIRELESS MANAGEMENT NETWORK PROCUREMENT CALL ACCOUNTING CHARGEBACK PHYSICAL AUDIT PROJECT MANAGEMENT", APART FROM THE MARK AS SHOWN.

THE COLOR(S) RED, ORANGE, YELLOW, GREEN, BLUE, VIOLET, BLACK, GRAY AND WHITE IS/ARE CLAIMED AS A FEATURE OF THE MARK. THE MARK CONSISTS OF LINEAR SPECTRUM OF COLORS THAT GO FROM RED ON THE FAR LEFT TO ORANGE TO YELLOW, TO GREEN, TO BLUE AND FINALLY TO VIOLET IN THE FAR RIGHT WITH THE WORDS "SOURCING/CONTRACT NEGOTIATIONS AUDIT

CLASS 38—(Continued).

& BILL PROCESSING INVENTORY MANAGEMENT WIRELESS MANAGEMENT NETWORK PROCUREMENT CALL ACCOUNTING CHARGEBACK PHYSICAL AUDIT PROJECT MANAGEMENT" ABOVE THE LINE AND A SQUARE BOX DIRECTLY UNDERNEATH EACH SEPARATE TERM. THE BOXES FADE FROM A COMPLETELY BLACK BOX ON THE LEFT TOWARDS A GREY BOX IN THE MIDDLE AND FINALLY A WHITE BOX ON THE RIGHT THE WORDS "FULL SPECTRUM OF TEM SERVICES" APPEARS UNDERNEATH THE LINE ON THE RIGHT SIDE. FOR TELECOMMUNICATIONS CONSULTATION (U.S. CLS. 100, 101 AND 104). FIRST USE 6-18-2007; IN COMMERCE 7-3-2007. GIANCARLO CASTRO, EXAMINING ATTORNEY

SN 77-276,677. ST. ANDREWS OF SCOTLAND INTERNATIONAL LTD, HOLLAND, MI. FILED 9-11-2007.

St.Andrews of Scotland

THE MARK CONSISTS OF STANDARD CHARACTERS WITHOUT CLAIM TO ANY PARTICULAR FONT, STYLE, SIZE, OR COLOR. FOR PROVIDING ACCESS TO ONLINE GAMES AND WEB PAGES AND INFORMATION RELATING TO GOLF ONLINE (U.S. CLS. 100, 101 AND 104). TOBY BULLOFF, EXAMINING ATTORNEY

SN 77-282,963. BAIDU.COM, INC., GRAND CAYMAN, CAYMAN ISLANDS, FILED 9-19-2007.



THE MARK CONSISTS OF THE WORD "BAIDU". THE WORD "BAIDU" HAS NO MEANING IN A FOREIGN LANGUAGE.

FOR BROADCAST OF CABLE TELEVISION PROGRAMMES; ELECTRONIC MESSAGE SENDING; COMMUNICATIONS BY COMPUTER TERMINALS; ELECTRONIC, ELECTRIC, AND DIGITAL TRANSMISSION OF VOICE, DATA, IMAGES, SIGNALS, AND MESSAGES; ELECTRONIC MAIL SERVICES; PROVIDING ON-LINE CHAT ROOMS AND ELECTRONIC BULLETIN BOARDS FOR TRANSMISSION OF MESSAGES AMONG USERS IN THE FIELD OF GENERAL INTEREST; PROVIDING TELECOMMUNICATIONS CONNECTIONS TO A GLOBAL COMPUTER NETWORK; PROVIDING MULTIPLE-USER ACCESS TO A GLOBAL COMPUTER INFORMATION NETWORK; PROVIDING INTERNET CHATROOMS; VOICE MAIL SERVICES (U.S. CLS. 100, 101 AND 104). MATTHEW EINSTEIN, EXAMINING ATTORNEY

CLASS 38—(Continued).

SN 77-290,447. INFINITEAGENT, DBA PIXEL, DUBLIN, IRELAND, FILED 9-27-2007.

AlwaysOn

THE MARK CONSISTS OF STANDARD CHARACTERS WITHOUT CLAIM TO ANY PARTICULAR FONT, STYLE, SIZE, OR COLOR.

FOR INSTANT MESSAGING SERVICES (U.S. CLS. 100, 101 AND 104).

TRACY CROSS, EXAMINING ATTORNEY

SN 77-290,619. DEUTSCHE TELEKOM AG, BONN 53113, FED REP GERMANY, FILED 9-27-2007.

web'n'walk Starter

THE MARK CONSISTS OF STANDARD CHARACTERS WITHOUT CLAIM TO ANY PARTICULAR FONT, STYLE, SIZE, OR COLOR.

PRIORITY CLAIMED UNDER SEC. 44(D) ON FED REP GERMANY APPLICATION NO. 30722937838, FILED 4-4-2007, REG. NO. 30722937, DATED 5-31-2007, EXPIRES 4-30-2017.

OWNER OF U.S. REG. NOS. 3,250,718, 3,257,839 AND OTHERS.

NO CLAIM IS MADE TO THE EXCLUSIVE RIGHT TO USE "STARTER", APART FROM THE MARK AS SHOWN.

FOR TELECOMMUNICATION AND INFORMATION TECHNOLOGY SERVICES, NAMELY, ELECTRIC, DIGITAL, CELLULAR AND WIRELESS TRANSMISSION OF VOICE, DATA, INFORMATION, IMAGES, SIGNALS AND MESSAGES AND TRANSMISSION OF VOICE, DATA, IMAGES, AUDIO, VIDEO AND INFORMATION VIA TELEPHONE, TELEVISION AND GLOBAL COMMUNICATION NETWORKS; PROVIDING TELECOMMUNICATIONS CONNECTIONS OVER A GLOBAL COMMUNICATIONS NETWORK, ELECTRONIC STORE-AND-FORWARD MESSAGING; RENTAL OF TELECOMMUNICATIONS EQUIPMENT, NAMELY, EQUIPMENT FOR ELECTRONIC ACCESS TO GLOBAL TELECOMMUNICATIONS NETWORK, EQUIPMENT FOR TRANSMITTING, RECEIVING, RECORDING AND MONITORING VOICE, DATA, INFORMATION, IMAGES, SIGNALS, MESSAGES COMPRISED OF DATA AND WORD PROCESSORS, AND TELECOMMUNICATIONS HARDWARE COMPONENTS AND PERIPHERALS THEREOF FOR USE IN THE TELECOMMUNICATIONS INDUSTRY, AND RENTAL OF TELECOMMUNICATIONS EQUIPMENT FOR TRANSMITTING, RECEIVING, RECORDING AND MONITORING COMPUTER PROGRAMS FOR USE IN OPERATING AND ACCESSING TELECOMMUNICATIONS SYSTEMS; AUDIO AND VIDEO BROADCASTING; PROVIDING MULTIPLE-USER DIAL-UP AND DEDICATED ACCESS TO THE INTERNET; PERSONAL COMMUNICATIONS SERVICES; PAGER SERVICES; TRANSMISSION AND BROADCAST OF AUDIO AND VIDEO PROGRAMMING; LEASING OF TELECOMMUNICATIONS EQUIPMENT, COMPONENTS AND SYSTEMS; PROVIDING INFORMATION VIA THE TELEPHONE AND THE GLOBAL COMMUNICATION NETWORKS IN THE FIELD OF TELECOMMUNICATIONS; CONSULTING IN THE FIELD OF TELECOMMUNICATIONS (U.S. CLS. 100, 101 AND 104).

STEPHEN AQUILA, EXAMINING ATTORNEY

CLASS 38—(Continued).

SN 77-302,305. STUMBLEUPON, INC., SAN FRANCISCO, CA. FILED 10-11-2007.



THE COLOR(S) WHITE, BLUE AND GREEN IS/ARE CLAIMED AS A FEATURE OF THE MARK.

THE COLOR WHITE APPEARS IN THE WORDING "SU"; THE COLOR BLUE APPEARS IN THE DESIGN AS THE LOWER PORTION OF THE CIRCLE; AND THE COLOR GREEN APPEARS IN THE DESIGN AS THE UPPER PORTION OF THE CIRCLE.

FOR PROVIDING ON-LINE COMMUNICATION LINKS WHICH TRANSFER THE WEBSITE USER TO OTHER LOCAL AND GLOBAL WEB PAGES; PROVIDING ONLINE CHAT ROOMS AND AN ELECTRONIC BULLETIN BOARD FOR TRANSMISSION OF MESSAGES WHICH ALLOWS COMPUTER USERS TO DISCUSS TOPICS OF GENERAL INTEREST AND CONTENT, LINKS, AND WEB PAGES THEY HAVE SHARED WITH EACH OTHER (U.S. CLS. 100, 101 AND 104).

FIRST USE 4-26-2005; IN COMMERCE 4-26-2005.

BENJAMIN OKEKE, EXAMINING ATTORNEY

SN 77-324,048. CREESE, ANDRE, DBA MEDJOBPULSE.COM, FORT LAUDERDALE, FL. FILED 11-7-2007.

MDJobPulse.com

THE MARK CONSISTS OF STANDARD CHARACTERS WITHOUT CLAIM TO ANY PARTICULAR FONT, STYLE, SIZE, OR COLOR.

FOR PROVIDING ON-LINE FORUMS FOR TRANSMISSION OF MESSAGES AND SHARING INFORMATION CONCERNING THE HEALTH CARE INDUSTRY; PROVIDING ON-LINE FORUMS FOR TRANSMISSION OF MESSAGES AND SHARING INFORMATION CONCERNING EMPLOYMENT IN THE HEALTH CARE INDUSTRY (U.S. CLS. 100, 101 AND 104).

AMY GEARIN, EXAMINING ATTORNEY

CLASS 38—(Continued).

SN 77-342,871. INKTREE, INC., CHARLOTTESVILLE, VA.
FILED 12-3-2007.

SHREDHED

THE MARK CONSISTS OF STANDARD CHARACTERS WITHOUT CLAIM TO ANY PARTICULAR FONT, STYLE, SIZE, OR COLOR.

THE WORDING "SHREDHED" HAS NO MEANING IN A FOREIGN LANGUAGE.

FOR SOCIAL NETWORKING TOOLS FOR COMMUNICATION AMONGST ONLINE COMPUTER USERS, NAMELY, PROVIDING ONLINE CHAT ROOMS, LIST-SERVERS, AND ELECTRONIC BULLETIN BOARDS FOR TRANSMISSION OF MESSAGES AMONG COMPUTER USERS, PROVIDING ONLINE FACILITIES FOR REAL-TIME INTERACTION WITH OTHER COMPUTER USERS, AND PROVIDING AN ONLINE FORUM FOR SHOWCASE, DISPLAY, AND DISCUSSION OF PRODUCTS AND EVENTS, ALL OF THE ABOVE CONCERNING MUSIC, MUSICIANS, INTERVIEWS WITH MUSICIANS AND OTHER MUSIC RELATED TOPICS, MUSICAL INSTRUMENTS, PLAYING MUSIC, LEARNING MUSIC, MUSICAL EDUCATION AND INSTRUCTION, AND INSTRUCTIONAL, EDUCATIONAL, AND TEACHING MATERIALS IN THE FIELDS OF MUSIC, MUSICAL EDUCATION AND MUSICAL INSTRUCTION (U.S. CLS. 100, 101 AND 104).

RAMONA ORTIGA, EXAMINING ATTORNEY

SN 77-343,066. LINKED SENIOR LLC, WASHINGTON, DC.
FILED 12-3-2007.

Linked Senior

THE MARK CONSISTS OF STANDARD CHARACTERS WITHOUT CLAIM TO ANY PARTICULAR FONT, STYLE, SIZE, OR COLOR.

NO CLAIM IS MADE TO THE EXCLUSIVE RIGHT TO USE "SENIOR", APART FROM THE MARK AS SHOWN.

FOR MOBILE MEDIA SERVICES IN THE NATURE OF ELECTRONIC TRANSMISSION OF ENTERTAINMENT MEDIA CONTENT (U.S. CLS. 100, 101 AND 104).

FIRST USE 3-1-2007; IN COMMERCE 3-1-2007.

TINA KUAN, EXAMINING ATTORNEY

CLASS 38—(Continued).

SN 77-362,465. MEDIA & CONSULTING CORP., FLUSHING, NY. FILED 1-2-2008.



NO CLAIM IS MADE TO THE EXCLUSIVE RIGHT TO USE "NATIONWIDE MORTGAGE NEWS", APART FROM THE MARK AS SHOWN.

THE COLOR(S) RED AND BLACK AND GREY IS/ARE CLAIMED AS A FEATURE OF THE MARK.

THE MARK CONSISTS OF THE LETTERS "NMN" REPRESENTING THE GRAPHIC OUTLINE OF A PERSON READING A BOOK. THE LETTER "M" COMPRISES THE OUTLINE OF AN OPEN BOOK. THE PARTIAL FACE OF A PERSON READING CAN BE SEEN PEERING OVER THE TOP OF THE BOOK. THE HANDS OF THE PERSON CAN ALSO BE SEEN HOLDING THE OPEN BOOK. THE WORDS "NATIONWIDE MORTGAGE NEWS" ARE BELOW THE GRAPHIC. THE LETTER "N" TO THE LEFT OF THE BOOK IS BLACK. THE LETTER "M" IS BETWEEN THE TWO LETTER "N" 'S AND IS RED IN COLOR. THE SECOND LETTER "N" IS BLACK. THE WORDS "NATIONWIDE MORTGAGE NEWS" ARE GREY. THE PARTIAL HEAD DESIGN PEERING OVER THE TOP OF THE OPEN BOOK IS BLACK.

FOR PROVIDING ON-LINE FORUMS FOR TRANSMISSION OF MESSAGES AMONG COMPUTER USERS CONCERNING INFORMATION ABOUT MORTGAGES FOR THE MORTGAGE PROFESSIONAL AND OTHER INTERESTED PARTIES (U.S. CLS. 100, 101 AND 104).

FIRST USE 12-15-2007; IN COMMERCE 12-15-2007.

SHAUNIA CARLYLE, EXAMINING ATTORNEY

SN 77-371,327. NATURAL HISTORY NEW ZEALAND LIMITED, DUNEDIN, NEW ZEALAND, FILED 1-14-2008.

ADVENTURE CENTRAL

THE MARK CONSISTS OF STANDARD CHARACTERS WITHOUT CLAIM TO ANY PARTICULAR FONT, STYLE, SIZE, OR COLOR.

OWNER OF U.S. REG. NO. 3,014,316.

FOR TELEVISION AND RADIO BROADCASTING; BROADCASTING PROGRAMS VIA A GLOBAL COMPUTER NETWORK (U.S. CLS. 100, 101 AND 104).

DANIEL CAPSHAW, EXAMINING ATTORNEY

CLASS 38—(Continued).

SN 77-388,295. ROW 44, INC., WESTLAKE VILLAGE, CA. FILED 2-4-2008.

GIVING BROADBAND WINGS

THE MARK CONSISTS OF STANDARD CHARACTERS WITHOUT CLAIM TO ANY PARTICULAR FONT, STYLE, SIZE, OR COLOR.

NO CLAIM IS MADE TO THE EXCLUSIVE RIGHT TO USE "BROADBAND", APART FROM THE MARK AS SHOWN.

FOR SERVICES FOR BROADBAND CONNECTIVITY ABOARD COMMERCIAL AIRCRAFT, NAMELY, PROVIDING ELECTRONIC TELECOMMUNICATION CONNECTIONS (U.S. CLS. 100, 101 AND 104).

ALEX KEAM, EXAMINING ATTORNEY

SN 77-399,323. BOB, LLC, DBA BUSINESS ONLY BROADBAND, LLC, WESTMONT, IL. FILED 2-18-2008.

Business Only Broadband 

NO CLAIM IS MADE TO THE EXCLUSIVE RIGHT TO USE "BUSINESS ONLY BROADBAND", APART FROM THE MARK AS SHOWN.

THE COLOR(S) BLUE, ORANGE, AND WHITE IS/ARE CLAIMED AS A FEATURE OF THE MARK.

THE MARK CONSISTS OF THE WORDS "BUSINESS ONLY BROADBAND" IN BLUE ITALICIZED LETTERS FOLLOWED BY AN ORANGE AND WHITE DRAWING REPRESENTING THE TRANSMISSION OF SOUND WAVES OR ELECTRONIC SIGNALS.

FOR WIRELESS BROADBAND COMMUNICATION SERVICES (U.S. CLS. 100, 101 AND 104).

FIRST USE 1-23-2008; IN COMMERCE 1-23-2008.
TEJBIR SINGH, EXAMINING ATTORNEY

SN 77-410,345. CABLE TELEVISION LABORATORIES, INC., LOUISVILLE, CO. FILED 2-29-2008.

<tru2way>

THE MARK CONSISTS OF THE WORDS "TRU2WAY" IN BETWEEN THE GREATER THAN AND LESSER THAN SIGNS.

FOR TELECOMMUNICATION SERVICES, NAMELY, TRANSMISSION OF INTERACTIVE VIDEO, IMAGE, VOICE, AUDIO, AND DATA INFORMATION BY MEANS OF A CABLE NETWORK; TRANSMISSION OF INTERACTIVE TELEVISION SERVICES; VIDEO-ON-DEMAND AND PAY-PER-VIEW TELEVISION TRANSMISSION SERVICES; TRANSMISSION OF INTERACTIVE TELEVISION PROGRAM GUIDES (U.S. CLS. 100, 101 AND 104).

ANNE FARRELL, EXAMINING ATTORNEY

CLASS 38—(Continued).

SN 77-412,555. NEDELCO, INC., AURORA, NE. FILED 3-4-2008.

SEE WHAT THEY SAY

THE MARK CONSISTS OF STANDARD CHARACTERS WITHOUT CLAIM TO ANY PARTICULAR FONT, STYLE, SIZE, OR COLOR.

FOR TELEPHONE RELAY SERVICES USING CAPTION TELEPHONE (U.S. CLS. 100, 101 AND 104).

ALLISON SCHRODY, EXAMINING ATTORNEY

SN 77-418,552. SLATER, DAVID A., IRVING, TX. FILED 3-11-2008.

MEDIJANUS

THE MARK CONSISTS OF STANDARD CHARACTERS WITHOUT CLAIM TO ANY PARTICULAR FONT, STYLE, SIZE, OR COLOR.

THE ENGLISH TRANSLATION OF THE CROATIAN WORD "MEDIJANUS" IN THE MARK IS "MEDIAN NERVE."

FOR TELEPHONE MESSAGE TRANSMISSIONS, NAMELY, SECURE PATIENT-TO-PHYSICIAN MESSAGE SERVICES FOR PROVIDING DOCTOR-PATIENT TELEMEDICAL CONSULTATIONS (U.S. CLS. 100, 101 AND 104).

JASON LOTT, EXAMINING ATTORNEY

SN 77-419,432. CARBON12, LLC, MONTEREY, CA. FILED 3-12-2008.

Carbon12

THE MARK CONSISTS OF STANDARD CHARACTERS WITHOUT CLAIM TO ANY PARTICULAR FONT, STYLE, SIZE, OR COLOR.

FOR TELECOMMUNICATIONS, NAMELY, PROVIDING CHAT ROOMS AND ELECTRONIC BULLETIN BOARDS VIA THE GLOBAL COMPUTER NETWORK FOR TRANSMISSION OF MESSAGES AMONG USERS REGARDING DISEASE, DISORDERS, HEALTH CONDITIONS, OR INJURIES (U.S. CLS. 100, 101 AND 104).

JORDAN BAKER, EXAMINING ATTORNEY

CLASS 38—(Continued).

SN 77-420,698. PAKISTAN HERALD PUBLICATIONS (PRIVATE) LIMITED, KARACHI, PAKISTAN, FILED 3-13-2008.

CLASS 38—(Continued).

SN 77-422,869. FACE TO FACE LIVE, INC., SCOTTSDALE, AZ. FILED 3-14-2008.

DAWNNEWS

THE MARK CONSISTS OF STANDARD CHARACTERS WITHOUT CLAIM TO ANY PARTICULAR FONT, STYLE, SIZE, OR COLOR.

OWNER OF U.S. REG. NOS. 2,608,759 AND 2,608,760. FOR TELECOMMUNICATIONS SERVICES, NAMELY, BROADCASTING A TELEVISION PROGRAM VIA SATELLITE, OR THE INTERNET, OR MOBILE/CELLULAR PHONE MEDIA (U.S. CLS. 100, 101 AND 104).
SHAUNIA CARLYLE, EXAMINING ATTORNEY



SN 77-421,600. CROWDGATHER, INC., WOODLAND HILLS, CA. FILED 3-13-2008.

GENMAY

THE MARK CONSISTS OF STANDARD CHARACTERS WITHOUT CLAIM TO ANY PARTICULAR FONT, STYLE, SIZE, OR COLOR.

FOR PROVIDING ON-LINE FORUMS FOR TRANSMISSION OF MESSAGES AMONG COMPUTER USERS CONCERNING HOBBIES, PARENTING, MUSIC, ACTING, CONSPIRACY THEORIES, GENERAL DISCUSSION, TECHNOLOGY, LITERATURE, HISTORY, SCIENCE, AND COMPUTING (U.S. CLS. 100, 101 AND 104).

FIRST USE 6-1-2007; IN COMMERCE 6-1-2007.
JOHN GARTNER, EXAMINING ATTORNEY

THE COLOR(S) BLACK, GREY, AND BLUE IS/ARE CLAIMED AS A FEATURE OF THE MARK.

THE MARK CONSISTS OF THE LETTER "F" FACING ANOTHER "F" WITH TWO SWIRL MARKS SURROUNDING THEM. THE FIRST "F" IS BLACK AND THE SECOND "F" IS BLUE. THE SWIRL MARKS START BLACK, THEN GREY AND THEN BLUE.

FOR AUDIO AND VIDEO BROADCASTING SERVICES OVER THE INTERNET; ELECTRONIC TRANSMISSION OF VOICE, DATA AND IMAGES BY TELEVISION AND VIDEO BROADCASTING; PROVIDING CO-LOCATION SERVICES FOR VOICE, VIDEO AND DATA COMMUNICATIONS APPLICATIONS; PROVIDING FACILITIES AND EQUIPMENT FOR VIDEO CONFERENCING; STREAMING OF VIDEO MATERIAL ON THE INTERNET; TELECOMMUNICATION SERVICES, NAMELY, LOCAL AND LONG DISTANCE TRANSMISSION OF VOICE, DATA, GRAPHICS AND VIDEO BY MEANS OF BROADBAND OPTICAL OR WIRELESS NETWORKS; TELECOMMUNICATION SERVICES, NAMELY, LOCAL AND LONG DISTANCE TRANSMISSION OF VOICE, DATA, GRAPHICS AND VIDEO BY MEANS OF BROADBAND, COPPER AND OPTICAL OR WIRELESS NETWORKS; TELECONFERENCING AND VIDEO CONFERENCING SERVICES; TRANSMISSION OF INFORMATION THROUGH VIDEO COMMUNICATION SYSTEMS; TRANSMISSION OF SOUND, VIDEO AND INFORMATION; VIDEO BROADCASTING; VIDEO BROADCASTING SERVICES VIA THE INTERNET; VIDEO CONFERENCING SERVICES; VIDEO STREAMING SERVICES VIA THE INTERNET, FEATURING INDEPENDENT FILMS AND MOVIES; VIDEO TELECONFERENCING; VIDEO TELEPHONE SERVICES (U.S. CLS. 100, 101 AND 104).

FIRST USE 2-25-2008; IN COMMERCE 2-26-2008.
CAROL SPILLS, EXAMINING ATTORNEY

CLASS 38—(Continued).

SN 77-422,907. FACE TO FACE LIVE, INC., SCOTTSDALE, AZ. FILED 3-14-2008.

Managed Telepresence. Simplified.

THE MARK CONSISTS OF STANDARD CHARACTERS WITHOUT CLAIM TO ANY PARTICULAR FONT, STYLE, SIZE, OR COLOR.

FOR AUDIO AND VIDEO BROADCASTING SERVICES OVER THE INTERNET; BROADCASTING SERVICES AND PROVISION OF TELECOMMUNICATION ACCESS TO VIDEO AND AUDIO CONTENT PROVIDED VIA A VIDEO-ON-DEMAND SERVICE VIA THE INTERNET; ELECTRONIC TRANSMISSION OF VOICE, DATA AND IMAGES BY TELEVISION AND VIDEO BROADCASTING; PROVIDING CO-LOCATION SERVICES FOR VOICE, VIDEO AND DATA COMMUNICATIONS APPLICATIONS; PROVIDING FACILITIES AND EQUIPMENT FOR VIDEO CONFERENCING; STREAMING OF VIDEO MATERIAL ON THE INTERNET; TELECOMMUNICATION SERVICES, NAMELY, LOCAL AND LONG DISTANCE TRANSMISSION OF VOICE, DATA, GRAPHICS AND VIDEO BY MEANS OF BROADBAND OPTICAL OR WIRELESS NETWORKS; TELECOMMUNICATION SERVICES, NAMELY, LOCAL AND LONG DISTANCE TRANSMISSION OF VOICE, DATA, GRAPHICS AND VIDEO BY MEANS OF BROADBAND, COPPER AND OPTICAL OR WIRELESS NETWORKS; TELECOMMUNICATION SERVICES, NAMELY, TRANSMISSION OF VOICE, DATA, GRAPHICS, SOUND AND VIDEO BY MEANS OF BROADBAND POWER LINE OR WIRELESS NETWORKS; TELECONFERENCING AND VIDEO CONFERENCING SERVICES; TRANSMISSION OF INFORMATION THROUGH VIDEO COMMUNICATION SYSTEMS; TRANSMISSION OF SOUND, VIDEO AND INFORMATION; VIDEO BROADCASTING; VIDEO BROADCASTING SERVICES VIA THE INTERNET; VIDEO CONFERENCING SERVICES; VIDEO STREAMING SERVICES VIA THE INTERNET, FEATURING INDEPENDENT FILMS AND MOVIES; VIDEO TELECONFERENCING; VIDEO TELEPHONE SERVICES (U.S. CLS. 100, 101 AND 104).

FIRST USE 2-25-2008; IN COMMERCE 2-26-2008.
CAROL SPILS, EXAMINING ATTORNEY

SN 77-423,680. NE COLORADO CELLULAR, INC., DBA VIAERO WIRELESS, FORT MORGAN, CO. FILED 3-17-2008.

MY GROUP

THE MARK CONSISTS OF STANDARD CHARACTERS WITHOUT CLAIM TO ANY PARTICULAR FONT, STYLE, SIZE, OR COLOR.

FOR WIRELESS MOBILE TELEPHONE CALLING PLAN (U.S. CLS. 100, 101 AND 104).
FIRST USE 2-28-2008; IN COMMERCE 2-28-2008.
ANGELA M. MICHELI, EXAMINING ATTORNEY

CLASS 38—(Continued).

SN 77-427,850. ZEBRA TELECOMMUNICATIONS INC., WELLINGTON, FL. FILED 3-20-2008.



THE MARK CONSISTS OF A RECTANGLE WITH BLACK AND WHITE STRIPES ABOVE THE STYLIZED TEXT "RIDE THE ZEBRA".

FOR CELLULAR TELEPHONE SERVICES (U.S. CLS. 100, 101 AND 104).

H. M. FISHER, EXAMINING ATTORNEY

SN 77-428,332. TPC OPERATIONS, LLC, MOORPARK, CA. FILED 3-21-2008.

THE PLAYERS CLUB

THE MARK CONSISTS OF STANDARD CHARACTERS WITHOUT CLAIM TO ANY PARTICULAR FONT, STYLE, SIZE, OR COLOR.

FOR PROVIDING ONLINE CHAT ROOMS AND ELECTRONIC BULLETIN BOARDS FOR TRANSMISSION OF MESSAGES AMONG USERS IN THE FIELD OF GENERAL INTEREST (U.S. CLS. 100, 101 AND 104).
MARK RADEMACHER, EXAMINING ATTORNEY

SN 77-428,736. MULTI-MEDIA DIGITAL BROADCAST CORPORATION, AKA MDBTV, ATLANTA, GA. FILED 3-21-2008.

mdbTV

THE MARK CONSISTS OF STANDARD CHARACTERS WITHOUT CLAIM TO ANY PARTICULAR FONT, STYLE, SIZE, OR COLOR.

FOR VIDEO BROADCASTING SERVICES VIA THE INTERNET (U.S. CLS. 100, 101 AND 104).
FIRST USE 6-1-2004; IN COMMERCE 6-1-2004.
LINDA POWELL, EXAMINING ATTORNEY

CLASS 38—(Continued).

SN 77-428,935. ZAVALA, EDUARDO A., FALLS CHURCH, VA. FILED 3-22-2008.

skycentro

THE MARK CONSISTS OF STANDARD CHARACTERS WITHOUT CLAIM TO ANY PARTICULAR FONT, STYLE, SIZE, OR COLOR.
FOR SATELLITE COMMUNICATION SERVICES (U.S. CLS. 100, 101 AND 104).
DAYNA BROWNE, EXAMINING ATTORNEY

SN 77-428,996. MARLON ZBIGNIEW KASPRZYK, WINFIELD, IL. FILED 3-22-2008.

RARO100

THE MARK CONSISTS OF STANDARD CHARACTERS WITHOUT CLAIM TO ANY PARTICULAR FONT, STYLE, SIZE, OR COLOR.
THE ENGLISH TRANSLATION OF THE WORD "RARO" IN THE MARK IS "RARE".
FOR ELECTRONIC TRANSMISSION OF MESSAGES AND DATA (U.S. CLS. 100, 101 AND 104).
JAMES STEIN, EXAMINING ATTORNEY

SN 77-429,851. TPC OPERATIONS, LLC, MOORPARK, CA. FILED 3-24-2008.

KEEP LIVING THE DREAM

THE MARK CONSISTS OF STANDARD CHARACTERS WITHOUT CLAIM TO ANY PARTICULAR FONT, STYLE, SIZE, OR COLOR.
FOR PROVIDING ONLINE CHAT ROOMS AND ELECTRONIC BULLETIN BOARDS FOR TRANSMISSION OF MESSAGES AMONG USERS IN THE FIELD OF GENERAL INTEREST (U.S. CLS. 100, 101 AND 104).
MARK RADEMACHER, EXAMINING ATTORNEY

CLASS 38—(Continued).

SN 77-430,204. DENNY SOMACH PRODUCTIONS, HAVERTOWN, PA. FILED 3-24-2008.

Rock of Your Life

THE MARK CONSISTS OF STANDARD CHARACTERS WITHOUT CLAIM TO ANY PARTICULAR FONT, STYLE, SIZE, OR COLOR.
FOR RADIO BROADCASTING (U.S. CLS. 100, 101 AND 104).
FIRST USE 4-1-1985; IN COMMERCE 5-1-1985.
SUZANNE BLANE, EXAMINING ATTORNEY

SN 77-430,482. MOBILE YODEL, ERDENHEIM, PA. FILED 3-25-2008.

mobileyodel 

THE MARK CONSISTS OF THE STYLIZED WORDS "MOBILE YODEL". TO THE RIGHT OF THE WORD "YODEL" APPEARS THREE HORIZONTAL LINES WITH THE TOP LINE DIRECTED ON AN UPWARDS SLANT AND THE BOTTOM LINE DIRECTED ON A DOWNWARDS SLANT. THE MIDDLE LINE APPEARS STRAIGHT HORIZONTAL.
FOR CELLULAR TELEPHONE COMMUNICATION (U.S. CLS. 100, 101 AND 104).
FIRST USE 2-15-2008; IN COMMERCE 3-4-2008.
KATHERINE M. DUBRAY, EXAMINING ATTORNEY

SN 77-431,306. LASENSKY, PETER, SAN DIEGO, CA. FILED 3-25-2008.

Your Ultimate C.Y.A.

THE MARK CONSISTS OF STANDARD CHARACTERS WITHOUT CLAIM TO ANY PARTICULAR FONT, STYLE, SIZE, OR COLOR.
FOR COMMUNICATION SERVICES, NAMELY, TRANSMISSION OF VOICE, AUDIO, VISUAL IMAGES AND DATA BY TELECOMMUNICATIONS NETWORKS, WIRELESS COMMUNICATION NETWORKS, THE INTERNET, INFORMATION SERVICES NETWORKS AND DATA NETWORKS; COMMUNICATIONS VIA MULTINATIONAL TELECOMMUNICATION NETWORKS; ELECTRONIC EXCHANGE OF DATA STORED IN DATABASES ACCESSIBLE VIA TELECOMMUNICATION NETWORKS (U.S. CLS. 100, 101 AND 104).
FIRST USE 3-10-2008; IN COMMERCE 3-10-2008.
RUDY R. SINGLETON, EXAMINING ATTORNEY

CLASS 38—(Continued).

SN 77-432,178. THE TRUSTEES OF TRUST B OF THE LORIN E. MILNER REVOCABLE TRUST, CHICAGO, IL. FILED 3-26-2008.

CLASS 38—(Continued).

SN 77-434,143. MDS AMERICA INC., DBA MDS AMERICA, STUART, FL. FILED 3-28-2008.

WFAV

THE MARK CONSISTS OF STANDARD CHARACTERS WITHOUT CLAIM TO ANY PARTICULAR FONT, STYLE, SIZE, OR COLOR.

FOR RADIO BROADCASTING (U.S. CLS. 100, 101 AND 104).

FIRST USE 10-1-2007; IN COMMERCE 10-1-2007.
COLLEEN KEARNEY, EXAMINING ATTORNEY



SN 77-433,686. PML WIRELESS, LLC, ATLANTA, GA. FILED 3-27-2008.

HAVE YOUR SAY

THE MARK CONSISTS OF STANDARD CHARACTERS WITHOUT CLAIM TO ANY PARTICULAR FONT, STYLE, SIZE, OR COLOR.

FOR MOBILE TELEPHONE COMMUNICATION; WIRELESS BROADBAND COMMUNICATION SERVICES (U.S. CLS. 100, 101 AND 104).

ELISSA GARBER KON, EXAMINING ATTORNEY



SN 77-433,763. PML WIRELESS, LLC, ATLANTA, GA. FILED 3-27-2008.

YOUR TERMS. YOUR WAY.

THE MARK CONSISTS OF STANDARD CHARACTERS WITHOUT CLAIM TO ANY PARTICULAR FONT, STYLE, SIZE, OR COLOR.

FOR MOBILE TELEPHONE COMMUNICATION; WIRELESS BROADBAND COMMUNICATION SERVICES (U.S. CLS. 100, 101 AND 104).

ELISSA GARBER KON, EXAMINING ATTORNEY

MVD-MAX

THE MARK CONSISTS OF STANDARD CHARACTERS WITHOUT CLAIM TO ANY PARTICULAR FONT, STYLE, SIZE, OR COLOR.

FOR WIRELESS BROADBAND COMMUNICATION SERVICES (U.S. CLS. 100, 101 AND 104).

ANDREA SAUNDERS, EXAMINING ATTORNEY



SN 77-434,528. AVIDAMED, INC., ANDOVER, MA. FILED 3-28-2008.

AVIDAMED

THE MARK CONSISTS OF STANDARD CHARACTERS WITHOUT CLAIM TO ANY PARTICULAR FONT, STYLE, SIZE, OR COLOR.

FOR PROVIDING MULTIPLE-USER ACCESS FOR HEALTHCARE PROVIDERS TO A GLOBAL COMPUTER INFORMATION NETWORK-BASED MEDICAL PRACTICE INFORMATION SYSTEM RESIDENT ON OR LINKED TO CENTRAL SERVERS THAT PERMITS DATA INPUT AND CONNECTIVITY FOR PATIENT REGISTRATION, SCHEDULING, BILL GENERATION AND TRACKING, FINANCIAL AND BUSINESS ADMINISTRATION SERVICES AND HEALTHCARE PRACTICE FINANCIAL REPORTING (U.S. CLS. 100, 101 AND 104).

SETH A. RAPPAPORT, EXAMINING ATTORNEY

CLASS 38—(Continued).

SN 77-434,959. TEAMTELL, INC., SPOKANE, WA. FILED 3-28-2008.

CLASS 38—(Continued).

SN 77-436,713. DISH NETWORK L.L.C., ENGLEWOOD, CO. FILED 4-1-2008.

ZELEPHONE



**AUTO RECORD
SERIES**

THE MARK CONSISTS OF STANDARD CHARACTERS WITHOUT CLAIM TO ANY PARTICULAR FONT, STYLE, SIZE, OR COLOR.

FOR AUTOMATED TELEPHONE VOICE MESSAGE SERVICES; COMMUNICATIONS BY TELEPHONE; AUDIO TELECONFERENCING; COMMUNICATION SERVICES, NAMELY, TRANSMISSION OF VOICE, AUDIO, VISUAL IMAGES AND DATA BY TELECOMMUNICATIONS NETWORKS, WIRELESS COMMUNICATION NETWORKS, THE INTERNET, INFORMATION SERVICES NETWORKS AND DATA NETWORKS; COMPUTER-AIDED TRANSMISSION OF MESSAGES; ELECTRONIC MESSAGE TRANSMISSION; ELECTRONIC, ELECTRIC, AND DIGITAL TRANSMISSION OF VOICE, DATA, IMAGES, SIGNALS, AND MESSAGES; MESSAGE SENDING, RECEIVING AND FORWARDING; PROVIDING EMAIL AND INSTANT MESSAGING SERVICES; PROVISION OF VOICE SHORT MESSAGE SERVICES (VSMS); SATELLITE, CABLE, NETWORK TRANSMISSION OF SOUNDS, IMAGES, SIGNALS AND DATA; TELECOMMUNICATION SERVICES, NAMELY, LOCAL AND LONG DISTANCE TRANSMISSION OF VOICE, DATA, GRAPHICS BY MEANS OF TELEPHONE, TELEGRAPHIC, CABLE, AND SATELLITE TRANSMISSIONS; TELECONFERENCING AND VIDEO CONFERENCING SERVICES; TELEPHONE COMMUNICATION SERVICES; TELEPHONE VOICE MESSAGING SERVICES; TRANSMISSION OF MESSAGES; VIDEO CONFERENCING SERVICES; VOICE MAIL SERVICES; WIRELESS ELECTRONIC TRANSMISSION OF VOICE SIGNALS, DATA, FACSIMILES, IMAGES AND INFORMATIONS (U.S. CLS. 100, 101 AND 104).

HENRY S. ZAK, EXAMINING ATTORNEY

NO CLAIM IS MADE TO THE EXCLUSIVE RIGHT TO USE "AUTO RECORD SERIES", APART FROM THE MARK AS SHOWN.

THE COLOR(S) BLACK, GREY AND RED IS/ARE CLAIMED AS A FEATURE OF THE MARK.

THE MARK CONSISTS OF A BUTTON THAT HAS AN INNER RED CIRCLE AND A BLACK AND GREY OUTER CIRCLE WITH THE STYLIZED BLACK WORDS "AUTO RECORD" UNDER THE CIRCLES. UNDER "AUTO RECORD" IS THE STYLIZED BLACK WORD "SERIES".

FOR SATELLITE COMMUNICATION SERVICES; SATELLITE TELEVISION BROADCASTING; SATELLITE TRANSMISSION SERVICES; SATELLITE, CABLE, NETWORK TRANSMISSION OF SOUNDS, IMAGES, SIGNALS AND DATA; TRANSMISSION OF DATA, SOUND AND IMAGES BY SATELLITE; PAY-PER-VIEW TELEVISION TRANSMISSION SERVICES; RENTAL OF SET-TOP BOXES FOR USE WITH TELEVISIONS; SUBSCRIPTION TELEVISION BROADCASTING; TELEVISION BROADCASTING (U.S. CLS. 100, 101 AND 104).

KOURTNEE HODGES, EXAMINING ATTORNEY

CLASS 38—(Continued).

SN 77-442,380. DISH NETWORK L.L.C., ENGLEWOOD, CO. FILED 4-8-2008.



AUTO RECORD SERIES

NO CLAIM IS MADE TO THE EXCLUSIVE RIGHT TO USE "AUTO RECORD SERIES", APART FROM THE MARK AS SHOWN.

THE COLOR(S) BLACK, GREY AND RED IS/ARE CLAIMED AS A FEATURE OF THE MARK.

THE MARK CONSISTS OF A BUTTON THAT HAS AN INNER RED CIRCLE AND A BLACK AND GREY OUTER CIRCLE WITH THE STYLIZED BLACK WORDS "AUTO RECORD" TO THE RIGHT OF THE CIRCLES. UNDER "AUTO RECORD" IS THE STYLIZED BLACK WORD "SERIES".

FOR SATELLITE COMMUNICATION SERVICES; SATELLITE TELEVISION BROADCASTING; SATELLITE TRANSMISSION SERVICES; SATELLITE, CABLE, NETWORK TRANSMISSION OF SOUNDS, IMAGES, SIGNALS AND DATA; TRANSMISSION OF DATA, SOUND AND IMAGES BY SATELLITE; PAY-PER-VIEW TELEVISION TRANSMISSION SERVICES; RENTAL OF SET-TOP BOXES FOR USE WITH TELEVISIONS; SUBSCRIPTION TELEVISION BROADCASTING; TELEVISION BROADCASTING (U.S. CLS. 100, 101 AND 104).

KOURTNEE HODGES, EXAMINING ATTORNEY

SN 77-464,203. QWEST COMMUNICATIONS INTERNATIONAL INC., DENVER, CO. FILED 5-2-2008.

MOE

THE MARK CONSISTS OF STANDARD CHARACTERS WITHOUT CLAIM TO ANY PARTICULAR FONT, STYLE, SIZE, OR COLOR.

FOR ELECTRONIC, ELECTRIC, AND DIGITAL TRANSMISSION OF VOICE, DATA, IMAGES, SIGNALS, AND MESSAGES (U.S. CLS. 100, 101 AND 104).

DAVID TAYLOR, EXAMINING ATTORNEY

CLASS 38—(Continued).

SN 77-471,798. NOTEVAULT, INC., SAN DIEGO, CA. FILED 5-12-2008.

The Ultimate C.Y.A.

THE MARK CONSISTS OF STANDARD CHARACTERS WITHOUT CLAIM TO ANY PARTICULAR FONT, STYLE, SIZE, OR COLOR.

FOR COMMUNICATION SERVICES, NAMELY, TRANSMISSION OF VOICE, AUDIO, VISUAL IMAGES AND DATA BY TELECOMMUNICATIONS NETWORKS, WIRELESS COMMUNICATION NETWORKS, THE INTERNET, INFORMATION SERVICE S NETWORKS AND DATA NETWORKS; COMMUNICATION VIA RADIO, TELEGRAPH, TELEPHONE AND TELEVISION TRANSMISSIONS; COMMUNICATIONS BY COMPUTER TERMINALS; COMMUNICATIONS BY MEANS OF MOBILE PHONES; COMMUNICATIONS BY TELEPHONE; COMMUNICATIONS SERVICES, NAMELY, TRANSMITTING STREAMED SOUND AND AUDIOVISUAL RECORDINGS VIA THE INTERNET (U.S. CLS. 100, 101 AND 104). FIRST USE 5-8-2008; IN COMMERCE 5-8-2008.

RUDY R. SINGLETON, EXAMINING ATTORNEY

SN 77-472,881. JMM LEE PROPERTIES, LLC, BURBANK, CA. FILED 5-13-2008.

AIRTOUCH

THE MARK CONSISTS OF STANDARD CHARACTERS WITHOUT CLAIM TO ANY PARTICULAR FONT, STYLE, SIZE, OR COLOR.

FOR TELECOMMUNICATION SERVICES, NAMELY, TRANSMISSION OF VOICE, DATA, GRAPHICS, SOUND AND VIDEO BY MEANS OF BROADBAND POWER LINE OR WIRELESS NETWORKS (U.S. CLS. 100, 101 AND 104).

MARGARET POWER, EXAMINING ATTORNEY

SN 77-472,891. JMM LEE PROPERTIES, LLC, BURBANK, CA. FILED 5-13-2008.

AIRTOUCH

THE MARK CONSISTS OF STANDARD CHARACTERS WITHOUT CLAIM TO ANY PARTICULAR FONT, STYLE, SIZE, OR COLOR.

FOR ELECTRONIC VOICE MESSAGING, NAMELY, THE RECORDING AND SUBSEQUENT TRANSMISSION OF VOICE MESSAGES BY TELEPHONE (U.S. CLS. 100, 101 AND 104).

MARGARET POWER, EXAMINING ATTORNEY

CLASS 38—(Continued).

SN 77-477,884. QWEST COMMUNICATIONS INTERNATIONAL INC., DENVER, CO. FILED 5-19-2008.

QWEST IQ

THE MARK CONSISTS OF STANDARD CHARACTERS WITHOUT CLAIM TO ANY PARTICULAR FONT, STYLE, SIZE, OR COLOR.

FOR ELECTRONIC, ELECTRIC, AND DIGITAL TRANSMISSION OF VOICE, DATA, IMAGES, SIGNALS, AND MESSAGES; RENTAL OF TELECOMMUNICATION EQUIPMENT (U.S. CLS. 100, 101 AND 104).

DAVID TAYLOR, EXAMINING ATTORNEY

SN 77-477,910. QWEST COMMUNICATIONS INTERNATIONAL INC., DENVER, CO. FILED 5-19-2008.

CONNECT. SIMPLIFY. ENHANCE.

THE MARK CONSISTS OF STANDARD CHARACTERS WITHOUT CLAIM TO ANY PARTICULAR FONT, STYLE, SIZE, OR COLOR.

FOR ELECTRONIC, ELECTRIC, AND DIGITAL TRANSMISSION OF VOICE, DATA, IMAGES, SIGNALS, AND MESSAGES; RENTAL OF TELECOMMUNICATION EQUIPMENT (U.S. CLS. 100, 101 AND 104).

DAVID TAYLOR, EXAMINING ATTORNEY

SN 77-490,075. MATTEL, INC., EL SEGUNDO, CA. FILED 6-3-2008.

BARBIE CHANNEL

THE MARK CONSISTS OF STANDARD CHARACTERS WITHOUT CLAIM TO ANY PARTICULAR FONT, STYLE, SIZE, OR COLOR.

OWNER OF U.S. REG. NOS. 741,208, 3,287,023 AND OTHERS.

NO CLAIM IS MADE TO THE EXCLUSIVE RIGHT TO USE "CHANNEL", APART FROM THE MARK AS SHOWN.

FOR CABLE TELEVISION BROADCASTING SERVICES FEATURING PROGRAMMING FOR CHILDREN (U.S. CLS. 100, 101 AND 104).

JOHN KELLY, EXAMINING ATTORNEY

CLASS 38—(Continued).

SN 77-975,477. YOUGHIOGHENY COMMUNICATIONS-IP, LLC, SAN ANTONIO, TX. FILED 11-16-2006.



The logo for "pocket COMMUNICATIONS" features the word "pocket" in a lowercase, bold, sans-serif font. Above the letter "o" in "pocket" are three curved lines representing a signal or Wi-Fi symbol. Below "pocket" is the word "COMMUNICATIONS" in a smaller, uppercase, sans-serif font.

OWNER OF U.S. REG. NO. 3,098,763.

NO CLAIM IS MADE TO THE EXCLUSIVE RIGHT TO USE "COMMUNICATIONS", APART FROM THE MARK AS SHOWN.

THE MARK CONSISTS OF "POCKET" WITH SOUND-WAVES AS THE LETTER "O".

SEC. 2(F).

FOR CELLULAR TELEPHONE SERVICES AND WIRELESS COMMUNICATIONS SERVICES, NAMELY, THE TRANSMISSION OF VOICE, DATA, IMAGES, AUDIO, VIDEO, PAGING, ELECTRONIC MAIL, VOICE MESSAGING, AND INFORMATION (U.S. CLS. 100, 101 AND 104).

FIRST USE 7-31-2006; IN COMMERCE 7-31-2006.

BENJAMIN OKEKE, EXAMINING ATTORNEY

SN 78-721,677. NBA PROPERTIES, INC., NEW YORK, NY. FILED 9-27-2005.

NBA CARES

THE MARK CONSISTS OF STANDARD CHARACTERS WITHOUT CLAIM TO ANY PARTICULAR FONT, STYLE, SIZE, OR COLOR.

OWNER OF U.S. REG. NOS. 2,118,226, 2,770,671 AND OTHERS.

FOR AUDIO BROADCASTING; CABLE TELEVISION BROADCASTING; RADIO BROADCASTING; SUBSCRIPTION TELEVISION BROADCASTING; TELEVISION BROADCASTING; VIDEO BROADCASTING; WEBCASTING SERVICES IN THE NATURE OF PROVIDING ON-LINE CHAT ROOMS AND ON-LINE INTERACTIVE CHAT ROOMS WITH GUESTS FOR TRANSMISSION OF MESSAGES AMONG COMPUTER USERS CONCERNING THE FIELD OF BASKETBALL; BROADCASTING PROGRAMS OVER THE INTERNET; PROVIDING ON-LINE ELECTRONIC BULLETIN BOARDS FOR TRANSMISSION OF MESSAGES AMONG COMPUTER USERS CONCERNING THE FIELD OF BASKETBALL; PROVIDING MULTIPLE-USER ACCESS TO A GLOBAL COMPUTER INFORMATION NETWORK FOR THE PURPOSE OF PARTICIPATING IN INTERACTIVE POLLING IN THE FIELD OF BASKETBALL; WIRELESS COMMUNICATIONS SERVICES, NAMELY, TRANSMISSION OF GRAPHICS TO MOBILE TELEPHONES; WIRELESS ELECTRONIC TRANSMISSION OF VOICE SIGNALS, DATA, FACSIMILES, IMAGES AND INFORMATION; WIRELESS BROADBAND COMMUNICATIONS SERVICES. (U.S. CLS. 100, 101 AND 104).

KATHRYN COWARD, EXAMINING ATTORNEY

CLASS 38—(Continued).

SN 78-766,488. INSIGHT COMMUNICATIONS COMPANY, INC., NEW YORK, NY. FILED 12-5-2005.



OWNER OF U.S. REG. NO. 1,520,156.
NO CLAIM IS MADE TO THE EXCLUSIVE RIGHT TO USE "BUSINESS", APART FROM THE MARK AS SHOWN. THE MARK CONSISTS OF A CLUSTER OF ELECTRIC WIRES AND THE WORDS "INSIGHT BUSINESS".

FOR TELECOMMUNICATION SERVICES, NAMELY, ELECTRONIC TRANSMISSION OF VOICE, DATA, VIDEO AND DIGITAL SIGNALS BY MEANS OF CABLE TELEVISION TRANSMISSIONS; TWO-WAY WIRELESS TRANSMISSION OF EMAIL AND TEXT BETWEEN WIRELESS TELECOMMUNICATIONS TERMINALS AND COMPUTERS THROUGH CABLE TELEVISION; PROVIDING HIGH-SPEED ACCESS TO THE INTERNET AND PRIVATE AREA NETWORKS; PROVIDING ON-LINE CHAT ROOMS AND NEWS GROUPS FOR TRANSMISSION OF MESSAGES AMONG COMPUTER USERS CONCERNING MATTERS OF GENERAL INTEREST; COMMUNICATIONS SERVICES, NAMELY, PROVIDING LOCAL AND LONG DISTANCE TELEPHONE SERVICES AND CALL MANAGEMENT SERVICES; AND TELEPHONE CALL MANAGEMENT SERVICES VIA THE INTERNET, NAMELY, WRITTEN AND VOICE MESSAGE NOTIFICATION, RECORDING, RETRIEVAL AND FORWARDING (U.S. CLS. 100, 101 AND 104).

FIRST USE 11-11-2005; IN COMMERCE 11-11-2005.
JOHN WILKE, EXAMINING ATTORNEY

SN 78-766,571. INSIGHT COMMUNICATIONS COMPANY, INC., NEW YORK, NY. FILED 12-5-2005.

INSIGHT BUSINESS

THE MARK CONSISTS OF STANDARD CHARACTERS WITHOUT CLAIM TO ANY PARTICULAR FONT, STYLE, SIZE, OR COLOR.

NO CLAIM IS MADE TO THE EXCLUSIVE RIGHT TO USE "BUSINESS", APART FROM THE MARK AS SHOWN.

FOR TELECOMMUNICATION SERVICES, NAMELY, ELECTRONIC TRANSMISSION OF VOICE, DATA, VIDEO AND DIGITAL SIGNALS BY MEANS OF CABLE TELEVISION TRANSMISSIONS; TWO-WAY WIRELESS TRANSMISSION OF EMAIL AND TEXT BETWEEN WIRELESS TELECOMMUNICATIONS TERMINALS AND COMPUTERS THROUGH CABLE TELEVISION; PROVIDING HIGH-SPEED ACCESS TO THE INTERNET AND PRIVATE AREA NETWORKS; PROVIDING ON-LINE CHAT ROOMS AND NEWS GROUPS FOR TRANSMISSION OF MESSAGES AMONG COMPUTER USERS CONCERNING MATTERS OF GENERAL INTEREST; COMMUNICATIONS SERVICES, NAMELY, PROVIDING LOCAL AND LONG DISTANCE TELEPHONE SERVICES AND CALL MANAGEMENT SERVICES; AND TELEPHONE CALL MANAGEMENT SERVICES VIA THE INTERNET, NAMELY, WRITTEN AND VOICE MESSAGE NOTIFICATION, RECORDING, RETRIEVAL AND FORWARDING (U.S. CLS. 100, 101 AND 104).

FIRST USE 11-11-2005; IN COMMERCE 11-11-2005.
JOHN WILKE, EXAMINING ATTORNEY

CLASS 38—(Continued).

SN 78-895,495. SOVEREIGN DEED, LLC, CHICAGO, IL. FILED 5-30-2006.



THE MARK CONSISTS OF STANDARD CHARACTERS WITHOUT CLAIM TO ANY PARTICULAR FONT, STYLE, SIZE, OR COLOR.

FOR AUDIO BROADCASTING; BROADCASTING PROGRAMS VIA A GLOBAL COMPUTER NETWORK; BROADCASTING SERVICES AND PROVISION OF TELECOMMUNICATION ACCESS TO VIDEO AND AUDIO CONTENT PROVIDED VIA A VIDEO-ON-DEMAND SERVICE VIA THE INTERNET; CABLE RADIO BROADCASTING; CABLE TELEVISION BROADCASTING; COMMUNICATION BY TELEGRAM; COMMUNICATION SERVICES, NAMELY, ELECTRONIC TRANSMISSION OF DATA AND DOCUMENTS AMONG USERS OF COMPUTERS; COMMUNICATION VIA RADIO, TELEGRAPH, TELEPHONE AND TELEVISION TRANSMISSIONS; COMMUNICATIONS BY COMPUTER TERMINALS; COMMUNICATIONS BY MOBILE PHONES; COMMUNICATIONS BY TELEVISION FOR MEETING; COMMUNICATIONS SERVICES, NAMELY, TRANSMITTING STREAMED SOUND AND AUDIO-VISUAL RECORDINGS VIA THE INTERNET; COMMUNICATIONS VIA FIBER-OPTIC NETWORKS; COMMUNICATIONS VIA MULTINATIONAL TELECOMMUNICATION NETWORKS; COMPUTER AIDED TRANSMISSION OF INFORMATION AND IMAGES; DATA COMMUNICATION BY ELECTRONIC MAIL; ELECTRONIC DATA TRANSMISSION; ELECTRONIC DELIVERY OF IMAGES AND PHOTOGRAPHS VIA A GLOBAL COMPUTER NETWORK; ELECTRONIC TRANSMISSION OF DATA AND DOCUMENTS VIA COMPUTER TERMINALS; ELECTRONIC TRANSMISSION OF FACSIMILE COMMUNICATIONS AND DATA FEATURING ENCRYPTION AND DECRYPTION; ELECTRONIC TRANSMISSION OF MESSAGES AND DATA; ELECTRONIC, ELECTRIC, AND DIGITAL TRANSMISSION OF VOICE, DATA, IMAGES, SIGNALS, AND MESSAGES; FACSIMILE TRANSMISSION; INFORMATION TRANSMISSION BY TELEMATIC CODES; INFORMATION TRANSMISSION BY TELETYPEWRITERS; INFORMATION TRANSMISSION VIA ELECTRONIC COMMUNICATIONS NETWORKS; MOBILE RADIO COMMUNICATION; PAY-PER-VIEW TELEVISION TRANSMISSION SERVICES; PODCASTING SERVICES; PROVIDING MULTIPLE-USER ACCESS TO A GLOBAL COMPUTER INFORMATION NETWORK; PROVIDING ON-LINE COMMUNICATIONS LINKS WHICH TRANSFER THE WEBSITE USER TO OTHER LOCAL AND GLOBAL WEB PAGES; PROVIDING PRIVATE AND SECURE REAL TIME ELECTRONIC COMMUNICATION OVER A COMPUTER NETWORK; PROVIDING TELECOMMUNICATIONS CONNECTIONS TO A GLOBAL COMPUTER NETWORK; PROVIDING THIRD PARTY USERS WITH ACCESS TO TELECOMMUNICATION INFRASTRUCTURE; PROVISION OF ACCESS TO ELECTRONIC SITES; RADIO BROADCASTING; RADIO BROADCASTING INFORMATION; RADIO COMMUNICATION; RADIO, TELEPHONE, TELEGRAPH COMMUNICATION SERVICES; RADIO PROGRAM BROADCASTING; RENTAL OF COMMUNICATION APPARATUS AND IMPLEMENTS; SATELLITE, CABLE, NETWORK TRANSMISSION OF SOUNDS, IMAGES, SIGNALS AND DATA; STREAMING OF VIDEO MATERIAL ON THE INTERNET; TELECOMMUNICATION SERVICES, NAMELY, LOCAL AND LONG DISTANCE TRANSMISSION OF VOICE, DATA, GRAPHICS BY MEANS OF TELEPHONE, TELEGRAPHIC, CABLE, AND SATELLITE TRANSMISSIONS; TELECOMMUNICATIONS BY E-MAIL; TELEGRAM TRANSMISSION; TELEMATIC SENDING OF INFORMATION; TELEPRINTING; TELEVISION BROADCASTING; TELEVISION BROADCASTING INFORMATION; TRANSMISSION AND RECEPTION OF DATABASE INFORMATION VIA THE TELECOMMUNICATION NETWORK; TRANSMISSION OF INFORMATION BY DATA

CLASS 38—(Continued).

COMMUNICATIONS FOR ASSISTING DECISION MAKING; TRANSMISSION OF INFORMATION BY ELECTRONIC COMMUNICATIONS NETWORKS; TRANSMISSION OF INFORMATION IN THE AUDIO-VISUAL FIELD; TRANSMISSION OF INFORMATION THROUGH VIDEO COMMUNICATION SYSTEMS; TRANSMISSION OF MESSAGES OVER ELECTRONIC MEDIA; TRANSMISSION OF SOUND, PICTURE AND DATA SIGNALS; TRANSMISSION OF SOUND, VIDEO AND INFORMATION; TRANSMISSION, RECEPTION AND PROCESSING OF CODED AND EMERGENCY SIGNALS; VIDEO BROADCASTING; VIDEO TELECONFERENCING; WIRELESS BROADBAND COMMUNICATION SERVICES (U.S. CLS. 100, 101 AND 104).

LINDA ORNDORFF, EXAMINING ATTORNEY

SN 78-964,336. LADEJOBI, GANIU A, BRONX, NY. FILED 8-30-2006.



NO CLAIM IS MADE TO THE EXCLUSIVE RIGHT TO USE "HIP HOP TELEVISION", APART FROM THE MARK AS SHOWN.

THE COLOR(S) ORANGE, RED, YELLOW, BLACK, LAVENDER, GRAY IS/ARE CLAIMED AS A FEATURE OF THE MARK.

THE MARK CONSISTS OF STYLIZED WORDING "HHTV" IN WHICH AN AMPLIFIER DESIGN IS FEATURED IN THE LETTER "H" AND THE WORDING "HIP HOP TELEVISION" BENEATH THE WORDING "HHTV". THE COLOR ORANGE APPEARS IN THE WORDING "HHTV" AND "HIP HOP TELEVISION" AND IN THE DESIGN ELEMENTS BENEATH "HIP HOP TELEVISION". THE COLOR RED APPEARS WITHIN THE LETTER "O" IN "HOP" AND "TELEVISION". THE COLOR YELLOW APPEARS IN THE CIRCLES OF THE AMPLIFIER DESIGN AND IN THE LETTER "O" IN "HOP" AND "TELEVISION". THE COLOR BLACK OUTLINES THE STYLIZED WORDING "HHTV", THE WORDING "HIP HOP TELEVISION" AND THE DESIGN ELEMENTS BENEATH "HIP HOP TELEVISION". THE COLOR LAVENDER APPEARS IN THE CENTER AND OUTER CIRCLES OF THE AMPLIFIER DESIGN. THE COLOR GRAY SURROUNDS THE STYLIZED WORDING "HHTV" AND "HIP HOP TELEVISION".

FOR TELEVISION, RADIO SATELLITE, TELEVISION SATELLITE, RADIO, CABLE TELEVISION AND GLOBAL COMPUTER NETWORK BROADCASTING IN THE AREAS OF ENTERTAINMENT, MUSIC, SPORTS, MOVIES, EDUCATION AND BUSINESS INFORMATION (U.S. CLS. 100, 101 AND 104).

MELISSA VALLILLO, EXAMINING ATTORNEY

CLASS 38—(Continued).

SN 79-039,369. ZAKRYTOE AKTSIONERNOE OBSCHESTVO; "KVANTUM", RUSSIAN FED., FILED 4-23-2007.

PROSTOR TELECOM

OWNER OF INTERNATIONAL REGISTRATION 0926354 DATED 4-23-2007, EXPIRES 4-23-2017.

NO CLAIM IS MADE TO THE EXCLUSIVE RIGHT TO USE "TELECOM", APART FROM THE MARK AS SHOWN.

FOR NEWS AGENCIES, NAMELY, THE TRANSMISSION OF NEWS ITEMS TO NEWS REPORTING ORGANIZATIONS; TELEVISION BROADCASTING; CABLE TELEVISION BROADCASTING; PROVIDING ON-LINE ELECTRONIC BULLETIN BOARDS FOR THE POSTING AND TRANSMISSION OF MESSAGES AMONG COMPUTER USERS CONCERNING TOPICS OF GENERAL INTEREST; TELECOMMUNICATIONS SERVICES, INTERNET SERVICE PROVIDER SERVICES, PROVIDING TELECOMMUNICATIONS CONNECTIONS TO A GLOBAL COMPUTER NETWORK, TELECOMMUNICATION ROUTING AND JUNCTION SERVICES, ELECTRONIC MAIL, WIRELESS TELEPHONE SERVICES, PROVIDING ACCESS TO PICTURES, VIDEO, ALARM STATUS, BUILDING PLANS AND OTHER BUILDING AND SECURITY INFORMATION AT A REMOTE STATION, PROVIDING ACCESS TO TELECOMMUNICATION NETWORKS, PROVIDING INTERNET ACCESS VIA BROADBAND OPTICAL OR WIRELESS NETWORKS, AND LOCAL AND LONG DISTANCE TRANSMISSION OF VOICE, DATA, GRAPHICS AND VIDEO BY MEANS OF BROADBAND, COPPER AND OPTICAL OR WIRELESS NETWORKS; INFORMATION ABOUT TELECOMMUNICATION; TELECOMMUNICATIONS ROUTING AND JUNCTION SERVICES; PROVIDING MULTIPLE-USER ACCESS TO A GLOBAL COMPUTER NETWORK; INTERNET SERVICE PROVIDER SERVICES; PROVIDING TELECOMMUNICATIONS CONNECTIONS TO A GLOBAL COMPUTER NETWORK; ELECTRONIC MESSAGE SENDING; COMPUTER AIDED TRANSMISSION OF ELECTRONIC MESSAGES AND IMAGES; SENDING OF TELEGRAMS; TRANSMISSION OF TELEGRAMS; ELECTRONIC MAIL; RENTAL OF MESSAGE SENDING APPARATUS AND TELECOMMUNICATIONS EQUIPMENT, NAMELY, TELEPHONES; TELEPHONE ACCESSORIES, AND EQUIPMENT, NAMELY, WIRELESS TELEPHONES; BATTERIES; CHARGERS; TELEPHONE CARRYING CASES, HANDS-FREE DEVICES, AND CARRYING CLIPS FOR WIRELESS TELEPHONES SOLD AS A UNIT IN COMBINATION WITH WIRELESS TELEPHONES; MICROPHONES; AUDIO RECEIVERS; SPEAKERS; TRANSCEIVERS; COMMUNICATIONS DEVICES IN THE NATURE OF WIRELESS APPLICATION PROTOCOL RECEIVERS AND TRANSMITTERS; COMMUNICATIONS DEVICES IN THE NATURE OF GENERAL PACKET RADIO SERVICE PROTOCOL RECEIVERS AND TRANSMITTERS; DATA TRANSCEIVERS; TELECOMMUNICATIONS TRANSMISSION EQUIPMENT, COMPONENTS, SWITCHING, AND NETWORK SYSTEMS COMPRISED OF - RADIO TRANSMITTERS AND RECEIVERS; ANTENNAS; SWITCHES; SIGNAL TRANSFER POINT SERVERS; SIGNAL CONTROL POINT SERVERS; SERVICE RESOURCE PLATFORM SERVERS; CALL ROUTING SERVERS AND SOFTWARE FOR THE FOREGOING; COMPUTERS AND COMPUTER SOFTWARE FOR THE ACTIVATION AND OPERATION OF WIRELESS TELECOMMUNICATIONS SERVICES; MACHINE READABLE MAGNETICALLY ENCODED CALLING CARDS, CALLER IDENTIFICATION CARDS, DEBIT AND CREDIT CARDS; PAGERS; CALLER IDENTIFICATION EQUIPMENT; WIRELESS HANDHELD COMMUNICATION DEVICES TO TRANSMIT, RECEIVE, OR OTHERWISE ACCESS COMMUNICATIONS NETWORKS; RENTAL OF MODEMS; RENTAL OF

CLASS 38—(Continued).

TELEPHONES; RENTAL OF FACSIMILE APPARATUS; RADIO BROADCASTING; COMMUNICATIONS BY FIBER OPTIC NETWORKS; CELLULAR TELEPHONE COMMUNICATION; COMMUNICATIONS BY ELECTRONIC COMPUTER TERMINAL; SATELLITE TRANSMISSION; COMMUNICATIONS BY TELEGRAMS; COMMUNICATIONS BY TELEPHONE; FACSIMILE TRANSMISSION; PAGING SERVICES, NAMELY, RADIO, TELEPHONE, OR OTHER MEANS OF ELECTRONIC COMMUNICATION; TELECONFERENCING SERVICES; TELEX SERVICES; TELEGRAPH SERVICES; TELEPHONE SERVICES (U.S. CLS. 100, 101 AND 104).
SALLY SHIH, EXAMINING ATTORNEY

CLASS 39—TRANSPORTATION AND STORAGE

SN 76-677,178. SWAIN AUSTRALIAN TOURS (2003), INC., ARDMORE, PA. FILED 5-21-2007.

SWAIN TOURS

THE MARK CONSISTS OF STANDARD CHARACTERS WITHOUT CLAIM TO ANY PARTICULAR FONT, STYLE, SIZE, OR COLOR.

OWNER OF U.S. REG. NOS. 1,975,220, 3,243,305 AND OTHERS.

NO CLAIM IS MADE TO THE EXCLUSIVE RIGHT TO USE "TOURS", APART FROM THE MARK AS SHOWN.

SEC. 2(F).

FOR TRAVEL AGENCY SERVICES, NAMELY, MAKING RESERVATIONS AND BOOKINGS FOR TRANSPORTATION (U.S. CLS. 100 AND 105).

FIRST USE 11-2-1986; IN COMMERCE 11-2-1986.

ELIZABETH KAJUBI, EXAMINING ATTORNEY

SN 76-687,291. MANNA FREIGHT SYSTEMS INC., MENDOTA HEIGHTS, MN. FILED 3-3-2008.

Manna Freight Systems, Inc.

THE MARK CONSISTS OF STANDARD CHARACTERS WITHOUT CLAIM TO ANY PARTICULAR FONT, STYLE, SIZE, OR COLOR.

OWNER OF U.S. REG. NO. 3,292,635.

NO CLAIM IS MADE TO THE EXCLUSIVE RIGHT TO USE "FREIGHT SYSTEMS, INC.", APART FROM THE MARK AS SHOWN.

FOR FREIGHT TRANSPORTATION OF GOODS BY AIR, TRAIN, OR TRUCK (U.S. CLS. 100 AND 105).

FIRST USE 3-14-1991; IN COMMERCE 3-14-1991.

MATTHEW EINSTEIN, EXAMINING ATTORNEY

CLASS 39—(Continued).

SN 77-043,644. SINGAMAS CONTAINER HOLDINGS LIMITED, WANCHAI, HONG KONG, FILED 11-14-2006.

SINGAMAS

PRIORITY CLAIMED UNDER SEC. 44(D) ON HONG KONG APPLICATION NO. 300753246, FILED 11-3-2006, REG. NO. 300753246, DATED 11-3-2006, EXPIRES 11-3-2016.

THE MARK CONSISTS OF THE WORD "SINGAMAS" WITH A LINE ABOVE AND BELOW.

FOR TRANSPORTATION OF FREIGHT AND CARGO BY SHIP, BOAT, TRUCK, AND RAIL; TRANSPORT, WAREHOUSE AND DELIVERY SERVICES, NAMELY, THE PACKAGING, CRATING, STORING, SHIPPING AND DELIVERY OF FREIGHT, CARGO AND THE MERCHANDISE OF OTHERS; ROAD HAULAGE SERVICES VIA TRUCK; CARTING OF CARGO AND FREIGHT VIA SHIP, RAIL, TRUCK AND LIGHTERAGE SERVICES; FREIGHT BROKERAGE AND FREIGHT FORWARDING SERVICES; MARINE TRANSPORT SERVICES; RIVER CARGO TRANSPORTATION SERVICES VIA SHIP, BOAT AND BARGE; RENTAL OF WAREHOUSES; WAREHOUSE STORAGE AND CARGO HANDLING SERVICES; STORAGE OF CARGO, FREIGHT AND GOODS; RENTAL OF CARGO CONTAINERS; OPERATION OF SHIPPING CONTAINER DEPOTS AND TERMINALS; MID-STREAM AND LOGISTICS SERVICES, NAMELY, SHIPPING CARGO VIA RAILWAY, SHIP, AND TRUCK; MAKING RESERVATIONS AND BOOKING FOR TRANSPORTATION; PASSENGER TRANSPORT SERVICES; RESCUE SERVICES; RESCUE OF SHIPS IN DISTRESS; CARGO, FREIGHT, AND PASSENGER SHIP TRANSPORT SERVICES; TRANSPORT RESERVATION SERVICES; ARRANGING OF TRANSPORTATION (U.S. CLS. 100 AND 105).

REBECCA EISINGER, EXAMINING ATTORNEY

SN 77-078,595. AIR CANADA, ST. LAURENT, QUEBEC, CANADA, FILED 1-9-2007.

THE FREEDOM TO FLY YOUR OWN WAY

THE MARK CONSISTS OF STANDARD CHARACTERS WITHOUT CLAIM TO ANY PARTICULAR FONT, STYLE, SIZE, OR COLOR.

OWNER OF CANADA REG. NO. TMA715136, DATED 5-23-2008, EXPIRES 5-23-2023.

FOR AIR TRANSPORTATION SERVICES OF PASSENGERS AND BAGGAGE (U.S. CLS. 100 AND 105).

MARCIE MILONE, EXAMINING ATTORNEY

CLASS 39—(Continued).

SN 77-240,049. LEONORA M. CHIANELLO, DBA ITALY IN STYLE, SANTA MONICA, CA. FILED 7-26-2007.

We make sure the Boot fits
you perfectly

THE MARK CONSISTS OF STANDARD CHARACTERS WITHOUT CLAIM TO ANY PARTICULAR FONT, STYLE, SIZE, OR COLOR.

FOR COORDINATING TRAVEL ARRANGEMENTS FOR INDIVIDUALS AND FOR GROUPS (U.S. CLS. 100 AND 105).

FIRST USE 1-17-2007; IN COMMERCE 1-17-2007.
CYNTHIA SLOAN, EXAMINING ATTORNEY

SN 77-242,870. ROVER TECHNOLOGY FUSIONS, TAMPA, FL. FILED 7-31-2007.

ECHO OFFSITE

THE MARK CONSISTS OF STANDARD CHARACTERS WITHOUT CLAIM TO ANY PARTICULAR FONT, STYLE, SIZE, OR COLOR.

NO CLAIM IS MADE TO THE EXCLUSIVE RIGHT TO USE "OFFSITE", APART FROM THE MARK AS SHOWN.

FOR ELECTRONIC STORAGE OF DATA, NAMELY, PROVIDING A BACKUP SOLUTION WHICH INCLUDES MULTIPLE COPIES OF DATA STORED IN MULTIPLE LOCATIONS, LOCALLY AND IN REMOTE SERVERS (U.S. CLS. 100 AND 105).

FIRST USE 6-24-2007; IN COMMERCE 6-24-2007.
AISHA SALEM, EXAMINING ATTORNEY

SN 77-249,687. TRAVEL ACQUISITIONS GROUP, LLC, EDEN PRAIRIE, MN. FILED 8-8-2007.



OWNER OF U.S. REG. NO. 1,662,796.
THE MARK CONSISTS OF THE WORDING "FLY4LESS" SURROUNDED BY A STYLIZED JET & CONTRAIL.

FOR TRAVEL AGENCY SERVICES, NAMELY, MAKING RESERVATIONS AND BOOKINGS FOR TRANSPORTATION, CRUISES AND TRAVEL TOURS (U.S. CLS. 100 AND 105).

BARBARA RUTLAND, EXAMINING ATTORNEY

CLASS 39—(Continued).

SN 77-275,417. ST. ANDREWS OF SCOTLAND INTERNATIONAL LTD, HOLLAND, MI. FILED 9-10-2007.

St.Andrews Golf

THE MARK CONSISTS OF STANDARD CHARACTERS WITHOUT CLAIM TO ANY PARTICULAR FONT, STYLE, SIZE, OR COLOR.

FOR PASSENGER TRANSPORT BY AIR; TRAVEL ARRANGEMENT; TRAVEL RESERVATION (U.S. CLS. 100 AND 105).

TOBY BULLOFF, EXAMINING ATTORNEY

SN 77-276,690. ST.ANDREWS OF SCOTLAND INTERNATIONAL LTD, HOLLAND, MI. FILED 9-11-2007.

St.Andrews of Scotland

THE MARK CONSISTS OF STANDARD CHARACTERS WITHOUT CLAIM TO ANY PARTICULAR FONT, STYLE, SIZE, OR COLOR.

FOR PASSENGER TRANSPORT BY AIR; TRAVEL ARRANGEMENT; TRAVEL RESERVATION (U.S. CLS. 100 AND 105).

TOBY BULLOFF, EXAMINING ATTORNEY

SN 77-296,704. CANADREAM CORPORATION, CALGARY, CANADA, FILED 10-4-2007.



OWNER OF CANADA REG. NO. TMA712906, DATED 4-25-2008, EXPIRES 4-25-2023.

OWNER OF U.S. REG. NOS. 3,304,191 AND 3,304,193.
NO CLAIM IS MADE TO THE EXCLUSIVE RIGHT TO USE "TRAVEL", APART FROM THE MARK AS SHOWN.

FOR RENTAL OF RECREATIONAL VEHICLES (U.S. CLS. 100 AND 105).

MICHELLE DUBOIS, EXAMINING ATTORNEY

CLASS 39—(Continued).

SN 77-306,164. THINKING INC., DALLAS, TX. FILED 10-17-2007.

Digitalassets

THE MARK CONSISTS OF STANDARD CHARACTERS WITHOUT CLAIM TO ANY PARTICULAR FONT, STYLE, SIZE, OR COLOR.

FOR DATA MANAGEMENT SERVICES, NAMELY, ELECTRONIC STORAGE OF GRAPHICS FILES, ILLUSTRATIONS, BROADCAST MEDIA AND FILES, AND PRINT AND GRAPHIC FILES (U.S. CLS. 100 AND 105).

FIRST USE 11-8-2005; IN COMMERCE 11-8-2005.
ANNE E. GUSTASON, EXAMINING ATTORNEY

SN 77-308,177. PENSKE SYSTEM, INC., WILMINGTON, DE. FILED 10-19-2007.

TRAILER PLUS

THE MARK CONSISTS OF STANDARD CHARACTERS WITHOUT CLAIM TO ANY PARTICULAR FONT, STYLE, SIZE, OR COLOR.

OWNER OF U.S. REG. NO. 3,142,911.
NO CLAIM IS MADE TO THE EXCLUSIVE RIGHT TO USE "TRAILER", APART FROM THE MARK AS SHOWN.
FOR LEASING TRUCK TRAILERS (U.S. CLS. 100 AND 105).

FIRST USE 1-9-1995; IN COMMERCE 1-9-1995.
LINDA ESTRADA, EXAMINING ATTORNEY

SN 77-330,165. BONA, JOHN R., VERO BEACH, FL. FILED 11-15-2007.

Park 'N Go

THE MARK CONSISTS OF STANDARD CHARACTERS WITHOUT CLAIM TO ANY PARTICULAR FONT, STYLE, SIZE, OR COLOR.

NO CLAIM IS MADE TO THE EXCLUSIVE RIGHT TO USE "PARK", APART FROM THE MARK AS SHOWN.

FOR CAR PARKING; PARKING LOT SERVICES; RENTAL OF CAR PARKING SPACES; RENTAL OF PARKING SPACES; RENTAL OF VEHICLE PARKING SPACES; VALET PARKING; VEHICLE PARKING (U.S. CLS. 100 AND 105).

FIRST USE 8-1-1984; IN COMMERCE 8-1-1984.
ANNE MADDEN, EXAMINING ATTORNEY

CLASS 39—(Continued).

SN 77-339,685. IF&P FOODS, INC., INDIANAPOLIS, IN. FILED 11-29-2007.

MCCARTNEY PRODUCE FRESH FRUITS & VEGETABLES

THE MARK CONSISTS OF STANDARD CHARACTERS WITHOUT CLAIM TO ANY PARTICULAR FONT, STYLE, SIZE, OR COLOR.

NO CLAIM IS MADE TO THE EXCLUSIVE RIGHT TO USE "PRODUCE FRESH FRUITS & VEGETABLES", APART FROM THE MARK AS SHOWN.

SEC. 2(F).
FOR DISTRIBUTION SERVICES, NAMELY, DELIVERY OF FRESH FRUITS AND FRESH VEGETABLES (U.S. CLS. 100 AND 105).

FIRST USE 0-0-1975; IN COMMERCE 0-0-1975.
JIM RINGLE, EXAMINING ATTORNEY

SN 77-358,789. HAMPTON ISLAND, LLC, ATLANTA, GA. FILED 12-22-2007.

HAMPTON ISLAND PRESERVE

THE MARK CONSISTS OF STANDARD CHARACTERS WITHOUT CLAIM TO ANY PARTICULAR FONT, STYLE, SIZE, OR COLOR.

FOR MARINA SERVICES; BOAT STORAGE; PROVIDING INFORMATION ON FISHING EXPEDITIONS (U.S. CLS. 100 AND 105).

FIRST USE 1-0-2004; IN COMMERCE 1-0-2004.
GEORGIA CARTY, EXAMINING ATTORNEY

SN 77-368,794. ARCADIUUM CUSTOMS, LLC, MONTICELLO, MN. FILED 1-10-2008.

ARCADIUM CUSTOMS

THE MARK CONSISTS OF STANDARD CHARACTERS WITHOUT CLAIM TO ANY PARTICULAR FONT, STYLE, SIZE, OR COLOR.

NO CLAIM IS MADE TO THE EXCLUSIVE RIGHT TO USE "CUSTOMS", APART FROM THE MARK AS SHOWN.

FOR ON-LINE RETAIL STORE SERVICES FEATURING CUSTOM COMPUTER COMPONENTS (U.S. CLS. 100 AND 105).

FIRST USE 1-1-2008; IN COMMERCE 1-1-2008.
ZHALEH DELANEY, EXAMINING ATTORNEY

CLASS 39—(Continued).

SN 77-372,456. HARVEY GULF INTERNATIONAL MARINE, INC., HARVEY, LA. FILED 1-15-2008.

CLASS 39—(Continued).

SN 77-396,377. SOUTH AFRICAN AIRWAYS LTD, FORT LAUDERDALE, FL. FILED 2-13-2008.

HARVEY GULF

SAA Vacations

THE MARK CONSISTS OF STANDARD CHARACTERS WITHOUT CLAIM TO ANY PARTICULAR FONT, STYLE, SIZE, OR COLOR.

FOR TRANSPORT BROKERAGE, NAMELY, MARINE TRANSPORTATION BROKERING (U.S. CLS. 100 AND 105).

FIRST USE 3-25-1975; IN COMMERCE 3-25-1975.
TINA BROWN, EXAMINING ATTORNEY

THE MARK CONSISTS OF STANDARD CHARACTERS WITHOUT CLAIM TO ANY PARTICULAR FONT, STYLE, SIZE, OR COLOR.

OWNER OF U.S. REG. NOS. 2,766,101 AND 2,875,297.
NO CLAIM IS MADE TO THE EXCLUSIVE RIGHT TO USE "VACATIONS", APART FROM THE MARK AS SHOWN.

FOR ARRANGING TRAVEL TOURS; TRAVEL AGENCY SERVICES, NAMELY, MAKING RESERVATIONS AND BOOKINGS FOR TRANSPORTATION; TRAVEL INFORMATION SERVICES (U.S. CLS. 100 AND 105).
SONYA STEPHENS, EXAMINING ATTORNEY

SN 77-372,490. HARVEY GULF INTERNATIONAL MARINE, INC., HARVEY, LA. FILED 1-15-2008.

SN 77-411,372. GENESIS LEASE LIMITED, WESTPARK, SHANNON, IRELAND, FILED 3-3-2008.



NO CLAIM IS MADE TO THE EXCLUSIVE RIGHT TO USE "INTERNATIONAL MARINE, INC.", APART FROM THE MARK AS SHOWN.

FOR TRANSPORT BROKERAGE, NAMELY, MARINE TRANSPORTATION BROKERING (U.S. CLS. 100 AND 105).

FIRST USE 4-0-1975; IN COMMERCE 4-0-1975.
TINA BROWN, EXAMINING ATTORNEY



NO CLAIM IS MADE TO THE EXCLUSIVE RIGHT TO USE "LEASE LIMITED", APART FROM THE MARK AS SHOWN.

THE COLOR(S) GREEN AND GRAY IS/ARE CLAIMED AS A FEATURE OF THE MARK.

THE MARK CONSISTS OF A DESIGN COMPOSED OF THREE TRIANGLES WITH TWO TRIANGLES IN GREEN AND THE CENTER TRIANGLE IN GRAY ABOVE THE WORDS "GENESIS LEASE" IN GREEN ABOVE THE WORD "LIMITED" IN GRAY.

FOR LEASING OF AIRPLANES (U.S. CLS. 100 AND 105).

FIRST USE 12-19-2006; IN COMMERCE 12-19-2006.
CHRISTINE BLOMQUIST, EXAMINING ATTORNEY

CLASS 39—(Continued).

SN 77-420,365. RENO-TAHOE AIRPORT AUTHORITY, DBA RENO-TAHOE INTERNATIONAL AIRPORT, RENO, NV. FILED 3-12-2008.

PARK TO TRAVEL

THE MARK CONSISTS OF STANDARD CHARACTERS WITHOUT CLAIM TO ANY PARTICULAR FONT, STYLE, SIZE, OR COLOR.

NO CLAIM IS MADE TO THE EXCLUSIVE RIGHT TO USE "PARK", APART FROM THE MARK AS SHOWN.

FOR PARKING LOT AND PARKING GARAGE SERVICES FOR PARKING VEHICLES ADJACENT TO AIRPORTS; TRANSPORTATION OF PASSENGERS AND PASSENGERS' LUGGAGE BY BUS, VAN, LIMOUSINE, SHUTTLE BUS, AND AUTOMOBILE (U.S. CLS. 100 AND 105).

JIM RINGLE, EXAMINING ATTORNEY

SN 77-423,488. LIKE A LOCAL, LLC, MIAMI, FL. FILED 3-17-2008.



THE COLOR(S) BLACK, PINK, YELLOW, BLUE IS/ARE CLAIMED AS A FEATURE OF THE MARK.

THE MARK CONSISTS OF THE BACKDROP OF THE COMPANY LOGO IS THE BLACK SILHOUETTE OF THE DOWNTOWN MIAMI BUILDINGS, ALSO KNOWN AS THE MIAMI SKYLINE. ALONG THE BOTTOM ARE THE WORDS "PARTY LIKE A LOCAL". UNDER THE WORDS "PARTY LIKE A LOCAL" IS THE REFLECTION THOSE SAME WORDS, APPEARING UPSIDE DOWN. THE LETTER FONT FOR THE TEXT, AND THE REFLECTION, CONSISTS OF A SERIES OF DOTS. THE WORD "PARTY" APPEARS IN THE COLOR PINK, THE WORD "LIKE" APPEARS IN THE COLOR YELLOW, THE WORD "A" APPEARS IN THE COLOR BLUE, THE WORD "LOCAL" APPEARS IN THE COLOR PINK. IN THE REFLECTION PART OF THE LOGO, ALL WORDS APPEAR IN THE COLOR BLUE. ADDITIONALLY, THE LETTER "E" IS STYLIZED. THE LEFT PART OF THE LETTER "E" IN THE WORD "LIKE" IS CONTINUED UPWARD, ALONG THE FRONT OF THE LOGO, USING THE SAME DOTTED FONT, THE UPWARD PART OF THE STYLIZED LETTER ENDS AT THE TIP OF THE ANTENNA OF ONE OF THE BUILDINGS ON THE SKYLINE SILHOUETTE.

FOR ARRANGING AND COORDINATING TRAVEL ARRANGEMENTS FOR INDIVIDUALS AND GROUPS, NAMELY, DESTINATIONS STAYS, HONEYMOONS, FAMILY VACATIONS, AND DESTINATION WEDDINGS; COORDINATING TRAVEL ARRANGEMENTS FOR INDIVIDUALS AND FOR GROUPS; PROVISION OF TRAVEL INFORMATION; RESERVATION AND BOOKING OF SEATS FOR TRAVEL; TRAVEL PLANNING FOR INDIVIDUALS, FAMILIES, AND GROUPS FOR SPECIAL OCCASIONS SUCH AS DESTINATION WEDDINGS AND HONEYMOONS; TRAVEL COURIER AND TRAVEL GUIDE SERVICES; TRAVEL GUIDE AND TRAVEL INFORMATION SERVICES; TRAVEL GUIDE SERVICES; TRAVEL INFORMATION SERVICES; TRAVEL INFORMATION SERVICES, NAMELY, PROVIDING A WEB SITE THAT NOTIFIES PEOPLE WHEN SOMEONE IS DUE BACK FROM A TRIP BUT HAS NOT YET ARRIVED; TRAVEL, EXCURSION AND CRUISE ARRANGEMENT; ESCORTING TRAVELLERS; ORGANIZATION OF TRAVEL; ORGANIZATION OF

CLASS 39—(Continued).

EXCURSIONS, SIGHTSEEING TOURS, HOLIDAYS, TOURS AND TRAVEL; ORGANIZATION OF TRAVEL AND BOAT TRIPS; PROVIDING AN ON-LINE COMPUTER DATABASE IN THE FIELD OF TRAVEL INFORMATION SERVICES; PROVIDING AUTOMATED CHECK-IN AND TICKETING SERVICES FOR AIR TRAVELERS; PROVIDING INFORMATION, NEWS AND COMMENTARY IN THE FIELD OF TRAVEL; PROVIDING LINKS TO WEB SITES OF OTHERS FEATURING TRAVEL; PROVIDING REVIEWS OF TRAVEL SERVICE PROVIDERS; TRANSPORT OF TRAVELLERS; TRANSPORTATION OF GOODS, PASSENGERS AND TRAVELLERS BY AIR; TRAVEL AGENCY SERVICES, NAMELY, MAKING RESERVATIONS AND BOOKINGS FOR TRANSPORTATION; TRAVEL AGENCY SERVICES, NAMELY, MAKING RESERVATIONS AND BOOKINGS FOR TRANSPORTATION FOR DOGS; TRAVEL AND TOUR INFORMATION SERVICE; TRAVEL AND TOUR TICKET RESERVATION SERVICE; TRAVEL BOOKING AGENCIES; TRAVEL CLUBS; ARRANGING FOR TRAVEL VISAS, PASSPORTS AND TRAVEL DOCUMENTS FOR PERSONS TRAVELING ABROAD; ARRANGING TRAVEL TOURS; ARRANGING TRAVEL TOURS AS A BONUS PROGRAM FOR CREDIT CARDS CUSTOMERS; BOOKING OF SEATS FOR TRAVEL (U.S. CLS. 100 AND 105).

FIRST USE 3-1-2008; IN COMMERCE 3-1-2008.
BARBARA GAYNOR, EXAMINING ATTORNEY

SN 77-425,551. RIDERPLANET, RENO, NV. FILED 3-18-2008.

RiderPlanet

THE MARK CONSISTS OF STANDARD CHARACTERS WITHOUT CLAIM TO ANY PARTICULAR FONT, STYLE, SIZE, OR COLOR.

FOR PROVIDING A WEB SITE AND WEB SITE LINKS TO GEOGRAPHIC INFORMATION, MAP IMAGES, AND TRIP ROUTING; PROVIDING AN ON-LINE COMPUTER DATABASE IN THE FIELD OF TRAVEL INFORMATION SERVICES (U.S. CLS. 100 AND 105).

FIRST USE 7-1-2002; IN COMMERCE 8-5-2002.
ASMAT KHAN, EXAMINING ATTORNEY

SN 77-427,877. FOX SHIPPING, LLC, CARPENTERSVILLE, IL. FILED 3-20-2008.

WE PACK AND SHIP FOR LESS.

THE MARK CONSISTS OF STANDARD CHARACTERS WITHOUT CLAIM TO ANY PARTICULAR FONT, STYLE, SIZE, OR COLOR.

FOR ARRANGING FOR TRAVEL VISAS, PASSPORTS AND TRAVEL DOCUMENTS FOR PERSONS TRAVELING ABROAD; MAIL BOX RENTAL; POSTAL SERVICES, NAMELY, PARCEL DELIVERY, PACKAGING ARTICLES FOR TRANSPORTATION, RENTAL OF MAIL BOXES; SHIPPING AND DELIVERY SERVICES, NAMELY, PICKUP, TRANSPORTATION, AND DELIVERY OF PACKAGES AND LETTERS BY VARIOUS MODES OF TRANSPORTATION (U.S. CLS. 100 AND 105).

TAMARA FRAZIER, EXAMINING ATTORNEY

CLASS 39—(Continued).

SN 77-429,329. 911 AIR CARGO, INC., DENTON, TX. FILED 3-24-2008.

BEYOND DOOR-TO-DOOR

THE MARK CONSISTS OF STANDARD CHARACTERS WITHOUT CLAIM TO ANY PARTICULAR FONT, STYLE, SIZE, OR COLOR.

FOR AIRCRAFT CHARTER TRANSPORT BROKERING SERVICES AND GOODS DELIVERY SERVICES (U.S. CLS. 100 AND 105).

JOHN WILKE, EXAMINING ATTORNEY

SN 77-429,484. WO NELLY! STORAGE, LLC, PUNTA GORDA, FL. FILED 3-24-2008.



NO CLAIM IS MADE TO THE EXCLUSIVE RIGHT TO USE "STORAGE", APART FROM THE MARK AS SHOWN.

THE STIPPLING IS FOR SHADING PURPOSES ONLY.

THE MARK CONSISTS OF THE STYLIZED TEXT "WO NELLY! STORAGE". THERE IS AN IMAGE OF A SPIRITED HORSE BETWEEN "WO" AND "NELLY".

FOR BOAT STORAGE; PROVIDING SELF-STORAGE FACILITIES FOR OTHERS; RENTAL OF MAIL BOXES; RENTAL OF MOVING EQUIPMENT, NAMELY, PADS, STRAPS, HITCHES, DOLLIES, BOXES, CARRIERS, AND HAND TRUCKS; RENTAL OF MOVING VANS; RENTAL OF PARKING SPACES; RENTAL OF STORAGE CONTAINERS; RENTAL OF VEHICLES; RENTAL OF WAREHOUSE SPACE; TRUCK AND TRAILER RENTAL (U.S. CLS. 100 AND 105).

FIRST USE 10-1-2007; IN COMMERCE 10-1-2007.

AMOS T. MATTHEWS, JR., EXAMINING ATTORNEY

SN 77-429,819. TAYLOR, CATHY ANN, SAUSALITO, CA. FILED 3-24-2008.

CATTARA ADVENTURES WITH INSIGHT

THE MARK CONSISTS OF STANDARD CHARACTERS WITHOUT CLAIM TO ANY PARTICULAR FONT, STYLE, SIZE, OR COLOR.

NO CLAIM IS MADE TO THE EXCLUSIVE RIGHT TO USE "ADVENTURES", APART FROM THE MARK AS SHOWN.

FOR ORGANIZING AND ARRANGING TRAVEL TOURS (U.S. CLS. 100 AND 105).

FIRST USE 1-0-2008; IN COMMERCE 1-0-2008.

TINA BROWN, EXAMINING ATTORNEY

CLASS 39—(Continued).

SN 77-430,479. JACK HENRY SOFTWARE/COMMLINK, L.P., MONETT, MO. FILED 3-25-2008.

JVAULT

THE MARK CONSISTS OF STANDARD CHARACTERS WITHOUT CLAIM TO ANY PARTICULAR FONT, STYLE, SIZE, OR COLOR.

FOR STORAGE SERVICES FOR ARCHIVING DATABASES, IMAGES AND OTHER ELECTRONIC DATA (U.S. CLS. 100 AND 105).

KATHERINE M. DUBRAY, EXAMINING ATTORNEY

SN 77-430,937. STUDIO360, INC., DBA DESTINATION360, SEATTLE, WA. FILED 3-25-2008.

Destination360

THE MARK CONSISTS OF STANDARD CHARACTERS WITHOUT CLAIM TO ANY PARTICULAR FONT, STYLE, SIZE, OR COLOR.

FOR PROVIDING AUTOMATED CHECK-IN AND TICKETING SERVICES FOR AIR TRAVELERS; PROVIDING INFORMATION, NEWS AND COMMENTARY IN THE FIELD OF TRAVEL; PROVISION OF TRAVEL INFORMATION; RESERVATION AND BOOKING OF SEATS FOR TRAVEL; TRAVEL AND TOUR INFORMATION SERVICE; TRAVEL AND TOUR TICKET RESERVATION SERVICE; ARRANGING TRAVEL TOURS AS A BONUS PROGRAM FOR CREDIT CARDS CUSTOMERS; BOOKING OF SEATS FOR TRAVEL; TRAVEL GUIDE AND TRAVEL INFORMATION SERVICES; TRAVEL INFORMATION; TRAVEL INFORMATION SERVICES; TRAVEL, EXCURSION AND CRUISE ARRANGEMENT (U.S. CLS. 100 AND 105).

FIRST USE 1-1-2001; IN COMMERCE 1-1-2001.

ANTHONY RINKER, EXAMINING ATTORNEY

SN 77-431,822. TORBERT, JASON, SAN DIEGO, CA. FILED 3-26-2008.

busy or not

THE MARK CONSISTS OF STANDARD CHARACTERS WITHOUT CLAIM TO ANY PARTICULAR FONT, STYLE, SIZE, OR COLOR.

FOR PROVIDING AN ON-LINE COMPUTER DATABASE IN THE FIELD OF TRAVEL INFORMATION SERVICES (U.S. CLS. 100 AND 105).

SONYA STEPHENS, EXAMINING ATTORNEY

CLASS 39—(Continued).

SN 77-434,743. HERGET, JAMES, FREMONT, CA. FILED 3-28-2008.

Balloonytoons

THE MARK CONSISTS OF STANDARD CHARACTERS WITHOUT CLAIM TO ANY PARTICULAR FONT, STYLE, SIZE, OR COLOR.

FOR DELIVERY OF GOODS AND MESSAGES ACCOMPANIED BY BALLOONS AND/OR NOVELTY PRESENTATIONS (U.S. CLS. 100 AND 105).

FIRST USE 12-1-2007; IN COMMERCE 12-1-2007.
STEVEN JACKSON, EXAMINING ATTORNEY

SN 77-454,470. AUTO EUROPE, LLC, PORTLAND, ME. FILED 4-22-2008.



OWNER OF U.S. REG. NOS. 2,827,877, 3,176,876 AND OTHERS.

THE MARK CONSISTS OF A FANCIFUL DEPICTION OF THE LETTERS "AE" WITHIN A CIRCLE.

FOR TRAVEL AGENCY SERVICES, NAMELY, MAKING RESERVATIONS AND BOOKINGS FOR TRANSPORTATION; CAR RENTAL (U.S. CLS. 100 AND 105).

FIRST USE 1-1-1961; IN COMMERCE 1-1-1961.
ANDREA SAUNDERS, EXAMINING ATTORNEY

CLASS 39—(Continued).

SN 77-465,477. ACCESS USA SHIPPING, INC., DBA FKA GAIL BAIRD & ASSOCIATES, INC., BRADENTON, FL. FILED 5-5-2008.

MyUS Shopper

THE MARK CONSISTS OF STANDARD CHARACTERS WITHOUT CLAIM TO ANY PARTICULAR FONT, STYLE, SIZE, OR COLOR.

NO CLAIM IS MADE TO THE EXCLUSIVE RIGHT TO USE "SHOPPER", APART FROM THE MARK AS SHOWN.

FOR SUPPLY CHAIN, LOGISTICS AND REVERSE LOGISTICS SERVICES, NAMELY, STORAGE, TRANSPORTATION AND DELIVERY OF DOCUMENTS, PACKAGES, RAW MATERIALS, AND OTHER FREIGHT FOR OTHERS BY AIR, RAIL, SHIP OR TRUCK (U.S. CLS. 100 AND 105).

FIRST USE 5-5-2008; IN COMMERCE 5-5-2008.
SUNG IN, EXAMINING ATTORNEY

SN 79-042,604. THIRSTY SWAGMAN PTY LTD, AUSTRALIA, FILED 7-19-2007.

THIRSTY SWAGMAN

THE MARK CONSISTS OF STANDARD CHARACTERS WITHOUT CLAIM TO ANY PARTICULAR FONT, STYLE, SIZE, OR COLOR.

PRIORITY DATE OF 1-25-2007 IS CLAIMED.

OWNER OF INTERNATIONAL REGISTRATION 0934455 DATED 7-19-2007. EXPIRES 7-19-2017.

FOR TOURISM SERVICES, NAMELY, ARRANGING TRAVEL TOURS; ARRANGING AND CONDUCTING TRAVEL TOURS; TRANSPORTATION OF TRAVELLERS BY BUS, AIR, RAIL AND BOAT; ESCORTING OF TRAVELLERS, NAMELY, TOUR ESCORTING; TRAVEL RESERVATIONS, NAMELY, TRAVEL AND TOUR TICKETS RESERVATION SERVICE; AND TRAVEL AGENCY SERVICES, NAMELY, MAKING RESERVATIONS AND BOOKINGS FOR TRANSPORTATION (U.S. CLS. 100 AND 105).

BENJAMIN OKEKE, EXAMINING ATTORNEY

CLASS 40—MATERIAL TREATMENT

SN 76-676,647. BERNHARD WOODWORK LTD., NORTH-BROOK, IL. FILED 5-10-2007.

BERNHARD WOODWORK LTD.

THE MARK CONSISTS OF STANDARD CHARACTERS WITHOUT CLAIM TO ANY PARTICULAR FONT, STYLE, SIZE, OR COLOR.

NO CLAIM IS MADE TO THE EXCLUSIVE RIGHT TO USE "WOODWORK LTD.", APART FROM THE MARK AS SHOWN.

FOR CUSTOM MANUFACTURE OF ARCHITECTURAL WOODWORK, CASEWORK, MILLWORK AND STORE FIXTURES FOR THE RESIDENTIAL, COMMERCIAL, AND RETAIL MARKETS (U.S. CLS. 100, 103 AND 106).

FIRST USE 9-1-1965; IN COMMERCE 9-1-1965.
DAVID TAYLOR, EXAMINING ATTORNEY

CLASS 40—(Continued).

SN 76-683,161. ANHUI YINGLIU ELECTROMECHANICAL INC., HEFEI ECON & TECH DEVELOPMENT ZONE ANHUI, CHINA, FILED 10-22-2007.

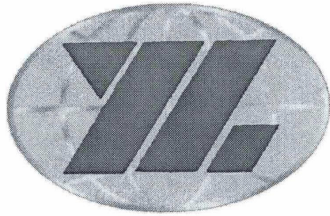

THE MARK CONSISTS IN PART OF A STYLIZED CAPITAL YL

FOR MANUFACTURE OF CASTINGS OF VALVES, PUMPS, METERS, RAILWAY, AUTOS, MINING AND CONSTRUCTION TOOLS AND MACHINERY IN CARBON STEEL, ALLOY STEEL, STAINLESS STEEL AND CUSTOMIZED STEEL TO THE ORDER AND/OR SPECIFICATION OF OTHERS; MACHINING SERVICES FOR OTHERS, NAMELY, MACHINING OF CASTINGS OF VALVES, PUMPS, METERS, RAILWAY, AUTOS, MINING AND CONSTRUCTION TOOLS AND MACHINERY IN CARBON STEEL, ALLOY STEEL, STAINLESS STEEL AND CUSTOMIZED STEEL (U.S. CLS. 100, 103 AND 106).

FIRST USE 3-1-2004; IN COMMERCE 3-1-2004.
PRISCILLA MILTON, EXAMINING ATTORNEY

SN 76-685,519. BILCARE, INC., PHOENIXVILLE, PA. FILED 1-4-2008.

SERVICE AND QUALITY BEYOND COMPLIANCE

THE MARK CONSISTS OF STANDARD CHARACTERS WITHOUT CLAIM TO ANY PARTICULAR FONT, STYLE, SIZE, OR COLOR.

NO CLAIM IS MADE TO THE EXCLUSIVE RIGHT TO USE "SERVICE AND QUALITY" AND "COMPLIANCE", APART FROM THE MARK AS SHOWN.

FOR MANUFACTURE OF PHARMACEUTICALS TO THE ORDER AND SPECIFICATION OF OTHERS; CUSTOM MANUFACTURE SERVICES, NAMELY, THE FORMULATION OF PHARMACEUTICALS FOR OTHERS; AND DESTRUCTION OF RETURNED SUPPLIES OF MEDICINES AND PHARMACEUTICALS IN CLINICAL STUDIES (U.S. CLS. 100, 103 AND 106).

JIM RINGLE, EXAMINING ATTORNEY

CLASS 40—(Continued).

SN 76-685,719. BILCARE, INC., PHOENIXVILLE, PA. FILED 1-11-2008.

CLIENT DELIGHT

THE MARK CONSISTS OF STANDARD CHARACTERS WITHOUT CLAIM TO ANY PARTICULAR FONT, STYLE, SIZE, OR COLOR.

NO CLAIM IS MADE TO THE EXCLUSIVE RIGHT TO USE "CLIENT", APART FROM THE MARK AS SHOWN.

FOR MANUFACTURE OF PHARMACEUTICALS TO THE ORDER AND SPECIFICATIONS OF OTHERS; CUSTOM MANUFACTURE SERVICES, NAMELY, THE FORMULATION OF PHARMACEUTICALS FOR OTHERS; AND DESTRUCTION OF RETURNED SUPPLIES OF MEDICINES AND PHARMACEUTICALS IN CLINICAL STUDIES (U.S. CLS. 100, 103 AND 106).

JIM RINGLE, EXAMINING ATTORNEY

SN 76-687,674. THERMAL TECHNOLOGY SERVICES, INC., LARGO, FL. FILED 3-13-2008.

THERMAL BALANCE

THE MARK CONSISTS OF STANDARD CHARACTERS WITHOUT CLAIM TO ANY PARTICULAR FONT, STYLE, SIZE, OR COLOR.

NO CLAIM IS MADE TO THE EXCLUSIVE RIGHT TO USE "THERMAL", APART FROM THE MARK AS SHOWN.

FOR CRYOGENIC TREATMENT OF METAL GOODS, NAMELY, BRAKE DRUMS, ROTORS AND BRAKE PARTS, FORMED METAL PARTS INCLUDING CYLINDERS, FIREARM PARTS, CUTTING BLADES INCLUDING MOWER BLADES AND EDGING BLADES, SPORTING GOODS INCLUDING GOLF CLUBS, BASEBALL BATS, TENNIS STRINGS, ENGINE COMPONENTS, JET ENGINE PARTS (U.S. CLS. 100, 103 AND 106).

FIRST USE 3-21-2007; IN COMMERCE 3-21-2007.
CHRISTOPHER BUONGIORNO, EXAMINING ATTORNEY

SN 77-041,403. OWENS INDUSTRIES, INC., DBA LINCOLN STRUCTURAL SOLUTIONS, LINCOLN, NE. FILED 11-10-2006.

LINCOLN STRUCTURAL SOLUTIONS

THE MARK CONSISTS OF STANDARD CHARACTERS WITHOUT CLAIM TO ANY PARTICULAR FONT, STYLE, SIZE, OR COLOR.

OWNER OF U.S. REG. NO. 2,542,298.

NO CLAIM IS MADE TO THE EXCLUSIVE RIGHT TO USE "STRUCTURAL", APART FROM THE MARK AS SHOWN.

FOR CUSTOM MANUFACTURING SERVICES, NAMELY, CUSTOM NUCLEAR GRADE STEEL MACHINING AND FABRICATION TO THE ORDER AND SPECIFICATION OF OTHERS (U.S. CLS. 100, 103 AND 106).

JENNIFER VASQUEZ, EXAMINING ATTORNEY

CLASS 40—(Continued).

SN 77-287,555. HARPER, BENJAMIN C, CARRBORO, NC. FILED 9-24-2007.

CLASS 40—(Continued).

SN 77-349,390. FUSION FORMULATIONS, INC., PHOENIX, AZ. FILED 12-11-2007.

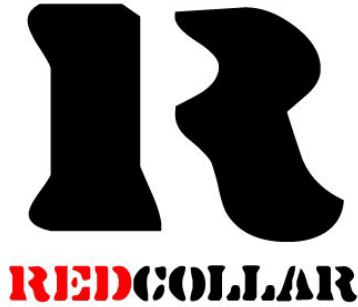

THE COLOR(S) RED, BLACK IS/ARE CLAIMED AS A FEATURE OF THE MARK.

THE MARK CONSISTS OF A LARGE LETTER "R" IN THE COLOR BLACK, THE WORD "RED" IN RED LETTERS AND THE WORD "COLLAR" IN BLACK LETTERS.

FOR IMPRINTING MESSAGES ON WEARING APPAREL, ACCESSORIES AND MUGS (U.S. CLS. 100, 103 AND 106).

MARK RADEMACHER, EXAMINING ATTORNEY

FUSION FORMULATIONS

THE MARK CONSISTS OF STANDARD CHARACTERS WITHOUT CLAIM TO ANY PARTICULAR FONT, STYLE, SIZE, OR COLOR.

NO CLAIM IS MADE TO THE EXCLUSIVE RIGHT TO USE "FORMULATIONS", APART FROM THE MARK AS SHOWN.

FOR CUSTOM MANUFACTURING OF DIETARY SUPPLEMENTS (U.S. CLS. 100, 103 AND 106).

KATHY DE JONGE, EXAMINING ATTORNEY

SN 77-301,890. JOSTENS, INC., MINNEAPOLIS, MN. FILED 10-11-2007.

SN 77-356,014. GRAPHIC SOLUTIONS ADVERTISING, INC., KITTLY HAWK, NC. FILED 12-19-2007.

IMAGE SCAN BY JOSTENS

MYPRINTPLUS

THE MARK CONSISTS OF STANDARD CHARACTERS WITHOUT CLAIM TO ANY PARTICULAR FONT, STYLE, SIZE, OR COLOR.

NO CLAIM IS MADE TO THE EXCLUSIVE RIGHT TO USE "IMAGE SCAN", APART FROM THE MARK AS SHOWN.

FOR ELECTRONIC DIGITIZING OF PHOTOGRAPHS INTO A COMPUTER READABLE MEDIA (U.S. CLS. 100, 103 AND 106).

MICHAEL LEWIS, EXAMINING ATTORNEY

THE MARK CONSISTS OF STANDARD CHARACTERS WITHOUT CLAIM TO ANY PARTICULAR FONT, STYLE, SIZE, OR COLOR.

FOR PRINTING SERVICES; DESIGN PRINTING FOR OTHERS (U.S. CLS. 100, 103 AND 106).

FIRST USE 12-20-2001; IN COMMERCE 12-20-2001.

MICHAEL KEATING, EXAMINING ATTORNEY

CLASS 40—(Continued).

SN 77-371,622. ARCHER, ROB D., SAN BRUNO, CA. FILED 1-14-2008.

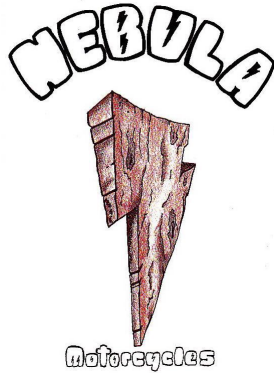

NO CLAIM IS MADE TO THE EXCLUSIVE RIGHT TO USE "MOTORCYCLES", APART FROM THE MARK AS SHOWN.

THE COLOR(S) BROWN, BLACK, AND WHITE IS/ARE CLAIMED AS A FEATURE OF THE MARK.

THE MARK CONSISTS OF A BROWN, BLACK, AND WHITE THREE DIMENSIONAL LIGHTNING BOLT, WITH STYLIZED BLACK AND WHITE WORDING "NEBULA MOTORCYCLES" WITH SMALL BLACK LIGHTNING BOLTS INSIDE THE LETTERS.

FOR CUSTOM BUILDING OF MOTORCYCLES (U.S. CLS. 100, 103 AND 106).

TEJBIR SINGH, EXAMINING ATTORNEY

CLASS 40—(Continued).

SN 77-398,814. ANTIQUE & SALVAGE LIQUIDATORS, INC., DBA ASL RECYCLING, SAN JOSE, CA. FILED 2-15-2008.



NO CLAIM IS MADE TO THE EXCLUSIVE RIGHT TO USE "RECYCLING", APART FROM THE MARK AS SHOWN.

THE MARK CONSISTS OF AN OPEN CIRCULAR DESIGN TO THE LEFT OF THE LETTERS "ASL" ABOVE THE WORD "RECYCLING".

FOR RECYCLING SERVICES, NAMELY RECYCLING OF ELECTRONIC WASTE (U.S. CLS. 100, 103 AND 106).

STEVEN R. FOSTER, EXAMINING ATTORNEY

SN 77-406,768. MADIGAN, SHAWNA C, PASO ROBLES, CA. FILED 2-26-2008.

805 Wine Company

THE MARK CONSISTS OF STANDARD CHARACTERS WITHOUT CLAIM TO ANY PARTICULAR FONT, STYLE, SIZE, OR COLOR.

NO CLAIM IS MADE TO THE EXCLUSIVE RIGHT TO USE "WINE COMPANY", APART FROM THE MARK AS SHOWN.

THE MARK "805" HAS NO MEANING IN A FOREIGN LANGUAGE.

FOR WINERY SERVICES (U.S. CLS. 100, 103 AND 106). TRACY CROSS, EXAMINING ATTORNEY

SN 77-386,709. HAINES, JORDAN S., LAKEWOOD, WA. FILED 2-1-2008.

COINFORCE.COM

THE MARK CONSISTS OF STANDARD CHARACTERS WITHOUT CLAIM TO ANY PARTICULAR FONT, STYLE, SIZE, OR COLOR.

FOR CUSTOMIZED PRINTING OF COMPANY NAMES AND LOGOS FOR PROMOTIONAL AND ADVERTISING PURPOSES ON THE GOODS OF OTHERS (U.S. CLS. 100, 103 AND 106).

FIRST USE 10-28-2005; IN COMMERCE 10-28-2005.

JESSICA A. POWERS, EXAMINING ATTORNEY

SN 77-415,808. CAFFREY, SHELBY, STATEN ISLAND, NY. FILED 3-7-2008.



NO CLAIM IS MADE TO THE EXCLUSIVE RIGHT TO USE "BABY", APART FROM THE MARK AS SHOWN.

THE MARK CONSISTS OF AN IMAGE OF A DEVIL BABY. TO THE RIGHT OF THE IMAGE IS THE STYLIZED WORDS "THE DEVIL BABY". A DEVIL TAIL COMING OUT OF THE "Y" AND HORNS ON THE "A".

FOR CUSTOM CONSTRUCTION OF PICTURE BOOKS FOR CHILDREN; PRINTING OF BOOKS (U.S. CLS. 100, 103 AND 106).

FIRST USE 3-2-2008; IN COMMERCE 3-2-2008.

B. PARADEWELAI, EXAMINING ATTORNEY

CLASS 40—(Continued).

SN 77-419,477. DOUGLAS VICTOR CHAPMAN, OCEANSIDE, CA. FILED 3-12-2008.

HotDoggie.com

THE MARK CONSISTS OF STANDARD CHARACTERS WITHOUT CLAIM TO ANY PARTICULAR FONT, STYLE, SIZE, OR COLOR.

FOR IMPRINTING MESSAGES ON T-SHIRTS (U.S. CLS. 100, 103 AND 106).

STEVEN PEREZ, EXAMINING ATTORNEY

CLASS 40—(Continued).

SN 77-429,045. SHE SEZ HOLDINGS CORPORATION, LOGANVILLE, GA. FILED 3-23-2008.

Robbie-Q

THE MARK CONSISTS OF STANDARD CHARACTERS WITHOUT CLAIM TO ANY PARTICULAR FONT, STYLE, SIZE, OR COLOR.

FOR CUSTOM FLAVORING OF SAUCES AND DRY SEASONINGS (U.S. CLS. 100, 103 AND 106).

RUDY R. SINGLETON, EXAMINING ATTORNEY

SN 77-427,227. GALLAGHER, GARELD LEE, DENVER, CO. FILED 3-20-2008.

TRANSOPROMOLIVE

THE MARK CONSISTS OF STANDARD CHARACTERS WITHOUT CLAIM TO ANY PARTICULAR FONT, STYLE, SIZE, OR COLOR.

FOR PRINTING (U.S. CLS. 100, 103 AND 106).

MATTHEW PAPPAS, EXAMINING ATTORNEY

SN 77-430,522. JACKSON, KEITH EDWARD, EAST BERLIN, PA. FILED 3-25-2008.

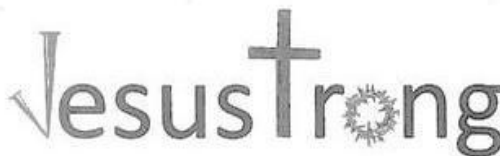

FOR IMPRINTING MESSAGES ON T-SHIRTS (U.S. CLS. 100, 103 AND 106).

MARCIE MILONE, EXAMINING ATTORNEY

SN 77-428,957. LUKAS INVESTMENTS LLC, DBA SHRED-MAX, WATERFORD, MI. FILED 3-22-2008.

SHRED-MAX

THE MARK CONSISTS OF STANDARD CHARACTERS WITHOUT CLAIM TO ANY PARTICULAR FONT, STYLE, SIZE, OR COLOR.

FOR DOCUMENT DESTRUCTION; DOCUMENT SHREDDING SERVICES (U.S. CLS. 100, 103 AND 106).

FIRST USE 11-20-2007; IN COMMERCE 1-1-2008.

KARANENDRA S. CHHINA, EXAMINING ATTORNEY

SN 77-430,654. COFFEE MATTERS, BROOKLYN PARK, MN. FILED 3-25-2008.

Coffee Matters, What's Your Coffee?

THE MARK CONSISTS OF STANDARD CHARACTERS WITHOUT CLAIM TO ANY PARTICULAR FONT, STYLE, SIZE, OR COLOR.

FOR IMPRINTING MESSAGES ON WEARING APPAREL, ACCESSORIES AND MUGS (U.S. CLS. 100, 103 AND 106).

JASON TURNER, EXAMINING ATTORNEY

CLASS 40—(Continued).

SN 77-430,662. SIGMATRON INTERNATIONAL, INC., ELK GROVE VILLAGE, IL. FILED 3-25-2008.

SIGMATRON

THE MARK CONSISTS OF STANDARD CHARACTERS WITHOUT CLAIM TO ANY PARTICULAR FONT, STYLE, SIZE, OR COLOR.

FOR CUSTOM MANUFACTURING OF ELECTRONIC COMPONENTS, PRINTED CIRCUIT BOARD ASSEMBLIES AND TURNKEY ELECTRONIC PRODUCTS TO THE ORDER AND/OR SPECIFICATIONS OF OTHERS (U.S. CLS. 100, 103 AND 106).

FIRST USE 5-12-1987; IN COMMERCE 5-12-1987.
ANDREA HACK, EXAMINING ATTORNEY

CLASS 40—(Continued).

SN 77-432,406. CASELLA WASTE SYSTEMS, INC., RUTLAND, VT. FILED 3-26-2008.

THINK SMART

THE MARK CONSISTS OF STANDARD CHARACTERS WITHOUT CLAIM TO ANY PARTICULAR FONT, STYLE, SIZE, OR COLOR.

FOR WASTE MANAGEMENT SERVICES, WASTE TREATMENT SERVICES, WASTE PROCESSING, COMPOSTING AND RECYCLING; GREEN POWER GENERATION SERVICES; CONSULTING SERVICES IN THE FIELD OF WASTE RECYCLING AND MANAGEMENT (U.S. CLS. 100, 103 AND 106).

KATHERINE STOIDES, EXAMINING ATTORNEY

SN 77-431,748. BIO-CAM, LC, WEST PALM BEACH, FL. FILED 3-26-2008.

SmileSecret

THE MARK CONSISTS OF STANDARD CHARACTERS WITHOUT CLAIM TO ANY PARTICULAR FONT, STYLE, SIZE, OR COLOR.

FOR CUSTOM MANUFACTURE OF DENTAL PROSTHETICS (U.S. CLS. 100, 103 AND 106).

FIRST USE 1-11-2008; IN COMMERCE 1-11-2008.
LANA PHAM, EXAMINING ATTORNEY

SN 77-433,017. COOPER STANDARD AUTOMOTIVE, AUBURN HILLS, MI. FILED 3-27-2008.

POSIBOND

THE MARK CONSISTS OF STANDARD CHARACTERS WITHOUT CLAIM TO ANY PARTICULAR FONT, STYLE, SIZE, OR COLOR.

OWNER OF U.S. REG. NO. 3,291,497.
FOR MANUFACTURING FUEL LINE ASSEMBLIES AND COMPONENTS, NAMELY, CONNECTORS, FOR OTHERS (U.S. CLS. 100, 103 AND 106).

WANDA KAY PRICE, EXAMINING ATTORNEY

SN 77-431,809. DESIGNS BY BG, INC., BIRMINGHAM, AL. FILED 3-26-2008.

poop buster

THE MARK CONSISTS OF STANDARD CHARACTERS WITHOUT CLAIM TO ANY PARTICULAR FONT, STYLE, SIZE, OR COLOR.

FOR EMBROIDERY (U.S. CLS. 100, 103 AND 106).
SONYA STEPHENS, EXAMINING ATTORNEY

SN 77-433,257. SPECTOR, JASON, FISHERS, IN. FILED 3-27-2008.

DO THE SHOE

THE MARK CONSISTS OF STANDARD CHARACTERS WITHOUT CLAIM TO ANY PARTICULAR FONT, STYLE, SIZE, OR COLOR.

FOR IMPRINTING MESSAGES ON WEARING APPAREL, ACCESSORIES AND MUGS (U.S. CLS. 100, 103 AND 106).

NORA BUCHANAN WILL, EXAMINING ATTORNEY

CLASS 40—(Continued).

SN 77-441,398. CROWN PACKAGING TECHNOLOGY, INC., ALSIP, IL. FILED 4-7-2008.

APUS

THE MARK CONSISTS OF STANDARD CHARACTERS WITHOUT CLAIM TO ANY PARTICULAR FONT, STYLE, SIZE, OR COLOR.

FOR DIGITAL PRINTING ON METAL CANS AND CONTAINERS FOR OTHERS (U.S. CLS. 100, 103 AND 106).

SUNG IN, EXAMINING ATTORNEY

SN 77-450,850. DISNEY ENTERPRISES, INC., BURBANK, CA. FILED 4-17-2008.

PHOTOTALES

THE MARK CONSISTS OF STANDARD CHARACTERS WITHOUT CLAIM TO ANY PARTICULAR FONT, STYLE, SIZE, OR COLOR.

FOR ON-DEMAND PRINTING SERVICES FOR PHOTOGRAPHS (U.S. CLS. 100, 103 AND 106).

DANNEAN HETZEL, EXAMINING ATTORNEY

SN 77-459,575. OUTHERE SMARTWEAR, INC., LAKE WORTH, FL. FILED 4-28-2008.

Allwoods Conceal

THE MARK CONSISTS OF STANDARD CHARACTERS WITHOUT CLAIM TO ANY PARTICULAR FONT, STYLE, SIZE, OR COLOR.

NO CLAIM IS MADE TO THE EXCLUSIVE RIGHT TO USE "ALLWOODS CONCEAL", APART FROM THE MARK AS SHOWN.

FOR PATTERN PRINTING (U.S. CLS. 100, 103 AND 106).

FIRST USE 3-31-2008; IN COMMERCE 4-28-2008.
RONALD AIKENS, EXAMINING ATTORNEY

CLASS 40—(Continued).

SN 77-471,825. MISSION PHARMACAL COMPANY, SAN ANTONIO, TX. FILED 5-12-2008.

PASSION STATEMENT

THE MARK CONSISTS OF STANDARD CHARACTERS WITHOUT CLAIM TO ANY PARTICULAR FONT, STYLE, SIZE, OR COLOR.

FOR MANUFACTURING SERVICES FOR OTHERS IN THE FIELD OF DIETARY SUPPLEMENTS AND PHARMACEUTICAL PREPARATIONS (U.S. CLS. 100, 103 AND 106).

JOHN GARTNER, EXAMINING ATTORNEY

SN 77-479,988. CASELLA WASTE SYSTEMS, INC., RUTLAND, VT. FILED 5-21-2008.

ZERO-SORT

THE MARK CONSISTS OF STANDARD CHARACTERS WITHOUT CLAIM TO ANY PARTICULAR FONT, STYLE, SIZE, OR COLOR.

FOR WASTE MANAGEMENT SERVICES, WASTE TREATMENT SERVICES, WASTE PROCESSING, COMPOSTING AND RECYCLING; GREEN POWER GENERATION SERVICES; CONSULTING SERVICES IN THE FIELD OF WASTE RECYCLING AND MANAGEMENT (U.S. CLS. 100, 103 AND 106).

KATHERINE STOIDES, EXAMINING ATTORNEY

CLASS 41—EDUCATION AND ENTERTAINMENT

SN 76-669,373. WESTCHESTER VIPERS HOCKEY ASSOCIATION, ELMSFORD, NY. FILED 11-22-2006.

WESTCHESTER VIPERS

THE MARK CONSISTS OF STANDARD CHARACTERS WITHOUT CLAIM TO ANY PARTICULAR FONT, STYLE, SIZE, OR COLOR.

NO CLAIM IS MADE TO THE EXCLUSIVE RIGHT TO USE "WESTCHESTER", APART FROM THE MARK AS SHOWN.

FOR ENTERTAINMENT IN THE NATURE OF ICE HOCKEY GAMES (U.S. CLS. 100, 101 AND 107).

FIRST USE 0-0-1999; IN COMMERCE 0-0-1999.
AMOS T. MATTHEWS, JR., EXAMINING ATTORNEY

CLASS 41—(Continued).

SN 76-672,784. HRT ROCKS, LLC, SHARON, MA. FILED 2-16-2007.

HRT

THE MARK CONSISTS OF STANDARD CHARACTERS WITHOUT CLAIM TO ANY PARTICULAR FONT, STYLE, SIZE, OR COLOR.

FOR ENTERTAINMENT IN THE NATURE OF VISUAL AND AUDIO PERFORMANCES RENDERED BY A VOCAL AND INSTRUMENTAL GROUP, MUSICAL BAND OR ROCK BAND (U.S. CLS. 100, 101 AND 107).

FIRST USE 5-13-2005; IN COMMERCE 9-1-2005.
JENNY PARK, EXAMINING ATTORNEY

CLASS 41—(Continued).

SN 76-681,440. DMTP PINAL HOLDINGS, L.L.C., TUCSON, AZ. FILED 9-4-2007.

DECADES MUSIC THEME PARK

THE MARK CONSISTS OF STANDARD CHARACTERS WITHOUT CLAIM TO ANY PARTICULAR FONT, STYLE, SIZE, OR COLOR.

NO CLAIM IS MADE TO THE EXCLUSIVE RIGHT TO USE "MUSIC THEME PARK", APART FROM THE MARK AS SHOWN.

FOR ENTERTAINMENT AND CULTURAL SERVICES, NAMELY, A HISTORICAL AMUSEMENT AND CULTURAL CENTER FEATURING MUSIC OF THE SECOND HALF OF THE TWENTIETH CENTURY (U.S. CLS. 100, 101 AND 107).

GEORGIA CARTY, EXAMINING ATTORNEY

SN 76-675,974. KWIBIT PRODUCTIONS LLC, SHERMAN OAKS, CA. FILED 4-25-2007.

KWIBIT

THE MARK CONSISTS OF STANDARD CHARACTERS WITHOUT CLAIM TO ANY PARTICULAR FONT, STYLE, SIZE, OR COLOR.

FOR PROVIDING ON-LINE COMPUTER GAMES, VIA A GLOBAL COMPUTER NETWORK, WHICH INVOLVES TALENT CONTESTANTS, TALENT CONTESTS, JUDGES FOR THE CONTESTS, AND AWARDING PRIZES TO BOTH THE CONTESTANTS AND THE JUDGES BASED ON GAME RULES (U.S. CLS. 100, 101 AND 107).

RUDY R. SINGLETON, EXAMINING ATTORNEY

SN 76-681,668. DMTP PINAL HOLDINGS, L.L.C., TUCSON, AZ. FILED 9-10-2007.

DECADES MUSIC

THE MARK CONSISTS OF STANDARD CHARACTERS WITHOUT CLAIM TO ANY PARTICULAR FONT, STYLE, SIZE, OR COLOR.

NO CLAIM IS MADE TO THE EXCLUSIVE RIGHT TO USE "MUSIC", APART FROM THE MARK AS SHOWN.

FOR ENTERTAINMENT AND CULTURAL SERVICES, NAMELY, A HISTORICAL AMUSEMENT AND CULTURAL CENTER FEATURING MUSIC OF THE SECOND HALF OF THE TWENTIETH CENTURY (U.S. CLS. 100, 101 AND 107).

GEORGIA CARTY, EXAMINING ATTORNEY

SN 76-677,783. ICFX, INC., FAIRFAX, CA. FILED 6-4-2007.

HIPPY GOURMET

THE MARK CONSISTS OF STANDARD CHARACTERS WITHOUT CLAIM TO ANY PARTICULAR FONT, STYLE, SIZE, OR COLOR.

NO CLAIM IS MADE TO THE EXCLUSIVE RIGHT TO USE "GOURMET", APART FROM THE MARK AS SHOWN.

FOR PUBLICATIONS, IN THE NATURE OF A NEWS-LETTER, FEATURING COOKING AND FOOD CONSUMPTION (U.S. CLS. 100, 101 AND 107).

FIRST USE 9-1-2000; IN COMMERCE 9-1-2000.
CAROLYN CATALDO, EXAMINING ATTORNEY

SN 76-685,010. BH SKATING PARKS LLC, ALAMEDA, CA. FILED 12-17-2007.

THE ICE GIRLS

THE MARK CONSISTS OF STANDARD CHARACTERS WITHOUT CLAIM TO ANY PARTICULAR FONT, STYLE, SIZE, OR COLOR.

NO CLAIM IS MADE TO THE EXCLUSIVE RIGHT TO USE "GIRLS", APART FROM THE MARK AS SHOWN.

FOR ENTERTAINMENT IN THE NATURE OF LIVE SHOW PERFORMANCES FEATURING YOUTH SKATERS (U.S. CLS. 100, 101 AND 107).

VERNA BETH RIRIE, EXAMINING ATTORNEY

CLASS 41—(Continued).

SN 76-687,721. COWBOY FAST DRAW ASSOCIATION, LLC, FERNLEY, NV. FILED 3-14-2008.

FASTEST GUN ALIVE

THE MARK CONSISTS OF STANDARD CHARACTERS WITHOUT CLAIM TO ANY PARTICULAR FONT, STYLE, SIZE, OR COLOR.

NO CLAIM IS MADE TO THE EXCLUSIVE RIGHT TO USE "FASTEST GUN", APART FROM THE MARK AS SHOWN.

FOR ENTERTAINMENT IN THE NATURE OF COMPETITIONS IN THE FIELD OF SHOOTING CONTESTS (U.S. CLS. 100, 101 AND 107).

FIRST USE 1-30-2008; IN COMMERCE 1-30-2008.
JOHN GARTNER, EXAMINING ATTORNEY

SN 76-687,729. PRESCOTT COLLEGE, INC., PRESCOTT, AZ. FILED 3-14-2008.

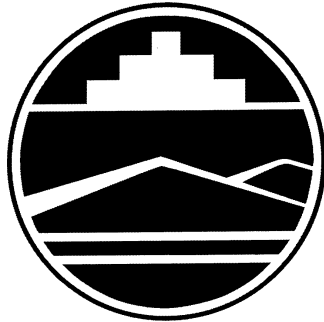

DESIGN OF LANDSCAPE, MOUNTAINS AND BUILDING WITHIN A CIRCLE

FOR EDUCATIONAL SERVICES, NAMELY, PROVIDING COURSES OF INSTRUCTION, AND TRAINING AT THE COLLEGE AND POST-GRADUATE LEVELS, AND THE DISTRIBUTION OF COURSE MATERIAL IN CONNECTION THEREWITH (U.S. CLS. 100, 101 AND 107).

FIRST USE 9-6-1988; IN COMMERCE 9-6-1988.
ALEX KEAM, EXAMINING ATTORNEY

SN 76-687,915. DEIGHAN PRODUCTIONS, LLC, MIDLOTHIAN, VA. FILED 3-19-2008.



THE MARK CONSISTS OF THE DESIGN OF A DRAGONFLY PERCHED ON A BRANCH.

FOR FILM PRODUCTION SERVICES (U.S. CLS. 100, 101 AND 107).

MARILYN IZZI, EXAMINING ATTORNEY

CLASS 41—(Continued).

SN 76-688,016. BYRNE, STEVEN J., NEW YORK, NY. FILED 3-24-2008.

KIMS OF COMEDY

THE MARK CONSISTS OF STANDARD CHARACTERS WITHOUT CLAIM TO ANY PARTICULAR FONT, STYLE, SIZE, OR COLOR.

NO CLAIM IS MADE TO THE EXCLUSIVE RIGHT TO USE "COMEDY", APART FROM THE MARK AS SHOWN.

FOR ENTERTAINMENT SERVICES IN THE NATURE OF ON-GOING TELEVISION PROGRAMS IN THE FIELD OF COMEDY; ENTERTAINMENT IN THE NATURE OF VISUAL AND AUDIO PERFORMANCES, AND MUSICAL, VARIETY, NEWS AND COMEDY SHOWS, ENTERTAINMENT IN THE NATURE OF LIVE COMEDY SHOWS; ENTERTAINMENT, NAMELY, A CONTINUING COMEDY SHOW BROADCAST OVER TELEVISION, SATELLITE, AUDIO AND VIDEO MEDIA (U.S. CLS. 100, 101 AND 107).

FIRST USE 3-13-2003; IN COMMERCE 3-13-2003.
ALEX KEAM, EXAMINING ATTORNEY

SN 76-688,070. WOMEN'S BASKETBALL COACHES ASSOCIATION, INC., LILBURN, GA. FILED 3-26-2008.

SHOOTAROUND

THE MARK CONSISTS OF STANDARD CHARACTERS WITHOUT CLAIM TO ANY PARTICULAR FONT, STYLE, SIZE, OR COLOR.

FOR ENTERTAINMENT SERVICES, NAMELY, PROVIDING PODCASTS IN THE FIELD OF BASKETBALL (U.S. CLS. 100, 101 AND 107).

TIMOTHY FINNEGAN, EXAMINING ATTORNEY

SN 76-688,088. EAGLES, LTD., LOS ANGELES, CA. FILED 3-27-2008.

EAGLES LIFE IN THE FAST LANE

THE MARK CONSISTS OF STANDARD CHARACTERS WITHOUT CLAIM TO ANY PARTICULAR FONT, STYLE, SIZE, OR COLOR.

FOR ENTERTAINMENT SERVICES, NAMELY, ENTERTAINMENT IN THE NATURE OF AN AMUSEMENT PARK RIDE (U.S. CLS. 100, 101 AND 107).

ELIZABETH BEYER, EXAMINING ATTORNEY

CLASS 41—(Continued).

SN 77-012,159. ROBINS, JASON, CAMARILLO, CA. FILED 10-3-2006.

Stone Wing

THE MARK CONSISTS OF STANDARD CHARACTERS WITHOUT CLAIM TO ANY PARTICULAR FONT, STYLE, SIZE, OR COLOR.

FOR ENTERTAINMENT, NAMELY, LIVE PERFORMANCES BY A MUSICAL BAND (U.S. CLS. 100, 101 AND 107).

ANDREA BUTLER, EXAMINING ATTORNEY

SN 77-012,680. ROMELING, ANNA LOUISE, CHESHIRE, ENGLAND, FILED 10-3-2006.

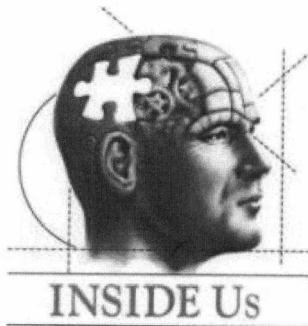

FOR EDUCATION SERVICES, NAMELY, CONDUCTING WORKSHOPS, SEMINARS, CLASSES AND ONE-TO-ONE SESSIONS IN THE FIELD OF EXECUTIVE COACHING; EXECUTIVE COACHING SERVICES IN THE FIELD OF BUSINESS MANAGEMENT; EDUCATION SERVICES, NAMELY, MENTORING IN THE FIELD OF BUSINESS MANAGEMENT AND PRODUCTIVITY, ONE-ON-ONE MENTORING IN THE FIELD OF BUSINESS, EXECUTIVE BUSINESS MENTORING; ARRANGING AND CONDUCTING EDUCATIONAL SEMINARS AND WORKSHOPS IN THE FIELD OF BUSINESS MANAGEMENT AND PRODUCTIVITY, AND EXECUTIVE COACHING; PROVISION OF TRAINING FACILITIES; PROVIDING INFORMATION IN THE FIELD OF EXECUTIVE COACHING; ADVISORY SERVICES IN THE FIELD OF EXECUTIVE COACHING (U.S. CLS. 100, 101 AND 107).

FIRST USE 6-15-2006; IN COMMERCE 6-15-2006.
REBECCA POVARCHUK, EXAMINING ATTORNEY

CLASS 41—(Continued).

SN 77-022,343. ALPHA MEDIA GROUP INC., NEW YORK, NY. FILED 10-16-2006.

MAXIM FILMS

THE MARK CONSISTS OF STANDARD CHARACTERS WITHOUT CLAIM TO ANY PARTICULAR FONT, STYLE, SIZE, OR COLOR.

OWNER OF U.S. REG. NOS. 2,976,337, 2,983,401 AND OTHERS.

NO CLAIM IS MADE TO THE EXCLUSIVE RIGHT TO USE "FILMS", APART FROM THE MARK AS SHOWN.

FOR ENTERTAINMENT IN THE NATURE OF THEATER PRODUCTIONS; MOTION PICTURE THEATERS; PRODUCTION AND DISTRIBUTION OF MOTION PICTURES; PRODUCTION AND DISTRIBUTION OF TELEVISION SHOWS AND MOVIES; TELEVISION SHOW PRODUCTION (U.S. CLS. 100, 101 AND 107).

MARGARET POWER, EXAMINING ATTORNEY

SN 77-035,605. OPTIONSPRESS HOLDINGS, INC., CHICAGO, IL. FILED 11-2-2006.

COMMODITIES 123

THE MARK CONSISTS OF STANDARD CHARACTERS WITHOUT CLAIM TO ANY PARTICULAR FONT, STYLE, SIZE, OR COLOR.

NO CLAIM IS MADE TO THE EXCLUSIVE RIGHT TO USE "COMMODITIES", APART FROM THE MARK AS SHOWN.

FOR PROVIDING EDUCATIONAL SERVICES VIA AN ONLINE COMPUTER NETWORK, NAMELY, PROVIDING SELF-STUDY COURSES, ONLINE SEMINARS AND WORKSHOPS, ALL RELATING TO COMMODITY FUTURES AND OPTIONS (U.S. CLS. 100, 101 AND 107).

FIRST USE 10-10-2006; IN COMMERCE 10-10-2006.
SOPHIA S. KIM, EXAMINING ATTORNEY

CLASS 41—(Continued).

SN 77-057,371. WORLD ALMANAC EDUCATION GROUP, NEW YORK, NY. FILED 12-5-2006.

READING FOR LEARNING

THE MARK CONSISTS OF STANDARD CHARACTERS WITHOUT CLAIM TO ANY PARTICULAR FONT, STYLE, SIZE, OR COLOR.

NO CLAIM IS MADE TO THE EXCLUSIVE RIGHT TO USE "READING", APART FROM THE MARK AS SHOWN.

FOR ON-LINE LIBRARY SERVICES, NAMELY, PROVIDING ELECTRONIC LIBRARY SERVICES WHICH FEATURE CURRICULUM-BASED SUPPLEMENTAL READING MATERIALS IN THE FIELD OF KINDERGARTEN THROUGH TWELFTH GRADE LANGUAGE ARTS, SOCIAL STUDIES, MATHEMATICS, AND SCIENCE FOR STUDENTS, TEACHERS AND PARENTS (U.S. CLS. 100, 101 AND 107).

JESSICA FATHY, EXAMINING ATTORNEY

SN 77-057,411. WEAPONS SPECIALISTS, LTD., NEW YORK, NY. FILED 12-5-2006.

WEAPONS SPECIALISTS

THE MARK CONSISTS OF STANDARD CHARACTERS WITHOUT CLAIM TO ANY PARTICULAR FONT, STYLE, SIZE, OR COLOR.

NO CLAIM IS MADE TO THE EXCLUSIVE RIGHT TO USE "WEAPONS", APART FROM THE MARK AS SHOWN. SEC. 2(F).

FOR RENTAL OF THEATRICAL PROPS IN THE NATURE OF WEAPONS; PROVIDING ON-SET INSTRUCTION IN THE USE OF THEATRICAL PROPS IN THE NATURE OF WEAPONS; CONSULTING IN THE USE OF THEATRICAL PROPS IN THE NATURE OF WEAPONS (U.S. CLS. 100, 101 AND 107).

FIRST USE 1-1-1981; IN COMMERCE 1-1-1981.
LAURA HAMMEL, EXAMINING ATTORNEY

SN 77-064,757. RK NETMEDIA, INC., MIAMI BEACH, FL. FILED 12-14-2006.

MILF NEXT DOOR

THE MARK CONSISTS OF STANDARD CHARACTERS WITHOUT CLAIM TO ANY PARTICULAR FONT, STYLE, SIZE, OR COLOR.

FOR ENTERTAINMENT SERVICES IN THE NATURE OF PHOTOGRAPHIC IMAGES, PICTURES, VIDEO AND AUDIO RECORDINGS, AND INFORMATION INVOLVING ADULT ORIENTED SUBJECT MATTER TRANSMITTED THROUGH A GLOBAL COMPUTER NETWORK (U.S. CLS. 100, 101 AND 107).

FIRST USE 12-29-2002; IN COMMERCE 12-29-2002.
KATHERINE CONNOLLY, EXAMINING ATTORNEY

CLASS 41—(Continued).

SN 77-073,088. C12 GROUP, LLC, GREENSBORO, NC. FILED 12-29-2006.



OWNER OF U.S. REG. NO. 2,720,517.

NO CLAIM IS MADE TO THE EXCLUSIVE RIGHT TO USE "GROUP", APART FROM THE MARK AS SHOWN.

FOR PERSONAL COACHING SERVICES FOR CHRISTIAN CEOs, PRESIDENTS, BUSINESS OWNERS AND BUSINESS EXECUTIVES IN THE FIELD OF LEADERSHIP, BUSINESS MANAGEMENT, GENERAL MANAGEMENT, ORGANIZATIONAL DEVELOPMENT, COMMUNICATION, PERFORMANCE MANAGEMENT, FINANCIAL MANAGEMENT AND SPIRITUALITY MANAGEMENT (U.S. CLS. 100, 101 AND 107).

FIRST USE 6-1-1992; IN COMMERCE 6-1-1992.
DANNEAN HETZEL, EXAMINING ATTORNEY

SN 77-083,911. AMERICAN NEWLAND COMMUNITIES, L.P., SAN DIEGO, CA. FILED 1-16-2007.

HEALTHY LIVING SYSTEMS

THE MARK CONSISTS OF STANDARD CHARACTERS WITHOUT CLAIM TO ANY PARTICULAR FONT, STYLE, SIZE, OR COLOR.

NO CLAIM IS MADE TO THE EXCLUSIVE RIGHT TO USE "SYSTEMS", APART FROM THE MARK AS SHOWN.

FOR PROVIDING RECREATIONAL AND ATHLETIC FACILITIES AT PLANNED COMMUNITIES; PROVIDING ONLINE INFORMATION REGARDING AMENITIES, ACTIVITIES AND/OR EVENTS AT PLANNED COMMUNITIES, NAMELY, PROVIDING A WEBSITE FEATURING INFORMATION ON A WIDE VARIETY OF INDOOR AND OUTDOOR RECREATIONAL ACTIVITIES AND CULTURAL EVENTS AVAILABLE TO COMMUNITY RESIDENTS (U.S. CLS. 100, 101 AND 107).

NATALIE POLZER, EXAMINING ATTORNEY

SN 77-097,142. WILLET, INC., WESTMINSTER, MD. FILED 2-1-2007.



THE MARK CONSISTS OF A BLACK BACKGROUND,

CLASS 41—(Continued).

AND A SMALL DASHED CIRCLE ENCLOSED BY A LARGE DASHED CIRCLE. WITHIN THE SMALL DASHED CIRCLE IS A CAPITAL LETTER "L" IN BLOCK LETTERS IN THE FORM OF A RIGHT ANGLE, DIRECTLY NEXT TO ANOTHER CAPITAL LETTER "L" WHICH FACES IN THE OPPOSITE DIRECTION; UNDERNEATH THE CIRCULAR IMAGE IN ALL CAPITAL LETTERS IS THE WORD "WILLET", WHEREIN THE LETTERS "LL" ARE ENCLOSED IN A CIRCLE. UNDERNEATH THE WORD "WILLET" IS THE WEBSITE ADDRESS, "WWW.WILLETONLINE.COM".

FOR ENTERTAINMENT SERVICES IN THE NATURE OF VISUAL AND AUDIO PERFORMANCES, AND MUSICAL, VARIETY, NEWS AND COMEDY SHOWS; ENTERTAINMENT SERVICES IN THE NATURE OF VISUAL AND AUDIO PERFORMANCES, NAMELY, LIVE MUSIC CONCERTS, LIVE PERFORMANCES BY A MUSICAL BAND, LIVE PERFORMANCES BY A ROCK GROUP, CONTEMPORARY MUSICIANS AND MUSICAL SOLOISTS; ENTERTAINMENT SERVICES, NAMELY, PROVIDING A WEB SITE FEATURING MUSICAL PERFORMANCES, MUSICAL VIDEOS, RELATED FILM CLIPS, PHOTOGRAPHS, AND OTHER MULTIMEDIA MATERIALS; MUSIC COMPOSITION AND TRANSCRIPTION FOR OTHERS; INSTRUCTION IN THE FIELD OF MUSIC COMPOSITION, MUSIC RECORDING, INSTRUMENTAL INSTRUCTION, VOCAL TRAINING; MUSIC PRODUCTION SERVICES, NAMELY, PRODUCTION OF SOUND AND MUSIC VIDEO AND AUDIO RECORDINGS; MUSIC PUBLISHING SERVICES (U.S. CLS. 100, 101 AND 107).

FIRST USE 10-1-2006; IN COMMERCE 10-1-2006.

SUSAN LESLIE DUBOIS, EXAMINING ATTORNEY

SN 77-103,424. REMY BUMPPPO THEATRE COMPANY, CHICAGO, IL. FILED 2-9-2007.



"REMY BUMPPPO" DOES NOT IDENTIFY A LIVING INDIVIDUAL.

FOR ENTERTAINMENT SERVICES, NAMELY, PRODUCTION AND PRESENTATION OF LIVE THEATRICAL PRODUCTIONS (U.S. CLS. 100, 101 AND 107).

FIRST USE 10-1-2006; IN COMMERCE 10-1-2006.

MARLENE BELL, EXAMINING ATTORNEY

CLASS 41—(Continued).

SN 77-104,869. TRUDY HUBERMAN, OAKVIEW, CA. FILED 2-12-2007.

TRAVELS WITH IDA

THE MARK CONSISTS OF STANDARD CHARACTERS WITHOUT CLAIM TO ANY PARTICULAR FONT, STYLE, SIZE, OR COLOR.

FOR ENTERTAINMENT AND EDUCATIONAL SERVICES IN THE NATURE OF LIVE MUSICAL AND THEATRICAL PERFORMANCES (U.S. CLS. 100, 101 AND 107).

ANGELA M. MICHELI, EXAMINING ATTORNEY

SN 77-108,711. THE MATTHEW ROLSTON FOUNDATION, BEVERLY HILLS, CA. FILED 2-15-2007.

THE ARCHITECTS OF THE NEW ENERGY

THE MARK CONSISTS OF STANDARD CHARACTERS WITHOUT CLAIM TO ANY PARTICULAR FONT, STYLE, SIZE, OR COLOR.

FOR ENTERTAINMENT IN THE NATURE OF PRODUCING AND EXHIBITING MOTION PICTURES, FILMS, DOCUMENTARIES AND ON-GOING TELEVISION AND CABLE PROGRAMS IN THE FIELD OF DOCUMENTARIES, NEWS, SCIENCE, TECHNOLOGY, ENERGY, HISTORY, BIOGRAPHIES, PUBLIC AFFAIRS, POLITICAL EVENTS AND AFFAIRS, PHOTOGRAPHY, MOVIES, FILM, TELEVISION, MUSIC, DRAMA, ARTISTIC PERFORMANCES, ENVIRONMENT, NATURE AND WILDLIFE, LITERATURE, CULTURE, HEALTH, FITNESS, NUTRITION, FOOD, COOKING, ACADEMICS, ART, ARCHITECTURE, ARTS AND CRAFTS, AUTOMOTIVE, BOATING, BUSINESS, E-COMMERCE, ENTREPRENEURSHIP, ON-LINE ACTIVITIES AND GAMES, CONSUMER ELECTRONICS, LAW AND LEGAL ISSUES, HOME IMPROVEMENT AND REPAIR, HOME GARDENING AND DECORATING, MONEY, FINANCE, TAXES, AND INVESTING, EDUCATION, AND CHILDREN'S ENTERTAINMENT; LIVE EVENTS IN THE NATURE OF EXHIBITIONS OF PHOTOGRAPHS AND ART AND PRESENTATIONS ON PHOTOGRAPHY AND ART; ENTERTAINMENT IN THE NATURE OF ON-GOING TELEVISION AND CABLE PROGRAMS IN THE FIELD OF DOCUMENTARIES, NEWS, SCIENCE, TECHNOLOGY, ENERGY, HISTORY, BIOGRAPHIES, PUBLIC AFFAIRS, POLITICAL EVENTS AND AFFAIRS, MOVIES, FILM, PHOTOGRAPHY, TELEVISION, MUSIC, DRAMA, ARTISTIC PERFORMANCES, ENVIRONMENT, NATURE AND WILDLIFE, LITERATURE, CULTURE, HEALTH, FITNESS, NUTRITION, FOOD, COOKING, ACADEMICS, ART, ARCHITECTURE, ARTS AND CRAFTS, AUTOMOTIVE, BOATING, BUSINESS, E-COMMERCE, ENTREPRENEURSHIP, ON-LINE ACTIVITIES AND GAMES, CONSUMER ELECTRONICS, LAW AND LEGAL ISSUES, HOME IMPROVEMENT AND REPAIR, HOME GARDENING AND DECORATING, MONEY, FINANCE, TAXES, AND INVESTING, EDUCATION, AND CHILDREN'S ENTERTAINMENT; PROVIDING AN INTERNET WEB SITE CONTAINING REFERENCE MATERIALS ON DOCUMENTARIES, HISTORY, PHOTOGRAPHY, ARTISTIC PERFORMANCES, NATURE AND WILDLIFE, LITERATURE, CULTURE, ACADEMICS, ART, ARCHITECTURE, ARTS AND CRAFTS, AUTOMOTIVE REPAIR INSTRUCTION, ON-LINE GAMES, PHOTOGRAPHY, AND CHILDREN'S

CLASS 41—(Continued).

EDUCATIONAL AND ENTERTAINMENT MATERIALS, NAMELY, CHILDREN'S GAMES; PRODUCTION OF AUDIO AND VIDEO RECORDINGS ON A WIDE VARIETY OF THEMES; ENTERTAINMENT SERVICES, NAMELY, PROVIDING A WEB SITE FEATURING MOTION PICTURES, TELEVISION, MUSIC, MOVIE AND FILM REVIEWS, INTERVIEWS, AND ONLINE COMPUTER GAMES; PROVIDING AN ONLINE MAGAZINE IN THE FIELD OF DOCUMENTARIES, SCIENCE, TECHNOLOGY, ENERGY, CHARITIES, HISTORY, NEWS, INFORMATIONAL, BIOGRAPHIES, PUBLIC AFFAIRS, POLITICAL EVENTS AND AFFAIRS, PHOTOGRAPHY, ARTISTIC PERFORMANCES, ENVIRONMENT, NATURE AND WILDLIFE, LITERATURE, CULTURE, MEDICINE, HEALTH, FITNESS, NUTRITION, FOOD, COOKING, ACADEMICS, ART, ARCHITECTURE, ARTS AND CRAFTS, AUTOMOTIVE, BOATING, BUSINESS, E-COMMERCE, ENTREPRENEURSHIP, ON-LINE ACTIVITIES AND GAMES, CONSUMER ELECTRONICS, LAW AND LEGAL ISSUES, HOME IMPROVEMENT AND REPAIR, HOME GARDENING AND DECORATING, MONEY, FINANCE, TAXES, INVESTING AND CHILDREN'S EDUCATION AND ENTERTAINMENT, ALL AVAILABLE VIA EMAIL AND A WEBSITE ON GLOBAL COMPUTER NETWORKS; EDUCATION SERVICES, NAMELY, PROVIDING CLASSES, SEMINARS, AND WORKSHOPS IN THE FIELD OF SCIENCE, TECHNOLOGY, ENERGY, HISTORY, NEWS, PUBLIC AFFAIRS, POLITICAL EVENTS AND AFFAIRS, PHOTOGRAPHY, ARTISTIC PERFORMANCES, ENVIRONMENT, NATURE AND WILDLIFE, LITERATURE, CULTURE, HEALTH, FITNESS, NUTRITION, FOOD, COOKING, ACADEMICS, ART, ARCHITECTURE, ARTS AND CRAFTS, AUTOMOTIVE, BOATING, BUSINESS, E-COMMERCE, ENTREPRENEURSHIP, ON-LINE ACTIVITIES AND GAMES, CONSUMER ELECTRONICS, LAW AND LEGAL ISSUES, HOME IMPROVEMENT AND REPAIR, HOME GARDENING AND DECORATING, MONEY, FINANCE, TAXES, INVESTING AND CHILDREN'S EDUCATION (U.S. CLS. 100, 101 AND 107).

TASNEEM HUSSAIN, EXAMINING ATTORNEY

SN 77-116,522. ROCKY MOUNTAIN ELITE PERFORMANCE SPORTS, INC., HIGHLANDS RANCH, CO. FILED 2-26-2007.



NO CLAIM IS MADE TO THE EXCLUSIVE RIGHT TO USE "ELITE", APART FROM THE MARK AS SHOWN.

THE MARK CONSISTS OF THE WORDS "ROCKY

CLASS 41—(Continued).

MOUNTAIN" CENTERED ABOVE THE WORD "ELITE", WHICH IS CENTERED ABOVE A FUZZY PAW PRINT. THE FUZZY PAW PRINT HAS FIVE TOES AND A CENTRAL PAD ALL SURROUNDED BY FUR HAVING FUZZY EDGES. THE MARK ALSO INCLUDES AN APPROXIMATELY OVAL-SHAPED BADGE SURROUNDING THE WORD "ELITE" AND FORMING A BACKGROUND BEHIND WORD "ELITE". THE WORDS "ROCKY MOUNTAIN" AND "ELITE" ARE FORMED OF ALL CAPITAL LETTERS.

FOR EDUCATION AND ENTERTAINMENT SERVICES IN THE NATURE OF COMPETITIONS IN THE FIELDS OF CHEERLEADING, GYMNASTICS, TUMBLING AND DANCE PERFORMANCES AND COMPETITIONS; ARRANGING AND CONDUCTING ATHLETIC INSTRUCTION, NAMELY, CHEERLEADING, GYMNASTICS, TUMBLING AND DANCE INSTRUCTION; PROVIDING FACILITIES FOR CHEERLEADING, GYMNASTICS, TUMBLING AND DANCE INSTRUCTION, COMPETITIONS AND TOURNAMENTS; DAY CAMP SERVICES IN THE FIELDS OF CHEERLEADING, GYMNASTICS, TUMBLING AND DANCE; AND SPORT CAMPS IN THE FIELDS OF CHEERLEADING, GYMNASTICS, TUMBLING AND DANCE (U.S. CLS. 100, 101 AND 107).

SUSAN STIGLITZ, EXAMINING ATTORNEY

SN 77-123,315. NIELSEN BUSINESS MEDIA, INC., NEW YORK, NY. FILED 3-6-2007.

RISKY BUSINESS

THE MARK CONSISTS OF STANDARD CHARACTERS WITHOUT CLAIM TO ANY PARTICULAR FONT, STYLE, SIZE, OR COLOR.

FOR PROVIDING ONLINE NEWSLETTERS AND ONLINE JOURNALS AND WEBLOGS FEATURING INFORMATION REGARDING ENTERTAINMENT AND THE ENTERTAINMENT INDUSTRY; PROVIDING ONLINE MAGAZINES AND ONLINE MAGAZINE COLUMNS ABOUT ENTERTAINMENT AND THE ENTERTAINMENT INDUSTRY (U.S. CLS. 100, 101 AND 107).

FIRST USE 10-7-2005; IN COMMERCE 10-7-2005.

JENNIFER HETU, EXAMINING ATTORNEY

SN 77-130,767. CHARGERS FOOTBALL COMPANY, LLC, SAN DIEGO, CA. FILED 3-14-2007.



OWNER OF U.S. REG. NOS. 2,956,462 AND 3,206,203.

THE COLOR(S) DARK BLUE, LIGHT BLUE, GOLD AND WHITE IS/ARE CLAIMED AS A FEATURE OF THE MARK.

THE MARK CONSISTS OF A CONFIGURATION AND COLOR SCHEME OF A FOOTBALL JERSEY CONSISTING OF A DARK BLUE BODY SHOWING WHITE NUMBERS OUTLINED IN LIGHT BLUE AND GOLD THAT APPEAR IN DOTTED LINES ON BOTH THE CHEST AND THE

CLASS 41—(Continued).

SHOULDERS OF THE JERSEY. THE NUMBERS ARE NOT CLAIMED AS A FEATURE OF THE TRADEMARK BUT ARE ONLY USED TO SHOW PLACEMENT OF THE NUMBER. THE JERSEY ALSO FEATURES A TAPERED WHITE STRIPE ON EACH SLEEVE WRAPPING AROUND THE SHOULDER OF THE JERSEY, FROM FRONT TO BACK, AT THE SEAM WHERE THE SLEEVE MEETS THE BODY; INCLUDED IN EACH OF THESE WHITE STRIPES IS A LIGHTNING BOLT DESIGN FEATURED IN GOLD AND OUTLINED FIRST IN LIGHT BLUE AND THEN IN DARK BLUE. THE NECKLINE OF THE JERSEY IS TRIMMED IN WHITE ALONG THE SIDES AND BACK OF THE NECKLINE AND GOLD AT THE FRONT, CENTER OF THE NECKLINE.

FOR ENTERTAINMENT SERVICES, NAMELY, PROFESSIONAL FOOTBALL GAMES AND EXHIBITIONS (U.S. CLS. 100, 101 AND 107).

DOMINICK J. SALEMI, EXAMINING ATTORNEY

CLASS 41—(Continued).

SN 77-132,269. THE PROFESSIONAL GOLFERS' ASSOCIATION OF AMERICA, PALM BEACH GARDENS, FL. FILED 3-15-2007.



SN 77-131,256. TELEvisa, S.A. DE C.V., COLONIA ZEDEC SANTA FE, MEXICO, FILED 3-14-2007.

FESTIVAL DEL HUMOR

THE MARK CONSISTS OF STANDARD CHARACTERS WITHOUT CLAIM TO ANY PARTICULAR FONT, STYLE, SIZE, OR COLOR.

OWNER OF MEXICO REG. NO. 790364, DATED 4-30-2003, EXPIRES 3-31-2013.

THE FOREIGN WORDING IN THE MARK TRANSLATES INTO ENGLISH AS "FESTIVAL OF HUMOR".

FOR ENTERTAINMENT SERVICES, NAMELY, AN ONGOING TELEVISION PROGRAM IN THE FIELD OF COMEDY (U.S. CLS. 100, 101 AND 107).

KATHRYN COWARD, EXAMINING ATTORNEY

OWNER OF U.S. REG. NOS. 578,653, 1,331,309 AND OTHERS.

NO CLAIM IS MADE TO THE EXCLUSIVE RIGHT TO USE "TEAM CHAMPIONSHIP", "1916" OR "2007", APART FROM THE MARK AS SHOWN.

FOR ORGANIZING AND CONDUCTING GOLF TOURNAMENTS (U.S. CLS. 100, 101 AND 107).

FIRST USE 3-15-2007; IN COMMERCE 3-15-2007.

ESTHER BELENKER, EXAMINING ATTORNEY

SN 77-131,351. GRAU, DAVID, TUSTIN, CO. FILED 3-14-2007.

SN 77-137,604. AEGIS PUBLICATIONS, LLC, NEWTOWN, PA. FILED 3-22-2007.

FUNCTIONAL ESTHETICS & RESTORATIVE DENTISTRY

Battlegrounds

THE MARK CONSISTS OF STANDARD CHARACTERS WITHOUT CLAIM TO ANY PARTICULAR FONT, STYLE, SIZE, OR COLOR.

FOR ENTERTAINMENT SERVICES, NAMELY, PROVIDING A WEB SITE FEATURING MUSICAL PERFORMANCES, MUSICAL VIDEOS, RELATED FILM CLIPS, PHOTOGRAPHS, AND OTHER MULTIMEDIA MATERIALS (U.S. CLS. 100, 101 AND 107).

BENJAMIN ALLEN, EXAMINING ATTORNEY

THE MARK CONSISTS OF STANDARD CHARACTERS WITHOUT CLAIM TO ANY PARTICULAR FONT, STYLE, SIZE, OR COLOR.

NO CLAIM IS MADE TO THE EXCLUSIVE RIGHT TO USE "RESTORATIVE DENTISTRY", APART FROM THE MARK AS SHOWN.

FOR PROVIDING CONTINUING DENTAL EDUCATION COURSES; PROVIDING ON-LINE PUBLICATIONS IN THE NATURE OF JOURNALS, NEWSLETTERS, SUPPLEMENTS, MONOGRAPHS AND FEATURE REPORTS IN THE FIELD OF DENTISTRY (U.S. CLS. 100, 101 AND 107).

DOMINICK J. SALEMI, EXAMINING ATTORNEY

CLASS 41—(Continued).

SN 77-140,837. HANDOUSH, DIMA M., PINOLE, CA. FILED 3-26-2007.



NO CLAIM IS MADE TO THE EXCLUSIVE RIGHT TO USE "WRITE-A-BOOK", APART FROM THE MARK AS SHOWN.

THE COLOR(S) BLUE, BROWN, BLACK, WHITE AND GRAY IS/ARE CLAIMED AS A FEATURE OF THE MARK.

THE MARK CONSISTS OF THE STYLIZED TEXT "THE" IN BLACK, FOLLOWED BY THE STYLIZED TEXT "WRITE-A-BOOK" IN BLUE, FOLLOWED BY THE STYLIZED TEXT "SHOP" IN BLACK. THE WORDING IS UNDERLINED IN BLACK AND ABOVE THE STYLIZED TEXT "WHERE KIDS WALK IN & AUTHORS WALK OUT" IN BLACK LETTERING OVERLAID ON FADING BROWN RECTANGLES REPRESENTING TYPEWRITER KEYS. THE DESIGN OF A COMPUTER KEYBOARD IN BLACK AND WHITE WITH GRAY SHADING APPEARS ABOVE THE WORDING IN THE MARK.

FOR CUSTOM WRITING SERVICES (U.S. CLS. 100, 101 AND 107).

CHRISTINE COOPER, EXAMINING ATTORNEY

SN 77-141,306. LIFE 101, LLC, FENTON, MI. FILED 3-27-2007.

GETLIFE101

THE MARK CONSISTS OF STANDARD CHARACTERS WITHOUT CLAIM TO ANY PARTICULAR FONT, STYLE, SIZE, OR COLOR.

FOR EDUCATIONAL SERVICES, NAMELY, TRAINING AND LIFE COACHING SERVICES IN THE NATURE OF CREDIT CARD MANAGEMENT SKILL IMPROVEMENT SERVICES, FINANCIAL PLANNING SKILL IMPROVEMENT SERVICES, MONEY MANAGEMENT SKILL IMPROVEMENT SERVICES, INSURANCE SKILL IMPROVEMENT SERVICES, MORTGAGE SKILL IMPROVEMENT SERVICES, CREDIT REPORT SKILL IMPROVEMENT SERVICES, AUTOMOBILE PURCHASE AND LEASING SKILL IMPROVEMENT SERVICES, REAL ESTATE PURCHASE SKILL IMPROVEMENT SERVICES; FACILITATING THE CREDIT CARD MANAGEMENT SKILL IMPROVEMENT SERVICES, FINANCIAL PLANNING SKILL IMPROVEMENT SERVICES, MONEY MANAGEMENT SKILL IMPROVEMENT SERVICES, INSURANCE SKILL IMPROVEMENT SERVICES, MORTGAGE SKILL IMPROVEMENT SERVICES, CREDIT REPORT SKILL IMPROVEMENT SERVICES, AUTOMOBILE PURCHASE AND LEASING SKILL IMPROVEMENT SERVICES, AND REAL ESTATE PURCHASE SKILL IMPROVEMENT SERVICES USING LIVE, ON-LINE OR SELF-STUDY CLASSES, COURSES, SEMINARS OR WORKSHOPS, AND THE DISTRIBUTION OF MULTI MEDIA INSTRUCTIONAL MATERIALS ASSOCIATED THEREWITH (U.S. CLS. 100, 101 AND 107).

MICHAEL LEWIS, EXAMINING ATTORNEY

CLASS 41—(Continued).

SN 77-143,078. UNITED FOOTBALL LEAGUE, LLC, NEW YORK, NY. FILED 3-28-2007.

UNITED FOOTBALL LEAGUE

THE MARK CONSISTS OF STANDARD CHARACTERS WITHOUT CLAIM TO ANY PARTICULAR FONT, STYLE, SIZE, OR COLOR.

NO CLAIM IS MADE TO THE EXCLUSIVE RIGHT TO USE "FOOTBALL LEAGUE", APART FROM THE MARK AS SHOWN.

FOR AMATEUR YOUTH SPORTS SERVICES, NAMELY, ORGANIZING, PROVIDING AND MANAGING YOUTH SPORTS ACTIVITIES; ARRANGING AND CONDUCTING ATHLETIC COMPETITIONS; ARRANGING AND CONDUCTING OF CONCERTS; ARRANGING FOR TICKET RESERVATIONS FOR SHOWS AND OTHER ENTERTAINMENT EVENTS; ARRANGING OF CONTESTS; ARRANGING OF EXHIBITIONS, SEMINARS AND CONFERENCES; CONDUCTING ENTERTAINMENT EXHIBITIONS IN THE NATURE OF SPORTING EVENTS; DIRECTION OF MAKING RADIO OR TELEVISION PROGRAMS; DISTRIBUTION OF TELEVISION PROGRAMMING TO CABLE TELEVISION SYSTEMS; DISTRIBUTION OF TELEVISION PROGRAMS FOR OTHERS; ENTERTAINMENT IN THE NATURE OF COMPETITIONS IN THE FIELD OF ATHLETICS; ENTERTAINMENT IN THE NATURE OF FOOTBALL GAMES; ENTERTAINMENT IN THE NATURE OF FOOTBALL GAMES; ENTERTAINMENT SERVICES, NAMELY, PARTICIPATION IN SPORTING EVENTS; ENTERTAINMENT SERVICES, NAMELY, PERSONAL APPEARANCES BY A SPORTS CELEBRITY; ENTERTAINMENT SERVICES, NAMELY, PROVIDING A RADIO PROGRAM IN THE FIELD OF SPORTS VIA A GLOBAL COMPUTER NETWORK; ENTERTAINMENT SERVICES, NAMELY, PROVIDING A TELEVISION PROGRAM IN THE FIELD OF SPORTS VIA A GLOBAL COMPUTER NETWORK; ENTERTAINMENT SERVICES, NAMELY, PROVIDING A WEB SITE FEATURING MUSICAL PERFORMANCES, MUSICAL VIDEOS, RELATED FILM CLIPS, PHOTOGRAPHS, AND OTHER MULTIMEDIA MATERIALS; ENTERTAINMENT SERVICES, NAMELY, PROVIDING AN ON-LINE COMPUTER GAME; ENTERTAINMENT SERVICES, NAMELY, PROVIDING ON-LINE REVIEWS OF SPORTS; ENTERTAINMENT SERVICES IN THE NATURE OF FANTASY SPORTS LEAGUES; FAN CLUBS; MULTIMEDIA ENTERTAINMENT SOFTWARE PRODUCTION SERVICES; MULTIMEDIA PUBLISHING OF BOOKS, MAGAZINES, JOURNALS, SOFTWARE, GAMES, MUSIC, AND ELECTRONIC PUBLICATIONS; OFFICIATING AT SPORTS CONTESTS; OPERATION OF SPORTS CAMPS; ORGANISATION OF GAMES; ORGANISATION OF SPORTS EVENTS IN THE FIELD OF FOOTBALL; ORGANIZING COMMUNITY SPORTING AND CULTURAL EVENTS; ORGANIZING EXHIBITIONS FOR SPORTING EVENTS; ORGANIZING SPORTING EVENTS, NAMELY, FOOTBALL GAMES AND COMPETITIONS; PRODUCTION AND DISTRIBUTION OF TELEVISION SHOWS AND MOVIES; PRODUCTION OF CABLE TELEVISION PROGRAMS; PRODUCTION OF CLOSED CAPTION TELEVISION PROGRAMS; PRODUCTION OF RADIO AND TELEVISION PROGRAMS; PRODUCTION OF RADIO OR TELEVISION PROGRAMS; PRODUCTION OF VIDEO DISCS AND TAPES; PROGRAMMING ON A GLOBAL COMPUTER NETWORK; PROVIDING A COMPUTER GAME THAT MAY BE ACCESSED NETWORK-

CLASS 41—(Continued).

WIDE BY NETWORK USERS; PROVIDING A WEBSITE THAT PROVIDES SPORTS LEAGUE PLAYER STATISTICS; PROVIDING A WEBSITE FEATURING SPORTING INFORMATION; PROVIDING SPORTS INFORMATION BY MEANS OF TELEPHONE PRERECORDED MESSAGES; PUBLICATION OF BOOKS, OF MAGAZINES, OF JOURNALS, OF NEWSPAPERS, OF PERIODICALS, OF CATALOGS, OF BROCHURES; RENTAL OF STADIUM FACILITIES; SPORT CAMPS; SPORTS REFEREEING AND OFFICIATING; TELEVISION PROGRAMMING; TELEVISION SCHEDULING; TIMING OF SPORTS EVENTS (U.S. CLS. 100, 101 AND 107).
JORDAN BAKER, EXAMINING ATTORNEY

CLASS 41—(Continued).

SN 77-160,990. TCS ENTERTAINMENT, INC., LA VERNE, CA. FILED 4-19-2007.

SN 77-147,164. MOORE, RICHARD, QUEENS, NY. FILED 4-3-2007.



THE COLOR(S) BLACK AND GRAY IS/ARE CLAIMED AS A FEATURE OF THE MARK.

THE MARK CONSISTS OF THE LETTERS "THINK B4U MOVE" ARE COLORED GRAY AND BOLD. THE CHESS PIECE IS IN BLACK, REPRESENTING A KNIGHT. THE CHESS PIECE INCLUDES A SHADOW OF GRAY AROUND IT.

FOR PROVIDES EDUCATIONAL SERVICES, NAMELY, PROVIDING TRAINING, CLASSES AND WORKSHOPS, IN THE FIELD OF STRATEGIC THINKING IN LIFE, UNDERSTANDING, FINANCE AND STRATEGIC INVESTMENTS (U.S. CLS. 100, 101 AND 107).

FIRST USE 2-2-2007; IN COMMERCE 2-2-2007.
ANDREA HACK, EXAMINING ATTORNEY



NO CLAIM IS MADE TO THE EXCLUSIVE RIGHT TO USE "AUDIO". APART FROM THE MARK AS SHOWN.

FOR ENTERTAINMENT SERVICES, NAMELY, PROVIDING PRE-RECORDED INFORMATION IN THE FIELD OF COMEDY, COMMENTARY ABOUT COMEDY AND PRE-RECORDED COMEDY PERFORMANCES, ALL ON-LINE VIA A GLOBAL COMPUTER NETWORK; ENTERTAINMENT SERVICES, NAMELY, PROVIDING COMEDY SPOTS, NAMELY, COMEDY CLIPS AND SOUND CLIPS FOR USE IN RADIO SHOWS; ONLINE SERVICES IN THE FIELD OF RADIO SHOW PRODUCTION, NAMELY, ONLINE PRODUCTION COMPANY SERVICES IN THE FIELD OF RADIO SHOW PRODUCTION; PREPARATION SERVICES FOR RADIO PERSONALITIES IN THE NATURE OF PROVIDING PRE-RECORDED INFORMATION IN THE FIELD OF COMEDY, COMMENTARY ABOUT COMEDY AND PRE-RECORDED COMEDY PERFORMANCES ALL ON-LINE VIA A GLOBAL COMPUTER NETWORK; ENTERTAINMENT SERVICES, NAMELY, CUSTOM WRITING SERVICES AND AUDIO RECORDING AND PRODUCTION OF SCRIPTED COMEDY SPOTS AND EDITING AND RECORDING OF SOUNDS AND IMAGES TO PROVIDE SOUND CLIPS FROM ENTERTAINMENT AND NEWS PROGRAMS FOR USE BY RADIO SHOWS; PROVIDING NEWS AND INFORMATION IN THE FIELDS OF ENTERTAINMENT AND SPORTS, AND PROVIDING NEWS IN THE NATURE OF CURRENT EVENT REPORTING FOR RADIO PERSONALITIES (U.S. CLS. 100, 101 AND 107).

FIRST USE 6-30-2004; IN COMMERCE 6-30-2004.
CARYN GLASSER, EXAMINING ATTORNEY

SN 77-150,508. CODFISH ENTERTAINMENT LLC, NEW YORK, NY. FILED 4-6-2007.

RANDOMALITY

THE MARK CONSISTS OF STANDARD CHARACTERS WITHOUT CLAIM TO ANY PARTICULAR FONT, STYLE, SIZE, OR COLOR.

FOR ENTERTAINMENT IN THE NATURE OF AN ONGOING TELEVISION GAME SHOW BROADCAST OVER WEBCASTS, RADIO BROADCASTS, TELEVISION, SATELLITE, INTERNET, AUDIO, AND VIDEO MEDIA (U.S. CLS. 100, 101 AND 107).

SHARON MEIER, EXAMINING ATTORNEY

CLASS 41—(Continued).

SN 77-176,524. THE REGENTS OF THE UNIVERSITY OF CALIFORNIA, OAKLAND, CA. FILED 5-9-2007.



OWNER OF U.S. REG. NO. 2,455,006.
NO CLAIM IS MADE TO THE EXCLUSIVE RIGHT TO USE "UNIVERSITY" AND "1868", APART FROM THE MARK AS SHOWN.

THE MARK CONSISTS OF A DEPICTION OF A SEAL WITH A CIRCULAR BANNER IN THE CENTER WITH THE WORDS "THE UNIVERSITY OF CALIFORNIA BERKELEY 1868". IN THE CENTER OF THE BANNER IS A DRAWING OF AN OPEN BOOK WITH A STAR AT THE TOP RADIATING LINES AND A RIBBON WITH THE WORDS "LET THERE BE LIGHT" AT THE BOTTOM. ALL OF WHICH IS SURROUNDED BY A DOTTED CIRCLE ENCLOSED IN A SOLID CIRCLE.

SEC. 2(F) AS TO "THE UNIVERSITY OF CALIFORNIA BERKELEY".

FOR EDUCATIONAL SERVICES, NAMELY, CONDUCTING CLASSES, CONFERENCES, AND WORKSHOPS IN THE FIELDS OF EDUCATION, PERSONAL AND PROFESSIONAL DEVELOPMENT, PHYSICAL DEVELOPMENT, SCIENCE, ENVIRONMENT, ECOLOGY, AND RECREATION; SPORT CAMPS; ARRANGING AND CONDUCTING ATHLETIC COMPETITIONS, PROVIDING INFORMATION IN THE FIELD OF ATHLETIC COMPETITIONS, NAMELY, MEN'S BASKETBALL, WOMEN'S BASKETBALL, MEN'S CREW, WOMEN'S CREW, MEN'S CROSS COUNTRY, WOMEN'S CROSS COUNTRY, FIELD HOCKEY, FOOTBALL, MEN'S GOLF, WOMEN'S GOLF, MEN'S SOCCER, WOMEN'S SOCCER, MEN'S SWIMMING, WOMEN'S SWIMMING, MEN'S DIVING, WOMEN'S DIVING, BASEBALL, SOFTBALL, MEN'S WATER POLO, WOMEN'S WATER POLO, MEN'S GYMNASTICS, WOMEN'S GYMNASTICS, LACROSSE, RUGBY, MEN'S TRACK AND FIELD, WOMEN'S TRACK AND FIELD, WOMEN'S VOLLEYBALL (U.S. CLS. 100, 101 AND 107).

FIRST USE 0-0-1868; IN COMMERCE 0-0-1868.
BARBARA GAYNOR, EXAMINING ATTORNEY

CLASS 41—(Continued).

SN 77-181,323. ARTVENTURES STUDIO, ROCKWALL, TX. FILED 5-15-2007.

ArtVentures

THE MARK CONSISTS OF STANDARD CHARACTERS WITHOUT CLAIM TO ANY PARTICULAR FONT, STYLE, SIZE, OR COLOR.

FOR EDUCATIONAL SERVICES IN THE NATURE OF FINE ARTS SCHOOLS; INSTRUCTION IN THE FIELD OF ART; WORKSHOPS AND SEMINARS IN THE FIELD OF ART; ART EXHIBITIONS (U.S. CLS. 100, 101 AND 107).

FIRST USE 4-1-1988; IN COMMERCE 4-1-1988.
SUSAN LESLIE DUBOIS, EXAMINING ATTORNEY

SN 77-193,057. TREASURE HD COMPANY LLC, NEW YORK, NY. FILED 5-30-2007.



"THE COLOR(S) BLUE, BLACK, WHITE, ORANGE AND YELLOW IS/ARE CLAIMED AS A FEATURE OF THE MARK."

"THE MARK CONSISTS OF THE COLORS ORANGE AND WHITE WHICH APPEAR IN THE WORDING "HOW THE" AND "IS DONE". THE COLOR WHITE WHICH APPEARS IN THE WORD "BEST" AND THE COLORS BLUE, BLACK, ORANGE, YELLOW AND WHITE WHICH APPEAR IN THE BACKGROUND DESIGN."

FOR ENTERTAINMENT IN THE NATURE OF ONGOING TELEVISION PROGRAMS REGARDING WELL KNOWN BRANDS OF CONSUMER PRODUCTS, SPAS, GOLF COURSES AND RESORTS (U.S. CLS. 100, 101 AND 107).

TRACY CROSS, EXAMINING ATTORNEY

CLASS 41—(Continued).

SN 77-194,919. ROLAND L. JONES, NASHVILLE, TN. FILED 5-31-2007.

BAREFOOT SERVICE

THE MARK CONSISTS OF STANDARD CHARACTERS WITHOUT CLAIM TO ANY PARTICULAR FONT, STYLE, SIZE, OR COLOR.

NO CLAIM IS MADE TO THE EXCLUSIVE RIGHT TO USE "SERVICE", APART FROM THE MARK AS SHOWN.

FOR EDUCATIONAL SERVICES, NAMELY, TRAINING COURSES, WORKSHOPS AND SEMINARS IN THE AREAS OF BUSINESS SERVICE, PLANNING, LEADERSHIP AND DEVELOPMENT; EDUCATIONAL SERVICES, NAMELY, CONDUCTING CLASSES, SEMINARS AND EDUCATIONAL CONFERENCES IN THE AREAS OF BUSINESS SERVICE, PLANNING, LEADERSHIP AND DEVELOPMENT AND DISTRIBUTION OF COURSE MATERIALS IN CONNECTION THEREWITH; DEVELOPING EDUCATIONAL MANUALS FOR OTHERS IN THE FIELD OF BUSINESS SERVICE, PLANNING LEADERSHIP AND DEVELOPMENT; PERSONAL COACHING SERVICES IN THE FIELD OF BUSINESS SERVICE, PLANNING LEADERSHIP AND DEVELOPMENT; PUBLICATION OF BOOKS, JOURNALS, BROCHURES AND LEAFLETS IN THE AREA OF BUSINESS SERVICE, PLANNING, LEADERSHIP AND DEVELOPMENT; TRAINING THE IN THE AREA OF BUSINESS SERVICE PLANNING LEADERSHIP AND DEVELOPMENT; EDUCATIONAL SERVICES, NAMELY, CONDUCTING TRAINING COURSES FOR BUSINESS SERVICE, PLANNING, LEADERSHIP AND DEVELOPMENT; EDUCATIONAL AND ENTERTAINMENT SERVICES, NAMELY, PROVIDING MOTIVATIONAL AND EDUCATIONAL SPEAKERS IN THE FIELDS OF BUSINESS SERVICE, PLANNING, LEADERSHIP AND DEVELOPMENT; EDUCATIONAL AND ENTERTAINMENT SERVICES, NAMELY, LIVE PERFORMANCES BY MOTIVATIONAL AND EDUCATIONAL SPEAKERS IN THE FIELDS OF BUSINESS SERVICE, PLANNING, LEADERSHIP AND DEVELOPMENT (U.S. CLS. 100, 101 AND 107).

DOMINIC J. FERRAIUOLO, EXAMINING ATTORNEY

SN 77-197,302. KIMORA LEE SIMMONS LICENSING, INC., NEW YORK, NY. FILED 6-4-2007.

KIMORA LEE SIMMONS

THE MARK CONSISTS OF STANDARD CHARACTERS WITHOUT CLAIM TO ANY PARTICULAR FONT, STYLE, SIZE, OR COLOR.

OWNER OF U.S. REG. NO. 2,926,512.

"KIMORA LEE SIMMONS" IDENTIFIES A LIVING INDIVIDUAL WHOSE CONSENT IS OF RECORD.

FOR ENTERTAINMENT, NAMELY, PRODUCTION OF TELEVISION SHOWS, FILMS, AND OTHER NEW MEDIA PROGRAMMING, IN THE NATURE OF TELEVISION SHOWS AND MOTION PICTURE FILMS DISTRIBUTED VIA THE INTERNET AND RADIO PROGRAMS; ENTERTAINMENT SERVICES, NAMELY, PROVIDING A TELEVISION PROGRAM IN THE FIELD OF ENTERTAINMENT AND NEWS VIA A GLOBAL COMPUTER NETWORK; PRODUCTION AND DISTRIBUTION OF TELEVISION SHOWS AND MOVIES; PRODUCTION OF RADIO OR TELEVISION PROGRAMS (U.S. CLS. 100, 101 AND 107).

KAELIE KUNG, EXAMINING ATTORNEY

CLASS 41—(Continued).

SN 77-197,309. KIMORA LEE SIMMONS LICENSING, INC., NEW YORK, NY. FILED 6-4-2007.

KIMORA LEE

THE MARK CONSISTS OF STANDARD CHARACTERS WITHOUT CLAIM TO ANY PARTICULAR FONT, STYLE, SIZE, OR COLOR.

OWNER OF U.S. REG. NO. 2,926,512.

"KIMORA LEE" IDENTIFIES A LIVING INDIVIDUAL WHOSE CONSENT IS OF RECORD.

FOR ENTERTAINMENT, NAMELY, PRODUCTION OF TELEVISION SHOWS, MOTION PICTURE FILMS, AND OTHER NEW MEDIA PROGRAMMING IN THE NATURE OF TELEVISION SHOWS AND MOTION PICTURE FILMS DISTRIBUTED VIA THE INTERNET AND RADIO PROGRAMS; ENTERTAINMENT SERVICES, NAMELY, PROVIDING A TELEVISION PROGRAM IN THE FIELD OF ENTERTAINMENT AND NEWS VIA A GLOBAL COMPUTER NETWORK; PRODUCTION AND DISTRIBUTION OF TELEVISION SHOWS AND MOVIES; PRODUCTION OF RADIO OR TELEVISION PROGRAMS (U.S. CLS. 100, 101 AND 107).

KAELIE KUNG, EXAMINING ATTORNEY

SN 77-197,310. KIMORA LEE SIMMONS LICENSING, INC., NEW YORK, NY. FILED 6-4-2007.

KIMORA

THE MARK CONSISTS OF STANDARD CHARACTERS WITHOUT CLAIM TO ANY PARTICULAR FONT, STYLE, SIZE, OR COLOR.

OWNER OF U.S. REG. NO. 2,926,512.

THE NAME "KIMORA" IDENTIFIES A LIVING INDIVIDUAL WHOSE CONSENT IS OF RECORD.

FOR ENTERTAINMENT, NAMELY, PRODUCTION OF TELEVISION SHOWS, MOTION PICTURE FILMS, AND OTHER NEW MEDIA PROGRAMMING IN THE NATURE OF TELEVISION SHOWS AND MOTION PICTURE FILMS DISTRIBUTED VIA THE INTERNET, AND RADIO PROGRAMS; ENTERTAINMENT SERVICES, NAMELY, PROVIDING A TELEVISION PROGRAM IN THE FIELD OF ENTERTAINMENT AND NEWS VIA A GLOBAL COMPUTER NETWORK; PRODUCTION AND DISTRIBUTION OF TELEVISION SHOWS AND MOVIES; PRODUCTION OF RADIO OR TELEVISION PROGRAMS (U.S. CLS. 100, 101 AND 107).

KAELIE KUNG, EXAMINING ATTORNEY

CLASS 41—(Continued).

SN 77-210,325. BOTTLEROCKET WINE & SPIRIT LLC, NEW YORK, NY. FILED 6-20-2007.

BOTTLEROCKET

THE MARK CONSISTS OF STANDARD CHARACTERS WITHOUT CLAIM TO ANY PARTICULAR FONT, STYLE, SIZE, OR COLOR.

OWNER OF U.S. REG. NO. 7,846,387.

FOR PARTY PLANNING CONSULTATION; CONDUCTING EDUCATIONAL EXHIBITIONS IN THE NATURE OF WINE AND FOOD; SPECIAL EVENT PLANNING CONSULTATION; CONDUCTING WORKSHOPS AND SEMINARS IN THE FIELD OF WINE AND FOOD; EDUCATION SERVICES, NAMELY, PROVIDING LIVE AND ON-LINE SEMINARS AND CLASSES IN THE FIELD OF WINE; ENTERTAINMENT SERVICES, NAMELY, WINE AND FOOD TASTINGS; ENTERTAINMENT SERVICES, NAMELY, WINE TASTINGS (U.S. CLS. 100, 101 AND 107).

FIRST USE 6-0-2004; IN COMMERCE 6-15-2006.
GEORGIA CARTY, EXAMINING ATTORNEY

SN 77-221,714. THOMAS WHITE INTERNATIONAL, LTD., CHICAGO, IL. FILED 7-3-2007.

THOMAS WHITE GLOBAL RESEARCH

THE MARK CONSISTS OF STANDARD CHARACTERS WITHOUT CLAIM TO ANY PARTICULAR FONT, STYLE, SIZE, OR COLOR.

OWNER OF U.S. REG. NOS. 2,317,687 AND 2,317,688.

NO CLAIM IS MADE TO THE EXCLUSIVE RIGHT TO USE "GLOBAL RESEARCH", APART FROM THE MARK AS SHOWN.

FOR PUBLISHING OF REPORTS, NEWSLETTERS, REVIEWS, TEXT AND GRAPHIC WORKS, AND ELECTRONIC PUBLICATIONS IN THE FIELD OF EQUITY RESEARCH (U.S. CLS. 100, 101 AND 107).

BARBARA BROWN, EXAMINING ATTORNEY

CLASS 41—(Continued).

SN 77-227,954. 23ANDME, INC., MOUNTAIN VIEW, CA. FILED 7-12-2007.

23ANDCME

THE MARK CONSISTS OF STANDARD CHARACTERS WITHOUT CLAIM TO ANY PARTICULAR FONT, STYLE, SIZE, OR COLOR.

FOR PROVIDING AN ONLINE RESOURCE CENTER, NAMELY, ONLINE ARTICLES AND PAPERS RELATING TO RESULTS OF GENETIC TESTING AND GENOTYPING TECHNOLOGIES; PROVIDING ONLINE JOURNALS, NAMELY, BLOGS FEATURING INFORMATION RELATING TO RESULTS OF GENETIC TESTING AND GENOTYPING TECHNOLOGIES; PROVIDING A WEBSITE FEATURING ONLINE PUBLICATIONS IN THE NATURE OF ARTICLES, BOOKS, MAGAZINES, JOURNALS, BROCHURES, LEAFLETS, GUIDES AND MANUALS RELATING TO RESULTS OF GENETIC TESTING AND GENOTYPING TECHNOLOGIES; PROVIDING AN ONLINE PUBLICATION IN THE NATURE OF AN INTERACTIVE ENCYCLOPEDIA RELATING TO RESULTS OF GENETIC TESTING AND GENOTYPING TECHNOLOGIES; EDUCATION SERVICES, NAMELY, DEVELOPING, ARRANGING, AND CONDUCTING LIVE AND ONLINE CLASSES, EDUCATIONAL SEMINARS, CONFERENCES, COLLOQUIA, EXHIBITIONS, LECTURES, PRESENTATIONS AND WORKSHOPS IN THE FIELDS OF GENETIC TESTING, GENETIC SCREENING, GENOTYPING, PHENOTYPING, MOLECULAR ANALYTICS, AND ANCESTRY, AND DISTRIBUTION OF PRINTED MATERIALS IN CONNECTION THEREWITH; PROVIDING CONTINUING MEDICAL EDUCATION COURSES (U.S. CLS. 100, 101 AND 107).

SCOTT BIBB, EXAMINING ATTORNEY

SN 77-242,143. POWER BRANDS INTERNATIONAL, LLC., STUDIO CITY, CA. FILED 7-30-2007.

PRO PLAYER POKER TOUR

THE MARK CONSISTS OF STANDARD CHARACTERS WITHOUT CLAIM TO ANY PARTICULAR FONT, STYLE, SIZE, OR COLOR.

NO CLAIM IS MADE TO THE EXCLUSIVE RIGHT TO USE "POKER TOUR", APART FROM THE MARK AS SHOWN.

FOR ENTERTAINMENT SERVICES, NAMELY, ORGANIZING, ARRANGING, CONDUCTING AND EXHIBITING POKER EVENTS RENDERED LIVE, ONLINE AND ON TELEVISION (U.S. CLS. 100, 101 AND 107).

JILL PRATER, EXAMINING ATTORNEY

CLASS 41—(Continued).

SN 77-246,197. EDUCATION CORPORATION OF AMERICA, BIRMINGHAM, AL. FILED 8-3-2007.

Virginia College Online

THE MARK CONSISTS OF STANDARD CHARACTERS WITHOUT CLAIM TO ANY PARTICULAR FONT, STYLE, SIZE, OR COLOR.

OWNER OF U.S. REG. NOS. 2,485,231 AND 2,575,830.

NO CLAIM IS MADE TO THE EXCLUSIVE RIGHT TO USE "COLLEGE ONLINE", APART FROM THE MARK AS SHOWN.

FOR EDUCATION SERVICES, NAMELY, PROVIDING ONLINE CLASSES AND GRANTING DIPLOMAS, ASSOCIATE, BACHELOR AND MASTER DEGREES IN THE FIELDS OF BUSINESS, CRIMINAL JUSTICE, INFORMATION TECHNOLOGY AND HEALTHCARE (U.S. CLS. 100, 101 AND 107).

FIRST USE 3-16-2004; IN COMMERCE 3-16-2004.

JESSICA FATHY, EXAMINING ATTORNEY

CLASS 41—(Continued).

SN 77-260,265. WINGS, INC., BOISE, ID. FILED 8-21-2007.

Wings Center

THE MARK CONSISTS OF STANDARD CHARACTERS WITHOUT CLAIM TO ANY PARTICULAR FONT, STYLE, SIZE, OR COLOR.

NO CLAIM IS MADE TO THE EXCLUSIVE RIGHT TO USE "CENTER", APART FROM THE MARK AS SHOWN.

FOR CHILDREN'S ACTIVITY AND LEARNING CENTER, NAMELY, PROVIDING FACILITIES FOR GROUP CELEBRATIONS, INDOOR PLAY, PRESCHOOL, AND DAY AND OVERNIGHT CAMPS; PROVIDING FACILITIES FOR GYMNASTICS, CHEER LEADING, SWIMMING, ROCK CLIMBING, MUSIC, ART, AND PHYSICAL EDUCATION; EDUCATIONAL SERVICES, NAMELY, PROVIDING CLASSES IN THE FIELD OF GYMNASTICS, CHEER LEADING, SWIMMING, ROCK CLIMBING, MUSIC, ART, AND PHYSICAL EDUCATION (U.S. CLS. 100, 101 AND 107).

FIRST USE 1-1-1991; IN COMMERCE 1-1-1991.

MICHAEL LITZAU, EXAMINING ATTORNEY

SN 77-262,201. WEIHS ANGELICA R, LOS ANGELES, CA. FILED 8-22-2007.

SN 77-256,386. SMITH, JEFF W., WEST BOUNTIFUL, UT. FILED 8-15-2007.

NORTH AMERICAN HILLCLIMBERS ASSOCIATION NAHA



NO CLAIM IS MADE TO THE EXCLUSIVE RIGHT TO USE "GREEN WEDDINGS & EVENTS", APART FROM THE MARK AS SHOWN.

THE COLOR(S) BEIGE, PINK AND BLACK IS/ARE CLAIMED AS A FEATURE OF THE MARK.

THE COLOR BLACK APPEARS IN THE WORDING, "GREEN WEDDINGS & EVENTS WHAT TRACE WILL YOU LEAVE?". THE COLORS PINK AND BLACK APPEARS IN THE FLOWER DESIGN, AND THE COLOR BEIGE APPEARS IN THE FOOTPRINT AND BACKGROUND SAND DESIGN.

FOR SPECIAL EVENT PLANNING AND COORDINATION (U.S. CLS. 100, 101 AND 107).

FIRST USE 6-6-2005; IN COMMERCE 3-5-2007.

KELLY CHOE, EXAMINING ATTORNEY

THE MARK CONSISTS OF STANDARD CHARACTERS WITHOUT CLAIM TO ANY PARTICULAR FONT, STYLE, SIZE, OR COLOR.

NO CLAIM IS MADE TO THE EXCLUSIVE RIGHT TO USE "NORTH AMERICAN HILLCLIMBERS ASSOCIATION", APART FROM THE MARK AS SHOWN.

FOR ENTERTAINMENT SERVICES, NAMELY, PARTICIPATION IN PROFESSIONAL MOTORCYCLE HILLCLIMBING (U.S. CLS. 100, 101 AND 107).

FIRST USE 1-1-1996; IN COMMERCE 1-1-1996.

PAUL MORENO, EXAMINING ATTORNEY

CLASS 41—(Continued).

SN 77-265,089. MCINTOSH, SCOTT, LOS ANGELES, CA. FILED 8-27-2007.



THE COLOR(S) GOLD, BLACK AND GREEN IS/ARE CLAIMED AS A FEATURE OF THE MARK.

THE COLOR GOLD APPEARS IN THE LETTERING OF "HOSPITALITY RX" AND IN THE PINEAPPLE AND BORDER OF THE DESIGN. THE COLOR GREEN APPEARS ON THE BRANCHES OF THE PINEAPPLE. THE COLOR BLACK APPEARS AS THE OUTLINE TO THE BORDER OF THE DESIGN AND OUTLINE OF THE PINEAPPLE DESIGN. THE COLOR WHITE APPEARS BACKGROUND AND IS NOT PART OF THE MARK.

FOR EDUCATIONAL SERVICES, NAMELY, CONDUCTING SEMINARS, WORKSHOPS AND TRAINING COURSES IN THE HEALTHCARE INDUSTRY IN THE FIELDS OF PATIENT CARE, CUSTOMER RELATIONS, HUMAN RESOURCES, AND DOCTOR-PATIENT RELATIONSHIPS (U.S. CLS. 100, 101 AND 107).

FIRST USE 6-3-2005; IN COMMERCE 6-3-2005.
LINDA ESTRADA, EXAMINING ATTORNEY

SN 77-267,545. EDUCATION FOR EMPLOYMENT FOUNDATION, WASHINGTON, D.C., DC. FILED 8-29-2007.

EFE

THE MARK CONSISTS OF STANDARD CHARACTERS WITHOUT CLAIM TO ANY PARTICULAR FONT, STYLE, SIZE, OR COLOR.

FOR EDUCATION SERVICES, NAMELY, DEVELOPING AND PROVIDING CLASSES AND CAREER TRAINING IN VOCATIONAL, TECHNICAL, AND MANAGERIAL SKILLS TO YOUNG PEOPLE IN MUSLIM COUNTRIES; CAREER COUNSELING; PROVIDING ON-LINE EDUCATION AND TRAINING, NAMELY, COMPUTER-BASED NON-DOWNLOADABLE EDUCATIONAL MODULES AND MATERIALS CENTERED ON VOCATIONAL, TECHNICAL, AND MANAGERIAL SKILLS; CHARITABLE SERVICES, NAMELY, PROVIDING TRAINING IN VOCATIONAL, TECHNICAL, AND MANAGERIAL SKILLS TO YOUNG PEOPLE IN MUSLIM COUNTRIES (U.S. CLS. 100, 101 AND 107).

FIRST USE 2-23-2006; IN COMMERCE 2-23-2006.
DAVID TOOLEY, EXAMINING ATTORNEY

CLASS 41—(Continued).

SN 77-268,000. GRAND HOSPITALITY, LLC, GRAND RAPIDS, MN. FILED 8-30-2007.

GRAND SPLASH

THE MARK CONSISTS OF STANDARD CHARACTERS WITHOUT CLAIM TO ANY PARTICULAR FONT, STYLE, SIZE, OR COLOR.

FOR ENTERTAINMENT SERVICE IN THE NATURE OF AN AMUSEMENT PARK, NAMELY, A WATER PARK PROVIDED AT A HOTEL (U.S. CLS. 100, 101 AND 107).

FIRST USE 8-1-2007; IN COMMERCE 8-1-2007.
DAVID TOOLEY, EXAMINING ATTORNEY

SN 77-269,064. CULVER FITNESS LLC, GILBERT, AZ. FILED 8-31-2007.

QUEEN OF LEAN

THE MARK CONSISTS OF STANDARD CHARACTERS WITHOUT CLAIM TO ANY PARTICULAR FONT, STYLE, SIZE, OR COLOR.

OWNER OF U.S. REG. NO. 3,215,907.

FOR PROVIDING A WEBSITE FEATURING INFORMATION REGARDING EXERCISE, PHYSICAL FITNESS, PHYSICAL STRENGTH AND CONDITIONING; PROVIDING AN ON-LINE COMPUTER DATABASE FEATURING INFORMATION REGARDING EXERCISE, PHYSICAL FITNESS, PHYSICAL STRENGTH AND CONDITIONING; ENTERTAINMENT SERVICES, NAMELY, CONTEST AND INCENTIVE AWARD PROGRAMS DESIGNED TO REWARD PROGRAM PARTICIPANTS WHO EXERCISE, MAKE HEALTHY EATING CHOICES, AND ENGAGE IN OTHER HEALTH PROMOTING ACTIVITIES; INSTRUCTION AND TRAINING IN THE FIELDS OF HEALTH, EXERCISE, PHYSICAL FITNESS, HEALTHY EATING CHOICES, STRENGTH, CONDITIONING, WELLNESS, LIFESTYLE AND COMBINATIONS THEREOF; CONSULTATION IN THE FIELDS OF EXERCISE, PHYSICAL FITNESS, PHYSICAL STRENGTH AND CONDITIONING; WRITING OF ARTICLES FOR JOURNALS AND PERIODICALS OTHER THAN FOR ADVERTISING OR PUBLICITY IN THE FIELDS OF HEALTH, EXERCISE, PHYSICAL FITNESS, HEALTHY EATING CHOICES, STRENGTH, CONDITIONING, WELLNESS, LIFESTYLE AND COMBINATIONS THEREOF; EDUCATION SERVICES, NAMELY, PROVIDING CONTINUING EDUCATIONAL SHOWS SUITABLE FOR BROADCAST OVER TELEVISION, RADIO, SATELLITE, CABLE, INTERNET IN THE FIELDS OF THE HEALTH, EXERCISE, PHYSICAL FITNESS, HEALTHY EATING CHOICES, STRENGTH, CONDITIONING, WELLNESS, LIFESTYLE AND COMBINATIONS THEREOF; PRODUCTION OF DVDS, VIDEOTAPES AND TELEVISION PROGRAMS FEATURING HEALTH, WELLNESS, FITNESS, AND WEIGHT LOSS, AND COMBINATIONS THEREOF; DIRECTION OF MAKING RADIO OR TELEVISION PROGRAMS IN

CLASS 41—(Continued).

THE FIELDS OF HEALTH, EXERCISE, PHYSICAL FITNESS, HEALTHY EATING CHOICES, STRENGTH, CONDITIONING, WELLNESS, LIFESTYLE AND COMBINATIONS THEREOF; PRODUCTION AND DISTRIBUTION, OF TELEVISION SHOWS AND RADIO PROGRAMS SUITABLE FOR BROADCAST OVER TELEVISION, RADIO, SATELLITE, CABLE, INTERNET IN THE FIELDS OF HEALTH, EXERCISE, PHYSICAL FITNESS, HEALTHY EATING CHOICES, STRENGTH, CONDITIONING, WELLNESS, LIFESTYLE AND COMBINATIONS THEREOF; RADIO PROGRAM SYNDICATION OF PROGRAMS IN THE FIELDS OF HEALTH, EXERCISE, PHYSICAL FITNESS, HEALTHY EATING CHOICES, STRENGTH, CONDITIONING, WELLNESS, LIFESTYLE AND COMBINATIONS THEREOF; TELEVISION PROGRAM SYNDICATION OF PROGRAMS IN THE FIELDS OF HEALTH, EXERCISE, PHYSICAL FITNESS, HEALTHY EATING CHOICES, STRENGTH, CONDITIONING, WELLNESS, LIFESTYLE AND COMBINATIONS THEREOF (U.S. CLS. 100, 101 AND 107).

MONIQUE MILLER, EXAMINING ATTORNEY

CLASS 41—(Continued).

SN 77-274,694. RECENTER CONSULTING, LLC, SAN DIEGO, CA. FILED 9-7-2007.

RECENTER YOUR LIFE

THE MARK CONSISTS OF STANDARD CHARACTERS WITHOUT CLAIM TO ANY PARTICULAR FONT, STYLE, SIZE, OR COLOR.

FOR LIFE COACHING SERVICES IN THE FIELD OF PROFESSIONAL AND PERSONAL DEVELOPMENT.; PERSONAL COACHING SERVICES IN THE FIELD OF REDUCING STRESS, ENHANCING WELL BEING, IMPROVING RELATIONSHIPS.; PROFESSIONAL COACHING SERVICES IN THE FIELD OF CAREER DEVELOPMENT (U.S. CLS. 100, 101 AND 107).

FIRST USE 5-21-1999; IN COMMERCE 5-21-1999.
SUNG IN, EXAMINING ATTORNEY

SN 77-275,427. RAPAGNOLA, CHRISTINE M., DBA NPE MUSIC, FISKDALE, MA. FILED 9-10-2007.

SN 77-273,857. BROCKWAY TRUCK PRESERVATION ASSOCIATION, HOMER, NY. FILED 9-7-2007.



NO CLAIM IS MADE TO THE EXCLUSIVE RIGHT TO USE "BROCKWAY TRUCK MUSEUM", APART FROM THE MARK AS SHOWN.

THE COLOR(S) WHITE, GOLD, RED AND BLACK IS/ARE CLAIMED AS A FEATURE OF THE MARK.

THE MARK CONSISTS OF THE WORD "BROCKWAY" IN GOLD WITHIN A GOLD AND RED LOGO OUTLINED IN BLACK; A GOLD HUSKY WITH BLACK OUTLINE AND SHADING; WHITE SNOW; THE WORDS "TRUCK MUSEUM" IN RED.

FOR MUSEUM AND EDUCATIONAL SERVICES, NAMELY, PROVIDING GUIDED TOURS OF MUSEUMS, GUIDED TOURS OF MOBILE MUSEUM DISPLAYS, CONDUCTING FIELD TRIPS, CLASSES, AND LECTURES, RELATING TO ALL FACETS OF AUTOMOTIVE HISTORY (U.S. CLS. 100, 101 AND 107).

DANIEL CAPSHAW, EXAMINING ATTORNEY



THE COLOR(S) PURPLE, YELLOW, BLUE, BLACK, WHITE, GRAY AND RED IS/ARE CLAIMED AS A FEATURE OF THE MARK.

THE MARK CONSISTS OF IN PART OF A STYLIZED HUMAN FORM BEE SITTING ON A STAR. THE COLOR BLUE APPEARS ON THE BEE'S ARMBAND AND AS A SHADOW OUTLINING THE BEE AND STAR DESIGN. THE COLOR PURPLE IS LOCATED INSIDE THE STAR, IN THE BEE'S SKIRT, IN THE WORD "CHIKI" ON THE BEE'S SHIRT AND ON THE LIPS AND EYELIDS OF THE BEE. THE COLOR YELLOW IS LOCATED IN THE FACE AND BODY OF THE BEE. THE COLOR BLACK IS LOCATED ON THE BODY OF THE BEE, ON THE BEE'S SHIRT, STOCKINGS AND SHOES, OUTLINING THE PURPLE STAR AND AS A RECTANGULAR BACKGROUND IN THE MARK. THE COLOR GRAY APPEARS ON THE BEE'S ARMBAND. THE COLOR RED IS LOCATED OUTLINING THE SPEECH CLOUD DESIGN, IN THE WORDING AND PUNCTUATION "HI, I'M LYDIA, THE CYBERBEE GET STUNG AT WWW.CHIKIMUSIC.COM" AND IN THE UNDERLINE BELOW "WWW.CHIKIMUSIC.COM". THE COLOR WHITE IS LOCATED INSIDE THE SPEECH CLOUD DESIGN AND INSIDE THE BEE'S OPEN EYE.

FOR ENTERTAINMENT IN THE NATURE OF VISUAL, AUDIO AND LIVE PERFORMANCE OF MUSIC BY AN INDIVIDUAL (U.S. CLS. 100, 101 AND 107).

NATALIE POLZER, EXAMINING ATTORNEY

CLASS 41—(Continued).

SN 77-276,680. CROSS COUNTRY EDUCATION, LLC, BOCA RATON, FL. FILED 9-11-2007.



CROSS COUNTRY
EDUCATION

NO CLAIM IS MADE TO THE EXCLUSIVE RIGHT TO USE "EDUCATION", APART FROM THE MARK AS SHOWN.

THE MARK CONSISTS OF THE WORDS "CROSS COUNTRY EDUCATION" DISPLAYED BELOW AN IMAGE OF A TREE.

FOR EDUCATION SERVICES, NAMELY, PROVIDING PROFESSIONAL DEVELOPMENT TRAINING SEMINARS IN THE HEALTHCARE INDUSTRY (U.S. CLS. 100, 101 AND 107).

FIRST USE 10-0-2005; IN COMMERCE 10-0-2005.
VERNA BETH RIRIE, EXAMINING ATTORNEY

SN 77-278,859. BONIFER, MICHAEL, LOS ANGELES, CA. FILED 9-13-2007.

GAMECHANGERS

THE MARK CONSISTS OF STANDARD CHARACTERS WITHOUT CLAIM TO ANY PARTICULAR FONT, STYLE, SIZE, OR COLOR.

FOR EDUCATIONAL SERVICES, NAMELY, PROVIDING TRAINING SERVICES, WORKSHOPS AND SEMINARS IN THE FIELD OF IMPROVISATION AND BUSINESS; CONSULTATION IN THE FIELD OF IMPROVISATION (U.S. CLS. 100, 101 AND 107).

FIRST USE 12-1-2006; IN COMMERCE 12-12-2006.
KYLE PEETE, EXAMINING ATTORNEY

CLASS 41—(Continued).

SN 77-278,928. AMERICAN BANG, INC., FRANKLIN, TN. FILED 9-13-2007.

AMERICAN BANG

THE MARK CONSISTS OF STANDARD CHARACTERS WITHOUT CLAIM TO ANY PARTICULAR FONT, STYLE, SIZE, OR COLOR.

NO CLAIM IS MADE TO THE EXCLUSIVE RIGHT TO USE "AMERICAN", APART FROM THE MARK AS SHOWN.

FOR ENTERTAINMENT IN THE NATURE OF LIVE PERFORMANCES BY A MUSICAL GROUP; ENTERTAINMENT IN THE NATURE OF VISUAL AND AUDIO PERFORMANCES, NAMELY, MUSICAL BAND, ROCK GROUP, GYMNASTIC, DANCE, AND BALLET PERFORMANCES; ENTERTAINMENT IN THE NATURE OF LIVE PERFORMANCES BY A MUSICAL GROUP; ENTERTAINMENT, NAMELY, LIVE PERFORMANCES BY A MUSICAL BAND; ENTERTAINMENT, NAMELY, LIVE MUSIC CONCERTS; ENTERTAINMENT, NAMELY, LIVE PERFORMANCES BY MUSICAL BANDS; ENTERTAINMENT, NAMELY, LIVE PERFORMANCES BY ROCK GROUPS (U.S. CLS. 100, 101 AND 107).

FIRST USE 9-7-2007; IN COMMERCE 9-7-2007.
SANDRA MANIOS, EXAMINING ATTORNEY

SN 77-280,014. CANCER DANCERS, INC., NEW YORK, NY. FILED 9-14-2007.

CANCER DANCERS

THE MARK CONSISTS OF STANDARD CHARACTERS WITHOUT CLAIM TO ANY PARTICULAR FONT, STYLE, SIZE, OR COLOR.

NO CLAIM IS MADE TO THE EXCLUSIVE RIGHT TO USE "CANCER", APART FROM THE MARK AS SHOWN.

FOR PROVIDING DANCE INSTRUCTION AND DANCE LESSONS FOR PEOPLE WITH CANCER AND CANCER SURVIVORS; ENTERTAINMENT IN THE NATURE OF DANCE PERFORMANCES BY PEOPLE WITH CANCER AND CANCER SURVIVORS; ENTERTAINMENT IN THE NATURE OF DANCE EVENTS BY PEOPLE WITH CANCER AND CANCER SURVIVORS; DANCE CAMPS FOR PEOPLE WITH CANCER AND CANCER SURVIVORS (U.S. CLS. 100, 101 AND 107).

FIRST USE 7-27-2007; IN COMMERCE 7-27-2007.
G. MAYERSCHOFF, EXAMINING ATTORNEY

CLASS 41—(Continued).

SN 77-280,549. JAIME PUJOL, MIAMI, FL. FILED 9-16-2007.

UNSINKABLE STARS AND STRIPES

THE MARK CONSISTS OF STANDARD CHARACTERS WITHOUT CLAIM TO ANY PARTICULAR FONT, STYLE, SIZE, OR COLOR.

FOR ENTERTAINMENT IN THE NATURE OF AIR SHOWS (U.S. CLS. 100, 101 AND 107).

DAVID MILLER, EXAMINING ATTORNEY

CLASS 41—(Continued).

SN 77-282,830. REAR VIEW MIRROR HOLDINGS INC., PASADENA, CA. FILED 9-18-2007.

THEDEEP

THE MARK CONSISTS OF STANDARD CHARACTERS WITHOUT CLAIM TO ANY PARTICULAR FONT, STYLE, SIZE, OR COLOR.

FOR CONDUCTING WORKSHOPS AND SEMINARS IN GROUP CONFIDENCE AND TEAM BUILDING EXERCISES (U.S. CLS. 100, 101 AND 107).

ANDREA BUTLER, EXAMINING ATTORNEY

SN 77-281,878. COUNCIL FOR RESPONSIBLE NUTRITION, WASHINGTON, DC. FILED 9-18-2007.



NO CLAIM IS MADE TO THE EXCLUSIVE RIGHT TO USE "STANDARDIZED INFORMATION ON DIETARY INGREDIENTS", APART FROM THE MARK AS SHOWN.

THE MARK CONSISTS IN PART, OF A BOX AND CHECKMARK DESIGN.

FOR PROVIDING ONLINE PUBLICATIONS IN THE NATURE OF BOOKS, PAMPHLETS, AND NEWSLETTERS IN THE FIELD OF DIETARY SUPPLEMENTS (U.S. CLS. 100, 101 AND 107).

FIRST USE 12-0-2006; IN COMMERCE 12-0-2006.
ROBIN CHOSID, EXAMINING ATTORNEY

SN 77-283,069. CBS BROADCASTING INC., NEW YORK, NY. FILED 9-19-2007.

CBS SPORTS

THE MARK CONSISTS OF STANDARD CHARACTERS WITHOUT CLAIM TO ANY PARTICULAR FONT, STYLE, SIZE, OR COLOR.

OWNER OF U.S. REG. NOS. 852,481, 2,928,976 AND OTHERS.

NO CLAIM IS MADE TO THE EXCLUSIVE RIGHT TO USE "SPORTS", APART FROM THE MARK AS SHOWN.

FOR ENTERTAINMENT SERVICES, NAMELY, PROVIDING VIDEO AND AUDIO CONTENT, NAMELY, ONGOING TELEVISION PROGRAMS IN THE NATURE OF CURRENT EVENTS, SPORTS NEWS AND ENTERTAINMENT NEWS ALL TRANSMITTED THROUGH A GLOBAL COMMUNICATIONS NETWORK VIA WIRELESS COMMUNICATION DEVICES, MOBILE PHONES, HAND-HELD DEVICES; PROVIDING INFORMATION IN THE FIELD OF ENTERTAINMENT VIA WIRELESS COMMUNICATION DEVICES, MOBILE PHONES, HAND-HELD DEVICES AND GLOBAL COMMUNICATION DEVICES; INTERACTIVE ONLINE NEWSLETTER PROVIDING SPORTS INFORMATION (U.S. CLS. 100, 101 AND 107).

AMY MCMENAMIN, EXAMINING ATTORNEY

SN 77-282,776. ANDREANI, DAPHNE, SAN RAFAEL, CA. FILED 9-18-2007.

SPEEDPIANO

THE MARK CONSISTS OF STANDARD CHARACTERS WITHOUT CLAIM TO ANY PARTICULAR FONT, STYLE, SIZE, OR COLOR.

FOR TEACHING IN THE FIELD OF MUSIC (U.S. CLS. 100, 101 AND 107).

COLLEEN DOMBROW, EXAMINING ATTORNEY

SN 77-283,485. GALLERYGONELIVE INC., CARBONDALE, IL. FILED 9-19-2007.

STRIPCLUBHOUSE.COM

THE MARK CONSISTS OF STANDARD CHARACTERS WITHOUT CLAIM TO ANY PARTICULAR FONT, STYLE, SIZE, OR COLOR.

FOR ENTERTAINMENT SERVICES, NAMELY, PROVIDING A WEB SITE FEATURING LIVE ADULT ENTERTAINMENT PERFORMANCES (U.S. CLS. 100, 101 AND 107).

FIRST USE 9-6-2007; IN COMMERCE 9-6-2007.
JENNIFER MARTIN, EXAMINING ATTORNEY

CLASS 41—(Continued).

SN 77-283,823. GALLERYGONELIVE INC., CARBONDALE, IL. FILED 9-19-2007.

WORLD'S FIRST LIVE STRIP CLUB

THE MARK CONSISTS OF STANDARD CHARACTERS WITHOUT CLAIM TO ANY PARTICULAR FONT, STYLE, SIZE, OR COLOR.

FOR ENTERTAINMENT SERVICES, NAMELY, PROVIDING A WEB SITE FEATURING LIVE ADULT ENTERTAINMENT PERFORMANCES (U.S. CLS. 100, 101 AND 107).

FIRST USE 9-6-2007; IN COMMERCE 9-6-2007.
JENNIFER MARTIN, EXAMINING ATTORNEY

SN 77-284,366. AMAZING GOODS, LLC, AUSTIN, TX. FILED 9-20-2007.

Disco Abs

THE MARK CONSISTS OF STANDARD CHARACTERS WITHOUT CLAIM TO ANY PARTICULAR FONT, STYLE, SIZE, OR COLOR.

FOR EDUCATIONAL SERVICES, NAMELY, CONDUCTING CLASSES, SEMINARS, CONFERENCES AND TRAINING FOR THE PURPOSE OF HEALTH AND FITNESS THROUGH THE USE OF DANCE ROUTINES USING VIDEO PROGRAMS AND PERSONAL INSTRUCTION (U.S. CLS. 100, 101 AND 107).

FRED MANDIR, EXAMINING ATTORNEY

SN 77-285,077. OLDE TYME TUTORS, LLC, ROGERS, AR. FILED 9-20-2007.

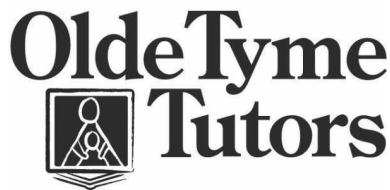

NO CLAIM IS MADE TO THE EXCLUSIVE RIGHT TO USE "TUTORS", APART FROM THE MARK AS SHOWN.

THE MARK CONSISTS OF TWO LINES, THE FIRST LINE

CLASS 41—(Continued).

CONTAINING THE WORDS, "OLDE TYME". THE SECOND LINE HAS A DESIGN FOLLOWED BY THE WORD, "TUTORS". THE DESIGN CONTAINS THREE "V" SHAPED ELEMENTS POSITIONED BELOW A BOX THAT SURROUNDS A SQUARE WITH THE SQUARE HAVING A SOLID BACKGROUND WITH LIGHTER AREAS SHOWING A TRIANGULAR BODIED PERSON WITH AN OVAL HEAD POSITIONED WITH ARMS EXTENDING DOWNWARD TO A SMALLER TRIANGULAR BODIED PERSON WITH AN OVAL HEAD.

FOR EDUCATION SERVICES, NAMELY, CLASSES, WORKSHOPS, INDIVIDUAL GROUP INSTRUCTION AND SMALL GROUP INSTRUCTION IN THE NATURE OF COURSES AT THE GRADE SCHOOL LEVEL AND UNIVERSITY LEVEL (U.S. CLS. 100, 101 AND 107).

FIRST USE 3-1-2006; IN COMMERCE 3-1-2006.
ARETHA SOMERVILLE, EXAMINING ATTORNEY

SN 77-285,269. BETTER LIFE DEVICES CORPORATION, SAN DIEGO, CA. FILED 9-21-2007.



NO CLAIM IS MADE TO THE EXCLUSIVE RIGHT TO USE "TECHNOLOGY" AND "WELLNESS SOLUTIONS", APART FROM THE MARK AS SHOWN.

THE COLOR(S) BLACK, GREEN IS/ARE CLAIMED AS A FEATURE OF THE MARK.

THE MARK CONSISTS OF WORDS "FITNESS FACTORY TECHNOLOGY" WHICH CONTAINS A STYLIZED LETTER "F". THE STYLIZED LETTER "F" IS WITH A BLACK BODY CONTOURED LIKE A LEAF WITH THE GREEN DOT ON THE TOP. FURTHER WORDS "COMPLETE WELLNESS SOLUTIONS" PLACED BENEATH THE STYLIZED WORDS "FITNESS FACTORY TECHNOLOGY".

FOR PROVIDING ASSISTANCE, PERSONAL TRAINING AND PHYSICAL FITNESS CONSULTATION TO CORPORATE CLIENTS TO HELP THEIR EMPLOYEES MAKE PHYSICAL FITNESS, STRENGTH, CONDITIONING, AND EXERCISE ALTERATIONS IN THEIR DAILY LIVING; PROVIDING ASSISTANCE, PERSONAL TRAINING AND PHYSICAL FITNESS CONSULTATION TO INDIVIDUALS TO HELP THEM MAKE PHYSICAL FITNESS, STRENGTH, CONDITIONING, AND EXERCISE IMPROVEMENT IN THEIR DAILY LIVING; PROVIDING FITNESS AND EXERCISE FACILITIES (U.S. CLS. 100, 101 AND 107).

JOHN WILKE, EXAMINING ATTORNEY

CLASS 41—(Continued).

SN 77-285,566. AOL LLC, DULLES, VA. FILED 9-21-2007.

QUEST ACROSS AMERICA

THE MARK CONSISTS OF STANDARD CHARACTERS WITHOUT CLAIM TO ANY PARTICULAR FONT, STYLE, SIZE, OR COLOR.

NO CLAIM IS MADE TO THE EXCLUSIVE RIGHT TO USE "AMERICA", APART FROM THE MARK AS SHOWN.

FOR ENTERTAINMENT SERVICES IN THE NATURE OF PROVIDING A NON-FICTION ONLINE SERIES AND PRERECORDED AUDIO-VISUAL CONTENT IN THE FIELDS OF TRAVEL, GEOGRAPHY, CULTURE, TOURISM, EXPLORATION, AND ADVENTURE PROVIDED VIA COMPUTER NETWORKS; PROVIDING A WEB SITE FEATURING PHOTOGRAPHIC, AUDIO, VIDEO, AND PROSE PRESENTATIONS IN THE FIELDS OF TRAVEL, GEOGRAPHY, CULTURE, TOURISM, EXPLORATION, AND ADVENTURE; ONLINE JOURNALS, NAMELY, BLOGS IN THE FIELD OF TRAVEL, GEOGRAPHY, CULTURE, TOURISM, EXPLORATION, AND ADVENTURE (U.S. CLS. 100, 101 AND 107).

H. M. FISHER, EXAMINING ATTORNEY

SN 77-285,717. GRUNDY MEDIA LIMITED, ST. JOHNS, ANTIGUA & BARBUDA, FILED 9-21-2007.

WHAT'S AMERICA THINKING?

THE MARK CONSISTS OF STANDARD CHARACTERS WITHOUT CLAIM TO ANY PARTICULAR FONT, STYLE, SIZE, OR COLOR.

FOR ENTERTAINMENT IN THE NATURE OF AN ONGOING TELEVISION GAME SHOW; EDUCATIONAL AND ENTERTAINMENT SERVICES, NAMELY, A CONTINUING TELEVISION PROGRAM FEATURING INFORMATIVE CONTENT; PRODUCTION AND DISTRIBUTION OF TELEVISION PROGRAMS; ORGANIZATION OF INTERACTIVE TELEVISION COMPETITIONS; INTERACTIVE TELEPHONE COMPETITIONS, ALSO KNOWN AS CONDUCTING CONTESTS VIA TELEPHONE; PROVISION OF EDUCATION AND ENTERTAINMENT, SPECIFICALLY, PROVIDING AN ONGOING TELEVISION GAME SHOW FEATURING INFORMATIVE CONTENT, BY MEANS OF TELEVISION, SATELLITE, CABLE, TELEPHONE AND THE INTERNET; INTERACTIVE ENTERTAINMENT SERVICES, SPECIFICALLY, ENABLING VIEWER PARTICIPATION IN A TELEVISION GAME SHOW (U.S. CLS. 100, 101 AND 107).

RONALD AIKENS, EXAMINING ATTORNEY

CLASS 41—(Continued).

SN 77-285,828. SILVERFLASH, INC., DBA SEAVID, LA JOLLA, CA. FILED 9-21-2007.



NO CLAIM IS MADE TO THE EXCLUSIVE RIGHT TO USE "TRAVEL", APART FROM THE MARK AS SHOWN.

THE COLOR(S) PURPLE, MAGENTA, BLUE, DARK BLUE, GRAY, WHITE AND BLACK IS/ARE CLAIMED AS A FEATURE OF THE MARK.

THE MARK CONSISTS OF A GLOBE ON A PEDESTAL WITH A MORTARBOARD ON TOP OF THE GLOBE. THE GLOBE, PEDESTAL AND MORTARBOARD CONTAIN THE COLORS PURPLE, MAGENTA, BLUE AND BLACK. A GRAY SHADOW APPEARS BELOW THE GLOBE. THE WORDS "TRAVEL" AND "TUTOR" APPEAR IN THE LOWER RIGHT CORNER OF THE MARK ENCASED IN AN IRREGULAR SHAPED BOX. THE LETTERS ARE IN DARK BLUE, OUTLINED IN PURPLE AND WHITE. THE INTERIOR BACKGROUND OF THE BOX IS PURPLE. THE BOX IS OUTLINED IN BLACK.

FOR ENTERTAINMENT AND EDUCATIONAL SERVICES, NAMELY, PROVIDING VACATION GUIDANCE INFORMATION, NAMELY, ENTERTAINMENT INFORMATION AND VACATION EDUCATIONAL INFORMATION, NAMELY, LOCATION HISTORICAL INFORMATION TO BE VIEWED VIA A PORTABLE MEDIA PLAYER; VIDEOTAPING PRODUCTION SERVICES (U.S. CLS. 100, 101 AND 107).

SHAUNIA CARLYLE, EXAMINING ATTORNEY

SN 77-286,229. SILVERFLASH, INC., DBA SEAVID, LA JOLLA, CA. FILED 9-21-2007.

EXPLORE ASHORE!

THE MARK CONSISTS OF STANDARD CHARACTERS WITHOUT CLAIM TO ANY PARTICULAR FONT, STYLE, SIZE, OR COLOR.

FOR ENTERTAINMENT AND EDUCATIONAL SERVICES, NAMELY, PROVIDING VACATION GUIDANCE INFORMATION, NAMELY, ENTERTAINMENT INFORMATION AND VACATION EDUCATIONAL INFORMATION, NAMELY, LOCATION HISTORICAL INFORMATION TO BE VIEWED VIA A PORTABLE MEDIA PLAYER; VIDEOTAPING PRODUCTION SERVICES (U.S. CLS. 100, 101 AND 107).

SHAUNIA CARLYLE, EXAMINING ATTORNEY

CLASS 41—(Continued).

SN 77-287,087. CHARLES & COLVARD, LTD., MORRISVILLE, NC. FILED 9-24-2007.

BRILLIANT ACHIEVERS

THE MARK CONSISTS OF STANDARD CHARACTERS WITHOUT CLAIM TO ANY PARTICULAR FONT, STYLE, SIZE, OR COLOR.

NO CLAIM IS MADE TO THE EXCLUSIVE RIGHT TO USE "ACHIEVERS", APART FROM THE MARK AS SHOWN.

FOR AWARDS PROGRAM RECOGNIZING THE ACHIEVEMENTS AND CONTRIBUTIONS OF WOMEN (U.S. CLS. 100, 101 AND 107).

REGINA DRUMMOND, EXAMINING ATTORNEY

CLASS 41—(Continued).

SN 77-288,102. WORLD WRESTLING ENTERTAINMENT, INC., STAMFORD, CT. FILED 9-25-2007.

NUNZIO

THE MARK CONSISTS OF STANDARD CHARACTERS WITHOUT CLAIM TO ANY PARTICULAR FONT, STYLE, SIZE, OR COLOR.

THE NAME(S), PORTRAIT(S), AND/OR SIGNATURE(S) SHOWN IN THE MARK DOES NOT IDENTIFY A PARTICULAR LIVING INDIVIDUAL.

FOR ENTERTAINMENT SERVICES, NAMELY, WRESTLING EXHIBITIONS AND PERFORMANCES BY A PROFESSIONAL WRESTLER AND ENTERTAINER; PROVIDING WRESTLING NEWS AND INFORMATION VIA A GLOBAL COMPUTER NETWORK (U.S. CLS. 100, 101 AND 107).

KEVIN DINALLO, EXAMINING ATTORNEY

SN 77-287,254. JUDD, JAMES BRIAN, SAN FRANCISCO, CA. FILED 9-24-2007.

SOLOCENTRAL

THE MARK CONSISTS OF STANDARD CHARACTERS WITHOUT CLAIM TO ANY PARTICULAR FONT, STYLE, SIZE, OR COLOR.

FOR PRESENTATION OF LIVE SHOW PERFORMANCES (U.S. CLS. 100, 101 AND 107).

DOMINIC J. FERRAIUOLO, EXAMINING ATTORNEY

SN 77-288,122. WORLD WRESTLING ENTERTAINMENT, INC., STAMFORD, CT. FILED 9-25-2007.

MONTEL VONTAVIOUS PORTER

THE MARK CONSISTS OF STANDARD CHARACTERS WITHOUT CLAIM TO ANY PARTICULAR FONT, STYLE, SIZE, OR COLOR.

THE NAME(S), PORTRAIT(S), AND/OR SIGNATURE(S) SHOWN IN THE MARK DOES NOT IDENTIFY A PARTICULAR LIVING INDIVIDUAL.

FOR ENTERTAINMENT SERVICES, NAMELY, WRESTLING EXHIBITIONS AND PERFORMANCES BY A PROFESSIONAL WRESTLER AND ENTERTAINER; PROVIDING WRESTLING NEWS AND INFORMATION VIA A GLOBAL COMPUTER NETWORK (U.S. CLS. 100, 101 AND 107).

KEVIN DINALLO, EXAMINING ATTORNEY

SN 77-287,718. DEITRICH, MITCHELL, HOLMESVILLE, OH. AND CRIDER, BRIAN B., HOLMESVILLE, OH. AND GURR, SHANE, HOLMESVILLE, OH. AND MOOREHOUSE II, MICHAEL R., HOLMESVILLE, OH. FILED 9-24-2007.

FADED HOPE

THE MARK CONSISTS OF STANDARD CHARACTERS WITHOUT CLAIM TO ANY PARTICULAR FONT, STYLE, SIZE, OR COLOR.

FOR ENTERTAINMENT, NAMELY, LIVE PERFORMANCES BY A MUSICAL BAND (U.S. CLS. 100, 101 AND 107).

FIRST USE 5-0-2004; IN COMMERCE 5-0-2004.

MICHAEL KEATING, EXAMINING ATTORNEY

SN 77-289,013. ABSHER II, CHARLIE A., POUNDING MILL, VA. FILED 9-26-2007.



FOR ENTERTAINMENT IN THE NATURE OF AUTOMOBILE RACES (U.S. CLS. 100, 101 AND 107).

MARCIE MILONE, EXAMINING ATTORNEY

CLASS 41—(Continued).

SN 77-292,024. EXODUS FILM FUND I, LLC, VENICE, CA. FILED 9-28-2007.



THE COLOR(S) BROWN, BLACK, WHITE, BEIGE, GRAY AND MAUVE IS/ARE CLAIMED AS A FEATURE OF THE MARK.

THE MARK CONSISTS OF A FANCIFUL CHARACTER DESIGN OF A BOY WITH A HUNCHBACK AND ARMS THAT HANG TO THE GROUND WEARING A SHIRT WITH PATCHES. THE COLORS BROWN, GRAY AND BLACK APPEAR IN THE CLOTHING AND SHOES OF THE BOY. THE COLOR BEIGE APPEARS AS THE FLESH TONE ON THE FACE AND HANDS OF THE BOY; THE COLOR BLACK APPEARS IN THE HAIR AND THE EYES OF THE BOY, AND THE COLOR WHITE APPEARS IN THE EYES OF THE BOY. THE COLOR MAUVE APPEARS IN THE BOOT CLIPS OF THE BOY'S BOOTS.

FOR ENTERTAINMENT SERVICES, NAMELY, PRODUCTION OF MOTION PICTURE FILMS AND TELEVISION PROGRAMS; DISTRIBUTION OF MOTION PICTURE FILMS AND TELEVISION PROGRAMS; PROVIDING INFORMATION IN THE FIELD OF MOTION PICTURE FILMS, MUSIC AND TELEVISION PROGRAMS VIA ELECTRONIC GLOBAL COMPUTER NETWORKS; PROVIDING INFORMATION FOR AND ACTUAL ENTERTAINMENT VIA ELECTRONIC GLOBAL COMPUTER NETWORKS IN THE NATURE OF MOTION PICTURE FILMS AND PROGRAMS; PRODUCTION OF ANIMATED MOTION PICTURE FILMS FOR DISTRIBUTION VIA GLOBAL COMPUTER NETWORKS; PROVIDING A WEBSITE FEATURING ANIMATED MOTION PICTURE FILMS VIA AN ELECTRONIC GLOBAL COMPUTER NETWORK (U.S. CLS. 100, 101 AND 107).

JANICE KIM, EXAMINING ATTORNEY

CLASS 41—(Continued).

SN 77-292,888. RICHARD FROM TEXAS, LLC, SAN ANTONIO, TX. FILED 10-1-2007.

Richard From Texas

THE MARK CONSISTS OF STANDARD CHARACTERS WITHOUT CLAIM TO ANY PARTICULAR FONT, STYLE, SIZE, OR COLOR.

NO CLAIM IS MADE TO THE EXCLUSIVE RIGHT TO USE "TEXAS", APART FROM THE MARK AS SHOWN.

THE NAME IN THE MARK IDENTIFIES A LIVING INDIVIDUAL WHOSE CONSENT IS OF RECORD.

FOR ENTERTAINMENT SERVICES, NAMELY, PROVIDING A WEBSITE FEATURING PHOTOGRAPHIC, AUDIO, VIDEO AND PROSE PRESENTATIONS FEATURING A LIVE PERFORMER ENTERTAINMENT IN THE NATURE OF AN ON-GOING SPECIAL VARIETY, NEWS, MUSIC OR COMEDY SHOW FEATURING A LIVE PERFORMER BROADCAST OVER TELEVISION, SATELLITE, AUDIO, AND VIDEO MEDIA; ENTERTAINMENT IN THE NATURE OF LIVE PROSE PERFORMANCES BY A LIVE INDIVIDUAL (U.S. CLS. 100, 101 AND 107).

PAUL F. GAST, EXAMINING ATTORNEY

SN 77-294,268. TIME INC., NEW YORK, NY. FILED 10-2-2007.

I REALLY LOVE MY...

THE MARK CONSISTS OF STANDARD CHARACTERS WITHOUT CLAIM TO ANY PARTICULAR FONT, STYLE, SIZE, OR COLOR.

FOR PROVIDING INFORMATION ONLINE IN THE FIELD OF CELEBRITY NEWS AND CELEBRITY FASHION (U.S. CLS. 100, 101 AND 107).

FIRST USE 2-1-2006; IN COMMERCE 2-1-2006.

DOMINIC FATHY, EXAMINING ATTORNEY

SN 77-294,270. LOVE & MONEY, LLC, LAS VEGAS, NV. FILED 10-2-2007.

POETRY

THE MARK CONSISTS OF STANDARD CHARACTERS WITHOUT CLAIM TO ANY PARTICULAR FONT, STYLE, SIZE, OR COLOR.

FOR NIGHT CLUBS (U.S. CLS. 100, 101 AND 107).

TRACY CROSS, EXAMINING ATTORNEY

CLASS 41—(Continued).

SN 77-295,561. GRUPO DE RADIODIFUSORAS, S.A. DE C.V., COL. POLANCO, MEXICO, FILED 10-3-2007.

LA MANO PELUDA

THE MARK CONSISTS OF STANDARD CHARACTERS WITHOUT CLAIM TO ANY PARTICULAR FONT, STYLE, SIZE, OR COLOR.

THE FOREIGN WORDING IN THE MARK TRANSLATES INTO ENGLISH AS "THE HAIRY HAND".

FOR ENTERTAINMENT SERVICES, NAMELY, CONTINUING RADIO PROGRAMS IN THE FIELD OF TALK RADIO (U.S. CLS. 100, 101 AND 107).

FIRST USE 8-15-1995; IN COMMERCE 8-15-1995.
ALEX KEAM, EXAMINING ATTORNEY

SN 77-295,986. ACADEMY OF GENERAL DENTISTRY, CHICAGO, IL. FILED 10-4-2007.

AGD Briefings

THE MARK CONSISTS OF STANDARD CHARACTERS WITHOUT CLAIM TO ANY PARTICULAR FONT, STYLE, SIZE, OR COLOR.

NO CLAIM IS MADE TO THE EXCLUSIVE RIGHT TO USE "BRIEFINGS", APART FROM THE MARK AS SHOWN.

FOR PUBLICATION OF ELECTRONIC PUBLICATIONS, NAMELY, NEWSLETTERS IN THE FIELD OF DENTISTRY (U.S. CLS. 100, 101 AND 107).

FIRST USE 1-0-2006; IN COMMERCE 1-0-2006.
STEVEN JACKSON, EXAMINING ATTORNEY

SN 77-296,415. COUNTRY MUSIC ASSOCIATION, INC., NASHVILLE, TN. FILED 10-4-2007.

BROADWAY MEETS COUNTRY

THE MARK CONSISTS OF STANDARD CHARACTERS WITHOUT CLAIM TO ANY PARTICULAR FONT, STYLE, SIZE, OR COLOR.

NO CLAIM IS MADE TO THE EXCLUSIVE RIGHT TO USE "BROADWAY" AND "COUNTRY", APART FROM THE MARK AS SHOWN.

FOR ENTERTAINMENT, NAMELY, LIVE MUSIC CONCERTS (U.S. CLS. 100, 101 AND 107).

FIRST USE 11-12-2005; IN COMMERCE 11-12-2005.
MICHELLE DUBOIS, EXAMINING ATTORNEY

CLASS 41—(Continued).

SN 77-296,670. SINGER LEARNING, INC., CINCINNATI, OH. FILED 10-4-2007.

SINGER LEARNING

THE MARK CONSISTS OF STANDARD CHARACTERS WITHOUT CLAIM TO ANY PARTICULAR FONT, STYLE, SIZE, OR COLOR.

NO CLAIM IS MADE TO THE EXCLUSIVE RIGHT TO USE "LEARNING", APART FROM THE MARK AS SHOWN.

FOR EDUCATION SERVICES, NAMELY, PROVIDING CLASSES, SEMINARS, WORKSHOPS, TUTORING, COACHING, AND MENTORING IN THE FIELD OF LEADERSHIP, TRAINING, PRESENTING, AND TEACHING TO BUSINESS AND TEACHING PROFESSIONALS, NOT INCLUDING COLLEGE COUNSELING (U.S. CLS. 100, 101 AND 107).

FIRST USE 7-0-2004; IN COMMERCE 7-0-2004.
MARK PILARO, EXAMINING ATTORNEY

SN 77-298,849. GRAPHITEX INC., DBA BURGESS PRODUCTIONS, SUNNYVALE, CA. FILED 10-8-2007.

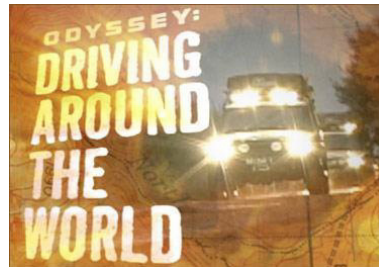

NO CLAIM IS MADE TO THE EXCLUSIVE RIGHT TO USE "DRIVING AROUND THE WORLD", APART FROM THE MARK AS SHOWN.

THE COLOR(S) ORANGE, WHITE, AND BLACK IS/ARE CLAIMED AS A FEATURE OF THE MARK.

THE MARK CONSISTS OF WHITE ALL-CAPS LETTERING OF THE WORDS "ODYSSEY: DRIVING AROUND THE WORLD"; THE LETTERING IS WHITE WITH A TEXTURIZED LAYER OF ORANGE. BLACK DETAILS OF CARS AND TEXTURE SHOW THROUGH THE ORANGE LAYER.

FOR ENTERTAINMENT SERVICES IN THE NATURE OF AN ON-GOING REALITY BASED TELEVISION PROGRAM (U.S. CLS. 100, 101 AND 107).

FIRST USE 6-1-2005; IN COMMERCE 10-1-2007.
DANIEL CAPSHAW, EXAMINING ATTORNEY

CLASS 41—(Continued).

SN 77-299,417. MADEIRA ENTERTAINMENT, VALENCIA, CA. FILED 10-9-2007.

CLASS 41—(Continued).

SN 77-303,379. STOUGAARD, JO, NORTH HOLLYWOOD, CA. AND CUBAK, JANET, NORTH HOLLYWOOD, CA. FILED 10-12-2007.

CHEF MONKEYS

JAMMIN' UNDER THE RADAR

THE MARK CONSISTS OF STANDARD CHARACTERS WITHOUT CLAIM TO ANY PARTICULAR FONT, STYLE, SIZE, OR COLOR.

OWNER OF U.S. REG. NO. 3,281,971.
FOR TRAINING SERVICES IN THE FIELD OF COOKING FOR CHILDREN (U.S. CLS. 100, 101 AND 107).
FIRST USE 6-1-2005; IN COMMERCE 6-1-2005.
TIMOTHY FINNEGAN, EXAMINING ATTORNEY

THE MARK CONSISTS OF STANDARD CHARACTERS WITHOUT CLAIM TO ANY PARTICULAR FONT, STYLE, SIZE, OR COLOR.

FOR ENTERTAINMENT SERVICES, NAMELY, LIVE MUSICAL SHOWS, RADIO SHOWS, TELEVISION SHOWS AND TELEVISION SHOWS FEATURING LIVE MUSICAL ENTERTAINMENT; ENTERTAINMENT SERVICES, NAMELY, PERSONAL APPEARANCES BY A MUSICAL ENTERTAINMENT BAND OR MUSIC GROUP; ENTERTAINMENT SERVICES, NAMELY, PROVIDING A RADIO PROGRAM IN THE FIELD OF LIVE AND PRE-RECORDED MUSICAL PERFORMANCES; ENTERTAINMENT SERVICES, NAMELY, PROVIDING A TELEVISION PROGRAM IN THE FIELD OF LIVE AND PRE-RECORDED MUSICAL PERFORMANCES; ENTERTAINMENT SERVICES, NAMELY, PROVIDING A RADIO PROGRAM IN THE FIELD OF LIVE AND PRE-RECORDED MUSICAL PERFORMANCES VIA A GLOBAL COMPUTER NETWORK; ENTERTAINMENT SERVICES, NAMELY, PROVIDING A TELEVISION PROGRAM IN THE FIELD OF LIVE AND PRE-RECORDED MUSICAL PERFORMANCES VIA A GLOBAL COMPUTER NETWORK; ENTERTAINMENT SERVICES, NAMELY, PROVIDING A WEB SITE FEATURING MUSICAL PERFORMANCES, MUSICAL VIDEOS, RELATED FILM CLIPS, PHOTOGRAPHS, AND OTHER MULTIMEDIA MATERIALS; ENTERTAINMENT SERVICES, NAMELY, PROVIDING ON-LINE REVIEWS OF MUSIC AND MUSICAL PERFORMANCES; ENTERTAINMENT SERVICES, NAMELY, PROVIDING PRERECORDED MUSIC, INFORMATION IN THE FIELD OF MUSIC, AND COMMENTARY AND ARTICLES ABOUT MUSIC, ALL ON-LINE VIA A GLOBAL COMPUTER NETWORK; ENTERTAINMENT SERVICES, NAMELY, ON-GOING RADIO PROGRAMS IN THE FIELD OF MUSICAL ENTERTAINMENT; ENTERTAINMENT SERVICES, NAMELY, ON-GOING TELEVISION PROGRAMS IN THE FIELD OF MUSICAL ENTERTAINMENT; ENTERTAINMENT SERVICES, NAMELY, PROVIDING WEBCASTS IN THE FIELD OF MUSIC AND MUSICAL PERFORMANCES; ENTERTAINMENT, NAMELY, LIVE MUSIC CONCERTS; MUSIC PRODUCTION SERVICES; PRODUCTION OF SOUND AND MUSIC VIDEO RECORDINGS; PRODUCTION OF SOUND AND MUSIC AUDIO RECORDINGS; ARRANGING AND CONDUCTING OF CONCERTS; CONCERT BOOKING; TELEVISION SHOW PRODUCTION; PRODUCTION OF RADIO AND TELEVISION PROGRAMS; PRODUCTION OF CABLE TELEVISION PROGRAMS; PRODUCTION OF DVDS, VIDEOTAPES AND TELEVISION PROGRAMS FEATURING MUSIC AND MUSICAL PERFORMANCES; PRODUCTION OF LIVE MUSICAL ENTERTAINMENT (U.S. CLS. 100, 101 AND 107).

APRIL ROACH, EXAMINING ATTORNEY

SN 77-304,283. HSP GAMING, LP, PHILADELPHIA, PA. FILED 10-15-2007.

SUGARHOUSE GAMING

THE MARK CONSISTS OF STANDARD CHARACTERS WITHOUT CLAIM TO ANY PARTICULAR FONT, STYLE, SIZE, OR COLOR.

NO CLAIM IS MADE TO THE EXCLUSIVE RIGHT TO USE "GAMING", APART FROM THE MARK AS SHOWN.
FOR CASINO SERVICES (U.S. CLS. 100, 101 AND 107).
BILL DAWE, EXAMINING ATTORNEY

SN 77-304,293. HSP GAMING, LP, PHILADELPHIA, PA. FILED 10-15-2007.

SUGARHOUSE CASINO

THE MARK CONSISTS OF STANDARD CHARACTERS WITHOUT CLAIM TO ANY PARTICULAR FONT, STYLE, SIZE, OR COLOR.

NO CLAIM IS MADE TO THE EXCLUSIVE RIGHT TO USE "CASINO", APART FROM THE MARK AS SHOWN.
FOR CASINO SERVICES (U.S. CLS. 100, 101 AND 107).
BILL DAWE, EXAMINING ATTORNEY

CLASS 41—(Continued).

SN 77-305,369. ORGANIZATION OF AMERICAN STATES, EXECUTIVE SECRETARIAT FOR INTEGRAL DEVELOPMENT, WASHINGTON, DC. FILED 10-16-2007.

MuNet

THE MARK CONSISTS OF STANDARD CHARACTERS WITHOUT CLAIM TO ANY PARTICULAR FONT, STYLE, SIZE, OR COLOR.

FOR EDUCATION SERVICES, NAMELY, PROVIDING TRAINING SEMINARS AND WORKSHOPS PROVIDED TO MUNICIPAL GOVERNMENTS IN THE FIELDS OF ELECTRONIC GOVERNMENT, CADASTRE AND GOVERNMENT PROCUREMENT WITH CONSULTATION RELATED THERETO (U.S. CLS. 100, 101 AND 107).

FIRST USE 0-0-2004; IN COMMERCE 0-0-2004.
JESSICA A. POWERS, EXAMINING ATTORNEY

SN 77-312,282. CREATIVITY CENTRAL, LLC, DENVER, CO. FILED 10-24-2007.

INNOVATORS IN RESIDENCE

THE MARK CONSISTS OF STANDARD CHARACTERS WITHOUT CLAIM TO ANY PARTICULAR FONT, STYLE, SIZE, OR COLOR.

FOR EDUCATIONAL SERVICES, NAMELY, CONDUCTING PROGRAMS DESIGNED TO STIMULATE CREATIVITY AND INNOVATION AND NURTURE THINKING, FACILITATE PROBLEM SOLVING AND SOLUTION FINDING (U.S. CLS. 100, 101 AND 107).

GINA FINK, EXAMINING ATTORNEY

SN 77-312,620. CODEMINION, WARSZAWA, POLAND, FILED 10-24-2007.



NO CLAIM IS MADE TO THE EXCLUSIVE RIGHT TO USE "GAME", APART FROM THE MARK AS SHOWN.

THE COLOR(S) BROWN, WHITE, BLACK, BLUE AND RED IS/ARE CLAIMED AS A FEATURE OF THE MARK.

THE COLOR WHITE APPEARS IN THE WORDING "GAME CLUB CAFE", AND IN THE DESIGN OF THE

CLASS 41—(Continued).

COFFEE CUP. THE COLOR BROWN APPEARS IN THE WORDING "GAME CLUB CAFE", THE WORDING "SERVING HOT GAMES", THE CIRCLE DESIGN ELEMENT, THE BANNER DESIGN ELEMENT, THE PUZZLE PIECE DESIGN ELEMENT, THE TABLE DESIGN ELEMENT, AND THE COFFEE CUP DESIGN ELEMENT. THE COLOR BLACK APPEARS AS A BORDER AROUND THE CIRCLE DESIGN ELEMENT AND THE BANNER DESIGN ELEMENT. THE COLOR BLUE APPEARS ON THE SHELL CANDY DESIGN ELEMENT. THE COLOR RED APPEARS ON THE SHELL CANDY DESIGN ELEMENT. THE COLOR GRAY APPEARS AS A BACKGROUND TO THE MARK AND IS NOT A CLAIMED ELEMENT OF THE MARK ITSELF.

FOR ENTERTAINMENT SERVICES, NAMELY, PROVIDING ONLINE COMPUTER GAMES; ENTERTAINMENT SERVICES, NAMELY, PROVIDING A WEB SITE FEATURING ONLINE COMPUTER GAMES AND INFORMATION IN THE FIELD OF GAMING (U.S. CLS. 100, 101 AND 107).

ANDREA K. NADELMAN, EXAMINING ATTORNEY

SN 77-316,003. BLACK ENTERTAINMENT TELEVISION LLC, DBA BET, WASHINGTON, DC. FILED 10-29-2007.

BET HONORS

THE MARK CONSISTS OF STANDARD CHARACTERS WITHOUT CLAIM TO ANY PARTICULAR FONT, STYLE, SIZE, OR COLOR.

OWNER OF U.S. REG. NOS. 1,511,259, 2,558,012 AND OTHERS.

NO CLAIM IS MADE TO THE EXCLUSIVE RIGHT TO USE "HONORS", APART FROM THE MARK AS SHOWN.

FOR ENTERTAINMENT IN THE NATURE OF TELEVISED AWARDS PROGRAMS; PROVIDING AN ANNUAL AWARDS PROGRAM FOR THE PRESENTATION OF AWARDS IN RECOGNITION OF AFRICAN AMERICANS' DISTINGUISHED ACHIEVEMENTS AND SUBSTANTIAL CONTRIBUTIONS TO SOCIETY; EDUCATIONAL SERVICES, NAMELY, PROVIDING INCENTIVES TO ENCOURAGE INDIVIDUALS TO DEMONSTRATE EXCELLENCE IN THE FIELD OF MAKING SIGNIFICANT CONTRIBUTIONS TO SOCIETY THROUGH THE ISSUANCE OF AWARDS (U.S. CLS. 100, 101 AND 107).

SETH A. RAPPAPORT, EXAMINING ATTORNEY

SN 77-316,263. FREMANTLE MEDIA OPERATIONS B.V., HILVERSUM, NETHERLANDS, FILED 10-29-2007.

TATTLETALES

THE MARK CONSISTS OF STANDARD CHARACTERS WITHOUT CLAIM TO ANY PARTICULAR FONT, STYLE, SIZE, OR COLOR.

FOR ENTERTAINMENT SERVICES IN THE NATURE OF AN ONGOING TELEVISION GAME SHOW; ENTERTAINMENT SERVICES, NAMELY, PROVIDING AN ONLINE COMPUTER GAME; PROVIDING DIGITIZED PRINT AND VISUAL INFORMATION ABOUT A TELEVISION SERIES VIA A GLOBAL COMPUTER NETWORK (U.S. CLS. 100, 101 AND 107).

MARGARET POWER, EXAMINING ATTORNEY

CLASS 41—(Continued).

SN 77-316,806. CEC ENTERPRISES, INC., SPRING, TX. FILED 10-30-2007.



OWNER OF U.S. REG. NO. 3,351,821.
 THE COLOR(S) RED, YELLOW, BLUE, GREEN, BLACK AND WHITE IS/ARE CLAIMED AS A FEATURE OF THE MARK.
 THE MARK CONSISTS OF A GREEN FROG WITH WHITE TEETH, BLACK PUPILS INSIDE WHITE EYES, WEARING BLUE SHORTS, A YELLOW BASEBALL CAP WITH A BLUE BILL AND A RED BUTTON ON TOP, A RED T-SHIRT WITH STYLIZED LETTERS "IW" IN YELLOW WITH BLUE SHADOWING, A YELLOW WRIST BAND WITH STYLIZED LETTERS "IW" IN YELLOW WITH BLUE SHADOWING AND WITH MOST ELEMENTS OUTLINED IN BLACK.
 SEC. 2(F).
 FOR PROVIDING RECREATIONAL AREAS IN THE NATURE OF CHILDREN'S PLAY AREAS (U.S. CLS. 100, 101 AND 107).
 SOPHIA S. KIM, EXAMINING ATTORNEY

CLASS 41—(Continued).

SN 77-318,056. PETRATOS, PANAGIOTIS, TURLOCK, CA. FILED 10-31-2007.



NO CLAIM IS MADE TO THE EXCLUSIVE RIGHT TO USE "CALIFORNIA ACADEMY OF SCIENCE AND RESEARCH", APART FROM THE MARK AS SHOWN.
 THE COLOR(S) GOLD IS/ARE CLAIMED AS A FEATURE OF THE MARK.
 THE MARK CONSISTS OF A GOLD MEDAL OF ATHENA WITH THE INSCRIPTION "CALIFORNIA ACADEMY OF SCIENCE AND RESEARCH".
 FOR EDUCATIONAL SERVICES, NAMELY, CONDUCTING CLASSES, SEMINARS, CONFERENCES, WORKSHOPS IN THE FIELD OF BUSINESS, SCIENCES, ENGINEERING, ARTS AND DISTRIBUTION OF COURSE MATERIAL IN CONNECTION THEREWITH (U.S. CLS. 100, 101 AND 107).
 SARA THOMAS, EXAMINING ATTORNEY

SN 77-317,321. THE HOLE IN THE WALL GANG FUND, INC., NEW HAVEN, CT. FILED 10-30-2007.



OWNER OF U.S. REG. NO. 2,081,582.
 NO CLAIM IS MADE TO THE EXCLUSIVE RIGHT TO USE "CAMP", APART FROM THE MARK AS SHOWN.
 THE COLOR(S) RED, BLUE, YELLOW, GREEN, PURPLE, LIGHT BLUE, ORANGE AND LIGHT GREEN IS/ARE CLAIMED AS A FEATURE OF THE MARK.
 THE MARK CONSISTS OF VERTICAL PANELS OF RED, BLUE, YELLOW, GREEN, PURPLE, LIGHT BLUE, ORANGE AND LIGHT GREEN. THE WORD "A" IS GREEN, "HOLE" IS IN BLUE, "IN" IS IN RED, "THE" IS IN YELLOW, "WALL" IS IN PURPLE, AND "CAMP" IS IN ORANGE.
 FOR RECREATIONAL SERVICES IN THE NATURE OF CAMPS FOR CHILDREN WITH CANCER AND OTHER LIFE-THREATENING ILLNESSES (U.S. CLS. 100, 101 AND 107).
 FIRST USE 1-1-2007; IN COMMERCE 2-1-2007.
 ALEX KEAM, EXAMINING ATTORNEY

SN 77-319,066. SHUFFLE MASTER, INC., LAS VEGAS, NV. FILED 11-1-2007.



OWNER OF U.S. REG. NO. 2,397,403.
 NO CLAIM IS MADE TO THE EXCLUSIVE RIGHT TO USE "THREE CARD DRAW POKER", APART FROM THE MARK AS SHOWN.
 THE MARK CONSISTS OF THREE FANNED CARDS ABOVE THE WORDS "THREE CARD DRAW POKER".
 FOR ENTERTAINMENT SERVICES, NAMELY, PROVIDING A LIVE GAME OF CHANCE IN A CASINO (U.S. CLS. 100, 101 AND 107).
 RICHARD A. STRASER, EXAMINING ATTORNEY

CLASS 41—(Continued).

SN 77-322,876. BLUE MAN PRODUCTIONS, INC., NEW YORK, NY. FILED 11-6-2007.

BLUE MAN CREATIVITY CENTER

THE MARK CONSISTS OF STANDARD CHARACTERS WITHOUT CLAIM TO ANY PARTICULAR FONT, STYLE, SIZE, OR COLOR.

NO CLAIM IS MADE TO THE EXCLUSIVE RIGHT TO USE "CREATIVITY CENTER", APART FROM THE MARK AS SHOWN.

FOR EDUCATIONAL SERVICES, NAMELY, PROVIDING CLASSES AND WORKSHOPS IN THE FIELDS OF LANGUAGE, SCIENCE, MATH, SOCIAL STUDIES, FINE ARTS, PERFORMING ARTS, PHYSICAL ARTS, FITNESS, TECHNOLOGY AND MEDIA LITERACY AND DISTRIBUTION OF COURSE MATERIALS IN CONNECTION THEREWITH (U.S. CLS. 100, 101 AND 107).

FIRST USE 8-0-2007; IN COMMERCE 8-0-2007.
MARY CRAWFORD, EXAMINING ATTORNEY

CLASS 41—(Continued).

SN 77-330,260. ENERGY TRAINING RESOURCES, L.L.C., HOUSTON, TX. FILED 11-15-2007.

Oil and Gas Boot Camp

THE MARK CONSISTS OF STANDARD CHARACTERS WITHOUT CLAIM TO ANY PARTICULAR FONT, STYLE, SIZE, OR COLOR.

NO CLAIM IS MADE TO THE EXCLUSIVE RIGHT TO USE "OIL AND GAS", APART FROM THE MARK AS SHOWN.

FOR ARRANGING OF SEMINARS AND CONFERENCES; EDUCATIONAL SERVICES, NAMELY, CONDUCTING CLASSES, SEMINARS, CONFERENCES AND WORKSHOPS IN THE FIELD OF ENERGY INDUSTRY MATTERS AND DISTRIBUTION OF COURSE MATERIAL IN CONNECTION THEREWITH (U.S. CLS. 100, 101 AND 107).

DEBRA LEE, EXAMINING ATTORNEY

SN 77-335,740. TEXAS CHEERLEADING ASSOCIATION, INC., DBA TCA CORP., BACLIF, TX. FILED 11-21-2007.

SN 77-325,797. INTELEX CORPORATION, CHARLOTTESVILLE, VA. FILED 11-9-2007.



Philosophy
ONLINE

NO CLAIM IS MADE TO THE EXCLUSIVE RIGHT TO USE "PHILOSOPHY ONLINE", APART FROM THE MARK AS SHOWN.

THE COLOR(S) BLUE, GRAY AND WHITE IS/ARE CLAIMED AS A FEATURE OF THE MARK.

THE MARK CONSISTS OF BLUE CIRCLE CONTAINING BLUE INTERCONNECTED LINES TO LEFT OF BLUE WORD "PHILOSOPHY" WHICH IS SEPARATED BY A GRAY LINE FROM THE GRAY WORD "ONLINE" BELOW, ALL ON A WHITE BACKGROUND.

FOR PUBLICATION OF ELECTRONIC PUBLICATIONS IN THE NATURE OF JOURNALS AND TEXTS IN THE FIELD OF PHILOSOPHY ACCESSIBLE VIA A GLOBAL COMPUTER NETWORK (U.S. CLS. 100, 101 AND 107).

RENEE MCCRAY, EXAMINING ATTORNEY



NO CLAIM IS MADE TO THE EXCLUSIVE RIGHT TO USE "CHEER" AND "DANCE" AND "GYM" AND "WORLD CHALLENGE", APART FROM THE MARK AS SHOWN.

THE MARK CONSISTS OF THE LITERAL TEXT "SMALL GYM" ACROSS THE MIDDLE OF THE IMAGE FROM LEFT TO RIGHT SUPERIMPOSED UPON AN ELONGATED GLOBE; ABOVE THIS TEXT ABOVE THE GLOBE IS LITERAL TEXT "CHEER DANCE" FROM LEFT TO RIGHT WITH A STAR IN THE MIDDLE; BELOW THE CENTRAL TEXT AND BELOW THE ELONGATED GLOBE IS LITERAL TEXT "WORLD CHALLENGE" FROM LEFT TO RIGHT.

FOR ENTERTAINMENT IN THE NATURE OF COMPETITIONS IN THE FIELD OF CHEERLEADING, DANCE, DRILL TEAMS, POM POM SQUADS; ORGANIZING SPORTING EVENTS, NAMELY, CHEERLEADING, DANCE, DRILL TEAMS, POM POM SQUADS; ENTERTAINMENT SERVICES, NAMELY, ARRANGING AND CONDUCTING OF COMPETITIONS FOR CHEERLEADING, DANCE, DRILL TEAMS, POM POM SQUADS (U.S. CLS. 100, 101 AND 107).

PAULA MAHONEY, EXAMINING ATTORNEY

CLASS 41—(Continued).

SN 77-337,485. CHICKIP, LLC, BEVERLY HILLS, CA. FILED 11-27-2007.

CAGEPOTATO

THE MARK CONSISTS OF STANDARD CHARACTERS WITHOUT CLAIM TO ANY PARTICULAR FONT, STYLE, SIZE, OR COLOR.

FOR PROVIDING A WEBSITE FEATURING INFORMATION ABOUT MIXED MARTIAL ARTS; ON-LINE JOURNALS, NAMELY, BLOGS FEATURING INFORMATION ABOUT MIXED MARTIAL ARTS (U.S. CLS. 100, 101 AND 107).

FIRST USE 10-0-2007; IN COMMERCE 10-0-2007.
STEVEN R. FOSTER, EXAMINING ATTORNEY

CLASS 41—(Continued).

SN 77-340,447. COVENANT COLLEGE, INC., LOOKOUT MOUNTAIN, GA. FILED 11-29-2007.



COVENANT
COLLEGE

NO CLAIM IS MADE TO THE EXCLUSIVE RIGHT TO USE "COLLEGE", APART FROM THE MARK AS SHOWN.

THE COLOR(S) DARK BLUE, LIGHT BLUE AND WHITE IS/ARE CLAIMED AS A FEATURE OF THE MARK.

THE MARK CONSISTS OF A DARK BLUE SHIELD WITH A SCOTTISH THISTLE IN WHITE DISPOSED IN THE MIDDLE LEFT OF THE SHIELD SYMBOL AND LIGHT BLUE DIAGONAL STRIPES ON THE RIGHT SIDE OF THE SHIELD WITH THE WORDS "COVENANT COLLEGE" ON TWO SEPARATE LINES BELOW THE SHIELD.

FOR EDUCATIONAL SERVICES, NAMELY, PROVIDING COURSES OF INSTRUCTION AT THE COLLEGE AND GRADUATE LEVEL (U.S. CLS. 100, 101 AND 107).

FIRST USE 6-15-2004; IN COMMERCE 6-15-2004.
KATHERINE CONNOLLY, EXAMINING ATTORNEY

SN 77-338,115. THE CENTER SPACE, LLC, NEW YORK, NY. FILED 11-27-2007.

CenterCare

THE MARK CONSISTS OF STANDARD CHARACTERS WITHOUT CLAIM TO ANY PARTICULAR FONT, STYLE, SIZE, OR COLOR.

FOR PHYSICAL FITNESS INSTRUCTION IN THE FORM OF A SERIES OF EXERCISES THAT COMBINE ELEMENTS OF YOGA AND PILATES, CONSISTING OF THE MOST PHYSICALLY THERAPEUTIC EXERCISES TAKEN FROM YOGA AND PILATES, TAUGHT IN A SPECIFIC ORDER, AND WITH THE GOAL OF HELPING PEOPLE IMPROVE FLEXIBILITY, FUNCTIONALITY AND AWARENESS (U.S. CLS. 100, 101 AND 107).

REGINA DRUMMOND, EXAMINING ATTORNEY

SN 77-345,954. NEOPLE, INC., SEOUL, REPUBLIC OF KOREA, FILED 12-6-2007.

Dungeon & Fighter

THE MARK CONSISTS OF STANDARD CHARACTERS WITHOUT CLAIM TO ANY PARTICULAR FONT, STYLE, SIZE, OR COLOR.

OWNER OF REPUBLIC OF KOREA REG. NO. 127464, DATED 2-7-2006, EXPIRES 2-7-2016.

FOR ENTERTAINMENT SERVICES, NAMELY, PROVIDING ON-LINE COMPUTER GAMES; PROVIDING INFORMATION ON ON-LINE GAMES; ENCOURAGING ON-LINE GAMES BY SPONSORING AND PROMOTING ON-LINE GAME PROGRAMS AND ACTIVITIES; ORGANIZATION OF ON-LINE GAME COMPETITIONS; PROVIDING AMUSEMENT ARCADE SERVICES (U.S. CLS. 100, 101 AND 107).

ANGELA M. MICHELI, EXAMINING ATTORNEY

CLASS 41—(Continued).

SN 77-345,973. NEOPLE, INC., SEOUL, REPUBLIC OF KOREA, FILED 12-6-2007.

dnf

THE MARK CONSISTS OF STANDARD CHARACTERS WITHOUT CLAIM TO ANY PARTICULAR FONT, STYLE, SIZE, OR COLOR.

FOR ENTERTAINMENT SERVICES, NAMELY, PROVIDING ON-LINE COMPUTER GAMES; PROVIDING INFORMATION ON ON-LINE GAMES; ENCOURAGING ON-LINE GAMES BY SPONSORING AND PROMOTING ON-LINE GAME PROGRAMS AND ACTIVITIES; ORGANIZATION OF ON-LINE GAME COMPETITIONS; PROVIDING AMUSEMENT ARCADE SERVICES (U.S. CLS. 100, 101 AND 107).

ANGELA M. MICHELI, EXAMINING ATTORNEY

CLASS 41—(Continued).

SN 77-353,327. CARLOS ABREU, BEVERLY HILLS, CA. FILED 12-17-2007.

HOLLYWOOD MOBILE AWARDS

THE MARK CONSISTS OF STANDARD CHARACTERS WITHOUT CLAIM TO ANY PARTICULAR FONT, STYLE, SIZE, OR COLOR.

OWNER OF U.S. REG. NOS. 2,493,697, 3,128,570 AND 3,150,407.

NO CLAIM IS MADE TO THE EXCLUSIVE RIGHT TO USE "MOBILE AWARDS", APART FROM THE MARK AS SHOWN.

SEC. 2(F) AS TO "HOLLYWOOD".

FOR PROVIDING RECOGNITION AND INCENTIVES BY THE WAY OF AWARDS AND CONTESTS TO DEMONSTRATE EXCELLENCE IN THE FIELD OF FILM AND MUSIC (U.S. CLS. 100, 101 AND 107).

FIRST USE 12-16-2007; IN COMMERCE 12-16-2007.

DAYNA BROWNE, EXAMINING ATTORNEY

SN 77-351,873. HOLMES, ERSLYNN ANNETTE, WASHINGTON, DC. FILED S.R. 12-13-2007; AM. P.R. 4-28-2008.

Tipping the Velvet
Entertainment

THE MARK CONSISTS OF STANDARD CHARACTERS WITHOUT CLAIM TO ANY PARTICULAR FONT, STYLE, SIZE, OR COLOR.

NO CLAIM IS MADE TO THE EXCLUSIVE RIGHT TO USE "ENTERTAINMENT", APART FROM THE MARK AS SHOWN.

FOR ARRANGING AND CONDUCTING NIGHTCLUB ENTERTAINMENT EVENTS; ARRANGING AND CONDUCTING NIGHTCLUB PARTIES; DANCE EVENTS; ORGANIZATION OF DANCING EVENTS; SPECIAL EVENT PLANNING (U.S. CLS. 100, 101 AND 107).

FIRST USE 9-30-2007; IN COMMERCE 10-9-2007.
ALYSSA PALADINO, EXAMINING ATTORNEY

SN 77-358,791. HAMPTON ISLAND, LLC, ATLANTA, GA. FILED 12-22-2007.

HAMPTON ISLAND PRESERVE

THE MARK CONSISTS OF STANDARD CHARACTERS WITHOUT CLAIM TO ANY PARTICULAR FONT, STYLE, SIZE, OR COLOR.

NO CLAIM IS MADE TO THE EXCLUSIVE RIGHT TO USE "PRESERVE", APART FROM THE MARK AS SHOWN.

FOR GOLF COURSES; GOLF CLUB SERVICES; PROVIDING FACILITIES FOR RECREATION ACTIVITIES; RECREATIONAL SERVICES IN THE NATURE OF POOLS, HORSEBACK RIDING FACILITIES; RECREATIONAL SERVICES, NAMELY, PROVIDING HUNTING PRESERVES; PROVIDING INFORMATION ON RECREATIONAL FISHING; PROVIDING TENNIS COURTS (U.S. CLS. 100, 101 AND 107).

FIRST USE 1-0-2004; IN COMMERCE 1-0-2004.
GEORGIA CARTY, EXAMINING ATTORNEY

CLASS 41—(Continued).

SN 77-360,078. SOLOMON, CRYSTAL, DBA GITA GIRLS FOUNDATION, WOODBRIDGE, VA. FILED 12-27-2007.



NO CLAIM IS MADE TO THE EXCLUSIVE RIGHT TO USE "GIRLS", APART FROM THE MARK AS SHOWN.

THE MARK CONSISTS OF THE WORD "GITA" IN LOWER CASE SCRIPT FONT; THE SLOGAN "GIRLS INSPIRED TO ACHIEVE" AND THE HIGHLY STYLIZED DESIGN OF A GIRL WITH LONG HAIR.

FOR PROVIDING MENTORING IN THE FIELD OF PERSONAL MOTIVATION AND GOAL ATTAINMENT; PROVIDING CAREER COUNSELING; PROVIDING LIFE TRAINING SKILLS, NAMELY, LIFE COACHING SERVICES IN THE FIELD OF PERSONAL MOTIVATION AND GOAL ATTAINMENT (U.S. CLS. 100, 101 AND 107).

FIRST USE 10-1-2006; IN COMMERCE 10-1-2006.

LEIGH CAROLINE CASE, EXAMINING ATTORNEY

SN 77-362,775. OK PRODUCTIONS THE ITALIAN RESTAURANTS TV NETWORK, NEW YORK, NY. FILED 1-2-2008.

BRINDIAMO

THE MARK CONSISTS OF STANDARD CHARACTERS WITHOUT CLAIM TO ANY PARTICULAR FONT, STYLE, SIZE, OR COLOR.

THE ENGLISH TRANSLATION OF "BRINDIAMO" IN THE MARK IS "LET'S TOAST."

FOR ENTERTAINMENT SERVICES, NAMELY, A TELEVISION PROGRAM THAT FEATURES RESTAURANTS, FOOD PREPARATION, COOKING AND FOOD PRODUCTS, DISCUSSIONS WITH GUESTS THAT PROVIDE INFORMATION RELATING TO DIVERSE HUMAN CULTURES, HISTORY, LIFESTYLES, FASHION, NEWS AND COMMENTARY IN THE FIELD OF TRAVEL (U.S. CLS. 100, 101 AND 107).

FIRST USE 10-6-2005; IN COMMERCE 10-6-2005.

JOHN KELLY, EXAMINING ATTORNEY

CLASS 41—(Continued).

SN 77-365,230. ROZANSKY & ASSOCIATES, LLC, DESPLAINES, IL. FILED 1-7-2008.

CONTINUITY123

THE MARK CONSISTS OF STANDARD CHARACTERS WITHOUT CLAIM TO ANY PARTICULAR FONT, STYLE, SIZE, OR COLOR.

FOR PROFESSIONAL COACHING SERVICES IN THE FIELD OF BUSINESS CONTINUITY AND DISASTER RECOVERY; TRAINING SERVICES IN THE FIELD OF BUSINESS CONTINUITY AND DISASTER RECOVERY (U.S. CLS. 100, 101 AND 107).

JAY FLOWERS, EXAMINING ATTORNEY

SN 77-369,320. VIACOM INTERNATIONAL INC., NEW YORK, NY. FILED 1-11-2008.

MTV TR3S DAME UN BREAK

THE MARK CONSISTS OF STANDARD CHARACTERS WITHOUT CLAIM TO ANY PARTICULAR FONT, STYLE, SIZE, OR COLOR.

OWNER OF U.S. REG. NOS. 3,277,975 AND 3,277,976.

THE ENGLISH TRANSLATION OF "DAME UN" IS "GIVE ME A".

FOR ENTERTAINMENT SERVICES IN THE NATURE OF TELEVISION SERIES, FEATURING LIVE ACTION, COMEDY AND DRAMA; PROVIDING ONLINE INFORMATION IN THE FIELD OF ENTERTAINMENT CONCERNING TELEVISION PROGRAMS (U.S. CLS. 100, 101 AND 107).

YAT SYE, LEE, EXAMINING ATTORNEY

CLASS 41—(Continued).

SN 77-371,562. PIMENTEL, LEON, NORTH HOLLYWOOD, CA. FILED 1-14-2008.



FOR ENTERTAINMENT IN THE NATURE OF LIVE PERFORMANCES BY A MUSICAL BAND; ENTERTAINMENT SERVICES, NAMELY, PROVIDING A WEB SITE FEATURING PHOTOGRAPHIC, AUDIO, VIDEO AND PROSE PRESENTATIONS FEATURING THE WORK OF A MUSICAL BAND (U.S. CLS. 100, 101 AND 107).
FIRST USE 6-7-2005; IN COMMERCE 7-14-2006.
KATHERINE CHANG, EXAMINING ATTORNEY

CLASS 41—(Continued).

SN 77-371,722. GRABARITS, MICHAEL, WHITEHALL, PA. FILED 1-15-2008.

**STRAIGHT TALK BY THE
AUTHORS**

THE MARK CONSISTS OF STANDARD CHARACTERS WITHOUT CLAIM TO ANY PARTICULAR FONT, STYLE, SIZE, OR COLOR.
NO CLAIM IS MADE TO THE EXCLUSIVE RIGHT TO USE "BY THE AUTHORS", APART FROM THE MARK AS SHOWN.
FOR EDUCATIONAL SERVICES, NAMELY, DEVELOPING, ARRANGING, AND CONDUCTING EDUCATIONAL CONFERENCES AND PROGRAMS AND PROVIDING COURSES OF INSTRUCTION IN THE FIELD OF LITERACY (U.S. CLS. 100, 101 AND 107).
MICHELLE DUBOIS, EXAMINING ATTORNEY

SN 77-371,668. FREMANTLEMEDIA NORTH AMERICA INC, BURBANK, CA. FILED 1-15-2008.

TAKE ME OUT

THE MARK CONSISTS OF STANDARD CHARACTERS WITHOUT CLAIM TO ANY PARTICULAR FONT, STYLE, SIZE, OR COLOR.
FOR ENTERTAINMENT SERVICES IN THE NATURE OF A TELEVISION SERIES IN THE FIELD OF DATING, ROMANCE, LIVE ACTION, COMEDY AND DRAMA; ENTERTAINMENT SERVICES, NAMELY, PROVIDING AN ON-LINE COMPUTER GAME; PROVIDING DIGITIZED PRINT AND VISUAL INFORMATION ABOUT A TELEVISION SERIES VIA A GLOBAL COMPUTER NETWORK; SWEEPSTAKES SERVICES (U.S. CLS. 100, 101 AND 107).
DEZMONA MIZELLE, EXAMINING ATTORNEY

SN 77-371,730. GRABARITS, MICHAEL, WHITEHALL, PA. FILED 1-15-2008.

STRAIGHT TALK POWER HOUR

THE MARK CONSISTS OF STANDARD CHARACTERS WITHOUT CLAIM TO ANY PARTICULAR FONT, STYLE, SIZE, OR COLOR.
NO CLAIM IS MADE TO THE EXCLUSIVE RIGHT TO USE "POWER HOUR", APART FROM THE MARK AS SHOWN.
FOR EDUCATIONAL SERVICES, NAMELY, DEVELOPING, ARRANGING, AND CONDUCTING EDUCATIONAL CONFERENCES AND PROGRAMS AND PROVIDING COURSES OF INSTRUCTION IN THE FIELD OF LITERACY (U.S. CLS. 100, 101 AND 107).
MICHELLE DUBOIS, EXAMINING ATTORNEY

CLASS 41—(Continued).

SN 77-376,174. KORPA, TOMAS, MELNIK, CZECH REPUBLIC, FILED 1-20-2008.

EuroRealtors

THE MARK CONSISTS OF STANDARD CHARACTERS WITHOUT CLAIM TO ANY PARTICULAR FONT, STYLE, SIZE, OR COLOR.

FOR COLLEGE CONSULTING SERVICES, NAMELY, ASSISTING STUDENTS IN FINDING COLLEGES AND UNIVERSITIES AND COMPLETING THE APPLICATION PROCESS; COLLEGE COUNSELING SERVICES, NAMELY, ASSISTING STUDENTS WHO STRUGGLE ACADEMICALLY DUE TO LEARNING DISABILITIES IN FINDING COLLEGES AND UNIVERSITIES AND COMPLETING THE APPLICATION PROCESS AND ASSISTING IN APPLYING FOR SCHOLARSHIPS AND FINANCIAL AID; EDUCATING AT UNIVERSITY OR COLLEGES; EDUCATION SERVICES IN THE NATURE OF COURSES AT THE UNIVERSITY LEVEL; PROVIDING A WEB SITE THAT FEATURES INFORMATION ON ATTENDING COLLEGE AND UNIVERSITY WITH AN EMPHASIS ON NEWLY ENROLLED STUDENTS (U.S. CLS. 100, 101 AND 107).

MARY BOAGNI, EXAMINING ATTORNEY

CLASS 41—(Continued).

SN 77-378,339. WASHINGTON ATHLETIC CLUB, SEATTLE, WA. FILED 1-23-2008.



OWNER OF U.S. REG. NOS. 2,280,699, 3,355,995 AND 3,355,996.

THE MARK CONSISTS OF STYLIZED WINGS WITH LETTERS "WAC".

FOR HEALTH, FITNESS AND ATHLETIC CLUB SERVICES, NAMELY, PROVIDING FITNESS, EXERCISE AND RECREATION FACILITIES; EDUCATION SERVICES, NAMELY, PROVIDING GROUP AND INDIVIDUAL CLASSES, CLINICS, SEMINARS, INSTRUCTIONS, WORKSHOPS, TRAINING AND EQUIPMENT IN THE FIELDS OF NUTRITION AND DIETARY MANAGEMENT, WEIGHT LOSS, HEALTH AND WELLNESS, RELAXATION, AQUATIC EXERCISE, EXERCISE AND PHYSICAL FITNESS, USE AND OPERATION OF EXERCISE EQUIPMENT, SWIMMING, SPORTS, PILATES, YOGA, CORE CONDITIONING, INCREASING STRENGTH, FLEXIBILITY AND CARDIOVASCULAR ENDURANCE, AND DISTRIBUTING MATERIALS IN CONNECTION THEREWITH; PERSONAL TRAINER SERVICES (U.S. CLS. 100, 101 AND 107).

FIRST USE 12-31-1930; IN COMMERCE 12-31-1930.

KATHLEEN LORENZO, EXAMINING ATTORNEY

SN 77-379,397. MASCOTTE HOLDINGS, INC., NEW YORK, NY. FILED 1-24-2008.

UNIVERSE CITY

THE MARK CONSISTS OF STANDARD CHARACTERS WITHOUT CLAIM TO ANY PARTICULAR FONT, STYLE, SIZE, OR COLOR.

FOR RECORD PRODUCTION; MUSIC PRODUCTION; AUDIO RECORDING AND PRODUCTION; VIDEOTAPE PRODUCTION; MOTION PICTURE SONG PRODUCTION; PRODUCTION OF VIDEO DISCS FOR OTHERS; RECORDING STUDIOS; ENTERTAINMENT SERVICES, NAMELY, PRODUCING MUSICAL AUDIO AND VIDEO PROGRAMS; DISTRIBUTION OF MUSICAL RADIO AND TELEVISION PROGRAMS OF OTHERS; MUSIC COMPOSITION AND TRANSCRIPTION FOR OTHERS; SONG WRITING SERVICES; MUSIC PUBLISHING SERVICES; ENTERTAINMENT IN THE NATURE OF LIVE PERFORMANCES BY A MUSICAL ARTIST, MUSICAL GROUP OR MUSICAL BAND; ENTERTAINMENT IN THE NATURE OF VISUAL AND AUDIO PERFORMANCES BY A MUSICAL ARTIST, MUSICAL GROUP AND MUSICAL BAND; ENTERTAINMENT, NAMELY, LIVE MUSIC CONCERTS; ENTERTAINMENT, NAMELY, PERSONAL APPEARANCES BY A MUSICIAN, MUSICAL GROUP, MUSICAL BAND, MOVIE ENTERTAINER, ACTOR OR SPORTS CELEBRITY OR COMEDIAN; ENTERTAINMENT SERVICES, NAMELY, PROVIDING A WEB SITE FEATURING MUSICAL PERFORMANCES, MUSICAL VIDEOS, RELATED FILM CLIPS, PHOTOGRAPHS, AND OTHER MULTIMEDIA MATERIALS; ENTERTAINMENT SERVICES, NAMELY, PROVIDING PRERECORDED MUSIC, INFORMATION IN THE FIELD OF MUSIC, COMMENTARY AND ARTICLES ABOUT MUSIC, ALL ONLINE VIA A GLO-

SN 77-378,091. JUST SO YOU KNOW, WESTPORT, CT. FILED 1-23-2008.

JUST SO YOU KNOW

THE MARK CONSISTS OF STANDARD CHARACTERS WITHOUT CLAIM TO ANY PARTICULAR FONT, STYLE, SIZE, OR COLOR.

FOR AUDIO AND VIDEO RECORDING SERVICES, NAMELY, RECORDING PERSONAL VIDEO MEMOIRS AND ORAL LIFE HISTORIES OF CANCER PATIENTS; PROVIDING FACILITIES AND EQUIPMENT FOR CANCER PATIENTS TO RECORD PERSONAL VIDEO MEMOIRS AND ORAL LIFE HISTORIES (U.S. CLS. 100, 101 AND 107).

RENEE SERVANCE, EXAMINING ATTORNEY

CLASS 41—(Continued).

BAL COMPUTER NETWORK; PROVIDING A WEBSITE FEATURING INFORMATION ABOUT ENTERTAINMENT, MUSIC, TELEVISION, FILMS, GAMES AND ARTS; TELEVISION AND RADIO PRODUCTION; RADIO ENTERTAINMENT PRODUCTION; MOTION PICTURE FILM PRODUCTION; ENTERTAINMENT IN THE NATURE OF ON-GOING TELEVISION, CABLE TELEVISION AND RADIO PROGRAMS FEATURING MUSIC, VARIETY REALITY-BASED ENTERTAINMENT, FASHION, BEAUTY, COMEDY, DRAMA, DRAMEDY, SPOKEN WORD, GAME SHOW, MODELING AND DOCUMENTARIES; TELEVISION AND CABLE TELEVISION PROGRAMS FEATURING MUSIC, VARIETY REALITY-BASED ENTERTAINMENT, FASHION, BEAUTY, COMEDY, DRAMA, DRAMEDY, SPOKEN WORD, GAME SHOW, MODELING AND DOCUMENTARIES; ENTERTAINMENT IN THE NATURE OF PROVIDING A VARIETY SHOW DISTRIBUTED OVER TELEVISION, CABLE TELEVISION, RADIO, SATELLITE, AUDIO AND VIDEO MEDIA; ENTERTAINMENT, NAMELY, A CONTINUING VARIETY AND MUSICAL SHOW BROADCAST OVER TELEVISION, SATELLITE, THE INTERNET, AUDIO AND VIDEO MEDIA; ENTERTAINMENT IN THE NATURE OF THEATER PRODUCTION; ENTERTAINMENT IN THE NATURE OF LIVE MUSICAL CONCERTS, LIVE DRAMATIC READINGS AND LIVE RELIGIOUS SPOKEN WORD PERFORMANCES IN CONNECTION WITH TRAVELING TOURS; ENTERTAINMENT SERVICES, NAMELY, PROVIDING AN ON-LINE COMPUTER GAME; ENTERTAINMENT SERVICES, NAMELY, PROVIDING AN ONLINE COMPUTER GAME THAT MAY BE ACCESSED NETWORK-WIDE BY NETWORK USERS; EDUCATIONAL SERVICES, NAMELY, PROVIDING CLASSES, SEMINARS OR WORKSHOPS IN THE FIELDS OF READING AND WRITING, MATHEMATICS, SCIENCE, HISTORY, SOCIAL STUDIES, POLITICAL SCIENCE, RELIGIOUS STUDIES, LANGUAGES, THE ARTS, MUSIC, FILM, DANCE, ENGINEERING, PHOTOGRAPHY, GRAPHIC DESIGN, COMPUTERS, HEALTH AND FITNESS, NUTRITION, PHYSICAL EDUCATION, DRUG AND GANG PREVENTION, TEENAGE PREGNANCY, SELF ESTEEM ISSUES, DISCIPLINE AND CONFLICT RESOLUTION; CHARITABLE SERVICES IN THE NATURE OF ACADEMIC MENTORING OF SCHOOL AGE CHILDREN; CHARITABLE SERVICES IN THE NATURE OF PROVIDING EDUCATIONAL CLASSES, WORKSHOPS, TUTORING AND MENTORING FOR STUDENTS IN THE FIELDS OF MUSIC, ENGINEERING, FILMMAKING, PHOTOGRAPHY, DANCE, THE ARTS, AND OTHER SUBJECT MATTERS, NAMELY, READING AND WRITING, MATHEMATICS, SCIENCE, HISTORY, SOCIAL STUDIES, POLITICAL SCIENCE, RELIGIOUS STUDIES, LANGUAGES, GRAPHIC DESIGN, COMPUTERS, HEALTH AND FITNESS, NUTRITION, PHYSICAL EDUCATION, DRUG AND GANG PREVENTION, TEENAGE PREGNANCY, SELF ESTEEM ISSUES, DISCIPLINE AND CONFLICT RESOLUTION AND DISTRIBUTING COURSE MATERIALS IN CONNECTION THEREWITH; CHARITABLE SERVICES IN THE NATURE OF PROVIDING TUTORIAL SESSIONS FOR STUDENTS IN THE FIELDS OF MUSIC, ENGINEERING, FILMMAKING, PHOTOGRAPHY, DANCE, THE ARTS, AND OTHER SUBJECT MATTERS, NAMELY, READING AND WRITING, MATHEMATICS, SCIENCE, HISTORY, SOCIAL STUDIES, POLITICAL SCIENCE, RELIGIOUS STUDIES, LANGUAGES, GRAPHIC DESIGN, COMPUTERS, HEALTH AND FITNESS, NUTRITION, PHYSICAL EDUCATION, DRUG AND GANG PREVENTION, TEENAGE PREGNANCY, SELF ESTEEM ISSUES, DISCIPLINE AND CONFLICT RESOLUTION AND DISTRIBUTING COURSE MATERIALS IN CONNECTION THEREWITH; EDUCATIONAL AND ENTERTAINMENT SERVICES, NAMELY, PROVIDING MOTIVATIONAL AND EDUCATIONAL SPEAKERS FOR STUDENTS; PROVIDING CAREER COUNSELING SERVICES FOR STUDENTS;

CLASS 41—(Continued).

CHARITABLE SERVICES IN THE NATURE OF PROVIDING BOOKS, SPORTING GOODS, TELEVISIONS AND TOYS TO NEEDY AND UNDERPRIVILEGED CHILDREN AND STUDENTS; AWARD PROGRAM FOR MAJOR CORPORATIONS AND INDIVIDUALS WHO HAVE MADE SIGNIFICANT CHARITABLE CONTRIBUTIONS; CHARITABLE SERVICES, NAMELY, PROVIDING RESOURCE LIBRARY SERVICES TO THOSE IN NEED AND SCHOOL AGE CHILDREN; CHARITABLE SERVICES, NAMELY, PROVIDING SCHOOL SUPPLIES AND EQUIPMENT TO CHILDREN IN NEED (U.S. CLS. 100, 101 AND 107).

GENE MACIOL, EXAMINING ATTORNEY

SN 77-380,448. LANDRY'S TRADEMARK, INC., HOUSTON, TX. FILED 1-25-2008.

TEXAS NUGGET

THE MARK CONSISTS OF STANDARD CHARACTERS WITHOUT CLAIM TO ANY PARTICULAR FONT, STYLE, SIZE, OR COLOR.

NO CLAIM IS MADE TO THE EXCLUSIVE RIGHT TO USE "TEXAS", APART FROM THE MARK AS SHOWN.

FOR ENTERTAINMENT SERVICES, NAMELY, CASINOS (U.S. CLS. 100, 101 AND 107).

DOMINIC J. FERRAIUOLO, EXAMINING ATTORNEY

SN 77-382,971. JKP, BARSANA DHAM, AUSTIN, TX. FILED 1-29-2008.

ROOP DHYAN

THE MARK CONSISTS OF STANDARD CHARACTERS WITHOUT CLAIM TO ANY PARTICULAR FONT, STYLE, SIZE, OR COLOR.

THE FOREIGN WORDING IN THE MARK TRANSLATES INTO ENGLISH AS CONCENTRATE ON THE FORM.

FOR MEDITATION TRAINING, NAMELY, TRAINING IN THE FIELD OF MEDITATION TECHNIQUE (U.S. CLS. 100, 101 AND 107).

TEJBIR SINGH, EXAMINING ATTORNEY

CLASS 41—(Continued).

SN 77-384,112. THEATRICAL WORKS, LLC, ATLANTA, GA.
FILED 1-30-2008.



NO CLAIM IS MADE TO THE EXCLUSIVE RIGHT TO USE "LIVE", APART FROM THE MARK AS SHOWN.

THE COLOR(S) BLACK, BROWN AND WHITE IS/ARE CLAIMED AS A FEATURE OF THE MARK.

THE MARK CONSISTS OF THE FOLLOWING, THE BACKGROUND IS BLACK, THE WORDS "NOAH'S ARK" ARE BROWN AND OUTLINED IN WHITE, THE WORDS "THE LIVE EXPERIENCE" ARE WHITE.

FOR ENTERTAINMENT IN THE NATURE OF THEATER PRODUCTIONS (U.S. CLS. 100, 101 AND 107).

TRACY CROSS, EXAMINING ATTORNEY

CLASS 41—(Continued).

SN 77-386,756. DANIELS, CHARLES E., LEBANON, TN.
FILED 2-1-2008.

DIXIE CONNECTION

THE MARK CONSISTS OF STANDARD CHARACTERS WITHOUT CLAIM TO ANY PARTICULAR FONT, STYLE, SIZE, OR COLOR.

FOR EDUCATIONAL AND ENTERTAINMENT SERVICES, NAMELY, A CONTINUING PROGRAM FEATURING MUSIC, MUSIC COMMENTARY, AND INTERVIEWS WITH MUSICAL ARTISTS, ACCESSIBLE BY RADIO, SATELLITE AND THE INTERNET (U.S. CLS. 100, 101 AND 107).

LOURDES AYALA, EXAMINING ATTORNEY

SN 77-384,459. RESTER, H.S, DBA CREATION TO REVELATION, SOUTH BEND, IN. FILED 1-30-2008.



THE MARK CONSISTS OF SCRIPTIVE LETTERING OF THE WORDS "CREATION TO REVELATION" IN WHICH A CROSS SYMBOL REPLACES THE LETTER "T" A TOTAL OF THREE TIMES. THE "T" IN THE WORD CREATION EXTENDS DOWN AND BECOMES THE LEFT PART OF THE LETTER "R" IN THE WORD REVELATION. THE WORD "TO" HAS THE CROSS SYMBOL REPLACING THE LETTER "T" AND THE WORD REVELATION HAS THE CROSS SYMBOL REPLACING THE LETTER "T".

FOR PROVIDING ONLINE RELIGIOUS INSTRUCTION PROMOTING CHRISTIAN AND FAMILY VALUES; RELIGIOUS INSTRUCTION SERVICES (U.S. CLS. 100, 101 AND 107).

FIRST USE 5-15-2007; IN COMMERCE 6-12-2007.

ALICIA COLLINS, EXAMINING ATTORNEY

SN 77-388,930. THE RITZ-CARLTON HOTEL COMPANY, L.L.C., BETHESDA, MD. FILED 2-5-2008.

NATURE'S WONDERS

THE MARK CONSISTS OF STANDARD CHARACTERS WITHOUT CLAIM TO ANY PARTICULAR FONT, STYLE, SIZE, OR COLOR.

FOR ENTERTAINMENT AND RECREATIONAL SERVICES, NAMELY, PROVIDING NATURE-THEMED ACTIVITIES IN THE FORM OF NATURE WALKS, BOAT RIDES, FIELD TRIPS, SCIENCE EXPERIMENTS, MOTION PICTURE EXHIBITIONS, AND PLANT AND ANIMAL EXHIBITIONS; EDUCATIONAL SERVICES, NAMELY, CONDUCTING PROGRAMS IN THE FIELDS OF ENVIRONMENTAL CONSERVATION, NATURE AND WILDLIFE (U.S. CLS. 100, 101 AND 107).

FIRST USE 10-1-2006; IN COMMERCE 10-1-2006.

JORDAN BAKER, EXAMINING ATTORNEY

CLASS 41—(Continued).

SN 77-392,112. SPEED SKOOL LLC, BAYSIDE, NY. FILED 2-8-2008.



NO CLAIM IS MADE TO THE EXCLUSIVE RIGHT TO USE "SCHOOL" AND "ALL ATHLETES..ALL SPORTS", APART FROM THE MARK AS SHOWN.

THE COLOR(S) BLACK, ORANGE, YELLOW AND WHITE IS/ARE CLAIMED AS A FEATURE OF THE MARK.

THE MARK CONSISTS OF THE WORDS "SPEED SKOOL" ARE USED IN BLACK COLOR, THE RUNNING MAN IS USE IN ORANGE, WHITE AND BLACK COLOR, THE DUST KICKED UP FROM THE RUNNING MAN IS ORANGE, YELLOW, BLACK AND WHITE. THE WORDS "ALL ATHLETES...ALL SPORTS" ARE ORANGE AND BLACK.

FOR PROVIDING ASSISTANCE, PERSONAL TRAINING AND PHYSICAL FITNESS CONSULTATION TO INDIVIDUALS TO HELP THEM MAKE PHYSICAL FITNESS, STRENGTH, CONDITIONING, AND EXERCISE IMPROVEMENT IN THEIR DAILY LIVING (U.S. CLS. 100, 101 AND 107).

FIRST USE 4-4-2007; IN COMMERCE 4-4-2007.
GRETTA YAO, EXAMINING ATTORNEY

CLASS 41—(Continued).

SN 77-396,479. MINDWORKS STUDIO LLC, TUCSON, AZ. FILED 2-13-2008.

MINDWORKS STUDIO LLC

THE MARK CONSISTS OF STANDARD CHARACTERS WITHOUT CLAIM TO ANY PARTICULAR FONT, STYLE, SIZE, OR COLOR.

NO CLAIM IS MADE TO THE EXCLUSIVE RIGHT TO USE "STUDIO LLC", APART FROM THE MARK AS SHOWN.

FOR EDUCATION SERVICES, NAMELY, PROVIDING CLASSES AND WORKSHOPS IN THE FIELDS OF MENTAL FITNESS, EMOTIONAL WELLNESS AND PEAK PERFORMANCE; TRAINING SERVICES IN THE FIELD OF MENTAL FITNESS, EMOTIONAL WELLNESS AND PEAK PERFORMANCE THROUGH BIOFEEDBACK, NEUROFEEDBACK AND COMPUTER GAMES (U.S. CLS. 100, 101 AND 107).

FIRST USE 9-1-2007; IN COMMERCE 11-7-2007.
MICHAEL WIENER, EXAMINING ATTORNEY

SN 77-398,878. MAY I HAVE THIS DANCE INC., CHICAGO, IL. FILED 2-15-2008.

DANCING WITH CLASS

THE MARK CONSISTS OF STANDARD CHARACTERS WITHOUT CLAIM TO ANY PARTICULAR FONT, STYLE, SIZE, OR COLOR.

NO CLAIM IS MADE TO THE EXCLUSIVE RIGHT TO USE "DANCING", APART FROM THE MARK AS SHOWN.

FOR DANCE CLASSES; ORGANIZING AND CONDUCTING DANCE PARTIES AND FORMAL DANCE EVENTS; DANCE CLUBS; ORGANIZING AND CONDUCTING DANCE CONVENTIONS; ENTERTAINMENT IN THE NATURE OF DANCE PERFORMANCES; PROVIDING PRIVATE AND GROUP DANCE LESSONS; PROVIDING YOUTH DANCE CLASSES AND ORGANIZING AND CONDUCTING YOUTH DANCE PARTIES AND DANCE EVENTS; PROVIDING DANCE CLASSES FOR SCHOOL CHILDREN IN PRE-KINDERGARTEN THROUGH TWELFTH GRADE AND ORGANIZING AND CONDUCTING SCHOOL DANCE PARTIES AND DANCE EVENTS FOR CHILDREN IN PRE-KINDERGARTEN THROUGH TWELFTH GRADE; HOSTING DANCE EVENTS (U.S. CLS. 100, 101 AND 107).

FIRST USE 3-22-2006; IN COMMERCE 3-22-2006.
LINDA LAVACHE, EXAMINING ATTORNEY

SN 77-394,162. YES! GLOBAL, INC., MARSHALL, NC. FILED 2-11-2008.

Presence-Based Coaching

THE MARK CONSISTS OF STANDARD CHARACTERS WITHOUT CLAIM TO ANY PARTICULAR FONT, STYLE, SIZE, OR COLOR.

NO CLAIM IS MADE TO THE EXCLUSIVE RIGHT TO USE "COACHING", APART FROM THE MARK AS SHOWN.

FOR PROFESSIONAL COACHING SERVICES IN THE FIELD OF LEADERSHIP AND MANAGEMENT SKILLS (U.S. CLS. 100, 101 AND 107).

DAWN FELDMAN, EXAMINING ATTORNEY

CLASS 41—(Continued).

SN 77-403,554. DINE CONSULT, INC., HUNTSVILLE, AL.
FILED 2-22-2008.

LIVEHUNTSVEGAS

THE MARK CONSISTS OF STANDARD CHARACTERS WITHOUT CLAIM TO ANY PARTICULAR FONT, STYLE, SIZE, OR COLOR.

FOR PROVIDING NEWS AND INFORMATION OVER AN INTERACTIVE GLOBAL COMPUTER NETWORK IN THE FIELD OF CURRENT EVENTS AND ENTERTAINMENT GENERALLY RELATED TO HUNTSVILLE, ALABAMA, MADISON COUNTY ALABAMA, AND NEIGHBORING COMMUNITIES (U.S. CLS. 100, 101 AND 107).

FIRST USE 5-15-2008; IN COMMERCE 5-15-2008.
AMY HELLA, EXAMINING ATTORNEY

SN 77-403,604. PLAYS FOR LIVING, INC., NEW YORK, NY.
FILED 2-22-2008.

PLAYS FOR LIVING

THE MARK CONSISTS OF STANDARD CHARACTERS WITHOUT CLAIM TO ANY PARTICULAR FONT, STYLE, SIZE, OR COLOR.

NO CLAIM IS MADE TO THE EXCLUSIVE RIGHT TO USE "PLAYS", APART FROM THE MARK AS SHOWN.

FOR EDUCATION SERVICES, NAMELY, PROVIDING WORKSHOPS AND SEMINARS IN THE FIELDS OF MULTI-CULTURAL EDUCATION, DIVERSITY TRAINING, ETHICS, CONFLICT RESOLUTION AND DOMESTIC VIOLENCE; ENTERTAINMENT IN THE NATURE OF THEATER PRODUCTIONS; SCRIPT WRITING SERVICES (U.S. CLS. 100, 101 AND 107).

FIRST USE 1-1-1959; IN COMMERCE 10-30-1959.
STEPHEN AQUILA, EXAMINING ATTORNEY

CLASS 41—(Continued).

SN 77-403,997. FAITH EDUCATIONAL MINISTRIES, INC.,
MONROE, GA. FILED 2-22-2008.

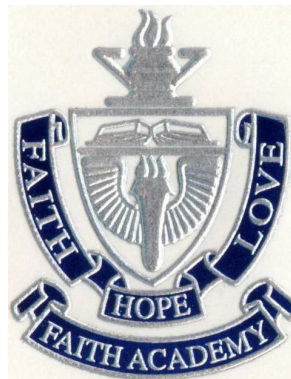

NO CLAIM IS MADE TO THE EXCLUSIVE RIGHT TO USE "ACADEMY", APART FROM THE MARK AS SHOWN. THE COLOR(S) BLUE AND SILVER IS/ARE CLAIMED AS A FEATURE OF THE MARK.

THE MARK CONSISTS OF A CREST WHERE THE MIDDLE PORTION IS SILVER, INCLUDING AN IMAGE OF AN OPEN BOOK; AND SURROUNDING BLUE BANNERS OUTLINED IN SILVER THAT INCLUDE THE WORDS "FAITH", "HOPE", "LOVE", AND "FAITH ACADEMY".

FOR EDUCATIONAL SERVICES, NAMELY, CONDUCTING NON-TRADITIONAL HIGH SCHOOL INSTRUCTION (U.S. CLS. 100, 101 AND 107).

MICHELE SWAIN, EXAMINING ATTORNEY

SN 77-405,783. BECKS, SUNNY, NASHVILLE, TN. FILED 2-26-2008.

Hooping for Hope

THE MARK CONSISTS OF STANDARD CHARACTERS WITHOUT CLAIM TO ANY PARTICULAR FONT, STYLE, SIZE, OR COLOR.

FOR DANCE INSTRUCTION USING HOOPS; ENTERTAINMENT IN THE NATURE OF DANCE PERFORMANCES USING HOOPS; TRAINING INSTRUCTORS IN THE FIELD OF USING HOOPS; CONDUCTING CLASSES IN THE FIELD OF DANCE USING HOOPS; EDUCATION SERVICES, NAMELY, CONDUCTING CLASSES IN THE FIELD OF DANCE USING HOOPS; PHYSICAL FITNESS INSTRUCTION UTILIZING HOOPS TO WOMEN WHO HAVE OR HAVE HAD BREAST CANCER; CHARITABLE SERVICES, NAMELY, PROVIDING ATHLETIC EQUIPMENT AND PHYSICAL FITNESS INSTRUCTION UTILIZING HULA HOOPS TO WOMEN WHO HAVE OR HAVE HAD BREAST CANCER (U.S. CLS. 100, 101 AND 107).

FIRST USE 2-23-2008; IN COMMERCE 2-23-2008.
DARRYL SPRUILL, EXAMINING ATTORNEY

CLASS 41—(Continued).

SN 77-406,023. MAINE ROAD MANAGEMENT, INC., NEW YORK, NY. FILED 2-26-2008.



THE COLOR(S) ORANGE, RED, YELLOW, AND WHITE IS/ARE CLAIMED AS A FEATURE OF THE MARK.

THE MARK CONSISTS OF THE WORD "CONSCIENCE" IN ORANGE BENEATH THE WORD "VOICES" IN RED WITH THE LETTER "O" IN "VOICES" CONSISTING OF A RED AND ORANGE LOTUS FLOWER, SURROUNDED BY A YELLOW CIRCULAR ELEMENT, AND THE WORD "OF" IN WHITE IN THE CENTER OF THE LOTUS FLOWER.

FOR ARRANGING AND CONDUCTING CONCERTS FEATURING MULTIPLE MUSICAL GROUPS AND BANDS; ARRANGING AND CONDUCTING FESTIVALS FEATURING MUSICAL GROUPS, AND THE DISSEMINATION THEREWITH OF LITERATURE AND INFORMATION ON PUBLIC-INTEREST ISSUES IN THE FIELD OF MUSIC; PROVIDING A WEB SITE ON GLOBAL COMPUTER NETWORKS FEATURING INFORMATION ON MUSIC, MUSICAL PERFORMANCES AND MUSICAL PERFORMERS; PRODUCING AND ARRANGING CONCERTS, EVENTS, NAMELY, MUSICAL PERFORMANCES, NIGHTCLUB PERFORMANCES AND OTHER PERFORMANCES, NAMELY, PERSONAL PERFORMANCES ON RADIO, TV, AND WEB CASTS VIA THE INTERNET; PROVIDING INFORMATION IN THE FIELD OF ENTERTAINMENT AND MUSIC BY MEANS OF A GLOBAL COMPUTER NETWORK; ENTERTAINMENT SERVICES, NAMELY, PROVIDING A WEB SITE FEATURING MUSICAL PERFORMANCES, MUSIC VIDEOS, PHOTOGRAPHS, AND OTHER MULTIMEDIA MATERIALS; PROVIDING WEB-BASED INFORMATION IN THE NATURE OF TICKET INFORMATION FOR EVENTS, NAMELY, THE AVAILABILITY OF CONCERT TICKETS FOR SALE AND WILL CALL SERVICES AT THE EVENT VENUES; PROVIDING ON-LINE INFORMATION REGARDING TELEVISION PROGRAMMING, ENTERTAINMENT, SPORTS AND CULTURAL ACTIVITIES, FROM A COMPUTER DATABASE OR THE INTERNET; ENTERTAINMENT SERVICES, NAMELY, PROVIDING WIRELESS GAMES, AND IMAGES THAT MAY BE ACCESSED BY WIRELESS NETWORK USERS (U.S. CLS. 100, 101 AND 107).

ODESSA BIBBINS, EXAMINING ATTORNEY

SN 77-406,443. SCHOLARLY EXCHANGE, BROOKLINE, MA. FILED 2-26-2008.

Scholarly Exchange

THE MARK CONSISTS OF STANDARD CHARACTERS WITHOUT CLAIM TO ANY PARTICULAR FONT, STYLE, SIZE, OR COLOR.

FOR PUBLISHING OF ELECTRONIC PUBLICATIONS (U.S. CLS. 100, 101 AND 107).

FIRST USE 9-27-2002; IN COMMERCE 9-27-2002.
ANGELA GAW, EXAMINING ATTORNEY

CLASS 41—(Continued).

SN 77-406,890. GOKHALE, ESTHER, STANFORD, CA. FILED 2-26-2008.

Posturenomics

THE MARK CONSISTS OF STANDARD CHARACTERS WITHOUT CLAIM TO ANY PARTICULAR FONT, STYLE, SIZE, OR COLOR.

FOR EDUCATIONAL SERVICES, NAMELY, PROVIDING PHYSICAL CULTURE CLASSES IN THE NATURE OF YOGA, DANCE, AND POSTURE AND MOVEMENT TRAINING, AND PROGRAMS TO TEACH INDIVIDUALS PROPER ALIGNMENT OF THEIR BODIES IN THE FIELDS OF POSTURE AND MOVEMENT (U.S. CLS. 100, 101 AND 107).

KATHERINE CONNOLLY, EXAMINING ATTORNEY

SN 77-408,279. ENERGETIC SOUL, L.L.C., ROYAL OAK, MI. FILED 2-28-2008.

ENERGETIC SALSA

THE MARK CONSISTS OF STANDARD CHARACTERS WITHOUT CLAIM TO ANY PARTICULAR FONT, STYLE, SIZE, OR COLOR.

NO CLAIM IS MADE TO THE EXCLUSIVE RIGHT TO USE "SALSA", APART FROM THE MARK AS SHOWN. FOR DANCE INSTRUCTION (U.S. CLS. 100, 101 AND 107).

EDWARD NELSON, EXAMINING ATTORNEY

SN 77-408,344. ENERGETIC SOUL, L.L.C., ROYAL OAK, MI. FILED 2-28-2008.

ENERGETIC SOULSA

THE MARK CONSISTS OF STANDARD CHARACTERS WITHOUT CLAIM TO ANY PARTICULAR FONT, STYLE, SIZE, OR COLOR.

THE WORDING "SOULSA" HAS NO MEANING IN A FOREIGN LANGUAGE.

FOR DANCE INSTRUCTION (U.S. CLS. 100, 101 AND 107).

EDWARD NELSON, EXAMINING ATTORNEY

CLASS 41—(Continued).

SN 77-408,593. ERIK KLUIBER, REDFORD, MI. FILED 2-28-2008.

Overloaded

THE MARK CONSISTS OF STANDARD CHARACTERS WITHOUT CLAIM TO ANY PARTICULAR FONT, STYLE, SIZE, OR COLOR.

FOR ENTERTAINMENT IN THE NATURE OF VISUAL AND AUDIO PERFORMANCES, NAMELY, MUSICAL BAND, ROCK GROUP, GYMNASTIC, DANCE, AND BALLET PERFORMANCES (U.S. CLS. 100, 101 AND 107).

FIRST USE 8-3-2004; IN COMMERCE 8-3-2004.
BARBARA RUTLAND, EXAMINING ATTORNEY

SN 77-410,319. LEADERSHIP GATHERING LLC, DBA SNAP!, BOULDER, CA. FILED 2-29-2008.

SNAP!

THE MARK CONSISTS OF STANDARD CHARACTERS WITHOUT CLAIM TO ANY PARTICULAR FONT, STYLE, SIZE, OR COLOR.

FOR EDUCATIONAL SERVICES, NAMELY, CONDUCTING CONFERENCES, SEMINARS AND WORKSHOPS IN THE FIELD OF SCIENCE, NATURE, ART, CULTURE, ENVIRONMENT, HUMAN RIGHTS AND HUMAN SOCIETY; ARRANGING AND CONDUCTING EDUCATIONAL CONFERENCES; EDUCATIONAL SERVICES, NAMELY, A LEARNING AND INNOVATION CENTER FEATURING FULLY CUSTOMIZED LEADERSHIP, MOTIVATIONAL, EDUCATIONAL, AND BRAINSTORMING TRAINING; EDUCATIONAL SERVICES, NAMELY, CONDUCTING PROGRAMS IN THE FIELD OF SCIENCE, NATURE, ART, CULTURE, ENVIRONMENT, HUMAN RIGHTS AND HUMAN SOCIETY (U.S. CLS. 100, 101 AND 107).

FIRST USE 11-14-2007; IN COMMERCE 11-14-2007.
ROBERT LAVACHE, EXAMINING ATTORNEY

SN 77-410,342. CABLE TELEVISION LABORATORIES, INC., LOUISVILLE, CO. FILED 2-29-2008.

TRU2WAY

THE MARK CONSISTS OF STANDARD CHARACTERS WITHOUT CLAIM TO ANY PARTICULAR FONT, STYLE, SIZE, OR COLOR.

FOR DISTRIBUTION OF INTERACTIVE TELEVISION PROGRAMMING BY MEANS OF A CABLE NETWORK FOR OTHERS; DISTRIBUTION OF INTERACTIVE VIDEO, IMAGE, VOICE, AUDIO, AND DATA INFORMATION BY MEANS OF A CABLE NETWORK FOR OTHERS (U.S. CLS. 100, 101 AND 107).

ANNE FARRELL, EXAMINING ATTORNEY

CLASS 41—(Continued).

SN 77-410,638. JW MANUAL INC., NASHVILLE, TN. FILED 3-1-2008.

PRINCESS OF POP

THE MARK CONSISTS OF STANDARD CHARACTERS WITHOUT CLAIM TO ANY PARTICULAR FONT, STYLE, SIZE, OR COLOR.

NO CLAIM IS MADE TO THE EXCLUSIVE RIGHT TO USE "POP", APART FROM THE MARK AS SHOWN.

FOR ENTERTAINMENT IN THE NATURE OF LIVE PERFORMANCES BY A MUSICAL ARTIST (U.S. CLS. 100, 101 AND 107).

TINA KUAN, EXAMINING ATTORNEY

SN 77-410,958. WILLIAM MORRIS AGENCY, LLC, BEVERLY HILLS, CA. FILED 3-3-2008.

SMOKIN' GROOVES

THE MARK CONSISTS OF STANDARD CHARACTERS WITHOUT CLAIM TO ANY PARTICULAR FONT, STYLE, SIZE, OR COLOR.

FOR ENTERTAINMENT SERVICES, NAMELY, PRODUCTION OF RADIO AND TELEVISION PROGRAMS FEATURING MUSICAL ENTERTAINMENT (U.S. CLS. 100, 101 AND 107).

EDWARD NELSON, EXAMINING ATTORNEY

SN 77-413,186. TROY L. LADD, APPLE VALLEY, CA. FILED 3-5-2008.

Hollywood Hot Rods

THE MARK CONSISTS OF STANDARD CHARACTERS WITHOUT CLAIM TO ANY PARTICULAR FONT, STYLE, SIZE, OR COLOR.

OWNER OF U.S. REG. NO. 3,312,394.

NO CLAIM IS MADE TO THE EXCLUSIVE RIGHT TO USE "HOT RODS", APART FROM THE MARK AS SHOWN.

FOR ENTERTAINMENT SERVICES, NAMELY, AN ON-GOING SERIES FEATURING AUTOMOBILE RELATED SUBJECTS PROVIDED THROUGH BROADCAST TELEVISION, CABLE TELEVISION, SATELLITE TELEVISION, AND WEB BASED PROGRAMS (U.S. CLS. 100, 101 AND 107).

FIRST USE 12-31-1991; IN COMMERCE 1-19-2005.
JULIE GUTTADAURO, EXAMINING ATTORNEY

CLASS 41—(Continued).

SN 77-413,768. IZEA, INC., ORLANDO, FL. FILED 3-5-2008.

POSTIE

THE MARK CONSISTS OF STANDARD CHARACTERS WITHOUT CLAIM TO ANY PARTICULAR FONT, STYLE, SIZE, OR COLOR.

FOR PROVIDING ONLINE BLOG CONTENT FEATURING COMMENTARY AND CONVERSATIONS PERTAINING TO WEBSITES, SOCIAL MEDIA AND CONSUMER PRODUCTS AND SERVICES (U.S. CLS. 100, 101 AND 107).

FIRST USE 4-14-2008; IN COMMERCE 4-14-2008.
AISHA CLARKE, EXAMINING ATTORNEY

SN 77-413,772. IZEA, INC., ORLANDO, FL. FILED 3-5-2008.

POSTIES

THE MARK CONSISTS OF STANDARD CHARACTERS WITHOUT CLAIM TO ANY PARTICULAR FONT, STYLE, SIZE, OR COLOR.

FOR PROVIDING ONLINE BLOG CONTENT FEATURING COMMENTARY AND CONVERSATIONS PERTAINING TO WEBSITES, SOCIAL MEDIA AND CONSUMER PRODUCTS AND SERVICES (U.S. CLS. 100, 101 AND 107).

AISHA CLARKE, EXAMINING ATTORNEY

SN 77-414,435. COLUMBIA BOOKS, INC., BETHESDA, MD. FILED 3-6-2008.



NO CLAIM IS MADE TO THE EXCLUSIVE RIGHT TO USE "GOVERNMENT RELATIONS" AND "LOBBYISTS INFO", APART FROM THE MARK AS SHOWN.

THE COLOR(S) RED, WHITE, BLUE, YELLOW IS/ARE CLAIMED AS A FEATURE OF THE MARK.

THE MARK CONSISTS OF A BLUE BANNER CONTAINING A DEPICTION OF THE U.S. CAPITOL DOME WITH THE LETTERS "GOVERNMENT RELATIONS" IN WHITE AND THE WORDS THE AND "ALERT" IN YELLOW OVER A RED BANNER BEARING THE WORDS "LOBBYISTS.INFO" IN WHITE.

FOR BI-WEEKLY EMAIL NEWSLETTER CONTAINING NEWS AND INFORMATION ON FEDERAL GOVERNMENT RELATIONS AND LOBBYING INDUSTRY (U.S. CLS. 100, 101 AND 107).

FIRST USE 1-7-2008; IN COMMERCE 1-7-2008.
GRETTA YAO, EXAMINING ATTORNEY

CLASS 41—(Continued).

SN 77-414,474. PARENTMAGIC, INC., GLEN ELLYN, IL. FILED 3-6-2008.

AMERICA'S SIMPLEST PARENTING PROGRAM

THE MARK CONSISTS OF STANDARD CHARACTERS WITHOUT CLAIM TO ANY PARTICULAR FONT, STYLE, SIZE, OR COLOR.

NO CLAIM IS MADE TO THE EXCLUSIVE RIGHT TO USE "PARENTING PROGRAM", APART FROM THE MARK AS SHOWN.

FOR EDUCATIONAL SERVICES, NAMELY, CONDUCTING CLASSES, SEMINARS AND WORKSHOPS IN THE FIELD OF PARENTING AND CHILD DISCIPLINE AND DISSEMINATION OF COURSE MATERIALS IN CONNECTION THEREWITH; EDUCATIONAL SERVICES, NAMELY, CONDUCTING PROGRAMS AND WORKSHOPS FOR TRAINERS IN THE FIELD OF PARENTING AND CHILD DISCIPLINE AND DISSEMINATION OF COURSE MATERIALS IN CONNECTION THEREWITH (U.S. CLS. 100, 101 AND 107).

FIRST USE 11-7-2007; IN COMMERCE 11-7-2007.
TAMARA FRAZIER, EXAMINING ATTORNEY

SN 77-415,051. CAROL C. AHEARN, NORWOOD, MA. FILED 3-6-2008.

Blue Max Dog

THE MARK CONSISTS OF STANDARD CHARACTERS WITHOUT CLAIM TO ANY PARTICULAR FONT, STYLE, SIZE, OR COLOR.

NO CLAIM IS MADE TO THE EXCLUSIVE RIGHT TO USE "DOG", APART FROM THE MARK AS SHOWN.

FOR DOG TRAINING (U.S. CLS. 100, 101 AND 107).

FIRST USE 4-15-2003; IN COMMERCE 4-15-2003.
BERYL GARDNER, EXAMINING ATTORNEY

SN 77-415,465. WELLHAVEN, MORTEN, ALAMEDA, CA. FILED 3-6-2008.

THE GOSPEL REFORMATION

THE MARK CONSISTS OF STANDARD CHARACTERS WITHOUT CLAIM TO ANY PARTICULAR FONT, STYLE, SIZE, OR COLOR.

NO CLAIM IS MADE TO THE EXCLUSIVE RIGHT TO USE "GOSPEL", APART FROM THE MARK AS SHOWN.

FOR ORGANIZATION OF SEMINARS, WORKING GROUPS, RESEARCH GROUPS, IN THE FIELD OF BIBLICAL AND HISTORICAL STUDIES (U.S. CLS. 100, 101 AND 107).

GIANCARLO CASTRO, EXAMINING ATTORNEY

CLASS 41—(Continued).

SN 77-415,806. CSJ LTD, FLOWER MOUND, TX. FILED 3-7-2008.

Boomerangs

THE MARK CONSISTS OF STANDARD CHARACTERS WITHOUT CLAIM TO ANY PARTICULAR FONT, STYLE, SIZE, OR COLOR.

FOR ENTERTAINMENT SERVICES RENDERED IN A SHOPPING MALL SPACE, NAMELY, INDOOR GYMNASIUMS FOR FAMILY AMUSEMENTS, PROVIDING PLAY FACILITIES FOR CHILDREN IN THE NATURE OF INTERACTIVE PLAY AREAS, PROVIDING FACILITIES WITH LARGE INFLATABLE PLAY STRUCTURES FOR CHILDREN'S PARTIES, AMUSEMENT ARCADES FEATURING VIDEO AND COIN OPERATED GAMES (U.S. CLS. 100, 101 AND 107).

B. PARADEWELAI, EXAMINING ATTORNEY

CLASS 41—(Continued).

SN 77-416,537. JAZZERCISE, INC., CARLSBAD, CA. FILED 3-7-2008.

JAZZERCISE TEAM DANCE

THE MARK CONSISTS OF STANDARD CHARACTERS WITHOUT CLAIM TO ANY PARTICULAR FONT, STYLE, SIZE, OR COLOR.

OWNER OF U.S. REG. NOS. 1,079,083, 2,658,984 AND 3,106,514.

NO CLAIM IS MADE TO THE EXCLUSIVE RIGHT TO USE "TEAM DANCE", APART FROM THE MARK AS SHOWN.

FOR EDUCATIONAL SERVICES, NAMELY, CONDUCTING CLASSES IN DANCE AND EXERCISE (U.S. CLS. 100, 101 AND 107).

FIRST USE 1-1-2006; IN COMMERCE 1-1-2006.

ASMAT KHAN, EXAMINING ATTORNEY

SN 77-416,447. ADVANCED COLLEGE, SOUTH GATE, CA. FILED 3-7-2008.



NO CLAIM IS MADE TO THE EXCLUSIVE RIGHT TO USE "ADVANCED COLLEGE", APART FROM THE MARK AS SHOWN.

THE COLOR(S) RED, BLUE, WHITE AND GREEN IS/ARE CLAIMED AS A FEATURE OF THE MARK.

THE COLOR RED APPEARS IN A CIRCLE WHICH ENCLOSES A BLUE AND GREEN GLOBE; THE COLOR WHITE APPEARS AS AN OUTLINE AROUND THE GLOBE AND IN THE WORDING "ADVANCE COLLEGE".

FOR EDUCATING AT UNIVERSITY OR COLLEGES (U.S. CLS. 100, 101 AND 107).

FIRST USE 7-1-1999; IN COMMERCE 7-1-1999.

JORDAN BAKER, EXAMINING ATTORNEY

SN 77-416,891. UNI.- PASS, LLC., CORPUS CHRISTI, TX. FILED 3-8-2008.



NO CLAIM IS MADE TO THE EXCLUSIVE RIGHT TO USE "LLC", APART FROM THE MARK AS SHOWN.

THE STIPPLING IS FOR SHADING PURPOSES ONLY.

THE MARK CONSISTS OF A SHIELD/CREST ON A BROAD BAND BACKGROUND WITH AN OPEN BOOK IN CENTER. BELOW THE DESIGN IS THE STYLIZED TEXT "UNI.-PASS LLC".

FOR EDUCATIONAL SERVICES, NAMELY, OBTAINING SCHOOL TRANSCRIPTS ON BEHALF OF CUSTOMERS AND PROVIDING THE CUSTOMER'S TRANSCRIPT TO SCHOOLS, AND PROVIDING ADVICE FOR POTENTIAL ADULT STUDENTS TO DECIDE ON CAREER AND EDUCATIONAL DIRECTION (U.S. CLS. 100, 101 AND 107).

CAROLINE WOOD, EXAMINING ATTORNEY

CLASS 41—(Continued).

SN 77-417,047. LEE, MARILYN, PHOENIX, AZ. AND MAY-FIELD, JOHN R., PHOENIX, AZ. FILED 3-9-2008.

COLLECTIVE FREQUENCY

THE MARK CONSISTS OF STANDARD CHARACTERS WITHOUT CLAIM TO ANY PARTICULAR FONT, STYLE, SIZE, OR COLOR.

FOR ENTERTAINMENT AND EDUCATIONAL SERVICES, NAMELY, PROVIDING SEMINARS ON A CULTURAL, SOCIOLOGICAL, AND SPIRITUAL PHILOSOPHY BOTH LIVE AND VIA A WEBSITE (U.S. CLS. 100, 101 AND 107).

KRISTIN CARLSON, EXAMINING ATTORNEY

SN 77-417,190. THE RIGHT SIDE PRODUCTIONS, INC., WASHINGTON, DC. FILED 3-10-2008.

reclaiming USA

THE MARK CONSISTS OF STANDARD CHARACTERS WITHOUT CLAIM TO ANY PARTICULAR FONT, STYLE, SIZE, OR COLOR.

NO CLAIM IS MADE TO THE EXCLUSIVE RIGHT TO USE "USA", APART FROM THE MARK AS SHOWN.

FOR ENTERTAINMENT, NAMELY, A CONTINUING POLITICS SHOW BROADCAST OVER TELEVISION, SATELLITE, AUDIO, AND VIDEO MEDIA; MEDIA PRODUCTION SERVICES, NAMELY, VIDEO AND FILM PRODUCTION; MOBILE MEDIA AND ENTERTAINMENT SERVICES IN THE NATURE OF CONTENT PREPARATION; CONTINUING PUBLIC SERVICE PROGRAMS IN THE FIELD OF POLITICS PRODUCED AND DISTRIBUTED OVER TELEVISION, SATELLITE, FILM, AUDIO, VIDEO, INTERNET, AND 3-D VIRTUAL REALITY MEDIA; INFORMATION RELATING TO ENTERTAINMENT AND EDUCATION, PROVIDED ON-LINE FROM A COMPUTER DATABASE OR THE INTERNET (U.S. CLS. 100, 101 AND 107).

JACQUELINE A. LAVINE, EXAMINING ATTORNEY

SN 77-417,512. MRS. WYOMING AMERICA PAGEANT, EATON, CO. FILED 3-10-2008.

MRS. WYOMING

THE MARK CONSISTS OF STANDARD CHARACTERS WITHOUT CLAIM TO ANY PARTICULAR FONT, STYLE, SIZE, OR COLOR.

FOR ENTERTAINMENT IN THE NATURE OF BEAUTY PAGEANTS (U.S. CLS. 100, 101 AND 107).

FIRST USE 7-29-1976; IN COMMERCE 1-29-1977.

HANNO RITTNER, EXAMINING ATTORNEY

CLASS 41—(Continued).

SN 77-417,590. CHULPAYEV, MARINA, FOREST HILLS, NY. FILED 3-10-2008.

Marina Chello

THE MARK CONSISTS OF STANDARD CHARACTERS WITHOUT CLAIM TO ANY PARTICULAR FONT, STYLE, SIZE, OR COLOR.

THE NAME "MARINA CHELLO" IDENTIFIES A LIVING INDIVIDUAL WHOSE CONSENT IS OF RECORD.

FOR ENTERTAINMENT SERVICES IN THE NATURE OF LIVE MUSICAL PERFORMANCES BY A SINGER; MUSIC COMPOSITION FOR OTHERS (U.S. CLS. 100, 101 AND 107).

KATHRYN COWARD, EXAMINING ATTORNEY

SN 77-417,681. RIPE DIGITAL ENTERTAINMENT, INC., LOS ANGELES, CA. FILED 3-10-2008.

I Want My VOD

THE MARK CONSISTS OF STANDARD CHARACTERS WITHOUT CLAIM TO ANY PARTICULAR FONT, STYLE, SIZE, OR COLOR.

NO CLAIM IS MADE TO THE EXCLUSIVE RIGHT TO USE "VOD", APART FROM THE MARK AS SHOWN.

FOR PROVISION OF NON-DOWNLOADABLE ONGOING AUDIO VISUAL FILM AND TELEVISION PROGRAMS VIA VIDEO ON DEMAND, TELEVISION BROADCAST, CABLE TELEVISION, BROADBAND, INTERNET AND MOBILE DEVICE SERVICES (U.S. CLS. 100, 101 AND 107).

CAROLYN CATALDO, EXAMINING ATTORNEY

SN 77-417,848. GAMESTRATA, INC., SAN MATEO, CA. FILED 3-10-2008.

GAMESTRATA

THE MARK CONSISTS OF STANDARD CHARACTERS WITHOUT CLAIM TO ANY PARTICULAR FONT, STYLE, SIZE, OR COLOR.

FOR PROVIDING INFORMATION IN THE FIELD OF VIDEO GAMES, NAMELY, COMPILATION OF STATISTICS, RANKINGS AND LEADER BOARDS RELATED TO VIDEO GAMES (U.S. CLS. 100, 101 AND 107).

FIRST USE 1-29-2008; IN COMMERCE 1-29-2008.

KATHERINE E. HALMEN, EXAMINING ATTORNEY

CLASS 41—(Continued).

SN 77-418,641. WOMEN'S WELLNESS AND MATERNITY CENTER, MADISONVILLE, TN. FILED 3-11-2008.



THE COLOR(S) GREEN AND BLACK IS/ARE CLAIMED AS A FEATURE OF THE MARK.

THE MARK CONSISTS OF THE STYLIZED WORDS "GET WITH IT" IN BLACK AND THE SILHOUETTE OF A WOMAN RUNNING IN GREEN. THE SOLE OF THE WOMAN'S LEFT SHOE IS ENLARGED AND THE WORD "IT" APPEARS INSIDE AS WELL AS GREEN WAVY LINES REPRESENTING TREAD.

FOR PROVIDING ASSISTANCE, PERSONAL TRAINING AND PHYSICAL FITNESS CONSULTATION TO INDIVIDUALS TO HELP THEM MAKE PHYSICAL FITNESS, STRENGTH, CONDITIONING, AND EXERCISE IMPROVEMENT IN THEIR DAILY LIVING; EDUCATION SERVICES, NAMELY, PROVIDING CLASSES AND WORKSHOPS IN THE FIELD OF HEALTH AND NUTRITION EDUCATION (U.S. CLS. 100, 101 AND 107).

FIRST USE 12-1-2007; IN COMMERCE 12-1-2007.
JERI J. FICKES, EXAMINING ATTORNEY

SN 77-418,644. ESPN STARWAVE PARTNERS, DBA D/B/A ESPN INTERNET VENTURES, BRISTOL, CT. FILED 3-11-2008.



NO CLAIM IS MADE TO THE EXCLUSIVE RIGHT TO USE "WWW.HOOPGURLZ.COM", APART FROM THE MARK AS SHOWN.

THE MARK CONSISTS OF THE WORDING "WWW.HOOPGURLZ.COM" WITH A DESIGN ELEMENT COMPRISED OF A BASKETBALL AND THE FEMALE SYMBOL.

FOR PROVIDING INFORMATION IN THE FIELD OF BASKETBALL VIA THE INTERNET (U.S. CLS. 100, 101 AND 107).

FIRST USE 12-0-2001; IN COMMERCE 12-0-2001.
JERI J. FICKES, EXAMINING ATTORNEY

CLASS 41—(Continued).

SN 77-419,722. PERRY, STEVEN, SUN CITY, AZ. FILED 3-12-2008.

Sun City Kids

THE MARK CONSISTS OF STANDARD CHARACTERS WITHOUT CLAIM TO ANY PARTICULAR FONT, STYLE, SIZE, OR COLOR.

NO CLAIM IS MADE TO THE EXCLUSIVE RIGHT TO USE "SUN CITY", APART FROM THE MARK AS SHOWN. FOR ENTERTAINMENT IN THE NATURE OF LIVE PERFORMANCES BY A MASTER OF CEREMONIES PROVIDING AN INTERACTIVE QUIZ SHOW (U.S. CLS. 100, 101 AND 107).

FIRST USE 5-1-2000; IN COMMERCE 5-1-2000.
WANDA KAY PRICE, EXAMINING ATTORNEY

SN 77-420,058. GODDESS DANCE, INC., HANAHAN, SC. FILED 3-12-2008.

GODDESS DANCE STUDIO

THE MARK CONSISTS OF STANDARD CHARACTERS WITHOUT CLAIM TO ANY PARTICULAR FONT, STYLE, SIZE, OR COLOR.

NO CLAIM IS MADE TO THE EXCLUSIVE RIGHT TO USE "DANCE STUDIO", APART FROM THE MARK AS SHOWN.

FOR DANCE INSTRUCTION; DANCE STUDIOS; TRAINING OF DANCE INSTRUCTORS (U.S. CLS. 100, 101 AND 107).

LANA PHAM, EXAMINING ATTORNEY

SN 77-420,445. RIPE DIGITAL ENTERTAINMENT, INC., LOS ANGELES, CA. FILED 3-12-2008.

RIPE DIGITAL

THE MARK CONSISTS OF STANDARD CHARACTERS WITHOUT CLAIM TO ANY PARTICULAR FONT, STYLE, SIZE, OR COLOR.

NO CLAIM IS MADE TO THE EXCLUSIVE RIGHT TO USE "DIGITAL", APART FROM THE MARK AS SHOWN.

FOR PROVISION OF NON-DOWNLOADABLE ON-GOING AUDIO VISUAL FILM AND TELEVISION PROGRAMS VIA VIDEO ON DEMAND, TELEVISION BROADCAST, CABLE TELEVISION, BROADBAND, INTERNET AND MOBILE DEVICE SERVICES (U.S. CLS. 100, 101 AND 107).

CAROLYN CATALDO, EXAMINING ATTORNEY

CLASS 41—(Continued).

SN 77-420,554. SALAS, ANTONIO, DBA LOS GUERREROS DEL ARPA, SANTA ROSA, CA. FILED 3-12-2008.



THE FOREIGN WORDING IN THE MARK TRANSLATES INTO ENGLISH AS "THE HARP WARRIORS".

FOR ENTERTAINMENT, NAMELY, LIVE PERFORMANCES BY A MUSICAL BAND (U.S. CLS. 100, 101 AND 107).

FIRST USE 1-1-2006; IN COMMERCE 1-1-2006.
RAUL CORDOVA, EXAMINING ATTORNEY

CLASS 41—(Continued).

SN 77-420,691. EXCELSIOR COLLEGE, ALBANY, NY. FILED 3-13-2008.

UExcel

THE MARK CONSISTS OF STANDARD CHARACTERS WITHOUT CLAIM TO ANY PARTICULAR FONT, STYLE, SIZE, OR COLOR.

OWNER OF U.S. REG. NOS. 2,500,388, 2,661,665 AND OTHERS.

FOR COLLEGE LEVEL TESTING SERVICES, NAMELY, PREPARING AND ADMINISTERING EXAMINATIONS DESIGNED TO PROVIDE A MEASURE OF COLLEGE LEVEL COURSE ACHIEVEMENT ON WHICH COLLEGE CREDIT MAY BE AWARDED; SCORING OF COLLEGE LEVEL EXAMINATIONS; PROVIDING TRANSCRIPTS FOR THE PURPOSE OF AWARDED COLLEGE LEVEL CREDIT (U.S. CLS. 100, 101 AND 107).
DAYNA BROWNE, EXAMINING ATTORNEY

SN 77-420,775. COURTROOM TELEVISION NETWORK LLC, NEW YORK, NY. FILED 3-13-2008.

RICH AND RECKLESS

SN 77-420,619. MAGNOLIAS INTERNATIONAL, LLC, DBA THEBEERCARTGIRL.COM, WASHINGTON, MI. FILED 3-13-2008.



THE MARK CONSISTS OF STANDARD CHARACTERS WITHOUT CLAIM TO ANY PARTICULAR FONT, STYLE, SIZE, OR COLOR.

FOR ENTERTAINMENT SERVICES, NAMELY, CONTINUING SCRIPTED AND UNSCRIPTED TELEVISION PROGRAM SERIES IN THE FIELD OF COMEDY, DRAMA, ACTION, ADVENTURE AND REALITY PROVIDED THROUGH CABLE TELEVISION, BROADCAST TELEVISION, INTERNET, VIDEO-ON-DEMAND, AND THROUGH OTHER DISTRIBUTION PLATFORMS; PROVIDING INFORMATION, NAMELY, ENTERTAINMENT INFORMATION, OVER THE INTERNET (U.S. CLS. 100, 101 AND 107).

LAURA HAMMEL, EXAMINING ATTORNEY

SN 77-420,907. SORIANO, ANTHONY S., NORTH BELLMORE, NY. AND COHEN, DANIEL T., NORTH BELLMORE, NY. AND SANCHEZ, RAYMOND C., NORTH BELLMORE, NY. FILED 3-13-2008.

The Mercurial

THE COLOR(S) ORANGE, BLACK, PEACH, GRAY, BROWN, BLUE, RED, PINK AND WHITE IS/ARE CLAIMED AS A FEATURE OF THE MARK.

THE MARK CONSISTS OF A GIRL WITH PEACH SKIN, ORANGE HAIR, BROWN EYEBROWS, BLACK EYELASHES, BLUE AND WHITE EYES WITH BLACK AND WHITE PUPILS AND DARK PEACH OUTLINE, A DARK PEACH NOSE AND INNER EAR, AND PINK AND RED LIPS. THE GIRL IS WEARING A BLUE HAIR TIE AND GRAY AND BLACK VISOR. THE WORDING THEBEERCARTGIRL.COM IS UNDER THE GIRL, WITH "BEER" AND "GIRL" IN ORANGE AND THE REMAINDER OF THE WORDING IN BLACK.

FOR PROVIDING A WEB SITE THROUGH WHICH GOLFERS LOCATE INFORMATION ABOUT GOLF COURSES AND GOLF TOURNAMENTS; PROVIDING A WEB SITE THROUGH WHICH GOLFERS RESERVE TEE TIMES AT GOLF COURSES (U.S. CLS. 100, 101 AND 107).

FIRST USE 3-12-2008; IN COMMERCE 3-13-2008.
ROBIN MITTLER, EXAMINING ATTORNEY

THE MARK CONSISTS OF STANDARD CHARACTERS WITHOUT CLAIM TO ANY PARTICULAR FONT, STYLE, SIZE, OR COLOR.

FOR ENTERTAINMENT, NAMELY, LIVE PERFORMANCES BY A MUSICAL BAND (U.S. CLS. 100, 101 AND 107).

FIRST USE 6-1-2004; IN COMMERCE 6-1-2004.
KELLY CHOE, EXAMINING ATTORNEY

CLASS 41—(Continued).

SN 77-421,444. BRICKYARD TRADEMARKS, INC., LAS VEGAS, NV. FILED 3-13-2008.

INDY LIGHTS

THE MARK CONSISTS OF STANDARD CHARACTERS WITHOUT CLAIM TO ANY PARTICULAR FONT, STYLE, SIZE, OR COLOR.

OWNER OF U.S. REG. NOS. 1,836,834, 1,924,339 AND OTHERS.

SEC. 2(F) AS TO "INDY".

FOR ENTERTAINMENT SERVICES, NAMELY, ARRANGING AND CONDUCTING OF COMPETITIONS FOR AN AUTOMOBILE RACING SERIES; ENTERTAINMENT IN THE NATURE OF AUTOMOBILE RACES (U.S. CLS. 100, 101 AND 107).

LYDIA BELZER, EXAMINING ATTORNEY

SN 77-421,496. TELIGENCE CANADA LTD., VANCOUVER, CANADA, FILED 3-13-2008.

SAFECALLBACK

THE MARK CONSISTS OF STANDARD CHARACTERS WITHOUT CLAIM TO ANY PARTICULAR FONT, STYLE, SIZE, OR COLOR.

FOR ENTERTAINMENT SERVICES, NAMELY, PROVIDING ONLINE COMPUTER GAMES; ENTERTAINMENT SERVICES, NAMELY, NON-DOWNLOADABLE PRE-RECORDED MUSIC, VIDEO GAMES, VIDEO AND GRAPHICS PRESENTED TO MOBILE COMMUNICATIONS DEVICES VIA A GLOBAL COMPUTER NETWORK AND WIRELESS NETWORKS; PROVISION OF INFORMATION IN THE FIELD OF ENTERTAINMENT VIA THE INTERNET (U.S. CLS. 100, 101 AND 107).

DEIRDRE ROBERTSON, EXAMINING ATTORNEY

SN 77-421,654. ZIGABID, LA CANADA, CA. FILED 3-13-2008.

A TICKET REVOLUTION

THE MARK CONSISTS OF STANDARD CHARACTERS WITHOUT CLAIM TO ANY PARTICULAR FONT, STYLE, SIZE, OR COLOR.

NO CLAIM IS MADE TO THE EXCLUSIVE RIGHT TO USE "TICKET", APART FROM THE MARK AS SHOWN.

FOR ONLINE ENTERTAINMENT TICKET AGENCY SERVICES (U.S. CLS. 100, 101 AND 107).

KHANH LE, EXAMINING ATTORNEY

CLASS 41—(Continued).

SN 77-421,815. WILDERNESS GRAPHICS, INC., TALLAHASSEE, FL. FILED 3-14-2008.

idea implementation

THE MARK CONSISTS OF STANDARD CHARACTERS WITHOUT CLAIM TO ANY PARTICULAR FONT, STYLE, SIZE, OR COLOR.

FOR ORGANIZING EXHIBITIONS FOR INDOOR AND OUTDOOR VENUES AND RELATED OPPORTUNITIES FOR INTERPRETATION AND PUBLIC USE IN THE SUBJECTS OF NATURAL AND CULTURAL HISTORY (U.S. CLS. 100, 101 AND 107).

FIRST USE 1-1-2004; IN COMMERCE 1-1-2004.

HOWARD B. LEVINE, EXAMINING ATTORNEY

SN 77-421,896. MARK L. ANDERSON, LLC, ROSWELL, GA. FILED 3-14-2008.

Casual Elegance Photography

THE MARK CONSISTS OF STANDARD CHARACTERS WITHOUT CLAIM TO ANY PARTICULAR FONT, STYLE, SIZE, OR COLOR.

NO CLAIM IS MADE TO THE EXCLUSIVE RIGHT TO USE "PHOTOGRAPHY", APART FROM THE MARK AS SHOWN.

FOR PHOTOGRAPHY (U.S. CLS. 100, 101 AND 107).

FIRST USE 11-1-2001; IN COMMERCE 11-1-2001.

CYNTHIA TRIPI, EXAMINING ATTORNEY

SN 77-422,175. MARSHAWN LYNCH, WALNUT CREEK, CA. FILED 3-14-2008.



THE MARK CONSISTS OF AN INDIVIDUAL HOLDING A FLAG WITH A CROWD IN THE BACKGROUND.

FOR FOOTBALL CAMPS (U.S. CLS. 100, 101 AND 107).

PAUL E. FAHRENKOPF, EXAMINING ATTORNEY

CLASS 41—(Continued).

SN 77-423,088. UNIVERSAL PARAMETRICS, INC., ANN ARBOR, MI. AND FREY, STEVEN J., DEARBORN HEIGHTS, MI. FILED 3-15-2008.

Pro/MENTOR

THE MARK CONSISTS OF STANDARD CHARACTERS WITHOUT CLAIM TO ANY PARTICULAR FONT, STYLE, SIZE, OR COLOR.

NO CLAIM IS MADE TO THE EXCLUSIVE RIGHT TO USE "MENTOR", APART FROM THE MARK AS SHOWN.

SEC. 2(F).

FOR EDUCATION SERVICES, NAMELY, PROVIDING MENTORING, TUTORING, CLASSES, SEMINARS AND WORKSHOPS IN THE FIELD OF COMPUTER SOFTWARE (U.S. CLS. 100, 101 AND 107).

FIRST USE 6-24-1999; IN COMMERCE 6-24-1999.

KATHERINE M. DUBRAY, EXAMINING ATTORNEY

SN 77-423,239. COAKLEY, PATRICIA, FRANKLIN, MA. FILED 3-16-2008.

SINGLE FOR A REASON

THE MARK CONSISTS OF STANDARD CHARACTERS WITHOUT CLAIM TO ANY PARTICULAR FONT, STYLE, SIZE, OR COLOR.

FOR INTERACTIVE ONLINE JOURNALS, NAMELY, A BLOG FEATURING ARTICLES ESSAYS PHOTOS VIDEOS AND COMMENTARY IN THE FIELDS OF HUMOR ENTERTAINMENT HUMAN INTEREST STORIES AND LIFESTYLE OBSERVATIONS (U.S. CLS. 100, 101 AND 107).

FIRST USE 3-10-2008; IN COMMERCE 3-10-2008.

ALICE BENMAMAN, EXAMINING ATTORNEY

SN 77-423,269. RON CUTLIP, NEW YORK, NY. AND CHERYL HEBERT CUTLIP, NEW YORK, NY. FILED 3-16-2008.

BROADWAY UNDERGROUND

THE MARK CONSISTS OF STANDARD CHARACTERS WITHOUT CLAIM TO ANY PARTICULAR FONT, STYLE, SIZE, OR COLOR.

OWNER OF U.S. REG. NO. 3,126,609.

NO CLAIM IS MADE TO THE EXCLUSIVE RIGHT TO USE "BROADWAY", APART FROM THE MARK AS SHOWN.

FOR ENTERTAINMENT IN THE NATURE OF A TELEVISION AND FILM SERIES FEATURING DANCE PERFORMANCES (U.S. CLS. 100, 101 AND 107).

ASMAT KHAN, EXAMINING ATTORNEY

CLASS 41—(Continued).

SN 77-423,346. APPDEV PRODUCTS, LLC, EDEN PRAIRIE, MN. FILED 3-17-2008.

KSOURCE ONLINE LEARNING

THE MARK CONSISTS OF STANDARD CHARACTERS WITHOUT CLAIM TO ANY PARTICULAR FONT, STYLE, SIZE, OR COLOR.

NO CLAIM IS MADE TO THE EXCLUSIVE RIGHT TO USE "ONLINE LEARNING", APART FROM THE MARK AS SHOWN.

FOR PROVIDING ON-LINE TRAINING, NAMELY, DEMONSTRATIONS, EXAMS, COURSES, SEMINARS AND WORKSHOPS, IN THE FIELD OF END USER SOFTWARE SYSTEMS (U.S. CLS. 100, 101 AND 107).

FIRST USE 2-22-2008; IN COMMERCE 2-22-2008.

NORA BUCHANAN WILL, EXAMINING ATTORNEY

SN 77-423,406. MONSTER MINI GOLF, LLC, DANIELSON, CT. FILED 3-17-2008.



NO CLAIM IS MADE TO THE EXCLUSIVE RIGHT TO USE "MINI GOLF", APART FROM THE MARK AS SHOWN. THE COLOR(S) BLACK, GREEN, AND YELLOW IS/ARE CLAIMED AS A FEATURE OF THE MARK.

THE MARK CONSISTS OF A BLACK BACKGROUND WITH GREEN LETTERS IN "MONSTER" AND "GOLF" WITH A YELLOW TRIM AND YELLOW LETTERS IN "MINI". THE EYE IN THE LETTER "O" OF MONSTER IS YELLOW.

FOR ENTERTAINMENT SERVICES, NAMELY, A GLOW IN THE DARK MINIATURE GOLF COURSE, VIDEO GAME ARCADE, REDEMPTION GAME ARCADE, NAMELY, AN AMUSEMENT ARCADE FEATURING GAMES THAT DISPENSE TICKETS WHICH MAY BE REDEEMED FOR PRIZES, AND CONDUCTING BIRTHDAY PARTIES (U.S. CLS. 100, 101 AND 107).

FIRST USE 3-17-2004; IN COMMERCE 3-17-2004.

GRETTA YAO, EXAMINING ATTORNEY

CLASS 41—(Continued).

SN 77-423,679. FLORIDA KEYS COMMUNITY COLLEGE, KEY WEST, FL. FILED 3-17-2008.



NO CLAIM IS MADE TO THE EXCLUSIVE RIGHT TO USE "FLORIDA KEYS COMMUNITY COLLEGE", APART FROM THE MARK AS SHOWN.

THE COLOR(S) LITTLE SPROUT GREEN, PURE CYAN AND WHITE IS/ARE CLAIMED AS A FEATURE OF THE MARK.

THE MARK CONSISTS OF A SQUARE, WITH ROUNDED EDGES, DIVIDED HORIZONTALLY AND EQUALLY BY A SINE WAVE; THE TOP HEMISPHERE COLORED PURE CYAN, THE BOTTOM HEMISPHERE COLORED LITTLE SPROUT GREEN; A WHITE THATCH PALM FROND COVERS BOTH HEMISPHERES, WITH THE HEAD IN THE TOP AND MOST OF THE STEM IN THE BOTTOM, AND THE WORDING "FLORIDA KEYS COMMUNITY COLLEGE ISLAND LIVING, ISLAND LEARNING" IN CYAN BLUE.

FOR EDUCATING AT UNIVERSITY OR COLLEGES (U.S. CLS. 100, 101 AND 107).

FIRST USE 1-28-2008; IN COMMERCE 2-1-2008.

ANGELA M. MICHELI, EXAMINING ATTORNEY

SN 77-423,751. SIGMA ALPHA LAMDA, INC., BRADENTON, FL. FILED 3-17-2008.



OWNER OF U.S. REG. NOS. 2,996,454 AND 3,061,557.

NO CLAIM IS MADE TO THE EXCLUSIVE RIGHT TO USE "LEADERSHIP", APART FROM THE MARK AS SHOWN.

THE MARK CONSISTS OF THREE HORIZONTALLY ALIGNED SHADED SQUARES WITH CONTRASTING SYMBOLOGY DEPICTING IN LEFT-TO-RIGHT ORDER, THREE HANDS INTERSECTING ABOUT A CENTER AXIS OF THE LEFT-MOST SQUARE, A STAR ABOVE AN ANTHROPOMORPHIC SHAPE IN THE CENTER SQUARE AND AN 8-POINT STAR IN THE RIGHT-MOST SQUARE. CENTERED UNDER THE THREE SQUARES THE WORDS, "SIGMA" "ALPHA" "LAMBDA", A LINE-BREAK AND WORDS "SERVICE" (A BULLET) "ACHIEVEMENT" (A BULLET) AND "LEADERSHIP".

FOR EDUCATIONAL SERVICES, NAMELY, ENCOURAGING ACADEMIC ACHIEVEMENT BY SPONSORING SCHOLAR GROUPS, STUDY GROUPS AND ACADEMIC MENTORING TO SCHOOL CHILDREN, ORGANIZING AND CONDUCTING CAMPUS AWARENESS ACTIVITIES IN THE NATURE OF CAMPUS FAIRS AND SPECIAL EVENTS THAT PROMOTE VOLUNTEERISM, PROVIDING RECOGNITION AND INCENTIVES BY THE WAY OF AWARDS TO NEW MEMBERS THAT DEMONSTRATE EXCELLENCE IN THE FIELD OF COMMUNITY SERVICE, PROVIDING LEADERSHIP TRAINING PROGRAMS IN THE FIELD OF LEADERSHIP DEVELOPMENT (U.S. CLS. 100, 101 AND 107).

FIRST USE 10-11-2005; IN COMMERCE 10-11-2005.

SARA THOMAS, EXAMINING ATTORNEY

CLASS 41—(Continued).

SN 77-423,781. BUSCH ENTERTAINMENT CORPORATION, ST. LOUIS, MO. FILED 3-17-2008.

WALHALLA WAVE

THE MARK CONSISTS OF STANDARD CHARACTERS WITHOUT CLAIM TO ANY PARTICULAR FONT, STYLE, SIZE, OR COLOR.

NO CLAIM IS MADE TO THE EXCLUSIVE RIGHT TO USE "WAVE", APART FROM THE MARK AS SHOWN.

FOR ENTERTAINMENT IN THE NATURE OF AN AMUSEMENT PARK RIDE (U.S. CLS. 100, 101 AND 107).

FIRST USE 3-1-2008; IN COMMERCE 3-1-2008.

CHRISIE B. KING, EXAMINING ATTORNEY

SN 77-423,837. ACKERMAN MCQUEEN INC., OKLAHOMA CITY, OK. FILED 3-17-2008.

BLOGWASH

THE MARK CONSISTS OF STANDARD CHARACTERS WITHOUT CLAIM TO ANY PARTICULAR FONT, STYLE, SIZE, OR COLOR.

FOR ONLINE NEWS AGENCY SERVICES, NAMELY, GATHERING AND DISSEMINATION OF NEWS; PROVIDING NEWS IN THE NATURE OF CURRENT EVENT REPORTING (U.S. CLS. 100, 101 AND 107).

KAPIL BHANOT, EXAMINING ATTORNEY

SN 77-424,139. BLDG213, INC., WOODBRIDGE, VA. FILED 3-17-2008.

BLDG213

THE MARK CONSISTS OF STANDARD CHARACTERS WITHOUT CLAIM TO ANY PARTICULAR FONT, STYLE, SIZE, OR COLOR.

FOR PROVIDING AN INTERACTIVE WEB SITE FEATURING USER-DEFINED DIGITAL CONTENT RELATING TO ENTERTAINMENT AND EDUCATION (U.S. CLS. 100, 101 AND 107).

SANDRA MANIOS, EXAMINING ATTORNEY

CLASS 41—(Continued).

SN 77-424,460. MOOERS, GREG, PACIFIC PALISADES, CA.
FILED 3-18-2008.

LifeCamp

THE MARK CONSISTS OF STANDARD CHARACTERS WITHOUT CLAIM TO ANY PARTICULAR FONT, STYLE, SIZE, OR COLOR.

OWNER OF U.S. REG. NO. 2,924,847.
FOR EDUCATIONAL SERVICES, NAMELY, PROVIDING PUBLIC SPEAKING SERVICES, RADIO HOSTING AND GUESTING SERVICES AND TRAINING SERVICES IN THE FIELDS OF EMPOWERMENT AND SELF-IMPROVEMENT (U.S. CLS. 100, 101 AND 107).

FIRST USE 10-10-1996; IN COMMERCE 10-10-1996.
JORDAN BAKER, EXAMINING ATTORNEY

SN 77-424,479. NEW YORK YACHT CLUB, NEW YORK, NY.
FILED 3-18-2008.

NEW YORK YACHT CLUB

THE MARK CONSISTS OF STANDARD CHARACTERS WITHOUT CLAIM TO ANY PARTICULAR FONT, STYLE, SIZE, OR COLOR.

NO CLAIM IS MADE TO THE EXCLUSIVE RIGHT TO USE "YACHT CLUB", APART FROM THE MARK AS SHOWN.

SEC. 2(F).
FOR YACHT CLUB SERVICES (U.S. CLS. 100, 101 AND 107).

FIRST USE 7-31-1844; IN COMMERCE 7-31-1844.
CHARLES L. JENKINS, EXAMINING ATTORNEY

SN 77-424,484. NEW YORK YACHT CLUB, NEW YORK, NY.
FILED 3-18-2008.

NYYC

THE MARK CONSISTS OF STANDARD CHARACTERS WITHOUT CLAIM TO ANY PARTICULAR FONT, STYLE, SIZE, OR COLOR.

OWNER OF U.S. REG. NO. 2,689,231.
FOR YACHT CLUB SERVICES (U.S. CLS. 100, 101 AND 107).

FIRST USE 7-31-1844; IN COMMERCE 7-31-1844.
CHARLES L. JENKINS, EXAMINING ATTORNEY

CLASS 41—(Continued).

SN 77-424,874. HAMAN, KEN, CARLSBAD, CA. FILED 3-18-2008.



NO CLAIM IS MADE TO THE EXCLUSIVE RIGHT TO USE "FITNESS" AND "FITNESS SERVICES", APART FROM THE MARK AS SHOWN.

THE COLOR(S) RED, BLACK, WHITE, BLUE AND GREEN IS/ARE CLAIMED AS A FEATURE OF THE MARK.

THE MARK CONSISTS OF A WHITE STYLIZED CUBE WITH BLACK OUTLINING, WITH THE WORD "ATHLETICS" IN RED, "EXERCUBE" IN BLUE, AND "FITNESS SERVICES" IN GREEN, WITH THE WORD "FITNESS" IN WHITE WITH A BLACK RECTANGULAR BACKGROUND.

FOR PHYSICAL FITNESS CONDITIONING CLASSES; PHYSICAL FITNESS CONSULTATION; PHYSICAL FITNESS INSTRUCTION; PHYSICAL FITNESS TRAINING SERVICES; PROVIDING A WEB SITE FEATURING INFORMATION ON EXERCISE AND FITNESS; PROVIDING FITNESS AND EXERCISE FACILITIES; HEALTH CLUB SERVICES, NAMELY, PROVIDING INSTRUCTION AND EQUIPMENT IN THE FIELD OF PHYSICAL EXERCISE; PROVIDING ASSISTANCE, PERSONAL TRAINING AND PHYSICAL FITNESS CONSULTATION TO CORPORATE CLIENTS TO HELP THEIR EMPLOYEES MAKE PHYSICAL FITNESS, STRENGTH, CONDITIONING, AND EXERCISE ALTERATIONS IN THEIR DAILY LIVING; PROVIDING ASSISTANCE, PERSONAL TRAINING AND PHYSICAL FITNESS CONSULTATION TO INDIVIDUALS TO HELP THEM MAKE PHYSICAL FITNESS, STRENGTH, CONDITIONING, AND EXERCISE IMPROVEMENT IN THEIR DAILY LIVING (U.S. CLS. 100, 101 AND 107).

FIRST USE 6-15-2002; IN COMMERCE 6-15-2002.
MARK PILARO, EXAMINING ATTORNEY

SN 77-424,990. PLANET HOLLYWOOD (REGION IV), INC., ORLANDO, FL. FILED 3-18-2008.



OWNER OF U.S. REG. NOS. 3,398,027 AND 3,400,112.
NO CLAIM IS MADE TO THE EXCLUSIVE RIGHT TO USE "RING", APART FROM THE MARK AS SHOWN.

THE MARK CONSISTS OF LOWER CASE LETTERS, "PH", THAT ARE PLACED WITHIN TWO CONCENTRIC SEMI-CIRCLES OF DIFFERENT DIAMETERS FOLLOWED BY THE WORD "RING" IN CAPITALIZED LETTERING.

FOR PROVIDING FACILITIES FOR SPORTS EXHIBITIONS (U.S. CLS. 100, 101 AND 107).

FIRST USE 3-13-2008; IN COMMERCE 3-13-2008.
JESSICA A. POWERS, EXAMINING ATTORNEY

CLASS 41—(Continued).

SN 77-425,010. HERNANDEZ, SANTIAGO, COMMERCE CITY, CO. FILED 3-18-2008.

Deafening Silense

THE MARK CONSISTS OF STANDARD CHARACTERS WITHOUT CLAIM TO ANY PARTICULAR FONT, STYLE, SIZE, OR COLOR.

FOR ENTERTAINMENT, NAMELY, LIVE PERFORMANCES BY A MUSICAL BAND (U.S. CLS. 100, 101 AND 107).

FIRST USE 7-7-2006; IN COMMERCE 7-7-2006.
LAURIE KAUFMAN, EXAMINING ATTORNEY

SN 77-425,020. RIPE DIGITAL ENTERTAINMENT, INC., LOS ANGELES, CA. FILED 3-18-2008.

Octane TV On Demand

THE MARK CONSISTS OF STANDARD CHARACTERS WITHOUT CLAIM TO ANY PARTICULAR FONT, STYLE, SIZE, OR COLOR.

NO CLAIM IS MADE TO THE EXCLUSIVE RIGHT TO USE "TV ON DEMAND", APART FROM THE MARK AS SHOWN.

FOR PROVISION OF NON-DOWNLOADABLE ONGOING AUDIO VISUAL FILM AND TELEVISION PROGRAMS VIA VIDEO ON DEMAND, TELEVISION PROGRAMS VIA VIDEO ON DEMAND, TELEVISION BROADCAST, CABLE TELEVISION, BROADBAND, INTERNET AND MOBILE DEVICE SERVICES (U.S. CLS. 100, 101 AND 107).

FIRST USE 6-1-2003; IN COMMERCE 6-1-2003.
CAROLYN CATALDO, EXAMINING ATTORNEY

SN 77-425,032. PLANET HOLLYWOOD (REGION IV), INC., ORLANDO, FL. FILED 3-18-2008.

IN THE  RING

OWNER OF U.S. REG. NOS. 3,398,027 AND 3,400,112.
NO CLAIM IS MADE TO THE EXCLUSIVE RIGHT TO USE "RING", APART FROM THE MARK AS SHOWN.

THE MARK CONSISTS OF LOWER CASE LETTERS, "PH", THAT ARE PLACED WITHIN TWO CONCENTRIC SEMI-CIRCLES OF DIFFERENT DIAMETERS WITH THE WORDS "IN", "THE", "AND RING" IN CAPITALIZED LETTERING.

FOR PROVIDING FACILITIES FOR SPORTS EXHIBITIONS (U.S. CLS. 100, 101 AND 107).

FIRST USE 3-18-2008; IN COMMERCE 3-18-2008.
JESSICA A. POWERS, EXAMINING ATTORNEY

CLASS 41—(Continued).

SN 77-425,199. T. JEANNIE JONES, LARGO, MD. FILED 3-18-2008.

KITTY OF THE CITY

THE MARK CONSISTS OF STANDARD CHARACTERS WITHOUT CLAIM TO ANY PARTICULAR FONT, STYLE, SIZE, OR COLOR.

FOR ENTERTAINMENT SERVICES, NAMELY, LIVE PERSONAL APPEARANCES BY AN ENTERTAINER, PERSONALITY, OR CELEBRITY PRESENTING LIVE PERFORMANCES; PROVIDING COMMENTARY ABOUT MUSIC, TELEVISION, FILM AND CELEBRITIES; PRESENTATION OF LIVE SHOW PERFORMANCES; ENTERTAINMENT SERVICES, NAMELY, PROVIDING INFORMATION, COMMENTARY AND ARTICLES ABOUT MUSIC, TELEVISION, MOVIES, AND GENERAL ENTERTAINMENT, ALL ON-LINE VIA A GLOBAL COMPUTER NETWORK; ENTERTAINMENT SERVICES, NAMELY, PROVIDING A WEB SITE FEATURING MUSICAL PERFORMANCES, MUSIC VIDEOS, RELATED FILM CLIPS, PHOTOGRAPHS, AND OTHER MULTIMEDIA MATERIALS; MUSIC COMPOSITION AND TRANSCRIPTION FOR OTHERS; SONGWRITING SERVICES; RECORDING STUDIOS; RADIO ENTERTAINMENT AND TELEVISION PRODUCTION, FILM EDITING, SPECIAL EFFECTS ANIMATION SERVICES FOR FILM AND VIDEO; ENTERTAINMENT SERVICES IN THE NATURE OF ON-GOING TELEVISION, CABLE TELEVISION AND RADIO PROGRAMS FEATURING MUSIC, NEWS, COMEDY, DRAMA, FASHION SHOWS, TALK, TALENT COMPETITIONS AND VARIETY; ENTERTAINMENT IN THE NATURE OF BEAUTY PAGEANTS AND FASHION SHOWS, ARRANGING CONTESTS; ENTERTAINMENT SERVICES, NAMELY, CONDUCTING PARTIES, EDUCATIONAL SERVICES, NAMELY, CONDUCTING COURSES, CLASSES, SEMINARS, WORKSHOPS, LECTURES, TUTORIAL SESSIONS AND CONFERENCES IN THE FIELDS OF MUSIC, RADIO, TELEVISION, FILM, FASHION, MODELING, ACTING, THE ARTS, PHYSICAL FITNESS, HEALTH AND NUTRITION, AND DISTRIBUTING COURSE MATERIALS IN CONNECTION THEREWITH; CHARITABLE SERVICES, NAMELY, ACADEMIC MENTORING OF SCHOOL AGE CHILDREN AND YOUNG ADULTS; ENTERTAINMENT IN THE NATURE OF THEATER PRODUCTIONS (U.S. CLS. 100, 101 AND 107).

FIRST USE 1-1-2000; IN COMMERCE 1-1-2000.
LAURIE KAUFMAN, EXAMINING ATTORNEY

SN 77-425,214. BREAKOUT ENDURANCE SPORTS COACHING, L.L.C., DBA MAYA HUNNEWELL, MEDFORD, NJ. FILED 3-18-2008.

BREAKOUT

THE MARK CONSISTS OF STANDARD CHARACTERS WITHOUT CLAIM TO ANY PARTICULAR FONT, STYLE, SIZE, OR COLOR.

FOR PERSONAL COACHING SERVICES IN THE FIELD OF ENDURANCE SPORTS; PROFESSIONAL COACHING SERVICES IN THE FIELD OF ENDURANCE SPORTS (U.S. CLS. 100, 101 AND 107).

FIRST USE 1-30-2008; IN COMMERCE 1-30-2008.
JOHN DWYER, EXAMINING ATTORNEY

CLASS 41—(Continued).

SN 77-425,573. BLOOM, ADAM, SAINT JAMES, NY. FILED 3-18-2008.

tsz tsz33 tristatez
tristatez33 ts350z
tristate350zclub
tristatezclub 350znyc

THE MARK CONSISTS OF STANDARD CHARACTERS WITHOUT CLAIM TO ANY PARTICULAR FONT, STYLE, SIZE, OR COLOR.

FOR SOCIAL CLUB SERVICES, NAMELY, ARRANGING, ORGANIZING, AND HOSTING SOCIAL EVENTS, GET-TOGETHERS, AND PARTIES FOR CLUB MEMBERS (U.S. CLS. 100, 101 AND 107).

ELLEN PERKINS, EXAMINING ATTORNEY

CLASS 41—(Continued).

SN 77-425,702. I SAW YOU ON TV, LLC, EDINBURGH, IN. FILED 3-19-2008.

ISYOTV

THE MARK CONSISTS OF STANDARD CHARACTERS WITHOUT CLAIM TO ANY PARTICULAR FONT, STYLE, SIZE, OR COLOR.

FOR MULTIMEDIA ENTERTAINMENT SERVICES IN THE NATURE OF RECORDING, PRODUCTION AND POST-PRODUCTION SERVICES IN THE FIELDS OF MUSIC, VIDEO, AND FILMS (U.S. CLS. 100, 101 AND 107).

LINDSEY RUBIN, EXAMINING ATTORNEY

SN 77-425,650. KARL WHITE, NASHVILLE, TN. FILED 3-18-2008.

Headless Horseman
Productions

THE MARK CONSISTS OF STANDARD CHARACTERS WITHOUT CLAIM TO ANY PARTICULAR FONT, STYLE, SIZE, OR COLOR.

NO CLAIM IS MADE TO THE EXCLUSIVE RIGHT TO USE "PRODUCTIONS", APART FROM THE MARK AS SHOWN.

FOR FILM AND VIDEO PRODUCTION (U.S. CLS. 100, 101 AND 107).

ARETHA SOMERVILLE, EXAMINING ATTORNEY

SN 77-425,830. INTERNET EDUCATION FOUNDATION, WASHINGTON, DC. FILED 3-19-2008.

STATE OF THE NET

THE MARK CONSISTS OF STANDARD CHARACTERS WITHOUT CLAIM TO ANY PARTICULAR FONT, STYLE, SIZE, OR COLOR.

NO CLAIM IS MADE TO THE EXCLUSIVE RIGHT TO USE "NET", APART FROM THE MARK AS SHOWN.

FOR EDUCATIONAL SERVICES, NAMELY, CONDUCTING CONFERENCES IN THE FIELD OF INTERNET TECHNOLOGY POLICY AND DISTRIBUTION OF COURSE MATERIAL IN CONNECTION THEREWITH (U.S. CLS. 100, 101 AND 107).

FIRST USE 5-9-2001; IN COMMERCE 5-9-2001.

CHRISTINA SOBRAL, EXAMINING ATTORNEY

SN 77-425,700. I SAW YOU ON TV, LLC, EDINBURGH, IN. FILED 3-19-2008.

I'LL SEE YOU ON TV

THE MARK CONSISTS OF STANDARD CHARACTERS WITHOUT CLAIM TO ANY PARTICULAR FONT, STYLE, SIZE, OR COLOR.

FOR MULTIMEDIA ENTERTAINMENT SERVICES IN THE NATURE OF RECORDING, PRODUCTION AND POST-PRODUCTION SERVICES IN THE FIELDS OF MUSIC, VIDEO, AND FILMS (U.S. CLS. 100, 101 AND 107).

LINDSEY RUBIN, EXAMINING ATTORNEY

SN 77-425,875. ORSA INSTITUTE LLC, EL PASO, TX. FILED 3-19-2008.



THE MARK CONSISTS OF THE IMAGE OF A HIGHWAY SIGN, THE WORDS ROADMAP TO ORSA AND A CURVED LINE UNDER THE WORD "ORSA".

FOR EDUCATIONAL SERVICES, NAMELY, PROVIDING SEMINARS AND CONDUCTING WORKSHOPS IN THE FIELD OF LEADERSHIP TRAINING (U.S. CLS. 100, 101 AND 107).

FIRST USE 9-7-2007; IN COMMERCE 9-7-2007.

BARBARA BROWN, EXAMINING ATTORNEY

CLASS 41—(Continued).

SN 77-425,893. WILD PURSUITS, INC., MILFORD, DE. FILED 3-19-2008.

WILD PURSUITS

THE MARK CONSISTS OF STANDARD CHARACTERS WITHOUT CLAIM TO ANY PARTICULAR FONT, STYLE, SIZE, OR COLOR.

FOR ENTERTAINMENT SERVICES IN THE NATURE OF ON-GOING TELEVISION PROGRAMS FEATURING CONTENT IN THE FIELDS OF HUNTING AND FISHING (U.S. CLS. 100, 101 AND 107).

G. MAYERSCHOFF, EXAMINING ATTORNEY

CLASS 41—(Continued).

SN 77-426,132. EXTREME OBSESSION INC., CARLINVILLE, IL. FILED 3-19-2008.

EXTREME OBSESSION

THE MARK CONSISTS OF STANDARD CHARACTERS WITHOUT CLAIM TO ANY PARTICULAR FONT, STYLE, SIZE, OR COLOR.

FOR ENTERTAINMENT SERVICES, NAMELY, PARTICIPATION IN HUNTING ACTIVITIES; PROVIDING SPORTS FACILITIES; GUIDED TOURS OF HUNTING SITES (U.S. CLS. 100, 101 AND 107).

DAWN HAN, EXAMINING ATTORNEY

SN 77-426,000. TRIPP, SUSAN, LA MIRADA, CA. FILED 3-19-2008.

Pet-Centered Practice

THE MARK CONSISTS OF STANDARD CHARACTERS WITHOUT CLAIM TO ANY PARTICULAR FONT, STYLE, SIZE, OR COLOR.

NO CLAIM IS MADE TO THE EXCLUSIVE RIGHT TO USE "PRACTICE", APART FROM THE MARK AS SHOWN. FOR EDUCATION SERVICES, NAMELY, PROVIDING LIVE AND ON-LINE LECTURES, CLASSES, SEMINARS, WORKSHOPS IN THE FIELD OF PET CARE AND PET BEHAVIOR (U.S. CLS. 100, 101 AND 107).

FIRST USE 1-1-2006; IN COMMERCE 1-1-2006.

DOMINICK J. SALEMI, EXAMINING ATTORNEY

SN 77-426,038. BIANCHI, GREGORY ALEXANDER, DBA BIANCHI FITNESS, SAN FRANCISCO, CA. FILED 3-19-2008.

THE CITY IS OUR GYM

THE MARK CONSISTS OF STANDARD CHARACTERS WITHOUT CLAIM TO ANY PARTICULAR FONT, STYLE, SIZE, OR COLOR.

FOR PHYSICAL FITNESS CONDITIONING CLASSES; PHYSICAL FITNESS CONSULTATION; PHYSICAL FITNESS INSTRUCTION (U.S. CLS. 100, 101 AND 107).

FIRST USE 6-0-2006; IN COMMERCE 6-0-2006.

BRENDAN REGAN, EXAMINING ATTORNEY

SN 77-426,166. DYAR, DAVID CHARLES, CARMEL, IN. FILED 3-19-2008.

Brave Rave

THE MARK CONSISTS OF STANDARD CHARACTERS WITHOUT CLAIM TO ANY PARTICULAR FONT, STYLE, SIZE, OR COLOR.

FOR ENTERTAINMENT, NAMELY, LIVE MUSIC CONCERTS (U.S. CLS. 100, 101 AND 107).

FIRST USE 1-20-2007; IN COMMERCE 1-27-2007.

MARY ROSSMAN, EXAMINING ATTORNEY

SN 77-426,497. TRUE INDEPENDENT STUDIOS, LLC, LAS VEGAS, NV. FILED 3-19-2008.

TRUE INDEPENDENT STUDIOS

THE MARK CONSISTS OF STANDARD CHARACTERS WITHOUT CLAIM TO ANY PARTICULAR FONT, STYLE, SIZE, OR COLOR.

NO CLAIM IS MADE TO THE EXCLUSIVE RIGHT TO USE "INDEPENDENT STUDIOS", APART FROM THE MARK AS SHOWN.

FOR ENTERTAINMENT, NAMELY, PRODUCTION OF TELEVISION SHOWS AND MOVIES AND DISTRIBUTION IN CONNECTION THEREWITH; FILM STUDIOS (U.S. CLS. 100, 101 AND 107).

THOMAS MANOR, EXAMINING ATTORNEY

CLASS 41—(Continued).

SN 77-426,521. TRUE INDEPENDENT STUDIOS, LLC, LAS VEGAS, NV. FILED 3-19-2008.



NO CLAIM IS MADE TO THE EXCLUSIVE RIGHT TO USE "INDEPENDENT", APART FROM THE MARK AS SHOWN.

THE MARK CONSISTS OF A STYLIZED "T" IN THE FORM OF A WATERMARK CROSS FOLLOWED WITH STYLIZED LETTERS "RUE INDEPENDENT", ENDING WITH A STYLIZED "T" IN THE FORM OF A WATERMARK CROSS.

FOR ENTERTAINMENT, NAMELY, PRODUCTION OF TELEVISION SHOWS AND MOVIES AND DISTRIBUTION IN CONNECTION THEREWITH; FILM STUDIOS (U.S. CLS. 100, 101 AND 107).

THOMAS MANOR, EXAMINING ATTORNEY

SN 77-426,671. BARSKI, ROGER, PARK FOREST, IL. FILED 3-19-2008.



NO CLAIM IS MADE TO THE EXCLUSIVE RIGHT TO USE "ARTIFACT PARK", APART FROM THE MARK AS SHOWN.

THE MARK CONSISTS OF AN IMAGE OF AN OCULUS EYE AND THE TEXT "ARTIFACT PARK".

FOR PROVIDING UNDERWATER ARCHEOLOGY TRAINING FACILITIES (U.S. CLS. 100, 101 AND 107).

FIRST USE 6-1-2007; IN COMMERCE 6-1-2007.

CHRISTINA SOBRAL, EXAMINING ATTORNEY

CLASS 41—(Continued).

SN 77-426,821. WILSON-COLEMAN, STEPHANIE E., CHICAGO, IL. FILED 3-20-2008.



THE COLOR(S) BLUE, WHITE, GOLD AND GRAY IS/ARE CLAIMED AS A FEATURE OF THE MARK.

THE COLOR GOLD APPEARS IN THE WORDING "CC" WHILE THE WHITE APPEARS IN THE SWIRLS BEHIND THE WORDING. THE BACKGROUND OF THE MARK IS A DIAMOND SHAPE IN THE COLOR BLUE AND THERE IS A GRAY SHADOW AROUND THE OUTSIDE OF THE ENTIRE MARK.

FOR PERSONAL APPEARANCES BY AN INSPIRATIONAL AND MOTIVATIONAL SPEAKER; EDUCATIONAL SERVICES, NAMELY, PROVIDING WORKSHOPS, SEMINARS AND TRAINING IN THE FIELD OF SELF IMPROVEMENT, SELF-EMPOWERMENT AND SELF-RELIANCE; MEETING FACILITATOR, NAMELY, ARRANGING WORKSHOPS, SEMINARS AND TRAINING COURSES IN THE FIELD OF SELF IMPROVEMENT, SELF-EMPOWERMENT, AND SELF-RELIANCE FOR BUSINESSES AND INDIVIDUALS (U.S. CLS. 100, 101 AND 107).

FIRST USE 1-15-1995; IN COMMERCE 1-15-1995.

MARCIE MILONE, EXAMINING ATTORNEY

SN 77-427,035. GOLDMAN, DAVID, SPRINGFIELD, IL. FILED 3-20-2008.

The Magic of Medicine - The Mystery of Law

THE MARK CONSISTS OF STANDARD CHARACTERS WITHOUT CLAIM TO ANY PARTICULAR FONT, STYLE, SIZE, OR COLOR.

FOR EDUCATIONAL SERVICES, NAMELY, CONDUCTING LECTURES IN THE FIELDS OF PSYCHIATRY, LAW, MEDICAL-LEGAL ISSUES AND LIFE-PERFORMANCE ENHANCEMENT (U.S. CLS. 100, 101 AND 107).

NICHOLAS ALTREE, EXAMINING ATTORNEY

CLASS 41—(Continued).

SN 77-427,072. FAYSON, SUPREME, BROOKLYN, NY.
FILED 3-20-2008.

PREAMO

THE MARK CONSISTS OF STANDARD CHARACTERS WITHOUT CLAIM TO ANY PARTICULAR FONT, STYLE, SIZE, OR COLOR.

FOR ENTERTAINMENT IN THE NATURE OF LIVE PERFORMANCES BY A HIP HOP ARTIST (U.S. CLS. 100, 101 AND 107).

DAVID YONTEF, EXAMINING ATTORNEY

CLASS 41—(Continued).

SN 77-427,241. MATTHEWS STUDIO EQUIPMENT, INC.,
BURBANK, CA. FILED 3-20-2008.

GRIPTIONARY

THE MARK CONSISTS OF STANDARD CHARACTERS WITHOUT CLAIM TO ANY PARTICULAR FONT, STYLE, SIZE, OR COLOR.

FOR PROVIDING AN ONLINE NON-DOWNLOADABLE ELECTRONIC GLOSSARY OF TERMS AND IDENTIFYING IMAGES FOR USE IN STUDIO AND NON-STUDIO LIGHTING, PHOTOGRAPHY AND MOTION PICTURE INDUSTRY (U.S. CLS. 100, 101 AND 107).

FIRST USE 12-1-1998; IN COMMERCE 12-1-1998.
MAYUR VAGHANI, EXAMINING ATTORNEY

SN 77-427,159. THE INSPIRATIONAL NETWORK, INC.,
INDIAN LAND, SC. FILED 3-20-2008.

SPEECHLESS

THE MARK CONSISTS OF STANDARD CHARACTERS WITHOUT CLAIM TO ANY PARTICULAR FONT, STYLE, SIZE, OR COLOR.

FOR ENTERTAINMENT SERVICES, NAMELY, A TELEVISION PROGRAMMING SERIES REGARDING RELIGIOUS TOPICS (U.S. CLS. 100, 101 AND 107).

FIRST USE 3-1-2008; IN COMMERCE 3-1-2008.
G. MAYERSCHOFF, EXAMINING ATTORNEY

SN 77-427,310. INTEGRATED GEOPHYSICS CORPORATION,
HOUSTON, TX. FILED 3-20-2008.

VIDL

THE MARK CONSISTS OF STANDARD CHARACTERS WITHOUT CLAIM TO ANY PARTICULAR FONT, STYLE, SIZE, OR COLOR.

FOR PROVIDING ON-LINE, VIRTUAL DIGITAL LIBRARY (U.S. CLS. 100, 101 AND 107).

FIRST USE 8-0-2002; IN COMMERCE 8-0-2002.
EMILY CARLSEN, EXAMINING ATTORNEY

SN 77-427,190. TOP DRIVER ACQUISITION, LLC, DBA TOP
DRIVER, NORTHBROOK, IL. FILED 3-20-2008.

DRIVER INTELLIGENCE

THE MARK CONSISTS OF STANDARD CHARACTERS WITHOUT CLAIM TO ANY PARTICULAR FONT, STYLE, SIZE, OR COLOR.

FOR EDUCATIONAL SERVICES, NAMELY, PROVIDING COURSES, PROGRAMS AND TRAINING IN THE FIELDS OF VEHICLE OPERATION AND SAFETY FOR INDIVIDUALS (U.S. CLS. 100, 101 AND 107).

TEJBIR SINGH, EXAMINING ATTORNEY

SN 77-427,323. INSPIRATIONAL NETWORK, INC., THE,
INDIAN LAND, SC. FILED 3-20-2008.

SILENCING THE CHRISTIANS

THE MARK CONSISTS OF STANDARD CHARACTERS WITHOUT CLAIM TO ANY PARTICULAR FONT, STYLE, SIZE, OR COLOR.

FOR ENTERTAINMENT SERVICES, NAMELY, A TELEVISION PROGRAMMING SERIES REGARDING RELIGIOUS TOPICS (U.S. CLS. 100, 101 AND 107).

FIRST USE 3-1-2008; IN COMMERCE 3-1-2008.
G. MAYERSCHOFF, EXAMINING ATTORNEY

CLASS 41—(Continued).

SN 77-427,446. AMERICAN NURSES ASSOCIATION, SILVER SPRING, MD. FILED 3-20-2008.

NDNQI Award for Outstanding Nursing Quality

THE MARK CONSISTS OF STANDARD CHARACTERS WITHOUT CLAIM TO ANY PARTICULAR FONT, STYLE, SIZE, OR COLOR.

OWNER OF U.S. REG. NO. 2,804,641.

NO CLAIM IS MADE TO THE EXCLUSIVE RIGHT TO USE "AWARD FOR OUTSTANDING NURSING QUALITY", APART FROM THE MARK AS SHOWN.

FOR PROVIDING RECOGNITION AND INCENTIVES BY THE WAY OF AWARDS TO DEMONSTRATE EXCELLENCE IN THE FIELD OF NURSING BY HOSPITALS THAT HAVE ACHIEVED SUSTAINED OVERALL EXCELLENCE IN NURSING-SENSITIVE QUALITY INDICATORS, INCLUDING RN SATISFACTION, PATIENT OUTCOMES AND NURSE STAFFING (U.S. CLS. 100, 101 AND 107).

FIRST USE 1-30-2008; IN COMMERCE 1-30-2008.
MONIQUE MILLER, EXAMINING ATTORNEY

SN 77-427,455. BADFISH, INC., NARRAGANSETT, RI. FILED 3-20-2008.

BADFISH

THE MARK CONSISTS OF STANDARD CHARACTERS WITHOUT CLAIM TO ANY PARTICULAR FONT, STYLE, SIZE, OR COLOR.

FOR ENTERTAINMENT SERVICES IN THE NATURE OF LIVE MUSICAL PERFORMANCES; ENTERTAINMENT, NAMELY, LIVE MUSIC CONCERTS; ENTERTAINMENT, NAMELY, LIVE PERFORMANCES BY A MUSICAL BAND; ENTERTAINMENT, NAMELY, LIVE PERFORMANCES BY ROCK GROUPS (U.S. CLS. 100, 101 AND 107).

FIRST USE 8-17-1996; IN COMMERCE 8-17-1996.
BRIAN NEVILLE, EXAMINING ATTORNEY

SN 77-427,525. THE CHILDREN'S MEMORIAL MEDICAL CENTER, CHICAGO, IL. FILED 3-20-2008.

KIPP

THE MARK CONSISTS OF STANDARD CHARACTERS WITHOUT CLAIM TO ANY PARTICULAR FONT, STYLE, SIZE, OR COLOR.

FOR EDUCATIONAL SERVICES, NAMELY, CONDUCTING A KNEE INJURY PREVENTION PROGRAM FOR FEMALE ATHLETES (U.S. CLS. 100, 101 AND 107).

FIRST USE 1-0-2005; IN COMMERCE 1-0-2005.
MICHELE SWAIN, EXAMINING ATTORNEY

CLASS 41—(Continued).

SN 77-427,878. 36 BLUE GEES, LLC, COLORADO SPRINGS, CO. FILED 3-20-2008.

Manfraction

THE MARK CONSISTS OF STANDARD CHARACTERS WITHOUT CLAIM TO ANY PARTICULAR FONT, STYLE, SIZE, OR COLOR.

FOR EDUCATION SERVICES, NAMELY, MENTORING IN THE FIELD OF MANLINESS (U.S. CLS. 100, 101 AND 107).

TAMARA FRAZIER, EXAMINING ATTORNEY

SN 77-427,941. ENGLISH, CYNTHIA S., DBA GREAT DATES, KINBURN, CANADA, FILED 3-20-2008.

great dates

THE MARK CONSISTS OF STANDARD CHARACTERS WITHOUT CLAIM TO ANY PARTICULAR FONT, STYLE, SIZE, OR COLOR.

OWNER OF U.S. REG. NO. 2,469,933.

NO CLAIM IS MADE TO THE EXCLUSIVE RIGHT TO USE "DATES", APART FROM THE MARK AS SHOWN.

FOR EDUCATION AND ENTERTAINMENT, NAMELY, PROVIDING INFORMATION ON-LINE REGARDING ENTERTAINMENT IDEAS FOR SPECIAL TIMES AND OUTINGS (U.S. CLS. 100, 101 AND 107).

FIRST USE 9-4-1998; IN COMMERCE 9-4-1998.
H. M. FISHER, EXAMINING ATTORNEY

SN 77-427,970. JAMES E. KEANY, MD, A PROFESSIONAL MEDICAL CORP, MISSION VIEJO, CA. FILED 3-21-2008.

Healthbuzz

THE MARK CONSISTS OF STANDARD CHARACTERS WITHOUT CLAIM TO ANY PARTICULAR FONT, STYLE, SIZE, OR COLOR.

FOR ENTERTAINMENT SERVICES, NAMELY, PROVIDING A RADIO PROGRAM IN THE FIELD OF HEALTH AND/OR MEDICINE VIA A GLOBAL COMPUTER NETWORK; ENTERTAINMENT SERVICES, NAMELY, PROVIDING AN ON-GOING RADIO PROGRAM IN THE FIELD OF HEALTH AND/OR MEDICINE; PRODUCTION AND DISTRIBUTION OF RADIO PROGRAMS; PRODUCTION OF RADIO PROGRAMS; ENTERTAINMENT SERVICES, NAMELY, PROVIDING PODCASTS IN THE FIELD OF HEALTH AND/OR MEDICINE; ON-LINE JOURNALS, NAMELY, BLOGS FEATURING HEALTH AND/OR MEDICINE (U.S. CLS. 100, 101 AND 107).

FIRST USE 11-29-2006; IN COMMERCE 11-29-2006.
MICHAEL TANNER, EXAMINING ATTORNEY

CLASS 41—(Continued).

SN 77-427,980. IMPROVEDGE LLC, POWELL, OH. FILED 3-21-2008.

EVERYDAY COACHING MODEL

THE MARK CONSISTS OF STANDARD CHARACTERS WITHOUT CLAIM TO ANY PARTICULAR FONT, STYLE, SIZE, OR COLOR.

NO CLAIM IS MADE TO THE EXCLUSIVE RIGHT TO USE "COACHING MODEL", APART FROM THE MARK AS SHOWN.

FOR EDUCATIONAL SERVICES, NAMELY, CONDUCTING SEMINARS AND WORKSHOPS IN THE FIELD OF USING IMPROVISATION AND IMPROVISATIONAL SKILLS IN BUSINESS MANAGEMENT AND CO-WORKER INTERACTIONS (U.S. CLS. 100, 101 AND 107).

JOHN WILKE, EXAMINING ATTORNEY

CLASS 41—(Continued).

SN 77-428,078. NBA PROPERTIES, INC., NEW YORK, NY. FILED 3-21-2008.

THERE CAN ONLY BE ONE

SN 77-427,983. SEGMIT, SEYMOUR, CORNWALL-ON-THE-HUDSON, NY. FILED 3-21-2008.

LIVE LIFE UNIVERSITY

THE MARK CONSISTS OF STANDARD CHARACTERS WITHOUT CLAIM TO ANY PARTICULAR FONT, STYLE, SIZE, OR COLOR.

NO CLAIM IS MADE TO THE EXCLUSIVE RIGHT TO USE "UNIVERSITY", APART FROM THE MARK AS SHOWN.

FOR CONDUCTING WORKSHOPS AND SEMINARS IN THE FIELDS OF BUSINESS, HEALTH, AND PERSONAL SKILLS AND PHILOSOPHY (U.S. CLS. 100, 101 AND 107).

TARA PATE, EXAMINING ATTORNEY

SN 77-428,043. SESSIONS.EDU, INC., NEW YORK, NY. FILED 3-21-2008.

SESSIONS ONLINE

THE MARK CONSISTS OF STANDARD CHARACTERS WITHOUT CLAIM TO ANY PARTICULAR FONT, STYLE, SIZE, OR COLOR.

NO CLAIM IS MADE TO THE EXCLUSIVE RIGHT TO USE "ONLINE", APART FROM THE MARK AS SHOWN.

FOR EDUCATIONAL SERVICES, NAMELY, PROVIDING PROGRAMS, COURSES AND CERTIFICATES IN GRAPHIC DESIGN, WEB SITE DESIGN, MULTIMEDIA ART DESIGN, FINE ARTS, GAME ART, DIGITAL ART AND PHOTOGRAPHY, BUSINESS MARKETING DESIGN AND BRAND IDENTITY (U.S. CLS. 100, 101 AND 107).

FIRST USE 2-19-2008; IN COMMERCE 2-19-2008.
JORDAN BAKER, EXAMINING ATTORNEY

THE MARK CONSISTS OF STANDARD CHARACTERS WITHOUT CLAIM TO ANY PARTICULAR FONT, STYLE, SIZE, OR COLOR.

FOR ENTERTAINMENT AND EDUCATIONAL SERVICES IN THE NATURE OF ONGOING TELEVISION AND RADIO PROGRAMS IN THE FIELD OF BASKETBALL AND RENDERING LIVE BASKETBALL GAMES AND BASKETBALL EXHIBITIONS; THE PRODUCTION AND DISTRIBUTION OF RADIO AND TELEVISION SHOWS FEATURING BASKETBALL GAMES, BASKETBALL EVENTS AND PROGRAMS IN THE FIELD OF BASKETBALL; CONDUCTING AND ARRANGING BASKETBALL CLINICS AND CAMPS, COACHES CLINICS AND CAMPS, DANCE TEAM CLINICS AND CAMPS AND BASKETBALL GAMES; ENTERTAINMENT SERVICES IN THE NATURE OF PERSONAL APPEARANCES BY A COSTUMED MASCOT OR DANCE TEAM AT BASKETBALL GAMES AND EXHIBITIONS, CLINICS, CAMPS, PROMOTIONS, AND OTHER BASKETBALL-RELATED EVENTS, SPECIAL EVENTS AND PARTIES; FAN CLUB SERVICES; ENTERTAINMENT SERVICES, NAMELY, PROVIDING A WEBSITE FEATURING MULTIMEDIA MATERIAL IN THE NATURE OF TELEVISION HIGHLIGHTS, INTERACTIVE TELEVISION HIGHLIGHTS, VIDEO RECORDINGS, VIDEO STREAM RECORDINGS, INTERACTIVE VIDEO HIGHLIGHT SELECTIONS, RADIO PROGRAMS, RADIO HIGHLIGHTS, AND AUDIO RECORDINGS IN THE FIELD OF BASKETBALL; PROVIDING NEWS AND INFORMATION IN THE NATURE OF STATISTICS AND TRIVIA IN THE FIELD OF BASKETBALL; ON-LINE NON-DOWNLOADABLE GAMES, NAMELY, COMPUTER GAMES, VIDEO GAMES, INTERACTIVE VIDEO GAMES, ACTION SKILL GAMES, ARCADE GAMES, ADULTS' AND CHILDREN'S PARTY GAMES, BOARD GAMES, PUZZLES, AND TRIVIA GAMES; ELECTRONIC PUBLISHING SERVICES, NAMELY, PUBLICATION OF MAGAZINES, GUIDES, NEWSLETTERS, COLORING BOOKS, AND GAME SCHEDULES OF OTHERS ON-LINE THROUGH THE INTERNET, ALL IN THE FIELD OF BASKETBALL; PROVIDING AN ONLINE COMPUTER DATABASE IN THE FIELD OF BASKETBALL (U.S. CLS. 100, 101 AND 107).

ANNE E. GUSTASON, EXAMINING ATTORNEY

CLASS 41—(Continued).

SN 77-428,127. TEEN DIARIES, LLC, SPARTA, NJ. FILED 3-21-2008.



Teen Entertainment
Education Network

NO CLAIM IS MADE TO THE EXCLUSIVE RIGHT TO USE "TEEN" AND "TEEN ENTERTAINMENT EDUCATION NETWORK", APART FROM THE MARK AS SHOWN.

THE MARK CONSISTS OF A CIRCLE COMPRISING A BOOK WITHIN IT AND A BANNER OVER THE BOOK COMPRISING THE "T.E.E.N. DIARIES" PHRASE, AND THE "TEEN ENTERTAINMENT EDUCATION NETWORK" WRITTEN BELOW THE CIRCLE.

FOR PUBLICATION OF ELECTRONIC MAGAZINES (U.S. CLS. 100, 101 AND 107).

CHRISTINA SOBRAL, EXAMINING ATTORNEY

SN 77-428,164. FREEDOM ACRES, LLC, UPLAND, CA. FILED 3-21-2008.

FREEDOM ACRES

THE MARK CONSISTS OF STANDARD CHARACTERS WITHOUT CLAIM TO ANY PARTICULAR FONT, STYLE, SIZE, OR COLOR.

FOR ADULT SOCIAL CLUB SERVICES, NAMELY, ARRANGING, ORGANIZING, AND HOSTING SOCIAL EVENTS, GET-TOGETHERS, AND PARTIES FOR CLUB MEMBERS (U.S. CLS. 100, 101 AND 107).

FIRST USE 2-19-1981; IN COMMERCE 2-19-1981.

GRETTA YAO, EXAMINING ATTORNEY

CLASS 41—(Continued).

SN 77-428,209. FORCE 10 HOOPS L.L.C., SEATTLE, WA. FILED 3-21-2008.

Force 10 Hoops

THE MARK CONSISTS OF STANDARD CHARACTERS WITHOUT CLAIM TO ANY PARTICULAR FONT, STYLE, SIZE, OR COLOR.

NO CLAIM IS MADE TO THE EXCLUSIVE RIGHT TO USE "HOOPS", APART FROM THE MARK AS SHOWN.

FOR ENTERTAINMENT IN THE NATURE OF BASKETBALL GAMES (U.S. CLS. 100, 101 AND 107).

CYNTHIA SLOAN, EXAMINING ATTORNEY

SN 77-428,226. HIGHPOINTS, DULUTH, GA. FILED 3-21-2008.

HIGHPOINTS

THE MARK CONSISTS OF STANDARD CHARACTERS WITHOUT CLAIM TO ANY PARTICULAR FONT, STYLE, SIZE, OR COLOR.

FOR EDUCATIONAL SERVICES, NAMELY, PROVIDING TUTORING IN THE FIELDS OF PRIMARY AND SECONDARY CLASSES; PROVIDING ON-LINE TRAINING BY MEANS OF COMPUTERS, INTERNET, SURVEYS, QUESTIONNAIRES, APPLICATIONS AND COURSES IN THE FIELD OF PRIMARY AND SECONDARY CLASSES (U.S. CLS. 100, 101 AND 107).

FIRST USE 2-28-2005; IN COMMERCE 2-28-2005.

MONIQUE MILLER, EXAMINING ATTORNEY

SN 77-428,244. NATIONAL ORGANIZATION OF CONCERNED BLACK MEN INC., DISTRICT OF COLUMBIA, DC. FILED 3-21-2008.

CBM Cares

THE MARK CONSISTS OF STANDARD CHARACTERS WITHOUT CLAIM TO ANY PARTICULAR FONT, STYLE, SIZE, OR COLOR.

FOR EDUCATION SERVICES, NAMELY, ONE-ON-ONE MENTORING IN THE FIELD OF YOUTH DEVELOPMENT (U.S. CLS. 100, 101 AND 107).

HOWARD B. LEVINE, EXAMINING ATTORNEY

CLASS 41—(Continued).

SN 77-428,251. CREME DE LA CREME, INC., GREENWOOD VILLAGE, CO. FILED 3-21-2008.



OWNER OF U.S. REG. NOS. 2,086,131, 3,135,025 AND OTHERS.

THE MARK CONSISTS OF THE WORD "CRÈME" WITH LETTERS ON A BACKGROUND OF ALTERNATELY LIGHT AND DARK SHADED BLOCKS.

THE FOREIGN WORDING IN THE MARK TRANSLATES INTO ENGLISH AS "CREAM"

FOR EDUCATIONAL SERVICES, NAMELY, PROVIDING COURSES OF INSTRUCTION AT THE PRE-SCHOOL LEVEL (U.S. CLS. 100, 101 AND 107).

FIRST USE 4-19-2004; IN COMMERCE 4-19-2004.
CYNTHIA SLOAN, EXAMINING ATTORNEY

CLASS 41—(Continued).

SN 77-428,459. WOMEN THAT SOAR, LLC, MESQUITE, TX. FILED 3-21-2008.

BRILLIANTLY YOU

THE MARK CONSISTS OF STANDARD CHARACTERS WITHOUT CLAIM TO ANY PARTICULAR FONT, STYLE, SIZE, OR COLOR.

FOR PROVIDING RECOGNITION AND INCENTIVES BY THE WAY OF AWARDS TO DEMONSTRATE EXCELLENCE IN THE FIELD OF PROFESSIONAL AND PERSONAL SUCCESS (U.S. CLS. 100, 101 AND 107).

CHRISTINE BLOMQUIST, EXAMINING ATTORNEY

SN 77-428,271. GLOBAL TRAINING SOLUTIONS, INC., RALEIGH, NC. FILED 3-21-2008.

CVE

THE MARK CONSISTS OF STANDARD CHARACTERS WITHOUT CLAIM TO ANY PARTICULAR FONT, STYLE, SIZE, OR COLOR.

FOR TRAINING SERVICES IN THE FIELD OF INFORMATION TECHNOLOGY (U.S. CLS. 100, 101 AND 107).

FIRST USE 9-3-2007; IN COMMERCE 9-3-2007.
TINA L. SNAPP, EXAMINING ATTORNEY

SN 77-428,466. LAB-AIDS INC, RONKONKOMA, NY. FILED 3-21-2008.

Experiencing Science

THE MARK CONSISTS OF STANDARD CHARACTERS WITHOUT CLAIM TO ANY PARTICULAR FONT, STYLE, SIZE, OR COLOR.

NO CLAIM IS MADE TO THE EXCLUSIVE RIGHT TO USE "SCIENCE", APART FROM THE MARK AS SHOWN.

FOR PROVIDING SCIENCE EDUCATIONAL MENTORING SERVICES AND PROGRAMS (U.S. CLS. 100, 101 AND 107).

KATHRYN COWARD, EXAMINING ATTORNEY

SN 77-428,289. MCCULLOUGH, ELIZABETH, GLENFORD, NY. FILED 3-21-2008.

ALPHA CAT

THE MARK CONSISTS OF STANDARD CHARACTERS WITHOUT CLAIM TO ANY PARTICULAR FONT, STYLE, SIZE, OR COLOR.

FOR ENTERTAINMENT IN THE NATURE OF LIVE PERFORMANCES BY SOLO ARTIST; ENTERTAINMENT SERVICES, NAMELY, PROVIDING A WEB SITE FEATURING MUSICAL PERFORMANCES, MUSICAL VIDEOS, RELATED FILM CLIPS, PHOTOGRAPHS, AND OTHER MULTIMEDIA MATERIALS; MULTIMEDIA ENTERTAINMENT SERVICES IN THE NATURE OF RECORDING, PRODUCTION AND POST-PRODUCTION SERVICES IN THE FIELDS OF MUSIC, VIDEO, AND FILMS (U.S. CLS. 100, 101 AND 107).

FIRST USE 9-0-1999; IN COMMERCE 9-0-1999.
AMOS T. MATTHEWS, JR., EXAMINING ATTORNEY

SN 77-428,490. RUSSELL, CURTIS L., CLIFTON, NJ. FILED 3-21-2008.

EPHL

THE MARK CONSISTS OF STANDARD CHARACTERS WITHOUT CLAIM TO ANY PARTICULAR FONT, STYLE, SIZE, OR COLOR.

FOR ENTERTAINMENT SERVICES, NAMELY PROVIDING PROFESSIONAL HOCKEY EXHIBITIONS (U.S. CLS. 100, 101 AND 107).

KIMBERLY FRYE, EXAMINING ATTORNEY

CLASS 41—(Continued).

SN 77-428,514. SUNNY JOHNSON, DBA SUNNY SAVAGE, TOPANGA, CA. FILED 3-21-2008.

YEEHAW PRODUCTIONS

THE MARK CONSISTS OF STANDARD CHARACTERS WITHOUT CLAIM TO ANY PARTICULAR FONT, STYLE, SIZE, OR COLOR.

NO CLAIM IS MADE TO THE EXCLUSIVE RIGHT TO USE "PRODUCTIONS", APART FROM THE MARK AS SHOWN.

FOR ENTERTAINMENT PRODUCTION SERVICES, NAMELY, VIDEO PRODUCTION, TELEVISION PRODUCTION, FILM PRODUCTION AND DOCUMENTARY TELEVISION, FILM AND VIDEO PRODUCTION (U.S. CLS. 100, 101 AND 107).

FIRST USE 11-15-2006; IN COMMERCE 11-15-2006.
JAY BESCH, EXAMINING ATTORNEY

CLASS 41—(Continued).

SN 77-428,732. MICHELE MORRIS, LITTLETON, CO. FILED 3-21-2008.

COOKING WITH MICHELE

THE MARK CONSISTS OF STANDARD CHARACTERS WITHOUT CLAIM TO ANY PARTICULAR FONT, STYLE, SIZE, OR COLOR.

FOR EDUCATIONAL SERVICES, NAMELY, CONDUCTING WORKSHOPS, IN-HOME INSTRUCTION, SEMINARS, AND LECTURES, IN THE FIELD OF COOKING, FOOD, AND CUISINE AND DISTRIBUTION OF COURSE MATERIAL IN CONNECTION THEREWITH; ON-LINE JOURNALS, NAMELY, BLOGS FEATURING DISCUSSION, COMMENTARY AND TREATMENT OF SUBJECTS RELATED TO COOKING, FOOD, AND CUISINE (U.S. CLS. 100, 101 AND 107).

FIRST USE 3-19-2008; IN COMMERCE 3-19-2008.
LINDA POWELL, EXAMINING ATTORNEY

SN 77-428,967. HILL, KIMBERLY Q, MYRTLE BEACH, SC. FILED 3-22-2008.

bliss

THE MARK CONSISTS OF STANDARD CHARACTERS WITHOUT CLAIM TO ANY PARTICULAR FONT, STYLE, SIZE, OR COLOR.

FOR PHOTOGRAPHY (U.S. CLS. 100, 101 AND 107).
NATALIE POLZER, EXAMINING ATTORNEY

SN 77-429,048. BRONX UNDERGROUND LLC, BRONX, NY. FILED 3-23-2008.

Bronx Underground

THE MARK CONSISTS OF STANDARD CHARACTERS WITHOUT CLAIM TO ANY PARTICULAR FONT, STYLE, SIZE, OR COLOR.

SEC. 2(F).
FOR ARRANGING AND CONDUCTING OF CONCERTS; CONCERT BOOKING; ENTERTAINMENT, NAMELY, LIVE MUSIC CONCERTS (U.S. CLS. 100, 101 AND 107).

FIRST USE 9-15-2000; IN COMMERCE 10-15-2000.
WILLIAM ROSSMAN, EXAMINING ATTORNEY

NO CLAIM IS MADE TO THE EXCLUSIVE RIGHT TO USE "PRODUCTIONS", APART FROM THE MARK AS SHOWN.

THE MARK CONSISTS OF STYLIZED WORDS "YEEHAW PRODUCTIONS" WITH STYLIZED SUN DESIGN.

FOR ENTERTAINMENT PRODUCTION SERVICES, NAMELY, VIDEO PRODUCTION, TELEVISION PRODUCTION, FILM PRODUCTION AND DOCUMENTARY TELEVISION, FILM AND VIDEO PRODUCTION (U.S. CLS. 100, 101 AND 107).

FIRST USE 3-7-2008; IN COMMERCE 3-7-2008.
JAY BESCH, EXAMINING ATTORNEY



CLASS 41—(Continued).

SN 77-429,121. JEFFERSON, CARLA M., LAS VEGAS, NV. AND TOWNSEND, SHANELL, LAS VEGAS, NV. FILED 3-23-2008.

Make Me A Star

THE MARK CONSISTS OF STANDARD CHARACTERS WITHOUT CLAIM TO ANY PARTICULAR FONT, STYLE, SIZE, OR COLOR.

FOR SOUND RECORDING STUDIOS; VIDEO RECORDING OF PERSONAL GENEALOGICAL DOCUMENTARIES; VIDEO TAPE RECORDING FOR OTHERS; PRODUCTION OF SOUND AND IMAGE RECORDINGS ON SOUND AND IMAGE CARRIERS; PRODUCTION OF SOUND AND MUSIC VIDEO RECORDINGS; PRODUCTION OF SOUND RECORDINGS; PROVIDING AUDIO OR VIDEO STUDIOS; PROVIDING VOICE OVERS FOR TAPES, RECORDS AND OTHER RECORDED MEDIA; RECORD MASTER PRODUCTION; RECORD PRODUCTION; RECORDING STUDIO SERVICES; RECORDING STUDIOS; RENTAL OF PHONOGRAPHIC AND MUSIC RECORDINGS; AUDIO AND VIDEO RECORDING SERVICES; AUDIO RECORDING AND PRODUCTION; CINEMA STUDIOS; CONSULTATION AND ADVICE REGARDING MUSICAL SELECTIONS AND ARRANGEMENTS FOR SOUND RECORDINGS AND LIVE PERFORMANCES; CONSULTATION AND ADVICE REGARDING THE RENTAL OF RECORDING STUDIOS AND VENUES; DANCE STUDIOS; EDITING OR RECORDING OF SOUNDS AND IMAGES; ENTERTAINMENT SERVICES, NAMELY, NON-DOWNLOADABLE RINGTONES, PRE-RECORDED MUSIC, VIDEO AND GRAPHICS PRESENTED TO MOBILE COMMUNICATIONS DEVICES VIA A GLOBAL COMPUTER NETWORK AND WIRELESS NETWORKS; FILM STUDIOS; MAINTAINING RECORDS AND CERTIFYING RECORD PERFORMANCES OF AMATEUR ATHLETES; MOVIE STUDIOS; MULTIMEDIA ENTERTAINMENT SERVICES IN THE NATURE OF RECORDING, PRODUCTION AND POST-PRODUCTION SERVICES IN THE FIELDS OF MUSIC, VIDEO, AND FILMS; OPERATING OF FILM STUDIOS; ENTERTAINMENT SERVICES, NAMELY, CONDUCTING PARTIES; PARTY PLANNING; SPECIAL EVENT, PARTY AND WEDDING PLANNING AND COORDINATION SERVICES; SPECIAL EVENT, PARTY AND WEDDING PLANNING CONSULTATION SERVICES (U.S. CLS. 100, 101 AND 107).

WILLIAM ROSSMAN, EXAMINING ATTORNEY

SN 77-429,167. ROY ELGHANAYAN, DBA KRAV MAGA L.A., LOS ANGELES, CA. FILED 3-24-2008.



THE MARK CONSISTS OF CLENCHED FIST INSIDE OF A DIAMOND, CENTERED ON A PAIR OF WINGS.

FOR MARTIAL ARTS INSTRUCTION; OPERATING OF MARTIAL ARTS' SCHOOLS; OPERATING OF MARTIAL ARTS' STUDIOS (U.S. CLS. 100, 101 AND 107).

FIRST USE 4-1-2007; IN COMMERCE 4-1-2007.

TARA PATE, EXAMINING ATTORNEY

CLASS 41—(Continued).

SN 77-429,180. MONTALTO, MICHAEL ALLEN, DWIGHT, IL. FILED 3-24-2008.

cement shoes studios

THE MARK CONSISTS OF STANDARD CHARACTERS WITHOUT CLAIM TO ANY PARTICULAR FONT, STYLE, SIZE, OR COLOR.

NO CLAIM IS MADE TO THE EXCLUSIVE RIGHT TO USE "STUDIOS", APART FROM THE MARK AS SHOWN.

FOR MULTIMEDIA ENTERTAINMENT SERVICES IN THE NATURE OF RECORDING, PRODUCTION AND POST-PRODUCTION SERVICES IN THE FIELDS OF MUSIC, VIDEO, AND FILMS (U.S. CLS. 100, 101 AND 107).

ELISSA GARBER KON, EXAMINING ATTORNEY

SN 77-429,323. BRADLEY, ELIZABETH BRANTLEY TURNER, NEW YORK, NY. FILED 3-24-2008.

CREATEXPLORE

THE MARK CONSISTS OF STANDARD CHARACTERS WITHOUT CLAIM TO ANY PARTICULAR FONT, STYLE, SIZE, OR COLOR.

FOR EDUCATION AND TRAINING, NAMELY, PROVIDING HIGH SCHOOL LEVEL EDUCATION THROUGH TRAVEL TO FOREIGN NATIONS, STUDYING ART, COMMERCE, ENVIRONMENTAL ISSUES, SOCIAL ISSUES, FOREIGN CULTURE AND FOREIGN LANGUAGES; ARRANGING AND CONDUCTING OF CONFERENCES, SEMINARS, AND EXHIBITIONS FOR CULTURAL OR EDUCATIONAL PURPOSES; CONDUCTING WORKSHOPS IN THE FIELDS OF ART APPRECIATION AND SELF-AWARENESS; PUBLICATION OF BOOKS AND EDUCATION MATERIALS REGARDING EDUCATION ABROAD ON A GLOBAL SCALE (U.S. CLS. 100, 101 AND 107).

FIRST USE 10-26-2007; IN COMMERCE 10-26-2007.

JOHN WILKE, EXAMINING ATTORNEY

SN 77-429,376. SHOTBEE EVENT PHOTOGRAPHY, INC., KANSAS CITY, MO. FILED 3-24-2008.

ShotBee

THE MARK CONSISTS OF STANDARD CHARACTERS WITHOUT CLAIM TO ANY PARTICULAR FONT, STYLE, SIZE, OR COLOR.

FOR PHOTOGRAPHY SERVICES (U.S. CLS. 100, 101 AND 107).

FIRST USE 1-1-2003; IN COMMERCE 1-1-2003.

STEVEN R. FINE, EXAMINING ATTORNEY

CLASS 41—(Continued).

SN 77-429,377. LIFE BLESSING INSTITUTE, THE, OREGON CITY, OR. FILED 3-24-2008.

Maiden Spirit

THE MARK CONSISTS OF STANDARD CHARACTERS WITHOUT CLAIM TO ANY PARTICULAR FONT, STYLE, SIZE, OR COLOR.

FOR EDUCATIONAL SERVICES, NAMELY, CONDUCTING PROGRAMS IN THE FIELD OF GIRLS SELF ESTEEM AND EMPOWERMENT AND DISTRIBUTION OF COURSE MATERIAL IN CONNECTION THEREWITH (U.S. CLS. 100, 101 AND 107).

FIRST USE 3-19-2003; IN COMMERCE 3-19-2004.
SANI KHOURI, EXAMINING ATTORNEY

SN 77-429,400. SIMMONS, CHARLES, NOLENSVILLE, TN. FILED 3-24-2008.

Tennessee Tastebud Ticklers

THE MARK CONSISTS OF STANDARD CHARACTERS WITHOUT CLAIM TO ANY PARTICULAR FONT, STYLE, SIZE, OR COLOR.

NO CLAIM IS MADE TO THE EXCLUSIVE RIGHT TO USE "TENNESSEE", APART FROM THE MARK AS SHOWN.

FOR ENTERTAINMENT IN THE NATURE OF COMPETITIONS IN THE FIELD OF COOKING (U.S. CLS. 100, 101 AND 107).

WENDY GOODMAN, EXAMINING ATTORNEY

SN 77-429,417. SHOTBEE EVENT PHOTOGRAPHY, INC., KANSAS CITY, MO. FILED 3-24-2008.



THE MARK CONSISTS OF THE WORD "SHOTBEE" PLUS BEE DESIGN.

FOR PHOTOGRAPHY SERVICES (U.S. CLS. 100, 101 AND 107).

FIRST USE 1-1-2003; IN COMMERCE 1-1-2003.
STEVEN R. FINE, EXAMINING ATTORNEY

CLASS 41—(Continued).

SN 77-429,468. YOUNG, JOHN, DALLASTOWN, PA. FILED 3-24-2008.

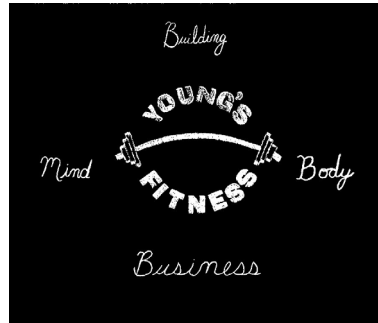

NO CLAIM IS MADE TO THE EXCLUSIVE RIGHT TO USE "FITNESS", APART FROM THE MARK AS SHOWN.

THE MARK CONSISTS OF A IMAGE OF A WEIGHTLIFTING BAR WITH WEIGHTS ON EACH SIDE. ABOVE THE BAR IS THE STYLIZED WORD "YOUNG'S" AND BELOW IS THE STYLIZED WORD "FITNESS". ABOVE THE WORD "YOUNG'S" IS THE STYLIZED WORD "BUILDING". BELOW THE WORD "FITNESS" IS THE STYLIZED WORD "BUSINESS". TO THE LEFT OF THE BAR IS THE STYLIZED WORD "MIND". TO THE RIGHT OF THE BAR IS THE STYLIZED WORD "BODY".

FOR PHYSICAL FITNESS CONDITIONING CLASSES; PHYSICAL FITNESS INSTRUCTION (U.S. CLS. 100, 101 AND 107).

MARIA-VICTORIA SUAREZ, EXAMINING ATTORNEY

SN 77-429,503. BRADY, DANIEL, SPEARFISH, SD. FILED 3-24-2008.



THE MARK CONSISTS OF THE NAME "AFTER AUTUMN", A CIRCULAR TRIBAL DESIGN SPELLING OUT THE NAME "AFTER AUTUMN" WITHIN THE LOGO. THE FOUNDATION THE LOGO IS BUILT OFF OF IS TWO REVERSE CAPITAL "A'S" THAT TOUCH AT THE BOTTOM, FORMING A LARGE "M" APPEARANCE.

FOR ENTERTAINMENT, NAMELY, LIVE PERFORMANCES BY A MUSICAL BAND (U.S. CLS. 100, 101 AND 107).

LINDA ESTRADA, EXAMINING ATTORNEY

CLASS 41—(Continued).

SN 77-429,526. CELEB 4 A DAY, AUSTIN, TX. FILED 3-24-2008.

CELEB 4 A DAY

THE MARK CONSISTS OF THE STYLIZED WORDS AND NUMBER "CELEB 4 A DAY". THE WORDS AND NUMBER "CELEB", "4", "A" IS FOLLOWED BY A STAR. FOR PHOTOGRAPHY SERVICES; VIDEO TAPE RECORDING FOR OTHERS (U.S. CLS. 100, 101 AND 107). FIRST USE 11-1-2007; IN COMMERCE 12-1-2007. BENJAMIN OKEKE, EXAMINING ATTORNEY

SN 77-429,545. LUCAS, EARL, GRANADA HILLS, CA. FILED 3-24-2008.

Chance to Have A New Growing Experience

THE MARK CONSISTS OF STANDARD CHARACTERS WITHOUT CLAIM TO ANY PARTICULAR FONT, STYLE, SIZE, OR COLOR. FOR EDUCATIONAL AND ENTERTAINMENT SERVICES, NAMELY, PROVIDING MOTIVATIONAL AND EDUCATIONAL SPEAKERS; ENTERTAINMENT IN THE NATURE OF LIVE MOTIVATIONAL SPEECHES (U.S. CLS. 100, 101 AND 107). LAURA HAMMEL, EXAMINING ATTORNEY

SN 77-429,548. LUCAS, EARL, GRANADA HILLS, CA. FILED 3-24-2008.

Train together Encourage each other Accountable to each other Mentor each other

THE MARK CONSISTS OF STANDARD CHARACTERS WITHOUT CLAIM TO ANY PARTICULAR FONT, STYLE, SIZE, OR COLOR. FOR EDUCATIONAL AND ENTERTAINMENT SERVICES, NAMELY, PROVIDING MOTIVATIONAL AND EDUCATIONAL SPEAKERS; ENTERTAINMENT IN THE NATURE OF LIVE MOTIVATIONAL SPEECHES (U.S. CLS. 100, 101 AND 107). LAURA HAMMEL, EXAMINING ATTORNEY

CLASS 41—(Continued).

SN 77-429,610. T.E.J., SPRING, TX. FILED 3-24-2008.

Remember When Kids Were Kids!

THE MARK CONSISTS OF STANDARD CHARACTERS WITHOUT CLAIM TO ANY PARTICULAR FONT, STYLE, SIZE, OR COLOR. FOR PROVIDING FACILITIES FOR RECREATION ACTIVITIES (U.S. CLS. 100, 101 AND 107). GRETTA YAO, EXAMINING ATTORNEY

SN 77-429,689. CHURCHILL DOWNS INCORPORATED, LOUISVILLE, KY. FILED 3-24-2008.

CPO

THE MARK CONSISTS OF STANDARD CHARACTERS WITHOUT CLAIM TO ANY PARTICULAR FONT, STYLE, SIZE, OR COLOR. FOR ENTERTAINMENT SERVICES, NAMELY, CONDUCTING CONTESTS (U.S. CLS. 100, 101 AND 107). FIRST USE 3-17-2008; IN COMMERCE 3-17-2008. KIM MONINGHOFF, EXAMINING ATTORNEY

SN 77-429,715. CHURCHILL DOWNS INCORPORATED, LOUISVILLE, KY. FILED 3-24-2008.

CHIEF PARTY OFFICER

THE MARK CONSISTS OF STANDARD CHARACTERS WITHOUT CLAIM TO ANY PARTICULAR FONT, STYLE, SIZE, OR COLOR. FOR ENTERTAINMENT SERVICES, NAMELY, CONDUCTING CONTESTS (U.S. CLS. 100, 101 AND 107). FIRST USE 3-17-2008; IN COMMERCE 3-17-2008. KIM MONINGHOFF, EXAMINING ATTORNEY

CLASS 41—(Continued).

SN 77-430,008. GAYLORD ENTERTAINMENT COMPANY, NASHVILLE, TN. FILED 3-24-2008.

ROAD TO THE OPRY

THE MARK CONSISTS OF STANDARD CHARACTERS WITHOUT CLAIM TO ANY PARTICULAR FONT, STYLE, SIZE, OR COLOR.

FOR ENTERTAINMENT SERVICES IN THE NATURE OF A TELEVISION PROGRAM FEATURING MUSIC, EDUCATION AND ENTERTAINMENT (U.S. CLS. 100, 101 AND 107).

JOHN SCHÜYLER YARD, EXAMINING ATTORNEY

SN 77-430,047. SONES, TODD S., VERNON HILLS, IL. FILED 3-24-2008.

FITTED THROUGH INSTRUCTION

THE MARK CONSISTS OF STANDARD CHARACTERS WITHOUT CLAIM TO ANY PARTICULAR FONT, STYLE, SIZE, OR COLOR.

FOR FITTING OF GOLF CLUBS TO INDIVIDUAL USERS (U.S. CLS. 100, 101 AND 107).

SANDRA MANIOS, EXAMINING ATTORNEY

SN 77-430,217. CENTER FOR AMERICAN PROGRESS ACTION FUND, WASHINGTON, DC. FILED 3-24-2008.

THINK PROGRESS

THE MARK CONSISTS OF STANDARD CHARACTERS WITHOUT CLAIM TO ANY PARTICULAR FONT, STYLE, SIZE, OR COLOR.

FOR PROVIDING ON-LINE PERIODICAL AND NEWSGATHERING INFORMATION IN THE FIELDS OF POLITICS AND POLICY-MAKING; ARRANGING AND ORGANIZING EDUCATIONAL CONFERENCES, SEMINARS, AND SYMPOSIA IN THE FIELDS OF POLITICS AND POLICY-MAKING (U.S. CLS. 100, 101 AND 107).

FIRST USE 1-0-2005; IN COMMERCE 1-0-2005.

GINA FINK, EXAMINING ATTORNEY

CLASS 41—(Continued).

SN 77-430,218. BARRIOS, ALDO, BURBANK, CA. FILED 3-24-2008.

Buccaneers of Tortuga

THE MARK CONSISTS OF STANDARD CHARACTERS WITHOUT CLAIM TO ANY PARTICULAR FONT, STYLE, SIZE, OR COLOR.

NO CLAIM IS MADE TO THE EXCLUSIVE RIGHT TO USE "BUCCANEERS", APART FROM THE MARK AS SHOWN.

FOR ENTERTAINMENT IN THE NATURE OF LIVE PERFORMANCES BY REENACTORS PORTRAYING PIRATES (U.S. CLS. 100, 101 AND 107).

GINA FINK, EXAMINING ATTORNEY

SN 77-430,228. CENTER FOR AMERICAN PROGRESS ACTION FUND, WASHINGTON, DC. FILED 3-24-2008.

CLIMATE PROGRESS

THE MARK CONSISTS OF STANDARD CHARACTERS WITHOUT CLAIM TO ANY PARTICULAR FONT, STYLE, SIZE, OR COLOR.

NO CLAIM IS MADE TO THE EXCLUSIVE RIGHT TO USE "CLIMATE", APART FROM THE MARK AS SHOWN.

FOR PROVIDING ON-LINE PERIODICAL AND NEWSGATHERING INFORMATION IN THE FIELDS OF CLIMATE, SCIENCE, POLITICS AND POLICY-MAKING; ARRANGING AND ORGANIZING EDUCATIONAL CONFERENCES, SEMINARS, AND SYMPOSIA IN THE FIELDS OF CLIMATE, SCIENCE, POLITICS AND POLICY-MAKING (U.S. CLS. 100, 101 AND 107).

FIRST USE 8-0-2006; IN COMMERCE 8-0-2006.

GINA FINK, EXAMINING ATTORNEY

SN 77-430,231. ANGLERS FOR CONSERVATION, SATELLITE BEACH, FL. FILED 3-24-2008.

HOOK KIDS ON FISHING

THE MARK CONSISTS OF STANDARD CHARACTERS WITHOUT CLAIM TO ANY PARTICULAR FONT, STYLE, SIZE, OR COLOR.

FOR INSTRUCTION IN THE FIELD OF FISHING AND HOW TO USE WATERWAYS FOR KIDS AND PARENTS (U.S. CLS. 100, 101 AND 107).

HEATHER BIDDULPH, EXAMINING ATTORNEY

CLASS 41—(Continued).

SN 77-430,234. BARRIOS, ALDO, BURBANK, CA. FILED 3-24-2008.



THE MARK CONSISTS OF A CUTLASS SWORD
CROSSED WITH A BLUNDERBUSS SHORT RIFLE OVER-
LAPPED IN THE CENTER BY A SLANT-EYED SKULL
REPRESENTATION. A.K.A SKULL AND CROSSBONES
REPRESENTATION USING WEAPONS INSTEAD OF
BONES.

FOR ENTERTAINMENT IN THE NATURE OF LIVE
PERFORMANCES BY REENACTORS PORTRAYING PI-
RATES (U.S. CLS. 100, 101 AND 107).
GINA FINK, EXAMINING ATTORNEY

SN 77-430,237. CENTER FOR AMERICAN PROGRESS AC-
TION FUND, WASHINGTON, DC. FILED 3-24-2008.

THE WONK ROOM

THE MARK CONSISTS OF STANDARD CHARACTERS
WITHOUT CLAIM TO ANY PARTICULAR FONT, STYLE,
SIZE, OR COLOR.

FOR PROVIDING ON-LINE PERIODICAL AND
NEWSGATHERING INFORMATION IN THE FIELDS
OF POLITICS, POLITICAL CAMPAIGNS AND POLICY-
MAKING; ARRANGING AND ORGANIZING EDUCA-
TIONAL CONFERENCES, SEMINARS, AND SYMPOSIA
IN THE FIELDS OF POLITICS, POLITICAL CAMPAIGNS
AND POLICY-MAKING (U.S. CLS. 100, 101 AND 107).
FIRST USE 3-17-2008; IN COMMERCE 3-17-2008.
GINA FINK, EXAMINING ATTORNEY

CLASS 41—(Continued).

SN 77-430,248. SKYZONE, LLC, LOS ANGELES, CA. FILED
3-24-2008.



THE MARK CONSISTS OF THE LETTERS "SZ" SUPER-
IMPOSED ON A GRID OF TWELVE SQUARES.

FOR PHYSICAL FITNESS INSTRUCTION, NAMELY,
AEROBIC CLASSES; ENTERTAINMENT SERVICES IN
THE NATURE OF PROVIDING ONGOING ATHLETIC
PROGRAMS FOR YOUNG ADULTS; ORGANIZING
AND CONDUCTING SPORTING CONTESTS AND
GAMES; AND PROVIDING RECREATIONAL FACIL-
ITIES THEREFOR (U.S. CLS. 100, 101 AND 107).
FIRST USE 2-0-2008; IN COMMERCE 2-0-2008.
JAMES LOVELACE, EXAMINING ATTORNEY

SN 77-430,259. MGM GRAND HOTEL, LLC, LAS VEGAS,
NV. FILED 3-24-2008.



FOR PROVIDING SWIMMING POOLS (U.S. CLS. 100,
101 AND 107).
FIRST USE 4-25-2008; IN COMMERCE 4-25-2008.
JAMES LOVELACE, EXAMINING ATTORNEY

SN 77-430,315. DOW, MICHAEL STEPHEN, TUCSON, AZ.
FILED 3-25-2008.

Create for your kids

THE MARK CONSISTS OF STANDARD CHARACTERS
WITHOUT CLAIM TO ANY PARTICULAR FONT, STYLE,
SIZE, OR COLOR.

FOR PROVIDING ADVICE AND INFORMATION IN
THE FIELD OF EDUCATIONAL AND ENTERTAIN-
MENT ACTIVITIES AND EVENTS FOR CHILDREN
(U.S. CLS. 100, 101 AND 107).
FIRST USE 3-24-2008; IN COMMERCE 3-24-2008.
ZHALEH DELANEY, EXAMINING ATTORNEY

CLASS 41—(Continued).

SN 77-430,391. LIFE ASSOCIATES LLC, POUGHKEEPSIE, NY. FILED 3-25-2008.

HIRING AND DEVELOPING WINNERS

THE MARK CONSISTS OF STANDARD CHARACTERS WITHOUT CLAIM TO ANY PARTICULAR FONT, STYLE, SIZE, OR COLOR.

SEC. 2(F).

FOR WORKSHOPS AND SEMINARS IN THE FIELD OF BUSINESS MANAGEMENT, LIFE COACHING AND CONSULTING SERVICES (U.S. CLS. 100, 101 AND 107).

FIRST USE 0-0-1993; IN COMMERCE 0-0-1993.
SUNG IN, EXAMINING ATTORNEY

SN 77-430,392. LIFE ASSOCIATES LLC, POUGHKEEPSIE, NY. FILED 3-25-2008.

MANAGING BY VALUES

THE MARK CONSISTS OF STANDARD CHARACTERS WITHOUT CLAIM TO ANY PARTICULAR FONT, STYLE, SIZE, OR COLOR.

SEC. 2(F).

FOR WORKSHOPS AND SEMINARS IN THE FIELD OF BUSINESS MANAGEMENT, LIFE COACHING AND CONSULTING SERVICES (U.S. CLS. 100, 101 AND 107).

FIRST USE 0-0-1994; IN COMMERCE 0-0-1994.
SUNG IN, EXAMINING ATTORNEY

SN 77-430,435. NORTHWEST EDUCATION LOAN ASSOCIATION, SEATTLE, WA. FILED 3-25-2008.

MENTOR 2 COLLEGE

THE MARK CONSISTS OF STANDARD CHARACTERS WITHOUT CLAIM TO ANY PARTICULAR FONT, STYLE, SIZE, OR COLOR.

FOR EDUCATIONAL SERVICES, NAMELY, CONDUCTING EDUCATIONAL PROGRAMS DIRECTED TO YOUTHS RELATING TO THE AVAILABILITY OF AND FINANCING FOR HIGHER EDUCATION OPPORTUNITIES; AND EDUCATIONAL SERVICES, NAMELY, PROVIDING THIRD PARTIES WITH EDUCATION PROGRAMS FOR ENABLING THOSE THIRD PARTIES TO CONDUCT EDUCATIONAL PROGRAMS DIRECTED TO YOUTHS RELATING TO THE AVAILABILITY OF AND FINANCING FOR HIGHER EDUCATIONAL OPPORTUNITIES (U.S. CLS. 100, 101 AND 107).

FIRST USE 9-30-2007; IN COMMERCE 9-30-2007.
SUZANNE BLANE, EXAMINING ATTORNEY

CLASS 41—(Continued).

SN 77-430,649. SMITH, AMY, DBA THE BUSINESS OF MOTHERHOOD, POTOMAC, MD. FILED 3-25-2008.

MOMTINI LOUNGE

THE MARK CONSISTS OF STANDARD CHARACTERS WITHOUT CLAIM TO ANY PARTICULAR FONT, STYLE, SIZE, OR COLOR.

FOR ON-LINE JOURNALS, NAMELY, BLOGS FEATURING INFORMATION ABOUT PARENTING (U.S. CLS. 100, 101 AND 107).

FIRST USE 7-31-2007; IN COMMERCE 7-31-2007.
LESLIE RICHARDS, EXAMINING ATTORNEY

SN 77-430,720. CLEAR SKY PSYCHOLOGY, INC., SAN RAMON, CA. FILED 3-25-2008.



THE MARK CONSISTS OF A PICTURE OF THE SUN WITH SUN RAYS RADIATING FROM IT OVER THE WORDS "CLEAR SKY" UNDERLINED AND BELOW THE LINE ARE THE WORDS "FINDING AND KEEPING JOY" FOLLOWED BY AN EXCLAMATION POINT.

FOR EDUCATION SERVICES, NAMELY, PROVIDING SEMINARS, WORKSHOPS, PODCASTS, TELESEMINARS, RADIO PROGRAMS IN THE FIELD OF PERINATAL MOOD DISORDERS; EDUCATIONAL SERVICES, NAMELY, PROVIDING SEMINARS, WORKSHOPS, PODCASTS, TELESEMINARS, RADIO & TELEVISION PROGRAMS IN THE FIELDS OF PERINATAL MOOD DISORDERS; INSTRUCTION IN THE FIELD OF TREATMENT AND ASSESSMENT OF PERINATAL MOOD DISORDERS; PROVIDING ON-LINE TRAINING FOR PROFESSIONALS IN THE ASSESSMENT AND TREATMENT IN THE FIELD OF PERINATAL MOOD DISORDERS; TELEVISION SHOW PRODUCTION; TRAINING SERVICES IN THE FIELD OF PERINATAL MOOD DISORDERS (U.S. CLS. 100, 101 AND 107).

MARIA-VICTORIA SUAREZ, EXAMINING ATTORNEY

CLASS 41—(Continued).

SN 77-430,917. ARTS FOR FITNESS, LLC, CHARLESTON, SC. FILED 3-25-2008.

ARTS FOR FITNESS

THE MARK CONSISTS OF STANDARD CHARACTERS WITHOUT CLAIM TO ANY PARTICULAR FONT, STYLE, SIZE, OR COLOR.

NO CLAIM IS MADE TO THE EXCLUSIVE RIGHT TO USE "FITNESS", APART FROM THE MARK AS SHOWN. FOR INSTRUCTION IN THE FIELD OF PHYSICAL ARTS AND FITNESS (U.S. CLS. 100, 101 AND 107). FIRST USE 9-1-2005; IN COMMERCE 9-1-2005. HEATHER THOMPSON, EXAMINING ATTORNEY

CLASS 41—(Continued).

SN 77-430,920. ARTS FOR FITNESS, LLC, CHARLESTON, SC. FILED 3-25-2008.



NO CLAIM IS MADE TO THE EXCLUSIVE RIGHT TO USE "FITNESS", APART FROM THE MARK AS SHOWN.

THE MARK CONSISTS OF THE LITERAL ELEMENT AND A GLOBE, BOTH OF WHICH ARE LOCATED WITHIN A CIRCLE AND THE GLOBE HAVING LONGITUDE AND LATITUDE LINES AND A MAN SILHOUETTE LOCATED WITHIN THE GLOBE.

FOR INSTRUCTION IN THE FIELD OF PHYSICAL ARTS AND FITNESS (U.S. CLS. 100, 101 AND 107).

FIRST USE 9-1-2005; IN COMMERCE 9-1-2005.

HEATHER THOMPSON, EXAMINING ATTORNEY

SN 77-431,026. HYMAN, MARTIN R., VALLEY STREAM, NY. FILED 3-25-2008.

MARTY HYMAN PHOTOGRAPHY

SN 77-430,918. ARTS FOR FITNESS, LLC, CHARLESTON, SC. FILED 3-25-2008.

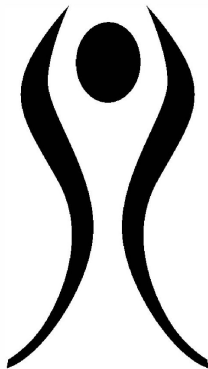

THE MARK CONSISTS OF STANDARD CHARACTERS WITHOUT CLAIM TO ANY PARTICULAR FONT, STYLE, SIZE, OR COLOR.

NO CLAIM IS MADE TO THE EXCLUSIVE RIGHT TO USE "PHOTOGRAPHY", APART FROM THE MARK AS SHOWN.

FOR PHOTOGRAPHY SERVICES (U.S. CLS. 100, 101 AND 107).

FIRST USE 7-0-1980; IN COMMERCE 7-0-1980.

AISHA CLARKE, EXAMINING ATTORNEY

SN 77-431,223. ROTAIVA LLC, LOS ANGELES, CA. FILED 3-25-2008.

Rotaiva

THE MARK CONSISTS OF STANDARD CHARACTERS WITHOUT CLAIM TO ANY PARTICULAR FONT, STYLE, SIZE, OR COLOR.

FOR AIRPLANE FLIGHT INSTRUCTION; ENTERTAINMENT IN THE NATURE OF THEATER PRODUCTIONS; FILM PRODUCTION; MULTIMEDIA ENTERTAINMENT SERVICES IN THE NATURE OF RECORDING, PRODUCTION AND POST-PRODUCTION SERVICES IN THE FIELDS OF MUSIC, VIDEO, AND FILMS; TELEVISION PRODUCTION (U.S. CLS. 100, 101 AND 107).

WANDA KAY PRICE, EXAMINING ATTORNEY

THE MARK CONSISTS OF A SILHOUETTE OF A MAN. FOR INSTRUCTION IN THE FIELD OF PHYSICAL ARTS AND FITNESS (U.S. CLS. 100, 101 AND 107). FIRST USE 1-14-2008; IN COMMERCE 1-14-2008. HEATHER THOMPSON, EXAMINING ATTORNEY

CLASS 41—(Continued).

SN 77-431,225. THE WISE DECISION, DETROIT, MI. FILED 3-25-2008.

TWD The Wise Decision

THE MARK CONSISTS OF STANDARD CHARACTERS WITHOUT CLAIM TO ANY PARTICULAR FONT, STYLE, SIZE, OR COLOR.

FOR PERSONAL TRAINER SERVICES (U.S. CLS. 100, 101 AND 107).

FIRST USE 4-14-2007; IN COMMERCE 5-14-2007.

WANDA KAY PRICE, EXAMINING ATTORNEY

SN 77-431,408. TUCH, LOS ANGELES, CA. FILED 3-25-2008.

Activities Children Enjoy

THE MARK CONSISTS OF STANDARD CHARACTERS WITHOUT CLAIM TO ANY PARTICULAR FONT, STYLE, SIZE, OR COLOR.

FOR PROVIDING AFTER SCHOOL EDUCATIONAL PROGRAMS FOR CHILDREN IN GRADES PRE-SCHOOL-8TH GRADE (U.S. CLS. 100, 101 AND 107).

FIRST USE 12-5-2007; IN COMMERCE 12-5-2007.

MELVIN AXILBUND, EXAMINING ATTORNEY

SN 77-431,413. GILCHREST, ANNELIESE, M, OTEGO, NY. FILED 3-25-2008.

Athelas

THE MARK CONSISTS OF STANDARD CHARACTERS WITHOUT CLAIM TO ANY PARTICULAR FONT, STYLE, SIZE, OR COLOR.

FOR RECREATIONAL SERVICES IN THE NATURE OF HORSEBACK RIDING FACILITIES (U.S. CLS. 100, 101 AND 107).

FIRST USE 1-26-2008; IN COMMERCE 1-26-2008.

ALEX KEAM, EXAMINING ATTORNEY

CLASS 41—(Continued).

SN 77-431,546. WERKHEISER, SETH, BROOKLYN, NY. FILED 3-26-2008.

BUZZGRINDER

THE MARK CONSISTS OF STANDARD CHARACTERS WITHOUT CLAIM TO ANY PARTICULAR FONT, STYLE, SIZE, OR COLOR.

FOR ENTERTAINMENT SERVICES, NAMELY, PROVIDING INFORMATION IN THE FIELD OF MUSIC NAMELY, NEWS, INFORMATION AND OPINIONS; PROVIDING COMMENTARY AND ARTICLES ABOUT MUSIC AND MUSIC PRODUCTION; ENTERTAINMENT SERVICES, NAMELY, PROVIDING A WEB SITE FEATURING MUSICAL PERFORMANCES, MUSICAL VIDEOS, RELATED FILM CLIPS, BAND PHOTOGRAPHS, MULTIMEDIA MATERIALS AND DISSEMINATION OF INFORMATION ABOUT BANDS, MUSICAL PERFORMANCES AND TELEVISION ON A GLOBAL COMPUTER NETWORK (U.S. CLS. 100, 101 AND 107).

FIRST USE 6-24-2001; IN COMMERCE 7-1-2002.

EDWARD NELSON, EXAMINING ATTORNEY

SN 77-431,577. AMERICAN CHEMICAL SOCIETY, DBA ACS, WASHINGTON, DC. FILED 3-26-2008.

CHEMTECH

THE MARK CONSISTS OF STANDARD CHARACTERS WITHOUT CLAIM TO ANY PARTICULAR FONT, STYLE, SIZE, OR COLOR.

OWNER OF U.S. REG. NO. 1,081,673.

FOR ON-LINE PUBLICATION OF JOURNAL IN THE FIELD OF CHEMISTRY TECHNOLOGY (U.S. CLS. 100, 101 AND 107).

FIRST USE 1-26-2008; IN COMMERCE 1-26-2008.

MONIQUE MILLER, EXAMINING ATTORNEY

CLASS 41—(Continued).

SN 77-431,599. GENERAL BOARD OF DISCIPLESHIP OF THE UNITED METHODIST CHURCH, NASHVILLE, TN. FILED 3-26-2008.

PREACHING FROM THE CENTER

THE MARK CONSISTS OF STANDARD CHARACTERS WITHOUT CLAIM TO ANY PARTICULAR FONT, STYLE, SIZE, OR COLOR.

FOR EDUCATIONAL SERVICES, NAMELY, CONDUCTING CLASSES, SEMINARS, CONFERENCES, COURSES, LECTURES, AND WORKSHOPS IN THE FIELDS OF CHRISTIAN, RELIGIOUS AND SPIRITUAL DEVELOPMENT, CHRISTIAN DISCIPLESHIP, CHRISTIAN, RELIGIOUS AND SPIRITUAL MINISTRY, CHRISTIAN STEWARDSHIP, CHURCH DEVELOPMENT, CHURCH LEADERSHIP, CHURCH MINISTRY, CHURCH REVITALIZATION, CONGREGATIONAL DEVELOPMENT, CONGREGATIONAL LEADERSHIP, CONGREGATIONAL MINISTRY, CONGREGATIONAL, INSPIRATIONAL AND RELIGIOUS PROGRAMS, DEVOTIONAL TOPICS, EVANGELISM, FAITH, FAITH FORMATION, LAY MINISTRIES, LEADERSHIP, LEADERSHIP DEVELOPMENT, LEADERSHIP FORMATION, LEADERSHIP SKILLS, PERSONAL DEVELOPMENT, PERSONAL PIETY, PERSONAL TRANSFORMATION, PRAYER, RELIGION, RELIGIOUS CONGREGATIONS, RELIGIOUS EDUCATION, RELIGIOUS LEADERSHIP, SPIRITUALITY, SPIRITUAL GROWTH, AND SPIRITUAL LEADERSHIP, AND DISTRIBUTING COURSE MATERIALS IN CONNECTION THEREWITH (U.S. CLS. 100, 101 AND 107).

FIRST USE 7-0-2002; IN COMMERCE 7-0-2002.
SUNG IN, EXAMINING ATTORNEY

SN 77-431,780. TENNESSEE NATIONAL, LLC, LOUDEN, TN. FILED 3-26-2008.



THE COLOR(S) BLUE, GREEN AND WHITE IS/ARE CLAIMED AS A FEATURE OF THE MARK.

THE MARK CONSISTS OF TWO STYLIZED DEPICTIONS OF GREEN MOUNTAINS AND A STYLIZED DEPICTION OF A BLUE RIVER RUNNING UNDERNEATH AND WHITE IN THE SPACES BETWEEN THE DEPICTIONS.

FOR COUNTRY CLUBS; GOLF CLUB SERVICES (U.S. CLS. 100, 101 AND 107).
LAURIE KAUFMAN, EXAMINING ATTORNEY

CLASS 41—(Continued).

SN 77-431,818. VAKALOPOULOS, NICK, WATERTOWN, MA. FILED 3-26-2008.

CatDoggraphy

THE MARK CONSISTS OF STANDARD CHARACTERS WITHOUT CLAIM TO ANY PARTICULAR FONT, STYLE, SIZE, OR COLOR.

FOR PHOTOGRAPHY SERVICES (U.S. CLS. 100, 101 AND 107).

FIRST USE 8-4-2006; IN COMMERCE 5-1-2007.

REGINA DRUMMOND, EXAMINING ATTORNEY

SN 77-431,829. CHONG, KYONG, PORT ANGELES, WA. FILED 3-26-2008.

NATURE FITNESS 24/7

THE MARK CONSISTS OF STANDARD CHARACTERS WITHOUT CLAIM TO ANY PARTICULAR FONT, STYLE, SIZE, OR COLOR.

NO CLAIM IS MADE TO THE EXCLUSIVE RIGHT TO USE "FITNESS 24/7", APART FROM THE MARK AS SHOWN.

FOR PHYSICAL FITNESS CONSULTATION; PHYSICAL FITNESS TRAINING SERVICES; PERSONAL TRAINING SERVICES, NAMELY, STRENGTH AND CONDITIONING TRAINING (U.S. CLS. 100, 101 AND 107).

H. M. FISHER, EXAMINING ATTORNEY

SN 77-431,923. RESOURCE VENTURES, LTD., COLUMBUS, OH. FILED 3-26-2008.

iCitizen

THE MARK CONSISTS OF STANDARD CHARACTERS WITHOUT CLAIM TO ANY PARTICULAR FONT, STYLE, SIZE, OR COLOR.

FOR EDUCATIONAL SERVICES, NAMELY, CONDUCTING SEMINARS, WORKSHOPS, AND SYMPOSIUMS IN THE FIELD OF CONSUMER RESEARCH AND MARKETING AND DISTRIBUTION OF COURSE MATERIAL IN CONNECTION THEREWITH (U.S. CLS. 100, 101 AND 107).

FIRST USE 5-5-2006; IN COMMERCE 5-5-2006.

SUZANNE BLANE, EXAMINING ATTORNEY

CLASS 41—(Continued).

SN 77-431,998. UNTAMED SPIRIT, CEDAR GLEN, CA.
FILED 3-26-2008.

A WIRE RUNS THROUGH IT

THE MARK CONSISTS OF STANDARD CHARACTERS WITHOUT CLAIM TO ANY PARTICULAR FONT, STYLE, SIZE, OR COLOR.

FOR EDUCATION SERVICES, NAMELY, PROVIDING LIVE JEWELRY MAKING CLASSES AND ON-LINE CLASSES, SEMINARS, INSTRUCTION AND TUTORIALS IN THE FIELD OF JEWELRY MAKING, AND DISTRIBUTING COURSE MATERIALS IN CONNECTION THEREWITH (U.S. CLS. 100, 101 AND 107).

MARK RADEMACHER, EXAMINING ATTORNEY

SN 77-432,008. UNTAMED SPIRIT, CEDAR GLEN, CA.
FILED 3-26-2008.

WIRED & INSPIRED

THE MARK CONSISTS OF STANDARD CHARACTERS WITHOUT CLAIM TO ANY PARTICULAR FONT, STYLE, SIZE, OR COLOR.

FOR EDUCATION SERVICES, NAMELY, PROVIDING LIVE JEWELRY MAKING CLASSES AND ON-LINE CLASSES, SEMINARS, INSTRUCTION AND TUTORIALS IN THE FIELD OF JEWELRY MAKING, AND DISTRIBUTING COURSE MATERIALS IN CONNECTION THEREWITH (U.S. CLS. 100, 101 AND 107).

MARK RADEMACHER, EXAMINING ATTORNEY

SN 77-432,014. UNTAMED SPIRIT, CEDAR GLEN, CA.
FILED 3-26-2008.

ALL STRUNG UP

THE MARK CONSISTS OF STANDARD CHARACTERS WITHOUT CLAIM TO ANY PARTICULAR FONT, STYLE, SIZE, OR COLOR.

FOR EDUCATION SERVICES, NAMELY, PROVIDING LIVE JEWELRY MAKING CLASSES AND ON-LINE CLASSES, SEMINARS, INSTRUCTION AND TUTORIALS IN THE FIELD OF JEWELRY MAKING, AND DISTRIBUTING COURSE MATERIALS IN CONNECTION THEREWITH (U.S. CLS. 100, 101 AND 107).

MARK RADEMACHER, EXAMINING ATTORNEY

CLASS 41—(Continued).

SN 77-432,169. BLOOMBERG L.P., NEW YORK, NY. FILED
3-26-2008.

FINAL WORD

THE MARK CONSISTS OF STANDARD CHARACTERS WITHOUT CLAIM TO ANY PARTICULAR FONT, STYLE, SIZE, OR COLOR.

FOR ENTERTAINMENT SERVICES IN THE NATURE OF PROGRAMMING DISTRIBUTED OVER BROADCAST, TELEVISION, RADIO, CABLE AND DIRECT SATELLITE IN THE FIELDS OF NEWS, BUSINESS, FINANCE, CURRENT EVENTS, SECURITIES AND ENERGY MARKETS AND INDUSTRIES; ENTERTAINMENT SERVICES IN THE NATURE OF PRODUCING AND DISTRIBUTING PROGRAMMING DISTRIBUTED OVER BROADCAST, TELEVISION, RADIO, CABLE AND DIRECT SATELLITES IN THE FIELDS OF NEWS, BUSINESS, FINANCE, CURRENT EVENTS, SECURITIES, SECURITIES MARKETS (U.S. CLS. 100, 101 AND 107).

FIRST USE 3-19-2007; IN COMMERCE 3-19-2007.

DOMINIC J. FERRAIUOLO, EXAMINING ATTORNEY

SN 77-432,221. IANNAcone, RONALD C., PHILADELPHIA,
PA. FILED 3-26-2008.

Mummer-able

THE MARK CONSISTS OF STANDARD CHARACTERS WITHOUT CLAIM TO ANY PARTICULAR FONT, STYLE, SIZE, OR COLOR.

FOR ENTERTAINMENT, NAMELY, LIVE PERFORMANCES BY A MUSICAL BAND (U.S. CLS. 100, 101 AND 107).

FIRST USE 1-1-1995; IN COMMERCE 11-1-2007.

JOHN DWYER, EXAMINING ATTORNEY

SN 77-432,250. AGVENTURE INC., KENTLAND, IN. FILED
3-26-2008.

WHERE KNOWLEDGE IS PROFIT

THE MARK CONSISTS OF STANDARD CHARACTERS WITHOUT CLAIM TO ANY PARTICULAR FONT, STYLE, SIZE, OR COLOR.

FOR TRAINING FOR OTHERS IN THE FIELD OF AGRICULTURE AND AGRICULTURE RELATED TECHNOLOGY (U.S. CLS. 100, 101 AND 107).

EMILY CARLSEN, EXAMINING ATTORNEY

CLASS 41—(Continued).

SN 77-432,332. CAMPANA, MICHAEL, FORT COLLINS, CO. FILED 3-26-2008.

IRON FIRE

THE MARK CONSISTS OF STANDARD CHARACTERS WITHOUT CLAIM TO ANY PARTICULAR FONT, STYLE, SIZE, OR COLOR.
FOR BOOK PUBLISHING (U.S. CLS. 100, 101 AND 107).
SONYA STEPHENS, EXAMINING ATTORNEY

SN 77-432,388. MIND SOLUTIONS INC., INDIANAPOLIS, IN. FILED 3-26-2008.

Stop Fixing, Start Leading

THE MARK CONSISTS OF STANDARD CHARACTERS WITHOUT CLAIM TO ANY PARTICULAR FONT, STYLE, SIZE, OR COLOR.
FOR EDUCATION SERVICES, NAMELY, PROVIDING CLASSES, SEMINARS, WORKSHOPS IN THE FIELD OF BUSINESS LEADERSHIP (U.S. CLS. 100, 101 AND 107).
MAUREEN DALL, EXAMINING ATTORNEY

SN 77-432,450. ART PROJECTS INTERNATIONAL, INC., DBA ART PROJECTS INTERNATIONAL, NEW YORK, NY. FILED 3-26-2008.

ART PROJECTS INTERNATIONAL

THE MARK CONSISTS OF STANDARD CHARACTERS WITHOUT CLAIM TO ANY PARTICULAR FONT, STYLE, SIZE, OR COLOR.

OWNER OF U.S. REG. NO. 1,992,315.
NO CLAIM IS MADE TO THE EXCLUSIVE RIGHT TO USE "ART", APART FROM THE MARK AS SHOWN.
SEC. 2(F) AS TO "PROJECTS INTERNATIONAL".

FOR CONSULTING SERVICES IN THE FIELD OF CURATING ART EXHIBITIONS, ART GALLERIES AND MUSEUMS; CONSULTING SERVICES IN THE FIELD OF RUNNING MUSEUMS; CONSULTING SERVICES IN THE FIELD OF ORGANIZING ART EXHIBITIONS; ARRANGING AND CONDUCTING EDUCATIONAL CONFERENCES AND SYMPOSIA FOR ART GALLERIES, INSTITUTIONS AND MUSEUMS (U.S. CLS. 100, 101 AND 107).

FIRST USE 9-1-1993; IN COMMERCE 9-1-1993.
SANDRA MANIOS, EXAMINING ATTORNEY

CLASS 41—(Continued).

SN 77-432,474. GUTTMANN, ERIC, MONTEREY, CA. FILED 3-26-2008.

When what you are speaks so loud no words are necessary.

THE MARK CONSISTS OF STANDARD CHARACTERS WITHOUT CLAIM TO ANY PARTICULAR FONT, STYLE, SIZE, OR COLOR.

FOR TRAINING SERVICES IN THE FIELD OF HEALTH AND MARTIAL ARTS DISCIPLINES (U.S. CLS. 100, 101 AND 107).

JOHN KELLY, EXAMINING ATTORNEY

SN 77-432,544. BODY TRANSIT INC., SCHWENKSVILLE, PA. FILED 3-26-2008.



NO CLAIM IS MADE TO THE EXCLUSIVE RIGHT TO USE "FITNESS", APART FROM THE MARK AS SHOWN.

THE STIPPLING IS FOR SHADING PURPOSES ONLY.
THE MARK CONSISTS OF THE STYLIZED TEXT "RASCALS FITNESS". TO THE LEFT OF THE TEXT IS A STYLIZED CIRCLE WITH A FACE THAT IS SPLIT UP IN FOUR PIECES.

FOR PROVIDING A WEB SITE FEATURING INFORMATION ON EXERCISE AND FITNESS; PROVIDING FITNESS AND EXERCISE FACILITIES (U.S. CLS. 100, 101 AND 107).

FIRST USE 7-1-2007; IN COMMERCE 9-1-2007.

ALEXANDER L. POWERS, EXAMINING ATTORNEY

SN 77-432,552. FUNKY DIVAS, LOS ANGELES, CA. FILED 3-26-2008.



THE STIPPLING IS FOR SHADING PURPOSES ONLY.
THE MARK CONSISTS OF A STYLIZED STAR TO THE LEFT OF THE STYLIZED TEXT "FUNKY DIVAS". THERE IS A STAR ABOVE THE LETTER "I" TO REPRESENT THE DOT IN THE TEXT "DIVAS".

FOR DANCE INSTRUCTION; PARTY PLANNING; SUMMER CAMPS (U.S. CLS. 100, 101 AND 107).

FIRST USE 1-15-2002; IN COMMERCE 1-15-2002.

KELLY MCCOY, EXAMINING ATTORNEY

CLASS 41—(Continued).

SN 77-432,665. BLACK WOLF BOOKS, INC., MANSFIELD, TX. FILED 3-26-2008.

Black Wolf Books

THE MARK CONSISTS OF STANDARD CHARACTERS WITHOUT CLAIM TO ANY PARTICULAR FONT, STYLE, SIZE, OR COLOR.

NO CLAIM IS MADE TO THE EXCLUSIVE RIGHT TO USE "BOOKS", APART FROM THE MARK AS SHOWN.

FOR BOOK PUBLISHING (U.S. CLS. 100, 101 AND 107).
FIRST USE 12-1-2005; IN COMMERCE 12-1-2005.

WILLIAM P. SHANAHAN, EXAMINING ATTORNEY

SN 77-432,668. NHN CORPORATION, SEONGNAM CITY, REPUBLIC OF KOREA, FILED 3-26-2008.

MINING BOY

THE MARK CONSISTS OF STANDARD CHARACTERS WITHOUT CLAIM TO ANY PARTICULAR FONT, STYLE, SIZE, OR COLOR.

FOR ENTERTAINMENT SERVICES, NAMELY, PROVIDING ON-LINE COMPUTER GAMES; PROVIDING A WEBSITE FEATURING COMPUTER GAMES; PROVIDING INFORMATION RELATING COMPUTER GAMES (U.S. CLS. 100, 101 AND 107).

CHARLES L. JENKINS, EXAMINING ATTORNEY

SN 77-432,670. BOLAND, DAVID M., ITHACA, NY. FILED 3-26-2008.

ADJACK

THE MARK CONSISTS OF STANDARD CHARACTERS WITHOUT CLAIM TO ANY PARTICULAR FONT, STYLE, SIZE, OR COLOR.

FOR ENTERTAINMENT SERVICES, NAMELY, PROGRAMS FEATURING COMMERCIALS BROADCAST OVER THE INTERNET AND WIRELESS AND MOBILE COMMUNICATIONS DEVICES; ENTERTAINMENT SERVICES, NAMELY, PROVIDING A WEBSITE FEATURING A PROGRAM FEATURING COMMERCIALS VIA A GLOBAL COMPUTER NETWORK OR ACCESSED BY ANY MOBILE COMMUNICATIONS DEVICE (U.S. CLS. 100, 101 AND 107).

FIRST USE 7-1-2007; IN COMMERCE 1-10-2008.

KELLY MCCOY, EXAMINING ATTORNEY

CLASS 41—(Continued).

SN 77-432,677. BLACK WOLF BOOKS, INC., MANSFIELD, TX. FILED 3-26-2008.



NO CLAIM IS MADE TO THE EXCLUSIVE RIGHT TO USE "BOOKS", APART FROM THE MARK AS SHOWN.

THE COLOR(S) BLACK, GRAY AND BLUE IS/ARE CLAIMED AS A FEATURE OF THE MARK.

THE MARK CONSISTS OF "BLACK WOLF BOOKS" IN STYLIZED LETTERING IN THE COLOR OF BLUE, BENEATH BLUE WOLF EYES AND DARK GRAY WOLF EYEBROWS, ALL ON A BLACK BACKGROUND.

FOR BOOK PUBLISHING (U.S. CLS. 100, 101 AND 107).
FIRST USE 12-1-2005; IN COMMERCE 12-1-2005.

WILLIAM P. SHANAHAN, EXAMINING ATTORNEY

SN 77-432,694. BE THE ALPHA, INC., NEW YORK, NY. FILED 3-26-2008.

BE THE ALPHA

THE MARK CONSISTS OF STANDARD CHARACTERS WITHOUT CLAIM TO ANY PARTICULAR FONT, STYLE, SIZE, OR COLOR.

FOR DOG TRAINING; PET TRAINING SERVICES (U.S. CLS. 100, 101 AND 107).

GISELLE AGOSTO, EXAMINING ATTORNEY

SN 77-432,783. MCGLYNN, CHRIS W., OAK RIDGE, NC. AND ATKINS, KEVIN L., KERNERSVILLE, NC. FILED 3-27-2008.

SOUL STALKAZ

THE MARK CONSISTS OF STANDARD CHARACTERS WITHOUT CLAIM TO ANY PARTICULAR FONT, STYLE, SIZE, OR COLOR.

FOR ENTERTAINMENT SERVICES IN THE NATURE OF LIVE MUSICAL PERFORMANCES; ENTERTAINMENT, NAMELY, LIVE PERFORMANCES BY MUSICAL BANDS (U.S. CLS. 100, 101 AND 107).

FIRST USE 8-13-2005; IN COMMERCE 10-21-2005.

CHRISTINA SOBRAL, EXAMINING ATTORNEY

CLASS 41—(Continued).

SN 77-432,810. RESOURCE VENTURES, LTD., COLUMBUS, OH. FILED 3-27-2008.

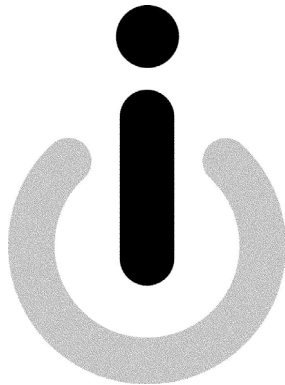

THE MARK CONSISTS OF THE LOWER CASE LETTERS "I" AND "C", WITH THE LETTER "C" WRAPPING AROUND THE LOWER PORTION OF THE LETTER "I".

FOR EDUCATIONAL SERVICES, NAMELY, CONDUCTING SEMINARS, WORKSHOPS, AND SYMPOSIUMS IN THE FIELD OF CONSUMER RESEARCH AND MARKETING AND DISTRIBUTION OF COURSE MATERIAL IN CONNECTION THEREWITH (U.S. CLS. 100, 101 AND 107).

FIRST USE 5-5-2006; IN COMMERCE 5-5-2006.
SUZANNE BLANE, EXAMINING ATTORNEY

SN 77-432,830. CAREER TRANSITION FOR DANCERS, INC., NEW YORK, NY. FILED 3-27-2008.

THE CONNECTION TO YOUR FUTURE

THE MARK CONSISTS OF STANDARD CHARACTERS WITHOUT CLAIM TO ANY PARTICULAR FONT, STYLE, SIZE, OR COLOR.

FOR CAREER COUNSELING SERVICES FOR PROFESSIONAL DANCERS TRANSITIONING INTO NEW CAREERS (U.S. CLS. 100, 101 AND 107).

REBECCA EISINGER, EXAMINING ATTORNEY

SN 77-432,839. CAREER TRANSITION FOR DANCERS, INC., NEW YORK, NY. FILED 3-27-2008.

WHERE PASSION MEETS OPPORTUNITY

THE MARK CONSISTS OF STANDARD CHARACTERS WITHOUT CLAIM TO ANY PARTICULAR FONT, STYLE, SIZE, OR COLOR.

FOR CAREER COUNSELING SERVICES FOR PROFESSIONAL DANCERS TRANSITIONING INTO NEW CAREERS (U.S. CLS. 100, 101 AND 107).

REBECCA EISINGER, EXAMINING ATTORNEY

CLASS 41—(Continued).

SN 77-432,891. PEN AMERICAN CENTER, INC., NEW YORK, NY. FILED 3-27-2008.

PEN WORLD VOICES

THE MARK CONSISTS OF STANDARD CHARACTERS WITHOUT CLAIM TO ANY PARTICULAR FONT, STYLE, SIZE, OR COLOR.

FOR ARRANGING AND CONDUCTING EDUCATIONAL CONFERENCES; EDUCATIONAL SERVICES, NAMELY, DEVELOPING, ARRANGING, AND CONDUCTING EDUCATIONAL CONFERENCES AND PROGRAMS AND PROVIDING COURSES OF INSTRUCTION IN THE FIELD OF INTERNATIONAL LITERATURE (U.S. CLS. 100, 101 AND 107).

FIRST USE 4-16-2005; IN COMMERCE 4-16-2005.
CURTIS FRENCH, EXAMINING ATTORNEY

SN 77-433,032. PRIMARY WAVE MUSIC PUBLISHING LLC, NEW YORK, NY. FILED 3-27-2008.

J. STACHE

THE MARK CONSISTS OF STANDARD CHARACTERS WITHOUT CLAIM TO ANY PARTICULAR FONT, STYLE, SIZE, OR COLOR.

THE NAME "J. STACHE" DOES NOT IDENTIFY A LIVING INDIVIDUAL.

FOR ENTERTAINMENT, NAMELY, AN ONGOING ANIMATED CARTOON SERIES DISTRIBUTED VIA BROADCAST OR TRANSMISSION OVER TELEVISION AND THE INTERNET (U.S. CLS. 100, 101 AND 107).

ANTHONY RINKER, EXAMINING ATTORNEY

SN 77-433,050. PRIMARY WAVE MUSIC PUBLISHING LLC, NEW YORK, NY. FILED 3-27-2008.

THE J. STACHE SHOW

THE MARK CONSISTS OF STANDARD CHARACTERS WITHOUT CLAIM TO ANY PARTICULAR FONT, STYLE, SIZE, OR COLOR.

NO CLAIM IS MADE TO THE EXCLUSIVE RIGHT TO USE "SHOW", APART FROM THE MARK AS SHOWN.

THE NAME "J. STACHE" DOES NOT IDENTIFY A LIVING INDIVIDUAL.

FOR ENTERTAINMENT, NAMELY, AN ONGOING ANIMATED CARTOON SERIES DISTRIBUTED VIA BROADCAST OR TRANSMISSION OVER TELEVISION AND THE INTERNET (U.S. CLS. 100, 101 AND 107).

ANTHONY RINKER, EXAMINING ATTORNEY

CLASS 41—(Continued).

SN 77-433,102. BLOOMBERG L.P., NEW YORK, NY. FILED 3-27-2008.

THE FINAL WORD

THE MARK CONSISTS OF STANDARD CHARACTERS WITHOUT CLAIM TO ANY PARTICULAR FONT, STYLE, SIZE, OR COLOR.

FOR ENTERTAINMENT SERVICES IN THE NATURE OF PROGRAMMING DISTRIBUTED OVER BROADCAST, TELEVISION, RADIO, CABLE AND DIRECT SATELLITE IN THE FIELDS OF NEWS, BUSINESS, FINANCE, CURRENT EVENTS, SECURITIES AND ENERGY MARKETS AND INDUSTRIES; ENTERTAINMENT SERVICES IN THE NATURE OF PRODUCING AND DISTRIBUTING PROGRAMMING DISTRIBUTED OVER BROADCAST, TELEVISION, RADIO, CABLE AND DIRECT SATELLITES IN THE FIELDS OF NEWS, BUSINESS, FINANCE, CURRENT EVENTS, SECURITIES, SECURITIES MARKETS (U.S. CLS. 100, 101 AND 107).

FIRST USE 3-19-2007; IN COMMERCE 3-19-2007.
DOMINIC J. FERRAIUOLO, EXAMINING ATTORNEY

SN 77-433,232. LIGHT, INC., THE, SOMERSET, NJ. FILED 3-27-2008.

TUGHRA

THE MARK CONSISTS OF STANDARD CHARACTERS WITHOUT CLAIM TO ANY PARTICULAR FONT, STYLE, SIZE, OR COLOR.

FOR BOOK PUBLISHING; MAGAZINE PUBLISHING; ONLINE ELECTRONIC PUBLISHING OF BOOKS AND PERIODICALS; PUBLISHING OF BOOKS, MAGAZINES; PUBLISHING OF ELECTRONIC PUBLICATIONS; PUBLISHING OF WEB MAGAZINES; MULTIMEDIA PUBLISHING OF BOOKS, MAGAZINES, JOURNALS, SOFTWARE, GAMES, MUSIC, AND ELECTRONIC PUBLICATIONS; DIGITAL VIDEO, AUDIO, AND MULTIMEDIA PUBLISHING SERVICES (U.S. CLS. 100, 101 AND 107).

JILL C. ALT, EXAMINING ATTORNEY

CLASS 41—(Continued).

SN 77-433,246. LIGHT, INC., THE, SOMERSET, NJ. FILED 3-27-2008.

BLUE DOME

THE MARK CONSISTS OF STANDARD CHARACTERS WITHOUT CLAIM TO ANY PARTICULAR FONT, STYLE, SIZE, OR COLOR.

FOR BOOK PUBLISHING; MAGAZINE PUBLISHING; ONLINE ELECTRONIC PUBLISHING OF BOOKS AND PERIODICALS; PUBLISHING OF BOOKS, MAGAZINES; PUBLISHING OF ELECTRONIC PUBLICATIONS; PUBLISHING OF WEB MAGAZINES; MULTIMEDIA PUBLISHING OF BOOKS, MAGAZINES, JOURNALS, SOFTWARE, GAMES, MUSIC, AND ELECTRONIC PUBLICATIONS; DIGITAL VIDEO, AUDIO, AND MULTIMEDIA PUBLISHING SERVICES (U.S. CLS. 100, 101 AND 107).

JILL C. ALT, EXAMINING ATTORNEY

SN 77-433,387. MCMONIGLE, JOHN, IRVINE, CA. FILED 3-27-2008.

TOP AGENT

THE MARK CONSISTS OF STANDARD CHARACTERS WITHOUT CLAIM TO ANY PARTICULAR FONT, STYLE, SIZE, OR COLOR.

FOR EDUCATION SERVICES, NAMELY, PROVIDING SALES TRAINING PROGRAMS IN THE FIELD OF REAL ESTATE (U.S. CLS. 100, 101 AND 107).

FIRST USE 9-11-2007; IN COMMERCE 9-11-2007.
JILL PRATER, EXAMINING ATTORNEY

SN 77-433,405. STANEART, DOUG M, DBA THE LEADER'S INSTITUTE, LLC, HURST, TX. FILED 3-27-2008.

Rescue Bear Workshop

THE MARK CONSISTS OF STANDARD CHARACTERS WITHOUT CLAIM TO ANY PARTICULAR FONT, STYLE, SIZE, OR COLOR.

NO CLAIM IS MADE TO THE EXCLUSIVE RIGHT TO USE "WORKSHOP", APART FROM THE MARK AS SHOWN.

FOR EDUCATION SERVICES, NAMELY, PROVIDING CLASSES, SEMINARS, AND WORKSHOPS IN THE FIELD OF TEAM BUILDING AND LEADERSHIP (U.S. CLS. 100, 101 AND 107).

FIRST USE 3-24-2008; IN COMMERCE 3-24-2008.
DANNEAN HETZEL, EXAMINING ATTORNEY

CLASS 41—(Continued).

SN 77-433,528. HOOPS BASKETBALL ACADEMY, LLC, LOUISVILLE, KY. FILED 3-27-2008.

CLASS 41—(Continued).

SN 77-433,820. ORANGE COUNTY DEPARTMENT OF EDUCATION, COSTA MESA, CA. FILED 3-27-2008.

Where the game is

THE MARK CONSISTS OF STANDARD CHARACTERS WITHOUT CLAIM TO ANY PARTICULAR FONT, STYLE, SIZE, OR COLOR.

FOR AMATEUR YOUTH SPORTS SERVICES, NAMELY, ORGANIZING, PROVIDING AND MANAGING YOUTH SPORTS ACTIVITIES (U.S. CLS. 100, 101 AND 107).

FIRST USE 1-2-2007; IN COMMERCE 1-2-2007.
JOHN KELLY, EXAMINING ATTORNEY

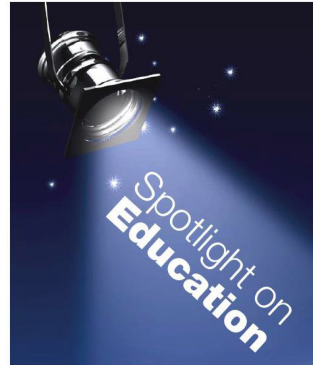

NO CLAIM IS MADE TO THE EXCLUSIVE RIGHT TO USE "EDUCATION", APART FROM THE MARK AS SHOWN.

THE COLOR(S) BLACK, WHITE, AND BLUE IS/ARE CLAIMED AS A FEATURE OF THE MARK.

THE MARK CONSISTS OF A BLACK STAGE LIGHT IN THE UPPER LEFT SHINING ON THE WORDING "SPOTLIGHT ON EDUCATION" IN WHITE, AGAINST A DARK BLUE BACKGROUND WITH WHITE STARS.

FOR ENTERTAINMENT IN THE NATURE OF ONGOING TELEVISION PROGRAMS IN THE FIELD OF EDUCATION (U.S. CLS. 100, 101 AND 107).

WANDA KAY PRICE, EXAMINING ATTORNEY

SN 77-433,670. ART PROJECTS INTERNATIONAL, INC., DBA ART PROJECTS INTERNATIONAL, NEW YORK, NY. FILED 3-27-2008.



SN 77-433,838. ORANGE COUNTY DEPARTMENT OF EDUCATION, COSTA MESA, CA. FILED 3-27-2008.

SPOTLIGHT ON EDUCATION

OWNER OF U.S. REG. NO. 1,992,315.
THE MARK CONSISTS OF THE LETTERS "A", "P" AND "I" IN OFFSET FASHION WITHIN A SQUARE.

FOR CONSULTING SERVICES IN THE FIELD OF CURATING ART EXHIBITIONS, ART GALLERIES AND MUSEUMS; CONSULTING SERVICES IN THE FIELD OF RUNNING MUSEUMS; CONSULTING SERVICES IN THE FIELD OF ORGANIZING ART EXHIBITIONS; ARRANGING AND CONDUCTING EDUCATIONAL CONFERENCES AND SYMPOSIA FOR ART GALLERIES, INSTITUTIONS AND MUSEUMS (U.S. CLS. 100, 101 AND 107).

FIRST USE 9-1-1993; IN COMMERCE 9-1-1993.
SANDRA MANIOS, EXAMINING ATTORNEY

THE MARK CONSISTS OF STANDARD CHARACTERS WITHOUT CLAIM TO ANY PARTICULAR FONT, STYLE, SIZE, OR COLOR.

NO CLAIM IS MADE TO THE EXCLUSIVE RIGHT TO USE "EDUCATION", APART FROM THE MARK AS SHOWN.

FOR ENTERTAINMENT IN THE NATURE OF ONGOING TELEVISION PROGRAMS IN THE FIELD OF EDUCATION (U.S. CLS. 100, 101 AND 107).

WANDA KAY PRICE, EXAMINING ATTORNEY

CLASS 41—(Continued).

SN 77-433,970. SYNCHRONICITY LIVE, LLC, JACKSONVILLE BEACH, FL. FILED 3-28-2008.

synclive.com

THE MARK CONSISTS OF STANDARD CHARACTERS WITHOUT CLAIM TO ANY PARTICULAR FONT, STYLE, SIZE, OR COLOR.

FOR ENTERTAINMENT SERVICES, NAMELY, PROVIDING A WEBSITE FEATURING LIVE PERFORMANCES, EVENTS, CONCERTS, VIDEOS, COMMENTARY AND ARTICLES ABOUT LIVE PERFORMANCES AND EVENTS AND RELATED FILM CLIPS, PHOTOGRAPHS, AND OTHER MULTI-MEDIA MATERIALS, ALL ON-LINE VIA THE INTERNET OR OTHER COMMUNICATIONS NETWORKS (U.S. CLS. 100, 101 AND 107).

TASNEEM HUSSAIN, EXAMINING ATTORNEY

SN 77-434,157. CARDRUNNERS, LLC, AURORA, IL. FILED 3-28-2008.

CARDRUNNERS

THE MARK CONSISTS OF STANDARD CHARACTERS WITHOUT CLAIM TO ANY PARTICULAR FONT, STYLE, SIZE, OR COLOR.

FOR PROVIDING POKER TRAINING SERVICES ACCESSED VIA AN INTERACTIVE WEBSITE (U.S. CLS. 100, 101 AND 107).

FIRST USE 1-1-2007; IN COMMERCE 1-1-2007.
DOUGLAS LEE, EXAMINING ATTORNEY

SN 77-434,164. THE CARTOON NETWORK, INC., ATLANTA, GA. FILED 3-28-2008.

JIB & CRASH

THE MARK CONSISTS OF STANDARD CHARACTERS WITHOUT CLAIM TO ANY PARTICULAR FONT, STYLE, SIZE, OR COLOR.

FOR ENTERTAINMENT SERVICES, NAMELY, A MULTIMEDIA PROGRAM SERIES FEATURING COMEDY, ACTION AND ADVENTURE DISTRIBUTED VIA VARIOUS PLATFORMS ACROSS MULTIPLE FORMS OF TRANSMISSION MEDIA (U.S. CLS. 100, 101 AND 107).

SAMUEL E. SHARPER JR., EXAMINING ATTORNEY

CLASS 41—(Continued).

SN 77-434,260. ROBERSON, DWAYNE A., WASHINGTON, DC. AND LEMAITRE, TANYA, DBA LEMAITRE, UPPER MARLBORO, MD. AND FARRIS JR., WILLIAM A., DBA BILLY WINN, WASHINGTON, DC. AND TAYLOR, BLAIR, DBA TINAB, WASHINGTON, DC. FILED 3-28-2008.

Auteur

THE MARK CONSISTS OF STANDARD CHARACTERS WITHOUT CLAIM TO ANY PARTICULAR FONT, STYLE, SIZE, OR COLOR.

FOR ENTERTAINMENT, NAMELY, LIVE MUSIC CONCERTS; ENTERTAINMENT, NAMELY, LIVE PERFORMANCES BY A MUSICAL BAND; ENTERTAINMENT IN THE NATURE OF A MUSICAL GROUP; ENTERTAINMENT IN THE NATURE OF ORCHESTRA PERFORMANCES; ENTERTAINMENT IN THE NATURE OF SYMPHONY ORCHESTRA PERFORMANCES; ENTERTAINMENT IN THE NATURE OF VISUAL AND AUDIO PERFORMANCES, AND MUSICAL, VARIETY, NEWS AND COMEDY SHOWS; ENTERTAINMENT IN THE NATURE OF VISUAL AND AUDIO PERFORMANCES, NAMELY, MUSICAL BAND, ROCK GROUP, GYMNASTIC, DANCE, AND BALLET PERFORMANCES; ENTERTAINMENT SERVICES IN THE NATURE OF AN ON-GOING REALITY BASED TELEVISION PROGRAM; ENTERTAINMENT SERVICES IN THE NATURE OF COMEDY SHOWS; ENTERTAINMENT SERVICES IN THE NATURE OF LIVE MUSICAL PERFORMANCES; ENTERTAINMENT SERVICES, NAMELY, AN ONLINE ACTIVITY WHERE YOU CREATE YOUR OWN MUSIC VIDEOS; ENTERTAINMENT SERVICES, NAMELY, CONDUCTING CONTESTS; ENTERTAINMENT SERVICES, NAMELY, NON-DOWNLOADABLE RINGTONES, PRE-RECORDED MUSIC, VIDEO AND GRAPHICS PRESENTED TO MOBILE COMMUNICATIONS DEVICES VIA A GLOBAL COMPUTER NETWORK AND WIRELESS NETWORKS; ENTERTAINMENT, NAMELY, LIVE PERFORMANCES BY MUSICAL BANDS (U.S. CLS. 100, 101 AND 107).

LOURDES AYALA, EXAMINING ATTORNEY

SN 77-434,327. GREGG AMERMAN COMPANIES, INC., ATLANTA, GA. FILED 3-28-2008.

EdgeUtainment

THE MARK CONSISTS OF STANDARD CHARACTERS WITHOUT CLAIM TO ANY PARTICULAR FONT, STYLE, SIZE, OR COLOR.

FOR EDUCATIONAL AND ENTERTAINMENT SERVICES, NAMELY, CONDUCTING CLASSES AND SEMINARS IN THE FIELDS OF PROFESSIONAL AND PERSONAL IMPROVEMENT (U.S. CLS. 100, 101 AND 107).

FIRST USE 1-1-2008; IN COMMERCE 1-1-2008.
MARGARET POWER, EXAMINING ATTORNEY

CLASS 41—(Continued).

SN 77-434,816. HARDIE, WILLIAM, CORONA, CA. FILED 3-28-2008.

MusInk

THE MARK CONSISTS OF STANDARD CHARACTERS WITHOUT CLAIM TO ANY PARTICULAR FONT, STYLE, SIZE, OR COLOR.

FOR CONDUCTING ENTERTAINMENT EXHIBITIONS IN THE NATURE OF TATTOO AND MUSIC FESTIVALS (U.S. CLS. 100, 101 AND 107).

FIRST USE 1-1-2006; IN COMMERCE 1-1-2006.
JEAN IM, EXAMINING ATTORNEY

CLASS 41—(Continued).

SN 77-434,911. DERIGO ENTERPRISES LLC, DALLAS, TX. FILED 3-28-2008.

MENERGY

THE MARK CONSISTS OF STANDARD CHARACTERS WITHOUT CLAIM TO ANY PARTICULAR FONT, STYLE, SIZE, OR COLOR.

FOR ORGANIZING COMMUNITY SPORTING AND CULTURAL EVENTS; ENTERTAINMENT IN THE NATURE OF BASKETBALL GAMES (U.S. CLS. 100, 101 AND 107).

LINDSEY RUBIN, EXAMINING ATTORNEY

SN 77-434,881. THE STATE BOARD OF GOVERNORS, ACTING BY AND THROUGH COLORADO STATE UNIVERSITY, DENVER, CO. FILED 3-28-2008.

MIGHTY MOVES

THE MARK CONSISTS OF STANDARD CHARACTERS WITHOUT CLAIM TO ANY PARTICULAR FONT, STYLE, SIZE, OR COLOR.

FOR DEVELOPMENT AND DISSEMINATION OF EDUCATION MATERIALS FOR OTHERS IN THE FIELDS OF ANTI-OBESITY AND EXERCISE; EDUCATIONAL SERVICES, NAMELY, A PROGRAM TO PROMOTE ANTI-OBESITY AND EXERCISE (U.S. CLS. 100, 101 AND 107).

FIRST USE 1-12-2006; IN COMMERCE 3-3-2006.
CORY BOONE, EXAMINING ATTORNEY

SN 77-434,990. EPPS, RODNEY J., RIVERDALE, GA. FILED 3-28-2008.

Complete Desire

THE MARK CONSISTS OF STANDARD CHARACTERS WITHOUT CLAIM TO ANY PARTICULAR FONT, STYLE, SIZE, OR COLOR.

FOR ENTERTAINMENT SERVICES, NAMELY, LIVE PERFORMANCES, BY A VOCAL AND MUSICAL GROUP (U.S. CLS. 100, 101 AND 107).

FIRST USE 1-12-1995; IN COMMERCE 1-12-1995.
DAVID H. STINE, EXAMINING ATTORNEY

SN 77-434,907. STEP 5 PRODUCTIONS, L.L.C., AVON, IN. FILED 3-28-2008.

blue transit

THE MARK CONSISTS OF STANDARD CHARACTERS WITHOUT CLAIM TO ANY PARTICULAR FONT, STYLE, SIZE, OR COLOR.

FOR ENTERTAINMENT, NAMELY, LIVE PERFORMANCES BY A MUSICAL BAND (U.S. CLS. 100, 101 AND 107).

FIRST USE 1-1-2006; IN COMMERCE 1-1-2006.
JAMES STEIN, EXAMINING ATTORNEY

SN 77-438,550. DIGITAL MEDIA INTERNATIONAL LLC, NEW YORK, NY. FILED 4-2-2008.

FLYPSIDE

THE MARK CONSISTS OF STANDARD CHARACTERS WITHOUT CLAIM TO ANY PARTICULAR FONT, STYLE, SIZE, OR COLOR.

FOR PUBLICATION OF ELECTRONIC MAGAZINES (U.S. CLS. 100, 101 AND 107).

FIRST USE 3-12-2008; IN COMMERCE 3-12-2008.
KATHERINE M. DUBRAY, EXAMINING ATTORNEY

CLASS 41—(Continued).

SN 77-438,551. DIGITAL MEDIA INTERNATIONAL LLC,
NEW YORK, NY. FILED 4-2-2008.

FLYP FLICKS

THE MARK CONSISTS OF STANDARD CHARACTERS WITHOUT CLAIM TO ANY PARTICULAR FONT, STYLE, SIZE, OR COLOR.

FOR PUBLICATION OF ELECTRONIC MAGAZINES (U.S. CLS. 100, 101 AND 107).

FIRST USE 3-12-2008; IN COMMERCE 3-12-2008.

KATHERINE M. DUBRAY, EXAMINING ATTORNEY

CLASS 41—(Continued).

SN 77-439,530. FEDERAL RESERVE BANK OF ST. LOUIS,
ST. LOUIS, MO. FILED 4-3-2008.

Exploring Innovation

THE MARK CONSISTS OF IN PART, A STYLIZED RING WITH TWO SPHERES.

FOR EDUCATIONAL SERVICES, NAMELY, DEVELOPING, ARRANGING, AND CONDUCTING EDUCATIONAL CONFERENCES IN THE FIELD OF COMMUNITY DEVELOPMENT FINANCE (U.S. CLS. 100, 101 AND 107).

FIRST USE 5-2-2007; IN COMMERCE 5-2-2007.

MARK SPARACINO, EXAMINING ATTORNEY

SN 77-438,925. DISH NETWORK L.L.C., ENGLEWOOD, CO.
FILED 4-3-2008.

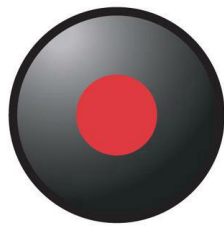

AUTO RECORD SERIES

NO CLAIM IS MADE TO THE EXCLUSIVE RIGHT TO USE "AUTO RECORD SERIES", APART FROM THE MARK AS SHOWN.

THE COLOR(S) BLACK, GREY AND RED IS/ARE CLAIMED AS A FEATURE OF THE MARK.

THE MARK CONSISTS OF A BUTTON THAT HAS AN INNER RED CIRCLE AND A BLACK AND GREY OUTER CIRCLE WITH THE STYLIZED BLACK WORDS "AUTO RECORD" UNDER THE CIRCLES. UNDER "AUTO RECORD" IS THE STYLIZED BLACK WORD "SERIES".

FOR TELEVISION PROGRAMMING; TELEVISION SCHEDULING; DISTRIBUTION OF TELEVISION PROGRAMS FOR OTHERS (U.S. CLS. 100, 101 AND 107).

KOURTNEE HODGES, EXAMINING ATTORNEY

SN 77-441,332. COMMUNITYSOUTH FINANCIAL CORPORATION, EASLEY, SC. FILED 4-7-2008.

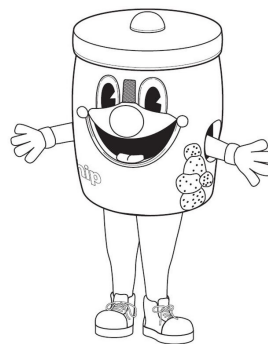

THE MARK CONSISTS OF A STYLIZED REPRESENTATION OF A PERSON COSTUMED AS A COOKIE JAR.

FOR ENTERTAINMENT SERVICES IN THE NATURE OF PERSONAL PERFORMANCES AND APPEARANCES OF A COSTUMED MASCOT INCIDENT TO PROVIDING BANKING AND FINANCIAL SERVICES (U.S. CLS. 100, 101 AND 107).

FIRST USE 8-20-2007; IN COMMERCE 8-20-2007.

TRICIA SONNEBORN, EXAMINING ATTORNEY

CLASS 41—(Continued).

SN 77-441,633. COURTROOM TELEVISION NETWORK LLC, NEW YORK, NY. FILED 4-7-2008.

CELEBRITY PANIC ROOM

THE MARK CONSISTS OF STANDARD CHARACTERS WITHOUT CLAIM TO ANY PARTICULAR FONT, STYLE, SIZE, OR COLOR.

NO CLAIM IS MADE TO THE EXCLUSIVE RIGHT TO USE "CELEBRITY", APART FROM THE MARK AS SHOWN.

FOR ENTERTAINMENT SERVICES, NAMELY, CONTINUING SCRIPTED AND UNSCRIPTED TELEVISION PROGRAM SERIES IN THE FIELD OF COMEDY, DRAMA, ACTION, ADVENTURE AND REALITY PROVIDED THROUGH CABLE TELEVISION, BROADCAST TELEVISION, INTERNET, VIDEO-ON-DEMAND, AND THROUGH OTHER DISTRIBUTION PLATFORMS; PROVIDING INFORMATION, NAMELY, ENTERTAINMENT INFORMATION, OVER THE INTERNET (U.S. CLS. 100, 101 AND 107).

Laura Hammel, Examining Attorney

CLASS 41—(Continued).

SN 77-445,982. KINGSLEY INVESTMENT COMPANY, LLC, PALM BEACH, FL. FILED 4-11-2008.

OKRC

THE MARK CONSISTS OF STANDARD CHARACTERS WITHOUT CLAIM TO ANY PARTICULAR FONT, STYLE, SIZE, OR COLOR.

FOR EDUCATION SERVICES, NAMELY, PROVIDING CLASSES, SEMINARS, CONFERENCES, AND LECTURES IN THE FIELD OF ORTHOPEDICS; PUBLISHING OF BOOKS AND HANDBOOKS (U.S. CLS. 100, 101 AND 107).

David YonTEF, Examining Attorney

SN 77-442,736. DISH NETWORK L.L.C., ENGLEWOOD, CO. FILED 4-8-2008.



AUTO RECORD SERIES

NO CLAIM IS MADE TO THE EXCLUSIVE RIGHT TO USE "AUTO RECORD SERIES", APART FROM THE MARK AS SHOWN.

THE COLOR(S) BLACK, GREY AND RED IS/ARE CLAIMED AS A FEATURE OF THE MARK.

THE MARK CONSISTS OF A BUTTON THAT HAS AN INNER RED CIRCLE AND A BLACK AND GREY OUTER CIRCLE WITH THE STYLIZED BLACK WORDS "AUTO RECORD" TO THE RIGHT OF THE CIRCLES. UNDER "AUTO RECORD" IS THE STYLIZED BLACK WORD "SERIES".

FOR TELEVISION PROGRAMMING; TELEVISION SCHEDULING; DISTRIBUTION OF TELEVISION PROGRAMS FOR OTHERS (U.S. CLS. 100, 101 AND 107).

Kourtnee Hodges, Examining Attorney

SN 77-446,702. GILCHREST, ANNELIESE, DBA ATHELAS, OTEGO, NY. FILED 4-11-2008.



NO CLAIM IS MADE TO THE EXCLUSIVE RIGHT TO USE "THERAPEUTIC RIDING", APART FROM THE MARK AS SHOWN.

THE MARK CONSISTS OF FIGURE OF HORSE AND RIDER WITH ARMS OUTSPREAD SURROUNDED BY CIRCLES AND THE WORDING ATHELAS THERAPEUTIC RIDING.

FOR RECREATIONAL SERVICES IN THE NATURE OF HORSEBACK RIDING FACILITIES (U.S. CLS. 100, 101 AND 107).

First Use 2-1-2008; In Commerce 2-1-2008.

Alex Keam, Examining Attorney

CLASS 41—(Continued).

SN 77-449,639. ROYAL CARIBBEAN CRUISES LTD., MIAMI, FL. FILED 4-16-2008.

ROYAL BABIES

THE MARK CONSISTS OF STANDARD CHARACTERS WITHOUT CLAIM TO ANY PARTICULAR FONT, STYLE, SIZE, OR COLOR.

OWNER OF U.S. REG. NOS. 1,397,148, 2,532,090 AND OTHERS.

NO CLAIM IS MADE TO THE EXCLUSIVE RIGHT TO USE "BABIES", APART FROM THE MARK AS SHOWN.

FOR PROVIDING RECREATIONAL FACILITIES AND ACTIVITIES FOR CHILDREN ABOARD CRUISE SHIPS (U.S. CLS. 100, 101 AND 107).

KEVON CHISOLM, EXAMINING ATTORNEY

SN 77-449,663. ROYAL CARIBBEAN CRUISES LTD., MIAMI, FL. FILED 4-16-2008.

ROYAL TOTS

THE MARK CONSISTS OF STANDARD CHARACTERS WITHOUT CLAIM TO ANY PARTICULAR FONT, STYLE, SIZE, OR COLOR.

OWNER OF U.S. REG. NOS. 1,397,148, 2,532,090 AND OTHERS.

NO CLAIM IS MADE TO THE EXCLUSIVE RIGHT TO USE "TOTS", APART FROM THE MARK AS SHOWN.

FOR PROVIDING RECREATIONAL FACILITIES AND ACTIVITIES FOR CHILDREN ABOARD CRUISE SHIPS (U.S. CLS. 100, 101 AND 107).

KEVON CHISOLM, EXAMINING ATTORNEY

CLASS 41—(Continued).

SN 77-449,703. PROELITE, INC., LOS ANGELES, CA. FILED 4-16-2008.

ELITE

THE MARK CONSISTS OF STANDARD CHARACTERS WITHOUT CLAIM TO ANY PARTICULAR FONT, STYLE, SIZE, OR COLOR.

FOR ENTERTAINMENT SERVICES, NAMELY, ORGANIZING AND PRODUCING SPORTING EVENTS AND COMPETITIONS IN THE AREA OF MARTIAL ARTS AND MIXED MARTIAL ARTS; ENTERTAINMENT SERVICES, NAMELY, LIVE STAGE SHOWS AND PERFORMANCES FEATURING SPORTS, MARTIAL ARTS, AND MIXED MARTIAL ARTS; PRODUCTION OF ENTERTAINMENT SHOWS AND EVENTS IN THE AREA OF MARTIAL ARTS, FIGHTING, AND MIXED MARTIAL ARTS FOR DISTRIBUTION VIA TELEVISION, CABLE, SATELLITE, AUDIO AND VIDEO MEDIA CARTRIDGES AND DISCS, COMPUTER DISCS AND OTHER ELECTRONIC MEANS, MOBILE TELEPHONES AND OTHER MOBILE DEVICES WITH AND WITHOUT TELEPHONY FUNCTIONALITY AND VIA GLOBAL COMPUTER NETWORKS; PRODUCTION AND DISTRIBUTION OF ENTERTAINMENT AND SPORTS SHOWS AND RELATED NEWS AND INFORMATION PROGRAMS VIA GLOBAL COMMUNICATION NETWORKS; EDUCATIONAL SERVICES, NAMELY, PROVIDING INFORMATION ON THE SUBJECT OF SPORTS AND ENTERTAINMENT, NAMELY, ALL ASPECTS OF MIXED MARTIAL ARTS AND FIGHTERS, INCLUDING COMPETITIONS, EVENTS, FIGHTER RANKINGS, FIGHTER BACKGROUNDS, AND FIGHTING STRATEGIES; PROVIDING A WEBSITE ON GLOBAL COMPUTER NETWORKS FEATURING INFORMATION ON THE SUBJECT OF SPORTS AND ENTERTAINMENT (U.S. CLS. 100, 101 AND 107).

HEATHER BIDDULPH, EXAMINING ATTORNEY

SN 77-451,677. MEDITATION AS TONIC, LLC, WOOSTER, OH. FILED 4-18-2008.



THE MARK CONSISTS OF A SEATED PERSON WITH PALMS PRESSED TOGETHER; AN AURA EMANATES FROM THE CHEST AND ENCOMPASSES THE UPPER BODY.

FOR MEDITATION TRAINING; YOGA INSTRUCTION (U.S. CLS. 100, 101 AND 107).

FIRST USE 3-31-2008; IN COMMERCE 3-31-2008.

BRENDAN MCCAULEY, EXAMINING ATTORNEY

CLASS 41—(Continued).

SN 77-452,461. TICKETMASTER CORPORATION, WEST HOLLYWOOD, CA. FILED 4-18-2008.

by Ticketmaster
ticketexchange

OWNER OF U.S. REG. NOS. 1,746,016, 2,128,449 AND 2,643,508.

NO CLAIM IS MADE TO THE EXCLUSIVE RIGHT TO USE "TICKETEXCHANGE", APART FROM THE MARK AS SHOWN.

THE MARK CONSISTS OF A STYLIZED FORM OF THE TERM "TICKETEXCHANGE" ASSOCIATED WITH THE "BY TICKETMASTER" TRADEMARK.

FOR TICKET PURCHASING AGENCY SERVICES AND SELF SERVICE TICKET INFORMATION FOR VENUES, SPORTING EVENTS, MUSICAL CONCERTS AND OTHER ENTERTAINMENT EVENTS, RENDERED ONLINE AND IN PERSON (U.S. CLS. 100, 101 AND 107).
CIMMERIAN COLEMAN, EXAMINING ATTORNEY

SN 77-454,029. KINGSLEY INVESTMENT COMPANY, LLC, PALM BEACH, FL. FILED 4-21-2008.

POND

THE MARK CONSISTS OF STANDARD CHARACTERS WITHOUT CLAIM TO ANY PARTICULAR FONT, STYLE, SIZE, OR COLOR.

FOR CUSTOM WRITING SERVICES, NAMELY, PREPARING WRITTEN SPEECHES, PRESENTATIONS AND RELATED PRESENTATION HANDOUTS AND LITERATURE AND PRESENTATION DISPLAYS FOR USE BY OTHERS IN THE FIELD OF ORTHOPEDICS (U.S. CLS. 100, 101 AND 107).

DAVID YONTEF, EXAMINING ATTORNEY

SN 77-455,025. PLAYFIRST, INC., SAN FRANCISCO, CA. FILED 4-22-2008.

Dash

THE MARK CONSISTS OF STANDARD CHARACTERS WITHOUT CLAIM TO ANY PARTICULAR FONT, STYLE, SIZE, OR COLOR.

FOR ENTERTAINMENT SERVICES, NAMELY, PROVIDING ON-LINE COMPUTER GAMES; PROVIDING INFORMATION ON-LINE RELATING TO COMPUTER GAMES AND COMPUTER ENHANCEMENTS FOR GAMES (U.S. CLS. 100, 101 AND 107).

MATTHEW PAPPAS, EXAMINING ATTORNEY

CLASS 41—(Continued).

SN 77-456,041. MICHAEL CAMPANA, FORT COLLINS, CO. FILED 4-23-2008.

Iron Fire

THE MARK CONSISTS OF "IRON" AND "FIRE" WITH A FRAME.

FOR BOOK PUBLISHING (U.S. CLS. 100, 101 AND 107).
SONYA STEPHENS, EXAMINING ATTORNEY

SN 77-458,103. UNITED STATES YOUTH SOCCER ASSOCIATION, INC., FRISCO, TX. FILED 4-25-2008.

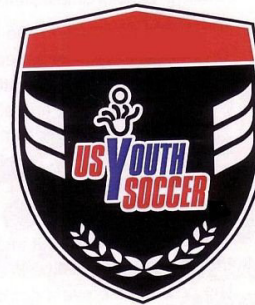

OWNER OF U.S. REG. NOS. 2,739,940, 3,200,986 AND OTHERS.

NO CLAIM IS MADE TO THE EXCLUSIVE RIGHT TO USE "YOUTH SOCCER", APART FROM THE MARK AS SHOWN.

THE COLOR(S) RED, WHITE, BLACK AND BLUE IS/ARE CLAIMED AS A FEATURE OF THE MARK.

THE MARK CONSISTS OF A SHIELD DESIGN WITH A BACKGROUND OF BLACK AND RED; THE WORDS "US" AND "SOCCER" IN RED; THE WORD "YOUTH" IN BLUE; THE COLOR WHITE IS A BORDER AROUND ALL WORDS; WHITE ALSO COMPOSES A LAUREL LEAF DESIGN AND 2 SETS OF STRIPES ON EITHER SIDE OF THE WORDING; A BLACK AND WHITE DESIGN ABOVE THE LETTER "Y" THAT IS OUTLINED IN WHITE.

SEC. 2(F) AS TO "US YOUTH SOCCER".

FOR ORGANIZING SOCCER LEAGUES, SOCCER EXHIBITIONS AND SOCCER GAMES (U.S. CLS. 100, 101 AND 107).

FIRST USE 9-0-2005; IN COMMERCE 9-0-2005.

LINDA LAVACHE, EXAMINING ATTORNEY

CLASS 41—(Continued).

SN 77-459,919. SECURING AMERICA'S FUTURE ENERGY ALLIANCE, INC., WASHINGTON, DC. AND SECURING AMERICA'S FUTURE ENERGY FOUNDATION, WASHINGTON, DC. FILED 4-28-2008.

SECURING AMERICA'S FUTURE
ENERGY

THE MARK CONSISTS OF STANDARD CHARACTERS WITHOUT CLAIM TO ANY PARTICULAR FONT, STYLE, SIZE, OR COLOR.

FOR EDUCATION SERVICES, NAMELY, PROVIDING CLASSES, SEMINARS, CONFERENCES, WORKSHOPS AND CONDUCTING PROGRAMS IN THE FIELDS OF FUEL AND ENERGY RESOURCES, POLICY, SECURITY, MANAGEMENT AND CONSERVATION, AND ALTERNATIVE FUEL SOURCES, ALTERNATIVE ENERGY SOURCES, AND ENVIRONMENTAL MATTERS CONCERNING FUEL AND ENERGY; EDUCATIONAL SERVICES, NAMELY, DEVELOPING, ARRANGING, AND CONDUCTING EDUCATIONAL CONFERENCES AND PROGRAMS AND PROVIDING COURSES OF INSTRUCTION IN THE FIELDS OF FUEL AND ENERGY RESOURCES, POLICY, SECURITY, MANAGEMENT AND CONSERVATION, AND ALTERNATIVE FUEL SOURCES, ALTERNATIVE ENERGY SOURCES, AND ENVIRONMENTAL MATTERS CONCERNING FUEL AND ENERGY; PROVIDING NEWSLETTERS IN THE FIELDS OF FUEL AND ENERGY RESOURCES, POLICY, SECURITY, MANAGEMENT AND CONSERVATION, AND ALTERNATIVE FUEL SOURCES, ALTERNATIVE ENERGY SOURCES, AND ENVIRONMENTAL MATTERS CONCERNING FUEL AND ENERGY VIA E-MAIL; ORGANIZATION OF LIVE EDUCATIONAL GAMES IN THE FIELDS OF FUEL AND ENERGY RESOURCES, POLICY, SECURITY, MANAGEMENT AND CONSERVATION, AND ALTERNATIVE FUEL SOURCES, ALTERNATIVE ENERGY SOURCES, AND ENVIRONMENTAL MATTERS CONCERNING FUEL AND ENERGY (U.S. CLS. 100, 101 AND 107).

CHERYL CLAYTON, EXAMINING ATTORNEY

SN 77-460,547. TRIPP, SUSAN, LA MIRADA, CA. FILED 4-29-2008.

POSITIVE PET PARENTING
SAVES LIVES

THE MARK CONSISTS OF STANDARD CHARACTERS WITHOUT CLAIM TO ANY PARTICULAR FONT, STYLE, SIZE, OR COLOR.

OWNER OF U.S. REG. NO. 3,433,607.
FOR EDUCATION SERVICES, NAMELY, PROVIDING CLASSES, SEMINARS, AND WORKSHOPS IN THE FIELD OF PET PARENTS WHO ADOPT PETS FROM SHELTERS OR RESCUE GROUPS FROM PARTICIPATING SHELTERS (U.S. CLS. 100, 101 AND 107).
FIRST USE 4-1-2006; IN COMMERCE 8-1-2007.
DOMINICK J. SALEMI, EXAMINING ATTORNEY

CLASS 41—(Continued).

SN 77-462,256. UNTAMED SPIRIT, CEDAR GLEN, CA. FILED 4-30-2008.

THE ART OF THE JUMP RING

THE MARK CONSISTS OF STANDARD CHARACTERS WITHOUT CLAIM TO ANY PARTICULAR FONT, STYLE, SIZE, OR COLOR.

FOR EDUCATION SERVICES, NAMELY, PROVIDING LIVE JEWELRY MAKING CLASSES AND ON-LINE CLASSES, SEMINARS, INSTRUCTION AND TUTORIALS IN THE FIELD OF JEWELRY MAKING, AND DISTRIBUTING COURSE MATERIALS IN CONNECTION THEREWITH (U.S. CLS. 100, 101 AND 107).
MARK RADEMACHER, EXAMINING ATTORNEY

SN 77-462,263. UNTAMED SPIRIT, CEDAR GLEN, CA. FILED 4-30-2008.

WIRED WOMEN IN THE WOODS

THE MARK CONSISTS OF STANDARD CHARACTERS WITHOUT CLAIM TO ANY PARTICULAR FONT, STYLE, SIZE, OR COLOR.

FOR EDUCATIONAL SERVICES, NAMELY, PROVIDING LIVE JEWELRY MAKING CLASSES, RETREATS, SEMINARS, AND INSTRUCTION IN THE FIELD OF JEWELRY MAKING, AND DISTRIBUTING COURSE MATERIALS IN CONNECTION THEREWITH (U.S. CLS. 100, 101 AND 107).
MARK RADEMACHER, EXAMINING ATTORNEY

CLASS 41—(Continued).

SN 77-465,357. NEW YORK YACHT CLUB, NEW YORK, NY.
FILED 5-5-2008.



NO CLAIM IS MADE TO THE EXCLUSIVE RIGHT TO USE "YACHT CLUB", APART FROM THE MARK AS SHOWN.

THE COLOR(S) RED, WHITE, BLUE AND GOLD IS/ARE CLAIMED AS A FEATURE OF THE MARK.

THE MARK CONSISTS OF A BLUE FLAG WITH RED CROSSED LINES AND A WHITE STAR WITHIN A GOLD CIRCLE CONTAINING THE WORDS "NEW YORK YACHT CLUB 1844".

SEC. 2(F).
FOR YACHT CLUB SERVICES (U.S. CLS. 100, 101 AND 107).

FIRST USE 7-31-1844; IN COMMERCE 7-31-1844.
CHARLES L. JENKINS, EXAMINING ATTORNEY

CLASS 41—(Continued).

SN 77-475,291. MILLER, PERCY, SANTA MONICA, CA.
FILED 5-15-2008.

PRM ENTERTAINMENT

THE MARK CONSISTS OF STANDARD CHARACTERS WITHOUT CLAIM TO ANY PARTICULAR FONT, STYLE, SIZE, OR COLOR.

NO CLAIM IS MADE TO THE EXCLUSIVE RIGHT TO USE "ENTERTAINMENT", APART FROM THE MARK AS SHOWN.

FOR ENTERTAINMENT IN THE NATURE OF LIVE PERFORMANCES BY MUSICAL GROUP; ENTERTAINMENT SERVICES, NAMELY, LIVE, TELEVISED AND MOVIE APPEARANCES BY A PROFESSIONAL ENTERTAINER; ENTERTAINMENT SERVICES, NAMELY, AN ON-GOING SERIES FEATURING COMEDIC, DRAMATIC, AND MUSICAL ENTERTAINMENT PROVIDED THROUGH TELEVISION, CINEMATIC, AND INTERNET-BASED MEDIA (U.S. CLS. 100, 101 AND 107).

ALICE BENMAMAN, EXAMINING ATTORNEY

SN 77-466,307. THINK COMPUTER CORPORATION, PALO ALTO, CA. FILED 5-5-2008.

INTERBOOK

THE MARK CONSISTS OF STANDARD CHARACTERS WITHOUT CLAIM TO ANY PARTICULAR FONT, STYLE, SIZE, OR COLOR.

FOR BOOK PUBLISHING; PUBLICATION OF BOOKS IN CONJUNCTION WITH RELATED WEB SITES RESPECTIVELY PROVIDING BIBLIOGRAPHIC AND SUPPLEMENTAL CONTEXTUAL INFORMATION ON THE BASIS OF EACH PAGE, LINE, PHRASE OR WORD (U.S. CLS. 100, 101 AND 107).

FIRST USE 4-26-2008; IN COMMERCE 4-26-2008.
AMY GEARIN, EXAMINING ATTORNEY

SN 77-475,297. MILLER, PERCY, SANTA MONICA, CA.
FILED 5-15-2008.

PRM ENT

THE MARK CONSISTS OF STANDARD CHARACTERS WITHOUT CLAIM TO ANY PARTICULAR FONT, STYLE, SIZE, OR COLOR.

NO CLAIM IS MADE TO THE EXCLUSIVE RIGHT TO USE "ENT", APART FROM THE MARK AS SHOWN.

FOR ENTERTAINMENT IN THE NATURE OF LIVE PERFORMANCES BY MUSICAL GROUP; ENTERTAINMENT SERVICES, NAMELY, LIVE, TELEVISED AND MOVIE APPEARANCES BY A PROFESSIONAL ENTERTAINER; ENTERTAINMENT SERVICES, NAMELY, AN ON-GOING SERIES FEATURING COMEDIC, DRAMATIC, AND MUSICAL ENTERTAINMENT PROVIDED THROUGH TELEVISION, CINEMATIC, AND INTERNET-BASED MEDIA (U.S. CLS. 100, 101 AND 107).

ALICE BENMAMAN, EXAMINING ATTORNEY

CLASS 41—(Continued).

SN 77-477,699. AMGEN INC., THOUSAND OAKS, CA. FILED 5-19-2008.



THE MARK CONSISTS OF A STYLIZED HUMAN FIGURE ON A BICYCLE.
FOR CONDUCTING AND SPONSORING BICYCLE RACES (U.S. CLS. 100, 101 AND 107).
FIRST USE 11-2-2005; IN COMMERCE 11-2-2005.
ASMAT KHAN, EXAMINING ATTORNEY

SN 77-480,450. THE NEW YORK TIMES COMPANY, NEW YORK, NY. FILED 5-21-2008.

Measure For Measure

THE MARK CONSISTS OF STANDARD CHARACTERS WITHOUT CLAIM TO ANY PARTICULAR FONT, STYLE, SIZE, OR COLOR.
FOR ON-LINE JOURNALS, NAMELY, BLOGS FEATURING INFORMATION IN THE FIELDS OF MUSIC AND SONGWRITING; PROVIDING ON-LINE PUBLICATIONS IN THE NATURE OF NEWSPAPER AND MAGAZINE COLUMNS IN THE FIELD OF MUSIC AND SONGWRITING (U.S. CLS. 100, 101 AND 107).
FIRST USE 3-26-2008; IN COMMERCE 3-26-2008.
SAMUEL E. SHARPER JR., EXAMINING ATTORNEY

SN 77-482,009. PINNACLE ENTERTAINMENT, INC., LAS VEGAS, NV. FILED 5-23-2008.

CASINO AT LONGWOOD PLANTATION

THE MARK CONSISTS OF STANDARD CHARACTERS WITHOUT CLAIM TO ANY PARTICULAR FONT, STYLE, SIZE, OR COLOR.
NO CLAIM IS MADE TO THE EXCLUSIVE RIGHT TO USE "CASINO", APART FROM THE MARK AS SHOWN.
FOR CASINOS; PROVIDING CASINO FACILITIES (U.S. CLS. 100, 101 AND 107).
SUZANNE BLANE, EXAMINING ATTORNEY

CLASS 41—(Continued).

SN 77-482,036. PINNACLE ENTERTAINMENT, INC., LAS VEGAS, NV. FILED 5-23-2008.

LONGWOOD PLANTATION CASINO

THE MARK CONSISTS OF STANDARD CHARACTERS WITHOUT CLAIM TO ANY PARTICULAR FONT, STYLE, SIZE, OR COLOR.
NO CLAIM IS MADE TO THE EXCLUSIVE RIGHT TO USE "CASINO", APART FROM THE MARK AS SHOWN.
FOR CASINOS; PROVIDING CASINO FACILITIES (U.S. CLS. 100, 101 AND 107).
SUZANNE BLANE, EXAMINING ATTORNEY

SN 77-482,042. PINNACLE ENTERTAINMENT, INC., LAS VEGAS, NV. FILED 5-23-2008.

LONGWOOD PLANTATION RESORT & CASINO

THE MARK CONSISTS OF STANDARD CHARACTERS WITHOUT CLAIM TO ANY PARTICULAR FONT, STYLE, SIZE, OR COLOR.
NO CLAIM IS MADE TO THE EXCLUSIVE RIGHT TO USE "RESORT AND CASINO", APART FROM THE MARK AS SHOWN.
FOR CASINOS; PROVIDING CASINO FACILITIES (U.S. CLS. 100, 101 AND 107).
SUZANNE BLANE, EXAMINING ATTORNEY

SN 77-488,481. FUSE NETWORKS LLC, NEW YORK, NY. FILED 6-2-2008.

FUSE'S EXCELLENT ADVENTURE

THE MARK CONSISTS OF STANDARD CHARACTERS WITHOUT CLAIM TO ANY PARTICULAR FONT, STYLE, SIZE, OR COLOR.
FOR ENTERTAINMENT SERVICES, NAMELY, AN ON-GOING CABLE TELEVISION PROGRAM IN THE FIELD OF MUSIC AND TRAVEL (U.S. CLS. 100, 101 AND 107).
ANNE MADDEN, EXAMINING ATTORNEY

CLASS 41—(Continued).

SN 77-501,685. MGM GRAND HOTEL, LLC, LAS VEGAS, NV. FILED 6-18-2008.

WET REPUBLIC

THE MARK CONSISTS OF STANDARD CHARACTERS WITHOUT CLAIM TO ANY PARTICULAR FONT, STYLE, SIZE, OR COLOR.

FOR AMUSEMENT ARCADES; AMUSEMENT PARKS; ANIMAL EXHIBITIONS; ARRANGING AND CONDUCTING ATHLETIC COMPETITIONS; ARRANGING FOR TICKET RESERVATIONS FOR SHOWS AND OTHER ENTERTAINMENT EVENTS; AUDIO RECORDING AND PRODUCTION; CASINOS; CONDUCTING AND PROVIDING FACILITIES FOR SPECIAL EVENTS FEATURING CASINO AND GAMING CONTESTS AND TOURNAMENTS; ENTERTAINMENT IN THE NATURE OF BOXING CONTESTS; ENTERTAINMENT IN THE NATURE OF THEATER PRODUCTIONS; ENTERTAINMENT IN THE NATURE OF VISUAL AND AUDIO PERFORMANCES, AND MUSICAL, VARIETY, NEWS AND COMEDY SHOWS; ENTERTAINMENT IN THE NATURE OF LIVE MUSIC CONCERTS; FIGURE SALONS; GOLF CLUB SERVICES; GYMNASIUMS; HEALTH CLUB SERVICES, NAMELY, PROVIDING INSTRUCTION AND EQUIPMENT IN THE FIELD OF PHYSICAL EXERCISE; MOVIE THEATERS; MUSEUMS; PROVIDING FACILITIES FOR RECREATION ACTIVITIES; SPECIAL EVENT PLANNING (U.S. CLS. 100, 101 AND 107).
JAMES LOVELACE, EXAMINING ATTORNEY

SN 77-975,606. SCHLUMBERGER TECHNOLOGY CORPORATION, HOUSTON, TX. FILED 9-28-2006.

OSPREY

THE MARK CONSISTS OF STANDARD CHARACTERS WITHOUT CLAIM TO ANY PARTICULAR FONT, STYLE, SIZE, OR COLOR.

FOR TRAINING SERVICES RELATING TO THE INTEGRATION OF SOFTWARE (U.S. CLS. 100, 101 AND 107).

FIRST USE 7-7-2004; IN COMMERCE 7-7-2004.
MARILYN IZZI, EXAMINING ATTORNEY

CLASS 41—(Continued).

SN 78-555,806. THE ART EXPLORERS, INC., CHICAGO, IL. FILED 1-28-2005.

THE ART EXPLORERS

THE MARK CONSISTS OF STANDARD CHARACTERS WITHOUT CLAIM TO ANY PARTICULAR FONT, STYLE, SIZE, OR COLOR.

NO CLAIM IS MADE TO THE EXCLUSIVE RIGHT TO USE "ART", APART FROM THE MARK AS SHOWN.

FOR EDUCATIONAL AND ENTERTAINMENT SERVICES, NAMELY, CREATING, DEVELOPING, PRODUCING AND DIRECTING EDUCATIONAL, ARTISTIC AND CULTURAL TRAVEL PROGRAMS FOR TELEVISION AND RADIO BROADCASTERS, FILM, VIDEO TAPE AND DIGITAL VIDEO DISK DISTRIBUTORS, AND FOR IN-DOOR AND OUT-DOOR PERFORMANCE PROMOTERS; EDUCATIONAL AND ENTERTAINMENT SERVICES, NAMELY, COORDINATING AND CONDUCTING EDUCATIONAL, ARTISTIC AND CULTURAL LECTURES, WORKSHOPS, AND SEMINARS FOR THE PUBLIC; EDUCATIONAL AND ENTERTAINMENT SERVICES, NAMELY, CREATING, DEVELOPING, AND WRITING ARTICLES, COMMENTARIES, AND NOTES FOR NEWSPAPER, MAGAZINE, PERIODICAL, AND BOOK PUBLISHERS (U.S. CLS. 100, 101 AND 107).

FIRST USE 8-1-2001; IN COMMERCE 1-1-2002.

PAUL E. FAHRENKOPF, EXAMINING ATTORNEY

SN 78-600,680. HOME WIZARDS, INC., LA CANADA-FLINTRIDGE, CA. FILED 4-2-2005.



NO CLAIM IS MADE TO THE EXCLUSIVE RIGHT TO USE "HOME", APART FROM THE MARK AS SHOWN.

THE COLOR(S) WHITE AND BLUE IS/ARE CLAIMED AS A FEATURE OF THE MARK.

THE MARK CONSISTS OF A STYLIZED HOUSE WITH THE ROOF ASKEW AND TOOLS FLYING OUT OF IT ALONG WITH THE PHRASE "HOME WIZARDS" AND A WIZARDS CAP. THERE IS ALSO A STYLIZED STAR IN THE "O" OF "HOME WIZARDS". THE COLOR WHITE APPEARS IN THE WORDING "HOME WIZARDS" AND IN THE ENTIRE DESIGN INCLUDING THE HOUSE, TOOLS, STARS AND THE WORDING "HOME IMPROVEMENT RADIO SHOW". THE COLOR BLUE APPEARS ELSEWHERE IN THE MARK INCLUDING THE BACKGROUND.

FOR ENTERTAINMENT IN THE NATURE OF ONGOING TELEVISION PROGRAMS IN THE FIELD OF HOME IMPROVEMENT AND DECORATING AND RADIO PROGRAMS FEATURING PERFORMANCES BY A RADIO PERSONALITY IN THE FIELD OF HOME IMPROVEMENT AND DECORATING (U.S. CLS. 100, 101 AND 107).

WARREN L. OLANDRIA, EXAMINING ATTORNEY

CLASS 41—(Continued).

SN 78-897,688. BAUMAN RARE BOOKS, INC., PHILADELPHIA, PA. FILED 5-31-2006.

RARE FINDS

THE MARK CONSISTS OF STANDARD CHARACTERS WITHOUT CLAIM TO ANY PARTICULAR FONT, STYLE, SIZE, OR COLOR.

FOR PROVIDING INFORMATION TO CUSTOMERS CONCERNING THE COLLECTION OF RARE BOOKS; PROVIDING INFORMATION TO CUSTOMERS ABOUT BOOK COLLECTING; PROVIDING REVIEWS TO CUSTOMERS ABOUT BOOKS AND ABOUT RARE AND COLLECTIBLE BOOKS; PROVIDING INFORMATION TO CUSTOMERS IN THE NATURE OF ONLINE JOURNALS, NAMELY, BLOGS, FEATURING RARE AND COLLECTIBLE BOOKS; PROVIDING INFORMATION TO CUSTOMERS VIA EMAIL IN THE FORM OF NEWSLETTERS CONTAINING EXPERT WRITINGS IN THE FIELD OF BOOKS, BOOK COLLECTING, AND RARE AND COLLECTIBLE BOOKS (U.S. CLS. 100, 101 AND 107).

FIRST USE 8-0-2005; IN COMMERCE 8-0-2005.
MICHELLE DUBOIS, EXAMINING ATTORNEY

CLASS 41—(Continued).

SN 78-959,509. NCNABB, WILMA, CHICAGO, IL. FILED 8-24-2006.

MAMA MCNABB

THE MARK CONSISTS OF STANDARD CHARACTERS WITHOUT CLAIM TO ANY PARTICULAR FONT, STYLE, SIZE, OR COLOR.

FOR PROVIDING INFORMATION REGARDING SPORTS VIA THE INTERNET; ENTERTAINMENT SERVICES, NAMELY, PERSONAL APPEARANCES BY A SPORTS AND PARENTING EXPERT; CONDUCTING SEMINARS, LECTURES AND WORKSHOPS IN THE FIELD OF SPORTS, CHILDREN, PARENTING, HEALTH AND NUTRITION (U.S. CLS. 100, 101 AND 107).

MATTHEW EINSTEIN, EXAMINING ATTORNEY

SN 78-924,179. BURSACK, ADAM JEREMY, FARGO, ND. FILED 7-7-2006.

VENUS IN FURS

THE MARK CONSISTS OF STANDARD CHARACTERS WITHOUT CLAIM TO ANY PARTICULAR FONT, STYLE, SIZE, OR COLOR.

FOR ENTERTAINMENT IN THE NATURE OF VISUAL AND AUDIO PERFORMANCES BY A MUSICAL GROUP, ENTERTAINMENT IN THE NATURE OF LIVE PERFORMANCES BY A MUSICAL GROUP (U.S. CLS. 100, 101 AND 107).

FIRST USE 0-0-1997; IN COMMERCE 5-7-1999.
KELLY BOULTON, EXAMINING ATTORNEY

SN 79-044,440. E-WISE B.V., AJ UTRECHT, NETHERLANDS, FILED 8-28-2007.



OWNER OF INTERNATIONAL REGISTRATION 0938992 DATED 8-28-2007, EXPIRES 8-28-2017.

FOR EDUCATION SERVICES, NAMELY, PROVIDING CLASSES, SEMINARS, AND WORKSHOPS IN THE FIELD OF MEDICINE; PROVIDING OF TRAINING AND COURSES IN THE MEDICAL FIELD; ONLINE ELECTRONIC PUBLISHING OF BOOKS AND PERIODICALS IN THE FIELD OF MEDICINE (U.S. CLS. 100, 101 AND 107).

DAVID HOFFMAN, EXAMINING ATTORNEY

CLASS 41—(Continued).

SN 79-046,334. INCHEON EXPO FOUNDATION, REPUBLIC OF KOREA, FILED 8-22-2007.

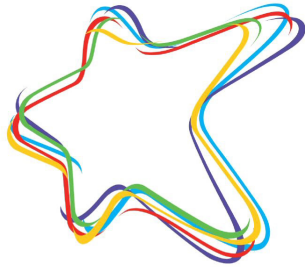

**World City Expo 2009
Incheon, Korea**

PRIORITY DATE OF 8-20-2007 IS CLAIMED.
OWNER OF INTERNATIONAL REGISTRATION 0943736
DATED 8-22-2007, EXPIRES 8-22-2017.

NO CLAIM IS MADE TO THE EXCLUSIVE RIGHT TO USE "WORLD CITY EXPO 2009 INCHEON, KOREA", APART FROM THE MARK AS SHOWN.

"THE COLOR(S) BLACK, WHITE, RED, YELLOW, GREEN, BLUE AND PURPLE IS/ARE CLAIMED AS A FEATURE OF THE MARK."

THE COLOR BLACK APPEARS IN THE WORDING "WORLD CITY EXPO 2009 INCHEON, KOREA"; THE COLOR WHITE APPEARS ON THE MARK BACKGROUND; THE COLORS RED, YELLOW, GREEN, BLUE AND PURPLE APPEAR ON THE STAR DESIGN ELEMENT.

FOR ORGANIZATION OF EXHIBITIONS FOR CULTURAL OR EDUCATIONAL PURPOSES; ARRANGING AND CONDUCTING OF COLLOQUIUMS IN THE FIELD OF URBAN PLANNING AND DEVELOPMENT, CITY PLANNING, REAL ESTATE PLANNING AND DEVELOPMENT; ARRANGING AND CONDUCTING OF EDUCATIONAL CONFERENCES; ARRANGING AND CONDUCTING OF EDUCATIONAL CONGRESSES; ARRANGING AND CONDUCTING OF SYMPOSIA IN THE FIELD OF URBAN PLANNING AND DEVELOPMENT, CITY PLANNING, REAL ESTATE PLANNING AND DEVELOPMENT; ARRANGING AND CONDUCTING OF WORKSHOPS IN THE FIELD OF URBAN PLANNING AND DEVELOPMENT, CITY PLANNING, REAL ESTATE PLANNING AND DEVELOPMENT; ORGANIZATION OF EXHIBITIONS FOR CULTURAL PURPOSES; ORGANIZATION OF EXHIBITIONS FOR EDUCATIONAL PURPOSES; PRODUCTION OF TELEVISION AND RADIO SHOWS (U.S. CLS. 100, 101 AND 107).

KAELIE KUNG, EXAMINING ATTORNEY

CLASS 42—SCIENTIFIC AND COMPUTER SERVICES

SN 76-664,116. OCEAN POWER TECHNOLOGIES, INC., PENNINGTON, NJ. FILED 8-4-2006.

MAKING WAVES IN POWER

THE MARK CONSISTS OF STANDARD CHARACTERS WITHOUT CLAIM TO ANY PARTICULAR FONT, STYLE, SIZE, OR COLOR.

FOR DESIGN AND DEVELOPMENT OF SYSTEMS FOR GENERATING ELECTRICAL POWER FROM WAVE ENERGY (U.S. CLS. 100 AND 101).

FIRST USE 1-25-2005; IN COMMERCE 3-15-2005.

ARETHA SOMERVILLE, EXAMINING ATTORNEY

SN 77-074,858. LOGICWEB INC, BAY SHORE, NY. FILED 1-3-2007.

LogicWeb

THE MARK CONSISTS OF STANDARD CHARACTERS WITHOUT CLAIM TO ANY PARTICULAR FONT, STYLE, SIZE, OR COLOR.

FOR COMPUTER SERVICES, NAMELY, HOSTING AND MAINTENANCE OF INTERNET SITES FOR THIRD PARTIES; HOSTING OF DIGITAL CONTENT ON THE INTERNET; HOSTING THE WEB SITES OF OTHERS ON A COMPUTER SERVER FOR A GLOBAL COMPUTER NETWORK; WEB SITE HOSTING SERVICES (U.S. CLS. 100 AND 101).

B. PARADEWELAI, EXAMINING ATTORNEY

SN 77-095,471. EXACTCOST, INC., HALLANDALE BEACH, FL. FILED 1-31-2007.



OWNER OF U.S. REG. NOS. 2,693,382, 2,722,880 AND OTHERS.

NO CLAIM IS MADE TO THE EXCLUSIVE RIGHT TO USE "HEALTHCARE PERFORMANCE TECHNOLOGIES", APART FROM THE MARK AS SHOWN.

THE COLOR(S) BLACK AND BLUE IS/ARE CLAIMED AS A FEATURE OF THE MARK.

THE MARK CONSISTS OF THE WORDS "EXACTCOST" AND "HEALTHCARE PERFORMANCE TECHNOLOGIES", IN BLACK, EXCEPT FOR THE "COST" WHICH IS IN BLUE, WITH A BLUE CIRCLE AND A BLUE ARROW POINTING UPWARD AND TO THE RIGHT INTERSECTING THE CIRCLE, THE ARROW FORMED BY DOTS.

SEC. 2(F) AS TO "EXACTCOST".

FOR APPLICATION SERVICE PROVIDER FEATURING SOFTWARE APPLICATIONS FOR DATA MANAGEMENT, ACTIVITY-BASED COST AND PERFORMANCE MANAGEMENT FOR USE IN THE HEALTHCARE FIELD, AND PROVIDING RELATED CONSULTING SERVICES (U.S. CLS. 100 AND 101).

FIRST USE 1-31-2007; IN COMMERCE 1-31-2007.

ELLEN PERKINS, EXAMINING ATTORNEY

CLASS 42—(Continued).

SN 77-095,479. EXACTCOST, INC., HALLANDALE BEACH, FL. FILED 1-31-2007.



OWNER OF U.S. REG. NOS. 2,693,382, 2,722,880 AND OTHERS.

THE COLOR(S) BLACK AND BLUE IS/ARE CLAIMED AS A FEATURE OF THE MARK.

THE MARK CONSISTS OF THE WORDS "EXACTCOST" IN BLACK, EXCEPT FOR THE "COST" WHICH IS IN BLUE, WITH A BLUE CIRCLE AND A BLUE ARROW POINTING UPWARD AND TO THE RIGHT INTERSECTING THE CIRCLE, THE ARROW FORMED BY DOTS.

SEC. 2(F).

FOR APPLICATION SERVICE PROVIDER FEATURING SOFTWARE APPLICATIONS FOR DATA MANAGEMENT, ACTIVITY-BASED COST AND PERFORMANCE MANAGEMENT FOR USE IN THE HEALTHCARE FIELD, AND PROVIDING RELATED CONSULTING SERVICES (U.S. CLS. 100 AND 101).

ELLEN PERKINS, EXAMINING ATTORNEY

SN 77-104,355. SURVEILLANCE DATA INC., PLYMOUTH MEETING, PA. FILED 2-10-2007.

VACCINETRACK

THE MARK CONSISTS OF STANDARD CHARACTERS WITHOUT CLAIM TO ANY PARTICULAR FONT, STYLE, SIZE, OR COLOR.

FOR PROVIDING AN ONLINE DATABASE IN THE FIELD OF RESEARCH INFORMATION ABOUT VACCINE USAGE AND AVAILABILITY (U.S. CLS. 100 AND 101).

MARK T. MULLEN, EXAMINING ATTORNEY

SN 77-112,982. BLITS, MANNY, NEWPORT BEACH, CA. FILED 2-21-2007.

AX-Solutions

THE MARK CONSISTS OF STANDARD CHARACTERS WITHOUT CLAIM TO ANY PARTICULAR FONT, STYLE, SIZE, OR COLOR.

FOR CONSULTING SERVICES IN THE FIELD OF DESIGN, SELECTION, IMPLEMENTATION AND USE OF COMPUTER HARDWARE AND SOFTWARE SYSTEMS FOR OTHERS (U.S. CLS. 100 AND 101).

FIRST USE 7-21-2006; IN COMMERCE 7-21-2006.

KEVON CHISOLM, EXAMINING ATTORNEY

CLASS 42—(Continued).

SN 77-117,698. SILVERSTONE, LEON, LAS VEGAS, NV. FILED 2-27-2007.

NEURAMED

THE MARK CONSISTS OF STANDARD CHARACTERS WITHOUT CLAIM TO ANY PARTICULAR FONT, STYLE, SIZE, OR COLOR.

FOR PRODUCT RESEARCH AND DEVELOPMENT (U.S. CLS. 100 AND 101).

PAUL F. GAST, EXAMINING ATTORNEY

SN 77-129,363. NEOCRAFT LTD., RAMAT-GAN, ISRAEL, FILED 3-13-2007.

STRUCTIVE

THE MARK CONSISTS OF STANDARD CHARACTERS WITHOUT CLAIM TO ANY PARTICULAR FONT, STYLE, SIZE, OR COLOR.

PRIORITY CLAIMED UNDER SEC. 44(D) ON ISRAEL APPLICATION NO. 193830, FILED 9-18-2006, REG. NO. 193830, DATED 3-9-2008, EXPIRES 3-9-2018.

FOR THE DEVELOPMENT OF COMPUTER SOFTWARE, NAMELY, THE DEVELOPMENT OF SOFTWARE FOR THE ANALYSIS, PROCESSING AND PRODUCTION OF AUDIO SOUNDS IN GENERAL, AND THE DEVELOPMENT OF SOFTWARE FOR THE ANALYSIS, PROCESSING AND PRODUCTION OF MUSIC SOUNDS IN PARTICULAR (U.S. CLS. 100 AND 101).

ZACHARY BELLO, EXAMINING ATTORNEY

CLASS 42—(Continued).

SN 77-158,261. NINTENDO CO., LTD., KYOTO-SHI, KYOTO, JAPAN, FILED 4-17-2007.

BROWNIE BROWN

THE MARK CONSISTS OF STANDARD CHARACTERS WITHOUT CLAIM TO ANY PARTICULAR FONT, STYLE, SIZE, OR COLOR.

PRIORITY CLAIMED UNDER SEC. 44(D) ON JAPAN APPLICATION NO. 2007-014420, FILED 2-21-2007, REG. NO. 5103575, DATED 1-11-2008, EXPIRES 1-11-2018.

FOR COMPUTER SOFTWARE DESIGN, COMPUTER PROGRAMMING, OR MAINTENANCE OF COMPUTER SOFTWARE; DESIGNING OF MACHINES, APPARATUS, INSTRUMENTS INCLUDING THEIR PARTS OR SYSTEMS COMPOSED OF SUCH MACHINES, APPARATUS AND INSTRUMENTS; DESIGNING, NAMELY, DESIGNING COMPUTER SOFTWARE FOR CONTROLLING SELF-SERVICE TERMINALS, DESIGNING OF PACKAGING AND WRAPPING MATERIALS, DESIGNING WEB SITES FOR ADVERTISING PURPOSES; PROVIDING COMPUTER PROGRAMS, NAMELY, PROVIDING TEMPORARY USE OF ON-LINE, NON-DOWNLOADABLE SOFTWARE FOR USE IN DATABASE MANAGEMENT, FOR INVENTORY CONTROL, FOR PRODUCT WARRANTY PROCESSING; TECHNOLOGICAL ADVICE RELATING TO PERFORMANCE, OPERATION OF COMPUTERS AND AUTOMOBILES, THAT REQUIRE HIGH LEVELS OF PERSONAL KNOWLEDGE, SKILL OR EXPERIENCE OF THE OPERATORS TO MEET THE REQUIRED ACCURACY IN OPERATING THEM; TESTING OR RESEARCH ON MACHINES, APPARATUS AND INSTRUMENTS; RENTAL OF ELECTRONIC COMPUTER AND VIDEO GAMES (U.S. CLS. 100 AND 101).

JILL C. ALT, EXAMINING ATTORNEY

SN 77-180,707. BEWICKE, CAL, SAN ANSELMO, CA. FILED 5-14-2007.

From Field To Pharmacy

THE MARK CONSISTS OF STANDARD CHARACTERS WITHOUT CLAIM TO ANY PARTICULAR FONT, STYLE, SIZE, OR COLOR.

FOR QUALITY CONTROL FOR OTHERS IN THE FIELD OF NATURAL PRODUCTS (U.S. CLS. 100 AND 101).

ELLEN BURNS, EXAMINING ATTORNEY

CLASS 42—(Continued).

SN 77-201,568. MULTIVIEW, INC., IRVING, TX. FILED 6-8-2007.



MULTIVIEW

THE COLOR(S) GREEN, VIOLET, YELLOW, BLUE, BLACK AND RED IS/ARE CLAIMED AS A FEATURE OF THE MARK.

THE MARK CONSISTS OF A RECTANGLE HAVING A GREEN, VIOLET, YELLOW AND BLUE INTERIOR RECTANGLE, EACH INTERIOR RECTANGLE COMPRISING AN ILLUSTRATION OF A BLACK COLORED EYE, THE RECTANGLE DISPOSED ADJACENT TO THE WORD "MULTIVIEW", THE "MULTI" DESIGNATION IN BLACK AND THE "VIEW" DESIGNATION IN RED.

FOR COMPUTER SERVICES, NAMELY, PROVIDING SOFTWARE INTERFACES AVAILABLE OVER A NETWORK IN ORDER TO CREATE PERSONALIZED ON-LINE INFORMATION SERVICES; EXTRACTION AND RETRIEVAL OF INFORMATION AND DATA MINING BY MEANS OF GLOBAL COMPUTER NETWORKS; CREATING INDEXES OF INFORMATION, INDEXES OF WEB SITES AND INDEXES OF OTHER INFORMATION SOURCES IN CONNECTION WITH GLOBAL COMPUTER NETWORK; PROVIDING INFORMATION FROM SEARCHABLE INDEXES AND DATABASES OF INFORMATION, NAMELY, TEXT, ELECTRONIC DOCUMENTS, DATABASES, GRAPHIC AND AUDIO VISUAL INFORMATION, BY MEANS OF GLOBAL COMPUTER INFORMATION NETWORKS; PROVIDING A WEB SITE THAT FEATURES INFORMATION GATHERED FROM THE SEARCHABLE INDEXES AND DATABASES (U.S. CLS. 100 AND 101).

FIRST USE 11-24-2000; IN COMMERCE 11-24-2000.
NAPOLEON SHARMA, EXAMINING ATTORNEY

SN 77-217,632. BELLAMY JR, LONNIE J, TRIANGLE, VA. FILED 6-28-2007.



NO CLAIM IS MADE TO THE EXCLUSIVE RIGHT TO USE "TIME SYSTEMS LLC", APART FROM THE MARK AS SHOWN.

THE COLOR(S) GREEN, GRAY AND BLACK IS/ARE CLAIMED AS A FEATURE OF THE MARK.

THE MARK CONSISTS OF THREE GREEN RIGHT SLANT COLUMNS BEHIND THREE GRAY CAPITAL LETTERS - "T", "M" AND "E"; ONE GRAY RIGHT SLANT COLUMN BEHIND A GREEN CAPITAL LETTER - "I"; ONE BLACK LINE ABOVE THE ALL CAPITALIZED AND CENTERED GRAY LETTERS - "SYSTEMS"; AND GRAY LETTERS - "LLC" TO THE IMMEDIATE RIGHT. IN ADDITION, THE COLOR GRAY IS USED TO SHADOW THE BACKGROUND OF THE FOUR RIGHT SLANT COLUMNS AND THE WORDING "SYSTEMS".

FOR INFORMATION TECHNOLOGY CONSULTATION; TECHNOLOGICAL CONSULTATION IN THE TECHNOLOGY FIELD OF KNOWLEDGE MANAGEMENT (U.S. CLS. 100 AND 101).

BRIAN CALLAGHAN, EXAMINING ATTORNEY

CLASS 42—(Continued).

SN 77-227,689. ZURICH INSURANCE COMPANY, ZURICH, SWITZERLAND, FILED 7-12-2007.

ZURICH NANOTECHNOLOGY
EXPOSURE PROTOCOL

THE MARK CONSISTS OF STANDARD CHARACTERS WITHOUT CLAIM TO ANY PARTICULAR FONT, STYLE, SIZE, OR COLOR.

OWNER OF U.S. REG. NOS. 1,941,954 AND 2,628,466. NO CLAIM IS MADE TO THE EXCLUSIVE RIGHT TO USE "NANOTECHNOLOGY EXPOSURE PROTOCOL", APART FROM THE MARK AS SHOWN.

SEC. 2(F) AS TO "ZURICH". FOR PROVIDING TEMPORARY USE OF ON-LINE NON-DOWNLOADABLE SOFTWARE THAT QUANTIFIES THE POTENTIAL TOXICITY OF NANOPARTICLES FOR USE IN THE INSURANCE UNDERWRITING AND RISK MANAGEMENT FIELD (U.S. CLS. 100 AND 101). JANICE KIM, EXAMINING ATTORNEY

CLASS 42—(Continued).

SN 77-238,039. REMITPRO, INC., OMAHA, NE. FILED 7-25-2007.

ICLExchange+

THE MARK CONSISTS OF STANDARD CHARACTERS WITHOUT CLAIM TO ANY PARTICULAR FONT, STYLE, SIZE, OR COLOR.

FOR PROVIDING ONLINE NON-DOWNLOADABLE SOFTWARE FOR NORMALIZING STANDARD-VARIANT X 9 37 FILES AMONG CORPORATIONS AND FINAL ORGANIZATIONS (U.S. CLS. 100 AND 101). ELLEN B. AWRICH, EXAMINING ATTORNEY

SN 77-253,129. HYDROGEOPHYSICS INC, ALBANY, CA. FILED 8-12-2007.

SN 77-235,093. THE GENERATIONS NETWORK, INC., PROVO, UT. FILED 7-20-2007.



OWNER OF U.S. REG. NO. 2,521,336. NO CLAIM IS MADE TO THE EXCLUSIVE RIGHT TO USE "GENEALOGY.COM", APART FROM THE MARK AS SHOWN.

THE MARK CONSISTS OF A STYLIZED CURLING LEAF ON AN ANGLE ABOVE THE LETTERS "ALOGY" IN THE WORD "GENEALOGY.COM" WITH THE STEM OF THE LEAF POINTING DOWN TO THE DOT IN "GENEALOGY.COM", AND THE CURLING POINT OF THE LEAF POINTING DOWN TO THE LETTER "L", AND THE WORD "GENEALOGY.COM" IN A LOWER-CASE STYLIZED FONT.

FOR PROVIDING GENEALOGICAL AND FAMILY HISTORY INFORMATION SERVICES, NAMELY, RETRIEVING, RECORDING AND REVIEWING ANCESTRAL DATA VIA THE GLOBAL COMPUTER NETWORK (U.S. CLS. 100 AND 101). FIRST USE 1-7-2007; IN COMMERCE 1-7-2007. RAMONA ORTIGA, EXAMINING ATTORNEY



THE COLOR(S) BLACK, BLUE, GREEN AND WHITE IS/ ARE CLAIMED AS A FEATURE OF THE MARK.

THE MARK CONSISTS OF A DESIGN WHERE THE TERM "H2O" IS BLUE; THE TERM "2U" IS GREEN; THE OUTSIDE BORDER IS BLACK; THE INTERIOR BACKGROUND IS WHITE.

FOR PROVIDING NON-DOWNLOADABLE WEB BASED COMPUTER SOFTWARE PLATFORM FOR PROVIDING INFORMATION MANAGEMENT, NAMELY, DATA ACQUISITION, REPORTING, SHARING AND ANALYSIS IN ENVIRONMENTAL ENGINEERING, CIVIL ENGINEERING AND RELATED AREAS, NAMELY, GEOSPATIAL DATA MONITORING, ENVIRONMENTAL DATA MONITORING, ECOLOGICAL DATA MONITORING, WASTE WATER TREATMENT, ENVIRONMENTAL RISK MONITORING AND ALERTS, WATER RESOURCES MANAGEMENT, SEWER OVERFLOW, AND SUSTAINABILITY MONITORING AND ANALYSIS (U.S. CLS. 100 AND 101). JEAN IM, EXAMINING ATTORNEY

CLASS 42—(Continued).

SN 77-253,131. HYDROGEOPHYSICS INC., ALBANY, CA. FILED 8-12-2007.



THE COLOR(S) BLACK, TEAL, BLUE, GREEN AND WHITE IS/ARE CLAIMED AS A FEATURE OF THE MARK. THE TERM "H2O" IS BLUE; THE TERM "WEB" IS GREEN; THE OUTSIDE BORDER IS TEAL WITH WHITE HIGHLIGHTING AND BLACK OUTLINING; THE INTERIOR BACKGROUND IS WHITE.

FOR PROVIDING NON-DOWNLOADABLE WEB BASED COMPUTER SOFTWARE PLATFORM FOR PROVIDING INFORMATION MANAGEMENT, NAMELY, DATA ACQUISITION, REPORTING, SHARING AND ANALYSIS IN ENVIRONMENTAL ENGINEERING, CIVIL ENGINEERING AND RELATED AREAS, NAMELY, GEOSPATIAL DATA MONITORING, ENVIRONMENTAL DATA MONITORING, ECOLOGICAL DATA MONITORING, WASTE WATER TREATMENT, ENVIRONMENTAL RISK MONITORING AND ALERTS, WATER RESOURCES MANAGEMENT, SEWER OVERFLOW, AND SUSTAINABILITY MONITORING AND ANALYSIS (U.S. CLS. 100 AND 101).

JEAN IM, EXAMINING ATTORNEY

SN 77-262,251. MULTI REGIONAL MULTIPLE LISTING SERVICE, INC., DBA MRMLS, POMONA, CA. FILED 8-22-2007.

SMART TRAC

THE MARK CONSISTS OF STANDARD CHARACTERS WITHOUT CLAIM TO ANY PARTICULAR FONT, STYLE, SIZE, OR COLOR.

NO CLAIM IS MADE TO THE EXCLUSIVE RIGHT TO USE "TRACK", APART FROM THE MARK AS SHOWN.

FOR PROVIDING TEMPORARY USE OF ONLINE NON-DOWNLOADABLE SOFTWARE FOR INTEGRATED TRACKING AND MANAGEMENT OF COMMERCIAL TRANSACTIONS ON A GLOBAL COMPUTER NETWORK (U.S. CLS. 100 AND 101).

FIRST USE 2-21-2006; IN COMMERCE 2-21-2006.

KATHERINE CONNOLLY, EXAMINING ATTORNEY

CLASS 42—(Continued).

SN 77-264,676. EMPLOYEESUGGESTIONBOX.COM, LLC, TAMPA, FL. FILED 8-27-2007.

EMPLOYEESUGGESTIONBOX

THE MARK CONSISTS OF STANDARD CHARACTERS WITHOUT CLAIM TO ANY PARTICULAR FONT, STYLE, SIZE, OR COLOR.

FOR APPLICATION SERVICE PROVIDER(ASP) FEATURING SOFTWARE FOR USE IN COLLECTING, STORING AND ANALYZING RECOMMENDATIONS MADE BY EMPLOYEES (U.S. CLS. 100 AND 101).

FIRST USE 3-1-2007; IN COMMERCE 3-1-2007.

TOBY BULLOFF, EXAMINING ATTORNEY

SN 77-266,113. CANADIAN MILL SERVICES ASSOCIATION, NEW WESTMINSTER, CANADA, FILED 8-28-2007.

CMSA

THE MARK CONSISTS OF STANDARD CHARACTERS WITHOUT CLAIM TO ANY PARTICULAR FONT, STYLE, SIZE, OR COLOR.

FOR GRADING OF LUMBER (U.S. CLS. 100 AND 101).

FIRST USE 5-16-2004; IN COMMERCE 5-16-2004.

CHERYL CLAYTON, EXAMINING ATTORNEY

SN 77-268,996. ROEPER, DANIEL L., GARDEN CITY, NY. FILED 8-31-2007.

Meet the Boneheads

THE MARK CONSISTS OF STANDARD CHARACTERS WITHOUT CLAIM TO ANY PARTICULAR FONT, STYLE, SIZE, OR COLOR.

FOR PROVIDING A WEBSITE FEATURING INFORMATION ON ENVIRONMENTAL ISSUES CONCERNING GLOBAL WARMING AND ITS EFFECT ON NATURE AND THE ENVIRONMENT (U.S. CLS. 100 AND 101).

FIRST USE 1-16-2006; IN COMMERCE 3-3-2006.

ATTIYA MALIK, EXAMINING ATTORNEY

CLASS 42—(Continued).

SN 77-269,005. DANIEL L. ROEPER, GARDEN CITY, NY. FILED 8-31-2007.

HOPE Help Our Planet Earth

THE MARK CONSISTS OF STANDARD CHARACTERS WITHOUT CLAIM TO ANY PARTICULAR FONT, STYLE, SIZE, OR COLOR.

FOR PROVIDING A WEBSITE FEATURING INFORMATION ON ENVIRONMENTAL ISSUES CONCERNING GLOBAL WARMING AND ITS EFFECT ON NATURE AND THE ENVIRONMENT (U.S. CLS. 100 AND 101).

FIRST USE 1-16-2006; IN COMMERCE 3-3-2006.
ATTIYA MALIK, EXAMINING ATTORNEY

SN 77-269,207. DATAART ENTERPRISES, INC., NEW YORK, NY. FILED 8-31-2007.

DATAART

THE MARK CONSISTS OF STANDARD CHARACTERS WITHOUT CLAIM TO ANY PARTICULAR FONT, STYLE, SIZE, OR COLOR.

FOR DESIGN, DEVELOPMENT AND IMPLEMENTATION OF SOFTWARE (U.S. CLS. 100 AND 101).

FIRST USE 10-31-1997; IN COMMERCE 10-31-1997.
JESSICA A. POWERS, EXAMINING ATTORNEY

SN 77-269,260. DATAART ENTERPRISES, INC., NEW YORK, NY. FILED 8-31-2007.

DATAART

THE MARK CONSISTS OF THE WORD "DATA" IN STYLIZED LETTERING FOLLOWED BY THE WORD "ART" IN STYLIZED LETTERING. "ART" IS ENCLOSED IN A SOLID RECTANGLE.

FOR DESIGN, DEVELOPMENT AND IMPLEMENTATION OF SOFTWARE (U.S. CLS. 100 AND 101).

FIRST USE 10-31-1997; IN COMMERCE 10-31-1997.
JESSICA A. POWERS, EXAMINING ATTORNEY

CLASS 42—(Continued).

SN 77-276,704. ST. ANDREWS OF SCOTLAND INTERNATIONAL LTD, HOLLAND, MI. FILED 9-11-2007.

St. Andrews of Scotland

THE MARK CONSISTS OF STANDARD CHARACTERS WITHOUT CLAIM TO ANY PARTICULAR FONT, STYLE, SIZE, OR COLOR.

FOR TECHNOLOGICAL SERVICES, NAMELY, TECHNOLOGICAL CONSULTATION IN THE FIELD OF GOLFING, AND DEVELOPMENT OF NEW TECHNOLOGY FOR OTHERS IN THE AREA OF GOLFING; DESIGN AND DEVELOPMENT OF COMPUTER HARDWARE AND SOFTWARE; DESIGN AND DEVELOPMENT OF GAMES PLAYED ON ELECTRIC OR ELECTRONIC DEVICES (U.S. CLS. 100 AND 101).

TOBY BULLOFF, EXAMINING ATTORNEY

SN 77-278,880. ARBOR AUDIO AND VIDEO, INC., DBA ANN ARBOR AUDIO, BRIGHTON, MI. FILED 9-13-2007.

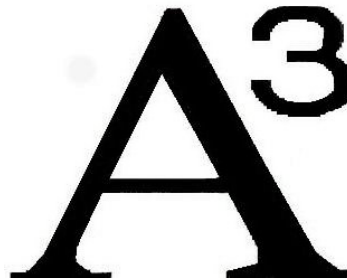

FOR DESIGN AND ENGINEERING OF AUDIO AND VIDEO SYSTEMS AND FACILITIES, COMPONENTS AND EQUIPMENT FOR OTHERS, AND CONSULTATION RELATED THERETO; ENVIRONMENTAL TESTING AND INSPECTION OF SOUND AND AUDIO PROPERTIES, NAMELY, ACOUSTICAL MODELING AND AURALIZATION SERVICES (U.S. CLS. 100 AND 101).

FIRST USE 6-30-1993; IN COMMERCE 6-30-1993.
JASON BLAIR, EXAMINING ATTORNEY

SN 77-281,384. GILLETT EVERNHAM MOTORSPORTS, LLC, VAIL, CO. FILED 9-17-2007.



NO CLAIM IS MADE TO THE EXCLUSIVE RIGHT TO USE "ENGINE TECHNOLOGY", APART FROM THE MARK AS SHOWN.

FOR DESIGN FOR OTHERS IN THE FIELD OF HIGH PERFORMANCE AUTOMOBILE ENGINES AND ENGINE PARTS; AND MANUFACTURE OF HIGH PERFORMANCE AUTOMOBILE ENGINES AND ENGINE PARTS TO ORDER AND/OR SPECIFICATION OF OTHERS (U.S. CLS. 100 AND 101).

GIANCARLO CASTRO, EXAMINING ATTORNEY

CLASS 42—(Continued).

SN 77-282,412. HEALTH MANAGEMENT SYSTEMS, INC., NEW YORK, NY. FILED 9-18-2007.

KIDCONNECT

THE MARK CONSISTS OF STANDARD CHARACTERS WITHOUT CLAIM TO ANY PARTICULAR FONT, STYLE, SIZE, OR COLOR.

FOR COMPUTER SOFTWARE SERVICES, NAMELY, ACTING AS AN APPLICATION SERVICE PROVIDER IN THE FIELD OF KNOWLEDGE MANAGEMENT TO HOST COMPUTER APPLICATION SOFTWARE FOR USE IN HEALTHCARE ENROLLMENT, CUSTOMER SERVICE, MEDICAID AND HEALTHCARE ELIGIBILITY DETERMINATION, COORDINATION WITH HEALTH PLANS, PREMIUM PROCESSING AND CAPITATION OR FIXED PER CAPITA PAYMENT CALCULATIONS (U.S. CLS. 100 AND 101).

BENJAMIN OKEKE, EXAMINING ATTORNEY

CLASS 42—(Continued).

SN 77-284,378. PROPERTYINFO CORPORATION, HOUSTON, TX. FILED 9-20-2007.

STEWART AGENCY GATEWAY

THE MARK CONSISTS OF STANDARD CHARACTERS WITHOUT CLAIM TO ANY PARTICULAR FONT, STYLE, SIZE, OR COLOR.

NO CLAIM IS MADE TO THE EXCLUSIVE RIGHT TO USE "AGENCY GATEWAY", APART FROM THE MARK AS SHOWN.

FOR PROVIDING TEMPORARY USE OF ONLINE NON-DOWNLOADABLE SOFTWARE FOR PROVIDING INFORMATION IN THE FIELD OF REAL ESTATE, FOR SEARCHING REAL ESTATE TITLE DATABASES, FOR SURVEYS AND MAPS, FOR CREATION OF REAL ESTATE MORTGAGE AND RELATED DOCUMENTATION, FOR CREATION OF DOCUMENTS FOR REAL ESTATE TRANSFERS AND SETTLEMENT SERVICES, FOR REAL ESTATE TITLE SEARCHING, AND FOR RECORDING LAND DOCUMENTS WITH COUNTY CLERKS OR COUNTY REGISTRARS (U.S. CLS. 100 AND 101).

ROBIN CHOSID, EXAMINING ATTORNEY

SN 77-282,966. BAIDU.COM, INC., GRAND CAYMAN, CAYMAN ISLANDS, FILED 9-19-2007.

baidu

THE MARK CONSISTS OF THE WORD "BAIDU". THE WORD "BAIDU" HAS NO MEANING IN A FOREIGN LANGUAGE.

FOR COMPUTER SERVICES, NAMELY, PROVIDING SEARCH ENGINES FOR OBTAINING DATA ON A GLOBAL COMPUTER NETWORK; COMPUTER PROGRAMMING; COMPUTER SOFTWARE DESIGN FOR OTHERS; MAINTENANCE OF COMPUTER SOFTWARE; COMPUTER SYSTEMS ANALYSIS; DESIGN AND DEVELOPMENT OF ON-LINE COMPUTER SOFTWARE SYSTEMS; DUPLICATION OF COMPUTER PROGRAMS; CONVERSION OF DATA OR DOCUMENTS FROM PHYSICAL TO ELECTRONIC MEDIA; CREATING OR MAINTAINING WEB SITES FOR OTHERS; WEB SITE HOSTING SERVICES (U.S. CLS. 100 AND 101).

MATTHEW EINSTEIN, EXAMINING ATTORNEY

SN 77-284,384. PROPERTYINFO CORPORATION, HOUSTON, TX. FILED 9-20-2007.

FIVE DIAMOND

THE MARK CONSISTS OF STANDARD CHARACTERS WITHOUT CLAIM TO ANY PARTICULAR FONT, STYLE, SIZE, OR COLOR.

FOR PROVIDING TEMPORARY USE OF ONLINE NON-DOWNLOADABLE SOFTWARE FOR PROVIDING INFORMATION IN THE FIELD OF REAL ESTATE, FOR SEARCHING REAL ESTATE TITLE DATABASES, FOR SURVEYS AND MAPS, FOR CREATION OF REAL ESTATE MORTGAGE AND RELATED DOCUMENTATION, FOR CREATION OF DOCUMENTS FOR REAL ESTATE TRANSFERS AND SETTLEMENT SERVICES, FOR REAL ESTATE TITLE SEARCHING, AND FOR RECORDING LAND DOCUMENTS WITH COUNTY CLERKS OR COUNTY REGISTRARS (U.S. CLS. 100 AND 101).

ROBIN CHOSID, EXAMINING ATTORNEY

CLASS 42—(Continued).

SN 77-290,114. G2MQ CONSULTING CORP., ALEXANDRIA, VA. FILED 9-27-2007.

G2MQ

THE MARK CONSISTS OF STANDARD CHARACTERS WITHOUT CLAIM TO ANY PARTICULAR FONT, STYLE, SIZE, OR COLOR.

FOR ACCREDITATION CONSULTING SERVICES, NAMELY, CONSULTING ON THE DEVELOPING, EVALUATING, AND TESTING STANDARDS FOR CELL PROCESSING LABORATORY SERVICES FOR THE PURPOSE OF ACCREDITATION; QUALITY MANAGEMENT CONSULTING SERVICES, NAMELY, CONSULTING ON QUALITY CONTROL MANAGEMENT SERVICES FOR THE HOSPITAL INDUSTRY; CLINICAL RESEARCH CONSULTING IN THE FIELD OF CLINICAL TRIALS THAT FEATURE CELL PROCESSING (U.S. CLS. 100 AND 101).

FIRST USE 12-5-2006; IN COMMERCE 12-5-2006.
TANYA AMOS, EXAMINING ATTORNEY

CLASS 42—(Continued).

SN 77-290,191. G2MQ CONSULTING CORP., ALEXANDRIA, VA. FILED 9-27-2007.



Taking organizations above and beyond..

FOR ACCREDITATION CONSULTING SERVICES, NAMELY, CONSULTING ON THE DEVELOPING, EVALUATING, AND TESTING STANDARDS FOR CELL PROCESSING LABORATORY SERVICES FOR THE PURPOSE OF ACCREDITATION; QUALITY MANAGEMENT CONSULTING SERVICES, NAMELY, CONSULTING ON QUALITY CONTROL MANAGEMENT SERVICES FOR THE HOSPITAL INDUSTRY; CLINICAL RESEARCH CONSULTING IN THE FIELD OF CLINICAL TRIALS THAT FEATURE CELL PROCESSING (U.S. CLS. 100 AND 101).

FIRST USE 12-6-2005; IN COMMERCE 12-6-2005.
TANYA AMOS, EXAMINING ATTORNEY

SN 77-290,150. G2MQ CONSULTING CORP., ALEXANDRIA, VA. FILED 9-27-2007.

Taking organizations above
and beyond...

THE MARK CONSISTS OF STANDARD CHARACTERS WITHOUT CLAIM TO ANY PARTICULAR FONT, STYLE, SIZE, OR COLOR.

FOR ACCREDITATION CONSULTING SERVICES, NAMELY, CONSULTING ON THE DEVELOPING, EVALUATING, AND TESTING STANDARDS FOR CELL PROCESSING LABORATORY SERVICES FOR THE PURPOSE OF ACCREDITATION; QUALITY MANAGEMENT CONSULTING SERVICES, NAMELY, CONSULTING ON QUALITY CONTROL MANAGEMENT SERVICES FOR THE HOSPITAL INDUSTRY; CLINICAL RESEARCH CONSULTING IN THE FIELD OF CLINICAL TRIALS THAT FEATURE CELL PROCESSING (U.S. CLS. 100 AND 101).

FIRST USE 12-5-2006; IN COMMERCE 12-5-2006.
TANYA AMOS, EXAMINING ATTORNEY

SN 77-292,288. SOPHOGEN CORPORATION, ROANOKE, VA. FILED 9-29-2007.



THE MARK CONSISTS OF A HELIX INTERTWINED WITH A ZIG-ZAG LINE.

FOR INDIVIDUAL GENETIC ANALYSIS SERVICES FOR MEDICAL RESEARCH PURPOSES (U.S. CLS. 100 AND 101).

MICHAEL SOUDERS, EXAMINING ATTORNEY

CLASS 42—(Continued).

SN 77-304,417. VIDOVICH, DENNIS, ALISO VIEJO, CA. FILED 10-15-2007.

SmartBroker

THE MARK CONSISTS OF STANDARD CHARACTERS WITHOUT CLAIM TO ANY PARTICULAR FONT, STYLE, SIZE, OR COLOR.

FOR PROVIDING ONLINE NON-DOWNLOADABLE SOFTWARE FOR USE IN THE MANAGEMENT OF REAL ESTATE BROKERAGES, NAMELY, TRANSACTION MANAGEMENT, AGENT SUPERVISION AND OFFICE ADMINISTRATION (U.S. CLS. 100 AND 101).

JORDAN BAKER, EXAMINING ATTORNEY

SN 77-304,444. VIDOVICH, DENNIS, ALISO VIEJO, CA. FILED 10-15-2007.

SmartAgent

THE MARK CONSISTS OF STANDARD CHARACTERS WITHOUT CLAIM TO ANY PARTICULAR FONT, STYLE, SIZE, OR COLOR.

FOR PROVIDING ONLINE NON-DOWNLOADABLE SOFTWARE FOR USE IN THE MANAGEMENT OF REAL ESTATE BROKERAGES, NAMELY, SOFTWARE FOR HOSTING THE WEB-PAGES OF REAL ESTATE AGENTS, AND FOR USE IN CUSTOMER CONTACT MANAGEMENT, AND THE ADVERTISING AND MARKETING OF REAL ESTATE PROPERTIES (U.S. CLS. 100 AND 101).

JORDAN BAKER, EXAMINING ATTORNEY

SN 77-305,285. ESLIDE, LLC, NEW YORK, NY. FILED 10-16-2007.

eSlide

THE MARK CONSISTS OF STANDARD CHARACTERS WITHOUT CLAIM TO ANY PARTICULAR FONT, STYLE, SIZE, OR COLOR.

SEC. 2(F).
FOR COMPUTER GRAPHIC DESIGN (U.S. CLS. 100 AND 101).

FIRST USE 12-31-2001; IN COMMERCE 12-31-2001.

DAWN HAN, EXAMINING ATTORNEY

CLASS 42—(Continued).

SN 77-306,723. WORTAL INC., PALO ALTO, CA. FILED 10-17-2007.



THE COLOR(S) BLUE, GREEN AND BLACK IS/ARE CLAIMED AS A FEATURE OF THE MARK.

THE COLOR BLACK APPEARS IN THE WORDING "WORTAL"; HOWEVER, THE "O" IN "WORTAL" IS REPRESENTED BY A GREEN SWIRL DESIGN; FINALLY THE COLOR BLUE APPEARS IN THE DESIGN OF THE JOYOUS PEOPLE ABOVE THE LITERAL ELEMENT.

FOR COMPUTER SERVICES IN THE NATURE OF PROVIDING A CUSTOMIZABLE WEBSITE FEATURING USER-DEFINED INFORMATION, PERSONAL PROFILES AND OTHER INFORMATION WHERE USERS CAN POST AND SHARE INFORMATION (U.S. CLS. 100 AND 101).

BENJAMIN OKEKE, EXAMINING ATTORNEY

SN 77-306,767. WORTAL INC., PALO ALTO, CA. FILED 10-17-2007.



THE COLOR(S) BLACK, GOLD AND WHITE IS/ARE CLAIMED AS A FEATURE OF THE MARK.

THE MARK CONSISTS OF THE STYLIZED WORDING "BUZZINTOWN," WHERE "BUZZ" AND "TOWN" ARE STYLIZED IN OUTLINED BLACK AND "IN" IS PLACED INSIDE A GOLDEN STAR IN WHITE ALL CAPS FONT.

FOR COMPUTER SERVICES IN THE NATURE OF PROVIDING A CUSTOMIZABLE WEBSITE FEATURING USER-DEFINED INFORMATION, PERSONAL PROFILES AND OTHER INFORMATION WHERE USERS CAN POST AND SHARE INFORMATION (U.S. CLS. 100 AND 101).

BENJAMIN OKEKE, EXAMINING ATTORNEY

CLASS 42—(Continued).

SN 77-306,794. WORTAL INC., PALO ALTO, CA. FILED 10-17-2007.

Are you buzzin' today?

THE COLOR(S) BLUE IS/ARE CLAIMED AS A FEATURE OF THE MARK.

THE MARK CONSISTS OF THE STYLIZED WORDING "ARE YOU BUZZIN' TODAY?" IN BLUE.

FOR COMPUTER SERVICES IN THE NATURE OF PROVIDING A CUSTOMIZABLE WEBSITE FEATURING USER-DEFINED INFORMATION, PERSONAL PROFILES AND OTHER INFORMATION WHERE USERS CAN POST AND SHARE INFORMATION (U.S. CLS. 100 AND 101).

BENJAMIN OKEKE, EXAMINING ATTORNEY

CLASS 42—(Continued).

SN 77-307,472. H2O INNOVATION (2000) INC., QUEBEC, CANADA, FILED 10-18-2007.



NO CLAIM IS MADE TO THE EXCLUSIVE RIGHT TO USE "H2O", APART FROM THE MARK AS SHOWN.

THE MARK CONSISTS OF THE NUMBER "2" AS A SUBSCRIPT BETWEEN THE "H" AND "O" WITH A HALF CIRCLE ABOVE THE "H" AND "2" WITH ONE END GOING THROUGH THE "O". A GLOBE REPLACES THE FIRST "O" IN THE WORD "INNOVATION".

FOR RESEARCH AND DEVELOPMENT SERVICES IN THE FIELD OF WATER TREATMENT; WATER TREATMENT ENGINEERING ADVISORY SERVICES (U.S. CLS. 100 AND 101).

FIRST USE 1-0-2000; IN COMMERCE 1-0-2000.
AMY GEARIN, EXAMINING ATTORNEY

SN 77-306,960. ESLIDE, LLC, NEW YORK, NY. FILED 10-18-2007.



SEC. 2(F) AS TO "ESLIDE".
FOR COMPUTER GRAPHIC DESIGN (U.S. CLS. 100 AND 101).

FIRST USE 12-31-2001; IN COMMERCE 12-31-2001.
DAWN HAN, EXAMINING ATTORNEY

SN 77-316,748. CRUMP GROUP, INC., ROSELAND, NJ. FILED 10-30-2007.

CRUMP

THE MARK CONSISTS OF STANDARD CHARACTERS WITHOUT CLAIM TO ANY PARTICULAR FONT, STYLE, SIZE, OR COLOR.

FOR PROVIDING ON-LINE TEMPORARY USE OF NON-DOWNLOADABLE CLIENT RELATIONSHIP MANAGEMENT SOFTWARE; PROVIDING ON-LINE TEMPORARY USE OF NON-DOWNLOADABLE SOFTWARE FOR USE IN INSURANCE ADMINISTRATION; PROVIDING ON-LINE TEMPORARY USE OF NON-DOWNLOADABLE SOFTWARE FOR USE IN INSURANCE PROCESSING (U.S. CLS. 100 AND 101).

MELVIN AXILBUND, EXAMINING ATTORNEY

CLASS 42—(Continued).

SN 77-316,920. ALLSCRIPTS, LLC, CHICAGO, IL. FILED 10-30-2007.

ALLSCRIPTS RECRUITASSIST

THE MARK CONSISTS OF STANDARD CHARACTERS WITHOUT CLAIM TO ANY PARTICULAR FONT, STYLE, SIZE, OR COLOR.

OWNER OF U.S. REG. NOS. 1,551,574 AND 3,287,641.
FOR PROVIDING TEMPORARY USE OF ONLINE NON-DOWNLOADABLE SOFTWARE FOR USE IN DETERMINING THE NUMBER OF CANDIDATES THAT QUALIFY FOR CLINICAL TRIALS BASED ON SUBMITTED SPECIFICATIONS; PROVIDING TEMPORARY USE OF ONLINE NON-DOWNLOADABLE SOFTWARE FOR USE BY MEDICAL GROUPS TO COMPARE THEIR ELECTRONIC HEALTH RECORD DATA COLLECTION METHODOLOGIES WITH OTHER MEDICAL GROUPS (U.S. CLS. 100 AND 101).

JOHN GARTNER, EXAMINING ATTORNEY

CLASS 42—(Continued).

SN 77-323,897. CRUMP GROUP, INC., ROSELAND, NJ. FILED 11-7-2007.



THE MARK CONSISTS OF THE WORD "CRUMP" IN STYLIZED LETTERING LOCATED AT THE BOTTOM RIGHT CORNER OF A RECTANGLE.

FOR PROVIDING ON-LINE TEMPORARY USE OF NON-DOWNLOADABLE CLIENT RELATIONSHIP MANAGEMENT SOFTWARE; PROVIDING ON-LINE TEMPORARY USE OF NON-DOWNLOADABLE SOFTWARE FOR USE IN INSURANCE ADMINISTRATION; PROVIDING ON-LINE TEMPORARY USE OF NON-DOWNLOADABLE SOFTWARE FOR USE IN INSURANCE PROCESSING (U.S. CLS. 100 AND 101).

MELVIN AXILBUND, EXAMINING ATTORNEY

SN 77-323,864. CRUMP GROUP, INC., ROSELAND, NJ. FILED 11-7-2007.



THE COLOR(S) WHITE AND BLUE IS/ARE CLAIMED AS A FEATURE OF THE MARK.

THE MARK CONSISTS OF THE WORD "CRUMP" IN STYLIZED WHITE LETTERING LOCATED AT THE BOTTOM OF A BLUE RECTANGLE.

FOR PROVIDING ON-LINE TEMPORARY USE OF NON-DOWNLOADABLE CLIENT RELATIONSHIP MANAGEMENT SOFTWARE; PROVIDING ON-LINE TEMPORARY USE OF NON-DOWNLOADABLE SOFTWARE FOR USE IN INSURANCE ADMINISTRATION; PROVIDING ON-LINE TEMPORARY USE OF NON-DOWNLOADABLE SOFTWARE FOR USE IN INSURANCE PROCESSING (U.S. CLS. 100 AND 101).

AHSEN KHAN, EXAMINING ATTORNEY

SN 77-331,005. EPIC RIVER, LLC, LEWISVILLE, TX. FILED 11-15-2007.



OWNER OF U.S. REG. NO. 3,205,090.

THE MARK CONSISTS OF A SHADED GLOBE HAVING THREE BANDS THAT BEGIN AT THE BOTTOM LEFT HAND SIDE OF THE GLOBE AND PROTRUDE UP TO THE TOP MIDDLE PORTION OF THE GLOBE THEN CURVE DOWNWARD AND MEET AT THE CENTER RIGHT HAND SIDE OF THE GLOBE AND APPEAR TO WRAP AROUND THE GLOBE AND EXTEND OUT FROM THE BOTTOM LEFT HAND SIDE OF THE GLOBE. THE WORDS "EPIC RIVER" APPEAR RIGHT OF THE GLOBE IN ALL CAPITAL LETTERS.

FOR DEVELOPING AND DESIGNING SOFTWARE FOR OTHERS FOR MISCELLANEOUS BUSINESS SOLUTIONS (U.S. CLS. 100 AND 101).

FIRST USE 11-11-2005; IN COMMERCE 11-11-2005.

DOMINIC J. FERRAIUOLO, EXAMINING ATTORNEY

CLASS 42—(Continued).

SN 77-335,297. BUD BEHLING LEASING, INC., BRIDGEVILLE, PA. FILED 11-21-2007.

LEASE CENTRAL

THE MARK CONSISTS OF STANDARD CHARACTERS WITHOUT CLAIM TO ANY PARTICULAR FONT, STYLE, SIZE, OR COLOR.

NO CLAIM IS MADE TO THE EXCLUSIVE RIGHT TO USE "LEASE", APART FROM THE MARK AS SHOWN.

FOR PROVIDING TEMPORARY USE OF ONLINE NON-DOWNLOADABLE SOFTWARE FOR MANAGEMENT OF VEHICLE FIXED AND VARIABLE COSTS, NAMELY, FINANCING, PURCHASES, FUEL MANAGEMENT, ROADSIDE ASSISTANCE, REMARKETING, ACQUISITION, REGISTRATION, TITLE TRANSFER AND MAINTENANCE, ASSOCIATED WITH VEHICLES AND VEHICLE FLEETS (U.S. CLS. 100 AND 101).

FIRST USE 1-1-2000; IN COMMERCE 1-1-2000.
KATHY DE JONGE, EXAMINING ATTORNEY

SN 77-336,103. TANAKA, DANIELLE F, DBA FISHER, DANIELLE O, NOKOMIS, FL. FILED 11-23-2007.

Our Family Town

THE MARK CONSISTS OF STANDARD CHARACTERS WITHOUT CLAIM TO ANY PARTICULAR FONT, STYLE, SIZE, OR COLOR.

FOR HOSTING AN ONLINE COMMUNITY WEB SITE FEATURING FAMILY-FRIENDLY PRODUCTS, SERVICES, RESOURCES, AND ACTIVITIES IN THE COMMUNITY (U.S. CLS. 100 AND 101).

DAVID YONTEF, EXAMINING ATTORNEY

SN 77-347,319. WEATHERVISTA, LLC, GREENSBORO, NC. FILED 12-7-2007.

WeatherVista

THE MARK CONSISTS OF STANDARD CHARACTERS WITHOUT CLAIM TO ANY PARTICULAR FONT, STYLE, SIZE, OR COLOR.

FOR PROVIDING WEATHER INFORMATION; WEATHER FORECASTING; WEATHER INFORMATION SERVICES; WEATHER REPORTING; METEOROLOGICAL FORECASTING; PROVIDING METEOROLOGICAL INFORMATION (U.S. CLS. 100 AND 101).

FIRST USE 8-1-2005; IN COMMERCE 12-7-2007.
HENRY S. ZAK, EXAMINING ATTORNEY

CLASS 42—(Continued).

SN 77-348,373. MESSAGEDANCE INC., SUNNYVALE, CA. FILED 12-10-2007.

Social Signature

THE MARK CONSISTS OF STANDARD CHARACTERS WITHOUT CLAIM TO ANY PARTICULAR FONT, STYLE, SIZE, OR COLOR.

NO CLAIM IS MADE TO THE EXCLUSIVE RIGHT TO USE "SIGNATURE", APART FROM THE MARK AS SHOWN.

FOR PROVIDING THE TEMPORARY USE OF NON-DOWNLOADABLE SOFTWARE FOR DISPLAYING USERS' CONTACT INFORMATION AS A DESCRIPTIVE, ATTRACTIVE, AND CONTEXTUAL INFORMATION BOX FROM EVERY EMAIL (U.S. CLS. 100 AND 101).

REBECCA POVARCHUK, EXAMINING ATTORNEY

SN 77-362,371. SEAWINKLE LLC, BROOKLYN, NY. FILED 1-2-2008.

SEA WINKLE

THE MARK CONSISTS OF STANDARD CHARACTERS WITHOUT CLAIM TO ANY PARTICULAR FONT, STYLE, SIZE, OR COLOR.

FOR PROVIDING A WEBSITE FEATURING TEMPORARY USE OF ON-LINE NON-DOWNLOADABLE SOFTWARE FOR USE IN DATABASING, VISUALIZATION, MANIPULATION AND INTEGRATION OF DATA WITH ONLINE MEMBER COMMUNITIES IN THE FIELD OF DIGITAL SCRAPBOOKING AND ONLINE RECORDS OF PEOPLE'S DAILY ACTIVITIES (U.S. CLS. 100 AND 101).

DANIEL CAPSHAW, EXAMINING ATTORNEY

CLASS 42—(Continued).

SN 77-370,143. CAPTARIS, INC., BELLEVUE, WA. FILED 1-11-2008.

RIGHTCONNECT

THE MARK CONSISTS OF STANDARD CHARACTERS WITHOUT CLAIM TO ANY PARTICULAR FONT, STYLE, SIZE, OR COLOR.

FOR PROVIDING COMPUTER AND INFORMATION TECHNOLOGY CONSULTING SERVICES FOR AUTOMATING AND MANAGING BUSINESS PROCESSES; PROVIDING COMPUTER AND INFORMATION TECHNOLOGY CONSULTING SERVICES TO THE FINANCIAL AND HEALTHCARE INDUSTRIES AND GOVERNMENTAL ENTITIES FOR AUTOMATING AND MANAGING BUSINESS PROCESSES; PROVIDING COMPUTER AND INFORMATION TECHNOLOGY CONSULTING SERVICES FOR DOCUMENT-CENTRIC BUSINESS PROCESSES AND WORKFLOWS AND HUMAN-BASED BUSINESS PROCESSES AND WORKFLOWS; PROVIDING COMPUTER AND INFORMATION TECHNOLOGY CONSULTING SERVICES FOR SOFTWARE APPLICATION AND TELECOMMUNICATIONS SOLUTIONS FOR DOCUMENT-CENTRIC BUSINESS PROCESSES AND WORKFLOWS AND HUMAN-BASED BUSINESS PROCESSES AND WORKFLOWS; PROVIDING COMPUTER AND INFORMATION TECHNOLOGY CONSULTING SERVICES FOR SOFTWARE APPLICATION AND TELECOMMUNICATIONS SOLUTIONS FOR DATA AND DOCUMENT MANAGEMENT, TRANSMISSION, STORAGE AND INDEXING; PROVIDING TEMPORARY USE OF ON-LINE NON-DOWNLOADABLE COMPUTER SOFTWARE FOR USE IN AUTOMATING AND MANAGING BUSINESS PROCESSES; PROVIDING TEMPORARY USE OF ON-LINE NON-DOWNLOADABLE COMPUTER SOFTWARE FOR DOCUMENT-CENTRIC AND HUMAN-BASED BUSINESS PROCESSES AND WORKFLOWS; PROVIDING TEMPORARY USE OF ON-LINE NON-DOWNLOADABLE COMPUTER SOFTWARE FOR ENHANCING THE TRANSMISSION, CLARITY, AND READABILITY, INTEROPERABILITY, AND CONVERTIBILITY OF FACSIMILE AND PRINT TECHNOLOGIES; PROVIDING TEMPORARY USE OF ON-LINE NON-DOWNLOADABLE COMPUTER SOFTWARE FOR USE IN THE FINANCIAL AND HEALTHCARE INDUSTRIES AND BY GOVERNMENTAL ENTITIES FOR AUTOMATING AND MANAGING BUSINESS PROCESSES; COMPUTER SERVICES FOR OTHERS, NAMELY, PROVIDING TROUBLESHOOTING OF COMPUTER HARDWARE AND SOFTWARE PROBLEMS; MAINTENANCE OF COMPUTER SOFTWARE (U.S. CLS. 100 AND 101).

JENNIFER HETU, EXAMINING ATTORNEY

CLASS 42—(Continued).

SN 77-374,887. INFOTECH BUILDERS LLC, PHILADELPHIA, PA. FILED 1-18-2008.

MyNetResearch
Empowering Collaboration

NO CLAIM IS MADE TO THE EXCLUSIVE RIGHT TO USE "RESEARCH", APART FROM THE MARK AS SHOWN. THE COLOR(S) YELLOW, ORANGE, BLACK AND BLUE IS/ARE CLAIMED AS A FEATURE OF THE MARK.

THE MARK CONSISTS OF YELLOW TO ORANGE TRANSITION FOR "MYNET" FROM THE TOP TO THE BOTTOM AND "RESEARCH" IS BLUE. "EMPOWERING COLLABORATION" IS BLACK.

FOR SCIENTIFIC RESEARCH AND DEVELOPMENT (U.S. CLS. 100 AND 101).

ELIZABETH KAJUBI, EXAMINING ATTORNEY

SN 77-376,247. GENSPERA, INC., SANTA MONICA, CA. FILED 1-20-2008.

**CREATING THERAPIES.
GENERATING HOPE.**

THE MARK CONSISTS OF STANDARD CHARACTERS WITHOUT CLAIM TO ANY PARTICULAR FONT, STYLE, SIZE, OR COLOR.

FOR DEVELOPMENT OF PHARMACEUTICAL PREPARATIONS AND MEDICINES; PHARMACEUTICAL DRUG DEVELOPMENT SERVICES; PHARMACEUTICAL RESEARCH AND DEVELOPMENT (U.S. CLS. 100 AND 101).

FIRST USE 3-31-2004; IN COMMERCE 3-31-2004.

DAYNA BROWNE, EXAMINING ATTORNEY

SN 77-376,278. GENSPERA, INC., SANTA MONICA, CA. FILED 1-20-2008.



THE MARK CONSISTS OF AN OVAL-SHAPED SOLID FIGURE DESCENDING ATTACHED TO A SOLID LINE, WITH THE FIGURE SURROUNDED BY SEVERAL CURVED-SHAPED LINES.

FOR DEVELOPMENT OF PHARMACEUTICAL PREPARATIONS AND MEDICINES; PHARMACEUTICAL DRUG DEVELOPMENT SERVICES; PHARMACEUTICAL RESEARCH AND DEVELOPMENT (U.S. CLS. 100 AND 101).

FIRST USE 3-31-2004; IN COMMERCE 3-31-2004.

DAYNA BROWNE, EXAMINING ATTORNEY

CLASS 42—(Continued).

SN 77-379,903. CAPTARIS, INC., BELLEVUE, WA. FILED 1-24-2008.

RIGHTRECO

THE MARK CONSISTS OF STANDARD CHARACTERS WITHOUT CLAIM TO ANY PARTICULAR FONT, STYLE, SIZE, OR COLOR.

FOR PROVIDING COMPUTER AND INFORMATION TECHNOLOGY CONSULTING SERVICES FOR AUTOMATING AND MANAGING BUSINESS PROCESSES; PROVIDING COMPUTER AND INFORMATION TECHNOLOGY CONSULTING SERVICES TO THE FINANCIAL AND HEALTHCARE INDUSTRIES AND GOVERNMENTAL ENTITIES FOR AUTOMATING AND MANAGING BUSINESS PROCESSES; PROVIDING COMPUTER AND INFORMATION TECHNOLOGY CONSULTING SERVICES FOR DOCUMENT-CENTRIC BUSINESS PROCESSES AND WORKFLOWS AND HUMAN-BASED BUSINESS PROCESSES AND WORKFLOWS; PROVIDING COMPUTER AND INFORMATION TECHNOLOGY CONSULTING SERVICES FOR SOFTWARE APPLICATION AND TELECOMMUNICATIONS SOLUTIONS FOR DOCUMENT-CENTRIC BUSINESS PROCESSES AND WORKFLOWS AND HUMAN-BASED BUSINESS PROCESSES AND WORKFLOWS; PROVIDING COMPUTER AND INFORMATION TECHNOLOGY CONSULTING SERVICES FOR SOFTWARE APPLICATION AND TELECOMMUNICATIONS SOLUTIONS FOR DATA AND DOCUMENT MANAGEMENT, TRANSMISSION, STORAGE AND INDEXING; PROVIDING TEMPORARY USE OF ON-LINE NON-DOWNLOADABLE COMPUTER SOFTWARE FOR USE IN AUTOMATING AND MANAGING BUSINESS PROCESSES; PROVIDING TEMPORARY USE OF ON-LINE NON-DOWNLOADABLE COMPUTER SOFTWARE FOR DOCUMENT-CENTRIC AND HUMAN-BASED BUSINESS PROCESSES AND WORKFLOWS; PROVIDING TEMPORARY USE OF ON-LINE NON-DOWNLOADABLE COMPUTER SOFTWARE FOR ENHANCING THE TRANSMISSION, CLARITY, AND READABILITY, INTEROPERABILITY, AND CONVERTIBILITY OF FACSIMILE AND PRINT TECHNOLOGIES; PROVIDING TEMPORARY USE OF ON-LINE NON-DOWNLOADABLE COMPUTER SOFTWARE FOR USE IN THE FINANCIAL AND HEALTHCARE INDUSTRIES AND BY GOVERNMENTAL ENTITIES FOR AUTOMATING AND MANAGING BUSINESS PROCESSES; COMPUTER SERVICES FOR OTHERS, NAMELY, PROVIDING TROUBLESHOOTING OF COMPUTER HARDWARE AND SOFTWARE PROBLEMS; MAINTENANCE OF COMPUTER SOFTWARE (U.S. CLS. 100 AND 101).

JENNIFER HETU, EXAMINING ATTORNEY

CLASS 42—(Continued).

SN 77-380,869. BANDCAMP, INC., SAN FRANCISCO, CA. FILED 1-25-2008.

BANDCAMP

THE MARK CONSISTS OF STANDARD CHARACTERS WITHOUT CLAIM TO ANY PARTICULAR FONT, STYLE, SIZE, OR COLOR.

FOR APPLICATION SERVICE PROVIDER (ASP) FEATURING SOFTWARE TO ENABLE OTHERS TO CREATE AND DESIGN WEBPAGES FOR THE TRANSMISSION, VIEWING, UPLOADING, DOWNLOADING, POSTING, SHOWING, DISPLAYING, BLOGGING, SHARING OR OTHERWISE PROVIDING OF ELECTRONIC MEDIA AND INFORMATION OVER THE INTERNET OR OTHER COMMUNICATIONS NETWORK; COMPUTER SERVICES, NAMELY, HOSTING AND MAINTAINING AN ONLINE WEBSITE FOR OTHERS TO FACILITATE THE TRANSMISSION, VIEWING, UPLOADING, DOWNLOADING, POSTING, SHOWING, DISPLAYING, BLOGGING, SHARING OR OTHERWISE PROVIDING OF ELECTRONIC MEDIA AND INFORMATION OVER THE INTERNET OR OTHER COMMUNICATIONS NETWORK (U.S. CLS. 100 AND 101).

ANDREA BUTLER, EXAMINING ATTORNEY

SN 77-381,511. IFAMILY INC., NEW YORK, NY. FILED 1-27-2008.

Family Builder

THE MARK CONSISTS OF STANDARD CHARACTERS WITHOUT CLAIM TO ANY PARTICULAR FONT, STYLE, SIZE, OR COLOR.

NO CLAIM IS MADE TO THE EXCLUSIVE RIGHT TO USE "FAMILY", APART FROM THE MARK AS SHOWN.

FOR PROVIDING ON-LINE NON-DOWNLOADABLE SOFTWARE AND A WEBSITE FEATURING INFORMATION ON GENEALOGY AND GENEALOGICAL RESEARCH; PROVIDING ON-LINE NON-DOWNLOADABLE SOFTWARE AND A WEBSITE THAT ALLOWS USERS TO RESEARCH GENEALOGY AND FAMILY HISTORY AND TO CREATE A GENEALOGICAL HISTORY AND FAMILY TREE (U.S. CLS. 100 AND 101).

FIRST USE 1-23-2008; IN COMMERCE 1-23-2008.
BARBARA RUTLAND, EXAMINING ATTORNEY

CLASS 42—(Continued).

SN 77-382,783. SANESCO INTERNATIONAL, INC., ASHEVILLE, NC. FILED 1-29-2008.

NEUROLAB

THE MARK CONSISTS OF STANDARD CHARACTERS WITHOUT CLAIM TO ANY PARTICULAR FONT, STYLE, SIZE, OR COLOR.

FOR MEDICAL LABORATORY SERVICES (U.S. CLS. 100 AND 101).

DEZMONA MIZELLE, EXAMINING ATTORNEY

SN 77-392,661. EAGLE GEOPHYSICAL, INC., HOUSTON, TX. FILED 2-8-2008.

EAGLE GEOPHYSICAL

THE MARK CONSISTS OF STANDARD CHARACTERS WITHOUT CLAIM TO ANY PARTICULAR FONT, STYLE, SIZE, OR COLOR.

NO CLAIM IS MADE TO THE EXCLUSIVE RIGHT TO USE "GEOPHYSICAL", APART FROM THE MARK AS SHOWN.

FOR SEISMOGRAPHIC EXPLORATION SERVICES, NAMELY, CONDUCTING PARAMETER DESIGN AND FEASIBILITY STUDIES, MAPPING, RECORDING AND INFELD PROCESSING OF DATA FOR OTHERS ON OPTICAL, DIGITAL AND MAGNETIC MEDIA FOR LATER ELECTRONIC STORAGE, ALL FOR THE OIL AND GAS INDUSTRY (U.S. CLS. 100 AND 101).

FIRST USE 5-22-1997; IN COMMERCE 5-22-1997.
DAVID MURRAY, EXAMINING ATTORNEY

SN 77-395,768. MERCURY DATA EXCHANGE, INC., SANDY SPRINGS, GA. FILED 2-13-2008.

R/T Extender

THE MARK CONSISTS OF STANDARD CHARACTERS WITHOUT CLAIM TO ANY PARTICULAR FONT, STYLE, SIZE, OR COLOR.

NO CLAIM IS MADE TO THE EXCLUSIVE RIGHT TO USE "R/T", APART FROM THE MARK AS SHOWN.

FOR APPLICATION SERVICE PROVIDER (ASP) FEATURING SOFTWARE FOR USE IN REAL-TIME PROCESSING OF DENTAL HEALTH INSURANCE TRANSACTIONS; PROVIDING ON-LINE NON-DOWNLOADABLE SOFTWARE FOR USE IN REAL-TIME PROCESSING OF DENTAL HEALTH INSURANCE TRANSACTIONS (U.S. CLS. 100 AND 101).

FIRST USE 1-0-2007; IN COMMERCE 1-0-2007.
CHRISTINE BLOMQUIST, EXAMINING ATTORNEY

CLASS 42—(Continued).

SN 77-398,008. COLO4DALLAS, L.P., DALLAS, TX. FILED 2-15-2008.

Unrivaled Support

THE MARK CONSISTS OF STANDARD CHARACTERS WITHOUT CLAIM TO ANY PARTICULAR FONT, STYLE, SIZE, OR COLOR.

FOR COMPUTER COLLOCATION SERVICES, NAMELY, PROVIDING FACILITIES FOR THE LOCATION OF COMPUTER SERVERS WITH THE EQUIPMENT OF OTHERS (U.S. CLS. 100 AND 101).

FIRST USE 3-5-2007; IN COMMERCE 3-5-2007.
YAT SYE, LEE, EXAMINING ATTORNEY

SN 77-398,719. DESORMEAUX, HORACE GREGORY, FORESTVILLE, MD. FILED 2-15-2008.

COMSYNC

THE MARK CONSISTS OF STANDARD CHARACTERS WITHOUT CLAIM TO ANY PARTICULAR FONT, STYLE, SIZE, OR COLOR.

FOR COMPUTER NETWORKING SERVICES, NAMELY, COMPUTER NETWORK CONSULTATION, DESIGN, DEVELOPMENT AND IMPLEMENTATION OF COMPUTER NETWORKS FOR OTHERS, COMPUTER SYSTEM ADMINISTRATION FOR OTHERS, COMPUTER SECURITY SERVICES, NAMELY, RESTRICTING ACCESS TO AND BY COMPUTER NETWORKS TO AND OF UNDESIRED WEBSITES, MEDIA AND INDIVIDUALS AND FACILITIES, REPAIR OF COMPUTER SOFTWARE, COMPUTER VIRUS PROTECTION SERVICES, NAMELY, VIRUS DETECTION AND REMOVAL (U.S. CLS. 100 AND 101).

FIRST USE 5-21-2002; IN COMMERCE 5-28-2002.
JULIE WATSON, EXAMINING ATTORNEY

CLASS 42—(Continued).

SN 77-399,120. IFAMILY INC., NEW YORK, NY. FILED 2-17-2008.

familybuilder

THE MARK CONSISTS OF STANDARD CHARACTERS WITHOUT CLAIM TO ANY PARTICULAR FONT, STYLE, SIZE, OR COLOR.

FOR PROVIDING ON-LINE NON-DOWNLOADABLE SOFTWARE AND A WEBSITE FEATURING INFORMATION ON GENEALOGY AND GENEALOGICAL RESEARCH; PROVIDING ON-LINE NON-DOWNLOADABLE SOFTWARE AND A WEBSITE THAT ALLOWS USERS TO RESEARCH GENEALOGY AND FAMILY HISTORY AND TO CREATE A GENEALOGICAL HISTORY AND FAMILY TREE (U.S. CLS. 100 AND 101).

FIRST USE 1-23-2007; IN COMMERCE 1-23-2007.
BARBARA RUTLAND, EXAMINING ATTORNEY

CLASS 42—(Continued).

SN 77-405,641. VALLEYCREST COMPANIES, CALABASAS, CA. FILED 2-25-2008.

Phil Graham Studio

ValleyCrest DesignGroup

SN 77-404,518. BRINNAND, JOHN, SAN JOSE, CA. FILED 2-23-2008.



THE COLOR(S) BLUE (DARK AND LIGHT), VIOLET (DARK AND LIGHT), GREEN AND GOLD IS/ARE CLAIMED AS A FEATURE OF THE MARK.

THE MARK CONSISTS OF THE WORDING "PAGEFIRE" IN THE COLOR GOLD WITH A GREEN BORDER, THE BACKGROUND APPEARS IN THE COLOR BLUE WITH A LIGHT BLUE SPOTLIGHT OVER THE WORDING "PAGEFIRE", AND TO THE RIGHT OF THE WORDING IS A VIOLET LOTUS ON A GREEN LOTUS/LILY PAD DESIGN.

FOR COMPUTER SERVICES, NAMELY, DESIGNING AND IMPLEMENTING NETWORK WEB PAGES FOR OTHERS; CREATION AND PROVISION OF WEB PAGES TO AND FOR THIRD PARTIES; DESIGN OF HOME PAGES; DESIGN OF HOME PAGES AND WEB SITES; DESIGN OF HOME PAGES, COMPUTER SOFTWARE AND WEB SITES; DEVELOPMENT, DESIGN AND UPDATING OF HOME PAGES; COMPUTER SERVICES IN THE NATURE OF CUSTOMIZED WEB PAGES FEATURING USER-DEFINED INFORMATION, PERSONAL PROFILES AND INFORMATION; PROVIDING CUSTOMIZED ON-LINE WEB PAGES FEATURING USER-DEFINED INFORMATION, WHICH INCLUDES SEARCH ENGINES AND ON-LINE WEB LINKS TO OTHER WEB SITES (U.S. CLS. 100 AND 101).

KELLY CHOE, EXAMINING ATTORNEY

OWNER OF U.S. REG. NOS. 2,889,769, 3,358,081 AND OTHERS.

NO CLAIM IS MADE TO THE EXCLUSIVE RIGHT TO USE "STUDIO" AND "DESIGN GROUP", APART FROM THE MARK AS SHOWN.

THE NAME(S), PORTRAIT(S), AND/OR SIGNATURE(S) SHOWN IN THE MARK IDENTIFIES "PHIL GRAHAM", WHOSE CONSENT(S) TO REGISTER IS SUBMITTED.

THE COLOR(S) ORANGE AND BLACK IS/ARE CLAIMED AS A FEATURE OF THE MARK.

THE MARK CONSISTS OF THE WORDS "PHIL GRAHAM" IN ORANGE LETTERS FOLLOWED BY "STUDIO" IN BLACK LETTERS ABOVE A BLACK DOTTED LINE WITH THE WORDS "VALLEYCREST DESIGNGROUP" IN BLACK LETTERS BELOW IT.

FOR LANDSCAPE ARCHITECTURAL DESIGN (U.S. CLS. 100 AND 101).

FIRST USE 12-31-2006; IN COMMERCE 12-31-2006.
LINDA ESTRADA, EXAMINING ATTORNEY

CLASS 42—(Continued).

SN 77-407,677. VECTOR ENGINEERING, INC., GRASS VALLEY, CA. FILED 2-27-2008.

VECTOR
ENGINEERING, INC.

OWNER OF U.S. REG. NO. 2,073,593.
NO CLAIM IS MADE TO THE EXCLUSIVE RIGHT TO USE "ENGINEERING, INC.", APART FROM THE MARK AS SHOWN.

THE MARK CONSISTS OF THE WORDS "VECTOR ENGINEERING, INC." IN ALL CAPITAL LETTERS AND SLIGHTLY INCLINED TO THE RIGHT WITH "VECTOR" ON ONE LINE AND "ENGINEERING, INC." ON ANOTHER BELOW THE FIRST. "VECTOR" IS LARGER THAN "ENGINEERING, INC." AND THE "V" IN "VECTOR" IS LARGER STILL, WITH THE "V" TAKING UP BOTH LINES OF THE MARK.

FOR CIVIL ENGINEERING; HYDROLOGIC AND ENGINEERING MODELING AND DESIGN OF MEASURES TO PROTECT AREAS LIKELY TO BE INUNDATED BY STORM-WATER AND FLOOD-WATERS; TESTING OR RESEARCH ON CIVIL ENGINEERING; ENVIRONMENTAL SERVICES, NAMELY, TECHNICAL CONSULTATION IN THE FIELD OF ENVIRONMENTAL SCIENCE, ENGINEERING SERVICES, DESIGN FOR OTHERS IN THE FIELD OF ENVIRONMENTAL ENGINEERING, DESIGNING AND TESTING OF NEW ENVIRONMENTALLY FRIENDLY PRODUCTS FOR OTHERS; ENGINEERING SERVICES FOR BUILDING AND PROPERTY CONDITION ASSESSMENT, FACILITY MANAGEMENT, REPAIR AND RESTORATION, BUILDING INSTRUMENTATION AND MONITORING, AND ENVIRONMENTAL CONSULTING; ENVIRONMENTAL SERVICES, NAMELY, DETECTION OF CONTAMINANTS IN WATER; GEOLOGICAL SURVEYS OR RESEARCH; ENGINEERING SERVICES FOR THE CONSTRUCTION OF WATER TREATMENT AND PURIFICATION PLANTS, SOLID WASTE TREATMENT PLANTS AND OTHER MUNICIPAL INFRASTRUCTURE FACILITIES; CIVIL ENGINEERING RELATING TO WATER IRRIGATION; CIVIL ENGINEERING FOR THE DESIGN OF HYDROLOGICAL, GEOTECHNICAL, MINING AND ENVIRONMENTAL STRUCTURES, FACILITIES AND IMPROVEMENTS (U.S. CLS. 100 AND 101).

FIRST USE 7-2-1986; IN COMMERCE 7-2-1986.
JILL C. ALT, EXAMINING ATTORNEY

CLASS 42—(Continued).

SN 77-407,883. STEVEN B. ROOSA, LANGHORNE, PA. FILED 2-27-2008.

MACROTHOUGHT

THE MARK CONSISTS OF STANDARD CHARACTERS WITHOUT CLAIM TO ANY PARTICULAR FONT, STYLE, SIZE, OR COLOR.

FOR PROVIDING A WEB SITE WITH INFORMATION RELATED TO ARTIFICIAL INTELLIGENCE; COMPUTER SERVICES, NAMELY, HOSTING ON-LINE WEB FACILITIES FOR OTHERS FOR ORGANIZING AND CONDUCTING INTERACTIVE DISCUSSIONS OF MODELS FOR ARTIFICIAL INTELLIGENCE IN THE PUBLIC DOMAIN VIA A GLOBAL COMMUNICATIONS NETWORK; DEVELOPMENT OF MODELS FOR ARTIFICIAL INTELLIGENCE FOR OTHERS PROVIDED VIA A GLOBAL COMMUNICATIONS NETWORK (U.S. CLS. 100 AND 101).

TRACY CROSS, EXAMINING ATTORNEY

SN 77-411,238. STEVENS, TERRI LEWIS, DBA LSARCHITECTURE, PLLC, BEAUMONT, TX. FILED 3-3-2008.



www.LSArchitecture.com

NO CLAIM IS MADE TO THE EXCLUSIVE RIGHT TO USE "ARCHITECTURE", APART FROM THE MARK AS SHOWN.

THE COLOR(S) RED, BLACK AND GREY IS/ARE CLAIMED AS A FEATURE OF THE MARK.

THE MARK CONSISTS OF THE COLOR GREY APPEARS IN THE FLEUR DE LIS, WITH LIGHT GREY HIGHLIGHTS, AND AS A SHADOW IN THE WORDING. THE COLOR RED APPEARS IN THE LETTERS "LS". THE COLOR BLACK APPEARS IN THE WORDING "ARCHITECTURE" AND "WWW.LSARCHITECTURE.COM".

FOR ARCHITECTURAL AND ENGINEERING SERVICES (U.S. CLS. 100 AND 101).

FIRST USE 4-30-2004; IN COMMERCE 4-30-2004.
DAYNA BROWNE, EXAMINING ATTORNEY

CLASS 42—(Continued).

SN 77-414,448. INFRASTRUCTURE, LLC, OMAHA, NE.
FILED 3-6-2008.



THE COLOR(S) RED AND WHITE IS/ARE CLAIMED AS A FEATURE OF THE MARK.

THE MARK CONSISTS OF A RED SQUARE WITH FIVE WHITE VERTICAL LINES AND FIVE WHITE HORIZONTAL LINES DEPICTING A GRID AND CONTAINING THE LETTER I IN WHITE AND THE LETTER S IN WHITE.

FOR ARCHITECTURAL AND ENGINEERING SERVICES; CIVIL ENGINEERING; CIVIL ENGINEERING FOR THE DESIGN OF PUBLIC AND PRIVATE INFRASTRUCTURES; COMPUTER-AIDED ENGINEERING SERVICES FOR OTHERS; CONDUCTING ENGINEERING SURVEYS; CONSULTING IN THE FIELDS OF ENGINEERING AND ARCHITECTURE; ENGINEERING; ENGINEERING SERVICES FOR BUILDING AND PROPERTY CONDITION ASSESSMENT, FACILITY MANAGEMENT, REPAIR AND RESTORATION, BUILDING INSTRUMENTATION AND MONITORING, AND ENVIRONMENTAL CONSULTING; ENGINEERING SERVICES, NAMELY, ENGINEERING OF PUBLIC AND PRIVATE INFRASTRUCTURES; ENVIRONMENTAL SERVICES, NAMELY, TECHNICAL CONSULTATION IN THE FIELD OF ENVIRONMENTAL SCIENCE, ENGINEERING SERVICES, DESIGN FOR OTHERS IN THE FIELD OF ENVIRONMENTAL ENGINEERING, DESIGNING AND TESTING OF NEW ENVIRONMENTALLY FRIENDLY PRODUCTS FOR OTHERS; SURVEYING AND ENGINEERING; PLANNING OF BUILDINGS AND INFRASTRUCTURE SYSTEMS FOR BUILDINGS; RESIDENTIAL BUILDING DESIGN; ARCHITECTURAL DESIGN; CONSULTING SERVICES IN THE FIELD OF ARCHITECTURAL DESIGN; DESIGN FOR OTHERS IN THE FIELD OF ARCHITECTURE, ENGINEERING AND CONSTRUCTION; DESIGN OF FACTORY BUILDINGS; INDUSTRIAL DESIGN; INDUSTRIAL DESIGN SERVICES; LANDSCAPE ARCHITECTURAL DESIGN; PLANNING AND LAYOUT DESIGN FOR THE INTERIOR SPACE OF RETAIL BUSINESS ESTABLISHMENTS; PROVIDING DESIGN SERVICES FOR OTHERS IN THE FIELD OF THEME PARKS, MUSEUMS, AND MINIATURE GOLF COURSES; CONSULTING SERVICES IN THE FIELD OF ENVIRONMENTAL ASSESSMENT, COMPLIANCE AND PLANNING (U.S. CLS. 100 AND 101).

ESTHER BELENKER, EXAMINING ATTORNEY

CLASS 42—(Continued).

SN 77-414,737. THUMBHEADS, LLC, SANTA MONICA, CA.
FILED 3-6-2008.



THE COLOR(S) TEAL, ORANGE, BLACK, WHITE, BROWN, YELLOW AND GRAY IS/ARE CLAIMED AS A FEATURE OF THE MARK.

THE MARK CONSISTS OF THE WORD "GAMEBEING" USING THE FONT BAVEUSE. THE LETTERS "GAME" ARE COLORED TEAL, THE LETTERS "BEING" ARE COLORED ORANGE. THE LETTERS "A" AND "I" ARE STYLIZED INTO CUSTOM CARTOON IMAGES OF A MALE PROGRAMMER AND A FEMALE PAINTER, RESPECTIVELY. THE MALE PROGRAMMER'S IMAGE, EYES, HANDS AND FEET ARE OUTLINED IN BLACK WITH A TEAL BOTTOM; FACE IS WHITE AND IS HOLDING A GRAY TELEPHONE. THE FEMALE PAINTER HAS AN ORANGE BODY, WHITISH BROWN FACE WITH BLACK HANDS AND LEGS, YELLOW EARRING, THE STEM OF THE PAINT BRUSH AND PAINT BOWL ARE BROWN WITH ORANGE PAINT ON THE BRUSH AND THE BOWL AS WELL AS YELLOW PAINT ON THE BOWL. THE BRISTLES OF THE PAINT BRUSH ARE BLACK.

FOR HOSTING AN ONLINE COMMUNITY WEB SITE FEATURING BUSINESS NETWORKING, ELECTRONIC RESUMES, PROJECTS DATABASE, USER CONTENT, USER RATINGS, JOB CLASSIFIEDS/MARKETPLACE FOR THE VIDEO GAMES INDUSTRY (U.S. CLS. 100 AND 101).

NAAKWAMA ANKRAH, EXAMINING ATTORNEY

SN 77-415,015. EQUINOX HOLDINGS, INC., NEW YORK, NY. FILED 3-6-2008.

MYEQ

THE MARK CONSISTS OF STANDARD CHARACTERS WITHOUT CLAIM TO ANY PARTICULAR FONT, STYLE, SIZE, OR COLOR.

FOR PROVIDING TEMPORARY USE OF NON-DOWNLOADABLE COMPUTER SOFTWARE FOR ONLINE FITNESS TRACKING AND PLANNING OF INDIVIDUAL EXERCISE ROUTINES, FITNESS GOALS, AND NUTRITIONAL INTAKE (U.S. CLS. 100 AND 101).

CHRISTINE COOPER, EXAMINING ATTORNEY

CLASS 42—(Continued).

SN 77-415,019. EQUINOX HOLDINGS, INC., NEW YORK, NY. FILED 3-6-2008.

MYEQX

THE MARK CONSISTS OF STANDARD CHARACTERS WITHOUT CLAIM TO ANY PARTICULAR FONT, STYLE, SIZE, OR COLOR.

FOR PROVIDING TEMPORARY USE OF NON-DOWNLOADABLE COMPUTER SOFTWARE FOR ONLINE FITNESS TRACKING AND PLANNING OF INDIVIDUAL EXERCISE ROUTINES, FITNESS GOALS, AND NUTRITIONAL INTAKE (U.S. CLS. 100 AND 101).

CHRISTINE COOPER, EXAMINING ATTORNEY

SN 77-416,348. PREFERRED SOURCING LLC, GREENFIELD, IN. FILED 3-7-2008.

CONTAINING IMPROVING SUSTAINING

THE MARK CONSISTS OF STANDARD CHARACTERS WITHOUT CLAIM TO ANY PARTICULAR FONT, STYLE, SIZE, OR COLOR.

FOR TECHNICAL CONSULTATION RELATING TO THE DETECTION, ANALYSIS, CONTAINMENT AND REPORTING OF NON-CONFORMING PARTS AND MATERIALS IN THE MANUFACTURING PROCESSES OF THE AUTOMOTIVE, AEROSPACE, ELECTRONICS AND AGRICULTURAL INDUSTRIES; QUALITY CONTROL SERVICES FOR OTHERS, NAMELY, THE DETECTION, ANALYSIS, CONTAINMENT AND REPORTING OF NON-CONFORMING PARTS AND MATERIALS IN THE MANUFACTURING PROCESSES OF THE AUTOMOTIVE, AEROSPACE, ELECTRONICS AND AGRICULTURAL INDUSTRIES (U.S. CLS. 100 AND 101).

FIRST USE 12-18-2007; IN COMMERCE 12-18-2007.
KATHERINE STOIDES, EXAMINING ATTORNEY

CLASS 42—(Continued).

SN 77-416,477. HOSTED FINANCIALS, INC., THOUSAND OAKS, CA. FILED 3-7-2008.

CLOUDWORKS 

THE MARK CONSISTS OF THE WORD "CLOUDWORKS" IN TWO DIFFERENT TYPEFACES FOLLOWED BY A CIRCLE CONTAINING SHAPES REMINISCENT OF DARK AND LIGHT CLOUDS.

FOR APPLICATION SERVICE PROVIDER (ASP), NAMELY, HOSTING COMPUTER SOFTWARE APPLICATIONS OF OTHERS; COMPUTER SERVICE, NAMELY, ACTING AS AN APPLICATION SERVICE PROVIDER IN THE FIELD OF KNOWLEDGE MANAGEMENT TO HOST COMPUTER APPLICATION SOFTWARE FOR THE COLLECTION, EDITING, ORGANIZING, MODIFYING, BOOK MARKING, TRANSMISSION, STORAGE AND SHARING OF DATA AND INFORMATION; COMPUTER SERVICES, NAMELY, REMOTE AND ON-SITE MANAGEMENT OF ELECTRONIC MESSAGING SYSTEMS AND APPLICATIONS FOR OTHERS; COMPUTER SERVICES, NAMELY, REMOTE MANAGEMENT OF COMPUTER APPLICATIONS FOR OTHERS; RENTAL OF APPLICATION SOFTWARE; COMPUTER CONSULTATION; COMPUTER CONSULTATION IN THE FIELD OF COMPUTER SECURITY; COMPUTER SOFTWARE CONSULTANCY; COMPUTER SOFTWARE CONSULTATION; CONSULTATION SERVICES IN THE FIELDS OF SELECTION, IMPLEMENTATION AND USE OF COMPUTER HARDWARE AND SOFTWARE SYSTEMS FOR OTHERS; CONSULTING SERVICES IN THE FIELD OF DESIGN, SELECTION, IMPLEMENTATION AND USE OF COMPUTER HARDWARE AND SOFTWARE SYSTEMS FOR OTHERS; INFORMATION TECHNOLOGY CONSULTATION (U.S. CLS. 100 AND 101).

FIRST USE 8-7-2007; IN COMMERCE 8-7-2007.
HOWARD SMIGA, EXAMINING ATTORNEY

SN 77-417,707. BINARY INERTIA LLC, OTTUMWA, IA. FILED 3-10-2008.

GLITTERFY

THE MARK CONSISTS OF STANDARD CHARACTERS WITHOUT CLAIM TO ANY PARTICULAR FONT, STYLE, SIZE, OR COLOR.

FOR PROVIDING A WEB SITE THAT GIVES COMPUTER USERS THE ABILITY TO UPLOAD, EXCHANGE AND SHARE PHOTOS, VIDEOS AND VIDEO LOGS; COMPUTER SERVICES, NAMELY, INTERACTIVE HOSTING SERVICES WHICH ALLOW THE USER TO PUBLISH AND SHARE THEIR OWN CONTENT AND IMAGES ON-LINE (U.S. CLS. 100 AND 101).

FIRST USE 11-30-2006; IN COMMERCE 11-30-2006.
KHANH LE, EXAMINING ATTORNEY

CLASS 42—(Continued).

SN 77-417,957. MATRIX RESOURCES, INC., ATLANTA, GA. FILED 3-10-2008.

MATRIX PROFESSIONAL SERVICES

THE MARK CONSISTS OF STANDARD CHARACTERS WITHOUT CLAIM TO ANY PARTICULAR FONT, STYLE, SIZE, OR COLOR.

NO CLAIM IS MADE TO THE EXCLUSIVE RIGHT TO USE "PROFESSIONAL SERVICES", APART FROM THE MARK AS SHOWN.

FOR INFORMATION TECHNOLOGY CONSULTING SERVICES (U.S. CLS. 100 AND 101).

BARBARA BROWN, EXAMINING ATTORNEY

SN 77-419,367. PATRICK, KEI L, TOWNSEND, DE. FILED 3-11-2008.

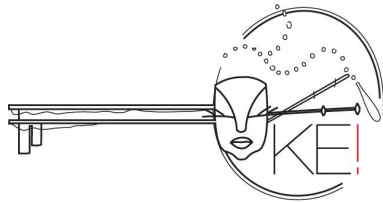

THE COLOR(S) RED AND BLACK IS/ARE CLAIMED AS A FEATURE OF THE MARK.

THE MARK CONSISTS OF A STYLIZED KEY DESIGN ALL IN BLACK AND CONTAINING A FACE, AND THE WORDING "KEY", WHEREIN THE LETTERS "K" AND "E" ARE BLACK AND "I" IS PRESENTED AS A RED EXCLAMATION POINT.

FOR DESIGN FOR OTHERS IN THE FIELD OF FASHION, DYEING AND BLEACHING, COMPUTERS, CLOTHING, DRESSES, SHIRTS, PANTS, FABRIC, TEXTILES, JACKETS, COATS, JEWELRY, HAIR ACCESSORIES, SHOES, HANDBAGS, PACKAGING, AND CLOTH; CUSTOM DESIGN OF WEARABLE APPAREL, PAPER GOODS, JEWELRY, HAIR ACCESSORIES, SHOES, TEXTILES, FABRIC BASED ON PERSONAL SELECTIONS MADE BY THE CUSTOMER; DESIGN OF HOMEPAGES AND WEB-SITES; DESIGN OF INTERIOR DECOR; DESIGN OF SPECIALTY INTERIOR AND EXTERIOR ENVIRONMENT SETTINGS; DESIGN OF TEXTILES; DESIGN SKETCHING OF PACKAGING, CONTAINERS, DINNERWARE AND TABLE UTENSILS; DESIGNING OF PACKAGING AND WRAPPING MATERIALS; DESIGNING THEME GRAPHICS AND MULTIMEDIA SHOWS FOR CONVENTIONS, PRODUCT LAUNCHES, TRADE SHOWS, KEY NOTE ADDRESSES AND AWARD CEREMONIES FOR OTHERS; DRESS DESIGN; DRESS DESIGNING; FURNITURE DESIGN SERVICES; GRAPHIC ART DESIGN; GRAPHIC ARTS DESIGNING; GRAPHIC DESIGN; GRAPHIC DESIGN SERVICES; PACKAGING DESIGN; PACKAGING DESIGN FOR OTHERS; SET DESIGN FOR THEATRICAL ENTERPRISES; SHOP INTERIOR DESIGN; VISUAL DESIGN SERVICES IN THE NATURE OF DESIGNING VISUAL ELEMENTS FOR ONLINE, BROADCAST, PRINT, OUTDOOR AND OTHER COMMUNICATION MEDIA (U.S. CLS. 100 AND 101).

REBECCA POVARCHUK, EXAMINING ATTORNEY

CLASS 42—(Continued).

SN 77-419,436. CARBON12, LLC, MONTEREY, CA. FILED 3-12-2008.

Carbon12

THE MARK CONSISTS OF STANDARD CHARACTERS WITHOUT CLAIM TO ANY PARTICULAR FONT, STYLE, SIZE, OR COLOR.

FOR COMPUTER AND TECHNOLOGICAL SERVICES, NAMELY, HOSTING ONLINE WEB FACILITIES FOR OTHERS FOR ORGANIZING AND CONDUCTING ONLINE MEETINGS, GATHERINGS, AND INTERACTIVE DISCUSSIONS REGARDING DISEASE, DISORDERS, HEALTH CONDITIONS, OR INJURIES; AND COMPUTER SERVICES IN THE NATURE OF CUSTOMIZED WEB PAGES FEATURING USER-DEFINED INFORMATION, PERSONAL PROFILES AND INFORMATION REGARDING DISEASE, DISORDERS, HEALTH CONDITIONS, OR INJURIES (U.S. CLS. 100 AND 101).

JORDAN BAKER, EXAMINING ATTORNEY

SN 77-419,829. XNINE CORPORATION, AMERICAN FORK, UT. FILED 3-12-2008.

XNINE Corporation

THE MARK CONSISTS OF STANDARD CHARACTERS WITHOUT CLAIM TO ANY PARTICULAR FONT, STYLE, SIZE, OR COLOR.

NO CLAIM IS MADE TO THE EXCLUSIVE RIGHT TO USE "CORPORATION", APART FROM THE MARK AS SHOWN.

FOR COMPUTER SERVICES, NAMELY, REMOTE MANAGEMENT OF COMPUTER APPLICATIONS FOR OTHERS (U.S. CLS. 100 AND 101).

CYNTHIA TRIPI, EXAMINING ATTORNEY

SN 77-421,006. SHAW, NANCY A., DBA RIPEPAPER, ACTON, MA. FILED 3-13-2008.

identity meeting information meeting interaction

THE MARK CONSISTS OF STANDARD CHARACTERS WITHOUT CLAIM TO ANY PARTICULAR FONT, STYLE, SIZE, OR COLOR.

FOR GRAPHIC DESIGN SERVICES (U.S. CLS. 100 AND 101).

NORA BUCHANAN WILL, EXAMINING ATTORNEY

CLASS 42—(Continued).

SN 77-421,515. ACCURATE DATA, LLC, COSTA MESA, CA.
FILED 3-13-2008.

CLASS 42—(Continued).

SN 77-423,399. OWNING ED LLC, NORTH PLAINFIELD, NJ.
FILED 3-17-2008.

Invoice In Process

THE MARK CONSISTS OF STANDARD CHARACTERS WITHOUT CLAIM TO ANY PARTICULAR FONT, STYLE, SIZE, OR COLOR.

FOR COMPUTER SERVICE, NAMELY, ACTING AS AN APPLICATION SERVICE PROVIDER IN THE FIELD OF KNOWLEDGE MANAGEMENT TO HOST COMPUTER APPLICATION SOFTWARE FOR THE COLLECTION, EDITING, ORGANIZING, MODIFYING, BOOK MARKING, TRANSMISSION, STORAGE AND SHARING OF DATA AND INFORMATION (U.S. CLS. 100 AND 101).

STEPHANIE ALI, EXAMINING ATTORNEY

SN 77-422,879. CREATIVE COMMONS CORPORATION, SAN FRANCISCO, CA. FILED 3-14-2008.

Health Commons

THE MARK CONSISTS OF STANDARD CHARACTERS WITHOUT CLAIM TO ANY PARTICULAR FONT, STYLE, SIZE, OR COLOR.

OWNER OF U.S. REG. NOS. 2,792,432, 3,272,095 AND OTHERS.

NO CLAIM IS MADE TO THE EXCLUSIVE RIGHT TO USE "HEALTH", APART FROM THE MARK AS SHOWN.

FOR DEVELOPMENT, UPDATING AND MAINTENANCE OF SOFTWARE AND DATA BASES (U.S. CLS. 100 AND 101).

YONG KIM, EXAMINING ATTORNEY

SN 77-422,935. ENOCK, MATTHEW, NEW YORK, NY.
FILED 3-14-2008.

Percepted

THE MARK CONSISTS OF STANDARD CHARACTERS WITHOUT CLAIM TO ANY PARTICULAR FONT, STYLE, SIZE, OR COLOR.

FOR GRAPHIC DESIGN (U.S. CLS. 100 AND 101).

FIRST USE 3-10-2008; IN COMMERCE 3-10-2008.

JOHN SCHUYLER YARD, EXAMINING ATTORNEY

OWNING ED

THE MARK CONSISTS OF STANDARD CHARACTERS WITHOUT CLAIM TO ANY PARTICULAR FONT, STYLE, SIZE, OR COLOR.

FOR COMPUTER SERVICES, NAMELY, HOSTING AN ON-LINE WEB FACILITY MEETING PLACE FOR EDUCATORS AND STUDENTS TO SHARE IDEAS AND DISCUSSIONS ABOUT THE NATURE OF LEARNING (U.S. CLS. 100 AND 101).

JILL PRATER, EXAMINING ATTORNEY

SN 77-423,591. OLYSOFT, MARIETTA, GA. FILED 3-17-2008.

OlySoft

THE MARK CONSISTS OF STANDARD CHARACTERS WITHOUT CLAIM TO ANY PARTICULAR FONT, STYLE, SIZE, OR COLOR.

FOR COMPUTER HARDWARE AND SOFTWARE CONSULTING SERVICES, NAMELY, COMPUTER SOFTWARE TECHNOLOGY CONSULTING AND SOFTWARE CONFIGURATION, MAINTENANCE AND UPDATING; COMPUTER AND RELATED IT DISASTER RECOVERY PLANNING AND CONSULTATION RENDERED IN CONNECTION THEREWITH; DESIGNING OF INTRANET AND EXTRANET DOCUMENT MANAGEMENT PORTALS AND WORKFLOW FOR BUSINESS PROCESS AUTOMATION (U.S. CLS. 100 AND 101).

FIRST USE 3-15-1988; IN COMMERCE 9-15-1996.

KATHLEEN M. VANSTON, EXAMINING ATTORNEY

CLASS 42—(Continued).

SN 77-424,391. SMOOTH COMMUNICATIONS, GRAND FORKS, ND. FILED 3-17-2008.



NO CLAIM IS MADE TO THE EXCLUSIVE RIGHT TO USE "COMMUNICATIONS", APART FROM THE MARK AS SHOWN.

THE MARK CONSISTS OF THE TEXT "SMOOTH COMMUNICATIONS" ADJACENT TO CIRCLE DESIGNS.

FOR COMPUTER SOFTWARE CONSULTATION; COMPUTER SOFTWARE DESIGN; COMPUTER SOFTWARE DESIGN FOR OTHERS; COMPUTER SOFTWARE DEVELOPMENT; APPLICATION SERVICE PROVIDER (ASP) FEATURING SOFTWARE FOR USE AS AN ONLINE ORGANIZER AND COMMUNICATION TOOL, NAMELY, AN ELECTRONIC CALENDAR, TASK MANAGER, E-MAIL SERVICE AND CONTACT MANAGER THAT ANALYZES PERSONAL DATA TO ADVERTISE AND PROMOTE SERVICES FROM INTERACTIVE CONTENT STORED IN A DATABASE; PROVIDING ON-LINE NON-DOWNLOADABLE SOFTWARE FOR AN ONLINE ORGANIZER AND COMMUNICATION TOOL, NAMELY, AN ELECTRONIC CALENDAR, TASK MANAGER, E-MAIL SERVICE AND CONTACT MANAGER THAT ANALYZES PERSONAL DATA TO ADVERTISE AND PROMOTE SERVICES FROM INTERACTIVE CONTENT STORED IN A DATABASE (U.S. CLS. 100 AND 101).

FIRST USE 3-7-2008; IN COMMERCE 3-7-2008.
MARY MUNSON, EXAMINING ATTORNEY

SN 77-424,499. NVIZN IT, LLC, PITTSBURGH, PA. FILED 3-18-2008.

nvizn IT

THE MARK CONSISTS OF STANDARD CHARACTERS WITHOUT CLAIM TO ANY PARTICULAR FONT, STYLE, SIZE, OR COLOR.

FOR CONSULTING IN THE FIELD OF INFORMATION TECHNOLOGY, NAMELY, OFFERING COMPREHENSIVE, MANAGED BUSINESS SOLUTIONS TO ENHANCE CUSTOMER BUSINESS OPERATIONS (U.S. CLS. 100 AND 101).

JAY FLOWERS, EXAMINING ATTORNEY

CLASS 42—(Continued).

SN 77-424,926. CASHEDGE, INC., NEW YORK, NY. FILED 3-18-2008.

SETUPNOW

THE MARK CONSISTS OF STANDARD CHARACTERS WITHOUT CLAIM TO ANY PARTICULAR FONT, STYLE, SIZE, OR COLOR.

FOR PROVIDING TEMPORARY USE OF NONDOWNLOADABLE SOFTWARE FOR COMPUTER APPLICATION CONFIGURATION, DEPLOYMENT AND MANAGEMENT, IN THE FIELD OF FINANCIAL SERVICES (U.S. CLS. 100 AND 101).

RUDY R. SINGLETON, EXAMINING ATTORNEY

SN 77-424,983. HU, JASON C., SAN JOSE, CA. FILED 3-18-2008.

VEEDBACK

THE MARK CONSISTS OF STANDARD CHARACTERS WITHOUT CLAIM TO ANY PARTICULAR FONT, STYLE, SIZE, OR COLOR.

FOR COMPUTER SERVICES, NAMELY, CREATING AN ONLINE COMMUNITY FOR USERS TO SUBMIT, DISPLAY, SHARE, AND DISCUSS CONSUMER FEEDBACKS AND REVIEWS ON PRODUCTS, SERVICES, BUSINESS ORGANIZATIONS, AND OTHER RESOURCES OVER THE INTERNET OR OTHER COMMUNICATIONS NETWORK (U.S. CLS. 100 AND 101).

FIRST USE 2-25-2008; IN COMMERCE 2-25-2008.
CIMMERIAN COLEMAN, EXAMINING ATTORNEY

SN 77-425,994. MUKTI INCORPORATED, DANA POINT, CA. FILED 3-19-2008.

BUZZcurve

THE STIPLING IS FOR SHADING PURPOSES ONLY. THE MARK CONSISTS OF A COMBINATION OF TWO WORDS: "BUZZ" AND "CURVE" PRESENTED AS ONE IN UPPER AND LOWER CASE TEXT.

FOR PROVIDING ON-LINE NON-DOWNLOADABLE SOFTWARE FOR AUTOMATION OF CONSUMER TESTING OF ADVERTISING, MIXED-MEDIA, HTML, AND PRINT AND VIDEO CONTENT ON SOCIAL NETWORKING SITES (U.S. CLS. 100 AND 101).

FIRST USE 5-1-2007; IN COMMERCE 6-1-2007.
MATTHEW PAPPAS, EXAMINING ATTORNEY

CLASS 42—(Continued).

SN 77-426,262. CLEARFUELS TECHNOLOGY, INC., AIEA, HI. FILED 3-19-2008.



NO CLAIM IS MADE TO THE EXCLUSIVE RIGHT TO USE TECHNOLOGY, INC., APART FROM THE MARK AS SHOWN.

THE COLOR(S) BLUE, GREEN, YELLOW AND WHITE IS/ARE CLAIMED AS A FEATURE OF THE MARK.

THE MARK CONSISTS OF THE WORDS "CLEARFUELS TECHNOLOGY, INC." AND A LEAF AND FLAME DESIGN. THE COLOR GRAY APPEARS IN THE TEXT OF THE WORDING "CLEARFUELS TECHNOLOGY, INC." HOWEVER, GRAY IS NOT CLAIMED AS A FEATURE OF THE MARK, AND IS FOR SHADING PURPOSES ONLY. THE COLOR BLUE APPEARS AS THE SHADING IN THE GAS FLAME DESIGN. THE COLOR GREEN APPEARS AT THE BASE OF THE LEAF DESIGN, AND GRADUALLY FADES UPWARD INTO YELLOW. THE COLOR WHITE APPEARS AS THE SHADING FOR THE STEM DESIGN IN THE LEAF, AND IN THE INTERIOR OF THE FLAME.

FOR RESEARCH AND DEVELOPMENT AND CONSULTATION RELATED THERETO IN THE FIELD OF ENERGY PRODUCTION (U.S. CLS. 100 AND 101).

FIRST USE 2-2-2005; IN COMMERCE 2-2-2005.

ELI HELLMAN, EXAMINING ATTORNEY

CLASS 42—(Continued).

SN 77-427,073. DIANNA L. HUND, LAKE FOREST, CA. FILED 3-20-2008.



NO CLAIM IS MADE TO THE EXCLUSIVE RIGHT TO USE "BEST DVD SOLUTIONS", APART FROM THE MARK AS SHOWN.

THE COLOR(S) PURPLE, LAVENDER, GOLD, WHITE, BLACK, MAGENTA AND GREEN IS/ARE CLAIMED AS A FEATURE OF THE MARK.

THE MARK CONSISTS OF THE WORDS "BEST DVD SOLUTIONS" IN PURPLE AND LAVENDER AROUND A STYLIZED THREE-DIMENSIONAL GOLD DISK WITH A WHITE AND BLACK CENTER AND GRADIENT HIGHLIGHTS OF MAGENTA, PURPLE AND GREEN EMANATING FROM THE CENTER ACROSS THE DISK.

FOR DIGITAL TRANSFER SERVICES FOR TRANSFERRING HOME VIDEOS AND FILM ON OLD MEDIA TO DVD AND CD (U.S. CLS. 100 AND 101).

FIRST USE 3-15-2006; IN COMMERCE 4-1-2006.

DAVID YONTEF, EXAMINING ATTORNEY

SN 77-427,165. KPIFIX INC., PASADENA, CA. FILED 3-20-2008.



THE COLOR(S) BLUE, GREEN, YELLOW, RED AND PURPLE IS/ARE CLAIMED AS A FEATURE OF THE MARK.

THE MARK CONSISTS OF A THREE DIMENSIONAL PIE CHART WITH COLORS BLUE, GREEN, YELLOW, RED AND PURPLE, FOLLOWED BY BLUE UPPERCASE LETTERS "KPI" AND GREEN LETTERS "FIX" IN LOWERCASE.

FOR PROVIDING ON-LINE NON-DOWNLOADABLE SOFTWARE FOR BUSINESS PERFORMANCE MANAGEMENT (U.S. CLS. 100 AND 101).

MARY MUNSON, EXAMINING ATTORNEY

CLASS 42—(Continued).

SN 77-427,264. HALL ENVIRONMENTAL ANALYSIS LABORATORY INC., ALBUQUERQUE, NM. FILED 3-20-2008.

CLASS 42—(Continued).

SN 77-427,417. RISK MITIGATION SYSTEMS, LLC, ATLANTA, GA. FILED 3-20-2008.

HALL ENVIRONMENTAL ANALYSIS LABORATORY

VIRTUALGUARDIAN

THE MARK CONSISTS OF STANDARD CHARACTERS WITHOUT CLAIM TO ANY PARTICULAR FONT, STYLE, SIZE, OR COLOR.

THE MARK CONSISTS OF STANDARD CHARACTERS WITHOUT CLAIM TO ANY PARTICULAR FONT, STYLE, SIZE, OR COLOR.

NO CLAIM IS MADE TO THE EXCLUSIVE RIGHT TO USE "ENVIRONMENTAL ANALYSIS LABORATORY", APART FROM THE MARK AS SHOWN.

FOR APPLICATION SERVICE PROVIDER, NAMELY, PROVIDING, HOSTING, MANAGING, DEVELOPING, RESEARCHING, ANALYZING, REPORTING, AND MAINTAINING APPLICATIONS, SOFTWARE, WEB SITES, AND DATABASES OF OTHERS IN THE FIELD OF SAFETY RISK MITIGATION VIA INCIDENT RESPONSE, MONITORING AND TWO-WAY COMMUNICATIONS TO ENSURE THE PERSONAL SAFETY OF EMPLOYEES, MILITARY PERSONNEL, GUESTS AND OTHER PERSONS WHILE AT WORK, ON DUTY, AT LEISURE FACILITIES SUCH AS STADIUMS AND MALLS, AND OTHER LOCATIONS (U.S. CLS. 100 AND 101).

FOR LABORATORY SERVICES, NAMELY, ENVIRONMENTAL ANALYSIS OF WATER, WASTEWATER, SOIL, SOLID WASTES, AIR, AND CONTAMINANTS (U.S. CLS. 100 AND 101).

FIRST USE 5-0-1991; IN COMMERCE 5-0-1991.
JUDITH HELFMAN, EXAMINING ATTORNEY

ZHALEH DELANEY, EXAMINING ATTORNEY

SN 77-427,391. HALL ENVIRONMENTAL ANALYSIS LABORATORY INC., ALBUQUERQUE, NM. FILED 3-20-2008.

SN 77-427,464. RISK MITIGATION SYSTEMS, LLC, ATLANTA, GA. FILED 3-20-2008.



VIRTUALGUARDIAN VISITOR

THE MARK CONSISTS OF A STYLIZED "H" COMPRISED OF FIVE RECTANGLES, WITH EACH RECTANGULAR LEG DIVIDED INTO AN UPPER AND LOWER SECTION. THE CENTER OF THE "H" AND THE OUTERMOST SECTIONS OF THE LEGS ARE FULLY SHADED.

THE MARK CONSISTS OF STANDARD CHARACTERS WITHOUT CLAIM TO ANY PARTICULAR FONT, STYLE, SIZE, OR COLOR.

NO CLAIM IS MADE TO THE EXCLUSIVE RIGHT TO USE "VISITOR", APART FROM THE MARK AS SHOWN.

FOR LABORATORY SERVICES, NAMELY, ENVIRONMENTAL ANALYSIS OF WATER, WASTEWATER, SOIL, SOLID WASTES, AIR, AND CONTAMINANTS (U.S. CLS. 100 AND 101).

FOR APPLICATION SERVICE PROVIDER, NAMELY, PROVIDING, HOSTING, MANAGING, DEVELOPING, RESEARCHING, ANALYZING, REPORTING, AND MAINTAINING APPLICATIONS, SOFTWARE, WEB SITES, AND DATABASES OF OTHERS IN THE FIELD OF SAFETY RISK MITIGATION VIA INCIDENT RESPONSE, MONITORING AND TWO-WAY COMMUNICATIONS TO ENSURE THE PERSONAL SAFETY OF EMPLOYEES, MILITARY PERSONNEL, GUESTS AND OTHER PERSONS WHILE AT WORK, ON DUTY, AT LEISURE FACILITIES SUCH AS STADIUMS AND MALLS, AND OTHER LOCATIONS (U.S. CLS. 100 AND 101).

FIRST USE 5-0-1991; IN COMMERCE 5-0-1991.
JUDITH HELFMAN, EXAMINING ATTORNEY

ZHALEH DELANEY, EXAMINING ATTORNEY

CLASS 42—(Continued).

SN 77-427,494. RISK MITIGATION SYSTEMS, LLC, ATLANTA, GA. FILED 3-20-2008.

VIRTUALGUARDIAN ESCORT

THE MARK CONSISTS OF STANDARD CHARACTERS WITHOUT CLAIM TO ANY PARTICULAR FONT, STYLE, SIZE, OR COLOR.

FOR APPLICATION SERVICE PROVIDER, NAMELY, PROVIDING, HOSTING, MANAGING, DEVELOPING, RESEARCHING, ANALYZING, REPORTING, AND MAINTAINING APPLICATIONS, SOFTWARE, WEB SITES, AND DATABASES OF OTHERS IN THE FIELD OF SAFETY RISK MITIGATION VIA INCIDENT RESPONSE, MONITORING AND TWO-WAY COMMUNICATIONS TO ENSURE THE PERSONAL SAFETY OF EMPLOYEES, MILITARY PERSONNEL, GUESTS AND OTHER PERSONS WHILE AT WORK, ON DUTY, AT LEISURE FACILITIES SUCH AS STADIUMS AND MALLS, AND OTHER LOCATIONS (U.S. CLS. 100 AND 101).

ZHALEH DELANEY, EXAMINING ATTORNEY

SN 77-427,558. RISK MITIGATION SYSTEMS, LLC, ATLANTA, GA. FILED 3-20-2008.

VIRTUALGUARDIAN ROLL CALL

THE MARK CONSISTS OF STANDARD CHARACTERS WITHOUT CLAIM TO ANY PARTICULAR FONT, STYLE, SIZE, OR COLOR.

FOR APPLICATION SERVICE PROVIDER, NAMELY, PROVIDING, HOSTING, MANAGING, DEVELOPING, RESEARCHING, ANALYZING, REPORTING, AND MAINTAINING APPLICATIONS, SOFTWARE, WEB SITES, AND DATABASES OF OTHERS IN THE FIELD OF SAFETY RISK MITIGATION VIA INCIDENT RESPONSE, MONITORING AND TWO-WAY COMMUNICATIONS TO ENSURE THE PERSONAL SAFETY OF EMPLOYEES, MILITARY PERSONNEL, GUESTS AND OTHER PERSONS WHILE AT WORK, ON DUTY, AT LEISURE FACILITIES SUCH AS STADIUMS AND MALLS, AND OTHER LOCATIONS (U.S. CLS. 100 AND 101).

ZHALEH DELANEY, EXAMINING ATTORNEY

CLASS 42—(Continued).

SN 77-427,863. JOHNSON, MIRMIRAN & THOMPSON, INC., SPARKS, MD. FILED 3-20-2008.

CREATING A BRIGHTER FUTURE

THE MARK CONSISTS OF STANDARD CHARACTERS WITHOUT CLAIM TO ANY PARTICULAR FONT, STYLE, SIZE, OR COLOR.

OWNER OF U.S. REG. NO. 2,912,944.

FOR ENGINEERING; ARCHITECTURAL AND ENGINEERING SERVICES; CIVIL ENGINEERING; DESIGN FOR OTHERS IN THE FIELD OF ENGINEERING; ARCHITECTURE; INFORMATION TECHNOLOGY CONSULTATION; CONSULTING SERVICES IN THE FIELD OF DESIGN, SELECTION, IMPLEMENTATION AND USE OF COMPUTER HARDWARE AND SOFTWARE SYSTEMS FOR OTHERS (U.S. CLS. 100 AND 101).
FIRST USE 11-29-2007; IN COMMERCE 1-15-2008.

MICHAEL TANNER, EXAMINING ATTORNEY

SN 77-427,866. REDLINE SOLUTIONS, INC., SANTA CLARA, CA. FILED 3-20-2008.

REDLINE SOLUTIONS

THE MARK CONSISTS OF STANDARD CHARACTERS WITHOUT CLAIM TO ANY PARTICULAR FONT, STYLE, SIZE, OR COLOR.

FOR SOFTWARE DEVELOPMENT AND SYSTEMS INTEGRATION SERVICES FOR WIRELESS AND MOBILE DEVICES (U.S. CLS. 100 AND 101).

FIRST USE 4-0-1997; IN COMMERCE 4-0-1997.

ALEXANDER L. POWERS, EXAMINING ATTORNEY

SN 77-427,880. CLIMATE CHECK CORPORATION, OTTAWA, CANADA, FILED 3-20-2008.

DriveNeutral

THE MARK CONSISTS OF STANDARD CHARACTERS WITHOUT CLAIM TO ANY PARTICULAR FONT, STYLE, SIZE, OR COLOR.

FOR CONSULTING SERVICES IN THE FIELD OF ENVIRONMENTAL ASSESSMENT, COMPLIANCE AND PLANNING; PROVIDING TECHNOLOGICAL AND SCIENTIFIC INFORMATION ABOUT ENVIRONMENTALLY-CONSCIOUS AND GREEN INNOVATIONS; COMPUTER SERVICES, NAMELY, HOSTING AND MAINTAINING AN ONLINE WEB SITE FOR OTHERS TO CALCULATE CARBON EMISSIONS (U.S. CLS. 100 AND 101).

FIRST USE 10-31-2005; IN COMMERCE 10-31-2005.

KAREN BRACEY, EXAMINING ATTORNEY

CLASS 42—(Continued).

SN 77-427,887. CLIMATE CHECK CORPORATION, OTTAWA, CANADA, FILED 3-20-2008.

FlyNeutral

THE MARK CONSISTS OF STANDARD CHARACTERS WITHOUT CLAIM TO ANY PARTICULAR FONT, STYLE, SIZE, OR COLOR.

FOR CONSULTING SERVICES IN THE FIELD OF ENVIRONMENTAL ASSESSMENT, COMPLIANCE AND PLANNING; PROVIDING TECHNOLOGICAL AND SCIENTIFIC INFORMATION ABOUT ENVIRONMENTALLY-CONSCIOUS AND GREEN INNOVATIONS; COMPUTER SERVICES, NAMELY, HOSTING AND MAINTAINING AN ONLINE WEB SITE FOR OTHERS TO CALCULATE CARBON EMISSIONS (U.S. CLS. 100 AND 101).

FIRST USE 5-31-2007; IN COMMERCE 5-31-2007.
KAREN BRACEY, EXAMINING ATTORNEY

SN 77-428,337. TPC OPERATIONS, LLC, MOORPARK, CA. FILED 3-21-2008.

THE PLAYERS CLUB

THE MARK CONSISTS OF STANDARD CHARACTERS WITHOUT CLAIM TO ANY PARTICULAR FONT, STYLE, SIZE, OR COLOR.

FOR COMPUTER SERVICES IN THE NATURE OF CUSTOMIZED WEB PAGES FEATURING USER-DESIGNED INFORMATION (U.S. CLS. 100 AND 101).
MARK RADEMACHER, EXAMINING ATTORNEY

SN 77-428,885. BAYSWATER, LLC, NORTH YARMOUTH, ME. FILED 3-22-2008.

BAYSWATER

THE MARK CONSISTS OF STANDARD CHARACTERS WITHOUT CLAIM TO ANY PARTICULAR FONT, STYLE, SIZE, OR COLOR.

FOR CONSULTING IN THE FIELD OF INFORMATION TECHNOLOGY (U.S. CLS. 100 AND 101).
SUSAN RICHARDS, EXAMINING ATTORNEY

CLASS 42—(Continued).

SN 77-428,930. LEXBE LC, AUSTIN, TX. FILED 3-22-2008.

Litigation Unleashed

THE MARK CONSISTS OF STANDARD CHARACTERS WITHOUT CLAIM TO ANY PARTICULAR FONT, STYLE, SIZE, OR COLOR.

NO CLAIM IS MADE TO THE EXCLUSIVE RIGHT TO USE "LITIGATION", APART FROM THE MARK AS SHOWN.

FOR COMPUTER SERVICES, NAMELY, HOSTING AND MAINTAINING AN ONLINE WEB SITE FOR OTHERS TO MANAGE LITIGATION AND LEGAL MATTERS, DOCUMENT, FILE AND DATA STORAGE, ANALYSIS AND RETRIEVAL, REPORTING, AND DATABASE FUNCTIONS (U.S. CLS. 100 AND 101).

FIRST USE 2-25-2008; IN COMMERCE 2-25-2008.
ERIN FALK, EXAMINING ATTORNEY

SN 77-429,310. ABATOR INFORMATION SERVICES, INC., PITTSBURGH, PA. FILED 3-24-2008.

ABATOR

THE MARK CONSISTS OF STANDARD CHARACTERS WITHOUT CLAIM TO ANY PARTICULAR FONT, STYLE, SIZE, OR COLOR.

OWNER OF U.S. REG. NO. 1,460,297.
FOR CONSULTING IN THE FIELD OF INFORMATION TECHNOLOGY (U.S. CLS. 100 AND 101).
FIRST USE 11-3-1993; IN COMMERCE 11-3-1993.
LINDSEY RUBIN, EXAMINING ATTORNEY

SN 77-429,353. ISLAND ADVANTAGE REALTY, LLC, HUNTINGTON, NY. FILED 3-24-2008.

ISLAND ADVANTAGE

THE MARK CONSISTS OF STANDARD CHARACTERS WITHOUT CLAIM TO ANY PARTICULAR FONT, STYLE, SIZE, OR COLOR.

FOR REAL ESTATE RESEARCH SERVICES; REAL ESTATE INSPECTION SERVICES TO DETERMINE A PROPERTY'S CONDITION, VERIFICATION OF OCCUPANCY OR VACANCY AND INTERVIEW OF BORROWER (U.S. CLS. 100 AND 101).

FIRST USE 10-6-1998; IN COMMERCE 10-6-1998.
WENDY GOODMAN, EXAMINING ATTORNEY

CLASS 42—(Continued).

SN 77-429,361. ISLAND ADVANTAGE REALTY, LLC, HUNTINGTON, NY. FILED 3-24-2008.



NO CLAIM IS MADE TO THE EXCLUSIVE RIGHT TO USE "REALTY, LLC", APART FROM THE MARK AS SHOWN.

THE MARK CONSISTS OF TWO SAILS WITHIN A CIRCLE, WHICH IS ENCLOSED IN A SQUARE, NEXT TO THE LITERAL ELEMENT "ISLAND", WHICH IS ON TOP OF THE LITERAL ELEMENT "ADVANTAGE", WHICH IS ON TOP OF THE LITERAL ELEMENT "REALTY, LLC", WHICH IS ENCLOSED IN A RECTANGLE.

FOR REAL ESTATE RESEARCH SERVICES; REAL ESTATE INSPECTION SERVICES TO DETERMINE A PROPERTY'S CONDITION, VERIFICATION OF OCCUPANCY OR VACANCY AND INTERVIEW OF BORROWER (U.S. CLS. 100 AND 101).

FIRST USE 10-6-1998; IN COMMERCE 10-6-1998.
WENDY GOODMAN, EXAMINING ATTORNEY

SN 77-429,375. ABATOR INFORMATION SERVICES, INC., PITTSBURGH, PA. FILED 3-24-2008.

LOLOPOP

THE MARK CONSISTS OF STANDARD CHARACTERS WITHOUT CLAIM TO ANY PARTICULAR FONT, STYLE, SIZE, OR COLOR.

FOR CONSULTING IN THE FIELD OF INFORMATION TECHNOLOGY (U.S. CLS. 100 AND 101).
LINDSEY RUBIN, EXAMINING ATTORNEY

CLASS 42—(Continued).

SN 77-429,690. DIGITAL BUSINESS SOLUTIONS, INC., LOUISVILLE, KY. FILED 3-24-2008.



THE COLOR(S) GREY, BLACK, ORANGE, GREEN AND WHITE IS/ARE CLAIMED AS A FEATURE OF THE MARK.

THE MARK CONSISTS OF A GREY AND BLACK SQUARE WITH GREEN AND ORANGE DIAGONAL LINES HAVING ROUNDED CORNERS; AT THE BOTTOM LEFT OF THE SQUARE THE WHITE-COLORED CHARACTERS ">—" WITH THE WHITE COLORED CHARACTER "—" BEING ELONGATED.

FOR COMPUTER PROGRAMMING AND MAINTENANCE OF COMPUTER PROGRAMS; COMPUTER PROGRAMMING SERVICES; PROGRAMMING OF MULTIMEDIA APPLICATIONS (U.S. CLS. 100 AND 101).
FIRST USE 4-1-2007; IN COMMERCE 5-1-2007.
CHARLES L. JENKINS, EXAMINING ATTORNEY

SN 77-429,826. MODEL METRICS, LLC, CHICAGO, IL. FILED 3-24-2008.

INNOVATE. ALWAYS.

THE MARK CONSISTS OF STANDARD CHARACTERS WITHOUT CLAIM TO ANY PARTICULAR FONT, STYLE, SIZE, OR COLOR.

FOR COMPUTER SOFTWARE CONSULTING SERVICES (U.S. CLS. 100 AND 101).
MATTHEW MCDOWELL, EXAMINING ATTORNEY

SN 77-429,871. TPC OPERATIONS, LLC, MOORPARK, CA. FILED 3-24-2008.

KEEP LIVING THE DREAM

THE MARK CONSISTS OF STANDARD CHARACTERS WITHOUT CLAIM TO ANY PARTICULAR FONT, STYLE, SIZE, OR COLOR.

FOR COMPUTER SERVICES IN THE NATURE OF CUSTOMIZED WEB PAGES FEATURING USER-DESIGNED INFORMATION (U.S. CLS. 100 AND 101).
MARK RADEMACHER, EXAMINING ATTORNEY

CLASS 42—(Continued).

SN 77-429,876. GIS CERTIFICATION INSTITUTE, PARK RIDGE, IL. FILED 3-24-2008.

GISCI

THE MARK CONSISTS OF STANDARD CHARACTERS WITHOUT CLAIM TO ANY PARTICULAR FONT, STYLE, SIZE, OR COLOR.

FOR TESTING, ANALYSIS AND EVALUATION OF THE SERVICES OF OTHERS FOR THE PURPOSE OF CERTIFICATION IN THE FIELD OF GEOGRAPHIC INFORMATION SYSTEMS (U.S. CLS. 100 AND 101).

FIRST USE 1-0-2004; IN COMMERCE 1-0-2004.
MARTHA SANTOMARTINO, EXAMINING ATTORNEY



SN 77-429,966. MEDDIUS, LLC, CHARLOTTESVILLE, VA. FILED 3-24-2008.

INTEGRATION DELIVERED

THE MARK CONSISTS OF STANDARD CHARACTERS WITHOUT CLAIM TO ANY PARTICULAR FONT, STYLE, SIZE, OR COLOR.

FOR CONSULTING SERVICES AND SOFTWARE DEVELOPMENT SERVICES FOR DATA EXCHANGE AND ENABLING DATA COMMUNICATION BETWEEN APPLICATION PROGRAMS AND DOCUMENTS (U.S. CLS. 100 AND 101).

FIRST USE 2-25-2008; IN COMMERCE 2-25-2008.
ATTIYA MALIK, EXAMINING ATTORNEY



SN 77-430,014. BUSINESS.COM, INC., SANTA MONICA, CA. FILED 3-24-2008.

WHAT WORKS

THE MARK CONSISTS OF STANDARD CHARACTERS WITHOUT CLAIM TO ANY PARTICULAR FONT, STYLE, SIZE, OR COLOR.

FOR COMPUTER SERVICES, NAMELY, PROVIDING SEARCH ENGINES FOR OBTAINING DATA VIA WIRELESS COMMUNICATIONS, EMAIL AND ON A GLOBAL COMPUTER NETWORK (U.S. CLS. 100 AND 101).

ALEXANDER L. POWERS, EXAMINING ATTORNEY

CLASS 42—(Continued).

SN 77-430,429. FKP ARCHITECTS, INC., HOUSTON, TX. FILED 3-25-2008.

TRANSFORMING BUSINESS BY DESIGN

THE MARK CONSISTS OF STANDARD CHARACTERS WITHOUT CLAIM TO ANY PARTICULAR FONT, STYLE, SIZE, OR COLOR.

FOR ARCHITECTURAL SERVICES, NAMELY, INTERIOR DESIGN, FACILITIES PLANNING, EQUIPMENT PLANNING, STRATEGIC PLANNING AND DESIGNING OF HEALTHCARE, SCIENCE AND EDUCATIONAL FACILITIES, COMPUTERIZED SIMULATION MODELING OF ARCHITECTURAL DESIGN, CONSULTING SERVICES IN THE FIELD OF ARCHITECTURAL DESIGN (U.S. CLS. 100 AND 101).

FIRST USE 8-20-2007; IN COMMERCE 9-28-2007.
DAVID TAYLOR, EXAMINING ATTORNEY



SN 77-430,528. ACCUGENIX INC., NEWARK, DE. FILED 3-25-2008.

Accugenix

OWNER OF U.S. REG. NO. 2,510,392.
FOR LABORATORY, ANALYSIS AND RESEARCH SERVICES IN THE FIELD OF COMPARATIVE DNA SEQUENCING AND MICROBIOLOGY (U.S. CLS. 100 AND 101).

MARCIE MILONE, EXAMINING ATTORNEY



SN 77-430,680. SIGMATRON INTERNATIONAL, INC., ELK GROVE VILLAGE, IL. FILED 3-25-2008.

SIGMATRON

THE MARK CONSISTS OF STANDARD CHARACTERS WITHOUT CLAIM TO ANY PARTICULAR FONT, STYLE, SIZE, OR COLOR.

FOR TESTING OF ELECTRONIC COMPONENTS, PRINTED CIRCUIT BOARD ASSEMBLIES AND TURN-KEY ELECTRONIC PRODUCTS (U.S. CLS. 100 AND 101).

FIRST USE 5-12-1987; IN COMMERCE 5-12-1987.
ANDREA HACK, EXAMINING ATTORNEY

CLASS 42—(Continued).

SN 77-430,703. NORTHWEST EDUCATION LOAN ASSOCIATION, SEATTLE, WA. FILED 3-25-2008.

NELA DEBT MANAGER

THE MARK CONSISTS OF STANDARD CHARACTERS WITHOUT CLAIM TO ANY PARTICULAR FONT, STYLE, SIZE, OR COLOR.

OWNER OF U.S. REG. NOS. 2,617,968, 3,346,818 AND OTHERS.

NO CLAIM IS MADE TO THE EXCLUSIVE RIGHT TO USE "DEBT MANAGER", APART FROM THE MARK AS SHOWN.

FOR PROVIDING TEMPORARY USE OF NON-DOWNLOADABLE COMPUTER DATABASE MANAGEMENT EDUCATION CREDIT SOFTWARE TO THOSE WORKING WITH STUDENT LOANS AND STUDENT LOAN BORROWERS TO ENABLE SUCH PERSONS TO MANAGE STUDENT LOAN BORROWER REPAYMENT AND INFORMATION ABOUT STUDENT LOAN BORROWERS (U.S. CLS. 100 AND 101).

FIRST USE 3-24-2008; IN COMMERCE 3-24-2008.
SUZANNE BLANE, EXAMINING ATTORNEY

SN 77-430,874. CAHOON, DAVID CRAWFORD, SPRING HILL, FL. FILED 3-25-2008.

SCREEN TEST AMERICA

THE MARK CONSISTS OF STANDARD CHARACTERS WITHOUT CLAIM TO ANY PARTICULAR FONT, STYLE, SIZE, OR COLOR.

FOR COMPUTER SERVICES, NAMELY, CREATING AN ONLINE COMMUNITY FOR REGISTERED USERS TO PARTICIPATE IN COMPETITIONS, SHOWCASE THEIR SKILLS, GET FEEDBACK FROM THEIR PEERS, FORM VIRTUAL COMMUNITIES, ENGAGE IN SOCIAL NETWORKING AND IMPROVE THEIR TALENT (U.S. CLS. 100 AND 101).

FIRST USE 2-5-2008; IN COMMERCE 3-15-2008.
WILLIAM P. SHANAHAN, EXAMINING ATTORNEY

CLASS 42—(Continued).

SN 77-431,019. ATHLETES FOR A FIT PLANET LLC, HOLLISTON, MA. FILED 3-25-2008.

WE ARE ENVIRONMENTAL

THE MARK CONSISTS OF STANDARD CHARACTERS WITHOUT CLAIM TO ANY PARTICULAR FONT, STYLE, SIZE, OR COLOR.

FOR CONSULTING SERVICES, NAMELY, ASSISTING RACE AND EVENT COORDINATORS IN IDENTIFYING AND ADOPTING SOLUTIONS TO REDUCING WASTE AND EMISSIONS AND SIMILAR ENVIRONMENTALLY RESPONSIBLE PRACTICES (U.S. CLS. 100 AND 101).

FIRST USE 3-24-2008; IN COMMERCE 3-24-2008.
AISHA CLARKE, EXAMINING ATTORNEY

SN 77-431,148. INTERNATIONAL GEMOLOGICAL INSTITUTE, INC., NEW YORK, NY. FILED 3-25-2008.

**THERE IS MORE TO THIS RING
THAN ITS SPARKLE**

THE MARK CONSISTS OF STANDARD CHARACTERS WITHOUT CLAIM TO ANY PARTICULAR FONT, STYLE, SIZE, OR COLOR.

FOR GEMOLOGICAL SERVICES, NAMELY, GRADING PRECIOUS STONES (U.S. CLS. 100 AND 101).

FIRST USE 3-1-2008; IN COMMERCE 3-1-2008.
WILLIAM ROSSMAN, EXAMINING ATTORNEY

SN 77-431,263. BREAKTHROUGH SOLUTIONS LLC, DBA SEEPATH SOLUTIONS, JERSEY CITY, NJ. FILED 3-25-2008.



THE STIPPLING IS FOR SHADING PURPOSES ONLY. THE MARK CONSISTS OF THE STYLIZED WORD "SEEPATHSOLUTIONS". ABOVE THE STYLIZED WORD IS AN ABSTRACT DESIGN.

FOR COMPUTER SOFTWARE TECHNOLOGY CONSULTING (U.S. CLS. 100 AND 101).

FIRST USE 12-1-2005; IN COMMERCE 12-1-2005.
LAURIE KAUFMAN, EXAMINING ATTORNEY

CLASS 42—(Continued).

SN 77-431,393. CHICTOPIA, SAN FRANCISCO, CA. FILED 3-25-2008.

Chictopia

THE MARK CONSISTS OF STANDARD CHARACTERS WITHOUT CLAIM TO ANY PARTICULAR FONT, STYLE, SIZE, OR COLOR.

FOR PROVIDING A WEBSITE FEATURING AN ONLINE COMMUNITY IN REGARDS TO FASHION, STYLE AND SHOPPING (U.S. CLS. 100 AND 101).

FIRST USE 12-4-2007; IN COMMERCE 1-9-2008.
LINDSEY RUBIN, EXAMINING ATTORNEY

SN 77-431,449. STEVE MORSA, THOUSAND OAKS, CA. FILED 3-25-2008.

DISCOVER. VACATION.
RELOCATION. COMMUNITY.

THE MARK CONSISTS OF STANDARD CHARACTERS WITHOUT CLAIM TO ANY PARTICULAR FONT, STYLE, SIZE, OR COLOR.

FOR COMPUTER SERVICES, NAMELY, HOSTING AN ONLINE WEBSITE FEATURING FACTS AND INFORMATION CONCERNING ONE OR MORE GEOGRAPHICAL LOCATIONS (U.S. CLS. 100 AND 101).

LAURIE KAUFMAN, EXAMINING ATTORNEY

SN 77-431,496. THOMAS, DAVEIA N., PATERSON, NJ. FILED 3-26-2008.

DyNamite!

THE MARK CONSISTS OF THE WORD "DYNAMITE" WITH MY INITIALS "DNT" IN CAPITAL LETTERS AND AN EXCLAMATION POINT AT THE END.

FOR GRAPHIC DESIGN SERVICES (U.S. CLS. 100 AND 101).

FIRST USE 12-1-2002; IN COMMERCE 12-1-2003.
SUNG IN, EXAMINING ATTORNEY

CLASS 42—(Continued).

SN 77-431,786. AMERICAN FOUNDATION FOR THE BLIND, INC., NEW YORK, NY. FILED 3-26-2008.

HELEN

THE MARK CONSISTS OF STANDARD CHARACTERS WITHOUT CLAIM TO ANY PARTICULAR FONT, STYLE, SIZE, OR COLOR.

FOR PROVIDING DOWNLOADABLE SOFTWARE FOR USE IN RATING THE ACCESSIBILITY OF INTERNET WEBSITES FOR THE VISUALLY IMPAIRED (U.S. CLS. 100 AND 101).

SUZANNE BLANE, EXAMINING ATTORNEY

SN 77-431,823. CORTELL INTERNATIONAL CORP., DALLAS, TX. FILED 3-26-2008.

Cortell

THE MARK CONSISTS OF STANDARD CHARACTERS WITHOUT CLAIM TO ANY PARTICULAR FONT, STYLE, SIZE, OR COLOR.

FOR COMPUTER SOFTWARE TECHNOLOGY CONSULTING (U.S. CLS. 100 AND 101).

FIRST USE 10-1-1996; IN COMMERCE 11-1-1996.
SUZANNE BLANE, EXAMINING ATTORNEY

SN 77-431,840. DESIGNING PATTERNS, RED BANK, NJ. FILED 3-26-2008.

Designing Patterns

THE MARK CONSISTS OF STANDARD CHARACTERS WITHOUT CLAIM TO ANY PARTICULAR FONT, STYLE, SIZE, OR COLOR.

FOR COMPUTER SOFTWARE DEVELOPMENT; DESIGN AND DEVELOPMENT OF COMPUTER HARDWARE AND SOFTWARE; DESIGN, DEVELOPMENT AND IMPLEMENTATION OF SOFTWARE; DESIGN, MAINTENANCE, DEVELOPMENT AND UPDATING OF COMPUTER SOFTWARE; COMPUTER SOFTWARE CONSULTATION; CREATING OR MAINTAINING WEB SITES FOR OTHERS; HOSTING OF DIGITAL CONTENT ON THE INTERNET; INFORMATION TECHNOLOGY CONSULTATION (U.S. CLS. 100 AND 101).

JILL C. ALT, EXAMINING ATTORNEY

CLASS 42—(Continued).

SN 77-432,098. BRISTOL-MYERS SQUIBB COMPANY, NEW YORK, NY. FILED 3-26-2008.

ABOVE

THE MARK CONSISTS OF STANDARD CHARACTERS WITHOUT CLAIM TO ANY PARTICULAR FONT, STYLE, SIZE, OR COLOR.

FOR MEDICAL AND SCIENTIFIC RESEARCH, NAMELY, CONDUCTING CLINICAL TRIALS RELATING TO PHARMACEUTICAL PREPARATIONS FOR HUMAN USE (U.S. CLS. 100 AND 101).

DOMINIC J. FERRAIUOLO, EXAMINING ATTORNEY

SN 77-432,106. BRISTOL-MYERS SQUIBB COMPANY, NEW YORK, NY. FILED 3-26-2008.

AREA

THE MARK CONSISTS OF STANDARD CHARACTERS WITHOUT CLAIM TO ANY PARTICULAR FONT, STYLE, SIZE, OR COLOR.

FOR MEDICAL AND SCIENTIFIC RESEARCH, NAMELY, CONDUCTING CLINICAL TRIALS RELATING TO PHARMACEUTICAL PREPARATIONS FOR HUMAN USE (U.S. CLS. 100 AND 101).

DOMINIC J. FERRAIUOLO, EXAMINING ATTORNEY

SN 77-432,257. INTERCOLLEGIATE SPORTS SCHEDULING, LLC, HARRISONBURG, VA. FILED 3-26-2008.

WHERE TEAMS CONNECT

THE MARK CONSISTS OF STANDARD CHARACTERS WITHOUT CLAIM TO ANY PARTICULAR FONT, STYLE, SIZE, OR COLOR.

FOR PROVIDING ON-LINE NON-DOWNLOADABLE SOFTWARE FOR USE BY COLLEGE COACHES, ATHLETIC ADMINISTRATORS AND CONFERENCE OFFICES IN SCHEDULING GAMES AND COMMUNICATION WITH OTHER COLLEGE COACHES, ATHLETIC ADMINISTRATORS AND CONFERENCE OFFICES (U.S. CLS. 100 AND 101).

FIRST USE 12-8-2006; IN COMMERCE 12-8-2006.

EMILY CARLSEN, EXAMINING ATTORNEY

CLASS 42—(Continued).

SN 77-432,414. CASELLA WASTE SYSTEMS, INC., RUTLAND, VT. FILED 3-26-2008.

THINK SMART

THE MARK CONSISTS OF STANDARD CHARACTERS WITHOUT CLAIM TO ANY PARTICULAR FONT, STYLE, SIZE, OR COLOR.

FOR CONSULTING SERVICES IN THE FIELD OF WASTE REGULATORY REQUIREMENTS, REPORTING REQUIREMENTS, PERMITTING AND COMPLIANCE MONITORING (U.S. CLS. 100 AND 101).

KATHERINE STOIDES, EXAMINING ATTORNEY

SN 77-432,426. MCDANIEL, TERRY, ALAMO, CA. FILED 3-26-2008.

RealAgile

THE MARK CONSISTS OF STANDARD CHARACTERS WITHOUT CLAIM TO ANY PARTICULAR FONT, STYLE, SIZE, OR COLOR.

FOR PROVIDING ONLINE, NON-DOWNLOADABLE SOFTWARE FOR USE IN PREDICTING THE LIKELIHOOD OF A HOMEOWNER SELLING THEIR HOME SO THAT THE AGENT CAN MORE EFFICIENTLY MARKET SERVICES (U.S. CLS. 100 AND 101).

FIRST USE 5-23-2007; IN COMMERCE 5-23-2007.

MARCIE MILONE, EXAMINING ATTORNEY

SN 77-432,459. COGENTES, INC., DAVISBORO, GA. FILED 3-26-2008.

BRIDGING STRATEGY AND SUCCESS

THE MARK CONSISTS OF STANDARD CHARACTERS WITHOUT CLAIM TO ANY PARTICULAR FONT, STYLE, SIZE, OR COLOR.

FOR INFORMATION TECHNOLOGY CONSULTING (U.S. CLS. 100 AND 101).

FIRST USE 9-10-2007; IN COMMERCE 9-10-2007.

KARANENDRA S. CHHINA, EXAMINING ATTORNEY

CLASS 42—(Continued).

SN 77-432,466. COGENTES, INC., DAVISBORO, GA. FILED 3-26-2008.

BUSINESS STRATEGY REALIZATION

THE MARK CONSISTS OF STANDARD CHARACTERS WITHOUT CLAIM TO ANY PARTICULAR FONT, STYLE, SIZE, OR COLOR.

FOR INFORMATION TECHNOLOGY CONSULTING (U.S. CLS. 100 AND 101).

FIRST USE 9-14-2007; IN COMMERCE 9-14-2007.

KARANENDRA S. CHHINA, EXAMINING ATTORNEY

CLASS 42—(Continued).

SN 77-433,006. BRIDGES, TERRANCE, AUSTIN, TX. FILED 3-27-2008.



THE STIPPLING IS FOR SHADING PURPOSES ONLY. THE MARK CONSISTS OF THE STYLIZED TEXT "DIVINE CONCEPTS" WITH AN ABSTRACT DESIGN IN THE BACKGROUND.

FOR GRAPHIC ART DESIGN (U.S. CLS. 100 AND 101). FIRST USE 6-5-2006; IN COMMERCE 7-11-2006.

HEATHER THOMPSON, EXAMINING ATTORNEY

SN 77-432,577. CATALYST SOLUTIONS LLC, REDMOND, WA. FILED 3-26-2008.

PROJECT360°

THE MARK CONSISTS OF STANDARD CHARACTERS WITHOUT CLAIM TO ANY PARTICULAR FONT, STYLE, SIZE, OR COLOR.

OWNER OF U.S. REG. NO. 3,450,915.

FOR PROVIDING ON-LINE NON-DOWNLOADABLE SOFTWARE FOR PROJECT MANAGEMENT, TIME TRACKING AND BILLING (U.S. CLS. 100 AND 101).

FIRST USE 6-0-2007; IN COMMERCE 6-0-2007.

GINA FINK, EXAMINING ATTORNEY

SN 77-433,047. FIREVAULT, INC., WYLIE, TX. FILED 3-27-2008.



SN 77-432,885. NITSCHKE, JAHN, AVENTURA, FL. FILED 3-27-2008.

NRS USA

THE MARK CONSISTS OF STANDARD CHARACTERS WITHOUT CLAIM TO ANY PARTICULAR FONT, STYLE, SIZE, OR COLOR.

NO CLAIM IS MADE TO THE EXCLUSIVE RIGHT TO USE "USA", APART FROM THE MARK AS SHOWN.

FOR CUSTOM DESIGN OF BRIDGE BUILDING EQUIPMENT (U.S. CLS. 100 AND 101).

LOURDES AYALA, EXAMINING ATTORNEY

THE MARK CONSISTS OF THE STYLIZED TEXT "FIREVAULT". TO THE RIGHT OF THE TEXT IS A CIRCLE WITH A FLAME. IN THE CENTER OF THE CIRCLE IS A LOCK HOLE.

FOR BACK-UP SERVICES FOR COMPUTER HARD DRIVE DATA (U.S. CLS. 100 AND 101).

FIRST USE 1-1-2008; IN COMMERCE 1-1-2008.

REGINA DRUMMOND, EXAMINING ATTORNEY

CLASS 42—(Continued).

SN 77-433,390. CH2M HILL ENGINEERS, INC., ENGLEWOOD, CO. FILED 3-27-2008.



THE MARK CONSISTS OF FOUR THICK LINES, ONE ABOVE THE OTHER, WITH DARK SQUARES ON THE RIGHT SIDE OF EACH LINE AND A DIAGONAL SLASH FROM THE LOWER LEFT SIDE TO THE UPPER RIGHT SIDE.

FOR CONSTRUCTION DESIGN; ARCHITECTURAL DESIGN; DESIGN ENGINEERING AND DESIGN PROCESS ENGINEERING OF MANUFACTURING PLANTS, INDUSTRIAL FACILITIES, LIFE SAFETY SYSTEMS, MECHANICAL, CHEMICAL, ELECTRICAL AND HVAC SYSTEMS AND CONTROLS USED IN CONNECTION THEREWITH (U.S. CLS. 100 AND 101).

JENNIFER HETU, EXAMINING ATTORNEY

SN 77-433,468. IN-VIRONMENTAL INTEGRITY, INC., LAKE ELMO, MN. FILED 3-27-2008.

ARCHITECTURAL SCENT

THE MARK CONSISTS OF STANDARD CHARACTERS WITHOUT CLAIM TO ANY PARTICULAR FONT, STYLE, SIZE, OR COLOR.

NO CLAIM IS MADE TO THE EXCLUSIVE RIGHT TO USE "SCENT", APART FROM THE MARK AS SHOWN.

FOR INTERIOR AROMA CONSULTING SERVICES IN THE SELECTION AND USE OF AROMAS FOR HOTELS, CASINOS, RESORTS, CONFERENCE FACILITIES, RETAIL STORES, SPORTS AND FITNESS CENTERS, SPAS, HEALTH CARE FACILITIES, RESIDENTIAL BUILDINGS AND PRIVATE RESIDENCES (U.S. CLS. 100 AND 101).

ALICE SUE CARRUTHERS, EXAMINING ATTORNEY

CLASS 42—(Continued).

SN 77-434,092. SYNCHRONICITY LIVE, LLC, JACKSONVILLE BEACH, FL. FILED 3-28-2008.

synclive.com

THE MARK CONSISTS OF STANDARD CHARACTERS WITHOUT CLAIM TO ANY PARTICULAR FONT, STYLE, SIZE, OR COLOR.

FOR PROVIDING AN ON-LINE, NON-DOWNLOADABLE WEB APPLICATION PLATFORM FOR STREAMING LIVE AUDIO AND VIDEO MATERIAL ON THE INTERNET AND FOR ENABLING USERS TO UPLOAD, POST, WATCH, TAG AND ELECTRONICALLY TRANSMIT DIGITAL CONTENT IN THE FIELDS OF LIVE PERFORMANCES, EVENTS, CONCERTS AND VIDEOS (U.S. CLS. 100 AND 101).

TASNEEM HUSSAIN, EXAMINING ATTORNEY

SN 77-434,242. POWER TRAIN INDUSTRIES, INC., GARDEN GROVE, CA. FILED 3-28-2008.

DriveshaftPro

THE MARK CONSISTS OF STANDARD CHARACTERS WITHOUT CLAIM TO ANY PARTICULAR FONT, STYLE, SIZE, OR COLOR.

FOR APPLICATION SERVICE PROVIDER (ASP) FEATURING SOFTWARE FOR USE IN CREATING WORK ORDERS, INVOICES AND PURCHASE ORDERS AS WELL KEEPING TRACK OF SALES SPECIFICALLY FOR DRIVE SHAFT REPAIR SHOPS (U.S. CLS. 100 AND 101).

FIRST USE 1-28-2007; IN COMMERCE 9-1-2007.

DAVID MURRAY, EXAMINING ATTORNEY

SN 77-434,391. VIABLE BYTES INC., INDIANAPOLIS, IN. FILED 3-28-2008.

Viable Bytes

THE MARK CONSISTS OF STANDARD CHARACTERS WITHOUT CLAIM TO ANY PARTICULAR FONT, STYLE, SIZE, OR COLOR.

FOR ENGINEERING SERVICES, NAMELY, ENGINEERING FOR THE SOFTWARE APPLICATIONS IN THE FIELDS OF MEDICAL, INDUSTRIAL, COMMERCIAL AND MILITARY (U.S. CLS. 100 AND 101).

FIRST USE 1-1-2007; IN COMMERCE 1-1-2007.

PAUL F. GAST, EXAMINING ATTORNEY

CLASS 42—(Continued).

SN 77-434,470. F&F MARKETING GROUP, LLC, CHARLOTTE, NC. FILED 3-28-2008.

REPYOURBRAND

THE MARK CONSISTS OF STANDARD CHARACTERS WITHOUT CLAIM TO ANY PARTICULAR FONT, STYLE, SIZE, OR COLOR.

FOR COMPUTER SERVICES, NAMELY, CREATING AN ONLINE COMMUNITY FOR REGISTERED USERS TO PARTICIPATE IN COMPETITIONS, SHOWCASE THEIR SKILLS, GET FEEDBACK FROM THEIR PEERS, FORM VIRTUAL COMMUNITIES, ENGAGE IN SOCIAL NETWORKING AND IMPROVE THEIR TALENT; APPLICATION SERVICE PROVIDER (ASP) FEATURING SOFTWARE FOR USE IN UPLOADING, POSTING, SHOWING, DISPLAYING, SHARING, OR OTHERWISE PROVIDING ELECTRONIC MEDIA OR INFORMATION OVER A COMMUNICATIONS NETWORK (U.S. CLS. 100 AND 101).

KELLY CHOE, EXAMINING ATTORNEY

CLASS 42—(Continued).

SN 77-434,807. CTUIT INC., NOVATO, CA. FILED 3-28-2008.

Ctuit Radar

THE MARK CONSISTS OF STANDARD CHARACTERS WITHOUT CLAIM TO ANY PARTICULAR FONT, STYLE, SIZE, OR COLOR.

FOR APPLICATION SERVICE PROVIDER FEATURING SOFTWARE IN THE RESTAURANT INDUSTRY FOR PROVIDING AN ONLINE DATA MANAGEMENT SYSTEM IN THE FIELDS OF DATA POLLING, FINANCIAL ANALYSIS AND REPORTING, INVENTORY CONTROL, GENERAL BUSINESS INTELLIGENCE AND DECISION SUPPORT, LABOR SCHEDULING, DATA INTEGRATION, TRANSACTION PROCESSING TO UPLOAD TRANSACTIONAL DATA, STATISTICAL ANALYSIS, PRODUCTION OF DASHBOARDS, REPORTS, AND EMAIL NOTIFICATIONS, EXTRACTION OF SALES, LABOR, INVENTORY, AND ACCOUNTING DATA; APPLICATION SERVICE PROVIDER, NAMELY, DEVELOPING, PROVIDING, HOSTING, REPORTING, MANAGING, AND MAINTAINING SOFTWARE, WEBSITES, AND DATABASES OF OTHERS IN THE RESTAURANT INDUSTRY; COMPUTER TECHNOLOGY SUPPORT SERVICES, NAMELY, HELP DESK SERVICES (U.S. CLS. 100 AND 101).

EUGENIA MARTIN, EXAMINING ATTORNEY

SN 77-436,758. FMR LLC, BOSTON, MA. FILED 4-1-2008.

WEALTHCENTRAL

THE MARK CONSISTS OF STANDARD CHARACTERS WITHOUT CLAIM TO ANY PARTICULAR FONT, STYLE, SIZE, OR COLOR.

FOR PROVIDING TEMPORARY USE OF ON-LINE NON-DOWNLOADABLE SOFTWARE FOR OBTAINING AND MANAGING INFORMATION RELATING TO FINANCIAL TRANSACTIONS AND INVESTMENT ACCOUNTS (U.S. CLS. 100 AND 101).

EMILY CARLSEN, EXAMINING ATTORNEY

SN 77-434,490. F&F MARKETING GROUP, LLC, CHARLOTTE, NC. FILED 3-28-2008.

BRANDTUBE

THE MARK CONSISTS OF STANDARD CHARACTERS WITHOUT CLAIM TO ANY PARTICULAR FONT, STYLE, SIZE, OR COLOR.

FOR APPLICATION SERVICE PROVIDER (ASP) FEATURING SOFTWARE FOR USE IN UPLOADING, POSTING, SHOWING, DISPLAYING, SHARING, OR OTHERWISE PROVIDING ELECTRONIC MEDIA OR INFORMATION OVER A COMMUNICATIONS NETWORK, IN THE FIELD OF COMMERCIAL ADVERTISING AND BRANDING (U.S. CLS. 100 AND 101).

KELLY CHOE, EXAMINING ATTORNEY

SN 77-439,482. ADCUENT, INC., DELRAY BEACH, FL. FILED 4-3-2008.

Go To Your Site

THE MARK CONSISTS OF STANDARD CHARACTERS WITHOUT CLAIM TO ANY PARTICULAR FONT, STYLE, SIZE, OR COLOR.

FOR PROVIDING TEMPORARY USE OF ON-LINE NON-DOWNLOADABLE SOFTWARE FOR THE DEVELOPMENT AND HOSTING OF WEBSITE APPLICATIONS (U.S. CLS. 100 AND 101).

FIRST USE 6-14-2007; IN COMMERCE 6-14-2007.

HEATHER THOMPSON, EXAMINING ATTORNEY

CLASS 42—(Continued).

SN 77-442,126. ADCUENT, INC., DELRAY BEACH, FL. FILED 4-7-2008.

GoToGreenPlanet

THE MARK CONSISTS OF STANDARD CHARACTERS WITHOUT CLAIM TO ANY PARTICULAR FONT, STYLE, SIZE, OR COLOR.

FOR PROVIDING TEMPORARY USE OF ON-LINE NON-DOWNLOADABLE SOFTWARE FOR THE PURPOSE OF ACCESSING A HOSTING ENVIRONMENT (U.S. CLS. 100 AND 101).

FIRST USE 4-15-2007; IN COMMERCE 4-15-2007.
HEATHER THOMPSON, EXAMINING ATTORNEY



SN 77-449,167. ADCUENT, INC., DELRAY BEACH, FL. FILED 4-15-2008.

GoToCleanInternet

THE MARK CONSISTS OF STANDARD CHARACTERS WITHOUT CLAIM TO ANY PARTICULAR FONT, STYLE, SIZE, OR COLOR.

FOR PROVIDING TEMPORARY USE OF ON-LINE NON-DOWNLOADABLE SOFTWARE FOR THE PURPOSE OF ACCESSING A HOSTING ENVIRONMENT (U.S. CLS. 100 AND 101).

FIRST USE 4-15-2007; IN COMMERCE 4-15-2007.
HEATHER THOMPSON, EXAMINING ATTORNEY



SN 77-451,690. MODEL METRICS, LLC, CHICAGO, IL. FILED 4-18-2008.

MODEL

THE MARK CONSISTS OF STANDARD CHARACTERS WITHOUT CLAIM TO ANY PARTICULAR FONT, STYLE, SIZE, OR COLOR.

FOR COMPUTER SOFTWARE CONSULTING SERVICES IN THE FIELD OF SOFTWARE FOR CUSTOMER RELATIONSHIP MANAGEMENT (U.S. CLS. 100 AND 101).

MATTHEW MCDOWELL, EXAMINING ATTORNEY

CLASS 42—(Continued).

SN 77-459,365. ASCA, INC., PORTSMOUTH, NH. FILED 4-28-2008.

FabTrac

THE MARK CONSISTS OF STANDARD CHARACTERS WITHOUT CLAIM TO ANY PARTICULAR FONT, STYLE, SIZE, OR COLOR.

FOR PROVIDING SPECIFIC INFORMATION AS REQUESTED BY CUSTOMERS VIA THE INTERNET (U.S. CLS. 100 AND 101).

FIRST USE 1-1-2001; IN COMMERCE 1-1-2001.
JILL PRATER, EXAMINING ATTORNEY



SN 77-472,959. LEE, GARY L., CHICAGO, IL. AND MCWALTERS, THOMAS J., CHICAGO, IL. FILED 5-13-2008.

T

G

COUTURE

NO CLAIM IS MADE TO THE EXCLUSIVE RIGHT TO USE "COUTURE". APART FROM THE MARK AS SHOWN. THE MARK CONSISTS OF THE LETTER "T" ON TOP OF THE LETTER "G" OVER THE WORD "COUTURE".

FOR FURNITURE DESIGN SERVICES (U.S. CLS. 100 AND 101).
ALEX KEAM, EXAMINING ATTORNEY



SN 77-474,095. INVERNESS MEDICAL SWITZERLAND GMBH, ZUG, SWITZERLAND, FILED 5-14-2008.

VADCARE

THE MARK CONSISTS OF STANDARD CHARACTERS WITHOUT CLAIM TO ANY PARTICULAR FONT, STYLE, SIZE, OR COLOR.

FOR APPLICATION SERVICE PROVIDER (ASP) FEATURING SOFTWARE FOR PATIENT MANAGEMENT (U.S. CLS. 100 AND 101).

LAURA HAMMEL, EXAMINING ATTORNEY

CLASS 42—(Continued).

SN 77-474,472. INVERNESS MEDICAL SWITZERLAND GMBH, ZUG, SWITZERLAND, FILED 5-14-2008.

FOBCARE

THE MARK CONSISTS OF STANDARD CHARACTERS WITHOUT CLAIM TO ANY PARTICULAR FONT, STYLE, SIZE, OR COLOR.

FOR APPLICATION SERVICE PROVIDER (ASP) FEATURING SOFTWARE FOR PATIENT MANAGEMENT (U.S. CLS. 100 AND 101).

LAURA HAMMEL, EXAMINING ATTORNEY

CLASS 42—(Continued).

SN 77-479,990. CASELLA WASTE SYSTEMS, INC., RUTLAND, VT. FILED 5-21-2008.

ZERO-SORT

THE MARK CONSISTS OF STANDARD CHARACTERS WITHOUT CLAIM TO ANY PARTICULAR FONT, STYLE, SIZE, OR COLOR.

FOR CONSULTING SERVICES IN THE FIELD OF WASTE REGULATORY REQUIREMENTS, REPORTING REQUIREMENTS, PERMITTING AND COMPLIANCE MONITORING (U.S. CLS. 100 AND 101).

KATHERINE STOIDES, EXAMINING ATTORNEY

SN 77-474,507. INVERNESS MEDICAL SWITZERLAND GMBH, ZUG, SWITZERLAND, FILED 5-14-2008.

BNPCARE

THE MARK CONSISTS OF STANDARD CHARACTERS WITHOUT CLAIM TO ANY PARTICULAR FONT, STYLE, SIZE, OR COLOR.

FOR APPLICATION SERVICE PROVIDER (ASP) FEATURING SOFTWARE FOR PATIENT MANAGEMENT (U.S. CLS. 100 AND 101).

LAURA HAMMEL, EXAMINING ATTORNEY

SN 77-975,179. ACE DRAGON CORP., HSINCHU CITY, TAIWAN, FILED 9-17-2007.

Sensor Look

THE MARK CONSISTS OF STANDARD CHARACTERS WITHOUT CLAIM TO ANY PARTICULAR FONT, STYLE, SIZE, OR COLOR.

NO CLAIM IS MADE TO THE EXCLUSIVE RIGHT TO USE "SENSOR", APART FROM THE MARK AS SHOWN.

FOR DESIGNING, UPGRADING AND MAINTAINING SOFTWARE AND COMPUTER PROGRAMS; ALL FOR USE IN TEMPERATURE, RELATIVE HUMIDITY AND GAS DETECTING, MONITORING AND ANALYZING APPARATUS (U.S. CLS. 100 AND 101).

HEATHER SAPP, EXAMINING ATTORNEY

SN 77-474,523. INVERNESS MEDICAL SWITZERLAND GMBH, ZUG, SWITZERLAND, FILED 5-14-2008.

VADWATCH

THE MARK CONSISTS OF STANDARD CHARACTERS WITHOUT CLAIM TO ANY PARTICULAR FONT, STYLE, SIZE, OR COLOR.

FOR APPLICATION SERVICE PROVIDER (ASP) FEATURING SOFTWARE FOR PATIENT MANAGEMENT (U.S. CLS. 100 AND 101).

LAURA HAMMEL, EXAMINING ATTORNEY

SN 78-286,933. TWINSTRAND THERAPEUTICS, INC., BURNABY, CANADA, FILED 8-13-2003.

TWINSTRAND THERAPEUTICS

OWNER OF CANADA REG. NO. TMA714180, DATED 5-12-2008, EXPIRES 5-12-2023.

NO CLAIM IS MADE TO THE EXCLUSIVE RIGHT TO USE "THERAPEUTICS", APART FROM THE MARK AS SHOWN.

FOR RESEARCH IN THE FIELD OF BIOPHARMACOLOGY, AND MEDICAL TESTING IN THE NATURE OF CLINICAL TRIALS IN THE FIELD OF BIOPHARMACOLOGY (U.S. CLS. 100 AND 101).

MELVIN AXILBUND, EXAMINING ATTORNEY

CLASS 42—(Continued).

SN 78-286,937. TWINSTRAND THERAPEUTICS, INC., BURNABY, CANADA, FILED 8-13-2003.

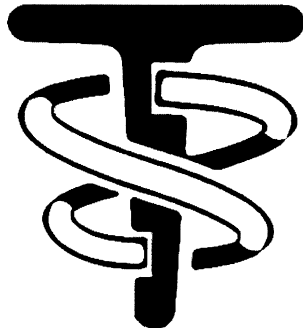

OWNER OF CANADA REG. NO. TMA705877, DATED 1-29-2008, EXPIRES 1-29-2023.

FOR RESEARCH IN THE FIELD OF BIOPHARMACOLOGY, AND MEDICAL TESTING IN THE NATURE OF CLINICAL TRIALS IN THE FIELD OF BIOPHARMACOLOGY (U.S. CLS. 100 AND 101).

MELVIN AXILBUND, EXAMINING ATTORNEY

SN 78-758,532. LIFETREE CLINICAL RESEARCH, L.C., SALT LAKE CITY, UT. FILED 11-21-2005.

LIFETREE
CLINICAL RESEARCH



Growing a Better Quality of Life

NO CLAIM IS MADE TO THE EXCLUSIVE RIGHT TO USE "CLINICAL RESEARCH", APART FROM THE MARK AS SHOWN.

THE MARK CONSISTS OF A STYLIZED TREE FOR PHARMACEUTICAL RESEARCH SERVICES (U.S. CLS. 100 AND 101).

FIRST USE 4-30-2003; IN COMMERCE 4-30-2003.
GIANCARLO CASTRO, EXAMINING ATTORNEY

CLASS 43—HOTEL AND RESTAURANT SERVICES

SN 76-468,636. THE ASHRAM LTD, CALABASAS, CA. FILED 11-21-2002.

THE ASHRAM

SEC. 2(F).

FOR HEALTH RESORT SERVICES, NAMELY, PROVIDING FOOD AND LODGING THAT SPECIALIZE IN PROMOTING PATRONS' GENERAL HEALTH AND WELL BEING (U.S. CLS. 100 AND 101).

FIRST USE 9-1-1974; IN COMMERCE 9-1-1974.
KATHERINE CONNOLLY, EXAMINING ATTORNEY

CLASS 43—(Continued).

SN 76-676,351. GRAND IMPERIAL, INC., CHICAGO, IL. FILED 5-3-2007.

 **GRAND IMPERIAL**

THE MARK CONSISTS OF THREE CHINESE CHARACTERS SURROUNDED BY A GENERALLY OVAL SHAPED CARRIER TO THE RIGHT OF WHICH APPEARS THE WORDING "GRAND IMPERIAL". THE "E" IN "IMPERIAL" IS STYLIZED TO LOOK LIKE THE CHINESE CHARACTER FOR THE ENGLISH WORD "EMPEROR" OR THE SURNAME "WANG".

THE ENGLISH TRANSLATION OF THE WORD "WANG FU JIN" IN THE MARK IS WELL OF THE WANG ESTATE. THE NON-LATIN CHARACTERS IN THE MARK TRANSLITERATE TO "WANG FU JIN," WHICH TRANSLATES TO "WELL OF THE WANG ESTATE" IN ENGLISH.

FOR HOTEL AND RESTAURANT SERVICES (U.S. CLS. 100 AND 101).

MARTHA FROMM, EXAMINING ATTORNEY

SN 76-682,019. RESTAURANT PEOPLE MANAGEMENT COMPANY, LLC, FORT LAUDERDALE, FL. FILED 9-18-2007.

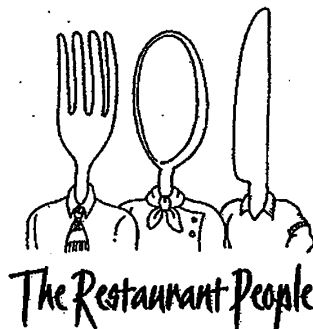

NO CLAIM IS MADE TO THE EXCLUSIVE RIGHT TO USE "RESTAURANT", APART FROM THE MARK AS SHOWN.

THE MARK CONSISTS OF FORK, SPOON, AND KNIFE CHARACTERS POSITIONED ABOVE THE STYLIZED WORDS "THE RESTAURANT PEOPLE".

FOR OPERATING RESTAURANTS AND BARS (U.S. CLS. 100 AND 101).

FIRST USE 0-0-1999; IN COMMERCE 0-0-1999.
ROBIN CHOSID, EXAMINING ATTORNEY

SN 76-684,298. B. O. M. DEVELOPMENT, INC., LOS ANGELES, CA. FILED 11-26-2007.

TASTE OF MEDITERRANEAN

THE MARK CONSISTS OF STANDARD CHARACTERS WITHOUT CLAIM TO ANY PARTICULAR FONT, STYLE, SIZE, OR COLOR.

NO CLAIM IS MADE TO THE EXCLUSIVE RIGHT TO USE "MEDITERRANEAN", APART FROM THE MARK AS SHOWN.

FOR RESTAURANT AND CAFE SERVICES (U.S. CLS. 100 AND 101).

SHANNON TWOHIG, EXAMINING ATTORNEY

CLASS 43—(Continued).

SN 76-687,928. BONNER, LAWRENCE, SOUTH ELGIN, IL.
FILED 3-20-2008.

BEANBERRY COFFEE

THE MARK CONSISTS OF STANDARD CHARACTERS
WITHOUT CLAIM TO ANY PARTICULAR FONT, STYLE,
SIZE, OR COLOR.

NO CLAIM IS MADE TO THE EXCLUSIVE RIGHT TO
USE "COFFEE", APART FROM THE MARK AS SHOWN.
FOR COFFEE SHOP (U.S. CLS. 100 AND 101).
LOURDES AYALA, EXAMINING ATTORNEY

SN 76-688,727. OBSIDIAN GROUP INC., MISSISSAUGA,
ONTARIO, CANADA, FILED 4-17-2008.

EGGHEADS

THE MARK CONSISTS OF STANDARD CHARACTERS
WITHOUT CLAIM TO ANY PARTICULAR FONT, STYLE,
SIZE, OR COLOR.

FOR RESTAURANT SERVICES (U.S. CLS. 100 AND
101).
JAY FLOWERS, EXAMINING ATTORNEY

SN 77-164,549. SANTA FE HOTEL LIMITED PARTNERSHIP,
SANTA FE, NM. FILED 4-24-2007.

Hotel Santa Fe

THE MARK CONSISTS OF STANDARD CHARACTERS
WITHOUT CLAIM TO ANY PARTICULAR FONT, STYLE,
SIZE, OR COLOR.

OWNER OF U.S. REG. NO. 1,731,817.
NO CLAIM IS MADE TO THE EXCLUSIVE RIGHT TO
USE "HOTEL", APART FROM THE MARK AS SHOWN.
SEC. 2(F).

FOR HOTEL SERVICES; HOTEL SERVICES FOR PRE-
FERRED CUSTOMERS; HOTEL, BAR AND RESTAU-
RANT SERVICES; HOTELS (U.S. CLS. 100 AND 101).
FIRST USE 3-1-1991; IN COMMERCE 3-1-1991.
MARY BOAGNI, EXAMINING ATTORNEY

CLASS 43—(Continued).

SN 77-190,063. KITROSSER, HOWARD, LOS ANGELES, CA.
AND DIVBAND, KAS, LOS ANGELES, CA. AND MACE,
DAVE, LOS ANGELES, CA. FILED 5-24-2007.

MOUTHFUL

THE MARK CONSISTS OF STANDARD CHARACTERS
WITHOUT CLAIM TO ANY PARTICULAR FONT, STYLE,
SIZE, OR COLOR.

FOR RESTAURANT AND DINER SERVICES; COCK-
TAIL LOUNGE SERVICES (U.S. CLS. 100 AND 101).
LESLEY LAMOTHE, EXAMINING ATTORNEY

SN 77-235,851. PEAK EXPERIENCE ENTERPRISES, LLC,
ESTES PARK, CO. FILED 7-23-2007.

Shakes Alive! Fruit Shakes

THE MARK CONSISTS OF STANDARD CHARACTERS
WITHOUT CLAIM TO ANY PARTICULAR FONT, STYLE,
SIZE, OR COLOR.

NO CLAIM IS MADE TO THE EXCLUSIVE RIGHT TO
USE "FRUIT SHAKES", APART FROM THE MARK AS
SHOWN.

FOR RESTAURANT SERVICES (U.S. CLS. 100 AND
101).

FIRST USE 12-21-1999; IN COMMERCE 12-21-1999.
BENJAMIN OKEKE, EXAMINING ATTORNEY

SN 77-238,537. THEO'S PIZZA & CATERING, INC., SHEBOY-
GAN, WI. FILED 7-25-2007.

THEO'S PIZZA & CATERING

THE MARK CONSISTS OF STANDARD CHARACTERS
WITHOUT CLAIM TO ANY PARTICULAR FONT, STYLE,
SIZE, OR COLOR.

NO CLAIM IS MADE TO THE EXCLUSIVE RIGHT TO
USE "PIZZA AND CATERING", APART FROM THE MARK
AS SHOWN.

FOR RESTAURANTS (U.S. CLS. 100 AND 101).
FIRST USE 4-1-2005; IN COMMERCE 4-1-2005.
DANIEL CAPSHAW, EXAMINING ATTORNEY

CLASS 43—(Continued).

SN 77-262,973. HAZ HOLDINGS, INC., FEDERAL WAY, WA. FILED 8-23-2007.



NO CLAIM IS MADE TO THE EXCLUSIVE RIGHT TO USE "HOTEL", APART FROM THE MARK AS SHOWN.

THE MARK CONSISTS OF THE LETTER "M" PARTIALLY WITHIN A CIRCLE WITH A CROWN ABOVE THE LETTER "M" AND THE WORDS "HOTEL MONARCHY" BELOW.

FOR HEALTH RESORT SERVICES, NAMELY, PROVIDING FOOD AND LODGING THAT SPECIALIZE IN PROMOTING PATRONS' GENERAL HEALTH AND WELL-BEING; HOTEL SERVICES; HOTEL SERVICES FOR PREFERRED CUSTOMERS; HOTEL, BAR AND RESTAURANT SERVICES; HOTELS; MAKING HOTEL RESERVATIONS FOR OTHERS; PROVIDING ON-LINE REVIEWS OF RESTAURANTS AND HOTELS; PROVIDING TEMPORARY LODGING SERVICES IN THE NATURE OF A CONDOMINIUM HOTEL; PROVIDING TRAVEL LODGING INFORMATION SERVICES AND TRAVEL LODGING BOOKING AGENCY SERVICES FOR TRAVELERS; RESERVATION OF HOTEL ROOMS FOR TRAVELERS; RESERVATION OF HOTEL ROOMS FOR TRAVELERS; RESORT HOTELS; RESORT LODGING SERVICES; TRAVEL AGENCY SERVICES, NAMELY, MAKING RESERVATIONS AND BOOKING FOR TEMPORARY LODGING (U.S. CLS. 100 AND 101).

FIRST USE 2-12-2007; IN COMMERCE 2-12-2007.
 GISELLE AGOSTO, EXAMINING ATTORNEY

SN 77-274,862. SALIH,YAHYA, H, DBA YAYA CUISINE, SAN FRANCISCO, CA. FILED 9-8-2007.



NO CLAIM IS MADE TO THE EXCLUSIVE RIGHT TO USE "CUISINE", APART FROM THE MARK AS SHOWN.

THE MARK CONSISTS OF THE WORD "YA YA" ABOVE THE WORD "CUISINE" ALL WITHIN AN OUTLINED BOX. THE WORDING "YA YA" HAS NO MEANING IN A FOREIGN LANGUAGE.

FOR RESTAURANTS (U.S. CLS. 100 AND 101).
 GEOFFREY FOSDICK, EXAMINING ATTORNEY

CLASS 43—(Continued).

SN 77-286,382. MADRIGAL, DARREN, LAGUNA BEACH, CA. FILED 9-22-2007.

Taco Bus

THE MARK CONSISTS OF STANDARD CHARACTERS WITHOUT CLAIM TO ANY PARTICULAR FONT, STYLE, SIZE, OR COLOR.

NO CLAIM IS MADE TO THE EXCLUSIVE RIGHT TO USE "TACO", APART FROM THE MARK AS SHOWN.

FOR RESTAURANT SERVICES (U.S. CLS. 100 AND 101).

JENNIFER MARTIN, EXAMINING ATTORNEY

SN 77-287,018. FIREHOUSE COFFEE, LLC., DENTON, MD. FILED S.R. 9-24-2007; AM. P.R. 6-27-2008.



NO CLAIM IS MADE TO THE EXCLUSIVE RIGHT TO USE "COFFEE" AND "A UNIQUE COFFEE CAFE", APART FROM THE MARK AS SHOWN.

THE COLOR(S) RED, BLACK, WHITE, GREY AND GOLD IS/ARE CLAIMED AS A FEATURE OF THE MARK.

THE MARK CONSISTS OF THE WORDING "FIREHOUSE COFFEE" IS RED, THE BODY OF THE FIRE TRUCK IS GREY, THE COFFEE POT IS BLACK, THE HORSES ARE BLACK AND WHITE, THE WORDING "A UNIQUE COFFEE CAFE" IS BLACK, AND THE OVAL RING SURROUNDING THE LOGO IS GOLD AND BLACK.

FOR COFFEE SHOPS; COFFEE-HOUSE AND SNACK-BAR SERVICES (U.S. CLS. 100 AND 101).

FIRST USE 4-1-2007; IN COMMERCE 4-12-2007.
 RONALD MCMORROW, EXAMINING ATTORNEY

CLASS 43—(Continued).

SN 77-287,107. RESTAURANTS 2000, LLC, MENOMONEE FALLS, WI. FILED 9-24-2007.



THE MARK CONSISTS OF A SILHOUETTE OF A COWBOY COOKING OVER AN OPEN FIRE IN A DESERT-LIKE SETTING, FEATURING CACTI AND A CLEAR NIGHT SKY.

FOR RESTAURANT AND TAVERN SERVICES (U.S. CLS. 100 AND 101).

FIRST USE 11-30-1999; IN COMMERCE 11-30-1999.

H. M. FISHER, EXAMINING ATTORNEY

CLASS 43—(Continued).

SN 77-319,626. MENCHIE'S, INC., STUDIO CITY, CA. FILED 11-2-2007.

MENCHIE'S

THE MARK CONSISTS OF STANDARD CHARACTERS WITHOUT CLAIM TO ANY PARTICULAR FONT, STYLE, SIZE, OR COLOR.

FOR ICE CREAM SHOP SERVICES IN THE NATURE OF A RESTAURANT (U.S. CLS. 100 AND 101).

FIRST USE 5-15-2007; IN COMMERCE 5-15-2007.

SANJEEV VOHRA, EXAMINING ATTORNEY

SN 77-293,713. AIRPORT PET PARKS, LLC, HOUSTON, TX. FILED 10-2-2007.

Airport Pet Parks Five Star Pet Resort

THE MARK CONSISTS OF STANDARD CHARACTERS WITHOUT CLAIM TO ANY PARTICULAR FONT, STYLE, SIZE, OR COLOR.

NO CLAIM IS MADE TO THE EXCLUSIVE RIGHT TO USE "AIRPORT PET PARKS" AND "PET RESORT", APART FROM THE MARK AS SHOWN.

FOR SMALL PET BOARDING WITH DOG DAYCARE (U.S. CLS. 100 AND 101).

DANIEL CAPSHAW, EXAMINING ATTORNEY

SN 77-319,664. BONTE FRANCHISE GROUP, LLC, PHILADELPHIA, PA. FILED 11-2-2007.



SN 77-310,327. CHAN TIEU, MARICOPA, AZ. FILED 10-22-2007.

UNPHOGETTABLE

THE MARK CONSISTS OF STANDARD CHARACTERS WITHOUT CLAIM TO ANY PARTICULAR FONT, STYLE, SIZE, OR COLOR.

FOR RESTAURANT SERVICES (U.S. CLS. 100 AND 101).

RENEE MCCRAY, EXAMINING ATTORNEY

THE MARK CONSISTS OF STYLIZED LETTER "B" SURROUNDED BY A CIRCLE WITH TWO BREAKS.

FOR PROVISION OF FOOD AND DRINK IN RESTAURANTS; RESTAURANT AND BAR SERVICES; RESTAURANTS; RESTAURANTS FEATURING HOME DELIVERY; TAKE-OUT RESTAURANT SERVICES; CAFE-RESTAURANTS; CARRY-OUT RESTAURANTS (U.S. CLS. 100 AND 101).

FIRST USE 6-1-2007; IN COMMERCE 6-1-2007.

KEVIN CORWIN, EXAMINING ATTORNEY

CLASS 43—(Continued).

SN 77-326,433. JACK IN THE BOX INC., SAN DIEGO, CA. FILED 11-9-2007.



OWNER OF U.S. REG. NOS. 2,968,770, 3,078,803 AND OTHERS.

THE COLOR(S) TAN, RED AND WHITE IS/ARE CLAIMED AS A FEATURE OF THE MARK.

THE MARK CONSISTS OF THE WORDS "GET CONNECTED" PLUS DESIGN (SILHOUETTE CLOWNHEAD) ARE CENTERED IN A RECTANGULAR DESIGN ELEMENT. THE COLOR TAN APPEARS AS BACKGROUND WITHIN THE RECTANGULAR DESIGN ELEMENT; THE COLOR RED APPEARS IN THE SOUND WAVE DESIGN ELEMENT; AND THE COLOR WHITE APPEARS IN THE WORDING OF THE MARK AND AS THE BORDER OF THE RECTANGULAR DESIGN.

FOR FAST FOOD AND NON-STOP RESTAURANT SERVICES (U.S. CLS. 100 AND 101).

NICHOLAS ALTREE, EXAMINING ATTORNEY

CLASS 43—(Continued).

SN 77-332,720. G-STAR INTERNATIONAL B.V., GH AMSTERDAM ZUIDOOST, NETHERLANDS, FILED 11-19-2007.



PRIORITY CLAIMED UNDER SEC. 44(D) ON ERP N CMNTY TM OFC APPLICATION NO. 005939947, FILED 5-25-2007.

NO CLAIM IS MADE TO THE EXCLUSIVE RIGHT TO USE "RAW CUISINE", APART FROM THE MARK AS SHOWN.

THE MARK CONSISTS OF THE TERM "RAW CUISINE G-STAR" IN A STYLIZED FORM.

FOR (BASED ON INTENT TO USE) PROVIDING OF FOOD AND DRINK (BASED ON 44(D) PRIORITY APPLICATION) PROVIDING OF FOOD AND DRINK (U.S. CLS. 100 AND 101).

MICHAEL TANNER, EXAMINING ATTORNEY

SN 77-327,883. ROBATA RESTAURANTS LIMITED, LONDON, KNIGHTSBRIDGE, UNITED KINGDOM, FILED 11-13-2007.

ROKA AKOR

THE MARK CONSISTS OF STANDARD CHARACTERS WITHOUT CLAIM TO ANY PARTICULAR FONT, STYLE, SIZE, OR COLOR.

OWNER OF U.S. REG. NO. 3,156,133.

THE MARK HAS NO SIGNIFICANCE IN THE RELEVANT TRADE, ANY GEOGRAPHICAL SIGNIFICANCE OR ANY MEANING IN A FOREIGN LANGUAGE.

FOR RESTAURANT AND BAR SERVICES (U.S. CLS. 100 AND 101).

PAULA MAHONEY, EXAMINING ATTORNEY

SN 77-336,083. TEQUILA CUERVO LA ROJENA, S.A. DE C.V., CODIGO, MEXICO, FILED 11-23-2007.

JOSE CUERVO

THE MARK CONSISTS OF STANDARD CHARACTERS WITHOUT CLAIM TO ANY PARTICULAR FONT, STYLE, SIZE, OR COLOR.

OWNER OF U.S. REG. NO. 2,495,080.

THE NAME "JOSE CUERVO" DOES NOT IDENTIFY A LIVING INDIVIDUAL.

THE FOREIGN WORDING IN THE MARK TRANSLATES INTO ENGLISH AS "CROW" OR "RAVEN".

FOR RESTAURANT, BAR, CAFE AND COCKTAIL LOUNGE SERVICES; HOTEL, MOTEL AND RESORT LODGING SERVICES (U.S. CLS. 100 AND 101).

PAUL CROWLEY, EXAMINING ATTORNEY

CLASS 43—(Continued).

SN 77-342,763. ARMADILLO PALACE, L.P., HOUSTON, TX. FILED 12-3-2007.



NO CLAIM IS MADE TO THE EXCLUSIVE RIGHT TO USE "PALACE", APART FROM THE MARK AS SHOWN.

THE STIPLING IS FOR SHADING PURPOSES ONLY. THE COLOR(S) YELLOW, DARK BLUE, LIGHT BLUE, RED, PINK, ORANGE, WHITE, BLACK, BROWN, TAN, GREEN AND CREAM IS/ARE CLAIMED AS A FEATURE OF THE MARK.

THE MARK CONSISTS OF "ARMADILLO" IN STYLIZED LETTERS HAVING THE COLOR YELLOW AT THE UPPER PORTION, THE COLOR GREEN IN THE MIDDLE PORTION, AND THE COLOR BLUE ON THE LOWER PORTION, FURTHER OUTLINED IN THE COLORS RED AND WHITE AND WITH SHADOWS IN THE COLOR BLACK, ON A BACKGROUND OF THE COLOR GREEN WHICH IS FURTHER OUTLINED IN THE COLOR YELLOW, FURTHER OUTLINED IN THE COLOR RED, FURTHER OUTLINED IN THE COLOR YELLOW, FURTHER OUTLINED IN THE COLOR BLUE; WITH THE STYLIZED REPRESENTATION OF AN ARMADILLO ON THE UPPER LEFT CORNER HAVING COLORS OF BROWN, CREAM, BLACK, WHITE AND ORANGE, OUTLINED IN BLUE; WITH "GOODE'S" APPEARING ON THE TOP CENTER OF THE MARK WITH STYLIZED LETTERS IN THE COLORS RED ON THE UPPER PORTION AND ORANGE ON THE LOWER PORTION, FURTHER OUTLINED IN THE COLOR BLUE; JUST TO THE RIGHT OF THE ARMADILLO'S NOSE IS A REPRESENTATION OF A CACTUS PLANT IN THE COLOR GREEN BEARING FLOWER BUDS IN THE COLORS RED AND CREAM AND A FLOWER IN THE COLORS RED, PINK, YELLOW, WHITE AND BLUE, OUTLINED IN YELLOW, WITH A BACKGROUND IN THE COLOR YELLOW WITH RADIATING LINES IN THE COLOR ORANGE; A FLAG POLE IN THE COLOR ORANGE AND CREAM AND WITH TASSELS IN THE COLORS ORANGE AND YELLOW; AND FINALLY, ON THE LOWER RIGHT OF THE MARK, "PALACE" IN STYLIZED LETTERS BEING BLUE OUTLINED IN THE COLORS WHITE AND RED, WITH SHADOWS IN THE COLOR BLUE, ON A BACKGROUND IN THE COLORS YELLOW AND ORANGE, WITH SMALL CIRCLES IN THE COLORS CREAM AND BLUE UNDERSCORING, AND A STAR ABOVE, THE STAR BEING IN THE COLORS CREAM, ORANGE, YELLOW AND RED, OUTLINED IN THE COLOR BLUE.

FOR BAR AND RESTAURANT SERVICES (U.S. CLS. 100 AND 101).

FIRST USE 4-25-2005; IN COMMERCE 4-25-2005.
KAELIE KUNG, EXAMINING ATTORNEY

CLASS 43—(Continued).

SN 77-358,510. '21' CLUB, INC., NEW YORK, NY. FILED 12-21-2007.

'21' HOTEL

THE MARK CONSISTS OF STANDARD CHARACTERS WITHOUT CLAIM TO ANY PARTICULAR FONT, STYLE, SIZE, OR COLOR.

OWNER OF U.S. REG. NOS. 955,398, 2,429,192 AND OTHERS.

NO CLAIM IS MADE TO THE EXCLUSIVE RIGHT TO USE "HOTEL", APART FROM THE MARK AS SHOWN.

FOR HOTEL SERVICES, HOTEL RESERVATION SERVICES, HOTEL BAR AND RESTAURANT SERVICES (U.S. CLS. 100 AND 101).

MICHAEL WIENER, EXAMINING ATTORNEY

SN 77-378,347. WASHINGTON ATHLETIC CLUB, SEATTLE, WA. FILED 1-23-2008.



OWNER OF U.S. REG. NOS. 2,280,699, 3,355,995 AND 3,355,996.

THE MARK CONSISTS OF STYLIZED WINGS WITH LETTERS "WAC".

FOR HOTEL, BAR, RESTAURANT, AND CATERING SERVICES; CHILD CARE SERVICES (U.S. CLS. 100 AND 101).

FIRST USE 12-31-1930; IN COMMERCE 12-31-1930.
KATHLEEN LORENZO, EXAMINING ATTORNEY

SN 77-385,072. FOUR ANGELS VENTURES, LLC, GRANITE BAY, CA. FILED 1-31-2008.



NO CLAIM IS MADE TO THE EXCLUSIVE RIGHT TO USE "DOG", APART FROM THE MARK AS SHOWN.

THE MARK CONSISTS OF A BUILDING AND A HOT DOG INSIDE A BUN, AND THE STYLIZED TEXT "CAPITOL DAWG".

FOR RESTAURANT SERVICES (U.S. CLS. 100 AND 101).

RAMONA ORTIGA, EXAMINING ATTORNEY

CLASS 43—(Continued).

SN 77-399,755. HIGH DIVE INC., DBA THE HIGH DIVE, SAN DIEGO, CA. FILED 2-18-2008.



NO CLAIM IS MADE TO THE EXCLUSIVE RIGHT TO USE "GRILL BY THE BAY", APART FROM THE MARK AS SHOWN.

THE COLOR(S) BLACK, WHITE, ORANGE, YELLOW, BLUE, RED IS/ARE CLAIMED AS A FEATURE OF THE MARK.

THE COLOR(S) DARK BROWN, LIGHT BROWN, WHITE, BLACK, YELLOW, ORANGE, FLESH AND BLUE IS/ARE CLAIMED AS A FEATURE OF THE MARK. THE MARK CONSISTS OF THE WORDING "THE HIGH DIVE" IN THE COLORS DARK BROWN AND LIGHT BROWN, THE SETTING SUN IS IN DARK BROWN AND LIGHT BROWN WITH WHITE CIRCLES ON THE OUTER EDGE AND THE OUTER MOST EDGE IS IN BLACK. THE WORDING "GRILL BY THE BAY" IS IN BLACK, THE BANNER IS IN YELLOW WITH BLACK ON THE OUTSIDE PART OF THE BANNER AND ORANGE ON THE BACK SIDE OF THE BANNER, THE HUMAN FIGURE HAS SKIN IN FLESH COLOR WITH BLACK HAIR AND THE BODY IS EDGED IN BLACK. THE SILHOUETTE OF THE HUMAN FIGURE IS IN WHITE, THE BATHING SUIT IS IN BLACK AND YELLOW AND THE GOGGLES ARE IN BLUE, BLACK AND WHITE.

FOR BAR AND RESTAURANT SERVICES (U.S. CLS. 100 AND 101).

FIRST USE 7-1-2006; IN COMMERCE 9-1-2006.
EDWARD NELSON, EXAMINING ATTORNEY

SN 77-401,295. PETER'S DRAGON LLC, COSTA MESA, CA. FILED 2-20-2008.

Calwain

THE MARK CONSISTS OF STANDARD CHARACTERS WITHOUT CLAIM TO ANY PARTICULAR FONT, STYLE, SIZE, OR COLOR.

FOR CAFES, RESTAURANTS, AND CATERING FOR THE PROVISION OF FOOD AND BEVERAGES (U.S. CLS. 100 AND 101).

TRACY CROSS, EXAMINING ATTORNEY

CLASS 43—(Continued).

SN 77-404,981. HYATT CORPORATION, CHICAGO, IL. FILED 2-25-2008.

A HAWAIIAN CLASSIC

THE MARK CONSISTS OF STANDARD CHARACTERS WITHOUT CLAIM TO ANY PARTICULAR FONT, STYLE, SIZE, OR COLOR.

NO CLAIM IS MADE TO THE EXCLUSIVE RIGHT TO USE "HAWAIIAN", APART FROM THE MARK AS SHOWN. FOR HOTEL AND RESTAURANT SERVICES (U.S. CLS. 100 AND 101).

FIRST USE 4-30-1989; IN COMMERCE 4-30-1989.
MICHAEL KEATING, EXAMINING ATTORNEY

SN 77-405,943. RAMIREZ, FREIDY, CHARLOTTE, NC. AND RAMIREZ, MARIA, CHARLOTTE, NC. FILED 2-26-2008.

NO CLAIM IS MADE TO THE EXCLUSIVE RIGHT TO USE "MESQUITE", APART FROM THE MARK AS SHOWN. THE STIPPLING IS FOR SHADING PURPOSES ONLY.

THE MARK CONSISTS OF THE STYLIZED WORD "MEXQUITE".

FOR RESTAURANT (U.S. CLS. 100 AND 101).
JENNIFER VASQUEZ, EXAMINING ATTORNEY

SN 77-406,333. BEST WESTERN INTERNATIONAL, INC., PHOENIX, AZ. FILED 2-26-2008.

BEST WESTERN RIDER

THE MARK CONSISTS OF STANDARD CHARACTERS WITHOUT CLAIM TO ANY PARTICULAR FONT, STYLE, SIZE, OR COLOR.

OWNER OF U.S. REG. NOS. 1,432,431, 2,116,079 AND OTHERS.

NO CLAIM IS MADE TO THE EXCLUSIVE RIGHT TO USE "RIDER", APART FROM THE MARK AS SHOWN.

FOR HOTEL SERVICES FOR PREFERRED CUSTOMERS (U.S. CLS. 100 AND 101).

GRETTA YAO, EXAMINING ATTORNEY

CLASS 43—(Continued).

SN 77-406,350. BEST WESTERN INTERNATIONAL, INC., PHOENIX, AZ. FILED 2-26-2008.

BW RIDER

THE MARK CONSISTS OF STANDARD CHARACTERS WITHOUT CLAIM TO ANY PARTICULAR FONT, STYLE, SIZE, OR COLOR.

OWNER OF U.S. REG. NO. 3,020,526.

NO CLAIM IS MADE TO THE EXCLUSIVE RIGHT TO USE "RIDER", APART FROM THE MARK AS SHOWN.

FOR HOTEL SERVICES FOR PREFERRED CUSTOMERS (U.S. CLS. 100 AND 101).

GRETTA YAO, EXAMINING ATTORNEY

SN 77-406,380. SKOR MANAGEMENT LLC, BIRMINGHAM, MI. FILED 2-26-2008.



NO CLAIM IS MADE TO THE EXCLUSIVE RIGHT TO USE "GREEK CAFE", APART FROM THE MARK AS SHOWN.

THE MARK CONSISTS OF A STYLIZED MARK FOR THE WORDING "KALAMATA" OVER "GREEK CAFE" INCLUDING AN OLIVE OVER "KALAMATA" AND AN OBLONG OVAL AROUND THE WORDING THAT RUNS THROUGH THE OLIVE.

FOR RESTAURANT; RESTAURANT SERVICES (U.S. CLS. 100 AND 101).

TASHIA BUNCH, EXAMINING ATTORNEY

SN 77-409,149. PETER'S DRAGON LLC, COSTA MESA, CA. FILED 2-28-2008.

Calwaiian

THE MARK CONSISTS OF STANDARD CHARACTERS WITHOUT CLAIM TO ANY PARTICULAR FONT, STYLE, SIZE, OR COLOR.

THE WORDING "CALWAIIAN" HAS NO MEANING IN A FOREIGN LANGUAGE.

FOR CAFES, RESTAURANTS, AND CATERING FOR THE PROVISION OF FOOD AND BEVERAGES (U.S. CLS. 100 AND 101).

TRACY CROSS, EXAMINING ATTORNEY

CLASS 43—(Continued).

SN 77-411,941. CAFFE D'AMORE, LLC, SAN FRANCISCO, CA. FILED 3-3-2008.

Tazza D'Amore

THE STIPPLING IS FOR SHADING PURPOSES ONLY. THE MARK CONSISTS OF THE TEXT "TAZZA D'AMORE" THAT SLANTS UP DIAGONALLY FROM LEFT TO RIGHT.

THE FOREIGN WORDING IN THE MARK TRANSLATES INTO ENGLISH AS CUP OF LOVE.

FOR COFFEE SHOPS (U.S. CLS. 100 AND 101).

MICHAEL KEATING, EXAMINING ATTORNEY

SN 77-412,496. MACK'S PIZZA, INC., WILDWOOD, NJ. FILED 3-4-2008.

MACKS

THE MARK CONSISTS OF STANDARD CHARACTERS WITHOUT CLAIM TO ANY PARTICULAR FONT, STYLE, SIZE, OR COLOR.

FOR RESTAURANT SERVICES (U.S. CLS. 100 AND 101).

FIRST USE 1-0-1955; IN COMMERCE 1-0-1955.

MARK SPARACINO, EXAMINING ATTORNEY

SN 77-412,671. US HOTELS, INC., NEW YORK, NY. FILED 3-4-2008.

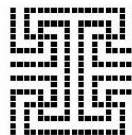

US HOTELS

NO CLAIM IS MADE TO THE EXCLUSIVE RIGHT TO USE "US HOTELS", APART FROM THE MARK AS SHOWN. THE MARK CONSISTS OF A TILE DESIGN ABOVE THE WORDS "US HOTELS".

FOR HOTELS, MOTELS, INNS, RESTAURANTS, BARS, AND CATERING SERVICES; HOTEL, MOTEL, INN, RESTAURANT, BAR AND CATERING SERVICES (U.S. CLS. 100 AND 101).

FIRST USE 3-3-2008; IN COMMERCE 3-3-2008.

TEJBIR SINGH, EXAMINING ATTORNEY

CLASS 43—(Continued).

SN 77-413,946. R-WILD HORSE RANCH, PLATINA, CA. FILED 3-5-2008.

R-WILD HORSE RANCH

THE MARK CONSISTS OF STANDARD CHARACTERS WITHOUT CLAIM TO ANY PARTICULAR FONT, STYLE, SIZE, OR COLOR.

NO CLAIM IS MADE TO THE EXCLUSIVE RIGHT TO USE "HORSE RANCH", APART FROM THE MARK AS SHOWN.

FOR PRIVATE RESIDENCE CLUB SERVICES, NAMELY, PROVISION TO CLUB MEMBERS OF TEMPORARY ACCOMMODATIONS IN COMPANY OWNED PRIVATE RESIDENCES LOCATED ON A HORSE RANCH WHERE MEMBERS HAVE FULL USE OF THE PROPERTY, HORSES AND ALL RECREATIONAL ACTIVITIES AVAILABLE (U.S. CLS. 100 AND 101).

FIRST USE 5-20-1985; IN COMMERCE 5-20-1985.
AMY GEARIN, EXAMINING ATTORNEY

SN 77-413,970. R-WILD HORSE RANCH, PLATINA, CA. FILED 3-5-2008.



THE MARK CONSISTS OF A STYLIZED SIDE VIEW OF A HORSES HEAD IN A CIRCLE.

FOR PRIVATE RESIDENCE CLUB SERVICES, NAMELY, PROVISION TO CLUB MEMBERS OF TEMPORARY ACCOMMODATIONS IN COMPANY OWNED PRIVATE RESIDENCES LOCATED ON A HORSE RANCH WHERE MEMBERS HAVE FULL USE OF THE PROPERTY, HORSES AND ALL RECREATIONAL ACTIVITIES AVAILABLE (U.S. CLS. 100 AND 101).

FIRST USE 5-20-1985; IN COMMERCE 5-20-1985.
AMY GEARIN, EXAMINING ATTORNEY

CLASS 43—(Continued).

SN 77-416,080. ENTREE VOUS FRANCHISING, LLC, LEXINGTON, KY. FILED 3-7-2008.



NO CLAIM IS MADE TO THE EXCLUSIVE RIGHT TO USE "FRESH TAKE & BAKE", APART FROM THE MARK AS SHOWN.

THE MARK CONSISTS OF A STYLIZED OUTLINE DRAWING OF AN OVEN MITT WITH THE WORDS "FRESH TAKE & BAKE", GRASPING A BOWL WITH STEAM RISING FROM IT.

FOR FOOD PREPARATION SERVICES (U.S. CLS. 100 AND 101).

DOMINIC J. FERRAIUOLO, EXAMINING ATTORNEY

SN 77-416,466. WERNER, JACK, BEVERLY HILLS, CA. FILED 3-7-2008.

American Flame Chicken

THE MARK CONSISTS OF STANDARD CHARACTERS WITHOUT CLAIM TO ANY PARTICULAR FONT, STYLE, SIZE, OR COLOR.

NO CLAIM IS MADE TO THE EXCLUSIVE RIGHT TO USE "AMERICAN" AND "CHICKEN", APART FROM THE MARK AS SHOWN.

FOR RESTAURANT SERVICES (U.S. CLS. 100 AND 101).

STEVEN JACKSON, EXAMINING ATTORNEY

CLASS 43—(Continued).

SN 77-417,152. DPR II ENTERPRISES, INC., DBA CAPITOL GROUNDS COFFEE, CLIFTON, VA. FILED 3-10-2008.



NO CLAIM IS MADE TO THE EXCLUSIVE RIGHT TO USE "COFFEE" AND "WASHINGTON, D.C.", APART FROM THE MARK AS SHOWN.

THE MARK CONSISTS OF A PLAIN LINE CIRCLE CONTAINING A STYLIZED DRAWING OF THE U.S. CAPITOL BUILDING WITH A COFFEE CUP WITH STEAM RISING FROM THE CUP ON TOP OF THE BUILDING AND THE WORDING "CAPITOL GROUNDS" IN THE TOP OF THE CIRCLE ABOVE THE BUILDING ON EITHER SIDE OF THE COFFEE CUP. THE WORD "COFFEE" APPEARS UNDER THE BUILDING AND IS UNDERLINED BY AN ARCHED LINE. THE WORDING "WASHINGTON, D.C." APPEARS IN THE BOTTOM OF THE CIRCLE.

FOR CAFE AND RESTAURANT SERVICES; COFFEE SHOPS; DELICATESSENS (U.S. CLS. 100 AND 101).
FIRST USE 1-1-1996; IN COMMERCE 1-1-1996.
RENEE SERVANCE, EXAMINING ATTORNEY

CLASS 43—(Continued).

SN 77-419,293. TJ PARTNERS, WARWICK, RI. FILED 3-11-2008.



NO CLAIM IS MADE TO THE EXCLUSIVE RIGHT TO USE "BAR & GRILLE", APART FROM THE MARK AS SHOWN.

THE COLOR(S) YELLOW, BLUE, GREEN, BEIGE, GREY, RED, BLACK AND WHITE IS/ARE CLAIMED AS A FEATURE OF THE MARK.

THE MARK CONSISTS OF THE DESIGN OF A SAILOR, DRESSED IN A YELLOW COAT, GREY SHIRT, GREEN PANTS, AND BLACK BELT. THE SAILOR'S FACE IS DEPICTED IN BEIGE, WITH A WHITE BEARD. HIS MOUTH IS OPEN, WITH A RED TONGUE VISIBLE. GREEN SEAWEED APPEARS ON THE SAILOR'S HEAD, SHOULDER AND RIGHT KNEE. THE SAILOR HAS HIS RIGHT FOOT ATOP A FISH, DEPICTED IN BLUE AND GREEN, WITH GREY SHADOWING UNDERNEATH. TO THE LEFT OF THE SAILOR IS THE PHRASE "CAPTAIN SEAWEEED'S", WHICH IS DEPICTED IN GREEN WITH BOTH WHITE AND BLACK OUTLINING. BELOW THAT APPEAR THE WORDS "BAR & GRILLE" DEPICTED IN BLACK.

FOR BAR AND RESTAURANT SERVICES; RESTAURANT; RESTAURANT, BAR AND CATERING SERVICES; RESTAURANTS; BAR SERVICES; RESTAURANT AND BAR SERVICES (U.S. CLS. 100 AND 101).

EMILY CARLSEN, EXAMINING ATTORNEY

SN 77-419,239. 21ST CENTURY GAMING, INC., BEVERLY HILLS, CA. FILED 3-11-2008.

FLAME INTERNATIONAL

THE MARK CONSISTS OF STANDARD CHARACTERS WITHOUT CLAIM TO ANY PARTICULAR FONT, STYLE, SIZE, OR COLOR.

NO CLAIM IS MADE TO THE EXCLUSIVE RIGHT TO USE "INTERNATIONAL", APART FROM THE MARK AS SHOWN.

FOR RESTAURANT SERVICES (U.S. CLS. 100 AND 101).
PETER B. BROMAGHIM, EXAMINING ATTORNEY

SN 77-419,561. 288 INC., WELLESLEY, MA. FILED 3-12-2008.

COMELLAS

THE MARK CONSISTS OF STANDARD CHARACTERS WITHOUT CLAIM TO ANY PARTICULAR FONT, STYLE, SIZE, OR COLOR.

FOR RESTAURANT AND CATERING SERVICES (U.S. CLS. 100 AND 101).
FIRST USE 0-0-1990; IN COMMERCE 0-0-1990.
JORDAN BAKER, EXAMINING ATTORNEY

CLASS 43—(Continued).

SN 77-420,039. ZA ZA OF NAPLES, LLC, N.W. NAPLES, FL. FILED 3-12-2008.

Sa Za Pizza

THE MARK CONSISTS OF STANDARD CHARACTERS WITHOUT CLAIM TO ANY PARTICULAR FONT, STYLE, SIZE, OR COLOR.

NO CLAIM IS MADE TO THE EXCLUSIVE RIGHT TO USE "PIZZA", APART FROM THE MARK AS SHOWN. FOR RESTAURANT SERVICES (U.S. CLS. 100 AND 101).

SOPHIA S. KIM, EXAMINING ATTORNEY

SN 77-420,062. ZA ZA OF NAPLES, LLC, N.W. NAPLES, FL. FILED 3-12-2008.



NO CLAIM IS MADE TO THE EXCLUSIVE RIGHT TO USE "ITALIAN FOOD", APART FROM THE MARK AS SHOWN.

THE COLOR(S) RED, GREEN, BLACK, AND WHITE IS/ ARE CLAIMED AS A FEATURE OF THE MARK.

THE MARK CONSISTS OF THE DESIGN OF A CIRCLE WITH A PIZZA SLICE IN RED WITH THE CRUST OF THE SLICE IN BLACK ON THE LEFT HALF OF THE CIRCLE AND A PIZZA SLICE IN GREEN WITH THE CRUST OF THE SLICE IN BLACK ON THE RIGHT SIDE OF THE CIRCLE. BENEATH THE DESIGN ELEMENT ARE THE WORDS "SA" AND "ZA" STYLIZED IN RED OUTLINED IN WHITE WITH A BLACK BORDER. THE WORDS "SERIOUS ITALIAN FOOD" APPEAR IN BLACK LETTERING BELOW THE WORDS "SA ZA".

FOR RESTAURANT SERVICES (U.S. CLS. 100 AND 101).

SOPHIA S. KIM, EXAMINING ATTORNEY

CLASS 43—(Continued).

SN 77-420,068. ZA ZA OF NAPLES, LLC, N.W. NAPLES, FL. FILED 3-12-2008.

"Eh I could eat"

THE MARK CONSISTS OF STANDARD CHARACTERS WITHOUT CLAIM TO ANY PARTICULAR FONT, STYLE, SIZE, OR COLOR.

FOR RESTAURANT SERVICES (U.S. CLS. 100 AND 101).

SOPHIA S. KIM, EXAMINING ATTORNEY

SN 77-420,517. DEMETRIOS K. PANTAZIS FAMILY LIMITED PARTNERSHIP, LA CANADA, CA. FILED 3-12-2008.



NO CLAIM IS MADE TO THE EXCLUSIVE RIGHT TO USE "CHICKEN AND BURGERS" AND "EST. 1968", APART FROM THE MARK AS SHOWN.

THE MARK CONSISTS OF THE OUTLINE OF A FANCIFUL CHICKEN INSIDE A DIAMOND WITH THE WORDS DINO'S CHICKEN AND BURGERS EST. 1968.

FOR RESTAURANT SERVICES (U.S. CLS. 100 AND 101).

FIRST USE 11-0-2006; IN COMMERCE 11-0-2006.

MICHAEL LITZAU, EXAMINING ATTORNEY

SN 77-421,157. BLOCKHEAD'S BURRITOS, INC., NEW YORK, NY. FILED 3-13-2008.

MOTHER BURGER

THE MARK CONSISTS OF STANDARD CHARACTERS WITHOUT CLAIM TO ANY PARTICULAR FONT, STYLE, SIZE, OR COLOR.

NO CLAIM IS MADE TO THE EXCLUSIVE RIGHT TO USE "BURGER", APART FROM THE MARK AS SHOWN.

FOR RESTAURANT SERVICES (U.S. CLS. 100 AND 101).

KIM MONINGHOFF, EXAMINING ATTORNEY

CLASS 43—(Continued).

SN 77-421,162. EZ TAKE OUT BURGER, LLC, ALISO VIEJO, CA. FILED 3-13-2008.



OWNER OF U.S. REG. NO. 1.656.497.
NO CLAIM IS MADE TO THE EXCLUSIVE RIGHT TO USE "TAKE OUT BURGER EST. 1969", APART FROM THE MARK AS SHOWN.

THE COLOR(S) RED, BLACK, AND WHITE IS/ARE CLAIMED AS A FEATURE OF THE MARK.

THE MARK CONSISTS OF THE WORDS "EZ TAKE OUT" IN ALL CAPS AND RED WITH A BLACK SHADOW EFFECT BEHIND THEM. BELOW THAT, THE WORD "BURGER" IN ALL CAPS AND BLACK. BELOW THAT, THE PHRASE "EST. 1969" IN ALL CAPS AND BLACK. ALL LETTERING ON A WHITE BACKGROUND WITH A THICK RED LINE SURROUNDING IT IN THE SHAPE OF A RECTANGLE WITH CURVED CORNERS.

FOR FAST-FOOD RESTAURANTS (U.S. CLS. 100 AND 101).

FIRST USE 0-0-1985; IN COMMERCE 1-0-2008.
AMY GEARIN, EXAMINING ATTORNEY

SN 77-421,168. BLOCKHEAD'S BURRITOS, INC., NEW YORK, NY. FILED 3-13-2008.



NO CLAIM IS MADE TO THE EXCLUSIVE RIGHT TO USE "BURGER", APART FROM THE MARK AS SHOWN.

FOR RESTAURANT SERVICES (U.S. CLS. 100 AND 101).

KIM MONINGHOFF, EXAMINING ATTORNEY

CLASS 43—(Continued).

SN 77-421,291. KENNY GAZIN, DBA SPECIALIZED RESTAURANTS INC, SAN LUIS OBISPO, CA. FILED 3-13-2008.

SCRUBBY AND LLOYDS

THE MARK CONSISTS OF STANDARD CHARACTERS WITHOUT CLAIM TO ANY PARTICULAR FONT, STYLE, SIZE, OR COLOR.

FOR CAFE-RESTAURANTS; CARRY-OUT RESTAURANTS; FAST-FOOD RESTAURANTS AND SNACK-BARS; RESTAURANT; RESTAURANT SERVICES, INCLUDING SIT-DOWN SERVICE OF FOOD AND TAKE-OUT RESTAURANT SERVICES; RESTAURANTS (U.S. CLS. 100 AND 101).

BENJAMIN ALLEN, EXAMINING ATTORNEY

SN 77-422,336. HAWAIIAN HUT L.L.C., WEST LAFAYETTE, IN. FILED 3-14-2008.



THE COLOR(S) GREEN, LIGHT BROWN, DARK BROWN, AND YELLOWISH GOLD IS/ARE CLAIMED AS A FEATURE OF THE MARK.

THE MARK CONSISTS OF A HUT WITH A DARK BROWN ROOF, LIGHT BROWN OUTLINE AROUND THE ROOF, AND YELLOWISH GOLD STRUCTURE UNDER THE ROOF, GREEN TREES, AND THE WORDS "HAWAIIAN HUT" IN YELLOWISH GOLD WITH DARK BROWN OUTLINE.

FOR RESTAURANT AND CATERING SERVICES (U.S. CLS. 100 AND 101).

DAYNA BROWNE, EXAMINING ATTORNEY

SN 77-424,463. FISCH USA CORPORATION, FLUSHING, NY. FILED 3-18-2008.



THE MARK CONSISTS OF THE WORD "FISCH" WITH A

CLASS 43—(Continued).

PAIR OF LARGE, CONCENTRIC, DOUBLE-RIMMED CIRCLES EXTENDING FROM LOCATIONS PROXIMATE THE LETTER "S" TO THE LEFT TO ENCIRCLE THE LETTERS "F" AND "I" WITH A SMALLER, DOUBLE-RIMMED CIRCLE WITHIN THE LARGEST CIRCLE AND OVERLAPPING A SMALL PORTION OF THE INNERMOST DOUBLE-RIMMED CIRCLE AND A LEFT SIDE, CENTRALLY LOCATED PORTION OF THE LETTER "F" AND A TRIANGLE FORMED ON THE RIGHT SIDE OF THE SMALLER CIRCLE.

FOR RESTAURANT, BAR AND CATERING SERVICES, RESTAURANT AND CAFE SERVICES, RESTAURANT AND CAFETERIA SERVICES, FAST FOOD AND NON-STOP RESTAURANT SERVICES, FAST-FOOD RESTAURANTS, RESTAURANTS, RESTAURANT SERVICES FEATURING SANDWICHES, RESTAURANT SERVICES, INCLUDING SIT-DOWN SERVICE OF FOOD AND TAKE-OUT OR CARRY-OUT RESTAURANT SERVICES, RESTAURANTS FEATURING HOME DELIVERY, SELF SERVICE RESTAURANTS, TAKE-OUT OR CARRY-OUT RESTAURANT SERVICES (U.S. CLS. 100 AND 101).

CHRISTINA SOBRAL, EXAMINING ATTORNEY

CLASS 43—(Continued).

SN 77-424,556. EARTH FARE, INC., FLETCHER, NC. FILED 3-18-2008.

THE FOODS YOU LOVE. ONLY
BETTER.

THE MARK CONSISTS OF STANDARD CHARACTERS WITHOUT CLAIM TO ANY PARTICULAR FONT, STYLE, SIZE, OR COLOR.

FOR RESTAURANT, CAFE AND DELICATESSEN SERVICES (U.S. CLS. 100 AND 101).

FIRST USE 1-3-2005; IN COMMERCE 1-3-2005.

MICHAEL TANNER, EXAMINING ATTORNEY

SN 77-424,469. FISCH USA CORPORATION, FLUSHING, NY. FILED 3-18-2008.



THE MARK CONSISTS OF THE WORD FISCH WITH A LARGE, OUTERMOST DOUBLE-RIMMED SLIGHTLY ELONGATED CIRCLE OR OVAL ENCIRCLING THE WORD AND ANOTHER, LARGE INNERMOST DOUBLE-RIMMED SLIGHTLY ELONGATED CIRCLE OR OVAL EXTENDING ON ONE SIDE FROM THE LETTER "F" AND ON THE OTHER SIDE FROM THE LETTER "H", AND A SMALLER, DOUBLE-RIMMED SLIGHTLY ELONGATED CIRCLE OR OVAL ABOVE THE WORD AND OVERLYING AN UPPER PORTION OF THE LARGE, INNERMOST SLIGHTLY ELONGATED CIRCLE OR OVAL AND A PART OF THE LARGE, OUTERMOST SLIGHTLY ELONGATED CIRCLE OR OVAL, AND A TRIANGLE FORMED ON THE RIGHT SIDE OF THE SMALLER SLIGHTLY ELONGATED CIRCLE OR OVAL.

FOR RESTAURANT, BAR AND CATERING SERVICES, RESTAURANT AND CAFE SERVICES, RESTAURANT AND CAFETERIA SERVICES, FAST FOOD AND NON-STOP RESTAURANT SERVICES, FAST-FOOD RESTAURANTS, RESTAURANTS, RESTAURANT SERVICES FEATURING SANDWICHES, RESTAURANT SERVICES, INCLUDING SIT-DOWN SERVICE OF FOOD AND TAKE-OUT OR CARRY-OUT RESTAURANT SERVICES, RESTAURANTS FEATURING HOME DELIVERY, SELF SERVICE RESTAURANTS, TAKE-OUT OR CARRY-OUT RESTAURANT SERVICES (U.S. CLS. 100 AND 101).

CHRISTINA SOBRAL, EXAMINING ATTORNEY

SN 77-425,618. MOSES, MARK, AURORA, CO. FILED 3-18-2008.

Ghetto Mac

THE MARK CONSISTS OF STANDARD CHARACTERS WITHOUT CLAIM TO ANY PARTICULAR FONT, STYLE, SIZE, OR COLOR.

FOR BAR AND RESTAURANT SERVICES (U.S. CLS. 100 AND 101).

MARCIE MILONE, EXAMINING ATTORNEY

SN 77-425,914. LOMBARDO, JESSICA, DENVER, CO. FILED 3-19-2008.

Supper Heroes

THE MARK CONSISTS OF STANDARD CHARACTERS WITHOUT CLAIM TO ANY PARTICULAR FONT, STYLE, SIZE, OR COLOR.

FOR PROVIDING REVIEWS OF RESTAURANTS; AND CONSULTATION SERVICES IN THE FIELD OF RESTAURANTS, NAMELY, PROVIDING ADVICE TO TOURISTS, BUSINESS TRAVELERS, AND LOCAL PEOPLE ON RESTAURANT DESTINATIONS (U.S. CLS. 100 AND 101).

ELLEN B. AWRICH, EXAMINING ATTORNEY

CLASS 43—(Continued).

SN 77-426,228. OTG MANAGEMENT, INC., PHILADELPHIA, PA. FILED 3-19-2008.



THE COLOR(S) RED AND BROWN IS/ARE CLAIMED AS A FEATURE OF THE MARK.

THE MARK CONSISTS OF THE COLORS RED AND BROWN, WITH THE COLOR RED APPEARING IN THE NUMBER "5" AND LETTERS "IVE", AND THE COLOR BROWN APPEARING IN THE LETTERS "STEAK"

FOR RESTAURANT AND BAR SERVICES (U.S. CLS. 100 AND 101).

DARRYL SPRUILL, EXAMINING ATTORNEY

CLASS 43—(Continued).

SN 77-427,189. UNITED VETERANS OF AMERICA, INC., LEEDS, MA. FILED 3-20-2008.



THE MARK CONSISTS OF STANDARD CHARACTERS WITHOUT CLAIM TO ANY PARTICULAR FONT, STYLE, SIZE, OR COLOR.

FOR PROVIDING TEMPORARY HOUSING ACCOMMODATIONS FOR VETERANS WHO ARE HOMELESS OR AT RISK OF HOMELESSNESS (U.S. CLS. 100 AND 101).

FIRST USE 11-28-2007; IN COMMERCE 11-28-2007. NICHOLAS COLEMAN, EXAMINING ATTORNEY

SN 77-426,369. ICON BURGER DEVELOPMENT COMPANY, LLC, DENVER, CO. FILED 3-19-2008.



THE COLOR(S) RED AND WHITE IS/ARE CLAIMED AS A FEATURE OF THE MARK.

THE MARK CONSISTS OF A RED OVAL CONTAINING THE WORD "SMASH" IN WHITE.

FOR CARRY-OUT RESTAURANTS; RESTAURANT, BAR AND CATERING SERVICES; SELF-SERVICE RESTAURANTS (U.S. CLS. 100 AND 101).

HANNO RITTNER, EXAMINING ATTORNEY

SN 77-427,369. ICON BURGER DEVELOPMENT COMPANY, LLC, DENVER, CO. FILED 3-20-2008.



THE COLOR(S) RED AND WHITE IS/ARE CLAIMED AS A FEATURE OF THE MARK.

THE MARK CONSISTS OF A WHITE OVAL CONTAINING THE WORDING "BURGER" IN RED WITHIN A RED OVAL CONTAINING THE TERM "SM*SH" IN WHITE.

FOR CARRY-OUT RESTAURANTS; RESTAURANT, BAR AND CATERING SERVICES; SELF-SERVICE RESTAURANTS (U.S. CLS. 100 AND 101).

HANNO RITTNER, EXAMINING ATTORNEY

SN 77-426,979. LEAN GOURMET, LLC, TULSA, OK. FILED 3-20-2008.



THE MARK CONSISTS OF STANDARD CHARACTERS WITHOUT CLAIM TO ANY PARTICULAR FONT, STYLE, SIZE, OR COLOR.

FOR RESTAURANT AND BAR SERVICES (U.S. CLS. 100 AND 101).

PAULA MAHONEY, EXAMINING ATTORNEY

SN 77-427,433. ICON BURGER DEVELOPMENT COMPANY, LLC, DENVER, CO. FILED 3-20-2008.



smash. sizzle. savor.

OWNER OF U.S. REG. NO. 3,432,241. THE COLOR(S) RED AND WHITE IS/ARE CLAIMED AS A FEATURE OF THE MARK.

THE MARK CONSISTS OF A RED OVAL CONTAINING THE WORD "SMASH" IN WHITE, AND, THE WORDING "SMASH. SIZZLE. SAVOR." IN RED.

FOR CARRY-OUT RESTAURANTS; RESTAURANT, BAR AND CATERING SERVICES; SELF-SERVICE RESTAURANTS (U.S. CLS. 100 AND 101).

HANNO RITTNER, EXAMINING ATTORNEY

CLASS 43—(Continued).

SN 77-427,451. ICON BURGER DEVELOPMENT COMPANY, LLC, DENVER, CO. FILED 3-20-2008.



THE COLOR(S) RED AND WHITE IS/ARE CLAIMED AS A FEATURE OF THE MARK.

THE MARK CONSISTS OF A WHITE OVAL CONTAINING THE WORD "BURGER" IN RED WITHIN A RED OVAL CONTAINING THE STYLIZED TERM "SM SH" IN WHICH A STYLIZED HAMBURGER APPEARS BETWEEN THE "SM" AND "SH" IN WHITE.

FOR CARRY-OUT RESTAURANTS; RESTAURANT, BAR AND CATERING SERVICES; SELF-SERVICE RESTAURANTS (U.S. CLS. 100 AND 101).

HANNO RITNER, EXAMINING ATTORNEY

SN 77-428,123. MAJESTIC BURGER, LLC, MADISON, MS. FILED 3-21-2008.

MAJESTIC BURGER

THE MARK CONSISTS OF STANDARD CHARACTERS WITHOUT CLAIM TO ANY PARTICULAR FONT, STYLE, SIZE, OR COLOR.

NO CLAIM IS MADE TO THE EXCLUSIVE RIGHT TO USE "BURGER", APART FROM THE MARK AS SHOWN.

FOR RESTAURANT SERVICES (U.S. CLS. 100 AND 101).

FIRST USE 9-17-2007; IN COMMERCE 9-17-2007.
TASNEEM HUSSAIN, EXAMINING ATTORNEY

SN 77-429,127. GOMEZ, MAURICIO, SUN CITY, CA. AND GOMEZ, JULIO, SUN CITY, CA. FILED 3-23-2008.

BACANORA MEXICAN GRILL

THE MARK CONSISTS OF STANDARD CHARACTERS WITHOUT CLAIM TO ANY PARTICULAR FONT, STYLE, SIZE, OR COLOR.

NO CLAIM IS MADE TO THE EXCLUSIVE RIGHT TO USE "MEXICAN GRILL", APART FROM THE MARK AS SHOWN.

THE ENGLISH TRANSLATION OF THE WORD "BACANORA" IN THE MARK IS AN AGAVE DISTILLED SPIRIT FROM THE SONORA REGION OF MEXICO.

FOR RESTAURANT AND BAR SERVICES (U.S. CLS. 100 AND 101).

MATTHEW MCDOWELL, EXAMINING ATTORNEY

CLASS 43—(Continued).

SN 77-429,340. CRAFT WORLDWIDE HOLDINGS, LLC, NEW YORK, NY. FILED 3-24-2008.

CRAFTBURGER

THE MARK CONSISTS OF STANDARD CHARACTERS WITHOUT CLAIM TO ANY PARTICULAR FONT, STYLE, SIZE, OR COLOR.

OWNER OF U.S. REG. NOS. 2,906,043 AND 2,947,414.
FOR RESTAURANT SERVICES (U.S. CLS. 100 AND 101).

CHRISTOPHER BUONGIORNO, EXAMINING ATTORNEY

SN 77-429,362. RCAB FRANCHISE, INC., LEAD HILL, AR. FILED 3-24-2008.

WORLD'S FASTEST FOOD AND FUN

THE MARK CONSISTS OF STANDARD CHARACTERS WITHOUT CLAIM TO ANY PARTICULAR FONT, STYLE, SIZE, OR COLOR.

FOR RESTAURANT SERVICES (U.S. CLS. 100 AND 101).

CHARLOTTE CORWIN, EXAMINING ATTORNEY

SN 77-429,915. LEAN GOURMET, LLC, TULSA, OK. FILED 3-24-2008.

THE TABLE AT 61

THE MARK CONSISTS OF STANDARD CHARACTERS WITHOUT CLAIM TO ANY PARTICULAR FONT, STYLE, SIZE, OR COLOR.

FOR BAR AND RESTAURANT SERVICES (U.S. CLS. 100 AND 101).

PAULA MAHONEY, EXAMINING ATTORNEY

SN 77-430,260. MGM GRAND HOTEL, LLC, LAS VEGAS, NV. FILED 3-24-2008.



FOR RESTAURANT AND BAR SERVICES; COCKTAIL LOUNGES (U.S. CLS. 100 AND 101).

FIRST USE 4-25-2008; IN COMMERCE 4-25-2008.
JAMES LOVELACE, EXAMINING ATTORNEY

CLASS 43—(Continued).

SN 77-430,283. MACRIS, MARIA E, CLEARWATER, FL. AND STATHOPOULOS, DIMITRA, BELLEAIR BEACH, FL. FILED 3-24-2008.

MANOULA

THE MARK CONSISTS OF STANDARD CHARACTERS WITHOUT CLAIM TO ANY PARTICULAR FONT, STYLE, SIZE, OR COLOR.

THE WORDING "MANOULA" HAS NO MEANING IN A FOREIGN LANGUAGE

FOR PRESCHOOLER AND INFANT CARE AT DAY-CARE CENTERS; CHILD CARE; CHILD CARE CENTERS; CHILD CARE SERVICES; DAY CARE CENTERS; NURSERIES AND DAY CARE CENTERS (U.S. CLS. 100 AND 101).

SETH A. RAPPAPORT, EXAMINING ATTORNEY

CLASS 43—(Continued).

SN 77-431,083. HAMBURGER MARY'S INTERNATIONAL, LLC, CHICAGO, IL. FILED 3-25-2008.

MARGARITA MARY'S

THE MARK CONSISTS OF STANDARD CHARACTERS WITHOUT CLAIM TO ANY PARTICULAR FONT, STYLE, SIZE, OR COLOR.

THE NAME "MARGARITA MARY" DOES NOT IDENTIFY A LIVING INDIVIDUAL.

FOR BAR AND RESTAURANT SERVICES; COCKTAIL LOUNGES; PROVIDING BANQUET AND SOCIAL FUNCTION FACILITIES FOR SPECIAL OCCASIONS; PROVIDING COMMUNITY CENTERS FOR SOCIAL GATHERINGS AND MEETINGS (U.S. CLS. 100 AND 101).

DORITT L. CARROLL, EXAMINING ATTORNEY

SN 77-430,395. RUMOR HAZIT, LLC, CLAYTON, GA. FILED 3-25-2008.

RUMOR HAZIT

THE MARK CONSISTS OF STANDARD CHARACTERS WITHOUT CLAIM TO ANY PARTICULAR FONT, STYLE, SIZE, OR COLOR.

FOR BAR AND RESTAURANT SERVICES (U.S. CLS. 100 AND 101).

FIRST USE 9-1-2007; IN COMMERCE 9-1-2007.

SUNG IN, EXAMINING ATTORNEY

SN 77-431,257. BEYU CAFFE, DURHAM, NC. FILED 3-25-2008.

WITHOUT PASSION, IT'S JUST COFFEE

THE MARK CONSISTS OF STANDARD CHARACTERS WITHOUT CLAIM TO ANY PARTICULAR FONT, STYLE, SIZE, OR COLOR.

FOR COFFEE-HOUSE AND SNACK-BAR SERVICES (U.S. CLS. 100 AND 101).

MICHAEL GAFFAR, EXAMINING ATTORNEY

SN 77-430,610. OMNI HOTELS MANAGEMENT CORPORATION, IRVING, TX. FILED 3-25-2008.

FIRST CUT STEAK HOUSE

THE MARK CONSISTS OF STANDARD CHARACTERS WITHOUT CLAIM TO ANY PARTICULAR FONT, STYLE, SIZE, OR COLOR.

NO CLAIM IS MADE TO THE EXCLUSIVE RIGHT TO USE "STEAK HOUSE", APART FROM THE MARK AS SHOWN.

FOR RESTAURANT SERVICES (U.S. CLS. 100 AND 101).

JOHN SCHUYLER YARD, EXAMINING ATTORNEY

SN 77-431,708. ABRAHAM, RAWADA, PITTSBURGH, PA. FILED 3-26-2008.

ANTOON'S PIZZA

THE MARK CONSISTS OF STANDARD CHARACTERS WITHOUT CLAIM TO ANY PARTICULAR FONT, STYLE, SIZE, OR COLOR.

NO CLAIM IS MADE TO THE EXCLUSIVE RIGHT TO USE "PIZZA", APART FROM THE MARK AS SHOWN.

FOR RESTAURANT SERVICES (U.S. CLS. 100 AND 101).

FIRST USE 9-1-1997; IN COMMERCE 9-1-1997.
YONG KIM, EXAMINING ATTORNEY

CLASS 43—(Continued).

SN 77-431,782. TENNESSEE NATIONAL, LLC, LOUDEN, TN.
FILED 3-26-2008.



THE COLOR(S) BLUE, GREEN AND WHITE IS/ARE CLAIMED AS A FEATURE OF THE MARK.

THE MARK CONSISTS OF TWO STYLIZED DEPICTIONS OF GREEN MOUNTAINS AND A STYLIZED DEPICTION OF A BLUE RIVER RUNNING UNDERNEATH AND WHITE IN THE SPACES BETWEEN THE DEPICTIONS.

FOR BAR AND RESTAURANT SERVICES (U.S. CLS. 100 AND 101).

Laurie Kaufman, Examining Attorney

SN 77-432,001. METROMEDIA STEAKHOUSES COMPANY, L.P., PLANO, TX. FILED 3-26-2008.

HOOTENANNY

THE MARK CONSISTS OF STANDARD CHARACTERS WITHOUT CLAIM TO ANY PARTICULAR FONT, STYLE, SIZE, OR COLOR.

FOR RESTAURANT SERVICES (U.S. CLS. 100 AND 101).

Karanendra S. Chhina, Examining Attorney

SN 77-432,605. ALOHA RESTAURANTS, INC., IRVINE, CA.
FILED 3-26-2008.

JOLLY ROGER

THE MARK CONSISTS OF STANDARD CHARACTERS WITHOUT CLAIM TO ANY PARTICULAR FONT, STYLE, SIZE, OR COLOR.

FOR RESTAURANT SERVICES (U.S. CLS. 100 AND 101).

Odesa Bibbins, Examining Attorney

CLASS 43—(Continued).

SN 77-432,860. VIVA GOOD LIFE INTERNATIONAL, INC., WYOMISSING, PA. FILED 3-27-2008.

ViVÁ Euro-Fusion Bistro

THE MARK CONSISTS OF STANDARD CHARACTERS WITHOUT CLAIM TO ANY PARTICULAR FONT, STYLE, SIZE, OR COLOR.

NO CLAIM IS MADE TO THE EXCLUSIVE RIGHT TO USE "EURO-FUSION BISTRO", APART FROM THE MARK AS SHOWN.

THE ENGLISH TRANSLATION OF "VIVA" IN THE MARK IS "LIVE."

FOR BAR AND RESTAURANT SERVICES (U.S. CLS. 100 AND 101).

Christina Sobral, Examining Attorney

SN 77-433,429. GRAND TRAVERSE BAND ECONOMIC DEVELOPMENT CORPORATION, PESHAWBESTOWN, MI. FILED 3-27-2008.

Bourbons 72

THE MARK CONSISTS OF STANDARD CHARACTERS WITHOUT CLAIM TO ANY PARTICULAR FONT, STYLE, SIZE, OR COLOR.

FOR RESTAURANT (U.S. CLS. 100 AND 101).

Alice Sue Carruthers, Examining Attorney

CLASS 43—(Continued).

SN 77-433,569. BAY ACQUISITIONS LLC, WEST PALM BEACH, FL. FILED 3-27-2008.



NO CLAIM IS MADE TO THE EXCLUSIVE RIGHT TO USE "AMERICAN GRILL", APART FROM THE MARK AS SHOWN.

THE COLOR(S) RED, WHITE, BLUE, GOLD AND DARK GREEN IS/ARE CLAIMED AS A FEATURE OF THE MARK.

THE MARK CONSISTS OF AN OVAL PRIMARILY IN DARK GREEN WITH GOLD INNER AND OUTER EDGES, WITH AN EAGLE AT THE TOP OF THE OVAL, THREE GOLD STARS ON EACH SIDE OF THE OVAL, AND THE WORDS "AMERICAN GRILL" AT THE BOTTOM OF THE OVAL; IN THE CENTER OF THE OVAL IS AN "AMERICAN FLAG" OVER WHICH IS SUPERIMPOSED THE WORD "BRADYS".

FOR BAR AND RESTAURANT SERVICES (U.S. CLS. 100 AND 101).

FIRST USE 8-1-1999; IN COMMERCE 8-1-1999.

REGINA DRUMMOND, EXAMINING ATTORNEY

SN 77-433,675. J. WINECOCK'S, LLC, BRUNSWICK, GA. FILED 3-27-2008.



THE STIPLING IS FOR SHADING PURPOSES ONLY. THE NAME "J. WINECOCK'S" DOES NOT IDENTIFY A LIVING INDIVIDUAL.

THE MARK CONSISTS OF THE STYLIZED LETTER AND WORD "J. WINECOCK'S". TO THE LEFT OF THE STYLIZED WORD IS A CARICATURE OF A ROOSTER PROFILE, AND THERE ARE ALSO SMALL DOTS AROUND THE STYLIZED WORDING.

FOR WINE BARS (U.S. CLS. 100 AND 101).

HOWARD FRIEDMAN, EXAMINING ATTORNEY

CLASS 43—(Continued).

SN 77-433,695. BEYU CAFFE, DURHAM, NC. FILED 3-27-2008.



THE MARK CONSISTS OF THE STYLIZED WORDING "BEYU CAFFE" ALONG WITH A STYLIZED DEPICTION OF A COFFEE CUP AND SAUCER, WITH STEAM RISING FROM THE CUP, ALL PLACED INSIDE AN OVAL. THE LETTERS "C" AND "A" ARE INSIDE THE COFFEE CUP, AND THE FIRST LETTER "F" FORMS THE HANDLE OF THE COFFEE CUP.

THE WORDING "BEYÚ" HAS NO MEANING IN A FOREIGN LANGUAGE.

THE ENGLISH TRANSLATION OF THE WORD "CAFFÉ" IN THE MARK IS "COFFEE".

FOR COFFEE-HOUSE AND SNACK-BAR SERVICES (U.S. CLS. 100 AND 101).

MICHAEL GAAFAR, EXAMINING ATTORNEY

SN 77-434,888. MOONDAYS, INC., PORTLAND, OR. FILED 3-28-2008.

Moondays

THE MARK CONSISTS OF STANDARD CHARACTERS WITHOUT CLAIM TO ANY PARTICULAR FONT, STYLE, SIZE, OR COLOR.

FOR RESTAURANT SERVICES; RESTAURANT; SERVING FOOD AND DRINKS (U.S. CLS. 100 AND 101).

CORY BOONE, EXAMINING ATTORNEY

SN 77-436,091. THE MINA GROUP, LLC, SAN FRANCISCO, CA. FILED 3-31-2008.

MICHAEL MINA

THE MARK CONSISTS OF STANDARD CHARACTERS WITHOUT CLAIM TO ANY PARTICULAR FONT, STYLE, SIZE, OR COLOR.

THE NAME "MICHAEL MINA" IDENTIFIES A LIVING INDIVIDUAL WHOSE CONSENT IS OF RECORD.

FOR RESTAURANT, BAR AND CATERING SERVICES; COCKTAIL LOUNGES (U.S. CLS. 100 AND 101).

FIRST USE 6-0-2003; IN COMMERCE 6-0-2003.

KATHERINE CONNOLLY, EXAMINING ATTORNEY

CLASS 43—(Continued).

SN 77-436,178. THE MINA GROUP, LLC, SAN FRANCISCO, CA. FILED 3-31-2008.



THE NAME "MICHAEL MINA" IDENTIFIES A LIVING INDIVIDUAL WHOSE CONSENT IS OF RECORD.

THE MARK CONSISTS OF THE LETTER "M" CENTERED OVER THE TEXT "MICHAEL MINA".

FOR RESTAURANT, BAR AND CATERING SERVICES; COCKTAIL LOUNGES (U.S. CLS. 100 AND 101). FIRST USE 6-0-2003; IN COMMERCE 6-0-2003.

KATHERINE CONNOLLY, EXAMINING ATTORNEY

SN 77-440,312. CELEBRATED MANAGEMENT COMPANY, INC., ATLANTA, GA. FILED 4-4-2008.

Celebrated Hotels

THE MARK CONSISTS OF STANDARD CHARACTERS WITHOUT CLAIM TO ANY PARTICULAR FONT, STYLE, SIZE, OR COLOR.

NO CLAIM IS MADE TO THE EXCLUSIVE RIGHT TO USE "HOTELS", APART FROM THE MARK AS SHOWN.

FOR HOTELS, RESORT HOTELS, A COLLECTION OF HOTELS, NAMELY, FULL SERVICES HOTELS, BOUTIQUE HOTELS, MAKING HOTEL RESERVATIONS FOR OTHERS, PROVIDING PERSONALIZED INFORMATION ABOUT HOTELS AND TEMPORARY ACCOMMODATIONS FOR TRAVEL VIA THE INTERNET (U.S. CLS. 100 AND 101).

FIRST USE 1-31-1989; IN COMMERCE 1-31-1989.
PAULA MAHONEY, EXAMINING ATTORNEY

CLASS 43—(Continued).

SN 77-453,042. ELINA NUBARYAN, ORLANDO, FL. FILED 4-21-2008.



THE MARK CONSISTS OF THE STYLIZED WORD "GURTZBERRY" WITH THREE LEAVES TO THE LEFT OF THE LETTER "G". THERE IS AN ARCH WITH THREE CIRCLES ABOVE THE LETTERS "URTZ".

FOR CAFE AND RESTAURANT SERVICES; CAFE-RESTAURANTS; CAFETERIA AND RESTAURANT SERVICES; CARRY-OUT RESTAURANTS; FAST FOOD AND NON-STOP RESTAURANT SERVICES; FAST-FOOD RESTAURANTS; FAST-FOOD RESTAURANTS AND SNACKBARS; ICE CREAM SHOP SERVICES IN THE NATURE OF A RESTAURANT; PROVISION OF FOOD AND DRINK IN RESTAURANTS; RESTAURANT; RESTAURANT AND BAR SERVICES; RESTAURANT AND CAFE SERVICES; RESTAURANT AND CATERING SERVICES; RESTAURANT SERVICES; RESTAURANT SERVICES, INCLUDING SIT-DOWN SERVICE OF FOOD AND TAKE-OUT RESTAURANT SERVICES; RESTAURANT, BAR AND CATERING SERVICES; RESTAURANTS; RESTAURANTS FEATURING HOME DELIVERY; SELF SERVICE RESTAURANTS; SELF-SERVICE RESTAURANTS; TAKE-OUT RESTAURANT SERVICES; CAFETERIAS; CATERING IN FAST-FOOD CAFETERIAS; CAFE; CAFE SERVICES, NAMELY, PROVIDING CAFE SERVICES IN A FUNERAL HOME ENVIRONMENT; CAFES; CATERING FOR THE PROVISION OF FOOD AND BEVERAGES; CATERING OF FOOD AND DRINKS; FOOD PREPARATION SERVICES; PREPARATION OF FOOD AND BEVERAGES; PROVIDING OF FOOD AND DRINK; SNACK BARS; SNACKBARS; JUICE BAR SERVICES; COFFEE SHOPS; COFFEE-HOUSE AND SNACK-BAR SERVICES; BAR AND RESTAURANT SERVICES; BAR SERVICES; DAIRY BAR SERVICES; SNACK BAR AND CANTEN SERVICES (U.S. CLS. 100 AND 101).

Laurie Kaufman, Examining Attorney

SN 77-466,262. DISNEY ENTERPRISES, INC., BURBANK, CA. FILED 5-5-2008.

BLUE BAYOU

THE MARK CONSISTS OF STANDARD CHARACTERS WITHOUT CLAIM TO ANY PARTICULAR FONT, STYLE, SIZE, OR COLOR.

FOR RESTAURANT SERVICES (U.S. CLS. 100 AND 101).

FIRST USE 3-18-1967; IN COMMERCE 3-18-1967.
DANNEAN HETZEL, EXAMINING ATTORNEY

CLASS 43—(Continued).

SN 77-479,544. HAWAIIAN HUT L.L.C., WEST LAFAYETTE, IN. FILED 5-20-2008.

Treat your taste buds to
the tropical vacation they
have always dreamed of.

THE MARK CONSISTS OF STANDARD CHARACTERS WITHOUT CLAIM TO ANY PARTICULAR FONT, STYLE, SIZE, OR COLOR.

FOR RESTAURANT AND CATERING SERVICES (U.S. CLS. 100 AND 101).

DAYNA BROWNE, EXAMINING ATTORNEY

SN 77-479,551. HAWAIIAN HUT L.L.C., WEST LAFAYETTE, IN. FILED 5-20-2008.

The tropical vacation your
taste buds have always
dreamed of.

THE MARK CONSISTS OF STANDARD CHARACTERS WITHOUT CLAIM TO ANY PARTICULAR FONT, STYLE, SIZE, OR COLOR.

FOR RESTAURANT AND CATERING SERVICES (U.S. CLS. 100 AND 101).

DAYNA BROWNE, EXAMINING ATTORNEY

SN 78-783,141. MONTEX FINANCIAL SERVICES CORP., TORONTO, ONTARIO, CANADA, FILED 12-30-2005.



OWNER OF CANADA REG. NO. TMA706718, DATED 2-6-2008, EXPIRES 2-6-2023.

THE MARK CONSISTS OF WAVY LINES WITH THE REPRESENTATION OF THE SUN APPEARING TO THE LEFT. THE MARK IS NOT IN COLOR.

FOR PLANNING OF VACATIONS FOR INDIVIDUALS AND GROUPS, NAMELY, MAKING RESERVATIONS FOR TEMPORARY LODGING; MAKING HOTEL AND LODGING RESERVATIONS FOR OTHERS, NAMELY, THE PROVISION OF VACATION PREMISES FOR OTHERS (U.S. CLS. 100 AND 101).

FIRST USE 6-0-1990; IN COMMERCE 6-0-1990.

SEAN CROWLEY, EXAMINING ATTORNEY

CLASS 43—(Continued).

SN 78-842,571. STAMPS, ALGERNON SR., JACKSON, MS. FILED 3-21-2006.

STAMPS SUPER Burgers

THE MARK CONSISTS OF STANDARD CHARACTERS WITHOUT CLAIM TO ANY PARTICULAR FONT, STYLE, SIZE, OR COLOR.

NO CLAIM IS MADE TO THE EXCLUSIVE RIGHT TO USE "SUPER BURGERS", APART FROM THE MARK AS SHOWN.

FOR RESTAURANTS (U.S. CLS. 100 AND 101).

FIRST USE 3-30-1993; IN COMMERCE 3-30-1993.

JOHN GARTNER, EXAMINING ATTORNEY

SN 78-956,892. GLOBAL BASECAMPs, SAN FRANCISCO, CA. FILED 8-21-2006.



global basecamps

NO CLAIM IS MADE TO THE EXCLUSIVE RIGHT TO USE GLOBAL BASECAMPs, APART FROM THE MARK AS SHOWN.

THE MARK CONSISTS OF THE WORDS "GLOBAL BASECAMPs" ALONG WITH THE SPECIALIZED IMAGE REPRESENTING THE COMPANY, AN ABSTRACT MOUNTAIN OR TENT IN THE NEGATIVE SPACE OF A CIRCLE, ENCLOSED BY ANOTHER BORDER CIRCLE.

FOR PROVIDING TRAVEL LODGING INFORMATION SERVICES AND TRAVEL LODGING BOOKING AGENCY SERVICES FOR TRAVELERS (U.S. CLS. 100 AND 101).

TASHIA BUNCH, EXAMINING ATTORNEY

SN 79-031,828. CHOCOLATERIE & GROSSKONDI TOREI; "AIDA" PROUSEK & CO., AUSTRIA, FILED 7-4-2006.

Aida

PRIORITY DATE OF 5-8-2006 IS CLAIMED.

OWNER OF INTERNATIONAL REGISTRATION 0905777 DATED 7-4-2006, EXPIRES 7-4-2016.

THE WORDING "AIDA" HAS NO MEANING IN A FOREIGN LANGUAGE.

FOR SERVING FOOD AND DRINKS, SERVING FOOD AND DRINKS IN CAFES OR PASTRY SHOPS, SERVING FOOD AND DRINKS IN RESTAURANTS, TAVERNS, LUNCHEONETTES; CATERING SERVICES; RENTAL OF TEMPORARY ACCOMMODATIONS FOR CATERED EVENTS; RENTAL OF TABLES AND CHAIRS, TABLE LINES, AND TABLEWARE (U.S. CLS. 100 AND 101).

STEVEN PEREZ, EXAMINING ATTORNEY

CLASS 43—(Continued).

SN 79-050,738. EKIN REKLAMCILIK; VE TURISM LIMITED SIRKETI, BESIKTAS ISTANBUL, TURKEY, FILED 12-10-2007.



OWNER OF INTERNATIONAL REGISTRATION 0955665 DATED 12-10-2007, EXPIRES 12-10-2017.

NO CLAIM IS MADE TO THE EXCLUSIVE RIGHT TO USE "HOTELS", APART FROM THE MARK AS SHOWN. THE COLOR(S) DARK YELLOW IS/ARE CLAIMED AS A FEATURE OF THE MARK.

THE MARK CONSISTS OF COLOR DARK YELLOW. FOR SERVICES FOR PROVIDING FOOD AND DRINK, TEMPORARY ACCOMMODATION (U.S. CLS. 100 AND 101).

CHARISMA HAMPTON, EXAMINING ATTORNEY

CLASS 44—(Continued).

SN 76-675,353. SAGE SUPPORT SERVICES INC., KAM-LOOPS, BRITISH COLUMBIA, CANADA, FILED 3-20-2008.

INERGY MIND SPA CENTERS

THE MARK CONSISTS OF STANDARD CHARACTERS WITHOUT CLAIM TO ANY PARTICULAR FONT, STYLE, SIZE, OR COLOR.

OWNER OF CANADA REG. NO. TMA713190, DATED 4-29-2008, EXPIRES 4-29-2023.

NO CLAIM IS MADE TO THE EXCLUSIVE RIGHT TO USE "SPA CENTERS", APART FROM THE MARK AS SHOWN.

FOR BODYWORK THERAPY FEATURING INDUCES LIGHT AND SOUND THERAPY; HEALTH CARE SERVICES, NAMELY, WELLNESS PROGRAMS FEATURING NEURO LINGUISTIC PROGRAMMING TECHNIQUES, HYPNOSIS AND HYPNOTHERAPY AS METHODS FOR ARCHIVING PERSONAL, CAREER AND/OR LIFE IMPROVEMENT; MEDICAL CONSULTATION ON BEHAVIORAL ISSUES, ADDICTIONS, PAIN MANAGEMENT, WEIGHT MANAGEMENT, STRESS MANAGEMENT, SMOKE CESSATION AND SLEEPLESSNESS (U.S. CLS. 100 AND 101).

ANDREA K. NADELMAN, EXAMINING ATTORNEY

SN 76-680,402. MUNASIFI, TALAL A., ARLINGTON, VA. FILED 8-6-2007.

CLASS 44—MEDICAL, BEAUTY AND AGRICULTURAL SERVICES

SN 76-662,095. MORTON PLANT MEASE HEALTH SERVICES, INC., NEW PORT RICHEY, FL. FILED 6-21-2006.

ADVANCED PLASTIC SURGERY CENTER**TRINITY OUTPATIENT CENTER**

THE MARK CONSISTS OF STANDARD CHARACTERS WITHOUT CLAIM TO ANY PARTICULAR FONT, STYLE, SIZE, OR COLOR.

OWNER OF U.S. REG. NO. 2,330,599.

NO CLAIM IS MADE TO THE EXCLUSIVE RIGHT TO USE "PLASTIC SURGERY CENTER", APART FROM THE MARK AS SHOWN.

SEC. 2(F).

FOR MEDICAL SERVICES, NAMELY, PROVIDING COSMETIC AND PLASTIC SURGERY (U.S. CLS. 100 AND 101).

FIRST USE 10-0-1997; IN COMMERCE 11-0-1997.

DAWN HAN, EXAMINING ATTORNEY

NO CLAIM IS MADE TO THE EXCLUSIVE RIGHT TO USE "OUTPATIENT CENTER", APART FROM THE MARK AS SHOWN.

FOR MEDICAL SERVICES (U.S. CLS. 100 AND 101).

FIRST USE 7-1-1996; IN COMMERCE 7-0-1996.

JILL C. ALT, EXAMINING ATTORNEY

CLASS 44—(Continued).

SN 76-687,246. BORST LANDSCAPE & DESIGN INC., ALLENDALE, NJ. FILED 2-29-2008.



NO CLAIM IS MADE TO THE EXCLUSIVE RIGHT TO USE "ORGANIC", APART FROM THE MARK AS SHOWN. THE COLOR(S) BLUE, BLACK AND GREEN IS/ARE CLAIMED AS A FEATURE OF THE MARK.

THE MARK IS PRESENTED WITH THE WORD "BORST" ON ONE LINE IN THE COLOR BLUE, THE WORD "ORGANIC" ON A SECOND LINE AND THE PHRASE, "THE SCIENCE OF NATURE" ON A THIRD LINE ARE BOTH IN THE COLOR BLACK. A DESIGN OF SIX BLADES OF GRASS IS SET OFF TO THE RIGHT SIDE OF THE WORDS "BORST" AND "ORGANIC" AND ABOVE THE LETTERS "U, R, AND E" IN THE WORD "NATURE". THESE ARE IN VARYING SHADES OF THE COLOR GREEN.

FOR LANDSCAPING SERVICES NAMELY, LAWN, TREE AND SHRUB CARE (U.S. CLS. 100 AND 101).

FIRST USE 10-16-2006; IN COMMERCE 11-30-2006.

RON FAIRBANKS, EXAMINING ATTORNEY

CLASS 44—(Continued).

SN 77-030,443. 7TH STREET VILLA DAY SPA, LTD, BENBROOK, TX. FILED 10-26-2006.



NO CLAIM IS MADE TO THE EXCLUSIVE RIGHT TO USE "7TH STREET" AND "DAY SPA", APART FROM THE MARK AS SHOWN.

THE MARK CONSISTS OF SCRIPT LETTERS "S" AND "V" WITH THE NUMBER "7" IN BETWEEN, ALL INSIDE A HORIZONTAL OVAL DESIGN, WITH A SCROLL DESIGN BELOW, AND THE WORDS "7TH STREET VILLA DAY SPA" BELOW THE SCROLL DESIGN.

FOR HEALTH SPA SERVICES, NAMELY, COSMETIC BODY CARE SERVICES (U.S. CLS. 100 AND 101).

FIRST USE 9-7-2006; IN COMMERCE 9-7-2006.

BRENDAN MCCAULEY, EXAMINING ATTORNEY

SN 76-687,685. MEDSHAPE WEIGHT LOSS CLINIC, LLC, MESA, AZ. FILED 3-13-2008.

MEDSHAPE

THE MARK CONSISTS OF STANDARD CHARACTERS WITHOUT CLAIM TO ANY PARTICULAR FONT, STYLE, SIZE, OR COLOR.

FOR WEIGHT LOSS, DIET AND NUTRITION PLANNING AND SUPERVISION FEATURING MEDICAL, EXERCISE, BEHAVIOR MODIFICATION, AND HORMONE AND PRESCRIPTION THERAPY SERVICES, AND COUNSELING RELATED THERETO (U.S. CLS. 100 AND 101).

FIRST USE 2-7-2007; IN COMMERCE 2-7-2007.

KARANENDRA S. CHHINA, EXAMINING ATTORNEY

SN 77-108,613. COMPREHENSIVE HEALTH SERVICES, INC., VIENNA, VA. FILED 2-15-2007.

THE TRUSTED CHOICE FOR
WORKFORCE HEALTH MANAGEMENT

THE MARK CONSISTS OF STANDARD CHARACTERS WITHOUT CLAIM TO ANY PARTICULAR FONT, STYLE, SIZE, OR COLOR.

FOR HEALTH CARE SERVICES PROVIDED AT THE WORKPLACE, NAMELY, HEALTH CARE, WELLNESS PROGRAMS, PHYSICIAN SERVICES, DISEASE MANAGEMENT PROGRAMS, MEDICAL SERVICES, AND FITNESS EVALUATION; WORKFORCE HEALTH PROGRAMS PROVIDED AT THE WORKPLACE WHICH PROVIDE ASSISTANCE, FITNESS EVALUATION AND CONSULTATION TO EMPLOYEES SO THEY MAY MAKE HEALTH, WELLNESS AND NUTRITIONAL CHANGES IN THEIR DAILY LIVING TO IMPROVE HEALTH; ONSITE HEALTH CENTERS IN THE NATURE OF MEDICAL CLINICS; MEDICAL TESTING SERVICES, NAMELY, ADMINISTERING NATIONAL FITNESS EVALUATION TESTS; HEALTH CARE SERVICES, NAMELY, WELLNESS PROGRAMS THAT PROMOTE PARTICIPANTS' HEALTH AND SAFETY; PHYSICIAN SERVICES; EMPLOYER-SPONSORED WORKSITE AND ONSITE HEALTH PROGRAMS, NAMELY, WELLNESS PROGRAMS AND MEDICAL CONSULTATION SERVICES; DISEASE MANAGEMENT AND HEALTH CARE SERVICES FOR EMPLOYEES AND EMPLOYEE DEPENDENTS PROVIDED BY PHYSICIANS, NURSES, AND OTHER HEALTH CARE PROVIDERS; COUNSELING SERVICES IN THE FIELDS OF HEALTH, NUTRITION AND LIFESTYLE WELLNESS WITH A FOCUS ON REDUCING ABSENTEEISM FROM WORK DUE TO SICKNESS (U.S. CLS. 100 AND 101).

FIRST USE 1-17-2007; IN COMMERCE 1-17-2007.

TOBY BULLOFF, EXAMINING ATTORNEY

SN 76-687,711. WALGREEN CO., DEERFIELD, IL. FILED 3-14-2008.

1-800-READYDOSE

THE MARK CONSISTS OF STANDARD CHARACTERS WITHOUT CLAIM TO ANY PARTICULAR FONT, STYLE, SIZE, OR COLOR.

FOR TELEPHONE SERVICES PROVIDING PRESCRIPTION REFILL REMINDERS WHICH INCLUDE PRESCRIPTION PACKAGING AND DOSAGE INFORMATION (U.S. CLS. 100 AND 101).

KRISTINA MORRIS, EXAMINING ATTORNEY

CLASS 44—(Continued).

SN 77-148,736. ANASTASIO ENTERPRISES, MOBILE, AL.
FILED 4-4-2007.

Smilz N Stylz Salon 4 Kidz

THE MARK CONSISTS OF STANDARD CHARACTERS WITHOUT CLAIM TO ANY PARTICULAR FONT, STYLE, SIZE, OR COLOR.

NO CLAIM IS MADE TO THE EXCLUSIVE RIGHT TO USE "SALON FOR KIDS", APART FROM THE MARK AS SHOWN.

FOR BEAUTY SALONS (U.S. CLS. 100 AND 101).
ELLEN B. AWRICH, EXAMINING ATTORNEY

CLASS 44—(Continued).

SN 77-205,234. CONSUMER HEALTHCARE ADVANTAGE LLC, CLEVELAND, OH. FILED 6-13-2007.

One Change at a Time

THE MARK CONSISTS OF STANDARD CHARACTERS WITHOUT CLAIM TO ANY PARTICULAR FONT, STYLE, SIZE, OR COLOR.

FOR PROVIDING WELLNESS PROGRAMS FOR THE PREVENTION OF CHRONIC ILLNESS, NAMELY, PROVIDING DIET, NUTRITION AND EXERCISE REGIMES, MONITORING PARTICIPANT PROGRESS WITH RESPECT TO DIET, NUTRITION AND EXERCISE REGIMES AND PROVIDING INFORMATION WITH RESPECT TO THE SUBJECTS OF DIET, NUTRITION, DISEASE, MEDICATION, PREVENTION OF CHRONIC ILLNESS AND THE PHYSIOLOGICAL IMPACT OF ILLNESS (U.S. CLS. 100 AND 101).

KEVIN DINALLO, EXAMINING ATTORNEY

SN 77-160,646. COZMEDIC SURGERY ASSOCIATES, LLC,
TROY, MI. FILED 4-19-2007.

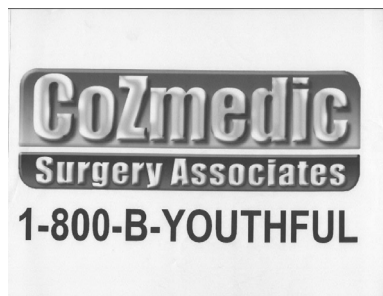

NO CLAIM IS MADE TO THE EXCLUSIVE RIGHT TO USE "SURGERY ASSOCIATES", APART FROM THE MARK AS SHOWN.

THE MARK CONSISTS OF THE WORDS "COZMEDIC SURGERY ASSOCIATES 1-800-B-YOUTHFUL"; THE WORD "COZMEDIC" WITH THE LETTERS "C" AND "Z" IN CAPITAL LETTERS APPEARING ABOVE THE WORDS "SURGERY ASSOCIATES" ALL APPEARING ABOVE "1-800-B-YOUTHFUL" WITH THE LETTER "B" AND THE WORD "YOUTHFUL" IN CAPITAL LETTERS.

FOR COSMETIC AND PLASTIC SURGERY (U.S. CLS. 100 AND 101).

KATHERINE E. HALMEN, EXAMINING ATTORNEY

SN 77-223,312. LIFELINE INTERVENTIONS, LOS ANGELES,
CA. FILED 7-6-2007.



NO CLAIM IS MADE TO THE EXCLUSIVE RIGHT TO USE "INTERVENTIONS", APART FROM THE MARK AS SHOWN.

THE COLOR(S) RED, BLACK, AND WHITE IS/ARE CLAIMED AS A FEATURE OF THE MARK.

THE MARK CONSISTS OF THE WORDS "LIFELINE INTERVENTIONS" IN WHITE WITH A RED LIFELINE AND A BLACK BACKGROUND.

FOR ADDICTION TREATMENT SERVICES (U.S. CLS. 100 AND 101).

FIRST USE 1-0-2004; IN COMMERCE 3-0-2005.

KAPIL BHANOT, EXAMINING ATTORNEY

CLASS 44—(Continued).

SN 77-224,781. HEALTHWAYS, INC., NASHVILLE, TN. FILED 7-9-2007.

HEALTHWAYS

THE MARK CONSISTS OF STANDARD CHARACTERS WITHOUT CLAIM TO ANY PARTICULAR FONT, STYLE, SIZE, OR COLOR.

OWNER OF U.S. REG. NOS. 3,226,699 AND 3,294,917.

FOR HEALTH CARE AND MEDICAL CARE MANAGEMENT SERVICES, NAMELY, COORDINATING A PATIENT'S HEALTH CARE AND MEDICAL CARE IN ORDER TO ACHIEVE A MORE SUCCESSFUL HEALTH OUTCOME (U.S. CLS. 100 AND 101).

FIRST USE 9-0-2005; IN COMMERCE 9-0-2005.

DEZMONA MIZELLE, EXAMINING ATTORNEY

SN 77-227,537. BELLA ESTHETICA, ALLEN, TX. FILED 7-11-2007.



NO CLAIM IS MADE TO THE EXCLUSIVE RIGHT TO USE THE CADUCEUS DESIGN, APART FROM THE MARK AS SHOWN.

THE MARK CONSISTS OF A CADUCEUS INTER-TWINED WITH VINES AND FLOWERS WITH THE WORD BELLA TO THE LEFT OF THE DESIGN AND ESTHETICA TO THE RIGHT OF THE DESIGN.

THE FOREIGN WORDING IN THE MARK TRANSLATES INTO ENGLISH AS BELLA FROM THE ITALIAN AND SPANISH FOR BEAUTIFUL.

THE NON-LATIN CHARACTER(S) IN THE MARK TRANSLITERATES INTO ESTHETICA IS DERIVED FROM THE LATIN AESTHETIC, AND THIS MEANS VISUALLY PLEASING IN ENGLISH.

FOR MEDICAL SPA SERVICES, NAMELY, MICRO-DERMABRASION, LASER HAIR REMOVAL, VARICOSE VEINS, AND WRINKLE REDUCTION USING BOTULINUM TOXIN AND DERMAL FILLERS (U.S. CLS. 100 AND 101).

SHAUNIA CARLYLE, EXAMINING ATTORNEY

SN 77-252,985. COLLAZO, MICHAEL ALLEN, HAMPTON, NJ. FILED 8-10-2007.

MochaLotion

THE MARK CONSISTS OF STANDARD CHARACTERS WITHOUT CLAIM TO ANY PARTICULAR FONT, STYLE, SIZE, OR COLOR.

FOR SKIN TANNING SERVICE FOR HUMANS FOR COSMETIC PURPOSES; TANNING SALONS (U.S. CLS. 100 AND 101).

KATHERINE E. HALMEN, EXAMINING ATTORNEY

CLASS 44—(Continued).

SN 77-254,036. ABLE TO CHANGE RECOVERY, INC., SAN JUAN CAPISTRANO, CA. FILED 8-13-2007.

ABLE TO CHANGE RECOVERY

THE MARK CONSISTS OF STANDARD CHARACTERS WITHOUT CLAIM TO ANY PARTICULAR FONT, STYLE, SIZE, OR COLOR.

FOR ADDICTION TREATMENT SERVICES; REHABILITATION OF ALCOHOL ADDICTED PATIENTS; REHABILITATION OF DRUG ADDICTED PATIENTS (U.S. CLS. 100 AND 101).

FIRST USE 12-31-2000; IN COMMERCE 12-31-2000.

TIMOTHY FINNEGAN, EXAMINING ATTORNEY

SN 77-255,146. HOLLYWOOD TANS, LLC, SEWELL, NJ. FILED 8-14-2007.

HT TANS

THE MARK CONSISTS OF STANDARD CHARACTERS WITHOUT CLAIM TO ANY PARTICULAR FONT, STYLE, SIZE, OR COLOR.

OWNER OF U.S. REG. NOS. 2,725,161 AND 3,074,282.

NO CLAIM IS MADE TO THE EXCLUSIVE RIGHT TO USE "TANS", APART FROM THE MARK AS SHOWN.

FOR TANNING SALONS (U.S. CLS. 100 AND 101).

DEZMONA MIZELLE, EXAMINING ATTORNEY

SN 77-268,632. WESTCARE FOUNDATION, INC., LAS VEGAS, NV. FILED 8-30-2007.

THE VILLAGE

THE MARK CONSISTS OF STANDARD CHARACTERS WITHOUT CLAIM TO ANY PARTICULAR FONT, STYLE, SIZE, OR COLOR.

FOR RESIDENTIAL AND OUT-PATIENT REHABILITATION OF DRUG ADDICTED PATIENTS AND SUBSTANCE ABUSE PATIENTS; MENTAL HEALTH SERVICES (U.S. CLS. 100 AND 101).

FIRST USE 0-0-1973; IN COMMERCE 0-0-1973.

WANDA KAY PRICE, EXAMINING ATTORNEY

CLASS 44—(Continued).

SN 77-280,011. HEALTHY LIVING BY RACHEL, INC., RYE BROOK, NY. FILED 9-14-2007.

PERSONAL WEB NUTRITION

THE MARK CONSISTS OF STANDARD CHARACTERS WITHOUT CLAIM TO ANY PARTICULAR FONT, STYLE, SIZE, OR COLOR.

NO CLAIM IS MADE TO THE EXCLUSIVE RIGHT TO USE "NUTRITION", APART FROM THE MARK AS SHOWN.

FOR PROVIDING INFORMATION ONLINE VIA THE INTERNET ABOUT FOOD NUTRITION AND NUTITION (U.S. CLS. 100 AND 101).

G. MAYERSCHOFF, EXAMINING ATTORNEY

SN 77-286,634. HERMAN, M.D., WESLEY K., DALLAS, TX. FILED 9-23-2007.

VISCO-CRACK

THE MARK CONSISTS OF STANDARD CHARACTERS WITHOUT CLAIM TO ANY PARTICULAR FONT, STYLE, SIZE, OR COLOR.

FOR MEDICAL SERVICES, NAMELY, PROVIDING A SURGICAL PROCEDURE, NAMELY, CRACKING THE OCULAR LENS NUCLEUS FOR CATARACT TREATMENT; MEDICAL SERVICES, NAMELY, OPHTHALMIC MEDICAL PROCEDURES; MEDICAL SERVICES, NAMELY, OCULAR SURGERY (U.S. CLS. 100 AND 101).

PAUL CROWLEY, EXAMINING ATTORNEY

SN 77-286,637. HERMAN, M.D., WESLEY K., DALLAS, TX. FILED 9-23-2007.

CHAOS

THE MARK CONSISTS OF STANDARD CHARACTERS WITHOUT CLAIM TO ANY PARTICULAR FONT, STYLE, SIZE, OR COLOR.

FOR MEDICAL SERVICES, NAMELY, PROVIDING A SURGICAL PROCEDURE, NAMELY, REMOVING THE OCULAR LENS NUCLEUS FOR TREATMENT OF CATARACT; MEDICAL SERVICES, NAMELY, OCULAR SURGERY (U.S. CLS. 100 AND 101).

PAUL CROWLEY, EXAMINING ATTORNEY

CLASS 44—(Continued).

SN 77-286,783. TIME INC., NEW YORK, NY. FILED 9-24-2007.

HALF THEIR SIZE!

THE MARK CONSISTS OF STANDARD CHARACTERS WITHOUT CLAIM TO ANY PARTICULAR FONT, STYLE, SIZE, OR COLOR.

FOR ONLINE INFORMATION SERVICES, NAMELY, PROVIDING INFORMATION ON THE SUBJECTS OF DIET, WEIGHT LOSS AND HUMAN INTEREST STORIES RELATING TO DIET AND WEIGHT LOSS (U.S. CLS. 100 AND 101).

FIRST USE 12-29-2006; IN COMMERCE 12-29-2006.
DOMINIC FATHY, EXAMINING ATTORNEY

SN 77-291,439. WOMANSAFEHEALTH, PC, ANN ARBOR, MI. FILED 9-28-2007.



THE COLOR(S) YELLOW, WHITE, GREEN AND BLACK IS/ARE CLAIMED AS A FEATURE OF THE MARK.

THE MARK CONSISTS OF A GREEN AND WHITE FLOWER WITH YELLOW BACKGROUND AND BLACK LETTERING CONTAINING THE SERVICE MARK NAME "WOMANSAFEHEALTH".

FOR MEDICAL SERVICES, NAMELY, PROVIDING GYNECOLOGICAL SERVICES AND GENERAL HEALTH AND MEDICAL SERVICES TO WOMEN (U.S. CLS. 100 AND 101).

FIRST USE 8-1-2007; IN COMMERCE 8-1-2007.
HEATHER SAPP, EXAMINING ATTORNEY

SN 77-291,632. ADVENTIST HEALTH SYSTEM/SUNBELT, INC., WINTER PARK, FL. FILED 9-28-2007.



NO CLAIM IS MADE TO THE EXCLUSIVE RIGHT TO USE "HOSPITAL HOME CARE SERVICES", APART FROM THE MARK AS SHOWN.

THE MARK CONSISTS OF AN OVERALL HEXAGONAL SHAPE FORMED BY THREE INTERLOCKED LETTER "FS" LOCATED WITHIN A STYLIZED REPRESENTATION OF A HOUSE, ALL POSITIONED GENERALLY TO THE LEFT OF THE WORDING OF THE MARK.

SEC. 2(F) AS TO "FLORIDA HOSPITAL".

FOR MEDICAL SERVICES (U.S. CLS. 100 AND 101).
FIRST USE 5-1-2007; IN COMMERCE 5-1-2007.
BARBARA BROWN, EXAMINING ATTORNEY

CLASS 44—(Continued).

SN 77-291,662. ADVENTIST HEALTH SYSTEM/SUNBELT, INC., WINTER PARK, FL. FILED 9-28-2007.

Florida Hospital Home Care
Services

THE MARK CONSISTS OF STANDARD CHARACTERS WITHOUT CLAIM TO ANY PARTICULAR FONT, STYLE, SIZE, OR COLOR.

NO CLAIM IS MADE TO THE EXCLUSIVE RIGHT TO USE "HOSPITAL HOME CARE SERVICES", APART FROM THE MARK AS SHOWN.

SEC. 2(F) AS TO "FLORIDA HOSPITAL".
FOR MEDICAL SERVICES (U.S. CLS. 100 AND 101).
FIRST USE 5-1-2007; IN COMMERCE 5-1-2007.
BARBARA BROWN, EXAMINING ATTORNEY

CLASS 44—(Continued).

SN 77-294,175. ADVENTIST HEALTH SYSTEM/SUNBELT, INC., WINTER PARK, FL. FILED 10-2-2007.



NO CLAIM IS MADE TO THE EXCLUSIVE RIGHT TO USE "HOSPITAL HOME CARE SERVICES SEBRING", APART FROM THE MARK AS SHOWN.

THE MARK CONSISTS OF AN OVERALL HEXAGONAL SHAPE FORMED BY THREE INTERLOCKED LETTER FS LOCATED WITHIN A STYLIZED REPRESENTATION OF A HOUSE, ALL POSITIONED GENERALLY TO THE LEFT OF THE WORDING OF THE MARK.

SEC. 2(F) AS TO "FLORIDA HOSPITAL".
FOR MEDICAL SERVICES (U.S. CLS. 100 AND 101).
BARBARA BROWN, EXAMINING ATTORNEY

SN 77-291,685. ADVENTIST HEALTH SYSTEM/SUNBELT, INC., WINTER PARK, FL. FILED 9-28-2007.

Florida Hospital Home Care
Services Sebring

THE MARK CONSISTS OF STANDARD CHARACTERS WITHOUT CLAIM TO ANY PARTICULAR FONT, STYLE, SIZE, OR COLOR.

NO CLAIM IS MADE TO THE EXCLUSIVE RIGHT TO USE "HOSPITAL HOME CARE SERVICES SEBRING", APART FROM THE MARK AS SHOWN.

SEC. 2(F) AS TO "FLORIDA HOSPITAL".
FOR MEDICAL SERVICES (U.S. CLS. 100 AND 101).
BARBARA BROWN, EXAMINING ATTORNEY

SN 77-298,851. KOWALS PEDIATRICS, BELLINGHAM, WA. FILED 10-8-2007.

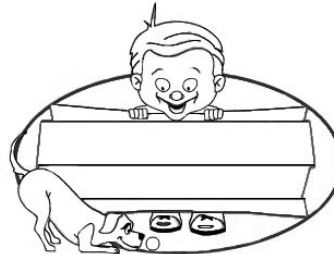

THE MARK CONSISTS OF GRAPHIC IMAGE OF A CHILD HOLDING A SIGN.

FOR MEDICAL SERVICES, NAMELY, PEDIATRIC CARE (U.S. CLS. 100 AND 101).
JOHN DWYER, EXAMINING ATTORNEY

SN 77-293,228. ROETHEL & ASSOCIATES, INC., MEQUON, WI. FILED 10-1-2007.

CORE HEALTH GROUP

THE MARK CONSISTS OF STANDARD CHARACTERS WITHOUT CLAIM TO ANY PARTICULAR FONT, STYLE, SIZE, OR COLOR.

NO CLAIM IS MADE TO THE EXCLUSIVE RIGHT TO USE "HEALTH GROUP", APART FROM THE MARK AS SHOWN.

FOR HEALTH CARE SERVICES, NAMELY, CREATING AND IMPLEMENTING WELLNESS PROGRAMS FOR HEALTH ENHANCEMENT AND DISEASE PREVENTION (U.S. CLS. 100 AND 101).

FIRST USE 9-20-2006; IN COMMERCE 9-20-2006.
TINA BROWN, EXAMINING ATTORNEY

SN 77-307,962. MIKAN, KAREN W., DBA THE LEADING EDGE LASER CENTER, SCOTTSDALE, AZ. FILED 10-18-2007.



NO CLAIM IS MADE TO THE EXCLUSIVE RIGHT TO USE "HAIR", APART FROM THE MARK AS SHOWN.

THE MARK CONSISTS OF A HARE HOLDING A SUITCASE, WAVING GOODBYE WITH THE STATEMENT "GOODBYE" HARE WITH THE HARE CROSSED OUT REPLACED WITH "HAIR".

FOR PERMANENT HAIR REMOVAL AND REDUCTION (U.S. CLS. 100 AND 101).
FIRST USE 12-5-2006; IN COMMERCE 12-5-2006.
TRACY CROSS, EXAMINING ATTORNEY

CLASS 44—(Continued).

SN 77-325,954. LAVI ENTERPRISES, LLC, BOCA RATON, FL. FILED 11-9-2007.

GET COOKIE THIN

THE MARK CONSISTS OF STANDARD CHARACTERS WITHOUT CLAIM TO ANY PARTICULAR FONT, STYLE, SIZE, OR COLOR.

FOR WEIGHT LOSS SERVICES, NAMELY, WEIGHT REDUCTION DIET PLANNING AND SUPERVISION (U.S. CLS. 100 AND 101).

CHRISTINE COOPER, EXAMINING ATTORNEY

CLASS 44—(Continued).

SN 77-345,384. LAVI ENTERPRISES, LLC, BOCA RATON, FL. FILED 12-6-2007.

POP A COOKIE

THE MARK CONSISTS OF STANDARD CHARACTERS WITHOUT CLAIM TO ANY PARTICULAR FONT, STYLE, SIZE, OR COLOR.

FOR WEIGHT LOSS SERVICES, NAMELY, CONSULTING TO INDIVIDUALS AND COMMUNITIES ENGAGED IN GROUP WEIGHT LOSS PROGRAMS (U.S. CLS. 100 AND 101).

CHRISTINE COOPER, EXAMINING ATTORNEY

SN 77-342,402. MEDIMIN, INC., GOODYEAR, AZ. FILED 12-3-2007.



OWNER OF U.S. REG. NO. 3,392,942.

NO CLAIM IS MADE TO THE EXCLUSIVE RIGHT TO USE "CONVENIENT MEDICAL CARE", APART FROM THE MARK AS SHOWN.

THE COLOR(S) BLUE, WHITE AND GREEN IS/ARE CLAIMED AS A FEATURE OF THE MARK.

THE COLOR(S) GREEN APPEARS IN THE MEDICAL CROSS AND THE TEXTUAL COMPONENT "MIN." THE COLOR WHITE APPEARS AS THE CLOCK HANDS DISPLAYED IN THE MEDICAL CROSS, AND THE COLOR BLUE APPEARS IN THE INCOMPLETE CIRCLE DESIGN AS WELL AS THE TEXTUAL COMPONENT "MED" AND THE TEXT "CONVENIENT MEDICAL CARE".

FOR MEDICAL CLINIC AND HEALTHCARE SERVICES FEATURING NON-EMERGENCY, WALK-IN MEDICAL DIAGNOSTIC AND TREATMENT SERVICES IN CONVENIENT LOCATIONS (U.S. CLS. 100 AND 101).

FIRST USE 4-1-2007; IN COMMERCE 5-1-2007.
RONALD AIKENS, EXAMINING ATTORNEY

SN 77-346,524. LAVI ENTERPRISES, LLC, BOCA RATON, FL. FILED 12-7-2007.

**WHO STOLE THE COOKIES FROM
THE COOKIE JAR**

SN 77-344,389. LAVI ENTERPRISES, LLC, BOCA RATON, FL. FILED 12-5-2007.

**EAT COOKIES. LOSE WEIGHT.
IT'S THAT SIMPLE.**

THE MARK CONSISTS OF STANDARD CHARACTERS WITHOUT CLAIM TO ANY PARTICULAR FONT, STYLE, SIZE, OR COLOR.

FOR WEIGHT LOSS SERVICES, NAMELY, CONSULTING TO INDIVIDUALS AND COMMUNITIES ENGAGED IN GROUP WEIGHT LOSS PROGRAMS (U.S. CLS. 100 AND 101).

FIRST USE 11-8-2007; IN COMMERCE 11-8-2007.
CHRISTINE COOPER, EXAMINING ATTORNEY

THE MARK CONSISTS OF STANDARD CHARACTERS WITHOUT CLAIM TO ANY PARTICULAR FONT, STYLE, SIZE, OR COLOR.

FOR WEIGHT LOSS SERVICES, NAMELY, CONSULTING TO INDIVIDUALS AND COMMUNITIES ENGAGED IN GROUP WEIGHT LOSS PROGRAMS (U.S. CLS. 100 AND 101).

CHRISTINE COOPER, EXAMINING ATTORNEY

CLASS 44—(Continued).

SN 77-358,798. HAMPTON ISLAND, LLC, ATLANTA, GA. FILED 12-22-2007.



NO CLAIM IS MADE TO THE EXCLUSIVE RIGHT TO USE "EST. 1769", APART FROM THE MARK AS SHOWN.

THE MARK CONSISTS OF THE WORDS "HAMPTON ISLAND PRESERVE" ON THE PERIMETER CREATING A CIRCULAR SHAPE. WITHIN THE CIRCULAR SHAPE CREATED BY THE WORDING ARE THE SHAPES OF A RADIATING SUN RISING OVER A PYRAMID, REPRESENTING A PALM FRAWN, WITH THE WORD "EST." AND THE NUMBERS "1769" AT THE BASE OF THE PYRAMID AND CENTERED OVER THE WORD "PRESERVE" AT THE BOTTOM OF THE PERIMETER OF THE CIRCULAR SHAPE.

FOR HEALTH SPA SERVICES FOR HEALTH AND WELLNESS OF THE BODY AND SPIRIT OFFERED AT A HEALTH RESORT; HEALTH SPA SERVICES, NAMELY, COSMETIC BODY CARE SERVICES; DAY SPA SERVICES, NAMELY NAIL CARE, MANICURES, PEDICURES AND NAIL ENHANCEMENTS (U.S. CLS. 100 AND 101).

FIRST USE 1-0-2004; IN COMMERCE 1-0-2004.
GEORGIA CARTY, EXAMINING ATTORNEY

SN 77-361,777. PAINTER, JOHN, SONOMA, CA. FILED 12-31-2007.

LAS MADRES VINEYARDS

THE MARK CONSISTS OF STANDARD CHARACTERS WITHOUT CLAIM TO ANY PARTICULAR FONT, STYLE, SIZE, OR COLOR.

NO CLAIM IS MADE TO THE EXCLUSIVE RIGHT TO USE "VINEYARDS", APART FROM THE MARK AS SHOWN.

THE FOREIGN WORDING IN THE MARK TRANSLATES INTO ENGLISH AS "THE MOTHERS".

FOR VINEYARD AND WINERY SERVICES, NAMELY, THE CULTIVATION OF GRAPES FOR OTHERS (U.S. CLS. 100 AND 101).

JOHN KELLY, EXAMINING ATTORNEY

CLASS 44—(Continued).

SN 77-363,802. MONROE, SUZANNE C., DBA INTELLIGENT HEALTH GROUP LLC, CEDARBURG, WI. FILED 1-3-2008.

real life food

THE MARK CONSISTS OF STANDARD CHARACTERS WITHOUT CLAIM TO ANY PARTICULAR FONT, STYLE, SIZE, OR COLOR.

NO CLAIM IS MADE TO THE EXCLUSIVE RIGHT TO USE "FOOD", APART FROM THE MARK AS SHOWN.

FOR FOOD NUTRITION CONSULTATION; NUTRITION COUNSELING; PROVIDING A WEBSITE FEATURING INFORMATION ON HEALTH AND NUTRITION; PROVIDING ASSISTANCE, FITNESS EVALUATION AND CONSULTATION TO CORPORATE CLIENTS TO HELP THEIR EMPLOYEES MAKE HEALTH, WELLNESS AND NUTRITIONAL CHANGES IN THEIR DAILY LIVING TO IMPROVE HEALTH; PROVIDING ASSISTANCE, FITNESS EVALUATION AND CONSULTATION TO INDIVIDUALS TO HELP THEM MAKE HEALTH, WELLNESS AND NUTRITIONAL CHANGES IN THEIR DAILY LIVING TO IMPROVE HEALTH (U.S. CLS. 100 AND 101).

FIRST USE 11-1-2007; IN COMMERCE 11-1-2007.
FRANK LATTUCA, EXAMINING ATTORNEY

SN 77-368,000. EDGEWATER URGENT MEDICAL CARE, LLC, GULFPORT, MS. FILED 1-9-2008.

EDGEWATER CONVENIENT CARE

THE MARK CONSISTS OF STANDARD CHARACTERS WITHOUT CLAIM TO ANY PARTICULAR FONT, STYLE, SIZE, OR COLOR.

NO CLAIM IS MADE TO THE EXCLUSIVE RIGHT TO USE "CONVENIENT CARE", APART FROM THE MARK AS SHOWN.

THE WORDING "EDGEWATER" HAS NO MEANING IN A FOREIGN LANGUAGE.

FOR HEALTHCARE AND MEDICAL SERVICES (U.S. CLS. 100 AND 101).

FIRST USE 12-20-2007; IN COMMERCE 12-20-2007.
REGINA DRUMMOND, EXAMINING ATTORNEY

CLASS 44—(Continued).

SN 77-369,380. KOSCO, KEVIN L., MIDLOTHIAN, VA. AND KOSCO, ANGELA, G., MIDLOTHIAN, VA. FILED 1-11-2008.

Divas-n-Dudes

THE MARK CONSISTS OF STANDARD CHARACTERS WITHOUT CLAIM TO ANY PARTICULAR FONT, STYLE, SIZE, OR COLOR.

FOR BEAUTY SALONS (U.S. CLS. 100 AND 101).
FIRST USE 11-6-2006; IN COMMERCE 11-6-2006.
JAY FLOWERS, EXAMINING ATTORNEY

SN 77-369,843. PIONEER HI-BRED INTERNATIONAL, INC., JOHNSTON, IA. FILED 1-11-2008.

The Silage Zone

THE MARK CONSISTS OF STANDARD CHARACTERS WITHOUT CLAIM TO ANY PARTICULAR FONT, STYLE, SIZE, OR COLOR.

NO CLAIM IS MADE TO THE EXCLUSIVE RIGHT TO USE "SILAGE", APART FROM THE MARK AS SHOWN.

FOR PROVIDING AGRONOMIC SERVICES, NAMELY, AGRICULTURAL SEED SELECTION; GENERAL AGRONOMIC SERVICES, FEED BUNKER MANAGEMENT, NAMELY, PROVIDING AGRICULTURAL ADVICE ON THE COMPOSITION AND STORAGE OF ANIMAL FEED (U.S. CLS. 100 AND 101).

SETH A. RAPPAPORT, EXAMINING ATTORNEY

SN 77-385,482. HELEN KELLER FOUNDATION, BIRMINGHAM, AL. FILED 1-31-2008.

HELEN KELLER EYE AND EAR HOSPITAL

THE MARK CONSISTS OF STANDARD CHARACTERS WITHOUT CLAIM TO ANY PARTICULAR FONT, STYLE, SIZE, OR COLOR.

NO CLAIM IS MADE TO THE EXCLUSIVE RIGHT TO USE "EYE AND EAR HOSPITAL", APART FROM THE MARK AS SHOWN.

THE NAME SHOWN IN THE MARK DOES NOT IDENTIFY A PARTICULAR LIVING INDIVIDUAL.

FOR HOSPITALS (U.S. CLS. 100 AND 101).
ELISSA GARBER KON, EXAMINING ATTORNEY

CLASS 44—(Continued).

SN 77-386,870. HYTHIAM, INC., LOS ANGELES, CA. FILED 2-1-2008.



NO CLAIM IS MADE TO THE EXCLUSIVE RIGHT TO USE "ENHANCED DM SOLUTIONS", APART FROM THE MARK AS SHOWN.

THE COLOR(S) BLACK AND BLUE IS/ARE CLAIMED AS A FEATURE OF THE MARK.

THE MARK CONSISTS OF "CATASYS ENHANCED DM SOLUTIONS" STYLIZED WITH "CATA" IN BLACK LETTERING AND "SYS ENHANCED DM SOLUTIONS" IN BLUE LETTERING.

FOR HEALTH CARE SERVICES, NAMELY, DISEASE MANAGEMENT PROGRAMS (U.S. CLS. 100 AND 101).
SAIMA MAKHDOOM, EXAMINING ATTORNEY

SN 77-392,416. RTW, INC., BLOOMINGTON, MN. FILED 2-8-2008.

RTW POTENTIAL FOR CHRONIC PAIN PROGRAM

THE MARK CONSISTS OF STANDARD CHARACTERS WITHOUT CLAIM TO ANY PARTICULAR FONT, STYLE, SIZE, OR COLOR.

OWNER OF U.S. REG. NOS. 1,968,095, 2,509,315 AND OTHERS.

NO CLAIM IS MADE TO THE EXCLUSIVE RIGHT TO USE "CHRONIC PAIN PROGRAM", APART FROM THE MARK AS SHOWN.

FOR MEDICAL SERVICES, NAMELY, CONDUCTING MEDICAL PHYSICAL EVALUATIONS FOR THE PURPOSE OF IDENTIFICATION OF INDIVIDUALS AT RISK FOR DEVELOPMENT OF CHRONIC PAIN AND FOR THE PURPOSE OF LATER ENROLLMENT IN MEDICAL TREATMENT PROGRAM FOR TREATMENT OF CHRONIC PAIN (U.S. CLS. 100 AND 101).

TANYA AMOS, EXAMINING ATTORNEY

SN 77-399,862. DURANTE HOLDINGS L.P., FORT WORTH, TX. FILED 2-18-2008.

LIPO-EX

THE MARK CONSISTS OF STANDARD CHARACTERS WITHOUT CLAIM TO ANY PARTICULAR FONT, STYLE, SIZE, OR COLOR.

FOR HEALTH SPA SERVICES, NAMELY, COSMETIC BODY CARE SERVICES FEATURING RADIO FREQUENCY ASSISTED LIPOPLASTY (U.S. CLS. 100 AND 101).

FIRST USE 1-9-2008; IN COMMERCE 2-1-2008.
REBECCA SMITH, EXAMINING ATTORNEY

CLASS 44—(Continued).

SN 77-399,863. DURANTE HOLDINGS L.P., FORT WORTH, TX. FILED 2-18-2008.

WE MELT FAT

THE MARK CONSISTS OF STANDARD CHARACTERS WITHOUT CLAIM TO ANY PARTICULAR FONT, STYLE, SIZE, OR COLOR.

FOR HEALTH SPA SERVICES, NAMELY, COSMETIC BODY CARE SERVICES FEATURING RADIO FREQUENCY ASSISTED LIPOPLASTY (U.S. CLS. 100 AND 101).

FIRST USE 11-1-2007; IN COMMERCE 2-1-2008.
REBECCA SMITH, EXAMINING ATTORNEY

SN 77-405,690. DOCTALK, INC., JACKSON, WY. FILED 2-25-2008.



THE COLOR(S) BLUE, RED, GRAY AND WHITE IS/ARE CLAIMED AS A FEATURE OF THE MARK.

THE MARK CONSISTS OF THE LOWER CASE LETTERS "WEB" IN BLUE WITH WHITE TRIM COMBINED WITH THE UPPER CASE LETTERS "LAB" IN RED WITH WHITE TRIM; THE FOREGOING IS CENTERED IN A GRAY OVAL TRIMMED WITH CONCENTRIC WHITE AND BLUE LINES AT THE BOTTOM EDGE OF SAID OVAL.

FOR PROVIDING AN INTERACTIVE WEB SITE THAT SERVES AS A REGULATION-COMPLIANT AND SECURE PLATFORM FOR COMPANIES TO OFFER DIRECTED MEDICAL LABORATORY TESTING SERVICES TO CONSUMERS, FOR THE PLACEMENT OF PHYSICIAN-APPROVED ORDERS FOR SUCH TESTING AND DELIVERY OF TEST RESULTS TO THE ORDERING PHYSICIAN, FOR PHYSICIAN DELIVERY OF MEDICAL LABORATORY TEST RESULTS TO CONSUMERS, TOGETHER WITH ACCESS TO CONSULTATIONS WITH PHYSICIANS CONCERNING TEST RESULTS (U.S. CLS. 100 AND 101).

MATTHEW EINSTEIN, EXAMINING ATTORNEY

CLASS 44—(Continued).

SN 77-409,006. BOSTWICK LABORATORIES, INC., GLEN ALLEN, VA. FILED 2-28-2008.

UROFISH

THE MARK CONSISTS OF STANDARD CHARACTERS WITHOUT CLAIM TO ANY PARTICULAR FONT, STYLE, SIZE, OR COLOR.

FOR HEALTHCARE AND MEDICAL SERVICES, NAMELY, PATHOLOGY SERVICES AND TESTING SERVICES FOR THE DIAGNOSIS AND TREATMENT OF DISEASE; HEALTHCARE AND MEDICAL SERVICES, NAMELY, ASSAY SERVICES TO DIAGNOSE AND TREAT DISEASE (U.S. CLS. 100 AND 101).

ANDREA HACK, EXAMINING ATTORNEY

SN 77-409,976. PENINSULA REGIONAL MEDICAL CENTER, SALISBURY, MD. FILED 2-29-2008.

PENINSULA REGIONAL MEDICAL GROUP

THE MARK CONSISTS OF STANDARD CHARACTERS WITHOUT CLAIM TO ANY PARTICULAR FONT, STYLE, SIZE, OR COLOR.

OWNER OF U.S. REG. NOS. 3,110,952 AND 3,125,420.

NO CLAIM IS MADE TO THE EXCLUSIVE RIGHT TO USE "REGIONAL MEDICAL GROUP", APART FROM THE MARK AS SHOWN.

FOR MEDICAL SERVICES; HOSPITALS (U.S. CLS. 100 AND 101).

HENRY S. ZAK, EXAMINING ATTORNEY

SN 77-415,173. MEDICINE HORSE PROGRAM, BOULDER, CO. FILED 3-6-2008.

HopeFoil Project

THE MARK CONSISTS OF STANDARD CHARACTERS WITHOUT CLAIM TO ANY PARTICULAR FONT, STYLE, SIZE, OR COLOR.

NO CLAIM IS MADE TO THE EXCLUSIVE RIGHT TO USE "PROJECT", APART FROM THE MARK AS SHOWN.

FOR MENTAL HEALTH SERVICES (U.S. CLS. 100 AND 101).

FIRST USE 10-15-2002; IN COMMERCE 10-15-2002.
KATHLEEN LORENZO, EXAMINING ATTORNEY

CLASS 44—(Continued).

SN 77-419,347. ABSOLUTE FIT, FORT OGLETHORPE, GA. FILED 3-11-2008.

Don't Cheat Your Body

THE MARK CONSISTS OF STANDARD CHARACTERS WITHOUT CLAIM TO ANY PARTICULAR FONT, STYLE, SIZE, OR COLOR.

FOR WEIGHT REDUCTION DIET PLANNING AND SUPERVISION (U.S. CLS. 100 AND 101).

FIRST USE 1-1-1992; IN COMMERCE 1-1-1992.
CYNTHIA TRIPI, EXAMINING ATTORNEY

SN 77-419,378. J. SCHWARTZ HAIRDRESSERS, LLC, ATLANTA, GA. FILED 3-11-2008.

Shear Salon

THE MARK CONSISTS OF STANDARD CHARACTERS WITHOUT CLAIM TO ANY PARTICULAR FONT, STYLE, SIZE, OR COLOR.

NO CLAIM IS MADE TO THE EXCLUSIVE RIGHT TO USE "SALON", APART FROM THE MARK AS SHOWN.

FOR HAIR SALON SERVICES, NAMELY, HAIR CUTTING, STYLING, COLORING, AND HAIR EXTENSION SERVICES (U.S. CLS. 100 AND 101).

REBECCA EISINGER, EXAMINING ATTORNEY

SN 77-419,438. CARBON12, LLC, MONTEREY, CA. FILED 3-12-2008.

Carbon12

THE MARK CONSISTS OF STANDARD CHARACTERS WITHOUT CLAIM TO ANY PARTICULAR FONT, STYLE, SIZE, OR COLOR.

FOR MEDICAL SERVICES, NAMELY, PROVIDING A WEB SITE FEATURING INFORMATION IN THE FIELD OF DISEASE, DISORDERS, HEALTH CONDITIONS, OR INJURIES (U.S. CLS. 100 AND 101).

JORDAN BAKER, EXAMINING ATTORNEY

CLASS 44—(Continued).

SN 77-422,007. MASSAGE EDEN, LLC, DBA MASSAGE EDEN, TAMARAC, FL. FILED 3-14-2008.



NO CLAIM IS MADE TO THE EXCLUSIVE RIGHT TO USE "MASSAGE", APART FROM THE MARK AS SHOWN.

THE MARK CONSISTS OF A CUSTOMIZED FLORAL SILHOUETTE DESIGN ENCLOSED A STYLIZED FULL CIRCLE BETWEEN THE WORDS "MASSAGE EDEN".

FOR BEAUTY SALONS; FACIAL TREATMENT SERVICES, NAMELY, COSMETIC PEELS; MASSAGE AND THERAPEUTIC SHIATSU MASSAGE (U.S. CLS. 100 AND 101).

FIRST USE 3-14-2008; IN COMMERCE 3-14-2008.
ZACHARY BELLO, EXAMINING ATTORNEY

SN 77-422,071. CANINE REHABILITATION & CONDITIONING GROUP, LLC, ENGLEWOOD, CO. FILED 3-14-2008.



**CANINE & CONDITIONING
REHABILITATION GROUP**

NO CLAIM IS MADE TO THE EXCLUSIVE RIGHT TO USE "CANINE REHABILITATION & CONDITIONING GROUP", APART FROM THE MARK AS SHOWN.

THE STIPPLING IS FOR SHADING PURPOSES ONLY. THE MARK CONSISTS OF THE LETTERS "CRCG" ABOVE A CROSS WITH THE HEAD OF A DOG ON WATER SUPERIMPOSED IN FRONT. THE WORDING "CANINE REHABILITATION & CONDITIONING GROUP" APPEARS BELOW.

FOR PHYSICAL REHABILITATION AND PHYSICAL THERAPY FOR CANINES (U.S. CLS. 100 AND 101).

FIRST USE 12-1-2004; IN COMMERCE 12-1-2004.
KELLY MCCOY, EXAMINING ATTORNEY

SN 77-422,877. MEJIA, JULIO, JASPER, GA. FILED 3-14-2008.

Big Daddy Mulch

THE MARK CONSISTS OF STANDARD CHARACTERS WITHOUT CLAIM TO ANY PARTICULAR FONT, STYLE, SIZE, OR COLOR.

NO CLAIM IS MADE TO THE EXCLUSIVE RIGHT TO USE "MULCH", APART FROM THE MARK AS SHOWN.

FOR LANDSCAPE GARDENING (U.S. CLS. 100 AND 101).

YONG KIM, EXAMINING ATTORNEY

CLASS 44—(Continued).

SN 77-423,511. THE PRINCETON LONGEVITY CENTER, LLC, SKILLMAN, NJ. FILED 3-17-2008.

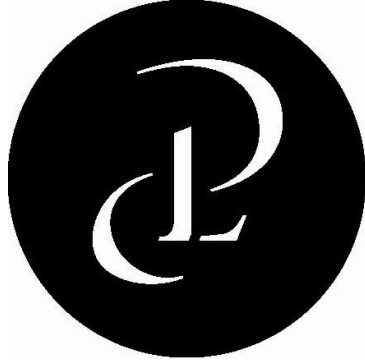

THE MARK CONSISTS OF THE LETTERS "PLC" WHICH INTERSECT IN AN OVAL DESIGN.
FOR PREVENTIVE MEDICAL CARE AND HEALTH CARE SERVICES (U.S. CLS. 100 AND 101).
FIRST USE 9-5-2002; IN COMMERCE 9-5-2002.
ROBERT LAVACHE, EXAMINING ATTORNEY

SN 77-423,552. LEWIS, MICHAEL, JENISON, MI. FILED 3-17-2008.

Tan Milan

THE MARK CONSISTS OF STANDARD CHARACTERS WITHOUT CLAIM TO ANY PARTICULAR FONT, STYLE, SIZE, OR COLOR.
NO CLAIM IS MADE TO THE EXCLUSIVE RIGHT TO USE "TAN", APART FROM THE MARK AS SHOWN.
FOR TANNING SALONS (U.S. CLS. 100 AND 101).
NANCY CLARKE, EXAMINING ATTORNEY

SN 77-424,515. DEFIBTECH, LLC, CHICAGO, IL. FILED 3-18-2008.

LIFE-SAVING TECHNOLOGY
WITHIN REACH

THE MARK CONSISTS OF STANDARD CHARACTERS WITHOUT CLAIM TO ANY PARTICULAR FONT, STYLE, SIZE, OR COLOR.
FOR PROVIDING HEALTH INFORMATION (U.S. CLS. 100 AND 101).
FIRST USE 5-23-2003; IN COMMERCE 5-23-2003.
STEVEN R. FINE, EXAMINING ATTORNEY

CLASS 44—(Continued).

SN 77-424,562. STAMPER EXECUTIVE SOLUTIONS INC., HIGHLAND HEIGHTS, KY. FILED 3-18-2008.



NO CLAIM IS MADE TO THE EXCLUSIVE RIGHT TO USE "PET", APART FROM THE MARK AS SHOWN.
THE STIPPLING IS FOR SHADING PURPOSES ONLY.
THE MARK CONSISTS OF THE STYLIZED WORDS "PET WÖW WELLNESS ON WHEELS". IMAGE OF TWO DOG BONES CROSSED TO THE LEFT OF THE STYLIZED WORDS. THERE ARE STYLIZED PAW PRINT MARKS ABOVE THE LETTER "O".
FOR ANIMAL GROOMING; PET CARE SERVICES, NAMELY, DOG WALKING, DOG BATHING, NON-MEDICATED PET GROOMING AND IN-HOME MEDICAL CARE; VETERINARY SERVICES (U.S. CLS. 100 AND 101).
FIRST USE 1-1-2008; IN COMMERCE 1-1-2008.
KELLY BOULTON, EXAMINING ATTORNEY

SN 77-425,572. CBLISS, LLC, INCLINE VILLAGE, NV. FILED 3-18-2008.



LOOK. FEEL. BEAUTIFUL.

THE STIPPLING IS FOR SHADING PURPOSES ONLY.
THE MARK CONSISTS OF A LETTER "C" WITH "BLISS" INSIDE OF IT. TAG LINE BELOW THAT SAYS "LOOK. FEEL. BEAUTIFUL."
FOR BEAUTY SALONS (U.S. CLS. 100 AND 101).
FIRST USE 2-1-2008; IN COMMERCE 2-1-2008.
ELLEN PERKINS, EXAMINING ATTORNEY

CLASS 44—(Continued).

SN 77-425,885. BRYAN, DALE, PELHAM, TN. FILED 3-19-2008.



NO CLAIM IS MADE TO THE EXCLUSIVE RIGHT TO USE "TREE.FARMS", APART FROM THE MARK AS SHOWN.

THE STIPPLING IS FOR SHADING PURPOSES ONLY.

THE MARK CONSISTS OF THE STYLIZED TEXT "FREEDOM" WITH AN IMAGE OF A LEAF ABOVE THE TEXT. THE STYLIZED TEXT "TREE • FARMS" IS CURVED UNDER "FREEDOM" WITH A LINE ABOVE AND BELOW THE TEXT.

FOR PLANT NURSERIES; TREE NURSERIES (U.S. CLS. 100 AND 101).

FIRST USE 5-1-2003; IN COMMERCE 5-1-2003.

ZACHARY BELLO, EXAMINING ATTORNEY

SN 77-427,094. ARI BLUMOFE, LINCOLNWOOD, IL. FILED 3-20-2008.

MY BAND MY LIFE

THE MARK CONSISTS OF STANDARD CHARACTERS WITHOUT CLAIM TO ANY PARTICULAR FONT, STYLE, SIZE, OR COLOR.

FOR HEALTH CARE SERVICES, NAMELY, DISEASE MANAGEMENT PROGRAMS; HEALTH CARE SERVICES, NAMELY, WELLNESS PROGRAMS; MEDICAL AND PHARMACEUTICAL CONSULTATION; MEDICAL ASSISTANCE CONSULTANCY PROVIDED BY DOCTORS AND OTHER SPECIALIZED MEDICAL PERSONNEL; MEDICAL CLINICS; MEDICAL COUNSELING; MEDICAL EVALUATION SERVICES, NAMELY, FUNCTIONAL ASSESSMENT PROGRAM FOR PATIENTS RECEIVING MEDICAL REHABILITATION SERVICES FOR PURPOSES OF GUIDING TREATMENT AND ASSESSING PROGRAM EFFECTIVENESS; MEDICAL SERVICES, NAMELY, SURGICAL GASTRIC BANDING, WEIGHT LOSS MANAGEMENT, PSYCHOLOGICAL COUNSELING FOR WEIGHT LOSS MANAGEMENT, AND NUTRITIONAL COUNSELING FOR WEIGHT LOSS MANAGEMENT; PROVIDING INFORMATION IN THE FIELD OF SURGICAL WEIGHT LOSS; WEIGHT REDUCTION DIET PLANNING AND SUPERVISION; PSYCHOLOGICAL CONSULTATION; PSYCHOLOGICAL COUNSELING; PROVIDING ASSISTANCE, FITNESS EVALUATION AND CONSULTATION TO INDIVIDUALS TO HELP THEM MAKE HEALTH, WELLNESS AND NUTRITIONAL CHANGES IN THEIR DAILY LIVING TO IMPROVE HEALTH; PROVIDING INFORMATION ABOUT DIETARY SUPPLEMENTS AND NUTRITION (U.S. CLS. 100 AND 101).

TRACY WHITTAKER-BROWN, EXAMINING ATTORNEY

CLASS 44—(Continued).

SN 77-427,366. RADIATION ONCOLOGY RESOURCES, INC., GOSHEN, IN. FILED 3-20-2008.

DOSIMETRY ON DEMAND

THE MARK CONSISTS OF STANDARD CHARACTERS WITHOUT CLAIM TO ANY PARTICULAR FONT, STYLE, SIZE, OR COLOR.

NO CLAIM IS MADE TO THE EXCLUSIVE RIGHT TO USE "DOSIMETRY", APART FROM THE MARK AS SHOWN.

FOR MEDICAL TREATMENT PLANNING, NAMELY, PROVIDING REMOTE TREATMENT PLANNING FOR RADIATION THERAPY (U.S. CLS. 100 AND 101).

DANNEAN HETZEL, EXAMINING ATTORNEY

SN 77-427,871. SHEP-TY INC., SAN DIEGO, CA. FILED 3-20-2008.

A HEALTHIER SAN DIEGO

THE MARK CONSISTS OF STANDARD CHARACTERS WITHOUT CLAIM TO ANY PARTICULAR FONT, STYLE, SIZE, OR COLOR.

NO CLAIM IS MADE TO THE EXCLUSIVE RIGHT TO USE "SAN DIEGO", APART FROM THE MARK AS SHOWN.

FOR COUNSELING SERVICES IN THE FIELDS OF HEALTH, NUTRITION AND LIFESTYLE WELLNESS (U.S. CLS. 100 AND 101).

MICHAEL GAAFAR, EXAMINING ATTORNEY

SN 77-427,953. GRAVESITE MASTERS, LLC, GYPSUM, KS. FILED 3-21-2008.

Gravesite Masters

THE MARK CONSISTS OF STANDARD CHARACTERS WITHOUT CLAIM TO ANY PARTICULAR FONT, STYLE, SIZE, OR COLOR.

NO CLAIM IS MADE TO THE EXCLUSIVE RIGHT TO USE "GRAVESITE", APART FROM THE MARK AS SHOWN.

FOR CEMETERY PLOT BEAUTIFICATION AND MAINTENANCE AND CONTINUAL UPKEEP OF FAMILY CEMETERY PLOTS (U.S. CLS. 100 AND 101).

FIRST USE 3-13-2008; IN COMMERCE 3-13-2008.

DAVID COLLIER, EXAMINING ATTORNEY

CLASS 44—(Continued).

SN 77-428,421. EVANGELICAL HOMES OF MICHIGAN, DETROIT, MI. FILED 3-21-2008.

Pathways to Independence

THE MARK CONSISTS OF STANDARD CHARACTERS WITHOUT CLAIM TO ANY PARTICULAR FONT, STYLE, SIZE, OR COLOR.

FOR NURSING CARE; NURSING HOMES; NURSING SERVICES; AUDITORY REHABILITATION SERVICES FOR BUILDING SPEECH UNDERSTANDING ABILITY; PHYSICAL REHABILITATION; PROVIDING MENTAL REHABILITATION FACILITIES; PROVIDING PHYSICAL REHABILITATION FACILITIES (U.S. CLS. 100 AND 101).

ALICE BENMAMAN, EXAMINING ATTORNEY

SN 77-428,644. PIERRE BRENNAN, MILLBRAE, CA. FILED 3-21-2008.

Developmental Rhythms

THE MARK CONSISTS OF STANDARD CHARACTERS WITHOUT CLAIM TO ANY PARTICULAR FONT, STYLE, SIZE, OR COLOR.

FOR MUSIC THERAPY FOR PHYSICAL, PSYCHOLOGICAL AND COGNITIVE PURPOSES; MUSIC THERAPY FOR SOCIAL ASSIMILATION PURPOSES (U.S. CLS. 100 AND 101).

FIRST USE 11-1-2004; IN COMMERCE 11-1-2004.
EMILY CARLSEN, EXAMINING ATTORNEY

SN 77-429,131. MICHAEL STEPHEN DOW, TUCSON, AZ. FILED 3-23-2008.

The Pen and Paper Diet

THE MARK CONSISTS OF STANDARD CHARACTERS WITHOUT CLAIM TO ANY PARTICULAR FONT, STYLE, SIZE, OR COLOR.

NO CLAIM IS MADE TO THE EXCLUSIVE RIGHT TO USE "DIET", APART FROM THE MARK AS SHOWN.

FOR WEIGHT REDUCTION DIET PLANNING AND SUPERVISION (U.S. CLS. 100 AND 101).

ZHALEH DELANEY, EXAMINING ATTORNEY

CLASS 44—(Continued).

SN 77-429,393. DEAN, JEFF, TEMPE, AZ. FILED 3-24-2008.

VibeMed Energetics

THE MARK CONSISTS OF STANDARD CHARACTERS WITHOUT CLAIM TO ANY PARTICULAR FONT, STYLE, SIZE, OR COLOR.

NO CLAIM IS MADE TO THE EXCLUSIVE RIGHT TO USE "ENERGETICS", APART FROM THE MARK AS SHOWN.

FOR STRESS REDUCTION THERAPY SERVICES UTILIZING ENERGETIC MEDICINE MODALITIES (U.S. CLS. 100 AND 101).

CHARLOTTE CORWIN, EXAMINING ATTORNEY

SN 77-429,547. PAMPER YOURSELF PRETTY, ROANOKE, VA. FILED 3-24-2008.

Pamper Yourself Pretty

THE MARK CONSISTS OF STANDARD CHARACTERS WITHOUT CLAIM TO ANY PARTICULAR FONT, STYLE, SIZE, OR COLOR.

FOR SALON SERVICES, NAMELY, FACIALS, COSMETIC BODY WRAPS, COSMETIC FACIAL CHEMICAL PEELS, MANICURES AND MASSAGES THAT ARE PROVIDED EITHER AT HOMES, BUSINESSES, OR EVENTS (U.S. CLS. 100 AND 101).

LAURA HAMMEL, EXAMINING ATTORNEY

SN 77-429,679. RICHARD R MOY, DPM INC, LAKE FOREST, CA. FILED 3-24-2008.

Dr. Richard R. Moy, DPM Inc

THE MARK CONSISTS OF STANDARD CHARACTERS WITHOUT CLAIM TO ANY PARTICULAR FONT, STYLE, SIZE, OR COLOR.

NO CLAIM IS MADE TO THE EXCLUSIVE RIGHT TO USE "DR." AND "DPM INC.", APART FROM THE MARK AS SHOWN.

FOR SURGERY (U.S. CLS. 100 AND 101).
FIRST USE 8-5-2002; IN COMMERCE 8-5-2002.

MARCIE MILONE, EXAMINING ATTORNEY

CLASS 44—(Continued).

SN 77-430,241. SYNERGY HEALTH AFFILIATES, LLC, BRENTWOOD, TN. FILED 3-24-2008.

SYNERGY IMAGING

THE MARK CONSISTS OF STANDARD CHARACTERS WITHOUT CLAIM TO ANY PARTICULAR FONT, STYLE, SIZE, OR COLOR.

NO CLAIM IS MADE TO THE EXCLUSIVE RIGHT TO USE "IMAGING", APART FROM THE MARK AS SHOWN.

FOR RADIOLOGICAL MEDICAL IMAGING SERVICES (U.S. CLS. 100 AND 101).

GINA FINK, EXAMINING ATTORNEY

SN 77-430,880. MORRIS, CECIL A, COHASSET, MA. FILED 3-25-2008.

Lemon Lime

THE MARK CONSISTS OF STANDARD CHARACTERS WITHOUT CLAIM TO ANY PARTICULAR FONT, STYLE, SIZE, OR COLOR.

FOR BEAUTY SALONS (U.S. CLS. 100 AND 101).

DORITT L. CARROLL, EXAMINING ATTORNEY

SN 77-431,136. LANCE ARMSTRONG FOUNDATION, AUSTIN, TX. FILED 3-25-2008.

LIVESTRONG

THE MARK CONSISTS OF STANDARD CHARACTERS WITHOUT CLAIM TO ANY PARTICULAR FONT, STYLE, SIZE, OR COLOR.

OWNER OF U.S. REG. NOS. 3,052,284, 3,202,553 AND OTHERS.

FOR PROVIDING A WEBSITE FEATURING INFORMATION IN THE FIELD OF MEDICAL SYMPTOMS, MEDICAL CONDITIONS, MEDICAL PRACTICE SPECIALTIES, MEDICAL PROCEDURES, HEALTHY LIVING, DIET, HEALTH ENHANCEMENT, ALTERNATIVE MEDICINE, PRESCRIPTION AND OVER-THE-COUNTER DRUGS, AND NUTRITION; PROVIDING A WEBSITE FEATURING MEDICAL INFORMATION; PROVIDING A WEB SITE FEATURING INFORMATION IN THE FIELD OF MENTAL HEALTH AND WELLNESS; MENTAL HEALTH SERVICES (U.S. CLS. 100 AND 101).

LAURA HAMMEL, EXAMINING ATTORNEY

CLASS 44—(Continued).

SN 77-431,250. HY GORGEOUS, LLC, BLOOMFIELD, NJ. FILED 3-25-2008.



THE MARK CONSISTS OF AN IMAGE OF TWO HEARTS SHAPED CHERRIES. THE STEMS OF THE HEART SHAPE CHERRIES ARE ATTACHED. WHERE THE STEMS ATTACH IS A LEAF. INSIDE THE LEFT HEART SHAPED CHERRY IS THE STYLIZED WORDS "HY GORGEOUS" IN A BANNER. IN THE BACKGROUNDS THE BANNER IS THE STYLED LETTERS "HG".

FOR BEAUTY SALON SERVICES (U.S. CLS. 100 AND 101).

FIRST USE 1-1-2007; IN COMMERCE 1-1-2008.

GISELLE AGOSTO, EXAMINING ATTORNEY

SN 77-431,855. LEAR, ANDREW, QUINCY, IL. FILED 3-26-2008.

**Alcohol or Drug Abuse Are
Not An Option**

THE MARK CONSISTS OF STANDARD CHARACTERS WITHOUT CLAIM TO ANY PARTICULAR FONT, STYLE, SIZE, OR COLOR.

FOR CHEMICAL DEPENDENCY COUNSELING (U.S. CLS. 100 AND 101).

MARIA-VICTORIA SUAREZ, EXAMINING ATTORNEY

CLASS 44—(Continued).

SN 77-432,095. SPECTRUM HEALTH SYSTEM, GRAND RAPIDS, MI. FILED 3-26-2008.

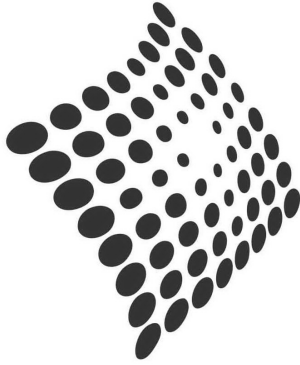

THE MARK CONSISTS OF DOTS IN A DIAMOND FORMATION.
FOR HOSPITAL AND HEALTH CARE SERVICES (U.S. CLS. 100 AND 101).
JERI J. FICKES, EXAMINING ATTORNEY

SN 77-433,239. ADIAL PHARMACEUTICALS, CHARLOTTEVILLE, VA. FILED 3-27-2008.

ADial Pharmaceuticals

THE MARK CONSISTS OF STANDARD CHARACTERS WITHOUT CLAIM TO ANY PARTICULAR FONT, STYLE, SIZE, OR COLOR.
NO CLAIM IS MADE TO THE EXCLUSIVE RIGHT TO USE "PHARMACEUTICALS", APART FROM THE MARK AS SHOWN.
FOR ADDICTION TREATMENT SERVICES (U.S. CLS. 100 AND 101).
GINA FINK, EXAMINING ATTORNEY

SN 77-433,583. SAVA SPA, INC., NEW YORK, NY. FILED 3-27-2008.

SAVA SPA

THE MARK CONSISTS OF STANDARD CHARACTERS WITHOUT CLAIM TO ANY PARTICULAR FONT, STYLE, SIZE, OR COLOR.
NO CLAIM IS MADE TO THE EXCLUSIVE RIGHT TO USE "SPA", APART FROM THE MARK AS SHOWN.
FOR DAY SPA SERVICES, NAMELY, NAIL CARE, MANICURES, PEDICURES AND NAIL ENHANCEMENTS; HEALTH SPA SERVICES, NAMELY, COSMETIC BODY CARE SERVICES (U.S. CLS. 100 AND 101).
FIRST USE 10-24-2003; IN COMMERCE 10-24-2003.
CHRISTINE BLOMQUIST, EXAMINING ATTORNEY

CLASS 44—(Continued).

SN 77-433,692. BLUE MEDSPA, LLC, ATLANTA, GA. FILED 3-27-2008.

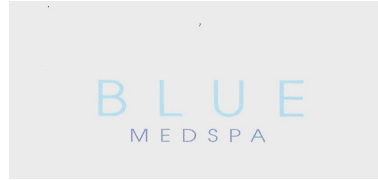

NO CLAIM IS MADE TO THE EXCLUSIVE RIGHT TO USE "MEDSPA", APART FROM THE MARK AS SHOWN.
THE COLOR(S) BLUE IS/ARE CLAIMED AS A FEATURE OF THE MARK.
THE MARK CONSISTS OF TEXT IN TWO SHADES OF THE COLOR BLUE.
FOR HEALTH SPA SERVICES, NAMELY, COSMETIC BODY CARE SERVICES (U.S. CLS. 100 AND 101).
FIRST USE 1-1-2006; IN COMMERCE 1-1-2006.
KARANENDRA S. CHHINA, EXAMINING ATTORNEY

SN 77-433,822. COOLTOUCH INCORPORATED, ROSEVILLE, CA. FILED 3-27-2008.

COOLCONTOUR

THE MARK CONSISTS OF STANDARD CHARACTERS WITHOUT CLAIM TO ANY PARTICULAR FONT, STYLE, SIZE, OR COLOR.
OWNER OF U.S. REG. NOS. 2,153,205, 3,374,858 AND OTHERS.
FOR PROVIDING AESTHETIC LASER THERAPY TREATMENT FOR MEDICAL AND SKIN CONDITIONS (U.S. CLS. 100 AND 101).
KARANENDRA S. CHHINA, EXAMINING ATTORNEY

SN 77-441,406. JOHNSON & JOHNSON, NEW BRUNSWICK, NJ. FILED 4-7-2008.

SHAPING THE MEDICINES OF TOMORROW

THE MARK CONSISTS OF STANDARD CHARACTERS WITHOUT CLAIM TO ANY PARTICULAR FONT, STYLE, SIZE, OR COLOR.
FOR WEBSITE PROVIDING INFORMATION ON SMALL MOLECULE DRUGS, BIOLOGICS, VACCINES, AND THE TECHNOLOGIES AND FORMULATIONS THEREOF (U.S. CLS. 100 AND 101).
FIRST USE 4-11-2007; IN COMMERCE 4-11-2007.
JERI J. FICKES, EXAMINING ATTORNEY

CLASS 44—(Continued).

SN 77-453,312. EVANGELICAL HOMES OF MICHIGAN, DETROIT, MI. FILED 4-21-2008.

Pathways TransitionCare

THE MARK CONSISTS OF STANDARD CHARACTERS WITHOUT CLAIM TO ANY PARTICULAR FONT, STYLE, SIZE, OR COLOR.

NO CLAIM IS MADE TO THE EXCLUSIVE RIGHT TO USE "TRANSITIONCARE", APART FROM THE MARK AS SHOWN.

FOR NURSING CARE; NURSING HOMES; NURSING SERVICES; AUDITORY REHABILITATION SERVICES FOR BUILDING SPEECH UNDERSTANDING ABILITY; PHYSICAL REHABILITATION; PROVIDING MENTAL REHABILITATION FACILITIES; PROVIDING PHYSICAL REHABILITATION FACILITIES (U.S. CLS. 100 AND 101).

ALICE BENMAMAN, EXAMINING ATTORNEY

SN 77-459,553. MARRIOTT INTERNATIONAL, INC., BETHESDA, MD. FILED 4-28-2008.



THE MARK CONSISTS OF BUBBLES FORMING A CIRCLE.

FOR HEALTH AND BEAUTY SPA SERVICES, NAMELY, PROVIDING FACIAL, HAIR, SKIN AND BODY TREATMENTS, MANICURE AND PEDICURE SERVICES, MASSAGE SERVICES, BODY WAXING SERVICES AND BEAUTY SALON SERVICES (U.S. CLS. 100 AND 101).

MARTHA SANTOMARTINO, EXAMINING ATTORNEY

SN 77-463,333. BLUE MEDSPA, LLC, ATLANTA, GA. FILED 5-1-2008.

Green People Salon

THE MARK CONSISTS OF STANDARD CHARACTERS WITHOUT CLAIM TO ANY PARTICULAR FONT, STYLE, SIZE, OR COLOR.

NO CLAIM IS MADE TO THE EXCLUSIVE RIGHT TO USE "SALON", APART FROM THE MARK AS SHOWN.

FOR HAIR SALON SERVICES (U.S. CLS. 100 AND 101). FIRST USE 10-1-2007; IN COMMERCE 10-1-2007.

KARANENDRA S. CHHINA, EXAMINING ATTORNEY

CLASS 44—(Continued).

SN 77-469,108. AMERICAN FOUNDATION FOR THE BLIND, INC., NEW YORK, NY. FILED 5-8-2008.

FAMILYCONNECT

THE MARK CONSISTS OF STANDARD CHARACTERS WITHOUT CLAIM TO ANY PARTICULAR FONT, STYLE, SIZE, OR COLOR.

FOR PROVIDING ON-LINE INFORMATION ON CONDITIONS OF THE EYE, AVAILABLE SERVICES AND EDUCATION FOR PARENTS AND FAMILIES OF CHILDREN WITH VISUAL IMPAIRMENTS (U.S. CLS. 100 AND 101).

FIRST USE 2-28-2008; IN COMMERCE 2-28-2008.

SUZANNE BLANE, EXAMINING ATTORNEY

SN 77-490,623. LANCE ARMSTRONG FOUNDATION, AUSTIN, TX. FILED 6-4-2008.

LIVESTRONG.COM

THE MARK CONSISTS OF STANDARD CHARACTERS WITHOUT CLAIM TO ANY PARTICULAR FONT, STYLE, SIZE, OR COLOR.

OWNER OF U.S. REG. NOS. 3,052,284, 3,202,553 AND OTHERS.

FOR PROVIDING A WEBSITE FEATURING INFORMATION IN THE FIELD OF MEDICAL SYMPTOMS, MEDICAL CONDITIONS, MEDICAL PRACTICE SPECIALTIES, MEDICAL PROCEDURES, HEALTHY LIVING, DIET, HEALTH ENHANCEMENT, ALTERNATIVE MEDICINE, PRESCRIPTION AND OVER-THE-COUNTER DRUGS, AND NUTRITION; PROVIDING A WEBSITE FEATURING MEDICAL INFORMATION; PROVIDING A WEB SITE FEATURING INFORMATION IN THE FIELD OF MENTAL HEALTH AND WELLNESS; MENTAL HEALTH SERVICES (U.S. CLS. 100 AND 101).

LAURA HAMMEL, EXAMINING ATTORNEY

CLASS 44—(Continued).

SN 78-766,320. BEHAVIOR MANAGEMENT ASSOCIATES, INC., CLEVELAND, OH. FILED 12-5-2005.

IMPACT Student Life Assistance

THE MARK CONSISTS OF STANDARD CHARACTERS WITHOUT CLAIM TO ANY PARTICULAR FONT, STYLE, SIZE, OR COLOR.

NO CLAIM IS MADE TO THE EXCLUSIVE RIGHT TO USE "STUDENT LIFE ASSISTANCE", APART FROM THE MARK AS SHOWN.

FOR CONSULTATION SERVICES IN THE FIELD OF BEHAVIOR HEALTHCARE, NAMELY, PROVIDING UNIVERSITY-BASED CONSULTATION, GUIDANCE AND ADVICE TO UNIVERSITY STUDENTS ON A ONE-ON-ONE BASIS IN THE AREA OF MENTAL HEALTH, AND PROVIDING FACE-TO-FACE MENTAL HEALTH COUNSELING TO UNIVERSITY STUDENTS (U.S. CLS. 100 AND 101).

BARBARA RUTLAND, EXAMINING ATTORNEY

SN 78-888,041. REFRACTEC, INC., IRVINE, CA. FILED 5-19-2006.

MYCLEARVISION

THE MARK CONSISTS OF STANDARD CHARACTERS WITHOUT CLAIM TO ANY PARTICULAR FONT, STYLE, SIZE, OR COLOR.

FOR PROVIDING A WEBSITE THAT FEATURES A COLLECTION OF INFORMATION ABOUT THE EYE, VISION AND VISION CORRECTION SURGERY (U.S. CLS. 100 AND 101).

FIRST USE 1-30-2001; IN COMMERCE 1-30-2001.
DAVID MILLER, EXAMINING ATTORNEY

CLASS 45—PERSONAL AND LEGAL SERVICES

SN 76-682,611. KINGDOM SINGLES CONNECTION, INC., OMAHA, NE. FILED 10-4-2007.

KINGDOM SINGLES CONNECTION

THE MARK CONSISTS OF STANDARD CHARACTERS WITHOUT CLAIM TO ANY PARTICULAR FONT, STYLE, SIZE, OR COLOR.

NO CLAIM IS MADE TO THE EXCLUSIVE RIGHT TO USE "SINGLES", APART FROM THE MARK AS SHOWN.

FOR PROVIDING ON-LINE SOCIAL NETWORKING SERVICES FOR THE EXCHANGE OF IDEAS, TOOLS AND RESOURCES FOR PURPOSE DRIVEN, CHRISTIAN SINGLES (U.S. CLS. 100 AND 101).

GRETTA YAO, EXAMINING ATTORNEY

CLASS 45—(Continued).

SN 76-686,462. MY GOOD DEED, IRVINE, CA. FILED 2-4-2008.

myGoodDeed

THE MARK CONSISTS OF STANDARD CHARACTERS WITHOUT CLAIM TO ANY PARTICULAR FONT, STYLE, SIZE, OR COLOR.

FOR PERSONAL AND SOCIAL SERVICES IN THE NATURE OF ENCOURAGING PEOPLE TO ENGAGE IN GOOD DEEDS, NAMELY, PERSONAL LIFESTYLE CONSULTING SERVICES FEATURING THE PROMOTION OF VOLUNTEERISM AND PARTICIPATION IN CHARITABLE SERVICES, PROVIDING INFORMATION CONCERNING CHARITABLE CAUSES AND HUMANITARIAN EFFORTS IN THE FIELD OF SOCIAL JUSTICE, AND ORGANIZING AND CONDUCTING SUPPORT GROUPS IN THE FIELD OF VOLUNTEERISM AND CHARITABLE SERVICE PARTICIPATION (U.S. CLS. 100 AND 101).

FIRST USE 8-10-2006; IN COMMERCE 8-10-2006.
JAY BESCH, EXAMINING ATTORNEY

SN 77-103,123. JABEZ VENTURES, ROCKLIN, CA. FILED 2-8-2007.

MYMISSIONSTRIP

THE MARK CONSISTS OF STANDARD CHARACTERS WITHOUT CLAIM TO ANY PARTICULAR FONT, STYLE, SIZE, OR COLOR.

FOR ONLINE SOCIAL NETWORKING SERVICES (U.S. CLS. 100 AND 101).

PAUL CROWLEY, EXAMINING ATTORNEY

SN 77-104,013. GENERAL STEAMSHIP AGENCIES, INC., MILL VALLEY, CA. FILED 2-9-2007.



NEPTUNE
Shoreside Services

NO CLAIM IS MADE TO THE EXCLUSIVE RIGHT TO USE "SHORESIDE SERVICES", APART FROM THE MARK AS SHOWN.

THE MARK CONSISTS OF A DEPICTION OF A MAN WITH PITCH FORK WITHIN A RECTANGLE WITH THE WORDS "NEPTUNE SHORESIDE SERVICES" TO THE RIGHT.

FOR SECURITY SERVICES FOR PASSENGER AND BAGGAGE SCREENING AT CRUISE SHIP TERMINALS (U.S. CLS. 100 AND 101).

FIRST USE 0-0-1999; IN COMMERCE 0-0-2000.
JANICE L. MCMORROW, EXAMINING ATTORNEY

CLASS 45—(Continued).

SN 77-121,712. COOPER, RODNEY A., TROPHY CLUB, TX. FILED 3-3-2007.

Protecting Assets of the Mind

THE MARK CONSISTS OF STANDARD CHARACTERS WITHOUT CLAIM TO ANY PARTICULAR FONT, STYLE, SIZE, OR COLOR.

FOR INTELLECTUAL PROPERTY CONSULTATION; LICENSING OF ARCHITECTURAL DRAWINGS TO OTHERS; LICENSING OF COMPUTER SOFTWARE; LICENSING OF INTELLECTUAL PROPERTY; LITIGATION SERVICES; PATENT AND INDUSTRIAL PROPERTY CONSULTATION; PATENT LICENSING (U.S. CLS. 100 AND 101).

FIRST USE 3-6-2006; IN COMMERCE 3-6-2006.
JIM RINGLE, EXAMINING ATTORNEY

SN 77-146,803. HODGSON LAW GROUP, BEVERLY HILLS, CA. FILED 4-2-2007.



THE COLOR(S) GOLD, WHITE, YELLOW AND BLUE IS/ ARE CLAIMED AS A FEATURE OF THE MARK.

THE EGG IS GOLD. THE GOOSE BODY IS WHITE, THE GOOSE'S LEGS ARE YELLOW, THE LETTERING IS WHITE, ALL ON A SHADED BLUE BACKGROUND.

FOR LEGAL SERVICES (U.S. CLS. 100 AND 101).
FIRST USE 5-1-2005; IN COMMERCE 5-1-2005.
PAUL E. FAHRENKOPF, EXAMINING ATTORNEY

SN 77-160,165. DENIRO MARKETING, LLC., STOCKTON, CA. FILED 4-18-2007.

datinggold.com

THE MARK CONSISTS OF STANDARD CHARACTERS WITHOUT CLAIM TO ANY PARTICULAR FONT, STYLE, SIZE, OR COLOR.

NO CLAIM IS MADE TO THE EXCLUSIVE RIGHT TO USE ".COM", APART FROM THE MARK AS SHOWN.

FOR WEB SITE SERVICES FEATURING ON-LINE DATING CLUB (U.S. CLS. 100 AND 101).

FIRST USE 5-13-2002; IN COMMERCE 5-13-2002.
MICHAEL LEWIS, EXAMINING ATTORNEY

CLASS 45—(Continued).

SN 77-180,925. ARRUDA & BEAUDOIN, LLP, BRAINTREE, MA. FILED 5-15-2007.



NO CLAIM IS MADE TO THE EXCLUSIVE RIGHT TO USE "SOCIAL SECURITY ADVOCATES FOR THE DISABLED" AND "DISABILITY (SSAD) ATTORNEYS", APART FROM THE MARK AS SHOWN.

THE COLOR(S) BLUE, BROWN, GRAY AND WHITE IS/ ARE CLAIMED AS A FEATURE OF THE MARK.

THE MARK CONSISTS OF THE WORDS "SOCIAL SECURITY ADVOCATES FOR THE DISABLED DISABILITY (SSAD) ATTORNEYS" IN THE COLOR BLUE, BROWN GAVEL AND LAW BOOKS ARE BROWN, COLUMNS ARE GRAY AND WHITE BACKGROUND.

FOR LEGAL SERVICES; PROVIDING INFORMATION RELATING TO LEGAL AFFAIRS (U.S. CLS. 100 AND 101).

FIRST USE 5-7-2007; IN COMMERCE 5-7-2007.
ARETHA SOMERVILLE, EXAMINING ATTORNEY

SN 77-218,006. JUSTIN COLE DAVIS, BUXTON, NC. FILED 6-28-2007.



NO CLAIM IS MADE TO THE EXCLUSIVE RIGHT TO USE "COLLECTION", APART FROM THE MARK AS SHOWN.

THE MARK CONSISTS OF THE LETTERS "JCNY" WITH A LINE UNDER THE LETTERS AND WITH "COLLECTION" UNDER THE LINE SURROUNDED BY THE OUTLINE OF A SQUARE.

FOR LICENSING OF VIRTUAL AND/OR INTERACTIVE IMAGES IN THE FIELD OF ON-LINE RETAIL STORE SERVICES (U.S. CLS. 100 AND 101).

FIRST USE 6-1-2007; IN COMMERCE 6-1-2007.
EDWARD NELSON, EXAMINING ATTORNEY

CLASS 45—(Continued).

SN 77-224,602. OSEA, INC., BLASDELL, NY. FILED 7-9-2007.

RSP

THE MARK CONSISTS OF STANDARD CHARACTERS WITHOUT CLAIM TO ANY PARTICULAR FONT, STYLE, SIZE, OR COLOR.

FOR ANALYSIS AND CONSULTATION PERTAINING TO JOB SITE SAFETY (U.S. CLS. 100 AND 101).

FIRST USE 8-23-1999; IN COMMERCE 8-23-1999.
CAROLYN CATALDO, EXAMINING ATTORNEY

SN 77-239,837. SUCCESSFUL RUNNING, LLC, DES MOINES, IA. FILED 7-26-2007.

RUNNERS' LOUNGE

THE MARK CONSISTS OF STANDARD CHARACTERS WITHOUT CLAIM TO ANY PARTICULAR FONT, STYLE, SIZE, OR COLOR.

NO CLAIM IS MADE TO THE EXCLUSIVE RIGHT TO USE "RUNNERS", APART FROM THE MARK AS SHOWN.

FOR ON-LINE SOCIAL NETWORKING SERVICES FOR RUNNING ENTHUSIASTS (U.S. CLS. 100 AND 101).

FIRST USE 6-1-2007; IN COMMERCE 6-1-2007.
BONNIE LUKEN, EXAMINING ATTORNEY

SN 77-258,529. IMAGINI HOLDINGS LTD, LONDON, UNITED KINGDOM, FILED 8-17-2007.

VISUALDNA

THE MARK CONSISTS OF STANDARD CHARACTERS WITHOUT CLAIM TO ANY PARTICULAR FONT, STYLE, SIZE, OR COLOR.

PRIORITY CLAIMED UNDER SEC. 44(D) ON UNITED KINGDOM APPLICATION NO. 2450089, FILED 3-20-2007, REG. NO. 2450089, DATED 10-26-2007, EXPIRES 3-20-2017.

FOR PERSONAL AND SOCIAL SERVICES RENDERED BY OTHERS TO MEET THE NEEDS OF INDIVIDUALS, NAMELY, SOCIAL NETWORKING SERVICES; SOCIAL INTRODUCTION AND DATING SERVICES; INTERNET BASED SOCIAL NETWORKING SERVICES; INTERNET BASED SOCIAL NETWORKING SERVICES; VISUALLY PROFILING CONSUMERS FOR NETWORKING, SOCIAL, AND PERSONAL PURPOSES; ANALYZING PERSONALITY AND PERSONAL PROFILE INFORMATION DATA FOR NETWORKING, SOCIAL AND PERSONAL PURPOSES (U.S. CLS. 100 AND 101).

ALEX KEAM, EXAMINING ATTORNEY

CLASS 45—(Continued).

SN 77-258,532. IMAGINI HOLDINGS LTD, LONDON, UNITED KINGDOM, FILED 8-17-2007.

IMAGINI

THE MARK CONSISTS OF STANDARD CHARACTERS WITHOUT CLAIM TO ANY PARTICULAR FONT, STYLE, SIZE, OR COLOR.

PRIORITY CLAIMED UNDER SEC. 44(D) ON UNITED KINGDOM APPLICATION NO. 2450088, FILED 3-20-2007, REG. NO. 2450088, DATED 10-26-2007, EXPIRES 3-20-2017.

FOR PERSONAL AND SOCIAL SERVICES RENDERED BY OTHERS TO MEET THE NEEDS OF INDIVIDUALS, NAMELY, SOCIAL NETWORKING SERVICES; SOCIAL INTRODUCTION AND DATING SERVICES; INTERNET BASED SOCIAL NETWORKING SERVICES; VISUALLY PROFILING CONSUMERS FOR NETWORKING, SOCIAL, AND PERSONAL PURPOSES; ANALYZING PERSONALITY AND PERSONAL PROFILE INFORMATION DATA FOR NETWORKING, SOCIAL AND PERSONAL PURPOSES (U.S. CLS. 100 AND 101).

ALEX KEAM, EXAMINING ATTORNEY

SN 77-261,656. SWAMBLE INC., LAS VEGAS, NV. FILED 8-22-2007.



THE COLOR(S) ORANGE, BLUE AND BLACK IS/ARE CLAIMED AS A FEATURE OF THE MARK.

THE MARK CONSISTS OF A BLACK BACKGROUND WITH THE LOWER CASE LETTERS "S", "W", "A", "M", "B" AND "L" IN BURNT ORANGE AND A SYMBOL, WHICH APPEARS TO BE THE LOWER CASE LETTER, "E", SLANTED UP AND TO THE RIGHT, IN SKY BLUE.

FOR ONLINE SOCIAL NETWORKING SERVICES (U.S. CLS. 100 AND 101).

FIRST USE 2-1-2007; IN COMMERCE 2-1-2007.
MICHELLE DUBOIS, EXAMINING ATTORNEY

CLASS 45—(Continued).

SN 77-282,012. BOETTCHER, BOETTCHER & LOBAUGH, INC., TULSA, OK. FILED 9-18-2007.



THE COLOR(S) SILVER, BLACK, RED, BLUE AND BROWN IS/ARE CLAIMED AS A FEATURE OF THE MARK.

THE MARK CONSISTS OF A DENTED HARD HAT SHOWN PREDOMINANTLY IN SILVER WITH BLACK SHADOWS AND HINTS OF RED, BLUE AND BROWN ON THE FRONT AND SIDE.

FOR LEGAL SERVICES (U.S. CLS. 100 AND 101).
FIRST USE 12-31-1982; IN COMMERCE 12-31-1982.
DAVID YONTEF, EXAMINING ATTORNEY

SN 77-319,630. EYE CONTROLS, LLC, CHANTILLY, VA. FILED 11-2-2007.

SafeMatch

THE MARK CONSISTS OF STANDARD CHARACTERS WITHOUT CLAIM TO ANY PARTICULAR FONT, STYLE, SIZE, OR COLOR.

FOR IDENTIFICATION VERIFICATION SERVICES, NAMELY, PROVIDING AUTHENTICATION OF PERSONAL IDENTIFICATION INFORMATION (U.S. CLS. 100 AND 101).

FIRST USE 3-29-2007; IN COMMERCE 3-29-2007.
BONNIE LUKEN, EXAMINING ATTORNEY

CLASS 45—(Continued).

SN 77-328,876. LOVEMYPETS, LLC, TAYLORS, SC. FILED 11-14-2007.



OWNER OF U.S. REG. NO. 3,376,516.

THE MARK CONSISTS OF THE WORDS "LOVEMY-PETSGPS" WITH STYLIZED IMAGE OF GLOBE.

FOR ASSISTING IN THE LOCATING OF LOST PETS; MAKING PET IDENTIFICATION TAGS AVAILABLE TO OTHERS FOR SECURITY OR LOCATION PURPOSES; MAKING PET IDENTIFICATION TRANSMITTERS AND RECEIVERS AVAILABLE TO OTHERS FOR SECURITY OR LOCATION PURPOSES; MAKING PET IDENTIFICATION COLLARS AVAILABLE TO OTHERS FOR SECURITY OR LOCATION PURPOSES (U.S. CLS. 100 AND 101).

FIRST USE 9-18-2007; IN COMMERCE 9-18-2007.
STEPHEN AQUILA, EXAMINING ATTORNEY

SN 77-362,326. THE LAW OFFICES OF JOSEPH L. BORNSTEIN, PORTLAND, ME. FILED 1-2-2008.

JOE BORNSTEIN

THE MARK CONSISTS OF STANDARD CHARACTERS WITHOUT CLAIM TO ANY PARTICULAR FONT, STYLE, SIZE, OR COLOR.

THE NAME "JOSEPH L. BORNSTEIN" IDENTIFIES A LIVING INDIVIDUAL WHOSE CONSENT IS OF RECORD. FOR LEGAL SERVICES (U.S. CLS. 100 AND 101).

FIRST USE 12-31-1974; IN COMMERCE 12-31-1999.
BILL DAWE, EXAMINING ATTORNEY

SN 77-362,328. THE LAW OFFICES OF JOSEPH L. BORNSTEIN, PORTLAND, ME. FILED 1-2-2008.

LAW OFFICES OF JOE BORNSTEIN

THE MARK CONSISTS OF STANDARD CHARACTERS WITHOUT CLAIM TO ANY PARTICULAR FONT, STYLE, SIZE, OR COLOR.

NO CLAIM IS MADE TO THE EXCLUSIVE RIGHT TO USE "LAW OFFICES OF", APART FROM THE MARK AS SHOWN.

THE NAME "JOSEPH L BORNSTEIN" IDENTIFIES A LIVING INDIVIDUAL WHOSE CONSENT IS OF RECORD. FOR LEGAL SERVICES (U.S. CLS. 100 AND 101).

FIRST USE 12-31-1974; IN COMMERCE 12-31-1999.
BILL DAWE, EXAMINING ATTORNEY

CLASS 45—(Continued).

SN 77-368,779. HURON CONSULTING GROUP INC., CHICAGO, IL. FILED 1-10-2008.



FOR LEGAL CONSULTING SERVICES, NAMELY, PROCESSING, HOSTING AND REVIEW OF DOCUMENTS AND EVIDENCE FOR LEGAL AND REGULATORY COMPLIANCE DEPARTMENTS (U.S. CLS. 100 AND 101).

FIRST USE 11-0-2007; IN COMMERCE 11-0-2007.
WILLIAM VERHOSEK, EXAMINING ATTORNEY

SN 77-394,875. ARBOGAST PROPERTY MANAGEMENT, LLC, GENOA, NV. FILED 2-12-2008.

BULLETPROOF

THE MARK CONSISTS OF STANDARD CHARACTERS WITHOUT CLAIM TO ANY PARTICULAR FONT, STYLE, SIZE, OR COLOR.

FOR LEGAL SERVICES; INTELLECTUAL PROPERTY CONSULTATION (U.S. CLS. 100 AND 101).
FIRST USE 6-0-2006; IN COMMERCE 6-0-2006.
MARY ROSSMAN, EXAMINING ATTORNEY

SN 77-395,741. FLORIDA RURAL LEGAL SERVICES, INC., FORT MYERS, FL. FILED 2-13-2008.

Florida Rural Legal Services, Inc.

THE MARK CONSISTS OF STANDARD CHARACTERS WITHOUT CLAIM TO ANY PARTICULAR FONT, STYLE, SIZE, OR COLOR.

NO CLAIM IS MADE TO THE EXCLUSIVE RIGHT TO USE "LEGAL SERVICES, INC.", APART FROM THE MARK AS SHOWN.

SEC. 2(F).
FOR ATTORNEY SERVICES (U.S. CLS. 100 AND 101).
FIRST USE 12-31-1966; IN COMMERCE 1-1-1977.
CARYN GLASSER, EXAMINING ATTORNEY

CLASS 45—(Continued).

SN 77-410,620. ZABAWA, BARBARA J, MADISON, WI. FILED 3-1-2008.

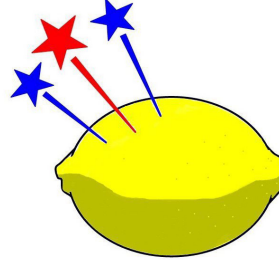

THE COLOR(S) YELLOW, BLUE, RED AND BLACK IS/ ARE CLAIMED AS A FEATURE OF THE MARK.

THE MARK CONSISTS OF A LEMON DESIGN WHICH IS IN YELLOW, TWO OUTSIDE STARBURSTS THAT ARE IN BLUE, A MIDDLE STARBURST IN RED AND THE ENTIRE DESIGN IS OUTLINED IN BLACK.

FOR PROVIDING INFORMATION IN THE FIELD OF SELF-IMPROVEMENT (U.S. CLS. 100 AND 101).

FIRST USE 2-19-2008; IN COMMERCE 2-19-2008.
JOHN GARTNER, EXAMINING ATTORNEY

SN 77-410,622. ZABAWA, BARBARA J., MADISON, WI. FILED 3-1-2008.

LemonSpark

THE MARK CONSISTS OF STANDARD CHARACTERS WITHOUT CLAIM TO ANY PARTICULAR FONT, STYLE, SIZE, OR COLOR.

FOR PROVIDING INFORMATION IN THE FIELD OF SELF-IMPROVEMENT (U.S. CLS. 100 AND 101).

FIRST USE 2-19-2008; IN COMMERCE 2-19-2008.
JOHN GARTNER, EXAMINING ATTORNEY

SN 77-414,746. MERRICK, TYLER, SOUTHLAKE, TX. FILED 3-6-2008.

WUNDERSTRUCK

THE MARK CONSISTS OF STANDARD CHARACTERS WITHOUT CLAIM TO ANY PARTICULAR FONT, STYLE, SIZE, OR COLOR.

FOR PROVIDING A WEBSITE FEATURING INFORMATION IN THE FIELD OF MINISTERIAL SERVICES FEATURING RESOURCES FOR THE CHRISTIAN COMMUNITY (U.S. CLS. 100 AND 101).

EVELYN BRADLEY, EXAMINING ATTORNEY

CLASS 45—(Continued).

SN 77-416,885. SELF LOVE CONSULTING, NEW YORK, NY.
FILED 3-8-2008.

Life Makeover Mentor

THE MARK CONSISTS OF STANDARD CHARACTERS WITHOUT CLAIM TO ANY PARTICULAR FONT, STYLE, SIZE, OR COLOR.

NO CLAIM IS MADE TO THE EXCLUSIVE RIGHT TO USE "MAKEOVER MENTOR", APART FROM THE MARK AS SHOWN.

FOR ORGANIZATIONAL SERVICES FOR HOME OR PERSONAL PURPOSES, NAMELY, ORGANIZING CLOSET SPACE AND PERSONAL SCHEDULES (U.S. CLS. 100 AND 101).

FIRST USE 12-1-2007; IN COMMERCE 12-1-2007.
CAROLINE WOOD, EXAMINING ATTORNEY

SN 77-419,439. CARBON12, LLC, MONTEREY, CA. FILED 3-12-2008.

Carbon12

THE MARK CONSISTS OF STANDARD CHARACTERS WITHOUT CLAIM TO ANY PARTICULAR FONT, STYLE, SIZE, OR COLOR.

FOR PROVIDING PERSONAL AND SOCIAL SERVICES, NAMELY, ON-LINE SOCIAL NETWORKING SERVICES IN THE AREA OF DISEASE, DISORDERS, HEALTH CONDITIONS, OR INJURIES (U.S. CLS. 100 AND 101).

JORDAN BAKER, EXAMINING ATTORNEY

SN 77-420,222. MCGARRY BAIR PC, GRAND RAPIDS, MI.
FILED 3-12-2008.

MCGARRY BAIR

THE MARK CONSISTS OF STANDARD CHARACTERS WITHOUT CLAIM TO ANY PARTICULAR FONT, STYLE, SIZE, OR COLOR.

FOR LEGAL SERVICES (U.S. CLS. 100 AND 101).
FIRST USE 10-1-2001; IN COMMERCE 10-1-2001.
STEVEN PEREZ, EXAMINING ATTORNEY

CLASS 45—(Continued).

SN 77-423,009. WATTS, NATALIE JANE, DBA BEYOURE-WIFE, ROME, GA. FILED 3-15-2008.

e-wife

THE MARK CONSISTS OF STANDARD CHARACTERS WITHOUT CLAIM TO ANY PARTICULAR FONT, STYLE, SIZE, OR COLOR.

FOR PERSONAL SHOPPING FOR OTHERS (U.S. CLS. 100 AND 101).

TARA PATE, EXAMINING ATTORNEY

SN 77-423,035. PEACE TALKS MEDIATION SERVICES, INC., PLAYA DEL REY, CA. FILED 3-15-2008.

TRUCE IS BETTER THAN FRICTION

THE MARK CONSISTS OF STANDARD CHARACTERS WITHOUT CLAIM TO ANY PARTICULAR FONT, STYLE, SIZE, OR COLOR.

FOR MEDIATION (U.S. CLS. 100 AND 101).
FIRST USE 2-15-2008; IN COMMERCE 2-15-2008.

JORDAN BAKER, EXAMINING ATTORNEY

SN 77-423,155. SERVANTS OF GOD, INC., GRETN, LA.
FILED 3-16-2008.

The Repairer Of The Breach/The Restorer Of Paths To Dwell In

THE MARK CONSISTS OF STANDARD CHARACTERS WITHOUT CLAIM TO ANY PARTICULAR FONT, STYLE, SIZE, OR COLOR.

FOR CONDUCTING RELIGIOUS PRAYER SERVICES; MINISTERIAL SERVICES, NAMELY, HOLDING SPIRITUAL RETREATS TO ASSIST RELIGIOUS LEADERS, BOTH CLERGY AND LAY, TO DEVELOP AND ENHANCE THEIR SPIRITUAL LIVES; RELIGIOUS AND SPIRITUAL SERVICES, NAMELY, PROVIDING GATHERINGS AND RETREATS TO DEVELOP AND ENHANCE THE SPIRITUAL LIVES OF INDIVIDUALS; RELIGIOUS MASS INTENTIONS SERVICES, NAMELY, PROVIDING FOR THE ARRANGEMENT OF MASS INTENTIONS FOR THE DECEASED AND OR LIVING; EVANGELISTIC AND MINISTERIAL SERVICES; EVANGELISTIC MINISTERIAL SERVICES; MINISTERIAL SERVICES (U.S. CLS. 100 AND 101).

ELLEN PERKINS, EXAMINING ATTORNEY

CLASS 45—(Continued).

SN 77-424,346. HULL VENTURES, LLC, AGOURA HILLS, CA. FILED 3-17-2008.



NO CLAIM IS MADE TO THE EXCLUSIVE RIGHT TO USE "HOME CARE" AND "A PROFESSIONAL HOME CARE SOLUTION", APART FROM THE MARK AS SHOWN.

THE STIPLING IS FOR SHADING PURPOSES ONLY. THE MARK CONSISTS OF A LETTER "S" INSIDE A HOME. ITALIZED WORD "SELECT" AND LOWER CASE WORDS "A PROFESSIONAL HOME CARE SOLUTION" BELOW DETACHED HOME AND WORD "SELECT".

FOR PROVIDING HOURLY AND LIVE-IN NON-MEDICAL PERSONAL ASSISTANCE SERVICES FOR OTHERS IN THE NATURE OF PLANNING, ORGANIZING, COORDINATING, ARRANGING AND ASSISTING INDIVIDUALS TO PERFORM DAILY TASKS ALSO KNOWN AS ACTIVITIES OF DAILY LIVING (U.S. CLS. 100 AND 101).

FIRST USE 8-1-2006; IN COMMERCE 10-1-2006. TANYA AMOS, EXAMINING ATTORNEY

SN 77-424,894. CATHOLIC MATCH, LLC, ZELIENOPLE, PA. FILED 3-18-2008.

Grow in faith - Fall in love

THE MARK CONSISTS OF STANDARD CHARACTERS WITHOUT CLAIM TO ANY PARTICULAR FONT, STYLE, SIZE, OR COLOR.

FOR INTERNET BASED SOCIAL NETWORKING, INTRODUCTION, AND DATING SERVICES (U.S. CLS. 100 AND 101).

FIRST USE 8-0-2006; IN COMMERCE 10-0-2006. DANIEL BRODY, EXAMINING ATTORNEY

CLASS 45—(Continued).

SN 77-424,996. UNITED SECURITY PROTECTIVE SERVICES LLC, WESTVILLE, NJ. FILED 3-18-2008.



THE COLOR(S) GOLD IS/ARE CLAIMED AS A FEATURE OF THE MARK.

THE MARK CONSISTS OF A GOLD EAGLE'S HEAD COMPOSED OF BROAD STROKES AND FILLING A CIRCULAR REGION.

FOR SECURITY GUARD SERVICES (U.S. CLS. 100 AND 101).

FIRST USE 6-1-2005; IN COMMERCE 10-1-2005. TOBY BULLOFF, EXAMINING ATTORNEY

SN 77-425,013. UNITED SECURITY PROTECTIVE SERVICES LLC, WESTVILLE, NJ. FILED 3-18-2008.

UNITED SECURITY PROTECTIVE SERVICES

THE MARK CONSISTS OF STANDARD CHARACTERS WITHOUT CLAIM TO ANY PARTICULAR FONT, STYLE, SIZE, OR COLOR.

NO CLAIM IS MADE TO THE EXCLUSIVE RIGHT TO USE "SECURITY PROTECTIVE SERVICES", APART FROM THE MARK AS SHOWN.

FOR SECURITY GUARD SERVICES (U.S. CLS. 100 AND 101).

FIRST USE 6-1-2005; IN COMMERCE 10-1-2005. TOBY BULLOFF, EXAMINING ATTORNEY

SN 77-425,087. BERGGREN LAW OFFICES, LLC, OAKDALE, MN. FILED 3-18-2008.

PROTECTING YOUR UNIQUENESS

THE MARK CONSISTS OF STANDARD CHARACTERS WITHOUT CLAIM TO ANY PARTICULAR FONT, STYLE, SIZE, OR COLOR.

FOR CONSULTING ON INTELLECTUAL PROPERTY MATTERS AND PERFORMING INTELLECTUAL PROPERTY LEGAL SERVICES (U.S. CLS. 100 AND 101).

JANICE L. MCMORROW, EXAMINING ATTORNEY

CLASS 45—(Continued).

SN 77-425,954. DEUTSCHE TELEKOM, BONN, FED REP GERMANY, FILED 3-19-2008.

T-Mobile Complete

THE MARK CONSISTS OF STANDARD CHARACTERS WITHOUT CLAIM TO ANY PARTICULAR FONT, STYLE, SIZE, OR COLOR.

PRIORITY CLAIMED UNDER SEC. 44(D) ON FED REP GERMANY APPLICATION NO. 30762180.4/3, FILED 9-21-2007, REG. NO. 30762180, DATED 11-5-2007, EXPIRES 9-30-2017.

OWNER OF U.S. REG. NOS. 3,076,000, 3,219,515 AND OTHERS.

FOR LICENSING OF INDUSTRIAL PROPERTY RIGHTS (U.S. CLS. 100 AND 101).

ANNE E. GUSTASON, EXAMINING ATTORNEY

CLASS 45—(Continued).

SN 77-426,926. CREATIF LICENSING CORP, MOUNT KISCO, NY. FILED 3-20-2008.

Creatif Licensing Corp

THE MARK CONSISTS OF STANDARD CHARACTERS WITHOUT CLAIM TO ANY PARTICULAR FONT, STYLE, SIZE, OR COLOR.

NO CLAIM IS MADE TO THE EXCLUSIVE RIGHT TO USE "LICENSING CORP", APART FROM THE MARK AS SHOWN.

THE FOREIGN WORDING IN THE MARK TRANSLATES INTO ENGLISH AS CREATIVE DESIGNER.

SEC. 2(F).

FOR LICENSING OF ARTWORK, ILLUSTRATION, DESIGN AND CONCEPTUAL PROPERTIES (U.S. CLS. 100 AND 101).

FIRST USE 6-6-1975; IN COMMERCE 9-29-1975.

RON FAIRBANKS, EXAMINING ATTORNEY

SN 77-426,047. ICOPYRIGHT, INC., DBA DATA DEPTH CORPORATION, ISSAQUAH, WA. FILED 3-19-2008.

Empowering creative works

THE MARK CONSISTS OF STANDARD CHARACTERS WITHOUT CLAIM TO ANY PARTICULAR FONT, STYLE, SIZE, OR COLOR.

FOR COPYRIGHT MANAGEMENT (U.S. CLS. 100 AND 101).

FIRST USE 3-7-2008; IN COMMERCE 3-17-2008.

STEVEN R. FOSTER, EXAMINING ATTORNEY

SN 77-427,969. SEVERANCE, SCOTT D., CHICAGO, IL. FILED 3-21-2008.

Buyadate

THE MARK CONSISTS OF STANDARD CHARACTERS WITHOUT CLAIM TO ANY PARTICULAR FONT, STYLE, SIZE, OR COLOR.

FOR ONLINE DATING SERVICES (U.S. CLS. 100 AND 101).

FIRST USE 10-31-2007; IN COMMERCE 12-8-2007.

CHRISTOPHER BUONGIORNO, EXAMINING ATTORNEY

SN 77-426,805. WALLS, JUDITH A., DBA THE MESS MEISTER, FRIENDSWOOD, TX. FILED 3-19-2008.

The Mess Meister

THE MARK CONSISTS OF STANDARD CHARACTERS WITHOUT CLAIM TO ANY PARTICULAR FONT, STYLE, SIZE, OR COLOR.

FOR ORGANIZATIONAL SERVICES FOR HOME OR PERSONAL PURPOSES, NAMELY, ORGANIZING THE POSSESSIONS AND THE ROOMS IN HOMES OR OFFICES THROUGH HANDS ON SORTING, PURGING AND ARRANGING ITEMS, AND MANAGEMENT OF FILES AND PAPERWORK (U.S. CLS. 100 AND 101).

FIRST USE 1-21-2006; IN COMMERCE 1-23-2006.

KAPIL BHANOT, EXAMINING ATTORNEY

SN 77-428,436. VISIONFIRST OMNIMEDIA, LLC, BIRMINGHAM, AL. FILED 3-21-2008.

crossconneXion.com

THE MARK CONSISTS OF THE WORDS CROSSCONNECTION.COM WITH THE "X" DEPICTED AS A STYLIZED CROSS SLANTED TO THE RIGHT, WITH THE PHRASE "CROSSCONNECTION" DISPLAYED IN LARGER FONT THAN ".COM".

FOR ONLINE CHRISTIAN SOCIAL NETWORKING SERVICES (U.S. CLS. 100 AND 101).

FIRST USE 11-12-2007; IN COMMERCE 11-12-2007.

JOHN WILKE, EXAMINING ATTORNEY

CLASS 45—(Continued).

SN 77-428,860. MCDONALD, MIA R., NEW MARKET, MD. FILED 3-22-2008.

MIAHUT...CAMPINGHOUSE

THE MARK CONSISTS OF STANDARD CHARACTERS WITHOUT CLAIM TO ANY PARTICULAR FONT, STYLE, SIZE, OR COLOR.

FOR SOCIAL SERVICE, NAMELY, COMPANIONSHIP SERVICES FOR ELDERLY (U.S. CLS. 100 AND 101). CHRISTOPHER BUONGIORNO, EXAMINING ATTORNEY

CLASS 45—(Continued).

SN 77-429,087. SMITH, PETER I., SEVERN, MD. FILED 3-23-2008.

ChildVillage

THE MARK CONSISTS OF STANDARD CHARACTERS WITHOUT CLAIM TO ANY PARTICULAR FONT, STYLE, SIZE, OR COLOR.

FOR ONLINE SOCIAL NETWORKING SERVICES (U.S. CLS. 100 AND 101). HEATHER THOMPSON, EXAMINING ATTORNEY

SN 77-428,956. POST, LUANA C., DULUTH, GA. AND BENELLI, ELLEN, DULUTH, GA. FILED 3-22-2008.

Pal Posse

FOR PROVIDING NON-MEDICAL PERSONAL ASSISTANT SERVICES FOR OTHERS IN THE NATURE OF PLANNING, ORGANIZING, COORDINATING, ARRANGING AND ASSISTING INDIVIDUALS TO PERFORM DAILY TASKS (U.S. CLS. 100 AND 101).

FIRST USE 3-13-2008; IN COMMERCE 3-13-2008. KARANENDRA S. CHHINA, EXAMINING ATTORNEY

SN 77-429,431. THE BAUE FUNERAL HOME CO., ST. CHARLES, MO. FILED 3-24-2008.

BAUE

THE MARK CONSISTS OF STANDARD CHARACTERS WITHOUT CLAIM TO ANY PARTICULAR FONT, STYLE, SIZE, OR COLOR.

SEC. 2(F). FOR FUNERAL HOME SERVICES; CREMATIONS (U.S. CLS. 100 AND 101).

FIRST USE 0-0-1935; IN COMMERCE 0-0-1935. CURTIS FRENCH, EXAMINING ATTORNEY

SN 77-428,966. SEAN HOGLE PC, SAN RAFAEL, CA. FILED 3-22-2008.

COUNSELORS TO INSPIRATION

THE MARK CONSISTS OF STANDARD CHARACTERS WITHOUT CLAIM TO ANY PARTICULAR FONT, STYLE, SIZE, OR COLOR.

NO CLAIM IS MADE TO THE EXCLUSIVE RIGHT TO USE "COUNSELORS", APART FROM THE MARK AS SHOWN.

FOR LEGAL SERVICES (U.S. CLS. 100 AND 101). FIRST USE 3-18-2008; IN COMMERCE 3-18-2008. DANNEAN HETZEL, EXAMINING ATTORNEY

SN 77-429,441. THE BAUE FUNERAL HOME CO., ST. CHARLES, MO. FILED 3-24-2008.

B BAUE

SEC. 2(F) AS TO "BAUE". FOR FUNERAL HOME SERVICES; CREMATIONS (U.S. CLS. 100 AND 101).

FIRST USE 0-0-1998; IN COMMERCE 0-0-1998. CURTIS FRENCH, EXAMINING ATTORNEY

CLASS 45—(Continued).

SN 77-429,478. LIVE TO EAT, MEQUON, WI. FILED 3-24-2008.



THE MARK CONSISTS OF THE STYLZIED TEXT "LIVE TO EAT".
FOR PERSONAL CHEF SERVICES (U.S. CLS. 100 AND 101).
FIRST USE 3-1-2007; IN COMMERCE 1-23-2008.
RENEE MCCRAY, EXAMINING ATTORNEY

SN 77-429,524. FAMFRIEND, LLC, FAIRFAX, VA. FILED 3-24-2008.

Bringing Family Friends Together

THE MARK CONSISTS OF STANDARD CHARACTERS WITHOUT CLAIM TO ANY PARTICULAR FONT, STYLE, SIZE, OR COLOR.
FOR ONLINE SOCIAL NETWORKING SERVICES (U.S. CLS. 100 AND 101).
ZACHARY BELLO, EXAMINING ATTORNEY

SN 77-429,562. SLOSHY.COM, PLACERVILLE, CA. FILED 3-24-2008.

FOR ME AND WE

THE MARK CONSISTS OF STANDARD CHARACTERS WITHOUT CLAIM TO ANY PARTICULAR FONT, STYLE, SIZE, OR COLOR.
FOR ONLINE SOCIAL NETWORKING SERVICES (U.S. CLS. 100 AND 101).
EUGENIA MARTIN, EXAMINING ATTORNEY

CLASS 45—(Continued).

SN 77-429,707. PROSKAUER ROSE LLP, NEW YORK, NY. FILED 3-24-2008.

STAYING POWER

THE MARK CONSISTS OF STANDARD CHARACTERS WITHOUT CLAIM TO ANY PARTICULAR FONT, STYLE, SIZE, OR COLOR.
FOR LEGAL SERVICES (U.S. CLS. 100 AND 101).
PATRICIA EVANKO, EXAMINING ATTORNEY

SN 77-429,956. ROYAL FUNERAL HOME, INC., HUNTSVILLE, AL. FILED 3-24-2008.

ROYAL FUNERAL HOME

THE MARK CONSISTS OF STANDARD CHARACTERS WITHOUT CLAIM TO ANY PARTICULAR FONT, STYLE, SIZE, OR COLOR.
NO CLAIM IS MADE TO THE EXCLUSIVE RIGHT TO USE "FUNERAL HOME", APART FROM THE MARK AS SHOWN.
FOR FUNERAL HOME SERVICES (U.S. CLS. 100 AND 101).
FIRST USE 12-31-1949; IN COMMERCE 12-31-1949.
MAUREEN DALL, EXAMINING ATTORNEY

SN 77-429,964. ROYAL FUNERAL HOME, INC., HUNTSVILLE, AL. FILED 3-24-2008.

WHEN ONLY MEMORIES REMAIN,
LET THEM BE BEAUTIFUL.

THE MARK CONSISTS OF STANDARD CHARACTERS WITHOUT CLAIM TO ANY PARTICULAR FONT, STYLE, SIZE, OR COLOR.
FOR FUNERAL HOME SERVICES (U.S. CLS. 100 AND 101).
FIRST USE 12-31-1967; IN COMMERCE 12-31-1967.
MAUREEN DALL, EXAMINING ATTORNEY

CLASS 45—(Continued).

SN 77-430,085. IDIGANSWERS RESEARCH ASSOCIATES, INC., JACKSONVILLE, FL. FILED 3-24-2008.

INSPECTADATE

THE MARK CONSISTS OF STANDARD CHARACTERS WITHOUT CLAIM TO ANY PARTICULAR FONT, STYLE, SIZE, OR COLOR.

FOR PERSONAL BACKGROUND INVESTIGATIONS; PROVIDING AN INTERACTIVE WEB SITE THAT FACILITATES THE VERIFICATION OF A PERSON'S BACKGROUND CREDENTIALS (U.S. CLS. 100 AND 101).

ARETHA SOMERVILLE, EXAMINING ATTORNEY

CLASS 45—(Continued).

SN 77-430,291. PUBSCHOLAR, INC., OAKTON, VA. FILED 3-24-2008.

PUBSCHOLAR

THE MARK CONSISTS OF STANDARD CHARACTERS WITHOUT CLAIM TO ANY PARTICULAR FONT, STYLE, SIZE, OR COLOR.

FOR ONLINE SOCIAL NETWORKING SERVICES (U.S. CLS. 100 AND 101).

FIRST USE 3-3-2008; IN COMMERCE 3-3-2008.

WANDA KAY PRICE, EXAMINING ATTORNEY

SN 77-430,095. IDIGANSWERS RESEARCH ASSOCIATES, INC., JACKSONVILLE, FL. FILED 3-24-2008.

LOOK BEFORE YOU LOVE

THE MARK CONSISTS OF STANDARD CHARACTERS WITHOUT CLAIM TO ANY PARTICULAR FONT, STYLE, SIZE, OR COLOR.

FOR PERSONAL BACKGROUND INVESTIGATIONS; PROVIDING AN INTERACTIVE WEB SITE THAT FACILITATES THE VERIFICATION OF A PERSON'S BACKGROUND CREDENTIALS (U.S. CLS. 100 AND 101).

ARETHA SOMERVILLE, EXAMINING ATTORNEY

SN 77-431,149. LANCE ARMSTRONG FOUNDATION, AUSTIN, TX. FILED 3-25-2008.

LIVESTRONG

THE MARK CONSISTS OF STANDARD CHARACTERS WITHOUT CLAIM TO ANY PARTICULAR FONT, STYLE, SIZE, OR COLOR.

OWNER OF U.S. REG. NOS. 3,052,284, 3,202,553 AND OTHERS.

FOR ONLINE SOCIAL NETWORKING SERVICES (U.S. CLS. 100 AND 101).

LAURA HAMMEL, EXAMINING ATTORNEY

SN 77-430,181. CHILDREN, FAMILIES AND COMMUNITIES, INC., DBA CENTER FOR INTEGRATED AWARENESS- MAINE, ELLSWORTH, ME. FILED 3-24-2008.

Parents Go First

THE MARK CONSISTS OF STANDARD CHARACTERS WITHOUT CLAIM TO ANY PARTICULAR FONT, STYLE, SIZE, OR COLOR.

FOR INFORMATION IN THE FIELD OF PARENTING CONCERNING INTRAFAMILY RELATIONSHIPS (U.S. CLS. 100 AND 101).

FIRST USE 6-1-2002; IN COMMERCE 6-1-2002.

MAUREEN DALL, EXAMINING ATTORNEY

SN 77-431,462. VERA COMPANY, LLC, THE, ATLANTA, GA. FILED 3-25-2008.

Get Bitten by the Ladybug

THE MARK CONSISTS OF STANDARD CHARACTERS WITHOUT CLAIM TO ANY PARTICULAR FONT, STYLE, SIZE, OR COLOR.

FOR LICENSING OF PRINTS, DESIGNS, ARTWORK, TRADEMARKS AND OTHER INTELLECTUAL PROPERTY RIGHTS TO OTHERS (U.S. CLS. 100 AND 101).

BRIAN NEVILLE, EXAMINING ATTORNEY

CLASS 45—(Continued).

SN 77-432,033. CENTRAL MINNESOTA LEGAL SERVICES, INC., MINNEAPOLIS, MN. FILED 3-26-2008.

CMLS

THE MARK CONSISTS OF STANDARD CHARACTERS WITHOUT CLAIM TO ANY PARTICULAR FONT, STYLE, SIZE, OR COLOR.

FOR LEGAL SERVICES (U.S. CLS. 100 AND 101).
FIRST USE 12-31-1977; IN COMMERCE 12-31-1978.
CHARLES L. JENKINS, EXAMINING ATTORNEY

SN 77-432,557. GONZALEZ, JOYCE M., TRACY, CA. FILED 3-26-2008.

Wrapper Girlz

THE MARK CONSISTS OF STANDARD CHARACTERS WITHOUT CLAIM TO ANY PARTICULAR FONT, STYLE, SIZE, OR COLOR.

FOR GIFT WRAPPING (U.S. CLS. 100 AND 101).
FIRST USE 10-15-2007; IN COMMERCE 11-1-2007.
WILLIAM P. SHANAHAN, EXAMINING ATTORNEY

SN 77-432,633. SBE ENTERTAINMENT GROUP, LOS ANGELES, CA. FILED 3-26-2008.

LIVE BY SBE

THE MARK CONSISTS OF STANDARD CHARACTERS WITHOUT CLAIM TO ANY PARTICULAR FONT, STYLE, SIZE, OR COLOR.

FOR PERSONAL CONCIERGE SERVICES FOR OTHERS COMPRISING MAKING REQUESTED PERSONAL ARRANGEMENTS AND RESERVATIONS AT RESTAURANTS, NIGHTCLUBS, LOUNGES, THEATRE AND MOVIES, RUNNING PERSONAL AND BUSINESS ERRANDS AND PROVIDING CUSTOMER SPECIFIC INFORMATION TO MEET INDIVIDUAL NEEDS ALL RENDERED IN HOTELS, RESTAURANTS, BARS, NIGHTCLUBS AND CASINOS (U.S. CLS. 100 AND 101).
BARBARA BROWN, EXAMINING ATTORNEY

CLASS 45—(Continued).

SN 77-432,638. SBE ENTERTAINMENT GROUP, LOS ANGELES, CA. FILED 3-26-2008.

LIFE BY SBE

THE MARK CONSISTS OF STANDARD CHARACTERS WITHOUT CLAIM TO ANY PARTICULAR FONT, STYLE, SIZE, OR COLOR.

FOR PERSONAL CONCIERGE SERVICES FOR OTHERS COMPRISING MAKING REQUESTED PERSONAL ARRANGEMENTS AND RESERVATIONS AT RESTAURANTS, NIGHTCLUBS, LOUNGES, THEATRE AND MOVIES, RUNNING PERSONAL AND BUSINESS ERRANDS AND PROVIDING CUSTOMER SPECIFIC INFORMATION TO MEET INDIVIDUAL NEEDS ALL RENDERED IN HOTELS, RESTAURANTS, BARS, NIGHTCLUBS AND CASINOS (U.S. CLS. 100 AND 101).
BARBARA BROWN, EXAMINING ATTORNEY

SN 77-432,642. SBE ENTERTAINMENT GROUP, LOS ANGELES, CA. FILED 3-26-2008.

LIVE WITH SBE

THE MARK CONSISTS OF STANDARD CHARACTERS WITHOUT CLAIM TO ANY PARTICULAR FONT, STYLE, SIZE, OR COLOR.

FOR PERSONAL CONCIERGE SERVICES FOR OTHERS COMPRISING MAKING REQUESTED PERSONAL ARRANGEMENTS AND RESERVATIONS AT RESTAURANTS, NIGHTCLUBS, LOUNGES, THEATRE AND MOVIES, RUNNING PERSONAL AND BUSINESS ERRANDS AND PROVIDING CUSTOMER SPECIFIC INFORMATION TO MEET INDIVIDUAL NEEDS ALL RENDERED IN HOTELS, RESTAURANTS, BARS, NIGHTCLUBS AND CASINOS (U.S. CLS. 100 AND 101).
BARBARA BROWN, EXAMINING ATTORNEY

SN 77-432,991. RESTAURANTMAFIA, INC., WHITE PLAINS, NY. FILED 3-27-2008.

RestaurantMafia

THE MARK CONSISTS OF STANDARD CHARACTERS WITHOUT CLAIM TO ANY PARTICULAR FONT, STYLE, SIZE, OR COLOR.

FOR ONLINE SOCIAL NETWORKING SERVICES (U.S. CLS. 100 AND 101).
KARANENDRA S. CHHINA, EXAMINING ATTORNEY

CLASS 45—(Continued).

SN 77-433,052. YADAHOME.COM, LLC, BALTIMORE, MD. FILED 3-27-2008.

CLASS 45—(Continued).

SN 77-433,626. WENZLAU LAW GROUP, PLLC, SCOTTSDALE, AZ. FILED 3-27-2008.

STAY CONNECTED

THE MARK CONSISTS OF STANDARD CHARACTERS WITHOUT CLAIM TO ANY PARTICULAR FONT, STYLE, SIZE, OR COLOR.
FOR ONLINE SOCIAL NETWORKING SERVICES (U.S. CLS. 100 AND 101).
ANTHONY RINKER, EXAMINING ATTORNEY

Who Owns The Rights

THE MARK CONSISTS OF STANDARD CHARACTERS WITHOUT CLAIM TO ANY PARTICULAR FONT, STYLE, SIZE, OR COLOR.
FOR LEGAL SERVICES (U.S. CLS. 100 AND 101).
FIRST USE 1-1-2008; IN COMMERCE 1-1-2008.
ANDREA SAUNDERS, EXAMINING ATTORNEY

SN 77-433,243. CLAUS, C. CONRAD, DBA CLAUS, C. CONRAD, LAS VEGAS, NV. FILED 3-27-2008.

SN 77-434,123. SYNCHRONICITY LIVE, LLC, JACKSONVILLE BEACH, FL. FILED 3-28-2008.

LAW IS WAR

THE MARK CONSISTS OF STANDARD CHARACTERS WITHOUT CLAIM TO ANY PARTICULAR FONT, STYLE, SIZE, OR COLOR.
FOR ATTORNEY SERVICES (U.S. CLS. 100 AND 101).
FIRST USE 2-1-2005; IN COMMERCE 2-1-2005.
CHRISTINE BLOMQUIST, EXAMINING ATTORNEY

synclive.com

THE MARK CONSISTS OF STANDARD CHARACTERS WITHOUT CLAIM TO ANY PARTICULAR FONT, STYLE, SIZE, OR COLOR.
FOR ONLINE SOCIAL NETWORKING SERVICES (U.S. CLS. 100 AND 101).
TASNEEM HUSSAIN, EXAMINING ATTORNEY

SN 77-433,568. WISOTZKI, DAVID, ENCINO, CA. FILED 3-27-2008.

SN 77-434,376. BOWSER-MINICH, INC., INDIANA, PA. FILED 3-28-2008.

In God we Trust. Everyone
else, we Polygraph!



CARECONCIERGE

THE MARK CONSISTS OF STANDARD CHARACTERS WITHOUT CLAIM TO ANY PARTICULAR FONT, STYLE, SIZE, OR COLOR.
FOR POLYGRAPH EXAMINATION SERVICES (U.S. CLS. 100 AND 101).
REGINA DRUMMOND, EXAMINING ATTORNEY

THE MARK CONSISTS OF THE WORDS "CARECONCIERGE" CENTERED BENEATH A STYLIZED TREE SURROUNDED BY A CIRCLE.
FOR FUNERAL ARRANGEMENT SERVICES (U.S. CLS. 100 AND 101).
ELISSA GARBER KON, EXAMINING ATTORNEY

CLASS 45—(Continued).

SN 77-434,409. TRAVERSE LEGAL PLC, TRAVERSE CITY, MI. FILED 3-28-2008.

Traverse Legal

THE MARK CONSISTS OF STANDARD CHARACTERS WITHOUT CLAIM TO ANY PARTICULAR FONT, STYLE, SIZE, OR COLOR.

NO CLAIM IS MADE TO THE EXCLUSIVE RIGHT TO USE "LEGAL", APART FROM THE MARK AS SHOWN.

FOR LEGAL SERVICES (U.S. CLS. 100 AND 101).

FIRST USE 1-1-2005; IN COMMERCE 1-1-2005.

ELIZABETH BEYER, EXAMINING ATTORNEY

SN 77-434,525. WISOTZKI, DAVID, ENCINO, CA. FILED 3-28-2008.

In God we trust, all others we Polygraph!

THE MARK CONSISTS OF STANDARD CHARACTERS WITHOUT CLAIM TO ANY PARTICULAR FONT, STYLE, SIZE, OR COLOR.

FOR POLYGRAPH EXAMINATION SERVICES (U.S. CLS. 100 AND 101).

REGINA DRUMMOND, EXAMINING ATTORNEY

SN 77-434,716. NOVIKOVA, SVETLANA, BEVERLY HILLS, CA. FILED 3-28-2008.

You have success in Business. Find success in Love.

THE MARK CONSISTS OF STANDARD CHARACTERS WITHOUT CLAIM TO ANY PARTICULAR FONT, STYLE, SIZE, OR COLOR.

FOR DATING SERVICES; ESCORT SERVICES; MARRIAGE PARTNER INTRODUCTION OR DATING SERVICES; MATCHMAKING SERVICES; VIDEO DATING SERVICES; WEB SITE SERVICES FEATURING ON-LINE DATING CLUB (U.S. CLS. 100 AND 101).

CURTIS FRENCH, EXAMINING ATTORNEY

CLASS 45—(Continued).

SN 77-443,044. VIDOOP LLC, TULSA, OK. FILED 4-8-2008.

Confident Technologies

THE MARK CONSISTS OF STANDARD CHARACTERS WITHOUT CLAIM TO ANY PARTICULAR FONT, STYLE, SIZE, OR COLOR.

NO CLAIM IS MADE TO THE EXCLUSIVE RIGHT TO USE "TECHNOLOGIES", APART FROM THE MARK AS SHOWN.

FOR AUTHENTICATION, ISSUANCE AND VALIDATION OF DIGITAL CERTIFICATES; IDENTIFICATION VERIFICATION SERVICES, NAMELY, PROVIDING AUTHENTICATION OF PERSONAL IDENTIFICATION INFORMATION; IDENTIFICATION VERIFICATION SERVICES, NAMELY, PROVIDING AUTHENTICATION OF PERSONAL IDENTIFICATION INFORMATION VIA SECURE STORAGE AND TRANSMITTING SUCH INFORMATION VIA THE INTERNET; PROVIDING USER AUTHENTICATION SERVICES IN E-COMMERCE TRANSACTIONS (U.S. CLS. 100 AND 101).

FIRST USE 3-25-2008; IN COMMERCE 3-25-2008.

LINDA M. KING, EXAMINING ATTORNEY

SN 77-451,615. WAG'N ENTERPRISES, LLC, HERNDON, VA. FILED 4-18-2008.

WAG'N ROVER RESPOND'R

THE MARK CONSISTS OF STANDARD CHARACTERS WITHOUT CLAIM TO ANY PARTICULAR FONT, STYLE, SIZE, OR COLOR.

OWNER OF U.S. REG. NOS. 3,427,952, 3,442,042 AND OTHERS.

NO CLAIM IS MADE TO THE EXCLUSIVE RIGHT TO USE "RESPONDER", APART FROM THE MARK AS SHOWN.

FOR PROVIDING EMERGENCY CARE NOTIFICATION, NAMELY, PROVIDING PET OWNERS WITH A 24 HOUR NUMBER TO CALL IN CASE THEY GET INJURED DURING A CAR ACCIDENT TO ALLOW TEMPORARY PET CARE, AND CONTACTING OF FAMILY AND FRIENDS TO PICK UP AND CARE FOR PETS INVOLVED IN THE ACCIDENT (U.S. CLS. 100 AND 101).

KATHERINE CONNOLLY, EXAMINING ATTORNEY

CLASS 45—(Continued).

SN 77-459,925. SECURING AMERICA'S FUTURE ENERGY ALLIANCE, INC., WASHINGTON, DC. AND SECURING AMERICA'S FUTURE ENERGY FOUNDATION, WASHINGTON, DC. FILED 4-28-2008.

SECURING AMERICA'S FUTURE ENERGY

THE MARK CONSISTS OF STANDARD CHARACTERS WITHOUT CLAIM TO ANY PARTICULAR FONT, STYLE, SIZE, OR COLOR.
FOR CONSULTING SERVICES IN THE FIELD OF NATIONAL SECURITY CONCERNING FUEL AND ENERGY; PROVIDING INFORMATION AND A WEBSITE FEATURING INFORMATION IN THE FIELD OF NATIONAL SECURITY CONCERNING FUEL AND ENERGY (U.S. CLS. 100 AND 101).
CHERYL CLAYTON, EXAMINING ATTORNEY

SN 77-459,945. SECURING AMERICA'S FUTURE ENERGY ALLIANCE, INC., WASHINGTON, DC. AND SECURING AMERICA'S FUTURE ENERGY FOUNDATION, WASHINGTON, DC. FILED 4-28-2008.



Securing America's Future Energy

FOR CONSULTING SERVICES IN THE FIELD OF NATIONAL SECURITY CONCERNING FUEL AND ENERGY; PROVIDING INFORMATION AND A WEBSITE FEATURING INFORMATION IN THE FIELD OF NATIONAL SECURITY CONCERNING FUEL AND ENERGY (U.S. CLS. 100 AND 101).
CHERYL CLAYTON, EXAMINING ATTORNEY

SN 77-464,172. TRUEBEGINNINGS, LLC, IRVING, TX. FILED 5-2-2008.

NAUGHTY OR NICE

THE MARK CONSISTS OF STANDARD CHARACTERS WITHOUT CLAIM TO ANY PARTICULAR FONT, STYLE, SIZE, OR COLOR.
FOR COMPUTER DATING SERVICES; DATING SERVICES; VIDEO DATING SERVICES; MATCHMAKING SERVICES; ONLINE SOCIAL NETWORKING SERVICES; PROVIDING INFORMATION IN THE FIELD OF SELF-IMPROVEMENT; PERSONAL BACKGROUND INVESTIGATIONS (U.S. CLS. 100 AND 101).
FIRST USE 12-1-2005; IN COMMERCE 12-1-2005.
WENDY GOODMAN, EXAMINING ATTORNEY

CLASS 45—(Continued).

SN 77-490,580. LANCE ARMSTRONG FOUNDATION, AUSTIN, TX. FILED 6-4-2008.

LIVESTRONG.COM

THE MARK CONSISTS OF STANDARD CHARACTERS WITHOUT CLAIM TO ANY PARTICULAR FONT, STYLE, SIZE, OR COLOR.
OWNER OF U.S. REG. NOS. 3,052,284, 3,202,553 AND OTHERS.
FOR ON-LINE SOCIAL NETWORKING SERVICES (U.S. CLS. 100 AND 101).
LAURA HAMMEL, EXAMINING ATTORNEY

SN 78-938,476. TELIGENCE (CANADA), INC., VANCOUVER, CANADA, FILED 7-26-2006.

LAVENDER LINE

THE MARK CONSISTS OF STANDARD CHARACTERS WITHOUT CLAIM TO ANY PARTICULAR FONT, STYLE, SIZE, OR COLOR.
NO CLAIM IS MADE TO THE EXCLUSIVE RIGHT TO USE "LINE", APART FROM THE MARK AS SHOWN.
FOR SOCIAL INTRODUCTION AGENCIES AND COMPUTER DATING SERVICES VIA A GLOBAL COMPUTER NETWORK (U.S. CLS. 100 AND 101).
JIM RINGLE, EXAMINING ATTORNEY

SN 79-049,272. OPTINOV, FRANCE, FILED 12-14-2007.

STICKNWIZZ

THE MARK CONSISTS OF STANDARD CHARACTERS WITHOUT CLAIM TO ANY PARTICULAR FONT, STYLE, SIZE, OR COLOR.
PRIORITY DATE OF 6-29-2007 IS CLAIMED.
OWNER OF INTERNATIONAL REGISTRATION 0951701 DATED 12-14-2007, EXPIRES 12-14-2017.
FOR ASSISTANCE IN TRACING LOST PROPERTY USING A PERSONALIZED CODING SYSTEM LINKED TO A WEBSITE VIA A VOICE AND TEXT MESSAGE SERVICE, NAMELY, TRACKING SERVICES FOR RETRIEVAL OF ENCODED PRODUCTS (U.S. CLS. 100 AND 101).
MATTHEW MCDOWELL, EXAMINING ATTORNEY

SECTION 4.—PRIOR UNITED STATES CLASSIFICATION

APPLICATION IN ONE CLASS

COLLECTIVE MEMBERSHIP MARKS

CLASS 200—COLLECTIVE MEMBERSHIP
SN 77-284,323. NATIONAL REVERSE MORTGAGE LENDERS ASSOCIATION, WASHINGTON, DC. FILED 9-20-2007.

National Reverse Mortgage Lenders Association

THE MARK CONSISTS OF STANDARD CHARACTERS WITHOUT CLAIM TO ANY PARTICULAR FONT, STYLE, SIZE, OR COLOR.

NO CLAIM IS MADE TO THE EXCLUSIVE RIGHT TO USE "ASSOCIATION", APART FROM THE MARK AS SHOWN.

SEC. 2(F).

FOR INDICATING MEMBERSHIP IN AN ORGANIZATION OF PROFESSIONALS IN THE REVERSE MORTGAGE INDUSTRY.

FIRST USE 11-1-1997; IN COMMERCE 11-1-1997.
DAVID MURRAY, EXAMINING ATTORNEY

SN 77-365,156. TRADITIONAL TANG SOO DO FEDERATION, BRIDGEND, UNITED KINGDOM, FILED 1-7-2008.



SN 77-306,104. NATIONAL AGING IN PLACE COUNCIL, WASHINGTON, DC. FILED 10-17-2007.



NO CLAIM IS MADE TO THE EXCLUSIVE RIGHT TO USE "NATIONAL AGING IN PLACE COUNCIL", APART FROM THE MARK AS SHOWN.

THE MARK CONSISTS OF A RECTANGLE WITH THE WORDS "NATIONAL AGING IN PLACE COUNCIL" ON INSIDE BORDER AND THE LETTERS "NAIPC" IN THE MIDDLE.

FOR INDICATING MEMBERSHIP IN AN ORGANIZATION OF PROFESSIONALS IN THE FIELD OF SENIOR CITIZEN AFFAIRS.

FIRST USE 11-18-2004; IN COMMERCE 11-18-2004.
CHARISMA HAMPTON, EXAMINING ATTORNEY

NO CLAIM IS MADE TO THE EXCLUSIVE RIGHT TO USE "TRADITIONAL TANG SOO DO" AND "FEDERATION", APART FROM THE MARK AS SHOWN.

THE COLOR(S) DARK BLUE, GOLD, RED AND GREEN IS/ARE CLAIMED AS A FEATURE OF THE MARK.

THE MARK CONSISTS OF CIRCULAR BADGE WITH GOLD EDGE. "TRADITIONAL TANG SOO DO" IN TRADITIONAL CHINESE LETTERING ON TOP HEMISHERE. "TRADITIONAL TANG SOO DO" IN GOLD LETTERING ON BOTTOM HEMISHERE. SEPERATING BOTH LETTERING TWO YIN YANG SYMBOLS IN RED AND BLUE TO THE LEFT AND RIGHT. INTERNAL GOLD CIRCLE. WITHIN THE CIRCLE THE "TANG SOO DO" FIST IN GOLD. A MASTERS BELT BELOW IN BLUE AND RED. LAUREL LEAF SURROUND IN GREEN.

THE FOREIGN WORDING IN THE MARK TRANSLATES INTO ENGLISH AS "TRADITIONAL TANG SOO DO" AND CHINESE HAND WAY.

THE NON-LATIN CHARACTER(S) IN THE MARK TRANSLITERATES INTO CHUAN TONG "TANG SOO DO" AND TANG MOO SOO, AND THIS MEANS "TRADITIONAL TANG SOO DO" AND MILITARY HAND WAY. IN ENGLISH.

FOR INDICATING MEMBERSHIP OF THE TRADITIONAL TANG SOO DO FEDERATION OF MARTIAL ARTS.

FIRST USE 4-3-2006; IN COMMERCE 6-3-2006.
ANNE E. GUSTASON, EXAMINING ATTORNEY

SN 77-383,590. GLOBALIZATION AND LOCALIZATION ASSOCIATION, INC., ANDOVER, MA. FILED 1-29-2008.

COMMUNICATE LOCALLY.
SUCCEED GLOBALLY.

THE MARK CONSISTS OF STANDARD CHARACTERS WITHOUT CLAIM TO ANY PARTICULAR FONT, STYLE, SIZE, OR COLOR.

FOR INDICATING MEMBERSHIP IN A TRADE ASSOCIATION FOR THE TRANSLATION, INTERNATIONALIZATION, LOCALIZATION AND GLOBALIZATION INDUSTRY.

FIRST USE 6-19-2007; IN COMMERCE 7-19-2007.
ELLEN B. AWRICH, EXAMINING ATTORNEY

THE MARK CONSISTS OF THE WORDS "MADE WITH CANOLA OIL" FORMING A CIRCLE AROUND A THREE-LEAF DESIGN.

THE CERTIFICATION MARK, AS INTENDED TO BE USED BY AUTHORIZED PERSONS, IS INTENDED TO CERTIFY THE OIL IN A FOOD PRODUCT MUST BE 100% PURE CANOLA OIL, NOT A BLEND; THE PRODUCT MUST BE LOW IN SATURATED FAT (1 GRAM OR LESS PER SERVING); AND THE PRODUCT MUST CONTAIN ZERO GRAMS OF TRANS FAT PER SERVING.

FOR FOOD PRODUCTS MADE WITH CANOLA OIL.
BENJAMIN OKEKE, EXAMINING ATTORNEY

SN 77-314,755. ALENE KORBY, PALOS HEIGHTS, IL. FILED 10-26-2007.

SN 77-424,502. NEW YORK YACHT CLUB, NEW YORK, NY. FILED 3-18-2008.

NYYC

THE MARK CONSISTS OF STANDARD CHARACTERS WITHOUT CLAIM TO ANY PARTICULAR FONT, STYLE, SIZE, OR COLOR.

OWNER OF U.S. REG. NO. 2,689,231.
FOR INDICATING MEMBERSHIP IN A YACHT CLUB.
FIRST USE 7-31-1844; IN COMMERCE 7-31-1844.
CHARLES L. JENKINS, EXAMINING ATTORNEY



Plum Suite

HOMES CERTIFIED FOR LIVING

CERTIFICATION MARKS

CLASS A—GOODS

SN 77-275,602. CANOLA COUNCIL OF CANADA, WINNIPEG, MANITOBA, CANADA, FILED 9-10-2007.



NO CLAIM IS MADE TO THE EXCLUSIVE RIGHT TO USE "SUITE" AND "HOMES CERTIFIED", APART FROM THE MARK AS SHOWN.

THE MARK CONSISTS OF A FANCIFUL DESIGN THAT INCLUDES A DISTINCTIVE PLUM IN A HOUSE SHAPE IN ADDITION TO THE LITERAL ELEMENT.

THE CERTIFICATION MARK, AS INTENDED TO BE USED BY AUTHORIZED PERSONS, IS INTENDED TO CERTIFY EITHER THAT A NEW OR RENOVATED INHABITABLE STRUCTURE HAS BEEN BUILT OR RENOVATED TO STANDARDS SET BY THE CERTIFIER OR THAT PERSONS USING THE MARK HAVE MET THE STANDARDS, QUALIFICATIONS, AND REQUIREMENTS ESTABLISHED BY THE CERTIFIER.

FOR HOUSES, DWELLINGS AND FIXTURES FOR DWELLINGS.

TRACY CROSS, EXAMINING ATTORNEY

NO CLAIM IS MADE TO THE EXCLUSIVE RIGHT TO USE "MADE WITH CANOLA OIL", APART FROM THE MARK AS SHOWN.

CLASS B—SERVICES

SN 76-663,100. INTERSOCIETAL ACCREDITATION COMMISSION, COLOMBIA, MD. FILED 7-14-2006.

SN 77-425,157. AMERICAN BOARD OF NEUROSCIENCE NURSING, GLENVIEW, IL. FILED 3-18-2008.



NO CLAIM IS MADE TO THE EXCLUSIVE RIGHT TO USE "NUCLEAR MEDICINE" AND "NUCLEAR MEDICINE LABORATORY", APART FROM THE MARK AS SHOWN.

THE CERTIFICATION MARK, AS USED BY PERSONS AUTHORIZED BY THE CERTIFIER, CERTIFIES THAT THE LABORATORY HAS UNDERGONE A QUALITY REVIEW THAT INCLUDES PERSONNEL, PHYSICAL FACILITIES, EQUIPMENT AND INSTRUMENTATION, PROTOCOLS AND PROCEDURES, AND IMAGE QUALITY AND REPORTING.

SEC. 2(F) AS TO "ACCREDITED NUCLEAR MEDICINE LABORATORY".

FOR NUCLEAR MEDICINE LABORATORIES.
FIRST USE 2-1-2006; IN COMMERCE 2-1-2006.
MICHAEL SOUDERS, EXAMINING ATTORNEY

SN 77-043,716. AMERICAN SPEECH-LANGUAGE-HEARING ASSOCIATION, ROCKVILLE, MD. FILED 11-14-2006.

BRS

THE MARK CONSISTS OF STANDARD CHARACTERS WITHOUT CLAIM TO ANY PARTICULAR FONT, STYLE, SIZE, OR COLOR.

THE CERTIFICATION MARK, AS USED BY PERSONS AUTHORIZED BY THE CERTIFIER, CERTIFIES THAT THE INDIVIDUAL PROVIDING THE SERVICES HAS MET THE STANDARDS FOR ENTRY INTO PRACTICE OF THE PROFESSION OF SPEECH-PATHOLOGY.

FOR PREVENTION, DIAGNOSIS, HABILITATION, AND REHABILITATION OF COMMUNICATION, SWALLOWING, OR OTHER UPPER AERO DIGESTIVE DISORDERS; ELECTIVE MODIFICATION OF COMMUNICATION BEHAVIORS; AND ENHANCEMENT OF COMMUNICATION.

FIRST USE 12-31-1999; IN COMMERCE 12-31-1999.
KELLY MCCOY, EXAMINING ATTORNEY

CNRN

THE MARK CONSISTS OF STANDARD CHARACTERS WITHOUT CLAIM TO ANY PARTICULAR FONT, STYLE, SIZE, OR COLOR.

THE CERTIFICATION MARK, AS USED BY AUTHORIZED PERSONS, CERTIFIES THAT THROUGH A COMBINATION OF LICENSURE, EDUCATION, WORK EXPERIENCE, AND EXAMINATION IN THE FIELD OF NEUROSCIENCE NURSING, THE PERSON MEETS MINIMUM QUALIFICATIONS FOR CERTIFICATION AS A REGISTERED NURSE IN THE CARE OF PATIENTS WITH NEUROLOGICAL TRAUMA AND ILLNESS.

FOR NURSING SERVICES, NAMELY, THE CARE OF PATIENTS WITH NEUROLOGICAL TRAUMA AND ILLNESS.

FIRST USE 12-31-1978; IN COMMERCE 12-31-1978.
MARTHA FROMM, EXAMINING ATTORNEY

SN 77-432,807. ORTHOPAEDIC NURSES CERTIFICATION BOARD, COLUMBIA, SC. FILED 3-27-2008.

OCNS-C

THE MARK CONSISTS OF STANDARD CHARACTERS WITHOUT CLAIM TO ANY PARTICULAR FONT, STYLE, SIZE, OR COLOR.

THE CERTIFICATION MARK, AS USED BY AUTHORIZED PERSONS, CERTIFIES THAT THESE PERSONS PROVIDE A CERTAIN TYPE OF SERVICE, NAMELY CLINICAL NURSE SPECIALIST LEVEL ORTHOPEDIC NURSING SERVICES, AND THAT THESE PERSONS PROVIDE SUCH SERVICES WITH A CERTAIN LEVEL OF EXPERTISE AS DEMONSTRATED BY THEIR RECEIVING ADVANCED EDUCATIONAL TRAINING AND/OR WORK EXPERIENCE AND SUPERVISION IN THE FIELD PROVIDED BY THE CERTIFIER AND SUCCESSFULLY SATISFYING AND CONTINUING TO SATISFY THE MINIMAL STANDARDS AND CRITERIA ESTABLISHED BY THE CERTIFIER.

FOR ORTHOPEDIC NURSING.
FIRST USE 4-30-2006; IN COMMERCE 7-1-2006.
CHRISTINA SOBRAL, EXAMINING ATTORNEY

AUGUST 5, 2008

U.S. PATENT AND TRADEMARK OFFICE

TM 1237

SN 77-432,823. ORTHOPAEDIC NURSES CERTIFICATION
BOARD, COLUMBIA, SC. FILED 3-27-2008.

ONP-C

THE MARK CONSISTS OF STANDARD CHARACTERS
WITHOUT CLAIM TO ANY PARTICULAR FONT, STYLE,
SIZE, OR COLOR.

THE CERTIFICATION MARK, AS USED BY AUTHORIZED PERSONS, CERTIFIES THAT THESE PERSONS PROVIDE A CERTAIN TYPE OF SERVICE, NAMELY NURSE PRACTITIONER LEVEL ORTHOPEDIC NURSING SERVICES, AND THAT THESE PERSONS PROVIDE SUCH SERVICES WITH A CERTAIN LEVEL OF EXPERTISE AS DEMONSTRATED BY THEIR RECEIVING ADVANCED EDUCATIONAL TRAINING AND/OR WORK EXPERIENCE AND SUPERVISION IN THE FIELD PROVIDED BY THE CERTIFIER AND SUCCESSFULLY SATISFYING AND CONTINUING TO SATISFY THE MINIMAL STANDARDS AND CRITERIA ESTABLISHED BY THE CERTIFIER.

FOR ORTHOPEDIC NURSING.

FIRST USE 4-30-2006; IN COMMERCE 7-1-2006.

CHRISTINA SOBRAL, EXAMINING ATTORNEY

* * * * *

TRADEMARK REGISTRATIONS ISSUED

PRINCIPAL REGISTER

SECTION 1.— INTERNATIONAL CLASSIFICATION

The short titles associated below with the international class numbers are terms designed merely for quick identification and are not an official part of the international classification. The full names of international classes are given in section 6.1 of the trademark rules of practice.

The designation "U.S. Cl." appearing in this section refers to the U.S. class in effect prior to Sep. 1, 1973 rather than the international class which applies to applications filed on or after that date. For adoption of international classification see notice in the OFFICIAL GAZETTE of Jun. 26, 1973 (911 O.G. TM 210).

CLASS 1—CHEMICALS

- 3,478,529. **PARAPET (BLOCK FORM)**. KURARAY CO., LTD., MULTIPLE CLASS, (INT. CLS. 1 AND 17), (U.S. CLS. 1, 5, 6, 10, 12, 13, 26, 35, 46 AND 50). SN 76-669,035. PUB. 11-6-2007. FILED 11-13-2006.
- 3,478,720. **RNANTIGEN (BLOCK FORM)**. CUREVAC GMBH, MULTIPLE CLASS, (INT. CLS. 1, 5 AND 44), (U.S. CLS. 1, 5, 6, 10, 18, 26, 44, 46, 51, 52, 100 AND 101). SN 77-067,574. PUB. 5-20-2008. FILED 12-19-2006.
- 3,478,770. **ND (BLOCK FORM)**. ND INDUSTRIES, INC., MULTIPLE CLASS, (INT. CLS. 1, 4, 17 AND 40), (U.S. CLS. 1, 5, 6, 10, 12, 13, 15, 26, 35, 46, 50, 100, 103 AND 106). SN 77-100,392. PUB. 5-20-2008. FILED 2-6-2007.
- 3,478,811. **LWP (BLOCK FORM)**. CANYON TECHNICAL SERVICES LTD., MULTIPLE CLASS, (INT. CLS. 1, 37, 40 AND 42), (U.S. CLS. 1, 5, 6, 10, 26, 46, 100, 101, 103 AND 106). SN 77-126,887. PUB. 5-20-2008. FILED 3-9-2007.
- 3,478,830. **TRCRTEST (BLOCK FORM)**. TOSOH CORPORATION, MULTIPLE CLASS, (INT. CLS. 1 AND 5), (U.S. CLS. 1, 5, 6, 10, 18, 26, 44, 46, 51 AND 52). SN 77-141,101. PUB. 5-20-2008. FILED 3-27-2007.
- 3,478,884. **ECCOSHIELD (BLOCK FORM)**. EASTERN COLOR & CHEMICAL COMPANY, (U.S. CLS. 1, 5, 6, 10, 26 AND 46). SN 77-167,769. PUB. 9-18-2007. FILED 4-27-2007.
- 3,478,886. **NEUROBASAL (BLOCK FORM)**. INVITROGEN CORPORATION, (U.S. CLS. 1, 5, 6, 10, 26 AND 46). SN 77-168,069. PUB. 5-20-2008. FILED 4-27-2007.
- 3,478,901. **MOTHER NATURE'S CUISINE FEED YOUR LAND FROM MOTHER NATURE AND DESIGN**. ORGANIC SALES & MARKETING, INC., (U.S. CLS. 1, 5, 6, 10, 26 AND 46). SN 77-175,088. PUB. 5-20-2008. FILED 5-8-2007.
- 3,478,922. **LENANOC (BLOCK FORM)**. NISSAN CHEMICAL INDUSTRIES, LTD., (U.S. CLS. 1, 5, 6, 10, 26 AND 46). SN 77-181,481. PUB. 5-20-2008. FILED 5-15-2007.
- 3,478,931. **EURX (BLOCK FORM)**. EURX SP.Z.00, MULTIPLE CLASS, (INT. CLS. 1, 5 AND 42), (U.S. CLS. 1, 5, 6, 10, 18, 26, 44, 46, 51, 52, 100 AND 101). SN 77-184,399. PUB. 5-20-2008. FILED 5-18-2007.
- 3,478,996. **AQUABIND (BLOCK FORM)**. AQUASOL CORPORATION, (U.S. CLS. 1, 5, 6, 10, 26 AND 46). SN 77-196,555. PUB. 5-20-2008. FILED 6-4-2007.
- 3,479,281. **UNIVERSAL MOLD RELEASE (BLOCK FORM)**. SMOOTH-ON, INC., (U.S. CLS. 1, 5, 6, 10, 26 AND 46). SN 77-234,783. PUB. 5-20-2008. FILED 7-20-2007.
- 3,479,320. **SWANCOR AND DESIGN**. SWANCOR IND. CO., LTD., (U.S. CLS. 1, 5, 6, 10, 26 AND 46). SN 77-244,620. PUB. 5-20-2008. FILED 8-1-2007.
- 3,479,371. **MAXIFRUIT (BLOCK FORM)**. COMPAGNIE FINANCIÈRE ET DE PARTICIPATIONS ROULLIER, (U.S. CLS. 1, 5, 6, 10, 26 AND 46). SN 77-259,053. PUB. 5-20-2008. FILED 8-20-2007.
- 3,479,407. **VERMIGREEN (BLOCK FORM)**. RW ENVIRONMENTS, LLC, (U.S. CLS. 1, 5, 6, 10, 26 AND 46). SN 77-268,821. PUB. 5-20-2008. FILED 8-30-2007.
- 3,479,479. **MAKING WATER WORK FOR YOU (BLOCK FORM)**. CH2O, INC., (U.S. CLS. 1, 5, 6, 10, 26 AND 46). SN 77-289,818. PUB. 5-20-2008. FILED 9-26-2007.
- 3,479,546. **CROPCARE AND DESIGN**. PAULB, LLC, MULTIPLE CLASS, (INT. CLS. 1, 6, 7 AND 8), (U.S. CLS. 1, 2, 5, 6, 10, 12, 13, 14, 19, 21, 23, 25, 26, 28, 31, 34, 35, 44, 46 AND 50). SN 77-304,262. PUB. 5-20-2008. FILED 10-15-2007.
- 3,479,645. **DYLIGHT (BLOCK FORM)**. PIERCE BIOTECHNOLOGY, INC., (U.S. CLS. 1, 5, 6, 10, 26 AND 46). SN 77-322,673. PUB. 5-20-2008. FILED 11-6-2007.
- 3,479,719. **THE BINDING SITE AND DESIGN**. THE BINDING SITE, LTD, MULTIPLE CLASS, (INT. CLS. 1, 5, 9 AND 10), (U.S. CLS. 1, 5, 6, 10, 18, 21, 23, 26, 36, 38, 39, 44, 46, 51 AND 52). SN 77-331,874. PUB. 5-20-2008. FILED 11-16-2007.
- 3,479,732. **M+ AND DESIGN**. T AND N, INC., (U.S. CLS. 1, 5, 6, 10, 26 AND 46). SN 77-334,325. PUB. 5-20-2008. FILED 11-20-2007.
- 3,479,772. **KEYCOTE (BLOCK FORM)**. DENTSPLY INTERNATIONAL INC., (U.S. CLS. 1, 5, 6, 10, 26 AND 46). SN 77-339,956. PUB. 5-20-2008. FILED 11-29-2007.
- 3,479,782. **TRIGGRR AND DESIGN**. WESTBRIDGE AGRICULTURAL PRODUCTS, (U.S. CLS. 1, 5, 6, 10, 26 AND 46). SN 77-341,049. PUB. 5-20-2008. FILED 11-30-2007.
- 3,480,034. **ECO-TABS (BLOCK FORM)**. ECO DISTRIBUTORS, LLC, (U.S. CLS. 1, 5, 6, 10, 26 AND 46). SN 77-357,395. PUB. 5-20-2008. FILED 12-20-2007.
- 3,480,122. **CEDAR GROVE AND DESIGN**. CEDAR GROVE COMPOSTING, INC., (U.S. CLS. 1, 5, 6, 10, 26 AND 46). SN 77-361,010. PUB. 5-20-2008. FILED 12-28-2007.
- 3,480,173. **JOHNSEN'S J AND DESIGN**. TECHNICAL CHEMICAL COMPANY, (U.S. CLS. 1, 5, 6, 10, 26 AND 46). SN 77-362,474. PUB. 5-20-2008. FILED 1-2-2008.
- 3,480,256. **AGRI-VISTA (BLOCK FORM)**. CAL AGRI PRODUCTS, LLC, (U.S. CLS. 1, 5, 6, 10, 26 AND 46). SN 77-363,763. PUB. 5-20-2008. FILED 1-3-2008.
- 3,480,284. **PUREMELT (BLOCK FORM)**. KISSNER MILLING COMPANY LIMITED, (U.S. CLS. 1, 5, 6, 10, 26 AND 46). SN 77-364,206. PUB. 5-20-2008. FILED 1-4-2008.
- 3,480,307. **DP (STYLIZED)**. STONER, INCORPORATED, (U.S. CLS. 1, 5, 6, 10, 26 AND 46). SN 77-364,537. PUB. 5-20-2008. FILED 1-4-2008.
- 3,480,358. **DEXELAR (BLOCK FORM)**. CANTOLINO, CHRISTOPHER R., (U.S. CLS. 1, 5, 6, 10, 26 AND 46). SN 77-365,354. PUB. 5-20-2008. FILED 1-7-2008.
- 3,480,465. **ECOPROMOTE (BLOCK FORM)**. NISSAN CHEMICAL INDUSTRIES, LTD., (U.S. CLS. 1, 5, 6, 10, 26 AND 46). SN 77-367,731. PUB. 5-20-2008. FILED 1-9-2008.
- 3,480,543. **PROVEN PROFESSIONALS - PROVEN PRODUCTS - PROVEN RESULTS (BLOCK FORM)**. THE MUD MASTER GROUP, LLC, MULTIPLE CLASS, (INT. CLS. 1 AND 35), (U.S. CLS. 1, 5, 6, 10, 26, 46, 100, 101 AND 102). SN 77-395,646. PUB. 5-20-2008. FILED 2-13-2008.
- 3,480,547. **MEGACEL (BLOCK FORM)**. BAYER AKTIENGESELLSCHAFT, MULTIPLE CLASS, (INT. CLS. 1 AND 17), (U.S. CLS. 1, 5, 6, 10, 12, 13, 26, 35, 46 AND 50). SN 77-399,557. PUB. 5-20-2008. FILED 2-18-2008.
- 3,480,734. **AMERICAN AGRITECH (BLOCK FORM)**. AMERICAN AGRITECH, L.L.C., (U.S. CLS. 1, 5, 6, 10, 26 AND 46). SN 78-968,918. PUB. 5-20-2008. FILED 9-7-2006.
- 3,480,740. **CANFLEX-ACR (BLOCK FORM)**. ATOMIC ENERGY OF CANADA LIMITED, (U.S. CLS. 1, 5, 6, 10, 26 AND 46). SN 78-974,659. PUB. 5-20-2008. FILED 9-14-2006.
- 3,480,804. **FUCHS (BLOCK FORM)**. DF WORLD OF SPICES GMBH, MULTIPLE CLASS, (INT. CLS. 1, 5, 21, 29 AND 30),

- (U.S. CLS. 1, 2, 5, 6, 10, 13, 18, 23, 26, 29, 30, 33, 40, 44, 46, 50, 51 AND 52). SN 79-036,362. PUB. 5-20-2008. FILED 6-15-2006.
- 3,480,845. **EPAX MARINE OMEGA-3 FORMULA AND DESIGN**. EPAX AS, MULTIPLE CLASS, (INT. CLS. 1, 5 AND 29), (U.S. CLS. 1, 5, 6, 10, 18, 26, 44, 46, 51 AND 52). SN 79-039,834. PUB. 5-20-2008. FILED 4-13-2007.
- 3,480,851. **WISESORB (BLOCK FORM)**. WISEPAC ACTIVE PACKAGING; COMPONENTS CORPORATION, (U.S. CLS. 1, 5, 6, 10, 26 AND 46). SN 79-040,124. PUB. 5-20-2008. FILED 5-30-2007.
- 3,480,861. **OMYA SYNCARB (BLOCK FORM)**. OMYA AG, (U.S. CLS. 1, 5, 6, 10, 26 AND 46). SN 79-040,916. PUB. 5-20-2008. FILED 4-11-2007.
- 3,480,887. **CISBIO AND DESIGN**. CIS BIO INTERNATIONAL, SOCIÉTÉ ANONYME, MULTIPLE CLASS, (INT. CLS. 1, 5, 10 AND 42), (U.S. CLS. 1, 5, 6, 10, 18, 26, 39, 44, 46, 51, 52, 100 AND 101). SN 79-041,578. PUB. 5-20-2008. FILED 6-28-2007.
- 3,480,924. **IMPULSE (BLOCK FORM)**. BASF SE, MULTIPLE CLASS, (INT. CLS. 1 AND 2), (U.S. CLS. 1, 5, 6, 10, 11, 16, 26 AND 46). SN 79-042,486. PUB. 5-20-2008. FILED 7-9-2007.
- 3,480,954. **KYOTEX (STYLIZED)**. ALC FLENCO GROUP S.R.L., MULTIPLE CLASS, (INT. CLS. 1, 7 AND 17), (U.S. CLS. 1, 5, 6, 10, 12, 13, 19, 21, 23, 26, 31, 34, 35, 46 AND 50). SN 79-043,441. PUB. 5-20-2008. FILED 7-13-2007.
- 3,480,973. **ELASTOSIL (STYLIZED)**. WACKER CHEMIE AG, MULTIPLE CLASS, (INT. CLS. 1, 16 AND 17), (U.S. CLS. 1, 2, 5, 6, 10, 12, 13, 22, 23, 26, 29, 35, 37, 38, 46 AND 50). SN 79-044,081. PUB. 5-20-2008. FILED 3-28-2007.
- 3,481,016. **PHYSIO ACTIVATOR (BLOCK FORM)**. LABORATOIRES GOEMAR, MULTIPLE CLASS, (INT. CLS. 1 AND 5), (U.S. CLS. 1, 5, 6, 10, 18, 26, 44, 46, 51 AND 52). SN 79-047,513. PUB. 5-20-2008. FILED 10-19-2007.

CLASS 2—PAINTS

- 3,478,581. **ILLUMINA (BLOCK FORM)**. XSE GROUP, INC., (U.S. CLS. 6, 11 AND 16). SN 76-682,598. PUB. 5-20-2008. FILED 10-4-2007.
- 3,478,582. **HYPERION (BLOCK FORM)**. XSE GROUP, INC., (U.S. CLS. 6, 11 AND 16). SN 76-682,599. PUB. 5-20-2008. FILED 10-4-2007.
- 3,478,896. **ENDURO-VAR (BLOCK FORM)**. DAVID E. EASTERDAY & CO., INC., (U.S. CLS. 6, 11 AND 16). SN 77-172,023. PUB. 5-20-2008. FILED 5-3-2007.
- 3,478,965. **AQUABAR (BLOCK FORM)**. SUN CHEMICAL CORPORATION, (U.S. CLS. 6, 11 AND 16). SN 77-192,087. PUB. 5-20-2008. FILED 5-29-2007.
- 3,479,069. **FABULOUS FINISHES (BLOCK FORM)**. SWIMC, INC., (U.S. CLS. 6, 11 AND 16). SN 77-208,224. PUB. 5-20-2008. FILED 6-18-2007.
- 3,479,117. **SHER-KEM (BLOCK FORM)**. SWIMC, INC., (U.S. CLS. 6, 11 AND 16). SN 77-215,797. PUB. 5-20-2008. FILED 6-26-2007.
- 3,479,194. **ECCOLASER (BLOCK FORM)**. INKJETWARE-HOUSE.COM INC., MULTIPLE CLASS, (INT. CLS. 2 AND 9), (U.S. CLS. 6, 11, 16, 21, 23, 26, 36 AND 38). SN 77-222,228. PUB. 5-20-2008. FILED 7-5-2007.
- 3,480,313. **SOUNDGUARD (BLOCK FORM)**. SISKIN ENTERPRISES, INC., (U.S. CLS. 6, 11 AND 16). SN 77-364,579. PUB. 5-20-2008. FILED 1-4-2008.
- 3,480,317. **RUSTGUARD (BLOCK FORM)**. SISKIN ENTERPRISES, INC., (U.S. CLS. 6, 11 AND 16). SN 77-364,604. PUB. 5-20-2008. FILED 1-4-2008.
- 3,480,754. **HEMPEL'S (BLOCK FORM)**. HEMPEL A/S, (U.S. CLS. 6, 11 AND 16). SN 79-029,634. PUB. 5-20-2008. FILED 9-22-2006.
- 3,480,850. **HEMPEL ESTD 1915 J.C.H. AND DESIGN**. HEMPEL A/S, (U.S. CLS. 6, 11 AND 16). SN 79-040,074. PUB. 5-20-2008. FILED 6-19-2007.
- 3,480,890. **INTERSHEEN (BLOCK FORM)**. AKZO NOBEL COATINGS INTERNATIONAL B.V., (U.S. CLS. 6, 11 AND 16). SN 79-041,602. PUB. 5-20-2008. FILED 6-22-2007.
- 3,480,924 (See Class 1 for this trademark).

CLASS 3—COSMETICS AND CLEANING PREPARATIONS

- 3,478,579. **KERATEIN AND DESIGN**. BEAUTY VENTURE, INC., AND BEAUTYVENTURE, INC., (U.S. CLS. 1, 4, 6, 50, 51 AND 52). SN 76-682,299. PUB. 5-20-2008. FILED 9-25-2007.
- 3,478,619. **HAIR COLOR FREESIASELIM (BLOCK FORM)**. FREESIA USA, INC., (U.S. CLS. 1, 4, 6, 50, 51 AND 52). SN 76-685,565. PUB. 5-20-2008. FILED 1-7-2008.
- 3,478,682. **BRONZE TROPIQUES (BLOCK FORM)**. LAN-COME PARFUMS ET BEAUTE & CIE, (U.S. CLS. 1, 4, 6, 50, 51 AND 52). SN 77-045,321. PUB. 5-20-2008. FILED 11-16-2006.
- 3,478,695. **COLOR FEVER PLUMPER (BLOCK FORM)**. LAN-COME PARFUMS ET BEAUTE & CIE, (U.S. CLS. 1, 4, 6, 50, 51 AND 52). SN 77-051,070. PUB. 5-20-2008. FILED 11-27-2006.
- 3,478,747. **ARDENT REEL KLEEN (BLOCK FORM)**. ARDENT OUTDOORS, INC., (U.S. CLS. 1, 4, 6, 50, 51 AND 52). SN 77-090,133. PUB. 5-20-2008. FILED 1-24-2007.
- 3,478,758. **FRESH SMOOTHIE BLANC BY IU (STYLIZED)**. IU COSMETICS S.A. DE C.V., MULTIPLE CLASS, (INT. CLS. 3 AND 16), (U.S. CLS. 1, 2, 4, 5, 6, 22, 23, 29, 37, 38, 50, 51 AND 52). SN 77-096,179. PUB. 5-20-2008. FILED 1-31-2007.
- 3,478,761. **THE FIRM FOR HIM BY IU (STYLIZED)**. IU COSMETICS S.A. DE C.V., MULTIPLE CLASS, (INT. CLS. 3 AND 16), (U.S. CLS. 1, 2, 4, 5, 6, 22, 23, 29, 37, 38, 50, 51 AND 52). SN 77-096,799. PUB. 5-20-2008. FILED 2-1-2007.
- 3,478,796. **MISCELLANEOUS DESIGN**. IOIP HOLDINGS, LLC, (U.S. CLS. 1, 4, 6, 50, 51 AND 52). SN 77-117,087. PUB. 5-20-2008. FILED 2-27-2007.
- 3,478,807. **MOROCCANOIL (BLOCK FORM)**. TAL, OFER, (U.S. CLS. 1, 4, 6, 50, 51 AND 52). SN 77-122,509. PUB. 5-20-2008. FILED 3-5-2007.
- 3,478,854. **BROWNBERRY AND DESIGN**. FISH, MEREDITH, MULTIPLE CLASS, (INT. CLS. 3 AND 44), (U.S. CLS. 1, 4, 6, 50, 51, 52, 100 AND 101). SN 77-153,750. PUB. 5-20-2008. FILED 4-11-2007.
- 3,478,875. **SUN PERFECT UV4 (BLOCK FORM)**. BIOACTIVE SKINCARE, LLC, (U.S. CLS. 1, 4, 6, 50, 51 AND 52). SN 77-164,969. PUB. 5-20-2008. FILED 4-25-2007.
- 3,478,902. **BODY & BOUNCE (BLOCK FORM)**. DAVIS, JENNIFER P., MULTIPLE CLASS, (INT. CLS. 3, 35 AND 44), (U.S. CLS. 1, 4, 6, 50, 51, 52, 100, 101 AND 102). SN 77-175,658. PUB. 5-20-2008. FILED 5-8-2007.
- 3,478,939. **SEXY AND DESIGN**. SEXY HAIR CONCEPTS, LLC, (U.S. CLS. 1, 4, 6, 50, 51 AND 52). SN 77-186,183. PUB. 5-20-2008. FILED 5-21-2007.
- 3,479,090. **RESTORA MD (BLOCK FORM)**. REID, DUSTIN, (U.S. CLS. 1, 4, 6, 50, 51 AND 52). SN 77-211,271. PUB. 5-20-2008. FILED 6-20-2007.
- 3,479,096. **LISS ULTIME (BLOCK FORM)**. L'OREAL, (U.S. CLS. 1, 4, 6, 50, 51 AND 52). SN 77-211,996. PUB. 5-20-2008. FILED 6-21-2007.
- 3,479,115. **C AND DESIGN**. CANIGLIA, RONALD J., MULTIPLE CLASS, (INT. CLS. 3 AND 44), (U.S. CLS. 1, 4, 6, 50, 51, 52, 100 AND 101). SN 77-215,026. PUB. 5-20-2008. FILED 6-25-2007.
- 3,479,116. **RANDALL INTERNATIONAL (BLOCK FORM)**. RANDALL INTERNATIONAL, L.P., MULTIPLE CLASS, (INT. CLS. 3 AND 5), (U.S. CLS. 1, 4, 6, 18, 44, 46, 50, 51 AND 52). SN 77-215,043. PUB. 5-20-2008. FILED 6-25-2007.
- 3,479,120. **BLISSFUL HOME (BLOCK FORM)**. DOPPELT, JOYCE, AND WOLVERTON, WHITNIE CROWN, (U.S. CLS. 1, 4, 6, 50, 51 AND 52). SN 77-216,164. PUB. 5-20-2008. FILED 6-26-2007.
- 3,479,148. **123 SESAME STREET AND DESIGN**. SESAME WORKSHOP, MULTIPLE CLASS, (INT. CLS. 3, 5, 8, 10, 11, 12, 14, 18, 20, 21, 24, 27, 29, 30 AND 32), (U.S. CLS. 1, 2, 3, 4, 6, 13, 18, 19, 20, 21, 22, 23, 25, 26, 27, 28, 29, 30, 31, 32, 33, 34, 35, 37, 39, 40, 41, 42, 44, 45, 46, 48, 50, 51 AND 52). SN 77-218,246. PUB. 5-20-2008. FILED 6-28-2007.
- 3,479,201. **LE JARDIN NATUREL (BLOCK FORM)**. LUTEX COMPANY LIMITED, (U.S. CLS. 1, 4, 6, 50, 51 AND 52). SN 77-223,666. PUB. 5-20-2008. FILED 7-6-2007.
- 3,479,233. **TRIUMPH PHARMACEUTICALS AND DESIGN**. TRIUMPH PHARMACEUTICALS INC., (U.S. CLS. 1, 4, 6, 50, 51 AND 52). SN 77-228,205. PUB. 5-20-2008. FILED 7-12-2007.

- 3,479,318. **BEAUTY DROPS (BLOCK FORM)**. COLONIAL DAMES COMPANY, LTD., (U.S. CLS. 1, 4, 6, 50, 51 AND 52). SN 77-243,981. PUB. 5-20-2008. FILED 8-1-2007.
- 3,479,416. **SIMPLE GREEN CLEAN BUILDING (STYLIZED)**. SUNSHINE MAKERS, INC., (U.S. CLS. 1, 4, 6, 50, 51 AND 52). SN 77-272,491. PUB. 5-20-2008. FILED 9-5-2007.
- 3,479,462. **AMORE (BLOCK FORM)**. AMOREPACIFIC CORPORATION, (U.S. CLS. 1, 4, 6, 50, 51 AND 52). SN 77-283,177. PUB. 5-20-2008. FILED 9-19-2007.
- 3,479,486. **SUMMER'S SECRET (BLOCK FORM)**. SUNFX IP PTY LTD, (U.S. CLS. 1, 4, 6, 50, 51 AND 52). SN 77-291,049. PUB. 5-20-2008. FILED 9-27-2007.
- 3,479,487. **MISCELLANEOUS DESIGN**. KING ARTHUR'S COURT, L.L.C., (U.S. CLS. 1, 4, 6, 50, 51 AND 52). SN 77-292,107. PUB. 5-20-2008. FILED 9-28-2007.
- 3,479,514. **CAROL COLE COLLECTION (BLOCK FORM)**. COLE, CAROL, (U.S. CLS. 1, 4, 6, 50, 51 AND 52). SN 77-299,770. PUB. 5-20-2008. FILED 10-9-2007.
- 3,479,541. **LIQUA VERSA-GEL (BLOCK FORM)**. UNITE EUROTHERAPY, INC., (U.S. CLS. 1, 4, 6, 50, 51 AND 52). SN 77-302,880. PUB. 5-20-2008. FILED 10-12-2007.
- 3,479,602. **SCIENCE OF YOUTH (BLOCK FORM)**. ADRIENNE DENESE, M.D., P.C., (U.S. CLS. 1, 4, 6, 50, 51 AND 52). SN 77-315,231. PUB. 5-20-2008. FILED 10-27-2007.
- 3,479,656. **PERSONAL CARE AND DESIGN**. PERSONAL CARE PRODUCTS, INC., (U.S. CLS. 1, 4, 6, 50, 51 AND 52). SN 77-324,280. PUB. 5-20-2008. FILED 11-8-2007.
- 3,479,678. **BATH ICE CREAM (BLOCK FORM)**. ME BATH EXPERIENCE INC., (U.S. CLS. 1, 4, 6, 50, 51 AND 52). SN 77-326,452. PUB. 5-20-2008. FILED 11-9-2007.
- 3,479,709. **HUMPHREYS...IT'S WHAT'S INSIDE (BLOCK FORM)**. HUMPHREYS PHARMACAL, INCORPORATED, MULTIPLE CLASS, (INT. CLS. 3 AND 5), (U.S. CLS. 1, 4, 6, 18, 44, 46, 50, 51 AND 52). SN 77-330,510. PUB. 5-20-2008. FILED 11-15-2007.
- 3,479,813. **AMAZÓNIA NUTRIENTS (BLOCK FORM)**. AMAZONIA NUTRIENTS INC., (U.S. CLS. 1, 4, 6, 50, 51 AND 52). SN 77-343,384. PUB. 5-20-2008. FILED 12-4-2007.
- 3,479,969. **EXTINGUISHER SPRAY HEAD (BLOCK FORM)**. KATZ, HAROLD, (U.S. CLS. 1, 4, 6, 50, 51 AND 52). SN 77-354,754. PUB. 5-20-2008. FILED 12-18-2007.
- 3,480,012. **FREEZE 24.7 ICECREAM DOUBLE SCOOP (BLOCK FORM)**. FREEZE 24/7 INTERNATIONAL LLC, (U.S. CLS. 1, 4, 6, 50, 51 AND 52). SN 77-356,817. PUB. 5-20-2008. FILED 12-20-2007.
- 3,480,061. **ANTIOX MD (BLOCK FORM)**. GIANNULLI, THOMAS C., (U.S. CLS. 1, 4, 6, 50, 51 AND 52). SN 77-358,649. PUB. 5-20-2008. FILED 12-21-2007.
- 3,480,087. **PETITE TREATS (BLOCK FORM)**. SMART BRANDS INC., (U.S. CLS. 1, 4, 6, 50, 51 AND 52). SN 77-359,470. PUB. 5-20-2008. FILED 12-26-2007.
- 3,480,088. **MISCELLANEOUS DESIGN**. CODDINGTON ENVIRONMENTAL, INC., (U.S. CLS. 1, 4, 6, 50, 51 AND 52). SN 77-359,535. PUB. 5-20-2008. FILED 12-26-2007.
- 3,480,160. **MOONMAID BOTANICALS (BLOCK FORM)**. MOONMAID BOTANICALS, (U.S. CLS. 1, 4, 6, 50, 51 AND 52). SN 77-362,296. PUB. 5-20-2008. FILED 1-2-2008.
- 3,480,181. **N CALIFORNIA NORTH (BLOCK FORM)**. MILLER, JAMES, P, (U.S. CLS. 1, 4, 6, 50, 51 AND 52). SN 77-362,632. PUB. 5-20-2008. FILED 1-2-2008.
- 3,480,183. **FAM FIAIR AND DESIGN**. BRISK SOURCES INC., (U.S. CLS. 1, 4, 6, 50, 51 AND 52). SN 77-362,654. PUB. 5-20-2008. FILED 1-2-2008.
- 3,480,246. **STAINLESS BUTLER (BLOCK FORM)**. ELKAY MANUFACTURING COMPANY, (U.S. CLS. 1, 4, 6, 50, 51 AND 52). SN 77-362,667. PUB. 5-20-2008. FILED 1-3-2008.
- 3,480,303. **CHARLIE'S SOAP (BLOCK FORM)**. SUTHERLAND PRODUCTS, INC., (U.S. CLS. 1, 4, 6, 50, 51 AND 52). SN 77-364,507. PUB. 5-20-2008. FILED 1-4-2008.
- 3,480,354. **AUDREY'S ORIGINAL SOAP CO. AND DESIGN**. WHITNELL, AUDREY L., DBA JOSIE'S ORIGINAL SOAP CO., (U.S. CLS. 1, 4, 6, 50, 51 AND 52). SN 77-365,305. PUB. 5-20-2008. FILED 1-7-2008.
- 3,480,383. **BERRY BUTTER SHEA BUTTER WITH A TWIST AND DESIGN**. BERRY BUTTER, LLC, (U.S. CLS. 1, 4, 6, 50, 51 AND 52). SN 77-365,992. PUB. 5-20-2008. FILED 1-7-2008.
- 3,480,388. **JOLLY RANCHER (BLOCK FORM)**. HUHTAMAKI FINANCE B.V., (U.S. CLS. 1, 4, 6, 50, 51 AND 52). SN 77-366,125. PUB. 5-20-2008. FILED 1-8-2008.
- 3,480,390. **GOOD & PLENTY (BLOCK FORM)**. HUHTAMAKI FINANCE B.V., (U.S. CLS. 1, 4, 6, 50, 51 AND 52). SN 77-366,127. PUB. 5-20-2008. FILED 1-8-2008.
- 3,480,391. **WHOPPERS (BLOCK FORM)**. HUHTAMAKI FINANCE B.V., (U.S. CLS. 1, 4, 6, 50, 51 AND 52). SN 77-366,129. PUB. 5-20-2008. FILED 1-8-2008.
- 3,480,420. **SESDERMA (BLOCK FORM)**. SESDERMA, S.L., (U.S. CLS. 1, 4, 6, 50, 51 AND 52). SN 77-366,696. PUB. 5-20-2008. FILED 1-8-2008.
- 3,480,421. **SES (BLOCK FORM)**. SESDERMA, S.L., (U.S. CLS. 1, 4, 6, 50, 51 AND 52). SN 77-366,700. PUB. 5-20-2008. FILED 1-8-2008.
- 3,480,440. **JOLLY RANCHER (BLOCK FORM)**. HUHTAMAKI FINANCE B.V., (U.S. CLS. 1, 4, 6, 50, 51 AND 52). SN 77-367,162. PUB. 5-20-2008. FILED 1-9-2008.
- 3,480,487. **BEAUTICONTROL MI NOVELA (BLOCK FORM)**. BC INTERNATIONAL COSMETIC & IMAGE SERVICES, INC., (U.S. CLS. 1, 4, 6, 50, 51 AND 52). SN 77-368,897. PUB. 5-20-2008. FILED 1-10-2008.
- 3,480,525. **MISCELLANEOUS DESIGN**. IDEASONE, INC., (U.S. CLS. 1, 4, 6, 50, 51 AND 52). SN 77-379,782. PUB. 5-20-2008. FILED 1-24-2008.
- 3,480,549. **VERY SEXY ATTRACTION (BLOCK FORM)**. VICTORIA'S SECRET STORES BRAND MANAGEMENT, INC., (U.S. CLS. 1, 4, 6, 50, 51 AND 52). SN 77-402,467. PUB. 5-20-2008. FILED 2-21-2008.
- 3,480,569. **ADRENALINE**. COTY B.V., (U.S. CLS. 1, 4, 6, 50, 51 AND 52). SN 78-129,455. PUB. 5-20-2008. FILED 5-17-2002.
- 3,480,587. **MYCHELLE (BLOCK FORM)**. MYCHELLE DERMACEUTICALS LLC, (U.S. CLS. 1, 4, 6, 50, 51 AND 52). SN 78-545,374. PUB. 5-20-2008. FILED 1-11-2005.
- 3,480,643. **2020 AC COURREGES (STYLIZED)**. COURREGES PARFUMS, (U.S. CLS. 1, 4, 6, 50, 51 AND 52). SN 78-829,962. PUB. 5-20-2008. FILED 3-6-2006.
- 3,480,672. **THE SCIENCE OF LOOKING YOUNG (BLOCK FORM)**. PRODUCT EXCELLENCE INC., (U.S. CLS. 1, 4, 6, 50, 51 AND 52). SN 78-892,446. PUB. 2-12-2008. FILED 5-25-2006.
- 3,480,680. **SECRET TOUCH (BLOCK FORM)**. GUERLAIN S.A., (U.S. CLS. 1, 4, 6, 50, 51 AND 52). SN 78-905,099. PUB. 5-20-2008. FILED 6-9-2006.
- 3,480,724. **COLOR RESCUE (BLOCK FORM)**. LA COUPE PRODUCTS INC., (U.S. CLS. 1, 4, 6, 50, 51 AND 52). SN 78-960,392. PUB. 5-20-2008. FILED 8-25-2006.
- 3,480,753. **CRO MAAT ANTIQUUS MYSTICUSQUE ORDO ROSAE CRUCIS ORDRE DE LA ROSE-CROIX A.M.O.R.C. AND DESIGN**. ANCIEN ET MYSTIQUE ORDRE DE LA ROSE CROIX. EN ABRÉGÉ A.M.O.R.C., ÉGALEMENT CONNU SOUS LE NOM DE ORDRE DE LA ROSE-CROIX, MULTIPLE CLASS, (INT. CLS. 3, 9, 16, 35, 38, 39 AND 41), (U.S. CLS. 1, 2, 4, 5, 6, 21, 22, 23, 26, 29, 36, 37, 38, 50, 51, 52, 100, 101, 102, 104, 105 AND 107). SN 79-028,705. PUB. 5-20-2008. FILED 9-6-2006.
- 3,480,755. **TENAILS AND DESIGN**. BES BEAUTY EXPRESS SERVICE; THOMAS BERNECKER, (U.S. CLS. 1, 4, 6, 50, 51 AND 52). SN 79-029,718. PUB. 5-20-2008. FILED 8-11-2006.
- 3,480,767. **NANO WEAR (BLOCK FORM)**. COTY DEUTSCHLAND GMBH, (U.S. CLS. 1, 4, 6, 50, 51 AND 52). SN 79-032,405. PUB. 5-20-2008. FILED 11-9-2006.
- 3,480,776. **BONJOUR L'AMOUR (BLOCK FORM)**. MÜLHENS GMBH & CO. KG, (U.S. CLS. 1, 4, 6, 50, 51 AND 52). SN 79-033,680. PUB. 5-20-2008. FILED 11-27-2006.
- 3,480,779. **PRO STATUS (STYLIZED)**. ZETT KABUSHIKI KAISHA, MULTIPLE CLASS, (INT. CLS. 3, 4, 9, 18, 20, 25 AND 28), (U.S. CLS. 1, 2, 3, 4, 6, 13, 15, 21, 22, 23, 25, 26, 32, 36, 38, 39, 41, 50, 51 AND 52). SN 79-033,948. PUB. 5-20-2008. FILED 11-4-2005.
- 3,480,800. **ABARTH AND DESIGN**. FIAT AUTO S.P.A., MULTIPLE CLASS, (INT. CLS. 3, 11, 12, 14, 16, 18, 20, 24, 25, 28, 30, 32 AND 33), (U.S. CLS. 1, 2, 3, 4, 5, 6, 13, 19, 21, 22, 23, 25, 27, 28, 29, 31, 32, 34, 35, 37, 38, 39, 41, 42, 44, 45, 46, 47, 48, 49, 50, 51 AND 52). SN 79-035,827. PUB. 5-20-2008. FILED 11-27-2006.
- 3,480,827. **LICHTENA (STYLIZED)**. LABORATORI FITOCOSMESI; & FARMACEUTICI S.R.L., (U.S. CLS. 1, 4, 6, 50, 51 AND 52). SN 79-038,881. PUB. 5-20-2008. FILED 11-24-2006.
- 3,480,839. **MISCELLANEOUS DESIGN**. TEORA VINCENZO,

- MULTIPLE CLASS, (INT. CLS. 3, 9, 14, 18 AND 25), (U.S. CLS. 1, 2, 3, 4, 6, 21, 22, 23, 26, 27, 28, 36, 38, 39, 41, 50, 51 AND 52). SN 79-039,695. PUB. 5-20-2008. FILED 1-8-2007.
- 3,480,844. **W MEN AND DESIGN. VAKKO HOLDING A.S.**, MULTIPLE CLASS, (INT. CLS. 3, 18, 24 AND 25), (U.S. CLS. 1, 2, 3, 4, 6, 22, 39, 41, 42, 50, 51 AND 52). SN 79-039,744. PUB. 2-12-2008. FILED 4-26-2007.
- 3,480,856. **WISHINGTOOTH (STYLIZED)**. DAVID JACK EVERETT, MULTIPLE CLASS, (INT. CLS. 3, 9, 16, 18, 25, 28, 30, 32 AND 41), (U.S. CLS. 1, 2, 3, 4, 5, 6, 21, 22, 23, 26, 29, 36, 37, 38, 39, 41, 45, 46, 48, 50, 51, 52, 100, 101 AND 107). SN 79-040,570. PUB. 5-20-2008. FILED 2-8-2007.
- 3,480,863. **EYE . OLOGY (STYLIZED)**. LA COLLINE INTERNATIONAL, (U.S. CLS. 1, 4, 6, 50, 51 AND 52). SN 79-040,947. PUB. 5-20-2008. FILED 11-14-2006.
- 3,480,869. **CURLYSUE (STYLIZED)**. DREAMSCO CO., LTD., (U.S. CLS. 1, 4, 6, 50, 51 AND 52). SN 79-041,075. PUB. 5-20-2008. FILED 1-31-2007.
- 3,480,871. **QAI (STYLIZED)**. BHL S.A., (U.S. CLS. 1, 4, 6, 50, 51 AND 52). SN 79-041,116. PUB. 5-20-2008. FILED 6-19-2007.
- 3,480,902. **HYALUDERM REVITALIZE (BLOCK FORM)**. LABORATOIRE DE CONTACTOLOGIE APPLIQUEE - LCA, MULTIPLE CLASS, (INT. CLS. 3, 5 AND 10), (U.S. CLS. 1, 4, 6, 18, 26, 39, 44, 46, 50, 51 AND 52). SN 79-041,847. PUB. 5-20-2008. FILED 6-5-2007.
- 3,480,930. **UPTOWN/DOWNTOWN, WINTERTIME LA VILLE EN HIVER (BLOCK FORM)**. SHEERINO'KHO, MULTIPLE CLASS, (INT. CLS. 3 AND 4), (U.S. CLS. 1, 4, 6, 15, 50, 51 AND 52). SN 79-042,562. PUB. 5-20-2008. FILED 7-17-2007.
- 3,480,933. **FRIDAY'S PROJECT AND DESIGN. IMAZ VILLAR, JULIAN**, MULTIPLE CLASS, (INT. CLS. 3, 18 AND 24), (U.S. CLS. 1, 2, 3, 4, 6, 22, 41, 42, 50, 51 AND 52). SN 79-042,618. PUB. 5-20-2008. FILED 6-27-2007.
- 3,480,938. **ROGER & GALLET (STYLIZED)**. ROGER & GALLET; SOCIÉTÉ PAR ACTIONS SIMPLIFIÉE, (U.S. CLS. 1, 4, 6, 50, 51 AND 52). SN 79-042,805. PUB. 5-20-2008. FILED 4-20-2007.
- 3,480,950. **EVENING DRESS NUIT D'ECLAT (BLOCK FORM)**. SHEERINO'KHO, MULTIPLE CLASS, (INT. CLS. 3 AND 4), (U.S. CLS. 1, 4, 6, 15, 50, 51 AND 52). SN 79-043,267. PUB. 5-20-2008. FILED 7-17-2007.
- 3,480,953. **OUTDOOR MEETINGS, WINTERTIME L'HIVER AU GRAND AIR (BLOCK FORM)**. SHEERINO'KHO, MULTIPLE CLASS, (INT. CLS. 3 AND 4), (U.S. CLS. 1, 4, 6, 15, 50, 51 AND 52). SN 79-043,432. PUB. 5-20-2008. FILED 7-17-2007.
- 3,480,994. **NEJMA AND DESIGN. MARIE-LISE BERCOVICI BISCHOFF**, (U.S. CLS. 1, 4, 6, 50, 51 AND 52). SN 79-045,760. PUB. 5-20-2008. FILED 9-12-2007.
- 3,481,032. **NIVEA AND DESIGN. BEIERSDORF AG**, MULTIPLE CLASS, (INT. CLS. 3 AND 5), (U.S. CLS. 1, 4, 6, 18, 44, 46, 50, 51 AND 52). SN 79-049,210. PUB. 5-20-2008. FILED 11-16-2007.

CLASS 4—LUBRICANTS AND FUELS

- 3,478,565. **WHERE YOU TURN (STYLIZED)**. THE TIMKEN COMPANY, MULTIPLE CLASS, (INT. CLS. 4, 7 AND 42), (U.S. CLS. 1, 6, 13, 15, 19, 21, 23, 31, 34, 35, 100 AND 101). SN 76-679,659. PUB. 5-20-2008. FILED 7-19-2007.
- 3,478,770 (*See Class 1 for this trademark*).
- 3,478,771. **WHOLEENERGY (BLOCK FORM)**. WHOLE ENERGY FUELS CORPORATION, MULTIPLE CLASS, (INT. CLS. 4 AND 35), (U.S. CLS. 1, 6, 15, 100, 101 AND 102). SN 77-100,798. PUB. 5-20-2008. FILED 2-6-2007.
- 3,478,975. **FLEET SUPREME EC (BLOCK FORM)**. CONOCOPHILLIPS COMPANY, (U.S. CLS. 1, 6 AND 15). SN 77-194,634. PUB. 5-20-2008. FILED 5-31-2007.
- 3,478,979. **SUPER-D XA (BLOCK FORM)**. CONOCOPHILLIPS COMPANY, (U.S. CLS. 1, 6 AND 15). SN 77-194,737. PUB. 5-20-2008. FILED 5-31-2007.
- 3,480,278. **SWEET SHOPPE CANDLES LOOK & SMELL SO REAL YOU CAN ALMOST TASTE THEM... AND DESIGN. GENNARI, LESLIE**, (U.S. CLS. 1, 6 AND 15). SN 77-364,131. PUB. 5-20-2008. FILED 1-4-2008.
- 3,480,337. **WILLOWBERRY CANDLE (BLOCK FORM)**. SHIELDS, LORETTA, (U.S. CLS. 1, 6 AND 15). SN 77-

- 365,013. PUB. 5-20-2008. FILED 1-6-2008.
- 3,480,618. **FUELING THE FUTURE (BLOCK FORM)**. SHELL TRADEMARK MANAGEMENT B.V., MULTIPLE CLASS, (INT. CLS. 4 AND 37), (U.S. CLS. 1, 6, 15, 100, 103 AND 106). SN 78-688,263. PUB. 5-20-2008. FILED 8-9-2005.
- 3,480,779 (*See Class 3 for this trademark*).
- 3,480,781. **THERMAMAX (BLOCK FORM)**. THERMAMAX; HOCHTEMPERATURDÄMMUNGEN GMBH, MULTIPLE CLASS, (INT. CLS. 4, 7, 17, 37 AND 42), (U.S. CLS. 1, 5, 6, 12, 13, 15, 19, 21, 23, 31, 34, 35, 50, 100, 101, 103 AND 106). SN 79-034,167. PUB. 5-20-2008. FILED 10-9-2006.
- 3,480,809. **PTMD (BLOCK FORM)**. POT EN MAND B.V., MULTIPLE CLASS, (INT. CLS. 4, 20, 21 AND 28), (U.S. CLS. 1, 2, 6, 13, 15, 22, 23, 25, 29, 30, 32, 33, 38, 40 AND 50). SN 79-037,128. PUB. 5-20-2008. FILED 2-1-2007.
- 3,480,930 (*See Class 3 for this trademark*).
- 3,480,936. **GRIZZLY (BLOCK FORM)**. GRIZZLY GAS HOLDING GMBH, MULTIPLE CLASS, (INT. CLS. 4, 6 AND 32), (U.S. CLS. 1, 2, 6, 12, 13, 14, 15, 23, 25, 45, 46, 48 AND 50). SN 79-042,758. PUB. 5-20-2008. FILED 6-11-2007.
- 3,480,950 (*See Class 3 for this trademark*).
- 3,480,953 (*See Class 3 for this trademark*).

CLASS 5—PHARMACEUTICALS

- 3,478,500. **TRANSFORMATION. SHANE SHEIBANI, M.D., INC., DBA NEW ME INSTITUTE**, (U.S. CLS. 6, 18, 44, 46, 51 AND 52). SN 76-541,563. PUB. 5-20-2008. FILED 8-18-2003.
- 3,478,518. **EXTREME VISUAL SHADE MATCHING AND DESIGN. DEGUDENT GMBH**, MULTIPLE CLASS, (INT. CLS. 5, 9 AND 10), (U.S. CLS. 6, 18, 21, 23, 26, 36, 38, 39, 44, 46, 51 AND 52). SN 76-660,751. PUB. 5-20-2008. FILED 5-30-2006.
- 3,478,531. **AYURVEDA MADE EASY (BLOCK FORM)**. KOMAL HERBALS, INC., (U.S. CLS. 6, 18, 44, 46, 51 AND 52). SN 76-670,280. PUB. 5-20-2008. FILED 12-13-2006.
- 3,478,585. **BIO CURCUMA (BLOCK FORM)**. DOLCAS BIOTECH, LLC, (U.S. CLS. 6, 18, 44, 46, 51 AND 52). SN 76-682,967. PUB. 5-20-2008. FILED 10-15-2007.
- 3,478,674. **SURGE (BLOCK FORM)**. BIOTEST LABORATORIES, LLC, (U.S. CLS. 6, 18, 44, 46, 51 AND 52). SN 77-042,209. PUB. 5-20-2008. FILED 11-13-2006.
- 3,478,678. **MISCELLANEOUS DESIGN. YUNNAN BAIYAO GROUP CO., LTD.**, MULTIPLE CLASS, (INT. CLS. 5 AND 30), (U.S. CLS. 6, 18, 44, 46, 51 AND 52). SN 77-044,152. PUB. 5-20-2008. FILED 11-15-2006.
- 3,478,680. **YNBY (STYLIZED)**. YUNNAN BAIYAO GROUP CO., LTD., MULTIPLE CLASS, (INT. CLS. 5 AND 30), (U.S. CLS. 6, 18, 44, 46, 51 AND 52). SN 77-044,210. PUB. 5-20-2008. FILED 11-15-2006.
- 3,478,713. **FIBER3SDIET (BLOCK FORM)**. RENEW LIFE FORMULAS, INC., (U.S. CLS. 6, 18, 44, 46, 51 AND 52). SN 77-064,988. PUB. 5-20-2008. FILED 12-15-2006.
- 3,478,720 (*See Class 1 for this trademark*).
- 3,478,830 (*See Class 1 for this trademark*).
- 3,478,832. **DETOX SECRET (BLOCK FORM)**. CYNTHIA KING, (U.S. CLS. 6, 18, 44, 46, 51 AND 52). SN 77-142,713. PUB. 5-20-2008. FILED 3-28-2007.
- 3,478,851. **HORSE RELIEF AND DESIGN. RZN NUTRACEUTICALS, INC.**, (U.S. CLS. 6, 18, 44, 46, 51 AND 52). SN 77-151,281. PUB. 5-20-2008. FILED 4-7-2007.
- 3,478,931 (*See Class 1 for this trademark*).
- 3,478,948. **BSN AND DESIGN. BIO-ENGINEERED SUPPLEMENTS & NUTRITION, INC.**, (U.S. CLS. 6, 18, 44, 46, 51 AND 52). SN 77-187,628. PUB. 5-20-2008. FILED 5-22-2007.
- 3,478,958. **EUROZYME (BLOCK FORM)**. NORDMARK ARZNEIMITTEL GMBH & CO. KG, (U.S. CLS. 6, 18, 44, 46, 51 AND 52). SN 77-190,592. PUB. 2-12-2008. FILED 5-25-2007.
- 3,479,041. **BIO-35 (BLOCK FORM)**. PRO-BIOTIKS LABS, INC., (U.S. CLS. 6, 18, 44, 46, 51 AND 52). SN 77-203,027. PUB. 5-20-2008. FILED 6-11-2007.
- 3,479,104. **HIL0 GOLD (BLOCK FORM)**. STRATICOM INC, T/A THE STRATIS GROUP, (U.S. CLS. 6, 18, 44, 46, 51 AND 52). SN 77-213,328. PUB. 5-20-2008. FILED 6-22-2007.
- 3,479,116 (*See Class 3 for this trademark*).
- 3,479,148 (*See Class 3 for this trademark*).

- 3,479,152. **ISO MASS (BLOCK FORM)**. ULTIMATE NUTRITION, INC., (U.S. CLS. 6, 18, 44, 46, 51 AND 52). SN 77-218,568. PUB. 5-20-2008. FILED 6-28-2007.
- 3,479,172. **P PROFARMACO AND DESIGN**. CAMBREX PROFARMACO MILANO S.R.L., (U.S. CLS. 6, 18, 44, 46, 51 AND 52). SN 77-220,547. PUB. 5-20-2008. FILED 7-2-2007.
- 3,479,179. **ALBA-LYBE (BLOCK FORM)**. TERAL INC., (U.S. CLS. 6, 18, 44, 46, 51 AND 52). SN 77-221,260. PUB. 5-20-2008. FILED 7-3-2007.
- 3,479,254. **ISOSENTIAL (BLOCK FORM)**. INDOMITUS ASSET MANAGEMENT, L.L.C., (U.S. CLS. 6, 18, 44, 46, 51 AND 52). SN 77-230,918. PUB. 5-20-2008. FILED 7-16-2007.
- 3,479,255. **BIFIDOBLEND (BLOCK FORM)**. AMERICAN LIFELINE, INC. (U.S. CLS. 6, 18, 44, 46, 51 AND 52). SN 77-230,967. PUB. 5-20-2008. FILED 7-16-2007.
- 3,479,271. **NEUROLIFT (BLOCK FORM)**. NUTRACEUTICAL SCIENCES INSTITUTE, INC., (U.S. CLS. 6, 18, 44, 46, 51 AND 52). SN 77-233,591. PUB. 5-20-2008. FILED 7-19-2007.
- 3,479,283. **VOLCANO OIL (BLOCK FORM)**. MAUI EXCELLENT, LLC, (U.S. CLS. 6, 18, 44, 46, 51 AND 52). SN 77-235,130. PUB. 5-20-2008. FILED 7-20-2007.
- 3,479,289. **ISO MASS XTREME GAINER (BLOCK FORM)**. ULTIMATE NUTRITIONS, INC., (U.S. CLS. 6, 18, 44, 46, 51 AND 52). SN 77-236,734. PUB. 5-20-2008. FILED 7-23-2007.
- 3,479,356. **NITROFUSION (STYLIZED)**. ARIZONA NUTRITIONAL SCIENCES, LLC, (U.S. CLS. 6, 18, 44, 46, 51 AND 52). SN 77-254,238. PUB. 2-12-2008. FILED 8-13-2007.
- 3,479,381. **CYDEX (BLOCK FORM)**. CYDEX PHARMACEUTICALS, INC., MULTIPLE CLASS, (INT. CLS. 5 AND 45), (U.S. CLS. 6, 18, 44, 46, 51, 100 AND 101). SN 77-262,367. PUB. 5-20-2008. FILED 8-23-2007.
- 3,479,398. **ANESTENKA (BLOCK FORM)**. APARICIO, JORGE, (U.S. CLS. 6, 18, 44, 46, 51 AND 52). SN 77-266,474. PUB. 5-20-2008. FILED 8-28-2007.
- 3,479,412. **TRI-SAN (BLOCK FORM)**. GENERAL CONVERTERS & ASSEMBLERS, INC., (U.S. CLS. 6, 18, 44, 46, 51 AND 52). SN 77-271,146. PUB. 5-20-2008. FILED 9-4-2007.
- 3,479,435. **THOMAS JEFFERSON CLARK (BLOCK FORM)**. HUB RESEARCH & DEVELOPMENT CO, INC., MULTIPLE CLASS, (INT. CLS. 5 AND 32), (U.S. CLS. 6, 18, 44, 45, 46, 48, 51 AND 52). SN 77-277,085. PUB. 5-20-2008. FILED 9-11-2007.
- 3,479,473. **SUPER 2 DAILY (BLOCK FORM)**. J.R. CARLSON LABORATORIES, INC., (U.S. CLS. 6, 18, 44, 46, 51 AND 52). SN 77-288,114. PUB. 5-20-2008. FILED 9-25-2007.
- 3,479,551. **NX PAIN FORMULA (BLOCK FORM)**. PHYSICIAN'S SCIENCE & NATURE, INC., (U.S. CLS. 6, 18, 44, 46, 51 AND 52). SN 77-305,765. PUB. 5-20-2008. FILED 10-17-2007.
- 3,479,584. **ORGONO LIVING SILICA AND DESIGN**. HIERRO JOAN CARLES, AND PEREZ MARIA ESTHER, (U.S. CLS. 6, 18, 44, 46, 51 AND 52). SN 77-311,497. PUB. 5-20-2008. FILED 10-23-2007.
- 3,479,618. **GRATIFY (BLOCK FORM)**. INDOMITUS ASSET MANAGEMENT LLC, (U.S. CLS. 6, 18, 44, 46, 51 AND 52). SN 77-317,821. PUB. 5-20-2008. FILED 10-31-2007.
- 3,479,685. **NATURENUTRITION AND DESIGN**. GUNLER, INC., (U.S. CLS. 6, 18, 44, 46, 51 AND 52). SN 77-326,852. PUB. 5-20-2008. FILED 11-12-2007.
- 3,479,709 (See Class 3 for this trademark).
- 3,479,719 (See Class 1 for this trademark).
- 3,479,739. **SL FOREAN (BLOCK FORM)**. INNOFRESH PRODUCTS, INC., (U.S. CLS. 6, 18, 44, 46, 51 AND 52). SN 77-335,084. PUB. 5-20-2008. FILED 11-21-2007.
- 3,479,766. **GLUCO-FLEX (BLOCK FORM)**. W.F. YOUNG, INCORPORATED, (U.S. CLS. 6, 18, 44, 46, 51 AND 52). SN 77-339,088. PUB. 5-20-2008. FILED 11-28-2007.
- 3,479,767. **SKIN RENOVATOR (BLOCK FORM)**. W.F. YOUNG, INCORPORATED, (U.S. CLS. 6, 18, 44, 46, 51 AND 52). SN 77-339,171. PUB. 5-20-2008. FILED 11-28-2007.
- 3,479,803. **POWER PEARL (BLOCK FORM)**. W.F. YOUNG, INCORPORATED, (U.S. CLS. 6, 18, 44, 46, 51 AND 52). SN 77-342,508. PUB. 5-20-2008. FILED 12-3-2007.
- 3,479,826. **JOINT FIX (BLOCK FORM)**. MEGESTER, INC., (U.S. CLS. 6, 18, 44, 46, 51 AND 52). SN 77-345,577. PUB. 5-20-2008. FILED 12-6-2007.
- 3,479,838. **AGE MANAGEMENT SUPPLEMENTS AND DESIGN**. MAIQUEZ INVESTMENTS, INC, (U.S. CLS. 6, 18, 44, 46, 51 AND 52). SN 77-346,208. PUB. 5-20-2008. FILED 12-6-2007.
- 3,480,018. **SORBOPLEX (BLOCK FORM)**. W.F. YOUNG, INCORPORATED, (U.S. CLS. 6, 18, 44, 46, 51 AND 52). SN 77-356,957. PUB. 5-20-2008. FILED 12-20-2007.
- 3,480,047. **STAYIN' ALIVE AND DESIGN**. NOURICHE NUTRITION LTD, (U.S. CLS. 6, 18, 44, 46, 51 AND 52). SN 77-357,945. PUB. 5-20-2008. FILED 12-21-2007.
- 3,480,086. **LOVE YOUR LIFE (BLOCK FORM)**. ARCIERI, STANLEY, DBA BIOPHARMACA, (U.S. CLS. 6, 18, 44, 46, 51 AND 52). SN 77-359,425. PUB. 5-20-2008. FILED 12-26-2007.
- 3,480,091. **ARTHRIPHASE (BLOCK FORM)**. TANGO ADVANCED NUTRITION, INC., (U.S. CLS. 6, 18, 44, 46, 51 AND 52). SN 77-359,568. PUB. 5-20-2008. FILED 12-26-2007.
- 3,480,162. **EVERCLEANSE (BLOCK FORM)**. HINDSIGHT NUTRITIONALS, LLC, (U.S. CLS. 6, 18, 44, 46, 51 AND 52). SN 77-362,354. PUB. 5-20-2008. FILED 1-2-2008.
- 3,480,168. **BAYMEC (BLOCK FORM)**. BAYER AKTIENGESELLSCHAFT, (U.S. CLS. 6, 18, 44, 46, 51 AND 52). SN 77-362,403. PUB. 5-20-2008. FILED 1-2-2008.
- 3,480,171. **OMEGAMAGIC (BLOCK FORM)**. CONSTANS, GEORGE, (U.S. CLS. 6, 18, 44, 46, 51 AND 52). SN 77-362,433. PUB. 5-20-2008. FILED 1-2-2008.
- 3,480,190. **PERSEPHONE VITAMINS (BLOCK FORM)**. PHULI COHAN MD, LLC, (U.S. CLS. 6, 18, 44, 46, 51 AND 52). SN 77-362,767. PUB. 5-20-2008. FILED 1-2-2008.
- 3,480,192. **MISCELLANEOUS DESIGN**. PHULI COHAN MD, LLC, (U.S. CLS. 6, 18, 44, 46, 51 AND 52). SN 77-362,809. PUB. 5-20-2008. FILED 1-2-2008.
- 3,480,198. **PRODDHA ELITE (BLOCK FORM)**. NORDIC NATURALS, INC., (U.S. CLS. 6, 18, 44, 46, 51 AND 52). SN 77-362,927. PUB. 5-20-2008. FILED 1-2-2008.
- 3,480,233. **MALIC ACID PLUS (STYLIZED)**. MMRC, LTD CO, (U.S. CLS. 6, 18, 44, 46, 51 AND 52). SN 77-363,468. PUB. 5-20-2008. FILED 1-3-2008.
- 3,480,249. **MANALEI (BLOCK FORM)**. PHARM EAST, INC., (U.S. CLS. 6, 18, 44, 46, 51 AND 52). SN 77-363,685. PUB. 5-20-2008. FILED 1-3-2008.
- 3,480,274. **CITRA AND DESIGN**. CITRA ANTICOAGULANTS, INC., (U.S. CLS. 6, 18, 44, 46, 51 AND 52). SN 77-364,037. PUB. 5-20-2008. FILED 1-4-2008.
- 3,480,283. **ROCK N' ROLL HANGOVER RELIEF (BLOCK FORM)**. DINOCO INTERNATIONAL CORPORATION, (U.S. CLS. 6, 18, 44, 46, 51 AND 52). SN 77-364,205. PUB. 5-20-2008. FILED 1-4-2008.
- 3,480,292. **B CONTROL (BLOCK FORM)**. HEALING POWER, INC., (U.S. CLS. 6, 18, 44, 46, 51 AND 52). SN 77-364,340. PUB. 5-20-2008. FILED 1-4-2008.
- 3,480,338. **CHL-CARE (BLOCK FORM)**. HEALING POWER, INC., (U.S. CLS. 6, 18, 44, 46, 51 AND 52). SN 77-365,057. PUB. 5-20-2008. FILED 1-6-2008.
- 3,480,339. **RUMO PLUS (BLOCK FORM)**. HEALING POWER, INC., (U.S. CLS. 6, 18, 44, 46, 51 AND 52). SN 77-365,059. PUB. 5-20-2008. FILED 1-6-2008.
- 3,480,472. **ISACRUNCH (BLOCK FORM)**. ISAGENIX WORLDWIDE, LLC, (U.S. CLS. 6, 18, 44, 46, 51 AND 52). SN 77-367,913. PUB. 5-20-2008. FILED 1-9-2008.
- 3,480,540. **BETADRENE-SR (BLOCK FORM)**. WHEAT, JARED R., (U.S. CLS. 6, 18, 44, 46, 51 AND 52). SN 77-392,826. PUB. 5-20-2008. FILED 2-8-2008.
- 3,480,559. **MISCELLANEOUS DESIGN**. WYETH, (U.S. CLS. 6, 18, 44, 46, 51 AND 52). SN 77-409,384. PUB. 5-20-2008. FILED 2-29-2008.
- 3,480,564. **ALLERTHERAPY (BLOCK FORM)**. PROACTIVE REMEDIES, LLC, (U.S. CLS. 6, 18, 44, 46, 51 AND 52). SN 77-425,989. PUB. 5-20-2008. FILED 3-19-2008.
- 3,480,582. **NUTRAMIN (BLOCK FORM)**. CALIFORNIA EARTH MINERALS, INC., (U.S. CLS. 6, 18, 44, 46, 51 AND 52). SN 78-508,337. PUB. 2-12-2008. FILED 10-29-2004.
- 3,480,630. **CAL MELTS (BLOCK FORM)**. HOLISTA HEALTH (CANADA) INC., (U.S. CLS. 6, 18, 44, 46, 51 AND 52). SN 78-751,590. PUB. 1-1-2008. FILED 11-10-2005.
- 3,480,645. **ESKAL AND DESIGN**. TRIALIA FOODS AUSTRALIA PTY LTD, MULTIPLE CLASS, (INT. CLS. 5, 29 AND 30), (U.S. CLS. 6, 18, 44, 46, 51 AND 52). SN 78-830,207. PUB. 5-20-2008. FILED 3-6-2006.
- 3,480,652. **ECHINAMAX (BLOCK FORM)**. WN PHARMA-

- CEUTICALS LTD., (U.S. CLS. 6, 18, 44, 46, 51 AND 52). SN 78-842,226. PUB. 10-31-2006. FILED 3-21-2006.
- 3,480,655. **CHOLESTEROL ESSENTIALS (BLOCK FORM)**. HEALTHY DIRECTIONS, LLC, (U.S. CLS. 6, 18, 44, 46, 51 AND 52). SN 78-848,668. PUB. 5-20-2008. FILED 3-29-2006.
- 3,480,662. **VICKI'S FLASH POPS COOLS HOT FLASHES FAST! AND DESIGN**. REDOBLE, VICTORIA, (U.S. CLS. 6, 18, 44, 46, 51 AND 52). SN 78-867,819. PUB. 5-20-2008. FILED 4-24-2006.
- 3,480,728. **ECO-JET (BLOCK FORM)**. ECO-SAFE USA, INC., (U.S. CLS. 6, 18, 44, 46, 51 AND 52). SN 78-965,428. PUB. 5-20-2008. FILED 8-31-2006.
- 3,480,778. **ENTRYBODY (BLOCK FORM)**. OÜ INBIO, (U.S. CLS. 6, 18, 44, 46, 51 AND 52). SN 79-033,945. PUB. 5-20-2008. FILED 12-20-2006.
- 3,480,789. **YEBIO AND DESIGN**. QINGDAO YEBIO BIOENGINEERING; CO., LTD., (U.S. CLS. 6, 18, 44, 46, 51 AND 52). SN 79-034,827. PUB. 5-20-2008. FILED 1-22-2007.
- 3,480,804 (*See Class 1 for this trademark*).
- 3,480,816. **NANOSAN (STYLIZED)**. SCHILL + SEILACHER AKTIENGESSELLSCHAFT, MULTIPLE CLASS, (INT. CLS. 5, 16, 24 AND 25), (U.S. CLS. 2, 5, 6, 18, 22, 23, 29, 37, 38, 39, 42, 44, 46, 50, 51 AND 52). SN 79-037,742. PUB. 5-20-2008. FILED 3-26-2007.
- 3,480,818. **DESERT (BLOCK FORM)**. DESERT ECO SYSTEMS PTY LTD, MULTIPLE CLASS, (INT. CLS. 5 AND 11), (U.S. CLS. 6, 13, 18, 21, 23, 31, 34, 44, 46, 51 AND 52). SN 79-038,327. PUB. 5-20-2008. FILED 3-26-2007.
- 3,480,845 (*See Class 1 for this trademark*).
- 3,480,887 (*See Class 1 for this trademark*).
- 3,480,902 (*See Class 3 for this trademark*).
- 3,480,985. **WAYENT (BLOCK FORM)**. NOVARTIS AG, (U.S. CLS. 6, 18, 44, 46, 51 AND 52). SN 79-045,010. PUB. 5-20-2008. FILED 8-31-2007.
- 3,480,989. **SUPER SENI (STYLIZED)**. TORUNSKIE ZAKLADY MATERIALÓW; OPATRUNKOWYCH SPÓŁKA AKCYJNA, (U.S. CLS. 6, 18, 44, 46, 51 AND 52). SN 79-045,331. PUB. 5-20-2008. FILED 7-13-2007.
- 3,480,990. **SENI LADY (BLOCK FORM)**. TORUNSKIE ZAKLADY MATERIALÓW; OPATRUNKOWYCH SPÓŁKA AKCYJNA, (U.S. CLS. 6, 18, 44, 46, 51 AND 52). SN 79-045,336. PUB. 5-20-2008. FILED 7-13-2007.
- 3,480,991. **SENI OPTIMA (STYLIZED)**. TORUNSKIE ZAKLADY MATERIALÓW; OPATRUNKOWYCH, SPÓŁKA AKCYJNA, (U.S. CLS. 6, 18, 44, 46, 51 AND 52). SN 79-045,349. PUB. 5-20-2008. FILED 7-13-2007.
- 3,480,996. **MISCELLANEOUS DESIGN**. PARMALAT SPA, MULTIPLE CLASS, (INT. CLS. 5, 29, 30 AND 32), (U.S. CLS. 6, 18, 44, 45, 46, 48, 51 AND 52). SN 79-045,937. PUB. 5-20-2008. FILED 11-15-2006.
- 3,481,016 (*See Class 1 for this trademark*).
- 3,481,032 (*See Class 3 for this trademark*).
- KG, MULTIPLE CLASS, (INT. CLS. 6, 7, 9 AND 37), (U.S. CLS. 2, 12, 13, 14, 19, 21, 23, 25, 26, 31, 34, 35, 36, 38, 50, 100, 103 AND 106). SN 77-054,797. PUB. 5-20-2008. FILED 12-1-2006.
- 3,478,746. **PARAMOUNT WINDOWS (BLOCK FORM)**. PARAMOUNT WINDOWS, (U.S. CLS. 2, 12, 13, 14, 23, 25 AND 50). SN 77-088,415. PUB. 5-20-2008. FILED 1-22-2007.
- 3,478,799. **ECHO AND DESIGN**. BLIND DOG PRODUCTIONS, LTD., (U.S. CLS. 2, 12, 13, 14, 23, 25 AND 50). SN 77-119,272. PUB. 5-20-2008. FILED 3-1-2007.
- 3,478,800. **ECHO SIERRA (BLOCK FORM)**. BLIND DOG PRODUCTIONS, LTD., (U.S. CLS. 2, 12, 13, 14, 23, 25 AND 50). SN 77-119,384. PUB. 5-20-2008. FILED 3-1-2007.
- 3,478,829. **RIG-RELEASE (BLOCK FORM)**. THE CALDWELL GROUP, INC., (U.S. CLS. 2, 12, 13, 14, 23, 25 AND 50). SN 77-140,563. PUB. 5-20-2008. FILED 3-26-2007.
- 3,478,907. **LIFTEX (BLOCK FORM)**. LIFTEX CORPORATION, MULTIPLE CLASS, (INT. CLS. 6 AND 22), (U.S. CLS. 1, 2, 7, 12, 13, 14, 19, 22, 23, 25, 42 AND 50). SN 77-176,584. PUB. 5-20-2008. FILED 5-9-2007.
- 3,479,306. **MACFORMET MOUNTING SOLUTIONS AND DESIGN**. RODRIGUEZ VILLARREAL, RUBEN, (U.S. CLS. 2, 12, 13, 14, 23, 25 AND 50). SN 77-240,125. PUB. 5-20-2008. FILED 7-26-2007.
- 3,479,314. **WAGI AND DESIGN**. NEWAY VALVE, INC., (U.S. CLS. 2, 12, 13, 14, 23, 25 AND 50). SN 77-242,805. PUB. 5-20-2008. FILED 7-31-2007.
- 3,479,333. **E-ZEE FEED (BLOCK FORM)**. ITT CORPORATION, (U.S. CLS. 2, 12, 13, 14, 23, 25 AND 50). SN 77-248,602. PUB. 5-20-2008. FILED 8-7-2007.
- 3,479,349. **FEENEY (BLOCK FORM)**. PACIFIC COAST WIRE ROPE & FITTINGS, INC., DBA FEENEY WIRE ROPE & FITTINGS, INC., (U.S. CLS. 2, 12, 13, 14, 23, 25 AND 50). SN 77-252,452. PUB. 5-20-2008. FILED 8-10-2007.
- 3,479,351. **FEENEY ARCHITECTURAL PRODUCTS (BLOCK FORM)**. PACIFIC COAST WIRE ROPE & FITTINGS, INC., DBA FEENEY WIRE ROPE & FITTINGS, INC., (U.S. CLS. 2, 12, 13, 14, 23, 25 AND 50). SN 77-252,667. PUB. 5-20-2008. FILED 8-10-2007.
- 3,479,400. **SUMMIT SAFE COMPANY (BLOCK FORM)**. SUMMIT BUSINESS ASSOCIATION, LLC, (U.S. CLS. 2, 12, 13, 14, 23, 25 AND 50). SN 77-267,086. PUB. 5-20-2008. FILED 8-29-2007.
- 3,479,546 (*See Class 1 for this trademark*).
- 3,479,616. **FIRST LADY (BLOCK FORM)**. OLDE MILL COMPANY, INC., MULTIPLE CLASS, (INT. CLS. 6, 8, 18, 21 AND 30), (U.S. CLS. 1, 2, 3, 12, 13, 14, 22, 23, 25, 28, 29, 30, 33, 40, 41, 44, 46 AND 50). SN 77-317,600. PUB. 5-20-2008. FILED 10-31-2007.
- 3,479,812. **RIFENG (BLOCK FORM)**. FOSHAN RIFENG ENTERPRISES CO., LTD, MULTIPLE CLASS, (INT. CLS. 6, 11, 17, 19 AND 20), (U.S. CLS. 1, 2, 5, 12, 13, 14, 21, 22, 23, 25, 31, 32, 33, 34, 35 AND 50). SN 77-343,245. PUB. 5-20-2008. FILED 12-4-2007.
- 3,479,814. **MISCELLANEOUS DESIGN**. FOSHAN RIFENG ENTERPRISES CO., LTD, MULTIPLE CLASS, (INT. CLS. 6, 11, 17, 19 AND 20), (U.S. CLS. 1, 2, 5, 12, 13, 14, 21, 22, 23, 25, 31, 32, 33, 34, 35 AND 50). SN 77-343,398. PUB. 5-20-2008. FILED 12-4-2007.
- 3,479,888. **STAUFF (BLOCK FORM)**. STAUFF CORPORATION, MULTIPLE CLASS, (INT. CLS. 6, 7, 9, 19 AND 20), (U.S. CLS. 1, 2, 12, 13, 14, 19, 21, 22, 23, 25, 26, 31, 32, 33, 34, 35, 36, 38 AND 50). SN 77-351,140. PUB. 5-20-2008. FILED 12-13-2007.
- 3,479,916. **S STAUFF AND DESIGN**. STAUFF CORPORATION, MULTIPLE CLASS, (INT. CLS. 6, 7, 9, 19 AND 20), (U.S. CLS. 1, 2, 12, 13, 14, 19, 21, 22, 23, 25, 26, 31, 32, 33, 34, 35, 36, 38 AND 50). SN 77-352,151. PUB. 5-20-2008. FILED 12-14-2007.
- 3,479,954. **STAKE-LOC (BLOCK FORM)**. F. BARKOW, INC., (U.S. CLS. 2, 12, 13, 14, 23, 25 AND 50). SN 77-354,308. PUB. 5-20-2008. FILED 12-18-2007.
- 3,480,019. **PRIORITY METALS, INC. (BLOCK FORM)**. MCCARROLL, DON, (U.S. CLS. 2, 12, 13, 14, 23, 25 AND 50). SN 77-356,965. PUB. 5-20-2008. FILED 12-20-2007.
- 3,480,032. **SHELTER ONE AND DESIGN**. SHELTER ONE, INC., (U.S. CLS. 2, 12, 13, 14, 23, 25 AND 50). SN 77-357,363. PUB. 5-20-2008. FILED 12-20-2007.

CLASS 6—METAL GOODS

- 3,480,102. **BOXHAUL (BLOCK FORM)**. ALLTECH MANUFACTURING, LLC, (U.S. CLS. 2, 12, 13, 14, 23, 25 AND 50). SN 77-360,031. PUB. 5-20-2008. FILED 12-27-2007.
- 3,480,118. **SECURETIP FASTENER (BLOCK FORM)**. 55 CONSULTANTS, INC., (U.S. CLS. 2, 12, 13, 14, 23, 25 AND 50). SN 77-360,779. PUB. 5-20-2008. FILED 12-28-2007.
- 3,480,167. **SKYSHIELD AND DESIGN**. SAVANNAH TRIMS, INC., (U.S. CLS. 2, 12, 13, 14, 23, 25 AND 50). SN 77-362,378. PUB. 5-20-2008. FILED 1-2-2008.
- 3,480,169. **THE BEAUTY OF COPPER. THE STRENGTH OF STEEL. (BLOCK FORM)**. SOUTHEASTERN METALS MANUFACTURING COMPANY, INC., (U.S. CLS. 2, 12, 13, 14, 23, 25 AND 50). SN 77-362,411. PUB. 5-20-2008. FILED 1-2-2008.
- 3,480,538. **OAK SUMMIT (BLOCK FORM)**. AMARR COMPANY, (U.S. CLS. 2, 12, 13, 14, 23, 25 AND 50). SN 77-392,059. PUB. 5-20-2008. FILED 2-8-2008.
- 3,480,666. **BULLET BOND 1000 (BLOCK FORM)**. THOMAS & BETTS INTERNATIONAL, INC., (U.S. CLS. 2, 12, 13, 14, 23, 25 AND 50). SN 78-880,225. PUB. 5-20-2008. FILED 5-10-2006.
- 3,480,699. **HI-LEX CORPORATION AND DESIGN**. HI-LEX CORPORATION, (U.S. CLS. 2, 12, 13, 14, 23, 25 AND 50). SN 78-913,258. PUB. 12-18-2007. FILED 6-21-2006.
- 3,480,786. **KHP (STYLIZED)**. GEBR. KEMPER GMBH + CO. KG METALLWERKE, MULTIPLE CLASS, (INT. CLS. 6 AND 40), (U.S. CLS. 2, 12, 13, 14, 23, 25, 50, 100, 103 AND 106). SN 79-034,525. PUB. 5-20-2008. FILED 12-12-2006.
- 3,480,822. **FIAL AND DESIGN**. CHARLES LAUZIER, MULTIPLE CLASS, (INT. CLS. 6, 19 AND 24), (U.S. CLS. 1, 2, 12, 13, 14, 23, 25, 33, 42 AND 50). SN 79-038,569. PUB. 5-20-2008. FILED 4-24-2007.
- 3,480,829. **JASON (STYLIZED)**. ZHEJIANG PUJIANG ZHONGXING CO., LTD., (U.S. CLS. 2, 12, 13, 14, 23, 25 AND 50). SN 79-039,061. PUB. 5-20-2008. FILED 5-8-2007.
- 3,480,835. **MISCELLANEOUS DESIGN**. NORINCO, (U.S. CLS. 2, 12, 13, 14, 23, 25 AND 50). SN 79-039,569. PUB. 5-20-2008. FILED 4-11-2007.
- 3,480,843. **DUCTIBOR (BLOCK FORM)**. ARCELORMITTAL FLAT CARBON EUROPE SA, MULTIPLE CLASS, (INT. CLS. 6 AND 12), (U.S. CLS. 2, 12, 13, 14, 19, 21, 23, 25, 31, 35, 44 AND 50). SN 79-039,731. PUB. 5-20-2008. FILED 5-21-2007.
- 3,480,884. **PE EXCELSENS AND DESIGN**. PONT EMBALLAGE, MULTIPLE CLASS, (INT. CLS. 6, 20 AND 21), (U.S. CLS. 2, 12, 13, 14, 22, 23, 25, 29, 30, 32, 33, 40 AND 50). SN 79-041,460. PUB. 5-20-2008. FILED 6-15-2007.
- 3,480,897. **BODYKEY (BLOCK FORM)**. KABA AG, MULTIPLE CLASS, (INT. CLS. 6 AND 9), (U.S. CLS. 2, 12, 13, 14, 21, 23, 25, 26, 36, 38 AND 50). SN 79-041,769. PUB. 5-20-2008. FILED 5-24-2007.
- 3,480,908. **PREON (BLOCK FORM)**. VALLOUREC & MANNESMANN TUBES, MULTIPLE CLASS, (INT. CLS. 6, 16 AND 42), (U.S. CLS. 2, 5, 12, 13, 14, 22, 23, 25, 29, 37, 38, 50, 100 AND 101). SN 79-041,991. PUB. 5-20-2008. FILED 5-14-2007.
- 3,480,921. **PIXQUICK (BLOCK FORM)**. KUNSTDÜNGER S.N.C.; DI C. WALZL & CO., MULTIPLE CLASS, (INT. CLS. 6, 16 AND 20), (U.S. CLS. 2, 5, 12, 13, 14, 22, 23, 25, 29, 32, 37, 38 AND 50). SN 79-042,299. PUB. 5-20-2008. FILED 3-16-2007.
- 3,480,936 (*See Class 4 for this trademark*).
- 3,480,939. **PEIKKO (BLOCK FORM)**. PEIKKO FINLAND OY, (U.S. CLS. 2, 12, 13, 14, 23, 25 AND 50). SN 79-042,827. PUB. 5-20-2008. FILED 5-7-2007.
- 3,480,961. **POLAR (BLOCK FORM)**. WOLFGANG BLINDOW, MULTIPLE CLASS, (INT. CLS. 6 AND 20), (U.S. CLS. 2, 12, 13, 14, 22, 23, 25, 32 AND 50). SN 79-043,819. PUB. 5-20-2008. FILED 8-16-2007.
- 3,481,025. **MIRRAX (STYLIZED)**. UDDEHOLM TOOLING AKTIEBOLAG, (U.S. CLS. 2, 12, 13, 14, 23, 25 AND 50). SN 79-048,270. PUB. 5-20-2008. FILED 12-17-2007.
- 3,481,038. **SLEIPNER (BLOCK FORM)**. UDDEHOLM TOOLING AKTIEBOLAG, (U.S. CLS. 2, 12, 13, 14, 23, 25 AND 50). SN 79-050,129. PUB. 5-20-2008. FILED 1-22-2008.

CLASS 7—MACHINERY

- 3,478,524. **HELIFLEX (BLOCK FORM)**. ITI SCOTLAND LIMITED, MULTIPLE CLASS, (INT. CLS. 7 AND 42), (U.S. CLS. 13, 19, 21, 23, 31, 34, 35, 100 AND 101). SN 76-666,319. PUB. 3-4-2008. FILED 9-19-2006.
- 3,478,565 (*See Class 4 for this trademark*).
- 3,478,617. **INTERLINK (BLOCK FORM)**. HEATCRAFT REFRIGERATION PRODUCTS LLC, MULTIPLE CLASS, (INT. CLS. 7, 9 AND 11), (U.S. CLS. 13, 19, 21, 23, 26, 31, 34, 35, 36 AND 38). SN 76-685,492. PUB. 5-20-2008. FILED 1-4-2008.
- 3,478,629. **RAPID ROPER (BLOCK FORM)**. ALLIED PACKAGING CORPORATION, (U.S. CLS. 13, 19, 21, 23, 31, 34 AND 35). SN 77-005,593. PUB. 5-20-2008. FILED 9-22-2006.
- 3,478,641. **C AND DESIGN**. COBB TUNING PRODUCTS, LLC, MULTIPLE CLASS, (INT. CLS. 7, 9, 12, 25, 35, 37, 40 AND 42), (U.S. CLS. 13, 19, 21, 22, 23, 26, 31, 34, 35, 36, 38, 39, 44, 100, 101, 102, 103 AND 106). SN 77-017,186. PUB. 5-20-2008. FILED 10-9-2006.
- 3,478,692. **DIAMOND-TRAC (BLOCK FORM)**. MITSUBISHI ELECTRIC CORPORATION, (U.S. CLS. 13, 19, 21, 23, 31, 34 AND 35). SN 77-049,865. PUB. 5-20-2008. FILED 11-22-2006.
- 3,478,699 (*See Class 6 for this trademark*).
- 3,478,724. **TITAN CL LUBER (BLOCK FORM)**. A.T.S. ELECTRO-LUBE HOLDINGS LTD., (U.S. CLS. 13, 19, 21, 23, 31, 34 AND 35). SN 77-073,638. PUB. 5-20-2008. FILED 12-29-2006.
- 3,478,741. **ACCUCAPPER (BLOCK FORM)**. ACCUTEK PACKAGING EQUIPMENT COMPANY, INC., (U.S. CLS. 13, 19, 21, 23, 31, 34 AND 35). SN 77-082,434. PUB. 5-20-2008. FILED 1-12-2007.
- 3,478,817. **NANOFRIKS (BLOCK FORM)**. KS KOLBENSCHMIDT GMBH, (U.S. CLS. 13, 19, 21, 23, 31, 34 AND 35). SN 77-129,636. PUB. 5-20-2008. FILED 3-13-2007.
- 3,478,899. **F FOGACCI (STYLIZED)**. B&C SRL, MULTIPLE CLASS, (INT. CLS. 7 AND 21), (U.S. CLS. 2, 13, 19, 21, 23, 29, 30, 31, 33, 34, 35, 40 AND 50). SN 77-174,626. PUB. 1-29-2008. FILED 5-7-2007.
- 3,478,924. **TORNADO (BLOCK FORM)**. SHINDAIWA, INC., (U.S. CLS. 13, 19, 21, 23, 31, 34 AND 35). SN 77-183,078. PUB. 5-20-2008. FILED 5-16-2007.
- 3,478,926. **RHINOPRO (STYLIZED)**. RHINO LININGS USA, INC., (U.S. CLS. 13, 19, 21, 23, 31, 34 AND 35). SN 77-183,637. PUB. 5-20-2008. FILED 5-17-2007.
- 3,479,036. **CIDAN (BLOCK FORM)**. PETERSEN MACHINERY GROUP A/S, (U.S. CLS. 13, 19, 21, 23, 31, 34 AND 35). SN 77-201,634. PUB. 5-20-2008. FILED 6-8-2007.
- 3,479,146. **VEL-MAX (BLOCK FORM)**. VELCON FILTERS, INC., (U.S. CLS. 13, 19, 21, 23, 31, 34 AND 35). SN 77-218,152. PUB. 5-20-2008. FILED 6-28-2007.
- 3,479,222. **METHANE BUSTER (BLOCK FORM)**. COMVEST CAPITAL, LLC, (U.S. CLS. 13, 19, 21, 23, 31, 34 AND 35). SN 77-226,679. PUB. 5-20-2008. FILED 7-11-2007.
- 3,479,229. **TOTE-ON-TOTE (BLOCK FORM)**. SEALED AIR CORPORATION (US), (U.S. CLS. 13, 19, 21, 23, 31, 34 AND 35). SN 77-227,400. PUB. 5-20-2008. FILED 7-11-2007.
- 3,479,238. **ALKAPPLY (BLOCK FORM)**. CITIZEN HOLDINGS KABUSHIKI KAISHA, TA CITIZEN HOLDINGS CO., LTD., MULTIPLE CLASS, (INT. CLS. 7, 9, 37 AND 42), (U.S. CLS. 13, 19, 21, 23, 26, 31, 34, 35, 36, 38, 100, 101, 103 AND 106). SN 77-229,302. PUB. 5-20-2008. FILED 7-13-2007.
- 3,479,239. **ALKARTPRO (BLOCK FORM)**. CITIZEN HOLDINGS KABUSHIKI KAISHA, TA CITIZEN HOLDINGS CO., LTD., MULTIPLE CLASS, (INT. CLS. 7 AND 9), (U.S. CLS. 13, 19, 21, 23, 26, 31, 34, 35, 36 AND 38). SN 77-229,325. PUB. 5-20-2008. FILED 7-13-2007.
- 3,479,360. **CRL (BLOCK FORM)**. USI, INC., MULTIPLE CLASS, (INT. CLS. 7 AND 16), (U.S. CLS. 2, 5, 13, 19, 21, 22, 23, 29, 31, 34, 35, 37, 38 AND 50). SN 77-256,182. PUB. 5-20-2008. FILED 8-15-2007.
- 3,479,543. **RETSCO (BLOCK FORM)**. CONTROL FLOW, INC., (U.S. CLS. 13, 19, 21, 23, 31, 34 AND 35). SN 77-303,482. PUB. 5-20-2008. FILED 10-13-2007.
- 3,479,546 (*See Class 1 for this trademark*).
- 3,479,552. **MIDWEST INTERNATIONAL (BLOCK FORM)**. MIDWEST INTERNATIONAL STANDARD PRODUCTS, INC., (U.S. CLS. 13, 19, 21, 23, 31, 34 AND 35). SN 77-305,769. PUB. 5-20-2008. FILED 10-17-2007.

- 3,479,597. **DYNA (BLOCK FORM)**. DYNOJET RESEARCH, INC., (U.S. CLS. 13, 19, 21, 23, 31, 34 AND 35). SN 77-314,027. PUB. 5-20-2008. FILED 10-25-2007.
- 3,479,598. **DYNATEK (BLOCK FORM)**. DYNOJET RESEARCH, INC., (U.S. CLS. 13, 19, 21, 23, 31, 34 AND 35). SN 77-314,035. PUB. 5-20-2008. FILED 10-25-2007.
- 3,479,708. **SUREFIRE (BLOCK FORM)**. HAYNES CORPORATION, (U.S. CLS. 13, 19, 21, 23, 31, 34 AND 35). SN 77-330,408. PUB. 5-20-2008. FILED 11-15-2007.
- 3,479,775. **NEOFLAM (BLOCK FORM)**. CHANG, TAE YOUNG, DBA HIGHGL, INC., MULTIPLE CLASS, (INT. CLS. 7, 8 AND 21), (U.S. CLS. 2, 13, 19, 21, 23, 28, 29, 30, 31, 33, 34, 35, 40, 44 AND 50). SN 77-340,056. PUB. 5-20-2008. FILED 11-29-2007.
- 3,479,827. **LESSMANN A AND DESIGN**. LESSMANN GMBH, MULTIPLE CLASS, (INT. CLS. 7 AND 21), (U.S. CLS. 2, 13, 19, 21, 23, 29, 30, 31, 33, 34, 35, 40 AND 50). SN 77-345,621. PUB. 5-20-2008. FILED 12-6-2007.
- 3,479,870. **GL 10 (BLOCK FORM)**. BSH BOSCH UND SIEMENS HAUSGERAETE GMBH, (U.S. CLS. 13, 19, 21, 23, 31, 34 AND 35). SN 77-350,050. PUB. 5-20-2008. FILED 12-12-2007.
- 3,479,871. **GL 20 (BLOCK FORM)**. BSH BOSCH UND SIEMENS HAUSGERAETE GMBH, (U.S. CLS. 13, 19, 21, 23, 31, 34 AND 35). SN 77-350,066. PUB. 5-20-2008. FILED 12-12-2007.
- 3,479,873. **GL 30 (BLOCK FORM)**. BSH BOSCH UND SIEMENS HAUSGERAETE GMBH, (U.S. CLS. 13, 19, 21, 23, 31, 34 AND 35). SN 77-350,094. PUB. 5-20-2008. FILED 12-12-2007.
- 3,479,874. **GL 40 (BLOCK FORM)**. BSH BOSCH UND SIEMENS HAUSGERAETE GMBH, (U.S. CLS. 13, 19, 21, 23, 31, 34 AND 35). SN 77-350,110. PUB. 5-20-2008. FILED 12-12-2007.
- 3,479,875. **GL 50 (BLOCK FORM)**. BSH BOSCH UND SIEMENS HAUSGERAETE GMBH, (U.S. CLS. 13, 19, 21, 23, 31, 34 AND 35). SN 77-350,133. PUB. 5-20-2008. FILED 12-12-2007.
- 3,479,876. **GL 60 (BLOCK FORM)**. BSH BOSCH UND SIEMENS HAUSGERAETE GMBH, (U.S. CLS. 13, 19, 21, 23, 31, 34 AND 35). SN 77-350,201. PUB. 5-20-2008. FILED 12-12-2007.
- 3,479,877. **GL 70 (BLOCK FORM)**. BSH BOSCH UND SIEMENS HAUSGERAETE GMBH, (U.S. CLS. 13, 19, 21, 23, 31, 34 AND 35). SN 77-350,218. PUB. 5-20-2008. FILED 12-12-2007.
- 3,479,878. **GL 80 (BLOCK FORM)**. BSH BOSCH UND SIEMENS HAUSGERAETE GMBH, (U.S. CLS. 13, 19, 21, 23, 31, 34 AND 35). SN 77-350,234. PUB. 5-20-2008. FILED 12-12-2007.
- 3,479,879. **GL 90 (BLOCK FORM)**. BSH BOSCH UND SIEMENS HAUSGERAETE GMBH, (U.S. CLS. 13, 19, 21, 23, 31, 34 AND 35). SN 77-350,248. PUB. 5-20-2008. FILED 12-12-2007.
- 3,479,888 (*See Class 6 for this trademark*).
- 3,479,889. **GS 40 (BLOCK FORM)**. BSH BOSCH UND SIEMENS HAUSGERAETE GMBH, (U.S. CLS. 13, 19, 21, 23, 31, 34 AND 35). SN 77-351,144. PUB. 5-20-2008. FILED 12-13-2007.
- 3,479,893. **GS 70 (BLOCK FORM)**. BSH BOSCH UND SIEMENS HAUSGERAETE GMBH, (U.S. CLS. 13, 19, 21, 23, 31, 34 AND 35). SN 77-351,201. PUB. 5-20-2008. FILED 12-13-2007.
- 3,479,894. **GS 80 (BLOCK FORM)**. BSH BOSCH UND SIEMENS HAUSGERAETE GMBH, (U.S. CLS. 13, 19, 21, 23, 31, 34 AND 35). SN 77-351,212. PUB. 5-20-2008. FILED 12-13-2007.
- 3,479,895. **GS 90 (BLOCK FORM)**. BSH BOSCH UND SIEMENS HAUSGERAETE GMBH, (U.S. CLS. 13, 19, 21, 23, 31, 34 AND 35). SN 77-351,223. PUB. 5-20-2008. FILED 12-13-2007.
- 3,479,916 (*See Class 6 for this trademark*).
- 3,479,957. **MISCELLANEOUS DESIGN**. QC AMERICAN, MULTIPLE CLASS, (INT. CLS. 7 AND 42), (U.S. CLS. 13, 19, 21, 23, 31, 34, 35, 100 AND 101). SN 77-354,430. PUB. 5-20-2008. FILED 12-18-2007.
- 3,480,042. **VARIOFLEXPLUS (STYLIZED)**. BSH BOSCH UND SIEMENS HAUSGERAETE GMBH, (U.S. CLS. 13, 19, 21, 23, 31, 34 AND 35). SN 77-357,706. PUB. 5-20-2008. FILED 12-21-2007.
- 3,480,099. **IWIND AND DESIGN**. LIN, CHUN-CHIH, (U.S. CLS. 13, 19, 21, 23, 31, 34 AND 35). SN 77-359,849. PUB. 5-20-2008. FILED 12-27-2007.
- 3,480,136. **ASV AND DESIGN**. A.S.V., INC., (U.S. CLS. 13, 19, 21, 23, 31, 34 AND 35). SN 77-361,656. PUB. 5-20-2008. FILED 12-31-2007.
- 3,480,137. **CXRACING (BLOCK FORM)**. SKYQUEST INC., DBA CXRACING, (U.S. CLS. 13, 19, 21, 23, 31, 34 AND 35). SN 77-361,664. PUB. 5-20-2008. FILED 12-31-2007.
- 3,480,184. **PIVART (BLOCK FORM)**. HI-VAC CORPORATION, (U.S. CLS. 13, 19, 21, 23, 31, 34 AND 35). SN 77-362,667. PUB. 5-20-2008. FILED 1-2-2008.
- 3,480,220. **SAW IT (BLOCK FORM)**. REED MANUFACTURING, (U.S. CLS. 13, 19, 21, 23, 31, 34 AND 35). SN 77-363,250. PUB. 5-20-2008. FILED 1-3-2008.
- 3,480,289. **CREATIVE (BLOCK FORM)**. VSM GROUP AKTIEBOLAG, (U.S. CLS. 13, 19, 21, 23, 31, 34 AND 35). SN 77-364,335. PUB. 5-20-2008. FILED 1-4-2008.
- 3,480,333. **MULTIBAGGER (BLOCK FORM)**. THE SANDBAGGER CORPORATION, (U.S. CLS. 13, 19, 21, 23, 31, 34 AND 35). SN 77-364,962. PUB. 5-20-2008. FILED 1-5-2008.
- 3,480,426. **SIDEWINDER (BLOCK FORM)**. ZEBRA SKIMMERS CORP., (U.S. CLS. 13, 19, 21, 23, 31, 34 AND 35). SN 77-366,762. PUB. 5-20-2008. FILED 1-8-2008.
- 3,480,449. **TORCHMATE (BLOCK FORM)**. APPLIED ROBOTICS, INC., (U.S. CLS. 13, 19, 21, 23, 31, 34 AND 35). SN 77-367,420. PUB. 5-20-2008. FILED 1-9-2008.
- 3,480,474. **AGR AND DESIGN**. AGR STONE & TOOLS USA, INC., (U.S. CLS. 13, 19, 21, 23, 31, 34 AND 35). SN 77-367,918. PUB. 5-20-2008. FILED 1-9-2008.
- 3,480,759. **GARANT AND DESIGN**. HOFFMANN GMBH QUALITÄTWERKZEUGE, MULTIPLE CLASS, (INT. CLS. 7, 8, 9 AND 20), (U.S. CLS. 2, 13, 19, 21, 22, 23, 25, 26, 28, 31, 32, 34, 35, 36, 38, 44 AND 50). SN 79-030,733. PUB. 5-20-2008. FILED 10-2-2006.
- 3,480,765. **HRSB AND DESIGN**. HEBEI HUABEI OILFIELD RONGSHENG; MACHINERY MANUFACTURE CO., LTD., (U.S. CLS. 13, 19, 21, 23, 31, 34 AND 35). SN 79-032,117. PUB. 5-20-2008. FILED 9-26-2006.
- 3,480,768. **HANSEN (BLOCK FORM)**. SA HANSEN TRANSMISSIONS - INTERNATIONAL NV.; NAAMLOZE VENNOOTSCHAP, (U.S. CLS. 13, 19, 21, 23, 31, 34 AND 35). SN 79-032,774. PUB. 12-18-2007. FILED 9-1-2006.
- 3,480,781 (*See Class 4 for this trademark*).
- 3,480,805. **SCHWING STETTER AND DESIGN**. SCHWING GMBH, MULTIPLE CLASS, (INT. CLS. 7, 9, 12 AND 42), (U.S. CLS. 13, 19, 21, 23, 26, 31, 34, 35, 36, 38, 44, 100 AND 101). SN 79-036,372. PUB. 5-20-2008. FILED 11-22-2006.
- 3,480,810. **EIRICH MOLARIS (STYLIZED)**. MASCHINENFABRIK GUSTAV EIRICH GMBH & CO. KG, MULTIPLE CLASS, (INT. CLS. 7 AND 9), (U.S. CLS. 13, 19, 21, 23, 26, 31, 34, 35, 36 AND 38). SN 79-037,140. PUB. 5-20-2008. FILED 2-8-2007.
- 3,480,860. **DIATEX AND DESIGN**. DIATEX S.P.A., (U.S. CLS. 13, 19, 21, 23, 31, 34 AND 35). SN 79-040,780. PUB. 5-20-2008. FILED 5-15-2007.
- 3,480,870. **PLATINO (BLOCK FORM)**. PRIMA INDUSTRIE SPA, (U.S. CLS. 13, 19, 21, 23, 31, 34 AND 35). SN 79-041,093. PUB. 5-20-2008. FILED 4-6-2007.
- 3,480,899. **ORIGNAIR AND DESIGN**. ATLAS COPCO AIRPOWER.; NAAMLOZE VENNOOTSCHAP, MULTIPLE CLASS, (INT. CLS. 7, 35 AND 37), (U.S. CLS. 13, 19, 21, 23, 31, 34, 35, 100, 101, 102, 103 AND 106). SN 79-041,773. PUB. 5-20-2008. FILED 5-11-2007.
- 3,480,907. **STEAMLAB (STYLIZED)**. STEAMLAB.SYSTEMS AG, MULTIPLE CLASS, (INT. CLS. 7, 37, 40 AND 42), (U.S. CLS. 13, 19, 21, 23, 31, 34, 35, 100, 101, 103 AND 106). SN 79-041,972. PUB. 5-20-2008. FILED 7-2-2007.
- 3,480,918. **ELME SWEDISH SPREADER SYSTEMS AND DESIGN**. ELMHULTS KONSTRUKTION AB, MULTIPLE CLASS, (INT. CLS. 7, 12 AND 37), (U.S. CLS. 13, 19, 21, 23, 31, 34, 35, 44, 100, 103 AND 106). SN 79-042,241. PUB. 5-20-2008. FILED 5-9-2007.
- 3,480,945. **FLAEM NUOVA (STYLIZED)**. FLAEM NUOVA S.P.A., MULTIPLE CLASS, (INT. CLS. 7 AND 10), (U.S. CLS. 13, 19, 21, 23, 26, 31, 34, 35, 39 AND 44). SN 79-043,085.

- PUB. 5-20-2008. FILED 7-4-2007.
 3,480,954 (*See Class 1 for this trademark*).
 3,480,976. **EMERALD (BLOCK FORM)**. VSM GROUP AB, (U.S. CLS. 13, 19, 21, 23, 31, 34 AND 35). SN 79-044,367. PUB. 5-20-2008. FILED 9-21-2007.
 3,480,995. **REGISTRONIC (BLOCK FORM)**. KOENIG & BAUER AG, MULTIPLE CLASS, (INT. CLS. 7, 9 AND 37), (U.S. CLS. 13, 19, 21, 23, 26, 31, 34, 35, 36, 38, 100, 103 AND 106). SN 79-045,814. PUB. 5-20-2008. FILED 5-16-2007.
 3,481,003. **RCS (STYLIZED)**. SATA GMBH & CO. KG, (U.S. CLS. 13, 19, 21, 23, 31, 34 AND 35). SN 79-046,559. PUB. 5-20-2008. FILED 10-26-2007.
 3,481,019. **UNILOCK (BLOCK FORM)**. UNILOCK DI UMBERTO CROSTI & C. S.A.S., (U.S. CLS. 13, 19, 21, 23, 31, 34 AND 35). SN 79-047,741. PUB. 5-20-2008. FILED 10-11-2007.
 3,481,035. **FLOCMASTER (STYLIZED)**. J. F. KNAUER INDUSTRIE-ELEKTRIONIK GMBH, (U.S. CLS. 13, 19, 21, 23, 31, 34 AND 35). SN 79-049,584. PUB. 5-20-2008. FILED 12-28-2007.

CLASS 8—HAND TOOLS

- 3,478,603. **OPTIMUS (STYLIZED)**. OPTIMUS ENTERPRISE, INC., (U.S. CLS. 23, 28 AND 44). SN 76-684,773. PUB. 5-20-2008. FILED 12-10-2007.
 3,478,628. **HAND ROPER (BLOCK FORM)**. ALLIED PACKAGING CORPORATION, (U.S. CLS. 23, 28 AND 44). SN 77-005,478. PUB. 5-20-2008. FILED 9-22-2006.
 3,478,662. **SCRUBWRIGHT (BLOCK FORM)**. FOAMEX ASIA CO., LTD., (U.S. CLS. 23, 28 AND 44). SN 77-034,161. PUB. 5-20-2008. FILED 11-1-2006.
 3,478,974. **CAPTIVA (BLOCK FORM)**. MAT-PAC, INC., MULTIPLE CLASS, (INT. CLS. 8, 16 AND 21), (U.S. CLS. 2, 5, 13, 22, 23, 28, 29, 30, 33, 37, 38, 40, 44 AND 50). SN 77-194,473. PUB. 5-20-2008. FILED 5-31-2007.
 3,479,148 (*See Class 3 for this trademark*).
 3,479,232. **THE FRANKLIN BENDER (BLOCK FORM)**. FRANKLIN TOOL SYSTEMS, INC., (U.S. CLS. 23, 28 AND 44). SN 77-227,661. PUB. 5-20-2008. FILED 7-12-2007.
 3,479,466. **TIGER PAW (BLOCK FORM)**. SHANGHAI ROBUSTWORKS HARDWARE TOOLS CO., LTD, (U.S. CLS. 23, 28 AND 44). SN 77-284,285. PUB. 5-20-2008. FILED 9-20-2007.
 3,479,494. **QC (BLOCK FORM)**. CHAIN DRUG MARKETING ASSOCIATION, INC., MULTIPLE CLASS, (INT. CLS. 8, 9 AND 21), (U.S. CLS. 2, 13, 21, 23, 26, 28, 29, 30, 33, 36, 38, 40, 44 AND 50). SN 77-293,093. PUB. 5-20-2008. FILED 10-1-2007.
 3,479,546 (*See Class 1 for this trademark*).
 3,479,616 (*See Class 6 for this trademark*).
 3,479,624. **PRINCESS CARE AND DESIGN**. PRINCESS CARE, LLC, (U.S. CLS. 23, 28 AND 44). SN 77-318,456. PUB. 5-20-2008. FILED 10-31-2007.
 3,479,775 (*See Class 7 for this trademark*).
 3,480,575. **M45 (BLOCK FORM)**. HECKLER & KOCH GMBH, MULTIPLE CLASS, (INT. CLS. 8, 13 AND 25), (U.S. CLS. 2, 9, 22, 23, 28, 39 AND 44). SN 78-440,944. PUB. 5-20-2008. FILED 6-24-2004.
 3,480,588. **SHORTCUT (BLOCK FORM)**. FISKARS BRANDS, INC., (U.S. CLS. 23, 28 AND 44). SN 78-554,096. PUB. 5-20-2008. FILED 1-26-2005.
 3,480,750. **MISCELLANEOUS DESIGN**. FENGHUA NANFANG MACHINUFACTURE CO., LTD., (U.S. CLS. 23, 28 AND 44). SN 79-026,670. PUB. 5-20-2008. FILED 3-8-2006.
 3,480,759 (*See Class 7 for this trademark*).
 3,480,771. **ELEMENTAIRE (BLOCK FORM)**. ORFEVRIERIE CHRISTOFLE, MULTIPLE CLASS, (INT. CLS. 8 AND 14), (U.S. CLS. 2, 23, 27, 28, 44 AND 50). SN 79-033,268. PUB. 11-13-2007. FILED 10-17-2006.
 3,480,841. **SEESA (STYLIZED)**. LI GUANJUN, (U.S. CLS. 23, 28 AND 44). SN 79-039,721. PUB. 5-20-2008. FILED 5-21-2007.
 3,480,912. **TOUCHBEAUTY (STYLIZED)**. ZHOU ELIN, (U.S. CLS. 23, 28 AND 44). SN 79-042,124. PUB. 5-20-2008. FILED 5-25-2007.

CLASS 9—ELECTRICAL AND SCIENTIFIC APPARATUS

- 3,478,493. **LASERTRIM**. JOHANSON DIELECTRICS, INC, (U.S. CLS. 21, 23, 26, 36 AND 38). SN 76-143,522. PUB. 5-20-2008. FILED 10-11-2000.
 3,478,498. **GESTAL AND DESIGN**. JYGA CONCEPT INC., (U.S. CLS. 21, 23, 26, 36 AND 38). SN 76-492,836. PUB. 5-10-2005. FILED 2-6-2003.
 3,478,512. **CARDIOPLANET (BLOCK FORM)**. EBIT AET S.P.A., (U.S. CLS. 21, 23, 26, 36 AND 38). SN 76-646,657. PUB. 10-23-2007. FILED 9-13-2005.
 3,478,513. **CELL/B.E. CELL BROADBAND ENGINE (STYLIZED)**. KABUSHIKI KAISHA SONY COMPUTER ENTERTAINMENT, TA SONY COMPUTER ENTERTAINMENT INC., (U.S. CLS. 21, 23, 26, 36 AND 38). SN 76-650,031. PUB. 5-20-2008. FILED 11-9-2005.
 3,478,515. **TUNEBUDS (BLOCK FORM)**. GRIFFIN TECHNOLOGY, INC., (U.S. CLS. 21, 23, 26, 36 AND 38). SN 76-658,117. PUB. 5-20-2008. FILED 4-10-2006.
 3,478,516. **BELLLITHO (BLOCK FORM)**. BELL LITHO, INC., MULTIPLE CLASS, (INT. CLS. 9, 35, 39, 40 AND 42), (U.S. CLS. 21, 23, 26, 36, 38, 100, 101, 102, 103, 105 AND 106). SN 76-659,775. PUB. 5-20-2008. FILED 5-9-2006.
 3,478,517. **OMNEX TRUSTED WIRELESS (BLOCK FORM)**. OMNEX CONTROL SYSTEMS ULC, (U.S. CLS. 21, 23, 26, 36 AND 38). SN 76-659,888. PUB. 5-20-2008. FILED 5-11-2006.
 3,478,518 (*See Class 5 for this trademark*).
 3,478,533. **TARGETOR (BLOCK FORM)**. TARGETOR OY, MULTIPLE CLASS, (INT. CLS. 9 AND 42), (U.S. CLS. 21, 23, 26, 36, 38, 100 AND 101). SN 76-670,945. PUB. 5-20-2008. FILED 1-3-2007.
 3,478,538. **TECHNIPPY (BLOCK FORM)**. WILZIG, IVAN, (U.S. CLS. 21, 23, 26, 36 AND 38). SN 76-674,201. PUB. 5-20-2008. FILED 3-19-2007.
 3,478,539. **SIR IVAN (BLOCK FORM)**. WILZIG, IVAN, MULTIPLE CLASS, (INT. CLS. 9, 21 AND 25), (U.S. CLS. 2, 13, 21, 22, 23, 26, 29, 30, 33, 36, 38, 39, 40 AND 50). SN 76-674,203. PUB. 5-20-2008. FILED 3-19-2007.
 3,478,560. **ECLIPSE ILM (BLOCK FORM)**. NEON ENTERPRISE SOFTWARE, INC., (U.S. CLS. 21, 23, 26, 36 AND 38). SN 76-678,796. PUB. 5-20-2008. FILED 6-27-2007.
 3,478,562. **AY AND DESIGN**. THE UNITED METHODIST PUBLISHING HOUSE, MULTIPLE CLASS, (INT. CLS. 9 AND 16), (U.S. CLS. 2, 5, 21, 22, 23, 26, 29, 36, 37, 38 AND 50). SN 76-679,073. PUB. 5-20-2008. FILED 7-3-2007.
 3,478,574. **LEAVING EARTH AND DESIGN**. LEAVING EARTH, LLC, (U.S. CLS. 21, 23, 26, 36 AND 38). SN 76-681,161. PUB. 5-20-2008. FILED 8-27-2007.
 3,478,575. **LEAVING EARTH AND DESIGN**. LEAVING EARTH, LLC, (U.S. CLS. 21, 23, 26, 36 AND 38). SN 76-681,162. PUB. 5-20-2008. FILED 8-27-2007.
 3,478,576. **MISCELLANEOUS DESIGN**. CREATIVE MANAGER, INC., MULTIPLE CLASS, (INT. CLS. 9 AND 42), (U.S. CLS. 21, 23, 26, 36, 38, 100 AND 101). SN 76-681,357. PUB. 5-20-2008. FILED 8-31-2007.
 3,478,590. **SPECTRALASE (STYLIZED)**. SPECTRA-LASE, INC., (U.S. CLS. 21, 23, 26, 36 AND 38). SN 76-683,587. PUB. 5-20-2008. FILED 11-2-2007.
 3,478,599. **DINASTIA NORTEÑA (BLOCK FORM)**. GOMEZ, FIDENCIO, MULTIPLE CLASS, (INT. CLS. 9 AND 41), (U.S. CLS. 21, 23, 26, 36, 38, 100, 101 AND 107). SN 76-684,378. PUB. 5-20-2008. FILED 11-28-2007.
 3,478,611. **CARMICHAEL TRAINING SYSTEMS (BLOCK FORM)**. CARMICHAEL TRAINING SYSTEMS, INC., MULTIPLE CLASS, (INT. CLS. 9, 16, 25, 41 AND 44), (U.S. CLS. 2, 5, 21, 22, 23, 26, 29, 36, 37, 38, 39, 50, 100, 101 AND 107). SN 76-685,195. PUB. 5-20-2008. FILED 12-26-2007.
 3,478,617 (*See Class 7 for this trademark*).
 3,478,641 (*See Class 7 for this trademark*).
 3,478,654. **HIGH 5 SOFTWARE (STYLIZED)**. COSMICSTEP SOFTWARE, INC, (U.S. CLS. 21, 23, 26, 36 AND 38). SN 77-030,543. PUB. 5-20-2008. FILED 10-26-2006.
 3,478,659. **WILD NATURE (BLOCK FORM)**. ATRONIC INTERNATIONAL GMBH, MULTIPLE CLASS, (INT. CLS. 9 AND 41), (U.S. CLS. 21, 23, 26, 36, 38, 100, 101 AND 107). SN 77-031,963. PUB. 5-20-2008. FILED 10-30-2006.
 3,478,661. **A GAME TECHNOLOGIES AND DESIGN**. RED STEER GLOVE COMPANY, (U.S. CLS. 21, 23, 26, 36 AND

- 38). SN 77-033,155. PUB. 5-20-2008. FILED 10-31-2006.
- 3,478,670. **ECOMAN (BLOCK FORM)**. GIERSCH, DANIEL, MULTIPLE CLASS, (INT. CLS. 9, 38 AND 41), (U.S. CLS. 21, 23, 26, 36, 38, 100, 101, 104 AND 107). SN 77-038,422. PUB. 5-20-2008. FILED 11-7-2006.
- 3,478,671. **LA Z BOY AND DESIGN**. LA-Z-BOY INCORPORATED, MULTIPLE CLASS, (INT. CLS. 9, 16, 18, 20, 21, 25 AND 28), (U.S. CLS. 1, 2, 3, 5, 13, 21, 22, 23, 25, 26, 29, 30, 32, 33, 36, 37, 38, 39, 40, 41 AND 50). SN 77-039,667. PUB. 5-20-2008. FILED 11-8-2006.
- 3,478,676. **CHILDHOOD FRIENDS (BLOCK FORM)**. ILIMA CONSIDINE, AND JACOB ROSE, (U.S. CLS. 21, 23, 26, 36 AND 38). SN 77-043,151. PUB. 5-20-2008. FILED 11-14-2006.
- 3,478,681. **FACILITIESLINK (BLOCK FORM)**. NETWORK DIGICALITY, INC., MULTIPLE CLASS, (INT. CLS. 9 AND 42), (U.S. CLS. 21, 23, 26, 36, 38, 100 AND 101). SN 77-044,563. PUB. 5-20-2008. FILED 11-15-2006.
- 3,478,684. **VIBROSYSTEM (BLOCK FORM)**. VIBROSYSTEM INC., (U.S. CLS. 21, 23, 26, 36 AND 38). SN 77-046,419. PUB. 5-20-2008. FILED 11-17-2006.
- 3,478,685. **VSM AND DESIGN**. VIBROSYSTEM INC., (U.S. CLS. 21, 23, 26, 36 AND 38). SN 77-046,533. PUB. 5-20-2008. FILED 11-17-2006.
- 3,478,688. **ROS (BLOCK FORM)**. RUGGEDCOM INC., (U.S. CLS. 21, 23, 26, 36 AND 38). SN 77-047,135. PUB. 5-20-2008. FILED 11-17-2006.
- 3,478,697. **SYMBILITY AND DESIGN**. SYMBILITY SOLUTIONS, INC., (U.S. CLS. 21, 23, 26, 36 AND 38). SN 77-052,439. PUB. 5-20-2008. FILED 11-28-2006.
- 3,478,699 (See Class 6 for this trademark).
- 3,478,723. **CHINESE GOLD (BLOCK FORM)**. ATRONIC INTERNATIONAL GMBH, MULTIPLE CLASS, (INT. CLS. 9 AND 41), (U.S. CLS. 21, 23, 26, 36, 38, 100, 101 AND 107). SN 77-070,421. PUB. 5-20-2008. FILED 12-22-2006.
- 3,478,729. **ENTASIS (BLOCK FORM)**. OPTIMUM CARE INTERNATIONAL TECH. INC., (U.S. CLS. 21, 23, 26, 36 AND 38). SN 77-074,782. PUB. 5-20-2008. FILED 1-3-2007.
- 3,478,730. **KINGBRIDGE (STYLIZED)**. OPTIMUM CARE INTERNATIONAL TECH. INC., (U.S. CLS. 21, 23, 26, 36 AND 38). SN 77-074,783. PUB. 5-20-2008. FILED 1-3-2007.
- 3,478,740. **DAIRY DOLLARS (BLOCK FORM)**. ARISTOCRAT TECHNOLOGIES AUSTRALIA PTY LTD., (U.S. CLS. 21, 23, 26, 36 AND 38). SN 77-082,347. PUB. 5-20-2008. FILED 1-12-2007.
- 3,478,744. **BUDDHA-LOUNGE (BLOCK FORM)**. SEQUOIA RECORDS, INC., (U.S. CLS. 21, 23, 26, 36 AND 38). SN 77-087,259. PUB. 2-12-2008. FILED 1-20-2007.
- 3,478,793. **NEONEX (STYLIZED)**. ARTER NEON SIGN, INC., (U.S. CLS. 21, 23, 26, 36 AND 38). SN 77-115,182. PUB. 5-20-2008. FILED 2-23-2007.
- 3,478,802. **WORLD IN CRYISIS (BLOCK FORM)**. CRYTEK GMBH, MULTIPLE CLASS, (INT. CLS. 9 AND 28), (U.S. CLS. 21, 22, 23, 26, 36, 38 AND 50). SN 77-120,140. PUB. 5-20-2008. FILED 3-1-2007.
- 3,478,805. **KAVEO (BLOCK FORM)**. KING PRODUCTS AND SOLUTIONS INC., MULTIPLE CLASS, (INT. CLS. 9, 38 AND 42), (U.S. CLS. 21, 23, 26, 36, 38, 100, 101 AND 104). SN 77-121,130. PUB. 5-20-2008. FILED 3-2-2007.
- 3,478,814. **RESCUE PAY AND DESIGN**. ARUZE CORPORATION, (U.S. CLS. 21, 23, 26, 36 AND 38). SN 77-128,817. PUB. 3-18-2008. FILED 3-12-2007.
- 3,478,816. **UPFLITE (BLOCK FORM)**. LOWE, MARK A, AND OLIVER, DWIGHT A, (U.S. CLS. 21, 23, 26, 36 AND 38). SN 77-129,564. PUB. 5-20-2008. FILED 3-13-2007.
- 3,478,818. **PIKA (BLOCK FORM)**. PIKA TECHNOLOGIES INC., MULTIPLE CLASS, (INT. CLS. 9 AND 42), (U.S. CLS. 21, 23, 26, 36, 38, 100 AND 101). SN 77-130,555. PUB. 3-11-2008. FILED 3-14-2007.
- 3,478,826. **ATLANTIS ENERGY (BLOCK FORM)**. ATLANTIS ENERGY, INC., (U.S. CLS. 21, 23, 26, 36 AND 38). SN 77-139,628. PUB. 5-20-2008. FILED 3-24-2007.
- 3,478,833. **KITCHENS.COM (BLOCK FORM)**. WORLDVIEW TECHNOLOGIES, INC., (U.S. CLS. 21, 23, 26, 36 AND 38). SN 77-142,921. PUB. 5-20-2008. FILED 3-28-2007.
- 3,478,842. **CENTAURHAULS (BLOCK FORM)**. CENTAUR TECHNOLOGY, (U.S. CLS. 21, 23, 26, 36 AND 38). SN 77-146,758. PUB. 5-20-2008. FILED 4-2-2007.
- 3,478,846. **GMD AND DESIGN**. VUZIX CORPORATION, (U.S. CLS. 21, 23, 26, 36 AND 38). SN 77-147,625. PUB. 5-20-2008. FILED 4-3-2007.
- 3,478,848. **DECIPHER (BLOCK FORM)**. INNOVATION ASSET GROUP, INC., MULTIPLE CLASS, (INT. CLS. 9 AND 42), (U.S. CLS. 21, 23, 26, 36, 38, 100 AND 101). SN 77-150,106. PUB. 5-20-2008. FILED 4-5-2007.
- 3,478,857. **OPEN UP YOUR DREAMS (BLOCK FORM)**. OKI ELECTRIC INDUSTRY CO., LTD., (U.S. CLS. 21, 23, 26, 36 AND 38). SN 77-154,786. PUB. 5-20-2008. FILED 4-12-2007.
- 3,478,860. **NIVOWAVE (BLOCK FORM)**. UWT GMBH, MULTIPLE CLASS, (INT. CLS. 9 AND 37), (U.S. CLS. 21, 23, 26, 36, 38, 100, 103 AND 106). SN 77-154,973. PUB. 5-20-2008. FILED 4-12-2007.
- 3,478,863. **FLIGHTCAST (BLOCK FORM)**. FLIGHTSAFETY DEVELOPMENT CORP., MULTIPLE CLASS, (INT. CLS. 9 AND 41), (U.S. CLS. 21, 23, 26, 36, 38, 100, 101 AND 107). SN 77-157,360. PUB. 5-20-2008. FILED 4-16-2007.
- 3,478,872. **BENTLEY (BLOCK FORM)**. BENTLEY SYSTEMS, INCORPORATED, MULTIPLE CLASS, (INT. CLS. 9, 41 AND 42), (U.S. CLS. 21, 23, 26, 36, 38, 100, 101 AND 107). SN 77-161,234. PUB. 5-20-2008. FILED 4-19-2007.
- 3,478,898. **HCS HOME CONTINUITY SOLUTIONS AND DESIGN**. MURPHY, LINDA M, (U.S. CLS. 21, 23, 26, 36 AND 38). SN 77-174,530. PUB. 5-20-2008. FILED 5-7-2007.
- 3,478,905. **RAMPMAP (BLOCK FORM)**. KNOWLEDGE BASED SYSTEMS, INC., (U.S. CLS. 21, 23, 26, 36 AND 38). SN 77-175,868. PUB. 5-20-2008. FILED 5-8-2007.
- 3,478,954. **QUOKKAPAD AND DESIGN**. UBIQ TECHNOLOGIES PTY. LTD., (U.S. CLS. 21, 23, 26, 36 AND 38). SN 77-189,140. PUB. 5-20-2008. FILED 5-24-2007.
- 3,478,960. **ANOTHER LEVEL RECORDS (BLOCK FORM)**. STUDIO 4 ENTERPRISES INC., MULTIPLE CLASS, (INT. CLS. 9 AND 41), (U.S. CLS. 21, 23, 26, 36, 38, 100, 101 AND 107). SN 77-191,557. PUB. 5-20-2008. FILED 5-28-2007.
- 3,478,971. **ZEROBURN (BLOCK FORM)**. IP MINING CORPORATION, (U.S. CLS. 21, 23, 26, 36 AND 38). SN 77-193,702. PUB. 5-20-2008. FILED 5-30-2007.
- 3,478,982. **MESSAGE STUDIO (BLOCK FORM)**. STRONG-MAIL SYSTEMS, INC., (U.S. CLS. 21, 23, 26, 36 AND 38). SN 77-195,537. PUB. 5-20-2008. FILED 6-1-2007.
- 3,478,989. **AUTOVUE (BLOCK FORM)**. CIMMETRY SYSTEMS CORP., (U.S. CLS. 21, 23, 26, 36 AND 38). SN 77-195,955. PUB. 5-20-2008. FILED 6-1-2007.
- 3,478,990. **AUTOVUE PROFESSIONAL (BLOCK FORM)**. CIMMETRY SYSTEMS CORP., (U.S. CLS. 21, 23, 26, 36 AND 38). SN 77-195,965. PUB. 5-20-2008. FILED 6-1-2007.
- 3,479,000. **MICRO12 (STYLIZED)**. SEPARATION TECHNOLOGY, INC., (U.S. CLS. 21, 23, 26, 36 AND 38). SN 77-197,006. PUB. 5-20-2008. FILED 6-4-2007.
- 3,479,009. **STREETFINDER WIRELESS (BLOCK FORM)**. RAND MCNALLY & COMPANY, (U.S. CLS. 21, 23, 26, 36 AND 38). SN 77-198,026. PUB. 5-20-2008. FILED 6-5-2007.
- 3,479,015. **CONVERGENCE AUDIT (BLOCK FORM)**. CLARITAS INC., MULTIPLE CLASS, (INT. CLS. 9, 16 AND 35), (U.S. CLS. 2, 5, 21, 22, 23, 26, 29, 36, 37, 38, 50, 100, 101 AND 102). SN 77-198,890. PUB. 5-20-2008. FILED 6-6-2007.
- 3,479,021. **MOELLER SMARTWIRE (BLOCK FORM)**. MOELLER GMBH, (U.S. CLS. 21, 23, 26, 36 AND 38). SN 77-199,455. PUB. 5-20-2008. FILED 6-6-2007.
- 3,479,022. **(365) NO OFF SEASON (BLOCK FORM)**. A-1 ARCHERY, (U.S. CLS. 21, 23, 26, 36 AND 38). SN 77-199,456. PUB. 5-20-2008. FILED 6-6-2007.
- 3,479,023. **SOLAR SMART (BLOCK FORM)**. MORETON BAY CORPORATION PTY LTD, (U.S. CLS. 21, 23, 26, 36 AND 38). SN 77-199,855. PUB. 5-20-2008. FILED 6-7-2007.
- 3,479,025. **EVMI SYSTEM (BLOCK FORM)**. HON HAI PRECISION INDUSTRY CO., LTD., (U.S. CLS. 21, 23, 26, 36 AND 38). SN 77-199,954. PUB. 5-20-2008. FILED 6-7-2007.
- 3,479,031. **SIE SUPER IMAGE ENHANCER (BLOCK FORM)**. NUVICO, LLC, (U.S. CLS. 21, 23, 26, 36 AND 38). SN 77-201,412. PUB. 5-20-2008. FILED 6-8-2007.
- 3,479,037. **KOZIO AND DESIGN**. KOZIO, INC., (U.S. CLS. 21, 23, 26, 36 AND 38). SN 77-201,813. PUB. 5-20-2008. FILED 6-8-2007.
- 3,479,039. **KDIAGNOSTICS (BLOCK FORM)**. KOZIO, INC., (U.S. CLS. 21, 23, 26, 36 AND 38). SN 77-201,966. PUB. 5-20-2008. FILED 6-8-2007.
- 3,479,052. **MAXFLIGHT (BLOCK FORM)**. MAXFLIGHT COR-

- PORATION, MULTIPLE CLASS, (INT. CLS. 9 AND 41), (U.S. CLS. 21, 23, 26, 36, 38, 100, 101 AND 107). SN 77-204,715. PUB. 5-20-2008. FILED 6-13-2007.
- 3,479,080. **IVM (BLOCK FORM)**. PHOENIX WORLDWIDE INDUSTRIES, INC., (U.S. CLS. 21, 23, 26, 36 AND 38). SN 77-209,736. PUB. 5-20-2008. FILED 6-20-2007.
- 3,479,106. **TORQ (BLOCK FORM)**. ARMOR HOLDINGS PRODUCTS, LLC, (U.S. CLS. 21, 23, 26, 36 AND 38). SN 77-213,644. PUB. 5-20-2008. FILED 6-22-2007.
- 3,479,108. **ON THE NOSE AND DESIGN**. SYMONS & CO. PTY. LIMITED, (U.S. CLS. 21, 23, 26, 36 AND 38). SN 77-213,686. PUB. 5-20-2008. FILED 6-22-2007.
- 3,479,122. **MY FLASH AND DESIGN**. A-DATA TECHNOLOGY CO., LTD., (U.S. CLS. 21, 23, 26, 36 AND 38). SN 77-216,464. PUB. 5-20-2008. FILED 6-27-2007.
- 3,479,125. **SOUNDGATE (BLOCK FORM)**. STILLWATER DESIGNS AND AUDIO, INC., (U.S. CLS. 21, 23, 26, 36 AND 38). SN 77-216,723. PUB. 5-20-2008. FILED 6-27-2007.
- 3,479,130. **SONIC (BLOCK FORM)**. PROGRESS SOFTWARE CORPORATION, (U.S. CLS. 21, 23, 26, 36 AND 38). SN 77-216,930. PUB. 5-20-2008. FILED 6-27-2007.
- 3,479,134. **PROGRESS SONIC AND DESIGN**. PROGRESS SOFTWARE CORPORATION, (U.S. CLS. 21, 23, 26, 36 AND 38). SN 77-217,028. PUB. 5-20-2008. FILED 6-27-2007.
- 3,479,145. **GREEN RAY (BLOCK FORM)**. INNER SIGHT, LLC, (U.S. CLS. 21, 23, 26, 36 AND 38). SN 77-218,120. PUB. 12-18-2007. FILED 6-28-2007.
- 3,479,161. **ABREVITY AND DESIGN**. ABREVITY, INC., (U.S. CLS. 21, 23, 26, 36 AND 38). SN 77-219,134. PUB. 5-20-2008. FILED 6-29-2007.
- 3,479,165. **THE ART OF MUSHIN (BLOCK FORM)**. ALL WAYS ZEN, (U.S. CLS. 21, 23, 26, 36 AND 38). SN 77-219,980. PUB. 5-20-2008. FILED 7-1-2007.
- 3,479,168. **UNI-RUPTER (BLOCK FORM)**. S&C ELECTRTIC CO., (U.S. CLS. 21, 23, 26, 36 AND 38). SN 77-220,252. PUB. 5-20-2008. FILED 7-2-2007.
- 3,479,170. **THE INTELLIGENT BODY (BLOCK FORM)**. WILDMAN, FRANK, PH.D., (U.S. CLS. 21, 23, 26, 36 AND 38). SN 77-220,497. PUB. 5-20-2008. FILED 7-2-2007.
- 3,479,174. **ROTATOR AND DESIGN**. GOTTRIX LLC, (U.S. CLS. 21, 23, 26, 36 AND 38). SN 77-220,738. PUB. 5-20-2008. FILED 7-2-2007.
- 3,479,188. **SCHLESSINGER MEDIA (BLOCK FORM)**. LIBRARY VIDEO COMPANY, (U.S. CLS. 21, 23, 26, 36 AND 38). SN 77-222,045. PUB. 5-20-2008. FILED 7-4-2007.
- 3,479,194 (*See Class 2 for this trademark*).
- 3,479,196. **ROSTROPOVICH (BLOCK FORM)**. ROSTROPOVICH, OLGA, (U.S. CLS. 21, 23, 26, 36 AND 38). SN 77-222,629. PUB. 5-20-2008. FILED 7-5-2007.
- 3,479,210. **JOOMLA! (BLOCK FORM)**. OPEN SOURCE MATTERS, INC., (U.S. CLS. 21, 23, 26, 36 AND 38). SN 77-224,536. PUB. 5-20-2008. FILED 7-9-2007.
- 3,479,224. **J JOOMLA! AND DESIGN**. OPEN SOURCE MATTERS, INC., (U.S. CLS. 21, 23, 26, 36 AND 38). SN 77-226,768. PUB. 5-20-2008. FILED 7-11-2007.
- 3,479,226. **POWERHOUSE (BLOCK FORM)**. EATON CORPORATION, (U.S. CLS. 21, 23, 26, 36 AND 38). SN 77-226,955. PUB. 5-20-2008. FILED 7-11-2007.
- 3,479,230. **COPS (BLOCK FORM)**. DATATRAC CORPORATION, (U.S. CLS. 21, 23, 26, 36 AND 38). SN 77-227,464. PUB. 5-20-2008. FILED 7-11-2007.
- 3,479,234. **W AND DESIGN**. WOWZATV LLC, DBA WOWZA MEDIA SYSTEMS, (U.S. CLS. 21, 23, 26, 36 AND 38). SN 77-228,211. PUB. 5-20-2008. FILED 7-12-2007.
- 3,479,238 (*See Class 7 for this trademark*).
- 3,479,239 (*See Class 7 for this trademark*).
- 3,479,250. **STEERINGWHEELS (BLOCK FORM)**. AUTO-DESK, INC., (U.S. CLS. 21, 23, 26, 36 AND 38). SN 77-230,385. PUB. 5-20-2008. FILED 7-16-2007.
- 3,479,252. **MISCELLANEOUS DESIGN**. CENTER FOR LEADERSHIP IN SCHOOL REFORM INC., DBA D/B/A THE SCHLECHTY CENTER, MULTIPLE CLASS, (INT. CLS. 9, 16 AND 41), (U.S. CLS. 2, 5, 21, 22, 23, 26, 29, 36, 37, 38, 50, 100, 101 AND 107). SN 77-230,513. PUB. 5-20-2008. FILED 7-16-2007.
- 3,479,269. **CUSTOMTUTOR (BLOCK FORM)**. BVS, INC., MULTIPLE CLASS, (INT. CLS. 9 AND 42), (U.S. CLS. 21, 23, 26, 36, 38, 100 AND 101). SN 77-232,854. PUB. 5-20-2008. FILED 7-18-2007.
- 3,479,291. **WIRSOL (BLOCK FORM)**. WIRSOL GMBH, MULTIPLE CLASS, (INT. CLS. 9, 11, 37, 40 AND 42), (U.S. CLS. 13, 21, 23, 26, 31, 34, 36, 38, 100, 101, 103 AND 106). SN 77-237,065. PUB. 5-20-2008. FILED 7-24-2007.
- 3,479,294. **LILTONE (BLOCK FORM)**. LILTONE, INC., (U.S. CLS. 21, 23, 26, 36 AND 38). SN 77-237,455. PUB. 5-20-2008. FILED 7-24-2007.
- 3,479,316. **GENE (BLOCK FORM)**. ELSEVIER BV, (U.S. CLS. 21, 23, 26, 36 AND 38). SN 77-243,665. PUB. 5-20-2008. FILED 7-31-2007.
- 3,479,323. **APPARELMAGIC (BLOCK FORM)**. MURPHY, JOHN S., DBA MURPHY & ASSOCIATES, INC., (U.S. CLS. 21, 23, 26, 36 AND 38). SN 77-245,911. PUB. 5-20-2008. FILED 8-2-2007.
- 3,479,324. **RPATH (BLOCK FORM)**. RPATH, INC., (U.S. CLS. 21, 23, 26, 36 AND 38). SN 77-246,145. PUB. 5-20-2008. FILED 8-3-2007.
- 3,479,330. **PORTAPEZE (BLOCK FORM)**. SPLAIN, JACQUELINE, DBA SPLAIN DEVELOPMENT, LLC, (U.S. CLS. 21, 23, 26, 36 AND 38). SN 77-247,311. PUB. 5-20-2008. FILED 8-4-2007.
- 3,479,334. **HOLIDAY HANG-UPS (BLOCK FORM)**. HOLIDAY HANG-UPS INC., DBA HOLIDAY HANG-UPS INC., (U.S. CLS. 21, 23, 26, 36 AND 38). SN 77-249,072. PUB. 5-20-2008. FILED 8-7-2007.
- 3,479,374. **FX GOOSE (BLOCK FORM)**. M25 INVESTMENTS, LLC, (U.S. CLS. 21, 23, 26, 36 AND 38). SN 77-261,505. PUB. 5-20-2008. FILED 8-22-2007.
- 3,479,376. **OCTANE (BLOCK FORM)**. LARCAN INC., (U.S. CLS. 21, 23, 26, 36 AND 38). SN 77-261,666. PUB. 5-20-2008. FILED 8-22-2007.
- 3,479,389. **DIRTY CHAMBER (BLOCK FORM)**. DIRTY CHAMBER MUSIC GROUP LLC, (U.S. CLS. 21, 23, 26, 36 AND 38). SN 77-264,561. PUB. 5-20-2008. FILED 8-26-2007.
- 3,479,395. **SEARCHLE IT! (BLOCK FORM)**. SEARCHLES, INC., (U.S. CLS. 21, 23, 26, 36 AND 38). SN 77-265,524. PUB. 5-20-2008. FILED 8-27-2007.
- 3,479,411. **ILLUMITEX (BLOCK FORM)**. ILLUMITEX, INC., DBA ILLUMITEX, INC., (U.S. CLS. 21, 23, 26, 36 AND 38). SN 77-270,338. PUB. 5-20-2008. FILED 9-3-2007.
- 3,479,454. **MYSTAR123.COM (BLOCK FORM)**. QPAY, INC., MULTIPLE CLASS, (INT. CLS. 9 AND 36), (U.S. CLS. 21, 23, 26, 36, 38, 100, 101 AND 102). SN 77-281,221. PUB. 5-20-2008. FILED 9-17-2007.
- 3,479,468. **ADVISOR WISDOM (BLOCK FORM)**. USA FINANCIAL MARKETING CORPORATION, (U.S. CLS. 21, 23, 26, 36 AND 38). SN 77-286,083. PUB. 5-20-2008. FILED 9-21-2007.
- 3,479,494 (*See Class 8 for this trademark*).
- 3,479,497. **Z-MAX (BLOCK FORM)**. CARPENTER ADVANCED CERAMICS, INC., (U.S. CLS. 21, 23, 26, 36 AND 38). SN 77-293,879. PUB. 5-20-2008. FILED 10-2-2007.
- 3,479,507. **RECEIVERNET (BLOCK FORM)**. ABACA TECHNOLOGY CORPORATION, MULTIPLE CLASS, (INT. CLS. 9 AND 42), (U.S. CLS. 21, 23, 26, 36, 38, 100 AND 101). SN 77-298,741. PUB. 5-20-2008. FILED 10-8-2007.
- 3,479,508. **THE MAIN STREET ECONOMIST (BLOCK FORM)**. FEDERAL RESERVE BANK OF KANSAS CITY, (U.S. CLS. 21, 23, 26, 36 AND 38). SN 77-298,847. PUB. 5-20-2008. FILED 10-8-2007.
- 3,479,515. **COMMONROOM (BLOCK FORM)**. THINK COMPUTER CORPORATION, (U.S. CLS. 21, 23, 26, 36 AND 38). SN 77-299,954. PUB. 5-20-2008. FILED 10-9-2007.
- 3,479,517. **SE7EN (BLOCK FORM)**. YG ENTERTAINMENT, INC., MULTIPLE CLASS, (INT. CLS. 9 AND 41), (U.S. CLS. 21, 23, 26, 36, 38, 100, 101 AND 107). SN 77-300,425. PUB. 5-20-2008. FILED 10-10-2007.
- 3,479,520. **KVH INDUSTRIES MINI-VSAT BROADBAND AND DESIGN**. KVH INDUSTRIES, INC., MULTIPLE CLASS, (INT. CLS. 9 AND 38), (U.S. CLS. 21, 23, 26, 36, 38, 100, 101 AND 104). SN 77-300,605. PUB. 5-20-2008. FILED 10-10-2007.
- 3,479,539. **INPORTER (BLOCK FORM)**. MANAGING EDITOR INC., DBA MEI, (U.S. CLS. 21, 23, 26, 36 AND 38). SN 77-302,621. PUB. 5-20-2008. FILED 10-12-2007.
- 3,479,542. **NORTHERN LIGHT (BLOCK FORM)**. DAVID STUART SANDLER, MULTIPLE CLASS, (INT. CLS. 9 AND 41), (U.S. CLS. 21, 23, 26, 36, 38, 100, 101 AND 107). SN 77-303,432. PUB. 5-20-2008. FILED 10-12-2007.

- 3,479,569. **BLUETHINK (BLOCK FORM)**. SELVAAG BLUE-THINK AS, MULTIPLE CLASS, (INT. CLS. 9, 37 AND 42), (U.S. CLS. 21, 23, 26, 36, 38, 100, 101, 103 AND 106). SN 77-309,737. PUB. 5-20-2008. FILED 10-22-2007.
- 3,479,593. **COLORADO RAPIDS 96 AND DESIGN**. MAJOR LEAGUE SOCCER, LLC, MULTIPLE CLASS, (INT. CLS. 9, 16, 25, 28 AND 41), (U.S. CLS. 2, 5, 21, 22, 23, 26, 29, 36, 37, 38, 39, 50, 100, 101 AND 107). SN 77-313,333. PUB. 5-20-2008. FILED 10-25-2007.
- 3,479,595. **LA GALAXY AND DESIGN**. MAJOR LEAGUE SOCCER, LLC, MULTIPLE CLASS, (INT. CLS. 9, 16, 25, 28 AND 41), (U.S. CLS. 2, 5, 21, 22, 23, 26, 29, 36, 37, 38, 39, 50, 100, 101 AND 107). SN 77-313,847. PUB. 5-20-2008. FILED 10-25-2007.
- 3,479,605. **LEADPOWER (BLOCK FORM)**. WARD MEDIA, INC., (U.S. CLS. 21, 23, 26, 36 AND 38). SN 77-315,849. PUB. 5-20-2008. FILED 10-29-2007.
- 3,479,620. **INTELLITRAP AND DESIGN**. AMCOR, INC., MULTIPLE CLASS, (INT. CLS. 9 AND 11), (U.S. CLS. 13, 21, 23, 26, 31, 34, 36 AND 38). SN 77-318,119. PUB. 5-20-2008. FILED 10-31-2007.
- 3,479,626. **MONGABAY (BLOCK FORM)**. BUTLER, RHETT A., (U.S. CLS. 21, 23, 26, 36 AND 38). SN 77-318,629. PUB. 5-20-2008. FILED 10-31-2007.
- 3,479,671. **THE LUCKY SHOP OF XAO FUNG (BLOCK FORM)**. ZUCCA VOLANTE LLP, (U.S. CLS. 21, 23, 26, 36 AND 38). SN 77-325,648. PUB. 5-20-2008. FILED 11-9-2007.
- 3,479,673. **XI XU PAO (BLOCK FORM)**. ZUCCA VOLANTE LLP, (U.S. CLS. 21, 23, 26, 36 AND 38). SN 77-325,766. PUB. 5-20-2008. FILED 11-9-2007.
- 3,479,713. **ONBOARD (BLOCK FORM)**. ATEK, INC., (U.S. CLS. 21, 23, 26, 36 AND 38). SN 77-331,051. PUB. 5-20-2008. FILED 11-15-2007.
- 3,479,719 (*See Class 1 for this trademark*).
- 3,479,725. **ADIRONDACK OPTICS (BLOCK FORM)**. ADIRONDACK DIGITAL IMAGING SYSTEMS, INC., MULTIPLE CLASS, (INT. CLS. 9 AND 13), (U.S. CLS. 2, 9, 21, 23, 26, 36 AND 38). SN 77-333,293. PUB. 5-20-2008. FILED 11-19-2007.
- 3,479,742. **MISCELLANEOUS DESIGN**. KONGPOWER TECHNOLOGY CO., LTD., (U.S. CLS. 21, 23, 26, 36 AND 38). SN 77-335,605. PUB. 5-20-2008. FILED 11-21-2007.
- 3,479,745. **COMPTONPLATING (BLOCK FORM)**. DAVID ROBERT ZABALZA, MULTIPLE CLASS, (INT. CLS. 9 AND 41), (U.S. CLS. 21, 23, 26, 36, 38, 100, 101 AND 107). SN 77-335,800. PUB. 5-20-2008. FILED 11-22-2007.
- 3,479,758. **DESTIN AND DESIGN**. E-DESTINACCESS, INC., (U.S. CLS. 21, 23, 26, 36 AND 38). SN 77-338,244. PUB. 5-20-2008. FILED 11-27-2007.
- 3,479,792. **APPLoader (BLOCK FORM)**. NEW RESOURCE GROUP CONSULTING, INC., (U.S. CLS. 21, 23, 26, 36 AND 38). SN 77-341,797. PUB. 5-20-2008. FILED 12-1-2007.
- 3,479,800. **THE MUSIC PRODUCER AND DESIGN**. BELKER, WHITNEY, (U.S. CLS. 21, 23, 26, 36 AND 38). SN 77-342,404. PUB. 5-20-2008. FILED 12-3-2007.
- 3,479,821. **QEAM (BLOCK FORM)**. THE WILL-BURT COMPANY, (U.S. CLS. 21, 23, 26, 36 AND 38). SN 77-344,369. PUB. 5-20-2008. FILED 12-5-2007.
- 3,479,822. **PLATINUM CS PROTECTION AND DESIGN**. RAIA, GABRIEL, (U.S. CLS. 21, 23, 26, 36 AND 38). SN 77-344,485. PUB. 5-20-2008. FILED 12-5-2007.
- 3,479,839. **STEAM PRO (BLOCK FORM)**. THERMOFLOW INC., (U.S. CLS. 21, 23, 26, 36 AND 38). SN 77-346,421. PUB. 5-20-2008. FILED 12-7-2007.
- 3,479,840. **STEAM MASTER (BLOCK FORM)**. THERMOFLOW INC., (U.S. CLS. 21, 23, 26, 36 AND 38). SN 77-346,440. PUB. 5-20-2008. FILED 12-7-2007.
- 3,479,843. **WHITETAIL FREAKS (BLOCK FORM)**. A.L.S. ENTERPRISES, INC., MULTIPLE CLASS, (INT. CLS. 9 AND 41), (U.S. CLS. 21, 23, 26, 36, 38, 100, 101 AND 107). SN 77-346,916. PUB. 5-20-2008. FILED 12-7-2007.
- 3,479,851. **BYTESIZE SCIENCE (BLOCK FORM)**. AMERICAN CHEMICAL SOCIETY, (U.S. CLS. 21, 23, 26, 36 AND 38). SN 77-348,223. PUB. 5-20-2008. FILED 12-10-2007.
- 3,479,866. **CORE CITATION (BLOCK FORM)**. THE AURI GROUP, LLC, (U.S. CLS. 21, 23, 26, 36 AND 38). SN 77-349,705. PUB. 5-20-2008. FILED 12-12-2007.
- 3,479,888 (*See Class 6 for this trademark*).
- 3,479,908. **MAKE TIME FOR MUSIC (BLOCK FORM)**. MASTRAN MUSIC GROUP, LLC, (U.S. CLS. 21, 23, 26, 36 AND 38). SN 77-351,790. PUB. 5-20-2008. FILED 12-13-2007.
- 3,479,916 (*See Class 6 for this trademark*).
- 3,479,934. **REVEAL (BLOCK FORM)**. CANFIELD SCIENTIFIC, INC., (U.S. CLS. 21, 23, 26, 36 AND 38). SN 77-353,342. PUB. 5-20-2008. FILED 12-17-2007.
- 3,479,936. **CAUCHO AND DESIGN**. CAUCHO TECHNOLOGY, INC., (U.S. CLS. 21, 23, 26, 36 AND 38). SN 77-353,595. PUB. 5-20-2008. FILED 12-17-2007.
- 3,479,949. **DATAKEY ELECTRONICS AND DESIGN**. DATAKEY ELECTRONICS, INC., (U.S. CLS. 21, 23, 26, 36 AND 38). SN 77-354,179. PUB. 5-20-2008. FILED 12-17-2007.
- 3,479,964. **PROXIMITY LAB (BLOCK FORM)**. KARATZAS, EVAN, MULTIPLE CLASS, (INT. CLS. 9 AND 42), (U.S. CLS. 21, 23, 26, 36, 38, 100 AND 101). SN 77-354,636. PUB. 5-20-2008. FILED 12-18-2007.
- 3,479,983. **THE MEAT HANDLER (BLOCK FORM)**. CHRISTOPHER M. KUEHNEL, (U.S. CLS. 21, 23, 26, 36 AND 38). SN 77-355,560. PUB. 5-20-2008. FILED 12-19-2007.
- 3,479,993. **VIDAONE AND DESIGN**. VIDAONE, INC., DBA EXPOSE SOFTWARE CORP., (U.S. CLS. 21, 23, 26, 36 AND 38). SN 77-356,251. PUB. 5-20-2008. FILED 12-19-2007.
- 3,480,005. **WHO WILL SPEAK FOR ME? (BLOCK FORM)**. CENTER FOR CHILDREN'S ADVOCACY, INC., MULTIPLE CLASS, (INT. CLS. 9 AND 16), (U.S. CLS. 2, 5, 21, 22, 23, 26, 29, 36, 37, 38 AND 50). SN 77-356,670. PUB. 5-20-2008. FILED 12-20-2007.
- 3,480,006. **I WILL SPEAK UP FOR MYSELF (BLOCK FORM)**. CENTER FOR CHILDREN'S ADVOCACY, INC., MULTIPLE CLASS, (INT. CLS. 9 AND 16), (U.S. CLS. 2, 5, 21, 22, 23, 26, 29, 36, 37, 38 AND 50). SN 77-356,684. PUB. 5-20-2008. FILED 12-20-2007.
- 3,480,009. **MYVAL (BLOCK FORM)**. MIHAYLOV, STEFAN V., (U.S. CLS. 21, 23, 26, 36 AND 38). SN 77-356,715. PUB. 5-20-2008. FILED 12-20-2007.
- 3,480,011. **MOBILE WORKMATE (BLOCK FORM)**. OFFICE CLUB, INC., THE, (U.S. CLS. 21, 23, 26, 36 AND 38). SN 77-356,801. PUB. 5-20-2008. FILED 12-20-2007.
- 3,480,015. **FORFILE (BLOCK FORM)**. LONGWOOD SOFTWARE, INC., (U.S. CLS. 21, 23, 26, 36 AND 38). SN 77-356,915. PUB. 5-20-2008. FILED 12-20-2007.
- 3,480,016. **DOLPHIN (STYLIZED)**. INVENSYS SYSTEMS, INC., AND INVENSYS SYSTEMS, INC., (U.S. CLS. 21, 23, 26, 36 AND 38). SN 77-356,921. PUB. 5-20-2008. FILED 12-20-2007.
- 3,480,039. **HYPERVELOCITY (BLOCK FORM)**. GLOBAL TECH RESOURCES LLC, (U.S. CLS. 21, 23, 26, 36 AND 38). SN 77-357,566. PUB. 5-20-2008. FILED 12-20-2007.
- 3,480,046. **KATSTAR AND DESIGN**. DALEYWARE.COM, (U.S. CLS. 21, 23, 26, 36 AND 38). SN 77-357,936. PUB. 5-20-2008. FILED 12-21-2007.
- 3,480,059. **SCS750 (BLOCK FORM)**. MAXWELL TECHNOLOGIES, INC., (U.S. CLS. 21, 23, 26, 36 AND 38). SN 77-358,574. PUB. 5-20-2008. FILED 12-21-2007.
- 3,480,067. **DI VITTORE (STYLIZED)**. STEMICK OPTICAL INC., (U.S. CLS. 21, 23, 26, 36 AND 38). SN 77-358,947. PUB. 5-20-2008. FILED 12-23-2007.
- 3,480,068. **PIPEWORKS (BLOCK FORM)**. BACKBONE ENTERTAINMENT, MULTIPLE CLASS, (INT. CLS. 9, 28 AND 42), (U.S. CLS. 21, 22, 23, 26, 36, 38, 50, 100 AND 101). SN 77-358,953. PUB. 5-20-2008. FILED 12-23-2007.
- 3,480,069. **PIPEWORKS PS AND DESIGN**. BACKBONE ENTERTAINMENT, MULTIPLE CLASS, (INT. CLS. 9, 28 AND 42), (U.S. CLS. 21, 22, 23, 26, 36, 38, 50, 100 AND 101). SN 77-358,954. PUB. 5-20-2008. FILED 12-23-2007.
- 3,480,071. **FARENHEIT (BLOCK FORM)**. EPSILON ELECTRONICS, INC., (U.S. CLS. 21, 23, 26, 36 AND 38). SN 77-359,063. PUB. 5-20-2008. FILED 12-24-2007.
- 3,480,072. **POWER ACOUSTIK (BLOCK FORM)**. EPSILON ELECTRONICS, INC., (U.S. CLS. 21, 23, 26, 36 AND 38). SN 77-359,065. PUB. 5-20-2008. FILED 12-24-2007.
- 3,480,090. **MISCELLANEOUS DESIGN**. WINNING KIDS, INCORPORATED, MULTIPLE CLASS, (INT. CLS. 9 AND 16), (U.S. CLS. 2, 5, 21, 22, 23, 26, 29, 36, 37, 38 AND 50). SN 77-359,556. PUB. 5-20-2008. FILED 12-26-2007.
- 3,480,095. **OPTIMUM (BLOCK FORM)**. GLOBAL EDUCATION ONLINE CORPORATION, DBA GLOBAL BUSI-

- NESS SERVICE CORPORATION, (U.S. CLS. 21, 23, 26, 36 AND 38). SN 77-359,691. PUB. 5-20-2008. FILED 12-26-2007.
- 3,480,104. **HOLOVEGA PLUS (BLOCK FORM)**, HALE, STEVE C., (U.S. CLS. 21, 23, 26, 36 AND 38). SN 77-360,125. PUB. 5-20-2008. FILED 12-27-2007.
- 3,480,105. **HOLOROADSHO PLUS (BLOCK FORM)**, HALE, STEVE C., (U.S. CLS. 21, 23, 26, 36 AND 38). SN 77-360,151. PUB. 5-20-2008. FILED 12-27-2007.
- 3,480,149. **FLOPHOUSE RECORDS (BLOCK FORM)**, FLOPHOUSE RECORDS, (U.S. CLS. 21, 23, 26, 36 AND 38). SN 77-361,960. PUB. 5-20-2008. FILED 12-31-2007.
- 3,480,151. **A AND DESIGN**, ANDERSON ARMOR & SECURITY LLC, (U.S. CLS. 21, 23, 26, 36 AND 38). SN 77-361,982. PUB. 5-20-2008. FILED 12-31-2007.
- 3,480,177. **GLASSCALE (BLOCK FORM)**, JOSHUA D. KESSELMAN, (U.S. CLS. 21, 23, 26, 36 AND 38). SN 77-362,502. PUB. 5-20-2008. FILED 1-2-2008.
- 3,480,182. **ACM RECORDS (BLOCK FORM)**, COHEN, ALAN, DBA ACM RECORDS, INC., AND EVELYNE COHEN, DBA ACM RECORDS, INC., MULTIPLE CLASS, (INT. CLS. 9 AND 41), (U.S. CLS. 21, 23, 26, 36, 38, 100, 101 AND 107). SN 77-362,636. PUB. 5-20-2008. FILED 1-2-2008.
- 3,480,189. **CV (STYLIZED)**, CERWIN VEGA, INC., (U.S. CLS. 21, 23, 26, 36 AND 38). SN 77-362,760. PUB. 5-20-2008. FILED 1-2-2008.
- 3,480,225. **BUILDINGCHURCHLEADERS (STYLIZED)**, CHRISTIANITY TODAY INTERNATIONAL, (U.S. CLS. 21, 23, 26, 36 AND 38). SN 77-363,290. PUB. 5-20-2008. FILED 1-3-2008.
- 3,480,226. **MISCELLANEOUS DESIGN**, NUHEAT INDUSTRIES LIMITED, MULTIPLE CLASS, (INT. CLS. 9 AND 11), (U.S. CLS. 13, 21, 23, 26, 31, 34, 36 AND 38). SN 77-363,307. PUB. 5-20-2008. FILED 1-3-2008.
- 3,480,232. **MATRIMIX (BLOCK FORM)**, MATRICAL, INC., (U.S. CLS. 21, 23, 26, 36 AND 38). SN 77-363,443. PUB. 5-20-2008. FILED 1-3-2008.
- 3,480,234. **CSEP (BLOCK FORM)**, CALGON CARBON CORPORATION, (U.S. CLS. 21, 23, 26, 36 AND 38). SN 77-363,470. PUB. 5-20-2008. FILED 1-3-2008.
- 3,480,235. **NUHEAT (BLOCK FORM)**, NUHEAT INDUSTRIES LIMITED, MULTIPLE CLASS, (INT. CLS. 9 AND 11), (U.S. CLS. 13, 21, 23, 26, 31, 34, 36 AND 38). SN 77-363,490. PUB. 5-20-2008. FILED 1-3-2008.
- 3,480,255. **ORGANIC MOTION (BLOCK FORM)**, ORGANIC MOTION, INC., MULTIPLE CLASS, (INT. CLS. 9 AND 42), (U.S. CLS. 21, 23, 26, 36, 38, 100 AND 101). SN 77-363,745. PUB. 5-20-2008. FILED 1-3-2008.
- 3,480,261. **LABORATORY LOOT (BLOCK FORM)**, PROGRESSIVE GAMING INTERNATIONAL CORP., (U.S. CLS. 21, 23, 26, 36 AND 38). SN 77-363,842. PUB. 5-20-2008. FILED 1-3-2008.
- 3,480,262. **TEAM BACKWOODS (BLOCK FORM)**, TEAM BACKWOODS, LLC, (U.S. CLS. 21, 23, 26, 36 AND 38). SN 77-363,851. PUB. 5-20-2008. FILED 1-3-2008.
- 3,480,270. **NFPA 1600 (BLOCK FORM)**, NATIONAL FIRE PROTECTION ASSOCIATION, INC., MULTIPLE CLASS, (INT. CLS. 9 AND 16), (U.S. CLS. 2, 5, 21, 22, 23, 26, 29, 36, 37, 38 AND 50). SN 77-363,952. PUB. 5-20-2008. FILED 1-4-2008.
- 3,480,271. **LEO (BLOCK FORM)**, EDDY, IAN, (U.S. CLS. 21, 23, 26, 36 AND 38). SN 77-363,994. PUB. 5-20-2008. FILED 1-4-2008.
- 3,480,276. **LITTLE DIPPER (BLOCK FORM)**, SCIGENE CORPORATION, (U.S. CLS. 21, 23, 26, 36 AND 38). SN 77-364,079. PUB. 5-20-2008. FILED 1-4-2008.
- 3,480,279. **MISCELLANEOUS DESIGN**, STROHL SYSTEMS GROUP, INC., MULTIPLE CLASS, (INT. CLS. 9 AND 35), (U.S. CLS. 21, 23, 26, 36, 38, 100, 101 AND 102). SN 77-364,141. PUB. 5-20-2008. FILED 1-4-2008.
- 3,480,290. **VIKING LODGE MUSIC AND DESIGN**, VIKING LODGE MUSIC, LLC, (U.S. CLS. 21, 23, 26, 36 AND 38). SN 77-364,338. PUB. 5-20-2008. FILED 1-4-2008.
- 3,480,311. **VOLT DETECTIVE AND DESIGN**, HI-TECH ELECTRONIC PRODUCTS & MFG., INC., (U.S. CLS. 21, 23, 26, 36 AND 38). SN 77-364,558. PUB. 5-20-2008. FILED 1-4-2008.
- 3,480,379. **BIOTRUST (BLOCK FORM)**, COGENT, INC., (U.S. CLS. 21, 23, 26, 36 AND 38). SN 77-365,943. PUB. 5-20-2008. FILED 1-7-2008.
- 3,480,392. **ZEUS (BLOCK FORM)**, KAPRO INDUSTRIES LTD, (U.S. CLS. 21, 23, 26, 36 AND 38). SN 77-366,176. PUB. 5-20-2008. FILED 1-8-2008.
- 3,480,401. **STOREFRONT 7.0 (BLOCK FORM)**, LAGARDE, INCORPORATED, MULTIPLE CLASS, (INT. CLS. 9 AND 42), (U.S. CLS. 21, 23, 26, 36, 38, 100 AND 101). SN 77-366,393. PUB. 5-20-2008. FILED 1-8-2008.
- 3,480,415. **MIND STEREO (BLOCK FORM)**, TRANSPARENT CORPORATION, DBA TRANSPARENT CORPORATION, (U.S. CLS. 21, 23, 26, 36 AND 38). SN 77-366,587. PUB. 5-20-2008. FILED 1-8-2008.
- 3,480,418. **NEURO PROGRAMMER (BLOCK FORM)**, TRANSPARENT CORPORATION, DBA TRANSPARENT CORPORATION, (U.S. CLS. 21, 23, 26, 36 AND 38). SN 77-366,620. PUB. 5-20-2008. FILED 1-8-2008.
- 3,480,450. **TITLEASSIST (BLOCK FORM)**, ODYSSEY MEDIA, INC., (U.S. CLS. 21, 23, 26, 36 AND 38). SN 77-367,439. PUB. 5-20-2008. FILED 1-9-2008.
- 3,480,455. **EMCAT PRO (BLOCK FORM)**, ALL-TEST PRO, LLC, (U.S. CLS. 21, 23, 26, 36 AND 38). SN 77-367,580. PUB. 5-20-2008. FILED 1-9-2008.
- 3,480,464. **LSK MEDIA (BLOCK FORM)**, ALASKA, INC., (U.S. CLS. 21, 23, 26, 36 AND 38). SN 77-367,726. PUB. 5-20-2008. FILED 1-9-2008.
- 3,480,481. **THE MOTHER OF ALL AUTOMATION PROGRAMS (BLOCK FORM)**, MANSION PRODUCTIONS, LLC, DBA MANSION PRODUCTIONS, INC., (U.S. CLS. 21, 23, 26, 36 AND 38). SN 77-368,119. PUB. 5-20-2008. FILED 1-9-2008.
- 3,480,499. **LUPROLINK (BLOCK FORM)**, TAP PHARMACEUTICAL PRODUCTS, INC., MULTIPLE CLASS, (INT. CLS. 9, 35 AND 42), (U.S. CLS. 21, 23, 26, 36, 38, 100, 101 AND 102). SN 77-372,724. PUB. 5-20-2008. FILED 1-16-2008.
- 3,480,500. **LUPROLINK AND DESIGN**, TAP PHARMACEUTICAL PRODUCTS, INC., MULTIPLE CLASS, (INT. CLS. 9, 35 AND 42), (U.S. CLS. 21, 23, 26, 36, 38, 100, 101 AND 102). SN 77-372,727. PUB. 5-20-2008. FILED 1-16-2008.
- 3,480,512. **HIPPIE (BLOCK FORM)**, TECHGUARD SECURITY, LLC, (U.S. CLS. 21, 23, 26, 36 AND 38). SN 77-376,523. PUB. 5-20-2008. FILED 1-21-2008.
- 3,480,521. **THE FUTURE IS BRIGHT (BLOCK FORM)**, SUNSHINE SYSTEMS, LLC., (U.S. CLS. 21, 23, 26, 36 AND 38). SN 77-378,058. PUB. 5-20-2008. FILED 1-23-2008.
- 3,480,531. **GAMESHIELD (BLOCK FORM)**, SOFTWARESHIELD TECHNOLOGIES, INC., (U.S. CLS. 21, 23, 26, 36 AND 38). SN 77-384,494. PUB. 5-20-2008. FILED 1-30-2008.
- 3,480,545. **CHEMGARD (BLOCK FORM)**, THE BAKER COMPANY, (U.S. CLS. 21, 23, 26, 36 AND 38). SN 77-397,224. PUB. 5-20-2008. FILED 2-14-2008.
- 3,480,573. **EMI AND DESIGN**, EMI (IP) LIMITED, (U.S. CLS. 21, 23, 26, 36 AND 38). SN 78-333,105. PUB. 9-26-2006. FILED 11-25-2003.
- 3,480,577. **FOREVER-KIDS (BLOCK FORM)**, SEARLES, LINDA, MULTIPLE CLASS, (INT. CLS. 9 AND 41), (U.S. CLS. 21, 23, 26, 36, 38, 100, 101 AND 107). SN 78-455,825. PUB. 8-22-2006. FILED 7-23-2004.
- 3,480,583. **SIGNATURE SERIES (BLOCK FORM)**, MONSTER, LLC, (U.S. CLS. 21, 23, 26, 36 AND 38). SN 78-509,886. PUB. 5-20-2008. FILED 11-2-2004.
- 3,480,584. **TELCEL DIRECTO (BLOCK FORM)**, ADMINISTRADORA DE MARCAS RD, S. DE R.L. DE C.V., MULTIPLE CLASS, (INT. CLS. 9, 16, 25, 35, 38 AND 41), (U.S. CLS. 2, 5, 21, 22, 23, 26, 29, 36, 37, 38, 39, 50, 100, 101, 102, 104 AND 107). SN 78-518,845. PUB. 5-20-2008. FILED 11-17-2004.
- 3,480,586. **MYCOLLECTION (BLOCK FORM)**, ESPRO INFORMATION TECHNOLOGIES LTD., MULTIPLE CLASS, (INT. CLS. 9, 16, 37 AND 42), (U.S. CLS. 2, 5, 21, 22, 23, 26, 29, 36, 37, 38, 50, 100, 101, 103 AND 106). SN 78-540,803. PUB. 8-7-2007. FILED 1-2-2005.
- 3,480,595. **TELCEL DIRECTO AND DESIGN**, ADMINISTRADORA DE MARCAS RD, S. DE R.L. DE C.V., MULTIPLE CLASS, (INT. CLS. 9, 16, 25, 35, 38 AND 41), (U.S. CLS. 2, 5, 21, 22, 23, 26, 29, 36, 37, 38, 39, 50, 100, 101, 102, 104 AND 107). SN 78-589,788. PUB. 5-20-2008. FILED 3-17-2005.
- 3,480,596. **TELCEL DIRECTO AND DESIGN**, ADMINISTRADORA DE MARCAS RD, S. DE R.L. DE C.V., MULTIPLE CLASS, (INT. CLS. 9, 16, 25, 35, 38 AND 41), (U.S. CLS. 2, 5, 21, 22, 23, 26, 29, 36, 37, 38, 39, 50, 100, 101, 102, 104 AND 107).

- SN 78-589,855. PUB. 5-20-2008. FILED 3-17-2005.
- 3,480,597. **TELCEL DIRECTO AND DESIGN**. ADMINISTRADORA DE MARCAS RD, S. DE R.L. DE C.V., MULTIPLE CLASS, (INT. CLS. 9, 16, 25, 35, 38 AND 41), (U.S. CLS. 2, 5, 21, 22, 23, 26, 29, 36, 37, 38, 39, 50, 100, 101, 102, 104 AND 107). SN 78-589,926. PUB. 5-20-2008. FILED 3-17-2005.
- 3,480,604. **SHAREWORKS (BLOCK FORM)**. SOLIUM CAPITAL INC., (U.S. CLS. 21, 23, 26, 36 AND 38). SN 78-618,942. PUB. 10-30-2007. FILED 4-28-2005.
- 3,480,605. **SOLIUM SHAREWORKS (BLOCK FORM)**. SOLIUM CAPITAL INC., (U.S. CLS. 21, 23, 26, 36 AND 38). SN 78-618,960. PUB. 10-30-2007. FILED 4-28-2005.
- 3,480,620. **Q5 (BLOCK FORM)**. QWIZDOM, INC., (U.S. CLS. 21, 23, 26, 36 AND 38). SN 78-695,326. PUB. 5-20-2008. FILED 8-18-2005.
- 3,480,622. **THE FORCE IN AIR (BLOCK FORM)**. DANTHERM FILTRATION HOLDING A/S, MULTIPLE CLASS, (INT. CLS. 9, 11 AND 37), (U.S. CLS. 13, 21, 23, 26, 31, 34, 36, 38, 100, 103 AND 106). SN 78-704,275. PUB. 5-20-2008. FILED 8-31-2005.
- 3,480,625. **B.R.A.T. BRUSH RAPID ATTACK TRUCK (BLOCK FORM)**. FIREMATIC MANUFACTURING INC., (U.S. CLS. 21, 23, 26, 36 AND 38). SN 78-708,723. PUB. 5-20-2008. FILED 9-8-2005.
- 3,480,628. **SAVIORLITE (BLOCK FORM)**. YUEN, SE KIT, MULTIPLE CLASS, (INT. CLS. 9, 11 AND 38), (U.S. CLS. 13, 21, 23, 26, 31, 34, 36, 38, 100, 101 AND 104). SN 78-737,203. PUB. 4-10-2007. FILED 10-20-2005.
- 3,480,644. **ILLUMIPRO (BLOCK FORM)**. MECCA WAREHOUSE LIMITED, (U.S. CLS. 21, 23, 26, 36 AND 38). SN 78-830,183. PUB. 5-20-2008. FILED 3-6-2006.
- 3,480,648. **POWER BLOCKER (BLOCK FORM)**. PHILIPS ELECTRONICS NORTH AMERICA CORPORATION, (U.S. CLS. 21, 23, 26, 36 AND 38). SN 78-837,955. PUB. 5-20-2008. FILED 3-15-2006.
- 3,480,681. **MISTAMEANA (BLOCK FORM)**. MARIN, JAIME S., (U.S. CLS. 21, 23, 26, 36 AND 38). SN 78-906,479. PUB. 5-20-2008. FILED 6-12-2006.
- 3,480,683. **IMPORTEK (BLOCK FORM)**. INVENTEC MULTIMEDIA & TELECOM CORPORATION, (U.S. CLS. 21, 23, 26, 36 AND 38). SN 78-909,257. PUB. 5-20-2008. FILED 6-15-2006.
- 3,480,706. **STRATA (BLOCK FORM)**. STRATA MARKETING, INC., MULTIPLE CLASS, (INT. CLS. 9, 41 AND 42), (U.S. CLS. 21, 23, 26, 36, 38, 100, 101 AND 107). SN 78-933,260. PUB. 5-20-2008. FILED 7-19-2006.
- 3,480,709. **SERVIDYNE (BLOCK FORM)**. SERVIDYNE, INC., MULTIPLE CLASS, (INT. CLS. 9, 36, 37 AND 42), (U.S. CLS. 21, 23, 26, 36, 38, 100, 101, 102, 103 AND 106). SN 78-936,401. PUB. 5-20-2008. FILED 7-24-2006.
- 3,480,718. **CLIMATE OF INNOVATION (BLOCK FORM)**. VIESSMANN WERKE GMBH & CO KG, MULTIPLE CLASS, (INT. CLS. 9, 11, 37 AND 41), (U.S. CLS. 13, 21, 23, 26, 31, 34, 36, 38, 100, 101, 103, 106 AND 107). SN 78-954,095. PUB. 3-4-2008. FILED 8-17-2006.
- 3,480,727. **COUGAR (BLOCK FORM)**. CONTEX A/S, (U.S. CLS. 21, 23, 26, 36 AND 38). SN 78-964,581. PUB. 5-20-2008. FILED 8-31-2006.
- 3,480,735. **CHEMBOOK (BLOCK FORM)**. ID BUSINESS SOLUTION LIMITED, MULTIPLE CLASS, (INT. CLS. 9, 16 AND 42), (U.S. CLS. 2, 5, 21, 22, 23, 26, 29, 36, 37, 38, 50, 100 AND 101). SN 78-971,633. PUB. 5-20-2008. FILED 9-11-2006.
- 3,480,736. **THE BROADWAY JUNIOR COLLECTION AND DESIGN**. MTI ENTERPRISES, INC., DBA MUSIC THEATRE INTERNATIONAL, MULTIPLE CLASS, (INT. CLS. 9 AND 16), (U.S. CLS. 2, 5, 21, 22, 23, 26, 29, 36, 37, 38 AND 50). SN 78-972,503. PUB. 5-20-2008. FILED 9-12-2006.
- 3,480,745. **GURU (STYLIZED)**. JAM SESSION S.R.L., MULTIPLE CLASS, (INT. CLS. 9, 18 AND 25), (U.S. CLS. 1, 2, 3, 21, 22, 23, 26, 36, 38, 39 AND 41). SN 79-013,972. PUB. 5-20-2008. FILED 5-3-2005.
- 3,480,753 (*See Class 3 for this trademark*).
- 3,480,756. **VIPEXPERIENCE (STYLIZED)**. VIP EXPERIENCE LIMITED, (U.S. CLS. 21, 23, 26, 36 AND 38). SN 79-030,309. PUB. 5-20-2008. FILED 9-6-2006.
- 3,480,757. **MISCELLANEOUS DESIGN**. TELEPO AB, MULTIPLE CLASS, (INT. CLS. 9, 38 AND 42), (U.S. CLS. 21, 23, 26, 36, 38, 100, 101 AND 104). SN 79-030,566. PUB. 5-20-2008. FILED 10-5-2006.
- 3,480,758. **EASYPAY AND DESIGN**. AKCIONERNO DRUJESTVO; "DATAMAX SISTEM HOLDING", MULTIPLE CLASS, (INT. CLS. 9, 35, 36, 38, 39 AND 42), (U.S. CLS. 21, 23, 26, 36, 38, 100, 101, 102, 104 AND 105). SN 79-030,593. PUB. 5-20-2008. FILED 9-25-2006.
- 3,480,759 (*See Class 7 for this trademark*).
- 3,480,760. **MISCELLANEOUS DESIGN**. WALL STREET SYSTEMS DELAWARE, INC., MULTIPLE CLASS, (INT. CLS. 9 AND 42), (U.S. CLS. 21, 23, 26, 36, 38, 100 AND 101). SN 79-031,006. PUB. 5-20-2008. FILED 10-2-2006.
- 3,480,769. **HOVAL (STYLIZED)**. HOVALWERK AKTIENGESELLSCHAFT, MULTIPLE CLASS, (INT. CLS. 9 AND 11), (U.S. CLS. 13, 21, 23, 26, 31, 34, 36 AND 38). SN 79-032,788. PUB. 5-20-2008. FILED 10-17-2006.
- 3,480,779 (*See Class 3 for this trademark*).
- 3,480,782. **ACE INTERACTIVE (BLOCK FORM)**. ARISTOCRAT TECHNOLOGIES AUSTRALIA PTY LTD, MULTIPLE CLASS, (INT. CLS. 9 AND 41), (U.S. CLS. 21, 23, 26, 36, 38, 100, 101 AND 107). SN 79-034,247. PUB. 5-20-2008. FILED 11-1-2006.
- 3,480,784. **WOSBEE (BLOCK FORM)**. SMILEHOUSE OY, MULTIPLE CLASS, (INT. CLS. 9 AND 35), (U.S. CLS. 21, 23, 26, 36, 38, 100, 101 AND 102). SN 79-034,361. PUB. 5-20-2008. FILED 12-19-2006.
- 3,480,787. **NOVACARD (BLOCK FORM)**. NOVACARD INFORMATIONSSYSTEME GMBH, MULTIPLE CLASS, (INT. CLS. 9 AND 16), (U.S. CLS. 2, 5, 21, 22, 23, 26, 29, 36, 37, 38 AND 50). SN 79-034,584. PUB. 5-20-2008. FILED 11-30-2006.
- 3,480,790. **FIELDGUARD (BLOCK FORM)**. OERLIKON CONTRAVES AG, MULTIPLE CLASS, (INT. CLS. 9 AND 13), (U.S. CLS. 2, 9, 21, 23, 26, 36 AND 38). SN 79-034,944. PUB. 5-20-2008. FILED 12-11-2006.
- 3,480,791. **SEAGUARD (BLOCK FORM)**. OERLIKON CONTRAVES AG, MULTIPLE CLASS, (INT. CLS. 9 AND 13), (U.S. CLS. 2, 9, 21, 23, 26, 36 AND 38). SN 79-034,946. PUB. 5-20-2008. FILED 12-11-2006.
- 3,480,792. **SKYSHIELD (BLOCK FORM)**. OERLIKON CONTRAVES AG, MULTIPLE CLASS, (INT. CLS. 9 AND 13), (U.S. CLS. 2, 9, 21, 23, 26, 36 AND 38). SN 79-034,947. PUB. 5-20-2008. FILED 12-11-2006.
- 3,480,795. **SKYGUARD (BLOCK FORM)**. OERLIKON CONTRAVES AG, MULTIPLE CLASS, (INT. CLS. 9 AND 13), (U.S. CLS. 2, 9, 21, 23, 26, 36 AND 38). SN 79-035,347. PUB. 5-20-2008. FILED 11-14-2006.
- 3,480,802. **MICROPASS (BLOCK FORM)**. INSIDE CONTACTLESS, MULTIPLE CLASS, (INT. CLS. 9 AND 42), (U.S. CLS. 21, 23, 26, 36, 38, 100 AND 101). SN 79-036,137. PUB. 5-20-2008. FILED 1-2-2007.
- 3,480,805 (*See Class 7 for this trademark*).
- 3,480,807. **MW AND DESIGN**. MW SECURITY AB, MULTIPLE CLASS, (INT. CLS. 9, 42 AND 45), (U.S. CLS. 21, 23, 26, 36, 38, 100 AND 101). SN 79-036,592. PUB. 5-20-2008. FILED 10-25-2006.
- 3,480,808. **WEISE (BLOCK FORM)**. FOWLERS OF BRISTOL LTD, MULTIPLE CLASS, (INT. CLS. 9, 18 AND 25), (U.S. CLS. 1, 2, 3, 21, 22, 23, 26, 36, 38, 39 AND 41). SN 79-037,034. PUB. 5-20-2008. FILED 1-29-2007.
- 3,480,810 (*See Class 7 for this trademark*).
- 3,480,811. **IATE (BLOCK FORM)**. LA COMMUNAUTE EUROPEENNE; REPRESENTÉE PAR LA COMMISSION DES COMMUNAUTES EUROPEENNES, MULTIPLE CLASS, (INT. CLS. 9, 38 AND 41), (U.S. CLS. 21, 23, 26, 36, 38, 100, 101, 104 AND 107). SN 79-037,207. PUB. 2-12-2008. FILED 2-7-2007.
- 3,480,815. **AD-ORION (STYLIZED)**. A&D COMPANY, LTD., MULTIPLE CLASS, (INT. CLS. 9 AND 42), (U.S. CLS. 21, 23, 26, 36, 38, 100 AND 101). SN 79-037,506. PUB. 5-20-2008. FILED 3-5-2007.
- 3,480,819. **NOKIA ORIGINAL ACCESSORIES AND DESIGN**. NOKIA CORPORATION, (U.S. CLS. 21, 23, 26, 36 AND 38). SN 79-038,477. PUB. 5-20-2008. FILED 4-13-2007.
- 3,480,831. **SILAN (BLOCK FORM)**. HANGZHOU SILAN MICROELECTRONICS CO., LTD., (U.S. CLS. 21, 23, 26, 36 AND 38). SN 79-039,181. PUB. 5-20-2008. FILED 5-21-2007.
- 3,480,834. **THE SEVEN OF DARAN (BLOCK FORM)**. LOU-

- RENS FISHER; DESIGN & INVESTMENTS N.V., MULTIPLE CLASS, (INT. CLS. 9, 25, 28 AND 41), (U.S. CLS. 21, 22, 23, 26, 36, 38, 39, 50, 100, 101 AND 107). SN 79-039,501. PUB. 5-20-2008. FILED 2-22-2007.
- 3,480,839 (*See Class 3 for this trademark*).
- 3,480,854. **COOLDESK (STYLIZED)**, KNÜRR AG, MULTIPLE CLASS, (INT. CLS. 9, 11, 20 AND 40), (U.S. CLS. 2, 13, 21, 22, 23, 25, 26, 31, 32, 34, 36, 38, 50, 100, 103 AND 106). SN 79-040,522. PUB. 5-20-2008. FILED 2-13-2007.
- 3,480,856 (*See Class 3 for this trademark*).
- 3,480,879. **MISCELLANEOUS DESIGN**, COMEFLY OUTDOOR CO., LTD., MULTIPLE CLASS, (INT. CLS. 9, 18, 20, 22 AND 25), (U.S. CLS. 1, 2, 3, 7, 13, 19, 21, 22, 23, 25, 26, 32, 36, 38, 39, 41, 42 AND 50). SN 79-041,367. PUB. 5-20-2008. FILED 4-23-2007.
- 3,480,882. **MELODY BEAR (BLOCK FORM)**, JILL EWING, MULTIPLE CLASS, (INT. CLS. 9, 16 AND 41), (U.S. CLS. 2, 5, 21, 22, 23, 26, 29, 36, 37, 38, 50, 100, 101 AND 107). SN 79-041,413. PUB. 5-20-2008. FILED 6-29-2007.
- 3,480,885. **YOUR MOBILE CUPPA MUSIC (BLOCK FORM)**, KONINKLIJKE PHILIPS ELECTRONICS N.V., (U.S. CLS. 21, 23, 26, 36 AND 38). SN 79-041,484. PUB. 5-20-2008. FILED 7-9-2007.
- 3,480,891. **ARRI ARRI AND DESIGN**, ARNOLD & RICHTER CINE TECHNIK GMBH & CO. BETRIEBS KG, MULTIPLE CLASS, (INT. CLS. 9 AND 11), (U.S. CLS. 13, 21, 23, 26, 31, 34, 36 AND 38). SN 79-041,604. PUB. 5-20-2008. FILED 6-4-2007.
- 3,480,892. **ARRI (BLOCK FORM)**, ARNOLD & RICHTER CINE TECHNIK GMBH & CO. BETRIEBS KG, MULTIPLE CLASS, (INT. CLS. 9 AND 11), (U.S. CLS. 13, 21, 23, 26, 31, 34, 36 AND 38). SN 79-041,605. PUB. 5-20-2008. FILED 6-4-2007.
- 3,480,893. **SNOWPULSE (BLOCK FORM)**, SNOWPULSE SA, (U.S. CLS. 21, 23, 26, 36 AND 38). SN 79-041,702. PUB. 5-20-2008. FILED 6-18-2007.
- 3,480,897 (*See Class 6 for this trademark*).
- 3,480,910. **DEFECTED AND DESIGN**, DEFECTED RECORDS LTD, MULTIPLE CLASS, (INT. CLS. 9, 18, 25, 35, 38 AND 41), (U.S. CLS. 1, 2, 3, 21, 22, 23, 26, 36, 38, 39, 41, 100, 101, 102, 104 AND 107). SN 79-042,098. PUB. 5-20-2008. FILED 5-24-2007.
- 3,480,911. **DENIMATION (BLOCK FORM)**, ANNUNZIATA, VINCENZO, MULTIPLE CLASS, (INT. CLS. 9, 18 AND 25), (U.S. CLS. 1, 2, 3, 21, 22, 23, 26, 36, 38, 39 AND 41). SN 79-042,122. PUB. 5-20-2008. FILED 6-20-2007.
- 3,480,916. **PROTECTORIA (BLOCK FORM)**, MESSAGE MANAGEMENT AS, MULTIPLE CLASS, (INT. CLS. 9, 38 AND 42), (U.S. CLS. 21, 23, 26, 36, 38, 100, 101 AND 104). SN 79-042,191. PUB. 5-20-2008. FILED 5-21-2007.
- 3,480,919. **OMNIA (BLOCK FORM)**, CONTROLLI S.R.L., (U.S. CLS. 21, 23, 26, 36 AND 38). SN 79-042,258. PUB. 5-20-2008. FILED 7-2-2007.
- 3,480,931. **RI4POWER (BLOCK FORM)**, RITTAL GMBH & CO. KG, (U.S. CLS. 21, 23, 26, 36 AND 38). SN 79-042,567. PUB. 5-20-2008. FILED 4-24-2007.
- 3,480,943. **SCOTT & YORK (BLOCK FORM)**, SCOTT & YORK, MULTIPLE CLASS, (INT. CLS. 9, 16, 35, 36, 38, 40, 41, 42 AND 45), (U.S. CLS. 2, 5, 21, 22, 23, 26, 29, 36, 37, 38, 50, 100, 101, 102, 103, 104, 106 AND 107). SN 79-043,002. PUB. 5-20-2008. FILED 2-23-2007.
- 3,480,947. **JS CABLE AND DESIGN**, JS CABLE CO., LTD., (U.S. CLS. 21, 23, 26, 36 AND 38). SN 79-043,167. PUB. 5-20-2008. FILED 7-3-2007.
- 3,480,952. **ACTARIS EASY (STYLIZED)**, ACTARIS S.A.S., MULTIPLE CLASS, (INT. CLS. 9, 35, 38 AND 42), (U.S. CLS. 21, 23, 26, 36, 38, 100, 101, 102 AND 104). SN 79-043,314. PUB. 5-20-2008. FILED 7-6-2007.
- 3,480,958. **KROMID (BLOCK FORM)**, KROMBERG & SCHUBERT GMBH & CO. KG, (U.S. CLS. 21, 23, 26, 36 AND 38). SN 79-043,673. PUB. 5-20-2008. FILED 8-6-2007.
- 3,480,960. **BATHIUM (BLOCK FORM)**, BOLLORE, MULTIPLE CLASS, (INT. CLS. 9 AND 37), (U.S. CLS. 21, 23, 26, 36, 38, 100, 103 AND 106). SN 79-043,715. PUB. 5-20-2008. FILED 7-13-2007.
- 3,480,962. **DIADENS AND DESIGN**, OBSHCHESTVO S OGRANNICHENNOY; OTVETSTVENNOSTYU "INTER-RA", MULTIPLE CLASS, (INT. CLS. 9, 10 AND 16), (U.S. CLS. 2, 5, 21, 22, 23, 26, 29, 36, 37, 38, 39, 44 AND 50). SN 79-043,823. PUB. 5-20-2008. FILED 7-25-2007.
- 3,480,963. **DENAS (BLOCK FORM)**, OBSHCHESTVO S OGRANNICHENNOY; OTVETSTVENNOSTYU "INTER-RA", MULTIPLE CLASS, (INT. CLS. 9, 10 AND 16), (U.S. CLS. 2, 5, 21, 22, 23, 26, 29, 36, 37, 38, 39, 44 AND 50). SN 79-043,824. PUB. 5-20-2008. FILED 7-25-2007.
- 3,480,965. **WICLER (STYLIZED)**, HOME MULTIENERGY, S.L., MULTIPLE CLASS, (INT. CLS. 9, 12 AND 28), (U.S. CLS. 19, 21, 22, 23, 26, 31, 35, 36, 38, 44 AND 50). SN 79-043,870. PUB. 5-20-2008. FILED 4-26-2007.
- 3,480,968. **PLANTCARE AND DESIGN**, PLANTCARE AG, MULTIPLE CLASS, (INT. CLS. 9, 11 AND 21), (U.S. CLS. 2, 13, 21, 23, 26, 29, 30, 31, 33, 34, 36, 38, 40 AND 50). SN 79-043,951. PUB. 5-20-2008. FILED 6-8-2007.
- 3,480,974. **GARHOPE (STYLIZED)**, YANGZHOU GARHOPE INSTRUMENT CO., LTD, (U.S. CLS. 21, 23, 26, 36 AND 38). SN 79-044,217. PUB. 5-20-2008. FILED 7-9-2007.
- 3,480,995 (*See Class 7 for this trademark*).
- 3,480,997. **TBEA (STYLIZED)**, TBEA CO., LTD., (U.S. CLS. 21, 23, 26, 36 AND 38). SN 79-045,993. PUB. 5-20-2008. FILED 4-30-2007.
- 3,481,012. **DRAGONOLOGY AND DESIGN**, THE TEMPLAR COMPANY PLC, MULTIPLE CLASS, (INT. CLS. 9, 16 AND 28), (U.S. CLS. 2, 5, 21, 22, 23, 26, 29, 36, 37, 38 AND 50). SN 79-047,357. PUB. 5-20-2008. FILED 9-27-2007.
- 3,481,026. **IRBIS (BLOCK FORM)**, INFRATEC GMBH INFRA-ROTSENSORIK; UND MESSTECHNIK, (U.S. CLS. 21, 23, 26, 36 AND 38). SN 79-048,408. PUB. 5-20-2008. FILED 11-16-2007.
- 3,481,036. **MEDIBAND (BLOCK FORM)**, RANDALL COMMUNICATIONS PTY LTD, MULTIPLE CLASS, (INT. CLS. 9, 16 AND 25), (U.S. CLS. 2, 5, 21, 22, 23, 26, 29, 36, 37, 38, 39 AND 50). SN 79-049,808. PUB. 5-20-2008. FILED 12-10-2007.
- 3,481,039. **P (STYLIZED)**, PIEZOCRYST ADVANCED SENSORIES GMBH, (U.S. CLS. 21, 23, 26, 36 AND 38). SN 79-051,097. PUB. 5-20-2008. FILED 12-6-2007.

CLASS 10—MEDICAL APPARATUS

- 3,478,518 (*See Class 5 for this trademark*).
- 3,478,651. **RMV (BLOCK FORM)**, VISUALSONICS, INC., (U.S. CLS. 26, 39 AND 44). SN 77-027,908. PUB. 5-20-2008. FILED 10-24-2006.
- 3,478,749. **PENTAFLEX (STYLIZED)**, HUNTLEIGH TECHNOLOGY PLC, MULTIPLE CLASS, (INT. CLS. 10 AND 20), (U.S. CLS. 2, 13, 22, 25, 26, 32, 39, 44 AND 50). SN 77-091,814. PUB. 3-4-2008. FILED 1-26-2007.
- 3,478,777. **EXTRUMED (BLOCK FORM)**, EXTRUMED, LLC, MULTIPLE CLASS, (INT. CLS. 10, 40 AND 42), (U.S. CLS. 26, 39, 44, 100, 101, 103 AND 106). SN 77-105,541. PUB. 5-20-2008. FILED 2-12-2007.
- 3,478,952. **NOVOLINPEN (BLOCK FORM)**, NOVO NORDISK A/S, (U.S. CLS. 26, 39 AND 44). SN 77-188,660. PUB. 5-20-2008. FILED 5-23-2007.
- 3,479,072. **AQUANOT (BLOCK FORM)**, COLBY MANUFACTURING CORP., (U.S. CLS. 26, 39 AND 44). SN 77-208,320. PUB. 5-20-2008. FILED 6-18-2007.
- 3,479,109. **FLESHLIGHT AND DESIGN**, SHUBIN, STEVE, (U.S. CLS. 26, 39 AND 44). SN 77-213,782. PUB. 5-20-2008. FILED 6-22-2007.
- 3,479,123. **ACUDRIVER (BLOCK FORM)**, EXACTECH, INC., (U.S. CLS. 26, 39 AND 44). SN 77-216,539. PUB. 5-20-2008. FILED 6-27-2007.
- 3,479,124. **ANCHOR FAST (BLOCK FORM)**, HOLLISTER INCORPORATED, (U.S. CLS. 26, 39 AND 44). SN 77-216,609. PUB. 5-20-2008. FILED 6-27-2007.
- 3,479,148 (*See Class 3 for this trademark*).
- 3,479,155. **DRY PRO (BLOCK FORM)**, DRY CORP, LLC, (U.S. CLS. 26, 39 AND 44). SN 77-218,669. PUB. 5-20-2008. FILED 6-29-2007.
- 3,479,160. **AURIPLEX (BLOCK FORM)**, CHIZARI, ABOLGHASEM, (U.S. CLS. 26, 39 AND 44). SN 77-218,979. PUB. 5-20-2008. FILED 6-29-2007.
- 3,479,162. **ERECT-CARE (BLOCK FORM)**, KOZAK, ANDRZEJ W, (U.S. CLS. 26, 39 AND 44). SN 77-219,446. PUB.

5-20-2008. FILED 6-29-2007.
 3,479,181. **DRY PRO AND DESIGN**. DRY CORP LLC, (U.S. CLS. 26, 39 AND 44). SN 77-221,548. PUB. 5-20-2008. FILED 7-3-2007.
 3,479,311. **AMS 700 LGX (BLOCK FORM)**. AMS RESEARCH CORPORATION, (U.S. CLS. 26, 39 AND 44). SN 77-241,747. PUB. 5-20-2008. FILED 7-30-2007.
 3,479,433. **FLESHLIGHT GIRLS (BLOCK FORM)**. SHUBIN, STEVE, (U.S. CLS. 26, 39 AND 44). SN 77-276,105. PUB. 5-20-2008. FILED 9-11-2007.
 3,479,442. **ESSENTIAL (BLOCK FORM)**. MERLYN ASSOCIATES, INC., DBA MERLYN MEDICAL, (U.S. CLS. 26, 39 AND 44). SN 77-279,226. PUB. 5-20-2008. FILED 9-13-2007.
 3,479,490. **CREASPINE AND DESIGN**. CREASPINE SAS, (U.S. CLS. 26, 39 AND 44). SN 77-292,566. PUB. 5-20-2008. FILED 10-1-2007.
 3,479,577. **CHESTNUT AND DESIGN**. KOMKIN, ANDREY V, (U.S. CLS. 26, 39 AND 44). SN 77-310,538. PUB. 5-20-2008. FILED 10-23-2007.
 3,479,578. **CHILLOWPLUS (BLOCK FORM)**. SOOTHSOFT INNOVATIONS WORLDWIDE, INC., MULTIPLE CLASS, (INT. CLS. 10, 11 AND 20), (U.S. CLS. 2, 13, 21, 22, 23, 25, 26, 31, 32, 34, 39, 44 AND 50). SN 77-311,048. PUB. 5-20-2008. FILED 10-23-2007.
 3,479,719 (*See Class 1 for this trademark*).
 3,479,869. **BURTON MOBILIZATION BELT (BLOCK FORM)**. BURTON, M. BENJAMIN, (U.S. CLS. 26, 39 AND 44). SN 77-349,893. PUB. 5-20-2008. FILED 12-12-2007.
 3,479,899. **VERGENZA (BLOCK FORM)**. VERGENZA INC., (U.S. CLS. 26, 39 AND 44). SN 77-351,407. PUB. 5-20-2008. FILED 12-13-2007.
 3,479,929. **VIVINLINEA AND DESIGN**. MASSIMO GUERRIERI, DBA VIVINLINEA, (U.S. CLS. 26, 39 AND 44). SN 77-353,208. PUB. 5-20-2008. FILED 12-16-2007.
 3,480,041. **DAAVLIN (BLOCK FORM)**. THE DAAVLIN DISTRIBUTING COMPANY, (U.S. CLS. 26, 39 AND 44). SN 77-357,627. PUB. 5-20-2008. FILED 12-21-2007.
 3,480,197. **EMPULSE (BLOCK FORM)**. EMPROBE, INC., (U.S. CLS. 26, 39 AND 44). SN 77-362,912. PUB. 5-20-2008. FILED 1-2-2008.
 3,480,366. **MELROSE (BLOCK FORM)**. MEDICAL UNIFORM MANUFACTURING INC, (U.S. CLS. 26, 39 AND 44). SN 77-365,524. PUB. 5-20-2008. FILED 1-7-2008.
 3,480,528. **BT-VISION (BLOCK FORM)**. SUZUKI, DAVID S., (U.S. CLS. 26, 39 AND 44). SN 77-382,632. PUB. 5-20-2008. FILED 1-28-2008.
 3,480,715. **SLENDERTONE FLEX MAX (BLOCK FORM)**. BIOMEDICAL RESEARCH LIMITED, MULTIPLE CLASS, (INT. CLS. 10 AND 28), (U.S. CLS. 22, 23, 26, 38, 39, 44 AND 50). SN 78-950,027. PUB. 5-20-2008. FILED 8-11-2006.
 3,480,796. **ELEGANZA (STYLIZED)**. LINET SPOL. S R.O., MULTIPLE CLASS, (INT. CLS. 10, 20 AND 37), (U.S. CLS. 2, 13, 22, 25, 26, 32, 39, 44, 50, 100, 103 AND 106). SN 79-035,404. PUB. 5-20-2008. FILED 10-29-2006.
 3,480,813. **BELLAVISTA (BLOCK FORM)**. IMTMEDICAL AG, (U.S. CLS. 26, 39 AND 44). SN 79-037,276. PUB. 5-20-2008. FILED 3-1-2007.
 3,480,865. **KRENKEL (BLOCK FORM)**. PROF. DR. MED. CHRISTIAN KRENKEL, (U.S. CLS. 26, 39 AND 44). SN 79-040,987. PUB. 5-20-2008. FILED 12-21-2006.
 3,480,883. **SIROLASER (BLOCK FORM)**. SIRONA DENTAL SYSTEMS GMBH, (U.S. CLS. 26, 39 AND 44). SN 79-041,416. PUB. 5-20-2008. FILED 3-22-2007.
 3,480,887 (*See Class 1 for this trademark*).
 3,480,902 (*See Class 3 for this trademark*).
 3,480,945 (*See Class 7 for this trademark*).
 3,480,949. **LIPO M6 (BLOCK FORM)**. LPG SYSTEMS (SOCIÉTÉ ANONYME), (U.S. CLS. 26, 39 AND 44). SN 79-043,255. PUB. 5-20-2008. FILED 7-20-2007.
 3,480,962 (*See Class 9 for this trademark*).
 3,480,963 (*See Class 9 for this trademark*).
 3,481,014. **RESOUND X-PLORE (BLOCK FORM)**. GN RESOUND A/S, (U.S. CLS. 26, 39 AND 44). SN 79-047,488. PUB. 5-20-2008. FILED 10-27-2007.
 3,481,028. **U-PEE (BLOCK FORM)**. PROSTALUND OPERATIONS AB, MULTIPLE CLASS, (INT. CLS. 10, 42 AND 44), (U.S. CLS. 26, 39, 44, 100 AND 101). SN 79-048,659. PUB. 5-20-2008. FILED 9-28-2007.

CLASS 11—ENVIRONMENTAL CONTROL APPARATUS

3,478,499. **VMC AND DESIGN**. VIBRATION MOUNTINGS & CONTROLS, INC., (U.S. CLS. 13, 21, 23, 31 AND 34). SN 76-510,373. PUB. 5-20-2008. FILED 4-11-2003.
 3,478,540 (*See Class 6 for this trademark*).
 3,478,541. **KRAUS (BLOCK FORM)**. ICG LICENSING, LLC, MULTIPLE CLASS, (INT. CLS. 11, 20 AND 21), (U.S. CLS. 2, 13, 21, 22, 23, 25, 29, 30, 31, 32, 33, 34, 40 AND 50). SN 76-674,397. PUB. 5-20-2008. FILED S.R. 3-22-2007; AM. P.R. 11-21-2007.
 3,478,617 (*See Class 7 for this trademark*).
 3,478,673. **TERRAZZO-WARE (BLOCK FORM)**. ACORN ENGINEERING COMPANY, (U.S. CLS. 13, 21, 23, 31 AND 34). SN 77-040,935. PUB. 5-20-2008. FILED 11-9-2006.
 3,478,755. **FOREVER HOT WHITEHAUS COLLECTION (BLOCK FORM)**. WHITE'S PLUMBING SUPPLIES, INC., (U.S. CLS. 13, 21, 23, 31 AND 34). SN 77-095,440. PUB. 5-20-2008. FILED 1-31-2007.
 3,478,822. **SWP SEAL WELL PRODUCTS AND DESIGN**. BOSHAUT INDUSTRIES, INC., (U.S. CLS. 13, 21, 23, 31 AND 34). SN 77-135,085. PUB. 5-20-2008. FILED 3-20-2007.
 3,478,831. **CONTROLLED CIRCULATION (BLOCK FORM)**. ALSTOM POWER INC., (U.S. CLS. 13, 21, 23, 31 AND 34). SN 77-142,667. PUB. 5-20-2008. FILED 3-28-2007.
 3,478,861. **POWERPURE (BLOCK FORM)**. CHARDON LABORATORIES INC., MULTIPLE CLASS, (INT. CLS. 11 AND 40), (U.S. CLS. 13, 21, 23, 31, 34, 100, 103 AND 106). SN 77-155,338. PUB. 5-20-2008. FILED 4-12-2007.
 3,478,878. **ECOBUE (BLOCK FORM)**. DESERT U.S.A. CORPORATION, (U.S. CLS. 13, 21, 23, 31 AND 34). SN 77-165,592. PUB. 4-15-2008. FILED 4-25-2007.
 3,478,912. **LOVEBULBS (BLOCK FORM)**. HUCUL, LESLIE, (U.S. CLS. 13, 21, 23, 31 AND 34). SN 77-178,167. PUB. 5-20-2008. FILED 5-10-2007.
 3,478,951. **ECOFAN (BLOCK FORM)**. CAFRAMO LIMITED, (U.S. CLS. 13, 21, 23, 31 AND 34). SN 77-188,444. PUB. 5-20-2008. FILED 5-23-2007.
 3,478,981. **QUICK-MOUNT (BLOCK FORM)**. ABL IP HOLDING LLC, (U.S. CLS. 13, 21, 23, 31 AND 34). SN 77-195,517. PUB. 5-20-2008. FILED 6-1-2007.
 3,479,068. **WORKING TODAY TO PROTECT TOMORROW'S ENVIRONMENT (BLOCK FORM)**. HOOT AEROBIC SYSTEMS, INC., (U.S. CLS. 13, 21, 23, 31 AND 34). SN 77-208,176. PUB. 5-20-2008. FILED 6-18-2007.
 3,479,148 (*See Class 3 for this trademark*).
 3,479,291 (*See Class 9 for this trademark*).
 3,479,401. **GREENBOX THERMAL MANAGEMENT SYSTEM AND DESIGN**. ENTROPY SOLUTIONS, INC., (U.S. CLS. 13, 21, 23, 31 AND 34). SN 77-267,485. PUB. 5-20-2008. FILED 8-29-2007.
 3,479,450. **SW SPRINGFIELD WIRE, INCORPORATED AND DESIGN**. SPRINGFIELD WIRE, INC., (U.S. CLS. 13, 21, 23, 31 AND 34). SN 77-280,890. PUB. 5-20-2008. FILED 9-17-2007.
 3,479,471. **ADVANCED BIOLOGICAL SERVICES BIO-FERMENTOR AND DESIGN**. ADVANCED BIOLOGICAL SERVICES, INC., (U.S. CLS. 13, 21, 23, 31 AND 34). SN 77-286,708. PUB. 5-20-2008. FILED 9-24-2007.
 3,479,524. **CENTRO DUO (BLOCK FORM)**. FRANZ KALDEWEI GMBH & CO. KG, (U.S. CLS. 13, 21, 23, 31 AND 34). SN 77-301,329. PUB. 5-20-2008. FILED 10-11-2007.
 3,479,526. **DUSCHPLAN (BLOCK FORM)**. FRANZ KALDEWEI GMBH & CO. KG, (U.S. CLS. 13, 21, 23, 31 AND 34). SN 77-301,347. PUB. 5-20-2008. FILED 10-11-2007.
 3,479,527. **SUPERPLAN (BLOCK FORM)**. FRANZ KALDEWEI GMBH & CO. KG, (U.S. CLS. 13, 21, 23, 31 AND 34). SN 77-301,356. PUB. 5-20-2008. FILED 10-11-2007.
 3,479,529. **MEGAPLAN (BLOCK FORM)**. FRANZ KALDEWEI GMBH & CO. KG, (U.S. CLS. 13, 21, 23, 31 AND 34). SN 77-301,366. PUB. 5-20-2008. FILED 10-11-2007.
 3,479,530. **CONODUO (BLOCK FORM)**. FRANZ KALDEWEI GMBH & CO. KG, (U.S. CLS. 13, 21, 23, 31 AND 34). SN 77-301,377. PUB. 5-20-2008. FILED 10-11-2007.
 3,479,532. **SANILUX (BLOCK FORM)**. FRANZ KALDEWEI GMBH & CO. KG, (U.S. CLS. 13, 21, 23, 31 AND 34). SN 77-301,383. PUB. 5-20-2008. FILED 10-11-2007.
 3,479,533. **SANIFORM (BLOCK FORM)**. FRANZ KALDEWEI GMBH & CO. KG, (U.S. CLS. 13, 21, 23, 31 AND 34). SN 77-

301,395. PUB. 5-20-2008. FILED 10-11-2007.
 3,479,534. **MEGA DUO (BLOCK FORM)**. FRANZ KALDEWEI GMBH & CO. KG, (U.S. CLS. 13, 21, 23, 31 AND 34). SN 77-301,416. PUB. 5-20-2008. FILED 10-11-2007.
 3,479,535. **KUSATSU POOL (BLOCK FORM)**. FRANZ KALDEWEI GMBH & CO. KG, (U.S. CLS. 13, 21, 23, 31 AND 34). SN 77-301,423. PUB. 5-20-2008. FILED 10-11-2007.
 3,479,550. **OCTOPUS (BLOCK FORM)**. VUE TECHNOLOGY LLC, (U.S. CLS. 13, 21, 23, 31 AND 34). SN 77-305,172. PUB. 5-20-2008. FILED 10-16-2007.
 3,479,553. **REEFLUX (BLOCK FORM)**. VUE TECHNOLOGY LLC, (U.S. CLS. 13, 21, 23, 31 AND 34). SN 77-305,880. PUB. 5-20-2008. FILED 10-17-2007.
 3,479,556. **CORALVUE (BLOCK FORM)**. VUE TECHNOLOGY LLC, (U.S. CLS. 13, 21, 23, 31 AND 34). SN 77-306,785. PUB. 5-20-2008. FILED 10-17-2007.
 3,479,578 (*See Class 10 for this trademark*).
 3,479,604. **SANI SEAT (BLOCK FORM)**. T. ELIOT, INC., (U.S. CLS. 13, 21, 23, 31 AND 34). SN 77-315,779. PUB. 5-20-2008. FILED 10-29-2007.
 3,479,620 (*See Class 9 for this trademark*).
 3,479,632. **HOLIDAY BRIGHT LIGHTS AND DESIGN**. HOLIDAY BRIGHT LIGHTS, INC., (U.S. CLS. 13, 21, 23, 31 AND 34). SN 77-320,122. PUB. 5-20-2008. FILED 11-2-2007.
 3,479,680. **ALKALINE BALANCE (BLOCK FORM)**. NUTRI-STAHN, INC., (U.S. CLS. 13, 21, 23, 31 AND 34). SN 77-326,487. PUB. 5-20-2008. FILED 11-9-2007.
 3,479,812 (*See Class 6 for this trademark*).
 3,479,814 (*See Class 6 for this trademark*).
 3,479,857. **OVATION (BLOCK FORM)**. APPLIANCE SCIENTIFIC, (U.S. CLS. 13, 21, 23, 31 AND 34). SN 77-348,535. PUB. 5-20-2008. FILED 12-10-2007.
 3,479,858. **OVATION BY APPLIANCE SCIENTIFIC (BLOCK FORM)**. APPLIANCE SCIENTIFIC, (U.S. CLS. 13, 21, 23, 31 AND 34). SN 77-348,539. PUB. 5-20-2008. FILED 12-10-2007.
 3,480,021. **STINGER DS (BLOCK FORM)**. STREAMLIGHT, INC., (U.S. CLS. 13, 21, 23, 31 AND 34). SN 77-356,987. PUB. 5-20-2008. FILED 12-20-2007.
 3,480,159. **HATCO (BLOCK FORM)**. HATCO CORPORATION, (U.S. CLS. 13, 21, 23, 31 AND 34). SN 77-362,288. PUB. 5-20-2008. FILED 1-2-2008.
 3,480,172. **GLOWPANEL (BLOCK FORM)**. SUNSHINE SYSTEMS, LLC., (U.S. CLS. 13, 21, 23, 31 AND 34). SN 77-362,442. PUB. 5-20-2008. FILED 1-2-2008.
 3,480,188. **WINDCHILL (BLOCK FORM)**. MIST AND COOL LLC, (U.S. CLS. 13, 21, 23, 31 AND 34). SN 77-362,729. PUB. 5-20-2008. FILED 1-2-2008.
 3,480,226 (*See Class 9 for this trademark*).
 3,480,235 (*See Class 9 for this trademark*).
 3,480,237. **COGENT TECHNOLOGIES (BLOCK FORM)**. COGENT TECHNOLOGIES, INC. DBA RESEARCH, INC., (U.S. CLS. 13, 21, 23, 31 AND 34). SN 77-363,506. PUB. 5-20-2008. FILED 1-3-2008.
 3,480,282. **PA AND DESIGN**. POWERED AIRE INC., (U.S. CLS. 13, 21, 23, 31 AND 34). SN 77-364,204. PUB. 5-20-2008. FILED 1-4-2008.
 3,480,340. **POOL-SAFE (BLOCK FORM)**. TURBOTEC PRODUCTS, INC., (U.S. CLS. 13, 21, 23, 31 AND 34). SN 77-365,087. PUB. 5-20-2008. FILED 1-6-2008.
 3,480,361. **WARMTH FOR THE SOLE (BLOCK FORM)**. NUHEAT INDUSTRIES LIMITED, (U.S. CLS. 13, 21, 23, 31 AND 34). SN 77-365,472. PUB. 5-20-2008. FILED 1-7-2008.
 3,480,378. **THE ROASTBOX (BLOCK FORM)**. DE LA FUENTE CASTRO, ALEJANDRO, (U.S. CLS. 13, 21, 23, 31 AND 34). SN 77-365,819. PUB. 5-20-2008. FILED 1-7-2008.
 3,480,462. **ICP AND DESIGN**. CARRIER CORPORATION, (U.S. CLS. 13, 21, 23, 31 AND 34). SN 77-367,716. PUB. 5-20-2008. FILED 1-9-2008.
 3,480,557. **ATTUNE (BLOCK FORM)**. GENLYTE THOMAS GROUP LLC, (U.S. CLS. 13, 21, 23, 31 AND 34). SN 77-408,760. PUB. 5-20-2008. FILED 2-28-2008.
 3,480,576. **INSTALLER'S CHOICE (BLOCK FORM)**. HUNTER FAN COMPANY, (U.S. CLS. 13, 21, 23, 31 AND 34). SN 77-446,318. PUB. 5-31-2005. FILED 7-6-2004.
 3,480,622 (*See Class 9 for this trademark*).
 3,480,628 (*See Class 9 for this trademark*).
 3,480,675. **TRAKKABEAM (BLOCK FORM)**. VECTORBEAM TECHNOLOGIES PTY LTD, (U.S. CLS. 13, 21, 23, 31 AND

34). SN 78-901,830. PUB. 3-25-2008. FILED 6-6-2006.
 3,480,676. **TRAKKA (BLOCK FORM)**. VECTORBEAM TECHNOLOGIES PTY LTD, (U.S. CLS. 13, 21, 23, 31 AND 34). SN 78-901,873. PUB. 3-25-2008. FILED 6-6-2006.
 3,480,718 (*See Class 9 for this trademark*).
 3,480,769 (*See Class 9 for this trademark*).
 3,480,783. **ACTIDISK (BLOCK FORM)**. OTV SA, (U.S. CLS. 13, 21, 23, 31 AND 34). SN 79-034,340. PUB. 5-20-2008. FILED 7-11-2006.
 3,480,800 (*See Class 3 for this trademark*).
 3,480,801. **ALDES AND DESIGN**. ALDES AERAILIQUE, (U.S. CLS. 13, 21, 23, 31 AND 34). SN 79-035,908. PUB. 5-20-2008. FILED 11-3-2006.
 3,480,818 (*See Class 5 for this trademark*).
 3,480,846. **BESTMINERAL (BLOCK FORM)**. BWT AKTIENGESELLSCHAFT, MULTIPLE CLASS, (INT. CLS. 11 AND 21), (U.S. CLS. 2, 13, 21, 23, 29, 30, 31, 33, 34, 40 AND 50). SN 79-039,855. PUB. 5-20-2008. FILED 5-14-2007.
 3,480,854 (*See Class 9 for this trademark*).
 3,480,891 (*See Class 9 for this trademark*).
 3,480,892 (*See Class 9 for this trademark*).
 3,480,968 (*See Class 9 for this trademark*).
 3,481,010. **SMARTFIX (BLOCK FORM)**. VILLEROY & BOCH AG, (U.S. CLS. 13, 21, 23, 31 AND 34). SN 79-047,297. PUB. 5-20-2008. FILED 9-4-2007.

CLASS 12—VEHICLES

3,478,528. **AB INFLATABLES (BLOCK FORM)**. HEYER, IVOR, (U.S. CLS. 19, 21, 23, 31, 35 AND 44). SN 76-668,929. PUB. 5-20-2008. FILED 11-13-2006.
 3,478,530. **AB (STYLIZED)**. HEYER, IVOR, (U.S. CLS. 19, 21, 23, 31, 35 AND 44). SN 76-669,530. PUB. 5-20-2008. FILED 11-27-2006.
 3,478,593. **SMARTKART (BLOCK FORM)**. HOME SLICE, LLC, (U.S. CLS. 19, 21, 23, 31, 35 AND 44). SN 76-683,831. PUB. 5-20-2008. FILED 11-8-2007.
 3,478,641 (*See Class 7 for this trademark*).
 3,478,727. **AMES (BLOCK FORM)**. AMES TRUE TEMPER PROPERTIES, INC., (U.S. CLS. 19, 21, 23, 31, 35 AND 44). SN 77-074,156. PUB. 5-20-2008. FILED 1-2-2007.
 3,478,812. **GBRACING (BLOCK FORM)**. LEWIS BANKS LTD., (U.S. CLS. 19, 21, 23, 31, 35 AND 44). SN 77-126,897. PUB. 5-20-2008. FILED 3-9-2007.
 3,478,916. **HISPEC (BLOCK FORM)**. HISPEC WHEEL & TIRE, INC., (U.S. CLS. 19, 21, 23, 31, 35 AND 44). SN 77-179,662. PUB. 5-20-2008. FILED 5-13-2007.
 3,478,917. **HWT (BLOCK FORM)**. HISPEC WHEEL & TIRE, INC., (U.S. CLS. 19, 21, 23, 31, 35 AND 44). SN 77-179,666. PUB. 5-20-2008. FILED 5-13-2007.
 3,478,940. **LSS (BLOCK FORM)**. KAYABA INDUSTRY CO., LTD., (U.S. CLS. 19, 21, 23, 31, 35 AND 44). SN 77-186,346. PUB. 2-19-2008. FILED 5-21-2007.
 3,479,006. **GPS AND DESIGN**. GLOBAL PARTS SUPPORT, INC., (U.S. CLS. 19, 21, 23, 31, 35 AND 44). SN 77-197,611. PUB. 5-20-2008. FILED 6-5-2007.
 3,479,094. **AGRI-FLEX (BLOCK FORM)**. TRINITY TRAILER MFG., INC., (U.S. CLS. 19, 21, 23, 31, 35 AND 44). SN 77-211,773. PUB. 5-20-2008. FILED 6-21-2007.
 3,479,148 (*See Class 3 for this trademark*).
 3,479,228. **TWIN N QUIK (BLOCK FORM)**. CLUTCH AUTO LIMITED, (U.S. CLS. 19, 21, 23, 31, 35 AND 44). SN 77-227,349. PUB. 5-20-2008. FILED 7-11-2007.
 3,479,307. **TRUCKMAR AND DESIGN**. TRUCKMAR IND. E COM. DE PRODUTOS EM METAIS LTDA., (U.S. CLS. 19, 21, 23, 31, 35 AND 44). SN 77-240,165. PUB. 5-20-2008. FILED 7-27-2007.
 3,479,516. **GROUNDSKEEPER (BLOCK FORM)**. BRENTWOOD INDUSTRIES, INC., (U.S. CLS. 19, 21, 23, 31, 35 AND 44). SN 77-300,218. PUB. 5-20-2008. FILED 10-10-2007.
 3,479,640. **TRU-BALANCE (BLOCK FORM)**. TRU-BALANCE, LLC, (U.S. CLS. 19, 21, 23, 31, 35 AND 44). SN 77-322,445. PUB. 5-20-2008. FILED 11-6-2007.
 3,479,670. **KWIK KLEAT (BLOCK FORM)**. HERZOGENRATH, KEITH, DBA TEXAS REDHEAD PRODUCTS, (U.S. CLS. 19, 21, 23, 31, 35 AND 44). SN 77-325,621. PUB. 5-20-2008.

FILED 11-9-2007.
 3,479,718. **GLOBE POW-R STEER (BLOCK FORM)**. GLOBE MOTORS, INC., (U.S. CLS. 19, 21, 23, 31, 35 AND 44). SN 77-331,871. PUB. 5-20-2008. FILED 11-16-2007.
 3,479,769. **XBR (BLOCK FORM)**. ALCOA INC., (U.S. CLS. 19, 21, 23, 31, 35 AND 44). SN 77-339,359. PUB. 5-20-2008. FILED 11-28-2007.
 3,479,773. **ZS MOTOR AND DESIGN**. COMERCIAL CARDEPORT LTDA., (U.S. CLS. 19, 21, 23, 31, 35 AND 44). SN 77-339,980. PUB. 5-20-2008. FILED 11-29-2007.
 3,480,027. **WHISKEYJACK PADDLES (BLOCK FORM)**. BROWN, DANIEL EDWARD, (U.S. CLS. 19, 21, 23, 31, 35 AND 44). SN 77-357,089. PUB. 5-20-2008. FILED 12-20-2007.
 3,480,297. **CLAMSHELL AND DESIGN**. TEKTRON TECHNOLOGY CORPORATION, (U.S. CLS. 19, 21, 23, 31, 35 AND 44). SN 77-364,438. PUB. 5-20-2008. FILED 1-4-2008.
 3,480,299. **EUROX (STYLIZED)**. TEKTRON TECHNOLOGY CORPORATION, (U.S. CLS. 19, 21, 23, 31, 35 AND 44). SN 77-364,479. PUB. 5-20-2008. FILED 1-4-2008.
 3,480,422. **PURDYBILT (BLOCK FORM)**. UPSCO, INC., (U.S. CLS. 19, 21, 23, 31, 35 AND 44). SN 77-366,737. PUB. 5-20-2008. FILED 1-8-2008.
 3,480,494. **EXPLORER (BLOCK FORM)**. FORD MOTOR COMPANY, (U.S. CLS. 19, 21, 23, 31, 35 AND 44). SN 77-369,888. PUB. 5-20-2008. FILED 1-11-2008.
 3,480,539. **VICTRA ASYMMET (BLOCK FORM)**. CHENG SHIN RUBBER USA, INC., (U.S. CLS. 19, 21, 23, 31, 35 AND 44). SN 77-392,463. PUB. 5-20-2008. FILED 2-8-2008.
 3,480,641. **MIRRA (BLOCK FORM)**. MIRRA, DAVID, (U.S. CLS. 19, 21, 23, 31, 35 AND 44). SN 78-812,968. PUB. 5-20-2008. FILED 2-12-2006.
 3,480,661. **HONDA LOCK (STYLIZED)**. HONDA LOCK MFG. CO., LTD., (U.S. CLS. 19, 21, 23, 31, 35 AND 44). SN 78-861,276. PUB. 4-15-2008. FILED S.R. 4-13-2006; AM. P.R. 2-11-2008.
 3,480,698. **HI-LEX CORPORATION AND DESIGN**. HI-LEX CORPORATION, (U.S. CLS. 19, 21, 23, 31, 35 AND 44). SN 78-913,191. PUB. 1-8-2008. FILED 6-21-2006.
 3,480,793. **VIBRAM (STYLIZED)**. VIBRAM S.P.A., MULTIPLE CLASS, (INT. CLS. 12, 26 AND 28), (U.S. CLS. 19, 21, 22, 23, 31, 35, 37, 38, 39, 40, 42, 44 AND 50). SN 79-035,149. PUB. 5-20-2008. FILED 1-30-2007.
 3,480,794. **VIBRAM AND DESIGN**. VIBRAM S.P.A., MULTIPLE CLASS, (INT. CLS. 12, 26 AND 28), (U.S. CLS. 19, 21, 22, 23, 31, 35, 37, 38, 39, 40, 42, 44 AND 50). SN 79-035,155. PUB. 5-20-2008. FILED 1-30-2007.
 3,480,800 (See Class 3 for this trademark).
 3,480,805 (See Class 7 for this trademark).
 3,480,824. **ARZANÁ (BLOCK FORM)**. ARZANA' SPA, (U.S. CLS. 19, 21, 23, 31, 35 AND 44). SN 79-038,642. PUB. 5-20-2008. FILED 5-4-2007.
 3,480,833. **TAP RAP TYRE REPAIRING SYSTEM AND DESIGN**. RFP SRL RICOSTRUZIONE; FASCIA PRESTAMPATA, MULTIPLE CLASS, (INT. CLS. 12 AND 37), (U.S. CLS. 19, 21, 23, 31, 35, 44, 100, 103 AND 106). SN 79-039,281. PUB. 5-20-2008. FILED 5-17-2006.
 3,480,843 (See Class 6 for this trademark).
 3,480,862. **V-MAXX AUTOSPORT (BLOCK FORM)**. HILTRAC B.V., (U.S. CLS. 19, 21, 23, 31, 35 AND 44). SN 79-040,941. PUB. 5-20-2008. FILED 12-12-2006.
 3,480,873. **MISCELLANEOUS DESIGN**. EMPACHER VERWALTUNGS GMBH & CO. KG, (U.S. CLS. 19, 21, 23, 31, 35 AND 44). SN 79-041,253. PUB. 5-20-2008. FILED 1-9-2007.
 3,480,888. **FONTAINE PAJOT CATAMARANS AND DESIGN**. FONTAINE PAJOT, MULTIPLE CLASS, (INT. CLS. 12, 22 AND 25), (U.S. CLS. 1, 2, 7, 19, 21, 22, 23, 31, 35, 39, 42, 44 AND 50). SN 79-041,583. PUB. 5-20-2008. FILED 6-11-2007.
 3,480,918 (See Class 7 for this trademark).
 3,480,932. **RODMAN MUSE AND DESIGN**. RODMAN POLYSHIPS, S.A., (U.S. CLS. 19, 21, 23, 31, 35 AND 44). SN 79-042,610. PUB. 5-20-2008. FILED 6-1-2007.
 3,480,955. **POGO (BLOCK FORM)**. SAMMELT, MARTIN, AND MÄRZ, JOACHIM, MULTIPLE CLASS, (INT. CLS. 12, 25 AND 28), (U.S. CLS. 19, 21, 22, 23, 31, 35, 38, 39, 44 AND 50). SN 79-043,462. PUB. 5-20-2008. FILED 7-20-2007.
 3,480,957. **VOLKSWAGEN.DAS AUTO. (BLOCK FORM)**. VOLKSWAGEN AKTIENGESELLSCHAFT, MULTIPLE

CLASS, (INT. CLS. 12, 35 AND 37), (U.S. CLS. 19, 21, 23, 31, 35, 44, 100, 101, 102, 103 AND 106). SN 79-043,628. PUB. 5-20-2008. FILED 7-26-2007.
 3,480,965 (See Class 9 for this trademark).
 3,480,981. **STARMAXX AND DESIGN**. PETLAS LASTIK; SANAYI VE TICARET ANONIM SIRKETI, (U.S. CLS. 19, 21, 23, 31, 35 AND 44). SN 79-044,688. PUB. 5-20-2008. FILED 9-12-2007.
 3,481,027. **NBWB AND DESIGN**. NINGBO SUNSHINE TRAFFIC; EQUIPMENT CO., LTD., (U.S. CLS. 19, 21, 23, 31, 35 AND 44). SN 79-048,618. PUB. 5-20-2008. FILED 1-7-2008.
 3,481,029. **RUFFNUTS (BLOCK FORM)**. RUFFNUTS PTY LTD; (ACN 092856105), (U.S. CLS. 19, 21, 23, 31, 35 AND 44). SN 79-048,669. PUB. 5-20-2008. FILED 12-19-2007.
 3,481,031. **SILVER GHOST (BLOCK FORM)**. BAYERISCHE MOTOREN WERKE AKTIENGESELLSCHAFT, MULTIPLE CLASS, (INT. CLS. 12 AND 28), (U.S. CLS. 19, 21, 22, 23, 31, 35, 38, 44 AND 50). SN 79-049,148. PUB. 5-20-2008. FILED 11-15-2007.
 3,481,033. **CONTIESCONTACT (BLOCK FORM)**. CONTINENTAL AKTIENGESELLSCHAFT, (U.S. CLS. 19, 21, 23, 31, 35 AND 44). SN 79-049,238. PUB. 5-20-2008. FILED 12-7-2007.

CLASS 13—FIREARMS

3,478,566. **SENTINEL (BLOCK FORM)**. WILSON'S GUN SHOP, INC., (U.S. CLS. 2 AND 9). SN 76-679,871. PUB. 5-20-2008. FILED 7-25-2007.
 3,478,909. **MISCELLANEOUS DESIGN**. SWAN, RICHARD E., (U.S. CLS. 2 AND 9). SN 77-177,555. PUB. 5-20-2008. FILED 5-10-2007.
 3,478,910. **MISCELLANEOUS DESIGN**. RICHARD E. SWAN, (U.S. CLS. 2 AND 9). SN 77-177,568. PUB. 5-20-2008. FILED 5-10-2007.
 3,479,725 (See Class 9 for this trademark).
 3,479,754. **POW-R-ENTRY (BLOCK FORM)**. IMLCORP LLC, (U.S. CLS. 2 AND 9). SN 77-337,788. PUB. 5-20-2008. FILED 11-27-2007.
 3,480,575 (See Class 8 for this trademark).
 3,480,790 (See Class 9 for this trademark).
 3,480,791 (See Class 9 for this trademark).
 3,480,792 (See Class 9 for this trademark).
 3,480,795 (See Class 9 for this trademark).

CLASS 14—JEWELRY

3,478,544. **SPECIAL OPERATIONS WARRIOR FOUNDATION AND DESIGN**. SPECIAL OPERATIONS WARRIOR FOUNDATION, INC., MULTIPLE CLASS, (INT. CLS. 14, 25, 36, 41 AND 45), (U.S. CLS. 2, 22, 27, 28, 39, 50, 100, 101, 102 AND 107). SN 76-674,922. PUB. 5-20-2008. FILED 3-30-2007.
 3,478,586. **ME AND CO. AND DESIGN**. BOWERMAN, COURTNEY, (U.S. CLS. 2, 27, 28 AND 50). SN 76-683,085. PUB. 5-20-2008. FILED 10-18-2007.
 3,478,725. **STICKI RICE (BLOCK FORM)**. STICKI RICE, LLC, AND JENKINS, AMY, MULTIPLE CLASS, (INT. CLS. 14, 20 AND 35), (U.S. CLS. 2, 13, 22, 25, 27, 28, 32, 50, 100, 101 AND 102). SN 77-073,776. PUB. 5-20-2008. FILED 12-30-2006.
 3,478,823. **DIRTBOY DESIGNS (BLOCK FORM)**. DIRTBOY DESIGNS, LLC, (U.S. CLS. 2, 27, 28 AND 50). SN 77-135,477. PUB. 5-20-2008. FILED 3-20-2007.
 3,478,929. **MISCELLANEOUS DESIGN**. THE UPPER ROOM, (U.S. CLS. 2, 27, 28 AND 50). SN 77-184,385. PUB. 5-20-2008. FILED 5-18-2007.
 3,479,107. **CANADAMARK AND DESIGN**. POINT LAKE MARKETING, INC., MULTIPLE CLASS, (INT. CLS. 14, 35, 40 AND 42), (U.S. CLS. 2, 27, 28, 50, 100, 101, 102, 103 AND 106). SN 77-213,664. PUB. 5-20-2008. FILED 6-22-2007.
 3,479,148 (See Class 3 for this trademark).
 3,479,296. **SHOE-DOODLES CHARMS FOR RUBBER CLOGS AND DESIGN**. PURE AND SIMPLE SOLUTIONS, LLC, (U.S. CLS. 2, 27, 28 AND 50). SN 77-238,148. PUB. 5-20-2008.

FILED 7-25-2007.
 3,479,331. **609 GREENWICH AND DESIGN**. ANDIN INTERNATIONAL INC., MULTIPLE CLASS, (INT. CLS. 14 AND 35), (U.S. CLS. 2, 27, 28, 50, 100, 101 AND 102). SN 77-248,000. PUB. 5-20-2008. FILED 8-6-2007.
 3,479,338. **LP LUCKY PIGGY AND DESIGN**. CAIN, MARC A, MULTIPLE CLASS, (INT. CLS. 14 AND 25), (U.S. CLS. 2, 22, 27, 28, 39 AND 50). SN 77-249,628. PUB. 2-12-2008. FILED 8-8-2007.
 3,479,404. **WELDER (BLOCK FORM)**. TIME FACTORY S.R.L., (U.S. CLS. 2, 27, 28 AND 50). SN 77-267,924. PUB. 5-13-2008. FILED 8-30-2007.
 3,479,475. **CHIC MAGNET (BLOCK FORM)**. O'CONNELL, MAUREEN, (U.S. CLS. 2, 27, 28 AND 50). SN 77-288,694. PUB. 5-20-2008. FILED 9-25-2007.
 3,479,505. **DON'T HARSH MY MELLOW (BLOCK FORM)**. DON'T HARSH MY MELLOW, LLC, MULTIPLE CLASS, (INT. CLS. 14, 16, 18, 20, 21, 25, 28 AND 35), (U.S. CLS. 1, 2, 3, 5, 13, 22, 23, 25, 27, 28, 29, 30, 32, 33, 37, 38, 39, 40, 41, 50, 100, 101 AND 102). SN 77-297,885. PUB. 5-20-2008. FILED 10-5-2007.
 3,479,880. **JENLARI (BLOCK FORM)**. UNCAS MANUFACTURING COMPANY, (U.S. CLS. 2, 27, 28 AND 50). SN 77-350,295. PUB. 5-20-2008. FILED 12-12-2007.
 3,480,195. **MISCELLANEOUS DESIGN**. HAPPY HEART, INC., MULTIPLE CLASS, (INT. CLS. 14 AND 16), (U.S. CLS. 2, 5, 22, 23, 27, 28, 29, 37, 38 AND 50). SN 77-362,847. PUB. 5-20-2008. FILED 1-2-2008.
 3,480,224. **BRIGHTNESS BEYOND COMPARE (BLOCK FORM)**. M.S. DAFFNER DIAMONDS INTERNATIONAL, INC, (U.S. CLS. 2, 27, 28 AND 50). SN 77-363,283. PUB. 5-20-2008. FILED 1-3-2008.
 3,480,323. **COMFORT CLOCK (BLOCK FORM)**. LESSER, KENNETH, (U.S. CLS. 2, 27, 28 AND 50). SN 77-364,695. PUB. 5-20-2008. FILED 1-4-2008.
 3,480,424. **TIME IN A BOTTLE (BLOCK FORM)**. INTERNATIONAL BULLION & METAL BROKERS (USA) INC., (U.S. CLS. 2, 27, 28 AND 50). SN 77-366,751. PUB. 5-20-2008. FILED 1-8-2008.
 3,480,484. **CHRISTIAN BENET (BLOCK FORM)**. FOSSIL, INC., (U.S. CLS. 2, 27, 28 AND 50). SN 77-368,337. PUB. 5-20-2008. FILED 1-10-2008.
 3,480,592. **NEWD (STYLIZED)**. ALESSANDRO MASINI, (U.S. CLS. 2, 27, 28 AND 50). SN 78-565,680. PUB. 5-20-2008. FILED 2-11-2005.
 3,480,743. **MARRYME (STYLIZED)**. BULGARI SPA, (U.S. CLS. 2, 27, 28 AND 50). SN 79-009,026. PUB. 5-20-2008. FILED 1-19-2005.
 3,480,771 (*See Class 8 for this trademark*).
 3,480,777. **R RIANI AND DESIGN**. RIANI BUCKI MODE GMBH, MULTIPLE CLASS, (INT. CLS. 14, 18, 24 AND 25), (U.S. CLS. 1, 2, 3, 22, 27, 28, 39, 41, 42 AND 50). SN 79-033,764. PUB. 5-20-2008. FILED 3-2-2006.
 3,480,800 (*See Class 3 for this trademark*).
 3,480,826. **MISCELLANEOUS DESIGN**. SOCIETE ANONYME DE LA MANUFACTURE; D'HORLOGERIE AUDEMARS PIGUET & CIE, (U.S. CLS. 2, 27, 28 AND 50). SN 79-038,879. PUB. 5-20-2008. FILED 12-18-2006.
 3,480,839 (*See Class 3 for this trademark*).
 3,480,867. **FANTASME (BLOCK FORM)**. JACRI SA, (U.S. CLS. 2, 27, 28 AND 50). SN 79-041,049. PUB. 5-20-2008. FILED 7-2-2007.
 3,480,889. **MEREA (BLOCK FORM)**. MILUS INTERNATIONAL S.A., (U.S. CLS. 2, 27, 28 AND 50). SN 79-041,600. PUB. 5-20-2008. FILED 7-3-2007.
 3,480,928. **LES MASQUES (BLOCK FORM)**. RICHEMONT INTERNATIONAL SA, (U.S. CLS. 2, 27, 28 AND 50). SN 79-042,545. PUB. 5-20-2008. FILED 8-3-2007.
 3,480,941. **PAUL AUDET (STYLIZED)**. MARC DANZINELLI, (U.S. CLS. 2, 27, 28 AND 50). SN 79-042,858. PUB. 5-20-2008. FILED 1-31-2007.
 3,480,969. **ORIS (BLOCK FORM)**. ORIS HOLDING AG, (U.S. CLS. 2, 27, 28 AND 50). SN 79-043,973. PUB. 5-20-2008. FILED 9-4-2007.
 3,480,972. **40-GOAL (BLOCK FORM)**. RICHEMONT INTERNATIONAL SA, (U.S. CLS. 2, 27, 28 AND 50). SN 79-044,029. PUB. 5-20-2008. FILED 9-10-2007.
 3,480,983. **SOPHIE BY SOPHIE (BLOCK FORM)**. SOPHIE

MATTSSON MED FIRMA; SOPHIE GALLERY, (U.S. CLS. 2, 27, 28 AND 50). SN 79-044,804. PUB. 5-20-2008. FILED 9-6-2007.
 3,480,999. **O'SOEZ (BLOCK FORM)**. TGN 409, (U.S. CLS. 2, 27, 28 AND 50). SN 79-046,311. PUB. 5-20-2008. FILED 10-12-2007.

CLASS 15—MUSICAL INSTRUMENTS

3,478,555. **RW AND DESIGN**. ROBERTO'S WINDS, INC., MULTIPLE CLASS, (INT. CLS. 15 AND 35), (U.S. CLS. 2, 21, 36, 100, 101 AND 102). SN 76-678,006. PUB. 5-20-2008. FILED 6-8-2007.
 3,478,885. **MISCELLANEOUS DESIGN**. COLLINGS GUITARS, INC., (U.S. CLS. 2, 21 AND 36). SN 77-167,960. PUB. 5-20-2008. FILED 4-27-2007.
 3,479,235. **GUY LAURENT (BLOCK FORM)**. SHAR PRODUCTS COMPANY, (U.S. CLS. 2, 21 AND 36). SN 77-228,302. PUB. 5-20-2008. FILED 7-12-2007.
 3,480,176. **DOUBLE TROUBLE (BLOCK FORM)**. VISUAL SOUND LLC, (U.S. CLS. 2, 21 AND 36). SN 77-362,497. PUB. 5-20-2008. FILED 1-2-2008.
 3,480,571. **SAN DIMAS (BLOCK FORM)**. JACKSON/CHARVEL MANUFACTURING, INC., (U.S. CLS. 2, 21 AND 36). SN 78-312,464. PUB. 5-20-2008. FILED 10-11-2003.

CLASS 16—PAPER GOODS AND PRINTED MATTER

3,478,523. **KALTOONS (BLOCK FORM)**. KALLAUGHER, KEVIN, (U.S. CLS. 2, 5, 22, 23, 29, 37, 38 AND 50). SN 76-664,376. PUB. 5-20-2008. FILED 8-9-2006.
 3,478,534. **FREESMART (BLOCK FORM)**. MARION, JOSEPH, (U.S. CLS. 2, 5, 22, 23, 29, 37, 38 AND 50). SN 76-672,088. PUB. 5-20-2008. FILED 2-1-2007.
 3,478,554. **DISPENSAPAK (BLOCK FORM)**. ELWOOD PACKAGING, INC., (U.S. CLS. 2, 5, 22, 23, 29, 37, 38 AND 50). SN 76-677,831. PUB. 5-20-2008. FILED 6-5-2007.
 3,478,562 (*See Class 9 for this trademark*).
 3,478,570. **VIVE MEJOR (BLOCK FORM)**. UNILEVER SUPPLY CHAIN, INC., MULTIPLE CLASS, (INT. CLS. 16, 43 AND 44), (U.S. CLS. 2, 5, 22, 23, 29, 37, 38, 50, 100 AND 101). SN 76-680,958. PUB. 5-20-2008. FILED 8-21-2007.
 3,478,605. **MANAGING YOUR EPILEPSY (BLOCK FORM)**. ASSOCIATES IN MEDICAL MARKETING CO., INC., (U.S. CLS. 2, 5, 22, 23, 29, 37, 38 AND 50). SN 76-684,902. PUB. 5-20-2008. FILED 12-13-2007.
 3,478,606. **A PATIENT'S HANDBOOK ON CHOLESTEROL DISORDERS (BLOCK FORM)**. ASSOCIATES IN MEDICAL MARKETING CO., INC., (U.S. CLS. 2, 5, 22, 23, 29, 37, 38 AND 50). SN 76-684,903. PUB. 5-20-2008. FILED 12-13-2007.
 3,478,611 (*See Class 9 for this trademark*).
 3,478,612. **TROUBLE TALK (BLOCK FORM)**. LUDWIG CREATIVE, INC., (U.S. CLS. 2, 5, 22, 23, 29, 37, 38 AND 50). SN 76-685,201. PUB. 5-20-2008. FILED 12-26-2007.
 3,478,613. **BALABAN AND KATZ (BLOCK FORM)**. BALABAN, DAVID, (U.S. CLS. 2, 5, 22, 23, 29, 37, 38 AND 50). SN 76-685,261. PUB. 5-20-2008. FILED 12-26-2007.
 3,478,636. **MAGNETNOTES AND DESIGN**. MAGNETNOTES, LTD., (U.S. CLS. 2, 5, 22, 23, 29, 37, 38 AND 50). SN 77-009,598. PUB. 5-20-2008. FILED 9-28-2006.
 3,478,671 (*See Class 9 for this trademark*).
 3,478,714. **FIBER35DIET (BLOCK FORM)**. RENEW LIFE FORMULAS, INC., (U.S. CLS. 2, 5, 22, 23, 29, 37, 38 AND 50). SN 77-065,001. PUB. 5-20-2008. FILED 12-15-2006.
 3,478,736. **AJM (BLOCK FORM)**. INTERNATIONAL PRESS OF BOSTON, INC., (U.S. CLS. 2, 5, 22, 23, 29, 37, 38 AND 50). SN 77-080,676. PUB. 5-20-2008. FILED 1-11-2007.
 3,478,758 (*See Class 3 for this trademark*).
 3,478,761 (*See Class 3 for this trademark*).
 3,478,766. **A LA CARTE COLLECTION (BLOCK FORM)**. BONITA PACKAGING PRODUCTS, INC., (U.S. CLS. 2, 5, 22, 23, 29, 37, 38 AND 50). SN 77-098,502. PUB. 5-20-2008.

- FILED 2-2-2007.
- 3,478,769. **BEST OF THE GOLD COAST CONNECTICUT AND DESIGN**. MOFFLY PUBLICATIONS, INC., MULTIPLE CLASS, (INT. CLS. 16, 35 AND 41), (U.S. CLS. 2, 5, 22, 23, 29, 37, 38, 50, 100, 101, 102 AND 107). SN 77-099,402. PUB. 5-20-2008. FILED 2-5-2007.
- 3,478,772. **ARTHUR FROMMER'S BUDGET TRAVEL (BLOCK FORM)**. NEWSWEEK BUDGET TRAVEL, INC., (U.S. CLS. 2, 5, 22, 23, 29, 37, 38 AND 50). SN 77-101,167. PUB. 5-20-2008. FILED 2-7-2007.
- 3,478,776. **CELEBRATE COOKING (STYLIZED)**. BROOKSHIRE GROCERY COMPANY, MULTIPLE CLASS, (INT. CLS. 16 AND 43), (U.S. CLS. 2, 5, 22, 23, 29, 37, 38, 50, 100 AND 101). SN 77-104,865. PUB. 5-20-2008. FILED 2-12-2007.
- 3,478,855. **AVIAT (BLOCK FORM)**. AVIAT AIRCRAFT, INC., MULTIPLE CLASS, (INT. CLS. 16, 35, 37 AND 40), (U.S. CLS. 2, 5, 22, 23, 29, 37, 38, 50, 100, 101, 102, 103 AND 106). SN 77-154,079. PUB. 5-20-2008. FILED 4-11-2007.
- 3,478,888. **EARLY BIRD BABY (BLOCK FORM)**. EARLY BIRD BABY, LLC, (U.S. CLS. 2, 5, 22, 23, 29, 37, 38 AND 50). SN 77-168,829. PUB. 5-20-2008. FILED 4-30-2007.
- 3,478,889. **MISCELLANEOUS DESIGN**. EARLY BIRD BABY, LLC, (U.S. CLS. 2, 5, 22, 23, 29, 37, 38 AND 50). SN 77-168,846. PUB. 5-20-2008. FILED 4-30-2007.
- 3,478,903. **GMA AND DESIGN**. GROCERY MANUFACTURERS ASSOCIATION, MULTIPLE CLASS, (INT. CLS. 16, 35 AND 41), (U.S. CLS. 2, 5, 22, 23, 29, 37, 38, 50, 100, 101, 102 AND 107). SN 77-175,671. PUB. 5-20-2008. FILED 5-8-2007.
- 3,478,908. **JA CAREERS WITH A PURPOSE (BLOCK FORM)**. JA WORLDWIDE, MULTIPLE CLASS, (INT. CLS. 16 AND 41), (U.S. CLS. 2, 5, 22, 23, 29, 37, 38, 50, 100, 101 AND 107). SN 77-176,854. PUB. 5-20-2008. FILED 5-9-2007.
- 3,478,932. **MISCELLANEOUS DESIGN**. THE UPPER ROOM, (U.S. CLS. 2, 5, 22, 23, 29, 37, 38 AND 50). SN 77-184,401. PUB. 5-20-2008. FILED 5-18-2007.
- 3,478,938. **FLATBOARD (BLOCK FORM)**. GREAT NORTHERN CORP., (U.S. CLS. 2, 5, 22, 23, 29, 37, 38 AND 50). SN 77-186,014. PUB. 5-20-2008. FILED 5-21-2007.
- 3,478,963. **M.V.P. MARKET VALUE PRICING (BLOCK FORM)**. LANE AUTOMOTIVE, MULTIPLE CLASS, (INT. CLS. 16 AND 35), (U.S. CLS. 2, 5, 22, 23, 29, 37, 38, 50, 100, 101 AND 102). SN 77-191,883. PUB. 5-20-2008. FILED 5-29-2007.
- 3,478,967. **BUSINESS OPPORTUNITIES JOURNAL (BLOCK FORM)**. BUSINESS SERVICE CORPORATION, (U.S. CLS. 2, 5, 22, 23, 29, 37, 38 AND 50). SN 77-192,362. PUB. 5-20-2008. FILED 5-29-2007.
- 3,478,968. **WINNING AT WORK (BLOCK FORM)**. AMERICAN DIABETES ASSOCIATION, INC., MULTIPLE CLASS, (INT. CLS. 16 AND 41), (U.S. CLS. 2, 5, 22, 23, 29, 37, 38, 50, 100, 101 AND 107). SN 77-192,745. PUB. 5-20-2008. FILED 5-30-2007.
- 3,478,974 (*See Class 8 for this trademark*).
- 3,478,987. **E AND DESIGN**. LG VERWALTUNGS, GMBH, (U.S. CLS. 2, 5, 22, 23, 29, 37, 38 AND 50). SN 77-195,922. PUB. 5-20-2008. FILED 6-1-2007.
- 3,479,015 (*See Class 9 for this trademark*).
- 3,479,016. **STILETTO MAGAZINE AND DESIGN**. STILETTO MAGAZINE, MULTIPLE CLASS, (INT. CLS. 16 AND 41), (U.S. CLS. 2, 5, 22, 23, 29, 37, 38, 50, 100, 101 AND 107). SN 77-198,922. PUB. 5-20-2008. FILED 6-6-2007.
- 3,479,026. **LA ESTRELLA (BLOCK FORM)**. MCCLATCHY U.S.A., INC., (U.S. CLS. 2, 5, 22, 23, 29, 37, 38 AND 50). SN 77-200,163. PUB. 5-20-2008. FILED 6-7-2007.
- 3,479,027. **LA ESTRELLA EN CASA (BLOCK FORM)**. MCCLATCHY U.S.A., INC., (U.S. CLS. 2, 5, 22, 23, 29, 37, 38 AND 50). SN 77-200,195. PUB. 5-20-2008. FILED 6-7-2007.
- 3,479,030. **CVI CLINICAL AND VACCINE IMMUNOLOGY (BLOCK FORM)**. AMERICAN SOCIETY FOR MICROBIOLOGY, (U.S. CLS. 2, 5, 22, 23, 29, 37, 38 AND 50). SN 77-200,627. PUB. 5-20-2008. FILED 6-7-2007.
- 3,479,046. **PARAMOUNT (BLOCK FORM)**. GOLDSTEIN, IRA, AND GOLDSTEIN, DAVID, (U.S. CLS. 2, 5, 22, 23, 29, 37, 38 AND 50). SN 77-204,211. PUB. 5-20-2008. FILED 6-12-2007.
- 3,479,070. **SILATINO (BLOCK FORM)**. TIME INC., (U.S. CLS. 2, 5, 22, 23, 29, 37, 38 AND 50). SN 77-208,274. PUB. 5-20-2008. FILED 6-18-2007.
- 3,479,091. **MISCELLANEOUS DESIGN**. CHINA DAILY NEWS, INC., (U.S. CLS. 2, 5, 22, 23, 29, 37, 38 AND 50). SN 77-211,375. PUB. 5-20-2008. FILED 6-20-2007.
- 3,479,097. **SAN DIEGO FORECLOSURES AND DESIGN**. ALVA & ASSOCIATES, (U.S. CLS. 2, 5, 22, 23, 29, 37, 38 AND 50). SN 77-212,209. PUB. 5-20-2008. FILED 6-21-2007.
- 3,479,121. **LICENSE QUEST (BLOCK FORM)**. DOLLAR EMPIRE LLC, (U.S. CLS. 2, 5, 22, 23, 29, 37, 38 AND 50). SN 77-216,336. PUB. 5-20-2008. FILED 6-27-2007.
- 3,479,141. **SECOND BILLION (BLOCK FORM)**. BILLION SOULS, INC., MULTIPLE CLASS, (INT. CLS. 16, 41 AND 45), (U.S. CLS. 2, 5, 22, 23, 29, 37, 38, 50, 100, 101 AND 107). SN 77-217,735. PUB. 5-20-2008. FILED 6-28-2007.
- 3,479,143. **POWERZONE (BLOCK FORM)**. FRANK DE FINA, MULTIPLE CLASS, (INT. CLS. 16 AND 41), (U.S. CLS. 2, 5, 22, 23, 29, 37, 38, 50, 100, 101 AND 107). SN 77-217,933. PUB. 5-20-2008. FILED 6-28-2007.
- 3,479,154. **SF EXPRESS AND DESIGN**. SF (IP) LIMITED, MULTIPLE CLASS, (INT. CLS. 16 AND 39), (U.S. CLS. 2, 5, 22, 23, 29, 37, 38, 50, 100 AND 105). SN 77-218,592. PUB. 4-8-2008. FILED 6-29-2007.
- 3,479,159. **ZOOM AND DESIGN**. SANOFI-AVENTIS, (U.S. CLS. 2, 5, 22, 23, 29, 37, 38 AND 50). SN 77-218,934. PUB. 5-20-2008. FILED 6-29-2007.
- 3,479,177. **CLUB VALET (BLOCK FORM)**. MAVERICK MULTIMEDIA, DBA MAVERICK LABEL, (U.S. CLS. 2, 5, 22, 23, 29, 37, 38 AND 50). SN 77-220,929. PUB. 5-20-2008. FILED 7-2-2007.
- 3,479,193. **BOOGALABOO (BLOCK FORM)**. MARVIN, DORIS MOORE, (U.S. CLS. 2, 5, 22, 23, 29, 37, 38 AND 50). SN 77-222,132. PUB. 5-20-2008. FILED 7-5-2007.
- 3,479,197. **MISCELLANEOUS DESIGN**. EMERGENCY COMMITTEE FOR AMERICAN TRADE, MULTIPLE CLASS, (INT. CLS. 16 AND 35), (U.S. CLS. 2, 5, 22, 23, 29, 37, 38, 50, 100, 101 AND 102). SN 77-222,641. PUB. 5-20-2008. FILED 7-5-2007.
- 3,479,219. **IT'S EASY AS 1 2 3 AND DESIGN**. MOMENTA, INC., (U.S. CLS. 2, 5, 22, 23, 29, 37, 38 AND 50). SN 77-225,980. PUB. 5-20-2008. FILED 7-10-2007.
- 3,479,252 (*See Class 9 for this trademark*).
- 3,479,277. **PAPER'ONI AND DESIGN**. HAPPY HANDS (HK) LIMITED, (U.S. CLS. 2, 5, 22, 23, 29, 37, 38 AND 50). SN 77-234,165. PUB. 5-20-2008. FILED 7-19-2007.
- 3,479,286. **AAS AUTO ADVISORY SERVICES AND DESIGN**. AUTO ADVISORY SERVICES, INC., (U.S. CLS. 2, 5, 22, 23, 29, 37, 38 AND 50). SN 77-236,001. PUB. 5-20-2008. FILED 7-23-2007.
- 3,479,360 (*See Class 7 for this trademark*).
- 3,479,427. **MAGIC EYE (BLOCK FORM)**. MAGIC EYE, INC., (U.S. CLS. 2, 5, 22, 23, 29, 37, 38 AND 50). SN 77-274,393. PUB. 5-20-2008. FILED 9-7-2007.
- 3,479,434. **PE PLAY MAP 1037 AND DESIGN**. WAYNE SEGER, (U.S. CLS. 2, 5, 22, 23, 29, 37, 38 AND 50). SN 77-276,205. PUB. 5-20-2008. FILED 9-11-2007.
- 3,479,477. **AN INDEPENDENT REVIEW OF HIGH YIELD COVENANTS FOR THE SOPHISTICATED INVESTOR (BLOCK FORM)**. COVENANT REVIEW, LLC, (U.S. CLS. 2, 5, 22, 23, 29, 37, 38 AND 50). SN 77-289,778. PUB. 5-20-2008. FILED 9-26-2007.
- 3,479,491. **GLOBE LIFE (BLOCK FORM)**. CTVGLOBEMEDIA PUBLISHING INC., MULTIPLE CLASS, (INT. CLS. 16 AND 41), (U.S. CLS. 2, 5, 22, 23, 29, 37, 38, 50, 100, 101 AND 107). SN 77-292,611. PUB. 5-20-2008. FILED 10-1-2007.
- 3,479,502. **LIGHTWORSHIP (BLOCK FORM)**. CURTIS, VICTOR, (U.S. CLS. 2, 5, 22, 23, 29, 37, 38 AND 50). SN 77-296,712. PUB. 5-20-2008. FILED 10-4-2007.
- 3,479,505 (*See Class 14 for this trademark*).
- 3,479,511. **I-4 (BLOCK FORM)**. GETRONICS INTELLECTUAL PROPERTY BV, MULTIPLE CLASS, (INT. CLS. 16 AND 41), (U.S. CLS. 2, 5, 22, 23, 29, 37, 38, 50, 100, 101 AND 107). SN 77-299,356. PUB. 5-20-2008. FILED 10-9-2007.
- 3,479,521. **NATIONAL CONSUMER LAW CENTER (BLOCK FORM)**. NATIONAL CONSUMER LAW CENTER, INC., MULTIPLE CLASS, (INT. CLS. 16, 35, 41 AND 45), (U.S. CLS. 2, 5, 22, 23, 29, 37, 38, 50, 100, 101, 102 AND 107). SN 77-300,892. PUB. 5-20-2008. FILED 10-10-2007.
- 3,479,522. **NCLC (BLOCK FORM)**. NATIONAL CONSUMER LAW CENTER, INC., MULTIPLE CLASS, (INT. CLS. 16, 35, 41 AND 45), (U.S. CLS. 2, 5, 22, 23, 29, 37, 38, 50, 100, 101, 102

- AND 107). SN 77-300,943. PUB. 5-20-2008. FILED 10-10-2007.
- 3,479,570. **CORE AND DESIGN**. CONSORTIUM ON READING EXCELLENCE, MULTIPLE CLASS, (INT. CLS. 16 AND 41), (U.S. CLS. 2, 5, 22, 23, 29, 37, 38, 50, 100, 101 AND 107). SN 77-309,785. PUB. 5-20-2008. FILED 10-22-2007.
- 3,479,593 (*See Class 9 for this trademark*).
- 3,479,595 (*See Class 9 for this trademark*).
- 3,479,639. **3-DEEP PHOTOS "MAKING YOUR PHOTOS COME TO LIFE" (BLOCK FORM)**. CONQUET, RUDOLPH A., (U.S. CLS. 2, 5, 22, 23, 29, 37, 38 AND 50). SN 77-322,163. PUB. 5-20-2008. FILED 11-6-2007.
- 3,479,658. **THE FIRST NAME IN VISUAL ARTS ENTERTAINMENT (BLOCK FORM)**. THREE J PRODUCTIONS, LLC, (U.S. CLS. 2, 5, 22, 23, 29, 37, 38 AND 50). SN 77-324,392. PUB. 5-20-2008. FILED 11-8-2007.
- 3,479,665. **JUST JIMMY (BLOCK FORM)**. BENTON, JAMES K., MULTIPLE CLASS, (INT. CLS. 16 AND 25), (U.S. CLS. 2, 5, 22, 23, 29, 37, 38, 39 AND 50). SN 77-324,754. PUB. 5-20-2008. FILED 11-8-2007.
- 3,479,684. **HERON-ON-HUDSON PRESS AND DESIGN. ART IN A BOX, INC.**, (U.S. CLS. 2, 5, 22, 23, 29, 37, 38 AND 50). SN 77-326,680. PUB. 5-20-2008. FILED 11-11-2007.
- 3,479,717. **BILLING & OSS WORLD (BLOCK FORM)**. VIRGO PUBLISHING, LLC, (U.S. CLS. 2, 5, 22, 23, 29, 37, 38 AND 50). SN 77-331,755. PUB. 5-20-2008. FILED 11-16-2007.
- 3,479,731. **DESKTOP LABELS (BLOCK FORM)**. MEYERS PRINTING COMPANY, (U.S. CLS. 2, 5, 22, 23, 29, 37, 38 AND 50). SN 77-334,285. PUB. 5-20-2008. FILED 11-20-2007.
- 3,479,778. **LIBRO COLLECTION (BLOCK FORM)**. BOOKSMART STUDIO, INC., (U.S. CLS. 2, 5, 22, 23, 29, 37, 38 AND 50). SN 77-340,304. PUB. 5-20-2008. FILED 11-29-2007.
- 3,479,806. **BEST OF NYC (BLOCK FORM)**. VILLAGE VOICE MEDIA HOLDINGS, LLC, MULTIPLE CLASS, (INT. CLS. 16 AND 41), (U.S. CLS. 2, 5, 22, 23, 29, 37, 38, 50, 100, 101 AND 107). SN 77-342,743. PUB. 5-20-2008. FILED 12-3-2007.
- 3,479,819. **AAR AFFIRMATIVE ACTION REGISTER AND DESIGN**. POTOMAC PUBLISHING, INC., MULTIPLE CLASS, (INT. CLS. 16 AND 35), (U.S. CLS. 2, 5, 22, 23, 29, 37, 38, 50, 100, 101 AND 102). SN 77-344,240. PUB. 5-20-2008. FILED 12-5-2007.
- 3,479,825. **PLAYSAM (BLOCK FORM)**. PLAYSAM I KALMAR AKTIEBOLAG, (U.S. CLS. 2, 5, 22, 23, 29, 37, 38 AND 50). SN 77-345,423. PUB. 5-20-2008. FILED 12-6-2007.
- 3,479,883. **REUSABLE ...DON'T THROW THIS BAG AWAY AND DESIGN**. COMMAND PACKAGING, (U.S. CLS. 2, 5, 22, 23, 29, 37, 38 AND 50). SN 77-350,474. PUB. 5-20-2008. FILED 12-12-2007.
- 3,479,887. **JUBILATION STATION (BLOCK FORM)**. COOK COMMUNICATIONS MINISTRIES, (U.S. CLS. 2, 5, 22, 23, 29, 37, 38 AND 50). SN 77-350,971. PUB. 5-20-2008. FILED 12-13-2007.
- 3,479,933. **PROFILES OF ORGANIZATIONAL INFLUENCE STRATEGIES (POIS) (BLOCK FORM)**. STUART M. SCHMIDT, (U.S. CLS. 2, 5, 22, 23, 29, 37, 38 AND 50). SN 77-353,271. PUB. 5-20-2008. FILED 12-16-2007.
- 3,479,945. **MISCELLANEOUS DESIGN. EMOTIONAL INTELLIGENCE AND DIVERSITY INSTITUTE, THE**, (U.S. CLS. 2, 5, 22, 23, 29, 37, 38 AND 50). SN 77-354,137. PUB. 5-20-2008. FILED 12-17-2007.
- 3,479,946. **E/I/D/I (BLOCK FORM)**. EMOTIONAL INTELLIGENCE AND DIVERSITY INSTITUTE, THE, (U.S. CLS. 2, 5, 22, 23, 29, 37, 38 AND 50). SN 77-354,139. PUB. 5-20-2008. FILED 12-17-2007.
- 3,479,955. **ATLAS AND DESIGN**. PINCEIS ATLAS S/A, (U.S. CLS. 2, 5, 22, 23, 29, 37, 38 AND 50). SN 77-354,358. PUB. 5-20-2008. FILED 12-18-2007.
- 3,479,965. **ACTIVATE (BLOCK FORM)**. UNIVERSITY OF MARYLAND, BALTIMORE COUNTY, (U.S. CLS. 2, 5, 22, 23, 29, 37, 38 AND 50). SN 77-354,667. PUB. 5-20-2008. FILED 12-18-2007.
- 3,479,977. **YEAH! YEAH! OUT LOUD! (BLOCK FORM)**. YYOL, LLC, MULTIPLE CLASS, (INT. CLS. 16 AND 28), (U.S. CLS. 2, 5, 22, 23, 29, 37, 38 AND 50). SN 77-355,155. PUB. 5-20-2008. FILED 12-18-2007.
- 3,480,005 (*See Class 9 for this trademark*).
- 3,480,006 (*See Class 9 for this trademark*).
- 3,480,037. **DAISYD'S AND DESIGN**. DAISY D'S PAPER COMPANY, (U.S. CLS. 2, 5, 22, 23, 29, 37, 38 AND 50). SN 77-357,473. PUB. 5-20-2008. FILED 12-20-2007.
- 3,480,057. **ASN (BLOCK FORM)**. AMERICAN SOCIETY FOR NUTRITION, MULTIPLE CLASS, (INT. CLS. 16, 35 AND 41), (U.S. CLS. 2, 5, 22, 23, 29, 37, 38, 50, 100, 101, 102 AND 107). SN 77-358,449. PUB. 5-20-2008. FILED 12-21-2007.
- 3,480,090 (*See Class 9 for this trademark*).
- 3,480,123. **MY PASSWORD PAD (BLOCK FORM)**. 55 CONSULTANTS, INC., (U.S. CLS. 2, 5, 22, 23, 29, 37, 38 AND 50). SN 77-361,037. PUB. 5-20-2008. FILED 12-28-2007.
- 3,480,180. **MEREDITH COLLEGE (BLOCK FORM)**. MEREDITH COLLEGE, (U.S. CLS. 2, 5, 22, 23, 29, 37, 38 AND 50). SN 77-362,591. PUB. 5-20-2008. FILED 1-2-2008.
- 3,480,195 (*See Class 14 for this trademark*).
- 3,480,270 (*See Class 9 for this trademark*).
- 3,480,275. **OUTERVERSE (BLOCK FORM)**. HARDY, PHILIP, (U.S. CLS. 2, 5, 22, 23, 29, 37, 38 AND 50). SN 77-364,054. PUB. 5-20-2008. FILED 1-4-2008.
- 3,480,300. **LAKELAND FLYING TIGERS AND DESIGN**. DETROIT TIGERS, INC., (U.S. CLS. 2, 5, 22, 23, 29, 37, 38 AND 50). SN 77-364,496. PUB. 5-20-2008. FILED 1-4-2008.
- 3,480,306. **BUZZ ABOUT IT! AND DESIGN**. SCHOLASTIC INC., (U.S. CLS. 2, 5, 22, 23, 29, 37, 38 AND 50). SN 77-364,527. PUB. 5-20-2008. FILED 1-4-2008.
- 3,480,309. **EZ COMICS (BLOCK FORM)**. SARLA SOFTWARE, L.L.C., (U.S. CLS. 2, 5, 22, 23, 29, 37, 38 AND 50). SN 77-364,552. PUB. 5-20-2008. FILED 1-4-2008.
- 3,480,374. **LANCASTER JETHAWKS AND DESIGN**. HAWKS NEST, LLC., (U.S. CLS. 2, 5, 22, 23, 29, 37, 38 AND 50). SN 77-365,725. PUB. 5-20-2008. FILED 1-7-2008.
- 3,480,395. **GTTESTED (STYLIZED)**. FXEXPRESS PUBLICATIONS, INC., (U.S. CLS. 2, 5, 22, 23, 29, 37, 38 AND 50). SN 77-366,246. PUB. 5-20-2008. FILED 1-8-2008.
- 3,480,425. **MYTHMATICAL BATTLES (BLOCK FORM)**. 4R, INC., (U.S. CLS. 2, 5, 22, 23, 29, 37, 38 AND 50). SN 77-366,755. PUB. 5-20-2008. FILED 1-8-2008.
- 3,480,428. **I-BALLERS (BLOCK FORM)**. UNIVERSITY GAMES CORPORATION, (U.S. CLS. 2, 5, 22, 23, 29, 37, 38 AND 50). SN 77-366,783. PUB. 5-20-2008. FILED 1-8-2008.
- 3,480,492. **BON APPÉTIT (STYLIZED)**. ADVANCE MAGAZINE PUBLISHERS INC., (U.S. CLS. 2, 5, 22, 23, 29, 37, 38 AND 50). SN 77-369,555. PUB. 5-20-2008. FILED 1-11-2008.
- 3,480,527. **BU2 (BLOCK FORM)**. SOCIETE BIC, (U.S. CLS. 2, 5, 22, 23, 29, 37, 38 AND 50). SN 77-381,743. PUB. 5-20-2008. FILED 1-28-2008.
- 3,480,532. **CASTLE TO THE ROCK (BLOCK FORM)**. MCCLATCHY U.S.A., INC., (U.S. CLS. 2, 5, 22, 23, 29, 37, 38 AND 50). SN 77-384,691. PUB. 5-20-2008. FILED 1-30-2008.
- 3,480,534. **EVERY SHOT COUNTS (BLOCK FORM)**. WYETH, (U.S. CLS. 2, 5, 22, 23, 29, 37, 38 AND 50). SN 77-388,098. PUB. 5-20-2008. FILED 2-4-2008.
- 3,480,537. **POINT (STYLIZED)**. SCHOLASTIC INC., (U.S. CLS. 2, 5, 22, 23, 29, 37, 38 AND 50). SN 77-391,029. PUB. 5-20-2008. FILED 2-7-2008.
- 3,480,546. **7 LEGUAS (BLOCK FORM)**. UNION TELECOM, INC., (U.S. CLS. 2, 5, 22, 23, 29, 37, 38 AND 50). SN 77-398,037. PUB. 5-20-2008. FILED 2-15-2008.
- 3,480,584 (*See Class 9 for this trademark*).
- 3,480,586 (*See Class 9 for this trademark*).
- 3,480,590. **OREGON SCIENTIFIC AND DESIGN**. OREGON SCIENTIFIC INTERNATIONAL LIMITED, MULTIPLE CLASS, (INT. CLS. 16 AND 35), (U.S. CLS. 2, 5, 22, 23, 29, 37, 38, 50, 100, 101 AND 102). SN 78-561,672. PUB. 4-8-2008. FILED 2-7-2005.
- 3,480,593. **SILENT BAGS (BLOCK FORM)**. COMPLETE PROPS, (U.S. CLS. 2, 5, 22, 23, 29, 37, 38 AND 50). SN 78-566,217. PUB. 5-20-2008. FILED 2-12-2005.
- 3,480,595 (*See Class 9 for this trademark*).
- 3,480,596 (*See Class 9 for this trademark*).
- 3,480,597 (*See Class 9 for this trademark*).
- 3,480,598. **ASTRO AMERICAN SOCIETY FOR THERAPEUTIC RADIOLOGY AND ONCOLOGY AND DESIGN**. AMERICAN SOCIETY FOR THERAPEUTIC RADIOLOGY AND ONCOLOGY, THE, MULTIPLE CLASS, (INT. CLS. 16, 35, 41, 42 AND 44), (U.S. CLS. 2, 5, 22, 23, 29, 37, 38, 50, 100, 101, 102 AND 107). SN 78-592,706. PUB. 5-20-2008. FILED 3-22-2005.
- 3,480,614. **BORSA ITALIANA (BLOCK FORM)**. BORSA ITALIANA S.P.A., MULTIPLE CLASS, (INT. CLS. 16, 35,

36 AND 38), (U.S. CLS. 2, 5, 22, 23, 29, 37, 38, 50, 100, 101, 102 AND 104). SN 78-668,479. PUB. 5-20-2008. FILED 7-12-2005.

3,480,632. **ASA AUTISM SOCIETY OF AMERICA AND DESIGN. AUTISM SOCIETY OF AMERICA, INC., MULTIPLE CLASS**, (INT. CLS. 16, 36, 41, 44 AND 45), (U.S. CLS. 2, 5, 22, 23, 29, 37, 38, 50, 100, 101, 102 AND 107). SN 78-779,923. PUB. 5-20-2008. FILED 12-22-2005.

3,480,649. **ALL-AMERICA ROSE SELECTIONS (BLOCK FORM)**. ALL-AMERICA ROSE SELECTIONS, INC., MULTIPLE CLASS, (INT. CLS. 16, 31, 35 AND 41), (U.S. CLS. 1, 2, 5, 22, 23, 29, 37, 38, 46, 50, 100, 101, 102 AND 107). SN 78-838,257. PUB. 5-20-2008. FILED 3-15-2006.

3,480,663. **EPIX AND DESIGN**. HENKEL KGAA, (U.S. CLS. 2, 5, 22, 23, 29, 37, 38 AND 50). SN 78-869,292. PUB. 5-20-2008. FILED 4-25-2006.

3,480,664. **TOBACCO BAD KIDS AND DESIGN**. DIPIETRO, JOSEPH, (U.S. CLS. 2, 5, 22, 23, 29, 37, 38 AND 50). SN 78-869,300. PUB. 2-13-2007. FILED 4-25-2006.

3,480,700. **MISS SPIDER'S SUNNY PATCH FRIENDS (BLOCK FORM)**. CALLAWAY & KIRK COMPANY LLC, (U.S. CLS. 2, 5, 22, 23, 29, 37, 38 AND 50). SN 78-913,761. PUB. 5-20-2008. FILED 6-21-2006.

3,480,712. **DCWV (BLOCK FORM)**. DCWV ACQUISITION CORPORATION, MULTIPLE CLASS, (INT. CLS. 16, 35 AND 41), (U.S. CLS. 2, 5, 22, 23, 29, 37, 38, 50, 100, 101, 102 AND 107). SN 78-943,527. PUB. 5-20-2008. FILED 8-2-2006.

3,480,723. **EKS (BLOCK FORM)**. EXPERT KNOWLEDGE SYSTEMS, LLC, (U.S. CLS. 2, 5, 22, 23, 29, 37, 38 AND 50). SN 78-959,006. PUB. 5-20-2008. FILED 8-23-2006.

3,480,735 (*See Class 9 for this trademark*).

3,480,736 (*See Class 9 for this trademark*).

3,480,753 (*See Class 3 for this trademark*).

3,480,761. **SMANIA (BLOCK FORM)**. SMANIA SPA, MULTIPLE CLASS, (INT. CLS. 16, 19, 20 AND 21), (U.S. CLS. 1, 2, 5, 12, 13, 22, 23, 25, 29, 30, 32, 33, 37, 38, 40 AND 50). SN 79-031,461. PUB. 5-20-2008. FILED 6-1-2006.

3,480,787 (*See Class 9 for this trademark*).

3,480,800 (*See Class 3 for this trademark*).

3,480,816 (*See Class 5 for this trademark*).

3,480,842. **ON COURSE FOR VALUE SHARING AN AMBI- TION AND DESIGN**. FREGATE, MULTIPLE CLASS, (INT. CLS. 16 AND 41), (U.S. CLS. 2, 5, 22, 23, 29, 37, 38, 50, 100, 101 AND 107). SN 79-039,723. PUB. 5-20-2008. FILED 3-23-2007.

3,480,856 (*See Class 3 for this trademark*).

3,480,858. **FOLDER AND DESIGN**. COLEBROOK BOSSON SAUNDERS PRODUCTS LTD., MULTIPLE CLASS, (INT. CLS. 16 AND 20), (U.S. CLS. 2, 5, 13, 22, 23, 25, 29, 32, 37, 38 AND 50). SN 79-040,614. PUB. 5-20-2008. FILED 6-1-2007.

3,480,882 (*See Class 9 for this trademark*).

3,480,905. **NOVOTEL CONÇU COMME UN ESPACE NATUREL (BLOCK FORM)**. ACCOR, MULTIPLE CLASS, (INT. CLS. 16, 21, 34, 39 AND 43), (U.S. CLS. 2, 5, 8, 9, 13, 17, 22, 23, 29, 30, 33, 37, 38, 40, 50, 100, 101 AND 105). SN 79-041,879. PUB. 5-20-2008. FILED 3-12-2007.

3,480,908 (*See Class 6 for this trademark*).

3,480,913. **REAKTSUN (STYLIZED)**. BMB-INSTITUTE GMBH & CO. KG, MULTIPLE CLASS, (INT. CLS. 16, 28, 35, 41 AND 42), (U.S. CLS. 2, 5, 22, 23, 29, 37, 38, 50, 100, 101, 102 AND 107). SN 79-042,132. PUB. 5-20-2008. FILED 4-30-2007.

3,480,921 (*See Class 6 for this trademark*).

3,480,943 (*See Class 9 for this trademark*).

3,480,944. **GENIO CREATIVO (BLOCK FORM)**. RICHEMONT ITALIA S.P.A., (U.S. CLS. 2, 5, 22, 23, 29, 37, 38 AND 50). SN 79-043,011. PUB. 5-20-2008. FILED 5-31-2007.

3,480,959. **STORIES OF US (BLOCK FORM)**. READYMADE PRODUCTIONS PTY LTD, MULTIPLE CLASS, (INT. CLS. 16 AND 41), (U.S. CLS. 2, 5, 22, 23, 29, 37, 38, 50, 100, 101 AND 107). SN 79-043,694. PUB. 5-20-2008. FILED 6-20-2007.

3,480,962 (*See Class 9 for this trademark*).

3,480,963 (*See Class 9 for this trademark*).

3,480,973 (*See Class 1 for this trademark*).

3,481,011. **UNI-MED AND DESIGN**. UNI-MED VERLAG AKTIENGESELLSCHAFT, (U.S. CLS. 2, 5, 22, 23, 29, 37, 38 AND 50). SN 79-047,325. PUB. 5-20-2008. FILED 11-16-2007.

3,481,012 (*See Class 9 for this trademark*).

3,481,022. **TAKTIFOL (BLOCK FORM)**. ALFRED STÖFFLER GMBH, (U.S. CLS. 2, 5, 22, 23, 29, 37, 38 AND 50). SN 79-

047,956. PUB. 5-20-2008. FILED 10-30-2007.

3,481,036 (*See Class 9 for this trademark*).

CLASS 17—RUBBER GOODS

3,478,529 (*See Class 1 for this trademark*).

3,478,742. **SINK SILENCER (BLOCK FORM)**. COFAIR PRODUCTS, INC., (U.S. CLS. 1, 5, 12, 13, 35 AND 50). SN 77-082,818. PUB. 5-20-2008. FILED 1-15-2007.

3,478,770 (*See Class 1 for this trademark*).

3,479,098. **PICASUS (BLOCK FORM)**. TORAY KABUSHIKI KAISHA, TA TORAY INDUSTRIES, INC., (U.S. CLS. 1, 5, 12, 13, 35 AND 50). SN 77-212,356. PUB. 5-20-2008. FILED 6-21-2007.

3,479,151. **THE NAME IN MINERAL WOOL (BLOCK FORM)**. THERMAFIBER, INC., MULTIPLE CLASS, (INT. CLS. 17 AND 19), (U.S. CLS. 1, 5, 12, 13, 33, 35 AND 50). SN 77-218,516. PUB. 5-20-2008. FILED S.R. 6-28-2007; AM. P.R. 4-8-2008.

3,479,588. **EVD (BLOCK FORM)**. ILLINOIS TOOL WORKS INC., (U.S. CLS. 1, 5, 12, 13, 35 AND 50). SN 77-312,238. PUB. 5-20-2008. FILED 10-24-2007.

3,479,686. **MINI HOOPER AND DESIGN**. BERGE, HONG XU, DBA DIMENSION TRADE COMPANY, LLC, (U.S. CLS. 1, 5, 12, 13, 35 AND 50). SN 77-326,950. PUB. 5-20-2008. FILED 11-12-2007.

3,479,812 (*See Class 6 for this trademark*).

3,479,814 (*See Class 6 for this trademark*).

3,479,918. **TEMP-TITE (BLOCK FORM)**. INDUSTRIAL GAS-KET & SHIM COMPANY, INC., (U.S. CLS. 1, 5, 12, 13, 35 AND 50). SN 77-352,183. PUB. 5-20-2008. FILED 12-14-2007.

3,479,971. **HAMMERHEAD (BLOCK FORM)**. GRANBERRY SUPPLY CORP., (U.S. CLS. 1, 5, 12, 13, 35 AND 50). SN 77-354,760. PUB. 5-20-2008. FILED 12-18-2007.

3,479,986. **ENERGY SHIELD PRODUCTS AND DESIGN**. LINDA P. COPELAND, (U.S. CLS. 1, 5, 12, 13, 35 AND 50). SN 77-355,695. PUB. 5-20-2008. FILED 12-19-2007.

3,480,547 (*See Class 1 for this trademark*).

3,480,642. **HOTTAPE (BLOCK FORM)**. HOTTAPE ACQUISITION, LLC, (U.S. CLS. 1, 5, 12, 13, 35 AND 50). SN 78-824,453. PUB. 5-20-2008. FILED 2-27-2006.

3,480,730. **MISCELLANEOUS DESIGN**. WEYERHAEUSER COMPANY, (U.S. CLS. 1, 5, 12, 13, 35 AND 50). SN 78-965,802. PUB. 5-20-2008. FILED 9-1-2006.

3,480,781 (*See Class 4 for this trademark*).

3,480,954 (*See Class 1 for this trademark*).

3,480,966. **SOFTSHINE (STYLIZED)**. TOYO BOSEKI KABUSHIKI KAISHA, (U.S. CLS. 1, 5, 12, 13, 35 AND 50). SN 79-043,935. PUB. 5-20-2008. FILED 9-4-2007.

3,480,967. **COSMOSHINE (STYLIZED)**. TOYO BOSEKI KABUSHIKI KAISHA, (U.S. CLS. 1, 5, 12, 13, 35 AND 50). SN 79-043,936. PUB. 5-20-2008. FILED 9-4-2007.

3,480,973 (*See Class 1 for this trademark*).

CLASS 18—LEATHER GOODS

3,478,501. **WP WEST PACIFICA (STYLIZED)**. EFFIGI INC., MULTIPLE CLASS, (INT. CLS. 18 AND 25), (U.S. CLS. 1, 2, 3, 22, 39 AND 41). SN 76-550,691. PUB. 5-20-2008. FILED 10-10-2003.

3,478,656. **KAIAPETERKA (BLOCK FORM)**. PETERKA, KAIA ELISABETH, (U.S. CLS. 1, 2, 3, 22 AND 41). SN 77-031,673. PUB. 5-20-2008. FILED 10-28-2006.

3,478,671 (*See Class 9 for this trademark*).

3,478,911. **GOSSAMERGEAR (STYLIZED)**. GOSSAMER GEAR, INC., (U.S. CLS. 1, 2, 3, 22 AND 41). SN 77-178,069. PUB. 5-20-2008. FILED 5-10-2007.

3,479,067. **KATE MOSS (BLOCK FORM)**. MOSS, KATE, (U.S. CLS. 1, 2, 3, 22 AND 41). SN 77-208,156. PUB. 5-20-2008. FILED 6-18-2007.

3,479,148 (*See Class 3 for this trademark*).

3,479,370. **GLASS 'N PACK (BLOCK FORM)**. BASS PRO TRADEMARKS, L.L.C., (U.S. CLS. 1, 2, 3, 22 AND 41). SN

77-258,950. PUB. 5-20-2008. FILED 8-20-2007.
 3,479,505 (*See Class 14 for this trademark*).
 3,479,616 (*See Class 6 for this trademark*).
 3,479,910. **NARGEAR (STYLIZED)**. CRONE, GEORGE RANDALL, (U.S. CLS. 1, 2, 3, 22 AND 41). SN 77-351,945. PUB. 5-20-2008. FILED 12-14-2007.
 3,479,952. **GIRLY GOLFER (BLOCK FORM)**. DELILA A. HARVEY, (U.S. CLS. 1, 2, 3, 22 AND 41). SN 77-354,297. PUB. 5-20-2008. FILED 12-18-2007.
 3,480,158. **WWW.4RPLANETBAG.COM (STYLIZED)**. HEBEGRACE, INC., (U.S. CLS. 1, 2, 3, 22 AND 41). SN 77-362,235. PUB. 5-20-2008. FILED 1-1-2008.
 3,480,210. **PIZZAZZ AND DESIGN**. JUST BASIC SPORTS, INC., (U.S. CLS. 1, 2, 3, 22 AND 41). SN 77-363,128. PUB. 5-20-2008. FILED 1-3-2008.
 3,480,253. **FLYBAG (BLOCK FORM)**. FOURHEADS, LLC, (U.S. CLS. 1, 2, 3, 22 AND 41). SN 77-363,722. PUB. 5-20-2008. FILED 1-3-2008.
 3,480,350. **BIG KAHUNA (BLOCK FORM)**. HIGH SIERRA SPORT COMPANY, (U.S. CLS. 1, 2, 3, 22 AND 41). SN 77-365,249. PUB. 5-20-2008. FILED 1-7-2008.
 3,480,403. **GREENCOW RAWHIDE (BLOCK FORM)**. RUSH DIRECT, INC., (U.S. CLS. 1, 2, 3, 22 AND 41). SN 77-366,485. PUB. 5-20-2008. FILED 1-8-2008.
 3,480,469. **WOLFGANG (BLOCK FORM)**. E-QUEST, INC., DBA CUSTOM SADDLERY, (U.S. CLS. 1, 2, 3, 22 AND 41). SN 77-367,851. PUB. 5-20-2008. FILED 1-9-2008.
 3,480,477. **CLAUDE & MONIQUE AND DESIGN**. CLAUDE AND MONIQUE, (U.S. CLS. 1, 2, 3, 22 AND 41). SN 77-367,969. PUB. 5-20-2008. FILED 1-9-2008.
 3,480,533. **VICTORIA'S SECRET (BLOCK FORM)**. VICTORIA'S SECRET STORES BRAND MANAGEMENT, INC., (U.S. CLS. 1, 2, 3, 22 AND 41). SN 77-387,829. PUB. 5-20-2008. FILED 2-4-2008.
 3,480,745 (*See Class 9 for this trademark*).
 3,480,752. **PUPPYANGEL (STYLIZED)**. PA TREND INC., (U.S. CLS. 1, 2, 3, 22 AND 41). SN 79-028,645. PUB. 5-20-2008. FILED 8-25-2006.
 3,480,763. **ONE OF 2 (STYLIZED)**. AUDLEY SHOES GMBH, MULTIPLE CLASS, (INT. CLS. 18 AND 25), (U.S. CLS. 1, 2, 3, 22, 39 AND 41). SN 79-031,966. PUB. 5-20-2008. FILED 11-16-2006.
 3,480,777 (*See Class 14 for this trademark*).
 3,480,779 (*See Class 3 for this trademark*).
 3,480,800 (*See Class 3 for this trademark*).
 3,480,808 (*See Class 9 for this trademark*).
 3,480,821. **ENVIROSAX (BLOCK FORM)**. MARK DAVID-TOOZE, AND BELINDA DAVID-TOOZE, MULTIPLE CLASS, (INT. CLS. 18 AND 25), (U.S. CLS. 1, 2, 3, 22, 39 AND 41). SN 79-038,555. PUB. 5-20-2008. FILED 4-13-2007.
 3,480,825. **LINDY (BLOCK FORM)**. HERMES INTERNATIONAL, (U.S. CLS. 1, 2, 3, 22 AND 41). SN 79-038,680. PUB. 5-20-2008. FILED 4-10-2007.
 3,480,839 (*See Class 3 for this trademark*).
 3,480,844 (*See Class 3 for this trademark*).
 3,480,856 (*See Class 3 for this trademark*).
 3,480,857. **MISCELLANEOUS DESIGN**. BOO FOO WOO CO., LTD., MULTIPLE CLASS, (INT. CLS. 18 AND 25), (U.S. CLS. 1, 2, 3, 22, 39 AND 41). SN 79-040,588. PUB. 5-20-2008. FILED 3-9-2007.
 3,480,879 (*See Class 9 for this trademark*).
 3,480,895. **EINSONSIEBEN (BLOCK FORM)**. DITTMAR GMBH & CO. KG, MULTIPLE CLASS, (INT. CLS. 18, 24 AND 25), (U.S. CLS. 1, 2, 3, 22, 39, 41, 42 AND 50). SN 79-041,758. PUB. 5-20-2008. FILED 5-23-2007.
 3,480,904. **PAMOISON (BLOCK FORM)**. LANCEL INTERNATIONAL SA, MULTIPLE CLASS, (INT. CLS. 18 AND 25), (U.S. CLS. 1, 2, 3, 22, 39 AND 41). SN 79-041,870. PUB. 5-20-2008. FILED 5-30-2007.
 3,480,910 (*See Class 9 for this trademark*).
 3,480,911 (*See Class 9 for this trademark*).
 3,480,923. **CH-57 (BLOCK FORM)**. NAF NAF DISTRIBUTION B.V., MULTIPLE CLASS, (INT. CLS. 18 AND 25), (U.S. CLS. 1, 2, 3, 22, 39 AND 41). SN 79-042,438. PUB. 5-20-2008. FILED 4-23-2007.
 3,480,933 (*See Class 3 for this trademark*).
 3,480,946. **SPLEENE (BLOCK FORM)**. RAINER KAUPER, MULTIPLE CLASS, (INT. CLS. 18, 25 AND 28), (U.S. CLS. 1,

2, 3, 22, 23, 38, 39, 41 AND 50). SN 79-043,130. PUB. 5-20-2008. FILED 4-26-2007.

CLASS 19—NON-METALLIC BUILDING MATERIALS

3,478,506. **MISCELLANEOUS DESIGN**. EWALD DÖRKEN AG, (U.S. CLS. 1, 12, 33 AND 50). SN 76-620,293. PUB. 5-20-2008. FILED 11-12-2004.
 3,478,509. **MURICLIC (BLOCK FORM)**. MURIDAL INC., MULTIPLE CLASS, (INT. CLS. 19 AND 40), (U.S. CLS. 1, 12, 33, 50, 100, 103 AND 106). SN 76-643,055. PUB. 5-20-2008. FILED 7-18-2005.
 3,478,510. **MURISEAL (BLOCK FORM)**. MURIDAL INC., MULTIPLE CLASS, (INT. CLS. 19 AND 40), (U.S. CLS. 1, 12, 33, 50, 100, 103 AND 106). SN 76-643,056. PUB. 5-20-2008. FILED 7-18-2005.
 3,478,594. **STORMBAG (BLOCK FORM)**. SWIIS-LINK, INC., (U.S. CLS. 1, 12, 33 AND 50). SN 76-683,884. PUB. 5-20-2008. FILED 11-9-2007.
 3,478,648. **SYSTEM 636 (BLOCK FORM)**. IPEX INC., (U.S. CLS. 1, 12, 33 AND 50). SN 77-021,080. PUB. 5-20-2008. FILED 10-13-2006.
 3,478,718. **DECKWAVE (BLOCK FORM)**. DOIG, DANIEL, (U.S. CLS. 1, 12, 33 AND 50). SN 77-065,373. PUB. 5-20-2008. FILED 12-15-2006.
 3,478,797. **NEXTSTONE (BLOCK FORM)**. CFMT LLC, (U.S. CLS. 1, 12, 33 AND 50). SN 77-117,259. PUB. 12-11-2007. FILED 2-27-2007.
 3,478,883. **TAIT TOWERS (BLOCK FORM)**. TAIT TOWERS, INC., MULTIPLE CLASS, (INT. CLS. 19, 37 AND 42), (U.S. CLS. 1, 12, 33, 50, 100, 101, 103 AND 106). SN 77-167,661. PUB. 5-20-2008. FILED 4-27-2007.
 3,478,988. **E AND DESIGN**. LG VERWALTUNGS, GMBH, (U.S. CLS. 1, 12, 33 AND 50). SN 77-195,935. PUB. 5-20-2008. FILED 6-1-2007.
 3,479,053. **DOLOMITE (BLOCK FORM)**. UNIBOARD CANADA INC., (U.S. CLS. 1, 12, 33 AND 50). SN 77-204,937. PUB. 5-20-2008. FILED 6-13-2007.
 3,479,054. **NOVAWHITE (BLOCK FORM)**. UNIBOARD CANADA INC., (U.S. CLS. 1, 12, 33 AND 50). SN 77-205,109. PUB. 5-20-2008. FILED 6-13-2007.
 3,479,093. **BUSCH STADIUM (BLOCK FORM)**. ANHEUSER-BUSCH, INCORPORATED, (U.S. CLS. 1, 12, 33 AND 50). SN 77-211,674. PUB. 5-20-2008. FILED 6-21-2007.
 3,479,151 (*See Class 17 for this trademark*).
 3,479,207. **MAXWALL (BLOCK FORM)**. NORMENT SECURITY GROUP, INC., (U.S. CLS. 1, 12, 33 AND 50). SN 77-224,205. PUB. 5-20-2008. FILED 7-8-2007.
 3,479,209. **GOTHICSTONE (BLOCK FORM)**. MANGIA SPECIALTIES INC., (U.S. CLS. 1, 12, 33 AND 50). SN 77-224,375. PUB. 5-20-2008. FILED 7-9-2007.
 3,479,276. **PACIFIC ALBUS (BLOCK FORM)**. UPPER COLUMBIA MILL, LLC, MULTIPLE CLASS, (INT. CLS. 19 AND 20), (U.S. CLS. 1, 2, 12, 13, 22, 25, 32, 33 AND 50). SN 77-233,958. PUB. 5-20-2008. FILED 7-19-2007.
 3,479,399. **EVERSTRONG PROFILES AND DESIGN**. EASTERN WHOLESALE FENCE CO., INC., (U.S. CLS. 1, 12, 33 AND 50). SN 77-266,475. PUB. 5-20-2008. FILED 8-28-2007.
 3,479,501. **DURADECK (BLOCK FORM)**. SIGNATURE FENCING & FLOORING, LLC, (U.S. CLS. 1, 12, 33 AND 50). SN 77-296,029. PUB. 5-20-2008. FILED 10-4-2007.
 3,479,691. **ASSISI (BLOCK FORM)**. SAROYAN LUMBER COMPANY, INC., (U.S. CLS. 1, 12, 33 AND 50). SN 77-327,363. PUB. 5-20-2008. FILED 11-12-2007.
 3,479,744. **AQUA-LOOP (BLOCK FORM)**. LOTUFO, ROBERT J, (U.S. CLS. 1, 12, 33 AND 50). SN 77-335,779. PUB. 5-20-2008. FILED 11-22-2007.
 3,479,812 (*See Class 6 for this trademark*).
 3,479,814 (*See Class 6 for this trademark*).
 3,479,828. **ROCK-ON-A-ROLL (BLOCK FORM)**. AQUATICA, INC., DBA AQUATICA WATER GARDENS, (U.S. CLS. 1, 12, 33 AND 50). SN 77-345,673. PUB. 5-20-2008. FILED 12-6-2007.
 3,479,888 (*See Class 6 for this trademark*).
 3,479,916 (*See Class 6 for this trademark*).

- 3,479,972. **EASY LIFE (BLOCK FORM)**. EPI 04, INC., (U.S. CLS. 1, 12, 33 AND 50). SN 77-354,819. PUB. 5-20-2008. FILED 12-18-2007.
- 3,480,020. **REZIST-IT (BLOCK FORM)**. MACDONALD, FRANK, AND MACDONALD, SUSANNA, (U.S. CLS. 1, 12, 33 AND 50). SN 77-356,978. PUB. 5-20-2008. FILED 12-20-2007.
- 3,480,076. **UNIQUE (BLOCK FORM)**. UNIQUE PAVING MATERIALS CORPORATION, (U.S. CLS. 1, 12, 33 AND 50). SN 77-359,239. PUB. 5-20-2008. FILED 12-26-2007.
- 3,480,211. **VIBRANCE COLLECTION (BLOCK FORM)**. TAMKO BUILDING PRODUCTS, INC., (U.S. CLS. 1, 12, 33 AND 50). SN 77-363,131. PUB. 5-20-2008. FILED 1-3-2008.
- 3,480,389. **ECOSHEL (BLOCK FORM)**. KIRKEY, BRYAN, (U.S. CLS. 1, 12, 33 AND 50). SN 77-366,126. PUB. 5-20-2008. FILED 1-8-2008.
- 3,480,476. **ECOMORTAR (BLOCK FORM)**. BUILDING MATERIAL IMPORTS, INC., (U.S. CLS. 1, 12, 33 AND 50). SN 77-367,968. PUB. 5-20-2008. FILED 1-9-2008.
- 3,480,626. **J.J. HAINES & COMPANY, INC. (BLOCK FORM)**. J.J. HAINES & COMPANY, INC., (U.S. CLS. 1, 12, 33 AND 50). SN 78-711,250. PUB. 5-20-2008. FILED 9-12-2005.
- 3,480,667. **WOOD COMPOSITE TECHNOLOGIES INC. AND DESIGN**. WOOD COMPOSITE TECHNOLOGIES INC., MULTIPLE CLASS, (INT. CLS. 19 AND 42), (U.S. CLS. 1, 12, 33, 50, 100 AND 101). SN 78-880,252. PUB. 3-25-2008. FILED 5-10-2006.
- 3,480,761 (*See Class 16 for this trademark*).
- 3,480,822 (*See Class 6 for this trademark*).
- 3,480,909. **TAP & GO (STYLIZED)**. YEKALON INDUSTRY, INC., (U.S. CLS. 1, 12, 33 AND 50). SN 79-042,013. PUB. 5-20-2008. FILED 2-6-2007.
- 3,481,030. **HAO YUN AND DESIGN**. ZHEJIANG HAOYUN MUYE YOUXIAN GONGSI, (U.S. CLS. 1, 12, 33 AND 50). SN 79-049,081. PUB. 5-20-2008. FILED 1-7-2008.
- 22, 25, 32, 42 AND 50). SN 77-309,977. PUB. 5-20-2008. FILED 10-22-2007.
- 3,479,578 (*See Class 10 for this trademark*).
- 3,479,627. **UPSIDE LIVING AND DESIGN**. UPSIDE LIVING, INC., MULTIPLE CLASS, (INT. CLS. 20, 21 AND 27), (U.S. CLS. 2, 13, 19, 20, 22, 23, 25, 29, 30, 32, 33, 37, 40, 42 AND 50). SN 77-318,795. PUB. 5-20-2008. FILED 11-1-2007.
- 3,479,629. **HANGEASE AND DESIGN**. LANDIS, GARY, AND LANDIS, CHERYL, (U.S. CLS. 2, 13, 22, 25, 32 AND 50). SN 77-319,843. PUB. 5-20-2008. FILED 11-2-2007.
- 3,479,664. **ANIMALS IN MOTION (BLOCK FORM)**. SAM RABY ENTERPRISES LLC, (U.S. CLS. 2, 13, 22, 25, 32 AND 50). SN 77-324,744. PUB. 5-20-2008. FILED 11-8-2007.
- 3,479,799. **EXACTSLIDE (BLOCK FORM)**. TCI SUPPLY, INC., (U.S. CLS. 2, 13, 22, 25, 32 AND 50). SN 77-342,326. PUB. 5-20-2008. FILED 12-3-2007.
- 3,479,812 (*See Class 6 for this trademark*).
- 3,479,814 (*See Class 6 for this trademark*).
- 3,479,888 (*See Class 6 for this trademark*).
- 3,479,916 (*See Class 6 for this trademark*).
- 3,479,953. **REGATTA (BLOCK FORM)**. SKYLINE DISPLAYS, INC., (U.S. CLS. 2, 13, 22, 25, 32 AND 50). SN 77-354,301. PUB. 5-20-2008. FILED 12-18-2007.
- 3,479,989. **LOCK-N-LOAD HANGERS (STYLIZED)**. OLSON, STEVEN P., (U.S. CLS. 2, 13, 22, 25, 32 AND 50). SN 77-355,973. PUB. 5-20-2008. FILED 12-19-2007.
- 3,480,126. **O2 AND DESIGN**. FLEXTANK INC., (U.S. CLS. 2, 13, 22, 25, 32 AND 50). SN 77-361,181. PUB. 5-20-2008. FILED 12-28-2007.
- 3,480,130. **ANA FURNITURE (BLOCK FORM)**. ANA GLOBAL INC., MULTIPLE CLASS, (INT. CLS. 20 AND 35), (U.S. CLS. 2, 13, 22, 25, 32, 50, 100, 101 AND 102). SN 77-361,318. PUB. 5-20-2008. FILED 12-28-2007.
- 3,480,150. **IE; BLINDS (BLOCK FORM)**. RAL & ASSOCIATES, INC., (U.S. CLS. 2, 13, 22, 25, 32 AND 50). SN 77-361,972. PUB. 5-20-2008. FILED 12-31-2007.
- 3,480,248. **DIVERSIBOX (BLOCK FORM)**. LIBERTY DIVERSIFIED INDUSTRIES, INC., (U.S. CLS. 2, 13, 22, 25, 32 AND 50). SN 77-363,681. PUB. 5-20-2008. FILED 1-3-2008.
- 3,480,393. **POW-R-PAX (BLOCK FORM)**. MANNA MARKETING & DEVELOPMENT GROUP, INC., (U.S. CLS. 2, 13, 22, 25, 32 AND 50). SN 77-366,221. PUB. 5-20-2008. FILED 1-8-2008.
- 3,480,488. **LANSHACK (BLOCK FORM)**. ATCOM SERVICES, INC., MULTIPLE CLASS, (INT. CLS. 20 AND 35), (U.S. CLS. 2, 13, 22, 25, 32, 50, 100, 101 AND 102). SN 77-369,227. PUB. 5-20-2008. FILED 1-11-2008.
- 3,480,489. **MISCELLANEOUS DESIGN**. ATCOM SERVICES, INC., MULTIPLE CLASS, (INT. CLS. 20 AND 35), (U.S. CLS. 2, 13, 22, 25, 32, 50, 100, 101 AND 102). SN 77-369,231. PUB. 5-20-2008. FILED 1-11-2008.
- 3,480,523. **TRADEWINDS (BLOCK FORM)**. SKYLINE DISPLAYS, INC., (U.S. CLS. 2, 13, 22, 25, 32 AND 50). SN 77-378,472. PUB. 5-20-2008. FILED 1-23-2008.
- 3,480,574. **CLINICA (BLOCK FORM)**. EFFIGI INC., MULTIPLE CLASS, (INT. CLS. 20, 24 AND 25), (U.S. CLS. 2, 13, 22, 25, 32, 39, 42 AND 50). SN 78-344,385. PUB. 5-20-2008. FILED 12-22-2003.
- 3,480,627. **ANSWER (BLOCK FORM)**. STEELCASE INC., (U.S. CLS. 2, 13, 22, 25, 32 AND 50). SN 78-730,651. PUB. 5-20-2008. FILED 10-11-2005.
- 3,480,677. **RAPTOR AND DESIGN**. UTILITY COMPOSITES INTL LTD, (U.S. CLS. 2, 13, 22, 25, 32 AND 50). SN 78-901,940. PUB. 5-20-2008. FILED 6-6-2006.
- 3,480,714. **RAPTOR (BLOCK FORM)**. UTILITY COMPOSITES INTERNATIONAL, L.P., (U.S. CLS. 2, 13, 22, 25, 32 AND 50). SN 78-949,797. PUB. 5-20-2008. FILED 8-10-2006.
- 3,480,759 (*See Class 7 for this trademark*).
- 3,480,761 (*See Class 16 for this trademark*).
- 3,480,762. **TEKHNE (BLOCK FORM)**. TEKHNE SRL, (U.S. CLS. 2, 13, 22, 25, 32 AND 50). SN 79-031,861. PUB. 5-20-2008. FILED 9-18-2006.
- 3,480,779 (*See Class 3 for this trademark*).
- 3,480,796 (*See Class 10 for this trademark*).
- 3,480,800 (*See Class 3 for this trademark*).
- 3,480,809 (*See Class 4 for this trademark*).
- 3,480,848. **LUXOS (BLOCK FORM)**. OKAMURA CORPORATION, (U.S. CLS. 2, 13, 22, 25, 32 AND 50). SN 79-040,013.

CLASS 20—FURNITURE AND ARTICLES NOT OTHERWISE CLASSIFIED

- 3,478,495. **CASA VERDE AND DESIGN**. MÓVEIS CASA VERDE LTDA., (U.S. CLS. 2, 13, 22, 25, 32 AND 50). SN 76-362,607. PUB. 5-20-2008. FILED 1-23-2002.
- 3,478,540 (*See Class 6 for this trademark*).
- 3,478,541 (*See Class 11 for this trademark*).
- 3,478,548. **MAC KAF AND DESIGN**. MAC KAF, INC., (U.S. CLS. 2, 13, 22, 25, 32 AND 50). SN 76-676,406. PUB. 5-20-2008. FILED 5-4-2007.
- 3,478,652. **MITRA (BLOCK FORM)**. SOFTCARE INNOVATIONS, INC., (U.S. CLS. 2, 13, 22, 25, 32 AND 50). SN 77-028,131. PUB. 11-20-2007. FILED 10-24-2006.
- 3,478,671 (*See Class 9 for this trademark*).
- 3,478,725 (*See Class 14 for this trademark*).
- 3,478,749 (*See Class 10 for this trademark*).
- 3,479,047. **KK AND DESIGN**. FAIRKEEP PRODUCTS, LLC, MULTIPLE CLASS, (INT. CLS. 20 AND 22), (U.S. CLS. 1, 2, 7, 13, 19, 22, 25, 32, 42 AND 50). SN 77-204,242. PUB. 5-20-2008. FILED 6-12-2007.
- 3,479,148 (*See Class 3 for this trademark*).
- 3,479,256. **BECAUSE CHILDREN GROW (BLOCK FORM)**. FLEXA GROUP A/S, MULTIPLE CLASS, (INT. CLS. 20, 24 AND 35), (U.S. CLS. 2, 13, 22, 25, 32, 42, 50, 100, 101 AND 102). SN 77-231,098. PUB. 5-20-2008. FILED 7-17-2007.
- 3,479,266. **NAKED LONGBOARDS (BLOCK FORM)**. NAKED LONGBOARDS, LLC, MULTIPLE CLASS, (INT. CLS. 20 AND 25), (U.S. CLS. 2, 13, 22, 25, 32, 39 AND 50). SN 77-232,381. PUB. 5-20-2008. FILED 7-18-2007.
- 3,479,276 (*See Class 19 for this trademark*).
- 3,479,327. **QWEST (BLOCK FORM)**. QWEST COMMUNICATIONS INTERNATIONAL INC., (U.S. CLS. 2, 13, 22, 25, 32 AND 50). SN 77-247,029. PUB. 5-20-2008. FILED 8-3-2007.
- 3,479,409. **EXO G2 (BLOCK FORM)**. VERSA-GARD, LLC, (U.S. CLS. 2, 13, 22, 25, 32 AND 50). SN 77-269,471. PUB. 5-20-2008. FILED 8-31-2007.
- 3,479,505 (*See Class 14 for this trademark*).
- 3,479,575. **KN LUXURY HOME (BLOCK FORM)**. KN LTD., MULTIPLE CLASS, (INT. CLS. 20 AND 24), (U.S. CLS. 2, 13,

PUB. 5-20-2008. FILED 5-23-2007.
 3,480,854 (*See Class 9 for this trademark.*)
 3,480,858 (*See Class 16 for this trademark.*)
 3,480,879 (*See Class 9 for this trademark.*)
 3,480,884 (*See Class 6 for this trademark.*)
 3,480,917. **MISCELLANEOUS DESIGN.** ZHEJIANG HENGLIN JIAJU; YOUXIAN GONGSI. (U.S. CLS. 2, 13, 22, 25, 32 AND 50). SN 79-042,224. PUB. 5-20-2008. FILED 8-2-2007.
 3,480,921 (*See Class 6 for this trademark.*)
 3,480,929. **WILKHAHN (BLOCK FORM).** WILKHAHN WILKENING + HAHNE GMBH + CO., (U.S. CLS. 2, 13, 22, 25, 32 AND 50). SN 79-042,561. PUB. 5-20-2008. FILED 7-23-2007.
 3,480,961 (*See Class 6 for this trademark.*)
 3,481,008. **VERSUS (BLOCK FORM).** GIANNI VERSACE S.P.A., (U.S. CLS. 2, 13, 22, 25, 32 AND 50). SN 79-046,874. PUB. 5-20-2008. FILED 10-30-2007.
 3,481,015. **COSI-SLEEP AND DESIGN.** MYKKO, NAAMLOZE VENNOOTSCHAP, (U.S. CLS. 2, 13, 22, 25, 32 AND 50). SN 79-047,512. PUB. 5-20-2008. FILED 10-18-2007.
 3,481,024. **PORCUPINE DESK (BLOCK FORM).** VITRA PATENTE AG, (U.S. CLS. 2, 13, 22, 25, 32 AND 50). SN 79-048,185. PUB. 5-20-2008. FILED 12-17-2007.

CLASS 21—HOUSEWARES AND GLASS

3,478,519. **STERLING CUT GLASS (BLOCK FORM).** STERLING CUT GLASS COMPANY, INC., MULTIPLE CLASS, (INT. CLS. 21 AND 35), (U.S. CLS. 2, 13, 23, 29, 30, 33, 40, 50, 100, 101 AND 102). SN 76-662,683. PUB. 5-20-2008. FILED 7-7-2006.
 3,478,539 (*See Class 9 for this trademark.*)
 3,478,540 (*See Class 6 for this trademark.*)
 3,478,541 (*See Class 11 for this trademark.*)
 3,478,671 (*See Class 9 for this trademark.*)
 3,478,767. **KURVE (BLOCK FORM).** ACORN ENGINEERING COMPANY, (U.S. CLS. 2, 13, 23, 29, 30, 33, 40 AND 50). SN 77-098,889. PUB. 5-20-2008. FILED 2-5-2007.
 3,478,788. **THE ORIGINAL BOBBLE BABES AND DESIGN.** BOBBLE BABES, LLC, MULTIPLE CLASS, (INT. CLS. 21, 25 AND 28), (U.S. CLS. 2, 13, 22, 23, 29, 30, 33, 38, 39, 40 AND 50). SN 77-111,824. PUB. 5-20-2008. FILED 2-20-2007.
 3,478,899 (*See Class 7 for this trademark.*)
 3,478,930. **MISCELLANEOUS DESIGN.** THE UPPER ROOM, (U.S. CLS. 2, 13, 23, 29, 30, 33, 40 AND 50). SN 77-184,389. PUB. 5-20-2008. FILED 5-18-2007.
 3,478,974 (*See Class 8 for this trademark.*)
 3,479,148 (*See Class 3 for this trademark.*)
 3,479,396. **ICE TUBES (BLOCK FORM).** ICE TUBES, INC., (U.S. CLS. 2, 13, 23, 29, 30, 33, 40 AND 50). SN 77-265,836. PUB. 5-20-2008. FILED 8-28-2007.
 3,479,494 (*See Class 8 for this trademark.*)
 3,479,504. **STICKYSWAT (BLOCK FORM).** MASTERCORE TECHNOLOGIES, INC., (U.S. CLS. 2, 13, 23, 29, 30, 33, 40 AND 50). SN 77-297,749. PUB. 5-20-2008. FILED 10-5-2007.
 3,479,505 (*See Class 14 for this trademark.*)
 3,479,616 (*See Class 6 for this trademark.*)
 3,479,627 (*See Class 20 for this trademark.*)
 3,479,674. **MISCELLANEOUS DESIGN.** KORN, JONATHAN, AND LO, GRACE, (U.S. CLS. 2, 13, 23, 29, 30, 33, 40 AND 50). SN 77-325,902. PUB. 5-20-2008. FILED 11-9-2007.
 3,479,729. **EARRING ANGEL (BLOCK FORM).** WILLIAMS, LYNN, (U.S. CLS. 2, 13, 23, 29, 30, 33, 40 AND 50). SN 77-334,034. PUB. 5-20-2008. FILED 11-20-2007.
 3,479,775 (*See Class 7 for this trademark.*)
 3,479,797. **SANTA ANITA (BLOCK FORM).** CINSÁ, S.A. DE C.V., (U.S. CLS. 2, 13, 23, 29, 30, 33, 40 AND 50). SN 77-342,179. PUB. 5-20-2008. FILED 12-3-2007.
 3,479,827 (*See Class 7 for this trademark.*)
 3,479,835. **PULLTEX (STYLIZED).** PULLTEX, S.L., (U.S. CLS. 2, 13, 23, 29, 30, 33, 40 AND 50). SN 77-346,038. PUB. 5-20-2008. FILED 12-6-2007.
 3,479,859. **CULINARY BUDDY (BLOCK FORM).** CULINARY BUDDY CORP., (U.S. CLS. 2, 13, 23, 29, 30, 33, 40 AND 50). SN 77-349,029. PUB. 5-20-2008. FILED 12-11-2007.
 3,479,920. **DOTPOTS AND DESIGN.** DOTPOTS, INC., (U.S. CLS. 2, 13, 23, 29, 30, 33, 40 AND 50). SN 77-352,226. PUB. 5-

20-2008. FILED 12-14-2007.
 3,479,932. **WISE-GLASS (BLOCK FORM).** LEFT BRAIN ENTERPRISES, LLC, (U.S. CLS. 2, 13, 23, 29, 30, 33, 40 AND 50). SN 77-353,241. PUB. 5-20-2008. FILED 12-16-2007.
 3,480,089. **VOODOO (BLOCK FORM).** C.S.B. COMMODITIES, INC., (U.S. CLS. 2, 13, 23, 29, 30, 33, 40 AND 50). SN 77-359,546. PUB. 5-20-2008. FILED 12-26-2007.
 3,480,124. **MISCELLANEOUS DESIGN.** C.S.B. COMMODITIES, INC., (U.S. CLS. 2, 13, 23, 29, 30, 33, 40 AND 50). SN 77-361,060. PUB. 5-20-2008. FILED 12-28-2007.
 3,480,335. **SKOY (BLOCK FORM).** SKOY ENTERPRISES, (U.S. CLS. 2, 13, 23, 29, 30, 33, 40 AND 50). SN 77-364,988. PUB. 5-20-2008. FILED 1-6-2008.
 3,480,407. **WILD BIRDS GALORE (BLOCK FORM).** BACON PRODUCTS CORPORATION, (U.S. CLS. 2, 13, 23, 29, 30, 33, 40 AND 50). SN 77-366,534. PUB. 5-20-2008. FILED 1-8-2008.
 3,480,408. **WILD BIRDS GALORE AND DESIGN.** BACON PRODUCTS CORPORATION, (U.S. CLS. 2, 13, 23, 29, 30, 33, 40 AND 50). SN 77-366,539. PUB. 5-20-2008. FILED 1-8-2008.
 3,480,458. **FUEL TANK (BLOCK FORM).** PETERSON, ANDREW, L, (U.S. CLS. 2, 13, 23, 29, 30, 33, 40 AND 50). SN 77-367,635. PUB. 5-20-2008. FILED 1-9-2008.
 3,480,566. **POO PEE (BLOCK FORM).** FOUR PAWS PRODUCTS, LTD., (U.S. CLS. 2, 13, 23, 29, 30, 33, 40 AND 50). SN 77-975,361. PUB. 5-20-2008. FILED 8-24-2007.
 3,480,616. **EXCALIBUR (BLOCK FORM).** MAYBRUN, INC., (U.S. CLS. 2, 13, 23, 29, 30, 33, 40 AND 50). SN 78-679,522. PUB. 5-20-2008. FILED 7-27-2005.
 3,480,761 (*See Class 16 for this trademark.*)
 3,480,797. **MEDIDO (BLOCK FORM).** INNOSPENSE CAPITAL BV, (U.S. CLS. 2, 13, 23, 29, 30, 33, 40 AND 50). SN 79-035,614. PUB. 5-20-2008. FILED 1-23-2007.
 3,480,804 (*See Class 1 for this trademark.*)
 3,480,809 (*See Class 4 for this trademark.*)
 3,480,846 (*See Class 11 for this trademark.*)
 3,480,884 (*See Class 6 for this trademark.*)
 3,480,900. **PININFARINA (STYLIZED).** PININFARINA EXTRA S.R.L., (U.S. CLS. 2, 13, 23, 29, 30, 33, 40 AND 50). SN 79-041,785. PUB. 5-20-2008. FILED 5-30-2007.
 3,480,905 (*See Class 16 for this trademark.*)
 3,480,968 (*See Class 9 for this trademark.*)
 3,481,018. **SUNTONIC (BLOCK FORM).** METAXA B.V., MULTIPLE CLASS, (INT. CLS. 21, 25 AND 33), (U.S. CLS. 2, 13, 22, 23, 29, 30, 33, 39, 40, 47, 49 AND 50). SN 79-047,665. PUB. 5-20-2008. FILED 10-16-2007.

CLASS 22—CORDAGE AND FIBERS

3,478,907 (*See Class 6 for this trademark.*)
 3,479,047 (*See Class 20 for this trademark.*)
 3,479,079. **CABLE CLIPPER (BLOCK FORM).** WILLIAM FRICK CORPORATION, (U.S. CLS. 1, 2, 7, 19, 22, 42 AND 50). SN 77-209,401. PUB. 5-20-2008. FILED 6-19-2007.
 3,480,327. **V THE VERDE BAG AND DESIGN.** SAMPLE, GINA M., DBA SAMPLE DESIGN, (U.S. CLS. 1, 2, 7, 19, 22, 42 AND 50). SN 77-364,750. PUB. 5-20-2008. FILED 1-4-2008.
 3,480,775. **DAYA FLEX AND DESIGN.** SOYANG TECHNOLOGIES CO., LTD., (U.S. CLS. 1, 2, 7, 19, 22, 42 AND 50). SN 79-033,622. PUB. 5-20-2008. FILED 3-13-2006.
 3,480,820. **CGEAR (BLOCK FORM).** CGEAR AUSTRALIA PTY LTD, MULTIPLE CLASS, (INT. CLS. 22, 24 AND 27), (U.S. CLS. 1, 2, 7, 19, 20, 22, 37, 42 AND 50). SN 79-038,542. PUB. 5-20-2008. FILED 2-28-2007.
 3,480,879 (*See Class 9 for this trademark.*)
 3,480,888 (*See Class 12 for this trademark.*)

CLASS 23—YARNS AND THREADS

3,479,985. **SIMPLY WOOL AND DESIGN.** THE GENTLE ART, INC., (U.S. CL. 43). SN 77-355,683. PUB. 5-20-2008. FILED S.R. 12-19-2007; AM. P.R. 4-9-2008.
 3,480,836. **NEXIS FIBERS AND DESIGN.** NEXIS FIBERS AG, (U.S. CL. 43). SN 79-039,594. PUB. 5-20-2008. FILED 5-21-

2007.

CLASS 24—FABRICS

- 3,478,505. **JELLY GIRLS (BLOCK FORM)**, PHILHOBAR DESIGN CANADA LTD., MULTIPLE CLASS, (INT. CLS. 24 AND 25), (U.S. CLS. 22, 39, 42 AND 50). SN 76-599,134. PUB. 3-4-2008. FILED 6-24-2004.
- 3,478,549. **STAR HOME FASHIONS AND DESIGN**, COJAB, JACOBO S., (U.S. CLS. 42 AND 50). SN 76-676,678. PUB. 5-20-2008. FILED 5-11-2007.
- 3,478,583. **SNAP DRAPE (BLOCK FORM)**, SNAP DRAPE INTERNATIONAL, INC., MULTIPLE CLASS, (INT. CLS. 24 AND 26), (U.S. CLS. 37, 39, 40, 42 AND 50). SN 76-682,638. PUB. 5-20-2008. FILED 10-5-2007.
- 3,478,623. **MICROFEATHER (BLOCK FORM)**, PACIFIC COAST FEATHER COMPANY, (U.S. CLS. 42 AND 50). SN 76-685,764. PUB. 5-20-2008. FILED 1-14-2008.
- 3,478,804. **PAROTEX AND DESIGN**, PAROTEX S.R.L., MULTIPLE CLASS, (INT. CLS. 24 AND 25), (U.S. CLS. 22, 39, 42 AND 50). SN 77-120,171. PUB. 5-20-2008. FILED 3-1-2007.
- 3,479,040. **STARK FABRIC (BLOCK FORM)**, STARK CARPET CORP., (U.S. CLS. 42 AND 50). SN 77-202,436. PUB. 5-20-2008. FILED 6-11-2007.
- 3,479,148 (*See Class 3 for this trademark*).
- 3,479,190. **THE COMPHY CO. (STYLIZED)**, THE COMPHY CO., MULTIPLE CLASS, (INT. CLS. 24 AND 25), (U.S. CLS. 22, 39, 42 AND 50). SN 77-222,051. PUB. 5-20-2008. FILED 7-4-2007.
- 3,479,256 (*See Class 20 for this trademark*).
- 3,479,459. **EMOTIONS AND DESIGN**, PYN, S.A. DE C.V., (U.S. CLS. 42 AND 50). SN 77-282,612. PUB. 5-20-2008. FILED 9-18-2007.
- 3,479,575 (*See Class 20 for this trademark*).
- 3,480,026. **CASA BINI TEXTILES (BLOCK FORM)**, MATAS LLC, DBA THE PEACOCK COLLECTION, (U.S. CLS. 42 AND 50). SN 77-357,061. PUB. 5-20-2008. FILED S.R. 12-20-2007; AM. P.R. 3-31-2008.
- 3,480,574 (*See Class 20 for this trademark*).
- 3,480,777 (*See Class 14 for this trademark*).
- 3,480,800 (*See Class 3 for this trademark*).
- 3,480,816 (*See Class 5 for this trademark*).
- 3,480,820 (*See Class 22 for this trademark*).
- 3,480,822 (*See Class 6 for this trademark*).
- 3,480,844 (*See Class 3 for this trademark*).
- 3,480,876. **CLASS 4X4 AND DESIGN**, TELASIS TEKSTIL URUNLERI; SANAYI VE TICARET ANONIM SIRKETI, (U.S. CLS. 42 AND 50). SN 79-041,265. PUB. 5-20-2008. FILED 1-11-2007.
- 3,480,895 (*See Class 18 for this trademark*).
- 3,480,933 (*See Class 3 for this trademark*).
- 3,480,984. **HICCUPS (BLOCK FORM)**, LINEN HOUSE PTY LTD, (U.S. CLS. 42 AND 50). SN 79-044,923. PUB. 5-20-2008. FILED 3-22-2007.

CLASS 25—CLOTHING

- 3,478,492. **SOS FALL MIGRATION**, SOCIETY OF STRANDERS, INC., (U.S. CLS. 22 AND 39). SN 75-698,872. PUB. 5-20-2008. FILED 5-6-1999.
- 3,478,501 (*See Class 18 for this trademark*).
- 3,478,502. **SPA**, SCHROEDER & TREMAYNE, INC., (U.S. CLS. 22 AND 39). SN 76-552,650. PUB. 5-20-2008. FILED 10-20-2003.
- 3,478,505 (*See Class 24 for this trademark*).
- 3,478,539 (*See Class 9 for this trademark*).
- 3,478,544 (*See Class 14 for this trademark*).
- 3,478,557. **FIST FIRST FIGHTING THE SCIENCE OF VICTORY FFF AND DESIGN**, FIST FIRST FIGHTING, LLC, (U.S. CLS. 22 AND 39). SN 76-678,365. PUB. 5-20-2008. FILED 6-18-2007.
- 3,478,580. **VINDICTIVE (BLOCK FORM)**, AL RUBA ADRBA SALES LLC, (U.S. CLS. 22 AND 39). SN 76-682,503. PUB. 5-

- 20-2008. FILED 10-1-2007.
- 3,478,602. **SINCERA USA AND DESIGN**, YOO, BYUNG HAK, (U.S. CLS. 22 AND 39). SN 76-684,759. PUB. 5-20-2008. FILED 12-10-2007.
- 3,478,611 (*See Class 9 for this trademark*).
- 3,478,637. **OPERATION ROMANCE (BLOCK FORM)**, BOGAN, TRACI, MULTIPLE CLASS, (INT. CLS. 25, 35 AND 45), (U.S. CLS. 22, 39, 100, 101 AND 102). SN 77-010,937. PUB. 5-20-2008. FILED 9-29-2006.
- 3,478,641 (*See Class 7 for this trademark*).
- 3,478,660. **PETER HUBER (BLOCK FORM)**, SL MARKETING SA, (U.S. CLS. 22 AND 39). SN 77-032,861. PUB. 10-23-2007. FILED 10-31-2006.
- 3,478,671 (*See Class 9 for this trademark*).
- 3,478,708. **TRIXXI (BLOCK FORM)**, TRIXXI CLOTHING COMPANY, INC., (U.S. CLS. 22 AND 39). SN 77-062,562. PUB. 5-20-2008. FILED 12-12-2006.
- 3,478,788 (*See Class 21 for this trademark*).
- 3,478,794. **BUHL AND DESIGN**, THE BUHL COMPANY INC., (U.S. CLS. 22 AND 39). SN 77-115,264. PUB. 5-20-2008. FILED 2-23-2007.
- 3,478,804 (*See Class 24 for this trademark*).
- 3,478,810. **GBRACING (BLOCK FORM)**, LEWIS BANKS LTD., (U.S. CLS. 22 AND 39). SN 77-126,864. PUB. 5-20-2008. FILED 3-9-2007.
- 3,478,859. **ONWARD TALOFOFO GOLF CLUB AND DESIGN**, KABUSHIKI KAISHA ONWARD HOLDINGS, TA ONWARD HOLDINGS CO., LTD., MULTIPLE CLASS, (INT. CLS. 25, 35, 41 AND 43), (U.S. CLS. 22, 39, 100, 101, 102 AND 107). SN 77-154,907. PUB. 5-20-2008. FILED 4-12-2007.
- 3,478,864. **MAGIC LUCK FRIENDSHIP (BLOCK FORM)**, FRIENDS & FRIENDS, INC., MULTIPLE CLASS, (INT. CLS. 25, 28, 35, 37, 41, 42 AND 45), (U.S. CLS. 22, 23, 38, 39, 50, 100, 101, 102, 103, 106 AND 107). SN 77-157,701. PUB. 5-20-2008. FILED 4-16-2007.
- 3,478,866. **BALANCE POINT (BLOCK FORM)**, DELTA GALIL INDUSTRIES LTD., (U.S. CLS. 22 AND 39). SN 77-158,113. PUB. 5-20-2008. FILED 4-17-2007.
- 3,478,867. **ERGOSTEP AND DESIGN**, DELTA GALIL INDUSTRIES LTD., (U.S. CLS. 22 AND 39). SN 77-158,117. PUB. 5-20-2008. FILED 4-17-2007.
- 3,478,997. **YES ICAN.CC (BLOCK FORM)**, YESICAN.CC, LLC, (U.S. CLS. 22 AND 39). SN 77-196,577. PUB. 5-20-2008. FILED 6-4-2007.
- 3,478,998. **YES I CAN.CC BELIEVE FAITH PRODUCE AND DESIGN**, YESICAN.CC, LLC, (U.S. CLS. 22 AND 39). SN 77-196,586. PUB. 5-20-2008. FILED 6-4-2007.
- 3,479,033. **MISCELLANEOUS DESIGN**, MC CORPORATION LIMITED, (U.S. CLS. 22 AND 39). SN 77-201,524. PUB. 5-20-2008. FILED 6-8-2007.
- 3,479,064. **DREAMY (BLOCK FORM)**, HORSTMAN, CHADLER M, (U.S. CLS. 22 AND 39). SN 77-207,818. PUB. 5-20-2008. FILED S.R. 6-15-2007; AM. P.R. 9-25-2007.
- 3,479,065. **ST. TROPEZ (BLOCK FORM)**, SUPRACOR, INC., (U.S. CLS. 22 AND 39). SN 77-207,840. PUB. 5-20-2008. FILED 6-15-2007.
- 3,479,071. **RED HEAD CWS (BLOCK FORM)**, BASS PRO TRADEMARKS, L.L.C., (U.S. CLS. 22 AND 39). SN 77-208,315. PUB. 5-20-2008. FILED 6-18-2007.
- 3,479,073. **RED HEAD ENDURASKIN (BLOCK FORM)**, BASS PRO TRADEMARKS, L.L.C., (U.S. CLS. 22 AND 39). SN 77-208,472. PUB. 5-20-2008. FILED 6-18-2007.
- 3,479,102. **A LITTLE BIT RISQUE (BLOCK FORM)**, GRANT, MOLLIE HUNTER, (U.S. CLS. 22 AND 39). SN 77-212,967. PUB. 5-20-2008. FILED 6-22-2007.
- 3,479,110. **LEAD SLED (BLOCK FORM)**, RUUD, ROBERT, D., (U.S. CLS. 22 AND 39). SN 77-213,950. PUB. 5-20-2008. FILED 6-23-2007.
- 3,479,164. **JF AND DESIGN**, ALLISON, JON P., (U.S. CLS. 22 AND 39). SN 77-219,933. PUB. 5-20-2008. FILED 7-1-2007.
- 3,479,178. **REVA (BLOCK FORM)**, RIVER LIGHT V, L.P., (U.S. CLS. 22 AND 39). SN 77-221,172. PUB. 5-20-2008. FILED 7-3-2007.
- 3,479,182. **YARDIE (BLOCK FORM)**, COOMBS, STANLENE F, DBA PICKNEY ENTERPRISES, (U.S. CLS. 22 AND 39). SN 77-221,709. PUB. 5-20-2008. FILED 7-3-2007.
- 3,479,190 (*See Class 24 for this trademark*).
- 3,479,221. **LOVE HEALS AND DESIGN**, LOVE HEALS, LLC,

- (U.S. CLS. 22 AND 39). SN 77-226,309. PUB. 5-20-2008. FILED 7-10-2007.
- 3,479,237. **WEAR CONSCIOUS CLOTHING AND DESIGN.** WEAR INCORPORATED, (U.S. CLS. 22 AND 39). SN 77-229,230. PUB. 2-12-2008. FILED 7-13-2007.
- 3,479,266 (*See Class 20 for this trademark.*).
- 3,479,292. **HURRICANE SURVIVOR AND DESIGN.** VINCENT, VICTOR N. AND SMITH, STEVEN J., (U.S. CLS. 22 AND 39). SN 77-237,248. PUB. 5-20-2008. FILED 7-24-2007.
- 3,479,338 (*See Class 14 for this trademark.*).
- 3,479,339. **FAULTLINE (BLOCK FORM).** FAULTLINE CORP., DBA FAULTLINE CLOTHING, (U.S. CLS. 22 AND 39). SN 77-249,632. PUB. 5-20-2008. FILED 8-8-2007.
- 3,479,342. **BLUSH BY US ANGELS AND DESIGN.** DBD, INC., (U.S. CLS. 22 AND 39). SN 77-250,114. PUB. 5-20-2008. FILED 8-8-2007.
- 3,479,346. **BUGATCHI WOMEN (BLOCK FORM).** BUGATCHI UOMO APPAREL, INC., (U.S. CLS. 22 AND 39). SN 77-250,982. PUB. 5-20-2008. FILED 8-9-2007.
- 3,479,352. **MIA BRAZILIA AND DESIGN.** MIA BRAZILIA LLC, (U.S. CLS. 22 AND 39). SN 77-253,134. PUB. 5-20-2008. FILED 8-12-2007.
- 3,479,354. **C'EST ATELIER (BLOCK FORM).** BMJ INTERNATIONAL CO. INC., (U.S. CLS. 22 AND 39). SN 77-253,593. PUB. 5-20-2008. FILED 8-13-2007.
- 3,479,402. **CARIBBEAN CARTEL (BLOCK FORM).** LIOW, TIAN KONG, (U.S. CLS. 22 AND 39). SN 77-267,670. PUB. 5-20-2008. FILED 8-29-2007.
- 3,479,413. **WALKER WEAR (STYLIZED).** WALKER, APRIL, (U.S. CLS. 22 AND 39). SN 77-271,445. PUB. 5-20-2008. FILED 9-4-2007.
- 3,479,423. **SUMMIT SERIES AND DESIGN.** THE NORTH FACE APPAREL CORP., (U.S. CLS. 22 AND 39). SN 77-273,817. PUB. 5-20-2008. FILED 9-7-2007.
- 3,479,424. **STATE PATROL COLORADO AND DESIGN.** COLORADO STATE PATROL, (U.S. CLS. 22 AND 39). SN 77-274,008. PUB. 2-12-2008. FILED 9-7-2007.
- 3,479,505 (*See Class 14 for this trademark.*).
- 3,479,554. **P.E.T.A.L. POSITIVELY EMPOWERING TEEN-GIRLS ABOUT LIFE AND DESIGN.** EVANS, TAMIKO, MULTIPLE CLASS, (INT. CLS. 25 AND 41), (U.S. CLS. 22, 39, 100, 101 AND 107). SN 77-306,365. PUB. 5-20-2008. FILED 10-17-2007.
- 3,479,561. **PEACE LOVE LIFE (BLOCK FORM).** BRAD GREEN, (U.S. CLS. 22 AND 39). SN 77-307,345. PUB. 5-20-2008. FILED S.R. 10-18-2007; AM. P.R. 4-2-2008.
- 3,479,593 (*See Class 9 for this trademark.*).
- 3,479,595 (*See Class 9 for this trademark.*).
- 3,479,625. **MISCELLANEOUS DESIGN.** EFCI DESIGNS, LLC, (U.S. CLS. 22 AND 39). SN 77-318,619. PUB. 5-20-2008. FILED 10-31-2007.
- 3,479,636. **BOOTIE BELT (BLOCK FORM).** TREFFILETTI, LUCI M., DBA BOOTIEBELT BY LOOLOO, (U.S. CLS. 22 AND 39). SN 77-320,948. PUB. 5-20-2008. FILED S.R. 11-4-2007; AM. P.R. 4-2-2008.
- 3,479,646. **ST.POLE (BLOCK FORM).** JULIE INTERNATIONAL, INC., (U.S. CLS. 22 AND 39). SN 77-323,033. PUB. 5-20-2008. FILED S.R. 11-6-2007; AM. P.R. 3-28-2008.
- 3,479,665 (*See Class 16 for this trademark.*).
- 3,479,669. **F AND DESIGN.** FRANK 151 MEDIA GROUP LLC, (U.S. CLS. 22 AND 39). SN 77-325,601. PUB. 5-20-2008. FILED 11-9-2007.
- 3,479,724. **APPAMAN AND DESIGN.** APPAMAN INC., (U.S. CLS. 22 AND 39). SN 77-333,282. PUB. 5-20-2008. FILED 11-19-2007.
- 3,479,746. **E ELDORA SPEEDWAY ROSSBURG, OHIO AND DESIGN.** ELDORA SPEEDWAY, INC., (U.S. CLS. 22 AND 39). SN 77-336,465. PUB. 5-20-2008. FILED 11-26-2007.
- 3,479,750. **ELDORA SPEEDWAY (BLOCK FORM).** ELDORA SPEEDWAY, INC., MULTIPLE CLASS, (INT. CLS. 25 AND 41), (U.S. CLS. 22, 39, 100, 101 AND 107). SN 77-336,492. PUB. 5-20-2008. FILED 11-26-2007.
- 3,479,762. **APPAMAN (BLOCK FORM).** APPAMAN INC., (U.S. CLS. 22 AND 39). SN 77-338,673. PUB. 5-20-2008. FILED 11-28-2007.
- 3,479,785. **BOXERCRAFT (BLOCK FORM).** BOXERCRAFT INCORPORATED, MULTIPLE CLASS, (INT. CLS. 25 AND 35), (U.S. CLS. 22, 39, 100, 101 AND 102). SN 77-341,410. PUB. 5-20-2008. FILED 11-30-2007.
- 3,479,788. **MISCELLANEOUS DESIGN.** BOXERCRAFT INCORPORATED, MULTIPLE CLASS, (INT. CLS. 25 AND 35), (U.S. CLS. 22, 39, 100, 101 AND 102). SN 77-341,518. PUB. 5-20-2008. FILED 11-30-2007.
- 3,479,796. **POPS POST-OP PAJAMAS AND DESIGN.** MARYED INTERNATIONAL, INC., (U.S. CLS. 22 AND 39). SN 77-342,053. PUB. 5-20-2008. FILED 12-2-2007.
- 3,479,865. **REGIUS VESTIO (BLOCK FORM).** REGIUS VESTIO, LLC, (U.S. CLS. 22 AND 39). SN 77-349,675. PUB. 5-20-2008. FILED 12-12-2007.
- 3,479,909. **HULA BABY (BLOCK FORM).** GRABLE, ANNA L., (U.S. CLS. 22 AND 39). SN 77-351,863. PUB. 5-20-2008. FILED 12-13-2007.
- 3,479,923. **HOPSCOTCH (BLOCK FORM).** CHILDREN'S APPAREL NETWORK, LTD., (U.S. CLS. 22 AND 39). SN 77-352,591. PUB. 5-20-2008. FILED 12-14-2007.
- 3,479,995. **BOOBIES 2 BOOTIES (BLOCK FORM).** HANDS OFF IT'S MINE, (U.S. CLS. 22 AND 39). SN 77-356,277. PUB. 5-20-2008. FILED 12-19-2007.
- 3,480,000. (,) **(BLOCK FORM).** BGB MOTORSPORTS. LLC, (U.S. CLS. 22 AND 39). SN 77-356,531. PUB. 5-20-2008. FILED 12-20-2007.
- 3,480,031. **MICROCELL (BLOCK FORM).** STUDIO IP HOLDINGS LLC, (U.S. CLS. 22 AND 39). SN 77-357,341. PUB. 5-20-2008. FILED 12-20-2007.
- 3,480,063. **K K-CLAW AND DESIGN.** K-CLAW, INC., (U.S. CLS. 22 AND 39). SN 77-358,826. PUB. 5-20-2008. FILED 12-22-2007.
- 3,480,084. **JILLIE WILLIE (BLOCK FORM).** GROVER, JILL W., DBA JILLIE WILLIE, (U.S. CLS. 22 AND 39). SN 77-359,385. PUB. 5-20-2008. FILED 12-26-2007.
- 3,480,127. **SPACE...IT'S CLOSER THAN YOU THINK (BLOCK FORM).** DESERT SKY HOLDINGS, LLC, (U.S. CLS. 22 AND 39). SN 77-361,184. PUB. 5-20-2008. FILED 12-28-2007.
- 3,480,133. **DOES THIS SKIRT MAKE MY BUTT LOOK FAST? (BLOCK FORM).** LANGENDORFER, HEATHER L, DBA ATALANTA ATHLETICWEAR, (U.S. CLS. 22 AND 39). SN 77-361,547. PUB. 5-20-2008. FILED 12-29-2007.
- 3,480,143. **GOLD CROWN DUNGAREES (BLOCK FORM).** JAZZMAN SPORTSWEAR CORP., (U.S. CLS. 22 AND 39). SN 77-361,835. PUB. 5-20-2008. FILED 12-31-2007.
- 3,480,154. **WHAT'S IN YOUR FLY? (BLOCK FORM).** MOORE, AARON, (U.S. CLS. 22 AND 39). SN 77-362,004. PUB. 5-20-2008. FILED 12-31-2007.
- 3,480,202. **PURE VEG AND DESIGN.** STEVEN T. GRUBART, (U.S. CLS. 22 AND 39). SN 77-363,002. PUB. 5-20-2008. FILED 1-2-2008.
- 3,480,241. **ONE MOORE CATCH (BLOCK FORM).** ONE MOORE CATCH INC., (U.S. CLS. 22 AND 39). SN 77-363,551. PUB. 5-20-2008. FILED 1-3-2008.
- 3,480,328. **LETHAL CURVES (BLOCK FORM).** ROSANNE BELLER, INC., (U.S. CLS. 22 AND 39). SN 77-364,767. PUB. 5-20-2008. FILED 1-4-2008.
- 3,480,352. **MISCELLANEOUS DESIGN.** BUCCANEERS LIMITED PARTNERSHIP, (U.S. CLS. 22 AND 39). SN 77-365,282. PUB. 5-20-2008. FILED 1-7-2008.
- 3,480,371. **LANCASTER JETHAWKS AND DESIGN.** HAWKS NEST, LLC., (U.S. CLS. 22 AND 39). SN 77-365,660. PUB. 5-20-2008. FILED 1-7-2008.
- 3,480,386. **LEXIEGIRL CLOTHING (BLOCK FORM).** LEXIEGIRL CLOTHING, INC., (U.S. CLS. 22 AND 39). SN 77-366,050. PUB. 5-20-2008. FILED 1-7-2008.
- 3,480,396. **VERTICAL CUT (BLOCK FORM).** HESTRAHANDSKEN AB, (U.S. CLS. 22 AND 39). SN 77-366,266. PUB. 5-20-2008. FILED 1-8-2008.
- 3,480,409. **WHITE'S PACS (BLOCK FORM).** WHITE'S BOOTS, INC., (U.S. CLS. 22 AND 39). SN 77-366,540. PUB. 5-20-2008. FILED 1-8-2008.
- 3,480,410. **WHITE'S SNOWCAT (BLOCK FORM).** WHITE'S BOOTS, INC., (U.S. CLS. 22 AND 39). SN 77-366,553. PUB. 5-20-2008. FILED 1-8-2008.
- 3,480,414. **HATHORN HI-LINE (BLOCK FORM).** WHITE'S BOOTS, INC., (U.S. CLS. 22 AND 39). SN 77-366,581. PUB. 5-20-2008. FILED 1-8-2008.
- 3,480,416. **HATHORN EXPLORER (BLOCK FORM).** WHITE'S BOOTS, INC., (U.S. CLS. 22 AND 39). SN 77-366,594. PUB. 5-

- 20-2008. FILED 1-8-2008.
 3,480,438. **6A (STYLIZED)**. BAYVI LLC, (U.S. CLS. 22 AND 39). SN 77-367,106. PUB. 5-20-2008. FILED 1-8-2008.
 3,480,442. **TAIKONHU (BLOCK FORM)**. URBAN OUTFITTERS (DELAWARE), INC., (U.S. CLS. 22 AND 39). SN 77-367,246. PUB. 5-20-2008. FILED 1-9-2008.
 3,480,443. **HAND KNIT BY DOLLIE (BLOCK FORM)**. URBAN OUTFITTERS (DELAWARE), INC., (U.S. CLS. 22 AND 39). SN 77-367,248. PUB. 5-20-2008. FILED 1-9-2008.
 3,480,480. **MISCELLANEOUS DESIGN**. CHILDREN'S PEDIATRICS CENTERS, LLC, (U.S. CLS. 22 AND 39). SN 77-368,110. PUB. 5-20-2008. FILED 1-9-2008.
 3,480,511. **FOSSIL (BLOCK FORM)**. FOSSIL, INC., (U.S. CLS. 22 AND 39). SN 77-375,645. PUB. 5-20-2008. FILED 1-18-2008.
 3,480,517. **SEXY LITTLE BRIDE (BLOCK FORM)**. VICTORIA'S SECRET STORES BRAND MANAGEMENT, INC., (U.S. CLS. 22 AND 39). SN 77-377,499. PUB. 5-20-2008. FILED 1-22-2008.
 3,480,520. **SEXY LITTLE THINGS (BLOCK FORM)**. VICTORIA'S SECRET STORES BRAND MANAGEMENT, INC., (U.S. CLS. 22 AND 39). SN 77-377,615. PUB. 5-20-2008. FILED 1-22-2008.
 3,480,524. **SPLENDID MILLS (BLOCK FORM)**. MO INDUSTRIES, LLC, (U.S. CLS. 22 AND 39). SN 77-379,528. PUB. 5-20-2008. FILED 1-24-2008.
 3,480,556. **MISCELLANEOUS DESIGN**. HAWKS NEST, LLC., (U.S. CLS. 22 AND 39). SN 77-407,428. PUB. 5-20-2008. FILED 2-27-2008.
 3,480,565. **REBAR (BLOCK FORM)**. KINNDER INDUSTRIES, LLC, (U.S. CLS. 22 AND 39). SN 77-975,072. PUB. 5-20-2008. FILED 9-26-2006.
 3,480,568. **PARISH (BLOCK FORM)**. BRAND X, L.L.C., (U.S. CLS. 22 AND 39). SN 77-975,635. PUB. 3-6-2007. FILED 10-6-2006.
 3,480,570. **SP**. WICKED FASHIONS, INC., (U.S. CLS. 22 AND 39). SN 78-204,707. PUB. 5-20-2008. FILED 1-17-2003.
 3,480,574 (*See Class 20 for this trademark*).
 3,480,575 (*See Class 8 for this trademark*).
 3,480,584 (*See Class 9 for this trademark*).
 3,480,595 (*See Class 9 for this trademark*).
 3,480,596 (*See Class 9 for this trademark*).
 3,480,597 (*See Class 9 for this trademark*).
 3,480,599. **T.O.N.Y. (BLOCK FORM)**. NILES, HASSAN M., (U.S. CLS. 22 AND 39). SN 78-596,729. PUB. 6-27-2006. FILED 3-29-2005.
 3,480,609. **2 CHIX AND DESIGN**. 2 CHIX, (U.S. CLS. 22 AND 39). SN 78-638,592. PUB. 5-20-2008. FILED 5-26-2005.
 3,480,613. **MISCELLANEOUS DESIGN**. GLOBAL COLLECTIVE DESIGN INCORPORATED, (U.S. CLS. 22 AND 39). SN 78-666,159. PUB. 5-20-2008. FILED 7-8-2005.
 3,480,619. **DIRTY SHIRT (BLOCK FORM)**. SHULHAFFER, ALEXANDRIA M., (U.S. CLS. 22 AND 39). SN 78-690,673. PUB. 5-20-2008. FILED 8-11-2005.
 3,480,654. **TONY BENNETT (BLOCK FORM)**. BENEDETTO ARTS GMBH, (U.S. CLS. 22 AND 39). SN 78-845,790. PUB. 5-20-2008. FILED 3-24-2006.
 3,480,669. **REAL DEAL TRACK CLUB 19 EST. 91 (STYLIZED)**. GREEN, JR. WALTER H. (U.S. CLS. 22 AND 39). SN 78-888,337. PUB. 5-20-2008. FILED 5-19-2006.
 3,480,719. **LUXURY KICKS (BLOCK FORM)**. IGUASU TRADING, USA, INC., (U.S. CLS. 22 AND 39). SN 78-957,096. PUB. 5-20-2008. FILED 8-21-2006.
 3,480,720. **L LUXURY KICKS LUXURY KICKS LUXURY KICKS AND DESIGN**. IGUASU TRADING, USA, INC., (U.S. CLS. 22 AND 39). SN 78-957,107. PUB. 5-20-2008. FILED 8-21-2006.
 3,480,745 (*See Class 9 for this trademark*).
 3,480,763 (*See Class 18 for this trademark*).
 3,480,774. **POLISTAS (BLOCK FORM)**. POLO RELATIONS LTD, (U.S. CLS. 22 AND 39). SN 79-033,541. PUB. 5-20-2008. FILED 5-22-2006.
 3,480,777 (*See Class 14 for this trademark*).
 3,480,779 (*See Class 3 for this trademark*).
 3,480,800 (*See Class 3 for this trademark*).
 3,480,808 (*See Class 9 for this trademark*).
 3,480,816 (*See Class 5 for this trademark*).
 3,480,821 (*See Class 18 for this trademark*).
 3,480,828. **MARIE JO STYLING AND DESIGN**. VAN DE VELDE N.V., (U.S. CLS. 22 AND 39). SN 79-038,946. PUB. 5-20-2008. FILED 4-10-2007.
 3,480,834 (*See Class 9 for this trademark*).
 3,480,837. **BIN BAO AND DESIGN**. SHANTOU JINXINXING; TRADING DEVELOPMENT CO., LTD., (U.S. CLS. 22 AND 39). SN 79-039,619. PUB. 5-20-2008. FILED 5-21-2007.
 3,480,838. **GABOR AND DESIGN**. GABOR SHOES AG, (U.S. CLS. 22 AND 39). SN 79-039,664. PUB. 4-15-2008. FILED 5-10-2007.
 3,480,839 (*See Class 3 for this trademark*).
 3,480,844 (*See Class 3 for this trademark*).
 3,480,849. **P ALBERTO INCANUTI (STYLIZED)**. ALBERTO INCANUTI S.R.L., (U.S. CLS. 22 AND 39). SN 79-040,058. PUB. 5-20-2008. FILED 5-16-2007.
 3,480,856 (*See Class 3 for this trademark*).
 3,480,857 (*See Class 18 for this trademark*).
 3,480,859. **AMBRÉ (BLOCK FORM)**. SANITA A/S, (U.S. CLS. 22 AND 39). SN 79-040,622. PUB. 5-20-2008. FILED 7-6-2007.
 3,480,874. **SOLOLA (STYLIZED)**. SOLOLA; SOCIÉTÉ PAR ACTIONS SIMPLIFIÉE, (U.S. CLS. 22 AND 39). SN 79-041,254. PUB. 2-12-2008. FILED 1-15-2007.
 3,480,879 (*See Class 9 for this trademark*).
 3,480,888 (*See Class 12 for this trademark*).
 3,480,895 (*See Class 18 for this trademark*).
 3,480,898. **BEYOND PERFORMANCE (STYLIZED)**. EIDER, SOCIÉTÉ PAR ACTIONS SIMPLIFIÉE, (U.S. CLS. 22 AND 39). SN 79-041,770. PUB. 5-20-2008. FILED 7-5-2007.
 3,480,904 (*See Class 18 for this trademark*).
 3,480,910 (*See Class 9 for this trademark*).
 3,480,911 (*See Class 9 for this trademark*).
 3,480,915. **VIVE LE SPORT (STYLIZED)**. VIVE LE SPORT DI MONTI FEDERICO, (U.S. CLS. 22 AND 39). SN 79-042,188. PUB. 5-20-2008. FILED 5-25-2007.
 3,480,922. **VERDE VERONICA AND DESIGN**. INTIMA MODA S.P.A., (U.S. CLS. 22 AND 39). SN 79-042,404. PUB. 5-20-2008. FILED 6-25-2007.
 3,480,923 (*See Class 18 for this trademark*).
 3,480,940. **VERDISSIMA (STYLIZED)**. INTIMA MODA S.P.A., (U.S. CLS. 22 AND 39). SN 79-042,849. PUB. 5-20-2008. FILED 6-8-2007.
 3,480,946 (*See Class 18 for this trademark*).
 3,480,955 (*See Class 12 for this trademark*).
 3,480,970. **TWO9'S AND DESIGN**. NEW MARBAS S.P.A., (U.S. CLS. 22 AND 39). SN 79-044,011. PUB. 5-20-2008. FILED 7-27-2007.
 3,480,971. **MISCELLANEOUS DESIGN**. "DR. MAERTENS" MARKETING GMBH, AND "DR. MARTENS" INTERNATIONAL; TRADING GMBH, (U.S. CLS. 22 AND 39). SN 79-044,013. PUB. 5-20-2008. FILED 8-23-2007.
 3,480,975. **MISCELLANEOUS DESIGN**. ZHEJIANG ZHONGHUI; FUR & LEATHER CO., LTD, (U.S. CLS. 22 AND 39). SN 79-044,297. PUB. 5-20-2008. FILED 8-28-2007.
 3,481,001. **PAKROS (BLOCK FORM)**. FANTASY SHOES S.R.L., (U.S. CLS. 22 AND 39). SN 79-046,526. PUB. 5-20-2008. FILED 10-11-2007.
 3,481,004. **NEOMOD AND DESIGN**. BEIJING NEOMOD ACCESSORIES CO., LTD., (U.S. CLS. 22 AND 39). SN 79-046,665. PUB. 5-20-2008. FILED 11-19-2007.
 3,481,006. **P AND DESIGN**. WUXI GUANG MING (GROUP) CO., LTD., (U.S. CLS. 22 AND 39). SN 79-046,826. PUB. 5-20-2008. FILED 11-15-2007.
 3,481,018 (*See Class 21 for this trademark*).
 3,481,036 (*See Class 9 for this trademark*).
-
- CLASS 26—FANCY GOODS**
- 3,478,583 (*See Class 24 for this trademark*).
 3,478,775. **MISCELLANEOUS DESIGN**. RENTOKIL INITIAL 1927 PLC, MULTIPLE CLASS, (INT. CLS. 26, 28, 31 AND 44), (U.S. CLS. 1, 22, 23, 37, 38, 39, 40, 42, 46, 50, 100 AND 101). SN 77-104,727. PUB. 5-20-2008. FILED 2-12-2007.
 3,478,801. **STICKY STRAPS (BLOCK FORM)**. SUNSHINE MARKETING OF N.E. FL., INC., (U.S. CLS. 37, 39, 40, 42 AND 50). SN 77-119,713. PUB. 5-20-2008. FILED 3-1-2007.
 3,478,941. **RYDER CLIPS (BLOCK FORM)**. RYDER CLIPS UNLIMITED, INC., (U.S. CLS. 37, 39, 40, 42 AND 50). SN 77-

186,368. PUB. 5-20-2008. FILED 5-21-2007.
 3,479,372. **THE VENETIAN V AND DESIGN. LAS VEGAS SANDS CORP.**, (U.S. CLS. 37, 39, 40, 42 AND 50). SN 77-259,095. PUB. 5-20-2008. FILED 8-20-2007.
 3,479,644. **HAIR TYES BY CAROLINE (BLOCK FORM). C-LINE, LLC**, (U.S. CLS. 37, 39, 40, 42 AND 50). SN 77-322,659. PUB. 5-20-2008. FILED 11-6-2007.
 3,479,787. **RIBBIES (STYLIZED). RIBBIES, INC.**, (U.S. CLS. 37, 39, 40, 42 AND 50). SN 77-341,496. PUB. 5-20-2008. FILED 11-30-2007.
 3,479,789. **RIBBIES (BLOCK FORM). RIBBIES, INC.**, (U.S. CLS. 37, 39, 40, 42 AND 50). SN 77-341,581. PUB. 5-20-2008. FILED 11-30-2007.
 3,480,793 (*See Class 12 for this trademark*).
 3,480,794 (*See Class 12 for this trademark*).

CLASS 27—FLOOR COVERINGS

3,478,900. **WEATHERED STONE (BLOCK FORM). SEAN HOWARD PRODUCTIONS, INC.**, (U.S. CLS. 19, 20, 37, 42 AND 50). SN 77-175,061. PUB. 5-20-2008. FILED 5-8-2007.
 3,479,148 (*See Class 3 for this trademark*).
 3,479,458. **GRIP TOUCH (BLOCK FORM). PYN, S.A. DE C.V.**, (U.S. CLS. 19, 20, 37, 42 AND 50). SN 77-282,568. PUB. 5-20-2008. FILED 9-18-2007.
 3,479,571. **CLOVER MAT (BLOCK FORM). SUMMIT FLEXIBLE PRODUCTS, LTD.**, (U.S. CLS. 19, 20, 37, 42 AND 50). SN 77-309,797. PUB. 5-20-2008. FILED 10-22-2007.
 3,479,627 (*See Class 20 for this trademark*).
 3,480,497. **SUPER DUTY (BLOCK FORM). FORD MOTOR COMPANY**, (U.S. CLS. 19, 20, 37, 42 AND 50). SN 77-371,164. PUB. 5-20-2008. FILED 1-14-2008.
 3,480,579. **CROSSPOINT FABRICS (BLOCK FORM). COLUMBIA INSURANCE COMPANY**, (U.S. CLS. 19, 20, 37, 42 AND 50). SN 78-472,460. PUB. 5-20-2008. FILED 8-24-2004.
 3,480,820 (*See Class 22 for this trademark*).

CLASS 28—TOYS AND SPORTING GOODS

3,478,536. **WILD BEARS (BLOCK FORM). SNUGGIE TOY INC.**, (U.S. CLS. 22, 23, 38 AND 50). SN 76-673,553. PUB. 5-20-2008. FILED 3-5-2007.
 3,478,537. **FRUITY BEARS (BLOCK FORM). SNUGGIE TOY INC.**, (U.S. CLS. 22, 23, 38 AND 50). SN 76-673,554. PUB. 5-20-2008. FILED 3-5-2007.
 3,478,671 (*See Class 9 for this trademark*).
 3,478,703. **TEN PIN POKER (BLOCK FORM). COSMODOG, LTD.**, (U.S. CLS. 22, 23, 38 AND 50). SN 77-060,264. PUB. 5-20-2008. FILED 12-8-2006.
 3,478,711. **OUTLAW (BLOCK FORM). CUESTIX, INC., DBA CUESTIX, INTERNATIONAL**, (U.S. CLS. 22, 23, 38 AND 50). SN 77-064,216. PUB. 5-20-2008. FILED 12-14-2006.
 3,478,712. **BLACK PLAGUE (BLOCK FORM). DICKSON, JASON**, (U.S. CLS. 22, 23, 38 AND 50). SN 77-064,473. PUB. 5-20-2008. FILED 12-14-2006.
 3,478,775 (*See Class 26 for this trademark*).
 3,478,788 (*See Class 21 for this trademark*).
 3,478,802 (*See Class 9 for this trademark*).
 3,478,828. **PENELOPE PITSTOP (BLOCK FORM). HANNA-BARBERA PRODUCTIONS, INC.**, (U.S. CLS. 22, 23, 38 AND 50). SN 77-140,377. PUB. 5-20-2008. FILED 3-26-2007.
 3,478,858. **THERACK AND DESIGN. BURRELL, TRAVIS, AND ZUCKERMAN, ROBERT**, (U.S. CLS. 22, 23, 38 AND 50). SN 77-154,885. PUB. 5-20-2008. FILED 4-12-2007.
 3,478,864 (*See Class 25 for this trademark*).
 3,478,869. **M AND DESIGN. NINTENDO CO., LTD.**, (U.S. CLS. 22, 23, 38 AND 50). SN 77-158,353. PUB. 5-20-2008. FILED 4-17-2007.
 3,478,946. **DEAD MAN'S HAND BLACKJACK A/8 A/8 AND DESIGN. MARK DUNOW**, (U.S. CLS. 22, 23, 38 AND 50). SN 77-187,155. PUB. 5-20-2008. FILED 5-22-2007.
 3,479,019. **POWERTEK AND DESIGN. 9061-4371 QUEBEC INC.**, (U.S. CLS. 22, 23, 38 AND 50). SN 77-199,329. PUB. 5-

20-2008. FILED 6-6-2007.
 3,479,077. **TITAN (BLOCK FORM). BASS PRO TRADE-MARKS, L.L.C.**, (U.S. CLS. 22, 23, 38 AND 50). SN 77-208,835. PUB. 5-20-2008. FILED 6-18-2007.
 3,479,167. **MBX STUNT XT (BLOCK FORM). MATTEL, INC.**, (U.S. CLS. 22, 23, 38 AND 50). SN 77-220,184. PUB. 5-20-2008. FILED 7-2-2007.
 3,479,260. **BIOCONNECT (BLOCK FORM). NAUTILUS, INC.**, (U.S. CLS. 22, 23, 38 AND 50). SN 77-231,536. PUB. 5-20-2008. FILED 7-17-2007.
 3,479,272. **HEALTH BOW (BLOCK FORM). HUPA INTERNATIONAL, INC.**, (U.S. CLS. 22, 23, 38 AND 50). SN 77-233,625. PUB. 12-18-2007. FILED 7-19-2007.
 3,479,288. **YOGFLEX AND DESIGN. HUPA INTERNATIONAL, INC.**, (U.S. CLS. 22, 23, 38 AND 50). SN 77-236,452. PUB. 12-18-2007. FILED 7-23-2007.
 3,479,446. **VOICESTREAM (BLOCK FORM). DEUTSCHE TELEKOM AG**, (U.S. CLS. 22, 23, 38 AND 50). SN 77-280,322. PUB. 2-26-2008. FILED 9-14-2007.
 3,479,482. **CHEWY TOYS AND DESIGN. CHEWY TOYS LLC**, (U.S. CLS. 22, 23, 38 AND 50). SN 77-290,443. PUB. 5-20-2008. FILED 9-27-2007.
 3,479,493. **TURKEY SKINZ (BLOCK FORM). A-WAY HUNTING PRODUCTS, INC.**, (U.S. CLS. 22, 23, 38 AND 50). SN 77-292,915. PUB. 5-20-2008. FILED 10-1-2007.
 3,479,505 (*See Class 14 for this trademark*).
 3,479,545. **WHOOOPS (BLOCK FORM). FUNDEX GAMES, LTD.**, (U.S. CLS. 22, 23, 38 AND 50). SN 77-304,196. PUB. 5-20-2008. FILED 10-15-2007.
 3,479,593 (*See Class 9 for this trademark*).
 3,479,595 (*See Class 9 for this trademark*).
 3,479,753. **THE SCIENCE + ART OF FISHING (BLOCK FORM). Z-MAN FISHING PRODUCTS, INC.**, (U.S. CLS. 22, 23, 38 AND 50). SN 77-337,612. PUB. 5-20-2008. FILED 11-27-2007.
 3,479,793. **FOTO FEUD (STYLIZED). POZZA, DEBORAH C.**, (U.S. CLS. 22, 23, 38 AND 50). SN 77-341,914. PUB. 5-20-2008. FILED 12-1-2007.
 3,479,829. **SWORD PRECISION SCALE MODELS AND DESIGN. SWORD, CHUCK**, (U.S. CLS. 22, 23, 38 AND 50). SN 77-345,740. PUB. 5-20-2008. FILED 12-6-2007.
 3,479,900. **ROCK'N ROLL DICE (BLOCK FORM). JOHN BONITO**, (U.S. CLS. 22, 23, 38 AND 50). SN 77-351,477. PUB. 5-20-2008. FILED 12-13-2007.
 3,479,919. **SMART AND DESIGN. DAIMLER AG**, (U.S. CLS. 22, 23, 38 AND 50). SN 77-352,193. PUB. 5-20-2008. FILED 12-14-2007.
 3,479,938. **MY NATURAL AND DESIGN. HOSUNG NEW YORK TRADING, INC.**, (U.S. CLS. 22, 23, 38 AND 50). SN 77-353,724. PUB. 5-20-2008. FILED 12-17-2007.
 3,479,958. **4C AND DESIGN. EXTREME PAINTBALL DESIGN LLC**, (U.S. CLS. 22, 23, 38 AND 50). SN 77-354,431. PUB. 5-20-2008. FILED 12-18-2007.
 3,479,977 (*See Class 16 for this trademark*).
 3,480,068 (*See Class 9 for this trademark*).
 3,480,069 (*See Class 9 for this trademark*).
 3,480,092. **ZEEBEEZ (BLOCK FORM). ZING TOYS, INC.**, (U.S. CLS. 22, 23, 38 AND 50). SN 77-359,651. PUB. 5-20-2008. FILED 12-26-2007.
 3,480,170. **FOR THOSE WHO WANT TO GET TO KNOW EACH OTHER BETTER FILL ME IN...? FMI AND DESIGN. FELTON, MARK**, (U.S. CLS. 22, 23, 38 AND 50). SN 77-362,429. PUB. 5-20-2008. FILED 1-2-2008.
 3,480,206. **FOLDFAST (BLOCK FORM). FOLDFAST GOALS, LLC**, (U.S. CLS. 22, 23, 38 AND 50). SN 77-363,052. PUB. 5-20-2008. FILED 1-3-2008.
 3,480,295. **PRIMO (BLOCK FORM). CLARENCE J. VENNE, L.L.C.**, (U.S. CLS. 22, 23, 38 AND 50). SN 77-364,396. PUB. 5-20-2008. FILED 1-4-2008.
 3,480,296. **PRIMO GOLD (BLOCK FORM). CLARENCE J. VENNE, L.L.C.**, (U.S. CLS. 22, 23, 38 AND 50). SN 77-364,399. PUB. 5-20-2008. FILED 1-4-2008.
 3,480,318. **FREE THE HEART (BLOCK FORM). SMALLWOOD JR., JAMES**, (U.S. CLS. 22, 23, 38 AND 50). SN 77-364,608. PUB. 5-20-2008. FILED 1-4-2008.
 3,480,406. **TEETER TWIRL (BLOCK FORM). TROXEL PRODUCTS, LLC**, (U.S. CLS. 22, 23, 38 AND 50). SN 77-366,519. PUB. 5-20-2008. FILED 1-8-2008.

- 3,480,486. **THE L WORD (BLOCK FORM)**. SHOWTIME NETWORKS INC., (U.S. CLS. 22, 23, 38 AND 50). SN 77-368,843. PUB. 5-20-2008. FILED 1-10-2008.
- 3,480,530. **BARBERSHOP BOYS (BLOCK FORM)**. ARISTOCRAT TECHNOLOGIES AUSTRALIA PTY LTD., (U.S. CLS. 22, 23, 38 AND 50). SN 77-384,255. PUB. 5-20-2008. FILED 1-30-2008.
- 3,480,562. **ADVENTUREQUEST (BLOCK FORM)**. ARTIX ENTERTAINMENT, LLC, (U.S. CLS. 22, 23, 38 AND 50). SN 77-414,283. PUB. 5-20-2008. FILED 3-5-2008.
- 3,480,594. **BATTLE KINGS (BLOCK FORM)**. MATTEL, INC., (U.S. CLS. 22, 23, 38 AND 50). SN 78-571,963. PUB. 5-20-2008. FILED 2-22-2005.
- 3,480,610. **LITTLE ROCKERS (BLOCK FORM)**. MATTEL, INC., (U.S. CLS. 22, 23, 38 AND 50). SN 78-645,711. PUB. 5-20-2008. FILED 6-7-2005.
- 3,480,634. **GROOVY-GLAM (BLOCK FORM)**. MATTEL, INC., (U.S. CLS. 22, 23, 38 AND 50). SN 78-788,232. PUB. 1-9-2007. FILED 1-10-2006.
- 3,480,678. **BULL RIDE (BLOCK FORM)**. MATTEL, INC., (U.S. CLS. 22, 23, 38 AND 50). SN 78-902,057. PUB. 5-20-2008. FILED 6-6-2006.
- 3,480,715 (*See Class 10 for this trademark*).
- 3,480,779 (*See Class 3 for this trademark*).
- 3,480,793 (*See Class 12 for this trademark*).
- 3,480,794 (*See Class 12 for this trademark*).
- 3,480,800 (*See Class 3 for this trademark*).
- 3,480,809 (*See Class 4 for this trademark*).
- 3,480,812. **ORTIK AND DESIGN**. PEDRO HENRIQUE VIEIRA XAVIER; CARRADINHA, (U.S. CLS. 22, 23, 38 AND 50). SN 79-037,275. PUB. 5-20-2008. FILED 2-1-2007.
- 3,480,834 (*See Class 9 for this trademark*).
- 3,480,856 (*See Class 3 for this trademark*).
- 3,480,906. **OMNIGRIP (STYLIZED)**. ORANGE INTERNATIONAL TRADING; (TIANJIN) INC., (U.S. CLS. 22, 23, 38 AND 50). SN 79-041,963. PUB. 5-20-2008. FILED 6-7-2007.
- 3,480,913 (*See Class 16 for this trademark*).
- 3,480,934. **OCTOGAME AND DESIGN**. MARIN FERNANDEZ, CRISTOBAL, MULTIPLE CLASS, (INT. CLS. 28, 35 AND 38); (U.S. CLS. 22, 23, 38, 50, 100, 101, 102 AND 104). SN 79-042,637. PUB. 5-20-2008. FILED 7-6-2007.
- 3,480,946 (*See Class 18 for this trademark*).
- 3,480,955 (*See Class 12 for this trademark*).
- 3,480,964. **GEE TOY (STYLIZED)**. BEIJING HUAYU WANJU YOUXIANGONGSI, (U.S. CLS. 22, 23, 38 AND 50). SN 79-043,827. PUB. 5-20-2008. FILED 8-21-2007.
- 3,480,965 (*See Class 9 for this trademark*).
- 3,480,978. **MARIE MAISON DE MIEUX CAT, CAT, CAT! AND DESIGN**. MARI MEZON DO MYU CO., LTD; (MARIE MAISON DE MIEUX CO., LTD), (U.S. CLS. 22, 23, 38 AND 50). SN 79-044,509. PUB. 5-20-2008. FILED 9-21-2007.
- 3,480,986. **WHEEL OF EXCELLENCE (STYLIZED)**. RONALD BUSSINK AMUSEMENT DESIGN GMBH, (U.S. CLS. 22, 23, 38 AND 50). SN 79-045,050. PUB. 5-20-2008. FILED 9-25-2007.
- 3,480,987. **WHEELS OF EXCELLENCE (STYLIZED)**. RONALD BUSSINK AMUSEMENT DESIGN GMBH, (U.S. CLS. 22, 23, 38 AND 50). SN 79-045,070. PUB. 5-20-2008. FILED 9-25-2007.
- 3,481,012 (*See Class 9 for this trademark*).
- 3,481,020. **MIZUMI (STYLIZED)**. STADLBAUER MARKETING + VERTRIEB; GESELLSCHAFT M.B.H., (U.S. CLS. 22, 23, 38 AND 50). SN 79-047,777. PUB. 5-20-2008. FILED 10-23-2007.
- 3,481,023. **R24 SPORTS AND DESIGN**. SHENZHEN SION TRADE CO., LTD., (U.S. CLS. 22, 23, 38 AND 50). SN 79-048,134. PUB. 5-20-2008. FILED 10-24-2007.
- 3,481,031 (*See Class 12 for this trademark*).
- 683,666. PUB. 5-20-2008. FILED 11-5-2007.
- 3,478,694. **MISCELLANEOUS DESIGN**. VITASOY INTERNATIONAL HOLDINGS LIMITED, MULTIPLE CLASS, (INT. CLS. 29 AND 30), (U.S. CL. 46). SN 77-050,919. PUB. 12-4-2007. FILED 11-27-2006.
- 3,478,715. **FIBER3SDIET (BLOCK FORM)**. RENEW LIFE FORMULAS, INC., (U.S. CL. 46). SN 77-065,020. PUB. 5-20-2008. FILED 12-15-2006.
- 3,478,870. **STEAKHOUSE ELITE (BLOCK FORM)**. KOBE BEEF AMERICA, INC., (U.S. CL. 46). SN 77-158,768. PUB. 5-20-2008. FILED 4-17-2007.
- 3,478,972. **STRAWBERRIES-BY-THE-SEA (BLOCK FORM)**. CARLSBAD GOURMET, MULTIPLE CLASS, (INT. CLS. 29 AND 30), (U.S. CL. 46). SN 77-193,770. PUB. 5-20-2008. FILED 5-30-2007.
- 3,479,139. **GLOBAL CHEESE MARKET (BLOCK FORM)**. ADVANTAGE INTERNATIONAL FOODS CORP., (U.S. CL. 46). SN 77-217,346. PUB. 5-20-2008. FILED 6-27-2007.
- 3,479,148 (*See Class 3 for this trademark*).
- 3,479,212. **AQ ABBAE DE QUEILES (STYLIZED)**. HACIENDA QUEILES, S.L., (U.S. CL. 46). SN 77-224,956. PUB. 5-20-2008. FILED 7-9-2007.
- 3,479,225. **S.O.B. SHRIMP, OYSTER & BEERHAUS AND DESIGN**. JEFFERSON, B. RUSSELL, JR., MULTIPLE CLASS, (INT. CLS. 29 AND 30), (U.S. CL. 46). SN 77-226,792. PUB. 5-20-2008. FILED 7-11-2007.
- 3,479,257. **TOMA TOMATO PASTE AND DESIGN**. AJ & R WORLDWIDE GROUP, INC., (U.S. CL. 46). SN 77-231,108. PUB. 5-20-2008. FILED 7-17-2007.
- 3,479,362. **MEXICAN SHRIMP PARADISE AND DESIGN**. PRODUCTORES DEL MAR DE MEXICO, S.A. DE C.V., MULTIPLE CLASS, (INT. CLS. 29 AND 35), (U.S. CLS. 46, 100, 101 AND 102). SN 77-256,352. PUB. 5-20-2008. FILED 8-15-2007.
- 3,479,386. **ADONIS AND DESIGN**. GARCIA-HUIDOBRO, RODRIGO, (U.S. CL. 46). SN 77-263,198. PUB. 5-20-2008. FILED 8-23-2007.
- 3,479,440. **LINNAEA FARM (BLOCK FORM)**. LINNAEA FARM, (U.S. CL. 46). SN 77-278,882. PUB. 5-20-2008. FILED 9-13-2007.
- 3,479,461. **CAPEWAY AND DESIGN**. MAR-LEES SEAFOOD, LLC, (U.S. CL. 46). SN 77-283,051. PUB. 5-20-2008. FILED 9-19-2007.
- 3,479,500. **BETTER THAN BEEF. NATURALLY. (BLOCK FORM)**. BUFFALO RUN, LLC, (U.S. CL. 46). SN 77-295,858. PUB. 5-20-2008. FILED 10-4-2007.
- 3,479,735. **MELLO-CUP (BLOCK FORM)**. FBC FINANCE CO., MULTIPLE CLASS, (INT. CLS. 29 AND 30), (U.S. CL. 46). SN 77-334,774. PUB. 5-20-2008. FILED 11-20-2007.
- 3,479,831. **THE FINEST ITALIAN CHEESES MONEY CAN BUY! (BLOCK FORM)**. GRANDE CHEESE COMPANY, (U.S. CL. 46). SN 77-345,839. PUB. 5-20-2008. FILED 12-6-2007.
- 3,479,834. **VEGETOL (BLOCK FORM)**. NEALANDERS INTERNATIONAL INC., (U.S. CL. 46). SN 77-345,897. PUB. 5-20-2008. FILED 12-6-2007.
- 3,479,850. **MILSTEAD (BLOCK FORM)**. ASSOCIATED WHOLESALE GROCERS, INC., MULTIPLE CLASS, (INT. CLS. 29 AND 30), (U.S. CL. 46). SN 77-348,222. PUB. 5-20-2008. FILED 12-10-2007.
- 3,479,862. **CORAZON DE RONDA (BLOCK FORM)**. ANGULO GENERAL QUESERA, S.L., (U.S. CL. 46). SN 77-349,249. PUB. 5-20-2008. FILED 12-11-2007.
- 3,479,868. **WAKEFIELD (BLOCK FORM)**. HARBOR SEAFOOD, INC., (U.S. CL. 46). SN 77-349,876. PUB. 5-20-2008. FILED 12-12-2007.
- 3,479,886. **JIMBOOO'S CHICAGO STYLE ITALIAN BEEF FROM THE NICEST GUY IN TOWN AND DESIGN**. LUNGARO, JIM, (U.S. CL. 46). SN 77-350,896. PUB. 5-20-2008. FILED 12-13-2007.
- 3,479,922. **WAKEFIELD (STYLIZED)**. HARBOR SEAFOOD, INC., (U.S. CL. 46). SN 77-352,275. PUB. 5-20-2008. FILED 12-14-2007.
- 3,479,930. **CHIP SHOTS AND DESIGN**. BRETT STERN, (U.S. CL. 46). SN 77-353,225. PUB. 5-20-2008. FILED 12-16-2007.
- 3,479,931. **HOT POTATOES AND DESIGN**. BRETT STERN, (U.S. CL. 46). SN 77-353,237. PUB. 5-20-2008. FILED 12-16-2007.

CLASS 29—MEATS AND PROCESSED FOODS

- 3,478,587. **PROTEUS IMPROVING THE WAY THE WORLD EATS AND DESIGN**. PROTEUS INDUSTRIES, INC., (U.S. CL. 46). SN 76-683,254. PUB. 5-20-2008. FILED 10-24-2007.
- 3,478,592. **JCB JAMAICAN COUNTRY BRAND AND DESIGN**. KINGSTON-MIAMI TRADING CO., (U.S. CL. 46). SN 76-

- 3,480,146. **ADAM'S FOOD PRODUCTS (BLOCK FORM)**. OCEAN DISTRIBUTORS INTERNATIONAL INC., (U.S. CL. 46). SN 77-361,946. PUB. 5-20-2008. FILED 12-31-2007.
- 3,480,196. **THE TASTE OF ITALY SINCE 1902 (BLOCK FORM)**. JOHN VOLPI & COMPANY, INC., (U.S. CL. 46). SN 77-362,904. PUB. 5-20-2008. FILED 1-2-2008.
- 3,480,227. **GENUINE. CLASSIC. ORIGINAL. (BLOCK FORM)**. HAWAIIAN HOST, INC., MULTIPLE CLASS, (INT. CLS. 29 AND 30), (U.S. CL. 46). SN 77-363,308. PUB. 5-20-2008. FILED 1-3-2008.
- 3,480,399. **DELICIOUS HAS A DARK SIDE (BLOCK FORM)**. LIFESTYLE EVOLUTION, INC., (U.S. CL. 46). SN 77-366,304. PUB. 5-20-2008. FILED 1-8-2008.
- 3,480,435. **THIS SALAD IS PACKED IN SUSTAINABLE RENEWABLE PACKAGING AND DESIGN**. VERITAS V, LLC, (U.S. CL. 46). SN 77-366,961. PUB. 5-20-2008. FILED 1-8-2008.
- 3,480,504. **COASTAL CRAB CAKE (BLOCK FORM)**. SB PHILLIPS LLC, (U.S. CL. 46). SN 77-373,263. PUB. 5-20-2008. FILED 1-16-2008.
- 3,480,505. **SILVER T BRAND (BLOCK FORM)**. CARGILL MEAT SOLUTIONS CORPORATION, (U.S. CL. 46). SN 77-373,435. PUB. 5-20-2008. FILED 1-16-2008.
- 3,480,506. **SILVER T BRAND AND DESIGN**. CARGILL MEAT SOLUTIONS CORPORATION, (U.S. CL. 46). SN 77-373,437. PUB. 5-20-2008. FILED 1-16-2008.
- 3,480,612. **TUNAYCHA AND DESIGN**. OBSCHESTVO S OGRANICHENNOY OTVETSTVENNOSTYU KOMPANIA "TUNAYCHA", MULTIPLE CLASS, (INT. CLS. 29, 31 AND 40), (U.S. CLS. 1, 46, 100, 103 AND 106). SN 78-661,979. PUB. 10-3-2006. FILED 6-30-2005.
- 3,480,615. **ELLEN AND DESIGN**. ELLENCHANNELL INC., MULTIPLE CLASS, (INT. CLS. 29 AND 30), (U.S. CL. 46). SN 78-673,864. PUB. 5-20-2008. FILED 7-19-2005.
- 3,480,629. **GORDON RAMSAY (BLOCK FORM)**. GORDON RAMSAY RESTAURANT HOLDING US LP, MULTIPLE CLASS, (INT. CLS. 29, 30 AND 43), (U.S. CLS. 46, 100 AND 101). SN 78-742,530. PUB. 5-20-2008. FILED 10-28-2005.
- 3,480,645 (*See Class 5 for this trademark*).
- 3,480,668. **SEASON SENSATIONS (BLOCK FORM)**. DAIRY FARMERS OF AMERICA, INC., (U.S. CL. 46). SN 78-884,445. PUB. 3-6-2007. FILED 5-16-2006.
- 3,480,748. **MAPME AND DESIGN**. OTKRYTOE AKTSIONERNOE OBSCHESTVO; "KONDIRITERSKAYA FABRIKA "UDARNITSA", MULTIPLE CLASS, (INT. CLS. 29 AND 30), (U.S. CL. 46). SN 79-025,957. PUB. 5-20-2008. FILED 4-26-2006.
- 3,480,780. **TERRA D'ALIGI AND DESIGN**. SPINELLI S.R.L., MULTIPLE CLASS, (INT. CLS. 29 AND 33), (U.S. CLS. 46, 47 AND 49). SN 79-034,089. PUB. 10-16-2007. FILED 11-27-2006.
- 3,480,798. **POCKET ESPRESSO TO GO AND DESIGN**. FERRERO S.P.A., MULTIPLE CLASS, (INT. CLS. 29, 30 AND 32), (U.S. CLS. 45, 46 AND 48). SN 79-035,807. PUB. 5-20-2008. FILED 1-10-2007.
- 3,480,804 (*See Class 1 for this trademark*).
- 3,480,823. **VECCHIA MALGA AND DESIGN**. FAMIGLIA CHIARI S.R.L., MULTIPLE CLASS, (INT. CLS. 29, 30, 31, 32, 33, 35 AND 43), (U.S. CLS. 1, 45, 46, 47, 48, 49, 100, 101 AND 102). SN 79-038,589. PUB. 5-20-2008. FILED 4-5-2007.
- 3,480,845 (*See Class 1 for this trademark*).
- 3,480,878. **YELLOW MOON (STYLIZED)**. NUNHEMS B.V., MULTIPLE CLASS, (INT. CLS. 29, 31 AND 44), (U.S. CLS. 1, 46, 100 AND 101). SN 79-041,336. PUB. 5-20-2008. FILED 6-29-2007.
- 3,480,896. **FLINNDAL (BLOCK FORM)**. NATUFIT NEDERLAND B.V., MULTIPLE CLASS, (INT. CLS. 29, 30 AND 44), (U.S. CLS. 46, 100 AND 101). SN 79-041,765. PUB. 5-20-2008. FILED 7-11-2007.
- 3,480,925. **ARGETA JUNIOR AND DESIGN**. DROGA KOLINSKA, ZIVILSKA INDUSTRIJA, D.D., (U.S. CL. 46). SN 79-042,500. PUB. 5-20-2008. FILED 6-26-2007.
- 3,480,926. **ARGETA JUNIOR AND DESIGN**. DROGA KOLINSKA, ZIVILSKA INDUSTRIJA, D.D., (U.S. CL. 46). SN 79-042,501. PUB. 5-20-2008. FILED 6-26-2007.
- 3,480,927. **ARGETA AND DESIGN**. DROGA KOLINSKA, ZIVILSKA INDUSTRIJA, D.D., (U.S. CL. 46). SN 79-042,502. PUB. 5-20-2008. FILED 6-26-2007.
- 3,480,942. **CONSERVERA GALLEGA, S.A. AND DESIGN**. CONSERVERA GALLEGA, S.A., (U.S. CL. 46). SN 79-042,910. PUB. 5-20-2008. FILED 6-22-2007.
- 3,480,996 (*See Class 5 for this trademark*).
- 3,481,002. **POLENGHI (BLOCK FORM)**. PARMALAT S.P.A., (U.S. CL. 46). SN 79-046,527. PUB. 5-20-2008. FILED 10-16-2007.
- 3,481,005. **BUTLERS FARMHOUSE CHEESES GREAT CHEESE TAKES TIME. AND DESIGN**. BUTLERS FARMHOUSE CHEESE LIMITED, (U.S. CL. 46). SN 79-046,736. PUB. 5-20-2008. FILED 10-15-2007.

CLASS 30—STAPLE FOODS

- 3,478,535. **HOT PUPPIES (BLOCK FORM)**. HOT TAR, INC., (U.S. CL. 46). SN 76-672,103. PUB. 5-20-2008. FILED 1-30-2007.
- 3,478,678 (*See Class 5 for this trademark*).
- 3,478,680 (*See Class 5 for this trademark*).
- 3,478,694 (*See Class 29 for this trademark*).
- 3,478,705. **NACHO (BLOCK FORM)**. AUGUST KIRCHNER, AND GOTTHARD KIRCHNER, (U.S. CL. 46). SN 77-061,366. PUB. 1-8-2008. FILED 12-11-2006.
- 3,478,783. **BLUE STAR COFFEE ROASTERS AND DESIGN**. BLUE STAR COFFEE ROASTERS, (U.S. CL. 46). SN 77-108,760. PUB. 5-20-2008. FILED 2-15-2007.
- 3,478,784. **CAPT. SUB AND DESIGN**. CAPT. SUB CANADA LTD., MULTIPLE CLASS, (INT. CLS. 30 AND 43), (U.S. CLS. 46, 100 AND 101). SN 77-109,757. PUB. 12-4-2007. FILED 2-16-2007.
- 3,478,790. **SCHWARTZ BROTHERS BAKERY (BLOCK FORM)**. GRETCHEN'S OF SCHWARTZ, (U.S. CL. 46). SN 77-113,509. PUB. 5-20-2008. FILED 2-22-2007.
- 3,478,815. **GOLDILOCKS (BLOCK FORM)**. GOLDILOCKS BAKE SHOP, INC., (U.S. CL. 46). SN 77-128,841. PUB. 5-20-2008. FILED 3-12-2007.
- 3,478,972 (*See Class 29 for this trademark*).
- 3,478,985. **FLAXMAX (BLOCK FORM)**. YZ ENTERPRISES, INC., (U.S. CL. 46). SN 77-195,597. PUB. 5-20-2008. FILED 6-1-2007.
- 3,479,008. **ULTIMATE GRAINS AND DESIGN**. H & S BAKERY, INC., (U.S. CL. 46). SN 77-197,791. PUB. 5-20-2008. FILED 6-5-2007.
- 3,479,013. **EL VENADO (BLOCK FORM)**. SJR FOODS, LTD., (U.S. CL. 46). SN 77-198,746. PUB. 5-20-2008. FILED 6-6-2007.
- 3,479,048. **DOLCE & GELATO MADE IN ITALY AND DESIGN**. INDIAN S.R.L., (U.S. CL. 46). SN 77-204,305. PUB. 5-20-2008. FILED 6-12-2007.
- 3,479,056. **FAMOUS CUPCAKES "ONE IS NEVER ENOUGH!" AND DESIGN**. ADL, DESIREE, (U.S. CL. 46). SN 77-205,979. PUB. 5-20-2008. FILED 6-14-2007.
- 3,479,087. **MCVITIE'S DIGESTIVE TASTE LIFE'S NATURAL BALANCE WHOLE WHEAT AND DESIGN**. UNITED BISCUITS (UK) LIMITED, (U.S. CL. 46). SN 77-210,997. PUB. 5-20-2008. FILED 6-20-2007.
- 3,479,127. **MORKES (BLOCK FORM)**. MORKES, INC., MULTIPLE CLASS, (INT. CLS. 30 AND 35), (U.S. CLS. 46, 100, 101 AND 102). SN 77-216,884. PUB. 5-20-2008. FILED 6-27-2007.
- 3,479,131. **MISCELLANEOUS DESIGN**. MORKES, INC., MULTIPLE CLASS, (INT. CLS. 30 AND 35), (U.S. CLS. 46, 100, 101 AND 102). SN 77-216,940. PUB. 5-20-2008. FILED 6-27-2007.
- 3,479,148 (*See Class 3 for this trademark*).
- 3,479,198. **HOTWICH (BLOCK FORM)**. SINELLI, JEFFREY, (U.S. CL. 46). SN 77-223,018. PUB. 5-20-2008. FILED 7-5-2007.
- 3,479,225 (*See Class 29 for this trademark*).
- 3,479,231. **SISTER NADINE'S AND DESIGN**. BERRY, ALI, (U.S. CL. 46). SN 77-227,546. PUB. 5-20-2008. FILED 7-11-2007.
- 3,479,251. **BHUTANESE RED RICE (BLOCK FORM)**. CHHARU TSHONGDEL, (U.S. CL. 46). SN 77-230,412. PUB. 5-20-2008. FILED 7-16-2007.
- 3,479,258. **CINNAYUMZ (BLOCK FORM)**. RICHMOND FOODS GROUP, INC., (U.S. CL. 46). SN 77-231,122. PUB. 5-20-2008. FILED 7-17-2007.

- 3,479,284. **PITACO (BLOCK FORM)**. WILLIAMS, JOHN D., AND WILLIAMS, NANCY D., (U.S. CL. 46). SN 77-235,161. PUB. 5-20-2008. FILED 7-20-2007.
- 3,479,425. **SCHARFFEN BERGER (BLOCK FORM)**. ARTISAN CONFECTIONS COMPANY, (U.S. CL. 46). SN 77-274,358. PUB. 5-20-2008. FILED 9-7-2007.
- 3,479,426. **SCHARFFEN BERGER (BLOCK FORM)**. ARTISAN CONFECTIONS COMPANY, (U.S. CL. 46). SN 77-274,360. PUB. 5-20-2008. FILED 9-7-2007.
- 3,479,428. **ERIC'S WICKED SEASONING AND DESIGN**. WICKED SEASONING, LLC, (U.S. CL. 46). SN 77-274,761. PUB. 5-20-2008. FILED 9-7-2007.
- 3,479,495. **SCHARFFEN BERGER (BLOCK FORM)**. ARTISAN CONFECTIONS COMPANY, (U.S. CL. 46). SN 77-293,234. PUB. 5-20-2008. FILED 10-1-2007.
- 3,479,594. **MISCELLANEOUS DESIGN**. WALONG MARKET-ING, INC., (U.S. CL. 46). SN 77-313,379. PUB. 5-20-2008. FILED 10-25-2007.
- 3,479,616 (*See Class 6 for this trademark*).
- 3,479,735 (*See Class 29 for this trademark*).
- 3,479,781. **PALACE STREET BAKERY (BLOCK FORM)**. KWIK TRIP, INC., (U.S. CL. 46). SN 77-341,001. PUB. 5-20-2008. FILED S.R. 11-30-2007; AM. P.R. 4-10-2008.
- 3,479,850 (*See Class 29 for this trademark*).
- 3,479,853. **EASY SKILLET (BLOCK FORM)**. ASSOCIATED WHOLESALE GROCERS, INC., (U.S. CL. 46). SN 77-348,306. PUB. 5-20-2008. FILED 12-10-2007.
- 3,479,867. **NUTTY BAR (BLOCK FORM)**. MCKEE FOODS KINGMAN, INC., (U.S. CL. 46). SN 77-349,859. PUB. 5-20-2008. FILED 12-12-2007.
- 3,479,962. **JOLLY SWEETS AND DESIGN**. BRAND NEW PRODUCTS, LLC, (U.S. CL. 46). SN 77-354,563. PUB. 5-20-2008. FILED 12-18-2007.
- 3,480,033. **BACOLINI COFFEE TRADERS (BLOCK FORM)**. DISPENSER BEVERAGES, INC., (U.S. CL. 46). SN 77-357,377. PUB. 5-20-2008. FILED 12-20-2007.
- 3,480,050. **BUBBLE BLAST (STYLIZED)**. BRAND NEW PRODUCTS, LLC, (U.S. CL. 46). SN 77-358,030. PUB. 5-20-2008. FILED 12-21-2007.
- 3,480,098. **ARIANNA FARMS 'ONO KONA COFFEE (BLOCK FORM)**. ARIANNA FARMS 'ONO KONA COFFEE, LLC, (U.S. CL. 46). SN 77-359,771. PUB. 5-20-2008. FILED 12-26-2007.
- 3,480,109. **FROM OUR FARM TO YOUR CUP (BLOCK FORM)**. ARIANNA FARMS 'ONO KONA COFFEE, LLC, (U.S. CL. 46). SN 77-360,381. PUB. 5-20-2008. FILED 12-27-2007.
- 3,480,110. **FROM FARM TO CUP (BLOCK FORM)**. ARIANNA FARMS 'ONO KONA COFFEE, LLC, (U.S. CL. 46). SN 77-360,399. PUB. 5-20-2008. FILED 12-27-2007.
- 3,480,111. **ARIANNA FARMS 'ONO KONA COFFEE AND DESIGN**. ARIANNA FARMS 'ONO KONA COFFEE, LLC, (U.S. CL. 46). SN 77-360,422. PUB. 5-20-2008. FILED 12-27-2007.
- 3,480,112. **ARIANNA FARMS 'ONO KONA COFFEE 100% HAND PICKED KONA COFFEE FROM THE BIG ISLAND OF HAWAII FROM OUR FARM TO YOUR CUP WWW.ARIANNAFARMS.COM AND DESIGN**. ARIANNA FARMS 'ONO KONA COFFEE, LLC, (U.S. CL. 46). SN 77-360,427. PUB. 5-20-2008. FILED 12-27-2007.
- 3,480,125. **CHELTON TEA COLLECTION (BLOCK FORM)**. CHELTON USA, INC., (U.S. CL. 46). SN 77-361,126. PUB. 5-20-2008. FILED 12-28-2007.
- 3,480,157. **THE ORIGINAL BUCKEYE GOURMET BARBECUE SAUCE (BLOCK FORM)**. BUCKEYE BARBECUE CO., (U.S. CL. 46). SN 77-362,228. PUB. 5-20-2008. FILED 1-1-2008.
- 3,480,208. **GRANDYOATS HAND MADE, HOME MADE MAINE MADE AND DESIGN**. BOUNTIFUL BERRY, INC., (U.S. CL. 46). SN 77-363,109. PUB. 5-20-2008. FILED 1-3-2008.
- 3,480,227 (*See Class 29 for this trademark*).
- 3,480,240. **POLITO'S PIZZA HOME OF THE BIG SLICE SIZE DOES MATTER (BLOCK FORM)**. POLITO'S PIZZA, LLC., (U.S. CL. 46). SN 77-363,543. PUB. 5-20-2008. FILED 1-3-2008.
- 3,480,243. **FHAZANI (BLOCK FORM)**. RED BRICK PIZZA, INC., (U.S. CL. 46). SN 77-363,625. PUB. 5-20-2008. FILED 1-3-2008.
- 3,480,269. **MARI'S (BLOCK FORM)**. MARI'S NEW YORK, INC., (U.S. CL. 46). SN 77-363,945. PUB. 5-20-2008. FILED 1-4-2008.
- 3,480,277. **CHI-CHI'S (BLOCK FORM)**. HORMEL FOODS, LLC, (U.S. CL. 46). SN 77-364,124. PUB. 5-20-2008. FILED 1-4-2008.
- 3,480,343. **MAMA'S SPECIAL MAPLE (BLOCK FORM)**. MAMA'S SPECIAL FAMILY, INC., (U.S. CL. 46). SN 77-365,129. PUB. 5-20-2008. FILED 1-6-2008.
- 3,480,344. **MAMA'S SPECIAL PLAIN JANES (BLOCK FORM)**. MAMA'S SPECIAL FAMILY, INC., (U.S. CL. 46). SN 77-365,130. PUB. 5-20-2008. FILED 1-6-2008.
- 3,480,347. **MAGNUS JOE (BLOCK FORM)**. COBB, BOBBY J., (U.S. CL. 46). SN 77-365,209. PUB. 5-20-2008. FILED 1-7-2008.
- 3,480,589. **CITY BREW (BLOCK FORM)**. J & B INC., MULTIPLE CLASS, (INT. CLS. 30, 35 AND 43), (U.S. CLS. 46, 100, 101 AND 102). SN 78-555,821. PUB. 5-20-2008. FILED 1-28-2005.
- 3,480,608. **KING CHEF AND DESIGN**. ACECOOK VIETNAM COMPANY LIMITED, (U.S. CL. 46). SN 78-626,330. PUB. 5-20-2008. FILED 5-10-2005.
- 3,480,615 (*See Class 29 for this trademark*).
- 3,480,629 (*See Class 29 for this trademark*).
- 3,480,645 (*See Class 5 for this trademark*).
- 3,480,651. **RUM CAKE FAIRY DESSERT COMPANY LLC DELICATELY FLAVORED DELICIOUSLY MOIST AND DESIGN**. RUM CAKE FAIRY DESSERT COMPANY LLC, (U.S. CL. 46). SN 78-842,190. PUB. 5-20-2008. FILED 3-21-2006.
- 3,480,656. **GUSTO ITALIA (BLOCK FORM)**. PIAZZA TOMASSO INTERNATIONAL INC., (U.S. CL. 46). SN 78-848,964. PUB. 5-20-2008. FILED 3-29-2006.
- 3,480,657. **GUSTO ITALIA AND DESIGN**. PIAZZA TOMASSO INTERNATIONAL INC., (U.S. CL. 46). SN 78-849,004. PUB. 5-20-2008. FILED 3-29-2006.
- 3,480,695. **VIJAYA FOODS (BLOCK FORM)**. VIJAYA FOODS INC., (U.S. CL. 46). SN 78-911,973. PUB. 5-20-2008. FILED 6-20-2006.
- 3,480,726. **VERACI PIZZA (BLOCK FORM)**. VERACI PIZZA, MULTIPLE CLASS, (INT. CLS. 30 AND 43), (U.S. CLS. 46, 100 AND 101). SN 78-963,264. PUB. 5-20-2008. FILED 8-29-2006.
- 3,480,746. **UDARNITSA (BLOCK FORM)**. OTKRYTOE AKTIONERNOE OBSHCHESTVO; "KONDITERSKAYA FABRIKA "UDARNITSA", (U.S. CL. 46). SN 79-025,867. PUB. 5-20-2008. FILED 4-20-2006.
- 3,480,747. **SHARMEL (BLOCK FORM)**. OTKRYTOE AKTIONERNOE OBSHCHESTVO; "KONDITERSKAYA FABRIKA "UDARNITSA", (U.S. CL. 46). SN 79-025,869. PUB. 5-20-2008. FILED 4-20-2006.
- 3,480,748 (*See Class 29 for this trademark*).
- 3,480,749. **MISCELLANEOUS DESIGN**. OTKRYTOE AKTIONERNOE OBSHCHESTVO; "KONDITERSKAYA FABRIKA "UDARNITSA", (U.S. CL. 46). SN 79-025,958. PUB. 5-20-2008. FILED 4-25-2006.
- 3,480,798 (*See Class 29 for this trademark*).
- 3,480,800 (*See Class 3 for this trademark*).
- 3,480,804 (*See Class 1 for this trademark*).
- 3,480,823 (*See Class 29 for this trademark*).
- 3,480,856 (*See Class 3 for this trademark*).
- 3,480,872. **POCKET ESPRESSO (STYLIZED)**. FERRERO S.P.A., (U.S. CL. 46). SN 79-041,251. PUB. 5-20-2008. FILED 2-14-2007.
- 3,480,880. **RIBLOT (BLOCK FORM)**. RELANGHE S.R.L., (U.S. CL. 46). SN 79-041,390. PUB. 5-20-2008. FILED 6-26-2007.
- 3,480,881. **REIROT (BLOCK FORM)**. RELANGHE S.R.L., (U.S. CL. 46). SN 79-041,391. PUB. 5-20-2008. FILED 5-31-2007.
- 3,480,896 (*See Class 29 for this trademark*).
- 3,480,901. **HOFBAUER WIEN AND DESIGN**. CHOCOLADE-FABRIKEN LINDT & SPRÜNGLI AG, (U.S. CL. 46). SN 79-041,833. PUB. 5-20-2008. FILED 6-1-2007.
- 3,480,914. **JOGOFINO (BLOCK FORM)**. SONNINA SÜBWAREN GMBH, (U.S. CL. 46). SN 79-042,151. PUB. 5-20-2008. FILED 6-29-2007.
- 3,480,948. **TEA-CADDY (BLOCK FORM)**. J.T. RONNEFELDT KG, (U.S. CL. 46). SN 79-043,240. PUB. 5-20-2008. FILED 8-8-2007.
- 3,480,996 (*See Class 5 for this trademark*).
- 3,481,009. **MISCELLANEOUS DESIGN**. ISHIMARU SEIMEN

KABUSHIKI KAISHA, (U.S. CL. 46). SN 79-047,279. PUB. 5-20-2008. FILED 8-10-2007.

CLASS 31—NATURAL AGRICULTURAL PRODUCTS

3,478,600. **BIG STUFF AND DESIGN. QUALITY CHRISTMAS TREE, LTD.**, (U.S. CLS. 1 AND 46). SN 76-684,580. PUB. 5-20-2008. FILED 12-3-2007.

3,478,642. **MAJOR (BLOCK FORM). MAJOR FARMS, INC.**, (U.S. CLS. 1 AND 46). SN 77-018,660. PUB. 5-20-2008. FILED 10-11-2006.

3,478,645. **SABER (BLOCK FORM). MAJOR FARMS, INC.**, (U.S. CLS. 1 AND 46). SN 77-018,740. PUB. 5-20-2008. FILED 10-11-2006.

3,478,722. **OSO SWEET 4166 PRODUCE OF CHILE OSOWEETONIONS.COM AND DESIGN. SAVEN CORPORATION**, (U.S. CLS. 1 AND 46). SN 77-070,405. PUB. 5-20-2008. FILED 12-22-2006.

3,478,734. **CLEVER (BLOCK FORM). GRUPO BIMBO, S.A. B. DE C.V.**, (U.S. CLS. 1 AND 46). SN 77-078,245. PUB. 10-23-2007. FILED 1-8-2007.

3,478,775 (*See Class 26 for this trademark*).

3,479,204. **BONNIE'S GOING GREENER FOR YOU (BLOCK FORM). ALABAMA FARMERS COOPERATIVE, INC.**, (U.S. CLS. 1 AND 46). SN 77-223,839. PUB. 5-20-2008. FILED 7-6-2007.

3,479,211. **LIVE GOURMET ABSOLUTELY FRESH BECAUSE IT'S STILL ALIVE! AND DESIGN. HOLLANDIA FLOWERS, INC.**, (U.S. CLS. 1 AND 46). SN 77-224,947. PUB. 5-20-2008. FILED 7-9-2007.

3,479,214. **OCEAN BLUE (BLOCK FORM). HEYWARD, MARK**, (U.S. CLS. 1 AND 46). SN 77-225,063. PUB. 5-20-2008. FILED 7-9-2007.

3,479,315. **AMERICAN CONIFER SOCIETY CONIFER OF THE YEAR AND DESIGN. AMERICAN CONIFER SOCIETY**, (U.S. CLS. 1 AND 46). SN 77-243,348. PUB. 5-20-2008. FILED 7-31-2007.

3,479,456. **6 KEY INGREDIENT GROUPS REAL FOOD NATURALLY BALANCED AND DESIGN. MARS, INCORPORATED**, (U.S. CLS. 1 AND 46). SN 77-281,844. PUB. 5-20-2008. FILED 9-18-2007.

3,479,544. **TASTY TWISTS (BLOCK FORM). SVOBODNY, RAY D.**, (U.S. CLS. 1 AND 46). SN 77-303,713. PUB. 5-20-2008. FILED 10-15-2007.

3,479,659. **NATIONAL MANGO BOARD AND DESIGN. NATIONAL MANGO BOARD INC., MULTIPLE CLASS, (INT. CLS. 31 AND 35)**, (U.S. CLS. 1, 46, 100, 101 AND 102). SN 77-324,411. PUB. 5-20-2008. FILED 11-8-2007.

3,479,801. **VERA WANG (BLOCK FORM). V.E.W., LTD.**, (U.S. CLS. 1 AND 46). SN 77-342,465. PUB. 5-20-2008. FILED 12-3-2007.

3,479,927. **RED DOG RANCH AND DESIGN. RICHARD WM. FESLER**, (U.S. CLS. 1 AND 46). SN 77-353,118. PUB. 5-20-2008. FILED 12-15-2007.

3,479,942. **LUCKY BUCK ANTLERS AND DESIGN. ODYSSEY PETS LLC, DBA ODYSSEY PETS**, (U.S. CLS. 1 AND 46). SN 77-354,094. PUB. 5-20-2008. FILED 12-17-2007.

3,480,106. **ORGANICGIRL GOOD CLEAN VEGGIES AND DESIGN. VERITAS V, LLC**, (U.S. CLS. 1 AND 46). SN 77-360,177. PUB. 5-20-2008. FILED 12-27-2007.

3,480,107. **ORGANICGIRL GOOD FRESH GREENS AND DESIGN. VERITAS V, LLC**, (U.S. CLS. 1 AND 46). SN 77-360,240. PUB. 5-20-2008. FILED 12-27-2007.

3,480,212. **RUNT'S DOGGIE TREATS AND DESIGN. JOHNSON, STACY L.**, (U.S. CLS. 1 AND 46). SN 77-363,140. PUB. 5-20-2008. FILED 1-3-2008.

3,480,357. **SADDLE KING (BLOCK FORM). CARGILL, INCORPORATED**, (U.S. CLS. 1 AND 46). SN 77-365,347. PUB. 5-20-2008. FILED 1-7-2008.

3,480,436. **THIS SALAD IS PACKED IN SUSTAINABLE RENEWABLE PACKAGING AND DESIGN. VERITAS V, LLC**, (U.S. CLS. 1 AND 46). SN 77-366,971. PUB. 5-20-2008. FILED 1-8-2008.

3,480,467. **ROYAL GLOBE (BLOCK FORM). FRANK CAPURRO & SON, LLC**, (U.S. CLS. 1 AND 46). SN 77-367,742. PUB.

5-20-2008. FILED 1-9-2008.

3,480,612 (*See Class 29 for this trademark*).

3,480,649 (*See Class 16 for this trademark*).

3,480,814. **D AND DESIGN. HUAIAN CITY KANGDA FEED CO., LTD.**, (U.S. CLS. 1 AND 46). SN 79-037,307. PUB. 5-20-2008. FILED 4-3-2007.

3,480,823 (*See Class 29 for this trademark*).

3,480,832. **VIDA VERDE AND DESIGN. FRUTA DEL PACÍFICO S.A.**, (U.S. CLS. 1 AND 46). SN 79-039,258. PUB. 5-20-2008. FILED 5-31-2007.

3,480,878 (*See Class 29 for this trademark*).

3,480,993. **PERFEXAN (BLOCK FORM). TROUW INTERNATIONAL B.V.**, (U.S. CLS. 1 AND 46). SN 79-045,710. PUB. 5-20-2008. FILED 9-21-2007.

3,481,007. **SYMPHONIE IN BLUE (BLOCK FORM). ANTON PLATTNER**, (U.S. CLS. 1 AND 46). SN 79-046,851. PUB. 5-20-2008. FILED 11-12-2007.

CLASS 32—LIGHT BEVERAGES

3,478,559. **WE (BLOCK FORM). PARK, JEE WOO**, (U.S. CLS. 45, 46 AND 48). SN 76-678,581. PUB. 5-20-2008. FILED 6-22-2007.

3,478,701. **AMERICA'S ORIGINAL HEFEWEIZEN (BLOCK FORM). WIDMER BROTHERS BREWING COMPANY**, (U.S. CLS. 45, 46 AND 48). SN 77-056,785. PUB. 2-12-2008. FILED 12-4-2006.

3,478,843. **BELLAVODA (BLOCK FORM). MAKHSUDOVA, NORA**, (U.S. CLS. 45, 46 AND 48). SN 77-146,928. PUB. 5-20-2008. FILED 4-2-2007.

3,479,043. **JUICE UP YOUR GAME! (BLOCK FORM). GAME JUICE, INC.**, (U.S. CLS. 45, 46 AND 48). SN 77-203,647. PUB. 5-20-2008. FILED 6-12-2007.

3,479,148 (*See Class 3 for this trademark*).

3,479,189. **GENNY LIGHT GENESEE BREWING COMPANY, ROCHESTER, NEW YORK AND DESIGN. HIGH FALLS BREWING COMPANY, LLC**, (U.S. CLS. 45, 46 AND 48). SN 77-222,047. PUB. 5-20-2008. FILED 7-4-2007.

3,479,191. **SINCE 1878 GENESEE . BEER . GENESEE BREWING COMPANY ROCHESTER, NEW YORK AND DESIGN. HIGH FALLS BREWING COMPANY, LLC**, (U.S. CLS. 45, 46 AND 48). SN 77-222,053. PUB. 5-20-2008. FILED 7-4-2007.

3,479,192. **SINCE 1878 GENESEE BREWING COMPANY GENESEE BREWING COMPANY ROCHESTER NEW YORK AND DESIGN. HIGH FALLS BREWING COMPANY, LLC**, (U.S. CLS. 45, 46 AND 48). SN 77-222,058. PUB. 5-20-2008. FILED 7-4-2007.

3,479,240. **JW DUNDEE'S IPA (BLOCK FORM). HIGH FALLS BREWING COMPANY, LLC**, (U.S. CLS. 45, 46 AND 48). SN 77-229,442. PUB. 5-20-2008. FILED 7-13-2007.

3,479,241. **JW DUNDEE'S HEFE WEIZEN (BLOCK FORM). HIGH FALLS BREWING COMPANY, LLC**, (U.S. CLS. 45, 46 AND 48). SN 77-229,460. PUB. 5-20-2008. FILED 7-13-2007.

3,479,245. **JW DUNDEE'S PALE BOCK (BLOCK FORM). HIGH FALLS BREWING COMPANY, LLC**, (U.S. CLS. 45, 46 AND 48). SN 77-229,806. PUB. 5-20-2008. FILED 7-14-2007.

3,479,246. **JW DUNDEE'S FESTIVE ALE (BLOCK FORM). HIGH FALLS BREWING COMPANY, LLC**, (U.S. CLS. 45, 46 AND 48). SN 77-229,808. PUB. 5-20-2008. FILED 7-14-2007.

3,479,299. **MISCELLANEOUS DESIGN. BROUWERIJ BOSTEELS**, (U.S. CLS. 45, 46 AND 48). SN 77-238,467. PUB. 1-15-2008. FILED 7-25-2007.

3,479,357. **DO ONE THING REALLY, REALLY WELL (BLOCK FORM). STEAM WHISTLE BREWING INC.**, (U.S. CLS. 45, 46 AND 48). SN 77-254,560. PUB. 5-20-2008. FILED 8-14-2007.

3,479,384. **CERVEZA ANCLA NAVAL SUPER PREMIUM (BLOCK FORM). BEVERAGES PRIVATE LABEL HOLDING INC.**, (U.S. CLS. 45, 46 AND 48). SN 77-263,102. PUB. 5-20-2008. FILED 8-23-2007.

3,479,435 (*See Class 5 for this trademark*).

3,479,439. **CRAZYHORSE ENERGY DRINK AND DESIGN. BEVERAGES UNLIMITED LLC**, (U.S. CLS. 45, 46 AND 48). SN 77-278,726. PUB. 2-12-2008. FILED 9-13-2007.

3,479,607. **RED BULL ENERGY DRINK AND DESIGN. RED BULL GMBH**, (U.S. CLS. 45, 46 AND 48). SN 77-316,470.

PUB. 5-27-2008. FILED 10-29-2007.
 3,479,999. **PANCHO BARNES (BLOCK FORM)**. PANCHO BARNES ENTERPRISES, INC., (U.S. CLS. 45, 46 AND 48). SN 77-356,436. PUB. 5-20-2008. FILED 12-20-2007.
 3,480,148. **E AND DESIGN**. ODWALLA, INC., (U.S. CLS. 45, 46 AND 48). SN 77-361,954. PUB. 5-20-2008. FILED 12-31-2007.
 3,480,254. **SERIOUS ENERGY (BLOCK FORM)**. ODWALLA, INC., (U.S. CLS. 45, 46 AND 48). SN 77-363,729. PUB. 5-20-2008. FILED 1-3-2008.
 3,480,326. **PREGGATINIS (BLOCK FORM)**. BOVIS-NELSEN, NATALIE, (U.S. CLS. 45, 46 AND 48). SN 77-364,747. PUB. 5-20-2008. FILED 1-4-2008.
 3,480,541. **OK! ORGANICS (BLOCK FORM)**. MEGESTER, INC., (U.S. CLS. 45, 46 AND 48). SN 77-393,783. PUB. 5-20-2008. FILED 2-11-2008.
 3,480,544. **BRETAÑA (BLOCK FORM)**. GASEOSAS POSADA TOBON S.A., (U.S. CLS. 45, 46 AND 48). SN 77-395,955. PUB. 5-20-2008. FILED 2-13-2008.
 3,480,798 (*See Class 29 for this trademark*).
 3,480,799. **HY AND DESIGN**. ZAGO S.R.L., (U.S. CLS. 45, 46 AND 48). SN 79-035,810. PUB. 5-20-2008. FILED 12-12-2006.
 3,480,800 (*See Class 3 for this trademark*).
 3,480,823 (*See Class 29 for this trademark*).
 3,480,856 (*See Class 3 for this trademark*).
 3,480,936 (*See Class 4 for this trademark*).
 3,480,937. **KICKUP (BLOCK FORM)**. ÀBECO R & M AB, MULTIPLE CLASS, (INT. CLS. 32 AND 34), (U.S. CLS. 2, 8, 9, 17, 45, 46 AND 48). SN 79-042,766. PUB. 5-20-2008. FILED 3-23-2007.
 3,480,980. **PIPER-HEIDSIECK (STYLIZED)**. PIPER-HEIDSIECK, ANCIENNE MAISON; HEIDSIECK FONDEE EN 1785; COMPAGNIE CHAMPENOISE; (SOCIÉTÉ PAR ACTIONS SIMPLIFIÉE; UNIPERSONNELLE), MULTIPLE CLASS, (INT. CLS. 32 AND 33), (U.S. CLS. 45, 46, 47, 48 AND 49). SN 79-044,651. PUB. 5-20-2008. FILED 5-29-2007.
 3,480,996 (*See Class 5 for this trademark*).

CLASS 33—WINES AND SPIRITS

3,478,511. **CHUNGHUA AND DESIGN**. SHANGHAI TOBACCO (GROUP) CORPORATION, (U.S. CLS. 47 AND 49). SN 76-643,764. PUB. 5-20-2008. FILED 7-28-2005.
 3,478,698. **THE FIRST DATE (BLOCK FORM)**. JC CELLARS, (U.S. CLS. 47 AND 49). SN 77-053,336. PUB. 5-20-2008. FILED 11-29-2006.
 3,478,704. **MAISON FONDEE EN 1785 - PIPER-HEIDSIECK - CHAMPAGNE - BRUT - A REIMS-FRANCE AND DESIGN**. PIPER-HEIDSIECK, ANCIENNE MAISON HEIDSIECK FONDEE EN 1785, COMPAGNIE CHAMPENOISE, (U.S. CLS. 47 AND 49). SN 77-061,316. PUB. 5-20-2008. FILED 12-11-2006.
 3,478,841. **MISCELLANEOUS DESIGN**. LONDON GROUP, LLC, (U.S. CLS. 47 AND 49). SN 77-146,629. PUB. 5-20-2008. FILED 4-2-2007.
 3,478,937. **PRAIRIE BERRY (BLOCK FORM)**. PRAIRIE BERRY, L.L.C., (U.S. CLS. 47 AND 49). SN 77-185,846. PUB. 5-20-2008. FILED 5-21-2007.
 3,479,089. **KING FISH (BLOCK FORM)**. DELICATO VINEYARDS, INC., (U.S. CLS. 47 AND 49). SN 77-211,251. PUB. 5-20-2008. FILED 6-20-2007.
 3,479,095. **BUCKELEY'S (BLOCK FORM)**. KOOKA WINES, INC., (U.S. CLS. 47 AND 49). SN 77-211,895. PUB. 5-20-2008. FILED 6-21-2007.
 3,479,631. **LOCO MATICO AND DESIGN**. LA FORTUNA S.A., (U.S. CLS. 47 AND 49). SN 77-320,096. PUB. 5-20-2008. FILED 11-2-2007.
 3,479,770. **M MORLET FAMILY VINEYARDS AND DESIGN**. THE MORLET SELECTION, INCORPORATED, (U.S. CLS. 47 AND 49). SN 77-339,368. PUB. 5-20-2008. FILED 11-28-2007.
 3,480,161. **FENNELLYS (BLOCK FORM)**. PHILLIPS PRODUCTS COMPANY, LLC, (U.S. CLS. 47 AND 49). SN 77-362,309. PUB. 5-20-2008. FILED 1-2-2008.
 3,480,194. **ANGELO CELLARS (BLOCK FORM)**. ANGELO CELLARS LLC, (U.S. CLS. 47 AND 49). SN 77-362,843. PUB. 5-20-2008. FILED 1-2-2008.

3,480,314. **AIRFIELD ESTATES (BLOCK FORM)**. AIRPORT RANCH ESTATES, LLC, DBA AIRFIELD ESTATES, (U.S. CLS. 47 AND 49). SN 77-364,582. PUB. 5-20-2008. FILED 1-4-2008.
 3,480,316. **A AND DESIGN**. AIRPORT RANCH ESTATES, LLC, DBA AIRFIELD ESTATES, (U.S. CLS. 47 AND 49). SN 77-364,602. PUB. 5-20-2008. FILED 1-4-2008.
 3,480,321. **GAMBOGI RANCH (BLOCK FORM)**. C AND C WINE SERVICES, INC., (U.S. CLS. 47 AND 49). SN 77-364,642. PUB. 5-20-2008. FILED 1-4-2008.
 3,480,448. **VODKA 7000' (BLOCK FORM)**. HIGH WEST DISTILLERY, LLC, (U.S. CLS. 47 AND 49). SN 77-367,365. PUB. 5-20-2008. FILED 1-9-2008.
 3,480,673. **WATER COLOR (BLOCK FORM)**. JOHNSON-MILLER & ASSOCIATES, LTD., DBA I & B IMPORTS, (U.S. CLS. 47 AND 49). SN 78-893,324. PUB. 1-2-2007. FILED 5-25-2006.
 3,480,744. **OUTLAWED (BLOCK FORM)**. KANGAROO RIDGE WINE COMPANY PTY LIMITED, (U.S. CLS. 47 AND 49). SN 79-009,428. PUB. 5-20-2008. FILED 10-27-2004.
 3,480,772. **ABADIA RETUERTA CUVÉE PALOMAR AND DESIGN**. ABADIA RETUERTA S.A., (U.S. CLS. 47 AND 49). SN 79-033,374. PUB. 5-20-2008. FILED 12-1-2006.
 3,480,773. **CUVÉE PALOMAR (STYLIZED)**. ABADIA RETUERTA S.A., (U.S. CLS. 47 AND 49). SN 79-033,460. PUB. 5-20-2008. FILED 12-1-2006.
 3,480,780 (*See Class 29 for this trademark*).
 3,480,800 (*See Class 3 for this trademark*).
 3,480,817. **CHAT ROUGE (BLOCK FORM)**. SOCIÉTÉ ANONYME; GRANDS TERROIRS ET SIGNATURES, (U.S. CLS. 47 AND 49). SN 79-038,235. PUB. 5-20-2008. FILED 4-10-2007.
 3,480,823 (*See Class 29 for this trademark*).
 3,480,847. **TERRE SOVRANE (BLOCK FORM)**. BATASIOLO SPA, (U.S. CLS. 47 AND 49). SN 79-039,988. PUB. 5-20-2008. FILED 5-15-2007.
 3,480,852. **NATUREO (BLOCK FORM)**. MIGUEL TORRES S.A., (U.S. CLS. 47 AND 49). SN 79-040,212. PUB. 5-20-2008. FILED 5-16-2007.
 3,480,853. **POLIAKOV (BLOCK FORM)**. SOCIÉTÉ DES VINS ET SPIRITUEUX; LA MARTINIQUEAISE (SOCIÉTÉ ANONYME), (U.S. CLS. 47 AND 49). SN 79-040,304. PUB. 5-20-2008. FILED 5-31-2007.
 3,480,866. **QUERCIOLO (BLOCK FORM)**. AZIENDA GOMBA SOCIETÀ' SEMPLICE AGRICOLA, (U.S. CLS. 47 AND 49). SN 79-041,031. PUB. 5-20-2008. FILED 6-20-2007.
 3,480,920. **VILLA PERINI AND DESIGN**. AZIENDA VINICOLA SAN GIOVANNI DI PERINI DORIGO BERNADETTE & C. - S.N.C., (U.S. CLS. 47 AND 49). SN 79-042,280. PUB. 5-20-2008. FILED 3-29-2007.
 3,480,980 (*See Class 32 for this trademark*).
 3,481,000. **RAFFAELLO (BLOCK FORM)**. SOYO FOODS GMBH, (U.S. CLS. 47 AND 49). SN 79-046,429. PUB. 5-20-2008. FILED 10-26-2007.
 3,481,018 (*See Class 21 for this trademark*).

CLASS 34—SMOKERS' ARTICLES

3,479,405. **SUPERIOR QUALITY CHEW AND DESIGN**. SWISHER INTERNATIONAL, INC., (U.S. CLS. 2, 8, 9 AND 17). SN 77-267,933. PUB. 5-20-2008. FILED 8-30-2007.
 3,479,606. **SOUTHERN SMOKELESS (STYLIZED)**. MASRI, RODNEY, (U.S. CLS. 2, 8, 9 AND 17). SN 77-315,963. PUB. 5-20-2008. FILED 10-29-2007.
 3,479,667. **MISCELLANEOUS DESIGN**. VIPER ROOM DEVELOPMENT, LLC, MULTIPLE CLASS, (INT. CLS. 34 AND 35), (U.S. CLS. 2, 8, 9, 17, 100, 101 AND 102). SN 77-325,062. PUB. 5-20-2008. FILED 11-8-2007.
 3,480,056. **BLACK & MILD WINE (BLOCK FORM)**. JMTM LLC, (U.S. CLS. 2, 8, 9 AND 17). SN 77-358,448. PUB. 5-20-2008. FILED 12-21-2007.
 3,480,165. **BLACK & MILD WINE AND DESIGN**. JMTM, LLC, (U.S. CLS. 2, 8, 9 AND 17). SN 77-362,372. PUB. 5-20-2008. FILED 1-2-2008.
 3,480,310. **BLACK & MILD CREAM (BLOCK FORM)**. JMTM, LLC, (U.S. CLS. 2, 8, 9 AND 17). SN 77-364,556. PUB. 5-20-2008. FILED 1-4-2008.

3,480,351. **BLACK & MILD CREAM AND DESIGN**. JM TM, INC., (U.S. CLS. 2, 8, 9 AND 17). SN 77-365,273. PUB. 5-20-2008. FILED 1-7-2008.
 3,480,427. **HOOKAH FREAK (BLOCK FORM)**. HOOKAH HOOKAH TOBACCO CO., (U.S. CLS. 2, 8, 9 AND 17). SN 77-366,766. PUB. 5-20-2008. FILED 1-8-2008.
 3,480,905 (*See Class 16 for this trademark*).
 3,480,937 (*See Class 32 for this trademark*).
 3,481,037. **VON EICKEN PIPETIME (BLOCK FORM)**. JOH. WILH. VON EICKEN GMBH, (U.S. CLS. 2, 8, 9 AND 17). SN 79-050,035. PUB. 5-20-2008. FILED 1-8-2008.

SERVICE MARKS

CLASS 35—ADVERTISING AND BUSINESS

- 3,478,516 (*See Class 9 for this trademark*).
 3,478,519 (*See Class 21 for this trademark*).
 3,478,521. **E361 (BLOCK FORM)**. THE EQUUS GROUP, INC., (U.S. CLS. 100, 101 AND 102). SN 76-664,117. PUB. 5-20-2008. FILED 8-4-2006.
 3,478,522. **ENTERPRISE 361 (BLOCK FORM)**. THE EQUUS GROUP, INC., (U.S. CLS. 100, 101 AND 102). SN 76-664,118. PUB. 5-20-2008. FILED 8-4-2006.
 3,478,525. **NATIONAL EXPRESS CREDIT CLUB (BLOCK FORM)**. NATIONAL EXPRESS CREDIT CORP., (U.S. CLS. 100, 101 AND 102). SN 76-667,068. PUB. 5-20-2008. FILED 10-6-2006.
 3,478,526. **INFORMATION AS AN ELEMENT OF POWER (BLOCK FORM)**. THE RENDON GROUP INCORPORATED, MULTIPLE CLASS, (INT. CLS. 35, 38, 41, 42 AND 45), (U.S. CLS. 100, 101, 102, 104 AND 107). SN 76-667,518. PUB. 5-20-2008. FILED 10-13-2006.
 3,478,542. **BIG BRAND BOOK (STYLIZED)**. CAMPBELL-EWALD COMPANY, (U.S. CLS. 100, 101 AND 102). SN 76-674,417. PUB. 5-20-2008. FILED 3-22-2007.
 3,478,545. **AMOR A LA MÚSICA (BLOCK FORM)**. UNIVISION COMMUNICATIONS INC., (U.S. CLS. 100, 101 AND 102). SN 76-674,949. PUB. 5-20-2008. FILED 4-3-2007.
 3,478,546. **LFI (BLOCK FORM)**. INTERNATIONAL ASSOCIATION OF LIGHTING DESIGNERS, LTD., AND PORTMAN LIGHTFAIR ASSOCIATES, L.P., AND ILLUMINATING ENGINEERING SOCIETY OF NORTH AMERICA, MULTIPLE CLASS, (INT. CLS. 35 AND 41), (U.S. CLS. 100, 101, 102 AND 107). SN 76-675,422. PUB. 5-20-2008. FILED 4-12-2007.
 3,478,547. **WORKNET (BLOCK FORM)**. J.P. KING AUCTION COMPANY, INC., (U.S. CLS. 100, 101 AND 102). SN 76-676,085. PUB. 5-20-2008. FILED 4-27-2007.
 3,478,555 (*See Class 15 for this trademark*).
 3,478,556. **VISION SELECT AND DESIGN**. VISION SELECT, LLC, (U.S. CLS. 100, 101 AND 102). SN 76-678,262. PUB. 5-20-2008. FILED 6-15-2007.
 3,478,564. **MISCELLANEOUS DESIGN**. TRANQUIL SPACE FOUNDATION, MULTIPLE CLASS, (INT. CLS. 35 AND 36), (U.S. CLS. 100, 101 AND 102). SN 76-679,606. PUB. 5-20-2008. FILED 7-17-2007.
 3,478,601. **STARFRUIT HAWAIIAN (BLOCK FORM)**. OHANA CAPITAL, LLC, (U.S. CLS. 100, 101 AND 102). SN 76-684,731. PUB. 5-20-2008. FILED 12-7-2007.
 3,478,607. **WORLD LINK FOR LAW (BLOCK FORM)**. WORLD LINK FOR LAW., (U.S. CLS. 100, 101 AND 102). SN 76-684,995. PUB. 5-20-2008. FILED 12-17-2007.
 3,478,614. **JUICE TO LIVE LIQUID NUTRITIOUS FUN! AND DESIGN**. HAWKINS, KEVIN W., DBA JUICE TO LIVE, (U.S. CLS. 100, 101 AND 102). SN 76-685,263. PUB. 5-20-2008. FILED 12-26-2007.
 3,478,624. **C 44 AND DESIGN**. PLUMADORE, PAUL, (U.S. CLS. 100, 101 AND 102). SN 76-685,871. PUB. 5-20-2008. FILED 1-17-2008.
 3,478,632. **ANTEO GROUP (BLOCK FORM)**. ANTEO GROUP, LLC, MULTIPLE CLASS, (INT. CLS. 35 AND 42), (U.S. CLS. 100, 101 AND 102). SN 77-008,002. PUB. 5-20-2008. FILED 9-26-2006.
 3,478,633. **ANTEO GROUP. AND DESIGN**. ANTEO GROUP, LLC, MULTIPLE CLASS, (INT. CLS. 35 AND 42), (U.S. CLS. 100, 101 AND 102). SN 77-008,017. PUB. 5-20-2008. FILED 9-26-2006.
 3,478,637 (*See Class 25 for this trademark*).
 3,478,638. **TELE ATLAS CONTENTLINK (BLOCK FORM)**. TELE ATLAS NORTH AMERICA, INC., MULTIPLE CLASS, (INT. CLS. 35, 39 AND 42), (U.S. CLS. 100, 101, 102 AND 105). SN 77-011,721. PUB. 5-20-2008. FILED 10-2-2006.
 3,478,640. **THE AMERICAN ACADEMY OF ORAL MEDICINE FOUNDED 1945 COOPERATION KNOWLEDGE UNDERSTANDING AND DESIGN**. THE AMERICAN ACADEMY OF ORAL MEDICINE, INC., (U.S. CLS. 100, 101 AND 102). SN 77-015,436. PUB. 5-20-2008. FILED 10-6-2006.
 3,478,641 (*See Class 7 for this trademark*).
 3,478,643. **INTERTECH (BLOCK FORM)**. THE INTERTECH GROUP, INC., MULTIPLE CLASS, (INT. CLS. 35, 36 AND 42), (U.S. CLS. 100, 101 AND 102). SN 77-018,699. PUB. 5-20-2008. FILED 10-11-2006.
 3,478,644. **THE INTERTECH GROUP (BLOCK FORM)**. THE INTERTECH GROUP, INC., MULTIPLE CLASS, (INT. CLS. 35, 36 AND 42), (U.S. CLS. 100, 101 AND 102). SN 77-018,733. PUB. 5-20-2008. FILED 10-11-2006.
 3,478,650. **GPS TIMETRACK (BLOCK FORM)**. XORA, INC., (U.S. CLS. 100, 101 AND 102). SN 77-027,724. PUB. 5-20-2008. FILED 10-24-2006.
 3,478,653. **MISCELLANEOUS DESIGN**. LA UNIDAD LATINA. LAMBDA UPSILON LAMBDA FRATERNITY, INC., (U.S. CLS. 100, 101 AND 102). SN 77-029,567. PUB. 5-20-2008. FILED 10-25-2006.
 3,478,655. **A GALA EVENT (BLOCK FORM)**. WUNDERMAN, HUGH, MULTIPLE CLASS, (INT. CLS. 35 AND 41), (U.S. CLS. 100, 101, 102 AND 107). SN 77-030,805. PUB. 5-20-2008. FILED 10-27-2006.
 3,478,658. **TIMETRACK (BLOCK FORM)**. XORA, INC., (U.S. CLS. 100, 101 AND 102). SN 77-031,897. PUB. 5-20-2008. FILED 10-30-2006.
 3,478,667. **BE THE LOVE GENERATION (BLOCK FORM)**. SMITH, KATHARINE, (U.S. CLS. 100, 101 AND 102). SN 77-037,382. PUB. 5-20-2008. FILED 11-6-2006.
 3,478,668. **ENERGY ADVANTAGE (BLOCK FORM)**. ENERGY ADVANTAGE INC., MULTIPLE CLASS, (INT. CLS. 35, 36 AND 42), (U.S. CLS. 100, 101 AND 102). SN 77-037,652. PUB. 5-20-2008. FILED 11-6-2006.
 3,478,690. **DIRECT FULFILLMENT (BLOCK FORM)**. WELDON, WILLIAMS & LICK, INC., (U.S. CLS. 100, 101 AND 102). SN 77-048,917. PUB. 5-20-2008. FILED 11-21-2006.
 3,478,700. **SIGMA ASSESSMENT SYSTEMS INC. AND DESIGN**. SIGMA ASSESSMENT SYSTEMS, INC., MULTIPLE CLASS, (INT. CLS. 35 AND 44), (U.S. CLS. 100, 101 AND 102). SN 77-054,987. PUB. 5-20-2008. FILED 12-1-2006.
 3,478,709. **NEDERLANDER (BLOCK FORM)**. NEDERLANDER ORGANIZATION, INC., MULTIPLE CLASS, (INT. CLS. 35 AND 41), (U.S. CLS. 100, 101, 102 AND 107). SN 77-062,702. PUB. 5-20-2008. FILED 12-12-2006.
 3,478,710. **ENDLESS (STYLIZED)**. AMAZON TECHNOLOGIES, INC., (U.S. CLS. 100, 101 AND 102). SN 77-063,205. PUB. 5-20-2008. FILED 12-13-2006.
 3,478,725 (*See Class 14 for this trademark*).
 3,478,733. **LAWNSITE (BLOCK FORM)**. MRP ACQUISITION LLC, DBA MOOSE RIVER PUBLISHING INC., MULTIPLE CLASS, (INT. CLS. 35, 38 AND 44), (U.S. CLS. 100, 101, 102 AND 104). SN 77-077,846. PUB. 2-12-2008. FILED 1-8-2007.
 3,478,748. **WHEATLEY PLAZA (BLOCK FORM)**. WHEATLEY PLAZA ASSOCIATES, MULTIPLE CLASS, (INT. CLS. 35, 36, 37 AND 41), (U.S. CLS. 100, 101, 102, 103, 106 AND 107). SN 77-091,174. PUB. 5-20-2008. FILED 1-25-2007.
 3,478,756. **GREATER DC CARES (BLOCK FORM)**. GREATER D.C. CARES, INC., (U.S. CLS. 100, 101 AND 102). SN 77-095,901. PUB. 5-20-2008. FILED 1-31-2007.
 3,478,757. **THE NEW CURRENCY OF SOCIAL CHANGE (BLOCK FORM)**. GREATER D.C. CARES, INC., (U.S. CLS. 100, 101 AND 102). SN 77-095,910. PUB. 5-20-2008. FILED 1-31-2007.
 3,478,759. **VANGUARD LOGISTICS SERVICES (BLOCK FORM)**. NACA LOGISTICS (USA), INC., MULTIPLE CLASS, (INT. CLS. 35 AND 39), (U.S. CLS. 100, 101, 102 AND 105). SN 77-096,283. PUB. 5-20-2008. FILED 1-31-2007.

- 3,478,760. **MISCELLANEOUS DESIGN**. GREATER D.C. CARES, INC., (U.S. CLS. 100, 101 AND 102). SN 77-096,488. PUB. 5-20-2008. FILED 2-1-2007.
- 3,478,769 (*See Class 16 for this trademark*).
- 3,478,771 (*See Class 4 for this trademark*).
- 3,478,773. **LOVEYOURRAISINS.COM AND DESIGN**. CALIFORNIA RAISIN MARKETING BOARD, AN INSTRUMENTALITY OF THE STATE OF CALIFORNIA, DEPARTMENT OF FOOD AND AGRICULTURE, (U.S. CLS. 100, 101 AND 102). SN 77-103,446. PUB. 5-20-2008. FILED 2-9-2007.
- 3,478,778. **CCSTAT (BLOCK FORM)**. BERKLEY ACCIDENT AND HEALTH, LLC, MULTIPLE CLASS, (INT. CLS. 35, 41 AND 44), (U.S. CLS. 100, 101, 102 AND 107). SN 77-105,942. PUB. 5-20-2008. FILED 2-13-2007.
- 3,478,779. **CART CENTER FOR APPLIED RESEARCH AND TECHNOLOGY, INC. AND DESIGN**. CENTER FOR APPLIED RESEARCH & TECHNOLOGY, INC., (U.S. CLS. 100, 101 AND 102). SN 77-106,839. PUB. 5-20-2008. FILED 2-13-2007.
- 3,478,781. **TOP BRANDS FOR THE PROFESSIONAL CHEF IN EACH OF US. (BLOCK FORM)**. OLIVE BRANDS, LLC, (U.S. CLS. 100, 101 AND 102). SN 77-108,035. PUB. 5-20-2008. FILED 2-15-2007.
- 3,478,782. **CLINICALLY ELITE (BLOCK FORM)**. NUCARA MANAGEMENT GROUP, (U.S. CLS. 100, 101 AND 102). SN 77-108,044. PUB. 5-20-2008. FILED 2-15-2007.
- 3,478,785. **BOVA (BLOCK FORM)**. BOVA DIAMONDS, INC., (U.S. CLS. 100, 101 AND 102). SN 77-110,858. PUB. 5-20-2008. FILED 2-19-2007.
- 3,478,787. **ONE CALL TRANSFER CENTER (BLOCK FORM)**. AIR METHODS CORPORATION, (U.S. CLS. 100, 101 AND 102). SN 77-111,762. PUB. 5-20-2008. FILED 2-20-2007.
- 3,478,792. **DISCZILLA (BLOCK FORM)**. DISCZILLA, LLC, (U.S. CLS. 100, 101 AND 102). SN 77-114,497. PUB. 5-20-2008. FILED 2-23-2007.
- 3,478,795. **SHOPRIZER (BLOCK FORM)**. ST TELECOM INC., (U.S. CLS. 100, 101 AND 102). SN 77-115,671. PUB. 5-20-2008. FILED 2-25-2007.
- 3,478,803. **DOHENY'S WATER WAREHOUSE AND DESIGN**. DOHENY ENTERPRISES, INC., (U.S. CLS. 100, 101 AND 102). SN 77-120,156. PUB. 5-20-2008. FILED 3-1-2007.
- 3,478,806. **MORGAN TAYLOR (BLOCK FORM)**. LAS VEGAS WHOLESALE JEWELERS, INC., (U.S. CLS. 100, 101 AND 102). SN 77-121,584. PUB. 5-20-2008. FILED 3-2-2007.
- 3,478,819. **INTERNATIONAL BILLIARDS ASSOCIATION IBA IBA AND DESIGN**. INTERNATIONAL BILLIARDS ASSOCIATION, MULTIPLE CLASS, (INT. CLS. 35 AND 41), (U.S. CLS. 100, 101, 102 AND 107). SN 77-131,237. PUB. 5-20-2008. FILED 3-14-2007.
- 3,478,820. **IMAP (STYLIZED)**. MEDICAL KNOWLEDGE GROUP LLC, (U.S. CLS. 100, 101 AND 102). SN 77-131,742. PUB. 5-20-2008. FILED 3-15-2007.
- 3,478,821. **LAPAROSCOPY INTERNATIONAL AND DESIGN**. BRISSON, PAUL, MULTIPLE CLASS, (INT. CLS. 35 AND 41), (U.S. CLS. 100, 101, 102 AND 107). SN 77-132,760. PUB. 5-20-2008. FILED 3-16-2007.
- 3,478,839. **ZOOM GROUP (BLOCK FORM)**. C.G.M. SERVICES, INC., MULTIPLE CLASS, (INT. CLS. 35, 41 AND 43), (U.S. CLS. 100, 101, 102 AND 107). SN 77-145,931. PUB. 5-20-2008. FILED 4-2-2007.
- 3,478,844. **ULTIMATE LEASING (BLOCK FORM)**. WESTERN AMERICA EQUITIES LLC, (U.S. CLS. 100, 101 AND 102). SN 77-147,221. PUB. 5-20-2008. FILED 4-3-2007.
- 3,478,852. **JP JAZZ PHARMACEUTICALS AND DESIGN**. JAZZ PHARMACEUTICALS, INC., (U.S. CLS. 100, 101 AND 102). SN 77-152,441. PUB. 5-20-2008. FILED 4-10-2007.
- 3,478,855 (*See Class 16 for this trademark*).
- 3,478,859 (*See Class 25 for this trademark*).
- 3,478,864 (*See Class 25 for this trademark*).
- 3,478,868. **SANITATION STRATEGIES AND DESIGN**. SANITATION STRATEGIES, LLC, (U.S. CLS. 100, 101 AND 102). SN 77-158,311. PUB. 5-20-2008. FILED 4-17-2007.
- 3,478,873. **PURCHASING POWER (BLOCK FORM)**. PURCHASING POWER, LLC, MULTIPLE CLASS, (INT. CLS. 35 AND 36), (U.S. CLS. 100, 101 AND 102). SN 77-161,815. PUB. 5-20-2008. FILED 4-20-2007.
- 3,478,879. **TALKBEAN (BLOCK FORM)**. INTERPARK CORPORATION, MULTIPLE CLASS, (INT. CLS. 35, 41 AND 42), (U.S. CLS. 100, 101, 102 AND 107). SN 77-165,995. PUB. 5-20-2008. FILED 4-26-2007.
- 3,478,887. **VALUBILL (BLOCK FORM)**. PRESCIENT WORLD-WIDE, LLC, (U.S. CLS. 100, 101 AND 102). SN 77-168,690. PUB. 5-20-2008. FILED 4-30-2007.
- 3,478,891. **PWC (BLOCK FORM)**. PROFESSIONAL WOMEN IN CONSTRUCTION CORP., (U.S. CLS. 100, 101 AND 102). SN 77-170,159. PUB. 5-20-2008. FILED 5-1-2007.
- 3,478,892. **PWC AND DESIGN**. PROFESSIONAL WOMEN IN CONSTRUCTION CORP., (U.S. CLS. 100, 101 AND 102). SN 77-170,165. PUB. 5-20-2008. FILED 5-1-2007.
- 3,478,893. **RENTECH AND DESIGN**. RENTECH, INC., MULTIPLE CLASS, (INT. CLS. 35, 37 AND 42), (U.S. CLS. 100, 101, 102, 103 AND 106). SN 77-170,198. PUB. 5-20-2008. FILED 5-1-2007.
- 3,478,895. **LOOK AT ME I'M DRUG FREE . I'M DRUG FREE . I'M DRUG FREE . I'M DRUG FREE AND DESIGN**. NATIONAL FAMILY PARTNERSHIP, (U.S. CLS. 100, 101 AND 102). SN 77-171,763. PUB. 5-20-2008. FILED 5-3-2007.
- 3,478,902 (*See Class 3 for this trademark*).
- 3,478,903 (*See Class 16 for this trademark*).
- 3,478,918. **THE HOTTEST OF THE HOT & THE COOLEST OF THE COOL (BLOCK FORM)**. CHINA MIST TEA COMPANY, (U.S. CLS. 100, 101 AND 102). SN 77-180,752. PUB. 5-20-2008. FILED 5-14-2007.
- 3,478,919. **MRS. GREEN'S NATURAL MARKET (BLOCK FORM)**. MRS. GREEN'S NATURAL MARKET, INC., (U.S. CLS. 100, 101 AND 102). SN 77-180,815. PUB. 5-20-2008. FILED 5-14-2007.
- 3,478,920. **WHEATLEYPLAZA.COM (BLOCK FORM)**. WHEATLEY PLAZA ASSOCIATES, MULTIPLE CLASS, (INT. CLS. 35, 36 AND 41), (U.S. CLS. 100, 101, 102 AND 107). SN 77-181,078. PUB. 5-20-2008. FILED 5-15-2007.
- 3,478,921. **SENIOR STAFF BRINGING EXPERIENCE BACK TO WORK AND DESIGN**. SENIOR STAFF LLC, (U.S. CLS. 100, 101 AND 102). SN 77-181,093. PUB. 5-20-2008. FILED 5-15-2007.
- 3,478,923. **HIRE ON-DEMAND AND DESIGN**. WALLINS, KIMBERLY, (U.S. CLS. 100, 101 AND 102). SN 77-182,934. PUB. 5-20-2008. FILED 5-16-2007.
- 3,478,927. **USABILITY BROADCAST NETWORK (BLOCK FORM)**. HUMAN FACTORS INTERNATIONAL, INC., (U.S. CLS. 100, 101 AND 102). SN 77-183,717. PUB. 5-20-2008. FILED 5-17-2007.
- 3,478,933. **VAL-U-ADS (STYLIZED)**. SPECIALTY PROMOTIONS & ADVERTISING, INC., (U.S. CLS. 100, 101 AND 102). SN 77-184,733. PUB. 5-20-2008. FILED 5-18-2007.
- 3,478,943. **GREENFIELD WORLDTRADE AND DESIGN**. GREENFIELD WORLD TRADE, INC., MULTIPLE CLASS, (INT. CLS. 35 AND 39), (U.S. CLS. 100, 101, 102 AND 105). SN 77-186,529. PUB. 5-20-2008. FILED 5-21-2007.
- 3,478,947. **KNOWLEDGE ALLIANCE (BLOCK FORM)**. NATIONAL EDUCATION KNOWLEDGE INDUSTRY ASSOCIATION, INC., (U.S. CLS. 100, 101 AND 102). SN 77-187,166. PUB. 5-20-2008. FILED 5-22-2007.
- 3,478,956. **BUYING. SELLING. CARING. (BLOCK FORM)**. PEACHTREE CITY MARKETING GROUP, L.L.C., DBA THE HOME SOURCE REALTORS, MULTIPLE CLASS, (INT. CLS. 35 AND 37), (U.S. CLS. 100, 101, 102, 103 AND 106). SN 77-189,711. PUB. 5-20-2008. FILED 5-24-2007.
- 3,478,963 (*See Class 16 for this trademark*).
- 3,478,964. **AVENIR ASSOCIATES, INC. (BLOCK FORM)**. AVENIR ASSOCIATES INC, MULTIPLE CLASS, (INT. CLS. 35 AND 42), (U.S. CLS. 100, 101 AND 102). SN 77-191,892. PUB. 5-20-2008. FILED 5-29-2007.
- 3,478,966. **YOUR FINANCES. OUR PROMISE. BALTIMORE COUNTY EMPLOYEES FEDERAL CREDIT UNION AND DESIGN**. BALTIMORE COUNTY EMPLOYEES FEDERAL CREDIT UNION, MULTIPLE CLASS, (INT. CLS. 35 AND 36), (U.S. CLS. 100, 101 AND 102). SN 77-192,219. PUB. 5-20-2008. FILED 5-29-2007.
- 3,478,970. **POINTSOURCE AND DESIGN**. POINTSOURCE, LLC, MULTIPLE CLASS, (INT. CLS. 35 AND 42), (U.S. CLS. 100, 101 AND 102). SN 77-193,198. PUB. 5-20-2008. FILED 5-30-2007.
- 3,478,973. **BROOKDALE SENIOR LIVING (BLOCK FORM)**. BROOKDALE SENIOR LIVING INC., MULTIPLE CLASS,

- (INT. CLS. 35, 36 AND 44), (U.S. CLS. 100, 101 AND 102). SN 77-194,038. PUB. 5-20-2008. FILED 5-31-2007.
- 3,478,976. **ALPHACARS AND DESIGN**. ALPHA TRADING, SERVICES, INC., (U.S. CLS. 100, 101 AND 102). SN 77-194,662. PUB. 5-20-2008. FILED 5-31-2007.
- 3,478,977. **ALPHACARS (BLOCK FORM)**. ALPHA TRADING, SERVICES, INC., (U.S. CLS. 100, 101 AND 102). SN 77-194,680. PUB. 5-20-2008. FILED 5-31-2007.
- 3,478,980. **ALPHACARS EXPECT TO BE IMPRESSED AND DESIGN**. ALPHA TRADING, SERVICES, INC., (U.S. CLS. 100, 101 AND 102). SN 77-194,743. PUB. 5-20-2008. FILED 5-31-2007.
- 3,478,986. **DM DIRECT METALS AND DESIGN**. DIRECT METALS CO., LLC, (U.S. CLS. 100, 101 AND 102). SN 77-195,876. PUB. 5-20-2008. FILED 6-1-2007.
- 3,478,991. **TRIADVOCATES LLC NAVIGATING GOVERNMENT AND DESIGN**. TRIADVOCATES LLC, (U.S. CLS. 100, 101 AND 102). SN 77-196,047. PUB. 5-20-2008. FILED 6-1-2007.
- 3,478,999. **CAREGIVERS GALAXY (BLOCK FORM)**. CGG, LLC, MULTIPLE CLASS, (INT. CLS. 35 AND 44), (U.S. CLS. 100, 101 AND 102). SN 77-196,938. PUB. 5-20-2008. FILED 6-4-2007.
- 3,479,001. **THE PEW CAMPAIGN FOR FUEL EFFICIENCY AND DESIGN**. THE PEW CHARITABLE TRUSTS, (U.S. CLS. 100, 101 AND 102). SN 77-197,075. PUB. 5-20-2008. FILED 6-4-2007.
- 3,479,005. **CLEAR SKY BURNERS (BLOCK FORM)**. CLEAR SKY BURNERS LLC, (U.S. CLS. 100, 101 AND 102). SN 77-197,399. PUB. 5-20-2008. FILED 6-4-2007.
- 3,479,007. **NSA NATIONAL SINGLES ASSOCIATION (STYLIZED)**. NATIONAL SINGLES ASSOCIATION, INC., (U.S. CLS. 100, 101 AND 102). SN 77-197,718. PUB. 5-20-2008. FILED 6-5-2007.
- 3,479,010. **ROBINSON LERER & MONTGOMERY (BLOCK FORM)**. ROBINSON LERER & MONTGOMERY, LLC, (U.S. CLS. 100, 101 AND 102). SN 77-198,309. PUB. 5-20-2008. FILED 6-5-2007.
- 3,479,011. **RLM (BLOCK FORM)**. ROBINSON LERER & MONTGOMERY, LLC, (U.S. CLS. 100, 101 AND 102). SN 77-198,331. PUB. 5-20-2008. FILED 6-5-2007.
- 3,479,012. **IDEASTORM (BLOCK FORM)**. INNOVATIONS & DEVELOPMENT INC, MULTIPLE CLASS, (INT. CLS. 35 AND 42), (U.S. CLS. 100, 101 AND 102). SN 77-198,713. PUB. 5-20-2008. FILED 6-6-2007.
- 3,479,014. **THE CARBO GROUP ABRASIVE INTELLIGENCE (BLOCK FORM)**. CARBO LUXEMBOURG HOLDING S.A., (U.S. CLS. 100, 101 AND 102). SN 77-198,795. PUB. 5-20-2008. FILED 6-6-2007.
- 3,479,015 (*See Class 9 for this trademark*).
- 3,479,017. **ASKMOBY (BLOCK FORM)**. NOWCASTING INTERNATIONAL LIMITED, MULTIPLE CLASS, (INT. CLS. 35 AND 42), (U.S. CLS. 100, 101 AND 102). SN 77-199,043. PUB. 5-20-2008. FILED 6-6-2007.
- 3,479,032. **PRESIDENT'S PICKS (BLOCK FORM)**. FRESH DIRECT, LLC, MULTIPLE CLASS, (INT. CLS. 35 AND 43), (U.S. CLS. 100, 101 AND 102). SN 77-201,505. PUB. 5-20-2008. FILED 6-8-2007.
- 3,479,038. **VIE IT SNAPSHOT (BLOCK FORM)**. VIRTUAL INFORMATION EXECUTIVES, LLC, (U.S. CLS. 100, 101 AND 102). SN 77-201,866. PUB. 5-20-2008. FILED 6-8-2007.
- 3,479,044. **SUSTAINABLE TABLE (BLOCK FORM)**. GRACE, (U.S. CLS. 100, 101 AND 102). SN 77-203,684. PUB. 5-20-2008. FILED 6-12-2007.
- 3,479,049. **MISCELLANEOUS DESIGN**. GRACE, (U.S. CLS. 100, 101 AND 102). SN 77-204,318. PUB. 5-20-2008. FILED 6-12-2007.
- 3,479,051. **FACTORY BARGAIN DRAPES AND DESIGN**. AMERICAN BLINDS AND DRAPERIES, INC., (U.S. CLS. 100, 101 AND 102). SN 77-204,407. PUB. 5-20-2008. FILED 6-12-2007.
- 3,479,055. **HR REMEDY (BLOCK FORM)**. HR REMEDY, LLC, (U.S. CLS. 100, 101 AND 102). SN 77-205,643. PUB. 5-20-2008. FILED 6-13-2007.
- 3,479,060. **CARD COPS (BLOCK FORM)**. TRILEGIANT CORPORATION, MULTIPLE CLASS, (INT. CLS. 35, 36 AND 45), (U.S. CLS. 100, 101 AND 102). SN 77-206,587. PUB. 5-20-2008. FILED 6-14-2007.
- 3,479,061. **SPROUT LOUD AND DESIGN**. SPROUTLOUD MEDIA NETWORKS, LLC, (U.S. CLS. 100, 101 AND 102). SN 77-206,597. PUB. 5-20-2008. FILED 6-14-2007.
- 3,479,066. **MONA LISA GALLERY & FRAMING (BLOCK FORM)**. MONA LISA GALLERY & FRAMING, INC., MULTIPLE CLASS, (INT. CLS. 35 AND 40), (U.S. CLS. 100, 101, 102, 103 AND 106). SN 77-208,148. PUB. 5-20-2008. FILED 6-18-2007.
- 3,479,074. **MOON DEVIL .COM AND DESIGN**. MOON DEVIL, (U.S. CLS. 100, 101 AND 102). SN 77-208,489. PUB. 5-20-2008. FILED 6-18-2007.
- 3,479,085. **NEXTDAY MOULDING AND DESIGN**. NEXT DAY MOULDING PORTLAND, MULTIPLE CLASS, (INT. CLS. 35 AND 37), (U.S. CLS. 100, 101, 102, 103 AND 106). SN 77-210,849. PUB. 5-20-2008. FILED 6-20-2007.
- 3,479,092. **FREEIQ (BLOCK FORM)**. FREEIQ, LLC, MULTIPLE CLASS, (INT. CLS. 35, 38 AND 41), (U.S. CLS. 100, 101, 102, 104 AND 107). SN 77-211,523. PUB. 5-20-2008. FILED 6-21-2007.
- 3,479,105. **SOCO AND DESIGN**. THE SOUTHERN CO., INC., MULTIPLE CLASS, (INT. CLS. 35 AND 37), (U.S. CLS. 100, 101, 102, 103 AND 106). SN 77-213,616. PUB. 5-20-2008. FILED 6-22-2007.
- 3,479,107 (*See Class 14 for this trademark*).
- 3,479,111. **H AND DESIGN**. HYDRANT, (U.S. CLS. 100, 101 AND 102). SN 77-214,518. PUB. 5-20-2008. FILED 6-25-2007.
- 3,479,112. **FLORIDA GONE WILD (BLOCK FORM)**. WEEKS, JASON, (U.S. CLS. 100, 101 AND 102). SN 77-214,734. PUB. 5-20-2008. FILED 6-25-2007.
- 3,479,114. **INTEGRAS (BLOCK FORM)**. CLARITAS INC., (U.S. CLS. 100, 101 AND 102). SN 77-215,020. PUB. 5-20-2008. FILED 6-25-2007.
- 3,479,118. **LIBERTY MEDIA GROUP (BLOCK FORM)**. COMMUNITY REDEVELOPMENT AGENCY LLC, (U.S. CLS. 100, 101 AND 102). SN 77-215,815. PUB. 5-20-2008. FILED 6-26-2007.
- 3,479,126. **IDOC AND DESIGN**. IDOC, LLC, MULTIPLE CLASS, (INT. CLS. 35 AND 41), (U.S. CLS. 100, 101, 102 AND 107). SN 77-216,727. PUB. 5-20-2008. FILED 6-27-2007.
- 3,479,127 (*See Class 30 for this trademark*).
- 3,479,131 (*See Class 30 for this trademark*).
- 3,479,136. **SALES EFFECTIVENESS FRAMEWORK (BLOCK FORM)**. FORCEMANAGEMENT, LLC, (U.S. CLS. 100, 101 AND 102). SN 77-217,095. PUB. 5-20-2008. FILED 6-27-2007.
- 3,479,138. **THE COMMON SENSE APPROACH TO MEDICARE (BLOCK FORM)**. THE WELLCARE MANAGEMENT GROUP, INC., MULTIPLE CLASS, (INT. CLS. 35, 36 AND 44), (U.S. CLS. 100, 101 AND 102). SN 77-217,237. PUB. 5-20-2008. FILED 6-27-2007.
- 3,479,158. **COLORADO NANOTECHNOLOGY ALLIANCE AND DESIGN**. COLORADO NANOTECHNOLOGY ALLIANCE, (U.S. CLS. 100, 101 AND 102). SN 77-218,800. PUB. 5-20-2008. FILED 6-29-2007.
- 3,479,163. **RADY CHILDRENS AND DESIGN**. RADY CHILDREN'S HOSPITAL AND HEALTH CENTER, MULTIPLE CLASS, (INT. CLS. 35, 42 AND 44), (U.S. CLS. 100, 101 AND 102). SN 77-219,712. PUB. 5-20-2008. FILED 6-29-2007.
- 3,479,169. **CORPAMERICA (BLOCK FORM)**. CORPORATION SERVICE COMPANY, (U.S. CLS. 100, 101 AND 102). SN 77-220,492. PUB. 5-20-2008. FILED 7-2-2007.
- 3,479,173. **JMI JOIN US IN CREATING EXCITEMENT LEADERSHIP FREEDOM EDIFY AND DESIGN**. JUICE MARKETING, INC., (U.S. CLS. 100, 101 AND 102). SN 77-220,567. PUB. 5-20-2008. FILED 7-2-2007.
- 3,479,175. **EXPONENT TRADING COMPANY AND DESIGN**. EXPONENT TRADING COMPANY L.L.C., (U.S. CLS. 100, 101 AND 102). SN 77-220,895. PUB. 5-20-2008. FILED 7-2-2007.
- 3,479,176. **EXPONENT TRADING COMPANY (BLOCK FORM)**. EXPONENT TRADING COMPANY L.L.C., (U.S. CLS. 100, 101 AND 102). SN 77-220,908. PUB. 5-20-2008. FILED 7-2-2007.
- 3,479,180. **ATOMIC HOLIDAY BAZAAR (BLOCK FORM)**. TUFF BETTY BAGS, AND CRANKY TIKI, INC., (U.S. CLS. 100, 101 AND 102). SN 77-221,283. PUB. 5-20-2008. FILED 7-3-2007.
- 3,479,184. **ASA UMPIRE (BLOCK FORM)**. AMATEUR SOFTBALL ASSOCIATION OF AMERICA, (U.S. CLS. 100, 101

- AND 102). SN 77-221,848. PUB. 5-20-2008. FILED 7-3-2007.
- 3,479,185. **PROJECT CUDDLE (BLOCK FORM)**. PROJECT CUDDLE, INC., MULTIPLE CLASS, (INT. CLS. 35 AND 45), (U.S. CLS. 100, 101 AND 102). SN 77-221,914. PUB. 5-20-2008. FILED 7-3-2007.
- 3,479,186. **PROJECT CUDDLE AND DESIGN**. PROJECT CUDDLE, INC., MULTIPLE CLASS, (INT. CLS. 35 AND 45), (U.S. CLS. 100, 101 AND 102). SN 77-221,921. PUB. 5-20-2008. FILED 7-3-2007.
- 3,479,197 (*See Class 16 for this trademark*).
- 3,479,202. **ORIGINALS (BLOCK FORM)**. THE COUNCIL OF INDEPENDENT RESTAURANTS OF AMERICA, D/B/A DINE ORIGINALS, (U.S. CLS. 100, 101 AND 102). SN 77-223,684. PUB. 5-20-2008. FILED 7-6-2007.
- 3,479,203. **GOthicSTONE (BLOCK FORM)**. MANGIA SPECIALTIES INC., (U.S. CLS. 100, 101 AND 102). SN 77-223,723. PUB. 5-20-2008. FILED 7-6-2007.
- 3,479,208. **CENTRAL STATES NUMISMATIC SOCIETY (BLOCK FORM)**. CENTRAL STATES NUMISMATIC SOCIETY, (U.S. CLS. 100, 101 AND 102). SN 77-224,246. PUB. 5-20-2008. FILED 7-8-2007.
- 3,479,213. **NYSUT (BLOCK FORM)**. NEW YORK STATE UNITED TEACHERS, (U.S. CLS. 100, 101 AND 102). SN 77-225,020. PUB. 5-20-2008. FILED 7-9-2007.
- 3,479,215. **21ST CENTURY ETC AND DESIGN**. VEGASEL SERVICES U.S.A., (U.S. CLS. 100, 101 AND 102). SN 77-225,128. PUB. 5-20-2008. FILED 7-9-2007.
- 3,479,217. **TOMATOMANIA (BLOCK FORM)**. DAIGRE, COLIN SCOTT, (U.S. CLS. 100, 101 AND 102). SN 77-225,334. PUB. 5-20-2008. FILED 7-9-2007.
- 3,479,223. **TAYLOR MADE MAY PROSPERITY LIE IN THIS TRANSACTION AND DESIGN**. TAYLOR MADE SALES AGENCY, INC., MULTIPLE CLASS, (INT. CLS. 35, 43 AND 44), (U.S. CLS. 100, 101 AND 102). SN 77-226,704. PUB. 5-20-2008. FILED 7-11-2007.
- 3,479,227. **SPOTZER (BLOCK FORM)**. SPOTZER MEDIA GROUP B.V., (U.S. CLS. 100, 101 AND 102). SN 77-227,179. PUB. 5-20-2008. FILED 7-11-2007.
- 3,479,236. **SUN RUN ELECTRICITY (BLOCK FORM)**. SUN RUN GENERATION LLC, MULTIPLE CLASS, (INT. CLS. 35, 39 AND 40), (U.S. CLS. 100, 101, 102, 103, 105 AND 106). SN 77-229,058. PUB. 5-20-2008. FILED 7-13-2007.
- 3,479,242. **FRASER (BLOCK FORM)**. ISCO INDUSTRIES, LLC, (U.S. CLS. 100, 101 AND 102). SN 77-229,486. PUB. 5-20-2008. FILED 7-13-2007.
- 3,479,243. **MINING & INDUSTRIAL SUPPLY FRASER AND DESIGN**. ISCO INDUSTRIES, LLC, (U.S. CLS. 100, 101 AND 102). SN 77-229,509. PUB. 5-20-2008. FILED 7-13-2007.
- 3,479,247. **WARWICK GARDENS (BLOCK FORM)**. JENNIFER A WARDELL, DBA WARWICK GARDENS, MULTIPLE CLASS, (INT. CLS. 35 AND 44), (U.S. CLS. 100, 101 AND 102). SN 77-230,021. PUB. 5-20-2008. FILED 7-15-2007.
- 3,479,253. **PRACTICEHELP (BLOCK FORM)**. HEALTH CARE EXCEL, INCORPORATED, (U.S. CLS. 100, 101 AND 102). SN 77-230,739. PUB. 5-20-2008. FILED 7-16-2007.
- 3,479,256 (*See Class 20 for this trademark*).
- 3,479,265. **BRADLEY-MORRIS, INC. DELIVERING MILITARY- EXPERIENCED TALENT TO AMERICA'S TOP COMPANIES AND DESIGN**. BRADLEY-MORRIS, INC., (U.S. CLS. 100, 101 AND 102). SN 77-232,344. PUB. 5-20-2008. FILED 7-18-2007.
- 3,479,270. **IKOR (STYLIZED)**. IKOR INCORPORATED, MULTIPLE CLASS, (INT. CLS. 35, 36, 42, 44 AND 45), (U.S. CLS. 100, 101 AND 102). SN 77-233,313. PUB. 5-20-2008. FILED 7-19-2007.
- 3,479,278. **MISCELLANEOUS DESIGN**. HEALTHCARE NEWS NETWORK, LLC, MULTIPLE CLASS, (INT. CLS. 35, 38 AND 41), (U.S. CLS. 100, 101, 102, 104 AND 107). SN 77-234,211. PUB. 5-20-2008. FILED 7-19-2007.
- 3,479,280. **4-ALL PRINTING GROUP ALWAYS ONE STEP AHEAD (STYLIZED)**. CICALESE, TONI, DBA ALL4-PRINTING GROUP, (U.S. CLS. 100, 101 AND 102). SN 77-234,729. PUB. 5-20-2008. FILED 7-20-2007.
- 3,479,293. **MINDS @ WORK (BLOCK FORM)**. SCOPE E-KNOWLEDGE CENTER PRIVATE LIMITED, MULTIPLE CLASS, (INT. CLS. 35, 42 AND 45), (U.S. CLS. 100, 101 AND 102). SN 77-237,396. PUB. 5-20-2008. FILED 7-24-2007.
- 3,479,295. **ASSH AMERICAN SOCIETY FOR SURGERY OF THE HAND AND DESIGN**. AMERICAN SOCIETY FOR SURGERY OF THE HAND, MULTIPLE CLASS, (INT. CLS. 35 AND 41), (U.S. CLS. 100, 101, 102 AND 107). SN 77-237,920. PUB. 5-20-2008. FILED 7-25-2007.
- 3,479,298. **INTELISTAF TRAVEL (BLOCK FORM)**. INTELISTAF HEALTHCARE, INC., (U.S. CLS. 100, 101 AND 102). SN 77-238,388. PUB. 5-20-2008. FILED 7-25-2007.
- 3,479,300. **NATIONAL SOCIETY OF COMPLIANCE PROFESSIONALS (BLOCK FORM)**. NATIONAL SOCIETY OF COMPLIANCE PROFESSIONALS, (U.S. CLS. 100, 101 AND 102). SN 77-238,621. PUB. 5-20-2008. FILED 7-25-2007.
- 3,479,302. **MISCELLANEOUS DESIGN**. SHEARER, DAVID M., (U.S. CLS. 100, 101 AND 102). SN 77-238,926. PUB. 5-20-2008. FILED 7-25-2007.
- 3,479,303. **FULL SERVICE MOVE AT A DO IT YOURSELF COST (BLOCK FORM)**. U-HAUL INTERNATIONAL, INC., (U.S. CLS. 100, 101 AND 102). SN 77-239,630. PUB. 5-20-2008. FILED 7-26-2007.
- 3,479,309. **GREENBLUE (BLOCK FORM)**. GREEN BLUE INSTITUTE, DBA GREENBLUE, MULTIPLE CLASS, (INT. CLS. 35 AND 41), (U.S. CLS. 100, 101, 102 AND 107). SN 77-241,079. PUB. 5-20-2008. FILED 7-27-2007.
- 3,479,312. **CATHOLIC SOCIAL WORKERS NATIONAL ASSOCIATION AND DESIGN**. CATHOLIC SOCIAL WORKERS NATIONAL ASSOCIATION, INC., (U.S. CLS. 100, 101 AND 102). SN 77-241,760. PUB. 5-20-2008. FILED 7-30-2007.
- 3,479,321. **CPBID AND DESIGN**. CONTRACTPOWER, LLC, (U.S. CLS. 100, 101 AND 102). SN 77-245,005. PUB. 5-20-2008. FILED 8-2-2007.
- 3,479,331 (*See Class 14 for this trademark*).
- 3,479,348. **DON LA FORCE ASSOCIATES, INC. (BLOCK FORM)**. BESAM US INC., MULTIPLE CLASS, (INT. CLS. 35 AND 37), (U.S. CLS. 100, 101, 102, 103 AND 106). SN 77-252,439. PUB. 5-20-2008. FILED 8-10-2007.
- 3,479,355. **CONSUMER STUDIO (BLOCK FORM)**. CONSUMER STUDIO LLC, (U.S. CLS. 100, 101 AND 102). SN 77-253,919. PUB. 5-20-2008. FILED 8-13-2007.
- 3,479,361. **JEWISHSOURCE (BLOCK FORM)**. HAMAKOR JUDAICA, INC., (U.S. CLS. 100, 101 AND 102). SN 77-256,211. PUB. 5-20-2008. FILED 8-15-2007.
- 3,479,362 (*See Class 29 for this trademark*).
- 3,479,375. **SUN RUN HOME (BLOCK FORM)**. SUN RUN GENERATION LLC, MULTIPLE CLASS, (INT. CLS. 35, 39 AND 40), (U.S. CLS. 100, 101, 102, 103, 105 AND 106). SN 77-261,542. PUB. 5-20-2008. FILED 8-22-2007.
- 3,479,380. **BHUNGRY.COM FEEDING THE HUNGRY (BLOCK FORM)**. BHUNGRY INC., (U.S. CLS. 100, 101 AND 102). SN 77-262,224. PUB. 5-20-2008. FILED 8-22-2007.
- 3,479,382. **FAST OFFICE (BLOCK FORM)**. FAST OFFICE, INC., (U.S. CLS. 100, 101 AND 102). SN 77-262,433. PUB. 5-20-2008. FILED 8-23-2007.
- 3,479,383. **FAST OFFICE AND DESIGN**. FAST OFFICE, INC., (U.S. CLS. 100, 101 AND 102). SN 77-262,446. PUB. 5-20-2008. FILED 8-23-2007.
- 3,479,387. **NAME YOUR OWN REWARDS (BLOCK FORM)**. VIPDESK.COM, INC., (U.S. CLS. 100, 101 AND 102). SN 77-264,018. PUB. 5-20-2008. FILED 8-24-2007.
- 3,479,408. **BUBBLES THERAPY AND DESIGN**. XO WINE GLASS INC., (U.S. CLS. 100, 101 AND 102). SN 77-268,886. PUB. 5-20-2008. FILED 8-30-2007.
- 3,479,414. **CREW OUTFITTERS AND DESIGN**. BLACKSTONE INVESTMENT GROUP, INC., (U.S. CLS. 100, 101 AND 102). SN 77-271,812. PUB. 5-20-2008. FILED 9-5-2007.
- 3,479,415. **BR AND DESIGN**. BALDWIN RICHARDS FOODS CO., MULTIPLE CLASS, (INT. CLS. 35, 40 AND 42), (U.S. CLS. 100, 101, 102, 103 AND 106). SN 77-272,349. PUB. 5-20-2008. FILED 9-5-2007.
- 3,479,419. **IMCA (BLOCK FORM)**. INVESTMENT MANAGEMENT CONSULTANTS ASSN. INC., MULTIPLE CLASS, (INT. CLS. 35, 41 AND 42), (U.S. CLS. 100, 101, 102 AND 107). SN 77-272,785. PUB. 5-20-2008. FILED 9-6-2007.
- 3,479,430. **WALL PROCESS (BLOCK FORM)**. MUNRO & ASSOCIATES, INC., MULTIPLE CLASS, (INT. CLS. 35, 40 AND 42), (U.S. CLS. 100, 101, 102, 103 AND 106). SN 77-275,773. PUB. 5-20-2008. FILED 9-10-2007.
- 3,479,436. **CLAO CONTACT LENS ASSOCIATION OF OPHTHALMOLOGISTS AN INTERNATIONAL EDUCATIONAL ASSOCIATION (STYLIZED)**. CONTACT LENS

- ASSOCIATION OF OPHTHALMOLOGISTS, INC., (U.S. CLS. 100, 101 AND 102). SN 77-277,308. PUB. 5-20-2008. FILED 9-12-2007.
- 3,479,444. **BLYK (BLOCK FORM)**. CVON GROUP LIMITED, MULTIPLE CLASS, (INT. CLS. 35, 38 AND 42), (U.S. CLS. 100, 101, 102 AND 104). SN 77-279,560. PUB. 5-20-2008. FILED 9-14-2007.
- 3,479,445. **SACRED CUT METAL DESIGNS AND DESIGN**. PRUKOP, SHANE, (U.S. CLS. 100, 101 AND 102). SN 77-279,647. PUB. 5-20-2008. FILED 9-14-2007.
- 3,479,447. **AFM AMERICAN FEDERATION OF MOTORCYCLISTS AND DESIGN**. AMERICAN FEDERATION OF MOTORCYCLISTS, INCORPORATED, MULTIPLE CLASS, (INT. CLS. 35 AND 41), (U.S. CLS. 100, 101, 102 AND 107). SN 77-280,345. PUB. 5-20-2008. FILED 9-14-2007.
- 3,479,448. **MORE POWER RACING (BLOCK FORM)**. GHUMAN, NEIL, (U.S. CLS. 100, 101 AND 102). SN 77-280,379. PUB. 5-20-2008. FILED 9-14-2007.
- 3,479,449. **A AND DESIGN**. AMAZON TECHNOLOGIES, INC., MULTIPLE CLASS, (INT. CLS. 35 AND 39), (U.S. CLS. 100, 101, 102 AND 105). SN 77-280,852. PUB. 5-20-2008. FILED 9-17-2007.
- 3,479,455. **GINGER PEACHY AND DESIGN**. GINGER PEACHY DESIGNS, LLC, (U.S. CLS. 100, 101 AND 102). SN 77-281,356. PUB. 5-20-2008. FILED 9-17-2007.
- 3,479,460. **BHPREMIER.COM (BLOCK FORM)**. BETTER HOMES REALTY & AUCTION, LLC, (U.S. CLS. 100, 101 AND 102). SN 77-282,736. PUB. 5-20-2008. FILED 9-18-2007.
- 3,479,470. **AUDITUTOPIA (BLOCK FORM)**. PHARMACEUTICAL SERVICES CORPORATION, AND BRANDRETH, EDWARD J., (U.S. CLS. 100, 101 AND 102). SN 77-286,421. PUB. 5-20-2008. FILED 9-22-2007.
- 3,479,472. **FOUR PAWS DESIGN (BLOCK FORM)**. MIDDLETON, CYNDI M., DBA FOUR PAWS DESIGN, (U.S. CLS. 100, 101 AND 102). SN 77-287,644. PUB. 5-20-2008. FILED 9-24-2007.
- 3,479,476. **ISKY (BLOCK FORM)**. 1 SKY FOUNDATION, MULTIPLE CLASS, (INT. CLS. 35, 41 AND 42), (U.S. CLS. 100, 101, 102 AND 107). SN 77-289,579. PUB. 5-20-2008. FILED 9-26-2007.
- 3,479,480. **VS ENERGY FREEDOM THROUGH ENERGY INDEPENDENCE AND DESIGN**. VS ENERGY, INC., MULTIPLE CLASS, (INT. CLS. 35, 41 AND 42), (U.S. CLS. 100, 101, 102 AND 107). SN 77-289,820. PUB. 5-20-2008. FILED 9-26-2007.
- 3,479,481. **BIG TURKEY BOWLING (BLOCK FORM)**. SEATTLE SPORTS LEAGUES, INC., (U.S. CLS. 100, 101 AND 102). SN 77-290,421. PUB. 5-20-2008. FILED 9-27-2007.
- 3,479,483. **UNDERDOG KICKBALL AND DESIGN**. SEATTLE SPORTS LEAGUES, INC., (U.S. CLS. 100, 101 AND 102). SN 77-290,459. PUB. 5-20-2008. FILED 9-27-2007.
- 3,479,484. **UNDERDOG SPORTS LEAGUES (BLOCK FORM)**. SEATTLE SPORTS LEAGUES, INC., (U.S. CLS. 100, 101 AND 102). SN 77-290,465. PUB. 5-20-2008. FILED 9-27-2007.
- 3,479,485. **UNDERDOG SPORTS LEAGUES AND DESIGN**. SEATTLE SPORTS LEAGUES, INC., (U.S. CLS. 100, 101 AND 102). SN 77-290,467. PUB. 5-20-2008. FILED 9-27-2007.
- 3,479,488. **CONFERENCE OF SOUTHWEST FOUNDATIONS CONNECTING GRANTMAKERS INSPIRING EXCELLENCE AND DESIGN**. CONFERENCE OF SOUTHWEST FOUNDATIONS, INC., MULTIPLE CLASS, (INT. CLS. 35 AND 41), (U.S. CLS. 100, 101, 102 AND 107). SN 77-292,532. PUB. 5-20-2008. FILED 10-1-2007.
- 3,479,489. **CONFERENCE OF SOUTHWEST FOUNDATIONS (BLOCK FORM)**. CONFERENCE OF SOUTHWEST FOUNDATIONS, INC., MULTIPLE CLASS, (INT. CLS. 35 AND 41), (U.S. CLS. 100, 101, 102 AND 107). SN 77-292,535. PUB. 5-20-2008. FILED 10-1-2007.
- 3,479,492. **US CONSUMER PROTECTION WWW.USCP.ORG US CONSUMER PROTECTION PROTECTING CONSUMERS . . . REFERRING BETTER BUSINESS! AND DESIGN**. U.S. CONSUMER PROTECTION, L.L.C., MULTIPLE CLASS, (INT. CLS. 35 AND 45), (U.S. CLS. 100, 101 AND 102). SN 77-292,633. PUB. 5-20-2008. FILED 10-1-2007.
- 3,479,505 (*See Class 14 for this trademark*).
- 3,479,509. **EASY MILES (BLOCK FORM)**. LOYALTY AWARD SERVICES, (U.S. CLS. 100, 101 AND 102). SN 77-299,308. PUB. 5-20-2008. FILED 10-9-2007.
- 3,479,513. **AGING IN PLACE (BLOCK FORM)**. COYLE, CECELIA, (U.S. CLS. 100, 101 AND 102). SN 77-299,555. PUB. 5-20-2008. FILED 10-9-2007.
- 3,479,518. **THE ANTIQUE BOAT MUSEUM 1000 ISLANDS/CLAYTON, NEW YORK AND DESIGN**. THE ANTIQUE BOAT MUSEUM, MULTIPLE CLASS, (INT. CLS. 35 AND 41), (U.S. CLS. 100, 101, 102 AND 107). SN 77-300,485. PUB. 5-20-2008. FILED 10-10-2007.
- 3,479,519. **THE ANTIQUE BOAT MUSEUM (BLOCK FORM)**. THE ANTIQUE BOAT MUSEUM, MULTIPLE CLASS, (INT. CLS. 35 AND 41), (U.S. CLS. 100, 101, 102 AND 107). SN 77-300,497. PUB. 5-20-2008. FILED 10-10-2007.
- 3,479,521 (*See Class 16 for this trademark*).
- 3,479,522 (*See Class 16 for this trademark*).
- 3,479,531. **MISCELLANEOUS DESIGN**. WIS SARL, (U.S. CLS. 100, 101 AND 102). SN 77-301,378. PUB. 5-20-2008. FILED 10-11-2007.
- 3,479,540. **BARNETT (BLOCK FORM)**. INTERLINE BRANDS, INC., (U.S. CLS. 100, 101 AND 102). SN 77-302,705. PUB. 5-20-2008. FILED 10-12-2007.
- 3,479,547. **PAULB AND DESIGN**. PAULB, LLC, (U.S. CLS. 100, 101 AND 102). SN 77-304,380. PUB. 5-20-2008. FILED 10-15-2007.
- 3,479,555. **READESIGN (BLOCK FORM)**. THE HEART OF AMERICA FOUNDATION, MULTIPLE CLASS, (INT. CLS. 35, 36, 37, 41, 42 AND 43), (U.S. CLS. 100, 101, 102, 103, 106 AND 107). SN 77-306,533. PUB. 5-20-2008. FILED 10-17-2007.
- 3,479,562. **JOBOJA (BLOCK FORM)**. PARKER, II, WILLIAM M., (U.S. CLS. 100, 101 AND 102). SN 77-307,514. PUB. 5-20-2008. FILED 10-18-2007.
- 3,479,565. **GITTEL ON THE GO (BLOCK FORM)**. GITTEL ON THE GO, INC., MULTIPLE CLASS, (INT. CLS. 35 AND 45), (U.S. CLS. 100, 101 AND 102). SN 77-308,530. PUB. 5-20-2008. FILED 10-19-2007.
- 3,479,572. **THUNDER BASH (BLOCK FORM)**. VARSITY GOLD, INC., (U.S. CLS. 100, 101 AND 102). SN 77-309,806. PUB. 5-20-2008. FILED 10-22-2007.
- 3,479,573. **VG2 AND DESIGN**. VARSITY GOLD, INC., (U.S. CLS. 100, 101 AND 102). SN 77-309,844. PUB. 5-20-2008. FILED 10-22-2007.
- 3,479,579. **JOHN TV (BLOCK FORM)**. SCOTT ADAMS, (U.S. CLS. 100, 101 AND 102). SN 77-311,054. PUB. 5-20-2008. FILED 10-23-2007.
- 3,479,580. **ADSELF (BLOCK FORM)**. KANNAX INC., (U.S. CLS. 100, 101 AND 102). SN 77-311,065. PUB. 5-20-2008. FILED 10-23-2007.
- 3,479,586. **KOLDWORKS (BLOCK FORM)**. UPSITE TECHNOLOGIES, INC., MULTIPLE CLASS, (INT. CLS. 35 AND 41), (U.S. CLS. 100, 101, 102 AND 107). SN 77-311,738. PUB. 5-20-2008. FILED 10-24-2007.
- 3,479,587. **KOLDCHECK (BLOCK FORM)**. UPSITE TECHNOLOGIES, INC., (U.S. CLS. 100, 101 AND 102). SN 77-311,743. PUB. 5-20-2008. FILED 10-24-2007.
- 3,479,589. **NATURAL KIDS (BLOCK FORM)**. LEWIS, DONNA DOLEMAN, (U.S. CLS. 100, 101 AND 102). SN 77-312,300. PUB. 5-20-2008. FILED 10-24-2007.
- 3,479,590. **NATURAL KIDS AND DESIGN**. LEWIS, DONNA DOLEMAN, (U.S. CLS. 100, 101 AND 102). SN 77-312,344. PUB. 5-20-2008. FILED 10-24-2007.
- 3,479,591. **FEDCO (BLOCK FORM)**. FEDCO LLC., (U.S. CLS. 100, 101 AND 102). SN 77-312,894. PUB. 5-20-2008. FILED 10-25-2007.
- 3,479,599. **PETRONOMICS (BLOCK FORM)**. PETRONOMICS PARTNERS OF TEXAS, G.P., L.L.C., (U.S. CLS. 100, 101 AND 102). SN 77-314,114. PUB. 5-20-2008. FILED 10-26-2007.
- 3,479,600. **RIDE4EVER SPORTS SNOW - WATER - LAND (STYLIZED)**. ANTIX PARTNERSHIP, LLC, (U.S. CLS. 100, 101 AND 102). SN 77-314,300. PUB. 5-20-2008. FILED 10-26-2007.
- 3,479,619. **HOT FINDZ AND DESIGN**. HOTFINDZ INC., (U.S. CLS. 100, 101 AND 102). SN 77-317,904. PUB. 4-15-2008. FILED 10-31-2007.
- 3,479,621. **TAKE A LOAD OFF, TEXAS (BLOCK FORM)**. ONCOR ELECTRIC DELIVERY COMPANY, (U.S. CLS. 100, 101 AND 102). SN 77-318,224. PUB. 5-20-2008. FILED 10-31-2007.
- 3,479,622. **TAKE A LOAD OFF, TEXAS SAVING ENERGY MAKES CENTS AND DESIGN**. ONCOR ELECTRIC DE-

- LIVERY COMPANY, (U.S. CLS. 100, 101 AND 102). SN 77-318,276. PUB. 5-20-2008. FILED 10-31-2007.
- 3,479,623. **TAKE A LOAD OFF, TEXAS SAVING ENERGY MAKES CENTS (BLOCK FORM)**. ONCOR ELECTRIC DELIVERY COMPANY, (U.S. CLS. 100, 101 AND 102). SN 77-318,305. PUB. 5-20-2008. FILED 10-31-2007.
- 3,479,628. **INTERNATIONAL RHINO FOUNDATION (BLOCK FORM)**. THE INTERNATIONAL RHINO FOUNDATION, MULTIPLE CLASS, (INT. CLS. 35, 36, 39, 41 AND 42), (U.S. CLS. 100, 101, 102, 105 AND 107). SN 77-319,182. PUB. 5-20-2008. FILED 11-1-2007.
- 3,479,633. **MISCELLANEOUS DESIGN**. BOWMAN DESIGN, INC., MULTIPLE CLASS, (INT. CLS. 35 AND 42), (U.S. CLS. 100, 101 AND 102). SN 77-320,129. PUB. 5-20-2008. FILED 11-2-2007.
- 3,479,634. **MISCELLANEOUS DESIGN**. WORLDWIDE PCE LLC, (U.S. CLS. 100, 101 AND 102). SN 77-320,197. PUB. 5-20-2008. FILED 11-2-2007.
- 3,479,641. **THINK NOCTURNAL (BLOCK FORM)**. THINK NOCTURNAL, LLC, MULTIPLE CLASS, (INT. CLS. 35 AND 42), (U.S. CLS. 100, 101 AND 102). SN 77-322,516. PUB. 5-20-2008. FILED 11-6-2007.
- 3,479,648. **ENFORCEMENT EXPO ON THE JOB SOLUTIONS FOR LAW ENFORCEMENT AND DESIGN**. CYGNUS BUSINESS MEDIA, INC., (U.S. CLS. 100, 101 AND 102). SN 77-323,449. PUB. 5-20-2008. FILED 11-7-2007.
- 3,479,655. **SOCIETY OF COMPETITIVE INTELLIGENCE PROFESSIONALS (BLOCK FORM)**. SOCIETY OF COMPETITIVE INTELLIGENCE PROFESSIONALS, MULTIPLE CLASS, (INT. CLS. 35 AND 41), (U.S. CLS. 100, 101, 102 AND 107). SN 77-323,821. PUB. 5-20-2008. FILED 11-7-2007.
- 3,479,659 (*See Class 31 for this trademark*).
- 3,479,663. **SAFETYWISE (BLOCK FORM)**. ROBERT J. WALKER, (U.S. CLS. 100, 101 AND 102). SN 77-324,702. PUB. 5-20-2008. FILED 11-8-2007.
- 3,479,666. **DIGITAL MILLIYARD AND DESIGN**. HUNTSMAN INTERNATIONAL LLC, (U.S. CLS. 100, 101 AND 102). SN 77-324,932. PUB. 5-20-2008. FILED 11-8-2007.
- 3,479,667 (*See Class 34 for this trademark*).
- 3,479,668. **MEMBER SENSE AND DESIGN**. CLAVERACK RURAL ELECTRIC COOPERATIVE, INC., AND NORTH-WESTERN RURAL ELECTRIC COOPERATIVE ASSOCIATION, INC., (U.S. CLS. 100, 101 AND 102). SN 77-325,588. PUB. 5-20-2008. FILED 11-9-2007.
- 3,479,672. **PAYMENT COVERAGE CODING BUILDING REIMBURSEMENT AND DESIGN**. INTEGRATED REIMBURSEMENT STRATEGIES, LLC, (U.S. CLS. 100, 101 AND 102). SN 77-325,717. PUB. 5-20-2008. FILED S.R. 11-9-2007; AM. P.R. 4-2-2008.
- 3,479,675. **MISCELLANEOUS DESIGN**. DENTAL KALEIDOSCOPE, (U.S. CLS. 100, 101 AND 102). SN 77-325,927. PUB. 5-20-2008. FILED 11-9-2007.
- 3,479,681. **MADRID 2016 AND DESIGN**. COMITÉ INTERNATIONAL OLYMPIQUE, DBA INTERNATIONAL OLYMPIC COMMITTEE, MULTIPLE CLASS, (INT. CLS. 35 AND 41), (U.S. CLS. 100, 101, 102 AND 107). SN 77-326,569. PUB. 5-20-2008. FILED 11-10-2007.
- 3,479,682. **RIO 2016 AND DESIGN**. COMITÉ INTERNATIONAL OLYMPIQUE, DBA INTERNATIONAL OLYMPIC COMMITTEE, MULTIPLE CLASS, (INT. CLS. 35 AND 41), (U.S. CLS. 100, 101, 102 AND 107). SN 77-326,573. PUB. 5-20-2008. FILED 11-10-2007.
- 3,479,683. **TOKYO 2016 AND DESIGN**. COMITÉ INTERNATIONAL OLYMPIQUE, DBA INTERNATIONAL OLYMPIC COMMITTEE, MULTIPLE CLASS, (INT. CLS. 35 AND 41), (U.S. CLS. 100, 101, 102 AND 107). SN 77-326,582. PUB. 5-20-2008. FILED 11-10-2007.
- 3,479,698. **BERNIE&PHYL'S - FURNITURE - QUALITY, COMFORT & PRICE... THAT'S NICE! AND DESIGN**. CONVERTIBLE CASTLES, INC., (U.S. CLS. 100, 101 AND 102). SN 77-328,165. PUB. 5-20-2008. FILED 11-13-2007.
- 3,479,701. **VOX ENTERTAINMENT (BLOCK FORM)**. VOX ENTERTAINMENT, MULTIPLE CLASS, (INT. CLS. 35 AND 41), (U.S. CLS. 100, 101, 102 AND 107). SN 77-328,605. PUB. 5-20-2008. FILED 11-13-2007.
- 3,479,707. **BRINGING YOUR BRAND IDENTITY TO LIFE (BLOCK FORM)**. VOX ENTERTAINMENT, INC., MULTIPLE CLASS, (INT. CLS. 35 AND 41), (U.S. CLS. 100, 101, 102 AND 107). SN 77-329,287. PUB. 5-20-2008. FILED 11-14-2007.
- 3,479,710. **NEW MAJORITY LOS ANGELES (BLOCK FORM)**. NEW MAJORITY CALIFORNIA, MULTIPLE CLASS, (INT. CLS. 35 AND 41), (U.S. CLS. 100, 101, 102 AND 107). SN 77-330,738. PUB. 5-20-2008. FILED 11-15-2007.
- 3,479,711. **NEW MAJORITY CALIFORNIA (BLOCK FORM)**. NEW MAJORITY CALIFORNIA, MULTIPLE CLASS, (INT. CLS. 35 AND 41), (U.S. CLS. 100, 101, 102 AND 107). SN 77-330,740. PUB. 5-20-2008. FILED 11-15-2007.
- 3,479,726. **RAZAVI GLOBAL MEDIA (BLOCK FORM)**. RAZAVI GLOBAL MEDIA, INC., (U.S. CLS. 100, 101 AND 102). SN 77-333,419. PUB. 5-20-2008. FILED 11-19-2007.
- 3,479,728. **PRICE POLICE (BLOCK FORM)**. COLE CHEVROLET-CADILLAC, INC., DBA COLE CHEVROLET-CADILLAC-GMC, (U.S. CLS. 100, 101 AND 102). SN 77-333,862. PUB. 5-20-2008. FILED 11-20-2007.
- 3,479,734. **APM (BLOCK FORM)**. ASSOCIATED PRODUCTION MUSIC LLC, MULTIPLE CLASS, (INT. CLS. 35 AND 41), (U.S. CLS. 100, 101, 102 AND 107). SN 77-334,695. PUB. 5-20-2008. FILED 11-20-2007.
- 3,479,737. **DEVEROES (BLOCK FORM)**. LAROHN, INC., (U.S. CLS. 100, 101 AND 102). SN 77-334,941. PUB. 5-20-2008. FILED 11-21-2007.
- 3,479,741. **BARFLY INTERACTIVE NETWORKS (BLOCK FORM)**. NATIONAL BROADCAST MEDIA CORPORATION, (U.S. CLS. 100, 101 AND 102). SN 77-335,565. PUB. 5-20-2008. FILED 11-21-2007.
- 3,479,751. **WREATHS ACROSS AMERICA (BLOCK FORM)**. WREATHS ACROSS AMERICA, (U.S. CLS. 100, 101 AND 102). SN 77-336,880. PUB. 5-20-2008. FILED 11-26-2007.
- 3,479,757. **AUTHENTIC INSIGHTS (BLOCK FORM)**. LEADERSHIP AUTHENTIC INSIGHTS, INC., (U.S. CLS. 100, 101 AND 102). SN 77-338,218. PUB. 5-20-2008. FILED 11-27-2007.
- 3,479,760. **GRAND HERITAGE (BLOCK FORM)**. TRADEMARKS HOLDING, LLC, MULTIPLE CLASS, (INT. CLS. 35 AND 43), (U.S. CLS. 100, 101 AND 102). SN 77-338,431. PUB. 5-20-2008. FILED 11-28-2007.
- 3,479,764. **LEADERS IN LUXURY (BLOCK FORM)**. PATERNO IMPORTS, LTD., DBA TERLATO WINES INTERNATIONAL, (U.S. CLS. 100, 101 AND 102). SN 77-339,024. PUB. 5-20-2008. FILED 11-28-2007.
- 3,479,768. **SAVORY CHEF (BLOCK FORM)**. SAVORY CHEF, LLC, (U.S. CLS. 100, 101 AND 102). SN 77-339,260. PUB. 5-20-2008. FILED 11-28-2007.
- 3,479,780. **MESQUITE TEXAS AND DESIGN**. THE CITY OF MESQUITE, MULTIPLE CLASS, (INT. CLS. 35, 36, 37, 39, 41, 42 AND 45), (U.S. CLS. 100, 101, 102, 103, 105, 106 AND 107). SN 77-340,914. PUB. 5-20-2008. FILED 11-30-2007.
- 3,479,785 (*See Class 25 for this trademark*).
- 3,479,786. **CREATING CAPACITY (BLOCK FORM)**. CAVALRY TRANSPORTATION, LLC, (U.S. CLS. 100, 101 AND 102). SN 77-341,441. PUB. 5-20-2008. FILED 11-30-2007.
- 3,479,788 (*See Class 25 for this trademark*).
- 3,479,807. **STUDIOBABY (BLOCK FORM)**. MUSICBABY LLC, (U.S. CLS. 100, 101 AND 102). SN 77-342,753. PUB. 5-20-2008. FILED 12-3-2007.
- 3,479,808. **HARDWARE SECRETS (BLOCK FORM)**. HARDWARE SECRETS, LLC, (U.S. CLS. 100, 101 AND 102). SN 77-342,913. PUB. 5-20-2008. FILED 12-3-2007.
- 3,479,810. **VOX PRODUCTIONS AND DESIGN**. VOX ENTERTAINMENT, INC., (U.S. CLS. 100, 101 AND 102). SN 77-342,990. PUB. 5-20-2008. FILED 12-3-2007.
- 3,479,816. **NASS NORTH AMERICAN SPINE SOCIETY AND DESIGN**. NORTH AMERICAN SPINE SOCIETY, (U.S. CLS. 100, 101 AND 102). SN 77-343,915. PUB. 5-20-2008. FILED 12-4-2007.
- 3,479,817. **KICKS & STICKS AND DESIGN**. KICKS & STICKS, LLC, (U.S. CLS. 100, 101 AND 102). SN 77-344,107. PUB. 5-20-2008. FILED 12-4-2007.
- 3,479,819 (*See Class 16 for this trademark*).
- 3,479,820. **JUST EDUCATION LOANS (BLOCK FORM)**. THE STUDENT LOAN PROCESSORS, INC., MULTIPLE CLASS, (INT. CLS. 35 AND 36), (U.S. CLS. 100, 101 AND 102). SN 77-344,247. PUB. 5-20-2008. FILED 12-5-2007.
- 3,479,836. **QH EXTEND (BLOCK FORM)**. MARKETING TECHNOLOGY SOLUTIONS INC., (U.S. CLS. 100, 101

- AND 102). SN 77-346,160. PUB. 5-20-2008. FILED 12-6-2007.
- 3,479,837. **QH CONNECT (BLOCK FORM)**. MARKETING TECHNOLOGY SOLUTIONS INC., (U.S. CLS. 100, 101 AND 102). SN 77-346,165. PUB. 5-20-2008. FILED 12-6-2007.
- 3,479,842. **BEER RUN AND DESIGN**. JJMD INVESTMENTS, INC., MULTIPLE CLASS, (INT. CLS. 35 AND 43), (U.S. CLS. 100, 101 AND 102). SN 77-346,830. PUB. 5-20-2008. FILED 12-7-2007.
- 3,479,844. **EVERYDAY BIOGRAPHIES (BLOCK FORM)**. EVERYDAY BIOGRAPHIES LTD, (U.S. CLS. 100, 101 AND 102). SN 77-346,972. PUB. 5-20-2008. FILED 12-7-2007.
- 3,479,854. **OBAGI P.R.O. SYSTEM PATIENT REFILLS ON-LINE (BLOCK FORM)**. OMP, INC., (U.S. CLS. 100, 101 AND 102). SN 77-348,340. PUB. 5-20-2008. FILED 12-10-2007.
- 3,479,855. **OBAGI P.R.O. SYSTEM PATIENT REFILLS ON-LINE AND DESIGN**. OMP, INC., (U.S. CLS. 100, 101 AND 102). SN 77-348,351. PUB. 5-20-2008. FILED 12-10-2007.
- 3,479,872. **SUGAR (BLOCK FORM)**. ODDESSE, INC., MULTIPLE CLASS, (INT. CLS. 35 AND 41), (U.S. CLS. 100, 101, 102 AND 107). SN 77-350,093. PUB. 5-20-2008. FILED 12-12-2007.
- 3,479,881. **LEADING THE SERVICE INDUSTRY (BLOCK FORM)**. THE DWYER GROUP, INC., (U.S. CLS. 100, 101 AND 102). SN 77-350,306. PUB. 5-20-2008. FILED 12-12-2007.
- 3,479,884. **FLU VACCINE BUSINESS PRACTICES INITIATIVE AND DESIGN**. HEALTH INDUSTRY DISTRIBUTORS ASSOCIATION, (U.S. CLS. 100, 101 AND 102). SN 77-350,565. PUB. 5-20-2008. FILED 12-12-2007.
- 3,479,892. **DENEZ (BLOCK FORM)**. MIMAAPPAREL, INC., (U.S. CLS. 100, 101 AND 102). SN 77-351,199. PUB. 5-20-2008. FILED 12-13-2007.
- 3,479,896. **BURN RUBBER SNEAKER BOUTIQUE (STYLIZED)**. SNEAKER HEADZ, LLC, DBA BURN RUBBER, (U.S. CLS. 100, 101 AND 102). SN 77-351,283. PUB. 5-20-2008. FILED 12-13-2007.
- 3,479,912. **COLLEGES AGAINST CANCER (BLOCK FORM)**. AMERICAN CANCER SOCIETY, INC., MULTIPLE CLASS, (INT. CLS. 35 AND 36), (U.S. CLS. 100, 101 AND 102). SN 77-352,019. PUB. 5-20-2008. FILED 12-14-2007.
- 3,479,914. **PARCELPORTR AND DESIGN**. PARCELPORTR, LLC, MULTIPLE CLASS, (INT. CLS. 35 AND 39), (U.S. CLS. 100, 101, 102 AND 105). SN 77-352,137. PUB. 5-20-2008. FILED 12-14-2007.
- 3,479,915. **JOIN THE EVOLUTION (BLOCK FORM)**. PARCELPORTR, LLC, MULTIPLE CLASS, (INT. CLS. 35 AND 39), (U.S. CLS. 100, 101, 102 AND 105). SN 77-352,148. PUB. 5-20-2008. FILED 12-14-2007.
- 3,479,917. **3PL EVOLVED (BLOCK FORM)**. PARCELPORTR, LLC, MULTIPLE CLASS, (INT. CLS. 35 AND 39), (U.S. CLS. 100, 101, 102 AND 105). SN 77-352,171. PUB. 5-20-2008. FILED 12-14-2007.
- 3,479,921. **ALV ABOUT LOW VISION INC. AND DESIGN**. ABOUT LOW VISION, INC., (U.S. CLS. 100, 101 AND 102). SN 77-352,237. PUB. 5-20-2008. FILED 12-14-2007.
- 3,479,937. **VIDEOMINING (BLOCK FORM)**. VIDEOMINING CORPORATION, (U.S. CLS. 100, 101 AND 102). SN 77-353,606. PUB. 5-20-2008. FILED 12-17-2007.
- 3,479,948. **MISCELLANEOUS DESIGN**. SOL NÉ COLLECTIONS, INC., (U.S. CLS. 100, 101 AND 102). SN 77-354,156. PUB. 5-20-2008. FILED 12-17-2007.
- 3,479,963. **REP REPUBLICANS FOR ENVIRONMENTAL PROTECTION AND DESIGN**. REP AMERICA, (U.S. CLS. 100, 101 AND 102). SN 77-354,612. PUB. 5-20-2008. FILED 12-18-2007.
- 3,479,968. **COMMNEXUS NEXTSTAGE (BLOCK FORM)**. COMMNEXUS SAN DIEGO, DBA SAN DIEGO TELECOM COUNCIL, (U.S. CLS. 100, 101 AND 102). SN 77-354,753. PUB. 5-20-2008. FILED 12-18-2007.
- 3,479,973. **SANDLOTCONNECT (BLOCK FORM)**. SILVERBACK, LLC, (U.S. CLS. 100, 101 AND 102). SN 77-354,875. PUB. 5-20-2008. FILED 12-18-2007.
- 3,479,987. **SCORPION AND DESIGN**. SCORPION PROTECTIVE COATINGS, INC., (U.S. CLS. 100, 101 AND 102). SN 77-355,785. PUB. 5-20-2008. FILED 12-19-2007.
- 3,479,988. **OUR GIRLS' GIFT SHOP AND DESIGN**. ELEPHANT SANCTUARY IN TENNESSEE, THE, (U.S. CLS. 100, 101 AND 102). SN 77-355,843. PUB. 5-20-2008. FILED 12-19-2007.
- 3,479,994. **SEASIDE MARKET (BLOCK FORM)**. CARDIFF SEASIDE MARKET, INC., MULTIPLE CLASS, (INT. CLS. 35 AND 43), (U.S. CLS. 100, 101 AND 102). SN 77-356,257. PUB. 5-20-2008. FILED 12-19-2007.
- 3,479,997. **POTOMACWAVE CONSULTING AND DESIGN**. POTOMACWAVE CONSULTING, INC., (U.S. CLS. 100, 101 AND 102). SN 77-356,401. PUB. 5-20-2008. FILED 12-19-2007.
- 3,479,998. **POTOMACWAVE CONSULTING (BLOCK FORM)**. POTOMACWAVE CONSULTING, INC, (U.S. CLS. 100, 101 AND 102). SN 77-356,405. PUB. 5-20-2008. FILED 12-19-2007.
- 3,480,003. **INTEREP INTEGRATION (BLOCK FORM)**. INTEREP NATIONAL RADIO SALES, INC., (U.S. CLS. 100, 101 AND 102). SN 77-356,661. PUB. 5-20-2008. FILED 12-20-2007.
- 3,480,017. **WE CARE FOR AND ABOUT YOUR CHILDREN (BLOCK FORM)**. NATIONAL ASSOCIATION OF PEDIATRIC NURSE PRACTITIONERS, (U.S. CLS. 100, 101 AND 102). SN 77-356,944. PUB. 5-20-2008. FILED 12-20-2007.
- 3,480,028. **CAREER RESCUE (BLOCK FORM)**. THOMPSON, KIMBERLY, (U.S. CLS. 100, 101 AND 102). SN 77-357,250. PUB. 5-20-2008. FILED 12-20-2007.
- 3,480,030. **CHIROSPA (BLOCK FORM)**. HILL, JOHN, (U.S. CLS. 100, 101 AND 102). SN 77-357,331. PUB. 5-20-2008. FILED 12-20-2007.
- 3,480,035. **HIPTIX (STYLIZED)**. ROUNDABOUT THEATRE COMPANY, INC., (U.S. CLS. 100, 101 AND 102). SN 77-357,415. PUB. 5-20-2008. FILED 12-20-2007.
- 3,480,051. **CARRIES KIDDIE CLOSET (BLOCK FORM)**. HUGHES, CARRIE, (U.S. CLS. 100, 101 AND 102). SN 77-358,072. PUB. 5-20-2008. FILED 12-21-2007.
- 3,480,054. **POP! AND DESIGN**. POP INTERNATIONAL GALLERIES, INC., (U.S. CLS. 100, 101 AND 102). SN 77-358,292. PUB. 5-20-2008. FILED 12-21-2007.
- 3,480,057 (*See Class 16 for this trademark*).
- 3,480,070. **NORTH AMERICAN TUNING (BLOCK FORM)**. ROMAIN, NICOLAS G, DBA NORTH AMERICAN TUNING, (U.S. CLS. 100, 101 AND 102). SN 77-359,034. PUB. 5-20-2008. FILED 12-24-2007.
- 3,480,073. **TREND AGITATOR (BLOCK FORM)**. THE SKYLINE STUDIOS, INC., DBA THE SKYLINE STUDIOS, (U.S. CLS. 100, 101 AND 102). SN 77-359,069. PUB. 5-20-2008. FILED 12-24-2007.
- 3,480,077. **CITIZEN RAIN (BLOCK FORM)**. KING BROADCASTING COMPANY, MULTIPLE CLASS, (INT. CLS. 35 AND 41), (U.S. CLS. 100, 101, 102 AND 107). SN 77-359,242. PUB. 5-20-2008. FILED 12-26-2007.
- 3,480,079. **SQUIDBID (BLOCK FORM)**. APPRECIATING ASSETS, LLC, (U.S. CLS. 100, 101 AND 102). SN 77-359,286. PUB. 5-20-2008. FILED 12-26-2007.
- 3,480,103. **TAG SPORTS (STYLIZED)**. TAG SPORTS, LLC, AKA THE AUBUCHON GROUP, LLC, (U.S. CLS. 100, 101 AND 102). SN 77-360,038. PUB. 5-20-2008. FILED 12-27-2007.
- 3,480,108. **CASS (BLOCK FORM)**. CASS INFORMATION SYSTEMS, INC., MULTIPLE CLASS, (INT. CLS. 35, 36 AND 42), (U.S. CLS. 100, 101 AND 102). SN 77-360,346. PUB. 5-20-2008. FILED 12-27-2007.
- 3,480,119. **INTEGRAL MANAGEMENT (BLOCK FORM)**. INTEGRAL MANAGEMENT, LLC, (U.S. CLS. 100, 101 AND 102). SN 77-360,835. PUB. 5-20-2008. FILED 12-28-2007.
- 3,480,130 (*See Class 20 for this trademark*).
- 3,480,132. **B AND DESIGN**. BONZOLIO, INCORPORATED, (U.S. CLS. 100, 101 AND 102). SN 77-361,350. PUB. 5-20-2008. FILED 12-28-2007.
- 3,480,138. **TRANSCRIPTSNOW (STYLIZED)**. EMMA HITT MEDICAL WRITING, LLC, (U.S. CLS. 100, 101 AND 102). SN 77-361,703. PUB. 5-20-2008. FILED 12-31-2007.
- 3,480,153. **T&A MARKETING PRODUCTS (BLOCK FORM)**. T&A MARKETING PRODUCTS, (U.S. CLS. 100, 101 AND 102). SN 77-361,991. PUB. 5-20-2008. FILED 12-31-2007.
- 3,480,155. **MIMI'S CURVY CORNER (BLOCK FORM)**. MJM ENTERPRISE, INC., DBA MIMI'S CURVY CORNER, (U.S. CLS. 100, 101 AND 102). SN 77-362,071. PUB. 5-20-2008. FILED 12-31-2007.
- 3,480,163. **WHAT'S THE SCOOP AND DESIGN**. SCOOP MANAGEMENT LLC, (U.S. CLS. 100, 101 AND 102). SN 77-362,355. PUB. 5-20-2008. FILED 1-2-2008.
- 3,480,164. **FACTORY 2-U AND DESIGN**. FP STORES, INC., (U.S. CLS. 100, 101 AND 102). SN 77-362,360. PUB. 5-20-2008. FILED 1-2-2008.
- 3,480,166. **M | P MALEK PARTNERS AND DESIGN**. MALEK

- PARTNERS LLC, (U.S. CLS. 100, 101 AND 102). SN 77-362,375. PUB. 5-20-2008. FILED 1-2-2008.
- 3,480,174. **TRUE MEDIA (BLOCK FORM)**. TRUE MEDIA, LLC., (U.S. CLS. 100, 101 AND 102). SN 77-362,481. PUB. 5-20-2008. FILED 1-2-2008.
- 3,480,175. **THE HUMAN POTENTIAL PROJECT (BLOCK FORM)**. CHRISTOPHER DEAN MAJER, (U.S. CLS. 100, 101 AND 102). SN 77-362,490. PUB. 5-20-2008. FILED 1-2-2008.
- 3,480,178. **ITOTA INTERNATIONAL TACTICAL OFFICERS TRAINING ASSOCIATION AND DESIGN**. INTERNATIONAL TACTICAL OFFICERS TRAINING ASSOCIATION, LLC, (U.S. CLS. 100, 101 AND 102). SN 77-362,510. PUB. 5-20-2008. FILED 1-2-2008.
- 3,480,185. **NO WATER NO LIFE (BLOCK FORM)**. NO WATER NO LIFE LLC, (U.S. CLS. 100, 101 AND 102). SN 77-362,678. PUB. 5-20-2008. FILED 1-2-2008.
- 3,480,193. **MISCELLANEOUS DESIGN**. RENT ME FLORIDA, LLC, (U.S. CLS. 100, 101 AND 102). SN 77-362,822. PUB. 5-20-2008. FILED 1-2-2008.
- 3,480,207. **MIS (BLOCK FORM)**. MISSOURI INSULATION & SUPPLY, INC., MULTIPLE CLASS, (INT. CLS. 35 AND 37), (U.S. CLS. 100, 101, 102, 103 AND 106). SN 77-363,075. PUB. 5-20-2008. FILED 1-3-2008.
- 3,480,215. **V. VV ALEXANDER & COMPANY, INC. (STYLIZED)**. V. ALEXANDER & CO., INC., MULTIPLE CLASS, (INT. CLS. 35, 36 AND 39), (U.S. CLS. 100, 101, 102 AND 105). SN 77-363,199. PUB. 5-20-2008. FILED 1-3-2008.
- 3,480,236. **INETGIANT ADVERTISE TO THE WORLD AND DESIGN**. INETGIANT, INC., (U.S. CLS. 100, 101 AND 102). SN 77-363,499. PUB. 5-20-2008. FILED 1-3-2008.
- 3,480,244. **ROXFOX (STYLIZED)**. ROXFOX CO., (U.S. CLS. 100, 101 AND 102). SN 77-363,634. PUB. 5-20-2008. FILED 1-3-2008.
- 3,480,252. **LATINO TAX INCOME TAX EN ESPAÑOL AND DESIGN**. LATINO TAX, LLC, (U.S. CLS. 100, 101 AND 102). SN 77-363,716. PUB. 5-20-2008. FILED 1-3-2008.
- 3,480,268. **ROCKHEM & CHICSTONE AND DESIGN**. LEATHER BOULEVARD, DBA ROCKHEM & CHICSTONE, (U.S. CLS. 100, 101 AND 102). SN 77-363,892. PUB. 5-20-2008. FILED 1-3-2008.
- 3,480,273. **THE EQUIPMENT SUPERSTORE (STYLIZED)**. THE EQUIPMENT SUPERSTORE, LLC, (U.S. CLS. 100, 101 AND 102). SN 77-364,025. PUB. 5-20-2008. FILED 1-4-2008.
- 3,480,279 (*See Class 9 for this trademark*).
- 3,480,281. **XQ (BLOCK FORM)**. FRANKLIN COVEY CO., (U.S. CLS. 100, 101 AND 102). SN 77-364,163. PUB. 5-20-2008. FILED 1-4-2008.
- 3,480,286. **EASYWHEELS AND DESIGN**. MIAMI UNIVERSITY COMMUNITY FEDERAL CREDIT UNION, (U.S. CLS. 100, 101 AND 102). SN 77-364,289. PUB. 5-20-2008. FILED 1-4-2008.
- 3,480,287. **TEXT2EXPRESS (BLOCK FORM)**. GREENFIELD ONLINE, INC., (U.S. CLS. 100, 101 AND 102). SN 77-364,313. PUB. 5-20-2008. FILED 1-4-2008.
- 3,480,293. **SF SHACKELFORD'S FLORIST (STYLIZED)**. SHACKELFORD'S FLORIST, INC., (U.S. CLS. 100, 101 AND 102). SN 77-364,355. PUB. 5-20-2008. FILED 1-4-2008.
- 3,480,302. **BONAMONDO (BLOCK FORM)**. BONAMONDO, INC., FORMERLY AD REWARD NETWORK, INC., FORMERLY ADYOURMONEY.COM, INC., (U.S. CLS. 100, 101 AND 102). SN 77-364,505. PUB. 5-20-2008. FILED 1-4-2008.
- 3,480,308. **HONEY'S PLACE (BLOCK FORM)**. HONEY'S PLACE, INC., (U.S. CLS. 100, 101 AND 102). SN 77-364,543. PUB. 5-20-2008. FILED 1-4-2008.
- 3,480,322. **NEWCAT (BLOCK FORM)**. NPI, INC., (U.S. CLS. 100, 101 AND 102). SN 77-364,680. PUB. 5-20-2008. FILED 1-4-2008.
- 3,480,324. **JACK'S COUNTRY STORE FOUNDED 1885 . GROCERIES, HARDWARE AND GENERAL MERCHANDISE AND DESIGN**. JACK'S COUNTRY STORE, INC., (U.S. CLS. 100, 101 AND 102). SN 77-364,712. PUB. 5-20-2008. FILED 1-4-2008.
- 3,480,325. **LIQUIDATION CONNECT (BLOCK FORM)**. LIQUIDATION CONNECT INC., (U.S. CLS. 100, 101 AND 102). SN 77-364,735. PUB. 5-20-2008. FILED 1-4-2008.
- 3,480,332. **SPASCENE (BLOCK FORM)**. GROOVY GIRL PUBLISHING, INC, MULTIPLE CLASS, (INT. CLS. 35 AND 41), (U.S. CLS. 100, 101, 102 AND 107). SN 77-364,936. PUB. 5-20-2008. FILED 1-5-2008.
- 3,480,342. **WEBPT (BLOCK FORM)**. BRAD JANNENGA, (U.S. CLS. 100, 101 AND 102). SN 77-365,097. PUB. 5-20-2008. FILED 1-6-2008.
- 3,480,348. **WESCO AND DESIGN**. WESCO, INC., (U.S. CLS. 100, 101 AND 102). SN 77-365,236. PUB. 5-20-2008. FILED 1-7-2008.
- 3,480,364. **CHAMBAX (BLOCK FORM)**. CHAMBAX LLC, (U.S. CLS. 100, 101 AND 102). SN 77-365,508. PUB. 5-20-2008. FILED 1-7-2008.
- 3,480,365. **CHAMBAX AND DESIGN**. CHAMBAX LLC, (U.S. CLS. 100, 101 AND 102). SN 77-365,518. PUB. 5-20-2008. FILED 1-7-2008.
- 3,480,370. **CASH IN A FLASH (BLOCK FORM)**. JTH TAX, INC., (U.S. CLS. 100, 101 AND 102). SN 77-365,636. PUB. 5-20-2008. FILED 1-7-2008.
- 3,480,376. **THE POWER OF ZERO (BLOCK FORM)**. SERVICE PAYMENT PLAN, INC., (U.S. CLS. 100, 101 AND 102). SN 77-365,781. PUB. 5-20-2008. FILED 1-7-2008.
- 3,480,387. **INSPIRE LIFE, BREATHE FREE (BLOCK FORM)**. AMERICAN LUNG ASSOCIATION OF THE SOUTHEAST, INCORPORATED, (U.S. CLS. 100, 101 AND 102). SN 77-366,085. PUB. 5-20-2008. FILED 1-7-2008.
- 3,480,394. **SFC (BLOCK FORM)**. SFC, LTD., MULTIPLE CLASS, (INT. CLS. 35, 40 AND 42), (U.S. CLS. 100, 101, 102, 103 AND 106). SN 77-366,236. PUB. 5-20-2008. FILED 1-8-2008.
- 3,480,412. **PLEXUS RESEARCH (BLOCK FORM)**. PLEXUS RESEARCH, INC., (U.S. CLS. 100, 101 AND 102). SN 77-366,576. PUB. 5-20-2008. FILED 1-8-2008.
- 3,480,433. **FARM TO FAMILY (BLOCK FORM)**. CALIFORNIA ASSOCIATION OF FOOD BANKS, (U.S. CLS. 100, 101 AND 102). SN 77-366,929. PUB. 5-20-2008. FILED 1-8-2008.
- 3,480,434. **350AD (BLOCK FORM)**. BRUNK, KEVIN, (U.S. CLS. 100, 101 AND 102). SN 77-366,951. PUB. 5-20-2008. FILED 1-8-2008.
- 3,480,437. **BURN RUBBER (STYLIZED)**. SNEAKER HEADZ, LLC, DBA BURN RUBBER, (U.S. CLS. 100, 101 AND 102). SN 77-367,031. PUB. 5-20-2008. FILED 1-8-2008.
- 3,480,441. **SANDY TOES FOOTWEAR (BLOCK FORM)**. VAHOVIUS, CHET J., (U.S. CLS. 100, 101 AND 102). SN 77-367,189. PUB. 5-20-2008. FILED 1-9-2008.
- 3,480,444. **THINGAMAJOB AND DESIGN**. ALLEGIS GROUP, INC., (U.S. CLS. 100, 101 AND 102). SN 77-367,262. PUB. 5-20-2008. FILED 1-9-2008.
- 3,480,451. **JURISTAFF (BLOCK FORM)**. JURISTAFF, INC., (U.S. CLS. 100, 101 AND 102). SN 77-367,454. PUB. 5-20-2008. FILED 1-9-2008.
- 3,480,460. **MISCELLANEOUS DESIGN**. GLOBAL NURSING SOLUTIONS, INC., (U.S. CLS. 100, 101 AND 102). SN 77-367,660. PUB. 5-20-2008. FILED 1-9-2008.
- 3,480,473. **DISRUPTION IN THE CHANNEL (BLOCK FORM)**. GRIFFITH, STEPHEN, AND BENFIELD, SCOTT, (U.S. CLS. 100, 101 AND 102). SN 77-367,914. PUB. 5-20-2008. FILED 1-9-2008.
- 3,480,479. **OFF THE PAGE (BLOCK FORM)**. HARRY AND DAVID, (U.S. CLS. 100, 101 AND 102). SN 77-368,052. PUB. 5-20-2008. FILED 1-9-2008.
- 3,480,488 (*See Class 20 for this trademark*).
- 3,480,489 (*See Class 20 for this trademark*).
- 3,480,496. **MISCELLANEOUS DESIGN**. THE KILPATRICK COMPANY, INC., (U.S. CLS. 100, 101 AND 102). SN 77-370,871. PUB. 5-20-2008. FILED 1-14-2008.
- 3,480,499 (*See Class 9 for this trademark*).
- 3,480,500 (*See Class 9 for this trademark*).
- 3,480,526. **MOTHER OM MEDIA (BLOCK FORM)**. WISE EARTH SCHOOL OF AYURVEDA, LTD., (U.S. CLS. 100, 101 AND 102). SN 77-381,509. PUB. 5-20-2008. FILED 1-27-2008.
- 3,480,529. **MISCELLANEOUS DESIGN**. HONEY'S PLACE, INC., (U.S. CLS. 100, 101 AND 102). SN 77-383,632. PUB. 5-20-2008. FILED 1-29-2008.
- 3,480,535. **N E S W AND DESIGN**. BILL A. DUFFY, INC., DBA BDA SPORTS MANAGEMENT, (U.S. CLS. 100, 101 AND 102). SN 77-389,396. PUB. 5-20-2008. FILED 2-5-2008.
- 3,480,543 (*See Class 1 for this trademark*).

- 3,480,551. **IT'S (YOUR) PRACTICE. MADE PERFECT. (BLOCK FORM)**. AMERICAN COLLEGE OF CARDIOLOGY FOUNDATION, (U.S. CLS. 100, 101 AND 102). SN 77-403,571. PUB. 5-20-2008. FILED 2-22-2008.
- 3,480,580. **PHILANTHROPÍA AND DESIGN**. MECENA FINANCE LTD., (U.S. CLS. 100, 101 AND 102). SN 78-475,547. PUB. 5-20-2008. FILED 8-30-2004.
- 3,480,581. **1-WORLD (BLOCK FORM)**. DAVIA BAILEY, (U.S. CLS. 100, 101 AND 102). SN 78-477,474. PUB. 5-20-2008. FILED 9-1-2004.
- 3,480,584 (*See Class 9 for this trademark*).
- 3,480,585. **AMMAS (BLOCK FORM)**. AMMAS.COM LIMITED, MULTIPLE CLASS, (INT. CLS. 35, 41, 42, 44 AND 45), (U.S. CLS. 100, 101, 102 AND 107). SN 78-530,521. PUB. 10-9-2007. FILED 12-10-2004.
- 3,480,589 (*See Class 30 for this trademark*).
- 3,480,590 (*See Class 16 for this trademark*).
- 3,480,591. **MAXPARTNER (BLOCK FORM)**. NUVO NETWORK MANAGEMENT INC., (U.S. CLS. 100, 101 AND 102). SN 78-564,390. PUB. 2-12-2008. FILED 2-10-2005.
- 3,480,595 (*See Class 9 for this trademark*).
- 3,480,596 (*See Class 9 for this trademark*).
- 3,480,597 (*See Class 9 for this trademark*).
- 3,480,598 (*See Class 16 for this trademark*).
- 3,480,614 (*See Class 16 for this trademark*).
- 3,480,617. **NEW MAJORITY (BLOCK FORM)**. NEW MAJORITY CALIFORNIA, MULTIPLE CLASS, (INT. CLS. 35 AND 41), (U.S. CLS. 100, 101, 102 AND 107). SN 78-682,257. PUB. 5-20-2008. FILED 7-31-2005.
- 3,480,623. **INDURADEX (BLOCK FORM)**. REFRIGIWEAR, INC., (U.S. CLS. 100, 101 AND 102). SN 78-707,002. PUB. 5-20-2008. FILED 9-6-2005.
- 3,480,624. **INDURASAFE (BLOCK FORM)**. REFRIGIWEAR, INC., (U.S. CLS. 100, 101 AND 102). SN 78-707,005. PUB. 5-20-2008. FILED 9-6-2005.
- 3,480,633. **TOWN OF MIAMI LAKES FLORIDA INCORPORATED 2001 AND DESIGN**. TOWN OF MIAMI LAKES, (U.S. CLS. 100, 101 AND 102). SN 78-785,509. PUB. 5-20-2008. FILED 1-5-2006.
- 3,480,647. **TEMPERATURE-CRITICAL DELIVERY EXPERTS (BLOCK FORM)**. MARITIME-ONTARIO FREIGHT LINES LIMITED, MULTIPLE CLASS, (INT. CLS. 35 AND 39), (U.S. CLS. 100, 101, 102 AND 105). SN 78-837,825. PUB. 3-11-2008. FILED 3-15-2006.
- 3,480,649 (*See Class 16 for this trademark*).
- 3,480,653. **RECESS (BLOCK FORM)**. RECESS FITNESS, HEALTH AND PLAY LLC, MULTIPLE CLASS, (INT. CLS. 35, 41 AND 44), (U.S. CLS. 100, 101, 102 AND 107). SN 78-845,045. PUB. 5-20-2008. FILED 3-24-2006.
- 3,480,658. **ARESCO (BLOCK FORM)**. AURELIO, JULIO FRANCISCO ANTONIO, MULTIPLE CLASS, (INT. CLS. 35 AND 42), (U.S. CLS. 100, 101 AND 102). SN 78-850,282. PUB. 10-9-2007. FILED 3-30-2006.
- 3,480,660. **BRIDGE LIGHTING (BLOCK FORM)**. INTERLINE BRANDS, INC., (U.S. CLS. 100, 101 AND 102). SN 78-857,731. PUB. 5-20-2008. FILED 4-10-2006.
- 3,480,671. **TALKABILITY (BLOCK FORM)**. FRANK PUBLIC RELATIONS, LTD., (U.S. CLS. 100, 101 AND 102). SN 78-891,380. PUB. 10-2-2007. FILED 5-24-2006.
- 3,480,682. **IMPORTEK AND DESIGN**. INVENTEC MULTIMEDIA & TELECOM CORPORATION, (U.S. CLS. 100, 101 AND 102). SN 78-909,223. PUB. 5-20-2008. FILED 6-15-2006.
- 3,480,689. **IMPORTEK (BLOCK FORM)**. INVENTEC MULTIMEDIA & TELECOM CORPORATION, (U.S. CLS. 100, 101 AND 102). SN 78-909,411. PUB. 5-20-2008. FILED 6-15-2006.
- 3,480,704. **AIRLIFT IDEAS (BLOCK FORM)**. AIRLIFT IDEAS, INC., (U.S. CLS. 100, 101 AND 102). SN 78-925,993. PUB. 5-20-2008. FILED 7-10-2006.
- 3,480,707. **GMS (BLOCK FORM)**. GUARDIAN MORTGAGE DOCUMENTS, INC., MULTIPLE CLASS, (INT. CLS. 35 AND 45), (U.S. CLS. 100, 101 AND 102). SN 78-934,180. PUB. 5-20-2008. FILED 7-20-2006.
- 3,480,712 (*See Class 16 for this trademark*).
- 3,480,713. **3WISHES.COM (BLOCK FORM)**. 3WISHES.COM, INC., (U.S. CLS. 100, 101 AND 102). SN 78-945,599. PUB. 5-20-2008. FILED 8-4-2006.
- 3,480,721. **METAPHOR STUDY (BLOCK FORM)**. D. P. BOSTWICK AND ASSOCIATES, INC., (U.S. CLS. 100, 101 AND 102). SN 78-958,736. PUB. 5-20-2008. FILED 8-23-2006.
- 3,480,722. **ESNIPE (BLOCK FORM)**. ESNIFE, INC., (U.S. CLS. 100, 101 AND 102). SN 78-958,752. PUB. 5-20-2008. FILED 8-23-2006.
- 3,480,729. **SPECTACULAR EVENTS DON'T JUST HAPPEN (BLOCK FORM)**. WUNDERMAN, HUGH, MULTIPLE CLASS, (INT. CLS. 35 AND 41), (U.S. CLS. 100, 101, 102 AND 107). SN 78-965,684. PUB. 5-20-2008. FILED 9-1-2006.
- 3,480,732. **TREES FOR TROOPS (BLOCK FORM)**. CHRISTMAS SPIRIT FOUNDATION, (U.S. CLS. 100, 101 AND 102). SN 78-967,502. PUB. 5-20-2008. FILED 9-5-2006.
- 3,480,733. **END OF THE ROLL (BLOCK FORM)**. ALARIS INCOME GROWTH FUND L.P., (U.S. CLS. 100, 101 AND 102). SN 78-968,753. PUB. 3-25-2008. FILED 9-7-2006.
- 3,480,737. **INTEGRA SCREEN ENHANCED DUE DILIGENCE AND DESIGN**. INTEGRASCREEN SINGAPORE PTE LTD, MULTIPLE CLASS, (INT. CLS. 35 AND 42), (U.S. CLS. 100, 101 AND 102). SN 78-973,936. PUB. 5-20-2008. FILED 9-13-2006.
- 3,480,738. **GPASS GLOBAL PARTNER ASSURANCE SCREENING SYSTEM AND DESIGN**. INTEGRASCREEN SINGAPORE PTE LTD, MULTIPLE CLASS, (INT. CLS. 35 AND 42), (U.S. CLS. 100, 101 AND 102). SN 78-974,005. PUB. 5-20-2008. FILED 9-14-2006.
- 3,480,742. **MISCELLANEOUS DESIGN**. NAKHEEL CO LLC, MULTIPLE CLASS, (INT. CLS. 35 AND 42), (U.S. CLS. 100, 101 AND 102). SN 78-979,992. PUB. 5-20-2008. FILED 7-20-2006.
- 3,480,753 (*See Class 3 for this trademark*).
- 3,480,758 (*See Class 9 for this trademark*).
- 3,480,770. **STARFACTORY AND DESIGN**. STARFACTORY INTERNATIONAL FOOTBALL MANAGEMENT AKTIENGESELLSCHAFT, (U.S. CLS. 100, 101 AND 102). SN 79-032,922. PUB. 5-20-2008. FILED 3-27-2006.
- 3,480,784 (*See Class 9 for this trademark*).
- 3,480,785. **ORTELIO AND DESIGN**. TERO LTD, MULTIPLE CLASS, (INT. CLS. 35 AND 42), (U.S. CLS. 100, 101 AND 102). SN 79-034,449. PUB. 5-20-2008. FILED 11-8-2006.
- 3,480,823 (*See Class 29 for this trademark*).
- 3,480,855. **ITALSEMPIONE (STYLIZED)**. ITALSEMPIONE -; SPEDIZIONI INTERNAZIONALI S.P.A., MULTIPLE CLASS, (INT. CLS. 35, 36 AND 39), (U.S. CLS. 100, 101, 102 AND 105). SN 79-040,556. PUB. 5-20-2008. FILED 5-22-2007.
- 3,480,864. **GOME (STYLIZED)**. BEIJING GOME APPLIANCE CO., LTD., (U.S. CLS. 100, 101 AND 102). SN 79-040,972. PUB. 5-20-2008. FILED 7-6-2007.
- 3,480,868. **TOREAD AND DESIGN**. DREAMSCO CO., LTD., (U.S. CLS. 100, 101 AND 102). SN 79-041,074. PUB. 5-20-2008. FILED 1-31-2007.
- 3,480,886. **SCOR GLOBAL LIFE (STYLIZED)**. SCOR, MULTIPLE CLASS, (INT. CLS. 35 AND 36), (U.S. CLS. 100, 101 AND 102). SN 79-041,558. PUB. 5-20-2008. FILED 5-29-2007.
- 3,480,894. **HOUSERVICES AND DESIGN**. FRANCISCO JAVIER LOPEZ PEREZ, MULTIPLE CLASS, (INT. CLS. 35, 36 AND 45), (U.S. CLS. 100, 101 AND 102). SN 79-041,735. PUB. 5-20-2008. FILED 5-28-2007.
- 3,480,899 (*See Class 7 for this trademark*).
- 3,480,903. **EXANE DERIVATIVES (BLOCK FORM)**. EXANE, MULTIPLE CLASS, (INT. CLS. 35 AND 36), (U.S. CLS. 100, 101 AND 102). SN 79-041,862. PUB. 5-20-2008. FILED 6-28-2007.
- 3,480,910 (*See Class 9 for this trademark*).
- 3,480,913 (*See Class 16 for this trademark*).
- 3,480,934 (*See Class 28 for this trademark*).
- 3,480,943 (*See Class 9 for this trademark*).
- 3,480,951. **MIRAX AND DESIGN**. TERRAVALLE LIMITED, MULTIPLE CLASS, (INT. CLS. 35, 36, 37 AND 42), (U.S. CLS. 100, 101, 102, 103 AND 106). SN 79-043,296. PUB. 5-20-2008. FILED 12-5-2006.
- 3,480,952 (*See Class 9 for this trademark*).
- 3,480,957 (*See Class 12 for this trademark*).
- 3,480,977. **PASTARITO (BLOCK FORM)**. PASTARITO S.R.L., MULTIPLE CLASS, (INT. CLS. 35 AND 43), (U.S. CLS. 100, 101 AND 102). SN 79-044,384. PUB. 5-20-2008. FILED 7-10-2007.
- 3,480,979. **AICHELE GROUP AND DESIGN**. AICHELE GROUP GMBH & CO. KG, (U.S. CLS. 100, 101 AND 102). SN 79-044,546. PUB. 5-20-2008. FILED 8-31-2007.

- 3,480,988. **KEYPLATFORM AND DESIGN**. KEYPLATFORM, (U.S. CLS. 100, 101 AND 102). SN 79-045,262. PUB. 5-20-2008. FILED 9-28-2007.
- 3,480,992. **FONCIA (BLOCK FORM)**. FONCIA, MULTIPLE CLASS, (INT. CLS. 35, 36, 42 AND 45), (U.S. CLS. 100, 101 AND 102). SN 79-045,445. PUB. 5-20-2008. FILED 5-4-2007.
- 3,480,998. **CHANTECLER AND DESIGN**. CHANTECLER S.P.A., (U.S. CLS. 100, 101 AND 102). SN 79-046,206. PUB. 5-20-2008. FILED 7-26-2007.
- 3,481,013. **HUB CONVENIENCE AND DESIGN**. LAGARDERE SERVICES, MULTIPLE CLASS, (INT. CLS. 35 AND 43), (U.S. CLS. 100, 101 AND 102). SN 79-047,389. PUB. 5-20-2008. FILED 9-6-2007.
- 3,481,017. **IMELOS (BLOCK FORM)**. EXHIBIT APS; C/O SØREN DANDANELL NIELSEN, MULTIPLE CLASS, (INT. CLS. 35, 38 AND 41), (U.S. CLS. 100, 101, 102, 104 AND 107). SN 79-047,550. PUB. 5-20-2008. FILED 9-13-2007.
- 3,481,021. **UNIENCE (STYLIZED)**. NOSTER FINANCE, S.L., MULTIPLE CLASS, (INT. CLS. 35, 36, 38 AND 42), (U.S. CLS. 100, 101, 102 AND 104). SN 79-047,953. PUB. 5-20-2008. FILED 10-22-2007.

CLASS 36—INSURANCE AND FINANCIAL

- 3,478,494. **LANDMARK NATIONAL BANK AND DESIGN**. LANDMARK NATIONAL BANK, (U.S. CLS. 100, 101 AND 102). SN 76-349,375. PUB. 11-16-2004. FILED 12-18-2001.
- 3,478,496. **ALFA CORPORATION**. ALFA CORPORATION, MULTIPLE CLASS, (INT. CLS. 36 AND 37), (U.S. CLS. 100, 101, 102, 103 AND 106). SN 76-372,299. PUB. 5-20-2008. FILED 2-20-2002.
- 3,478,497. **PATIENT CHOICE**. PATIENT CHOICE HEALTHCARE, INC., (U.S. CLS. 100, 101 AND 102). SN 76-449,786. PUB. 5-20-2008. FILED 9-12-2002.
- 3,478,544 (*See Class 14 for this trademark*).
- 3,478,561. **BUY WITHOUT THE BANK (BLOCK FORM)**. SPS PARTNERS LLC, (U.S. CLS. 100, 101 AND 102). SN 76-678,845. PUB. 5-20-2008. FILED 6-28-2007.
- 3,478,564 (*See Class 35 for this trademark*).
- 3,478,568. **LET'S TAKE A STAND AND DESIGN**. ALZHEIMER'S FOUNDATION OF AMERICA, INC., (U.S. CLS. 100, 101 AND 102). SN 76-680,597. PUB. 5-20-2008. FILED 8-13-2007.
- 3,478,591. **DATADOE (BLOCK FORM)**. DATADOE, (U.S. CLS. 100, 101 AND 102). SN 76-683,655. PUB. 5-20-2008. FILED 11-5-2007.
- 3,478,615. **PENSION MAXIMA (BLOCK FORM)**. PENSION MAXIMA INVESTMENT ADVISORY, (U.S. CLS. 100, 101 AND 102). SN 76-685,464. PUB. 5-20-2008. FILED 12-28-2007.
- 3,478,627. **MEGAFX (BLOCK FORM)**. THE GAMES PORTAL LIMITED, MULTIPLE CLASS, (INT. CLS. 36 AND 41), (U.S. CLS. 100, 101, 102 AND 107). SN 77-005,391. PUB. 12-18-2007. FILED 9-22-2006.
- 3,478,630. **LIFE NET (BLOCK FORM)**. FARMERS GROUP, INC., (U.S. CLS. 100, 101 AND 102). SN 77-006,895. PUB. 5-20-2008. FILED 9-25-2006.
- 3,478,643 (*See Class 35 for this trademark*).
- 3,478,644 (*See Class 35 for this trademark*).
- 3,478,647. **IDB BANK AND DESIGN**. ISRAEL DISCOUNT BANK OF NEW YORK, (U.S. CLS. 100, 101 AND 102). SN 77-020,074. PUB. 2-12-2008. FILED 10-12-2006.
- 3,478,664. **MAGNETAR CAPITAL (BLOCK FORM)**. MAGNETAR CAPITAL L.L.C., (U.S. CLS. 100, 101 AND 102). SN 77-034,366. PUB. 5-20-2008. FILED 11-1-2006.
- 3,478,665. **MAGNETAR (BLOCK FORM)**. MAGNETAR CAPITAL L.L.C., (U.S. CLS. 100, 101 AND 102). SN 77-034,369. PUB. 5-20-2008. FILED 11-1-2006.
- 3,478,668 (*See Class 35 for this trademark*).
- 3,478,675. **COLLATERALFACTS (BLOCK FORM)**. KROLL INC., MULTIPLE CLASS, (INT. CLS. 36 AND 45), (U.S. CLS. 100, 101 AND 102). SN 77-042,836. PUB. 5-20-2008. FILED 11-13-2006.
- 3,478,687. **BARTON & GRAY MARINERS CLUB AND DESIGN**. BARTON & GRAY LLC, (U.S. CLS. 100, 101 AND 102). SN 77-046,811. PUB. 5-20-2008. FILED 11-17-2006.
- 3,478,696. **SYMBILITY.NET (BLOCK FORM)**. SYMBILITY SOLUTIONS, INC., (U.S. CLS. 100, 101 AND 102). SN 77-052,305. PUB. 5-20-2008. FILED 11-28-2006.
- 3,478,706. **EOS TWENTY-ONE (BLOCK FORM)**. ALEXANDRIA CONDOMINIUMS, L.L.C., (U.S. CLS. 100, 101 AND 102). SN 77-061,711. PUB. 5-20-2008. FILED 12-11-2006.
- 3,478,707. **EOS TWENTY-ONE AND DESIGN**. ALEXANDRIA CONDOMINIUMS, L.L.C., (U.S. CLS. 100, 101 AND 102). SN 77-061,721. PUB. 5-20-2008. FILED 12-11-2006.
- 3,478,721. **REVOLUTIONIZING CASH ACCESS TECHNOLOGY FOR THE GAMING INDUSTRY (BLOCK FORM)**. CASH SYSTEMS, INC., (U.S. CLS. 100, 101 AND 102). SN 77-068,812. PUB. 5-20-2008. FILED 12-20-2006.
- 3,478,726. **CASINO PC (BLOCK FORM)**. CASH SYSTEMS, INC., (U.S. CLS. 100, 101 AND 102). SN 77-074,003. PUB. 5-20-2008. FILED 1-1-2007.
- 3,478,745. **THE OPTIONS INSIDER (BLOCK FORM)**. THE OPTIONS INSIDER INCORPORATED, (U.S. CLS. 100, 101 AND 102). SN 77-087,493. PUB. 5-20-2008. FILED 1-21-2007.
- 3,478,748 (*See Class 35 for this trademark*).
- 3,478,753. **THE SMARTER BANKING CHOICE FOR GROWING TECHNOLOGY COMPANIES (BLOCK FORM)**. BRIDGE BANK, N.A., (U.S. CLS. 100, 101 AND 102). SN 77-095,090. PUB. 2-12-2008. FILED 1-30-2007.
- 3,478,765. **MICHIGAN FIRST WEALTH MANAGEMENT GROUP (BLOCK FORM)**. MICHIGAN FIRST CREDIT UNION, (U.S. CLS. 100, 101 AND 102). SN 77-097,577. PUB. 5-20-2008. FILED 2-2-2007.
- 3,478,768. **INVICTA CAPITAL (BLOCK FORM)**. INVICTA CAPITAL LIMITED, MULTIPLE CLASS, (INT. CLS. 36 AND 41), (U.S. CLS. 100, 101, 102 AND 107). SN 77-099,007. PUB. 5-20-2008. FILED 2-5-2007.
- 3,478,827. **MISCELLANEOUS DESIGN**. WESTPORT CAPITAL PARTNERS LLC, (U.S. CLS. 100, 101 AND 102). SN 77-140,110. PUB. 5-20-2008. FILED 3-26-2007.
- 3,478,834. **CHARITABLE INSTALLMENT PURCHASE (CHIP) (BLOCK FORM)**. NEW LIFE INTERNATIONAL, (U.S. CLS. 100, 101 AND 102). SN 77-143,016. PUB. 5-20-2008. FILED 3-28-2007.
- 3,478,847. **CHASE ULTIMATE FAN REWARDS (BLOCK FORM)**. JPMORGAN CHASE & CO., (U.S. CLS. 100, 101 AND 102). SN 77-148,098. PUB. 5-20-2008. FILED 4-4-2007.
- 3,478,873 (*See Class 35 for this trademark*).
- 3,478,874. **PI FINANCIAL (BLOCK FORM)**. PI FINANCIAL CORP, (U.S. CLS. 100, 101 AND 102). SN 77-163,753. PUB. 5-20-2008. FILED 4-24-2007.
- 3,478,906. **ACI FOUNDATION AND DESIGN**. AMERICAN CONCRETE INSTITUTE, MULTIPLE CLASS, (INT. CLS. 36 AND 41), (U.S. CLS. 100, 101, 102 AND 107). SN 77-176,428. PUB. 5-20-2008. FILED 5-9-2007.
- 3,478,915. **CAPITAL GROWTH WITH PEACE OF MIND (BLOCK FORM)**. TBP ADVISORS, LTD., (U.S. CLS. 100, 101 AND 102). SN 77-179,569. PUB. 5-20-2008. FILED 5-12-2007.
- 3,478,920 (*See Class 35 for this trademark*).
- 3,478,942. **DELAWARE POOLED (BLOCK FORM)**. DELAWARE MANAGEMENT HOLDINGS, INC., (U.S. CLS. 100, 101 AND 102). SN 77-186,410. PUB. 5-20-2008. FILED 5-21-2007.
- 3,478,944. **DELAWARE TREND (BLOCK FORM)**. DELAWARE MANAGEMENT HOLDINGS, INC., (U.S. CLS. 100, 101 AND 102). SN 77-186,734. PUB. 5-20-2008. FILED 5-22-2007.
- 3,478,945. **DELAWARE GROUP (BLOCK FORM)**. DELAWARE MANAGEMENT HOLDINGS, INC., (U.S. CLS. 100, 101 AND 102). SN 77-186,753. PUB. 5-20-2008. FILED 5-22-2007.
- 3,478,955. **FNB FIRST NATIONAL BANK & TRUST CO. AND DESIGN**. FIRST NATIONAL BANK & TRUST CO., (U.S. CLS. 100, 101 AND 102). SN 77-189,284. PUB. 5-20-2008. FILED 5-24-2007.
- 3,478,957. **AMERICAN NATIONAL BANK AND DESIGN**. AMERICAN NATIONAL BANK, (U.S. CLS. 100, 101 AND 102). SN 77-189,917. PUB. 5-20-2008. FILED 5-24-2007.
- 3,478,961. **FREEDOM CHOICE (BLOCK FORM)**. NORTH AMERICAN COMPANY FOR LIFE AND HEALTH INSURANCE, (U.S. CLS. 100, 101 AND 102). SN 77-191,686. PUB. 5-20-2008. FILED 5-29-2007.

- 3,478,962. **"RALEIGH'S SOURCE FOR INSURANCE" (BLOCK FORM)**. DANNY NEWTON FINANCIAL SERVICES INC, (U.S. CLS. 100, 101 AND 102). SN 77-191,856. PUB. 5-20-2008. FILED 5-29-2007.
- 3,478,966 (*See Class 35 for this trademark*).
- 3,478,969. **WWW.MCKINLEY.COM LIVE. WORK. SHOP. PLAY. (STYLIZED)**. MCKINLEY, INC., (U.S. CLS. 100, 101 AND 102). SN 77-193,108. PUB. 5-20-2008. FILED 5-30-2007.
- 3,478,973 (*See Class 35 for this trademark*).
- 3,478,993. **SELECTLINK (BLOCK FORM)**. PERSHING INVESTMENTS LLC, (U.S. CLS. 100, 101 AND 102). SN 77-196,471. PUB. 5-20-2008. FILED 6-4-2007.
- 3,478,994. **S.E.L.E.C.T LINK AND DESIGN**. PERSHING INVESTMENTS LLC, (U.S. CLS. 100, 101 AND 102). SN 77-196,475. PUB. 5-20-2008. FILED 6-4-2007.
- 3,479,002. **PREFERRED PROFESSIONAL INSURANCE COMPANY (BLOCK FORM)**. PREFERRED PROFESSIONAL INSURANCE COMPANY, (U.S. CLS. 100, 101 AND 102). SN 77-197,118. PUB. 5-20-2008. FILED 6-4-2007.
- 3,479,020. **SEG PARTNERS (BLOCK FORM)**. SELECT EQUITY GROUP, INC., (U.S. CLS. 100, 101 AND 102). SN 77-199,450. PUB. 5-20-2008. FILED 6-6-2007.
- 3,479,060 (*See Class 35 for this trademark*).
- 3,479,076. **MLSFINDER.COM (BLOCK FORM)**. WOLFNET TECHNOLOGIES, LLC, (U.S. CLS. 100, 101 AND 102). SN 77-208,777. PUB. 5-20-2008. FILED 6-18-2007.
- 3,479,084. **PEDIATRIC BRAIN TUMOR FOUNDATION (BLOCK FORM)**. THE PEDIATRIC BRAIN TUMOR FOUNDATION OF THE UNITED STATES, INC., (U.S. CLS. 100, 101 AND 102). SN 77-210,783. PUB. 5-20-2008. FILED 6-20-2007.
- 3,479,099. **JOHN DAUGHERTY REALTORS (BLOCK FORM)**. JOHN DAUGHERTY REAL ESTATE, INC., DBA JOHN DAUGHERTY, REALTORS, (U.S. CLS. 100, 101 AND 102). SN 77-212,507. PUB. 5-20-2008. FILED 6-21-2007.
- 3,479,103. **DIGITAL DEPOSIT (BLOCK FORM)**. INDEPENDENT BANKERS' BANK, (U.S. CLS. 100, 101 AND 102). SN 77-213,077. PUB. 5-20-2008. FILED 6-22-2007.
- 3,479,119. **MONDRIAN (BLOCK FORM)**. MONDRIAN HOLDINGS, LLC, MULTIPLE CLASS, (INT. CLS. 36 AND 37), (U.S. CLS. 100, 101, 102, 103 AND 106). SN 77-216,140. PUB. 5-20-2008. FILED 6-26-2007.
- 3,479,138 (*See Class 35 for this trademark*).
- 3,479,147. **SUCCESS BUILT ON COMMITMENT (BLOCK FORM)**. MOUNTAIN WEST REAL ESTATE, INC., (U.S. CLS. 100, 101 AND 102). SN 77-218,241. PUB. 5-20-2008. FILED 6-28-2007.
- 3,479,156. **NELLIE MAE'S PARENT RESOURCES FOR EDUCATION PREPARATION (PREP) (BLOCK FORM)**. NELLIE MAE CORPORATION, (U.S. CLS. 100, 101 AND 102). SN 77-218,677. PUB. 5-20-2008. FILED 6-29-2007.
- 3,479,157. **NELLIE MAE'S FINANCIAL SUCCESS SERIES (BLOCK FORM)**. NELLIE MAE CORPORATION, (U.S. CLS. 100, 101 AND 102). SN 77-218,710. PUB. 5-20-2008. FILED 6-29-2007.
- 3,479,218. **UNIVERSITY LANDING (BLOCK FORM)**. UNIVERSITY LANDING LLC, (U.S. CLS. 100, 101 AND 102). SN 77-225,389. PUB. 5-20-2008. FILED 7-10-2007.
- 3,479,249. **SELL THAT REAL ESTATE (BLOCK FORM)**. TAHOE UNITED MANAGEMENT, INC., (U.S. CLS. 100, 101 AND 102). SN 77-230,354. PUB. 5-20-2008. FILED 7-16-2007.
- 3,479,270 (*See Class 35 for this trademark*).
- 3,479,275. **LIQUIDATE THAT REAL ESTATE (BLOCK FORM)**. TAHOE UNITED MANAGEMENT, INC., (U.S. CLS. 100, 101 AND 102). SN 77-233,893. PUB. 5-20-2008. FILED 7-19-2007.
- 3,479,279. **HIDEAWAY VACATION HOMES (BLOCK FORM)**. TESTA, MICHAEL T, (U.S. CLS. 100, 101 AND 102). SN 77-234,360. PUB. 5-20-2008. FILED 7-20-2007.
- 3,479,297. **ARSI MOVING AND DESIGN**. ALL RELO-SERVICES, INC., (U.S. CLS. 100, 101 AND 102). SN 77-238,353. PUB. 5-20-2008. FILED 7-25-2007.
- 3,479,359. **ANNUITY RESCUE CENTER (BLOCK FORM)**. JEFFERSON NATIONAL FINANCIAL CORP., (U.S. CLS. 100, 101 AND 102). SN 77-255,612. PUB. 5-20-2008. FILED 8-15-2007.
- 3,479,368. **WINDPAK WIND POWER INSURANCE FOR THE 21ST CENTURY AND DESIGN**. THE TRAVELERS INDEMNITY COMPANY, (U.S. CLS. 100, 101 AND 102). SN 77-257,332. PUB. 5-20-2008. FILED 8-16-2007.
- 3,479,373. **SUITESPOT AND DESIGN**. STAFFME.NET, LLC, (U.S. CLS. 100, 101 AND 102). SN 77-259,621. PUB. 5-20-2008. FILED 8-20-2007.
- 3,479,379. **DRIVE-SURE (BLOCK FORM)**. KREX, INC., (U.S. CLS. 100, 101 AND 102). SN 77-261,887. PUB. 5-20-2008. FILED 8-22-2007.
- 3,479,403. **MISCELLANEOUS DESIGN**. LOCKE, NELSON, (U.S. CLS. 100, 101 AND 102). SN 77-267,758. PUB. 5-20-2008. FILED 8-29-2007.
- 3,479,431. **RELATED AND DESIGN**. THE RELATED COMPANIES, L.P., MULTIPLE CLASS, (INT. CLS. 36, 37 AND 45), (U.S. CLS. 100, 101, 102, 103 AND 106). SN 77-275,917. PUB. 5-20-2008. FILED 9-10-2007.
- 3,479,437. **PATIENT OPTION (BLOCK FORM)**. PATIENT OPTION, INC., (U.S. CLS. 100, 101 AND 102). SN 77-277,937. PUB. 5-20-2008. FILED 9-12-2007.
- 3,479,454 (*See Class 9 for this trademark*).
- 3,479,478. **CAPITAL PAYMENTS PROCESSING LLC. YOUR MERCHANT SERVICE PROVIDER AND DESIGN**. CAPITAL PAYMENTS PROCESSING, LLC, (U.S. CLS. 100, 101 AND 102). SN 77-289,810. PUB. 5-20-2008. FILED 9-26-2007.
- 3,479,496. **DUBHGLAIS FAICHE AND DESIGN**. CHRYSLER, DOUGLAS, (U.S. CLS. 100, 101 AND 102). SN 77-293,712. PUB. 5-20-2008. FILED 10-2-2007.
- 3,479,503. **AFRICA LIFE AID (BLOCK FORM)**. WOYOME FOUNDATION FOR AFRICA, (U.S. CLS. 100, 101 AND 102). SN 77-297,064. PUB. 5-20-2008. FILED 10-5-2007.
- 3,479,537. **BUILT BY REFERRAL REALTY GROUP (BLOCK FORM)**. BUILT BY REFERRAL REALTY GROUP, LTD., (U.S. CLS. 100, 101 AND 102). SN 77-302,040. PUB. 5-20-2008. FILED 10-11-2007.
- 3,479,555 (*See Class 35 for this trademark*).
- 3,479,567. **RETIRED PROFESSIONAL FOOTBALL PLAYERS OF CHICAGO DOLLARS FOR SCHOLARS 501C3 AND DESIGN**. RETIRED PROFESSIONAL FOOTBALL PLAYERS OF CHICAGO/DOLLARS FOR SCHOLARS, A DIVISION OF SCHOLARSHIP AMERICA, INC., (U.S. CLS. 100, 101 AND 102). SN 77-309,321. PUB. 5-20-2008. FILED 10-21-2007.
- 3,479,610. **CAROLINA CARE PLAN AND DESIGN**. MEDICAL MUTUAL OF OHIO, (U.S. CLS. 100, 101 AND 102). SN 77-317,030. PUB. 5-20-2008. FILED 10-30-2007.
- 3,479,614. **AMERICA'S CHOICE WARRANTY, LLC AND DESIGN**. AMERICA'S CHOICE WARRANTY, LLC, (U.S. CLS. 100, 101 AND 102). SN 77-317,332. PUB. 5-20-2008. FILED 10-30-2007.
- 3,479,628 (*See Class 35 for this trademark*).
- 3,479,630. **IF (BLOCK FORM)**. METROPOLITAN LIFE INSURANCE COMPANY, (U.S. CLS. 100, 101 AND 102). SN 77-319,854. PUB. 5-20-2008. FILED 11-2-2007.
- 3,479,638. **BEEHIVE INSURANCE A CLYDE COMPANY AND DESIGN**. CLYDE COMPANIES, INC., (U.S. CLS. 100, 101 AND 102). SN 77-321,681. PUB. 5-20-2008. FILED 11-5-2007.
- 3,479,657. **AFRICA LIFE AID AND DESIGN**. WOYOME FOUNDATION FOR AFRICA, (U.S. CLS. 100, 101 AND 102). SN 77-324,378. PUB. 5-20-2008. FILED 11-8-2007.
- 3,479,676. **MAXIMUM REWARDS (BLOCK FORM)**. FIRST NATIONAL OF NEBRASKA, INC., (U.S. CLS. 100, 101 AND 102). SN 77-325,982. PUB. 5-20-2008. FILED 11-9-2007.
- 3,479,677. **INNOVATIVE PRODUCTIVITY SOLUTIONS (BLOCK FORM)**. HARTFORD LIFE INSURANCE COMPANY, (U.S. CLS. 100, 101 AND 102). SN 77-326,011. PUB. 5-20-2008. FILED 11-9-2007.
- 3,479,688. **ELECTRONIC MERCHANT SYSTEMS AND DESIGN**. ELECTRONIC MERCHANT SYSTEMS, (U.S. CLS. 100, 101 AND 102). SN 77-327,134. PUB. 5-20-2008. FILED 11-12-2007.
- 3,479,692. **EMPOWERING YOU WITH THE POWER OF MANY (BLOCK FORM)**. BREAKAWAY PARTNERS, (U.S. CLS. 100, 101 AND 102). SN 77-327,545. PUB. 5-20-2008. FILED 11-12-2007.
- 3,479,705. **SAND CAPITAL (BLOCK FORM)**. SAND CAPITAL LLC, (U.S. CLS. 100, 101 AND 102). SN 77-329,139. PUB. 5-20-2008. FILED 11-14-2007.

- 3,479,706. **WE PERFORM WHEN YOUR LOANS DON'T (BLOCK FORM)**. SAND CAPITAL LLC, (U.S. CLS. 100, 101 AND 102). SN 77-329,194. PUB. 5-20-2008. FILED 11-14-2007.
- 3,479,714. **RENTAL FINDERS (BLOCK FORM)**. VASILIOS MANIATIS, (U.S. CLS. 100, 101 AND 102). SN 77-331,132. PUB. 5-20-2008. FILED 11-16-2007.
- 3,479,727. **ADVISER INVESTMENTS AND DESIGN**. ADVISER INVESTMENT MANAGEMENT, INC., (U.S. CLS. 100, 101 AND 102). SN 77-333,835. PUB. 5-20-2008. FILED 11-20-2007.
- 3,479,740. **TELADVOCATE COMMUNICATIONS AND DESIGN**. TELADVOCATE COMMUNICATIONS, LLC, (U.S. CLS. 100, 101 AND 102). SN 77-335,250. PUB. 5-20-2008. FILED 11-21-2007.
- 3,479,765. **FORECLOSURESDAILY.COM AND DESIGN**. FORECLOSURESDAILY.COM, (U.S. CLS. 100, 101 AND 102). SN 77-339,036. PUB. 5-20-2008. FILED 11-28-2007.
- 3,479,771. **TICKTOCKSTOCK.COM EXPLORING EXPLOSIVE NEW GROWTH OPPORTUNITES AND DESIGN**. TICKTOCKSTOCK.COM, (U.S. CLS. 100, 101 AND 102). SN 77-339,901. PUB. 5-20-2008. FILED 11-29-2007.
- 3,479,780 (*See Class 35 for this trademark*).
- 3,479,815. **SUCCESSION PROTECTOR (BLOCK FORM)**. AMERIPRISE FINANCIAL, INC., (U.S. CLS. 100, 101 AND 102). SN 77-343,445. PUB. 5-20-2008. FILED 12-4-2007.
- 3,479,820 (*See Class 35 for this trademark*).
- 3,479,848. **ROOF ADVISORY GROUP, INC. INVESTEMENT ADVISORY & FINANCIAL PLANNING SERVICES AND DESIGN**. ROOF ADVISORY GROUP, INC., (U.S. CLS. 100, 101 AND 102). SN 77-347,892. PUB. 5-20-2008. FILED 12-10-2007.
- 3,479,856. **ACADEMY OF FINANCIAL LITERACY (BLOCK FORM)**. DAY, PHILLIP, (U.S. CLS. 100, 101 AND 102). SN 77-348,363. PUB. 5-20-2008. FILED 12-10-2007.
- 3,479,863. **PROXY REAL ESTATE (BLOCK FORM)**. PROXY REAL ESTATE, LLC, (U.S. CLS. 100, 101 AND 102). SN 77-349,481. PUB. 5-20-2008. FILED 12-11-2007.
- 3,479,891. **NETWORK FOR GOOD AND DESIGN**. NETWORK FOR GOOD, INC., (U.S. CLS. 100, 101 AND 102). SN 77-351,190. PUB. 5-20-2008. FILED 12-13-2007.
- 3,479,903. **STERLING OPTION III (BLOCK FORM)**. STERLING LIFE INSURANCE COMPANY, (U.S. CLS. 100, 101 AND 102). SN 77-351,684. PUB. 5-20-2008. FILED 12-13-2007.
- 3,479,904. **STERLING OPTION IV (BLOCK FORM)**. STERLING LIFE INSURANCE COMPANY, (U.S. CLS. 100, 101 AND 102). SN 77-351,691. PUB. 5-20-2008. FILED 12-13-2007.
- 3,479,905. **STERLING OPTION II (BLOCK FORM)**. STERLING LIFE INSURANCE COMPANY, (U.S. CLS. 100, 101 AND 102). SN 77-351,693. PUB. 5-20-2008. FILED 12-13-2007.
- 3,479,906. **STERLING RX PLUS (BLOCK FORM)**. STERLING LIFE INSURANCE COMPANY, (U.S. CLS. 100, 101 AND 102). SN 77-351,696. PUB. 5-20-2008. FILED 12-13-2007.
- 3,479,907. **STERLING RX (BLOCK FORM)**. STERLING LIFE INSURANCE COMPANY, (U.S. CLS. 100, 101 AND 102). SN 77-351,710. PUB. 5-20-2008. FILED 12-13-2007.
- 3,479,912 (*See Class 35 for this trademark*).
- 3,479,924. **THE CFHE HOMESTART SOLUTION (BLOCK FORM)**. CAPITAL FINANCIAL HOME EQUITY LLC, (U.S. CLS. 100, 101 AND 102). SN 77-352,773. PUB. 5-20-2008. FILED 12-14-2007.
- 3,479,980. **JEFFERSON SCHOLARS FOUNDATION (BLOCK FORM)**. JEFFERSON SCHOLARS FOUNDATION, (U.S. CLS. 100, 101 AND 102). SN 77-355,206. PUB. 5-20-2008. FILED 12-18-2007.
- 3,479,990. **SLEEPSMARTER PROTECTION HEALTH COMFORT (BLOCK FORM)**. FABRICTECH 2000, LLC, (U.S. CLS. 100, 101 AND 102). SN 77-356,165. PUB. 5-20-2008. FILED 12-19-2007.
- 3,480,038. **SUNROCK VENTURES (BLOCK FORM)**. SUNROCK VENTURES MANAGEMENT, LLC, (U.S. CLS. 100, 101 AND 102). SN 77-357,525. PUB. 5-20-2008. FILED 12-20-2007.
- 3,480,066. **RETURNING VALUE TO OUR CREDIT DRIVEN ECONOMY (BLOCK FORM)**. ASSET ACCEPTANCE LLC, (U.S. CLS. 100, 101 AND 102). SN 77-358,938. PUB. 5-20-2008. FILED 12-23-2007.
- 3,480,097. **RENT IT TODAY (BLOCK FORM)**. GLASS, JASON S., DBA RENT IT TODAY, (U.S. CLS. 100, 101 AND 102). SN 77-359,763. PUB. 5-20-2008. FILED 12-26-2007.
- 3,480,108 (*See Class 35 for this trademark*).
- 3,480,113. **"THE GATEWAY TO VENTURE OUT!" (BLOCK FORM)**. TRISH ROY, PA, (U.S. CLS. 100, 101 AND 102). SN 77-360,475. PUB. 5-20-2008. FILED 12-27-2007.
- 3,480,116. **SONICCASH (BLOCK FORM)**. SONIC CASH, INC., (U.S. CLS. 100, 101 AND 102). SN 77-360,629. PUB. 5-20-2008. FILED 12-27-2007.
- 3,480,117. **ALLWRITE INK AND DESIGN**. DEBORAH CHADDOCK BROWN, DBA ALLWRITE INK, (U.S. CLS. 100, 101 AND 102). SN 77-360,631. PUB. 5-20-2008. FILED 12-27-2007.
- 3,480,128. **THE PROSPECT FUND (BLOCK FORM)**. PROSPECT MANAGEMENT, LLC, (U.S. CLS. 100, 101 AND 102). SN 77-361,243. PUB. 5-20-2008. FILED 12-28-2007.
- 3,480,129. **PROSPECT FUND (BLOCK FORM)**. PROSPECT MANAGEMENT, LLC, (U.S. CLS. 100, 101 AND 102). SN 77-361,313. PUB. 5-20-2008. FILED 12-28-2007.
- 3,480,141. **VALLEY FORGE FINANCIAL, LLC INSURANCE * INVESTMENTS * INTEGRITY AND DESIGN**. VALLEY FORGE FINANCIAL, (U.S. CLS. 100, 101 AND 102). SN 77-361,804. PUB. 5-20-2008. FILED 12-31-2007.
- 3,480,215 (*See Class 35 for this trademark*).
- 3,480,216. **EXPRESS-MOVE (BLOCK FORM)**. EXPRESS CAPITAL MORTGAGE INC., (U.S. CLS. 100, 101 AND 102). SN 77-363,206. PUB. 5-20-2008. FILED 1-3-2008.
- 3,480,250. **YOUR DESTINATION FOR MI (BLOCK FORM)**. AMERICAN INTERNATIONAL GROUP, INC., (U.S. CLS. 100, 101 AND 102). SN 77-363,694. PUB. 5-20-2008. FILED 1-3-2008.
- 3,480,263. **NMC NATIONAL MORTGAGE COMPLIANCE AND DESIGN**. NATIONAL MORTGAGE COMPLIANCE, LLC, (U.S. CLS. 100, 101 AND 102). SN 77-363,868. PUB. 5-20-2008. FILED 1-3-2008.
- 3,480,298. **TRUSTMARK AFFINITY MARKETS (BLOCK FORM)**. TRUSTMARK INSURANCE COMPANY, (U.S. CLS. 100, 101 AND 102). SN 77-364,451. PUB. 5-20-2008. FILED 1-4-2008.
- 3,480,301. **TRUSTMARK AFFINITY MARKETS AN AFFINITY FOR EXCELLENCE AND DESIGN**. TRUSTMARK INSURANCE COMPANY, (U.S. CLS. 100, 101 AND 102). SN 77-364,498. PUB. 5-20-2008. FILED 1-4-2008.
- 3,480,312. **AIG IDENTITY THEFT AND FRAUD GROUP (BLOCK FORM)**. AMERICAN INTERNATIONAL GROUP, INC., (U.S. CLS. 100, 101 AND 102). SN 77-364,569. PUB. 5-20-2008. FILED 1-4-2008.
- 3,480,319. **PARTNERS THROUGH TIME (BLOCK FORM)**. SANTA FE TRUST INC., (U.S. CLS. 100, 101 AND 102). SN 77-364,622. PUB. 5-20-2008. FILED 1-4-2008.
- 3,480,320. **SOUTH STREET (BLOCK FORM)**. SOUTH STREET CAPITAL MANAGEMENT L.P., (U.S. CLS. 100, 101 AND 102). SN 77-364,633. PUB. 5-20-2008. FILED 1-4-2008.
- 3,480,336. **DELECTABLE (BLOCK FORM)**. MENDWELL LLC, (U.S. CLS. 100, 101 AND 102). SN 77-364,989. PUB. 5-20-2008. FILED 1-6-2008.
- 3,480,356. **WEDSAFE (BLOCK FORM)**. WEDSAFE, INC., (U.S. CLS. 100, 101 AND 102). SN 77-365,342. PUB. 5-20-2008. FILED 1-7-2008.
- 3,480,419. **AHEAD OF THE CURVE (BLOCK FORM)**. RLI INSURANCE COMPANY, (U.S. CLS. 100, 101 AND 102). SN 77-366,637. PUB. 5-20-2008. FILED 1-8-2008.
- 3,480,430. **THANK YOUR VET FOR A HEALTHY PET (BLOCK FORM)**. MORRIS ANIMAL FOUNDATION, MULTIPLE CLASS, (INT. CLS. 36 AND 41), (U.S. CLS. 100, 101, 102 AND 107). SN 77-366,859. PUB. 5-20-2008. FILED 1-8-2008.
- 3,480,431. **BUILDING NEIGHBORHOODS - CREATING NEIGHBORS (BLOCK FORM)**. FIEL, PAUL, (U.S. CLS. 100, 101 AND 102). SN 77-366,865. PUB. 5-20-2008. FILED 1-8-2008.
- 3,480,439. **TIME MEANS MONEY (BLOCK FORM)**. DIRECT FUTURES, LLC, (U.S. CLS. 100, 101 AND 102). SN 77-367,111. PUB. 5-20-2008. FILED 1-8-2008.
- 3,480,447. **ARC COMPREPORT (BLOCK FORM)**. AMERICAN RESEARCH COMPANY, INC., (U.S. CLS. 100, 101 AND 102). SN 77-367,310. PUB. 5-20-2008. FILED 1-9-2008.
- 3,480,463. **DMB FINANCIAL YOUR PARTNERS IN DEBT RESOLUTION AND DESIGN**. DMB FINANCIAL, LLC,

- (U.S. CLS. 100, 101 AND 102). SN 77-367,725. PUB. 5-20-2008. FILED 1-9-2008.
- 3,480,483. **THE BANK OF INVERNESS (BLOCK FORM)**. BRANNEN BANKS OF FLORIDA, INC., (U.S. CLS. 100, 101 AND 102). SN 77-368,263. PUB. 5-20-2008. FILED 1-10-2008.
- 3,480,485. **CASTLE BANK AND DESIGN**. FIRST NATIONAL OF NEBRASKA, INC., (U.S. CLS. 100, 101 AND 102). SN 77-368,578. PUB. 5-20-2008. FILED 1-10-2008.
- 3,480,493. **THE REAL ESTATE MAN (BLOCK FORM)**, SENTER, RANDALL HALL, (U.S. CLS. 100, 101 AND 102). SN 77-369,570. PUB. 5-20-2008. FILED 1-11-2008.
- 3,480,495. **DIRECTSOURCE (BLOCK FORM)**. AMERICAN INTERNATIONAL GROUP, INC., (U.S. CLS. 100, 101 AND 102). SN 77-370,775. PUB. 5-20-2008. FILED 1-14-2008.
- 3,480,498. **PROPRICING (BLOCK FORM)**. CARGILL, INCORPORATED, (U.S. CLS. 100, 101 AND 102). SN 77-371,735. PUB. 5-20-2008. FILED 1-15-2008.
- 3,480,508. **PREMIERE 7 (BLOCK FORM)**. AMERICAN INTERNATIONAL GROUP, INC., (U.S. CLS. 100, 101 AND 102). SN 77-375,061. PUB. 5-20-2008. FILED 1-18-2008.
- 3,480,509. **PREMIERE 5 (BLOCK FORM)**. AMERICAN INTERNATIONAL GROUP, INC., (U.S. CLS. 100, 101 AND 102). SN 77-375,079. PUB. 5-20-2008. FILED 1-18-2008.
- 3,480,513. **DOING IT RIGHT. RIGHT NOW. (BLOCK FORM)**. CALDWELL WATSON REAL ESTATE GROUP, INC., MULTIPLE CLASS, (INT. CLS. 36 AND 37), (U.S. CLS. 100, 101, 102, 103 AND 106). SN 77-376,612. PUB. 5-20-2008. FILED 1-21-2008.
- 3,480,536. **HAVE IT ALL (BLOCK FORM)**. WINTRUST FINANCIAL CORPORATION, (U.S. CLS. 100, 101 AND 102). SN 77-389,893. PUB. 5-20-2008. FILED 2-6-2008.
- 3,480,550. **MISCELLANEOUS DESIGN**. HOME LOAN INVESTMENT BANK, FSB, (U.S. CLS. 100, 101 AND 102). SN 77-402,522. PUB. 5-20-2008. FILED 2-21-2008.
- 3,480,572. **ABACUS FEDERAL SAVINGS BANK AND DESIGN**. ABACUS FEDERAL SAVINGS BANK, (U.S. CLS. 100, 101 AND 102). SN 78-332,506. PUB. 5-20-2008. FILED 11-24-2003.
- 3,480,600. **THE LEGEND GROUP (BLOCK FORM)**. LEGEND GROUP HOLDINGS, LLC, (U.S. CLS. 100, 101 AND 102). SN 78-607,443. PUB. 5-20-2008. FILED 4-12-2005.
- 3,480,601. **BANK OF IRELAND BUSINESS ON LINE AND DESIGN**. THE GOVERNOR AND COMPANY OF THE BANK OF IRELAND, DBA BANK OF IRELAND GROUP, (U.S. CLS. 100, 101 AND 102). SN 78-607,917. PUB. 2-5-2008. FILED 4-13-2005.
- 3,480,602. **BANK OF IRELAND BUSINESS ON LINE AND DESIGN**. THE GOVERNOR AND COMPANY OF THE BANK OF IRELAND, DBA BANK OF IRELAND GROUP, (U.S. CLS. 100, 101 AND 102). SN 78-607,965. PUB. 2-12-2008. FILED 4-13-2005.
- 3,480,603. **CONNEXIS (BLOCK FORM)**. BNP PARIBAS, (U.S. CLS. 100, 101 AND 102). SN 78-611,959. PUB. 5-20-2008. FILED 4-19-2005.
- 3,480,614 (*See Class 16 for this trademark*).
- 3,480,632 (*See Class 16 for this trademark*).
- 3,480,684. **IMPORTEK AND DESIGN**. INVENTEC MULTIMEDIA & TELECOM CORPORATION, (U.S. CLS. 100, 101 AND 102). SN 78-909,273. PUB. 5-20-2008. FILED 6-15-2006.
- 3,480,693. **IMPORTEK (BLOCK FORM)**. INVENTEC MULTIMEDIA & TELECOM CORPORATION, (U.S. CLS. 100, 101 AND 102). SN 78-909,455. PUB. 5-20-2008. FILED 6-15-2006.
- 3,480,709 (*See Class 9 for this trademark*).
- 3,480,758 (*See Class 9 for this trademark*).
- 3,480,766. **INGENICO AND DESIGN**. COMPAGNIE INDUSTRIELLE ET; FINANCIERE D'INGENIERIE - INGENICO, (U.S. CLS. 100, 101 AND 102). SN 79-032,118. PUB. 12-18-2007. FILED 10-27-2006.
- 3,480,830. **SSEINDEX (STYLIZED)**. SHANGHAI STOCK EXCHANGE, (U.S. CLS. 100, 101 AND 102). SN 79-039,119. PUB. 5-20-2008. FILED 5-30-2007.
- 3,480,840. **SG AND DESIGN**. SOCIETE GENERALE, (U.S. CLS. 100, 101 AND 102). SN 79-039,700. PUB. 5-20-2008. FILED 4-10-2007.
- 3,480,855 (*See Class 35 for this trademark*).
- 3,480,886 (*See Class 35 for this trademark*).
- 3,480,894 (*See Class 35 for this trademark*).
- 3,480,903 (*See Class 35 for this trademark*).
- 3,480,943 (*See Class 9 for this trademark*).
- 3,480,951 (*See Class 35 for this trademark*).
- 3,480,956. **OXAM (STYLIZED)**. THE OXFORD ASSET; MANAGEMENT COMPANY LIMITED, (U.S. CLS. 100, 101 AND 102). SN 79-043,502. PUB. 5-20-2008. FILED 3-23-2007.
- 3,480,992 (*See Class 35 for this trademark*).
- 3,481,021 (*See Class 35 for this trademark*).

CLASS 37—CONSTRUCTION AND REPAIR

- 3,478,496 (*See Class 36 for this trademark*).
- 3,478,503. **THAI (BLOCK FORM)**. ARCHON TECHNOLOGIES LTD., MULTIPLE CLASS, (INT. CLS. 37 AND 40), (U.S. CLS. 100, 103 AND 106). SN 76-573,108. PUB. 10-2-2007. FILED 1-30-2004.
- 3,478,578. **RUBEN'S TIRES (BLOCK FORM)**. FELIZ, RUBEN D., (U.S. CLS. 100, 103 AND 106). SN 76-681,461. PUB. 5-20-2008. FILED 9-4-2007.
- 3,478,616. **DELWEST (BLOCK FORM)**. DELZOTTO, JOSEPH A., (U.S. CLS. 100, 103 AND 106). SN 76-685,489. PUB. 5-20-2008. FILED 1-4-2008.
- 3,478,622. **DOWNY CREATIONS AND DESIGN**. DOWNEY CREATIONS, LLC, MULTIPLE CLASS, (INT. CLS. 37 AND 42), (U.S. CLS. 100, 101, 103 AND 106). SN 76-685,666. PUB. 5-20-2008. FILED 1-11-2008.
- 3,478,641 (*See Class 7 for this trademark*).
- 3,478,663. **PARADISE VALLEY (STYLIZED)**. GLC ENTERPRISES, LLC, (U.S. CLS. 100, 103 AND 106). SN 77-034,204. PUB. 5-20-2008. FILED 11-1-2006.
- 3,478,666 (*See Class 6 for this trademark*).
- 3,478,669. **NAVHOUSE (BLOCK FORM)**. NAVHOUSE CORPORATION, (U.S. CLS. 100, 103 AND 106). SN 77-037,816. PUB. 5-20-2008. FILED 11-6-2006.
- 3,478,691. **CANAAN TECHNOLOGY (BLOCK FORM)**. CANAAN TECHNOLOGY, LLC, AND FELTON, DAVID R., (U.S. CLS. 100, 103 AND 106). SN 77-049,668. PUB. 5-20-2008. FILED 11-22-2006.
- 3,478,699 (*See Class 6 for this trademark*).
- 3,478,702. **AT&T ALL DISTANCE ONLINE SELECT (BLOCK FORM)**. AT&T INTELLECTUAL PROPERTY II, L.P., MULTIPLE CLASS, (INT. CLS. 37 AND 38), (U.S. CLS. 100, 101, 103, 104 AND 106). SN 77-058,277. PUB. 5-20-2008. FILED 12-6-2006.
- 3,478,737. **VASA (BLOCK FORM)**. VASA TECHNOLOGY SOLUTIONS, INC., (U.S. CLS. 100, 103 AND 106). SN 77-081,149. PUB. 5-20-2008. FILED 1-11-2007.
- 3,478,738. **PHYSICAL REALITY FOR AN ELECTRONIC WORLD (BLOCK FORM)**. VASA TECHNOLOGY SOLUTIONS, INC., (U.S. CLS. 100, 103 AND 106). SN 77-081,204. PUB. 5-20-2008. FILED 1-11-2007.
- 3,478,739. **V AND DESIGN**. VASA TECHNOLOGY SOLUTIONS, INC., (U.S. CLS. 100, 103 AND 106). SN 77-081,259. PUB. 5-20-2008. FILED 1-11-2007.
- 3,478,748 (*See Class 35 for this trademark*).
- 3,478,798. **EASTERN PCM, LLC E P C M AND DESIGN**. EASTERN PCM, LLC, (U.S. CLS. 100, 103 AND 106). SN 77-117,384. PUB. 5-20-2008. FILED 2-27-2007.
- 3,478,811 (*See Class 1 for this trademark*).
- 3,478,855 (*See Class 16 for this trademark*).
- 3,478,856. **ALL STATES ROOFING & CONSTRUCTION, INC "GOTTA LEAK? - GOTCHA COVERED" AND DESIGN**. ALL STATES ROOFING & CONSTRUCTION, INC., (U.S. CLS. 100, 103 AND 106). SN 77-154,540. PUB. 5-20-2008. FILED 4-11-2007.
- 3,478,860 (*See Class 9 for this trademark*).
- 3,478,864 (*See Class 25 for this trademark*).
- 3,478,881. **A MR ADVANCED METAL ROOFING.COM AND DESIGN**. ADVANCED METAL CORP., (U.S. CLS. 100, 103 AND 106). SN 77-167,162. PUB. 5-20-2008. FILED 4-27-2007.
- 3,478,883 (*See Class 19 for this trademark*).
- 3,478,893 (*See Class 35 for this trademark*).
- 3,478,956 (*See Class 35 for this trademark*).
- 3,478,983. **STRONGSTART (BLOCK FORM)**. STRONGMAIL SYSTEMS, INC., MULTIPLE CLASS, (INT. CLS. 37 AND 42), (U.S. CLS. 100, 101, 103 AND 106). SN 77-195,544. PUB. 5-20-2008. FILED 6-1-2007.

- 3,479,085 (*See Class 35 for this trademark.*)
 3,479,105 (*See Class 35 for this trademark.*)
 3,479,119 (*See Class 36 for this trademark.*)
 3,479,150. **STINGER (BLOCK FORM)**. STINGER WELLHEAD PROTECTION, INC., MULTIPLE CLASS, (INT. CLS. 37 AND 40), (U.S. CLS. 100, 103 AND 106). SN 77-218,337. PUB. 5-20-2008. FILED 6-28-2007.
 3,479,166. **TECH 2U (BLOCK FORM)**. TECH SERVICE 2U, MULTIPLE CLASS, (INT. CLS. 37 AND 42), (U.S. CLS. 100, 101, 103 AND 106). SN 77-220,052. PUB. 5-20-2008. FILED 7-2-2007.
 3,479,183. **REDNP (BLOCK FORM)**. REDNP LLC, (U.S. CLS. 100, 103 AND 106). SN 77-221,745. PUB. 5-20-2008. FILED 7-3-2007.
 3,479,216. **NEATWALLS AND DESIGN**. NEATWALL, (U.S. CLS. 100, 103 AND 106). SN 77-225,310. PUB. 5-20-2008. FILED 7-9-2007.
 3,479,238 (*See Class 7 for this trademark.*)
 3,479,273. **TUSCAN LAKES (BLOCK FORM)**. KENWOOD DEVELOPMENT, L.P., DBA TUSCAN LAKES DEVELOPMENT, L.P., (U.S. CLS. 100, 103 AND 106). SN 77-233,836. PUB. 5-20-2008. FILED 7-19-2007.
 3,479,274. **MISCELLANEOUS DESIGN**. KENWOOD DEVELOPMENT, L.P., DBA TUSCAN LAKES DEVELOPMENT, L.P., (U.S. CLS. 100, 103 AND 106). SN 77-233,889. PUB. 5-20-2008. FILED 7-19-2007.
 3,479,291 (*See Class 9 for this trademark.*)
 3,479,340. **BELFOR ENVIRONMENTAL (BLOCK FORM)**. BELFOR USA GROUP INC., (U.S. CLS. 100, 103 AND 106). SN 77-249,808. PUB. 5-20-2008. FILED 8-8-2007.
 3,479,348 (*See Class 35 for this trademark.*)
 3,479,397. **EDT SIGN OF QUALITY AND DESIGN**. ENGINEERING DESIGN TECHNOLOGIES, INC., (U.S. CLS. 100, 103 AND 106). SN 77-266,407. PUB. 5-20-2008. FILED 8-28-2007.
 3,479,431 (*See Class 36 for this trademark.*)
 3,479,432. **PRESSURE WASHING SYSTEMS (BLOCK FORM)**. MOLOGOUSIS, WILLIAM A., (U.S. CLS. 100, 103 AND 106). SN 77-275,977. PUB. 5-20-2008. FILED 9-10-2007.
 3,479,457. **WE SUCK YOUR GUTTERS CLEAN (BLOCK FORM)**. GUTTERSUCKERS, INC., (U.S. CLS. 100, 103 AND 106). SN 77-282,499. PUB. 5-20-2008. FILED 9-18-2007.
 3,479,555 (*See Class 35 for this trademark.*)
 3,479,557. **HERITAGE SOLAR (BLOCK FORM)**. HERITAGE SOLAR, INC., (U.S. CLS. 100, 103 AND 106). SN 77-306,824. PUB. 5-20-2008. FILED 10-17-2007.
 3,479,558. **ELECTRIC ELVES (BLOCK FORM)**. GUTTERSUCKERS, INC., (U.S. CLS. 100, 103 AND 106). SN 77-306,920. PUB. 5-20-2008. FILED 10-18-2007.
 3,479,569 (*See Class 9 for this trademark.*)
 3,479,581. **HUSBAND FOR A DAY WE DO WHAT YOU SAY AND DESIGN**. HUSBAND FOR A DAY, INC., (U.S. CLS. 100, 103 AND 106). SN 77-311,091. PUB. 5-20-2008. FILED 10-23-2007.
 3,479,592. **PYLON (BLOCK FORM)**. PYLON ELECTRONICS, INC., MULTIPLE CLASS, (INT. CLS. 37 AND 42), (U.S. CLS. 100, 101, 103 AND 106). SN 77-312,898. PUB. 5-20-2008. FILED 10-25-2007.
 3,479,693. **THE RIGHT PRICE! (BLOCK FORM)**. HALLMARK HOMES, INC., (U.S. CLS. 100, 103 AND 106). SN 77-328,023. PUB. 5-20-2008. FILED 11-13-2007.
 3,479,695. **YOUR FAMILY IS GOING TO LOVE LIVING HERE! (BLOCK FORM)**. HALLMARK HOMES, INC., (U.S. CLS. 100, 103 AND 106). SN 77-328,098. PUB. 5-20-2008. FILED 11-13-2007.
 3,479,696. **THE RIGHT PRICE IN NEW JERSEY! (BLOCK FORM)**. HALLMARK HOMES, INC., (U.S. CLS. 100, 103 AND 106). SN 77-328,140. PUB. 5-20-2008. FILED 11-13-2007.
 3,479,699. **THE RIGHT PRICE IN NJ! (BLOCK FORM)**. HALLMARK HOMES, INC., (U.S. CLS. 100, 103 AND 106). SN 77-328,190. PUB. 5-20-2008. FILED 11-13-2007.
 3,479,763. **MISTER GREEN BUILD (BLOCK FORM)**. CORWIN, THOMAS N, (U.S. CLS. 100, 103 AND 106). SN 77-338,725. PUB. 5-20-2008. FILED 11-28-2007.
 3,479,779. **HOME SWEET HOME IMPROVEMENTS (BLOCK FORM)**. WOTTON, THOMAS H., DBA HOME SWEET HOME IMPROVEMENTS, (U.S. CLS. 100, 103 AND 106). SN 77-340,759. PUB. 5-20-2008. FILED 11-30-2007.
 3,479,780 (*See Class 35 for this trademark.*)
 3,479,791. **COMFORTPASS (BLOCK FORM)**. GRA-TAC, INC., (U.S. CLS. 100, 103 AND 106). SN 77-341,770. PUB. 5-20-2008. FILED 11-30-2007.
 3,479,911. **GLOBAL CO2OLING (STYLIZED)**. WANGLER, THOMAS M., (U.S. CLS. 100, 103 AND 106). SN 77-352,018. PUB. 5-20-2008. FILED 12-14-2007.
 3,479,939. **GEMURGENCY (BLOCK FORM)**. GEM PLUMBING & HEATING CO., INC., (U.S. CLS. 100, 103 AND 106). SN 77-353,793. PUB. 5-20-2008. FILED 12-17-2007.
 3,479,960. **MAXWELL THE CLEANER (BLOCK FORM)**. ELLIOTT, RICK, (U.S. CLS. 100, 103 AND 106). SN 77-354,533. PUB. 5-20-2008. FILED 12-18-2007.
 3,479,975. **UNITED SPACE ALLIANCE (BLOCK FORM)**. UNITED SPACE ALLIANCE, LLC, (U.S. CLS. 100, 103 AND 106). SN 77-354,954. PUB. 5-20-2008. FILED 12-18-2007.
 3,479,979. **THE GLASS CLEANERS AND DESIGN**. LEVITT, DAVID, (U.S. CLS. 100, 103 AND 106). SN 77-355,188. PUB. 5-20-2008. FILED 12-18-2007.
 3,480,001. **SD WINDOW CLEANING L.L.C. QUALITY SERVICE AND DEPENDABILITY SINCE 1977 AND DESIGN**. S&D WINDOW CLEANING LLC, (U.S. CLS. 100, 103 AND 106). SN 77-356,631. PUB. 5-20-2008. FILED 12-20-2007.
 3,480,013. **SERVICE KING (BLOCK FORM)**. SERVICE KING PAINT & BODY, LLC, (U.S. CLS. 100, 103 AND 106). SN 77-356,843. PUB. 5-20-2008. FILED 12-20-2007.
 3,480,014. **SERVICE KING COLLISION REPAIR CENTERS (BLOCK FORM)**. SERVICE KING PAINT & BODY, LLC, (U.S. CLS. 100, 103 AND 106). SN 77-356,849. PUB. 5-20-2008. FILED 12-20-2007.
 3,480,024. **SERVICE KING AND DESIGN**. SERVICE KING PAINT & BODY, LLC, (U.S. CLS. 100, 103 AND 106). SN 77-357,037. PUB. 5-20-2008. FILED 12-20-2007.
 3,480,053. **RELIABLE ELEVATOR (BLOCK FORM)**. RELIABLE ELEVATOR, INC., (U.S. CLS. 100, 103 AND 106). SN 77-358,184. PUB. 5-20-2008. FILED 12-21-2007.
 3,480,083. **H ROCKER ELECTRIC AND DESIGN**. H. ROCKER ELECTRIC CO., INC., (U.S. CLS. 100, 103 AND 106). SN 77-359,360. PUB. 5-20-2008. FILED 12-26-2007.
 3,480,139. **LIFEZONES (BLOCK FORM)**. GRAND HAVEN HOMES, (U.S. CLS. 100, 103 AND 106). SN 77-361,762. PUB. 5-20-2008. FILED 12-31-2007.
 3,480,207 (*See Class 35 for this trademark.*)
 3,480,221. **FLORIDA PEST CONTROL & CHEMICAL CO. SINCE 1949 AND DESIGN**. FLORIDA PEST CONTROL & CHEMICAL CO., (U.S. CLS. 100, 103 AND 106). SN 77-363,257. PUB. 5-20-2008. FILED 1-3-2008.
 3,480,223. **ANYTHING'S POSSIBLE (BLOCK FORM)**. M & M CONSTRUCTION CONCEPTS & GUTTERS, LLC, (U.S. CLS. 100, 103 AND 106). SN 77-363,279. PUB. 5-20-2008. FILED 1-3-2008.
 3,480,257. **WE FIX UGLY DENTS (BLOCK FORM)**. HOCHSTEDLER, MARK, (U.S. CLS. 100, 103 AND 106). SN 77-363,781. PUB. 5-20-2008. FILED 1-3-2008.
 3,480,294. **BUCKETS & BLADES (BLOCK FORM)**. BLAYLOCK, WILLIAM, (U.S. CLS. 100, 103 AND 106). SN 77-364,372. PUB. 5-20-2008. FILED 1-4-2008.
 3,480,304. **ANV (BLOCK FORM)**. ANV CONSTRUCTION GROUP, INCORPORATED, (U.S. CLS. 100, 103 AND 106). SN 77-364,514. PUB. 5-20-2008. FILED 1-4-2008.
 3,480,341. **ADVANCED LOGIC TECHNOLOGIES (BLOCK FORM)**. ADVANCED LOGIC TECHNOLOGIES, LLC., (U.S. CLS. 100, 103 AND 106). SN 77-365,093. PUB. 5-20-2008. FILED 1-6-2008.
 3,480,359. **KING CLEANING SERVICE WE MOP 'TIL WE DROP. AND DESIGN**. D&B KING, INC., (U.S. CLS. 100, 103 AND 106). SN 77-365,388. PUB. 5-20-2008. FILED 1-7-2008.
 3,480,397. **PIT STOP (BLOCK FORM)**. PIT STOP RESTORATION LLC, (U.S. CLS. 100, 103 AND 106). SN 77-366,281. PUB. 5-20-2008. FILED 1-8-2008.
 3,480,402. **BUILDING NEIGHBORHOODS - CREATING NEIGHBORS (BLOCK FORM)**. FIEL, PAUL, (U.S. CLS. 100, 103 AND 106). SN 77-366,432. PUB. 5-20-2008. FILED 1-8-2008.
 3,480,471. **ACU-TRU (BLOCK FORM)**. THE WHEEL WAREHOUSE INC., (U.S. CLS. 100, 103 AND 106). SN 77-367,911. PUB. 5-20-2008. FILED 1-9-2008.
 3,480,513 (*See Class 36 for this trademark.*)

3,480,586 (*See Class 9 for this trademark.*)
 3,480,618 (*See Class 4 for this trademark.*)
 3,480,622 (*See Class 9 for this trademark.*)
 3,480,635. **MISCELLANEOUS DESIGN.** AIR SERV CORPORATION, MULTIPLE CLASS, (INT. CLS. 37, 39 AND 45), (U.S. CLS. 100, 101, 103, 105 AND 106). SN 78-790,393. PUB. 5-20-2008. FILED 1-12-2006.
 3,480,685. **IMPORTEK AND DESIGN.** INVENTEC MULTIMEDIA & TELECOM CORPORATION, (U.S. CLS. 100, 103 AND 106). SN 78-909,299. PUB. 5-20-2008. FILED 6-15-2006.
 3,480,694. **IMPORTEK (BLOCK FORM).** INVENTEC MULTIMEDIA & TELECOM CORPORATION, (U.S. CLS. 100, 103 AND 106). SN 78-909,458. PUB. 5-20-2008. FILED 6-15-2006.
 3,480,709 (*See Class 9 for this trademark.*)
 3,480,718 (*See Class 9 for this trademark.*)
 3,480,781 (*See Class 4 for this trademark.*)
 3,480,796 (*See Class 10 for this trademark.*)
 3,480,833 (*See Class 12 for this trademark.*)
 3,480,899 (*See Class 7 for this trademark.*)
 3,480,907 (*See Class 7 for this trademark.*)
 3,480,918 (*See Class 7 for this trademark.*)
 3,480,951 (*See Class 35 for this trademark.*)
 3,480,957 (*See Class 12 for this trademark.*)
 3,480,960 (*See Class 9 for this trademark.*)
 3,480,995 (*See Class 7 for this trademark.*)

CLASS 38—COMMUNICATION

3,478,526 (*See Class 35 for this trademark.*)
 3,478,527. **GET TO THE GOOD STUFF (BLOCK FORM).** GOTUIT MEDIA CORP., (U.S. CLS. 100, 101 AND 104). SN 76-668,361. PUB. 5-20-2008. FILED 11-1-2006.
 3,478,532. **SCENEMAKER (BLOCK FORM).** GOTUIT MEDIA CORP., (U.S. CLS. 100, 101 AND 104). SN 76-670,944. PUB. 5-20-2008. FILED 12-29-2006.
 3,478,589. **CONNECT2BUSINESS (BLOCK FORM).** KUDER, INC., (U.S. CLS. 100, 101 AND 104). SN 76-683,585. PUB. 5-20-2008. FILED 11-2-2007.
 3,478,595. **LINK2COLLEGE (BLOCK FORM).** KUDER, INC., (U.S. CLS. 100, 101 AND 104). SN 76-683,935. PUB. 5-20-2008. FILED 11-13-2007.
 3,478,670 (*See Class 37 for this trademark.*)
 3,478,672. **STRESS-FREE TV (BLOCK FORM).** AVTV NETWORKS, INC., (U.S. CLS. 100, 101 AND 104). SN 77-039,907. PUB. 5-20-2008. FILED 11-8-2006.
 3,478,702 (*See Class 37 for this trademark.*)
 3,478,733 (*See Class 35 for this trademark.*)
 3,478,805 (*See Class 9 for this trademark.*)
 3,478,836. **INDYA.COM AND DESIGN.** STAR TELEVISION PRODUCTIONS LIMITED, (U.S. CLS. 100, 101 AND 104). SN 77-144,830. PUB. 5-20-2008. FILED 3-30-2007.
 3,478,953. **REAL-VIDEO.TV AND DESIGN.** EYE JEWELS, INC., (U.S. CLS. 100, 101 AND 104). SN 77-188,917. PUB. 5-20-2008. FILED 5-23-2007.
 3,479,042. **AIX (BLOCK FORM).** TECHNOLOGY ADVANCEMENT GROUP, INC., (U.S. CLS. 100, 101 AND 104). SN 77-203,632. PUB. 5-20-2008. FILED 6-12-2007.
 3,479,092 (*See Class 35 for this trademark.*)
 3,479,205. **BOOZE MAIL (BLOCK FORM).** RENKOO, INC., (U.S. CLS. 100, 101 AND 104). SN 77-224,011. PUB. 5-20-2008. FILED 7-6-2007.
 3,479,278 (*See Class 35 for this trademark.*)
 3,479,377. **HOLISTIC ANARCHY (BLOCK FORM).** WHOLISTIC DIALOGUE, LLC, (U.S. CLS. 100, 101 AND 104). SN 77-261,847. PUB. 5-20-2008. FILED 8-22-2007.
 3,479,391. **SEARCHLES TV (BLOCK FORM).** SEARCHLES, INC., (U.S. CLS. 100, 101 AND 104). SN 77-265,015. PUB. 5-20-2008. FILED 8-27-2007.
 3,479,392. **SEARCHLES (BLOCK FORM).** SEARCHLES, INC., MULTIPLE CLASS, (INT. CLS. 38, 42 AND 45), (U.S. CLS. 100, 101 AND 104). SN 77-265,241. PUB. 5-20-2008. FILED 8-27-2007.
 3,479,441. **E-MARKETINGPLUS (BLOCK FORM).** LONG & FOSTER COMPANIES, INC., (U.S. CLS. 100, 101 AND 104). SN 77-279,050. PUB. 5-20-2008. FILED 9-13-2007.
 3,479,444 (*See Class 35 for this trademark.*)

3,479,520 (*See Class 9 for this trademark.*)
 3,479,538. **WARRIOR FORUM (BLOCK FORM).** SAYS JR, CLIFTON A., (U.S. CLS. 100, 101 AND 104). SN 77-302,153. PUB. 5-20-2008. FILED 10-11-2007.
 3,479,564. **NEVER MISS A STORY (BLOCK FORM).** SPokane TELEVISION, INC., (U.S. CLS. 100, 101 AND 104). SN 77-308,159. PUB. 5-20-2008. FILED 10-19-2007.
 3,479,566. **INDIA BROADCAST LIVE IBL AND DESIGN.** INDIA BROADCAST LIVE, INC., (U.S. CLS. 100, 101 AND 104). SN 77-308,994. PUB. 5-20-2008. FILED 10-19-2007.
 3,479,596. **YOU LIVE IN A HOTSPOT! (BLOCK FORM).** FRANK AND STEIN ASSOCIATES, LLC, (U.S. CLS. 100, 101 AND 104). SN 77-314,006. PUB. 5-20-2008. FILED 10-25-2007.
 3,479,653. **ONE COMPANY- CONNECTING YOUR WORLD (BLOCK FORM).** HARGRAY COMMUNICATIONS GROUP, INC., (U.S. CLS. 100, 101 AND 104). SN 77-323,611. PUB. 5-20-2008. FILED 11-7-2007.
 3,479,654. **ONEBOX CONNECTS THE WORLD TO YOU. (BLOCK FORM).** CALL SCIENCES, INC., (U.S. CLS. 100, 101 AND 104). SN 77-323,760. PUB. 5-20-2008. FILED 11-7-2007.
 3,479,736. **EPINOYPINAY (BLOCK FORM).** QUIAMBAAO, ROMEO BUGAY, DBA PHONE CARD CONNECTION, (U.S. CLS. 100, 101 AND 104). SN 77-334,824. PUB. 5-20-2008. FILED 11-21-2007.
 3,479,794. **NEW TANG DYNASTY TELEVISION (BLOCK FORM).** UNIVERSAL COMMUNICATIONS NETWORK, INC., DBA NEW TANG DYNASTY TELEVISION, (U.S. CLS. 100, 101 AND 104). SN 77-341,987. PUB. 5-20-2008. FILED 12-2-2007.
 3,479,795. **NEW TANG DYNASTY TELEVISION AND DESIGN.** UNIVERSAL COMMUNICATIONS NETWORK, INC., DBA NEW TANG DYNASTY TELEVISION, (U.S. CLS. 100, 101 AND 104). SN 77-341,994. PUB. 5-20-2008. FILED 12-2-2007.
 3,479,864. **CONNECT & DELIVER. (BLOCK FORM).** PETROCOM, L.L.C., (U.S. CLS. 100, 101 AND 104). SN 77-349,552. PUB. 5-20-2008. FILED 12-11-2007.
 3,479,940. **VOIP FOR SMART BUSINESS (BLOCK FORM).** ADAPTION TECHNOLOGIES VENTURES, LTD., (U.S. CLS. 100, 101 AND 104). SN 77-354,064. PUB. 5-20-2008. FILED 12-17-2007.
 3,479,992. **BSTAR (BLOCK FORM).** SITELIFE, INC., (U.S. CLS. 100, 101 AND 104). SN 77-356,235. PUB. 5-20-2008. FILED 12-19-2007.
 3,480,200. **FAFARAZZI (BLOCK FORM).** EASTLAND MEDIA, INC., MULTIPLE CLASS, (INT. CLS. 38 AND 41), (U.S. CLS. 100, 101, 104 AND 107). SN 77-362,977. PUB. 5-20-2008. FILED 1-2-2008.
 3,480,238. **MONYCALL (BLOCK FORM).** HALL, GARY L., (U.S. CLS. 100, 101 AND 104). SN 77-363,527. PUB. 5-20-2008. FILED 1-3-2008.
 3,480,398. **WMMR (BLOCK FORM).** GREATER MEDIA, INC., (U.S. CLS. 100, 101 AND 104). SN 77-366,295. PUB. 5-20-2008. FILED 1-8-2008.
 3,480,400. **WRIF (BLOCK FORM).** GREATER MEDIA, INC., (U.S. CLS. 100, 101 AND 104). SN 77-366,331. PUB. 5-20-2008. FILED 1-8-2008.
 3,480,468. **GUESTLINE (BLOCK FORM).** QWEST COMMUNICATIONS INTERNATIONAL INC., (U.S. CLS. 100, 101 AND 104). SN 77-367,764. PUB. 5-20-2008. FILED 1-9-2008.
 3,480,490. **SWITCHED (BLOCK FORM).** AOL LLC, (U.S. CLS. 100, 101 AND 104). SN 77-369,244. PUB. 5-20-2008. FILED 1-11-2008.
 3,480,515. **AM 1570 WIGO THE LIGHT AND DESIGN.** SHERIDAN BROADCASTING CORPORATION, MULTIPLE CLASS, (INT. CLS. 38 AND 41), (U.S. CLS. 100, 101, 104 AND 107). SN 77-377,168. PUB. 5-20-2008. FILED 1-22-2008.
 3,480,516. **THE LIGHT AND DESIGN.** SHERIDAN BROADCASTING CORPORATION, MULTIPLE CLASS, (INT. CLS. 38 AND 41), (U.S. CLS. 100, 101, 104 AND 107). SN 77-377,185. PUB. 5-20-2008. FILED 1-22-2008.
 3,480,522. **SIP ADVANTAGE OFFICETRUNK (BLOCK FORM).** ADAPTION TECHNOLOGIES VENTURES, LTD., (U.S. CLS. 100, 101 AND 104). SN 77-378,168. PUB. 5-20-2008. FILED 1-23-2008.
 3,480,584 (*See Class 9 for this trademark.*)

3,480,595 (*See Class 9 for this trademark.*)
 3,480,596 (*See Class 9 for this trademark.*)
 3,480,597 (*See Class 9 for this trademark.*)
 3,480,611. **LIPMAN (BLOCK FORM)**. VERIFONE ISRAEL LTD., MULTIPLE CLASS, (INT. CLS. 38 AND 42), (U.S. CLS. 100, 101 AND 104). SN 78-656,945. PUB. 5-20-2008. FILED 6-23-2005.
 3,480,614 (*See Class 16 for this trademark.*)
 3,480,628 (*See Class 9 for this trademark.*)
 3,480,686. **IMPORTEK AND DESIGN**. INVENTEC MULTIMEDIA & TELECOM CORPORATION, (U.S. CLS. 100, 101 AND 104). SN 78-909,314. PUB. 5-20-2008. FILED 6-15-2006.
 3,480,692. **IMPORTEK (BLOCK FORM)**. INVENTEC MULTIMEDIA & TELECOM CORPORATION, (U.S. CLS. 100, 101 AND 104). SN 78-909,443. PUB. 5-20-2008. FILED 6-15-2006.
 3,480,697. **IMMEDIA (BLOCK FORM)**. IMMEDIA, LLC, (U.S. CLS. 100, 101 AND 104). SN 78-912,736. PUB. 5-20-2008. FILED 6-20-2006.
 3,480,701. **IMMEDIA LLC AUDIO VISUAL SOLUTIONS AND DESIGN**. IMMEDIA, LLC, (U.S. CLS. 100, 101 AND 104). SN 78-914,849. PUB. 5-20-2008. FILED 6-22-2006.
 3,480,753 (*See Class 3 for this trademark.*)
 3,480,757 (*See Class 9 for this trademark.*)
 3,480,758 (*See Class 9 for this trademark.*)
 3,480,803. **BLUE ZONE (BLOCK FORM)**. AD COMMUNICATIONS PTY LTD, (U.S. CLS. 100, 101 AND 104). SN 79-036,143. PUB. 5-20-2008. FILED 12-7-2006.
 3,480,811 (*See Class 9 for this trademark.*)
 3,480,877. **LAST POST (STYLIZED)**. LAST POST LIMITED, MULTIPLE CLASS, (INT. CLS. 38, 41, 42 AND 45), (U.S. CLS. 100, 101, 104 AND 107). SN 79-041,329. PUB. 5-20-2008. FILED 3-29-2007.
 3,480,910 (*See Class 9 for this trademark.*)
 3,480,916 (*See Class 9 for this trademark.*)
 3,480,934 (*See Class 28 for this trademark.*)
 3,480,943 (*See Class 9 for this trademark.*)
 3,480,952 (*See Class 9 for this trademark.*)
 3,481,017 (*See Class 35 for this trademark.*)
 3,481,021 (*See Class 35 for this trademark.*)

CLASS 39—TRANSPORTATION AND STORAGE

3,478,516 (*See Class 9 for this trademark.*)
 3,478,638 (*See Class 35 for this trademark.*)
 3,478,677. **SOURCEMEDICAL THE FUTURE STARTS HERE. AND DESIGN**. SOURCE MEDICAL SOLUTIONS, INC., MULTIPLE CLASS, (INT. CLS. 39 AND 42), (U.S. CLS. 100, 101 AND 105). SN 77-043,269. PUB. 5-20-2008. FILED 11-14-2006.
 3,478,759 (*See Class 35 for this trademark.*)
 3,478,813. **BRONZE WORLD TRAVEL (BLOCK FORM)**. BRONZE WORLD TRAVEL LLC, (U.S. CLS. 100 AND 105). SN 77-127,840. PUB. 10-2-2007. FILED 3-11-2007.
 3,478,943 (*See Class 35 for this trademark.*)
 3,478,949. **ISRAIR AND DESIGN**. ISRAIR AIRLINES AND TOURISM LTD., (U.S. CLS. 100 AND 105). SN 77-188,187. PUB. 5-20-2008. FILED 5-23-2007.
 3,479,062. **GOLDRING GULF DISTRIBUTING (BLOCK FORM)**. N GOLDRING CORPORATION, (U.S. CLS. 100 AND 105). SN 77-207,071. PUB. 5-20-2008. FILED 6-15-2007.
 3,479,154 (*See Class 16 for this trademark.*)
 3,479,236 (*See Class 35 for this trademark.*)
 3,479,308. **ENTERPRISE AND DESIGN**. ENTERPRISE RENT-A-CAR COMPANY, (U.S. CLS. 100 AND 105). SN 77-240,964. PUB. 5-20-2008. FILED 7-27-2007.
 3,479,332. **CORPSTAR (BLOCK FORM)**. CORPSTAR LIMOUSINE SERVICES, LLC, (U.S. CLS. 100 AND 105). SN 77-248,467. PUB. 5-20-2008. FILED 8-6-2007.
 3,479,347. **ELVIS (BLOCK FORM)**. ELVIS PRESLEY ENTERPRISES, INC., (U.S. CLS. 100 AND 105). SN 77-251,593. PUB. 5-20-2008. FILED 8-9-2007.
 3,479,375 (*See Class 35 for this trademark.*)
 3,479,438. **MISCELLANEOUS DESIGN**. OPTIMAL NUTRITION INC, (U.S. CLS. 100 AND 105). SN 77-278,621. PUB. 5-20-2008. FILED 9-13-2007.

3,479,449 (*See Class 35 for this trademark.*)
 3,479,463. **ULTIMATE INDIA UNLIMITED ACCESS (BLOCK FORM)**. GREAVES TOURS LLC, MULTIPLE CLASS, (INT. CLS. 39 AND 43), (U.S. CLS. 100, 101 AND 105). SN 77-283,622. PUB. 5-20-2008. FILED 9-19-2007.
 3,479,465. **AARON'S AMERICAN TRANSPORTATION (BLOCK FORM)**. RICHARD, CAROL A., (U.S. CLS. 100 AND 105). SN 77-283,939. PUB. 5-20-2008. FILED 9-19-2007.
 3,479,510. **WILD CAR (BLOCK FORM)**. THRIFTY, INC., (U.S. CLS. 100 AND 105). SN 77-299,333. PUB. 5-20-2008. FILED 10-9-2007.
 3,479,523. **SLL (BLOCK FORM)**. STEMLIFELINE INC., MULTIPLE CLASS, (INT. CLS. 39 AND 44), (U.S. CLS. 100, 101 AND 105). SN 77-301,309. PUB. 5-20-2008. FILED 10-11-2007.
 3,479,525. **PROTECTING THE FUTURE (BLOCK FORM)**. STEMLIFELINE INC., MULTIPLE CLASS, (INT. CLS. 39 AND 44), (U.S. CLS. 100, 101 AND 105). SN 77-301,333. PUB. 5-20-2008. FILED 10-11-2007.
 3,479,528. **MISCELLANEOUS DESIGN**. STEMLIFELINE INC., MULTIPLE CLASS, (INT. CLS. 39 AND 44), (U.S. CLS. 100, 101 AND 105). SN 77-301,360. PUB. 5-20-2008. FILED 10-11-2007.
 3,479,628 (*See Class 35 for this trademark.*)
 3,479,689. **THE BONEYARD INC AND DESIGN**. THE BONEYARD INC, (U.S. CLS. 100 AND 105). SN 77-327,147. PUB. 5-20-2008. FILED 11-12-2007.
 3,479,690. **AHSTF (BLOCK FORM)**. LAKELAND FINANCE LLC, (U.S. CLS. 100 AND 105). SN 77-327,291. PUB. 5-20-2008. FILED 11-12-2007.
 3,479,702. **LAWRY (STYLIZED)**. LAWRY FREIGHT SYSTEM, INC., (U.S. CLS. 100 AND 105). SN 77-328,873. PUB. 5-20-2008. FILED 11-14-2007.
 3,479,730. **BRINGING YOU THE BEST OF INDIA (BLOCK FORM)**. GREAVES TOURS, LLC, MULTIPLE CLASS, (INT. CLS. 39 AND 43), (U.S. CLS. 100, 101 AND 105). SN 77-334,037. PUB. 5-20-2008. FILED 11-20-2007.
 3,479,776. **PIAZZA PRODUCE (STYLIZED)**. IF&P FOODS, INC., (U.S. CLS. 100 AND 105). SN 77-340,146. PUB. 5-20-2008. FILED 11-29-2007.
 3,479,780 (*See Class 35 for this trademark.*)
 3,479,823. **DELIVERED GREEN BY EA LOGISTICS AND DESIGN**. MCS CARGO SYSTEMS, INC., (U.S. CLS. 100 AND 105). SN 77-344,997. PUB. 5-20-2008. FILED 12-5-2007.
 3,479,882. **WOMEN TRAVELING TOGETHER AND DESIGN**. ASBERRY, DEBRA, (U.S. CLS. 100 AND 105). SN 77-350,467. PUB. 5-20-2008. FILED 12-12-2007.
 3,479,901. **BEST STORAGE VALUE IN THE WEST (BLOCK FORM)**. OVERTON BOAT & RV STORAGE, LLC, (U.S. CLS. 100 AND 105). SN 77-351,503. PUB. 5-20-2008. FILED 12-13-2007.
 3,479,914 (*See Class 35 for this trademark.*)
 3,479,915 (*See Class 35 for this trademark.*)
 3,479,917 (*See Class 35 for this trademark.*)
 3,480,075. **TRAVELERS DIGEST (BLOCK FORM)**. TRAVELERS DIGEST, (U.S. CLS. 100 AND 105). SN 77-359,207. PUB. 5-20-2008. FILED 12-26-2007.
 3,480,096. **HERO MILES AND DESIGN**. FISHER HOUSE FOUNDATION, (U.S. CLS. 100 AND 105). SN 77-359,705. PUB. 5-20-2008. FILED 12-26-2007.
 3,480,215 (*See Class 35 for this trademark.*)
 3,480,280. **POWER OF RED (BLOCK FORM)**. ROEHL TRANSPORT, INC., (U.S. CLS. 100 AND 105). SN 77-364,150. PUB. 5-20-2008. FILED 1-4-2008.
 3,480,345. **WLG (BLOCK FORM)**. WLG, INC., (U.S. CLS. 100 AND 105). SN 77-365,197. PUB. 5-20-2008. FILED 1-7-2008.
 3,480,360. **UNITED HANDY CAN (BLOCK FORM)**. SOYKA, STEVE, (U.S. CLS. 100 AND 105). SN 77-365,425. PUB. 5-20-2008. FILED 1-7-2008.
 3,480,466. **6 S (STYLIZED)**. MEYER, KARL R., MULTIPLE CLASS, (INT. CLS. 39 AND 40), (U.S. CLS. 100, 103, 105 AND 106). SN 77-367,735. PUB. 5-20-2008. FILED 1-9-2008.
 3,480,475. **BAREFOOT EXPEDITIONS (BLOCK FORM)**. ALTAMIRANO, ANTONIO, (U.S. CLS. 100 AND 105). SN 77-367,919. PUB. 5-20-2008. FILED 1-9-2008.
 3,480,635 (*See Class 37 for this trademark.*)
 3,480,647 (*See Class 35 for this trademark.*)
 3,480,659. **P&O CRUISES (BLOCK FORM)**. THE PENINSULAR AND ORIENTAL STEAM NAVIGATION COMPANY,

MULTIPLE CLASS, (INT. CLS. 39, 41 AND 43), (U.S. CLS. 100, 101, 105 AND 107). SN 78-854,499. PUB. 5-20-2008. FILED 4-5-2006.

3,480,708. **QUESTAR GAS MANAGEMENT (BLOCK FORM)**. QUESTAR CORPORATION, MULTIPLE CLASS, (INT. CLS. 39 AND 40), (U.S. CLS. 100, 103, 105 AND 106). SN 78-935,743. PUB. 7-31-2007. FILED 7-24-2006.

3,480,751. **PULLMANTUR CRUISES AND DESIGN**. PULLMANTUR, S.A., (U.S. CLS. 100 AND 105). SN 79-026,943. PUB. 5-20-2008. FILED 2-27-2006.

3,480,753 (*See Class 3 for this trademark*).

3,480,758 (*See Class 9 for this trademark*).

3,480,855 (*See Class 35 for this trademark*).

3,480,905 (*See Class 16 for this trademark*).

CLASS 40—MATERIAL TREATMENT

3,478,503 (*See Class 37 for this trademark*).

3,478,509 (*See Class 19 for this trademark*).

3,478,510 (*See Class 19 for this trademark*).

3,478,516 (*See Class 9 for this trademark*).

3,478,543. **TRUE REFLECTIONS FOR WOMEN (BLOCK FORM)**. WRIGHT & FILIPPIS, INC., MULTIPLE CLASS, (INT. CLS. 40 AND 44), (U.S. CLS. 100, 101, 103 AND 106). SN 76-674,614. PUB. 5-20-2008. FILED 3-26-2007.

3,478,604. **RESTORE AND DESIGN**. RHODE ISLAND RESOURCE RECOVERY CORPORATION, (U.S. CLS. 100, 103 AND 106). SN 76-684,899. PUB. 5-20-2008. FILED 12-13-2007.

3,478,641 (*See Class 7 for this trademark*).

3,478,666 (*See Class 6 for this trademark*).

3,478,689. **DIRECT FULFILLMENT (BLOCK FORM)**. WELDON, WILLIAMS & LICK, INC., (U.S. CLS. 100, 103 AND 106). SN 77-048,899. PUB. 5-20-2008. FILED 11-21-2006.

3,478,770 (*See Class 1 for this trademark*).

3,478,777 (*See Class 10 for this trademark*).

3,478,809. **ESPRESSIO (BLOCK FORM)**. THE BOOK DEPOSITORY LTD., (U.S. CLS. 100, 103 AND 106). SN 77-125,169. PUB. 5-20-2008. FILED 3-8-2007.

3,478,811 (*See Class 1 for this trademark*).

3,478,855 (*See Class 16 for this trademark*).

3,478,861 (*See Class 11 for this trademark*).

3,478,934. **GILERO (BLOCK FORM)**. GILERO, LLC, MULTIPLE CLASS, (INT. CLS. 40 AND 42), (U.S. CLS. 100, 101, 103 AND 106). SN 77-184,845. PUB. 5-20-2008. FILED 5-18-2007.

3,478,935. **G AND DESIGN**. GILERO, LLC, MULTIPLE CLASS, (INT. CLS. 40 AND 42), (U.S. CLS. 100, 101, 103 AND 106). SN 77-184,857. PUB. 5-20-2008. FILED 5-18-2007.

3,479,066 (*See Class 35 for this trademark*).

3,479,107 (*See Class 14 for this trademark*).

3,479,150 (*See Class 37 for this trademark*).

3,479,187. **DO IT WITH A CLICK (BLOCK FORM)**. ARIZONA FAST SHIRTS, LLC, (U.S. CLS. 100, 103 AND 106). SN 77-221,996. PUB. 5-20-2008. FILED 7-3-2007.

3,479,199. **ELEMENTSHIELD (BLOCK FORM)**. ELEMENTSHIELD, (U.S. CLS. 100, 103 AND 106). SN 77-223,124. PUB. 5-20-2008. FILED 7-6-2007.

3,479,236 (*See Class 35 for this trademark*).

3,479,248. **RMR RIVER METALS RECYCLING LLC AND DESIGN**. RIVER METALS RECYCLING LLC, (U.S. CLS. 100, 103 AND 106). SN 77-230,167. PUB. 5-20-2008. FILED 7-16-2007.

3,479,291 (*See Class 9 for this trademark*).

3,479,341. **BELFOR ENVIRONMENTAL (BLOCK FORM)**. BELFOR USA GROUP INC., (U.S. CLS. 100, 103 AND 106). SN 77-249,936. PUB. 5-20-2008. FILED 8-8-2007.

3,479,375 (*See Class 35 for this trademark*).

3,479,390. **TKO GRAPHIX AND DESIGN**. TKO ENTERPRISES, INC., (U.S. CLS. 100, 103 AND 106). SN 77-264,902. PUB. 5-20-2008. FILED 8-27-2007.

3,479,415 (*See Class 35 for this trademark*).

3,479,430 (*See Class 35 for this trademark*).

3,479,720. **CLEAN LAND PRODUCTS AND DESIGN**. KTK ASSOCIATES, INC., (U.S. CLS. 100, 103 AND 106). SN 77-331,943. PUB. 5-20-2008. FILED 11-16-2007.

3,479,913. **WALCH PRINTING AND DESIGN**. J. WESTON WALCH, PUBLISHER, (U.S. CLS. 100, 103 AND 106). SN 77-

352,057. PUB. 5-20-2008. FILED 12-14-2007.

3,480,093. **MISCELLANEOUS DESIGN**. BREENE GRAPHICS, INC., (U.S. CLS. 100, 103 AND 106). SN 77-359,659. PUB. 5-20-2008. FILED 12-26-2007.

3,480,372. **ONE COMPANY ONE PROCESS ONE TEAM HV AND DESIGN**. HOLLINGSWORTH & VOSE COMPANY, (U.S. CLS. 100, 103 AND 106). SN 77-365,681. PUB. 5-20-2008. FILED 1-7-2008.

3,480,394 (*See Class 35 for this trademark*).

3,480,466 (*See Class 39 for this trademark*).

3,480,563. **REZENATE! (BLOCK FORM)**. STRATEGIC PARTNERS, INC., (U.S. CLS. 100, 103 AND 106). SN 77-416,031. PUB. 5-20-2008. FILED 3-7-2008.

3,480,612 (*See Class 29 for this trademark*).

3,480,631. **COMMAND NUTRITIONALS (BLOCK FORM)**. COMMAND NUTRITIONALS, LLC, MULTIPLE CLASS, (INT. CLS. 40 AND 42), (U.S. CLS. 100, 101, 103 AND 106). SN 78-760,161. PUB. 5-20-2008. FILED 11-23-2005.

3,480,639. **AI (STYLIZED)**. ANDROID INDUSTRIES, L.L.C., (U.S. CLS. 100, 103 AND 106). SN 78-802,583. PUB. 5-20-2008. FILED 1-30-2006.

3,480,708 (*See Class 39 for this trademark*).

3,480,786 (*See Class 6 for this trademark*).

3,480,854 (*See Class 9 for this trademark*).

3,480,907 (*See Class 7 for this trademark*).

3,480,943 (*See Class 9 for this trademark*).

3,480,982. **OROGENTA (BLOCK FORM)**. GLATT GMBH, MULTIPLE CLASS, (INT. CLS. 40 AND 42), (U.S. CLS. 100, 101, 103 AND 106). SN 79-044,706. PUB. 5-20-2008. FILED 6-12-2007.

3,481,034. **S STUDIO LABELS AND DESIGN**. STUDIO LABELS PTY LTD; ACN 125 870 304, (U.S. CLS. 100, 103 AND 106). SN 79-049,365. PUB. 5-20-2008. FILED 1-2-2008.

CLASS 41—EDUCATION AND ENTERTAINMENT

3,478,507. **UR UNTOUCHABLE RECORDS MUSIC IS OUR BUSINESS AND DESIGN**. MUHAMMAD, GENGHIS KHALID (GKM), (U.S. CLS. 100, 101 AND 107). SN 76-638,205. PUB. 5-20-2008. FILED 5-9-2005.

3,478,508. **M MANCHESTER WHO'S WHO (STYLIZED)**. PROMAN, MATTHEW, (U.S. CLS. 100, 101 AND 107). SN 76-642,694. PUB. 5-20-2008. FILED 7-12-2005.

3,478,526 (*See Class 35 for this trademark*).

3,478,544 (*See Class 14 for this trademark*).

3,478,546 (*See Class 35 for this trademark*).

3,478,551. **MAXIMUM LIVING (BLOCK FORM)**. RANDALL S. CORPORATION, (U.S. CLS. 100, 101 AND 107). SN 76-676,832. PUB. 5-20-2008. FILED 5-14-2007.

3,478,563. **NATIONAL SAFETY COMPLIANCE (BLOCK FORM)**. NATIONAL SAFETY COMPLIANCE, INC., MULTIPLE CLASS, (INT. CLS. 41, 42 AND 44), (U.S. CLS. 100, 101 AND 107). SN 76-679,483. PUB. 5-20-2008. FILED 7-13-2007.

3,478,571. **FSP NATIONAL REGISTRY OF FOOD SAFETY PROFESSIONALS CERTIFIED FOOD SAFETY MANAGER AND DESIGN**. ENVIRONMENTAL HEALTH TESTING, LLC, (U.S. CLS. 100, 101 AND 107). SN 76-680,983. PUB. 5-20-2008. FILED 8-22-2007.

3,478,584. **THE PROJECT WAY (BLOCK FORM)**. CAVALUZZI, FRANK A., (U.S. CLS. 100, 101 AND 107). SN 76-682,705. PUB. 5-20-2008. FILED 10-9-2007.

3,478,597. **TCC THE CROSSTRaining CLUB (STYLIZED)**. THE CROSSTRaining CLUB FRANCHISE COMPANY, (U.S. CLS. 100, 101 AND 107). SN 76-684,159. PUB. 5-20-2008. FILED 11-19-2007.

3,478,599 (*See Class 9 for this trademark*).

3,478,608. **BELLE VIE PHOTOGRAPHY (BLOCK FORM)**. BELLE VIE PHOTOGRAPHY, (U.S. CLS. 100, 101 AND 107). SN 76-685,022. PUB. 5-20-2008. FILED 12-17-2007.

3,478,610. **IWONDER (STYLIZED)**. SMITHSONIAN INSTITUTION, (U.S. CLS. 100, 101 AND 107). SN 76-685,097. PUB. 5-20-2008. FILED 12-19-2007.

3,478,611 (*See Class 9 for this trademark*).

3,478,626. **MISSIONNETWORK AND DESIGN**. CATHOLIC

- YOUTH WORLD NETWORK, INC., (U.S. CLS. 100, 101 AND 107). SN 77-000,158. PUB. 5-20-2008. FILED 9-15-2006. 3,478,627 (*See Class 36 for this trademark*).
- 3,478,631. **PLANET DANCE (BLOCK FORM)**. PLANET DANCE LLC, (U.S. CLS. 100, 101 AND 107). SN 77-007,884. PUB. 5-20-2008. FILED 9-26-2006.
- 3,478,649. **FAB FOREVER (BLOCK FORM)**. FAB FOREVER LLC, (U.S. CLS. 100, 101 AND 107). SN 77-022,317. PUB. 5-20-2008. FILED 10-16-2006.
- 3,478,655 (*See Class 35 for this trademark*).
- 3,478,657. **HOT PINK TV (BLOCK FORM)**. BECKY LEBEAU, DBA FANTASYONE, (U.S. CLS. 100, 101 AND 107). SN 77-031,769. PUB. 5-20-2008. FILED 10-29-2006.
- 3,478,659 (*See Class 9 for this trademark*).
- 3,478,670 (*See Class 9 for this trademark*).
- 3,478,679. **WRITE READ SUCCEED (BLOCK FORM)**. GOLDSTEIN, SAMANTHA, (U.S. CLS. 100, 101 AND 107). SN 77-044,165. PUB. 5-20-2008. FILED 11-15-2006.
- 3,478,686. **FEEL GOOD FAST FOOD (BLOCK FORM)**. AMANDA'S RESTAURANTS, LLC, (U.S. CLS. 100, 101 AND 107). SN 77-046,603. PUB. 5-20-2008. FILED 11-17-2006.
- 3,478,693. **GREEN ZONE INTERNATIONAL FACILITY MANAGEMENT ASSOCIATION (STYLIZED)**. INTERNATIONAL FACILITY MANAGEMENT ASSOCIATION, (U.S. CLS. 100, 101 AND 107). SN 77-050,772. PUB. 5-20-2008. FILED 11-27-2006.
- 3,478,709 (*See Class 35 for this trademark*).
- 3,478,717. **LA PICOSA (BLOCK FORM)**. BROADCAST ONE, INC., (U.S. CLS. 100, 101 AND 107). SN 77-065,203. PUB. 5-20-2008. FILED 12-15-2006.
- 3,478,723 (*See Class 9 for this trademark*).
- 3,478,728. **I WANT TO BE A STAR AND DESIGN**. SPURR, THURLOW, (U.S. CLS. 100, 101 AND 107). SN 77-074,492. PUB. 5-20-2008. FILED 1-2-2007.
- 3,478,731. **HOT WHEELS MONSTER TRUCK SMASHDOWN (BLOCK FORM)**. MATTEL, INC., (U.S. CLS. 100, 101 AND 107). SN 77-075,463. PUB. 5-20-2008. FILED 1-3-2007.
- 3,478,732. **SPAMEDICA (BLOCK FORM)**. SPAMEDICA INTERNATIONAL SRL, MULTIPLE CLASS, (INT. CLS. 41 AND 44), (U.S. CLS. 100, 101 AND 107). SN 77-076,750. PUB. 5-20-2008. FILED 1-5-2007.
- 3,478,735. **JUPITER ONE (BLOCK FORM)**. JUPITER ONE MUSIC, INC., (U.S. CLS. 100, 101 AND 107). SN 77-079,181. PUB. 2-12-2008. FILED 1-9-2007.
- 3,478,748 (*See Class 35 for this trademark*).
- 3,478,754. **NEW VISIONS NEW VOICES (BLOCK FORM)**. TRUSTEES OF THE JOHN F. KENNEDY CENTER FOR THE PERFORMING ARTS, (U.S. CLS. 100, 101 AND 107). SN 77-095,147. PUB. 5-20-2008. FILED 1-30-2007.
- 3,478,762. **UPSTREAM STANDARDS. BOTTOM LINE RESULTS. (BLOCK FORM)**. ENERGETISTICS CONSORTIUM, INC., (U.S. CLS. 100, 101 AND 107). SN 77-096,827. PUB. 5-20-2008. FILED 2-1-2007.
- 3,478,768 (*See Class 36 for this trademark*).
- 3,478,769 (*See Class 16 for this trademark*).
- 3,478,774. **AT THE END OF YOUR LEASH! (BLOCK FORM)**. JENNIFER M. FREILICH, (U.S. CLS. 100, 101 AND 107). SN 77-104,500. PUB. 5-20-2008. FILED 2-10-2007.
- 3,478,778 (*See Class 35 for this trademark*).
- 3,478,786. **CHIPPENDALES AND DESIGN**. CHIPPENDALES USA, LLC, (U.S. CLS. 100, 101 AND 107). SN 77-111,444. PUB. 5-20-2008. FILED 2-20-2007.
- 3,478,808. **CASTABLE TYPES (BLOCK FORM)**. WHITE, CYNTHIA, (U.S. CLS. 100, 101 AND 107). SN 77-124,874. PUB. 5-20-2008. FILED 3-7-2007.
- 3,478,819 (*See Class 35 for this trademark*).
- 3,478,821 (*See Class 35 for this trademark*).
- 3,478,824. **JLPHOTO (BLOCK FORM)**. JP STUDIOS INC., (U.S. CLS. 100, 101 AND 107). SN 77-136,143. PUB. 5-20-2008. FILED 3-21-2007.
- 3,478,825. **FARMS FOR CITY KIDS SPRING BROOK FARM READING, VERMONT AND DESIGN**. FARMS FOR CITY KIDS FOUNDATION, INC., (U.S. CLS. 100, 101 AND 107). SN 77-139,348. PUB. 5-20-2008. FILED 3-23-2007.
- 3,478,837. **INDYA.COM AND DESIGN**. STAR TELEVISION PRODUCTIONS LIMITED, (U.S. CLS. 100, 101 AND 107). SN 77-144,834. PUB. 5-20-2008. FILED 3-30-2007.
- 3,478,839 (*See Class 35 for this trademark*).
- 3,478,840. **PASSPORT APPROVED (BLOCK FORM)**. PAN-GAEA ENTERTAINMENT GROUP, (U.S. CLS. 100, 101 AND 107). SN 77-146,421. PUB. 5-20-2008. FILED 4-2-2007.
- 3,478,845. **HAUNTED HISTORY TOURS (BLOCK FORM)**. SMITH, SIDNEY HOFFMAN, (U.S. CLS. 100, 101 AND 107). SN 77-147,406. PUB. 5-20-2008. FILED S.R. 4-3-2007; AM. P.R. 4-2-2008.
- 3,478,849. **ASYST INSTITUTE AND DESIGN**. ANALYTIC SERVICES INC. DBA ANSER, MULTIPLE CLASS, (INT. CLS. 41 AND 42), (U.S. CLS. 100, 101 AND 107). SN 77-150,450. PUB. 5-20-2008. FILED 4-6-2007.
- 3,478,850. **APPLIED SYSTEMS THINKING INSTITUTE (BLOCK FORM)**. ANALYTIC SERVICES INC. DBA ANSER, MULTIPLE CLASS, (INT. CLS. 41 AND 42), (U.S. CLS. 100, 101 AND 107). SN 77-150,454. PUB. 5-20-2008. FILED 4-6-2007.
- 3,478,859 (*See Class 25 for this trademark*).
- 3,478,863 (*See Class 9 for this trademark*).
- 3,478,864 (*See Class 25 for this trademark*).
- 3,478,865. **ASK LORNA (BLOCK FORM)**. PREFERRED NUTRITION INC., (U.S. CLS. 100, 101 AND 107). SN 77-157,900. PUB. 5-20-2008. FILED 4-16-2007.
- 3,478,871. **TCS THE COMPLETE SHEET YOUR VIRTUAL SHOW PRODUCER AND DESIGN**. TCS ENTERTAINMENT, INC., (U.S. CLS. 100, 101 AND 107). SN 77-160,997. PUB. 5-20-2008. FILED 4-19-2007.
- 3,478,872 (*See Class 9 for this trademark*).
- 3,478,877. **MS. MONSTER (BLOCK FORM)**. AMY KATHERINE SMITH, (U.S. CLS. 100, 101 AND 107). SN 77-165,104. PUB. 5-20-2008. FILED 4-25-2007.
- 3,478,879 (*See Class 35 for this trademark*).
- 3,478,882. **HLS (BLOCK FORM)**. MCCABE FUNERAL HOME, (U.S. CLS. 100, 101 AND 107). SN 77-167,269. PUB. 5-20-2008. FILED 4-27-2007.
- 3,478,894. **SEDUCE A CELEB (BLOCK FORM)**. GOFISH CORPORATION, (U.S. CLS. 100, 101 AND 107). SN 77-171,222. PUB. 10-16-2007. FILED 5-2-2007.
- 3,478,897. **ANCHORAGE PRESS (BLOCK FORM)**. ANCHORAGE FOUNDATION OF TEXAS, (U.S. CLS. 100, 101 AND 107). SN 77-174,194. PUB. 5-20-2008. FILED 5-7-2007.
- 3,478,903 (*See Class 16 for this trademark*).
- 3,478,904. **SAN FRANPSYCHO (STYLIZED)**. ROUTZEN, CHRISTIAN, (U.S. CLS. 100, 101 AND 107). SN 77-175,808. PUB. 5-20-2008. FILED 5-8-2007.
- 3,478,906 (*See Class 36 for this trademark*).
- 3,478,908 (*See Class 16 for this trademark*).
- 3,478,920 (*See Class 35 for this trademark*).
- 3,478,928. **IMAGINATION IN EDUCATION (BLOCK FORM)**. PCS EDVENTURES!.COM, INC., (U.S. CLS. 100, 101 AND 107). SN 77-184,052. PUB. 5-20-2008. FILED 5-17-2007.
- 3,478,936. **THE LEATHER MASKED BALL (BLOCK FORM)**. BOUND SOUTH, INC., (U.S. CLS. 100, 101 AND 107). SN 77-185,037. PUB. 5-20-2008. FILED 5-18-2007.
- 3,478,960 (*See Class 9 for this trademark*).
- 3,478,968 (*See Class 16 for this trademark*).
- 3,478,992. **REWIRING (BLOCK FORM)**. SEDLAR, JERI, DBA JS ENTERPRISES, (U.S. CLS. 100, 101 AND 107). SN 77-196,180. PUB. 5-20-2008. FILED 6-2-2007.
- 3,478,995. **WINNING ONE CUSTOMER AT A TIME (BLOCK FORM)**. LEVY FOOD SERVICE LIMITED PARTNERSHIP, (U.S. CLS. 100, 101 AND 107). SN 77-196,525. PUB. 5-20-2008. FILED 6-4-2007.
- 3,479,016 (*See Class 16 for this trademark*).
- 3,479,024. **THE WORLD STANDARD IN STAGING EDUCATION (BLOCK FORM)**. BARB, INC. DBA STAGED HOMES, (U.S. CLS. 100, 101 AND 107). SN 77-199,939. PUB. 5-20-2008. FILED 6-7-2007.
- 3,479,028. **RODS & RIDES TV STORE AND DESIGN**. DAVE BOWMAN ENTERPRISES, INC., (U.S. CLS. 100, 101 AND 107). SN 77-200,493. PUB. 5-20-2008. FILED 6-7-2007.
- 3,479,035. **GOLFTARDS (BLOCK FORM)**. SMITH, BRENN, (U.S. CLS. 100, 101 AND 107). SN 77-201,581. PUB. 5-20-2008. FILED 6-8-2007.
- 3,479,045. **PSDS (BLOCK FORM)**. DR. ING. H.C. F. PORSCHE AG, (U.S. CLS. 100, 101 AND 107). SN 77-204,065. PUB. 5-20-2008. FILED 6-12-2007.
- 3,479,050. **CLUB SCIENTIFIC AND DESIGN**. SUMMER SCIENCE DAY CAMPS, INC., (U.S. CLS. 100, 101 AND

- 107). SN 77-204,355. PUB. 5-20-2008. FILED 6-12-2007.
 3,479,052 (*See Class 9 for this trademark*).
 3,479,059. **NATIONAL ACADEMY FOR CONTINUING EDUCATION NACE AND DESIGN**. WELCH, RITA, A. AND WELCH, CRAIG, A., (U.S. CLS. 100, 101 AND 107). SN 77-206,508. PUB. 5-20-2008. FILED 6-14-2007.
 3,479,063. **BLACK MACHISMO (BLOCK FORM)**. TNA ENTERTAINMENT, LLC, (U.S. CLS. 100, 101 AND 107). SN 77-207,486. PUB. 5-20-2008. FILED 6-15-2007.
 3,479,082. **MCCLATCHY (BLOCK FORM)**. THE MCCLATCHY COMPANY, (U.S. CLS. 100, 101 AND 107). SN 77-210,178. PUB. 5-20-2008. FILED 6-19-2007.
 3,479,086. **MOUNTAIN CRAFT DAYS (BLOCK FORM)**. HISTORICAL & GENEALOGICAL SOCIETY OF SOMERSET COUNTY, (U.S. CLS. 100, 101 AND 107). SN 77-210,887. PUB. 5-20-2008. FILED 6-20-2007.
 3,479,092 (*See Class 35 for this trademark*).
 3,479,101. **THE WHOLE CHILD LEARNING COMPANY (BLOCK FORM)**. WHOLE CHILD FRANCHISING, LLC, (U.S. CLS. 100, 101 AND 107). SN 77-212,647. PUB. 5-20-2008. FILED 6-21-2007.
 3,479,126 (*See Class 35 for this trademark*).
 3,479,128. **PROGRESS SONIC AND DESIGN**. PROGRESS SOFTWARE CORPORATION, (U.S. CLS. 100, 101 AND 107). SN 77-216,915. PUB. 5-20-2008. FILED 6-27-2007.
 3,479,132. **SONIC (BLOCK FORM)**. PROGRESS SOFTWARE CORPORATION, (U.S. CLS. 100, 101 AND 107). SN 77-216,995. PUB. 5-20-2008. FILED 6-27-2007.
 3,479,135. **WINKY DINK (BLOCK FORM)**. HARRY W. PRICHETT AND EDWIN BRIT WYCKOFF PARTNERSHIP, THE, (U.S. CLS. 100, 101 AND 107). SN 77-217,058. PUB. 5-20-2008. FILED 6-27-2007.
 3,479,137. **SMOKY MOUNTAINS STORYTELLING FESTIVAL (BLOCK FORM)**. CITY OF PIGEON FORGE, TENNESSEE, (U.S. CLS. 100, 101 AND 107). SN 77-217,193. PUB. 5-20-2008. FILED 6-27-2007.
 3,479,140. **HORIZONTAL FUSION (BLOCK FORM)**. HORIZONTAL FUSION, LLC, (U.S. CLS. 100, 101 AND 107). SN 77-217,725. PUB. 5-20-2008. FILED 6-28-2007.
 3,479,141 (*See Class 16 for this trademark*).
 3,479,142. **TODAY'S TRAINING BECOMES TOMORROW'S WEAPON (BLOCK FORM)**. HORIZONTAL FUSION, LLC, (U.S. CLS. 100, 101 AND 107). SN 77-217,860. PUB. 5-20-2008. FILED 6-28-2007.
 3,479,143 (*See Class 16 for this trademark*).
 3,479,149. **BOULDER CREEK FESTIVAL (BLOCK FORM)**. CITY OF BOULDER, COLORADO, (U.S. CLS. 100, 101 AND 107). SN 77-218,280. PUB. 5-20-2008. FILED 6-28-2007.
 3,479,171. **MEATBALLS OF COMEDY (BLOCK FORM)**. SORICE, DEMUS JOSEPH, (U.S. CLS. 100, 101 AND 107). SN 77-220,505. PUB. 5-20-2008. FILED 7-2-2007.
 3,479,195. **BOOKFLIX AND DESIGN**. SCHOLASTIC INC., (U.S. CLS. 100, 101 AND 107). SN 77-222,446. PUB. 5-20-2008. FILED 7-5-2007.
 3,479,252 (*See Class 9 for this trademark*).
 3,479,261. **CARLOW UNIVERSITY (BLOCK FORM)**. CARLOW UNIVERSITY, (U.S. CLS. 100, 101 AND 107). SN 77-231,729. PUB. 5-20-2008. FILED 7-17-2007.
 3,479,262. **CARLOW (BLOCK FORM)**. CARLOW UNIVERSITY, (U.S. CLS. 100, 101 AND 107). SN 77-231,747. PUB. 5-20-2008. FILED 7-17-2007.
 3,479,263. **COUNCIL ON EDUCATION IN MANAGEMENT AND DESIGN**. COUNCIL ON EDUCATION IN MANAGEMENT, INC., (U.S. CLS. 100, 101 AND 107). SN 77-231,919. PUB. 5-20-2008. FILED 7-17-2007.
 3,479,267. **MMA TODAY (BLOCK FORM)**. GOFISH CORPORATION, (U.S. CLS. 100, 101 AND 107). SN 77-232,610. PUB. 10-16-2007. FILED 7-18-2007.
 3,479,268. **BEST FORK FORWARD (BLOCK FORM)**. YMCA OF METROPOLITAN WASHINGTON, MULTIPLE CLASS, (INT. CLS. 41 AND 45), (U.S. CLS. 100, 101 AND 107). SN 77-232,822. PUB. 5-20-2008. FILED 7-18-2007.
 3,479,278 (*See Class 35 for this trademark*).
 3,479,282. **TEEN CITY PRODUCTIONS (BLOCK FORM)**. TEEN CITY PRODUCTIONS, INC., (U.S. CLS. 100, 101 AND 107). SN 77-234,870. PUB. 5-20-2008. FILED 7-20-2007.
 3,479,285. **SHOOTERS BILLIARDS & SPORTS BAR AND DESIGN**. SHOOTERS BILLIARDS & SPORTS BAR, LP, MULTIPLE CLASS, (INT. CLS. 41 AND 43), (U.S. CLS. 100, 101 AND 107). SN 77-235,443. PUB. 5-20-2008. FILED 7-21-2007.
 3,479,290. **WILD SHEEP FOUNDATION (BLOCK FORM)**. FOUNDATION FOR NORTH AMERICAN WILD SHEEP, (U.S. CLS. 100, 101 AND 107). SN 77-236,882. PUB. 5-20-2008. FILED 7-24-2007.
 3,479,295 (*See Class 35 for this trademark*).
 3,479,301. **SANCTUM (BLOCK FORM)**. CONCEPT VENUES LTD, MULTIPLE CLASS, (INT. CLS. 41 AND 43), (U.S. CLS. 100, 101 AND 107). SN 77-238,775. PUB. 5-20-2008. FILED 7-25-2007.
 3,479,309 (*See Class 35 for this trademark*).
 3,479,310. **SENIOR MONEY MATTERS! AND DESIGN**. LOCKE, NELSON, (U.S. CLS. 100, 101 AND 107). SN 77-241,262. PUB. 5-20-2008. FILED 7-27-2007.
 3,479,313. **MAGID MEDIA LABS (BLOCK FORM)**. FRANK N. MAGID ASSOCIATES, INC., (U.S. CLS. 100, 101 AND 107). SN 77-241,772. PUB. 5-20-2008. FILED 7-30-2007.
 3,479,317. **GENE (BLOCK FORM)**. ELSEVIER BV, (U.S. CLS. 100, 101 AND 107). SN 77-243,672. PUB. 5-20-2008. FILED 7-31-2007.
 3,479,325. **WALL OF RED (BLOCK FORM)**. BIO-ENGINEERED SUPPLEMENTS & NUTRITION, INC., (U.S. CLS. 100, 101 AND 107). SN 77-246,634. PUB. 5-20-2008. FILED 8-3-2007.
 3,479,326. **FURTOGRAPHS (BLOCK FORM)**. STOLAREK, ANDY, DBA ANDREW STOLAREK, (U.S. CLS. 100, 101 AND 107). SN 77-247,022. PUB. 5-20-2008. FILED 8-3-2007.
 3,479,328. **EE EMPOWERMENT ENTERPRISE AND DESIGN**. EMPOWERMENT ENTERPRISE, LLC, (U.S. CLS. 100, 101 AND 107). SN 77-247,066. PUB. 5-20-2008. FILED 8-3-2007.
 3,479,335. **GO SNOWBALL AND DESIGN**. EMUSE MEDIA LIMITED, (U.S. CLS. 100, 101 AND 107). SN 77-249,177. PUB. 5-20-2008. FILED 8-7-2007.
 3,479,337. **LOS CAZADORES DEL NORTE AND DESIGN**. VERA VICTOR JR., (U.S. CLS. 100, 101 AND 107). SN 77-249,591. PUB. 5-20-2008. FILED 8-7-2007.
 3,479,344. **BRAINSTORM (BLOCK FORM)**. BRAINSTORM TUTORING, LLC, (U.S. CLS. 100, 101 AND 107). SN 77-250,582. PUB. 5-20-2008. FILED 8-8-2007.
 3,479,345. **LANGUAGE INSURANCE (BLOCK FORM)**. FONEIN LTD., (U.S. CLS. 100, 101 AND 107). SN 77-250,858. PUB. 2-12-2008. FILED 8-9-2007.
 3,479,353. **THE GET REAL GUIDE (BLOCK FORM)**. KAREN COLLIGAN, DBA PEOPLETHINK, (U.S. CLS. 100, 101 AND 107). SN 77-253,483. PUB. 5-20-2008. FILED 8-13-2007.
 3,479,363. **F FARMINGTON AREA PUBLIC SCHOOLS AND DESIGN**. INDEPENDENT SCHOOL DISTRICT #192, DBA FARMINGTON AREA PUBLIC SCHOOLS, (U.S. CLS. 100, 101 AND 107). SN 77-256,661. PUB. 5-20-2008. FILED 8-16-2007.
 3,479,364. **FARMINGTON AREA COMMUNITY EDUCATION AND DESIGN**. INDEPENDENT SCHOOL DISTRICT #192, DBA FARMINGTON SCHOOL DISTRICT, (U.S. CLS. 100, 101 AND 107). SN 77-256,989. PUB. 5-20-2008. FILED 8-16-2007.
 3,479,366. **FITNESS TRAINERS TO GO (BLOCK FORM)**. FITNESS TRAINERS TO GO, INC., (U.S. CLS. 100, 101 AND 107). SN 77-257,255. PUB. 5-20-2008. FILED 8-16-2007.
 3,479,367. **LADY TRAINERS TO GO (BLOCK FORM)**. FITNESS TRAINERS TO GO, INC., (U.S. CLS. 100, 101 AND 107). SN 77-257,280. PUB. 5-20-2008. FILED 8-16-2007.
 3,479,369. **SHARE THE WEALTH (BLOCK FORM)**. HARRAH'S LICENSE COMPANY, LLC, (U.S. CLS. 100, 101 AND 107). SN 77-258,237. PUB. 5-20-2008. FILED 8-17-2007.
 3,479,406. **CBCCT CERTIFICATION BOARD OF CARDIOVASCULAR COMPUTED TECHNOLOGY AND DESIGN**. CERTIFICATION BOARD OF CARDIOVASCULAR COMPUTED TOMOGRAPHY, (U.S. CLS. 100, 101 AND 107). SN 77-268,463. PUB. 5-20-2008. FILED 8-30-2007.
 3,479,418. **THE UTEACH INSTITUTE (BLOCK FORM)**. THE BOARD OF REGENTS OF THE UNIVERSITY OF TEXAS SYSTEM, (U.S. CLS. 100, 101 AND 107). SN 77-272,774. PUB. 5-20-2008. FILED 9-6-2007.
 3,479,419 (*See Class 35 for this trademark*).
 3,479,420. **JEFF K (BLOCK FORM)**. JEFF KOVARSKY, (U.S. CLS. 100, 101 AND 107). SN 77-272,968. PUB. 5-20-2008.

- FILED 9-6-2007.
- 3,479,421. **STAY WHERE THE COWBOYS PLAY! (BLOCK FORM)**. BOYD GAMING CORPORATION, (U.S. CLS. 100, 101 AND 107). SN 77-273,340. PUB. 2-12-2008. FILED 9-6-2007.
- 3,479,443. **CAMP SHANE (BLOCK FORM)**. CAMP SHANE LLC, (U.S. CLS. 100, 101 AND 107). SN 77-279,482. PUB. 5-20-2008. FILED 9-14-2007.
- 3,479,447 (*See Class 35 for this trademark*).
- 3,479,451. **ONGOING FAMILY COUNCIL (BLOCK FORM)**. THE HERITAGE INSTITUTE, (U.S. CLS. 100, 101 AND 107). SN 77-281,002. PUB. 5-20-2008. FILED 9-17-2007.
- 3,479,453. **24 CHALLENGE MATH PROGRAM (STYLIZED)**. SUNTEX INTERNATIONAL INC., (U.S. CLS. 100, 101 AND 107). SN 77-281,209. PUB. 5-20-2008. FILED 9-17-2007.
- 3,479,464. **CONNECTING THE GENERATIONS (BLOCK FORM)**. WELLPOINT, INC., (U.S. CLS. 100, 101 AND 107). SN 77-283,635. PUB. 5-20-2008. FILED 9-19-2007.
- 3,479,467. **WELCOMEHOMEDEARBORN (BLOCK FORM)**. CITY OF DEARBORN, MICHIGAN, (U.S. CLS. 100, 101 AND 107). SN 77-285,922. PUB. 5-20-2008. FILED 9-21-2007.
- 3,479,469. **COLOR ACCOUNTING (BLOCK FORM)**. ACCOUNTING COMES ALIVE, INC., DBA LEARNING COMES ALIVE, (U.S. CLS. 100, 101 AND 107). SN 77-286,363. PUB. 5-20-2008. FILED 9-21-2007.
- 3,479,476 (*See Class 35 for this trademark*).
- 3,479,480 (*See Class 35 for this trademark*).
- 3,479,488 (*See Class 35 for this trademark*).
- 3,479,489 (*See Class 35 for this trademark*).
- 3,479,491 (*See Class 16 for this trademark*).
- 3,479,506. **AMBASSADOR CHORUS (BLOCK FORM)**. BIG APPLE PERFORMING ARTS, INC., (U.S. CLS. 100, 101 AND 107). SN 77-298,528. PUB. 5-20-2008. FILED 10-8-2007.
- 3,479,511 (*See Class 16 for this trademark*).
- 3,479,517 (*See Class 9 for this trademark*).
- 3,479,518 (*See Class 35 for this trademark*).
- 3,479,519 (*See Class 35 for this trademark*).
- 3,479,521 (*See Class 16 for this trademark*).
- 3,479,522 (*See Class 16 for this trademark*).
- 3,479,536. **MASONRY CONSTRUCTION'S CHALLENGE (BLOCK FORM)**. HANLEY-WOOD, LLC, (U.S. CLS. 100, 101 AND 107). SN 77-301,907. PUB. 5-20-2008. FILED 10-11-2007.
- 3,479,542 (*See Class 9 for this trademark*).
- 3,479,548. **AMERICAN CASH FLOW INSTITUTE ACFI (BLOCK FORM)**. AMERICAN CASH FLOW CORPORATION, (U.S. CLS. 100, 101 AND 107). SN 77-304,880. PUB. 5-20-2008. FILED 10-16-2007.
- 3,479,549. **MISS AMERICAN STATES (BLOCK FORM)**. EFFIE HORNING, (U.S. CLS. 100, 101 AND 107). SN 77-305,085. PUB. 5-20-2008. FILED 10-16-2007.
- 3,479,554 (*See Class 25 for this trademark*).
- 3,479,555 (*See Class 35 for this trademark*).
- 3,479,559. **HED HIGHER EDUCATION FOR DEVELOPMENT AND DESIGN**. AMERICAN COUNCIL ON EDUCATION, (U.S. CLS. 100, 101 AND 107). SN 77-307,030. PUB. 5-20-2008. FILED 10-18-2007.
- 3,479,568. **FIND YOURSELF A GOOD MATE (BLOCK FORM)**. JERKINS JR., FRED, (U.S. CLS. 100, 101 AND 107). SN 77-309,408. PUB. 5-20-2008. FILED 10-21-2007.
- 3,479,570 (*See Class 16 for this trademark*).
- 3,479,576. **POPULAR (BLOCK FORM)**. TOM WHITMAN PRESENTS, INC., (U.S. CLS. 100, 101 AND 107). SN 77-310,457. PUB. 5-20-2008. FILED 10-22-2007.
- 3,479,585. **SIZE (BLOCK FORM)**. TOM WHITMAN PRESENTS, INC., (U.S. CLS. 100, 101 AND 107). SN 77-311,527. PUB. 5-20-2008. FILED 10-23-2007.
- 3,479,586 (*See Class 35 for this trademark*).
- 3,479,593 (*See Class 9 for this trademark*).
- 3,479,595 (*See Class 9 for this trademark*).
- 3,479,601. **BE THE FLOW (BLOCK FORM)**. HALF MOON YOGA, INC., (U.S. CLS. 100, 101 AND 107). SN 77-315,150. PUB. 5-20-2008. FILED 10-26-2007.
- 3,479,603. **POTTYBOY PRODUCTIONS AND DESIGN**. BERNDT, MICHAEL E, (U.S. CLS. 100, 101 AND 107). SN 77-315,462. PUB. 5-20-2008. FILED 10-29-2007.
- 3,479,609. **THE PLAYROOM AND DESIGN**. PLAYROOM FOR KIDS, INC., THE, (U.S. CLS. 100, 101 AND 107). SN 77-316,675. PUB. 5-20-2008. FILED 10-30-2007.
- 3,479,611. **DIGITAL HOME D.I.Y. AND DESIGN**. D-LINK SYSTEMS, INC., (U.S. CLS. 100, 101 AND 107). SN 77-317,065. PUB. 5-20-2008. FILED 10-30-2007.
- 3,479,612. **BBI (BLOCK FORM)**. BBI, INC., DBA BARNETT BICYCLE INSTITUTE, (U.S. CLS. 100, 101 AND 107). SN 77-317,122. PUB. 5-20-2008. FILED 10-30-2007.
- 3,479,613. **D-LINK TV (STYLIZED)**. D-LINK SYSTEMS, INC., (U.S. CLS. 100, 101 AND 107). SN 77-317,298. PUB. 5-20-2008. FILED 10-30-2007.
- 3,479,615. **EMPOWERED FOR THE 21ST CENTURY (BLOCK FORM)**. GIANT CAMPUS, INC., (U.S. CLS. 100, 101 AND 107). SN 77-317,417. PUB. 5-20-2008. FILED 10-30-2007.
- 3,479,617. **REAL PEOPLE, REAL TRADES, REAL PROFITS (BLOCK FORM)**. GLOBALTEC SOLUTIONS, L.L.P., (U.S. CLS. 100, 101 AND 107). SN 77-317,678. PUB. 5-20-2008. FILED 10-31-2007.
- 3,479,628 (*See Class 35 for this trademark*).
- 3,479,635. **CAP STS AND DESIGN**. COLLEGE OF AMERICAN PATHOLOGISTS, MULTIPLE CLASS, (INT. CLS. 41 AND 44), (U.S. CLS. 100, 101 AND 107). SN 77-320,659. PUB. 5-20-2008. FILED 11-2-2007.
- 3,479,651. **SPECIALIZE FITNESS (BLOCK FORM)**. SPECIALIZE FITNESS, INC., (U.S. CLS. 100, 101 AND 107). SN 77-323,550. PUB. 5-20-2008. FILED 11-7-2007.
- 3,479,655 (*See Class 35 for this trademark*).
- 3,479,661. **RATHSKELLER PRESS AND DESIGN**. RATHSKELLER PRESS LLC, (U.S. CLS. 100, 101 AND 107). SN 77-324,451. PUB. 5-20-2008. FILED 11-8-2007.
- 3,479,662. **CAVALERA CONSPIRACY (BLOCK FORM)**. CAVALERA, MASSIMILIANO, AND CAVALERA, IGOR, (U.S. CLS. 100, 101 AND 107). SN 77-324,619. PUB. 5-20-2008. FILED 11-8-2007.
- 3,479,679. **JOGO THE PURSUIT OF PLAY AND DESIGN**. MAYJUH LLC, DBA JOGO, (U.S. CLS. 100, 101 AND 107). SN 77-326,480. PUB. 5-20-2008. FILED 11-9-2007.
- 3,479,681 (*See Class 35 for this trademark*).
- 3,479,682 (*See Class 35 for this trademark*).
- 3,479,683 (*See Class 35 for this trademark*).
- 3,479,694. **HOWLIN WOLF STUDIO (BLOCK FORM)**. LEE, HARRY, (U.S. CLS. 100, 101 AND 107). SN 77-328,028. PUB. 5-20-2008. FILED 11-13-2007.
- 3,479,697. **SUCCESS FOR THE SOUL AND DESIGN**. ALMA PUBLISHING INC., (U.S. CLS. 100, 101 AND 107). SN 77-328,146. PUB. 5-20-2008. FILED 11-13-2007.
- 3,479,700. **TASTE OF THE EMERALD COAST (BLOCK FORM)**. WALTON COUNTY CHAMBER OF COMMERCE, (U.S. CLS. 100, 101 AND 107). SN 77-328,521. PUB. 5-20-2008. FILED 11-13-2007.
- 3,479,701 (*See Class 35 for this trademark*).
- 3,479,704. **FROCKS ROCKS & COCKTAILS (BLOCK FORM)**. MANN, WANDA, (U.S. CLS. 100, 101 AND 107). SN 77-329,107. PUB. 5-20-2008. FILED 11-14-2007.
- 3,479,707 (*See Class 35 for this trademark*).
- 3,479,710 (*See Class 35 for this trademark*).
- 3,479,711 (*See Class 35 for this trademark*).
- 3,479,733. **ROBERT PARKER JR. KEVIN ZRALY WINE CERTIFICATION PROGRAM PARKER & ZRALY AND DESIGN**. THE WINE ADVOCATE, INC., (U.S. CLS. 100, 101 AND 107). SN 77-334,371. PUB. 5-20-2008. FILED 11-20-2007.
- 3,479,734 (*See Class 35 for this trademark*).
- 3,479,738. **THEATREWORKSUSA AND DESIGN**. THEATREWORKS/USA CORP., (U.S. CLS. 100, 101 AND 107). SN 77-335,046. PUB. 5-20-2008. FILED 11-21-2007.
- 3,479,745 (*See Class 9 for this trademark*).
- 3,479,748. **BIG E ELDORA SPEEDWAY ROSSBURG, OHIO AND DESIGN**. ELDORA SPEEDWAY, INC., (U.S. CLS. 100, 101 AND 107). SN 77-336,477. PUB. 5-20-2008. FILED 11-26-2007.
- 3,479,749. **4-CROWN NATIONALS (BLOCK FORM)**. ELDORA SPEEDWAY, INC., (U.S. CLS. 100, 101 AND 107). SN 77-336,478. PUB. 5-20-2008. FILED 11-26-2007.
- 3,479,750 (*See Class 25 for this trademark*).
- 3,479,752. **KORRECT KRITTERS (BLOCK FORM)**. KORRECT KRITTERS, LLC, MULTIPLE CLASS, (INT. CLS. 41 AND 44), (U.S. CLS. 100, 101 AND 107). SN 77-336,941. PUB. 5-20-2008. FILED 11-26-2007.
- 3,479,755. **BLACK20 (BLOCK FORM)**. BLACK20, INC., (U.S.

- CLS. 100, 101 AND 107). SN 77-337,929. PUB. 5-20-2008. FILED 11-27-2007.
- 3,479,756. **THE OPA WAY (BLOCK FORM)**. DUNDON, ELAINE GM, (U.S. CLS. 100, 101 AND 107). SN 77-338,153. PUB. 5-20-2008. FILED 11-27-2007.
- 3,479,774. **FISHSTOCK (BLOCK FORM)**. WORLD PUBLICATIONS, LLC, (U.S. CLS. 100, 101 AND 107). SN 77-339,982. PUB. 5-20-2008. FILED 11-29-2007.
- 3,479,777. **WHEN YOU'RE READY TO DO WHAT YOU CAME HERE FOR. (BLOCK FORM)**. SPEISER, AARON, (U.S. CLS. 100, 101 AND 107). SN 77-340,174. PUB. 5-20-2008. FILED 11-29-2007.
- 3,479,780 (*See Class 35 for this trademark*).
- 3,479,790. **FITISTICS FITNESS IN A FLASH AND DESIGN**. SEAN MCKIRDY, AND ROBERT NUTINI, (U.S. CLS. 100, 101 AND 107). SN 77-341,589. PUB. 5-20-2008. FILED 11-30-2007.
- 3,479,804. **THE MEDICAL COMMUNITY SPEAKS (BLOCK FORM)**, 2 UNDER ENTERTAINMENT, (U.S. CLS. 100, 101 AND 107). SN 77-342,568. PUB. 5-20-2008. FILED 12-3-2007.
- 3,479,806 (*See Class 16 for this trademark*).
- 3,479,809. **KINGS & PRIESTS (BLOCK FORM)**. KINGS & PRIESTS UNLIMITED, INC., (U.S. CLS. 100, 101 AND 107). SN 77-342,924. PUB. 5-20-2008. FILED 12-3-2007.
- 3,479,830. **RED CARPET TONIGHT AND DESIGN**. VIPRMEDIA LLC, (U.S. CLS. 100, 101 AND 107). SN 77-345,761. PUB. 5-20-2008. FILED 12-6-2007.
- 3,479,832. **ADVANCED (BLOCK FORM)**. ADVANCE EDUCATION, INC., MULTIPLE CLASS, (INT. CLS. 41 AND 42), (U.S. CLS. 100, 101 AND 107). SN 77-345,885. PUB. 5-20-2008. FILED 12-6-2007.
- 3,479,841. **THE VIRTUAL LECTURE HALL (BLOCK FORM)**. MEDICAL DIRECTIONS, INC., (U.S. CLS. 100, 101 AND 107). SN 77-346,467. PUB. 5-20-2008. FILED 12-7-2007.
- 3,479,843 (*See Class 9 for this trademark*).
- 3,479,849. **UNTAMED HEART PHOTOGRAPHY (BLOCK FORM)**. MICHELLE HUESGEN, DBA MICHELLE VOLKERDING, (U.S. CLS. 100, 101 AND 107). SN 77-348,131. PUB. 5-20-2008. FILED 12-10-2007.
- 3,479,872 (*See Class 35 for this trademark*).
- 3,479,925. **ARTSCIENCE (BLOCK FORM)**. SILER, TODD, (U.S. CLS. 100, 101 AND 107). SN 77-352,847. PUB. 5-20-2008. FILED 12-14-2007.
- 3,479,926. **NEW HOLLYWOOD AWARDS (BLOCK FORM)**. ABREU, CARLOS, (U.S. CLS. 100, 101 AND 107). SN 77-353,008. PUB. 5-20-2008. FILED 12-14-2007.
- 3,479,928. **STEVENS-HENAGER COLLEGE (BLOCK FORM)**. STEVENS-HENAGER COLLEGE, INC., (U.S. CLS. 100, 101 AND 107). SN 77-353,145. PUB. 5-20-2008. FILED 12-15-2007.
- 3,479,935. **SPEEDWAY (BLOCK FORM)**. AVNET, INC., (U.S. CLS. 100, 101 AND 107). SN 77-353,561. PUB. 5-20-2008. FILED 12-17-2007.
- 3,479,943. **NEWSCHOOLERS (BLOCK FORM)**. WMG PRODUCTIONS LLC, (U.S. CLS. 100, 101 AND 107). SN 77-354,095. PUB. 5-20-2008. FILED 12-17-2007.
- 3,479,944. **MISCELLANEOUS DESIGN**. EMOTIONAL INTELLIGENCE AND DIVERSITY INSTITUTE, THE, (U.S. CLS. 100, 101 AND 107). SN 77-354,134. PUB. 5-20-2008. FILED 12-17-2007.
- 3,479,947. **E/I/D/I (BLOCK FORM)**. EMOTIONAL INTELLIGENCE AND DIVERSITY INSTITUTE, THE, (U.S. CLS. 100, 101 AND 107). SN 77-354,144. PUB. 5-20-2008. FILED 12-17-2007.
- 3,479,950. **TRIANGLE MARTIAL ARTS ASSOCIATION ESTABLISHED 1998 AND DESIGN**. TRIANGLE MARTIAL ARTS ASSOCIATION, (U.S. CLS. 100, 101 AND 107). SN 77-354,184. PUB. 5-20-2008. FILED 12-17-2007.
- 3,479,956. **B9 BACK NINE GOLF ACADEMY AND DESIGN**. CARMELCO, LLC, DBA BACK NINE GOLF ACADEMY, (U.S. CLS. 100, 101 AND 107). SN 77-354,365. PUB. 5-20-2008. FILED 12-18-2007.
- 3,479,959. **AIR ZONE (BLOCK FORM)**. KIRBY ASH ENTERPRISES, INC., (U.S. CLS. 100, 101 AND 107). SN 77-354,499. PUB. 5-20-2008. FILED 12-18-2007.
- 3,479,966. **ACTIVATE (BLOCK FORM)**. UNIVERSITY OF MARYLAND, BALTIMORE COUNTY, (U.S. CLS. 100, 101 AND 107). SN 77-354,674. PUB. 5-20-2008. FILED 12-18-2007.
- 3,479,976. **SELF START (BLOCK FORM)**. BIRGE, BARBARA, (U.S. CLS. 100, 101 AND 107). SN 77-355,015. PUB. 5-20-2008. FILED 12-18-2007.
- 3,479,978. **PICKRSET (STYLIZED)**. SIGLIN, CHRISTOPHER, (U.S. CLS. 100, 101 AND 107). SN 77-355,181. PUB. 5-20-2008. FILED 12-18-2007.
- 3,479,982. **MULTI-INTENSO (BLOCK FORM)**. REGELIN, DAVID A., (U.S. CLS. 100, 101 AND 107). SN 77-355,429. PUB. 5-20-2008. FILED 12-19-2007.
- 3,479,984. **THE SHUFFLEJUNKIES (BLOCK FORM)**. MARGOLIS, ANDREW B, AND SHEPHEARD, ROGER, AND HOLLAND, JONATHAN, (U.S. CLS. 100, 101 AND 107). SN 77-355,612. PUB. 5-20-2008. FILED 12-19-2007.
- 3,479,991. **MILAN INSTITUTE (BLOCK FORM)**. ACR, INC., (U.S. CLS. 100, 101 AND 107). SN 77-356,224. PUB. 5-20-2008. FILED 12-19-2007.
- 3,480,002. **YOU FILL THE SEATS. WE FILL THEIR MINDS. (BLOCK FORM)**. DIRECT MARKETING ASSOCIATION, INC., (U.S. CLS. 100, 101 AND 107). SN 77-356,644. PUB. 5-20-2008. FILED 12-20-2007.
- 3,480,004. **WHO'S BUILDING YOUR FUTURE (BLOCK FORM)**. INSTITUTE OF CONSTRUCTION MANAGEMENT & TECHNOLOGY, (U.S. CLS. 100, 101 AND 107). SN 77-356,665. PUB. 5-20-2008. FILED 12-20-2007.
- 3,480,007. **SHA SHA LADIES (BLOCK FORM)**. SHA SHA LADIES INTERNATIONAL LLC, (U.S. CLS. 100, 101 AND 107). SN 77-356,689. PUB. 5-20-2008. FILED 12-20-2007.
- 3,480,023. **FOX CHASE CANCER CENTER (STYLIZED)**. FOX CHASE CANCER CENTER, MULTIPLE CLASS, (INT. CLS. 41, 42, 44 AND 45), (U.S. CLS. 100, 101 AND 107). SN 77-357,021. PUB. 5-20-2008. FILED 12-20-2007.
- 3,480,025. **WEB MARKETING SYSTEMS THAT WORK (BLOCK FORM)**. PRO STEP MARKETING, INC., (U.S. CLS. 100, 101 AND 107). SN 77-357,041. PUB. 5-20-2008. FILED 12-20-2007.
- 3,480,036. **TELLURIDE (BLOCK FORM)**. CARTER, JOHN R, DBA TELLURIDE, (U.S. CLS. 100, 101 AND 107). SN 77-357,458. PUB. 5-20-2008. FILED 12-20-2007.
- 3,480,043. **KETSU-KA (BLOCK FORM)**. HAMZY, HASSAN A., SR., (U.S. CLS. 100, 101 AND 107). SN 77-357,756. PUB. 5-20-2008. FILED 12-21-2007.
- 3,480,044. **FOX CHASE CANCER CENTER PARTNERS AND DESIGN**. FOX CHASE CANCER CENTER, MULTIPLE CLASS, (INT. CLS. 41, 42 AND 44), (U.S. CLS. 100, 101 AND 107). SN 77-357,833. PUB. 5-20-2008. FILED 12-21-2007.
- 3,480,045. **NATIONAL CAREGIVER TRAINING PROGRAM (BLOCK FORM)**. HEALTH CARE TRAINING SYSTEMS, INC., (U.S. CLS. 100, 101 AND 107). SN 77-357,881. PUB. 5-20-2008. FILED 12-21-2007.
- 3,480,048. **REGENESIS (BLOCK FORM)**. REGENESIS, INC., (U.S. CLS. 100, 101 AND 107). SN 77-357,979. PUB. 5-20-2008. FILED 12-21-2007.
- 3,480,049. **THE FOCUS COACHING SYSTEM (BLOCK FORM)**. WORTHLEY, BRAD, (U.S. CLS. 100, 101 AND 107). SN 77-358,023. PUB. 5-20-2008. FILED 12-21-2007.
- 3,480,057 (*See Class 16 for this trademark*).
- 3,480,058. **IMPACT BASEBALL, INC. (BLOCK FORM)**. IMPACT BASEBALL, INC., (U.S. CLS. 100, 101 AND 107). SN 77-358,545. PUB. 5-20-2008. FILED 12-21-2007.
- 3,480,062. **LAS VOCES DEL BAJIO (BLOCK FORM)**. VASQUEZ, JOSE LUCIO, AND CRUZ CRUZ, JOSE LUIS, (U.S. CLS. 100, 101 AND 107). SN 77-358,692. PUB. 5-20-2008. FILED 12-21-2007.
- 3,480,064. **POWERSHIFT (BLOCK FORM)**. SUCCESS NRG INC., (U.S. CLS. 100, 101 AND 107). SN 77-358,829. PUB. 5-20-2008. FILED 12-22-2007.
- 3,480,074. **NEON CHEF (BLOCK FORM)**. LEASE-TECH GROUP, INC, (U.S. CLS. 100, 101 AND 107). SN 77-359,145. PUB. 5-20-2008. FILED 12-25-2007.
- 3,480,077 (*See Class 35 for this trademark*).
- 3,480,078. **OUTLAW PHOTOGRAPHY (BLOCK FORM)**. DITTMAN III, WILLIAM, (U.S. CLS. 100, 101 AND 107). SN 77-359,250. PUB. 5-20-2008. FILED 12-26-2007.
- 3,480,080. **C.M.M.C CERTIFIED MASTERMIND CONSULTANTS C2 AND DESIGN**. INCREASE GLOBAL NETWORK INC, (U.S. CLS. 100, 101 AND 107). SN 77-359,304. PUB. 5-20-2008. FILED 12-26-2007.
- 3,480,081. **PLATEMATE AND DESIGN**. PLATEMATE.BIZ, DBA PLATEMATE STUDIOS, INC., (U.S. CLS. 100, 101

- AND 107). SN 77-359,330. PUB. 5-20-2008. FILED 12-26-2007.
- 3,480,082. **SIX STRING IMPRESSIONS (BLOCK FORM)**. MOLINA, NESTOR A., (U.S. CLS. 100, 101 AND 107). SN 77-359,341. PUB. 5-20-2008. FILED 12-26-2007.
- 3,480,085. **SNOWANGEL (BLOCK FORM)**. SNOWANGEL FITNESS, LLC, (U.S. CLS. 100, 101 AND 107). SN 77-359,423. PUB. 5-20-2008. FILED 12-26-2007.
- 3,480,114. **ASK A PORN STAR - EVERYTHING YOU WANTED TO ASK A PORN STAR BUT WERE AFRAID TO ASK. (BLOCK FORM)**. LEASE-TECH GROUP, INC, (U.S. CLS. 100, 101 AND 107). SN 77-360,570. PUB. 5-20-2008. FILED 12-27-2007.
- 3,480,115. **QWOTE (BLOCK FORM)**. JIMMY J. LEONARD, (U.S. CLS. 100, 101 AND 107). SN 77-360,585. PUB. 5-20-2008. FILED 12-27-2007.
- 3,480,135. **CREATIVE PHOTOGRAPHY BY SALISHA AND DESIGN**. BLOM, SALISHA, (U.S. CLS. 100, 101 AND 107). SN 77-361,653. PUB. 5-20-2008. FILED 12-31-2007.
- 3,480,142. **IRON HAUS FITNESS AND DESIGN**. IRON HAUS, (U.S. CLS. 100, 101 AND 107). SN 77-361,822. PUB. 5-20-2008. FILED 12-31-2007.
- 3,480,152. **PILATES MUSE (BLOCK FORM)**. PIERCE, CATHERINE, (U.S. CLS. 100, 101 AND 107). SN 77-361,989. PUB. 5-20-2008. FILED 12-31-2007.
- 3,480,179. **MEREDITH COLLEGE (BLOCK FORM)**. MEREDITH COLLEGE, (U.S. CLS. 100, 101 AND 107). SN 77-362,590. PUB. 5-20-2008. FILED 1-2-2008.
- 3,480,182 (*See Class 9 for this trademark*).
- 3,480,186. **MADISON-CHICAGO MC200 -200- RELAY AND DESIGN**. RELAY PRODUCTIONS LLC, (U.S. CLS. 100, 101 AND 107). SN 77-362,701. PUB. 5-20-2008. FILED 1-2-2008.
- 3,480,191. **TOAST OF THE COAST (BLOCK FORM)**. MCCLATCHY U.S.A., INC., (U.S. CLS. 100, 101 AND 107). SN 77-362,783. PUB. 5-20-2008. FILED 1-2-2008.
- 3,480,199. **LIVING ART AND DESIGN**. XIE, HANG, (U.S. CLS. 100, 101 AND 107). SN 77-362,928. PUB. 5-20-2008. FILED 1-2-2008.
- 3,480,200 (*See Class 38 for this trademark*).
- 3,480,204. **ANARCHY CLUB (BLOCK FORM)**. BUHLER, ADAM M. AND SMITH, KEITH D. (U.S. CLS. 100, 101 AND 107). SN 77-363,025. PUB. 5-20-2008. FILED 1-3-2008.
- 3,480,205. **DAVEAWESOME (BLOCK FORM)**. OWSIANY, DAVID, MATTHEW, DBA DAVEAWESOME, (U.S. CLS. 100, 101 AND 107). SN 77-363,029. PUB. 5-20-2008. FILED 1-3-2008.
- 3,480,214. **CHEFS AT PLAY (BLOCK FORM)**. NORTON, KATHLEEN, DBA CHEFS AT PLAY, (U.S. CLS. 100, 101 AND 107). SN 77-363,194. PUB. 5-20-2008. FILED 1-3-2008.
- 3,480,217. **IGN INCREASE GLOBAL NETWORK AND DESIGN**. INCREASE GLOBAL NETWORK INC., (U.S. CLS. 100, 101 AND 107). SN 77-363,216. PUB. 5-20-2008. FILED 1-3-2008.
- 3,480,219. **SAN FRANCISCO FORTY NINERS (BLOCK FORM)**. SAN FRANCISCO FORTY NINERS, LIMITED, DBA SAN FRANCISCO FORTY NINERS, (U.S. CLS. 100, 101 AND 107). SN 77-363,236. PUB. 5-20-2008. FILED 1-3-2008.
- 3,480,228. **HARLEMLIVE (BLOCK FORM)**. HARLEMLIVE, INC., (U.S. CLS. 100, 101 AND 107). SN 77-363,315. PUB. 5-20-2008. FILED 1-3-2008.
- 3,480,229. **ONE MOORE CATCH (BLOCK FORM)**. ONE MOORE CATCH INC., (U.S. CLS. 100, 101 AND 107). SN 77-363,322. PUB. 5-20-2008. FILED 1-3-2008.
- 3,480,231. **MISCELLANEOUS DESIGN**. WILSON, JESSICA, (U.S. CLS. 100, 101 AND 107). SN 77-363,358. PUB. 5-20-2008. FILED 1-3-2008.
- 3,480,239. **HACP (BLOCK FORM)**. CURTIS, RICHARD, (U.S. CLS. 100, 101 AND 107). SN 77-363,542. PUB. 5-20-2008. FILED 1-3-2008.
- 3,480,251. **ULTIMATE BOOTCAMP (BLOCK FORM)**. KANADY, BETH, (U.S. CLS. 100, 101 AND 107). SN 77-363,702. PUB. 5-20-2008. FILED 1-3-2008.
- 3,480,272. **LEO (BLOCK FORM)**. EDDY, IAN, (U.S. CLS. 100, 101 AND 107). SN 77-363,998. PUB. 5-20-2008. FILED 1-4-2008.
- 3,480,285. **LAKELAND FLYING TIGERS (BLOCK FORM)**. DETROIT TIGERS, INC., (U.S. CLS. 100, 101 AND 107). SN 77-364,279. PUB. 5-20-2008. FILED 1-4-2008.
- 3,480,288. **DIMENSIONTYPE (BLOCK FORM)**. J.P. CORR III, (U.S. CLS. 100, 101 AND 107). SN 77-364,332. PUB. 5-20-2008. FILED 1-4-2008.
- 3,480,291. **GYMNOTYPE (BLOCK FORM)**. J.P. CORR III, (U.S. CLS. 100, 101 AND 107). SN 77-364,339. PUB. 5-20-2008. FILED 1-4-2008.
- 3,480,315. **VICTORY DAYS (BLOCK FORM)**. VICTORY DAYS CORPORATION, (U.S. CLS. 100, 101 AND 107). SN 77-364,587. PUB. 5-20-2008. FILED 1-4-2008.
- 3,480,329. **TAKING CHARGE OF CHANGE (BLOCK FORM)**. NATIONAL-LOUIS UNIVERSITY, (U.S. CLS. 100, 101 AND 107). SN 77-364,884. PUB. 5-20-2008. FILED 1-5-2008.
- 3,480,330. **THE ARMENOIDIS (BLOCK FORM)**. ROSTOMYAN, EDGAR, (U.S. CLS. 100, 101 AND 107). SN 77-364,889. PUB. 5-20-2008. FILED 1-5-2008.
- 3,480,331. **SCRIBBIT (BLOCK FORM)**. MITTON, MICHELLE R., (U.S. CLS. 100, 101 AND 107). SN 77-364,906. PUB. 5-20-2008. FILED 1-5-2008.
- 3,480,332 (*See Class 35 for this trademark*).
- 3,480,349. **WORKING WITHIN TO BRING OUT THE BEST (BLOCK FORM)**. INNOVATIVE LEARNING STRATEGIES LLC, (U.S. CLS. 100, 101 AND 107). SN 77-365,245. PUB. 5-20-2008. FILED 1-7-2008.
- 3,480,355. **HIT DOCTOR (BLOCK FORM)**. HIT DOCTOR INC., (U.S. CLS. 100, 101 AND 107). SN 77-365,337. PUB. 5-20-2008. FILED 1-7-2008.
- 3,480,368. **VALENCIA SUREHUNTER (BLOCK FORM)**. ARTIX ENTERTAINMENT, LLC, (U.S. CLS. 100, 101 AND 107). SN 77-365,611. PUB. 5-20-2008. FILED 1-7-2008.
- 3,480,373. **VIEWS YOU CAN USE (BLOCK FORM)**. MORTGAGE MARKET GUIDE, LLC, (U.S. CLS. 100, 101 AND 107). SN 77-365,699. PUB. 5-20-2008. FILED 1-7-2008.
- 3,480,375. **MOGLIN PUNTER (BLOCK FORM)**. ARTIX ENTERTAINMENT, LLC, (U.S. CLS. 100, 101 AND 107). SN 77-365,733. PUB. 5-20-2008. FILED 1-7-2008.
- 3,480,377. **JIMMY THE EYE (BLOCK FORM)**. ARTIX ENTERTAINMENT, LLC, (U.S. CLS. 100, 101 AND 107). SN 77-365,788. PUB. 5-20-2008. FILED 1-7-2008.
- 3,480,381. **SHACKLE (BLOCK FORM)**. DANIEL J. MASSEY AND SAMUEL L. MASSEY, (U.S. CLS. 100, 101 AND 107). SN 77-365,972. PUB. 5-20-2008. FILED 1-7-2008.
- 3,480,405. **PHARMATELEVISION (BLOCK FORM)**. PHARMA VENTURES LTD, (U.S. CLS. 100, 101 AND 107). SN 77-366,511. PUB. 5-20-2008. FILED 1-8-2008.
- 3,480,417. **ESCAPE TO THE WILD (BLOCK FORM)**. VERSUS, L.P., (U.S. CLS. 100, 101 AND 107). SN 77-366,616. PUB. 5-20-2008. FILED 1-8-2008.
- 3,480,430 (*See Class 36 for this trademark*).
- 3,480,432. **GENERATION YES (BLOCK FORM)**. GENERATION YES CORPORATION, (U.S. CLS. 100, 101 AND 107). SN 77-366,908. PUB. 5-20-2008. FILED 1-8-2008.
- 3,480,445. **BROOKSIE WAY (BLOCK FORM)**. COUNT YOUR STEPS, (U.S. CLS. 100, 101 AND 107). SN 77-367,287. PUB. 5-20-2008. FILED 1-9-2008.
- 3,480,446. **IF NOBODY LOVES YOU CREATE THE DEMAND (BLOCK FORM)**. FREEMAN, JOEL A., (U.S. CLS. 100, 101 AND 107). SN 77-367,305. PUB. 5-20-2008. FILED 1-9-2008.
- 3,480,453. **ALL ABOUT BEER (BLOCK FORM)**. CHAUTAUQUA, INC., (U.S. CLS. 100, 101 AND 107). SN 77-367,476. PUB. 5-20-2008. FILED 1-9-2008.
- 3,480,461. **LIMA BEAN RIOT (BLOCK FORM)**. KIELB, FRANK, (U.S. CLS. 100, 101 AND 107). SN 77-367,669. PUB. 5-20-2008. FILED 1-9-2008.
- 3,480,470. **B4P AND DESIGN**. NEW MOTION, INC., (U.S. CLS. 100, 101 AND 107). SN 77-367,872. PUB. 5-20-2008. FILED 1-9-2008.
- 3,480,502. **LEXGO (BLOCK FORM)**. MCCLATCHY U.S.A., INC., (U.S. CLS. 100, 101 AND 107). SN 77-373,128. PUB. 5-20-2008. FILED 1-16-2008.
- 3,480,507. **HOLLYWOOD NETWORK (BLOCK FORM)**. ABREU, CARLOS, (U.S. CLS. 100, 101 AND 107). SN 77-374,800. PUB. 5-20-2008. FILED 1-17-2008.
- 3,480,510. **GENYES (BLOCK FORM)**. GENERATION YES CORPORATION, (U.S. CLS. 100, 101 AND 107). SN 77-375,431. PUB. 5-20-2008. FILED 1-18-2008.
- 3,480,515 (*See Class 38 for this trademark*).
- 3,480,516 (*See Class 38 for this trademark*).
- 3,480,518. **APERTURE AND DESIGN**. APERTURE TECH-

- NOLOGIES, INC., (U.S. CLS. 100, 101 AND 107). SN 77-377,513. PUB. 5-20-2008. FILED 1-22-2008.
- 3,480,542. **FOCUS (BLOCK FORM)**, NORTHWESTERN COLLEGE, (U.S. CLS. 100, 101 AND 107). SN 77-395,105. PUB. 5-20-2008. FILED 2-12-2008.
- 3,480,548. **CHIC REPORT (BLOCK FORM)**, INTERNATIONAL MERCHANDISING CORPORATION, (U.S. CLS. 100, 101 AND 107). SN 77-400,742. PUB. 5-20-2008. FILED 2-19-2008.
- 3,480,554. **PHANTOM GOURMET BBQ BEACH PARTY (BLOCK FORM)**, PHANTOM GOURMET, INC., (U.S. CLS. 100, 101 AND 107). SN 77-406,238. PUB. 5-20-2008. FILED 2-26-2008.
- 3,480,555. **PAWN KINGS (BLOCK FORM)**, FUJISANKEI COMMUNICATIONS INTERNATIONAL, INC., (U.S. CLS. 100, 101 AND 107). SN 77-406,471. PUB. 5-20-2008. FILED 2-26-2008.
- 3,480,558. **MISCELLANEOUS DESIGN**, FULL SAIL, INC., (U.S. CLS. 100, 101 AND 107). SN 77-408,805. PUB. 5-20-2008. FILED 2-28-2008.
- 3,480,560. **FIRST COUNCIL CASINO (BLOCK FORM)**, OTOEMISSOURIA TRIBE OF OKLAHOMA, (U.S. CLS. 100, 101 AND 107). SN 77-411,264. PUB. 5-20-2008. FILED 3-3-2008.
- 3,480,561. **CRAZY SEXY (BLOCK FORM)**, RED HOUSE PICTURES, LLC, (U.S. CLS. 100, 101 AND 107). SN 77-414,146. PUB. 5-20-2008. FILED 3-5-2008.
- 3,480,577 (*See Class 9 for this trademark*).
- 3,480,578. **POWER NAPPING (BLOCK FORM)**, DELUCA, TOM, (U.S. CLS. 100, 101 AND 107). SN 78-465,403. PUB. 5-20-2008. FILED 8-11-2004.
- 3,480,584 (*See Class 9 for this trademark*).
- 3,480,585 (*See Class 35 for this trademark*).
- 3,480,595 (*See Class 9 for this trademark*).
- 3,480,596 (*See Class 9 for this trademark*).
- 3,480,597 (*See Class 9 for this trademark*).
- 3,480,598 (*See Class 16 for this trademark*).
- 3,480,617 (*See Class 35 for this trademark*).
- 3,480,621. **AMERICA'S LEADER IN CREATIVE EDUCATION (BLOCK FORM)**, EDUCATION MANAGEMENT LLC, (U.S. CLS. 100, 101 AND 107). SN 78-703,333. PUB. 9-26-2006. FILED 8-30-2005.
- 3,480,632 (*See Class 16 for this trademark*).
- 3,480,637. **WILD ADVENTURES (BLOCK FORM)**, WILD ADVENTURES VALDOSTA, LLC, (U.S. CLS. 100, 101 AND 107). SN 78-797,176. PUB. 5-20-2008. FILED 1-23-2006.
- 3,480,646. **MUSIC RHAPSODY (BLOCK FORM)**, LYNN KLEINER'S MUSIC RHAPSODY, (U.S. CLS. 100, 101 AND 107). SN 78-834,783. PUB. 5-20-2008. FILED 3-10-2006.
- 3,480,649 (*See Class 16 for this trademark*).
- 3,480,653 (*See Class 35 for this trademark*).
- 3,480,659 (*See Class 39 for this trademark*).
- 3,480,674. **RED HOT DATELINE (BLOCK FORM)**, TELIGENCE (US), INC., (U.S. CLS. 100, 101 AND 107). SN 78-896,144. PUB. 5-20-2008. FILED 5-30-2006.
- 3,480,687. **IMPORTEK AND DESIGN**, INVENTEC MULTIMEDIA & TELECOM CORPORATION, (U.S. CLS. 100, 101 AND 107). SN 78-909,336. PUB. 5-20-2008. FILED 6-15-2006.
- 3,480,691. **IMPORTEK (BLOCK FORM)**, INVENTEC MULTIMEDIA & TELECOM CORPORATION, (U.S. CLS. 100, 101 AND 107). SN 78-909,433. PUB. 5-20-2008. FILED 6-15-2006.
- 3,480,703. **STARSIAN (BLOCK FORM)**, CJ MEDIA, INC., (U.S. CLS. 100, 101 AND 107). SN 78-923,610. PUB. 5-13-2008. FILED 7-6-2006.
- 3,480,706 (*See Class 9 for this trademark*).
- 3,480,710. **SANSUM CLINIC AND DESIGN**, SANSUM-SANTA BARBARA MEDICAL FOUNDATION CLINIC, MULTIPLE CLASS, (INT. CLS. 41, 42 AND 44), (U.S. CLS. 100, 101 AND 107). SN 78-937,427. PUB. 5-20-2008. FILED 7-25-2006.
- 3,480,711. **SANSUM CLINIC (BLOCK FORM)**, SANSUM-SANTA BARBARA MEDICAL FOUNDATION CLINIC, MULTIPLE CLASS, (INT. CLS. 41, 42 AND 44), (U.S. CLS. 100, 101 AND 107). SN 78-937,428. PUB. 5-20-2008. FILED 7-25-2006.
- 3,480,712 (*See Class 16 for this trademark*).
- 3,480,716. **GRAND CIRCUIT (BLOCK FORM)**, GRAND CIRCUIT, INC., (U.S. CLS. 100, 101 AND 107). SN 78-951,451. PUB. 5-20-2008. FILED 8-14-2006.
- 3,480,717. **OLD SCHOOL OMEGA BY THE SEA (BLOCK FORM)**, SPORTS PERSPECTIVES INTERNATIONAL, INC., (U.S. CLS. 100, 101 AND 107). SN 78-953,215. PUB. 5-20-2008. FILED 8-16-2006.
- 3,480,718 (*See Class 9 for this trademark*).
- 3,480,725. **POJACK (BLOCK FORM)**, PO-JACK L.L.C., (U.S. CLS. 100, 101 AND 107). SN 78-960,977. PUB. 5-20-2008. FILED 8-25-2006.
- 3,480,729 (*See Class 35 for this trademark*).
- 3,480,741. **WAHINE (BLOCK FORM)**, QUIKSILVER, INC., (U.S. CLS. 100, 101 AND 107). SN 78-979,966. PUB. 5-20-2008. FILED 8-10-2006.
- 3,480,753 (*See Class 3 for this trademark*).
- 3,480,782 (*See Class 9 for this trademark*).
- 3,480,806. **PILSNER URQUELL INTERNATIONAL PHOTOGRAPHY AWARDS AND DESIGN**, PLZENSKY PRAZDROJ, A.S., (U.S. CLS. 100, 101 AND 107). SN 79-036,579. PUB. 5-20-2008. FILED 12-21-2006.
- 3,480,811 (*See Class 9 for this trademark*).
- 3,480,834 (*See Class 9 for this trademark*).
- 3,480,842 (*See Class 16 for this trademark*).
- 3,480,856 (*See Class 3 for this trademark*).
- 3,480,875. **WHY NOT (BLOCK FORM)**, EDYMA RESTAURADORES, S.L.; SOCIEDAD UNIPERSONAL, (U.S. CLS. 100, 101 AND 107). SN 79-041,262. PUB. 5-20-2008. FILED 2-6-2007.
- 3,480,877 (*See Class 38 for this trademark*).
- 3,480,882 (*See Class 9 for this trademark*).
- 3,480,910 (*See Class 9 for this trademark*).
- 3,480,913 (*See Class 16 for this trademark*).
- 3,480,935. **TRIPLE POCKET (BLOCK FORM)**, ANDERS ERICSSON, AND ANDREAS HURTIG, AND MATHIAS RINGBLOM, (U.S. CLS. 100, 101 AND 107). SN 79-042,644. PUB. 5-20-2008. FILED 6-8-2007.
- 3,480,943 (*See Class 9 for this trademark*).
- 3,480,959 (*See Class 16 for this trademark*).
- 3,481,017 (*See Class 35 for this trademark*).
- 3,481,040. **RS REAL SILVER QUALITY AND DESIGN**, AZIENDA SPECIALE; "REAL PRECIOUS QUALITY", MULTIPLE CLASS, (INT. CLS. 41 AND 42), (U.S. CLS. 100, 101 AND 107). SN 79-975,031. PUB. 5-20-2008. FILED 11-18-2005.
- 3,481,041. **RP REAL PRECIOUS QUALITY AND DESIGN**, AZIENDA SPECIALE; "REAL PRECIOUS QUALITY", MULTIPLE CLASS, (INT. CLS. 41 AND 42), (U.S. CLS. 100, 101 AND 107). SN 79-975,032. PUB. 5-20-2008. FILED 11-18-2005.

CLASS 42—SCIENTIFIC AND COMPUTER SERVICES

- 3,478,516 (*See Class 9 for this trademark*).
- 3,478,524 (*See Class 7 for this trademark*).
- 3,478,526 (*See Class 35 for this trademark*).
- 3,478,533 (*See Class 9 for this trademark*).
- 3,478,550. **IEASYSITE (BLOCK FORM)**, IHOST NETWORKS, INC., (U.S. CLS. 100 AND 101). SN 76-676,820. PUB. 5-20-2008. FILED 5-14-2007.
- 3,478,563 (*See Class 41 for this trademark*).
- 3,478,565 (*See Class 4 for this trademark*).
- 3,478,572. **MISCELLANEOUS DESIGN**, EVO PARTNERS, LP, DBA ENTRUST TECHNOLOGY CONSULTING SERVICES, (U.S. CLS. 100 AND 101). SN 76-681,091. PUB. 5-20-2008. FILED 8-24-2007.
- 3,478,576 (*See Class 9 for this trademark*).
- 3,478,577. **NETWORK STRATEGIES, INC. (BLOCK FORM)**, NETWORK STRATEGIES, INC., (U.S. CLS. 100 AND 101). SN 76-681,455. PUB. 5-20-2008. FILED 9-4-2007.
- 3,478,622 (*See Class 37 for this trademark*).
- 3,478,632 (*See Class 35 for this trademark*).
- 3,478,633 (*See Class 35 for this trademark*).
- 3,478,634. **CHINA ONECHECK (BLOCK FORM)**, INTEGRASCREEN SINGAPORE PTE LTD, (U.S. CLS. 100 AND 101). SN 77-008,224. PUB. 5-20-2008. FILED 9-27-2006.
- 3,478,635. **INDIA ONECHECK (BLOCK FORM)**, INTEGRASCREEN SINGAPORE PTE LTD, (U.S. CLS. 100 AND 101). SN 77-008,225. PUB. 5-20-2008. FILED 9-27-2006.

- 3,478,638 (*See Class 35 for this trademark.*)
 3,478,639. **NAVICORE AND DESIGN.** NAVICORE OY, (U.S. CLS. 100 AND 101). SN 77-013,875. PUB. 5-20-2008. FILED 10-4-2006.
 3,478,641 (*See Class 7 for this trademark.*)
 3,478,643 (*See Class 35 for this trademark.*)
 3,478,644 (*See Class 35 for this trademark.*)
 3,478,666 (*See Class 6 for this trademark.*)
 3,478,668 (*See Class 35 for this trademark.*)
 3,478,677 (*See Class 39 for this trademark.*)
 3,478,681 (*See Class 9 for this trademark.*)
 3,478,719. **CEI AND DESIGN.** COASTAL ENVIRONMENTS, INCORPORATED, (U.S. CLS. 100 AND 101). SN 77-066,609. PUB. 5-20-2008. FILED 12-18-2006.
 3,478,743. **AEROTONOMY (BLOCK FORM).** AEROTONOMY, INCORPORATED, (U.S. CLS. 100 AND 101). SN 77-083,610. PUB. 5-20-2008. FILED 1-16-2007.
 3,478,752. **ESPENWISE (BLOCK FORM).** CLEANWISE, INC., (U.S. CLS. 100 AND 101). SN 77-094,968. PUB. 5-20-2008. FILED 1-30-2007.
 3,478,763. **UPSTREAM STANDARDS. BOTTOM LINE RESULTS. (BLOCK FORM).** ENERGISTICS CONSORTIUM, INC., (U.S. CLS. 100 AND 101). SN 77-096,829. PUB. 5-20-2008. FILED 2-1-2007.
 3,478,777 (*See Class 10 for this trademark.*)
 3,478,780. **IDEASTORM (BLOCK FORM).** DELL INC., (U.S. CLS. 100 AND 101). SN 77-107,743. PUB. 2-12-2008. FILED 2-14-2007.
 3,478,791. **TECHNET (BLOCK FORM).** CFC TECHNOLOGY CORPORATION, (U.S. CLS. 100 AND 101). SN 77-113,650. PUB. 5-20-2008. FILED 2-22-2007.
 3,478,805 (*See Class 9 for this trademark.*)
 3,478,811 (*See Class 1 for this trademark.*)
 3,478,818 (*See Class 9 for this trademark.*)
 3,478,835. **PAPERLESS ENVIRONMENTS AND DESIGN.** PAPERLESS ENVIRONMENTS, LLC, (U.S. CLS. 100 AND 101). SN 77-144,645. PUB. 5-20-2008. FILED S.R. 3-30-2007; AM. P.R. 2-21-2008.
 3,478,848 (*See Class 9 for this trademark.*)
 3,478,849 (*See Class 41 for this trademark.*)
 3,478,850 (*See Class 41 for this trademark.*)
 3,478,862. **FRANCHISE ROADMAP (BLOCK FORM).** GRANITE TECHNOLOGIES, INC., (U.S. CLS. 100 AND 101). SN 77-156,521. PUB. 5-20-2008. FILED 4-13-2007.
 3,478,864 (*See Class 25 for this trademark.*)
 3,478,872 (*See Class 9 for this trademark.*)
 3,478,876. **PIXELSTREAMS SECURITY, APPLICATIONS, ACCESS, SUPPORT AND DESIGN.** PIXEL STREAMS, LLC, (U.S. CLS. 100 AND 101). SN 77-165,094. PUB. 5-20-2008. FILED 4-25-2007.
 3,478,879 (*See Class 35 for this trademark.*)
 3,478,880. **BEBORDERLESS (BLOCK FORM).** BE BORDERLESS, INC., (U.S. CLS. 100 AND 101). SN 77-166,227. PUB. 5-20-2008. FILED 4-26-2007.
 3,478,883 (*See Class 19 for this trademark.*)
 3,478,893 (*See Class 35 for this trademark.*)
 3,478,931 (*See Class 1 for this trademark.*)
 3,478,934 (*See Class 40 for this trademark.*)
 3,478,935 (*See Class 40 for this trademark.*)
 3,478,950. **RED LEVEL NETWORKS (STYLIZED).** RED LEVEL NETWORKS LLC, (U.S. CLS. 100 AND 101). SN 77-188,315. PUB. 5-20-2008. FILED 5-23-2007.
 3,478,964 (*See Class 35 for this trademark.*)
 3,478,970 (*See Class 35 for this trademark.*)
 3,478,978. **RELOCALIZATION NETWORK (BLOCK FORM).** METAFUNDATION DBA POST CARBON INSTITUTE, (U.S. CLS. 100 AND 101). SN 77-194,695. PUB. 5-20-2008. FILED 5-31-2007.
 3,478,983 (*See Class 37 for this trademark.*)
 3,479,012 (*See Class 35 for this trademark.*)
 3,479,017 (*See Class 35 for this trademark.*)
 3,479,018. **WIDGETONE (BLOCK FORM).** EMTRACE TECHNOLOGIES, INC., (U.S. CLS. 100 AND 101). SN 77-199,210. PUB. 5-20-2008. FILED 6-6-2007.
 3,479,057. **OCO INTELLIGENT DATA SCHEMA (BLOCK FORM).** OCO, INC., (U.S. CLS. 100 AND 101). SN 77-206,135. PUB. 5-20-2008. FILED 6-14-2007.
 3,479,075. **VISUALIZING E-COMMERCE (BLOCK FORM).** LIQUIDPIXELS, INCORPORATED, (U.S. CLS. 100 AND 101). SN 77-208,724. PUB. 5-20-2008. FILED 6-18-2007.
 3,479,078. **IPQA (BLOCK FORM).** BEYOND6, LLC, (U.S. CLS. 100 AND 101). SN 77-209,143. PUB. 5-20-2008. FILED 6-18-2007.
 3,479,100. **THE REAL ESTATE TOMATO AND DESIGN.** THE REAL ESTATE TOMATO, (U.S. CLS. 100 AND 101). SN 77-212,586. PUB. 5-20-2008. FILED 6-21-2007.
 3,479,107 (*See Class 14 for this trademark.*)
 3,479,129. **PROGRESS SONIC AND DESIGN.** PROGRESS SOFTWARE CORPORATION, (U.S. CLS. 100 AND 101). SN 77-216,924. PUB. 5-20-2008. FILED 6-27-2007.
 3,479,133. **SONIC (BLOCK FORM).** PROGRESS SOFTWARE CORPORATION, (U.S. CLS. 100 AND 101). SN 77-217,000. PUB. 5-20-2008. FILED 6-27-2007.
 3,479,163 (*See Class 35 for this trademark.*)
 3,479,166 (*See Class 37 for this trademark.*)
 3,479,238 (*See Class 7 for this trademark.*)
 3,479,264. **PACE ANALYTICAL LIFE SCIENCES (BLOCK FORM).** PACE ANALYTICAL SERVICES, INC., (U.S. CLS. 100 AND 101). SN 77-231,935. PUB. 5-20-2008. FILED 7-17-2007.
 3,479,269 (*See Class 9 for this trademark.*)
 3,479,270 (*See Class 35 for this trademark.*)
 3,479,291 (*See Class 9 for this trademark.*)
 3,479,293 (*See Class 35 for this trademark.*)
 3,479,336. **GO SNOWBALL AND DESIGN.** EMUSE MEDIA LIMITED, (U.S. CLS. 100 AND 101). SN 77-249,188. PUB. 5-20-2008. FILED 8-7-2007.
 3,479,343. **CONNECTED - SECURE - AVAILABLE (BLOCK FORM).** LIBERTY LAKE INTERNET EXCHANGE, LLC, (U.S. CLS. 100 AND 101). SN 77-250,130. PUB. 5-20-2008. FILED 8-8-2007.
 3,479,358. **ROOMSPINNERS (BLOCK FORM).** ROOMSPINNERS REDESIGN, DBA ROOMSPINNERS, AND ROOMSPINNERS REDESIGN, DBA ROOMSPINNERS, (U.S. CLS. 100 AND 101). SN 77-254,995. PUB. 5-20-2008. FILED 8-14-2007.
 3,479,388. **PERFECT POSTAGE AND DESIGN.** ANNE C. SLENTZ, (U.S. CLS. 100 AND 101). SN 77-264,267. PUB. 5-20-2008. FILED 8-24-2007.
 3,479,392 (*See Class 38 for this trademark.*)
 3,479,393. **SEARCHLES LIVE! (BLOCK FORM).** SEARCHLES, INC., (U.S. CLS. 100 AND 101). SN 77-265,286. PUB. 5-20-2008. FILED 8-27-2007.
 3,479,415 (*See Class 35 for this trademark.*)
 3,479,419 (*See Class 35 for this trademark.*)
 3,479,429. **YODLE (BLOCK FORM).** YODLE, INC., (U.S. CLS. 100 AND 101). SN 77-275,390. PUB. 2-12-2008. FILED 9-10-2007.
 3,479,430 (*See Class 35 for this trademark.*)
 3,479,444 (*See Class 35 for this trademark.*)
 3,479,476 (*See Class 35 for this trademark.*)
 3,479,480 (*See Class 35 for this trademark.*)
 3,479,499. **WEB2EXPENSE (BLOCK FORM).** BEYOND PORTALS, INC., (U.S. CLS. 100 AND 101). SN 77-294,373. PUB. 5-20-2008. FILED 10-2-2007.
 3,479,507 (*See Class 9 for this trademark.*)
 3,479,555 (*See Class 35 for this trademark.*)
 3,479,569 (*See Class 9 for this trademark.*)
 3,479,574. **FIREBRAND ARCHITECT (BLOCK FORM).** KOSTENKO, CONSTANTIN, (U.S. CLS. 100 AND 101). SN 77-309,889. PUB. 5-20-2008. FILED 10-22-2007.
 3,479,582. **PHYSICAL FIRST (BLOCK FORM).** OMNIRIM SOLUTIONS, INC., (U.S. CLS. 100 AND 101). SN 77-311,290. PUB. 5-20-2008. FILED 10-23-2007.
 3,479,583. **PHYSICAL FIRST AND DESIGN.** OMNIRIM SOLUTIONS, INC., (U.S. CLS. 100 AND 101). SN 77-311,440. PUB. 5-20-2008. FILED 10-23-2007.
 3,479,592 (*See Class 37 for this trademark.*)
 3,479,608. **1-800-GOT-MOLD? (BLOCK FORM).** MYCELIUM HOLDINGS LLC, (U.S. CLS. 100 AND 101). SN 77-316,651. PUB. 5-20-2008. FILED 10-30-2007.
 3,479,628 (*See Class 35 for this trademark.*)
 3,479,633 (*See Class 35 for this trademark.*)
 3,479,641 (*See Class 35 for this trademark.*)
 3,479,643. **RED PEAR (STYLIZED).** WILLEY, BRANDON, (U.S. CLS. 100 AND 101). SN 77-322,567. PUB. 5-20-2008.

- FILED 11-6-2007.
- 3,479,647. **SKYLON (BLOCK FORM)**. SKYLON INNOVATIONS, INC., (U.S. CLS. 100 AND 101). SN 77-323,363. PUB. 5-20-2008. FILED 11-7-2007.
- 3,479,650. **CLEAN AIR. PURE WATER. REAL HEALTH. (BLOCK FORM)**. SKYLON INNOVATIONS, INC., (U.S. CLS. 100 AND 101). SN 77-323,468. PUB. 5-20-2008. FILED 11-7-2007.
- 3,479,652. **SKYLON INNOVATIONS CLEAN AIR. PURE WATER. REAL HEALTH. AND DESIGN**. SKYLON INNOVATIONS, INC., (U.S. CLS. 100 AND 101). SN 77-323,596. PUB. 5-20-2008. FILED 11-7-2007.
- 3,479,660. **NEXGEN SOFTWARE SERVICES (BLOCK FORM)**. NEXGEN SOFTWARE SERVICES, INC., (U.S. CLS. 100 AND 101). SN 77-324,436. PUB. 5-20-2008. FILED 11-8-2007.
- 3,479,703. **ETPL AND DESIGN**. EASTERN TEXAS PATHOLOGY LABORATORIES, (U.S. CLS. 100 AND 101). SN 77-329,103. PUB. 5-20-2008. FILED 11-14-2007.
- 3,479,715. **CIMP CENTER FOR IDENTITY MANAGEMENT AND INFORMATION PROTECTION (STYLIZED)**. UTICA COLLEGE, (U.S. CLS. 100 AND 101). SN 77-331,201. PUB. 5-20-2008. FILED 11-16-2007.
- 3,479,716. **USER FIRST DESIGN FORMULA (BLOCK FORM)**. CUSTOMER EFFECTIVE, INC., (U.S. CLS. 100 AND 101). SN 77-331,437. PUB. 5-20-2008. FILED 11-16-2007.
- 3,479,722. **THE TRUTH SEEKER (BLOCK FORM)**. SEGMA LLC, (U.S. CLS. 100 AND 101). SN 77-332,501. PUB. 5-20-2008. FILED 11-18-2007.
- 3,479,723. **AUSTEX WEBSITES AND DESIGN**. COOK, STEVE C., (U.S. CLS. 100 AND 101). SN 77-332,661. PUB. 5-20-2008. FILED 11-19-2007.
- 3,479,747. **CITYLIGHT (BLOCK FORM)**. GEOCENTRIC LLC, (U.S. CLS. 100 AND 101). SN 77-336,468. PUB. 5-20-2008. FILED 11-26-2007.
- 3,479,761. **KARDIA HEALTH SYSTEMS (BLOCK FORM)**. KARDIA HEALTH SYSTEMS, INC., (U.S. CLS. 100 AND 101). SN 77-338,488. PUB. 5-20-2008. FILED 11-28-2007.
- 3,479,780 (*See Class 35 for this trademark*).
- 3,479,805. **NUSTART ENERGY (BLOCK FORM)**. NUSTART ENERGY DEVELOPMENT, LLC, (U.S. CLS. 100 AND 101). SN 77-342,585. PUB. 5-20-2008. FILED 12-3-2007.
- 3,479,811. **KEYMETRIC (BLOCK FORM)**. KEYMETRIC, INC., (U.S. CLS. 100 AND 101). SN 77-343,010. PUB. 5-20-2008. FILED 12-3-2007.
- 3,479,832 (*See Class 41 for this trademark*).
- 3,479,833. **ACTIVECAMPAIGN (BLOCK FORM)**. ACTIVECAMPAIGN, INC., (U.S. CLS. 100 AND 101). SN 77-345,888. PUB. 5-20-2008. FILED 12-6-2007.
- 3,479,847. **CONCEP (BLOCK FORM)**. CONCEP GROUP LIMITED, (U.S. CLS. 100 AND 101). SN 77-347,859. PUB. 5-20-2008. FILED 12-10-2007.
- 3,479,897. **MYTALENTLINK (BLOCK FORM)**. MY TALENT LINK, LLC, (U.S. CLS. 100 AND 101). SN 77-351,356. PUB. 5-20-2008. FILED 12-13-2007.
- 3,479,898. **MYTALENTLINK AND DESIGN**. MY TALENT LINK, LLC, (U.S. CLS. 100 AND 101). SN 77-351,367. PUB. 5-20-2008. FILED 12-13-2007.
- 3,479,941. **THE TRADEWINDS GROUP (BLOCK FORM)**. SAYEN, MICHAEL E, DBA THE TRADEWINDS GROUP, (U.S. CLS. 100 AND 101). SN 77-354,083. PUB. 5-20-2008. FILED 12-17-2007.
- 3,479,957 (*See Class 7 for this trademark*).
- 3,479,964 (*See Class 9 for this trademark*).
- 3,479,967. **COMMANDGRID (BLOCK FORM)**. SECURITY WITH ADVANCED TECHNOLOGY, INC., (U.S. CLS. 100 AND 101). SN 77-354,705. PUB. 5-20-2008. FILED 12-18-2007.
- 3,479,974. **BUILDING CODE CONSULTING SERVICES AND DESIGN**. BUILDING CODE CONSULTING SERVICES, L.L.P., (U.S. CLS. 100 AND 101). SN 77-354,917. PUB. 5-20-2008. FILED 12-18-2007.
- 3,480,010. **AE AEHELPER (STYLIZED)**. AEHELPER, LLC, (U.S. CLS. 100 AND 101). SN 77-356,762. PUB. 5-20-2008. FILED 12-20-2007.
- 3,480,022. **INSITE ARCHITECTURE INC (BLOCK FORM)**. INSITE ARCHITECTURE, INC., (U.S. CLS. 100 AND 101). SN 77-357,010. PUB. 5-20-2008. FILED 12-20-2007.
- 3,480,023 (*See Class 41 for this trademark*).
- 3,480,029. **DEVICEKEEPER AND DESIGN**. SCHIFF PARTNERS, INC., (U.S. CLS. 100 AND 101). SN 77-357,274. PUB. 5-20-2008. FILED 12-20-2007.
- 3,480,044 (*See Class 41 for this trademark*).
- 3,480,055. **DEVICECONFIRM (BLOCK FORM)**. IOVATION INC., MULTIPLE CLASS, (INT. CLS. 42 AND 45), (U.S. CLS. 100 AND 101). SN 77-358,358. PUB. 5-20-2008. FILED 12-21-2007.
- 3,480,060. **SAINT JOE (BLOCK FORM)**. SAINT JOE, INC., (U.S. CLS. 100 AND 101). SN 77-358,603. PUB. 5-20-2008. FILED 12-21-2007.
- 3,480,065. **SCHOOL SYSTEMS LLC AND DESIGN**. SCHOOL-SYSTEMS, LLC, (U.S. CLS. 100 AND 101). SN 77-358,929. PUB. 5-20-2008. FILED 12-23-2007.
- 3,480,068 (*See Class 9 for this trademark*).
- 3,480,069 (*See Class 9 for this trademark*).
- 3,480,094. **P PEOPLE SEARCH MEDIA AND DESIGN**. PEOPLE SEARCH MEDIA, LLC, (U.S. CLS. 100 AND 101). SN 77-359,669. PUB. 5-20-2008. FILED 12-26-2007.
- 3,480,100. **AUTOWALK (BLOCK FORM)**. AZIMA, INC., (U.S. CLS. 100 AND 101). SN 77-359,982. PUB. 5-20-2008. FILED 12-27-2007.
- 3,480,101. **ADVANTAGE (BLOCK FORM)**. AZIMA, INC., (U.S. CLS. 100 AND 101). SN 77-359,986. PUB. 5-20-2008. FILED 12-27-2007.
- 3,480,108 (*See Class 35 for this trademark*).
- 3,480,120. **COMMUNICATION FOR YOUR BRAND (BLOCK FORM)**. OXBOX DESIGN, (U.S. CLS. 100 AND 101). SN 77-360,873. PUB. 5-20-2008. FILED 12-28-2007.
- 3,480,140. **PEPE'S STUDIO AND DESIGN**. WAGNON, JOSEPH, (U.S. CLS. 100 AND 101). SN 77-361,786. PUB. 5-20-2008. FILED 12-31-2007.
- 3,480,147. **JBSERVERS (BLOCK FORM)**. JBSERVERS.NET, (U.S. CLS. 100 AND 101). SN 77-361,951. PUB. 5-20-2008. FILED 12-31-2007.
- 3,480,203. **G GINKIS AND DESIGN**. ROGAN, BRANDON T, DBA GINKIS, (U.S. CLS. 100 AND 101). SN 77-363,009. PUB. 5-20-2008. FILED 1-2-2008.
- 3,480,209. **NOTSOLDSEPARATELY (BLOCK FORM)**. NOTSOLDSEPARATELY.COM, LLC, (U.S. CLS. 100 AND 101). SN 77-363,120. PUB. 5-20-2008. FILED 1-3-2008.
- 3,480,230. **PREVENTION TO RECOVERY (BLOCK FORM)**. NETSWITCH, INC., DBA NETSWITCH TECHNOLOGY MANAGEMENT, (U.S. CLS. 100 AND 101). SN 77-363,326. PUB. 5-20-2008. FILED 1-3-2008.
- 3,480,242. **CHANGING THE WAY COMPANIES RUN THEIR DATA CENTERS (BLOCK FORM)**. APERTURE TECHNOLOGIES, INC., (U.S. CLS. 100 AND 101). SN 77-363,552. PUB. 5-20-2008. FILED 1-3-2008.
- 3,480,255 (*See Class 9 for this trademark*).
- 3,480,264. **WE MAKE THE COMPACTION SPECS WORK (BLOCK FORM)**. EARTHWORK SOLUTIONS, INC., (U.S. CLS. 100 AND 101). SN 77-363,877. PUB. 5-20-2008. FILED 1-3-2008.
- 3,480,265. **ADVANCING INDUSTRY, IMPROVING ECONOMY & BETTERING OUR WORLD (BLOCK FORM)**. EARTHWORK SOLUTIONS, INC., (U.S. CLS. 100 AND 101). SN 77-363,879. PUB. 5-20-2008. FILED 1-3-2008.
- 3,480,266. **ESOL (BLOCK FORM)**. EARTHWORK SOLUTIONS, INC., (U.S. CLS. 100 AND 101). SN 77-363,881. PUB. 5-20-2008. FILED 1-3-2008.
- 3,480,267. **BILLY RAYGUN DESIGN, INC. (BLOCK FORM)**. ROOZEE, WILLIAM P., (U.S. CLS. 100 AND 101). SN 77-363,882. PUB. 5-20-2008. FILED 1-3-2008.
- 3,480,305. **ETERNALIZE (BLOCK FORM)**. TERASEM MOVEMENT FOUNDATION, INC., (U.S. CLS. 100 AND 101). SN 77-364,522. PUB. 5-20-2008. FILED 1-4-2008.
- 3,480,334. **CRUSHTOWN AND DESIGN**. CRUSHTOWN, LLC, (U.S. CLS. 100 AND 101). SN 77-364,984. PUB. 5-20-2008. FILED 1-6-2008.
- 3,480,367. **TAP. . . POTENTIAL REALIZED (BLOCK FORM)**. TAP PHARMACEUTICAL PRODUCTS, INC., (U.S. CLS. 100 AND 101). SN 77-365,531. PUB. 5-20-2008. FILED 1-7-2008.
- 3,480,369. **DRAW LOUD! (STYLIZED)**. SHABOT, EDWARD J, (U.S. CLS. 100 AND 101). SN 77-365,628. PUB. 5-20-2008. FILED 1-7-2008.
- 3,480,394 (*See Class 35 for this trademark*).
- 3,480,401 (*See Class 9 for this trademark*).

3,480,404. **ENTEGRION (BLOCK FORM)**, ENTEGRION, INC., (U.S. CLS. 100 AND 101). SN 77-366,509. PUB. 5-20-2008. FILED 1-8-2008.

3,480,411. **VOICEFORGE (BLOCK FORM)**, CEPSTRAL, LLC, (U.S. CLS. 100 AND 101). SN 77-366,564. PUB. 5-20-2008. FILED 1-8-2008.

3,480,429. **ELEMENTS OF CHANGE (BLOCK FORM)**, SIMMONS, LEAH D. (U.S. CLS. 100 AND 101). SN 77-366,851. PUB. 5-20-2008. FILED 1-8-2008.

3,480,457. **NETSPROUT (BLOCK FORM)**, NETSPROUT, INC., (U.S. CLS. 100 AND 101). SN 77-367,621. PUB. 5-20-2008. FILED 1-9-2008.

3,480,459. **STAGING TURNS COLD INTO SOLD! (BLOCK FORM)**, ROEMMER, CAROL, (U.S. CLS. 100 AND 101). SN 77-367,649. PUB. 5-20-2008. FILED 1-9-2008.

3,480,478. **DRAWN BY INNOVATION (BLOCK FORM)**, LAND ARCHITECTURE, INC., (U.S. CLS. 100 AND 101). SN 77-368,020. PUB. 5-20-2008. FILED 1-9-2008.

3,480,491. **RENTALMAN (BLOCK FORM)**, WYNNE SYSTEMS, INC., (U.S. CLS. 100 AND 101). SN 77-369,485. PUB. 5-20-2008. FILED 1-11-2008.

3,480,499 (*See Class 9 for this trademark.*).

3,480,500 (*See Class 9 for this trademark.*).

3,480,503. **PEAKSAVER (BLOCK FORM)**, CITY PUBLIC SERVICE, (U.S. CLS. 100 AND 101). SN 77-373,184. PUB. 5-20-2008. FILED 1-16-2008.

3,480,519. **APERTURE AND DESIGN**, APERTURE TECHNOLOGIES, INC., (U.S. CLS. 100 AND 101). SN 77-377,528. PUB. 5-20-2008. FILED 1-22-2008.

3,480,567. **EFUEL (BLOCK FORM)**, COLT INTERNATIONAL, INC., (U.S. CLS. 100 AND 101). SN 77-975,404. PUB. 5-20-2008. FILED 6-27-2007.

3,480,585 (*See Class 35 for this trademark.*).

3,480,586 (*See Class 9 for this trademark.*).

3,480,598 (*See Class 16 for this trademark.*).

3,480,606. **THE COMMUNITY OF PRACTICE COMPANY (BLOCK FORM)**, TOMOYE CORPORATION, (U.S. CLS. 100 AND 101). SN 78-618,980. PUB. 11-6-2007. FILED 4-28-2005.

3,480,611 (*See Class 38 for this trademark.*).

3,480,631 (*See Class 40 for this trademark.*).

3,480,636. **INTERTEK (BLOCK FORM)**, INTERTEK GROUP PLC., (U.S. CLS. 100 AND 101). SN 78-795,876. PUB. 5-20-2008. FILED 1-20-2006.

3,480,658 (*See Class 35 for this trademark.*).

3,480,667 (*See Class 19 for this trademark.*).

3,480,670. **STYLEHIVE (STYLIZED)**, STYLEHIVE, INC., (U.S. CLS. 100 AND 101). SN 78-890,653. PUB. 5-20-2008. FILED 5-23-2006.

3,480,688. **IMPORTEK AND DESIGN**, INVENTEC MULTIMEDIA & TELECOM CORPORATION, (U.S. CLS. 100 AND 101). SN 78-909,354. PUB. 5-20-2008. FILED 6-15-2006.

3,480,690. **IMPORTEK (BLOCK FORM)**, INVENTEC MULTIMEDIA & TELECOM CORPORATION, (U.S. CLS. 100 AND 101). SN 78-909,413. PUB. 5-20-2008. FILED 6-15-2006.

3,480,696. **CHEAP GEEK (BLOCK FORM)**, FALTSKOG, MARGARET C. (U.S. CLS. 100 AND 101). SN 78-912,138. PUB. 5-20-2008. FILED 6-20-2006.

3,480,705. **FACES OF EARTH (BLOCK FORM)**, AMERICAN GEOLOGICAL INSTITUTE, (U.S. CLS. 100 AND 101). SN 78-928,902. PUB. 5-20-2008. FILED 7-13-2006.

3,480,706 (*See Class 9 for this trademark.*).

3,480,709 (*See Class 9 for this trademark.*).

3,480,710 (*See Class 41 for this trademark.*).

3,480,711 (*See Class 41 for this trademark.*).

3,480,735 (*See Class 9 for this trademark.*).

3,480,737 (*See Class 35 for this trademark.*).

3,480,738 (*See Class 35 for this trademark.*).

3,480,742 (*See Class 35 for this trademark.*).

3,480,757 (*See Class 9 for this trademark.*).

3,480,758 (*See Class 9 for this trademark.*).

3,480,760 (*See Class 9 for this trademark.*).

3,480,781 (*See Class 4 for this trademark.*).

3,480,785 (*See Class 35 for this trademark.*).

3,480,788. **ADSOX (STYLIZED)**, BOC ASSET MANAGEMENT GMBH, (U.S. CLS. 100 AND 101). SN 79-034,820. PUB. 2-12-2008. FILED 1-22-2007.

3,480,802 (*See Class 9 for this trademark.*).

3,480,805 (*See Class 7 for this trademark.*).

3,480,807 (*See Class 9 for this trademark.*).

3,480,815 (*See Class 9 for this trademark.*).

3,480,877 (*See Class 38 for this trademark.*).

3,480,887 (*See Class 1 for this trademark.*).

3,480,907 (*See Class 7 for this trademark.*).

3,480,908 (*See Class 6 for this trademark.*).

3,480,913 (*See Class 16 for this trademark.*).

3,480,916 (*See Class 9 for this trademark.*).

3,480,943 (*See Class 9 for this trademark.*).

3,480,951 (*See Class 35 for this trademark.*).

3,480,952 (*See Class 9 for this trademark.*).

3,480,982 (*See Class 40 for this trademark.*).

3,480,992 (*See Class 35 for this trademark.*).

3,481,021 (*See Class 35 for this trademark.*).

3,481,028 (*See Class 10 for this trademark.*).

3,481,040 (*See Class 41 for this trademark.*).

3,481,041 (*See Class 41 for this trademark.*).

CLASS 43—HOTEL AND RESTAURANT SERVICES

3,478,504. **RISING STAR LEARNING CENTER (BLOCK FORM)**, RISING STAR LEARNING CENTER, INC., (U.S. CLS. 100 AND 101). SN 76-588,682. PUB. 5-20-2008. FILED 4-26-2004.

3,478,514. **VIVO (BLOCK FORM)**, DIAZ, ROGER, (U.S. CLS. 100 AND 101). SN 76-657,550. PUB. 5-20-2008. FILED 3-30-2006.

3,478,558. **SAVOY (BLOCK FORM)**, SAVOY LINEN SERVICES, INC., MULTIPLE CLASS, (INT. CLS. 43 AND 45), (U.S. CLS. 100 AND 101). SN 76-678,567. PUB. 5-20-2008. FILED 6-22-2007.

3,478,570 (*See Class 16 for this trademark.*).

3,478,573. **HOME OF THE D CUP (BLOCK FORM)**, AISLINN COFFEE ENTERPRISES LLC, (U.S. CLS. 100 AND 101). SN 76-681,094. PUB. 5-20-2008. FILED 8-24-2007.

3,478,598. **CHEF'S INNOVATIONS PREPARED FRESH FOR YOU! AND DESIGN**, RESTAURANT DEVELOPERS CORPORATION, (U.S. CLS. 100 AND 101). SN 76-684,228. PUB. 5-20-2008. FILED 11-21-2007.

3,478,609. **MICHEL RICHARD (BLOCK FORM)**, MICHEL RICHARD, LLC, (U.S. CLS. 100 AND 101). SN 76-685,034. PUB. 5-20-2008. FILED 12-18-2007.

3,478,620. **SOUPER FRY (STYLIZED)**, OK COOL, INC., (U.S. CLS. 100 AND 101). SN 76-685,576. PUB. 5-20-2008. FILED 12-31-2007.

3,478,683. **CROWD PLEAZERS (BLOCK FORM)**, 99 RESTAURANTS, LLC, (U.S. CLS. 100 AND 101). SN 77-045,987. PUB. 5-20-2008. FILED 11-16-2006.

3,478,776 (*See Class 16 for this trademark.*).

3,478,784 (*See Class 30 for this trademark.*).

3,478,839 (*See Class 35 for this trademark.*).

3,478,859 (*See Class 25 for this trademark.*).

3,478,913. **REAL LIFE. REAL CHANGE. (BLOCK FORM)**, URBAN PEAK DENVER, (U.S. CLS. 100 AND 101). SN 77-179,169. PUB. 5-20-2008. FILED 5-11-2007.

3,478,914. **URBAN PEAK AND DESIGN**, URBAN PEAK DENVER, (U.S. CLS. 100 AND 101). SN 77-179,188. PUB. 5-20-2008. FILED 5-11-2007.

3,478,984. **DON'T WORRY BE CRABBY CRABBY BILL'S SEAFOOD AND DESIGN**, CRABBY BILL'S U.S.A., LLC, (U.S. CLS. 100 AND 101). SN 77-195,548. PUB. 5-20-2008. FILED 6-1-2007.

3,479,003. **STONE HEARTH PIZZA CO. (BLOCK FORM)**, ASILLEM LLC, (U.S. CLS. 100 AND 101). SN 77-197,161. PUB. 5-20-2008. FILED 6-4-2007.

3,479,029. **FLYING TOMATO (BLOCK FORM)**, HAWKINS, CHARLES JOSEPH, (U.S. CLS. 100 AND 101). SN 77-200,580. PUB. 5-20-2008. FILED 6-7-2007.

3,479,032 (*See Class 35 for this trademark.*).

3,479,034. **ONCE UPON A TART (BLOCK FORM)**, ONCE UPON A TART, INC., (U.S. CLS. 100 AND 101). SN 77-201,549. PUB. 5-20-2008. FILED 6-8-2007.

3,479,081. **SOCIALE MAKE & TAKE GOURMET (STYLIZED)**, SOCIALE, INC., (U.S. CLS. 100 AND 101). SN 77-209,856.

- PUB. 5-20-2008. FILED 6-19-2007.
- 3,479,083. **FRESHWAY FOOD SYSTEMS AND DESIGN.** FRESHWAY FOOD SYSTEMS, INC., (U.S. CLS. 100 AND 101). SN 77-210,778. PUB. 5-20-2008. FILED 6-20-2007.
- 3,479,144. **SANDWICH QBANO (BLOCK FORM).** MARIO ENRICO MAYA, (U.S. CLS. 100 AND 101). SN 77-218,040. PUB. 5-20-2008. FILED 6-28-2007.
- 3,479,206. **KATERED KAMPING AND DESIGN.** FLOYD, JACK L., (U.S. CLS. 100 AND 101). SN 77-224,138. PUB. 5-20-2008. FILED 7-7-2007.
- 3,479,223 (*See Class 35 for this trademark.*)
- 3,479,285 (*See Class 41 for this trademark.*)
- 3,479,301 (*See Class 41 for this trademark.*)
- 3,479,305. **MOULIN D'OR (BLOCK FORM).** MOULIN D'OR COMPANY SARL, (U.S. CLS. 100 AND 101). SN 77-239,875. PUB. 5-20-2008. FILED 7-26-2007.
- 3,479,319. **CALIFORNIA VEGAN (BLOCK FORM).** NATIVE FOODS, INCORPORATED, (U.S. CLS. 100 AND 101). SN 77-244,494. PUB. 5-20-2008. FILED 8-1-2007.
- 3,479,385. **SFOGLIA AND DESIGN.** THE SUHANOSKY FAMILY, (U.S. CLS. 100 AND 101). SN 77-263,170. PUB. 5-20-2008. FILED 8-23-2007.
- 3,479,394. **INTOWN SUITES EXTENDED-STAY LIVING (STYLIZED).** INTOWN SUITES MANAGEMENT, INC., (U.S. CLS. 100 AND 101). SN 77-265,413. PUB. 5-20-2008. FILED 8-27-2007.
- 3,479,410. **HOT STEAKS HOT MUSIC HOT ITALIAN COOL PLACE! (BLOCK FORM).** WHALEN, MICHAEL L., (U.S. CLS. 100 AND 101). SN 77-269,583. PUB. 5-20-2008. FILED 8-31-2007.
- 3,479,422. **STAY WHERE THE COWBOYS PLAY! (BLOCK FORM).** BOYD GAMING CORPORATION, (U.S. CLS. 100 AND 101). SN 77-273,513. PUB. 2-12-2008. FILED 9-6-2007.
- 3,479,463 (*See Class 39 for this trademark.*)
- 3,479,474. **FLEMING'S 100 (BLOCK FORM).** OSI/FLEMING'S, LLC, (U.S. CLS. 100 AND 101). SN 77-288,386. PUB. 5-20-2008. FILED 9-25-2007.
- 3,479,555 (*See Class 35 for this trademark.*)
- 3,479,560. **CHAIR COVERS & LINENS AND DESIGN.** CHAIR COVERS & LINENS, INC., (U.S. CLS. 100 AND 101). SN 77-307,160. PUB. 5-20-2008. FILED 10-18-2007.
- 3,479,637. **WESTCOTT LAKES AT SOUTHWOOD AND DESIGN.** PRAXEIS, LLC, (U.S. CLS. 100 AND 101). SN 77-321,668. PUB. 5-20-2008. FILED 11-5-2007.
- 3,479,649. **VINAIGRETTE AND DESIGN.** VINAIGRETTE, INC., (U.S. CLS. 100 AND 101). SN 77-323,451. PUB. 5-20-2008. FILED 11-7-2007.
- 3,479,712. **MARISCOS LA SIRENITA (BLOCK FORM).** YBANEZ-GONZALES, INC., (U.S. CLS. 100 AND 101). SN 77-330,989. PUB. 5-20-2008. FILED 11-15-2007.
- 3,479,730 (*See Class 39 for this trademark.*)
- 3,479,743. **STEVE'S SNAPPIN' DOGS AND DESIGN.** CARRIED AWAY, LLC, (U.S. CLS. 100 AND 101). SN 77-335,655. PUB. 5-20-2008. FILED 11-21-2007.
- 3,479,760 (*See Class 35 for this trademark.*)
- 3,479,783. **OLGA'S KITCHEN AND DESIGN.** OLGA'S KITCHEN, INC., (U.S. CLS. 100 AND 101). SN 77-341,138. PUB. 5-20-2008. FILED 11-30-2007.
- 3,479,802. **VERA WANG (BLOCK FORM).** V.E.W., LTD., (U.S. CLS. 100 AND 101). SN 77-342,471. PUB. 5-20-2008. FILED 12-3-2007.
- 3,479,842 (*See Class 35 for this trademark.*)
- 3,479,852. **THE CLUB AT TRISTANT (BLOCK FORM).** EPIPHANY TELLURIDE, LLC, (U.S. CLS. 100 AND 101). SN 77-348,291. PUB. 5-20-2008. FILED 12-10-2007.
- 3,479,885. **AZUMA (BLOCK FORM).** AZUMA LEASING CT, LP, (U.S. CLS. 100 AND 101). SN 77-350,889. PUB. 5-20-2008. FILED 12-13-2007.
- 3,479,902. **PLUM V.I.P. LOUNGE (BLOCK FORM).** SEMINOLE TRIBE OF FLORIDA, (U.S. CLS. 100 AND 101). SN 77-351,522. PUB. 5-20-2008. FILED 12-13-2007.
- 3,479,961. **WINEOLOGY (BLOCK FORM).** NAPOLITANO, LEONARD SEVERIN, (U.S. CLS. 100 AND 101). SN 77-354,539. PUB. 5-20-2008. FILED 12-18-2007.
- 3,479,994 (*See Class 35 for this trademark.*)
- 3,480,131. **CUQUITA'S (BLOCK FORM).** VILLAFRANCA, ENRIQUE, (U.S. CLS. 100 AND 101). SN 77-361,339. PUB. 5-20-2008. FILED 12-28-2007.
- 3,480,187. **ELEPHANT HUT (BLOCK FORM).** KASEMSANT, PIYASAK, (U.S. CLS. 100 AND 101). SN 77-362,722. PUB. 5-20-2008. FILED 1-2-2008.
- 3,480,201. **ELEPHANT HUT AND DESIGN.** KASEMSANT, PIYASAK, (U.S. CLS. 100 AND 101). SN 77-362,985. PUB. 5-20-2008. FILED 1-2-2008.
- 3,480,213. **EVEREST (BLOCK FORM).** LETTUCE ENTERTAIN YOU ENTERPRISES, INC., (U.S. CLS. 100 AND 101). SN 77-363,142. PUB. 5-20-2008. FILED 1-3-2008.
- 3,480,222. **SISTERS TEA PARLOR & BOUTIQUE (BLOCK FORM).** SISTERS, INC., (U.S. CLS. 100 AND 101). SN 77-363,258. PUB. 5-20-2008. FILED 1-3-2008.
- 3,480,258. **MINDFUL DINING FOR ALL SEASONS AND DESIGN.** JBT, LLC, (U.S. CLS. 100 AND 101). SN 77-363,797. PUB. 5-20-2008. FILED 1-3-2008.
- 3,480,259. **FEED THE WHOLE GROUP (BLOCK FORM).** NOODLES & COMPANY, (U.S. CLS. 100 AND 101). SN 77-363,806. PUB. 5-20-2008. FILED 1-3-2008.
- 3,480,260. **ROCK CREEK AND DESIGN.** JBT, LLC, (U.S. CLS. 100 AND 101). SN 77-363,816. PUB. 5-20-2008. FILED 1-3-2008.
- 3,480,346. **MAGNUS JOE (BLOCK FORM).** COBB, BOBBY J., (U.S. CLS. 100 AND 101). SN 77-365,204. PUB. 5-20-2008. FILED 1-7-2008.
- 3,480,362. **Z 3 (STYLIZED).** FERALON GROUP L.L.C., (U.S. CLS. 100 AND 101). SN 77-365,476. PUB. 5-20-2008. FILED 1-7-2008.
- 3,480,380. **HOT BOX PIZZA (BLOCK FORM).** HOT BOX PIZZA, LLC, (U.S. CLS. 100 AND 101). SN 77-365,962. PUB. 5-20-2008. FILED 1-7-2008.
- 3,480,382. **HOTBOX PIZZA AND DESIGN.** HOT BOX PIZZA, LLC, (U.S. CLS. 100 AND 101). SN 77-365,990. PUB. 5-20-2008. FILED 1-7-2008.
- 3,480,384. **THE DRUNKEN FISH (BLOCK FORM).** MUNSOK SO, (U.S. CLS. 100 AND 101). SN 77-366,005. PUB. 5-20-2008. FILED 1-7-2008.
- 3,480,385. **HOT BOX PIZZA AND DESIGN.** HOT BOX PIZZA, LLC, (U.S. CLS. 100 AND 101). SN 77-366,012. PUB. 5-20-2008. FILED 1-7-2008.
- 3,480,452. **KNUCKLEHEADS (BLOCK FORM).** SMOKEY'S PEANUTS, INC., (U.S. CLS. 100 AND 101). SN 77-367,473. PUB. 5-20-2008. FILED 1-9-2008.
- 3,480,501. **THE DRUNKEN FISH AND DESIGN.** MUNSOK SO, (U.S. CLS. 100 AND 101). SN 77-372,868. PUB. 5-20-2008. FILED 1-16-2008.
- 3,480,552. **LITTLE SIX (BLOCK FORM).** SHAKOPEE MDEWAKANTON SIOUX COMMUNITY, (U.S. CLS. 100 AND 101). SN 77-406,190. PUB. 5-20-2008. FILED 2-26-2008.
- 3,480,553. **LITTLE SIX AND DESIGN.** SHAKOPEE MDEWAKANTON SIOUX COMMUNITY, (U.S. CLS. 100 AND 101). SN 77-406,201. PUB. 5-20-2008. FILED 2-26-2008.
- 3,480,589 (*See Class 30 for this trademark.*)
- 3,480,607. **PASTAGINA (BLOCK FORM).** PASTARIA, LLC, (U.S. CLS. 100 AND 101). SN 78-621,436. PUB. 5-20-2008. FILED 5-2-2005.
- 3,480,629 (*See Class 29 for this trademark.*)
- 3,480,638. **B.T.BONES TEXAS STEAKHOUSE AND DESIGN.** BONE'S STEAKHOUSE, INC., (U.S. CLS. 100 AND 101). SN 78-799,707. PUB. 5-20-2008. FILED 1-26-2006.
- 3,480,659 (*See Class 39 for this trademark.*)
- 3,480,679. **THE GARAGE (BLOCK FORM).** LUCKY 13, INC., (U.S. CLS. 100 AND 101). SN 78-902,644. PUB. 5-20-2008. FILED 6-7-2006.
- 3,480,726 (*See Class 30 for this trademark.*)
- 3,480,731. **EOAKWOOD (BLOCK FORM).** R & B REALTY GROUP DBA OAKWOOD WORLDWIDE, (U.S. CLS. 100 AND 101). SN 78-966,009. PUB. 5-20-2008. FILED 9-1-2006.
- 3,480,739. **CASANOVA GRILL (BLOCK FORM).** OPPKNOX, LLC, (U.S. CLS. 100 AND 101). SN 78-974,447. PUB. 5-20-2008. FILED 9-14-2006.
- 3,480,764. **KJC CAFÉ (BLOCK FORM).** CHOI, HAK LAK, (U.S. CLS. 100 AND 101). SN 79-032,050. PUB. 5-20-2008. FILED 10-16-2006.
- 3,480,823 (*See Class 29 for this trademark.*)
- 3,480,905 (*See Class 16 for this trademark.*)
- 3,480,977 (*See Class 35 for this trademark.*)
- 3,481,013 (*See Class 35 for this trademark.*)

CLASS 44—MEDICAL, BEAUTY AND AGRICULTURAL SERVICES

- 3,478,543 (*See Class 40 for this trademark.*)
 3,478,563 (*See Class 41 for this trademark.*)
 3,478,567. **THE WALLACE METHOD AND DESIGN.** WALLACE, HEATHER, (U.S. CLS. 100 AND 101). SN 76-680,176. PUB. 5-20-2008. FILED 8-2-2007.
 3,478,570 (*See Class 16 for this trademark.*)
 3,478,611 (*See Class 9 for this trademark.*)
 3,478,618. **RUMM COLOR STUDIO (BLOCK FORM).** RUMM COLOR STUDIO, LLC, (U.S. CLS. 100 AND 101). SN 76-685,542. PUB. 5-20-2008. FILED 1-7-2008.
 3,478,625. **DIABETES MINE (BLOCK FORM).** AMY TENDER-ICH LLC, (U.S. CLS. 100 AND 101). SN 76-686,792. PUB. 5-20-2008. FILED 2-12-2008.
 3,478,646. **PROFITABLE SPEECH LLC A SOUND INVESTMENT AND DESIGN.** PROFITABLE SPEECH, LLC, AND KLEIN, DALE G., (U.S. CLS. 100 AND 101). SN 77-018,871. PUB. 5-20-2008. FILED 10-11-2006.
 3,478,700 (*See Class 35 for this trademark.*)
 3,478,716. **FIBER35DIET (BLOCK FORM).** RENEW LIFE FORMULAS, INC., (U.S. CLS. 100 AND 101). SN 77-065,034. PUB. 5-20-2008. FILED 12-15-2006.
 3,478,720 (*See Class 1 for this trademark.*)
 3,478,732 (*See Class 41 for this trademark.*)
 3,478,733 (*See Class 35 for this trademark.*)
 3,478,775 (*See Class 26 for this trademark.*)
 3,478,778 (*See Class 35 for this trademark.*)
 3,478,854 (*See Class 3 for this trademark.*)
 3,478,890. **MULTICARE (BLOCK FORM).** MULTICARE HEALTH SYSTEM, (U.S. CLS. 100 AND 101). SN 77-169,195. PUB. 5-20-2008. FILED 4-30-2007.
 3,478,902 (*See Class 3 for this trademark.*)
 3,478,925. **SPLIT ENDZ (BLOCK FORM).** SPLIT ENDZ HAIRCUTTERS, INC, AND DIGIACOMO, ARTHUR J, (U.S. CLS. 100 AND 101). SN 77-183,342. PUB. 5-20-2008. FILED 5-17-2007.
 3,478,973 (*See Class 35 for this trademark.*)
 3,478,999 (*See Class 35 for this trademark.*)
 3,479,113. **MISCELLANEOUS DESIGN.** BROWN, SUSAN M., (U.S. CLS. 100 AND 101). SN 77-214,775. PUB. 5-20-2008. FILED 6-25-2007.
 3,479,115 (*See Class 3 for this trademark.*)
 3,479,138 (*See Class 35 for this trademark.*)
 3,479,163 (*See Class 35 for this trademark.*)
 3,479,223 (*See Class 35 for this trademark.*)
 3,479,244. **QISCAN (BLOCK FORM).** JACKSON, GLORIA M, (U.S. CLS. 100 AND 101). SN 77-229,721. PUB. 5-20-2008. FILED 7-13-2007.
 3,479,247 (*See Class 35 for this trademark.*)
 3,479,270 (*See Class 35 for this trademark.*)
 3,479,304. **LASER VAGINAL REJUVENATION (BLOCK FORM).** ENTREPRENEURIAL MEDICAL CONSULTING, LLC, (U.S. CLS. 100 AND 101). SN 77-239,871. PUB. 5-20-2008. FILED 7-26-2007.
 3,479,322. **H TEXAS HAND THERAPY CENTER AND DESIGN.** TEXAS HAND THERAPY CENTER, INC., (U.S. CLS. 100 AND 101). SN 77-245,429. PUB. 5-20-2008. FILED 8-2-2007.
 3,479,350. **MISCELLANEOUS DESIGN.** JAVIER R. RIOS MD A PROFESSIONAL CORPORATION, DBA MAGNOLIA CLINICA MEDICA FAMILIAR, CHICAGO CLINICA MEDICA FAMILIAR, (U.S. CLS. 100 AND 101). SN 77-252,465. PUB. 2-12-2008. FILED 8-10-2007.
 3,479,365. **MED-STAFF HOME HEALTH, LLC AND DESIGN.** MED-STAFF, LLC, (U.S. CLS. 100 AND 101). SN 77-257,051. PUB. 5-20-2008. FILED 8-16-2007.
 3,479,378. **HOLISTIC ANARCHY (BLOCK FORM).** WHOLISTIC DIALOGUE, LLC, (U.S. CLS. 100 AND 101). SN 77-261,870. PUB. 5-20-2008. FILED 8-22-2007.
 3,479,417. **THE ROSE LADY WOODEN ROSES (BLOCK FORM).** IRVIN, GAYLE, (U.S. CLS. 100 AND 101). SN 77-272,503. PUB. 5-20-2008. FILED 9-5-2007.
 3,479,452. **ON THE GO SPA STEP INTO CONVENIENCE & RELAXATION AND DESIGN.** SIMONIDES, VERONICA M., (U.S. CLS. 100 AND 101). SN 77-281,146. PUB. 5-20-2008. FILED 9-17-2007.
 3,479,498. **REAL SIMPLE REWARDS (BLOCK FORM).** TIME INC., (U.S. CLS. 100 AND 101). SN 77-294,022. PUB. 5-20-2008. FILED 10-2-2007.
 3,479,523 (*See Class 39 for this trademark.*)
 3,479,525 (*See Class 39 for this trademark.*)
 3,479,528 (*See Class 39 for this trademark.*)
 3,479,635 (*See Class 41 for this trademark.*)
 3,479,642. **BIG TREE FARM (BLOCK FORM).** BIG TREE FARM, LLC, (U.S. CLS. 100 AND 101). SN 77-322,561. PUB. 5-20-2008. FILED 11-6-2007.
 3,479,687. **TSAVO (BLOCK FORM).** BOHINC, GARY, (U.S. CLS. 100 AND 101). SN 77-326,961. PUB. 5-20-2008. FILED 11-12-2007.
 3,479,721. **ACNE FYI (BLOCK FORM).** CAPTAIN, LAURA G., (U.S. CLS. 100 AND 101). SN 77-332,383. PUB. 5-20-2008. FILED 11-17-2007.
 3,479,752 (*See Class 41 for this trademark.*)
 3,479,759. **THORNBURG PEDIATRICS AND DESIGN.** BRIAN THORNBURG, DO, PA, (U.S. CLS. 100 AND 101). SN 77-338,279. PUB. 5-20-2008. FILED 11-27-2007.
 3,479,784. **KIDS. HAIRCUTS. PARTIES. FUN. (BLOCK FORM).** THE SNIP-ITS CORPORATION, (U.S. CLS. 100 AND 101). SN 77-341,277. PUB. 5-20-2008. FILED 11-30-2007.
 3,479,798. **LEAVE YOUR TAN LINES AT THE DOOR... (BLOCK FORM).** BRONZE BAY TANNING, LLC, (U.S. CLS. 100 AND 101). SN 77-342,300. PUB. 5-20-2008. FILED 12-3-2007.
 3,479,818. **FRUIT TREE 101 (BLOCK FORM).** THE FRUIT TREE PLANTING FOUNDATION, DBA FTPF, (U.S. CLS. 100 AND 101). SN 77-344,232. PUB. 5-20-2008. FILED 12-5-2007.
 3,479,824. **VIP RECOVERY COACHING (BLOCK FORM).** WILLIAMS, ROLAND, (U.S. CLS. 100 AND 101). SN 77-345,056. PUB. 5-20-2008. FILED 12-5-2007.
 3,479,845. **WEBCNP (BLOCK FORM).** THE TRUSTEES OF THE UNIVERSITY OF PENNSYLVANIA, (U.S. CLS. 100 AND 101). SN 77-347,028. PUB. 5-20-2008. FILED 12-7-2007.
 3,479,846. **ACTIVE BODY CHIROPRACTIC AND DESIGN.** ACTIVE BODY CHIROPRACTIC, LTD, (U.S. CLS. 100 AND 101). SN 77-347,134. PUB. 5-20-2008. FILED 12-7-2007.
 3,479,860. **PENN HEART RESCUE (BLOCK FORM).** TRUSTEES OF THE UNIVERSITY OF PENNSYLVANIA, THE, (U.S. CLS. 100 AND 101). SN 77-349,039. PUB. 5-20-2008. FILED 12-11-2007.
 3,479,861. **ISPORTGAMES AND DESIGN.** I SPORT, LLC, (U.S. CLS. 100 AND 101). SN 77-349,215. PUB. 5-20-2008. FILED 12-11-2007.
 3,479,951. **PEDIATRIC DENTAL HEALTHCARE AND DESIGN.** PEDIATRIC DENTAL HEALTHCARE, INC., (U.S. CLS. 100 AND 101). SN 77-354,230. PUB. 5-20-2008. FILED 12-17-2007.
 3,479,981. **DOG GONE CLEAN AND DESIGN.** DOG GONE CLEAN INC., (U.S. CLS. 100 AND 101). SN 77-355,267. PUB. 5-20-2008. FILED 12-18-2007.
 3,480,008. **HEART WIZARD (BLOCK FORM).** ADVANCED WELLNESS SOLUTIONS LLC, (U.S. CLS. 100 AND 101). SN 77-356,703. PUB. 5-20-2008. FILED 12-20-2007.
 3,480,023 (*See Class 41 for this trademark.*)
 3,480,040. **DYNEMIA (BLOCK FORM).** GEDDES, DAVID HAMLIN, DBA DYNEMIA.COM, (U.S. CLS. 100 AND 101). SN 77-357,570. PUB. 5-20-2008. FILED S.R. 12-20-2007; AM. P.R. 4-3-2008.
 3,480,044 (*See Class 41 for this trademark.*)
 3,480,121. **THE MINDFUL DOG, INC. AND DESIGN.** THE MINDFUL DOG, INC., (U.S. CLS. 100 AND 101). SN 77-360,981. PUB. 5-20-2008. FILED 12-28-2007.
 3,480,134. **SPATASTIC (BLOCK FORM).** LINH T. LUUMURPHY, (U.S. CLS. 100 AND 101). SN 77-361,587. PUB. 5-20-2008. FILED 12-30-2007.
 3,480,218. **SMILE BUILDERS (BLOCK FORM).** ROBYN LESSER D.M.D., P.A., (U.S. CLS. 100 AND 101). SN 77-363,230. PUB. 5-20-2008. FILED 1-3-2008.
 3,480,245. **STEPPING IT UP! (BLOCK FORM).** LIFELONG FITNESS ALLIANCE, (U.S. CLS. 100 AND 101). SN 77-363,643. PUB. 5-20-2008. FILED S.R. 1-3-2008; AM. P.R. 4-2-2008.
 3,480,413. **CITY SMILES (BLOCK FORM).** SIMON AND SIMON, P.C., (U.S. CLS. 100 AND 101). SN 77-366,578. PUB. 5-20-2008. FILED 1-8-2008.

- 3,480,423. **ORTHOBETHESDA (BLOCK FORM)**. BETHESDA-CHEVY CHASE ORTHOPAEDIC ASSOCIATES, LLP, (U.S. CLS. 100 AND 101). SN 77-366,747. PUB. 5-20-2008. FILED 1-8-2008.
- 3,480,454. **PHYSIO@WORK (BLOCK FORM)**. PHYSIOTHERAPY CORPORATION, (U.S. CLS. 100 AND 101). SN 77-367,490. PUB. 5-20-2008. FILED 1-9-2008.
- 3,480,456. **YOU LOSE, YOU GAIN (BLOCK FORM)**. RODALE INC., (U.S. CLS. 100 AND 101). SN 77-367,609. PUB. 5-20-2008. FILED 1-9-2008.
- 3,480,482. **WASHINGTON HEART (BLOCK FORM)**. WASHINGTON HOSPITAL CENTER CORPORATION, (U.S. CLS. 100 AND 101). SN 77-368,233. PUB. 5-20-2008. FILED 1-10-2008.
- 3,480,514. **PHYSIOKIDS (BLOCK FORM)**. PHYSIOTHERAPY CORPORATION, (U.S. CLS. 100 AND 101). SN 77-377,028. PUB. 5-20-2008. FILED 1-22-2008.
- 3,480,585 (*See Class 35 for this trademark*).
- 3,480,598 (*See Class 16 for this trademark*).
- 3,480,632 (*See Class 16 for this trademark*).
- 3,480,640. **WEEDPRO (BLOCK FORM)**. WEEDPRO, INC., (U.S. CLS. 100 AND 101). SN 78-807,606. PUB. 5-20-2008. FILED 2-6-2006.
- 3,480,650. **MONKEY DIET TYPE (BLOCK FORM)**. HAUSER, MARION A., AND HAUSER, ROSS A., (U.S. CLS. 100 AND 101). SN 78-840,199. PUB. 5-20-2008. FILED 3-17-2006.
- 3,480,653 (*See Class 35 for this trademark*).
- 3,480,702. **MANGO SALON AND DESIGN**. HEANEY, PATRICK D., (U.S. CLS. 100 AND 101). SN 78-920,989. PUB. 5-20-2008. FILED 6-30-2006.
- 3,480,710 (*See Class 41 for this trademark*).
- 3,480,711 (*See Class 41 for this trademark*).
- 3,480,878 (*See Class 29 for this trademark*).
- 3,480,896 (*See Class 29 for this trademark*).
- 3,481,028 (*See Class 10 for this trademark*).
- 3,479,185 (*See Class 35 for this trademark*).
- 3,479,186 (*See Class 35 for this trademark*).
- 3,479,259. **TEENS FOR CHRIST (BLOCK FORM)**. LIMALAND TEENS FOR CHRIST, INC., DBA TEENS FOR CHRIST, (U.S. CLS. 100 AND 101). SN 77-231,320. PUB. 5-20-2008. FILED 7-17-2007.
- 3,479,268 (*See Class 41 for this trademark*).
- 3,479,270 (*See Class 35 for this trademark*).
- 3,479,287. **AAS AUTO ADVISORY SERVICES AND DESIGN**. AUTO ADVISORY SERVICES, INC., (U.S. CLS. 100 AND 101). SN 77-236,007. PUB. 5-20-2008. FILED 7-23-2007.
- 3,479,293 (*See Class 35 for this trademark*).
- 3,479,329. **EGO IMPACT (BLOCK FORM)**. WHEELER, AN-NEMARIE R., (U.S. CLS. 100 AND 101). SN 77-247,130. PUB. 5-20-2008. FILED 8-3-2007.
- 3,479,381 (*See Class 5 for this trademark*).
- 3,479,392 (*See Class 38 for this trademark*).
- 3,479,431 (*See Class 36 for this trademark*).
- 3,479,492 (*See Class 35 for this trademark*).
- 3,479,512. **JY AND DESIGN**. JESUS YOUTH, (U.S. CLS. 100 AND 101). SN 77-299,404. PUB. 5-20-2008. FILED 10-9-2007.
- 3,479,521 (*See Class 16 for this trademark*).
- 3,479,522 (*See Class 16 for this trademark*).
- 3,479,563. **MEDI-LAW SOLUTIONS, LLC (BLOCK FORM)**. MEDI-LAW SOLUTIONS, (U.S. CLS. 100 AND 101). SN 77-307,842. PUB. 5-20-2008. FILED 10-18-2007.
- 3,479,565 (*See Class 35 for this trademark*).
- 3,479,780 (*See Class 35 for this trademark*).
- 3,479,890. **GMI GOSPEL MISSIONS INTERNATIONAL "TAKING THE GOSPEL TO THE NATIONS!" AND DESIGN**. ADEYEMI, YATO, AND GOSPEL MISSIONS INTERNATIONAL, (U.S. CLS. 100 AND 101). SN 77-351,188. PUB. 5-20-2008. FILED 12-13-2007.
- 3,479,970. **EC EMPLOYCHECK AND DESIGN**. EMPLOY CHECK, INC., (U.S. CLS. 100 AND 101). SN 77-354,757. PUB. 5-20-2008. FILED 12-18-2007.
- 3,479,996. **INTELLIGENT DATING (BLOCK FORM)**. IT'S JUST LUNCH INTERNATIONAL, LLC, (U.S. CLS. 100 AND 101). SN 77-356,300. PUB. 5-20-2008. FILED 12-19-2007.
- 3,480,023 (*See Class 41 for this trademark*).
- 3,480,052. **WHITE PAWS PET SITTING (BLOCK FORM)**. WHITE, MELISSA A., DBA WHITE PAWS PET SITTING, (U.S. CLS. 100 AND 101). SN 77-358,120. PUB. 5-20-2008. FILED 12-21-2007.
- 3,480,055 (*See Class 42 for this trademark*).
- 3,480,144. **INSIDER DATING (BLOCK FORM)**. RUMETAGRO LLC, (U.S. CLS. 100 AND 101). SN 77-361,904. PUB. 5-20-2008. FILED 12-31-2007.
- 3,480,145. **MYWORLDIS.COM BRINGING THE WORLD TOGETHER IN ONE PLACE AND DESIGN**. MYWORLDIS INCORPORATED, (U.S. CLS. 100 AND 101). SN 77-361,907. PUB. 5-20-2008. FILED 12-31-2007.
- 3,480,156. **PLACE - PLANNED LEGAL ADVOCACY CARE FOR EVERYONE (BLOCK FORM)**. LABROSSE, LUC R., DBA PLANNED LEGAL ADVOCACY CARE FOR EVERYONE, (U.S. CLS. 100 AND 101). SN 77-362,208. PUB. 5-20-2008. FILED 1-1-2008.
- 3,480,353. **IRETURN (BLOCK FORM)**. IRETURN INC., (U.S. CLS. 100 AND 101). SN 77-365,293. PUB. 5-20-2008. FILED 1-7-2008.
- 3,480,363. **ME-AND-THE-WORLD.COM AND DESIGN**. PENA, JOSE, (U.S. CLS. 100 AND 101). SN 77-365,478. PUB. 5-20-2008. FILED 1-7-2008.
- 3,480,585 (*See Class 35 for this trademark*).
- 3,480,632 (*See Class 16 for this trademark*).
- 3,480,635 (*See Class 37 for this trademark*).
- 3,480,707 (*See Class 35 for this trademark*).
- 3,480,807 (*See Class 9 for this trademark*).
- 3,480,877 (*See Class 38 for this trademark*).
- 3,480,894 (*See Class 35 for this trademark*).
- 3,480,943 (*See Class 9 for this trademark*).
- 3,480,992 (*See Class 35 for this trademark*).

* * * * *

CLASS 45—PERSONAL AND LEGAL SERVICES

- 3,478,526 (*See Class 35 for this trademark*).
- 3,478,544 (*See Class 14 for this trademark*).
- 3,478,558 (*See Class 43 for this trademark*).
- 3,478,588. **SKYWATCH (BLOCK FORM)**. SKY WATCH, LLC., (U.S. CLS. 100 AND 101). SN 76-683,327. PUB. 5-20-2008. FILED 10-25-2007.
- 3,478,637 (*See Class 25 for this trademark*).
- 3,478,675 (*See Class 36 for this trademark*).
- 3,478,750. **THE EPISCOPAL DIOCESE OF CENTRAL FLORIDA (BLOCK FORM)**. DIOCESE OF CENTRAL FLORIDA, INCORPORATED, (U.S. CLS. 100 AND 101). SN 77-092,531. PUB. 5-20-2008. FILED 1-26-2007.
- 3,478,751. **THE EPISCOPAL CHURCH IN CENTRAL FLORIDA (BLOCK FORM)**. DIOCESE OF CENTRAL FLORIDA, INCORPORATED, (U.S. CLS. 100 AND 101). SN 77-092,553. PUB. 5-20-2008. FILED 1-26-2007.
- 3,478,764. **SECURITY AMERICA (BLOCK FORM)**. SECURITY AMERICA, INC., (U.S. CLS. 100 AND 101). SN 77-097,079. PUB. 5-20-2008. FILED 2-1-2007.
- 3,478,838. **INDYA.COM AND DESIGN**. STAR TELEVISION PRODUCTIONS LIMITED, (U.S. CLS. 100 AND 101). SN 77-144,840. PUB. 5-20-2008. FILED 3-30-2007.
- 3,478,853. **20/20 LEGAL VISION (BLOCK FORM)**. MBV LAW LLP, (U.S. CLS. 100 AND 101). SN 77-152,871. PUB. 5-20-2008. FILED 4-10-2007.
- 3,478,864 (*See Class 25 for this trademark*).
- 3,478,959. **IC INVESTIGATIVE CONSULTANTS AND DESIGN**. BUCKNER, KRISTOPHER T., (U.S. CLS. 100 AND 101). SN 77-191,233. PUB. 5-20-2008. FILED 5-26-2007.
- 3,479,060 (*See Class 35 for this trademark*).
- 3,479,088. **CHAKRANICITY (STYLIZED)**. CHAKRANICITY LLC, (U.S. CLS. 100 AND 101). SN 77-211,148. PUB. 5-20-2008. FILED 6-20-2007.
- 3,479,141 (*See Class 16 for this trademark*).
- 3,479,153. **MOTHERWOMAN (BLOCK FORM)**. MOTHERWOMAN, INC., (U.S. CLS. 100 AND 101). SN 77-218,575. PUB. 5-20-2008. FILED 6-29-2007.

SECTION 2.—PRIOR UNITED STATES CLASSIFICATION

COLLECTIVE MEMBERSHIP MARKS

CLASS 200—COLLECTIVE MEMBERSHIP

3,478,789. **KNIGHT RIDERS (BLOCK FORM)**, KNIGHTRIDERS MOTORCYCLE CLUB, SN 77-112,011. PUB. 2-12-2008. FILED 2-20-2007.

3,479,220. **IONGIA INTERNATIONAL OUTLAW MOTORCYCLE GANG INVESTIGATORS ASSOCIATION FOUNDED 1974 AND DESIGN**, INTERNATIONAL OUTLAW MOTORCYCLE GANG INVESTIGATORS ASSOCIATION, SN 77-226,033. PUB. 5-20-2008. FILED 7-10-2007.

CERTIFICATION MARKS

CLASS A—GOODS

3,478,552. **UOP AND DESIGN**, UNION OF ORTHODOX JEWISH CONGREGATIONS OF AMERICA, SN 76-677,437. PUB. 5-20-2008. FILED 5-25-2007.

3,479,200. **ENVIRONMENTAL STEWARDSHIP PROGRAM KCMA AND DESIGN**, KITCHEN CABINET MANUFACTURERS ASSOCIATION, SN 77-223,459. PUB. 5-20-2008. FILED 7-6-2007.

CLASS B—SERVICES

3,478,520. **ICANL NUCLEAR CARDIOLOGY ACCREDITED NUCLEAR CARDIOLOGY LABORATORY AND DESIGN**, INTERSOCIETAL ACCREDITATION COMMISSION, SN 76-663,031. PUB. 5-20-2008. FILED 7-14-2006.

3,479,004. **RFMP RETAIL FACILITY MAINTENANCE PROFESSIONAL AND DESIGN**, PROFESSIONAL RETAIL STORE MAINTENANCE ASSOCIATION, SN 77-197,171. PUB. 5-20-2008. FILED 6-4-2007.

3,479,058. **COE (BLOCK FORM)**, AMERICAN SOCIETY OF CATARACT AND REFRACTIVE SURGERY, SN 77-206,394. PUB. 5-20-2008. FILED 6-14-2007.

3,480,247. **ECO-CERTIFIED SUSTAINABLE TRAVEL SELF-ASSESSMENT COMPLETED EXPIRES AND DESIGN**, SUSTAINABLE TRAVEL INTERNATIONAL, SN 77-363,677. PUB. 5-20-2008. FILED 1-3-2008.

3,480,665. **PRO CIRCLE (BLOCK FORM)**, EMERSON ELECTRIC CO., SN 78-878,533. PUB. 5-20-2008. FILED 5-8-2006.

* * * * *

TRADEMARK REGISTRATIONS ISSUED UNDER SECTION 1(d)

The following marks have registered on the Principal Register pursuant to the intent-to-use provisions of Section 1(d) of the Trademark Act of 1946, as amended.

SECTION 1.— INTERNATIONAL CLASSIFICATION

The short titles associated below with the international class numbers are terms designed merely for quick identification and are not an official part of the international classification. The full names of international classes are given in section 6.1 of the trademark rules of practice.

The designation "U.S. Cl." appearing in this section refers to the U.S. class in effect prior to Sep. 1, 1973 rather than the international class which applies to applications filed on or after that date. For adoption of international classification see notice in the OFFICIAL GAZETTE of Jun. 26, 1973 (911 O.G. TM 210).

Application in more than one class

3,481,050. AGEWELL, P.C., INDIANAPOLIS, IN. SN 76-404,069. PUB. 6-29-2004, FILED 5-6-2002.

YOUR HEALTH IS OUR BIZ

CLASS 3—COSMETICS AND CLEANING PREPARATIONS

FOR COSMETIC PREPARATIONS, NAMELY, SKIN CREAM, LOTIONS, CLEANSERS FOR THE BODY (U.S. CLS. 1, 4, 6, 50, 51 AND 52).
FIRST USE 8-6-2007; IN COMMERCE 8-6-2007.

CLASS 5—PHARMACEUTICALS

FOR THERAPEUTIC, HYGIENIC, AND PHARMACEUTICAL PREPARATIONS FOR THE TREATMENT OF COLDS, DRY SKIN, MEMORY LOSS, ARTHRITIS, SLEEPING DISORDERS, VITAMINS, MINERALS, NUTRITIONAL AND DIETARY SUPPLEMENTS (U.S. CLS. 6, 18, 44, 46, 51 AND 52).
FIRST USE 8-6-2007; IN COMMERCE 8-6-2007.

CLASS 10—MEDICAL APPARATUS

FOR SURGICAL AND MEDICAL APPARATUS AND INSTRUMENTS, NAMELY, MEDICATION DISPENSERS (U.S. CLS. 26, 39 AND 44).
FIRST USE 8-6-2007; IN COMMERCE 8-6-2007.

CLASS 28—TOYS AND SPORTING GOODS

FOR SPORTING GOODS EQUIPMENT, NAMELY, EXERCISE BALLS, AND RESISTANCE BANDS (U.S. CLS. 22, 23, 38 AND 50).
FIRST USE 8-6-2007; IN COMMERCE 8-6-2007.

3,481,051. BUSQUETS, CARMEN, KEY BISCAYNE, FL. SN 76-494,344. PUB. 3-29-2005, FILED 3-4-2003.

COUTURE LAB

NO CLAIM IS MADE TO THE EXCLUSIVE RIGHT TO USE "COUTURE", APART FROM THE MARK AS SHOWN.

CLASS 18—LEATHER GOODS

FOR LEATHER AND IMITATION LEATHER PRODUCTS, NAMELY, TRUNKS AND VALISES, HANDBAGS, STORAGE BAGS; ANIMAL SKINS AND PELTS; AND UMBRELLAS (U.S. CLS. 1, 2, 3, 22 AND 41).
FIRST USE 10-30-2006; IN COMMERCE 11-0-2005.

CLASS 25—CLOTHING

FOR CLOTHING FOR MEN, WOMEN AND CHILDREN, NAMELY, SHOES OTHER THAN ORTHOPEDIC SHOES, BOOTS, SANDALS, MULES AND SLIPPERS; BELTS, GLOVES AND HATS; LINGERIE AND UNDERWEAR; SWIMWEAR; SHIRTS, BLOUSES, VEST, CARDIGANS, T-SHIRTS, SWEATSHIRTS AND POLO SHIRTS; CASHMERE SCARVES, SWEATERS, PULLOVERS AND CARDIGANS; PANTS, JEANS AND CORDUROY; SKIRTS; SUITS AND DRESSES; JACKETS, COATS, CAPES; AND TUXEDOS AND EVENING GOWNS (U.S. CLS. 22 AND 39).
FIRST USE 10-30-2006; IN COMMERCE 11-0-2005.

CLASS 42—SCIENTIFIC AND COMPUTER SERVICES

FOR PROVIDING THE SERVICES OF FASHION DESIGNERS AND INDUSTRIAL DESIGNERS; RESEARCH AND DEVELOPMENT OF NEW PRODUCTS FOR OTHERS; AND CREATION OF DESIGN AND FASHION PATTERNS FOR OTHERS (U.S. CLS. 100 AND 101).
FIRST USE 10-30-2006; IN COMMERCE 11-0-2005.

3,481,060. CRIO INVERSIONES, S.A. DE C.V., ANTIGUO CUSCATLAN, EL SALVADOR. SN 76-554,266. PUB. 9-13-2005, FILED 10-27-2003.

DOÑA LITA

THE NAME(S), PORTRAIT(S), AND/OR SIGNATURE(S) SHOWN IN THE MARK DOES NOT IDENTIFY A PARTICULAR LIVING INDIVIDUAL.

THE ENGLISH TRANSLATION OF THE WORD "DOÑA LITA" IN THE MARK IS "LADY LITA".

CLASS 29—MEATS AND PROCESSED FOODS

FOR CANDIED FRUITS (U.S. CL. 46).
FIRST USE 12-16-2004; IN COMMERCE 12-16-2004.

CLASS 30—STAPLE FOODS

FOR SWEET BREADS, PASTRIES AND OTHER BREADS WITH OR WITHOUT FRUIT FILLING; COOKIES AND OTHER SIMILAR BAKED GOODS; TORTILLAS STUFFED WITH MEAT, CHEESE, AND/OR VEGETABLES NAMELY 'PUPUSAS'; CORN PASTE STUFFED WITH MEAT, CHEESE, AND/OR VEGETABLES, NAMELY, 'TAMALES'; OTHER BREADS STUFFED WITH MEAT, CHEESE, AND/OR VEGETABLES; PASTRIES STUFFED WITH FRUIT FILLING, NAMELY, 'PEPERECHAS' (U.S. CL. 46).
FIRST USE 12-16-2004; IN COMMERCE 12-16-2004.

3,481,064. BASIC SPIRIT INCORPORATED, PUGWASH, NOVA SCOTIA, CANADA. SN 76-590,173. PUB. 8-28-2007, FILED 5-3-2004.

BASICSPIRIT

THE MARK CONSISTS OF STANDARD CHARACTERS WITHOUT CLAIM TO ANY PARTICULAR FONT, STYLE, SIZE, OR COLOR.

PRIORITY CLAIMED UNDER SEC. 44(D) ON CANADA APPLICATION NO. 1,196,017, FILED 11-6-2003.

CLASS 6—METAL GOODS

FOR METAL CLOTHING HOOKS AND PICTURE HOOKS; 3-D PEWTER FIGURINES, STATUETTES OF NON-PRECIOUS METAL; METAL SCULPTURES; DECORATIVE METAL BOXES; METAL JEWELRY BOXES; METAL PILL BOXES; METAL COLLECTABLE BOXES; METAL KEY RINGS AND CHAINS; CHRISTMAS TABLE TOP ORNAMENTS, NAMELY PEWTER FIGURINES (U.S. CLS. 2, 12, 13, 14, 23, 25 AND 50).
FIRST USE 1-15-2002; IN COMMERCE 1-15-2007.

CLASS 14—JEWELRY

FOR JEWELRY; JEWELRY NAMELY PENDANTS, PINS, LAPEL PINS AND BROOCHES; COMMEMORATIVE METAL COINS AND TOKENS; COLLECTIBLE DECORATIVE METAL COINS AND TOKENS; JEWELRY, NAMELY EARRINGS, NECKLACES, RINGS, BRACELETS, BANGLES (U.S. CLS. 2, 27, 28 AND 50).
FIRST USE 1-1-2002; IN COMMERCE 1-15-2007.

CLASS 21—HOUSEWARES AND GLASS

FOR IKEBANA FLOWER HOLDERS; FLOWER BLOSSOM HOLDERS; CANDLESTICKS NOT OF PRECIOUS METAL; CANDLE HOLDERS NOT OF PRECIOUS METAL; CANDLE SNUFFERS NOT OF PRECIOUS METAL; SERVING SPOONS; SERVING FORKS; SALAD SERVING SPOONS AND FORKS; SPOON RACKS; CUTTING BOARDS; CUTTING BOARD AND KNIFE SETS SOLD AS A UNIT; WOOD SERVING TRAYS WITH PEWTER HANDLES; NAPKIN RINGS NOT OF PRECIOUS METAL; TRIVETS; PIE SERVERS; COASTERS NOT OF PAPER AND NOT BEING TABLE LINEN; NAPKIN HOLDERS; CORK SCREWS; HORS D'OEUVRES TOOTH-PICKS; HOLLOWWARE, NAMELY SERVING DISHES, PLATES, SERVING TRAYS NOT OF PRECIOUS METAL, MUGS, CUPS, GOBLETS, WINE TASTERS AND BOWLS; TEA STRAINERS; HONEY DIPPERS; COFFEE SCOOPS; PIE AND CAKE SERVERS; SERVING SPOONS; INCENSE HOLDERS FOR DOMESTIC USE (U.S. CLS. 2, 13, 23, 29, 30, 33, 40 AND 50).
FIRST USE 1-1-2002; IN COMMERCE 7-1-2007.

3,481,081. INMAN, RONALD CALVIN, ELIZABETHTOWN, NC. AND INMAN, SUSAN, ELIZABETHTOWN, NC. AND INMAN, ALBERT LEROY, ELIZABETHTOWN, NC. AND INMAN, BRENDA SEYER, ELIZABETHTOWN, NC. AND FAIRCLOTH, SUSANNE INMAN, ELIZABETHTOWN, NC. AND FAIRCLOTH, DAVID JAMES, ELIZABETHTOWN, NC. SN 76-650,705. PUB. 3-13-2007, FILED 11-22-2005.

YOHAN

THE MARK CONSISTS OF STANDARD CHARACTERS WITHOUT CLAIM TO ANY PARTICULAR FONT, STYLE, SIZE, OR COLOR.

CLASS 18—LEATHER GOODS

FOR CARRYING ARTICLES, NAMELY, BACKPACKS, RUCKSACKS, DUFTLE BAGS, SHOULDER BAGS, DAY-PACKS, AND SOFT-SIDED LUGGAGE (U.S. CLS. 1, 2, 3, 22 AND 41).
FIRST USE 12-1-2007; IN COMMERCE 12-1-2007.

CLASS 28—TOYS AND SPORTING GOODS

FOR CARRYING ARTICLES, NAMELY, PORTABLE SNOW SKI AND ACCESSORIES CARRIERS (U.S. CLS. 22, 23, 38 AND 50).
FIRST USE 12-1-2007; IN COMMERCE 12-1-2007.

3,481,087. NEW JERSEY TRANSIT CORPORATION, NEWARK, NJ. SN 76-653,825. PUB. 9-26-2006, FILED 1-23-2006.

**HUDSON-BERGEN
LIGHTRAIL**



NO CLAIM IS MADE TO THE EXCLUSIVE RIGHT TO USE "HUDSON-BERGEN LIGHT RAIL", APART FROM THE MARK AS SHOWN.

THE COLOR(S) BLUE, YELLOW AND GRAY IS/ARE CLAIMED AS A FEATURE OF THE MARK.

THE COLOR BLUE APPEARS AS THE WORD "LIGHT" AND IN THE LEFT STRIPE IN THE DESIGN IN THE MARK; THE COLOR YELLOW APPEARS AS THE WORD "RAIL" AND IN THE RIGHT STRIPE IN THE DESIGN IN THE MARK; THE COLOR GRAY APPEARS AS THE WORDS "HUDSON-BERGEN" AND AS THE MIDDLE STRIPE IN THE DESIGN IN THE MARK.

CLASS 35—ADVERTISING AND BUSINESS

FOR PROMOTING THE GOODS AND SERVICES OF OTHERS THROUGH THE DISTRIBUTION OF DISCOUNT CARDS FOR SCIENCE CENTERS, THEATER, ENTERTAINMENT, SHOPPING DESTINATIONS, HOTEL AND RESORT ACCOMMODATIONS, SPORT EVENTS AND AMUSEMENT PARKS (U.S. CLS. 100, 101 AND 102).

FIRST USE 8-18-1999; IN COMMERCE 4-22-2000.

CLASS 39—TRANSPORTATION AND STORAGE

FOR MASS TRANSIT FOR THE GENERAL PUBLIC AND TRAVEL INFORMATION SERVICES, NAMELY, TRANSPORTATION OF PASSENGERS BY LIGHT RAIL TO DESTINATIONS IN HUDSON COUNTY AND BERGEN COUNTY, NEW JERSEY (U.S. CLS. 100 AND 105).

FIRST USE 8-18-1999; IN COMMERCE 4-22-2000.

3,481,088. NEW JERSEY TRANSIT CORPORATION, NEW-ARK, NJ. SN 76-653,826. PUB. 9-26-2006, FILED 1-23-2006.



NO CLAIM IS MADE TO THE EXCLUSIVE RIGHT TO USE "HUDSON-BERGEN LIGHT RAIL", APART FROM THE MARK AS SHOWN.

CLASS 35—ADVERTISING AND BUSINESS

FOR PROMOTING THE GOODS AND SERVICES OF OTHERS THROUGH THE DISTRIBUTION OF DISCOUNT CARDS FOR SCIENCE CENTERS, THEATER, ENTERTAINMENT, SHOPPING DESTINATIONS, HOTEL AND RESORT ACCOMMODATIONS, SPORT EVENTS AND AMUSEMENT PARKS (U.S. CLS. 100, 101 AND 102).

FIRST USE 8-18-1999; IN COMMERCE 4-22-2000.

CLASS 39—TRANSPORTATION AND STORAGE

FOR MASS TRANSIT FOR THE GENERAL PUBLIC AND TRAVEL INFORMATION SERVICES, NAMELY, TRANSPORTATION OF PASSENGERS BY LIGHT RAIL TO DESTINATIONS IN HUDSON COUNTY AND BERGEN COUNTY, NEW JERSEY (U.S. CLS. 100 AND 105).

FIRST USE 8-18-1999; IN COMMERCE 4-22-2000.

3,481,089. NEW JERSEY TRANSIT CORPORATION, NEW-ARK, NJ. SN 76-653,827. PUB. 9-26-2006, FILED 1-23-2006.



NO CLAIM IS MADE TO THE EXCLUSIVE RIGHT TO USE "HUDSON-BERGEN LIGHT RAIL", APART FROM THE MARK AS SHOWN.

CLASS 35—ADVERTISING AND BUSINESS

FOR PROMOTING THE GOODS AND SERVICES OF OTHERS THROUGH THE DISTRIBUTION OF DISCOUNT CARDS FOR SCIENCE CENTERS, THEATER, ENTERTAINMENT, SHOPPING DESTINATIONS, HOTEL AND RESORT ACCOMMODATIONS, SPORT EVENTS AND AMUSEMENT PARKS (U.S. CLS. 100, 101 AND 102).

FIRST USE 4-22-2000; IN COMMERCE 4-22-2000.

CLASS 39—TRANSPORTATION AND STORAGE

FOR MASS TRANSIT FOR THE GENERAL PUBLIC AND TRAVEL INFORMATION SERVICES, NAMELY, TRANSPORTATION OF PASSENGERS BY LIGHT RAIL TO DESTINATIONS IN HUDSON COUNTY AND BERGEN COUNTY, NEW JERSEY (U.S. CLS. 100 AND 105).

FIRST USE 4-22-2000; IN COMMERCE 4-22-2000.

3,481,096. WENCO L.L.C., DBA SILVERMARK, NEW YORK CITY, NY. SN 76-658,145. PUB. 8-28-2007, FILED 4-10-2006.

FRESHPREP

THE MARK CONSISTS OF STANDARD CHARACTERS WITHOUT CLAIM TO ANY PARTICULAR FONT, STYLE, SIZE, OR COLOR.

CLASS 8—HAND TOOLS

FOR HOUSEHOLD SCISSORS AND SHEARS (U.S. CLS. 23, 28 AND 44).

FIRST USE 3-0-2006; IN COMMERCE 3-0-2006.

CLASS 9—ELECTRICAL AND SCIENTIFIC APPARATUS

FOR MEASURING CUPS (U.S. CLS. 21, 23, 26, 36 AND 38).

FIRST USE 3-0-2006; IN COMMERCE 3-0-2006.

CLASS 21—HOUSEWARES AND GLASS

FOR BOWLS; CUTTING BOARDS; LADLES FOR KITCHEN USE; HOUSEHOLD UTENSILS, NAMELY, SPATULAS, SPAGHETTI SERVERS, AND STRAINERS AND TURNERS FOR KITCHEN USE; TEXTILE CLEANING CLOTHS (U.S. CLS. 2, 13, 23, 29, 30, 33, 40 AND 50).

FIRST USE 3-0-2006; IN COMMERCE 3-0-2006.

3,481,100. NATIONAL REGISTRY OF REHABILITATION TECHNOLOGY SUPPLIERS, LAGO VISTA, TX. SN 76-659,450. PUB. 2-13-2007, FILED 4-27-2006.

REGISTERED REHABILITATION TECHNOLOGY SUPPLIER

THE MARK CONSISTS OF STANDARD CHARACTERS WITHOUT CLAIM TO ANY PARTICULAR FONT, STYLE, SIZE, OR COLOR.

OWNER OF U.S. REG. NOS. 2,283,562 AND 2,520,389.

NO CLAIM IS MADE TO THE EXCLUSIVE RIGHT TO USE "REHABILITATION TECHNOLOGY SUPPLIER", APART FROM THE MARK AS SHOWN.

CLASS 40—MATERIAL TREATMENT

FOR CUSTOM MANUFACTURING AND FITTING OF REHABILITATION THERAPY PRODUCTS TO MEET INDIVIDUAL USER REQUIREMENTS (U.S. CLS. 100, 103 AND 106).

FIRST USE 4-26-2006; IN COMMERCE 4-26-2006.

CLASS 41—EDUCATION AND ENTERTAINMENT

FOR INSTRUCTING OTHERS ON THE USE OF AND CARE FOR REHABILITATION THERAPY PRODUCTS (U.S. CLS. 100, 101 AND 107).

FIRST USE 4-26-2006; IN COMMERCE 4-26-2006.

CLASS 42—SCIENTIFIC AND COMPUTER SERVICES

FOR CUSTOM DESIGNING AND TESTING OF REHABILITATION THERAPY PRODUCTS, EVALUATING THE NEEDS OF USERS OF WHEELCHAIRS, SEATING SYSTEMS AND OTHER REHABILITATION THERAPY PRODUCTS (U.S. CLS. 100 AND 101).

FIRST USE 4-26-2006; IN COMMERCE 4-26-2006.

3,481,107. RHINO-HIDE, L.L.C., LAKELAND, FL. SN 76-664,624. PUB. 9-25-2007, FILED 8-15-2006.

ROCKET BOND

THE MARK CONSISTS OF STANDARD CHARACTERS WITHOUT CLAIM TO ANY PARTICULAR FONT, STYLE, SIZE, OR COLOR.

OWNER OF U.S. REG. NOS. 2,985,122, 3,250,159, AND OTHERS.

NO CLAIM IS MADE TO THE EXCLUSIVE RIGHT TO USE "BOND", APART FROM THE MARK AS SHOWN.

CLASS 1—CHEMICALS

FOR ADHESIVE AND REPAIR MATERIALS, NAMELY, POLYURETHANE ADHESIVES, INDUSTRIAL ADHESIVES FOR USE IN COATING AND SEALING, EPOXY GLUE FOR GENERAL BONDING AND REPAIR PURPOSES, FILLER FOR AUTOMOTIVE BODY REPAIR, SYNTHETIC POLYMER MODIFIED RESIN COMPOUND FOR USE IN CEMENTITIOUS REPAIRS; REPAIR MATERIALS, NAMELY ADHESIVE FOR SHOE SOLE REPAIR (U.S. CLS. 1, 5, 6, 10, 26 AND 46).

FIRST USE 10-31-2007; IN COMMERCE 10-31-2007.

CLASS 16—PAPER GOODS AND PRINTED MATTER

FOR ADHESIVE MATERIALS, NAMELY, BONDING ADHESIVE FOR HOUSEHOLD PURPOSES (U.S. CLS. 2, 5, 22, 23, 29, 37, 38 AND 50).

FIRST USE 10-31-2007; IN COMMERCE 10-31-2007.

CLASS 19—NON-METALLIC BUILDING MATERIALS

FOR ADHESIVE AND REPAIR MATERIALS, NAMELY, ADHESIVE MORTAR FOR BUILDING PURPOSES (U.S. CLS. 1, 12, 33 AND 50).

FIRST USE 10-31-2007; IN COMMERCE 10-31-2007.

3,481,134. D.G YUENGLING & SON, INC., POTTSVILLE, PA. SN 76-673,621. PUB. 9-4-2007, FILED 3-5-2007.

JAMES RIVER STEAM BREWERY

THE MARK CONSISTS OF STANDARD CHARACTERS WITHOUT CLAIM TO ANY PARTICULAR FONT, STYLE, SIZE, OR COLOR.

OWNER OF U.S. REG. NO. 2,059,723.

CLASS 16—PAPER GOODS AND PRINTED MATTER

FOR POSTERS, POSTCARDS (U.S. CLS. 2, 5, 22, 23, 29, 37, 38 AND 50).

FIRST USE 11-12-2007; IN COMMERCE 11-12-2007.

CLASS 21—HOUSEWARES AND GLASS

FOR STEINS, MUGS, COASTERS, CUPS, INSULATED COOLERS, PLASTIC CUPS, PLASTIC PITCHERS, PLASTIC DRINK BOTTLES, AND BEVERAGE GLASSWARE (U.S. CLS. 2, 13, 23, 29, 30, 33, 40 AND 50).

FIRST USE 11-12-2007; IN COMMERCE 11-12-2007.

CLASS 25—CLOTHING

FOR CLOTHING, NAMELY, HATS, CAPS, T-SHIRTS, SWEATSHIRTS, SWEATPANTS, SHORTS, SWEATERS, GOLF SHIRTS, SHIRTS, AND JACKETS (U.S. CLS. 22 AND 39).

FIRST USE 11-12-2007; IN COMMERCE 11-12-2007.

CLASS 28—TOYS AND SPORTING GOODS

FOR TOYS, NAMELY, TOY TRUCKS AND TOY VEHICLES; CHRISTMAS TREE ORNAMENTS; PLAYING CARDS (U.S. CLS. 22, 23, 38 AND 50).

FIRST USE 11-12-2007; IN COMMERCE 11-12-2007.

3,481,142. EFINANCE PORTAL, INC., MANASQUAN, NJ. SN 76-675,463. PUB. 2-19-2008, FILED 4-13-2007.



NO CLAIM IS MADE TO THE EXCLUSIVE RIGHT TO USE "FINANCE" AND "PORTAL", APART FROM THE

MARK AS SHOWN.

THE STIPPLING IS NOT CONSIDERED PART OF THE MARK AND IS FOR SHADING PURPOSES ONLY.

CLASS 35—ADVERTISING AND BUSINESS

FOR PROMOTING FINANCIAL SERVICES AND FINANCIAL PRODUCTS OF OTHERS WITH DEDICATED SEARCH ENGINES ON A GLOBAL COMPUTER NETWORK (U.S. CLS. 100, 101 AND 102).

FIRST USE 6-1-2007; IN COMMERCE 6-1-2007.

CLASS 38—COMMUNICATION

FOR PROVIDING ON-LINE FORUMS FOR TRANSMISSION OF MESSAGES AMONG COMPUTER USERS CONCERNING FINANCIAL SERVICES AND FINANCIAL PRODUCTS (U.S. CLS. 100, 101 AND 104).

FIRST USE 6-1-2007; IN COMMERCE 6-1-2007.

3,481,151. LE REVE DESTINATION SERVICES, INC., LAGUNA NIGUEL, CA. SN 76-677,754. PUB. 12-4-2007, FILED 6-4-2007.

LE REVE DESTINATION SERVICES

THE MARK CONSISTS OF STANDARD CHARACTERS WITHOUT CLAIM TO ANY PARTICULAR FONT, STYLE, SIZE, OR COLOR.

NO CLAIM IS MADE TO THE EXCLUSIVE RIGHT TO USE "DESTINATION SERVICES", APART FROM THE MARK AS SHOWN.

THE FOREIGN WORDING IN THE MARK TRANSLATES INTO ENGLISH AS THE DREAM.

CLASS 39—TRANSPORTATION AND STORAGE

FOR TRAVEL AGENCY SERVICES FOR THE BUSINESS AND VACATION TRAVELER, NAMELY, MAKING RESERVATIONS AND BOOKINGS FOR TRANSPORTATION; COORDINATING TRAVEL ARRANGEMENTS FOR INDIVIDUALS AND FOR GROUPS FOR BUSINESS AND VACATION TRAVEL (U.S. CLS. 100 AND 105).

FIRST USE 11-15-2007; IN COMMERCE 2-10-2008.

CLASS 43—HOTEL AND RESTAURANT SERVICES

FOR TRAVEL AGENCY SERVICES FOR THE BUSINESS AND VACATION TRAVELER, NAMELY, MAKING RESERVATIONS AND BOOKING FOR TEMPORARY LODGING, RESTAURANTS AND MEALS; PROVIDING TRAVEL LODGING INFORMATION SERVICES AND TRAVEL LODGING BOOKING AGENCY SERVICES FOR BUSINESS AND VACATION TRAVELERS (U.S. CLS. 100 AND 101).

FIRST USE 11-15-2007; IN COMMERCE 2-10-2008.

CLASS 45—PERSONAL AND LEGAL SERVICES

FOR CONCIERGE SERVICES FOR OTHERS COMPRISING MAKING REQUESTED PERSONAL ARRANGEMENTS AND RESERVATIONS AND PROVIDING CUSTOMER-SPECIFIC INFORMATION TO MEET INDIVIDUAL NEEDS RENDERED TOGETHER IN VILLAS, RENTAL HOMES, AND TIMESHARE HOTELS (U.S. CLS. 100 AND 101).

FIRST USE 11-15-2007; IN COMMERCE 3-14-2008.

3,481,159. WAL-MART STORES, INC., BENTONVILLE, AR. SN 76-978,770. PUB. 9-27-2005, FILED 10-31-2003.

NOBO

CLASS 9—ELECTRICAL AND SCIENTIFIC APPARATUS

FOR EYEGLASSES AND EYEGLASS FRAMES (U.S. CLS. 21, 23, 26, 36 AND 38).

FIRST USE 7-31-2003; IN COMMERCE 7-31-2003.

CLASS 14—JEWELRY

FOR JEWELRY; CLOCKS (U.S. CLS. 2, 27, 28 AND 50).

FIRST USE 7-31-2006; IN COMMERCE 7-31-2006.

CLASS 18—LEATHER GOODS

FOR HANDBAGS (U.S. CLS. 1, 2, 3, 22 AND 41).

FIRST USE 7-31-2003; IN COMMERCE 7-31-2003.

CLASS 24—FABRICS

FOR HOUSEHOLD LINENS FOR BED (U.S. CLS. 42 AND 50).

FIRST USE 6-30-2004; IN COMMERCE 6-30-2004.

3,481,160. CORNELIA ZICU INTERNATIONAL, LLC, NEW YORK, NY. SN 76-978,812. PUB. 7-10-2007, FILED 8-25-2004.

CORNELIA

THE MARK CONSISTS OF STANDARD CHARACTERS WITHOUT CLAIM TO ANY PARTICULAR FONT, STYLE, SIZE, OR COLOR.

CLASS 18—LEATHER GOODS

FOR COSMETIC BAGS SOLD EMPTY (U.S. CLS. 1, 2, 3, 22 AND 41).

FIRST USE 2-14-2005; IN COMMERCE 2-14-2005.

CLASS 24—FABRICS

FOR BEDDING AND HOME FURNISHINGS, NAMELY, BED BLANKETS, WOOL BLANKETS, TOWELS, TOWELS, BED SHEETS, COMFORTERS, NON-SCENTED PILLOWS AND NECK SUPPORTING PILLOWS (U.S. CLS. 42 AND 50).

FIRST USE 2-14-2005; IN COMMERCE 2-14-2005.

CLASS 30—STAPLE FOODS

FOR BEVERAGES MADE OF TEA; TEA; HONEY (U.S. CL. 46).

FIRST USE 1-30-2006; IN COMMERCE 1-30-2006.

CLASS 35—ADVERTISING AND BUSINESS

FOR RETAIL STORE SERVICES FEATURING SKIN AND HAIR CARE PREPARATIONS, COSMETICS, MEDICATED SKIN CARE PREPARATIONS, AMBIANCE PRODUCTS, NAMELY, OILS AND ROOM SPRAYS, COSMETIC BAGS, COSMETICS AND SKIN CARE APPLICATORS AND HAIR BRUSHES, HOME FURNISHINGS, BEDDING, FOOD AND BEVERAGES AND TEA; MAIL ORDER CATALOG AND ONLINE RETAIL STORE SERVICES FEATURING SKIN AND HAIR CARE PREPARATIONS, COSMETICS, MEDICATED SKIN CARE PREPARATIONS, AMBIANCE PRODUCTS, NAMELY, CANDLES, OILS AND ROOM SPRAY, COSMETIC BAGS, COSMETIC AND SKIN CARE APPLICATORS, HAIR BRUSHES, HOME FURNISHINGS, BEDDING, FOOD AND BEVERAGES AND TEA (U.S. CLS. 100, 101 AND 102).

FIRST USE 2-14-2005; IN COMMERCE 2-14-2005.

CLASS 43—HOTEL AND RESTAURANT SERVICES

FOR BEAUTY SPA SERVICES, NAMELY, PROVIDING TEMPORARY ACCOMMODATIONS AND MEALS TO CLIENTS OF A HEALTH OR BEAUTY SPA; TEA ROOM SERVICES (U.S. CLS. 100 AND 101).

FIRST USE 2-14-2008; IN COMMERCE 2-14-2008.

3,481,178. EMPORDALIA S.C.C.L., PAU, GIRONA, SPAIN. SN 77-005,916. PUB. 5-8-2007, FILED 9-23-2006.



THE COLOR(S) BROWN AND BLACK IS/ARE CLAIMED AS A FEATURE OF THE MARK.

THE MARK CONSISTS OF THE WORD "EMPORDALIA" IN STYLIZED BROWN LETTERS, THE LETTER "E" IN CAPITAL LETTERS AND THE REST OF THE LETTERS IN LOWER CASE. THE ACCENT ABOVE THE FIRST LETTER "A" IS IN COLOR BLACK. THE COLOR BROWN APPEARS IN THE LETTERS AND THE COLOR BLACK APPEARS IN THE ACCENT ABOVE THE FIRST LETTER "A".

CLASS 29—MEATS AND PROCESSED FOODS

FOR CANNED PROCESSED OLIVES; EDIBLE OIL; PRESERVED, DRIED AND COOKED OLIVES; PROCESSED OLIVES (U.S. CL. 46).

FIRST USE 4-28-2005; IN COMMERCE 1-1-2007.

CLASS 33—WINES AND SPIRITS

FOR WINES (U.S. CLS. 47 AND 49).

FIRST USE 4-28-2005; IN COMMERCE 1-1-2007.

3,481,162. WALGREEN CO., DEERFIELD, IL. SN 76-978,844. PUB. 12-11-2007, FILED 12-4-2006.

DEERFIELD TRADING CO.

THE MARK CONSISTS OF STANDARD CHARACTERS WITHOUT CLAIM TO ANY PARTICULAR FONT, STYLE, SIZE, OR COLOR.

OWNER OF U.S. REG. NO. 3,108,568.

NO CLAIM IS MADE TO THE EXCLUSIVE RIGHT TO USE "TRADING CO.", APART FROM THE MARK AS SHOWN.

CLASS 30—STAPLE FOODS

FOR BEVERAGES, NAMELY, TEAS AND COFFEE; COOKIES; CRACKERS; CONFECTIONS, NAMELY, CANDY, GUM, MINTS AND CHOCOLATES; PROCESSED CEREALS AND PROCESSED WHOLE GRAINS; CORN CHIPS, PITA CHIPS AND TORTILLA CHIPS; SUGAR; FLOUR; SPICES; POWDERED FOODSTUFFS, NAMELY, FLAVORED AND SWEETENED GELATIN; CANNED CONDIMENTS, NAMELY, KETCHUP (U.S. CL. 46).

FIRST USE 12-12-2006; IN COMMERCE 12-12-2006.

CLASS 32—LIGHT BEVERAGES

FOR BEVERAGES, NAMELY, ENERGY DRINKS AND WATER; NON-ALCOHOLIC BEVERAGES, NAMELY, FLAVORED CARBONATED BEVERAGES; DRINK MIX PREPARATIONS FOR MIXING FRUIT DRINKS (U.S. CLS. 45, 46 AND 48).

FIRST USE 7-17-2007; IN COMMERCE 7-17-2007.

3,481,180. SIP XTREME, L.L.C., ANTHEM, AZ. SN 77-007,904. PUB. 9-11-2007, FILED 9-26-2006.

SIP XTREME

THE MARK CONSISTS OF STANDARD CHARACTERS WITHOUT CLAIM TO ANY PARTICULAR FONT, STYLE, SIZE, OR COLOR.

NO CLAIM IS MADE TO THE EXCLUSIVE RIGHT TO USE "SIP", APART FROM THE MARK AS SHOWN.

CLASS 9—ELECTRICAL AND SCIENTIFIC APPARATUS

FOR TELECOMMUNICATIONS SOFTWARE USED IN CONJUNCTION WITH VOICE OVER INTERNET PROTOCOL TELEPHONES; TELECOMMUNICATIONS SOFTWARE; AND TELECOMMUNICATIONS HARDWARE USED IN CONJUNCTION WITH VOICE OVER INTERNET PROTOCOL TELEPHONES, NAMELY, SPEAKERS, CAMERAS, AND MICROPHONES (U.S. CLS. 21, 23, 26, 36 AND 38).

FIRST USE 11-0-2006; IN COMMERCE 11-0-2006.

CLASS 38—COMMUNICATION

FOR TELECOMMUNICATIONS SERVICES OVER THE INTERNET, NAMELY, VOICE OVER INTERNET PROTOCOL SERVICES, VIDEO TRANSMISSION, VIDEO STREAMING, AND INSTANT MESSAGING SERVICES (U.S. CLS. 100, 101 AND 104).

FIRST USE 11-0-2006; IN COMMERCE 11-0-2006.

3,481,184. BRYAN, FREDERICK D., CHATSWORTH, CA. SN 77-011,066. PUB. 11-6-2007, FILED 9-29-2006.

KAZ

THE MARK CONSISTS OF STANDARD CHARACTERS WITHOUT CLAIM TO ANY PARTICULAR FONT, STYLE, SIZE, OR COLOR.

"KAZ" IDENTIFIES A LIVING INDIVIDUAL WHOSE CONSENT IS OF RECORD.

CLASS 9—ELECTRICAL AND SCIENTIFIC APPARATUS

FOR DOWNLOADABLE RING TONES, GRAPHICS AND MUSIC VIA A GLOBAL COMPUTER NETWORK AND WIRELESS DEVICES; MUSICAL SOUND RECORDINGS; DOWNLOADABLE MUSICAL SOUND RECORDINGS; PRE-RECORDED CD'S FEATURING MUSIC; PRERECORDED AUDIO TAPES FEATURING MUSIC; PHONOGRAPH RECORDS FEATURING MUSIC; PRE-RECORDED DIGITAL AUDIO TAPE FEATURING MUSIC; DOWNLOADABLE VIDEO RECORDINGS FEATURING MUSIC AND MUSICAL PERFORMANCES (U.S. CLS. 21, 23, 26, 36 AND 38).
FIRST USE 12-31-1991; IN COMMERCE 12-31-1991.

CLASS 41—EDUCATION AND ENTERTAINMENT

FOR ENTERTAINMENT, NAMELY, LIVE PERFORMANCES BY AN INDIVIDUAL MUSICIAN AND A MUSICAL BAND; SONG WRITING SERVICES; MUSIC COMPOSITION FOR OTHERS; MUSIC PRODUCTION SERVICES (U.S. CLS. 100, 101 AND 107).
FIRST USE 12-31-1985; IN COMMERCE 11-14-1989.

3,481,201. KRISTIANSSEN, KATE, BEAVERTON, OR. SN 77-022,281. PUB. 7-10-2007, FILED 10-16-2006.

Souvenir Cosmetics

THE MARK CONSISTS OF STANDARD CHARACTERS WITHOUT CLAIM TO ANY PARTICULAR FONT, STYLE, SIZE, OR COLOR.

NO CLAIM IS MADE TO THE EXCLUSIVE RIGHT TO USE "COSMETICS", APART FROM THE MARK AS SHOWN.

CLASS 2—PAINTS

FOR LIQUID PIGMENTS (U.S. CLS. 6, 11 AND 16).
FIRST USE 6-1-2008; IN COMMERCE 6-1-2008.

CLASS 3—COSMETICS AND CLEANING PREPARATIONS

FOR COSMETICS, NAMELY, LIQUID, POWDER AND SEMI-SOLID MAKE-UP, NAMELY, FOUNDATION, MASCARA, PENCILS, COSMETIC GLITTERS FOR EYE SHADOW, CHEEK AND FACE HIGHLIGHTER, FOR SHOULDERS, ARMS OR DECOLLETE SHIMMER, FOR ACCENT TO HAIRSTYLES, BODY ART AND NAIL ART, MAKE-UP KITS COMPRISING A SINGLE PRESSED FACIAL POWDER, A SINGLE SHADE OF BLUSHER, A SINGLE SHADE OF BRONZER FOR FACE OR DECOLLETE, A DUO AND A QUAD OF EYE SHADOW COLORS, AND A LIPSTICK AND LIP GLOSS PALETTE; PERFUMES, HAIR LOTIONS, NAIL POLISH, ESSENTIAL OILS, SOAPS, SHAVING CREAMS AND LOTIONS, AND COMPACTS CONTAINING MAKE-UP (U.S. CLS. 1, 4, 6, 50, 51 AND 52).
FIRST USE 6-1-2008; IN COMMERCE 6-1-2008.

CLASS 21—HOUSEWARES AND GLASS

FOR COSMETIC BRUSHES, HAIR BRUSHES WITH NATURAL OR SYNTHETIC BRISTLES, EMPTY COSMETIC COMPACTS, SHAVING BRUSHES AND SHAVING BRUSH STANDS (U.S. CLS. 2, 13, 23, 29, 30, 33, 40 AND 50).
FIRST USE 6-1-2008; IN COMMERCE 6-1-2008.

3,481,204. MY GIZMOS, INC., MINDEN, NV. SN 77-023,176. PUB. 10-9-2007, FILED 10-17-2006.



THE COLOR(S) YELLOW, BLUE, BLACK AND WHITE IS/ ARE CLAIMED AS A FEATURE OF THE MARK.

THE MARK CONSISTS OF A BLACK SPRING-LIKE SPIRAL DESIGN WITH WHITE AND BLACK EYES ON A SHADED YELLOW OVAL TO THE RIGHT OF, AND OVERLAPPING, A SHADED BLUE RECTANGLE CONTAINING THE WORDING "MY GIZMOS" IN WHITE.

CLASS 37—CONSTRUCTION AND REPAIR

FOR PROVIDING COMPUTER, COMPUTER HARDWARE AND COMPUTER NETWORK SUPPORT SERVICES, NAMELY, INSTALLATION, REPAIR, MAINTENANCE, UPDATING, AND UPGRADING OF COMPUTER HARDWARE, COMPUTER SYSTEMS AND COMPUTER NETWORKS (U.S. CLS. 100, 103 AND 106).
FIRST USE 10-18-2006; IN COMMERCE 10-18-2006.

CLASS 42—SCIENTIFIC AND COMPUTER SERVICES

FOR COMPUTER NETWORK DESIGN FOR OTHERS; COMPUTER NETWORK DESIGN AND COMPUTER SOFTWARE DESIGN FOR BUSINESSES; COMPUTER SERVICES, NAMELY, DESIGNING AND IMPLEMENTING NETWORK WEB PAGES FOR OTHERS; COMPUTER SERVICES, NAMELY, PROVIDING SEARCH ENGINES FOR OBTAINING DATA ON A GLOBAL COMPUTER NETWORK; COMPUTER SERVICES, NAMELY, CREATING INDEXES OF INFORMATION, SITES AND OTHER RESOURCES AVAILABLE ON COMPUTER NETWORKS; DESIGN OF COMPUTER HARDWARE, INTEGRATED CIRCUITS, COMMUNICATIONS HARDWARE AND SOFTWARE AND COMPUTER NETWORKS FOR OTHERS; DESIGN OF COMPUTER NETWORKS AND SOFTWARE FOR OTHERS FOR BUSINESSES; DEVELOPMENT OF SOFTWARE FOR SECURE NETWORK OPERATIONS; HOSTING THE WEB SITES OF OTHERS ON A COMPUTER SERVER FOR A GLOBAL COMPUTER NETWORK; PROVIDING COMPUTER SOFTWARE SUPPORT SERVICES, NAMELY, COMPUTER SOFTWARE INSTALLATION, REPAIR AND MAINTENANCE, AND UPDATING AND UPGRADING OF COMPUTER SOFTWARE FOR OTHERS; TECHNICAL SUPPORT SERVICES, NAMELY, MONITORING OF NETWORK SYSTEMS (U.S. CLS. 100 AND 101).

FIRST USE 10-18-2006; IN COMMERCE 10-18-2006.

3,481,207. CONSTELLATION ENERGY GROUP, INC., BALTIMORE, MD. SN 77-023,499. PUB. 9-25-2007, FILED 10-18-2006.

BGE HOME FOR YOUR BUSINESS

THE MARK CONSISTS OF STANDARD CHARACTERS WITHOUT CLAIM TO ANY PARTICULAR FONT, STYLE, SIZE, OR COLOR.

OWNER OF U.S. REG. NOS. 1,964,556, 2,596,900, AND OTHERS.

NO CLAIM IS MADE TO THE EXCLUSIVE RIGHT TO USE "FOR YOUR BUSINESS", APART FROM THE MARK AS SHOWN.

CLASS 35—ADVERTISING AND BUSINESS

FOR ON-LINE RETAIL STORE SERVICES, AND TELEPHONE ORDERING SERVICES IN THE FIELD OF HUMIDIFIERS, INDOOR AIR QUALITY SYSTEMS, DEHUMIDIFIERS, PLUMBING EQUIPMENT AND SYSTEMS, ELECTRICAL SYSTEMS, SURGE PROTECTION SYSTEMS, THERMOSTATS, AND HEATING, VENTILATION AND AIR CONDITIONING (HVAC) EQUIPMENT AND SYSTEMS; BUSINESS CONSULTING SERVICES FOR WHOLESALE, INDUSTRIAL AND COMMERCIAL CUSTOMERS IN THE FIELDS OF DESIGN, MAINTENANCE, UPGRADE AND OPERATIONS OF BUILDING AUTOMATION SYSTEMS, ENERGY POWER MONITORING AND CONTROL, HEATING, VENTILATION AND AIR CONDITIONING (HVAC), LIGHTING, ELECTRICAL AND ENVIRONMENTAL SYSTEMS, POWER DESIGN AND CONSTRUCTION; BUSINESS MANAGEMENT OF ALL BUILDING AND COMMERCIAL MECHANICAL, ELECTRICAL AND ELECTRONIC SYSTEMS FOR OTHERS (U.S. CLS. 100, 101 AND 102).

FIRST USE 11-1-2006; IN COMMERCE 11-1-2006.

CLASS 37—CONSTRUCTION AND REPAIR

FOR INSTALLATION, MAINTENANCE AND REPAIR OF BUILDING AND COMMERCIAL MECHANICAL SYSTEMS AND HEATING, AIR CONDITIONING AND PLUMBING SYSTEMS; INSTALLATION OF AUTOMATED ELECTRONIC LIGHTING AND ENERGY CONTROLS; INSTALLATION, MAINTENANCE AND REPAIR OF BUILDING AUTOMATION AND ENERGY SYSTEMS, ELECTRICAL, HEATING, VENTILATION AND AIR CONDITIONING (HVAC) EQUIPMENT AND MAJOR APPLIANCES FOR WHOLESALE, INDUSTRIAL AND COMMERCIAL CUSTOMERS; PIPE FITTING INSTALLATION AND INDUSTRIAL CONSTRUCTION AND PIPE FITTING CONTRACTOR SERVICES; INSTALLATION, MAINTENANCE AND REPAIR OF ELECTRONIC EQUIPMENT, HUMIDIFIERS, INDOOR AIR QUALITY SYSTEMS, DEHUMIDIFIERS, PLUMBING SYSTEMS, ELECTRICAL SYSTEMS, SURGE PROTECTION SYSTEMS, THERMOSTATS, AND HEATING, VENTILATION AND AIR CONDITIONING EQUIPMENT AND SYSTEMS; PLUMBING SERVICES; ELECTRICAL CONTRACTING SERVICES; INSTALLATION OF LIGHTING, HEATING, COOLING AND REFRIGERATION SYSTEMS; INSTALLATION AND REPAIR OF ELECTRICAL AND ELECTRONIC DEVICES AND EQUIPMENT, NAMELY COMMERCIAL UTILITY SYSTEMS, HEATING, COOLING, LIGHTING, REFRIGERATION SYSTEMS, AND ELECTRIC POWER SYSTEMS INCLUDING GENERATION, TRANSMISSION, AND DISTRIBUTION FACILITIES (U.S. CLS. 100, 103 AND 106).

FIRST USE 11-1-2006; IN COMMERCE 11-1-2006.

3,481,210. THE HARTZ MOUNTAIN CORPORATION, SECAUCUS, NJ. SN 77-025,363. PUB. 2-20-2007, FILED 10-19-2006.

CLEAN EARTH

THE MARK CONSISTS OF STANDARD CHARACTERS WITHOUT CLAIM TO ANY PARTICULAR FONT, STYLE, SIZE, OR COLOR.

CLASS 1—CHEMICALS

FOR CHEMICAL SPRAYS USED TO AID IN HOUSE-BREAKING DOGS (U.S. CLS. 1, 5, 6, 10, 26 AND 46).

FIRST USE 1-1-2007; IN COMMERCE 1-1-2007.

CLASS 3—COSMETICS AND CLEANING PREPARATIONS

FOR ALL PURPOSE SHAMPOO, BODY SPRAY, DEODORIZING SPRAY; SCENTED ROOM SPRAY (U.S. CLS. 1, 4, 6, 50, 51 AND 52).

FIRST USE 1-1-2007; IN COMMERCE 1-1-2007.

3,481,211. LUMINEX CORPORATION, AUSTIN, TX. SN 77-026,132. PUB. 5-15-2007, FILED 10-20-2006.

3,481,215. PRISM, INCORPORATED, OVIEDO, FL. SN 77-028,300. PUB. 7-24-2007, FILED 10-24-2006.

MAGPLEX

THE MARK CONSISTS OF STANDARD CHARACTERS WITHOUT CLAIM TO ANY PARTICULAR FONT, STYLE, SIZE, OR COLOR.

CLASS 1—CHEMICALS

FOR DIAGNOSTIC REAGENTS AND MICROSPHERES FOR SCIENTIFIC OR RESEARCH USE FOR CONDUCTING MOLECULAR ANALYSIS FOR HEALTHCARE, ENVIRONMENTAL, AGRICULTURAL, DIAGNOSTIC, AND OTHER APPLICATIONS (U.S. CLS. 1, 5, 6, 10, 26 AND 46).

FIRST USE 2-0-2007; IN COMMERCE 2-0-2007.

CLASS 5—PHARMACEUTICALS

FOR DIAGNOSTIC REAGENTS AND MICROSPHERES FOR CLINICAL OR MEDICAL USE FOR CONDUCTING MOLECULAR ANALYSIS FOR HEALTHCARE, ENVIRONMENTAL, AGRICULTURAL, DIAGNOSTIC, AND OTHER APPLICATIONS (U.S. CLS. 6, 18, 44, 46, 51 AND 52).

FIRST USE 2-0-2007; IN COMMERCE 2-0-2007.

3,481,212. LUMINEX CORPORATION, AUSTIN, TX. SN 77-026,207. PUB. 5-15-2007, FILED 10-20-2006.

MICROPLEX

THE MARK CONSISTS OF STANDARD CHARACTERS WITHOUT CLAIM TO ANY PARTICULAR FONT, STYLE, SIZE, OR COLOR.

CLASS 1—CHEMICALS

FOR DIAGNOSTIC REAGENTS AND MICROSPHERES FOR SCIENTIFIC OR RESEARCH USE FOR CONDUCTING MOLECULAR ANALYSIS FOR HEALTHCARE, ENVIRONMENTAL, AGRICULTURAL, DIAGNOSTIC, AND OTHER APPLICATIONS (U.S. CLS. 1, 5, 6, 10, 26 AND 46).

FIRST USE 5-2-2008; IN COMMERCE 5-2-2008.

CLASS 5—PHARMACEUTICALS

FOR DIAGNOSTIC REAGENTS AND MICROSPHERES FOR CLINICAL OR MEDICAL USE FOR CONDUCTING MOLECULAR ANALYSIS FOR HEALTHCARE, ENVIRONMENTAL, AGRICULTURAL, DIAGNOSTIC, AND OTHER APPLICATIONS (U.S. CLS. 6, 18, 44, 46, 51 AND 52).

FIRST USE 5-2-2008; IN COMMERCE 5-2-2008.

CAREFRONTING

THE MARK CONSISTS OF STANDARD CHARACTERS WITHOUT CLAIM TO ANY PARTICULAR FONT, STYLE, SIZE, OR COLOR.

CLASS 35—ADVERTISING AND BUSINESS

FOR BUSINESS LEADERSHIP CONSULTATION IN THE FIELD OF PROFESSIONAL LEADERSHIP FOR BUSINESSES AND EMPLOYEES, EXECUTIVE AND MANAGERIAL PERFORMANCE, HUMAN RESOURCES FOR BUSINESS PROFESSIONALS, AND BUSINESS SUCCESSION PLANNING AND JOB TRANSITIONS; BUSINESS EVALUATION OF HUMAN CAPITAL AS RELATED TO PROFESSIONAL LEADERSHIP FOR BUSINESSES AND EMPLOYEES, EXECUTIVE AND MANAGERIAL PERFORMANCE, HUMAN RESOURCES FOR BUSINESS PROFESSIONALS, BUSINESS SUCCESSION PLANNING AND JOB TRANSITIONS (U.S. CLS. 100, 101 AND 102).

FIRST USE 12-11-2007; IN COMMERCE 12-11-2007.

CLASS 41—EDUCATION AND ENTERTAINMENT

FOR EDUCATIONAL SERVICES, NAMELY, CONDUCTING SEMINARS AND PROFESSIONAL PERSONAL COACHING IN THE FIELD OF PROFESSIONAL LEADERSHIP FOR BUSINESSES AND EMPLOYEES, EXECUTIVE AND MANAGERIAL PERFORMANCE, HUMAN RESOURCES FOR BUSINESS PROFESSIONALS, BUSINESS SUCCESSION PLANNING AND JOB TRANSITIONS; AND ON-LINE TRAINING AND EDUCATIONAL EVALUATIONS IN THE FIELD OF PROFESSIONAL LEADERSHIP FOR BUSINESSES AND EMPLOYEES, EXECUTIVE AND MANAGERIAL PERFORMANCE, HUMAN RESOURCES FOR BUSINESS PROFESSIONALS, BUSINESS SUCCESSION PLANNING AND JOB TRANSITIONS (U.S. CLS. 100, 101 AND 107).

FIRST USE 11-27-2007; IN COMMERCE 11-27-2007.

3,481,216. PRISM, INCORPORATED, OVIEDO, FL. SN 77-028,325. PUB. 7-24-2007, FILED 10-24-2006.

RELATIONAL INTELLIGENCE

THE MARK CONSISTS OF STANDARD CHARACTERS WITHOUT CLAIM TO ANY PARTICULAR FONT, STYLE, SIZE, OR COLOR.

CLASS 35—ADVERTISING AND BUSINESS

FOR BUSINESS LEADERSHIP CONSULTATION IN THE FIELD OF PROFESSIONAL LEADERSHIP FOR BUSINESSES AND EMPLOYEES, EXECUTIVE AND MANAGERIAL PERFORMANCE, HUMAN RESOURCES FOR BUSINESS PROFESSIONALS, AND BUSINESS SUCCESSION PLANNING AND JOB TRANSITIONS; BUSINESS EVALUATION OF HUMAN CAPITAL AS RELATED TO PROFESSIONAL LEADERSHIP FOR BUSINESSES AND EMPLOYEES, EXECUTIVE AND MANAGERIAL PERFORMANCE, HUMAN RESOURCES FOR BUSINESS PROFESSIONALS, BUSINESS SUCCESSION PLANNING AND JOB TRANSITIONS (U.S. CLS. 100, 101 AND 102).

FIRST USE 12-11-2007; IN COMMERCE 12-11-2007.

CLASS 41—EDUCATION AND ENTERTAINMENT

FOR EDUCATIONAL SERVICES, NAMELY, CONDUCTING SEMINARS AND PROFESSIONAL PERSONAL COACHING IN THE FIELD OF PROFESSIONAL LEADERSHIP FOR BUSINESSES AND EMPLOYEES, EXECUTIVE AND MANAGERIAL PERFORMANCE, HUMAN RESOURCES FOR BUSINESS PROFESSIONALS, BUSINESS SUCCESSION PLANNING AND JOB TRANSITIONS; AND ON-LINE TRAINING AND EDUCATIONAL EVALUATIONS IN THE FIELD OF PROFESSIONAL LEADERSHIP FOR BUSINESSES AND EMPLOYEES, EXECUTIVE AND MANAGERIAL PERFORMANCE, HUMAN RESOURCES FOR BUSINESS PROFESSIONALS, BUSINESS SUCCESSION PLANNING AND JOB TRANSITIONS (U.S. CLS. 100, 101 AND 107).

FIRST USE 11-27-2007; IN COMMERCE 11-27-2007.

3,481,226. ROLEX WATCH USA, INC., NEW YORK, NY. SN 77-032,562. PUB. 5-15-2007, FILED 10-30-2006.

THE ROLEX INSTITUTE

THE MARK CONSISTS OF STANDARD CHARACTERS WITHOUT CLAIM TO ANY PARTICULAR FONT, STYLE, SIZE, OR COLOR.

NO CLAIM IS MADE TO THE EXCLUSIVE RIGHT TO USE "INSTITUTE", APART FROM THE MARK AS SHOWN.

CLASS 36—INSURANCE AND FINANCIAL

FOR FINANCIAL SPONSORSHIP AND PATRONAGE IN THE NATURE OF PROVIDING GRANTS AND FINANCIAL MANAGEMENT OF ARTISTIC, CULTURAL, EDUCATIONAL, PHILANTHROPIC AND SCIENTIFIC PROGRAMS AND ACTIVITIES (U.S. CLS. 100, 101 AND 102).

FIRST USE 5-31-2005; IN COMMERCE 5-31-2005.

CLASS 41—EDUCATION AND ENTERTAINMENT

FOR EDUCATION AND TRAINING SERVICES, NAMELY, CONDUCTING PROGRAMS AND ACTIVITIES IN THE NATURE OF CLASSES, SEMINARS AND WORKSHOPS IN THE FIELDS OF ARTS, CULTURE, EDUCATION, PHILANTHROPY AND SCIENCE (U.S. CLS. 100, 101 AND 107).

FIRST USE 5-31-2005; IN COMMERCE 5-31-2005.

3,481,256. WL HOMES LLC, NEWPORT BEACH, CA. SN 77-049,143. PUB. 8-14-2007, FILED 11-21-2006.

JOHN LAING HOMES
U R B A N

OWNER OF U.S. REG. NOS. 2,567,065, 2,653,451, AND OTHERS.

NO CLAIM IS MADE TO THE EXCLUSIVE RIGHT TO USE "HOMES" AND "URBAN", APART FROM THE MARK AS SHOWN.

THE NAME(S), PORTRAIT(S), AND/OR SIGNATURE(S) SHOWN IN THE MARK DOES NOT IDENTIFY A PARTICULAR LIVING INDIVIDUAL.

THE MARK CONSISTS OF THE WORDS "JOHN LAING HOMES" WITH THE WORD "URBAN" APPEARING BELOW, ALL IN A STYLIZED FONT.

CLASS 36—INSURANCE AND FINANCIAL

FOR REAL ESTATE ACQUISITION SERVICES; REAL ESTATE AGENCIES, REAL ESTATE BROKERAGE SERVICES, REAL ESTATE CONSULTATION, REAL ESTATE APPRAISAL; REAL ESTATE ESCROW SERVICES; REAL ESTATE INVESTMENT; REAL ESTATE LISTING; REAL ESTATE MANAGEMENT; REAL ESTATE MANAGEMENT CONSULTATION; REAL ESTATE PROCUREMENT FOR OTHERS; REAL ESTATE SYNDICATION; REAL ESTATE VALUATION SERVICES; PROVIDING INFORMATION IN THE FIELD OF REAL ESTATE BY MEANS OF WEBSITES FEATURING REAL ESTATE INFORMATION AND LINKING TO OTHER WEBSITES FEATURING REAL ESTATE INFORMATION; MORTGAGE LENDING, MORTGAGE BROKERAGE, MORTGAGE PROCUREMENT FOR OTHERS, MORTGAGE SERVICES, NAMELY, BUYER PRE-QUALIFICATION OF MORTGAGES FOR MORTGAGE BROKERS AND FINANCIAL INSTITUTIONS; MAINTAINING MORTGAGE ESCROW ACCOUNTS (U.S. CLS. 100, 101 AND 102).

FIRST USE 1-17-2007; IN COMMERCE 1-17-2007.

CLASS 37—CONSTRUCTION AND REPAIR

FOR REAL ESTATE DEVELOPMENT SERVICES, RESIDENTIAL AND COMMERCIAL BUILDING CONSTRUCTION, REAL ESTATE SITE SELECTION; CONSTRUCTION, MAINTENANCE AND RENOVATION OF PROPERTY; CONSTRUCTION CONSULTATION; CONSTRUCTION MANAGEMENT; CONSTRUCTION SERVICES, NAMELY, PLANNING, LAYING OUT AND CONSTRUCTION OF RESIDENTIAL AND COMMERCIAL COMMUNITIES; GENERAL CONSTRUCTION CONTRACTING; CUSTOM CONSTRUCTION OF HOMES; ROAD CONSTRUCTION (U.S. CLS. 100, 103 AND 106).

FIRST USE 1-17-2007; IN COMMERCE 1-17-2007.

3,481,259. DURHAM CONVENTION & VISITORS BUREAU, DURHAM, NC. SN 77-050,894. PUB. 11-13-2007, FILED 11-27-2006.

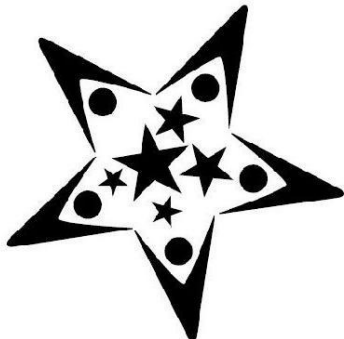

THE MARK CONSISTS OF A FIVE-POINTED STAR WITH EACH POINT REPRESENTING RAISED ARMS ENCLOSING ONE EACH OF FIVE CIRCLES REPRESENTING HEADS OF CITIZENS, AND WITH A CONSTELLATION OF FIVE STARS IN THE CENTER.

CLASS 14—JEWELRY

FOR JEWELRY (U.S. CLS. 2, 27, 28 AND 50).
FIRST USE 9-29-2006; IN COMMERCE 9-29-2006.

CLASS 16—PAPER GOODS AND PRINTED MATTER

FOR PRINTED MATTER, NAMELY, CALENDARS, MAPS, BLANK CARDS, STICKERS, PAPER POSTERS AND BANNERS, AND PRINTED PUBLICATIONS, NAMELY, MAGAZINES, PAMPHLETS, REPORTS AND BROCHURES, ALL FEATURING INFORMATION ON ARTS, CULTURE, EVENTS, ACTIVITIES, ACCOMMODATIONS AND RESTAURANTS (U.S. CLS. 2, 5, 22, 23, 29, 37, 38 AND 50).
FIRST USE 9-9-2006; IN COMMERCE 9-9-2006.

CLASS 35—ADVERTISING AND BUSINESS

FOR CONVENTION AND VISITORS BUREAU SERVICES, NAMELY, PROMOTING TRAVEL, TOURISM AND BUSINESS IN THE DURHAM AREA, REFERRAL SERVICES IN THE FIELD OF VENDORS FOR CONVENTION ORGANIZERS (U.S. CLS. 100, 101 AND 102).
FIRST USE 9-29-2006; IN COMMERCE 9-29-2006.

3,481,269. RECKITT BENCKISER INC., PARSIPPANY, NJ. SN 77-054,162. PUB. 6-19-2007, FILED 11-30-2006.

LAVENDER BREEZE

THE MARK CONSISTS OF STANDARD CHARACTERS WITHOUT CLAIM TO ANY PARTICULAR FONT, STYLE, SIZE, OR COLOR.

NO CLAIM IS MADE TO THE EXCLUSIVE RIGHT TO USE "LAVENDER", APART FROM THE MARK AS SHOWN.

CLASS 3—COSMETICS AND CLEANING PREPARATIONS

FOR ALL PURPOSE CLEANING PREPARATION; GENERAL PURPOSE CLEANER WITH DISINFECTING PROPERTIES; GENERAL PURPOSE CLEANING, POLISHING AND SCOURING PREPARATIONS IN LIQUID, POWDER AND GEL FORM FOR HOUSEHOLD, COMMERCIAL, INDUSTRIAL AND INSTITUTIONAL USE; WIPES IMPREGNATED WITH CHEMICALS OR COMPOUNDS FOR CLEANING AND DISINFECTING HARD SURFACES (U.S. CLS. 1, 4, 6, 50, 51 AND 52).

FIRST USE 12-19-2005; IN COMMERCE 12-19-2005.

CLASS 5—PHARMACEUTICALS

FOR ALL PURPOSE DISINFECTING PREPARATIONS; ALL PURPOSE DISINFECTANT SPRAY; SANITIZERS FOR HOUSEHOLD, COMMERCIAL, INDUSTRIAL AND INSTITUTIONAL USE; GERMICIDES; DEODORIZERS AND SANITIZERS FOR BATHROOMS AND TOILETS; ROOM DEODORANTS; ODOR NEUTRALIZING PREPARATIONS FOR USE ON CARPETS, TEXTILES AND IN THE AIR (U.S. CLS. 6, 18, 44, 46, 51 AND 52).

FIRST USE 12-19-2005; IN COMMERCE 12-19-2005.

3,481,273. WANKER, WILLIAM P., SANTA FE, NM. AND KELLY, PAMELA W., SANTA FE, NM. SN 77-056,403. PUB. 6-26-2007, FILED 12-4-2006.

Willy Wanker Wear

THE MARK CONSISTS OF STANDARD CHARACTERS WITHOUT CLAIM TO ANY PARTICULAR FONT, STYLE, SIZE, OR COLOR.

CLASS 10—MEDICAL APPARATUS

FOR CONDOMS (U.S. CLS. 26, 39 AND 44).
FIRST USE 5-7-2008; IN COMMERCE 6-7-2008.

CLASS 25—CLOTHING

FOR BERMUDA SHORTS; BOARD SHORTS; BOXER SHORTS; CAPS; CARGO PANTS; GYM SHORTS; HATS; JOGGING PANTS; PANTIES, SHORTS AND BRIEFS; PANTS; RUGBY SHORTS; SHIRTS; SHORT TROUSERS; SHORT-SLEEVED OR LONG-SLEEVED T-SHIRTS; SKI PANTS; SNOW PANTS; SWEAT PANTS; SWEAT SHORTS; SWIMSUITS; T-SHIRTS; TIES (U.S. CLS. 22 AND 39).

FIRST USE 5-17-2008; IN COMMERCE 6-6-2008.

3,481,280. SOS-BOLTING, INC., NEWARK, DE. SN 77-060,674. PUB. 10-2-2007, FILED 12-8-2006.



NO CLAIM IS MADE TO THE EXCLUSIVE RIGHT TO USE "BOLTING" AND THE ILLUSTRATION OF A BOLTING ASSEMBLY, APART FROM THE MARK AS SHOWN. THE MARK CONSISTS OF "SOS BOLTING" AND DESIGN.

CLASS 7—MACHINERY

FOR POWER TOOLS, NAMELY, HYDRAULIC TORQUE WRENCHES, HYDRAULIC BOLT TENSIONERS, HYDRAULIC PUMPS, IMPACT SOCKETS, AND INDUCTION BOLT HEATING MACHINERY (U.S. CLS. 13, 19, 21, 23, 31, 34 AND 35).
FIRST USE 1-1-2007; IN COMMERCE 1-1-2007.

CLASS 37—CONSTRUCTION AND REPAIR

FOR INDUSTRIAL BOLTING SERVICES, NAMELY, RENTAL OF BOLTING EQUIPMENT AND MACHINERY; CONSULTING IN THE OPERATION OF BOLTING EQUIPMENT AND MACHINERY (U.S. CLS. 100, 103 AND 106).
FIRST USE 1-1-2007; IN COMMERCE 1-1-2007.

CLASS 42—SCIENTIFIC AND COMPUTER SERVICES

FOR INDUSTRIAL BOLTING SERVICES, NAMELY, CONSULTING IN THE DESIGN OF BOLTING EQUIPMENT AND MACHINERY (U.S. CLS. 100 AND 101).
FIRST USE 1-1-2007; IN COMMERCE 1-1-2007.

3,481,284. HARRIS, CHERYL, ACTON, CA. SN 77-062,100. PUB. 7-17-2007, FILED 12-12-2006.

Small Dog Day

THE MARK CONSISTS OF STANDARD CHARACTERS WITHOUT CLAIM TO ANY PARTICULAR FONT, STYLE, SIZE, OR COLOR.

NO CLAIM IS MADE TO THE EXCLUSIVE RIGHT TO USE "SMALL DOG", APART FROM THE MARK AS SHOWN.

CLASS 16—PAPER GOODS AND PRINTED MATTER

FOR GREETING CARDS; STATIONERY (U.S. CLS. 2, 5, 22, 23, 29, 37, 38 AND 50).
FIRST USE 11-10-2007; IN COMMERCE 11-10-2007.

CLASS 21—HOUSEWARES AND GLASS

FOR PET FEEDING DISHES (U.S. CLS. 2, 13, 23, 29, 30, 33, 40 AND 50).
FIRST USE 10-1-2007; IN COMMERCE 10-1-2007.

CLASS 25—CLOTHING

FOR CLOTHING, NAMELY, T-SHIRTS, SHIRTS, SWEATS PANTS, SWEAT SUITS, SWEAT SHIRTS, HATS (U.S. CLS. 22 AND 39).
FIRST USE 10-1-2007; IN COMMERCE 10-1-2007.

3,481,293. NATIONAL MULTIPLE SCLEROSIS SOCIETY, NEW YORK, NY. SN 77-066,611. PUB. 12-11-2007, FILED 12-18-2006.



OWNER OF U.S. REG. NOS. 1,484,593, 2,915,135, AND OTHERS.

NO CLAIM IS MADE TO THE EXCLUSIVE RIGHT TO USE "MS", APART FROM THE MARK AS SHOWN. THE MARK CONSISTS OF "MS" SLASHED DESIGN.

CLASS 36—INSURANCE AND FINANCIAL

FOR CHARITABLE FUNDRAISING SERVICES (U.S. CLS. 100, 101 AND 102).
FIRST USE 11-0-2006; IN COMMERCE 11-0-2006.

CLASS 41—EDUCATION AND ENTERTAINMENT

FOR EDUCATION SERVICES, NAMELY, A PROGRAM TO RAISE AWARENESS OF MULTIPLE SCLEROSIS (U.S. CLS. 100, 101 AND 107).
FIRST USE 11-0-2006; IN COMMERCE 11-0-2006.

3,481,299. CINNAFILM, INC., ALBUQUERQUE, NM. SN 77-069,371. PUB. 10-2-2007, FILED 12-21-2006.

CINNAFILM

THE MARK CONSISTS OF STANDARD CHARACTERS WITHOUT CLAIM TO ANY PARTICULAR FONT, STYLE, SIZE, OR COLOR.

CLASS 41—EDUCATION AND ENTERTAINMENT

FOR ENTERTAINMENT, NAMELY, PREPARATION OF SPECIAL EFFECTS FOR FILM AND VIDEO AND SPECIAL EFFECTS ANIMATION SERVICES FOR FILM AND VIDEO (U.S. CLS. 100, 101 AND 107).

FIRST USE 5-1-2007; IN COMMERCE 5-1-2007.

CLASS 42—SCIENTIFIC AND COMPUTER SERVICES

FOR SPECIAL EFFECTS SERVICES FOR FILM AND VIDEO, NAMELY, ANIMATION AND SPECIAL EFFECTS DESIGN FOR OTHERS (U.S. CLS. 100 AND 101).

FIRST USE 5-1-2007; IN COMMERCE 5-1-2007.

CLASS 35—ADVERTISING AND BUSINESS

FOR HEALTH CARE REFERRAL SERVICES, NAMELY, DOCTOR REFERRALS; HEALTH CARE PRICING SERVICES, NAMELY, MEDICAL COST MANAGEMENT (U.S. CLS. 100, 101 AND 102).

FIRST USE 2-27-2007; IN COMMERCE 9-1-2007.

CLASS 44—MEDICAL, BEAUTY AND AGRICULTURAL SERVICES

FOR HEALTH CARE SERVICES; AND HEALTH CARE DATABASE REPOSITORY SERVICES, NAMELY, MAINTAINING PERSONAL MEDICAL HISTORY RECORDS AND FILES (U.S. CLS. 100 AND 101).

FIRST USE 2-27-2007; IN COMMERCE 9-1-2007.

3,481,301. GANNETT SATELLITE INFORMATION NETWORK, INC., MCLEAN, VA. SN 77-070,123. PUB. 11-6-2007, FILED 12-22-2006.

3,481,317. VISION FUELS, LLC, URBAN DALE, IA. SN 77-077,035. PUB. 7-10-2007, FILED 1-5-2007.

TODAY IN PT

THE MARK CONSISTS OF STANDARD CHARACTERS WITHOUT CLAIM TO ANY PARTICULAR FONT, STYLE, SIZE, OR COLOR.

NO CLAIM IS MADE TO THE EXCLUSIVE RIGHT TO USE "PT", APART FROM THE MARK AS SHOWN.

CLASS 16—PAPER GOODS AND PRINTED MATTER

FOR PRINTED PUBLICATION, NAMELY, A MAGAZINE CONTAINING ARTICLES, INFORMATION AND ADVERTISING, ON THE SUBJECT OF PHYSICAL THERAPY AND ADDRESSING TOPICS OF INTEREST TO MEMBERS OF THE PHYSICAL THERAPIST PROFESSION (U.S. CLS. 2, 5, 22, 23, 29, 37, 38 AND 50).

FIRST USE 2-19-2007; IN COMMERCE 2-19-2007.

CLASS 41—EDUCATION AND ENTERTAINMENT

FOR ONLINE PERIODICALS PROVIDING NEWS, INFORMATION, AND EMPLOYMENT OPPORTUNITIES IN THE PHYSICAL THERAPY FIELD (U.S. CLS. 100, 101 AND 107).

FIRST USE 4-2-2007; IN COMMERCE 4-2-2007.

3,481,313. INEXMARKET LLC, PALO ALTO, CA. SN 77-076,166. PUB. 2-26-2008, FILED 1-4-2007.

REMAKEHEALTH

THE MARK CONSISTS OF STANDARD CHARACTERS WITHOUT CLAIM TO ANY PARTICULAR FONT, STYLE, SIZE, OR COLOR.

VISIONFUELS

THE MARK CONSISTS OF STANDARD CHARACTERS WITHOUT CLAIM TO ANY PARTICULAR FONT, STYLE, SIZE, OR COLOR.

CLASS 35—ADVERTISING AND BUSINESS

FOR DEVELOPMENT AND MANAGEMENT OF BIO-FUEL MANUFACTURING, PROCESSING, AND TREATMENT PLANTS (U.S. CLS. 100, 101 AND 102).

FIRST USE 10-1-2006; IN COMMERCE 10-1-2006.

CLASS 40—MATERIAL TREATMENT

FOR MANUFACTURE, PROCESSING, AND TREATMENT OF FUELS, NAMELY, BIOFUELS (U.S. CLS. 100, 103 AND 106).

FIRST USE 10-1-2006; IN COMMERCE 10-1-2006.

3,481,321. COOKSON ELECTRONICS, INC., JERSEY CITY, NJ. SN 77-080,966. PUB. 7-10-2007, FILED 1-11-2007.

NANOSCIENCE

THE MARK CONSISTS OF STANDARD CHARACTERS WITHOUT CLAIM TO ANY PARTICULAR FONT, STYLE, SIZE, OR COLOR.

CLASS 1—CHEMICALS

FOR COATINGS USED IN THE MANUFACTURE OF PRINTED CIRCUIT BOARDS; AND METAL PLATING CHEMICAL COMPOSITIONS (U.S. CLS. 1, 5, 6, 10, 26 AND 46).

FIRST USE 11-1-2007; IN COMMERCE 11-1-2007.

CLASS 2—PAINTS

FOR COATINGS IN THE NATURE OF CONDUCTIVE INKS FOR USE IN THE MANUFACTURE OF PRINTED CIRCUIT BOARDS; COATINGS FOR METALS AND PLASTICS, WHICH PROVIDE A DECORATIVE APPEARANCE; AND CORROSION INHIBITING IN THE NATURE OF A COATING (U.S. CLS. 6, 11 AND 16).

FIRST USE 11-1-2007; IN COMMERCE 11-1-2007.

CLASS 6—METAL GOODS

FOR SOLDER PASTES; AND PLATING COMPOSITIONS COMPOSED OF METALS (U.S. CLS. 2, 12, 13, 14, 23, 25 AND 50).

FIRST USE 11-1-2007; IN COMMERCE 11-1-2007.

3,481,326. REMINGTON HOTEL CORPORATION, DALLAS, TX. SN 77-082,307. PUB. 8-21-2007, FILED 1-12-2007.

ONE OCEAN

THE MARK CONSISTS OF STANDARD CHARACTERS WITHOUT CLAIM TO ANY PARTICULAR FONT, STYLE, SIZE, OR COLOR.

CLASS 43—HOTEL AND RESTAURANT SERVICES

FOR HEALTH RESORT SERVICES, NAMELY, PROVIDING FOOD AND LODGING THAT SPECIALIZE IN PROMOTING PATRONS' GENERAL HEALTH AND WELL-BEING; HOTEL SERVICES; HOTEL, BAR AND RESTAURANT SERVICES; RESORT HOTELS; RESORT LODGING SERVICES; SPA SERVICES, NAMELY, PROVIDING TEMPORARY ACCOMMODATIONS AND MEALS TO CLIENTS OF A HEALTH OR BEAUTY SPA (U.S. CLS. 100 AND 101).

FIRST USE 6-30-2007; IN COMMERCE 5-1-2008.

CLASS 44—MEDICAL, BEAUTY AND AGRICULTURAL SERVICES

FOR HEALTH SPA SERVICES FOR HEALTH AND WELLNESS OF THE BODY AND SPIRIT OFFERED AT A HEALTH RESORT; HEALTH SPA SERVICES, NAMELY, COSMETIC BODY CARE SERVICES (U.S. CLS. 100 AND 101).

FIRST USE 6-30-2007; IN COMMERCE 5-1-2008.

3,481,327. L8-P INC, MISSISSAUGA, ONTARIO. SN 77-082,366. PUB. 8-21-2007, FILED 1-12-2007.

<3

THE MARK CONSISTS OF STANDARD CHARACTERS WITHOUT CLAIM TO ANY PARTICULAR FONT, STYLE, SIZE, OR COLOR.

CLASS 14—JEWELRY

FOR JEWELRY (U.S. CLS. 2, 27, 28 AND 50).
FIRST USE 3-1-2007; IN COMMERCE 7-1-2007.

CLASS 25—CLOTHING

FOR MEN'S, WOMAN'S, CHILDREN'S TODDLER'S AND BABIES' CLOTHING, NAMELY, DRESSES, SKIRTS, BLOUSES, JACKETS, COATS, BELTS, CAPS, HATS, FLEECE PULLOVERS, SWEATERS, JACKETS, JEANS, PANTS, OVERALLS, SWEAT PANTS, T-SHIRTS, POLO SHIRTS, UNDERSHIRTS, SWEATSHIRTS, TANK TOPS, SHORTS, UNDERWEAR, BRIEFS, THERMAL UNDERWEAR, THONGS, PANTIES, SWIM SUITS, TRUNKS, YOGA PANTS, CAPRI PANTS, SPORTS BRAS, BANDANAS, SOCKS, SHOES (U.S. CLS. 22 AND 39).

FIRST USE 3-1-2007; IN COMMERCE 7-1-2007.

3,481,334. ISA-THE INSTRUMENTATION, SYSTEMS, AND AUTOMATION SOCIETY, RESEARCH TRIANGLE PARK, NC. SN 77-084,858. PUB. 9-4-2007, FILED 1-17-2007.

WE CONTROL THE WORLD

THE MARK CONSISTS OF STANDARD CHARACTERS WITHOUT CLAIM TO ANY PARTICULAR FONT, STYLE, SIZE, OR COLOR.

CLASS 35—ADVERTISING AND BUSINESS

FOR ASSOCIATION SERVICES, NAMELY, THE PROMOTION OF THE INTERESTS OF THOSE IN THE INSTRUMENTATION, SYSTEMS, AND AUTOMATION FIELDS INCLUDING THE DISSEMINATION OF INFORMATION IN THE FIELD OF INSTRUMENTATION, SYSTEMS, AND AUTOMATION AND INSTRUMENTATION TECHNOLOGY (U.S. CLS. 100, 101 AND 102).

FIRST USE 4-1-2007; IN COMMERCE 4-1-2007.

CLASS 41—EDUCATION AND ENTERTAINMENT

FOR CONDUCTING LECTURES, SEMINARS, CONFERENCES, MEETINGS, WORKSHOPS, TRAINING COURSES, EXHIBITIONS, PRESENTATIONS, CONVENTIONS, AND EDUCATIONAL DEMONSTRATIONS IN OR RELATED TO THE FIELDS OF INSTRUMENTATION, MEASUREMENT AND CONTROL, SYSTEMS, AND AUTOMATION, AND THE DEVELOPMENT AND DISSEMINATION OF EDUCATIONAL MATERIALS IN CONNECTION THEREWITH (U.S. CLS. 100, 101 AND 107).

FIRST USE 4-1-2007; IN COMMERCE 4-1-2007.

3,481,338. RACINGTHEPLANET LIMITED, THE PEAK, HONG KONG. SN 77-087,587. PUB. 10-2-2007, FILED 1-22-2007.

4 Deserts

THE MARK CONSISTS OF STANDARD CHARACTERS WITHOUT CLAIM TO ANY PARTICULAR FONT, STYLE, SIZE, OR COLOR.

CLASS 25—CLOTHING

FOR CLOTHING, NAMELY, SHIRTS AND SHORTS; FOOTWEAR; HEADGEAR, NAMELY, HATS AND CAPS; SHOES; SLIPPERS; SANDALS; COATS; VESTS; GLOVES; HOSIERY; JACKETS; JUMPERS; MOTORISTS' CLOTHING, NAMELY, SHIRTS AND SHORTS; CYCLISTS' CLOTHING, NAMELY, PANTS, SHIRTS AND SHORTS; TIES; OUTERCLOTHING, NAMELY, COATS AND JACKETS; OVERALLS; PANTS; SCARVES; SHIRTS; SKIRTS; SOCKS; STOCKINGS; SWEATERS; SWIMSUITS; T-SHIRTS; TROUSERS; UNDERWEAR; BELTS (U.S. CLS. 22 AND 39).

FIRST USE 3-0-2005; IN COMMERCE 3-0-2005.

CLASS 41—EDUCATION AND ENTERTAINMENT

FOR ENTERTAINMENT SERVICES, NAMELY, ENTERTAINMENT IN THE NATURE OF SPORTS COMPETITIONS IN THE FIELD OF HUMAN ENDURANCE RACING; ORGANIZING SPORTING EVENTS, NAMELY, HUMAN ENDURANCE RACES; ORGANIZING EXHIBITIONS FOR OUTDOOR HUMAN ENDURANCE SPORTING PURPOSES; PROVIDING A WEBSITE FEATURING SPORTING INFORMATION AND ENTERTAINMENT INFORMATION IN THE NATURE OF HUMAN ENDURANCE RACING COMPETITIONS; PROVIDING AN ONGOING TELEVISION PROGRAM IN THE FIELDS OF SPORTS CONTESTS, SPORTS COMPETITIONS AND SPORTS EVENTS (U.S. CLS. 100, 101 AND 107).

FIRST USE 3-0-2005; IN COMMERCE 3-0-2005.

3,481,351. BEGIN SMART LLC, NEW YORK, NY. SN 77-093,743. PUB. 7-24-2007, FILED 1-29-2007.

BEGIN SMART

THE MARK CONSISTS OF STANDARD CHARACTERS WITHOUT CLAIM TO ANY PARTICULAR FONT, STYLE, SIZE, OR COLOR.

CLASS 16—PAPER GOODS AND PRINTED MATTER

FOR CHILDREN'S BOOKS, EDUCATIONAL BOOKS FEATURING A DEVELOPMENTAL PROGRAM FOR CHILDREN (U.S. CLS. 2, 5, 22, 23, 29, 37, 38 AND 50).

FIRST USE 6-4-2008; IN COMMERCE 6-4-2008.

CLASS 41—EDUCATION AND ENTERTAINMENT

FOR BOOK PUBLISHING SERVICES (U.S. CLS. 100, 101 AND 107).

FIRST USE 6-4-2008; IN COMMERCE 6-4-2008.

3,481,355. FRISDOO, LLC, ATLANTA, GA. SN 77-094,840. PUB. 9-18-2007, FILED 1-30-2007.

FRISDOO

THE MARK CONSISTS OF STANDARD CHARACTERS WITHOUT CLAIM TO ANY PARTICULAR FONT, STYLE, SIZE, OR COLOR.

CLASS 25—CLOTHING

FOR CLOTHING, NAMELY, T-SHIRTS, SHORTS, HATS, SWEATSHIRTS, FLEECE JACKETS, AND SWIMWEAR (U.S. CLS. 22 AND 39).

FIRST USE 7-1-2007; IN COMMERCE 7-1-2007.

CLASS 28—TOYS AND SPORTING GOODS

FOR EQUIPMENT SOLD AS A UNIT FOR PLAYING A COMPETITIVE WATER SPORTS GAME COMPRISED OF FLYING DISCS, COURSE MARKERS, AND FLOATING DEVICES, TO BE USED IN CONJUNCTION WITH A PERSONAL WATER CRAFT (U.S. CLS. 22, 23, 38 AND 50).

FIRST USE 7-3-2007; IN COMMERCE 7-3-2007.

3,481,358. DONG IN, CHO, YOOSUNG-GU, DAEJUN, REPUBLIC OF KOREA. SN 77-096,904. PUB. 1-1-2008, FILED 2-1-2007.

HACKERS

THE MARK CONSISTS OF STANDARD CHARACTERS WITHOUT CLAIM TO ANY PARTICULAR FONT, STYLE, SIZE, OR COLOR.

OWNER OF REPUBLIC OF KOREA REG. NO. 144595, DATED 2-14-2007, EXPIRES 2-14-2017.

OWNER OF REPUBLIC OF KOREA REG. NO. 687814, DATED 12-1-2006, EXPIRES 12-1-2016.

CLASS 16—PAPER GOODS AND PRINTED MATTER

FOR NOTEBOOKS, MEMO PAPER, BUSINESS CARD PAPER, ENVELOPES, STATIONERY PADS, FILE FOLDERS FOR PAPER, POCKET NOTEBOOKS, PHOTOGRAPH AND SCRAPBOOK ALBUMS, PICTURE POSTCARDS, CALENDARS, BANK CHECKS, CHECKBOOK HOLDERS AND COVERS, BLANK WRITING AND DRAWING BOOKS, POSTCARDS, COMMEMORATIVE POSTAGE STAMP SHEETS, PRINTED FORMS, PRINTED TIMETABLES, DIARIES, TELEPHONE DIRECTORIES, GEOGRAPHICAL MAPS, PRINTED TICKETS, POSTERS AND FLASH CARDS; PRINTED INSTRUCTIONAL, EDUCATIONAL, AND TEACHING MATERIALS IN THE FIELDS OF ENGLISH, ENGLISH AS A SECOND LANGUAGE, FOREIGN LANGUAGES, HANDWRITING AND SCHOLASTIC TEST PREPARATION; AND BOOKS, BOOKLETS, NEWSPAPERS, MAGAZINES, PERIODICALS, CATALOGUES, PAMPHLETS, STUDY BOOKS, HANDBOOKS, AND NEWSLETTERS IN THE FIELDS OF ENGLISH, ENGLISH AS A SECOND LANGUAGE, FOREIGN LANGUAGES, HANDWRITING AND SCHOLASTIC TEST PREPARATION (U.S. CLS. 2, 5, 22, 23, 29, 37, 38 AND 50).

CLASS 38—COMMUNICATION

FOR TRANSMISSION OF INFORMATION IN THE FIELDS OF ENGLISH, ENGLISH AS A SECOND LANGUAGE, FOREIGN LANGUAGES, HANDWRITING AND SCHOLASTIC TEST PREPARATION BY ELECTRONIC COMMUNICATIONS NETWORKS, COMPUTER NETWORKS AND WIRELESS COMMUNICATIONS NETWORKS; ELECTRONIC TRANSMISSION OF MESSAGES AND DATA IN THE FIELDS OF ENGLISH, ENGLISH AS A SECOND LANGUAGE, FOREIGN LANGUAGES, HANDWRITING AND SCHOLASTIC TEST PREPARATION; PROVIDING MULTIPLE-USER ACCESS TO A GLOBAL COMPUTER INFORMATION NETWORK IN THE FIELDS OF ENGLISH, ENGLISH AS A SECOND LANGUAGE, FOREIGN LANGUAGES, HANDWRITING AND SCHOLASTIC TEST PREPARATION; PROVIDING ON-LINE ELECTRONIC BULLETIN BOARDS FOR TRANSMISSION OF MESSAGES AMONG COMPUTER USERS CONCERNING ENGLISH, ENGLISH AS A SECOND LANGUAGE, FOREIGN LANGUAGES, HANDWRITING AND SCHOLASTIC TEST PREPARATION; ELECTRONIC MAIL SERVICES IN THE FIELDS OF ENGLISH, ENGLISH AS A SECOND LANGUAGE, FOREIGN LANGUAGES, HANDWRITING AND SCHOLASTIC TEST PREPARATION; AND BROADCASTING PROGRAMS IN THE FIELDS OF ENGLISH, ENGLISH AS A SECOND LANGUAGE, FOREIGN LANGUAGES, HANDWRITING AND SCHOLASTIC TEST PREPARATION VIA A GLOBAL COMPUTER NETWORK, RADIO, AND TELEVISION (U.S. CLS. 100, 101 AND 104).

FIRST USE 2-28-2007; IN COMMERCE 2-28-2007.

CLASS 41—EDUCATION AND ENTERTAINMENT

FOR PUBLICATION OF TEXTS, BOOKS, MAGAZINES AND OTHER PRINTED MATTER IN THE FIELDS OF ENGLISH, ENGLISH AS A SECOND LANGUAGE, FOREIGN LANGUAGES, HANDWRITING AND SCHOLASTIC TEST PREPARATION; ONLINE PUBLICATION OF ELECTRONIC BOOKS AND JOURNALS IN THE FIELDS OF ENGLISH, ENGLISH AS A SECOND LANGUAGE, FOREIGN LANGUAGES, HANDWRITING AND SCHOLASTIC TEST PREPARATION; PROVIDING ON-LINE ELECTRONIC PUBLICATIONS IN THE NATURE OF BOOKS, BOOKLETS, NEWSPAPERS, MAGAZINES, PERIODICALS, CATALOGUES, PAMPHLETS, STUDY BOOKS, HANDBOOKS, AND NEWSLETTERS IN THE FIELDS OF ENGLISH, ENGLISH AS A SECOND LANGUAGE, FOREIGN LANGUAGES, HANDWRITING AND SCHOLASTIC TEST PREPARATION; NEWS REPORTING SERVICES IN THE FIELDS OF ENGLISH, ENGLISH AS A SECOND LANGUAGE, FOREIGN LANGUAGES, HANDWRITING AND SCHOLASTIC TEST PREPARATION; BOARDING SCHOOLS; ARRANGING AND CONDUCTING CLASSES, SEMINARS AND WORKSHOPS IN THE FIELDS OF ENGLISH, ENGLISH AS A SECOND LANGUAGE, FOREIGN LANGUAGES, HANDWRITING AND SCHOLASTIC TEST PREPARATION, AND DISTRIBUTION OF COURSE MATERIALS

IN CONNECTION THEREWITH; LIBRARY AND READING ROOM SERVICES; ORGANIZATION OF EDUCATIONAL EXHIBITIONS IN THE FIELDS OF ENGLISH, ENGLISH AS A SECOND LANGUAGE, FOREIGN LANGUAGES, HANDWRITING AND SCHOLASTIC TEST PREPARATION FOR EDUCATIONAL PURPOSES; NURSERY SCHOOLS; EDUCATIONAL SERVICES, NAMELY, PROVIDING COURSES OF INSTRUCTION AT THE KINDERGARTEN LEVEL AND DISTRIBUTION OF COURSE MATERIAL IN CONNECTION THEREWITH; ARRANGING OF OVERSEAS CLASSES, SEMINARS AND WORKSHOPS IN THE FIELDS OF ENGLISH, ENGLISH AS A SECOND LANGUAGE, FOREIGN LANGUAGES, HANDWRITING AND SCHOLASTIC TEST PREPARATION; MOBILE LIBRARY SERVICES; EDUCATIONAL SERVICES IN THE NATURE OF CORRESPONDENCE SCHOOLS IN THE FIELDS OF ENGLISH, ENGLISH AS A SECOND LANGUAGE, FOREIGN LANGUAGES, HANDWRITING AND SCHOLASTIC TEST PREPARATION; SPORTS CAMP SERVICES—ENTERTAINMENT SERVICES, NAMELY, PROVIDING ON-LINE COMPUTER GAMES; AMUSEMENT PARKS; PROVIDING SPORTS FACILITIES; PHYSICAL EDUCATION SERVICES; RECREATIONAL CAMPS; MICROFILM AND VIDEO FILM RECORDING SERVICES FOR OTHERS; PHOTOGRAPHY SERVICES; TRANSLATION SERVICES; VOCATIONAL GUIDANCE; AND EDUCATIONAL SERVICES, NAMELY, DEVELOPING, ARRANGING, AND CONDUCTING EDUCATIONAL CONFERENCES AND PROGRAMS AND PROVIDING COURSES OF INSTRUCTION IN THE FIELDS OF ENGLISH, ENGLISH AS A SECOND LANGUAGE, FOREIGN LANGUAGES, HANDWRITING AND SCHOLASTIC TEST PREPARATION (U.S. CLS. 100, 101 AND 107).

3,481,359. DONG IN, CHO, YOOSUNG-GU, DAEJUN, REPUBLIC OF KOREA. SN 77-096,955. PUB. 2-12-2008, FILED 2-1-2007.

해커스

OWNER OF REPUBLIC OF KOREA REG. NO. 144597, DATED 2-14-2007, EXPIRES 2-14-2017.

OWNER OF REPUBLIC OF KOREA REG. NO. 687815, DATED 12-1-2006, EXPIRES 12-1-2016.

THE MARK CONSISTS OF KOREAN LANGUAGE PHONETIC CHARACTERS THAT ARE LOOSELY PRONOUNCED AS HACKERS.

THE FOREIGN WORDING IN THE MARK TRANSLATES INTO ENGLISH AS HACKERS.

THE NON-LATIN CHARACTER(S) IN THE MARK TRANSLITERATE INTO HEH KUH SE, AND THIS MEANS HACKERS IN ENGLISH.

CLASS 16—PAPER GOODS AND PRINTED MATTER

FOR (BASED ON 44(E)) NOTEBOOKS, MEMO PAPER, BUSINESS CARD PAPER, ENVELOPES, STATIONERY PADS, FILE FOLDERS FOR PAPER, POCKET NOTEBOOKS, PHOTOGRAPH AND SCRAPBOOK ALBUMS, PICTURE POSTCARDS, CALENDARS, BANK CHECKS, CHECKBOOK HOLDERS AND COVERS, BLANK WRITING AND DRAWING BOOKS, POSTCARDS, COMMEMORATIVE POSTAGE STAMP SHEETS, PRINTED FORMS, PRINTED TIMETABLES, DIARIES, TELEPHONE DIRECTORIES, GEOGRAPHICAL MAPS, PRINTED TICKETS, POSTERS AND FLASH CARDS; PRINTED INSTRUCTIONAL, EDUCATIONAL, AND TEACHING MATERIALS IN THE FIELDS OF ENGLISH, ENGLISH AS A SECOND LANGUAGE, FOREIGN LANGUAGES, HANDWRITING AND SCHOLASTIC TEST PREPARATION; AND BOOKS, BOOKLETS, NEWSPAPERS, MAGAZINES, PERIODICALS, CATALOGUES, PAMPHLETS, STUDY BOOKS, HANDBOOKS, AND NEWSLETTERS IN THE FIELDS OF ENGLISH, ENGLISH AS A SECOND LANGUAGE, FOREIGN LANGUAGES, HANDWRITING AND SCHOLASTIC TEST PREPARATION (U.S. CLS. 2, 5, 22, 23, 29, 37, 38 AND 50).

CLASS 38—COMMUNICATION

FOR (BASED ON USE IN COMMERCE) TRANSMISSION OF INFORMATION IN THE FIELDS OF ENGLISH, ENGLISH AS A SECOND LANGUAGE, FOREIGN LANGUAGES, HANDWRITING AND SCHOLASTIC TEST PREPARATION BY ELECTRONIC COMMUNICATIONS NETWORKS, COMPUTER NETWORKS AND WIRELESS COMMUNICATIONS NETWORKS; ELECTRONIC TRANSMISSION OF MESSAGES AND DATA IN THE FIELDS OF ENGLISH, ENGLISH AS A SECOND LANGUAGE, FOREIGN LANGUAGES, HANDWRITING AND SCHOLASTIC TEST PREPARATION; PROVIDING MULTIPLE-USER ACCESS TO A GLOBAL COMPUTER INFORMATION NETWORK IN THE FIELDS OF ENGLISH, ENGLISH AS A SECOND LANGUAGE, FOREIGN LANGUAGES, HANDWRITING AND SCHOLASTIC TEST PREPARATION; PROVIDING ON-LINE ELECTRONIC BULLETIN BOARDS FOR TRANSMISSION OF MESSAGES AMONG COMPUTER USERS CONCERNING ENGLISH, ENGLISH AS A SECOND LANGUAGE, FOREIGN LANGUAGES, HANDWRITING AND SCHOLASTIC TEST PREPARATION; ELECTRONIC MAIL SERVICES IN THE FIELDS OF ENGLISH, ENGLISH AS A SECOND LANGUAGE, FOREIGN LANGUAGES, HANDWRITING AND SCHOLASTIC TEST PREPARATION; AND BROADCASTING PROGRAMS IN THE FIELDS OF ENGLISH, ENGLISH AS A SECOND LANGUAGE, FOREIGN LANGUAGES, HANDWRITING AND SCHOLASTIC TEST PREPARATION VIA A GLOBAL COMPUTER NETWORK, RADIO, AND TELEVISION (U.S. CLS. 100, 101 AND 104).

FIRST USE 2-28-2007; IN COMMERCE 2-28-2007.

CLASS 41—EDUCATION AND ENTERTAINMENT

FOR (BASED ON 44(E)) PUBLICATION OF TEXTS, BOOKS, MAGAZINES AND OTHER PRINTED MATTER IN THE FIELDS OF ENGLISH, ENGLISH AS A SECOND LANGUAGE, FOREIGN LANGUAGES, HANDWRITING AND SCHOLASTIC TEST PREPARATION; ONLINE PUBLICATION OF ELECTRONIC BOOKS AND JOURNALS IN THE FIELDS OF ENGLISH, ENGLISH AS A SECOND LANGUAGE, FOREIGN LANGUAGES, HANDWRITING AND SCHOLASTIC TEST PREPARATION; PROVIDING ON-LINE ELECTRONIC PUBLICATIONS IN THE NATURE OF BOOKS, BOOKLETS, NEWSPAPERS, MAGAZINES, PERIODICALS, CATALOGUES, PAMPHLETS, STUDY BOOKS, HANDBOOKS, AND NEWSLETTERS IN THE FIELDS OF ENGLISH, ENGLISH AS A SECOND LANGUAGE, FOREIGN LANGUAGES, HANDWRITING AND SCHOLASTIC TEST PREPARATION; BOARDING SCHOOLS; ARRANGING AND CONDUCTING CLASSES, SEMINARS AND WORKSHOPS IN THE FIELDS OF ENGLISH, ENGLISH AS A SECOND LANGUAGE, FOREIGN LANGUAGES, HANDWRITING

AND SCHOLASTIC TEST PREPARATION, AND DISTRIBUTION OF COURSE MATERIALS IN CONNECTION THEREWITH; LIBRARY AND READING ROOM SERVICES; ORGANIZATION OF EDUCATIONAL EXHIBITIONS IN THE FIELDS OF ENGLISH, ENGLISH AS A SECOND LANGUAGE, FOREIGN LANGUAGES, HANDWRITING AND SCHOLASTIC TEST PREPARATION FOR EDUCATIONAL PURPOSES; NURSERY SCHOOLS; EDUCATIONAL SERVICES, NAMELY, PROVIDING COURSES OF INSTRUCTION AT THE KINDERGARTEN LEVEL AND DISTRIBUTION OF COURSE MATERIAL IN CONNECTION THEREWITH; ARRANGING OF OVERSEAS CLASSES, SEMINARS AND WORKSHOPS IN THE FIELDS OF ENGLISH, ENGLISH AS A SECOND LANGUAGE, FOREIGN LANGUAGES, HANDWRITING AND SCHOLASTIC TEST PREPARATION; MOBILE LIBRARY SERVICES; EDUCATIONAL SERVICES IN THE NATURE OF CORRESPONDENCE SCHOOLS IN THE FIELDS OF ENGLISH, ENGLISH AS A SECOND LANGUAGE, FOREIGN LANGUAGES, HANDWRITING AND SCHOLASTIC TEST PREPARATION; SPORTS CAMP SERVICES—ENTERTAINMENT SERVICES, NAMELY, PROVIDING ON-LINE COMPUTER GAMES; AMUSEMENT PARKS; PROVIDING SPORTS FACILITIES; PHYSICAL EDUCATION SERVICES; RECREATIONAL CAMPS; MICROFILM AND VIDEO FILM RECORDING SERVICES FOR OTHERS; PHOTOGRAPHY SERVICES; TRANSLATION SERVICES; VOCATIONAL GUIDANCE; AND EDUCATIONAL SERVICES, NAMELY, DEVELOPING, ARRANGING, AND CONDUCTING EDUCATIONAL CONFERENCES AND PROGRAMS AND PROVIDING COURSES OF INSTRUCTION IN THE FIELDS OF ENGLISH, ENGLISH AS A SECOND LANGUAGE, FOREIGN LANGUAGES, HANDWRITING AND SCHOLASTIC TEST PREPARATION (U.S. CLS. 100, 101 AND 107).

3,481,365. FOOD SOLUTIONS, INC., GREENSBORO, NC. SN 77-100,117. PUB. 8-7-2007, FILED 2-6-2007.

Sports Mania

THE MARK CONSISTS OF STANDARD CHARACTERS WITHOUT CLAIM TO ANY PARTICULAR FONT, STYLE, SIZE, OR COLOR.

NO CLAIM IS MADE TO THE EXCLUSIVE RIGHT TO USE "SPORTS" AS TO CLASS 32, APART FROM THE MARK AS SHOWN.

CLASS 30—STAPLE FOODS

FOR CEREAL-BASED SNACK FOODS; TORTILLA CHIPS (U.S. CL. 46).

FIRST USE 10-23-2007; IN COMMERCE 10-23-2007.

CLASS 32—LIGHT BEVERAGES

FOR NON-ALCOHOLIC COCKTAIL MIXES (U.S. CLS. 45, 46 AND 48).

FIRST USE 10-23-2007; IN COMMERCE 10-23-2007.

3,481,373. AKEENA SOLAR INC., LOS GATOS, CA. SN 77-104,221. PUB. 12-11-2007, FILED 2-9-2007.

Andalay

THE MARK CONSISTS OF STANDARD CHARACTERS WITHOUT CLAIM TO ANY PARTICULAR FONT, STYLE, SIZE, OR COLOR.

CLASS 9—ELECTRICAL AND SCIENTIFIC APPARATUS

FOR COMPUTER SOFTWARE FOR PHOTOVOLTAIC SYSTEMS FOR EVALUATING ELECTRIC CONSUMPTION, DETERMINING SYSTEM SIZING, ESTIMATING ELECTRICAL OUTPUT, ESTIMATING CUSTOMER COSTS, AND ESTIMATING FINANCIAL LIFE CYCLES SAVINGS, FOR USE BY CONSUMERS AND BUSINESSES (U.S. CLS. 21, 23, 26, 36 AND 38).

FIRST USE 7-15-2007; IN COMMERCE 7-15-2007.

CLASS 37—CONSTRUCTION AND REPAIR

FOR INSTALLATION OF RENEWABLE ENERGY SYSTEMS, NAMELY, PHOTOVOLTAIC SYSTEMS COMPOSED OF PHOTOVOLTAIC SOLAR MODULES, BATTERIES, VOLTAGE REGULATORS, INVERTERS, RACKS, AND ELECTRIC CONTROLS (U.S. CLS. 100, 103 AND 106).

FIRST USE 7-15-2007; IN COMMERCE 7-15-2007.

3,481,399. EATWARE INTELLECTUAL PROPERTIES LIMITED, KWUN TONG, HONG KONG. SN 77-114,447. PUB. 9-4-2007, FILED 2-23-2007.



THE MARK CONSISTS OF STYLIZED DESIGN OF THREE FISH ABOVE THE LITERAL ELEMENT "EATPLUS".

CLASS 16—PAPER GOODS AND PRINTED MATTER

FOR BIODEGRADABLE AND RECYCLABLE PAPER PULP-BASED BOXES AND LIDS FOR USE IN SERVING FOOD AND FOR SHORT-TERM STORAGE OF FOOD (U.S. CLS. 2, 5, 22, 23, 29, 37, 38 AND 50).

FIRST USE 5-19-2008; IN COMMERCE 5-19-2008.

CLASS 21—HOUSEWARES AND GLASS

FOR BIODEGRADABLE AND RECYCLABLE PAPER PULP-BASED PLATES, BOWLS AND TRAYS FOR USE IN SERVING FOOD AND FOR SHORT-TERM STORAGE OF FOOD (U.S. CLS. 2, 13, 23, 29, 30, 33, 40 AND 50).

FIRST USE 5-6-2008; IN COMMERCE 5-6-2008.

3,481,390. PRIMLAND LTD., MEADOWS OF DAN, VA. SN 77-111,119. PUB. 8-14-2007, FILED 2-20-2007.

Above and Beyond

THE MARK CONSISTS OF STANDARD CHARACTERS WITHOUT CLAIM TO ANY PARTICULAR FONT, STYLE, SIZE, OR COLOR.

CLASS 41—EDUCATION AND ENTERTAINMENT

FOR HORSEBACK RIDING CAMPS; PROVIDING FACILITIES FOR RECREATION ACTIVITIES; PROVIDING GOLF FACILITIES; RECREATIONAL SERVICES IN THE NATURE OF FISHING, HUNTING, HORSEBACK RIDING, SKEET SHOOTING, HIKING, GOLFING, AND ALL-TERRAIN VEHICLES RIDING FACILITIES; RECREATIONAL SERVICES, NAMELY, PROVIDING HUNTING PRESERVES (U.S. CLS. 100, 101 AND 107).

FIRST USE 5-5-2008; IN COMMERCE 5-5-2008.

CLASS 43—HOTEL AND RESTAURANT SERVICES

FOR RESORT HOTELS; RESORT LODGING SERVICES (U.S. CLS. 100 AND 101).

FIRST USE 5-5-2008; IN COMMERCE 5-5-2008.

3,481,404. THOR, INC., MANHATTAN BEACH, CA. SN 77-115,203. PUB. 8-21-2007, FILED 2-23-2007.

TGI

THE MARK CONSISTS OF STANDARD CHARACTERS WITHOUT CLAIM TO ANY PARTICULAR FONT, STYLE, SIZE, OR COLOR.

CLASS 35—ADVERTISING AND BUSINESS

FOR PROVIDING TEMPORARY, LONG-TERM, PERMANENT, AND CONTRACTUAL EMPLOYMENT STAFFING SERVICES; PROVIDING EXECUTIVE PERSONNEL SEARCH AND PLACEMENT SERVICES; BUSINESS CONSULTING SERVICES IN THE FIELDS OF CUSTOMER RELATIONSHIP MANAGEMENT, ENTERPRISE RESOURCE PLANNING, STRATEGIC VENDOR PARTNERING, BUSINESS ALLIANCES, OUTSOURCING, PROJECT MANAGEMENT, DATA GATHERING AND ANALYSIS, BUSINESS PROCEDURES AND INFORMATION TECHNOLOGY AUDITS, AND TELECOMMUNICATIONS (U.S. CLS. 100, 101 AND 102).

FIRST USE 10-0-1998; IN COMMERCE 10-0-1998.

CLASS 42—SCIENTIFIC AND COMPUTER SERVICES

FOR COMPUTER CONSULTING SERVICES TO OTHERS (U.S. CLS. 100 AND 101).

FIRST USE 10-0-1998; IN COMMERCE 10-0-1998.

3,481,405. PFIZER INC, NEW YORK, NY. SN 77-116,136.
PUB. 8-28-2007, FILED 2-26-2007.



NO CLAIM IS MADE TO THE EXCLUSIVE RIGHT TO USE "SEXUAL HEALTH DOCTORS", APART FROM THE MARK AS SHOWN.

THE MARK CONSISTS OF THE TERMS SEXUAL HEALTH OVER THE TERM DOCTOR WITH A DESIGN OF A STETHOSCOPE WHICH IS ATTACHED TO A COMPUTER MOUSE. THE COMPUTER MOUSE REPLACES THE SECOND "O" IN THE WORD DOCTORS.

CLASS 35—ADVERTISING AND BUSINESS

FOR PHYSICIAN AND THERAPIST REFERRAL SERVICES (U.S. CLS. 100, 101 AND 102).
FIRST USE 3-29-2007; IN COMMERCE 3-29-2007.

CLASS 44—MEDICAL, BEAUTY AND AGRICULTURAL SERVICES

FOR MEDICAL INFORMATION SERVICES, NAMELY, PROVIDING INFORMATION REGARDING PHYSICIANS AND THERAPISTS WHO PRACTICE IN A FIELD RELATED TO MEN'S SEXUAL HEALTH; ON-LINE INFORMATION SERVICES, NAMELY, PROVIDING INFORMATION REGARDING PHYSICIANS AND THERAPISTS WHO PRACTICE IN A FIELD RELATED TO MEN'S SEXUAL HEALTH (U.S. CLS. 100 AND 101).
FIRST USE 3-29-2007; IN COMMERCE 3-29-2007.

3,481,408. GUITAR CENTER, INC., WEST LAKE VILLAGE, CA. SN 77-117,443. PUB. 3-11-2008, FILED 2-27-2007.

LAGUNA

THE MARK CONSISTS OF STANDARD CHARACTERS WITHOUT CLAIM TO ANY PARTICULAR FONT, STYLE, SIZE, OR COLOR.

CLASS 9—ELECTRICAL AND SCIENTIFIC APPARATUS

FOR CARRYING CASES AND COVERS SPECIFICALLY ADAPTED FOR DEEJAY EQUIPMENT, NAMELY, AUDIO VISUAL AND SPECIAL EFFECTS EQUIPMENT; SOUND REINFORCEMENT AND RECORDING EQUIPMENT, NAMELY, AUDIO TAPE RECORDERS, AMPLIFIERS, PUBLIC ADDRESS SYSTEMS, DIGITAL SOUND BOARDS FOR AMPLIFIERS, RACK EQUIPMENT, NAMELY, RACKS FOR LOUDSPEAKERS AND AMPLIFIERS, AUDIO CORDS FOR USE WITH SOUND AMPLIFIERS, ELECTRONIC EFFECTS PEDALS FOR USE WITH SOUND AMPLIFIERS, SIGNAL PROCESSORS, RACKS FOR LOUDSPEAKERS AND AMPLIFIERS, STANDS FOR MICROPHONES, MICROPHONES (U.S. CLS. 21, 23, 26, 36 AND 38).
FIRST USE 7-1-2007; IN COMMERCE 7-1-2007.

CLASS 15—MUSICAL INSTRUMENTS

FOR STRINGED MUSICAL INSTRUMENTS, NAMELY, ACOUSTIC, ACOUSTIC/ELECTRIC AND ELECTRIC GUITARS; MUSICAL INSTRUMENTS, NAMELY, ELECTRIC SPANISH GUITARS, MANDOLINS, ELECTRIC BASSES, ACOUSTIC GUITARS, PEDAL STEEL GUITARS, AND STEEL GUITARS, AND COMPONENTS AND ACCESSORIES FOR GUITARS AND THE LIKE, NAMELY, LEGS, CASES, BAGS, STRINGS, POLISH, WAIST BELTS, STANDS, PICKS, STEELS, NECKS, HEADS, PICKUPS, PICKUP COVERS, PICKGUARDS, BRIDGE COVERS, TREMOLO HANDLES, CONTROL KNOBS AND STRAPS; CARRYING CASES AND COVERS SPECIFICALLY ADAPTED FOR MUSICAL INSTRUMENTS (U.S. CLS. 2, 21 AND 36).
FIRST USE 7-1-2007; IN COMMERCE 7-1-2007.

3,481,416. THE TRUSTEE OF JK INVESTMENT TRUST, HALEIWA, HI. SN 77-121,124. PUB. 9-4-2007, FILED 3-2-2007.

7SSPA

THE MARK CONSISTS OF STANDARD CHARACTERS WITHOUT CLAIM TO ANY PARTICULAR FONT, STYLE, SIZE, OR COLOR.

CLASS 3—COSMETICS AND CLEANING PREPARATIONS

FOR BEAUTY CREAMS FOR BODY CARE; BODY AND BEAUTY CARE COSMETICS; COSMETIC PREPARATIONS FOR BODY CARE; FACE AND BODY BEAUTY CREAMS; HAIR CARE CREAMS; HAIR CARE LOTIONS; HAIR CARE PREPARATIONS; LOTIONS FOR FACE AND BODY CARE (U.S. CLS. 1, 4, 6, 50, 51 AND 52).
FIRST USE 4-1-2007; IN COMMERCE 4-1-2007.

CLASS 44—MEDICAL, BEAUTY AND AGRICULTURAL SERVICES

FOR HEALTH SPA SERVICES FOR HEALTH AND WELLNESS OF THE BODY AND SPIRIT OFFERED AT A HEALTH RESORT; HEALTH SPA SERVICES FOR HEALTH AND WELLNESS OF THE MIND, BODY AND SPIRIT OFFERED IN OR FROM A REMOTE, MOBILE OR TEMPORARY ON-SITE LOCATION; HEALTH SPA SERVICES, NAMELY, COSMETIC BODY CARE SERVICES (U.S. CLS. 100 AND 101).
FIRST USE 4-1-2007; IN COMMERCE 4-1-2007.

3,481,423. POWER PLATE NORTH AMERICA, INC.,
NORTHBROOK, IL. SN 77-123,040. PUB. 1-15-2008,
FILED 3-6-2007.

3,481,463. RBLOCK, INC., SUNNYVALE, CA. SN 77-130,312.
PUB. 9-11-2007, FILED 3-13-2007.



RBLOCK

OWNER OF U.S. REG. NO. 3,059,186.
NO CLAIM IS MADE TO THE EXCLUSIVE RIGHT TO
USE "PLATE", APART FROM THE MARK AS SHOWN.
THE STIPPLING IS A FEATURE OF THE MARK.

THE MARK CONSISTS OF STANDARD CHARACTERS
WITHOUT CLAIM TO ANY PARTICULAR FONT, STYLE,
SIZE, OR COLOR.

CLASS 10—MEDICAL APPARATUS

FOR MEDICAL MACHINE PRODUCING MECHANICAL VIBRATIONS FOR STIMULATION OF MUSCLES FOR USE IN CONNECTION WITH A MEDICAL TREATMENT PROGRAM (U.S. CLS. 26, 39 AND 44).
FIRST USE 3-31-2007; IN COMMERCE 3-31-2007.

CLASS 35—ADVERTISING AND BUSINESS

FOR PROMOTING, MARKETING AND ADVERTISING THE GOODS AND SERVICES OF OTHERS VIA THE INTERNET (U.S. CLS. 100, 101 AND 102).
FIRST USE 4-1-2007; IN COMMERCE 4-1-2007.

CLASS 28—TOYS AND SPORTING GOODS

FOR FITNESS AND BODY BUILDING MACHINE PRODUCING MECHANICAL VIBRATIONS FOR STIMULATION OF MUSCLES FOR USE IN FITNESS AND BODY BUILDING PROGRAMS TO INCREASE STRENGTH AND MUSCLE FLEXIBILITY (U.S. CLS. 22, 23, 38 AND 50).
FIRST USE 3-31-2007; IN COMMERCE 3-31-2007.

CLASS 38—COMMUNICATION

FOR PROVIDING ON-LINE ELECTRONIC BULLETIN BOARDS FOR TRANSMISSION OF MESSAGES AMONG COMPUTER USERS CONCERNING A GEOGRAPHICALLY DEFINED SOCIAL NETWORK (U.S. CLS. 100, 101 AND 104).
FIRST USE 4-1-2007; IN COMMERCE 4-1-2007.

CLASS 42—SCIENTIFIC AND COMPUTER SERVICES

FOR COMPUTER SERVICES, NAMELY, CREATING AN ONLINE COMMUNITY FOR REGISTERED USERS TO ENGAGE IN SOCIAL NETWORKING; COMPUTER SERVICES, NAMELY, ACTING AS AN APPLICATION SERVICE PROVIDER IN THE FIELDS OF COLLABORATION AND KNOWLEDGE MANAGEMENT TO HOST COMPUTER APPLICATION SOFTWARE FOR THE CAPTURING, EXCHANGING, ORGANIZING, STORING, RETRIEVING, TRANSMITTING AND SHARING OF DATA AND INFORMATION; COMPUTER SERVICES, NAMELY, HOSTING ONLINE WEB FACILITIES FOR OTHERS FOR ORGANIZING AND CONDUCTING ONLINE MEETINGS, GATHERINGS, AND INTERACTIVE DISCUSSIONS; COMPUTER SERVICES IN THE NATURE OF CUSTOMIZED WEB PAGES FEATURING USER-DEFINED INFORMATION, PERSONAL PROFILES AND INFORMATION; PROVIDING AN ON-LINE COMPUTER DATABASE CONTAINING CUSTOMIZED WEB PAGES FEATURING USER DEFINED INFORMATION IN THE NATURE OF DATA ABOUT INDIVIDUALS CONSISTING OF THE RELATIONSHIPS BETWEEN THE INDIVIDUALS, THEIR CONTACT INFORMATION, PERSONAL CHARACTERISTICS, NAMELY, SKILLS, HOBBIES, INTERESTS, EDUCATIONAL INFORMATION, CAREER INFORMATION, HEALTH INFORMATION, DATING INFORMATION, RESULTS OF SELF ASSESSMENT TESTS, AND OTHER PERSONAL INFORMATION (U.S. CLS. 100 AND 101).
FIRST USE 4-1-2007; IN COMMERCE 4-1-2007.

3,481,455. RAYMOND CREATIVE, LLC, ST. LOUIS, MO. SN
77-129,126. PUB. 9-18-2007, FILED 3-13-2007.

THE RAYMOND EXPERIENCE

THE MARK CONSISTS OF STANDARD CHARACTERS
WITHOUT CLAIM TO ANY PARTICULAR FONT, STYLE,
SIZE, OR COLOR.

CLASS 35—ADVERTISING AND BUSINESS

FOR PUBLIC RELATIONS; CONSULTANCY SERVICES REGARDING BUSINESS STRATEGIES, PERSONNEL AND INTERNAL CORPORATE INITIATIVES AND COMMUNICATIONS (U.S. CLS. 100, 101 AND 102).
FIRST USE 6-30-2007; IN COMMERCE 6-30-2007.

CLASS 41—EDUCATION AND ENTERTAINMENT

FOR SPECIAL EVENT PLANNING; ARRANGING OF SEMINARS AND CONFERENCES (U.S. CLS. 100, 101 AND 107).
FIRST USE 6-30-2007; IN COMMERCE 6-30-2007.

CLASS 45—PERSONAL AND LEGAL SERVICES

FOR INTERNET BASED SOCIAL NETWORKING, INTRODUCTION SERVICES TO FOSTER COMMUNITY BUILDING, INTRODUCTION, AND DATING SERVICES (U.S. CLS. 100 AND 101).
FIRST USE 4-1-2007; IN COMMERCE 4-1-2007.

3,481,495. NEXSTAR, INC., LITTLE CANADA, MN. SN 77-135,481. PUB. 11-13-2007, FILED 3-20-2007.

AT YOUR SERVICE

THE MARK CONSISTS OF STANDARD CHARACTERS WITHOUT CLAIM TO ANY PARTICULAR FONT, STYLE, SIZE, OR COLOR.

CLASS 9—ELECTRICAL AND SCIENTIFIC APPARATUS

FOR DOWNLOADABLE ELECTRONIC NEWSLETTERS RELATING TO SERVICE PROVIDERS IN THE PLUMBING, ELECTRICAL, HEATING, VENTILATING, AND AIR CONDITIONING INDUSTRIES (U.S. CLS. 21, 23, 26, 36 AND 38).

FIRST USE 5-30-2002; IN COMMERCE 5-30-2002.

CLASS 16—PAPER GOODS AND PRINTED MATTER

FOR PRINTED NEWSLETTERS RELATING TO SERVICE PROVIDERS IN THE PLUMBING, ELECTRICAL, HEATING, VENTILATING, AND AIR CONDITIONING INDUSTRIES (U.S. CLS. 2, 5, 22, 23, 29, 37, 38 AND 50).

FIRST USE 5-30-2002; IN COMMERCE 5-30-2002.

3,481,501. FIFTH THIRD BANCORP, CINCINNATI, OH. SN 77-136,201. PUB. 10-30-2007, FILED 3-21-2007.



OWNER OF U.S. REG. NOS. 1,120,703 AND 1,712,167.

THE NAME(S), PORTRAIT(S), AND/OR SIGNATURE(S) SHOWN IN THE MARK DOES NOT IDENTIFY A PARTICULAR LIVING INDIVIDUAL.

THE MARK CONSISTS OF THE WORD "JEANIE" WITH A STARBURST DESIGN OVER THE "I".

CLASS 35—ADVERTISING AND BUSINESS

FOR OPERATION AND MANAGEMENT OF TELEPHONE CALL CENTERS FOR OTHERS; BANKING SERVICES, NAMELY, ELECTRONIC SIGNATURE VERIFICATION SERVICES PROVIDED IN CONNECTION WITH BANKING SERVICES; BANKING SERVICES, NAMELY, FACILITATING GROUP PURCHASE OF BANKING SERVICES (U.S. CLS. 100, 101 AND 102).

FIRST USE 1-0-2007; IN COMMERCE 1-0-2007.

CLASS 36—INSURANCE AND FINANCIAL

FOR FINANCIAL PAYMENT NETWORK SERVICES, NAMELY, FINANCIAL TRANSACTION SERVICES, NAMELY, PROVIDING SECURE COMMERCIAL TRANSACTIONS AND PAYMENT OPTIONS VIA A COMPUTER NETWORK; FINANCIAL PAYMENT NETWORK SERVICES, NAMELY, PROVIDING BILL PAYMENT SERVICES; FINANCIAL PAYMENT NETWORK SERVICES, NAMELY, ELECTRONIC PROCESSING AND TRANSMISSION OF BILL PAYMENT DATA; CREDIT CARD SERVICES; DEBIT CARD SERVICES; ATM AND POINT OF SALE SERVICES, NAMELY, PROVIDING SECURE COMMERCIAL TRANSACTIONS AND PAYMENT OPTIONS USING A MOBILE DEVICE AT A POINT OF SALE AND ATM; ATM SERVICES, NAMELY, CASH REPLENISHMENT OF ATM MACHINES; AND BANKING SERVICES, NAMELY, INVESTMENT BANKING SERVICES; BANKING SERVICES, NAMELY, MORTGAGE BANKING, AND IN PARTICULAR, ORIGINATION, ACQUISITION, SERVICING, SECURITIZATION, AND BROKERAGE OF MORTGAGE LOANS; BANKING SERVICES, NAMELY, ON-LINE BANKING SERVICES (U.S. CLS. 100, 101 AND 102).

FIRST USE 1-0-2007; IN COMMERCE 1-0-2007.

3,481,515. SAFETGARD SPORT OPTICS, LLC, LAKEWOOD, CO. SN 77-138,484. PUB. 1-1-2008, FILED 3-23-2007.

COLD FUSION TECHNOLOGY

THE MARK CONSISTS OF STANDARD CHARACTERS WITHOUT CLAIM TO ANY PARTICULAR FONT, STYLE, SIZE, OR COLOR.

NO CLAIM IS MADE TO THE EXCLUSIVE RIGHT TO USE "TECHNOLOGY", APART FROM THE MARK AS SHOWN.

CLASS 2—PAINTS

FOR OPTICAL LENS COATING TO ENHANCE THE LIGHT GATHERING CAPABILITY OF SPORT OPTIC LENSES (U.S. CLS. 6, 11 AND 16).

FIRST USE 1-31-2007; IN COMMERCE 1-31-2007.

CLASS 9—ELECTRICAL AND SCIENTIFIC APPARATUS

FOR SPORT OPTICS EQUIPMENT, NAMELY, BINOCULARS, HUNTING BINOCULARS, GUN SCOPES, PISTOL SCOPES, RIFLE SCOPES, AND SPOTTING SCOPES INCORPORATING SPECIALIZED LENS COATING AND APPLICATION TO ENHANCE THE LIGHT GATHERING CAPABILITY OF THE EQUIPMENT (U.S. CLS. 21, 23, 26, 36 AND 38).

FIRST USE 1-31-2007; IN COMMERCE 1-31-2007.

3,481,516. SAFETGARD SPORT OPTICS, LLC, LAKEWOOD, CO. SN 77-138,497. PUB. 1-1-2008, FILED 3-23-2007.

CFT

THE MARK CONSISTS OF STANDARD CHARACTERS

WITHOUT CLAIM TO ANY PARTICULAR FONT, STYLE, SIZE, OR COLOR.

CLASS 2—PAINTS

FOR OPTICAL LENS COATING TO ENHANCE THE LIGHT GATHERING CAPABILITY OF SPORT OPTIC LENSES (U.S. CLS. 6, 11 AND 16).

FIRST USE 1-31-2007; IN COMMERCE 1-31-2007.

CLASS 9—ELECTRICAL AND SCIENTIFIC APPARATUS

FOR SPORT OPTICS EQUIPMENT, NAMELY, BINOCULARS, HUNTING BINOCULARS, GUN SCOPES, PISTOL SCOPES, RIFLE SCOPES, AND SPOTTING SCOPES INCORPORATING SPECIALIZED LENS COATING AND APPLICATION TO ENHANCE THE LIGHT GATHERING CAPABILITY OF THE EQUIPMENT (U.S. CLS. 21, 23, 26, 36 AND 38).

FIRST USE 1-31-2007; IN COMMERCE 1-31-2007.

3,481,517. ORIGENE TECHNOLOGIES, INC., ROCKVILLE, MD. SN 77-138,541. PUB. 9-25-2007, FILED 3-23-2007.

TurboFectin

THE MARK CONSISTS OF STANDARD CHARACTERS WITHOUT CLAIM TO ANY PARTICULAR FONT, STYLE, SIZE, OR COLOR.

CLASS 1—CHEMICALS

FOR REAGENTS FOR SCIENTIFIC OR MEDICAL RESEARCH USE (U.S. CLS. 1, 5, 6, 10, 26 AND 46).

FIRST USE 4-1-2007; IN COMMERCE 4-1-2007.

CLASS 5—PHARMACEUTICALS

FOR BIOLOGICAL AND CHEMICAL PREPARATIONS AND REAGENTS FOR MEDICAL OR VETERINARY USE (U.S. CLS. 6, 18, 44, 46, 51 AND 52).

FIRST USE 4-1-2007; IN COMMERCE 4-1-2007.

3,481,529. JMV SERVICES, INC., DALLAS, TX. SN 77-141,087. PUB. 9-25-2007, FILED 3-27-2007.



THE MARK CONSISTS OF THE LETTERS "ITS" IN A STYLIZED FORMAT IN A PARTIAL OVAL DESIGN.

CLASS 35—ADVERTISING AND BUSINESS

FOR BUSINESS CONSULTING SERVICES RELATING TO OPERATIONS MANAGEMENT IN THE FIELDS OF LIFE AND HEALTH AND PROPERTY AND CASUALTY INSURANCE; OUTSOURCING SERVICES IN THE FIELDS OF LIFE AND HEALTH AND PROPERTY AND CASUALTY INSURANCE AND SOFTWARE APPLICATION DEVELOPMENT; EMPLOYMENT HIRING, RECRUITING, PLACEMENT, AND STAFFING SERVICES FOR THE INSURANCE INDUSTRY (U.S. CLS. 100, 101 AND 102).

FIRST USE 1-1-1998; IN COMMERCE 1-1-1998.

CLASS 41—EDUCATION AND ENTERTAINMENT

FOR EDUCATIONAL SERVICES, NAMELY, CONDUCTING TRAINING COURSES IN THE FIELD OF INSURANCE (U.S. CLS. 100, 101 AND 107).

FIRST USE 11-1-2005; IN COMMERCE 11-1-2005.

CLASS 42—SCIENTIFIC AND COMPUTER SERVICES

FOR INFORMATION TECHNOLOGY CONSULTING SERVICES RELATING TO SYSTEMS AUTOMATION AND COMPUTER PROCESSING IN THE FIELDS OF LIFE AND HEALTH AND PROPERTY AND CASUALTY INSURANCE; INFORMATION TECHNOLOGY SUPPORT SERVICES, NAMELY, SOFTWARE APPLICATION CUSTOMIZATION, DEVELOPMENT, TESTING, INTEGRATION, CONVERSION, AND MAINTENANCE FOR THE INSURANCE INDUSTRY (U.S. CLS. 100 AND 101).

FIRST USE 1-1-1998; IN COMMERCE 1-1-1998.

3,481,537. THE SELLING SOURCE, INC., LAS VEGAS, NV. SN 77-142,502. PUB. 10-2-2007, FILED 3-28-2007.



SELLINGSOURCE.COM
Technology Driven Marketing Solutions

OWNER OF U.S. REG. NO. 3,050,772.

NO CLAIM IS MADE TO THE EXCLUSIVE RIGHT TO USE "TECHNOLOGY DRIVEN MARKETING SOLUTIONS", APART FROM THE MARK AS SHOWN.

THE COLOR(S) BLUE, WHITE, AND BLACK IS/ARE CLAIMED AS A FEATURE OF THE MARK.

THE MARK CONSISTS OF EGG SHAPED BLUE CIRCLE WITH WHITE SLASHES IN THE SHAPE OF AN "S", WORDING BELOW IN BLACK.

CLASS 35—ADVERTISING AND BUSINESS

FOR ONLINE MARKETING AND ADVERTISING SERVICES FOR OTHERS (U.S. CLS. 100, 101 AND 102).

FIRST USE 1-15-1998; IN COMMERCE 1-15-1998.

CLASS 42—SCIENTIFIC AND COMPUTER SERVICES

FOR HOSTING AND MAINTENANCE OF WEBSITES FOR OTHERS (U.S. CLS. 100 AND 101).

FIRST USE 1-15-1998; IN COMMERCE 1-15-1998.

3,481,538. SONY ERICSSON MOBILE COMMUNICATIONS AB, LUND, SWEDEN. SN 77-142,556. PUB. 7-24-2007, FILED 3-28-2007.

3,481,539. ASSOCIATED SPACE DESIGN, INC., ATLANTA, GA. SN 77-142,591. PUB. 9-25-2007, FILED 3-28-2007.

W580i

ASD

THE MARK CONSISTS OF STANDARD CHARACTERS WITHOUT CLAIM TO ANY PARTICULAR FONT, STYLE, SIZE, OR COLOR.

OWNER OF U.S. REG. NOS. 3,218,258 AND 3,228,100.

CLASS 9—ELECTRICAL AND SCIENTIFIC APPARATUS

FOR CELLULAR OR MOBILE PHONES; CELLULAR OR MOBILE PHONES FEATURING THE CAPACITY TO FUNCTION IN ANY NUMBER OF EXTRA WAYS BEYOND JUST AS A PHONE, NAMELY, TO FUNCTION AS A CAMERA, TO PERFORM INSTANT MESSAGING, TO CONDUCT MULTIMEDIA MESSAGING, TO ACCESS AND COMMUNICATE WITH E-MAIL, TO ACCESS AND COMMUNICATE WITH THE INTERNET, TO ACCESS AND COMMUNICATE WITH INTRANETS OR PRIVATE COMPUTER NETWORKS, TO ACCESS AND COMMUNICATE DATA, TO FUNCTION AS A RADIO, TO RECORD, PLAY, TRANSMIT, RECEIVE, AND/OR MANAGE MUSIC, TO RECORD, PLAY, TRANSMIT, RECEIVE, EDIT, AND/OR MANAGE AUDIO OR VOICE, TO RECORD, PLAY, TRANSMIT, RECEIVE, EDIT, AND/OR MANAGE VIDEO, TO CREATE, VIEW, TRANSMIT, RECEIVE, EDIT, AND/OR MANAGE PHOTOGRAPHS OR PICTURES, TO UPLOAD, VIEW, TRANSMIT, RECEIVE, EDIT, AND/OR MANAGE GRAPHICS OR IMAGES, TO PLAY ELECTRONIC GAMES, TO UPLOAD PHOTOGRAPHS AND TEXT ONTO ONLINE JOURNALS OR WEB LOGS ALSO KNOWN AS BLOGS, TO MANAGE A CALENDAR AND CONTACT INFORMATION AND OTHERWISE FUNCTION AS A PERSONAL DIGITAL ASSISTANT (PDA), TO EFFECTUATE MOBILE PRINTING, TO PERFORM SATELLITE NAVIGATION, TO VIEW ELECTRONIC CITY GUIDES, TO FUNCTION AS A REMOTE CONTROL FOR COMPUTERS AND RUN MULTIMEDIA PRESENTATIONS, AND/OR TO TRANSMIT VIDEO, SOUND, AND/OR DATA TO WEBSITES; DOWNLOADABLE ELECTRONIC MANUALS IN THE FIELD OF CELLULAR OR MOBILE PHONES; ACCESSORIES FOR CELLULAR OR MOBILE PHONES IN THE NATURE OF HEADSETS AND DEVICES FOR HANDS-FREE PHONE USE; AND ACCESSORIES FOR CELLULAR OR MOBILE PHONES IN THE NATURE OF CHARGERS, BATTERIES, CASES, COVERS, HOLDERS, DOCKING STANDS, AND CABLES (U.S. CLS. 21, 23, 26, 36 AND 38).

FIRST USE 7-0-2007; IN COMMERCE 7-0-2007.

CLASS 38—COMMUNICATION

FOR TELECOMMUNICATIONS SERVICES IN THE NATURE OF TRANSMISSION OF SOUND, PICTURE, IMAGE, VIDEO, AND DATA SIGNALS; TRANSMISSION OF SOUND, PICTURE, IMAGE, VIDEO, AND DATA SIGNALS TO PERSONALIZE OR ENHANCE CELLULAR OR MOBILE PHONES; PROVIDING A WEBSITE THAT ENABLES TRANSMISSION OF SOUND, PICTURE, GRAPHIC, IMAGE, AND VIDEO SIGNALS TO THE WEBSITE, SO THE SIGNALS MAY BE EDITED, AND THEN DELIVERING THE EDITED SIGNALS TO COMPUTERS OR CELLULAR OR MOBILE PHONES (U.S. CLS. 100, 101 AND 104).

FIRST USE 7-0-2007; IN COMMERCE 7-0-2007.

THE MARK CONSISTS OF STANDARD CHARACTERS WITHOUT CLAIM TO ANY PARTICULAR FONT, STYLE, SIZE, OR COLOR.

CLASS 37—CONSTRUCTION AND REPAIR

FOR RESIDENTIAL AND BUILDING CONSTRUCTION CONSULTING; CONSTRUCTION PLANNING; LAND DEVELOPMENT SERVICES, NAMELY, PLANNING AND LAYING OUT OF RESIDENTIAL AND/OR COMMERCIAL COMMUNITIES (U.S. CLS. 100, 103 AND 106).

FIRST USE 9-1-1963; IN COMMERCE 9-1-1963.

CLASS 42—SCIENTIFIC AND COMPUTER SERVICES

FOR ARCHITECTURAL DESIGN; COMMERCIAL ART DESIGN; DESIGN OF HOMEPAGES AND WEBSITES; GRAPHIC DESIGN SERVICES; DESIGN OF SPECIALTY INTERIOR AND EXTERIOR ENVIRONMENT SETTINGS; PACKAGING DESIGN FOR OTHERS; INTERIOR DECORATION CONSULTATION; INTERIOR DECORATING; LAND USE PLANNING SERVICES; GRAPHIC ILLUSTRATION SERVICES FOR OTHERS; GRAPHIC ART DESIGN (U.S. CLS. 100 AND 101).

FIRST USE 9-1-1963; IN COMMERCE 9-1-1963.

3,481,540. SONY ERICSSON MOBILE COMMUNICATIONS AB, LUND, SWEDEN. SN 77-142,595. PUB. 7-24-2007, FILED 3-28-2007.

Z750a

THE MARK CONSISTS OF STANDARD CHARACTERS WITHOUT CLAIM TO ANY PARTICULAR FONT, STYLE, SIZE, OR COLOR.

CLASS 9—ELECTRICAL AND SCIENTIFIC APPARATUS

FOR CELLULAR OR MOBILE PHONES; CELLULAR OR MOBILE PHONES FEATURING THE CAPACITY TO FUNCTION IN ANY NUMBER OF EXTRA WAYS BEYOND JUST AS A PHONE, NAMELY, TO FUNCTION AS A CAMERA, TO PERFORM INSTANT MESSAGING, TO CONDUCT MULTIMEDIA MESSAGING, TO ACCESS AND COMMUNICATE WITH E-MAIL, TO ACCESS AND COMMUNICATE WITH THE INTERNET, TO ACCESS AND COMMUNICATE WITH INTRANETS OR PRIVATE COMPUTER NETWORKS, TO ACCESS AND COMMUNICATE DATA, TO FUNCTION AS A RADIO, TO RECORD, PLAY, TRANSMIT, RECEIVE, AND/OR MANAGE MUSIC, TO RECORD, PLAY, TRANSMIT, RECEIVE, EDIT, AND/OR MANAGE AUDIO OR VOICE, TO RECORD, PLAY, TRANSMIT, RECEIVE, EDIT, AND/OR MANAGE VIDEO, TO CREATE, VIEW, TRANSMIT, RECEIVE, EDIT, AND/OR MANAGE PHOTOGRAPHS OR PICTURES, TO UPLOAD, VIEW, TRANSMIT, RECEIVE, EDIT, AND/OR MANAGE GRAPHICS OR IMAGES, TO PLAY ELECTRONIC GAMES, TO UPLOAD PHOTOGRAPHS AND TEXT ONTO ONLINE JOURNALS OR WEB LOGS ALSO KNOWN AS BLOGS, TO MANAGE A CALENDAR AND CONTACT INFORMATION AND OTHERWISE FUNCTION AS A PERSONAL DIGITAL ASSISTANT (PDA), TO EFFECTUATE MOBILE PRINTING, TO PERFORM SATELLITE NAVIGATION, TO VIEW ELECTRONIC CITY GUIDES, TO FUNCTION AS A REMOTE CONTROL FOR COMPUTERS AND RUN MULTIMEDIA PRESENTATIONS, AND/OR TO TRANSMIT VIDEO, SOUND, AND/OR DATA TO WEBSITES; DOWNLOADABLE ELECTRONIC MANUALS IN THE FIELD OF CELLULAR OR MOBILE PHONES; ACCESSORIES FOR CELLULAR OR MOBILE PHONES IN THE NATURE OF HEADSETS AND DEVICES FOR HANDS-FREE PHONE USE; AND ACCESSORIES FOR CELLULAR OR MOBILE PHONES IN THE NATURE OF CHARGERS, BATTERIES, CASES, COVERS, HOLDERS, DOCKING STANDS, AND CABLES (U.S. CLS. 21, 23, 26, 36 AND 38).

FIRST USE 3-0-2008; IN COMMERCE 3-0-2008.

3,481,541. WHOLE FOODS MARKET IP, L.P., AUSTIN, TX.
SN 77-142,878. PUB. 9-18-2007, FILED 3-28-2007.



THE COLOR(S) GREEN, RED, BROWN, GRAY, WHITE AND BLACK IS/ARE CLAIMED AS A FEATURE OF THE MARK.

THE MARK CONSISTS OF THE COLOR GREEN APPEARS IN DIFFERENT SHADES IN THE DESIGN OF THE LEAVES, FIELDS, BUSHES AND TREES; THE COLOR RED APPEARS IN THE DESIGN OF THE TRUCK; THE COLOR BROWN APPEARS IN DIFFERENT SHADES IN THE DEPICTION OF THE GROUND, ROAD, THE STRUCTURES' WALLS, THE TRUCK'S CARGO, THE BACKGROUND HILLS AND SKY, AS THE BACKGROUND FOR THE BANNER AND THE EDGING OF THE WORDING "LOCALLY GROWN", AND AS SHADING IN THE DESIGN OF THE LEAVES, FIELDS, BUSHES AND TREES; THE COLOR GRAY APPEARS IN DIFFERENT SHADES IN THE DESIGN OF THE STRUCTURES' ROOFS, AND THE TRUCK'S HUB CAPS, BUMPER, HEADLIGHTS, GRILL AND CARGO; THE COLOR WHITE APPEARS IN THE DESIGN OF THE FENCE; THE COLOR BLACK APPEARS IN THE WORDING "LOCALLY GROWN", THE TRUCK TIRES, THE STRUCTURES' WINDOWS AND DOORS, AND AS A BORDER AND EDGING TO THE VARIOUS DESIGN ELEMENTS DEPICTED IN THE MARK.

CLASS 38—COMMUNICATION

FOR TELECOMMUNICATIONS SERVICES IN THE NATURE OF TRANSMISSION OF SOUND, PICTURE, IMAGE, VIDEO, AND DATA SIGNALS; TRANSMISSION OF SOUND, PICTURE, IMAGE, VIDEO, AND DATA SIGNALS TO PERSONALIZE OR ENHANCE CELLULAR OR MOBILE PHONES; PROVIDING A WEBSITE THAT ENABLES TRANSMISSION OF SOUND, PICTURE, GRAPHIC, IMAGE, AND VIDEO SIGNALS TO THE WEBSITE, SO THE SIGNALS MAY BE EDITED, AND THEN DELIVERING THE EDITED SIGNALS TO COMPUTERS OR CELLULAR OR MOBILE PHONES (U.S. CLS. 100, 101 AND 104).

FIRST USE 3-0-2008; IN COMMERCE 3-0-2008.

CLASS 35—ADVERTISING AND BUSINESS

FOR RETAIL GROCERY STORE SERVICES; PROMOTING THE GOODS AND SERVICES OF OTHERS BY DISTRIBUTING ADVERTISING MATERIALS THROUGH A VARIETY OF METHODS; PROMOTING PUBLIC AWARENESS OF, AND THE NEED TO SUPPORT, LOCAL FARMERS, GROWERS AND FOOD PRODUCERS (U.S. CLS. 100, 101 AND 102).

FIRST USE 6-0-2004; IN COMMERCE 6-0-2004.

CLASS 36—INSURANCE AND FINANCIAL

FOR FINANCIAL SERVICES IN THE FIELD OF MONEY LENDING (U.S. CLS. 100, 101 AND 102).

FIRST USE 4-0-2007; IN COMMERCE 4-0-2007.

3,481,565. FRANKLIN INTERNATIONAL, INC., COLUMBUS, OH. SN 77-147,312. PUB. 10-2-2007, FILED 4-3-2007.

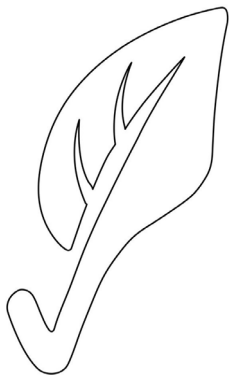

THE MARK CONSISTS OF A LEAF.

CLASS 1—CHEMICALS

FOR CONSTRUCTION ADHESIVES (U.S. CLS. 1, 5, 6, 10, 26 AND 46).
FIRST USE 8-0-2007; IN COMMERCE 8-0-2007.

CLASS 17—RUBBER GOODS

FOR ADHESIVE SEALANTS FOR GENERAL USE; CAULKING (U.S. CLS. 1, 5, 12, 13, 35 AND 50).
FIRST USE 8-0-2007; IN COMMERCE 8-0-2007.

3,481,566. RED SLATE BRANDS, INC., ROAD TOWN, BR. VIRGIN ISLANDS. SN 77-147,327. PUB. 9-11-2007, FILED 4-3-2007.

TREETOPIA

THE MARK CONSISTS OF STANDARD CHARACTERS WITHOUT CLAIM TO ANY PARTICULAR FONT, STYLE, SIZE, OR COLOR.

CLASS 26—FANCY GOODS

FOR ARTIFICIAL GARLANDS; ARTIFICIAL PLANTS; ARTIFICIAL WREATHS (U.S. CLS. 37, 39, 40, 42 AND 50).
FIRST USE 9-10-2007; IN COMMERCE 9-10-2007.

CLASS 28—TOYS AND SPORTING GOODS

FOR ARTIFICIAL CHRISTMAS GARLANDS; ARTIFICIAL CHRISTMAS TREES; CHRISTMAS TREE DECORATIONS; CHRISTMAS TREE SKIRTS; CHRISTMAS TREE STAND COVERS; CHRISTMAS TREE STANDS (U.S. CLS. 22, 23, 38 AND 50).
FIRST USE 9-10-2007; IN COMMERCE 9-10-2007.

3,481,569. HEALTHY INNOVATIONS INC., CARLSBAD, CA. SN 77-147,908. PUB. 10-2-2007, FILED 4-3-2007.

vida tea

THE MARK CONSISTS OF STANDARD CHARACTERS WITHOUT CLAIM TO ANY PARTICULAR FONT, STYLE, SIZE, OR COLOR.

NO CLAIM IS MADE TO THE EXCLUSIVE RIGHT TO USE "TEA", APART FROM THE MARK AS SHOWN.
THE ENGLISH TRANSLATION OF "VIDA" IS LIFE.

CLASS 30—STAPLE FOODS

FOR BEVERAGES MADE OF TEA; GREEN TEA; TEA; TEA-BASED BEVERAGES WITH FRUIT FLAVORING (U.S. CL. 46).
FIRST USE 2-1-2007; IN COMMERCE 8-16-2007.

CLASS 32—LIGHT BEVERAGES

FOR SOFT DRINKS FLAVORED WITH TEA (U.S. CLS. 45, 46 AND 48).
FIRST USE 2-1-2007; IN COMMERCE 8-16-2007.

3,481,583. F+W PUBLICATIONS, INC., CINCINNATI, OH. SN 77-150,279. PUB. 10-2-2007, FILED 4-5-2007.

I CAN DO THAT

THE MARK CONSISTS OF STANDARD CHARACTERS WITHOUT CLAIM TO ANY PARTICULAR FONT, STYLE, SIZE, OR COLOR.

CLASS 16—PAPER GOODS AND PRINTED MATTER

FOR MAGAZINE COLUMNS AND BOOKS IN THE AREA OF WOODWORKING AND DO-IT-YOURSELF PROJECTS (U.S. CLS. 2, 5, 22, 23, 29, 37, 38 AND 50).
FIRST USE 6-0-2006; IN COMMERCE 6-0-2006.

CLASS 40—MATERIAL TREATMENT

FOR PROVIDING INFORMATION IN THE FIELD OF WOODWORKING AND DO-IT-YOURSELF WOODWORKING PROJECTS VIA THE INTERNET (U.S. CLS. 100, 103 AND 106).
FIRST USE 6-0-2006; IN COMMERCE 6-0-2006.

3,481,603. HUBBARD MEDIA GROUP, LLC, ST. PAUL, MN.
SN 77-152,559. PUB. 10-9-2007, FILED 4-10-2007.

3,481,615. CALLE SOCCER LLC, PROVO, UT. SN 77-156,102.
PUB. 10-16-2007, FILED 4-13-2007.

EVERYTHING ABOUT MOVIES –
24/7

THE MARK CONSISTS OF STANDARD CHARACTERS WITHOUT CLAIM TO ANY PARTICULAR FONT, STYLE, SIZE, OR COLOR.

CLASS 38—COMMUNICATION

FOR TELEVISION, DIGITAL TELEVISION, CABLE TELEVISION, AND SATELLITE TELEVISION BROADCASTING AND TRANSMISSION SERVICES; BROADCASTING AND TRANSMISSION OF TELEVISION PROGRAMS VIA THE INTERNET (U.S. CLS. 100, 101 AND 104).

FIRST USE 5-9-2008; IN COMMERCE 5-9-2008.

CLASS 41—EDUCATION AND ENTERTAINMENT

FOR TELEVISION, DIGITAL TELEVISION, CABLE TELEVISION, AND SATELLITE TELEVISION PROGRAMMING; PROGRAMMING ON A GLOBAL COMPUTER NETWORK, NAMELY, PROGRAMMING ON THE INTERNET; PRODUCTION OF TELEVISION PROGRAMS; DISTRIBUTION OF TELEVISION PROGRAMS FOR OTHERS; PROVIDING ENTERTAINMENT INFORMATION AND TELEVISION PROGRAMS IN THE FIELD OF MOVIES AND CINEMA OVER A GLOBAL COMPUTER NETWORK (U.S. CLS. 100, 101 AND 107).

FIRST USE 5-9-2008; IN COMMERCE 5-9-2008.

3,481,607. NOODLE & BOO, LLC, SAN JOSE, CA. SN 77-154,379. PUB. 10-9-2007, FILED 4-11-2007.

GLOWOLOGY

THE MARK CONSISTS OF STANDARD CHARACTERS WITHOUT CLAIM TO ANY PARTICULAR FONT, STYLE, SIZE, OR COLOR.

CLASS 3—COSMETICS AND CLEANING PREPARATIONS

FOR BODY WASHES; BODY SCRUB; SOAPS FOR BODY CARE; TONING GELS; BATH OILS, BODY OILS, LOTIONS FOR HANDS AND FEET, HAND LOTIONS, SKIN LOTIONS, AND BODY CREAMS (U.S. CLS. 1, 4, 6, 50, 51 AND 52).

FIRST USE 10-2-2007; IN COMMERCE 10-2-2007.

CLASS 4—LUBRICANTS AND FUELS

FOR CANDLES (U.S. CLS. 1, 6 AND 15).
FIRST USE 6-27-2008; IN COMMERCE 6-27-2008.

CALLE

THE MARK CONSISTS OF STANDARD CHARACTERS WITHOUT CLAIM TO ANY PARTICULAR FONT, STYLE, SIZE, OR COLOR.

CLASS 25—CLOTHING

FOR CLOTHING, NAMELY, SHIRTS, SHORTS, SWEATSHIRTS, FOOTWEAR, AND HEADWEAR (U.S. CLS. 22 AND 39).

FIRST USE 6-1-2006; IN COMMERCE 6-1-2006.

CLASS 28—TOYS AND SPORTING GOODS

FOR SOCCER SPORTS EQUIPMENT, NAMELY, SOCCER BALLS AND SOCCER BALL SACKS, AND BACKPACKS SPECIALLY ADAPTED AND DESIGNED FOR HOLDING SOCCER EQUIPMENT (U.S. CLS. 22, 23, 38 AND 50).

FIRST USE 6-1-2006; IN COMMERCE 6-1-2006.

3,481,616. CALLE SOCCER LLC, PROVO, UT. SN 77-156,171.
PUB. 10-16-2007, FILED 4-13-2007.



THE MARK CONSISTS OF A PIGEON.

CLASS 25—CLOTHING

FOR CLOTHING, NAMELY, SHIRTS, SHORTS, SWEATSHIRTS, FOOTWEAR, AND HEADWEAR (U.S. CLS. 22 AND 39).

FIRST USE 6-1-2006; IN COMMERCE 6-1-2006.

CLASS 28—TOYS AND SPORTING GOODS

FOR SOCCER SPORTS EQUIPMENT, NAMELY, SOCCER BALLS, SOCCER BALL SACKS, AND BACKPACKS SPECIALLY ADAPTED AND DESIGNED FOR HOLDING SOCCER EQUIPMENT (U.S. CLS. 22, 23, 38 AND 50).

FIRST USE 6-1-2006; IN COMMERCE 6-1-2006.

3,481,634. THORNTON-TERMOHLEN GROUP CORPORATION, HENDERSON, NV. SN 77-159,864. PUB. 12-18-2007, FILED 4-18-2007.

3,481,664. THORNTON-TERMOHLEN GROUP CORPORATION, HENDERSON, NV. SN 77-167,533. PUB. 12-4-2007, FILED 4-27-2007.

TTG



thornton :: termohlen
G R O U P

THE MARK CONSISTS OF STANDARD CHARACTERS WITHOUT CLAIM TO ANY PARTICULAR FONT, STYLE, SIZE, OR COLOR.

CLASS 37—CONSTRUCTION AND REPAIR

FOR REAL ESTATE DEVELOPMENT SERVICES AND CONSTRUCTION OF BUILDINGS (U.S. CLS. 100, 103 AND 106).

FIRST USE 6-0-2007; IN COMMERCE 6-0-2007.

CLASS 42—SCIENTIFIC AND COMPUTER SERVICES

FOR CONSTRUCTION DESIGN SERVICES FOR OTHERS IN THE FIELD OF CONSTRUCTION, NAMELY, FOR THE CONSTRUCTION OF NEW BUILDINGS AND FOR THE RENOVATION OF PRE-EXISTING BUILDINGS (U.S. CLS. 100 AND 101).

FIRST USE 6-0-2007; IN COMMERCE 6-0-2007.

NO CLAIM IS MADE TO THE EXCLUSIVE RIGHT TO USE "GROUP", APART FROM THE MARK AS SHOWN.

THE MARK CONSISTS OF AN OUTLINED SHADED RECTANGLE WITH THE LETTERS "TTG" INSIDE OF THE RECTANGLE AND WITH THE WORDS "THORNTON TERMOHLEN GROUP" UNDERNEATH THE RECTANGLE.

CLASS 37—CONSTRUCTION AND REPAIR

FOR REAL ESTATE DEVELOPMENT SERVICES AND CONSTRUCTION OF BUILDINGS (U.S. CLS. 100, 103 AND 106).

FIRST USE 6-0-2007; IN COMMERCE 6-0-2007.

CLASS 42—SCIENTIFIC AND COMPUTER SERVICES

FOR CONSTRUCTION DESIGN SERVICES FOR OTHERS IN THE FIELD OF CONSTRUCTION, NAMELY, FOR THE CONSTRUCTION OF NEW BUILDINGS AND FOR THE RENOVATION OF PRE-EXISTING BUILDINGS (U.S. CLS. 100 AND 101).

FIRST USE 6-0-2007; IN COMMERCE 6-0-2007.

3,481,661. JPJ INVESTMENT HOLDING CO., CARSON CITY, NV. SN 77-167,316. PUB. 10-30-2007, FILED 4-27-2007.

IWORK

THE MARK CONSISTS OF STANDARD CHARACTERS WITHOUT CLAIM TO ANY PARTICULAR FONT, STYLE, SIZE, OR COLOR.

CLASS 7—MACHINERY

FOR POWER TOOLS, NAMELY, DRILLS, GRINDERS, ELECTRIC SCREWDRIVERS, SANDERS AND HOT-MELT GLUE GUNS; POWER TOOL ACCESSORIES, NAMELY, DRILL BITS, SCREWDRIVER BITS AND NUT DRIVERS (U.S. CLS. 13, 19, 21, 23, 31, 34 AND 35).

FIRST USE 4-4-2007; IN COMMERCE 8-13-2007.

CLASS 8—HAND TOOLS

FOR HAND TOOLS, NAMELY, HAMMERS, SCREWDRIVERS, PLIERS, WRENCHES, NUT DRIVERS, SQUARES, FILES AND KNIVES (U.S. CLS. 23, 28 AND 44).

FIRST USE 4-4-2007; IN COMMERCE 8-13-2007.

CLASS 9—ELECTRICAL AND SCIENTIFIC APPARATUS

FOR TAPE MEASURES AND BUBBLE LEVELS (U.S. CLS. 21, 23, 26, 36 AND 38).

FIRST USE 4-4-2007; IN COMMERCE 8-13-2007.

3,481,695. CARNIVAL CORPORATION, MIAMI, FL. SN 77-175,757. PUB. 10-2-2007, FILED 5-8-2007.

CARNIVAL FANTASY

THE MARK CONSISTS OF STANDARD CHARACTERS WITHOUT CLAIM TO ANY PARTICULAR FONT, STYLE, SIZE, OR COLOR.

OWNER OF U.S. REG. NOS. 1,495,405, 3,189,529, AND OTHERS.

CLASS 39—TRANSPORTATION AND STORAGE

FOR CRUISE SHIP SERVICES (U.S. CLS. 100 AND 105).

FIRST USE 6-15-2007; IN COMMERCE 6-15-2007.

CLASS 41—EDUCATION AND ENTERTAINMENT

FOR ENTERTAINMENT SERVICES, NAMELY, CASINO SERVICES, ORGANIZING AND CONDUCTING STAGE SHOWS, NIGHTCLUB SHOWS, CONTESTS, DANCES AND PARTIES (U.S. CLS. 100, 101 AND 107).

FIRST USE 6-15-2007; IN COMMERCE 6-15-2007.

CLASS 43—HOTEL AND RESTAURANT SERVICES

FOR HOTEL SERVICES AND RESTAURANT SERVICES (U.S. CLS. 100 AND 101).
FIRST USE 6-15-2007; IN COMMERCE 6-15-2007.

3,481,696. CARNIVAL CORPORATION, MIAMI, FL. SN 77-175,777. PUB. 9-25-2007, FILED 5-8-2007.

CARNIVAL FASCINATION

THE MARK CONSISTS OF STANDARD CHARACTERS WITHOUT CLAIM TO ANY PARTICULAR FONT, STYLE, SIZE, OR COLOR.

OWNER OF U.S. REG. NOS. 1,495,405, 3,189,529, AND OTHERS.

CLASS 39—TRANSPORTATION AND STORAGE

FOR CRUISE SHIP SERVICES (U.S. CLS. 100 AND 105).
FIRST USE 6-15-2007; IN COMMERCE 6-15-2007.

CLASS 41—EDUCATION AND ENTERTAINMENT

FOR ENTERTAINMENT SERVICES, NAMELY, CASINO SERVICES, ORGANIZING AND CONDUCTING STAGE SHOWS, NIGHTCLUB SHOWS, CONTESTS, DANCES AND PARTIES (U.S. CLS. 100, 101 AND 107).
FIRST USE 6-15-2007; IN COMMERCE 6-15-2007.

CLASS 43—HOTEL AND RESTAURANT SERVICES

FOR HOTEL SERVICES AND RESTAURANT SERVICES (U.S. CLS. 100 AND 101).
FIRST USE 6-15-2007; IN COMMERCE 6-15-2007.

3,481,697. CARNIVAL CORPORATION, MIAMI, FL. SN 77-175,780. PUB. 9-25-2007, FILED 5-8-2007.

CARNIVAL ELATION

THE MARK CONSISTS OF STANDARD CHARACTERS WITHOUT CLAIM TO ANY PARTICULAR FONT, STYLE, SIZE, OR COLOR.

OWNER OF U.S. REG. NOS. 1,495,405, 3,189,529, AND OTHERS.

CLASS 39—TRANSPORTATION AND STORAGE

FOR CRUISE SHIP SERVICES (U.S. CLS. 100 AND 105).
FIRST USE 6-15-2007; IN COMMERCE 6-15-2007.

CLASS 41—EDUCATION AND ENTERTAINMENT

FOR ENTERTAINMENT SERVICES, NAMELY, CASINO SERVICES, ORGANIZING AND CONDUCTING STAGE SHOWS, NIGHTCLUB SHOWS, CONTESTS, DANCES AND PARTIES (U.S. CLS. 100, 101 AND 107).
FIRST USE 6-15-2007; IN COMMERCE 6-15-2007.

CLASS 43—HOTEL AND RESTAURANT SERVICES

FOR HOTEL SERVICES AND RESTAURANT SERVICES (U.S. CLS. 100 AND 101).
FIRST USE 6-15-2007; IN COMMERCE 6-15-2007.

3,481,698. CARNIVAL CORPORATION, MIAMI, FL. SN 77-175,787. PUB. 9-25-2007, FILED 5-8-2007.

CARNIVAL ECSTASY

THE MARK CONSISTS OF STANDARD CHARACTERS WITHOUT CLAIM TO ANY PARTICULAR FONT, STYLE, SIZE, OR COLOR.

OWNER OF U.S. REG. NOS. 1,495,405, 3,189,529, AND OTHERS.

CLASS 39—TRANSPORTATION AND STORAGE

FOR CRUISE SHIP SERVICES (U.S. CLS. 100 AND 105).
FIRST USE 6-15-2007; IN COMMERCE 6-15-2007.

CLASS 41—EDUCATION AND ENTERTAINMENT

FOR ENTERTAINMENT SERVICES, NAMELY, CASINO SERVICES, ORGANIZING AND CONDUCTING STAGE SHOWS, NIGHTCLUB SHOWS, CONTESTS, DANCES AND PARTIES (U.S. CLS. 100, 101 AND 107).
FIRST USE 6-15-2007; IN COMMERCE 6-15-2007.

CLASS 43—HOTEL AND RESTAURANT SERVICES

FOR HOTEL SERVICES AND RESTAURANT SERVICES (U.S. CLS. 100 AND 101).
FIRST USE 6-15-2007; IN COMMERCE 6-15-2007.

3,481,699. CARNIVAL CORPORATION, MIAMI, FL. SN 77-175,793. PUB. 9-25-2007, FILED 5-8-2007.

CARNIVAL SENSATION

THE MARK CONSISTS OF STANDARD CHARACTERS WITHOUT CLAIM TO ANY PARTICULAR FONT, STYLE, SIZE, OR COLOR.

OWNER OF U.S. REG. NOS. 1,495,405, 3,189,529, AND OTHERS.

CLASS 39—TRANSPORTATION AND STORAGE

FOR CRUISE SHIP SERVICES (U.S. CLS. 100 AND 105).
FIRST USE 6-15-2007; IN COMMERCE 6-15-2007.

CLASS 41—EDUCATION AND ENTERTAINMENT

FOR ENTERTAINMENT SERVICES, NAMELY, CASINO SERVICES, ORGANIZING AND CONDUCTING STAGE SHOWS, NIGHTCLUB SHOWS, CONTESTS, DANCES AND PARTIES (U.S. CLS. 100, 101 AND 107).
FIRST USE 6-15-2007; IN COMMERCE 6-15-2007.

CLASS 43—HOTEL AND RESTAURANT SERVICES

FOR HOTEL SERVICES AND RESTAURANT SERVICES (U.S. CLS. 100 AND 101).
FIRST USE 6-15-2007; IN COMMERCE 6-15-2007.

3,481,700. CARNIVAL CORPORATION, MIAMI, FL. SN 77-175,798. PUB. 9-25-2007, FILED 5-8-2007.

CARNIVAL PARADISE

THE MARK CONSISTS OF STANDARD CHARACTERS WITHOUT CLAIM TO ANY PARTICULAR FONT, STYLE, SIZE, OR COLOR.

OWNER OF U.S. REG. NOS. 1,495,405, 3,189,529, AND OTHERS.

CLASS 39—TRANSPORTATION AND STORAGE

FOR CRUISE SHIP SERVICES (U.S. CLS. 100 AND 105).
FIRST USE 6-15-2007; IN COMMERCE 6-15-2007.

CLASS 41—EDUCATION AND ENTERTAINMENT

FOR ENTERTAINMENT SERVICES, NAMELY, CASINO SERVICES, ORGANIZING AND CONDUCTING STAGE SHOWS, NIGHTCLUB SHOWS, CONTESTS, DANCES AND PARTIES (U.S. CLS. 100, 101 AND 107).
FIRST USE 6-15-2007; IN COMMERCE 6-15-2007.

CLASS 43—HOTEL AND RESTAURANT SERVICES

FOR HOTEL SERVICES AND RESTAURANT SERVICES (U.S. CLS. 100 AND 101).
FIRST USE 6-15-2007; IN COMMERCE 6-15-2007.

3,481,701. CARNIVAL CORPORATION, MIAMI, FL. SN 77-175,804. PUB. 9-25-2007, FILED 5-8-2007.

CARNIVAL IMAGINATION

THE MARK CONSISTS OF STANDARD CHARACTERS WITHOUT CLAIM TO ANY PARTICULAR FONT, STYLE, SIZE, OR COLOR.

OWNER OF U.S. REG. NOS. 1,495,405, 3,189,529, AND OTHERS.

CLASS 39—TRANSPORTATION AND STORAGE

FOR CRUISE SHIP SERVICES (U.S. CLS. 100 AND 105).
FIRST USE 6-15-2007; IN COMMERCE 6-15-2007.

CLASS 41—EDUCATION AND ENTERTAINMENT

FOR ENTERTAINMENT SERVICES, NAMELY, CASINO SERVICES, ORGANIZING AND CONDUCTING STAGE SHOWS, NIGHTCLUB SHOWS, CONTESTS, DANCES AND PARTIES (U.S. CLS. 100, 101 AND 107).
FIRST USE 6-15-2007; IN COMMERCE 6-15-2007.

CLASS 43—HOTEL AND RESTAURANT SERVICES

FOR HOTEL SERVICES AND RESTAURANT SERVICES (U.S. CLS. 100 AND 101).
FIRST USE 6-15-2007; IN COMMERCE 6-15-2007.

3,481,703. KABUSHIKI KAISHA SQUARE ENIX, TA SQUARE ENIX CO., LTD., TOKYO, JAPAN. SN 77-177,784. PUB. 10-30-2007, FILED 5-10-2007.

WINGS OF THE GODDESS

THE MARK CONSISTS OF STANDARD CHARACTERS WITHOUT CLAIM TO ANY PARTICULAR FONT, STYLE, SIZE, OR COLOR.

CLASS 9—ELECTRICAL AND SCIENTIFIC APPARATUS

FOR COMPUTER GAME SOFTWARE; VIDEO GAME SOFTWARE (U.S. CLS. 21, 23, 26, 36 AND 38).
FIRST USE 11-20-2007; IN COMMERCE 11-20-2007.

CLASS 41—EDUCATION AND ENTERTAINMENT

FOR PROVIDING ON-LINE COMPUTER GAMES AND/OR ON-LINE VIDEO GAMES; PROVIDING INFORMATION ON COMPUTER GAME STRATEGIES AND/OR VIDEO GAME STRATEGIES VIA COMPUTER NETWORKS AND/OR GLOBAL COMMUNICATION NETWORKS (U.S. CLS. 100, 101 AND 107).
FIRST USE 11-20-2007; IN COMMERCE 11-20-2007.

3,481,716. AMERICAN CAR CARE CENTERS, INC., MEMPHIS, TN. SN 77-181,290. PUB. 11-27-2007, FILED 5-15-2007.

3,481,720. PARTITION SYSTEMS INCORPORATED OF SOUTH CAROLINA, COLUMBIA, SC. SN 77-183,240. PUB. 11-20-2007, FILED 5-17-2007.

MAXPAK

THE MARK CONSISTS OF THE WORD "MAXPAK" IN 3-D STYLIZED UPPER CASE LETTERS WITH AN OUTLINE OF AN EAGLE'S HEAD WITHIN THE LETTER "M".

CLASS 35—ADVERTISING AND BUSINESS

FOR PROVIDING AUTOMOTIVE PRODUCTS INFORMATION TO AUTOMOTIVE PARTS AND SERVICES RETAILERS FOR ADVERTISING PURPOSES; PROVIDING MARKETING, NAMELY, DIRECT MARKETING ADVERTISING FOR OTHERS AND COOPERATIVE MARKETING; PREPARING PROMOTIONAL AND MERCHANDISING MATERIAL FOR OTHERS IN THE TIRE BUSINESS; PREPARING ADVERTISEMENT FOR OTHERS IN THE TIRE BUSINESS; GROUP ADVERTISING, NAMELY, COOPERATIVE ADVERTISING AND MARKETING, DIRECT MAIL ADVERTISING, DISSEMINATION OF ADVERTISING FOR OTHERS VIA THE INTERNET AND DISSEMINATION OF ADVERTISING MATTER FOR OTHERS IN THE AUTOMOBILE TIRE BUSINESS; PRODUCT MERCHANDISING SERVICES TO INDEPENDENT CO-OPERATIVE DEALERS; ASSISTANCE IN MANAGEMENT OF BUSINESS ACTIVITIES; BUSINESS MANAGEMENT CONSULTANCY, AND BUSINESS MARKETING CONSULTATION, NAMELY, THE DEVELOPMENT OF PROCESSES FOR THE ANALYSIS AND THE IMPLEMENTATION OF MARKETING STRATEGIES AND PROJECT MANAGEMENT; PROVIDING BUSINESS MANAGEMENT INFORMATION ON A WIDE VARIETY OF VEHICLE-RELATED TOPICS TO THOSE IN THE VEHICLE SERVICE INDUSTRY; PROVIDING INFORMATION ABOUT AUTOMOBILES FOR SALE VIA THE INTERNET (U.S. CLS. 100, 101 AND 102).
FIRST USE 1-13-2007; IN COMMERCE 3-13-2007.

CLASS 37—CONSTRUCTION AND REPAIR

FOR PROVIDING AUTOMOTIVE-RELATED INFORMATION, NAMELY, INFORMATION ABOUT AUTOMOTIVE REPAIRS TO AUTOMOTIVE TECHNICIANS AND REPAIR SHOPS VIA THE INTERNET (U.S. CLS. 100, 103 AND 106).
FIRST USE 3-13-2007; IN COMMERCE 3-13-2007.

CLASS 41—EDUCATION AND ENTERTAINMENT

FOR PROVIDING EDUCATIONAL SERVICES IN THE NATURE OF ORGANIZING AND CONDUCTING CLASSES, SEMINARS, WORKSHOPS AND CONFERENCES IN THE FIELD OF AUTOMOTIVE REPAIR AND MAINTENANCE, AND DISTRIBUTION OF PRINTED, AUDIO, VISUAL AND MULTIMEDIA COURSE MATERIALS IN CONNECTION THEREWITH (U.S. CLS. 100, 101 AND 107).
FIRST USE 3-13-2007; IN COMMERCE 3-13-2007.

RESTROOM
IN A BOX
TOILET PARTITIONS LOCKERS
SHOWER STALLS ACCESSORIES

NO CLAIM IS MADE TO THE EXCLUSIVE RIGHT TO USE "TOILET", "PARTITIONS", "LOCKERS", "SHOWER", "STALLS" AND "ACCESSORIES", APART FROM THE MARK AS SHOWN.

THE MARK CONSISTS OF THE WORD "RESTROOM" IN BOLD OVER THE WORDS "IN A BOX" NOT IN BOLD WITH A HORIZONTAL HOLLOW BAR BETWEEN THEM AND THE WORDS "TOILET PARTITIONS LOCKERS" IN A SMALLER FONT SIZE BELOW "IN A BOX" AND THE WORDS "SHOWER STALLS ACCESSORIES" IN THE SAME SMALLER FONT BELOW THAT.

CLASS 11—ENVIRONMENTAL CONTROL APPARATUS

FOR ELECTRIC HOT AIR HAND DRYERS; WATER CLOSETS (U.S. CLS. 13, 21, 23, 31 AND 34).
FIRST USE 3-1-2007; IN COMMERCE 3-1-2007.

CLASS 20—FURNITURE AND ARTICLES NOT OTHERWISE CLASSIFIED

FOR LOCKERS; FURNITURE PARTITIONS; BATHROOM VANITIES; LOCKER MIRRORS (U.S. CLS. 2, 13, 22, 25, 32 AND 50).
FIRST USE 3-1-2007; IN COMMERCE 3-1-2007.

3,481,731. KALLENBACH, THOMAS J., BOZEMAN, MT. SN 77-188,003. PUB. 10-9-2007, FILED 5-23-2007.

SQUIRT

THE MARK CONSISTS OF STANDARD CHARACTERS WITHOUT CLAIM TO ANY PARTICULAR FONT, STYLE, SIZE, OR COLOR.

CLASS 9—ELECTRICAL AND SCIENTIFIC APPARATUS

FOR COMPUTER SOFTWARE FOR DESIGNING WASTEWATER TREATMENT SYSTEMS FOR HOMES, CLUSTERED COMMUNITIES AND COMMERCIAL DEVELOPMENTS THAT ARE NOT CONNECTED TO MUNICIPAL WASTEWATER TREATMENT PLANTS AND CANNOT BE SERVED BY STANDARD SEPTIC TANK/GRAVITY-DOSED DRAINFIELD COMBINATIONS (U.S. CLS. 21, 23, 26, 36 AND 38).
FIRST USE 11-8-2007; IN COMMERCE 11-8-2007.

CLASS 42—SCIENTIFIC AND COMPUTER SERVICES

FOR PROVIDING ONLINE NON-DOWNLOADABLE COMPUTER SOFTWARE FOR DESIGNING WASTEWATER TREATMENT SYSTEMS FOR HOMES, CLUSTERED COMMUNITIES AND COMMERCIAL DEVELOPMENTS THAT ARE NOT CONNECTED TO MUNICIPAL WASTEWATER TREATMENT PLANTS AND CANNOT BE SERVED BY STANDARD SEPTIC TANK/GRAVITY-DOSED DRAINFIELD COMBINATIONS (U.S. CLS. 100 AND 101).

FIRST USE 4-28-2008; IN COMMERCE 4-28-2008.

3,481,732. BURNES HOME ACCENTS, LLC, ROUND ROCK, TX. SN 77-188,647. PUB. 11-6-2007, FILED 5-23-2007.



BURNES

OWNER OF U.S. REG. NOS. 1,055,591 AND 1,645,234.
THE MARK CONSISTS OF A BACKWARD B NEXT TO THE LETTER B IN A CIRCLE OVER THE WORD BURNES.

CLASS 16—PAPER GOODS AND PRINTED MATTER

FOR PHOTO ALBUMS (U.S. CLS. 2, 5, 22, 23, 29, 37, 38 AND 50).

FIRST USE 10-31-2007; IN COMMERCE 10-31-2007.

CLASS 20—FURNITURE AND ARTICLES NOT OTHERWISE CLASSIFIED

FOR PICTURE FRAMES (U.S. CLS. 2, 13, 22, 25, 32 AND 50).

FIRST USE 2-22-2008; IN COMMERCE 2-22-2008.

3,481,733. BURNES HOME ACCENTS, LLC, ROUND ROCK, TX. SN 77-188,663. PUB. 11-6-2007, FILED 5-23-2007.



OWNER OF U.S. REG. NOS. 1,055,591 AND 1,645,234.
THE MARK CONSISTS OF A BACKWARD B NEXT TO THE LETTER B IN A CIRCLE.

CLASS 16—PAPER GOODS AND PRINTED MATTER

FOR PHOTO ALBUMS (U.S. CLS. 2, 5, 22, 23, 29, 37, 38 AND 50).

FIRST USE 10-31-2007; IN COMMERCE 10-31-2007.

CLASS 20—FURNITURE AND ARTICLES NOT OTHERWISE CLASSIFIED

FOR PICTURE FRAMES (U.S. CLS. 2, 13, 22, 25, 32 AND 50).

FIRST USE 10-31-2007; IN COMMERCE 10-31-2007.

3,481,746. WELLS FARGO & COMPANY, MINNEAPOLIS, MN. SN 77-192,102. PUB. 2-19-2008, FILED 5-29-2007.

WELLS FARGO PAYMENT GATEWAY

THE MARK CONSISTS OF STANDARD CHARACTERS WITHOUT CLAIM TO ANY PARTICULAR FONT, STYLE, SIZE, OR COLOR.

OWNER OF U.S. REG. NOS. 1,136,497, 2,846,212, AND OTHERS.

NO CLAIM IS MADE TO THE EXCLUSIVE RIGHT TO USE "PAYMENT GATEWAY", APART FROM THE MARK AS SHOWN.

CLASS 36—INSURANCE AND FINANCIAL

FOR BANKING AND FINANCIAL SERVICES, NAMELY, CREDIT CARD TRANSACTION PROCESSING SERVICES; ELECTRONIC PAYMENT PROCESSING SERVICES; FINANCIAL FRAUD AND RISK MANAGEMENT SERVICES WITH RESPECT TO CREDIT CARDS, AND ELECTRONIC CHECKS, NAMELY, FINANCIAL RISK MANAGEMENT IN THE FIELD OF CREDIT CARD, AND ELECTRONIC CHECKS (U.S. CLS. 100, 101 AND 102).

FIRST USE 8-31-2007; IN COMMERCE 8-31-2007.

CLASS 45—PERSONAL AND LEGAL SERVICES

FOR FRAUD SERVICES WITH RESPECT TO CREDIT CARDS AND ELECTRONIC CHECKS, NAMELY, FRAUD DETECTION SERVICES IN THE FIELD OF CREDIT CARD AND ELECTRONIC CHECKS (U.S. CLS. 100 AND 101).

FIRST USE 8-31-2007; IN COMMERCE 8-31-2007.

3,481,762. STERIS INC., TEMECULA, CA. SN 77-202,496. PUB. 10-9-2007, FILED 6-11-2007.

VAPROSURE

THE MARK CONSISTS OF STANDARD CHARACTERS WITHOUT CLAIM TO ANY PARTICULAR FONT, STYLE, SIZE, OR COLOR.

CLASS 10—MEDICAL APPARATUS

FOR VAPORIZED HYDROGEN PEROXIDE STERILIZERS AND BIODECONTAMINATION SYSTEM COMPRISED OF STERILIZATION UNITS FOR MEDICAL USE (U.S. CLS. 26, 39 AND 44).

FIRST USE 7-30-2007; IN COMMERCE 7-30-2007.

CLASS 11—ENVIRONMENTAL CONTROL APPARATUS

FOR VAPORIZED HYDROGEN PEROXIDE STERILIZERS AND BIODECONTAMINATION SYSTEM COMPRISED OF STERILIZERS NOT FOR MEDICAL USE (U.S. CLS. 13, 21, 23, 31 AND 34).

FIRST USE 7-30-2007; IN COMMERCE 7-30-2007.

3,481,763. PIONEER HI-BRED INTERNATIONAL, INC., JOHNSTON, IA. SN 77-202,544. PUB. 4-1-2008, FILED 6-11-2007.

MARKETPOINT

THE MARK CONSISTS OF STANDARD CHARACTERS WITHOUT CLAIM TO ANY PARTICULAR FONT, STYLE, SIZE, OR COLOR.

CLASS 35—ADVERTISING AND BUSINESS

FOR PROVIDING AN ON-LINE EXCHANGE TO FACILITATE THE SALE AND PURCHASE OF AGRICULTURAL GRAIN BETWEEN FARMERS AND END-USERS BASED ON GRAIN CHARACTERISTICS, QUALITIES, AND QUANTITIES (U.S. CLS. 100, 101 AND 102).

FIRST USE 9-19-2007; IN COMMERCE 9-19-2007.

CLASS 42—SCIENTIFIC AND COMPUTER SERVICES

FOR AGRICULTURAL RESEARCH, NAMELY, MONITORING GRAIN CHARACTERISTICS, QUALITIES, AND QUANTITIES FOR ON-LINE AGRICULTURAL GRAIN EXCHANGE LISTINGS (U.S. CLS. 100 AND 101).

FIRST USE 9-19-2007; IN COMMERCE 9-19-2007.

3,481,773. THOMPSON & CO. OF TAMPA, INC., TAMPA, FL. SN 77-206,882. PUB. 1-1-2008, FILED 6-15-2007.

CIGAR SAVVY

THE MARK CONSISTS OF STANDARD CHARACTERS WITHOUT CLAIM TO ANY PARTICULAR FONT, STYLE, SIZE, OR COLOR.

NO CLAIM IS MADE TO THE EXCLUSIVE RIGHT TO USE "CIGAR", APART FROM THE MARK AS SHOWN.

CLASS 16—PAPER GOODS AND PRINTED MATTER

FOR PRINT CATALOGS IN THE FIELD OF CIGARS (U.S. CLS. 2, 5, 22, 23, 29, 37, 38 AND 50).

FIRST USE 9-7-2007; IN COMMERCE 9-7-2007.

CLASS 35—ADVERTISING AND BUSINESS

FOR ELECTRONIC CATALOG SERVICES FEATURING CIGARS (U.S. CLS. 100, 101 AND 102).

FIRST USE 9-7-2007; IN COMMERCE 9-7-2007.

3,481,777. JUSTICE CO., LTD., OSAKA, JAPAN. SN 77-209,634. PUB. 1-8-2008, FILED 6-19-2007.

Activage

CLASS 3—COSMETICS AND CLEANING PREPARATIONS

FOR CAKES OF TOILET SOAP, COSMETIC CREAMS, SKIN WHITENING CREAMS, LOTIONS FOR COSMETIC PURPOSES, NAMELY, FOR ANTI-AGING, BEAUTY MASKS, NON-MEDICATED COSMETIC PREPARATIONS FOR SKIN CARE AND NON-MEDICATED TOILETRIES (U.S. CLS. 1, 4, 6, 50, 51 AND 52).

FIRST USE 10-20-2007; IN COMMERCE 2-3-2008.

CLASS 5—PHARMACEUTICALS

FOR DIETARY SUPPLEMENTS (U.S. CLS. 6, 18, 44, 46, 51 AND 52).

FIRST USE 10-20-2007; IN COMMERCE 2-3-2008.

3,481,816. EEYE, INC., IRVINE, CA. SN 77-228,448. PUB. 1-1-2008, FILED 7-12-2007.

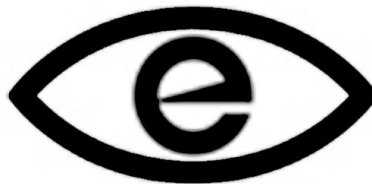

OWNER OF U.S. REG. NOS. 2,484,500, 2,773,771, AND 3,102,116.

THE MARK CONSISTS OF AN OVAL, ENCIRCLING A LOWER CASE "E", RESEMBLING A HUMAN EYE AND IRIS.

CLASS 9—ELECTRICAL AND SCIENTIFIC APPARATUS

FOR COMPUTER SOFTWARE FOR USE IN COMPUTER NETWORK SECURITY (U.S. CLS. 21, 23, 26, 36 AND 38).

FIRST USE 2-27-2007; IN COMMERCE 2-27-2007.

CLASS 42—SCIENTIFIC AND COMPUTER SERVICES

FOR COMPUTER AND CONSULTING SERVICES, NAMELY, COMPUTER SOFTWARE DESIGN, DEVELOPMENT AND ANALYSIS RELATED TO COMPUTER NETWORK SECURITY; PROVIDING INFORMATION VIA A GLOBAL COMPUTER NETWORK RELATED TO COMPUTER NETWORK SECURITY (U.S. CLS. 100 AND 101).

FIRST USE 1-16-2007; IN COMMERCE 1-16-2007.

3,481,831. MAINTENANCENET, INC., CARLSBAD, CA. SN 77-237,309. PUB. 2-12-2008, FILED 7-24-2007.

Service360

THE MARK CONSISTS OF STANDARD CHARACTERS WITHOUT CLAIM TO ANY PARTICULAR FONT, STYLE, SIZE, OR COLOR.

CLASS 9—ELECTRICAL AND SCIENTIFIC APPARATUS

FOR COMPUTER SOFTWARE USED TO TRACK AND MANAGE MAINTENANCE CONTRACTS, NAMELY, PROVIDING SERVICE CONTRACT MANAGEMENT SERVICES, PARTNER PERFORMANCE MANAGEMENT SERVICES AND SERVICE SALES MANAGEMENT SERVICES (U.S. CLS. 21, 23, 26, 36 AND 38).

FIRST USE 4-1-2008; IN COMMERCE 4-1-2008.

CLASS 42—SCIENTIFIC AND COMPUTER SERVICES

FOR PROVIDING TEMPORARY USE OF ONLINE, NON-DOWNLOADABLE SOFTWARE TO STORE, MANAGE, TRACK, ANALYZE AND REPORT DATA IN THE FIELD OF TECHNOLOGY MAINTENANCE CONTRACTS; PROVIDING TEMPORARY USE OF ON-LINE NON-DOWNLOADABLE SOFTWARE TO FACILITATE COMMUNICATING WITH TECHNOLOGY MANUFACTURERS AND THEIR CHANNEL PARTNERS IN THE ADVERTISING, MARKETING AND SALE OF MAINTENANCE SERVICE CONTRACTS (U.S. CLS. 100 AND 101).

FIRST USE 4-1-2008; IN COMMERCE 4-1-2008.

3,481,832. BILLY B BEAUTY, L.L.C., WEST HOLLYWOOD, CA. SN 77-237,457. PUB. 1-8-2008, FILED 7-24-2007.

billybBEAUTY

THE MARK CONSISTS OF STANDARD CHARACTERS WITHOUT CLAIM TO ANY PARTICULAR FONT, STYLE, SIZE, OR COLOR.

CLASS 3—COSMETICS AND CLEANING PREPARATIONS

FOR MAKE-UP FOR THE FACE AND BODY (U.S. CLS. 1, 4, 6, 50, 51 AND 52).

FIRST USE 5-1-2008; IN COMMERCE 5-1-2008.

CLASS 21—HOUSEWARES AND GLASS

FOR MAKE-UP BRUSHES (U.S. CLS. 2, 13, 23, 29, 30, 33, 40 AND 50).

FIRST USE 1-1-2006; IN COMMERCE 1-1-2007.

3,481,840. NAMCO BANDAI GAMES INC., TOKYO, JAPAN. SN 77-240,619. PUB. 12-25-2007, FILED 7-27-2007.

PAC-MAN PLUS

THE MARK CONSISTS OF STANDARD CHARACTERS WITHOUT CLAIM TO ANY PARTICULAR FONT, STYLE, SIZE, OR COLOR.

OWNER OF U.S. REG. NOS. 1,259,524, 3,048,436, AND OTHERS.

CLASS 9—ELECTRICAL AND SCIENTIFIC APPARATUS

FOR VIDEO GAME CARTRIDGES, COMPUTER GAME PROGRAMS (U.S. CLS. 21, 23, 26, 36 AND 38).

FIRST USE 10-8-2007; IN COMMERCE 10-8-2007.

CLASS 41—EDUCATION AND ENTERTAINMENT

FOR ENTERTAINMENT, NAMELY, PROVIDING A COMPUTER GAME THAT MAY BE ACCESSED NETWORK-WIDE BY NETWORK USERS VIA MOBILE PHONES AND COMPUTERS; PROVIDING COMPUTER GAMES VIA NETWORK BETWEEN COMMUNICATIONS NETWORKS AND COMPUTERS (U.S. CLS. 100, 101 AND 107).

FIRST USE 10-8-2007; IN COMMERCE 10-8-2007.

3,481,850. PHNOM PENH EXPRESS, INC., LONG BEACH, CA. SN 77-245,738. PUB. 2-26-2008, FILED 8-2-2007.



NO CLAIM IS MADE TO THE EXCLUSIVE RIGHT TO USE "PHNOM PENH" AND "EXPRESS", APART FROM THE MARK AS SHOWN.

THE COLOR(S) RED, BLUE, ORANGE, WHITE IS/ARE CLAIMED AS A FEATURE OF THE MARK.

THE MARK CONSISTS OF THE WORDS "PHNOM PENH" APPEARING IN BLUE, IN WHICH AN AIRPLANE IS DISPLAYED IN THE LETTER O - THE AIRPLANE CONSISTS OF THE FUSELAGE AND WINGS APPEARING IN WHITE, THE COCKPIT WINDOW AND NOSE GEAR APPEARING IN LIGHT BLUE, THE JET ENGINE AND PASSENGER WINDOWS LOCATED ON THE LEFT SIDE OF THE FUSELAGE APPEARING IN ORANGE - ALL OF

WHICH IS DISPLAYED ABOVE FOUR SETS OF LINES, THE TOP TWO APPEARING IN RED AND THE BOTTOM TWO APPEARING IN BLUE, WHICH RUN INTO THE LETTER E OF EXPRESS APPEARING IN RED, WITH ONE LINE DISPLAYED DIAGONALLY PER EACH LETTER S.

CLASS 36—INSURANCE AND FINANCIAL

FOR MONEY TRANSFER SERVICES, SPECIFICALLY TO CAMBODIA; ELECTRONIC TRANSFERS OF MONEY, SPECIFICALLY TO CAMBODIA (U.S. CLS. 100, 101 AND 102).
FIRST USE 10-6-2004; IN COMMERCE 1-6-2008.

CLASS 39—TRANSPORTATION AND STORAGE

FOR TRAVEL AGENCY SERVICES, NAMELY, MAKING RESERVATIONS AND BOOKINGS FOR TRANSPORTATION (U.S. CLS. 100 AND 105).
FIRST USE 10-6-2004; IN COMMERCE 1-6-2008.

3,481,874. KARNOVA CORP., BURBANK, NJ. SN 77-252,346. PUB. 2-12-2008, FILED 8-10-2007.

BLINGSTRIPS

THE MARK CONSISTS OF STANDARD CHARACTERS WITHOUT CLAIM TO ANY PARTICULAR FONT, STYLE, SIZE, OR COLOR.

CLASS 16—PAPER GOODS AND PRINTED MATTER

FOR APPLIQUES IN THE FORM OF DECALS; DECALS; PLASTIC, VINYL TRANSFERS; STICKERS; DECORATIVE STICKERS FOR HELMETS; ADHESIVE PLASTIC FILM USED FOR MOUNTING IMAGES (U.S. CLS. 2, 5, 22, 23, 29, 37, 38 AND 50).
FIRST USE 8-10-2007; IN COMMERCE 8-10-2007.

CLASS 20—FURNITURE AND ARTICLES NOT OTHERWISE CLASSIFIED

FOR VINYL APPLIQUES FOR ATTACHMENT TO WINDOWS, MIRRORS, AND OTHER SOLID SURFACES (U.S. CLS. 2, 13, 22, 25, 32 AND 50).
FIRST USE 8-10-2007; IN COMMERCE 8-10-2007.

3,481,915. MARSHFIELD DOORSYSTEMS, INC., MARSHFIELD, WI. SN 77-268,399. PUB. 2-26-2008, FILED 8-30-2007.

CARTE BLANCHE

THE MARK CONSISTS OF STANDARD CHARACTERS WITHOUT CLAIM TO ANY PARTICULAR FONT, STYLE, SIZE, OR COLOR.

CLASS 19—NON-METALLIC BUILDING MATERIALS

FOR NON-METAL DOOR UNITS; NON-METAL DOORS (U.S. CLS. 1, 12, 33 AND 50).
FIRST USE 10-2-2007; IN COMMERCE 10-2-2007.

CLASS 40—MATERIAL TREATMENT

FOR CUSTOM MANUFACTURE OF DOORS (U.S. CLS. 100, 103 AND 106).
FIRST USE 10-2-2007; IN COMMERCE 10-2-2007.

3,481,922. HOLLISTER INCORPORATED, LIBERTYVILLE, IL. SN 77-273,252. PUB. 3-18-2008, FILED 9-6-2007.

C3life

THE MARK CONSISTS OF STANDARD CHARACTERS WITHOUT CLAIM TO ANY PARTICULAR FONT, STYLE, SIZE, OR COLOR.

CLASS 38—COMMUNICATION

FOR PROVIDING ON-LINE CHAT ROOMS AND ELECTRONIC BULLETIN BOARDS FOR TRANSMISSION OF MESSAGES AMONG USERS IN THE FIELD OF OSTOMY AND CONTINENCE ISSUES (U.S. CLS. 100, 101 AND 104).
FIRST USE 1-9-2008; IN COMMERCE 1-9-2008.

CLASS 44—MEDICAL, BEAUTY AND AGRICULTURAL SERVICES

FOR PROVIDING INFORMATION REGARDING OSTOMY AND CONTINENCE ISSUES; PROVIDING AN INTERACTIVE WEBSITE REGARDING OSTOMY AND CONTINENCE ISSUES (U.S. CLS. 100 AND 101).
FIRST USE 1-9-2008; IN COMMERCE 1-9-2008.

3,481,923. HOLLISTER INCORPORATED, LIBERTYVILLE, IL. SN 77-273,257. PUB. 3-18-2008, FILED 9-6-2007.



THE MARK CONSISTS OF STYLIZED TREE FORMED WITH THE WORDS "LIVE MY LIFE LOVE MY LIFE".

CLASS 38—COMMUNICATION

FOR PROVIDING ON-LINE CHAT ROOMS AND ELECTRONIC BULLETIN BOARDS FOR TRANSMISSION OF MESSAGES AMONG USERS IN THE FIELD OF OSTOMY AND CONTINENCE ISSUES (U.S. CLS. 100, 101 AND 104).

FIRST USE 1-9-2008; IN COMMERCE 1-9-2008.

CLASS 44—MEDICAL, BEAUTY AND AGRICULTURAL SERVICES

FOR PROVIDING INFORMATION REGARDING OSTOMY AND CONTINENCE ISSUES; PROVIDING AN INTERACTIVE WEBSITE REGARDING OSTOMY AND CONTINENCE ISSUES (U.S. CLS. 100 AND 101).

FIRST USE 1-9-2008; IN COMMERCE 1-9-2008.

3,481,956. NORTHEAST ENTREPRENEUR FUND, INC., VIRGINIA, MN. SN 77-291,117. PUB. 3-18-2008, FILED 9-28-2007.

GREENSTONE GROUP

THE MARK CONSISTS OF STANDARD CHARACTERS WITHOUT CLAIM TO ANY PARTICULAR FONT, STYLE, SIZE, OR COLOR.

NO CLAIM IS MADE TO THE EXCLUSIVE RIGHT TO USE "GROUP", APART FROM THE MARK AS SHOWN.

CLASS 35—ADVERTISING AND BUSINESS

FOR PROVIDING AN ONLINE DIRECTORY OF SERVICE PROVIDERS FOR ENTREPRENEURS TO ASSIST IN BUSINESS DEVELOPMENT (U.S. CLS. 100, 101 AND 102).

FIRST USE 3-14-2008; IN COMMERCE 3-14-2008.

CLASS 41—EDUCATION AND ENTERTAINMENT

FOR EDUCATIONAL SERVICES, NAMELY, PROVIDING GROUP AND INDIVIDUAL TRAINING AND MENTORING TO OWNERS OF EXISTING AND START-UP BUSINESSES FOR THE PURPOSE OF TEACHING ENTREPRENEURIAL SKILLS TO FOSTER BUSINESS DEVELOPMENT AND GROWTH AND ASSISTING EDUCATIONAL INSTITUTIONS IN THE DEVELOPMENT OF CURRICULUM WHICH TEACHES ENTREPRENEURIAL SKILLS (U.S. CLS. 100, 101 AND 107).

FIRST USE 4-3-2008; IN COMMERCE 4-3-2008.

3,481,975. BACANI, SHARON L., ANTIOCH, CA. SN 77-305,184. PUB. 3-18-2008, FILED 10-16-2007.

DON'T BE A BASTARD

THE MARK CONSISTS OF STANDARD CHARACTERS WITHOUT CLAIM TO ANY PARTICULAR FONT, STYLE, SIZE, OR COLOR.

CLASS 16—PAPER GOODS AND PRINTED MATTER

FOR STICKERS; POSTERS; PAPER HANG TAGS (U.S. CLS. 2, 5, 22, 23, 29, 37, 38 AND 50).

FIRST USE 6-15-2008; IN COMMERCE 6-15-2008.

CLASS 25—CLOTHING

FOR SHIRTS; HATS; PANTS; JACKETS; UNDERWEAR; SWEATERS; BELTS; SWEAT BANDS; HEADBANDS AGAINST SWEATING (U.S. CLS. 22 AND 39).

FIRST USE 6-15-2008; IN COMMERCE 6-15-2008.

3,481,987. O'NEILL, ROSALINDA, CALABASAS, CA. SN 77-975,341. PUB. 6-5-2007, FILED 10-25-2006.

QUICKSAND

THE MARK CONSISTS OF STANDARD CHARACTERS WITHOUT CLAIM TO ANY PARTICULAR FONT, STYLE, SIZE, OR COLOR.

CLASS 35—ADVERTISING AND BUSINESS

FOR MANAGEMENT AND BUSINESS CONSULTING SERVICES IN THE FIELD OF EMPLOYMENT COUNSELING IN LEADERSHIP, BUSINESS RELATIONSHIP AND MANAGEMENT TRAINING, CONFLICT RESOLUTION, STRATEGIC PLANNING, EMPLOYEE AND EXECUTIVE CONFLICT, WORK AND STRESS MANAGEMENT (U.S. CLS. 100, 101 AND 102).

FIRST USE 1-31-2007; IN COMMERCE 1-31-2007.

CLASS 41—EDUCATION AND ENTERTAINMENT

FOR EDUCATION SERVICES, NAMELY, PROVIDING CLASSES AND WORKSHOPS IN THE FIELD OF LEADERSHIP, RELATIONSHIP AND MANAGEMENT TRAINING, CONFLICT RESOLUTION, STRATEGIC PLANNING, EMPLOYEE AND EXECUTIVE CONFLICT, STRESS REDUCTION AND FAMILY TRAINING (U.S. CLS. 100, 101 AND 107).

FIRST USE 1-31-2007; IN COMMERCE 1-31-2007.

3,481,989. BENSON, GEORGE L., ELCHO, WI. SN 77-975,561. PUB. 5-22-2007, FILED 9-28-2006.

ORIGINAL SOCCERVOLLEYBALL

THE MARK CONSISTS OF STANDARD CHARACTERS WITHOUT CLAIM TO ANY PARTICULAR FONT, STYLE, SIZE, OR COLOR.

NO CLAIM IS MADE TO THE EXCLUSIVE RIGHT TO USE "ORIGINAL", APART FROM THE MARK AS SHOWN.

CLASS 16—PAPER GOODS AND PRINTED MATTER

FOR PRINTED LITERATURE, NAMELY, RULE BOOKS AND DIAGRAMS IN THE FIELD OF SPORTS INSTRUCTION (U.S. CLS. 2, 5, 22, 23, 29, 37, 38 AND 50).
FIRST USE 3-12-2008; IN COMMERCE 4-9-2008.

CLASS 28—TOYS AND SPORTING GOODS

FOR ATHLETIC GAME PLAYING EQUIPMENT, NAMELY, NETS FOR BALL GAMES AND BALLS FOR GAMES (U.S. CLS. 22, 23, 38 AND 50).
FIRST USE 3-12-2008; IN COMMERCE 4-18-2008.

3,481,990. GUCCI AMERICA, INC., NEW YORK, NY. SN 77-975,650. PUB. 11-27-2007, FILED 5-8-2007.

SIGNORIA

THE MARK CONSISTS OF STANDARD CHARACTERS WITHOUT CLAIM TO ANY PARTICULAR FONT, STYLE, SIZE, OR COLOR.

THE FOREIGN WORDING IN THE MARK TRANSLATES INTO ENGLISH AS "LORDSHIP".

CLASS 14—JEWELRY

FOR WATCHES (U.S. CLS. 2, 27, 28 AND 50).
FIRST USE 4-0-2007; IN COMMERCE 4-0-2007.

CLASS 18—LEATHER GOODS

FOR WALLETS, PURSES, HANDBAGS, SHOULDER BAGS, CLUTCH BAGS, TOTE BAGS, DUFFEL BAGS, KEY CASES, COSMETIC CASES SOLD EMPTY (U.S. CLS. 1, 2, 3, 22 AND 41).
FIRST USE 9-0-2007; IN COMMERCE 9-0-2007.

3,481,995. EDISON INTERNATIONAL, ROSEMEAD, CA. SN 77-975,686. PUB. 9-18-2007, FILED 3-15-2007.

LEADING THE WAY IN ELECTRICITY

THE MARK CONSISTS OF STANDARD CHARACTERS WITHOUT CLAIM TO ANY PARTICULAR FONT, STYLE, SIZE, OR COLOR.

CLASS 35—ADVERTISING AND BUSINESS

FOR PROVIDING CONSUMERS WITH INFORMATION REGARDING ENERGY PRICING AND COST MANAGEMENT; PROMOTING PUBLIC AWARENESS OF ENERGY CONSERVATION, RENEWABLE ENERGY SOURCES AND THE USE OF NON-CARBON FUELS (U.S. CLS. 100, 101 AND 102).
FIRST USE 3-0-2007; IN COMMERCE 3-0-2007.

CLASS 39—TRANSPORTATION AND STORAGE

FOR UTILITY SERVICES, NAMELY, THE TRANSMISSION AND DISTRIBUTION OF ELECTRICITY AND WHOLESALE DISTRIBUTION OF ELECTRICITY TO OTHER UTILITIES AND ENERGY SERVICE PROVIDERS (U.S. CLS. 100 AND 105).
FIRST USE 3-0-2007; IN COMMERCE 3-0-2007.

CLASS 40—MATERIAL TREATMENT

FOR GENERATING ELECTRICITY (U.S. CLS. 100, 103 AND 106).
FIRST USE 3-0-2007; IN COMMERCE 3-0-2007.

CLASS 42—SCIENTIFIC AND COMPUTER SERVICES

FOR DEVELOPING HYDROGEN-POWERED ELECTRICITY PRODUCING POWER PLANTS; REAL-TIME MONITORING ELECTRIC POWER CONSUMPTION BY THIRD PARTIES FOR ELECTRIC POWER PROVIDERS (U.S. CLS. 100 AND 101).
FIRST USE 3-0-2007; IN COMMERCE 3-0-2007.

3,482,004. THE STATE OF OREGON ACTING BY AND THROUGH THE STATE BOARD OF HIGHER EDUCATION ON BEHALF OF THE UNIVERSITY OF OREGON, EUGENE, OR. SN 78-208,840. PUB. 3-22-2005, FILED 1-30-2003.

STANDARDS FOR SUCCESS

CLASS 9—ELECTRICAL AND SCIENTIFIC APPARATUS

FOR PRERECORDED CD-ROMS FEATURING INFORMATION ABOUT COLLEGE PREPARATION, PLACEMENT, AND RETENTION (U.S. CLS. 21, 23, 26, 36 AND 38).
FIRST USE 0-0-2003; IN COMMERCE 0-0-2003.

CLASS 16—PAPER GOODS AND PRINTED MATTER

FOR PRINTED MATERIALS, NAMELY, BOOKS AND BOOKLETS RELATING TO COLLEGE PREPARATION, PLACEMENT, AND RETENTION (U.S. CLS. 2, 5, 22, 23, 29, 37, 38 AND 50).
FIRST USE 0-0-2003; IN COMMERCE 0-0-2003.

CLASS 41—EDUCATION AND ENTERTAINMENT

FOR CONDUCTING EDUCATIONAL RESEARCH; DEVELOPING KNOWLEDGE AND SKILLS STATEMENTS FOR AREAS OF CURRICULUM; MAKING PUBLIC PRESENTATIONS ABOUT COLLEGE PREPARATION, PLACEMENT AND RETENTION; CONSULTING SERVICES IN THE FIELDS OF EDUCATIONAL CURRICULUM, TESTING, ANALYSIS, AND RESEARCH, INCLUDING COLLEGE PREPARATION, APPLICATION TO COLLEGE, PLACEMENT, AND RETENTION; AND CONSULTING SERVICES IN THE FIELD OF DEVELOPMENT OF TESTS AND OTHER INSTRUMENTS RELATING TO EDUCATIONAL RESEARCH (U.S. CLS. 100, 101 AND 107).
FIRST USE 0-0-2003; IN COMMERCE 0-0-2003.

3,482,009. FLYING LAB SOFTWARE, LLC, SEATTLE, WA.
SN 78-297,045. PUB. 3-22-2005, FILED 9-7-2003.

3,482,015. 1058822 ONTARIO LTD., LONDON, ONTARIO,
CANADA. SN 78-331,507. PUB. 2-20-2007, FILED 11-21-
2003.

PIRATES OF THE BURNING SEA

CLASS 9—ELECTRICAL AND SCIENTIFIC APPARATUS

FOR COMPUTER GAME SOFTWARE (U.S. CLS. 21, 23,
26, 36 AND 38).
FIRST USE 11-13-2007; IN COMMERCE 11-13-2007.

CLASS 41—EDUCATION AND ENTERTAIN- MENT

FOR ENTERTAINMENT SERVICES, NAMELY, PRO-
VIDING A REAL TIME, ROLE PLAYING COMPUTER
GAME FOR OTHERS VIA THE GLOBAL COMPUTER
NETWORK (U.S. CLS. 100, 101 AND 107).
FIRST USE 2-7-2003; IN COMMERCE 7-16-2007.

3,482,014. WATER ENVIRONMENT FEDERATION, ALEX-
ANDRIA, VA. SN 78-323,401. PUB. 2-15-2005, FILED 11-5-
2003.

THE WATER QUALITY PEOPLE

THE MARK CONSISTS OF STANDARD CHARACTERS
WITHOUT CLAIM TO ANY PARTICULAR FONT, STYLE,
SIZE, OR COLOR.

NO CLAIM IS MADE TO THE EXCLUSIVE RIGHT TO
USE "WATER QUALITY", APART FROM THE MARK AS
SHOWN.

CLASS 35—ADVERTISING AND BUSINESS

FOR PROMOTING THE INTERESTS OF INDIVI-
DUALS AND ORGANIZATIONS WHO SHARE AN IN-
TEREST IN WATER QUALITY AND WATER
CONSERVATION AND PROMOTING PUBLIC AWARE-
NESS OF THE NEED FOR PRESERVATION AND EN-
HANCEMENT OF THE GLOBAL WATER
ENVIRONMENT (U.S. CLS. 100, 101 AND 102).
FIRST USE 11-30-2003; IN COMMERCE 12-31-2004.

CLASS 41—EDUCATION AND ENTERTAIN- MENT

FOR EDUCATIONAL SERVICES, NAMELY, ORGA-
NIZING AND CONDUCTING SEMINARS AND CON-
FERENCES AND DISTRIBUTING RELATED
EDUCATIONAL MATERIAL IN THE FIELD OF WATER
QUALITY AND WATER CONSERVATION (U.S. CLS.
100, 101 AND 107).
FIRST USE 11-30-2003; IN COMMERCE 1-31-2004.

DARK SECTOR

THE MARK CONSISTS OF STANDARD CHARACTERS
WITHOUT CLAIM TO ANY PARTICULAR FONT, STYLE,
SIZE, OR COLOR.

PRIORITY CLAIMED UNDER SEC. 44(D) ON CANADA
APPLICATION NO. 1,193,798, FILED 10-23-2003, REG. NO.
TMA670,656, DATED 8-22-2006, EXPIRES 8-22-2021.

CLASS 9—ELECTRICAL AND SCIENTIFIC APPARATUS

FOR COMPUTER GAME SOFTWARE, ELECTRONIC
GAME PROGRAMS, VIDEO GAME CARTRIDGES, AND
VIDEO GAME SOFTWARE; AUDIO-VISUAL RECORD-
INGS IN THE FIELD OF VIDEO GAMES OR ACTION
ADVENTURE (U.S. CLS. 21, 23, 26, 36 AND 38).
FIRST USE 3-25-2008; IN COMMERCE 3-25-2008.

CLASS 41—EDUCATION AND ENTERTAIN- MENT

FOR ENTERTAINMENT SERVICES, NAMELY, THE
PROVISION OF INTERACTIVE AND NON-INTERAC-
TIVE INFORMATION ON THE GLOBAL COMPUTER
NETWORK IN THE FIELD OF VIDEO GAMES AND
ELECTRONIC GAME PROGRAMS (U.S. CLS. 100, 101
AND 107).
FIRST USE 3-25-2008; IN COMMERCE 3-25-2008.

3,482,036. TURNERWORLD LLC, CUMMING, GA. SN 78-
411,510. PUB. 2-22-2005, FILED 4-30-2004.

BECAUSE. . .

THE MARK CONSISTS OF STANDARD CHARACTERS
WITHOUT CLAIM TO ANY PARTICULAR FONT, STYLE,
SIZE, OR COLOR.

CLASS 16—PAPER GOODS AND PRINTED MATTER

FOR OFFICE SUPPLIES, NAMELY, PEN AND PENCIL SETS, NOTE BOOKS, WRITING PAPER PADS, NOTE PAPER PADS, STATIONERY, COASTERS MADE OF PAPER, CALENDARS, DAILY PLANNERS, DESK TOP PLANNERS, PAPERWEIGHTS, 3-RING BINDERS, POSTERS, STATIONERY-TYPE PORTFOLIOS AND STICKERS; TELEPHONE CALLING CARDS, NOT MAGNETICALLY ENCODED; BUSINESS CARDS; CREDIT CARDS WITHOUT MAGNETIC CODING; PLAYING CARDS; DECALS; POSTCARDS; GREETING CARDS (U.S. CLS. 2, 5, 22, 23, 29, 37, 38 AND 50).

FIRST USE 8-0-2003; IN COMMERCE 8-0-2003.

CLASS 25—CLOTHING

FOR CLOTHING FOR MEN, WOMEN, AND CHILDREN, NAMELY, SWEAT PANTS AND SWEATSHIRTS; SWIM WEAR; BATHING SUITS; BEACH AND BATHING COVER-UPS; SWEAT SHORTS; GYM SHORTS; TOPS; JACKETS; COATS; SHIRTS; SPORT SHIRTS; T-SHIRTS; KNIT SHIRTS; POLO SHIRTS; PULLOVERS; SWEATERS; VESTS; TANK TOPS; CASUAL FOOTWEAR; SANDALS; HEAD WEAR; HATS; CAPS; VISORS; HEADBANDS; SWEATBANDS; WRIST BANDS; NECKWEAR; NECKTIES; NECKERCHIEFS; SCARVES; BANDANNAS; SLEEPWEAR; ROBES; PAJAMAS; NIGHT SHIRTS; BOXERS SHORTS; BELTS; LINGERIE, UNDERGARMENTS, HOSIERY; SOCKS; AFTER SKI BOOTS; ANKLET SOCKS; ANORAKS AND PARKAS; APRONS; ASCOTS; ATHLETIC FOOTWEAR; ATHLETIC SHOES; ATHLETIC UNIFORMS; BABUSHKAS; BABY BUNTING; BAGS FOR SKI BOOTS; BALLOON PANTS; BANDEAUX; NECK BANDS; BATHING CAPS; BATHING TRUNKS; BATHROBES; BEACHWEAR; BED JACKETS; GARTER BELTS; MONEY BELTS; BERETS; CLOTH BIBS; SKI BIBS; BIKINIS; BLAZERS; BLOOMERS; BLOUSES; BLOUSON; BOAS; BODY SHAPERS; BODY SUITS; BOLEROS; BONNETS; BOOTIES; BOOTS; SKI BOOTS; BOTTOMS; BOW TIES; BRAS; BRASSIERES; BREECHES; UNDERWEAR BRIEFS; BUSTIERS; CAFTANS; CAMISOLES; CAPES; BATHING CAPS; SHOWER CAPS; CARDIGANS; CASOCKS; CHAPS; CHEMISES; CLOGS; CLOTH BIBS; CLOTH DIAPERS; INFANT CLOTH DIAPERS; FUR COATS; LAB COATS; LEATHER COATS; OVERCOATS; RAINCOATS; SPORT COATS; SUIT COATS; TOP COATS; COLLARS; CORSELETS; CORSETS; HALLOWEEN COSTUMES; MASQUERADE COSTUMES; MASQUERADE COSTUMES AND MASKS SOLD IN CONNECTION THEREWITH; COVERALLS; COVER-UPS; CRAVATS; CREEPERS; CUFFS; CULOTTES; CUMMERBUNDS; DICKIES; DRESSES; DRESSING GOWNS; DUNGAREES; DUSTERS; EAR MUFFS; ESPADRILLES; EVENING GOWNS; FISHING VESTS; FISHING WADERS; FLIGHT SUITS; FOOTWEAR, ATHLETIC; FOUL WEATHER GEAR; FROCKS; FUR JACKETS; FUR STOLEES; GABARDINES; GAITERS; GALOSHES; GAUCHOS; GIRDLES; GLOVES; SKI GLOVES; GOLF SHIRTS; GOLF SHOES; GOWNS; DRESSING GOWNS; NIGHTGOWNS; WEDDING GOWNS; GREATCOATS; GYM SUITS; HALTER TOPS; HEADWEAR; HEEL INSERTS; HEELS; HOODS; HOUSECOATS; INFANTWEAR; INNER SOLES; INSOLES; LEATHER JACKETS; WIND RESISTANT JACKETS; JEANS; JERSEYS; JODHPURS; JOGGING SUITS; JUMPERS; JUMPSUITS; KERCHIEFS; KILTS; KIMONOS; KNEE HIGHS; KNICKERS; LEG WARMERS; LEGGINGS; LEOTARDS; LINGERIE; LOUNGEWEAR; MAILLOTS; MANTILLAS; MANTLES; MINISKIRTS; MITTENS; MOCCASINS; MUFFLERS; MUFFS; EAR MUFFS; MUKLUKS; MUU MUUS; NECK BANDS; NEGLIGEEES; OVERALLS; OVERCOATS; OVERSHOES; SHOULDER PADS FOR CLOTHING; PANTALOONS; PANTIES; PANTS; SKI PANTS; SNOW PANTS; TAP PANTS; PANTSUITS; PANTYHOSE; PAREU; PEDAL PUSHERS; PEIGNOIRS; PETTICOATS; PINAFORES; PLAY SUITS; POCKET SQUARES; PONCHOS; QUILTED VESTS; RAIN COATS; RAINWEAR; ROMPERS; SARONGS; SASHES; SHAWLS; SHIFTS; UNDERSHIRTS; SHOES; SHORTALLS; SHORTS; BERMUDA SHORTS; BOXER SHORTS; SHOWER CAPS; SINGLET; SKI SUITS; SKI WEAR; SKIRTS; SLACKS; SLIPPERS; SLIPS; SMOCKS; SNEAKERS; SNOW SUITS; THERMAL SOCKS; STOCKINGS; STOLEES; FUR STOLEE; SUITS; VESTED

SUITS; WARM-UP SUITS; WET SUITS; SUN VISORS; SUSPENDERS; SWADDLING CLOTHES; SWEAT SUITS; TURTLENECK SWEATERS; V-NECK SWEATERS; SWEATSOCKS; SWIM TRUNKS; SWIMSUITS; TAILLEURS; TANGAS; TEDDIES; TENNIS WEAR; FOOTWEAR THONGS; TIES; TIGHTS; TOGAS; TOQUES; TRACKSUITS; TROUSERS; TUNICS; TURBANS; TUXEDOS; UNDERCLOTHES; UNDERGARMENTS; UNDERPANTS; UNDERSHIRTS; UNIFORMS; UNITARDS; VEILS; WAISTCOAT; WARM UP SUITS; LEG WARMERS; CLOTHING WRAPS; AND ZORI (U.S. CLS. 22 AND 39).

FIRST USE 8-0-2003; IN COMMERCE 8-0-2003.

3,482,039. JOHN BOOS & CO., EFFINGHAM, IL. SN 78-415,992. PUB. 4-5-2005, FILED 5-10-2004.

4COOKS

THE MARK CONSISTS OF STANDARD CHARACTERS WITHOUT CLAIM TO ANY PARTICULAR FONT, STYLE, SIZE, OR COLOR.

CLASS 20—FURNITURE AND ARTICLES NOT OTHERWISE CLASSIFIED

FOR FURNITURE, NAMELY, TABLES, ISLANDS (U.S. CLS. 2, 13, 22, 25, 32 AND 50).

FIRST USE 11-0-2007; IN COMMERCE 11-0-2007.

CLASS 21—HOUSEWARES AND GLASS

FOR CUTTING BOARDS (U.S. CLS. 2, 13, 23, 29, 30, 33, 40 AND 50).

FIRST USE 7-0-2005; IN COMMERCE 7-0-2005.

3,482,040. JOHN BOOS & CO., EFFINGHAM, IL. SN 78-416,007. PUB. 3-1-2005, FILED 5-10-2004.

4COOKS BY JOHN BOOS

THE MARK CONSISTS OF STANDARD CHARACTERS WITHOUT CLAIM TO ANY PARTICULAR FONT, STYLE, SIZE, OR COLOR.

CLASS 20—FURNITURE AND ARTICLES NOT OTHERWISE CLASSIFIED

FOR FURNITURE, NAMELY, TABLES, ISLANDS, CARTS (U.S. CLS. 2, 13, 22, 25, 32 AND 50).
FIRST USE 11-0-2007; IN COMMERCE 11-0-2007.

CLASS 21—HOUSEWARES AND GLASS

FOR CUTTING BOARDS (U.S. CLS. 2, 13, 23, 29, 30, 33, 40 AND 50).
FIRST USE 7-0-2005; IN COMMERCE 7-0-2005.

CLASS 20—FURNITURE AND ARTICLES NOT OTHERWISE CLASSIFIED

FOR PILLOWS, WINDOW BLINDS, WINDOW SHADES, DECORATIVE BEAD CURTAINS, LAUNDRY HAMPERS, PICTURE FRAMES NOT OF PRECIOUS METAL, JEWELRY BOXES NOT OF METAL, SHELVING, SHELVES FOR BOOKS AND MEDIA, MODULAR SHELVING UNITS FEATURING STACKABLE AND REMOVABLE SHELVES, STEP STOOLS, CHAIRS, OTTOMANS, END TABLES, AND BEDS (U.S. CLS. 2, 13, 22, 25, 32 AND 50).
FIRST USE 6-0-2004; IN COMMERCE 6-0-2004.

CLASS 24—FABRICS

FOR BEDDING AND ACCESSORIES, NAMELY, BED SHEETS, COMFORTERS, BLANKETS, DUVETS, DUVET COVERS, BED SPREADS, QUILTS, TROWS, PILLOW CASES, PILLOW COVERS, MATTRESS PADS, MATTRESS TOPPERS, BED SKIRTS, CANOPIES; TOWELS, WASHCLOTHS, SHOWER CURTAINS, TABLE LINENS, TEXTILE NAPKINS, PLACE MATS NOT OF PAPER, UNFITTED FURNITURE COVERS, WINDOW CURTAINS, TEXTILE WALL HANGINGS (U.S. CLS. 42 AND 50).
FIRST USE 6-0-2004; IN COMMERCE 6-0-2004.

3,482,042. EASTWAY FAIR COMPANY LIMITED, TORTOLA, BR.VIRGIN ISLANDS. SN 78-421,112. PUB. 10-31-2006, FILED 5-18-2004.

**NO DOWNTIME...
GUARANTEED!**

THE MARK CONSISTS OF STANDARD CHARACTERS WITHOUT CLAIM TO ANY PARTICULAR FONT, STYLE, SIZE, OR COLOR.

CLASS 7—MACHINERY

FOR CORDLESS POWER TOOLS, NAMELY, DRILLS, CIRCULAR SAWS, RECIPROCATING SAWS, IMPACT DRIVERS, PLANERS, JIGSAWS AND CAULK GUNS (U.S. CLS. 13, 19, 21, 23, 31, 34 AND 35).
FIRST USE 5-31-2007; IN COMMERCE 5-31-2007.

CLASS 9—ELECTRICAL AND SCIENTIFIC APPARATUS

FOR BATTERIES AND BATTERY CHARGERS (U.S. CLS. 21, 23, 26, 36 AND 38).
FIRST USE 5-31-2007; IN COMMERCE 5-31-2007.

3,482,045. LNT MERCHANDISING COMPANY, LLC, CLIFTON, NJ. SN 78-427,854. PUB. 6-19-2007, FILED 6-1-2004.

ATTITUDE

THE MARK CONSISTS OF STANDARD CHARACTERS WITHOUT CLAIM TO ANY PARTICULAR FONT, STYLE, SIZE, OR COLOR.

CLASS 11—ENVIRONMENTAL CONTROL APPARATUS

FOR LAMPS, DESK LAMPS, READING LAMPS (U.S. CLS. 13, 21, 23, 31 AND 34).
FIRST USE 6-0-2004; IN COMMERCE 6-0-2004.

3,482,054. DRIVER, JOHN A, WATERFORD, CA. SN 78-466,767. PUB. 10-4-2005, FILED 8-12-2004.

CandyCot

THE MARK CONSISTS OF STANDARD CHARACTERS WITHOUT CLAIM TO ANY PARTICULAR FONT, STYLE, SIZE, OR COLOR.

CLASS 29—MEATS AND PROCESSED FOODS

FOR DRIED APRICOTS (U.S. CL. 46).
FIRST USE 12-31-2007; IN COMMERCE 12-31-2007.

CLASS 31—NATURAL AGRICULTURAL PRODUCTS

FOR RAW APRICOT FRUITS (U.S. CLS. 1 AND 46).
FIRST USE 1-11-2008; IN COMMERCE 1-11-2008.

3,482,056. BAHASH, TIMOTHY J., PHILADELPHIA, PA. SN 78-473,999. PUB. 8-30-2005, FILED 8-26-2004.

The Natural Order of Things

THE MARK CONSISTS OF STANDARD CHARACTERS WITHOUT CLAIM TO ANY PARTICULAR FONT, STYLE, SIZE, OR COLOR.

CLASS 3—COSMETICS AND CLEANING PREPARATIONS

FOR BATH PRODUCTS, NAMELY, SOAPS, LOTIONS, SKIN CLEANSERS, FACIAL CLEANSERS AND ESSENTIAL OILS FOR PERSONAL USE (U.S. CLS. 1, 4, 6, 50, 51 AND 52).

FIRST USE 7-28-2003; IN COMMERCE 3-15-2004.

CLASS 21—HOUSEWARES AND GLASS

FOR STORAGE CONTAINERS, NAMELY CONTAINERS FOR STORAGE OF SPICES, OILS AND OTHER FOOD PRODUCTS (U.S. CLS. 2, 13, 23, 29, 30, 33, 40 AND 50).

FIRST USE 7-28-2003; IN COMMERCE 1-15-2008.

3,482,066. NETSTAIRS.COM, INC., FT. LAUDERDALE, FL. SN 78-491,937. PUB. 2-6-2007, FILED 9-30-2004.

e-iV8

THE MARK CONSISTS OF STANDARD CHARACTERS WITHOUT CLAIM TO ANY PARTICULAR FONT, STYLE, SIZE, OR COLOR.

CLASS 9—ELECTRICAL AND SCIENTIFIC APPARATUS

FOR VIDEO E-MAIL SOFTWARE PROGRAM CONTAINED ON A COMPACT DISC; VIDEO E-MAIL SOFTWARE PROGRAM DOWNLOADABLE FROM THE INTERNET (U.S. CLS. 21, 23, 26, 36 AND 38).

FIRST USE 3-21-2005; IN COMMERCE 3-21-2005.

CLASS 38—COMMUNICATION

FOR INTERNET BASED E-MAIL AND VIDEO TRANSMISSION SERVICES (U.S. CLS. 100, 101 AND 104). FIRST USE 3-21-2005; IN COMMERCE 3-21-2005.

3,482,074. BATH & BODY WORKS BRAND MANAGEMENT, INC., REYNOLDSBURG, OH. SN 78-515,132. PUB. 3-28-2006, FILED 11-11-2004.

TROPICAL COLADA

THE MARK CONSISTS OF STANDARD CHARACTERS WITHOUT CLAIM TO ANY PARTICULAR FONT, STYLE, SIZE, OR COLOR.

CLASS 3—COSMETICS AND CLEANING PREPARATIONS

FOR PERSONAL CARE PRODUCTS, NAMELY, BATH CREAM, BODY BUTTER SKIN MOISTURIZING LOTIONS, BODY CREAM, FRAGRANT BODY SPRAY, BODY LOTION, BODY MIST, BODY SCRUB, BODY SMOOTHING SKIN MOISTURIZERS, BODY SOAP, BODY WASH, BUBBLE BATH, CREAM BODY WASH, CREAM CLEANSER, ESSENTIAL OILS FOR PERSONAL USE, FACE LOTION, FACE SOAP, FACE WASH, FACE CLEANSER, FACE CREAM, FOAM BATH, NON-MEDICATED FOOT CREAMS, NON-MEDICATED FOOT LOTIONS, FRAGRANT FOOT SPRAY, HAIR SHAMPOO, HAND MOISTURIZING BALMS, HAND CREAM, HAND LOTION, SHOWER CREAM, SHOWER FOAM, SHOWER GEL, SKIN CREAM, SKIN LOTION, SKIN MOISTURIZER (U.S. CLS. 1, 4, 6, 50, 51 AND 52).

FIRST USE 5-9-2005; IN COMMERCE 5-9-2005.

CLASS 4—LUBRICANTS AND FUELS

FOR CANDLES (U.S. CLS. 1, 6 AND 15). FIRST USE 5-9-2005; IN COMMERCE 5-9-2005.

3,482,079. SIEGEL, DANIEL J., LOS ANGELES, CA. SN 78-518,989. PUB. 3-14-2006, FILED 11-18-2004.

THE MINDFUL BRAIN

THE MARK CONSISTS OF STANDARD CHARACTERS WITHOUT CLAIM TO ANY PARTICULAR FONT, STYLE, SIZE, OR COLOR.

CLASS 9—ELECTRICAL AND SCIENTIFIC APPARATUS

FOR PRERECORDED DVDS, CD-ROMS, DIGITAL AUDIO TAPES FEATURING THE SUBJECT OF HUMAN DEVELOPMENT AND PERSONAL GROWTH (U.S. CLS. 21, 23, 26, 36 AND 38).

FIRST USE 10-0-2006; IN COMMERCE 10-0-2006.

CLASS 41—EDUCATION AND ENTERTAINMENT

FOR EDUCATIONAL SERVICES, NAMELY, CONDUCTING PROGRAMS AND SEMINARS IN THE FIELD OF HUMAN DEVELOPMENT AND PERSONAL GROWTH; PROVIDING A WEB SITE FEATURING INFORMATION ON THE SUBJECT OF HUMAN DEVELOPMENT AND PERSONAL GROWTH (U.S. CLS. 100, 101 AND 107).

FIRST USE 8-0-2006; IN COMMERCE 8-0-2006.

3,482,091. HUSSEIN, DAVID A., OAKLAND, CA. SN 78-539,346. PUB. 5-30-2006, FILED 12-28-2004.

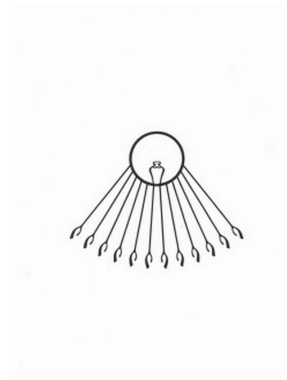

THE MARK CONSISTS OF A DESIGN OF THE SUN WITH TWELVE SUN RAY LIKE PROJECTIONS. INSIDE OF THE SUN IS A COBRA THAT RESTS ON THE INSIDE BOTTOM RING OF THE SUN.

3,482,080. SIEGEL, DANIEL J., LOS ANGELES, CA. SN 78-518,991. PUB. 3-14-2006, FILED 11-18-2004.

MINDSIGHT

THE MARK CONSISTS OF STANDARD CHARACTERS WITHOUT CLAIM TO ANY PARTICULAR FONT, STYLE, SIZE, OR COLOR.

CLASS 9—ELECTRICAL AND SCIENTIFIC APPARATUS

FOR PRERECORDED DVDS, CD-ROMS, DIGITAL AUDIO TAPES FEATURING THE SUBJECT OF HUMAN DEVELOPMENT AND PERSONAL GROWTH (U.S. CLS. 21, 23, 26, 36 AND 38).

FIRST USE 12-0-2005; IN COMMERCE 12-0-2005.

CLASS 41—EDUCATION AND ENTERTAINMENT

FOR EDUCATIONAL SERVICES, NAMELY, CONDUCTING PROGRAMS AND SEMINARS IN THE FIELD OF HUMAN DEVELOPMENT AND PERSONAL GROWTH; PROVIDING A WEB SITE FEATURING INFORMATION ON THE SUBJECT OF HUMAN DEVELOPMENT AND PERSONAL GROWTH (U.S. CLS. 100, 101 AND 107).

FIRST USE 12-0-2005; IN COMMERCE 12-0-2005.

CLASS 14—JEWELRY

FOR WATCHES AND JEWELRY (U.S. CLS. 2, 27, 28 AND 50).

FIRST USE 12-1-2004; IN COMMERCE 2-17-2005.

CLASS 25—CLOTHING

FOR SHOES, HATS, JACKETS, PANTS, SHIRTS, UNDERWEAR, DRESSES, SKIRTS, BLAZERS (U.S. CLS. 22 AND 39).

FIRST USE 10-15-2004; IN COMMERCE 12-1-2004.

3,482,092. HAMMOND, CATHY, SAN DIEGO, CA. SN 78-544,259. PUB. 1-10-2006, FILED 1-7-2005.

PINK POSITIVE

THE MARK CONSISTS OF STANDARD CHARACTERS WITHOUT CLAIM TO ANY PARTICULAR FONT, STYLE, SIZE, OR COLOR.

CLASS 16—PAPER GOODS AND PRINTED MATTER

FOR BOOKS, WORKBOOKS, NOTEBOOKS, MAGAZINES, JOURNALS, PAMPHLETS, GREETING CARDS, NEWSLETTERS, BROCHURES, CALENDARS, BUMPER STICKERS, POSTERS, AND PREPRINTED PRODUCTS, NAMELY, QUESTIONNAIRES, SURVEY ANSWER SHEETS; SURVEY RESULTS, NAMELY, REPORTS; PRINTED ARTICLES, SPEECHES, AND CHECKLISTS, ALL IN THE FIELD OF CANCER EDUCATION, RESEARCH, TREATMENT, CARE, SELF-CARE, REHABILITATION, AND LIFESTYLE CHANGES (U.S. CLS. 2, 5, 22, 23, 29, 37, 38 AND 50).

FIRST USE 3-1-2007; IN COMMERCE 3-1-2007.

CLASS 41—EDUCATION AND ENTERTAINMENT

FOR PROVIDING EDUCATIONAL SERVICES IN THE FIELD OF CANCER RESEARCH, TREATMENT, CARE, SELF-CARE, REHABILITATION, AND LIFESTYLE CHANGES IN THE FORM OF LECTURES, WORKSHOPS, SEMINARS, COURSES, CLASSES, RETREATS, CONFERENCES, INDIVIDUAL INSTRUCTION, PERSONAL COACHING, AND DISTANCE EDUCATION ON THE INTERNET, BY TELEPHONE, AND VIA OTHER DISTANCE EDUCATION MEDIA; PROVIDING NON-DOWNLOADABLE ONLINE JOURNALS, NEWSLETTERS AND SURVEY RESULTS, NAMELY, REPORTS, ALL IN THE FIELD OF CANCER EDUCATION, RESEARCH, TREATMENT, CARE, SELF-CARE, REHABILITATION, AND LIFESTYLE CHANGES (U.S. CLS. 100, 101 AND 107).

FIRST USE 10-20-2006; IN COMMERCE 10-20-2006.

CLASS 44—MEDICAL, BEAUTY AND AGRICULTURAL SERVICES

FOR PROVIDING ONLINE WEBSITES FEATURING HEALTH INFORMATION AND LINKS TO OTHER WEBSITES, IN THE FIELD OF CANCER EDUCATION, RESEARCH, TREATMENT, CARE, SELF-CARE, REHABILITATION, AND LIFESTYLE CHANGES (U.S. CLS. 100 AND 101).

FIRST USE 8-11-2005; IN COMMERCE 10-20-2006.

3,482,093. INTERNATIONAL INTIMATES, INC., DBA BON BEBE, NEW YORK, NY. SN 78-545,338. PUB. 7-31-2007, FILED 1-11-2005.

ONLY GIRLS

THE MARK CONSISTS OF STANDARD CHARACTERS WITHOUT CLAIM TO ANY PARTICULAR FONT, STYLE, SIZE, OR COLOR.

NO CLAIM IS MADE TO THE EXCLUSIVE RIGHT TO USE "GIRLS", APART FROM THE MARK AS SHOWN.

CLASS 24—FABRICS

FOR ACCESSORIES FOR BABIES, NAMELY, WASH-CLOTHS, TOWELS, CRIB BLANKETS, CRIB PADS, BUMPER AND LINENS (U.S. CLS. 42 AND 50).

FIRST USE 11-4-2005; IN COMMERCE 11-4-2005.

CLASS 25—CLOTHING

FOR CLOTHING AND APPAREL FOR CHILDREN AND INFANTS, NAMELY, UNDERGARMENTS, PAJAMAS, BODYSUITS, ONE-PIECE PLAYSUITS, LAYETTES, BIBS, BOOTIES AND HEADWEAR (U.S. CLS. 22 AND 39).

FIRST USE 9-12-2005; IN COMMERCE 9-12-2005.

3,482,096. HANSEN BEVERAGE COMPANY, CORONA, CA. SN 78-559,365. PUB. 10-9-2007, FILED 2-2-2005.

ENERGY PRO

THE MARK CONSISTS OF STANDARD CHARACTERS WITHOUT CLAIM TO ANY PARTICULAR FONT, STYLE, SIZE, OR COLOR.

NO CLAIM IS MADE TO THE EXCLUSIVE RIGHT TO USE "ENERGY", APART FROM THE MARK AS SHOWN.

CLASS 5—PHARMACEUTICALS

FOR NUTRITIONAL SUPPLEMENTS AND CARBONATED DRINKS, AND ENERGY SODAS FORTIFIED WITH VITAMINS, MINERALS, NUTRIENTS, AMINO ACIDS AND/OR HERBS (U.S. CLS. 6, 18, 44, 46, 51 AND 52).

FIRST USE 0-0-2006; IN COMMERCE 0-0-2006.

CLASS 32—LIGHT BEVERAGES

FOR BEVERAGES, NAMELY, ENERGY DRINKS (U.S. CLS. 45, 46 AND 48).

FIRST USE 0-0-2006; IN COMMERCE 0-0-2006.

3,482,103. ALFRED P. SLOAN FOUNDATION, NEW YORK, NY. SN 78-579,065. PUB. 1-23-2007, FILED 3-3-2005.



Sloan Career Cornerstone Center

OWNER OF U.S. REG. NOS. 2,396,401, 2,627,856, AND OTHERS.

NO CLAIM IS MADE TO THE EXCLUSIVE RIGHT TO USE "CAREER" AND "CENTER", APART FROM THE MARK AS SHOWN.

THE MARK CONSISTS OF AN OPEN CUBE DESIGN DISPLAYING THE SIX SIDES OF A CUBE WITH NO MARKINGS. DISPLAYED TO THE SIDE OF THE CUBE IS A RECTANGLE WITH THE WORDS "SLOAN CAREER CORNERSTONE CENTER" DEPICTED INSIDE.

CLASS 35—ADVERTISING AND BUSINESS

FOR PROVIDING CAREER INFORMATION VIA THE INTERNET ON NETWORKING, JOB HUNTING, CAREERS AND CAREER PLANNING IN THE FIELDS OF ENGINEERING, MATHEMATICS, INFORMATION TECHNOLOGY, AND THE PHYSICAL SCIENCES; AND PROVIDING INFORMATION VIA THE INTERNET RELATING TO THE TYPICAL WORK DAY OF PROFESSIONALS IN THE AFOREMENTIONED FIELDS (U.S. CLS. 100, 101 AND 102).

FIRST USE 4-15-2003; IN COMMERCE 4-15-2003.

CLASS 41—EDUCATION AND ENTERTAINMENT

FOR PROVIDING INFORMATION VIA THE INTERNET ON EDUCATION IN THE FIELDS OF ENGINEERING, MATHEMATICS, INFORMATION TECHNOLOGY, AND THE PHYSICAL SCIENCES (U.S. CLS. 100, 101 AND 107).

FIRST USE 4-15-2003; IN COMMERCE 4-15-2003.

3,482,110. GATHER INC., BOSTON, MA. SN 78-597,499. PUB. 7-4-2006, FILED 3-29-2005.

**CLASS 35—ADVERTISING AND BUSINESS**

FOR ADVERTISING TARGETING, PLACEMENT, TRACKING AND REPORTING SERVICES (U.S. CLS. 100, 101 AND 102).

FIRST USE 6-1-2005; IN COMMERCE 6-1-2005.

CLASS 38—COMMUNICATION

FOR INTEGRATED ON-LINE COMMUNITY AND COMMUNICATIONS SERVICES, NAMELY, GROUP MESSAGING, GROUP MODERATION AND A MODERATING FORUM; NOTIFICATION SERVICE IN THE NATURE OF PROVIDING AUTOMATIC MESSAGES TO MEMBERS IN A GROUP; PROVIDING ELECTRONIC MAIL SERVICES; PROVIDING ONLINE CHAT ROOMS AND ELECTRONIC BULLETIN BOARDS FOR TRANSMISSION OF MESSAGES AMONG USERS IN A FIELD OF GENERAL INTEREST (U.S. CLS. 100, 101 AND 104).

FIRST USE 6-1-2005; IN COMMERCE 6-1-2005.

CLASS 41—EDUCATION AND ENTERTAINMENT

FOR ONLINE PUBLISHING OF TEXT AND GRAPHIC WORKS IN ALL FIELDS; HOSTING PARTIES FOR THE PURPOSE OF SOCIAL INTRODUCTION AND NETWORKING; ORGANIZING COMMUNITY ACTIVITIES AND CULTURAL EVENTS (U.S. CLS. 100, 101 AND 107).

FIRST USE 6-1-2005; IN COMMERCE 6-1-2005.

CLASS 42—SCIENTIFIC AND COMPUTER SERVICES

FOR COMPUTER SERVICES, NAMELY, PROVIDING A SEARCH ENGINE FOR OBTAINING INFORMATION FROM A GLOBAL OR LOCAL COMPUTER NETWORK; INTEGRATED ON-LINE COMMUNITY AND COMMUNICATIONS SERVICES, NAMELY, PROVIDING SHARED GROUP-HOSTING SPACE (U.S. CLS. 100 AND 101).

FIRST USE 9-15-2005; IN COMMERCE 9-15-2005.

CLASS 45—PERSONAL AND LEGAL SERVICES

FOR INTERNET-BASED COMMUNITY NETWORKING SERVICES, PROVIDING FOR SOCIAL NETWORKING AND PROVIDING PERSONAL INFORMATION ABOUT OTHER MEMBERS IN A GROUP (U.S. CLS. 100 AND 101).

FIRST USE 6-1-2005; IN COMMERCE 6-1-2005.

3,482,114. INTERNATIONAL BUSINESS MACHINES CORPORATION, ARMONK, NY. SN 78-603,450. PUB. 11-8-2005, FILED 4-6-2005.

DS4000

THE MARK CONSISTS OF STANDARD CHARACTERS WITHOUT CLAIM TO ANY PARTICULAR FONT, STYLE, SIZE, OR COLOR.

CLASS 9—ELECTRICAL AND SCIENTIFIC APPARATUS

FOR COMPUTER HARDWARE AND COMPUTER SOFTWARE FOR USE IN DATA STORAGE, DATA ENCRYPTION, CONSOLIDATION OF DATA, DISASTER TOLERANCE AND RECOVERY FOR DATA, DATA PROTECTION, AND NETWORK SHARING, AND INSTRUCTION MANUALS SOLD AS A UNIT THEREWITH (U.S. CLS. 21, 23, 26, 36 AND 38).

FIRST USE 9-3-2004; IN COMMERCE 9-3-2004.

CLASS 16—PAPER GOODS AND PRINTED MATTER

FOR PRINTED MATTER, NAMELY, BROCHURES, WRITTEN PRESENTATIONS AND TEACHING MATERIALS IN THE FIELD OF DATA STORAGE (U.S. CLS. 2, 5, 22, 23, 29, 37, 38 AND 50).

FIRST USE 9-3-2004; IN COMMERCE 9-3-2004.

CLASS 42—SCIENTIFIC AND COMPUTER SERVICES

FOR COMPUTER CONSULTATION AND DESIGN SERVICES IN THE FIELD OF DATA STORAGE (U.S. CLS. 100 AND 101).

FIRST USE 9-3-2004; IN COMMERCE 9-3-2004.

3,482,115. ZILA PHARMACEUTICALS, INC., PHOENIX, AZ.
SN 78-604,255. PUB. 9-26-2006, FILED 4-7-2005.

3,482,131. NAACH COMPANY, SAN JOSE, CA. SN 78-639,068.
PUB. 9-19-2006, FILED 5-27-2005.

TBLUE

THE MARK CONSISTS OF STANDARD CHARACTERS WITHOUT CLAIM TO ANY PARTICULAR FONT, STYLE, SIZE, OR COLOR.

CLASS 5—PHARMACEUTICALS

FOR MEDICAL PRODUCTS, NAMELY, CLINICAL MEDICAL REAGENTS AND DIAGNOSTIC PREPARATIONS FOR CLINICAL AND MEDICAL LABORATORY USE (U.S. CLS. 6, 18, 44, 46, 51 AND 52).
FIRST USE 1-30-2006; IN COMMERCE 1-30-2006.

CLASS 10—MEDICAL APPARATUS

FOR MEDICAL DEVICES, NAMELY, ORAL PROBES FOR USE IN THE EXAMINATION AND EVALUATION OF PATIENTS; MEDICAL APPARATUS FOR INTRODUCING PHARMACEUTICAL PREPARATIONS INTO THE HUMAN BODY CONTAINING AN ORAL SWABBING APPARATUS CONTAINING PHARMACEUTICAL PREPARATIONS FOR USE IN THE EXAMINATION AND EVALUATION OF PATIENTS (U.S. CLS. 26, 39 AND 44).
FIRST USE 1-30-2006; IN COMMERCE 1-30-2006.

3,482,130. QUALCOMM INCORPORATED, SAN DIEGO, CA.
SN 78-637,391. PUB. 11-14-2006, FILED 5-25-2005.

UIONE

THE MARK CONSISTS OF STANDARD CHARACTERS WITHOUT CLAIM TO ANY PARTICULAR FONT, STYLE, SIZE, OR COLOR.

CLASS 38—COMMUNICATION

FOR ELECTRONIC AND DIGITAL TRANSMISSION OF DATA, NAMELY, DOWNLOADING OF USER INTERFACES AND DIGITAL CONTENT FOR WIRELESS DEVICES (U.S. CLS. 100, 101 AND 104).
FIRST USE 6-2-2005; IN COMMERCE 6-2-2005.

CLASS 42—SCIENTIFIC AND COMPUTER SERVICES

FOR COMPUTER SERVICES, NAMELY, COMPUTER CONSULTATION IN THE FIELD OF USER INTERFACES AND CONTENT FOR WIRELESS DEVICES, PRODUCT DEVELOPMENT IN THE FIELD OF USER INTERFACES AND CONTENT FOR WIRELESS DEVICES, AND PRODUCT EVALUATION IN THE FIELD OF USER INTERFACES AND CONTENT FOR WIRELESS DEVICES (U.S. CLS. 100 AND 101).
FIRST USE 6-2-2005; IN COMMERCE 6-2-2005.



NO CLAIM IS MADE TO THE EXCLUSIVE RIGHT TO USE "NAACH", APART FROM THE MARK AS SHOWN.

THE COLOR(S) WHITE, ORANGE, GOLD, AND RED IS/ARE CLAIMED AS A FEATURE OF THE MARK.

THE COLOR(S) WHITE APPEARS IN THE LETTERS, THE COLOR ORANGE APPEARS IN THE RECTANGLE FORMING THE BACKGROUND BEHIND THE LETTERS "NAA". THE COLOR RED APPEARS IN THE CROSS BARS IN THE LETTERS "N" AND "H" AND IN THE VERTICAL BARS AT THE RIGHT AND LEFT SIDES OF THE MARK, AND THE COLOR ORANGE APPEARS IN THE RECTANGLE FORMING THE BACK GROUND BEHIND THE LETTERS "CH".

THE FOREIGN WORDING IN THE MARK TRANSLATES INTO ENGLISH AS "MOVEMENT".

CLASS 25—CLOTHING

FOR CLOTHING FOR DANCE, NAMELY, SHIRTS, TROUSERS, TRACK PANTS, T-SHIRTS, JACKETS, WRISTBANDS, BANDANAS, CAPS, SOCKS, SHORTS, BLOUSES, TOPS, SWEAT SHIRTS AND SWEAT PANTS (U.S. CLS. 22 AND 39).

FIRST USE 5-31-2006; IN COMMERCE 5-31-2006.

CLASS 41—EDUCATION AND ENTERTAINMENT

FOR ENTERTAINMENT SERVICES, NAMELY, LIVE DANCE PERFORMANCES INCLUDING ETHNIC DANCES; EDUCATIONAL SERVICES, NAMELY, CLASSES IN THE FIELD OF DANCE; ENTERTAINMENT, NAMELY, PRODUCTION OF MOVIES AND STAGE EVENTS (U.S. CLS. 100, 101 AND 107).

FIRST USE 5-31-2006; IN COMMERCE 5-31-2006.

3,482,136. NZN INTERNATIONAL LICENSING PTY LIMITED, SYDNEY, AUSTRALIA. SN 78-649,334. PUB. 10-10-2006, FILED 6-13-2005.



THE MARK CONSISTS OF A FANCIFUL DESIGN OF A LEAF.

CLASS 29—MEATS AND PROCESSED FOODS

FOR YOGHURT BASED BEVERAGES, NAMELY, YOGHURT SMOOTHIES, YOGHURT DRINKS INCLUDING FRUIT; MILK PRODUCTS, NAMELY, MILK SMOOTHIES (U.S. CL. 46).

FIRST USE 4-0-2005; IN COMMERCE 4-0-2005.

CLASS 30—STAPLE FOODS

FOR FROZEN YOGHURT; ICE CREAM; FLAVORED ICES; MILK SHAKES (U.S. CL. 46).

FIRST USE 4-0-2005; IN COMMERCE 4-0-2005.

CLASS 35—ADVERTISING AND BUSINESS

FOR WHOLESALE AND RETAIL OUTLET AND STORE SERVICES FEATURING ICE CREAM, ICES, ICED COFFEE, FROZEN YOGHURT AND RELATED EDIBLE FROZEN PRODUCTS (U.S. CLS. 100, 101 AND 102).

FIRST USE 7-13-2007; IN COMMERCE 7-13-2007.

3,482,137. SUIZA DAIRY CORPORATION, SAN JUAN, PUERTO RICO. SN 78-649,432. PUB. 4-25-2006, FILED 6-13-2005.



THE COLOR(S) RED AND WHITE IS/ARE CLAIMED AS A FEATURE OF THE MARK.

THE MARK CONSISTS OF THE SUN AND THE WORD "SUIZA" ARE RED AND THE BACKGROUND IS WHITE.

THE FOREIGN WORDING IN THE MARK TRANSLATES INTO ENGLISH AS "SWISS".

CLASS 29—MEATS AND PROCESSED FOODS

FOR MILK AND COTTAGE CHEESE (U.S. CL. 46).

FIRST USE 1-22-2005; IN COMMERCE 1-22-2005.

CLASS 30—STAPLE FOODS

FOR ICE CREAM AND CHEESECAKE (U.S. CL. 46).

FIRST USE 1-22-2005; IN COMMERCE 1-22-2005.

CLASS 32—LIGHT BEVERAGES

FOR NON-ALCOHOLIC BEVERAGES, NAMELY, FRUIT JUICES (U.S. CLS. 45, 46 AND 48).

FIRST USE 1-22-2005; IN COMMERCE 1-22-2005.

CLASS 35—ADVERTISING AND BUSINESS

FOR DISTRIBUTORSHIPS IN THE FIELD OF DAIRY PRODUCTS (U.S. CLS. 100, 101 AND 102).

FIRST USE 1-22-2005; IN COMMERCE 1-22-2005.

3,482,139. IMPRESSLINE, INC., DALLAS, TX. SN 78-650,655. PUB. 10-10-2006, FILED 6-14-2005.

**CLASS 35—ADVERTISING AND BUSINESS**

FOR PROMOTING THE GOODS AND SERVICES OF OTHERS THROUGH THE MARKETING AND DISTRIBUTION OF PROMOTIONAL ITEMS; ONLINE WHOLESALE STORE SERVICES FEATURING PROMOTIONAL ITEMS, NAMELY, CALCULATORS, CAPS, CARD-HOLDERS, CIGARETTE LIGHTERS, CLOCKS, COIN BANKS, COMPACT DISC CASES, FOAM SPORTS BALLS, INSULATED BEVERAGE MUGS AND CONTAINERS, INSULATED CASES FOR BEVERAGES, KEY CHAINS, LETTER OPENERS, NOTEBOOKS, PENS, PEN AND PENCIL HOLDERS, PORTABLE RADIOS, SEWING KITS, AND UMBRELLAS (U.S. CLS. 100, 101 AND 102).

FIRST USE 7-0-2002; IN COMMERCE 2-0-2005.

CLASS 40—MATERIAL TREATMENT

FOR CUSTOM MANUFACTURE OF PROMOTIONAL ITEMS, NAMELY, CALCULATORS, CAPS, CARD-HOLDERS, CIGARETTE LIGHTERS, CLOCKS, COIN BANKS, COMPACT DISC CASES, FOAM SPORTS BALLS, INSULATED BEVERAGE MUGS AND CONTAINERS, INSULATED CASES FOR BEVERAGES, KEY CHAINS, LETTER OPENERS, NOTEBOOKS, PENS, PEN AND PENCIL HOLDERS, PORTABLE RADIOS, SEWING KITS, AND UMBRELLAS (U.S. CLS. 100, 103 AND 106).

FIRST USE 7-0-2002; IN COMMERCE 2-0-2005.

3,482,150. RUSSULA S.A., LA CORUÑA, SPAIN. SN 78-665,738. PUB. 9-25-2007, FILED 7-7-2005.

RUSSULA

THE MARK CONSISTS OF STANDARD CHARACTERS WITHOUT CLAIM TO ANY PARTICULAR FONT, STYLE, SIZE, OR COLOR.

CLASS 37—CONSTRUCTION AND REPAIR

FOR TECHNOLOGICAL SERVICES, NAMELY, INSTALLATION OF ELECTRONIC AND MECHANICAL COMPONENTS AND SYSTEMS IN THE FIELD OF METALS MANUFACTURING AND RELATED INDUSTRIES; INSTALLATION OF COMPUTER SYSTEMS (U.S. CLS. 100, 103 AND 106).

FIRST USE 0-0-1988; IN COMMERCE 11-0-2000.

CLASS 42—SCIENTIFIC AND COMPUTER SERVICES

FOR SCIENTIFIC AND TECHNOLOGICAL SERVICES, NAMELY, PROVIDING DESIGN SERVICES FOR OTHERS IN THE FIELD OF ENGINEERING AND METALS MANUFACTURING AND RELATED INDUSTRIES AND SCIENTIFIC RESEARCH RELATED THERETO; INDUSTRIAL RESEARCH AND ANALYSIS, NAMELY, ENGINEERING ANALYSIS OF ELECTRONIC AND MECHANICAL CONTROL SYSTEMS FOR THE METALS MANUFACTURING INDUSTRY TO IMPROVE PRODUCTIVITY AND EFFICIENCY; DESIGN AND DEVELOPMENT OF COMPUTERS AND SOFTWARE FOR OTHERS; AND ENGINEERING CONSULTATION SERVICES (U.S. CLS. 100 AND 101).

FIRST USE 0-0-1988; IN COMMERCE 11-0-2000.

3,482,157. JOHNS MANVILLE, DENVER, CO. SN 78-675,063.
PUB. 4-18-2006, FILED 7-21-2005.

PermaFlash

THE MARK CONSISTS OF STANDARD CHARACTERS WITHOUT CLAIM TO ANY PARTICULAR FONT, STYLE, SIZE, OR COLOR.

CLASS 1—CHEMICALS

FOR ROOFING ADHESIVE (U.S. CLS. 1, 5, 6, 10, 26 AND 46).

FIRST USE 3-6-2007; IN COMMERCE 3-6-2007.

CLASS 19—NON-METALLIC BUILDING MATERIALS

FOR ROOFING FABRICS (U.S. CLS. 1, 12, 33 AND 50).

FIRST USE 3-6-2007; IN COMMERCE 3-6-2007.

3,482,171. ELLIPTIC SEMICONDUCTOR INC., OTTAWA, CANADA. SN 78-702,921. PUB. 8-28-2007, FILED 8-29-2005.

ELLIPTIC SEMICONDUCTOR

THE MARK CONSISTS OF STANDARD CHARACTERS WITHOUT CLAIM TO ANY PARTICULAR FONT, STYLE, SIZE, OR COLOR.

NO CLAIM IS MADE TO THE EXCLUSIVE RIGHT TO USE "SEMICONDUCTOR", APART FROM THE MARK AS SHOWN.

CLASS 9—ELECTRICAL AND SCIENTIFIC APPARATUS

FOR SEMICONDUCTORS, INTEGRATED CIRCUITS, ELECTRONIC DESIGN AUTOMATIONS (EDA) COMPUTER SOFTWARE PROGRAMS FOR DESIGN, SUPPORT AND ANALYSIS OF ELECTRONIC INTEGRATED CIRCUITS, INTEGRATED CIRCUIT LAYOUTS, INTEGRATED CIRCUIT DESIGN BLOCKS, SOFTWARE APPLICATION DESIGN TOOLS FOR USE IN THE DESIGN OF INTEGRATED CIRCUITS, AND CD ROMS CONTAINING NON-CUSTOMISED INTEGRATED CIRCUIT DESIGNS, SUCH AS PRINTED CIRCUIT BOARDS, ALL FOR USE IN THE FIELD OF NETWORK SECURITY (U.S. CLS. 21, 23, 26, 36 AND 38).

FIRST USE 11-18-2002; IN COMMERCE 11-18-2002.

CLASS 16—PAPER GOODS AND PRINTED MATTER

FOR PRINTED DIAGRAMS AND DESIGNS OF INTEGRATED CIRCUITS FOR USE IN THE FIELD OF NETWORK SECURITY INCLUDING HIGH-LEVEL DESIGN LANGUAGE REPRESENTATIONS FOR INTEGRATED CIRCUITS OF COMMUNICATIONS AND SECURITY HARDWARE, ALGORITHMS, AND PROTOCOLS (U.S. CLS. 2, 5, 22, 23, 29, 37, 38 AND 50).

FIRST USE 11-18-2002; IN COMMERCE 11-18-2002.

CLASS 42—SCIENTIFIC AND COMPUTER SERVICES

FOR INTEGRATED CIRCUIT DESIGN SERVICES, CONSULTING SERVICES RELATING TO INTEGRATED CIRCUIT DESIGN, AND DIAGNOSTIC TESTING OF INTEGRATED CIRCUITS, ALL FOR OTHERS, INTEGRATED CIRCUIT DESIGN SERVICES, NAMELY, PROVIDING CUSTOM DESIGNS OF INTEGRATED CIRCUITS INCLUDING HIGH LEVEL DESIGN LANGUAGE REPRESENTATIONS AND DIAGRAMS FOR INTEGRATED CIRCUITS FOR COMMUNICATIONS, ALGORITHMS, AND PROTOCOLS, ALL FOR USE IN THE FIELD OF NETWORK SECURITY (U.S. CLS. 100 AND 101).

FIRST USE 11-18-2002; IN COMMERCE 11-18-2002.

3,482,174. HULME, NAOMI, ADDISON, TX. SN 78-707,150.
PUB. 5-23-2006, FILED 9-6-2005.

Exhibiting 101

THE MARK CONSISTS OF STANDARD CHARACTERS WITHOUT CLAIM TO ANY PARTICULAR FONT, STYLE, SIZE, OR COLOR.

NO CLAIM IS MADE TO THE EXCLUSIVE RIGHT TO USE "EXHIBITING", APART FROM THE MARK AS SHOWN.

CLASS 16—PAPER GOODS AND PRINTED MATTER

FOR PRINTED CORRESPONDENCE COURSE MATERIALS IN THE FIELD OF CONSUMER SHOW EXHIBITING; PRINTED GUIDES FOR CONSUMER SHOW EXHIBITING (U.S. CLS. 2, 5, 22, 23, 29, 37, 38 AND 50).

FIRST USE 9-13-2005; IN COMMERCE 9-13-2005.

CLASS 41—EDUCATION AND ENTERTAINMENT

FOR ARRANGING OF EXHIBITIONS, SEMINARS AND CONFERENCES; EDUCATION SERVICES, NAMELY, PROVIDING SEMINARS AND CONFERENCES IN THE FIELD OF CONSUMER SHOW EXHIBITING (U.S. CLS. 100, 101 AND 107).

FIRST USE 9-13-2005; IN COMMERCE 9-13-2005.

3,482,191. KOHLER CO., KOHLER, WI. SN 78-734,653. PUB. 5-29-2007, FILED 10-17-2005.

PURIST

THE MARK CONSISTS OF STANDARD CHARACTERS WITHOUT CLAIM TO ANY PARTICULAR FONT, STYLE, SIZE, OR COLOR.

OWNER OF U.S. REG. NOS. 2,855,038 AND 2,960,915.

CLASS 6—METAL GOODS

FOR METAL ROBE HOOKS (U.S. CLS. 2, 12, 13, 14, 23, 25 AND 50).

FIRST USE 8-0-2001; IN COMMERCE 8-0-2001.

CLASS 11—ENVIRONMENTAL CONTROL APPARATUS

FOR SHOWER DOORS; SHOWERS, NAMELY, SHOWER RECEPTORS; SHOWERHEADS; BATHTUBS; BATH SPOUTS; WHIRLPOOLS; LAVATORIES; FAUCETS; TOILETS; PLUMBING FITTINGS, NAMELY, FAUCET TRIM AND VALVE TRIM; BATH DRAINS (U.S. CLS. 13, 21, 23, 31 AND 34).

FIRST USE 8-0-2001; IN COMMERCE 8-0-2001.

3,482,193. NYSE GROUP, INC., NEW YORK, NY. SN 78-742,250. PUB. 1-9-2007, FILED 10-28-2005.

NYSE e-Quote

THE MARK CONSISTS OF STANDARD CHARACTERS WITHOUT CLAIM TO ANY PARTICULAR FONT, STYLE, SIZE, OR COLOR.

OWNER OF U.S. REG. NOS. 909,350, 2,284,340, AND OTHERS.

NO CLAIM IS MADE TO THE EXCLUSIVE RIGHT TO USE "E-QUOTE", APART FROM THE MARK AS SHOWN.

CLASS 36—INSURANCE AND FINANCIAL

FOR CONDUCTING A SECURITIES EXCHANGE FEATURING DUAL AUCTION MARKET CAPABILITIES AND AUTOMATIC TRANSACTION EXECUTION CAPABILITIES VIA PHYSICAL CONVENTION AND ELECTRONICALLY; PROVIDING STOCK MARKET INFORMATION (U.S. CLS. 100, 101 AND 102).

FIRST USE 9-0-2006; IN COMMERCE 9-0-2006.

CLASS 38—COMMUNICATION

FOR TRANSMISSION OF SECURITIES INFORMATION, NAMELY, BIDS AND OFFERS, TO AND BY OTHERS VIA ELECTRONIC COMMUNICATIONS NETWORKS (U.S. CLS. 100, 101 AND 104).

FIRST USE 9-0-2006; IN COMMERCE 9-0-2006.

3,482,197. NYSE GROUP, INC., NEW YORK, NY. SN 78-742,274. PUB. 1-16-2007, FILED 10-28-2005.

NYSE s-Quote

THE MARK CONSISTS OF STANDARD CHARACTERS WITHOUT CLAIM TO ANY PARTICULAR FONT, STYLE, SIZE, OR COLOR.

OWNER OF U.S. REG. NOS. 909,350, 2,284,340, AND OTHERS.

CLASS 36—INSURANCE AND FINANCIAL

FOR CONDUCTING A SECURITIES EXCHANGE FEATURING DUAL AUCTION MARKET CAPABILITIES AND AUTOMATIC TRANSACTION EXECUTION CAPABILITIES VIA PHYSICAL CONVENTION AND ELECTRONICALLY; PROVIDING STOCK MARKET INFORMATION (U.S. CLS. 100, 101 AND 102).

FIRST USE 9-0-2006; IN COMMERCE 9-0-2006.

CLASS 38—COMMUNICATION

FOR TRANSMISSION OF SECURITIES INFORMATION TO AND BY OTHERS VIA ELECTRONIC COMMUNICATIONS NETWORKS (U.S. CLS. 100, 101 AND 104).

FIRST USE 9-0-2006; IN COMMERCE 9-0-2006.

3,482,198. NYSE GROUP, INC., NEW YORK, NY. SN 78-742,285. PUB. 1-9-2007, FILED 10-28-2005.

NYSE Specialist API

THE MARK CONSISTS OF STANDARD CHARACTERS WITHOUT CLAIM TO ANY PARTICULAR FONT, STYLE, SIZE, OR COLOR.

OWNER OF U.S. REG. NOS. 909,350, 2,284,340, AND OTHERS.

NO CLAIM IS MADE TO THE EXCLUSIVE RIGHT TO USE "SPECIALIST API", APART FROM THE MARK AS SHOWN.

CLASS 36—INSURANCE AND FINANCIAL

FOR CONDUCTING A SECURITIES EXCHANGE FEATURING DUAL AUCTION MARKET CAPABILITIES AND AUTOMATIC TRANSACTION EXECUTION CAPABILITIES VIA PHYSICAL CONVENTION AND ELECTRONICALLY FOR DESIGNATED SECURITIES ORDERS; PROVIDING STOCK MARKET INFORMATION (U.S. CLS. 100, 101 AND 102).

FIRST USE 9-0-2006; IN COMMERCE 9-0-2006.

CLASS 38—COMMUNICATION

FOR ELECTRONIC TRANSMISSION OF SECURITIES DATA CONTAINING PROPRIETARY ALGORITHMS FROM EXTERNAL PROGRAMMING INTERFACES VIA ELECTRONIC COMMUNICATION NETWORKS (U.S. CLS. 100, 101 AND 104).

FIRST USE 9-0-2006; IN COMMERCE 9-0-2006.

3,482,204. PUBLISHING DATA MANAGEMENT INC., NEW YORK, NY. SN 78-744,851. PUB. 4-3-2007, FILED 11-1-2005.

PROOFPLUS

THE MARK CONSISTS OF STANDARD CHARACTERS WITHOUT CLAIM TO ANY PARTICULAR FONT, STYLE, SIZE, OR COLOR.

CLASS 35—ADVERTISING AND BUSINESS

FOR WORKFLOW PROCESS SERVICES, NAMELY, MANAGING THE ACTIVITIES OF A BUSINESS BY MONITORING AND FACILITATING THE FLOW OF WORK-IN-PROGRESS DOCUMENTS IN THE FIELD OF PUBLISHING (U.S. CLS. 100, 101 AND 102).

FIRST USE 6-18-2007; IN COMMERCE 6-18-2007.

CLASS 40—MATERIAL TREATMENT

FOR DOCUMENT TYPESETTING (U.S. CLS. 100, 103 AND 106).

FIRST USE 6-18-2007; IN COMMERCE 6-18-2007.

CLASS 41—EDUCATION AND ENTERTAINMENT

FOR WRITTEN DOCUMENT EDITING; DOCUMENT CREATION, NAMELY, DESKTOP PUBLISHING FOR OTHERS (U.S. CLS. 100, 101 AND 107).

FIRST USE 6-18-2007; IN COMMERCE 6-18-2007.

3,482,209. HEAVYOCITY MEDIA, INC., NEW YORK, NY. SN 78-750,339. PUB. 8-8-2006, FILED 11-9-2005.

HEAVYOCITY

THE MARK CONSISTS OF STANDARD CHARACTERS WITHOUT CLAIM TO ANY PARTICULAR FONT, STYLE, SIZE, OR COLOR.

CLASS 35—ADVERTISING AND BUSINESS

FOR RETAIL STORES FEATURING AUDIO RECORDINGS THAT FEATURE AUDIO SAMPLING (U.S. CLS. 100, 101 AND 102).

FIRST USE 1-16-2008; IN COMMERCE 5-20-2008.

CLASS 41—EDUCATION AND ENTERTAINMENT

FOR AUDIO SAMPLING RECORDING AND PRODUCTION (U.S. CLS. 100, 101 AND 107).

FIRST USE 1-16-2008; IN COMMERCE 5-20-2008.

CLASS 42—SCIENTIFIC AND COMPUTER SERVICES

FOR LICENSING OF INTELLECTUAL PROPERTY ON BEHALF OF COMPOSERS AND PRODUCERS; DEVELOPMENT OF COMPUTER SOFTWARE WHICH ALLOWS THE USER TO CREATE, CONTROL AND DISTRIBUTE AUDIO SAMPLES AND VIRTUAL INSTRUMENTS (U.S. CLS. 100 AND 101).

FIRST USE 1-16-2008; IN COMMERCE 5-20-2008.

3,482,223. FLOWERS, INC., BOGART, GA. SN 78-763,583. PUB. 10-2-2007, FILED 11-30-2005.

burton
+BURTON
the TOTAL gift experience

OWNER OF U.S. REG. NO. 2,658,030.

NO CLAIM IS MADE TO THE EXCLUSIVE RIGHT TO USE "GIFT", APART FROM THE MARK AS SHOWN.

CLASS 11—ENVIRONMENTAL CONTROL APPARATUS

FOR LAMPS (U.S. CLS. 13, 21, 23, 31 AND 34).

FIRST USE 6-5-2006; IN COMMERCE 6-19-2006.

CLASS 16—PAPER GOODS AND PRINTED MATTER

FOR PAPER BAGS FOR PACKAGING GIFTS, GIFT WRAPPING PAPER AND TISSUE; PRINTED CARDBOARD YARD SIGNS; SHREDDED PLASTIC AND PAPER STRIPS USED AS MATERIAL FOR PACKAGING GIFTS; CATALOGS AND NEWSLETTERS IN THE FIELD OF BALLOONS AND BALLOON ACCESSORIES, GIFTS AND GIFT ACCESSORIES, AND FLORAL AND CRAFT SUPPLIES; FLORAL AND CRAFT SUPPLIES, SPECIFICALLY, PAPER RIBBONS AND PAPER GIFT WRAPPING RIBBONS, CARDBOARD AND PAPER BOXES; PAPER, PLASTIC AND METALLIC GIFT WRAP; SHREDDED PAPER FOR PACKAGING, TISSUE PAPER FOR PACKAGING AND GIFT WRAPPING PURPOSES IN THE FORM OF SHEETS; PAPER, PLASTIC AND POLYETHYLENE BAGS FOR PACKAGING, PLASTIC SHRINK WRAP FOR PACKAGING, PLASTIC ROLLS FOR GIFT WRAPPING AND PACKAGING; AND PAPER LINERS FOR BASKETS (U.S. CLS. 2, 5, 22, 23, 29, 37, 38 AND 50).

FIRST USE 6-5-2006; IN COMMERCE 6-19-2006.

CLASS 20—FURNITURE AND ARTICLES NOT OTHERWISE CLASSIFIED

FOR HOME ACCENT ITEMS, SPECIFICALLY, WINE RACKS, STOOLS, CHAIRS, TABLES AND MIRRORS; FURNITURE AND PICTURE FRAMES; DECORATIVE TABLE TOP ITEMS, SPECIFICALLY, SCULPTURES IN THE FORM OF CHERUBS AND FIGURINES ALL MADE OF IVORY, WOOD, POLYSTONE AND POLYRESIN; PLANT STANDS AND PLANT RACKS; AND PLASTIC INSERTS FOR USE AS CONTAINER LINERS (U.S. CLS. 2, 13, 22, 25, 32 AND 50).

FIRST USE 6-5-2006; IN COMMERCE 6-19-2006.

CLASS 21—HOUSEWARES AND GLASS

FOR MUGS AND GIFT PAILS; CERAMIC, CHINA AND PORCELAIN PRODUCTS, NAMELY, CUPS, MUGS, PLATES, PITCHERS, TEA POTS, BOWLS, PLATTERS, ORNAMENTS, FIGURES, SCULPTURES IN THE FORM OF CHERUBS, STATUES AND SCULPTURES; BASKETS FOR FLOWERS AND PLANTS, DECORATIVE BASKETS, AND BASKETS FOR USE AS HOME DECOR ITEMS, HOME ACCENT ITEMS, AND HOME FURNITURE ITEMS; PLANTERS, VASES, AND CANDLEHOLDERS; NON-METAL PIGGY BANKS; AND TRAYS (U.S. CLS. 2, 13, 23, 29, 30, 33, 40 AND 50).

FIRST USE 6-5-2006; IN COMMERCE 6-19-2006.

CLASS 24—FABRICS

FOR FABRIC GIFT WRAP, TEXTILE TABLE RUNNERS, TEXTILE PLACEMATS, AND TEXTILE WALL HANGINGS; AND FABRIC LINERS FOR BASKETS (U.S. CLS. 42 AND 50).

FIRST USE 6-5-2006; IN COMMERCE 6-19-2006.

CLASS 28—TOYS AND SPORTING GOODS

FOR FOIL AND LATEX BALLOONS; PLUSH STUFFED TOY ANIMALS AND DOLLS AND OTHER PLUSH TOYS (U.S. CLS. 22, 23, 38 AND 50).

FIRST USE 6-5-2006; IN COMMERCE 6-19-2006.

CLASS 35—ADVERTISING AND BUSINESS

FOR DISTRIBUTORSHIP SERVICES IN THE FIELD OF BALLOONS AND BALLOON ACCESSORIES, GIFTS AND GIFT ACCESSORIES, FLORAL SUPPLIES, HOME ACCENT ITEMS, HOME DECOR ITEMS, CERAMIC ITEMS, TABLE SETTING ITEMS, DECORATIVE TABLE-TOP ITEMS, PLUSH TOY ANIMALS AND OTHER PLUSH ITEMS, MUGS, GIFTS, GIFT PACKAGING, ORNAMENTS, FIGURES, STATUES AND SCULPTURES, BASKETS, PLANTERS, VASES, CANDLEHOLDERS, AND SPECIALTY FOOD AND BEVERAGE ITEMS (U.S. CLS. 100, 101 AND 102).

FIRST USE 1-9-2006; IN COMMERCE 1-9-2006.

3,482,224. FLOWERS, INC., BOGART, GA. SN 78-763,721.
PUB. 10-2-2007, FILED 11-30-2005.

burton
+BURTON

OWNER OF U.S. REG. NO. 2,658,030.

CLASS 16—PAPER GOODS AND PRINTED MATTER

FOR PAPER BAGS FOR PACKAGING GIFTS, GIFT WRAPPING PAPER AND TISSUE; PRINTED CARDBOARD YARD SIGNS; SHREDDED PLASTIC AND PAPER STRIPS USED AS MATERIAL FOR PACKAGING GIFTS; CATALOGS AND NEWSLETTERS IN THE FIELD OF BALLOONS AND BALLOON ACCESSORIES, GIFTS AND GIFT ACCESSORIES, AND FLORAL AND CRAFT SUPPLIES; FLORAL AND CRAFT SUPPLIES, SPECIFICALLY, PAPER RIBBONS AND PAPER GIFT WRAPPING RIBBONS, CARDBOARD AND PAPER BOXES; PAPER, PLASTIC AND METALLIC GIFT WRAP; SHREDDED PAPER FOR PACKAGING, TISSUE PAPER FOR PACKAGING AND GIFT WRAPPING PURPOSES IN THE FORM OF SHEETS; PAPER, PLASTIC AND POLYETHYLENE BAGS FOR PACKAGING, PLASTIC SHRINK WRAP FOR PACKAGING, PLASTIC ROLLS FOR GIFT WRAPPING AND PACKAGING; AND PAPER LINERS FOR BASKETS (U.S. CLS. 2, 5, 22, 23, 29, 37, 38 AND 50).

FIRST USE 6-5-2006; IN COMMERCE 6-19-2006.

CLASS 20—FURNITURE AND ARTICLES NOT OTHERWISE CLASSIFIED

FOR HOME ACCENT ITEMS, SPECIFICALLY, WINE RACKS, STOOLS, CHAIRS, TABLES AND MIRRORS; FURNITURE AND PICTURE FRAMES; DECORATIVE TABLE TOP ITEMS, SPECIFICALLY, SCULPTURES IN THE FORM OF CHERUBS AND FIGURINES ALL MADE OF IVORY, WOOD, POLYSTONE AND POLYRESIN; PLANT STANDS AND PLANT RACKS; AND PLASTIC INSERTS FOR USE AS CONTAINER LINERS (U.S. CLS. 2, 13, 22, 25, 32 AND 50).

FIRST USE 6-5-2006; IN COMMERCE 6-19-2006.

CLASS 21—HOUSEWARES AND GLASS

FOR MUGS AND GIFT PAILS; CERAMIC, CHINA AND PORCELAIN PRODUCTS, NAMELY, CUPS, MUGS, PLATES, PITCHERS, TEA POTS, BOWLS, PLATTERS, ORNAMENTS, FIGURES, SCULPTURES IN THE FORM OF CHERUBS, STATUES AND SCULPTURES; BASKETS FOR FLOWERS AND PLANTS, DECORATIVE BASKETS, AND BASKETS FOR USE AS HOME DECOR ITEMS, HOME ACCENT ITEMS, AND HOME FURNITURE ITEMS; PLANTERS, VASES, AND CANDLEHOLDERS; NON-METAL PIGGY BANKS; AND TRAYS (U.S. CLS. 2, 13, 23, 29, 30, 33, 40 AND 50).

FIRST USE 6-5-2006; IN COMMERCE 6-19-2006.

CLASS 28—TOYS AND SPORTING GOODS

FOR FOIL AND LATEX BALLOONS; PLUSH STUFFED TOY ANIMALS AND DOLLS AND OTHER PLUSH TOYS (U.S. CLS. 22, 23, 38 AND 50).

FIRST USE 6-5-2006; IN COMMERCE 6-19-2006.

CLASS 35—ADVERTISING AND BUSINESS

FOR DISTRIBUTORSHIP SERVICES IN THE FIELD OF BALLOONS AND BALLOON ACCESSORIES, GIFTS AND GIFT ACCESSORIES, FLORAL SUPPLIES, HOME ACCENT ITEMS, HOME DECOR ITEMS, CERAMIC ITEMS, TABLE SETTING ITEMS, DECORATIVE TABLE-TOP ITEMS, PLUSH TOY ANIMALS AND OTHER PLUSH ITEMS, MUGS, GIFTS, GIFT PACKAGING, ORNAMENTS, FIGURES, STATUES AND SCULPTURES, BASKETS, PLANTERS, VASES, CANDLEHOLDERS, AND SPECIALTY FOOD AND BEVERAGE ITEMS (U.S. CLS. 100, 101 AND 102).

FIRST USE 6-5-2006; IN COMMERCE 6-19-2006.

3,482,226. FLOWERS, INC., BOGART, GA. SN 78-763,884.
PUB. 10-2-2007, FILED 11-30-2005.

theTOTAL gift experience

NO CLAIM IS MADE TO THE EXCLUSIVE RIGHT TO USE "GIFT", APART FROM THE MARK AS SHOWN.

CLASS 16—PAPER GOODS AND PRINTED MATTER

FOR PAPER BAGS FOR PACKAGING GIFTS, GIFT WRAPPING PAPER AND TISSUE; PRINTED CARDBOARD YARD SIGNS; SHREDDED PLASTIC AND PAPER STRIPS USED AS MATERIAL FOR PACKAGING GIFTS; CATALOGS AND NEWSLETTERS IN THE FIELD OF BALLOONS AND BALLOON ACCESSORIES, GIFTS AND GIFT ACCESSORIES, AND FLORAL AND CRAFT SUPPLIES; FLORAL AND CRAFT SUPPLIES, SPECIFICALLY, PAPER RIBBONS AND PAPER GIFT WRAPPING RIBBONS, CARDBOARD AND PAPER BOXES; PAPER, PLASTIC AND METALLIC GIFT WRAP; SHREDDED PAPER FOR PACKAGING, TISSUE PAPER FOR PACKAGING AND GIFT WRAPPING PURPOSES IN THE FORM OF SHEETS; PAPER, PLASTIC AND POLYETHYLENE BAGS FOR PACKAGING, PLASTIC SHRINK WRAP FOR PACKAGING, PLASTIC ROLLS FOR GIFT WRAPPING AND PACKAGING; AND PAPER LINERS FOR BASKETS (U.S. CLS. 2, 5, 22, 23, 29, 37, 38 AND 50).

FIRST USE 6-5-2006; IN COMMERCE 6-19-2006.

CLASS 20—FURNITURE AND ARTICLES NOT OTHERWISE CLASSIFIED

FOR HOME ACCENT ITEMS, SPECIFICALLY, WINE RACKS, STOOLS, CHAIRS, TABLES AND MIRRORS; FURNITURE AND PICTURE FRAMES; DECORATIVE TABLE TOP ITEMS, SPECIFICALLY, SCULPTURES IN THE FORM OF CHERUBS AND FIGURINES ALL MADE OF IVORY, WOOD, POLYSTONE AND POLYRESIN; PLANT STANDS AND PLANT RACKS; AND PLASTIC INSERTS FOR USE AS CONTAINER LINERS (U.S. CLS. 2, 13, 22, 25, 32 AND 50).

FIRST USE 6-5-2006; IN COMMERCE 6-19-2006.

CLASS 21—HOUSEWARES AND GLASS

FOR MUGS AND GIFT PAILS; CERAMIC, CHINA AND PORCELAIN PRODUCTS, NAMELY, CUPS, MUGS, PLATES, PITCHERS, TEA POTS, BOWLS, PLATTERS, ORNAMENTS, FIGURES, SCULPTURES IN THE FORM OF CHERUBS, STATUES AND SCULPTURES; BASKETS FOR FLOWERS AND PLANTS, DECORATIVE BASKETS, AND BASKETS FOR USE AS HOME DÉCOR ITEMS, HOME ACCENT ITEMS, AND HOME FURNITURE ITEMS; PLANTERS, VASES, AND CANDLEHOLDERS; NON-METAL PIGGY BANKS; AND TRAYS (U.S. CLS. 2, 13, 23, 29, 30, 33, 40 AND 50).

FIRST USE 6-5-2006; IN COMMERCE 6-19-2006.

CLASS 28—TOYS AND SPORTING GOODS

FOR FOIL AND LATEX BALLOONS; PLUSH STUFFED TOY ANIMALS AND DOLLS AND OTHER PLUSH TOYS (U.S. CLS. 22, 23, 38 AND 50).

FIRST USE 6-5-2006; IN COMMERCE 6-19-2006.

CLASS 35—ADVERTISING AND BUSINESS

FOR DISTRIBUTORSHIP SERVICES IN THE FIELD OF BALLOONS AND BALLOON ACCESSORIES, GIFTS AND GIFT ACCESSORIES, FLORAL SUPPLIES, HOME ACCENT ITEMS, HOME DECOR ITEMS, CERAMIC ITEMS, TABLE SETTING ITEMS, DECORATIVE TABLE TOP ITEMS, PLUSH TOY ANIMALS AND OTHER PLUSH ITEMS, MUGS, GIFTS, GIFT PACKAGING, ORNAMENTS, FIGURES, STATUES AND SCULPTURES, BASKETS, PLANTERS, VASES, CANDLEHOLDERS, AND SPECIALTY FOOD AND BEVERAGE ITEMS (U.S. CLS. 100, 101 AND 102).

FIRST USE 1-9-2006; IN COMMERCE 1-9-2006.

3,482,227. FLOWERS, INC., BOGART, GA. SN 78-763,898.
PUB. 10-2-2007, FILED 11-30-2005.

**burton
+BURTON**

OWNER OF U.S. REG. NO. 2,658,030.

CLASS 11—ENVIRONMENTAL CONTROL APPARATUS

FOR LAMPS (U.S. CLS. 13, 21, 23, 31 AND 34).
FIRST USE 6-5-2006; IN COMMERCE 6-19-2006.

CLASS 16—PAPER GOODS AND PRINTED MATTER

FOR PAPER BAGS FOR PACKAGING GIFTS, GIFT WRAPPING PAPER AND TISSUE; PRINTED CARDBOARD YARD SIGNS; SHREDDED PLASTIC AND PAPER STRIPS USED AS MATERIAL FOR PACKAGING GIFTS; CATALOGS AND NEWSLETTERS IN THE FIELD OF BALLOONS AND BALLOON ACCESSORIES, GIFTS AND GIFT ACCESSORIES, AND FLORAL AND CRAFT SUPPLIES; FLORAL AND CRAFT SUPPLIES, SPECIFICALLY, PAPER RIBBONS AND PAPER GIFT WRAPPING RIBBONS, CARDBOARD AND PAPER BOXES; PAPER, PLASTIC AND METALLIC GIFT WRAP; SHREDDED PAPER FOR PACKAGING, TISSUE PAPER FOR PACKAGING AND GIFT WRAPPING PURPOSES IN THE FORM OF SHEETS; PAPER, PLASTIC AND POLYETHYLENE BAGS FOR PACKAGING, PLASTIC SHRINK WRAP FOR PACKAGING, PLASTIC ROLLS FOR GIFT WRAPPING AND PACKAGING; AND PAPER LINERS FOR BASKETS (U.S. CLS. 2, 5, 22, 23, 29, 37, 38 AND 50).

FIRST USE 6-5-2006; IN COMMERCE 6-19-2006.

CLASS 20—FURNITURE AND ARTICLES NOT OTHERWISE CLASSIFIED

FOR HOME ACCENT ITEMS, SPECIFICALLY, WINE RACKS, STOOLS, CHAIRS, TABLES AND MIRRORS; FURNITURE AND PICTURE FRAMES; DECORATIVE TABLE TOP ITEMS, SPECIFICALLY, SCULPTURES IN THE FORM OF CHERUBS AND FIGURINES ALL MADE OF IVORY, WOOD, POLYSTONE AND POLYRESIN; PLANT STANDS AND PLANT RACKS; AND PLASTIC INSERTS FOR USE AS CONTAINER LINERS (U.S. CLS. 2, 13, 22, 25, 32 AND 50).

FIRST USE 6-5-2006; IN COMMERCE 6-19-2006.

CLASS 21—HOUSEWARES AND GLASS

FOR MUGS AND GIFT PAILS; CERAMIC, CHINA AND PORCELAIN PRODUCTS, NAMELY, CUPS, MUGS, PLATES, PITCHERS, TEA POTS, BOWLS, PLATTERS, ORNAMENTS, FIGURES, SCULPTURES IN THE FORM OF CHERUBS, STATUES AND SCULPTURES; BASKETS FOR FLOWERS AND PLANTS, DECORATIVE BASKETS, AND BASKETS FOR USE AS HOME DÉCOR ITEMS, HOME ACCENT ITEMS, AND HOME FURNITURE ITEMS; PLANTERS, VASES, AND CANDLEHOLDERS; NON-METAL PIGGY BANKS; AND TRAYS (U.S. CLS. 2, 13, 23, 29, 30, 33, 40 AND 50).

FIRST USE 6-5-2006; IN COMMERCE 6-19-2006.

CLASS 24—FABRICS

FOR FABRIC GIFT WRAP, TEXTILE TABLE RUNNERS, TEXTILE PLACEMATS, AND TEXTILE WALL HANGINGS; AND FABRIC LINERS FOR BASKETS (U.S. CLS. 42 AND 50).

FIRST USE 6-5-2006; IN COMMERCE 6-19-2006.

CLASS 28—TOYS AND SPORTING GOODS

FOR FOIL AND LATEX BALLOONS; PLUSH STUFFED TOY ANIMALS AND DOLLS AND OTHER PLUSH TOYS (U.S. CLS. 22, 23, 38 AND 50).

FIRST USE 6-5-2006; IN COMMERCE 6-19-2006.

CLASS 35—ADVERTISING AND BUSINESS

FOR DISTRIBUTORSHIP SERVICES IN THE FIELD OF BALLOONS AND BALLOON ACCESSORIES, GIFTS AND GIFT ACCESSORIES, FLORAL SUPPLIES, HOME ACCENT ITEMS, HOME DECOR ITEMS, CERAMIC ITEMS, TABLE SETTING ITEMS, DECORATIVE TABLETOP ITEMS, PLUSH TOY ANIMALS AND OTHER PLUSH ITEMS, MUGS, GIFTS, GIFT PACKAGING, ORNAMENTS, FIGURES, STATUES AND SCULPTURES, BASKETS, PLANTERS, VASES, CANDLEHOLDERS, AND SPECIALTY FOOD AND BEVERAGE ITEMS (U.S. CLS. 100, 101 AND 102).

FIRST USE 1-9-2006; IN COMMERCE 1-9-2006.

3,482,228. THE SOLOMON R. GUGGENHEIM FOUNDATION, NEW YORK, NY. SN 78-768,162. PUB. 3-20-2007, FILED 12-7-2005.

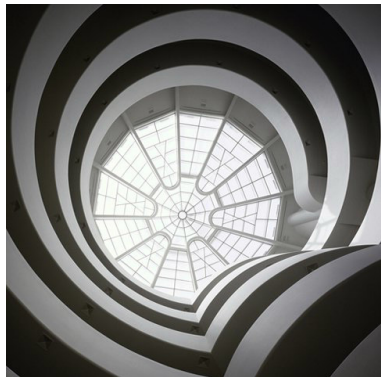

THE MARK CONSISTS OF A REPRESENTATION OF THE INTERIOR OF A BUILDING.

CLASS 9—ELECTRICAL AND SCIENTIFIC APPARATUS

FOR MAGNET, MOUSE PAD (U.S. CLS. 21, 23, 26, 36 AND 38).

FIRST USE 6-3-2008; IN COMMERCE 6-3-2008.

CLASS 11—ENVIRONMENTAL CONTROL APPARATUS

FOR ELECTRIC NIGHT LIGHTS (U.S. CLS. 13, 21, 23, 31 AND 34).

FIRST USE 6-3-2008; IN COMMERCE 6-3-2008.

CLASS 16—PAPER GOODS AND PRINTED MATTER

FOR SKETCHBOOKS, NOTE PADS, PENCILS, POSTERS, BOOKS FEATURING INFORMATION ABOUT ART, ARTISTS AND ARCHITECTURE, BOOKMARKS, POSTCARDS, GIFT CARDS, PRINTS (U.S. CLS. 2, 5, 22, 23, 29, 37, 38 AND 50).

FIRST USE 3-31-2007; IN COMMERCE 3-31-2007.

CLASS 18—LEATHER GOODS

FOR UMBRELLAS, TOTE BAGS (U.S. CLS. 1, 2, 3, 22 AND 41).

FIRST USE 8-31-2007; IN COMMERCE 8-31-2007.

CLASS 20—FURNITURE AND ARTICLES NOT OTHERWISE CLASSIFIED

FOR PICTURE FRAMES, DECORATIVE MOBILES (U.S. CLS. 2, 13, 22, 25, 32 AND 50).

FIRST USE 6-9-2008; IN COMMERCE 6-9-2008.

CLASS 21—HOUSEWARES AND GLASS

FOR MUGS, CREAMER PITCHERS, PORCELAIN STORAGE JARS, TEAPOTS NOT OF PRECIOUS METAL, BOWLS, HOLIDAY ORNAMENTS OF PORCELAIN OR CERAMIC (U.S. CLS. 2, 13, 23, 29, 30, 33, 40 AND 50).

FIRST USE 11-30-2007; IN COMMERCE 11-30-2007.

CLASS 25—CLOTHING

FOR T-SHIRTS, CAPS, SCARVES, TIES (U.S. CLS. 22 AND 39).

FIRST USE 3-31-2007; IN COMMERCE 3-31-2007.

CLASS 28—TOYS AND SPORTING GOODS

FOR SPRING TOYS, MOBILES FOR CHILDREN, SPINNING TOPS, CHRISTMAS TREE ORNAMENTS (U.S. CLS. 22, 23, 38 AND 50).

FIRST USE 3-31-2007; IN COMMERCE 3-31-2007.

3,482,233. LIQUID PUBLISHING, LLC, NORTH MIAMI BEACH, FL. SN 78-772,411. PUB. 10-10-2006, FILED 12-13-2005.

DEATH+TAXES

THE MARK CONSISTS OF STANDARD CHARACTERS WITHOUT CLAIM TO ANY PARTICULAR FONT, STYLE, SIZE, OR COLOR.

CLASS 9—ELECTRICAL AND SCIENTIFIC APPARATUS

FOR PRE-RECORDED DVDS AND CDS FEATURING MUSIC, BAND TOURS, AND MUSICAL ENTERTAINMENT (U.S. CLS. 21, 23, 26, 36 AND 38).

FIRST USE 3-30-2006; IN COMMERCE 3-30-2006.

CLASS 16—PAPER GOODS AND PRINTED MATTER

FOR PRINTED MATTER, NAMELY, MAGAZINES AND POSTERS IN THE FIELD OF MUSIC ENTERTAINMENT; MAGAZINES IN THE FIELD OF MUSIC, BAND TOURS, AND MUSICAL ENTERTAINMENT; NEWSPAPERS; SYNDICATED COLUMNS DEALING WITH EDITORIALS; STICKERS; POSTERS, PENS, PRINTED LABELS, PAPER BANNERS; PRINTED DVD AND CD COVERS IN THE FIELD OF MUSIC, BAND TOURS AND MUSICAL ENTERTAINMENT (U.S. CLS. 2, 5, 22, 23, 29, 37, 38 AND 50).

FIRST USE 3-13-2006; IN COMMERCE 3-30-2006.

CLASS 25—CLOTHING

FOR T-SHIRTS, BASEBALL CAPS, CAPS, HATS, VESTS, BLOUSES (U.S. CLS. 22 AND 39).

FIRST USE 3-27-2006; IN COMMERCE 3-27-2006.

3,482,235. COMPBENEFITS CORPORATION, LOUISVILLE, KY. SN 78-773,147. PUB. 3-20-2007, FILED 12-14-2005.



OWNER OF U.S. REG. NO. 2,706,012.

NO CLAIM IS MADE TO THE EXCLUSIVE RIGHT TO USE "DIRECT", APART FROM THE MARK AS SHOWN.

THE COLOR(S) BLUE, BLACK, GRAY AND WHITE IS/ARE CLAIMED AS A FEATURE OF THE MARK.

THE MARK CONSISTS OF THE COLOR BLUE INCORPORATED INTO THE WORD PREFIX "COMP," THE WORD "DIRECT" AND WITHIN THE CIRCLE DESIGN. THE WORD COMPONENT "BENEFITS" IS IN BLACK. TWO OF THE STYLIZED FIGURES WITHIN THE BLUE CIRCLE ARE WHITE, WHEREAS ONE OF THESE FIGURES IS IN GRAY.

CLASS 36—INSURANCE AND FINANCIAL

FOR ADMINISTRATION OF MANAGED DENTAL AND VISION CARE SUBSCRIPTION PLANS; DENTAL AND VISION HEALTH INSURANCE SERVICES IN THE NATURE OF PRE-PAID DENTAL AND VISION BENEFITS; ADMINISTERING DISCOUNT FEE-FOR-SERVICE DENTAL PLANS, PRE-PAID DENTAL PLANS, PPO DENTAL PLANS AND INDEMNITY DENTAL PLANS; ADMINISTERING DISCOUNT FEE-FOR-SERVICE VISION PLANS, PRE-PAID VISION PLANS, PPO VISION PLANS AND INDEMNITY VISION PLANS; ADMINISTRATION OF PREFERRED PROVIDER PROGRAMS IN THE FIELD OF DENTAL AND VISION CARE (U.S. CLS. 100, 101 AND 102).

FIRST USE 10-4-2005; IN COMMERCE 11-1-2005.

CLASS 44—MEDICAL, BEAUTY AND AGRICULTURAL SERVICES

FOR MANAGED DENTAL AND VISION CARE SERVICES (U.S. CLS. 100 AND 101).

FIRST USE 10-4-2005; IN COMMERCE 11-1-2005.

3,482,243. INNUITY, INC., REDMOND, WA. SN 78-777,496. PUB. 4-10-2007, FILED 12-20-2005.

SMALL IS THE NEW BIG

THE MARK CONSISTS OF STANDARD CHARACTERS WITHOUT CLAIM TO ANY PARTICULAR FONT, STYLE, SIZE, OR COLOR.

CLASS 35—ADVERTISING AND BUSINESS

FOR PROMOTING THE GOODS AND SERVICES OF OTHERS BY PROVIDING A WEB SITE AT WHICH USERS CAN LINK TO MARKETING TOOLS, INFORMATION REGARDING SALES LEADS, PAY-PER-CLICK CAMPAIGN MANAGEMENT, AFFILIATE MARKETING MANAGEMENT, SEARCH ENGINE SUBMISSION, PERMISSION EMAIL MARKETING, WEB ANALYTICS TOOLS AND MANAGEMENT, DOMAIN NAME REGISTRATION, BUSINESS AND E-COMMERCE WEBSITES, CUSTOM DESIGN SERVICES, MERCHANT ACCOUNTS AND PAYMENT PROCESSING SERVICES FOR CREDIT CARDS AND AUTOMATED CLEARINGHOUSE (ACH) TRANSACTIONS, AND BILL PRESENTMENT AND PAYMENT; PROVIDING A SEARCHABLE ONLINE ADVERTISING GUIDE FEATURING THE GOODS AND SERVICES OF OTHER ONLINE VENDORS ON THE INTERNET; PROMOTING THE GOODS AND SERVICES OF OTHERS BY MEANS OF OPERATING AN ON-LINE SHOPPING MALL WITH LINKS TO THE RETAIL WEB SITES OF OTHERS; RETAIL STORE SERVICES FEATURING POINT-OF-SALE (POS) HARDWARE, SOFTWARE FOR ACCOUNTING, PAYROLL, CUSTOMER CARE, HUMAN RESOURCES, AND OTHER MANAGEMENT INFORMATION APPLICATIONS FOR E-COMMERCE AND SMALL BUSINESSES (U.S. CLS. 100, 101 AND 102).

FIRST USE 11-0-2005; IN COMMERCE 11-0-2005.

CLASS 36—INSURANCE AND FINANCIAL

FOR CREDIT CARD TRANSACTION PROCESSING SERVICES (U.S. CLS. 100, 101 AND 102).

FIRST USE 5-0-2007; IN COMMERCE 5-0-2007.

3,482,244. RYERSON PROCUREMENT CORPORATION, CHICAGO, IL. SN 78-777,519. PUB. 2-27-2007, FILED 12-20-2005.



OWNER OF U.S. REG. NOS. 567,013, 2,631,496, AND 2,649,199.

THE MARK CONSISTS OF A STYLIZED "R" DESIGN WITHIN A CIRCLE.

CLASS 6—METAL GOODS

FOR STEEL IN BAR, ROD, SHEET, AND PLATE FORM; STEEL FLOOR PLATES AND TREAD PLATES; STRUCTURAL STEEL TUBING; EXPANDED STEEL SHEETS; CORRUGATED STEEL SHEETS; CORRUGATED STEEL SHEETS FOR CONSTRUCTION PURPOSES, NAMELY, IN THE WALL AND ROOF SECTION OF BUILDINGS; STAINLESS STEEL SOLD IN BULK; METAL CONSTRUCTION MATERIALS, NAMELY, BAR, ROD, SHEET, AND PLATE SHAPES; METAL ROOFING AND ALUMINUM SIDING; METAL FLOOR PLATES AND TREAD PLATES; METAL OPEN FLOORING AND GRATING; ARCHITECTURAL METAL ROOFING IN STEEL AND ALUMINUM; METAL STRUCTURAL TUBING; METAL EXPANDED SHEETS AND GRATING; METAL PERFORATED SHEETS; METAL MECHANICAL TUBING; METAL THREADED TUBING AND BARS; METAL STRUCTURAL SHAPES FOR USE IN THE FURTHER MANUFACTURE OR FINISHED GOODS; METAL PIPE AND PIPE FITTINGS; CARBON STEEL; ALLOY STEEL; STRIP STEEL; SCREW STEEL; METAL SOLD IN BULK FOR FURTHER MANUFACTURING; STAINLESS STEEL; METAL FORGINGS; COLD ROLLED STEEL, FLAME CUT METAL SHAPES, FLAME CUT STEEL SHAPES AND METAL BANDS AND HOOPS; METAL SHAFTING; MACHINED METAL RINGS AND DISCS (U.S. CLS. 2, 12, 13, 14, 23, 25 AND 50).
FIRST USE 3-31-2006; IN COMMERCE 3-31-2006.

CLASS 35—ADVERTISING AND BUSINESS

FOR WHOLESALE DISTRIBUTORSHIP AND RETAIL SERVICES BY DIRECT SOLICITATION BY SALES AGENTS IN THE FIELD OF STEEL, METAL AND FABRICATED METAL AND STEEL PRODUCTS MANUFACTURED BY OTHERS; AND PROVIDING PERSONAL COMPUTER-BASED ON-LINE ORDERING SERVICES FOR CARBON STEEL, STAINLESS STEEL, ALLOY STEEL, COPPER, NICKEL, PLASTIC, AND ALUMINUM STRUCTURAL COMPONENTS, NAMELY, ANGLES, BEAMS, CHANNELS, TEES, PLATES, BARS, SHEETS, COILS, TUBING, PIPE AND FLOORING AND GRATING PRODUCTS, AND FOR THE PROCESSING, MACHINING, AND FINISHING THEREOF; INVENTORY CONTROL SERVICES IN THE NATURE OF VENDOR MANAGEMENT OF CUSTOMER INVENTORIES AND RECEIPT OF GOODS FOR CUSTOMER INVENTORIES, PROVIDING A MAIL ORDER AND AN ON-LINE CATALOG OF THE GOODS AND SERVICES OF OTHERS IN THE FIELD OF STEEL, METAL, AND RELATED CONSTRUCTION EQUIPMENT (U.S. CLS. 100, 101 AND 102).
FIRST USE 3-31-2006; IN COMMERCE 3-31-2006.

CLASS 40—MATERIAL TREATMENT

FOR FABRICATION, PREPARATION, AND TREATMENT OF METALS AND METAL PRODUCTS COMPRISING FLAME CUTTING, SAWING, THREADING, PUNCHING, BENDING, WELDING, DRILLING, GRINDING, AND SHEARING, AND FABRICATION, PREPARATION, AND TREATMENT OF PLASTICS COMPRISING OF MILLING, SANDING, TURNING AND SPECIAL EXTRUSIONS (U.S. CLS. 100, 103 AND 106).
FIRST USE 3-31-2006; IN COMMERCE 3-31-2006.

3,482,262. BAXA, THOMAS, MICHAEL, LOS ANGELES, CA.
SN 78-788,769. PUB. 9-19-2006, FILED 1-10-2006.

Wicked Fairies

THE MARK CONSISTS OF STANDARD CHARACTERS WITHOUT CLAIM TO ANY PARTICULAR FONT, STYLE, SIZE, OR COLOR.

NO CLAIM IS MADE TO THE EXCLUSIVE RIGHT TO USE "FAIRIES", APART FROM THE MARK AS SHOWN.

CLASS 16—PAPER GOODS AND PRINTED MATTER

FOR ART PRINTS; CALENDARS; GREETING CARDS; POSTCARDS; STATIONERY; STICKERS; STORY BOOKS (U.S. CLS. 2, 5, 22, 23, 29, 37, 38 AND 50).
FIRST USE 5-25-2008; IN COMMERCE 5-25-2008.

CLASS 25—CLOTHING

FOR T-SHIRTS (U.S. CLS. 22 AND 39).
FIRST USE 5-25-2008; IN COMMERCE 5-25-2008.

3,482,275. MONTEFIORE MEDICAL CENTER, BRONX, NY.
SN 78-794,562. PUB. 3-20-2007, FILED 1-19-2006.

**CLASS 9—ELECTRICAL AND SCIENTIFIC APPARATUS**

FOR COMPUTER SOFTWARE IN THE FIELD OF HEALTH CARE TO ALLOW USERS TO TRACK PATIENT CARE AND PROGRESS AND THE PROCESSES AND EFFICIENCY OF A HEALTH CARE SYSTEM THROUGH ALL STAGES OF MEDICAL TREATMENTS, HOSPITAL VISITS, LABORATORY SERVICES, REHABILITATION AND ANY OTHERS ASPECT OF THE CONTINUUM OF CARE AND TO PROVIDE DATA AND STATISTICS IN CONNECTION WITH MEDICAL TREATMENT AND HEALTH CARE REGARDING PATIENTS, PATIENT DIAGNOSIS, PATIENT DEMOGRAPHICS, FACILITY/CARE CENTERS AND MANAGED HEALTH CARE PROGRAMS (U.S. CLS. 21, 23, 26, 36 AND 38).
FIRST USE 5-5-2005; IN COMMERCE 6-5-2008.

CLASS 42—SCIENTIFIC AND COMPUTER SERVICES

FOR PROVIDING TEMPORARY ONLINE USE OF NON-DOWNLOADABLE SOFTWARE IN THE FIELD OF HEALTH CARE TO ALLOW USERS TO TRACK PATIENT CARE AND PROGRESS AND THE PROCESSES AND EFFICIENCY OF A HEALTH CARE SYSTEM THROUGH ALL STAGES OF MEDICAL TREATMENTS, HOSPITAL VISITS, LABORATORY SERVICES, REHABILITATION AND ANY OTHER ASPECT OF THE CONTINUUM OF CARE AND TO PROVIDE DATA AND STATISTICS IN CONNECTION WITH MEDICAL TREATMENT AND HEALTH CARE REGARDING PATIENTS, PATIENT DIAGNOSIS, PATIENT DEMOGRAPHICS, FACILITY/CARE CENTERS AND MANAGED HEALTH CARE PROGRAMS (U.S. CLS. 100 AND 101).
FIRST USE 3-7-2005; IN COMMERCE 3-29-2006.

3,482,276. ABBOTT LABORATORIES, ABBOTT PARK, IL.
SN 78-795,107. PUB. 8-21-2007, FILED 1-19-2006.

3,482,295. ENCORE ASSOCIATES, INC, SAN RAMON, CA.
SN 78-812,925. PUB. 12-26-2006, FILED 2-12-2006.

DRIVING FOR SAFETY

THE MARK CONSISTS OF STANDARD CHARACTERS WITHOUT CLAIM TO ANY PARTICULAR FONT, STYLE, SIZE, OR COLOR.

CLASS 16—PAPER GOODS AND PRINTED MATTER

FOR PRINTED MATERIALS, NAMELY, BROCHURES, PAMPHLETS, NEWSLETTERS AND REFERENCE MANUALS, ALL RELATED TO SAFE DRIVING FOR EMPLOYEES (U.S. CLS. 2, 5, 22, 23, 29, 37, 38 AND 50).
FIRST USE 5-31-2002; IN COMMERCE 5-31-2002.

CLASS 41—EDUCATION AND ENTERTAINMENT

FOR EDUCATIONAL SERVICES, NAMELY, CLASSES AND WORKSHOPS IN THE FIELD OF SAFE DRIVING FOR EMPLOYEES (U.S. CLS. 100, 101 AND 107).
FIRST USE 5-31-2002; IN COMMERCE 5-31-2002.

3,482,289. MANSON, DORIAN, YONKERS, NY. SN 78-806,026. PUB. 9-26-2006, FILED 2-2-2006.

HOOKS

THE MARK CONSISTS OF STANDARD CHARACTERS WITHOUT CLAIM TO ANY PARTICULAR FONT, STYLE, SIZE, OR COLOR.

CLASS 9—ELECTRICAL AND SCIENTIFIC APPARATUS

FOR MUSICAL SOUND RECORDINGS (U.S. CLS. 21, 23, 26, 36 AND 38).
FIRST USE 4-30-2008; IN COMMERCE 4-30-2008.

CLASS 41—EDUCATION AND ENTERTAINMENT

FOR ENTERTAINMENT, NAMELY, LIVE PERFORMANCES BY A MUSICAL ARTIST AND/OR MUSICAL BAND (U.S. CLS. 100, 101 AND 107).
FIRST USE 1-31-2001; IN COMMERCE 1-31-2001.

AgriWise

THE MARK CONSISTS OF STANDARD CHARACTERS WITHOUT CLAIM TO ANY PARTICULAR FONT, STYLE, SIZE, OR COLOR.

CLASS 9—ELECTRICAL AND SCIENTIFIC APPARATUS

FOR COMPUTER SOFTWARE PLATFORMS FOR AGRICULTURAL DATA COLLECTION AND TRANSMITTAL SOFTWARE APPLICATIONS; COMPUTER SOFTWARE THAT PROVIDES REAL-TIME, INTEGRATED BUSINESS MANAGEMENT INTELLIGENCE BY COMBINING INFORMATION FROM VARIOUS DATABASES AND PRESENTING IT IN AN EASY-TO-UNDERSTAND USER INTERFACE; COMPUTER SOFTWARE TO AUTOMATE DATA WAREHOUSING (U.S. CLS. 21, 23, 26, 36 AND 38).
FIRST USE 5-7-2008; IN COMMERCE 5-7-2008.

CLASS 42—SCIENTIFIC AND COMPUTER SERVICES

FOR AGRICULTURAL RESEARCH; APPLICATION SERVICE PROVIDER (ASP) FEATURING SOFTWARE IN THE FIELD OF AGRICULTURAL DATA COLLECTION AND TRANSMITTAL SOFTWARE APPLICATIONS; APPLICATION SERVICE PROVIDER (ASP), NAMELY, HOSTING COMPUTER SOFTWARE APPLICATIONS OF OTHERS; COMPUTER SERVICE, NAMELY, ACTING AS AN APPLICATION SERVICE PROVIDER IN THE FIELD OF KNOWLEDGE MANAGEMENT TO HOST COMPUTER APPLICATION SOFTWARE FOR CREATING SEARCHABLE DATABASES OF INFORMATION AND DATA (U.S. CLS. 100 AND 101).
FIRST USE 3-5-2008; IN COMMERCE 3-5-2008.

3,482,302. KNOWLEDGE LEARNING CORPORATION, PORTLAND, OR. SN 78-820,322. PUB. 9-18-2007, FILED 2-22-2006.

KLC SCHOOL PARTNERSHIPS

THE MARK CONSISTS OF STANDARD CHARACTERS WITHOUT CLAIM TO ANY PARTICULAR FONT, STYLE, SIZE, OR COLOR.

NO CLAIM IS MADE TO THE EXCLUSIVE RIGHT TO USE "SCHOOL PARTNERSHIPS", APART FROM THE MARK AS SHOWN.

CLASS 41—EDUCATION AND ENTERTAINMENT

FOR EDUCATIONAL SERVICES, NAMELY, PROVIDING COURSES OF INSTRUCTION AT THE PRE-SCHOOL AND PRIMARY LEVELS; AND SUMMER RECREATIONAL CAMPS (U.S. CLS. 100, 101 AND 107).
FIRST USE 9-1-2004; IN COMMERCE 9-1-2004.

CLASS 43—HOTEL AND RESTAURANT SERVICES

FOR CHILD CARE SERVICES AND BEFORE AND AFTER SCHOOL EXTENDED DAY CARE SERVICES (U.S. CLS. 100 AND 101).

FIRST USE 9-1-2004; IN COMMERCE 9-1-2004.

CLASS 39—TRANSPORTATION AND STORAGE

FOR PROVIDING INFORMATION IN THE FIELD OF TRAVEL INFORMATION, NAMELY, PROVIDING USER-CONTRIBUTED ARTICLES ON MODES OF TRANSPORTATION, TRAVEL INFORMATION SERVICES, AND TRAVEL INFORMATION PLANNING; ALL VIA A GLOBAL COMPUTER NETWORK (U.S. CLS. 100 AND 105).

FIRST USE 8-29-2006; IN COMMERCE 8-29-2006.

3,482,305. HELIUM, INC., ANDOVER, MA. SN 78-824,036. PUB. 8-28-2007, FILED 2-27-2006.

Helium

THE MARK CONSISTS OF STANDARD CHARACTERS WITHOUT CLAIM TO ANY PARTICULAR FONT, STYLE, SIZE, OR COLOR.

CLASS 35—ADVERTISING AND BUSINESS

FOR PROVIDING INFORMATION IN THE FIELD OF BUSINESS, NAMELY, PROVIDING USER-CONTRIBUTED ARTICLES ON BUSINESS, MARKETING, ADVERTISING, ENTREPRENEURSHIP, HUMAN RESOURCES, TRADE, INTERNATIONAL BUSINESS, MANAGEMENT, ONLINE BUSINESSES, SALES, AND HOME BUSINESSES; PROVIDING INFORMATION IN THE FIELD OF AUTOS, NAMELY, PROVIDING USER-CONTRIBUTED ARTICLES ON BUYING AND SELLING CARS, AND CONSUMER INFORMATION IN THE NATURE OF AUTOMOBILE REVIEWS; PROVIDING INFORMATION IN THE FIELD OF CAREERS, NAMELY, PROVIDING USER-CONTRIBUTED ARTICLES ON EMPLOYERS, JOB SEARCHING, OCCUPATIONS, AND ONLINE JOBS; PROVIDING INFORMATION IN THE FIELD OF AUTOS NAMELY PROVIDING USER-CONTRIBUTED ARTICLES PROMOTING PUBLIC AWARENESS OF SAFE AUTOMOBILE DRIVING, AUTOMOBILE SAFETY, AND FUEL EFFICIENT DRIVING; PROVIDING INFORMATION IN THE FIELD OF POLITICS, NAMELY PROVIDING USER-CONTRIBUTED ARTICLES ON POLITICAL CONFLICTS, ENVIRONMENTAL POLITICS, GENERAL POLITICS, AND GOVERNMENT; PROVIDING INFORMATION IN THE FIELD OF TECHNOLOGY, NAMELY PROVIDING USER-CONTRIBUTED ARTICLES FEATURING CONSUMER INFORMATION ON COMPUTING, ELECTRONICS, HARDWARE, SOFTWARE, TELEPHONES, AND ONLINE SHOPPING; ALL VIA A GLOBAL COMPUTER NETWORK; PROVIDING AN ONLINE DIRECTORY INFORMATION SERVICE FEATURING INFORMATION REGARDING ARTS, HUMANITIES, AUTOMOTIVE, BUSINESS, COMPUTING, TECHNOLOGY, EDUCATION, ENTERTAINMENT, FOOD, DRINK, HEALTH, FITNESS, HOBBIES, GAMES, HOME, GARDEN, JOBS, CAREERS, PREGNANCY, PERSONAL FINANCE, PETS, ANIMALS, POLITICS, NEWS, RELATIONSHIPS, FAMILY, RELIGION, SPIRITUALITY, SCIENCE, SOCIETY, LIFESTYLE, SPORTS, OUTDOORS, STYLE, BEAUTY, AND TRAVEL (U.S. CLS. 100, 101 AND 102).

FIRST USE 8-29-2006; IN COMMERCE 8-29-2006.

CLASS 36—INSURANCE AND FINANCIAL

FOR PROVIDING INFORMATION IN THE FIELD OF FINANCE, NAMELY, PROVIDING USER-CONTRIBUTED ARTICLES ON FINANCE; PROVIDING INFORMATION IN THE FIELD OF REAL ESTATE, NAMELY PROVIDING USER-CONTRIBUTED ARTICLES ON REAL ESTATE; ALL VIA A GLOBAL COMPUTER NETWORK (U.S. CLS. 100, 101 AND 102).

FIRST USE 8-29-2006; IN COMMERCE 8-29-2006.

CLASS 41—EDUCATION AND ENTERTAINMENT

FOR PROVIDING INFORMATION IN THE FIELD OF EDUCATION, NAMELY, PROVIDING USER-CONTRIBUTED ARTICLES ON ADULT EDUCATION, ALTERNATIVE EDUCATION, COLLEGE AND UNIVERSITY EDUCATION, EARLY CHILDHOOD EDUCATION, GRADE SCHOOL EDUCATION, HIGH SCHOOL EDUCATION, LANGUAGES EDUCATION, AND SPECIAL NEEDS CLASSES; PROVIDING INFORMATION IN THE FIELD OF SPORTS, NAMELY, PROVIDING USER-CONTRIBUTED ARTICLES ON BASEBALL, BASKETBALL, FOOTBALL, GOLF, OUTDOORS, RECREATIONAL AND YOUTH SPORTS, SOCCER, SPORTS CELEBRITIES, SPORTS TRAINING, EQUIPMENT, EXERCISE, AND FITNESS; PROVIDING INFORMATION IN THE FIELD OF ENTERTAINMENT, NAMELY, PROVIDING USER-CONTRIBUTED ARTICLES ON ENTERTAINMENT, CELEBRITIES, MOVIES, TELEVISION, MUSIC, MUSICAL INSTRUMENTS, MUSIC EDUCATION, MUSICIANS, BANDS, MUSIC PRODUCTION, MUSIC ENGINEERING, MUSIC REVIEWS; PROVIDING INFORMATION IN THE FIELD OF HOBBIES, NAMELY PROVIDING USER-CONTRIBUTED ARTICLES ON HOBBIES, ANTIQUES, COLLECTING, AND CRAFTS; PROVIDING INFORMATION IN THE FIELD OF GAMES, NAMELY, PROVIDING USER-CONTRIBUTED ARTICLES ON ELECTRONIC GAMES, BOARD GAMES, CARD GAMES, FANTASY GAMES, ROLE PLAYING GAMES, AND VIDEO GAMES; ALL VIA A GLOBAL COMPUTER NETWORK; INFORMATION IN THE FIELD OF PARENTING CONCERNING EDUCATION OF CHILDREN; INFORMATION IN THE FIELD OF PARENTING CONCERNING ENTERTAINMENT OF CHILDREN (U.S. CLS. 100, 101 AND 107).

FIRST USE 8-29-2006; IN COMMERCE 8-29-2006.

CLASS 42—SCIENTIFIC AND COMPUTER SERVICES

FOR PROVIDING INFORMATION IN THE FIELD OF COMPUTER AND INFORMATION TECHNOLOGY, NAMELY, PROVIDING USER-CONTRIBUTED ARTICLES ABOUT THE INTERNET, ONLINE COMPUTER SECURITY, AND WEB DESIGN; PROVIDING INFORMATION IN THE FIELD OF SCIENCE, NAMELY, PROVIDING USER-CONTRIBUTED ARTICLES ON BIOLOGY, EARTH SCIENCE, MEDICAL SCIENCE, PHYSICAL SCIENCE, AND SOCIAL SCIENCE; ALL VIA A GLOBAL COMPUTER NETWORK; APPLICATION SERVICE PROVIDER, FEATURING SOFTWARE FOR USE IN RATING AND RANKING INFORMATION CONCERNING VARIOUS GENERAL INTEREST AND SPECIFIC INTEREST TOPICS (U.S. CLS. 100 AND 101).

FIRST USE 8-29-2006; IN COMMERCE 8-29-2006.

CLASS 44—MEDICAL, BEAUTY AND AGRICULTURAL SERVICES

FOR PROVIDING INFORMATION IN THE FIELD OF STYLE, NAMELY, PROVIDING USER-CONTRIBUTED ARTICLES ON INFORMATION ABOUT BEAUTY, BODY CARE, HAIR CARE, AND SKIN CARE; PROVIDING INFORMATION IN THE FIELD OF HOME AND GARDEN, NAMELY, PROVIDING USER-CONTRIBUTED ARTICLES ON LAWN CARE, AND GARDEN CARE; PROVIDING INFORMATION IN THE FIELD OF HEALTH CONDITIONS, NAMELY, PROVIDING USER-CONTRIBUTED ARTICLES ON, ALLERGIES, ASTHMA, ALTERNATIVE HEALTH, DENTISTRY, WEIGHT REDUCTION DIET PLANNING, VARIOUS DISEASES, FIRST AID CARE, GENERAL HEALTH, MEDICAL

ISSUES, MENTAL HEALTH, NUTRITION, PEDIATRIC CARE, HEALTH, SUBSTANCE ABUSE, ADDICTION, AND VISION; PROVIDING INFORMATION IN THE FIELD OF PETS AND ANIMALS, NAMELY, PROVIDING USER-CONTRIBUTED ARTICLES ON FEEDING AND HOUSING PETS, ANIMAL PEDIGREE AND BREEDING, AND ANIMAL HEALTH; ALL VIA A GLOBAL COMPUTER NETWORK; INFORMATION ABOUT PARENTING TOPICS, NAMELY, DRUG AND ALCOHOL AWARENESS; INFORMATION IN THE FIELD OF PARENTING CONCERNING THE HEALTH OF CHILDREN (U.S. CLS. 100 AND 101).

FIRST USE 8-29-2006; IN COMMERCE 8-29-2006.

CLASS 45—PERSONAL AND LEGAL SERVICES

FOR PROVIDING INFORMATION RELATING TO DIVERSE HUMAN CULTURES, BELIEFS, LIFESTYLES AND RELATIONSHIPS, NAMELY PROVIDING USER-CONTRIBUTED ARTICLES ON FAMILY RELATIONSHIPS, HUMAN COMMUNICATION, CHILD DISCIPLINE, DATING, MARRIAGE, AND IMPROVING FRIENDSHIPS; PROVIDING INFORMATION IN THE FIELD OF RELIGION, NAMELY PROVIDING USER-CONTRIBUTED ARTICLES ON SPIRITUALITY, RELIGIOUS BELIEFS, AND RELIGIOUS THEORIES; ALL VIA A GLOBAL COMPUTER NETWORK; INFORMATION IN THE FIELD OF PARENTING CONCERNING INTRA-FAMILY RELATIONSHIPS (U.S. CLS. 100 AND 101).

FIRST USE 8-29-2006; IN COMMERCE 8-29-2006.

3,482,317. HEALTHSTAT, LLC, WILLOW GROVE, PA. SN 78-835,734. PUB. 8-21-2007, FILED 3-13-2006.

Healogix

THE MARK CONSISTS OF STANDARD CHARACTERS WITHOUT CLAIM TO ANY PARTICULAR FONT, STYLE, SIZE, OR COLOR.

CLASS 16—PAPER GOODS AND PRINTED MATTER

FOR PRINTED REPORTS FEATURING INFORMATION PERTAINING TO THE HEALTH CARE AND PHARMACEUTICAL INDUSTRIES (U.S. CLS. 2, 5, 22, 23, 29, 37, 38 AND 50).

FIRST USE 9-1-2006; IN COMMERCE 9-1-2006.

CLASS 35—ADVERTISING AND BUSINESS

FOR BUSINESS CONSULTATION SERVICES; MARKET RESEARCH SERVICES; CREATING BUSINESS REPORTS RELATING TO THE HEALTH CARE AND PHARMACEUTICAL INDUSTRIES (U.S. CLS. 100, 101 AND 102).

FIRST USE 9-1-2006; IN COMMERCE 9-1-2006.

3,482,320. ANTHRO CORPORATION, TUALATIN, OR. SN 78-837,569. PUB. 7-17-2007, FILED 3-15-2006.

SHOP ABOUT

THE MARK CONSISTS OF STANDARD CHARACTERS WITHOUT CLAIM TO ANY PARTICULAR FONT, STYLE, SIZE, OR COLOR.

CLASS 9—ELECTRICAL AND SCIENTIFIC APPARATUS

FOR POWER SUPPLIES (U.S. CLS. 21, 23, 26, 36 AND 38).

FIRST USE 3-1-2006; IN COMMERCE 3-15-2006.

CLASS 20—FURNITURE AND ARTICLES NOT OTHERWISE CLASSIFIED

FOR MODULAR, MOBILE FURNITURE FOR COMPUTERS, ELECTRONIC CASH REGISTERS, BATTERY POWERED MOBILE CASH REGISTERS, SCANNERS, BAR-CODE READERS, LABEL PRINTERS, AND OTHER HARDWARE AND ACCESSORIES, NAMELY, SHELVES, DRAWERS, AND NON-METAL HANDLES (U.S. CLS. 2, 13, 22, 25, 32 AND 50).

FIRST USE 3-1-2006; IN COMMERCE 3-15-2006.

3,482,333. WATERSMOLITOR, INC., MINNEAPOLIS, MN. SN 78-851,380. PUB. 9-11-2007, FILED 3-31-2006.

WOMANWISE

THE MARK CONSISTS OF STANDARD CHARACTERS WITHOUT CLAIM TO ANY PARTICULAR FONT, STYLE, SIZE, OR COLOR.

CLASS 9—ELECTRICAL AND SCIENTIFIC APPARATUS

FOR PRE-RECORDED CDS, DVDS, VIDEOTAPES AND DOWNLOADABLE VIDEO RECORDINGS OF PODCASTS FEATURING INFORMATION RELATED TO ADVERTISING, MARKETING, BRANDING AND CONSUMER INSIGHT (U.S. CLS. 21, 23, 26, 36 AND 38).

FIRST USE 9-5-2006; IN COMMERCE 9-5-2006.

CLASS 16—PAPER GOODS AND PRINTED MATTER

FOR PRINTED LECTURES; PRINTED SPEECHES; BOOKS IN THE FIELDS OF ADVERTISING, MARKETING, BRANDING AND CONSUMER INSIGHT; NEWSLETTERS IN THE FIELDS OF ADVERTISING, MARKETING, BRANDING AND CONSUMER INSIGHT; PRINTED VISUALS IN THE NATURE OF PHOTOGRAPHS, INFORMATION GRAPHICS AND PROMOTIONAL MATERIALS; PRINTED WHITE PAPERS FEATURING INFORMATION RELATED TO ADVERTISING, MARKETING, BRANDING AND CONSUMER INSIGHT; A SERIES OF WRITTEN ARTICLES IN THE FIELDS OF ADVERTISING, MARKETING, BRANDING AND CONSUMER INSIGHT; PRINTED SEMINAR NOTES (U.S. CLS. 2, 5, 22, 23, 29, 37, 38 AND 50).
FIRST USE 9-5-2006; IN COMMERCE 9-5-2006.

CLASS 35—ADVERTISING AND BUSINESS

FOR ADVERTISING AND MARKETING SERVICES, NAMELY, CONSUMER RESEARCH, CONSUMER INSIGHT, MARKET RESEARCH, CONDUCTING MARKETING STUDIES AND MARKET RESEARCH CONSULTATION; BUSINESS CONSULTING SERVICES IN THE FIELDS OF MARKETING, ADVERTISING, PROMOTION, PUBLIC RELATIONS, DIRECT MARKETING AND EVENTS (U.S. CLS. 100, 101 AND 102).
FIRST USE 9-5-2006; IN COMMERCE 9-5-2006.

CLASS 41—EDUCATION AND ENTERTAINMENT

FOR PROVIDING NEWSLETTERS IN THE FIELDS OF ADVERTISING, MARKETING, BRANDING AND CONSUMER RESEARCH VIA E-MAIL; PROVIDING ON-LINE PUBLICATIONS, NAMELY, BOOKS, NEWSLETTERS, WHITE PAPERS, AND ARTICLES FEATURING INFORMATION RELATED TO ADVERTISING, MARKETING, BRANDING AND CONSUMER INSIGHT; ARRANGING OF SEMINARS; EDUCATIONAL SERVICES, NAMELY, PROVIDING SEMINARS AND GIVING SPEECHES IN THE FIELDS OF ADVERTISING, MARKETING, BRANDING AND CONSUMER INSIGHT (U.S. CLS. 100, 101 AND 107).
FIRST USE 9-5-2006; IN COMMERCE 9-5-2006.

3,482,334. KAJEET, INC., BETHESDA, MD. SN 78-851,944. PUB. 3-20-2007, FILED 4-1-2006.



CLASS 9—ELECTRICAL AND SCIENTIFIC APPARATUS

FOR MOBILE ELECTRONIC DEVICE PROVIDING TRANSMISSION AND STORAGE OF VOICE AND DATA, MESSAGING, GAMES, LOCATION SERVICES, PHOTOGRAPHY, AND OTHER MEDIA AND CONTENT AND RELATED TELECOMMUNICATIONS SERVICES, WITH OPTIONAL PARENTAL CONTROLS; COMPUTER HARDWARE AND SOFTWARE RELATED THERETO, AND DOWNLOADABLE COMPUTER GAMES, MUSIC AND EDUCATIONAL ACTIVITIES AND GAMES (U.S. CLS. 21, 23, 26, 36 AND 38).
FIRST USE 10-31-2006; IN COMMERCE 10-31-2006.

CLASS 38—COMMUNICATION

FOR TELECOMMUNICATIONS SERVICES VIA A MOBILE ELECTRONIC DEVICE, NAMELY, TRANSMISSION OF VOICE AND DATA, MESSAGING, GAMES, LOCATION SERVICES, PHOTOGRAPHY, AND OTHER MEDIA AND CONTENT, WITH OPTIONAL PARENTAL CONTROLS (U.S. CLS. 100, 101 AND 104).
FIRST USE 10-31-2006; IN COMMERCE 10-31-2006.

CLASS 41—EDUCATION AND ENTERTAINMENT

FOR ENTERTAINMENT SERVICES, NAMELY, PROVIDING ON-LINE NON-DOWNLOADABLE COMPUTER GAMES AND MUSIC VIA A MOBILE ELECTRONIC DEVICE; EDUCATION SERVICES, NAMELY, PROVIDING ON-LINE, NON-DOWNLOADABLE EDUCATIONAL ACTIVITIES FOR CHILDREN VIA A MOBILE ELECTRONIC DEVICE (U.S. CLS. 100, 101 AND 107).
FIRST USE 10-31-2006; IN COMMERCE 10-31-2006.

3,482,335. SYNQ SOLUTIONS, INC., ATLANTA, GA. SN 78-852,289. PUB. 7-17-2007, FILED 4-3-2006.



THE MARK CONSISTS OF STANDARD CHARACTERS WITHOUT CLAIM TO ANY PARTICULAR FONT, STYLE, SIZE, OR COLOR.

CLASS 35—ADVERTISING AND BUSINESS

FOR DEMAND PUBLISHING, NAMELY, PUBLISHING OF ADVERTISING TEXTS; REPROGRAPHIC SERVICES, NAMELY, PUBLISHING OF ADVERTISING TEXTS (U.S. CLS. 100, 101 AND 102).
FIRST USE 3-7-2007; IN COMMERCE 3-7-2007.

CLASS 40—MATERIAL TREATMENT

FOR DEMAND PUBLISHING, NAMELY, PUBLISHING OF BOOKS, MAGAZINES; REPROGRAPHIC SERVICES, NAMELY, PUBLISHING OF BOOKS, MAGAZINES (U.S. CLS. 100, 103 AND 106).
FIRST USE 3-7-2007; IN COMMERCE 3-7-2007.

3,482,337. FRESH EXPRESS INCORPORATED, SALINAS, CA. SN 78-854,235. PUB. 12-25-2007, FILED 4-5-2006.



OWNER OF U.S. REG. NOS. 2,323,851, 3,028,912, AND OTHERS.
NO CLAIM IS MADE TO THE EXCLUSIVE RIGHT TO

USE "FRESH", APART FROM THE MARK AS SHOWN.
THE MARK CONSISTS OF THE WORDS "FRESH EXPRESS" INSIDE A DARK BACKGROUND AND STYLIZED LEAVES ABOVE THE WORD "FRESH".

3,482,341. MONTEFIORE MEDICAL CENTER, BRONX, NY.
SN 78-854,900. PUB. 5-8-2007, FILED 4-5-2006.

CLASS 29—MEATS AND PROCESSED FOODS

FOR SALAD TOPPING, NAMELY, SHREDDED CHEESE, BACON BITS, DRIED VEGETABLES AND FRUITS (U.S. CL. 46).
FIRST USE 4-1-2005; IN COMMERCE 4-1-2005.

CLASS 30—STAPLE FOODS

FOR SALAD TOPPING, NAMELY, CROUTONS AND TORTILLA STRIPS (U.S. CL. 46).
FIRST USE 4-1-2005; IN COMMERCE 4-1-2005.



CLASS 9—ELECTRICAL AND SCIENTIFIC APPARATUS

FOR COMPUTER SOFTWARE IN THE FIELD OF HEALTH CARE TO ALLOW USERS TO TRACK PATIENT CARE AND PROGRESS AND THE PROCESSES AND EFFICIENCY OF A HEALTH CARE SYSTEM THROUGH ALL STAGES OF MEDICAL TREATMENTS, HOSPITAL VISITS, LABORATORY SERVICES, REHABILITATION AND ANY OTHERS ASPECT OF THE CONTINUUM OF CARE AND TO PROVIDE DATA AND STATISTICS IN CONNECTION WITH MEDICAL TREATMENT AND HEALTH CARE REGARDING PATIENTS, PATIENT DIAGNOSIS, PATIENT DEMOGRAPHICS, FACILITY/CARE CENTERS AND MANAGED HEALTH CARE PROGRAMS (U.S. CLS. 21, 23, 26, 36 AND 38).

FIRST USE 5-19-2006; IN COMMERCE 6-5-2008.

CLASS 42—SCIENTIFIC AND COMPUTER SERVICES

FOR PROVIDING TEMPORARY ONLINE USE OF NON-DOWNLOADABLE SOFTWARE IN THE FIELD OF HEALTH CARE TO ALLOW USERS TO TRACK PATIENT CARE AND PROGRESS AND THE PROCESSES AND EFFICIENCY OF A HEALTH CARE SYSTEM THROUGH ALL STAGES OF MEDICAL TREATMENTS, HOSPITAL VISITS, LABORATORY SERVICES, REHABILITATION AND ANY OTHER ASPECT OF THE CONTINUUM OF CARE AND TO PROVIDE DATA AND STATISTICS IN CONNECTION WITH MEDICAL TREATMENT AND HEALTH CARE REGARDING PATIENTS, PATIENT DIAGNOSIS, PATIENT DEMOGRAPHICS, FACILITY/CARE CENTERS AND MANAGED HEALTH CARE PROGRAMS (U.S. CLS. 100 AND 101).

FIRST USE 1-16-2007; IN COMMERCE 1-16-2007.

FRESH EXPRESS

THE MARK CONSISTS OF STANDARD CHARACTERS WITHOUT CLAIM TO ANY PARTICULAR FONT, STYLE, SIZE, OR COLOR.

OWNER OF U.S. REG. NOS. 2,346,673, 2,363,302, AND OTHERS.

NO CLAIM IS MADE TO THE EXCLUSIVE RIGHT TO USE "FRESH", APART FROM THE MARK AS SHOWN.

CLASS 29—MEATS AND PROCESSED FOODS

FOR SALAD TOPPING, NAMELY, SHREDDED CHEESE, BACON BITS AND DRIED VEGETABLES AND FRUITS (U.S. CL. 46).
FIRST USE 4-1-2005; IN COMMERCE 4-1-2005.

CLASS 30—STAPLE FOODS

FOR SALAD TOPPING, NAMELY, CROUTONS AND TORTILLA STRIPS (U.S. CL. 46).
FIRST USE 4-1-2005; IN COMMERCE 4-1-2005.

3,482,346. WASHINGTON MUTUAL, INC., SEATTLE, WA.
SN 78-856,967. PUB. 10-10-2006, FILED 4-7-2006.

ACCOUNT AUTOGRAPH

THE MARK CONSISTS OF STANDARD CHARACTERS WITHOUT CLAIM TO ANY PARTICULAR FONT, STYLE, SIZE, OR COLOR.

NO CLAIM IS MADE TO THE EXCLUSIVE RIGHT TO USE "ACCOUNT", APART FROM THE MARK AS SHOWN.

CLASS 36—INSURANCE AND FINANCIAL

FOR BANKING SERVICES (U.S. CLS. 100, 101 AND 102).
FIRST USE 4-29-2006; IN COMMERCE 4-29-2006.

CLASS 45—PERSONAL AND LEGAL SERVICES

FOR ELECTRONIC SIGNATURE VERIFICATION SERVICES PROVIDED IN CONNECTION WITH BANKING AND FINANCIAL SERVICES (U.S. CLS. 100 AND 101).

FIRST USE 4-29-2006; IN COMMERCE 4-29-2006.

3,482,380. LANXESS DEUTSCHLAND GMBH, LEVERKUSEN, FED REP GERMANY. SN 78-885,831. PUB. 1-23-2007, FILED 5-17-2006.

NANOPRENE

THE MARK CONSISTS OF STANDARD CHARACTERS WITHOUT CLAIM TO ANY PARTICULAR FONT, STYLE, SIZE, OR COLOR.

CLASS 1—CHEMICALS

FOR CHEMICAL PRODUCTS FOR INDUSTRIAL USE, NAMELY, SYNTHETICALLY PREPARED POLYMER PARTICLES; CHEMICAL ADDITIVES FOR USE IN THE MANUFACTURE OF RUBBER COMPOSITIONS; POLYMER PREPARATIONS FOR INDUSTRIAL USE, NAMELY, POLYMER COMPOSITIONS USED IN THE MANUFACTURE OF COMMERCIAL AND INDUSTRIAL GOODS (U.S. CLS. 1, 5, 6, 10, 26 AND 46).

FIRST USE 4-0-2007; IN COMMERCE 4-0-2007.

CLASS 17—RUBBER GOODS

FOR SYNTHETIC RUBBER (U.S. CLS. 1, 5, 12, 13, 35 AND 50).

FIRST USE 4-0-2007; IN COMMERCE 4-0-2007.

3,482,381. GRIFFIN INTERNATIONAL COMPANIES, INC., MINNEAPOLIS, MN. SN 78-886,560. PUB. 8-21-2007, FILED 5-18-2006.

GLITZ & GLITTER

THE MARK CONSISTS OF STANDARD CHARACTERS WITHOUT CLAIM TO ANY PARTICULAR FONT, STYLE, SIZE, OR COLOR.

CLASS 9—ELECTRICAL AND SCIENTIFIC APPARATUS

FOR ACCESSORIES FOR ELECTRONIC DEVICES, NAMELY, EARPHONES, AUDIO SPEAKERS (U.S. CLS. 21, 23, 26, 36 AND 38).

FIRST USE 8-12-2006; IN COMMERCE 8-12-2006.

CLASS 16—PAPER GOODS AND PRINTED MATTER

FOR STICKERS; ADHESIVE GEMS, NAMELY, ADHESIVE-BACKED DECORATIVE GEMS FOR APPLICATION TO PERSONAL ELECTRONICS (U.S. CLS. 2, 5, 22, 23, 29, 37, 38 AND 50).

FIRST USE 8-12-2006; IN COMMERCE 8-12-2006.

3,482,390. SONORA MILLS FOODS, INC., RANCHO DOMINGUEZ, CA. SN 78-892,669. PUB. 1-2-2007, FILED 5-25-2006.

POPCHIPS

THE MARK CONSISTS OF STANDARD CHARACTERS WITHOUT CLAIM TO ANY PARTICULAR FONT, STYLE, SIZE, OR COLOR.

CLASS 29—MEATS AND PROCESSED FOODS

FOR POTATO-BASED SNACK FOODS; VEGETABLE-BASED SNACK FOODS (U.S. CL. 46).

FIRST USE 3-1-2007; IN COMMERCE 5-1-2007.

CLASS 30—STAPLE FOODS

FOR PUFFED CORN SNACKS, EXCLUDING BREAKFAST CEREALS AND CEREAL BARS; RICE-BASED SNACK FOODS, EXCLUDING BREAKFAST CEREALS AND CEREAL BARS; CORN-BASED SNACK FOODS, EXCLUDING BREAKFAST CEREALS AND CEREAL BARS; GRAIN-BASED CHIPS, EXCLUDING BREAKFAST CEREALS AND CEREAL BARS (U.S. CL. 46).

FIRST USE 3-1-2007; IN COMMERCE 5-1-2007.

3,482,394. SUGAR PUBLISHING INCORPORATED, SAN FRANCISCO, CA. SN 78-897,027. PUB. 9-4-2007, FILED 5-31-2006.

FITSUGAR

THE MARK CONSISTS OF STANDARD CHARACTERS WITHOUT CLAIM TO ANY PARTICULAR FONT, STYLE, SIZE, OR COLOR.

CLASS 38—COMMUNICATION

FOR PROVIDING ON-LINE ELECTRONIC BULLETIN BOARDS FOR TRANSMISSION OF MESSAGES AMONG COMPUTER USERS CONCERNING HEALTH, BEAUTY, AND FITNESS (U.S. CLS. 100, 101 AND 104).

FIRST USE 11-2-2006; IN COMMERCE 11-2-2006.

CLASS 41—EDUCATION AND ENTERTAINMENT

FOR PROVIDING ADVICE AND INFORMATION OVER THE INTERNET IN THE FIELD OF FITNESS; ON-LINE JOURNALS, NAMELY, BLOGS FEATURING INFORMATION ABOUT HEALTH, BEAUTY, AND FITNESS (U.S. CLS. 100, 101 AND 107).

FIRST USE 11-2-2006; IN COMMERCE 11-2-2006.

CLASS 44—MEDICAL, BEAUTY AND AGRICULTURAL SERVICES

FOR PROVIDING ADVICE AND INFORMATION OVER THE INTERNET IN THE FIELDS OF HEALTH AND BEAUTY (U.S. CLS. 100 AND 101).

FIRST USE 11-2-2006; IN COMMERCE 11-2-2006.

3,482,395. SUGAR PUBLISHING INCORPORATED, SAN FRANCISCO, CA. SN 78-897,042. PUB. 9-4-2007, FILED 5-31-2006.

GIGGLESUGAR

THE MARK CONSISTS OF STANDARD CHARACTERS WITHOUT CLAIM TO ANY PARTICULAR FONT, STYLE, SIZE, OR COLOR.

CLASS 38—COMMUNICATION

FOR PROVIDING ON-LINE ELECTRONIC BULLETIN BOARDS FOR TRANSMISSION OF MESSAGES AMONG COMPUTER USERS CONCERNING JOKES, ANECDOTES, AND OTHER HUMOROUS MATERIAL (U.S. CLS. 100, 101 AND 104).

FIRST USE 11-9-2006; IN COMMERCE 11-9-2006.

CLASS 41—EDUCATION AND ENTERTAINMENT

FOR ENTERTAINMENT SERVICES, NAMELY, PROVIDING A WEB SITE FEATURING JOKES, ANECDOTES, AND OTHER HUMOROUS MATERIAL; ON-LINE JOURNALS, NAMELY, BLOGS FEATURING JOKES, ANECDOTES, AND OTHER HUMOROUS MATERIAL (U.S. CLS. 100, 101 AND 107).

FIRST USE 11-9-2006; IN COMMERCE 11-9-2006.

3,482,396. SUGAR PUBLISHING INCORPORATED, SAN FRANCISCO, CA. SN 78-897,178. PUB. 9-4-2007, FILED 5-31-2006.

YUMSUGAR

THE MARK CONSISTS OF STANDARD CHARACTERS WITHOUT CLAIM TO ANY PARTICULAR FONT, STYLE, SIZE, OR COLOR.

CLASS 38—COMMUNICATION

FOR PROVIDING ON-LINE ELECTRONIC BULLETIN BOARDS FOR TRANSMISSION OF MESSAGES AMONG COMPUTER USERS CONCERNING FOOD AND COOKING (U.S. CLS. 100, 101 AND 104).

FIRST USE 12-14-2006; IN COMMERCE 12-14-2006.

CLASS 41—EDUCATION AND ENTERTAINMENT

FOR ON-LINE JOURNALS, NAMELY, BLOGS FEATURING FOOD AND COOKING (U.S. CLS. 100, 101 AND 107).

FIRST USE 12-14-2006; IN COMMERCE 12-14-2006.

CLASS 43—HOTEL AND RESTAURANT SERVICES

FOR PROVIDING INFORMATION AND ADVICE OVER THE INTERNET IN THE FIELDS OF FOOD AND COOKING (U.S. CLS. 100 AND 101).

FIRST USE 12-14-2006; IN COMMERCE 12-14-2006.

3,482,397. SUGAR PUBLISHING INCORPORATED, SAN FRANCISCO, CA. SN 78-897,210. PUB. 9-4-2007, FILED 5-31-2006.

PETSUGAR

THE MARK CONSISTS OF STANDARD CHARACTERS WITHOUT CLAIM TO ANY PARTICULAR FONT, STYLE, SIZE, OR COLOR.

CLASS 38—COMMUNICATION

FOR PROVIDING ON-LINE ELECTRONIC BULLETIN BOARDS FOR TRANSMISSION OF MESSAGES AMONG COMPUTER USERS CONCERNING PETS AND ANIMAL CARE (U.S. CLS. 100, 101 AND 104).

FIRST USE 10-19-2007; IN COMMERCE 10-19-2007.

CLASS 41—EDUCATION AND ENTERTAINMENT

FOR ON-LINE JOURNALS, NAMELY, BLOGS FEATURING DISCUSSIONS ABOUT PETS AND ANIMAL CARE (U.S. CLS. 100, 101 AND 107).

FIRST USE 10-19-2007; IN COMMERCE 10-19-2007.

CLASS 44—MEDICAL, BEAUTY AND AGRICULTURAL SERVICES

FOR PROVIDING ADVICE AND INFORMATION OVER THE INTERNET IN THE FIELDS OF PETS AND ANIMAL CARE (U.S. CLS. 100 AND 101).

FIRST USE 10-19-2007; IN COMMERCE 10-19-2007.

3,482,403. INTERNATIONAL ENGINE INTELLECTUAL PROPERTY COMPANY, LLC, WARRENVILLE, IL. SN 78-904,576. PUB. 9-18-2007, FILED 6-9-2006.

MAXXFORCE
INTERNATIONAL DIESEL POWER

NO CLAIM IS MADE TO THE EXCLUSIVE RIGHT TO USE "INTERNATIONAL DIESEL POWER", APART FROM THE MARK AS SHOWN.

THE NAME(S), PORTRAIT(S), AND/OR SIGNATURE(S) SHOWN IN THE MARK IDENTIFIES "MAXXFORCE", WHOSE CONSENT(S) TO REGISTER IS SUBMITTED.

CLASS 7—MACHINERY

FOR INTERNAL COMBUSTION ENGINES, EXCEPT FOR LAND VEHICLES AND REPLACEMENT PARTS THEREFOR (U.S. CLS. 13, 19, 21, 23, 31, 34 AND 35).
FIRST USE 3-23-2007; IN COMMERCE 3-23-2007.

CLASS 12—VEHICLES

FOR INTERNAL COMBUSTION ENGINES FOR LAND VEHICLES (U.S. CLS. 19, 21, 23, 31, 35 AND 44).
FIRST USE 3-23-2007; IN COMMERCE 3-23-2007.

3,482,404. GRILL MEDIC, INC., MOORESVILLE, NC. SN 78-904,694. PUB. 6-19-2007, FILED 6-9-2006.



NO CLAIM IS MADE TO THE EXCLUSIVE RIGHT TO USE "GRILL", APART FROM THE MARK AS SHOWN.

THE COLOR(S) BLACK, GRAY, RED AND WHITE IS/ARE CLAIMED AS A FEATURE OF THE MARK.

THE MARK CONSISTS OF THE IMAGE OF A CHEF IN THE FOREGROUND. THE CHEF'S FACE IS WHITE AND HIS HAIR AND FACIAL FEATURES ARE BLACK. HE IS WEARING A RED SCARF. HIS HAT IS GRAY AND HAS A RED CROSS WITH A WHITE BACKGROUND ON THE LOWER PART OF THE HAT. IN THE BACKGROUND IS A FOUR SIDED SQUARE SIGN RESTING ON ONE CORNER. THE SIGN IS BLACK WITH A WHITE BORDER AND WHITE LETTERING. THE WHITE LETTERING STATES "THE GRILL MEDIC". ALSO DEPICTED IN WHITE IS THE OUTLINE OF A GENERIC GAS GRILL.

CLASS 35—ADVERTISING AND BUSINESS

FOR RETAIL STORE SERVICES AND ONLINE RETAIL STORE SERVICES FEATURING GAS, CHARCOAL AND ELECTRIC GRILLS AND SMOKERS, GRILL ACCESSORIES, COOKING ACCESSORIES AND UTENSILS, OUTDOOR COOKING APPLIANCES AND OUTDOOR HEATING SYSTEMS (U.S. CLS. 100, 101 AND 102).
FIRST USE 11-14-2007; IN COMMERCE 11-14-2007.

CLASS 37—CONSTRUCTION AND REPAIR

FOR INSTALLATION, MAINTENANCE AND/OR REPAIR OF GAS, CHARCOAL AND ELECTRIC GRILLS AND SMOKERS; REPAIR OF GAS LAMPS, GAS LOGS AND OUTDOOR HEATING SYSTEMS (U.S. CLS. 100, 103 AND 106).
FIRST USE 11-14-2007; IN COMMERCE 11-14-2007.

3,482,406. THE PROCTER & GAMBLE COMPANY, CINCINNATI, OH. SN 78-905,772. PUB. 2-27-2007, FILED 6-12-2006.

PRINGLES SELECT

THE MARK CONSISTS OF STANDARD CHARACTERS WITHOUT CLAIM TO ANY PARTICULAR FONT, STYLE, SIZE, OR COLOR.

OWNER OF U.S. REG. NOS. 875,749, 1,665,957, AND 2,670,298.

NO CLAIM IS MADE TO THE EXCLUSIVE RIGHT TO USE "SELECT", APART FROM THE MARK AS SHOWN.

CLASS 29—MEATS AND PROCESSED FOODS

FOR SNACK FOODS, NAMELY, THOSE DERIVED FROM POTATO OR SWEET POTATO IN CHIP, STICK, CRACKER OR BREADSTICK FORM (U.S. CL. 46).
FIRST USE 12-11-2006; IN COMMERCE 12-11-2006.

CLASS 30—STAPLE FOODS

FOR SNACK FOODS, NAMELY, THOSE DERIVED FROM RICE IN CHIP, STICK, CRACKER OR BREADSTICK FORM (U.S. CL. 46).
FIRST USE 12-11-2006; IN COMMERCE 12-11-2006.

3,482,409. BRADY WORLDWIDE, INC., MILWAUKEE, WI. SN 78-906,548. PUB. 11-20-2007, FILED 6-13-2006.

VARIQUEST

THE MARK CONSISTS OF STANDARD CHARACTERS WITHOUT CLAIM TO ANY PARTICULAR FONT, STYLE, SIZE, OR COLOR.

CLASS 9—ELECTRICAL AND SCIENTIFIC APPARATUS

FOR PRINTERS, COMPUTER SOFTWARE FOR OPERATING PRINTERS AND LAMINATING MACHINES, ELECTRONICALLY-OPERATED CUTTING DIES SOLD AS A UNIT WITH PRINTERS AND ELECTRONIC CUT-OUT MAKERS (U.S. CLS. 21, 23, 26, 36 AND 38).

FIRST USE 12-18-2006; IN COMMERCE 1-15-2007.

CLASS 16—PAPER GOODS AND PRINTED MATTER

FOR PAPER FOR PRINTING MULTI-COLOR SIGNS, DOCUMENTS AND POSTERS FOR SCHOOLS AND EDUCATIONAL INSTITUTIONS; AUTOMATIC AND HAND-OPERATED LAMINATING MACHINES FOR OFFICE, SCHOOL, RETAIL, COMMERCIAL AND INDUSTRIAL USE AND SOFTWARE FOR OPERATING THE SAME SOLD AS A UNIT AND RELATED EQUIPMENT AND SUPPLIES, NAMELY PAPER TAPES AND ADHESIVE PAPER STICKERS (U.S. CLS. 2, 5, 22, 23, 29, 37, 38 AND 50).

FIRST USE 12-18-2006; IN COMMERCE 1-15-2007.

3,482,410. HEALTHSTRING, LLC, CHICAGO, IL. SN 78-907,194. PUB. 2-13-2007, FILED 6-13-2006.

HEALTHSTRING

THE MARK CONSISTS OF STANDARD CHARACTERS WITHOUT CLAIM TO ANY PARTICULAR FONT, STYLE, SIZE, OR COLOR.

CLASS 42—SCIENTIFIC AND COMPUTER SERVICES

FOR PROVIDING TEMPORARY USE OF ON-LINE, NON-DOWNLOADABLE DATABASE MANAGEMENT SOFTWARE FOR PURPOSES OF HEALTH RISK ASSESSMENT AND HEALTH RISK PROFILING BY ANALYZING USER-PROVIDED INFORMATION IN THE FIELD OF PREVENTATIVE HEALTH (U.S. CLS. 100 AND 101).

FIRST USE 7-15-2006; IN COMMERCE 7-15-2006.

CLASS 44—MEDICAL, BEAUTY AND AGRICULTURAL SERVICES

FOR CONSULTATION SERVICES, NAMELY, ADVISING INDIVIDUALS HOW TO COLLECT, INPUT AND REVIEW MEDICAL AND HEALTH CARE DATA AND RELATED STORED INFORMATION VIA A PERSONALIZED ONLINE COMPUTER DATABASE; HEALTH INFORMATION SERVICES, NAMELY, PROVIDING A PRIVATE USERS' ONLINE DATABASE OF PHYSICAL AND MENTAL HEALTH RECORDS, AND ASSESSMENT SERVICES FOR PURPOSES OF GUIDING PHYSICAL AND MENTAL HEALTH MAINTENANCE (U.S. CLS. 100 AND 101).

FIRST USE 7-15-2006; IN COMMERCE 7-15-2006.

3,482,411. HEALTHSTRING, LLC, CHICAGO, IL. SN 78-907,214. PUB. 2-13-2007, FILED 6-13-2006.



THE COLOR(S) BLUE IS/ARE CLAIMED AS A FEATURE OF THE MARK.

THE MARK CONSISTS OF THE STYLIZED TEXT "HEALTHSTRING" WITH A FANCIFUL STRING-LIKE DESIGN OF A HEART TO THE LEFT OF THE TEXT AND BOTH THE DESIGN AND TEXT APPEAR ENTIRELY IN THE COLOR BLUE. NO SPECIFIC COLOR CLAIM IS MADE WITH RESPECT TO THE BACKGROUND.

CLASS 42—SCIENTIFIC AND COMPUTER SERVICES

FOR PROVIDING TEMPORARY USE OF ON-LINE, NON-DOWNLOADABLE DATABASE MANAGEMENT SOFTWARE FOR PURPOSES OF HEALTH RISK ASSESSMENT AND HEALTH RISK PROFILING BY ANALYZING USER-PROVIDED INFORMATION IN THE FIELD OF PREVENTATIVE HEALTH (U.S. CLS. 100 AND 101).

FIRST USE 7-15-2006; IN COMMERCE 7-15-2006.

CLASS 44—MEDICAL, BEAUTY AND AGRICULTURAL SERVICES

FOR CONSULTATION SERVICES, NAMELY, ADVISING INDIVIDUALS HOW TO COLLECT, INPUT AND REVIEW MEDICAL AND HEALTH CARE DATA AND RELATED STORED INFORMATION VIA A PERSONALIZED ONLINE COMPUTER DATABASE; HEALTH INFORMATION SERVICES, NAMELY, PROVIDING A PRIVATE USERS' ONLINE DATABASE OF PHYSICAL AND MENTAL HEALTH RECORDS, AND ASSESSMENT SERVICES FOR PURPOSES OF GUIDING PHYSICAL AND MENTAL HEALTH MAINTENANCE (U.S. CLS. 100 AND 101).

FIRST USE 7-15-2006; IN COMMERCE 7-15-2006.

3,482,419. GO MODULAR INC., NORTH DARTMOUTH, MA. SN 78-913,457. PUB. 9-4-2007, FILED 6-21-2006.



NO CLAIM IS MADE TO THE EXCLUSIVE RIGHT TO USE "MODULAR" AND "NEW ENGLAND", APART FROM THE MARK AS SHOWN.

THE MARK CONSISTS OF THE WORDS "GO MODULAR OF NEW ENGLAND" AND THE DESIGN OF A RAMS HEAD AND FINIAL DOOR PEDIMENT WITH A SINGLE SUPPORTING COLUMN.

CLASS 35—ADVERTISING AND BUSINESS

FOR RETAIL STORE SERVICES AND WHOLESALE DISTRIBUTORSHIPS IN THE FIELD OF MODULAR RESIDENCES AND OTHER BUILDINGS (U.S. CLS. 100, 101 AND 102).

FIRST USE 3-5-2008; IN COMMERCE 3-5-2008.

CLASS 37—CONSTRUCTION AND REPAIR

FOR CONSTRUCTION, REMODELING AND REPAIR OF MODULAR RESIDENCES AND OTHER BUILDINGS (U.S. CLS. 100, 103 AND 106).

FIRST USE 3-5-2008; IN COMMERCE 3-5-2008.

CLASS 42—SCIENTIFIC AND COMPUTER SERVICES

FOR DESIGN FOR OTHERS IN THE FIELD OF MODULAR RESIDENCES AND OTHER BUILDINGS (U.S. CLS. 100 AND 101).

FIRST USE 3-5-2008; IN COMMERCE 3-5-2008.

CLASS 36—INSURANCE AND FINANCIAL

FOR FINANCIAL CONSULTING SERVICES; INVESTMENT PORTFOLIO MANAGER EVALUATION SERVICES; INVESTMENT PORTFOLIO MONITORING SERVICES; INVESTMENT PORTFOLIO PERFORMANCE ANALYSIS SERVICES; SECURITIES, COMMODITIES AND REAL ESTATE INVESTMENT RESEARCH SERVICES; TRUST AND INVESTMENT MANAGEMENT SERVICES; PROVIDING FINANCIAL INFORMATION BY ELECTRONIC MEANS; AND PROVIDING ON-LINE FINANCIAL CALCULATORS (U.S. CLS. 100, 101 AND 102).

FIRST USE 7-0-2006; IN COMMERCE 7-0-2006.

3,482,432. FRANK RUSSELL COMPANY, TACOMA, WA. SN 78-921,923. PUB. 2-13-2007, FILED 7-3-2006.

3,482,437. DYNAMOTIVE ENERGY SYSTEMS CORPORATION, VANCOUVER, B.C., CANADA. SN 78-926,777. PUB. 9-11-2007, FILED 7-11-2006.

RUSSELL PENSION FUNDING REPORT CARD

THE MARK CONSISTS OF STANDARD CHARACTERS WITHOUT CLAIM TO ANY PARTICULAR FONT, STYLE, SIZE, OR COLOR.

OWNER OF U.S. REG. NOS. 1,576,348, 2,533,922, AND OTHERS.

NO CLAIM IS MADE TO THE EXCLUSIVE RIGHT TO USE "PENSION FUNDING", APART FROM THE MARK AS SHOWN.

CLASS 9—ELECTRICAL AND SCIENTIFIC APPARATUS

FOR DOWNLOADABLE ELECTRONIC PUBLICATIONS, NAMELY, FINANCIAL REPORTS, FINANCIAL BOOKLETS, FINANCIAL NEWSLETTERS, AND FINANCIAL BROCHURES, ALL IN THE RETIREMENT PLAN AND NON-QUALIFIED PLAN FIELDS; COMPUTER PROGRAMS FOR FINANCIAL ANALYSIS AND MEASUREMENT, GRAPHICAL PRESENTATION, OPERATIONS RESEARCH, DATA STORAGE AND RETRIEVAL AND COMMUNICATIONS, ALL IN THE RETIREMENT PLAN AND NON-QUALIFIED PLAN FIELDS; ELECTRONIC, MAGNETIC, OPTICAL AND OTHER MACHINE-READABLE MEDIA, NAMELY, COMPACT DISKS AND MAGNETIC DISKS CONTAINING FINANCIAL INFORMATION FOR USE IN THE RETIREMENT PLAN AND NON-QUALIFIED PLAN FIELDS; AUDIO VISUAL RECORDINGS FEATURING FINANCIAL INFORMATION IN THE RETIREMENT PLAN AND NON-QUALIFIED PLAN FIELDS (U.S. CLS. 21, 23, 26, 36 AND 38).

FIRST USE 7-0-2006; IN COMMERCE 7-0-2006.

CLASS 16—PAPER GOODS AND PRINTED MATTER

FOR FINANCIAL PUBLICATIONS, NAMELY, FINANCIAL REPORTS, FINANCIAL BOOKLETS, FINANCIAL NEWSLETTERS, AND FINANCIAL BROCHURES, ALL IN THE RETIREMENT PLAN AND NON-QUALIFIED PLAN FIELDS (U.S. CLS. 2, 5, 22, 23, 29, 37, 38 AND 50).

FIRST USE 7-0-2006; IN COMMERCE 7-0-2006.

THE EVOLUTION OF ENERGY

THE MARK CONSISTS OF STANDARD CHARACTERS WITHOUT CLAIM TO ANY PARTICULAR FONT, STYLE, SIZE, OR COLOR.

PRIORITY CLAIMED UNDER SEC. 44(D) ON CANADA APPLICATION NO. 1306170, FILED 6-2-2006, REG. NO. TMA692258, DATED 7-18-2007, EXPIRES 7-18-2022.

NO CLAIM IS MADE TO THE EXCLUSIVE RIGHT TO USE "ENERGY", APART FROM THE MARK AS SHOWN.

CLASS 37—CONSTRUCTION AND REPAIR

FOR CONSTRUCTION OF INDUSTRIAL PLANTS USED TO CONVERT FOREST AND AGRICULTURAL WASTE PRODUCTS INTO FUEL TO BE USED FOR HEAT AND POWER GENERATION AND OTHER DERIVATIVE PRODUCTS (U.S. CLS. 100, 103 AND 106).

FIRST USE 11-30-2006; IN COMMERCE 11-30-2006.

CLASS 39—TRANSPORTATION AND STORAGE

FOR DISTRIBUTION OF FUEL PRODUCED FROM FOREST AND AGRICULTURAL WASTE PRODUCTS FOR USE IN HEAT AND POWER GENERATION AND OTHER DERIVATIVE PRODUCTS, NAMELY, FUEL PRODUCED FROM FOREST AND AGRICULTURAL WASTE PRODUCTS FOR USE IN HEAT AND POWER GENERATION AND OTHER DERIVATIVE PRODUCTS DISTRIBUTION, TRANSPORTATION, AND STORAGE OF FUEL PRODUCED FROM FOREST AND AGRICULTURAL WASTE PRODUCTS FOR USE IN HEAT AND POWER GENERATION AND OTHER DERIVATIVE PRODUCTS (U.S. CLS. 100 AND 105).

FIRST USE 11-30-2006; IN COMMERCE 11-30-2006.

CLASS 40—MATERIAL TREATMENT

FOR PRODUCTION OF ENERGY, NAMELY, PRODUCTION OF FUEL PRODUCED FROM FOREST AND AGRICULTURAL WASTE PRODUCTS FOR USE IN HEAT AND POWER GENERATION AND OTHER DERIVATIVE PRODUCTS (U.S. CLS. 100, 103 AND 106).

FIRST USE 11-30-2006; IN COMMERCE 11-30-2006.

3,482,444. ARGYLE HOLDINGS, LLC, PORTLAND, ME. SN 78-929,859. PUB. 8-7-2007, FILED 7-14-2006.

3,482,474. STARLING, ELAINE, SHINGLE SPRINGS, CA. SN 78-939,269. PUB. 3-13-2007, FILED 7-27-2006.

ANGELA ADAMS

THE MARK CONSISTS OF STANDARD CHARACTERS WITHOUT CLAIM TO ANY PARTICULAR FONT, STYLE, SIZE, OR COLOR.

OWNER OF U.S. REG. NOS. 3,058,433 AND 3,142,756.

THE NAME(S), PORTRAIT(S), AND/OR SIGNATURE(S) SHOWN IN THE MARK IDENTIFIES "ANGELA ADAMS", WHOSE CONSENT(S) TO REGISTER IS SUBMITTED.

CLASS 19—NON-METALLIC BUILDING MATERIALS

FOR FLOOR COVERINGS, NAMELY, CONCRETE TILES, CERAMIC TILES, AND NON-METAL TILES (U.S. CLS. 1, 12, 33 AND 50).

FIRST USE 9-0-2005; IN COMMERCE 9-0-2005.

CLASS 27—FLOOR COVERINGS

FOR FLOOR COVERINGS, NAMELY, CARPET TILES AND CARPETS (U.S. CLS. 19, 20, 37, 42 AND 50).

FIRST USE 12-0-2006; IN COMMERCE 12-0-2006.

3,482,448. THE MELTING POT RESTAURANTS, INC., TAMPA, FL. SN 78-931,174. PUB. 8-7-2007, FILED 7-17-2006.

THE MELTING POT

THE MARK CONSISTS OF STANDARD CHARACTERS WITHOUT CLAIM TO ANY PARTICULAR FONT, STYLE, SIZE, OR COLOR.

OWNER OF U.S. REG. NOS. 2,218,991, 2,270,457, AND OTHERS.

CLASS 29—MEATS AND PROCESSED FOODS

FOR CHEESE; CHEESE FONDUE (U.S. CL. 46).
FIRST USE 1-1-2008; IN COMMERCE 1-1-2008.

CLASS 30—STAPLE FOODS

FOR SAUCES; CHOCOLATE; CHOCOLATE FONDUE (U.S. CL. 46).
FIRST USE 1-1-2008; IN COMMERCE 1-1-2008.

PROMISE POWER

THE MARK CONSISTS OF STANDARD CHARACTERS WITHOUT CLAIM TO ANY PARTICULAR FONT, STYLE, SIZE, OR COLOR.

CLASS 14—JEWELRY

FOR JEWELRY (U.S. CLS. 2, 27, 28 AND 50).
FIRST USE 5-1-2007; IN COMMERCE 5-1-2007.

CLASS 35—ADVERTISING AND BUSINESS

FOR ON-LINE RETAIL STORE SERVICES FEATURING JEWELRY, BOOKS, CALENDARS, VIDEOS, DVDS (U.S. CLS. 100, 101 AND 102).
FIRST USE 2-1-2008; IN COMMERCE 2-1-2008.

3,482,477. PUSH INC., DBA KAREN KARCH, NEW YORK, NY. SN 78-940,178. PUB. 3-27-2007, FILED 7-28-2006.

KAREN KARCH

THE MARK CONSISTS OF STANDARD CHARACTERS WITHOUT CLAIM TO ANY PARTICULAR FONT, STYLE, SIZE, OR COLOR.

THE NAME "KAREN KARCH" IDENTIFIES A LIVING INDIVIDUAL WHOSE CONSENT IS OF RECORD.

CLASS 14—JEWELRY

FOR ANKLE BRACELETS; BELT BUCKLES OF PRECIOUS METAL; BRACELETS; BROOCHES; CHARMS; CHOKERS; CLIP EARRINGS; CUFFLINKS; EARRINGS; EAR STUDS; FANCY KEY RINGS OF PRECIOUS METAL; IDENTIFICATION BRACELETS; LEATHER BRACELETS; MONEY CLIPS OF PRECIOUS METAL; NECKLACES; PENDANTS ON A LEATHER CORD; RINGS; SHIRT STUDS; TIARAS (U.S. CLS. 2, 27, 28 AND 50).

FIRST USE 9-19-2006; IN COMMERCE 10-5-2006.

CLASS 35—ADVERTISING AND BUSINESS

FOR RETAIL STORE SERVICES AND ONLINE RETAIL STORE SERVICES FEATURING JEWELRY (U.S. CLS. 100, 101 AND 102).

FIRST USE 9-19-2006; IN COMMERCE 9-19-2006.

3,482,498. BELLA PORTA LLC, HEMPSTEAD, NY. SN 78-947,145. PUB. 3-20-2007, FILED 8-8-2006.

BELLA PORTA

THE MARK CONSISTS OF STANDARD CHARACTERS

WITHOUT CLAIM TO ANY PARTICULAR FONT, STYLE, SIZE, OR COLOR.

NO CLAIM IS MADE TO THE EXCLUSIVE RIGHT TO USE "PORTA", APART FROM THE MARK AS SHOWN.

THE ENGLISH TRANSLATION OF THE WORD "BELLA PORTA" IN THE MARK IS BEAUTIFUL DOOR.

CLASS 35—ADVERTISING AND BUSINESS

FOR RETAIL STORES FEATURING DOORS AND ACCESSORIES (U.S. CLS. 100, 101 AND 102).

FIRST USE 5-15-2006; IN COMMERCE 5-15-2006.

CLASS 37—CONSTRUCTION AND REPAIR

FOR INSTALLATION OF DOORS AND ACCESSORIES (U.S. CLS. 100, 103 AND 106).

FIRST USE 5-15-2006; IN COMMERCE 5-15-2006.

3,482,505. RENOWN HEALTH, RENO, NV. SN 78-949,670. PUB. 9-4-2007, FILED 8-10-2006.

RENOWN

THE MARK CONSISTS OF STANDARD CHARACTERS WITHOUT CLAIM TO ANY PARTICULAR FONT, STYLE, SIZE, OR COLOR.

CLASS 42—SCIENTIFIC AND COMPUTER SERVICES

FOR MEDICAL RESEARCH SERVICES, MEDICAL LABORATORIES AND NEUROSCIENCE RESEARCH SERVICES, CLINICAL TRIAL SERVICES (U.S. CLS. 100 AND 101).

FIRST USE 9-21-2006; IN COMMERCE 9-21-2006.

CLASS 44—MEDICAL, BEAUTY AND AGRICULTURAL SERVICES

FOR HOSPITAL; MEDICAL SERVICES; INPATIENT AND OUTPATIENT DIAGNOSTIC IMAGING SERVICES; ACUTE INPATIENT AND OUTPATIENT REHABILITATION SERVICES; MENTAL REHABILITATION SERVICES; COMPLETE HEALTH CARE ORGANIZATION NAMELY, CANCER DIAGNOSTIC AND TREATMENT SERVICES, DIAGNOSIS AND TREATMENT OF HEART DISEASE, CARDIAC SURGERY SERVICES, ORTHOPEDIC SURGERY SERVICES, HEALTH AND WELLNESS PROGRAMS, HOME HEALTH CARE SERVICES, MENTAL HEALTH AND SUBSTANCE ABUSE TREATMENT; PSYCHIATRIC CONSULTATIONS, NAMELY MEDICATION MANAGEMENT, PSYCHOLOGICAL TESTING, PSYCHOLOGICAL THERAPY AND COUNSELING; PEDIATRIC MEDICAL SERVICES; PHYSICAL, OCCUPATIONAL AND SPEECH REHABILITATION AND THERAPY SERVICES; MEDICAL COUNSELING SERVICES (U.S. CLS. 100 AND 101).

FIRST USE 9-21-2006; IN COMMERCE 9-21-2006.

CLASS 45—PERSONAL AND LEGAL SERVICES

FOR PROVIDING PERSONAL SUPPORT SERVICES FOR FAMILIES OF PATIENTS WITH LIFE THREATENING DISORDERS, NAMELY, COMPANIONSHIP, HELP WITH MEDICAL FORMS, COUNSELING AND EMOTIONAL SUPPORT (U.S. CLS. 100 AND 101).

FIRST USE 9-21-2006; IN COMMERCE 9-21-2006.

3,482,507. BRODEUR & PARTNERS, LLC, BOSTON, MA. SN 78-951,249. PUB. 8-28-2007, FILED 8-14-2006.

Rx Mosaic Health

THE MARK CONSISTS OF STANDARD CHARACTERS WITHOUT CLAIM TO ANY PARTICULAR FONT, STYLE, SIZE, OR COLOR.

NO CLAIM IS MADE TO THE EXCLUSIVE RIGHT TO USE "RX" AND "HEALTH", APART FROM THE MARK AS SHOWN.

CLASS 35—ADVERTISING AND BUSINESS

FOR PUBLIC RELATIONS SERVICES IN THE PHARMACEUTICAL AND HEALTHCARE FIELDS; ORGANIZING AND IMPLEMENTING PHARMACEUTICAL PRODUCT LAUNCHES; ARRANGING AND CONDUCTING TRADE SHOWS IN THE PHARMACEUTICAL FIELD (U.S. CLS. 100, 101 AND 102).

FIRST USE 8-1-2006; IN COMMERCE 8-1-2006.

CLASS 45—PERSONAL AND LEGAL SERVICES

FOR PROVIDING ASSISTANCE TO PHARMACEUTICAL COMPANIES IN CONNECTION WITH THE REGULATORY APPROVAL PROCESS, NAMELY, REVIEWING STANDARDS AND PRACTICES TO ASSURE COMPLIANCE WITH PHARMACEUTICAL LAWS AND REGULATIONS (U.S. CLS. 100 AND 101).

FIRST USE 8-1-2006; IN COMMERCE 8-1-2006.

3,482,514. 1673911 ONTARIO LTD., MISSISSAUGA, ONTARIO. SN 78-953,075. PUB. 9-4-2007, FILED 8-16-2006.

HYDROTHER

THE MARK CONSISTS OF STANDARD CHARACTERS WITHOUT CLAIM TO ANY PARTICULAR FONT, STYLE, SIZE, OR COLOR.

CLASS 10—MEDICAL APPARATUS

FOR MASSAGE BEDS (U.S. CLS. 26, 39 AND 44).

FIRST USE 9-1-2006; IN COMMERCE 9-1-2006.

CLASS 11—ENVIRONMENTAL CONTROL APPARATUS

FOR HOT TUBS AND SPA PRODUCTS, NAMELY, SAUNAS, WHIRLPOOL BATHS, AND SHOWERS FOR USE IN SPAS (U.S. CLS. 13, 21, 23, 31 AND 34).

FIRST USE 9-1-2006; IN COMMERCE 9-1-2006.

3,482,523. UNITED FEATHER & DOWN, INC., DES PLAINES, IL. SN 78-954,884. PUB. 4-3-2007, FILED 8-17-2006.

SILVER FILL

THE MARK CONSISTS OF STANDARD CHARACTERS WITHOUT CLAIM TO ANY PARTICULAR FONT, STYLE, SIZE, OR COLOR.

NO CLAIM IS MADE TO THE EXCLUSIVE RIGHT TO USE "FILL", APART FROM THE MARK AS SHOWN.

CLASS 20—FURNITURE AND ARTICLES NOT OTHERWISE CLASSIFIED

FOR PILLOWS (U.S. CLS. 2, 13, 22, 25, 32 AND 50).
FIRST USE 2-29-2008; IN COMMERCE 2-29-2008.

CLASS 22—CORDAGE AND FIBERS

FOR SYNTHETIC FIBERS (U.S. CLS. 1, 2, 7, 19, 22, 42 AND 50).
FIRST USE 2-29-2008; IN COMMERCE 2-29-2008.

CLASS 24—FABRICS

FOR BED BLANKETS; COMFORTERS; MATTRESS COVERS; MATTRESS PADS (U.S. CLS. 42 AND 50).
FIRST USE 2-29-2008; IN COMMERCE 2-29-2008.

3,482,532. PRIMORIGEN BIOSCIENCES LLC, MADISON, WI. SN 78-959,099. PUB. 9-4-2007, FILED 8-23-2006.

PRIMORIGEN

THE MARK CONSISTS OF STANDARD CHARACTERS WITHOUT CLAIM TO ANY PARTICULAR FONT, STYLE, SIZE, OR COLOR.

CLASS 1—CHEMICALS

FOR CHEMICAL AND BIOCHEMICAL REAGENTS AND BIOLOGICAL PRODUCTS FOR COMMERCIAL, INDUSTRIAL, SCIENTIFIC, CLINICAL LABORATORY OR RESEARCH USE, NAMELY, CELLS, STEM CELLS, CELL LINE ARRAYS, CELL LINE SLIDES, CELL CULTURE MEDIA, CELL GROWTH SUPPLEMENTS, NAMELY, HYPOTHALAMIC EXTRACTS, TISSUE ARRAYS, TISSUE SLIDES, ANTIBODIES, NAMELY, MONOCLONAL AND POLYCLONAL ANTIBODIES, ANTIBODY ARRAYS, LIGANDS, ENZYMES, ENZYME INHIBITORS FOR IN VITRO RESEARCH USE, VECTORS, LIPIDS, ASSAY KITS COMPRISED OF SLIDES ARRAYED WITH CAPTURE ANTIBODIES AND FRAMED WITH WELL FORMERS, PROTEIN STANDARDS AND CONTROLS, BIOTYNYLATED DETECTION ANTIBODIES, STREPTAVIDIN FLUOR, WASH REAGENTS AND ASSOCIATED REAGENTS, LOADING CONTROLS IN THE NATURE OF LOADING CONTROL ANTIBODIES AND PROTEINS, TAGS AND MARKERS, NAMELY, TAG AND MARKER ANTIBODIES AND PROTEINS, PEPTIDES, MODIFIED AND PURIFIED RECOMBINANT PROTEINS, PURIFIED NATURAL PROTEINS; PROTEINS CONTAINING NON NATURAL AMINO ACIDS, PROTEIN ARRAYS, AND KITS FOR THE EXPRESSION, AMPLIFICATION, PURIFICATION AND ANALYSIS OF BIOLOGICAL SAMPLES, SAID KITS CONSISTING PRIMARILY OF ONE OR MORE OF THE FOLLOWING PROTEINS, NUCLEIC ACIDS, ANTIBODIES, CELLS, GELS, PROBES, BUFFERS, STAINS AND ASSOCIATED REAGENTS AND DEVICES, NAMELY, SLIDES FOR QUANTITATION OF PROTEINS AND PEPTIDES FOR CARRYING OUT SAID PURPOSES, ALL FOR COMMERCIAL, INDUSTRIAL, SCIENTIFIC, CLINICAL LABORATORY OR RESEARCH USE (U.S. CLS. 1, 5, 6, 10, 26 AND 46).
FIRST USE 10-1-2007; IN COMMERCE 10-1-2007.

CLASS 40—MATERIAL TREATMENT

FOR ANTIBODY GENERATION AND ANTIBODY PRODUCTION FOR OTHERS, ANTIBODY PURIFICATION, ANTIBODY FRAGMENTATION, MANUFACTURE OF ANTIBODIES FOR OTHERS (U.S. CLS. 100, 103 AND 106).
FIRST USE 9-30-2006; IN COMMERCE 12-26-2006.

CLASS 42—SCIENTIFIC AND COMPUTER SERVICES

FOR PHARMACEUTICAL RESEARCH SERVICES, NAMELY, ANTIBODY AND ANTISERA SERVICES, NAMELY, ANTIBODY SCREENING, ANTIBODY LABELING, ANTIBODY PACKAGING, ANTIBODY TESTING, ANTIBODY CHARACTERIZATION, HYBRIDOMA CELL LINE DEVELOPMENT, IMMUNOGEN PREPARATION, IMMUNIZATION AND PRODUCTION, CUSTOM TISSUE CULTURE SERVICES, IMMUNOASSAY DEVELOPMENT AND TESTING (U.S. CLS. 100 AND 101).
FIRST USE 9-30-2006; IN COMMERCE 12-25-2006.

3,482,534. MATUR, S.L., 07800 IBIZA, SPAIN. SN 78-959,786. PUB. 9-18-2007, FILED 8-24-2006.



NO CLAIM IS MADE TO THE EXCLUSIVE RIGHT TO USE "HOTELS", APART FROM THE MARK AS SHOWN.

THE COLOR(S) BLUE, ORANGE, YELLOW AND WHITE IS/ARE CLAIMED AS A FEATURE OF THE MARK.

THE COLOR BLUE APPEARS IN THE WORDING AND IN THE DESIGN OF OCEAN WAVES; THE MERMAID DESIGN IS ORANGE; THE OVAL IS YELLOW, THE DESIGN AND WORDS ARE AGAINST A WHITE BACKGROUND.

THE FOREIGN WORDING IN THE MARK TRANSLATES INTO ENGLISH AS OF THE MERMAID.

CLASS 35—ADVERTISING AND BUSINESS

FOR HOTEL BUSINESS ADMINISTRATION AND MANAGEMENT CONSULTATION (U.S. CLS. 100, 101 AND 102).

FIRST USE 1-1-2001; IN COMMERCE 1-1-2001.

CLASS 43—HOTEL AND RESTAURANT SERVICES

FOR PROVIDING TEMPORARY ACCOMMODATION, CAFE, RESTAURANT AND BAR SERVICES (U.S. CLS. 100 AND 101).

FIRST USE 1-1-2001; IN COMMERCE 1-1-2001.

3,482,538. PHILIP B. PARKER AND WAYNE M. WILLIAMS, DBA MUZLINK, LLC, SHERMAN OAKS, CA. SN 78-960,925. PUB. 4-24-2007, FILED 8-25-2006.



THE COLOR(S) BLUE AND RED IS/ARE CLAIMED AS A FEATURE OF THE MARK.

THE MARK CONSISTS OF THE WORD "MUZLINK" IN BLUE WITH SOUND WAVES IN RED AT THE END OF THE WORD "MUZLINK" AND AN EIGHTH NOTE USED FOR THE DOT OF THE "I" IN THE WORD "MUZLINK".

CLASS 9—ELECTRICAL AND SCIENTIFIC APPARATUS

FOR DOWNLOADABLE MULTIMEDIA FILE CONTAINING ARTWORK, TEXT, AUDIO, VIDEO, GAMES, AND INTERNET WEB LINKS RELATING TO MUSIC (U.S. CLS. 21, 23, 26, 36 AND 38).

FIRST USE 8-2-2006; IN COMMERCE 11-18-2006.

CLASS 35—ADVERTISING AND BUSINESS

FOR ADVERTISING AND COMMERCIAL INFORMATION SERVICES, VIA THE INTERNET; ADVERTISING VIA ELECTRONIC MEDIA AND SPECIFICALLY THE INTERNET; ADVICE AND INFORMATION ABOUT CUSTOMER SERVICES AND PRODUCT MANAGEMENT AND PRICES ON INTERNET SITES IN CONNECTION WITH PURCHASES MADE OVER THE INTERNET; DISSEMINATION OF ADVERTISING FOR OTHERS VIA AN ONLINE COMMUNICATIONS NETWORK ON THE INTERNET; DISSEMINATION OF ADVERTISING FOR OTHERS VIA THE INTERNET; PROVIDING A SEARCHABLE ONLINE ADVERTISING GUIDE FEATURING THE GOODS AND SERVICES OF OTHER ONLINE VENDORS ON THE INTERNET; PROVIDING AN ONLINE COMMERCIAL INFORMATION DIRECTORY ON THE INTERNET; PROVIDING AND RENTAL OF ADVERTISING SPACE ON THE INTERNET; PROVIDING BUSINESS INFORMATION, ALSO VIA INTERNET, THE CABLE NETWORK OR OTHER FORMS OF DATA TRANSFER; PROVIDING CONSUMER PRODUCT INFORMATION VIA THE INTERNET (U.S. CLS. 100, 101 AND 102).

FIRST USE 8-2-2006; IN COMMERCE 8-2-2006.

CLASS 38—COMMUNICATION

FOR COMMUNICATIONS SERVICES, NAMELY, TRANSMITTING STREAMED SOUND AND AUDIO-VISUAL RECORDINGS VIA THE INTERNET; STREAMING OF AUDIO MATERIAL ON THE INTERNET; STREAMING OF VIDEO MATERIAL ON THE INTERNET (U.S. CLS. 100, 101 AND 104).

FIRST USE 8-2-2006; IN COMMERCE 11-18-2006.

CLASS 42—SCIENTIFIC AND COMPUTER SERVICES

FOR DESIGN, CREATION, HOSTING AND MAINTENANCE OF INTERNET SITES FOR THIRD PARTIES; HOSTING OF DIGITAL CONTENT ON THE INTERNET; PROVIDING SPECIFIC INFORMATION AS REQUESTED BY CUSTOMERS VIA THE INTERNET (U.S. CLS. 100 AND 101).

FIRST USE 8-2-2006; IN COMMERCE 11-18-2006.

3,482,541. SILICON GENESIS CORPORATION, SAN JOSE, CA. SN 78-961,539. PUB. 11-6-2007, FILED 8-28-2006.



NO CLAIM IS MADE TO THE EXCLUSIVE RIGHT TO USE "SILICON", APART FROM THE MARK AS SHOWN.

CLASS 7—MACHINERY

FOR ENGINEERED SUBSTRATE PROCESSING AND AUTOMATED HANDLING EQUIPMENT AND COMPONENTS, NAMELY, PLASMA ION IMPLANTERS, SURFACE FINISHERS, PLASMA ACTIVATORS, BONDRERS, SUBSTRATE SEPARATORS AND CLEANERS; AND COMPUTER SOFTWARE SOLD AS A UNIT AND USED IN ASSOCIATION THEREWITH (U.S. CLS. 13, 19, 21, 23, 31, 34 AND 35).

FIRST USE 9-29-2006; IN COMMERCE 9-29-2006.

CLASS 42—SCIENTIFIC AND COMPUTER SERVICES

FOR SCIENTIFIC RESEARCH AND DEVELOPMENT; PRODUCT RESEARCH AND DEVELOPMENT (U.S. CLS. 100 AND 101).

FIRST USE 7-26-2007; IN COMMERCE 7-26-2007.

CLASS 45—PERSONAL AND LEGAL SERVICES

FOR LICENSING OF PATENTED TECHNOLOGY (U.S. CLS. 100 AND 101).

FIRST USE 7-26-2007; IN COMMERCE 7-26-2007.

3,482,543. WIGWAM MILLS, INC., SHEBOYGAN, WI. SN 78-961,996. PUB. 10-16-2007, FILED 8-28-2006.

LIFE IS MOVEMENT

THE MARK CONSISTS OF STANDARD CHARACTERS WITHOUT CLAIM TO ANY PARTICULAR FONT, STYLE,

SIZE, OR COLOR.

CLASS 3—COSMETICS AND CLEANING PREPARATIONS

FOR NON-MEDICATED FOOT CARE LOTIONS, GELS, SOAPS, SOAKS AND SPRAYS; SOAPS AND DETERGENT FOR WASHING KNITTED TEXTILE PRODUCTS (U.S. CLS. 1, 4, 6, 50, 51 AND 52).

FIRST USE 6-3-2008; IN COMMERCE 6-3-2008.

CLASS 25—CLOTHING

FOR MEN'S, WOMEN'S AND CHILDREN'S SOCKS AND HOSIERY FOR THE FEET AND LEGS; SLIPPER SOCKS; HEAD WEAR, NAMELY, KNITTED HATS, SKI HATS, AND CAPS; EARMUFFS; HEADBANDS; ATHLETIC MASKS IN THE NATURE OF CLOTHING, NAMELY, KNITTED SKI MASKS, HEAD AND FACE MASKS, AND ANTI-COLD MASKS; NECKWEAR, NAMELY, KNITTED SCARVES, NECK WARMERS, AND DICKIES; GLOVES AND MITTENS FOR CLOTHING, NAMELY, KNITTED ANTI-COLD GLOVES, MITTENS AND GLOVE LINERS FOR USE IN OUTDOOR ACTIVITIES; GLOVES AND MITTENS FOR CLOTHING, NAMELY, KNITTED ANTI-HEAT GLOVES, MITTENS, AND GLOVE LINERS FOR USE IN OUTDOOR ACTIVITIES, AND NOT INTENDED FOR USE TO PROTECT INDIVIDUALS FROM GRAVE INJURY SUCH AS FIRE PROTECTION (U.S. CLS. 22 AND 39).

FIRST USE 1-21-2008; IN COMMERCE 1-21-2008.

3,482,545. WIGWAM MILLS, INC., SHEBOYGAN, WI. SN 78-962,633. PUB. 12-4-2007, FILED 8-29-2006.

WIGWAM

OWNER OF U.S. REG. NOS. 543,445, 1,221,849, AND OTHERS.

CLASS 3—COSMETICS AND CLEANING PREPARATIONS

FOR NON-MEDICATED FOOT CARE LOTIONS, GELS, SOAPS, SOAKS AND SPRAYS; SOAPS AND DETERGENT FOR WASHING KNITTED TEXTILE PRODUCTS (U.S. CLS. 1, 4, 6, 50, 51 AND 52).

FIRST USE 6-3-2008; IN COMMERCE 6-3-2008.

CLASS 25—CLOTHING

FOR MEN'S, WOMEN'S AND CHILDREN'S SOCKS AND HOSIERY FOR THE FEET AND LEGS; SOCKS; SLIPPERS; HEADWEAR, NAMELY, KNITTED HATS, SKI HATS, AND CAPS; EARMUFFS; HEADBANDS; ATHLETIC MASKS IN THE NATURE OF CLOTHING, NAMELY, KNITTED SKI MASKS, HEAD AND FACE MASKS, AND ANTI-COLD MASKS; NECK WEAR, NAMELY, KNITTED SCARVES, NECK WARMERS, AND DICKIES; GLOVES AND MITTENS FOR CLOTHING, NAMELY, KNITTED ANTI-COLD GLOVES, MITTENS AND GLOVE LINERS FOR USE IN OUTDOOR ACTIVITIES; GLOVES AND MITTENS FOR CLOTHING, NAMELY, KNITTED ANTI-HEAT GLOVES, MITTENS, AND GLOVE LINERS FOR USE IN OUTDOOR ACTIVITIES, AND NOT INTENDED FOR USE TO PROTECT INDIVIDUALS FROM GRAVE INJURY SUCH AS FIRE PROTECTION (U.S. CLS. 22 AND 39).

FIRST USE 1-21-2008; IN COMMERCE 1-21-2008.

3,482,552. HIRAIWA, TAKANORI, WAKAYAMA, JAPAN. SN 78-964,841. PUB. 10-16-2007, FILED 8-31-2006.



THE MARK CONSISTS OF THE REPRESENTATION OF A SCARY FACE.

CLASS 25—CLOTHING

FOR CLOTHING, NAMELY, SWEATERS, SHIRTS, TROUSERS, RAIN COATS, HEADGEAR IN THE NATURE OF HATS, CAPS AND FISHING WADERS (U.S. CLS. 22 AND 39).

FIRST USE 10-1-1999; IN COMMERCE 11-1-2007.

CLASS 28—TOYS AND SPORTING GOODS

FOR FISHING TACKLE (U.S. CLS. 22, 23, 38 AND 50).

FIRST USE 10-1-1999; IN COMMERCE 11-1-2007.

3,482,556. A&M AQUATICS, INC., LANSING, MI. SN 78-969,017. PUB. 7-3-2007, FILED 9-7-2006.

SALT MADE EASY

THE MARK CONSISTS OF STANDARD CHARACTERS WITHOUT CLAIM TO ANY PARTICULAR FONT, STYLE, SIZE, OR COLOR.

CLASS 21—HOUSEWARES AND GLASS

FOR AQUARIUMS, AQUARIUM FISH NETS, AQUARIUM HOODS, AQUARIUM COVERS (U.S. CLS. 2, 13, 23, 29, 30, 33, 40 AND 50).

FIRST USE 10-0-2006; IN COMMERCE 10-0-2006.

CLASS 31—NATURAL AGRICULTURAL PRODUCTS

FOR LIVE TROPICAL FISH, CORALS, AND LIVE INVERTEBRATES, NAMELY, ANEMONE, ALGAE, NUDIBRANCHS, CLAMS, CRABS, FEATHER DUSTERS, GORGONIAS, SHRIMP, SNAILS, SPONGES, STARFISH, AND URCHINS (U.S. CLS. 1 AND 46).

FIRST USE 11-0-2007; IN COMMERCE 11-0-2007.

CLASS 37—CONSTRUCTION AND REPAIR

FOR PROVIDING INFORMATION IN THE FIELD OF CARE AND MAINTENANCE OF AQUARIUMS (U.S. CLS. 100, 103 AND 106).

FIRST USE 11-0-2007; IN COMMERCE 11-0-2007.

CLASS 44—MEDICAL, BEAUTY AND AGRICULTURAL SERVICES

FOR PROVIDING INFORMATION IN THE FIELD OF CARE AND MAINTENANCE OF LIVE TROPICAL FISH, CORALS, AND LIVE INVERTEBRATES, NAMELY, ANEMONE, ALGAE, NUDIBRANCHS, CLAMS, CRABS, FEATHER DUSTERS, GORGONIAS, SHRIMP, SNAILS, SPONGES, STARFISH, AND URCHINS (U.S. CLS. 100 AND 101).

FIRST USE 10-0-2007; IN COMMERCE 10-0-2007.

CLASS 41—EDUCATION AND ENTERTAINMENT

FOR ENTERTAINMENT SERVICES, NAMELY, PROVIDING ON-LINE COMPUTER GAMES; PROVIDING ON-LINE COMPUTER DATABASE IN THE FIELD OF COMPUTER GAMES; PROVIDING INFORMATION ABOUT COMPUTER GAMES THROUGH THE WEB SITES (U.S. CLS. 100, 101 AND 107).

FIRST USE 12-5-2006; IN COMMERCE 12-5-2006.

3,482,565. PENKY LLC, WILMINGTON, DE. SN 78-973,926. PUB. 9-25-2007, FILED 9-13-2006.

INTELLECTUAL VENTURES

THE MARK CONSISTS OF STANDARD CHARACTERS WITHOUT CLAIM TO ANY PARTICULAR FONT, STYLE, SIZE, OR COLOR.

CLASS 35—ADVERTISING AND BUSINESS

FOR BUSINESS CONSULTING SERVICES; BUSINESS MANAGEMENT AND ADMINISTRATION FOR OTHERS OF INVENTIONS, TECHNOLOGIES, METHODS, PROCESSES, IDEAS, DISCOVERIES, PATENT APPLICATIONS, PATENTS, TRADEMARKS, COPYRIGHTS AND TRADE SECRETS; BUSINESS CONSULTING, MANAGEMENT AND SUPERVISION IN THE FIELD OF THE DEVELOPMENT, ACQUISITION, AND LICENSING OF INTELLECTUAL PROPERTY RIGHTS, INVENTIONS, PATENT APPLICATIONS, PATENTS, TRADEMARKS, COPYRIGHTS AND TRADE SECRETS; SERVICES RELATING TO THE ANALYSIS, EVALUATION, CREATION AND BRAND ESTABLISHMENT OF TRADEMARKS; BUSINESS CONSULTING, MANAGEMENT AND SUPERVISION FOR OTHERS, NAMELY, THE EVALUATION, RECRUITING AND MANAGEMENT OF INVENTORS TO FACILITATE THE CREATION OF INVENTIONS, TECHNOLOGIES, METHODS, PROCESSES, IDEAS, AND DISCOVERIES, AND OF LEGAL, TECHNICAL, FINANCIAL AND OTHER PROFESSIONALS TO FACILITATE THE CREATION AND ADMINISTRATION OF INTELLECTUAL PROPERTY RIGHTS, INVENTIONS, PATENTS, PATENT APPLICATIONS, TRADEMARKS, COPYRIGHTS AND TRADE SECRETS; BUSINESS EVALUATION AND APPRAISALS OF INVENTIONS, TECHNOLOGIES, METHODS, PROCESSES, IDEAS, DISCOVERIES, INTELLECTUAL PROPERTY, PATENTS, PATENT APPLICATIONS, TRADEMARKS, COPYRIGHTS AND TRADE SECRETS FOR THE BENEFIT OF OTHERS; BRINGING TOGETHER, FOR THE BENEFIT OF OTHERS, INTELLECTUAL PROPERTY RIGHTS, INVENTIONS, PATENTS, PATENT APPLICATIONS, TRADEMARKS, COPYRIGHTS AND TRADE SECRETS TO FACILITATE OTHERS' ASSESSMENT AND LICENSING OF SUCH INTELLECTUAL PROPERTY ASSETS; PROMOTION OF BUSINESS OPPORTUNITIES IN THE FIELD OF INTELLECTUAL PROPERTY; PROMOTING PUBLIC AWARENESS OF THE SOCIAL, POLITICAL AND ECONOMIC IMPORTANCE AND VALUE OF INTELLECTUAL PROPERTY RIGHTS, INVENTIONS, PATENTS, PATENT APPLICATIONS, TRADEMARKS, COPYRIGHTS AND TRADE SECRETS (U.S. CLS. 100, 101 AND 102).

FIRST USE 6-2-2008; IN COMMERCE 6-2-2008.

3,482,558. KONAMI DIGITAL ENTERTAINMENT CO., LTD., TOKYO, JAPAN. SN 78-970,152. PUB. 8-28-2007, FILED 9-8-2006.

METAL GEAR SOLID PORTABLE OPS

THE MARK CONSISTS OF STANDARD CHARACTERS WITHOUT CLAIM TO ANY PARTICULAR FONT, STYLE, SIZE, OR COLOR.

OWNER OF U.S. REG. NOS. 2,797,719, 2,960,377, AND OTHERS.

NO CLAIM IS MADE TO THE EXCLUSIVE RIGHT TO USE "PORTABLE", APART FROM THE MARK AS SHOWN.

CLASS 9—ELECTRICAL AND SCIENTIFIC APPARATUS

FOR VIDEO GAME SOFTWARE; VIDEO GAME PROGRAMS; CARTRIDGES AND CASSETTES CONTAINING GAME PROGRAMS FOR USE WITH HAND-HELD VIDEO GAME MACHINE; GAME DISCS AND CIRCUIT BOARDS CONTAINING GAME PROGRAMS FOR USE WITH HAND-HELD VIDEO GAME MACHINE (U.S. CLS. 21, 23, 26, 36 AND 38).

FIRST USE 12-5-2006; IN COMMERCE 12-5-2006.

CLASS 45—PERSONAL AND LEGAL SERVICES

FOR COPYRIGHT MANAGEMENT; COPYRIGHT MANAGEMENT CONSULTING; LICENSING OF INTELLECTUAL PROPERTY; PATENT AND PATENT APPLICATION LICENSING; LEGAL SERVICES; LICENSING SERVICES FOR INVENTORS, INVESTORS, FUNDS, UNIVERSITIES, RESEARCH INSTITUTIONS AND COMMERCIAL AND NON-PROFIT ENTITIES IN THE FIELDS OF INVENTIONS, TECHNOLOGIES, METHODS, PROCESSES, IDEAS, DISCOVERIES, INTELLECTUAL PROPERTY, PATENTS AND PATENT APPLICATIONS; INTELLECTUAL PROPERTY LICENSING SERVICES, NAMELY, LICENSING SERVICES FOR INVENTORS, INVESTORS, FUNDS, UNIVERSITIES, RESEARCH INSTITUTIONS AND COMMERCIAL AND NON-PROFIT ENTITIES IN THE FIELDS OF INVENTIONS, TECHNOLOGIES, METHODS, PROCESSES, IDEAS, DISCOVERIES, INTELLECTUAL PROPERTY, PATENTS AND PATENT APPLICATIONS; INTELLECTUAL PROPERTY CONSULTATION SERVICES FOR INVENTORS, UNIVERSITIES, RESEARCH INSTITUTIONS AND COMMERCIAL AND NON-PROFIT ENTITIES IN THE FIELDS OF INVENTIONS, TECHNOLOGIES, METHODS, PROCESSES, IDEAS, DISCOVERIES, PATENTS AND PATENT APPLICATIONS (U.S. CLS. 100 AND 101).
FIRST USE 6-2-2008; IN COMMERCE 6-2-2008.

3,482,571. OFFICIAL PILLOWTEX LLC, WILMINGTON, DE. SN 78-979,504. PUB. 1-25-2005, FILED 7-8-2004.

ROYAL FAMILY CANNON

THE MARK CONSISTS OF STANDARD CHARACTERS WITHOUT CLAIM TO ANY PARTICULAR FONT, STYLE, SIZE, OR COLOR.

OWNER OF U.S. REG. NOS. 729,513, 1,127,537, AND OTHERS.

CLASS 21—HOUSEWARES AND GLASS

FOR SOAP CONTAINERS; SOAP DISHES; SOAP DISPENSERS; TOOTHBRUSH HOLDERS; TRASH CANS; WASTEPAPER BASKETS (U.S. CLS. 2, 13, 23, 29, 30, 33, 40 AND 50).

FIRST USE 9-0-2007; IN COMMERCE 9-0-2007.

CLASS 24—FABRICS

FOR BATH LINEN; BATH TOWELS; BED LINEN (U.S. CLS. 42 AND 50).

FIRST USE 9-0-2007; IN COMMERCE 9-0-2007.

3,482,567. US AIR GUITAR LLC, NEW YORK, NY. SN 78-974,105. PUB. 9-4-2007, FILED 9-14-2006.



NO CLAIM IS MADE TO THE EXCLUSIVE RIGHT TO USE "US" FOR CLASS 25 AND "US" AND "AIR GUITAR" FOR CLASS 41, APART FROM THE MARK AS SHOWN.

CLASS 25—CLOTHING

FOR CLOTHING, NAMELY, T-SHIRTS, SWEATSHIRTS, HATS AND ACCESSORIES, NAMELY, WRISTBANDS AND HEADBANDS, THAT PROMOTES AN ANNUAL CONTEST OR CONTESTS IN WHICH PARTICIPANTS ARE JUDGED ON THEIR ABILITY TO SIMULATE THE STRUMMING OF AN INVISIBLE GUITAR TO LIVE OR RECORDED MUSIC (U.S. CLS. 22 AND 39).
FIRST USE 6-6-2003; IN COMMERCE 6-6-2003.

CLASS 41—EDUCATION AND ENTERTAINMENT

FOR ENTERTAINMENT IN THE NATURE OF AN ANNUAL CONTEST OR CONTESTS IN WHICH PARTICIPANTS ARE JUDGED ON THEIR ABILITY TO SIMULATE THE STRUMMING OF AN INVISIBLE GUITAR TO LIVE OR RECORDED MUSIC (U.S. CLS. 100, 101 AND 107).
FIRST USE 6-6-2003; IN COMMERCE 6-6-2003.

3,482,573. STUDENTS IN FREE ENTERPRISE, INC., SPRINGFIELD, MO. SN 78-979,673. PUB. 8-7-2007, FILED 8-9-2006.



OWNER OF U.S. REG. NOS. 2,045,546 AND 2,810,580.

CLASS 25—CLOTHING

FOR SHIRTS AND JACKETS (U.S. CLS. 22 AND 39).
FIRST USE 5-0-2007. THE MARK WAS FIRST USED ANYWHERE IN A DIFFERENT FORM OTHER THAN THAT SOUGHT TO BE REGISTERED ON 00/00/1975.; IN COMMERCE 5-0-2007.

CLASS 41—EDUCATION AND ENTERTAINMENT

FOR EDUCATION SERVICES, NAMELY, PROVIDING CLASSES, SEMINARS, WORKSHOPS AND COMPETITIONS IN THE FIELD OF THE FREE ENTERPRISE SYSTEM; PROVIDING RECOGNITION AND INCENTIVES BY THE WAY OF AWARDS TO DEMONSTRATE EXCELLENCE IN THE FIELDS OF EDUCATION AND BUSINESS (U.S. CLS. 100, 101 AND 107).

FIRST USE 9-0-2006. THE MARK WAS FIRST USED ANYWHERE IN A DIFFERENT FORM OTHER THAN THAT SOUGHT TO BE REGISTERED ON 00/00/1975.; IN COMMERCE 9-0-2006.

3,482,577. RETAIL LICENSING COMPANY, LAS VEGAS, NV. SN 78-980,278. PUB. 2-6-2007, FILED 10-19-2005.

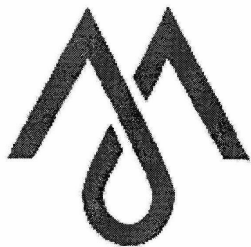

CLASS 18—LEATHER GOODS

FOR BACKPACKS, BEACH BAGS, DUFFEL BAGS, TOTE BAGS, PURSES, COIN PURSES, SHOULDER BAGS, WALLETS, BUSINESS CARD CASES, CALLING CARD CASES, CREDIT CARD CASES, AND TOILETRY CASES SOLD EMPTY (U.S. CLS. 1, 2, 3, 22 AND 41).
FIRST USE 9-6-2006; IN COMMERCE 9-6-2006.

CLASS 25—CLOTHING

FOR CLOTHING AND CLOTHING ACCESSORIES, NAMELY, CLOTHING BELTS, BLAZERS, BLOUSES, BOTTOMS, CAPES, COATS, RAIN WEAR, SPORT COATS, DRESSES, FOUL WEATHER GEAR, GLOVES, TOPS, HOSIERY, JACKETS, JEANS, JERSEYS, KERICHS, LOUNGEWEAR, NECKWEAR, PANTS, SCARVES, SHAWLS, SHIRTS, SWEATSHIRTS, SHORTS, SKIRTS, SWEATERS, VESTS, FOOTWEAR, AND HEADWEAR (U.S. CLS. 22 AND 39).
FIRST USE 9-6-2006; IN COMMERCE 9-6-2006.

CLASS 35—ADVERTISING AND BUSINESS

FOR RETAIL STORE SERVICES, MAIL ORDER SERVICES, AND ELECTRONIC RETAIL SERVICES USING A GLOBAL COMPUTER AND/OR COMMUNICATIONS NETWORK, ALL IN THE FIELD OF CLOTHING, CLOTHING ACCESSORIES, FOOTWEAR, HEADWEAR, BACKPACKS, PURSES, WALLETS, SUNGLASSES, JEWELRY, AND CANDLES (U.S. CLS. 100, 101 AND 102).
FIRST USE 9-6-2006; IN COMMERCE 9-6-2006.

CLASS 36—INSURANCE AND FINANCIAL

FOR STORED-VALUE CARD SERVICES (U.S. CLS. 100, 101 AND 102).
FIRST USE 9-6-2006; IN COMMERCE 9-6-2006.

3,482,583. KITCHEN CABINET CONSULTING, LLC, RE-NSSELAERVILLE, NY. SN 78-980,378. PUB. 8-1-2006, FILED 3-18-2004.

ONE BIG TABLE

THE MARK CONSISTS OF STANDARD CHARACTERS WITHOUT CLAIM TO ANY PARTICULAR FONT, STYLE, SIZE, OR COLOR.

CLASS 35—ADVERTISING AND BUSINESS

FOR PROMOTION OF PUBLIC AWARENESS OF THE NEED TO END HUNGER AND ITS ROOT CAUSES (U.S. CLS. 100, 101 AND 102).
FIRST USE 6-0-2004; IN COMMERCE 6-0-2004.

CLASS 36—INSURANCE AND FINANCIAL

FOR CHARITABLE FUNDRAISING SERVICES (U.S. CLS. 100, 101 AND 102).
FIRST USE 6-0-2004; IN COMMERCE 6-0-2004.

3,482,587. NEUSOFT GROUP LTD., SHENYANG LIAONING PROVINCE, CHINA. SN 78-980,426. PUB. 3-27-2007, FILED 1-10-2006.

Neusoft

CLASS 9—ELECTRICAL AND SCIENTIFIC APPARATUS

FOR RECORDED SOFTWARE FOR NETWORK SECURITY; RECORDED SOFTWARE FOR BUDGETING, BUSINESS ACCOUNTING AND CAPITAL MANAGEMENT OF ENTERPRISES; RECORDED SOFTWARE FOR THE MANAGEMENT OF HUMAN RESOURCES; RECORDED E-LEARNING SOFTWARE FOR NETWORK STUDYING AND TRAINING, NAMELY, SOFTWARE, WITH MANAGEMENT AND SUPPORT OF WEB INTERFACE, FOR STUDYING AND TRAINING IN THE FIELD OF COMPUTER APPLICATIONS AND LANGUAGES; MEDICAL PICTURE ARCHIVING AND COMMUNICATION SOFTWARE (PACS), NAMELY, FOR COMPUTER-BASED IMAGE-STORAGE-AND-RETRIEVAL SYSTEM SOFTWARE THAT CAN STORE AND RECALL IMAGES IN DIGITAL FORMAT FROM SEVERAL DIFFERENT DIAGNOSTIC IMAGING MODALITIES, SUCH AS CT, MRI, COMPUTED RADIOGRAPHY (CR), DIGITAL RADIOGRAPHY, DIGITAL ANGIOGRAPHY, NUCLEAR MEDICINE, AND ULTRASOUND CONSISTING OF IMAGE MANIPULATION AND DISPLAY STATIONS COUPLED WITH IMAGE-ARCHIVING DEVICES AND NETWORKING CAPABILITIES, FOR ALLOWING DIGITAL IMAGE TRANSMISSION TO ANY NETWORKED PART OF THE HOSPITAL OR OUTSIDE THE HOSPITAL VIA A WIDE AREA NETWORK (WAN) OR THE INTERNET (U.S. CLS. 21, 23, 26, 36 AND 38).
FIRST USE 3-22-2005; IN COMMERCE 2-19-2008.

CLASS 42—SCIENTIFIC AND COMPUTER SERVICES

FOR SOFTWARE DESIGN AND PROGRAMMING SERVICES FOR AUTOMOTIVE ELECTRONICS; SOFTWARE DESIGN AND PROGRAMMING SERVICES FOR FINANCIAL AND SECURITY INDUSTRY; SOFTWARE DESIGN AND PROGRAMMING SERVICES FOR HEALTH CARE; SOFTWARE DESIGN AND PROGRAMMING SERVICES FOR MOBILE PHONES; SOFTWARE DESIGN AND PROGRAMMING SERVICES FOR TELECOMMUNICATION INDUSTRY; SOFTWARE DESIGN AND PROGRAMMING SERVICES FOR TRAFFIC INDUSTRY; ERP (ENTERPRISE RESOURCES PLANNING) IMPLEMENTING AND SERVICES, NAMELY, THE SYSTEMIZATION AND TRANSFERRING OF THE INFORMATION RELATED TO RAW MATERIALS, STORAGE, FINANCE, MANUFACTURE AND DISTRIBUTION THROUGH COMPUTER SOFTWARE SYSTEMS FOR THE PURPOSES OF RATIONALIZATION OF DEPLOYING AND USING OF THE ENTERPRISES; INSTALLATION SERVICES OF COMPUTER SOFTWARE (U.S. CLS. 100 AND 101).
FIRST USE 3-22-2005; IN COMMERCE 2-19-2008.

3,482,588. BLOOMBERG L.P., NEW YORK, NY. SN 78-980,427. PUB. 10-11-2005, FILED 6-4-2004.

BLOOMBERG LAW

THE MARK CONSISTS OF STANDARD CHARACTERS WITHOUT CLAIM TO ANY PARTICULAR FONT, STYLE, SIZE, OR COLOR.

OWNER OF U.S. REG. NOS. 2,045,947, 2,736,744, AND OTHERS.

NO CLAIM IS MADE TO THE EXCLUSIVE RIGHT TO USE "LAW", APART FROM THE MARK AS SHOWN.

SEC. 2(F) AS TO "BLOOMBERG".

CLASS 9—ELECTRICAL AND SCIENTIFIC APPARATUS

FOR DOWNLOADABLE ELECTRONIC PUBLICATIONS IN THE NATURE OF REPORTS, DIGESTS, DIRECTORIES, CHARTS, BROCHURES, REFERENCE MATERIALS, MANUALS, NEWSLETTERS, BOOKLETS, PAMPHLETS AND JOURNALS IN THE FIELDS OF NEWS, RESEARCH, COMPUTERIZED DATABASES AND OTHER INDEXES OF INFORMATION, LAW, GOVERNMENT AND PUBLIC RECORDS, BUSINESS (U.S. CLS. 21, 23, 26, 36 AND 38).
FIRST USE 2-4-2003; IN COMMERCE 2-4-2003.

CLASS 16—PAPER GOODS AND PRINTED MATTER

FOR PUBLICATIONS, NAMELY, REPORTS, DIGESTS, DIRECTORIES, CHARTS, BROCHURES, REFERENCE MATERIALS, BOOKLETS, PAMPHLETS, JOURNALS AND MAGAZINES IN THE FIELDS OF NEWS, RESEARCH, COMPUTERIZED DATABASES AND OTHER INDEXES OF INFORMATION, LAW, GOVERNMENT AND PUBLIC RECORDS, BUSINESS AND POLITICS (U.S. CLS. 2, 5, 22, 23, 29, 37, 38 AND 50).
FIRST USE 2-4-2003; IN COMMERCE 2-4-2003.

CLASS 35—ADVERTISING AND BUSINESS

FOR BUSINESS NEWS AND INFORMATION SERVICES, NAMELY, COLLECTING AND PROVIDING BUSINESS, MANAGEMENT, DEMOGRAPHIC, ECONOMIC, MARKETING, SALES, ADVERTISING, TAX, ACCOUNTING, CREDIT RATING AND PERSONNEL DATA, REPORTS AND INFORMATION; BUSINESS, ECONOMIC AND MARKET RESEARCH SERVICES; PROMOTING THE GOODS AND SERVICES OF OTHERS BY DISSEMINATING ADVERTISEMENTS OVER, BY OR THROUGH LOCAL OR WIDE AREA COMPUTER NETWORKS, WIRELESS COMMUNICATION NETWORKS, GLOBAL COMPUTER INFORMATION NETWORKS AND OTHER ELECTRONIC COMMUNICATION NETWORKS; ARRANGING AND CONDUCTING BUSINESS CONFERENCES; PROVIDING AN ON-LINE COMPUTER DATABASE IN THE FIELDS OF BUSINESS, MANAGEMENT, FINANCIAL, ADVERTISING, TAX, REPORTS AND INFORMATION (U.S. CLS. 100, 101 AND 102).
FIRST USE 2-4-2003; IN COMMERCE 2-4-2003.

CLASS 38—COMMUNICATION

FOR PROVIDING MULTIPLE USER ACCESS TO DATABASES OVER, BY OR THROUGH LOCAL OR WIDE AREA COMPUTER NETWORKS, WIRELESS COMMUNICATION NETWORKS, GLOBAL COMPUTER INFORMATION NETWORKS AND OTHER ELECTRONIC COMMUNICATION NETWORKS (U.S. CLS. 100, 101 AND 104).
FIRST USE 2-4-2003; IN COMMERCE 2-4-2003.

CLASS 41—EDUCATION AND ENTERTAINMENT

FOR COMPUTER SERVICES, NAMELY, PROVIDING ON-LINE PUBLICATIONS IN THE NATURE OF REPORTS, DIGESTS, DIRECTORIES, BROCHURES, REFERENCE MATERIALS, NEWSLETTERS, NEWSPAPERS, BOOKLETS, PAMPHLETS, AND TRADE AND PROFESSIONAL BOOKS IN THE FIELDS OF NEWS, RESEARCH, COMPUTERIZED DATABASES AND OTHER INDEXES OF INFORMATION, LAW, GOVERNMENT AND PUBLIC RECORDS, BUSINESS, FINANCE; NEWS AGENCIES AND NEWS REPORTING SERVICES, NAMELY, GATHERING AND DISSEMINATION OF NEWS BY COMPUTER (U.S. CLS. 100, 101 AND 107).
FIRST USE 2-4-2003; IN COMMERCE 2-4-2003.

CLASS 42—SCIENTIFIC AND COMPUTER SERVICES

FOR LEGAL RESEARCH SERVICES; COMPUTER SERVICES, NAMELY, COMPUTERIZED LEGAL RESEARCH SERVICES OVER, BY OR THROUGH LOCAL OR WIDE AREA COMPUTER NETWORKS, WIRELESS COMMUNICATION NETWORKS, GLOBAL COMPUTER INFORMATION NETWORKS AND OTHER ELECTRONIC COMMUNICATION NETWORKS (U.S. CLS. 100 AND 101).
FIRST USE 2-4-2003; IN COMMERCE 2-4-2003.

* * * * *

SECTION 2.— INTERNATIONAL CLASSIFICATION

The short titles associated below with the international class numbers are terms designed merely for quick identification and are not an official part of the international classification. The full names of international classes are given in section 6.1 of the trademark rules of practice.

The designation "U.S. Cl." appearing in this section refers to the U.S. class in effect prior to Sep. 1, 1973 rather than the international class which applies to applications filed on or after that date. For adoption of international classification see notice in the OFFICIAL GAZETTE of Jun. 26, 1973 (911 O.G. TM 210).

Application in one class

CLASS 1—CHEMICALS

3,481,053. COMPO GMBH & CO. KG, MUENSTER, FED REP GERMANY. SN 76-523,886. PUB. 3-22-2005, FILED 6-18-2003.

CLASS 1—(Continued).

3,481,203. PERFORMANCE POLYMER SOLUTIONS, INC., CENTERVILLE, OH. SN 77-022,952. PUB. 10-30-2007, FILED 10-17-2006.

COMPO ENTEC

OWNER OF U.S. REG. NO. 2,703,125.
FOR CHEMICALS FOR USE IN THE MANUFACTURE OF FERTILIZERS; FERTILIZERS FOR AGRICULTURAL, HORTICULTURE AND FORESTRY USES (U.S. CLS. 1, 5, 6, 10, 26 AND 46).
FIRST USE 5-14-2008; IN COMMERCE 5-14-2008.

LIQUIMIDE

THE MARK CONSISTS OF STANDARD CHARACTERS WITHOUT CLAIM TO ANY PARTICULAR FONT, STYLE, SIZE, OR COLOR.
FOR CHEMICALS, NAMELY, IMIDE-BASED COMPOSITIONS FOR USE IN THE MANUFACTURE OF RESINS AND ADHESIVES (U.S. CLS. 1, 5, 6, 10, 26 AND 46).
FIRST USE 6-10-2007; IN COMMERCE 6-10-2007.

3,481,109. FORESTRY RESOURCES, INC., FORT MYERS, FL. SN 76-665,060. PUB. 9-11-2007, FILED 8-24-2006.

3,481,393. WILBUR-ELLIS COMPANY, SAN FRANCISCO, CA. SN 77-111,977. PUB. 8-21-2007, FILED 2-20-2007.

FLORIGANIC

THE MARK CONSISTS OF STANDARD CHARACTERS WITHOUT CLAIM TO ANY PARTICULAR FONT, STYLE, SIZE, OR COLOR.

FOR COMPOST, PLANTING SOIL, AND POTTING SOIL HAVING ELEVATED CONTENT OF ORGANIC MATERIAL, MINERALS, AND NUTRIENTS (U.S. CLS. 1, 5, 6, 10, 26 AND 46).
FIRST USE 4-1-2008; IN COMMERCE 4-1-2008.

NDEMAND

THE MARK CONSISTS OF STANDARD CHARACTERS WITHOUT CLAIM TO ANY PARTICULAR FONT, STYLE, SIZE, OR COLOR.

OWNER OF U.S. REG. NO. 2,780,090.
FOR FERTILIZERS (U.S. CLS. 1, 5, 6, 10, 26 AND 46).
FIRST USE 3-29-2007; IN COMMERCE 3-29-2007.

CLASS 1—(Continued).

3,481,414. FLORIKAN-E.S.A. CORP., SARASOTA, FL. SN 77-120,533. PUB. 3-18-2008, FILED 3-2-2007.

DYNAMITE

THE MARK CONSISTS OF STANDARD CHARACTERS WITHOUT CLAIM TO ANY PARTICULAR FONT, STYLE, SIZE, OR COLOR.

OWNER OF U.S. REG. NOS. 1,903,310 AND 3,283,154. FOR SOILS, NAMELY, POTTING SOILS, TREE AND SHRUB PLANTING SOILS, ANNUAL AND PERENNIAL BEDDING SOILS FOR PLANTING (U.S. CLS. 1, 5, 6, 10, 26 AND 46).

FIRST USE 2-15-2008; IN COMMERCE 2-15-2008.

3,481,454. FIBER-LINE, INC., HATFIELD, PA. SN 77-129,124. PUB. 10-2-2007, FILED 3-13-2007.

Wear-Coat

THE MARK CONSISTS OF STANDARD CHARACTERS WITHOUT CLAIM TO ANY PARTICULAR FONT, STYLE, SIZE, OR COLOR.

FOR NON-METALLIC CHEMICAL FORMULATION FOR USE IN PROVIDING ABRASION-RESISTANT LAYERS OR IMPREGNATION ON FIBERS USED IN ROPE, CABLE, BELTS, HOSES, AND INDUSTRIAL FABRICS (U.S. CLS. 1, 5, 6, 10, 26 AND 46).

FIRST USE 4-4-2008; IN COMMERCE 4-4-2008.

3,481,580. VITAL PHARMACEUTICALS, INC., DAVIE, FL. SN 77-149,604. PUB. 9-18-2007, FILED 4-5-2007.

SUCRALEAN

THE MARK CONSISTS OF STANDARD CHARACTERS WITHOUT CLAIM TO ANY PARTICULAR FONT, STYLE, SIZE, OR COLOR.

FOR ARTIFICIAL SWEETENERS (U.S. CLS. 1, 5, 6, 10, 26 AND 46).

FIRST USE 5-23-2008; IN COMMERCE 5-23-2008.

CLASS 1—(Continued).

3,481,606. STERIS INC., TEMECULA, CA. SN 77-153,802. PUB. 10-9-2007, FILED 4-11-2007.

SIXCESS

THE MARK CONSISTS OF STANDARD CHARACTERS WITHOUT CLAIM TO ANY PARTICULAR FONT, STYLE, SIZE, OR COLOR.

FOR CHEMICAL INDICATORS FOR USE IN MONITORING THE FUNCTION AND PERFORMANCE OF STERILIZATION PROCESSES AND EQUIPMENT, NAMELY, CARRIERS IMPREGNATED WITH CHEMICALS FOR HEALTH CARE AND INDUSTRIAL USE TO TEST THE FUNCTION AND PERFORMANCE OF STERILIZATION PROCESSES AND EQUIPMENT (U.S. CLS. 1, 5, 6, 10, 26 AND 46).

FIRST USE 10-31-2007; IN COMMERCE 10-31-2007.

3,481,860. BAKER HUGHES INCORPORATED, HOUSTON, TX. SN 77-247,927. PUB. 1-29-2008, FILED 8-6-2007.

TOPGUARD

THE MARK CONSISTS OF STANDARD CHARACTERS WITHOUT CLAIM TO ANY PARTICULAR FONT, STYLE, SIZE, OR COLOR.

FOR CHEMICALS AND CHEMICAL ADDITIVES FOR CONTROLLING OVERHEAD CORROSION IN REFINERIES AND PETROCHEMICAL PLANTS (U.S. CLS. 1, 5, 6, 10, 26 AND 46).

FIRST USE 10-1-2007; IN COMMERCE 10-1-2007.

3,481,924. WILLIS, LARRELL I., LAKELAND, FL. SN 77-275,045. PUB. 3-4-2008, FILED 9-9-2007.

COLD-PLUS

THE MARK CONSISTS OF STANDARD CHARACTERS WITHOUT CLAIM TO ANY PARTICULAR FONT, STYLE, SIZE, OR COLOR.

FOR CHEMICAL ADDITIVES FOR COOLING SYSTEMS, NAMELY, AIR CONDITIONING, REFRIGERATION EQUIPMENT, CHILLERS, AND AUTOMOTIVE AND TRUCK AIR CONDITIONING (U.S. CLS. 1, 5, 6, 10, 26 AND 46).

FIRST USE 1-29-2008; IN COMMERCE 1-29-2008.

CLASS 1—(Continued).

3,481,949. MARS FISHCARE NORTH AMERICA, INC., CHALFONT, PA. SN 77-286,274. PUB. 2-12-2008, FILED 9-21-2007.

NATURAL TRACE

THE MARK CONSISTS OF STANDARD CHARACTERS WITHOUT CLAIM TO ANY PARTICULAR FONT, STYLE, SIZE, OR COLOR.

FOR CHEMICAL AND BACTERIA PREPARATIONS FOR THE TREATMENT, CONDITIONING, AND CLEANING OF AQUARIUMS AND AQUARIUM WATER (U.S. CLS. 1, 5, 6, 10, 26 AND 46).

FIRST USE 10-0-2007; IN COMMERCE 10-0-2007.

3,481,984. MFA INCORPORATED, COLUMBIA, MO. SN 77-330,148. PUB. 3-4-2008, FILED 11-15-2007.

AMS-EZ PLUS

THE MARK CONSISTS OF STANDARD CHARACTERS WITHOUT CLAIM TO ANY PARTICULAR FONT, STYLE, SIZE, OR COLOR.

OWNER OF U.S. REG. NOS. 2,319,411 AND 2,470,250. FOR AGRICULTURAL ADJUVANT TO ENHANCE HERBICIDE AND PESTICIDE PERFORMANCE (U.S. CLS. 1, 5, 6, 10, 26 AND 46).

FIRST USE 3-19-2008; IN COMMERCE 3-19-2008.

3,482,133. J.R. SIMPLOT COMPANY, BOISE, ID. SN 78-646,360. PUB. 2-21-2006, FILED 6-8-2005.

SPRAY-STICKER

THE MARK CONSISTS OF STANDARD CHARACTERS WITHOUT CLAIM TO ANY PARTICULAR FONT, STYLE, SIZE, OR COLOR.

FOR ADJUVANTS AND SURFACTANTS FOR USE WITH PESTICIDES AND FERTILIZERS FOR AGRICULTURAL, TURF, AND HORTICULTURAL USE (U.S. CLS. 1, 5, 6, 10, 26 AND 46).

FIRST USE 3-27-2007; IN COMMERCE 3-27-2007.

CLASS 1—(Continued).

3,482,154. NATURALCHECK, LLC, WILMINGTON, DE. SN 78-671,109. PUB. 4-25-2006, FILED 7-15-2005.

TEST TODAY FOR A HEALTHIER TOMORROW

THE MARK CONSISTS OF STANDARD CHARACTERS WITHOUT CLAIM TO ANY PARTICULAR FONT, STYLE, SIZE, OR COLOR.

FOR TEST KITS CONSISTING PRIMARILY OF REAGENTS FOR SCIENTIFIC USE AND INSTRUCTIONAL BOOKLETS (U.S. CLS. 1, 5, 6, 10, 26 AND 46).

FIRST USE 4-21-2008; IN COMMERCE 4-21-2008.

3,482,207. NORTHERN TECHNOLOGIES INTERNATIONAL CORPORATION, BEACHWOOD, OH. SN 78-749,729. PUB. 7-11-2006, FILED 11-8-2005.

NATUR-TEC

THE MARK CONSISTS OF STANDARD CHARACTERS WITHOUT CLAIM TO ANY PARTICULAR FONT, STYLE, SIZE, OR COLOR.

FOR BIODEGRADABLE AND/OR COMPOSTABLE POLYMER RESINS; BLENDED, COMPOUNDED AND/OR ALLOYED MIXTURES OF BIODEGRADABLE AND/OR COMPOSTABLE POLYMER RESINS; AND BIODEGRADABLE AND/OR COMPOSTABLE POLYMER BASE COMPOSITIONS, ALL USED IN THE MANUFACTURE OF COMMERCIAL, INDUSTRIAL AND DOMESTIC GOODS (U.S. CLS. 1, 5, 6, 10, 26 AND 46).

FIRST USE 4-10-2007; IN COMMERCE 4-10-2007.

3,482,270. DISTINCTIVE COSMETIC INGREDIENTS, SOUTH CLINTON AVE., NM. SN 78-792,151. PUB. 9-5-2006, FILED 1-16-2006.

Maxigloss

THE MARK CONSISTS OF STANDARD CHARACTERS WITHOUT CLAIM TO ANY PARTICULAR FONT, STYLE, SIZE, OR COLOR.

FOR CHEMICAL ADDITIVES FOR USE IN THE MANUFACTURE OF COSMETICS (U.S. CLS. 1, 5, 6, 10, 26 AND 46).

FIRST USE 1-20-2006; IN COMMERCE 1-20-2006.

CLASS 2—PAINTS

CLASS 2—(Continued).

3,481,340. TOR MINERALS INTERNATIONAL, INC., CORPUS CHRISTI, TX. SN 77-088,361. PUB. 9-4-2007, FILED 1-22-2007.

TIOPREM

THE MARK CONSISTS OF STANDARD CHARACTERS WITHOUT CLAIM TO ANY PARTICULAR FONT, STYLE, SIZE, OR COLOR.

FOR TITANIUM DIOXIDE PIGMENT (U.S. CLS. 6, 11 AND 16).

FIRST USE 5-1-2008; IN COMMERCE 5-1-2008.

CLASS 2—(Continued).

3,481,759. MASTERCHEM INDUSTRIES LLC, IMPERIAL, MO. SN 77-201,025. PUB. 3-11-2008, FILED 6-8-2007.



3,481,403. BURKE INDUSTRIAL COATINGS, RIDGEFIELD, WA. SN 77-114,639. PUB. 9-11-2007, FILED 2-23-2007.

STEEL TUFF 316

THE MARK CONSISTS OF STANDARD CHARACTERS WITHOUT CLAIM TO ANY PARTICULAR FONT, STYLE, SIZE, OR COLOR.

NO CLAIM IS MADE TO THE EXCLUSIVE RIGHT TO USE "STEEL" AND "316", APART FROM THE MARK AS SHOWN.

FOR COATING COMPOSITION IN THE NATURE OF PAINT FOR INDUSTRIAL APPLICATIONS (U.S. CLS. 6, 11 AND 16).

FIRST USE 2-23-2007; IN COMMERCE 2-23-2007.

NO CLAIM IS MADE TO THE EXCLUSIVE RIGHT TO USE "GREEN LOW VOC", APART FROM THE MARK AS SHOWN.

THE MARK CONSISTS OF A SQUARE WITH THE WORDS "GO GREEN" WITHIN A TREE AND THE WORDS "LOW VOC" ACROSS THE BOTTOM OF THE SQUARE.

FOR INTERIOR AND EXTERIOR PAINTS AND PAINT PRIMERS (U.S. CLS. 6, 11 AND 16).

FIRST USE 6-5-2007; IN COMMERCE 6-5-2007.

3,481,756. MASTERCHEM INDUSTRIES LLC, IMPERIAL, MO. SN 77-200,434. PUB. 3-11-2008, FILED 6-7-2007.

GO GREEN

THE MARK CONSISTS OF STANDARD CHARACTERS WITHOUT CLAIM TO ANY PARTICULAR FONT, STYLE, SIZE, OR COLOR.

NO CLAIM IS MADE TO THE EXCLUSIVE RIGHT TO USE "GREEN", APART FROM THE MARK AS SHOWN.

FOR INTERIOR AND EXTERIOR PAINTS AND PAINT PRIMERS (U.S. CLS. 6, 11 AND 16).

FIRST USE 6-5-2007; IN COMMERCE 6-5-2007.

3,481,838. KOP-COAT, INC., PITTSBURGH, PA. SN 77-240,409. PUB. 1-15-2008, FILED 7-27-2007.

WORKHORSE

THE MARK CONSISTS OF STANDARD CHARACTERS WITHOUT CLAIM TO ANY PARTICULAR FONT, STYLE, SIZE, OR COLOR.

FOR WOOD PRESERVATIVES FOR WOOD AND WOOD-BASED COMPOSITES FOR RESISTING DECAY, STAIN, AND FUNGI (U.S. CLS. 6, 11 AND 16).

FIRST USE 4-15-2008; IN COMMERCE 4-15-2008.

CLASS 2—(Continued).

3,482,072. VERBATIM AMERICAS LLC, CHARLOTTE, NC.
SN 78-514,524. PUB. 1-24-2006, FILED 11-10-2004.

VIDEOGARD

THE MARK CONSISTS OF STANDARD CHARACTERS WITHOUT CLAIM TO ANY PARTICULAR FONT, STYLE, SIZE, OR COLOR.

FOR COMPONENT FEATURE OF BLANK AND PRE-FORMATTED OPTICAL DISKS, NAMELY, SCRATCH-RESISTANT COATINGS OF BLANK AND PREFORMATTED DVDS, MINI-DVDS, AND CDS (U.S. CLS. 6, 11 AND 16).

FIRST USE 1-6-2005; IN COMMERCE 1-6-2005.

3,482,382. MATSUI INTERNATIONAL CO., INC., GARDENA, CA. SN 78-886,897. PUB. 3-20-2007, FILED 5-18-2006.

THERMOLOCK

THE MARK CONSISTS OF STANDARD CHARACTERS WITHOUT CLAIM TO ANY PARTICULAR FONT, STYLE, SIZE, OR COLOR.

FOR COLOR CHANGING DYES, COLORANTS, PAINTS, AND PRINTING INKS FOR GENERAL INDUSTRIAL USE AND USE IN THE SECURITY FIELD (U.S. CLS. 6, 11 AND 16).

FIRST USE 4-17-2008; IN COMMERCE 4-17-2008.

3,482,547. THE SHERWIN-WILLIAMS COMPANY, CLEVELAND, OH. SN 78-962,749. PUB. 2-27-2007, FILED 8-29-2006.

FLUOROKEM

THE MARK CONSISTS OF STANDARD CHARACTERS WITHOUT CLAIM TO ANY PARTICULAR FONT, STYLE, SIZE, OR COLOR.

FOR PAINT (U.S. CLS. 6, 11 AND 16).

FIRST USE 6-20-2007; IN COMMERCE 6-20-2007.

CLASS 3—COSMETICS AND CLEANING PREPARATIONS

3,481,099. NOAH'S NATURALS, LLC, LOS ANGELES, CA.
SN 76-658,919. PUB. 2-20-2007, FILED 4-24-2006.

IT'S ALL GOOD

FOR AROMATHERAPY BODY CARE PRODUCTS, NAMELY, BODY LOTION, SHOWER GEL, CUTICLE CREAM, SHAMPOO, CONDITIONER, NON-MEDICATED LIP BALM, SOAP, BODY POLISH, BODY AND FOOT SCRUB AND NON-MEDICATED FOOT CREAM (U.S. CLS. 1, 4, 6, 50, 51 AND 52).

FIRST USE 10-1-2006; IN COMMERCE 10-1-2006.

3,481,113. VODOO RIDE, LLC, CHICAGO, IL. SN 76-666,206.
PUB. 5-15-2007, FILED 9-18-2006.



FOR AUTOMOTIVE SURFACE CARE PRODUCTS, NAMELY, AUTOMOBILE CLEANERS, AUTOMOBILE POLISHES AND WAXES (U.S. CLS. 1, 4, 6, 50, 51 AND 52).

FIRST USE 1-7-2008; IN COMMERCE 1-7-2008.

3,481,129. WALSH, JOHN P., NORTH ANDOVER, MA. SN 76-672,718. PUB. 8-14-2007, FILED 2-15-2007.

STEAMY

THE MARK CONSISTS OF STANDARD CHARACTERS WITHOUT CLAIM TO ANY PARTICULAR FONT, STYLE, SIZE, OR COLOR.

FOR COLOGNE AND BODY WASH (U.S. CLS. 1, 4, 6, 50, 51 AND 52).

FIRST USE 7-31-2007; IN COMMERCE 7-31-2007.

CLASS 3—(Continued).

3,481,307. BNG ENTERPRISES, INC., PHOENIX, AZ. SN 77-072,797. PUB. 12-18-2007, FILED 12-28-2006.

PROGESTIA

THE MARK CONSISTS OF STANDARD CHARACTERS WITHOUT CLAIM TO ANY PARTICULAR FONT, STYLE, SIZE, OR COLOR.

FOR COSMETICS, NAMELY, BODY CREAMS AND BODY OILS (U.S. CLS. 1, 4, 6, 50, 51 AND 52).

FIRST USE 5-15-2007; IN COMMERCE 5-15-2007.

3,481,339. NEOCUTIS SA, PULLY, SWITZERLAND. SN 77-087,676. PUB. 6-12-2007, FILED 1-22-2007.

HYALIS

THE MARK CONSISTS OF STANDARD CHARACTERS WITHOUT CLAIM TO ANY PARTICULAR FONT, STYLE, SIZE, OR COLOR.

FOR COSMETIC PREPARATIONS FOR SKIN RENEWAL (U.S. CLS. 1, 4, 6, 50, 51 AND 52).

FIRST USE 11-12-2007; IN COMMERCE 11-12-2007.

3,481,368. NICHOLS, MARKYIA, OWINGS MILLS, MD. SN 77-102,159. PUB. 8-14-2007, FILED 2-8-2007.

DIVI NEVA

THE MARK CONSISTS OF THE WORD "DIVINEVA" WITH THE "N" IN DIFFERENT FONT AND SIZE THAN THE REMAINDER OF THE LETTERS FOR EMPHASIS.

FOR BODY OIL; BODY POWDER; BODY SCRUB; BODY WASHES; FACE AND BODY BEAUTY CREAMS; SOAPS FOR BODY CARE (U.S. CLS. 1, 4, 6, 50, 51 AND 52).

FIRST USE 9-1-2007; IN COMMERCE 11-1-2007.

CLASS 3—(Continued).

3,481,370. ANORGA, ALFONSO JOSE, JR., COMMERCE, CA. SN 77-103,526. PUB. 8-14-2007, FILED 2-9-2007.

JOHNNY B. FUDDY GEL

THE MARK CONSISTS OF STANDARD CHARACTERS WITHOUT CLAIM TO ANY PARTICULAR FONT, STYLE, SIZE, OR COLOR.

OWNER OF U.S. REG. NO. 2,504,361.

NO CLAIM IS MADE TO THE EXCLUSIVE RIGHT TO USE "GEL", APART FROM THE MARK AS SHOWN.

THE NAME(S), PORTRAIT(S), AND/OR SIGNATURE(S) SHOWN IN THE MARK DOES NOT IDENTIFY A PARTICULAR LIVING INDIVIDUAL.

FOR HAIR CARE PREPARATIONS; HAIR GEL; HAIR STYLING GEL; HAIR STYLING PREPARATIONS (U.S. CLS. 1, 4, 6, 50, 51 AND 52).

FIRST USE 4-9-2007; IN COMMERCE 4-9-2007.

3,481,371. ANORGA, ALFONSO JOSE, JR., COMMERCE, CA. SN 77-103,528. PUB. 8-14-2007, FILED 2-9-2007.

JOHNNY B. MODE GEL

THE MARK CONSISTS OF STANDARD CHARACTERS WITHOUT CLAIM TO ANY PARTICULAR FONT, STYLE, SIZE, OR COLOR.

OWNER OF U.S. REG. NO. 2,504,361.

NO CLAIM IS MADE TO THE EXCLUSIVE RIGHT TO USE "GEL", APART FROM THE MARK AS SHOWN.

THE NAME(S), PORTRAIT(S), AND/OR SIGNATURE(S) SHOWN IN THE MARK DOES NOT IDENTIFY A PARTICULAR LIVING INDIVIDUAL.

FOR HAIR CARE PREPARATIONS; HAIR GEL; HAIR STYLING GEL; HAIR STYLING PREPARATIONS (U.S. CLS. 1, 4, 6, 50, 51 AND 52).

FIRST USE 4-9-2007; IN COMMERCE 4-9-2007.

CLASS 3—(Continued).

3,481,426. ABERCROMBIE & FITCH TRADING CO., NEW ALBANY, OH. SN 77-123,598. PUB. 2-19-2008, FILED 3-6-2007.

ABERCROMBIE & FITCH NEW
YORK COLOGNE 41

THE MARK CONSISTS OF STANDARD CHARACTERS WITHOUT CLAIM TO ANY PARTICULAR FONT, STYLE, SIZE, OR COLOR.

OWNER OF U.S. REG. NOS. 1,999,665 AND 2,500,146.

NO CLAIM IS MADE TO THE EXCLUSIVE RIGHT TO USE "NEW YORK COLOGNE", APART FROM THE MARK AS SHOWN.

FOR COLOGNE; FRAGRANCES FOR PERSONAL USE; PERFUME (U.S. CLS. 1, 4, 6, 50, 51 AND 52).
FIRST USE 10-0-2007; IN COMMERCE 10-0-2007.

3,481,427. ABERCROMBIE & FITCH TRADING CO., NEW ALBANY, OH. SN 77-123,611. PUB. 2-19-2008, FILED 3-6-2007.

ABERCROMBIE & FITCH NEW
YORK PERFUME 41

THE MARK CONSISTS OF STANDARD CHARACTERS WITHOUT CLAIM TO ANY PARTICULAR FONT, STYLE, SIZE, OR COLOR.

OWNER OF U.S. REG. NOS. 1,999,665 AND 2,500,146.

NO CLAIM IS MADE TO THE EXCLUSIVE RIGHT TO USE "NEW YORK PERFUME", APART FROM THE MARK AS SHOWN.

FOR COLOGNE; FRAGRANCES FOR PERSONAL USE; PERFUME (U.S. CLS. 1, 4, 6, 50, 51 AND 52).
FIRST USE 10-0-2007; IN COMMERCE 10-0-2007.

3,481,443. NU VISION GROUP LLC, NEW YORK, NY. SN 77-127,345. PUB. 9-11-2007, FILED 3-9-2007.

MADemoiselle Debutante

THE MARK CONSISTS OF STANDARD CHARACTERS WITHOUT CLAIM TO ANY PARTICULAR FONT, STYLE, SIZE, OR COLOR.

FOR COLOGNE; COLOGNE WATER; EAU DE COLOGNE; FRAGRANCES FOR PERSONAL USE; PERFUME; TOILET WATER (U.S. CLS. 1, 4, 6, 50, 51 AND 52).

FIRST USE 5-0-2008; IN COMMERCE 5-0-2008.

CLASS 3—(Continued).

3,481,449. PERFORMANCE BRANDS, INC., SUNRISE, FL. SN 77-128,215. PUB. 9-18-2007, FILED 3-12-2007.

Disciple

THE MARK CONSISTS OF STANDARD CHARACTERS WITHOUT CLAIM TO ANY PARTICULAR FONT, STYLE, SIZE, OR COLOR.

FOR SUNTANNING PREPARATIONS (U.S. CLS. 1, 4, 6, 50, 51 AND 52).

FIRST USE 10-1-2007; IN COMMERCE 10-1-2007.

3,481,450. PERFORMANCE BRANDS, INC., SUNRISE, FL. SN 77-128,218. PUB. 9-18-2007, FILED 3-12-2007.

Juicy Story

THE MARK CONSISTS OF STANDARD CHARACTERS WITHOUT CLAIM TO ANY PARTICULAR FONT, STYLE, SIZE, OR COLOR.

FOR SUNTANNING PREPARATIONS (U.S. CLS. 1, 4, 6, 50, 51 AND 52).

FIRST USE 10-1-2007; IN COMMERCE 10-1-2007.

3,481,467. MICHAUD, JULIE, BOSTON, MA. SN 77-131,529. PUB. 10-2-2007, FILED 3-15-2007.

PRETTY PEN

THE MARK CONSISTS OF STANDARD CHARACTERS WITHOUT CLAIM TO ANY PARTICULAR FONT, STYLE, SIZE, OR COLOR.

NO CLAIM IS MADE TO THE EXCLUSIVE RIGHT TO USE "PEN", APART FROM THE MARK AS SHOWN.

FOR COSMETICS; CONCEALERS AND FACIAL HIGHLIGHTERS FOR COSMETIC USE (U.S. CLS. 1, 4, 6, 50, 51 AND 52).

FIRST USE 4-30-2007; IN COMMERCE 4-30-2007.

CLASS 3—(Continued).

3,481,481. MAURICE RASGON, INC., VENICE, CA. SN 77-133,009. PUB. 12-11-2007, FILED 3-16-2007.



OWNER OF U.S. REG. NO. 2,583,832.
NO CLAIM IS MADE TO THE EXCLUSIVE RIGHT TO USE "NATURAL BEAUTY", APART FROM THE MARK AS SHOWN.

THE MARK CONSISTS OF AN OVAL CONTAINING THE WORD "DOLL" ABOVE THE WORD "FACE" AND THE WORDS "NATURAL BEAUTY COCKTAILS" AND TWO STARS ON EITHER SIDE OF THE WORDS "DOLL FACE".

FOR SKIN CARE PRODUCTS, NAMELY, FACE AND BODY CLEANSER AND WASHES, TONER, FACE AND BODY LOTION AND GELS, FRUIT ACID BASED FACIAL PEELS, MASKS, EYE CREAM AND GELS, BEAUTY SERUM (U.S. CLS. 1, 4, 6, 50, 51 AND 52).

FIRST USE 1-1-1999; IN COMMERCE 1-1-1999.

3,481,505. LAURENT D PRODUCT, INC. D/B/A PRIVE PRODUCTS, LOS ANGELES, CA. SN 77-137,097. PUB. 9-25-2007, FILED 3-21-2007.

FLASH BRILLIANCE

THE MARK CONSISTS OF STANDARD CHARACTERS WITHOUT CLAIM TO ANY PARTICULAR FONT, STYLE, SIZE, OR COLOR.

FOR HAIR STYLING PREPARATIONS TO IMPART SHINE TO THE HAIR (U.S. CLS. 1, 4, 6, 50, 51 AND 52).
FIRST USE 8-1-2007; IN COMMERCE 8-1-2007.

CLASS 3—(Continued).

3,481,586. LG HOUSEHOLD & HEALTH CARE LTD., SEOUL, REPUBLIC OF KOREA. SN 77-150,458. PUB. 10-2-2007, FILED 4-6-2007.

PERIOE

THE MARK CONSISTS OF STANDARD CHARACTERS WITHOUT CLAIM TO ANY PARTICULAR FONT, STYLE, SIZE, OR COLOR.

OWNER OF U.S. REG. NO. 1,304,566.

FOR COSMETIC TOOTH WHITENING PREPARATIONS; PENCILS FOR TOOTH WHITENING PURPOSES; TOOTH WHITENING PATCHES (U.S. CLS. 1, 4, 6, 50, 51 AND 52).

FIRST USE 8-12-2007; IN COMMERCE 2-15-2008.

3,481,619. ALFALFA NAIL SUPPLY, INC., BATON ROUGE, LA. SN 77-157,580. PUB. 10-16-2007, FILED 4-16-2007.

BOTANICAL ESCAPES

THE MARK CONSISTS OF STANDARD CHARACTERS WITHOUT CLAIM TO ANY PARTICULAR FONT, STYLE, SIZE, OR COLOR.

NO CLAIM IS MADE TO THE EXCLUSIVE RIGHT TO USE "BOTANICAL", APART FROM THE MARK AS SHOWN.

FOR AROMATIC PRODUCTS, NAMELY, SKIN CREAMS AND LOTIONS, BATH AND SHOWER SALTS, NON-MEDICATED FOOT GEL, NAIL STRENGTHENER, CUTICLE OIL AND FOOT AND HAND MASKS (U.S. CLS. 1, 4, 6, 50, 51 AND 52).

FIRST USE 7-0-2007; IN COMMERCE 7-0-2007.

3,481,644. THE BUTCHER COMPANY, STURTEVANT, WI. SN 77-162,073. PUB. 10-2-2007, FILED 4-20-2007.

NIAGARA

THE MARK CONSISTS OF STANDARD CHARACTERS WITHOUT CLAIM TO ANY PARTICULAR FONT, STYLE, SIZE, OR COLOR.

FOR FLOOR CARE PREPARATIONS, NAMELY, FLOOR FINISHING PREPARATIONS (U.S. CLS. 1, 4, 6, 50, 51 AND 52).

FIRST USE 7-6-2007; IN COMMERCE 7-6-2007.

CLASS 3—(Continued).

3,481,656. AVON PRODUCTS, INC., NEW YORK, NY. SN 77-166,663. PUB. 10-9-2007, FILED 4-26-2007.

SUPERSHOCK

THE MARK CONSISTS OF STANDARD CHARACTERS WITHOUT CLAIM TO ANY PARTICULAR FONT, STYLE, SIZE, OR COLOR.

FOR MASCARA (U.S. CLS. 1, 4, 6, 50, 51 AND 52).
FIRST USE 1-24-2008; IN COMMERCE 1-24-2008.

CLASS 3—(Continued).

3,481,753. REVLON CONSUMER PRODUCTS CORPORATION, NEW YORK, NY. SN 77-198,691. PUB. 12-4-2007, FILED 6-6-2007.

TRULY LASTING COLOR

THE MARK CONSISTS OF STANDARD CHARACTERS WITHOUT CLAIM TO ANY PARTICULAR FONT, STYLE, SIZE, OR COLOR.

NO CLAIM IS MADE TO THE EXCLUSIVE RIGHT TO USE "LASTING COLOR", APART FROM THE MARK AS SHOWN.

FOR COSMETICS; MAKE-UP (U.S. CLS. 1, 4, 6, 50, 51 AND 52).
FIRST USE 11-7-2007; IN COMMERCE 11-7-2007.

3,481,706. AVON PRODUCTS, INC., NEW YORK, NY. SN 77-178,547. PUB. 10-9-2007, FILED 5-11-2007.

WISH OF HAPPINESS

THE MARK CONSISTS OF STANDARD CHARACTERS WITHOUT CLAIM TO ANY PARTICULAR FONT, STYLE, SIZE, OR COLOR.

FOR EAU DE TOILETTE; SHOWER GEL; BODY LOTION (U.S. CLS. 1, 4, 6, 50, 51 AND 52).
FIRST USE 12-13-2007; IN COMMERCE 12-13-2007.

3,481,766. SOCIETE PARISIENNE DE PARFUMS ET COSMETIQUES, PARIS, FRANCE. SN 77-203,957. PUB. 10-23-2007, FILED 6-12-2007.

FRENCH CLUB

THE MARK CONSISTS OF STANDARD CHARACTERS WITHOUT CLAIM TO ANY PARTICULAR FONT, STYLE, SIZE, OR COLOR.

NO CLAIM IS MADE TO THE EXCLUSIVE RIGHT TO USE "FRENCH", APART FROM THE MARK AS SHOWN.

FOR PERFUMES AND COLOGNES (U.S. CLS. 1, 4, 6, 50, 51 AND 52).
FIRST USE 0-0-1995; IN COMMERCE 3-0-2008.

3,481,715. THE DIAL CORPORATION, SCOTTSDALE, AZ. SN 77-181,149. PUB. 9-18-2007, FILED 5-15-2007.

STEALTHSOLID

THE MARK CONSISTS OF STANDARD CHARACTERS WITHOUT CLAIM TO ANY PARTICULAR FONT, STYLE, SIZE, OR COLOR.

FOR PERSONAL CARE PRODUCTS, NAMELY, ANTI-PERSPIRANTS AND DEODORANTS (U.S. CLS. 1, 4, 6, 50, 51 AND 52).
FIRST USE 1-15-2008; IN COMMERCE 1-15-2008.

3,481,788. DE CARACOL CORPORATION, GAITHERSBURG, MD. SN 77-212,974. PUB. 12-4-2007, FILED 6-22-2007.

DERMA SECRETS

THE MARK CONSISTS OF STANDARD CHARACTERS WITHOUT CLAIM TO ANY PARTICULAR FONT, STYLE, SIZE, OR COLOR.

NO CLAIM IS MADE TO THE EXCLUSIVE RIGHT TO USE "DERMA", APART FROM THE MARK AS SHOWN.

FOR SKIN CARE PREPARATIONS, NAMELY, LOTIONS, BODY CREAMS, FACE CREAMS, SKIN TONERS FOR COMETIC PURPOSES; HAIR CARE PRODUCTS, NAMELY, SHAMPOOS AND CONDITIONERS (U.S. CLS. 1, 4, 6, 50, 51 AND 52).
FIRST USE 5-18-2008; IN COMMERCE 5-18-2008.

CLASS 3—(Continued).

3,481,801. BATTLE, SHANE, ANTIOCH, CA. SN 77-220,836.
PUB. 12-11-2007, FILED 7-2-2007.

lipnotize

THE MARK CONSISTS OF STANDARD CHARACTERS WITHOUT CLAIM TO ANY PARTICULAR FONT, STYLE, SIZE, OR COLOR.

FOR LIP BALM; LIP GLOSS; LIP GLOSS PALATTE; LIP LINER; LIP POLISHER; MAKE-UP KITS COMPRISED OF LIPSTICK, LIP GLOSS, LIP LINER, LIP POLISH; NON-MEDICATED LIP CARE PREPARATIONS; NON-MEDICATED LIP PROTECTOR; CLEANER FOR COSMETIC BRUSHES; COSMETIC PENCILS (U.S. CLS. 1, 4, 6, 50, 51 AND 52).

FIRST USE 5-21-2008; IN COMMERCE 5-21-2008.

3,481,844. MAY, SANDRA J, SOUTH AMBOY, NJ. SN 77-242,594. PUB. 3-11-2008, FILED 7-30-2007.



NO CLAIM IS MADE TO THE EXCLUSIVE RIGHT TO USE "SPA", APART FROM THE MARK AS SHOWN.

THE COLOR(S) BLACK, WHITE, PINK, GREEN, ORANGE IS/ARE CLAIMED AS A FEATURE OF THE MARK.

THE MARK CONSISTS OF BLACK LITERAL ELEMENT WITH BLACK SKETCH OF GIRL IN WHITE SPA ROBE AND TURBAN WITH GREEN CUCUMBERS ON EYES, PINK CIRCLES, PINK ICE CREAM CONE, PINK, GREEN AND ORANGE LOLLIPOPS IN PINK CIRCLES.

THE FOREIGN WORDING "SUCRERIES" IN THE MARK TRANSLATES INTO ENGLISH AS SWEETS OR ANYTHING MADE FROM SUGAR.

FOR ALMOND SOAPS; BAR SOAP; BATH SOAPS; BATH SOAPS IN LIQUID, SOLID OR GEL FORM; BODY CREAM SOAP; COSMETIC SOAPS; CREAM SOAPS; GRANULATED SOAPS; HAND SOAPS; LIQUID BATH SOAPS; LIQUID SOAP; LIQUID SOAP USED IN FOOT BATH; LIQUID SOAPS; LIQUID SOAPS FOR HANDS AND FACE; LIQUID SOAPS FOR HANDS, FACE AND BODY; PERFUMED SOAP; PERFUMED SOAPS; SHAVING SOAP; SKIN SOAP; SOAP POWDER; SOAPS; SOAPS FOR BODY CARE; SOAPS FOR PERSONAL USE; WATERLESS SOAP (U.S. CLS. 1, 4, 6, 50, 51 AND 52).

FIRST USE 7-7-2007; IN COMMERCE 10-30-2007.

CLASS 3—(Continued).

3,481,845. DESIGNER SKIN, LLC, TEMPE, AZ. SN 77-242,940.
PUB. 1-22-2008, FILED 7-31-2007.

ETERNAL FLAMES

THE MARK CONSISTS OF STANDARD CHARACTERS WITHOUT CLAIM TO ANY PARTICULAR FONT, STYLE, SIZE, OR COLOR.

FOR INDOOR TANNING PREPARATIONS (U.S. CLS. 1, 4, 6, 50, 51 AND 52).

FIRST USE 1-1-2008; IN COMMERCE 1-1-2008.

3,481,851. DESIGNER SKIN, LLC, INDIANAPOLIS, IN. SN 77-245,866. PUB. 1-22-2008, FILED 8-2-2007.

AROMACOLOR

THE MARK CONSISTS OF STANDARD CHARACTERS WITHOUT CLAIM TO ANY PARTICULAR FONT, STYLE, SIZE, OR COLOR.

FOR INDOOR TANNING PREPARATIONS (U.S. CLS. 1, 4, 6, 50, 51 AND 52).

FIRST USE 1-1-2008; IN COMMERCE 1-1-2008.

3,481,852. DESIGNER SKIN, LLC, INDIANAPOLIS, IN. SN 77-245,946. PUB. 1-22-2008, FILED 8-2-2007.

GOLD MINE

THE MARK CONSISTS OF STANDARD CHARACTERS WITHOUT CLAIM TO ANY PARTICULAR FONT, STYLE, SIZE, OR COLOR.

FOR INDOOR TANNING PREPARATIONS FOR SALE IN TANNING SALONS (U.S. CLS. 1, 4, 6, 50, 51 AND 52).

FIRST USE 1-1-2008; IN COMMERCE 1-1-2008.

CLASS 3—(Continued).

3,481,853. DESIGNER SKIN, LLC, INDIANAPOLIS, IN. SN 77-246,894. PUB. 1-22-2008, FILED 8-3-2007.

CLASS 3—(Continued).

3,481,856. DESIGNER SKIN, LLC, INDIANAPOLIS, IN. SN 77-247,017. PUB. 1-22-2008, FILED 8-3-2007.

BRONZE REDEMPTION

THE MARK CONSISTS OF STANDARD CHARACTERS WITHOUT CLAIM TO ANY PARTICULAR FONT, STYLE, SIZE, OR COLOR.
FOR INDOOR TANNING PREPARATIONS (U.S. CLS. 1, 4, 6, 50, 51 AND 52).
FIRST USE 1-1-2008; IN COMMERCE 1-1-2008.



3,481,854. DESIGNER SKIN, LLC, TEMPE, AZ. SN 77-246,949. PUB. 1-22-2008, FILED 8-3-2007.

WOW!

THE MARK CONSISTS OF STANDARD CHARACTERS WITHOUT CLAIM TO ANY PARTICULAR FONT, STYLE, SIZE, OR COLOR.
FOR INDOOR TANNING LOTIONS (U.S. CLS. 1, 4, 6, 50, 51 AND 52).
FIRST USE 1-1-2008; IN COMMERCE 1-1-2008.



DIVINE WISDOM

THE MARK CONSISTS OF STANDARD CHARACTERS WITHOUT CLAIM TO ANY PARTICULAR FONT, STYLE, SIZE, OR COLOR.
FOR INDOOR TANNING PREPARATIONS (U.S. CLS. 1, 4, 6, 50, 51 AND 52).
FIRST USE 1-1-2008; IN COMMERCE 1-1-2008.



3,481,855. DESIGNER SKIN, LLC, INDIANAPOLIS, IN. SN 77-246,980. PUB. 1-22-2008, FILED 8-3-2007.

3,481,864. AVEDA CORPORATION, MINNEAPOLIS, MN. SN 77-248,770. PUB. 1-15-2008, FILED 8-7-2007.



CROWN JEWEL

THE MARK CONSISTS OF STANDARD CHARACTERS WITHOUT CLAIM TO ANY PARTICULAR FONT, STYLE, SIZE, OR COLOR.
FOR INDOOR TANNING PREPARATIONS (U.S. CLS. 1, 4, 6, 50, 51 AND 52).
FIRST USE 1-1-2008; IN COMMERCE 1-1-2008.

THE MARK CONSISTS OF A SANSKRIT CHARACTER WITHIN A CIRCULAR-SHAPED DEVICE.
THE NON-LATIN CHARACTER(S) IN THE MARK TRANSLITERATE INTO "MULADHARA", AND THIS MEANS ROOT OR SUPPORT IN ENGLISH.
FOR FRAGRANCES FOR PERSONAL USE; ESSENTIAL OILS FOR PERSONAL USE; SCENTED BODY SPRAY (U.S. CLS. 1, 4, 6, 50, 51 AND 52).
FIRST USE 3-31-2008; IN COMMERCE 3-31-2008.

CLASS 3—(Continued).

3,481,865. AVEDA CORPORATION, MINNEAPOLIS, MN. SN 77-248,782. PUB. 1-15-2008, FILED 8-7-2007.

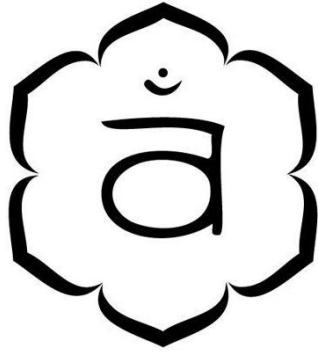

THE MARK CONSISTS OF A SANSKRIT CHARACTER WITHIN A CIRCULAR-SHAPED DEVICE.
THE NON-LATIN CHARACTER(S) IN THE MARK TRANSLITERATE INTO "SVADHISTHANA", AND THIS MEANS SWEETNESS IN ENGLISH.
FOR FRAGRANCES FOR PERSONAL USE; ESSENTIAL OILS FOR PERSONAL USE (U.S. CLS. 1, 4, 6, 50, 51 AND 52).
FIRST USE 3-31-2008; IN COMMERCE 3-31-2008.

CLASS 3—(Continued).

3,481,867. AVEDA CORPORATION, MINNEAPOLIS, MN. SN 77-248,801. PUB. 1-15-2008, FILED 8-7-2007.

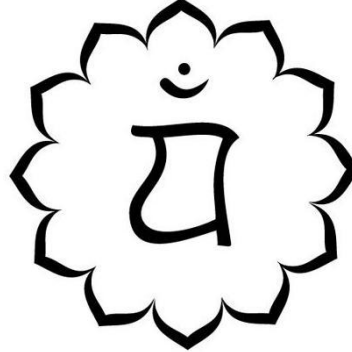

THE MARK CONSISTS OF A SANSKRIT CHARACTER WITHIN A CIRCULAR-SHAPED DEVICE.
THE NON-LATIN CHARACTER(S) IN THE MARK TRANSLITERATE INTO "ANAHATA", AND THIS MEANS UNSTRUCK IN ENGLISH.
FOR FRAGRANCES FOR PERSONAL USE; ESSENTIAL OILS FOR PERSONAL USE (U.S. CLS. 1, 4, 6, 50, 51 AND 52).
FIRST USE 3-31-2008; IN COMMERCE 3-31-2008.

3,481,866. AVEDA CORPORATION, MINNEAPOLIS, MN. SN 77-248,791. PUB. 1-15-2008, FILED 8-7-2007.

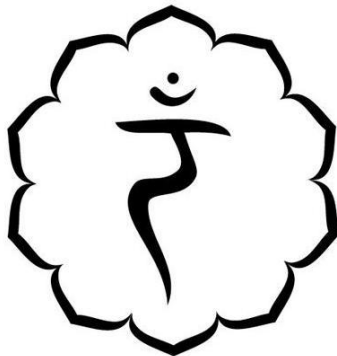

THE MARK CONSISTS OF A SANSKRIT CHARACTER WITHIN A CIRCULAR-SHAPED DEVICE.
THE NON-LATIN CHARACTER(S) IN THE MARK TRANSLITERATE INTO "MANIPURA", AND THIS MEANS LUSTROUS JEWEL IN ENGLISH.
FOR FRAGRANCES FOR PERSONAL USE; ESSENTIAL OILS FOR PERSONAL USE (U.S. CLS. 1, 4, 6, 50, 51 AND 52).
FIRST USE 3-31-2008; IN COMMERCE 3-31-2008.

3,481,868. AVEDA CORPORATION, MINNEAPOLIS, MN. SN 77-248,815. PUB. 1-15-2008, FILED 8-7-2007.

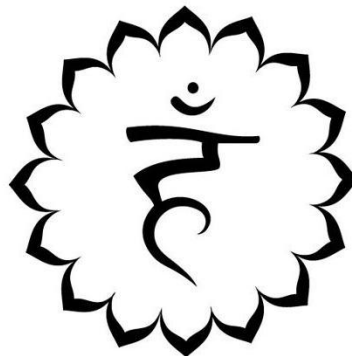

THE MARK CONSISTS OF A SANSKRIT CHARACTER WITHIN A CIRCULAR-SHAPED DEVICE.
THE NON-LATIN CHARACTER(S) IN THE MARK TRANSLITERATE INTO "VISSHUDHA", AND THIS MEANS TO PURIFY IN ENGLISH.
FOR FRAGRANCES FOR PERSONAL USE; ESSENTIAL OILS FOR PERSONAL USE (U.S. CLS. 1, 4, 6, 50, 51 AND 52).
FIRST USE 3-31-2008; IN COMMERCE 3-31-2008.

CLASS 3—(Continued).

3,481,869. AVEDA CORPORATION, MINNEAPOLIS, MN. SN 77-248,827. PUB. 1-15-2008, FILED 8-7-2007.



THE MARK CONSISTS OF A SANSKRIT CHARACTER WITH A STYLIZED BRACKET ON THE LEFT AND RIGHT SIDES.

THE NON-LATIN CHARACTER(S) IN THE MARK TRANSLITERATE INTO "AJNA", AND THIS MEANS TO PERCEIVE IN ENGLISH.

FOR FRAGRANCES FOR PERSONAL USE; ESSENTIAL OILS FOR PERSONAL USE (U.S. CLS. 1, 4, 6, 50, 51 AND 52).

FIRST USE 3-31-2008; IN COMMERCE 3-31-2008.

3,481,870. AVEDA CORPORATION, MINNEAPOLIS, MN. SN 77-248,832. PUB. 1-15-2008, FILED 8-7-2007.

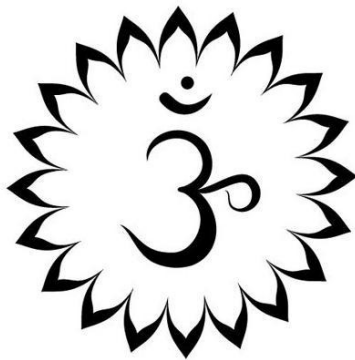

THE MARK CONSISTS OF A SANSKRIT CHARACTER WITHIN A CIRCULAR-SHAPED OR FLOWER-SHAPED DEVICE.

THE NON-LATIN CHARACTER(S) IN THE MARK TRANSLITERATE INTO "SAHASRARA", AND THIS MEANS THOUSAND-FOLD IN ENGLISH.

FOR FRAGRANCES FOR PERSONAL USE; ESSENTIAL OILS FOR PERSONAL USE (U.S. CLS. 1, 4, 6, 50, 51 AND 52).

FIRST USE 3-31-2008; IN COMMERCE 3-31-2008.

CLASS 3—(Continued).

3,481,877. DYNAMO HOUSE PROPRIETARY LIMITED, MITCHAM, AUSTRALIA. SN 77-252,824. PUB. 2-26-2008, FILED 8-10-2007.

DYNAMO HOUSE RED TEA

THE MARK CONSISTS OF STANDARD CHARACTERS WITHOUT CLAIM TO ANY PARTICULAR FONT, STYLE, SIZE, OR COLOR.

NO CLAIM IS MADE TO THE EXCLUSIVE RIGHT TO USE "RED TEA", APART FROM THE MARK AS SHOWN.

FOR MASSAGE OILS AND CREAMS; PERSONAL CARE PRODUCTS FOR BODY, HAIR AND FACE, NAMELY, BODY LOTIONS, BODY MASKS, BODY MILKS, BODY POWDERS, BODY SCRUBS, BODY OILS, BODY SPRAYS, BODY WASHES, HAIR CARE PREPARATIONS, HAIR SHAMPOO, FACE CREAMS, AND FACE POWDERS; SCENTED PERFUMES FOR THE BODY (U.S. CLS. 1, 4, 6, 50, 51 AND 52).

FIRST USE 6-0-2007; IN COMMERCE 6-0-2007.

3,481,878. DYNAMO HOUSE PROPRIETARY LIMITED, MITCHAM, AUSTRALIA. SN 77-252,832. PUB. 2-26-2008, FILED 8-10-2007.

DYNAMO HOUSE YUZU

THE MARK CONSISTS OF STANDARD CHARACTERS WITHOUT CLAIM TO ANY PARTICULAR FONT, STYLE, SIZE, OR COLOR.

NO CLAIM IS MADE TO THE EXCLUSIVE RIGHT TO USE "YUZU", APART FROM THE MARK AS SHOWN.

FOR MASSAGE OILS AND CREAMS; PERSONAL CARE PRODUCTS FOR BODY, HAIR AND FACE, NAMELY, BODY LOTIONS, BODY MASKS, BODY MILKS, BODY POWDERS, BODY SCRUBS, BODY OILS, BODY SPRAYS, BODY WASHES, HAIR CARE PREPARATIONS, HAIR SHAMPOO, FACE CREAMS, AND FACE POWDERS; SCENTED PERFUMES FOR THE BODY (U.S. CLS. 1, 4, 6, 50, 51 AND 52).

FIRST USE 4-0-2007; IN COMMERCE 4-0-2007.

CLASS 3—(Continued).

3,481,911. FOR THE BEST IN YOU...MISTER BLACKWELL COSMETICS INC., DBA ARTIE FITZGERALD, DECATUR, GA. SN 77-265,610. PUB. 2-26-2008, FILED 8-27-2007.

for the best in you...
mister blackwell cosmetics

THE MARK CONSISTS OF STANDARD CHARACTERS WITHOUT CLAIM TO ANY PARTICULAR FONT, STYLE, SIZE, OR COLOR.

NO CLAIM IS MADE TO THE EXCLUSIVE RIGHT TO USE "COSMETICS", APART FROM THE MARK AS SHOWN.

FOR HAIR CARE KITS COMPRISING NON-MEDICATED HAIR CARE PREPARATIONS, NAMELY, SPRITZ, LEAVE-IN CONDITIONERS, GELS AND MOUSSES (U.S. CLS. 1, 4, 6, 50, 51 AND 52).

FIRST USE 2-6-2008; IN COMMERCE 2-6-2008.

3,481,917. FISHER, DAWN, PORTLAND, OR. SN 77-270,225. PUB. 3-4-2008, FILED 9-2-2007.

Lash Sleeve

THE MARK CONSISTS OF STANDARD CHARACTERS WITHOUT CLAIM TO ANY PARTICULAR FONT, STYLE, SIZE, OR COLOR.

NO CLAIM IS MADE TO THE EXCLUSIVE RIGHT TO USE "LASH", APART FROM THE MARK AS SHOWN.

FOR MASCARAS (U.S. CLS. 1, 4, 6, 50, 51 AND 52).

FIRST USE 6-15-2008; IN COMMERCE 6-15-2008.

3,481,942. THE PROCTER & GAMBLE COMPANY, CINCINNATI, OH. SN 77-282,292. PUB. 3-4-2008, FILED 9-18-2007.

STAINSCRUBBERS

THE MARK CONSISTS OF STANDARD CHARACTERS WITHOUT CLAIM TO ANY PARTICULAR FONT, STYLE, SIZE, OR COLOR.

FOR LAUNDRY DETERGENT (U.S. CLS. 1, 4, 6, 50, 51 AND 52).

FIRST USE 1-21-2008; IN COMMERCE 1-21-2008.

CLASS 3—(Continued).

3,481,945. THE PROCTER & GAMBLE COMPANY, CINCINNATI, OH. SN 77-282,306. PUB. 3-4-2008, FILED 9-18-2007.

DAWN

THE MARK CONSISTS OF STANDARD CHARACTERS WITHOUT CLAIM TO ANY PARTICULAR FONT, STYLE, SIZE, OR COLOR.

OWNER OF U.S. REG. NOS. 562,962, 3,060,902, AND OTHERS.

FOR LAUNDRY DETERGENT (U.S. CLS. 1, 4, 6, 50, 51 AND 52).

FIRST USE 1-21-2008; IN COMMERCE 1-21-2008.

3,481,948. BALTZ, BRUCE, MIAMI, FL. SN 77-285,063. PUB. 3-11-2008, FILED 9-20-2007.

SPIRIPHYSICAL

THE MARK CONSISTS OF STANDARD CHARACTERS WITHOUT CLAIM TO ANY PARTICULAR FONT, STYLE, SIZE, OR COLOR.

OWNER OF U.S. REG. NOS. 3,217,886 AND 3,227,569.

FOR SKIN LOTION; LOTIONS FOR FACE AND BODY CARE; FACIAL LOTION; BEAUTY CREAMS; BODY CREAM; CLEANSING CREAMS; COSMETIC CREAMS; CREAM SOAPS; EXFOLIANT CREAMS; FACE AND BODY CREAMS; HAND CREAMS; BODY SCRUB; FACIAL SCRUBS; BEAUTY MASKS; FACIAL MASKS; EYE CREAM; EXFOLIANTS FOR SKIN AND FACE; COSMETIC SOAPS; HAND SOAPS; SKIN SOAP; FACE AND BODY LOTIONS; MOISTURIZING CREAMS; SKIN MOISTURIZER; SKIN MOISTURIZER MASKS; BODY OIL; SKIN TONERS (U.S. CLS. 1, 4, 6, 50, 51 AND 52).

FIRST USE 1-0-2008; IN COMMERCE 1-0-2008.

CLASS 3—(Continued).

3,481,954. PRODUCT QUEST MANUFACTURING, INC., HOLLY HILL, FL. SN 77-290,197. PUB. 3-4-2008, FILED 9-27-2007.

SOLAR RADIANCE

THE MARK CONSISTS OF STANDARD CHARACTERS WITHOUT CLAIM TO ANY PARTICULAR FONT, STYLE, SIZE, OR COLOR.

NO CLAIM IS MADE TO THE EXCLUSIVE RIGHT TO USE "SOLAR", APART FROM THE MARK AS SHOWN.

FOR NON-MEDICATED SKIN CARE PREPARATIONS, NAMELY, SUNSCREEN AND SUN BLOCK PREPARATIONS, SUNTANNING PREPARATIONS, AFTERSUN LOTIONS (U.S. CLS. 1, 4, 6, 50, 51 AND 52).

FIRST USE 1-8-2008; IN COMMERCE 1-8-2008.

3,481,991. ABERCROMBIE & FITCH TRADING CO., NEW ALBANY, OH. SN 77-975,657. PUB. 9-18-2007, FILED 3-29-2007.

CRYSTAL COVE

THE MARK CONSISTS OF STANDARD CHARACTERS WITHOUT CLAIM TO ANY PARTICULAR FONT, STYLE, SIZE, OR COLOR.

FOR FRAGRANCES FOR PERSONAL USE; BODY LOTION; BODY SPRAYS AND BODY WASHES (U.S. CLS. 1, 4, 6, 50, 51 AND 52).

FIRST USE 9-0-2007; IN COMMERCE 9-0-2007.

3,481,992. ABERCROMBIE & FITCH TRADING CO., NEW ALBANY, OH. SN 77-975,675. PUB. 9-18-2007, FILED 3-29-2007.

BALBOA

THE MARK CONSISTS OF STANDARD CHARACTERS WITHOUT CLAIM TO ANY PARTICULAR FONT, STYLE, SIZE, OR COLOR.

FOR FRAGRANCES FOR PERSONAL USE; BODY SPRAY USED AS A PERSONAL DEODORANT AND AS FRAGRANCE; BODY SPRAYS; BODY WASHES; DEODORANTS AND ANTIPERSPIRANTS; AND DEODORANTS FOR BODY CARE (U.S. CLS. 1, 4, 6, 50, 51 AND 52).

FIRST USE 9-0-2007; IN COMMERCE 9-0-2007.

CLASS 3—(Continued).

3,482,013. AKIRO LLC, BROOKLYN, NY. SN 78-315,209. PUB. 4-19-2005, FILED 10-17-2003.

MISS JESSIE'S

FOR COSMETIC AND HAIRCARE PRODUCTS, NAMELY, HAIR CREAMS AND HAIR MILKS; HAIRCARE PRODUCTS, NAMELY, SHAMPOOS, CONDITIONERS, AND HAIR MOISTURIZING CREAMS (U.S. CLS. 1, 4, 6, 50, 51 AND 52).

FIRST USE 12-0-2003; IN COMMERCE 12-0-2003.

3,482,016. KOHGENDO CO., LTD., TOKYO, JAPAN. SN 78-334,685. PUB. 4-12-2005, FILED 12-1-2003.



The logo for Koh Gen Do features the brand name in a classic, serif typeface. The letters are black and set against a light, rectangular background.

FOR SKIN CLEANING CREAMS, SKIN LOTIONS, EMOLLIENT CREAMS FOR SKIN CARE; FOUNDATION MAKEUP, NAMELY, CREAMY FOUNDATIONS, LOOSE FACE POWDERS FOR MAKE-UP PREPARATIONS (U.S. CLS. 1, 4, 6, 50, 51 AND 52).

FIRST USE 2-23-1987; IN COMMERCE 6-23-2007.

3,482,026. PHILOSOPHY, INC., PHOENIX, AZ. SN 78-377,834. PUB. 3-22-2005, FILED 3-3-2004.

PRE-OP

THE MARK CONSISTS OF STANDARD CHARACTERS WITHOUT CLAIM TO ANY PARTICULAR FONT, STYLE, SIZE, OR COLOR.

FOR MAKE-UP KITS AND GIFT SETS COMPRISED OF LIP BALM, NON-MEDICATED SKIN CARE PRODUCTS, NAMELY, SCRUBS, EXFOLIATORS (U.S. CLS. 1, 4, 6, 50, 51 AND 52).

FIRST USE 4-28-2008; IN COMMERCE 4-28-2008.

CLASS 3—(Continued).

3,482,031. PERFORMANCE BRANDS, INC., SUNRISE, FL. SN 78-400,156. PUB. 1-18-2005, FILED 4-12-2004.

BRONZE ILLUSIONS

THE MARK CONSISTS OF STANDARD CHARACTERS WITHOUT CLAIM TO ANY PARTICULAR FONT, STYLE, SIZE, OR COLOR.

NO CLAIM IS MADE TO THE EXCLUSIVE RIGHT TO USE "BRONZE". APART FROM THE MARK AS SHOWN.

FOR INDOOR AND OUTDOOR SUN TANNING PREPARATIONS, SUNLESS TANNING LOTIONS AND GELS (U.S. CLS. 1, 4, 6, 50, 51 AND 52).

FIRST USE 4-1-2008; IN COMMERCE 4-1-2008.

3,482,055. KULWUTHIVILAS, VICHAI, BANGKOK, THAILAND. SN 78-469,920. PUB. 11-1-2005, FILED 8-19-2004.

POP
POPULAR
宝美娜

THE MARK CONSISTS OF THE STYLIZED WORDS "POP POPULAR" WITH THAI WORDING UNDERNEATH.

THE FOREIGN WORDING IN THE MARK TRANSLATES INTO ENGLISH AS PAO MAI NAR.

THE NON-LATIN CHARACTERS IN THE MARK TRANSLITERATES INTO PAO MAI NAR, AND THIS MEANS BEAUTY AS GOLD IN ENGLISH.

FOR SHAMPOO, HAIR CONDITIONER, FRAGRANT SOAP, DEODORANT FOR PERSONAL USE, HAIR-DYE, LIPSTICK, FACIAL POWDER, FACIAL CREAM, TOOTHPASTE, NAIL COATING, NAMELY, NAIL POLISH, COTTON BUDS FOR COSMETIC PURPOSES, SKIN CLEANING LOTION, BODY LOTION, AND NAIL CREAM FOR NOURISHING PURPOSES (U.S. CLS. 1, 4, 6, 50, 51 AND 52).

FIRST USE 3-24-1999; IN COMMERCE 3-0-1999.

CLASS 3—(Continued).

3,482,108. BAGBLOCKER, INC., GREENWOOD, IN. SN 78-592,363. PUB. 7-17-2007, FILED 3-22-2005.

Eye LOVELY
THERAPEUTIC EYE WRAP

NO CLAIM IS MADE TO THE EXCLUSIVE RIGHT TO USE "EYE" AND "THERAPEUTIC EYE WRAP", APART FROM THE MARK AS SHOWN.

THE MARK CONSISTS OF THE WORDING "EYE LOVELY THERAPEUTIC EYE WRAP" WITH AN OVAL AROUND THE TERM "EYE".

FOR FACIAL EYE COMPRESSION MASKS FOR COSMETIC PURPOSES (U.S. CLS. 1, 4, 6, 50, 51 AND 52).

FIRST USE 5-1-2006; IN COMMERCE 5-1-2006.

3,482,122. COSMETIC DERMATOLOGY, INC., MIAMI, FL. SN 78-627,660. PUB. 1-24-2006, FILED 5-11-2005.

ACTIVE RENEWAL SHIELD

THE MARK CONSISTS OF STANDARD CHARACTERS WITHOUT CLAIM TO ANY PARTICULAR FONT, STYLE, SIZE, OR COLOR.

FOR AFTER SUN CREAMS, AFTER SUN LOTIONS, SUN BLOCKS, SUN CARE LOTIONS, SUN CREAMS AND SUN SCREENS (U.S. CLS. 1, 4, 6, 50, 51 AND 52).

FIRST USE 3-16-2006; IN COMMERCE 3-16-2006.

3,482,217. ENVIROSMART LLC, CHICAGO, IL. SN 78-758,393. PUB. 11-7-2006, FILED 11-21-2005.

EnviroSmart

THE MARK CONSISTS OF STANDARD CHARACTERS WITHOUT CLAIM TO ANY PARTICULAR FONT, STYLE, SIZE, OR COLOR.

FOR ENVIRONMENTALLY SAFE PRODUCTS FOR THE HOME AND GARDEN, NAMELY, CLEANING PREPARATIONS FOR HOUSEHOLD PURPOSES (U.S. CLS. 1, 4, 6, 50, 51 AND 52).

FIRST USE 11-21-2005; IN COMMERCE 9-1-2007.

CLASS 3—(Continued).

3,482,329. CLOROX COMPANY, THE, OAKLAND, CA. SN 78-846,872. PUB. 9-19-2006, FILED 3-27-2006.

REFRESHING CLEAN

THE MARK CONSISTS OF STANDARD CHARACTERS WITHOUT CLAIM TO ANY PARTICULAR FONT, STYLE, SIZE, OR COLOR.

FOR FRAGRANCE SOLD AS INTEGRAL PART OF ALL-PURPOSE CLEANERS (U.S. CLS. 1, 4, 6, 50, 51 AND 52).

FIRST USE 1-31-2007; IN COMMERCE 1-31-2007.

3,482,350. ALBERTO-CULVER USA, INC., MELROSE PARK, IL. SN 78-859,058. PUB. 10-31-2006, FILED 4-11-2006.

NEXXUS LEVEL

THE MARK CONSISTS OF STANDARD CHARACTERS WITHOUT CLAIM TO ANY PARTICULAR FONT, STYLE, SIZE, OR COLOR.

OWNER OF U.S. REG. NOS. 2,444,553, 2,521,278, AND OTHERS.

FOR HAIR CARE PREPARATIONS (U.S. CLS. 1, 4, 6, 50, 51 AND 52).

FIRST USE 12-31-2005; IN COMMERCE 12-31-2005.

3,482,384. YG LABORATORIES, INC., HUNTINGTON BEACH, CA. SN 78-887,849. PUB. 8-28-2007, FILED 5-19-2006.

DECIRCLING SERUM

THE MARK CONSISTS OF STANDARD CHARACTERS WITHOUT CLAIM TO ANY PARTICULAR FONT, STYLE, SIZE, OR COLOR.

NO CLAIM IS MADE TO THE EXCLUSIVE RIGHT TO USE "SERUM", APART FROM THE MARK AS SHOWN.

FOR NON-MEDICATED SKIN CARE PREPARATIONS, NAMELY, SERUMS, LOTIONS, CREAMS, GELS, MASKS AND SPRAYS (U.S. CLS. 1, 4, 6, 50, 51 AND 52).

FIRST USE 10-0-2006; IN COMMERCE 10-0-2006.

CLASS 3—(Continued).

3,482,387. NORTHSIDE DEVELOPMENT, INC., NEW YORK, NY. SN 78-888,771. PUB. 2-26-2008, FILED 5-22-2006.

LIQUID NATURE

THE MARK CONSISTS OF STANDARD CHARACTERS WITHOUT CLAIM TO ANY PARTICULAR FONT, STYLE, SIZE, OR COLOR.

NO CLAIM IS MADE TO THE EXCLUSIVE RIGHT TO USE "LIQUID", APART FROM THE MARK AS SHOWN.

FOR PERSONAL CARE PRODUCTS IN THE AREA OF GROOMING AND HYGIENE, NAMELY, LIQUID SOAPS AND CLEANSERS FOR HANDS, FACE AND BODY; SHAMPOOS (U.S. CLS. 1, 4, 6, 50, 51 AND 52).

FIRST USE 9-1-2006; IN COMMERCE 9-1-2006.

3,482,392. MIRACLE WORLD CORPORATION, SANTA CLARA, CA. SN 78-895,800. PUB. 3-25-2008, FILED 5-30-2006.



OWNER OF U.S. REG. NO. 3,134,339.

NO CLAIM IS MADE TO THE EXCLUSIVE RIGHT TO USE "HAIR GROW", APART FROM THE MARK AS SHOWN.

THE COLOR(S) RED AND BLACK IS/ARE CLAIMED AS A FEATURE OF THE MARK.

THE MARK CONSISTS OF "HAIR GROW MIRACLE" WORDS ARE IN RED. THERE IS A BLACK HAIR-LIKE IMAGE ON THE TOP OF THE LETTER "O" IN THE WORD "GROW".

FOR HAIR SHAMPOO AND CONDITIONER (U.S. CLS. 1, 4, 6, 50, 51 AND 52).

FIRST USE 5-1-2007; IN COMMERCE 5-1-2007.

3,482,451. NOVOCOL, INC., NEW CASTLE, DE. SN 78-932,549. PUB. 2-20-2007, FILED 7-19-2006.

CONFI-DERM

THE MARK CONSISTS OF STANDARD CHARACTERS WITHOUT CLAIM TO ANY PARTICULAR FONT, STYLE, SIZE, OR COLOR.

FOR HAND CREAM (U.S. CLS. 1, 4, 6, 50, 51 AND 52).

FIRST USE 5-9-2008; IN COMMERCE 5-9-2008.

CLASS 3—(Continued).

3,482,500. JACK BLACK, L.L.C., CARROLLTON, TX. SN 78-947,252. PUB. 4-3-2007, FILED 8-8-2006.

Triple Cushion

THE MARK CONSISTS OF STANDARD CHARACTERS WITHOUT CLAIM TO ANY PARTICULAR FONT, STYLE, SIZE, OR COLOR.
FOR SHAVING CREAM (U.S. CLS. 1, 4, 6, 50, 51 AND 52).
FIRST USE 10-1-2006; IN COMMERCE 10-1-2006.

3,482,533. THE PROCTER & GAMBLE COMPANY, CINCINNATI, OH. SN 78-959,694. PUB. 4-10-2007, FILED 8-24-2006.

HYDROCLEAN ACTION

THE MARK CONSISTS OF STANDARD CHARACTERS WITHOUT CLAIM TO ANY PARTICULAR FONT, STYLE, SIZE, OR COLOR.
FOR AUTOMATIC DISHWASHING DETERGENT (U.S. CLS. 1, 4, 6, 50, 51 AND 52).
FIRST USE 3-5-2007; IN COMMERCE 3-5-2007.

3,482,540. VICTORIA'S SECRET STORES BRAND MANAGEMENT, INC., REYNOLDSBURG, OH. SN 78-961,452. PUB. 4-24-2007, FILED 8-28-2006.

BLOSSOMING ROMANCE

THE MARK CONSISTS OF STANDARD CHARACTERS WITHOUT CLAIM TO ANY PARTICULAR FONT, STYLE, SIZE, OR COLOR.
FOR PERSONAL CARE PRODUCTS, NAMELY, BODY WASH, SMOOTHING BODY SCRUB, WHIPPED BODY CREAM, BODY BUTTER, BODY LOTIONS, HAND CREAM, BODY MIST, BODY SCRUB, BODY WASH, BUBBLE BATH, COLOGNE, CREAM FOR THE BODY, CREAM FOR THE HANDS (U.S. CLS. 1, 4, 6, 50, 51 AND 52).
FIRST USE 1-18-2007; IN COMMERCE 1-18-2007.

CLASS 3—(Continued).

3,482,553. LIZ CLAIBORNE, INC., NEW YORK, NY. SN 78-965,250. PUB. 9-25-2007, FILED 8-31-2006.

GRAPHITE BLUE BY REALITIES

THE MARK CONSISTS OF STANDARD CHARACTERS WITHOUT CLAIM TO ANY PARTICULAR FONT, STYLE, SIZE, OR COLOR.
OWNER OF U.S. REG. NO. 1,663,741.
FOR PERFUMES, COLOGNES (U.S. CLS. 1, 4, 6, 50, 51 AND 52).
FIRST USE 1-15-2007; IN COMMERCE 1-15-2007.

CLASS 4—LUBRICANTS AND FUELS

3,481,690. HEAVEN TO HOME, LLC, GILBERT, AZ. SN 77-174,856. PUB. 10-30-2007, FILED 5-7-2007.

HEAVEN TO HOME

THE MARK CONSISTS OF STANDARD CHARACTERS WITHOUT CLAIM TO ANY PARTICULAR FONT, STYLE, SIZE, OR COLOR.
FOR CANDLES (U.S. CLS. 1, 6 AND 15).
FIRST USE 6-1-2008; IN COMMERCE 6-1-2008.

3,481,757. HEAVEN TO HOME, LLC, GILBERT, AZ. SN 77-200,595. PUB. 10-30-2007, FILED 6-7-2007.

ANGELS FOR ANIMALS

THE MARK CONSISTS OF STANDARD CHARACTERS WITHOUT CLAIM TO ANY PARTICULAR FONT, STYLE, SIZE, OR COLOR.
FOR CANDLES (U.S. CLS. 1, 6 AND 15).
FIRST USE 6-1-2008; IN COMMERCE 6-1-2008.

CLASS 4—(Continued).

3,481,906. BRIGHT OF AMERICA, LLC, SUMMERSVILLE, WV. SN 77-264,143. PUB. 3-18-2008, FILED 8-24-2007.



NO CLAIM IS MADE TO THE EXCLUSIVE RIGHT TO USE "NATURAL", APART FROM THE MARK AS SHOWN.

THE MARK CONSISTS OF OUTER OVAL WITH RUFFLED EDGES CONTAINING INTERNAL OVAL WITH INCOMPLETE SHADED LINE THROUGH CENTER AND SHADED CURVED LINES ON EITHER SIDE IN OUTER OVAL; CURVED WORD "NATURAL" AT TOP OF OUTER OVAL AND CURVED WORD "PERFECTION" AT BOTTOM OF OUTER OVAL AND WORDS "MORE SCENT" ABOVE THE SHADED LINE IN INNER OVAL AND "LESS SOOT" BELOW SHADED LINE IN INNER OVAL.

FOR SOY BASED CANDLES AND CANDLES CONTAINING SOY DERIVATIVES (U.S. CLS. 1, 6 AND 15). FIRST USE 1-1-2008; IN COMMERCE 1-1-2008.

CLASS 4—(Continued).

3,482,564. STANDARD ETHANOL, LLC, NORTH PLATTE, NE. SN 78-973,572. PUB. 10-2-2007, FILED 9-13-2006.

STANDARD ETHANOL

THE MARK CONSISTS OF STANDARD CHARACTERS WITHOUT CLAIM TO ANY PARTICULAR FONT, STYLE, SIZE, OR COLOR.

NO CLAIM IS MADE TO THE EXCLUSIVE RIGHT TO USE "ETHANOL", APART FROM THE MARK AS SHOWN. FOR ETHANOL FUEL (U.S. CLS. 1, 6 AND 15). FIRST USE 11-30-2006; IN COMMERCE 6-17-2008.

CLASS 5—PHARMACEUTICALS

3,481,105. MCNEIL NUTRITIONALS, LLC, FORT WASHINGTON, PA. SN 76-664,492. PUB. 10-16-2007, FILED 8-11-2006.

BERRY BREEZE

THE MARK CONSISTS OF STANDARD CHARACTERS WITHOUT CLAIM TO ANY PARTICULAR FONT, STYLE, SIZE, OR COLOR.

NO CLAIM IS MADE TO THE EXCLUSIVE RIGHT TO USE "BERRY", APART FROM THE MARK AS SHOWN.

FOR VITAMINS AND DIETARY SUPPLEMENTS (U.S. CLS. 6, 18, 44, 46, 51 AND 52). FIRST USE 3-1-2007; IN COMMERCE 3-1-2007.

3,482,259. PROFI-TECH GMBH, GINGEN, FED REP GERMANY. SN 78-786,354. PUB. 12-26-2006, FILED 1-6-2006.



NO CLAIM IS MADE TO THE EXCLUSIVE RIGHT TO USE "PROFESSIONAL CAR TECHNOLOGY", APART FROM THE MARK AS SHOWN.

THE COLOR(S) RED, BLUE, BLACK AND WHITE IS/ARE CLAIMED AS A FEATURE OF THE MARK.

THE MARK CONSISTS OF THE WORDS "PROFI-CAR" IN A BOX. THE COLOR BLUE APPEARS IN THE CIRCLE AND WORDING "PROFI-CAR". THE COLOR RED APPEARS IN THE TRIANGLE WHICH OVERLIES THE BLUE CIRCLE AT LEFT SIDE OF MARK. THE COLOR BLACK APPEARS IN THE WORDING "PROFESSIONAL - CAR - TECHNOLOGY" AND THE OUTLINE OF THE BOX, AND THE COLOR WHITE APPEARS IN THE BOX. THE COLOR WHITE APPEARING IN THE CIRCLE AND TRIANGLE DESIGN APPEARS AS BACKGROUND AND IS NOT CLAIMED AS A FEATURE OF THE MARK.

FOR AUTOMOTIVE LUBRICANTS AND FUELS (U.S. CLS. 1, 6 AND 15). FIRST USE 7-5-2005; IN COMMERCE 7-5-2005.

3,481,106. MCNEIL NUTRITIONALS, LLC, FORT WASHINGTON, PA. SN 76-664,493. PUB. 9-25-2007, FILED 8-11-2006.

FLAVOR GLIDES

THE MARK CONSISTS OF STANDARD CHARACTERS WITHOUT CLAIM TO ANY PARTICULAR FONT, STYLE, SIZE, OR COLOR.

NO CLAIM IS MADE TO THE EXCLUSIVE RIGHT TO USE "FLAVOR", APART FROM THE MARK AS SHOWN.

FOR VITAMINS AND DIETARY SUPPLEMENTS (U.S. CLS. 6, 18, 44, 46, 51 AND 52). FIRST USE 3-1-2007; IN COMMERCE 3-1-2007.

CLASS 5—(Continued).

3,481,202. FLOR A. MAYORAL, M.D., P.A., MIAMI, FL. SN 77-022,570. PUB. 6-19-2007, FILED 10-17-2006.

CLEARITUP

THE MARK CONSISTS OF STANDARD CHARACTERS WITHOUT CLAIM TO ANY PARTICULAR FONT, STYLE, SIZE, OR COLOR.

FOR MEDICATED SKIN PREPARATION FOR USE IN TREATING ACNE AND MELASMA; MEDICINAL CREAMS FOR SKIN CARE (U.S. CLS. 6, 18, 44, 46, 51 AND 52).

FIRST USE 2-1-2008; IN COMMERCE 2-1-2008.

CLASS 5—(Continued).

3,481,331. KOEHN, RICHARD K., SALT LAKE CITY, UT. SN 77-083,578. PUB. 10-2-2007, FILED 1-16-2007.

EQUITRX

THE MARK CONSISTS OF STANDARD CHARACTERS WITHOUT CLAIM TO ANY PARTICULAR FONT, STYLE, SIZE, OR COLOR.

FOR WOUND HEALING TREATMENT FOR VETERINARY USE, NAMELY, TOPICAL CREAM, TOPICAL OINTMENT, PRE-MEDICATED FILM, PRE-MEDICATED WIPES, WOUND TREATMENT KITS CONTAINING GAUZE, BANDAGES, TOPICAL CREAM, BANDAGING TAPE, ANTISEPTIC STICKS (U.S. CLS. 6, 18, 44, 46, 51 AND 52).

FIRST USE 9-1-2007; IN COMMERCE 2-1-2008.

3,481,228. ROTAM LTD., CHAI WAN, HONG KONG. SN 77-033,223. PUB. 10-23-2007, FILED 10-31-2006.

MONTANA

THE MARK CONSISTS OF STANDARD CHARACTERS WITHOUT CLAIM TO ANY PARTICULAR FONT, STYLE, SIZE, OR COLOR.

FOR INSECTICIDES (U.S. CLS. 6, 18, 44, 46, 51 AND 52).

FIRST USE 7-0-2007; IN COMMERCE 7-0-2007.

3,481,332. KOEHN, RICHARD K., SALT LAKE CITY, UT. SN 77-083,585. PUB. 10-2-2007, FILED 1-16-2007.

FELITRX

THE MARK CONSISTS OF STANDARD CHARACTERS WITHOUT CLAIM TO ANY PARTICULAR FONT, STYLE, SIZE, OR COLOR.

FOR WOUND HEALING TREATMENT FOR VETERINARY USE, NAMELY, TOPICAL CREAM, TOPICAL OINTMENT, WOUND TREATMENT KITS CONTAINING GAUZE, BANDAGES, TOPICAL CREAM, BANDAGING TAPE, ANTISEPTIC STICKS (U.S. CLS. 6, 18, 44, 46, 51 AND 52).

FIRST USE 9-1-2007; IN COMMERCE 2-1-2008.

3,481,229. ROTAM LTD., CHAI WAN, HONG KONG. SN 77-033,421. PUB. 10-23-2007, FILED 10-31-2006.

VOLTA

THE MARK CONSISTS OF STANDARD CHARACTERS WITHOUT CLAIM TO ANY PARTICULAR FONT, STYLE, SIZE, OR COLOR.

FOR AGRICULTURAL HERBICIDES (U.S. CLS. 6, 18, 44, 46, 51 AND 52).

FIRST USE 12-0-2007; IN COMMERCE 12-0-2007.

3,481,389. IDEASONE, INC., KAMUELA, HI. SN 77-110,740. PUB. 6-26-2007, FILED 2-19-2007.

GET REAL. GET WELL.

THE MARK CONSISTS OF STANDARD CHARACTERS WITHOUT CLAIM TO ANY PARTICULAR FONT, STYLE, SIZE, OR COLOR.

FOR DIETARY SUPPLEMENTS (U.S. CLS. 6, 18, 44, 46, 51 AND 52).

FIRST USE 8-16-2007; IN COMMERCE 8-16-2007.

CLASS 5—(Continued).

3,481,409. DERMARITE INDUSTRIES, LLC, HAWTHORNE, NJ. SN 77-119,354. PUB. 9-11-2007, FILED 3-1-2007.

SILVAKOLLAGEN

THE MARK CONSISTS OF STANDARD CHARACTERS WITHOUT CLAIM TO ANY PARTICULAR FONT, STYLE, SIZE, OR COLOR.
FOR ANTIBIOTIC OINTMENTS (U.S. CLS. 6, 18, 44, 46, 51 AND 52).
FIRST USE 1-1-2008; IN COMMERCE 3-1-2008.

CLASS 5—(Continued).

3,481,460. HERBAL GROUPS INC., CHATSWORTH, CA. SN 77-129,766. PUB. 9-18-2007, FILED 3-13-2007.

IntraCleanse

THE MARK CONSISTS OF STANDARD CHARACTERS WITHOUT CLAIM TO ANY PARTICULAR FONT, STYLE, SIZE, OR COLOR.
FOR HERBAL SUPPLEMENTS (U.S. CLS. 6, 18, 44, 46, 51 AND 52).
FIRST USE 2-10-2006; IN COMMERCE 2-10-2006.

3,481,420. WASSERMANN, THOMAS, ALEXANDRIA, VA. SN 77-122,659. PUB. 9-4-2007, FILED 3-5-2007.

TRIMFIZZ

THE MARK CONSISTS OF STANDARD CHARACTERS WITHOUT CLAIM TO ANY PARTICULAR FONT, STYLE, SIZE, OR COLOR.
FOR DIETARY FOOD SUPPLEMENTS (U.S. CLS. 6, 18, 44, 46, 51 AND 52).
FIRST USE 4-0-2008; IN COMMERCE 4-0-2008.

3,481,510. BIOFORCE SOUTH AFRICA (PROPRIETARY) LIMITED, MIDRAND, GAUTENG, SOUTH AFRICA. SN 77-137,831. PUB. 2-12-2008, FILED 3-22-2007.

MULTIFORCE

THE MARK CONSISTS OF STANDARD CHARACTERS WITHOUT CLAIM TO ANY PARTICULAR FONT, STYLE, SIZE, OR COLOR.
FOR SUPPLEMENT IN THE FORM OF A MINERAL ALKALINE POWDER THAT CONTROLS/BALANCES THE ACIDITY LEVEL IN ALL BODY FLUIDS (U.S. CLS. 6, 18, 44, 46, 51 AND 52).
FIRST USE 8-10-2007; IN COMMERCE 8-10-2007.

3,481,446. GAVEY, JAMES E, FAIRFIELD, CT. SN 77-127,715. PUB. 8-28-2007, FILED 3-10-2007.

The Ultimate Diet Formula

THE MARK CONSISTS OF STANDARD CHARACTERS WITHOUT CLAIM TO ANY PARTICULAR FONT, STYLE, SIZE, OR COLOR.
NO CLAIM IS MADE TO THE EXCLUSIVE RIGHT TO USE "DIET FORMULA", APART FROM THE MARK AS SHOWN.
FOR DIETARY SUPPLEMENTS (U.S. CLS. 6, 18, 44, 46, 51 AND 52).
FIRST USE 3-1-2008; IN COMMERCE 3-1-2008.

3,481,544. TBC WORLDWIDE, INC., SAN MATEO, CA. SN 77-144,257. PUB. 10-2-2007, FILED 3-29-2007.

PHENOLMENAL! BALANCE

THE MARK CONSISTS OF STANDARD CHARACTERS WITHOUT CLAIM TO ANY PARTICULAR FONT, STYLE, SIZE, OR COLOR.
FOR DIETARY SUPPLEMENT DRINKS COMPRISED OF JUICES, HERBS, VITAMINS, MINERALS, FRUIT EXTRACTS, AND OTHER PHYTONUTRIENTS (U.S. CLS. 6, 18, 44, 46, 51 AND 52).
FIRST USE 6-1-2007; IN COMMERCE 6-1-2007.

CLASS 5—(Continued).

3,481,550. NUTRAMAX LABORATORIES, INC., EDGEWOOD, MD. SN 77-145,079. PUB. 9-18-2007, FILED 3-30-2007.

PROVIABLE

THE MARK CONSISTS OF STANDARD CHARACTERS WITHOUT CLAIM TO ANY PARTICULAR FONT, STYLE, SIZE, OR COLOR.
FOR DIETARY AND NUTRITIONAL SUPPLEMENTS (U.S. CLS. 6, 18, 44, 46, 51 AND 52).
FIRST USE 2-7-2008; IN COMMERCE 2-7-2008.

3,481,676. DOW AGROSCIENCES LLC, INDIANAPOLIS, IN. SN 77-171,626. PUB. 10-30-2007, FILED 5-3-2007.

DURAMAX

THE MARK CONSISTS OF STANDARD CHARACTERS WITHOUT CLAIM TO ANY PARTICULAR FONT, STYLE, SIZE, OR COLOR.
FOR PESTICIDES AND PREPARATIONS FOR DESTROYING VERMIN, NAMELY, HERBICIDES, INSECTICIDES AND FUNGICIDES FOR AGRICULTURE, HORTICULTURE, FORESTRY, TURF AND ORNAMENTAL, COMMERCIAL, INDUSTRIAL AND DOMESTIC USE (U.S. CLS. 6, 18, 44, 46, 51 AND 52).
FIRST USE 12-10-2007; IN COMMERCE 12-10-2007.

3,481,694. NATURAL ORGANICS, INC., MELVILLE, NY. SN 77-175,749. PUB. 11-6-2007, FILED 5-8-2007.

UNIVERSAL FOODZYME

THE MARK CONSISTS OF STANDARD CHARACTERS WITHOUT CLAIM TO ANY PARTICULAR FONT, STYLE, SIZE, OR COLOR.
FOR DIETARY SUPPLEMENTS (U.S. CLS. 6, 18, 44, 46, 51 AND 52).
FIRST USE 6-2-2008; IN COMMERCE 6-2-2008.

CLASS 5—(Continued).

3,481,741. RTM ENTERPRISES, LLC, NEW YORK, NY. SN 77-190,469. PUB. 9-18-2007, FILED 5-25-2007.

TRIPLE FIT

THE MARK CONSISTS OF STANDARD CHARACTERS WITHOUT CLAIM TO ANY PARTICULAR FONT, STYLE, SIZE, OR COLOR.
FOR NUTRITIONAL SUPPLEMENTS (U.S. CLS. 6, 18, 44, 46, 51 AND 52).
FIRST USE 6-5-2007; IN COMMERCE 6-5-2007.

3,481,761. TRX LABS INC., PHOENIX, AZ. SN 77-202,171. PUB. 3-11-2008, FILED 6-9-2007.

Calcium MD

THE MARK CONSISTS OF STANDARD CHARACTERS WITHOUT CLAIM TO ANY PARTICULAR FONT, STYLE, SIZE, OR COLOR.
NO CLAIM IS MADE TO THE EXCLUSIVE RIGHT TO USE "CALCIUM", APART FROM THE MARK AS SHOWN.
FOR CALCIUM SUPPLEMENTS; DIETARY AND NUTRITIONAL SUPPLEMENTS; DIETARY SUPPLEMENTS FOR HUMAN CONSUMPTION (U.S. CLS. 6, 18, 44, 46, 51 AND 52).
FIRST USE 1-15-2008; IN COMMERCE 4-15-2008.

3,481,768. PROMAX NUTRITION, INC., CONCORD, CA. SN 77-205,502. PUB. 11-27-2007, FILED 6-13-2007.

JOINT XPRESS

THE MARK CONSISTS OF STANDARD CHARACTERS WITHOUT CLAIM TO ANY PARTICULAR FONT, STYLE, SIZE, OR COLOR.
NO CLAIM IS MADE TO THE EXCLUSIVE RIGHT TO USE "JOINT", APART FROM THE MARK AS SHOWN.
FOR NUTRITIONAL SUPPLEMENTS (U.S. CLS. 6, 18, 44, 46, 51 AND 52).
FIRST USE 8-1-2007; IN COMMERCE 8-1-2007.

CLASS 5—(Continued).

3,481,859. WALKER, RICHARD F., INDIAN ROCKS BEACH, FL. SN 77-247,572. PUB. 1-29-2008, FILED 8-6-2007.

LongeviPlex

THE MARK CONSISTS OF STANDARD CHARACTERS WITHOUT CLAIM TO ANY PARTICULAR FONT, STYLE, SIZE, OR COLOR.

FOR DIETARY SUPPLEMENTS (U.S. CLS. 6, 18, 44, 46, 51 AND 52).
FIRST USE 11-19-2007; IN COMMERCE 11-19-2007.

3,481,894. VON LUTZOW, JAMES ANTHONY, GILBERT, AZ. SN 77-259,034. PUB. 2-26-2008, FILED 8-20-2007.

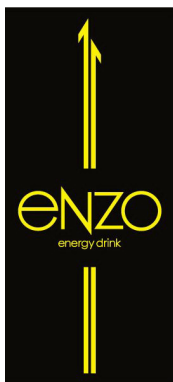

NO CLAIM IS MADE TO THE EXCLUSIVE RIGHT TO USE "ENERGY DRINK", APART FROM THE MARK AS SHOWN.

THE COLOR(S) BLACK AND YELLOW IS/ARE CLAIMED AS A FEATURE OF THE MARK.

THE MARK CONSISTS OF THE WORD "ENZO" IN A LARGE FONT IN YELLOW. THE WORDS "ENERGY DRINK" BELOW THE WORD "ENZO" IN YELLOW. TWO VERTICAL ARROWS IN YELLOW. ONE OF THE POINTS REACHES HIGHER THAN THE OTHER.

FOR VITAMIN FORTIFIED BEVERAGES (U.S. CLS. 6, 18, 44, 46, 51 AND 52).
FIRST USE 8-20-2007; IN COMMERCE 5-15-2008.

3,481,921. WN PHARMACEUTICALS LTD., COQUITLAM, BC, CANADA. SN 77-273,026. PUB. 12-4-2007, FILED 9-6-2007.

TOTALBERRY

CLASS 5—(Continued).

THE MARK CONSISTS OF STANDARD CHARACTERS WITHOUT CLAIM TO ANY PARTICULAR FONT, STYLE, SIZE, OR COLOR.

FOR DIETARY AND NUTRITIONAL SUPPLEMENTS (U.S. CLS. 6, 18, 44, 46, 51 AND 52).
FIRST USE 11-28-2007; IN COMMERCE 11-28-2007.

3,481,941. PHARMA-NATURAL INC., HIALEAH, FL. SN 77-281,366. PUB. 3-4-2008, FILED 9-17-2007.

HEPATROL

THE MARK CONSISTS OF STANDARD CHARACTERS WITHOUT CLAIM TO ANY PARTICULAR FONT, STYLE, SIZE, OR COLOR.

FOR DIETARY SUPPLEMENTS; NUTRITIONAL SUPPLEMENTS (U.S. CLS. 6, 18, 44, 46, 51 AND 52).
FIRST USE 11-1-2007; IN COMMERCE 11-1-2007.

3,481,972. BUXTON, DONNA PATRICK, PANAMA CITY BEACH, FL. AND BUXTON, DAVID LLOYD, PANAMA CITY BEACH, FL. SN 77-301,083. PUB. 3-11-2008, FILED 10-10-2007.

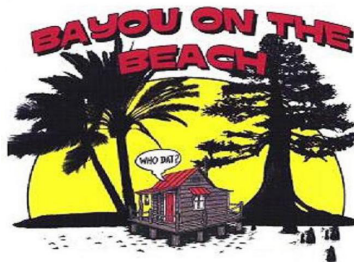

THE COLOR(S) RED, BLACK, YELLOW, BROWN, AND WHITE IS/ARE CLAIMED AS A FEATURE OF THE MARK.

THE MARK CONSISTS OF A BLACK PALM TREE AND CYPRESS TREE, A YELLOW SETTING SUN IN BACKGROUND, A BROWN HOUSE WITH A RED ROOF, DOOR, AND AWNING, THE COLOR WHITE APPEARS IN THE WINDOW AND THE CAPTION WITH THE WORDING "WHO DAT" IN BLACK, WITH A WHITE BACKGROUND FOR THE WHOLE MARK AND THE WORDING "BAYOU ON THE BEACH" IN RED WITH BLACK OUTLINING.

FOR BISCUITS, BREAD, BREAD ROLLS, CAKES, CEREAL PRODUCTS, CONFECTIONERY, CRACKERS, NOODLES, FISH SAUCE, RELISH, SAUCES, CEREAL-BASED SNACK-FOODS AND PREPARED DIETARY ITEMS THAT ARE GLUTEN-FREE TO ACCOMMODATE SPECIAL MEDICAL AND HEALTH CONDITIONS (U.S. CLS. 6, 18, 44, 46, 51 AND 52).
FIRST USE 6-1-2001; IN COMMERCE 2-1-2002.

CLASS 5—(Continued).

3,481,976. SYNERFIED CAPITAL INC., MIAMI, FL. SN 77-306,815. PUB. 3-4-2008, FILED 10-17-2007.

Lose the odor, keep your
lover. NodorO, get some.

THE MARK CONSISTS OF STANDARD CHARACTERS WITHOUT CLAIM TO ANY PARTICULAR FONT, STYLE, SIZE, OR COLOR.

FOR MEDICATED ANTIFUNGAL CREAM FOR MEDICAL USE THAT REMOVES ODORS (U.S. CLS. 6, 18, 44, 46, 51 AND 52).

FIRST USE 6-1-2007; IN COMMERCE 11-1-2007.

CLASS 5—(Continued).

3,482,033. BAYER AKTIENGESELLSCHAFT, LEVERKUSEN-BAYERWERK, FED REP GERMANY. SN 78-406,263. PUB. 4-12-2005, FILED 4-22-2004.

BOLSTER

THE MARK CONSISTS OF STANDARD CHARACTERS WITHOUT CLAIM TO ANY PARTICULAR FONT, STYLE, SIZE, OR COLOR.

FOR INSECTICIDES FOR DOMESTIC AND AGRICULTURAL USE (U.S. CLS. 6, 18, 44, 46, 51 AND 52).

FIRST USE 3-1-2005; IN COMMERCE 3-1-2005.

3,481,985. ROEX, INC., IRVINE, CA. SN 77-335,804. PUB. 2-26-2008, FILED 11-22-2007.

NUTRISEEDS

THE MARK CONSISTS OF STANDARD CHARACTERS WITHOUT CLAIM TO ANY PARTICULAR FONT, STYLE, SIZE, OR COLOR.

FOR DIETARY SUPPLEMENTS (U.S. CLS. 6, 18, 44, 46, 51 AND 52).

FIRST USE 2-12-2008; IN COMMERCE 2-12-2008.

3,482,043. NATURAL PLANT PROTECTION S.A., 64150 NOGUERES, FRANCE. SN 78-422,865. PUB. 4-19-2005, FILED 5-21-2004.

BIOMITE

3,482,025. LUPIN PHARMACEUTICALS, INC., BALTIMORE, MD. SN 78-374,877. PUB. 3-8-2005, FILED 2-26-2004.

BIG-BERRY

THE MARK CONSISTS OF STANDARD CHARACTERS WITHOUT CLAIM TO ANY PARTICULAR FONT, STYLE, SIZE, OR COLOR.

FOR PHARMACEUTICAL PREPARATIONS FOR THE TREATMENT OF BACTERIAL INFECTIONS (U.S. CLS. 6, 18, 44, 46, 51 AND 52).

FIRST USE 3-0-2004; IN COMMERCE 3-0-2004.

THE MARK CONSISTS OF STANDARD CHARACTERS WITHOUT CLAIM TO ANY PARTICULAR FONT, STYLE, SIZE, OR COLOR.

FOR AGRICULTURAL AND HORTICULTURAL PESTICIDE SPECIFIC TO CONTROL AND/OR ELIMINATE MITES (U.S. CLS. 6, 18, 44, 46, 51 AND 52).

FIRST USE 6-1-2008; IN COMMERCE 6-1-2008.

CLASS 5—(Continued).

3,482,050. ALOECORP, INC., LACEY, WA. SN 78-443,298. PUB. 4-18-2006, FILED 6-29-2004.

CLASS 5—(Continued).

3,482,065. SEPRACOR INC., MARLBOROUGH, MA. SN 78-491,661. PUB. 9-13-2005, FILED 9-29-2004.

QMATRIX

SEPRACOR

THE MARK CONSISTS OF STANDARD CHARACTERS WITHOUT CLAIM TO ANY PARTICULAR FONT, STYLE, SIZE, OR COLOR.

OWNER OF U.S. REG. NO. 2,252,782.

FOR PHARMACEUTICAL PREPARATIONS, NAMELY, ANALGESICS; ANTI-INFECTIVE; ANTI-INFLAMMATORIES; PHARMACEUTICAL PREPARATIONS FOR THE PREVENTION AND TREATMENT OF DISORDERS AND DISEASES OF THE CENTRAL NERVOUS, PERIPHERAL NERVOUS, RESPIRATORY AND UROGENITAL SYSTEMS; PHARMACEUTICAL PREPARATIONS FOR THE PREVENTION AND TREATMENT OF SLEEP DISORDERS (U.S. CLS. 6, 18, 44, 46, 51 AND 52).

FIRST USE 4-16-1999; IN COMMERCE 4-16-1999.

3,482,077. ALCON, INC., CH-6331 HÜNENBERG, SWITZERLAND. SN 78-516,934. PUB. 9-13-2005, FILED 11-15-2004.

THE MARK CONSISTS OF STANDARD CHARACTERS WITHOUT CLAIM TO ANY PARTICULAR FONT, STYLE, SIZE, OR COLOR.

FOR DIETARY AND NUTRITIONAL SUPPLEMENTS; NUTRACEUTICALS FOR USE AS DIETARY SUPPLEMENTS; VETERINARY DIETARY SUPPLEMENTS; MEDICATED TRANSDERMAL PATCHES FOR ADMINISTERING NUTRITIONAL SUPPLEMENTS AND WOUND DRESSINGS; ANTISEPTICS; MEDICATION INFUSED DISPOSABLE DIAPERS FOR ADMINISTERING MOISTURIZER, WOUND DRESSING AND ANTI-INFLAMMATORY, MEDICATION INFUSED FACIAL TISSUE FOR ADMINISTERING MOISTURIZER, WOUND DRESSING AND ANTI-INFLAMMATORY, MEDICATION INFUSED TOILET PAPER FOR ADMINISTERING MOISTURIZER, WOUND DRESSING AND ANTI-INFLAMMATORY AND MEDICATION INFUSED DISPOSABLE INCONTINENCE PADS (U.S. CLS. 6, 18, 44, 46, 51 AND 52).

FIRST USE 9-9-2005; IN COMMERCE 9-9-2005.

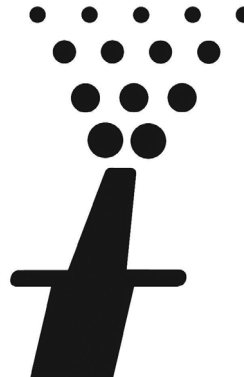

THE MARK CONSISTS OF PRODUCT APPLICATOR ACCOMPANIED BY A GEOMETRICAL ARRANGEMENT OF LIQUID DROPLETS.

FOR OTORHINOLARYNGOLOGICAL PHARMACEUTICAL PREPARATIONS (U.S. CLS. 6, 18, 44, 46, 51 AND 52).

FIRST USE 4-28-2008; IN COMMERCE 4-28-2008.

CLASS 5—(Continued).

3,482,124. OBESITY RESEARCH INSTITUTE, LLC, CARLSBAD, CA. SN 78-632,186. PUB. 1-31-2006, FILED 5-18-2005.

ZYLOTRIM

THE MARK CONSISTS OF STANDARD CHARACTERS WITHOUT CLAIM TO ANY PARTICULAR FONT, STYLE, SIZE, OR COLOR.

FOR DIETARY SUPPLEMENT (U.S. CLS. 6, 18, 44, 46, 51 AND 52).

FIRST USE 3-7-2008; IN COMMERCE 3-7-2008.

3,482,169. NITTO DENKO CORPORATION, OSAKA, JAPAN. SN 78-702,479. PUB. 9-26-2006, FILED 8-29-2005.

XTRATA

THE MARK CONSISTS OF STANDARD CHARACTERS WITHOUT CLAIM TO ANY PARTICULAR FONT, STYLE, SIZE, OR COLOR.

FOR ADHESIVE TAPES FOR MEDICAL PURPOSES, NAMELY, ADHESIVE PLASTER, SURGICAL TAPES, SURGICAL DRESSINGS, AND ADHESIVE DRESSINGS, EXCEPT FOR PHARMACEUTICAL PREPARATIONS (U.S. CLS. 6, 18, 44, 46, 51 AND 52).

FIRST USE 12-0-2005; IN COMMERCE 8-0-2007.

3,482,186. CYTOSPORT, INC., BENICIA, CA. SN 78-723,462. PUB. 6-13-2006, FILED 9-29-2005.

CYTO GAINER

THE MARK CONSISTS OF STANDARD CHARACTERS WITHOUT CLAIM TO ANY PARTICULAR FONT, STYLE, SIZE, OR COLOR.

FOR DIETARY AND NUTRITIONAL SUPPLEMENT; POWDERED NUTRITIONAL SUPPLEMENT FOR ADDING LIQUID BEVERAGE (U.S. CLS. 6, 18, 44, 46, 51 AND 52).

FIRST USE 6-0-1999; IN COMMERCE 6-0-1999.

CLASS 5—(Continued).

3,482,231. NUTRASENTIAL HEALTH PRODUCTS, INC., MIAMI, FL. SN 78-771,950. PUB. 9-19-2006, FILED 12-13-2005.

NUTRASENTIAL

THE MARK CONSISTS OF STANDARD CHARACTERS WITHOUT CLAIM TO ANY PARTICULAR FONT, STYLE, SIZE, OR COLOR.

FOR NUTRITIONAL SUPPLEMENTS (U.S. CLS. 6, 18, 44, 46, 51 AND 52).

FIRST USE 6-18-2007; IN COMMERCE 6-18-2007.

3,482,234. ECOVAL CORPORATION, WILLIAMSVILLE, NY. SN 78-772,442. PUB. 8-22-2006, FILED 12-13-2005.

EcoSharp

THE MARK CONSISTS OF STANDARD CHARACTERS WITHOUT CLAIM TO ANY PARTICULAR FONT, STYLE, SIZE, OR COLOR.

FOR HERBICIDES FOR AGRICULTURAL, DOMESTIC AND HORTICULTURAL USE (U.S. CLS. 6, 18, 44, 46, 51 AND 52).

FIRST USE 2-7-2007; IN COMMERCE 2-7-2007.

3,482,292. HAIR TECH, INC., ATLANTA, GA. SN 78-809,482. PUB. 9-26-2006, FILED 2-7-2006.

FOLLICLE FOOD

THE MARK CONSISTS OF STANDARD CHARACTERS WITHOUT CLAIM TO ANY PARTICULAR FONT, STYLE, SIZE, OR COLOR.

FOR VITAMIN SUPPLEMENT FOR THE HAIR (U.S. CLS. 6, 18, 44, 46, 51 AND 52).

FIRST USE 9-1-2006; IN COMMERCE 9-1-2006.

CLASS 5—(Continued).

3,482,299. AGRI LABORATORIES, LTD., ST. JOSEPH, MO.
SN 78-816,700. PUB. 3-27-2007, FILED 2-16-2006.



THE COLOR(S) BLUE, PURPLE, WHITE, BLACK AND GRAY IS/ARE CLAIMED AS A FEATURE OF THE MARK. THE COLOR BLUE APPEARS IN THE LEFT SIDE OF THE RINGS; THE COLOR PURPLE APPEARS IN THE RIGHT SIDE OF THE RINGS; THE COLOR BLACK APPEARS IN THE WORDING; THE COLOR GRAY APPEARS IN SHADOWING IN THE TERM "FORCE"; AND THE COLOR WHITE COMPOSES THE BACKGROUND FOR THE MARK. FOR FLEA AND TICK TOPICAL SOLUTION (U.S. CLS. 6, 18, 44, 46, 51 AND 52).
FIRST USE 2-7-2008; IN COMMERCE 4-1-2008.

CLASS 5—(Continued).

3,482,426. TECHNOLOGIE BIOLACTIS INC., LA BAIE, CANADA. SN 78-918,779. PUB. 2-20-2007, FILED 6-28-2006.



NO CLAIM IS MADE TO THE EXCLUSIVE RIGHT TO USE "100% LAITIER/DAIRY", APART FROM THE MARK AS SHOWN.

THE COLOR(S) PURPLE, RED AND WHITE IS/ARE CLAIMED AS A FEATURE OF THE MARK.

THE COLORS PURPLE, RED AND WHITE APPEAR IN THE MARK, SPECIFICALLY, THE FLOWER DESIGN IS WHITE WITH A PURPLE OUTLINE WITH A RED HEART IN THE MIDDLE, THE WORDING IS WHITE ON A PURPLE BACKGROUND.

THE ENGLISH TRANSLATION OF THE FRENCH WORDING "LAITIER" IS "DAIRY".

FOR DIETARY SUPPLEMENT, NAMELY, A MALLEABLE MOULD MADE OF LACTOSERUM PROTEINS (U.S. CLS. 6, 18, 44, 46, 51 AND 52).

FIRST USE 11-23-2006; IN COMMERCE 11-23-2006.

3,482,431. TRADITIONAL MEDICINALS, INC., SEBASTOPOL, CA. SN 78-921,680. PUB. 5-1-2007, FILED 7-2-2006.

FIRST IN ORGANIC MEDICINE

THE MARK CONSISTS OF STANDARD CHARACTERS WITHOUT CLAIM TO ANY PARTICULAR FONT, STYLE, SIZE, OR COLOR.

OWNER OF U.S. REG. NO. 2,090,512.

NO CLAIM IS MADE TO THE EXCLUSIVE RIGHT TO USE "ORGANIC MEDICINE", APART FROM THE MARK AS SHOWN.

SEC. 2(F) AS TO "FIRST IN".

FOR ANTI-COUGH DROPS; ASTRINGENTS; ASTRINGENTS FOR MEDICINAL PURPOSES; COUGH DROPS; COUGH LOZENGES; COUGH TREATMENT PREPARATIONS; HEMORRHOID TREATMENT PREPARATIONS; HERB TEAS FOR MEDICINAL PURPOSES; HERBAL TEAS FOR MEDICINAL PURPOSES; LAXATIVES; MEDICINAL PREPARATIONS FOR THE MOUTH TO BE APPLIED IN THE FORM OF DROPS, CAPSULES, TABLETS AND COMPRESSED TABLETS; ORAL ANALGESICS; PAIN RELIEF MEDICATION; PHARMACEUTICAL ANTITUSSIVE-COLD PREPARATIONS; PHARMACEUTICAL PREPARATIONS FOR THE TREATMENT OF DIGESTIVE CONDITIONS; PREPARATIONS FOR TREATING COLDS; THROAT LOZENGES (U.S. CLS. 6, 18, 44, 46, 51 AND 52).

FIRST USE 9-0-2006; IN COMMERCE 9-0-2006.

3,482,370. TRIVITA, INC., SCOTTSDALE, AZ. SN 78-875,916.
PUB. 11-7-2006, FILED 5-3-2006.

Optima4

THE MARK CONSISTS OF STANDARD CHARACTERS WITHOUT CLAIM TO ANY PARTICULAR FONT, STYLE, SIZE, OR COLOR.

FOR NUTRITIONAL SUPPLEMENT (U.S. CLS. 6, 18, 44, 46, 51 AND 52).

FIRST USE 6-28-2006; IN COMMERCE 6-28-2006.

CLASS 5—(Continued).

3,482,434. LEE, YOUNG MIN, BUENA PARK, CA. SN 78-925,010. PUB. 7-17-2007, FILED 7-7-2006.



FOR HERBAL DIETARY SUPPLEMENT TO ENHANCE SEXUAL PERFORMANCE (U.S. CLS. 6, 18, 44, 46, 51 AND 52).
FIRST USE 2-5-2008; IN COMMERCE 2-5-2008.

3,482,470. BRADLEY PHARMACEUTICALS, INC., FAIRFIELD, NJ. SN 78-938,573. PUB. 9-25-2007, FILED 7-27-2006.

RELIEF PAD

THE MARK CONSISTS OF STANDARD CHARACTERS WITHOUT CLAIM TO ANY PARTICULAR FONT, STYLE, SIZE, OR COLOR.

NO CLAIM IS MADE TO THE EXCLUSIVE RIGHT TO USE "PAD", APART FROM THE MARK AS SHOWN.

FOR MEDICATED TOPICAL PREPARATIONS FOR HUMAN USE TO PREVENT OR ALLEVIATE THE SYMPTOMS OF PRURITUS, ECZEMA, DERMATITIS AND OTHER SKIN DISORDERS, AND APPLICATORS OR PADS SOLD AS A COMPONENT THEREWITH (U.S. CLS. 6, 18, 44, 46, 51 AND 52).
FIRST USE 6-1-2008; IN COMMERCE 6-1-2008.

3,482,513. FNC MEDICAL CORPORATION, VENTURA, CA. SN 78-952,704. PUB. 4-3-2007, FILED 8-15-2006.

SHOO FLY

THE MARK CONSISTS OF STANDARD CHARACTERS WITHOUT CLAIM TO ANY PARTICULAR FONT, STYLE, SIZE, OR COLOR.

FOR NATURAL INSECTICIDE FOR HORSES (U.S. CLS. 6, 18, 44, 46, 51 AND 52).
FIRST USE 4-0-2006; IN COMMERCE 4-0-2006.

CLASS 5—(Continued).

3,482,549. CSL BEHRING AG, BERN 22, SWITZERLAND. SN 78-963,560. PUB. 8-21-2007, FILED 8-30-2006.

PRIVIGEN

THE MARK CONSISTS OF STANDARD CHARACTERS WITHOUT CLAIM TO ANY PARTICULAR FONT, STYLE, SIZE, OR COLOR.

PRIORITY CLAIMED UNDER SEC. 44(D) ON AUSTRALIA APPLICATION NO. 1130631, FILED 8-21-2006.

FOR INTRAVENOUS IMMUNOGLOBULINS FOR USE IN TREATMENT OF IMMUNODEFICIENCY DISORDERS AND IN IMMUNE REPLACEMENT THERAPY (U.S. CLS. 6, 18, 44, 46, 51 AND 52).
FIRST USE 12-20-2007; IN COMMERCE 12-20-2007.

3,482,579. ROTAM LTD., CHAI WAN, HONG KONG. SN 78-980,316. PUB. 8-21-2007, FILED 9-5-2006.

FOR PHARMACEUTICAL AND VETERINARY PREPARATIONS, NAMELY, CATTLE DIP; PREPARATIONS FOR DESTROYING VERMIN; FUNGICIDES, HERBICIDES, AND INSECTICIDES, ALL FOR AGRICULTURAL USE (U.S. CLS. 6, 18, 44, 46, 51 AND 52).
FIRST USE 10-0-2007; IN COMMERCE 10-0-2007.

CLASS 6—METAL GOODS

CLASS 6—(Continued).

3,481,101. CHANGZHOU HAWK DISPLAY APPLIANCE MANUFACTURE CO., LTD., CHANGZHOU CITY, JIANGSU PROVINCE, CHINA. SN 76-659,461. PUB. 9-18-2007, FILED 4-27-2006.



FOR LATHS OF METAL; PROPS OF METAL, NAMELY, METAL POSTER STANDS, METAL EXHIBITION STANDS; ADVERTISEMENT COLUMNS OF METAL; FENCES OF METAL; SIGNBOARDS OF METAL; WORKS OF ART OF COMMON METAL; POSTS OF METAL; BUILDINGS OF METAL; METAL BUILDING MATERIALS, NAMELY, METAL BOARDS AND METAL BUILDING PANELS (U.S. CLS. 2, 12, 13, 14, 23, 25 AND 50).

FIRST USE 11-1-2002; IN COMMERCE 6-15-2005.

3,481,127. TY-LAN ENTERPRISES INC., LONDON, CANADA. SN 76-671,894. PUB. 9-11-2007, FILED 1-26-2007.

THE HIDDEN LINK

THE MARK CONSISTS OF STANDARD CHARACTERS WITHOUT CLAIM TO ANY PARTICULAR FONT, STYLE, SIZE, OR COLOR.

PRIORITY CLAIMED UNDER SEC. 44(D) ON CANADA APPLICATION NO. 1,325,758, FILED 11-21-2006.

FOR METAL FASTENERS, NAMELY, BRACKETS AND CLIPS FOR USE IN THE CONSTRUCTION AND ASSEMBLY OF DECKING (U.S. CLS. 2, 12, 13, 14, 23, 25 AND 50).

FIRST USE 1-1-2007; IN COMMERCE 1-1-2007.

3,481,363. SKORKA, RICHARD, FLOWER MOUND, TX. SN 77-097,912. PUB. 8-7-2007, FILED 2-2-2007.

ALLWALL

THE MARK CONSISTS OF STANDARD CHARACTERS WITHOUT CLAIM TO ANY PARTICULAR FONT, STYLE, SIZE, OR COLOR.

FOR METAL FASTENING ANCHORS FOR SECURING OBJECTS TO WALLS (U.S. CLS. 2, 12, 13, 14, 23, 25 AND 50).

FIRST USE 9-1-2007; IN COMMERCE 9-1-2007.

CLASS 6—(Continued).

3,481,528. METALS USA BUILDING PRODUCTS, L.P., DALLAS, TX. SN 77-141,066. PUB. 9-25-2007, FILED 3-27-2007.

ELITEWOOD

THE MARK CONSISTS OF STANDARD CHARACTERS WITHOUT CLAIM TO ANY PARTICULAR FONT, STYLE, SIZE, OR COLOR.

FOR METAL ROOF AND PATIO SYSTEM COMPONENTS COMPRISING OF BEAMS, POSTS, RAFTERS, TUBES, AND SINGLE SKIN AND STRUCTURAL INSULATED ROOF PANELS, ALL MADE OF ALUMINUM OR METAL ALLOY (U.S. CLS. 2, 12, 13, 14, 23, 25 AND 50).

FIRST USE 10-10-2007; IN COMMERCE 10-10-2007.

3,481,822. SIVACO WIRE GROUP 2004 L.P., MONTREAL, QUEBEC, CANADA. SN 77-232,561. PUB. 1-8-2008, FILED 7-18-2007.



OWNER OF CANADA REG. NO. 515831, DATED 8-31-1999, EXPIRES 8-31-2014.

OWNER OF U.S. REG. NO. 1,092,655.

NO CLAIM IS MADE TO THE EXCLUSIVE RIGHT TO USE "SERIES", APART FROM THE MARK AS SHOWN.

THE MARK CONSISTS OF THE WORDS "SIVACO 9000 SERIES" AND A SPOOL OF WIRE DESIGN. THE NUMBER "9000" IS STYLIZED TO APPEAR THAT IT IS WIRE UNWINDING FROM THE SPOOL OF WIRE.

FOR SPECIALTY HIGH CARBON WIRE FOR THE MANUFACTURE OF AUTOMOTIVE, COMMERCIAL AND DYNAMICALLY LOADED LOW CYCLE PRODUCTS (U.S. CLS. 2, 12, 13, 14, 23, 25 AND 50).

FIRST USE 11-0-1996; IN COMMERCE 11-0-1996.

CLASS 6—(Continued).

3,481,837. JACK HOLT LTD, LONDON, UNITED KINGDOM.
SN 77-239,011. PUB. 1-15-2008, FILED 7-26-2007.



THE MARK CONSISTS OF FANCY BLACK LETTERS, WITH THE LETTER "O" SYMBOLIZED AS A SQUARE WITH A BLACK BOAT OVER A WHITE BACKGROUND.

FOR ANCHORS; MARINE ANCHORS; BUCKLES OF COMMON METAL; CABLE THIMBLES OF METAL; EYE BOLTS; METAL EYE BOLTS; FERRULES OF METAL FOR CANES AND WALKING-STICKS; METAL BOLLARDS; METAL CABLE WIRE; METAL CHAINS; METAL CLOSURES FOR CONTAINERS; METAL EXPANSION JOINTS FOR PIPING AND DUCTING; METAL HARDWARE NAMELY, PULLEYS; METAL HARDWARE, NAMELY, WASHERS; METAL HINGES; METAL HOOKS; METAL KEY RINGS; METAL LADDERS; METAL LATCHES; METAL MARINE HARDWARE, NAMELY, THIMBLES; METAL NUTS; METAL PIPE COUPLINGS AND JOINTS; METAL PLUGS; METAL POLES; METAL POSTS; METAL PULLEYS, SPRINGS AND VALVES; METAL RIVETS; METAL SCREWS; METAL WEATHER VANES; METAL WINDOW FRAMES; NAILS; WIRE; WIRE ROPES; MOORING BOLLARDS OF METAL (U.S. CLS. 2, 12, 13, 14, 23, 25 AND 50).

FIRST USE 5-1-2008; IN COMMERCE 5-1-2008.

3,481,973. AMERICAN GREASE STICK COMPANY, DBA AGS, MUSKEGON, MI. SN 77-301,447. PUB. 3-11-2008, FILED 10-11-2007.

NICOPP

THE MARK CONSISTS OF STANDARD CHARACTERS WITHOUT CLAIM TO ANY PARTICULAR FONT, STYLE, SIZE, OR COLOR.

FOR METAL TUBING (U.S. CLS. 2, 12, 13, 14, 23, 25 AND 50).

FIRST USE 12-15-2007; IN COMMERCE 1-30-2008.

CLASS 6—(Continued).

3,482,120. AVF GROUP LIMITED, TF1 7YE, UNITED KINGDOM. SN 78-621,775. PUB. 9-26-2006, FILED 5-3-2005.

AVF NEXUS

THE MARK CONSISTS OF STANDARD CHARACTERS WITHOUT CLAIM TO ANY PARTICULAR FONT, STYLE, SIZE, OR COLOR.

FOR METAL LCD AND PLASMA TELEVISION WALL MOUNTS (U.S. CLS. 2, 12, 13, 14, 23, 25 AND 50).

FIRST USE 10-31-2005; IN COMMERCE 10-31-2005.

CLASS 7—MACHINERY

3,481,090. SKC INC., EIGHTY FOUR, PA. SN 76-654,526. PUB. 6-19-2007, FILED 2-3-2006.

DIESEL DETECTIVE

THE MARK CONSISTS OF STANDARD CHARACTERS WITHOUT CLAIM TO ANY PARTICULAR FONT, STYLE, SIZE, OR COLOR.

NO CLAIM IS MADE TO THE EXCLUSIVE RIGHT TO USE "DIESEL", APART FROM THE MARK AS SHOWN.

FOR VACUUM PUMPS THAT DISPLAY CONCENTRATION OF DIESEL IN THE AIR WHEN CONNECTED TO AIR SAMPLING COLLECTION MEDIA (U.S. CLS. 13, 19, 21, 23, 31, 34 AND 35).

FIRST USE 10-15-2007; IN COMMERCE 10-15-2007.

3,481,110. RON TAI IRON FACTORY, TAICHUNG CITY, TAIWAN. SN 76-665,159. PUB. 10-16-2007, FILED 8-24-2006.



THE ENGLISH TRANSLATION OF THE WORD "BACCA" IN THE MARK IS BERRY.

FOR MOTORS, NAMELY, ELECTRIC STARTER MOTORS, ELEVATOR MOTORS, LINEAR MOTORS, STARTER MOTORS; MACHINE PARTS, NAMELY, CONTROLLED DECELERATORS FOR STOPPING MOVING PARTS OF INDUSTRIAL MACHINERY AND ABSORBING THE KINETIC ENERGY OF THE PARTS; POWER-OPERATED BLOWERS (U.S. CLS. 13, 19, 21, 23, 31, 34 AND 35).

FIRST USE 6-27-2007; IN COMMERCE 4-12-2008.

CLASS 7—(Continued).

3,481,115. YANG BEY INDUSTRIAL CO., LTD., TAICHUNG HSIEN 427, TAIWAN. SN 76-666,491. PUB. 1-22-2008, FILED 9-22-2006.



"THE MARK CONSISTS OF POWER-HI IN A STYLIZED FONT WITHIN A RECTANGLE."
FOR PACKERS FOR PACKING PACKAGES, BOXES OR CASES (U.S. CLS. 13, 19, 21, 23, 31, 34 AND 35).
FIRST USE 12-6-2007; IN COMMERCE 12-6-2007.

3,481,300. NOVANITEK, INC., DALLAS, TX. SN 77-069,866. PUB. 7-24-2007, FILED 12-21-2006.

NITEK

THE MARK CONSISTS OF STANDARD CHARACTERS WITHOUT CLAIM TO ANY PARTICULAR FONT, STYLE, SIZE, OR COLOR.
FOR ELECTRIC MOTORS FOR MACHINES (U.S. CLS. 13, 19, 21, 23, 31, 34 AND 35).
FIRST USE 6-8-2007; IN COMMERCE 6-8-2007.

3,481,336. SCHLAGE LOCK COMPANY, CARMEL, IN. SN 77-086,910. PUB. 7-10-2007, FILED 1-19-2007.

1260

THE MARK CONSISTS OF STANDARD CHARACTERS WITHOUT CLAIM TO ANY PARTICULAR FONT, STYLE, SIZE, OR COLOR.
FOR NON-ELECTRONIC, HYDRAULIC DOOR CLOSERS (U.S. CLS. 13, 19, 21, 23, 31, 34 AND 35).
FIRST USE 1-0-2008; IN COMMERCE 1-0-2008.

CLASS 7—(Continued).

3,481,337. SCHLAGE LOCK COMPANY, CARMEL, IN. SN 77-086,918. PUB. 7-10-2007, FILED 1-19-2007.

1261

THE MARK CONSISTS OF STANDARD CHARACTERS WITHOUT CLAIM TO ANY PARTICULAR FONT, STYLE, SIZE, OR COLOR.
FOR NON-ELECTRONIC, HYDRAULIC DOOR CLOSERS (U.S. CLS. 13, 19, 21, 23, 31, 34 AND 35).
FIRST USE 1-0-2008; IN COMMERCE 1-0-2008.

3,481,341. SLAMAN, PAUL, MISSION VIEJO, CA. SN 77-089,854. PUB. 10-9-2007, FILED 1-24-2007.

The Mini Sew Wonder

THE MARK CONSISTS OF STANDARD CHARACTERS WITHOUT CLAIM TO ANY PARTICULAR FONT, STYLE, SIZE, OR COLOR.
NO CLAIM IS MADE TO THE EXCLUSIVE RIGHT TO USE "MINI SEW", APART FROM THE MARK AS SHOWN.
FOR MINI SEWING MACHINE (U.S. CLS. 13, 19, 21, 23, 31, 34 AND 35).
FIRST USE 4-1-2007; IN COMMERCE 4-1-2007.

3,481,357. A. O. SMITH CORPORATION, MILWAUKEE, WI. SN 77-095,956. PUB. 7-24-2007, FILED 1-31-2007.

ECONOMASTER

THE MARK CONSISTS OF STANDARD CHARACTERS WITHOUT CLAIM TO ANY PARTICULAR FONT, STYLE, SIZE, OR COLOR.
FOR ELECTRIC MOTORS FOR MACHINES (U.S. CLS. 13, 19, 21, 23, 31, 34 AND 35).
FIRST USE 1-0-2008; IN COMMERCE 1-0-2008.

CLASS 7—(Continued).

3,481,397. HAMILTON BEACH BRANDS, INC., GLEN ALLEN, VA. SN 77-113,653. PUB. 8-28-2007, FILED 2-22-2007.

THE PERFECT ICE BREAKER

THE MARK CONSISTS OF STANDARD CHARACTERS WITHOUT CLAIM TO ANY PARTICULAR FONT, STYLE, SIZE, OR COLOR.

FOR KITCHEN APPLIANCES, NAMELY, ELECTRIC FOOD AND BEVERAGE BLENDERS (U.S. CLS. 13, 19, 21, 23, 31, 34 AND 35).

FIRST USE 4-24-2007; IN COMMERCE 4-24-2007.

CLASS 7—(Continued).

3,481,520. BLUE LINE EQUIPMENT, LLC, PRESCOTT, AZ. SN 77-140,681. PUB. 10-2-2007, FILED 3-26-2007.

BLUELINE COBALT

THE MARK CONSISTS OF STANDARD CHARACTERS WITHOUT CLAIM TO ANY PARTICULAR FONT, STYLE, SIZE, OR COLOR.

OWNER OF U.S. REG. NO. 3,056,753.
FOR CARPET AND FLOOR CLEANING MACHINES (U.S. CLS. 13, 19, 21, 23, 31, 34 AND 35).

FIRST USE 7-25-2007; IN COMMERCE 7-25-2007.

3,481,490. CONAIR CORPORATION, STAMFORD, CT. SN 77-134,411. PUB. 9-11-2007, FILED 3-19-2007.

POWER ADVANTAGE

THE MARK CONSISTS OF STANDARD CHARACTERS WITHOUT CLAIM TO ANY PARTICULAR FONT, STYLE, SIZE, OR COLOR.

FOR KITCHEN MACHINES, NAMELY, ELECTRIC STANDING MIXERS (U.S. CLS. 13, 19, 21, 23, 31, 34 AND 35).

FIRST USE 5-0-2007; IN COMMERCE 5-0-2007.

3,481,633. THE DARIEN GROUP, INC., DARIEN CENTER, NY. SN 77-159,856. PUB. 10-16-2007, FILED 4-18-2007.



NO CLAIM IS MADE TO THE EXCLUSIVE RIGHT TO USE "YARD TRIMMER", APART FROM THE MARK AS SHOWN.

THE MARK CONSISTS OF A SWIRLING CARNIVOROUS-LOOKING HEDGE HOG ADJACENT THE LITERAL ELEMENT OF THE MARK.

FOR POWER-OPERATED ROTARY HEDGE TRIMMERS (U.S. CLS. 13, 19, 21, 23, 31, 34 AND 35).

FIRST USE 5-21-2008; IN COMMERCE 5-21-2008.

3,481,496. GENERAL ELECTRIC COMPANY, SCHENECTADY, NY. SN 77-135,493. PUB. 11-20-2007, FILED 3-20-2007.

LP PLUS

THE MARK CONSISTS OF STANDARD CHARACTERS WITHOUT CLAIM TO ANY PARTICULAR FONT, STYLE, SIZE, OR COLOR.

NO CLAIM IS MADE TO THE EXCLUSIVE RIGHT TO USE "LP", APART FROM THE MARK AS SHOWN.

FOR STEAM TURBINE COMPONENTS, NAMELY, ROTORS, DIAPHRAGMS AND INNER SHELLS (U.S. CLS. 13, 19, 21, 23, 31, 34 AND 35).

FIRST USE 4-30-2005; IN COMMERCE 4-30-2005.

3,481,680. SCAG POWER EQUIPMENT, MAYVILLE, WI. SN 77-172,326. PUB. 11-27-2007, FILED 5-3-2007.

PRO-V

THE MARK CONSISTS OF STANDARD CHARACTERS WITHOUT CLAIM TO ANY PARTICULAR FONT, STYLE, SIZE, OR COLOR.

FOR LAWN MOWERS (U.S. CLS. 13, 19, 21, 23, 31, 34 AND 35).

FIRST USE 10-1-2007; IN COMMERCE 12-13-2007.

CLASS 7—(Continued).

3,481,813. DYNAMIC HARDWARE CONCEPTS LLC, PLAIN-FIELD, NJ. SN 77-227,632. PUB. 1-1-2008, FILED 7-12-2007.

ALLPOWER+

THE MARK CONSISTS OF STANDARD CHARACTERS WITHOUT CLAIM TO ANY PARTICULAR FONT, STYLE, SIZE, OR COLOR.

FOR MULTI-PURPOSE HIGH PRESSURE WASHERS; PORTABLE ELECTRIC POWER GENERATORS (U.S. CLS. 13, 19, 21, 23, 31, 34 AND 35).

FIRST USE 3-15-2008; IN COMMERCE 3-15-2008.

CLASS 7—(Continued).

3,482,028. MBRP INC., ONTARIO, CANADA. SN 78-386,791. PUB. 8-14-2007, FILED 3-18-2004.

COOL DUALS

THE MARK CONSISTS OF STANDARD CHARACTERS WITHOUT CLAIM TO ANY PARTICULAR FONT, STYLE, SIZE, OR COLOR.

PRIORITY CLAIMED UNDER SEC. 44(D) ON CANADA APPLICATION NO. 1,210,154, FILED 3-18-2004, REG. NO. TMA685680, DATED 4-5-2007, EXPIRES 4-5-2022.

FOR VEHICULAR PRODUCTS, NAMELY, EXHAUST PIPES FOR DIESEL TRUCKS (U.S. CLS. 13, 19, 21, 23, 31, 34 AND 35).

FIRST USE 1-31-2007; IN COMMERCE 1-31-2007.

3,481,834. TOMLINSON, CHARLES, MESA, AZ. SN 77-238,176. PUB. 1-15-2008, FILED 7-25-2007.

SLURRY KING

THE MARK CONSISTS OF STANDARD CHARACTERS WITHOUT CLAIM TO ANY PARTICULAR FONT, STYLE, SIZE, OR COLOR.

NO CLAIM IS MADE TO THE EXCLUSIVE RIGHT TO USE "SLURRY", APART FROM THE MARK AS SHOWN.

FOR MOTORIZED DEWATERING MACHINE FOR USE IN THE TREATMENT OF LIQUIDS, NAMELY, FOR REMOVING WATER FROM A SLURRY MIXTURE OF CONCRETE DUST AND WATER (U.S. CLS. 13, 19, 21, 23, 31, 34 AND 35).

FIRST USE 6-11-2007; IN COMMERCE 6-11-2007.

3,482,156. MIELE, INC., PRINCETON, NJ. SN 78-674,545. PUB. 4-4-2006, FILED 7-20-2005.

3,481,904. THE GLEASON WORKS, ROCHESTER, NY. SN 77-263,325. PUB. 3-18-2008, FILED 8-24-2007.

OPTI-CUT

THE MARK CONSISTS OF STANDARD CHARACTERS WITHOUT CLAIM TO ANY PARTICULAR FONT, STYLE, SIZE, OR COLOR.

OWNER OF U.S. REG. NO. 2,529,739.

FOR POWER-OPERATED CUTTING TOOLS, NAMELY, GASHING, SHAPING AND HOBGING TOOLS HAVING REPLACEABLE CUTTING INSERTS, FOR THE MANUFACTURE OF GEARS AND OTHER TOOTHED ARTICLES; CUTTING INSERTS AND REPLACEMENT PARTS FOR SUCH TOOLS (U.S. CLS. 13, 19, 21, 23, 31, 34 AND 35).

FIRST USE 9-17-2007; IN COMMERCE 2-12-2008.

ADVANTA SERIES

THE MARK CONSISTS OF STANDARD CHARACTERS WITHOUT CLAIM TO ANY PARTICULAR FONT, STYLE, SIZE, OR COLOR.

NO CLAIM IS MADE TO THE EXCLUSIVE RIGHT TO USE "SERIES", APART FROM THE MARK AS SHOWN.

FOR DISH WASHING MACHINES (U.S. CLS. 13, 19, 21, 23, 31, 34 AND 35).

FIRST USE 1-1-2005; IN COMMERCE 6-30-2005.

CLASS 7—(Continued).

3,482,278. STRUCTUS BUILDING TECHNOLOGIES, INC., BEND, OR. SN 78-796,536. PUB. 9-25-2007, FILED 1-21-2006.

CLASS 7—(Continued).

3,482,465. CTB IP, INC., WILMINGTON, DE. SN 78-937,681. PUB. 3-6-2007, FILED 7-26-2006.

DOUBLE BARREL HOPPER

THE MARK CONSISTS OF STANDARD CHARACTERS WITHOUT CLAIM TO ANY PARTICULAR FONT, STYLE, SIZE, OR COLOR.
NO CLAIM IS MADE TO THE EXCLUSIVE RIGHT TO USE "HOPPER", APART FROM THE MARK AS SHOWN.
THE WORDING "DOUBLE BARREL" HAS NO MEANING IN A FOREIGN LANGUAGE.
FOR MACHINES, NAMELY, DRYWALL MUD HOPPERS (U.S. CLS. 13, 19, 21, 23, 31, 34 AND 35).
FIRST USE 5-1-2000; IN COMMERCE 5-1-2000.

ADVANTI-FLOW

THE MARK CONSISTS OF STANDARD CHARACTERS WITHOUT CLAIM TO ANY PARTICULAR FONT, STYLE, SIZE, OR COLOR.
FOR MECHANICAL WATERING UNITS FOR POULTRY (U.S. CLS. 13, 19, 21, 23, 31, 34 AND 35).
FIRST USE 6-12-2008; IN COMMERCE 6-12-2008.

3,482,309. PENTAIR WATER POOL AND SPA, INC., SANFORD, NC. SN 78-828,411. PUB. 10-10-2006, FILED 3-3-2006.

3,482,478. BUD'S BIKER PARTS, INC., HELENA, MT. SN 78-940,222. PUB. 3-27-2007, FILED 7-28-2006.

DYNA-PRO

THE MARK CONSISTS OF STANDARD CHARACTERS WITHOUT CLAIM TO ANY PARTICULAR FONT, STYLE, SIZE, OR COLOR.
FOR CENTRIFUGAL PUMP FOR SWIMMING POOLS AND SPAS (U.S. CLS. 13, 19, 21, 23, 31, 34 AND 35).
FIRST USE 1-7-2008; IN COMMERCE 1-7-2008.

OIL BUD

THE MARK CONSISTS OF STANDARD CHARACTERS WITHOUT CLAIM TO ANY PARTICULAR FONT, STYLE, SIZE, OR COLOR.
NO CLAIM IS MADE TO THE EXCLUSIVE RIGHT TO USE "OIL", APART FROM THE MARK AS SHOWN.
FOR MOTORCYCLE OIL COOLERS (U.S. CLS. 13, 19, 21, 23, 31, 34 AND 35).
FIRST USE 6-10-2008; IN COMMERCE 6-10-2008.

3,482,364. POLLARD, ALBERT C., WHITE STONE, VA. SN 78-867,657. PUB. 5-29-2007, FILED 4-24-2006.

LUMBER SMITH

THE MARK CONSISTS OF STANDARD CHARACTERS WITHOUT CLAIM TO ANY PARTICULAR FONT, STYLE, SIZE, OR COLOR.
NO CLAIM IS MADE TO THE EXCLUSIVE RIGHT TO USE "LUMBER", APART FROM THE MARK AS SHOWN.
FOR LUMBERING BAND SAWS (U.S. CLS. 13, 19, 21, 23, 31, 34 AND 35).
FIRST USE 1-1-2006; IN COMMERCE 3-7-2008.

CLASS 8—HAND TOOLS

CLASS 8—(Continued).

3,481,242. SUNEX INTERNATIONAL INC., TRAVELERS REST, SC. SN 77-039,210. PUB. 6-12-2007, FILED 11-8-2006.



THE MARK CONSISTS OF THE REPRESENTATION OF THE HEAD OF A DOG WITH ITS MOUTH OPEN ENCLOSED IN A CIRCLE.

FOR HAND TOOLS, NAMELY, SOCKETS, SOCKET RATCHETS, AND EXTENSIONS; SOCKET WRENCH SETS, NAMELY, SOCKETS, SOCKET RATCHETS, AND EXTENSIONS SOLD AS A UNIT (U.S. CLS. 23, 28 AND 44).

FIRST USE 2-21-2008; IN COMMERCE 2-21-2008.

CLASS 8—(Continued).

3,481,614. SAY, STEVEN R, PEORIA, AZ. SN 77-155,635. PUB. 10-9-2007, FILED 4-12-2007.

Lift-N-Go

THE MARK CONSISTS OF STANDARD CHARACTERS WITHOUT CLAIM TO ANY PARTICULAR FONT, STYLE, SIZE, OR COLOR.

FOR HAND OPERATED LIFTING JACKS (U.S. CLS. 23, 28 AND 44).

FIRST USE 1-15-2008; IN COMMERCE 5-12-2008.

3,481,734. MENARD, INC., EAU CLAIRE, WI. SN 77-189,082. PUB. 10-23-2007, FILED 5-24-2007.

XTREME GARAGE

POUND-IT-OUT

THE MARK CONSISTS OF STANDARD CHARACTERS WITHOUT CLAIM TO ANY PARTICULAR FONT, STYLE, SIZE, OR COLOR.

FOR PLASTIC POUNDING DEVICE FOR USE AS A TENDERIZER FOR MEAT, POULTRY, VEGETABLE AND FISH (U.S. CLS. 23, 28 AND 44).

FIRST USE 5-7-2008; IN COMMERCE 5-7-2008.

THE MARK CONSISTS OF STANDARD CHARACTERS WITHOUT CLAIM TO ANY PARTICULAR FONT, STYLE, SIZE, OR COLOR.

OWNER OF U.S. REG. NOS. 3,126,317 AND 3,129,290.

NO CLAIM IS MADE TO THE EXCLUSIVE RIGHT TO USE "GARAGE", APART FROM THE MARK AS SHOWN.

FOR MANUALLY-OPERATED JACKS (U.S. CLS. 23, 28 AND 44).

FIRST USE 1-24-2008; IN COMMERCE 1-24-2008.

3,481,343. LIMMER, ROBERT, CLOSTER, NJ. SN 77-090,129. PUB. 11-20-2007, FILED 1-24-2007.

CLASS 8—(Continued).

3,481,738. MENARD, INC., EAU CLAIRE, WI. SN 77-189,099.
PUB. 10-23-2007, FILED 5-24-2007.



OWNER OF U.S. REG. NOS. 3,126,317 AND 3,129,290.
NO CLAIM IS MADE TO THE EXCLUSIVE RIGHT TO
USE "GARAGE", APART FROM THE MARK AS SHOWN.
THE COLOR(S) RED, BLACK AND SILVER IS/ARE
CLAIMED AS A FEATURE OF THE MARK.

THE MARK CONSISTS OF A BLACK GARAGE-SHAPE
OUTLINE; THE WORD "XTREME" IN RED WITH THE
LETTER "X" BEING LARGER THAN THE OTHER LET-
TERS IN THE WORD; THE WORD "XTREME" IN A
STYLIZED FONT; THE WORD "GARAGE" APPEARING
AS IF IT IS SILVER CHROME AND PORTRAYED AS
THOUGH THERE ARE CHROME RIVETS ON THE LET-
TERING.

FOR MANUALLY-OPERATED JACKS (U.S. CLS. 23, 28
AND 44).
FIRST USE 1-24-2008; IN COMMERCE 1-24-2008.

3,481,925. UNGER MARKETING INTERNATIONAL, LLC,
BRIDGEPORT, CT. SN 77-276,098. PUB. 3-11-2008, FILED 9-
11-2007.

UNGER REACH & GRAB

THE MARK CONSISTS OF STANDARD CHARACTERS
WITHOUT CLAIM TO ANY PARTICULAR FONT, STYLE,
SIZE, OR COLOR.

OWNER OF U.S. REG. NOS. 1,369,049 AND 2,550,555.
FOR HAND OPERATED GRIPPER TOOL (U.S. CLS. 23,
28 AND 44).
FIRST USE 4-21-2008; IN COMMERCE 4-21-2008.

CLASS 8—(Continued).

3,482,269. ANNIE INTERNATIONAL, INC., NORTH WALES,
PA. SN 78-792,112. PUB. 3-27-2007, FILED 1-16-2006.

SALERNO

THE MARK CONSISTS OF STANDARD CHARACTERS
WITHOUT CLAIM TO ANY PARTICULAR FONT, STYLE,
SIZE, OR COLOR.

FOR HAIRCUTTING SCISSORS (U.S. CLS. 23, 28 AND
44).
FIRST USE 6-17-2008; IN COMMERCE 6-17-2008.

3,482,422. LLOYDCO, LLC, MENLO PARK, CA. SN 78-
913,949. PUB. 9-4-2007, FILED 6-22-2006.

It's a Corker!

THE MARK CONSISTS OF STANDARD CHARACTERS
WITHOUT CLAIM TO ANY PARTICULAR FONT, STYLE,
SIZE, OR COLOR.

FOR MANUALLY OPERATED APPARATUS FOR IN-
SERTING A RESILIENT STOPPER INTO A BEVERAGE
BOTTLE OR A WINE BOTTLE (U.S. CLS. 23, 28 AND 44).
FIRST USE 1-15-2007; IN COMMERCE 1-15-2007.

3,482,508. BATTENFELD TECHNOLOGIES, INC., COLUM-
BIA, MO. SN 78-951,746. PUB. 10-16-2007, FILED 8-14-2006.

F.A.T. WRENCH

THE MARK CONSISTS OF STANDARD CHARACTERS
WITHOUT CLAIM TO ANY PARTICULAR FONT, STYLE,
SIZE, OR COLOR.

NO CLAIM IS MADE TO THE EXCLUSIVE RIGHT TO
USE "WRENCH", APART FROM THE MARK AS SHOWN.

FOR MANUALLY OPERATED HAND TOOLS,
NAMELY, WRENCHES USED EXCLUSIVELY WITH
FIREARMS (U.S. CLS. 23, 28 AND 44).
FIRST USE 7-26-2006; IN COMMERCE 7-26-2006.

CLASS 8—(Continued).

3,482,524. TAYLOR BRANDS LLC, KINGSPORT, TN. SN 78-955,527. PUB. 4-3-2007, FILED 8-18-2006.

SPRINGER

THE MARK CONSISTS OF STANDARD CHARACTERS WITHOUT CLAIM TO ANY PARTICULAR FONT, STYLE, SIZE, OR COLOR.

FOR CUTLERY, NAMELY, KNIVES (U.S. CLS. 23, 28 AND 44).
FIRST USE 5-14-2008; IN COMMERCE 5-14-2008.

CLASS 9—ELECTRICAL AND SCIENTIFIC APPARATUS

3,481,052. WAI LAN YOGA TRUST, MALIBU, CA. SN 76-520,306. PUB. 9-14-2004, FILED 5-28-2003.

WAI LANA'S LITTLE YOGIS

OWNER OF U.S. REG. NOS. 2,315,533 AND 2,729,584. THE NAME "WAI LANA" IDENTIFIES A LIVING INDIVIDUAL WHOSE CONSENT IS OF RECORD.

FOR PRERECORDED VIDEO TAPES FEATURING YOGA EXERCISES, CDS FEATURING RELAXATION MUSIC, PRE-RECORDED DVDS FEATURING YOGA EXERCISES AND RELAXATION MUSIC (U.S. CLS. 21, 23, 26, 36 AND 38).

FIRST USE 9-30-2003; IN COMMERCE 9-30-2003.

3,481,063. CRS RETAIL SYSTEMS, INC., NEWBURGH, NY. SN 76-566,710. PUB. 3-8-2005, FILED 12-23-2003.

CRS RETAILSTORE

NO CLAIM IS MADE TO THE EXCLUSIVE RIGHT TO USE "RETAIL STORE", APART FROM THE MARK AS SHOWN.

FOR COMPUTER SOFTWARE FOR OPERATING RETAIL AND CASH REGISTER SYSTEMS FOR POINT OF SALE AND OFFICE APPLICATIONS RELATING TO INVENTORY MANAGEMENT, TIME AND ATTENDANCE, STORE OPERATIONS, QUICK VIEWS, LEARNING MANAGEMENT AND PAYMENT AUTHORIZATION (U.S. CLS. 21, 23, 26, 36 AND 38).

FIRST USE 3-31-2005; IN COMMERCE 3-31-2005.

CLASS 9—(Continued).

3,481,065. 1099 PRO, INC., CALABASAS, CA. SN 76-590,488. PUB. 2-22-2005, FILED 5-5-2004.

PUSH A BUTTON AND IT'S DONE

FOR COMPUTER SOFTWARE PROGRAM FOR TAX COMPLIANCE (U.S. CLS. 21, 23, 26, 36 AND 38).
FIRST USE 5-1-2008; IN COMMERCE 5-1-2008.

3,481,079. ATLANTIC REPRESENTATIONS, INC., DBA ATLANTIC INC., SANTA FE SPRINGS, CA. SN 76-649,906. PUB. 8-14-2007, FILED 11-7-2005.

GAMEKEEPER

THE MARK CONSISTS OF STANDARD CHARACTERS WITHOUT CLAIM TO ANY PARTICULAR FONT, STYLE, SIZE, OR COLOR.

FOR HARD AND SOFT CONTAINERS AND CARRYING CASES FOR VIDEO GAMES AND FOR VIDEO GAME EQUIPMENT (U.S. CLS. 21, 23, 26, 36 AND 38).

FIRST USE 1-31-2006; IN COMMERCE 1-31-2006.

3,481,085. DIABLOSPORT, LLC, BOCA RATON, FL. SN 76-652,854. PUB. 9-12-2006, FILED 1-4-2006.



The logo for Trinity features the word "Trinity" in a bold, sans-serif font. A thick, black curved line starts under the 'T', goes under the 'i', and then curves back up under the 'y', resembling a stylized smile or a swoosh.

OWNER OF U.S. REG. NO. 2,947,507.

FOR VEHICLE PERFORMANCE PROGRAMMER AND DISPLAY APPARATUS, NAMELY, A FLASH PROGRAMMER HAVING ADVANCED DIAGNOSTICS WHICH ANALYZE VEHICLE INFORMATION, PERFORMS REAL TIME DATA MONITORING AND CAN CALIBRATE AND RECALIBRATE VEHICLE AND ENGINE PARAMETERS TO ENHANCE PERFORMANCE WHILE DISPLAYING ALL RELEVANT INFORMATION TO THE VEHICLE OCCUPANT (U.S. CLS. 21, 23, 26, 36 AND 38).

FIRST USE 12-9-2005; IN COMMERCE 8-0-2007.

CLASS 9—(Continued).

3,481,091. VENTEX TECHNOLOGIES, INC., RIVIERA BEACH, FL. SN 76-654,615. PUB. 10-3-2006, FILED 2-6-2006.

ADVANTAGE

THE MARK CONSISTS OF STANDARD CHARACTERS WITHOUT CLAIM TO ANY PARTICULAR FONT, STYLE, SIZE, OR COLOR.

FOR ELECTRONIC FLUORESCENT BALLASTS AND ELECTRONIC POWER SUPPLIES (U.S. CLS. 21, 23, 26, 36 AND 38).

FIRST USE 11-30-2006; IN COMMERCE 1-0-2008.

3,481,094. ECIL NORTH AMERICA LLC, AKRON, OH. SN 76-658,045. PUB. 10-24-2006, FILED 4-10-2006.

OXILAB

THE MARK CONSISTS OF STANDARD CHARACTERS WITHOUT CLAIM TO ANY PARTICULAR FONT, STYLE, SIZE, OR COLOR.

FOR ELECTRONIC DEVICES FOR PROVIDING CHEMICAL AND TEMPERATURE MEASUREMENTS FOR MOLTEN METAL BATHS (U.S. CLS. 21, 23, 26, 36 AND 38).

FIRST USE 1-15-2007; IN COMMERCE 1-15-2007.

3,481,095. ECIL NORTH AMERICA LLC, AKRON, OH. SN 76-658,046. PUB. 2-13-2007, FILED 4-10-2006.

OXYTIP

THE MARK CONSISTS OF STANDARD CHARACTERS WITHOUT CLAIM TO ANY PARTICULAR FONT, STYLE, SIZE, OR COLOR.

FOR EXPENDABLE IMMERSION SENSORS FOR USE IN MOLTEN METAL BATHS TO MEASURE THE OXYGEN CONTENT (U.S. CLS. 21, 23, 26, 36 AND 38).

FIRST USE 2-22-2007; IN COMMERCE 2-22-2007.

CLASS 9—(Continued).

3,481,126. YAMAHA CORPORATION, SHIZUOKA, JAPAN. SN 76-671,829. PUB. 9-11-2007, FILED 1-25-2007.



OWNER OF U.S. REG. NOS. 2,020,855, 2,517,013, AND 2,621,927.

NO CLAIM IS MADE TO THE EXCLUSIVE RIGHT TO USE "GRAPHICS", APART FROM THE MARK AS SHOWN.

FOR PRE-RECORDED OPTICAL DISCS WITH DIGITAL FILES THAT CONTAIN AUDIO, TEXT, STILL IMAGES AND GRAPHICS FILES FOR USE IN THE OPERATION OF PLAYER PIANOS AND ELECTRONIC MUSICAL INSTRUMENTS; PRE-RECORDED OPTICAL DISCS FEATURING MUSIC AND STILL IMAGES (U.S. CLS. 21, 23, 26, 36 AND 38).

FIRST USE 1-17-2008; IN COMMERCE 1-17-2008.

3,481,144. ABNP PRODUCTIONS LLC, WILLOUGHBY, OH. SN 76-675,615. PUB. 10-16-2007, FILED 4-17-2007.

WAGON WHEEL

THE MARK CONSISTS OF STANDARD CHARACTERS WITHOUT CLAIM TO ANY PARTICULAR FONT, STYLE, SIZE, OR COLOR.

FOR VIDEO RECORDINGS FEATURING HISTORICAL AND SPECIAL INTEREST DOCUMENTARIES (U.S. CLS. 21, 23, 26, 36 AND 38).

FIRST USE 5-0-2007; IN COMMERCE 5-0-2007.

3,481,145. FARAR, JORDAN MARK, SAN DIEGO, CA. SN 76-676,022. PUB. 10-30-2007, FILED 4-26-2007.

**THE GOOD & THE HARD TIMES
IN LA**

THE MARK CONSISTS OF STANDARD CHARACTERS WITHOUT CLAIM TO ANY PARTICULAR FONT, STYLE, SIZE, OR COLOR.

NO CLAIM IS MADE TO THE EXCLUSIVE RIGHT TO USE "LA", APART FROM THE MARK AS SHOWN.

FOR COMPACT DISCS FEATURING MUSIC (U.S. CLS. 21, 23, 26, 36 AND 38).

FIRST USE 3-3-2007; IN COMMERCE 3-23-2007.

CLASS 9—(Continued).

3,481,157. SARTORIUS AG, D-37075 GOETTINGEN, FED REP GERMANY. SN 76-679,846. PUB. 1-8-2008, FILED 7-23-2007.

COSYNUS

THE MARK CONSISTS OF STANDARD CHARACTERS WITHOUT CLAIM TO ANY PARTICULAR FONT, STYLE, SIZE, OR COLOR.

FOR ELECTRONIC LABORATORY INSTRUMENTS AND WEIGHING APPARATUS, NAMELY, SCALES, METAL DETECTORS AND ASSOCIATED MECHANICAL, ELECTRICAL AND ELECTRONIC COMPONENTS WITH SOFTWARE, DATA ENTRY, DISPLAY, TRANSFER AND CONTROL EQUIPMENT THEREFOR (U.S. CLS. 21, 23, 26, 36 AND 38).

FIRST USE 3-31-2008; IN COMMERCE 3-31-2008.

3,481,177. DISNEY ENTERPRISES, INC., BURBANK, CA. SN 77-005,161. PUB. 8-7-2007, FILED 9-22-2006.

THE SUITE LIFE

THE MARK CONSISTS OF STANDARD CHARACTERS WITHOUT CLAIM TO ANY PARTICULAR FONT, STYLE, SIZE, OR COLOR.

FOR VIDEO GAME CARTRIDGES (U.S. CLS. 21, 23, 26, 36 AND 38).

FIRST USE 10-31-2006; IN COMMERCE 10-31-2006.

3,481,182. RAYTHEON COMPANY, WALTHAM, MA. SN 77-009,336. PUB. 3-13-2007, FILED 9-28-2006.

ADAPT

THE MARK CONSISTS OF STANDARD CHARACTERS WITHOUT CLAIM TO ANY PARTICULAR FONT, STYLE, SIZE, OR COLOR.

FOR COMPUTER SOFTWARE FOR SIMULATING THE OPERATION OF A SURVEILLANCE SYSTEM (U.S. CLS. 21, 23, 26, 36 AND 38).

FIRST USE 12-31-2006; IN COMMERCE 12-31-2006.

CLASS 9—(Continued).

3,481,186. SIDE TRACKED RECORDS, CARMEL, IN. SN 77-012,813. PUB. 6-12-2007, FILED 10-3-2006.

side tracked records

THE MARK CONSISTS OF STANDARD CHARACTERS WITHOUT CLAIM TO ANY PARTICULAR FONT, STYLE, SIZE, OR COLOR.

NO CLAIM IS MADE TO THE EXCLUSIVE RIGHT TO USE "RECORDS", APART FROM THE MARK AS SHOWN.

FOR AUDIO RECORDINGS FEATURING MUSIC (U.S. CLS. 21, 23, 26, 36 AND 38).

FIRST USE 1-1-2008; IN COMMERCE 1-1-2008.

3,481,224. MITEK CORPORATION, PHOENIX, AZ. SN 77-031,501. PUB. 10-9-2007, FILED 10-27-2006.

RE-Q

THE MARK CONSISTS OF STANDARD CHARACTERS WITHOUT CLAIM TO ANY PARTICULAR FONT, STYLE, SIZE, OR COLOR.

FOR INTERFACE DEVICE FOR AUDIO EQUIPMENT, NAMELY, AMPLIFIERS AND HEAD UNITS (U.S. CLS. 21, 23, 26, 36 AND 38).

FIRST USE 1-0-2007; IN COMMERCE 1-0-2007.

3,481,233. CREATIVE TECHNOLOGY LTD., SINGAPORE, SINGAPORE. SN 77-035,810. PUB. 9-18-2007, FILED 11-2-2006.

XDOCK

THE MARK CONSISTS OF STANDARD CHARACTERS WITHOUT CLAIM TO ANY PARTICULAR FONT, STYLE, SIZE, OR COLOR.

FOR APPARATUS FOR TRANSMISSION OR REPRODUCTION OF SOUND; COMPUTER HARDWARE; COMPUTER SOFTWARE TO CONTROL AND IMPROVE COMPUTER AND AUDIO EQUIPMENT SOUND QUALITY AND COMPUTER SOFTWARE FOR THE STORAGE, REPRODUCTION, TRANSMISSION AND EDITING OF SOUND IN COMPUTER AUDIO COMPONENTS AND MULTIMEDIA APPLICATIONS; COMPUTER PERIPHERALS; DOWNLOADABLE ELECTRONIC MANUALS DISTRIBUTED THEREWITH; AUDIO VISUAL CONTROL SYSTEMS; AUDIO SIGNAL PROCESSOR (U.S. CLS. 21, 23, 26, 36 AND 38).

FIRST USE 1-31-2007; IN COMMERCE 1-31-2007.

CLASS 9—(Continued).

3,481,234. ACCU-SORT SYSTEMS, INC., HATFIELD, PA. SN 77-036,183. PUB. 6-19-2007, FILED 11-3-2006.

EZREADER

THE MARK CONSISTS OF STANDARD CHARACTERS WITHOUT CLAIM TO ANY PARTICULAR FONT, STYLE, SIZE, OR COLOR.

FOR RADIO FREQUENCY IDENTIFICATION (RFID) CREDENTIALS, NAMELY, CARDS AND TAGS, AND READERS FOR RADIO FREQUENCY IDENTIFICATION CREDENTIALS (U.S. CLS. 21, 23, 26, 36 AND 38).

FIRST USE 3-14-2007; IN COMMERCE 3-14-2007.

3,481,235. ACCU-SORT SYSTEMS, INC., HATFIELD, PA. SN 77-036,193. PUB. 6-19-2007, FILED 11-3-2006.

EZTUNE

THE MARK CONSISTS OF STANDARD CHARACTERS WITHOUT CLAIM TO ANY PARTICULAR FONT, STYLE, SIZE, OR COLOR.

FOR ANTENNAE FOR AUTOMATIC TUNING ON A RADIO FREQUENCY IDENTIFICATION DEVICE (U.S. CLS. 21, 23, 26, 36 AND 38).

FIRST USE 3-14-2007; IN COMMERCE 3-14-2007.

3,481,245. LEUPOLD & STEVENS, INC., BEAVERTON, OR. SN 77-042,824. PUB. 7-31-2007, FILED 11-13-2006.

SWITCH/POWER

THE MARK CONSISTS OF STANDARD CHARACTERS WITHOUT CLAIM TO ANY PARTICULAR FONT, STYLE, SIZE, OR COLOR.

FOR BINOCULARS; FEATURE OF OPTICAL LENS SCOPES, NAMELY, A MAGNIFICATION ADJUSTMENT DEVICE (U.S. CLS. 21, 23, 26, 36 AND 38).

FIRST USE 1-22-2008; IN COMMERCE 1-22-2008.

CLASS 9—(Continued).

3,481,247. LEUPOLD & STEVENS, INC., BEAVERTON, OR. SN 77-044,332. PUB. 7-31-2007, FILED 11-15-2006.

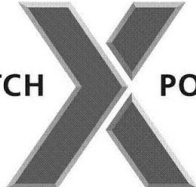
SWITCH  POWER

THE MARK CONSISTS OF THE WORDS "SWITCH" AND "POWER" ON EITHER SIDE OF A DESIGN UNIFYING ELEMENTS OF THE OPTICAL MAGNIFICATION SYMBOL AND THE GREATER THAN/LESS THAN SYMBOLS.

FOR BINOCULARS; FEATURE OF OPTICAL LENS SCOPES, NAMELY, A MAGNIFICATION ADJUSTMENT DEVICE (U.S. CLS. 21, 23, 26, 36 AND 38).

FIRST USE 1-22-2008; IN COMMERCE 1-22-2008.

3,481,275. LIPYANEK, SUSAN E, BRICK, NJ. SN 77-058,302. PUB. 6-26-2007, FILED 12-6-2006.

STEEL
MX



THE MARK CONSISTS OF A DESIGN WITH WORDS, THE LETTER "X" INSIDE A CIRCLE WITH THE "X" PROTRUDING OUT OF THE CIRCLE.

FOR GOGGLES FOR SPORTS (U.S. CLS. 21, 23, 26, 36 AND 38).

FIRST USE 5-5-2005; IN COMMERCE 1-1-2007.

3,481,277. CALLPOD, INC., CHICAGO, IL. SN 77-059,196. PUB. 7-3-2007, FILED 12-7-2006.

dragon

THE COLOR(S) BLACK AND GREEN IS/ARE CLAIMED AS A FEATURE OF THE MARK.

THE MARK CONSISTS OF "D" "R" "A" "G" AND "N" ARE BLACK AND "O" IS GREEN.

FOR WIRELESS CELLULAR TELEPHONE HEADSETS (U.S. CLS. 21, 23, 26, 36 AND 38).

FIRST USE 12-7-2006; IN COMMERCE 12-7-2006.

CLASS 9—(Continued).

3,481,304. SONY KABUSHIKI KAISHA, TA SONY CORPORATION, TOKYO, JAPAN. SN 77-071,619. PUB. 10-9-2007, FILED 12-27-2006.



NO CLAIM IS MADE TO THE EXCLUSIVE RIGHT TO USE "FACE DETECTION", APART FROM THE MARK AS SHOWN.

THE MARK CONSISTS OF THE WORDS "FACE DETECTION" WITH A HIGHLY STYLIZED DESIGN OF A FACE WITHIN A RECTANGLE.

FOR DIGITAL STILL CAMERAS (U.S. CLS. 21, 23, 26, 36 AND 38).
FIRST USE 3-31-2007; IN COMMERCE 3-31-2007.

3,481,318. RESEARCH CREDIT GROUP, INC., HUDSON, OH. SN 77-078,707. PUB. 8-21-2007, FILED 1-9-2007.

RCG Research Credit Group

THE MARK CONSISTS OF STANDARD CHARACTERS WITHOUT CLAIM TO ANY PARTICULAR FONT, STYLE, SIZE, OR COLOR.

FOR COMPUTER SOFTWARE FOR MAINTAINING RECORDS AND PROCESSING DATA RELATED TO STATE AND FEDERAL RESEARCH AND DEVELOPMENT TAX CREDITS (U.S. CLS. 21, 23, 26, 36 AND 38).
FIRST USE 5-8-2008; IN COMMERCE 5-8-2008.

3,481,320. PHARMACEUTICAL SERVICES CORPORATION, POMONA, CA. SN 77-080,297. PUB. 8-21-2007, FILED 1-10-2007.

AuditCA

THE MARK CONSISTS OF STANDARD CHARACTERS WITHOUT CLAIM TO ANY PARTICULAR FONT, STYLE, SIZE, OR COLOR.

THE WORDING "AUDITCA" HAS NO MEANING OTHER THAN TRADEMARK SIGNIFICANCE.

FOR COMPUTER SOFTWARE THAT ENABLES THE USER TO SEARCH RELEVANT LAWS AND REGULATIONS, AND TO PREPARE OBSERVATIONS AND REPORTS WITH USER-INPUT TEXT WHICH UTILIZES TEXT FROM THE SELECTED REGULATIONS (U.S. CLS. 21, 23, 26, 36 AND 38).
FIRST USE 12-15-2006; IN COMMERCE 12-15-2006.

CLASS 9—(Continued).

3,481,324. RESEARCH CREDIT GROUP, INC., HUDSON, OH. SN 77-081,589. PUB. 8-21-2007, FILED 1-12-2007.

CrediTrack

THE MARK CONSISTS OF STANDARD CHARACTERS WITHOUT CLAIM TO ANY PARTICULAR FONT, STYLE, SIZE, OR COLOR.

FOR COMPUTER SOFTWARE FOR MAINTAINING RECORDS AND PROCESSING DATA RELATED TO STATE AND FEDERAL RESEARCH AND DEVELOPMENT TAX CREDITS (U.S. CLS. 21, 23, 26, 36 AND 38).
FIRST USE 5-7-2007; IN COMMERCE 5-7-2007.

3,481,342. EURASIA CONCEPTS, INC., SUITE 300, CA. SN 77-089,887. PUB. 6-26-2007, FILED 1-24-2007.

ONEPASS

THE MARK CONSISTS OF STANDARD CHARACTERS WITHOUT CLAIM TO ANY PARTICULAR FONT, STYLE, SIZE, OR COLOR.

FOR ELECTRIC FLAT IRONS; ELECTRIC HAIR CRIMPER; ELECTRIC HAIR CURLERS; ELECTRIC HAIR CURLING IRONS; ELECTRIC HAIR ROLLERS; ELECTRIC HAIR STRAIGHTENER; ELECTRIC HAIR STRAIGHTENING IRONS; ELECTRIC HAIR-CURLERS; ELECTRIC HAND-HELD HAIR STYLING IRONS; ELECTRIC IRONS FOR STYLING HAIR; ELECTRIC ROTARY HAIR BRUSH FOR STYLING A USER'S HAIR; ELECTRICALLY HEATED HAIR BRUSHES; HOT AIR HAIR BRUSHES (U.S. CLS. 21, 23, 26, 36 AND 38).
FIRST USE 1-27-2007; IN COMMERCE 6-5-2007.

3,481,349. CRACKPOT ENTERTAINMENT LLC, SHELBURNE FALLS, MA. SN 77-093,014. PUB. 7-10-2007, FILED 1-28-2007.

INSECTICIDE

THE MARK CONSISTS OF STANDARD CHARACTERS WITHOUT CLAIM TO ANY PARTICULAR FONT, STYLE, SIZE, OR COLOR.

FOR VIDEO GAME CARTRIDGES; VIDEO GAME SOFTWARE (U.S. CLS. 21, 23, 26, 36 AND 38).
FIRST USE 3-0-2008; IN COMMERCE 3-0-2008.

CLASS 9—(Continued).

3,481,361. BRONZE AGE SOFTWARE CORPORATION, OTTAWA, CANADA. SN 77-097,620. PUB. 11-13-2007, FILED 2-2-2007.

Athena Backup

THE MARK CONSISTS OF STANDARD CHARACTERS WITHOUT CLAIM TO ANY PARTICULAR FONT, STYLE, SIZE, OR COLOR.

NO CLAIM IS MADE TO THE EXCLUSIVE RIGHT TO USE "BACKUP", APART FROM THE MARK AS SHOWN.

FOR BACKUP DRIVES FOR COMPUTERS (U.S. CLS. 21, 23, 26, 36 AND 38).

FIRST USE 8-6-2007; IN COMMERCE 2-4-2008.

3,481,364. SONY KABUSHIKI KAISHA (ALSO TRADING AS SONY CORPORATION), TOKYO, JAPAN. SN 77-099,921. PUB. 8-28-2007, FILED 2-6-2007.



THE MARK CONSISTS OF THE WORD "MOTIONFLOW" IN STYLIZED TYPE WITH A PATTERN OF ELONGATING RECTANGLES APPEARING UNDERNEATH.

FOR TELEVISION SETS; LCD TELEVISION SETS; PROJECTION TELEVISION SETS (U.S. CLS. 21, 23, 26, 36 AND 38).

FIRST USE 6-30-2007; IN COMMERCE 6-30-2007.

3,481,372. SIERRA ENTERTAINMENT, INC., LOS ANGELES, CA. SN 77-103,543. PUB. 10-2-2007, FILED 2-9-2007.

M.A.C.H.

THE MARK CONSISTS OF STANDARD CHARACTERS WITHOUT CLAIM TO ANY PARTICULAR FONT, STYLE, SIZE, OR COLOR.

FOR COMPUTER GAME SOFTWARE; ENTERTAINMENT SOFTWARE IN THE NATURE OF A GAME CAPABLE OF BEING PLAYED ON A PORTABLE GAMING SYSTEM; VIDEO GAME CARTRIDGES (U.S. CLS. 21, 23, 26, 36 AND 38).

FIRST USE 1-5-2007; IN COMMERCE 2-20-2007.

CLASS 9—(Continued).

3,481,386. SPAMEDICA INTERNATIONAL SRL, WARRENS, ST. MICHAEL, BARBADOS. SN 77-109,767. PUB. 7-31-2007, FILED 2-16-2007.

SPAMEDWARE

THE MARK CONSISTS OF STANDARD CHARACTERS WITHOUT CLAIM TO ANY PARTICULAR FONT, STYLE, SIZE, OR COLOR.

FOR COMPUTER SOFTWARE FOR USE IN MANAGING AND OPERATING MEDICAL SPAS, AND PLASTIC SURGERY, DERMATOLOGY, COSMETIC AND AESTHETIC PRACTICES (U.S. CLS. 21, 23, 26, 36 AND 38).

FIRST USE 12-31-2004; IN COMMERCE 3-1-2007.

3,481,388. HARRIS CORPORATION, MELBOURNE, FL. SN 77-110,640. PUB. 8-28-2007, FILED 2-19-2007.

GEN-STAR

THE MARK CONSISTS OF STANDARD CHARACTERS WITHOUT CLAIM TO ANY PARTICULAR FONT, STYLE, SIZE, OR COLOR.

FOR ELECTRONIC TEST AND MEASUREMENT DEVICES FOR USE IN THE FIELDS OF RADIO AND TELEVISION BROADCASTING, NAMELY, VIDEO SIGNAL GENERATORS (U.S. CLS. 21, 23, 26, 36 AND 38).

FIRST USE 4-30-2008; IN COMMERCE 4-30-2008.

3,481,391. ARISTOCRAT TECHNOLOGIES AUSTRALIA PTY LTD, LANE COVE, NSW, AUSTRALIA. SN 77-111,831. PUB. 8-14-2007, FILED 2-20-2007.

ALL THE KING'S GOLD

THE MARK CONSISTS OF STANDARD CHARACTERS WITHOUT CLAIM TO ANY PARTICULAR FONT, STYLE, SIZE, OR COLOR.

FOR GAMING MACHINES; COMPUTER HARDWARE; DOWNLOADABLE GAME SOFTWARE; ELECTRONIC GAME SOFTWARE (U.S. CLS. 21, 23, 26, 36 AND 38).

FIRST USE 12-20-2007; IN COMMERCE 12-20-2007.

CLASS 9—(Continued).

3,481,394. CHIPNUTS TECHNOLOGY (SHANGHAI) INC., PUDONG, SHANGHAI, CHINA. SN 77-112,557. PUB. 8-21-2007, FILED 2-21-2007.

SOLUTION-ON-CHIP

THE MARK CONSISTS OF STANDARD CHARACTERS WITHOUT CLAIM TO ANY PARTICULAR FONT, STYLE, SIZE, OR COLOR.

FOR ELECTRIC POCKET TRANSLATORS; BLANK INTEGRATED CIRCUIT CARDS; DOWNLOADABLE SOFTWARE FOR USE IN DATABASE MANAGEMENT; DOWNLOADABLE SOFTWARE FOR USE AS A SPREADSHEET; DOWNLOADABLE SOFTWARE FOR WORD PROCESSING; ELECTRIC NAVIGATIONAL INSTRUMENTS; VIDEO-TELEPHONES; COMPUTER MONITORS; VIDEO MONITORS; AMUSEMENT APPARATUS ADAPTED FOR USE WITH TELEVISION RECEIVERS ONLY, NAMELY, VIDEO OUTPUT GAME MACHINES FOR USE WITH TELEVISIONS; CAMCORDERS; PERSONAL STEREOS; EARPHONES; CD PLAYERS; DVD PLAYERS; DIGITAL AUDIO PLAYERS; MEDIA PLAYERS; MP3 PLAYERS; MP4 PLAYERS (U.S. CLS. 21, 23, 26, 36 AND 38).

FIRST USE 10-8-2006; IN COMMERCE 2-15-2007.

3,481,396. TRINTECH TECHNOLOGIES LIMITED, LEOPARDSTOWN DUBLIN, IRELAND. SN 77-113,609. PUB. 10-2-2007, FILED 2-22-2007.

XLNET

THE MARK CONSISTS OF STANDARD CHARACTERS WITHOUT CLAIM TO ANY PARTICULAR FONT, STYLE, SIZE, OR COLOR.

FOR SOFTWARE FOR FINANCIAL SPREADSHEET INVENTORY, MIGRATION, ANALYSIS, REPORTING, AND AUDITING IN THE FIELD OF FINANCIAL SERVICES (U.S. CLS. 21, 23, 26, 36 AND 38).

FIRST USE 5-10-2007; IN COMMERCE 5-10-2007.

3,481,400. RADIIENT TECHNOLOGIES, INC., SANTA CLARA, CA. SN 77-114,506. PUB. 8-28-2007, FILED 2-23-2007.

RADIIENT TECHNOLOGIES

THE MARK CONSISTS OF STANDARD CHARACTERS WITHOUT CLAIM TO ANY PARTICULAR FONT, STYLE,

CLASS 9—(Continued).

SIZE, OR COLOR.

NO CLAIM IS MADE TO THE EXCLUSIVE RIGHT TO USE "TECHNOLOGIES", APART FROM THE MARK AS SHOWN.

FOR WIRED ELECTRONIC EQUIPMENT FOR HOME ENTERTAINMENT, NAMELY, AUDIO TRANSMISSION APPARATUS, VIDEO TRANSMISSION APPARATUS, AND INTERNAL OPERATIONAL SOFTWARE FOR THE ABOVE MENTIONED ITEMS; WIRED ELECTRONIC EQUIPMENT FOR HOME ENTERTAINMENT, NAMELY, AUDIO SPEAKERS AND AUDIO SPEAKER ENCLOSURES; ELECTRONIC ACCESSORIES FOR ELECTRONIC EQUIPMENT FOR HOME ENTERTAINMENT, NAMELY, AUDIO AND VIDEO SIGNAL CABLES, AND AUDIO AND VIDEO SIGNAL WIRES; WIRED ELECTRONIC EQUIPMENT FOR HOME ENTERTAINMENT, NAMELY, AUDIO RECEIVERS, AUDIO-VIDEO RECEIVERS, AUDIO AMPLIFIERS, AND INTERNAL OPERATIONAL SOFTWARE FOR THE ABOVE MENTIONED ITEMS; WIRELESS ELECTRONIC EQUIPMENT FOR HOME ENTERTAINMENT, NAMELY, AUDIO RECEIVERS, AUDIO-VIDEO RECEIVERS, AUDIO TRANSMISSION APPARATUS, VIDEO TRANSMISSION APPARATUS, AUDIO AMPLIFIERS, AND INTERNAL OPERATIONAL SOFTWARE AND SEMICONDUCTOR CHIPS FOR THE ABOVE MENTIONED ITEMS; SOFTWARE APPLICATION SPECIFIC SEMICONDUCTOR DEVICES (U.S. CLS. 21, 23, 26, 36 AND 38).

FIRST USE 6-7-2006; IN COMMERCE 6-7-2006.

3,481,434. LEGACY OF TRUTH MINISTRIES, INC., DULUTH, GA. SN 77-125,315. PUB. 10-9-2007, FILED 3-8-2007.

LEGACY OF TRUTH

THE MARK CONSISTS OF STANDARD CHARACTERS WITHOUT CLAIM TO ANY PARTICULAR FONT, STYLE, SIZE, OR COLOR.

OWNER OF U.S. REG. NO. 2,311,587.

FOR PRE-RECORDED CDS AND DVDS FEATURING RELIGION AND RELIGIOUS INSTRUCTION (U.S. CLS. 21, 23, 26, 36 AND 38).

FIRST USE 5-0-2008; IN COMMERCE 5-0-2008.

3,481,438. ARGARD CO., LTD., WANGTHONGLANG, BANGKOK, THAILAND. SN 77-126,445. PUB. 9-11-2007, FILED 3-9-2007.



FOR WIRELESS HEADSET FOR TELEPHONES (U.S. CLS. 21, 23, 26, 36 AND 38).

FIRST USE 2-7-2007; IN COMMERCE 2-15-2008.

CLASS 9—(Continued).

3,481,439. MASTER LOCK COMPANY LLC, OAK CREEK, WI. SN 77-126,465. PUB. 10-16-2007, FILED 3-9-2007.



NO CLAIM IS MADE TO THE EXCLUSIVE RIGHT TO USE "STARTER", APART FROM THE MARK AS SHOWN.

THE MARK CONSISTS OF THE WORD "STARTER" IN A RECTANGLE SHAPE AND THE WORD "SENTRY" APPEARING AFTER THAT.

FOR ANTI-THEFT DEVICES FOR VEHICLES IN THE NATURE OF ELECTRONIC VEHICLE IMMOBILIZERS (U.S. CLS. 21, 23, 26, 36 AND 38).

FIRST USE 10-1-2006; IN COMMERCE 10-1-2006.

3,481,440. ARGARD CO., LTD., WANGTHONGLANG, BANGKOK, THAILAND. SN 77-126,468. PUB. 9-11-2007, FILED 3-9-2007.

ARGARD

THE MARK CONSISTS OF STANDARD CHARACTERS WITHOUT CLAIM TO ANY PARTICULAR FONT, STYLE, SIZE, OR COLOR.

FOR WIRELESS HEADSET FOR TELEPHONES (U.S. CLS. 21, 23, 26, 36 AND 38).

FIRST USE 2-7-2007; IN COMMERCE 2-15-2008.

3,481,441. MASTER LOCK COMPANY LLC, OAK CREEK, WI. SN 77-126,473. PUB. 10-16-2007, FILED 3-9-2007.

MASTER LOCK STARTER SENTRY

THE MARK CONSISTS OF STANDARD CHARACTERS WITHOUT CLAIM TO ANY PARTICULAR FONT, STYLE, SIZE, OR COLOR.

NO CLAIM IS MADE TO THE EXCLUSIVE RIGHT TO USE "STARTER", APART FROM THE MARK AS SHOWN.

FOR ANTI-THEFT DEVICES FOR VEHICLES IN THE NATURE OF ELECTRONIC VEHICLE IMMOBILIZERS (U.S. CLS. 21, 23, 26, 36 AND 38).

FIRST USE 10-1-2006; IN COMMERCE 10-1-2006.

CLASS 9—(Continued).

3,481,456. LEGACY OF TRUTH MINISTRIES, INC., DULUTH, GA. SN 77-129,231. PUB. 10-9-2007, FILED 3-13-2007.



OWNER OF U.S. REG. NO. 2,311,587.

THE MARK CONSISTS OF THE WORD "LEGACY" FOLLOWED BY THE WORD "OF" FOLLOWED BY A SWORD SHAPED IN THE IMAGE OF A CROSS, FOLLOWED BY THE WORD "TRUTH".

FOR PRE-RECORDED CDS AND DVDS FEATURING RELIGION AND RELIGIOUS INSTRUCTION (U.S. CLS. 21, 23, 26, 36 AND 38).

FIRST USE 5-0-2008; IN COMMERCE 5-0-2008.

3,481,489. SABEUS, INC., CALABASAS, CA. SN 77-134,268. PUB. 9-18-2007, FILED 3-19-2007.

MVCS

THE MARK CONSISTS OF STANDARD CHARACTERS WITHOUT CLAIM TO ANY PARTICULAR FONT, STYLE, SIZE, OR COLOR.

FOR OPTICAL COMPONENTS AND SUB-SYSTEMS FOR FIBER OPTIC NETWORKS AND SYSTEMS, NAMELY, NON-MICROPHONIC, LOW-PHASE NOISE SOURCE LASERS, AND TUNABLE DFB (DISTRIBUTED FEEDBACK) LASERS FOR VARIOUS APPLICATIONS, NAMELY, STRUCTURAL IMAGING, STRUCTURAL, MONITORING, METROPOLITAN AND LONG HAUL DWDM (DENSE WAVELENGTH DIVISION MULTIPLEXING) NETWORKS, TEST AND MEASUREMENT SYSTEMS, DWDM/EDFA (DENSE WAVELENGTH DIVISION MULTIPLEXING/ERBIUM-DOPED FIBER AMPLIFIER), INTERFEROMETRIC INTERROGATION SYSTEMS, AND SYSTEMS THAT MONITOR ACOUSTIC PRESSURE WAVES (U.S. CLS. 21, 23, 26, 36 AND 38).

FIRST USE 4-30-2007; IN COMMERCE 4-30-2007.

CLASS 9—(Continued).

3,481,494. W2BI, INC., UNION, NJ. SN 77-135,429. PUB. 9-25-2007, FILED 3-20-2007.

Q-SECURE

THE MARK CONSISTS OF STANDARD CHARACTERS WITHOUT CLAIM TO ANY PARTICULAR FONT, STYLE, SIZE, OR COLOR.

FOR COMPUTER SOFTWARE FOR DEVICE MANAGEMENT OF MOBILE TELEPHONES AND SMART DEVICES, NAMELY, POCKET PERSONAL COMPUTERS, PERSONAL DIGITAL ASSISTANTS, HANDHELD ELECTRONIC WIRELESS COMMUNICATION DEVICES, TABLET PERSONAL COMPUTERS, MP3 PLAYERS, MULTI-FUNCTION ELECTRONIC WIRELESS DIGITAL DEVICES FOR MANAGING, PLAYING AND RECORDING AUDIO, TEXT, AND DATA FILES, AND PERSONAL MESSAGING DEVICES; FOR THE REGISTERING OF USERS; CONFIGURING COMPANY AND USER PROFILES; ISSUING LICENSES TO COMPANIES AND USERS; ORGANIZING DEVICES INTO GROUPS AND DEPLOYING COMMON SOFTWARE APPLICATIONS, CONFIGURATIONS AND SETTINGS; SOFTWARE FOR DEVICE ASSET MANAGEMENT, VIEWING DEVICE ASSETS, AND VIEWING DEVICE FILES; SOFTWARE FOR REMOTE LAUNCHING OF COMMANDS ON THE SPECIFIED DEVICES; SOFTWARE FOR GENERATION OF OPERATIONAL REPORTS FOR SPECIFIED DEVICES; SOFTWARE FOR TRACKING DEVICES, LOCKING SELECTED DEVICES, AND DISABLING OR RESETTING SELECTED DEVICES (U.S. CLS. 21, 23, 26, 36 AND 38).

FIRST USE 3-26-2007; IN COMMERCE 3-26-2007.

3,481,508. THE FANFARE GROUP, INC., MOUNTAIN VIEW, CA. SN 77-137,654. PUB. 9-25-2007, FILED 3-22-2007.

ITEST

THE MARK CONSISTS OF STANDARD CHARACTERS WITHOUT CLAIM TO ANY PARTICULAR FONT, STYLE, SIZE, OR COLOR.

FOR COMPUTER SOFTWARE FOR SYSTEMS VERIFICATION TESTING; COMPUTER SOFTWARE FOR TESTING AND ANALYZING THE PERFORMANCE AND INTEGRITY OF DEVICES AND PRODUCT FEATURES IN THE FIELD OF PRODUCT AND/OR SYSTEMS DESIGN, THE FIELD OF PRODUCT QUALITY ASSURANCE, AND THE FIELD OF PRODUCT AND/OR SYSTEMS TESTING; COMPUTER SOFTWARE FOR PRODUCT, DEVICE, AND/OR SYSTEM DESIGN MODELING AND TESTING; COMPUTER SOFTWARE FOR USE IN DEVICE, PRODUCT AND/OR SYSTEM TEST PLANNING, TEST CASE DESIGN, TEST EXECUTION, TEST AUTOMATION, DEFECT ANALYSIS AND DOCUMENTATION, AND TEST RESULT TRACKING AND REPORTING (U.S. CLS. 21, 23, 26, 36 AND 38).

FIRST USE 7-11-2007; IN COMMERCE 7-11-2007.

CLASS 9—(Continued).

3,481,521. SPERIAN RESPIRATORY PROTECTION USA, LLC, SANTA ANA, CA. SN 77-140,719. PUB. 9-25-2007, FILED 3-26-2007.

WARRIOR

THE MARK CONSISTS OF STANDARD CHARACTERS WITHOUT CLAIM TO ANY PARTICULAR FONT, STYLE, SIZE, OR COLOR.

FOR SELF-CONTAINED BREATHING APPARATUS FOR USE BY INDUSTRIAL WORKERS, FIREFIGHTERS, SAFETY WORKERS, HAZARDOUS MATERIALS WORKERS, RESCUE WORKERS, AND CONSTRUCTION WORKERS (U.S. CLS. 21, 23, 26, 36 AND 38).

FIRST USE 5-0-2007; IN COMMERCE 5-0-2007.

3,481,562. ECI SOFTWARE, INC., CAMARILLO, CA. SN 77-146,791. PUB. 3-4-2008, FILED 4-2-2007.

LET SEAGREEN DO THE HARD STUFF

THE MARK CONSISTS OF STANDARD CHARACTERS WITHOUT CLAIM TO ANY PARTICULAR FONT, STYLE, SIZE, OR COLOR.

FOR COMPUTER SOFTWARE FOR ACCESSING DATABASES, NAMELY, COMPUTER SOFTWARE USED TO BUILD GRAPHICAL USER INTERFACES FOR ACCESSING A DATABASE VIA A GLOBAL COMPUTER NETWORK (U.S. CLS. 21, 23, 26, 36 AND 38).

FIRST USE 12-1-2007; IN COMMERCE 12-1-2007.

CLASS 9—(Continued).

3,481,571. ANDALE SOFTWARE, LLC, EAGAN, MN. SN 77-148,091. PUB. 8-28-2007, FILED 4-4-2007.



THE COLOR(S) GREEN, RED, BLUE, AND BLACK IS/ ARE CLAIMED AS A FEATURE OF THE MARK.

THE MARK CONSISTS OF ONE LARGE GREEN SLASH GOING TO THE RIGHT WITH A MEDIUM RED SLASH TO THE UPPER RIGHT OF A SMALLER BLUE SLASH ABOVE THE WORD "AVIONTE" IN BLACK.

FOR COMPUTER SOFTWARE FOR HUMAN RESOURCES, STAFFING AND PAYROLL COMPANIES THAT ASSIST IN TRACKING INTERNAL RESOURCES SUCH AS EMPLOYEES, EXTERNAL RESOURCES SUCH AS CUSTOMERS, AND ORDERS, ASSIGNMENTS, PAYROLL, BILLING AND ACCOUNTS RECEIVABLE (U.S. CLS. 21, 23, 26, 36 AND 38).

FIRST USE 5-0-2007; IN COMMERCE 5-0-2007.

CLASS 9—(Continued).

3,481,601. POWER TOOLS INC., WOBURN, MA. SN 77-151,976. PUB. 10-9-2007, FILED 4-9-2007.

AXCELER

THE MARK CONSISTS OF STANDARD CHARACTERS WITHOUT CLAIM TO ANY PARTICULAR FONT, STYLE, SIZE, OR COLOR.

FOR COMPUTER SOFTWARE FOR DESIGNING, DEVELOPING, CUSTOMIZING, MAINTAINING AND MANAGING APPLICATION SOFTWARE; AND USER MANUALS SOLD AS A UNIT (U.S. CLS. 21, 23, 26, 36 AND 38).

FIRST USE 6-25-2008; IN COMMERCE 6-25-2008.

3,481,600. ARCADIA GROUP, ATLANTA, GA. SN 77-151,957. PUB. 10-9-2007, FILED 4-9-2007.

INSIGHT

THE MARK CONSISTS OF STANDARD CHARACTERS WITHOUT CLAIM TO ANY PARTICULAR FONT, STYLE, SIZE, OR COLOR.

FOR BATHROOM SCALES (U.S. CLS. 21, 23, 26, 36 AND 38).

FIRST USE 6-20-2008; IN COMMERCE 6-20-2008.

3,481,602. GAMING, KARAWAY, TUCSON, AZ. SN 77-152,300. PUB. 10-9-2007, FILED 4-9-2007.

PERFECT HIT

THE MARK CONSISTS OF STANDARD CHARACTERS WITHOUT CLAIM TO ANY PARTICULAR FONT, STYLE, SIZE, OR COLOR.

FOR ELECTRONIC GAME SOFTWARE (U.S. CLS. 21, 23, 26, 36 AND 38).

FIRST USE 9-1-2007; IN COMMERCE 9-1-2007.

CLASS 9—(Continued).

3,481,623. VAUNIX TECHNOLOGY CORPORATION, HAVERHILL, MA. SN 77-158,468. PUB. 2-19-2008, FILED 4-17-2007.

LAB BRICK

THE MARK CONSISTS OF STANDARD CHARACTERS WITHOUT CLAIM TO ANY PARTICULAR FONT, STYLE, SIZE, OR COLOR.

NO CLAIM IS MADE TO THE EXCLUSIVE RIGHT TO USE "LAB", APART FROM THE MARK AS SHOWN.

FOR ELECTRONIC TEST EQUIPMENT, NAMELY, VOLTMETERS, AMMETERS, OHMMETERS, SIGNAL ANALYZERS, VOLTAGE MONITORS, CURRENT MONITORS, SIGNAL MONITORS, AND RECORDERS FOR CALIBRATION OF SCIENTIFIC, MEDICAL, TELECOMMUNICATIONS OR ELECTRONIC EQUIPMENT; APPARATUS AND INSTRUMENTS, NAMELY, SPECTRUM ANALYZERS, WAVEFORM ANALYZERS, DATA ANALYZERS, LOGIC ANALYZERS, TRANSMISSION ANALYZERS, NETWORK ANALYZERS, OSCILLOSCOPES, POWER METERS, POWER MONITORS, FREQUENCY COUNTERS AND MULTIMETERS FOR MEASURING AND TESTING SIGNAL GENERATION, SIGNAL PROCESSING, SIGNAL AMPLIFICATION, SIGNAL CONVERSION, OR SIGNAL CONTROL; APPARATUS AND INSTRUMENTS, NAMELY, SIGNAL GENERATORS, FUNCTION GENERATORS, SYNTHESIZERS, AMPLIFIERS, ATTENUATORS, FILTERS, CONDITIONERS, CONVERTERS, MIXERS, MODULATORS, DEMODULATORS, PRESCALERS, DIVIDERS, COMBINERS, ISOLATORS, CIRCULATORS, SWITCHES AND ROUTERS FOR PERFORMING SIGNAL GENERATION, SIGNAL PROCESSING, SIGNAL AMPLIFICATION, SIGNAL CONVERSION, OR SIGNAL CONTROL; COMPUTER HARDWARE FOR MEASURING AND TESTING SIGNAL GENERATION, SIGNAL PROCESSING, SIGNAL AMPLIFICATION, SIGNAL CONVERSION, OR SIGNAL CONTROL; COMPUTER SOFTWARE FOR MEASURING AND TESTING SIGNAL GENERATION, SIGNAL PROCESSING, SIGNAL AMPLIFICATION, SIGNAL CONVERSION, OR SIGNAL CONTROL (U.S. CLS. 21, 23, 26, 36 AND 38).

FIRST USE 9-26-2007; IN COMMERCE 12-5-2007.

3,481,626. CONAIR CORPORATION, STAMFORD, CT. SN 77-158,662. PUB. 9-18-2007, FILED 4-17-2007.

CERAMIC SILK

THE MARK CONSISTS OF STANDARD CHARACTERS WITHOUT CLAIM TO ANY PARTICULAR FONT, STYLE, SIZE, OR COLOR.

OWNER OF U.S. REG. NO. 3,056,567.

NO CLAIM IS MADE TO THE EXCLUSIVE RIGHT TO USE "CERAMIC", APART FROM THE MARK AS SHOWN.

FOR ELECTRIC FLAT IRONS; ELECTRIC HAIR CURLING IRONS; ELECTRIC HAIR STRAIGHTENING IRONS; ELECTRIC HAND-HELD HAIR STYLING IRONS; ELECTRIC IRONS FOR STYLING HAIR (U.S. CLS. 21, 23, 26, 36 AND 38).

FIRST USE 3-0-2007; IN COMMERCE 3-0-2007.

CLASS 9—(Continued).

3,481,629. CHECKPOINT SYSTEMS, INC., THOROFARE, NJ. SN 77-159,438. PUB. 9-4-2007, FILED 4-18-2007.

EVOLVE

THE MARK CONSISTS OF STANDARD CHARACTERS WITHOUT CLAIM TO ANY PARTICULAR FONT, STYLE, SIZE, OR COLOR.

FOR ELECTRONIC ANTENNAS FOR CONTROL AND TRACKING OF ASSETS; ANTENNAS FOR RADIO FREQUENCY TRACKING OF ASSETS (U.S. CLS. 21, 23, 26, 36 AND 38).

FIRST USE 6-11-2007; IN COMMERCE 6-11-2007.

3,481,630. VOID STAR CREATIONS LLC, SOUTH CAROLINA, SC. SN 77-159,737. PUB. 3-11-2008, FILED 4-18-2007.

Poker Smash

THE MARK CONSISTS OF STANDARD CHARACTERS WITHOUT CLAIM TO ANY PARTICULAR FONT, STYLE, SIZE, OR COLOR.

NO CLAIM IS MADE TO THE EXCLUSIVE RIGHT TO USE "POKER", APART FROM THE MARK AS SHOWN.

FOR COMPUTER GAME PROGRAMS; COMPUTER GAME SOFTWARE; INTERACTIVE MULTIMEDIA COMPUTER GAME PROGRAM (U.S. CLS. 21, 23, 26, 36 AND 38).

FIRST USE 5-1-2007; IN COMMERCE 2-6-2008.

3,481,631. RADCAL CORPORATION, MONROVIA, CA. SN 77-159,753. PUB. 10-2-2007, FILED 4-18-2007.

RAPIDOSE

THE MARK CONSISTS OF STANDARD CHARACTERS WITHOUT CLAIM TO ANY PARTICULAR FONT, STYLE, SIZE, OR COLOR.

FOR RADIATION IONIZING MEASURING INSTRUMENTS (U.S. CLS. 21, 23, 26, 36 AND 38).

FIRST USE 11-26-2007; IN COMMERCE 11-20-2007.

CLASS 9—(Continued).

3,481,637. OCWEN FINANCIAL CORPORATION, WEST PALM BEACH, FL. SN 77-160,695. PUB. 8-21-2007, FILED 4-19-2007.

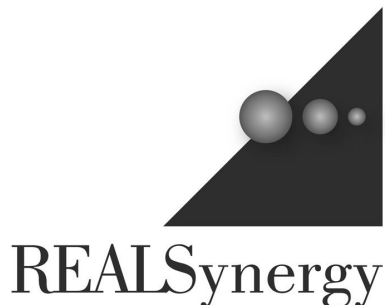

OWNER OF U.S. REG. NO. 2,729,544.
FOR COMPUTER SOFTWARE USED FOR THE MANAGEMENT AND ADMINISTRATION OF MORTGAGE LOANS AND INCOME-PRODUCING PROPERTY IN THE FIELD OF COMMERCIAL REAL-ESTATE, FINANCE, AND INVESTMENT (U.S. CLS. 21, 23, 26, 36 AND 38).
FIRST USE 4-26-2007; IN COMMERCE 6-1-2007.

3,481,639. NEWPORT CORPORATION, IRVINE, CA. SN 77-161,202. PUB. 10-16-2007, FILED 4-19-2007.

SOLSTICE

THE MARK CONSISTS OF STANDARD CHARACTERS WITHOUT CLAIM TO ANY PARTICULAR FONT, STYLE, SIZE, OR COLOR.
FOR LASERS FOR NON-MEDICAL USE; LASER AMPLIFIERS (U.S. CLS. 21, 23, 26, 36 AND 38).
FIRST USE 3-21-2008; IN COMMERCE 3-21-2008.

3,481,643. CROSSROADS SYSTEMS, INC., AUSTIN, TX. SN 77-161,652. PUB. 11-27-2007, FILED 4-20-2007.

RVA

THE MARK CONSISTS OF STANDARD CHARACTERS WITHOUT CLAIM TO ANY PARTICULAR FONT, STYLE, SIZE, OR COLOR.
FOR COMPUTER SOFTWARE FOR MONITORING, VALIDATING, AND REPORTING ON THE PERFORMANCE AND UTILIZATION OF BACK UP TAPES AND STORED DATA (U.S. CLS. 21, 23, 26, 36 AND 38).
FIRST USE 10-10-2007; IN COMMERCE 10-10-2007.

CLASS 9—(Continued).

3,481,660. NOIR LASER COMPANY, L.L.C., SOUTH LYON, MI. SN 77-167,209. PUB. 10-9-2007, FILED 4-27-2007.



FOR PROTECTIVE EYEWEAR (U.S. CLS. 21, 23, 26, 36 AND 38).
FIRST USE 12-18-2002; IN COMMERCE 1-1-2003.

3,481,667. CAPCOM CO. LTD., CHOU-KU, OSAKA, JAPAN. SN 77-169,259. PUB. 9-18-2007, FILED 4-30-2007.

LOST PLANET COLONIES

THE MARK CONSISTS OF STANDARD CHARACTERS WITHOUT CLAIM TO ANY PARTICULAR FONT, STYLE, SIZE, OR COLOR.
FOR COMPUTER GAME SOFTWARE; COMPUTER GAME IN THE FORM OF CARTRIDGES, CASSETTES, DISCS OR TAPES; VIDEO GAME CARTRIDGES; VIDEO GAME MACHINES FOR USE WITH TELEVISION RECEIVERS; DOWNLOADABLE GAME SOFTWARE; DOWNLOADABLE COMPUTER GAMES; DOWNLOADABLE GAME SOFTWARE FOR PLAYING ON MOBILE PHONES; SCREEN SAVER SOFTWARE AND WALLPAPER SOFTWARE; DOWNLOADABLE SCREEN SAVER SOFTWARE AND WALLPAPER SOFTWARE FOR MOBILE PHONES; DOWNLOADABLE IMAGES, MOVING IMAGES AND MUSIC FOR MOBILE PHONES (U.S. CLS. 21, 23, 26, 36 AND 38).
FIRST USE 5-27-2008; IN COMMERCE 5-27-2008.

CLASS 9—(Continued).

3,481,685. EYE-HUGS, LLC, COLUMBUS, OH. SN 77-174,273. PUB. 11-27-2007, FILED 5-7-2007.

EYE-HUGS

THE MARK CONSISTS OF STANDARD CHARACTERS WITHOUT CLAIM TO ANY PARTICULAR FONT, STYLE, SIZE, OR COLOR.

FOR DECORATIVE EYEWEAR ACCESSORIES, NAMELY, ATTACHMENTS FOR THE EAR STEMS OF EYEGLASSES (U.S. CLS. 21, 23, 26, 36 AND 38). FIRST USE 8-7-2007; IN COMMERCE 8-11-2007.

3,481,693. AIRCELL LLC, LOUISVILLE, CO. SN 77-175,191. PUB. 9-25-2007, FILED 5-8-2007.

AIRCELL AXXESS

THE MARK CONSISTS OF STANDARD CHARACTERS WITHOUT CLAIM TO ANY PARTICULAR FONT, STYLE, SIZE, OR COLOR.

FOR COMPUTER AND TELECOMMUNICATIONS NETWORK HARDWARE AND SOFTWARE FOR IMPLEMENTING LOCAL AREA NETWORKS ONBOARD AIRCRAFTS TO ENABLE USERS TO TRANSMIT AND RECEIVE VOICE, VIDEO, AND DATA WITHIN THE AIRCRAFTS, BETWEEN THE AIRCRAFTS, BETWEEN THE AIRCRAFTS AND THE GROUND, AND BETWEEN THE GROUND AND THE AIRCRAFTS; LOCAL AREA NETWORK ACCESS POINTS FOR COMMUNICATING WITH COMPUTER AND TELECOMMUNICATIONS USERS LOCATED ONBOARD AIRCRAFTS FOR TRANSMITTING AND RECEIVING VOICE, VIDEO, AND DATA WITHIN THE AIRCRAFTS, BETWEEN THE AIRCRAFTS, BETWEEN THE AIRCRAFTS AND THE GROUND, AND BETWEEN THE GROUND AND THE AIRCRAFTS; COMPUTER AND TELECOMMUNICATIONS NETWORK HARDWARE AND SOFTWARE FOR TRANSMITTING AND RECEIVING VOICE, VIDEO, AND DATA BETWEEN COMPUTER AND TELECOMMUNICATIONS USERS, LOCATED ONBOARD AN AIRCRAFT, AND COMPUTER, AND TELECOMMUNICATIONS SYSTEMS LOCATED ONBOARD THE AIRCRAFT, COMPUTER AND TELECOMMUNICATION SYSTEMS LOCATED ONBOARD ANOTHER AIRCRAFT, AND COMPUTER AND TELECOMMUNICATIONS SYSTEMS LOCATED ON THE GROUND; COMPUTER AND TELECOMMUNICATIONS NETWORK ACCESS SERVER HARDWARE AND SOFTWARE ONBOARD AIRCRAFTS FOR TRANSMITTING AND RECEIVING VOICE, VIDEO, AND DATA FROM THE GROUND TO IDENTIFIED USERS LOCATED ONBOARD THE AIRCRAFTS, FROM IDENTIFIED USERS LOCATED ONBOARD THE AIRCRAFTS TO THE GROUND, AND FROM IDENTIFIED USERS LOCATED ONBOARD ONE AIRCRAFT TO IDENTIFIED USERS ONBOARD ANOTHER AIRCRAFT, AND BETWEEN IDENTIFIED USERS WITHIN AN AIRCRAFT (U.S. CLS. 21, 23, 26, 36 AND 38). FIRST USE 4-27-2005; IN COMMERCE 4-27-2005.

CLASS 9—(Continued).

3,481,702. GARMIN LTD., CAMANA BAY, CAYMAN ISLANDS. SN 77-177,783. PUB. 9-18-2007, FILED 5-10-2007.

SensRcore

THE MARK CONSISTS OF STANDARD CHARACTERS WITHOUT CLAIM TO ANY PARTICULAR FONT, STYLE, SIZE, OR COLOR.

FOR COMPUTER HARDWARE AND SOFTWARE FOR THE DEVELOPMENT OF WIRELESS DATA COMMUNICATION (U.S. CLS. 21, 23, 26, 36 AND 38). FIRST USE 4-0-2007; IN COMMERCE 4-0-2007.

3,481,725. DENATALE JR, JOHN, MORICHES, NY. SN 77-184,417. PUB. 11-20-2007, FILED 5-18-2007.

MovieSpin

THE MARK CONSISTS OF STANDARD CHARACTERS WITHOUT CLAIM TO ANY PARTICULAR FONT, STYLE, SIZE, OR COLOR.

FOR ROTATING DISPLAY HOLDER FOR DVDS, VIDEO GAMES, AND VCR TAPES (U.S. CLS. 21, 23, 26, 36 AND 38). FIRST USE 4-30-2008; IN COMMERCE 4-30-2008.

3,481,726. LITHOTEL SOFTWARE DESIGN LTD., WHITBY, CANADA. SN 77-184,431. PUB. 11-6-2007, FILED 5-18-2007.

DynaLinx

THE MARK CONSISTS OF STANDARD CHARACTERS WITHOUT CLAIM TO ANY PARTICULAR FONT, STYLE, SIZE, OR COLOR.

FOR COMPUTER SOFTWARE FOR FACILITATING THE LOCALIZED AND/OR REMOTE DIGITAL DISPLAY OF PRE-PRESS COLOR CORRECTED IMAGES (U.S. CLS. 21, 23, 26, 36 AND 38). FIRST USE 2-28-2008; IN COMMERCE 4-23-2008.

CLASS 9—(Continued).

3,481,727. NOTION MUSIC, INC., GREENSBORO, NC. SN 77-184,693. PUB. 11-6-2007, FILED 5-18-2007.

PROGRESSION

THE MARK CONSISTS OF STANDARD CHARACTERS WITHOUT CLAIM TO ANY PARTICULAR FONT, STYLE, SIZE, OR COLOR.

FOR MUSICAL SOFTWARE, NAMELY, COMPUTER SOFTWARE FOR MUSICAL COMPOSITION, PERFORMANCE, PRODUCTION, AND EDUCATION (U.S. CLS. 21, 23, 26, 36 AND 38).

FIRST USE 9-17-2007; IN COMMERCE 9-17-2007.

3,481,744. TECHNOLOGY PATHWAYS, LLC, CORONADO, CA. SN 77-191,932. PUB. 11-20-2007, FILED 5-29-2007.

E.S.I.DISCOVER

THE MARK CONSISTS OF STANDARD CHARACTERS WITHOUT CLAIM TO ANY PARTICULAR FONT, STYLE, SIZE, OR COLOR.

FOR COMPUTER SOFTWARE AND HARDWARE FOR IDENTIFYING, LOCATING OR EXTRACTING RELEVANT COMPUTER STORED INFORMATION DURING AN INVESTIGATION OR ELECTRONIC DISCOVERY PROCESS (U.S. CLS. 21, 23, 26, 36 AND 38).

FIRST USE 6-2-2008; IN COMMERCE 6-2-2008.

CLASS 9—(Continued).

3,481,754. INNOVATIVE WIRELESS TECHNOLOGIES, INC., FOREST, VA. SN 77-198,761. PUB. 11-6-2007, FILED 6-6-2007.



OWNER OF U.S. REG. NO. 3,253,060.

THE COLOR(S) BLUE, WHITE AND GRAY IS/ARE CLAIMED AS A FEATURE OF THE MARK.

THE MARK CONSISTS OF A LIGHT GRAY SHADED LETTER "M" AND DARK BLUE SHADED "PROV" SUPERIMPOSED ON A BACKGROUND OF A VARIOUSLY BLUE-SHADED DIAMOND CONTAINING THREE WHITE CRESCENTS AND A WHITE CIRCLE.

FOR COMPUTER SOFTWARE FOR MANAGING, OPERATING, MONITORING AND CONTROLLING NETWORKS OF WIRELESS RADIO TRANSCEIVER NETWORKS AND OTHER ELECTRONIC DEVICES (U.S. CLS. 21, 23, 26, 36 AND 38).

FIRST USE 4-6-2006; IN COMMERCE 8-4-2006.

3,481,764. AMETEK, INC., PAOLI, PA. SN 77-202,753. PUB. 11-27-2007, FILED 6-11-2007.

TURBO-MASS

THE MARK CONSISTS OF STANDARD CHARACTERS WITHOUT CLAIM TO ANY PARTICULAR FONT, STYLE, SIZE, OR COLOR.

FOR FLOWMETERS (U.S. CLS. 21, 23, 26, 36 AND 38).

FIRST USE 1-28-2008; IN COMMERCE 1-28-2008.

CLASS 9—(Continued).

3,481,771. MITSUBISHI MOTORS NORTH AMERICA, INC., CYPRESS, CA. SN 77-206,507. PUB. 12-11-2007, FILED 6-14-2007.

DIAMOND LANE GUIDANCE

THE MARK CONSISTS OF STANDARD CHARACTERS WITHOUT CLAIM TO ANY PARTICULAR FONT, STYLE, SIZE, OR COLOR.

NO CLAIM IS MADE TO THE EXCLUSIVE RIGHT TO USE "LANE GUIDANCE", APART FROM THE MARK AS SHOWN.

FOR NAVIGATION APPARATUS FOR VEHICLES, NAMELY, A NAVIGATION SYSTEM COMPRISING ON-BOARD TRANSMITTERS, RECEIVERS, COMPUTER HARDWARE, MEMORY CARDS AND COMPUTER SOFTWARE FOR OPERATION AND INTEGRATION OF SUCH SYSTEM, AND, CDROMS, DVDS, AND ELECTRONIC DATABASES RECORDED ON COMPUTER MEDIA ALL FEATURING ROADWAY, GEOGRAPHIC, MAP, CARPOOL, AND TRAVEL INFORMATION (U.S. CLS. 21, 23, 26, 36 AND 38).

FIRST USE 8-31-2007; IN COMMERCE 8-31-2007.

3,481,794. ROSANDER, CHRISTINE, LOS ANGELES, CA. SN 77-216,390. PUB. 12-4-2007, FILED 6-27-2007.

DEVCAT

THE MARK CONSISTS OF STANDARD CHARACTERS WITHOUT CLAIM TO ANY PARTICULAR FONT, STYLE, SIZE, OR COLOR.

FOR SOUND RECORDINGS FEATURING MUSIC, NAMELY, PRE-RECORDED PHONOGRAPH RECORDS, AUDIO TAPES, ENHANCED CD'S AND COMPACT DISCS FEATURING MUSIC (U.S. CLS. 21, 23, 26, 36 AND 38).

FIRST USE 3-10-2008; IN COMMERCE 3-10-2008.

CLASS 9—(Continued).

3,481,798. BROGAARD, RIKKE, LAGUNA HILLS, CA. SN 77-220,549. PUB. 12-11-2007, FILED 7-2-2007.



THE COLOR(S) RED IS/ARE CLAIMED AS A FEATURE OF THE MARK.

THE MARK CONSISTS OF STYLIZED, SCRIPT TEXT "ENTOURAGE OF" FOLLOWED IMMEDIATELY BY A STYLIZED, SCRIPT NUMERAL "7." ALL LETTERS IN THE SAME RED SCRIPT TEXT.

FOR EYEGLASSES AND EYEGLASS FRAMES, SUNGLASSES AND SUNGLASS FRAMES, EYEGLASS LENSES AND SUNGLASS LENSES, READING GLASSES AND READING GLASSES FRAMES, READING GLASS LENSES, EYEGLASS, SUNGLASS AND READING GLASS CASES (U.S. CLS. 21, 23, 26, 36 AND 38).

FIRST USE 7-2-2007; IN COMMERCE 7-2-2007.

3,481,799. BROGAARD, RIKKE, LAGUNA HILLS, CA. SN 77-220,559. PUB. 12-11-2007, FILED 7-2-2007.



THE COLOR(S) RED IS/ARE CLAIMED AS A FEATURE OF THE MARK.

THE MARK CONSISTS OF STYLIZED, SCRIPT TEXT CAPITAL "E" FOLLOWED IMMEDIATELY BY A STYLIZED, SCRIPT NUMERAL "7," ENCLOSED IN A RED CIRCLE. ALL LETTERS IN THE SAME RED SCRIPT TEXT.

FOR EYEGLASSES AND EYEGLASS FRAMES, SUNGLASSES AND SUNGLASS FRAMES, EYEGLASS LENSES AND SUNGLASS LENSES, READING GLASSES AND READING GLASSES FRAMES, READING GLASS LENSES, EYEGLASS, SUNGLASS AND READING GLASS CASES (U.S. CLS. 21, 23, 26, 36 AND 38).

FIRST USE 7-2-2007; IN COMMERCE 7-2-2007.

CLASS 9—(Continued).

3,481,803. CEREBRAL CHOICE SOFTWARE SOLUTIONS, INC., SYRACUSE, NY. SN 77-221,299. PUB. 1-8-2008, FILED 7-3-2007.

Cerebral Project

THE MARK CONSISTS OF STANDARD CHARACTERS WITHOUT CLAIM TO ANY PARTICULAR FONT, STYLE, SIZE, OR COLOR.

NO CLAIM IS MADE TO THE EXCLUSIVE RIGHT TO USE "PROJECT", APART FROM THE MARK AS SHOWN.

FOR COMPUTER SOFTWARE FOR PROJECT MANAGEMENT (U.S. CLS. 21, 23, 26, 36 AND 38).
FIRST USE 1-1-2007; IN COMMERCE 1-1-2007.

3,481,810. SITESPECT, INC., BOSTON, MA. SN 77-226,256. PUB. 2-26-2008, FILED 7-10-2007.

SiteSpect QuickChange

THE MARK CONSISTS OF STANDARD CHARACTERS WITHOUT CLAIM TO ANY PARTICULAR FONT, STYLE, SIZE, OR COLOR.

OWNER OF U.S. REG. NO. 2,940,146.

NO CLAIM IS MADE TO THE EXCLUSIVE RIGHT TO USE "QUICKCHANGE", APART FROM THE MARK AS SHOWN.

FOR COMPUTER SOFTWARE FOR TESTING, MEASURING AND VALIDATING WEB CONTENT CHANGES (U.S. CLS. 21, 23, 26, 36 AND 38).

FIRST USE 11-9-2007; IN COMMERCE 11-9-2007.

3,481,818. DAYMEN PHOTO MARKETING LP, MARKHAM, ONTARIO, CANADA. SN 77-229,752. PUB. 12-25-2007, FILED 7-13-2007.

SPECTRUM

THE MARK CONSISTS OF STANDARD CHARACTERS WITHOUT CLAIM TO ANY PARTICULAR FONT, STYLE, SIZE, OR COLOR.

FOR BAGS FOR CAMERAS AND PHOTOGRAPHIC EQUIPMENT (U.S. CLS. 21, 23, 26, 36 AND 38).
FIRST USE 2-12-2008; IN COMMERCE 2-12-2008.

CLASS 9—(Continued).

3,481,821. GENMAR IP LLC, MINNEAPOLIS, MN. SN 77-231,610. PUB. 3-4-2008, FILED 7-17-2007.

BIOS

THE MARK CONSISTS OF STANDARD CHARACTERS WITHOUT CLAIM TO ANY PARTICULAR FONT, STYLE, SIZE, OR COLOR.

FOR ELECTRONIC INSTRUMENT PANELS FOR BOATS (U.S. CLS. 21, 23, 26, 36 AND 38).

FIRST USE 7-1-2007; IN COMMERCE 7-1-2007.

3,481,846. COMPUTER SERVICES, INC., PADUCAH, KY. SN 77-243,400. PUB. 1-15-2008, FILED 7-31-2007.

NUPOINT

THE MARK CONSISTS OF STANDARD CHARACTERS WITHOUT CLAIM TO ANY PARTICULAR FONT, STYLE, SIZE, OR COLOR.

FOR COMPUTER SOFTWARE FOR USE IN THE BANKING INDUSTRY BY BANK EMPLOYEES FOR SELECTIVELY INTERFACING CLIENT DATA RESIDING ON ENTERPRISE SYSTEMS (U.S. CLS. 21, 23, 26, 36 AND 38).

FIRST USE 9-1-2007; IN COMMERCE 9-1-2007.

3,481,863. AXYGEN SCIENTIFIC, INC., UNION CITY, CA. SN 77-248,468. PUB. 1-22-2008, FILED 8-6-2007.

PLATEMAX

THE MARK CONSISTS OF STANDARD CHARACTERS WITHOUT CLAIM TO ANY PARTICULAR FONT, STYLE, SIZE, OR COLOR.

FOR HEAT SEALING MACHINES FOR APPLYING HEAT-SEALING FILMS TO MULTI-WELL MICROPLATES, HEAT SEALING FILMS FOR APPLICATION TO MULTI-WELL MICROPLATES OR ADHESIVE SEALING FILMS FOR APPLYING TO MULTI-WELL MICROPLATES; PLATES, GLASS SLIDES OR CHIPS HAVING MULTI-WELL ARRAYS THAT CAN BE USED IN CHEMICAL ANALYSIS, BIOLOGICAL ANALYSIS OR PATTERNING FOR SCIENTIFIC, LABORATORY OR MEDICAL RESEARCH USE; LABORATORY ROBOTS (U.S. CLS. 21, 23, 26, 36 AND 38).

FIRST USE 9-25-2007; IN COMMERCE 12-11-2007.

CLASS 9—(Continued).

3,481,885. FUTURELOGIC INCORPORATED, GLENDALE, CA. SN 77-255,231. PUB. 1-15-2008, FILED 8-14-2007.

EVOLUTION

THE MARK CONSISTS OF STANDARD CHARACTERS WITHOUT CLAIM TO ANY PARTICULAR FONT, STYLE, SIZE, OR COLOR.

FOR THERMAL TICKET PRINTERS FOR CASHLESS GAMING MACHINES (U.S. CLS. 21, 23, 26, 36 AND 38). FIRST USE 10-11-2007; IN COMMERCE 10-11-2007.

3,481,888. IWIN, INC., SAN FRANCISCO, CA. SN 77-256,318. PUB. 1-1-2008, FILED 8-15-2007.

JEWEL QUEST EXPEDITIONS

THE MARK CONSISTS OF STANDARD CHARACTERS WITHOUT CLAIM TO ANY PARTICULAR FONT, STYLE, SIZE, OR COLOR.

OWNER OF U.S. REG. NO. 3,047,845.

NO CLAIM IS MADE TO THE EXCLUSIVE RIGHT TO USE "JEWEL", APART FROM THE MARK AS SHOWN.

FOR PROGRAMMED COMPUTER GAME MEMORY CARDS, COMPUTER GAME PROGRAMS, COMPUTER GAME SOFTWARE, PROGRAMMED ELECTRONIC GAME MEMORY CARDS, ELECTRONIC GAME PROGRAMS, ELECTRONIC GAME SOFTWARE, PROGRAMMED INTERACTIVE GAME MEMORY CARDS, INTERACTIVE GAME PROGRAMS, INTERACTIVE GAME SOFTWARE, PROGRAMMED VIDEO GAME MEMORY CARDS, VIDEO GAME PROGRAMS, INTERACTIVE VIDEO GAME SOFTWARE, CARTRIDGES FEATURING ENTERTAINMENT CONTENT, NAMELY, GAMES, ELECTRONIC GAME CARTRIDGES, VIDEO GAME CARTRIDGES, AND VIDEO GAME SOFTWARE FOR USE WITH A PUZZLE GAME, THE OBJECT OF WHICH IS TO ALIGN THREE SIMILAR JEWELS VERTICALLY AND HORIZONTALLY (U.S. CLS. 21, 23, 26, 36 AND 38).

FIRST USE 9-15-2007; IN COMMERCE 9-15-2007.

3,481,895. ROSNER, CARY, BELLEROSE, NY. SN 77-260,272. PUB. 3-4-2008, FILED 8-21-2007.

TURN-TURN-TURN

THE MARK CONSISTS OF STANDARD CHARACTERS WITHOUT CLAIM TO ANY PARTICULAR FONT, STYLE, SIZE, OR COLOR.

FOR COMPUTER SOFTWARE FOR FACILITATING THE DISPLAY OF DIGITAL DOCUMENTS (U.S. CLS. 21, 23, 26, 36 AND 38).

FIRST USE 11-5-2007; IN COMMERCE 11-5-2007.

CLASS 9—(Continued).

3,481,914. THINKLOGICAL, MILFORD, CT. SN 77-267,383. PUB. 2-26-2008, FILED 8-29-2007.

AlterImage

THE MARK CONSISTS OF STANDARD CHARACTERS WITHOUT CLAIM TO ANY PARTICULAR FONT, STYLE, SIZE, OR COLOR.

FOR COMPUTER NETWORK HUBS, SWITCHES AND ROUTERS (U.S. CLS. 21, 23, 26, 36 AND 38). FIRST USE 2-2-2008; IN COMMERCE 2-2-2008.

3,481,952. SAFEHOIST TECHNOLOGIES, INC., DBA SAFEHOIST, INC., SPOKANE, WA. SN 77-289,210. PUB. 3-11-2008, FILED 9-26-2007.

SkipRanger

THE MARK CONSISTS OF STANDARD CHARACTERS WITHOUT CLAIM TO ANY PARTICULAR FONT, STYLE, SIZE, OR COLOR.

FOR ACCELEROMETERS (U.S. CLS. 21, 23, 26, 36 AND 38).

FIRST USE 12-17-2007; IN COMMERCE 5-7-2008.

3,481,953. HALL, SHELLIE L., CHICAGO, IL. SN 77-290,075. PUB. 3-18-2008, FILED 9-27-2007.

get creative 

FOR AUDIO AND VIDEO RECORDINGS FEATURING CREATIVE MEDIA PUBLISHING; DOWNLOADABLE MP3 FILES, MP3 RECORDINGS, ONLINE DISCUSSION BOARDS, WEBCASTS AND PODCASTS FEATURING MUSIC, AUDIO BOOKS AND NEWS BROADCASTS; DOWNLOADABLE MULTIMEDIA FILE CONTAINING ARTWORK, TEXT, AUDIO, VIDEO, GAMES, AND INTERNET WEB LINKS RELATING TO CREATIVE MEDIA PUBLISHING; DOWNLOADABLE PODCASTS IN THE FIELD OF CREATIVE MEDIA PUBLISHING; DOWNLOADABLE VIDEO RECORDINGS FEATURING CREATIVE MEDIA PUBLISHING (U.S. CLS. 21, 23, 26, 36 AND 38).

FIRST USE 11-1-2007; IN COMMERCE 11-1-2007.

CLASS 9—(Continued).

3,481,963. VIVENDI GAMES EUROPE S.A., DBA VIVENDI GAMES MOBILE, MEUDON-LA-FORET CEDEX, FRANCE. SN 77-296,612. PUB. 2-19-2008, FILED 10-4-2007.

URBAN ATTACK

THE MARK CONSISTS OF STANDARD CHARACTERS WITHOUT CLAIM TO ANY PARTICULAR FONT, STYLE, SIZE, OR COLOR.

FOR COMPUTER GAME SOFTWARE; DOWNLOADABLE SOFTWARE FOR USE IN CONNECTION WITH COMPUTER GAMES; INTERACTIVE MULTIMEDIA COMPUTER GAME PROGRAM (U.S. CLS. 21, 23, 26, 36 AND 38).

FIRST USE 12-25-2007; IN COMMERCE 12-25-2007.

CLASS 9—(Continued).

3,482,008. AHA! STUDIOS, INC., RACINE, WI. SN 78-287,558. PUB. 12-21-2004, FILED 8-14-2003.

BABY SPROUT

FOR PRE-RECORDED DVD'S FEATURING MUSIC AND STORIES; PRE-RECORDED COMPACT DISCS FEATURING MUSIC AND STORIES (U.S. CLS. 21, 23, 26, 36 AND 38).

FIRST USE 3-15-2008; IN COMMERCE 3-15-2008.

3,481,969. SPORIAN MICROSYSTEMS, INC., LAFAYETTE, CO. SN 77-299,331. PUB. 3-25-2008, FILED 10-9-2007.

ASSETOVERSEER

THE MARK CONSISTS OF STANDARD CHARACTERS WITHOUT CLAIM TO ANY PARTICULAR FONT, STYLE, SIZE, OR COLOR.

FOR ELECTRIC OR ELECTRONIC SENSORS FOR TEMPERATURE, PRESSURE, HUMIDITY, VIBRATION, SHOCK, LOCATION, AND GAS SPECIES (U.S. CLS. 21, 23, 26, 36 AND 38).

FIRST USE 10-2-2007; IN COMMERCE 10-2-2007.

3,482,029. GOODMAN COMPANY, L.P., HOUSTON, TX. SN 78-391,296. PUB. 3-15-2005, FILED 3-26-2004.

DIGISMART

3,482,000. THE BRAINY BABY COMPANY, LLC, ALPHARETTA, GA. SN 78-081,057. PUB. 5-15-2007, FILED 8-24-2001.

BRAINY BOYS

OWNER OF U.S. REG. NO. 2,315,020.
FOR A SERIES OF PRERECORDED VIDEO TAPES, AUDIO CASSETTES, COMPACT DISCS AND DIGITAL VIDEO DISCS INTENDED TO IMPROVE AND DEVELOP THE CREATIVE AND INTELLECTUAL FACULTIES OF INFANTS AND CHILDREN (U.S. CLS. 21, 23, 26, 36 AND 38).

FIRST USE 1-15-2008; IN COMMERCE 1-15-2008.

THE MARK CONSISTS OF STANDARD CHARACTERS WITHOUT CLAIM TO ANY PARTICULAR FONT, STYLE, SIZE, OR COLOR.

FOR CONTROLS FOR AIR CONDITIONING AND HEATING EQUIPMENT (U.S. CLS. 21, 23, 26, 36 AND 38).

FIRST USE 6-1-2008; IN COMMERCE 6-1-2008.

CLASS 9—(Continued).

3,482,037. DRESSER, INC., ADDISON, TX. SN 78-412,012. PUB. 2-15-2005, FILED 5-3-2004.

ISENSE

THE MARK CONSISTS OF STANDARD CHARACTERS WITHOUT CLAIM TO ANY PARTICULAR FONT, STYLE, SIZE, OR COLOR.

FOR HARDWARE AND SOFTWARE THAT CONTROLS AND MONITORS FUEL DISPENSERS, FUEL DISPENSING SYSTEMS, CREDIT, DEBIT AND SMART CARD PROCESSING, ELECTRONIC CASH REGISTERS, VIDEO SECURITY SYSTEMS, CAR WASH MACHINERY AND UNDERGROUND TANKS (U.S. CLS. 21, 23, 26, 36 AND 38).

FIRST USE 7-0-2006; IN COMMERCE 7-0-2006.

3,482,049. ORBIMAGE SI OPCO INC., DBA/AKA/TA: DBA GEOEYE, DULLES, VA. SN 78-441,732. PUB. 10-4-2005, FILED 6-25-2004.

RoadTracker

THE MARK CONSISTS OF STANDARD CHARACTERS WITHOUT CLAIM TO ANY PARTICULAR FONT, STYLE, SIZE, OR COLOR.

FOR COMPUTER SOFTWARE FOR EXTRACTING LINEAR FEATURES FROM IMAGERY FOR USE IN GEOGRAPHIC INFORMATION SYSTEMS TO MAKE DERIVED PRODUCTS FROM THE INFORMATION STORED IN THE GEOGRAPHIC INFORMATION SYSTEM DATABASES (U.S. CLS. 21, 23, 26, 36 AND 38).

FIRST USE 4-23-2008; IN COMMERCE 4-23-2008.

CLASS 9—(Continued).

3,482,052. AMERICAN HOFMANN CORPORATION, LYNCHBURG, VA. SN 78-455,846. PUB. 3-28-2006, FILED 7-23-2004.



NO CLAIM IS MADE TO THE EXCLUSIVE RIGHT TO USE "AMERICAN" AND "CORPORATION", APART FROM THE MARK AS SHOWN.

THE MARK CONSISTS IN PART OF A STYLIZED LETTER "H" WITHIN A SQUARE.

FOR MEASURING AND BALANCING MACHINES AND EQUIPMENT, NAMELY, MANUAL, SEMI-AUTOMATIC OR FULLY AUTOMATIC MACHINES INTENDED TO MEASURE OR CORRECT INDUSTRIAL OR COMMERCIAL ROTATING PARTS, COMPONENTS OR ASSEMBLIES, ALL OF THE ABOVE SOLD WITH INSTRUCTION MANUALS AS A UNIT; EXCLUDING WHEEL BALANCERS, TIRE CHARGERS, WHEEL ALIGNERS, TEST STANDS FOR VEHICLE BRAKES, TEST STANDS FOR AUTOMOBILE ENGINES, TEST STANDS FOR TESTING WASTE GASES FROM AUTOMOBILE ENGINES (U.S. CLS. 21, 23, 26, 36 AND 38).

FIRST USE 6-1-2006; IN COMMERCE 6-1-2006.

3,482,060. HUGHES, WILLIAM R., WESTLAKE, OH. SN 78-484,471. PUB. 9-6-2005, FILED 9-16-2004.



N10M

FOR APPARATUS FOR RECORDING, TRANSMISSION OR REPRODUCTION OF SOUND OR IMAGES, NAMELY, COMPACT DISCS, RECORDS, AND PRE-RECORDED AUDIO AND VIDEO TAPES FEATURING MUSICAL ENTERTAINMENT AND INTERVIEWS (U.S. CLS. 21, 23, 26, 36 AND 38).

FIRST USE 10-30-1983; IN COMMERCE 5-6-2008.

CLASS 9—(Continued).

3,482,078. VISIONMOS INTERNATIONAL, INC., TEMPE, AZ. SN 78-517,302. PUB. 9-20-2005, FILED 11-15-2004.

VISIONMOS

THE MARK CONSISTS OF STANDARD CHARACTERS WITHOUT CLAIM TO ANY PARTICULAR FONT, STYLE, SIZE, OR COLOR.

FOR COMPUTER HARDWARE; PRINTED CIRCUIT BOARDS; ELECTRONIC CIRCUIT BOARDS; COMPUTER CHIPSETS, NAMELY, FOR USE IN MULTIMEDIA DEVICES AND DIGITAL CAMERAS; COMPUTER PERIPHERALS; COMPUTER FIRMWARE, NAMELY, COMPUTER UTILITY SOFTWARE AND OTHER COMPUTER SOFTWARE USED TO MAINTAIN AND OPERATE COMPUTER SYSTEMS ALL STORED IN A COMPUTER'S READ-ONLY MEMORY (ROM) OR ELSEWHERE IN THE COMPUTER'S CIRCUITRY, AND OPERATING SYSTEM SOFTWARE; COMPUTER FIRMWARE FOR OPERATING AND MAINTAINING COMPUTER SYSTEMS, DIGITAL CAMERAS, DIGITAL VIDEO CAMERAS, PERSONAL MEDIA PLAYERS, PERSONAL RECORDING DEVICES, CELLULAR TELEPHONES, PDAS, AND COMPUTER PERIPHERAL DEVICES; ALL THE FOREGOING SOLD WITH OR WITHOUT USER MANUALS FOR USE THEREWITH AND PARTS THEREFORE (U.S. CLS. 21, 23, 26, 36 AND 38).

FIRST USE 3-0-2007; IN COMMERCE 3-0-2007.

3,482,085. CASIO KEISANKI KABUSHIKI KAISHA, DBA CASIO COMPUTER CO., LTD., SHIBUYA-KU, JAPAN. SN 78-529,929. PUB. 10-3-2006, FILED 12-9-2004.

MOVIE BEST SHOT

THE MARK CONSISTS OF STANDARD CHARACTERS WITHOUT CLAIM TO ANY PARTICULAR FONT, STYLE, SIZE, OR COLOR.

OWNER OF U.S. REG. NO. 2,778,270.

NO CLAIM IS MADE TO THE EXCLUSIVE RIGHT TO USE "MOVIE", APART FROM THE MARK AS SHOWN.

FOR DIGITAL CAMERAS (U.S. CLS. 21, 23, 26, 36 AND 38).

FIRST USE 2-0-2005; IN COMMERCE 2-0-2005.

CLASS 9—(Continued).

3,482,095. KOOLSPAN, INC., NORTH BETHESDA, MD. SN 78-550,581. PUB. 10-11-2005, FILED 1-20-2005.

TRUSTCHIP

THE MARK CONSISTS OF STANDARD CHARACTERS WITHOUT CLAIM TO ANY PARTICULAR FONT, STYLE, SIZE, OR COLOR.

FOR COMPUTER CHIPS ENCODED TO ENABLE ENCRYPTION AND SMART CARD FUNCTIONALITY AS WELL AS SECURITY AND AUTHENTICATION USED IN CONNECTION WITH INTERNET AND NETWORK ACCESSIBLE DEVICES (U.S. CLS. 21, 23, 26, 36 AND 38).

FIRST USE 2-0-2005; IN COMMERCE 4-0-2008.

3,482,100. AUTO ADDITIONS, INC., SALEM, OR. SN 78-572,562. PUB. 9-12-2006, FILED 2-22-2005.

PATROL POWER

THE MARK CONSISTS OF STANDARD CHARACTERS WITHOUT CLAIM TO ANY PARTICULAR FONT, STYLE, SIZE, OR COLOR.

NO CLAIM IS MADE TO THE EXCLUSIVE RIGHT TO USE "POWER", APART FROM THE MARK AS SHOWN.

FOR ELECTRICAL APPARATUS, NAMELY, ELECTRICAL PANELS, WIRING PANELS, WIRING DIAGRAMS, FUSE PANELS, ELECTRICAL WIRING HARNESSES FOR USE WITHIN MOTOR VEHICLES (U.S. CLS. 21, 23, 26, 36 AND 38).

FIRST USE 10-10-2005; IN COMMERCE 10-10-2005.

CLASS 9—(Continued).

3,482,106. RIAZI, SHIRIN, WEST HILLS, CA. SN 78-582,750.
PUB. 11-22-2005, FILED 3-8-2005.

EYE & EYE

THE MARK CONSISTS OF STANDARD CHARACTERS WITHOUT CLAIM TO ANY PARTICULAR FONT, STYLE, SIZE, OR COLOR.

FOR EYE GLASSES CASE (U.S. CLS. 21, 23, 26, 36 AND 38).

FIRST USE 11-10-2007; IN COMMERCE 1-20-2008.

3,482,118. SUNBEAM PRODUCTS, INC., BOCA RATON, FL.
SN 78-613,390. PUB. 4-4-2006, FILED 4-21-2005.

TURBO STEAM

THE MARK CONSISTS OF STANDARD CHARACTERS WITHOUT CLAIM TO ANY PARTICULAR FONT, STYLE, SIZE, OR COLOR.

NO CLAIM IS MADE TO THE EXCLUSIVE RIGHT TO USE "STEAM", APART FROM THE MARK AS SHOWN.

FOR ELECTRIC PRESSING IRONS AND ELECTRIC STEAM IRONS (U.S. CLS. 21, 23, 26, 36 AND 38).

FIRST USE 12-29-2007; IN COMMERCE 12-29-2007.

3,482,126. MILLER, SCOTT A., TRENTON, NJ. SN 78-636,241.
PUB. 3-14-2006, FILED 5-24-2005.

EXIT 7A

THE MARK CONSISTS OF STANDARD CHARACTERS WITHOUT CLAIM TO ANY PARTICULAR FONT, STYLE, SIZE, OR COLOR.

FOR PRE-RECORDED CD'S, DVD'S, AND VIDEOS FEATURING MUSIC AND MUSICAL PERFORMANCES (U.S. CLS. 21, 23, 26, 36 AND 38).

FIRST USE 1-8-2005; IN COMMERCE 1-8-2005.

CLASS 9—(Continued).

3,482,127. TRENDIUM, INC., SUNRISE, FL. SN 78-636,388.
PUB. 2-14-2006, FILED 5-24-2005.

DSLXCEND

THE MARK CONSISTS OF STANDARD CHARACTERS WITHOUT CLAIM TO ANY PARTICULAR FONT, STYLE, SIZE, OR COLOR.

FOR COMPUTER SOFTWARE USED FOR MANAGEMENT, MONITORING, MEASURING AND ANALYZING THE PERFORMANCE, TRAFFIC, USAGE AND UTILIZATION LEVELS OF GLOBAL COMPUTER AND BROADBAND TELECOMMUNICATIONS NETWORKS (U.S. CLS. 21, 23, 26, 36 AND 38).

FIRST USE 6-30-2006; IN COMMERCE 6-30-2006.

3,482,138. WINTROUB, BARBARA L., SANTA MONICA, CA.
SN 78-649,745. PUB. 2-28-2006, FILED 6-13-2005.

RETROFIT AEROBIC PILATES RX

THE MARK CONSISTS OF STANDARD CHARACTERS WITHOUT CLAIM TO ANY PARTICULAR FONT, STYLE, SIZE, OR COLOR.

OWNER OF U.S. REG. NO. 2,934,977.

NO CLAIM IS MADE TO THE EXCLUSIVE RIGHT TO USE "AEROBIC PILATES", APART FROM THE MARK AS SHOWN.

FOR PRE-RECORDED DVD'S FEATURING CONTENT IN THE FIELD OF PILATES INSTRUCTION (U.S. CLS. 21, 23, 26, 36 AND 38).

FIRST USE 5-14-2008; IN COMMERCE 5-14-2008.

3,482,151. ALBIREO STUDIOS, LLC, FREE UNION, VA. SN
78-665,914. PUB. 6-27-2006, FILED 7-7-2005.



NO CLAIM IS MADE TO THE EXCLUSIVE RIGHT TO USE "STUDIOS", APART FROM THE MARK AS SHOWN.

THE STIPPLING IS FOR SHADING PURPOSES ONLY. FOR VIDEO GAME SOFTWARE, ELECTRONIC GAME PROGRAMS (U.S. CLS. 21, 23, 26, 36 AND 38).

FIRST USE 8-28-2006; IN COMMERCE 8-28-2006.

CLASS 9—(Continued).

3,482,153. ANGELANTONI INDUSTRIE S.P.A., MASSA MARTANA (PERUGIA), ITALY. SN 78-667,409. PUB. 10-3-2006, FILED 7-11-2005.

E-GLUE

THE MARK CONSISTS OF STANDARD CHARACTERS WITHOUT CLAIM TO ANY PARTICULAR FONT, STYLE, SIZE, OR COLOR.

PRIORITY CLAIMED UNDER SEC. 44(D) ON ERP CMNTY TM OFC APPLICATION NO. 004498788, FILED 6-21-2005.

FOR INTEROPERABILITY SOFTWARE FOR SCIENTIFIC DATA MANAGEMENT SYSTEMS FOR USE IN MANAGING BIO-REPOSITORIES AND STORING BIOLOGICAL SAMPLES (U.S. CLS. 21, 23, 26, 36 AND 38).
FIRST USE 4-30-2006; IN COMMERCE 4-30-2006.

3,482,158. PARADIGM GEOPHYSICAL CORP., HOUSTON, TX. SN 78-675,585. PUB. 9-26-2006, FILED 7-21-2005.

STRATIMAGIC

THE MARK CONSISTS OF STANDARD CHARACTERS WITHOUT CLAIM TO ANY PARTICULAR FONT, STYLE, SIZE, OR COLOR.

FOR COMPUTER SOFTWARE FOR GENERATING, CHARACTERIZING, AND ANALYZING IMAGES OF THE SUBSURFACE FOR ALL STAGES OF OIL AND GAS EXPLORATION, APPRAISAL, AND PRODUCTION; COMPUTER SOFTWARE THAT EMPLOYS NEURAL NETWORK AND OTHER CLASSIFICATION METHODOLOGIES TO RELATE SUBSURFACE IMAGES OF SEISMIC DATA TO GEOLOGIC FEATURES IN THE FIELDS OF OIL AND GAS EXPLORATION AND PRODUCTION (U.S. CLS. 21, 23, 26, 36 AND 38).
FIRST USE 0-0-1997; IN COMMERCE 0-0-1997.

CLASS 9—(Continued).

3,482,159. INTEL VAC CORPORATION, GEORGETOWN, ONTARIO, CANADA. SN 78-678,177. PUB. 9-19-2006, FILED 7-26-2005.

NANOCHROME

THE MARK CONSISTS OF STANDARD CHARACTERS WITHOUT CLAIM TO ANY PARTICULAR FONT, STYLE, SIZE, OR COLOR.

PRIORITY CLAIMED UNDER SEC. 44(D) ON CANADA APPLICATION NO. 1247628, FILED 2-17-2005, REG. NO. TMA665,224, DATED 5-30-2006, EXPIRES 5-30-2021.

FOR ELECTRON BEAM EVAPORATORS (U.S. CLS. 21, 23, 26, 36 AND 38).

FIRST USE 4-24-2008; IN COMMERCE 4-24-2008.

3,482,160. AMPHENOL-TUCHEL ELECTRONICS GMBH, HEILBRONN, FED REP GERMANY. SN 78-679,984. PUB. 5-1-2007, FILED 7-27-2005.

medi|mate

PRIORITY CLAIMED UNDER SEC. 44(D) ON FED REP GERMANY APPLICATION NO. 30504484.2, FILED 1-27-2005, REG. NO. 30504484, DATED 3-31-2005, EXPIRES 3-31-2015.

FOR ELECTRIC AND ELECTRONIC CONNECTORS AND PARTS THEREOF, NAMELY, ELECTRIC AND ELECTRONIC CONTACTS AND CONTACTING APPARATUS, IN PARTICULAR FOR POWER CONNECTORS, HEAVY DUTY CONNECTORS, CHIP CARDS AND MEMORY CARDS; ELECTRIC CONNECTORS FOR CONNECTION CABLES; ELECTRIC COUPLINGS; COUPLERS FOR DATA PROCESSING DEVICES; ELECTRIC PLUGS, ELECTRIC SOCKETS, ELECTRIC CONNECTORS; MICROPROCESSORS; CONNECTION CABLES FOR ELECTRIC LINES; ELECTRICAL CABLES FOR USE IN CONNECTIONS; ELECTRIC SWITCHES; ENCODED ELECTRONIC TAGS FOR USE IN THE FIELD OF PASSIVE LABELING, TRACING OR TRACKING OF GOODS; SMART CARD ELECTRONIC CONNECTORS; SIM CARD READERS; ELECTRONIC MULTIMEDIA CARD CONNECTORS, NOT INCLUDING DATA TRANSMISSION APPARATUS FOR PERSONAL MEDICAL EMERGENCY RESPONSE PURPOSES (U.S. CLS. 21, 23, 26, 36 AND 38).

FIRST USE 10-4-2007; IN COMMERCE 10-4-2007.

CLASS 9—(Continued).

3,482,162. V4 HOLDINGS, LLC, ANN ARBOR, MI. SN 78-680,450. PUB. 8-22-2006, FILED 7-28-2005.

GHOSTLY

THE MARK CONSISTS OF STANDARD CHARACTERS WITHOUT CLAIM TO ANY PARTICULAR FONT, STYLE, SIZE, OR COLOR.

FOR MOTION PICTURE FILMS AND DOWNLOADABLE MOTION PICTURE FILMS FEATURING LIVE ACTION, MUSIC, MUSIC GROUPS, ANIMATION AND/OR DOCUMENTARY THEMES; DOWNLOADABLE VIDEO RECORDINGS, NAMELY, RECORDINGS OF MOTION PICTURE FILMS FEATURING LIVE ACTION, MUSIC, MUSIC GROUPS, ANIMATION AND/OR DOCUMENTARY THEMES (U.S. CLS. 21, 23, 26, 36 AND 38). FIRST USE 5-13-2008; IN COMMERCE 5-13-2008.

3,482,163. V4 HOLDINGS, LLC, ANN ARBOR, MI. SN 78-680,491. PUB. 2-14-2006, FILED 7-28-2005.



THE MARK CONSISTS OF AN ARTISTIC RENDERING OF A GHOST INSIDE A CIRCLE.

FOR MOTION PICTURE FILMS AND DOWNLOADABLE MOTION PICTURE FILMS FEATURING LIVE ACTION, MUSIC, MUSIC GROUPS, ANIMATION AND/OR DOCUMENTARY THEMES; DOWNLOADABLE VIDEO RECORDINGS, NAMELY, RECORDINGS OF MOTION PICTURE FILMS FEATURING LIVE ACTION, MUSIC, MUSIC GROUPS, ANIMATION AND/OR DOCUMENTARY THEMES (U.S. CLS. 21, 23, 26, 36 AND 38). FIRST USE 6-1-2007; IN COMMERCE 6-1-2007.

CLASS 9—(Continued).

3,482,214. TERUMO MEDICAL CORPORATION, SOMERSET, NJ. SN 78-756,033. PUB. 9-25-2007, FILED 11-17-2005.



NO CLAIM IS MADE TO THE EXCLUSIVE RIGHT TO USE "TOTAL SYSTEM", APART FROM THE MARK AS SHOWN.

FOR COMPUTER SOFTWARE FOR THE MONITORING, RECORDING, OUTPUTTING, AND MANAGING OF DATA AND INFORMATION; ELECTRONIC DEVICES FOR USE IN THE FIELD OF WELDING FOR MANAGING DATA, NAMELY, MONITORING, RECORDING, AND OUTPUTTING DATA ON WELDING EQUIPMENT USED TO CONNECT SECTIONS OF MEDICAL GRADE THERMOPLASTIC TUBING (U.S. CLS. 21, 23, 26, 36 AND 38).

FIRST USE 3-7-2008; IN COMMERCE 3-7-2008.

3,482,215. DANIEL, SIMON RICHARD, SURREY, UNITED KINGDOM. SN 78-756,382. PUB. 9-25-2007, FILED 11-17-2005.

MOIXA

THE MARK CONSISTS OF STANDARD CHARACTERS WITHOUT CLAIM TO ANY PARTICULAR FONT, STYLE, SIZE, OR COLOR.

OWNER OF UNITED KINGDOM REG. NO. 2345732, DATED 5-14-2004, EXPIRES 10-11-2013.

FOR CONSUMER BATTERY PRODUCTS, NAMELY, ALKALINE DRY CELLS, BATTERIES, RECHARGEABLE BATTERIES, BATTERY CHARGERS, HEAVY DUTY BATTERIES, AUTOMOTIVE BATTERIES, INDUSTRIAL BATTERIES; COMPUTERS; COMPUTER HARDWARE; MODEMS; COMPUTER SOFTWARE FOR BROWSING OR ACCESSING THE INTERNET, FOR VISUALIZING INTERNET ACCESS, FOR CONTROL OF APPLICATIONS IN THE FIELD OF SOLAR TECHNOLOGIES, WIND, OR OFF-GRID POWER GENERATION TECHNOLOGIES, OR FOR MANAGING THE CHARGING OF RECHARGEABLE BATTERIES, PORTABLE ELECTRONIC DEVICES, AND PHONES; SOUND SYSTEMS, NAMELY, AUDIO RECEIVERS, AMPLIFIERS, AND SPEAKERS; OPTICAL SYSTEMS, NAMELY, OPTICAL READERS, SCANNERS, AND CABLES; SCIENTIFIC EQUIPMENT, NAMELY, OPTICAL SENSORS, ELECTRONIC SENSORS, AND QUANTUM SENSORS FOR MEASURING MICROSCOPIC, NANO AND QUANTUM PLANCK LENGTH EFFECTS VIA QUANTUM MEASUREMENT MEANS; LIFE-SAVING APPARATUS, NAMELY, LIFE SAVING RAFTS; VENDING MACHINES; FIRE EXTINGUISHERS; STORAGE DEVICES, NAMELY, CD STORAGE RACKS AND COMPUTER HARD DRIVES; PHONE ACCESSORIES, NAMELY, CELL PHONE COVERS AND DEVICES FOR HANDS-FREE USE OF MOBILE PHONES (U.S. CLS. 21, 23, 26, 36 AND 38).

FIRST USE 9-30-2006; IN COMMERCE 9-30-2006.

CLASS 9—(Continued).

3,482,237. LS INDUSTRIAL SYSTEMS CO., LTD., SEOUL, REPUBLIC OF KOREA. SN 78-774,087. PUB. 9-18-2007, FILED 12-15-2005.

CLASS 9—(Continued).

3,482,239. ALLIED TELESIS, INC., BOTHELL, WA. SN 78-775,318. PUB. 8-22-2006, FILED 12-16-2005.

Susol

FOR CIRCUIT BREAKERS; MOLDED CASE CIRCUIT BREAKERS; CONTACTORS; MAGNETIC SWITCHES; RELAYS; WATT HOUR METERS; ELECTRICITY TRANSFORMERS; ELECTRICITY INVERTERS; PROGRAMMABLE LOGIC CONTROLLERS; RADIO FREQUENCY TAG READERS; RADIO FREQUENCY TAG RECOGNIZERS; TRANSPONDERS USED AS RADIO FREQUENCY RECOGNIZERS; RADIO FREQUENCY IDENTIFICATION (U.S. CLS. 21, 23, 26, 36 AND 38).
FIRST USE 3-1-2006; IN COMMERCE 3-1-2006.

IMAP

3,482,238. AGILENT TECHNOLOGIES, INC., SANTA CLARA, CA. SN 78-774,658. PUB. 9-26-2006, FILED 12-15-2005.

AGILENT OPENLAB

THE MARK CONSISTS OF STANDARD CHARACTERS WITHOUT CLAIM TO ANY PARTICULAR FONT, STYLE, SIZE, OR COLOR.

OWNER OF U.S. REG. NOS. 2,461,406, 2,643,345, AND OTHERS.

FOR CHEMICAL AND BIOLOGICAL ANALYTICAL EQUIPMENT, NAMELY, A LABORATORY OPERATING SYSTEMS COMPRISING OF COMPUTER HARDWARE AND COMPUTER SOFTWARE TO FACILITATE THE INTERACTION AND MANAGEMENT OF INSTRUMENTS, SCIENTIFIC DATA AND BUSINESS PROCESS ELECTRONIC DATA (U.S. CLS. 21, 23, 26, 36 AND 38).
FIRST USE 6-0-2007; IN COMMERCE 6-0-2007.

THE MARK CONSISTS OF STANDARD CHARACTERS WITHOUT CLAIM TO ANY PARTICULAR FONT, STYLE, SIZE, OR COLOR.

FOR COMPUTER NETWORKING HARDWARE, NAMELY, SWITCHES; FIRMWARE FOR USE IN COMMUNICATIONS NETWORKS USED IN CONNECTION THEREWITH (U.S. CLS. 21, 23, 26, 36 AND 38).
FIRST USE 2-0-2006; IN COMMERCE 2-0-2006.

CLASS 9—(Continued).

3,482,249. INVENTEC BESTA CO., LTD., TAIPEI, TAIWAN.
SN 78-781,413. PUB. 10-2-2007, FILED 12-28-2005.



THE MARK CONSISTS OF THREE KOREAN CHARACTERS AND THEIR TRANSLITERATION "NURIAN" AS WELL AS A "NU" DESIGN.

THE TRANSLITERATION AND TRANSLATION OF THE KOREAN CHARACTERS CONTAINED IN THE MARK ARE "NU; RI; AN" AND "PEOPLE IN THE WORLD", RESPECTIVELY.

FOR ELECTRONIC DICTIONARIES; ELECTRONIC NOTEBOOKS; ELECTRONIC GAME SOFTWARE; ELECTRONIC TRANSLATION MACHINES; ELECTRONIC PUBLICATIONS, NAMELY, ELECTRONIC BOOKS, MAGAZINES AND MANUALS FEATURING LANGUAGE INSTRUCTION AND MUSIC RECORDED ON COMPUTER MEDIA; INTEGRATED CIRCUIT CARDS; MEMORY CARDS; COMPUTERS; LIGHT PENS; INTERFACE CARDS; SOUND CARDS; APPARATUS FOR TRANSMITTING AND REPRODUCING SOUND OR IMAGES; TELEPHONE SETS; MOBILE TELEPHONES; CELLULAR TELEPHONES; CORDLESS TELEPHONES; TELEPHONE ANSWERING MACHINES; VIDEO TELEPHONES COMMUNICATIONS APPARATUS; PERSONAL DIGITAL ASSISTANTS; COMPUTER SOFTWARE FOR INSERTING DIGITAL IMAGES INTO MP3 PLAYERS OR DIGITAL AUDIO FILES; DIGITAL CAMERAS; VIDEO GAME SOFTWARE; TELEPHONE NETWORKS COMPRISING CELLULAR TELEPHONES, COMPUTER MONITORS, CAMERAS, MODEMS, HEADPHONES, MICROPHONES AND COMPUTERS; ELECTRONIC PUBLICATIONS, NAMELY, BOOKS, AND NOTEBOOKS FEATURING NEWS, WEATHER, SPORTS, CURRENT EVENTS, AND REFERENCE MATERIALS RECORDED ON FLOPPY DISKS, COMPACT DISCS; MP3 PLAYERS; DIGITAL VIDEO CAMERAS; COMPUTER CONNECTING CORDS; TELEVISION SETS; DIGITAL TELEVISIONS; PLASMA TELEVISIONS (U.S. CLS. 21, 23, 26, 36 AND 38).

FIRST USE 12-1-2006; IN COMMERCE 1-22-2007.

CLASS 9—(Continued).

3,482,251. ENER1 HOLDINGS, INC., FORT LAUDERDALE, FL. SN 78-782,458. PUB. 9-25-2007, FILED 12-29-2005.

ENERFUEL

THE MARK CONSISTS OF STANDARD CHARACTERS WITHOUT CLAIM TO ANY PARTICULAR FONT, STYLE, SIZE, OR COLOR.

FOR ELECTRO-CHEMICAL FUEL CELLS FOR GENERATING ELECTRICITY (U.S. CLS. 21, 23, 26, 36 AND 38).

FIRST USE 8-24-2007; IN COMMERCE 8-24-2007.

3,482,256. M GROUP LLC, AKRON, OH. SN 78-784,182. PUB. 9-18-2007, FILED 1-3-2006.

SIGNET

THE MARK CONSISTS OF STANDARD CHARACTERS WITHOUT CLAIM TO ANY PARTICULAR FONT, STYLE, SIZE, OR COLOR.

FOR APPARATUS FOR TRANSMITTING AND REPRODUCING SOUND (U.S. CLS. 21, 23, 26, 36 AND 38).

FIRST USE 8-0-2006; IN COMMERCE 8-0-2006.

3,482,272. O2MICRO, INC., SANTA CLARA, CA. SN 78-792,703. PUB. 10-31-2006, FILED 1-17-2006.

SIFOSCOPIES

THE MARK CONSISTS OF STANDARD CHARACTERS WITHOUT CLAIM TO ANY PARTICULAR FONT, STYLE, SIZE, OR COLOR.

FOR COMPUTER SOFTWARE FOR BROWSING WEBSITES, NAMELY, FOR MONITORING OR ANALYZING THE USE OF THE INTERNET (U.S. CLS. 21, 23, 26, 36 AND 38).

FIRST USE 7-1-2006; IN COMMERCE 7-1-2006.

CLASS 9—(Continued).

3,482,280. RFID MEXICO, S.A. DE C.V., SAN PEDRO GARZA GARCIA, NUEVO LEON C.P., MEXICO. SN 78-798,118. PUB. 7-31-2007, FILED 1-24-2006.

RFID NATIVE

THE MARK CONSISTS OF STANDARD CHARACTERS WITHOUT CLAIM TO ANY PARTICULAR FONT, STYLE, SIZE, OR COLOR.

NO CLAIM IS MADE TO THE EXCLUSIVE RIGHT TO USE "RFID", APART FROM THE MARK AS SHOWN.

FOR RADIO FREQUENCY IDENTIFICATION EQUIPMENT, NAMELY, READERS, ANTENNAS, TAGS, AND COMPUTERS FOR RECOGNIZING PRODUCTS, TOOLS, MACHINERY, AND INDIVIDUALS AND FOR INITIATING ACTIONS IN RESPONSE TO SUCH RECOGNITION; COMPUTER HARDWARE FOR RADIO FREQUENCY IDENTIFICATION EQUIPMENT; COMPUTER SOFTWARE FOR MONITORING PRODUCTS, TOOLS, MACHINERY AND WORKERS AND FOR RECOMMENDING ACTIONS BASED ON SUCH INFORMATION, ALL FOR USE IN OPERATING RADIO FREQUENCY IDENTIFICATION EQUIPMENT (U.S. CLS. 21, 23, 26, 36 AND 38).

FIRST USE 8-0-2007; IN COMMERCE 8-0-2007.

3,482,293. DAIRYCHEQ INC., WATERLOO, ONTARIO, CANADA. SN 78-810,773. PUB. 10-3-2006, FILED 2-9-2006.

DAIRYCHEQ

THE MARK CONSISTS OF STANDARD CHARACTERS WITHOUT CLAIM TO ANY PARTICULAR FONT, STYLE, SIZE, OR COLOR.

FOR ELECTRONIC EQUIPMENT, NAMELY, TIME AND TEMPERATURE RECORDERS, DIGITAL AND INTERLOG SENSORS AND MODEMS FOR RECORDING AND MONITORING DAIRY FARM PROCESSES (U.S. CLS. 21, 23, 26, 36 AND 38).

FIRST USE 3-8-2001; IN COMMERCE 3-8-2001.

CLASS 9—(Continued).

3,482,296. IGT, RENO, NV. SN 78-813,278. PUB. 9-12-2006, FILED 2-13-2006.

RED LIONS

THE MARK CONSISTS OF STANDARD CHARACTERS WITHOUT CLAIM TO ANY PARTICULAR FONT, STYLE, SIZE, OR COLOR.

FOR GAMING MACHINES, NAMELY, DEVICES WHICH ACCEPT A WAGER (U.S. CLS. 21, 23, 26, 36 AND 38).

FIRST USE 11-6-2007; IN COMMERCE 11-6-2007.

3,482,298. IGT, RENO, NV. SN 78-815,346. PUB. 9-12-2006, FILED 2-15-2006.

KILIMANJARO

THE MARK CONSISTS OF STANDARD CHARACTERS WITHOUT CLAIM TO ANY PARTICULAR FONT, STYLE, SIZE, OR COLOR.

FOR GAMING MACHINES, NAMELY, DEVICES WHICH ACCEPT A WAGER (U.S. CLS. 21, 23, 26, 36 AND 38).

FIRST USE 2-13-2008; IN COMMERCE 3-12-2008.

3,482,312. MYERS, HAROLD KEITH, MONTREAL, QUEBEC, CANADA. SN 78-832,434. PUB. 10-17-2006, FILED 3-8-2006.

Thought Technologies

THE MARK CONSISTS OF STANDARD CHARACTERS WITHOUT CLAIM TO ANY PARTICULAR FONT, STYLE, SIZE, OR COLOR.

OWNER OF U.S. REG. NO. 2,966,846. NO CLAIM IS MADE TO THE EXCLUSIVE RIGHT TO USE "TECHNOLOGIES", APART FROM THE MARK AS SHOWN.

FOR COMPUTER HARDWARE FOR MEDICAL DATA ACQUISITION (U.S. CLS. 21, 23, 26, 36 AND 38).

FIRST USE 11-1-2004; IN COMMERCE 11-1-2004.

CLASS 9—(Continued).

3,482,326. BIT9, INC., CAMBRIDGE, MA. SN 78-842,067. PUB. 7-3-2007, FILED 3-21-2006.

BIT9 PARITYCENTER

THE MARK CONSISTS OF STANDARD CHARACTERS WITHOUT CLAIM TO ANY PARTICULAR FONT, STYLE, SIZE, OR COLOR.

NO CLAIM IS MADE TO THE EXCLUSIVE RIGHT TO USE "PARITYCENTER", APART FROM THE MARK AS SHOWN.

FOR COMPUTER PROGRAMS FOR USE IN TRACKING SOFTWARE AND EXECUTABLE FILES IN COMPUTER NETWORKS, FOR USE IN IDENTIFYING NEW AND UNKNOWN SOFTWARE AND EXECUTABLE FILES AND FOR BLOCKING UNAUTHORIZED SOFTWARE EXECUTIONS (U.S. CLS. 21, 23, 26, 36 AND 38).
FIRST USE 3-22-2006; IN COMMERCE 3-22-2006.

3,482,339. ALTA HEIGHTS TECHNOLOGY CORPORATION, LOS GATOS, CA. SN 78-854,302. PUB. 8-21-2007, FILED 4-5-2006.

StudentMate

THE MARK CONSISTS OF STANDARD CHARACTERS WITHOUT CLAIM TO ANY PARTICULAR FONT, STYLE, SIZE, OR COLOR.

FOR COMPUTER HARDWARE AND SOFTWARE FOR USE IN INDIVIDUALIZED STUDENT ASSESSMENT AND INSTRUCTION, USED TO IMPROVE SKILLS, MONITOR AND TRACK PERFORMANCE (U.S. CLS. 21, 23, 26, 36 AND 38).

FIRST USE 4-0-2008; IN COMMERCE 4-0-2008.

CLASS 9—(Continued).

3,482,340. HOOPS L. P., MEMPHIS, TN. SN 78-854,360. PUB. 9-25-2007, FILED 4-5-2006.



OWNER OF U.S. REG. NOS. 2,861,210, 3,056,500, AND OTHERS.

NO CLAIM IS MADE TO THE EXCLUSIVE RIGHT TO USE "MEMPHIS", APART FROM THE MARK AS SHOWN.

THE MARK CONSISTS OF A PICTURE OF A BEAR'S HEAD.

FOR AUDIO RECORDINGS AND VIDEO RECORDINGS IN THE FIELD OF BASKETBALL; AUDIO, VIDEO, COMPUTER AND LASER DISCS, PRE-RECORDED AUDIO AND VIDEO CASSETTES, PRE-RECORDED AUDIO AND VIDEO TAPES, PRE-RECORDED COMPACT DISCS, PRE-RECORDED COMPUTER DISCS, ALL RELATED TO BASKETBALL; COMPUTER ACCESSORIES, NAMELY, MOUSE PADS, MICE, DISC CASES, COMPUTER CARRY-ON CASES, KEYBOARD WRIST PADS, COMPUTER MONITOR CARDBOARD FRAMES, ALL RELATED TO BASKETBALL; COMPUTER PROGRAMS FOR VIEWING INFORMATION, STATISTICS OR TRIVIA ABOUT BASKETBALL; COMPUTER SOFTWARE, NAMELY, SCREEN SAVERS FEATURING BASKETBALL THEMES, COMPUTER SOFTWARE TO ACCESS AND VIEW COMPUTER WALLPAPER, COMPUTER BROWSERS, COMPUTER SKINS AND COMPUTER CURSORS; COMPUTER GAME SOFTWARE; VIDEO GAME SOFTWARE, VIDEO GAME CARTRIDGES AND VIDEO GAME MACHINES FOR USE WITH TELEVISIONS; WIRELESS TELEPHONES; RADIOS, TELEPHONES, AND CELL PHONE ACCESSORIES, NAMELY, FACE PLATES AND CELL PHONE COVERS; VIDEO MONITORS, COMPUTER MONITORS, BINOCULARS; SUNGLASSES; EYEGLASS FRAMES; EYEWEAR STRAPS AND CHAINS; EYEGLASS AND SUNGLASS CASES; MAGNETS; DISPOSABLE CAMERAS; CREDIT CARDS AND PRE-PAID TELEPHONE CALLING CARDS MAGNETICALLY ENCODED, DOWNLOADABLE VIDEO RECORDINGS, VIDEO STREAM RECORDINGS, AND AUDIO RECORDINGS IN THE FIELD OF BASKETBALL PROVIDED OVER THE INTERNET; DOWNLOADABLE COMPUTER SOFTWARE FOR VIEWING DATABASES OF INFORMATION, STATISTICAL INFORMATION, TRIVIA, POLLING INFORMATION, AND INTERACTIVE POLLING IN THE FIELD OF BASKETBALL PROVIDED OVER THE INTERNET; DOWNLOADABLE COMPUTER GAME SOFTWARE; VIDEO GAME PROGRAMS, INTERACTIVE VIDEO GAMES AND TRIVIA GAME SOFTWARE PROVIDED OVER THE INTERNET; DOWNLOADABLE COMPUTER SOFTWARE FOR USE AS SCREENSAVERS, WALLPAPER, BROWSERS, SKINS, AVATARS AND CURSORS OVER THE INTERNET; DOWNLOADABLE ELECTRONIC PUBLICATIONS IN THE NATURE OF MAGAZINES, NEWSLETTERS, COLORING BOOKS, GAME SCHEDULES ALL IN THE FIELD OF BASKETBALL PROVIDED OVER THE INTERNET; DOWNLOADABLE CATALOGS PROVIDED OVER THE INTERNET FEATURING AN ARRAY OF BASKETBALL-THEMED PRODUCTS (U.S. CLS. 21, 23, 26, 36 AND 38).

FIRST USE 10-1-2007; IN COMMERCE 10-1-2007.

CLASS 9—(Continued).

3,482,342. GENERAL CABLE TECHNOLOGIES CORPORATION, HIGHLAND HEIGHTS, KY. SN 78-855,261. PUB. 10-24-2006, FILED 4-6-2006.

MV-RIG

THE MARK CONSISTS OF STANDARD CHARACTERS WITHOUT CLAIM TO ANY PARTICULAR FONT, STYLE, SIZE, OR COLOR.

FOR ELECTRICAL CABLES (U.S. CLS. 21, 23, 26, 36 AND 38).

FIRST USE 3-0-2008; IN COMMERCE 3-0-2008.

3,482,344. DEFENSTECH INTERNATIONAL, INC., IRVINE, CA. SN 78-856,167. PUB. 12-5-2006, FILED 4-6-2006.

**PROTECTING THOSE WHO
PROTECT AND SERVE**

THE MARK CONSISTS OF STANDARD CHARACTERS WITHOUT CLAIM TO ANY PARTICULAR FONT, STYLE, SIZE, OR COLOR.

FOR BULLET, BLAST AND ATTACK RESISTANT BODY ARMOR (U.S. CLS. 21, 23, 26, 36 AND 38).

FIRST USE 2-18-2006; IN COMMERCE 2-18-2006.

3,482,367. ALBANY INTERNATIONAL CORP., ALBANY, NY. SN 78-872,251. PUB. 9-4-2007, FILED 4-28-2006.

MCCVECTORCONTROL

THE MARK CONSISTS OF STANDARD CHARACTERS WITHOUT CLAIM TO ANY PARTICULAR FONT, STYLE, SIZE, OR COLOR.

FOR ELECTRIC CONTROL PANEL FOR A DOOR (U.S. CLS. 21, 23, 26, 36 AND 38).

FIRST USE 5-11-2006; IN COMMERCE 5-11-2006.

CLASS 9—(Continued).

3,482,375. ST. JUDE MEDICAL, ATRIAL FIBRILLATION DIVISION, INC., MINNETONKA, MN. SN 78-883,617. PUB. 2-6-2007, FILED 5-15-2006.

ENSITE CONNECT

THE MARK CONSISTS OF STANDARD CHARACTERS WITHOUT CLAIM TO ANY PARTICULAR FONT, STYLE, SIZE, OR COLOR.

OWNER OF U.S. REG. NOS. 2,084,362, 2,908,660, AND OTHERS.

NO CLAIM IS MADE TO THE EXCLUSIVE RIGHT TO USE "CONNECT", APART FROM THE MARK AS SHOWN.

FOR COMPUTER HARDWARE AND COMPUTER SOFTWARE FOR FACILITATING REMOTE SUPPORT SERVICES FOR ELECTROPHYSIOLOGY (U.S. CLS. 21, 23, 26, 36 AND 38).

FIRST USE 6-0-2006; IN COMMERCE 6-0-2006.

3,482,383. GARCIA, ROBERT T., CAMP PENDLETON, CA. SN 78-887,445. PUB. 4-3-2007, FILED 5-19-2006.

TEST MATE

THE MARK CONSISTS OF STANDARD CHARACTERS WITHOUT CLAIM TO ANY PARTICULAR FONT, STYLE, SIZE, OR COLOR.

NO CLAIM IS MADE TO THE EXCLUSIVE RIGHT TO USE "TEST", APART FROM THE MARK AS SHOWN.

FOR COMPUTER SOFTWARE FOR SELF-EVALUATION OF SUBJECT MATTER COMPREHENSION, IN PREPARATION FOR STANDARDIZED TESTS, THAT MAY BE DOWNLOADED FROM A GLOBAL COMPUTER NETWORK (U.S. CLS. 21, 23, 26, 36 AND 38).

FIRST USE 4-1-2008; IN COMMERCE 4-1-2008.

3,482,402. RITE TRACK EQUIPMENT SERVICES, INC., WEST CHESTER, OH. SN 78-903,829. PUB. 9-4-2007, FILED 6-8-2006.

ARDIMUS

THE MARK CONSISTS OF STANDARD CHARACTERS WITHOUT CLAIM TO ANY PARTICULAR FONT, STYLE, SIZE, OR COLOR.

FOR SOFTWARE FOR CONFIGURING, SETTING AND MONITORING THE OPERATIONS OF SUBSTRATE PROCESSING EQUIPMENT (U.S. CLS. 21, 23, 26, 36 AND 38).

FIRST USE 4-3-2006; IN COMMERCE 4-3-2006.

CLASS 9—(Continued).

3,482,418. DUOS TECHNOLOGIES, INC., JACKSONVILLE, FL. SN 78-910,667. PUB. 1-16-2007, FILED 6-17-2006.



NO CLAIM IS MADE TO THE EXCLUSIVE RIGHT TO USE "DIGITAL OPTICAL READING", APART FROM THE MARK AS SHOWN.

THE MARK CONSISTS OF THE LETTERS "D" "O" "R" AND "A" IN UPPER CASE WITH THE LETTER "O" WITH A SET OF DARKENED PORTIONS TO DEPICT A CAMERA LENS.

FOR VIDEO OPTICAL RECOGNITION, NAMELY, AN ELECTRONIC DEVICE TO PROVIDE OPTICAL CHARACTER RECOGNITION FOR INBOUND AND OUTBOUND TRAFFIC WHICH WILL CAPTURE THE CAR NUMBER, THE STENCIL INFORMATION ON THE CAR, CAPTURE AN IMAGE OF THE CAR AND INCORPORATE THIS INFORMATION TO THE DATABASE (U.S. CLS. 21, 23, 26, 36 AND 38).

FIRST USE 6-17-2006; IN COMMERCE 6-17-2006.

3,482,425. APPPOSITE TECHNOLOGIES, INC., BEVERLY HILLS, CA. SN 78-917,357. PUB. 9-4-2007, FILED 6-26-2006.

Linktropy

THE MARK CONSISTS OF STANDARD CHARACTERS WITHOUT CLAIM TO ANY PARTICULAR FONT, STYLE, SIZE, OR COLOR.

FOR COMPUTER NETWORK HUBS, SWITCHES AND ROUTERS; COMPUTER NETWORKING HARDWARE; TELECOMMUNICATIONS AND DATA NETWORKING HARDWARE, NAMELY, DEVICES FOR TRANSPORTING AND AGGREGATING VOICE, DATA, AND VIDEO COMMUNICATIONS ACROSS MULTIPLE NETWORK INFRASTRUCTURES AND COMMUNICATIONS PROTOCOLS; WAN (WIDE AREA NETWORK) OPERATING SOFTWARE (U.S. CLS. 21, 23, 26, 36 AND 38).

FIRST USE 5-22-2007; IN COMMERCE 7-2-2007.

CLASS 9—(Continued).

3,482,441. TOOLE, RODNEY MAURICE, NEW YORK, NY. SN 78-929,154. PUB. 8-21-2007, FILED 7-13-2006.

YOUNG HOT ROD

THE MARK CONSISTS OF STANDARD CHARACTERS WITHOUT CLAIM TO ANY PARTICULAR FONT, STYLE, SIZE, OR COLOR.

FOR MUSICAL SOUND RECORDINGS; AUDIO-VISUAL RECORDINGS, NAMELY, COMPACT DISCS, AUDIO DISCS, RECORDS, VIDEO DISCS, PHONOGRAPHIC RECORDS, DVDS, MP3S, ALL FEATURING MUSIC; DOWNLOADABLE MUSICAL SOUND RECORDINGS; DOWNLOADABLE VIDEO RECORDINGS FEATURING MUSIC (U.S. CLS. 21, 23, 26, 36 AND 38).

FIRST USE 7-0-2006; IN COMMERCE 10-0-2006.

3,482,446. RECOGNITION INSIGHT, LLC, FORT MYERS, FL. SN 78-930,547. PUB. 2-27-2007, FILED 7-17-2006.

SHADOW PRO

THE MARK CONSISTS OF STANDARD CHARACTERS WITHOUT CLAIM TO ANY PARTICULAR FONT, STYLE, SIZE, OR COLOR.

NO CLAIM IS MADE TO THE EXCLUSIVE RIGHT TO USE "PRO", APART FROM THE MARK AS SHOWN.

FOR COMPUTER SOFTWARE IN THE FIELD OF SPORTS INSTRUCTION, NAMELY, SOFTWARE FOR TRANSMITTING, RECORDING, STORING AND PROVIDING AUDIO FEEDBACK AND VIDEO DISPLAY OF INFORMATION RELATED TO THE SWINGING OF AN APPARATUS IN VARIOUS SPORTS (U.S. CLS. 21, 23, 26, 36 AND 38).

FIRST USE 8-15-2006; IN COMMERCE 10-1-2006.

3,482,458. LIGHTEL TECHNOLOGIES, INC., KENT, WA. SN 78-934,213. PUB. 10-23-2007, FILED 7-20-2006.

ViewConn

THE MARK CONSISTS OF STANDARD CHARACTERS WITHOUT CLAIM TO ANY PARTICULAR FONT, STYLE, SIZE, OR COLOR.

FOR FIBER OPTIC CONNECTOR INSPECTION EQUIPMENT, NAMELY, VIDEO MICROSCOPES USED TO INSPECT AND CLEAN CONNECTOR END-FACES (U.S. CLS. 21, 23, 26, 36 AND 38).

FIRST USE 12-20-2006; IN COMMERCE 2-2-2007.

CLASS 9—(Continued).

3,482,480. AVID TECHNOLOGY, INC., TEWKSBURY, MA. SN 78-940,919. PUB. 3-13-2007, FILED 7-31-2006.

XPONENT

THE MARK CONSISTS OF STANDARD CHARACTERS WITHOUT CLAIM TO ANY PARTICULAR FONT, STYLE, SIZE, OR COLOR.

FOR DJ EQUIPMENT, NAMELY, COMPUTER SOFTWARE FOR AUDIO PRODUCTION AND COMPUTER PERIPHERALS (U.S. CLS. 21, 23, 26, 36 AND 38).

FIRST USE 5-21-2007; IN COMMERCE 5-21-2007.

CLASS 9—(Continued).

3,482,482. PERFORMANCE MOTION DEVICES, INC., LINCOLN, MA. SN 78-941,427. PUB. 3-13-2007, FILED 7-31-2006.

PRODIGY

THE MARK CONSISTS OF STANDARD CHARACTERS WITHOUT CLAIM TO ANY PARTICULAR FONT, STYLE, SIZE, OR COLOR.

FOR MOTION CONTROL CARDS TO CONTROL SERVO AND STEP MOTORS FOR USE BY ORIGINAL EQUIPMENT MANUFACTURERS IN THE FIELD OF MOTION CONTROL (U.S. CLS. 21, 23, 26, 36 AND 38).

FIRST USE 7-31-2006; IN COMMERCE 11-10-2006.

3,482,485. AGAMATRIX, INC., SALEM, NH. SN 78-943,040. PUB. 4-10-2007, FILED 8-2-2006.

ZERO-Click

THE MARK CONSISTS OF THE WORDS "ZERO-CLICK" WHEREIN THE "O" OF THE WORD "ZERO" IS STYLIZED.

FOR DIGITAL SIGNAL PROCESSING APPARATUS, NAMELY, A PROGRAMMED MICROPROCESSOR FOR INCORPORATION INTO ELECTROCHEMICAL METERS FOR THE MEDICAL PURPOSE OF ELECTROCHEMICAL MONITORING OF ANALYTES IN BIOLOGICAL FLUIDS; DIGITAL SIGNAL PROCESSING APPARATUS, NAMELY, A PROGRAMMED MICROPROCESSOR FOR INCORPORATION INTO ELECTROCHEMICAL METERS FOR THE MEDICAL PURPOSE OF ELECTROCHEMICAL MONITORING OF GLUCOSE IN BIOLOGICAL FLUIDS; DIGITAL SIGNAL PROCESSING APPARATUS, NAMELY, A PROGRAMMED MICROPROCESSOR FOR INCORPORATION INTO ELECTROCHEMICAL METERS FOR THE MEDICAL PURPOSE OF ELECTROCHEMICAL IMMUNOASSAYS OF BIOLOGICAL FLUIDS; DIGITAL SIGNAL PROCESSING APPARATUS, NAMELY, A PROGRAMMED MICROPROCESSOR FOR INCORPORATION INTO INSULIN PUMPS FOR THE MEDICAL PURPOSE OF CONTROLLING THE DELIVERY OF INSULIN TO A USER; DIGITAL SIGNAL PROCESSING APPARATUS, NAMELY, A PROGRAMMED MICROPROCESSOR FOR INCORPORATION INTO A COMBINED ELECTROCHEMICAL METER/INSULIN PUMP FOR THE MEDICAL PURPOSES OF MONITORING GLUCOSE IN BLOOD AND CONTROLLING THE DELIVERY OF INSULIN TO A USER; WIRED OR WIRELESS COMMUNICATION DEVICES FOR COMMUNICATION BETWEEN ANY OF THE DIGITAL SIGNAL PROCESSING APPARATUSES DESCRIBED HEREIN AND DATA TRANSFER OR EXTERNAL OR REMOTE STORAGE DEVICES, FOR EXAMPLE A CABLE FOR CONNECTING A DIGITAL SIGNAL PROCESSING APPARATUS TO A PERSONAL COMPUTER OR WIRELESS COMMUNICATION HARDWARE SUCH AS TRANSMITTERS AND RECEIVERS; SOFTWARE FOR CONTROLLING ELECTROCHEMICAL METERS FOR THE MEDICAL PURPOSE OF ELECTROCHEMICAL MONITORING OF ANALYTES IN BIOLOGICAL

3,482,481. VICTAULIC COMPANY, EASTON, PA. SN 78-941,288. PUB. 10-9-2007, FILED 7-31-2006.

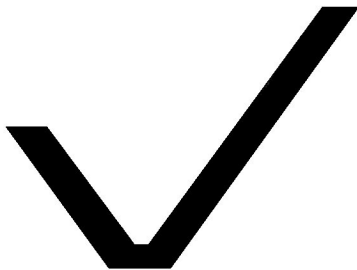

THE MARK CONSISTS OF THE LETTER "V" IN STYLIZED FORM.

FOR AUTOMATICALLY ACTIVATED VALVES FOR CONTROLLING THE FLOW OF FLUIDS; FIRE EXTINGUISHING WATER SPRINKLER HEADS; GAUGES, NAMELY, LEVEL GAUGES AND PRESSURE GAUGES; WATER METERS; FIRE ALARMS, CONTROL SWITCHES AND WATER SPRINKLER NOZZLES, ALL USED WITH FIRE PROTECTION SYSTEMS (U.S. CLS. 21, 23, 26, 36 AND 38).

FIRST USE 5-15-2002; IN COMMERCE 5-15-2002.

CLASS 9—(Continued).

FLUIDS; SOFTWARE FOR CONTROLLING ELECTROCHEMICAL METERS FOR THE MEDICAL PURPOSE OF ELECTROCHEMICAL MONITORING OF GLUCOSE IN BIOLOGICAL FLUIDS; SOFTWARE FOR CONTROLLING ELECTROCHEMICAL METERS FOR THE MEDICAL PURPOSE OF ELECTROCHEMICAL IMMUNOASSAYS OF BIOLOGICAL FLUIDS; SOFTWARE FOR CONTROLLING INSULIN PUMPS FOR THE MEDICAL PURPOSE OF CONTROLLING THE DELIVERY OF INSULIN TO A USER; SOFTWARE FOR CONTROLLING A COMBINED ELECTROCHEMICAL METER/INSULIN PUMP FOR THE MEDICAL PURPOSES OF MONITORING GLUCOSE IN BLOOD AND CONTROLLING THE DELIVERY OF INSULIN TO A USER; SOFTWARE FOR CONTROLLING WIRED OR WIRELESS COMMUNICATION DEVICES FOR COMMUNICATION BETWEEN ANY OF THE DIGITAL SIGNAL PROCESSING APPARATUSES DESCRIBED HEREIN AND A DATA TRANSFER OR EXTERNAL OR REMOTE STORAGE DEVICE; AND COMBINATIONS THEREOF SOLD AS A UNIT (U.S. CLS. 21, 23, 26, 36 AND 38).

FIRST USE 1-24-2007; IN COMMERCE 1-24-2007.

3,482,517. BOSTON ACOUSTICS, INC., PEABODY, MA. SN 78-954,084. PUB. 10-2-2007, FILED 8-17-2006.

TVEE

THE MARK CONSISTS OF STANDARD CHARACTERS WITHOUT CLAIM TO ANY PARTICULAR FONT, STYLE, SIZE, OR COLOR.

FOR LOUDSPEAKERS; AMPLIFIERS; RADIOS; HOME THEATER SYSTEMS COMPRISED OF PRE-AMPLIFIERS, STEREO SIGNAL PROCESSORS, POWER AMPLIFIERS AND LOUDSPEAKER SYSTEMS; RADIO FREQUENCY TRANSMITTERS; RADIO FREQUENCY RECEIVERS; AND WIRELESS AUDIO PRODUCTS, NAMELY, WIRELESS LOUDSPEAKERS (U.S. CLS. 21, 23, 26, 36 AND 38).

FIRST USE 9-1-2007; IN COMMERCE 9-1-2007.

CLASS 9—(Continued).

3,482,520. MUSICIP CORPORATION, MONROVIA, CA. SN 78-954,599. PUB. 10-2-2007, FILED 8-17-2006.

MUSICIP MIXER

THE MARK CONSISTS OF STANDARD CHARACTERS WITHOUT CLAIM TO ANY PARTICULAR FONT, STYLE, SIZE, OR COLOR.

NO CLAIM IS MADE TO THE EXCLUSIVE RIGHT TO USE "MIXER", APART FROM THE MARK AS SHOWN.

FOR CONTROL SOFTWARE FOR MANAGING, IDENTIFYING AND SELECTING MUSIC AND FOR CREATING MUSIC PLAYLISTS; SOFTWARE DEVELOPMENT KITS (SDK) FOR ADAPTING SUCH CONTROL SOFTWARE FOR USE WITH CONSUMER PRODUCTS SUCH AS MP3 PLAYERS, AND FIRMWARE EMBEDDED IN THIRD PARTY CONSUMER PRODUCTS AND ENTERPRISE NETWORK SERVERS TO ENABLE SUCH CONTROL SOFTWARE (U.S. CLS. 21, 23, 26, 36 AND 38).

FIRST USE 4-0-2006; IN COMMERCE 4-0-2006.

3,482,527. GLOBAL GAMING GROUP, LAS VEGAS, NV. SN 78-956,708. PUB. 4-10-2007, FILED 8-21-2006.

Boogie Monsters

THE MARK CONSISTS OF STANDARD CHARACTERS WITHOUT CLAIM TO ANY PARTICULAR FONT, STYLE, SIZE, OR COLOR.

FOR GAMING EQUIPMENT, NAMELY, SLOT MACHINES WITH OR WITHOUT VIDEO OUTPUT (U.S. CLS. 21, 23, 26, 36 AND 38).

FIRST USE 2-15-2008; IN COMMERCE 2-15-2008.

3,482,529. GLOBAL GAMING GROUP, LAS VEGAS, NV. SN 78-956,778. PUB. 4-10-2007, FILED 8-21-2006.

Big Bite

THE MARK CONSISTS OF STANDARD CHARACTERS WITHOUT CLAIM TO ANY PARTICULAR FONT, STYLE, SIZE, OR COLOR.

FOR GAMING EQUIPMENT, NAMELY, SLOT MACHINES WITH OR WITHOUT VIDEO OUTPUT (U.S. CLS. 21, 23, 26, 36 AND 38).

FIRST USE 1-5-2008; IN COMMERCE 1-5-2008.

CLASS 9—(Continued).

3,482,530. SFC FLUIDICS, LLC, FAYETTEVILLE, AR. SN 78-958,646. PUB. 10-9-2007, FILED 8-23-2006.

EPUMP

THE MARK CONSISTS OF STANDARD CHARACTERS WITHOUT CLAIM TO ANY PARTICULAR FONT, STYLE, SIZE, OR COLOR.

FOR TECHNICAL AND SCIENTIFIC APPARATUS, NAMELY, ELECTROCHEMICAL PUMP FOR CONTROL OF FLUID FLOW IN CHEMICAL AND BIOLOGICAL SYSTEM (U.S. CLS. 21, 23, 26, 36 AND 38).

FIRST USE 12-5-2005; IN COMMERCE 12-5-2005.

3,482,531. SFC FLUIDICS, LLC, FAYETTEVILLE, AR. SN 78-958,705. PUB. 10-2-2007, FILED 8-23-2006.

MPUMP

THE MARK CONSISTS OF STANDARD CHARACTERS WITHOUT CLAIM TO ANY PARTICULAR FONT, STYLE, SIZE, OR COLOR.

FOR TECHNICAL AND SCIENTIFIC APPARATUS, NAMELY, MAGNETOHYDRODYNAMIC PUMP FOR MOVING AND STIRRING LIQUIDS IN CHEMICAL AND BIOLOGICAL SYSTEMS (U.S. CLS. 21, 23, 26, 36 AND 38).

FIRST USE 7-1-2006; IN COMMERCE 11-1-2007.

3,482,539. OPTESSA INC., EDMONTON ALBERTA, CANADA. SN 78-960,931. PUB. 1-8-2008, FILED 8-25-2006.

OPTESSA

THE MARK CONSISTS OF STANDARD CHARACTERS WITHOUT CLAIM TO ANY PARTICULAR FONT, STYLE, SIZE, OR COLOR.

FOR COMPUTER SOFTWARE PROGRAMS RELATED TO MANUFACTURING RESOURCE PLANNING, SCHEDULING AND SEQUENCING AND OPERATIONS MANUALS FOR USE THEREWITH, SOLD AS A UNIT (U.S. CLS. 21, 23, 26, 36 AND 38).

FIRST USE 11-1-2006; IN COMMERCE 11-1-2006.

CLASS 9—(Continued).

3,482,542. DREW TECHNOLOGIES, INC, ANN ARBOR, MI. SN 78-961,922. PUB. 4-24-2007, FILED 8-28-2006.

DashDAQ

THE MARK CONSISTS OF STANDARD CHARACTERS WITHOUT CLAIM TO ANY PARTICULAR FONT, STYLE, SIZE, OR COLOR.

FOR LCD COMPUTER DISPLAYS AND RELATED COMPUTER SOFTWARE TO COMMUNICATE WITH MOTOR VEHICLE ONBOARD DATA EQUIPMENT, AND TO DISPLAY MOTOR VEHICLE ENGINE PARAMETERS OTHER VEHICLE DATA IN NUMERIC AND GRAPHICAL FORMATS (U.S. CLS. 21, 23, 26, 36 AND 38).

FIRST USE 8-16-2006; IN COMMERCE 7-27-2007.

3,482,572. FITMOM, INC., TORONTO, ONTARIO. SN 78-979,544. PUB. 6-13-2006, FILED 2-14-2005.

FITMOM

THE MARK CONSISTS OF STANDARD CHARACTERS WITHOUT CLAIM TO ANY PARTICULAR FONT, STYLE, SIZE, OR COLOR.

FOR PRE-RECORDED VIDEO TAPES FEATURING EXERCISE AND FITNESS PROGRAMS AND TRAINING (U.S. CLS. 21, 23, 26, 36 AND 38).

FIRST USE 8-18-2006; IN COMMERCE 8-18-2006.

CLASS 9—(Continued).

3,482,580. SHARP KABUSHIKI KAISHA, TA SHARP CORPORATION, OSAKA, JAPAN. SN 78-980,333. PUB. 8-28-2007, FILED 11-10-2005.

SHARP OSA

THE MARK CONSISTS OF STANDARD CHARACTERS WITHOUT CLAIM TO ANY PARTICULAR FONT, STYLE, SIZE, OR COLOR.

OWNER OF U.S. REG. NOS. 1,405,542, 1,985,630, AND OTHERS.

NO CLAIM IS MADE TO THE EXCLUSIVE RIGHT TO USE "OSA", APART FROM THE MARK AS SHOWN.

FOR SOFTWARE FOR OPERATING COPYING MACHINES, PRINTERS, FACSIMILE MACHINES AND SCANNERS (U.S. CLS. 21, 23, 26, 36 AND 38).

FIRST USE 5-31-2006; IN COMMERCE 5-31-2006.

3,482,581. ORACLE INTERNATIONAL CORPORATION, REDWOOD CITY, CA. SN 78-980,351. PUB. 6-6-2006, FILED 4-25-2005.

ORACLE FUSION

THE MARK CONSISTS OF STANDARD CHARACTERS WITHOUT CLAIM TO ANY PARTICULAR FONT, STYLE, SIZE, OR COLOR.

OWNER OF U.S. REG. NOS. 1,200,239, 2,997,144, AND OTHERS.

FOR COMPUTER SOFTWARE, NAMELY, A FULL LINE OF MIDDLEWARE SOFTWARE (U.S. CLS. 21, 23, 26, 36 AND 38).

FIRST USE 12-30-2005; IN COMMERCE 12-30-2005.

CLASS 10—MEDICAL APPARATUS

3,481,049. C. R. BARD, INC., MURRAY HILL, NJ. SN 76-336,490. PUB. 10-10-2006, FILED 11-13-2001.

CONQUEST

FOR PERCUTANEOUS TRANSLUMINAL ANGIOPLASTY (PTA) BALLOON CATHETER (U.S. CLS. 26, 39 AND 44).

FIRST USE 3-27-2002; IN COMMERCE 3-27-2002.

CLASS 10—(Continued).

3,481,073. ORTHO-TAIN, INC., WINNETKA, IL. SN 76-630,333. PUB. 3-14-2006, FILED 2-3-2005.

SMILERETAINER

THE MARK CONSISTS OF STANDARD CHARACTERS WITHOUT CLAIM TO ANY PARTICULAR FONT, STYLE, SIZE, OR COLOR.

FOR ORTHODONTIC APPLIANCES, NAMELY, DENTAL AND ORTHODONTIC RETAINERS, REMOVABLE ORTHODONTIC APPLIANCES, TOOTH POSITIONERS, RETENTION DEVICES AND ACTIVATORS (U.S. CLS. 26, 39 AND 44).

FIRST USE 5-25-2007; IN COMMERCE 5-25-2007.

3,481,147. ELLMAN INNOVATIONS, LLC, OCEANSIDE, NY. SN 76-676,328. PUB. 11-6-2007, FILED 5-2-2007.

LESS IS MORE

THE MARK CONSISTS OF STANDARD CHARACTERS WITHOUT CLAIM TO ANY PARTICULAR FONT, STYLE, SIZE, OR COLOR.

FOR MEDICAL DEVICES FOR THE PERFORMANCE OF ELECTROSURGICAL PROCEDURES INVOLVING THE USE OF RADIO-FREQUENCY ENERGY AND ACCESSORIES THEREFOR IN THE NATURE OF ELECTROSURGICAL ELECTRODES AND ELECTROSURGICAL HANDPIECES (U.S. CLS. 26, 39 AND 44).

FIRST USE 4-22-2008; IN COMMERCE 4-22-2008.

CLASS 10—(Continued).

3,481,173. SANACOR, L.L.C., AMERICAN FORK, UT. SN 77-003,203. PUB. 5-1-2007, FILED 9-20-2006.

SANACOR

THE MARK CONSISTS OF STANDARD CHARACTERS WITHOUT CLAIM TO ANY PARTICULAR FONT, STYLE, SIZE, OR COLOR.

FOR MEDICAL AND SURGICAL APPARATUS AND INSTRUMENTS, NAMELY, SURGICAL IMPLANTS COMPOSED OF ARTIFICIAL MATERIALS FOR THE TREATMENT OF DISEASES OF THE SPINE; VERTEBRAL DISCECTOMY APPARATUS AND INSTRUMENTS; VERTEBRAL ORTHOPEDIC APPARATUS AND INSTRUMENTS; ORTHOPEDIC FIXATION DEVICES USED IN VERTEBRAL IMPLANT SURGERY; PEDICLE SCREWS AND CONNECTING RODS USED IN VERTEBRAL SURGERY; SURGICAL INTERBODY SPACERS, CAGES, AND ASSOCIATED INSTRUMENTS, NAMELY, SURGICAL CUTTERS FOR IMPLANT SITE PREPARATION, IMPLANT TRIALS FOR VERIFYING A FIT BETWEEN THE SURGICAL SITE SIZE AND THE IMPLANT SIZE, AND IMPLANT HOLDERS AND INSERTION TOOLS FOR HOLDING AND INSERTING THE IMPLANT INTO THE SITE; AND PARTS AND FITTINGS FOR MEDICAL IMAGING APPARATUS PROVIDING PATIENT AND INSTRUMENT POSITIONING DATA IN SPINAL SURGERY INCLUDING MINIMAL INVASIVE SURGICAL INSTRUMENTS (U.S. CLS. 26, 39 AND 44).

FIRST USE 1-1-2007; IN COMMERCE 1-1-2007.

3,481,230. ALLUX MEDICAL, INC., MENLO PARK, CA. SN 77-033,527. PUB. 10-2-2007, FILED 10-31-2006.

BEAM REACH

THE MARK CONSISTS OF STANDARD CHARACTERS WITHOUT CLAIM TO ANY PARTICULAR FONT, STYLE, SIZE, OR COLOR.

FOR PHOTOTHERAPEUTIC APPARATUS FOR MEDICAL PURPOSES (U.S. CLS. 26, 39 AND 44).

FIRST USE 3-0-2007; IN COMMERCE 3-0-2007.

3,481,263. HITACHI MEDICAL CORPORATION, CHIYODAKU, TOKYO, JAPAN. SN 77-052,041. PUB. 6-26-2007, FILED 11-28-2006.

OASIS

CLASS 10—(Continued).

THE MARK CONSISTS OF STANDARD CHARACTERS WITHOUT CLAIM TO ANY PARTICULAR FONT, STYLE, SIZE, OR COLOR.

FOR MAGNETIC RESONANCE IMAGING APPARATUS (MRI) (U.S. CLS. 26, 39 AND 44).

FIRST USE 11-26-2006; IN COMMERCE 11-26-2006.

3,481,282. CHANG, CALVIN, ANAHEIM, CA. SN 77-061,708. PUB. 7-17-2007, FILED 12-11-2006.

ACCUFIT

THE MARK CONSISTS OF STANDARD CHARACTERS WITHOUT CLAIM TO ANY PARTICULAR FONT, STYLE, SIZE, OR COLOR.

FOR ORTHOPEDIC FOOTWEAR; ORTHOPEDIC SOLES; ORTHOPEDIC SUPPORTS; ORTHOTIC INSERTS FOR FOOTWEAR; ORTHOTICS FOR FOOT; SUPPORTS FOR ANKLE, WRIST FOR MEDICAL USE (U.S. CLS. 26, 39 AND 44).

FIRST USE 8-1-2007; IN COMMERCE 8-1-2007.

3,481,287. G&H WIRE HOLDINGS, INC., CHICAGO, IL. SN 77-064,597. PUB. 7-17-2007, FILED 12-14-2006.

G&H

THE MARK CONSISTS OF STANDARD CHARACTERS WITHOUT CLAIM TO ANY PARTICULAR FONT, STYLE, SIZE, OR COLOR.

FOR ORTHODONTIC APPLIANCES AND DENTAL INSTRUMENTS, NAMELY, ARCH-WIRES, STRAIGHT-LINED SYSTEM BRACKETS, NICKEL TITANIUM AND STAINLESS STEEL COIL SPRINGS, BUCCAL TUBES AND LINGUAL ATTACHMENTS, PATIENT ELASTIC BANDS, ELASTIC BAND DISPENSERS, HEADGEAR, ELASTOMERIC CHAINS, ELASTOMERIC LIGATURES, ELASTOMERIC THREADS, STAINLESS STEEL LIGATURES, STAINLESS STEEL PALATAL BARS, BONDING AND BANDING APPARATUS, MIRRORS, RETAINER CASES, DENTAL STORAGE CASES, ELASTIC-KEY RING STERILIZATION CASSETTES, BITE STICKS, EXPANSION SCREWS, ORTHODONTIC PLIERS, AND BRACKET POSITIONING INSTRUMENTS (U.S. CLS. 26, 39 AND 44).

FIRST USE 12-31-1981; IN COMMERCE 12-31-1981.

CLASS 10—(Continued).

3,481,288. G&H WIRE HOLDINGS, INC., CHICAGO, IL. SN 77-064,603. PUB. 7-17-2007, FILED 12-14-2006.

G&H WIRE COMPANY

THE MARK CONSISTS OF STANDARD CHARACTERS WITHOUT CLAIM TO ANY PARTICULAR FONT, STYLE, SIZE, OR COLOR.

NO CLAIM IS MADE TO THE EXCLUSIVE RIGHT TO USE "WIRE COMPANY", APART FROM THE MARK AS SHOWN.

FOR ORTHODONTIC APPLIANCES AND DENTAL INSTRUMENTS, NAMELY, ARCH-WIRES, STRAIGHT-LINED SYSTEM BRACKETS, NICKEL TITANIUM AND STAINLESS STEEL COIL SPRINGS, BUCCAL TUBES AND LINGUAL ATTACHMENTS, PATIENT ELASTIC BANDS, ELASTIC BAND DISPENSERS, HEADGEAR, ELASTOMERIC CHAINS, ELASTOMERIC LIGATURES, ELASTOMERIC THREADS, STAINLESS STEEL LIGATURES, STAINLESS STEEL PALATAL BARS, BONDING AND BANDING APPARATUS, MIRRORS, RETAINER CASES, DENTAL STORAGE CASES, ELASTIC-KEY RING STERILIZATION CASSETTES, BITE STICKS, EXPANSION SCREWS, ORTHODONTIC PLIERS, AND BRACKET POSITIONING INSTRUMENTS (U.S. CLS. 26, 39 AND 44).

FIRST USE 12-31-1981; IN COMMERCE 12-31-1981.

3,481,311. OLYMPUS MEDICAL SYSTEMS CORP., TOKYO, JAPAN. SN 77-074,542. PUB. 7-31-2007, FILED 1-2-2007.

OBCU

THE MARK CONSISTS OF STANDARD CHARACTERS WITHOUT CLAIM TO ANY PARTICULAR FONT, STYLE, SIZE, OR COLOR.

FOR MEDICAL APPARATUS AND INSTRUMENTS, NAMELY, BALLOON INFLATING AND DEFLATING UNIT FOR ENDOSCOPES (U.S. CLS. 26, 39 AND 44).

FIRST USE 5-19-2007; IN COMMERCE 5-19-2007.

CLASS 10—(Continued).

3,481,436. ROCKY MOUNTAIN BIOSYSTEMS, INC., WHEAT RIDGE, CO. SN 77-125,638. PUB. 9-11-2007, FILED 3-8-2007.

FAST

THE MARK CONSISTS OF STANDARD CHARACTERS WITHOUT CLAIM TO ANY PARTICULAR FONT, STYLE, SIZE, OR COLOR.

FOR DEVICE FOR MECHANICALLY REMOVING LAYERS OF SKIN FOR TREATMENT OR DIAGNOSIS (U.S. CLS. 26, 39 AND 44).

FIRST USE 7-11-2007; IN COMMERCE 7-11-2007.

3,481,437. ABBOTT LABORATORIES, ABBOTT PARK, IL. SN 77-125,873. PUB. 1-1-2008, FILED 3-8-2007.

ci16200

THE MARK CONSISTS OF STANDARD CHARACTERS WITHOUT CLAIM TO ANY PARTICULAR FONT, STYLE, SIZE, OR COLOR.

OWNER OF U.S. REG. NO. 2,900,555.

FOR DIAGNOSTIC APPARATUS FOR THE MEDICAL ANALYSIS OF BODILY FLUIDS AND TISSUE (U.S. CLS. 26, 39 AND 44).

FIRST USE 1-31-2008; IN COMMERCE 1-31-2008.

3,481,469. CONAIR CORPORATION, STAMFORD, CT. SN 77-131,712. PUB. 9-11-2007, FILED 3-15-2007.

AIR COMFORT

THE MARK CONSISTS OF STANDARD CHARACTERS WITHOUT CLAIM TO ANY PARTICULAR FONT, STYLE, SIZE, OR COLOR.

FOR MASSAGE APPARATUS (U.S. CLS. 26, 39 AND 44).

FIRST USE 8-30-2007; IN COMMERCE 8-30-2007.

CLASS 10—(Continued).

3,481,560. PLEXUS BIOMEDICAL, INC., OAKLAND, TN. SN 77-146,552. PUB. 10-2-2007, FILED 4-2-2007.

HEM-AVERT

THE MARK CONSISTS OF STANDARD CHARACTERS WITHOUT CLAIM TO ANY PARTICULAR FONT, STYLE, SIZE, OR COLOR.

FOR MEDICAL DEVICE IN THE NATURE OF A PERIANAL STABILIZER USED TO PREVENT OR REDUCE HEMORRHOID SEVERITY (U.S. CLS. 26, 39 AND 44).

FIRST USE 8-10-2007; IN COMMERCE 8-10-2007.

CLASS 10—(Continued).

3,481,672. AROBELLA MEDICAL, LLC, MINNETONKA, MN. SN 77-170,761. PUB. 9-18-2007, FILED 5-2-2007.

Qoustic Qurette

THE MARK CONSISTS OF STANDARD CHARACTERS WITHOUT CLAIM TO ANY PARTICULAR FONT, STYLE, SIZE, OR COLOR.

NO CLAIM IS MADE TO THE EXCLUSIVE RIGHT TO USE "CURETTE", APART FROM THE MARK AS SHOWN. FOR MEDICAL ULTRASOUND APPARATUS (U.S. CLS. 26, 39 AND 44).

FIRST USE 4-10-2008; IN COMMERCE 4-10-2008.

3,481,561. AROBELLA MEDICAL, LLC, MINNETONKA, MN. SN 77-146,737. PUB. 9-18-2007, FILED 4-2-2007.

SOUND TOUCH FOR WOUND CARE

THE MARK CONSISTS OF STANDARD CHARACTERS WITHOUT CLAIM TO ANY PARTICULAR FONT, STYLE, SIZE, OR COLOR.

NO CLAIM IS MADE TO THE EXCLUSIVE RIGHT TO USE "FOR WOUND CARE", APART FROM THE MARK AS SHOWN.

FOR MEDICAL ULTRASOUND APPARATUS (U.S. CLS. 26, 39 AND 44).

FIRST USE 4-10-2008; IN COMMERCE 4-10-2008.

3,481,673. ACIST MEDICAL SYSTEMS, INC., EDEN PRAIRIE, MN. SN 77-170,853. PUB. 10-30-2007, FILED 5-2-2007.



THE MARK CONSISTS OF STYLIZED LETTERS. FOR HAND HELD MEDICAL APPARATUS FOR MEASURING THE LEVEL OF RENAL FUNCTION PARAMETERS IN A PATIENT'S BLOOD (U.S. CLS. 26, 39 AND 44).

FIRST USE 8-30-2007; IN COMMERCE 8-30-2007.

3,481,613. MEDTRONIC XOMED, INC., JACKSONVILLE, FL. SN 77-155,368. PUB. 9-18-2007, FILED 4-12-2007.

NIM-ECLIPSE

THE MARK CONSISTS OF STANDARD CHARACTERS WITHOUT CLAIM TO ANY PARTICULAR FONT, STYLE, SIZE, OR COLOR.

OWNER OF U.S. REG. NOS. 1,727,352, 2,942,892, AND OTHERS.

FOR NERVE INTEGRITY MONITOR AND COMPONENT PARTS THEREFOR (U.S. CLS. 26, 39 AND 44).

FIRST USE 5-30-2008; IN COMMERCE 5-30-2008.

3,481,679. AROBELLA MEDICAL, LLC, MINNETONKA, MN. SN 77-172,279. PUB. 9-18-2007, FILED 5-3-2007.

Qoustic Wound Therapy System

THE MARK CONSISTS OF STANDARD CHARACTERS WITHOUT CLAIM TO ANY PARTICULAR FONT, STYLE, SIZE, OR COLOR.

NO CLAIM IS MADE TO THE EXCLUSIVE RIGHT TO USE "WOUND THERAPY SYSTEM", APART FROM THE MARK AS SHOWN.

FOR MEDICAL ULTRASOUND APPARATUS (U.S. CLS. 26, 39 AND 44).

FIRST USE 4-10-2008; IN COMMERCE 4-10-2008.

CLASS 10—(Continued).

3,481,767. ICAD, INC., NASHUA, NH. SN 77-205,065. PUB. 11-27-2007, FILED 6-13-2007.

NEVER STOP LOOKING

THE MARK CONSISTS OF STANDARD CHARACTERS WITHOUT CLAIM TO ANY PARTICULAR FONT, STYLE, SIZE, OR COLOR.

FOR MEDICAL APPARATUS, NAMELY, DIAGNOSTIC IMAGING APPARATUS FOR COMPUTER-ASSISTED ANALYSIS OF ABNORMALITIES IN MEDICAL IMAGES AND RELATED OPERATING SOFTWARE, SOLD AS A UNIT (U.S. CLS. 26, 39 AND 44).

FIRST USE 6-15-2007; IN COMMERCE 6-15-2007.

3,481,891. NEOMED, INC., WOODSTOCK, GA. SN 77-257,715. PUB. 3-4-2008, FILED 8-17-2007.



THE COLOR(S) BLUE AND RED IS/ARE CLAIMED AS A FEATURE OF THE MARK.

THE MARK CONSISTS OF THE WORD "NEOMED" IN BLUE EXCEPT FOR THE "O" WHICH IS IN RED AS THE OUTLINE OF A SMILING FACE WITH A LOCK OF HAIR CURLING AWAY FROM IT.

FOR NEONATAL PRODUCTS, NAMELY, CATHETERIZATION TRAYS, NEONATAL PROCEDURE KITS COMPOSED OF STERILE FORCEPS, HEMOSTATS, SCISSORS, NEEDLES, STERILE SALINE, SCALPELS FOR USE IN CUT-DOWN PROCEDURES OR CATHETERIZATION PROCEDURES, URINARY DRAINAGE KITS COMPOSED OF URINARY CATHETER AND COLLECTION BURETTE, LUMBAR PUNCTURE KITS COMPOSED OF LUMBAR PUNCTURE NEEDLE AND SPINAL FLUID COLLECTION VIALS; NEONATAL AND PEDIATRIC ENTERAL PRODUCTS, NAMELY, FEEDING TUBES, ORAL SYRINGES AND ENTERAL EXTENSIONS THAT TOGETHER COMPRISE AN ENTERAL NUTRITION DELIVERY SYSTEM; CATHETERS, NAMELY, UMBILICAL CATHETERS AND URINARY DRAINAGE CATHETERS; SPECIALTY NEONATAL AND PEDIATRIC ITEMS, NAMELY, POLYETHYLENE OCCLUSIVE SURGICAL DRAPES AND DRAPES USED FOR EXAMINATION PURPOSES DURING REHABILITATION, THAT DO NOT BLOCK HEAT (U.S. CLS. 26, 39 AND 44).

FIRST USE 2-28-2007; IN COMMERCE 3-31-2007.

CLASS 10—(Continued).

3,481,947. SPORTWALL INTERNATIONAL INC., CARPINTERIA, CA. SN 77-284,586. PUB. 1-22-2008, FILED 9-20-2007.

XerGames

THE MARK CONSISTS OF STANDARD CHARACTERS WITHOUT CLAIM TO ANY PARTICULAR FONT, STYLE, SIZE, OR COLOR.

FOR MEDICAL EQUIPMENT, NAMELY, PHYSICAL EXERCISE APPARATUS FOR TREATMENT OF MOTOR CO-ORDINATION AND INACTIVITY BASED ILLNESSES SUCH AS: TYPE 2 DIABETES, DYSLEXIA, ADHD, ALZHEIMER'S AND OBESITY (U.S. CLS. 26, 39 AND 44).

FIRST USE 4-0-2007; IN COMMERCE 4-0-2007.

3,481,950. QUADRA PRO ALOFT LLC, SCOTTSDALE, AZ. SN 77-287,590. PUB. 3-18-2008, FILED 9-24-2007.

QUADRA PRO ALOFT

THE MARK CONSISTS OF STANDARD CHARACTERS WITHOUT CLAIM TO ANY PARTICULAR FONT, STYLE, SIZE, OR COLOR.

NO CLAIM IS MADE TO THE EXCLUSIVE RIGHT TO USE "PRO", APART FROM THE MARK AS SHOWN.

FOR BOXED KIT COMPRISED OF SURGICAL MASK, ANTISEPTIC HAND WIPES, NASAL SALINE SPRAY, AND VITAMINS AND MINERAL SUPPLEMENTS, WHICH IS USED TO REDUCE TRANSMISSION OF THE COMMON COLD (U.S. CLS. 26, 39 AND 44).

FIRST USE 1-15-2008; IN COMMERCE 1-15-2008.

3,481,982. CALIFORNIA EXOTIC NOVELTIES LLC, CHINO, CA. SN 77-317,166. PUB. 3-25-2008, FILED 10-30-2007.

NIPPLETTE

THE MARK CONSISTS OF STANDARD CHARACTERS WITHOUT CLAIM TO ANY PARTICULAR FONT, STYLE, SIZE, OR COLOR.

FOR ADULT SEXUAL AIDS, NAMELY, VIBRATING NIPPLE CLAMPS (U.S. CLS. 26, 39 AND 44).

FIRST USE 6-1-2008; IN COMMERCE 6-1-2008.

CLASS 10—(Continued).

3,481,986. BOSTON SCIENTIFIC SCIMED, INC., MAPLE GROVE, MN. SN 77-347,941. PUB. 3-25-2008, FILED 12-10-2007.

ADVANTAGE Fit

THE MARK CONSISTS OF STANDARD CHARACTERS WITHOUT CLAIM TO ANY PARTICULAR FONT, STYLE, SIZE, OR COLOR.

NO CLAIM IS MADE TO THE EXCLUSIVE RIGHT TO USE "FIT", APART FROM THE MARK AS SHOWN.

FOR TRANS-VAGINAL MID-URETHRAL SLING (U.S. CLS. 26, 39 AND 44).

FIRST USE 4-17-2008; IN COMMERCE 4-17-2008.

3,482,019. AMERICAN INSTITUTE FOR PLASTIC SURGERY, PLANO, TX. SN 78-354,755. PUB. 10-25-2005, FILED 1-21-2004.

SurgiSil

THE MARK CONSISTS OF STANDARD CHARACTERS WITHOUT CLAIM TO ANY PARTICULAR FONT, STYLE, SIZE, OR COLOR.

FOR SURGICAL IMPLANTS MADE OF SILICONE (U.S. CLS. 26, 39 AND 44).

FIRST USE 10-0-2007; IN COMMERCE 10-0-2007.

CLASS 10—(Continued).

3,482,032. ICON INTERVENTIONAL SYSTEMS, INC., ATLANTA, GA. SN 78-401,425. PUB. 9-27-2005, FILED 4-14-2004.

DESTINY

THE MARK CONSISTS OF STANDARD CHARACTERS WITHOUT CLAIM TO ANY PARTICULAR FONT, STYLE, SIZE, OR COLOR.

FOR GRAFTS AND COATED GRAFTS, NAMELY, VASCULAR GRAFTS NOT OF LIVING TISSUE; STENTS; AND ANGIOPLASTY PRODUCTS, NAMELY, BALLOON CATHETERS, GUIDING CATHETERS, GUIDE WIRES, INTRODUCER SHEATHS, GRAFT OR STENT INFLATION DEVICES, ARTERIAL ACCESS CLOSURE DEVICES (U.S. CLS. 26, 39 AND 44).

FIRST USE 5-13-2008; IN COMMERCE 5-13-2008.

3,482,061. SILK, JEFFREY E., OREM, UT. SN 78-485,798. PUB. 9-27-2005, FILED 9-17-2004.

Gaitometer

THE MARK CONSISTS OF STANDARD CHARACTERS WITHOUT CLAIM TO ANY PARTICULAR FONT, STYLE, SIZE, OR COLOR.

FOR MEDICAL DEVICE, NAMELY, A DEVICE FOR GAIT ANALYSIS AND PHYSICAL THERAPY OF THE LOWER EXTREMITIES TO TREAT GAIT IRREGULARITIES (U.S. CLS. 26, 39 AND 44).

FIRST USE 6-2-2008; IN COMMERCE 6-2-2008.

CLASS 10—(Continued).

3,482,168. EDWARDS LIFESCIENCES CORPORATION, IRVINE, CA. SN 78-700,425. PUB. 5-9-2006, FILED 8-25-2005.

EMBOL-X GLIDE

THE MARK CONSISTS OF STANDARD CHARACTERS WITHOUT CLAIM TO ANY PARTICULAR FONT, STYLE, SIZE, OR COLOR.

OWNER OF U.S. REG. NOS. 2,501,037, 2,685,967, AND OTHERS.

FOR MEDICAL DEVICE, NAMELY, CANNULA (U.S. CLS. 26, 39 AND 44).

FIRST USE 10-31-2005; IN COMMERCE 10-31-2005.

3,482,248. OLIVA OCHOA, JOSEP, GRANOLLERS, SPAIN. AND OLIVA OCHOA, XAVIER, GRANOLLERS, SPAIN. SN 78-780,553. PUB. 2-27-2007, FILED 12-23-2005.

CeraCrown

THE MARK CONSISTS OF STANDARD CHARACTERS WITHOUT CLAIM TO ANY PARTICULAR FONT, STYLE, SIZE, OR COLOR.

FOR DENTAL APPARATUS AND INSTRUMENTS, NAMELY, DENTAL IMPLANTS; ARTIFICIAL LIMBS, EYES AND TEETH; ORTHOPEDIC ARTICLES, NAMELY, ORTHOPEDIC BRACES; SUTURE MATERIALS, NAMELY, SUTURES (U.S. CLS. 26, 39 AND 44).

FIRST USE 1-1-2004; IN COMMERCE 1-1-2004.

3,482,250. OSBORNE ORTHOPEDIC GROUP, INC., NASSAWADOX, VA. SN 78-782,457. PUB. 4-3-2007, FILED 12-29-2005.

BOW  TIE

THE MARK CONSISTS OF THE WORDS "BOW" AND "TIE" SEPARATED BY A FIGURE EIGHT, INFINITY SYMBOL, OR "BOW TIE" -STYLE ELEMENT.

FOR SURGICAL AND MEDICAL APPARATUSES FOR USE IN GENERAL SURGERY; MEDICAL DEVICES, NAMELY, HOLDERS FOR ORGANIZING WIRES, CABLES, HOSES, TUBES, OR OTHER LINES (U.S. CLS. 26, 39 AND 44).

FIRST USE 4-0-2006; IN COMMERCE 4-0-2006.

CLASS 10—(Continued).

3,482,266. OPTIMEDICA CORPORATION, SANTA CLARA, CA. SN 78-791,112. PUB. 9-12-2006, FILED 1-13-2006.



FOR LASERS FOR MEDICAL USE (U.S. CLS. 26, 39 AND 44).

FIRST USE 6-21-2006; IN COMMERCE 6-21-2006.

3,482,285. VYCOR MEDICAL LLC, CORAM, NY. SN 78-803,141. PUB. 9-19-2006, FILED 1-31-2006.

VYCOR MEDICAL

THE MARK CONSISTS OF STANDARD CHARACTERS WITHOUT CLAIM TO ANY PARTICULAR FONT, STYLE, SIZE, OR COLOR.

NO CLAIM IS MADE TO THE EXCLUSIVE RIGHT TO USE "MEDICAL", APART FROM THE MARK AS SHOWN.

FOR SURGICAL INSTRUMENTS FOR USE IN CRANIAL, SPINAL AND GENERAL SURGERY (U.S. CLS. 26, 39 AND 44).

FIRST USE 11-1-2005; IN COMMERCE 10-31-2007.

3,482,307. NOMIR MEDICAL TECHNOLOGIES, INC., WALTHAM, MA. SN 78-827,356. PUB. 9-19-2006, FILED 3-2-2006.

LIGHTING THE WAY TO HEALING

THE MARK CONSISTS OF STANDARD CHARACTERS WITHOUT CLAIM TO ANY PARTICULAR FONT, STYLE, SIZE, OR COLOR.

FOR LASERS FOR SURGICAL AND MEDICAL USE (U.S. CLS. 26, 39 AND 44).

FIRST USE 2-1-2007; IN COMMERCE 11-1-2007.

CLASS 10—(Continued).

3,482,460. MICROVENTION, INC., ALISO VIEJO, CA. SN 78-935,835. PUB. 2-27-2007, FILED 7-24-2006.

HYDROSOFT

THE MARK CONSISTS OF STANDARD CHARACTERS WITHOUT CLAIM TO ANY PARTICULAR FONT, STYLE, SIZE, OR COLOR.

FOR MEDICAL DEVICES, NAMELY, INTRAVASCULAR IMPLANTS COMPRISED OF ARTIFICIAL MATERIAL (U.S. CLS. 26, 39 AND 44).

FIRST USE 6-30-2007; IN COMMERCE 6-30-2007.

3,482,551. MICROVENTION, INC., ALISO VIEJO, CA. SN 78-964,648. PUB. 3-6-2007, FILED 8-31-2006.

COMPASS

THE MARK CONSISTS OF STANDARD CHARACTERS WITHOUT CLAIM TO ANY PARTICULAR FONT, STYLE, SIZE, OR COLOR.

FOR MEDICAL DEVICES, NAMELY, INTRAVASCULAR IMPLANTS COMPRISED OF ARTIFICIAL MATERIAL (U.S. CLS. 26, 39 AND 44).

FIRST USE 9-30-2006; IN COMMERCE 9-30-2006.

3,482,554. KLEIMAN, PAUL L., CULVER CITY, CA. SN 78-967,261. PUB. 4-24-2007, FILED 9-5-2006.

MASSAGE U

THE MARK CONSISTS OF STANDARD CHARACTERS WITHOUT CLAIM TO ANY PARTICULAR FONT, STYLE, SIZE, OR COLOR.

NO CLAIM IS MADE TO THE EXCLUSIVE RIGHT TO USE "MASSAGE", APART FROM THE MARK AS SHOWN.

FOR NON-ELECTRIC AND ELECTRIC MASSAGE APPARATUSES (U.S. CLS. 26, 39 AND 44).

FIRST USE 1-3-2008; IN COMMERCE 2-14-2008.

CLASS 11—ENVIRONMENTAL CONTROL APPARATUS

CLASS 11—(Continued).

3,481,061. MISTERS UNLIMITED, LLC, FORT LAUDERDALE, FL. SN 76-554,940. PUB. 9-27-2005, FILED 10-23-2003.

MISTERS UNLIMITED

NO CLAIM IS MADE TO THE EXCLUSIVE RIGHT TO USE "MISTERS", APART FROM THE MARK AS SHOWN.

FOR EVAPORATIVE COOLING AND MISTING SYSTEMS COMPRISED PRIMARILY OF PUMPS, NOZZLES, FITTINGS, TUBING, FILTERS, FLUSH MOUNTS AND HOUSINGS, AND ACCESSORIES THEREFOR, NAMELY, MISTING RINGS, DRAIN VALVES, SOLENOID VALVES, BALL VALVES, TUBING CUTTERS, RELIEF VALVES, COUNTER BORE AND PILOT BIT, TAP AND DRILL AND REMOTE CONTRACTOR FOR REMOTE OPERATION OF PUMPS (U.S. CLS. 13, 21, 23, 31 AND 34).

FIRST USE 10-0-2003; IN COMMERCE 10-0-2003.

3,481,103. MR. AQUA CO., LTD., SHULIN CITY, TAIPEI COUNTY, TAIWAN. SN 76-661,281. PUB. 12-4-2007, FILED 6-8-2006.



FOR AQUARIUM LIGHTS, LIGHT BULBS, FLUORESCENT ELECTRIC LIGHT BULBS, ILLUMINATING LIGHT BULBS, AQUARIUM WATER TANK THERMOPHORES, AQUARIUM WATER TANK FILTERS, AQUARIUM HEATERS, AND AQUARIUM WATER CLEANING UNITS (U.S. CLS. 13, 21, 23, 31 AND 34).

FIRST USE 4-0-2001; IN COMMERCE 9-0-2003.

3,481,198. PERKINELMER, INC., WALTHAM, MA. SN 77-018,731. PUB. 9-4-2007, FILED 10-11-2006.

VIGI-Lux

THE MARK CONSISTS OF STANDARD CHARACTERS WITHOUT CLAIM TO ANY PARTICULAR FONT, STYLE, SIZE, OR COLOR.

FOR INFRARED ILLUMINATORS (U.S. CLS. 13, 21, 23, 31 AND 34).

FIRST USE 5-10-2006; IN COMMERCE 5-10-2006.

CLASS 11—(Continued).

3,481,328. HICKOK, RICHARD, FIFIELD, BUCHANAN, MI.
SN 77-082,650. PUB. 9-25-2007, FILED 1-14-2007.

Tile-A-Drain

THE MARK CONSISTS OF STANDARD CHARACTERS WITHOUT CLAIM TO ANY PARTICULAR FONT, STYLE, SIZE, OR COLOR.

FOR PLUMBING FIXTURES, NAMELY, SHOWER DRAIN HEIGHT EXTENSION AND FLOOR TILE ADAPTER (U.S. CLS. 13, 21, 23, 31 AND 34).

FIRST USE 1-1-2008; IN COMMERCE 1-1-2008.

CLASS 11—(Continued).

3,481,596. VILLEROY & BOCH A.G., METTLACH, FED REP GERMANY. SN 77-151,478. PUB. 10-9-2007, FILED 4-9-2007.

ELODY

THE MARK CONSISTS OF STANDARD CHARACTERS WITHOUT CLAIM TO ANY PARTICULAR FONT, STYLE, SIZE, OR COLOR.

FOR SANITARY EQUIPMENT, NAMELY, BATH TUBS, WASH BASINS, LAVATORIES, TOILET TANKS, AND TOILET SEATS (U.S. CLS. 13, 21, 23, 31 AND 34).

FIRST USE 0-0-2007; IN COMMERCE 0-0-2007.

3,481,418. SIMA PRODUCTS CORPORATION, OAKMONT, PA. SN 77-122,103. PUB. 2-5-2008, FILED 3-5-2007.

EXTENHD
beyond HD

NO CLAIM IS MADE TO THE EXCLUSIVE RIGHT TO USE "HD", APART FROM THE MARK AS SHOWN.

FOR SHELF MOUNTED LIGHTS (U.S. CLS. 13, 21, 23, 31 AND 34).

FIRST USE 10-10-2007; IN COMMERCE 10-10-2007.

3,481,597. VILLEROY & BOCH A.G., METTLACH, FED REP GERMANY. SN 77-151,481. PUB. 10-9-2007, FILED 4-9-2007.

TWIST

THE MARK CONSISTS OF STANDARD CHARACTERS WITHOUT CLAIM TO ANY PARTICULAR FONT, STYLE, SIZE, OR COLOR.

FOR SANITARY EQUIPMENT, NAMELY, BATH TUBS, WASH BASINS, LAVATORIES, TOILET TANKS AND SEATS (U.S. CLS. 13, 21, 23, 31 AND 34).

FIRST USE 0-0-2007; IN COMMERCE 0-0-2007.

3,481,511. FENTON ENVIRONMENTAL TECHNOLOGIES, INC., NEW ORLEANS, LA. SN 77-137,916. PUB. 9-18-2007, FILED 3-22-2007.



FENIX

THE MARK CONSISTS OF THE HEAD AND WING OF A BIRD ABOVE THE WORD FENIX.

FOR MUNICIPAL AND INDUSTRIAL WASTE DEHYDRATORS (U.S. CLS. 13, 21, 23, 31 AND 34).

FIRST USE 5-5-2008; IN COMMERCE 5-5-2008.

3,481,765. BEGHELLI NORTH AMERICA, MIRAMAR, FL. SN 77-203,730. PUB. 3-11-2008, FILED 6-12-2007.

SPYDER

THE MARK CONSISTS OF STANDARD CHARACTERS WITHOUT CLAIM TO ANY PARTICULAR FONT, STYLE, SIZE, OR COLOR.

"SPYDER" OR "SPIDER" HAS NO MEANING IN A FOREIGN LANGUAGE.

FOR ELECTRIC LUMINAIRES, LIGHT POST LUMINAIRES, LUMINAIRE REFRACTORS, LINEAR AND COMPACT FLUORESCENT LAMP SOURCES, NAMELY, FLUORESCENT LAMPS AND FLUORESCENT LAMP TUBES; HIGH PERFORMANCE, HIGH EFFICIENCY LINEAR LUMINAIRES FOR INDOOR AND OUTDOOR INDUSTRIAL USE (U.S. CLS. 13, 21, 23, 31 AND 34).

FIRST USE 12-0-2007; IN COMMERCE 12-0-2007.

CLASS 11—(Continued).

3,481,797. CRAFTMADE INTERNATIONAL INC., COPPELL, TX. SN 77-220,322. PUB. 12-11-2007, FILED 7-2-2007.

CLASS 11—(Continued).

3,481,887. HUNTER FAN COMPANY, MEMPHIS, TN. SN 77-255,951. PUB. 2-12-2008, FILED 8-15-2007.

METRO

ASHLYN

THE MARK CONSISTS OF STANDARD CHARACTERS WITHOUT CLAIM TO ANY PARTICULAR FONT, STYLE, SIZE, OR COLOR.
FOR CEILING FANS (U.S. CLS. 13, 21, 23, 31 AND 34).
FIRST USE 6-1-2007; IN COMMERCE 10-1-2007.

THE MARK CONSISTS OF STANDARD CHARACTERS WITHOUT CLAIM TO ANY PARTICULAR FONT, STYLE, SIZE, OR COLOR.
FOR CEILING FANS (U.S. CLS. 13, 21, 23, 31 AND 34).
FIRST USE 12-2-2007; IN COMMERCE 12-2-2007.

3,481,804. MORALES,ROBERT M., SAN ANTONIO, TX. SN 77-222,445. PUB. 12-18-2007, FILED 7-5-2007.

3,481,898. ELUMX LLC, FAYETTEVILLE, GA. SN 77-261,344. PUB. 2-19-2008, FILED 8-22-2007.

Keep Me Cool

TASKO

THE MARK CONSISTS OF STANDARD CHARACTERS WITHOUT CLAIM TO ANY PARTICULAR FONT, STYLE, SIZE, OR COLOR.
FOR COLD PACKS FOR COOLING THE BODY AND NOT FOR MEDICAL PURPOSES (U.S. CLS. 13, 21, 23, 31 AND 34).
FIRST USE 1-1-2006; IN COMMERCE 3-19-2007.

THE MARK CONSISTS OF STANDARD CHARACTERS WITHOUT CLAIM TO ANY PARTICULAR FONT, STYLE, SIZE, OR COLOR.
FOR LIGHTING FIXTURES; PORTABLE BATTERY-OPERATED LIGHTS THAT CAN BE PLACED ON SURFACES WHERE OTHER LIGHT SOURCES ARE UNAVAILABLE; LED AND HID LIGHT FIXTURES; ELECTRIC LIGHTING FIXTURES; FIXTURES FOR INCANDESCENT LIGHT BULBS (U.S. CLS. 13, 21, 23, 31 AND 34).
FIRST USE 6-8-2008; IN COMMERCE 6-16-2008.

3,481,819. HOLLINGSWORTH & VOSE COMPANY, EAST WALPOLE, MA. SN 77-231,085. PUB. 2-26-2008, FILED 7-17-2007.

3,481,926. HUNTER FAN COMPANY, MEMPHIS, TN. SN 77-276,373. PUB. 2-12-2008, FILED 9-11-2007.

NANOWAVE

DISCOVERY

THE MARK CONSISTS OF STANDARD CHARACTERS WITHOUT CLAIM TO ANY PARTICULAR FONT, STYLE, SIZE, OR COLOR.
FOR FILTER MEDIA COMPOSED OF SYNTHETIC FIBERS FOR LIQUID AND AIR FILTRATION APPLICATIONS (U.S. CLS. 13, 21, 23, 31 AND 34).
FIRST USE 7-27-2007; IN COMMERCE 7-27-2007.

THE MARK CONSISTS OF STANDARD CHARACTERS WITHOUT CLAIM TO ANY PARTICULAR FONT, STYLE, SIZE, OR COLOR.
FOR CEILING FANS (U.S. CLS. 13, 21, 23, 31 AND 34).
FIRST USE 11-2-2007; IN COMMERCE 11-2-2007.

CLASS 11—(Continued).

3,481,927. HUNTER FAN COMPANY, MEMPHIS, TN. SN 77-276,379. PUB. 2-12-2008, FILED 9-11-2007.

CLASS 11—(Continued).

3,481,944. HUNTER FAN COMPANY, MEMPHIS, TN. SN 77-282,302. PUB. 3-11-2008, FILED 9-18-2007.

STONINGTON

THE MARK CONSISTS OF STANDARD CHARACTERS WITHOUT CLAIM TO ANY PARTICULAR FONT, STYLE, SIZE, OR COLOR.
FOR CEILING FANS (U.S. CLS. 13, 21, 23, 31 AND 34).
FIRST USE 10-29-2007; IN COMMERCE 10-29-2007.

MARSALA

THE MARK CONSISTS OF STANDARD CHARACTERS WITHOUT CLAIM TO ANY PARTICULAR FONT, STYLE, SIZE, OR COLOR.
FOR CEILING FANS (U.S. CLS. 13, 21, 23, 31 AND 34).
FIRST USE 1-16-2008; IN COMMERCE 1-16-2008.

3,481,928. HUNTER FAN COMPANY, MEMPHIS, TN. SN 77-276,385. PUB. 2-12-2008, FILED 9-11-2007.

WESTBROOK

THE MARK CONSISTS OF STANDARD CHARACTERS WITHOUT CLAIM TO ANY PARTICULAR FONT, STYLE, SIZE, OR COLOR.
FOR CEILING FANS (U.S. CLS. 13, 21, 23, 31 AND 34).
FIRST USE 12-6-2007; IN COMMERCE 12-6-2007.

3,481,978. HUNTER FAN COMPANY, MEMPHIS, TN. SN 77-308,187. PUB. 3-11-2008, FILED 10-19-2007.

3,481,943. HUNTER FAN COMPANY, MEMPHIS, TN. SN 77-282,294. PUB. 3-11-2008, FILED 9-18-2007.

SUGAR N SPICE**STOCKBRIDGE**

THE MARK CONSISTS OF STANDARD CHARACTERS WITHOUT CLAIM TO ANY PARTICULAR FONT, STYLE, SIZE, OR COLOR.
FOR CEILING FANS (U.S. CLS. 13, 21, 23, 31 AND 34).
FIRST USE 3-10-2008; IN COMMERCE 3-10-2008.

THE MARK CONSISTS OF STANDARD CHARACTERS WITHOUT CLAIM TO ANY PARTICULAR FONT, STYLE, SIZE, OR COLOR.
FOR CEILING FANS (U.S. CLS. 13, 21, 23, 31 AND 34).
FIRST USE 1-16-2008; IN COMMERCE 1-16-2008.

CLASS 11—(Continued).

3,482,059. ZANOTTI S.P.A., PEGOGNAGA (MANTOVA), ITALY. SN 78-482,689. PUB. 7-10-2007, FILED 9-13-2004.



OWNER OF ITALY REG. NO. 684242, DATED 7-25-1996, EXPIRES 2-19-2016.

FOR AIR CONDITIONING, DESICCATING, DRYING AND REFRIGERATING APPARATUS AND DEVICES, NAMELY, AIR CONDITIONERS, DRYERS, DEHUMIDIFIERS, EVAPORATORS, STEAM CONDENSERS AND REFRIGERATORS INTENDED FOR USE IN ENVIRONMENTS WITH MODIFIED ATMOSPHERE, SUCH AS CHEESE AND SALAMI SEASONING ROOMS, MEAT PROCESSING ROOMS, STORAGE BINS; PARTS AND FITTINGS THEREOF; AIR CONDITIONERS AND REFRIGERATORS FOR SHIPPING CONTAINERS (U.S. CLS. 13, 21, 23, 31 AND 34).

FIRST USE 9-2-1996; IN COMMERCE 5-5-1997.

3,482,179. KWAK, TAE Y., IRVINE, CA. SN 78-711,475. PUB. 9-12-2006, FILED 9-12-2005.

Precision Technology

THE MARK CONSISTS OF STANDARD CHARACTERS WITHOUT CLAIM TO ANY PARTICULAR FONT, STYLE, SIZE, OR COLOR.

NO CLAIM IS MADE TO THE EXCLUSIVE RIGHT TO USE "TECHNOLOGY", APART FROM THE MARK AS SHOWN.

FOR WATER HEATERS FOR DOMESTIC AND SPACE HEATING (U.S. CLS. 13, 21, 23, 31 AND 34).

FIRST USE 6-2-2008; IN COMMERCE 6-2-2008.

CLASS 11—(Continued).

3,482,258. TAMER PRODUCTS, INC., CORAL SPRINGS, FL. SN 78-785,713. PUB. 10-10-2006, FILED 1-5-2006.

NIGHT TAMER

THE MARK CONSISTS OF STANDARD CHARACTERS WITHOUT CLAIM TO ANY PARTICULAR FONT, STYLE, SIZE, OR COLOR.

FOR CHEMICALLY-ACTIVATED LIGHT STICKS (U.S. CLS. 13, 21, 23, 31 AND 34).

FIRST USE 8-0-2005; IN COMMERCE 8-0-2005.

3,482,267. ROBERN, INC., BRISTOL, PA. SN 78-791,606. PUB. 3-13-2007, FILED 1-13-2006.

ROBERN

THE MARK CONSISTS OF STANDARD CHARACTERS WITHOUT CLAIM TO ANY PARTICULAR FONT, STYLE, SIZE, OR COLOR.

OWNER OF U.S. REG. NO. 2,105,339.

FOR ELECTRIC LIGHTING FIXTURES (U.S. CLS. 13, 21, 23, 31 AND 34).

FIRST USE 0-0-1982; IN COMMERCE 0-0-1982.

3,482,271. MEDICAL SOLUTIONS, INC., CHANTILLY, VA. SN 78-792,450. PUB. 9-19-2006, FILED 1-16-2006.

16 N 1

THE MARK CONSISTS OF STANDARD CHARACTERS WITHOUT CLAIM TO ANY PARTICULAR FONT, STYLE, SIZE, OR COLOR.

FOR MEDICAL AND SURGICAL WARMING CABINETS FOR MEDICAL AND SURGICAL FLUIDS, SOLUTIONS, INSTRUMENTS, MATERIALS, AND EQUIPMENT (U.S. CLS. 13, 21, 23, 31 AND 34).

FIRST USE 1-3-2008; IN COMMERCE 1-3-2008.

CLASS 11—(Continued).

3,482,283. CONAIR CORPORATION, STAMFORD, CT. SN 78-802,029. PUB. 8-29-2006, FILED 1-30-2006.

HYDROXY

THE MARK CONSISTS OF STANDARD CHARACTERS WITHOUT CLAIM TO ANY PARTICULAR FONT, STYLE, SIZE, OR COLOR.

FOR SHOWER HEADS (U.S. CLS. 13, 21, 23, 31 AND 34).

FIRST USE 1-1-2007; IN COMMERCE 1-1-2007.

3,482,318. BARBIER, JOHAN, FORT LAUDERDALE, FL. AND BELHOSTE, MARC, FORT LAUDERDALE, FL. SN 78-835,947. PUB. 10-24-2006, FILED 3-13-2006.

ABYSS

THE MARK CONSISTS OF STANDARD CHARACTERS WITHOUT CLAIM TO ANY PARTICULAR FONT, STYLE, SIZE, OR COLOR.

FOR MARINE AND OCEANOGRAPHIC EQUIPMENT AND PARTS THEREOF, NAMELY, UNDERWATER LIGHTS (U.S. CLS. 13, 21, 23, 31 AND 34).

FIRST USE 3-15-2006; IN COMMERCE 3-15-2006.

3,482,331. COLLINS INTERNATIONAL CO., LTD., FAIR LAWN, NJ. SN 78-849,760. PUB. 10-10-2006, FILED 3-30-2006.

MAGIC FLAME

THE MARK CONSISTS OF STANDARD CHARACTERS WITHOUT CLAIM TO ANY PARTICULAR FONT, STYLE, SIZE, OR COLOR.

FOR BARBECUE GRILLS (U.S. CLS. 13, 21, 23, 31 AND 34).

FIRST USE 5-30-2007; IN COMMERCE 5-30-2007.

CLASS 11—(Continued).

3,482,357. HANSGROHE AG, SCHILTACH, FED REP GERMANY. SN 78-863,494. PUB. 4-3-2007, FILED 4-18-2006.

SHOWERARC

THE MARK CONSISTS OF STANDARD CHARACTERS WITHOUT CLAIM TO ANY PARTICULAR FONT, STYLE, SIZE, OR COLOR.

FOR PLUMBING FITTINGS, NAMELY, MIXING VALVES WITH MANUAL AND AUTOMATIC CONTROLS; COMBINATION SHOWERS, NAMELY, PREASSEMBLED MULTIFUNCTION SHOWERS, SHOWERS AND SHOWER FITTINGS, NAMELY, SHOWER CONTROL VALVES, SHOWER SPRAYERS, SHOWER COMBINATIONS, NAMELY, HAND SHOWERS, BODY SHOWERS, SHOWER HEADS, LATERAL-JET SHOWERS, PIPES BEING PARTS OF SANITARY FACILITIES, NAMELY, SANITARY FLEXIBLE TUBES, SPRAY NOZZLES, BEING PARTS FOR MULTIFUNCTION SHOWERS; PARTS OF THE AFORESAID GOODS (U.S. CLS. 13, 21, 23, 31 AND 34).

FIRST USE 6-28-2006; IN COMMERCE 6-28-2006.

3,482,363. EQUICAP INVESTMENTS, LLC, DALLAS, TX. SN 78-866,667. PUB. 5-22-2007, FILED 4-21-2006.

LUXTILE

THE MARK CONSISTS OF STANDARD CHARACTERS WITHOUT CLAIM TO ANY PARTICULAR FONT, STYLE, SIZE, OR COLOR.

FOR TILE REPLACEMENT PRODUCT, NAMELY, SHOWER ENCLOSURES AND SHOWER PANELS (U.S. CLS. 13, 21, 23, 31 AND 34).

FIRST USE 1-18-2007; IN COMMERCE 1-18-2007.

CLASS 11—(Continued).

3,482,372. CONAIR CORPORATION, STAMFORD, DE. SN 78-877,668. PUB. 6-5-2007, FILED 5-5-2006.

**TOURMALINE
CERAMIC**

NO CLAIM IS MADE TO THE EXCLUSIVE RIGHT TO USE "TOURMALINE CERAMIC", APART FROM THE MARK AS SHOWN.

THE MARK CONSISTS OF THE TERMS "TOURMALINE CERAMIC" WITH A DESIGN OF A JEWEL IN THE PLACE OF THE "O".

FOR HAND-HELD ELECTRIC HAIR DRYERS (U.S. CLS. 13, 21, 23, 31 AND 34).

FIRST USE 10-1-2006; IN COMMERCE 10-1-2006.

CLASS 11—(Continued).

3,482,447. CHEMICO INTERNATIONAL, INC., CORPUS CHRISTI, TX. SN 78-931,148. PUB. 9-18-2007, FILED 7-17-2006.

HICYCLER

THE MARK CONSISTS OF STANDARD CHARACTERS WITHOUT CLAIM TO ANY PARTICULAR FONT, STYLE, SIZE, OR COLOR.

OWNER OF U.S. REG. NO. 3,160,434.

FOR WATER TREATMENT EQUIPMENT, NAMELY, SIDESTREAM SOFTENING EQUIPMENT, COMPRISED OF MANIFOLDS, FLUID LEVEL CONTROLLERS, PUMPS AND VALVES (U.S. CLS. 13, 21, 23, 31 AND 34).

FIRST USE 6-10-2005; IN COMMERCE 6-10-2005.

3,482,501. NUC ELECTRONICS CO., LTD., DAEGU, REPUBLIC OF KOREA. SN 78-947,326. PUB. 5-29-2007, FILED 8-8-2006.

KUVINGS

THE MARK CONSISTS OF STANDARD CHARACTERS WITHOUT CLAIM TO ANY PARTICULAR FONT, STYLE, SIZE, OR COLOR.

FOR ELECTRIC SOYMILK MAKER, ELECTRIC YOGURT MAKERS, ELECTRICAL ICE-CREAM MAKERS, ELECTRIC BREWING MACHINES FOR COFFEE, LIQUOR AND TEA FOR HOUSEHOLD PURPOSES, ELECTRIC DISH DISINFECTANT APPARATUS FOR HOUSEHOLD PURPOSES, ELECTRIC AIR DEODORIZING APPARATUS, ELECTRIC COOKING OVENS (U.S. CLS. 13, 21, 23, 31 AND 34).

FIRST USE 6-2-2008; IN COMMERCE 6-2-2008.

3,482,391. STOKES, ELBERT HARVEY, JR., GLENWOOD, AR. SN 78-895,661. PUB. 5-29-2007, FILED 5-30-2006.



THE COLOR(S) MAROON, GREEN AND WHITE IS/ARE CLAIMED AS A FEATURE OF THE MARK.

THE COLOR MAROON IS INSIDE THE LETTERING OF THE MARK WITH A WHITE OUTLINE. THE MARK IS PLACED ON A GREEN BACKGROUND AND THE COMPLETE MARK IS OUTLINED WITH A THIN LINE OF WHITE.

FOR COOKING APPARATUS THAT SITS ON TOP OF THE GAS GRILL; IT USES WATER AND WOOD CHIPS AND THE GREASE FROM THE MEAT TO COOK THE MEAT WITH LITTLE OR NO MAINTENANCE (U.S. CLS. 13, 21, 23, 31 AND 34).

FIRST USE 11-27-2007; IN COMMERCE 11-27-2007.

CLASS 12—VEHICLES

3,481,093. VOGUE TYRE & RUBBER COMPANY, MOUNT PROSPECT, IL. SN 76-656,988. PUB. 11-7-2006, FILED 3-21-2006.

ROLLIN ON VOGUES

THE MARK CONSISTS OF STANDARD CHARACTERS WITHOUT CLAIM TO ANY PARTICULAR FONT, STYLE, SIZE, OR COLOR.

OWNER OF U.S. REG. NOS. 212,547 AND 1,803,710.

FOR VEHICLE TIRES (U.S. CLS. 19, 21, 23, 31, 35 AND 44).

FIRST USE 5-31-2008; IN COMMERCE 5-31-2008.

CLASS 12—(Continued).

3,481,121. WALD LLC, MAYSVILLE, KY. SN 76-670,370. PUB. 2-12-2008, FILED 12-15-2006.

DON'T WORRY, THE BRAND IS WALD

THE MARK CONSISTS OF STANDARD CHARACTERS WITHOUT CLAIM TO ANY PARTICULAR FONT, STYLE, SIZE, OR COLOR.

OWNER OF U.S. REG. NOS. 576,907 AND 1,029,657.
FOR BICYCLE PARTS AND BICYCLE ACCESSORIES, NAMELY, FENDER BRACES, CHAIN GUARDS, REAR STANDS, SIDE STANDS, WIRE BASKETS, WIRE BASKET CLAMP SETS COMPRISED OF CLAMPS FOR SECURING WIRE BASKETS TO BICYCLE HANDLEBARS, WIRE BASKET BRACE SUPPORTS, MESH BASKETS, FOLDING BASKETS, BASKET HOLDERS, SADDLE BASKETS, SADDLE BASKET BRACKETS, HANDLEBAR STEMS, EXPANSION LUGS, HANDLEBARS, AXLES, HANDLEBAR STEM ASSEMBLY, KEY WASHERS, HEAD CUPS, ADJUSTABLE HEAD CONES, STATIONARY HEAD CONES, REPAIR CONES, FLASHLIGHT HOLDERS, SEAT POSTS, COASTER BRAKE STRAPS, CRANK HANGER CUPS, FORK STEMS, REPAIR FORKS, BIKE BALANCERS, TRAINING WHEELS/STABILIZERS, WIRE CARRIERS, REAR RACKS, FENDERS, FENDER FITTINGS, SPLASH GUARDS, SPROCKETS, REFLECTOR BRACKET, WATER BOTTLE HOLDER MOUNTING BRACKET AND PEDALS (U.S. CLS. 19, 21, 23, 31, 35 AND 44).

FIRST USE 6-14-2007; IN COMMERCE 6-14-2007.

3,481,189. CLIX SYSTEMS, INC., CAMBRIDGE, MA. SN 77-014,476. PUB. 10-16-2007, FILED 10-5-2006.

CLIX

THE MARK CONSISTS OF STANDARD CHARACTERS WITHOUT CLAIM TO ANY PARTICULAR FONT, STYLE, SIZE, OR COLOR.

FOR BICYCLE WHEELS FEATURING A QUICK-RELEASE LEVER; BICYCLE PARTS, NAMELY, FORKS FEATURING A QUICK-RELEASE LEVER FOR WHEELS (U.S. CLS. 19, 21, 23, 31, 35 AND 44).

FIRST USE 7-0-2006; IN COMMERCE 7-0-2006.

3,481,192. VALLEY CUSTOM TIRE, INC., VERNON, CA. SN 77-016,854. PUB. 8-28-2007, FILED 10-9-2006.

VALENTE

THE MARK CONSISTS OF STANDARD CHARACTERS WITHOUT CLAIM TO ANY PARTICULAR FONT, STYLE, SIZE, OR COLOR.

CLASS 12—(Continued).

THE ENGLISH TRANSLATION OF "VALENTE" IS "EFFICIENT".

FOR LAND VEHICLE AND OFF-ROAD VEHICLE PARTS; NAMELY, WHEELS AND WHEEL CAPS (U.S. CLS. 19, 21, 23, 31, 35 AND 44).

FIRST USE 6-14-2007; IN COMMERCE 6-14-2007.

3,481,236. DAVIS, WAYNE N., HUDDLESTON, VA. SN 77-036,402. PUB. 6-5-2007, FILED 11-3-2006.

Da-Vee-Hull

THE MARK CONSISTS OF STANDARD CHARACTERS WITHOUT CLAIM TO ANY PARTICULAR FONT, STYLE, SIZE, OR COLOR.

FOR BOAT HULLS (U.S. CLS. 19, 21, 23, 31, 35 AND 44).

FIRST USE 8-29-2007; IN COMMERCE 2-15-2008.

3,481,251. LEGACY PADDLESPOrts LLC, GREENSBORO, NC. SN 77-046,815. PUB. 9-11-2007, FILED 11-17-2006.



NO CLAIM IS MADE TO THE EXCLUSIVE RIGHT TO USE "WATERCRAFT", APART FROM THE MARK AS SHOWN.

THE COLOR(S) YELLOW AND BLACK IS/ARE CLAIMED AS A FEATURE OF THE MARK.

THE MARK CONSISTS OF A YELLOW PETROGLYPH OF A FISH ON A BLACK FIELD TO THE LEFT OF A CURVED RECTANGULAR CARRIER, WITH THE DEPICTION OF THE WORDS "NATIVE WATERCRAFT" IN BLACK ON A YELLOW BACKGROUND TO THE RIGHT OF THE CURVED RECTANGULAR CARRIER.

FOR RECREATIONAL WATERCRAFT, NAMELY, KAYAKS AND KAYAK-LIKE BOATS (U.S. CLS. 19, 21, 23, 31, 35 AND 44).

FIRST USE 8-15-2006; IN COMMERCE 8-15-2006.

CLASS 12—(Continued).

3,481,267. BRIDGESTONE CORPORATION, TOKYO, JAPAN.
SN 77-053,766. PUB. 5-1-2007, FILED 11-30-2006.

IT'S BRIDGESTONE OR NOTHING

THE MARK CONSISTS OF STANDARD CHARACTERS
WITHOUT CLAIM TO ANY PARTICULAR FONT, STYLE,
SIZE, OR COLOR.

OWNER OF U.S. REG. NOS. 1,342,473, 3,085,843, AND
OTHERS.

FOR VEHICLE TIRES (U.S. CLS. 19, 21, 23, 31, 35 AND
44).

FIRST USE 3-12-2007; IN COMMERCE 3-12-2007.

3,481,374. BRIDGESTONE CORPORATION, CHUO-KU, TO-
KYO, JAPAN. SN 77-104,807. PUB. 10-23-2007, FILED 2-12-
2007.

POTENZA G019 GRID

THE MARK CONSISTS OF STANDARD CHARACTERS
WITHOUT CLAIM TO ANY PARTICULAR FONT, STYLE,
SIZE, OR COLOR.

OWNER OF U.S. REG. NOS. 1,281,463 AND 2,788,718.

THE FOREIGN WORDING IN THE MARK TRANSLATES
INTO ENGLISH AS POWER.

FOR VEHICLE TIRES (U.S. CLS. 19, 21, 23, 31, 35 AND
44).

FIRST USE 1-1-2008; IN COMMERCE 1-1-2008.

3,481,401. CORECON, INC., SANDWICH, IL. SN 77-114,531.
PUB. 8-21-2007, FILED 2-23-2007.

IMPERCEPTIBLE MOTION

THE MARK CONSISTS OF STANDARD CHARACTERS
WITHOUT CLAIM TO ANY PARTICULAR FONT, STYLE,
SIZE, OR COLOR.

FOR AUTOMATED GUIDED VEHICLES (U.S. CLS. 19,
21, 23, 31, 35 AND 44).

FIRST USE 10-15-2007; IN COMMERCE 10-15-2007.

CLASS 12—(Continued).

3,481,491. BRAVO SPORTS, SANTA FE SPRINGS, CA. SN 77-
134,751. PUB. 9-25-2007, FILED 3-19-2007.

KICK 'N GO

THE MARK CONSISTS OF STANDARD CHARACTERS
WITHOUT CLAIM TO ANY PARTICULAR FONT, STYLE,
SIZE, OR COLOR.

FOR NON-MOTORIZED SCOOTERS (U.S. CLS. 19, 21,
23, 31, 35 AND 44).

FIRST USE 2-1-2008; IN COMMERCE 2-1-2008.

3,481,568. WEBER, STEVEN, HIDDEN HILLS, CA. SN 77-
147,726. PUB. 3-4-2008, FILED 4-3-2007.

MOTO GATE

THE MARK CONSISTS OF STANDARD CHARACTERS
WITHOUT CLAIM TO ANY PARTICULAR FONT, STYLE,
SIZE, OR COLOR.

NO CLAIM IS MADE TO THE EXCLUSIVE RIGHT TO
USE "GATE", APART FROM THE MARK AS SHOWN.

FOR AUTOMOTIVE PARTS, NAMELY, TRUCK BED
EXTENDERS (U.S. CLS. 19, 21, 23, 31, 35 AND 44).

FIRST USE 12-1-2007; IN COMMERCE 6-1-2008.

3,481,595. YONGFANG, GUO, WEIHAI CITY, CHINA. SN 77-
151,464. PUB. 10-16-2007, FILED 4-9-2007.

DURATOUGH

THE MARK CONSISTS OF "DURATOUGH" WITH STY-
LIZED LETTERS "D" AND "O".

FOR INNER TUBES; INNER TUBES FOR VEHICLE
TIRES; TIRES; TIRES FOR LAND VEHICLES; TREAD
USED TO RETREAD TIRES; TREADS FOR RETREAD-
ING TIRES FOR CIVIL ENGINEERING VEHICLES;
TREADS FOR RETREADING TIRES FOR FORESTRY
VEHICLES; TREADS FOR RETREADING TIRES FOR
VEHICLES USED IN THE CIVIL ENGINEERING IN-
DUSTRY; TIRES AND INNER TUBES FOR THE
WHEELS OF FORESTRY VEHICLES (U.S. CLS. 19, 21,
23, 31, 35 AND 44).

FIRST USE 1-1-2006; IN COMMERCE 1-1-2007.

CLASS 12—(Continued).

3,481,599. WTW WHOLESALE TIRES & WHEELS, INC., SANTA FE SPRINGS, CA. SN 77-151,901. PUB. 9-11-2007, FILED 4-9-2007.



OWNER OF U.S. REG. NO. 2,824,605.
NO CLAIM IS MADE TO THE EXCLUSIVE RIGHT TO USE "WHEELS", APART FROM THE MARK AS SHOWN.
THE MARK CONSISTS OF A LARGE STYLIZED "G" WITH THE WORD "GIOVANNA" WITHIN THE "G" AND WITH TWO LINES UNDER THE "G" AND THE WORD "WHEELS" BELOW THE TWO LINES.
FOR AUTOMOBILE WHEELS (U.S. CLS. 19, 21, 23, 31, 35 AND 44).
FIRST USE 2-28-1998; IN COMMERCE 2-28-1998.

3,481,620. FLEETWOOD ENTERPRISES, INC., RIVERSIDE, CA. SN 77-157,794. PUB. 10-16-2007, FILED 4-16-2007.

AMERICAN ALLEGIANCE

THE MARK CONSISTS OF STANDARD CHARACTERS WITHOUT CLAIM TO ANY PARTICULAR FONT, STYLE, SIZE, OR COLOR.
OWNER OF U.S. REG. NOS. 1,759,144, 2,318,980, AND OTHERS.
FOR MOTOR HOMES (U.S. CLS. 19, 21, 23, 31, 35 AND 44).
FIRST USE 12-0-2007; IN COMMERCE 12-0-2007.

3,481,674. ELRAE ENTERPRISES, INC., MORTON, IL. SN 77-171,049. PUB. 10-23-2007, FILED 5-2-2007.

XTREME PEDESTAL COVER

THE MARK CONSISTS OF STANDARD CHARACTERS WITHOUT CLAIM TO ANY PARTICULAR FONT, STYLE, SIZE, OR COLOR.
NO CLAIM IS MADE TO THE EXCLUSIVE RIGHT TO USE "PEDESTAL COVER", APART FROM THE MARK AS SHOWN.
FOR BOAT ACCESSORIES, NAMELY, METAL OR PLASTIC PEDESTAL COVERS (U.S. CLS. 19, 21, 23, 31, 35 AND 44).
FIRST USE 6-17-2008; IN COMMERCE 6-17-2008.

CLASS 12—(Continued).

3,481,704. POLARIS INDUSTRIES INC., MEDINA, MN. SN 77-177,905. PUB. 3-18-2008, FILED 5-10-2007.

RANGER CREW

THE MARK CONSISTS OF STANDARD CHARACTERS WITHOUT CLAIM TO ANY PARTICULAR FONT, STYLE, SIZE, OR COLOR.
FOR ALL-TERRAIN UTILITY VEHICLES AND STRUCTURAL PARTS THEREFOR (U.S. CLS. 19, 21, 23, 31, 35 AND 44).
FIRST USE 11-1-2007; IN COMMERCE 11-1-2007.

3,481,721. MENARD, INC., EAU CLAIRE, WI. SN 77-183,284. PUB. 10-23-2007, FILED 5-17-2007.



NO CLAIM IS MADE TO THE EXCLUSIVE RIGHT TO USE "GARAGE", APART FROM THE MARK AS SHOWN.
THE COLOR(S) RED, BLACK AND SILVER IS/ARE CLAIMED AS A FEATURE OF THE MARK.
THE MARK CONSISTS OF A BLACK GARAGE-SHAPE OUTLINE; THE WORD "XTREME" IN RED WITH THE LETTER "X" BEING LARGER THAN THE OTHER LETTERS IN THE WORD; THE WORD "XTREME" IN A STYLIZED FONT; THE WORD "GARAGE" APPEARING AS IF IT IS SILVER CHROME AND PORTRAYED AS THOUGH THERE ARE CHROME RIVETS ON THE LETTERING.
FOR SEMI-FITTED VEHICLE COVERS, NAMELY, COVERS FOR BOATS, PERSONAL WATERCRAFT, SNOWMOBILES, MOTORCYCLES, ALL-TERRAIN VEHICLES, AND AUTOMOBILES (U.S. CLS. 19, 21, 23, 31, 35 AND 44).
FIRST USE 4-0-2007; IN COMMERCE 4-0-2007.

3,481,722. MENARD, INC., EAU CLAIRE, WI. SN 77-183,613. PUB. 10-23-2007, FILED 5-17-2007.

XTREME GARAGE

THE MARK CONSISTS OF STANDARD CHARACTERS WITHOUT CLAIM TO ANY PARTICULAR FONT, STYLE,

CLASS 12—(Continued).

SIZE, OR COLOR.

NO CLAIM IS MADE TO THE EXCLUSIVE RIGHT TO USE "GARAGE", APART FROM THE MARK AS SHOWN.

FOR SEMI-FITTED VEHICLE COVERS, NAMELY, COVERS FOR BOATS, PERSONAL WATERCRAFT, SNOWMOBILES, MOTORCYCLES, ALL-TERRAIN VEHICLES, AND AUTOMOBILES (U.S. CLS. 19, 21, 23, 31, 35 AND 44).

FIRST USE 4-0-2007; IN COMMERCE 4-0-2007.

3,481,735. MENARD, INC., EAU CLAIRE, WI. SN 77-189,085.
PUB. 10-23-2007, FILED 5-24-2007.OWNER OF U.S. REG. NOS. 3,126,317 AND 3,129,290.
NO CLAIM IS MADE TO THE EXCLUSIVE RIGHT TO USE "GARAGE", APART FROM THE MARK AS SHOWN.
THE COLOR(S) RED, BLACK AND SILVER IS/ARE CLAIMED AS A FEATURE OF THE MARK.

THE MARK CONSISTS OF A BLACK GARAGE-SHAPE OUTLINE; THE WORD "XTREME" IN RED WITH THE "X" BEING LARGER THAN THE OTHER LETTERS IN THE WORD; THE WORD "XTREME" IN A STYLIZED FONT; THE WORD "GARAGE" APPEARING AS IF IT IS SILVER CHROME AND PORTRAYED AS THOUGH THERE ARE CHROME RIVETS ON THE LETTERING.

FOR MECHANICS CREEPERS, DOLLIES (U.S. CLS. 19, 21, 23, 31, 35 AND 44).

FIRST USE 5-18-2006; IN COMMERCE 5-18-2006.

3,481,903. THE ARMORED GROUP, PHOENIX, AZ. SN 77-262,604. PUB. 2-26-2008, FILED 8-23-2007.

BATT

THE MARK CONSISTS OF STANDARD CHARACTERS WITHOUT CLAIM TO ANY PARTICULAR FONT, STYLE, SIZE, OR COLOR.

FOR ARMORED VEHICLES (U.S. CLS. 19, 21, 23, 31, 35 AND 44).

FIRST USE 4-3-2006; IN COMMERCE 4-3-2006.

CLASS 12—(Continued).

3,481,931. POLARIS INDUSTRIES INC., MEDINA, MN. SN 77-277,430. PUB. 3-4-2008, FILED 9-12-2007.

POLARIS

THE MARK CONSISTS OF STANDARD CHARACTERS WITHOUT CLAIM TO ANY PARTICULAR FONT, STYLE, SIZE, OR COLOR.

OWNER OF U.S. REG. NOS. 2,851,927, 3,343,562, AND OTHERS.

FOR BICYCLES AND STRUCTURAL PARTS THEREFOR (U.S. CLS. 19, 21, 23, 31, 35 AND 44).

FIRST USE 8-0-2007; IN COMMERCE 8-0-2007.

3,482,012. GUNITE CORPORATION, ROCKFORD, IL. SN 78-308,442. PUB. 4-19-2005, FILED 10-2-2003.

TRU-SET

FOR SYSTEM COMPRISED OF A BEARING SPACER, BEARING CUPS, BEARING CONES AND OIL/GREASE SEAL FOR WHEEL HUBS FOR TRUCKS, TRUCK TRACTORS AND TRAILERS (U.S. CLS. 19, 21, 23, 31, 35 AND 44).

FIRST USE 12-0-2007; IN COMMERCE 12-0-2007.

3,482,101. ZODIAC INTERNATIONAL, ISSY LES MOULINEAUX CEDEX, FRANCE. SN 78-573,330. PUB. 1-24-2006, FILED 2-23-2005.

**ANY TIME, ANY
WEATHER**

THE MARK CONSISTS OF STANDARD CHARACTERS WITHOUT CLAIM TO ANY PARTICULAR FONT, STYLE, SIZE, OR COLOR.

FOR BOATS, INFLATABLE BOATS, TENDERS, AND DINGHIES; COMPONENT PARTS FOR BOATS, INFLATABLE BOATS, AND DINGHIES, NAMELY, BENCHES, SEATS, AND SEAT BACKS, STEERING WHEELS, WINDSHIELDS, DECK SECTIONS, DECK DASHBOARDS, BOAT HOOKS, BOAT TOPS, AND COVERS (U.S. CLS. 19, 21, 23, 31, 35 AND 44).

FIRST USE 4-0-2008; IN COMMERCE 4-0-2008.

CLASS 12—(Continued).

3,482,123. THOR TECH, INC., SAGINAW, MI. SN 78-631,818.
PUB. 3-28-2006, FILED 5-17-2005.

TRANS SHUTTLE

THE MARK CONSISTS OF STANDARD CHARACTERS WITHOUT CLAIM TO ANY PARTICULAR FONT, STYLE, SIZE, OR COLOR.
FOR COMMERCIAL BUSES (U.S. CLS. 19, 21, 23, 31, 35 AND 44).
FIRST USE 0-0-2005; IN COMMERCE 0-0-2005.

3,482,180. THE HERCULES TIRE & RUBBER COMPANY, FINDLAY, OH. SN 78-714,648. PUB. 1-23-2007, FILED 9-16-2005.

ROAD FORCE

THE MARK CONSISTS OF STANDARD CHARACTERS WITHOUT CLAIM TO ANY PARTICULAR FONT, STYLE, SIZE, OR COLOR.
FOR TIRES (U.S. CLS. 19, 21, 23, 31, 35 AND 44).
FIRST USE 5-1-2008; IN COMMERCE 5-1-2008.

3,482,218. GULF STREAM COACH, INC., NAPPANEE, IN. SN 78-759,355. PUB. 3-20-2007, FILED 11-22-2005.

WIDE OPEN

THE MARK CONSISTS OF STANDARD CHARACTERS WITHOUT CLAIM TO ANY PARTICULAR FONT, STYLE, SIZE, OR COLOR.
FOR RECREATIONAL VEHICLES, NAMELY, MOTOR HOMES, FIFTH WHEEL TRAILERS AND TRAVEL TRAILERS (U.S. CLS. 19, 21, 23, 31, 35 AND 44).
FIRST USE 2-10-2006; IN COMMERCE 2-10-2006.

CLASS 12—(Continued).

3,482,336. RPS TECHNOLOGIES, INC., MIAMISBURG, OH. SN 78-853,220. PUB. 8-7-2007, FILED 4-4-2006.

RAIN PROTECTION SYSTEMS

THE MARK CONSISTS OF STANDARD CHARACTERS WITHOUT CLAIM TO ANY PARTICULAR FONT, STYLE, SIZE, OR COLOR.
NO CLAIM IS MADE TO THE EXCLUSIVE RIGHT TO USE "RAIN" OR "SYSTEMS", APART FROM THE MARK AS SHOWN.
FOR WINDSHIELD WIPER BLADES (U.S. CLS. 19, 21, 23, 31, 35 AND 44).
FIRST USE 10-1-2007; IN COMMERCE 10-1-2007.

3,482,343. CARGO BED LICENSING INC., EDMONTON, CANADA. SN 78-855,990. PUB. 11-14-2006, FILED 4-6-2006.



THE COLOR(S) BLACK AND GREY IS/ARE CLAIMED AS A FEATURE OF THE MARK.
THE MARK CONSISTS OF A STYLIZED LETTER C AT THE FIRST LETTER OF THE WORD "CARGO" AND A STYLIZED LETTER D AT THE LAST LETTER OF THE WORD "BED"; ALL WORDS ARE IN BLACK UPPER CASE LETTERS APPEARING BETWEEN A SPLIT STYLIZED CIRCLE IN GREY.
FOR ROLLING ACCESS DECK FOR VEHICLES (U.S. CLS. 19, 21, 23, 31, 35 AND 44).
FIRST USE 9-30-2005; IN COMMERCE 9-30-2005.

CLASS 12—(Continued).

3,482,462. ATF, INC., LINCOLNWOOD, IL. SN 78-936,032.
PUB. 8-21-2007, FILED 7-24-2006.



NO CLAIM IS MADE TO THE EXCLUSIVE RIGHT TO USE "TECHNOLOGIES", APART FROM THE MARK AS SHOWN.

FOR MULTIPLE COMPONENT ASSEMBLIES FOR AUTOMOBILES CONSISTING OF VARIOUS COMBINATIONS OF THE FOLLOWING COMPONENT PARTS: METAL FASTENERS AND CLIPS, PLASTIC FASTENERS AND CLIPS, HINGES, AIRBAG CHUTES, AIRBAG MOUNTING BRACKETS, AIRBAG RETAINER BRACKETS, AND/OR DRUM BRAKE ADJUSTERS; STAMPED METAL ASSEMBLIES AND COMPONENTS FOR VEHICLES, NAMELY, STUD PLATES, HALO BRACKETS, AND RETAINER BRACKETS (U.S. CLS. 19, 21, 23, 31, 35 AND 44).

FIRST USE 6-5-2008; IN COMMERCE 6-5-2008.

CLASS 13—(Continued).

3,482,506. PRICE, DONALD H., PORT TOWNSEND, WA. SN 78-950,144. PUB. 4-3-2007, FILED 8-11-2006.

SPEED SIGHTS

THE MARK CONSISTS OF STANDARD CHARACTERS WITHOUT CLAIM TO ANY PARTICULAR FONT, STYLE, SIZE, OR COLOR.

NO CLAIM IS MADE TO THE EXCLUSIVE RIGHT TO USE "SIGHTS", APART FROM THE MARK AS SHOWN.

FOR NON-TELESCOPIC AIMING AND SIGHTING DEVICES FOR FIREARMS (U.S. CLS. 2 AND 9).

FIRST USE 11-15-2006; IN COMMERCE 11-15-2006.

CLASS 14—JEWELRY

3,481,070. SHARON LOEFF DESIGNS, LLC, SCOTTSDALE, AZ. SN 76-625,317. PUB. 9-27-2005, FILED 12-21-2004.

COUPLINGS

THE MARK CONSISTS OF STANDARD CHARACTERS WITHOUT CLAIM TO ANY PARTICULAR FONT, STYLE, SIZE, OR COLOR.

FOR JEWELRY (U.S. CLS. 2, 27, 28 AND 50).

FIRST USE 1-24-2007; IN COMMERCE 1-24-2007.

MX-5

3,482,560. MAZDA MOTOR CORPORATION, HIROSHIMA, JAPAN. SN 78-972,384. PUB. 9-25-2007, FILED 9-12-2006.

THE MARK CONSISTS OF STANDARD CHARACTERS WITHOUT CLAIM TO ANY PARTICULAR FONT, STYLE, SIZE, OR COLOR.

OWNER OF U.S. REG. NO. 1,738,207.

FOR AUTOMOBILES AND STRUCTURAL PARTS THEREOF, BUT EXCLUDING TIRES (U.S. CLS. 19, 21, 23, 31, 35 AND 44).

FIRST USE 2-10-1989; IN COMMERCE 2-10-1989.

3,481,240. BULOVA CORPORATION, WOODSIDE, NY. SN 77-038,513. PUB. 9-25-2007, FILED 11-7-2006.

MIRADOR

THE MARK CONSISTS OF STANDARD CHARACTERS WITHOUT CLAIM TO ANY PARTICULAR FONT, STYLE, SIZE, OR COLOR.

THE SPANISH WORD "MIRADOR" TRANSLATES INTO ENGLISH AS "BAY WINDOW", "LOOKOUT", AND "SPECTATOR".

FOR WATCHES AND CLOCKS (U.S. CLS. 2, 27, 28 AND 50).

FIRST USE 1-15-2007; IN COMMERCE 1-15-2007.

CLASS 13—FIREARMS

CLASS 14—(Continued).

3,481,268. ARTSY DOTS, LLC, PEMBROKE PINES, FL. SN 77-053,817. PUB. 6-26-2007, FILED 11-30-2006.

ARTSY DOTS

THE MARK CONSISTS OF STANDARD CHARACTERS WITHOUT CLAIM TO ANY PARTICULAR FONT, STYLE, SIZE, OR COLOR.

FOR BRACELETS; CHARMS; JEWELRY (U.S. CLS. 2, 27, 28 AND 50).

FIRST USE 10-0-2006; IN COMMERCE 2-0-2008.

CLASS 14—(Continued).

3,481,640. GLOVEBRUSH CORP., SIMI VALLEY, CA. SN 77-161,321. PUB. 10-16-2007, FILED 4-19-2007.

Père de Temps

THE MARK CONSISTS OF STANDARD CHARACTERS WITHOUT CLAIM TO ANY PARTICULAR FONT, STYLE, SIZE, OR COLOR.

THE FOREIGN WORDING IN THE MARK TRANSLATES INTO ENGLISH AS FATHER OF TIME.

FOR WATCHES, AND OTHER TIMING DEVICES, NAMELY, CHRONOGRAPHS FOR USE AS TIMEPIECES AND AS WATCHES (U.S. CLS. 2, 27, 28 AND 50).

FIRST USE 1-9-2008; IN COMMERCE 1-22-2008.

3,481,322. MOBBSIX, LLC, LAKE OSWEGO, OR. SN 77-081,014. PUB. 9-4-2007, FILED 1-11-2007.

EPMartin

THE NAME(S), PORTRAIT(S), AND/OR SIGNATURE(S) SHOWN IN THE MARK DOES NOT IDENTIFY A PARTICULAR LIVING INDIVIDUAL.

THE MARK CONSISTS OF LETTERS WITH TWO (RT) IN STYLIZED FORM.

FOR MECHANICAL AND AUTOMATIC WATCHES; WATCH BOXES; WATCH FACES; WATCHES; WRIST WATCHES (U.S. CLS. 2, 27, 28 AND 50).

FIRST USE 8-30-2007; IN COMMERCE 8-30-2007.

3,481,650. XOSKELETON, INC., COLUMBIA, MD. SN 77-165,074. PUB. 2-12-2008, FILED 4-25-2007.

XOSKELETON

THE MARK CONSISTS OF STANDARD CHARACTERS WITHOUT CLAIM TO ANY PARTICULAR FONT, STYLE, SIZE, OR COLOR.

FOR WATCH BANDS AND STRAPS; WATCH FACES; WATCH PARTS; WATCHES; WRIST WATCHES; CLOCKS; TIMEPIECES AND CHRONOMETRIC INSTRUMENTS (U.S. CLS. 2, 27, 28 AND 50).

FIRST USE 6-4-2007; IN COMMERCE 6-4-2007.

3,481,549. NUAW DESIGNS, LLC, WILMINGTON, DE. SN 77-144,941. PUB. 10-2-2007, FILED 3-30-2007.

ZAZEN

THE MARK CONSISTS OF STANDARD CHARACTERS WITHOUT CLAIM TO ANY PARTICULAR FONT, STYLE, SIZE, OR COLOR.

FOR JEWELRY (U.S. CLS. 2, 27, 28 AND 50).
FIRST USE 1-23-2008; IN COMMERCE 1-23-2008.

3,481,688. SIMA K, LLC, NEW YORK, NY. SN 77-174,790. PUB. 10-30-2007, FILED 5-7-2007.

Sima K

THE MARK CONSISTS OF STANDARD CHARACTERS WITHOUT CLAIM TO ANY PARTICULAR FONT, STYLE, SIZE, OR COLOR.

THE NAME(S), PORTRAIT(S), AND/OR SIGNATURE(S) SHOWN IN THE MARK IDENTIFIES "SIMA KHORSANDI", WHOSE CONSENT(S) TO REGISTER IS MADE OF RECORD.

FOR JEWELRY (U.S. CLS. 2, 27, 28 AND 50).
FIRST USE 1-0-2008; IN COMMERCE 1-0-2008.

CLASS 14—(Continued).

3,481,723. SPEIDEL, LLC., EAST PROVIDENCE, RI. SN 77-183,839. PUB. 11-6-2007, FILED 5-17-2007.

ROMUNDA

THE MARK CONSISTS OF STANDARD CHARACTERS WITHOUT CLAIM TO ANY PARTICULAR FONT, STYLE, SIZE, OR COLOR.
OWNER OF U.S. REG. NO. 1,059,182.
FOR WATCH BANDS AND STRAPS; WATCH BRACELETS; WATCHES (U.S. CLS. 2, 27, 28 AND 50).
FIRST USE 11-1-2007; IN COMMERCE 11-1-2007.

CLASS 14—(Continued).

3,481,775. DANIEL ROTH ET GÉRARD GENTA HAUTE HORLOGERIE SA, 1217 MEYRIN, SWITZERLAND. SN 77-208,393. PUB. 11-20-2007, FILED 6-18-2007.

GEFICA

THE MARK CONSISTS OF STANDARD CHARACTERS WITHOUT CLAIM TO ANY PARTICULAR FONT, STYLE, SIZE, OR COLOR.
FOR PRECIOUS METALS AND THEIR ALLOYS SOLD IN BULK; JEWELLERY, JEWELS, PRECIOUS STONES; HOROLOGICAL AND CHRONOMETRIC INSTRUMENTS, NAMELY, CLOCKS, WATCHES, WRISTWATCHES, TABLE CLOCKS AND CHRONOMETERS (U.S. CLS. 2, 27, 28 AND 50).
FIRST USE 0-0-1985; IN COMMERCE 0-0-1987.

3,481,740. MERIT DIAMOND CORPORATION, HOLLYWOOD, FL. SN 77-190,374. PUB. 11-13-2007, FILED 5-25-2007.



NO CLAIM IS MADE TO THE EXCLUSIVE RIGHT TO USE "FIT", APART FROM THE MARK AS SHOWN.
THE MARK CONSISTS OF THE LETTER "M" DISPOSED IN A RING SHAPED DESIGN ELEMENT AND THE ELEMENT "FIT" DISPOSED ADJACENT THERETO.
FOR JEWELRY; PRECIOUS METALS; PRECIOUS STONES; AND SEMI-PRECIOUS STONES (U.S. CLS. 2, 27, 28 AND 50).
FIRST USE 5-10-2007; IN COMMERCE 5-15-2007.

3,481,793. STRICKLAND-FULLER PARTNERSHIP, WICHITA, KS. SN 77-216,184. PUB. 12-4-2007, FILED 6-26-2007.



THE MARK CONSISTS OF TWO CONCENTRIC CIRCLES. THE WORDING "NOW IS THE TIME" APPEARS IN THE SPACE BETWEEN THE CIRCLES. THE BACKGROUND AROUND THE WORD "NOW" IS SHADED. THE INNER CIRCLE HAS A LOTUS FLOWER AND ALTERNATING SHADED AND LIGHT LINES RADIATING OUT FROM THE CENTER REPRESENTING THE VARIOUS POSITIONS ON A CLOCK FACE.
FOR JEWELRY, BRACELETS, PENDANTS, WATCHES AND CLOCKS (U.S. CLS. 2, 27, 28 AND 50).
FIRST USE 6-0-2007; IN COMMERCE 6-0-2007.

CLASS 14—(Continued).

3,481,843. OSNAT GAD, INC., NEW YORK, NY. SN 77-241,852. PUB. 1-22-2008, FILED 7-30-2007.

OCIE

THE MARK CONSISTS OF STANDARD CHARACTERS WITHOUT CLAIM TO ANY PARTICULAR FONT, STYLE, SIZE, OR COLOR.

OWNER OF U.S. REG. NO. 3,024,718.
FOR JEWELRY (U.S. CLS. 2, 27, 28 AND 50).
FIRST USE 2-20-2006; IN COMMERCE 2-20-2006.

3,482,147. THE CARTOON NETWORK, INC., ATLANTA, GA. SN 78-665,173. PUB. 3-28-2006, FILED 7-7-2005.

FOSTER'S HOME FOR IMAGINARY FRIENDS

THE MARK CONSISTS OF STANDARD CHARACTERS WITHOUT CLAIM TO ANY PARTICULAR FONT, STYLE, SIZE, OR COLOR.

FOR CHARMS, LAPEL PINS AND COSTUME JEWELRY (U.S. CLS. 2, 27, 28 AND 50).
FIRST USE 4-30-2007; IN COMMERCE 4-30-2007.

3,482,297. TARMA DESIGNS, PETALUMA, CA. SN 78-814,424. PUB. 5-1-2007, FILED 2-14-2006.

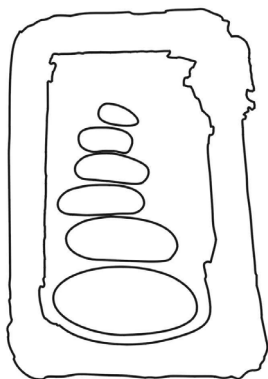

FOR JEWELRY (U.S. CLS. 2, 27, 28 AND 50).
FIRST USE 1-31-2007; IN COMMERCE 1-31-2007.

CLASS 14—(Continued).

3,482,476. PUSH INC., DBA KAREN KARCH, NEW YORK, NY. SN 78-940,167. PUB. 3-27-2007, FILED 7-28-2006.



THE MARK CONSISTS OF THE LETTER K WITH A ROSE IN THE CENTER.

FOR ANKLE BRACELETS; BELT BUCKLES OF PRECIOUS METAL; BRACELETS; BROOCHES; CHARMS; CHOKERS; CLIP EARRINGS; CUFFLINKS; EARRINGS; EAR STUDS; FANCY KEY RINGS OF PRECIOUS METAL; IDENTIFICATION BRACELETS; LEATHER BRACELETS; MONEY CLIPS OF PRECIOUS METAL; NECKLACES; PENDANTS ON A LEATHER CORD; RINGS; SHIRT STUDS; TIARAS (U.S. CLS. 2, 27, 28 AND 50).

FIRST USE 9-16-2006; IN COMMERCE 10-5-2006.

CLASS 15—MUSICAL INSTRUMENTS

3,481,532. GLOBAL SOURCING & INNOVATIONS, INC., LEE, MA. SN 77-141,373. PUB. 9-18-2007, FILED 3-27-2007.



THE MARK CONSISTS OF THE WORDS "GEN ONE" SUPERIMPOSED UPON A LARGE NUMERAL "1", THE NUMERAL "1" HAVING A SYMBOL FOR A MUSICAL NOTE CENTRALLY LOCATED UPON THE NUMERAL "1", AND THE WORDS "GEN ONE" AND THE NUMERAL "1" ARE SUPERIMPOSED UPON A MUSICAL SCALE THAT IS SLIGHTLY CURVED ALONG ITS HORIZONTAL AXIS AND EXTENDS BEHIND AND SLIGHTLY BEYOND THE LEFT AND RIGHT MARGINS OF THE WORDS "GEN ONE."

FOR MUSICAL INSTRUMENTS (U.S. CLS. 2, 21 AND 36).

FIRST USE 5-29-2008; IN COMMERCE 5-29-2008.

CLASS 15—(Continued).

3,482,412. KAHLER, GARY, OCEANSIDE, CA. SN 78-907,716.
PUB. 3-4-2008, FILED 6-14-2006.

X-TREM

THE MARK CONSISTS OF STANDARD CHARACTERS WITHOUT CLAIM TO ANY PARTICULAR FONT, STYLE, SIZE, OR COLOR.

FOR GUITAR PARTS; GUITAR TREMOLO DEVICES (U.S. CLS. 2, 21 AND 36).

FIRST USE 1-0-2007; IN COMMERCE 1-0-2007.

CLASS 16—PAPER GOODS AND PRINTED MATTER

3,481,055. WORKMAN PUBLISHING CO., INC., NEW YORK, NY. AND SCHILLER, DAVID, NEW YORK, NY. SN 76-533,292. PUB. 3-4-2008, FILED 7-16-2003.

CAR-I-OKE

FOR SERIES OF NON-FICTION BOOKS IN THE FIELD OF ENTERTAINMENT, FEATURING SONG LYRICS, INFORMATION ABOUT SONGS, TRIVIA, ACTIVITIES AND GAMES AND PRE-RECORDED COMPACT DISCS FEATURING INSTRUMENTAL MUSIC WITHOUT VOCALS, SOLD AS A UNIT, FOR USE WITH AUTOMOBILES (U.S. CLS. 2, 5, 22, 23, 29, 37, 38 AND 50).
FIRST USE 6-0-2003; IN COMMERCE 6-0-2003.

3,481,056. ZWICKER SERVICES, INC., GLENSIDE, PA. SN 76-542,486. PUB. 9-4-2007, FILED 9-4-2003.

JOY JOURNAL

NO CLAIM IS MADE TO THE EXCLUSIVE RIGHT TO USE "JOURNAL", APART FROM THE MARK AS SHOWN.

FOR BOOKS PARTIALLY PRINTED AND FORMATTED FOR REGULARLY RECORDING PERSONAL INFORMATION INCLUDING EXPERIENCES, IDEAS AND REFLECTIONS FOR KEEPSAKE PURPOSES (U.S. CLS. 2, 5, 22, 23, 29, 37, 38 AND 50).

FIRST USE 5-1-2004; IN COMMERCE 5-1-2004.

CLASS 16—(Continued).

3,481,066. PROBASCO, TIMOTHY C., FORT LAUDERDALE, FL. SN 76-604,199. PUB. 9-27-2005, FILED 7-26-2004.



The logo for Sun Tattoos features the word "SUN" in a stylized, bold, black font with a white outline, positioned above the word "TATTOOS" in a similar but slightly smaller font. The letters are thick and blocky.

NO CLAIM IS MADE TO THE EXCLUSIVE RIGHT TO USE "SUN TATTOOS", APART FROM THE MARK AS SHOWN.

FOR COLORED APPLIQUES FOR BODY ORNAMENTATION, NAMELY, TEMPORARY TATTOOS (U.S. CLS. 2, 5, 22, 23, 29, 37, 38 AND 50).

FIRST USE 2-27-2008; IN COMMERCE 2-27-2008.

3,481,077. SAMBRAILO PACKAGING, WATSONVILLE, CA. SN 76-647,428. PUB. 1-9-2007, FILED 9-26-2005.

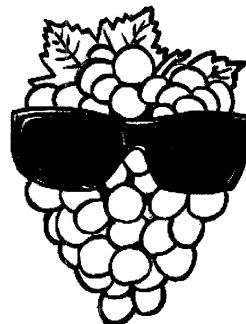

OWNER OF U.S. REG. NO. 2,821,024.
THE MARK CONSISTS OF A DRAWING OF A BUNCH OF GRAPES WEARING GLASSES.

FOR PROMOTIONAL MATERIALS, NAMELY, BROCHURES, AND NEWSLETTERS FEATURING VARIOUS PACKAGING PRODUCTS AND PACKAGING MATERIALS; DECALS, CALENDARS, DISTRIBUTED IN CONJUNCTION WITH APPLICANT'S PACKAGING PRODUCTS AND PACKAGING MATERIALS; PRINTED MATERIALS, NAMELY, PAPER SIGNS, PAPER LABELS, AND NOTEPADS (U.S. CLS. 2, 5, 22, 23, 29, 37, 38 AND 50).

FIRST USE 9-5-2005; IN COMMERCE 11-4-2005.

CLASS 16—(Continued).

3,481,118. TIMELY INVENTIONS LLC, BEVERLY HILLS, CA. SN 76-668,434. PUB. 8-28-2007, FILED 11-2-2006.

DR GORILLA PACK

THE MARK CONSISTS OF STANDARD CHARACTERS WITHOUT CLAIM TO ANY PARTICULAR FONT, STYLE, SIZE, OR COLOR.

NO CLAIM IS MADE TO THE EXCLUSIVE RIGHT TO USE "PACK", APART FROM THE MARK AS SHOWN.

FOR PACKAGING, NAMELY, BLISTER PACKS AND BLISTER CARDS (U.S. CLS. 2, 5, 22, 23, 29, 37, 38 AND 50).

FIRST USE 11-0-2006; IN COMMERCE 11-0-2006.

3,481,187. AQUARIAN FOUNDATION, SEATTLE, WA. SN 77-013,033. PUB. 11-27-2007, FILED 10-3-2006.

PSYCHIC OBSERVER

THE MARK CONSISTS OF STANDARD CHARACTERS WITHOUT CLAIM TO ANY PARTICULAR FONT, STYLE, SIZE, OR COLOR.

NO CLAIM IS MADE TO THE EXCLUSIVE RIGHT TO USE "PSYCHIC", APART FROM THE MARK AS SHOWN.

FOR PRINTED MATERIALS, NAMELY, NEWSPAPERS, MAGAZINES, AND PICTORIAL JOURNALS ALL IN THE FIELD OF METAPHYSICS, PSYCHIC PHENOMENA AND SPIRITUALISM (U.S. CLS. 2, 5, 22, 23, 29, 37, 38 AND 50).

FIRST USE 0-0-1956; IN COMMERCE 4-30-2007.

3,481,188. AQUARIAN FOUNDATION, SEATTLE, WA. SN 77-013,046. PUB. 11-27-2007, FILED 10-3-2006.

CHIMES

THE MARK CONSISTS OF STANDARD CHARACTERS WITHOUT CLAIM TO ANY PARTICULAR FONT, STYLE, SIZE, OR COLOR.

FOR PRINTED MATERIALS, NAMELY, NEWSPAPERS, MAGAZINES, AND PICTORIAL JOURNALS ALL IN THE FIELD OF METAPHYSICS, PSYCHIC PHENOMENA AND SPIRITUALISM (U.S. CLS. 2, 5, 22, 23, 29, 37, 38 AND 50).

FIRST USE 0-0-1955; IN COMMERCE 4-30-2007.

CLASS 16—(Continued).

3,481,225. IBASIS, INC., BURLINGTON, MA. SN 77-031,551. PUB. 3-20-2007, FILED 10-27-2006.

Luminosa

THE MARK CONSISTS OF STANDARD CHARACTERS WITHOUT CLAIM TO ANY PARTICULAR FONT, STYLE, SIZE, OR COLOR.

THE FOREIGN WORDING IN THE MARK TRANSLATES INTO ENGLISH AS ILLUMINATED.

FOR PRE-PAID TELEPHONE CALLING CARDS, NOT MAGNETICALLY ENCODED; TELEPHONE CALLING CARDS, NOT MAGNETICALLY ENCODED (U.S. CLS. 2, 5, 22, 23, 29, 37, 38 AND 50).

FIRST USE 5-30-2008; IN COMMERCE 5-30-2008.

3,481,244. ENPAPER MFG. CO., LTD., GYEONGGI-DO, REPUBLIC OF KOREA. SN 77-042,358. PUB. 10-9-2007, FILED 11-13-2006.



NO CLAIM IS MADE TO THE EXCLUSIVE RIGHT TO USE "PAPER", APART FROM THE MARK AS SHOWN.

THE FOREIGN WORDING IN THE MARK TRANSLATES INTO ENGLISH AS NEW LAKE.

FOR CORRUGATED CARDBOARDS; PAPER FOR RECORDING MACHINES; ACID-RESISTANT PAPER; NAPKIN PAPER; STATIONERY STENCILS; RICE PAPER; EKG PAPER; LUMINOUS PAPER; WATERPROOF PAPER; OILPROOF PAPER; FIREPROOF PAPER; WHITE PAPERBOARD; DUPLICATING PAPER; CARDBOARD MADE FROM PAPER MULBERRY; CELLOPHANE PAPER; NEWSPRINT PAPER; ELECTROCARDIOGRAPH PAPER; ANPEE PAPER (WIKSTROEMIA SIKOKIANA PAPER); WET RECORDING PAPER FOR FISH DETECTOR, NAMELY, PAPER FOR RECORDING MACHINES; FILTER PAPER; PARAFFINED PAPER; OILED PAPER NOT FOR MEDICAL PURPOSES; PRINTING PAPER; HEAT TRANSFER PAPER; HANDKERCHIEFS OF PAPER; TOWELS OF PAPER; FACE TOWELS OF PAPER; CARBON PAPER; PAPER FILTERS FOR COFFEE MAKERS; BLANK PAPER TAPES AND CARDS FOR THE RECORDAL OF COMPUTER PROGRAMS; TYPEWRITING PAPER; PAPERBOARD; FACSIMILE TRANSMISSION PAPER; POSTCARD PAPER; PACKING PAPER; MILLBOARD; WRITING AND DRAWING PAPER; XUAN PAPER FOR CHINESE PAINTING AND CALLIGRAPHY, NAMELY, ART PAPER; PAPIER MACHE; TOILET PAPER; COSMETIC REMOVING PAPER; TOILET TISSUE; PARCHMENT PAPER; STRAWBOARD, NAMELY, CARDBOARD MADE OF STRAW PULP (U.S. CLS. 2, 5, 22, 23, 29, 37, 38 AND 50).

FIRST USE 3-1-2008; IN COMMERCE 3-1-2008.

CLASS 16—(Continued).

3,481,248. PERIOD FINANCIAL CORPORATION, FREDERICK, MD. SN 77-045,117. PUB. 6-19-2007, FILED 11-15-2006.

Period PayCheck

THE MARK CONSISTS OF STANDARD CHARACTERS WITHOUT CLAIM TO ANY PARTICULAR FONT, STYLE, SIZE, OR COLOR.

OWNER OF U.S. REG. NOS. 3,088,418 AND 3,125,818.

NO CLAIM IS MADE TO THE EXCLUSIVE RIGHT TO USE "PAYCHECK", APART FROM THE MARK AS SHOWN. FOR BANK CHECKS; CHECK BOOKS (U.S. CLS. 2, 5, 22, 23, 29, 37, 38 AND 50).

FIRST USE 7-15-2004; IN COMMERCE 7-15-2004.

3,481,281. DAUGERDAS, PAUL MICHAEL, HENDERSON, NV. SN 77-061,257. PUB. 7-3-2007, FILED 12-11-2006.

BEWARE OF GUN

THE MARK CONSISTS OF STANDARD CHARACTERS WITHOUT CLAIM TO ANY PARTICULAR FONT, STYLE, SIZE, OR COLOR.

FOR ADVERTISING SIGNS OF PAPER OR CARDBOARD (U.S. CLS. 2, 5, 22, 23, 29, 37, 38 AND 50).

FIRST USE 6-22-2008; IN COMMERCE 6-22-2008.

3,481,291. OUG PRESS, PITTSBURGH, PA. SN 77-065,823. PUB. 2-12-2008, FILED 12-16-2006.

GOSPEL FOR THE PEOPLE

THE MARK CONSISTS OF STANDARD CHARACTERS WITHOUT CLAIM TO ANY PARTICULAR FONT, STYLE, SIZE, OR COLOR.

NO CLAIM IS MADE TO THE EXCLUSIVE RIGHT TO USE "GOSPEL", APART FROM THE MARK AS SHOWN.

FOR BIBLES (U.S. CLS. 2, 5, 22, 23, 29, 37, 38 AND 50). FIRST USE 5-29-2008; IN COMMERCE 5-29-2008.

CLASS 16—(Continued).

3,481,325. FREEMAN, VIVIAN V., NEWSOMS, VA. SN 77-082,186. PUB. 10-2-2007, FILED 1-12-2007.

Sower Notes

THE MARK CONSISTS OF STANDARD CHARACTERS WITHOUT CLAIM TO ANY PARTICULAR FONT, STYLE, SIZE, OR COLOR.

OWNER OF U.S. REG. NO. 2,854,951.

NO CLAIM IS MADE TO THE EXCLUSIVE RIGHT TO USE "NOTES", APART FROM THE MARK AS SHOWN.

FOR A SERIES OF BOOKS, WRITTEN ARTICLES, HANDOUTS AND WORKSHEETS IN THE FIELD OF RELIGIOUS INSPIRATIONAL MATERIAL AND PERSONAL MOTIVATIONAL MATERIAL; BOOKS IN THE FIELD OF RELIGIOUS INSPIRATIONAL MATERIAL AND PERSONAL MOTIVATIONAL MATERIAL; CARDS FEATURING RELIGIOUS INSPIRATIONAL MATERIAL AND PERSONAL MOTIVATIONAL MATERIAL; CHILDREN'S ACTIVITY BOOKS; CHILDREN'S BOOKS; COLORING BOOKS; EDUCATIONAL BOOKS FEATURING RELIGIOUS INSPIRATIONAL MATERIAL AND PERSONAL MOTIVATIONAL MATERIAL; FLIP BOOKS; GREETING CARDS; HOLIDAY CARDS; INDEX BOOKS; INDEX CARDS; INVITATION CARDS; MOTIVATIONAL CARDS; NOTE BOOKS; NOTE CARDS; OCCASION CARDS; POCKET MEMORANDUM BOOKS; PRAYER BOOKS; PRINTED INFORMATIONAL CARDS IN THE FIELD OF RELIGIOUS INSPIRATIONAL MATERIAL AND PERSONAL MOTIVATIONAL MATERIAL; RELIGIOUS BOOKS; STORY BOOKS; VISITING CARDS; WIREBOUND BOOKS (U.S. CLS. 2, 5, 22, 23, 29, 37, 38 AND 50).

FIRST USE 2-8-2007; IN COMMERCE 9-24-2007.

3,481,330. THE TAUNTON PRESS, INC., NEWTOWN, CT. SN 77-083,473. PUB. 9-18-2007, FILED 1-16-2007.

TAUNTON'S SEWSTYLISH

THE MARK CONSISTS OF STANDARD CHARACTERS WITHOUT CLAIM TO ANY PARTICULAR FONT, STYLE, SIZE, OR COLOR.

OWNER OF U.S. REG. NOS. 2,791,259, 3,071,680, AND OTHERS.

FOR PRINTED PUBLICATIONS, NAMELY, MAGAZINES AND BOOKS ON THE SUBJECTS OF SEWING AND FASHION (U.S. CLS. 2, 5, 22, 23, 29, 37, 38 AND 50). FIRST USE 2-13-2007; IN COMMERCE 2-13-2007.

CLASS 16—(Continued).

3,481,377. FOXY'S LAIR, INC., CAPE CANAVERAL, FL. SN 77-106,992. PUB. 9-18-2007, FILED 2-14-2007.



THE MARK CONSISTS OF DESIGN OF FOX HEAD WITH NUMBER "4" IN CENTER OF BOW TIE.
 FOR PAPER GOODS AND PRINTED MATERIALS, NAMELY, TRADING CARDS, COLLECTIBLE CARDS FEATURING PHOTOGRAPHS OF FEMALE MODELS, POSTERS, COUPONS, PHOTOGRAPHIC PRINTS AND PHOTOGRAPHS FEATURING MODELS, TEMPORARY TATTOOS, BUMPER STICKERS, DECALS AND STICKERS (U.S. CLS. 2, 5, 22, 23, 29, 37, 38 AND 50).
 FIRST USE 2-14-2007; IN COMMERCE 1-0-2008.

3,481,422. THE MEYER RESOURCE GROUP, INC., WACO, TX. SN 77-122,869. PUB. 9-4-2007, FILED 3-6-2007.

A PROGRAM DESIGNED TO BUILD A WINNING ATTITUDE

THE MARK CONSISTS OF STANDARD CHARACTERS WITHOUT CLAIM TO ANY PARTICULAR FONT, STYLE, SIZE, OR COLOR.
 FOR BOOKS, BOOKLETS, MANUALS AND PRINTED INSTRUCTIONAL MATERIALS RELATING TO PERSONAL DEVELOPMENT, SELF-MOTIVATION AND IMPROVEMENT, GOAL SETTING, PLANNING, LEADERSHIP AND MANAGEMENT (U.S. CLS. 2, 5, 22, 23, 29, 37, 38 AND 50).
 FIRST USE 0-0-1985; IN COMMERCE 0-0-1985.

CLASS 16—(Continued).

3,481,428. MOMENTA, INC., NORTHWOOD, NH. SN 77-123,618. PUB. 9-4-2007, FILED 3-6-2007.



THE COLOR(S) BLUE AND ORANGE IS/ARE CLAIMED AS A FEATURE OF THE MARK.
 THE MARK CONSISTS OF THE WORD "MOMENTA" IN BLUE WITH THE EXCEPTION OF THE LETTER "O" WHICH IS IN ORANGE.
 FOR ALBUMS FOR STICKERS, STICKERS, ENVELOPES FOR STATIONERY USE, PAPER STATIONERY, PASTES AND OTHER ADHESIVES FOR STATIONERY OR HOUSEHOLD PURPOSES, ADHESIVE WALL STICKERS (U.S. CLS. 2, 5, 22, 23, 29, 37, 38 AND 50).
 FIRST USE 6-30-2007; IN COMMERCE 6-30-2007.

3,481,444. IBASIS, INC., BURLINGTON, MA. SN 77-127,416. PUB. 1-22-2008, FILED 3-9-2007.

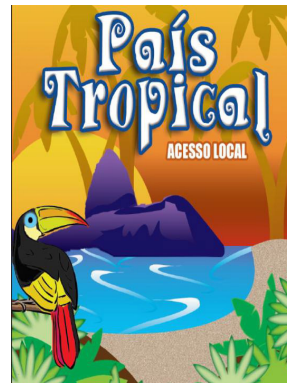

NO CLAIM IS MADE TO THE EXCLUSIVE RIGHT TO USE "ACESSO LOCAL", APART FROM THE MARK AS SHOWN.
 THE COLOR(S) RED, ORANGE, PURPLE, BLUE, GREEN, BLACK, YELLOW AND BROWN IS/ARE CLAIMED AS A FEATURE OF THE MARK.
 THE MARK CONSISTS OF AN IMAGE OF A TROPICAL BEACH WITH A BIRD ON FOLIAGE IN THE FOREGROUND AND MOUNTAINS IN THE BACKGROUND, GREEN APPEARS IN THE FOLIAGE, BLACK, ORANGE, YELLOW, RED AND BLUE ON THE BIRD, BLUE IN THE WATER, BROWN ON THE BEACH AND AN ORANGE SUNSET IN THE BACKGROUND.
 THE FOREIGN WORDING IN THE MARK TRANSLATES INTO ENGLISH AS COUNTRY TROPICAL LOCAL ACCESS.
 FOR PRE-PAID TELEPHONE CALLING CARDS, NOT MAGNETICALLY ENCODED; TELEPHONE CALLING CARDS, NOT MAGNETICALLY ENCODED (U.S. CLS. 2, 5, 22, 23, 29, 37, 38 AND 50).
 FIRST USE 6-1-2008; IN COMMERCE 6-1-2008.

CLASS 16—(Continued).

3,481,482. ALDINE INC., NEW YORK, NY. SN 77-133,142.
PUB. 9-18-2007, FILED 3-16-2007.

ENVIRO-TAB

THE MARK CONSISTS OF STANDARD CHARACTERS WITHOUT CLAIM TO ANY PARTICULAR FONT, STYLE, SIZE, OR COLOR.

FOR REINFORCED STATIONERY TABS (U.S. CLS. 2, 5, 22, 23, 29, 37, 38 AND 50).

FIRST USE 4-20-2007; IN COMMERCE 4-20-2007.

3,481,488. SANKEI SHIMBUN CO., LTD., TOKYO, JAPAN.
SN 77-133,860. PUB. 8-14-2007, FILED 3-18-2007.

THE SANKEI SHIMBUN

THE MARK CONSISTS OF STANDARD CHARACTERS WITHOUT CLAIM TO ANY PARTICULAR FONT, STYLE, SIZE, OR COLOR.

NO CLAIM IS MADE TO THE EXCLUSIVE RIGHT TO USE "SHIMBUN", APART FROM THE MARK AS SHOWN.

THE FOREIGN WORDING IN THE MARK TRANSLATES INTO ENGLISH AS SANKEI NEWSPAPER. THE WORDING "SANKEI" HAS NO MEANING IN A FOREIGN LANGUAGE.

FOR NEWSPAPERS (U.S. CLS. 2, 5, 22, 23, 29, 37, 38 AND 50).

FIRST USE 9-0-1969; IN COMMERCE 9-0-1969.

3,481,507. MARVEL CHARACTERS, INC., BEVERLY HILLS, CA. SN 77-137,294. PUB. 7-31-2007, FILED 3-22-2007.

WEREWOLF BY NIGHT

THE MARK CONSISTS OF STANDARD CHARACTERS WITHOUT CLAIM TO ANY PARTICULAR FONT, STYLE, SIZE, OR COLOR.

FOR PUBLICATIONS, NAMELY, COMIC BOOKS AND COMIC MAGAZINES AND PRINTED STORIES IN ILLUSTRATED FORM FEATURED IN BOOKS AND MAGAZINES (U.S. CLS. 2, 5, 22, 23, 29, 37, 38 AND 50).

FIRST USE 10-31-2005; IN COMMERCE 10-31-2005.

CLASS 16—(Continued).

3,481,533. ZANER-BLOSER, INC., COLUMBUS, OH. SN 77-141,566. PUB. 9-25-2007, FILED 3-27-2007.

**Zaner-Bloser Handwriting
On the Road to Writing and
Reading for Prekindergarten**

THE MARK CONSISTS OF STANDARD CHARACTERS WITHOUT CLAIM TO ANY PARTICULAR FONT, STYLE, SIZE, OR COLOR.

OWNER OF U.S. REG. NO. 2,763,322.

NO CLAIM IS MADE TO THE EXCLUSIVE RIGHT TO USE "HANDWRITING" AND "WRITING AND READING FOR PREKINDERGARTEN", APART FROM THE MARK AS SHOWN.

FOR EDUCATIONAL BOOKS FEATURING MATERIALS GEARED TO PRE-KINDERGARTEN STUDENTS AND TEACHERS CONTAINING BEGINNING INSTRUCTION IN HANDWRITING (U.S. CLS. 2, 5, 22, 23, 29, 37, 38 AND 50).

FIRST USE 8-1-2007; IN COMMERCE 8-1-2007.

3,481,545. WELDON OWEN, INC., SAN FRANCISCO, CA. SN 77-144,395. PUB. 10-2-2007, FILED 3-30-2007.

TOP READERS

THE MARK CONSISTS OF STANDARD CHARACTERS WITHOUT CLAIM TO ANY PARTICULAR FONT, STYLE, SIZE, OR COLOR.

NO CLAIM IS MADE TO THE EXCLUSIVE RIGHT TO USE "READERS", APART FROM THE MARK AS SHOWN.

FOR CHILDREN'S BOOKS (U.S. CLS. 2, 5, 22, 23, 29, 37, 38 AND 50).

FIRST USE 2-1-2008; IN COMMERCE 2-1-2008.

CLASS 16—(Continued).

3,481,546. SANTORO, LUCIO AND SANTORO, MEERA, LONDON, UNITED KINGDOM. SN 77-144,542. PUB. 10-2-2007, FILED 3-30-2007.

SQUEEZE THE JUICE

THE MARK CONSISTS OF STANDARD CHARACTERS WITHOUT CLAIM TO ANY PARTICULAR FONT, STYLE, SIZE, OR COLOR.

FOR GREETING CARDS, POSTCARDS, MINI GREETING CARDS, GIFT WRAPPING PAPER; STATIONERY, NAMELY DIARIES, LOCKABLE DIARIES; PENCIL TINS, FABRIC PENCIL CASES; ZIP AROUND BINDERS, ASSIGNMENT NOTE BOOKS, AGENDAS, DIE CUT PAPER NOTEBOOKS; ERASERS; PAPER FOLDERS; PENS; PENCILS; CALENDARS; NOTEBOOKS; NOTE-PADS; FABRIC COVERED NOTEBOOKS; ADDRESS BOOKS; LEVER ARCH FILE FOLDERS; RING BINDERS; PHOTO ALBUMS; PAPER GIFT BAGS; CARDBOARD STORAGE BOXES; STICKERS; ADDRESS LABELS; PAPER DOOR HANGERS; MEMO PADS; SKETCHBOOKS; FOUNTAIN PENS; BALLPOINT PENS; GEL ROLLER PENS; CRAYON PASTELS; COLOURING PENS; GLUE FOR STATIONERY OR HOUSEHOLD USE; PENCIL SHARPENERS; PAPER KNIFE; PAPER CUTTER; STATIONERY SETS COMPRISED OF PAPER NOTEBOOKS, PAPER, ENVELOPES, PENS, PENCILS, RULERS, ERASERS, SOLD TOGETHER AS A UNIT; CARDBOARD GIFT BOXES; PHOTOGRAPHS; OFFICE REQUISITES, NAMELY STAPLERS, PAPER HOLE PUNCHES; ARTISTS MATERIALS, NAMELY PAINTBRUSHES; LUNCHBAGS AND FABRIC LUNCH BAGS (U.S. CLS. 2, 5, 22, 23, 29, 37, 38 AND 50).
FIRST USE 6-1-2008; IN COMMERCE 6-1-2008.

3,481,548. IBASIS, INC., BURLINGTON, MA. SN 77-144,546. PUB. 7-10-2007, FILED 3-30-2007.

Am Lich Vietnam

THE MARK CONSISTS OF STANDARD CHARACTERS WITHOUT CLAIM TO ANY PARTICULAR FONT, STYLE, SIZE, OR COLOR.

NO CLAIM IS MADE TO THE EXCLUSIVE RIGHT TO USE "VIETNAM", APART FROM THE MARK AS SHOWN. THE FOREIGN WORDING IN THE MARK TRANSLATES INTO ENGLISH AS MY COUNTRY VIETNAM.

FOR PRE-PAID TELEPHONE CALLING CARDS, NOT MAGNETICALLY ENCODED; TELEPHONE CALLING CARDS, NOT MAGNETICALLY ENCODED (U.S. CLS. 2, 5, 22, 23, 29, 37, 38 AND 50).
FIRST USE 6-1-2008; IN COMMERCE 6-1-2008.

CLASS 16—(Continued).

3,481,552. IBASIS, INC., BURLINGTON, MA. SN 77-145,298. PUB. 1-22-2008, FILED 3-30-2007.



NO CLAIM IS MADE TO THE EXCLUSIVE RIGHT TO USE "QUALITY CALLS", APART FROM THE MARK AS SHOWN.

THE COLOR(S) RED, YELLOW, ORANGE, BLUE, WHITE, BLACK AND GREEN IS/ARE CLAIMED AS A FEATURE OF THE MARK.

THE MARK CONSISTS OF AN ANIMATED CHARACTER CONSISTING OF A PEPPER WEARING A HAT AND SUNGLASSES NEXT TO THE STYLIZED WORDS "CHILE PICANTE" IN A WHITE COLOR WITH AN ORANGE BORDER AND THE TERM "QUALITY CALL FROM IBASIS", WITH THE TERM "IBASIS" IN A RED AND BLUE STYLIZED FORMAT.

THE ENGLISH TRANSLATION OF THE WORD "PICANTE" IN THE MARK IS PEPPER.

FOR PRE-PAID TELEPHONE CALLING CARDS, NOT MAGNETICALLY ENCODED; TELEPHONE CALLING CARDS, NOT MAGNETICALLY ENCODED (U.S. CLS. 2, 5, 22, 23, 29, 37, 38 AND 50).

FIRST USE 6-1-2008; IN COMMERCE 6-1-2008.

3,481,553. IBASIS, INC., BURLINGTON, MA. SN 77-145,359. PUB. 7-17-2007, FILED 3-30-2007.

ARTILHIERO

THE MARK CONSISTS OF STANDARD CHARACTERS WITHOUT CLAIM TO ANY PARTICULAR FONT, STYLE, SIZE, OR COLOR.

FOR PRE-PAID TELEPHONE CALLING CARDS, NOT MAGNETICALLY ENCODED; TELEPHONE CALLING CARDS, NOT MAGNETICALLY ENCODED (U.S. CLS. 2, 5, 22, 23, 29, 37, 38 AND 50).

FIRST USE 5-29-2008; IN COMMERCE 5-29-2008.

3,481,556. MIND STRONG MEDIA, INC., DES PLAINES, IL. SN 77-145,716. PUB. 10-9-2007, FILED 4-1-2007.

Northwest Avenues

THE MARK CONSISTS OF STANDARD CHARACTERS WITHOUT CLAIM TO ANY PARTICULAR FONT, STYLE,

CLASS 16—(Continued).

SIZE, OR COLOR.

NO CLAIM IS MADE TO THE EXCLUSIVE RIGHT TO USE "NORTHWEST", APART FROM THE MARK AS SHOWN.

FOR MAGAZINES FEATURING ARTICLES AND EDITORIALS RELEVANT TO RESIDENTS OF THE NORTHWEST CHICAGO SUBURBS AND SURROUNDING AREAS (U.S. CLS. 2, 5, 22, 23, 29, 37, 38 AND 50).

FIRST USE 8-1-2007; IN COMMERCE 8-1-2007.

3,481,584. HANDI-FOIL CORPORATION, WHEELING, IL.
SN 77-150,409. PUB. 9-18-2007, FILED 4-6-2007.

HANDI-FILM

THE MARK CONSISTS OF STANDARD CHARACTERS WITHOUT CLAIM TO ANY PARTICULAR FONT, STYLE, SIZE, OR COLOR.

FOR PLASTIC WRAP AND PLASTIC WRAPPING FILM FOR HOUSEHOLD USE (U.S. CLS. 2, 5, 22, 23, 29, 37, 38 AND 50).

FIRST USE 6-10-2008; IN COMMERCE 6-10-2008.

3,481,617. WORLD WRESTLING ENTERTAINMENT, INC., STAMFORD, CT. SN 77-156,582. PUB. 10-2-2007, FILED 4-13-2007.

VENGEANCE

THE MARK CONSISTS OF STANDARD CHARACTERS WITHOUT CLAIM TO ANY PARTICULAR FONT, STYLE, SIZE, OR COLOR.

OWNER OF U.S. REG. NO. 2,978,955.

FOR PAPER HANGTAGS, CARDBOARD HANGTAGS; PACKAGING, NAMELY, BLISTER CARDS, PAPER FOR WRAPPING AND PACKAGING, PAPER POUCHES FOR PACKAGING, PLASTIC BAGS FOR PACKAGING, PLASTIC BUBBLE PACKS FOR WRAPPING OR PACKAGING; COLLECTOR ALBUMS, NAMELY, FOR STICKER COLLECTABLE CARDS, PHOTO COLLECTABLES; LABELS, NAMELY, PRINTED PAPER LABELS, PRINTED SHIPPING LABELS; RETURN ADDRESS LABELS NOT OF TEXTILE; FOLDERS; PLASTIC BAGS FOR GENERAL USE; PAPER TABLEWARE, NAMELY, PAPER PLACE MATS, PAPER TABLE MATS, PAPER NAPKINS, PAPER TABLE LINENS, PAPER TABLECLOTHS; PAPER LUNCH BAGS; STICKERS; BUMPER STICKERS; WINDOW DECALS; PENS; PENCILS; PENCIL SHARPENERS; PENCIL CASES; CHALK; ERASERS, NAMELY, RUBBER ERASERS, CHALK ERASERS, BLACKBOARD ERASERS; POSTERS; NOTEBOOKS; TRADING CARDS; CALENDARS; PHOTOGRAPHS; FRAMED PICTURES; PHOTOGRAPHIC PRINTS; PICTURES; PHOTO ALBUMS; BROCHURES, NEWSLETTERS, MAGAZINES, AND

CLASS 16—(Continued).

NEWSPAPERS CONCERNING SPORTS ENTERTAINMENT; POSTCARDS; GREETING CARDS; DECALS; TEMPORARY TATTOO TRANSFERS; COLORING BOOKS; CHILDREN'S ACTIVITY BOOKS; SOUVENIR PROGRAMS CONCERNING SPORTS ENTERTAINMENT; BOOKS FEATURING PICTORIAL BIOGRAPHIES; AUTOGRAPH BOOKS; COMIC BOOKS; PICTURE BOOKS; STICKER ALBUMS; BOOK COVERS; PAPER BOOK MARKERS; BOOKPLATES; MEMO PADS; SCRIBBLE PADS; DATE BOOKS; ADDRESS BOOKS; AGENDA BOOKS; RUBBER STAMPS; STAMP PADS; COLLECTIBLE PREPAID TELEPHONE CARDS NOT MAGNETICALLY ENCODED; COLLECTOR STAMPS, NAMELY, COMMEMORATIVE STAMP SHEETS; CUSTOMIZED PERSONAL CHECKS; CHECKBOOK COVERS; PAPER BANNERS; PRINTED PAPER SIGNS FOR DOORS; DRAWING RULERS; LITHOGRAPHS; PAPER PARTY BAGS; PAPER PARTY FAVORS, NAMELY, PAPER HATS; STENCILS FOR TRACING DESIGNS ONTO PAPER; PAPER GIFT WRAP; PAPER CAKE DECORATIONS (U.S. CLS. 2, 5, 22, 23, 29, 37, 38 AND 50).
FIRST USE 12-9-2001; IN COMMERCE 12-9-2001.

3,481,635. NEW HEIGHTS MEDIA, INC., FORT LEE, NJ. SN 77-160,230. PUB. 10-16-2007, FILED 4-18-2007.

The People Skills Experts

THE MARK CONSISTS OF STANDARD CHARACTERS WITHOUT CLAIM TO ANY PARTICULAR FONT, STYLE, SIZE, OR COLOR.

FOR A SERIES OF BOOKS, WRITTEN ARTICLES, HANDOUTS AND WORKSHEETS IN THE FIELD OF BUSINESS COMMUNICATIONS (U.S. CLS. 2, 5, 22, 23, 29, 37, 38 AND 50).

FIRST USE 6-1-2007; IN COMMERCE 10-1-2007.

CLASS 16—(Continued).

3,481,686. BLOOMSBURY PUBLISHING PLC, LONDON, UNITED KINGDOM. SN 77-174,547. PUB. 9-25-2007, FILED 5-7-2007.

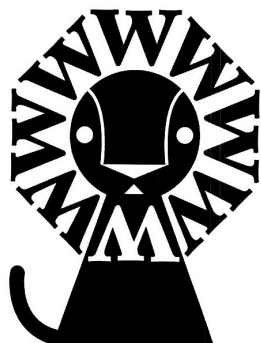

THE MARK CONSISTS OF A LION WITH A MANE MADE UP OF "W"'S.

FOR PUBLICATIONS, NAMELY, BOOKS, MAGAZINES, JOURNALS, BROCHURES, BOOKLETS, AND TEACHING MATERIALS ON A VARIETY OF TOPICS (U.S. CLS. 2, 5, 22, 23, 29, 37, 38 AND 50).

FIRST USE 1-0-2007; IN COMMERCE 1-0-2007.

3,481,692. 4W INTERNACIONAL, S.A., PANAMA, PANAMA. SN 77-175,038. PUB. 2-26-2008, FILED 5-8-2007.

4W

THE MARK CONSISTS OF STANDARD CHARACTERS WITHOUT CLAIM TO ANY PARTICULAR FONT, STYLE, SIZE, OR COLOR.

FOR PAPER; CARTOON STRIPS; ARTICLES, NAMELY, MAGAZINE ARTICLES AND REPORTS RELATED TO LUXURY PRODUCTS AND SERVICES OF INTEREST TO A PUBLIC WITH A HIGH PURCHASING POWER; PRINT PRODUCTS, NAMELY, GENERAL FEATURE MAGAZINES (U.S. CLS. 2, 5, 22, 23, 29, 37, 38 AND 50).

FIRST USE 2-28-2007; IN COMMERCE 2-28-2007.

CLASS 16—(Continued).

3,481,709. LESOWSKE, CHARLES J, SISTERS, OR. SN 77-179,507. PUB. 1-22-2008, FILED 5-12-2007.

BookPlot

THE MARK CONSISTS OF STANDARD CHARACTERS WITHOUT CLAIM TO ANY PARTICULAR FONT, STYLE, SIZE, OR COLOR.

FOR RELIGIOUS BOOKS (U.S. CLS. 2, 5, 22, 23, 29, 37, 38 AND 50).

FIRST USE 0-0-2004; IN COMMERCE 0-0-2004.

3,481,711. SOUTHEASTERN NEWSPAPERS COMPANY, LLC, AUGUSTA, GA. SN 77-180,240. PUB. 11-6-2007, FILED 5-14-2007.

CONNECT AIKEN COUNTY

THE MARK CONSISTS OF STANDARD CHARACTERS WITHOUT CLAIM TO ANY PARTICULAR FONT, STYLE, SIZE, OR COLOR.

NO CLAIM IS MADE TO THE EXCLUSIVE RIGHT TO USE "AIKEN COUNTY", APART FROM THE MARK AS SHOWN.

FOR MAGAZINE SUPPLEMENTS TO NEWSPAPERS IN THE FIELD OF COMMUNITY EVENTS, CULTURE, ENTERTAINMENT, SHOPPING, DINING, PRODUCTS AND SERVICES OF INTEREST IN NORTH AUGUSTA, SOUTH CAROLINA AND AIKEN, SOUTH CAROLINA; MAGAZINES FEATURING COMMUNITY EVENTS, CULTURE, ENTERTAINMENT, SHOPPING, DINING, PRODUCTS AND SERVICES OF INTEREST IN NORTH AUGUSTA, SOUTH CAROLINA AND AIKEN, SOUTH CAROLINA (U.S. CLS. 2, 5, 22, 23, 29, 37, 38 AND 50).

FIRST USE 9-0-2007; IN COMMERCE 9-0-2007.

CLASS 16—(Continued).

3,481,714. SOUTHEASTERN NEWSPAPERS COMPANY, LLC, AUGUSTA, GA. SN 77-180,916. PUB. 10-2-2007, FILED 5-15-2007.

CONNECT COLUMBIA COUNTY

THE MARK CONSISTS OF STANDARD CHARACTERS WITHOUT CLAIM TO ANY PARTICULAR FONT, STYLE, SIZE, OR COLOR.

NO CLAIM IS MADE TO THE EXCLUSIVE RIGHT TO USE "COLUMBIA COUNTY", APART FROM THE MARK AS SHOWN.

FOR MAGAZINE SUPPLEMENTS TO NEWSPAPERS IN THE FIELD OF COMMUNITY EVENTS, CULTURE, ENTERTAINMENT, SHOPPING, DINING, PRODUCTS AND SERVICES OF INTEREST IN THE AUGUSTA, GEORGIA METRO AREA; MAGAZINES FEATURING COMMUNITY EVENTS, CULTURE, ENTERTAINMENT, SHOPPING, DINING, PRODUCTS AND SERVICES OF INTEREST IN THE AUGUSTA, GEORGIA METRO AREA (U.S. CLS. 2, 5, 22, 23, 29, 37, 38 AND 50).
FIRST USE 5-0-2007; IN COMMERCE 5-0-2007.

3,481,770. CRAYOLA PROPERTIES, INC., EASTON, PA. SN 77-206,461. PUB. 11-20-2007, FILED 6-14-2007.

FUSION

THE MARK CONSISTS OF STANDARD CHARACTERS WITHOUT CLAIM TO ANY PARTICULAR FONT, STYLE, SIZE, OR COLOR.

FOR MODELING MATERIALS AND COMPOUNDS FOR USE BY CHILDREN (U.S. CLS. 2, 5, 22, 23, 29, 37, 38 AND 50).

FIRST USE 7-30-2007; IN COMMERCE 7-30-2007.

3,481,781. SELLARS ABSORBENT MATERIALS, INC., MILWAUKEE, WI. SN 77-211,555. PUB. 12-11-2007, FILED 6-21-2007.



FOR PAPER TOWELS COMPRISED OF WOOD PULP AND BINDING AGENTS (U.S. CLS. 2, 5, 22, 23, 29, 37, 38 AND 50).

FIRST USE 9-7-2007; IN COMMERCE 9-7-2007.

CLASS 16—(Continued).

3,481,827. PRESCRIPTIVE MUSIC, LLC, WOODLAND HILLS, CA. SN 77-235,222. PUB. 3-18-2008, FILED 7-20-2007.

ON KEY

THE MARK CONSISTS OF STANDARD CHARACTERS WITHOUT CLAIM TO ANY PARTICULAR FONT, STYLE, SIZE, OR COLOR.

FOR PRINTED PROMOTIONAL PACKAGING MADE OF PAPER OF VARYING WEIGHTS, FOR HOLDING GIFT CARDS, CARD KEYS AND CDS/DVDS (U.S. CLS. 2, 5, 22, 23, 29, 37, 38 AND 50).

FIRST USE 1-0-2006; IN COMMERCE 1-0-2006.

3,481,849. WEINER, LORI, BOCA RATON, FL. AND STONER, JODI, BOCA RATON, FL. SN 77-244,013. PUB. 2-5-2008, FILED 8-1-2007.

GOOD MANNERS ARE
CONTAGIOUS, PASS IT ON!

THE MARK CONSISTS OF STANDARD CHARACTERS WITHOUT CLAIM TO ANY PARTICULAR FONT, STYLE, SIZE, OR COLOR.

FOR CHILDREN'S BOOKS; CHILDREN'S ADHESIVE STICKERS IN SAID BOOKS (U.S. CLS. 2, 5, 22, 23, 29, 37, 38 AND 50).

FIRST USE 11-14-2007; IN COMMERCE 11-14-2007.

3,481,858. HIGHLANDS PUBLICATIONS, INC., BIRMINGHAM, AL. SN 77-247,414. PUB. 3-11-2008, FILED 8-5-2007.

MODERN CONTRACTOR SOLUTIONS

THE MARK CONSISTS OF STANDARD CHARACTERS WITHOUT CLAIM TO ANY PARTICULAR FONT, STYLE, SIZE, OR COLOR.

NO CLAIM IS MADE TO THE EXCLUSIVE RIGHT TO USE "CONTRACTOR", APART FROM THE MARK AS SHOWN.

FOR MAGAZINES FEATURING INFORMATION FOR GENERAL AND CONCRETE CONTRACTORS (U.S. CLS. 2, 5, 22, 23, 29, 37, 38 AND 50).

FIRST USE 7-15-2007; IN COMMERCE 8-10-2007.

CLASS 16—(Continued).

3,481,899. UNISOURCE WORLDWIDE, INC., NORCROSS, GA. SN 77-261,616. PUB. 2-19-2008, FILED 8-22-2007.

uGLOSS

THE MARK CONSISTS OF STANDARD CHARACTERS WITHOUT CLAIM TO ANY PARTICULAR FONT, STYLE, SIZE, OR COLOR.

FOR PRINTING PAPER COATED ON EITHER ONE OR TWO SIDES IN A VARIETY OF BASIS WEIGHTS AND FINISHES, USED IN COMMERCIAL PRINTING APPLICATIONS (U.S. CLS. 2, 5, 22, 23, 29, 37, 38 AND 50).
FIRST USE 3-1-2008; IN COMMERCE 3-1-2008.

3,481,909. UNISOURCE WORLDWIDE, INC., NORCROSS, GA. SN 77-264,890. PUB. 2-19-2008, FILED 8-27-2007.

uLABEL

THE MARK CONSISTS OF STANDARD CHARACTERS WITHOUT CLAIM TO ANY PARTICULAR FONT, STYLE, SIZE, OR COLOR.

FOR PRINTING PAPER COATED ON EITHER ONE OR TWO SIDES IN A VARIETY OF BASIS WEIGHTS AND FINISHES, USED IN COMMERCIAL PRINTING APPLICATIONS (U.S. CLS. 2, 5, 22, 23, 29, 37, 38 AND 50).
FIRST USE 3-1-2008; IN COMMERCE 3-1-2008.

CLASS 16—(Continued).

3,481,918. WETSPOT PRODUCTIONS, CANTON, MI. SN 77-271,451. PUB. 3-4-2008, FILED 9-4-2007.



THE MARK CONSISTS OF THE IMAGE OF A WOMAN IN THE MIDDLE WITH TWO OVALS AROUND HER, AND THE TEXT "WET SPOT" UNDER THE WOMAN, WITH RAIN DROPS THROUGHOUT AND WATER RUNNING DOWN THE TEXT. THERE IS A SLIGHT REFLECTION OF THE WORD "SPOT" DIRECTLY BELOW IT.

FOR GENERAL FEATURE MAGAZINES; MAGAZINES FEATURING ADULT CONTENT AND EROTICA (U.S. CLS. 2, 5, 22, 23, 29, 37, 38 AND 50).
FIRST USE 12-22-2007; IN COMMERCE 12-22-2007.

3,481,966. UNISOURCE WORLDWIDE, INC., NORCROSS, GA. SN 77-298,215. PUB. 2-19-2008, FILED 10-8-2007.

COMET OPAQUE

THE MARK CONSISTS OF STANDARD CHARACTERS WITHOUT CLAIM TO ANY PARTICULAR FONT, STYLE, SIZE, OR COLOR.

NO CLAIM IS MADE TO THE EXCLUSIVE RIGHT TO USE "OPAQUE", APART FROM THE MARK AS SHOWN.
FOR PRINTING PAPER (U.S. CLS. 2, 5, 22, 23, 29, 37, 38 AND 50).
FIRST USE 3-20-2008; IN COMMERCE 3-20-2008.

CLASS 16—(Continued).

3,481,993. VIRGIN COMICS, LLC, NEW YORK, NY. SN 77-975,679. PUB. 9-18-2007, FILED 3-8-2007.

ECONAUTS

THE MARK CONSISTS OF STANDARD CHARACTERS WITHOUT CLAIM TO ANY PARTICULAR FONT, STYLE, SIZE, OR COLOR.

FOR PRINTED MATTER, NAMELY, COMIC BOOKS AND GRAPHIC NOVELS; LUNCH BAGS (U.S. CLS. 2, 5, 22, 23, 29, 37, 38 AND 50).

FIRST USE 3-1-2008; IN COMMERCE 3-1-2008.

CLASS 16—(Continued).

3,482,047. HALLMARK LICENSING, INC., KANSAS CITY, MO. SN 78-433,288. PUB. 10-18-2005, FILED 6-10-2004.

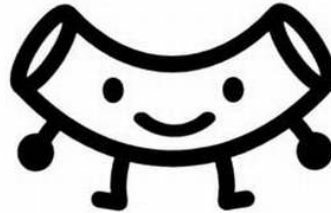

THE MARK CONSISTS OF AN ANTHROPOMORPHIC CURVED CYLINDER.

FOR STICKERS; ACTIVITY KITS CONSISTING PRIMARILY OF STICKERS FOR USE BY CHILDREN; VINYL BAGS, NAMELY, PLASTIC BAGS FOR CARRYING STICKERS; CARDBOARD CONTAINERS FOR CARRYING STICKERS; TOY KITS CONSISTING PRIMARILY OF STICKERS FOR USE BY CHILDREN; TOY CARRYING CASES FOR CONTAINING STICKERS (U.S. CLS. 2, 5, 22, 23, 29, 37, 38 AND 50).

FIRST USE 2-14-2005; IN COMMERCE 2-14-2005.

3,482,046. HALLMARK LICENSING, INC., KANSAS CITY, MO. SN 78-433,174. PUB. 10-18-2005, FILED 6-10-2004.

3,482,067. NATIONAL CASA ASSOCIATION, SEATTLE, WA. SN 78-495,099. PUB. 1-10-2006, FILED 10-5-2004.

STICKERONI

THE MARK CONSISTS OF STANDARD CHARACTERS WITHOUT CLAIM TO ANY PARTICULAR FONT, STYLE, SIZE, OR COLOR.

FOR STICKERS; ACTIVITY KITS CONSISTING PRIMARILY OF STICKERS FOR USE BY CHILDREN; VINYL BAGS, NAMELY, PLASTIC BAGS FOR CARRYING STICKERS; CARDBOARD CONTAINERS FOR CARRYING STICKERS; TOY KITS CONSISTING PRIMARILY OF STICKERS FOR USE BY CHILDREN; TOY CARRYING CASES FOR CONTAINING STICKERS (U.S. CLS. 2, 5, 22, 23, 29, 37, 38 AND 50).

FIRST USE 2-14-2005; IN COMMERCE 2-14-2005.

LIGHT OF HOPE

THE MARK CONSISTS OF STANDARD CHARACTERS WITHOUT CLAIM TO ANY PARTICULAR FONT, STYLE, SIZE, OR COLOR.

OWNER OF U.S. REG. NO. 2,576,010.

FOR PRINTED MATERIALS, NAMELY, BROCHURES AND NEWSLETTERS RELATING TO CHILD WELFARE, CHILDREN INVOLVED IN LEGAL ACTIONS AND VOLUNTEERS ACTING ON BEHALF OF CHILDREN; TRAINING MANUALS IN THE FIELDS OF CHILD WELFARE, CHILDREN INVOLVED IN LEGAL ACTIONS AND VOLUNTEERS ACTING ON BEHALF OF CHILDREN (U.S. CLS. 2, 5, 22, 23, 29, 37, 38 AND 50).

FIRST USE 10-0-1999; IN COMMERCE 10-0-1999.

CLASS 16—(Continued).

3,482,102. DATA SAFE-MEDIA LTD., NEWBRIDGE, EDINBURGH, LOTHIAN, UNITED KINGDOM. SN 78-578,097. PUB. 11-21-2006, FILED 3-2-2005.

RiDiSc

FOR PRINTED MATTER, NAMELY, MAGAZINES FEATURING INFORMATION ON PROTECTING COMPUTERS, DATA MANAGEMENT AND STORAGE; AND JOURNALS FEATURING INFORMATION ON PROTECTING COMPUTERS, DATA MANAGEMENT AND STORAGE; STATIONERY (U.S. CLS. 2, 5, 22, 23, 29, 37, 38 AND 50).

FIRST USE 9-0-2005; IN COMMERCE 11-0-2006.

3,482,176. THE HERFF JONES COMPANY OF INDIANA, INC., INDIANAPOLIS, IN. SN 78-709,271. PUB. 5-23-2006, FILED 9-8-2005.

THIN MAN

THE MARK CONSISTS OF STANDARD CHARACTERS WITHOUT CLAIM TO ANY PARTICULAR FONT, STYLE, SIZE, OR COLOR.

FOR ANATOMICAL MODELS FOR INSTRUCTIONAL AND EDUCATIONAL PURPOSES (U.S. CLS. 2, 5, 22, 23, 29, 37, 38 AND 50).

FIRST USE 0-0-1993; IN COMMERCE 0-0-1993.

3,482,203. CELLYNNE CORPORATION, HAINES CITY, FL. SN 78-744,583. PUB. 5-8-2007, FILED 11-1-2005.

CONFIDENCE

THE MARK CONSISTS OF STANDARD CHARACTERS WITHOUT CLAIM TO ANY PARTICULAR FONT, STYLE, SIZE, OR COLOR.

FOR PAPER GOODS, NAMELY, TOILET PAPER, FACIAL TISSUE, TABLE NAPKINS AND PAPER TOWELS (U.S. CLS. 2, 5, 22, 23, 29, 37, 38 AND 50).

FIRST USE 4-18-2008; IN COMMERCE 4-18-2008.

CLASS 16—(Continued).

3,482,206. THE CALIFORNIA SPEEDWAY CORPORATION, DAYTONA BEACH, FL. SN 78-746,953. PUB. 9-25-2007, FILED 11-4-2005.



FOR POSTERS, CALENDARS, STICKERS, BUMPERS STICKERS, DECALS, TRADING CARDS, TRADING CARD ALBUMS, POSTCARDS, BOOK COVERS, POSTERS NOTEBOOKS, LOOSE LEAF BINDERS, AND MEMO PADS; PENS, PENCILS, AND ERASERS; PAPER NAPKINS AND PAPER PLACE MATS; AND CREDENTIAL HOLDERS (U.S. CLS. 2, 5, 22, 23, 29, 37, 38 AND 50).

FIRST USE 2-24-2006; IN COMMERCE 2-24-2006.

3,482,208. NORTHERN TECHNOLOGIES INTERNATIONAL CORPORATION, BEACHWOOD, OH. SN 78-749,762. PUB. 7-11-2006, FILED 11-8-2005.

NATUR-TEC

THE MARK CONSISTS OF STANDARD CHARACTERS WITHOUT CLAIM TO ANY PARTICULAR FONT, STYLE, SIZE, OR COLOR.

FOR PAPER, NAMELY, CARDBOARD, CRAFT PAPER, COPIER PAPER, AND CORRUGATED PAPER, COATED WITH AND/OR CONTAINING ONE OR MORE BIODEGRADABLE AND/OR COMPOSTABLE POLYMER RESINS, AND/OR ONE OR MORE BLENDED, COMPOUNDED AND/OR ALLOYED MIXTURES OF BIODEGRADABLE AND/OR COMPOSTABLE POLYMER RESINS; AND PAPER BAGS COATED WITH AND/OR CONTAINING ONE OR MORE BIODEGRADABLE AND/OR COMPOSTABLE POLYMER RESINS, AND/OR ONE OR MORE BLENDED, COMPOUNDED AND/OR ALLOYED MIXTURES OF BIODEGRADABLE AND/OR COMPOSTABLE POLYMER RESINS (U.S. CLS. 2, 5, 22, 23, 29, 37, 38 AND 50).

FIRST USE 9-0-2007; IN COMMERCE 9-0-2007.

CLASS 16—(Continued).

3,482,213. TATE, MICHAEL ALAN, BIRMINGHAM, AL. SN 78-756,016. PUB. 2-20-2007, FILED 11-17-2005.



ON THE SAME PAGE PLANNER

NO CLAIM IS MADE TO THE EXCLUSIVE RIGHT TO USE "PLANNER", APART FROM THE MARK AS SHOWN. THE COLOR(S) BLACK, WHITE, LIGHT GREY AND DARK GREY IS/ARE CLAIMED AS A FEATURE OF THE MARK.

THE MARK CONSISTS OF AN INVERTED PYRAMID, WITH BLACK BASE, BLACK LEFT SIDE, A LIGHT GREY RIGHT SIDE AND A RHOMBOIDAL SHADOW CAST IN DARK GREY BENEATH APEX OF THE INVERTED PYRAMIDAL STRUCTURE. THE COLOR WHITE APPEARS IN THE OUTLINE OF THE INVERTED PYRAMID AND IN HORIZONTAL LINES CROSSING THE PYRAMID.

FOR NON-FICTION BOOKS ON A VARIETY OF TOPICS (U.S. CLS. 2, 5, 22, 23, 29, 37, 38 AND 50). FIRST USE 3-15-2006; IN COMMERCE 10-15-2006.

3,482,255. INFLEXXION, INC., NEWTON, MA. SN 78-783,477. PUB. 4-3-2007, FILED 12-31-2005.

CURRENT OPIOID MISUSE MEASURE (COMM)

THE MARK CONSISTS OF STANDARD CHARACTERS WITHOUT CLAIM TO ANY PARTICULAR FONT, STYLE, SIZE, OR COLOR.

NO CLAIM IS MADE TO THE EXCLUSIVE RIGHT TO USE "CURRENT OPIOID MISUSE MEASURE", APART FROM THE MARK AS SHOWN.

FOR QUESTIONNAIRE IN THE NATURE OF A TEST IN THE FIELD OF PAIN MANAGEMENT AND PRESCRIPTION DRUGS (U.S. CLS. 2, 5, 22, 23, 29, 37, 38 AND 50).

FIRST USE 8-22-2007; IN COMMERCE 8-22-2007.

CLASS 16—(Continued).

3,482,274. FIRST QUALITY RETAIL SERVICES, LLC, GREAT NECK, NY. SN 78-794,459. PUB. 7-25-2006, FILED 1-19-2006.

WOBLERROOM

THE MARK CONSISTS OF STANDARD CHARACTERS WITHOUT CLAIM TO ANY PARTICULAR FONT, STYLE, SIZE, OR COLOR.

FOR ADHESIVE TABS FOR A DISPOSABLE DIAPER SOLD AS A COMPONENT PART THEREOF (U.S. CLS. 2, 5, 22, 23, 29, 37, 38 AND 50).

FIRST USE 8-31-2006; IN COMMERCE 8-31-2006.

3,482,328. WARNER PRESS, INC., ANDERSON, IN. SN 78-845,703. PUB. 3-6-2007, FILED 3-24-2006.



OWNER OF U.S. REG. NOS. 1,174,577 AND 2,739,650. NO CLAIM IS MADE TO THE EXCLUSIVE RIGHT TO USE "PRESS KIDS", APART FROM THE MARK AS SHOWN.

FOR PRINTED MATERIALS, NAMELY, RELIGIOUS BOOKS, AND CHILDREN'S BOOKS, PRINTED ATTENDANCE CHARTS, BULLETIN BOARDS, CHURCH BULLETINS, POSTERS, PAPER BANNERS, STORY BOARDS, MEMORY CARDS, NAMELY, STICKER BOOKS, ACTIVITY BOOKS, NAMELY CHILDREN ACTIVITY BOOKS, COLORING BOOKS, CARDS, NAMELY, BLANK CARDS AND MOTIVATIONAL CARDS, PENCILS, PENCIL SHARPENERS, PAPER FANS, AND CRAYONS (U.S. CLS. 2, 5, 22, 23, 29, 37, 38 AND 50).

FIRST USE 5-0-2006; IN COMMERCE 7-0-2006.

3,482,352. BEGIN SMART LLC, NEW YORK, NY. SN 78-859,638. PUB. 11-28-2006, FILED 4-12-2006.

BEGIN SMART

THE MARK CONSISTS OF STANDARD CHARACTERS WITHOUT CLAIM TO ANY PARTICULAR FONT, STYLE, SIZE, OR COLOR.

FOR EDUCATIONAL BOOKS FEATURING A DEVELOPMENTAL PROGRAM FOR CHILDREN (U.S. CLS. 2, 5, 22, 23, 29, 37, 38 AND 50).

FIRST USE 6-4-2008; IN COMMERCE 6-4-2008.

CLASS 16—(Continued).

3,482,366. APDN (B.V.I.) INC., ROADTOWN, BR.VIRGIN ISLANDS. SN 78-871,967. PUB. 3-18-2008, FILED 4-28-2006.

SIGNATURE

THE MARK CONSISTS OF STANDARD CHARACTERS WITHOUT CLAIM TO ANY PARTICULAR FONT, STYLE, SIZE, OR COLOR.

FOR ANTI-COUNTERFEITING SYSTEM COMPRISED OF DNA COATING, NAMELY, MARKING INK AND COATINGS CONTAINING DNA FOR THE ENCRYPTION AND AUTHENTICATION OF OBJECTS (U.S. CLS. 2, 5, 22, 23, 29, 37, 38 AND 50).
FIRST USE 1-28-2008; IN COMMERCE 1-28-2008.

3,482,376. MEDIMEDIA USA, INC., YARDLEY, PA. SN 78-883,864. PUB. 7-17-2007, FILED 5-15-2006.

COMPENDIUM CONTINUING EDUCATION FOR VETERINARIANS

THE MARK CONSISTS OF STANDARD CHARACTERS WITHOUT CLAIM TO ANY PARTICULAR FONT, STYLE, SIZE, OR COLOR.

NO CLAIM IS MADE TO THE EXCLUSIVE RIGHT TO USE "CONTINUING EDUCATION FOR VETERINARIANS", APART FROM THE MARK AS SHOWN.

SEC. 2(F) AS TO "COMPENDIUM".
FOR PERIODICAL PUBLICATIONS, NAMELY, MAGAZINES FEATURING ARTICLES IN THE FIELD OF VETERINARY MEDICINE (U.S. CLS. 2, 5, 22, 23, 29, 37, 38 AND 50).

FIRST USE 6-15-2006; IN COMMERCE 6-15-2006.

3,482,377. KLEFEKER, JOHN M., DBA FAMILY HEARING CARE CENTER, WEYMOUTH, MA. SN 78-884,561. PUB. 2-26-2008, FILED 5-16-2006.

Sound Advice

THE MARK CONSISTS OF STANDARD CHARACTERS WITHOUT CLAIM TO ANY PARTICULAR FONT, STYLE, SIZE, OR COLOR.

FOR SYNDICATED COLUMNS DEALING WITH HEARING LOSS, HEARING AIDS, AND RELATED HEARING PRODUCTS AND SERVICES (U.S. CLS. 2, 5, 22, 23, 29, 37, 38 AND 50).

FIRST USE 5-17-2006; IN COMMERCE 5-22-2006.

CLASS 16—(Continued).

3,482,445. GARZA, RAYNALDO, MONARCH BEACH, CA. SN 78-930,273. PUB. 3-13-2007, FILED 7-14-2006.



NO CLAIM IS MADE TO THE EXCLUSIVE RIGHT TO USE "KIDS MEAL", APART FROM THE MARK AS SHOWN. THE COLOR(S) YELLOW AND RED IS/ARE CLAIMED AS A FEATURE OF THE MARK.

THE MARK CONSISTS OF THE WORDING "KIDZMEAL" IN WHICH THE LETTERS ARE RED, EACH OUTLINED IN YELLOW, AND TWO STARS, THE FIRST WHICH FORMS PART OF THE LETTER "A" IN YELLOW, AND THE SECOND IN RED WITH YELLOW OUTLINE OVER THE LETTER "I".

FOR PAPER AND CARDBOARD CONTAINERS, NAMELY, SANDWICH BAGS AND BOXES FOR FOOD (U.S. CLS. 2, 5, 22, 23, 29, 37, 38 AND 50).

FIRST USE 5-18-2001; IN COMMERCE 7-1-2007.

3,482,461. TIME INC., NEW YORK, NY. SN 78-936,002. PUB. 9-11-2007, FILED 7-24-2006.

TRUSTED CONNECTIONS

THE MARK CONSISTS OF STANDARD CHARACTERS WITHOUT CLAIM TO ANY PARTICULAR FONT, STYLE, SIZE, OR COLOR.

FOR PRINTED PUBLICATIONS, NAMELY, MAGAZINES IN THE FIELD OF NEWS AND GENERAL INTEREST INFORMATION, STICKERS, PRINTED PROMOTIONAL MATERIALS, NAMELY, BROCHURES IN THE FIELD OF NEWS AND GENERAL INTEREST INFORMATION (U.S. CLS. 2, 5, 22, 23, 29, 37, 38 AND 50).

FIRST USE 7-31-2007; IN COMMERCE 7-31-2007.

CLASS 16—(Continued).

3,482,468. EDGEWATER MARINE INDUSTRIES, LLC, NEW BEDFORD, MA. SN 78-938,044. PUB. 3-6-2007, FILED 7-26-2006.

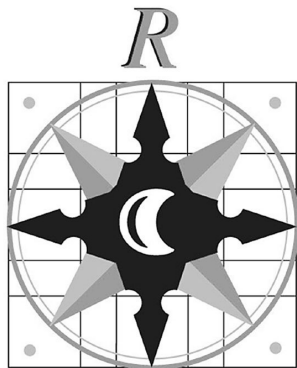

THE MARK CONSISTS OF A STYLISTIC COMPASS ROSE WITH THE LETTER "R" THEREABOVE.

FOR BOOKS, BOOKLETS, AND PAMPHLETS PERTAINING TO NAVIGATION; PRINTED NAUTICAL CHARTS, NAMELY, WATERPROOF NAUTICAL CHARTS; NAUTICAL CHARTS BOUND INTO BOOKLET FORM; NAUTICAL-CHART BOOKLETS WITH SYNTHETIC-STOCK WATERPROOF PAGES; CHARTBOOKS INCORPORATING SUPPLEMENTAL INFORMATION, NAMELY, NAVIGATIONAL INFORMATION, CRUISING INFORMATION, AND HARBOR AND FACILITY INFORMATION (U.S. CLS. 2, 5, 22, 23, 29, 37, 38 AND 50). FIRST USE 12-31-1996; IN COMMERCE 12-31-1996.

3,482,483. REMARKABLE CONCEPTS LIMITED, CHRISTCHURCH, NEW ZEALAND. SN 78-941,868. PUB. 7-17-2007, FILED 8-1-2006.

STRIKE 'N SWIPE

THE MARK CONSISTS OF STANDARD CHARACTERS WITHOUT CLAIM TO ANY PARTICULAR FONT, STYLE, SIZE, OR COLOR.

PRIORITY CLAIMED UNDER SEC. 44(D) ON NEW ZEALAND APPLICATION NO. 742307, FILED 2-2-2006, REG. NO. 742307, DATED 2-2-2006, EXPIRES 2-2-2013.

FOR IMPACT MARKERS IN THE NATURE OF PRESSURE SENSITIVE, RE-USABLE IMPACT LABELS; IMPACT MARKERS IN THE NATURE OF PRESSURE SENSITIVE, RE-USABLE IMPACT LABELS FOR SPORTING ARTICLES (U.S. CLS. 2, 5, 22, 23, 29, 37, 38 AND 50). FIRST USE 1-1-2007; IN COMMERCE 1-1-2007.

CLASS 16—(Continued).

3,482,490. WORLD RADIO MISSIONARY FELLOWSHIP, INC., COLORADO SPRINGS, CO. SN 78-944,654. PUB. 8-28-2007, FILED 8-3-2006.

HCJB GLOBAL VOICE

THE MARK CONSISTS OF STANDARD CHARACTERS WITHOUT CLAIM TO ANY PARTICULAR FONT, STYLE, SIZE, OR COLOR.

NO CLAIM IS MADE TO THE EXCLUSIVE RIGHT TO USE "GLOBAL", APART FROM THE MARK AS SHOWN.

FOR PRINTED INSTRUCTIONAL, EDUCATIONAL, AND TEACHING MATERIALS FOR USE IN THE FIELDS OF HUMAN CULTURES, COMMUNICATION AND COMMUNICATION TECHNOLOGY, HEALTHCARE AND HEALTHCARE TECHNOLOGY, AND CHRISTIAN THEOLOGY, MISSIONS AND PRACTICAL MINISTRY; PRINTED MATTER, NAMELY, MAGAZINES, FLIERS, NEWSLETTERS, BROCHURES AND BOOKS, ALL IN THE FIELD OF CHRISTIAN THEOLOGY, MISSIONS AND PRACTICAL MINISTRY (U.S. CLS. 2, 5, 22, 23, 29, 37, 38 AND 50).

FIRST USE 1-1-2007; IN COMMERCE 1-1-2007.

3,482,493. WORLD RADIO MISSIONARY FELLOWSHIP, INC., COLORADO SPRINGS, CO. SN 78-944,658. PUB. 8-21-2007, FILED 8-3-2006.

HCJB GLOBAL HANDS

THE MARK CONSISTS OF STANDARD CHARACTERS WITHOUT CLAIM TO ANY PARTICULAR FONT, STYLE, SIZE, OR COLOR.

NO CLAIM IS MADE TO THE EXCLUSIVE RIGHT TO USE "GLOBAL", APART FROM THE MARK AS SHOWN.

FOR PRINTED INSTRUCTIONAL, EDUCATIONAL, AND TEACHING MATERIALS FOR USE IN THE FIELDS OF HUMAN CULTURES, COMMUNICATION AND COMMUNICATION TECHNOLOGY, HEALTHCARE AND HEALTHCARE TECHNOLOGY, AND CHRISTIAN THEOLOGY, MISSIONS AND PRACTICAL MINISTRY; PRINTED MATTER, NAMELY, MAGAZINES, FLIERS, NEWSLETTERS, BROCHURES AND BOOKS, ALL IN THE FIELD OF CHRISTIAN THEOLOGY, MISSIONS AND PRACTICAL MINISTRY (U.S. CLS. 2, 5, 22, 23, 29, 37, 38 AND 50).

FIRST USE 1-1-2007; IN COMMERCE 1-1-2007.

CLASS 16—(Continued).

3,482,575. SEVEN LIGHTS, LLC, CHICAGO, IL. SN 78-980,191. PUB. 9-4-2007, FILED 7-19-2006.



FOR PRINTED MATERIAL AND PUBLICATIONS, NAMELY, COMIC BOOKS (U.S. CLS. 2, 5, 22, 23, 29, 37, 38 AND 50).

FIRST USE 8-9-2006; IN COMMERCE 8-9-2006.

CLASS 16—(Continued).

3,482,582. NINTENDO OF AMERICA INC., REDMOND, WA. SN 78-980,359. PUB. 5-29-2007, FILED 4-27-2006.

Wii

THE MARK CONSISTS OF STANDARD CHARACTERS WITHOUT CLAIM TO ANY PARTICULAR FONT, STYLE, SIZE, OR COLOR.

PRIORITY CLAIMED UNDER SEC. 44(D) ON ITALY APPLICATION NO. 119872005M, FILED 11-11-2005.

OWNER OF JAPAN REG. NO. 4992560, DATED 9-29-2006, EXPIRES 9-29-2016.

FOR (BASED ON USE) CALENDARS; GIFT WRAPPING PAPER; MAGAZINES, BOOKLETS, STRATEGY GUIDES, AND MANUALS REGARDING VIDEO GAMES, COMPUTER GAMES AND ENTERTAINMENT; PENS; POSTERS; AND MAGAZINES AND OTHER PRINTED MATTER, NAMELY, BOOKLETS AND MANUALS PERTAINING TO VIDEO GAMES; (BASED ON SECTION 44(E)) PAPER BANNERS; PAPER FLAGS; PAPER LABELS FOR BAGGAGE; CALLIGRAPHIC WORKS AND CALLIGRAPHIC PICTURES; PHOTOGRAPHS; STATIONERY; ADHESIVES FOR STATIONERY OR HOUSEHOLD USE; AND ELECTRICAL PENCIL SHARPENERS (U.S. CLS. 2, 5, 22, 23, 29, 37, 38 AND 50). FIRST USE 11-19-2006; IN COMMERCE 11-19-2006.

3,482,576. SEVEN LIGHTS, LLC, CHICAGO, IL. SN 78-980,192. PUB. 9-11-2007, FILED 9-8-2006.

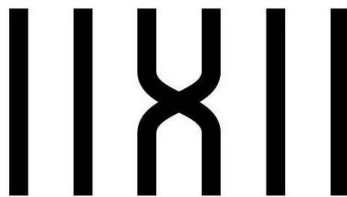

THE MARK CONSISTS OF TWO CROSSED LINES BETWEEN TWO PARALLEL VERTICAL LINES ON EACH SIDE OF THE TWO CROSSED LINES.

FOR PRINTED MATERIAL AND PUBLICATIONS, NAMELY, COMIC BOOKS (U.S. CLS. 2, 5, 22, 23, 29, 37, 38 AND 50).

FIRST USE 8-9-2006; IN COMMERCE 8-9-2006.

3,482,584. FIRST QUALITY TISSUE, LLC, GREAT NECK, NY. SN 78-980,379. PUB. 11-21-2006, FILED 6-16-2006.

PANDA

THE MARK CONSISTS OF STANDARD CHARACTERS WITHOUT CLAIM TO ANY PARTICULAR FONT, STYLE, SIZE, OR COLOR.

FOR TOILET TISSUE (U.S. CLS. 2, 5, 22, 23, 29, 37, 38 AND 50).

FIRST USE 2-27-2008; IN COMMERCE 2-27-2008.

CLASS 17—RUBBER GOODS

CLASS 17—(Continued).

3,481,076. CANALPLAST S.P.A., 20051 - LIMBIATE (MI), ITALY. SN 76-646,814. PUB. 11-14-2006, FILED 9-14-2005.

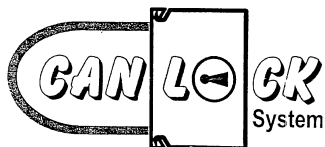

NO CLAIM IS MADE TO THE EXCLUSIVE RIGHT TO USE "SYSTEM", APART FROM THE MARK AS SHOWN.

FOR NON-METAL PLASTIC TUBES FOR ELECTRIC INSULATION AND TELEPHONE APPLICATIONS; AND PLASTIC BARS USED AS BASEBOARDS (U.S. CLS. 1, 5, 12, 13, 35 AND 50).

FIRST USE 9-20-2005; IN COMMERCE 10-3-2005.

3,481,470. OWENS CORNING INTELLECTUAL CAPITAL, LLC, TOLEDO, OH. SN 77-131,745. PUB. 9-11-2007, FILED 3-15-2007.

ACOUSTICR

THE MARK CONSISTS OF STANDARD CHARACTERS WITHOUT CLAIM TO ANY PARTICULAR FONT, STYLE, SIZE, OR COLOR.

FOR BUILDING INSULATION MATERIALS, NAMELY, INSULATION USED IN DUCTWORK, INSULATION USED AS DUCT LINER (U.S. CLS. 1, 5, 12, 13, 35 AND 50).

FIRST USE 6-25-2007; IN COMMERCE 6-25-2007.

3,481,471. OWENS CORNING INTELLECTUAL CAPITAL, LLC, TOLEDO, OH. SN 77-131,782. PUB. 9-18-2007, FILED 3-15-2007.

ACOUSTITEX

THE MARK CONSISTS OF STANDARD CHARACTERS WITHOUT CLAIM TO ANY PARTICULAR FONT, STYLE, SIZE, OR COLOR.

FOR BUILDING INSULATION MATERIALS, NAMELY, INSULATION USED IN DUCTWORK, INSULATION USED AS DUCT LINER (U.S. CLS. 1, 5, 12, 13, 35 AND 50).

FIRST USE 10-19-2007; IN COMMERCE 10-19-2007.

CLASS 17—(Continued).

3,481,512. PAWLING CORPORATION, PAWLING, NY. SN 77-137,970. PUB. 11-27-2007, FILED 3-22-2007.

ZERO

THE MARK CONSISTS OF STANDARD CHARACTERS WITHOUT CLAIM TO ANY PARTICULAR FONT, STYLE, SIZE, OR COLOR.

FOR NON-METAL SEALS FOR USE IN SEALING INJECTION PORTS OF GAS CHROMATOGRAPHS (U.S. CLS. 1, 5, 12, 13, 35 AND 50).

FIRST USE 9-17-2007; IN COMMERCE 9-17-2007.

3,481,579. CORTEC CORPORATION, ST. PAUL, MN. SN 77-149,412. PUB. 10-9-2007, FILED 4-5-2007.

BIOCUSHION

THE MARK CONSISTS OF STANDARD CHARACTERS WITHOUT CLAIM TO ANY PARTICULAR FONT, STYLE, SIZE, OR COLOR.

FOR PROTECTIVE PACKAGING MATERIALS, NAMELY, INFLATABLE PLASTIC BLADDERS USED TO FILL PACKAGE VOID SPACES AND CUSHION CONTENTS (U.S. CLS. 1, 5, 12, 13, 35 AND 50).

FIRST USE 6-13-2008; IN COMMERCE 6-13-2008.

CLASS 17—(Continued).

3,482,222. THERMAFIBER, INC., WABASH, IN. SN 78-762,951. PUB. 8-1-2006, FILED 11-29-2005.

TopStop

THE MARK CONSISTS OF STANDARD CHARACTERS WITHOUT CLAIM TO ANY PARTICULAR FONT, STYLE, SIZE, OR COLOR.

FOR ACOUSTICAL INSULATION FOR BUILDINGS, NAMELY, SOUND ABSORBERS AND DIFFUSERS; MINERAL WOOL FOR USE IN AND AROUND THE VOID SPACES ABOVE THE TOPS OF BUILDING WALLS CREATED BY THE INTERSECTION OF THE WALL AND THE METAL OR CONCRETE DECK TO SERVE AS AN ACOUSTICAL BARRIER BETWEEN ROOMS OR FLOORS; HIGH TEMPERATURE MINERAL WOOL INSULATION, INCLUDING PRE-FORMED BLOCKS, FOR USE IN AREAS ABOVE AND AROUND WINDOWS AND IN VERTICAL SPACES BETWEEN METAL OR CONCRETE DECKS TO DELAY THE SPREAD AND/OR TRANSFER OF FLAMES, HOT GASES AND HEAT BETWEEN FLOORS AND ADD FIRE PROTECTION TO THE UNDERSIDE OF THE DECKS; WHEN INSTALLED IN COMBINATION WITH CLASSIFIED SMOKE SEAL PRODUCTS TO PROVIDE A SEALED BARRIER AGAINST SPREAD AND/OR TRANSFER OF PARTICULATE SMOKE AND AIR (U.S. CLS. 1, 5, 12, 13, 35 AND 50).

FIRST USE 1-1-2005; IN COMMERCE 1-1-2005.

3,482,232. APPLIED SEALS CO., LTD., CHANGHUA COUNTY, TAIWAN. SN 78-772,128. PUB. 9-25-2007, FILED 12-13-2005.

PERFREZ

THE COLOR(S) BLACK, RED AND YELLOW IS/ARE CLAIMED AS A FEATURE OF THE MARK.

THE COLOR BLACK APPEARS IN THE WORD "PERFREZ" AND THE TOP OF THE DESIGN TO THE RIGHT OF THE WORD IS YELLOW AND THE BOTTOM HALF IS RED.

THE WORDING "PERFREZ" HAS NO MEANING IN A FOREIGN LANGUAGE.

FOR SEALING COMPONENTS MADE OF SYNTHETIC RUBBER, NAMELY, SEALS, RODS, TUBES, SHEETS, SLABS, O-RINGS, AND V-RINGS FOR USE IN MANUFACTURING AND SEMICONDUCTOR INDUSTRIES (U.S. CLS. 1, 5, 12, 13, 35 AND 50).

FIRST USE 1-12-2007; IN COMMERCE 1-0-2008.

CLASS 17—(Continued).

3,482,536. DELSTAR TECHNOLOGIES INC., MIDDLETOWN, DE. SN 78-960,311. PUB. 4-17-2007, FILED 8-25-2006.

CORETEC

THE MARK CONSISTS OF STANDARD CHARACTERS WITHOUT CLAIM TO ANY PARTICULAR FONT, STYLE, SIZE, OR COLOR.

FOR PROFILE EXTRUDED SOLID AND HOLLOW SHAFTS, NAMELY, THERMOPLASTIC AND FLUOROPOLYMER RODS, CORES, TUBES AND SHAFTS (U.S. CLS. 1, 5, 12, 13, 35 AND 50).

FIRST USE 4-2-2008; IN COMMERCE 4-2-2008.

CLASS 18—LEATHER GOODS

3,481,074. APPLIED SEWING RESOURCES, INC., BENICIA, CA. SN 76-633,565. PUB. 6-13-2006, FILED 3-15-2005.

TOTAL TRAVEL SYSTEM

THE MARK CONSISTS OF STANDARD CHARACTERS WITHOUT CLAIM TO ANY PARTICULAR FONT, STYLE, SIZE, OR COLOR.

NO CLAIM IS MADE TO THE EXCLUSIVE RIGHT TO USE "TRAVEL SYSTEM", APART FROM THE MARK AS SHOWN.

FOR LUGGAGE (U.S. CLS. 1, 2, 3, 22 AND 41).

FIRST USE 8-24-2005; IN COMMERCE 8-24-2005.

3,481,139. TRI-COASTAL DESIGN GROUP, INC., GARDEN CITY, NY. SN 76-674,794. PUB. 9-4-2007, FILED 3-29-2007.

BAD TO THE BONE

THE MARK CONSISTS OF STANDARD CHARACTERS WITHOUT CLAIM TO ANY PARTICULAR FONT, STYLE, SIZE, OR COLOR.

FOR DOG CLOTHING, DOG LEASHES, DOG COLLARS, DOG HARNESSSES, DOG SHOES, DOG HATS (U.S. CLS. 1, 2, 3, 22 AND 41).

FIRST USE 5-30-2007; IN COMMERCE 5-30-2007.

CLASS 18—(Continued).

3,481,161. BICYCLE CITY, LLC, CINCINNATI, OH. SN 76-978,842. PUB. 9-25-2007, FILED 10-12-2006.

CLASS 18—(Continued).

3,481,611. NEOPAX, NORTHRIDGE, CA. SN 77-154,961. PUB. 2-12-2008, FILED 4-12-2007.

BICYCLE CITY

THE MARK CONSISTS OF STANDARD CHARACTERS WITHOUT CLAIM TO ANY PARTICULAR FONT, STYLE, SIZE, OR COLOR.
FOR BAGS, NAMELY, BACKPACKS (U.S. CLS. 1, 2, 3, 22 AND 41).
FIRST USE 4-23-2008; IN COMMERCE 4-23-2008.

NEOPAX

THE MARK CONSISTS OF STANDARD CHARACTERS WITHOUT CLAIM TO ANY PARTICULAR FONT, STYLE, SIZE, OR COLOR.
FOR NEOPRENE BELTS WORN ON THE BODY WITH POUCHES SEWN ON THAT ATTACH WITH HOOK AND LOOP FASTENERS DESIGNED TO HOLD WIRELESS TRANSMITTERS THAT ARE TYPICALLY USED IN THE FILM AND TELEVISION INDUSTRY (U.S. CLS. 1, 2, 3, 22 AND 41).
FIRST USE 8-15-2007; IN COMMERCE 8-15-2007.

3,481,208. O.C. TANNER COMPANY, SALT LAKE CITY, UT. SN 77-024,810. PUB. 9-4-2007, FILED 10-19-2006.

EPOCH

THE MARK CONSISTS OF STANDARD CHARACTERS WITHOUT CLAIM TO ANY PARTICULAR FONT, STYLE, SIZE, OR COLOR.
FOR GOODS MADE FROM LEATHER AND IMITATION LEATHER, NAMELY, LUGGAGE (U.S. CLS. 1, 2, 3, 22 AND 41).
FIRST USE 5-27-2008; IN COMMERCE 5-27-2008.

3,481,825. NGUYEN, TAN, SAN DIEGO, CA. SN 77-233,990. PUB. 1-8-2008, FILED 7-19-2007.

3,481,366. FAGES, CATHERINE, DENVER, CO. SN 77-100,262. PUB. 12-18-2007, FILED 2-6-2007.

LOGISTERRA

Cat Walks Dog

THE MARK CONSISTS OF STANDARD CHARACTERS WITHOUT CLAIM TO ANY PARTICULAR FONT, STYLE, SIZE, OR COLOR.
FOR PET ACCESSORIES, NAMELY, COLLARS, LEASHES, CARRYING BAGS, AND HARNESSSES, PET BACKPACKS, PET CLOTHING, AND PROTECTIVE GARMENTS FOR PETS, NAMELY, BOOTIES, JACKETS AND VESTS (U.S. CLS. 1, 2, 3, 22 AND 41).
FIRST USE 12-4-2007; IN COMMERCE 12-4-2007.

THE MARK CONSISTS OF STANDARD CHARACTERS WITHOUT CLAIM TO ANY PARTICULAR FONT, STYLE, SIZE, OR COLOR.
FOR HANDBAGS, BRIEFCASES, LUGGAGE, TOTE BAGS, COSMETIC CASES SOLD EMPTY, TOILETRY CASES SOLD EMPTY, SPORTS BAGS, BACKPACKS AND FANNY PACKS, WALLETS, KEY CASES AND CARRYING CASES (U.S. CLS. 1, 2, 3, 22 AND 41).
FIRST USE 6-19-2008; IN COMMERCE 6-19-2008.

CLASS 18—(Continued).

3,482,113. TWENTIETH CENTURY FOX FILM CORPORATION, LOS ANGELES, CA. SN 78-599,692. PUB. 1-17-2006, FILED 3-31-2005.

FOX FILM ICONS

THE MARK CONSISTS OF STANDARD CHARACTERS WITHOUT CLAIM TO ANY PARTICULAR FONT, STYLE, SIZE, OR COLOR.

OWNER OF U.S. REG. NOS. 2,553,757 AND 2,882,856. NO CLAIM IS MADE TO THE EXCLUSIVE RIGHT TO USE "FILM ICONS", APART FROM THE MARK AS SHOWN.

FOR HANDBAGS; TOTE BAGS (U.S. CLS. 1, 2, 3, 22 AND 41).

FIRST USE 8-31-2004; IN COMMERCE 8-31-2004.

CLASS 18—(Continued).

3,482,246. GARRISON, BRANDY, OCEANSIDE, CA. AND GARRISON, PATRICK, OCEANSIDE, CA. SN 78-780,238. PUB. 10-2-2007, FILED 12-23-2005.

OM MY DOG

THE MARK CONSISTS OF STANDARD CHARACTERS WITHOUT CLAIM TO ANY PARTICULAR FONT, STYLE, SIZE, OR COLOR.

NO CLAIM IS MADE TO THE EXCLUSIVE RIGHT TO USE "DOG", APART FROM THE MARK AS SHOWN.

THE WORDING "OM" HAS NO MEANING IN A FOREIGN LANGUAGE.

FOR DOG COLLARS, DOG LEASHES (U.S. CLS. 1, 2, 3, 22 AND 41).

FIRST USE 8-18-2006; IN COMMERCE 8-18-2006.

3,482,128. DISNEY ENTERPRISES, INC., BURBANK, CA. SN 78-637,112. PUB. 9-19-2006, FILED 5-25-2005.



OWNER OF U.S. REG. NOS. 2,516,004, 2,784,058, AND OTHERS.

FOR CALLING CARD CASES; DUFFEL BAGS; KNAPSACKS; OVERNIGHT BAGS (U.S. CLS. 1, 2, 3, 22 AND 41).

FIRST USE 5-15-2008; IN COMMERCE 5-15-2008.

3,482,247. BOOM INTERNATIONAL MARKETPLACE INC., LONDON, ONTARIO, CANADA. SN 78-780,292. PUB. 8-29-2006, FILED 12-23-2005.



FOR HANDBAGS, WALLETS AND BEACH UMBRELLAS (U.S. CLS. 1, 2, 3, 22 AND 41).

FIRST USE 5-18-2008; IN COMMERCE 5-18-2008.

CLASS 18—(Continued).

3,482,322. COLEMAN, ANDREA, STEVENSONRANCH, CA. SN 78-839,212. PUB. 10-31-2006, FILED 3-16-2006.

FENDERBUNNY

THE MARK CONSISTS OF STANDARD CHARACTERS WITHOUT CLAIM TO ANY PARTICULAR FONT, STYLE, SIZE, OR COLOR.

FOR CHANGE PURSES; CLUTCH PURSES; CLUTCHES; COIN PURSES; COIN PURSES NOT MADE OF PRECIOUS METAL; COIN PURSES, NOT OF PRECIOUS METALS; LEATHER PURSES; MULTI-PURPOSE PURSES; PURSES; SMALL CLUTCH PURSES; SMALL PURSES; WRIST MOUNTED PURSES (U.S. CLS. 1, 2, 3, 22 AND 41).
FIRST USE 7-1-2006; IN COMMERCE 7-1-2006.

CLASS 18—(Continued).

3,482,361. HARTZ MOUNTAIN CORPORATION, THE, SECAUCUS, NJ. SN 78-865,952. PUB. 7-17-2007, FILED 4-20-2006.

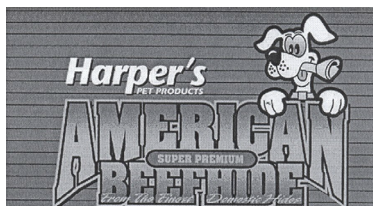

OWNER OF U.S. REG. NOS. 2,307,034, 2,666,934, AND 3,072,575.

NO CLAIM IS MADE TO THE EXCLUSIVE RIGHT TO USE "PET PRODUCTS", "AMERICAN", "BEEFHIDE", "SUPER PREMIUM", AND "FROM THE FINEST DOMESTIC HIDES", APART FROM THE MARK AS SHOWN.

FOR PET ACCESSORIES, NAMELY, RAWHIDE DOG CHEWS (U.S. CLS. 1, 2, 3, 22 AND 41).

FIRST USE 4-11-2005; IN COMMERCE 4-11-2005.

CLASS 19—NON-METALLIC BUILDING MATERIALS

3,481,042. MASONITE HOLDINGS, INC., TAMPA, FL. SN 75-670,593. PUB. 8-30-2005, FILED 3-29-1999.

HERITAGE

FOR NON-METAL INTERIOR RESIDENTIAL DOORS (U.S. CLS. 1, 12, 33 AND 50).

FIRST USE 1-1-2005; IN COMMERCE 9-10-2007.

3,482,360. HARTZ MOUNTAIN CORPORATION, THE, SECAUCUS, NJ. SN 78-865,140. PUB. 10-31-2006, FILED 4-19-2006.



OWNER OF U.S. REG. NO. 3,072,575.
NO CLAIM IS MADE TO THE EXCLUSIVE RIGHT TO USE "AMERICAN BEEFHIDE", APART FROM THE MARK AS SHOWN.

FOR PET ACCESSORIES, NAMELY, RAWHIDE DOG CHEWS AND DOG LEASHES AND PET COLLARS (U.S. CLS. 1, 2, 3, 22 AND 41).

FIRST USE 4-0-2006; IN COMMERCE 4-0-2006.

3,481,097. TA CHEN INTERNATIONAL, INC., LONG BEACH, CA. SN 76-658,427. PUB. 8-21-2007, FILED 4-14-2006.

POLYTEC

THE MARK CONSISTS OF STANDARD CHARACTERS WITHOUT CLAIM TO ANY PARTICULAR FONT, STYLE, SIZE, OR COLOR.

FOR WINDOW COVERINGS AND WINDOW TREATMENTS, INCLUDING REINFORCED WINDOW COVERINGS AND REINFORCED WINDOW TREATMENTS, NAMELY, WINDOW SHUTTERS MADE PRIMARILY OF NONMETAL, INCLUDING REINFORCED WINDOW SHUTTERS MADE PRIMARILY OF NONMETAL (U.S. CLS. 1, 12, 33 AND 50).

FIRST USE 3-1-2006; IN COMMERCE 3-1-2007.

CLASS 19—(Continued).

3,481,098. TA CHEN INTERNATIONAL, INC., LONG BEACH, CA. SN 76-658,429. PUB. 8-21-2007, FILED 4-14-2006.



FOR WINDOW COVERINGS AND WINDOW TREATMENTS, INCLUDING REINFORCED WINDOW COVERINGS AND REINFORCED WINDOW TREATMENTS, NAMELY, WINDOW SHUTTERS MADE PRIMARILY OF NONMETAL, INCLUDING REINFORCED WINDOW SHUTTERS MADE PRIMARILY OF NONMETAL (U.S. CLS. 1, 12, 33 AND 50).

FIRST USE 3-1-2006; IN COMMERCE 3-1-2007.

3,481,155. GSE LINING TECHNOLOGY, INC., HOUSTON, TX. SN 76-678,917. PUB. 12-25-2007, FILED 6-29-2007.

BIODRAIN

THE MARK CONSISTS OF STANDARD CHARACTERS WITHOUT CLAIM TO ANY PARTICULAR FONT, STYLE, SIZE, OR COLOR.

FOR GEOCOMPOSITE MATERIAL FOR USE AS A DRAINAGE MEDIUM, NAMELY, A PLASTIC GEONET MATERIAL LAMINATED WITH A NONWOVEN GEOTEXTILE ON ONE SIDE AND A WOVEN GEOTEXTILE ON THE OTHER SIDE (U.S. CLS. 1, 12, 33 AND 50).

FIRST USE 2-20-2004; IN COMMERCE 2-20-2004.

3,481,232. HIDDEN WATER POOLS, INC., DEL MAR, CA. SN 77-035,534. PUB. 6-19-2007, FILED 11-2-2006.

HIDDEN WATER POOLS

THE MARK CONSISTS OF STANDARD CHARACTERS WITHOUT CLAIM TO ANY PARTICULAR FONT, STYLE, SIZE, OR COLOR.

NO CLAIM IS MADE TO THE EXCLUSIVE RIGHT TO USE "WATER POOLS", APART FROM THE MARK AS SHOWN.

FOR NON-METAL IN-GROUND SWIMMING POOLS CONTAINING METAL REINFORCEMENTS (U.S. CLS. 1, 12, 33 AND 50).

FIRST USE 1-1-2008; IN COMMERCE 2-1-2008.

CLASS 19—(Continued).

3,481,333. GEORGIA FOAM, INC., FREDERICKSBURG, VA. SN 77-084,413. PUB. 8-21-2007, FILED 1-17-2007.

PRECISION SHIFT

THE MARK CONSISTS OF STANDARD CHARACTERS WITHOUT CLAIM TO ANY PARTICULAR FONT, STYLE, SIZE, OR COLOR.

FOR VINYL SIDING FOR USE ON THE EXTERIOR OF BUILDINGS AND HOMES (U.S. CLS. 1, 12, 33 AND 50).

FIRST USE 6-1-2007; IN COMMERCE 6-1-2007.

3,481,598. PELLA CORPORATION, PELLA, IA. SN 77-151,668. PUB. 10-2-2007, FILED 4-9-2007.

ENDURAGUARD

THE MARK CONSISTS OF STANDARD CHARACTERS WITHOUT CLAIM TO ANY PARTICULAR FONT, STYLE, SIZE, OR COLOR.

OWNER OF U.S. REG. NOS. 2,054,961 AND 2,297,705. FOR NON-METAL TREATED WINDOWS AND DOORS AND THE COMPONENT PARTS SOLD AS AN INTEGRAL PART THEREOF (U.S. CLS. 1, 12, 33 AND 50).

FIRST USE 1-31-2008; IN COMMERCE 1-31-2008.

3,481,807. WOODMASTER DESIGNS INC., HAYWARD, CA. SN 77-225,280. PUB. 1-8-2008, FILED 7-9-2007.



NO CLAIM IS MADE TO THE EXCLUSIVE RIGHT TO USE "DECORATIVE MILLWORK", APART FROM THE MARK AS SHOWN.

THE MARK CONSISTS OF A SIDE VIEW OF A CORBEL IN LINE ART WITH THE WORDS "FOSTER DECORATIVE MILLWORK" IN TIMES NEW ROMAN TYPEFACE.

FOR DECORATIVE ARCHITECTURAL MILLWORK, NAMELY, MANTELS, CORBELS, COLUMNS AND MOULDINGS (U.S. CLS. 1, 12, 33 AND 50).

FIRST USE 9-1-2007; IN COMMERCE 9-1-2007.

CLASS 19—(Continued).

3,481,960. PEBBLE TECHNOLOGY, INC., SCOTTSDALE, AZ. SN 77-296,096. PUB. 3-11-2008, FILED 10-4-2007.

FIRE OPAL

THE MARK CONSISTS OF STANDARD CHARACTERS WITHOUT CLAIM TO ANY PARTICULAR FONT, STYLE, SIZE, OR COLOR.

FOR TILES FOR THE INTERIOR, BOTTOM, SIDES, AND PERIMETER OF SWIMMING POOLS AND SPAS, NAMELY, TILES MADE OF GLASS (U.S. CLS. 1, 12, 33 AND 50).

FIRST USE 10-0-2007; IN COMMERCE 10-0-2007.

3,481,961. PEBBLE TECHNOLOGY, INC., SCOTTSDALE, AZ. SN 77-296,097. PUB. 3-11-2008, FILED 10-4-2007.

FINISHING TOUCHES

THE MARK CONSISTS OF STANDARD CHARACTERS WITHOUT CLAIM TO ANY PARTICULAR FONT, STYLE, SIZE, OR COLOR.

FOR TILES FOR INTERIOR, BOTTOM, SIDES, AND PERIMETER OF SWIMMING POOLS AND SPAS, NAMELY, TILES MADE OF GLASS, CERAMIC, PORCELAIN, VINYL, GYPSUM AND CLAY (U.S. CLS. 1, 12, 33 AND 50).

FIRST USE 10-0-2007; IN COMMERCE 10-0-2007.

3,482,260. THE ENKEBOLL CO., DBA ENKEBOLL DESIGNS, CARSON, CA. SN 78-786,896. PUB. 10-3-2006, FILED 1-6-2006.

ARCHITECTURALLY YOURS

THE MARK CONSISTS OF STANDARD CHARACTERS WITHOUT CLAIM TO ANY PARTICULAR FONT, STYLE, SIZE, OR COLOR.

FOR ARCHITECTURAL WOOD CARVINGS, NAMELY, CORBELS, ONLAYS, COLUMNS AND PILASTERS; AND ARCHITECTURAL WOOD MOLDINGS, NAMELY, BASE MOLDINGS, CROWN MOLDINGS, ASTRAGAL MOLDINGS AND TRIM MOLDINGS (U.S. CLS. 1, 12, 33 AND 50).

FIRST USE 1-1-2006; IN COMMERCE 1-1-2006.

CLASS 19—(Continued).

3,482,286. RO-MAC LUMBER AND SUPPLY, INC, LEESBURG, FL. SN 78-803,537. PUB. 5-15-2007, FILED 1-31-2006.



FOR NON-METAL BUILDING MATERIALS, NAMELY, SOFFITTS (U.S. CLS. 1, 12, 33 AND 50). FIRST USE 8-7-2007; IN COMMERCE 8-7-2007.

3,482,303. U.S. POLYMERS, INC., MONTEBELLO, CA. SN 78-823,021. PUB. 5-1-2007, FILED 2-24-2006.

**SIMPLICITY OF A COMPOSITE
DECK BUT ALL THE
ADVANTAGES OF RIGID VINYL**

THE MARK CONSISTS OF STANDARD CHARACTERS WITHOUT CLAIM TO ANY PARTICULAR FONT, STYLE, SIZE, OR COLOR.

NO CLAIM IS MADE TO THE EXCLUSIVE RIGHT TO USE "DECK", APART FROM THE MARK AS SHOWN.

FOR VINYL DECK BUILDING MATERIALS, NAMELY, VINYL DECK PLANKS, VINYL END COVERS AND VINYL FASCIA BOARDS (U.S. CLS. 1, 12, 33 AND 50).

FIRST USE 6-0-2008; IN COMMERCE 6-0-2008.

CLASS 20—FURNITURE AND ARTICLES NOT OTHERWISE CLASSIFIED

CLASS 20—(Continued).

3,481,152. CHANNELL COMMERCIAL CORPORATION, TEMECULA, CA. SN 76-678,455. PUB. 12-11-2007, FILED 6-20-2007.

BUSHMAN TANKS

THE MARK CONSISTS OF STANDARD CHARACTERS WITHOUT CLAIM TO ANY PARTICULAR FONT, STYLE, SIZE, OR COLOR.

OWNER OF U.S. REG. NO. 3,268,901.

NO CLAIM IS MADE TO THE EXCLUSIVE RIGHT TO USE "TANKS", APART FROM THE MARK AS SHOWN.

FOR POLYETHYLENE TANKS, NAMELY, RAIN-WATER STORAGE TANKS, MOLASSES TANKS, TRANSPORTER TANKS, BELLY TANKS; OTHER POLYETHYLENE PRODUCTS, NAMELY, GRADE LEVEL BOXES, VAULTS, AND HAND HOLES (U.S. CLS. 2, 13, 22, 25, 32 AND 50).

FIRST USE 5-12-2008; IN COMMERCE 5-12-2006.

CLASS 20—(Continued).

3,481,376. BAUR, DAVIDA ANN, SATELLITE BEACH, FL. AND YOUNG, JOANNE, MERRITT ISLAND, FL. SN 77-106,717. PUB. 11-20-2007, FILED 2-13-2007.

Angel's Hands

NO CLAIM IS MADE TO THE EXCLUSIVE RIGHT TO USE "HANDS", APART FROM THE MARK AS SHOWN.

FOR FOAM FINGER SEPARATORS FOR USE IN MANICURES, NAMELY, REUSABLE FOAM DISC FOR HOLDING, SEPARATING AND STEADYING FINGERS FOR MANICURES (U.S. CLS. 2, 13, 22, 25, 32 AND 50).

FIRST USE 6-10-2007; IN COMMERCE 6-10-2007.

3,481,209. O.C.TANNER COMPANY, SALT LAKE CITY, UT. SN 77-024,816. PUB. 9-4-2007, FILED 10-19-2006.

EPOCH

THE MARK CONSISTS OF STANDARD CHARACTERS WITHOUT CLAIM TO ANY PARTICULAR FONT, STYLE, SIZE, OR COLOR.

FOR NON-METAL GOODS MADE FROM LUCITE OR WOOD, NAMELY, TROPHIES AND PLAQUES (U.S. CLS. 2, 13, 22, 25, 32 AND 50).

FIRST USE 5-28-2008; IN COMMERCE 5-28-2008.

3,481,419. DACS, INC., PORTSMOUTH, VA. SN 77-122,429. PUB. 9-25-2007, FILED 3-5-2007.

FLUEKEEPER

THE MARK CONSISTS OF STANDARD CHARACTERS WITHOUT CLAIM TO ANY PARTICULAR FONT, STYLE, SIZE, OR COLOR.

FOR STORAGE SPACING DEVICE, NAMELY, METAL STORAGE RACKS, FOR USE IN STORAGE FACILITIES (U.S. CLS. 2, 13, 22, 25, 32 AND 50).

FIRST USE 6-1-2008; IN COMMERCE 6-1-2008.

3,481,314. IRIS USA, INC., PLEASANT PRARIE, WI. SN 77-076,211. PUB. 9-4-2007, FILED 1-4-2007.

ACTIVE STORAGE SERIES

THE MARK CONSISTS OF STANDARD CHARACTERS WITHOUT CLAIM TO ANY PARTICULAR FONT, STYLE, SIZE, OR COLOR.

NO CLAIM IS MADE TO THE EXCLUSIVE RIGHT TO USE "STORAGE SERIES", APART FROM THE MARK AS SHOWN.

FOR PLASTIC STORAGE UNITS FOR OFFICE USE (U.S. CLS. 2, 13, 22, 25, 32 AND 50).

FIRST USE 2-11-2008; IN COMMERCE 2-11-2008.

3,481,554. NEUSTAT, PAULA, NEW CITY, NY. SN 77-145,636. PUB. 10-2-2007, FILED 4-1-2007.

Posture Advantage

THE MARK CONSISTS OF STANDARD CHARACTERS WITHOUT CLAIM TO ANY PARTICULAR FONT, STYLE, SIZE, OR COLOR.

FOR CUSHIONS; FITTED FABRIC FURNITURE COVERS (U.S. CLS. 2, 13, 22, 25, 32 AND 50).

FIRST USE 2-15-2008; IN COMMERCE 2-15-2008.

CLASS 20—(Continued).

3,481,646. HENSCHEL-STEINAU, INC., ENGLEWOOD, NJ. SN 77-162,782. PUB. 10-23-2007, FILED 4-23-2007.

EZ LOAD

THE MARK CONSISTS OF STANDARD CHARACTERS WITHOUT CLAIM TO ANY PARTICULAR FONT, STYLE, SIZE, OR COLOR.

FOR POINT-OF-PURCHASE MERCHANDISE DISPLAY AND DISPENSING SYSTEMS, NAMELY, SHELF-MOUNTED DIVIDERS AND MERCHANDISE TRACKS, PUSHERS AND GATES FOR THE SELECTIVE DISPENSING OF MERCHANDISE PACKAGES AT A POINT-OF-PURCHASE LOCATION ALONG A DISPLAY SHELF (U.S. CLS. 2, 13, 22, 25, 32 AND 50).

FIRST USE 8-27-2007; IN COMMERCE 8-28-2007.

3,481,647. CONAIR CORPORATION, STAMFORD, CT. SN 77-164,399. PUB. 9-18-2007, FILED 4-24-2007.

CONAIR

THE MARK CONSISTS OF STANDARD CHARACTERS WITHOUT CLAIM TO ANY PARTICULAR FONT, STYLE, SIZE, OR COLOR.

OWNER OF U.S. REG. NOS. 2,238,852 AND 2,533,081. FOR SEAT CUSHIONS (U.S. CLS. 2, 13, 22, 25, 32 AND 50).

FIRST USE 6-1-2007; IN COMMERCE 6-1-2007.

3,481,687. MIDWEST PRINTING, INCORPORATED, WHEATON, IL. SN 77-174,725. PUB. 9-25-2007, FILED 5-7-2007.

Glidulator

THE MARK CONSISTS OF STANDARD CHARACTERS WITHOUT CLAIM TO ANY PARTICULAR FONT, STYLE, SIZE, OR COLOR.

FOR DISPENSING CAPS MADE PRIMARILY NOT FROM METAL TO DELIVER GRADUATED AMOUNTS OF MATERIALS FROM CONTAINERS (U.S. CLS. 2, 13, 22, 25, 32 AND 50).

FIRST USE 2-16-2007; IN COMMERCE 2-16-2007.

CLASS 20—(Continued).

3,481,713. NEUSTAT, PAULA, NEW CITY, NY. SN 77-180,884. PUB. 10-2-2007, FILED 5-15-2007.

Simply Ergonomic

THE MARK CONSISTS OF STANDARD CHARACTERS WITHOUT CLAIM TO ANY PARTICULAR FONT, STYLE, SIZE, OR COLOR.

NO CLAIM IS MADE TO THE EXCLUSIVE RIGHT TO USE "ERGONOMIC", APART FROM THE MARK AS SHOWN.

FOR FITTED FABRIC FURNITURE COVERS; CUSHIONS (U.S. CLS. 2, 13, 22, 25, 32 AND 50).

FIRST USE 2-15-2008; IN COMMERCE 2-15-2008.

3,481,736. MENARD, INC., EAU CLAIRE, WI. SN 77-189,088. PUB. 10-23-2007, FILED 5-24-2007.



OWNER OF U.S. REG. NOS. 3,126,317 AND 3,129,290. NO CLAIM IS MADE TO THE EXCLUSIVE RIGHT TO USE "GARAGE", APART FROM THE MARK AS SHOWN.

THE COLOR(S) RED, BLACK AND SILVER IS/ARE CLAIMED AS A FEATURE OF THE MARK.

THE MARK CONSISTS OF A BLACK GARAGE-SHAPE OUTLINE; THE WORD "XTREME" IN RED WITH THE LETTER "X" BEING LARGER THAN THE OTHER LETTERS IN THE WORD; THE WORD "XTREME" IN A STYLIZED FONT; THE WORD "GARAGE" APPEARING AS IF IT IS SILVER CHROME AND PORTRAYED AS THOUGH THERE ARE CHROME RIVETS ON THE LETTERING.

FOR SEATS, PLASTIC WHEEL CHOCKS (U.S. CLS. 2, 13, 22, 25, 32 AND 50).

FIRST USE 1-24-2008; IN COMMERCE 1-24-2008.

3,481,737. MENARD, INC., EAU CLAIRE, WI. SN 77-189,090. PUB. 10-23-2007, FILED 5-24-2007.

XTREME GARAGE

THE MARK CONSISTS OF STANDARD CHARACTERS WITHOUT CLAIM TO ANY PARTICULAR FONT, STYLE,

CLASS 20—(Continued).

SIZE, OR COLOR.

OWNER OF U.S. REG. NOS. 3,126,317 AND 3,129,290.
 NO CLAIM IS MADE TO THE EXCLUSIVE RIGHT TO
 USE "GARAGE", APART FROM THE MARK AS SHOWN.
 FOR SEATS, PLASTIC WHEEL CHOCKS (U.S. CLS. 2,
 13, 22, 25, 32 AND 50).
 FIRST USE 1-24-2008; IN COMMERCE 1-24-2008.

CLASS 20—(Continued).

3,482,084. HNI TECHNOLOGIES INC., MUSCATINE, IA. SN
 78-526,543. PUB. 9-27-2005, FILED 12-3-2004.

3,481,783. ARC LUXE LLC, CHARLOTTE, NC. SN 77-211,906.
 PUB. 11-6-2007, FILED 6-21-2007.

REFLECT



THE MARK CONSISTS OF STANDARD CHARACTERS
 WITHOUT CLAIM TO ANY PARTICULAR FONT, STYLE,
 SIZE, OR COLOR.
 FOR FURNITURE (U.S. CLS. 2, 13, 22, 25, 32 AND 50).
 FIRST USE 0-0-2003; IN COMMERCE 0-0-2003.

THE MARK CONSISTS OF THE STYLIZED WORDING
 "KUSH" HAVING THE GRAPHIC REPRESENTATION OF A
 STAR SUPERIMPOSED OVER THE POINT OF INTERSEC-
 TION FOR ALL THE LINES IN THE LETTER "K".
 FOR BREAST SEPARATOR, NAMELY, AN ANTI-SLIP
 SEPARATOR USED IN BETWEEN THE BREASTS OF A
 HUMAN BEING FOR USE DURING SLEEP (U.S. CLS. 2,
 13, 22, 25, 32 AND 50).
 FIRST USE 8-1-2007; IN COMMERCE 8-1-2007.

3,482,119. BUTTERFLY WORLDWIDE, LLC, ANN ARBOR,
 MI. SN 78-617,663. PUB. 2-21-2006, FILED 4-27-2005.

BUTTERFLY

3,481,932. NAME BADGE PRODUCTIONS, LLC, MIDDLE-
 TON, WI. SN 77-277,807. PUB. 3-4-2008, FILED 9-12-2007.

THE MARK CONSISTS OF STANDARD CHARACTERS
 WITHOUT CLAIM TO ANY PARTICULAR FONT, STYLE,
 SIZE, OR COLOR.
 FOR METAL PICTURE FRAMES, METAL CURTAIN
 RINGS (U.S. CLS. 2, 13, 22, 25, 32 AND 50).
 FIRST USE 7-27-2007; IN COMMERCE 7-27-2007.

3,482,149. NEWELL OPERATING COMPANY, ATLANTA,
 GA. SN 78-665,547. PUB. 3-28-2006, FILED 7-7-2005.

MyMagneTag

SLIDE-IT

THE MARK CONSISTS OF STANDARD CHARACTERS
 WITHOUT CLAIM TO ANY PARTICULAR FONT, STYLE,
 SIZE, OR COLOR.
 FOR PLASTIC NAME BADGE HOLDER WITH MAG-
 NETIC MOUNT (U.S. CLS. 2, 13, 22, 25, 32 AND 50).
 FIRST USE 10-1-2007; IN COMMERCE 10-1-2007.

THE MARK CONSISTS OF STANDARD CHARACTERS
 WITHOUT CLAIM TO ANY PARTICULAR FONT, STYLE,
 SIZE, OR COLOR.
 FOR FURNITURE CASTERS, NAMELY, GLIDES
 MADE OF PLASTIC (U.S. CLS. 2, 13, 22, 25, 32 AND 50).
 FIRST USE 8-22-2007; IN COMMERCE 8-22-2007.

CLASS 20—(Continued).

3,482,173. NUSSDORF, JEFFREY MARK, HENDERSON, NV.
SN 78-705,156. PUB. 11-6-2007, FILED 9-1-2005.

EV-EX

THE MARK CONSISTS OF STANDARD CHARACTERS WITHOUT CLAIM TO ANY PARTICULAR FONT, STYLE, SIZE, OR COLOR.

FOR PORTABLE DISPLAY BOARDS AND PANELS FOR USE AT EVENTS AND EXHIBITIONS FOR THE USER TO DISPLAY AND PROMOTE GOODS AND SERVICES (U.S. CLS. 2, 13, 22, 25, 32 AND 50).
FIRST USE 10-19-2005; IN COMMERCE 1-22-2007.

3,482,254. HAREBRAIN, INC., MINNEAPOLIS, MN. SN 78-782,916. PUB. 4-3-2007, FILED 12-30-2005.

THE SOUND OF LEARNING

THE MARK CONSISTS OF STANDARD CHARACTERS WITHOUT CLAIM TO ANY PARTICULAR FONT, STYLE, SIZE, OR COLOR.

FOR VOCALIZING ASSIST DEVICES, NAMELY, PLASTIC, NON-ELECTRONIC DEVICES CONSISTING OF COMPONENTS CONFIGURED TO DIRECT A USER'S VOCALIZATIONS TO THE USER'S EAR TO ASSIST THAT PERSON TO HEAR HIMSELF OR HERSELF FOR PURPOSES OF VOCALIZATION ANALYSIS (U.S. CLS. 2, 13, 22, 25, 32 AND 50).
FIRST USE 1-1-2006; IN COMMERCE 1-1-2006.

3,482,488. MERBETH, LAURA J., SUSSEX, WI. SN 78-944,300.
PUB. 3-18-2008, FILED 8-3-2006.

SHOWOFF

THE MARK CONSISTS OF STANDARD CHARACTERS WITHOUT CLAIM TO ANY PARTICULAR FONT, STYLE, SIZE, OR COLOR.

FOR RACKS FOR RETAINING AWARDS, RIBBONS, METALS OR TROPHIES (U.S. CLS. 2, 13, 22, 25, 32 AND 50).
FIRST USE 10-19-2006; IN COMMERCE 10-19-2006.

CLASS 20—(Continued).

3,482,509. MULVANEY, KATHLEEN, WEST BABYLON, NY.
SN 78-951,926. PUB. 8-28-2007, FILED 8-15-2006.

A SAFE PLACE

THE MARK CONSISTS OF STANDARD CHARACTERS WITHOUT CLAIM TO ANY PARTICULAR FONT, STYLE, SIZE, OR COLOR.

FOR WOOD BOXES (U.S. CLS. 2, 13, 22, 25, 32 AND 50).
FIRST USE 3-15-2008; IN COMMERCE 3-15-2008.

CLASS 21—HOUSEWARES AND GLASS

3,481,412. BOBBILEE GRANT, CHATTEROY, WA. SN 77-120,147. PUB. 9-11-2007, FILED 3-1-2007.

BUZZKUV

THE MARK CONSISTS OF STANDARD CHARACTERS WITHOUT CLAIM TO ANY PARTICULAR FONT, STYLE, SIZE, OR COLOR.

FOR DECORATIVE COVERS AND CASES WITH A WOOD HOUSING FOR USE IN OBSCURING AND RETAINING INSECT TRAPS; HOUSINGS, NAMELY, SPECIALLY ADAPTED CASES FOR HANGING, RETAINING AND OBSCURING BEE AND YELLOW JACK-ET TRAPS (U.S. CLS. 2, 13, 23, 29, 30, 33, 40 AND 50).
FIRST USE 2-27-2007; IN COMMERCE 2-27-2007.

3,481,472. MR. H2O, LLC, SANTA MONICA, CA. SN 77-131,910. PUB. 9-4-2007, FILED 3-15-2007.

Cooler CAP

THE MARK CONSISTS OF STANDARD CHARACTERS WITHOUT CLAIM TO ANY PARTICULAR FONT, STYLE, SIZE, OR COLOR.

NO CLAIM IS MADE TO THE EXCLUSIVE RIGHT TO USE "COOLER", APART FROM THE MARK AS SHOWN.

FOR PLASTIC STORAGE CONTAINERS FOR DOMESTIC USE; ALL PURPOSE PORTABLE HOUSEHOLD CONTAINERS (U.S. CLS. 2, 13, 23, 29, 30, 33, 40 AND 50).
FIRST USE 5-15-2008; IN COMMERCE 5-15-2008.

CLASS 21—(Continued).

3,481,478. CONAIR CORPORATION, STAMFORD, CT. SN 77-132,800. PUB. 9-11-2007, FILED 3-16-2007.

CORSET

THE MARK CONSISTS OF STANDARD CHARACTERS WITHOUT CLAIM TO ANY PARTICULAR FONT, STYLE, SIZE, OR COLOR.

FOR HAIR BRUSHES; MAKE-UP BRUSHES; COMBS; ELECTRIC HAIR COMBS; HAIR COMBS (U.S. CLS. 2, 13, 23, 29, 30, 33, 40 AND 50).

FIRST USE 1-25-2007; IN COMMERCE 1-25-2007.

3,481,479. CONAIR CORPORATION, STAMFORD, CT. SN 77-132,830. PUB. 9-11-2007, FILED 3-16-2007.

HEAT WAVES

THE MARK CONSISTS OF STANDARD CHARACTERS WITHOUT CLAIM TO ANY PARTICULAR FONT, STYLE, SIZE, OR COLOR.

FOR COSMETIC BRUSHES; HAIR BRUSHES; MAKE-UP BRUSHES; COMBS; ELECTRIC HAIR COMBS; HAIR COMBS (U.S. CLS. 2, 13, 23, 29, 30, 33, 40 AND 50).

FIRST USE 1-25-2007; IN COMMERCE 1-25-2007.

3,481,480. CONAIR CORPORATION, STAMFORD, CT. SN 77-132,838. PUB. 9-11-2007, FILED 3-16-2007.

THE HEAT IS ON FOR A BRAND NEW WAVE

THE MARK CONSISTS OF STANDARD CHARACTERS WITHOUT CLAIM TO ANY PARTICULAR FONT, STYLE, SIZE, OR COLOR.

FOR COSMETIC BRUSHES; HAIR BRUSHES; MAKE-UP BRUSHES; COMBS; ELECTRIC HAIR COMBS; HAIR COMBS (U.S. CLS. 2, 13, 23, 29, 30, 33, 40 AND 50).

FIRST USE 1-25-2007; IN COMMERCE 1-25-2007.

CLASS 21—(Continued).

3,481,498. TAI-PAN TRADING INTERNATIONAL, INC., SANDY, UT. SN 77-135,906. PUB. 9-18-2007, FILED 3-20-2007.

Cérene

THE MARK CONSISTS OF STANDARD CHARACTERS WITHOUT CLAIM TO ANY PARTICULAR FONT, STYLE, SIZE, OR COLOR.

FOR DINNERWARE, FOOD PREPARATION AND SERVING DISHES AND VESSELS, AND BEVERAGE SERVING VESSELS, ALL MADE FROM CERAMICS (U.S. CLS. 2, 13, 23, 29, 30, 33, 40 AND 50).

FIRST USE 8-0-2007; IN COMMERCE 8-0-2007.

3,481,530. FLANNERY, NEIL M., MANTOLOKING, PA. SN 77-141,282. PUB. 9-25-2007, FILED 3-27-2007.



THE COLOR(S) GREEN, BLACK, WHITE, AND YELLOW IS/ARE CLAIMED AS A FEATURE OF THE MARK.

THE MARK CONSISTS OF A CARICATURE OF THREE DRINKING GLASSES. THE CARICATURES ARE OUTLINED IN BLACK; THE COLORS YELLOW AND GREEN APPEAR IN THE FACIAL FEATURES OF THE GLASSES; AND THE COLOR WHITE APPEARS IN TEETH AND EYES OF THE FACES ON THE GLASSES AND AS A BACKGROUND COLOR FOR THE UNFILLED PORTION OF THE GLASSES.

FOR BEVERAGE TRAY NOT MADE OF PRECIOUS METAL FOR HOLDING OR CONTAINING DRINKING VESSELS, DRINKING CUPS, DRINKING GLASSES AND BEVERAGE GLASSWARE WHILE IN USE; DRINKING VESSELS, DRINKING CUPS NOT OF PRECIOUS METAL, DRINKING GLASSES, AND BEVERAGE GLASSWARE (U.S. CLS. 2, 13, 23, 29, 30, 33, 40 AND 50).

FIRST USE 4-0-2008; IN COMMERCE 5-0-2008.

3,481,750. CHRISTINE'S LLC, EASLEY, SC. SN 77-196,980. PUB. 3-4-2008, FILED 6-4-2007.



CLASS 21—(Continued).

NO CLAIM IS MADE TO THE EXCLUSIVE RIGHT TO USE "CAKE" AND "WHEEL", APART FROM THE MARK AS SHOWN.

THE MARK CONSISTS OF THE WORDING "THE CAKE WHEEL" AND A DESIGN SHOWING A SERIES OF SWIRLS AND CURVED LINES DEPICTING A LAYERED CAKE.

FOR CAKE STANDS (U.S. CLS. 2, 13, 23, 29, 30, 33, 40 AND 50).

FIRST USE 6-18-2007; IN COMMERCE 6-18-2007.

CLASS 21—(Continued).

3,482,062. CHURCH & DWIGHT CO., INC., PRINCETON, NJ. SN 78-487,830. PUB. 9-13-2005, FILED 9-22-2004.

3,481,847. BEACH BRANDS, MARINA DEL REY, CA. SN 77-243,743. PUB. 2-5-2008, FILED 7-31-2007.

AIM

The Perfect Pasta Plate

THE MARK CONSISTS OF STANDARD CHARACTERS WITHOUT CLAIM TO ANY PARTICULAR FONT, STYLE, SIZE, OR COLOR.

NO CLAIM IS MADE TO THE EXCLUSIVE RIGHT TO USE "PLATE", APART FROM THE MARK AS SHOWN.

FOR CERAMIC SCULPTURES, VASES, VESSELS, BOWLS, PLATES AND POTS; DINNERWARE, NAMELY, CERAMIC, PLASTIC, MELAMINE PLATES; DISHES AND PLATES; DISPOSABLE TABLE PLATES (U.S. CLS. 2, 13, 23, 29, 30, 33, 40 AND 50).

FIRST USE 8-1-2007; IN COMMERCE 9-1-2007.

THE MARK CONSISTS OF STANDARD CHARACTERS WITHOUT CLAIM TO ANY PARTICULAR FONT, STYLE, SIZE, OR COLOR.

OWNER OF U.S. REG. NO. 950,960.

FOR TOOTHBRUSHES (U.S. CLS. 2, 13, 23, 29, 30, 33, 40 AND 50).

FIRST USE 1-9-2008; IN COMMERCE 1-9-2008.

3,481,951. AUGUSTINE, DAVID, LAGUNA NIGUEL, CA. SN 77-288,813. PUB. 3-11-2008, FILED 9-25-2007.

3,482,089. INDUSTRIAS ALEN, S.A. DE C.V., SANTA CATARINA, N.L., MEXICO. SN 78-537,567. PUB. 10-11-2005, FILED 12-23-2004.

CLORALEX PLUS

MICROSMORES

THE MARK CONSISTS OF STANDARD CHARACTERS WITHOUT CLAIM TO ANY PARTICULAR FONT, STYLE, SIZE, OR COLOR.

FOR COOKING POTS AND PANS (U.S. CLS. 2, 13, 23, 29, 30, 33, 40 AND 50).

FIRST USE 6-5-2008; IN COMMERCE 6-5-2008.

THE MARK CONSISTS OF STANDARD CHARACTERS WITHOUT CLAIM TO ANY PARTICULAR FONT, STYLE, SIZE, OR COLOR.

OWNER OF U.S. REG. NOS. 1,489,799, 1,809,859, AND 2,669,415.

FOR CLEANING PRODUCTS, NAMELY, PRE-MOISTENED TOWELETTES FOR CLEANING (U.S. CLS. 2, 13, 23, 29, 30, 33, 40 AND 50).

FIRST USE 2-28-2007; IN COMMERCE 2-28-2007.

CLASS 21—(Continued).

3,482,090. MUNGO, PAUL, VIRGINIA BEACH, VA. SN 78-538,536. PUB. 1-31-2006, FILED 12-27-2004.



NO CLAIM IS MADE TO THE EXCLUSIVE RIGHT TO USE "BOTTLE" AND "WORLDS FINEST BOTTLE HOLDER", APART FROM THE MARK AS SHOWN.

THE COLOR(S) RED AND BLACK IS/ARE CLAIMED AS A FEATURE OF THE MARK.

THE MARKS CONSISTS OF THE WORDS "THE" AND "BOTTLE" AND THE BOTTLE/BAR DESIGN IN THE COLOR RED AND THE WORDING "BEVEL" AND "THE WORLD'S FINEST BOTTLE HOLDER" IS IN BLACK.

THE WORDING "BEVEL" HAS NO MEANING IN A FOREIGN LANGUAGE.

FOR BOTTLE HOLDER IN THE NATURE OF A WINE RACK THAT HOLDS BOTTLES IN A HORIZONTAL POSITION (U.S. CLS. 2, 13, 23, 29, 30, 33, 40 AND 50).

FIRST USE 11-15-2007; IN COMMERCE 12-1-2007.

3,482,172. WHITNEY DESIGN, INC., BRIDGETON, MO. SN 78-704,094. PUB. 9-26-2006, FILED 8-31-2005.

WINDOW VISION

THE MARK CONSISTS OF STANDARD CHARACTERS WITHOUT CLAIM TO ANY PARTICULAR FONT, STYLE, SIZE, OR COLOR.

FOR ALL PURPOSE CONTAINERS FOR HOUSEHOLD USE (U.S. CLS. 2, 13, 23, 29, 30, 33, 40 AND 50).

FIRST USE 4-11-2008; IN COMMERCE 4-11-2008.

3,482,308. SARAMAR, L.L.C., CHICAGO, IL. SN 78-828,335. PUB. 8-29-2006, FILED 3-3-2006.



FOR DECANTERS (U.S. CLS. 2, 13, 23, 29, 30, 33, 40 AND 50).

FIRST USE 6-30-2006; IN COMMERCE 6-30-2006.

CLASS 21—(Continued).

3,482,362. ABRAHMS, DARRYL, REDMOND, WA. SN 78-866,295. PUB. 1-15-2008, FILED 4-20-2006.

NITRILE GARDEN CLUB

THE MARK CONSISTS OF STANDARD CHARACTERS WITHOUT CLAIM TO ANY PARTICULAR FONT, STYLE, SIZE, OR COLOR.

NO CLAIM IS MADE TO THE EXCLUSIVE RIGHT TO USE "NITRILE", APART FROM THE MARK AS SHOWN.

FOR GARDENING GLOVES (U.S. CLS. 2, 13, 23, 29, 30, 33, 40 AND 50).

FIRST USE 4-5-2006; IN COMMERCE 4-5-2006.

3,482,423. WHITE, DENNIS R., YORBA LINDA, CA. SN 78-914,309. PUB. 5-1-2007, FILED 6-22-2006.



FOR SPECIALTY PET FEEDING DISHES AND STANDS FOR DISHES (U.S. CLS. 2, 13, 23, 29, 30, 33, 40 AND 50).

FIRST USE 5-16-2008; IN COMMERCE 5-16-2008.

3,482,442. EXPRESSLY YOURS, INC., CENTENNIAL, CO. SN 78-929,240. PUB. 3-6-2007, FILED 7-13-2006.



THE COLOR(S) RED AND BLACK IS/ARE CLAIMED AS A FEATURE OF THE MARK.

THE MARK CONSISTS OF A BLACK STYLIZED SCRIPT CAPITAL LETTER E HAVING A RED WINTER CAP ON THE "E", AND THE BLACK WORDING "EXPRESSLY YOURS" NEXT TO IT.

FOR HAND-PAINTED POTTERY DINNERWARE (U.S. CLS. 2, 13, 23, 29, 30, 33, 40 AND 50).

FIRST USE 6-0-1991; IN COMMERCE 1-0-1995.

CLASS 21—(Continued).

3,482,443. EXPRESSLY YOURS, INC., CENTENNIAL, CO. SN 78-929,248. PUB. 3-6-2007, FILED 7-13-2006.

SNOWARE

THE MARK CONSISTS OF STANDARD CHARACTERS WITHOUT CLAIM TO ANY PARTICULAR FONT, STYLE, SIZE, OR COLOR.

FOR HAND PAINTED POTTERY DINNERWARE (U.S. CLS. 2, 13, 23, 29, 30, 33, 40 AND 50).

FIRST USE 1-0-1995; IN COMMERCE 1-0-1995.

3,482,449. STARMAX RESOURCE LLC, CLEVELAND, OH. SN 78-931,474. PUB. 6-19-2007, FILED 7-18-2006.

WOW WHAT A CLOTH!

THE MARK CONSISTS OF STANDARD CHARACTERS WITHOUT CLAIM TO ANY PARTICULAR FONT, STYLE, SIZE, OR COLOR.

NO CLAIM IS MADE TO THE EXCLUSIVE RIGHT TO USE "CLOTH", APART FROM THE MARK AS SHOWN.

FOR CLEANING CLOTHS (U.S. CLS. 2, 13, 23, 29, 30, 33, 40 AND 50).

FIRST USE 2-25-2008; IN COMMERCE 2-25-2008.

3,482,450. THE ARMOR ALL/STP PRODUCTS COMPANY, OAKLAND, CA. SN 78-931,812. PUB. 2-27-2007, FILED 7-18-2006.

ARMOR ALL

THE MARK CONSISTS OF STANDARD CHARACTERS WITHOUT CLAIM TO ANY PARTICULAR FONT, STYLE, SIZE, OR COLOR.

OWNER OF U.S. REG. NOS. 986,280, 2,004,078, AND OTHERS.

FOR WIPING CLOTHS, NAMELY, CHAMOIS; CLEANING, POLISHING, AND WASHING CLOTHS; WINDOW CLEANER SQUEEGEE; SCRUBBING AND WASHING BRUSHES (U.S. CLS. 2, 13, 23, 29, 30, 33, 40 AND 50).

FIRST USE 1-30-2008; IN COMMERCE 1-30-2008.

CLASS 21—(Continued).

3,482,464. JERICHI, TERESA, GARDEN GROVE, CA. SN 78-936,256. PUB. 9-18-2007, FILED 7-24-2006.

LOEWYAL DOGTIN

THE MARK CONSISTS OF STANDARD CHARACTERS WITHOUT CLAIM TO ANY PARTICULAR FONT, STYLE, SIZE, OR COLOR.

NO CLAIM IS MADE TO THE EXCLUSIVE RIGHT TO USE "DOGTIN", APART FROM THE MARK AS SHOWN.

FOR PET FEEDING DISHES (U.S. CLS. 2, 13, 23, 29, 30, 33, 40 AND 50).

FIRST USE 3-1-2008; IN COMMERCE 3-1-2008.

3,482,475. WILTON INDUSTRIES, INC., WOODRIDGE, IL. SN 78-939,995. PUB. 3-6-2007, FILED 7-28-2006.

CUPCAKES N' MORE

THE MARK CONSISTS OF STANDARD CHARACTERS WITHOUT CLAIM TO ANY PARTICULAR FONT, STYLE, SIZE, OR COLOR.

OWNER OF U.S. REG. NO. 3,033,051.

NO CLAIM IS MADE TO THE EXCLUSIVE RIGHT TO USE "CUPCAKES", APART FROM THE MARK AS SHOWN.

FOR BAKEWARE (U.S. CLS. 2, 13, 23, 29, 30, 33, 40 AND 50).

FIRST USE 7-31-2004; IN COMMERCE 7-31-2004.

CLASS 22—CORDAGE AND FIBERS

3,481,108. WILD ROOT, LLC, DALLAS, TX. SN 76-664,651. PUB. 8-21-2007, FILED 8-16-2006.

PLANTECTOR

THE MARK CONSISTS OF STANDARD CHARACTERS WITHOUT CLAIM TO ANY PARTICULAR FONT, STYLE, SIZE, OR COLOR.

FOR POLYPROPYLENE BAG COVERS FOR PLANTS (U.S. CLS. 1, 2, 7, 19, 22, 42 AND 50).

FIRST USE 10-0-2007; IN COMMERCE 10-0-2007.

CLASS 22—(Continued).

3,481,808. YOUNG, NANCY, TRACY, CA. AND YOUNG, MARCELLUS, TRACY, CA. SN 77-225,300. PUB. 3-18-2008, FILED 7-9-2007.

Pull-EZ

THE MARK CONSISTS OF STANDARD CHARACTERS WITHOUT CLAIM TO ANY PARTICULAR FONT, STYLE, SIZE, OR COLOR.

FOR SACKS OR BAGS FOR THE TRANSPORTATION OR STORAGE OF MATERIALS IN BULK; POLY PROPYLENE BAGS USED FOR THE STORAGE OF RIBBON; CLOTH BAGS FOR STORAGE (U.S. CLS. 1, 2, 7, 19, 22, 42 AND 50).

FIRST USE 9-1-2007; IN COMMERCE 7-31-2007.

3,482,546. ALPHASOURCE INC., PHILADELPHIA, PA. SN 78-962,701. PUB. 10-16-2007, FILED 8-29-2006.

TOOLS AVER

THE MARK CONSISTS OF STANDARD CHARACTERS WITHOUT CLAIM TO ANY PARTICULAR FONT, STYLE, SIZE, OR COLOR.

FOR DEVICE IN THE NATURE OF A LANYARD USED TO RETAIN HAND TOOLS, IMPLEMENTS AND INSTRUMENTS WORN BY A USER ON THE ARM, LEG OR NECK OR AS AN ATTACHMENT TO A TOOL BELT, TOOL BAG, TOOL POUCH OR SCUBA GEAR (U.S. CLS. 1, 2, 7, 19, 22, 42 AND 50).

FIRST USE 5-10-2006; IN COMMERCE 5-10-2006.

CLASS 24—FABRICS

3,481,190. GORDINI U.S.A. INC., ESSEX JUNCTION, VT. SN 77-014,753. PUB. 5-15-2007, FILED 10-5-2006.

THE WARMTH OF WOOL + THE COMFORT OF FLEECE

THE MARK CONSISTS OF STANDARD CHARACTERS WITHOUT CLAIM TO ANY PARTICULAR FONT, STYLE, SIZE, OR COLOR.

FOR POLYESTER AND WOOL FABRIC FOR USE IN CLOTHING, NAMELY, SOCKS, FACE PROTECTORS, UNDERWEAR AND LINING OF GLOVES (U.S. CLS. 42 AND 50).

FIRST USE 12-11-2006; IN COMMERCE 12-11-2006.

CLASS 24—(Continued).

3,481,582. STANDARD TEXTILE CO., INC., CINCINNATI, OH. SN 77-149,993. PUB. 10-9-2007, FILED 4-5-2007.

LYNOVA

THE MARK CONSISTS OF STANDARD CHARACTERS WITHOUT CLAIM TO ANY PARTICULAR FONT, STYLE, SIZE, OR COLOR.

FOR TEXTILE NAPKINS, TABLECLOTHS, AND BANQUET TABLECLOTHS (U.S. CLS. 42 AND 50).

FIRST USE 5-0-2007; IN COMMERCE 5-0-2007.

3,482,129. DISNEY ENTERPRISES, INC., BURBANK, CA. SN 78-637,123. PUB. 9-19-2006, FILED 5-25-2005.



OWNER OF U.S. REG. NOS. 2,516,004, 2,784,058, AND OTHERS.

FOR BATH LINEN; BED LINEN; BED SHEETS; BED SKIRTS; COMFORTERS; CURTAINS; HOODED TOWELS; HOUSEHOLD LINEN; KITCHEN TOWELS; PILLOW CASES; PILLOW COVERS; POT HOLDERS; TABLE LINEN; TEXTILE PLACE MATS; WASHCLOTHS (U.S. CLS. 42 AND 50).

FIRST USE 5-15-2008; IN COMMERCE 5-15-2008.

CLASS 24—(Continued).

3,482,288. JAB DISTRIBUTORS, LLC, DBA PROTECT-A-BED, GLENVIEW, IL. SN 78-805,290. PUB. 9-26-2006, FILED 2-2-2006.

HEALTHSHEET

THE MARK CONSISTS OF STANDARD CHARACTERS WITHOUT CLAIM TO ANY PARTICULAR FONT, STYLE, SIZE, OR COLOR.

NO CLAIM IS MADE TO THE EXCLUSIVE RIGHT TO USE "SHEET", APART FROM THE MARK AS SHOWN.

FOR POLYURETHANE MEMBRANE LAMINATED ANTI-ALLERGENIC BED SHEETS (U.S. CLS. 42 AND 50).

FIRST USE 3-1-2008; IN COMMERCE 3-1-2008.

3,482,311. K&K HOME FASHIONS, LTD., SCARSDALE, NY. SN 78-832,345. PUB. 10-23-2007, FILED 3-8-2006.

PICK & BAG

THE MARK CONSISTS OF STANDARD CHARACTERS WITHOUT CLAIM TO ANY PARTICULAR FONT, STYLE, SIZE, OR COLOR.

FOR BED BLANKETS; BED CANOPIES; BED LINEN; BED PADS; BED SHEETS; BED SHEETS OF PAPER; BED SKIRTS; BED SPREADS; FEATHER BEDS; PAPER BED COVERS; SILK BED BLANKETS (U.S. CLS. 42 AND 50).

FIRST USE 5-1-2008; IN COMMERCE 5-1-2008.

3,482,521. FABRIC EDITIONS, LLC., GREENVILLE, SC. SN 78-954,677. PUB. 9-11-2007, FILED 8-17-2006.

FABRIC EXPRESSIONS

THE MARK CONSISTS OF STANDARD CHARACTERS WITHOUT CLAIM TO ANY PARTICULAR FONT, STYLE, SIZE, OR COLOR.

NO CLAIM IS MADE TO THE EXCLUSIVE RIGHT TO USE "FABRIC", APART FROM THE MARK AS SHOWN.

FOR PRE-CUT, INDIVIDUALLY-PACKAGED COTTON FABRIC PIECES FOR USE AS COMPONENTS IN CRAFT PROJECTS (U.S. CLS. 42 AND 50).

FIRST USE 10-4-2006; IN COMMERCE 10-4-2006.

CLASS 25—CLOTHING**CLASS 25—(Continued).**

3,481,067. C.B. FLEET INVESTMENT CORPORATION, WILMINGTON, DE. SN 76-617,313. PUB. 9-27-2005, FILED 10-20-2004.

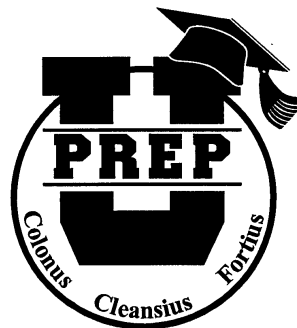

FOR CLOTHING, NAMELY, BUTTON DOWN SHIRTS (U.S. CLS. 22 AND 39).

FIRST USE 10-0-2004; IN COMMERCE 10-0-2004.

3,481,123. STRANGE, VALERIE, MIDDLEBURG, FL. AND WOODESHICK, ROCHELLE, NESCOPECK, PA. AND KROLIKOWSKI, JUNE, NESCOPECK, PA. SN 76-670,995. PUB. 8-28-2007, FILED 1-3-2007.

VV SKIVVYS

THE MARK CONSISTS OF STANDARD CHARACTERS WITHOUT CLAIM TO ANY PARTICULAR FONT, STYLE, SIZE, OR COLOR.

NO CLAIM IS MADE TO THE EXCLUSIVE RIGHT TO USE "SKIVVYS", APART FROM THE MARK AS SHOWN.

FOR WOMEN'S PANTIES (U.S. CLS. 22 AND 39).

FIRST USE 5-9-2008; IN COMMERCE 5-9-2008.

3,481,138. TULLE HAT COMPANY, CASTLE ROCK, CO. SN 76-674,741. PUB. 10-2-2007, FILED 3-28-2007.

SHIVAREE

THE MARK CONSISTS OF STANDARD CHARACTERS WITHOUT CLAIM TO ANY PARTICULAR FONT, STYLE, SIZE, OR COLOR.

FOR HEADGEAR, NAMELY, HATS AND VEILS (U.S. CLS. 22 AND 39).

FIRST USE 4-30-2007; IN COMMERCE 4-30-2007.

CLASS 25—(Continued).

3,481,154. 291 FROM VENICE, INC., VENICE, CA. SN 76-678,842. PUB. 2-5-2008, FILED 6-28-2007.

291

THE MARK CONSISTS OF STANDARD CHARACTERS WITHOUT CLAIM TO ANY PARTICULAR FONT, STYLE, SIZE, OR COLOR.

FOR CLOTHING, NAMELY, TOPS, BOTTOMS, HATS, T-SHIRTS, SWEATSHIRTS, AND RELATED ACCESSORIES, NAMELY, SCARVES (U.S. CLS. 22 AND 39).

FIRST USE 1-0-2008; IN COMMERCE 1-0-2008.

3,481,156. C.D.B. APPAREL, INC., NEW YORK, NY. SN 76-679,056. PUB. 12-11-2007, FILED 7-2-2007.

GS-115

THE MARK CONSISTS OF STANDARD CHARACTERS WITHOUT CLAIM TO ANY PARTICULAR FONT, STYLE, SIZE, OR COLOR.

FOR CLOTHING, NAMELY, JEANS, SHORTS, SHIRTS, TOPS, SWEATSHIRTS, SWIMWEAR, JACKETS, HATS, SCARVES, GLOVES, UNDERWEAR AND BELTS (U.S. CLS. 22 AND 39).

FIRST USE 11-0-2006; IN COMMERCE 11-0-2006.

3,481,158. BICYCLE CITY, LLC, CINCINNATI, OH. SN 76-978,711. PUB. 9-25-2007, FILED 10-12-2006.

BICYCLE CITY

THE MARK CONSISTS OF STANDARD CHARACTERS WITHOUT CLAIM TO ANY PARTICULAR FONT, STYLE, SIZE, OR COLOR.

OWNER OF U.S. REG. NO. 3,451,431.

FOR CLOTHING, NAMELY, T-SHIRTS AND HEADWEAR (U.S. CLS. 22 AND 39).

FIRST USE 4-23-2008; IN COMMERCE 4-23-2008.

CLASS 25—(Continued).

3,481,166. RULE 66, LLC, ESCONDIDO, CA. SN 77-000,713. PUB. 8-21-2007, FILED 9-15-2006.



FOR WEARING APPAREL, NAMELY, SHIRTS, SHORTS, PANTS AND CAPS (U.S. CLS. 22 AND 39).

FIRST USE 1-1-2008; IN COMMERCE 1-1-2008.

3,481,175. JSA INTERNATIONAL, POMPANO BEACH, FL. SN 77-004,345. PUB. 8-28-2007, FILED 9-21-2006.



FOR BOXER BRIEFS; SHORT-SLEEVED OR LONG-SLEEVED T-SHIRTS; UNDERWEAR (U.S. CLS. 22 AND 39).

FIRST USE 0-0-2005; IN COMMERCE 7-2-2007.

3,481,181. WALKER, C.S., OLYMPIA FIELDS, IL. SN 77-008,278. PUB. 7-31-2007, FILED 9-27-2006.

GIRRL U KNOW U WEARIN' DEM JEANZ

THE MARK CONSISTS OF STANDARD CHARACTERS WITHOUT CLAIM TO ANY PARTICULAR FONT, STYLE, SIZE, OR COLOR.

FOR CLOTHING, NAMELY, T-SHIRTS, SWEATSHIRTS, SWEAT-SUITS, JACKETS, SHIRTS, AND BLOUSES (U.S. CLS. 22 AND 39).

FIRST USE 4-15-2008; IN COMMERCE 4-15-2008.

CLASS 25—(Continued).

3,481,191. GONZALEZ, FEDERICO, CATHEDRAL CITY, CA.
SN 77-015,383. PUB. 5-22-2007, FILED 10-6-2006.

FUNSIZE

THE MARK CONSISTS OF STANDARD CHARACTERS WITHOUT CLAIM TO ANY PARTICULAR FONT, STYLE, SIZE, OR COLOR.

FOR APPAREL, NAMELY, SHIRTS, SHOES, SWEATSHIRTS, SWEATPANTS, PANTS, SHORTS, SWIM SUITS, JACKETS, SKIRTS, OVERALLS, LEGGINGS, UNDERWEAR, SWEATERS, AND HATS (U.S. CLS. 22 AND 39).
FIRST USE 6-1-2007; IN COMMERCE 6-1-2007.

3,481,196. NORTH AMERICAN POLO LEAGUE, LLC, HOUSTON, TX. SN 77-018,229. PUB. 8-21-2007, FILED 10-10-2006.

NORTH AMERICAN POLO LEAGUE

THE MARK CONSISTS OF STANDARD CHARACTERS WITHOUT CLAIM TO ANY PARTICULAR FONT, STYLE, SIZE, OR COLOR.

NO CLAIM IS MADE TO THE EXCLUSIVE RIGHT TO USE "NORTH AMERICAN", APART FROM THE MARK AS SHOWN.

FOR CAPS; HATS; T-SHIRTS; SHIRTS; PANTS; JACKETS; SHORTS; SKIRTS; SHOES; SWEATERS; SOCKS; VESTS; SWEATSHIRTS; BELTS; TIES; SCARVES (U.S. CLS. 22 AND 39).

FIRST USE 3-9-2007; IN COMMERCE 3-9-2007.

3,481,227. SHAFFER, MARIE KENNEDY, LOS ANGELES, CA. AND SHAFFER, JAMES, LOS ANGELES, CA. SN 77-033,187. PUB. 10-16-2007, FILED 10-31-2006.

BELLBOTTOM BLUES

THE MARK CONSISTS OF STANDARD CHARACTERS WITHOUT CLAIM TO ANY PARTICULAR FONT, STYLE, SIZE, OR COLOR.

NO CLAIM IS MADE TO THE EXCLUSIVE RIGHT TO USE "BELLBOTTOM", APART FROM THE MARK AS SHOWN.

FOR BLOUSES; BOTTOMS; COATS; DRESSES; JACKETS; PANTS; SHIRTS; SHORT-SLEEVED OR LONG-SLEEVED T-SHIRTS; SHORTS; SKIRTS; T-SHIRTS; TOPS; VESTS (U.S. CLS. 22 AND 39).

FIRST USE 6-19-2007; IN COMMERCE 6-19-2007.

CLASS 25—(Continued).

3,481,237. MAJOR LEAGUE LACROSSE LLC, BRIGHTON, MA. SN 77-037,801. PUB. 6-5-2007, FILED 11-6-2006.



OWNER OF U.S. REG. NOS. 2,764,957 AND 2,764,958.
NO CLAIM IS MADE TO THE EXCLUSIVE RIGHT TO USE "WASHINGTON", APART FROM THE MARK AS SHOWN.

FOR CLOTHING, NAMELY, SHIRTS, T-SHIRTS, TANK TOPS, SWEAT SHIRTS, SWEAT SHORTS, SWEAT PANTS, PULLOVERS, JACKETS, JERSEYS, SHORTS, HEADWEAR, CAPS AND HATS (U.S. CLS. 22 AND 39).
FIRST USE 5-12-2007; IN COMMERCE 5-12-2007.

3,481,241. DEINDE TUNDE DAWODU, WASHINGTON, DC. AND SEGUNDO NAZATI, WASHINGTON, DC. SN 77-038,811. PUB. 8-28-2007, FILED 11-7-2006.

DOPEVILLE

THE MARK CONSISTS OF STANDARD CHARACTERS WITHOUT CLAIM TO ANY PARTICULAR FONT, STYLE, SIZE, OR COLOR.

FOR T-SHIRTS; HATS; JEANS; JACKETS; OUTERWEAR, NAMELY, COATS, WIND-RESISTANT JACKETS, HOODED SWEATSHIRTS, RAINCOATS; SHORTS; UNDERWEAR; SHOES; SNEAKERS; BOOTS; GARMENTS, NAMELY, POLO SHIRTS, BLOUSES, SHIRTS, PANTS, SWEAT PANTS, SUITS; SWEATSHIRTS; HOODED SWEATSHIRTS; TANK TOPS; WOMEN'S COATS; WOMEN'S SHOES; WOMEN'S JEANS; WOMEN'S T-SHIRTS; WOMEN'S TOPS; WOMEN'S OUTERWEAR, NAMELY, COATS, WIND-RESISTANT JACKETS, HOODED SWEATSHIRTS, RAINCOATS; AND WOMEN'S SHOES (U.S. CLS. 22 AND 39).

FIRST USE 3-1-2003; IN COMMERCE 4-1-2003.

CLASS 25—(Continued).

3,481,243. NEW BALANCE ATHLETIC SHOE, INC., BOSTON, MA. SN 77-042,280. PUB. 3-11-2008, FILED 11-13-2006.



OWNER OF U.S. REG. NOS. 1,584,799 AND 2,832,197.
THE MARK CONSISTS OF STYLIZED "NBX".
FOR CLOTHING, NAMELY, T-SHIRTS, SHORTS,
PANTS, JACKETS; FOOTWEAR; HEADWEAR (U.S.
CLS. 22 AND 39).
FIRST USE 1-1-2007; IN COMMERCE 7-1-2007.

3,481,246. THE CARTOON NETWORK, INC., ATLANTA, GA.
SN 77-043,203. PUB. 4-17-2007, FILED 11-14-2006.



THE MARK CONSISTS OF AN IMAGE OF A SKULL
WITH STYLIZED WINGS AND THE WORDING "METALO-
CALYPSE".

FOR CLOTHING FOR MEN, WOMEN AND CHILDREN
FEATURING CHARACTERS FROM ANIMATED,
ACTION ADVENTURE, COMEDY AND/OR DRAMA
FEATURES, NAMELY, T-SHIRTS (U.S. CLS. 22 AND 39).
FIRST USE 1-18-2008; IN COMMERCE 1-18-2008.

CLASS 25—(Continued).

3,481,258. CHOICE FIRST DISTRIBUTION, LLC, PHOENIX,
AZ. SN 77-050,347. PUB. 6-19-2007, FILED 11-23-2006.

KRONIK ENERGY

THE MARK CONSISTS OF STANDARD CHARACTERS
WITHOUT CLAIM TO ANY PARTICULAR FONT, STYLE,
SIZE, OR COLOR.

FOR BASEBALL CAPS; BEANIES; BERETS; BLOUSES;
CAMISOLES; CAP VISORS; CAPS; CAPS WITH VISORS;
COATS FOR MEN AND WOMEN; CYCLISTS' JERSEYS;
DENIM JACKETS; DO RAGS; DRESS SHIRTS; GLOVES;
GYM SHORTS; GYM SUITS; HALTER TOPS; HATS;
HEAD SCARVES; HEAD SWEATBANDS; HEAD WEAR;
HEADBANDS; HEADGEAR, NAMELY, FLAT BRIM
HATS; JACKETS; JEANS; JERSEYS; JOGGING OUTFITS;
JOGGING PANTS; JOGGING SUITS; KERCHIEFS; KNIT
SHIRTS; KNITTED CAPS; LEATHER BELTS; LEATHER
COATS; LEATHER HEADWEAR; LEATHER JACKETS;
LEATHER PANTS; LONG JACKETS; MUSCLE TOPS;
NECKERCHIEFS; PANTIES; PANTIES, SHORTS AND
BRIEFS; SCARVES; SHIRTS; SHORTS; SKULL CAPS;
SPORT COATS; SPORT SHIRTS; SPORTS JACKETS;
SPORTS JERSEYS; SUN VISORS; SWEAT BANDS;
SWEAT PANTS; SWEAT SHIRTS; SWEAT SHORTS;
SWEAT SUITS; SWEATERS; T-SHIRTS; TANK TOPS;
THONGS; THONGS; TURBANS; TURTLENECKS; V-
NECK SWEATERS; VISORS; WIND-JACKETS; WOOLLY
HATS; WRIST BANDS (U.S. CLS. 22 AND 39).
FIRST USE 1-4-2007; IN COMMERCE 1-4-2007.

3,481,271. MOORE, ANDREW, OTTAWA, KS. AND MAX-
WELL, ANDREW, OTTAWA, KS. SN 77-055,455. PUB. 7-10-
2007, FILED 12-1-2006.

Bulstif

THE MARK CONSISTS OF STANDARD CHARACTERS
WITHOUT CLAIM TO ANY PARTICULAR FONT, STYLE,
SIZE, OR COLOR.

FOR BERMUDA SHORTS; DENIM JACKETS; GYM
SHORTS; JACKETS; JOGGING PANTS; SHORT-
SLEEVED OR LONG-SLEEVED T-SHIRTS; SPORT
SHIRTS; SPORTS JACKETS; SPORTS SHIRTS; SPORTS
SHIRTS WITH SHORT SLEEVES; SWEAT PANTS;
SWEAT SHIRTS; T-SHIRTS (U.S. CLS. 22 AND 39).
FIRST USE 4-22-2008; IN COMMERCE 4-22-2008.

CLASS 25—(Continued).

3,481,285. WILFLO, CINCINNATI, OH. SN 77-063,677. PUB. 9-4-2007, FILED 12-13-2006.

WILFLO

THE MARK CONSISTS OF STANDARD CHARACTERS WITHOUT CLAIM TO ANY PARTICULAR FONT, STYLE, SIZE, OR COLOR.

FOR CLOTHING, NAMELY, T-SHIRTS, SHIRTS, JACKETS, HEADWEAR, SWEATSHIRTS, AND SWEAT-PANTS (U.S. CLS. 22 AND 39).

FIRST USE 11-1-2007; IN COMMERCE 11-1-2007.

3,481,302. PEEP, INC., LOS ANGELES, CA. SN 77-070,853. PUB. 7-24-2007, FILED 12-22-2006.

SWEET LOVE

THE MARK CONSISTS OF STANDARD CHARACTERS WITHOUT CLAIM TO ANY PARTICULAR FONT, STYLE, SIZE, OR COLOR.

FOR DRESSES; JACKETS; SHIRTS; T-SHIRTS (U.S. CLS. 22 AND 39).

FIRST USE 2-4-2008; IN COMMERCE 2-4-2008.

3,481,385. BIG ISLAND OUTDOOR GROUP, LLC, EXCELSIOR, MN. SN 77-109,286. PUB. 8-28-2007, FILED 2-16-2007.

ODOR CHECK

THE MARK CONSISTS OF STANDARD CHARACTERS WITHOUT CLAIM TO ANY PARTICULAR FONT, STYLE, SIZE, OR COLOR.

NO CLAIM IS MADE TO THE EXCLUSIVE RIGHT TO USE "ODOR", APART FROM THE MARK AS SHOWN.

FOR ODOR CONTROL INSERTS FOR USE IN CONNECTION WITH FOOTWEAR, NAMELY, NON-ORTHOPEDIC FOOTWEAR INSERTS (U.S. CLS. 22 AND 39).

FIRST USE 3-0-2008; IN COMMERCE 3-0-2008.

CLASS 25—(Continued).

3,481,430. ZIDZIK, JOHN, HENDERSON, NV. AND ZIDZIK, KRISTEN, HENDERSON, NV. SN 77-124,479. PUB. 2-12-2008, FILED 3-7-2007.

Monkey Girl

NO CLAIM IS MADE TO THE EXCLUSIVE RIGHT TO USE "GIRL", APART FROM THE MARK AS SHOWN.

THE MARK CONSISTS OF A STYLIZED FORM OF THE WORDS "MONKEY GIRL".

FOR HATS; JACKETS; PANTS; SWEAT SHIRTS; T-SHIRTS; TANK-TOPS; UNDERGARMENTS (U.S. CLS. 22 AND 39).

FIRST USE 3-0-2007; IN COMMERCE 3-0-2007.

3,481,432. VANITY FAIR, INC., BOWLING GREEN, KY. SN 77-124,704. PUB. 8-14-2007, FILED 3-7-2007.

YOU ARE SEXY

THE MARK CONSISTS OF STANDARD CHARACTERS WITHOUT CLAIM TO ANY PARTICULAR FONT, STYLE, SIZE, OR COLOR.

FOR LINGERIE (U.S. CLS. 22 AND 39).

FIRST USE 6-1-2007; IN COMMERCE 6-1-2007.

3,481,464. GREENSPAN, AVIVA, TORONTO, CANADA. SN 77-130,347. PUB. 9-11-2007, FILED 3-13-2007.

PI DROP

THE MARK CONSISTS OF STANDARD CHARACTERS WITHOUT CLAIM TO ANY PARTICULAR FONT, STYLE, SIZE, OR COLOR.

FOR SHIRTS; SWEAT SHIRTS; T-SHIRTS (U.S. CLS. 22 AND 39).

FIRST USE 3-16-2007; IN COMMERCE 3-16-2007.

CLASS 25—(Continued).

3,481,465. GREENSPAN, AVIVA, TORONTO, CANADA. SN 77-130,350. PUB. 9-11-2007, FILED 3-13-2007.

GIANT PI

THE MARK CONSISTS OF STANDARD CHARACTERS WITHOUT CLAIM TO ANY PARTICULAR FONT, STYLE, SIZE, OR COLOR.

FOR SHIRTS; SWEAT SHIRTS; T-SHIRTS (U.S. CLS. 22 AND 39).

FIRST USE 3-15-2007; IN COMMERCE 3-15-2007.

3,481,473. JOHN H. DANIEL COMPANY, KNOXVILLE, TN. SN 77-132,202. PUB. 9-11-2007, FILED 3-15-2007.

EVERY STITCH EVERY TIME

THE MARK CONSISTS OF STANDARD CHARACTERS WITHOUT CLAIM TO ANY PARTICULAR FONT, STYLE, SIZE, OR COLOR.

FOR MEN'S CLOTHING, NAMELY, PANTS, COATS, SUITS, SHIRTS AND TIES (U.S. CLS. 22 AND 39).

FIRST USE 10-1-2007; IN COMMERCE 10-1-2007.

3,481,504. NORTH AMERICAN POLO LEAGUE, LLC, HOUSTON, TX. SN 77-136,991. PUB. 3-11-2008, FILED 3-21-2007.



NO CLAIM IS MADE TO THE EXCLUSIVE RIGHT TO USE "NORTH AMERICAN", APART FROM THE MARK AS SHOWN.

THE MARK CONSISTS OF THE LETTERS "NAPL" AND THE WORDS "NORTH AMERICAN POLO LEAGUE" WITH DESIGN CONSISTING OF A POLO PLAYER ON HORSE.

FOR BELTS; GOLF SHIRTS; PAJAMAS; SHIRTS; T-SHIRTS; JACKETS; PANTS; FOOTWEAR; SHORTS; SOCKS; SWEAT PANTS; SWEAT SHIRTS; SWEAT SHORTS; SWEATERS; TIES; SCARVES; VESTS; SUSPENDERS; GLOVES; HEADGEAR, NAMELY, CAPS; HATS; HEADBANDS (U.S. CLS. 22 AND 39).

FIRST USE 3-9-2007; IN COMMERCE 3-9-2007.

CLASS 25—(Continued).

3,481,506. SHANTOU SAYONA FOOTWEAR CO., LTD., SHANTOU, CHINA. SN 77-137,267. PUB. 3-18-2008, FILED 3-22-2007.



THE COLOR(S) BROWN AND BLACK IS/ARE CLAIMED AS A FEATURE OF THE MARK.

THE COLOR BROWN APPEARS IN A RECTANGLE AND IN A SERIES OF FANNED-OUT SHOE SOLES. WITHIN THE BROWN RECTANGLE, THE TEXT "SAYONA" APPEARS IN BLACK. WHITE APPEARS IN THE DRAWING TO INDICATE A TRANSPARENT BACKGROUND.

FOR THONGS; FLIP FLOPS; FOOTWEAR FOR MEN; FOOTWEAR FOR MEN AND WOMEN; FOOTWEAR FOR WOMEN (U.S. CLS. 22 AND 39).

FIRST USE 3-15-2004; IN COMMERCE 1-1-2008.

3,481,514. JOHNSON TECHNOLOGIES CORPORATION, NASHVILLE, TN. SN 77-138,430. PUB. 9-25-2007, FILED 3-23-2007.

APPLYING THE SCIENCE OF ERGONOMICS TO FOOTWEAR

THE MARK CONSISTS OF STANDARD CHARACTERS WITHOUT CLAIM TO ANY PARTICULAR FONT, STYLE, SIZE, OR COLOR.

FOR FOOTWEAR; SHOES; SHOE INSERTS FOR PRIMARILY NON-ORTHOPEDIC PURPOSES; INSOLES FOR SHOES AND BOOTS (U.S. CLS. 22 AND 39).

FIRST USE 3-0-2007; IN COMMERCE 3-0-2007.

CLASS 25—(Continued).

3,481,522. SHAFER BOWERS CORPORATION, VERNON, CA. SN 77-140,865. PUB. 9-25-2007, FILED 3-26-2007.



OWNER OF U.S. REG. NO. 2,502,605.
THE MARK CONSISTS OF THREE FOUR POINT STARS SURROUNDING A CHEVRON.
FOR CLOTHING, NAMELY, JACKETS, SHIRTS, PANTS, JEANS, SHORTS, HEADWEAR (U.S. CLS. 22 AND 39).
FIRST USE 1-1-2006; IN COMMERCE 3-1-2006.

3,481,523. SHAFER BOWERS CORPORATION, VERNON, CA. SN 77-140,900. PUB. 9-25-2007, FILED 3-26-2007.

LOUD, FAST & OUTTA' CONTROL

THE MARK CONSISTS OF STANDARD CHARACTERS WITHOUT CLAIM TO ANY PARTICULAR FONT, STYLE, SIZE, OR COLOR.
FOR CLOTHING, NAMELY, JACKETS, SHIRTS, AND HEADWEAR (U.S. CLS. 22 AND 39).
FIRST USE 11-1-2005; IN COMMERCE 1-6-2006.

CLASS 25—(Continued).

3,481,524. KIM, JEONG HO, NEW YORK, NY. SN 77-140,932. PUB. 10-2-2007, FILED 3-27-2007.

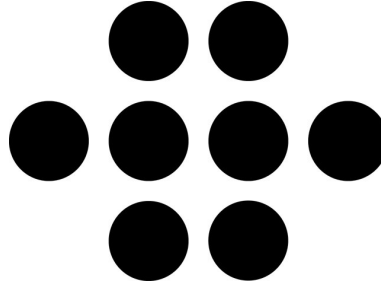

FOR BELTS; BIBS NOT OF CLOTH OR PAPER; CAPS; CHILDREN'S AND INFANTS' CLOTH BIBS; CHILDREN'S CLOTH EATING BIBS; CLOTH BIBS; CLOTH BIBS FOR ADULT DINERS; CLOTH BIBS FOR USE BY SENIOR CITIZENS OR PHYSICALLY- OR MENTALLY-CHALLENGED PERSONS; CLOTH DIAPERS; CLOTHING FOR WEAR IN JUDO PRACTICES; CLOTHING FOR WEAR IN WRESTLING GAMES; CLOTHING, NAMELY, ARM WARMERS; CLOTHING, NAMELY, FOLK COSTUMES; CLOTHING, NAMELY, KNEE WARMERS; CLOTHING, NAMELY, NECK TUBES; CLOTHING, NAMELY, WRAP-AROUNDS; CORSETS; DUSTERS; FIGURE SKATING CLOTHING, NAMELY, ONE-PIECE BODY SUITS, TIGHTS, SHIRTS, DRESSES, SKIRTS, AND PANTS; FOULARDS; HOODS; INFANT AND TODDLER ONE PIECE CLOTHING; INFANT CLOTH DIAPERS; JERSEYS; LEATHER BELTS; MANTLES; MUFFLERS; NON-DISPOSABLE CLOTH TRAINING PANTS; PAPER HATS FOR USE AS CLOTHING ITEMS; PARTS OF CLOTHING, NAMELY, GUSSETS FOR TIGHTS, GUSSETS FOR STOCKINGS, GUSSETS FOR BATHING SUITS, GUSSETS FOR UNDERWEAR, GUSSETS FOR LEOTARDS AND GUSSETS FOR FOOTLETS; PERSPIRATION ABSORBENT UNDERWEAR CLOTHING; SHIRTS; SHORT SETS; SHOULDER WRAPS; SWADDLING CLOTHES; TIES; TOPS; UNDERARM CLOTHING SHIELDS; WRAPS (U.S. CLS. 22 AND 39).
FIRST USE 10-23-2006; IN COMMERCE 8-3-2006.

3,481,527. 4004 INCORPORATED, PORT WASHINGTON, NY. SN 77-141,046. PUB. 9-25-2007, FILED 3-27-2007.



THE MARK CONSISTS OF A STYLIZED NUMERAL "3".
FOR PANTS, JEANS, SHIRTS, SHORTS, SWEATSHIRTS, FOOTWEAR, HEADWEAR (U.S. CLS. 22 AND 39).
FIRST USE 8-17-2006; IN COMMERCE 8-17-2006.

CLASS 25—(Continued).

3,481,543. ELLIE SHOES, INC, ORANGE, CA. SN 77-143,548.
PUB. 9-25-2007, FILED 3-29-2007.

CLASS 25—(Continued).

3,481,576. KIM, JEONG HO, NEW YORK, NY. SN 77-149,008.
PUB. 10-2-2007, FILED 4-4-2007.

1031

THE MARK CONSISTS OF STANDARD CHARACTERS WITHOUT CLAIM TO ANY PARTICULAR FONT, STYLE, SIZE, OR COLOR.

FOR WOMEN'S SHOES, NAMELY, HIGH FASHION AND EXOTIC PUMPS, SANDALS, STILETTOS, PLATFORMS AND BOOTS (U.S. CLS. 22 AND 39).
FIRST USE 6-1-2007; IN COMMERCE 6-1-2007.

SPOLDA

3,481,547. BEIJING AIMER LINGERIE CO., LTD., CHAOYANG DISTRICT, CHINA. SN 77-144,545. PUB. 9-11-2007, FILED 3-30-2007.

AYYMU

THE MARK CONSISTS OF STANDARD CHARACTERS WITHOUT CLAIM TO ANY PARTICULAR FONT, STYLE, SIZE, OR COLOR.

THE WORDING "AYYMU" HAS NO MEANING IN A FOREIGN LANGUAGE.

FOR CLOTHING, NAMELY, SWIMWEAR, FOOTWEAR, CAPS, SOCKS, GLOVES, SCARVES, NECK CLOTH, NAMELY, NECK TUBES, NECK BANDS, GIRDLES, UNDERWEAR, LAYETTES (U.S. CLS. 22 AND 39).
FIRST USE 2-0-2007; IN COMMERCE 2-0-2007.

THE MARK CONSISTS OF STANDARD CHARACTERS WITHOUT CLAIM TO ANY PARTICULAR FONT, STYLE, SIZE, OR COLOR.

FOR BELTS; BIBS NOT OF CLOTH OR PAPER; CAPS; CHILDREN'S AND INFANTS' CLOTH BIBS; CHILDREN'S CLOTH EATING BIBS; CLOTH BIBS; CLOTH BIBS FOR ADULT DINERS; CLOTH BIBS FOR USE BY SENIOR CITIZENS OR PHYSICALLY- OR MENTALLY-CHALLENGED PERSONS; CLOTH DIAPERS; CLOTHING FOR WEAR IN JUDO PRACTICES; CLOTHING FOR WEAR IN WRESTLING GAMES; CLOTHING, NAMELY, ARM WARMERS; CLOTHING, NAMELY, FOLK COSTUMES; CLOTHING, NAMELY, KNEE WARMERS; CLOTHING, NAMELY, NECK TUBES; CLOTHING, NAMELY, WRAP-AROUNDS; CORSETS; DUSTERS; FIGURE SKATING CLOTHING, NAMELY, ONE-PIECE BODY SUITS, TIGHTS, SHIRTS, DRESSES, SKIRTS, AND PANTS; FOULARDS; HOODS; INFANT AND TODDLER ONE PIECE CLOTHING; INFANT CLOTH DIAPERS; JERSEYS; LEATHER BELTS; MANTLES; MUFFLERS; NON-DISPOSABLE CLOTH TRAINING PANTS; PAPER HATS FOR USE AS CLOTHING ITEMS; PARTS OF CLOTHING, NAMELY, GUSSETS FOR TIGHTS, GUSSETS FOR STOCKINGS, GUSSETS FOR BATHING SUITS, GUSSETS FOR UNDERWEAR, GUSSETS FOR LEOTARDS AND GUSSETS FOR FOOTLETS; PERSPIRATION ABSORBENT UNDERWEAR CLOTHING; SHIFTS; SHORT SETS; SHOULDER WRAPS; SWADDLING CLOTHES; TIES; TOPS; UNDERARM CLOTHING SHIELDS; WRAPS (U.S. CLS. 22 AND 39).
FIRST USE 10-23-2006; IN COMMERCE 8-3-2006.

CLASS 25—(Continued).

3,481,577. KIM, JEONG HO, NEW YORK, NY. SN 77-149,038.
PUB. 10-2-2007, FILED 4-4-2007.



FOR INFANT CLOTH DIAPERS; JERSEYS; LEATHER BELTS; MANTLES; MUFFLERS; NON-DISPOSABLE CLOTH TRAINING PANTS; PAPER HATS FOR USE AS CLOTHING ITEMS; PARTS OF CLOTHING, NAMELY, GUSSETS FOR TIGHTS, GUSSETS FOR STOCKINGS, GUSSETS FOR BATHING SUITS, GUSSETS FOR UNDERWEAR, GUSSETS FOR LEOTARDS AND GUSSETS FOR FOOTLETS; PERSPIRATION ABSORBENT UNDERWEAR CLOTHING; SHIRTS; SHORT SETS; SHOULDER WRAPS; SWADDLING CLOTHES; TIES; TOPS; UNDER-ARM CLOTHING SHIELDS; WRAPS; CAPS; CHILDREN'S AND INFANTS' CLOTH BIBS; CHILDREN'S CLOTH EATING BIBS; CLOTH BIBS; CLOTH BIBS FOR ADULT DINERS; CLOTH BIBS FOR USE BY SENIOR CITIZENS OR PHYSICALLY- OR MENTALLY-CHALLENGED PERSONS; CLOTH DIAPERS; CLOTHING FOR WEAR IN JUDO PRACTICES; CLOTHING FOR WEAR IN WRESTLING GAMES; CLOTHING, NAMELY, ARM WARMERS; CLOTHING, NAMELY, FOLK COSTUMES; CLOTHING, NAMELY, KNEE WARMERS; CLOTHING, NAMELY, NECK TUBES; CLOTHING, NAMELY, WRAP-AROUNDS; CORSETS; DUSTERS; FIGURE SKATING CLOTHING, NAMELY, ONE-PIECE BODY SUITS, TIGHTS, SHIRTS, DRESSES, SKIRTS, AND PANTS; FOULARDS; HOODS; INFANT AND TODDLER ONE PIECE CLOTHING; BELTS; BIBS NOT OF CLOTH OR PAPER (U.S. CLS. 22 AND 39).
FIRST USE 10-23-2006; IN COMMERCE 8-3-2006.

CLASS 25—(Continued).

3,481,590. UNIVERSITY OF CENTRAL FLORIDA, ORLANDO, FL. SN 77-150,557. PUB. 10-2-2007, FILED 4-6-2007.



OWNER OF U.S. REG. NOS. 2,118,135, 3,062,706, AND OTHERS.

THE MARK CONSISTS OF KNIGHT HOLDING SWORD (HALF BODY) ABOVE TERM "UCF" WITH WORD "KNIGHTS" BELOW "UCF".

FOR CLOTHING, FOR MEN, WOMEN AND CHILDREN, NAMELY, T-SHIRTS, SWEATSHIRTS, TANK TOPS, SHIRTS, AND HATS AND CAPS (U.S. CLS. 22 AND 39).

FIRST USE 7-0-2007; IN COMMERCE 7-0-2007.

3,481,591. UNIVERSITY OF CENTRAL FLORIDA, ORLANDO, FL. SN 77-150,572. PUB. 10-2-2007, FILED 4-6-2007.



OWNER OF U.S. REG. NOS. 2,118,135, 3,062,706, AND OTHERS.

THE MARK CONSISTS OF KNIGHT WITH SWORD (HALF BODY) ABOVE TERM "UCF".

FOR CLOTHING, FOR MEN, WOMEN AND CHILDREN, NAMELY, JOGGING SUITS, SWEAT SUITS, T-SHIRTS, SWEATSHIRTS, SHIRTS, PANTS, PONCHOS, HATS AND CAPS, TIES, AND FOOTWEAR (U.S. CLS. 22 AND 39).

FIRST USE 7-0-2007; IN COMMERCE 7-0-2007.

CLASS 25—(Continued).

3,481,592. SWEET ROMEO LLC, NEW YORK, NY. SN 77-150,649. PUB. 10-2-2007, FILED 4-6-2007.

SWEET ROMEO

THE MARK CONSISTS OF STANDARD CHARACTERS WITHOUT CLAIM TO ANY PARTICULAR FONT, STYLE, SIZE, OR COLOR.

FOR CLOTHING FOR USE BY WOMEN, NAMELY, BLAZERS; BLOUSES; BODYSUITS; BOLEROS; CAMISOLES; CAPES; CARDIGANS; DRESSES; HALTER TOPS; JACKETS; JEANS; JOGGING SUITS; LEGGINGS; PANTS; PONCHOS; PULLOVERS; SCARVES; SHAWLS; SHIRTS; SHORTS; UNDERSHIRTS; SWEAT SHORTS; SKIRTS; SPORT COATS; SPORT SHIRTS; STOCKINGS; SUITS; SWEAT PANTS; SWEAT SHIRTS; SWEATERS; T-SHIRTS; TROUSERS; VESTS; AND WARM-UP SUITS (U.S. CLS. 22 AND 39).

FIRST USE 1-31-1997; IN COMMERCE 1-31-1997.

3,481,604. JAPNA INC., EDISON, NJ. SN 77-152,659. PUB. 3-18-2008, FILED 4-10-2007.

FUN & FLIRT BY JAPNA

THE MARK CONSISTS OF STANDARD CHARACTERS WITHOUT CLAIM TO ANY PARTICULAR FONT, STYLE, SIZE, OR COLOR.

FOR CLOTHING, NAMELY, LADIES TOPS, TUNICS, SHIRTS, BLOUSES, SWEATERS, JERSEYS, SKIRTS, DRESSES AND SWIMSUITS (U.S. CLS. 22 AND 39).

FIRST USE 1-1-2008; IN COMMERCE 1-1-2008.

3,481,608. 2FEETSOUTH LLC, GARDNER, MA. SN 77-154,568. PUB. 10-9-2007, FILED 4-11-2007.

2FEETSOUTH

THE MARK CONSISTS OF STANDARD CHARACTERS WITHOUT CLAIM TO ANY PARTICULAR FONT, STYLE, SIZE, OR COLOR.

FOR HATS; PANTS; SHORTS; SWEAT SHIRTS; T-SHIRTS; WRISTBANDS (U.S. CLS. 22 AND 39).

FIRST USE 4-1-2007; IN COMMERCE 8-1-2007.

CLASS 25—(Continued).

3,481,632. KROTHER, JASON N, BLOOMINGTON, IN. SN 77-159,836. PUB. 10-16-2007, FILED 4-18-2007.



THE MARK CONSISTS OF A CROSS OVERLAIN ON AN ANGULAR SHAPE.

FOR AFTER SKI BOOTS; ANGLERS' SHOES; ANKLE BOOTS; ANKLE GARTERS; ANKLE SOCKS; ANKLETS; ANORAKS; ANTI-PERSPIRANT SOCKS; APRES-SKI SHOES; APRONS; ASCOTS; ATHLETIC FOOTWEAR; ATHLETIC SHOES; BANDANAS; BASEBALL CAPS; BASKETBALL SNEAKERS; BATH SLIPPERS; BATHING CAPS; BATHING SUITS; BATHING SUITS FOR MEN; BATHING TRUNKS; BATHROBES; BEACH COVERUPS; BEACH FOOTWEAR; BEACH SHOES; BEACHWEAR; BEANIES; BED JACKETS; BELTS; BELTS MADE OF LEATHER; BELTS OF TEXTILE; BERMUDA SHORTS; BIB OVERALLS; BICYCLE GLOVES; BICYCLING GLOVES; BIKINIS; BLAZERS; BLOOMERS; BLOUSES; BOARD SHORTS; BOARDSHORTS; BODY SUITS; BOLEROS; BOLO TIES; BONNETS; BOOTIES; BOOTS; BOTTOMS; BOW TIES; BOWLING SHOES; BOXER BRIEFS; BOXER SHORTS; BOXING SHOES; BRAS; BRASSIERES; BRIEFS; BRIEFS; BUTTON-FRONT ALOHA SHIRTS; CAMISOLES; CAMP SHIRTS; CANVAS SHOES; CAP VISORS; CAPELETS; CAPRI PANTS; CAPRIS; CAPS; CAPS WITH VISORS; CARDIGANS; CARGO PANTS; CHEMISES; CHEMISETTES; CHILDREN'S AND INFANTS' CLOTH BIBS; CHILDREN'S CLOTH EATING BIBS; CHILDREN'S HEADWEAR; CLOGS; CLOTHING, NAMELY, ARM WARMERS; CLOTHING, NAMELY, KNEE WARMERS; CLOTHING, NAMELY, NECK TUBES; CLOTHING, NAMELY, WRAP-AROUNDS; COATS; COATS FOR MEN AND WOMEN; COATS MADE OF COTTON; COATS OF DENIM; COVERALLS; COVERUPS; CYCLISTS' JERSEYS; DECK-SHOES; DENIM JACKETS; DENIMS; DICKIES; DO RAGS; DOWN JACKETS; DRESS SHIELDS; DRESS SHIRTS; DRESS SUITS; DRESSES; DRIVERS; DRY SUITS; DUNGAREES; EAR MUFFS; EARBANDS; FABRIC BELTS; FISHERMEN'S JACKETS; FISHING VESTS; FISHING WADERS; FLEECE PULLOVERS; FLEECE SHORTS; FLIP FLOPS; FOOTWEAR; FOOTWEAR; FOOTWEAR FOR MEN; FOOTWEAR FOR MEN AND WOMEN; FOOTWEAR FOR TRACK AND FIELD ATHLETICS; FOOTWEAR FOR WOMEN; FOOTWEAR MADE OF WOOD; FOOTWEAR NOT FOR SPORTS; FOOTWEAR, NAMELY, PUMPS; FOOTWEAR, NAMELY, RUBBERS; FOUL WEATHER GEAR; FUR COATS; FUR COATS AND JACKETS; FUR HATS; FUR JACKETS; FUR MUFFS; G-STRINGS; GALOSHES; GAUCHOS; GLOVES; GLOVES INCLUDING THOSE MADE OF SKIN, HIDE OR FUR; GOLF CAPS; GOLF SHIRTS; GOLF SHOES; GOLF TROUSERS; GREATCOATS; GYM SHORTS; GYM SUITS; HALTER TOPS; HAT BANDS; HATS; HEAD SCARVES; HEAD SWEATBANDS; HEAD WEAR; HEADBANDS; HEADBANDS AGAINST SWEATING; HEADWEAR; HEAVY JACKETS; HEELS; HIGH RAIN CLOGS (ASHIDA); HIKING BOOTS; HOODS; HOODS; HOUSECOATS; INFANT AND TODDLER ONE PIECE CLOTHING; INFANT SLEEPERS; INFANTS' SHOES AND BOOTS; INFANTS' TROUSERS; INFANTWEAR; JACKETS; JEANS; JERSEYS; JOGGING OUTFITS; JOGGING PANTS; JOGGING SUITS; JUMPERS; JUMPSUITS;

CLASS 25—(Continued).

KILTS; KNEE HIGHS; KNEE-HIGH STOCKINGS; KNICKERS; KNIT SHIRTS; KNITTED CAPS; KNITTED UNDERWEAR; LACE BOOTS; LADIES' BOOTS; LADIES' SUITS; LADIES' UNDERWEAR; LEATHER BELTS; LEATHER COATS; LEATHER HEADWEAR; LEATHER JACKETS; LEATHER PANTS; LEATHER SHOES; LEATHER SLIPPERS; LEG WARMERS; LEG-WARMERS; LEGGINGS; LIGHT-REFLECTING COATS; LIGHT-REFLECTING JACKETS; LONG JACKETS; LONG SLEEVED VESTS; LOUNGEWEAR; MEN AND WOMEN JACKETS, COATS, TROUSERS, VESTS; MEN'S SOCKS; MEN'S SUITS; MEN'S SUITS, WOMEN'S SUITS; MINISKIRTS; MITTENS; MOCCASINS; MOCK TURTLE-NECK SWEATERS; MONEY BELTS; MORNING COATS; MOTORCYCLE GLOVES; MOTORCYCLIST BOOTS; MUSCLE TOPS; NECK BANDS; NECK GAITERS; NECKERCHIEFS; NECKERCHIEVES; NECKTIES; NECKWEAR; NIGHT GOWNS; NIGHT SHIRTS; NIGHTCAPS; NIGHTDRESSES; NIGHTIES; NIGHTWEAR; ONE PIECE GARMENT FOR INFANTS AND TODDLERS; OPEN-NECKED SHIRTS; OVER COATS; OVER-TROUSERS; OVERALLS; OVERCOATS; OVERSHOES; PAJAMAS; PANTIES; PANTIES, SHORTS AND BRIEFS; PANTS; PANTSUITS; PARKAS; PERSPIRATION ABSORBENT UNDERWEAR CLOTHING; PETTICOATS; PIQUE SHIRTS; PLASTIC BABY BIBS; PLAY SUITS; POCKET KERCHIEFS; POCKET SQUARES; POLO SHIRTS; PONCHOS; PULLOVERS; PUMPS; PYJAMAS; QUILTED VESTS; RAIN BOOTS; RAIN COATS; RAIN JACKETS; RAIN SLICKERS; RAIN SUITS; RAIN TROUSERS; RAINCOATS; RAINPROOF JACKETS; RAINWEAR; ROBES; RUBBER SHOES; RUBBERS; RUGBY SHORTS; RUGBY TOPS; RUNNING SHOES; SANDAL-CLOGS; SANDALS; SARIS; SARONGS; SASHES; SCARVES; SCRUBS NOT FOR MEDICAL PURPOSES; SHAWLS; SHAWLS; SHAWLS AND HEADSCARVES; SHAWLS AND STOLES; SHIRTS; SHIRTS FOR SUITS; SHOES; SHORT PETTICOATS; SHORT SETS; SHORT TROUSERS; SHORT-SLEEVED OR LONG-SLEEVED T-SHIRTS; SHORT-SLEEVED SHIRTS; SHOWER CAPS; SILK SCARVES; SKI AND SNOWBOARD SHOES AND PARTS THEREOF; SKI BIBS; SKI BOOT BAGS; SKI GLOVES; SKI JACKETS; SKI MASKS; SKI PANTS; SKI SUITS; SKI SUITS FOR COMPETITION; SKI WEAR; SKIING SHOES; SKIRT SUITS; SKIRTS; SKIRTS AND DRESSES; SKIWEAR; SKULL CAPS; SKULLIES; SLACKS; SLEEP SHIRTS; SLEEPING GARMENTS; SLEEPWEAR; SLEEVED OR SLEEVELESS JACKETS; SLEEVELESS JERSEYS; SLIPPERS; SMALL HATS; SMOKING JACKETS; SNEAKERS; SNOW BOARDING SUITS; SNOW PANTS; SNOW SUITS; SNOWBOARD BOOTS; SNOWBOARD GLOVES; SNOWBOARD PANTS; SOCK SUSPENDERS; SOCKS; SOCKS AND STOCKINGS; SPORT COATS; SPORT SHIRTS; SPORTS JACKETS; SPORTS JERSEYS; SPORTS JERSEYS AND BREECHES FOR SPORTS; SPORTS OVERUNIFORMS; SPORTS SHIRTS; SPORTS SHIRTS WITH SHORT SLEEVES; STOCKINGS; STOCKINGS; STUFF JACKETS; SUEDE JACKETS; SUIT COATS; SUITS; SUITS OF LEATHER; SUN VISORS; SUNSUITS; SURF WEAR; SUSPENDER BELTS FOR MEN; SUSPENDER BELTS FOR WOMEN; SUSPENDERS; SWEAT BANDS; SWEAT PANTS; SWEAT SHIRTS; SWEAT SHORTS; SWEAT SUITS; SWEATBANDS; SWEATERS; SWEATSOCKS; SWIM CAPS; SWIM TRUNKS; SWIM WEAR; SWIM WEAR FOR GENTLEMEN AND LADIES; SWIMMING CAPS; SWIMMING CAPS; SWIMMING COSTUMES; SWIMMING TRUNKS; SWIMSUITS; T-SHIRTS; TANK TOPS; TANK-TOPS; TEDDIES; TENNIS SHOES; TENNIS WEAR; THERMAL SOCKS; THERMAL UNDERWEAR; THONGS; TIES; TIGHTS; TOBOGGAN HATS, PANTS AND CAPS; TOP COATS; TOPCOATS; TOPS; TRACK PANTS; TRACK SUITS;

CLASS 25—(Continued).

TRACKSUITS; TRAINING SHOES; TRAINING SUITS; TRENCH COATS; TROUSERS; TROUSERS FOR SWEATING; TROUSERS OF LEATHER; TRUNKS; TUBE TOPS; TURTLENECK SWEATERS; TURTLENECKS; TUXEDO BELTS; TUXEDOS; UNDER GARMENTS; UNDERCLOTHES; UNDERGARMENTS; UNDERPANTS; UNDERSHIRTS; UNDERSKIRTS; UNDERWEAR; UNIFORMS; V-NECK SWEATERS; VESTED SUITS; VESTS; VISORS; WAIST BELTS; WAISTCOATS; WALKING SHORTS; WARM UP SUITS; WATER SOCKS; WATERPROOF JACKETS AND PANTS; WET SUIT GLOVES; WET SUITS; WET SUITS FOR WATER-SKIING AND SUB-AQUA; WIND COATS; WIND RESISTANT JACKETS; WIND SHIRTS; WIND VESTS; WIND-JACKETS; WINDSHIRTS; WINTER BOOTS; WOMEN'S SHOES; WOMEN'S UNDERWEAR; WOOLEN SOCKS; WOOLLY HATS; WORK SHOES AND BOOTS; WORKING OVERALLS; WOVEN OR KNITTED UNDERWEAR; WRIST BANDS; WRISTBANDS; WRISTBANDS CONTAINING A COOLING SUBSTANCE TO COOL THE WEARER; ZOOT SUITS (U.S. CLS. 22 AND 39).

FIRST USE 5-20-2007; IN COMMERCE 5-20-2007.

3,481,668. JONQUIL, INC., SANTA MONICA, CA. SN 77-169,520. PUB. 9-11-2007, FILED 4-30-2007.

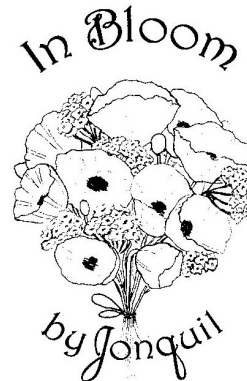

OWNER OF U.S. REG. NO. 2,346,965.

THE MARK CONSISTS OF A BUNCH OR BOUQUET OF FLOWERS SURROUNDED BY THE STYLIZED WORDS "IN BLOOM" ABOVE THE FLOWERS AND "BY JONQUIL" BELOW THE FLOWERS.

FOR LINGERIE; SLEEPWEAR; PAJAMAS; GOWNS; NIGHT GOWNS; ROBES; CHEMISES; BABY DOLL PYJAMAS; PEIGNOIRS; NIGHT SHIRTS; SLEEP SHIRTS; LOUNGEWEAR; WRAPS; COVERUPS (U.S. CLS. 22 AND 39).

FIRST USE 8-10-2007; IN COMMERCE 1-31-2008.

CLASS 25—(Continued).

3,481,682. JOHNSON TECHNOLOGIES CORPORATION, NASHVILLE, TN. SN 77-173,099. PUB. 10-2-2007, FILED 5-4-2007.

ERGO COMFORT

THE MARK CONSISTS OF STANDARD CHARACTERS WITHOUT CLAIM TO ANY PARTICULAR FONT, STYLE, SIZE, OR COLOR.

NO CLAIM IS MADE TO THE EXCLUSIVE RIGHT TO USE "COMFORT", APART FROM THE MARK AS SHOWN, FOR FOOTWEAR; INSOLES; SHOES; SHOE INSERTS FOR PRIMARILY NON-ORTHOPEDIC PURPOSES (U.S. CLS. 22 AND 39).

FIRST USE 3-0-2007; IN COMMERCE 3-0-2007.

CLASS 25—(Continued).

3,481,717. CARLEN ENTERPRISES, INC., LONG BEACH, CA. SN 77-182,392. PUB. 10-9-2007, FILED 5-16-2007.

CLASS PLAYER

THE MARK CONSISTS OF STANDARD CHARACTERS WITHOUT CLAIM TO ANY PARTICULAR FONT, STYLE, SIZE, OR COLOR.

FOR CLOTHING, NAMELY, SHIRTS, BLAZERS, JACKETS, HOODED-JACKETS, T-SHIRTS, SHORTS, DRESSES, SKIRTS, UNDERWEAR, LINGERIE, SWEAT-SHIRTS, SWEATPANTS, SWEATERS, BELTS, HATS, SLACKS, PANTS AND JEANS (U.S. CLS. 22 AND 39).

FIRST USE 11-12-2007; IN COMMERCE 11-12-2007.

3,481,752. URBAN OUTFITTERS (DELAWARE), INC., PHILADELPHIA, PA. SN 77-198,082. PUB. 10-9-2007, FILED 6-5-2007.

SALT VALLEY WESTERN

THE MARK CONSISTS OF STANDARD CHARACTERS WITHOUT CLAIM TO ANY PARTICULAR FONT, STYLE, SIZE, OR COLOR.

NO CLAIM IS MADE TO THE EXCLUSIVE RIGHT TO USE "WESTERN", APART FROM THE MARK AS SHOWN, FOR SHIRTS (U.S. CLS. 22 AND 39).

FIRST USE 2-15-2007; IN COMMERCE 2-15-2007.

3,481,708. CONVERSE INC., NORTH ANDOVER, MA. SN 77-179,299. PUB. 10-2-2007, FILED 5-11-2007.



3,481,760. MAHAFFEY, ANITA C, SAN DIEGO, CA. SN 77-201,826. PUB. 11-20-2007, FILED 6-8-2007.

Cooljam

OWNER OF U.S. REG. NOS. 583,097 AND 938,918. THE NAME "JACK PURCELL" DOES NOT IDENTIFY A LIVING INDIVIDUAL.

THE MARK CONSISTS OF A SIGNATURE.

FOR FOOTWEAR; CLOTHING, NAMELY, T-SHIRTS, SHORTS, PANTS, TANK TOPS, VESTS, JACKETS, SWEATERS, JEANS, FLEECE TOPS AND BOTTOMS, WIND-RESISTANT SUITS AND JACKETS, WOVEN SHIRTS, SOCKS, SHORT AND LONG SLEEVED TOPS, SHORT AND LONG SLEEVED T-SHIRTS, TROUSERS, SKIRTS, BELTS, SCARVES, AND BLAZERS; EXERCISE WEAR, NAMELY, SWEAT SUITS, SWIMWEAR, SWEAT PANTS, SWEAT SHIRTS, GYM SHORTS, AND SWEAT SHORTS; AND HEADGEAR, NAMELY, SPORTS CAPS AND KNIT CAPS (U.S. CLS. 22 AND 39).

FIRST USE 12-31-1935; IN COMMERCE 12-31-1935.

THE MARK CONSISTS OF STANDARD CHARACTERS WITHOUT CLAIM TO ANY PARTICULAR FONT, STYLE, SIZE, OR COLOR.

FOR PAJAMA BOTTOMS; PAJAMAS; BATHROBES; NIGHTWEAR; CAPRI PANTS; LOUNGE PANTS; SWEAT PANTS; NIGHT SHIRTS; SLEEP SHIRTS IN CONNECTION WITH MOISTURE-WICKING SLEEPWEAR AMELIORATING PHYSICAL DISCOMFORT FROM NIGHT SWEATS (U.S. CLS. 22 AND 39).

FIRST USE 6-1-2005; IN COMMERCE 3-1-2006.

CLASS 25—(Continued).

3,481,779. J&M SALES, INC., GARDENA, CA. SN 77-210,439.
PUB. 12-4-2007, FILED 6-20-2007.

BEVERLY HILLS PRINCESS

THE MARK CONSISTS OF STANDARD CHARACTERS WITHOUT CLAIM TO ANY PARTICULAR FONT, STYLE, SIZE, OR COLOR.

NO CLAIM IS MADE TO THE EXCLUSIVE RIGHT TO USE "BEVERLY HILLS", APART FROM THE MARK AS SHOWN.

FOR CLOTHING, NAMELY, PANTS, SHIRTS, DRESSES, SKIRTS, BLOUSES AND JACKETS (U.S. CLS. 22 AND 39).

FIRST USE 6-3-2008; IN COMMERCE 6-3-2008.

3,481,826. GLOBAL CLOTHING NETWORK, INC., WAYNE, NJ. SN 77-235,186. PUB. 12-25-2007, FILED 7-20-2007.

PRETTY ZEN

THE MARK CONSISTS OF STANDARD CHARACTERS WITHOUT CLAIM TO ANY PARTICULAR FONT, STYLE, SIZE, OR COLOR.

FOR CLOTHING, NAMELY, T-SHIRTS, SHIRTS, SWEATERS, JACKETS, PANTS, SHORTS, ROMPERS, JOGGING SUITS, VESTS, DRESSES, JUMP SUITS, HATS, SKIRTS, TOPS (U.S. CLS. 22 AND 39).

FIRST USE 12-30-2007; IN COMMERCE 12-30-2007.

3,481,828. GLOBAL CLOTHING NETWORK, INC., WAYNE, NJ. SN 77-235,529. PUB. 12-25-2007, FILED 7-22-2007.

PRETTY SMART

THE MARK CONSISTS OF STANDARD CHARACTERS WITHOUT CLAIM TO ANY PARTICULAR FONT, STYLE, SIZE, OR COLOR.

FOR CLOTHING, NAMELY, T-SHIRTS, SHIRTS, SWEATERS, JACKETS, PANTS, SHORTS, ROMPERS, JOGGING SUITS, VESTS, DRESSES, JUMP SUITS, HATS, SKIRTS, TOPS (U.S. CLS. 22 AND 39).

FIRST USE 12-30-2007; IN COMMERCE 12-30-2007.

CLASS 25—(Continued).

3,481,857. YEN, ALAIN, MORENO VALLEY, CA. SN 77-247,372. PUB. 1-22-2008, FILED 8-5-2007.

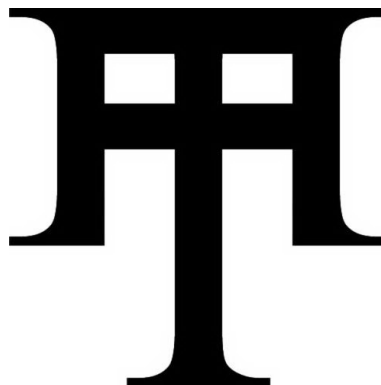

THE MARK CONSISTS OF THE LOGO REPRESENTATIVE OF THE COMPANY CALLED "THE ALLIANCE OF ART AND APPAREL" (AKA "THE ARTEL"). IT CONSISTS OF 2 LETTER "A'S THAT CONNECT TO FORM ONE LARGE "A" AND A LOWERCASE "T" IN THE CENTER.

FOR T-SHIRTS; DENIMS; LEATHER PANTS; SWEAT PANTS; HATS; POLO SHIRTS; SHORT-SLEEVED OR LONG-SLEEVED T-SHIRTS; ATHLETIC SHOES; SHOES (U.S. CLS. 22 AND 39).

FIRST USE 6-1-2008; IN COMMERCE 6-1-2008.

3,481,872. MALIBU DREAM GIRL, BELL, CA. SN 77-251,179.
PUB. 2-19-2008, FILED 8-9-2007.

BEACH DIVA

THE MARK CONSISTS OF STANDARD CHARACTERS WITHOUT CLAIM TO ANY PARTICULAR FONT, STYLE, SIZE, OR COLOR.

NO CLAIM IS MADE TO THE EXCLUSIVE RIGHT TO USE "BEACH", APART FROM THE MARK AS SHOWN.

FOR SWIMWEAR AND COVER-UPS (U.S. CLS. 22 AND 39).

FIRST USE 7-14-2006; IN COMMERCE 3-5-2007.

CLASS 25—(Continued).

3,481,875. YEN, ALAIN, MORENO VALLEY, CA. SN 77-252,399. PUB. 2-12-2008, FILED 8-10-2007.

The Alliance of Art and Apparel

THE MARK CONSISTS OF STANDARD CHARACTERS WITHOUT CLAIM TO ANY PARTICULAR FONT, STYLE, SIZE, OR COLOR.

FOR SHORT-SLEEVED OR LONG-SLEEVED T-SHIRTS; T-SHIRTS; DENIM JACKETS; DENIMS; LEATHER PANTS; PANTS; SWEAT PANTS; HATS; ATHLETIC SHOES; SHOES; POLO SHIRTS; BELTS (U.S. CLS. 22 AND 39).

FIRST USE 6-1-2008; IN COMMERCE 6-1-2008.

CLASS 25—(Continued).

3,481,905. TEMBLADOR, JOHN, SALINAS, CA. SN 77-263,561. PUB. 2-19-2008, FILED 8-24-2007.



THE MARK CONSISTS OF THE STYLIZED TEXT "WATER BOONY COOL HEADS PREVAIL!", WITH A CURVED LINE AND A HALF CIRCLE ABOVE THE CURVED LINE.

FOR HATS (U.S. CLS. 22 AND 39).
FIRST USE 1-1-2008; IN COMMERCE 1-1-2008.

3,481,876. YEN, ALAIN, MORENO VALLEY, CA. SN 77-252,575. PUB. 1-22-2008, FILED 8-10-2007.

The Artel

THE MARK CONSISTS OF STANDARD CHARACTERS WITHOUT CLAIM TO ANY PARTICULAR FONT, STYLE, SIZE, OR COLOR.

FOR SHORT-SLEEVED OR LONG-SLEEVED T-SHIRTS; T-SHIRTS; DENIM JACKETS; DENIMS; LEATHER PANTS; PANTS; SWEAT PANTS; HATS; SHIRTS; POLO SHIRTS; ATHLETIC SHOES; SHOES (U.S. CLS. 22 AND 39).

FIRST USE 6-1-2008; IN COMMERCE 6-1-2008.

3,481,971. BABYLEGS, LLC, SEATTLE, WA. SN 77-299,880. PUB. 3-18-2008, FILED 10-9-2007.

NOTSOX

THE MARK CONSISTS OF STANDARD CHARACTERS WITHOUT CLAIM TO ANY PARTICULAR FONT, STYLE, SIZE, OR COLOR.

FOR CLOTHING, NAMELY, LEG AND ARM WARMERS FOR CHILDREN AND ADULTS (U.S. CLS. 22 AND 39).

FIRST USE 9-0-2007; IN COMMERCE 9-0-2007.

3,481,879. OZIO LIFESTYLES, LLC, CULVER CITY, CA. SN 77-253,600. PUB. 2-12-2008, FILED 8-13-2007.

MOVING AT THE SPEED OF LEISURE

THE MARK CONSISTS OF STANDARD CHARACTERS WITHOUT CLAIM TO ANY PARTICULAR FONT, STYLE, SIZE, OR COLOR.

FOR CLOTHING, NAMELY, SWEAT SUITS, SHIRTS, PANTS, JACKETS, ROBES, AND SHORTS (U.S. CLS. 22 AND 39).

FIRST USE 8-0-2007; IN COMMERCE 8-0-2007.

3,481,980. AMAZON TECHNOLOGIES, INC., RENO, NV. SN 77-314,459. PUB. 2-26-2008, FILED 10-26-2007.



THE MARK CONSISTS OF THE WORD "CREATESPACE" WITH TWO CRESCENT SHAPES, ONE UPTURNED BELOW THE FIRST HALF OF THE WORD AND ONE DOWNTURNED ABOVE THE SECOND HALF OF THE WORD.

FOR T-SHIRTS (U.S. CLS. 22 AND 39).
FIRST USE 1-21-2008; IN COMMERCE 1-21-2008.

CLASS 25—(Continued).

3,481,996. ACADIA OUTDOORS HOLDINGS C.V., AMSTELVEEN, NETHERLANDS. SN 77-975,698. PUB. 9-25-2007, FILED 3-20-2007.



THE MARK CONSISTS OF A RECTANGLE POSITIONED HORIZONTALLY OVER WHICH APPEARS A LIZARD, AND ABOVE THIS DESIGN THE WORD "TUKEKE" IN STYLIZED CAPITAL LETTERS.

FOR OVERCOATS; ANORAKS; CAPES; FUR CLOAKS; SKI JACKETS; WIND RESISTANT JACKETS; WIND-JACKETS; JACKETS; LEATHER JACKETS; SLEEVED OR SLEEVELESS JACKETS; RAINPROOF JACKETS; BLAZERS; MEN'S SUITS; CLOTH BIBS; OVERALLS; TROUSERS; BREECHES; SHORTS; LADIES' SUITS; SKIRTS; DRESSES; BLOUSES; SHIRTS; SINGLET; T-SHIRTS; TANK TOPS; PULLOVERS; SWEATERS; SWEAT SHIRTS; WAISTCOATS; VESTS; SKI SUITS; TRACK SUITS; SWIM WEAR; PANTYHOSE; SOCKS; STOCKINGS; TIGHTS; HOSIERY; FOOTWEAR; GLOVES; MITTENS; COATS; BELTS MADE OF LEATHER; HEADGEAR, NAMELY, HATS AND CAPS; HOODS (U.S. CLS. 22 AND 39).

FIRST USE 12-22-2005; IN COMMERCE 1-23-2008.

3,482,001. GURU DENIM INC., VERNON, CA. SN 78-168,317. PUB. 10-23-2007, FILED 9-26-2002.

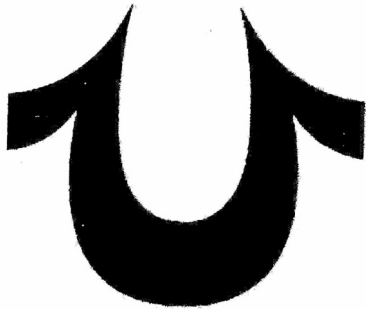

OWNER OF U.S. REG. NO. 3,147,224.
THE MARK CONSISTS OF A STYLIZED REPRESENTATION OF THE LETTER "U".

FOR CLOTHING, NAMELY, MEN'S, WOMEN'S, AND CHILDREN'S PANTS, JEANS, SHORTS, OVERALLS, SHIRTS, T-SHIRTS, BLOUSES, VESTS, SKIRTS, JACKETS, COATS, SWEATERS, SWEATSHIRTS, SWEATPANTS, HATS, BELTS AND SHOES (U.S. CLS. 22 AND 39).

FIRST USE 9-1-2002; IN COMMERCE 9-1-2002.

CLASS 25—(Continued).

3,482,005. HAYWARD, COLIN B., SANTA BARBARA, CA. SN 78-261,454. PUB. 3-22-2005, FILED 6-12-2003.

IN GOLD I TRUST

FOR CAPS AND SPORTSWEAR, NAMELY, PANTS, SHIRTS, T-SHIRTS, SWEAT PANTS AND SWEATSHIRTS OFFERED FOR SALE AT COMMODITY TRADE SHOWS (U.S. CLS. 22 AND 39).

FIRST USE 2-8-2008; IN COMMERCE 2-8-2008.

3,482,010. B.I.G. CORPORATION, DENVER, CO. SN 78-298,781. PUB. 3-8-2005, FILED 9-10-2003.

BIG BELIEVE IN GOD

OWNER OF U.S. REG. NO. 2,331,575.
FOR CLOTHING, NAMELY, SWEAT SHIRTS, SHIRTS, HATS, COATS, JACKETS (U.S. CLS. 22 AND 39).

FIRST USE 9-30-2007; IN COMMERCE 9-30-2007.

3,482,035. NBA PROPERTIES, INC., NEW YORK, NY. SN 78-411,063. PUB. 5-9-2006, FILED 4-30-2004.



NO CLAIM IS MADE TO THE EXCLUSIVE RIGHT TO USE "BASKETBALL CLASSIC NEW YORK CITY", APART FROM THE MARK AS SHOWN.

FOR CLOTHING, NAMELY, HOSIERY, FOOTWEAR, BASKETBALL SHOES, BASKETBALL SNEAKERS, T-SHIRTS, SHIRTS, SWEATSHIRTS, SWEATPANTS, PANTS, TANK TOPS, JERSEYS, SHORTS, PAJAMAS, SPORT SHIRTS, RUGBY SHIRTS, SWEATERS, BELTS, TIES, NIGHTSHIRTS, HATS, CAPS, VISORS, WARM-UP SUITS, WARM-UP PANTS, WARM-UP TOPS/SHOOTING SHIRTS, JACKETS, WIND RESISTANT JACKETS, PARKAS, COATS, BABY BIBS NOT OF PAPER, HEAD BANDS, WRIST BANDS, APRONS, UNDERGARMENTS, BOXER SHORTS, SLACKS, CAPS, EAR MUFFS, GLOVES, MITTENS, SCARVES, WOVEN AND KNIT SHIRTS, JERSEY DRESSES, DRESSES, CHEERLEADING DRESSES AND UNIFORMS, SWIM WEAR, BATHING SUITS, BEACH COVER-UPS, BATHING SUIT COVER-UPS, BATH SUIT WRAPS, AND BEACH SANDALS, NOVELTY HEADWEAR WITH WIGS (U.S. CLS. 22 AND 39).

FIRST USE 6-30-2005; IN COMMERCE 6-30-2005.

CLASS 25—(Continued).

3,482,038. JASIC, INC., AUSTIN, TX. SN 78-413,666. PUB. 5-17-2005, FILED 5-5-2004.

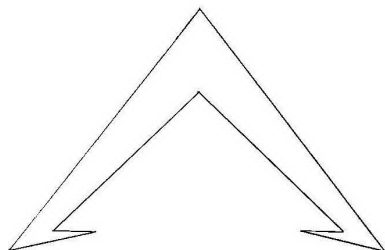

FOR FULL LINE OF SPORTS CLOTHING, NAMELY, CAPS, GLOVES, HATS, JACKETS, PANTS, RAINWEAR, SHIRTS, SKIRTS, SWEATERS, SHORTS, SOCKS, SWEATSHIRTS, T-SHIRTS, VESTS, VISORS, SANDALS, HEADBANDS, FOOTWEAR, SPORTS SHOES, ATHLETIC SHOES, JOGGING SHOES, BASKETBALL SHOES, AMERICAN FOOTBALL SHOES, FOOTBALL SHOES, SOCCER SHOES, WEIGHTLIFTING SHOES, BOXING SHOES, WRESTLING SHOES, COURT SHOES, BASEBALL SHOES, TRACK AND FIELD SHOES, TRACK AND FIELD SPIKED SHOES, MARATHON SHOES, RUNNING SHOES (U.S. CLS. 22 AND 39).

FIRST USE 10-12-2007; IN COMMERCE 10-12-2007.

3,482,041. SONHO DE CRIANÇA PRODUTOS INFANTIS LTDA., CIDADE DE BIRIGUI, ESTADO DE SÃO PAULO, BRAZIL. SN 78-419,164. PUB. 9-27-2005, FILED 5-14-2004.



NO CLAIM IS MADE TO THE EXCLUSIVE RIGHT TO USE "CRIANÇA", APART FROM THE MARK AS SHOWN. THE MARK CONSISTS OF THE PHRASE "SONHO DE CRIANÇA" IS STYLIZED LETTERS.

THE FOREIGN WORDING IN THE MARK TRANSLATES INTO ENGLISH AS CHILD'S DREAM.

FOR SHOES, TENNIS SHOES, SANDALS, SLIPPERS, BOOTS, AND CLOGS FOR MEN, WOMEN AND CHILDREN (U.S. CLS. 22 AND 39).

FIRST USE 2-12-1997; IN COMMERCE 7-24-2007.

3,482,058. HOLMES, SCOTT W., LOS ANGELES, CA. SN 78-482,135. PUB. 9-20-2005, FILED 9-12-2004.

**CLASS 25—(Continued).**

THE MARK CONSISTS OF IN PART A STYLIZED EYEBALL OVER THE LETTER "I".

FOR CLOTHING, NAMELY, SHIRTS, JERSEYS, HOODS, BELTS, LEATHER BELTS, UNDERWEAR CLOTHING; FOOTWEAR; HEADGEAR, NAMELY, CAPS, HATS (U.S. CLS. 22 AND 39).

FIRST USE 9-1-2006; IN COMMERCE 5-10-2008.

3,482,069. BEATTIE, CHRISTOPHER C., LOS ANGELES, CA. SN 78-503,570. PUB. 12-27-2005, FILED 10-21-2004.

**BRIDGEPORT
REPUBLIC**

THE MARK CONSISTS OF STANDARD CHARACTERS WITHOUT CLAIM TO ANY PARTICULAR FONT, STYLE, SIZE, OR COLOR.

NO CLAIM IS MADE TO THE EXCLUSIVE RIGHT TO USE "BRIDGEPORT", APART FROM THE MARK AS SHOWN.

FOR CLOTHING, NAMELY, SHIRTS, SHORTS, HATS, PANTS, SWEATSHIRTS, JACKETS (U.S. CLS. 22 AND 39).

FIRST USE 3-15-2007; IN COMMERCE 3-15-2007.

3,482,075. VANITY FAIR, INC., BOWLING GREEN, KY. SN 78-515,194. PUB. 4-4-2006, FILED 11-11-2004.

SEXY LIFT

THE MARK CONSISTS OF STANDARD CHARACTERS WITHOUT CLAIM TO ANY PARTICULAR FONT, STYLE, SIZE, OR COLOR.

NO CLAIM IS MADE TO THE EXCLUSIVE RIGHT TO USE "LIFT", APART FROM THE MARK AS SHOWN.

FOR LINGERIE (U.S. CLS. 22 AND 39).

FIRST USE 10-15-2007; IN COMMERCE 10-15-2007.

CLASS 25—(Continued).

3,482,081. BALLET MAKERS, INC., TOTOWA, NJ. SN 78-519,101. PUB. 4-4-2006, FILED 11-18-2004.

FUTURE STAR

THE MARK CONSISTS OF STANDARD CHARACTERS WITHOUT CLAIM TO ANY PARTICULAR FONT, STYLE, SIZE, OR COLOR.

FOR FOOTWEAR; BODY WEAR, NAMELY, SKIRTS, DRESSES, LEOTARDS, WARM-UPS, COSTUMES AND UNIFORMS FOR DANCE, SHIRTS, PANTS, SHORTS, AND TIGHTS; ACCESSORIES FOR DANCE, NAMELY, LEG WARMERS, BELTS, CAMISOLES, AND LEGGINGS (U.S. CLS. 22 AND 39).

FIRST USE 8-1-2005; IN COMMERCE 8-1-2005.

3,482,083. SOLE COMFORT, INC., NEWPORT BEACH, CA. SN 78-525,532. PUB. 11-15-2005, FILED 12-1-2004.

JOHN CRAIG

THE MARK CONSISTS OF STANDARD CHARACTERS WITHOUT CLAIM TO ANY PARTICULAR FONT, STYLE, SIZE, OR COLOR.

THE NAME, "JOHN CRAIG" SHOWN IN THE MARK DOES NOT IDENTIFY A PARTICULAR LIVING INDIVIDUAL.

FOR FOOTWEAR (U.S. CLS. 22 AND 39).
FIRST USE 3-3-2006; IN COMMERCE 3-3-2006.

3,482,134. HBI BRANDED APPAREL ENTERPRISES, LLC, WINSTON-SALEM, NC. SN 78-647,994. PUB. 10-23-2007, FILED 6-10-2005.

DOWNTIME

CLASS 25—(Continued).

THE MARK CONSISTS OF STANDARD CHARACTERS WITHOUT CLAIM TO ANY PARTICULAR FONT, STYLE, SIZE, OR COLOR.

OWNER OF U.S. REG. NO. 2,958,027.
FOR PANTIES, BRIEFS (U.S. CLS. 22 AND 39).
FIRST USE 5-15-2006; IN COMMERCE 5-15-2006.

3,482,140. PAULITH USA, INC., COMMERCE, CA. SN 78-652,599. PUB. 2-28-2006, FILED 6-16-2005.

Austus

THE MARK CONSISTS OF STANDARD CHARACTERS WITHOUT CLAIM TO ANY PARTICULAR FONT, STYLE, SIZE, OR COLOR.

FOR CLOTHING AND APPAREL, NAMELY, SHIRTS, JERSEYS, KNIT SHIRTS, POLO SHIRTS, SPORT SHIRTS, T-SHIRTS AND TOPS; CAPS, HATS, SWEATERS, JACKETS, PANTS, SWEAT PANTS, SKIRTS, UNDERWEAR, SOCKS, FOOTWEAR AND BELTS (U.S. CLS. 22 AND 39).
FIRST USE 1-1-2006; IN COMMERCE 1-1-2006.

3,482,178. CAMERON, WILLIAM, L., MATTHEWS, NC. SN 78-711,345. PUB. 5-23-2006, FILED 9-12-2005.

TSOL-7

THE MARK CONSISTS OF STANDARD CHARACTERS WITHOUT CLAIM TO ANY PARTICULAR FONT, STYLE, SIZE, OR COLOR.

FOR CLOTHING, NAMELY, SHIRTS (U.S. CLS. 22 AND 39).
FIRST USE 7-12-2007; IN COMMERCE 7-15-2007.

CLASS 25—(Continued).

3,482,181. WHITE HORSES TRADING COMPANY LIMITED, ST. MARTIN, GUERNSEY, UNITED KINGDOM. SN 78-714,688. PUB. 10-10-2006, FILED 9-16-2005.

CLASS 25—(Continued).

NO CLAIM IS MADE TO THE EXCLUSIVE RIGHT TO USE "LONG ISLAND", APART FROM THE MARK AS SHOWN. FOR CLOTHING, NAMELY, SHIRTS, T-SHIRTS, TANK TOPS, SWEAT SHIRTS, SWEAT SHORTS, SWEAT PANTS, PULLOVERS, JACKETS, ATHLETIC UNIFORMS, JERSEYS, SHORTS, HEADWEAR, CAPS AND HATS (U.S. CLS. 22 AND 39). FIRST USE 5-1-2004; IN COMMERCE 5-1-2004.

RELIGION VINTAGE

THE MARK CONSISTS OF STANDARD CHARACTERS WITHOUT CLAIM TO ANY PARTICULAR FONT, STYLE, SIZE, OR COLOR.

OWNER OF U.S. REG. NO. 2,798,396. FOR CLOTHING, NAMELY, TROUSERS, T-SHIRTS, AND SWEATSHIRTS (U.S. CLS. 22 AND 39). FIRST USE 3-0-2008; IN COMMERCE 3-0-2008.

3,482,219. KARAM PRASAD, LLC, WHITE PLAINS, NY. SN 78-762,060. PUB. 9-26-2006, FILED 11-28-2005.

3,482,205. SOLE ASSETS HOLDINGS, INC., AGOURA HILLS, CA. SN 78-746,870. PUB. 3-6-2007, FILED 11-3-2005.

BISHOP OF SEVENTH

THE MARK CONSISTS OF STANDARD CHARACTERS WITHOUT CLAIM TO ANY PARTICULAR FONT, STYLE, SIZE, OR COLOR.

FOR DRESSES, SKIRTS AND JACKETS (U.S. CLS. 22 AND 39). FIRST USE 3-0-2008; IN COMMERCE 3-0-2008.



THE MARK CONSISTS OF A HUMANIZED LIGHTNING BOLT DESIGN.

FOR APPAREL, NAMELY, BELTS, BOTTOMS, CAMISOLES, JACKETS, JEANS, JERSEYS, PANTS, SHIRTS, SHORTS, SKIRTS, SWEAT PANTS, SWEATERS, SWEAT SHIRTS, TANK TOPS, TOPS, T-SHIRTS (U.S. CLS. 22 AND 39).

FIRST USE 1-25-2006; IN COMMERCE 7-1-2006.

3,482,291. MAJOR LEAGUE LACROSSE LLC, BRIGHTON, MA. SN 78-808,214. PUB. 8-15-2006, FILED 2-6-2006.



3,482,212. MAJOR LEAGUE LACROSSE LLC, BRIGHTON, MA. SN 78-755,635. PUB. 8-15-2006, FILED 11-16-2005.

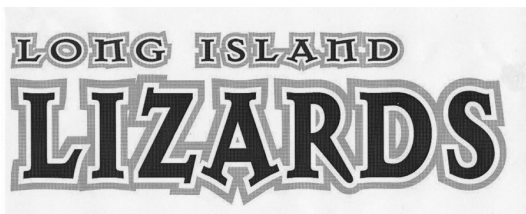

OWNER OF U.S. REG. NOS. 2,762,354, 2,976,647, AND OTHERS.

NO CLAIM IS MADE TO THE EXCLUSIVE RIGHT TO USE "LONG ISLAND" OR "LACROSSE", APART FROM THE MARK AS SHOWN.

FOR CLOTHING, NAMELY, SHIRTS, T-SHIRTS, TANK TOPS, SWEAT SHIRTS, SWEAT SHORTS, SWEAT PANTS, PULLOVERS, JACKETS, JERSEYS, SHORTS, HEADWEAR, CAPS AND HATS (U.S. CLS. 22 AND 39).

FIRST USE 5-1-2005; IN COMMERCE 5-1-2005.

OWNER OF U.S. REG. NOS. 2,762,354 AND 2,976,647.

CLASS 25—(Continued).

3,482,321. PAYLESS SHOESOURCE WORLDWIDE, INC., TOPEKA, KS. SN 78-839,032. PUB. 9-26-2006, FILED 3-16-2006.



OWNER OF U.S. REG. NOS. 2,126,943, 2,301,896, AND OTHERS.

THE MARK CONSISTS OF A STYLIZED LETTER "P" WHICH FORMS PART OF A CIRCLE, ALL IN CLOSE PROXIMITY TO THE WORDS PAYLESS SHOESOURCE.

FOR FOOTWEAR AND APPAREL, NAMELY, HEADWEAR, NECKWEAR, SCARVES, HATS, GLOVES, BELTS, SOCKS, HOSIERY, PANTYHOSE, KNEE-HIGH STOCKINGS, AND TIGHTS (U.S. CLS. 22 AND 39).

FIRST USE 12-1-2007; IN COMMERCE 12-1-2007.

3,482,347. GALES, MELANIE M., HARVEY, IL. SN 78-857,390. PUB. 11-21-2006, FILED 4-9-2006.



THE MARK CONSISTS OF THE WORD "MAJLEO" WITH A DESIGN OF A "J" AND "L" WITH A CIRCLE AROUND IT. FOR CLOTHING, NAMELY, T-SHIRTS, PANTS, JACKETS, SWEATSHIRTS, SWEATPANTS, HEADWEAR (U.S. CLS. 22 AND 39).

FIRST USE 4-14-2007; IN COMMERCE 7-20-2007.

3,482,355. IMAJEN, LLC, BALTIMORE, MD. SN 78-861,652. PUB. 3-13-2007, FILED 4-14-2006.

IMA WIFE

THE MARK CONSISTS OF STANDARD CHARACTERS WITHOUT CLAIM TO ANY PARTICULAR FONT, STYLE, SIZE, OR COLOR.

FOR CLOTHING, NAMELY, T-SHIRTS, TANK TOPS, SWEATSHIRTS, SWEATPANTS, PANTS, LINGERIE, SKIRTS, BEACH COVER-UPS, PAJAMAS, HATS (U.S. CLS. 22 AND 39).

FIRST USE 2-1-2008; IN COMMERCE 2-1-2008.

CLASS 25—(Continued).

3,482,356. ARIZONA MAIL ORDER COMPANY, INC., TUCSON, AZ. SN 78-861,661. PUB. 1-2-2007, FILED 4-14-2006.

JUDY BOND

THE MARK CONSISTS OF STANDARD CHARACTERS WITHOUT CLAIM TO ANY PARTICULAR FONT, STYLE, SIZE, OR COLOR.

THE NAME(S), PORTRAIT(S), AND/OR SIGNATURE(S) SHOWN IN THE MARK DOES NOT IDENTIFY A PARTICULAR LIVING INDIVIDUAL.

FOR WOMEN'S CLOTHING, NAMELY, BLOUSES, COATS, DRESSES, JACKETS, SHIRTS, SKIRTS, SLACKS, SWEATSHIRTS, SWEATERS, T-TOPS (U.S. CLS. 22 AND 39).

FIRST USE 9-5-2006; IN COMMERCE 9-5-2006.

3,482,368. DONAHOE, JAMES JOSEPH, WHITE PLAINS, NY. SN 78-873,853. PUB. 9-4-2007, FILED 5-1-2006.

A tradition of dominance

THE MARK CONSISTS OF STANDARD CHARACTERS WITHOUT CLAIM TO ANY PARTICULAR FONT, STYLE, SIZE, OR COLOR.

FOR T-SHIRTS (U.S. CLS. 22 AND 39).

FIRST USE 4-0-2007; IN COMMERCE 4-0-2007.

3,482,378. DE HERRERA, JOHN ALLEN, MONTECITO, CA. SN 78-884,765. PUB. 1-16-2007, FILED 5-16-2006.



THE MARK CONSISTS OF A DOT, A FIVE-POINTED STAR, A CIRCLE, TWO WINGS AND THE WORD "ALIPES". FOR HEADGEAR, NAMELY, HATS, CAPS, VISORS (U.S. CLS. 22 AND 39).

FIRST USE 1-10-2005; IN COMMERCE 1-10-2005.

CLASS 25—(Continued).

3,482,389. SCHOTT BROS. INC., ELIZABETH, NJ. SN 78-890,194. PUB. 9-25-2007, FILED 5-23-2006.

CROWN BY SCHOTT N.Y.C.

THE MARK CONSISTS OF STANDARD CHARACTERS WITHOUT CLAIM TO ANY PARTICULAR FONT, STYLE, SIZE, OR COLOR.

OWNER OF U.S. REG. NOS. 1,167,412 AND 2,786,813.
NO CLAIM IS MADE TO THE EXCLUSIVE RIGHT TO USE "N.Y.C.", APART FROM THE MARK AS SHOWN.
FOR CLOTHING, NAMELY, COATS, JACKETS AND PARKAS (U.S. CLS. 22 AND 39).
FIRST USE 1-31-2008; IN COMMERCE 1-31-2008.

3,482,399. WILLIAMS, DOUGLAS, LOS ANGELES, CA. SN 78-903,239. PUB. 8-28-2007, FILED 6-7-2006.

Breezy

THE MARK CONSISTS OF STANDARD CHARACTERS WITHOUT CLAIM TO ANY PARTICULAR FONT, STYLE, SIZE, OR COLOR.

FOR RESORT CLOTHING, NAMELY, ATHLETIC SHOES; BASEBALL CAPS; BERMUDA SHORTS; BOARD SHORTS; CANVAS SHOES; CAP VISORS; CAPS; CAPS WITH VISORS; DECK-SHOES; DRESSES; FLEECE PULL-OVERS; GLOVES; GOLF CAPS; GOLF SHIRTS; GOLF SHOES; GYM SHORTS; HATS; JACKETS; JEANS; JERSEYS; JOGGING SUITS; KNITTED CAPS; LEATHER BELTS; LEATHER COATS; LEATHER HEADWEAR; LEATHER SHOES; LEATHER SLIPPERS; PANTS; RAIN SUITS; RUNNING SHOES; SANDALS; SHIRTS; SHOES; SHORT SETS; SHORTS; SKI SUITS; SKIRT SUITS; SKIRTS; SNOW SUITS; SOCCER SHOES; SOCKS; SPORT SHIRTS; SPORTS JACKETS; SPORTS JERSEYS; SWEAT PANTS; SWEAT SHIRTS; SWEAT SHORTS; SWEAT SUITS; SWEATERS; SWIM CAPS; T-SHIRTS; TENNIS SHOES; TRACK SUITS; TRAINING SHOES; TRAINING SUITS; WARM UP SUITS (U.S. CLS. 22 AND 39).
FIRST USE 10-1-2007; IN COMMERCE 10-1-2007.

CLASS 25—(Continued).

3,482,405. RAHMANI, MAURICE, BEVERLY HILLS, CA. SN 78-905,353. PUB. 3-13-2007, FILED 6-10-2006.

SPICE & ROSES

THE MARK CONSISTS OF STANDARD CHARACTERS WITHOUT CLAIM TO ANY PARTICULAR FONT, STYLE, SIZE, OR COLOR.

FOR CLOTHING, NAMELY, BLOUSES, CAMISOLES, DRESSES, JACKETS, KNICKERBOCKERS, LEATHER JACKETS, PANTS, SHIRTS, SKIRTS, TANK TOPS, TOPS, T-SHIRTS, AND TUNICS (U.S. CLS. 22 AND 39).
FIRST USE 2-27-2007; IN COMMERCE 2-27-2007.

3,482,408. ZUITSPOORTS, INC., VISTA, CA. SN 78-906,316. PUB. 1-2-2007, FILED 6-12-2006.

SPEEDZOOT

THE MARK CONSISTS OF STANDARD CHARACTERS WITHOUT CLAIM TO ANY PARTICULAR FONT, STYLE, SIZE, OR COLOR.

FOR SPORTSWEAR, NAMELY, SHORTS, PANTS, SHIRTS, HATS, AND WETSUITS (U.S. CLS. 22 AND 39).
FIRST USE 6-0-2006; IN COMMERCE 2-0-2007.

3,482,414. DON MART CLOTHES, INC., PHILLIPSBURG, PA. SN 78-908,940. PUB. 9-4-2007, FILED 6-15-2006.

FALCONE

THE MARK CONSISTS OF STANDARD CHARACTERS WITHOUT CLAIM TO ANY PARTICULAR FONT, STYLE, SIZE, OR COLOR.

OWNER OF U.S. REG. NO. 1,179,323.
THE ENGLISH TRANSLATION OF "FALCONE" IS FALCON.
FOR MEN'S, LADIES AND BOYS' CLOTHING, NAMELY, SHOES, SHIRTS, SHIRT SETS, TIES, BELTS, AND HATS (U.S. CLS. 22 AND 39).
FIRST USE 9-19-2006; IN COMMERCE 9-19-2006.

CLASS 25—(Continued).

3,482,420. SHABAZZ-EL, WISE, SCRANTON, PA. SN 78-913,576. PUB. 8-21-2007, FILED 6-21-2006.

CLASS 25—(Continued).

3,482,435. TRUSTUS INTERNATIONAL TRADING INC., VANCOUVER, BRITISH COLUMBIA, CANADA. SN 78-925,558. PUB. 3-6-2007, FILED 7-10-2006.

TRAPPERBOY

THE MARK CONSISTS OF STANDARD CHARACTERS WITHOUT CLAIM TO ANY PARTICULAR FONT, STYLE, SIZE, OR COLOR.

FOR CLOTHING, NAMELY, SWEATSHIRTS, SHIRTS, JEANS, HATS, AND CAPS (U.S. CLS. 22 AND 39).
FIRST USE 3-0-2008; IN COMMERCE 3-0-2008.

IS EYEWEAR

THE MARK CONSISTS OF STANDARD CHARACTERS WITHOUT CLAIM TO ANY PARTICULAR FONT, STYLE, SIZE, OR COLOR.

FOR CLOTHING, NAMELY, T-SHIRTS, SWEATSHIRTS, CREW NECK SWEATSHIRTS, HOODED SWEATSHIRTS, ZIPPERED FRONT SWEATSHIRTS, HATS, BEANIES AND CLOTHING BELTS (U.S. CLS. 22 AND 39).

FIRST USE 1-0-2008; IN COMMERCE 1-0-2008.

3,482,424. ADAMSON DESIGN GROUP, INC, SALEM, OR. SN 78-915,039. PUB. 1-23-2007, FILED 6-22-2006.

JESUS FOR LIFE

THE MARK CONSISTS OF STANDARD CHARACTERS WITHOUT CLAIM TO ANY PARTICULAR FONT, STYLE, SIZE, OR COLOR.

FOR T-SHIRTS, SWEATSHIRTS, SPORT SHIRTS (U.S. CLS. 22 AND 39).
FIRST USE 6-24-2004; IN COMMERCE 6-15-2008.

3,482,457. LARKSPUR HOTELS, LLC, LARKSPUR, CA. SN 78-934,120. PUB. 9-18-2007, FILED 7-20-2006.

3,482,427. KARSTEN MANUFACTURING CORPORATION, PHOENIX, AZ. SN 78-918,787. PUB. 2-20-2007, FILED 6-28-2006.

LARKSPUR**G10**

THE MARK CONSISTS OF STANDARD CHARACTERS WITHOUT CLAIM TO ANY PARTICULAR FONT, STYLE, SIZE, OR COLOR.

OWNER OF U.S. REG. NO. 3,451,349.
FOR CLOTHING, NAMELY, SHIRTS, CAPS, SWEATERS AND SUN VISORS (U.S. CLS. 22 AND 39).
FIRST USE 9-24-2007; IN COMMERCE 9-24-2007.

THE MARK CONSISTS OF STANDARD CHARACTERS WITHOUT CLAIM TO ANY PARTICULAR FONT, STYLE, SIZE, OR COLOR.

OWNER OF U.S. REG. NOS. 3,054,357, 3,100,004, AND 3,125,907.

FOR CLOTHING, NAMELY, BATHROBES, JACKETS AND SHIRTS; HEADGEAR, NAMELY, CAPS; FOOTWEAR (U.S. CLS. 22 AND 39).
FIRST USE 6-0-2004; IN COMMERCE 3-0-2006.

CLASS 25—(Continued).

3,482,484. FRAZIER, LARRY, NEWBURGH, NY. SN 78-942,909. PUB. 3-20-2007, FILED 8-2-2006.

CLASS 25—(Continued).

3,482,511. OCTEAU, GUY, MONTREAL, QUEBEC, CANADA. SN 78-952,332. PUB. 9-11-2007, FILED 8-15-2006.

AFTER THE SWEAT DRY

THE MARK CONSISTS OF STANDARD CHARACTERS WITHOUT CLAIM TO ANY PARTICULAR FONT, STYLE, SIZE, OR COLOR.

FOR ANKLE SOCKS; ANTI-PERSPIRANT SOCKS; ATHLETIC UNIFORMS; BERMUDA SHORTS; BOARD SHORTS; BOXER SHORTS; CAMP SHIRTS; DRESS SHIRTS; GOLF SHIRTS; GYM SHORTS; HAT BANDS; HATS; HEADBANDS AGAINST SWEATING; HEADGEAR, NAMELY, HATS, CAPS; HEAVY JACKETS; JACKETS; MEN AND WOMEN JACKETS, COATS, TROUSERS, MEN'S SOCKS; OPEN-NECKED SHIRTS; SHORTS AND BRIEFS; PANTS; POLO SHIRTS; RAIN JACKETS; RAINPROOF JACKETS; SHIRTS; SHORT SETS; SHORT TROUSERS; SHORT-SLEEVED OR LONG-SLEEVED T-SHIRTS; SHORT-SLEEVED SHIRTS; SHORTS; SOCKS; SPORT SHIRTS; SPORTS SHIRTS WITH SHORT SLEEVES; SWEAT BANDS; SWEAT SHIRTS; T-SHIRTS (U.S. CLS. 22 AND 39).
FIRST USE 2-28-2007; IN COMMERCE 2-28-2007.

SOUL LONDON

THE MARK CONSISTS OF STANDARD CHARACTERS WITHOUT CLAIM TO ANY PARTICULAR FONT, STYLE, SIZE, OR COLOR.

OWNER OF CANADA REG. NO. TMA629,591, DATED 1-6-2005, EXPIRES 1-6-2020.

THE NAME(S), PORTRAIT(S), AND/OR SIGNATURE(S) SHOWN IN THE MARK DOES NOT IDENTIFY A PARTICULAR LIVING INDIVIDUAL.

FOR SHIRTS (U.S. CLS. 22 AND 39).
FIRST USE 1-0-2006; IN COMMERCE 1-0-2006.

3,482,503. LUCY ACTIVEWEAR, INC., PORTLAND, OR. SN 78-948,297. PUB. 10-2-2007, FILED 8-9-2006.

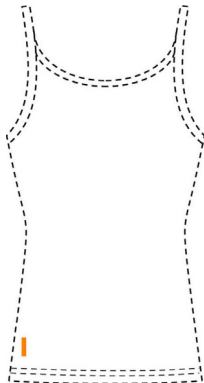

THE COLOR(S) ORANGE IS/ARE CLAIMED AS A FEATURE OF THE MARK.

THE MARK CONSISTS OF AN ORANGE (PMS 144) LOWER CASE LETTER "L" APPLIED TO THE LOWER LEFT SIDE OF THE BACK OF THE GOODS. THE DOTTED LINES SHOWING THE OUTLINE OF A GARMENT FORM NO PART OF THE MARK, BUT SHOW THE PLACEMENT OF THE MARK ONLY.

FOR CLOTHING, NAMELY, TOPS, TANKS, T-SHIRTS, JACKETS, VESTS, WARM-UP SUITS, DRESSES, AND BRAS (U.S. CLS. 22 AND 39).
FIRST USE 12-0-2006; IN COMMERCE 12-0-2006.

3,482,522. NEIL PRYDE LIMITED, TUEN MUN, HONG KONG. SN 78-954,690. PUB. 10-2-2007, FILED 8-17-2006.



FOR CLOTHING, NAMELY, SHIRTS, HATS, JACKETS, PANTS, SWIMSUITS AND WETSUITS (U.S. CLS. 22 AND 39).
FIRST USE 3-0-2003; IN COMMERCE 3-0-2003.

CLASS 25—(Continued).

3,482,535. COED SPORTSWEAR, INC., NEWFIELDS, NH. SN 78-960,274. PUB. 9-4-2007, FILED 8-25-2006.

Me Time

THE MARK CONSISTS OF STANDARD CHARACTERS WITHOUT CLAIM TO ANY PARTICULAR FONT, STYLE, SIZE, OR COLOR.

FOR (FIRST USE 11-30-2006; IN COMMERCE 11-30-2006) IMPRINTED APPAREL, NAMELY, T-SHIRTS, SWEATSHIRTS AND TANKTOPS; (FIRST USE 09-30-2007; IN COMMERCE 09-30-2007) IMPRINTED APPAREL, NAMELY, SHORTS AND HEADWEAR (U.S. CLS. 22 AND 39).

FIRST USE 11-30-2006; IN COMMERCE 11-30-2006.

3,482,585. JORDAN OUTDOOR ENTERPRISES, LTD., COLUMBUS, GA. SN 78-980,400. PUB. 7-4-2006, FILED 12-6-2005.

REALTREE GIRL

THE MARK CONSISTS OF STANDARD CHARACTERS WITHOUT CLAIM TO ANY PARTICULAR FONT, STYLE, SIZE, OR COLOR.

OWNER OF U.S. REG. NOS. 1,736,108, 2,206,463, AND OTHERS.

NO CLAIM IS MADE TO THE EXCLUSIVE RIGHT TO USE "GIRL", APART FROM THE MARK AS SHOWN.

FOR CLOTHING, NAMELY, SHIRTS, PANTS, JACKETS, SKIRTS, DRESSES, BELTS AND HATS (U.S. CLS. 22 AND 39).

FIRST USE 2-13-2007; IN COMMERCE 2-13-2007.

CLASS 26—FANCY GOODS

3,481,075. JOHN B KEENE, LAKE CITY, FL. SN 76-643,465. PUB. 5-16-2006, FILED 7-22-2005.

EXPAND-A-BUTT

THE MARK CONSISTS OF STANDARD CHARACTERS WITHOUT CLAIM TO ANY PARTICULAR FONT, STYLE, SIZE, OR COLOR.

FOR CLOTH AND LEATHER PATCHES FOR CLOTHING (U.S. CLS. 37, 39, 40, 42 AND 50).

FIRST USE 10-1-2006; IN COMMERCE 5-23-2008.

CLASS 26—(Continued).

3,481,910. HOBBY LOBBY STORES, INC., OKLAHOMA CITY, OK. SN 77-265,412. PUB. 1-1-2008, FILED 8-27-2007.

THE FLYING TRAPEZE

THE MARK CONSISTS OF STANDARD CHARACTERS WITHOUT CLAIM TO ANY PARTICULAR FONT, STYLE, SIZE, OR COLOR.

FOR FEATHERS FOR ORNAMENTATION (U.S. CLS. 37, 39, 40, 42 AND 50).

FIRST USE 12-16-2007; IN COMMERCE 12-16-2007.

3,482,351. GENERAL WIG MANUFACTURERS, INC., MIAMI LAKES, FL. SN 78-859,301. PUB. 3-13-2007, FILED 4-11-2006.

SO SOFT SO REAL

THE MARK CONSISTS OF STANDARD CHARACTERS WITHOUT CLAIM TO ANY PARTICULAR FONT, STYLE, SIZE, OR COLOR.

FOR WIGS AND HAIRPIECES (U.S. CLS. 37, 39, 40, 42 AND 50).

FIRST USE 6-7-2006; IN COMMERCE 6-7-2006.

CLASS 27—FLOOR COVERINGS

3,481,179. MANNINGTON MILLS, INC., SALEM, NJ. SN 77-006,236. PUB. 9-4-2007, FILED 9-25-2006.

QUANTUM GUARD

THE MARK CONSISTS OF STANDARD CHARACTERS WITHOUT CLAIM TO ANY PARTICULAR FONT, STYLE, SIZE, OR COLOR.

FOR VINYL FLOOR COVERINGS (U.S. CLS. 19, 20, 37, 42 AND 50).

FIRST USE 1-3-2008; IN COMMERCE 1-3-2008.

CLASS 27—(Continued).

3,481,889. MANNINGTON MILLS, INC., SALEM, NJ. SN 77-256,711. PUB. 11-27-2007, FILED 8-16-2007.

PRIMUS

THE MARK CONSISTS OF STANDARD CHARACTERS WITHOUT CLAIM TO ANY PARTICULAR FONT, STYLE, SIZE, OR COLOR.

FOR VINYL FLOOR COVERINGS (U.S. CLS. 19, 20, 37, 42 AND 50).

FIRST USE 1-3-2008; IN COMMERCE 1-3-2008.

3,482,034. LORD AND MASON ENTERPRISES, INC., GERMANTOWN, MD. SN 78-407,934. PUB. 9-6-2005, FILED 4-26-2004.



FOR FLOOR MATS FOR VEHICLES (U.S. CLS. 19, 20, 37, 42 AND 50).

FIRST USE 10-0-2007; IN COMMERCE 10-0-2007.

3,482,044. NAN'S TROPISCAPES, INC., NAPLES, FL. SN 78-426,233. PUB. 8-16-2005, FILED 5-27-2004.

NANS TROPISCAPES

THE MARK CONSISTS OF STANDARD CHARACTERS WITHOUT CLAIM TO ANY PARTICULAR FONT, STYLE, SIZE, OR COLOR.

FOR CLOTH WALL COVERINGS; NON-TEXTILE WALL COVERINGS; NON-TEXTILE WALL HANGINGS (U.S. CLS. 19, 20, 37, 42 AND 50).

FIRST USE 10-16-2006; IN COMMERCE 10-16-2006.

CLASS 27—(Continued).

3,482,051. STRUDEX FIBRES LIMITED, WATERLOO, CANADA. SN 78-444,052. PUB. 9-11-2007, FILED 6-30-2004.

SOFTRELLE

THE MARK CONSISTS OF STANDARD CHARACTERS WITHOUT CLAIM TO ANY PARTICULAR FONT, STYLE, SIZE, OR COLOR.

FOR FLOOR COVERINGS (U.S. CLS. 19, 20, 37, 42 AND 50).

FIRST USE 5-1-2004; IN COMMERCE 5-1-2004.

3,482,070. SAFETY HELMETS CANADA, INC., MEMPHIS, TN. SN 78-511,988. PUB. 10-11-2005, FILED 11-5-2004.

FUEL

THE MARK CONSISTS OF STANDARD CHARACTERS WITHOUT CLAIM TO ANY PARTICULAR FONT, STYLE, SIZE, OR COLOR.

FOR AUTOMOTIVE ACCESSORIES, NAMELY, FLOOR MATS (U.S. CLS. 19, 20, 37, 42 AND 50).

FIRST USE 9-8-2005; IN COMMERCE 9-8-2005.

CLASS 28—TOYS AND SPORTING GOODS

CLASS 28—(Continued).

3,481,083. KONAMI DIGITAL ENTERTAINMENT CO., LTD., TOKYO, JAPAN. SN 76-651,950. PUB. 9-4-2007, FILED 12-15-2005.



OWNER OF U.S. REG. NOS. 2,339,276, 2,848,207, AND OTHERS.

THE COLOR(S) BLACK, GREY, RED, ORANGE, YELLOW AND WHITE IS/ARE CLAIMED AS A FEATURE OF THE MARK.

THE COLOR BLACK APPEARS IN THE INSIDE AND OUTSIDE LINING OF EACH LETTER, THROUGHOUT PORTIONS OF THE STYLIZED CIRCLE LOCATED BEHIND THE WORDS "DANCE DANCE REVOLUTION SUPERNOVA", ALONG THE PERIMETER OF THE INNER SPHERE LOCATED IN THE CENTER OF THE STYLIZED CIRCLE AND AROUND THE PERIMETER OF THE ENTIRE MARK; THE COLOR GREY APPEARS IN THE OUTSIDE LINING ALONG THE BOTTOM OF THE WORD "SUPERNOVA", ALONG THE PERIMETER OF THE INNER SPHERE LOCATED IN THE CENTER OF THE STYLIZED CIRCLE AND ALONG THE OUTERMOST PERIMETER OF THE ENTIRE MARK; THE COLOR RED APPEARS IN THE LINING OF EACH LETTER, AS THE COLOR OF THE GRAPH DESIGN LOCATED IN THE STYLIZED CIRCLE BEHIND THE WORDS "DANCE DANCE REVOLUTION SUPERNOVA", AND AT THE BOTTOM AND TOP OF THE INNER SPHERE LOCATED WITHIN THE STYLIZED CIRCLE; THE COLOR ORANGE APPEARS IN THE MIDDLE OF THE INNER SPHERE LOCATED WITHIN THE STYLIZED CIRCLE BEHIND THE WORDS "DANCE DANCE REVOLUTION SUPERNOVA"; THE COLOR YELLOW APPEARS IN THE CENTER OF THE INNER SPHERE LOCATED WITHIN THE STYLIZED CIRCLE BEHIND THE WORDS "DANCE DANCE REVOLUTION SUPERNOVA"; AND THE COLOR WHITE APPEARS IN THE LETTERING OF THE WORDS "DANCE DANCE REVOLUTION SUPERNOVA".

FOR ARCADE GAMES; ARCADE GAME MACHINES FOR USE IN AMUSEMENT ARCADES; STAND-ALONE VIDEO GAME MACHINES; COIN-OPERATED VIDEO GAMES (U.S. CLS. 22, 23, 38 AND 50).

FIRST USE 6-30-2006; IN COMMERCE 6-30-2006.

3,481,214. ALL SEASONS ARCHERY, INC., WATERVLIET, MI. SN 77-027,742. PUB. 9-11-2007, FILED 10-24-2006.

SPYDERWEB

THE MARK CONSISTS OF STANDARD CHARACTERS WITHOUT CLAIM TO ANY PARTICULAR FONT, STYLE, SIZE, OR COLOR.

FOR ARCHERY TARGETS, ARCHERY TARGET ACCESSORIES, NAMELY, TARGET STANDS, TARGET SUPPORTS, PINS AND TARGET COVERS, FOR COMMERCIAL ARCHERY RANGES AND ARCHERY PROSHOPS (U.S. CLS. 22, 23, 38 AND 50).

FIRST USE 1-31-2007; IN COMMERCE 1-31-2007.

CLASS 28—(Continued).

3,481,238. ELMER'S PRODUCTS, INC., COLUMBUS, OH. SN 77-037,842. PUB. 3-20-2007, FILED 11-6-2006.

CREATE 'N PLAY

THE MARK CONSISTS OF STANDARD CHARACTERS WITHOUT CLAIM TO ANY PARTICULAR FONT, STYLE, SIZE, OR COLOR.

FOR HOBBY CRAFT SETS FOR CREATING PAPER CRAFTS (U.S. CLS. 22, 23, 38 AND 50).

FIRST USE 12-1-2006; IN COMMERCE 12-1-2006.

3,481,239. BOEING MANAGEMENT COMPANY, SEAL BEACH, CA. SN 77-037,884. PUB. 8-21-2007, FILED 11-6-2006.

DELTA

THE MARK CONSISTS OF STANDARD CHARACTERS WITHOUT CLAIM TO ANY PARTICULAR FONT, STYLE, SIZE, OR COLOR.

FOR TOY ROCKETS; TOY ROCKETS MADE OF BUILDING BLOCKS; TOY MODEL ROCKETS IN KIT FORM (U.S. CLS. 22, 23, 38 AND 50).

FIRST USE 12-20-2002; IN COMMERCE 9-30-2003.

3,481,252. PLANET TOYS, INC., NEW YORK, NY. SN 77-046,939. PUB. 9-18-2007, FILED 11-17-2006.

BABY JAMZ

THE MARK CONSISTS OF STANDARD CHARACTERS WITHOUT CLAIM TO ANY PARTICULAR FONT, STYLE, SIZE, OR COLOR.

NO CLAIM IS MADE TO THE EXCLUSIVE RIGHT TO USE "BABY", APART FROM THE MARK AS SHOWN.

FOR TOYS, NAMELY, TOY CHAIRS, TOY RADIOS, TOY KEY CHAINS, TOY BOOM-BOXES, TOY PHONES, TOY VEHICLES AND TOY DANCE MATS (U.S. CLS. 22, 23, 38 AND 50).

FIRST USE 8-1-2007; IN COMMERCE 8-1-2007.

CLASS 28—(Continued).

3,481,254. MATTEL, INC., EL SEGUNDO, CA. SN 77-048,119.
PUB. 9-18-2007, FILED 11-20-2006.

GLAM-OBILE

THE MARK CONSISTS OF STANDARD CHARACTERS WITHOUT CLAIM TO ANY PARTICULAR FONT, STYLE, SIZE, OR COLOR.

FOR TOYS, GAMES AND PLAYTHINGS, NAMELY, DOLLS, DOLL CLOTHING AND DOLL ACCESSORIES, DOLL PLAYSETS, TOY FIGURES, TOY VEHICLES, TOY ANIMALS, AND ACCESSORIES FOR ALL OF THE FOREGOING (U.S. CLS. 22, 23, 38 AND 50).

FIRST USE 5-2-2008; IN COMMERCE 5-2-2008.

CLASS 28—(Continued).

3,481,298. DICK'S SPORTING GOODS, INC., PITTSBURGH, PA. SN 77-068,834. PUB. 7-24-2007, FILED 12-20-2006.

TOUR FIRE

THE MARK CONSISTS OF STANDARD CHARACTERS WITHOUT CLAIM TO ANY PARTICULAR FONT, STYLE, SIZE, OR COLOR.

OWNER OF U.S. REG. NO. 2,333,113.
FOR GOLF EQUIPMENT, NAMELY, GOLF BALLS (U.S. CLS. 22, 23, 38 AND 50).

FIRST USE 5-0-2007; IN COMMERCE 5-0-2007.

3,481,286. LANDSCAPE STRUCTURES, INC., DELANO, MN.
SN 77-064,130. PUB. 7-10-2007, FILED 12-14-2006.

WOBBLE POD

THE MARK CONSISTS OF STANDARD CHARACTERS WITHOUT CLAIM TO ANY PARTICULAR FONT, STYLE, SIZE, OR COLOR.

FOR PLAYGROUND EQUIPMENT, NAMELY, BALANCING BOARD, CLIMBING STRUCTURES (U.S. CLS. 22, 23, 38 AND 50).

FIRST USE 12-7-2006; IN COMMERCE 12-7-2006.

3,481,329. AQUA-VEE, LLC., MIAMI, FL. SN 77-082,819. PUB. 8-28-2007, FILED 1-15-2007.

AQUAVEE

3,481,289. TUPMAN, EILEEN N., OCEANSIDE, CA. SN 77-065,509. PUB. 6-26-2007, FILED 12-15-2006.

**OHANA MANA HAWAIIAN
ADVENTURE GAME**

THE MARK CONSISTS OF STANDARD CHARACTERS WITHOUT CLAIM TO ANY PARTICULAR FONT, STYLE, SIZE, OR COLOR.

NO CLAIM IS MADE TO THE EXCLUSIVE RIGHT TO USE "HAWAIIAN ADVENTURE GAME", APART FROM THE MARK AS SHOWN.

THE FOREIGN WORDING IN THE MARK TRANSLATES INTO ENGLISH AS FAMILY SPIRITUAL ENERGY.

FOR BOARD GAMES; CARD GAMES (U.S. CLS. 22, 23, 38 AND 50).

FIRST USE 3-22-2007; IN COMMERCE 3-22-2007.

THE MARK CONSISTS OF STANDARD CHARACTERS WITHOUT CLAIM TO ANY PARTICULAR FONT, STYLE, SIZE, OR COLOR.

FOR SWIMMING EXERCISE DEVICE COMPRISED OF HANDLES AND A BELT THAT CONNECTS TO RESISTANCE BANDS FOR IN POOL RESISTANCE TRAINING (U.S. CLS. 22, 23, 38 AND 50).

FIRST USE 2-0-2007; IN COMMERCE 2-0-2007.

CLASS 28—(Continued).

3,481,375. ROCKET BALL, LTD., HOUSTON, TX. SN 77-106,300. PUB. 8-14-2007, FILED 2-13-2007.

LIVE IT.

THE MARK CONSISTS OF STANDARD CHARACTERS WITHOUT CLAIM TO ANY PARTICULAR FONT, STYLE, SIZE, OR COLOR.

FOR TOYS, GAMES AND SPORTING GOODS, NAMELY, BASKETBALLS, GOLF BALLS, PLAYGROUND BALLS, SPORTS BALLS, RUBBER ACTION BALLS AND FOAM ACTION BALLS, PLUSH BALLS, PLASTIC BALLS, BASKETBALL NETS, BASKETBALL BACKBOARDS, MINIATURE BASKETBALL BACKBOARDS, PUMPS FOR INFLATING BASKETBALLS, NEEDLES FOR INFLATING BASKETBALLS, GOLF CLUBS, GOLF BAGS, GOLF PUTTERS, GOLF ACCESSORIES, NAMELY, DIVOT REPAIR TOOLS, TEES, BALL MARKERS, GOLF BAG COVERS, CLUB HEAD COVERS, GOLF GLOVES, GOLF BALL SLEEVES, ELECTRONIC BASKETBALL TABLE TOP GAMES, BASKETBALL TABLE TOP GAMES, BASKETBALL BOARD GAMES, ACTION SKILL GAMES, ADULT'S AND CHILDREN'S PARTY GAMES, TRIVIA INFORMATION GAMES AND ELECTRONIC VIDEO ARCADE GAME MACHINES, BASKETBALL KIT COMPRISED OF A NET AND WHISTLE, DOLLS, DECORATIVE DOLLS, COLLECTIBLE DOLLS, TOY ACTION FIGURES, BOBBLEHEAD ACTION FIGURES, STUFFED TOYS, NOVELTY PLUSH TOYS WITH WIGS, JIGSAW PUZZLES AND CHRISTMAS TREE ORNAMENTS, CHRISTMAS STOCKINGS; TOY VEHICLES IN THE NATURE OF CARS, TRUCKS, TRAINS AND VANS, ALL CONTAINING BASKETBALL THEMES, NOVELTY FOAM TOYS IN THE SHAPES OF FINGERS AND TROPHIES, TOY TROPHIES, PLAYING CARDS, CARD GAMES, NOISEMAKERS, PET TOYS; BEACH TOYS, NAMELY, BEACH BALLS, INFLATABLE BALLS, TOY PAILS, TOY SHOVELS, SAND TOYS, SAND BOX TOYS, WATER-SQUIRTING TOYS; BEACH AND POOL ACCESSORIES, NAMELY, SWIM FLOATS, POOL FLOATS, FOAM FLOATS, SWIM RINGS, POOL RINGS, FOAM RINGS, BODY BOARDS, SURF BOARDS, SWIM FINS, SURF FINS, ARM FLOATS AND WATER WING SWIM AIDS FOR RECREATIONAL USE; INFLATABLE TOYS; TOY BUILDING BLOCKS, VOLLEYBALL GAME KITS COMPRISED OF BALL, NET, SIDELINES AND WHISTLE, AND WATER POLO GAME KITS COMPRISED OF BALL, NET AND WHISTLE (U.S. CLS. 22, 23, 38 AND 50).

FIRST USE 1-1-2008; IN COMMERCE 1-1-2008.

3,481,466. WILSON SPORTING GOODS CO., CHICAGO, IL. SN 77-130,569. PUB. 9-4-2007, FILED 3-14-2007.

SPINE

THE MARK CONSISTS OF STANDARD CHARACTERS WITHOUT CLAIM TO ANY PARTICULAR FONT, STYLE, SIZE, OR COLOR.

FOR GOLF CLUBS (U.S. CLS. 22, 23, 38 AND 50).
FIRST USE 11-1-2007; IN COMMERCE 11-1-2007.

CLASS 28—(Continued).

3,481,492. PEDRO J. LASALDE, SAN GERMAN, PUERTO RICO. SN 77-134,945. PUB. 9-18-2007, FILED 3-19-2007.

NiñaDelMar

THE MARK CONSISTS OF STANDARD CHARACTERS WITHOUT CLAIM TO ANY PARTICULAR FONT, STYLE, SIZE, OR COLOR.

THE ENGLISH TRANSLATION OF "NIÑA DEL MAR" IS "GIRL OF THE SEA".

FOR FISHING RODS; FISHING REELS; ARTIFICIAL FISHING LURES (U.S. CLS. 22, 23, 38 AND 50).

FIRST USE 4-1-2007; IN COMMERCE 10-1-2007.

3,481,497. KAYTEE PRODUCTS INCORPORATED, CHILTON, WI. SN 77-135,578. PUB. 10-30-2007, FILED 3-20-2007.

FEATHERED FUN

THE MARK CONSISTS OF STANDARD CHARACTERS WITHOUT CLAIM TO ANY PARTICULAR FONT, STYLE, SIZE, OR COLOR.

FOR PET TOYS, NAMELY, PET BIRD ACTIVITY CENTERS AND PET BIRD TOYS (U.S. CLS. 22, 23, 38 AND 50).

FIRST USE 3-1-2008; IN COMMERCE 3-1-2008.

3,481,513. CHARISMA SALES, INC., SAINT CLOUD, FL. SN 77-138,414. PUB. 10-30-2007, FILED 3-23-2007.

BLESS ME BEAR

THE MARK CONSISTS OF STANDARD CHARACTERS WITHOUT CLAIM TO ANY PARTICULAR FONT, STYLE, SIZE, OR COLOR.

NO CLAIM IS MADE TO THE EXCLUSIVE RIGHT TO USE "BEAR", APART FROM THE MARK AS SHOWN.

FOR STUFFED TOY BEARS (U.S. CLS. 22, 23, 38 AND 50).

FIRST USE 3-1-2007; IN COMMERCE 3-1-2007.

CLASS 28—(Continued).

3,481,519. PURE FISHING, INC., SPIRIT LAKE, IA. SN 77-139,323. PUB. 9-25-2007, FILED 3-23-2007.

CLASS 28—(Continued).

3,481,669. BVS ENTERTAINMENT, INC., BURBANK, CA. SN 77-170,454. PUB. 10-23-2007, FILED 5-1-2007.

OUTLASTS LIVE!

THE MARK CONSISTS OF STANDARD CHARACTERS WITHOUT CLAIM TO ANY PARTICULAR FONT, STYLE, SIZE, OR COLOR.

OWNER OF U.S. REG. NO. 3,022,276.
FOR ARTIFICIAL FISHING BAIT (U.S. CLS. 22, 23, 38 AND 50).

FIRST USE 11-0-2006; IN COMMERCE 6-15-2007.

POWER RANGERS JUNGLE FURY

3,481,536. GOPET, LLC, MARTINDALE, PA. SN 77-142,306. PUB. 3-4-2008, FILED 3-28-2007.

GoPet

THE MARK CONSISTS OF STANDARD CHARACTERS WITHOUT CLAIM TO ANY PARTICULAR FONT, STYLE, SIZE, OR COLOR.

FOR ACTION FIGURES AND ACCESSORIES THEREFORE; BALLOONS; ELECTRIC ACTION TOYS; MECHANICAL TOYS; SOCCER BALLS; TALKING TOYS; TOY ACTION FIGURES; TOY VEHICLES; TOY CARS; TOY FIGURES; BEACH BALLS (U.S. CLS. 22, 23, 38 AND 50).

FIRST USE 6-9-2008; IN COMMERCE 6-9-2008.

THE MARK CONSISTS OF STANDARD CHARACTERS WITHOUT CLAIM TO ANY PARTICULAR FONT, STYLE, SIZE, OR COLOR.

FOR EXERCISE MACHINES, NAMELY, ROTATABLE WHEELS FOR EXERCISING ANIMALS, PARTICULARLY CANINES (U.S. CLS. 22, 23, 38 AND 50).

FIRST USE 8-6-2007; IN COMMERCE 2-6-2008.

3,481,677. HORIZON HOBBY, INC., CHAMPAIGN, IL. SN 77-172,126. PUB. 9-25-2007, FILED 5-3-2007.

LOSI

PUSH FIGHT

THE MARK CONSISTS OF STANDARD CHARACTERS WITHOUT CLAIM TO ANY PARTICULAR FONT, STYLE, SIZE, OR COLOR.

FOR GAME BOARD, PLAYING PIECES AND DOCUMENTATION SOLD AS A UNIT (U.S. CLS. 22, 23, 38 AND 50).

FIRST USE 6-6-2008; IN COMMERCE 6-6-2008.

THE MARK CONSISTS OF STANDARD CHARACTERS WITHOUT CLAIM TO ANY PARTICULAR FONT, STYLE, SIZE, OR COLOR.

OWNER OF U.S. REG. NO. 1,528,416.
FOR REMOTE CONTROLLED HOBBY MODEL LAND VEHICLES AND PARTS AND ACCESSORIES THEREFOR (U.S. CLS. 22, 23, 38 AND 50).

FIRST USE 10-31-2007; IN COMMERCE 10-31-2007.

CLASS 28—(Continued).

3,481,719. PADDLE SURF HAWAII, LLC, AIEA, HI. SN 77-183,155. PUB. 10-30-2007, FILED 5-16-2007.

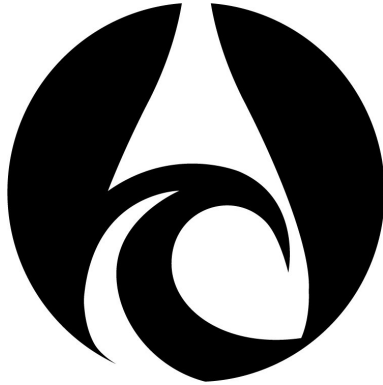

THE MARK CONSISTS OF A PADDLE CENTERED WITHIN A CIRCLE WITH AN OCEAN WAVE IN IT. FOR PADDLE BOARDS; SURF BOARDS (U.S. CLS. 22, 23, 38 AND 50). FIRST USE 11-1-2007; IN COMMERCE 11-1-2007.

3,481,729. TRAXXAS LP, PLANO, TX. SN 77-185,780. PUB. 11-6-2007, FILED 5-21-2007.

VELINEON

THE MARK CONSISTS OF STANDARD CHARACTERS WITHOUT CLAIM TO ANY PARTICULAR FONT, STYLE, SIZE, OR COLOR. FOR SCALE MODEL VEHICLES AND PARTS THEREFOR (U.S. CLS. 22, 23, 38 AND 50). FIRST USE 7-23-2007; IN COMMERCE 7-23-2007.

3,481,742. DREAMGEAR, LLC, TORRANCE, CA. SN 77-190,724. PUB. 10-16-2007, FILED 5-25-2007.

SHREDMASTER

THE MARK CONSISTS OF STANDARD CHARACTERS WITHOUT CLAIM TO ANY PARTICULAR FONT, STYLE, SIZE, OR COLOR. FOR TOY GUITAR FOR USE WITH VIDEO GAMES (U.S. CLS. 22, 23, 38 AND 50). FIRST USE 10-30-2007; IN COMMERCE 10-30-2007.

CLASS 28—(Continued).

3,481,747. OVERTON'S, INC., GREENVILLE, NC. SN 77-192,720. PUB. 11-20-2007, FILED 5-30-2007.

Poolmate

THE MARK CONSISTS OF STANDARD CHARACTERS WITHOUT CLAIM TO ANY PARTICULAR FONT, STYLE, SIZE, OR COLOR. FOR INFLATABLE FLOAT MATTRESSES OR TUBES FOR RECREATIONAL USE (U.S. CLS. 22, 23, 38 AND 50). FIRST USE 5-0-2008; IN COMMERCE 5-0-2008.

3,481,751. MASCHOTT LLC, FAIRFAX, VA. SN 77-197,511. PUB. 11-6-2007, FILED 6-5-2007.

SOCTOPUS BABIES

THE MARK CONSISTS OF STANDARD CHARACTERS WITHOUT CLAIM TO ANY PARTICULAR FONT, STYLE, SIZE, OR COLOR. NO CLAIM IS MADE TO THE EXCLUSIVE RIGHT TO USE "BABIES", APART FROM THE MARK AS SHOWN. FOR PLUSH TOYS (U.S. CLS. 22, 23, 38 AND 50). FIRST USE 5-21-2008; IN COMMERCE 5-21-2008.

3,481,782. MINDFULL CORPORATION, CHESTERFIELD, MO. SN 77-211,866. PUB. 1-15-2008, FILED 6-21-2007.

VERBAL VOLLEY

THE MARK CONSISTS OF STANDARD CHARACTERS WITHOUT CLAIM TO ANY PARTICULAR FONT, STYLE, SIZE, OR COLOR. NO CLAIM IS MADE TO THE EXCLUSIVE RIGHT TO USE "VERBAL", APART FROM THE MARK AS SHOWN. FOR EDUCATIONAL CARD GAMES (U.S. CLS. 22, 23, 38 AND 50). FIRST USE 9-0-2007; IN COMMERCE 9-0-2007.

CLASS 28—(Continued).

3,481,787. SPIRIT RIVER, INC., ROSEBURG, OR. SN 77-212,486. PUB. 12-4-2007, FILED 6-21-2007.

CLASS 28—(Continued).

3,481,841. NAMCO BANDAI GAMES INC., TOKYO, JAPAN. SN 77-240,629. PUB. 12-4-2007, FILED 7-27-2007.

FLIG

THE MARK CONSISTS OF STANDARD CHARACTERS WITHOUT CLAIM TO ANY PARTICULAR FONT, STYLE, SIZE, OR COLOR.

FOR ARTIFICIAL FISHING LURES (U.S. CLS. 22, 23, 38 AND 50).

FIRST USE 12-0-2007; IN COMMERCE 12-0-2007.

SUPER SCOOPER

THE MARK CONSISTS OF STANDARD CHARACTERS WITHOUT CLAIM TO ANY PARTICULAR FONT, STYLE, SIZE, OR COLOR.

FOR COIN-OPERATED AMUSEMENT GAME MACHINES (U.S. CLS. 22, 23, 38 AND 50).

FIRST USE 2-12-2008; IN COMMERCE 2-12-2008.

3,481,791. SPIRIT RIVER, INC., ROSEBURG, OR. SN 77-214,565. PUB. 12-4-2007, FILED 6-25-2007.

3,481,873. SPORTWALL INTERNATIONAL INC., CARPINTERIA, CA. SN 77-251,482. PUB. 2-12-2008, FILED 8-9-2007.

Spear-It

THE MARK CONSISTS OF STANDARD CHARACTERS WITHOUT CLAIM TO ANY PARTICULAR FONT, STYLE, SIZE, OR COLOR.

FOR ARTIFICIAL FISHING LURES (U.S. CLS. 22, 23, 38 AND 50).

FIRST USE 10-0-2007; IN COMMERCE 10-0-2007.

XerDance

THE MARK CONSISTS OF STANDARD CHARACTERS WITHOUT CLAIM TO ANY PARTICULAR FONT, STYLE, SIZE, OR COLOR.

FOR EXERCISE MACHINES INCORPORATING ELECTRONIC AND VIDEO GAME CONTROLLERS, NAMELY, INTERACTIVE PORTABLE DANCE FLOOR (U.S. CLS. 22, 23, 38 AND 50).

FIRST USE 3-0-2008; IN COMMERCE 3-0-2008.

3,481,835. NOSSE, ROBERT T, ANN ARBOR, MI. SN 77-238,194. PUB. 1-8-2008, FILED 7-25-2007.

3,481,946. COLUMBUS PRECISION TOOL, INC., WESTERVILLE, OH. SN 77-284,109. PUB. 3-11-2008, FILED 9-20-2007.

BRIDGE PLAYER'S COMPANION

THE MARK CONSISTS OF STANDARD CHARACTERS WITHOUT CLAIM TO ANY PARTICULAR FONT, STYLE, SIZE, OR COLOR.

NO CLAIM IS MADE TO THE EXCLUSIVE RIGHT TO USE "BRIDGE", APART FROM THE MARK AS SHOWN.

FOR CASES FOR PLAY ACCESSORIES (U.S. CLS. 22, 23, 38 AND 50).

FIRST USE 3-12-2007; IN COMMERCE 3-12-2007.

FINGERLOOP

THE MARK CONSISTS OF STANDARD CHARACTERS WITHOUT CLAIM TO ANY PARTICULAR FONT, STYLE, SIZE, OR COLOR.

FOR GOLF CLUB SWING AIDS, NAMELY, A DEVICE TO ASSIST THE GOLFER WITH PROPER CLUB POSITIONING IN THE HAND (U.S. CLS. 22, 23, 38 AND 50).

FIRST USE 3-6-2008; IN COMMERCE 3-6-2008.

CLASS 28—(Continued).

3,481,955. FRANKLIN SPORTS, INC., STOUGHTON, MA. SN 77-290,977. PUB. 12-11-2007, FILED 9-27-2007.

SOFT-TOSS

THE MARK CONSISTS OF STANDARD CHARACTERS WITHOUT CLAIM TO ANY PARTICULAR FONT, STYLE, SIZE, OR COLOR.

FOR BASEBALL AND SOFTBALL TRAINING APPARATUS USED AS NET ASSEMBLY FOR CATCHING BASEBALLS AND SOFTBALLS (U.S. CLS. 22, 23, 38 AND 50).

FIRST USE 4-1-2008; IN COMMERCE 4-1-2008.

3,481,957. KARSTEN MANUFACTURING CORPORATION, PHOENIX, AZ. SN 77-293,204. PUB. 3-4-2008, FILED 10-1-2007.

ZB

THE MARK CONSISTS OF STANDARD CHARACTERS WITHOUT CLAIM TO ANY PARTICULAR FONT, STYLE, SIZE, OR COLOR.

FOR GOLF CLUBS (U.S. CLS. 22, 23, 38 AND 50).

FIRST USE 4-1-2008; IN COMMERCE 4-1-2008.

3,481,999. INRAY FITNESS PRODUCTS CORP., TAOYUAN, TAIWAN. SN 78-078,772. PUB. 3-27-2007, FILED 8-11-2001.



FOR GYMNAS TIC HORIZONTAL BARS; SPRING BARS FOR EXERCISING; MANUALLY-OPERATED EXERCISE EQUIPMENT; STATIONARY EXERCISE BICYCLES; AEROBIC STEP MACHINES; EXERCISE TRAMPOLINES; LEG WEIGHTS FOR EXERCISING; EXERCISING EQUIPMENT, NAMELY, ROWING MACHINES, WEIGHT LIFTING MACHINES, PULLEYS, MANUALLY OPERATED JOGGING MACHINES AND CHEST EXPANDERS (U.S. CLS. 22, 23, 38 AND 50).

FIRST USE 5-10-2005; IN COMMERCE 8-25-2006.

CLASS 28—(Continued).

3,482,003. KARSTEN MANUFACTURING CORPORATION, PHOENIX, AZ. SN 78-206,741. PUB. 3-4-2008, FILED 1-24-2003.

PING U

OWNER OF U.S. REG. NOS. 704,552, 1,647,448, AND OTHERS.

FOR GOLF CLUBS (U.S. CLS. 22, 23, 38 AND 50).

FIRST USE 9-6-2006; IN COMMERCE 9-6-2006.

3,482,027. ST. PIERRE, TRACY M., WAKEFIELD, MA. SN 78-384,606. PUB. 12-28-2004, FILED 3-15-2004.



THE MARK CONSISTS OF STANDARD CHARACTERS WITHOUT CLAIM TO ANY PARTICULAR FONT, STYLE, SIZE, OR COLOR.

FOR PET TOYS (U.S. CLS. 22, 23, 38 AND 50).

FIRST USE 10-1-2006; IN COMMERCE 3-9-2007.

3,482,073. MATTEL, INC., EL SEGUNDO, CA. SN 78-514,530. PUB. 2-14-2006, FILED 11-10-2004.

SUNNY DAY

THE MARK CONSISTS OF STANDARD CHARACTERS WITHOUT CLAIM TO ANY PARTICULAR FONT, STYLE, SIZE, OR COLOR.

FOR TOYS, GAMES AND PLAYTHINGS, NAMELY, DOLL CLOTHING AND DOLL ACCESSORIES (U.S. CLS. 22, 23, 38 AND 50).

FIRST USE 5-3-2008; IN COMMERCE 5-3-2008.

CLASS 28—(Continued).

3,482,098. AMERICAN GIRL, LLC, EL SEGUNDO, CA. SN 78-563,106. PUB. 11-8-2005, FILED 2-8-2005.

FOLLOW YOUR INNER STAR

THE MARK CONSISTS OF STANDARD CHARACTERS WITHOUT CLAIM TO ANY PARTICULAR FONT, STYLE, SIZE, OR COLOR.

FOR DOLLS, DOLL CLOTHING, DOLL ACCESSORIES, TOYS, NAMELY, STUFFED TOYS, CLOTHING AND ACCESSORIES FOR STUFFED TOYS; PAPER DOLLS, CHILDREN'S GAMES, NAMELY, CHILDREN'S PARTY GAMES, BOARD GAMES AND PUZZLES (U.S. CLS. 22, 23, 38 AND 50).

FIRST USE 11-30-2006; IN COMMERCE 11-30-2006.

CLASS 28—(Continued).

3,482,161. MISSION ITECH HOCKEY, INC., IRVINE, CA. SN 78-680,385. PUB. 8-29-2006, FILED 7-28-2005.

MISSION FUEL

THE MARK CONSISTS OF STANDARD CHARACTERS WITHOUT CLAIM TO ANY PARTICULAR FONT, STYLE, SIZE, OR COLOR.

OWNER OF U.S. REG. NOS. 2,211,348, 2,267,286, AND 2,323,531.

FOR ICE HOCKEY SKATES; HOCKEY PROTECTIVE GEAR, NAMELY, SHOULDER PADS, ELBOW PADS, SHIN GUARDS; AND HOCKEY GLOVES (U.S. CLS. 22, 23, 38 AND 50).

FIRST USE 1-0-2006; IN COMMERCE 1-0-2006.

3,482,117. HUONG MY TRADING CO., INC., FOUNTAIN VALLEY, CA. SN 78-612,005. PUB. 9-12-2006, FILED 4-19-2005.



FOR TENNIS BALLS (U.S. CLS. 22, 23, 38 AND 50).
FIRST USE 1-0-2008; IN COMMERCE 1-0-2008.

3,482,165. LAVELLE, GERALYN A., PALATINE, IL. SN 78-684,472. PUB. 10-3-2006, FILED 8-3-2005.

PUPPY POWER

THE MARK CONSISTS OF STANDARD CHARACTERS WITHOUT CLAIM TO ANY PARTICULAR FONT, STYLE, SIZE, OR COLOR.

FOR BOARD GAMES (U.S. CLS. 22, 23, 38 AND 50).

FIRST USE 4-15-2008; IN COMMERCE 4-15-2008.

3,482,145. AQUA-LEISURE INDUSTRIES, INC., AVON, MA. SN 78-659,835. PUB. 9-11-2007, FILED 6-28-2005.

SprayZone

THE MARK CONSISTS OF STANDARD CHARACTERS WITHOUT CLAIM TO ANY PARTICULAR FONT, STYLE, SIZE, OR COLOR.

FOR TOYS FOR USE IN AND AROUND WATER, NAMELY, WATER SQUIRTING TOYS; TARGET GAMES USED IN AND AROUND WATER; WATER BASKETBALL GOAL SETS; WEIGHTED STICKS, DISCS, AND RINGS FOR DIVE GAMES; WEIGHTED TOY HOOPS FOR USE IN SWIMMING POOL GAMES; INFLATABLE FLOATS FOR RECREATIONAL USE IN WATER; FLOAT ON WATER SPORTS GAMES UTILIZING BALLS AND FLOATS; INFLATABLE FLOATING WATER BOARDS; UNDERWATER GLIDERS, SKIMMERS AND DISCS; WATER SOAKING TOYS (U.S. CLS. 22, 23, 38 AND 50).

FIRST USE 5-0-2008; IN COMMERCE 5-0-2008.

3,482,184. JT SPORTS LLC, BENTONVILLE, AR. SN 78-721,659. PUB. 8-1-2006, FILED 9-27-2005.

VLOCITY

THE MARK CONSISTS OF STANDARD CHARACTERS WITHOUT CLAIM TO ANY PARTICULAR FONT, STYLE, SIZE, OR COLOR.

OWNER OF U.S. REG. NO. 2,603,615.

FOR PAINTBALL GAME EQUIPMENT, NAMELY, LOADERS (U.S. CLS. 22, 23, 38 AND 50).

FIRST USE 6-0-2005; IN COMMERCE 6-0-2005.

CLASS 28—(Continued).

3,482,192. THREE LUCK CO., LTD., HIGASHIOSAKASHI, JAPAN. SN 78-741,877. PUB. 7-4-2006, FILED 10-27-2005.

CLASS 28—(Continued).

3,482,236. MANHATTAN GROUP, LLC, MINNEAPOLIS, MN. SN 78-773,961. PUB. 6-5-2007, FILED 12-15-2005.

CAROUSEL BY MANHATTAN TOY



THE MARK CONSISTS OF STANDARD CHARACTERS WITHOUT CLAIM TO ANY PARTICULAR FONT, STYLE, SIZE, OR COLOR.

OWNER OF U.S. REG. NOS. 1,370,328, 2,695,090, AND OTHERS.

NO CLAIM IS MADE TO THE EXCLUSIVE RIGHT TO USE "TOY", APART FROM THE MARK AS SHOWN.

FOR TOYS, NAMELY, STUFFED TOY ANIMALS, STUFFED TOYS, PLUSH TOYS, PULL TOYS, SOFT SCULPTURE TOYS, CHILDREN'S MULTIPLE ACTIVITY TOYS, INFANT TOYS, INFANT DEVELOPMENT TOYS, SQUEAKING TOYS, TOYS CONTAINING CRINKLE PAPER, FANTASY CHARACTER TOYS, TRAVEL TOYS, MUSICAL TOYS, CRIB TOYS, NOISE-MAKING TOYS, NAMELY, TOYS DESIGNED TO BE ATTACHED TO CAR SEATS, CRIBS AND HIGH CHAIRS (U.S. CLS. 22, 23, 38 AND 50).

FIRST USE 7-31-2006; IN COMMERCE 7-31-2006.

THE MARK CONSISTS OF STANDARD CHARACTERS WITHOUT CLAIM TO ANY PARTICULAR FONT, STYLE, SIZE, OR COLOR.

FOR GOLF CLUBS AND HEAD COVERS FOR GOLF CLUBS (U.S. CLS. 22, 23, 38 AND 50).

FIRST USE 3-1-2006; IN COMMERCE 3-10-2008.

3,482,301. EDU-SCIENCE (H.K.) LIMITED, KOWLOON, HONG KONG. SN 78-819,972. PUB. 6-26-2007, FILED 2-21-2006.

3,482,225. LAVELLE, GERALYN A., PALATINE, IL. SN 78-763,778. PUB. 10-10-2006, FILED 11-30-2005.

SPY TECH

PUPPY POKER

THE MARK CONSISTS OF STANDARD CHARACTERS WITHOUT CLAIM TO ANY PARTICULAR FONT, STYLE, SIZE, OR COLOR.

NO CLAIM IS MADE TO THE EXCLUSIVE RIGHT TO USE "SPY", APART FROM THE MARK AS SHOWN.

FOR SPY ROLE PLAYING TOYS, NAMELY TOY ELECTRONIC GLOVES, TOY CAMERAS, TOY BINOCULARS, TOY TELESCOPES, TOY MAGNIFYING GLASS, TOY ROOM DEFENDERS, NAMELY, MOTION SENSORS, TOY LISTENING DEVICES, TOY ALARMS, TOY COMPASS, TOY CARBINEER, TOY FLASHLIGHTS, TOY SECRET MESSAGE DEVICES, TOY WALKIE TALKIES, TOY SPY LAB KIT, NAMELY, KITS CONSISTING PRIMARILY OF BINOCULARS, HEARING AIDS, SONIC EXPLORERS AND FINGER PRINT TESTING KITS FOR USE IN SPY ROLE PLAYING (U.S. CLS. 22, 23, 38 AND 50).

FIRST USE 10-1-2007; IN COMMERCE 10-1-2007.

THE MARK CONSISTS OF STANDARD CHARACTERS WITHOUT CLAIM TO ANY PARTICULAR FONT, STYLE, SIZE, OR COLOR.

NO CLAIM IS MADE TO THE EXCLUSIVE RIGHT TO USE "POKER", APART FROM THE MARK AS SHOWN.

FOR CARD GAMES; PLAYING CARDS (U.S. CLS. 22, 23, 38 AND 50).

FIRST USE 4-15-2008; IN COMMERCE 4-15-2008.

CLASS 28—(Continued).

3,482,439. MACGREGOR GOLF NORTH AMERICA, INC., ALBANY, GA. SN 78-928,024. PUB. 2-13-2007, FILED 7-12-2006.

FACEOFF

THE MARK CONSISTS OF STANDARD CHARACTERS WITHOUT CLAIM TO ANY PARTICULAR FONT, STYLE, SIZE, OR COLOR.

FOR GOLF CLUBS; GOLF PUTTERS (U.S. CLS. 22, 23, 38 AND 50).

FIRST USE 10-1-2006; IN COMMERCE 10-1-2006.

3,482,469. GOALKEEPER INCENTIVE SYSTEMS, DEL MAR, CA. SN 78-938,497. PUB. 10-2-2007, FILED 7-26-2006.

STELLAR DEFENDER

THE MARK CONSISTS OF STANDARD CHARACTERS WITHOUT CLAIM TO ANY PARTICULAR FONT, STYLE, SIZE, OR COLOR.

FOR ACTION FIGURES AND ACCESSORIES THEREFOR; BOARD GAMES; CARD GAMES; DICE GAMES; PUZZLES; HAND-HELD UNIT FOR PLAYING ELECTRONIC GAMES; HAND-HELD UNIT FOR PLAYING VIDEO GAMES; STUFFED PLUSH TOYS; PUPPETS; LAWN TOYS, NAMELY, SPRINKLERS, WATER SLIDES, INFLATABLE SWIMMING POOLS, INFLATABLE POOL TOYS, SWINGS, SEESAWS, SLIDES, TUNNELS, CLIMBING FRAMES, JUNGLE GYMS, PLAY HOUSES, AND CLIMBING UNITS; SAND TOYS; INFLATABLE TOYS; BATTERY-POWERED ACTION TOYS; RIDE-ON TOYS; TOY MASKS; PLAYGROUND BALLS; BALLOONS; YO-YOS; ACTION PLAY SETS SOLD AS A UNIT FOR MAKE-BELIEVE PLAY BATTLE OR ADVENTURE ACTIVITIES; TOY CHESTS; TOY BANKS; BUBBLE-MAKING WAND AND SOLUTION SETS; KITES; FLYING DISCS; TOY WATCHES; TOY MODEL HOBBYCRAFT KITS; TOY WEAPONS; THROW-AND-CATCH TOYS, NAMELY, BALLS AND GLOVES, MITTS; MARBLES; TOY VEHICLES AND ACCESSORIES THEREFOR; WATER-PLAY TOYS, NAMELY, SQUIRTERS AND FLOATING TOYS (U.S. CLS. 22, 23, 38 AND 50).

FIRST USE 10-6-2006; IN COMMERCE 2-14-2007.

CLASS 28—(Continued).

3,482,537. MATTEL, INC., EL SEGUNDO, CA. SN 78-960,537. PUB. 10-2-2007, FILED 8-25-2006.

BAD BAGGER

THE MARK CONSISTS OF STANDARD CHARACTERS WITHOUT CLAIM TO ANY PARTICULAR FONT, STYLE, SIZE, OR COLOR.

FOR TOYS, GAMES AND PLAYTHINGS, NAMELY, TOY VEHICLES AND ACCESSORIES THEREFOR (U.S. CLS. 22, 23, 38 AND 50).

FIRST USE 12-1-2007; IN COMMERCE 12-1-2007.

3,482,566. KITCHENS, ANTHONY DANIEL, SANTA MONICA, CA. SN 78-974,017. PUB. 5-1-2007, FILED 9-14-2006.

bunnyfish

THE MARK CONSISTS OF STANDARD CHARACTERS WITHOUT CLAIM TO ANY PARTICULAR FONT, STYLE, SIZE, OR COLOR.

FOR KNIT STUFFED ANIMAL (U.S. CLS. 22, 23, 38 AND 50).

FIRST USE 6-1-2006; IN COMMERCE 6-1-2006.

CLASS 29—MEATS AND PROCESSED FOODS

3,481,153. TROPICAL CHEESE INDUSTRIES, INC., PERTH AMBOY, NJ. SN 76-678,623. PUB. 12-18-2007, FILED 6-22-2007.

THE FLAVOR OF EL SALVADOR

THE MARK CONSISTS OF STANDARD CHARACTERS WITHOUT CLAIM TO ANY PARTICULAR FONT, STYLE, SIZE, OR COLOR.

OWNER OF U.S. REG. NOS. 2,358,191, 2,419,501, AND OTHERS.

NO CLAIM IS MADE TO THE EXCLUSIVE RIGHT TO USE "EL SALVADOR", APART FROM THE MARK AS SHOWN.

FOR CHEESE, SOUR CREAM, MEAT, AND HEAVY CREAM (U.S. CL. 46).

FIRST USE 7-1-2007; IN COMMERCE 7-1-2007.

CLASS 29—(Continued).

3,481,200. KELLOGG NORTH AMERICA COMPANY, BATTLE CREEK, MI. SN 77-021,339. PUB. 5-22-2007, FILED 10-14-2006.

LOMA LINDA

THE MARK CONSISTS OF STANDARD CHARACTERS WITHOUT CLAIM TO ANY PARTICULAR FONT, STYLE, SIZE, OR COLOR.

OWNER OF U.S. REG. NOS. 1,049,152, 1,050,845, AND 1,079,971.

FOR VEGGIE FOOD PRODUCTS, NAMELY, VEGETABLE BASED MEAT SUBSTITUTES; TEXTURED VEGETABLE OR SOY PROTEIN TO BE USED AS A MEAT SUBSTITUTE (U.S. CL. 46).

FIRST USE 10-1-1934; IN COMMERCE 10-1-1934.

3,481,297. AU'SOME, INC., MONMOUTH, NJ. SN 77-068,778. PUB. 7-3-2007, FILED 12-20-2006.

POCKET FRUIT

THE MARK CONSISTS OF STANDARD CHARACTERS WITHOUT CLAIM TO ANY PARTICULAR FONT, STYLE, SIZE, OR COLOR.

NO CLAIM IS MADE TO THE EXCLUSIVE RIGHT TO USE "FRUIT", APART FROM THE MARK AS SHOWN.

FOR FRUIT-BASED SNACK FOOD (U.S. CL. 46).

FIRST USE 5-29-2007; IN COMMERCE 5-29-2007.

3,481,303. NEPHRO CUISINE, INC., COLTON, CA. SN 77-070,975. PUB. 7-31-2007, FILED 12-23-2006.

Meals for LIFE

THE MARK CONSISTS OF STANDARD CHARACTERS WITHOUT CLAIM TO ANY PARTICULAR FONT, STYLE, SIZE, OR COLOR.

NO CLAIM IS MADE TO THE EXCLUSIVE RIGHT TO USE "MEALS", APART FROM THE MARK AS SHOWN.

FOR FROZEN MEALS CONSISTING PRIMARILY OF MEAT, FISH, POULTRY OR VEGETABLES (U.S. CL. 46).

FIRST USE 4-2-2008; IN COMMERCE 4-2-2008.

CLASS 29—(Continued).

3,481,352. JONMOR INVESTMENTS, INC., WILMINGTON, DE. SN 77-093,769. PUB. 7-10-2007, FILED 1-29-2007.

SIZZLE & SERVE

THE MARK CONSISTS OF STANDARD CHARACTERS WITHOUT CLAIM TO ANY PARTICULAR FONT, STYLE, SIZE, OR COLOR.

FOR SAUSAGE (U.S. CL. 46).

FIRST USE 7-13-2007; IN COMMERCE 7-13-2007.

3,481,564. MANN PACKING CO., INC., SALINAS, CA. SN 77-147,098. PUB. 2-12-2008, FILED 4-3-2007.



FOR PACKAGE COMBINATIONS CONSISTING PRIMARILY OF FRESH PRE-CUT VEGETABLES AND SAUCE (U.S. CL. 46).

FIRST USE 5-18-2007; IN COMMERCE 5-18-2007.

3,481,920. AB FOODS, LLC, ST. LOUIS, MO. SN 77-272,798. PUB. 1-29-2008, FILED 9-6-2007.



THE MARK CONSISTS OF A STYLIZED "M".

FOR MEAT SUBSTITUTES; PROTEIN FOR USE AS AN INGREDIENT IN COOKING, BAKED GOODS AND AS A MEAT ADDITIVE; PROTEIN FOOD PRODUCTS, NAMELY, CHOPPED BEEF SUBSTITUTE, CHICKEN SUBSTITUTE, PORK SUBSTITUTE, CRAB SUBSTITUTE, LAMB SUBSTITUTE, FISH SUBSTITUTE, SAUSAGE SUBSTITUTE, MEAT SUBSTITUTES, HAM SUBSTITUTE, BACON SUBSTITUTE, VEAL SUBSTITUTE (U.S. CL. 46).

FIRST USE 11-0-2007; IN COMMERCE 11-0-2007.

CLASS 29—(Continued).

3,482,076. CHIPPER SNAX, INC., SALT LAKE CITY, UT. SN 78-515,565. PUB. 9-4-2007, FILED 11-11-2004.

CHIPPER

THE MARK CONSISTS OF STANDARD CHARACTERS WITHOUT CLAIM TO ANY PARTICULAR FONT, STYLE, SIZE, OR COLOR.

FOR BEEF JERKY (U.S. CL. 46).

FIRST USE 12-31-2006; IN COMMERCE 12-31-2006.

3,482,135. C.K.F. FOODS, INC., MOUNT PROSPECT, IL. SN 78-648,466. PUB. 6-19-2007, FILED 6-10-2005.



OWNER OF U.S. REG. NOS. 2,051,556 AND 2,626,024.

NO CLAIM IS MADE TO THE EXCLUSIVE RIGHT TO USE "EST. 1958", "FINEST QUALITY MEATS", AND "GREAT APPETIZER OR ENTRÉE!", APART FROM THE MARK AS SHOWN.

THE COLOR(S) WHITE, YELLOW, GOLD, RED, GREEN, BROWN, SILVER, AND BLACK IS/ARE CLAIMED AS A FEATURE OF THE MARK.

THE MARK CONSISTS OF THE COLOR BROWN APPEARS IN THE FOOD ON AND NEXT TO THE PLATE, IN THE SAUCE IN THE CUP, IN THE HANDLES OF THE UTENSILS, ON THE TRAY (BASKET) IN UPPER RIGHT PORTION OF THE MARK, IN THE OUTLINE OF THE STYLIZED WORDS "GREAT APPETIZER OR ENTRÉE!", AND IN THE OUTLINE OF THE BANNER FOR THE STYLIZED WORDS "GREAT APPETIZER OR ENTRÉE!" THE COLOR BLACK APPEARS ON THE FOOD ON AND NEXT TO THE PLATE, AS AN OUTLINE FOR THE STYLIZED WORDS "AUNT BESSIE'S EST. 1958", AS AN OUTLINE FOR THE WHITE BANNER FOR THE STYLIZED WORDS "AUNT BESSIE'S EST. 1958", AND AS AN OUTLINE FOR THE RED BANNER FOR THE STYLIZED WORDS "FINEST QUALITY MEATS". THE COLOR WHITE APPEARS IN THE STYLIZED WORDS "GREAT APPETIZER OR ENTRÉE!", IN THE STYLIZED WORDS "FINEST QUALITY MEATS", IN THE BACKGROUND OF THE RECTANGULAR BANNER WITH ROUNDED CORNERS FOR THE STYLIZED WORDS "AUNT BESSIE'S EST. 1958", ON THE PLATE, ON THE RIM OF THE SAUCE CUP, ON PARTS OF THE CHECKERED NAPKIN ON AND NEXT TO THE TRAY (BASKET) IN THE UPPER RIGHT PORTION OF THE MARK. THE COLOR SILVER APPEARS IN THE FORK AND FORWARD ENDS OF THE UTENSILS. THE COLOR GOLD APPEARS IN THE BANNER FOR THE STYLIZED WORDS "GREAT APPETIZER OR ENTRÉE!", AND ON THE FOOD (CORNBREAD) ON THE TRAY (BASKET) IN THE UPPER RIGHT PORTION OF THE MARK. THE COLOR YELLOW APPEARS ON THE TABLE NEXT TO THE PLATE

CLASS 29—(Continued).

AND THE UTENSILS, AND ON THE FOOD (CORN BREAD) IN THE TRAY (BASKET) IN THE UPPER RIGHT PORTION OF THE MARK. THE COLOR GREEN APPEARS IN PARSLEY ON AND NEXT TO THE PLATE, ON THE STEMS OF THE TOMATOES, ON THE CHECKERED NAPKIN ON AND NEXT TO THE TRAY (BASKET) IN THE UPPER RIGHT PORTION OF THE MARK. THE COLOR RED APPEAR IN THE TOMATOES, IN THE FOR THE STYLIZED WORDS "AUNT BESSIE'S EST. 1958", IN THE BANNER FOR THE STYLIZED WORDS "FINEST QUALITY MEATS", AND AS BACKGROUND TO THE LEFT OF THE COFFEE CUP AND CHERRIES.

FOR PORK; PORK SPARE RIB TIPS; MEAT; FROZEN ENTREES CONSISTING PRIMARILY OF MEAT; PREPARED ENTREES CONSISTING PRIMARILY OF MEAT; PACKAGED ENTREES CONSISTING PRIMARILY OF MEAT; FROZEN MEAT; PREPARED MEAT; AND PROCESSED MEAT, NAMELY, PORK (U.S. CL. 46).

FIRST USE 4-30-2005; IN COMMERCE 4-30-2005.

3,482,170. LANZO, CHARLES PATRICK, ACWORTH, GA. SN 78-702,578. PUB. 5-9-2006, FILED 8-29-2005.

Oyster King

THE MARK CONSISTS OF STANDARD CHARACTERS WITHOUT CLAIM TO ANY PARTICULAR FONT, STYLE, SIZE, OR COLOR.

NO CLAIM IS MADE TO THE EXCLUSIVE RIGHT TO USE "OYSTER", APART FROM THE MARK AS SHOWN.

FOR SEAFOOD (U.S. CL. 46).

FIRST USE 5-1-2007; IN COMMERCE 5-1-2007.

3,482,415. HEB GROCERY COMPANY, L.P., SAN ANTONIO, TX. SN 78-910,246. PUB. 7-10-2007, FILED 6-16-2006.



NO CLAIM IS MADE TO THE EXCLUSIVE RIGHT TO USE "WILD CAUGHT" AND "PRODUCT OF THE U.S.A.", APART FROM THE MARK AS SHOWN.

FOR FRESH, FROZEN, PROCESSED OR UNPROCESSED SEAFOOD (U.S. CL. 46).

FIRST USE 4-0-2007; IN COMMERCE 4-0-2007.

CLASS 30—STAPLE FOODS

CLASS 30—(Continued).

3,481,068. LIANG, SAM, EL MONTE, CA. SN 76-620,091. PUB. 10-11-2005, FILED 11-10-2004.



THE COLOR(S) RED, YELLOW, GREEN AND BLUE IS/ ARE CLAIMED AS A FEATURE OF THE MARK.

THE MARK CONSISTS OF THREE BELLS WITH YELLOW AND RED COLORS INSIDE A GREEN CIRCLE SURROUNDED BY A YELLOW CIRCULAR BOUNDARY; SAID BOUNDARY BEING ON TOP OF TWO RED TRIANGLES CONNECTING TO EACH OTHER BY AND AT AN EDGE OF EACH OF SAID TRIANGLES. THE WORDS "GOLDEN BELL" APPEAR IN BLUE IN THE MARK UNDERNEATH THE IMAGE OF THE BELLS.

FOR FLOUR, SAUCES, SEASONINGS, SPICES, SEASONING PASTES, AND FOOD ADDITIVES FOR NON-NUTRITIONAL PURPOSES FOR USE AS A FLAVORING OR FLAVORINGS (U.S. CL. 46).

FIRST USE 6-18-2008; IN COMMERCE 6-18-2008.

3,481,080. AUNT BETSY'S LLC, WEST HAVEN, CT. SN 76-650,248. PUB. 9-19-2006, FILED 11-14-2005.

AUNT BETSY'S

THE MARK CONSISTS OF STANDARD CHARACTERS WITHOUT CLAIM TO ANY PARTICULAR FONT, STYLE, SIZE, OR COLOR.

THE NAME "AUNT BETSY" DOES NOT IDENTIFY A PARTICULAR LIVING INDIVIDUAL.

FOR RICE, SPICES (U.S. CL. 46).
FIRST USE 10-10-2006; IN COMMERCE 10-10-2006.

3,481,125. SEELECT, INC., ORANGE, CA. SN 76-671,620. PUB. 7-17-2007, FILED 1-22-2007.

SEELECT ORGANIC SYRUPS

THE MARK CONSISTS OF STANDARD CHARACTERS WITHOUT CLAIM TO ANY PARTICULAR FONT, STYLE,

CLASS 30—(Continued).

SIZE, OR COLOR.

OWNER OF U.S. REG. NO. 3,057,028.

NO CLAIM IS MADE TO THE EXCLUSIVE RIGHT TO USE "ORGANIC SYRUPS", APART FROM THE MARK AS SHOWN.

FOR FLAVORING SYRUP (U.S. CL. 46).

FIRST USE 9-1-2002; IN COMMERCE 9-1-2002.

3,481,163. MOLINOS DE EL SALVADOR, SOCIEDAD ANONIMA DE CAPITAL VARIABLE, SAN SALVADOR, EL SALVADOR. SN 77-000,152. PUB. 5-8-2007, FILED 9-15-2006.

CHOCOCHIP - O!

THE MARK CONSISTS OF STANDARD CHARACTERS WITHOUT CLAIM TO ANY PARTICULAR FONT, STYLE, SIZE, OR COLOR.

NO CLAIM IS MADE TO THE EXCLUSIVE RIGHT TO USE "CHOCOCHIP", APART FROM THE MARK AS SHOWN.

FOR COOKIES (U.S. CL. 46).

FIRST USE 3-14-2007; IN COMMERCE 3-14-2007.

3,481,170. CEREAL INGREDIENTS, INC., LEAVENWORTH, KS. SN 77-002,271. PUB. 5-1-2007, FILED 9-19-2006.

NUTRI-WAVES

THE MARK CONSISTS OF STANDARD CHARACTERS WITHOUT CLAIM TO ANY PARTICULAR FONT, STYLE, SIZE, OR COLOR.

OWNER OF U.S. REG. NO. 3,104,646.

FOR CEREAL GRAIN-BASED NUTRITIONALLY-FORTIFIED FOOD PARTICLES USED AS AN INGREDIENT FOR COMMERCIAL FOOD PRODUCTS (U.S. CL. 46).

FIRST USE 6-13-2008; IN COMMERCE 6-13-2008.

CLASS 30—(Continued).

3,481,171. CEREAL INGREDIENTS, INC., LEAVENWORTH, KS. SN 77-002,275. PUB. 5-1-2007, FILED 9-19-2006.

NUTRI-TWIGS

THE MARK CONSISTS OF STANDARD CHARACTERS WITHOUT CLAIM TO ANY PARTICULAR FONT, STYLE, SIZE, OR COLOR.

OWNER OF U.S. REG. NO. 3,104,646.
FOR CEREAL GRAIN-BASED NUTRITIONALLY-FORTIFIED FOOD PARTICLES USED AS AN INGREDIENT FOR COMMERCIAL FOOD PRODUCTS (U.S. CL. 46).

FIRST USE 6-12-2008; IN COMMERCE 6-12-2008.

3,481,218. RETAIL ROYALTY COMPANY, LAS VEGAS, NV. SN 77-029,087. PUB. 3-20-2007, FILED 10-25-2006.

AERIE

THE MARK CONSISTS OF STANDARD CHARACTERS WITHOUT CLAIM TO ANY PARTICULAR FONT, STYLE, SIZE, OR COLOR.

FOR CANDY (U.S. CL. 46).
FIRST USE 10-0-2006; IN COMMERCE 10-0-2006.

3,481,272. MARS, INCORPORATED, MCLEAN, VA. SN 77-055,499. PUB. 3-27-2007, FILED 12-1-2006.

**YOUR FAVORITE CHOCOLATE
BAR IN PERFECT PORTIONS**

THE MARK CONSISTS OF STANDARD CHARACTERS WITHOUT CLAIM TO ANY PARTICULAR FONT, STYLE, SIZE, OR COLOR.

FOR CONFECTIONERY, NAMELY, CANDY; AND A COOKIE AND CHOCOLATE SNACK (U.S. CL. 46).
FIRST USE 6-8-2007; IN COMMERCE 6-8-2007.

CLASS 30—(Continued).

3,481,276. NO LIMIT, LLC, WESTPORT, CT. SN 77-058,868. PUB. 9-18-2007, FILED 12-7-2006.

NATURAL SALAD MIST

THE MARK CONSISTS OF STANDARD CHARACTERS WITHOUT CLAIM TO ANY PARTICULAR FONT, STYLE, SIZE, OR COLOR.

NO CLAIM IS MADE TO THE EXCLUSIVE RIGHT TO USE "SALAD MIST", APART FROM THE MARK AS SHOWN.

FOR SALAD DRESSINGS (U.S. CL. 46).
FIRST USE 12-27-2007; IN COMMERCE 12-27-2007.

3,481,316. WM. WRIGLEY JR. COMPANY, CHICAGO, IL. SN 77-076,976. PUB. 11-13-2007, FILED 1-5-2007.

CURIOSLY CHOCOLATE

THE MARK CONSISTS OF STANDARD CHARACTERS WITHOUT CLAIM TO ANY PARTICULAR FONT, STYLE, SIZE, OR COLOR.

OWNER OF U.S. REG. NOS. 1,250,585, 2,125,980, AND OTHERS.

NO CLAIM IS MADE TO THE EXCLUSIVE RIGHT TO USE "CHOCOLATE", APART FROM THE MARK AS SHOWN.

FOR CONFECTIONERY, NAMELY, CHOCOLATE (U.S. CL. 46).
FIRST USE 11-1-2006; IN COMMERCE 11-1-2006.

3,481,344. LYNN DAVIS LASHER, HOUSTON, TX. SN 77-091,148. PUB. 8-7-2007, FILED 1-25-2007.

SOMEBODY'S MOTHER'S

THE MARK CONSISTS OF STANDARD CHARACTERS WITHOUT CLAIM TO ANY PARTICULAR FONT, STYLE, SIZE, OR COLOR.

FOR SAUCES (U.S. CL. 46).
FIRST USE 6-15-2007; IN COMMERCE 6-15-2007.

CLASS 30—(Continued).

3,481,447. GENERAL CONTAINER COMPANY, LLC, HILLS-DALE, MI. SN 77-127,990. PUB. 9-18-2007, FILED 3-12-2007.

CARAMEL MOUNTAIN TRACKS

THE MARK CONSISTS OF STANDARD CHARACTERS WITHOUT CLAIM TO ANY PARTICULAR FONT, STYLE, SIZE, OR COLOR.

NO CLAIM IS MADE TO THE EXCLUSIVE RIGHT TO USE "CARAMEL", APART FROM THE MARK AS SHOWN. FOR ICE CREAM (U.S. CL. 46). FIRST USE 7-11-2002; IN COMMERCE 1-29-2003.

CLASS 30—(Continued).

3,481,567. DEMET'S CANDY COMPANY, GREENWICH, CT. SN 77-147,517. PUB. 10-2-2007, FILED 4-3-2007.

DEMET'S

THE MARK CONSISTS OF STANDARD CHARACTERS WITHOUT CLAIM TO ANY PARTICULAR FONT, STYLE, SIZE, OR COLOR.

FOR CANDY (U.S. CL. 46). FIRST USE 2-1-2008; IN COMMERCE 2-1-2008.

3,481,477. THE BLEVINS GROUP, LLC, NEW YORK, NY. SN 77-132,781. PUB. 9-18-2007, FILED 3-16-2007.

WHOLEMATO

THE MARK CONSISTS OF STANDARD CHARACTERS WITHOUT CLAIM TO ANY PARTICULAR FONT, STYLE, SIZE, OR COLOR.

FOR KETCHUP (U.S. CL. 46). FIRST USE 4-26-2007; IN COMMERCE 4-26-2007.

3,481,651. PEPPERIDGE FARM, INCORPORATED, NORWALK, CT. SN 77-165,297. PUB. 10-23-2007, FILED 4-25-2007.

SNACKING HAS NEVER FELT SO
NATURAL

THE MARK CONSISTS OF STANDARD CHARACTERS WITHOUT CLAIM TO ANY PARTICULAR FONT, STYLE, SIZE, OR COLOR.

FOR CEREAL-BASED SNACK FOODS (U.S. CL. 46). FIRST USE 6-0-2007; IN COMMERCE 6-0-2007.

3,481,487. JUDSON JAY PATTERSON, APEX, NC. SN 77-133,684. PUB. 9-18-2007, FILED 3-17-2007.

Chocolate Pi

THE MARK CONSISTS OF STANDARD CHARACTERS WITHOUT CLAIM TO ANY PARTICULAR FONT, STYLE, SIZE, OR COLOR.

NO CLAIM IS MADE TO THE EXCLUSIVE RIGHT TO USE "CHOCOLATE", APART FROM THE MARK AS SHOWN. FOR CHOCOLATE CANDIES (U.S. CL. 46). FIRST USE 6-1-2007; IN COMMERCE 11-1-2007.

3,481,653. THE KROGER CO. OF MICHIGAN, LIVONIA, MI. SN 77-166,382. PUB. 10-23-2007, FILED 4-26-2007.

BIRTHDAY BASH

THE MARK CONSISTS OF STANDARD CHARACTERS WITHOUT CLAIM TO ANY PARTICULAR FONT, STYLE, SIZE, OR COLOR.

FOR COOKIE DOUGH (U.S. CL. 46). FIRST USE 6-1-2008; IN COMMERCE 6-1-2008.

CLASS 30—(Continued).

3,481,689. PARKER PRODUCTS, INC., FORT WORTH, TX.
SN 77-174,804. PUB. 10-2-2007, FILED 5-7-2007.



NO CLAIM IS MADE TO THE EXCLUSIVE RIGHT TO USE "ORGANIC CONFECTIONS", APART FROM THE MARK AS SHOWN.
FOR CANDY (U.S. CL. 46).
FIRST USE 1-16-2008; IN COMMERCE 1-16-2008.

3,481,739. AVB, INC., MILWAUKIE, OR. SN 77-189,955. PUB.
11-13-2007, FILED 5-24-2007.

PEACE BOMB

THE MARK CONSISTS OF STANDARD CHARACTERS WITHOUT CLAIM TO ANY PARTICULAR FONT, STYLE, SIZE, OR COLOR.
FOR BREAD (U.S. CL. 46).
FIRST USE 9-0-2007; IN COMMERCE 9-0-2007.

3,481,772. DR. DAVE'S OMEGA-3 FOODS, SEATTLE, WA. SN
77-206,811. PUB. 11-27-2007, FILED 6-15-2007.

dr. dave's mega-O

THE MARK CONSISTS OF STANDARD CHARACTERS WITHOUT CLAIM TO ANY PARTICULAR FONT, STYLE, SIZE, OR COLOR.
FOR CHOCOLATE-BASED READY-TO-EAT FOOD BARS; CHOCOLATE CANDIES; CHOCOLATE TRUFFLES (U.S. CL. 46).
FIRST USE 11-3-2007; IN COMMERCE 11-12-2007.

CLASS 30—(Continued).

3,481,774. HEALTHY HANDFULS, LLC, SAN FRANCISCO, CA. SN 77-207,628. PUB. 2-26-2008, FILED 6-15-2007.

KOALA KRACKERS

THE MARK CONSISTS OF STANDARD CHARACTERS WITHOUT CLAIM TO ANY PARTICULAR FONT, STYLE, SIZE, OR COLOR.

OWNER OF U.S. REG. NO. 3,186,398.
NO CLAIM IS MADE TO THE EXCLUSIVE RIGHT TO USE "CRACKERS", APART FROM THE MARK AS SHOWN.
FOR CRACKERS (U.S. CL. 46).
FIRST USE 6-3-2004; IN COMMERCE 6-4-2004.

3,481,785. NEW WORLD PASTA COMPANY, HARRISBURG, PA. SN 77-212,018. PUB. 12-4-2007, FILED 6-21-2007.

SIMPLY PERFECT PASTA

THE MARK CONSISTS OF STANDARD CHARACTERS WITHOUT CLAIM TO ANY PARTICULAR FONT, STYLE, SIZE, OR COLOR.

NO CLAIM IS MADE TO THE EXCLUSIVE RIGHT TO USE "PASTA", APART FROM THE MARK AS SHOWN.
FOR PASTA (U.S. CL. 46).
FIRST USE 12-7-2007; IN COMMERCE 12-7-2007.

3,481,812. DIERBERGS MARKETS, INC., CHESTERFIELD, MO. SN 77-227,335. PUB. 1-1-2008, FILED 7-11-2007.

FLAT AND FABULOUS

THE MARK CONSISTS OF STANDARD CHARACTERS WITHOUT CLAIM TO ANY PARTICULAR FONT, STYLE, SIZE, OR COLOR.

FOR CRACKERS (U.S. CL. 46).
FIRST USE 8-6-2007; IN COMMERCE 8-6-2007.

CLASS 30—(Continued).

3,481,829. RECKITT BENCKISER INC., PARSIPPANY, NJ. SN 77-236,230. PUB. 1-8-2008, FILED 7-23-2007.



OWNER OF U.S. REG. NOS. 545,030, 1,786,915, AND OTHERS.
THE COLOR(S) BLACK AND YELLOW IS/ARE CLAIMED AS A FEATURE OF THE MARK.
THE MARK CONSISTS OF THE WORDS "FOOD" AND "FRENCH'S" SEPARATED BY A HEART SHAPE ALL IN THE COLOR YELLOW WITH BLACK SHADOWING.
FOR MUSTARD; DRIED MUSTARD; PREPARED MUSTARD POWDER; FOOD FLAVORINGS, NOT ESSENTIAL OILS; MARINADES FOR FOOD, NAMELY, WORCESTERSHIRE SAUCE, MUSTARD (U.S. CL. 46).
FIRST USE 3-13-2008; IN COMMERCE 3-13-2008.

CLASS 30—(Continued).

3,481,882. TODDCO, LLC, SEVERNA PARK, MD. SN 77-254,248. PUB. 3-18-2008, FILED 8-13-2007.



FOR SEASONINGS, MARINADES, DIPPING SAUCES, SALAD DRESSING (U.S. CL. 46).
FIRST USE 9-1-2007; IN COMMERCE 9-6-2007.

3,481,896. KELLOGG NORTH AMERICA COMPANY, BATTLE CREEK, MI. SN 77-260,423. PUB. 2-26-2008, FILED 8-21-2007.

KELLOGG'S FROSTED FLAKES GOLD

THE MARK CONSISTS OF STANDARD CHARACTERS WITHOUT CLAIM TO ANY PARTICULAR FONT, STYLE, SIZE, OR COLOR.
OWNER OF U.S. REG. NOS. 1,411,563, 1,422,158, AND 3,322,369.
NO CLAIM IS MADE TO THE EXCLUSIVE RIGHT TO USE "FROSTED FLAKES", APART FROM THE MARK AS SHOWN.
FOR PROCESSED CEREAL-DERIVED FOOD PRODUCT TO BE USED AS A BREAKFAST CEREAL, SNACK FOOD OR INGREDIENT FOR MAKING FOOD (U.S. CL. 46).
FIRST USE 12-31-2007; IN COMMERCE 12-31-2007.

3,481,833. MEI, YUE QIN WILLIAM, CHICAGO, IL. SN 77-237,467. PUB. 1-8-2008, FILED 7-24-2007.



THE NON-LATIN CHARACTER(S) IN THE MARK TRANSLITERATE INTO "TAIKU", AND THIS MEANS ANTIQUITY IN ENGLISH.
FOR PASTRIES (U.S. CL. 46).
FIRST USE 7-1-2007; IN COMMERCE 7-1-2007.

3,481,901. KELLEY, NICHOLAS T, SAN FRANCISCO, CA. SN 77-262,109. PUB. 2-26-2008, FILED 8-22-2007.

The Process Matters

THE MARK CONSISTS OF STANDARD CHARACTERS WITHOUT CLAIM TO ANY PARTICULAR FONT, STYLE, SIZE, OR COLOR.
FOR CEREAL BASED SNACK FOOD; CEREAL-BASED SNACK FOODS; GRANOLA; GRANOLA SNACKS; GRANOLA-BASED SNACK BARS (U.S. CL. 46).
FIRST USE 9-1-2007; IN COMMERCE 9-1-2007.

CLASS 30—(Continued).

3,481,968. BP PRODUCTS NORTH AMERICA INC., WARRENVILLE, IL. SN 77-299,080. PUB. 3-4-2008, FILED 10-9-2007.

ESSENCE

THE MARK CONSISTS OF STANDARD CHARACTERS WITHOUT CLAIM TO ANY PARTICULAR FONT, STYLE, SIZE, OR COLOR.

FOR ICED TEA (U.S. CL. 46).
FIRST USE 3-10-2008; IN COMMERCE 3-10-2008.

3,482,002. BARMAR, LLC, DBA LA PALAPA, NEW YORK, NY. SN 78-176,433. PUB. 2-15-2005, FILED 10-21-2002.



THE LINING IS A FEATURE OF THE MARK AND DOES NOT INDICATE COLOR.

FOR SALSAS, SAUCES, COFFEE BEANS, CORN-BASED TORTILLA CHIPS, PRE-PACKAGED KITS FOR MAKING MEXICAN-STYLE MEALS, CONSISTING PRIMARILY OF SAUCES, FLOUR, AND CHILES (U.S. CL. 46).

FIRST USE 1-28-2008; IN COMMERCE 1-28-2008.

3,482,007. CULINARY INNOVATIONS LLC, LACKHAWAXEN, PA. SN 78-273,692. PUB. 3-22-2005, FILED 7-14-2003.

CONSCIOUS CUISINE

OWNER OF U.S. REG. NO. 2,777,602.
NO CLAIM IS MADE TO THE EXCLUSIVE RIGHT TO USE "CUISINE", APART FROM THE MARK AS SHOWN.

FOR FRESH, FROZEN, PACKAGED AND PREPARED ENTREES CONSISTING PRIMARILY OF PASTA OR RICE; SALAD DRESSINGS, SAUCES (U.S. CL. 46).

FIRST USE 9-18-2007; IN COMMERCE 9-18-2007.

CLASS 30—(Continued).

3,482,068. EMBARE INDUSTRIAS ALIMENTICIAS S/A, LAGOA DA PRATA, MINAS GERAIS, BRAZIL. SN 78-501,214. PUB. 12-27-2005, FILED 10-18-2004.



OWNER OF BRAZIL REG. NO. 820283690, DATED 8-22-2000, EXPIRES 8-22-2010.

THE MARK CONSISTS OF AN OVAL WITH THE WORD "EMBARÉ" IN THE CENTER OF THE OVAL.

THE ENGLISH TRANSLATION OF EMBARE IS "TREE".
FOR CARAMELS (U.S. CL. 46).

FIRST USE 0-0-1947; IN COMMERCE 0-0-1989.

3,482,086. GUAN POH DIM SUM PTE LTD, SINGAPORE, SINGAPORE. SN 78-532,191. PUB. 2-13-2007, FILED 12-14-2004.



THE MARK CONSISTS OF THE TELESCOPED WORDS "GUANPOH" WITH LETTER "O" IN THE SHAPE OF AN INGOT, IN A RECTANGLE AND CHINESE CHARACTERS OUTSIDE THE RECTANGLE.

THE FOREIGN WORDING AND IDEOGRAMS IN THE MARK TRANSLATE INTO ENGLISH AS "SOURCE" AND "TREASURE".

THE NON-LATIN CHARACTERS IN THE MARK TRANSLITERATE INTO YUAN BAO.

FOR BREAD; PASTRIES; CONFECTIONERY CRYSTAL SUGAR PIECES, FONDANTS, ICE CREAM AND FROZEN CONFECTIONERY; BUNS; CAKES; CANDY FOR FOOD; CHOCOLATE; COFFEE; TEA; COCOA-BASED BEVERAGES; COOKIES; FARINACEOUS FOOD PASTES; FLOUR FOR FOOD; MEAT GRAVIES; NOODLES; INSTANT-COOKING NOODLES; PASTA; PEANUT CONFECTIONERY; ALMOND CONFECTIONERY; NUT CONFECTIONERY; CASHEW NUT CONFECTIONERY; PIES; RICE; SANDWICHES; SAUCES AND SEASONINGS, NAMELY, LIGHT SOYA SAUCE, PLUM PASTE IN THE NATURE OF A CONDIMENT, GARLIC GINGER CHILI SAUCE, DARK SOYA SAUCE, PLUM SAUCE, TIM SUM CHILI SAUCE, OYSTER SAUCE, HOT BEAN PASTE, SWEET AND SOUR SAUCE, LEMON SAUCE, BLACK BEAN GARLIC SAUCE, BARBECUE PORK RIB SAUCE, YELLOW BEAN PASTE, SAMBAL BELACAN CHILI PASTE; SPICES; BISCUITS; BAKERY DESSERTS AND DESSERT PUDDINGS; TARTS; SPRING ROLLS; RICE NOODLES; DUMPLINGS; PASTRY SKIN FOR SPRING ROLLS; SOY-BASED FOOD PRODUCTS, NAMELY, SOY-BASED DESSERT PUDDINGS, SOY-BASED FOOD PRODUCTS, NAMELY, SOY-BASED DESSERT PUDDINGS, SOY SAUCE, SOY-BASED ICE CREAM SUBSTITUTE, SOYBEAN MILK SOY MILK (U.S. CL. 46).

FIRST USE 4-30-1994; IN COMMERCE 11-30-2001.

CLASS 30—(Continued).

3,482,155. FCW IMPORTS & EXPORTS, LLC, SOUTH SAN FRANCISCO, CA. SN 78-673,368. PUB. 4-4-2006, FILED 7-19-2005.



NO CLAIM IS MADE TO THE EXCLUSIVE RIGHT TO USE "FINEST", APART FROM THE MARK AS SHOWN.

THE COLOR(S) DARK BLUE, GOLD, GREEN, RED AND WHITE IS/ARE CLAIMED AS A FEATURE OF THE MARK.

THE MARK CONSISTS OF THE STYLIZED WORDS "OROBELLO'S FINEST" AND A WHEAT SHEAF DESIGN SUPERIMPOSED ON A SEMI-RECTANGULAR DARK BLUE BACKGROUND WITH RED AND GOLD BORDERS. THE LEADING LETTERS "O," "R" AND "O" OF THE WORD "OROBELLO'S" ARE GOLD IN COLOR AND THE FOLLOWING LETTERS "B," "E," "L," "L," "O" AND "S" ARE WHITE IN COLOR. THE LETTERS OF THE WORD "FINEST" ARE DARK BLUE AND EACH LETTER IS OUTLINED IN WHITE WITH A DARK BLUE SHADOW. THE WHEAT SHEAF DESIGN IS SUBSTANTIALLY GOLD WITH GREEN HIGHLIGHTS AT THE TIPS.

FOR BAKERY GOODS, COOKIES, CRACKERS AND FLATBREAD (U.S. CL. 46).

FIRST USE 8-20-2007; IN COMMERCE 8-23-2007.

3,482,245. LEWIS BROTHERS BAKERIES, INCORPORATED, DBA LEWIS BAKERIES, INC., EVANSVILLE, IN. SN 78-777,987. PUB. 9-19-2006, FILED 12-21-2005.

THE ORIGINAL DIETER'S DREAM

THE MARK CONSISTS OF STANDARD CHARACTERS WITHOUT CLAIM TO ANY PARTICULAR FONT, STYLE, SIZE, OR COLOR.

NO CLAIM IS MADE TO THE EXCLUSIVE RIGHT TO USE "ORIGINAL DIETER'S", APART FROM THE MARK AS SHOWN.

FOR BAGELS; MUFFINS (U.S. CL. 46).

FIRST USE 11-0-2007; IN COMMERCE 11-0-2007.

CLASS 30—(Continued).

3,482,257. TOPCO ASSOCIATES, LLC, SKOKIE, IL. SN 78-784,907. PUB. 4-17-2007, FILED 1-4-2006.



NO CLAIM IS MADE TO THE EXCLUSIVE RIGHT TO USE "FRUIT", APART FROM THE MARK AS SHOWN. FOR BREAKFAST CEREALS (U.S. CL. 46). FIRST USE 11-0-2005; IN COMMERCE 11-0-2005.

3,482,261. SHILLING, LYNNDON, ALTOONA, IA. SN 78-788,581. PUB. 8-29-2006, FILED 1-10-2006.

FREEZET

THE MARK CONSISTS OF STANDARD CHARACTERS WITHOUT CLAIM TO ANY PARTICULAR FONT, STYLE, SIZE, OR COLOR.

FOR PALATABLE ICE (U.S. CL. 46).

FIRST USE 11-15-2007; IN COMMERCE 11-15-2007.

3,482,294. MCILHENNY COMPANY, AVERY ISLAND, LA. SN 78-812,904. PUB. 9-18-2007, FILED 2-12-2006.

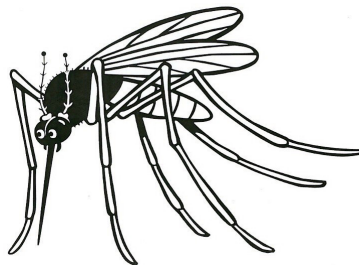

THE MARK CONSISTS OF A DESIGN OF A MOSQUITO. FOR CONDIMENT, NAMELY, PEPPER SAUCE (U.S. CL. 46).

FIRST USE 6-9-2008; IN COMMERCE 6-9-2008.

CLASS 30—(Continued).

3,482,300. BLACKMUSTARD, INC., COLUMBIA, SC. SN 78-819,290. PUB. 10-24-2006, FILED 2-21-2006.



NO CLAIM IS MADE TO THE EXCLUSIVE RIGHT TO USE "BLACK MUSTARD BARBECUE SLATHER" AND "BBQ SLATHER.COM", APART FROM THE MARK AS SHOWN.

THE COLOR(S) RED, YELLOW, BLACK, TAN AND WHITE ARE CLAIMED AS A FEATURE OF THE MARK.

THE MARK CONSISTS OF THE WORDS "BLACKMUSTARD BARBECUE SLATHER", "BBQSLATHER.COM" AND A STYLIZED DEPICTION OF A CHICKEN AND PIG ON AN OVAL BACKGROUND. THE COLOR(S) RED APPEARS IN THE OUTLINE OF THE OVAL CARRIER AND IN THE BACKGROUND OF THE BANNER. THE COLOR YELLOW APPEARS IN THE INSIDE OF THE OVAL CARRIER, IN THE OUTLINE OF THE BANNER, AND IN THE WORDS "BARBECUE SLATHER". THE COLOR BLACK APPEARS IN THE OUTLINE OF THE OVAL CARRIER, THE WORDS "BLACKMUSTARD" AND "BBQSLATHER.COM", THE OUTLINE AND DETAILS OF THE CHICKEN AND PIG. THE COLORS TAN AND WHITE APPEAR INSIDE THE DESIGNS OF THE CHICKEN AND PIG.

FOR BARBECUE SAUCE (U.S. CL. 46).

FIRST USE 7-5-2006; IN COMMERCE 7-5-2006.

3,482,304. PAROMI TEA, LLC, BETHESDA, MD. SN 78-823,989. PUB. 3-20-2007, FILED 2-27-2006.

Paromi

THE MARK CONSISTS OF STANDARD CHARACTERS WITHOUT CLAIM TO ANY PARTICULAR FONT, STYLE, SIZE, OR COLOR.

FOR BEVERAGES MADE OF TEA; BLACK TEA; FLAVOURINGS OF TEA; FRUIT TEAS; GREEN TEA; HERB TEA; HERBAL TEA; ICED TEA; JAPANESE GREEN TEA; LIME TEA; OOLONG TEA; SAGE TEA; TEA; TEA FOR INFUSIONS; TEA-BASED BEVERAGES WITH FRUIT FLAVORING (U.S. CL. 46).

FIRST USE 10-16-2006; IN COMMERCE 10-16-2006.

CLASS 30—(Continued).

3,482,374. ORION CORPORATION, YONGSAN-KU SEOUL, REPUBLIC OF KOREA. SN 78-881,776. PUB. 9-4-2007, FILED 5-11-2006.



THE COLOR(S) GREEN, YELLOW, BROWN, RED, BLACK, ORANGE AND WHITE IS/ARE CLAIMED AS A FEATURE OF THE MARK.

THE MARK CONSISTS OF A GREEN BACKGROUND. THE COLOR YELLOW APPEARS AS AN OVAL IN THE CENTER OF THE GREEN BACKGROUND. THE YELLOW OVAL IN THE MIDDLE OF THE MARK IS SURROUNDED BY A BROWN BORDER, WHICH IN TURN IS SURROUNDED BY A WHITE BORDER. BROWN ALSO APPEARS AS THE COLOR OF THE TEXT FOR THE WORD "ZANGLE", SHADED IN BLACK, WHICH IS IN THE MIDDLE OF THE YELLOW OVAL. THE BROWN TEXT "ZANGLE" IS SURROUNDED BY A WHITE BORDER. THE WORDS "ON SAFARI" APPEAR IN YELLOW ON A RED BACKGROUND WITH AN ORANGE BORDER.

FOR BREADS; COOKIES AND CHOCOLATE CHIPS; PEANUT BRITTLE; BISCUITS; CHEWING GUM NOT FOR MEDICAL PURPOSES; SWEETMEATS CANDY; CANDY FOR FOOD; ALMOND CANDIES AND ALMOND CAKES; CHOCOLATE; CUSTARD; CARAMEL CANDY; CAKES; PIES; PASTRIES; SPONGE CAKE (U.S. CL. 46).

FIRST USE 9-30-2007; IN COMMERCE 9-30-2007.

3,482,393. WM. H. LEAHY ASSOCIATES, INC., GLENVIEW, IL. SN 78-896,115. PUB. 7-3-2007, FILED 5-30-2006.

POWER GEL

THE MARK CONSISTS OF STANDARD CHARACTERS WITHOUT CLAIM TO ANY PARTICULAR FONT, STYLE, SIZE, OR COLOR.

NO CLAIM IS MADE TO THE EXCLUSIVE RIGHT TO USE "GEL", APART FROM THE MARK AS SHOWN.

FOR FLAVORED GELATINS (U.S. CL. 46).

FIRST USE 2-15-2008; IN COMMERCE 2-15-2008.

CLASS 30—(Continued).

3,482,407. GONZÁLEZ-TORRES, ABRAHAM MARCELO, TIZAYUCA, HIDALGO, MEXICO. SN 78-905,858. PUB. 9-12-2006, FILED 6-12-2006.



THE COLORS BLUE, RED, WHITE, BLACK, GREEN, YELLOW AND ORANGE ARE CLAIMED AS A FEATURE OF THE MARK.

THE MARK CONSISTS OF A SMILING ADOLESCENT WHITE MALE RABBIT WITH GREEN EYES AND YELLOW AND ORANGE LINED EARS. HIS EARS ARE TWISTED. THE RABBIT IS WEARING A RED CAP BACKWARDS AND A YELLOW, BLUE AND RED LONG-SLEEVED T-SHIRT. HIS LOWER BODY IS NOT SEEN. HE IS HOLDING HIMSELF UP BY HIS RIGHT ARM AND HAS HIS LEFT ARM RAISED STRAIGHT UP.

FOR PUFFED CORN SNACKS; WHEAT-BASED SNACK FOODS (U.S. CL. 46).

FIRST USE 5-20-2008; IN COMMERCE 5-20-2008.

3,482,453. VITALICIOUS, INC., NEW YORK, NY. SN 78-933,081. PUB. 2-20-2007, FILED 7-19-2006.

BAKE IT HAPPEN

THE MARK CONSISTS OF STANDARD CHARACTERS WITHOUT CLAIM TO ANY PARTICULAR FONT, STYLE, SIZE, OR COLOR.

FOR CAKE BATTER AND MUFFIN BATTER; PREPARED FOOD MIXES, NAMELY, BREAD MIXES AND MIXES WITH BREAD AS A SUBSTANTIAL INGREDIENT, NAMELY, HOT BREAD MIXES, STUFFING MIXES CONTAINING BREAD; MUFFIN MIXES, PANCAKE MIXES, DOUGHNUT MIXES, CAKE MIXES, FROSTING MIXES, PASTRY MIXES, FLOUR-BASED BAKING MIXES FOR MAKING BAKERY GOODS AND BREAD CRUMBS; BROWNIES, CAKES, MUFFINS, MUFFIN TOPS, PROCESSED CEREALS, COOKIES (U.S. CL. 46).

FIRST USE 6-16-2008; IN COMMERCE 6-16-2008.

CLASS 30—(Continued).

3,482,459. PB BRANDS, LLC, MASPETH, NY. SN 78-934,835. PUB. 9-11-2007, FILED 7-21-2006.

PATEL FOODS

THE MARK CONSISTS OF STANDARD CHARACTERS WITHOUT CLAIM TO ANY PARTICULAR FONT, STYLE, SIZE, OR COLOR.

OWNER OF U.S. REG. NOS. 1,647,559, 2,955,255, AND OTHERS.

NO CLAIM IS MADE TO THE EXCLUSIVE RIGHT TO USE "FOODS", APART FROM THE MARK AS SHOWN.

SEC. 2(F) "PATEL".

FOR FLOUR AND RICE (U.S. CL. 46).

FIRST USE 1-0-2007; IN COMMERCE 1-0-2007.

3,482,472. DISTRIBUTION MARKETING SERVICES, L.P., HOUSTON, TX. SN 78-938,828. PUB. 3-27-2007, FILED 7-27-2006.

TRESCERRO

THE MARK CONSISTS OF STANDARD CHARACTERS WITHOUT CLAIM TO ANY PARTICULAR FONT, STYLE, SIZE, OR COLOR.

THE ENGLISH TRANSLATION OF THE WORDING TRESCERRO IN THE MARK IS THREE HILL.

FOR COFFEE, TEA, COCOA AND HOT CHOCOLATE BEVERAGES, CAPPUCCINO (U.S. CL. 46).

FIRST USE 1-31-2007; IN COMMERCE 1-31-2007.

3,482,473. DISTRIBUTION MARKETING SERVICES, L.P., HOUSTON, TX. SN 78-938,834. PUB. 3-27-2007, FILED 7-27-2006.

RIDGELINE COFFEE ROASTERS

THE MARK CONSISTS OF STANDARD CHARACTERS WITHOUT CLAIM TO ANY PARTICULAR FONT, STYLE, SIZE, OR COLOR.

NO CLAIM IS MADE TO THE EXCLUSIVE RIGHT TO USE "COFFEE ROASTERS", APART FROM THE MARK AS SHOWN.

FOR COFFEE, BEVERAGES MADE FROM COFFEE (U.S. CL. 46).

FIRST USE 4-30-2007; IN COMMERCE 4-30-2007.

CLASS 30—(Continued).

3,482,496. OLD II WARSAW BAKERY, INC., BENSENVILLE, IL. SN 78-946,160. PUB. 8-21-2007, FILED 8-7-2006.

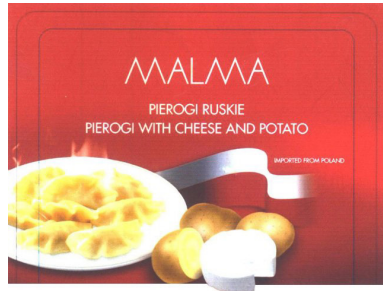

NO CLAIM IS MADE TO THE EXCLUSIVE RIGHT TO USE "PIEROGI" AND "WITH CHEESE AND POTATO" AND "IMPORTED FROM POLAND", APART FROM THE MARK AS SHOWN.

THE COLOR(S) RED, WHITE AND YELLOW IS/ARE CLAIMED AS A FEATURE OF THE MARK.

THE MARK CONSISTS, IN PART, OF A PLATE OF WARM PIEROGIS ADJACENT TO POTATOES AND CHEESE. THE COLOR RED APPEARS IN THE BACKGROUND, THE COLOR WHITE APPEARS IN THE WORDING AND IN THE SPECIAL FORM DRAWING OF A PLATE AND THE COLOR YELLOW APPEARS IN THE FOOD ITEMS DEPICTED IN THE DRAWING.

THE TERMS "MALMA" AND "PIEROGI" HAVE NO MEANING IN ANY FOREIGN LANGUAGE.

FOR DUMPLINGS (U.S. CL. 46).

FIRST USE 9-1-2007; IN COMMERCE 9-1-2007.

CLASS 30—(Continued).

3,482,574. EMBARE INDUSTRIAS ALIMENTICIAS S/A, LAGOA DA PRATA, BRAZIL. SN 78-980,033. PUB. 6-28-2005, FILED 7-29-2004.

EMBARÉ

THE MARK CONSISTS OF STANDARD CHARACTERS WITHOUT CLAIM TO ANY PARTICULAR FONT, STYLE, SIZE, OR COLOR.

OWNER OF BRAZIL REG. NO. 005006791, DATED 9-29-1948, RENEWED AS REG. NO. 005006791, DATED 9-29-1998, EXPIRES 9-28-2008.

FOR CAMELS (U.S. CL. 46).

FIRST USE 0-0-1947; IN COMMERCE 0-0-1989.

3,482,578. KELLOGG NORTH AMERICA COMPANY, BATTLE CREEK, MI. SN 78-980,312. PUB. 9-19-2006, FILED 10-11-2005.

KELLOGG'S

THE MARK CONSISTS OF STANDARD CHARACTERS WITHOUT CLAIM TO ANY PARTICULAR FONT, STYLE, SIZE, OR COLOR.

OWNER OF U.S. REG. NOS. 147,454, 2,364,732, AND OTHERS.

FOR PROCESSED CEREAL-DERIVED FOOD PRODUCT, TO BE USED AS BREAKFAST CEREAL, CEREAL-BASED SNACK FOODS AND AN INGREDIENT FOR MAKING FOOD; TOASTER PASTRIES, WAFFLES, PANCAKES, CEREAL BASED SNACK FOOD BARS, GRAIN BASED SNACK FOODS (U.S. CL. 46).

FIRST USE 5-1-1907; IN COMMERCE 5-1-1907.

3,482,512. MARS, INCORPORATED, MCLEAN, VA. SN 78-952,548. PUB. 3-27-2007, FILED 8-15-2006.

TWIX

THE MARK CONSISTS OF STANDARD CHARACTERS WITHOUT CLAIM TO ANY PARTICULAR FONT, STYLE, SIZE, OR COLOR.

OWNER OF U.S. REG. NOS. 1,533,495, 2,618,227, AND OTHERS.

FOR SNACK FOODS, NAMELY, CHOCOLATE AND GRANOLA FOODS BARS, AND GRAIN-BASED SNACKS CONTAINING VARIOUS FILLINGS (U.S. CL. 46).

FIRST USE 6-29-2007; IN COMMERCE 6-29-2007.

CLASS 31—NATURAL AGRICULTURAL PRODUCTS

CLASS 31—(Continued).

3,481,283. BAILEY NURSERIES, INC., SAINT PAUL, MN. SN 77-061,965. PUB. 1-1-2008, FILED 12-12-2006.

FIRST EDITIONS

THE MARK CONSISTS OF STANDARD CHARACTERS WITHOUT CLAIM TO ANY PARTICULAR FONT, STYLE, SIZE, OR COLOR.
FOR LIVE PLANTS (U.S. CLS. 1 AND 46).
FIRST USE 1-9-2007; IN COMMERCE 4-20-2007.

3,481,392. NATURAL SELECTION FOODS, LLC, SAN JUAN BAUTISTA, CA. SN 77-111,946. PUB. 9-11-2007, FILED 2-20-2007.



OWNER OF U.S. REG. NOS. 2,365,489, 3,244,499, AND 3,244,500.

NO CLAIM IS MADE TO THE EXCLUSIVE RIGHT TO USE "GREEN" OR "ORGANIC", APART FROM THE MARK AS SHOWN.

THE COLOR(S) GREEN, WHITE, YELLOW, AND BLUE IS/ARE CLAIMED AS A FEATURE OF THE MARK.

THE COLOR WHITE APPEARS IN THE WORDING "GREEN HARVEST," OUTLINES THE WORD "ORGANIC," APPEARS BEHIND THE SUN DESIGN, AND APPEARS IN STRIPED LINES BEHIND THE WORD "ORGANIC." THE COLOR YELLOW APPEARS IN THE HALF SUN DESIGN; THE COLOR BLUE APPEARS IN THE WORD "ORGANIC;" THE COLOR GREEN APPEARS IN THE OVAL DESIGN, HILL DESIGN, AND IN THE STRIPED LINES BEHIND THE WORD "ORGANIC".

FOR FRESH FRUITS; FRESH VEGETABLES; RAW VEGETABLES; FRESH LETTUCE AND FRESH LEAFY VEGETABLES (U.S. CLS. 1 AND 46).

FIRST USE 6-0-2006; IN COMMERCE 5-15-2008.

3,481,435. CARGILL, INCORPORATED, WAYZATA, MN. SN 77-125,428. PUB. 2-19-2008, FILED 3-8-2007.

Smart Grain Technology

THE MARK CONSISTS OF STANDARD CHARACTERS WITHOUT CLAIM TO ANY PARTICULAR FONT, STYLE, SIZE, OR COLOR.

NO CLAIM IS MADE TO THE EXCLUSIVE RIGHT TO USE "GRAIN TECHNOLOGY", APART FROM THE MARK AS SHOWN.

FOR ANIMAL FEED (U.S. CLS. 1 AND 46).

FIRST USE 3-31-2007; IN COMMERCE 3-31-2007.

CLASS 31—(Continued).

3,481,442. BIONOVA PRODUCE, INC., NOGALES, AZ. SN 77-126,947. PUB. 9-11-2007, FILED 3-9-2007.

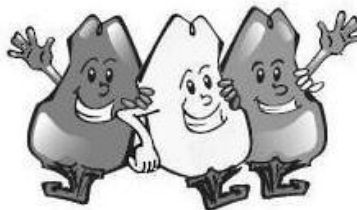

THE MARK CONSISTS OF A STYLIZED REPRESENTATION OF THREE PEPPERS.

FOR FRESH FRUITS AND VEGETABLES (U.S. CLS. 1 AND 46).

FIRST USE 8-1-2007; IN COMMERCE 8-1-2007.

3,481,485. SHUMAN PRODUCE, INC., COBBTOWN, GA. SN 77-133,420. PUB. 9-18-2007, FILED 3-16-2007.

TASTE THE REAL DIFFERENCE

THE MARK CONSISTS OF STANDARD CHARACTERS WITHOUT CLAIM TO ANY PARTICULAR FONT, STYLE, SIZE, OR COLOR.

FOR FRESH ONIONS (U.S. CLS. 1 AND 46).

FIRST USE 1-1-2006; IN COMMERCE 1-1-2006.

3,481,665. VILLAGE FARMS, L.P., EATONTOWN, NJ. SN 77-167,599. PUB. 10-2-2007, FILED 4-27-2007.

TRIANA

THE MARK CONSISTS OF STANDARD CHARACTERS WITHOUT CLAIM TO ANY PARTICULAR FONT, STYLE, SIZE, OR COLOR.

FOR FRESH VEGETABLES; RAW VEGETABLES; RAW FRUITS; UNPROCESSED FRUITS (U.S. CLS. 1 AND 46).

FIRST USE 6-10-2008; IN COMMERCE 6-10-2008.

CLASS 31—(Continued).

3,481,748. HERGENREDER, JAMES E., LONGMONT, CO. SN 77-192,966. PUB. 11-20-2007, FILED 5-30-2007.



NO CLAIM IS MADE TO THE EXCLUSIVE RIGHT TO USE "CORN INTERNATIONAL", APART FROM THE MARK AS SHOWN.

THE STIPPLING IS FOR SHADING PURPOSES ONLY.

THE MARK CONSISTS OF CORN SEEDS ON A CORN COB WITH A SUNSET IN THE MIDDLE OF THE CORN COB. THE WORDS "PLANET CORN" ON TOP WITH THE WORD "INTERNATIONAL" ON THE BANNER.

FOR CORN SEEDS (U.S. CLS. 1 AND 46).
FIRST USE 2-16-2008; IN COMMERCE 3-8-2008.

3,481,778. PET VALU CANADA INC., MARKHAM, CANADA. SN 77-209,790. PUB. 12-4-2007, FILED 6-19-2007.

FRESH 4 LIFE

THE MARK CONSISTS OF STANDARD CHARACTERS WITHOUT CLAIM TO ANY PARTICULAR FONT, STYLE, SIZE, OR COLOR.

FOR CAT LITTER (U.S. CLS. 1 AND 46).

FIRST USE 2-29-2008; IN COMMERCE 2-29-2008.

3,481,839. SOUTHERN STATES COOPERATIVE, INCORPORATED, RICHMOND, VA. SN 77-240,506. PUB. 1-29-2008, FILED 7-27-2007.

PERFORMANCETECH

THE MARK CONSISTS OF STANDARD CHARACTERS WITHOUT CLAIM TO ANY PARTICULAR FONT, STYLE, SIZE, OR COLOR.

FOR ANIMAL FEED (U.S. CLS. 1 AND 46).

FIRST USE 11-12-2007; IN COMMERCE 11-26-2007.

CLASS 31—(Continued).

3,481,916. SOCIETE DES PRODUITS NESTLE S.A., VEVEY, SWITZERLAND. SN 77-269,153. PUB. 2-19-2008, FILED 8-31-2007.

DRM DERMATOLOGIC MANAGEMENT

THE MARK CONSISTS OF STANDARD CHARACTERS WITHOUT CLAIM TO ANY PARTICULAR FONT, STYLE, SIZE, OR COLOR.

NO CLAIM IS MADE TO THE EXCLUSIVE RIGHT TO USE "DERMATOLOGIC MANAGEMENT", APART FROM THE MARK AS SHOWN.

FOR PET FOOD (U.S. CLS. 1 AND 46).

FIRST USE 2-14-2008; IN COMMERCE 2-14-2008.

3,482,006. HAZERA GENETICS LTD., M.P. SHIKMIM 79837, ISRAEL. SN 78-261,633. PUB. 3-8-2005, FILED 6-12-2003.

LYCOSWEET

FOR PLANT PROPAGATING MATERIAL (U.S. CLS. 1 AND 46).

FIRST USE 11-30-2007; IN COMMERCE 11-30-2007.

3,482,087. FLORAGEM, LLC, VISTA, CA. SN 78-533,475. PUB. 10-25-2005, FILED 12-16-2004.

TOUGH AS NAILS

THE MARK CONSISTS OF STANDARD CHARACTERS WITHOUT CLAIM TO ANY PARTICULAR FONT, STYLE, SIZE, OR COLOR.

FOR LIVE PLANTS (U.S. CLS. 1 AND 46).

FIRST USE 6-15-2008; IN COMMERCE 6-15-2008.

CLASS 31—(Continued).

3,482,148. ATWOOD, AARON D., PALMYRA, IL. SN 78-665,479. PUB. 4-11-2006, FILED 7-7-2005.

JORDAN STREET

THE MARK CONSISTS OF STANDARD CHARACTERS WITHOUT CLAIM TO ANY PARTICULAR FONT, STYLE, SIZE, OR COLOR.

FOR LIVING TREES (U.S. CLS. 1 AND 46).
FIRST USE 1-5-2008; IN COMMERCE 3-15-2008.

3,482,349. GREAT PLAINS FLAX SEEDS, INC., LITTLETON, CO. SN 78-857,901. PUB. 11-21-2006, FILED 4-10-2006.

Great Plains Flax Seeds

THE MARK CONSISTS OF STANDARD CHARACTERS WITHOUT CLAIM TO ANY PARTICULAR FONT, STYLE, SIZE, OR COLOR.

NO CLAIM IS MADE TO THE EXCLUSIVE RIGHT TO USE "FLAX SEEDS", APART FROM THE MARK AS SHOWN.

FOR FLAX SEEDS (U.S. CLS. 1 AND 46).
FIRST USE 2-20-2007; IN COMMERCE 2-20-2007.

3,482,413. WEST PAK AVOCADO, INC., TEMECULA, CA. SN 78-908,465. PUB. 1-23-2007, FILED 6-14-2006.

JUSTRIPE!

THE MARK CONSISTS OF STANDARD CHARACTERS WITHOUT CLAIM TO ANY PARTICULAR FONT, STYLE, SIZE, OR COLOR.

FOR FRESH FRUITS (U.S. CLS. 1 AND 46).
FIRST USE 1-1-2008; IN COMMERCE 6-1-2008.

CLASS 31—(Continued).

3,482,525. SUN SEED COMPANY, INC., BOWLING GREEN, OH. SN 78-956,566. PUB. 9-11-2007, FILED 8-21-2006.

SUNSCRIPTION VITA

THE MARK CONSISTS OF STANDARD CHARACTERS WITHOUT CLAIM TO ANY PARTICULAR FONT, STYLE, SIZE, OR COLOR.

FOR FOOD AND TREATS FOR ANIMALS, NAMELY, BIRD FOOD AND TREATS, PET FOOD AND TREATS AND ANIMAL FOOD AND TREATS; FOOD AND TREATS FOR ANIMALS INCORPORATING VITAMINS AND MINERALS, NAMELY, BIRD FOOD AND TREATS, PET FOOD AND TREATS AND ANIMAL FOOD AND TREATS (U.S. CLS. 1 AND 46).
FIRST USE 9-0-2006; IN COMMERCE 9-0-2006.

3,482,526. SUN SEED COMPANY, INC., BOWLING GREEN, OH. SN 78-956,605. PUB. 9-11-2007, FILED 8-21-2006.



FOR FOOD AND TREATS FOR ANIMALS, NAMELY, BIRD FOOD AND TREATS, PET FOOD AND TREATS AND ANIMAL FOOD AND TREATS; FOOD AND TREATS FOR ANIMALS INCORPORATING VITAMINS AND MINERALS, NAMELY, BIRD FOOD AND TREATS, PET FOOD AND TREATS AND ANIMAL FOOD AND TREATS (U.S. CLS. 1 AND 46).

FIRST USE 9-0-2006; IN COMMERCE 9-0-2006.

3,482,528. SUN SEED COMPANY, INC., BOWLING GREEN, OH. SN 78-956,723. PUB. 9-11-2007, FILED 8-21-2006.



FOR FOOD AND TREATS FOR ANIMALS, NAMELY, BIRD FOOD AND TREATS, PET FOOD AND TREATS AND ANIMAL FOOD AND TREATS; FOOD AND TREATS FOR ANIMALS INCORPORATING VITAMINS AND MINERALS, NAMELY, BIRD FOOD AND TREATS, PET FOOD AND TREATS AND ANIMAL FOOD AND TREATS (U.S. CLS. 1 AND 46).

FIRST USE 8-0-2007; IN COMMERCE 8-0-2007.

CLASS 32—LIGHT BEVERAGES

3,481,165. RWI RESOURCES, LLC, MARIETTA, GA. SN 77-000,613. PUB. 3-20-2007, FILED 9-15-2006.

RIPTIDE SPLIT

THE MARK CONSISTS OF STANDARD CHARACTERS WITHOUT CLAIM TO ANY PARTICULAR FONT, STYLE, SIZE, OR COLOR.

OWNER OF U.S. REG. NO. 2,875,637.

FOR BEVERAGES, NAMELY, FLAVORED AND NON-FLAVORED SPARKLING WATER AND SPRING WATER; CAFFEINATED AND NON-CAFFEINATED DRINKS, NAMELY, SOFT DRINKS WITH OR WITHOUT FRUIT FLAVORING; FRUIT JUICES (U.S. CLS. 45, 46 AND 48).

FIRST USE 3-28-2008; IN COMMERCE 3-28-2008.

3,481,382. COORS BREWING COMPANY, DENVER, CO. SN 77-108,007. PUB. 6-19-2007, FILED 2-15-2007.

RISING MOON

THE MARK CONSISTS OF STANDARD CHARACTERS WITHOUT CLAIM TO ANY PARTICULAR FONT, STYLE, SIZE, OR COLOR.

FOR BEER (U.S. CLS. 45, 46 AND 48).

FIRST USE 1-7-2008; IN COMMERCE 1-7-2008.

3,481,417. JUICY COUTURE, INC., PACOIMA, CA. SN 77-121,192. PUB. 7-10-2007, FILED 3-2-2007.

CHOOSE WATER

THE MARK CONSISTS OF STANDARD CHARACTERS WITHOUT CLAIM TO ANY PARTICULAR FONT, STYLE, SIZE, OR COLOR.

NO CLAIM IS MADE TO THE EXCLUSIVE RIGHT TO USE "WATER", APART FROM THE MARK AS SHOWN.

FOR BOTTLED DRINKING WATER; BOTTLED WATER; DRINKING WATER (U.S. CLS. 45, 46 AND 48).

FIRST USE 8-1-2007; IN COMMERCE 8-1-2007.

CLASS 32—(Continued).

3,481,572. AMERICAN INSTANTS, INC., FLANDERS, NJ. SN 77-148,434. PUB. 10-30-2007, FILED 4-4-2007.

D FIB

THE MARK CONSISTS OF STANDARD CHARACTERS WITHOUT CLAIM TO ANY PARTICULAR FONT, STYLE, SIZE, OR COLOR.

FOR NON-ALCOHOLIC BEVERAGES, NAMELY, ENERGY DRINKS AND SPORTS DRINKS (U.S. CLS. 45, 46 AND 48).

FIRST USE 11-21-2007; IN COMMERCE 4-18-2008.

3,481,609. KRAFT FOODS HOLDINGS, INC., NORTHFIELD, IL. SN 77-154,718. PUB. 9-11-2007, FILED 4-12-2007.

CHERRY WAVES

THE MARK CONSISTS OF STANDARD CHARACTERS WITHOUT CLAIM TO ANY PARTICULAR FONT, STYLE, SIZE, OR COLOR.

NO CLAIM IS MADE TO THE EXCLUSIVE RIGHT TO USE "CHERRY", APART FROM THE MARK AS SHOWN.

FOR FLAVORED WATERS (U.S. CLS. 45, 46 AND 48).

FIRST USE 1-1-2008; IN COMMERCE 1-1-2008.

3,481,809. DEAN INTELLECTUAL PROPERTY SERVICES II, L.P., DALLAS, TX. SN 77-226,163. PUB. 10-30-2007, FILED 7-10-2007.

APPLE-RIFFIC

THE MARK CONSISTS OF STANDARD CHARACTERS WITHOUT CLAIM TO ANY PARTICULAR FONT, STYLE, SIZE, OR COLOR.

OWNER OF U.S. REG. NO. 1,458,563.

FOR FRUIT JUICES (U.S. CLS. 45, 46 AND 48).

FIRST USE 9-0-2007; IN COMMERCE 9-0-2007.

CLASS 32—(Continued).

3,481,836. AIELLO, ANGELO M., HOPE, RI. AND AIELLO, DAVID J., HOPE, RI. SN 77-238,370. PUB. 2-5-2008, FILED 7-25-2007.



NO CLAIM IS MADE TO THE EXCLUSIVE RIGHT TO USE "ACAIBERRI", APART FROM THE MARK AS SHOWN. FOR FRUIT JUICES (U.S. CLS. 45, 46 AND 48). FIRST USE 12-15-2007; IN COMMERCE 12-15-2007.

3,481,907. DR PEPPER/SEVEN UP, INC., PLANO, TX. SN 77-264,722. PUB. 2-19-2008, FILED 8-27-2007.

BERRY LIMEADE BLAST

THE MARK CONSISTS OF STANDARD CHARACTERS WITHOUT CLAIM TO ANY PARTICULAR FONT, STYLE, SIZE, OR COLOR.

NO CLAIM IS MADE TO THE EXCLUSIVE RIGHT TO USE "BERRY LIMEADE", APART FROM THE MARK AS SHOWN.

FOR FRUIT FLAVORED DRINK CONTAINING WATER (U.S. CLS. 45, 46 AND 48). FIRST USE 1-0-2008; IN COMMERCE 1-0-2008.

3,481,977. FIREHOUSE NATURAL SPRING WATER II, FLORHAM PARK, NJ. SN 77-307,829. PUB. 3-11-2008, FILED 10-18-2007.

AQUAPERK

THE MARK CONSISTS OF STANDARD CHARACTERS WITHOUT CLAIM TO ANY PARTICULAR FONT, STYLE, SIZE, OR COLOR.

FOR BOTTLED CAFFEINATED SPRING DRINKING WATER (U.S. CLS. 45, 46 AND 48). FIRST USE 1-11-2008; IN COMMERCE 4-4-2008.

CLASS 32—(Continued).

3,482,109. NEUMARKTER LAMMSBRÄU GEBR. EHRNSPERGER E.K., NEUMARKT IN DER OBERPFALZ, FED REP GERMANY. SN 78-593,133. PUB. 2-7-2006, FILED 3-23-2005.

Lammsbräu

THE MARK CONSISTS OF STANDARD CHARACTERS WITHOUT CLAIM TO ANY PARTICULAR FONT, STYLE, SIZE, OR COLOR.

FOR BEER, MINERAL WATER, LEMONADES, FRUIT JUICES, FRUIT NECTARS (U.S. CLS. 45, 46 AND 48). FIRST USE 2-14-2008; IN COMMERCE 2-14-2008.

3,482,327. H2O TO GO, LLC, MERCHANTVILLE, NJ. SN 78-842,121. PUB. 9-5-2006, FILED 3-21-2006.

BEVITA

THE MARK CONSISTS OF STANDARD CHARACTERS WITHOUT CLAIM TO ANY PARTICULAR FONT, STYLE, SIZE, OR COLOR.

FOR DISTILLED DRINKING WATER, SPRING WATER, TABLE WATER (U.S. CLS. 45, 46 AND 48). FIRST USE 5-23-2008; IN COMMERCE 5-23-2008.

CLASS 32—(Continued).

3,482,438. VITALITA NUTRITIONAL PRODUCTS, LLC, CHICAGO, IL. SN 78-927,684. PUB. 2-13-2007, FILED 7-12-2006.

embodi

FOR NON ALCOHOLIC FUNCTIONAL BEVERAGES IN THE NATURE OF A FRUIT DRINKS CONTAINING BOTANICAL EXTRACTS AND HIGH IN ANTIOXIDANTS; FRUIT JUICES (U.S. CLS. 45, 46 AND 48).
FIRST USE 5-6-2008; IN COMMERCE 5-6-2008.

CLASS 33—(Continued).

3,481,082. THE SOLOMON WINE COMPANY, MODESTO, CA. SN 76-650,948. PUB. 8-22-2006, FILED 11-25-2005.

Carnivale

THE MARK CONSISTS OF STANDARD CHARACTERS WITHOUT CLAIM TO ANY PARTICULAR FONT, STYLE, SIZE, OR COLOR.

FOR WINES (U.S. CLS. 47 AND 49).
FIRST USE 4-25-2008; IN COMMERCE 4-25-2008.

3,482,518. L.R.A., L.L.C., OKLAHOMA CITY, OK. SN 78-954,279. PUB. 10-2-2007, FILED 8-17-2006.



OWNER OF U.S. REG. NO. 2,855,717.
THE COLOR(S) GREEN, YELLOW, RED, BLACK AND WHITE IS/ARE CLAIMED AS A FEATURE OF THE MARK.
THE COLOR GREEN APPEARS IN THE WORDING "GLORIA VIEJO" WHICH WORDS ARE SURROUNDED BY A YELLOW LINE AND FURTHER SURROUNDED BY A RED BORDER. THE DESIGN ELEMENT REPRESENTATION OF AN EAGLE APPEARS WITH THE EAGLE'S BODY AND WINGS IN RED AND THE HEAD IN WHITE AND THE EAGLE'S BEAK AND FEET ARE YELLOW. THE WORDS "EL AGUILA" APPEAR IN BLACK.

THE ENGLISH TRANSLATION OF THE WORD "GLORIA VIEJO EL AGUILA" IN THE MARK IS OLD GLORY THE EAGLE.

FOR SOFT DRINKS, NAMELY, NON-CARBONATED FRUIT JUICE DRINKS AND ENERGY DRINKS ENHANCED WITH VITAMINS, MINERALS, CAFFEINE, NUTRIENTS, AMINO ACIDS AND/OR HERBS (U.S. CLS. 45, 46 AND 48).

FIRST USE 6-30-2006; IN COMMERCE 6-30-2006.

CLASS 33—WINES AND SPIRITS

3,481,169. WILLIAM HATCHER WINES, LLC, DUNDEE, OR. SN 77-001,774. PUB. 5-1-2007, FILED 9-18-2006.

OREGONICALLY GROWN

THE MARK CONSISTS OF STANDARD CHARACTERS WITHOUT CLAIM TO ANY PARTICULAR FONT, STYLE, SIZE, OR COLOR.

FOR WINES (U.S. CLS. 47 AND 49).
FIRST USE 5-0-2008; IN COMMERCE 5-0-2008.

3,481,194. NICKEL & NICKEL VINEYARDS, LLC, OAKVILLE, CA. SN 77-016,969. PUB. 5-15-2007, FILED 10-9-2006.

ENROUTE

THE MARK CONSISTS OF STANDARD CHARACTERS WITHOUT CLAIM TO ANY PARTICULAR FONT, STYLE, SIZE, OR COLOR.

FOR WINE (U.S. CLS. 47 AND 49).
FIRST USE 5-28-2008; IN COMMERCE 5-28-2008.

CLASS 33—(Continued).

3,481,253. ZHEJIANG CEREALS, OILS & FOODSTUFFS IMPORT & EXPORT CO., LTD., HANGZHOU, CHINA. SN 77-047,463. PUB. 9-18-2007, FILED 11-20-2006.



OWNER OF U.S. REG. NOS. 1,452,435, 1,703,597, AND 1,888,774.

NO CLAIM IS MADE TO THE EXCLUSIVE RIGHT TO USE "BRAND" AND "AGED SHAO XING RICE WINE" AND THE REPRESENTATION OF THE CHINESE CHARACTERS THAT TRANSLATE IN ENGLISH TO MEAN "BRAND" AND "EIGHT YEAR OLD" AND "AGED SHAO XING RICE WINE", APART FROM THE MARK AS SHOWN.

THE ENGLISH TRANSLATION OF THE WORDING THE MARK IS AS FOLLOWS: "TA" MEANS "PAGODA"; "PAI" MEANS "BRAND"; "BA NIAN CHEN" MEANS "EIGHT-YEAR OLD"; "SHAO XING" MEANS "SHAOXING"; "HUA" MEANS "FLOWER"; "DIAO" MEANS "TO CARVE"; AND "JIU" MEANS "WINE."

THE NON-LATIN CHARACTERS IN THE MARK TRANSLITERATE TO TA; PAI; BA; NIAN; CHEN; SHAO; XING; HUA; DIAO; JIU.

FOR WINE (U.S. CLS. 47 AND 49).
FIRST USE 9-8-2000; IN COMMERCE 1-2-2007.

3,481,306. STIRRINGS, LLC, FALLS RIVER, MA. SN 77-072,669. PUB. 9-4-2007, FILED 12-28-2006.

OWNER OF U.S. REG. NO. 3,087,636.

THE MARK CONSISTS OF A STYLIZED CURVED LINE PLACED ABOVE THE WORD, "STIRRINGS" IN STYLIZED TEXT.

FOR ALCOHOLIC BEVERAGES, NAMELY, ALCOHOLIC COCKTAIL MIXES (U.S. CLS. 47 AND 49).
FIRST USE 10-5-2007; IN COMMERCE 10-5-2007.

CLASS 33—(Continued).

3,481,312. E. & J. GALLO WINERY, MODESTO, CA. SN 77-075,432. PUB. 7-3-2007, FILED 1-3-2007.

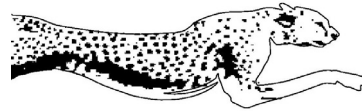

SEBEKA

THE MARK CONSISTS OF A RUNNING CHEETAH. THE WORDING "SEBEKA" HAS NO MEANING IN A FOREIGN LANGUAGE.
FOR WINES (U.S. CLS. 47 AND 49).
FIRST USE 1-15-2007; IN COMMERCE 1-15-2007.

3,481,356. ADLER FELS WINERY, LLC, SANTA ROSA, CA. SN 77-095,199. PUB. 7-24-2007, FILED 1-30-2007.

VINTERRA

THE MARK CONSISTS OF STANDARD CHARACTERS WITHOUT CLAIM TO ANY PARTICULAR FONT, STYLE, SIZE, OR COLOR.

FOR WINE (U.S. CLS. 47 AND 49).
FIRST USE 6-13-2008; IN COMMERCE 6-13-2008.

3,481,451. MT. DEFIANCE WINE COMPANY, HOOD RIVER, OR. SN 77-128,300. PUB. 9-11-2007, FILED 3-12-2007.

HELLFIRE

THE MARK CONSISTS OF STANDARD CHARACTERS WITHOUT CLAIM TO ANY PARTICULAR FONT, STYLE, SIZE, OR COLOR.

FOR WINE (U.S. CLS. 47 AND 49).
FIRST USE 4-10-2008; IN COMMERCE 4-10-2008.

CLASS 33—(Continued).

3,481,459. PACIFIC VISION PROPRIETARY LTD., SURRY HILLS NSW 2010, AUSTRALIA. SN 77-129,621. PUB. 9-11-2007, FILED 3-13-2007.

THE CATCHER

THE MARK CONSISTS OF STANDARD CHARACTERS WITHOUT CLAIM TO ANY PARTICULAR FONT, STYLE, SIZE, OR COLOR.
FOR WINES (U.S. CLS. 47 AND 49).
FIRST USE 4-15-2007; IN COMMERCE 4-15-2007.

3,481,461. DESTILADORA SANTA VIRGINIA S.A. DE C.V., TEPATITLÁN DE MORELOS, JALISCO, MEXICO. SN 77-129,847. PUB. 10-30-2007, FILED 3-13-2007.



THE MARK CONSISTS OF A STYLIZED LETTER "L", "A" STYLIZED LETTER "I".
THE FOREIGN WORDING IN THE MARK TRANSLATES INTO ENGLISH AS THE ILLEGALS.
FOR TEQUILA (U.S. CLS. 47 AND 49).
FIRST USE 5-30-2008; IN COMMERCE 6-2-2008.

3,481,659. BRONCO WINE COMPANY, CERES, CA. SN 77-166,961. PUB. 9-11-2007, FILED 4-26-2007.

ROCKBROOK

THE MARK CONSISTS OF STANDARD CHARACTERS WITHOUT CLAIM TO ANY PARTICULAR FONT, STYLE, SIZE, OR COLOR.
FOR WINE (U.S. CLS. 47 AND 49).
FIRST USE 9-4-2007; IN COMMERCE 9-4-2007.

CLASS 33—(Continued).

3,481,678. ANDERSON & MIDDLETON COMPANY, HOQUIAM, WA. SN 77-172,197. PUB. 10-2-2007, FILED 5-3-2007.

ADOBE

THE MARK CONSISTS OF STANDARD CHARACTERS WITHOUT CLAIM TO ANY PARTICULAR FONT, STYLE, SIZE, OR COLOR.
FOR WINE (U.S. CLS. 47 AND 49).
FIRST USE 4-4-2006; IN COMMERCE 4-14-2006.

3,481,728. RICHARD HART, ALEXANDRIA, VA. SN 77-185,155. PUB. 1-8-2008, FILED 5-18-2007.

RICARDUS CORCULUM

THE MARK CONSISTS OF STANDARD CHARACTERS WITHOUT CLAIM TO ANY PARTICULAR FONT, STYLE, SIZE, OR COLOR.
THE NAME "RICARDUS CORCULUM" DOES NOT IDENTIFY A LIVING INDIVIDUAL.
FOR WINE (U.S. CLS. 47 AND 49).
FIRST USE 12-17-2007; IN COMMERCE 12-17-2007.

3,481,823. CONSTELLATION SPIRITS INC., CHICAGO, IL. SN 77-232,831. PUB. 1-8-2008, FILED 7-18-2007.

THIS IS YOUR WAKE-UP CALL

THE MARK CONSISTS OF STANDARD CHARACTERS WITHOUT CLAIM TO ANY PARTICULAR FONT, STYLE, SIZE, OR COLOR.
FOR ALCOHOLIC BEVERAGES, NAMELY, SCHNAPPS (U.S. CLS. 47 AND 49).
FIRST USE 9-1-2007; IN COMMERCE 9-1-2007.

CLASS 33—(Continued).

3,481,893. OTUWHERE ESTATE WINES LIMITED, CHRISTCHURCH, NEW ZEALAND. SN 77-258,943. PUB. 1-8-2008, FILED 8-20-2007.

O:TU

THE MARK CONSISTS OF STANDARD CHARACTERS WITHOUT CLAIM TO ANY PARTICULAR FONT, STYLE, SIZE, OR COLOR.

FOR WINE (U.S. CLS. 47 AND 49).
FIRST USE 10-31-2006; IN COMMERCE 12-31-2007.

3,482,104. VILLANUEVA, CELIA. HOUSTON, TX. SN 78-579,272. PUB. 5-1-2007, FILED 3-3-2005.

Divino

THE MARK CONSISTS OF STANDARD CHARACTERS WITHOUT CLAIM TO ANY PARTICULAR FONT, STYLE, SIZE, OR COLOR.

THE ENGLISH TRANSLATION OF THE WORD "DIVINO" IN THE MARK IS "DIVINE".

FOR MEZCAL (U.S. CLS. 47 AND 49).
FIRST USE 1-1-2005; IN COMMERCE 1-1-2005.

3,482,323. BACARDI & COMPANY LIMITED, VADUZ, LIECHTENSTEIN. SN 78-839,939. PUB. 6-5-2007, FILED 3-17-2006.

**CLASS 33—(Continued).**

THE MARK CONSISTS OF A TROOP OF MARCHING SCOTTISH HIGHLANDERS.

FOR ALCOHOLIC BEVERAGES, NAMELY, SCOTCH WHISKY (U.S. CLS. 47 AND 49).
FIRST USE 7-31-2005; IN COMMERCE 7-31-2005.

3,482,325. BACARDI & COMPANY LIMITED, VADUZ, LIECHTENSTEIN. SN 78-840,276. PUB. 7-24-2007, FILED 3-17-2006.

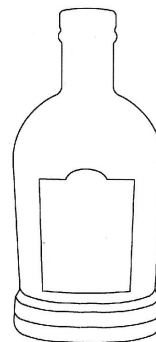

THE MARK CONSISTS OF A DESIGN OF A BOTTLE WITH A LABEL.

FOR ALCOHOLIC BEVERAGES, NAMELY, WHISKY (U.S. CLS. 47 AND 49).

FIRST USE 1-12-2006; IN COMMERCE 8-18-2006.

3,482,428. ASV WINES, INC., DELANO, CA. SN 78-920,262. PUB. 1-9-2007, FILED 6-29-2006.

COPPERFISH

THE MARK CONSISTS OF STANDARD CHARACTERS WITHOUT CLAIM TO ANY PARTICULAR FONT, STYLE, SIZE, OR COLOR.

FOR WINES (U.S. CLS. 47 AND 49).
FIRST USE 2-16-2007; IN COMMERCE 2-16-2007.

3,482,440. JACK DANIEL'S PROPERTIES, INC., SAN RAFAEL, CA. SN 78-929,051. PUB. 2-27-2007, FILED 7-13-2006.

JACKARITA

THE MARK CONSISTS OF STANDARD CHARACTERS WITHOUT CLAIM TO ANY PARTICULAR FONT, STYLE, SIZE, OR COLOR.

OWNER OF U.S. REG. NOS. 1,758,658, 2,815,221, AND

CLASS 33—(Continued).

OTHERS.

THE WORDING "JACKARITA" HAS NO MEANING OTHER THAN TRADEMARK SIGNIFICANCE.

FOR ALCOHOLIC BEVERAGES, NAMELY, DISTILLED SPIRITS (U.S. CLS. 47 AND 49).

FIRST USE 12-20-2000; IN COMMERCE 12-20-2000.

CLASS 34—(Continued).

3,481,429. BLACK PATCH CIGAR CO., LLC, LEXINGTON, KY. SN 77-123,731. PUB. 8-28-2007, FILED 3-6-2007.

KENBANO

THE MARK CONSISTS OF STANDARD CHARACTERS WITHOUT CLAIM TO ANY PARTICULAR FONT, STYLE, SIZE, OR COLOR.

THE MARK "KENBANO" DOES NOT IDENTIFY ANY LIVING INDIVIDUAL.

FOR CIGARS (U.S. CLS. 2, 8, 9 AND 17).

FIRST USE 5-1-2008; IN COMMERCE 5-1-2008.

3,482,479. J. GARCIA CARRION, S.A., JUMILLA (MURCIA), SPAIN. SN 78-940,247. PUB. 9-4-2007, FILED 7-28-2006.

OPERA PRIMA

THE MARK CONSISTS OF STANDARD CHARACTERS WITHOUT CLAIM TO ANY PARTICULAR FONT, STYLE, SIZE, OR COLOR.

OWNER OF SPAIN REG. NO. 2583814, DATED 7-29-2004, EXPIRES 3-1-2014.

THE ENGLISH TRANSLATION OF "OPERA PRIMA" IN THE MARK IS FIRST ACT.

FOR WINES AND SPARKLING WINES (U.S. CLS. 47 AND 49).

FIRST USE 0-0-2004; IN COMMERCE 0-0-2005.

3,482,022. EWESTERN INC., COLVILLE, WA. SN 78-367,466. PUB. 9-20-2005, FILED 2-13-2004.



THE COLOR(S) RED AND GREEN ARE CLAIMED AS A FEATURE OF THE MARK.

THE LETTERING APPEARS IN RED AND THE TWO ARCHES APPEAR IN GREEN.

FOR SMOKING PIPES (U.S. CLS. 2, 8, 9 AND 17).

FIRST USE 1-1-2005; IN COMMERCE 1-1-2005.

3,482,504. ROBERT MONDAVI WINERY, NAPA, CA. SN 78-948,743. PUB. 4-3-2007, FILED 8-9-2006.

VINETTA

THE MARK CONSISTS OF STANDARD CHARACTERS WITHOUT CLAIM TO ANY PARTICULAR FONT, STYLE, SIZE, OR COLOR.

FOR WINE (U.S. CLS. 47 AND 49).

FIRST USE 1-0-2007; IN COMMERCE 1-0-2007.

3,482,216. HOLT'S COMPANY, PHILADELPHIA, PA. SN 78-758,150. PUB. 5-23-2006, FILED 11-21-2005.

BABALU

THE MARK CONSISTS OF STANDARD CHARACTERS WITHOUT CLAIM TO ANY PARTICULAR FONT, STYLE, SIZE, OR COLOR.

FOR CIGAR BANDS, CIGAR BOXES NOT OF PRECIOUS METAL, CIGARS (U.S. CLS. 2, 8, 9 AND 17).

FIRST USE 5-16-2008; IN COMMERCE 5-16-2008.

CLASS 34—SMOKERS' ARTICLES

CLASS 34—(Continued).

3,482,281. JONATHAN DREW, INC., DBA DREW ESTATE, MIAMI, FL. SN 78-799,207. PUB. 2-20-2007, FILED 1-25-2006.

LIGA PRIVADA NO. 9

THE MARK CONSISTS OF STANDARD CHARACTERS WITHOUT CLAIM TO ANY PARTICULAR FONT, STYLE, SIZE, OR COLOR.

NO CLAIM IS MADE TO THE EXCLUSIVE RIGHT TO USE "LIGA", APART FROM THE MARK AS SHOWN.

THE ENGLISH TRANSLATION OF THE WORD "LIGA PRIVADA" IN THE MARK IS "PRIVATE BLEND".

FOR CIGARS, TOBACCO, AND RELATED PRODUCTS, NAMELY, CIGARETTES, CIGAR BOXES, LIGHTERS AND HOLDERS NOT OF PRECIOUS METAL, ASHTRAYS, CIGAR BANDS, CIGAR CUTTERS, HUMIDORS, AND CIGAR TUBES (U.S. CLS. 2, 8, 9 AND 17).

FIRST USE 7-25-2007; IN COMMERCE 7-25-2007.

SERVICE MARKS**CLASS 35—ADVERTISING AND BUSINESS**

3,481,084. IBIQUITY DIGITAL CORPORATION, COLUMBIA, MD. SN 76-652,278. PUB. 4-10-2007, FILED 12-13-2005.



NO CLAIM IS MADE TO THE EXCLUSIVE RIGHT TO USE "DIGITAL RADIO ALLIANCE", APART FROM THE MARK AS SHOWN.

FOR PROMOTING THE PUBLIC AWARENESS OF DIGITAL RADIO TECHNOLOGY AND PROMOTING THE ADOPTION AND USE OF DIGITAL RADIO TECHNOLOGY (U.S. CLS. 100, 101 AND 102).

FIRST USE 2-21-2006; IN COMMERCE 2-21-2006.

CLASS 35—(Continued).

3,481,112. THE TRUSTEES OF THE RODNEY A. HAMILTON LIVING TRUST A CALIFORNIA TRUST, COMPRISING RODNEY A. HAMILTON, A UNITED STATES C, LOS ANGELES, CA. SN 76-665,413. PUB. 11-27-2007, FILED 8-31-2006.

GenuineStores

THE MARK CONSISTS OF STANDARD CHARACTERS WITHOUT CLAIM TO ANY PARTICULAR FONT, STYLE, SIZE, OR COLOR.

FOR ADVERTISING SERVICES FOR COMPUTERIZED ON-LINE ORDERING SERVICES, ON-LINE RETAIL STORES SERVICES, WHOLESALE DISTRIBUTORSHIPS AND DISTRIBUTORSHIPS ALL FEATURING APPLIANCES, JEWELRY, ELECTRONICS, AUTOS, CLOTHES, MUSIC, FOOD, MOTION PICTURES AND MULTIMEDIA PRODUCTS (U.S. CLS. 100, 101 AND 102).

FIRST USE 10-30-2007; IN COMMERCE 10-30-2007.

3,481,116. BICYCLE CITY, LLC, CINCINNATI, OH. SN 76-667,406. PUB. 9-25-2007, FILED 10-12-2006.

BICYCLE CITY

THE MARK CONSISTS OF STANDARD CHARACTERS WITHOUT CLAIM TO ANY PARTICULAR FONT, STYLE, SIZE, OR COLOR.

FOR PROMOTING BUSINESS AND TOURISM IN ALTERNATIVE COMMUNITIES, NAMELY, ENVIRONMENTALLY-FRIENDLY RESIDENTIAL AND COMMERCIAL PLANNED COMMUNITIES (U.S. CLS. 100, 101 AND 102).

FIRST USE 7-0-2007; IN COMMERCE 7-0-2007.

3,481,140. MEDEX MERCHANDISING, INC., MELROSE PARK, IL. SN 76-674,996. PUB. 10-2-2007, FILED 4-3-2007.



NO CLAIM IS MADE TO THE EXCLUSIVE RIGHT TO USE "AMERICA'S LEADING MEDICATIONS", APART FROM THE MARK AS SHOWN.

FOR DISTRIBUTORSHIPS IN THE FIELD OF OVER-THE-COUNTER MEDICATIONS (U.S. CLS. 100, 101 AND 102).

FIRST USE 2-1-2006; IN COMMERCE 2-1-2006.

CLASS 35—(Continued).

3,481,141. SAFEWAY INC., PLEASANTON, CA. SN 76-675,383. PUB. 9-11-2007, FILED 4-11-2007.

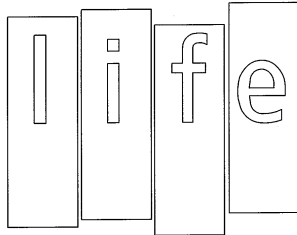

FOR RETAIL GROCERY STORE, PHARMACY AND DRUGSTORE SERVICES; RETAIL STORE SERVICES FEATURING CONVENIENCE STORE ITEMS AND GASOLINE; RETAIL STORE SERVICES FEATURING A FULL LINE OF GROCERIES, PREPARED FOODS, PHARMACEUTICAL GOODS AND OTHER SUPERMARKET PRODUCTS (U.S. CLS. 100, 101 AND 102).
FIRST USE 4-18-2005; IN COMMERCE 4-18-2005.

3,481,146. TEO, SIE P., BROOKLYN, NY. SN 76-676,202. PUB. 9-18-2007, FILED 4-27-2007.

HOUSE OF TINY EGOS

THE MARK CONSISTS OF STANDARD CHARACTERS WITHOUT CLAIM TO ANY PARTICULAR FONT, STYLE, SIZE, OR COLOR.
FOR ART GALLERY SERVICES (U.S. CLS. 100, 101 AND 102).
FIRST USE 6-5-2008; IN COMMERCE 6-5-2008.

3,481,148. CASH ENTERTAINMENT, INC., NYC, NY. SN 76-676,965. PUB. 11-20-2007, FILED 5-16-2007.

ERIC CASH

THE NAME "ERIC CASH" IDENTIFIES A LIVING INDIVIDUAL WHOSE CONSENT IS OF RECORD.
FOR TALENT AGENCY SERVICES, NAMELY, REPRESENTATION AND MANAGEMENT OF MUSIC RECORDING ARTISTS; PROMOTING THE PARTIES AND SPECIAL EVENTS OF OTHERS (U.S. CLS. 100, 101 AND 102).
FIRST USE 8-19-2007; IN COMMERCE 8-19-2007.

CLASS 35—(Continued).

3,481,174. KISER, JOSEPH KENT, TROY, OH. AND KISER, JOSEPH KENT, TROY, OH. SN 77-004,053. PUB. 5-29-2007, FILED 9-21-2006.

1st-choice directory

THE MARK CONSISTS OF STANDARD CHARACTERS WITHOUT CLAIM TO ANY PARTICULAR FONT, STYLE, SIZE, OR COLOR.

NO CLAIM IS MADE TO THE EXCLUSIVE RIGHT TO USE "DIRECTORY", APART FROM THE MARK AS SHOWN.

FOR ON LINE BUSINESS DIRECTORY FEATURING ATTORNEYS, RETAIL STORES, WHOLESALE STORES, MANUFACTURING COMPANIES, RESTAURANTS, BARS, AUTOMOTIVE DEALERS, AUTOMOTIVE REPAIR COMPANIES, CHURCHES, SCHOOLS, EMPLOYMENT AGENCIES, MUSIC AND LESSONS, PLASTIC COMPANIES, SIGN COMPANIES, TRAVEL AGENCIES, GENERAL CONSTRUCTION CONTRACTORS AND PHYSICIANS AND CONTACT INFORMATION THEREOF (U.S. CLS. 100, 101 AND 102).

FIRST USE 9-1-2006; IN COMMERCE 4-6-2007.

3,481,205. EXPRESS SCRIPTS, INC., ST. LOUIS, MO. SN 77-023,222. PUB. 10-23-2007, FILED 10-17-2006.

EXPRESS SAVINGS STATEMENT

THE MARK CONSISTS OF STANDARD CHARACTERS WITHOUT CLAIM TO ANY PARTICULAR FONT, STYLE, SIZE, OR COLOR.

NO CLAIM IS MADE TO THE EXCLUSIVE RIGHT TO USE "SAVINGS STATEMENT", APART FROM THE MARK AS SHOWN.

FOR PROVIDING INFORMATION TO MEMBERS IN A CONSUMER-DRIVEN HEALTHCARE BENEFIT PLAN REGARDING GENERIC PRESCRIPTION DRUGS, COST SAVINGS OPPORTUNITIES, AND MAXIMIZING BENEFITS (U.S. CLS. 100, 101 AND 102).

FIRST USE 4-15-2008; IN COMMERCE 4-15-2008.

3,481,206. EXPRESS SCRIPTS, INC., ST. LOUIS, MO. SN 77-023,223. PUB. 10-30-2007, FILED 10-17-2006.

EXPRESS SAVINGS ALERT

THE MARK CONSISTS OF STANDARD CHARACTERS WITHOUT CLAIM TO ANY PARTICULAR FONT, STYLE,

CLASS 35—(Continued).

SIZE, OR COLOR.

NO CLAIM IS MADE TO THE EXCLUSIVE RIGHT TO USE "SAVINGS ALERT", APART FROM THE MARK AS SHOWN.

FOR PROVIDING INFORMATION TO MEMBERS IN A CONSUMER-DRIVEN HEALTHCARE BENEFIT PLAN REGARDING GENERIC PRESCRIPTION DRUGS, COST SAVINGS OPPORTUNITIES, AND MAXIMIZING BENEFITS (U.S. CLS. 100, 101 AND 102).

FIRST USE 5-27-2008; IN COMMERCE 5-27-2008.

3,481,223. ADP OF NORTH AMERICA, INC., SAN RAMON, CA. SN 77-031,277. PUB. 1-15-2008, FILED 10-27-2006.



ADP TotalSource
Bottom Line. Your team just got better.

OWNER OF U.S. REG. NOS. 1,128,022, 2,338,000, AND OTHERS.

FOR EMPLOYEE LEASING SERVICES, NAMELY, HUMAN RESOURCES MANAGEMENT, PAYROLL PREPARATION, PAYROLL TAX DEPOSIT FILING AND REPORTING (U.S. CLS. 100, 101 AND 102).

FIRST USE 7-31-2005; IN COMMERCE 7-31-2005.

3,481,250. HOLLAND USA, INC., NORTH MANKATO, MN. SN 77-046,454. PUB. 6-19-2007, FILED 11-17-2006.



THE MARK CONSISTS OF CIRCLE WITH HEART AND HANDS INSIDE.

FOR ONLINE AND CATALOG ORDERING SERVICES FEATURING PROMOTIONAL ITEMS, ADVERTISING SPECIALTY ITEMS AND BUSINESS GIFT ITEMS (U.S. CLS. 100, 101 AND 102).

FIRST USE 3-31-2004; IN COMMERCE 3-31-2004.

CLASS 35—(Continued).

3,481,260. WILLIAM FRICK AND COMPANY, LIBERTYVILLE, IL. SN 77-051,052. PUB. 8-28-2007, FILED 11-27-2006.



GEO-TAG
GPS BASED TRACKING SOLUTIONS

NO CLAIM IS MADE TO THE EXCLUSIVE RIGHT TO USE "GPS BASED TRACKING SOLUTIONS", APART FROM THE MARK AS SHOWN.

THE COLOR(S) WHITE, BLUE AND GREEN IS/ARE CLAIMED AS A FEATURE OF THE MARK.

THE MARK CONSISTS OF THE COLOR BLUE IS IN THE TOP PART OF THE WORD "GEO-TAG" AND IS OVER THE COLOR GREEN WHICH IS IN THE BOTTOM PART OF THE WORD "GEO-TAG". THE WORDING IS DISSECTED BY A WHITE HORIZON AND WHITE STAR. UNDER THAT, THE LETTERS "GPS BASED" ARE IN BLUE AND THE WORDS "TRACKING SOLUTIONS" ARE IN GREEN.

FOR COLLECTION, PREPARATION, COMPOSITION, STORAGE, PROCESSING, ACQUISITION AND PROVISION OF BUSINESS INFORMATION, DATA, STATISTICS AND INDICES; COMPUTERIZED TRACKING AND TRACING OF PACKAGES IN TRANSIT; DATA PROCESSING SERVICES; INFORMATION AND DATA COMPILING AND ANALYZING RELATING TO BUSINESS MANAGEMENT; INFORMATION, ADVISORY AND CONSULTANCY SERVICES RELATING TO BUSINESS AND MANAGEMENT OR BUSINESS ADMINISTRATION, INCLUDING SUCH SERVICES PROVIDED ON LINE OR VIA THE INTERNET; INTEGRATED TRACKING AND MANAGEMENT OF COMMERCIAL TRANSACTIONS ON A GLOBAL COMPUTER NETWORK; INVENTORY MANAGEMENT IN THE FIELD OF OUTDOOR DEPLOYED RESOURCES; MANAGEMENT AND BUSINESS CONSULTING SERVICES IN THE FIELD OF OUTDOOR DEPLOYED RESOURCES; MANAGEMENT AND COMPILATION OF COMPUTERIZED DATABASES; MANAGEMENT ASSISTANCE; MONITORING AND TRACKING OF PACKAGE SHIPMENTS; PROVIDING BUSINESS INFORMATION, ALSO VIA INTERNET, THE CABLE NETWORK OR OTHER FORMS OF DATA TRANSFER; PROVIDING ELECTRONIC TRACKING OF FREIGHT INFORMATION TO OTHERS; RENTAL OF DATA PROCESSING EQUIPMENT; STATISTICAL EVALUATIONS OF MARKETING DATA (U.S. CLS. 100, 101 AND 102).

FIRST USE 5-1-2007; IN COMMERCE 5-1-2007.

3,481,262. ANTARUS BIOTECH, INC., HUNTSVILLE, AL. SN 77-051,948. PUB. 6-26-2007, FILED 11-28-2006.

ANTARUS

THE MARK CONSISTS OF STANDARD CHARACTERS WITHOUT CLAIM TO ANY PARTICULAR FONT, STYLE, SIZE, OR COLOR.

FOR COMPUTERIZED ONLINE RETAIL STORE SERVICES FEATURING DNA ANALYSIS EQUIPMENT, NAMELY, THERMOCYCLERS, ASSOCIATED SOFTWARE, KITS OF REAGENTS FOR PCR AND NUCLEIC ACID BASED RESEARCH AND DIAGNOSTICS (U.S. CLS. 100, 101 AND 102).

FIRST USE 12-31-2006; IN COMMERCE 12-31-2006.

CLASS 35—(Continued).

3,481,265. THE NAKED ORCHID, LLC, SOUTHERN PINES, NC. SN 77-052,620. PUB. 7-31-2007, FILED 11-29-2006.



THE MARK CONSISTS OF THE STYLIZED IMAGE OF A WOMAN EMERGING FROM A FLOWER.

FOR ONLINE RETAIL STORE SERVICES IN THE FIELD OF LINGERIE, INTIMATES AND SLEEPWEAR, PERFUMES, PLANTS AND NOVELTY GIFTS (U.S. CLS. 100, 101 AND 102).

FIRST USE 5-24-2008; IN COMMERCE 5-24-2008.

3,481,266. THE NAKED ORCHID, LLC, SOUTHERN PINES, NC. SN 77-052,622. PUB. 7-31-2007, FILED 11-29-2006.



THE MARK CONSISTS OF THE WORDING "THE NAKED ORCHID" NEXT TO THE STYLIZED IMAGE OF A WOMAN EMERGING FROM A FLOWER.

FOR ONLINE RETAIL STORE SERVICES IN THE FIELD OF LINGERIE, INTIMATES AND SLEEPWEAR, PERFUMES, AND PLANTS AND NOVELTY GIFTS (U.S. CLS. 100, 101 AND 102).

FIRST USE 5-24-2008; IN COMMERCE 5-24-2008.

CLASS 35—(Continued).

3,481,270. HAMPTON ROADS PARTNERSHIP, NORFOLK, VA. SN 77-055,265. PUB. 9-18-2007, FILED 12-1-2006.

America's First Region

THE MARK CONSISTS OF STANDARD CHARACTERS WITHOUT CLAIM TO ANY PARTICULAR FONT, STYLE, SIZE, OR COLOR.

FOR PROMOTING THE ECONOMIC DEVELOPMENT IN THE HAMPTON ROADS REGION (U.S. CLS. 100, 101 AND 102).

FIRST USE 12-13-2006; IN COMMERCE 12-13-2006.

3,481,278. BASKIN ASSOCIATES INC., GLENCOE, IL. SN 77-059,773. PUB. 9-4-2007, FILED 12-8-2006.

Brand is Behavior

THE MARK CONSISTS OF STANDARD CHARACTERS WITHOUT CLAIM TO ANY PARTICULAR FONT, STYLE, SIZE, OR COLOR.

FOR ADVERTISING AND MARKETING; ADVERTISING SERVICES, NAMELY, PROMOTING AND MARKETING THE GOODS AND SERVICES OF OTHERS THROUGH ALL PUBLIC COMMUNICATION MEANS; ADVERTISING, MARKETING AND PROMOTION SERVICES; ADVICE IN THE FIELD OF BUSINESS MANAGEMENT AND MARKETING; ARRANGING AND CONDUCTING MARKETING PROMOTIONAL EVENTS FOR OTHERS; BUSINESS ADVICE AND ANALYSIS OF MARKETS; BUSINESS CONSULTATION AND MANAGEMENT REGARDING MARKETING ACTIVITIES AND LAUNCHING OF NEW PRODUCTS; BUSINESS MANAGEMENT CONSULTING WITH RELATION TO STRATEGY, MARKETING, PRODUCTION, PERSONNEL AND RETAIL SALE MATTERS; BUSINESS MARKETING AND DIRECT MAIL CONSULTING SERVICES; BUSINESS MARKETING CONSULTING SERVICES; CONDUCTING BUSINESS AND MARKET RESEARCH SURVEYS; CONDUCTING MARKETING STUDIES; COOPERATIVE ADVERTISING AND MARKETING; COOPERATIVE ADVERTISING AND MARKETING SERVICES BY WAY OF SOLICITATION, CUSTOMER SERVICE AND PROVIDING MARKETING INFORMATION VIA WEBSITES ON A GLOBAL COMPUTER NETWORK; CREATION OF MARKETING TOOLS DESIGNED TO INCREASE A CLIENT COMPANY'S KNOWLEDGE OF CUSTOMER NEEDS, AND ITS COMPETITORS' PRODUCTS AND SERVICES, PRICING, ADVERTISING STRATEGY AND SALES STRATEGY; DEVELOPMENT OF MARKETING STRATEGIES AND CONCEPTS; DIRECT MARKETING ADVERTISING FOR OTHERS; DIRECT MARKETING SERVICES; GENERAL BUSINESS MERCHANDISING SERVICES, NAMELY, MARKETING; IMPLEMENTATION AND FOLLOW-UP OF ADVICE IN THE FIELDS OF MARKETING; INFORMATION OR ENQUIRIES ON BUSINESS AND MARKETING; MARKET ANALYSIS; MARKET MANIPULATION, RESEARCH AND ANALYSIS, WHETHER OR NOT VIA THE INTERNET; MARKET OPINION POLLING STUDIES; MARKET REPORTS AND STUDIES; MARKET RESEARCH; MARKET RESEARCH CONSULTATION; MARKET RESEARCH SERVICES; MARKET RESEARCH STUDIES; MARKET SEGMENTATION CONSULTA-

CLASS 35—(Continued).

TION; MARKET STUDY AND ANALYSIS OF MARKET STUDIES; MARKETING CONSULTING; MARKETING PLAN DEVELOPMENT; MARKETING SERVICES, NAMELY PROVIDING INFORMATIONAL WEB PAGES DESIGNED TO GENERATE SALES TRAFFIC VIA HYPERLINKS TO OTHER WEB SITES; MEDIA PLANNING, NAMELY, ADVISING THE CLIENT ON THE CORRECT TIMES AND STATIONS TO ADVERTISE BASED ON MEDIA ANALYSIS OF THE MARKET FOR THAT MEDIA; MULTI-LEVEL MARKETING BUSINESS SERVICES; ON-LINE ADVERTISING AND MARKETING SERVICES; OUTSOURCING IN THE FIELD OF SALES AND MARKETING OF COMPUTER SOFTWARE; PROMOTING, ADVERTISING AND MARKETING OF THE ON-LINE WEBSITES OF OTHERS; PROMOTION AND MARKETING SERVICES AND RELATED CONSULTING; PROMOTION, ADVERTISING AND MARKETING OF ON-LINE WEBSITES; PROVIDING ADVERTISING, MARKETING AND PROMOTIONAL SERVICES FOR THE PHARMACEUTICAL AND MEDICAL INDUSTRY; PROVIDING ADVERTISING, MARKETING AND PROMOTIONAL SERVICES FOR THE PHARMACEUTICAL AND MEDICAL PRODUCTS OF OTHERS; PROVIDING BUSINESS MARKETING INFORMATION; PROVIDING MARKETING AND PROMOTION OF SPECIAL EVENTS; PROVIDING PROMOTIONAL MARKETING SERVICES TO BUSINESSES IN THE BROADBAND AND MEDIA INDUSTRIES; STATISTICAL EVALUATIONS OF MARKETING DATA (U.S. CLS. 100, 101 AND 102).

FIRST USE 11-1-2004; IN COMMERCE 11-1-2004.

3,481,290. SMARTTALENT LLC, SEATTLE, WA. SN 77-065,707. PUB. 12-11-2007, FILED 12-15-2006.

SMARTCALL

THE MARK CONSISTS OF STANDARD CHARACTERS WITHOUT CLAIM TO ANY PARTICULAR FONT, STYLE, SIZE, OR COLOR.

FOR BUSINESS SERVICES, NAMELY, BUSINESS CONSULTING IN THE FIELD OF HUMAN RESOURCES; TEMPORARY EMPLOYMENT STAFFING SERVICES, EMPLOYMENT RECRUITING AND PLACEMENT SERVICES IN AREAS INCLUDING INBOUND/OUTBOUND ACCOUNTS RECEIVABLES, SALES AND SALES SUPPORT, FULFILLMENT OF PURCHASE ORDERS, CREDIT AND COLLECTIONS, INTERNET OFFICE SUPPORT, MULTIMEDIA GAME SUPPORT, WIRELESS PHONE SUPPORT, AND CATALOG ORDERING CUSTOMER SERVICE; EMPLOYMENT PLACEMENT AGENCY SERVICES, NAMELY, ASSISTING CLIENTS OBTAIN EMPLOYMENT BY PROVIDING ONE HOUR REMINDER CALLS PRIOR TO THEIR INTERVIEW AND FOR HIRED CLIENTS PRIOR TO THEIR FIRST DAY OF WORK ON A NEW ASSIGNMENT (U.S. CLS. 100, 101 AND 102).

FIRST USE 0-0-2001; IN COMMERCE 0-0-2007.

CLASS 35—(Continued).

3,481,292. SMARTTALENT LLC, SEATTLE, WA. SN 77-066,397. PUB. 12-11-2007, FILED 12-18-2006.

SMARTLABOR

THE MARK CONSISTS OF STANDARD CHARACTERS WITHOUT CLAIM TO ANY PARTICULAR FONT, STYLE, SIZE, OR COLOR.

FOR BUSINESS SERVICES, NAMELY, BUSINESS CONSULTING IN THE FIELDS OF HUMAN RESOURCES, MANAGEMENT CONSULTING, AND SCREENING, EVALUATION AND TRAINING JOB RECRUITS; TEMPORARY EMPLOYMENT STAFFING SERVICES; EMPLOYMENT RECRUITING PLACEMENT SERVICES IN THE FIELDS/POSITIONS/ROLES INCLUDING WAREHOUSE, PRODUCTION, DISTRIBUTION, TRANSPORTATION, FORKLIFT, SHIPPING AND RECEIVING, PACKAGING, MATERIAL HANDLER, STOCK CLERK, DRIVING, INSPECTION/QC CLERK, INVENTORY CONTROL, MACHINE OPERATORS, ASSEMBLY WORKERS - MECHANICAL/ELECTRONIC, SOLDERING, TECHNICIANS, ASSEMBLERS, INSPECTION/QC CLERK, INVENTORY CONTROL, AND INJECTION MOLD (U.S. CLS. 100, 101 AND 102).

FIRST USE 0-0-2001; IN COMMERCE 0-0-2007.

3,481,319. PROFESSIONAL CONVENTION MANAGEMENT ASSOCIATION, CHICAGO, IL. SN 77-078,988. PUB. 9-11-2007, FILED 1-9-2007.

PCMA I-ZONE

THE MARK CONSISTS OF STANDARD CHARACTERS WITHOUT CLAIM TO ANY PARTICULAR FONT, STYLE, SIZE, OR COLOR.

FOR PROVIDING A LIVE FORUM FOR COMPANIES TO SHOWCASE, DISPLAY, DEMONSTRATE AND PROMOTE NEW AND INNOVATIVE IDEAS, PRODUCTS AND SERVICES IN THE CONVENTION/MEETING MANAGEMENT ARENA (U.S. CLS. 100, 101 AND 102).

FIRST USE 1-0-2007; IN COMMERCE 1-0-2007.

CLASS 35—(Continued).

3,481,345. MYMENU CANADA INC., KITCHENER, ONTARIO, CANADA. SN 77-092,116. PUB. 7-10-2007, FILED 1-26-2007.

CLASS 35—(Continued).

3,481,347. SMARTTALENT LLC, SEATTLE, WA. SN 77-092,598. PUB. 12-18-2007, FILED 1-26-2007.

SMARTMORTGAGE

HUNDREDS OF MEAL IDEAS

THE MARK CONSISTS OF STANDARD CHARACTERS WITHOUT CLAIM TO ANY PARTICULAR FONT, STYLE, SIZE, OR COLOR.

FOR ONLINE AND TRADITIONAL RETAIL STORE SERVICES FEATURING FOOD PRODUCTS (U.S. CLS. 100, 101 AND 102).

FIRST USE 5-30-2008; IN COMMERCE 5-30-2008.

THE MARK CONSISTS OF STANDARD CHARACTERS WITHOUT CLAIM TO ANY PARTICULAR FONT, STYLE, SIZE, OR COLOR.

FOR BUSINESS SERVICES, NAMELY, BUSINESS CONSULTING SERVICES IN THE FIELD OF HUMAN RESOURCES; EMPLOYMENT STAFFING, RECRUITING, AND PLACEMENT SERVICES IN THE MORTGAGE AND BANKING FIELDS, INCLUDING, CREDIT ANALYST, LENDING OPERATIONS ANALYST, LOAN COORDINATOR, LOAN PROCESSOR, LOAN OFFICER, COMPLIANCE SPECIALIST, UNDERWRITER, FUNDER, DOCUMENT DRAWER, DEFAULT SPECIALIST, RECONVEYANCE REPRESENTATIVE, SETTLEMENTS AND CASH OPERATIONS, ABTRACTOR, CUSTOMER SERVICE REPRESENTATIVE, ESCROW ASSISTANT, ESCROW CLOSER, EXECUTIVE SECRETARY, LPO, PAYOFF EXPERT, POST CLOSER, SR/JR; ESCROW OFFICER, SR/JR; ESCROW PROCESSOR, TAX SPECIALIST, TITLE ASSISTANT, TITLE OFFICER, TITLE PROCESSOR, TITLE EXAMINER, CALL CENTER REPRESENTATIVE, CONSUMER LOAN PROCESSOR, FINANCIAL SERVICES REPRESENTATIVE, LETTER OF CREDIT SPECIALIST, LOAN REPRESENTATIVE, LINE/VAULT TELLER, LOAN CONSULTANT, LOAN DOCUMENTATION CLERK, BANKING LOAN PROCESSOR, LOAN SERVICING SPECIALIST, PORTFOLIO ANALYST, PERSONAL BANKER AND RECEPTIONIST (U.S. CLS. 100, 101 AND 102).

FIRST USE 0-0-2007; IN COMMERCE 0-0-2007.

3,481,346. MYMENU CANADA INC., KITCHENER, ONTARIO, CANADA. SN 77-092,118. PUB. 7-10-2007, FILED 1-26-2007.

3,481,348. SMARTTALENT LLC, SEATTLE, WA. SN 77-092,602. PUB. 12-18-2007, FILED 1-26-2007.

**HUNDREDS OF MEAL IDEAS.
ONE AISLE.**

SMARTV.I.S.

THE MARK CONSISTS OF STANDARD CHARACTERS WITHOUT CLAIM TO ANY PARTICULAR FONT, STYLE, SIZE, OR COLOR.

FOR ONLINE AND TRADITIONAL RETAIL STORE SERVICES FEATURING FOOD PRODUCTS (U.S. CLS. 100, 101 AND 102).

FIRST USE 5-30-2008; IN COMMERCE 5-30-2008.

THE MARK CONSISTS OF STANDARD CHARACTERS WITHOUT CLAIM TO ANY PARTICULAR FONT, STYLE, SIZE, OR COLOR.

FOR BUSINESS SERVICES, NAMELY, BUSINESS CONSULTING IN THE FIELD OF HUMAN RESOURCES; EMPLOYMENT VERIFICATION IN THE NATURE OF VERIFYING THE EMPLOYMENT ELIGIBILITY OF ALL NEW HIRES AS PART OF EMPLOYMENT STAFFING SERVICES (U.S. CLS. 100, 101 AND 102).

FIRST USE 0-0-2006; IN COMMERCE 0-0-2007.

CLASS 35—(Continued).

3,481,354. IFIND GROUP LLC, NEW YORK, NY. SN 77-093,862. PUB. 7-24-2007, FILED 1-29-2007.

IFIND GROUP

THE MARK CONSISTS OF STANDARD CHARACTERS WITHOUT CLAIM TO ANY PARTICULAR FONT, STYLE, SIZE, OR COLOR.

NO CLAIM IS MADE TO THE EXCLUSIVE RIGHT TO USE "GROUP", APART FROM THE MARK AS SHOWN.

FOR PERSONNEL PLACEMENT AND RECRUITMENT; EMPLOYMENT CONSULTING AND RECRUITING SERVICES, NAMELY, EXECUTIVE AND PROFESSIONAL SEARCH, RECRUITING, AND CONSULTING SERVICES (U.S. CLS. 100, 101 AND 102).
FIRST USE 2-1-2007; IN COMMERCE 2-1-2007.

3,481,367. THE UNITED STATES SHOE CORPORATION, PORT WASHINGTON, NY. SN 77-101,106. PUB. 8-14-2007, FILED 2-7-2007.

OPEN YOUR EYES

THE MARK CONSISTS OF STANDARD CHARACTERS WITHOUT CLAIM TO ANY PARTICULAR FONT, STYLE, SIZE, OR COLOR.

FOR RETAIL OPTICAL STORE SERVICES (U.S. CLS. 100, 101 AND 102).

FIRST USE 3-12-2007; IN COMMERCE 3-12-2007.

3,481,383. NEWAGE MARKETING CORPORATION, EAST PROVIDENCE, RI. SN 77-108,087. PUB. 9-18-2007, FILED 2-15-2007.

PITSTOP MEDIA

THE MARK CONSISTS OF STANDARD CHARACTERS WITHOUT CLAIM TO ANY PARTICULAR FONT, STYLE, SIZE, OR COLOR.

NO CLAIM IS MADE TO THE EXCLUSIVE RIGHT TO USE "MEDIA", APART FROM THE MARK AS SHOWN.

FOR ADVERTISING AND MARKETING SERVICES, NAMELY, DISSEMINATION OF INDOOR AND RESTROOM ADVERTISEMENTS; PROVIDING PROFESSIONAL ADVERTISING AND MARKETING SERVICES TO RESTROOM SPONSORS AND CLIENTS, NAMELY, PREPARING AND PLACING ADVERTISEMENTS (U.S. CLS. 100, 101 AND 102).
FIRST USE 5-19-2008; IN COMMERCE 5-19-2008.

CLASS 35—(Continued).

3,481,384. BIOTECHNOLOGY INDUSTRY ORGANIZATION, WASHINGTON, DC. SN 77-108,127. PUB. 8-14-2007, FILED 2-15-2007.

We Put The BIO In Biofuels

THE MARK CONSISTS OF STANDARD CHARACTERS WITHOUT CLAIM TO ANY PARTICULAR FONT, STYLE, SIZE, OR COLOR.

FOR ORGANIZATION SERVICES, NAMELY, PROMOTING THE INTERESTS OF BIOTECHNOLOGY COMPANIES (U.S. CLS. 100, 101 AND 102).

FIRST USE 12-21-2007; IN COMMERCE 12-21-2007.

3,481,387. THE MARSTON GROUP, P.C., MEMPHIS, TN. SN 77-110,530. PUB. 10-16-2007, FILED 2-19-2007.

INSIGHT BEYOND THE NUMBERS

THE MARK CONSISTS OF STANDARD CHARACTERS WITHOUT CLAIM TO ANY PARTICULAR FONT, STYLE, SIZE, OR COLOR.

FOR BUSINESS ANALYSIS SERVICES, NAMELY, BUSINESS ADVICE AND ANALYSIS OF MARKETS AND COMPANIES; PERFORMANCE REPORTING SERVICES, NAMELY, ANALYZING AND COMPILING DATA FOR MEASURING THE PERFORMANCE OF MARKETS AND COMPANIES; BUSINESS STRATEGIC ADVICE, NAMELY, CONSULTATION, BUSINESS ACCOUNTING AND INTERNAL AUDITING SERVICES; TAX PLANNING, CONSULTING, ADVISORY AND COMPLIANCE SERVICES; BUSINESS SUSTAINABILITY ADVISORY SERVICES IN THE NATURE OF REVIEW OF TROUBLED BUSINESSES (U.S. CLS. 100, 101 AND 102).

FIRST USE 2-16-2007; IN COMMERCE 2-16-2007.

3,481,402. CAMPANELLA, DIANA, SCOTTSDALE, AZ. SN 77-114,559. PUB. 10-16-2007, FILED 2-23-2007.

Universeling

THE MARK CONSISTS OF STANDARD CHARACTERS WITHOUT CLAIM TO ANY PARTICULAR FONT, STYLE, SIZE, OR COLOR.

FOR PROMOTING PUBLIC AWARENESS ABOUT HOW TO ELIMINATE STEREOTYPING WITH NEW LABELING OF PERSONS AND GROUPS (U.S. CLS. 100, 101 AND 102).

FIRST USE 3-3-1991; IN COMMERCE 4-29-2008.

CLASS 35—(Continued).

3,481,406. CELLFISH MEDIA LLC, NEW YORK, NY. SN 77-116,911. PUB. 10-30-2007, FILED 2-27-2007.



The logo for Cellfish Media features the word "Cellfish" in a bold, sans-serif font. The letter "i" in "fish" is stylized with a vertical line of dots extending upwards. Below "Cellfish" is the word "MEDIA" in a smaller, all-caps, sans-serif font.

NO CLAIM IS MADE TO THE EXCLUSIVE RIGHT TO USE "MEDIA", APART FROM THE MARK AS SHOWN.

THE MARK CONSISTS OF THE WORD "CELLFISH" WITH "CELL" IN BOLD LETTERS AND A STYLIZED "I" ABOVE THE WORD "MEDIA" IN CAPITAL LETTERS.

FOR COMMERCIAL ADMINISTRATION OF THE LICENSING FOR OTHERS OF THEIR ELECTRONIC CONTENT, NAMELY, PICTURES, GRAPHICS, TEXTUAL MATERIALS, DATA, POSTCARDS, GROUP MESSAGES, ONLINE CHAT SERVICES, VOICE, SOUND RECORDINGS, MOVIES, RADIO PROGRAMMING, TELEVISION PROGRAMMING, VIDEO, MUSIC, GAMES AND RINGTONES, FOR USE WITH MOBILE COMMUNICATIONS DEVICES; ONLINE RETAIL STORE SERVICES FEATURING THE ELECTRONIC CONTENT OF OTHERS, NAMELY, PICTURES, GRAPHICS, TEXTUAL MATERIALS, DATA, POSTCARDS, GROUP MESSAGES, ONLINE CHAT SERVICES, VOICE, SOUND RECORDINGS, MOVIES, RADIO PROGRAMMING, TELEVISION PROGRAMMING, VIDEO, MUSIC, GAMES AND RINGTONES, TO USERS OF MOBILE COMMUNICATIONS DEVICES (U.S. CLS. 100, 101 AND 102).

FIRST USE 4-10-2006; IN COMMERCE 4-10-2006.

3,481,407. CELLFISH MEDIA LLC, NEW YORK, NY. SN 77-116,918. PUB. 10-30-2007, FILED 2-27-2007.

CELLFISH MEDIA

THE MARK CONSISTS OF STANDARD CHARACTERS WITHOUT CLAIM TO ANY PARTICULAR FONT, STYLE, SIZE, OR COLOR.

NO CLAIM IS MADE TO THE EXCLUSIVE RIGHT TO USE "MEDIA", APART FROM THE MARK AS SHOWN.

FOR COMMERCIAL ADMINISTRATION OF THE LICENSING FOR OTHERS OF THEIR ELECTRONIC CONTENT, NAMELY, PICTURES, GRAPHICS, TEXTUAL MATERIALS, DATA, POSTCARDS, GROUP MESSAGES, ONLINE CHAT SERVICES, VOICE, SOUND RECORDINGS, MOVIES, RADIO PROGRAMMING, TELEVISION PROGRAMMING, VIDEO, MUSIC, GAMES AND RINGTONES, FOR USE WITH MOBILE COMMUNICATIONS DEVICES; ONLINE RETAIL STORE SERVICES FEATURING THE ELECTRONIC CONTENT OF OTHERS, NAMELY, PICTURES, GRAPHICS, TEXTUAL MATERIALS, DATA, POSTCARDS, GROUP MESSAGES, ONLINE CHAT SERVICES, VOICE, SOUND RECORDINGS, MOVIES, RADIO PROGRAMMING, TELEVISION PROGRAMMING, VIDEO, MUSIC, GAMES AND RINGTONES, TO USERS OF MOBILE COMMUNICATIONS DEVICES (U.S. CLS. 100, 101 AND 102).

FIRST USE 4-10-2006; IN COMMERCE 4-10-2006.

CLASS 35—(Continued).

3,481,413. NUTANDBOLTGYU INC., PINE BUSH, NY. SN 77-120,301. PUB. 9-18-2007, FILED 3-1-2007.

NutandBoltGuy Inc.

THE MARK CONSISTS OF STANDARD CHARACTERS WITHOUT CLAIM TO ANY PARTICULAR FONT, STYLE, SIZE, OR COLOR.

NO CLAIM IS MADE TO THE EXCLUSIVE RIGHT TO USE "INC.", APART FROM THE MARK AS SHOWN.

FOR DISTRIBUTORSHIPS IN THE FIELD OF INDUSTRIAL THREADED FASTENERS AND OTHER INDUSTRIAL MRO SUPPLIES (U.S. CLS. 100, 101 AND 102).

FIRST USE 1-2-2008; IN COMMERCE 1-2-2008.

3,481,415. COUNCIL FOR RESPONSIBLE NUTRITION, WASHINGTON, DC. SN 77-120,777. PUB. 8-28-2007, FILED 3-2-2007.

LIFE...SUPPLEMENTED

THE MARK CONSISTS OF STANDARD CHARACTERS WITHOUT CLAIM TO ANY PARTICULAR FONT, STYLE, SIZE, OR COLOR.

FOR PROMOTING PUBLIC AWARENESS OF THE NEED FOR AND THE IMPORTANCE OF DIETARY SUPPLEMENTS (U.S. CLS. 100, 101 AND 102).

FIRST USE 6-18-2007; IN COMMERCE 9-0-2007.

3,481,424. FURNITURE ROW, LLC, DENVER, CO. SN 77-123,051. PUB. 9-4-2007, FILED 3-6-2007.

HOME TO A DIFFERENT KIND OF SHOPPING EXPERIENCE

THE MARK CONSISTS OF STANDARD CHARACTERS WITHOUT CLAIM TO ANY PARTICULAR FONT, STYLE, SIZE, OR COLOR.

FOR RETAIL STORE SERVICES FEATURING FURNITURE, MATTRESSES, AND HOUSEHOLD ACCESSORIES (U.S. CLS. 100, 101 AND 102).

FIRST USE 7-15-2006; IN COMMERCE 7-15-2006.

CLASS 35—(Continued).

3,481,452. TALENTSPRING, INC., REDMOND, WA. SN 77-128,774. PUB. 9-11-2007, FILED 3-12-2007.

TALENTSPRING

THE MARK CONSISTS OF STANDARD CHARACTERS WITHOUT CLAIM TO ANY PARTICULAR FONT, STYLE, SIZE, OR COLOR.

FOR EMPLOYMENT HIRING, RECRUITING, PLACEMENT, STAFFING, AND CAREER NETWORKING SERVICES; PROVIDING ON-LINE EMPLOYMENT HIRING, RECRUITING, PLACEMENT, STAFFING, AND CAREER NETWORKING SERVICES OVER COMPUTER NETWORKS; COMPUTERIZED DATABASE MANAGEMENT, TRACKING, AND RANKING SERVICES FOR THE HUMAN RESOURCES, EMPLOYMENT, RECRUITING, AND STAFFING FIELDS (U.S. CLS. 100, 101 AND 102).
FIRST USE 5-18-2008; IN COMMERCE 5-18-2008.



3,481,462. FLOORING 101, INC., OXNARD, CA. SN 77-130,278. PUB. 9-18-2007, FILED 3-13-2007.

Floors101.com

THE MARK CONSISTS OF STANDARD CHARACTERS WITHOUT CLAIM TO ANY PARTICULAR FONT, STYLE, SIZE, OR COLOR.

FOR ON-LINE RETAIL STORE SERVICES FEATURING CARPETS AND OTHER FLOOR COVERINGS (U.S. CLS. 100, 101 AND 102).
FIRST USE 4-10-2008; IN COMMERCE 4-29-2008.



3,481,476. BROWN BROTHERS HARRIMAN & CO., NEW YORK, NY. SN 77-132,361. PUB. 9-18-2007, FILED 3-15-2007.

BBH INFOFX

THE MARK CONSISTS OF STANDARD CHARACTERS WITHOUT CLAIM TO ANY PARTICULAR FONT, STYLE, SIZE, OR COLOR.

FOR FINANCIAL RECORDS MANAGEMENT (U.S. CLS. 100, 101 AND 102).
FIRST USE 10-0-2007; IN COMMERCE 10-0-2007.

CLASS 35—(Continued).

3,481,500. THE OUTSOURCING PARTNERSHIP, LLC D/B/A ACCUME PARTNERS LLC, MOORESTOWN, NJ. SN 77-136,189. PUB. 9-18-2007, FILED 3-21-2007.

FOCUS IS EVERYTHING

THE MARK CONSISTS OF STANDARD CHARACTERS WITHOUT CLAIM TO ANY PARTICULAR FONT, STYLE, SIZE, OR COLOR.

FOR BUSINESS AUDITING (U.S. CLS. 100, 101 AND 102).
FIRST USE 10-7-2007; IN COMMERCE 10-7-2007.



3,481,531. BLUE 2, LLC, ST. LOUIS, MO. SN 77-141,361. PUB. 9-25-2007, FILED 3-27-2007.

BLUE 2

THE MARK CONSISTS OF STANDARD CHARACTERS WITHOUT CLAIM TO ANY PARTICULAR FONT, STYLE, SIZE, OR COLOR.

FOR PROMOTION AND MARKETING SERVICES AND RELATED CONSULTING (U.S. CLS. 100, 101 AND 102).
FIRST USE 2-22-2007; IN COMMERCE 2-22-2007.



3,481,542. LA FROMAGERIE, INC., LOS ANGELES, CA. SN 77-143,183. PUB. 10-2-2007, FILED 3-28-2007.

Froma on Melrose

THE MARK CONSISTS OF STANDARD CHARACTERS WITHOUT CLAIM TO ANY PARTICULAR FONT, STYLE, SIZE, OR COLOR.

NO CLAIM IS MADE TO THE EXCLUSIVE RIGHT TO USE "ON MELROSE", APART FROM THE MARK AS SHOWN.
FOR RETAIL GOURMET AND SPECIALTY FOODS AND FINE WINES STORES (U.S. CLS. 100, 101 AND 102).
FIRST USE 1-1-2008; IN COMMERCE 1-1-2008.

CLASS 35—(Continued).

3,481,555. SAAL, ELAINE, DEER PARK, NY. SN 77-145,639. PUB. 10-2-2007, FILED 4-1-2007.

DONT FIX IT - SELL IT

THE MARK CONSISTS OF STANDARD CHARACTERS WITHOUT CLAIM TO ANY PARTICULAR FONT, STYLE, SIZE, OR COLOR.
 FOR PROVIDING USED CAR SALES LEADS FOR OTHERS (U.S. CLS. 100, 101 AND 102).
 FIRST USE 2-22-2003; IN COMMERCE 2-22-2003.

3,481,557. GERE, TRAVIS M, WRJ, VT. SN 77-146,138. PUB. 10-2-2007, FILED 4-2-2007.

Go Zippin!

THE MARK CONSISTS OF STANDARD CHARACTERS WITHOUT CLAIM TO ANY PARTICULAR FONT, STYLE, SIZE, OR COLOR.
 FOR DISSEMINATION OF ADVERTISING MAINLY LOCAL EVENTS AND AREA HAPPENINGS FOR OTHERS VIA THE INTERNET; PROMOTING SPORTS COMPETITIONS AND/OR EVENTS OF OTHERS; PROMOTING THE PARTIES AND SPECIAL EVENTS OF OTHERS; PROVIDING CONSUMER INFORMATION SERVICES AND MAKING REFERRALS IN THE FIELD OF ENTERTAINMENT SERVICES FOR PRODUCTS, SERVICES, EVENTS, ACTIVITIES, FACILITIES AND LOCATIONS; PROVIDING MARKETING AND PROMOTION OF SPECIAL EVENTS; PROVIDING SPACE AT A WEB SITE FOR USER-DEFINED ADVERTISEMENTS OF THE GOODS AND SERVICES OF OTHERS, WHICH INCLUDES ON-LINE LINKS TO OTHER WEB SITES; PROVIDING ON-LINE DIRECTORY INFORMATION SERVICES ALSO FEATURING HYPERLINKS TO OTHER WEB SITES; PROVIDING A WEB SITE WHICH FEATURES ADVERTISEMENTS FOR THE GOODS AND SERVICES OF OTHERS ON A GLOBAL COMPUTER NETWORK; PROVIDING A WEB SITE THAT ENABLES USERS TO POST ITEMS FOR SALE THROUGH ON-LINE CLASSIFIED ADVERTISEMENTS; PROVIDING AN ON-LINE SEARCHABLE DATABASE FEATURING CLASSIFIED AD LISTINGS AND EMPLOYMENT OPPORTUNITIES; PROVIDING A WEB SITE AT WHICH USERS CAN OFFER GOODS FOR SALE AND BUY GOODS OFFERED BY OTHERS; DISSEMINATION OF ADVERTISING FOR OTHERS VIA AN ON-LINE COMMUNICATIONS NETWORK ON THE INTERNET; ADVERTISING VIA ELECTRONIC MEDIA AND SPECIFICALLY THE INTERNET (U.S. CLS. 100, 101 AND 102).
 FIRST USE 6-20-2008; IN COMMERCE 6-20-2008.

CLASS 35—(Continued).

3,481,570. BELTER FINANCIAL SERVICES, INC., NAPERVILLE, IL. SN 77-147,995. PUB. 10-2-2007, FILED 4-3-2007.



THE COLOR(S) MAROON IS/ARE CLAIMED AS A FEATURE OF THE MARK.
 THE MARK CONSISTS OF THREE DIMENSIONAL CAPITAL LETTER "T" BEING SOLID MAROON AND A SHADOWING CAPITAL LETTER "T" THAT IS WHITE AND OUTLINED IN MAROON. THE CAPITAL LETTER "T" HAS THE LARGEST FONT SIZE. THE REMAINING LETTERS ARE SOLID MAROON, SMALLER FONT THAN THE LETTER "T" AND ALL CAPITAL, WITH THE LETTERS "XX" BEING BOLD AND A SLIGHTLY LARGER FONT THAN THE OTHER LETTERS (BUT SMALLER THAN THE FONT FOR THE LETTER "T").
 FOR BOOKKEEPING, TAX CONSULTATION AND TAX PREPARATION SERVICES (U.S. CLS. 100, 101 AND 102).
 FIRST USE 1-3-2007; IN COMMERCE 1-3-2007.

3,481,588. PRESTIGE REWARDS PROGRAM, INC., NEW PORT RICHEY, FL. SN 77-150,542. PUB. 10-9-2007, FILED 4-6-2007.

PRESTIGE REWARDS PROGRAM

THE MARK CONSISTS OF STANDARD CHARACTERS WITHOUT CLAIM TO ANY PARTICULAR FONT, STYLE, SIZE, OR COLOR.
 NO CLAIM IS MADE TO THE EXCLUSIVE RIGHT TO USE "REWARDS PROGRAM", APART FROM THE MARK AS SHOWN.
 FOR CUSTOMER LOYALTY SERVICES AND CUSTOMER CLUB SERVICES, FOR COMMERCIAL, PROMOTIONAL AND/OR ADVERTISING PURPOSES (U.S. CLS. 100, 101 AND 102).
 FIRST USE 5-5-2008; IN COMMERCE 5-5-2008.

3,481,594. KRISTEN JANE EDWARDS, HERMOSA BEACH, CA. SN 77-151,410. PUB. 1-8-2008, FILED 4-8-2007.



THE COLOR(S) GREEN AND WHITE IS/ARE CLAIMED

CLASS 35—(Continued).

AS A FEATURE OF THE MARK.

THE MARK CONSISTS OF RECTANGULAR FLAG FEATURING A GREEN RECTANGLE IN THE UPPER HOIST-SIDE CORNER BEARING 50 SMALL, WHITE, FIVE-POINTED STARS ARRANGED IN NINE OFFSET HORIZONTAL ROWS OF SIX STARS IN THE TOP AND BOTTOM ROWS ALTERNATING WITH ROWS OF FIVE STARS. TO THE RIGHT AND BENEATH THE GREEN RECTANGULAR FIELD ARE THIRTEEN EQUAL HORIZONTAL STRIPES OF GREEN AT THE TOP AND BOTTOM ALTERNATING WITH WHITE STRIPES.

FOR RETAIL STORE SERVICES FEATURING CLOTHING SUCH AS ORGANIC SHIRTS, HATS, PANTS, AND JACKETS, HANDBAGS, TOTE BAGS, AND JEWELRY; RETAIL STORE SERVICES FEATURING ECO-LIFESTYLE PRODUCTS IN THE NATURE OF SOLAR BACKPACKS, COMPOST KITS, AND CLEAN TECHNOLOGY MACHINES, TOOLS, AND ELECTRONICS; PROMOTING PUBLIC AWARENESS OF SOLUTIONS TO ENVIRONMENTAL PROBLEMS (U.S. CLS. 100, 101 AND 102).

FIRST USE 5-31-2007; IN COMMERCE 12-1-2007.

3,481,624. RAISE YOUR HAND FOR PUBLIC SCHOOLS, SAN ANTONIO, TX. SN 77-158,501. PUB. 9-11-2007, FILED 4-17-2007.

RAISE YOUR HAND

THE MARK CONSISTS OF STANDARD CHARACTERS WITHOUT CLAIM TO ANY PARTICULAR FONT, STYLE, SIZE, OR COLOR.

FOR ASSOCIATION SERVICES, NAMELY, PROMOTING PUBLIC AWARENESS OF THE NEED FOR CHANGES IN STATE, LOCAL, AND NATIONAL EDUCATIONAL POLICIES AND EDUCATIONAL FUNDING; PROMOTING AND ADVOCATING CHANGES IN STATE, LOCAL, AND NATIONAL EDUCATIONAL POLICIES AND EDUCATIONAL FUNDING; COORDINATION OF LOBBYING AND ADVOCACY EFFORTS TO PROMOTE AND ADVOCATE CHANGES IN STATE, LOCAL, AND NATIONAL EDUCATIONAL POLICIES AND EDUCATIONAL FUNDING; CHARITABLE SERVICES, NAMELY, ORGANIZING AND CONDUCTING VOLUNTEER PROGRAMS AND COMMUNITY SERVICE PROJECTS (U.S. CLS. 100, 101 AND 102).

FIRST USE 1-0-2007; IN COMMERCE 1-0-2007.

CLASS 35—(Continued).

3,481,625. RAISE YOUR HAND FOR PUBLIC SCHOOLS, SAN ANTONIO, TX. SN 77-158,613. PUB. 9-11-2007, FILED 4-17-2007.

RAISE YOUR HAND TEXAS

THE MARK CONSISTS OF STANDARD CHARACTERS WITHOUT CLAIM TO ANY PARTICULAR FONT, STYLE, SIZE, OR COLOR.

NO CLAIM IS MADE TO THE EXCLUSIVE RIGHT TO USE "TEXAS", APART FROM THE MARK AS SHOWN.

FOR ASSOCIATION SERVICES, NAMELY, PROMOTING PUBLIC AWARENESS OF THE NEED FOR CHANGES IN STATE, LOCAL, AND NATIONAL EDUCATIONAL POLICIES AND EDUCATIONAL FUNDING; PROMOTING AND ADVOCATING CHANGES IN STATE, LOCAL, AND NATIONAL EDUCATIONAL POLICIES AND EDUCATIONAL FUNDING; COORDINATION OF LOBBYING AND ADVOCACY EFFORTS TO PROMOTE AND ADVOCATE CHANGES IN STATE, LOCAL, AND NATIONAL EDUCATIONAL POLICIES AND EDUCATIONAL FUNDING; CHARITABLE SERVICES, NAMELY, ORGANIZING AND CONDUCTING VOLUNTEER PROGRAMS AND COMMUNITY SERVICE PROJECTS (U.S. CLS. 100, 101 AND 102).

FIRST USE 1-0-2007; IN COMMERCE 1-0-2007.

3,481,627. RAISE YOUR HAND FOR PUBLIC SCHOOLS, SAN ANTONIO, TX. SN 77-159,384. PUB. 9-11-2007, FILED 4-18-2007.



FOR ASSOCIATION SERVICES, NAMELY, PROMOTING PUBLIC AWARENESS OF THE NEED FOR CHANGES IN STATE, LOCAL, AND NATIONAL EDUCATIONAL POLICIES AND EDUCATIONAL FUNDING; PROMOTING AND ADVOCATING CHANGES IN STATE, LOCAL, AND NATIONAL EDUCATIONAL POLICIES AND EDUCATIONAL FUNDING; COORDINATION OF LOBBYING AND ADVOCACY EFFORTS TO PROMOTE AND ADVOCATE CHANGES IN STATE, LOCAL, AND NATIONAL EDUCATIONAL POLICIES AND EDUCATIONAL FUNDING; CHARITABLE SERVICES, NAMELY, ORGANIZING AND CONDUCTING VOLUNTEER PROGRAMS AND COMMUNITY SERVICE PROJECTS (U.S. CLS. 100, 101 AND 102).

FIRST USE 1-0-2007; IN COMMERCE 1-0-2007.

CLASS 35—(Continued).

3,481,628. RAISE YOUR HAND FOR PUBLIC SCHOOLS, SAN ANTONIO, TX. SN 77-159,423. PUB. 9-11-2007, FILED 4-18-2007.



NO CLAIM IS MADE TO THE EXCLUSIVE RIGHT TO USE "TEXAS", APART FROM THE MARK AS SHOWN.

FOR ASSOCIATION SERVICES, NAMELY, PROMOTING PUBLIC AWARENESS OF THE NEED FOR CHANGES IN STATE, LOCAL, AND NATIONAL EDUCATIONAL POLICIES AND EDUCATIONAL FUNDING; PROMOTING AND ADVOCATING CHANGES IN STATE, LOCAL, AND NATIONAL EDUCATIONAL POLICIES AND EDUCATIONAL FUNDING; COORDINATION OF LOBBYING AND ADVOCACY EFFORTS TO PROMOTE AND ADVOCATE CHANGES IN STATE, LOCAL, AND NATIONAL EDUCATIONAL POLICIES AND EDUCATIONAL FUNDING; CHARITABLE SERVICES, NAMELY, ORGANIZING AND CONDUCTING VOLUNTEER PROGRAMS AND COMMUNITY SERVICE PROJECTS (U.S. CLS. 100, 101 AND 102).

FIRST USE 1-0-2007; IN COMMERCE 1-0-2007.

3,481,638. TRIGUYS, ARLINGTON HEIGHTS, IL. SN 77-161,197. PUB. 10-30-2007, FILED 4-19-2007.



discover triathlon

NO CLAIM IS MADE TO THE EXCLUSIVE RIGHT TO USE "TRIATHLON", APART FROM THE MARK AS SHOWN.

THE MARK CONSISTS OF THREE STICK FIGURES, EACH ONE WITH A SMILE, EACH ONE WITH HAIR SPIKED UP. (FROM LEFT TO RIGHT) ONE SWIMMING, ONE BIKING, ONE RUNNING. THERE IS A VERTICAL BAR SEPARATING THE SWIMMER FROM THE BIKER AND A VERTICAL BAR SEPARATING THE BIKER FROM THE RUNNER.

FOR ON-LINE RETAIL STORE SERVICES FEATURING HATS, SHIRTS, SOCKS, WATER BOTTLES, MUGS, MAGNETS, STICKERS, SHOES, BUTTONS, BAGS, NAMELY, DUFFLE, BACK PACK, TRAVEL, AND TOTE BAGS, CARDS, POSTERS, CALENDARS, STAMPS, HELMETS, BIKES, BIKE JERSEYS, SHORTS, SWEAT SHIRTS, T-SHIRTS, SWEAT PANTS, PENS, KNIVES, GLASSWARE, BOOKS, MAGAZINES, COLORING BOOKS, TOWELS, WATCHES, NECK TIES; RETAIL STORE SERVICES FEATURING HATS, SHIRTS, SOCKS, WATER BOTTLES, MUGS, MAGNETS, STICKERS, SHOES, BUTTONS, BAGS, NAMELY, DUFFLE, BACK PACK, TRAVEL, AND TOTE BAGS, CARDS, POSTERS, CALENDARS, STAMPS, HELMETS, BIKES, BIKE JERSEYS, SHORTS, SWEAT SHIRTS, T-SHIRTS, SWEAT PANTS, PENS, KNIVES, GLASSWARE, BOOKS, MAGAZINES, COLORING BOOKS, TOWELS, WATCHES, NECK TIES (U.S. CLS. 100, 101 AND 102).

FIRST USE 4-19-2007; IN COMMERCE 8-8-2007.

CLASS 35—(Continued).

3,481,683. DAVID MILLER, FORT HUACHUCA, AZ. SN 77-174,017. PUB. 2-12-2008, FILED 5-7-2007.

Times is Hard

THE MARK CONSISTS OF STANDARD CHARACTERS WITHOUT CLAIM TO ANY PARTICULAR FONT, STYLE, SIZE, OR COLOR.

FOR ONLINE STORE SERVICES FEATURING APPAREL, POSTERS, BUMPER STICKERS, AND MUGS (U.S. CLS. 100, 101 AND 102).

FIRST USE 4-14-2007; IN COMMERCE 5-8-2007.

3,481,718. POWER-SELLES IMPORTS, INC., WOODINVILLE, WA. SN 77-182,590. PUB. 1-8-2008, FILED 5-16-2007.

Culinary Collective

THE MARK CONSISTS OF STANDARD CHARACTERS WITHOUT CLAIM TO ANY PARTICULAR FONT, STYLE, SIZE, OR COLOR.

NO CLAIM IS MADE TO THE EXCLUSIVE RIGHT TO USE "CULINARY", APART FROM THE MARK AS SHOWN.

FOR GOODS IMPORT-EXPORT AGENCIES; BUSINESS MANAGEMENT SERVICES, NAMELY, MANAGING LOGISTICS, REVERSE LOGISTICS, SUPPLY CHAIN SERVICES, SUPPLY CHAIN VISIBILITY AND SYNCHRONIZATION, SUPPLY AND DEMAND FORECASTING AND PRODUCT DISTRIBUTION PROCESSES FOR OTHERS (U.S. CLS. 100, 101 AND 102).

FIRST USE 7-1-2007; IN COMMERCE 7-1-2007.

3,481,743. VALASSIS COMMUNICATIONS, INC., LIVONIA, MI. SN 77-190,841. PUB. 2-26-2008, FILED 5-25-2007.

REDPLUM

THE MARK CONSISTS OF STANDARD CHARACTERS WITHOUT CLAIM TO ANY PARTICULAR FONT, STYLE, SIZE, OR COLOR.

FOR PROMOTING THE GOODS AND SERVICES OF OTHERS THROUGH THE DISTRIBUTION OF COUPONS, SAMPLES AND PRINTED ADVERTISING; ADVERTISING AND MEDIA PLANNING SERVICES, NAMELY, BUSINESS MARKETING CONSULTING SERVICES; MARKET ANALYSIS; DISSEMINATION OF ADVERTISING FOR OTHERS VIA ON-LINE ELECTRONIC COMMUNICATIONS NETWORK (U.S. CLS. 100, 101 AND 102).

FIRST USE 1-3-2008; IN COMMERCE 1-3-2008.

CLASS 35—(Continued).

3,481,749. HIGHWAYHARBOR MANAGEMENT CO., NORTH MANKATO, MN. SN 77-195,634. PUB. 11-20-2007, FILED 6-1-2007.

HIGHWAYHARBOR MANAGEMENT CO

THE MARK CONSISTS OF STANDARD CHARACTERS WITHOUT CLAIM TO ANY PARTICULAR FONT, STYLE, SIZE, OR COLOR.

NO CLAIM IS MADE TO THE EXCLUSIVE RIGHT TO USE "MANAGEMENT CO", APART FROM THE MARK AS SHOWN.

FOR BUSINESS CONSULTING SERVICES IN THE FIELD OF HOTEL AND MOTEL MANAGEMENT; HOTEL AND MOTEL MANAGEMENT FOR OTHERS; ACCOUNTING CONSULTATION AND ACCOUNTING SERVICES FOR OTHERS (U.S. CLS. 100, 101 AND 102).

FIRST USE 3-22-2007; IN COMMERCE 3-22-2007.

3,481,776. BANK OF AMERICA CORPORATION, CHARLOTTE, NC. SN 77-209,558. PUB. 3-11-2008, FILED 6-19-2007.

EXPRESS INVOICING

THE MARK CONSISTS OF STANDARD CHARACTERS WITHOUT CLAIM TO ANY PARTICULAR FONT, STYLE, SIZE, OR COLOR.

NO CLAIM IS MADE TO THE EXCLUSIVE RIGHT TO USE "INVOICING", APART FROM THE MARK AS SHOWN.

FIRST USE 8-0-2007; IN COMMERCE 8-0-2007.

CLASS 35—(Continued).

3,481,790. LOVER'S LANE I.P., LTD., PLYMOUTH, MI. SN 77-214,365. PUB. 12-4-2007, FILED 6-25-2007.

THE PLEASURE IS YOURS

THE MARK CONSISTS OF STANDARD CHARACTERS WITHOUT CLAIM TO ANY PARTICULAR FONT, STYLE, SIZE, OR COLOR.

FOR RETAIL STORE SERVICES, SHOP-AT-HOME PARTY SERVICES, ONLINE, MAIL ORDER AND CATALOG ORDERING SERVICES ALL FEATURING NOVELTY ITEMS, TOYS, MARITAL AIDS, SEXUAL AIDS, SEXUAL ENHANCEMENT PRODUCTS, GIFT ITEMS, ADULT THEME MOVIES AND BOOKS, GREETING CARDS, LINGERIE, UNDERWEAR, SWIMWEAR, CLOTHING, COSTUMES AND ACCESSORIES FOR WOMEN AND MEN (U.S. CLS. 100, 101 AND 102).

FIRST USE 1-13-2008; IN COMMERCE 1-13-2008.

3,481,814. LUNCHBAGZ, LLC, HEWLETT, NY. SN 77-227,653. PUB. 1-15-2008, FILED 7-12-2007.

LUNCHBAGZ

THE MARK CONSISTS OF STANDARD CHARACTERS WITHOUT CLAIM TO ANY PARTICULAR FONT, STYLE, SIZE, OR COLOR.

FOR ADVERTISING AND MARKETING; ADVERTISING, MARKETING AND PROMOTION SERVICES; BUSINESS MARKETING AND DIRECT MAIL CONSULTING SERVICES; BUSINESS MARKETING CONSULTING SERVICES; BUSINESS MARKETING SERVICES; CREATIVE MARKETING DESIGN SERVICES; DEVELOPMENT OF MARKETING STRATEGIES AND CONCEPTS; DIRECT MARKETING ADVERTISING FOR OTHERS; DIRECT MARKETING SERVICES; MARKETING PLAN DEVELOPMENT; PROMOTION AND MARKETING SERVICES AND RELATED CONSULTING (U.S. CLS. 100, 101 AND 102).

FIRST USE 8-24-2007; IN COMMERCE 8-24-2007.

CLASS 35—(Continued).

3,481,830. ELLIANOS, LLC, LAKE CITY, FL. SN 77-236,995. PUB. 12-11-2007, FILED 7-24-2007.



THE MARK CONSISTS OF HERO FRAN & DESIGN. FOR FRANCHISE SERVICES, NAMELY, OFFERING TECHNICAL AND BUSINESS MANAGEMENT ASSISTANCE IN THE ESTABLISHMENT AND OPERATION OF RESTAURANTS AND FEATURING AN INCENTIVE PROGRAM TO ENCOURAGE PARTICIPATION OF CURRENT AND FORMER MILITARY, LAW ENFORCEMENT AND FIRE FIGHTING PERSONNEL IN FRANCHISING OPPORTUNITIES (U.S. CLS. 100, 101 AND 102). FIRST USE 6-1-2007; IN COMMERCE 6-1-2007.

3,481,871. P&D ENTERPRISES, INC., DBA WALLABY'S LIQUOR WAREHOUSE, PARKER, CO. SN 77-249,012. PUB. 2-12-2008, FILED 8-7-2007.



THE MARK CONSISTS OF THE WORDING "WALLABY'S", WHICH IS CREATED BY USING TWO WALLABIES TO FORM THE LETTER "W." FOR RETAIL LIQUOR STORES (U.S. CLS. 100, 101 AND 102). FIRST USE 10-31-2007; IN COMMERCE 10-31-2007.

CLASS 35—(Continued).

3,481,883. DONMAR ENTERPRISES, INC., ROCHELLE PARK, NJ. SN 77-254,743. PUB. 2-19-2008, FILED 8-14-2007.



NO CLAIM IS MADE TO THE EXCLUSIVE RIGHT TO USE "ENTERPRISES, INC.", APART FROM THE MARK AS SHOWN.

THE MARK CONSISTS OF A OUTLINE OF CAT AND DOG, THE WORDS "DONMAR ENTERPRISES, INC" TO THE LEFT OF OUTLINE.

FOR ON-LINE RETAIL STORE SERVICES FEATURING PET SUPPLIES, BEDS, CARRIERS, HEALTH ITEMS SUCH AS VITAMINS AND HEALTH AIDS, FLEA AND TICK PRODUCTS, DINNERWARE, HOUSEBREAKING TRAINING AIDS SUCH AS HALTER COLLARS, INFORMATIONAL DVDS, AND TREATS (U.S. CLS. 100, 101 AND 102).

FIRST USE 8-3-2007; IN COMMERCE 8-3-2007.

3,481,886. FLATBURGER, INC., TROY, NY. SN 77-255,500. PUB. 2-26-2008, FILED 8-15-2007.

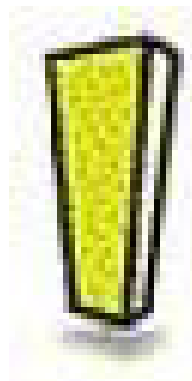

THE COLOR(S) YELLOW, DARK GRAY, AND GRAY IS/ ARE CLAIMED AS A FEATURE OF THE MARK.

THE MARK CONSISTS OF A MONOLITH. THE COLOR YELLOW APPEARS IN THE DESIGN, THE COLOR DARK GRAY APPEARS AROUND THE PERIMETER, AND THE COLOR GRAY APPEARS IN THE SHADOW BEHIND THE DESIGN.

FOR ON-LINE TRADING SERVICES TO FACILITATE THE SALE OF GOODS BY OTHERS VIA A COMPUTER NETWORK AND PROVIDING EVALUATIVE FEEDBACK AND RATINGS OF SELLERS' GOODS AND SERVICES, THE VALUE AND PRICES OF SELLERS' GOODS, BUYERS' AND SELLERS' PERFORMANCE, DELIVERY, AND OVERALL TRADING EXPERIENCE IN CONNECTION THEREWITH (U.S. CLS. 100, 101 AND 102).

FIRST USE 10-1-2007; IN COMMERCE 10-1-2007.

CLASS 35—(Continued).

3,481,900. VALASSIS COMMUNICATIONS, INC., LIVONIA, MI. SN 77-261,642. PUB. 2-26-2008, FILED 8-22-2007.



THE MARK CONSISTS OF THE TOP OUTLINE OF A LEAF WITH THE TOP OUTLINE OF A PLUM UNDERNEATH, OUTLINE CONNECTS FROM THE "R" TO THE "M" OF THE MARK "REDPLUM" BELOW.

FOR PROMOTING THE GOODS AND SERVICES OF OTHERS THROUGH THE DISTRIBUTION OF COUPONS, SAMPLES AND PRINTED ADVERTISING; ADVERTISING AND MEDIA PLANNING SERVICES, NAMELY, BUSINESS MARKETING CONSULTING SERVICES; MARKET ANALYSIS; DISSEMINATION OF ADVERTISING FOR OTHERS VIA ON-LINE ELECTRONIC COMMUNICATIONS NETWORK (U.S. CLS. 100, 101 AND 102).

FIRST USE 1-3-2008; IN COMMERCE 1-3-2008.

3,481,913. MARKETING ARCHITECTS, INC., MINNEAPOLIS, MN. SN 77-266,301. PUB. 2-26-2008, FILED 8-28-2007.

AUDIOSMART

THE MARK CONSISTS OF STANDARD CHARACTERS WITHOUT CLAIM TO ANY PARTICULAR FONT, STYLE, SIZE, OR COLOR.

FOR ADVERTISING, MARKETING AND BUSINESS CONSULTING SERVICES IN CONNECTION WITH AUDIO MEDIA (U.S. CLS. 100, 101 AND 102).

FIRST USE 10-1-2007; IN COMMERCE 10-1-2007.

3,481,930. NOTESHUFFLE.COM, LLC, SHERMAN OAKE, CA. SN 77-276,981. PUB. 3-4-2008, FILED 9-11-2007.

NOTESHUFFLE.COM

THE MARK CONSISTS OF STANDARD CHARACTERS WITHOUT CLAIM TO ANY PARTICULAR FONT, STYLE, SIZE, OR COLOR.

FOR OPERATING ON-LINE MARKETPLACES FEATURING THE BUYING AND SELLING OF COLLEGE LECTURE NOTES (U.S. CLS. 100, 101 AND 102).

FIRST USE 2-19-2008; IN COMMERCE 2-19-2008.

CLASS 35—(Continued).

3,481,934. GEMMA, ANTHONY, LINCOLN, RI. SN 77-278,813. PUB. 3-11-2008, FILED 9-13-2007.

**DRIVING PERFORMANCE
EXCELLENCE**

THE MARK CONSISTS OF STANDARD CHARACTERS WITHOUT CLAIM TO ANY PARTICULAR FONT, STYLE, SIZE, OR COLOR.

FOR BUSINESS CONSULTING SERVICES RELATING TO SERVICE DELIVERY INDUSTRIES; BUSINESS ORGANIZATION CONSULTING AND BUSINESS MANAGEMENT CONSULTING RELATING TO SOFTWARE FOR STRUCTURING AND MANAGEMENT OF BUSINESSES IN SERVICE DELIVERY INDUSTRIES (U.S. CLS. 100, 101 AND 102).

FIRST USE 9-0-2007; IN COMMERCE 9-0-2007.

3,481,937. DIGITAL IMS, INC, LINCOLN, NE. SN 77-279,625. PUB. 3-4-2008, FILED 9-14-2007.



THE MARK CONSISTS OF A CIRCULAR SHAPE WITH A STYLIZED "F" MEANDERING THROUGH THE MIDDLE AND THE TEXT "FIRESPRING" NEXT TO IT.

FOR ADVERTISING AGENCIES, NAMELY, PROMOTING THE GOODS AND SERVICES OF OTHERS; ADVERTISING SERVICES, NAMELY, CREATING CORPORATE AND BRAND IDENTITY FOR OTHERS; ADVERTISING SERVICES, NAMELY, PROMOTING AND MARKETING THE GOODS AND SERVICES OF OTHERS THROUGH ALL PUBLIC COMMUNICATION MEANS; ADVERTISING, MARKETING AND PROMOTION SERVICES; FRANCHISE SERVICES, NAMELY, OFFERING TECHNICAL AND BUSINESS MANAGEMENT ASSISTANCE IN THE ESTABLISHMENT AND OPERATION OF INTERNET BASED ADVERTISING AGENCY AND WEB SITE DEVELOPMENT BUSINESSES (U.S. CLS. 100, 101 AND 102).

FIRST USE 10-1-2007; IN COMMERCE 10-1-2007.

3,481,938. NIELSEN BUSINESS MEDIA, INC., NEW YORK, NY. SN 77-279,744. PUB. 3-11-2008, FILED 9-14-2007.

NEW YORK IS BOOK COUNTRY

THE MARK CONSISTS OF STANDARD CHARACTERS WITHOUT CLAIM TO ANY PARTICULAR FONT, STYLE, SIZE, OR COLOR.

CLASS 35—(Continued).

NO CLAIM IS MADE TO THE EXCLUSIVE RIGHT TO USE "NEW YORK", APART FROM THE MARK AS SHOWN.

FOR ARRANGING AND CONDUCTING TRADE SHOWS AND BUSINESS CONFERENCES IN THE FIELD OF BOOKS AND LITERATURE, DIRECTED TO THE LITERARY INDUSTRY (U.S. CLS. 100, 101 AND 102).

FIRST USE 8-1-2007; IN COMMERCE 8-1-2007.

CLASS 35—(Continued).

3,481,981. E & H DISTRIBUTING CO., NORTH LAS VEGAS, NV. SN 77-315,241. PUB. 3-11-2008, FILED 10-27-2007.

3,481,940. EDL TECHNOLOGY, LLC, FREDERICK, MD. SN 77-280,858. PUB. 3-4-2008, FILED 9-17-2007.

THE WANT OUTLET

THE MARK CONSISTS OF STANDARD CHARACTERS WITHOUT CLAIM TO ANY PARTICULAR FONT, STYLE, SIZE, OR COLOR.

NO CLAIM IS MADE TO THE EXCLUSIVE RIGHT TO USE "OUTLET", APART FROM THE MARK AS SHOWN.

FOR PROVIDING AN ON-LINE SEARCHABLE DATABASE FEATURING CLASSIFIED AD LISTINGS OF WANTED ITEMS (U.S. CLS. 100, 101 AND 102).

FIRST USE 7-3-2007; IN COMMERCE 8-16-2007.

YOUR PARTNER BEYOND THE PLATE

THE MARK CONSISTS OF STANDARD CHARACTERS WITHOUT CLAIM TO ANY PARTICULAR FONT, STYLE, SIZE, OR COLOR.

FOR WHOLESALE DISTRIBUTORSHIPS FEATURING FOOD, PAPER PRODUCTS, SUPPLIES AND EQUIPMENT RELATED TO THE FOOD SERVICE INDUSTRY (U.S. CLS. 100, 101 AND 102).

FIRST USE 2-0-2008; IN COMMERCE 2-0-2008.

3,482,011. BELLA FIGURA, INC., DENVER, CO. SN 78-302,288. PUB. 10-3-2006, FILED 9-18-2003.

3,481,967. PERLMAN ERIC, GRANADA HILLS, CA. SN 77-298,320. PUB. 3-18-2008, FILED 10-8-2007.

IT'S YOUR LIFE...FREE IT UP!

THE MARK CONSISTS OF STANDARD CHARACTERS WITHOUT CLAIM TO ANY PARTICULAR FONT, STYLE, SIZE, OR COLOR.

FOR COMPUTERIZED ON-LINE GIFT ORDERING SERVICE WHICH MATCHES THE GIFT GIVER'S REQUIREMENTS WITH THE GIFT RECIPIENT'S WANTS AND NEEDS (U.S. CLS. 100, 101 AND 102).

FIRST USE 2-1-2003; IN COMMERCE 1-1-2008.

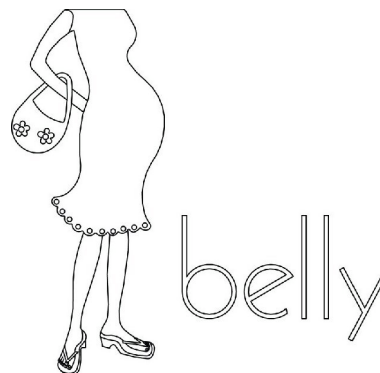

THE MARK CONSISTS OF OUTLINE OF A PREGNANT WOMAN.

FOR RETAIL STORE SERVICES IN THE FIELD OF MATERNITY CLOTHING (U.S. CLS. 100, 101 AND 102).

FIRST USE 12-1-2002; IN COMMERCE 12-1-2002.

CLASS 35—(Continued).

3,482,018. FOSSIL, INC., RICHARDSON, TX. SN 78-343,554. PUB. 4-5-2005, FILED 12-19-2003.

CLASS 35—(Continued).

3,482,121. JOURNEY EDUCATION MARKETING, INC., DALLAS, TX. SN 78-624,893. PUB. 1-24-2006, FILED 5-6-2005.

MICHELE

**STUDENTS SAVE. OTHERS
DON'T.**

THE MARK CONSISTS OF STANDARD CHARACTERS WITHOUT CLAIM TO ANY PARTICULAR FONT, STYLE, SIZE, OR COLOR.

OWNER OF U.S. REG. NOS. 1,812,074, 2,129,528, AND 2,715,932.

FOR ONLINE RETAIL STORE SERVICES FEATURING SUNGLASSES AND WATCHES (U.S. CLS. 100, 101 AND 102).

FIRST USE 9-0-2006; IN COMMERCE 9-0-2006.

THE MARK CONSISTS OF STANDARD CHARACTERS WITHOUT CLAIM TO ANY PARTICULAR FONT, STYLE, SIZE, OR COLOR.

FOR CATALOG AND ONLINE RETAIL STORE SERVICES FEATURING COMPUTER SOFTWARE, COMPUTER HARDWARE AND BOOKS RELATING THERETO (U.S. CLS. 100, 101 AND 102).

FIRST USE 2-28-2006; IN COMMERCE 2-28-2006.

3,482,053. HARPER, CLETE D., BAKERSFIELD, CA. SN 78-457,957. PUB. 9-27-2005, FILED 7-28-2004.

3,482,152. THE ITALIAN TRADE COMMISSION, CHICAGO, IL. SN 78-666,813. PUB. 3-21-2006, FILED 7-8-2005.

REDNECK WINERY



**Machines
Italia**

Turning innovation into productivity.

THE MARK CONSISTS OF STANDARD CHARACTERS WITHOUT CLAIM TO ANY PARTICULAR FONT, STYLE, SIZE, OR COLOR.

OWNER OF U.S. REG. NO. 2,695,589.

NO CLAIM IS MADE TO THE EXCLUSIVE RIGHT TO USE "WINERY", APART FROM THE MARK AS SHOWN.

FOR COMPUTERIZED ON-LINE RETAIL AND WHOLESALE STORE SERVICES IN THE FIELD OF BEER AND WINE (U.S. CLS. 100, 101 AND 102).

FIRST USE 6-1-2008; IN COMMERCE 6-1-2008.

NO CLAIM IS MADE TO THE EXCLUSIVE RIGHT TO USE "MACHINES ITALIA", APART FROM THE MARK AS SHOWN.

THE ENGLISH TRANSLATION OF THE WORDING "ITALIA" IS "ITALY".

FOR ORGANIZING EXHIBITIONS TO PROMOTE MACHINERY, TECHNOLOGY AND MANUFACTURING PROCESSES FROM ITALY (U.S. CLS. 100, 101 AND 102).

FIRST USE 10-10-2007; IN COMMERCE 10-10-2007.

CLASS 35—(Continued).

3,482,182. AMERICAN PUBLIC POWER ASSOCIATION, WASHINGTON, DC. SN 78-720,177. PUB. 9-18-2007, FILED 9-26-2005.

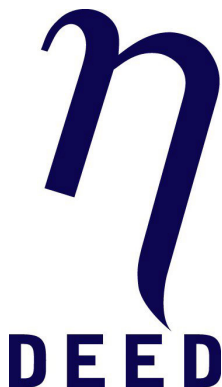

THE COLOR(S) NAVY IS/ARE CLAIMED AS A FEATURE OF THE MARK.

THE MARK CONSISTS OF THE GREEK LETTER "ETA" ABOVE THE WORD "DEED", ALL IN THE COLOR NAVY.

FOR PROMOTING PUBLIC AWARENESS OF ENERGY GENERATION AND SAFETY INNOVATION AND EFFICIENCY ON BEHALF OF THIRD PARTY MEMBERS (U.S. CLS. 100, 101 AND 102).

FIRST USE 5-29-2008; IN COMMERCE 5-29-2008.

3,482,188. FIREHOUSE RESTAURANT GROUP, INC., JACKSONVILLE, FL. SN 78-725,806. PUB. 12-25-2007, FILED 10-4-2005.



FOUNDED BY FIREMEN

OWNER OF U.S. REG. NOS. 1,903,135, 2,606,263, AND OTHERS.

NO CLAIM IS MADE TO THE EXCLUSIVE RIGHT TO USE "SUBS" AND "FOUNDED BY FIREMEN", APART FROM THE MARK AS SHOWN.

THE COLOR(S) RED, GOLD, WHITE AND BLACK IS/ARE CLAIMED AS A FEATURE OF THE MARK.

THE MARK CONSISTS OF THE WORDING "FIREHOUSE" LETTERED IN WHITE WITH BLACK OUTLINING ON A RED BACKGROUND AND THE WORDING "SUBS" IN GOLD ON A BLACK BACKGROUND, ALL ON A PLAQUE HAVING GOLD OUTLINING AND RIVETS AND THE WORDS "FOUNDED BY FIREMEN" IN BLACK.

FOR RESTAURANT FRANCHISING (U.S. CLS. 100, 101 AND 102).

FIRST USE 12-31-2005; IN COMMERCE 12-31-2005.

CLASS 35—(Continued).

3,482,211. PROVIDE COMMERCE, INC., SAN DIEGO, CA. SN 78-753,655. PUB. 7-18-2006, FILED 11-14-2005.

SECRET SPOON

THE MARK CONSISTS OF STANDARD CHARACTERS WITHOUT CLAIM TO ANY PARTICULAR FONT, STYLE, SIZE, OR COLOR.

FOR RETAIL AND ONLINE RETAIL STORE SERVICES FEATURING CANDY, CHOCOLATES, CONFECTIONS, COOKIES, DESSERTS, NUTS, GIFT BASKETS, BALLOONS AND STUFFED ANIMALS (U.S. CLS. 100, 101 AND 102).

FIRST USE 11-30-2005; IN COMMERCE 11-30-2005.

3,482,264. PITNEY BOWES INC., STAMFORD, CT. SN 78-789,509. PUB. 3-27-2007, FILED 1-11-2006.

CLEARPATH

THE MARK CONSISTS OF STANDARD CHARACTERS WITHOUT CLAIM TO ANY PARTICULAR FONT, STYLE, SIZE, OR COLOR.

FOR TRANSPORTATION LOGISTICS SERVICES, NAMELY, PROVIDING ON-LINE SHIPPING AND CUSTOMS CLEARANCE INFORMATION FEATURING CALCULATIONS OF LOGISTICS AND REVERSE LOGISTICS COSTS FOR SHIPPING AND HANDLING, CALCULATION OF TAXES, CUSTOMS DUTIES AND REVERSE LOGISTICS PROCESS; PROVIDING INFORMATION ABOUT CUSTOMS CLEARANCE IN THE NATURE OF INFORMATION ABOUT COMPLETION AND CLEARANCE OF CUSTOMS FORMS, PAYMENT OF TAXES, DUTIES, PAYMENT OF SHIPPERS AND HANDLERS; COMPUTERIZED TRACKING OF SHIPMENTS AND PACKAGES IN TRANSIT (U.S. CLS. 100, 101 AND 102).

FIRST USE 5-30-2006; IN COMMERCE 5-30-2006.

CLASS 35—(Continued).

3,482,265. MONSTER (CALIFORNIA), INC., LOS ANGELES, CA. SN 78-790,668. PUB. 8-29-2006, FILED 1-12-2006.

QUICKHIRE

THE MARK CONSISTS OF STANDARD CHARACTERS WITHOUT CLAIM TO ANY PARTICULAR FONT, STYLE, SIZE, OR COLOR.

OWNER OF U.S. REG. NO. 2,356,181.
FOR ONLINE RECRUITING SERVICES, NAMELY, PROVIDING SEARCHABLE JOB POSTINGS (U.S. CLS. 100, 101 AND 102).
FIRST USE 6-1-1996; IN COMMERCE 6-1-1996.

3,482,282. GREEN FOR GOOD, INC., EDMONDS, WA. SN 78-799,504. PUB. 9-19-2006, FILED 1-25-2006.

GREEN FOR GOOD

THE MARK CONSISTS OF STANDARD CHARACTERS WITHOUT CLAIM TO ANY PARTICULAR FONT, STYLE, SIZE, OR COLOR.

FOR ON-LINE RETAIL STORE SERVICES FEATURING A WIDE VARIETY OF ENVIRONMENTALLY CONSCIOUS CONSUMER GOODS OF OTHERS AND PROVIDING CONSUMER INFORMATION IN THE FIELD OF ENVIRONMENTAL CONSCIOUSNESS VIA THE GLOBAL COMPUTER NETWORK (U.S. CLS. 100, 101 AND 102).

FIRST USE 8-30-2005; IN COMMERCE 8-30-2005.

3,482,313. ONCUE MARKETING, LLC, STILLWATER, OK. SN 78-832,569. PUB. 9-25-2007, FILED 3-8-2006.

ONCUE EXPRESS

THE MARK CONSISTS OF STANDARD CHARACTERS WITHOUT CLAIM TO ANY PARTICULAR FONT, STYLE, SIZE, OR COLOR.

NO CLAIM IS MADE TO THE EXCLUSIVE RIGHT TO USE "EXPRESS", APART FROM THE MARK AS SHOWN.

FOR WHOLESALE DISTRIBUTORSHIPS FEATURING GASOLINE (U.S. CLS. 100, 101 AND 102).
FIRST USE 5-1-2006; IN COMMERCE 5-1-2006.

CLASS 35—(Continued).

3,482,314. ROSS-SIMONS OF WARWICK, INC., CRANSTON, RI. SN 78-832,983. PUB. 2-12-2008, FILED 3-9-2006.

RSVP

THE MARK CONSISTS OF STANDARD CHARACTERS WITHOUT CLAIM TO ANY PARTICULAR FONT, STYLE, SIZE, OR COLOR.

FOR RETAIL STORE SERVICES FEATURING JEWELRY (U.S. CLS. 100, 101 AND 102).
FIRST USE 7-0-2007; IN COMMERCE 7-0-2007.

3,482,319. CALSOTA SUPPLY, LLC, ST. PAUL, MN. SN 78-837,438. PUB. 11-7-2006, FILED 3-15-2006.

CALSOTA

THE MARK CONSISTS OF STANDARD CHARACTERS WITHOUT CLAIM TO ANY PARTICULAR FONT, STYLE, SIZE, OR COLOR.

FOR ON-LINE RETAIL STORE SERVICES AND WHOLESALE DISTRIBUTORSHIP SERVICES FEATURING NETTING USED IN OR ON HOOP HOUSES, GREENHOUSES, FIELDS, CROPLAND, VINEYARDS AND ORCHARDS TO SHIELD AND PROTECT GRAPES, BLUEBERRIES, RASPBERRIES, STRAWBERRIES AND OTHER FRUITS FROM BIRD DAMAGE, AGRICULTURAL AND HORTICULTURAL PRODUCTS, NAMELY, NETTING USED IN OR ON HOOP HOUSES, GREENHOUSES, FIELDS, CROPLAND, VINEYARDS AND ORCHARDS TO SHIELD AND PROTECT GRAPES, BLUEBERRIES, RASPBERRIES, STRAWBERRIES AND OTHER FRUITS FROM BIRD DAMAGE, CONSTRUCTION MATERIALS AND PRODUCTS, NAMELY, ELECTRICAL TAPE, FLAGGING TAPE, BARRICADE TAPE, SILT FENCING AND SAND BAGS, INDUSTRIAL SUPPLIES AND PRODUCTS, NAMELY, ELECTRICAL TAPE, FLAGGING TAPE, BARRICADE TAPE, SILT FENCING AND SAND BAGS, COMMERCIAL NETS USED ON AND IN MONUMENTS, BUILDINGS AND OTHER STRUCTURES TO PREVENT ACCESS OR PERCHING BY BIRDS, AND AGRICULTURAL AND HORTICULTURAL PRODUCTS, NAMELY, NETS USED ON AND IN MONUMENTS, BUILDINGS AND OTHER STRUCTURES TO PREVENT ACCESS OR PERCHING BY BIRDS (U.S. CLS. 100, 101 AND 102).

FIRST USE 6-0-2006; IN COMMERCE 6-0-2006.

CLASS 35—(Continued).

3,482,324. PAYLESS SHOESOURCE WORLDWIDE, INC., TOPEKA, KS. SN 78-840,254. PUB. 9-19-2006, FILED 3-17-2006.



OWNER OF U.S. REG. NOS. 2,126,943, 2,301,896, AND OTHERS.

THE COLOR(S) ORANGE AND PALE BLUE IS/ARE CLAIMED AS A FEATURE OF THE MARK.

THE COLOR ORANGE APPEARS IN THE STYLIZED LETTER P AND THE TERMS PAYLESS SHOESOURCE; THE COLOR BLUE APPEARS IN THE ARC SHAPE OPPOSITE THE STYLIZED ORANGE LETTER P.

THE MARK CONSISTS OF A STYLIZED LETTER "P" WHICH FORMS PART OF A CIRCLE, ALL IN CLOSE PROXIMITY TO THE WORDS "PAYLESS SHOESOURCE".

FOR RETAIL SHOE AND FASHION ACCESSORIES STORE SERVICES; COMPUTERIZED ON-LINE RETAIL SERVICES IN THE FIELD OF FOOTWEAR, APPAREL, PURSES, HANDBAGS, AND BACKPACKS, ACCESSIBLE VIA GLOBAL COMPUTER NETWORKS (U.S. CLS. 100, 101 AND 102).

FIRST USE 12-6-2007; IN COMMERCE 12-6-2007.

3,482,330. JOHNSON, JEAN, CHESTERFIELD, MO. SN 78-849,540. PUB. 10-31-2006, FILED 3-29-2006.

All Moms Go To Heaven

THE MARK CONSISTS OF STANDARD CHARACTERS WITHOUT CLAIM TO ANY PARTICULAR FONT, STYLE, SIZE, OR COLOR.

FOR ONLINE RETAIL STORE SERVICES FEATURING T-SHIRTS, GREETING CARDS, JEWELRY, MAGNETS, FLORAL ARRANGEMENTS, PHOTO ALBUMS, PICTURE FRAMES, BOOKS, CALENDARS, COFFEE MUGS, SUN VISORS, CHRISTMAS ORNAMENTS, JOURNALS, BOOKMARKS, AND GIFT ITEMS (U.S. CLS. 100, 101 AND 102).

FIRST USE 4-1-2006; IN COMMERCE 4-1-2006.

CLASS 35—(Continued).

3,482,332. X, INC., DBA ONE STOP SHOP, CANOGA PARK, CA. SN 78-850,594. PUB. 5-1-2007, FILED 3-30-2006.



THE MARK CONSISTS OF THE LOGO BEING USED WITH THE WORD MARK IN THE CLASSES APPLIED FOR.

FOR DISTRIBUTORSHIP SERVICES IN THE FIELDS OF TONER AND TONER CARTRIDGES FOR PRINTERS, FACSIMILE, PHOTOCOPYING AND OTHER IMAGE REPRODUCING MACHINES; DISTRIBUTORSHIP SERVICES IN THE FIELD OF INK CARTRIDGES FOR PRINTERS, FACSIMILE, PHOTOCOPYING AND OTHER IMAGE REPRODUCING MACHINES (U.S. CLS. 100, 101 AND 102).

FIRST USE 6-0-2006; IN COMMERCE 6-0-2006.

3,482,345. TARGETSMART COMMUNICATIONS, INC., WASHINGTON, DC. SN 78-856,738. PUB. 10-2-2007, FILED 4-7-2006.

TargetSmart Communications

THE MARK CONSISTS OF STANDARD CHARACTERS WITHOUT CLAIM TO ANY PARTICULAR FONT, STYLE, SIZE, OR COLOR.

NO CLAIM IS MADE TO THE EXCLUSIVE RIGHT TO USE "COMMUNICATIONS", APART FROM THE MARK AS SHOWN.

FOR PROVIDING ONLINE AND DOWNLOADABLE DEMOGRAPHIC DATA, AND DATA INTEGRATION SERVICES FOR USE IN CONNECTION WITH POLITICAL CONSULTATION AND ANALYSIS (U.S. CLS. 100, 101 AND 102).

FIRST USE 3-0-2006; IN COMMERCE 3-0-2006.

CLASS 35—(Continued).

3,482,348. EDX ELECTRONICS, INC., WINTER SPRINGS, FL. SN 78-857,666. PUB. 8-7-2007, FILED 4-10-2006.



FOR PROVIDING ON-LINE BUSINESS INFORMATION IN THE FIELDS OF SALES AND PURCHASE OF ELECTRONIC COMPONENTS, NAMELY, PROVIDING INFORMATION ABOUT COMPONENT AVAILABILITY, BENCHMARK PRICING, FACTORY LEAD TIME, SALES HISTORY, PURCHASE HISTORY AND GLOBAL AVAILABILITY SHOWING SUPPLIER INFORMATION SPECIFICS, NAMELY, QUANTITY OF PART COMPONENT AVAILABILITY AND PART COMPONENT PRICING AND FACTORY DELIVERY LEAD TIME, ON ELECTRONIC PART COMPONENTS BEING SEARCHED, PAST CUSTOMER SALES AND ORDER HISTORY AND MANUFACTURERS REQUESTS FOR PRICES (U.S. CLS. 100, 101 AND 102).

FIRST USE 4-11-2006; IN COMMERCE 4-11-2006.

CLASS 35—(Continued).

3,482,359. TURTLE BAY INSTITUTE, INC., PRINCETON, NJ. SN 78-864,650. PUB. 3-27-2007, FILED 4-19-2006.

TBI CLARITY

THE MARK CONSISTS OF STANDARD CHARACTERS WITHOUT CLAIM TO ANY PARTICULAR FONT, STYLE, SIZE, OR COLOR.

FOR MARKET RESEARCH SERVICES (U.S. CLS. 100, 101 AND 102).

FIRST USE 7-12-2006; IN COMMERCE 7-12-2006.

3,482,371. JOHNSON, JEAN, CHESTERFIELD, MO. SN 78-875,988. PUB. 11-7-2006, FILED 5-3-2006.

all moms go to heaven

3,482,353. CONNOR, ROBERT A., MINNEAPOLIS, MN. SN 78-861,475. PUB. 4-3-2007, FILED 4-13-2006.



THE COLOR(S) RED, ORANGE AND YELLOW IS/ARE CLAIMED AS A FEATURE OF THE MARK.

THE COLOR YELLOW APPEARS IN THE WORD, "HOLOPLAYERS" AND IN THE OVAL, THE COLOR RED APPEARS IN THE OUTLINES OF THE WORD, "HOLOPLAYERS", AND THE COLOR ORANGE APPEARS IN THE OVAL.

FOR DISSEMINATION OF ADVERTISING FOR OTHERS VIA THE INTERNET (U.S. CLS. 100, 101 AND 102).

FIRST USE 6-22-2008; IN COMMERCE 6-22-2008.

THE MARK CONSISTS OF STYLIZED TEXT OF THE WORDING "ALL MOMS GO TO HEAVEN".

FOR ON-LINE RETAIL STORE SERVICES FEATURING T-SHIRTS, GREETING CARDS, JEWELRY, MAGNETS, FLORAL ARRANGEMENTS, PHOTO ALBUMS, PICTURE FRAMES, BOOKS, CALENDARS, COFFEE MUGS, SUN VISORS, CHRISTMAS ORNAMENTS, JOURNALS, BOOKMARKS, AWARDS, TROPHIES, AND GIFT ITEMS (U.S. CLS. 100, 101 AND 102).

FIRST USE 6-1-2006; IN COMMERCE 6-1-2006.

CLASS 35—(Continued).

3,482,373. JOHNSON, JEAN, CHESTERFIELD, MO. SN 78-879,209. PUB. 10-31-2006, FILED 5-8-2006.



THE MARK CONSISTS OF "A" STYLIZED "M" WITH A HALO.

FOR ON-LINE RETAIL STORE SERVICES FEATURING T-SHIRTS, GREETING CARDS, JEWELRY, MAGNETS, FLORAL ARRANGEMENTS, PHOTO ALBUMS, PICTURE FRAMES, BOOKS, CALENDARS, COFFEE MUGS, SUN VISORS, CHRISTMAS ORNAMENTS, JOURNALS, BOOKMARKS, AND GIFT ITEMS; RETAIL STORES FEATURING T-SHIRTS, GREETING CARDS, JEWELRY, MAGNETS, FLORAL ARRANGEMENTS, PHOTO ALBUMS, PICTURE FRAMES, BOOKS, CALENDARS, COFFEE MUGS, SUN VISORS, CHRISTMAS ORNAMENTS, JOURNALS, BOOKMARKS, AND GIFT ITEMS (U.S. CLS. 100, 101 AND 102).

FIRST USE 6-1-2006; IN COMMERCE 6-1-2006.

3,482,416. DOCSI CORPORATION, LOS ANGELES, CA. SN 78-910,365. PUB. 2-13-2007, FILED 6-16-2006.

THE FAMOUS RADIO RANCH

THE MARK CONSISTS OF STANDARD CHARACTERS WITHOUT CLAIM TO ANY PARTICULAR FONT, STYLE, SIZE, OR COLOR.

NO CLAIM IS MADE TO THE EXCLUSIVE RIGHT TO USE "RADIO", APART FROM THE MARK AS SHOWN.

FOR CREATIVE PRODUCTION OF RADIO COMMERCIALS (U.S. CLS. 100, 101 AND 102).

FIRST USE 3-0-1995; IN COMMERCE 3-0-1995.

3,482,421. BRAINCRUMBS DESIGN, INC., DBA THE BOKKA GROUP, DENVER, CO. SN 78-913,738. PUB. 4-3-2007, FILED 6-21-2006.

THE BOKKA GROUP

THE MARK CONSISTS OF STANDARD CHARACTERS WITHOUT CLAIM TO ANY PARTICULAR FONT, STYLE,

CLASS 35—(Continued).

SIZE, OR COLOR.

NO CLAIM IS MADE TO THE EXCLUSIVE RIGHT TO USE GROUP, APART FROM THE MARK AS SHOWN.

FOR ADVERTISING AGENCIES; ADVERTISING AGENCIES, NAMELY, PROMOTING THE GOODS AND SERVICES OF OTHERS; ADVERTISING AGENCIES, NAMELY, PROMOTING THE SERVICES OF RESIDENTIAL/COMMERCIAL DEVELOPERS AND MUSEUMS THROUGH THE DISTRIBUTION OF PRINTED AND AUDIO PROMOTIONAL MATERIALS AND BY RENDERING SALES PROMOTION ADVICE; ADVERTISING AND PUBLICITY SERVICES, NAMELY, PROMOTING THE GOODS, SERVICES, BRAND IDENTITY AND COMMERCIAL INFORMATION AND NEWS OF THIRD PARTIES THROUGH PRINT, AUDIO, VIDEO, DIGITAL AND ON-LINE MEDIUM; ADVERTISING, MARKETING AND PROMOTION SERVICES; PROMOTING, ADVERTISING AND MARKETING OF THE ON-LINE WEBSITES OF OTHERS (U.S. CLS. 100, 101 AND 102).

FIRST USE 11-1-2006; IN COMMERCE 11-1-2006.

3,482,429. THE WOODSIDE INSTITUTE, INC., WOODSIDE, CA. SN 78-920,610. PUB. 3-20-2007, FILED 6-30-2006.

MLAB

THE MARK CONSISTS OF STANDARD CHARACTERS WITHOUT CLAIM TO ANY PARTICULAR FONT, STYLE, SIZE, OR COLOR.

FOR ARRANGING AND CONDUCTING BUSINESS MANAGEMENT CONFERENCES AND SEMINARS (U.S. CLS. 100, 101 AND 102).

FIRST USE 5-28-2008; IN COMMERCE 5-28-2008.

3,482,430. THE WOODSIDE INSTITUTE, INC., WOODSIDE, CA. SN 78-920,623. PUB. 3-20-2007, FILED 6-30-2006.

MANAGEMENT 2.0

THE MARK CONSISTS OF STANDARD CHARACTERS WITHOUT CLAIM TO ANY PARTICULAR FONT, STYLE, SIZE, OR COLOR.

NO CLAIM IS MADE TO THE EXCLUSIVE RIGHT TO USE "MANAGEMENT", APART FROM THE MARK AS SHOWN.

FOR ARRANGING AND CONDUCTING BUSINESS MANAGEMENT CONFERENCES AND SEMINARS (U.S. CLS. 100, 101 AND 102).

FIRST USE 5-28-2008; IN COMMERCE 5-28-2008.

CLASS 35—(Continued).

3,482,466. WAGGENER EDSTROM WORLDWIDE, INC., LAKE OSWEGO, OR. SN 78-937,816. PUB. 3-20-2007, FILED 7-26-2006.

INNOVATION CONTEXT

THE MARK CONSISTS OF STANDARD CHARACTERS WITHOUT CLAIM TO ANY PARTICULAR FONT, STYLE, SIZE, OR COLOR.

FOR PUBLIC RELATIONS SERVICES; MARKET RESEARCH SERVICES (U.S. CLS. 100, 101 AND 102). FIRST USE 11-12-2007; IN COMMERCE 11-12-2007.

3,482,467. WAGGENER EDSTROM WORLDWIDE, INC., LAKE OSWEGO, OR. SN 78-937,827. PUB. 3-20-2007, FILED 7-26-2006.

MASTER NARRATIVE

THE MARK CONSISTS OF STANDARD CHARACTERS WITHOUT CLAIM TO ANY PARTICULAR FONT, STYLE, SIZE, OR COLOR.

FOR PUBLIC RELATIONS SERVICES; MARKET RESEARCH SERVICES (U.S. CLS. 100, 101 AND 102). FIRST USE 12-18-2006; IN COMMERCE 12-18-2006.

3,482,487. BLANCHARD TRAINING AND DEVELOPMENT, INC., ESCONDIDO, CA. SN 78-944,092. PUB. 8-21-2007, FILED 8-3-2006.

HPO SCORES

THE MARK CONSISTS OF STANDARD CHARACTERS WITHOUT CLAIM TO ANY PARTICULAR FONT, STYLE, SIZE, OR COLOR.

NO CLAIM IS MADE TO THE EXCLUSIVE RIGHT TO USE "HPO", APART FROM THE MARK AS SHOWN.

FOR BUSINESS CONSULTATION SERVICES IN THE FIELD OF MANAGEMENT PRACTICES (U.S. CLS. 100, 101 AND 102).

FIRST USE 10-1-2006; IN COMMERCE 10-1-2006.

CLASS 35—(Continued).

3,482,494. VETESSA PHARMACEUTICAL, INC., DORAL, FL. SN 78-946,018. PUB. 3-20-2007, FILED 8-7-2006.



NO CLAIM IS MADE TO THE EXCLUSIVE RIGHT TO USE "PHARMACEUTICAL", APART FROM THE MARK AS SHOWN.

FOR MAIL ORDER CATALOG, INTERNET CATALOG AND DISTRIBUTORSHIP SERVICES FEATURING VETERINARY EQUIPMENT AND SUPPLIES (U.S. CLS. 100, 101 AND 102).

FIRST USE 1-1-2007; IN COMMERCE 1-1-2007.

3,482,495. GWR MEDICAL, INC., CHADDS FORD, PA. SN 78-946,020. PUB. 8-28-2007, FILED 8-7-2006.

FIRST IN TOPICAL OXYGEN THERAPY

THE MARK CONSISTS OF STANDARD CHARACTERS WITHOUT CLAIM TO ANY PARTICULAR FONT, STYLE, SIZE, OR COLOR.

OWNER OF U.S. REG. NO. 2,223,320.

NO CLAIM IS MADE TO THE EXCLUSIVE RIGHT TO USE "TOPICAL OXYGEN THERAPY", APART FROM THE MARK AS SHOWN.

FOR DISTRIBUTORSHIPS IN THE FIELD OF TOPICAL OXYGEN APPLICATION DEVICES, WOUND DRESSINGS, AND MEDICAL APPARATUS FOR APPLYING OXYGEN TO A WOUND (U.S. CLS. 100, 101 AND 102).

FIRST USE 2-0-2008; IN COMMERCE 2-0-2008.

3,482,499. TRUSTCITE LIMITED, NORTH SHORE CITY, AU, NEW ZEALAND. SN 78-947,151. PUB. 4-3-2007, FILED 8-8-2006.

TRUSTCITE

THE MARK CONSISTS OF STANDARD CHARACTERS WITHOUT CLAIM TO ANY PARTICULAR FONT, STYLE, SIZE, OR COLOR.

FOR ONLINE BUSINESS REFERRAL AND DIRECTORY SERVICES FEATURING CONSUMER RATINGS, RECOMMENDATIONS AND REVIEWS REGARDING THE SERVICES OF OTHERS (U.S. CLS. 100, 101 AND 102).

FIRST USE 3-24-2006; IN COMMERCE 3-24-2006.

CLASS 35—(Continued).

3,482,519. E-MILES, LLC, DALLAS, TX. SN 78-954,435. PUB. 4-3-2007, FILED 8-17-2006.

YOUR TIME HAS NEVER BEEN
MORE REWARDING

THE MARK CONSISTS OF STANDARD CHARACTERS WITHOUT CLAIM TO ANY PARTICULAR FONT, STYLE, SIZE, OR COLOR.

FOR ADVERTISING SERVICES FOR OTHERS; BUSINESS AND TECHNICAL CONSULTING SERVICES IN THE FIELD OF ADVERTISING SERVICES AND CUSTOMER RELATIONSHIP MANAGEMENT (CRM) PROGRAMS; DESIGN, IMPLEMENTATION AND MANAGEMENT OF CUSTOMER LOYALTY PROGRAMS; CONDUCTING BUSINESS AND MARKET RESEARCH, SURVEYS, AND ANALYSES FOR OTHERS; PROMOTING THE GOODS AND SERVICE OF OTHERS THROUGH INCENTIVE PROGRAMS; AND MARKETING TECHNOLOGY OUTSOURCING SERVICES (U.S. CLS. 100, 101 AND 102).

FIRST USE 10-17-2007; IN COMMERCE 10-17-2007.

3,482,555. SNUGHOUSE ENERGY AUDITS LLC, EAST TROY, WI. SN 78-967,410. PUB. 10-9-2007, FILED 9-5-2006.

SNUGHOUSE

THE MARK CONSISTS OF STANDARD CHARACTERS WITHOUT CLAIM TO ANY PARTICULAR FONT, STYLE, SIZE, OR COLOR.

FOR CONSULTING, ANALYSIS AND TESTING SERVICES IN THE FIELD OF ENERGY EFFICIENCY, CONSERVATION AND RENEWABLE ENERGY, NAMELY, ENERGY AUDITING AND TESTING OF THE CUSTOMER'S PREMISES; REVIEWING THE CUSTOMER'S ENERGY NEEDS, USES AND COSTS; PROVIDING ADVICE AND RECOMMENDATIONS REGARDING ENERGY OPTIONS, COST OBJECTIVES AND SOLUTIONS TO PROBLEMS (U.S. CLS. 100, 101 AND 102).

FIRST USE 7-26-2007; IN COMMERCE 11-9-2007.

CLASS 35—(Continued).

3,482,569. THE JOHNS HOPKINS HEALTH SYSTEM CORPORATION, BALTIMORE, MD. SN 78-977,820. PUB. 3-6-2007, FILED 2-23-2006.

PACE

THE MARK CONSISTS OF STANDARD CHARACTERS WITHOUT CLAIM TO ANY PARTICULAR FONT, STYLE, SIZE, OR COLOR.

FOR BUSINESS CONSULTATION IN THE FIELD OF NURSING COMPENSATION AND PRACTICE AND NURSE RECRUITMENT AND RETENTION (U.S. CLS. 100, 101 AND 102).

FIRST USE 2-0-2001; IN COMMERCE 1-24-2002.

CLASS 36—INSURANCE AND FINANCIAL

3,481,072. AMERICAN NEWLAND COMMUNITIES, LP, SAN DIEGO, CA. SN 76-628,568. PUB. 4-11-2006, FILED 1-13-2005.



FOR ONLINE INFORMATION SERVICES IN THE FIELD OF REAL ESTATE; PROVIDING WEBSITES IN THE FIELD OF REAL ESTATE (U.S. CLS. 100, 101 AND 102).

FIRST USE 9-28-2004; IN COMMERCE 9-28-2004.

3,481,104. ASIAN PACIFIC BANCORP INC, CLAYTON, MO. SN 76-664,299. PUB. 9-11-2007, FILED 8-8-2006.



NO CLAIM IS MADE TO THE EXCLUSIVE RIGHT TO USE "ASIAN PACIFIC BANK CORP INC", APART FROM THE MARK AS SHOWN.

THE COLOR(S) RED, WHITE AND GOLD IS/ARE

CLASS 36—(Continued).

CLAIMED AS A FEATURE OF THE MARK.

THE COLOR RED APPEARS IN THE WORDS "ASIAN PACIFIC BANCORP INC"; IN THE HORIZONTAL STRAIGHT LINE; AND IN THE FILLING WITH THE CIRCLE DESIGN AND SURROUNDING THE WAVE PORTION OF THE DESIGN. THE COLOR GOLD APPEARS IN THE WORDS "PEOPLE AND OPPORTUNITIES" AND IN THE PERIMETER RING OF THE DESIGN. THE COLOR WHITE APPEARS IN THE WAVE PORTION OF THE DESIGN WITHIN THE RING.

FOR BANKING SERVICES AND FINANCIAL SERVICES, NAMELY, MONEY LENDING AND INVESTMENT BANKING SERVICES (U.S. CLS. 100, 101 AND 102).

FIRST USE 9-15-2006; IN COMMERCE 9-15-2006.

3,481,122. DELTA EDGE MANAGEMENT GROUP, LP, MONSEY, NY. SN 76-670,659. PUB. 8-21-2007, FILED 12-21-2006.

DeltaEdge 

FOR INVESTMENT ADVISORY AND MANAGEMENT SERVICES FOR DOMESTIC AND OFFSHORE CLIENTS, NAMELY, INVESTMENT MANAGEMENT TO ONE OR MORE PRIVATE INVESTMENT FUNDS (U.S. CLS. 100, 101 AND 102).

FIRST USE 3-3-2008; IN COMMERCE 3-3-2008.

3,481,124. MARTIN, SAMUEL B., WALKERTON, VA. SN 76-671,450. PUB. 8-21-2007, FILED 1-17-2007.



NO CLAIM IS MADE TO THE EXCLUSIVE RIGHT TO USE "VIRGINIA CLASSIC CAR SHOWS", APART FROM THE MARK AS SHOWN.

THE COLOR(S) BLUE, RED, AND WHITE IS/ARE CLAIMED AS A FEATURE OF THE MARK.

THE COLOR BLUE APPEARS ON THE WORDS "VIRGINIA CLASSIC CAR SHOWS"; THE COLORS BLUE, RED, AND WHITE APPEAR ON THE TRIANGULAR DESIGN.

FOR CHARITABLE FUND RAISING, NAMELY, GIVING PROCEEDS TO LOCAL FIRE DEPARTMENTS, RESCUE SQUADS, AND OTHER NON-PROFIT ORGANIZATIONS (U.S. CLS. 100, 101 AND 102).

FIRST USE 7-20-2007; IN COMMERCE 7-20-2007.

CLASS 36—(Continued).

3,481,143. CHILDREN OF DAVAONN'E, CHESAPEAKE, VA. SN 76-675,468. PUB. 10-9-2007, FILED 4-13-2007.

Children Of Davaonn'e

THE MARK CONSISTS OF STANDARD CHARACTERS WITHOUT CLAIM TO ANY PARTICULAR FONT, STYLE, SIZE, OR COLOR.

FOR ESTABLISHING INTEREST YIELD ACCOUNTS WITH CHILDREN FOR THEIR COMPLETION OF GRADE SCHOOL FOR PRIVATE OR PUBLIC SCHOOLING COMPLETING SCHOOL BY 20TH BIRTHDAY (U.S. CLS. 100, 101 AND 102).

FIRST USE 1-5-2008; IN COMMERCE 3-31-2007.

3,481,150. ALWAYS HOME REAL ESTATE, INC., BRENTWOOD, TN. SN 76-677,660. PUB. 12-11-2007, FILED 5-31-2007.

ALWAYS HOME REAL ESTATE

THE MARK CONSISTS OF STANDARD CHARACTERS WITHOUT CLAIM TO ANY PARTICULAR FONT, STYLE, SIZE, OR COLOR.

NO CLAIM IS MADE TO THE EXCLUSIVE RIGHT TO USE "REAL ESTATE", APART FROM THE MARK AS SHOWN.

FOR REAL ESTATE BROKERAGE (U.S. CLS. 100, 101 AND 102).

FIRST USE 1-28-2007; IN COMMERCE 1-28-2007.

3,481,172. INDEPENDENT FUNDING, LLC, WAYNE, PA. SN 77-003,125. PUB. 8-28-2007, FILED 9-20-2006.

THE INSTITUTIONAL SOLUTION

THE MARK CONSISTS OF STANDARD CHARACTERS WITHOUT CLAIM TO ANY PARTICULAR FONT, STYLE, SIZE, OR COLOR.

FOR INSURANCE AND FINANCIAL AFFAIRS SERVICES, NAMELY, FACILITATING FINANCIAL TRANSACTIONS IN THE NATURE OF VALUATION, LIQUIDATION, CONSOLIDATION, BROKERAGE, AND TRANSFER OF FRACTIONALIZED LIFE INSURANCE INTERESTS (U.S. CLS. 100, 101 AND 102).

FIRST USE 1-1-2007; IN COMMERCE 1-1-2007.

CLASS 36—(Continued).

3,481,193. PERIGEE INVESTMENT ADVISORS, LLC, HER-SHEY, PA. SN 77-016,862. PUB. 6-5-2007, FILED 10-9-2006.



THE MARK CONSISTS OF A CURVED EDGE SQUARE AND A LARGE CIRCLE WITHIN THE SQUARE. INSIDE THE LARGE CIRCLE IS A SMALL CIRCLE TOWARDS THE UPPER RIGHT PART OF THE LARGE CIRCLE. HALFWAY BETWEEN THE SQUARE AND THE LARGE CIRCLE, IN THE UPPER RIGHT SIDE, IS A SMALLER CIRCLE WHICH ALSO IS PARTIALLY IN THE SMALL CIRCLE.

FOR INVESTMENT ADVISORY SERVICES (U.S. CLS. 100, 101 AND 102).

FIRST USE 11-1-2005; IN COMMERCE 6-11-2008.

CLASS 36—(Continued).

3,481,221. ADP OF NORTH AMERICA, INC., SAN RAMON, CA. SN 77-030,320. PUB. 1-15-2008, FILED 10-26-2006.



OWNER OF U.S. REG. NOS. 1,128,022, 2,338,000, AND OTHERS.

FOR EMPLOYEE BENEFITS SERVICES FOR OTHERS, NAMELY, ADMINISTRATION OF EMPLOYEE BENEFIT PLANS, EMPLOYEE PENSION AND INVESTMENT PLANS, AND WORKERS UNEMPLOYMENT COMPEN-SATION CLAIMS AND PLANS (U.S. CLS. 100, 101 AND 102).

FIRST USE 7-31-2005; IN COMMERCE 7-31-2005.

3,481,380. THE EVANGELICAL FREE CHURCH OF AMER-ICA, MINNEAPOLIS, MN. SN 77-107,715. PUB. 10-9-2007, FILED 2-14-2007.

GLOBALFINGERPRINTS

3,481,219. CMT ASSET MANAGEMENT LIMITED, CHICA-GO, IL. SN 77-029,403. PUB. 9-25-2007, FILED 10-25-2006.

THE MARK CONSISTS OF STANDARD CHARACTERS WITHOUT CLAIM TO ANY PARTICULAR FONT, STYLE, SIZE, OR COLOR.

FOR CHARITABLE FUND RAISING SERVICES; PHI-LANTHROPIC SERVICES CONCERNING MONETARY DONATIONS (U.S. CLS. 100, 101 AND 102).

FIRST USE 2-19-2008; IN COMMERCE 2-19-2008.

CMT ASSET MANAGEMENT

3,481,421. GARDNER, COLIN J, TEMPE, AZ. SN 77-122,847. PUB. 9-11-2007, FILED 3-6-2007.

THE MARK CONSISTS OF STANDARD CHARACTERS WITHOUT CLAIM TO ANY PARTICULAR FONT, STYLE, SIZE, OR COLOR.

NO CLAIM IS MADE TO THE EXCLUSIVE RIGHT TO USE "ASSET MANAGEMENT", APART FROM THE MARK AS SHOWN.

FOR FINANCIAL MANAGEMENT SERVICES, NAMELY, HEDGE FUND MANAGEMENT SERVICES; INVESTMENT MANAGEMENT SERVICES; AND OFF SHORE HEDGE FUND MANAGEMENT SERVICES (U.S. CLS. 100, 101 AND 102).

FIRST USE 12-0-2005; IN COMMERCE 12-0-2005.

REBATEJUNKIE.COM

THE MARK CONSISTS OF STANDARD CHARACTERS WITHOUT CLAIM TO ANY PARTICULAR FONT, STYLE, SIZE, OR COLOR.

FOR PROVIDING REBATES AT PARTICIPATING ESTABLISHMENTS OF OTHERS THROUGH USE OF A MEMBERSHIP CARD (U.S. CLS. 100, 101 AND 102).

FIRST USE 6-1-2007; IN COMMERCE 6-30-2007.

CLASS 36—(Continued).

3,481,458. VAZQUEZ, RONALDO, CHULA VISTA, CA. AND VAZQUEZ, RITA, CHULA VISTA, CA. SN 77-129,347. PUB. 9-18-2007, FILED 3-13-2007.



THE MARK CONSISTS OF A SQUARE ON A GRID THAT'S ENCLOSED IN A CIRCLE WITH STYLIZED TEXT. FOR CHARITABLE FUND RAISING (U.S. CLS. 100, 101 AND 102).

FIRST USE 6-1-2007; IN COMMERCE 3-1-2008.

3,481,475. BROWN BROTHERS HARRIMAN & CO., NEW YORK, NY. SN 77-132,344. PUB. 9-18-2007, FILED 3-15-2007.

INFOFX

THE MARK CONSISTS OF STANDARD CHARACTERS WITHOUT CLAIM TO ANY PARTICULAR FONT, STYLE, SIZE, OR COLOR.

FOR FINANCIAL INFORMATION PROCESSING; FINANCIAL INFORMATION PROVIDED BY ELECTRONIC MEANS; FINANCIAL MANAGEMENT; FINANCIAL PORTFOLIO MANAGEMENT; FINANCIAL RESEARCH; FINANCIAL SERVICES, NAMELY, ASSISTING OTHERS WITH THE COMPLETION OF FINANCIAL TRANSACTIONS FOR STOCKS, BONDS, SECURITIES AND EQUITIES; FINANCIAL SERVICES, NAMELY, PROVIDING INFORMATION IN THE FIELDS OF FOREIGN CURRENCY, COMMODITIES, FINANCIAL DERIVATIVES, INTEREST RATE PRODUCTS, AND EQUITIES VIA THE INTERNET AND INTRANET SYSTEMS; FINANCIAL SERVICES, NAMELY, PROVIDING ON-LINE STORED VALUE ACCOUNTS IN AN ELECTRONIC ENVIRONMENT; FINANCIAL SERVICES, NAMELY, INVESTMENT FUND TRANSFER AND TRANSACTION SERVICES; FINANCIAL SERVICES, NAMELY, PROVIDING FOR THE EXCHANGE OF FOREIGN CURRENCY, COMMODITIES, FINANCIAL DERIVATIVES, INTEREST RATE PRODUCTS, AND EQUITIES VIA THE INTERNET AND INTRANET SYSTEMS (U.S. CLS. 100, 101 AND 102).

FIRST USE 10-0-2007; IN COMMERCE 10-0-2007.

CLASS 36—(Continued).

3,481,493. W.R. HAMBRECHT + CO., INC., SAN FRANCISCO, CA. SN 77-135,009. PUB. 11-6-2007, FILED 3-20-2007.

WRH+CO

THE MARK CONSISTS OF STANDARD CHARACTERS WITHOUT CLAIM TO ANY PARTICULAR FONT, STYLE, SIZE, OR COLOR.

FOR INVESTMENT BANKING SERVICES; FINANCIAL SERVICES IN THE NATURE OF UNDERWRITING, DISTRIBUTION AND TRADING OF SECURITIES FOR OTHERS; SECURITIES BROKERAGE SERVICES; INVESTMENT RESEARCH SERVICES; INVESTMENT MANAGEMENT AND ADVICE; FINANCIAL SERVICES IN THE NATURE OF TRADING OPTIONS FOR OTHERS; MUTUAL FUND BROKERAGE, DISTRIBUTION AND INVESTMENT; DERIVATIVE SECURITIES INVESTMENT; FINANCIAL PLANNING SERVICES; BANKING SERVICES; VENTURE CAPITAL FUNDING SERVICES; PROVIDING FINANCIAL NEWS AND INFORMATION VIA A GLOBAL COMMUNICATIONS NETWORK; FINANCIAL SERVICES IN THE NATURE OF MERGER, ACQUISITION, AND RESTRUCTURING; PROVIDING FINANCIAL SERVICES VIA A GLOBAL COMMUNICATIONS NETWORK, NAMELY, UNDERWRITING, DISTRIBUTION AND TRADING OF SECURITIES FOR OTHERS, SECURITIES BROKERAGE, INVESTMENT RESEARCH, INVESTMENT MANAGEMENT AND ADVICE, TRADING OPTIONS FOR OTHERS (U.S. CLS. 100, 101 AND 102).

FIRST USE 9-0-1999; IN COMMERCE 9-0-1999.

3,481,503. GMAC LLC, DETROIT, MI. SN 77-136,814. PUB. 8-28-2007, FILED 3-21-2007.

PEOPLE ARE SMART

THE MARK CONSISTS OF STANDARD CHARACTERS WITHOUT CLAIM TO ANY PARTICULAR FONT, STYLE, SIZE, OR COLOR.

FOR MORTGAGE BANKING SERVICES, NAMELY, ORIGINATION, ACQUISITION, SERVICING, SECURITIZATION, AND BROKERAGE OF MORTGAGE LOANS (U.S. CLS. 100, 101 AND 102).

FIRST USE 5-21-2008; IN COMMERCE 5-21-2008.

CLASS 36—(Continued).

3,481,518. PLANNED ADMINISTRATORS, INC., COLUMBIA, SC. SN 77-138,751. PUB. 9-25-2007, FILED 3-23-2007.

HOSPITALITYCARE

THE MARK CONSISTS OF STANDARD CHARACTERS WITHOUT CLAIM TO ANY PARTICULAR FONT, STYLE, SIZE, OR COLOR.

FOR INSURANCE UNDERWRITING IN THE FIELD OF HEALTH (U.S. CLS. 100, 101 AND 102).
FIRST USE 1-1-2007; IN COMMERCE 1-1-2007.

CLASS 36—(Continued).

3,481,563. VAN HOUTEN, LYNN ROSS, EDGEWOOD, WA. SN 77-146,917. PUB. 9-11-2007, FILED 4-2-2007.

Freedom Cove

THE MARK CONSISTS OF STANDARD CHARACTERS WITHOUT CLAIM TO ANY PARTICULAR FONT, STYLE, SIZE, OR COLOR.

FOR ADVICE RELATING TO INVESTMENTS; FINANCIAL ANALYSIS AND CONSULTATION; FINANCIAL CONSULTATION; FINANCIAL PLANNING; FINANCIAL PLANNING CONSULTATION; FINANCIAL PLANNING FOR RETIREMENT; FINANCIAL PLANNING, NAMELY THE CREATION OF PERSONALIZED STRATEGIES TO ACHIEVE FINANCIAL INDEPENDENCE; FINANCIAL PORTFOLIO MANAGEMENT; FINANCIAL SERVICES IN THE NATURE OF AN INVESTMENT SECURITY; FINANCIAL SERVICES, NAMELY ASSISTING OTHERS WITH THE COMPLETION OF FINANCIAL TRANSACTIONS FOR STOCKS, BONDS, SECURITIES AND EQUITIES; FINANCIAL SERVICES, NAMELY, A TOTAL PORTFOLIO OFFERING FOR HIGH NET WORTH CLIENTS CONSISTING OF BOTH SEPARATE ACCOUNTS AND MUTUAL FUNDS FOR EQUITY AND FIXED INCOME INVESTMENTS; FUND INVESTMENT CONSULTATION; INVESTMENT ADVICE; INVESTMENT ADVISORY SERVICES; INVESTMENT CONSULTATION; INVESTMENT MANAGEMENT; INVESTMENT OF FUNDS FOR OTHERS (U.S. CLS. 100, 101 AND 102).
FIRST USE 10-31-2007; IN COMMERCE 10-31-2007.

3,481,551. IORIO, MATTHEW T., GREENWICH, CT. SN 77-145,221. PUB. 10-2-2007, FILED 3-30-2007.

WHITE ELM

THE MARK CONSISTS OF STANDARD CHARACTERS WITHOUT CLAIM TO ANY PARTICULAR FONT, STYLE, SIZE, OR COLOR.

FOR FINANCIAL SERVICES, NAMELY, INVESTMENT MANAGEMENT SERVICES (U.S. CLS. 100, 101 AND 102).
FIRST USE 9-0-2007; IN COMMERCE 9-0-2007.

3,481,578. NATIONAL LIFE INSURANCE COMPANY, MONTEPELIER, VT. SN 77-149,088. PUB. 9-18-2007, FILED 4-5-2007.

NLGROUP

THE MARK CONSISTS OF STANDARD CHARACTERS WITHOUT CLAIM TO ANY PARTICULAR FONT, STYLE, SIZE, OR COLOR.

OWNER OF U.S. REG. NOS. 2,504,266, 3,160,254, AND OTHERS.

FOR LIFE INSURANCE UNDERWRITING; ANNUITY UNDERWRITING; FINANCIAL ADMINISTRATION OF RETIREMENT PLANS; BROKERAGE OF SHARES OR STOCKS AND OTHER SECURITIES; FINANCIAL SERVICES, NAMELY, ASSISTING OTHERS WITH THE COMPLETION OF FINANCIAL TRANSACTIONS FOR STOCKS, BONDS, SECURITIES AND EQUITIES; INVESTMENT MANAGEMENT (U.S. CLS. 100, 101 AND 102).

FIRST USE 6-6-2008; IN COMMERCE 6-6-2008.

CLASS 36—(Continued).

3,481,652. NEW YORK MERCANTILE EXCHANGE, INC., NEW YORK, NY. SN 77-165,516. PUB. 9-25-2007, FILED 4-25-2007.

NYMEX 3-2-1 PLUS

THE MARK CONSISTS OF STANDARD CHARACTERS WITHOUT CLAIM TO ANY PARTICULAR FONT, STYLE, SIZE, OR COLOR.

OWNER OF U.S. REG. NOS. 1,731,593, 3,087,793, AND OTHERS.

FOR PROVIDING FINANCIAL AND INVESTMENT INFORMATION SERVICES; PROVIDING FINANCIAL SERVICES, NAMELY, TRADING OF FUTURES AND OPTIONS ON FUTURES CONTRACTS BASED ON A COMMODITY INDEX FOR OTHERS, THROUGH A COMPUTER NETWORK AND PROVIDING INFORMATION CONCERNING THE TRADING OF FUTURES AND OPTIONS ON FUTURES CONTRACTS BASED ON A COMMODITY INDEX, THROUGH A COMPUTER NETWORK (U.S. CLS. 100, 101 AND 102).

FIRST USE 12-21-2006; IN COMMERCE 12-21-2006.

CLASS 36—(Continued).

3,481,724. 1031 ADVISERS, INC., JACKSONVILLE, FL. SN 77-184,213. PUB. 11-6-2007, FILED 5-17-2007.



NO CLAIM IS MADE TO THE EXCLUSIVE RIGHT TO USE "1031", APART FROM THE MARK AS SHOWN.

THE MARK CONSISTS OF THE NUMBER "1031" ABOVE "DVISERS", ALL BETWEEN AN OIL RIG DESIGN AND A BUILDING DESIGN AND UPPER AND LOWER SWIRL DESIGNS, WITH THE OIL RIG DESIGN FORMING A LETTER "A".

FOR FINANCIAL CONSULTATION; REAL ESTATE CONSULTATION (U.S. CLS. 100, 101 AND 102).

FIRST USE 5-27-2008; IN COMMERCE 5-27-2008.

3,481,666. NOVELLUS CAPITAL MANAGEMENT, LLC, BELLEVUE, WA. SN 77-168,179. PUB. 9-25-2007, FILED 4-27-2007.

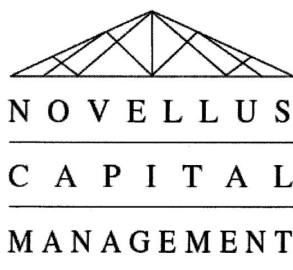

NO CLAIM IS MADE TO THE EXCLUSIVE RIGHT TO USE "CAPITAL MANAGEMENT", APART FROM THE MARK AS SHOWN.

THE MARK CONSISTS OF A GEOMETRICAL TRIANGULAR DESIGN ABOVE THE LITERAL ELEMENT.

THE LATIN WORDING "NOVELLUS" IN THE MARK TRANSLATES INTO ENGLISH AS NEW, FRESH OR RECENT.

FOR FINANCIAL SERVICES, NAMELY, THE PURCHASE OF RESIDENTIAL MORTGAGES ON BEHALF OF OTHERS AND THE ISSUANCE OF MORTGAGE-BACKED SECURITIES; FINANCIAL SERVICES IN THE NATURE OF AN INVESTMENT SECURITY; INVESTMENT ADVISORY SERVICES; INVESTMENT MANAGEMENT; MUTUAL FUND DISTRIBUTION (U.S. CLS. 100, 101 AND 102).

FIRST USE 4-1-2007; IN COMMERCE 4-1-2007.

3,481,786. RONK, THOMAS C., CORONA DEL MAR, CA. SN 77-212,231. PUB. 12-4-2007, FILED 6-21-2007.

Precise, Predictive, Profitable

THE MARK CONSISTS OF STANDARD CHARACTERS WITHOUT CLAIM TO ANY PARTICULAR FONT, STYLE, SIZE, OR COLOR.

FOR ADVICE RELATING TO INVESTMENTS; CAPITAL INVESTMENT CONSULTATION; COMMODITY INVESTMENT ADVICE; EQUITY CAPITAL INVESTMENT; FINANCIAL SERVICES IN THE NATURE OF AN INVESTMENT SECURITY; FINANCIAL SERVICES, NAMELY, A TOTAL PORTFOLIO OFFERING FOR HIGH NET WORTH CLIENTS CONSISTING OF BOTH SEPARATE ACCOUNTS AND MUTUAL FUNDS FOR EQUITY AND FIXED INCOME INVESTMENTS; HEDGE FUND INVESTMENT SERVICES; INVESTMENT ADVICE; INVESTMENT ADVISORY SERVICES; INVESTMENT BROKERAGE; INVESTMENT BY ELECTRONIC MEANS; INVESTMENT CONSULTATION; INVESTMENT MANAGEMENT; INVESTMENT OF FUNDS FOR OTHERS; INVESTMENT SERVICES, NAMELY, ASSET ACQUISITION, CONSULTATION, DEVELOPMENT AND MANAGEMENT SERVICES; MANAGEMENT OF A CAPITAL INVESTMENT FUND; PUBLIC EQUITY INVESTMENT MANAGEMENT; SECURITIES TRADING AND INVESTING SERVICES FOR OTHERS VIA THE INTERNET (U.S. CLS. 100, 101 AND 102).

FIRST USE 6-21-2007; IN COMMERCE 6-21-2007.

CLASS 36—(Continued).

3,481,789. TCS FINANCIAL SERVICES, INC., WESTTOWN, PA. SN 77-213,973. PUB. 12-4-2007, FILED 6-24-2007.

Build...Grow...Protect

THE MARK CONSISTS OF STANDARD CHARACTERS WITHOUT CLAIM TO ANY PARTICULAR FONT, STYLE, SIZE, OR COLOR.

FOR ADVICE RELATING TO INVESTMENTS; INVESTMENT ADVICE; INVESTMENT ADVISORY SERVICES; INVESTMENT BROKERAGE; INVESTMENT CONSULTATION; INVESTMENT MANAGEMENT; INVESTMENT OF FUNDS FOR OTHERS; INVESTMENT SERVICES, NAMELY, ASSET ACQUISITION, CONSULTATION, DEVELOPMENT AND MANAGEMENT SERVICES; MUTUAL FUND INVESTMENT; PRIVATE EQUITY FUND INVESTMENT SERVICES; SECURITIES TRADING AND INVESTING SERVICES FOR OTHERS VIA THE INTERNET; CAPITAL INVESTMENT CONSULTATION; COMMODITY INVESTMENT ADVICE; EQUITY CAPITAL INVESTMENT; FINANCIAL SERVICES IN THE NATURE OF AN INVESTMENT SECURITY; FINANCIAL SERVICES, NAMELY, A TOTAL PORTFOLIO OFFERING FOR HIGH NET WORTH CLIENTS CONSISTING OF BOTH SEPARATE ACCOUNTS AND MUTUAL FUNDS FOR EQUITY AND FIXED INCOME INVESTMENTS; FUND INVESTMENT CONSULTATION; FINANCIAL ANALYSIS AND CONSULTATION; FINANCIAL CONSULTATION; FINANCIAL EVALUATION FOR INSURANCE PURPOSES; FINANCIAL GUARANTEE AND SURETY; FINANCIAL MANAGEMENT; FINANCIAL PLANNING; FINANCIAL PLANNING CONSULTATION; FINANCIAL PLANNING FOR RETIREMENT; FINANCIAL PLANNING, NAMELY, THE CREATION OF PERSONALIZED STRATEGIES TO ACHIEVE FINANCIAL INDEPENDENCE; FINANCIAL PORTFOLIO MANAGEMENT; FINANCIAL RISK MANAGEMENT; FINANCIAL SERVICES, NAMELY, ASSISTING OTHERS WITH THE COMPLETION OF FINANCIAL TRANSACTIONS FOR STOCKS, BONDS, SECURITIES AND EQUITIES; PROVIDING ONLINE FINANCIAL CALCULATORS; INSURANCE AGENCY AND BROKERAGE; INSURANCE BROKERAGE; INSURANCE CONSULTATION; INSURANCE UNDERWRITING CONSULTATION; INSURANCE UNDERWRITING SERVICES FOR ALL TYPES OF INSURANCE; LIFE INSURANCE UNDERWRITING; MEDICAL INSURANCE UNDERWRITING; PROVIDING INFORMATION IN INSURANCE MATTERS (U.S. CLS. 100, 101 AND 102).

FIRST USE 7-1-2007; IN COMMERCE 7-1-2007.

CLASS 36—(Continued).

3,481,802. WEALTH ARCHITECTS, LLC, PALO ALTO, CA. SN 77-221,282. PUB. 12-25-2007, FILED 7-3-2007.

Building Wealthier Lives

THE MARK CONSISTS OF STANDARD CHARACTERS WITHOUT CLAIM TO ANY PARTICULAR FONT, STYLE, SIZE, OR COLOR.

FOR FINANCIAL PLANNING, NAMELY, THE CREATION OF PERSONALIZED STRATEGIES TO ACHIEVE FINANCIAL INDEPENDENCE (U.S. CLS. 100, 101 AND 102).

FIRST USE 3-13-2008; IN COMMERCE 3-13-2008.

3,481,806. Y-ME NATIONAL BREAST CANCER ORGANIZATION, CHICAGO, IL. SN 77-223,612. PUB. 12-18-2007, FILED 7-6-2007.

RIDE TO EMPOWER

THE MARK CONSISTS OF STANDARD CHARACTERS WITHOUT CLAIM TO ANY PARTICULAR FONT, STYLE, SIZE, OR COLOR.

OWNER OF U.S. REG. NO. 3,095,498.
FOR CHARITABLE FUND RAISING (U.S. CLS. 100, 101 AND 102).

FIRST USE 10-15-2007; IN COMMERCE 10-15-2007.

3,481,820. ABSOLUTE ADVANTAGE MORTGAGE CORPORATION LLC, ADAMSTOWN, MD. SN 77-231,254. PUB. 12-4-2007, FILED 7-17-2007.

Giving You The Absolute Advantage

THE MARK CONSISTS OF STANDARD CHARACTERS WITHOUT CLAIM TO ANY PARTICULAR FONT, STYLE, SIZE, OR COLOR.

FOR MORTGAGE BROKERAGE, NAMELY, ORIGINATION OF MORTGAGES FOR RESIDENTIAL AND COMMERCIAL REAL ESTATE (U.S. CLS. 100, 101 AND 102).

FIRST USE 9-9-2007; IN COMMERCE 9-9-2007.

CLASS 36—(Continued).

3,481,890. INTERCONTINENTALEXCHANGE, INC., ATLANTA, GA. SN 77-256,972. PUB. 2-19-2008, FILED 8-16-2007.

ICE FUTURES U.S.

THE MARK CONSISTS OF STANDARD CHARACTERS WITHOUT CLAIM TO ANY PARTICULAR FONT, STYLE, SIZE, OR COLOR.

OWNER OF U.S. REG. NOS. 2,442,215, 3,277,230, AND OTHERS.

NO CLAIM IS MADE TO THE EXCLUSIVE RIGHT TO USE "FUTURES U.S.", APART FROM THE MARK AS SHOWN.

FOR ELECTRONIC COMMODITIES EXCHANGE SERVICES; PROVIDING FINANCIAL SERVICES IN THE NATURE OF PROVIDING AN EXCHANGE FOR COMMODITIES AND COMMODITIES DERIVATIVES, PROVIDING ONLINE EXCHANGE SERVICES IN THE NATURE OF ONLINE PURCHASING AND/OR SELLING OF COMMODITIES AND COMMODITIES DERIVATIVES; PROVIDING ONLINE COMMODITIES AND COMMODITY DERIVATIVES PRICING AND RELATED INFORMATION; FINANCIAL SERVICES IN THE NATURE OF ASSISTING OTHERS WITH THE COMPLETION OF FINANCIAL TRANSACTIONS FOR COMMODITIES AND COMMODITY DERIVATIVES; SERVICES RELATING TO FINANCIAL TRANSACTIONS, NAMELY, TRADING OF COMMODITIES AND COMMODITY DERIVATIVES; PROVIDING FINANCIAL SERVICES IN THE NATURE OF OFFERING, SPONSORING, MANAGING AND/OR ADMINISTERING COMMODITIES, COMMODITY DERIVATIVES AND RELATED FINANCIAL INSTRUMENTS (U.S. CLS. 100, 101 AND 102).

FIRST USE 8-31-2007; IN COMMERCE 8-31-2007.

3,481,919. FARRIS ENTERPRISES, LLC, WHITEFISH, MT. SN 77-271,617. PUB. 3-4-2008, FILED 9-5-2007.

CROSSING TRAILS

THE MARK CONSISTS OF STANDARD CHARACTERS WITHOUT CLAIM TO ANY PARTICULAR FONT, STYLE, SIZE, OR COLOR.

FOR LEASING OF REAL ESTATE (U.S. CLS. 100, 101 AND 102).

FIRST USE 10-1-2007; IN COMMERCE 10-1-2007.

CLASS 36—(Continued).

3,481,933. ZACKIN PUBLICATIONS, INC., OXFORD, CT. SN 77-278,487. PUB. 3-4-2008, FILED 9-13-2007.

MORTGAGEORB

THE MARK CONSISTS OF STANDARD CHARACTERS WITHOUT CLAIM TO ANY PARTICULAR FONT, STYLE, SIZE, OR COLOR.

FOR PROVIDING WEB SITE FEATURING INFORMATION PERTAINING TO THE REAL ESTATE FINANCING INDUSTRY, THE MORTGAGE MARKET, AND THE FINANCE INDUSTRY (U.S. CLS. 100, 101 AND 102). FIRST USE 10-0-2007; IN COMMERCE 10-0-2007.

3,481,964. JANUS INTERNATIONAL HOLDING LLC, DENVER, CO. SN 77-297,448. PUB. 3-18-2008, FILED 10-5-2007.

GO FURTHER

THE MARK CONSISTS OF STANDARD CHARACTERS WITHOUT CLAIM TO ANY PARTICULAR FONT, STYLE, SIZE, OR COLOR.

FOR FINANCIAL AND INVESTMENT SERVICES, NAMELY, MANAGEMENT AND BROKERAGE IN THE FIELDS OF STOCKS, BONDS, OPTIONS, COMMODITIES, FUTURES AND OTHER SECURITIES, AND THE INVESTMENT OF FUNDS OF OTHERS (U.S. CLS. 100, 101 AND 102).

FIRST USE 10-31-2007; IN COMMERCE 10-31-2007.

3,481,965. STEPHENS INVESTMENT MANAGEMENT GROUP, LLC, LITTLE ROCK, AR. SN 77-297,676. PUB. 3-18-2008, FILED 10-5-2007.

The Power of Growth

THE MARK CONSISTS OF STANDARD CHARACTERS WITHOUT CLAIM TO ANY PARTICULAR FONT, STYLE, SIZE, OR COLOR.

FOR FINANCIAL ANALYSIS AND CONSULTATION; INVESTMENT ADVICE; INVESTMENT MANAGEMENT; MUTUAL FUND DISTRIBUTION AND MUTUAL FUND INVESTMENT (U.S. CLS. 100, 101 AND 102).

FIRST USE 3-28-2008; IN COMMERCE 3-28-2008.

CLASS 36—(Continued).

3,481,998. EAST RIVER REALTY COMPANY, LLC, NEW YORK, NY. SN 77-975,725. PUB. 1-15-2008, FILED 2-23-2007.



NO CLAIM IS MADE TO THE EXCLUSIVE RIGHT TO USE "TURTLE BAY", APART FROM THE MARK AS SHOWN.

THE COLOR(S) RED AND BLACK IS/ARE CLAIMED AS A FEATURE OF THE MARK.

THE MARK CONSISTS OF A DRAWING IN RED OF A TURTLE AND A LINE OVER THE WORDS "TURTLE BAY SOUTH".

FOR REAL ESTATE MANAGEMENT SERVICES IN MANHATTAN, NEW YORK; RENTAL OF APARTMENTS, RENTAL OF OFFICE SPACE, RENTAL OF BUILDINGS FOR PERMANENT OCCUPANCY, IN MANHATTAN, NEW YORK (U.S. CLS. 100, 101 AND 102).

FIRST USE 4-6-2008; IN COMMERCE 4-6-2008.

3,482,021. UNIFIEDMARKET, INC., ENCINITAS, CA. SN 78-360,967. PUB. 3-7-2006, FILED 2-2-2004.

UNIFIEDMARKET

THE MARK CONSISTS OF STANDARD CHARACTERS WITHOUT CLAIM TO ANY PARTICULAR FONT, STYLE, SIZE, OR COLOR.

FOR PROVIDING FINANCIAL INFORMATION BY ELECTRONIC MEANS RELATING TO ON-LINE MARKETS FOR LISTING FINANCIAL ASSETS USING THIRD PARTY CLEARING FACILITIES (U.S. CLS. 100, 101 AND 102).

FIRST USE 5-28-2008; IN COMMERCE 5-28-2008.

CLASS 36—(Continued).

3,482,024. ESCO GLOBAL REALTY CORP., MILL BAY, BC, CANADA. SN 78-372,011. PUB. 2-7-2006, FILED 2-22-2004.

OWN YOUR FUTURE

THE MARK CONSISTS OF STANDARD CHARACTERS WITHOUT CLAIM TO ANY PARTICULAR FONT, STYLE, SIZE, OR COLOR.

FOR REAL ESTATE AGENCIES; LEASING OF REAL ESTATE FOR OTHERS; PERFORMING REAL ESTATE APPRAISALS AND EVALUATIONS; PROVIDING REAL ESTATE LISTINGS (U.S. CLS. 100, 101 AND 102).

FIRST USE 4-1-2006; IN COMMERCE 4-1-2006.

3,482,088. MARSHALL BANKFIRST CORP., MINNEAPOLIS, MN. SN 78-533,672. PUB. 3-28-2006, FILED 12-16-2004.



NO CLAIM IS MADE TO THE EXCLUSIVE RIGHT TO USE "BANK, N.A.", APART FROM THE MARK AS SHOWN.

THE COLOR(S) BLUE AND WHITE IS/ARE CLAIMED AS A FEATURE OF THE MARK.

THE MARK CONSISTS OF A DISTINCTIVE LOGO COMPRISING THE DESIGN OF A MOUNTAIN IN THE COLOR WHITE WITH A STYLIZED LETTER "M" IN THE COLOR BLUE INSIDE THE MOUNTAIN AND THE "MARSHALL BANK, N.A." MARK APPEARING IN THE COLOR WHITE BENEATH THE MOUNTAIN, ALL ON A BLUE COLORED BACKGROUND.

FOR BANKING SERVICES (U.S. CLS. 100, 101 AND 102).

FIRST USE 2-0-2004; IN COMMERCE 2-0-2004.

CLASS 36—(Continued).

3,482,125. MARRIOTT INTERNATIONAL, INC., BETHESDA, MD. SN 78-636,118. PUB. 2-14-2006, FILED 5-24-2005.



OWNER OF U.S. REG. NO. 2,268,939 AND OTHERS. THE MARK CONSISTS OF DESIGN OF A GRIFFIN. FOR REAL ESTATE SERVICES, NAMELY, LISTING, LEASING, BROKERAGE, MANAGEMENT AND OPERATION OF CONDOMINIUM RESIDENT UNITS; REAL ESTATE FINANCING (U.S. CLS. 100, 101 AND 102). FIRST USE 10-30-2004; IN COMMERCE 10-30-2004.

3,482,132. FMR LLC, BOSTON, MA. SN 78-642,912. PUB. 10-30-2007, FILED 6-3-2005.

FIDELITY PERSONAL RETIREMENT ANNUITY

THE MARK CONSISTS OF STANDARD CHARACTERS WITHOUT CLAIM TO ANY PARTICULAR FONT, STYLE, SIZE, OR COLOR.

OWNER OF U.S. REG. NOS. 1,481,037, 2,156,688, AND OTHERS.

NO CLAIM IS MADE TO THE EXCLUSIVE RIGHT TO USE "PERSONAL RETIREMENT ANNUITY", APART FROM THE MARK AS SHOWN.

FOR ANNUITY UNDERWRITING AND INVESTMENT MANAGEMENT SERVICES (U.S. CLS. 100, 101 AND 102). FIRST USE 8-15-2005; IN COMMERCE 8-15-2005.

CLASS 36—(Continued).

3,482,141. AMERICAN FARM BUREAU FEDERATION, WASHINGTON, DC. SN 78-654,313. PUB. 6-19-2007, FILED 6-20-2005.

FB TEN

THE MARK CONSISTS OF STANDARD CHARACTERS WITHOUT CLAIM TO ANY PARTICULAR FONT, STYLE, SIZE, OR COLOR.

OWNER OF U.S. REG. NOS. 985,201, 2,960,158, AND OTHERS.

FOR PROVIDING A PROGRAM UNDER WHICH HOLDERS OF TOBACCO QUOTAS MAY RECEIVE ONE LUMP SUM PAYMENT, AT A DISCOUNTED RATE, FOR THEIR TOBACCO QUOTAS, IN LIEU OF ANNUAL PAYMENTS TO BUY OUT THEIR QUOTAS UNDER THE USDA TOBACCO TRANSITION PAYMENT PROGRAM, AND PROVIDING FINANCIAL ADVICE IN CONNECTION THEREWITH, NAMELY, FINANCIAL PLANNING SERVICES AND ESTATE, RETIREMENT AND INVESTMENT PLANNING SERVICES (U.S. CLS. 100, 101 AND 102).

FIRST USE 8-1-2005; IN COMMERCE 8-1-2005.

3,482,164. LENGA INVESTMENT MANAGEMENT HOLD-CO, LLC, CHICAGO, IL. SN 78-682,433. PUB. 4-25-2006, FILED 8-1-2005.

TALL TREE

THE MARK CONSISTS OF STANDARD CHARACTERS WITHOUT CLAIM TO ANY PARTICULAR FONT, STYLE, SIZE, OR COLOR.

FOR ADVICE RELATING TO INVESTMENTS; FINANCIAL MANAGEMENT; FUNDS INVESTMENT; INVESTMENT ADVICE; INVESTMENT MANAGEMENT; INVESTMENT SERVICES, NAMELY, ASSET ACQUISITION, CONSULTATION, DEVELOPMENT AND MANAGEMENT SERVICES (U.S. CLS. 100, 101 AND 102).

FIRST USE 7-31-2005; IN COMMERCE 7-31-2005.

3,482,185. HOAG MEMORIAL HOSPITAL PRESBYTERIAN, NEWPORT BEACH, CA. SN 78-721,768. PUB. 2-27-2007, FILED 9-27-2005.

HOAG INVITATIONAL REGATTA

THE MARK CONSISTS OF STANDARD CHARACTERS WITHOUT CLAIM TO ANY PARTICULAR FONT, STYLE,

CLASS 36—(Continued).

SIZE, OR COLOR.

OWNER OF U.S. REG. NO. 1,977,913.

NO CLAIM IS MADE TO THE EXCLUSIVE RIGHT TO USE "INVITATIONAL REGATTA", APART FROM THE MARK AS SHOWN.

FOR CONDUCTING AN ANNUAL CHARITABLE FUNDRAISING CAMPAIGN WHICH BENEFITS A NON-PROFIT ORGANIZATION (U.S. CLS. 100, 101 AND 102).

FIRST USE 4-7-2008; IN COMMERCE 4-7-2008.

3,482,194. NYSE GROUP, INC., NEW YORK, NY. SN 78-742,258. PUB. 1-9-2007, FILED 10-28-2005.

NYSE Auction Limit Order

THE MARK CONSISTS OF STANDARD CHARACTERS WITHOUT CLAIM TO ANY PARTICULAR FONT, STYLE, SIZE, OR COLOR.

OWNER OF U.S. REG. NOS. 909,350, 2,284,340, AND OTHERS.

NO CLAIM IS MADE TO THE EXCLUSIVE RIGHT TO USE "AUCTION LIMIT ORDER", APART FROM THE MARK AS SHOWN.

FOR CONDUCTING A SECURITIES EXCHANGE FEATURING DUAL AUCTION MARKET CAPABILITIES AND AUTOMATIC TRANSACTION EXECUTION CAPABILITIES VIA PHYSICAL CONVENTION AND ELECTRONICALLY FOR DESIGNATED SECURITIES ORDERS; PROVIDING STOCK MARKET INFORMATION (U.S. CLS. 100, 101 AND 102).

FIRST USE 0-0-2006; IN COMMERCE 0-0-2006.

3,482,195. NYSE GROUP, INC., NEW YORK, NY. SN 78-742,262. PUB. 1-9-2007, FILED 10-28-2005.

NYSE Auction Market Order

THE MARK CONSISTS OF STANDARD CHARACTERS WITHOUT CLAIM TO ANY PARTICULAR FONT, STYLE, SIZE, OR COLOR.

OWNER OF U.S. REG. NOS. 909,350, 2,284,340, AND OTHERS.

NO CLAIM IS MADE TO THE EXCLUSIVE RIGHT TO USE "AUCTION MARKET ORDER", APART FROM THE MARK AS SHOWN.

FOR CONDUCTING A SECURITIES EXCHANGE FEATURING DUAL AUCTION MARKET CAPABILITIES AND AUTOMATIC TRANSACTION EXECUTION CAPABILITIES VIA PHYSICAL CONVENTION AND ELECTRONICALLY FOR DESIGNATED SECURITIES ORDERS; PROVIDING STOCK MARKET INFORMATION (U.S. CLS. 100, 101 AND 102).

FIRST USE 0-0-2006; IN COMMERCE 0-0-2006.

CLASS 36—(Continued).

3,482,196. NYSE GROUP, INC., NEW YORK, NY. SN 78-742,268. PUB. 1-9-2007, FILED 10-28-2005.

NYSE Liquidity Replenishment Point

THE MARK CONSISTS OF STANDARD CHARACTERS WITHOUT CLAIM TO ANY PARTICULAR FONT, STYLE, SIZE, OR COLOR.

OWNER OF U.S. REG. NOS. 909,350, 2,284,340, AND OTHERS.

NO CLAIM IS MADE TO THE EXCLUSIVE RIGHT TO USE "LIQUIDITY REPLENISHMENT POINT", APART FROM THE MARK AS SHOWN.

FOR CONDUCTING A SECURITIES EXCHANGE FEATURING DUAL AUCTION MARKET CAPABILITIES AND AUTOMATIC TRANSACTION EXECUTION CAPABILITIES VIA PHYSICAL CONVENTION AND ELECTRONICALLY AND ELECTRONIC REGULATION OF PRICE MOVEMENTS OF LISTED SECURITIES; PROVIDING STOCK MARKET INFORMATION (U.S. CLS. 100, 101 AND 102).

FIRST USE 9-0-2006; IN COMMERCE 9-0-2006.

3,482,221. UNITED STATES ARTISTS, INC., LOS ANGELES, CA. SN 78-762,897. PUB. 3-13-2007, FILED 11-29-2005.



United States Artists

NO CLAIM IS MADE TO THE EXCLUSIVE RIGHT TO USE "USA UNITED STATES ARTISTS", APART FROM THE MARK AS SHOWN.

FOR CHARITABLE FUND RAISING; PROVIDING GRANTS TO INDIVIDUAL ARTISTS (U.S. CLS. 100, 101 AND 102).

FIRST USE 9-0-2006; IN COMMERCE 9-0-2006.

3,482,229. FIRST NATIONAL BUSINESS CORPORATION, SPRINGFIELD, MO. SN 78-770,071. PUB. 8-21-2007, FILED 12-9-2005.

FIRST NATIONAL BUSINESS CORPORATION

CLASS 36—(Continued).

THE MARK CONSISTS OF STANDARD CHARACTERS WITHOUT CLAIM TO ANY PARTICULAR FONT, STYLE, SIZE, OR COLOR.

NO CLAIM IS MADE TO THE EXCLUSIVE RIGHT TO USE "NATIONAL BUSINESS CORPORATION", APART FROM THE MARK AS SHOWN.

FOR BUSINESS BROKERAGE SERVICES; CONSULTING SERVICES, NAMELY, PROVIDING ASSISTANCE IN THE NATURE OF FINANCING TO BUSINESS OWNERS AND BUSINESS BUYERS FOR BUYING AND SELLING BUSINESSES (U.S. CLS. 100, 101 AND 102).

FIRST USE 1-1-1999; IN COMMERCE 1-1-1999.

3,482,287. ENT FEDERAL CREDIT UNION, COLORADO SPRINGS, CO. SN 78-804,789. PUB. 9-26-2006, FILED 2-1-2006.

SECURE@ENT

THE MARK CONSISTS OF STANDARD CHARACTERS WITHOUT CLAIM TO ANY PARTICULAR FONT, STYLE, SIZE, OR COLOR.

FOR BANKING; BANKING CONSULTATION; CHECKING ACCOUNT SERVICES; ON-LINE BANKING SERVICES (U.S. CLS. 100, 101 AND 102).

FIRST USE 4-1-2007; IN COMMERCE 4-1-2007.

3,482,316. ASSURANCEAMERICA CORPORATION, ATLANTA, GA. SN 78-834,412. PUB. 6-12-2007, FILED 3-10-2006.



OWNER OF U.S. REG. NOS. 2,961,353 AND 3,144,163. NO CLAIM IS MADE TO THE EXCLUSIVE RIGHT TO USE "LATINO", APART FROM THE MARK AS SHOWN, FOR INSURANCE AGENCIES (U.S. CLS. 100, 101 AND 102).

FIRST USE 4-1-2004; IN COMMERCE 4-1-2004.

CLASS 36—(Continued).

3,482,379. ATAPIC REAL ESTATE INVESTMENT, LLC, JACKSONVILLE, FL. SN 78-885,495. PUB. 12-26-2006, FILED 5-17-2006.



NO CLAIM IS MADE TO THE EXCLUSIVE RIGHT TO USE "SERVICE" AND "COMPANIES", APART FROM THE MARK AS SHOWN.

THE MARK CONSISTS OF CIRCULAR TWIST BEARING STARS AND THE WORDS "ATAPIC COMPANIES"; PYRAMID, CASTLE TOWER WITH DOME, HORSE HEAD AND CHEST PROFILE, SPROUTING SEEDS AND BANNER ACROSS BOTTOM INTERIOR BEARING WORDS "SIX STAR SERVICE".

FOR FINANCIAL INVESTMENT IN THE FIELD OF REAL ESTATE (U.S. CLS. 100, 101 AND 102).

FIRST USE 5-17-2006; IN COMMERCE 5-17-2006.

3,482,433. AUTOMATED INSTALLMENT SYSTEMS, INC., ST. LOUIS, MO. SN 78-922,955. PUB. 2-27-2007, FILED 7-5-2006.

OWN YOUR OWN

THE MARK CONSISTS OF STANDARD CHARACTERS WITHOUT CLAIM TO ANY PARTICULAR FONT, STYLE, SIZE, OR COLOR.

FOR INSURANCE PREMIUM FINANCING SERVICES FOR USE BY OTHERS BY MEANS OF THE INTERNET (U.S. CLS. 100, 101 AND 102).

FIRST USE 10-0-2005; IN COMMERCE 10-0-2005.

CLASS 36—(Continued).

3,482,471. FINANCIAL MANAGEMENT GROUP, INC., CINCINNATI, OH. SN 78-938,763. PUB. 3-13-2007, FILED 7-27-2006.

QUIET MILLIONAIRE

THE MARK CONSISTS OF STANDARD CHARACTERS WITHOUT CLAIM TO ANY PARTICULAR FONT, STYLE, SIZE, OR COLOR.

FOR FINANCIAL SERVICES, NAMELY, PROVIDING COMPREHENSIVE FINANCIAL PLANNING AND INVESTMENT ADVISORY SERVICES (U.S. CLS. 100, 101 AND 102).

FIRST USE 6-30-2007; IN COMMERCE 6-30-2007.

3,482,497. CLIENTS FIRST FINANCIAL, HINGHAM, MA. SN 78-946,873. PUB. 3-11-2008, FILED 8-7-2006.

Second Opinion Estate
Planning

THE MARK CONSISTS OF STANDARD CHARACTERS WITHOUT CLAIM TO ANY PARTICULAR FONT, STYLE, SIZE, OR COLOR.

NO CLAIM IS MADE TO THE EXCLUSIVE RIGHT TO USE "ESTATE PLANNING", APART FROM THE MARK AS SHOWN.

FOR ESTATE PLANNING CONSULTATION REGARDING USE OF INSURANCE AS A PRIMARY RETIREMENT FUNDING SOURCE, INCLUDING ADVICE ON TITLING ASSETS AND INSURANCE PLACEMENT AND EXCLUDING SERVICES RELATING TO SALE OF SECURITIES, INVESTMENT ADVICE OR FINANCIAL RESEARCH (U.S. CLS. 100, 101 AND 102).

FIRST USE 6-5-2008; IN COMMERCE 6-5-2008.

CLASS 36—(Continued).

3,482,561. ABSOLUTE PLUS MANAGEMENT LLC, NEW YORK, NY. SN 78-973,048. PUB. 10-16-2007, FILED 9-13-2006.

APM

THE MARK CONSISTS OF STANDARD CHARACTERS WITHOUT CLAIM TO ANY PARTICULAR FONT, STYLE, SIZE, OR COLOR.

APM" HAS NO MEANING IN A FOREIGN LANGUAGE. FOR INVESTMENT ADVISORY AND MANAGEMENT SERVICES FOR SUBSCRIPTION BY PRIVATE INVESTORS FEATURING A SYSTEMATIC PRICE-BASED STRATEGY BASED ON PROPRIETARY METHODOLOGIES TO CAPTURE MARKET BEHAVIOR (U.S. CLS. 100, 101 AND 102).

FIRST USE 12-14-2006; IN COMMERCE 12-14-2006.

3,482,562. ABSOLUTE PLUS MANAGEMENT LLC, NEW YORK, NY. SN 78-973,081. PUB. 9-18-2007, FILED 9-13-2006.

ABSOLUTE PLUS MANAGEMENT

THE MARK CONSISTS OF STANDARD CHARACTERS WITHOUT CLAIM TO ANY PARTICULAR FONT, STYLE, SIZE, OR COLOR.

NO CLAIM IS MADE TO THE EXCLUSIVE RIGHT TO USE "MANAGEMENT", APART FROM THE MARK AS SHOWN.

FOR INVESTMENT ADVISORY AND MANAGEMENT SERVICES FOR SUBSCRIPTION BY PRIVATE INVESTORS FEATURING A SYSTEMATIC PRICE BASED STRATEGY BASED ON PROPRIETARY METHODOLOGIES TO CAPTURE RECURRING MARKET BEHAVIOR (U.S. CLS. 100, 101 AND 102).

FIRST USE 12-14-2006; IN COMMERCE 12-14-2006.

CLASS 37—CONSTRUCTION AND REPAIR

CLASS 37—(Continued).

3,481,062. APPLIED MATERIALS, INC., SANTA CLARA, CA. SN 76-561,365. PUB. 5-17-2005, FILED 11-21-2003.

APPLIED GLOBAL SERVICES

THE MARK CONSISTS OF STANDARD CHARACTERS WITHOUT CLAIM TO ANY PARTICULAR FONT, STYLE, SIZE, OR COLOR.

NO CLAIM IS MADE TO THE EXCLUSIVE RIGHT TO USE "GLOBAL SERVICES", APART FROM THE MARK AS SHOWN.

FOR MAINTENANCE AND REPAIR OF SEMICONDUCTOR PROCESSING AND PRODUCTION EQUIPMENT (U.S. CLS. 100, 103 AND 106).

FIRST USE 4-30-2008; IN COMMERCE 4-30-2008.

3,481,111. HAAS OUTDOORS, INC., WEST POINT, MS. SN 76-665,164. PUB. 8-14-2007, FILED 8-25-2006.

MOSSY OAK LAND ENHANCEMENT SERVICES

THE MARK CONSISTS OF STANDARD CHARACTERS WITHOUT CLAIM TO ANY PARTICULAR FONT, STYLE, SIZE, OR COLOR.

OWNER OF U.S. REG. NOS. 1,525,739, 3,155,948, AND OTHERS.

NO CLAIM IS MADE TO THE EXCLUSIVE RIGHT TO USE "LAND ENHANCEMENT SERVICES", APART FROM THE MARK AS SHOWN.

FOR LAND DEVELOPMENT SERVICES; NAMELY, PLANNING AND LAYING OUT OF PROPERTY AND RESIDENTIAL FACILITIES FOR AGRICULTURE, HUNTING, FISHING, AND WILDLIFE MANAGEMENT; CONSTRUCTION OF HUNTING CAMPS, HUNTING PROPERTY, AND WILDLIFE MANAGEMENT AREAS (U.S. CLS. 100, 103 AND 106).

FIRST USE 3-31-2005; IN COMMERCE 3-31-2005.

3,481,213. S&D CARWASH MANAGEMENT, LLC, CARMICHAEL, CA. SN 77-026,557. PUB. 5-29-2007, FILED 10-21-2006.

DON'T DRIVE DIRTY!

THE MARK CONSISTS OF STANDARD CHARACTERS WITHOUT CLAIM TO ANY PARTICULAR FONT, STYLE, SIZE, OR COLOR.

FOR AUTOMOBILE WASHING; CAR CLEANING; CAR WASHING (U.S. CLS. 100, 103 AND 106).

FIRST USE 7-11-2005; IN COMMERCE 7-11-2005.

CLASS 37—(Continued).

3,481,294. INTERNATIONAL PIPELINING TECHNOLOGIES, INC., SAN DIEGO, CA. SN 77-067,015. PUB. 8-21-2007, FILED 12-19-2006.

LIGHTSTREAM

THE MARK CONSISTS OF STANDARD CHARACTERS WITHOUT CLAIM TO ANY PARTICULAR FONT, STYLE, SIZE, OR COLOR.

FOR PIPELINE REHABILITATION SERVICES, NAMELY, THE REPAIR AND RELINING OF EXISTING PIPELINE; PIPELINE RESTORATION AND MAINTENANCE SERVICES (U.S. CLS. 100, 103 AND 106).

FIRST USE 12-1-2006; IN COMMERCE 12-1-2006.

3,481,295. INTERNATIONAL PIPELINING TECHNOLOGIES, INC., SAN DIEGO, CA. SN 77-067,029. PUB. 7-31-2007, FILED 12-19-2006.

SPINTECH

THE MARK CONSISTS OF STANDARD CHARACTERS WITHOUT CLAIM TO ANY PARTICULAR FONT, STYLE, SIZE, OR COLOR.

FOR PIPELINE REHABILITATION SERVICES, NAMELY, THE REPAIR AND RELINING OF EXISTING PIPELINE; PIPELINE RESTORATION AND MAINTENANCE SERVICES (U.S. CLS. 100, 103 AND 106).

FIRST USE 12-1-2006; IN COMMERCE 12-1-2006.

3,481,296. INTERNATIONAL PIPELINING TECHNOLOGIES, INC., SAN DIEGO, CA. SN 77-067,043. PUB. 7-31-2007, FILED 12-19-2006.

AIRSTREAM

THE MARK CONSISTS OF STANDARD CHARACTERS WITHOUT CLAIM TO ANY PARTICULAR FONT, STYLE, SIZE, OR COLOR.

FOR PIPELINE REHABILITATION SERVICES, NAMELY, THE REPAIR AND RELINING OF EXISTING PIPELINE; PIPELINE RESTORATION AND MAINTENANCE SERVICES (U.S. CLS. 100, 103 AND 106).

FIRST USE 12-1-2006; IN COMMERCE 12-1-2006.

CLASS 37—(Continued).

3,481,309. BARONE, MICHAEL A., LAS VEGAS, NV. SN 77-074,076. PUB. 8-7-2007, FILED 1-1-2007.



NO CLAIM IS MADE TO THE EXCLUSIVE RIGHT TO USE "STONE", APART FROM THE MARK AS SHOWN.

THE COLOR(S) BLUE, RED, WHITE, BLACK IS/ARE CLAIMED AS A FEATURE OF THE MARK.

THE MARK CONSISTS OF A BLUE HORIZONTAL OVAL CONTAINING WHITE LINING, A RED FLATLINE HORIZONTALLY THROUGH THE CENTER OF THE OVAL, THE BLACK WORDING "THE STONE" INSIDE THE OVAL TO THE RIGHT AND ABOVE THE RED FLATLINE, THE BLACK WORDING "SURGEON" INSIDE THE OVAL TO THE RIGHT AND BELOW THE RED FLATLINE AND THE BLACK WORDING "SETTING NEW STANDARDS WITH NEW TECHNOLOGY" CURVED BELOW AND OUTSIDE THE BLUE OVAL.

FOR STONE REPAIR (U.S. CLS. 100, 103 AND 106).
FIRST USE 6-15-2007; IN COMMERCE 6-15-2007.

3,481,593. SEARS BRANDS, LLC, HOFFMAN ESTATES, IL. SN 77-150,797. PUB. 10-2-2007, FILED 4-6-2007.

HEROES AT HOME

THE MARK CONSISTS OF STANDARD CHARACTERS WITHOUT CLAIM TO ANY PARTICULAR FONT, STYLE, SIZE, OR COLOR.

FOR CHARITABLE SERVICES, NAMELY, BUILDING RESIDENTIAL HOUSING FOR WAR VETERANS (U.S. CLS. 100, 103 AND 106).

FIRST USE 5-0-2007; IN COMMERCE 5-0-2007.

3,481,622. MR LUCK, INC., GREENTOWN, PA. SN 77-158,175. PUB. 10-30-2007, FILED 4-17-2007.

Luck Log Homes

THE MARK CONSISTS OF STANDARD CHARACTERS WITHOUT CLAIM TO ANY PARTICULAR FONT, STYLE,

CLASS 37—(Continued).

SIZE, OR COLOR.

NO CLAIM IS MADE TO THE EXCLUSIVE RIGHT TO USE "LOG HOMES", APART FROM THE MARK AS SHOWN.

FOR CUSTOM CONSTRUCTION OF HOMES (U.S. CLS. 100, 103 AND 106).

FIRST USE 2-1-2007; IN COMMERCE 2-1-2007.

3,481,780. FREEDOM CONCRETE PUMPING, LLC, CANTON, MI. SN 77-211,332. PUB. 11-20-2007, FILED 6-20-2007.

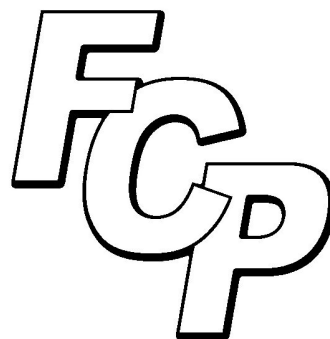

THE MARK CONSISTS OF THE LETTERS "FCP" IN A STYLIZED TEXT.

FOR PUMPING CONCRETE SERVICES (U.S. CLS. 100, 103 AND 106).

FIRST USE 1-2-2006; IN COMMERCE 1-16-2006.

CLASS 37—(Continued).

3,481,848. LOVE, TIMOTHY, EDWARDS, MS. SN 77-243,911.
PUB. 1-22-2008, FILED 8-1-2007.

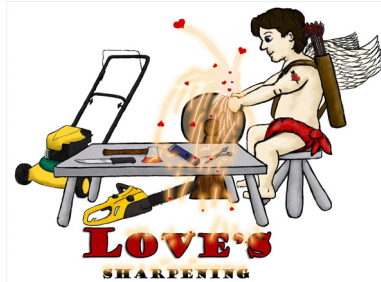

NO CLAIM IS MADE TO THE EXCLUSIVE RIGHT TO USE "SHARPENING", APART FROM THE MARK AS SHOWN.

THE COLOR(S) RED, BLACK, BROWN, GRAY, BEIGE, GREEN, WHITE, PINK, AND YELLOW IS/ARE CLAIMED AS A FEATURE OF THE MARK.

THE MARK CONSISTS OF A CUPID HAVING BLACK OUTLINE DETAILING, BEIGE SKIN, BROWN HAIR, WHITE AND GRAY WINGS, AND HAVING A RED AND BLACK HEART TATTOO, WEARING RED TRUNKS, AND CARRYING BLACK AND RED ARROWS IN A BROWN QUIVER; THE TABLE AND STOOL APPEAR IN GRAY WITH BLACK OUTLINE, THE GRINDING WHEEL APPEARS IN BROWN, THE INSTRUMENTS ON THE TABLE APPEAR IN BROWN AND BLACK; THE STYLIZED SPARKS APPEAR IN PINK WITH RED HEARTS; THE LAWNMOWER APPEARS IN BLACK, YELLOW, AND GREEN, THE POWER SAW APPEARS IN YELLOW AND BLACK; THE WORD "LOVE'S" APPEARS IN RED; THE WORD "SHARPENING" APPEARS IN BLACK.

FOR SHARPENING AND REPAIR OF HAIR CLIPPER BLADES, SCISSORS, LAWN AND GARDEN TOOLS AND CHAIN SAWS (U.S. CLS. 100, 103 AND 106).

FIRST USE 1-1-2007; IN COMMERCE 1-1-2007.

3,481,880. RESOURCE COMMERCIAL FLOORING NETWORK, LLC, AURORA, CO. SN 77-254,025. PUB. 2-19-2008, FILED 8-13-2007.

Ecollect

THE MARK CONSISTS OF STANDARD CHARACTERS WITHOUT CLAIM TO ANY PARTICULAR FONT, STYLE, SIZE, OR COLOR.

FOR COLLECTION FOR RECYCLING OF USED FLOORING MATERIALS (U.S. CLS. 100, 103 AND 106).
FIRST USE 1-1-2008; IN COMMERCE 1-1-2008.

CLASS 37—(Continued).

3,482,094. DE YOUNG COMMUNITIES, INC., FRESNO, CA.
SN 78-548,872. PUB. 9-27-2005, FILED 1-17-2005.

DE YOUNG HOMES

THE MARK CONSISTS OF STANDARD CHARACTERS WITHOUT CLAIM TO ANY PARTICULAR FONT, STYLE, SIZE, OR COLOR.

NO CLAIM IS MADE TO THE EXCLUSIVE RIGHT TO USE "HOMES", APART FROM THE MARK AS SHOWN.

FOR CONSTRUCTION SERVICES, NAMELY, PLANNING, LAYING OUT AND CUSTOM CONSTRUCTION OF RESIDENTIAL COMMUNITIES, REAL ESTATE DEVELOPMENT AND CONSTRUCTION MANAGEMENT (U.S. CLS. 100, 103 AND 106).

FIRST USE 3-29-2008; IN COMMERCE 3-29-2008.

3,482,277. GODART, F. THOMAS, FORT LAUDERDALE, FL.
SN 78-795,992. PUB. 9-12-2006, FILED 1-20-2006.

INVISIBLE CAPTAIN

THE MARK CONSISTS OF STANDARD CHARACTERS WITHOUT CLAIM TO ANY PARTICULAR FONT, STYLE, SIZE, OR COLOR.

FOR MAINTENANCE OF BOATS AND YACHTS (U.S. CLS. 100, 103 AND 106).

FIRST USE 2-0-2002; IN COMMERCE 2-0-2002.

3,482,279. GALPIN AUTO SPORTS LLC, VAN NUYS, CA. SN 78-797,631. PUB. 3-27-2007, FILED 1-23-2006.

GALPIN AUTO SPORTS

THE MARK CONSISTS OF STANDARD CHARACTERS WITHOUT CLAIM TO ANY PARTICULAR FONT, STYLE, SIZE, OR COLOR.

NO CLAIM IS MADE TO THE EXCLUSIVE RIGHT TO USE "AUTO SPORTS", APART FROM THE MARK AS SHOWN.

FOR AUTOMOBILE CUSTOMIZATION SERVICES (U.S. CLS. 100, 103 AND 106).
FIRST USE 1-31-2006; IN COMMERCE 1-31-2006.

CLASS 38—COMMUNICATION

3,481,130. GOTVMAIL COMMUNICATIONS, LLC, WESTON, MA. SN 76-673,181. PUB. 8-28-2007, FILED 2-26-2007.

**THE PROFESSIONAL SOUND
FOR GO-ANYWHERE ENTREPRENEURS**

THE MARK CONSISTS OF STANDARD CHARACTERS WITHOUT CLAIM TO ANY PARTICULAR FONT, STYLE, SIZE, OR COLOR.
FOR TELECOMMUNICATIONS SERVICES, NAMELY, VOICE MAIL SERVICES, TOLL FREE TELEPHONE SERVICES, AND WIRELESS PBX SERVICES (U.S. CLS. 100, 101 AND 104).
FIRST USE 5-6-2008; IN COMMERCE 5-6-2008.

CLASS 38—(Continued).

3,481,133. GOTVMAIL COMMUNICATIONS, LLC, WESTON, MA. SN 76-673,184. PUB. 8-21-2007, FILED 2-26-2007.

CONNECT YOUR PEOPLE PROTECT YOUR PRIVACY SOUND MORE PROFESSIONAL

THE MARK CONSISTS OF STANDARD CHARACTERS WITHOUT CLAIM TO ANY PARTICULAR FONT, STYLE, SIZE, OR COLOR.
FOR TELECOMMUNICATIONS SERVICES, NAMELY, VOICE MAIL SERVICES, TOLL FREE TELEPHONE SERVICES, AND WIRELESS PBX SERVICES (U.S. CLS. 100, 101 AND 104).
FIRST USE 5-6-2008; IN COMMERCE 5-6-2008.

3,481,131. GOTVMAIL COMMUNICATIONS, LLC, WESTON, MA. SN 76-673,182. PUB. 8-21-2007, FILED 2-26-2007.

CONNECT YOUR PEOPLE

THE MARK CONSISTS OF STANDARD CHARACTERS WITHOUT CLAIM TO ANY PARTICULAR FONT, STYLE, SIZE, OR COLOR.
FOR TELECOMMUNICATIONS SERVICES, NAMELY, VOICE MAIL SERVICES, TOLL FREE TELEPHONE SERVICES, AND WIRELESS PBX SERVICES (U.S. CLS. 100, 101 AND 104).
FIRST USE 5-6-2008; IN COMMERCE 5-6-2008.

3,481,135. GOTVMAIL COMMUNICATIONS, LLC, WESTON, MA. SN 76-673,672. PUB. 8-21-2007, FILED 3-5-2007.

STAY CONNECTED. SOUND MORE PROFESSIONAL.

THE MARK CONSISTS OF STANDARD CHARACTERS WITHOUT CLAIM TO ANY PARTICULAR FONT, STYLE, SIZE, OR COLOR.
FOR TELECOMMUNICATION SERVICES, NAMELY, VOICE MAIL SERVICES, TOLL FREE TELEPHONE SERVICES, AND WIRELESS PBX SERVICES (U.S. CLS. 100, 101 AND 104).
FIRST USE 5-6-2008; IN COMMERCE 5-6-2008.

3,481,132. GOTVMAIL COMMUNICATIONS, LLC, WESTON, MA. SN 76-673,183. PUB. 8-21-2007, FILED 2-26-2007.

**CONNECT YOUR PEOPLE
SOUND MORE PROFESSIONAL**

THE MARK CONSISTS OF STANDARD CHARACTERS WITHOUT CLAIM TO ANY PARTICULAR FONT, STYLE, SIZE, OR COLOR.
FOR TELECOMMUNICATIONS SERVICES, NAMELY, VOICE MAIL SERVICES, TOLL FREE TELEPHONE SERVICES, AND WIRELESS PBX SERVICES (U.S. CLS. 100, 101 AND 104).
FIRST USE 5-6-2008; IN COMMERCE 5-6-2008.

3,481,136. GOTVMAIL COMMUNICATIONS, LLC, WESTON, MA. SN 76-673,977. PUB. 8-21-2007, FILED 3-12-2007.

GO-ANYWHERE ENTREPRENEUR

THE MARK CONSISTS OF STANDARD CHARACTERS WITHOUT CLAIM TO ANY PARTICULAR FONT, STYLE, SIZE, OR COLOR.
FOR TELECOMMUNICATION SERVICES, NAMELY, VOICE MAIL SERVICES, TOLL FREE TELEPHONE SERVICES, AND WIRELESS PBX SERVICES (U.S. CLS. 100, 101 AND 104).
FIRST USE 5-6-2008; IN COMMERCE 5-6-2008.

CLASS 38—(Continued).

3,481,137. BRIGHT HOUSE NETWORKS LLC, EAST SYRACUSE, NY. SN 76-674,557. PUB. 10-9-2007, FILED 3-26-2007.

YOU ON DEMAND

THE MARK CONSISTS OF STANDARD CHARACTERS WITHOUT CLAIM TO ANY PARTICULAR FONT, STYLE, SIZE, OR COLOR.

NO CLAIM IS MADE TO THE EXCLUSIVE RIGHT TO USE "ON DEMAND", APART FROM THE MARK AS SHOWN.

FOR COMMUNICATION SERVICES, NAMELY, TRANSMITTING PRE-RECORDED AUDIO AND VIDEO MATERIAL THROUGH TELEVISION, CABLE AND SATELLITE SYSTEMS AND ON THE INTERNET; TRANSMISSION OF INFORMATION THROUGH VIDEO AND AUDIO VIA DIGITAL NETWORKS, ELECTRONIC COMMUNICATIONS NETWORKS, CABLE AND SATELLITE SYSTEMS (U.S. CLS. 100, 101 AND 104).

FIRST USE 4-25-2007; IN COMMERCE 4-25-2007.

3,481,641. SPC DIGITAL, INC., BIRMINGHAM, AL. SN 77-161,479. PUB. 9-25-2007, FILED 4-20-2007.

MYRECIPES.COM

THE MARK CONSISTS OF STANDARD CHARACTERS WITHOUT CLAIM TO ANY PARTICULAR FONT, STYLE, SIZE, OR COLOR.

FOR STREAMING OF AUDIO AND VIDEO MATERIAL ON THE INTERNET AND THROUGH MOBILE COMMUNICATIONS DEVICES IN THE FIELDS OF COOKING, FOODS, BEVERAGES, ENTERTAINING, KITCHEN EQUIPMENT AND LIFESTYLES (U.S. CLS. 100, 101 AND 104).

FIRST USE 6-26-2007; IN COMMERCE 6-26-2007.

3,481,642. SPC DIGITAL, INC., BIRMINGHAM, AL. SN 77-161,484. PUB. 9-25-2007, FILED 4-20-2007.

MYRECIPES

THE MARK CONSISTS OF STANDARD CHARACTERS WITHOUT CLAIM TO ANY PARTICULAR FONT, STYLE, SIZE, OR COLOR.

FOR STREAMING OF AUDIO AND VIDEO MATERIAL ON THE INTERNET AND THROUGH MOBILE COMMUNICATIONS DEVICES IN THE FIELDS OF COOKING, FOODS, BEVERAGES, ENTERTAINING, KITCHEN EQUIPMENT AND LIFESTYLES (U.S. CLS. 100, 101 AND 104).

FIRST USE 6-26-2007; IN COMMERCE 6-26-2007.

CLASS 38—(Continued).

3,481,649. GRANDE COMMUNICATIONS NETWORKS, INC., SAN MARCOS, TX. SN 77-164,788. PUB. 10-23-2007, FILED 4-24-2007.

GRANDEVISION

THE MARK CONSISTS OF STANDARD CHARACTERS WITHOUT CLAIM TO ANY PARTICULAR FONT, STYLE, SIZE, OR COLOR.

FOR TELECOMMUNICATION SERVICES, NAMELY, TELECOMMUNICATION ACCESS SERVICES; TELEVISION, CABLE TELEVISION, SUBSCRIPTION TELEVISION AND RADIO BROADCASTING SERVICES; VIDEO BROADCASTING SERVICES; SATELLITE TELEVISION BROADCASTING SERVICES; COMMUNICATIONS BY MEANS OF RADIO, SATELLITE, CABLE, FIBER OPTIC NETWORKS, AND COMPUTER TERMINALS, NAMELY, TRANSMISSION OF DATA, SOUND, IMAGES AND MESSAGES BY MEANS OF RADIO, SATELLITE, CABLE, FIBER OPTIC NETWORKS, AND COMPUTER TERMINALS (U.S. CLS. 100, 101 AND 104).

FIRST USE 5-8-2007; IN COMMERCE 5-8-2007.

3,481,842. VALIDAS, INC., MISSOURI CITY, TX. SN 77-241,839. PUB. 1-15-2008, FILED 7-30-2007.

**THE WORST CELL PHONE BILL
IN AMERICA**

THE MARK CONSISTS OF STANDARD CHARACTERS WITHOUT CLAIM TO ANY PARTICULAR FONT, STYLE, SIZE, OR COLOR.

FOR TELECOMMUNICATIONS AND WIRELESS TELEPHONE COMMUNICATION SERVICES NAMELY, TELECOMMUNICATION CONSULTATION TO THIRD-PARTY USERS WITH ACCESS TO TELECOMMUNICATION INFRASTRUCTURE FOR PERSONAL COMMUNICATIONS SERVICES CONCERNING BILLING AND TELEPHONE CALLING PLANS BASED ON DATA TRANSMISSION AND RECEPTION SERVICES AND EXCHANGE OF DATA STORED IN A DATABASE ACCESSIBLE VIA TELECOMMUNICATION MEANS (U.S. CLS. 100, 101 AND 104).

FIRST USE 9-10-2007; IN COMMERCE 9-10-2007.

CLASS 38—(Continued).

3,482,023. LIFESIZE COMMUNICATIONS, INC., AUSTIN, TX. SN 78-371,705. PUB. 3-29-2005, FILED 2-20-2004.

LIFESIZE

THE MARK CONSISTS OF STANDARD CHARACTERS WITHOUT CLAIM TO ANY PARTICULAR FONT, STYLE, SIZE, OR COLOR.

FOR AUDIO AND VIDEO CONFERENCING SERVICES, NAMELY, PROVIDING INFORMATION ABOUT AUDIO AND VIDEO CONFERENCING (U.S. CLS. 100, 101 AND 104).

FIRST USE 10-23-2007; IN COMMERCE 10-23-2007.

CLASS 38—(Continued).

3,482,385. ELYNX, LTD., CINCINNATI, OH. SN 78-888,078. PUB. 1-2-2007, FILED 5-19-2006.



FOR ELECTRONIC TRANSMISSION OF DATA AND DOCUMENTS VIA THE WORLDWIDE WEB (U.S. CLS. 100, 101 AND 104).

FIRST USE 11-1-2007; IN COMMERCE 11-1-2007.

3,482,241. KROEGER MEDIA INC., LA SALLE, CANADA. SN 78-776,558. PUB. 6-5-2007, FILED 12-19-2005.

"Plays Everything Country"

THE MARK CONSISTS OF STANDARD CHARACTERS WITHOUT CLAIM TO ANY PARTICULAR FONT, STYLE, SIZE, OR COLOR.

NO CLAIM IS MADE TO THE EXCLUSIVE RIGHT TO USE "COUNTRY", APART FROM THE MARK AS SHOWN. FOR RADIO BROADCASTING SERVICE (U.S. CLS. 100, 101 AND 104).

FIRST USE 1-5-2007; IN COMMERCE 1-5-2007.

3,482,386. ELYNX, LTD., CINCINNATI, OH. SN 78-888,088. PUB. 1-2-2007, FILED 5-19-2006.

ENTER THE WORLD OF E

THE MARK CONSISTS OF STANDARD CHARACTERS WITHOUT CLAIM TO ANY PARTICULAR FONT, STYLE, SIZE, OR COLOR.

FOR ELECTRONIC TRANSMISSION OF DATA AND DOCUMENTS VIA THE WORLDWIDE WEB (U.S. CLS. 100, 101 AND 104).

FIRST USE 11-1-2007; IN COMMERCE 11-1-2007.

CLASS 38—(Continued).

3,482,491. WORLD RADIO MISSIONARY FELLOWSHIP, INC., COLORADO SPRINGS, CO. SN 78-944,655. PUB. 8-28-2007, FILED 8-3-2006.

HCJB GLOBAL VOICE

THE MARK CONSISTS OF STANDARD CHARACTERS WITHOUT CLAIM TO ANY PARTICULAR FONT, STYLE, SIZE, OR COLOR.

NO CLAIM IS MADE TO THE EXCLUSIVE RIGHT TO USE "GLOBAL", APART FROM THE MARK AS SHOWN.

FOR VIDEO, SATELLITE, AND AUDIO BROADCASTING; BROADCASTING PROGRAMS VIA A GLOBAL COMPUTER NETWORK; BROADCASTING AND STREAMING OF AUDIO MATERIAL ON THE INTERNET; BROADCASTING AND STREAMING OF VIDEO MATERIAL ON THE INTERNET (U.S. CLS. 100, 101 AND 104).

FIRST USE 4-1-2008; IN COMMERCE 4-1-2008.

3,482,510. 800 RESPONSE MARKETING LLC, BURLINGTON, VT. SN 78-952,297. PUB. 12-25-2007, FILED 8-15-2006.

800response

THE MARK CONSISTS OF STANDARD CHARACTERS WITHOUT CLAIM TO ANY PARTICULAR FONT, STYLE, SIZE, OR COLOR.

OWNER OF U.S. REG. NO. 1,521,210.

FOR TELEPHONE CALL MONITORING SERVICES (U.S. CLS. 100, 101 AND 104).

FIRST USE 5-7-2003; IN COMMERCE 8-7-2003.

3,482,586. HORSELAND LLC, VERNON HILL, IL. SN 78-980,417. PUB. 10-9-2007, FILED 8-30-2006.

HORSELAND

THE MARK CONSISTS OF STANDARD CHARACTERS WITHOUT CLAIM TO ANY PARTICULAR FONT, STYLE, SIZE, OR COLOR.

FOR PROVIDING ON-LINE CHAT ROOMS AND FORUMS FOR TRANSMISSION OF MESSAGES AMONG COMPUTER USERS CONCERNING TOPIC OF COMPUTER GAMING ENTERTAINMENT; PROVIDING ON-LINE ELECTRONIC BULLETIN BOARDS FOR TRANSMISSION OF MESSAGES AMONG COMPUTER USERS CONCERNING TOPIC OF COMPUTER GAMING ENTERTAINMENT (U.S. CLS. 100, 101 AND 104).

FIRST USE 8-1-1996; IN COMMERCE 8-1-1996.

CLASS 39—TRANSPORTATION AND STORAGE

3,481,086. NEW JERSEY TRANSIT CORPORATION, NEWARK, NJ. SN 76-653,793. PUB. 9-26-2006, FILED 1-23-2006.



NO CLAIM IS MADE TO THE EXCLUSIVE RIGHT TO USE "TUNNEL", APART FROM THE MARK AS SHOWN.

THE MARK CONSISTS OF RAILROAD TRACKS LEADING INTO A TUNNEL WITH THE WORDS "THE TUNNEL" ABOVE THE TUNNEL AND THE WORDS "DIG IT" BELOW THE RAILROAD TRACKS CONTAINED WITHIN A CIRCLE.

FOR TICKETING SERVICES BY MAIL FOR MASS TRANSIT PASSENGERS; AND MASS TRANSIT FOR THE GENERAL PUBLIC AND TRAVEL INFORMATION SERVICES; TRAVEL SERVICES, NAMELY, TRANSPORTATION OF PASSENGERS BY RAIL TO DESTINATIONS IN NEW JERSEY AND NEW YORK (U.S. CLS. 100 AND 105).

FIRST USE 1-13-2006; IN COMMERCE 1-13-2006.

3,481,483. IRON PONY MOTORCYCLE RENTAL, LLC, MENTOR, OH. SN 77-133,212. PUB. 9-18-2007, FILED 3-16-2007.

POWER PONY

THE MARK CONSISTS OF STANDARD CHARACTERS WITHOUT CLAIM TO ANY PARTICULAR FONT, STYLE, SIZE, OR COLOR.

FOR MOTORCYCLE RENTAL (U.S. CLS. 100 AND 105).

FIRST USE 4-0-2008; IN COMMERCE 4-0-2008.

CLASS 39—(Continued).

3,481,535. HIGHLAND FORWARDING, INC., MANCHESTER, NH. SN 77-141,795. PUB. 1-29-2008, FILED 3-27-2007.

HIGHLAND FORWARDING

THE MARK CONSISTS OF STANDARD CHARACTERS WITHOUT CLAIM TO ANY PARTICULAR FONT, STYLE, SIZE, OR COLOR.

NO CLAIM IS MADE TO THE EXCLUSIVE RIGHT TO USE "FORWARDING", APART FROM THE MARK AS SHOWN.

FOR FREIGHT FORWARDING SERVICES FOR THE AREAS OF AIR AND OCEAN EXPORTS, AIR AND OCEAN IMPORTS, SMALL PACKAGE COURIER SHIPMENTS, DANGEROUS GOODS SHIPMENTS, FREIGHT SHIPPED BY DOMESTIC TRUCKING, DOMESTIC AIR FREIGHT, AND PROVIDING CUSTOM TRANSPORT CONSULTATION SERVICES AND OVERSEAS CUSTOMER CLEARANCE SERVICES (U.S. CLS. 100 AND 105).
FIRST USE 7-1-1998; IN COMMERCE 7-1-1998.

3,481,730. SUNDEEN, NANCY, MAPLE GROVE, MN. SN 77-185,799. PUB. 11-27-2007, FILED 5-21-2007.

KEEPSAKE WITH A MESSAGE

THE MARK CONSISTS OF STANDARD CHARACTERS WITHOUT CLAIM TO ANY PARTICULAR FONT, STYLE, SIZE, OR COLOR.

FOR DELIVERY OF GREETINGS ACCOMPANIED BY A PILLOW (U.S. CLS. 100 AND 105).
FIRST USE 8-31-2007; IN COMMERCE 8-31-2007.

3,481,939. KMGJ CORP., SUNNY ISLES BEACH, FL. SN 77-280,449. PUB. 2-26-2008, FILED 9-15-2007.

Fine Food. Fast.

THE MARK CONSISTS OF STANDARD CHARACTERS WITHOUT CLAIM TO ANY PARTICULAR FONT, STYLE, SIZE, OR COLOR.

NO CLAIM IS MADE TO THE EXCLUSIVE RIGHT TO USE "FOOD", APART FROM THE MARK AS SHOWN.
FOR FOOD DELIVERY (U.S. CLS. 100 AND 105).
FIRST USE 12-7-2007; IN COMMERCE 12-7-2007.

CLASS 39—(Continued).

3,482,183. TOY BOX, LLC., BELLINGHAM, WA. SN 78-721,157. PUB. 6-13-2006, FILED 9-27-2005.



NO CLAIM IS MADE TO THE EXCLUSIVE RIGHT TO USE "STORAGE", APART FROM THE MARK AS SHOWN.
THE COLORS RED, ORANGE, YELLOW, AND BLACK ARE CLAIMED AS A FEATURE OF THE MARK.

THE "X" IN "EXTREME" APPEARS AS A PAINTED "X" IN ORANGE AND YELLOW, THE WORD "EXTREME" APPEARS IN RED, AND THE WORD "STORAGE" APPEARS IN BLACK.

FOR STORAGE OF MOTOR VEHICLES, WATER CRAFT, TRAILERS, RECREATIONAL VEHICLES AND OTHER LARGE ITEMS (U.S. CLS. 100 AND 105).

FIRST USE 9-27-2005; IN COMMERCE 9-27-2005.

3,482,220. SDS GLOBAL LOGISTICS, INC., LONG ISLAND CITY, NY. SN 78-762,299. PUB. 9-12-2006, FILED 11-29-2005.



NO CLAIM IS MADE TO THE EXCLUSIVE RIGHT TO USE "GLOBAL LOGISTICS", APART FROM THE MARK AS SHOWN.

THE COLOR(S) GREEN, BLACK, AND GRAY IS/ARE CLAIMED AS A FEATURE OF THE MARK.

THE COLOR BLACK APPEARS IN THE WORDS "GLOBAL LOGISTICS." THE COLOR GRAY APPEARS IN THE DESIGN OF A GLOBE. THE COLOR GREEN APPEARS IN THE LINES BORDERING THE ENTIRE MARK AND THE LETTERS "SDS".

THE MARK CONSISTS OF THE WORDS "SDS" GLOBAL LOGISTICS ALONG WITH A GLOBE DESIGN.

FOR GLOBAL TRANSPORTATION OF FREIGHT FOR OTHERS BY ALL AVAILABLE MEANS (U.S. CLS. 100 AND 105).

FIRST USE 1-1-2006; IN COMMERCE 1-1-2006.

CLASS 39—(Continued).

3,482,268. HAWAII FOREST & TRAIL, LTD., KAILUA-KONA, HI. SN 78-791,748. PUB. 9-12-2006, FILED 1-13-2006.

PinzTrekHawaii.com

THE MARK CONSISTS OF STANDARD CHARACTERS WITHOUT CLAIM TO ANY PARTICULAR FONT, STYLE, SIZE, OR COLOR.

FOR CONDUCTING SIGHTSEEING TOURS FOR OTHERS (U.S. CLS. 100 AND 105).

FIRST USE 6-2-2006; IN COMMERCE 6-2-2006.

3,482,452. BENCHMARK PERFORMANCE GROUP, INC., HOUSTON, TX. SN 78-932,775. PUB. 9-25-2007, FILED 7-19-2006.

BDS

THE MARK CONSISTS OF STANDARD CHARACTERS WITHOUT CLAIM TO ANY PARTICULAR FONT, STYLE, SIZE, OR COLOR.

FOR SUPPLY CHAIN, LOGISTICS AND REVERSE LOGISTICS SERVICES, NAMELY, STORAGE, TRANSPORTATION AND DELIVERY OF RAW MATERIALS, FINISHED GOODS, AND OTHER FREIGHT IN THE FIELD OF INDUSTRIAL AND OIL FIELD CHEMICALS AND INDUSTRIAL AND OIL FIELD EQUIPMENT BY BULK-LIQUID TANKERS, INDUSTRY STANDARD TRANSPORT CONTAINERS, BULK LIQUID CONTAINERS, DRY BULK CONTAINERS, CURTAIN-SIDE TRAILERS, DRY VANS, AND FLATBED TRAILERS; WAREHOUSING SERVICES IN THE FIELD OF INDUSTRIAL AND OIL FIELD CHEMICALS AND INDUSTRIAL AND OIL FIELD EQUIPMENT; TRANSPORTATION SERVICES, NAMELY, TRANSPORT OF GOODS BY LAND IN THE FIELD OF INDUSTRIAL AND OIL FIELD CHEMICALS AND INDUSTRIAL AND OIL FIELD EQUIPMENT; DISTRIBUTION SERVICES, NAMELY, DELIVERY OF RAW MATERIALS, FINISHED GOODS AND OTHER FREIGHT IN THE FIELD OF INDUSTRIAL AND OIL FIELD CHEMICALS AND INDUSTRIAL AND OIL FIELD EQUIPMENT BY BULK-LIQUID TANKERS, INDUSTRY STANDARD TRANSPORT CONTAINERS, BULK LIQUID CONTAINERS, DRY BULK CONTAINERS, CURTAIN-SIDE TRAILERS, DRY VANS, AND FLATBED TRAILERS (U.S. CLS. 100 AND 105).

FIRST USE 7-1-2006; IN COMMERCE 7-1-2006.

CLASS 39—(Continued).

3,482,454. BENCHMARK PERFORMANCE GROUP, INC., HOUSTON, TX. SN 78-933,437. PUB. 9-25-2007, FILED 7-20-2006.



OWNER OF U.S. REG. NO. 3,062,236.

"THE MARK CONSISTS OF THE STYLIZED WORDING BDS, HAVING A BANNER FORMED BY TWO WAVY LINES TO THE LEFT OF THE WORDING."

FOR SUPPLY CHAIN, LOGISTICS AND REVERSE LOGISTICS SERVICES, NAMELY, STORAGE, TRANSPORTATION AND DELIVERY OF RAW MATERIALS, FINISHED GOODS, AND OTHER FREIGHT IN THE FIELD OF INDUSTRIAL AND OILFIELD CHEMICALS AND INDUSTRIAL AND OILFIELD EQUIPMENT BY BULK-LIQUID TANKERS, INDUSTRY STANDARD TRANSPORT CONTAINERS, BULK LIQUID CONTAINERS, DRY BULK CONTAINERS, CURTAIN-SIDE TRAILERS, DRY VANS, AND FLATBED TRAILERS; WAREHOUSING SERVICES IN THE FIELD OF INDUSTRIAL AND OILFIELD CHEMICALS AND INDUSTRIAL AND OILFIELD EQUIPMENT; TRANSPORTATION SERVICES, NAMELY, TRANSPORT OF GOODS BY LAND IN THE FIELD OF INDUSTRIAL AND OILFIELD CHEMICALS AND INDUSTRIAL AND OILFIELD EQUIPMENT; DISTRIBUTION SERVICES, NAMELY, DELIVERY OF RAW MATERIALS, FINISHED GOODS AND OTHER FREIGHT IN THE FIELD OF INDUSTRIAL AND OILFIELD CHEMICALS AND INDUSTRIAL AND OILFIELD EQUIPMENT BY BULK-LIQUID TANKERS, INDUSTRY STANDARD TRANSPORT CONTAINERS, BULK LIQUID CONTAINERS, DRY BULK CONTAINERS, CURTAIN-SIDE TRAILERS, DRY VANS, AND FLATBED TRAILERS (U.S. CLS. 100 AND 105).

FIRST USE 7-1-2006; IN COMMERCE 7-1-2006.

CLASS 40—MATERIAL TREATMENT

3,481,353. DURGIN & CROWELL LUMBER COMPANY, INC., NEW LONDON, NH. SN 77-093,793. PUB. 9-25-2007, FILED 1-29-2007.

Asure

THE MARK CONSISTS OF STANDARD CHARACTERS WITHOUT CLAIM TO ANY PARTICULAR FONT, STYLE, SIZE, OR COLOR.

FOR APPLYING PROTECTIVE COATINGS TO WOOD, NAMELY, APPLYING ULTRAVIOLET COATINGS TO PINE WOOD BOARDS (U.S. CLS. 100, 103 AND 106).

FIRST USE 8-1-2007; IN COMMERCE 8-1-2007.

CLASS 40—(Continued).

3,481,654. GENERAL ELECTRIC COMPANY, SCHENECTADY, NY. SN 77-166,546. PUB. 9-18-2007, FILED 4-26-2007.

WATERMD

THE MARK CONSISTS OF STANDARD CHARACTERS WITHOUT CLAIM TO ANY PARTICULAR FONT, STYLE, SIZE, OR COLOR.

FOR TREATMENT OF WATER USED IN NUCLEAR REACTORS (U.S. CLS. 100, 103 AND 106).

FIRST USE 10-31-2007; IN COMMERCE 10-31-2007.

3,482,273. CPACKET NETWORKS INC., MOUNTAIN VIEW, CA. SN 78-792,961. PUB. 9-12-2006, FILED 1-17-2006.



NO CLAIM IS MADE TO THE EXCLUSIVE RIGHT TO USE "NETWORKS", APART FROM THE MARK AS SHOWN.

THE COLOR(S) BLUE, BLACK AND WHITE IS/ARE CLAIMED AS A FEATURE OF THE MARK.

THE COLOR BLUE APPEARS IN THE PORTION OF THE BORDER OF THE CIRCLE COMPRISING THE TOP, LEFT, AND BOTTOM SIDES OF THE CIRCLE; THE COLOR BLACK APPEARS IN THE DOT INSIDE THE CIRCLE, THE PORTION OF THE BORDER OF THE CIRCLE COMPRISING THE RIGHT SIDE OF THE CIRCLE, AND IN THE WORDING "CPACKET NETWORKS"; THE COLOR WHITE APPEARS IN THE BREAKS IN THE BORDER OF THE CIRCLE AND THE BACKGROUND OF THE MARK.

FOR CUSTOM MANUFACTURE OF COMPUTER HARDWARE WITH OR CONTAINING COMPUTER SOFTWARE FOR USE IN MONITORING, SECURING, RESPONDING TO AND CONTROLLING COMPUTER AND COMMUNICATIONS NETWORK TRAFFIC (U.S. CLS. 100, 103 AND 106).

FIRST USE 3-1-2006; IN COMMERCE 3-1-2006.

CLASS 40—(Continued).

3,482,550. FIVE RIVERS, INC., BOISE, ID. SN 78-964,288. PUB. 10-9-2007, FILED 8-30-2006.

FIVE RIVERS

THE MARK CONSISTS OF STANDARD CHARACTERS WITHOUT CLAIM TO ANY PARTICULAR FONT, STYLE, SIZE, OR COLOR.

FOR CUSTOM MANUFACTURE OF FURNITURE FOR OTHERS (U.S. CLS. 100, 103 AND 106).

FIRST USE 4-0-1990; IN COMMERCE 4-0-1990.

3,482,563. PHOINIX GLOBAL LLC, ALICE, TX. SN 78-973,191. PUB. 8-28-2007, FILED 9-13-2006.

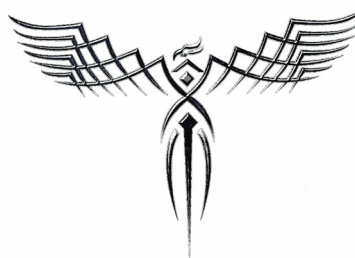

FOR CUSTOM MANUFACTURE AND FABRICATION OF HIGH PRESSURE WELL SERVICING EQUIPMENT (U.S. CLS. 100, 103 AND 106).

FIRST USE 8-0-2007; IN COMMERCE 8-0-2007.

CLASS 41—EDUCATION AND ENTERTAINMENT

3,481,071. PLANET HOLLYWOOD (REGION IV), INC., ORLANDO, FL. SN 76-628,403. PUB. 10-25-2005, FILED 1-20-2005.

MIDNIGHT PLANET

THE MARK CONSISTS OF STANDARD CHARACTERS WITHOUT CLAIM TO ANY PARTICULAR FONT, STYLE, SIZE, OR COLOR.

FOR ENTERTAINMENT IN THE NATURE OF TELEVISION PRODUCTION AND NIGHTCLUB ENTERTAINMENT (U.S. CLS. 100, 101 AND 107).

FIRST USE 3-25-2008; IN COMMERCE 3-25-2008.

CLASS 41—(Continued).

3,481,078. ALTA COLLEGES, INC., DENVER, CO. SN 76-647,629. PUB. 12-19-2006, FILED 9-28-2005.

REDSTONE COLLEGE

THE MARK CONSISTS OF STANDARD CHARACTERS WITHOUT CLAIM TO ANY PARTICULAR FONT, STYLE, SIZE, OR COLOR.

NO CLAIM IS MADE TO THE EXCLUSIVE RIGHT TO USE "COLLEGE", APART FROM THE MARK AS SHOWN.

FOR EDUCATIONAL SERVICES, NAMELY, PROVIDING COURSES OF INSTRUCTION AT THE COLLEGE, UNIVERSITY, AND ADULT EDUCATION LEVELS IN THE FIELDS OF AVIATION MECHANICS, AVIONICS, ELECTRONICS AND CABLING, HEATING, AIR CONDITIONING, AND REFRIGERATION, AUTOMOTIVE REPAIR AND MAINTENANCE, CONSTRUCTION MANAGEMENT, COMPUTER AIDED DESIGN, SURVEYING, AND LANDSCAPE DESIGN, AND DISTRIBUTING COURSE MATERIALS IN CONNECTION THEREWITH (U.S. CLS. 100, 101 AND 107).

FIRST USE 3-0-2006; IN COMMERCE 3-0-2006.

3,481,102. AGA, SUSIE, ALPHARETTA, GA. SN 76-660,171. PUB. 4-17-2007, FILED 5-17-2006.



NO CLAIM IS MADE TO THE EXCLUSIVE RIGHT TO USE "ATLANTA DOG TRAINER LLC", APART FROM THE MARK AS SHOWN.

THE COLOR(S) BLUE AND BLACK IS/ARE CLAIMED AS A FEATURE OF THE MARK.

THE MARK CONSISTS OF A SMALL DOG COLORED BLUE STANDING IN FRONT OF A LARGE DOG COLORED BLACK ON THE LEFT-HAND SIDE OF THE MARK. THE WORDING "ATLANTA DOG TRAINER" APPEARS IN BLACK TO THE RIGHT OF THE DESIGN.

FOR EDUCATIONAL SERVICES, NAMELY, CONDUCTING IN-HOME LESSONS, GROUP CLASSES AND IN-KENNEL TRAINING SESSIONS IN THE FIELDS OF PET OBEDIENCE AND AGILITY (U.S. CLS. 100, 101 AND 107).

FIRST USE 1-1-2007; IN COMMERCE 1-1-2007.

3,481,114. TEAM EDGE, LLC, EATONTOWN, NJ. SN 76-666,237. PUB. 10-23-2007, FILED 9-18-2006.



FOR HEALTH CLUB SERVICES THAT PROMOTE FITNESS AND SPORTS PARTICIPATION AND ENHANCE ATHLETIC AND PERSONAL SKILL LEVELS (U.S. CLS. 100, 101 AND 107).

FIRST USE 10-15-2006; IN COMMERCE 10-15-2006.

CLASS 41—(Continued).

3,481,119. DANIELS, KATHARINE, MONTEREY, CA. SN 76-668,644. PUB. 1-8-2008, FILED 11-7-2006.

THE WIP

THE MARK CONSISTS OF STANDARD CHARACTERS WITHOUT CLAIM TO ANY PARTICULAR FONT, STYLE, SIZE, OR COLOR.

FOR ON-LINE PUBLICATIONS IN THE NATURE OF NEWS MAGAZINES FEATURING ARTICLES BY WOMEN JOURNALISTS IN THE FIELDS OF ARTS AND CULTURE, ECONOMICS, EDUCATION, POLITICS, SCIENCE, TECHNOLOGY, AND WORLD NEWS (U.S. CLS. 100, 101 AND 107).

FIRST USE 3-8-2007; IN COMMERCE 3-8-2007.

3,481,128. PERFECT IMAGE MEDICAL CORP., LOS ANGELES, CA. SN 76-672,530. PUB. 9-11-2007, FILED 2-12-2007.

AMERICAN ELITE

THE MARK CONSISTS OF STANDARD CHARACTERS WITHOUT CLAIM TO ANY PARTICULAR FONT, STYLE, SIZE, OR COLOR.

FOR EDUCATIONAL SERVICES AT THE UNIVERSITY LEVEL, NAMELY, CONDUCTING CLASSES, SEMINARS AND WORKSHOPS ON GENERAL EDUCATION AND PROFESSIONAL EDUCATION COURSES (U.S. CLS. 100, 101 AND 107).

FIRST USE 2-22-2007; IN COMMERCE 2-22-2007.

3,481,176. WATV, LLC, LOS ANGELES, CA. SN 77-004,815. PUB. 5-8-2007, FILED 9-21-2006.

On the Auction Block

THE MARK CONSISTS OF STANDARD CHARACTERS WITHOUT CLAIM TO ANY PARTICULAR FONT, STYLE, SIZE, OR COLOR.

FOR ENTERTAINMENT IN THE NATURE OF ONGOING TELEVISION PROGRAMS IN THE FIELD OF VEHICLES (U.S. CLS. 100, 101 AND 107).

FIRST USE 10-1-2006; IN COMMERCE 10-1-2006.

CLASS 41—(Continued).

3,481,183. SUSTAINABLECIRCLES CORP., SAN FRANCISCO, CA. SN 77-009,484. PUB. 3-20-2007, FILED 9-28-2006.

STUMBLING TOWARDS THE
FUTURE

THE MARK CONSISTS OF STANDARD CHARACTERS WITHOUT CLAIM TO ANY PARTICULAR FONT, STYLE, SIZE, OR COLOR.

FOR ENTERTAINMENT SERVICES, NAMELY, CONTINUING HEALTH, SOCIO-ECONOMIC, POLITICAL AND PUBLIC POLICY EDUCATION SHOWS BROADCAST VIA TELEVISION, SATELLITE, COMPUTER, AUDIO AND VIDEO MEDIA (U.S. CLS. 100, 101 AND 107).

FIRST USE 1-12-2007; IN COMMERCE 1-12-2007.

3,481,220. ELLIOTT, SHARON NORRIS, SOUTH GATE, CA. SN 77-029,845. PUB. 5-22-2007, FILED 10-26-2006.



THE MARK CONSISTS OF A FEATHER PEN ATTACHED TO THE STYLIZED TEXT OF THE WORDING "AUTHORIZEME".

FOR TRAINING SERVICES IN THE FIELD OF WRITING; WRITTEN TEXT EDITING; EDUCATIONAL SERVICES, NAMELY, CONDUCTING SEMINARS IN THE FIELD OF WRITING AND DISTRIBUTION OF COURSE MATERIAL IN CONNECTION THEREWITH (U.S. CLS. 100, 101 AND 107).

FIRST USE 1-1-2007; IN COMMERCE 1-1-2007.

3,481,249. CHARLES, PATRICK, WOODLAND HILLS, CA. SN 77-045,244. PUB. 10-2-2007, FILED 11-16-2006.

SOLEIL RECORDS

THE MARK CONSISTS OF STANDARD CHARACTERS WITHOUT CLAIM TO ANY PARTICULAR FONT, STYLE, SIZE, OR COLOR.

NO CLAIM IS MADE TO THE EXCLUSIVE RIGHT TO USE "RECORDS", APART FROM THE MARK AS SHOWN.

CLASS 41—(Continued).

THE ENGLISH TRANSLATION OF THE WORD "SOLEIL" IN THE MARK IS SUN.

FOR MUSIC PRODUCTION SERVICES (U.S. CLS. 100, 101 AND 107).

FIRST USE 5-0-2008; IN COMMERCE 5-0-2008.

3,481,257. LOTUS GARDEN MEDITATION CENTER, CARMICHAEL, CA. SN 77-050,132. PUB. 12-18-2007, FILED 11-22-2006.

Lotus Garden Meditation
Center

THE MARK CONSISTS OF STANDARD CHARACTERS WITHOUT CLAIM TO ANY PARTICULAR FONT, STYLE, SIZE, OR COLOR.

NO CLAIM IS MADE TO THE EXCLUSIVE RIGHT TO USE "MEDITATION CENTER", APART FROM THE MARK AS SHOWN.

FOR EDUCATIONAL SERVICES, NAMELY, CONDUCTING CLASSES, SEMINARS, WORKSHOPS, AND RETREATS IN THE FIELD OF THE PHILOSOPHY AND PRACTICE OF THE SCIENCE OF YOGA AND MEDITATION, VEGETARIAN COOKING, HEALTHY EATING HABITS AND HOW TO LIVE A HEALTHIER LIFESTYLE, TAI CHI AND CHI KUNG, SUSTAINABLE AGRICULTURE, ORGANIC GARDENING AND DISTRIBUTION OF COURSE MATERIAL IN CONNECTION THEREWITH; YOGA INSTRUCTION (U.S. CLS. 100, 101 AND 107).

FIRST USE 12-23-2007; IN COMMERCE 3-1-2008.

3,481,261. HU-MAN ELEMENT PRODUCTIONS, INC., LOS ANGELES, CA. SN 77-051,936. PUB. 8-28-2007, FILED 11-28-2006.

Hu-Man Element

THE MARK CONSISTS OF STANDARD CHARACTERS WITHOUT CLAIM TO ANY PARTICULAR FONT, STYLE, SIZE, OR COLOR.

FOR ENTERTAINMENT SERVICES FEATURING FILM AND TELEVISION PRODUCTS, NAMELY, MOTION PICTURE, TELEVISION, AND VIDEO AND AUDIO TAPE PRODUCTION SERVICES; VIDEO EDITING, AND VIDEO TAPE EDITING; FILM EDITING; AND MULTIMEDIA ENTERTAINMENT PRODUCTION SERVICES IN THE FIELDS OF VIDEO AND FILMS (U.S. CLS. 100, 101 AND 107).

FIRST USE 1-24-2008; IN COMMERCE 1-24-2008.

CLASS 41—(Continued).

3,481,264. CONNECTICUT RESOURCES RECOVERY AUTHORITY, HARTFORD, CT. SN 77-052,166. PUB. 6-19-2007, FILED 11-28-2006.

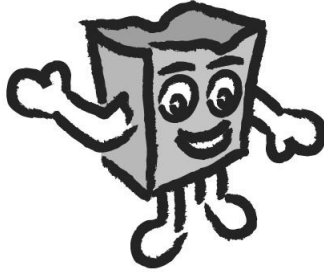

THE MARK CONSISTS OF A STYLIZED PAPER BAG WITH HUMAN FEATURES, CONSISTING OF ARMS, LEGS AND A FACE ON THE BODY OF THE BAG.

FOR EDUCATION SERVICES CONDUCTED OR SPONSORED BY STATE, REGIONAL, TOWN, LOCAL, OR MUNICIPAL GOVERNMENTAL AGENCIES, AUTHORITIES, OR AFFILIATES, INCLUDING THE STATE OF CONNECTICUT, NAMELY, PROVIDING LECTURES, APPEARANCES, EDUCATIONAL PROGRAMS, HANDS-ON AND INTERACTIVE EXHIBITS AND MUSEUM SERVICES IN THE FIELD OF RECYCLING AND SOLID WASTE MANAGEMENT (U.S. CLS. 100, 101 AND 107).

FIRST USE 4-3-2007; IN COMMERCE 4-3-2007.

3,481,274. AARP, WASHINGTON, DC. SN 77-056,878. PUB. 8-21-2007, FILED 12-5-2006.

OWNER OF U.S. REG. NOS. 741,334, 2,623,034, AND OTHERS.

THE COLOR(S) RED IS/ARE CLAIMED AS A FEATURE OF THE MARK.

THE MARK CONSISTS OF "AARP" SHOWN ALL IN RED, WITH A STYLIZED BANNER-LIKE DESIGN PROJECTING FROM THE HORIZONTAL ELEMENT OF THE FIRST "A".

FOR PROVIDING ONLINE MAGAZINES AND NEWSLETTERS PROMOTING THE INTERESTS OF MATURE INDIVIDUALS AND IN THE FIELDS OF CAREGIVING, CHILDCARE, EDUCATION, MEDICAL SERVICES, ELDERCARE, EMPLOYMENT, ASSISTED CARE FACILITIES, LEGAL ASSISTANCE, BUSINESS, INSURANCE, REAL ESTATE, TRAVEL, ELDER ASSISTANCE, RETIREMENT, MATURE OR RETIRED LIFESTYLES, FINANCE, HEALTH, AGING, FAMILY RELATIONSHIPS, VOLUNTEER ACTIVITIES, CONSUMER ISSUES, ECONOMIC SECURITY, WORK, INDEPENDENT LIVING, EXERCISE, FITNESS, ATHLETICS AND SPORTS; EDUCATION AND TRAINING SERVICES, NAMELY, ARRANGING AND CONDUCTING CLASSES, ONLINE CLASSES, SEMINARS, CONFERENCES AND WORKSHOPS IN THE FIELDS CAREGIVING, CHILDCARE, EDUCATION, MEDICAL SERVICES, ELDERCARE, EMPLOYMENT, ASSISTED CARE FACILITIES, LEGAL ASSISTANCE, BUSINESS, INSURANCE, REAL ESTATE, TRAVEL, ELDER ASSISTANCE, RETIREMENT, MA-

CLASS 41—(Continued).

TURE OR RETIRED LIFESTYLES, FINANCE, HEALTH, AGING, FAMILY RELATIONSHIPS, VOLUNTEER ACTIVITIES, CONSUMER ISSUES, ECONOMIC SECURITY, WORK, INDEPENDENT LIVING, EXERCISE, FITNESS, ATHLETICS AND SPORTS; DISTRIBUTION OF COURSE MATERIALS IN CONNECTION THEREWITH; PROVIDING RECOGNITION AND INCENTIVES BY THE WAY OF AWARDS TO DEMONSTRATE EXCELLENCE IN THE FIELDS OF PUBLIC SERVICE, SIGNIFICANT ACHIEVEMENTS, MILESTONES AND CHARITABLE CONTRIBUTIONS IN THE FIELDS OF RETIREMENT, MATURE OR RETIRED LIFESTYLES, FINANCE, HEALTH, AGING, FAMILY RELATIONSHIPS, CONSUMER ISSUES, ECONOMIC SECURITY, WORK, INDEPENDENT LIVING, AND ELDER ISSUES; ENTERTAINMENT SERVICES, NAMELY, CONDUCTING CONTESTS IN MAGAZINES FOR RECOGNITION IN THE FIELDS OF PUBLIC SERVICE, SIGNIFICANT ACHIEVEMENTS, MILESTONES AND CHARITABLE CONTRIBUTIONS IN THE FIELDS OF RETIREMENT, MATURE OR RETIRED LIFESTYLES, FINANCE, HEALTH, AGING, FAMILY RELATIONSHIPS, CONSUMER ISSUES, ECONOMIC SECURITY, WORK, INDEPENDENT LIVING, AND ELDER ISSUES; ARRANGING AND CONDUCTING EXERCISE, FITNESS, ATHLETIC AND SPORTS COMPETITIONS, CONTESTS, RACES AND EVENTS; CONSULTATION SERVICES PROVIDED IN CONNECTION THEREWITH; AND PROVIDING RADIO PROGRAMS PROMOTING THE INTERESTS OF MATURE INDIVIDUALS AND IN THE FIELDS OF CAREGIVING, CHILDCARE, EDUCATION, MEDICAL SERVICES, ELDERCARE, EMPLOYMENT, ASSISTED CARE FACILITIES, LEGAL ASSISTANCE, BUSINESS, INSURANCE, REAL ESTATE, TRAVEL, ELDER ASSISTANCE, RETIREMENT, MATURE OR RETIRED LIFESTYLES, FINANCE, HEALTH, AGING, FAMILY RELATIONSHIPS, VOLUNTEER ACTIVITIES, CONSUMER ISSUES, ECONOMIC SECURITY, WORK, INDEPENDENT LIVING, EXERCISE, FITNESS, ATHLETICS AND SPORTS; ARRANGING AND PRESENTATION OF MUSICAL PERFORMANCES (U.S. CLS. 100, 101 AND 107).

FIRST USE 1-0-2007; IN COMMERCE 1-0-2007.

3,481,305. COLUMBIA BIBLE COLLEGE BROADCASTING CO., COLUMBIA, SC. SN 77-072,171. PUB. 10-2-2007, FILED 12-27-2006.

FAITH, FAMILY AND FREEDOM
CELEBRATION

THE MARK CONSISTS OF STANDARD CHARACTERS WITHOUT CLAIM TO ANY PARTICULAR FONT, STYLE, SIZE, OR COLOR.

NO CLAIM IS MADE TO THE EXCLUSIVE RIGHT TO USE "CELEBRATION", APART FROM THE MARK AS SHOWN.

FOR ENTERTAINMENT, NAMELY, LIVE MUSIC CONCERTS (U.S. CLS. 100, 101 AND 107).

FIRST USE 6-22-2008; IN COMMERCE 6-22-2008.

CLASS 41—(Continued).

3,481,308. FAMILY FINANCIAL NETWORK, L.L.C., GREENWICH, CT. SN 77-073,430. PUB. 3-4-2008, FILED 12-29-2006.

The Millionaire Zone

THE MARK CONSISTS OF STANDARD CHARACTERS WITHOUT CLAIM TO ANY PARTICULAR FONT, STYLE, SIZE, OR COLOR.

FOR EDUCATIONAL SERVICES, NAMELY, PROVIDING ONLINE AND OFFLINE CLASSES AND WORKSHOPS IN THE FIELD OF CAREERS, ENTREPRENEURSHIP, INVESTMENTS AND FINANCIAL PLANNING; PROVIDING ONLINE AND OFFLINE EVENTS, NAMELY, CONFERENCES, SEMINARS AND WEBINARS IN THE FIELDS OF CAREERS, ENTREPRENEURSHIP, INVESTMENTS AND FINANCIAL PLANNING (U.S. CLS. 100, 101 AND 107).

FIRST USE 2-15-2006; IN COMMERCE 4-15-2006.

3,481,335. ENTRACITY, CARLSBAD, CA. SN 77-085,017. PUB. 8-21-2007, FILED 1-17-2007.

*precise*Ticker

THE MARK CONSISTS OF THE WORD "PRECISE" ITALICIZED AND THE WORD "TICKER" HAVING A CAPITAL "T", BOTH WORDS BEING JOINED IN COMPOUND FORM.

FOR PROVIDING NEWS IN THE NATURE OF CURRENT EVENT REPORTING (U.S. CLS. 100, 101 AND 107).

FIRST USE 2-1-2007; IN COMMERCE 2-1-2007.

3,481,350. OPTIMO, INC., ATLANTA, GA. SN 77-093,048. PUB. 7-10-2007, FILED 1-28-2007.

PDUS TO GO

THE MARK CONSISTS OF STANDARD CHARACTERS WITHOUT CLAIM TO ANY PARTICULAR FONT, STYLE, SIZE, OR COLOR.

NO CLAIM IS MADE TO THE EXCLUSIVE RIGHT TO USE "PDUS", APART FROM THE MARK AS SHOWN.

FOR PROVIDING CONTINUING PROJECT MANAGEMENT EDUCATION COURSES (U.S. CLS. 100, 101 AND 107).

FIRST USE 1-28-2007; IN COMMERCE 1-28-2007.

CLASS 41—(Continued).

3,481,395. LAWSON PRODUCTS, INC., DES PLAINES, IL. SN 77-113,325. PUB. 9-4-2007, FILED 2-22-2007.



NO CLAIM IS MADE TO THE EXCLUSIVE RIGHT TO USE "OPERATION SAFETY", APART FROM THE MARK AS SHOWN.

THE MARK CONSISTS OF THE LETTERS "OS" WITH A CROSS IN THE LETTER "O"; WITH THE WORD "OPERATION" ON THE NEXT LINE AND THE WORD "SAFETY" ON THE FOLLOWING LINE.

FOR EDUCATIONAL SERVICES, NAMELY, CONDUCTING CLASSES, SEMINARS, CONFERENCES AND WORKSHOPS IN THE FIELD OF INDUSTRIAL, COMMERCIAL AND INSTITUTIONAL MAINTENANCE, REPAIR AND REPLACEMENT PRODUCTS AND DISTRIBUTION OF COURSE MATERIAL IN CONNECTION THEREWITH (U.S. CLS. 100, 101 AND 107).

FIRST USE 1-18-2007; IN COMMERCE 2-27-2007.

3,481,398. VERSUS, L.P., PHILADELPHIA, PA. SN 77-114,411. PUB. 8-21-2007, FILED 2-23-2007.

RED WHITE BLACK & BLUE SUMMER

THE MARK CONSISTS OF STANDARD CHARACTERS WITHOUT CLAIM TO ANY PARTICULAR FONT, STYLE, SIZE, OR COLOR.

FOR ENTERTAINMENT SERVICES IN THE NATURE OF TELEVISION PROGRAMMING; PRODUCTION OF TELEVISION PROGRAMS AND DISTRIBUTION OF TELEVISION PROGRAMMING TO CABLE TELEVISION SYSTEMS; PROVIDING INFORMATION RELATING TO TELEVISION PROGRAMMING VIA A GLOBAL COMPUTER NETWORK (U.S. CLS. 100, 101 AND 107).

FIRST USE 5-15-2007; IN COMMERCE 5-15-2007.

CLASS 41—(Continued).

3,481,410. GLR NETWORKS LLC, MIAMI, FL. SN 77-119,538.
PUB. 9-4-2007, FILED 3-1-2007.

CITA CON EL DOCTOR

THE MARK CONSISTS OF STANDARD CHARACTERS WITHOUT CLAIM TO ANY PARTICULAR FONT, STYLE, SIZE, OR COLOR.

THE ENGLISH TRANSLATION OF "CITA CON EL DOCTOR" IS "APPOINTMENT WITH THE DOCTOR"

FOR RADIO ENTERTAINMENT, NAMELY, RADIO PROGRAMS FEATURING NEWS, ENTERTAINMENT, TALK, SPORTS AND INTERVIEWS (U.S. CLS. 100, 101 AND 107).

FIRST USE 3-12-2007; IN COMMERCE 3-12-2007.

3,481,425. INDIANA HEMOPHILIA & THROMBOSIS CENTER, INC., INDIANAPOLIS, IN. SN 77-123,271. PUB. 9-18-2007, FILED 3-6-2007.

CEO--CAREER EDUCATION & OPPORTUNITIES

THE MARK CONSISTS OF STANDARD CHARACTERS WITHOUT CLAIM TO ANY PARTICULAR FONT, STYLE, SIZE, OR COLOR.

NO CLAIM IS MADE TO THE EXCLUSIVE RIGHT TO USE "CAREER EDUCATION", APART FROM THE MARK AS SHOWN.

FOR EDUCATIONAL SERVICES, NAMELY, PROVIDING SEMINARS AND WORKSHOPS IN THE AREAS OF SELF ESTEEM, COLLEGE PLANNING, CAREER PLANNING, AND ADULTHOOD PLANNING (U.S. CLS. 100, 101 AND 107).

FIRST USE 8-1-2006; IN COMMERCE 8-1-2006.

3,481,431. YJ LICENSING COMPANY, INC., EAST POINT, GA. SN 77-124,677. PUB. 9-11-2007, FILED 3-7-2007.

USDA

THE MARK CONSISTS OF STANDARD CHARACTERS WITHOUT CLAIM TO ANY PARTICULAR FONT, STYLE, SIZE, OR COLOR.

FOR ENTERTAINMENT SERVICES, NAMELY, MUSICAL PERFORMANCES BY A MUSICAL GROUP (U.S. CLS. 100, 101 AND 107).

FIRST USE 5-22-2007; IN COMMERCE 5-22-2007.

CLASS 41—(Continued).

3,481,448. MINISTERIO INTERNACIONAL EL REY JESUS, INC., MIAMI, FL. SN 77-128,071. PUB. 9-11-2007, FILED 3-12-2007.

KING JESUS INTERNATIONAL MINISTRY

THE MARK CONSISTS OF STANDARD CHARACTERS WITHOUT CLAIM TO ANY PARTICULAR FONT, STYLE, SIZE, OR COLOR.

OWNER OF U.S. REG. NOS. 2,900,337, 2,933,642, AND OTHERS.

NO CLAIM IS MADE TO THE EXCLUSIVE RIGHT TO USE "JESUS" OR "INTERNATIONAL MINISTRY", APART FROM THE MARK AS SHOWN.

FOR EDUCATIONAL SERVICES, NAMELY, SPONSORING, HOSTING AND CONDUCTING SEMINARS, CLASSES, SUNDAY SCHOOL CLASSES AND COURSES OF INSTRUCTION ON RELIGION, BIBLE STUDY, CHRISTIAN WORSHIP, EVANGELISM AND MUSIC; AND FOR PRODUCTION AND DISTRIBUTION OF LIVE AND PRE-RECORDED RADIO AND TELEVISION BROADCASTS FEATURING WORSHIP SERVICES, SERMONS, RELIGIOUS MUSIC AND CHRISTIAN EDUCATIONAL INSTRUCTION (U.S. CLS. 100, 101 AND 107).

FIRST USE 1-31-2007; IN COMMERCE 1-31-2007.

3,481,453. LIBERATION ENTERTAINMENT INC., LOS ANGELES, CA. SN 77-128,974. PUB. 9-11-2007, FILED 3-12-2007.



NO CLAIM IS MADE TO THE EXCLUSIVE RIGHT TO USE "ENTERTAINMENT", APART FROM THE MARK AS SHOWN.

THE COLOR(S) BLUE, BEIGE, GREEN, BLACK AND WHITE IS/ARE CLAIMED AS A FEATURE OF THE MARK.

THE MARK CONSISTS OF A FANCIFUL RENDITION OF A BEIGE HAND OUTLINED IN BLACK HOLDING A BLACK LINED TORCH WITH A TWO-TONED GREEN FLAME AND BLACK FLAME ON A BEIGE PENNANT SHAPED BACKGROUND, ALL TO THE LEFT OF THE LITERAL ELEMENT, "LIBERATION ENTERTAINMENT", WITH THE TERM "LIBERATION" IN WHITE OUTLINED IN BLACK APPEARING AGAINST A BLUE BACKGROUND, AND ABOVE THE TERM "ENTERTAINMENT", WHICH HAS BLACK LETTERS.

FOR PRODUCTION AND DISTRIBUTION OF TELEVISION SHOWS AND MOVIES (U.S. CLS. 100, 101 AND 107).

FIRST USE 11-30-2005; IN COMMERCE 11-30-2005.

CLASS 41—(Continued).

3,481,457. LEGACY OF TRUTH MINISTRIES, INC., DULUTH, GA. SN 77-129,260. PUB. 10-2-2007, FILED 3-13-2007.



OWNER OF U.S. REG. NO. 2,311,587.
THE MARK CONSISTS OF THE WORD "LEGACY" FOLLOWED BY THE WORD "OF" FOLLOWED BY A SWORD SHAPED IN THE IMAGE OF A CROSS, FOLLOWED BY THE WORD "TRUTH".
FOR EDUCATIONAL SERVICES, NAMELY, CONDUCTING CLASSES, SEMINARS, CONFERENCES, AND WORKSHOPS IN THE FIELD OF RELIGION (U.S. CLS. 100, 101 AND 107).
FIRST USE 4-0-2008; IN COMMERCE 4-0-2008.

3,481,486. BOARDOM, INC., HUNTINGTON BEACH, CA. SN 77-133,475. PUB. 9-18-2007, FILED 3-16-2007.

BOARDFEST TRIPLE THREAT

THE MARK CONSISTS OF STANDARD CHARACTERS WITHOUT CLAIM TO ANY PARTICULAR FONT, STYLE, SIZE, OR COLOR.
OWNER OF U.S. REG. NO. 3,059,540.
FOR ORGANIZING COMPETITIONS, EXHIBITIONS, AND FESTIVALS IN THE FIELD OF SNOWBOARDING, SURFING, AND SKATEBOARDING (U.S. CLS. 100, 101 AND 107).
FIRST USE 4-2-2007; IN COMMERCE 4-2-2007.

3,481,499. BOUNCING BRAIN PRODUCTIONS, LLC, CHARLOTTE, NC. SN 77-135,908. PUB. 9-18-2007, FILED 3-20-2007.



THE MARK CONSISTS OF A DEPICTION OF A HUMAN BRAIN AS VIEWED FROM ABOVE. THE BRAIN IMAGE IS TRAILED BY A DOTTED LINE IN A "V" TRAJECTORY STEMMING FROM THE BOTTOM OF THE IMAGE.
FOR TELEVISION SHOW PRODUCTION (U.S. CLS. 100, 101 AND 107).
FIRST USE 6-11-2008; IN COMMERCE 6-11-2008.

CLASS 41—(Continued).

3,481,526. NORTH AMERICAN POLO LEAGUE, LLC, HOUSTON, TX. SN 77-140,965. PUB. 3-11-2008, FILED 3-27-2007.



NO CLAIM IS MADE TO THE EXCLUSIVE RIGHT TO USE "NORTH AMERICAN POLO LEAGUE", APART FROM THE MARK AS SHOWN.
THE MARK CONSISTS OF THE LETTERS "NAPL" AND THE WORDS "NORTH AMERICAN POLO LEAGUE" WITH DESIGN CONSISTING OF A POLO PLAYER ON HORSE.
FOR ENTERTAINMENT SERVICES, NAMELY, ONGOING TELEVISION AND RADIO PROGRAMS IN THE FIELD OF POLO; ENTERTAINMENT SERVICES, NAMELY, PRODUCTION OF SPORTS AND SPORTS RELATED PROGRAMS AND DISTRIBUTION BY MEANS OF TELEVISION BROADCASTING, CABLE TRANSMISSION, SATELLITE TRANSMISSION, AND VIA THE INTERNET; PROVIDING A WEB SITE FEATURING POLO NEWS AND INFORMATION (U.S. CLS. 100, 101 AND 107).
FIRST USE 3-9-2007; IN COMMERCE 3-9-2007.

3,481,534. WORLD WRESTLING ENTERTAINMENT, INC., STAMFORD, CT. SN 77-141,758. PUB. 9-25-2007, FILED 3-27-2007.

JOHNNY NITRO

THE MARK CONSISTS OF STANDARD CHARACTERS WITHOUT CLAIM TO ANY PARTICULAR FONT, STYLE, SIZE, OR COLOR.
THE NAME(S), PORTRAIT(S), AND/OR SIGNATURE(S) SHOWN IN THE MARK DOES NOT IDENTIFY A PARTICULAR LIVING INDIVIDUAL.
FOR ENTERTAINMENT SERVICES, NAMELY, WRESTLING EXHIBITIONS AND PERFORMANCES BY A PROFESSIONAL WRESTLER AND ENTERTAINER; PROVIDING WRESTLING NEWS AND INFORMATION VIA A GLOBAL COMPUTER NETWORK (U.S. CLS. 100, 101 AND 107).
FIRST USE 3-31-2004; IN COMMERCE 3-31-2004.

CLASS 41—(Continued).

3,481,574. GAMING LABORATORIES INTERNATIONAL, INC., LAKEWOOD, NJ. SN 77-148,760. PUB. 10-9-2007, FILED 4-4-2007.

GLI UNIVERSITY

THE MARK CONSISTS OF STANDARD CHARACTERS WITHOUT CLAIM TO ANY PARTICULAR FONT, STYLE, SIZE, OR COLOR.

OWNER OF U.S. REG. NO. 2,800,298.

NO CLAIM IS MADE TO THE EXCLUSIVE RIGHT TO USE "UNIVERSITY", APART FROM THE MARK AS SHOWN.

FOR EDUCATIONAL SERVICES, NAMELY, PROVIDING TRAINING COURSES FOR REGULATORS, SUPPLIERS, AND CASINO OWNERS AND OPERATORS WITH REGARD TO GAMING EQUIPMENT AND GAMING REGULATIONS (U.S. CLS. 100, 101 AND 107).
FIRST USE 5-13-2008; IN COMMERCE 5-13-2008.

CLASS 41—(Continued).

3,481,589. UNIVERSITY OF CENTRAL FLORIDA, ORLANDO, FL. SN 77-150,549. PUB. 10-2-2007, FILED 4-6-2007.



OWNER OF U.S. REG. NOS. 2,118,135, 3,156,265, AND OTHERS.

THE MARK CONSISTS OF KNIGHT HOLDING SWORD (HALF BODY) ABOVE TERM "UCF" WITH WORD "KNIGHTS" BELOW "UCF".

FOR ENTERTAINMENT SERVICES, NAMELY, ORGANIZING AND CONDUCTING COLLEGE SPORTS COMPETITIONS, ATHLETIC EVENTS, TOURNAMENTS AND LIVE PERFORMANCES (U.S. CLS. 100, 101 AND 107).
FIRST USE 7-0-2007; IN COMMERCE 7-0-2007.

3,481,587. UNIVERSITY OF CENTRAL FLORIDA, ORLANDO, FL. SN 77-150,468. PUB. 10-2-2007, FILED 4-6-2007.

3,481,621. PRIME FITNESS, LLC, BONNEY LAKE, WA. SN 77-157,915. PUB. 9-25-2007, FILED 4-16-2007.

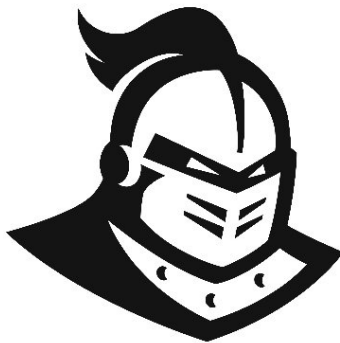

OWNER OF U.S. REG. NOS. 2,121,912, 3,156,265, AND OTHERS.

THE MARK CONSISTS OF KNIGHT HEAD WITH HELMET MASK WITH PLUME.

FOR ENTERTAINMENT SERVICES, NAMELY, ORGANIZING AND CONDUCTING COLLEGE SPORTS COMPETITIONS, ATHLETIC EVENTS, TOURNAMENTS AND LIVE PERFORMANCES (U.S. CLS. 100, 101 AND 107).
FIRST USE 7-0-2007; IN COMMERCE 7-0-2007.



THE COLOR(S) RED, LIGHT GREY, DARK GREY, AND WHITE IS/ARE CLAIMED AS A FEATURE OF THE MARK.

THE MARK CONSISTS OF A STYLIZED RUNNER IN RED ON A DARK GRAY PATH IN THE FOREGROUND, WITH A MOUNTAIN IN THE BACKGROUND DEFINED BY LIGHT GREY SHADING AND INCLUDING WHITE AREAS TO DEPICT A SNOW COVERED MOUNTAIN.

FOR HEALTH CLUB SERVICES, NAMELY, PROVIDING INSTRUCTION AND EQUIPMENT IN THE FIELD OF PHYSICAL EXERCISE, PROVIDING CLASSROOM WORKSHOPS AND CLINICS IN THE FIELD OF EXERCISE, SPORTS, AND STRENGTH TRAINING (U.S. CLS. 100, 101 AND 107).
FIRST USE 11-30-2005; IN COMMERCE 1-31-2007.

CLASS 41—(Continued).

3,481,636. BALARES, ANALISA, NEW YORK, NY. SN 77-160,387. PUB. 9-18-2007, FILED 4-19-2007.

womensphere

THE MARK CONSISTS OF STANDARD CHARACTERS WITHOUT CLAIM TO ANY PARTICULAR FONT, STYLE, SIZE, OR COLOR.

FOR PROVIDING CURRENT EVENT NEWS AND INFORMATION; PUBLICATION OF BOOKS, MAGAZINES AND JOURNALS; PROVIDING TELEVISION PROGRAMS IN THE FIELD OF SOCIAL INTRODUCTION, GENERAL INTEREST, GENDER ISSUES, BUSINESS, POLITICS, GLOBAL LEADERSHIP, COMMUNITY LEADERSHIP, ENTREPRENEURSHIP, EDUCATION, ENVIRONMENT, SCIENCE AND TECHNOLOGY, THEATER, ARTS, MUSIC, TRAVEL, HEALTH, SOCIAL CAUSES, FAMILY LIFE, AND CAMPUS LIFE; ARRANGING EDUCATIONAL MEETINGS, SEMINARS AND CONFERENCES IN THE FIELD OF SOCIAL INTRODUCTION, GENERAL INTEREST, GENDER ISSUES, BUSINESS, POLITICS, GLOBAL LEADERSHIP, COMMUNITY LEADERSHIP, ENTREPRENEURSHIP, EDUCATION, ENVIRONMENT, SCIENCE AND TECHNOLOGY, THEATER, ARTS, MUSIC, TRAVEL, HEALTH, SOCIAL CAUSES, FAMILY LIFE, AND CAMPUS LIFE; ON-LINE JOURNALS, NAMELY, BLOGS FEATURING VARIOUS TOPICS, NAMELY, SOCIAL INTRODUCTION, GENERAL INTEREST, GENDER ISSUES, BUSINESS, POLITICS, GLOBAL LEADERSHIP, COMMUNITY LEADERSHIP, ENTREPRENEURSHIP, EDUCATION, ENVIRONMENT, SCIENCE AND TECHNOLOGY, THEATER, ARTS, MUSIC, TRAVEL, HEALTH, SOCIAL CAUSES, FAMILY LIFE, AND CAMPUS LIFE; PROVIDING A WEBSITE FEATURING INTERACTIVE EDUCATIONAL MEETINGS FEATURING VARIOUS TOPICS, NAMELY, SOCIAL INTRODUCTION, GENERAL INTEREST, GENDER ISSUES, BUSINESS, POLITICS, GLOBAL LEADERSHIP, COMMUNITY LEADERSHIP, ENTREPRENEURSHIP, EDUCATION, ENVIRONMENT, SCIENCE AND TECHNOLOGY, THEATER, ARTS, MUSIC, TRAVEL, HEALTH, SOCIAL CAUSES, FAMILY LIFE, AND CAMPUS LIFE; ORGANIZING AND PLANNING SPECIAL EVENTS (U.S. CLS. 100, 101 AND 107).

FIRST USE 4-2-2007; IN COMMERCE 4-2-2007.

3,481,655. THE COCA-COLA COMPANY, ATLANTA, GA. SN 77-166,566. PUB. 9-18-2007, FILED 4-26-2007.

DISCOVER THE SECRET FORMULA

THE MARK CONSISTS OF STANDARD CHARACTERS WITHOUT CLAIM TO ANY PARTICULAR FONT, STYLE, SIZE, OR COLOR.

FOR EXHIBITION SERVICES, NAMELY, THE OPERATION OF A PAVILION WHICH DISPLAYS EXHIBITS AND MEMORABILIA CONCERNING THE COCA-COLA COMPANY, ITS HISTORY AND ITS PRODUCTS FOR PUBLIC VIEWING (U.S. CLS. 100, 101 AND 107).

FIRST USE 5-0-2007; IN COMMERCE 5-0-2007.

CLASS 41—(Continued).

3,481,658. SOUTHERN COMFORT PROPERTIES, INC., SAN RAFAEL, CA. SN 77-166,951. PUB. 3-11-2008, FILED 4-26-2007.

SOCO MUSIC EXPERIENCE

THE MARK CONSISTS OF STANDARD CHARACTERS WITHOUT CLAIM TO ANY PARTICULAR FONT, STYLE, SIZE, OR COLOR.

OWNER OF U.S. REG. NOS. 1,522,030, 2,254,264, AND 2,650,502.

NO CLAIM IS MADE TO THE EXCLUSIVE RIGHT TO USE "MUSIC", APART FROM THE MARK AS SHOWN.

FOR ARRANGING AND CONDUCTING OF CONCERTS (U.S. CLS. 100, 101 AND 107).

FIRST USE 5-20-2006; IN COMMERCE 5-20-2006.

3,481,662. MINNESOTA VIKINGS FOOTBALL, LLC, EDEN PRAIRIE, MN. SN 77-167,476. PUB. 9-25-2007, FILED 4-27-2007.

YOU MADE THE TEAM

THE MARK CONSISTS OF STANDARD CHARACTERS WITHOUT CLAIM TO ANY PARTICULAR FONT, STYLE, SIZE, OR COLOR.

FOR ENTERTAINMENT SERVICES, NAMELY, PRESENTATIONS IN THE NATURE OF PROFESSIONAL FOOTBALL GAMES AND EXHIBITIONS (U.S. CLS. 100, 101 AND 107).

FIRST USE 4-28-2007; IN COMMERCE 4-28-2007.

3,481,663. MINNESOTA VIKINGS FOOTBALL, LLC, EDEN PRAIRIE, MN. SN 77-167,478. PUB. 9-25-2007, FILED 4-27-2007.

EVERYTHING PURPLE

THE MARK CONSISTS OF STANDARD CHARACTERS WITHOUT CLAIM TO ANY PARTICULAR FONT, STYLE, SIZE, OR COLOR.

FOR ENTERTAINMENT SERVICES, NAMELY, PRESENTATIONS IN THE NATURE OF PROFESSIONAL FOOTBALL GAMES AND EXHIBITIONS (U.S. CLS. 100, 101 AND 107).

FIRST USE 3-1-2006; IN COMMERCE 3-1-2006.

CLASS 41—(Continued).

3,481,691. HAWKINS, KEVIN LAWRENCE, LOS ANGELES, CA. SN 77-175,019. PUB. 11-20-2007, FILED 5-8-2007.



NO CLAIM IS MADE TO THE EXCLUSIVE RIGHT TO USE "GYM", APART FROM THE MARK AS SHOWN.

THE COLOR(S) RED, GRAY AND BLACK IS/ARE CLAIMED AS A FEATURE OF THE MARK.

THE MARK CONSISTS OF A GRAY EMBOSSED HORIZONTAL OVAL CONTAINING THE RED STYLIZED WORDS "GYM SENSE" SET ON TOP OF A GRAY HORIZONTAL BARBELL WITH SETS OF THREE (3) BLACK IMAGES OF WEIGHTS ON THE RIGHT AND LEFT SIDES OF THE BARBELL. A BLACK GRADUATION CAP IMAGE IS ON TOP OF THE LETTER "G" IN THE WORD "GYM SENSE".

FOR PROVIDING INFORMATION IN THE FIELD OF EXERCISE TRAINING; PROVIDING A WEBSITE THAT FEATURES INFORMAL INSTRUCTION ON PROPER GYM ETIQUETTE, AND EQUIPMENT USAGE (U.S. CLS. 100, 101 AND 107).

FIRST USE 6-2-2008; IN COMMERCE 6-2-2008.

CLASS 41—(Continued).

3,481,755. ADOLFO, CARCAÑO RICALDE GUSTAVO, MERIDA, MEXICO. SN 77-199,293. PUB. 2-12-2008, FILED 6-6-2007.

eccelingua

THE MARK CONSISTS OF STANDARD CHARACTERS WITHOUT CLAIM TO ANY PARTICULAR FONT, STYLE, SIZE, OR COLOR.

FOR EDUCATION SERVICES, NAMELY, PROVIDING LIVE AND ON-LINE CLASSES, SEMINARS, WORKSHOPS IN THE FIELD OF LANGUAGES (U.S. CLS. 100, 101 AND 107).

FIRST USE 2-2-2007; IN COMMERCE 4-1-2007.

3,481,758. HENLEY-PUTNAM UNIVERSITY, SAN JOSE, CA. SN 77-200,693. PUB. 11-20-2007, FILED 6-7-2007.

3,481,712. RICHMOND, RAQUEL (KELI), FORT WAYNE, IN. AND JOUSTRA, DIANNE, NEW HAVEN, IN. SN 77-180,377. PUB. 12-11-2007, FILED 5-14-2007.

PROTECT THE FUTURE

LITERACY SPEAKS!

THE MARK CONSISTS OF STANDARD CHARACTERS WITHOUT CLAIM TO ANY PARTICULAR FONT, STYLE, SIZE, OR COLOR.

NO CLAIM IS MADE TO THE EXCLUSIVE RIGHT TO USE "LITERACY", APART FROM THE MARK AS SHOWN.

FOR PROVIDING CLASSES IN SPEECH, LANGUAGE AND LITERACY DEVELOPMENT FOR YOUNG CHILDREN (U.S. CLS. 100, 101 AND 107).

FIRST USE 3-7-2008; IN COMMERCE 3-7-2008.

THE MARK CONSISTS OF STANDARD CHARACTERS WITHOUT CLAIM TO ANY PARTICULAR FONT, STYLE, SIZE, OR COLOR.

FOR EDUCATIONAL SERVICES, NAMELY, PROVIDING UNDERGRADUATE, GRADUATE, AND PROFESSIONAL COURSES TO OTHERS; PROVIDING INFORMATION ABOUT UNIVERSITY LEVEL EDUCATION AND RESEARCH VIA A WEBSITE ON A GLOBAL COMPUTER NETWORK; ONLINE EDUCATIONAL SERVICES, NAMELY, PROVIDING UNDERGRADUATE, GRADUATE, AND PROFESSIONAL COURSES OF INSTRUCTION VIA A GLOBAL COMPUTER NETWORK (U.S. CLS. 100, 101 AND 107).

FIRST USE 5-14-2007; IN COMMERCE 5-14-2007.

CLASS 41—(Continued).

3,481,805. THE ZONDERVAN CORPORATION L.L.C., GRAND RAPIDS, MI. SN 77-222,497. PUB. 1-22-2008, FILED 7-5-2007.

INSPIRING YOUNG LIVES

THE MARK CONSISTS OF STANDARD CHARACTERS WITHOUT CLAIM TO ANY PARTICULAR FONT, STYLE, SIZE, OR COLOR.

FOR BOOK PUBLISHING SERVICES; PROVIDING ON-LINE NEWSLETTERS IN THE FIELDS OF RELIGION, BOOKS, LIFESTYLE AND EDUCATION (U.S. CLS. 100, 101 AND 107).

FIRST USE 6-14-2007; IN COMMERCE 6-14-2007.

3,481,824. HAZELDEN FOUNDATION, CENTER CITY, MN. SN 77-232,861. PUB. 12-11-2007, FILED 7-18-2007.

OLWEUS

THE MARK CONSISTS OF STANDARD CHARACTERS WITHOUT CLAIM TO ANY PARTICULAR FONT, STYLE, SIZE, OR COLOR.

FOR TRAINING FOR OTHERS REGARDING BULLYING AND ANTISOCIAL BEHAVIOR PREVENTION PROGRAMS IN SCHOOLS AND ATHLETICS (U.S. CLS. 100, 101 AND 107).

FIRST USE 6-0-2006; IN COMMERCE 6-0-2006.

3,481,861. JOURNAL SENTINEL INC., MILWAUKEE, WI. SN 77-248,257. PUB. 3-4-2008, FILED 8-6-2007.

SPORTSBUBBLER

THE MARK CONSISTS OF STANDARD CHARACTERS WITHOUT CLAIM TO ANY PARTICULAR FONT, STYLE, SIZE, OR COLOR.

FOR PROVIDING A WEBSITE FEATURING NEWS IN THE FIELD OF SPORTS, STORIES RELATED TO SPORTS, AND INFORMATION OF INTEREST TO SPORTS ENTHUSIASTS, NAMELY, INFORMATION IN THE FIELD OF SPORTS (U.S. CLS. 100, 101 AND 107).

FIRST USE 12-1-2007; IN COMMERCE 12-1-2007.

CLASS 41—(Continued).

3,481,862. JOURNAL SENTINEL INC., MILWAUKEE, WI. SN 77-248,265. PUB. 3-4-2008, FILED 8-6-2007.

SPORTSBUBBLER.COM

THE MARK CONSISTS OF STANDARD CHARACTERS WITHOUT CLAIM TO ANY PARTICULAR FONT, STYLE, SIZE, OR COLOR.

FOR PROVIDING A WEBSITE FEATURING NEWS IN THE FIELD OF SPORTS, STORIES RELATED TO SPORTS, AND INFORMATION OF INTEREST TO SPORTS ENTHUSIASTS, NAMELY, INFORMATION IN THE FIELD OF SPORTS (U.S. CLS. 100, 101 AND 107).

FIRST USE 12-1-2007; IN COMMERCE 12-1-2007.

3,481,897. MEDISYNC HEALTHCARE SOLUTIONS, LLC, CINCINNATI, OH. SN 77-261,089. PUB. 2-26-2008, FILED 8-21-2007.

NOTE THE DIFFERENCE

THE MARK CONSISTS OF STANDARD CHARACTERS WITHOUT CLAIM TO ANY PARTICULAR FONT, STYLE, SIZE, OR COLOR.

FOR TRAINING OF PHYSICIANS AND OTHER MEDICAL PROFESSIONALS BY OFFERING SMALL SEMINARS WITH TRAINING MATERIALS, NAMELY, PATIENT ENCOUNTER RECORDING FORMS, IN THE FIELD OF MAINTENANCE AND RECORDING OF INFORMATION ABOUT PATIENTS (U.S. CLS. 100, 101 AND 107).

FIRST USE 3-31-2008; IN COMMERCE 3-31-2008.

3,481,902. GONZALES, JONATHAN M, VENTURA, CA. SN 77-262,269. PUB. 3-4-2008, FILED 8-22-2007.

Nikki Sexx

THE MARK CONSISTS OF STANDARD CHARACTERS WITHOUT CLAIM TO ANY PARTICULAR FONT, STYLE, SIZE, OR COLOR.

THE NAME "NIKKI SEXX" IDENTIFIES A LIVING INDIVIDUAL WHOSE CONSENT IS OF RECORD.

FOR ENTERTAINMENT IN THE NATURE OF NUDE DANCING (U.S. CLS. 100, 101 AND 107).

FIRST USE 6-3-2008; IN COMMERCE 6-3-2008.

CLASS 41—(Continued).

3,481,908. ENGENDERHEALTH, INC., NEW YORK, NY. SN 77-264,773. PUB. 2-26-2008, FILED 8-27-2007.

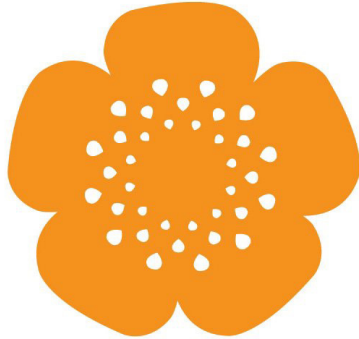

THE COLOR(S) ORANGE AND WHITE IS/ARE CLAIMED AS A FEATURE OF THE MARK.

THE MARK CONSISTS OF AN ORANGE FLOWER, CONTAINING FIVE PETALS AND VARIOUS SIZED WHITE CIRCULAR HOLES IN THE SHAPE OF TEARDROP-SHAPED STAMENS RINGING THE CENTER OF THE FLOWER.

FOR ARRANGING PROFESSIONAL WORKSHOP AND TRAINING COURSES; CONDUCTING WORKSHOPS AND SEMINARS IN REPRODUCTIVE HEALTH AND FAMILY PLANNING; DEVELOPING EDUCATIONAL MANUALS FOR OTHERS IN THE FIELD OF REPRODUCTIVE HEALTH AND FAMILY PLANNING; EDUCATION SERVICES, NAMELY, PROVIDING TRAINING AND WORKSHOPS IN THE FIELDS OF REPRODUCTIVE HEALTH AND FAMILY PLANNING; MEDICAL TRAINING AND TEACHING; PRODUCTION OF DVDS, VIDEOTAPES AND TELEVISION PROGRAMS FEATURING REPRODUCTIVE HEALTH AND FAMILY PLANNING; PROVIDING NEWSLETTERS IN THE FIELD OF REPRODUCTIVE HEALTH AND FAMILY PLANNING VIA E-MAIL; PUBLICATION OF BOOKS, OF MAGAZINES, OF JOURNALS, OF NEWSPAPERS, OF PERIODICALS, OF CATALOGS, OF BROCHURES (U.S. CLS. 100, 101 AND 107).

FIRST USE 12-1-2007; IN COMMERCE 12-1-2007.

3,481,912. XM SATELLITE RADIO INC., WASHINGTON, DC. SN 77-265,825. PUB. 2-26-2008, FILED 8-28-2007.

WHEREVER YOU ARE SATURDAYS

THE MARK CONSISTS OF STANDARD CHARACTERS WITHOUT CLAIM TO ANY PARTICULAR FONT, STYLE, SIZE, OR COLOR.

FOR ENTERTAINMENT SERVICES, NAMELY, AN ONGOING AUDIO PROGRAM IN THE FIELD OF SPORTS (U.S. CLS. 100, 101 AND 107).

FIRST USE 9-1-2007; IN COMMERCE 9-1-2007.

CLASS 41—(Continued).

3,481,959. SNYDER, CHRISTOPHER J, PORTAGE, MI. SN 77-295,626. PUB. 3-25-2008, FILED 10-3-2007.



NO CLAIM IS MADE TO THE EXCLUSIVE RIGHT TO USE "DOJO", APART FROM THE MARK AS SHOWN.

THE NAME(S), PORTRAIT(S), AND/OR SIGNATURE(S) SHOWN IN THE MARK IDENTIFIES "CHRISTOPHER J SNYDER", WHOSE CONSENT(S) TO REGISTER IS MADE OF RECORD.

THE MARK CONSISTS OF IT A STYLIZED KNOTTED BELT WITH THE TWO BELT ENDS HANGING DOWN. "SNYDER" IS ABOVE BUT SLIGHTLY OVERLAPPING THE BELT WITH "DOJO" BELOW THE BELT.

THE FOREIGN WORDING IN THE MARK TRANSLATES INTO ENGLISH AS MARTIAL ARTS SCHOOL.

FOR JUDO INSTRUCTION (U.S. CLS. 100, 101 AND 107).

FIRST USE 5-20-2007; IN COMMERCE 10-15-2007.

3,481,962. NATIONAL AMUSEMENTS, INC., DEDHAM, MA. SN 77-296,444. PUB. 2-19-2008, FILED 10-4-2007.

LUX LEVEL

THE MARK CONSISTS OF STANDARD CHARACTERS WITHOUT CLAIM TO ANY PARTICULAR FONT, STYLE, SIZE, OR COLOR.

FOR PROVIDING FACILITIES FOR ENTERTAINMENT SERVICES IN THE NATURE OF MOTION PICTURES PRESENTATIONS AND LIVE PERFORMANCES (U.S. CLS. 100, 101 AND 107).

FIRST USE 12-0-2007; IN COMMERCE 12-0-2007.

CLASS 41—(Continued).

3,481,974. THE CREATIVE WORKPLACE, LLC, LOUISVILLE, KY. SN 77-303,953. PUB. 3-25-2008, FILED 10-15-2007.



NO CLAIM IS MADE TO THE EXCLUSIVE RIGHT TO USE "WORKSHOP", APART FROM THE MARK AS SHOWN.

THE MARK CONSISTS OF AN OUTLINE OF A LIGHTBULB WITH A W IN THE MIDDLE OF IT AND 3 IDEA MARKS ON TOP, AND THE STYLIZED TEXT "WORKSHOP THE CREATIVE WORKPLACE".

FOR ARRANGING PROFESSIONAL WORKSHOP AND TRAINING COURSES; EDUCATION SERVICES, NAMELY, PROVIDING CLASSES AND WORKSHOPS IN THE FIELDS OF PERSONAL AND PROFESSIONAL ENRICHMENT (U.S. CLS. 100, 101 AND 107).

FIRST USE 1-1-1994; IN COMMERCE 1-15-1998.

3,481,983. TWENTIETH CENTURY FOX FILM CORPORATION, LOS ANGELES, CA. SN 77-324,893. PUB. 3-18-2008, FILED 11-8-2007.

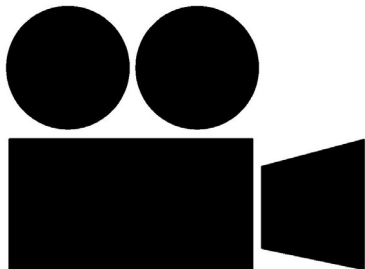

FOR ENTERTAINMENT SERVICES IN THE NATURE OF ON-GOING TELEVISION SEGMENTS FEATURING SPORTS; PROVIDING ON-LINE INFORMATION IN THE FIELD OF SPORTS, NEWS AND ENTERTAINMENT (U.S. CLS. 100, 101 AND 107).

FIRST USE 8-27-2007; IN COMMERCE 8-27-2007.

CLASS 41—(Continued).

3,482,048. GAMELOGIC INC., WALTHAM, MA. SN 78-433,895. PUB. 9-6-2005, FILED 6-11-2004.

HAVE A NICE WIN

THE MARK CONSISTS OF STANDARD CHARACTERS WITHOUT CLAIM TO ANY PARTICULAR FONT, STYLE, SIZE, OR COLOR.

FOR ENTERTAINMENT SERVICES, NAMELY, PROVIDING AN ONLINE COMPUTER GAME; ELECTRONIC CASINO GAMING SERVICES (U.S. CLS. 100, 101 AND 107).

FIRST USE 5-28-2008; IN COMMERCE 5-28-2008.

3,482,071. SEA FOR YOURSELF, INC., MENLO PARK, CA. SN 78-514,148. PUB. 2-21-2006, FILED 11-9-2004.

SEE FOR YOURSELF

THE MARK CONSISTS OF STANDARD CHARACTERS WITHOUT CLAIM TO ANY PARTICULAR FONT, STYLE, SIZE, OR COLOR.

FOR CONDUCTING WORKSHOPS AND SEMINARS IN THE FIELD OF PHOTOGRAPHY (U.S. CLS. 100, 101 AND 107).

FIRST USE 1-14-2008; IN COMMERCE 1-14-2008.

3,482,082. NSS MUSIC, NEW YORK, NY. SN 78-519,668. PUB. 5-1-2007, FILED 11-18-2004.

NSS MUSIC

NO CLAIM IS MADE TO THE EXCLUSIVE RIGHT TO USE "MUSIC", APART FROM THE MARK AS SHOWN.

THE COLORS BLACK, GRAY, ORANGE ARE CLAIMED AS A FEATURE OF THE MARK.

THE LETTERING IS BLACK. THE TWO LINES ABOVE AND BELOW ARE BLACK WITH GRAY SHADOWING. THE SMALL LOGO TO THE RIGHT IS ORANGE WITH A THIN BLACK LINING.

FOR MUSIC AND RECORD PRODUCTION SERVICES (U.S. CLS. 100, 101 AND 107).

FIRST USE 10-1-2006; IN COMMERCE 10-1-2006.

CLASS 41—(Continued).

3,482,097. KACZANOWSKI, CONNIE, NEW YORK, NY. SN 78-562,940. PUB. 10-25-2005, FILED 2-8-2005.

**LIQUID METAL JESUS
FILMS**

THE MARK CONSISTS OF STANDARD CHARACTERS WITHOUT CLAIM TO ANY PARTICULAR FONT, STYLE, SIZE, OR COLOR.

NO CLAIM IS MADE TO THE EXCLUSIVE RIGHT TO USE "FILMS", APART FROM THE MARK AS SHOWN. FOR ENTERTAINMENT SERVICES, NAMELY, SCRIPT WRITING SERVICES; TELEVISION AND MOTION PICTURE FILM PRODUCTIONS (U.S. CLS. 100, 101 AND 107).

FIRST USE 5-1-2008; IN COMMERCE 5-1-2008.

3,482,099. 26 BRIX. LLC, DBA B CELLARS, SAN JUAN CAPISTRANO, CA. SN 78-569,058. PUB. 12-20-2005, FILED 2-16-2005.



THE COLOR RED IS ARE CLAIMED AS A FEATURE OF THE MARK.

THE COLOR RED APPEARS IN THE RECTANGULAR BACKGROUND OF THE MARK.

FOR ENTERTAINMENT SERVICES, NAMELY, WINE TASTINGS (U.S. CLS. 100, 101 AND 107).

FIRST USE 9-25-2007; IN COMMERCE 9-25-2007.

CLASS 41—(Continued).

3,482,105. HBBS, COPPEROPOLIS, CA. SN 78-581,410. PUB. 6-20-2006, FILED 3-7-2005.

HBBS

THE MARK CONSISTS OF STANDARD CHARACTERS WITHOUT CLAIM TO ANY PARTICULAR FONT, STYLE, SIZE, OR COLOR.

FOR PROVIDING INFORMATION VIA THE INTERNET IN THE FIELD OF TRAINING COURSES IN STRATEGIC PLANNING RELATING TO ADVERTISING, PROMOTION, MARKETING AND BUSINESS; PROVIDING INFORMATION VIA THE INTERNET IN THE FIELD OF ONE-ON-ONE MENTORING IN THE FIELD OF ENTREPRENEURIAL SKILLS; PROVIDING INFORMATION VIA THE INTERNET IN THE FIELD OF PUBLICATION OF ELECTRONIC BUSINESS-RELATED NEWSPAPERS ACCESSIBLE VIA A GLOBAL COMPUTER NETWORK (U.S. CLS. 100, 101 AND 107).

FIRST USE 12-29-2004; IN COMMERCE 3-12-2005.

3,482,111. MOIST, SHARON, BOSEMAN, MT. SN 78-597,507. PUB. 9-12-2006, FILED 3-29-2005.

THE INDUSTRY COACH

THE MARK CONSISTS OF STANDARD CHARACTERS WITHOUT CLAIM TO ANY PARTICULAR FONT, STYLE, SIZE, OR COLOR.

NO CLAIM IS MADE TO THE EXCLUSIVE RIGHT TO USE "COACH", APART FROM THE MARK AS SHOWN.

FOR EDUCATIONAL SERVICES, NAMELY, CONDUCTING CLASSES, TELEVISED CLASSES, WORKSHOPS, SEMINARS, TELEVISED SEMINARS AND CONFERENCES IN THE FIELDS OF ACTING, ENTERTAINMENT, BUSINESS, EDUCATION AND CAREER DEVELOPMENT AND DISTRIBUTING COURSE MATERIAL, NAMELY, WORKBOOKS, HANDOUTS, PAMPHLETS, FLYERS AND BOOKS IN CONNECTION THEREWITH; PROVIDING INFORMATION IN THE FIELDS OF ACTING, ENTERTAINMENT, EDUCATION AND CAREER DEVELOPMENT VIA A GLOBAL COMPUTER NETWORK; EDUCATIONAL SERVICES, NAMELY, PERSONAL COACHING, PUBLIC AND PRIVATE SPEAKING ENGAGEMENTS IN THE FIELDS OF ACTING, ENTERTAINMENT, EDUCATION AND CAREER PERSONAL DEVELOPMENT (U.S. CLS. 100, 101 AND 107).

FIRST USE 4-23-2005; IN COMMERCE 4-23-2005.

CLASS 41—(Continued).

3,482,112. A PHANTOM VOX CORPORATION, SANTURCE, PUERTO RICO. SN 78-599,614. PUB. 8-1-2006, FILED 3-31-2005.

PHANTOM ★ VOX

FOR ENTERTAINMENT SERVICES, NAMELY, PROVIDING A WEB SITE FEATURING MUSICAL PERFORMANCES, MUSICAL VIDEOS, RELATED FILM CLIPS, PHOTOGRAPHS, AND OTHER MULTIMEDIA MATERIALS (U.S. CLS. 100, 101 AND 107).

FIRST USE 10-31-2001; IN COMMERCE 10-31-2001.

CLASS 41—(Continued).

3,482,144. PROTECT THE PLANET, INC., HONOLULU, HI. SN 78-655,485. PUB. 3-14-2006, FILED 6-21-2005.

EARTH AGENTS

THE MARK CONSISTS OF STANDARD CHARACTERS WITHOUT CLAIM TO ANY PARTICULAR FONT, STYLE, SIZE, OR COLOR.

FOR EDUCATIONAL AND ENTERTAINMENT SERVICES, NAMELY, PROVIDING A WEBSITE FEATURING VIDEOS, MOTION PICTURE CLIPS, PHOTOGRAPHS AND OTHER MULTIMEDIA MATERIALS RELATED TO ENVIRONMENTAL EDUCATION AND ENTERTAINMENT (U.S. CLS. 100, 101 AND 107).

FIRST USE 2-14-2008; IN COMMERCE 2-14-2008.

3,482,116. NCM ASSOCIATES, INC., OVERLAND PARK, KS. SN 78-608,081. PUB. 3-21-2006, FILED 4-13-2005.

PARTS MANAGEMENT BOOTCAMP

THE MARK CONSISTS OF STANDARD CHARACTERS WITHOUT CLAIM TO ANY PARTICULAR FONT, STYLE, SIZE, OR COLOR.

NO CLAIM IS MADE TO THE EXCLUSIVE RIGHT TO USE "PARTS MANAGEMENT", APART FROM THE MARK AS SHOWN.

FOR AUTOMOTIVE DEALER TRAINING (U.S. CLS. 100, 101 AND 107).

FIRST USE 3-18-2008; IN COMMERCE 3-18-2008.

3,482,146. BRIGHTON MANOR COMPANY, CLEVELAND, OH. SN 78-661,951. PUB. 3-21-2006, FILED 6-30-2005.

MAUI SANDS RESORT

THE MARK CONSISTS OF STANDARD CHARACTERS WITHOUT CLAIM TO ANY PARTICULAR FONT, STYLE, SIZE, OR COLOR.

NO CLAIM IS MADE TO THE EXCLUSIVE RIGHT TO USE "RESORT", APART FROM THE MARK AS SHOWN.

FOR AMUSEMENT PARK SERVICES FEATURING WATER RIDES AND ATTRACTIONS (U.S. CLS. 100, 101 AND 107).

FIRST USE 5-30-2008; IN COMMERCE 5-30-2008.

3,482,142. JML INDUSTRIES, INC., JONESBORO, AR. SN 78-654,550. PUB. 3-14-2006, FILED 6-20-2005.

The Seven Minute Coach

THE MARK CONSISTS OF STANDARD CHARACTERS WITHOUT CLAIM TO ANY PARTICULAR FONT, STYLE, SIZE, OR COLOR.

FOR ORGANIZING AND CONDUCTING SEMINARS IN THE FIELD OF FINANCIAL AND PERSONAL PLANNING (U.S. CLS. 100, 101 AND 107).

FIRST USE 6-14-2005; IN COMMERCE 6-14-2005.

3,482,166. BIGFOOT ENTERTAINMENT LTD., SINGAPORE, SINGAPORE. SN 78-691,225. PUB. 3-6-2007, FILED 8-12-2005.

FASHIONONE

THE MARK CONSISTS OF STANDARD CHARACTERS WITHOUT CLAIM TO ANY PARTICULAR FONT, STYLE, SIZE, OR COLOR.

FOR ENTERTAINMENT IN THE NATURE OF BEAUTY PAGEANTS, FASHION SHOWS AND MODELING SHOWS IN THE FIELD OF FASHION (U.S. CLS. 100, 101 AND 107).

FIRST USE 10-1-2007; IN COMMERCE 10-1-2007.

CLASS 41—(Continued).

3,482,167. XM SATELLITE RADIO INC., WASHINGTON, DC. SN 78-691,494. PUB. 2-5-2008, FILED 8-12-2005.

CLASS 41—(Continued).

3,482,199. WOLFINGTON, RYAN, LAS VEGAS, NV. SN 78-743,161. PUB. 9-5-2006, FILED 10-29-2005.

TAKE 5

THE MARK CONSISTS OF STANDARD CHARACTERS WITHOUT CLAIM TO ANY PARTICULAR FONT, STYLE, SIZE, OR COLOR.

FOR ENTERTAINMENT SERVICES, NAMELY, PROVIDING SATELLITE RADIO AUDIO PROGRAMS FEATURING TALK AND LIFESTYLE ISSUES, SPECIFICALLY GEARED TO WOMEN, OFFERED EXCLUSIVELY TO SUBSCRIBERS AND PARTNERS OF XM SATELLITE RADIO'S DIGITAL AUDIO RADIO SERVICES (U.S. CLS. 100, 101 AND 107).

FIRST USE 10-3-2005; IN COMMERCE 10-3-2005.



3,482,175. MUNOZ, MICHAEL, GLENDORA, CA. SN 78-708,418. PUB. 4-10-2007, FILED 9-7-2005.



NO CLAIM IS MADE TO THE EXCLUSIVE RIGHT TO USE "TRAFFIC SCHOOL", APART FROM THE MARK AS SHOWN.

FOR EDUCATION SERVICES, NAMELY, PROVIDING ONLINE COURSES IN THE FIELD OF DRIVERS' EDUCATION (U.S. CLS. 100, 101 AND 107).

FIRST USE 1-1-2006; IN COMMERCE 1-1-2006.

NO CLAIM IS MADE TO THE EXCLUSIVE RIGHT TO USE "LAS VEGAS TENNIS HALL OF FAME", APART FROM THE MARK AS SHOWN.

THE COLOR(S) BLUE, WHITE AND GREY IS/ARE CLAIMED AS A FEATURE OF THE MARK.

THE COLOR WHITE APPEARS IN THE LITERAL ELEMENTS OF THE MARK WHICH ARE OUTLINED IN BLUE; THE COLORS BLUE AND WHITE APPEAR IN THE TWO STYLIZED TENNIS BALLS; THE COLORS BLUE AND GREY APPEAR IN THE QUADRILATERAL AND TRIANGULAR ABSTRACT SHAPES AT THE CENTER OF THE MARK; THE COLOR BLUE APPEARS IN THE LINING THROUGHOUT THE MARK AGAINST A WHITE BACKGROUND.

FOR ARRANGING FOR TICKET RESERVATIONS FOR SHOWS AND OTHER ENTERTAINMENT EVENTS; CONDUCTING ENTERTAINMENT EXHIBITIONS IN THE NATURE OF TENNIS HISTORY; EDUCATION SERVICES, NAMELY, MENTORING IN THE FIELD OF TENNIS; EDUCATION SERVICES, NAMELY, ONE-ON-ONE MENTORING IN THE FIELD OF TENNIS; EDUCATION SERVICES, NAMELY, PROVIDING INSTRUCTION, CLASSES AND CLINICS IN THE FIELD OF TENNIS; EDUCATIONAL AND ENTERTAINMENT SERVICES, NAMELY, PROVIDING MOTIVATIONAL AND EDUCATIONAL SPEAKERS; EDUCATIONAL DEMONSTRATIONS; EDUCATIONAL SERVICES, NAMELY, PROVIDING INCENTIVES TO PROFESSIONALS TO DEMONSTRATE EXCELLENCE IN THE FIELD OF TENNIS; EDUCATIONAL SERVICES, NAMELY, PROVIDING INCENTIVES TO PROFESSIONALS TO DEMONSTRATE EXCELLENCE IN THE FIELD OF TENNIS THROUGH THE ISSUANCE OF AWARDS; ENTERTAINMENT IN THE NATURE OF TENNIS TOURNAMENTS; ENTERTAINMENT SERVICES, NAMELY, PARTICIPATION IN TENNIS CLINICS AND TOURNAMENTS; ENTERTAINMENT SERVICES, NAMELY, PERSONAL APPEARANCES BY A SPORTS CELEBRITY; MUSEUMS; RUNNING OF MUSEUMS; TENNIS INSTRUCTION (U.S. CLS. 100, 101 AND 107).

FIRST USE 5-10-2008; IN COMMERCE 5-10-2008.

CLASS 41—(Continued).

3,482,200. WOLFINGTON, RYAN, LAS VEGAS, NV. SN 78-743,166. PUB. 9-5-2006, FILED 10-29-2005.



CLASS 41—(Continued).

3,482,201. WOLFINGTON, RYAN, LAS VEGAS, NV. SN 78-743,173. PUB. 9-5-2006, FILED 10-29-2005.



NO CLAIM IS MADE TO THE EXCLUSIVE RIGHT TO USE "NEVADA TENNIS HALL OF FAME", APART FROM THE MARK AS SHOWN.

THE COLOR(S) BLUE, WHITE AND GREY IS/ARE CLAIMED AS A FEATURE OF THE MARK.

THE COLOR WHITE APPEARS IN THE LITERAL ELEMENTS OF THE MARK WHICH ARE OUTLINED IN BLUE; THE COLORS BLUE AND WHITE APPEAR IN THE TWO STYLIZED TENNIS BALLS; THE COLORS BLUE AND GREY APPEAR IN THE QUADRILATERAL AND TRIANGULAR ABSTRACT SHAPES AT THE CENTER OF THE MARK; THE COLOR BLUE APPEARS IN THE LINING THROUGHOUT THE MARK AGAINST A WHITE BACKGROUND.

FOR ARRANGING FOR TICKET RESERVATIONS FOR SHOWS AND OTHER ENTERTAINMENT EVENTS; CONDUCTING ENTERTAINMENT EXHIBITIONS IN THE NATURE OF TENNIS HISTORY; EDUCATION SERVICES, NAMELY, MENTORING IN THE FIELD OF TENNIS; EDUCATION SERVICES, NAMELY, ONE-ON-ONE MENTORING IN THE FIELD OF TENNIS; EDUCATION SERVICES, NAMELY, PROVIDING INSTRUCTION, CLASSES AND CLINICS IN THE FIELD OF TENNIS; EDUCATIONAL AND ENTERTAINMENT SERVICES, NAMELY, PROVIDING MOTIVATIONAL AND EDUCATIONAL SPEAKERS; EDUCATIONAL DEMONSTRATIONS; EDUCATIONAL SERVICES, NAMELY, PROVIDING INCENTIVES TO PROFESSIONALS TO DEMONSTRATE EXCELLENCE IN THE FIELD OF TENNIS; EDUCATIONAL SERVICES, NAMELY, PROVIDING INCENTIVES TO PROFESSIONALS TO DEMONSTRATE EXCELLENCE IN THE FIELD OF TENNIS THROUGH THE ISSUANCE OF AWARDS; ENTERTAINMENT IN THE NATURE OF TENNIS TOURNAMENTS; ENTERTAINMENT SERVICES, NAMELY, PARTICIPATION IN TENNIS CLINICS AND TOURNAMENTS; ENTERTAINMENT SERVICES, NAMELY, PERSONAL APPEARANCES BY A SPORTS CELEBRITY; MUSEUMS; RUNNING OF MUSEUMS; TENNIS INSTRUCTION (U.S. CLS. 100, 101 AND 107).
FIRST USE 5-10-2008; IN COMMERCE 5-10-2008.

NO CLAIM IS MADE TO THE EXCLUSIVE RIGHT TO USE "TENNIS HALL OF FAME OF NEVADA", APART FROM THE MARK AS SHOWN.

THE COLOR(S) BLUE, WHITE AND GREY IS/ARE CLAIMED AS A FEATURE OF THE MARK.

THE COLOR WHITE APPEARS IN THE LITERAL ELEMENTS OF THE MARK WHICH ARE OUTLINED IN BLUE; THE COLORS BLUE AND WHITE APPEAR IN THE TWO STYLIZED TENNIS BALLS; THE COLORS BLUE AND GREY APPEAR IN THE QUADRILATERAL AND TRIANGULAR ABSTRACT SHAPES AT THE CENTER OF THE MARK; THE COLOR BLUE APPEARS IN THE LINING THROUGHOUT THE MARK AGAINST A WHITE BACKGROUND.

FOR ARRANGING FOR TICKET RESERVATIONS FOR SHOWS AND OTHER ENTERTAINMENT EVENTS; CONDUCTING ENTERTAINMENT EXHIBITIONS IN THE NATURE OF TENNIS HISTORY; EDUCATION SERVICES, NAMELY, MENTORING IN THE FIELD OF TENNIS; EDUCATION SERVICES, NAMELY, ONE-ON-ONE MENTORING IN THE FIELD OF TENNIS; EDUCATION SERVICES, NAMELY, PROVIDING INSTRUCTION, CLASSES AND CLINICS IN THE FIELD OF TENNIS; EDUCATIONAL AND ENTERTAINMENT SERVICES, NAMELY, PROVIDING MOTIVATIONAL AND EDUCATIONAL SPEAKERS; EDUCATIONAL DEMONSTRATIONS; EDUCATIONAL SERVICES, NAMELY, PROVIDING INCENTIVES TO PROFESSIONALS TO DEMONSTRATE EXCELLENCE IN THE FIELD OF TENNIS; EDUCATIONAL SERVICES, NAMELY, PROVIDING INCENTIVES TO PROFESSIONALS TO DEMONSTRATE EXCELLENCE IN THE FIELD OF TENNIS THROUGH THE ISSUANCE OF AWARDS; ENTERTAINMENT IN THE NATURE OF TENNIS TOURNAMENTS; ENTERTAINMENT SERVICES, NAMELY, PARTICIPATION IN TENNIS CLINICS AND TOURNAMENTS; ENTERTAINMENT SERVICES, NAMELY, PERSONAL APPEARANCES BY A SPORTS CELEBRITY; MUSEUMS; RUNNING OF MUSEUMS; TENNIS INSTRUCTION (U.S. CLS. 100, 101 AND 107).
FIRST USE 5-10-2008; IN COMMERCE 5-10-2008.

CLASS 41—(Continued).

3,482,202. BAILEY, HELEN, CHICAGO, IL. SN 78-744,459.
PUB. 8-21-2007, FILED 11-1-2005.

URBAN LIVIN'

THE MARK CONSISTS OF STANDARD CHARACTERS WITHOUT CLAIM TO ANY PARTICULAR FONT, STYLE, SIZE, OR COLOR.
FOR TELEVISION SHOW PRODUCTION (U.S. CLS. 100, 101 AND 107).
FIRST USE 0-0-2002; IN COMMERCE 0-0-2002.

CLASS 41—(Continued).

3,482,242. MORPHOGENIX, LLC, NEW YORK, NY. SN 78-777,402. PUB. 10-2-2007, FILED 12-20-2005.

**REAL MOMS, REAL STORIES,
REAL SAVVY**

THE MARK CONSISTS OF STANDARD CHARACTERS WITHOUT CLAIM TO ANY PARTICULAR FONT, STYLE, SIZE, OR COLOR.
FOR EDUCATIONAL SERVICES, NAMELY, ON-GOING TELEVISION PROGRAMS FEATURING INFORMATION ON HEALTH AND PARENTING (U.S. CLS. 100, 101 AND 107).
FIRST USE 1-0-2006; IN COMMERCE 1-0-2006.

3,482,210. CHAPMAN, DALE A., PLEASANT VALLEY, NY. AND BEGLEY, ROBERT, VERO BEACH, FL. SN 78-751,449. PUB. 10-23-2007, FILED 11-10-2005.

THE NOW

THE MARK CONSISTS OF STANDARD CHARACTERS WITHOUT CLAIM TO ANY PARTICULAR FONT, STYLE, SIZE, OR COLOR.
FOR ENTERTAINMENT IN THE NATURE OF WRITING CONTESTS (U.S. CLS. 100, 101 AND 107).
FIRST USE 1-15-2006; IN COMMERCE 2-5-2006.

3,482,252. INTELLISPHERE, LLC, PLAINSBORO, NJ. SN 78-782,850. PUB. 9-5-2006, FILED 12-30-2005.

IntelliLabs

THE MARK CONSISTS OF STANDARD CHARACTERS WITHOUT CLAIM TO ANY PARTICULAR FONT, STYLE, SIZE, OR COLOR.
FOR PUBLISHING OF REVIEWS (U.S. CLS. 100, 101 AND 107).
FIRST USE 7-0-2003; IN COMMERCE 7-0-2003.

3,482,240. GAMELOGIC INC., WALTHAM, MA. SN 78-776,312. PUB. 9-4-2007, FILED 12-19-2005.

PIT CREW PAYOUT

THE MARK CONSISTS OF STANDARD CHARACTERS WITHOUT CLAIM TO ANY PARTICULAR FONT, STYLE, SIZE, OR COLOR.
NO CLAIM IS MADE TO THE EXCLUSIVE RIGHT TO USE "PAYOUT", APART FROM THE MARK AS SHOWN.
FOR ENTERTAINMENT SERVICES, NAMELY, PROVIDING ONLINE COMPUTER GAMES; ELECTRONIC CASINO GAMING SERVICES (U.S. CLS. 100, 101 AND 107).
FIRST USE 4-12-2006; IN COMMERCE 4-12-2006.

3,482,263. VIACOM INTERNATIONAL INC., NEW YORK, NY. SN 78-789,235. PUB. 4-10-2007, FILED 1-11-2006.

NICKTROPOLIS

THE MARK CONSISTS OF STANDARD CHARACTERS WITHOUT CLAIM TO ANY PARTICULAR FONT, STYLE, SIZE, OR COLOR.
OWNER OF U.S. REG. NOS. 2,808,509, 3,044,795, AND OTHERS.
FOR ENTERTAINMENT SERVICES, NAMELY, PROVIDING VIDEO AND AUDIO CONTENT FEATURING SEGMENTS AND ELEMENTS OF ON-GOING TELEVISION PROGRAMS IN THE FIELD OF COMEDY AND DRAMA; PROVIDING INFORMATION IN THE FIELD OF TELEVISION VIA A GLOBAL COMPUTER NETWORK (U.S. CLS. 100, 101 AND 107).
FIRST USE 3-30-2006; IN COMMERCE 1-30-2007.

CLASS 41—(Continued).

3,482,290. WHITE, JENNIFER E., DBA LAUGHING DOG ENTERPRISES, WOODINVILLE, WA. SN 78-806,991. PUB. 9-26-2006, FILED 2-3-2006.

No Force No Fear

THE MARK CONSISTS OF STANDARD CHARACTERS WITHOUT CLAIM TO ANY PARTICULAR FONT, STYLE, SIZE, OR COLOR.

FOR ANIMAL TRAINING (U.S. CLS. 100, 101 AND 107).

FIRST USE 4-22-2008; IN COMMERCE 4-22-2008.

3,482,310. BLACK ENTERTAINMENT TELEVISION LLC, WASHINGTON, DC. SN 78-831,571. PUB. 5-23-2006, FILED 3-7-2006.

BETJ

THE MARK CONSISTS OF STANDARD CHARACTERS WITHOUT CLAIM TO ANY PARTICULAR FONT, STYLE, SIZE, OR COLOR.

OWNER OF U.S. REG. NOS. 1,511,259, 2,572,634, AND OTHERS.

FOR ENTERTAINMENT SERVICES, NAMELY, PROVIDING TELEVISION PROGRAMS IN THE FIELDS OF MUSIC AND NEWS AND INFORMATION RELATED TO MUSIC VIA THE INTERNET (U.S. CLS. 100, 101 AND 107).

FIRST USE 3-8-2006; IN COMMERCE 3-8-2006.

CLASS 41—(Continued).

3,482,315. ABBOTT, VINNIE, NEW YORK, NY. SN 78-833,102. PUB. 5-15-2007, FILED 3-9-2006.



"THE BIG RED V ROCKS!"

FOR ENTERTAINMENT SERVICES, NAMELY, AUDIO RECORDING AND PRODUCTION; MUSIC PRODUCTION SERVICES; RECORD PRODUCTION; VIDEO-TAPE PRODUCTION; SOUND RECORDING STUDIOS; ENTERTAINMENT SERVICES, NAMELY, LIVE MUSIC CONCERTS; ENTERTAINMENT SERVICES, NAMELY, PROVIDING PRERECORDED MUSIC, INFORMATION IN THE FIELD OF MUSIC, AND COMMENTARY AND ARTICLES ABOUT MUSIC, ALL ON-LINE VIA A GLOBAL COMPUTER NETWORK; ENTERTAINMENT SERVICES, NAMELY, PROVIDING A WEB SITE FEATURING MUSICAL PERFORMANCES, MUSICAL VIDEOS, RELATED FILM CLIPS, PHOTOGRAPHS, AND OTHER MULTIMEDIA MATERIALS; PRODUCTION AND DISTRIBUTION OF MOTION PICTURES; PRODUCTION OF TELEVISION PROGRAMS; DISTRIBUTION OF TELEVISION PROGRAMS FOR OTHERS; PROVIDING A SUBSCRIPTION BASED WEBSITE FEATURING NEWS AND INFORMATION IN THE FIELD OF ENTERTAINMENT (U.S. CLS. 100, 101 AND 107).

FIRST USE 5-1-2006; IN COMMERCE 5-1-2006.

3,482,358. FORT KNOCKS ENTERTAINMENT, INC., MIAMI, FL. SN 78-863,875. PUB. 10-9-2007, FILED 4-18-2006.



THE LINING IS A FEATURE OF THE MARK AND DOES NOT INDICATE COLOR.

FOR RECORD LABEL SERVICES, NAMELY, RECORD PRODUCTION AND AUDIO RECORDING; RECORDING STUDIO SERVICES; PROVIDING PRERECORDED MUSIC ON-LINE VIA A GLOBAL COMPUTER NETWORK (U.S. CLS. 100, 101 AND 107).

FIRST USE 10-0-2001; IN COMMERCE 10-0-2001.

CLASS 41—(Continued).

3,482,369. BONUS.COM, INC., PALO ALTO, CA. SN 78-874,788. PUB. 9-4-2007, FILED 5-2-2006.



FOR ENTERTAINMENT SERVICES, NAMELY, AN ON-LINE COMIC ADVENTURE SERIES (U.S. CLS. 100, 101 AND 107).
FIRST USE 9-4-2007; IN COMMERCE 9-4-2007.

CLASS 41—(Continued).

3,482,486. DREAMWORKS ANIMATION L.L.C., GLENDALE, CA. SN 78-943,459. PUB. 3-20-2007, FILED 8-2-2006.

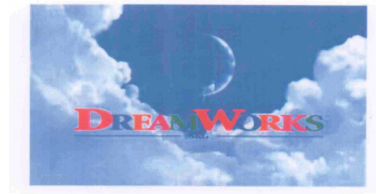

OWNER OF U.S. REG. NOS. 2,316,096, 2,326,951, AND 2,416,011.

THE COLOR(S) BLUE, WHITE, RED, ORANGE, PURPLE, AND GREEN IS/ARE CLAIMED AS A FEATURE OF THE MARK.

THE MARK CONSISTS OF A BOY FISHING IN THE MOON ABOVE THE WORDS "DREAMWORKS SKG" AGAINST A BACKGROUND OF CLOUDS. THE BACKGROUND IS BLUE WITH WHITE AND BLUE CLOUDS. THE BOY IN THE MOON IS IN BLUE AND WHITE. THE LETTERS "D" AND "W" ARE IN RED. THE LETTERS "R" AND "O" ARE IN BLUE. THE LETTERS "E" AND "R" ARE IN ORANGE. THE LETTERS "A" AND "K" ARE IN PURPLE. THE LETTERS "M" AND "S" ARE IN GREEN. THE LETTERS "SKG" ARE IN BLUE.

FOR ENTERTAINMENT SERVICES, NAMELY, MOTION PICTURE, TELEVISION, DVD, AND VIDEO AND AUDIOTAPE PRODUCTION SERVICES (U.S. CLS. 100, 101 AND 107).

FIRST USE 1-31-2008; IN COMMERCE 1-31-2008.

3,482,398. KIDSCOUNT, LLC, NEW HOPE, PA. SN 78-900,009. PUB. 10-2-2007, FILED 6-4-2006.

KIDSCOUNT

THE MARK CONSISTS OF STANDARD CHARACTERS WITHOUT CLAIM TO ANY PARTICULAR FONT, STYLE, SIZE, OR COLOR.

FOR EDUCATIONAL PROGRAM FOR CHILDREN, NAMELY, CONDUCTING AT-HOME OR ON-LINE LEARNING IN THE FIELD OF WEIGHT LOSS WITH PARENT SUPERVISION FEATURING THE USE OF EXERCISE EQUIPMENT, GAMES, MAGNETIC TRACKING CHART, AND BOOKS (U.S. CLS. 100, 101 AND 107).
FIRST USE 1-10-2006; IN COMMERCE 2-1-2008.

3,482,492. WORLD RADIO MISSIONARY FELLOWSHIP, INC., COLORADO SPRINGS, CO. SN 78-944,657. PUB. 8-28-2007, FILED 8-3-2006.

HCJB GLOBAL VOICE

THE MARK CONSISTS OF STANDARD CHARACTERS WITHOUT CLAIM TO ANY PARTICULAR FONT, STYLE, SIZE, OR COLOR.

NO CLAIM IS MADE TO THE EXCLUSIVE RIGHT TO USE "GLOBAL", APART FROM THE MARK AS SHOWN.

FOR EDUCATION SERVICES, NAMELY, PROVIDING CLASSES, SEMINARS, WORKSHOPS, TUTORING, AND MENTORING IN THE FIELDS OF HUMAN CULTURES, COMMUNICATION AND COMMUNICATION TECHNOLOGY, HEALTHCARE AND HEALTHCARE TECHNOLOGY, AND CHRISTIAN THEOLOGY, MISSIONS AND PRACTICAL MINISTRY; CHARITABLE SERVICES, NAMELY, PROVIDING TRAINING IN THE FIELDS OF HUMAN CULTURES, COMMUNICATION AND COMMUNICATION TECHNOLOGY, HEALTHCARE AND HEALTHCARE TECHNOLOGY, PUBLIC HEALTH, AND CHRISTIAN THEOLOGY, MISSIONS AND PRACTICAL MINISTRY; PRODUCTION OF RADIO PROGRAMS (U.S. CLS. 100, 101 AND 107).
FIRST USE 4-8-2008; IN COMMERCE 4-8-2008.

CLASS 41—(Continued).

3,482,502. OPTIONS A TO Z, DELRAY BEACH, FL. SN 78-947,792. PUB. 5-29-2007, FILED 8-8-2006.

OPTIONS A TO Z

THE MARK CONSISTS OF STANDARD CHARACTERS WITHOUT CLAIM TO ANY PARTICULAR FONT, STYLE, SIZE, OR COLOR.

NO CLAIM IS MADE TO THE EXCLUSIVE RIGHT TO USE "OPTIONS", APART FROM THE MARK AS SHOWN.

FOR EDUCATION SERVICES, NAMELY, PROVIDING CLASSES, WORKSHOPS, SEMINARS AND COMPUTER SOFTWARE PRESENTATIONS IN THE FIELDS OF INVESTMENT, FINANCES, OPTIONS INVESTING AND FINANCIAL MANAGEMENT, AND DISTRIBUTING COURSE MATERIALS, NAMELY PRINTED MATERIALS AND VIDEOS, THEREWITH; EDUCATIONAL SERVICES, NAMELY, CONDUCTING PROGRAMS IN THE FIELD OF INVESTMENT, FINANCES, OPTIONS INVESTING, AND FINANCIAL MANAGEMENT; DEVELOPMENT AND DISSEMINATION OF EDUCATIONAL MATERIALS OF OTHERS IN THE FIELDS OF INVESTMENT, FINANCES, OPTIONS INVESTING AND FINANCIAL MANAGEMENT (U.S. CLS. 100, 101 AND 107).

FIRST USE 11-30-2007; IN COMMERCE 11-30-2007.

3,482,544. GOTTLIEB, THEODORE B., ZEPHYR COVE, NV. AND BUTLER, PAMELA L., ZEPHYR COVE, NV. SN 78-962,089. PUB. 4-17-2007, FILED 8-28-2006.

SUM IT UP

THE MARK CONSISTS OF STANDARD CHARACTERS WITHOUT CLAIM TO ANY PARTICULAR FONT, STYLE, SIZE, OR COLOR.

FOR CASINO SERVICES, NAMELY, CONDUCTING A CASINO TABLE GAME OF CHANCE WHERE A PLAYER RANKS THEIR POKER HAND AGAINST THE HOUSE (U.S. CLS. 100, 101 AND 107).

FIRST USE 10-22-2006; IN COMMERCE 10-22-2006.

CLASS 41—(Continued).

3,482,548. FIT & HEALTHY SCHOOLS, INC., WOODBRIDGE, VA. SN 78-963,368. PUB. 5-8-2007, FILED 8-29-2006.



NO CLAIM IS MADE TO THE EXCLUSIVE RIGHT TO USE "SCHOOLS", APART FROM THE MARK AS SHOWN.

THE MARK CONSISTS OF THREE BODIES AND THE STYLIZED TEXT OF THE WORDING "FIT & HEALTHY SCHOOLS".

FOR TEACHING IN THE FIELD OF HEALTHY LIVING, NAMELY, FITNESS, NUTRITIONAL, AND WELLNESS (U.S. CLS. 100, 101 AND 107).

FIRST USE 6-1-2006; IN COMMERCE 12-1-2006.

CLASS 42—SCIENTIFIC AND COMPUTER SERVICES

3,481,043. PLANET EARTH FOUNDATION, SEATTLE, WA. SN 76-044,558. PUB. 4-19-2005, FILED 5-9-2000.

PLANET EARTH VIDEO

NO CLAIM IS MADE TO THE EXCLUSIVE RIGHT TO USE "VIDEO", APART FROM THE MARK AS SHOWN.

FOR NEWS AGENCY SERVICES, NAMELY, DISSEMINATION OF NEWS AND INFORMATION OF LOCAL, NATIONAL AND GLOBAL INTEREST VIA PRINTED PUBLICATIONS, AUDIO MEDIA, AUDIO-VISUAL MEDIA, AND VIA A GLOBAL COMPUTER NETWORK (U.S. CLS. 100 AND 101).

FIRST USE 5-1-2000; IN COMMERCE 5-1-2000.

3,481,044. PLANET EARTH FOUNDATION, SEATTLE, WA. SN 76-044,578. PUB. 4-19-2005, FILED 5-9-2000.

PLANET EARTH BROADCAST

NO CLAIM IS MADE TO THE EXCLUSIVE RIGHT TO USE "BROADCAST", APART FROM THE MARK AS SHOWN.

FOR NEWS AGENCY SERVICES, NAMELY, DISSEMINATION OF NEWS AND INFORMATION OF LOCAL, NATIONAL AND GLOBAL INTEREST VIA PRINTED PUBLICATIONS, AUDIO MEDIA, AUDIO-VISUAL MEDIA, AND VIA A GLOBAL COMPUTER NETWORK (U.S. CLS. 100 AND 101).

FIRST USE 5-1-2000; IN COMMERCE 5-1-2000.

CLASS 42—(Continued).

3,481,045. PLANET EARTH FOUNDATION, SEATTLE, WA.
SN 76-044,709. PUB. 4-19-2005, FILED 5-9-2000.

PLANET EARTH AUDIO

NO CLAIM IS MADE TO THE EXCLUSIVE RIGHT TO USE "AUDIO", APART FROM THE MARK AS SHOWN.

FOR NEWS AGENCY SERVICES, NAMELY, DISSEMINATION OF NEWS AND INFORMATION OF LOCAL, NATIONAL AND GLOBAL INTEREST VIA PRINTED PUBLICATIONS, AUDIO MEDIA, AUDIO-VISUAL MEDIA, AND VIA A GLOBAL COMPUTER NETWORK (U.S. CLS. 100 AND 101).

FIRST USE 5-1-2000; IN COMMERCE 5-1-2000.

3,481,046. PLANET EARTH FOUNDATION, SEATTLE, WA.
SN 76-044,710. PUB. 4-19-2005, FILED 5-9-2000.

PLANET EARTH TELECOM

NO CLAIM IS MADE TO THE EXCLUSIVE RIGHT TO USE "TELECOM", APART FROM THE MARK AS SHOWN.

FOR NEWS AGENCY SERVICES, NAMELY, DISSEMINATION OF NEWS AND INFORMATION OF LOCAL, NATIONAL AND GLOBAL INTEREST VIA PRINTED PUBLICATIONS, AUDIO MEDIA, AUDIO-VISUAL MEDIA, AND VIA A GLOBAL COMPUTER NETWORK (U.S. CLS. 100 AND 101).

FIRST USE 5-1-2000; IN COMMERCE 5-1-2000.

3,481,047. PLANET EARTH FOUNDATION, SEATTLE, WA.
SN 76-044,868. PUB. 4-19-2005, FILED 5-9-2000.

**PLANET EARTH
BROADBAND**

NO CLAIM IS MADE TO THE EXCLUSIVE RIGHT TO USE "BROADBAND", APART FROM THE MARK AS SHOWN.

FOR NEWS AGENCY SERVICES, NAMELY, DISSEMINATION OF NEWS AND INFORMATION OF LOCAL, NATIONAL AND GLOBAL INTEREST VIA PRINTED PUBLICATIONS, AUDIO MEDIA, AUDIO-VISUAL MEDIA, AND VIA A GLOBAL COMPUTER NETWORK (U.S. CLS. 100 AND 101).

FIRST USE 5-1-2000; IN COMMERCE 5-1-2000.

3,481,048. PLANET EARTH FOUNDATION, SEATTLE, WA.
SN 76-044,869. PUB. 4-19-2005, FILED 5-9-2000.

PLANET EARTH REPORT

NO CLAIM IS MADE TO THE EXCLUSIVE RIGHT TO USE "REPORT", APART FROM THE MARK AS SHOWN.

FOR NEWS AGENCY SERVICES, NAMELY, DISSEMINATION OF NEWS AND INFORMATION OF LOCAL, NATIONAL AND GLOBAL INTEREST VIA PRINTED PUBLICATIONS, AUDIO MEDIA, AUDIO-VISUAL MEDIA, AND VIA A GLOBAL COMPUTER NETWORK (U.S. CLS. 100 AND 101).

FIRST USE 5-1-2000; IN COMMERCE 5-1-2000.

CLASS 42—(Continued).

3,481,092. INGLEY, CAROL, WASHINGTON, DC. SN 76-654,797. PUB. 9-11-2007, FILED 2-7-2006.

MEDIA MOGUL OF THE HOME

THE MARK CONSISTS OF STANDARD CHARACTERS WITHOUT CLAIM TO ANY PARTICULAR FONT, STYLE, SIZE, OR COLOR.

FOR PROVIDING INFORMATION VIA A WEB SITE FEATURING INFORMATION TECHNOLOGY FOR THE DIGITAL CONSUMER AND THE DIGITAL HOME (U.S. CLS. 100 AND 101).

FIRST USE 11-1-2007; IN COMMERCE 2-17-2008.

3,481,117. ASSOCIATION RESERVES, INC., CALABASAS, CA. SN 76-667,525. PUB. 7-17-2007, FILED 10-16-2006.

QUICKRESERVES

THE MARK CONSISTS OF STANDARD CHARACTERS WITHOUT CLAIM TO ANY PARTICULAR FONT, STYLE, SIZE, OR COLOR.

FOR PROVIDING ONLINE NON-DOWNLOADABLE SOFTWARE USED FOR FINANCIAL CALCULATIONS AND REPORTS FOR FACILITY FUTURE EXPENSES AND CAPITAL PLANNING NEEDS (U.S. CLS. 100 AND 101).

FIRST USE 12-1-2007; IN COMMERCE 12-1-2007.

3,481,149. MA 2, INC., SAN FRANCISCO, CA. SN 76-677,220.
PUB. 11-6-2007, FILED 5-21-2007.



NO CLAIM IS MADE TO THE EXCLUSIVE RIGHT TO USE "MEDIA APPLICATION & ARCHITECTURE", APART FROM THE MARK AS SHOWN.

FOR DESIGNING AND IMPLEMENTING SOFTWARE AND HARDWARE IN THE FIELD OF MEDIA BROADCASTING AND STORAGE AND STREAMING TECHNOLOGIES (U.S. CLS. 100 AND 101).

FIRST USE 10-10-2007; IN COMMERCE 10-10-2007.

CLASS 42—(Continued).

3,481,199. FUTURE MERCHANTS, INC., NEW YORK, NY. SN 77-021,098. PUB. 10-16-2007, FILED 10-13-2006.

CLASS 42—(Continued).

3,481,360. AVEDA CORPORATION, MINNEAPOLIS, MN. SN 77-097,390. PUB. 3-4-2008, FILED 2-1-2007.

FUTURE MERCHANTS

THE MARK CONSISTS OF STANDARD CHARACTERS WITHOUT CLAIM TO ANY PARTICULAR FONT, STYLE, SIZE, OR COLOR.

FOR BUILDING AND CREATING INTERACTIVE WEBSITES AND ONLINE RETAIL SALES PORTALS POPULATED WITH PROPRIETARY SALES-ORIENTED VIDEO CONTENT, FOR OTHERS (U.S. CLS. 100 AND 101).

FIRST USE 11-2-2006; IN COMMERCE 11-2-2006.

SOIL TO BOTTLE

THE MARK CONSISTS OF STANDARD CHARACTERS WITHOUT CLAIM TO ANY PARTICULAR FONT, STYLE, SIZE, OR COLOR.

FOR RESEARCH AND DEVELOPMENT IN THE FIELD OF ECOLOGICALLY AND ENVIRONMENTALLY-FRIENDLY SOURCES FOR ORGANIC, BIODYNAMIC OR WILD-HARVESTED INGREDIENTS FOR FRAGRANCES, BODY AND BEAUTY CARE PREPARATIONS, NON-MEDICATED SKIN CARE PREPARATIONS AND HAIR CARE PREPARATIONS (U.S. CLS. 100 AND 101).

FIRST USE 4-14-2008; IN COMMERCE 4-14-2008.

3,481,323. USHINO, ANTHONY T., LOS ANGELES, CA. AND DAO, PATRICIA, WEST LOS ANGELES, CA. SN 77-081,524. PUB. 8-7-2007, FILED 1-11-2007.

3,481,468. ALLEN, ANN DE WEES, ST. PETERSBURG, FL. SN 77-131,597. PUB. 12-4-2007, FILED 3-15-2007.

urecho

THE MARK CONSISTS OF STANDARD CHARACTERS WITHOUT CLAIM TO ANY PARTICULAR FONT, STYLE, SIZE, OR COLOR.

THE WORDING "URECHO" HAS NO MEANING IN A FOREIGN LANGUAGE.

FOR COMPUTER SERVICES IN THE NATURE OF CUSTOMIZED WEB PAGES FEATURING USER-DEFINED INFORMATION, PERSONAL PROFILES AND INFORMATION; COMPUTER SERVICES, NAMELY, HOSTING ON-LINE WEB FACILITIES FOR OTHERS FOR ORGANIZING AND CONDUCTING ONLINE MEETINGS, GATHERINGS, AND INTERACTIVE DISCUSSIONS (U.S. CLS. 100 AND 101).

FIRST USE 5-1-2007; IN COMMERCE 7-1-2007.

SKINNY SCIENCE

THE MARK CONSISTS OF STANDARD CHARACTERS WITHOUT CLAIM TO ANY PARTICULAR FONT, STYLE, SIZE, OR COLOR.

NO CLAIM IS MADE TO THE EXCLUSIVE RIGHT TO USE "SCIENCE", APART FROM THE MARK AS SHOWN.

FOR SCIENTIFIC RESEARCH FOR DEVELOPING NUTRACEUTICAL AND PHARMACEUTICAL FOOD AND BEVERAGE PRODUCTS THAT ARE LOW IN GLYCEMIC CONTENT, NAMELY, DIET, NUTRITION, FOODS AND DIETARY SUPPLEMENTS (U.S. CLS. 100 AND 101).

FIRST USE 1-1-2008; IN COMMERCE 1-1-2008.

CLASS 42—(Continued).

3,481,525. ELUMA, INC., TEWKSBURY, MA. SN 77-140,946.
PUB. 9-25-2007, FILED 3-27-2007.



FOR COMPUTER CONSULTATION; COMPUTER PROGRAMMING; COMPUTER SERVICES IN THE NATURE OF CUSTOMIZED WEB PAGES FEATURING USER-DEFINED INFORMATION; PERSONAL PROFILES AND INFORMATION; COMPUTER SERVICES, NAMELY CREATING INDEXES OF INFORMATION, SITES AND OTHER RESOURCES AVAILABLE ON COMPUTER NETWORKS; COMPUTER SERVICES, NAMELY, CREATING AN ONLINE COMMUNITY FOR REGISTERED USERS TO PARTICIPATE IN COMPETITIONS, SHOWCASE THEIR SKILLS, GET FEEDBACK FROM THEIR PEERS, FORM VIRTUAL COMMUNITIES, ENGAGE IN SOCIAL NETWORKING AND IMPROVE THEIR TALENT; COMPUTER SERVICES, NAMELY, DESIGNING AND IMPLEMENTING NETWORK WEB PAGES FOR OTHERS; COMPUTER SERVICES, NAMELY, HOSTING ON-LINE INTERACTIVE PUBLIC CALENDARS THAT ALLOW MULTIPLE PARTICIPANTS TO SHARE EVENT SCHEDULES, FACILITY RESERVATIONS, AND TRANSPORTATION REQUESTS; COMPUTER SERVICES, NAMELY, HOSTING ON-LINE WEB FACILITIES FOR OTHERS FOR ORGANIZING AND CONDUCTING ONLINE MEETINGS, GATHERINGS, AND INTERACTIVE DISCUSSIONS; COMPUTER SERVICES, NAMELY, PROVIDING SEARCH ENGINES FOR OBTAINING DATA ON A GLOBAL COMPUTER NETWORK; COMPUTER SOFTWARE CONSULTANCY; COMPUTER SOFTWARE CONSULTATION; COMPUTER SOFTWARE DESIGN, COMPUTER PROGRAMMING, OR MAINTENANCE OF COMPUTER SOFTWARE; CREATION AND PROVISION OF WEB PAGES TO AND FOR THIRD PARTIES; CUSTOMIZATION OF COMPUTER HARDWARE AND SOFTWARE; DESIGN AND DEVELOPMENT OF ON-LINE COMPUTER SOFTWARE SYSTEMS; DESIGN OF HOME PAGES; DESIGN OF HOME PAGES, COMPUTER SOFTWARE AND WEB SITES; DESIGN OF HOMEPAGES AND WEB-SITES; DESIGN OF HOMEPAGES AND WEBSITES; DESIGN, CREATION, HOSTING AND MAINTENANCE OF INTERNET SITES FOR THIRD PARTIES; DESIGN, CREATION, HOSTING, MAINTENANCE OF WEBSITES FOR OTHERS; HOSTING THE WEB SITES OF OTHERS ON A COMPUTER SERVER FOR A GLOBAL COMPUTER NETWORK; INSTALLATION OF COMPUTER SOFTWARE; INTEGRATION OF COMPUTER SYSTEMS AND NETWORKS; PROVIDING CUSTOMIZED ON-LINE WEB PAGES FEATURING USER-DEFINED INFORMATION, WHICH INCLUDES SEARCH ENGINES AND ON-LINE WEB LINKS TO OTHER WEB SITES; WEB SITE HOSTING SERVICES; WEBSITE DEVELOPMENT FOR OTHERS (U.S. CLS. 100 AND 101).

FIRST USE 12-18-2007; IN COMMERCE 12-18-2007.

CLASS 42—(Continued).

3,481,558. TETRA TECHNOLOGIES, INC., THE WOODLANDS, TX. SN 77-146,469. PUB. 10-2-2007, FILED 4-2-2007.

CV-PRO

THE MARK CONSISTS OF STANDARD CHARACTERS WITHOUT CLAIM TO ANY PARTICULAR FONT, STYLE, SIZE, OR COLOR.

FOR ENGINEERING SERVICES, NAMELY, USING PHYSICAL WELL DATA TO ASSIST IN SELECTION OF WELL FLUIDS (U.S. CLS. 100 AND 101).

FIRST USE 3-30-2007; IN COMMERCE 3-30-2007.

3,481,559. TETRA TECHNOLOGIES, INC., THE WOODLANDS, TX. SN 77-146,511. PUB. 10-2-2007, FILED 4-2-2007.

TP-PRO

THE MARK CONSISTS OF STANDARD CHARACTERS WITHOUT CLAIM TO ANY PARTICULAR FONT, STYLE, SIZE, OR COLOR.

FOR ENGINEERING SERVICES, NAMELY, USING PHYSICAL WELL DATA TO ASSIST IN SELECTION OF WELL FLUIDS (U.S. CLS. 100 AND 101).

FIRST USE 3-30-2007; IN COMMERCE 3-30-2007.

3,481,573. CE PRIME, INC., CARLSBAD, CA. SN 77-148,509.
PUB. 10-9-2007, FILED 4-4-2007.

CE PRIME

THE MARK CONSISTS OF STANDARD CHARACTERS WITHOUT CLAIM TO ANY PARTICULAR FONT, STYLE, SIZE, OR COLOR.

NO CLAIM IS MADE TO THE EXCLUSIVE RIGHT TO USE "CE", APART FROM THE MARK AS SHOWN.

FOR CIVIL ENGINEERING CONSULTING; SURVEYING AND ENGINEERING CONSULTING (U.S. CLS. 100 AND 101).

FIRST USE 6-1-2007; IN COMMERCE 6-1-2007.

CLASS 42—(Continued).

3,481,575. CE PRIME, INC., CARLSBAD, CA. SN 77-148,825. PUB. 10-9-2007, FILED 4-4-2007.



THE MARK CONSISTS OF THE STYLIZED WORD "CEPRIMEINC" PRECEDED BY THREE CURVES BEFORE THE LETTER "C".

FOR CIVIL ENGINEERING CONSULTING; SURVEYING AND ENGINEERING CONSULTING (U.S. CLS. 100 AND 101).

FIRST USE 6-1-2007; IN COMMERCE 6-1-2007.

CLASS 42—(Continued).

3,481,657. MARKET PLANNING SOLUTIONS INC., TULSA, OK. SN 77-166,815. PUB. 10-23-2007, FILED 4-26-2007.

MAPMETRIX

THE MARK CONSISTS OF STANDARD CHARACTERS WITHOUT CLAIM TO ANY PARTICULAR FONT, STYLE, SIZE, OR COLOR.

OWNER OF U.S. REG. NO. 2,413,669.

FOR PROVIDING TEMPORARY USE OF ONLINE NON-DOWNLOADABLE SOFTWARE FOR INTERACTIVE MARKET ANALYSIS, NAMELY, FOR GEOGRAPHIC ANALYSIS, MAP PRODUCTION, AND INTERACTIVE ANALYSIS OF BUSINESS PLANNING DATA (U.S. CLS. 100 AND 101).

FIRST USE 3-28-2008; IN COMMERCE 3-28-2008.

3,481,670. INGENIOUS SYSTEMS RESEARCH, LLC, WILMINGTON, DE. SN 77-170,484. PUB. 10-23-2007, FILED 5-1-2007.

MAILVICE

THE MARK CONSISTS OF STANDARD CHARACTERS WITHOUT CLAIM TO ANY PARTICULAR FONT, STYLE, SIZE, OR COLOR.

FOR COMPUTER SERVICES, NAMELY, FILTERING OF UNWANTED E-MAILS (U.S. CLS. 100 AND 101).

FIRST USE 1-1-2007; IN COMMERCE 1-1-2007.

3,481,605. INTERNATIONAL ASSOCIATION OF PLUMBING AND MECHANICAL OFFICIALS, ONTARIO, CA. SN 77-153,242. PUB. 10-30-2007, FILED 4-10-2007.



THE COLOR(S) BLACK, LIGHT BLUE, AND DARK BLUE IS/ARE CLAIMED AS A FEATURE OF THE MARK.

THE MARK CONSISTS OF THE WORDING "IAPMO" IN BLACK ABOUT A SHIELD SHADED IN LIGHT BLUE TO THE LEFT AND DARK BLUE TO THE RIGHT. THE SHIELD IS WITHIN AN OVAL SHADED IN DARK BLUE. THE LETTERING "ES" APPEARS IN BLACK ON THE SHIELD.

FOR EVALUATION OF BUILDING, CONSTRUCTION, AND SAFETY MATERIALS AND PRODUCTS OF OTHERS FOR PURPOSES OF CERTIFICATION (U.S. CLS. 100 AND 101).

FIRST USE 1-1-2006; IN COMMERCE 1-1-2006.

3,481,675. DSCI, FREEHOLD, NJ. SN 77-171,405. PUB. 9-25-2007, FILED 5-2-2007.

MRS

THE MARK CONSISTS OF STANDARD CHARACTERS WITHOUT CLAIM TO ANY PARTICULAR FONT, STYLE, SIZE, OR COLOR.

FOR COMPUTER SERVICE, NAMELY, ACTING AS AN APPLICATION SERVICE PROVIDER IN THE FIELD OF KNOWLEDGE MANAGEMENT TO HOST COMPUTER APPLICATION SOFTWARE FOR THE COLLECTION, EDITING, ORGANIZING, MODIFYING, BOOK MARKING, TRANSMISSION, STORAGE AND SHARING OF DATA AND INFORMATION (U.S. CLS. 100 AND 101).

FIRST USE 6-2-2008; IN COMMERCE 6-2-2008.

CLASS 42—(Continued).

3,481,710. TOPLINE SOLUTIONS, INC., OAKLAND, CA. SN 77-179,715. PUB. 11-20-2007, FILED 5-13-2007.

SMART ELIGIBILITY

THE MARK CONSISTS OF STANDARD CHARACTERS WITHOUT CLAIM TO ANY PARTICULAR FONT, STYLE, SIZE, OR COLOR.

NO CLAIM IS MADE TO THE EXCLUSIVE RIGHT TO USE "ELIGIBILITY", APART FROM THE MARK AS SHOWN.

FOR COMPUTER SERVICES, NAMELY, PROVIDING TEMPORARY USE OF INTERNET-BASED NON-DOWNLOADABLE SOFTWARE FOR EXTRACTING AND PRESENTING INFORMATION REGARDING SPECIFIC TYPES OF HEALTH CARE SERVICES FOR USE IN ESTIMATING AND/OR COLLECTING PATIENT PAYMENTS AT THE TIME OF SERVICE (U.S. CLS. 100 AND 101).

FIRST USE 10-26-2007; IN COMMERCE 10-26-2007.

3,481,745. RIGHTPOINT GROUP, LLC., NORTHBROOK, IL. SN 77-192,064. PUB. 12-4-2007, FILED 5-29-2007.

RIGHTPOINT CONSULTING

THE MARK CONSISTS OF STANDARD CHARACTERS WITHOUT CLAIM TO ANY PARTICULAR FONT, STYLE, SIZE, OR COLOR.

NO CLAIM IS MADE TO THE EXCLUSIVE RIGHT TO USE "CONSULTING", APART FROM THE MARK AS SHOWN.

FOR CONSULTING SERVICES IN THE FIELD OF DESIGN, SELECTION, IMPLEMENTATION AND USE OF COMPUTER HARDWARE AND SOFTWARE SYSTEMS FOR OTHERS (U.S. CLS. 100 AND 101).

FIRST USE 5-7-2007; IN COMMERCE 5-7-2007.

3,481,784. MEDICAL DEVELOPMENT INTERNATIONAL LTD., INC., PONTE VEDRA BEACH, FL. SN 77-211,962. PUB. 10-16-2007, FILED 6-21-2007.

EARL

THE MARK CONSISTS OF STANDARD CHARACTERS WITHOUT CLAIM TO ANY PARTICULAR FONT, STYLE, SIZE, OR COLOR.

FOR PROVIDING TEMPORARY USE OF NONDOWNLOADABLE MEDICAL CARE SOFTWARE ON THE INTERNET FOR ADMINISTRATION, TRACKING AND ANALYSIS OF HEALTH ISSUES, SEVERITY, TREATMENT, CLAIMS AND SPECIFIC EXPENDITURES PER INDIVIDUAL PATIENT (U.S. CLS. 100 AND 101).

FIRST USE 3-30-2007; IN COMMERCE 3-30-2007.

CLASS 42—(Continued).

3,481,811. BRANDJUICE CONSULTING INC, DENVER, CO. SN 77-226,393. PUB. 1-22-2008, FILED 7-10-2007.

BATTLE TESTING

THE MARK CONSISTS OF STANDARD CHARACTERS WITHOUT CLAIM TO ANY PARTICULAR FONT, STYLE, SIZE, OR COLOR.

NO CLAIM IS MADE TO THE EXCLUSIVE RIGHT TO USE "TESTING", APART FROM THE MARK AS SHOWN.

FOR PRODUCT RESEARCH, NAMELY, CONDUCTING ALTERNATIVE AND NON-TRADITIONAL CONSUMER PRODUCT TESTS; PRODUCT DEVELOPMENT CONSULTATION, NAMELY, PROVIDING ANALYSIS OF ALTERNATIVE AND NON-TRADITIONAL CONSUMER PRODUCT TESTS (U.S. CLS. 100 AND 101).

FIRST USE 11-0-2007; IN COMMERCE 11-0-2007.

3,481,815. FI-SOFT, LLC, SPRING, TX. SN 77-228,292. PUB. 1-1-2008, FILED 7-12-2007.

PayGuard

THE MARK CONSISTS OF STANDARD CHARACTERS WITHOUT CLAIM TO ANY PARTICULAR FONT, STYLE, SIZE, OR COLOR.

FOR INTEGRATED AND ON-LINE SECURITY SERVICES, NAMELY, PROVIDING SECURITY AND ANONYMITY FOR ELECTRONIC PAYMENT TRANSACTIONS (U.S. CLS. 100 AND 101).

FIRST USE 7-12-2007; IN COMMERCE 7-12-2007.

3,481,884. FACES IN THE CROWD, INC., WESTON, CT. SN 77-254,836. PUB. 2-12-2008, FILED 8-14-2007.

FACES IN THE CROWD

THE MARK CONSISTS OF STANDARD CHARACTERS WITHOUT CLAIM TO ANY PARTICULAR FONT, STYLE, SIZE, OR COLOR.

FOR COMPUTER SERVICES, NAMELY, HOSTING AN ONLINE COMMUNITY FOR REGISTERED USERS TO PARTICIPATE IN COMPETITIONS, SHOWCASE THEIR SKILLS, GET FEEDBACK FROM THEIR PEERS, FORM VIRTUAL COMMUNITIES, ENGAGE IN SOCIAL NETWORKING AND IMPROVE THEIR TALENT (U.S. CLS. 100 AND 101).

FIRST USE 9-1-2007; IN COMMERCE 1-1-2008.

CLASS 42—(Continued).

3,481,929. PLANETWIDE GAMES, INC., ALISO VIEJO, CA. SN 77-276,944. PUB. 3-4-2008, FILED 9-11-2007.

MASHON

THE MARK CONSISTS OF STANDARD CHARACTERS WITHOUT CLAIM TO ANY PARTICULAR FONT, STYLE, SIZE, OR COLOR.

FOR COMPUTER SERVICES, NAMELY, HOSTING AND MAINTAINING AN ONLINE WEBSITE FOR OTHERS TO OBTAIN SOFTWARE AND TO COLLABORATE WITH OTHER USERS FOR THE CREATION OF IMAGES, STORIES AND ARTWORK; PROVIDING A WEBSITE FEATURING TEMPORARY USE OF NON-DOWNLOADABLE SOFTWARE ALLOWING WEBSITE USERS TO UPLOAD ONLINE VIDEOS FOR SHARING WITH OTHERS FOR ENTERTAINMENT PURPOSES (U.S. CLS. 100 AND 101).

FIRST USE 9-11-2007; IN COMMERCE 5-17-2008.

3,481,935. O. M. I. CREATIONS, LLC, WINSTON-SALEM, NC. SN 77-278,832. PUB. 3-11-2008, FILED 9-13-2007.

PEOPLE THINKS.COM

THE MARK CONSISTS OF STANDARD CHARACTERS WITHOUT CLAIM TO ANY PARTICULAR FONT, STYLE, SIZE, OR COLOR.

NO CLAIM IS MADE TO THE EXCLUSIVE RIGHT TO USE "PEOPLE", APART FROM THE MARK AS SHOWN.

FOR PROVIDING CUSTOMIZED ON-LINE WEB PAGES FEATURING USER-DEFINED INFORMATIONAL POSTINGS IN RESPONSE TO QUESTIONS RAISED BY OTHERS ON VARIOUS TOPICS (U.S. CLS. 100 AND 101).

FIRST USE 2-18-2008; IN COMMERCE 2-18-2008.

CLASS 42—(Continued).

3,481,988. RADAR NETWORKS, INC., SAN FRANCISCO, CA. SN 77-975,464. PUB. 1-1-2008, FILED 7-17-2007.

TWINE

THE MARK CONSISTS OF STANDARD CHARACTERS WITHOUT CLAIM TO ANY PARTICULAR FONT, STYLE, SIZE, OR COLOR.

FOR COMPUTER SERVICES, NAMELY, PROVIDING ONLINE NON-DOWNLOADABLE COMPUTER SOFTWARE INTERFACES VIA GLOBAL COMPUTER NETWORKS FOR USE AS DATABASE APPLICATIONS BASED ON SEMANTIC STORAGE AND RETRIEVAL TECHNOLOGIES, FOR USE IN STORING, SEARCHING, NAVIGATING, COLLECTING, ORGANIZING, AUTHORIZING, EDITING, PUBLISHING, SHARING, MANAGING, AND TRANSMITTING DATA AND DOCUMENTS; COMPUTER SERVICES, NAMELY, PROVIDING ONLINE NON-DOWNLOADABLE SOFTWARE VIA GLOBAL COMPUTER NETWORKS TO ALLOW USERS TO PERFORM COLLABORATION AND MANAGE KNOWLEDGE TO PERMIT MULTIPLE USERS TO AUTHOR, EDIT AND SHARE DATA AND DOCUMENTS, TO NAVIGATE AND SEARCH DATA AND DOCUMENTS, TO COLLECT AND ORGANIZE DATA AND DOCUMENTS, AND TO PERFORM ELECTRONIC TRANSACTIONS RELATED TO DATA AND DOCUMENTS; COMPUTER SERVICES, NAMELY, PROVIDING ONLINE NON-DOWNLOADABLE SOFTWARE VIA GLOBAL COMPUTER NETWORKS FOR ONLINE COLLABORATION, SOCIAL NETWORKING, SOCIAL MEDIA, MESSAGING, COLLABORATION, SEARCHING, COMMUNITY, PUBLISHING, ENTERTAINMENT, ADVERTISING AND E-COMMERCE (U.S. CLS. 100 AND 101).

FIRST USE 10-3-2007; IN COMMERCE 10-3-2007.

3,481,994. TABOOLA.COM LTD., BET DAGAN, ISRAEL. SN 77-975,684. PUB. 9-18-2007, FILED 3-2-2007.

TABOOLA

THE MARK CONSISTS OF STANDARD CHARACTERS WITHOUT CLAIM TO ANY PARTICULAR FONT, STYLE, SIZE, OR COLOR.

FOR APPLICATION SERVICE PROVIDER, NAMELY, PROVIDING, HOSTING, MANAGING, DEVELOPING, AND MAINTAINING APPLICATIONS, SOFTWARE, WEBSITES, AND DATABASES IN THE FIELDS OF PERSONAL PRODUCTIVITY, WIRELESS COMMUNICATION, MOBILE INFORMATION ACCESS, AND REMOTE DATA MANAGEMENT, INCLUDING AUDIO, AUDIO-VISUAL AND VIDEO CONTENT, FOR WIRELESS DELIVERY OF CONTENT TO HANDHELD COMPUTERS, LAPTOPS AND MOBILE ELECTRONIC DEVICES (U.S. CLS. 100 AND 101).

FIRST USE 5-0-2008; IN COMMERCE 5-0-2008.

CLASS 42—(Continued).

3,481,997. TABOOLA.COM LTD., BET DAGAN, ISRAEL. SN 77-975,721. PUB. 9-18-2007, FILED 3-2-2007.

TABOOLA.COM

THE MARK CONSISTS OF STANDARD CHARACTERS WITHOUT CLAIM TO ANY PARTICULAR FONT, STYLE, SIZE, OR COLOR.

FOR APPLICATION SERVICE PROVIDER, NAMELY, PROVIDING, HOSTING, MANAGING, DEVELOPING, AND MAINTAINING APPLICATIONS, SOFTWARE, WEBSITES, AND DATABASES IN THE FIELDS OF PERSONAL PRODUCTIVITY, WIRELESS COMMUNICATION, MOBILE INFORMATION ACCESS, AND REMOTE DATA MANAGEMENT, INCLUDING AUDIO, AUDIO-VISUAL AND VIDEO CONTENT, FOR WIRELESS DELIVERY OF CONTENT TO HANDHELD COMPUTERS, LAPTOPS AND MOBILE ELECTRONIC DEVICES (U.S. CLS. 100 AND 101).

FIRST USE 5-0-2008; IN COMMERCE 5-0-2008.

3,482,017. LERCHL, WOLFGANG, 01109 DRESDEN, FED REP GERMANY. SN 78-340,905. PUB. 4-5-2005, FILED 12-15-2003.

print24

THE MARK CONSISTS OF STANDARD CHARACTERS WITHOUT CLAIM TO ANY PARTICULAR FONT, STYLE, SIZE, OR COLOR.

FOR PROVIDING TEMPORARY USE OF NON-DOWNLOADABLE SOFTWARE TO OBTAIN QUOTATIONS FOR PRINTING SERVICES VIA THE INTERNET (U.S. CLS. 100 AND 101).

FIRST USE 6-19-2008; IN COMMERCE 6-19-2008.

3,482,030. SOMBRERO MAN ENTERPRISES, INC., MARIETTA, GA. SN 78-393,940. PUB. 1-18-2005, FILED 3-31-2004.

SOMBRERO MAN

THE MARK CONSISTS OF STANDARD CHARACTERS WITHOUT CLAIM TO ANY PARTICULAR FONT, STYLE, SIZE, OR COLOR.

FOR GRAPHIC ART DESIGN (U.S. CLS. 100 AND 101). FIRST USE 1-31-2004; IN COMMERCE 1-31-2004.

CLASS 42—(Continued).

3,482,063. XEROX CORPORATION, NORWALK, CT. SN 78-490,891. PUB. 3-27-2007, FILED 9-28-2004.

METERASSISTANT

THE MARK CONSISTS OF STANDARD CHARACTERS WITHOUT CLAIM TO ANY PARTICULAR FONT, STYLE, SIZE, OR COLOR.

FOR MONITORING AND MEASUREMENT OF USE, PERFORMANCE AND PRODUCTIVITY OF THIRD PARTY REPRODUCTION AND OFFICE EQUIPMENT VIA ACCESSED SOFTWARE INSTALLED IN SUCH THIRD PARTY EQUIPMENT (U.S. CLS. 100 AND 101).

FIRST USE 12-1-2005; IN COMMERCE 12-1-2005.

3,482,064. XEROX CORPORATION, NORWALK, CT. SN 78-490,896. PUB. 3-27-2007, FILED 9-28-2004.

SUPPLIESASSISTANT

THE MARK CONSISTS OF STANDARD CHARACTERS WITHOUT CLAIM TO ANY PARTICULAR FONT, STYLE, SIZE, OR COLOR.

FOR MONITORING AND MEASUREMENT OF CONSUMABLES OF THIRD PARTY REPRODUCTION AND OFFICE EQUIPMENT VIA ACCESSED SOFTWARE INSTALLED IN SUCH THIRD PARTY EQUIPMENT (U.S. CLS. 100 AND 101).

FIRST USE 12-1-2005; IN COMMERCE 12-1-2005.

3,482,143. INSPIRED DESIGN, LLC, CLARKSVILLE, MI. SN 78-655,083. PUB. 8-29-2006, FILED 6-21-2005.

BY DESIGN

THE MARK CONSISTS OF STANDARD CHARACTERS WITHOUT CLAIM TO ANY PARTICULAR FONT, STYLE, SIZE, OR COLOR.

FOR DESIGN FOR OTHERS IN THE FIELD OF JEWELRY (U.S. CLS. 100 AND 101).

FIRST USE 5-16-2008; IN COMMERCE 5-16-2008.

CLASS 42—(Continued).

3,482,354. DZMITRY KHAUSTOVICH, RICHMOND HILL, NY. SN 78-861,518. PUB. 11-21-2006, FILED 4-14-2006.

ANSIKO

THE MARK CONSISTS OF STANDARD CHARACTERS WITHOUT CLAIM TO ANY PARTICULAR FONT, STYLE, SIZE, OR COLOR.

FOR CHARITABLE SERVICES, NAMELY, PROVIDING WEB SITE DESIGN FOR OTHERS; COMPUTER SECURITY SERVICE, NAMELY, RESTRICTING ACCESS TO AND BY COMPUTER NETWORKS TO AND OF UNDESIRABLE WEB SITES, MEDIA AND INDIVIDUALS AND FACILITIES; COMPUTER SERVICES, NAMELY, CREATING AND MAINTAINING WEB SITES FOR OTHERS; COMPUTER SERVICES, NAMELY, DESIGNING AND IMPLEMENTING WEB SITES FOR OTHERS; COMPUTER SERVICES, NAMELY, MANAGING WEB SITES FOR OTHERS; CREATING OR MAINTAINING WEB SITES FOR OTHERS; CREATION AND MAINTENANCE OF WEB SITES FOR OTHERS; DESIGN OF HOME PAGES, COMPUTER SOFTWARE AND WEB SITES; DESIGN OF HOMEPAGES AND WEB-SITES; DISPLAYING THE WEB SITES AND IMAGES OF OTHERS ON A COMPUTER SERVER; ELABORATION AND MAINTENANCE OF WEB SITES FOR THIRD PARTIES; HOSTING THE WEB SITES OF OTHERS ON A COMPUTER SERVER FOR A GLOBAL COMPUTER NETWORK; PROVIDING CUSTOMIZED ON-LINE WEB PAGES FEATURING USER-DEFINED INFORMATION, WHICH INCLUDES SEARCH ENGINES AND ON-LINE WEB LINKS TO OTHER WEB SITES (U.S. CLS. 100 AND 101).

FIRST USE 11-19-2004; IN COMMERCE 1-6-2007.

3,482,365. GETTY IMAGES, INC., SEATTLE, WA. SN 78-868,438. PUB. 9-18-2007, FILED 4-24-2006.

PICTURECAST

THE MARK CONSISTS OF STANDARD CHARACTERS WITHOUT CLAIM TO ANY PARTICULAR FONT, STYLE, SIZE, OR COLOR.

FOR HOSTING OF DIGITAL CONTENT VIA A GLOBAL COMPUTER NETWORK, WIRED AND WIRELESS NETWORKS; PROVIDING INFORMATION IN RESPONSE TO END-USERS' REQUESTS VIA A GLOBAL COMPUTER NETWORK, WIRED AND WIRELESS NETWORKS; APPLICATION SERVICE PROVIDER (ASP) FEATURING SOFTWARE FOR USE IN CAPTURING, PROCESSING, DISTRIBUTING AND STREAMING DIGITAL CONTENT VIA A GLOBAL COMPUTER NETWORK, WIRED AND WIRELESS NETWORKS; PROVIDING ON-LINE NON-DOWNLOADABLE COMPUTER SOFTWARE FOR USE IN CAPTURING, PROCESSING, DISTRIBUTING AND STREAMING DIGITAL CONTENT VIA A GLOBAL COMPUTER NETWORK, WIRED AND WIRELESS NETWORKS (U.S. CLS. 100 AND 101).

FIRST USE 4-30-2006; IN COMMERCE 4-30-2006.

CLASS 42—(Continued).

3,482,401. ROUX ASSOCIATES, INC., ISLANDIA, NY. SN 78-903,639. PUB. 8-28-2007, FILED 6-8-2006.

BROWN TO GREEN

THE MARK CONSISTS OF STANDARD CHARACTERS WITHOUT CLAIM TO ANY PARTICULAR FONT, STYLE, SIZE, OR COLOR.

FOR ENVIRONMENTAL SERVICES, NAMELY, TECHNICAL CONSULTING SERVICES RELATING TO ENVIRONMENTAL RESTORATION AND SUSTAINABLE DEVELOPMENT; CONSULTING SERVICES RELATING TO ENGINEERING IN THE FIELD OF ENVIRONMENTAL RESTORATION AND SUSTAINABLE DEVELOPMENT (U.S. CLS. 100 AND 101).

FIRST USE 4-21-2008; IN COMMERCE 4-21-2008.

3,482,515. NYFIX, INC., STAMFORD, CT. SN 78-953,103. PUB. 8-28-2007, FILED 8-16-2006.

POWERED BY NYFIX

THE MARK CONSISTS OF STANDARD CHARACTERS WITHOUT CLAIM TO ANY PARTICULAR FONT, STYLE, SIZE, OR COLOR.

OWNER OF U.S. REG. NOS. 2,446,661, 2,576,274, AND OTHERS.

FOR APPLICATION HOSTING SERVICES FEATURING SOFTWARE FOR USE IN CONNECTION WITH FINANCIAL ORDER MANAGEMENT, EXECUTION MANAGEMENT AND MESSAGING FOR USE BY INSTITUTIONAL INVESTORS BY MEANS OF THE INTERNET (U.S. CLS. 100 AND 101).

FIRST USE 8-0-2006; IN COMMERCE 8-0-2006.

CLASS 42—(Continued).

3,482,570. AUTOMOTIVE CASTING TECHNOLOGY, INC., FRUITPORT, MI. SN 78-979,144. PUB. 11-21-2006, FILED 3-30-2005.

OPTIMAL DESIGN INITIATIVE

THE MARK CONSISTS OF STANDARD CHARACTERS WITHOUT CLAIM TO ANY PARTICULAR FONT, STYLE, SIZE, OR COLOR.

NO CLAIM IS MADE TO THE EXCLUSIVE RIGHT TO USE "OPTIMAL DESIGN", APART FROM THE MARK AS SHOWN.

FOR NEW ALLOY PRODUCT DEVELOPMENT IN THE FIELD OF ALUMINUM CASTINGS; ADVANCED COMPUTER AIDED ENGINEERING SERVICES FOR OTHERS IN THE FIELD OF ALUMINUM CASTINGS FOR AUTOMOTIVE AND NON-AUTOMOTIVE APPLICATIONS, INCLUDING CHASSIS AND SUSPENSION COMPONENTS AND COMMERCIAL TRANSPORTATION COMPONENTS THAT REQUIRE STRUCTURAL STRENGTH; DESIGN FOR OTHERS IN THE FIELD OF ALUMINUM CASTINGS FOR AUTOMOTIVE AND NON-AUTOMOTIVE APPLICATIONS, INCLUDING CHASSIS AND SUSPENSION COMPONENTS AND COMMERCIAL TRANSPORTATION COMPONENTS THAT REQUIRE STRUCTURAL STRENGTH (U.S. CLS. 100 AND 101).

FIRST USE 7-0-2004; IN COMMERCE 7-0-2004.

CLASS 43—HOTEL AND RESTAURANT SERVICES

3,481,058. CONVOY OF HOPE, SPRINGFIELD, MO. SN 76-543,948. PUB. 7-18-2006, FILED 9-9-2003.

HOPE NETWORK

FOR CHARITABLE SERVICES, NAMELY, PROVIDING FOOD TO DISADVANTAGED PEOPLE; CHARITABLE AND DISASTER RELIEF SERVICES, NAMELY, PROVIDING HOUSEHOLD ITEMS, NAMELY, APPLIANCES, FURNITURE, WATER PURIFICATION SYSTEMS, GENERATORS, AND COOKING SUPPLIES TO VICTIMS OF NATURAL DISASTERS AND DISADVANTAGED PEOPLE (U.S. CLS. 100 AND 101).

FIRST USE 5-28-2003; IN COMMERCE 5-28-2003.

3,481,069. HARTZ HOTEL SERVICES, INC., DBA GRAND HOSPITALITY, SECAUCUS, NJ. SN 76-621,804. PUB. 3-14-2006, FILED 11-22-2004.

ChelseaGrandHotel.com

THE MARK CONSISTS OF STANDARD CHARACTERS WITHOUT CLAIM TO ANY PARTICULAR FONT, STYLE,

CLASS 43—(Continued).

SIZE, OR COLOR.

OWNER OF U.S. REG. NOS. 2,191,860 AND 2,705,826. FOR RESERVATION SERVICES, NAMELY, MAKING RESERVATIONS FOR LODGING (U.S. CLS. 100 AND 101).

FIRST USE 0-0-2004; IN COMMERCE 0-0-2004.

3,481,120. SAGE HOSPITALITY RESOURCES LLC, DENVER, CO. SN 76-670,284. PUB. 5-29-2007, FILED 12-13-2006.

MERCAT

FOR RESTAURANT SERVICES (U.S. CLS. 100 AND 101).

FIRST USE 3-10-2008; IN COMMERCE 3-10-2008.

3,481,168. BOJANGLES' INTERNATIONAL, LLC, CHARLOTTE, NC. SN 77-001,460. PUB. 5-1-2007, FILED 9-18-2006.

Our food is famous. Our
customers love us.

THE MARK CONSISTS OF STANDARD CHARACTERS WITHOUT CLAIM TO ANY PARTICULAR FONT, STYLE, SIZE, OR COLOR.

FOR RESTAURANT SERVICES (U.S. CLS. 100 AND 101).

FIRST USE 12-10-2007; IN COMMERCE 12-10-2007.

3,481,217. DS WATERS OF AMERICA, INC., ATLANTA, GA. SN 77-028,792. PUB. 5-29-2007, FILED 10-25-2006.

ROAST 2 COAST

THE MARK CONSISTS OF STANDARD CHARACTERS WITHOUT CLAIM TO ANY PARTICULAR FONT, STYLE, SIZE, OR COLOR.

FOR COFFEE SUPPLY SERVICES FOR OFFICES (U.S. CLS. 100 AND 101).

FIRST USE 12-1-2007; IN COMMERCE 12-1-2007.

CLASS 43—(Continued).

3,481,310. BAD DAWGS, INC., PLYMOUTH, NH. SN 77-074,220. PUB. 8-28-2007, FILED 1-2-2007.



THE MARK CONSISTS OF A STYLIZED DOG'S FACE, CHEWING A BONE AND WEARING SUNGLASSES. FOR RESTAURANT SERVICES (U.S. CLS. 100 AND 101).

FIRST USE 8-31-2006; IN COMMERCE 9-30-2007.

3,481,315. FUZION FOOD GROUP, INC., SIOUX FALLS, SD. SN 77-076,594. PUB. 6-5-2007, FILED 1-5-2007.

CRAZY PARROT

THE MARK CONSISTS OF STANDARD CHARACTERS WITHOUT CLAIM TO ANY PARTICULAR FONT, STYLE, SIZE, OR COLOR. FOR RESTAURANT AND BAR SERVICES (U.S. CLS. 100 AND 101).

FIRST USE 9-0-2007; IN COMMERCE 9-0-2007.

3,481,369. ZORKAFOR'S SANDVEG INC, ALEXANDRIA, VA. SN 77-102,274. PUB. 8-7-2007, FILED 2-8-2007.

Zorkafor

THE MARK CONSISTS OF STANDARD CHARACTERS WITHOUT CLAIM TO ANY PARTICULAR FONT, STYLE, SIZE, OR COLOR. FOR FAST-FOOD RESTAURANTS (U.S. CLS. 100 AND 101).

FIRST USE 4-12-2008; IN COMMERCE 4-12-2008.

CLASS 43—(Continued).

3,481,411. GUNFLINT DEVELOPMENT GROUP, LLC, CHANHASSEN, MN. SN 77-119,747. PUB. 9-11-2007, FILED 3-1-2007.

NEW PERSPECTIVE

THE MARK CONSISTS OF STANDARD CHARACTERS WITHOUT CLAIM TO ANY PARTICULAR FONT, STYLE, SIZE, OR COLOR.

FOR PROVIDING SENIOR HOUSING COMMUNITIES SERVICES, NAMELY, PROVIDING CONGREGATE LIVING FACILITIES, ASSISTED LIVING FACILITIES AND MEMORY CARE ASSISTED LIVING FACILITIES (U.S. CLS. 100 AND 101).

FIRST USE 6-6-2006; IN COMMERCE 6-6-2006.

3,481,433. ISLE OF CAPRI CASINOS, INC., ST. LOUIS, MO. SN 77-125,129. PUB. 8-28-2007, FILED 3-7-2007.

tracksidebar



THE MARK CONSISTS OF THE WORDING "TRACKSIDE BAR" AND A DESIGN OF A HORSE AND BUGGY ATOP THREE CURVED LINES.

FOR RESTAURANT AND BAR SERVICES (U.S. CLS. 100 AND 101).

FIRST USE 6-0-2007; IN COMMERCE 6-0-2007.

3,481,445. SCREAMING GIRAFFE, INC., DENVER, CO. SN 77-127,562. PUB. 9-11-2007, FILED 3-9-2007.

Beatrice & Woodsley

THE MARK CONSISTS OF STANDARD CHARACTERS WITHOUT CLAIM TO ANY PARTICULAR FONT, STYLE, SIZE, OR COLOR.

FOR RESTAURANTS (U.S. CLS. 100 AND 101).

FIRST USE 5-2-2008; IN COMMERCE 5-2-2008.

CLASS 43—(Continued).

3,481,484. CSSR HOLDINGS, LLC, AMERICAN FORK, UT.
SN 77-133,283. PUB. 9-18-2007, FILED 3-16-2007.

FRESHNESS...TASTE THE DIFFERENCE

THE MARK CONSISTS OF STANDARD CHARACTERS
WITHOUT CLAIM TO ANY PARTICULAR FONT, STYLE,
SIZE, OR COLOR.

FOR RESTAURANT SERVICES (U.S. CLS. 100 AND
101).

FIRST USE 5-1-2008; IN COMMERCE 5-1-2008.

3,481,502. MARRIOTT INTERNATIONAL, INC., BETHESDA,
MD. SN 77-136,223. PUB. 9-18-2007, FILED 3-21-2007.

BLUE JEWEL

THE MARK CONSISTS OF STANDARD CHARACTERS
WITHOUT CLAIM TO ANY PARTICULAR FONT, STYLE,
SIZE, OR COLOR.

FOR COCKTAIL LOUNGES; RESTAURANT AND BAR
SERVICES (U.S. CLS. 100 AND 101).

FIRST USE 7-0-2007; IN COMMERCE 7-0-2007.

3,481,581. RIVERA, ALEXANDRIA NICOLE, LAS VEGAS,
NV. SN 77-149,923. PUB. 10-2-2007, FILED 4-5-2007.

TOYS

THE MARK CONSISTS OF STANDARD CHARACTERS
WITHOUT CLAIM TO ANY PARTICULAR FONT, STYLE,
SIZE, OR COLOR.

FOR RESTAURANTS (U.S. CLS. 100 AND 101).
FIRST USE 2-17-2000; IN COMMERCE 1-5-2008.

CLASS 43—(Continued).

3,481,618. LA DUNI CONCEPTS LLC, DALLAS, TX. SN 77-
157,459. PUB. 10-9-2007, FILED 4-16-2007.

SIP.BITE.SHARE

THE MARK CONSISTS OF STANDARD CHARACTERS
WITHOUT CLAIM TO ANY PARTICULAR FONT, STYLE,
SIZE, OR COLOR.

FOR RESTAURANT, CAFÉ, COFFEE HOUSE, CATER-
ING AND BAR SERVICES (U.S. CLS. 100 AND 101).

FIRST USE 1-0-2007; IN COMMERCE 1-0-2007.

3,481,645. RICHMAN, MARK, NEWPORT BEACH, CA. AND
PACINO, ROBERTA, NEWPORT BEACH, CA. SN 77-
162,664. PUB. 10-23-2007, FILED 4-22-2007.

ROBERTA PACINO'S HOLLYWOOD ESPRESSO

THE MARK CONSISTS OF STANDARD CHARACTERS
WITHOUT CLAIM TO ANY PARTICULAR FONT, STYLE,
SIZE, OR COLOR.

NO CLAIM IS MADE TO THE EXCLUSIVE RIGHT TO
USE "ESPRESSO", APART FROM THE MARK AS SHOWN.

FOR COFFEE SHOPS; COFFEE-HOUSE AND SNACK-
BAR SERVICES (U.S. CLS. 100 AND 101).

FIRST USE 5-0-2008; IN COMMERCE 5-0-2008.

3,481,648. BRINKER INTERNATIONAL HOLDINGS, L.P.,
DALLAS, TX. SN 77-164,593. PUB. 9-25-2007, FILED 4-24-
2007.

LET'S PLAY RESTAURANT

THE MARK CONSISTS OF STANDARD CHARACTERS
WITHOUT CLAIM TO ANY PARTICULAR FONT, STYLE,
SIZE, OR COLOR.

NO CLAIM IS MADE TO THE EXCLUSIVE RIGHT TO
USE "RESTAURANT", APART FROM THE MARK AS
SHOWN.

FOR RESTAURANT, BAR AND CATERING SERVICES
(U.S. CLS. 100 AND 101).

FIRST USE 9-8-2006; IN COMMERCE 9-8-2006.

CLASS 43—(Continued).

3,481,681. AMC BURGERS, INC., SOUTHFIELD, MI. SN 77-172,731. PUB. 10-30-2007, FILED 5-4-2007.

BAGGER DAVE'S

THE MARK CONSISTS OF STANDARD CHARACTERS WITHOUT CLAIM TO ANY PARTICULAR FONT, STYLE, SIZE, OR COLOR.

FOR RESTAURANT SERVICES (U.S. CLS. 100 AND 101).

FIRST USE 1-11-2008; IN COMMERCE 1-11-2008.

3,481,705. K&N MANAGEMENT, AUSTIN, TX. SN 77-178,478. PUB. 1-22-2008, FILED 5-11-2007.



NO CLAIM IS MADE TO THE EXCLUSIVE RIGHT TO USE "BURGERS FRIES SHAKES", APART FROM THE MARK AS SHOWN.

THE MARK CONSISTS OF THE WORD "MIGHTY FINE" WITH A STAR ABOVE THE MARK AND THE WORDS "BURGERS", "FRIES" AND "SHAKES" BELOW IT.

FOR RESTAURANT SERVICES (U.S. CLS. 100 AND 101).

FIRST USE 12-6-2007; IN COMMERCE 12-6-2007.

3,481,707. SRG, INC., PLEASANTON, CA. SN 77-179,276. PUB. 11-27-2007, FILED 5-11-2007.



THE COLOR(S) DARK ORANGE, ORANGE, PEACH AND GREEN IS/ARE CLAIMED AS A FEATURE OF THE MARK.

THE MARK CONSISTS OF FOUR TRIANGLES WITH CURVED SIDES BEING DARK ORANGE IN THE UPPER RIGHT CORNER, ORANGE IN THE LOWER RIGHT CORNER, PEACH IN THE LOWER LEFT CORNER, AND ORANGE IN THE UPPER LEFT CORNER WITH A GREEN POLYGON SHAPE TO THE LEFT OF THE TRIANGLE AND THE WORDING "CITRINE" BEING DARK ORANGE LOCATED TO THE RIGHT OF THE DESIGN AND BELOW "CITRINE" IS THE WORDING "DISCOVER A NEW WORLD OF FLAVOR" BEING IN ORANGE.

FOR RESTAURANT SERVICES (U.S. CLS. 100 AND 101).

FIRST USE 6-7-2007; IN COMMERCE 6-7-2007.

CLASS 43—(Continued).

3,481,769. HUNTINGTON HILL VENTURES, LLC., TUALATIN, OR. SN 77-205,696. PUB. 2-26-2008, FILED S.R. 6-14-2007; AM. P.R. 11-16-2007.



THE NAME "GRANDMA LEETH" DOES NOT IDENTIFY A LIVING INDIVIDUAL.

THE MARK CONSISTS OF THE PHRASE "GRANDMA LEETH'S" STACKED AND POSITIONED ACROSS THE OPENING AND WITHIN A ROUGH BRUSHSTROKE THAT IS PAINTED CLOCKWISE IN THE SHAPE OF A PARTIAL CIRCLE DESIGN THAT SURROUNDS THE WORDING IN THE MARK.

FOR CAFE-RESTAURANTS; CAFES; CARRY-OUT RESTAURANTS; CATERING OF FOOD AND DRINKS; CHILD CARE; CHILD CARE CENTERS; CHILD CARE SERVICES; CHILD WELFARE SERVICES, NAMELY, PROVIDING RESIDENTIAL HOMES AND HOUSING FOR AT-RISK CHILDREN AND YOUTH; CHILDREN'S CRECHES; DAY CARE CENTERS; DELICATESSENS; HOTEL, BAR AND RESTAURANT SERVICES; FAST FOOD AND NON-STOP RESTAURANT SERVICES; PREPARATION OF FOOD AND BEVERAGES; PRESCHOOLER AND INFANT CARE AT DAYCARE CENTERS; PROVIDING OF FOOD AND DRINK FOR PATIENTS AND GUESTS; RESTAURANT AND BAR SERVICES; RESTAURANT SERVICES; RESTAURANTS; RESTAURANTS FEATURING HOME DELIVERY; SERVING FOOD AND DRINKS; SERVING OF FOOD AND DRINK/BEVERAGES; TAKE-OUT RESTAURANT SERVICES; TEA ROOMS (U.S. CLS. 100 AND 101).

FIRST USE 4-9-2007; IN COMMERCE 7-1-2007.

3,481,795. ABITA BREWING COMPANY, LLC, ABITA SPRINGS, LA. SN 77-219,396. PUB. 2-19-2008, FILED 6-29-2007.

ABITA

THE MARK CONSISTS OF STANDARD CHARACTERS WITHOUT CLAIM TO ANY PARTICULAR FONT, STYLE, SIZE, OR COLOR.

OWNER OF U.S. REG. NOS. 1,927,815 AND 2,178,241. FOR RESTAURANT, BREWPUB, AND BAR SERVICES (U.S. CLS. 100 AND 101).

FIRST USE 5-1-1995; IN COMMERCE 5-1-1995.

CLASS 43—(Continued).

3,481,796. GARCIA, LAZARO, MIAMI, FL. AND GARCIA, JOSE, MIAMI, FL. SN 77-220,129. PUB. 12-11-2007, FILED 7-2-2007.

CASAVANA

THE MARK CONSISTS OF STANDARD CHARACTERS WITHOUT CLAIM TO ANY PARTICULAR FONT, STYLE, SIZE, OR COLOR.

FOR CAFE-RESTAURANTS; RESTAURANT AND BAR SERVICES; RESTAURANT SERVICES; RESTAURANTS; RESTAURANTS FEATURING HOME DELIVERY; SELF SERVICE RESTAURANTS; SELF-SERVICE RESTAURANTS; TAKE-OUT RESTAURANT SERVICES; CARRY-OUT RESTAURANTS; DELICATESSENS; FAST FOOD AND NON-STOP RESTAURANT SERVICES; FAST-FOOD RESTAURANTS; FAST-FOOD RESTAURANTS AND SNACKBARS; HOTEL, BAR AND RESTAURANT SERVICES (U.S. CLS. 100 AND 101).

FIRST USE 6-15-2007; IN COMMERCE 6-15-2007.

3,481,817. RICHMAN, MARK, LOS ANGELES, CA. AND PACINO, ROBERTA, LOS ANGELES, CA. SN 77-229,727. PUB. 10-9-2007, FILED 7-13-2007.

HOLLYWOOD ESPRESSO

THE MARK CONSISTS OF STANDARD CHARACTERS WITHOUT CLAIM TO ANY PARTICULAR FONT, STYLE, SIZE, OR COLOR.

NO CLAIM IS MADE TO THE EXCLUSIVE RIGHT TO USE "ESPRESSO", APART FROM THE MARK AS SHOWN. FOR COFFEE SHOPS; COFFEE-HOUSE AND SNACK-BAR SERVICES (U.S. CLS. 100 AND 101).

FIRST USE 5-0-2008; IN COMMERCE 5-0-2008.

3,481,881. 818 VENTURE PARTNERS, LLC, LONGMONT, CO. SN 77-254,109. PUB. 2-12-2008, FILED 8-13-2007.

BIMBAMBOO

THE MARK CONSISTS OF STANDARD CHARACTERS WITHOUT CLAIM TO ANY PARTICULAR FONT, STYLE, SIZE, OR COLOR.

FOR RESTAURANT AND BAR SERVICES (U.S. CLS. 100 AND 101).

FIRST USE 12-20-2007; IN COMMERCE 12-20-2007.

CLASS 43—(Continued).

3,481,892. GARCIA, LAZARO, MIAMI, FL. AND GARCIA, JOSE, MIAMI, FL. SN 77-258,484. PUB. 12-11-2007, FILED 8-17-2007.



NO CLAIM IS MADE TO THE EXCLUSIVE RIGHT TO USE "CUBAN CUISINE", APART FROM THE MARK AS SHOWN.

THE MARK CONSISTS OF A SOLID DARK CIRCLE SUPERIMPOSED ON TOP OF A LARGER WHITE CIRCLE (WITH A DARK OUTLINE/BORDER) SLIGHTLY OFF-CENTER TOWARDS THE TOP OF THE IMAGE, WITH THE TEXT "CASAVANA CUBAN CUISINE" APPEARING IN A CONTRASTING LIGHTER SHADE ACROSS THE CENTER OF THE DARK CIRCLE. THE LIGHTER CIRCLE ALSO CONSISTS OF A SET OF FOUR STYLIZED FLAMES LOCATED AT THE TOP OF THE CIRCLE AND RISING DOWNWARD TOWARDS THE TEXT, SEEMING TO PENETRATE THE DARKER CIRCLE FROM ABOVE.

FOR CAFE-RESTAURANTS; CARRY-OUT RESTAURANTS; DELICATESSENS; FAST FOOD AND NON-STOP RESTAURANT SERVICES; FAST-FOOD RESTAURANTS; FAST-FOOD RESTAURANTS AND SNACKBARS; HOTEL, BAR AND RESTAURANT SERVICES; RESTAURANT AND BAR SERVICES; RESTAURANT SERVICES; RESTAURANTS; RESTAURANTS FEATURING HOME DELIVERY; SELF SERVICE RESTAURANTS; SELF-SERVICE RESTAURANTS; TAKE-OUT RESTAURANT SERVICES (U.S. CLS. 100 AND 101).

FIRST USE 6-15-2007; IN COMMERCE 6-15-2007.

3,481,936. VAIL TRADEMARKS, INC., VAIL, CO. SN 77-279,180. PUB. 3-4-2008, FILED 9-13-2007.

APPETITE FOR LIFE

THE MARK CONSISTS OF STANDARD CHARACTERS WITHOUT CLAIM TO ANY PARTICULAR FONT, STYLE, SIZE, OR COLOR.

FOR RESORT FOOD AND BEVERAGE SERVICES, NAMELY, RESTAURANT, CAFETERIA, SNACK BAR AND SNACK-STAND SERVICES (U.S. CLS. 100 AND 101).

FIRST USE 11-5-2007; IN COMMERCE 11-5-2007.

CLASS 43—(Continued).

3,481,970. WHG TM CORP., LAS VEGAS, NV. SN 77-299,710. PUB. 2-26-2008, FILED 10-9-2007.



OWNER OF U.S. REG. NOS. 3,172,962, 3,226,449, AND 3,232,172.

NO CLAIM IS MADE TO THE EXCLUSIVE RIGHT TO USE "BREAKFAST", APART FROM THE MARK AS SHOWN.

THE COLOR(S) BLUE, YELLOW, RED, WHITE IS/ARE CLAIMED AS A FEATURE OF THE MARK.

THE MARK CONSISTS OF THE WORDS "BAYMONT BREAKFAST CORNER"; THE WORD "BAYMONT" APPEARS AGAINST A BLUE OVAL; "BAYMONT" IS IN WHITE; THREE BANNERS APPEAR ABOVE THE WORD "BAYMONT"; THE FIRST BANNER IN BLUE, THE SECOND BANNER IN RED, THE THIRD BANNER IN YELLOW; THE WORDS "BREAKFAST CORNER" APPEAR AGAINST A SINGLE BANNER WRAPPED AROUND THE MIDDLE OF THE OVAL; "BREAKFAST CORNER" APPEARS IN WHITE; THE SINGLE BANNER APPEARS IN RED; A GLASS, A PLATE OF FOOD AND A MUG ON A PLATE APPEAR AGAINST THE BLUE OVAL BELOW THE RED BANNER. THE GLASS, PLATE AND MUG APPEAR IN WHITE.

FOR RESTAURANT SERVICES PROVIDED IN HOTELS AND MOTELS (U.S. CLS. 100 AND 101).

FIRST USE 11-0-2007; IN COMMERCE 11-0-2007.

3,482,020. RON MATUSALEM & MATUSA OF FLORIDA, INC., MIAMI, FL. SN 78-356,036. PUB. 8-30-2005, FILED 12-22-2004.

THE SPIRIT OF CUBA

THE MARK CONSISTS OF STANDARD CHARACTERS WITHOUT CLAIM TO ANY PARTICULAR FONT, STYLE, SIZE, OR COLOR.

NO CLAIM IS MADE TO THE EXCLUSIVE RIGHT TO USE "CUBA", APART FROM THE MARK AS SHOWN.

FOR RESTAURANT AND BAR SERVICES EXCLUDING RESTAURANT AND BAR SERVICES PROVIDED ON A CRUISE SHIP; SERVING FOOD AND DRINK EXCLUDING SERVICES FOR PROVIDING FOOD AND DRINK ON A CRUISE SHIP (U.S. CLS. 100 AND 101).

FIRST USE 2-18-2005; IN COMMERCE 2-18-2005.

CLASS 43—(Continued).

3,482,177. WESTIN HOTEL MANAGEMENT, L.P., WHITE PLAINS, NY. SN 78-710,676. PUB. 3-4-2008, FILED 9-11-2005.

WESTIN KIDS CLUB DISCOVERY ROOM

THE MARK CONSISTS OF STANDARD CHARACTERS WITHOUT CLAIM TO ANY PARTICULAR FONT, STYLE, SIZE, OR COLOR.

NO CLAIM IS MADE TO THE EXCLUSIVE RIGHT TO USE "KIDS CLUB", APART FROM THE MARK AS SHOWN. FOR HOTEL, MOTEL AND RESORT LODGING SERVICES; CHILDREN'S DAY CARE SERVICES (U.S. CLS. 100 AND 101).

FIRST USE 8-0-2005; IN COMMERCE 8-0-2005.

3,482,187. FIREHOUSE RESTAURANT GROUP, INC., JACKSONVILLE, FL. SN 78-725,800. PUB. 12-25-2007, FILED 10-4-2005.

**FOUNDED BY FIREMEN**

OWNER OF U.S. REG. NOS. 1,903,135, 2,606,263, AND OTHERS.

NO CLAIM IS MADE TO THE EXCLUSIVE RIGHT TO USE "SUBS" AND "FOUNDED BY FIREMEN", APART FROM THE MARK AS SHOWN.

THE COLOR(S) RED, GOLD, WHITE AND BLACK IS/ARE CLAIMED AS A FEATURE OF THE MARK.

THE MARK CONSISTS OF THE WORDING "FIREHOUSE" LETTERED IN WHITE WITH BLACK OUTLINING ON A RED BACKGROUND AND THE WORDING "SUBS" IN GOLD ON A BLACK BACKGROUND, ALL ON A PLAQUE HAVING GOLD OUTLINING AND RIVETS, AND THE WORDS "FOUNDED BY FIREMEN" IN BLACK.

FOR RESTAURANT SERVICES (U.S. CLS. 100 AND 101).

FIRST USE 12-31-2005; IN COMMERCE 12-31-2005.

3,482,190. PORTER, STARR, MILL VALLEY, CA. SN 78-733,676. PUB. 9-19-2006, FILED 10-14-2005.

STARR GRILL

THE MARK CONSISTS OF STANDARD CHARACTERS WITHOUT CLAIM TO ANY PARTICULAR FONT, STYLE, SIZE, OR COLOR.

OWNER OF U.S. REG. NO. 1,991,761.

CLASS 43—(Continued).

NO CLAIM IS MADE TO THE EXCLUSIVE RIGHT TO USE "GRILL", APART FROM THE MARK AS SHOWN.
FOR QUICK-CAUSAL RESTAURANT (U.S. CLS. 100 AND 101).
FIRST USE 2-15-2008; IN COMMERCE 2-15-2008.

CLASS 43—(Continued).

3,482,455. SODEXHO ALLIANCE, 78180 MONTIGNY-LE-BRETONNEUX, FRANCE. SN 78-933,841. PUB. 8-28-2007, FILED 7-20-2006.

3,482,230. LING, WONG SIU, HONG KONG, HONG KONG.
SN 78-770,935. PUB. 2-20-2007, FILED 12-12-2005.



THE MARK CONSISTS OF CHINESE CHARACTERS AND ENGLISH CHARACTERS SPELLING "WING LAI YUEN".
THE FOREIGN WORDING IN THE MARK TRANSLATES INTO ENGLISH AS CHANTING, SINGING; GOOSEFOOT AND A GARDEN, A PARK.

THE NON-LATIN CHARACTER(S) IN THE MARK TRANSLITERATES INTO YONG LI YUAN, AND THIS MEANS NOTHING IN ENGLISH.

FOR BAR SERVICES; CAFE-RESTAURANTS; CAFES; CAFETERIAS; CANTEEN SERVICES; CARRY-OUT RESTAURANTS; CATERING OF FOOD AND DRINKS; COFFEE-HOUSE AND SNACK-BAR SERVICES; HOTELS; RESTAURANTS; SELF SERVICE RESTAURANTS; SELF-SERVICE RESTAURANTS; SNACK BARS; TEA ROOMS (U.S. CLS. 100 AND 101).

FIRST USE 1-1-2003; IN COMMERCE 1-1-2007.



3,482,284. SOUTHERN RESTAURANT GROUP, INC., DES-TIN, FL. SN 78-802,072. PUB. 10-24-2006, FILED 1-30-2006.

REGGAE J'S ISLAND GRILL

THE MARK CONSISTS OF STANDARD CHARACTERS WITHOUT CLAIM TO ANY PARTICULAR FONT, STYLE, SIZE, OR COLOR.

NO CLAIM IS MADE TO THE EXCLUSIVE RIGHT TO USE "GRILL", APART FROM THE MARK AS SHOWN.

FOR RESTAURANT SERVICES (U.S. CLS. 100 AND 101).

FIRST USE 6-13-2008; IN COMMERCE 6-13-2008.

THE COLOR(S) DARK GREEN, MID GREEN, LIGHT GREEN AND WHITE IS/ARE CLAIMED AS A FEATURE OF THE MARK.

THE MARK CONSISTS OF THE WORD "ASPRETO" IN WHITE LOWER CASE LETTERS, ABOVE THE WORDS "GOING FORWARD BY GIVING BACK" IN WHITE LOWER CASE LETTERS, AND A SHORT WHITE HORIZONTAL LINE BENEATH THOSE WORDS, ALL SHOWN BENEATH A WHITE QUADRILATERAL SHAPE WHOSE TOP IS WIDER THAN ITS BOTTOM AND WHICH IS SURROUNDED BY A LIGHT GREEN LINE HAVING THE SAME OVERALL SHAPE, WHICH IS IN TURN ENCLOSED WITHIN A SIMILAR MID GREEN LINE FORMED IN TWO SEGMENTS WITH ARROWS ON THE END OF EACH SEGMENT, ALL OF WHICH IS SHOWN ON A DARK GREEN BACKGROUND.

FOR SERVICES FOR PROVIDING DRINK (U.S. CLS. 100 AND 101).

FIRST USE 9-0-2006; IN COMMERCE 9-0-2006.

CLASS 43—(Continued).

3,482,456. SODEXHO ALLIANCE, MONTIGNY-LE-BRETON-NEUX, FRANCE. SN 78-933,878. PUB. 9-18-2007, FILED 7-20-2006.



THE COLOR(S) DARK GREEN, MID GREEN AND LIGHT GREEN IS/ARE CLAIMED AS A FEATURE OF THE MARK. THE MARK CONSISTS OF THE WORD "ASPRETO" IN DARK GREEN LOWER CASE LETTERS, ABOVE THE WORDS "GOING FORWARD BY GIVING BACK" IN DARK GREEN LOWER CASE LETTERS, AND A SHORT DARK GREEN HORIZONTAL LINE BENEATH THOSE WORDS, ALL SHOWN BENEATH A DARK GREEN QUADRILATERAL SHAPE WHOSE TOP IS WIDER THAN ITS BOTTOM AND WHICH IS SURROUNDED BY A MID GREEN LINE HAVING THE SAME OVERALL SHAPE, WHICH IS IN TURN ENCLOSED WITHIN A SIMILAR LIGHT GREEN LINE FORMED IN TWO SEGEMENTS WITH ARROWS ON THE END OF EACH SEGMENT. ALL SHOWN ON A WHITE BACKGROUND, WHICH BACKGROUND ALSO IS VISIBLE BETWEEN THE QUADRILATERAL SHAPE AND ITS SURROUNDING LINES. THE COLOR WHITE IS NOT CLAIMED AS PART OF THE MARK."

FOR SERVICES FOR PROVIDING DRINK (U.S. CLS. 100 AND 101).

FIRST USE 9-0-2006; IN COMMERCE 9-0-2006.

3,482,568. JOHNSON, SHEILA C., THE PLAINS, VA. SN 78-975,178. PUB. 3-22-2005, FILED 10-23-2002.

SALAMANDER

FOR HOTEL AND SPA SERVICES (U.S. CLS. 100 AND 101).

FIRST USE 4-0-2007; IN COMMERCE 4-0-2007.

CLASS 44—MEDICAL, BEAUTY AND AGRICULTURAL SERVICES

3,481,057. CONVOY OF HOPE, SPRINGFIELD, MO. SN 76-543,947. PUB. 7-18-2006, FILED 9-9-2003.

HOPE NETWORK

FOR CHARITABLE SERVICES, NAMELY, PROVIDING MEDICAL AND HEALTHCARE SERVICES TO DISADVANTAGED PEOPLE; CHARITABLE AND DISASTER RELIEF SERVICES, NAMELY, PROVIDING BLANKETS FOR FIRST AID USE AND PERSONAL HYGIENE PRODUCTS TO VICTIMS OF NATURAL DISASTERS AND DISADVANTAGED PEOPLE (U.S. CLS. 100 AND 101).

FIRST USE 5-28-2003; IN COMMERCE 5-28-2003.

CLASS 44—(Continued).

3,481,164. COMPREHENSIVE AGE MANAGEMENT SYSTEMS & AESTHETIC PLASTIC SURGERY, PLLC, NEW YORK, NY. SN 77-000,291. PUB. 10-23-2007, FILED 9-15-2006.

SKIN REFABRICATION

THE MARK CONSISTS OF STANDARD CHARACTERS WITHOUT CLAIM TO ANY PARTICULAR FONT, STYLE, SIZE, OR COLOR.

NO CLAIM IS MADE TO THE EXCLUSIVE RIGHT TO USE "SKIN", APART FROM THE MARK AS SHOWN.

FOR MEDICAL SERVICES; MEDICAL CARE, NAMELY, LASER RESURFACING OF THE SKIN; HYGIENIC AND BEAUTY CARE SERVICES, NAMELY, LASER RESURFACING OF THE SKIN IN THE FIELD OF MEDICINE (U.S. CLS. 100 AND 101).

FIRST USE 1-31-2008; IN COMMERCE 1-31-2008.

3,481,167. NERDHEALTH, LLC, POMPANO, FL. SN 77-001,014. PUB. 3-27-2007, FILED 9-15-2006.

NERDHEALTH

THE MARK CONSISTS OF STANDARD CHARACTERS WITHOUT CLAIM TO ANY PARTICULAR FONT, STYLE, SIZE, OR COLOR.

FOR PROVIDING A WEBSITE THAT FEATURES INFORMATION ON CHILDREN'S NUTRITION (U.S. CLS. 100 AND 101).

FIRST USE 2-23-2008; IN COMMERCE 2-23-2008.

CLASS 44—(Continued).

3,481,185. ROCHE DIAGNOSTICS GMBH, 68305 MANNHEIM, FED REP GERMANY. SN 77-012,287. PUB. 3-27-2007, FILED 10-3-2006.

ACCU-CHEK INNER CIRCLE

THE MARK CONSISTS OF STANDARD CHARACTERS WITHOUT CLAIM TO ANY PARTICULAR FONT, STYLE, SIZE, OR COLOR.

OWNER OF U.S. REG. NOS. 1,277,867, 3,076,905, AND OTHERS.

FOR PROVIDING CUSTOMIZED MEDICAL HEALTH CARE CONSULTANCY IN THE FIELD OF DIABETES, NAMELY, MAINTAINING FILES AND RECORDS CONCERNING THE MEDICAL CONDITION OF INDIVIDUALS AND PROVIDING INFORMATION ABOUT DIABETES VIA A WEBSITE ON THE INTERNET (U.S. CLS. 100 AND 101).

FIRST USE 3-31-2007; IN COMMERCE 3-31-2007.

CLASS 44—(Continued).

3,481,222. CURA HOME CARE SERVICES, LLC, PHOENIX, AZ. SN 77-031,064. PUB. 9-18-2007, FILED 10-27-2006.



THE COLOR(S) BLUE, BLACK, AND WHITE IS/ARE CLAIMED AS A FEATURE OF THE MARK.

THE MARK CONSISTS OF FIGURES OUTLINED IN BLACK; THE FIGURES HAVE A MAINLY BLUE INTERIOR WITH SOME WHITE.

FOR HOME HEALTH CARE SERVICES (U.S. CLS. 100 AND 101).

FIRST USE 11-0-2006; IN COMMERCE 11-0-2006.

3,481,195. DIABETES WIRELESS, LLC, HOUSTON, TX. SN 77-017,214. PUB. 2-19-2008, FILED 10-9-2006.

WELLNESS WIRELESS

THE MARK CONSISTS OF STANDARD CHARACTERS WITHOUT CLAIM TO ANY PARTICULAR FONT, STYLE, SIZE, OR COLOR.

FOR HEALTH CARE; HEALTH CARE SERVICES, NAMELY, WELLNESS PROGRAMS; HEALTH CARE SERVICES, NAMELY, DISEASE MANAGEMENT PROGRAMS; HOME HEALTH CARE SERVICES; MANAGED HEALTH CARE SERVICES; PROVIDING HEALTH CARE INFORMATION BY TELEPHONE; PROVIDING HEALTH CARE INFORMATION BY TELEPHONE AND THE INTERNET (U.S. CLS. 100 AND 101).

FIRST USE 5-0-2007; IN COMMERCE 5-0-2007.

3,481,231. CENTENE CORPORATION, CLAYTON, MO. SN 77-035,387. PUB. 5-8-2007, FILED 11-2-2006.



3,481,197. BARDEEN AGENCY, INC., LOS ANGELES, CA. SN 77-018,412. PUB. 4-17-2007, FILED 10-11-2006.

JILLIAN DEMPSEY

THE MARK CONSISTS OF STANDARD CHARACTERS WITHOUT CLAIM TO ANY PARTICULAR FONT, STYLE, SIZE, OR COLOR.

FOR CONSULTING SERVICES IN THE FIELD OF COSMETICS (U.S. CLS. 100 AND 101).

FIRST USE 10-0-2004; IN COMMERCE 10-0-2004.

NO CLAIM IS MADE TO THE EXCLUSIVE RIGHT TO USE "SUPERIOR HEALTH PLAN", APART FROM THE MARK AS SHOWN.

FOR MANAGED HEALTH CARE SERVICES (U.S. CLS. 100 AND 101).

FIRST USE 1-0-2007; IN COMMERCE 1-0-2007.

CLASS 44—(Continued).

3,481,255. NERDHEALTH, LLC, POMPANO BEACH, FL. SN 77-048,314. PUB. 5-1-2007, FILED 11-20-2006.

Nerdhealth.com

THE MARK CONSISTS OF STANDARD CHARACTERS WITHOUT CLAIM TO ANY PARTICULAR FONT, STYLE, SIZE, OR COLOR.

FOR PROVIDING A WEBSITE THAT FEATURES INFORMATION ON CHILDREN'S NUTRITION (U.S. CLS. 100 AND 101).

FIRST USE 2-23-2008; IN COMMERCE 2-23-2008.

CLASS 44—(Continued).

3,481,362. AGUA DULCE EXTENDED CARE, INC., TUCSON, AZ. SN 77-097,676. PUB. 10-2-2007, FILED 2-2-2007.

AGUA DULCE

THE MARK CONSISTS OF STANDARD CHARACTERS WITHOUT CLAIM TO ANY PARTICULAR FONT, STYLE, SIZE, OR COLOR.

THE FOREIGN WORDING IN THE MARK TRANSLATES INTO ENGLISH AS FRESH WATER.

FOR MENTAL AND BEHAVIORAL HEALTH CARE SERVICES FOR WOMEN (U.S. CLS. 100 AND 101).

FIRST USE 6-24-2008; IN COMMERCE 6-24-2008.

3,481,684. ALLERGAN, INC., IRVINE, CA. SN 77-174,255. PUB. 10-2-2007, FILED 5-7-2007.

TO EACH HER OWN

THE MARK CONSISTS OF STANDARD CHARACTERS WITHOUT CLAIM TO ANY PARTICULAR FONT, STYLE, SIZE, OR COLOR.

FOR PROVIDING MEDICAL INFORMATION TO PATIENTS CONSIDERING AUGMENTATION AND RECONSTRUCTIVE SURGERY AND BREAST IMPLANTS (U.S. CLS. 100 AND 101).

FIRST USE 4-30-2007; IN COMMERCE 4-30-2007.

3,481,792. THALER, LISA J., NEW YORK, NY. SN 77-214,924. PUB. 12-4-2007, FILED 6-25-2007.

ROCKSHRINK

THE MARK CONSISTS OF STANDARD CHARACTERS WITHOUT CLAIM TO ANY PARTICULAR FONT, STYLE, SIZE, OR COLOR.

FOR PSYCHOTHERAPY SERVICES (U.S. CLS. 100 AND 101).

FIRST USE 6-25-2007; IN COMMERCE 6-25-2007.

3,481,279. GENESIS HEALTHCARE HOLDING COMPANY II, INC., KENNETT SQUARE, PA. SN 77-060,035. PUB. 11-27-2007, FILED 12-8-2006.



THE MARK CONSISTS OF THE WORDS "LIFE AT HOME" BELOW A DESIGN CONSISTING OF THREE HOUSES WITH A HEART SHAPE CUT OUT OF THE CENTER HOUSE, ALL UNDER A SOLID BLACK CIRCLE.

FOR HEALTH CARE SERVICES; HEALTH CARE SERVICES, NAMELY, PROVIDING PRIMARY HEALTH CARE CLINICS, PROVIDING HEALTH CARE SERVICES TO GERIATRIC PATIENTS, HOME HEALTH CARE SERVICES AND PHYSICAL REHABILITATION SERVICES (U.S. CLS. 100 AND 101).

FIRST USE 5-0-2006; IN COMMERCE 5-0-2006.

CLASS 44—(Continued).

3,481,958. MACHINERYLINK, INC., KANSAS CITY, MO. SN 77-293,521. PUB. 3-18-2008, FILED 10-2-2007.

MACHINERYLINK THE SMARTER
HARVEST

THE MARK CONSISTS OF STANDARD CHARACTERS WITHOUT CLAIM TO ANY PARTICULAR FONT, STYLE, SIZE, OR COLOR.

OWNER OF U.S. REG. NOS. 2,554,960, 3,306,385, AND OTHERS.

FOR LEASING AND RENTAL OF AGRICULTURAL AND FARM EQUIPMENT (U.S. CLS. 100 AND 101).

FIRST USE 12-14-2007; IN COMMERCE 12-14-2007.

CLASS 44—(Continued).

3,482,107. THE CENTER FOR CASE MANAGEMENT, INC., SOUTH NATICK, MA. SN 78-590,029. PUB. 8-15-2006, FILED 3-18-2005.

MOST VULNERABLE
UNIT

THE MARK CONSISTS OF STANDARD CHARACTERS WITHOUT CLAIM TO ANY PARTICULAR FONT, STYLE, SIZE, OR COLOR.

FOR CONSULTATION IN THE FIELD OF NURSING AND HEALTH CARE; PROVIDING NURSING AND HEALTH CARE INFORMATION; PROVIDING NURSING AND HEALTH CARE INFORMATION RELATING TO LOCATIONS IN HEALTH CARE FACILITIES WITH WHICH RISKS ARE ASSOCIATED (U.S. CLS. 100 AND 101).

FIRST USE 0-0-2005; IN COMMERCE 0-0-2005.

3,482,189. ASTRAZENECA UK LIMITED, LONDON, ENGLAND. SN 78-730,586. PUB. 3-13-2007, FILED 10-11-2005.

GETBCFACTS.COM

THE MARK CONSISTS OF STANDARD CHARACTERS WITHOUT CLAIM TO ANY PARTICULAR FONT, STYLE, SIZE, OR COLOR.

FOR PROVISION OF INFORMATION AND ADVICE RELATING TO THE DIAGNOSIS AND TREATMENT OF CANCER (U.S. CLS. 100 AND 101).

FIRST USE 9-30-2005; IN COMMERCE 9-30-2005.

3,482,057. UNCOMMON KNOWLEDGE LIMITED, HOVE, UNITED KINGDOM. SN 78-480,848. PUB. 9-11-2007, FILED 9-9-2004.

UNCOMMON KNOWLEDGE

3,482,253. WILEY SUBSCRIPTION SERVICES, INC., HOBOKEN, NJ. SN 78-782,889. PUB. 9-12-2006, FILED 12-30-2005.

THE MARK CONSISTS OF STANDARD CHARACTERS WITHOUT CLAIM TO ANY PARTICULAR FONT, STYLE, SIZE, OR COLOR.

PRIORITY CLAIMED UNDER SEC. 44(D) ON UNITED KINGDOM APPLICATION NO. 2357958, FILED 3-10-2004, REG. NO. 2357958, DATED 9-3-2004, EXPIRES 3-10-2014.

FOR THERAPY SERVICES, NAMELY, HYPNOTHERAPY, PSYCHOTHERAPY, SOLUTION FOCUSED BRIEF THERAPY, COGNITIVE THERAPY, BEHAVIOURAL THERAPY, HYPNOSIS, ANTI-SMOKING THERAPY, AND PHYSICAL THERAPY (U.S. CLS. 100 AND 101).

FIRST USE 6-4-2008; IN COMMERCE 6-4-2008.

POEMS: PATIENT-ORIENTED
EVIDENCE THAT MATTERS

THE MARK CONSISTS OF STANDARD CHARACTERS WITHOUT CLAIM TO ANY PARTICULAR FONT, STYLE, SIZE, OR COLOR.

FOR PROVIDING MEDICAL INFORMATION (U.S. CLS. 100 AND 101).

FIRST USE 8-0-2001; IN COMMERCE 8-0-2001.

CLASS 44—(Continued).

3,482,306. BILLEDEAUX HEARING CENTER, L.L.C., LA-FAYETTE, LA. SN 78-824,424. PUB. 10-17-2006, FILED 2-27-2006.

Sound Solutions Hearing Center

THE MARK CONSISTS OF STANDARD CHARACTERS WITHOUT CLAIM TO ANY PARTICULAR FONT, STYLE, SIZE, OR COLOR.

NO CLAIM IS MADE TO THE EXCLUSIVE RIGHT TO USE "HEARING CENTER", APART FROM THE MARK AS SHOWN.

FOR HEARING AID SERVICES (U.S. CLS. 100 AND 101).

FIRST USE 4-1-2006; IN COMMERCE 4-1-2006.

CLASS 44—(Continued).

3,482,436. MISTER TWISTER IP, LLC, IRVINE, CA. SN 78-926,518. PUB. 2-20-2007, FILED 7-11-2006.

BRAIN BUILDING AND MIND RECONSTRUCTION

THE MARK CONSISTS OF STANDARD CHARACTERS WITHOUT CLAIM TO ANY PARTICULAR FONT, STYLE, SIZE, OR COLOR.

FOR REHABILITATION OF ALCOHOL, DRUG AND NARCOTIC ADDICTED PATIENTS (U.S. CLS. 100 AND 101).

FIRST USE 8-31-2007; IN COMMERCE 8-31-2007.

3,482,489. WORLD RADIO MISSIONARY FELLOWSHIP, INC., COLORADO SPRINGS, CO. SN 78-944,647. PUB. 8-21-2007, FILED 8-3-2006.

HCJB GLOBAL

3,482,388. JOSEPH A. MENNA DMD, INC., HOPKINTON, MA. SN 78-889,733. PUB. 6-19-2007, FILED 5-23-2006.



THE COLOR(S) GREEN, BROWN, BLACK, WHITE, GOLD, YELLOW, AND BLUE IS/ARE CLAIMED AS A FEATURE OF THE MARK.

THE PALM LEAVES ARE GREEN AND BLACK, THE TREE TRUNKS ARE BROWN AND BLACK, THE SUNGLASSES ARE BLACK, THE TOOTH IS WHITE WITH GOLD OUTLINES, THE SANDS ARE YELLOW AND BLACK AND THE HAMMOCK IS BLUE AND BLACK.

FOR DENTISTRY SERVICES (U.S. CLS. 100 AND 101).
FIRST USE 3-30-2006; IN COMMERCE 3-30-2006.

THE MARK CONSISTS OF STANDARD CHARACTERS WITHOUT CLAIM TO ANY PARTICULAR FONT, STYLE, SIZE, OR COLOR.

NO CLAIM IS MADE TO THE EXCLUSIVE RIGHT TO USE "GLOBAL", APART FROM THE MARK AS SHOWN.

FOR CHARITABLE SERVICES, NAMELY, PROVIDING MEDICAL SERVICES, FIRST AID SUPPLIES AND MEDICAL SUPPLIES PRIMARILY TO UNDERDEVELOPED COUNTRIES (U.S. CLS. 100 AND 101).

FIRST USE 1-1-2007; IN COMMERCE 1-1-2007.

CLASS 45—PERSONAL AND LEGAL SERVICES

3,481,054. TELIGENCE (CANADA), INC., VANCOUVER, CANADA. SN 76-524,873. PUB. 5-11-2004, FILED 6-12-2003.

LINEA VIVA

THE ENGLISH TRANSLATION OF "LINEA VIVA" IS "LIVE LINE".

FOR SOCIAL INTRODUCTION AGENCIES AND COMPUTER DATING SERVICES VIA A GLOBAL COMPUTER NETWORK (U.S. CLS. 100 AND 101).

FIRST USE 6-1-2007; IN COMMERCE 6-1-2007.

CLASS 45—(Continued).

3,481,059. CONVOY OF HOPE, SPRINGFIELD, MO. SN 76-543,949. PUB. 7-18-2006, FILED 9-9-2003.

HOPE NETWORK

FOR CHARITABLE AND DISASTER RELIEF SERVICES, NAMELY, PROVIDING CLOTHING AND BLANKETS FOR BEDDING TO VICTIMS OF NATURAL DISASTERS AND DISADVANTAGED PEOPLE; DISASTER RELIEF SERVICES, NAMELY, DEVELOPING PLANS AND PROCEDURES FOR PROVIDING EMERGENCY AID AND SUPPLIES, WATER PURIFICATION, AND SANITATION FOR VICTIMS OF NATURAL DISASTERS, DISADVANTAGED PEOPLE, AND COMMUNITIES IN NEED; PROVIDING AND COORDINATING SOCIAL SERVICES PROGRAMS THAT OFFER SOCIAL SERVICE SUPPORT TO VICTIMS OF NATURAL DISASTERS AND DISADVANTAGED PEOPLE, NAMELY, GRIEF COUNSELING; PROVIDING INFORMATION VIA A GLOBAL COMMUNICATIONS NETWORK IN THE FIELDS OF CHARITABLE SERVICES, NAMELY, PROVIDING CLOTHING AND BLANKETS FOR BEDDING TO VICTIMS OF NATURAL DISASTERS AND DISADVANTAGED PEOPLE, DEVELOPING PLANS AND PROCEDURES FOR PROVIDING EMERGENCY AID AND SUPPLIES, WATER PURIFICATION, AND SANITATION FOR VICTIMS OF NATURAL DISASTERS, DISADVANTAGED PEOPLE, AND COMMUNITIES IN NEED, AND GRIEF COUNSELING SERVICE PROGRAMS (U.S. CLS. 100 AND 101).
FIRST USE 5-28-2003; IN COMMERCE 5-28-2003.

3,481,378. THE EVANGELICAL FREE CHURCH OF AMERICA, MINNEAPOLIS, MN. SN 77-107,679. PUB. 10-9-2007, FILED 2-14-2007.

LIVE 

THE MARK CONSISTS OF THE WORD "LIVE" TO THE POWER OF ZERO WITH THE NUMERAL ZERO CROSSED-OUT.

FOR EVANGELICAL MISSIONARY AND MINISTERIAL SERVICES; CHARITABLE SERVICES, NAMELY, ORGANIZING GROUPS TO UNDERTAKE PROJECTS TO BENEFIT THE NEEDY AND THE COMMUNITY TO ENCOURAGE LEADERSHIP, CHARACTER, COMPASSION, AND GOOD CITIZENSHIP; COUNSELING SERVICES IN THE FIELD OF CHRISTIAN CONDUCT IN PERSONAL RELATIONSHIPS; PROVIDING ON-LINE INFORMATION IN THE FIELD OF RELIGION, SPIRITUALITY, SELF-HELP, AND PERSONAL EMPOWERMENT SUBJECT MATTERS (U.S. CLS. 100 AND 101).
FIRST USE 12-1-2006; IN COMMERCE 12-1-2006.

CLASS 45—(Continued).

3,481,379. THE EVANGELICAL FREE CHURCH OF AMERICA, MINNEAPOLIS, MN. SN 77-107,693. PUB. 10-9-2007, FILED 2-14-2007.

LIVE TO THE POWER OF NOTHING

THE MARK CONSISTS OF STANDARD CHARACTERS WITHOUT CLAIM TO ANY PARTICULAR FONT, STYLE, SIZE, OR COLOR.

FOR EVANGELICAL MISSIONARY AND MINISTERIAL SERVICES; CHARITABLE SERVICES, NAMELY, ORGANIZING GROUPS TO UNDERTAKE PROJECTS TO BENEFIT THE NEEDY AND THE COMMUNITY TO ENCOURAGE LEADERSHIP, CHARACTER, COMPASSION, AND GOOD CITIZENSHIP; COUNSELING SERVICES IN THE FIELD OF CHRISTIAN CONDUCT IN PERSONAL RELATIONSHIPS; PROVIDING ON-LINE INFORMATION IN THE FIELD OF RELIGION, SPIRITUALITY, SELF-HELP, AND PERSONAL EMPOWERMENT SUBJECT MATTERS (U.S. CLS. 100 AND 101).
FIRST USE 12-1-2006; IN COMMERCE 12-1-2006.

3,481,381. THE EVANGELICAL FREE CHURCH OF AMERICA, MINNEAPOLIS, MN. SN 77-107,775. PUB. 10-9-2007, FILED 2-14-2007.

REACHGLOBAL

THE MARK CONSISTS OF STANDARD CHARACTERS WITHOUT CLAIM TO ANY PARTICULAR FONT, STYLE, SIZE, OR COLOR.

FOR EVANGELICAL MISSIONARY AND MINISTERIAL SERVICES; CHARITABLE SERVICES, NAMELY, ORGANIZING GROUPS TO UNDERTAKE PROJECTS TO BENEFIT THE NEEDY AND THE COMMUNITY TO ENCOURAGE LEADERSHIP, CHARACTER, COMPASSION, AND GOOD CITIZENSHIP; COUNSELING SERVICES IN THE FIELD OF CHRISTIAN CONDUCT IN PERSONAL RELATIONSHIPS; PROVIDING ON-LINE INFORMATION IN THE FIELD OF RELIGION, SPIRITUALITY, SELF-HELP, AND PERSONAL EMPOWERMENT SUBJECT MATTERS (U.S. CLS. 100 AND 101).
FIRST USE 4-1-2007; IN COMMERCE 4-1-2007.

3,481,474. BISHOP ROCK SOFTWARE LLC, LAKE FOREST, CA. SN 77-132,255. PUB. 9-18-2007, FILED 3-15-2007.

BISHOP ROCK SOFTWARE

CLASS 45—(Continued).

THE MARK CONSISTS OF STANDARD CHARACTERS WITHOUT CLAIM TO ANY PARTICULAR FONT, STYLE, SIZE, OR COLOR.

NO CLAIM IS MADE TO THE EXCLUSIVE RIGHT TO USE "SOFTWARE", APART FROM THE MARK AS SHOWN.

FOR COMPUTER SERVICES, NAMELY, PROVIDING INTERACTIVE COMPUTERIZED INFORMATION BY MEANS OF A GLOBAL COMPUTER INFORMATION NETWORK TO AID IN THE DEPLOYMENT OF LAW ENFORCEMENT RESOURCES (U.S. CLS. 100 AND 101).
FIRST USE 3-15-2007; IN COMMERCE 4-1-2007.

3,481,509. BISHOP ROCK SOFTWARE LLC, LAKE FOREST, CA. SN 77-137,822. PUB. 9-11-2007, FILED 3-22-2007.

FORCESIGHT

THE MARK CONSISTS OF STANDARD CHARACTERS WITHOUT CLAIM TO ANY PARTICULAR FONT, STYLE, SIZE, OR COLOR.

FOR COMPUTER SERVICES, NAMELY, PROVIDING INTERACTIVE COMPUTERIZED INFORMATION BY MEANS OF A GLOBAL COMPUTER INFORMATION NETWORK TO AID IN THE DEPLOYMENT OF LAW ENFORCEMENT RESOURCES (U.S. CLS. 100 AND 101).
FIRST USE 3-15-2007; IN COMMERCE 4-1-2007.

3,481,610. BLAISE ANDRESKI, CRYSTAL FALLS, MI. AND JOAN ANDRESKI, CRYSTAL FALLS, MI. SN 77-154,872. PUB. 10-30-2007, FILED 4-12-2007.



THE MARK CONSISTS OF AN IMAGE OF THE LADY OF JUSTICE.

FOR ALTERNATIVE DISPUTE RESOLUTION (U.S. CLS. 100 AND 101).
FIRST USE 4-1-2008; IN COMMERCE 6-18-2008.

CLASS 45—(Continued).

3,481,612. INTERSECTIONS INC., CHANTILLY, VA. SN 77-154,984. PUB. 1-8-2008, FILED 4-12-2007.

EZ DOB

THE MARK CONSISTS OF STANDARD CHARACTERS WITHOUT CLAIM TO ANY PARTICULAR FONT, STYLE, SIZE, OR COLOR.

NO CLAIM IS MADE TO THE EXCLUSIVE RIGHT TO USE "DOB", APART FROM THE MARK AS SHOWN.

FOR IDENTIFICATION VERIFICATION SERVICES, NAMELY, PROVIDING AUTHENTICATION OF PERSONAL IDENTIFICATION INFORMATION (U.S. CLS. 100 AND 101).

FIRST USE 5-28-2007; IN COMMERCE 5-28-2007.

3,481,671. INTERSECTIONS INC., CHANTILLY, VA. SN 77-170,689. PUB. 1-8-2008, FILED 5-2-2007.



NO CLAIM IS MADE TO THE EXCLUSIVE RIGHT TO USE "DOB", APART FROM THE MARK AS SHOWN.

THE MARK CONSISTS OF THE LETTERS "EZ" IN WHITE SET IN IN A DARK SHADE OF GRAY AND THE LETTERS "DOB" IN WHITE IN A LIGHTER SHADE OF GRAY.

FOR IDENTIFICATION VERIFICATION SERVICES, NAMELY, PROVIDING AUTHENTICATION OF PERSONAL IDENTIFICATION INFORMATION (U.S. CLS. 100 AND 101).

FIRST USE 5-28-2007; IN COMMERCE 5-28-2007.

3,481,800. ROSENN, JENKINS & GREENWALD, L.L.P., WILKES-BARRE, PA. SN 77-220,647. PUB. 11-20-2007, FILED 7-2-2007.

THE POWER TO PRESERVE

THE MARK CONSISTS OF STANDARD CHARACTERS WITHOUT CLAIM TO ANY PARTICULAR FONT, STYLE, SIZE, OR COLOR.

FOR LEGAL SERVICES (U.S. CLS. 100 AND 101).
FIRST USE 11-1-2007; IN COMMERCE 11-1-2007.

CLASS 45—(Continued).

3,481,979. INSPIRE ME TODAY, LLC, BOULDER, CO. SN 77-308,993. PUB. 3-11-2008, FILED 10-19-2007.

INSPIRE ME TODAY

THE MARK CONSISTS OF STANDARD CHARACTERS WITHOUT CLAIM TO ANY PARTICULAR FONT, STYLE, SIZE, OR COLOR.

FOR PROVIDING A WEBSITE FEATURING SELF HELP AND PERSONAL IMPROVEMENT INFORMATION (U.S. CLS. 100 AND 101).

FIRST USE 4-15-2008; IN COMMERCE 4-15-2008.

3,482,400. HOBBS, MARK, TRABUCO CANYON, CA. SN 78-903,345. PUB. 10-2-2007, FILED 6-7-2006.

LIFE MINDERS

THE MARK CONSISTS OF STANDARD CHARACTERS WITHOUT CLAIM TO ANY PARTICULAR FONT, STYLE, SIZE, OR COLOR.

FOR PROVIDING INFORMATION ON PERSONAL ACTIVITY GOALS, NAMELY, PERSONAL GROWTH, SELF HELP AND MOTIVATION; REMINDER SERVICES IN THE AREA OF UPCOMING IMPORTANT DATES AND EVENTS (U.S. CLS. 100 AND 101).

FIRST USE 6-23-2008; IN COMMERCE 6-23-2008.

3,482,417. IDENTITY THEFT RESOURCE CENTER, SAN DIEGO, CA. SN 78-910,615. PUB. 2-20-2007, FILED 6-16-2006.



Identity Theft Resource Center

NO CLAIM IS MADE TO THE EXCLUSIVE RIGHT TO USE "IDENTITY THEFT RESOURCE CENTER", APART FROM THE MARK AS SHOWN.

THE MARK CONSISTS OF THE STYLIZED LETTERS "ITRC" AND THE WORDS "IDENTITY THEFT RESOURCE CENTER".

FOR CONSULTATION IN THE FIELD OF DATA THEFT AND IDENTITY THEFT (U.S. CLS. 100 AND 101). FIRST USE 4-22-2006; IN COMMERCE 4-22-2006.

CLASS 45—(Continued).

3,482,463. THE SERGIO CORPORATION, SOUTH BEND, IN. SN 78-936,050. PUB. 9-11-2007, FILED 7-24-2006.

DOCUSURE

THE MARK CONSISTS OF STANDARD CHARACTERS WITHOUT CLAIM TO ANY PARTICULAR FONT, STYLE, SIZE, OR COLOR.

FOR COMPILING INVENTORIES OF PERSONAL PROPERTY ITEMS FOR OTHERS FOR INSURANCE AND RISK MANAGEMENT PURPOSES (U.S. CLS. 100 AND 101).

FIRST USE 5-30-2008; IN COMMERCE 5-30-2008.

3,482,557. SILVA, DAVE, BOISE, ID. SN 78-969,292. PUB. 4-24-2007, FILED 9-7-2006.

FORESTARY

THE MARK CONSISTS OF STANDARD CHARACTERS WITHOUT CLAIM TO ANY PARTICULAR FONT, STYLE, SIZE, OR COLOR.

FOR FUNERAL ARRANGEMENT SERVICES FEATURING CREMATION AND BURIAL FACILITIES (U.S. CLS. 100 AND 101).

FIRST USE 5-14-2008; IN COMMERCE 5-14-2008.

3,482,559. SILVA, DAVE, BOISE, ID. SN 78-971,037. PUB. 4-24-2007, FILED 9-11-2006.



FOR FUNERAL ARRANGEMENT SERVICES FEATURING CREMATION AND BURIAL FACILITIES (U.S. CLS. 100 AND 101).

FIRST USE 5-14-2008; IN COMMERCE 5-14-2008.

CLASS 45—(Continued).

TM 1642

OFFICIAL GAZETTE

AUGUST 5, 2008

CLASS 45—(Continued).

* * * * *

PRIOR UNITED STATES CLASSIFICATION

APPLICATION IN ONE CLASS

CERTIFICATION MARKS

CLASS B—SERVICES

3,482,516. ANIMAL PROTECTION INSTITUTE, SACRAMENTO, CA. SN 78-953,704. PUB. 9-18-2007, FILED 8-16-2006.

NO ANIMAL FUR WAS USED TO MAKE PRODUCTS SOLD BY THIS RETAILER.
FOR RETAIL STORE SERVICES (U.S. CL. B).
FIRST USE 3-17-2008; IN COMMERCE 3-17-2008.

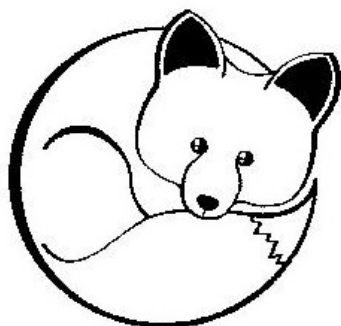

THE MARK CONSISTS OF A STYLIZED REPRESENTATION OF A FOX CURLED INTO A CIRCULAR CONFIGURATION.

* * * * *

SUPPLEMENTAL REGISTER

These registrations are not subject to opposition.

SECTION 1.— INTERNATIONAL CLASSIFICATION

The short titles associated below with the international class numbers are terms designed merely for quick identification and are not an official part of the international classification. The full names of international classes are given in section 6.1 of the trademark rules of practice.

The designation "U.S. Cl." appearing in this section refers to the U.S. class in effect prior to Sep. 1, 1973 rather than the international class which applies to applications filed on or after that date. For adoption of international classification see notice in the OFFICIAL GAZETTE of Jun. 26, 1973 (911 O.G. TM 210).

Application in more than one class

3,482,594. PROGRESSIVE GAMING INTERNATIONAL CORP., LAS VEGAS, NV. SN 77-001,016. FILED P.R. 9-15-2006; AM. S.R. 3-20-2008.

P2P

THE MARK CONSISTS OF STANDARD CHARACTERS WITHOUT CLAIM TO ANY PARTICULAR FONT, STYLE, SIZE, OR COLOR.

CLASS 9—ELECTRICAL AND SCIENTIFIC APPARATUS

FOR GAMING EQUIPMENT, NAMELY, GAMING MACHINES AND GAME SOFTWARE (U.S. CLS. 21, 23, 26, 36 AND 38).
FIRST USE 11-14-2006; IN COMMERCE 11-14-2006.

CLASS 41—EDUCATION AND ENTERTAINMENT

FOR CASINO SERVICES, NAMELY, PROVIDING GAMES OF CHANCE AND WAGERING OPPORTUNITIES (U.S. CLS. 100, 101 AND 107).
FIRST USE 11-14-2006; IN COMMERCE 11-14-2006.

3,482,600. ONE OF THE SEVENTY, INC., SAN DIEGO, CA. SN 77-043,740. FILED P.R. 11-14-2006; AM. S.R. 5-15-2007.

BOWLING WITH THE STARS

THE MARK CONSISTS OF STANDARD CHARACTERS WITHOUT CLAIM TO ANY PARTICULAR FONT, STYLE, SIZE, OR COLOR.
NO CLAIM IS MADE TO THE EXCLUSIVE RIGHT TO USE "BOWLING", APART FROM THE MARK AS SHOWN.

CLASS 36—INSURANCE AND FINANCIAL

FOR CHARITABLE FUNDRAISING THROUGH ORGANIZING AND CONDUCTING SPORT BOWLING COMPETITIONS (U.S. CLS. 100, 101 AND 102).
FIRST USE 9-1-2003; IN COMMERCE 9-1-2003.

CLASS 41—EDUCATION AND ENTERTAINMENT

FOR ENTERTAINMENT SERVICES IN THE NATURE OF ORGANIZING SPORT BOWLING COMPETITIONS FOR CHARITY (U.S. CLS. 100, 101 AND 107).
FIRST USE 9-1-2003; IN COMMERCE 9-1-2003.

3,482,603. EARTH FRIENDS WILDLIFE FOUNDATION, JACKSON, WY. SN 77-089,167. FILED P.R. 1-23-2007; AM. S.R. 6-17-2008.

CONSERVATION'S COMMUNITY FOUNDATION

THE MARK CONSISTS OF STANDARD CHARACTERS WITHOUT CLAIM TO ANY PARTICULAR FONT, STYLE, SIZE, OR COLOR.
NO CLAIM IS MADE TO THE EXCLUSIVE RIGHT TO USE "COMMUNITY FOUNDATION", APART FROM THE MARK AS SHOWN.

CLASS 35—ADVERTISING AND BUSINESS

FOR PROMOTING PUBLIC AWARENESS CONCERNING WILDLIFE PROTECTION (U.S. CLS. 100, 101 AND 102).
FIRST USE 12-0-2006; IN COMMERCE 12-0-2006.

CLASS 36—INSURANCE AND FINANCIAL

FOR CHARITABLE FUNDRAISING AND MAKING GRANTS FOR CONSERVATION AND WILDLIFE PROTECTION (U.S. CLS. 100, 101 AND 102).
FIRST USE 12-0-2006; IN COMMERCE 12-0-2006.

CLASS 42—SCIENTIFIC AND COMPUTER SERVICES

FOR PROVIDING INFORMATION CONCERNING CONSERVATION AND WILDLIFE PROTECTION (U.S. CLS. 100 AND 101).

FIRST USE 12-0-2006; IN COMMERCE 12-0-2006.

3,482,619. CLINICAL TOPICALS LLC, NEW YORK, NY. SN 77-181,593. FILED P.R. 5-15-2007; AM. S.R. 6-10-2008.

CLINICAL TOPICALS

THE MARK CONSISTS OF STANDARD CHARACTERS WITHOUT CLAIM TO ANY PARTICULAR FONT, STYLE, SIZE, OR COLOR.

NO CLAIM IS MADE TO THE EXCLUSIVE RIGHT TO USE "TOPICALS", APART FROM THE MARK AS SHOWN.

CLASS 3—COSMETICS AND CLEANING PREPARATIONS

FOR SKIN CARE PRODUCTS, NAMELY, NON-MEDICATED ACNE CREAMS AND PREPARATIONS (U.S. CLS. 1, 4, 6, 50, 51 AND 52).

FIRST USE 5-15-2007; IN COMMERCE 5-15-2007.

CLASS 5—PHARMACEUTICALS

FOR ANALGESICS (U.S. CLS. 6, 18, 44, 46, 51 AND 52).
FIRST USE 3-16-2007; IN COMMERCE 3-16-2007.

3,482,623. NEW ORLEANS JAZZ & HERITAGE FESTIVAL AND FOUNDATION, INC., NEW ORLEANS, LA. SN 77-217,675. FILED P.R. 6-28-2007; AM. S.R. 5-28-2008.

OWNER OF U.S. REG. NOS. 2,607,336, 3,302,364, AND OTHERS.

NO CLAIM IS MADE TO THE EXCLUSIVE RIGHT TO USE "CAJUN ZYDECO FESTIVAL" AS TO CLASS 41, APART FROM THE MARK AS SHOWN.

THE MARK CONSISTS OF THE WORD "LOUISIANA" PRINTED VERTICALLY, BOTTOM TO TOP, ON THE LEFT; IN THE MIDDLE, THE WORD "CAJUN" PRINTED HORIZONTALLY; BELOW "CAJUN", THE WORD "ZYDECO" PRINTED HORIZONTALLY; AND THE WORD "FESTIVAL" PRINTED VERTICALLY, BOTTOM TO TOP.

CLASS 25—CLOTHING

FOR T-SHIRTS; SHIRTS; PANTS; CAPS; HATS; APRONS (U.S. CLS. 22 AND 39).

FIRST USE 6-8-2007; IN COMMERCE 6-8-2007.

CLASS 41—EDUCATION AND ENTERTAINMENT

FOR CONDUCTING ENTERTAINMENT EXHIBITIONS IN THE NATURE OF MUSIC FESTIVALS; EDUCATION SERVICES, NAMELY, PROVIDING LECTURES, SEMINARS, WORKSHOPS AND CONFERENCES IN THE FIELDS OF SOUTH LOUISIANA CULTURE (U.S. CLS. 100, 101 AND 107).

FIRST USE 5-23-2007; IN COMMERCE 5-23-2007.

3,482,629. SOCIETY FOR SCIENCE & THE PUBLIC, WASHINGTON, DC. SN 77-232,316. FILED P.R. 7-18-2007; AM. S.R. 1-15-2008.

Society for Science & the Public

THE MARK CONSISTS OF STANDARD CHARACTERS WITHOUT CLAIM TO ANY PARTICULAR FONT, STYLE, SIZE, OR COLOR.

NO CLAIM IS MADE TO THE EXCLUSIVE RIGHT TO USE "SOCIETY", APART FROM THE MARK AS SHOWN.

CLASS 35—ADVERTISING AND BUSINESS

FOR PROFESSIONAL ASSOCIATION SERVICES, NAMELY, PROMOTING THE INTERESTS OF SCIENCE TEACHERS, SCIENCE STUDENTS, AND PEOPLE INTERESTED IN SCIENCE (U.S. CLS. 100, 101 AND 102).

FIRST USE 1-10-2008; IN COMMERCE 1-10-2008.

CLASS 41—EDUCATION AND ENTERTAINMENT

FOR EDUCATIONAL SERVICES, NAMELY, PROVIDING INCENTIVES THROUGH COMPETITIVE EXHIBITION AND AWARDS TO STUDENTS WHO DEMONSTRATE EXCELLENCE IN THE FIELD OF SCIENCE AND ENGINEERING (U.S. CLS. 100, 101 AND 107).

FIRST USE 1-10-2008; IN COMMERCE 1-10-2008.

3,482,646. NATIONAL INDUSTRIES FOR THE BLIND, ALEXANDRIA, VA. SN 77-277,690. FILED P.R. 9-12-2007; AM. S.R. 7-1-2008.

DIGITAL DATA SCAN

THE MARK CONSISTS OF STANDARD CHARACTERS WITHOUT CLAIM TO ANY PARTICULAR FONT, STYLE, SIZE, OR COLOR.

NO CLAIM IS MADE TO THE EXCLUSIVE RIGHT TO USE "SCAN", APART FROM THE MARK AS SHOWN.

CLASS 35—ADVERTISING AND BUSINESS

FOR RECORDS MANAGEMENT, NAMELY, DOCUMENT INDEXING AND DOCUMENT INVENTORY MANAGEMENT FOR OTHERS; AND RECORDS MANAGEMENT, NAMELY, DOCUMENT CODING FOR INVENTORY MANAGEMENT PURPOSES (U.S. CLS. 100, 101 AND 102).

FIRST USE 11-19-2006; IN COMMERCE 11-19-2006.

CLASS 39—TRANSPORTATION AND STORAGE

FOR ELECTRONIC STORAGE OF DATA AND DOCUMENTS; AND PHYSICAL STORAGE OF ELECTRONICALLY-STORED DATA AND DOCUMENTS (U.S. CLS. 100 AND 105).

FIRST USE 11-19-2006; IN COMMERCE 11-19-2006.

CLASS 40—MATERIAL TREATMENT

FOR ELECTRONIC SCANNING OF DOCUMENTS (U.S. CLS. 100, 103 AND 106).

FIRST USE 11-19-2006; IN COMMERCE 11-19-2006.

CLASS 41—EDUCATION AND ENTERTAINMENT

FOR DIGITAL IMAGING SERVICES (U.S. CLS. 100, 101 AND 107).

FIRST USE 11-19-2006; IN COMMERCE 11-19-2006.

CLASS 42—SCIENTIFIC AND COMPUTER SERVICES

FOR CONVERSION OF DOCUMENTS FROM PHYSICAL TO ELECTRONIC MEDIA; AND DATA ENCRYPTION SERVICES, NAMELY, DOCUMENT CODING SERVICES (U.S. CLS. 100 AND 101).

FIRST USE 11-19-2006; IN COMMERCE 11-19-2006.

3,482,661. MEDIA-SCREEN LLC, SAN FRANCISCO, CA. SN 77-286,289. FILED P.R. 9-21-2007; AM. S.R. 6-30-2008.

KNOWLEDGE OF THE MODERN
CONSUMER MARKET

THE MARK CONSISTS OF STANDARD CHARACTERS WITHOUT CLAIM TO ANY PARTICULAR FONT, STYLE, SIZE, OR COLOR.

NO CLAIM IS MADE TO THE EXCLUSIVE RIGHT TO USE "KNOWLEDGE", APART FROM THE MARK AS SHOWN.

CLASS 16—PAPER GOODS AND PRINTED MATTER

FOR PRINTED MATTER, NAMELY, PRINTED GRAPHS, REPORTS AND INFORMATION GRAPHICS FEATURING INFORMATION IN THE FIELDS OF MARKETING, ADVERTISING, AND AUDIENCE MEASUREMENT (U.S. CLS. 2, 5, 22, 23, 29, 37, 38 AND 50).

FIRST USE 11-1-2006; IN COMMERCE 11-1-2006.

CLASS 42—SCIENTIFIC AND COMPUTER SERVICES

FOR ANALYSIS AND RESEARCH SERVICES, NAMELY, MARKET RESEARCH AND CONSULTING SERVICES (U.S. CLS. 100 AND 101).

FIRST USE 11-1-2006; IN COMMERCE 11-1-2006.

3,482,672. MIR MAQBOOL ALAM KHAN, NEW YORK, NY. SN 77-303,020. FILED P.R. 10-12-2007; AM. S.R. 6-26-2008.

MOBILE MARKETER

THE MARK CONSISTS OF STANDARD CHARACTERS WITHOUT CLAIM TO ANY PARTICULAR FONT, STYLE, SIZE, OR COLOR.

CLASS 9—ELECTRICAL AND SCIENTIFIC APPARATUS

FOR ELECTRONIC PUBLICATIONS, NAMELY, MAGAZINES, BOOKS, NEWSLETTERS, VIDEO MAGAZINES, BLOGS AND NEWSPAPERS FEATURING INFORMATION ABOUT MARKETING, COMMERCE, CONTENT, MEDIA, TECHNOLOGY AND TECHNOLOGY CARRIERS ALL RECORDED ON COMPUTER MEDIA (U.S. CLS. 21, 23, 26, 36 AND 38).

FIRST USE 11-26-2007; IN COMMERCE 11-26-2007.

CLASS 41—EDUCATION AND ENTERTAINMENT

FOR PUBLICATION OF BOOKS, OF MAGAZINES, OF JOURNALS, OF NEWSPAPERS, OF PERIODICALS, OF CATALOGS, OF BROCHURES (U.S. CLS. 100, 101 AND 107).

FIRST USE 1-9-2008; IN COMMERCE 1-9-2008.

3,482,690. GEBAL CO., INC., DBA FANCY FLAVORS, JENSEN BEACH, FL. SN 77-379,199. FILED P.R. 1-24-2008; AM. S.R. 6-29-2008.

FANCY FLAVORS

THE MARK CONSISTS OF STANDARD CHARACTERS WITHOUT CLAIM TO ANY PARTICULAR FONT, STYLE, SIZE, OR COLOR.

CLASS 29—MEATS AND PROCESSED FOODS

FOR YOGURT; FRUIT SALADS AND VEGETABLE SALADS (U.S. CL. 46).

FIRST USE 1-20-2008; IN COMMERCE 1-20-2008.

CLASS 30—STAPLE FOODS

FOR SANDWICHES (U.S. CL. 46).
FIRST USE 1-20-2008; IN COMMERCE 1-20-2008.

CLASS 32—LIGHT BEVERAGES

FOR SMOOTHIES (U.S. CLS. 45, 46 AND 48).
FIRST USE 1-20-2008; IN COMMERCE 1-20-2008.

3,482,698. LONG HAUL CLINCS LLC, FORT MYERS, FL. SN
77-393,467. FILED P.R. 2-11-2008; AM. S.R. 6-25-2008.

CLASS 9—ELECTRICAL AND SCIENTIFIC APPARATUS

FOR PRE-RECORDED DVD'S FEATURING EMERGENCY FIRST AID TRAINING (U.S. CLS. 21, 23, 26, 36 AND 38).
FIRST USE 1-7-2008; IN COMMERCE 2-15-2008.

CLASS 16—PAPER GOODS AND PRINTED MATTER

FOR PRINTED MANUALS AND BROCHURES RELATING TO EMERGENCY FIRST AID TRAINING (U.S. CLS. 2, 5, 22, 23, 29, 37, 38 AND 50).
FIRST USE 1-7-2008; IN COMMERCE 2-15-2008.

Roadside Medical

THE MARK CONSISTS OF STANDARD CHARACTERS WITHOUT CLAIM TO ANY PARTICULAR FONT, STYLE, SIZE, OR COLOR.

NO CLAIM IS MADE TO THE EXCLUSIVE RIGHT TO USE "MEDICAL", APART FROM THE MARK AS SHOWN.

CLASS 35—ADVERTISING AND BUSINESS

FOR PROVIDING ASSISTANCE, FITNESS EVALUATION AND CONSULTATION TO CORPORATE CLIENTS TO HELP THEIR EMPLOYEES MAKE HEALTH, WELLNESS AND NUTRITIONAL CHANGES IN THEIR DAILY LIVING TO INCREASE PRODUCTIVITY AND LOWER HEALTH CARE COSTS (U.S. CLS. 100, 101 AND 102).
FIRST USE 3-1-2007; IN COMMERCE 1-10-2008.

CLASS 44—MEDICAL, BEAUTY AND AGRICULTURAL SERVICES

FOR MEDICAL CLINICS; MEDICAL SERVICES, NAMELY, PRE-EMPLOYMENT DRUG SCREENING; HEALTH CARE; HEALTH CARE SERVICES, NAMELY, DISEASE MANAGEMENT PROGRAMS; HEALTH CARE SERVICES, NAMELY, WELLNESS PROGRAMS; HEALTHCARE SERVICES, NAMELY, TREATMENT OF PATIENTS WITH SNORING AND SLEEP APNEA DISORDERS; MEDICAL SERVICES, NAMELY, CONVENIENT CARE (U.S. CLS. 100 AND 101).

FIRST USE 3-1-2007; IN COMMERCE 1-10-2008.
3,482,702. GOLD CROSS AMBULANCE SERVICE, INC., MENASHA, WI. SN 77-400,099. FILED P.R. 2-19-2008; AM. S.R. 6-26-2008.

first care reality series

THE MARK CONSISTS OF STANDARD CHARACTERS WITHOUT CLAIM TO ANY PARTICULAR FONT, STYLE, SIZE, OR COLOR.

3,482,717. HABEAS MIRTH CORP., LOS ANGELES, CA. SN
77-429,829. FILED P.R. 3-24-2008; AM. S.R. 6-27-2008.

WINE IMBIBER

THE MARK CONSISTS OF STANDARD CHARACTERS WITHOUT CLAIM TO ANY PARTICULAR FONT, STYLE, SIZE, OR COLOR.

NO CLAIM IS MADE TO THE EXCLUSIVE RIGHT TO USE "WINE", APART FROM THE MARK AS SHOWN.

CLASS 35—ADVERTISING AND BUSINESS

FOR ADVERTISING SERVICES, NAMELY, PROVIDING INFORMATION AS TO THE AVAILABILITY OF WINE AND FOOD PRODUCTS AND SERVICES FOR RENT OR PURCHASE (U.S. CLS. 100, 101 AND 102).
FIRST USE 1-1-2008; IN COMMERCE 1-1-2008.

CLASS 43—HOTEL AND RESTAURANT SERVICES

FOR PROVIDING INFORMATION ABOUT WINE CHARACTERISTICS (U.S. CLS. 100 AND 101).
FIRST USE 1-1-2008; IN COMMERCE 1-1-2008.

3,482,720. MODERN LUXURY MEDIA, LLC, CHICAGO, IL.
SN 78-549,822. FILED P.R. 1-19-2005; AM. S.R. 5-25-2006.

CLASS 43—HOTEL AND RESTAURANT SERVICES

FOR PROVIDING VIA THE INTERNET RECIPES THAT ARE CALORIE-, FAT- AND SODIUM-CONSCIOUS AND RECIPES THAT SHOWCASE A WIDE VARIETY OF FRUITS AND VEGETABLES, ALL FOCUSING ON THE IMPORTANCE OF NUTRITION IN A FAMILY'S LIFE (U.S. CLS. 100 AND 101).

FIRST USE 4-3-2008; IN COMMERCE 4-3-2008.

DC

3,482,732. GRM INFORMATION MANAGEMENT SERVICES, INC., JERSEY CITY, NJ. SN 78-940,293. FILED P.R. 7-28-2006; AM. S.R. 5-16-2008.

CLASS 9—ELECTRICAL AND SCIENTIFIC APPARATUS

FOR ELECTRONIC PUBLICATIONS, NAMELY, A MAGAZINE IN THE FIELD OF FASHION, ACCESSORIES, JEWELRY, HOME DESIGN, TRAVEL, FINE FOOD AND WINE, CULTURE, ART, REAL ESTATE, SOCIETY, CELEBRITY, AND GENERAL LUXURY LIFESTYLE (U.S. CLS. 21, 23, 26, 36 AND 38).

FIRST USE 9-12-2005; IN COMMERCE 9-12-2005.

CLASS 16—PAPER GOODS AND PRINTED MATTER

FOR MAGAZINE IN THE FIELD OF FASHION, ACCESSORIES, JEWELRY, HOME DESIGN, TRAVEL, FINE FOOD AND WINE, CULTURE, ART, REAL ESTATE, SOCIETY, CELEBRITY, AND GENERAL LUXURY LIFESTYLE (U.S. CLS. 2, 5, 22, 23, 29, 37, 38 AND 50).

FIRST USE 9-12-2005; IN COMMERCE 9-12-2005.

ONECLICK CAPTURE

THE MARK CONSISTS OF STANDARD CHARACTERS WITHOUT CLAIM TO ANY PARTICULAR FONT, STYLE, SIZE, OR COLOR.

CLASS 38—COMMUNICATION

FOR PROVISION OF ACCESS TO DATA OR DOCUMENTS STORED ELECTRONICALLY IN CENTRAL FILES FOR REMOTE CONSULTATION (U.S. CLS. 100, 101 AND 104).

FIRST USE 8-31-2006; IN COMMERCE 8-31-2006.

CLASS 39—TRANSPORTATION AND STORAGE

FOR DOCUMENT DELIVERY; ELECTRONIC STORAGE OF FILES AND DOCUMENTS; STORAGE OF ELECTRONIC MEDIA, NAMELY, IMAGES, TEXT AND AUDIO DATA; STORAGE SERVICES FOR ARCHIVING DATABASES, IMAGES AND OTHER ELECTRONIC DATA; WAREHOUSING SERVICES, NAMELY, STORAGE, DISTRIBUTION, PICK-UP, AND PACKING FOR SHIPMENT OF DOCUMENTS, PACKAGES, RAW MATERIALS, AND OTHER FREIGHT FOR OTHERS (U.S. CLS. 100 AND 105).

FIRST USE 8-31-2006; IN COMMERCE 8-31-2006.

3,482,725. MEREDITH CORPORATION, DES MOINES, IA.
SN 78-811,193. FILED P.R. 2-9-2006; AM. S.R. 8-23-2007.

HEALTHY FAMILY DINNERS

THE MARK CONSISTS OF STANDARD CHARACTERS WITHOUT CLAIM TO ANY PARTICULAR FONT, STYLE, SIZE, OR COLOR.

CLASS 16—PAPER GOODS AND PRINTED MATTER

FOR PRINTED PUBLICATIONS, NAMELY, A MAGAZINE COLUMN, MAGAZINES AND BOOKS THAT CONTAIN RECIPES THAT ARE CALORIE-, FAT- AND SODIUM-CONSCIOUS AND RECIPES THAT SHOWCASE A WIDE VARIETY OF FRUITS AND VEGETABLES, ALL FOCUSING ON THE IMPORTANCE OF NUTRITION IN A FAMILY'S LIFE (U.S. CLS. 2, 5, 22, 23, 29, 37, 38 AND 50).

FIRST USE 4-18-2006; IN COMMERCE 4-18-2006.

CLASS 40—MATERIAL TREATMENT

FOR DIGITAL COMPRESSION OF PAPER, DOCUMENTS, DATA, FILMS, RECORDINGS, BLUEPRINTS, DRAWINGS, X-RAYS, BOOKS, RECORDS AND FILES; DIGITAL ON-DEMAND PRINTING SERVICES OF BOOKS AND OTHER DOCUMENTS; DOCUMENT DESTRUCTION; ELECTRONIC DIGITIZING OF PHOTOGRAPHS INTO A COMPUTER READABLE MEDIA; ELECTRONIC IMAGING, SCANNING, DIGITIZING, ALTERATION AND/OR RETOUCHING OF PAPER, DOCUMENTS, DATA, FILMS, RECORDINGS, BLUEPRINTS, DRAWINGS, X-RAYS, BOOKS, RECORDS AND FILES; MEDIA DUPLICATION OF DATA AND DIGITAL INFORMATION; PHOTOGRAPHIC COMPUTER IMAGING (U.S. CLS. 100, 103 AND 106).

FIRST USE 8-31-2006; IN COMMERCE 8-31-2006.

AUGUST 5, 2008

U.S. PATENT AND TRADEMARK OFFICE

TM 1649

3,482,735. LTC FINANCIAL PARTNERS, LLC, KIRKLAND,
WA. SN 78-978,873. FILED P.R. 4-26-2006; AM. S.R. 6-24-
2008.

**LONG TERM CARE OUTREACH
& EDUCATION PROGRAM**

THE MARK CONSISTS OF STANDARD CHARACTERS
WITHOUT CLAIM TO ANY PARTICULAR FONT, STYLE,
SIZE, OR COLOR.

NO CLAIM IS MADE TO THE EXCLUSIVE RIGHT TO
USE "EDUCATION PROGRAM", APART FROM THE
MARK AS SHOWN.

**CLASS 16—PAPER GOODS AND PRINTED
MATTER**

FOR PRINTED INSTRUCTIONAL AND EDUCA-
TIONAL MATERIAL IN THE FIELD OF LONG-TERM
CARE AND INSURANCE (U.S. CLS. 2, 5, 22, 23, 29, 37, 38
AND 50).

FIRST USE 12-31-2005; IN COMMERCE 12-31-2005.

**CLASS 41—EDUCATION AND ENTERTAIN-
MENT**

FOR EDUCATIONAL SERVICES, NAMELY, PROVID-
ING COURSES, WORKSHOPS AND SEMINARS IN THE
FIELD OF LONG-TERM CARE AND INSURANCE, AND
DISTRIBUTION OF COURSE MATERIALS THEREWITH
(U.S. CLS. 100, 101 AND 107).

FIRST USE 12-31-2005; IN COMMERCE 12-31-2005.

* * * * *

SECTION 2.— INTERNATIONAL CLASSIFICATION

The short titles associated below with the international class numbers are terms designed merely for quick identification and are not an official part of the international classification. The full names of international classes are given in section 6.1 of the trademark rules of practice.

The designation "U.S. Cl." appearing in this section refers to the U.S. class in effect prior to Sep. 1, 1973 rather than the international class which applies to applications filed on or after that date. For adoption of international classification see notice in the OFFICIAL GAZETTE of Jun. 26, 1973 (911 O.G. TM 210).

Application in one class

CLASS 1—CHEMICALS

3,482,657. DESICCARE, INC., POMONA, CA. SN 77-283,959.
FILED P.R. 9-19-2007; AM. S.R. 7-2-2008.

SHOE DRYER

THE MARK CONSISTS OF STANDARD CHARACTERS WITHOUT CLAIM TO ANY PARTICULAR FONT, STYLE, SIZE, OR COLOR.

FOR MOISTURE REMOVERS, NAMELY, CHEMICAL COMPOUNDS IN THE FORM OF GRANULAR ABSORBENT MATERIAL PACKAGED IN PLASTIC PERFORATED CONTAINERS FOR USE IN THE TEXTILE AND SHOE INDUSTRY (U.S. CLS. 1, 5, 6, 10, 26 AND 46).
FIRST USE 12-31-2007; IN COMMERCE 12-31-2007.

CLASS 3—(Continued).

3,482,610. NOVARTIS AG, BASEL, SWITZERLAND. SN 77-110,414. FILED P.R. 2-19-2007; AM. S.R. 6-20-2008.

REPAIR COMPLEX

THE MARK CONSISTS OF STANDARD CHARACTERS WITHOUT CLAIM TO ANY PARTICULAR FONT, STYLE, SIZE, OR COLOR.

FOR NON-MEDICATED SKIN CARE PREPARATIONS (U.S. CLS. 1, 4, 6, 50, 51 AND 52).
FIRST USE 7-31-2007; IN COMMERCE 7-31-2007.

3,482,633. BARNHARDT MANUFACTURING COMPANY, CHARLOTTE, NC. SN 77-244,628. FILED P.R. 8-1-2007; AM. S.R. 6-19-2008.

CLASS 3—COSMETICS AND CLEANING PREPARATIONS

3,482,593. SPRAY NINE CORPORATION, JOHNSTOWN, NY. SN 76-683,703. FILED P.R. 11-5-2007; AM. S.R. 6-13-2008.

GREEN MARINE

THE MARK CONSISTS OF STANDARD CHARACTERS WITHOUT CLAIM TO ANY PARTICULAR FONT, STYLE, SIZE, OR COLOR.

FOR ALL PURPOSE CLEANING PREPARATION (U.S. CLS. 1, 4, 6, 50, 51 AND 52).
FIRST USE 10-12-2007; IN COMMERCE 10-12-2007.

CAROLINA COTTON

THE MARK CONSISTS OF STANDARD CHARACTERS WITHOUT CLAIM TO ANY PARTICULAR FONT, STYLE, SIZE, OR COLOR.

NO CLAIM IS MADE TO THE EXCLUSIVE RIGHT TO USE "COTTON", APART FROM THE MARK AS SHOWN.

FOR COTTON FOR COSMETIC PURPOSES, NAMELY, COTTON TOWELETTES, COTTON TISSUES, COTTON WIPES, COTTON GAUZE, COTTON BALLS, COTTON SWABS, COTTON STICKS, COTTON COILS, COTTON APPLICATORS AND COTTON ROLLS (U.S. CLS. 1, 4, 6, 50, 51 AND 52).
FIRST USE 0-0-1998; IN COMMERCE 0-0-1998.

CLASS 5—PHARMACEUTICALS

CLASS 5—(Continued).

3,482,721. WATSON, TRACI R., COMPTON, CA. SN 78-671,329. FILED P.R. 7-15-2005; AM. S.R. 12-11-2007.

**A Personal Space Air
Freshener**

THE MARK CONSISTS OF STANDARD CHARACTERS WITHOUT CLAIM TO ANY PARTICULAR FONT, STYLE, SIZE, OR COLOR.

NO CLAIM IS MADE TO THE EXCLUSIVE RIGHT TO USE "AIR FRESHENER", APART FROM THE MARK AS SHOWN.

FOR AIR FRESHNER (U.S. CLS. 6, 18, 44, 46, 51 AND 52).

FIRST USE 2-1-2005; IN COMMERCE 5-24-2005.

CLASS 6—(Continued).

3,482,595. GARAGA INC., QUEBEC, CANADA. SN 77-004,253. FILED P.R. 9-21-2006; AM. S.R. 8-21-2007.

OWNER OF CANADA REG. NO. TMA715586, DATED 5-30-2008, EXPIRES 5-30-2023.

FOR METAL GARAGE DOORS (U.S. CLS. 2, 12, 13, 14, 23, 25 AND 50).

3,482,729. ZICAM, LLC, PHOENIX, AZ. SN 78-852,939. FILED P.R. 4-3-2006; AM. S.R. 6-17-2008.

GET OVER YOUR COLD FASTER

THE MARK CONSISTS OF STANDARD CHARACTERS WITHOUT CLAIM TO ANY PARTICULAR FONT, STYLE, SIZE, OR COLOR.

FOR OVER-THE-COUNTER PHARMACEUTICAL AND HOMEOPATHIC PREPARATIONS FOR THE RELIEF OF COLD AND ALLERGY SYMPTOMS (U.S. CLS. 6, 18, 44, 46, 51 AND 52).

FIRST USE 12-31-2002; IN COMMERCE 12-31-2002.

CLASS 7—MACHINERY

3,482,726. ROYAL APPLIANCE MFG. CO., GLENWILLOW, OH. SN 78-822,501. FILED P.R. 2-24-2006; AM. S.R. 3-5-2008.

KONE

3,482,731. NATUR RESEARCH, INC., LOS ANGELES, CA. SN 78-910,636. FILED P.R. 6-16-2006; AM. S.R. 12-21-2007.

**Prostate
Therapy**

THE MARK CONSISTS OF STANDARD CHARACTERS WITHOUT CLAIM TO ANY PARTICULAR FONT, STYLE, SIZE, OR COLOR.

FOR ELECTRICAL VACUUM CLEANERS FOR BOTH DOMESTIC AND COMMERCIAL USE (U.S. CLS. 13, 19, 21, 23, 31, 34 AND 35).

FIRST USE 2-28-2006; IN COMMERCE 2-28-2006.

THE MARK CONSISTS OF STANDARD CHARACTERS WITHOUT CLAIM TO ANY PARTICULAR FONT, STYLE, SIZE, OR COLOR.

NO CLAIM IS MADE TO THE EXCLUSIVE RIGHT TO USE "PROSTATE", APART FROM THE MARK AS SHOWN.

FOR DIETARY SUPPLEMENTS (U.S. CLS. 6, 18, 44, 46, 51 AND 52).

FIRST USE 5-1-2006; IN COMMERCE 5-1-2006.

CLASS 6—METAL GOODS

CLASS 8—HAND TOOLS

CLASS 8—(Continued).

3,482,647. ACME UNITED CORPORATION, FAIRFIELD, CT.
SN 77-278,135. FILED P.R. 9-12-2007; AM. S.R. 6-19-2008.



THE COLOR(S) GRAY, LIGHT ORANGE, DARK ORANGE, BLACK AND WHITE IS/ARE CLAIMED AS A FEATURE OF THE MARK.

THE MARK CONSISTS OF THE CONFIGURATION OF A SCISSORS DESIGN WITH A LION HEAD ABOVE THE SCISSOR BLADES. THE FACE IS LIGHT ORANGE, BLACK AND WHITE, THE LIONS MAIN IS DARK ORANGE WITH LIGHT ORANGE LINES AND BLACK EYEBROWS. THE HANDLES ARE LIGHT ORANGE WITH A DARK ORANGE TAIL ON THE LEFT HANDLE. THE RIGHT BLADE IS LIGHT ORANGE WITH DARK ORANGE SPLASH OF COLOR AT THE TIP AND THE LEFT BLADE IS THE COLOR GRAY.

FOR SCISSORS (U.S. CLS. 23, 28 AND 44).
FIRST USE 9-15-2006; IN COMMERCE 9-15-2006.

CLASS 8—(Continued).

3,482,649. ACME UNITED CORPORATION, FAIRFIELD, CT.
SN 77-278,145. FILED P.R. 9-12-2007; AM. S.R. 6-19-2008.



THE MARK CONSISTS OF THE CONFIGURATION OF A SCISSORS DESIGN WITH A ZEBRA HEAD JUST ABOVE THE BLADES. THE ZEBRA HEAD IS WHITE WITH BLACK STRIPES ON THE FACE, BLACK MUZZLE, WHITE MOUTH AND NOSTRILS AND BLACK AND WHITE EYES, BLACK AND WHITE EARS AND A BLACK TUFT OF HAIR ON THE FOREHEAD. THE HANDLES ARE WHITE WITH BLACK ZEBRA STRIPES. A BLACK TAIL IS LOCATED ON THE TOP OF THE LEFT HANDLE. THE RIGHT BLADE IS WHITE WITH BLACK STRIPES AND THE LEFT BLADE IS GRAY.

FOR SCISSORS (U.S. CLS. 23, 28 AND 44).
FIRST USE 9-15-2006; IN COMMERCE 9-15-2006.

3,482,648. ACME UNITED CORPORATION, FAIRFIELD, CT.
SN 77-278,140. FILED P.R. 9-12-2007; AM. S.R. 6-19-2008.



THE COLOR(S) GRAY, ORANGE, BLACK AND WHITE IS/ARE CLAIMED AS A FEATURE OF THE MARK.

THE MARK CONSISTS OF THE CONFIGURATION OF A SCISSORS DESIGN WITH A TIGER HEAD ABOVE THE SCISSOR BLADES. THE TIGER HEAD IS ORANGE, BLACK AND WHITE. THE HANDLES HAVE ORANGE AND BLACK TIGER STRIPES WITH THE TOP OF THE LEFT HANDLE BEING A TIGER FOOT. THE RIGHT BLADE HAS ORANGE AND BLACK TIGER STRIPES AND THE LEFT BLADE IS THE COLOR GRAY.

FOR SCISSORS (U.S. CLS. 23, 28 AND 44).
FIRST USE 9-15-2006; IN COMMERCE 9-15-2006.

3,482,650. ACME UNITED CORPORATION, FAIRFIELD, CT.
SN 77-278,152. FILED P.R. 9-12-2007; AM. S.R. 6-19-2008.



THE COLOR(S) GRAY, YELLOW, WHITE AND BROWN IS/ARE CLAIMED AS A FEATURE OF THE MARK.

THE MARK CONSISTS OF OF THE CONFIGURATION OF A SCISSORS DESIGN WITH A GIRAFFE HEAD ABOVE THE SCISSOR BLADES. THE GIRAFFE HEAD IS YELLOW AND BROWN WITH BROWN AND WHITE EYES, BROWN ON THE NOSE AND BROWN ON THE MOUTH. THE SCISSOR HANDLES AND RIGHT SCISSOR BLADE HAVE BROWN AND YELLOW GIRAFFE STRIPES. THE LEFT SCISSOR BLADE APPEARS IN GRAY. A BROWN TAIL IS LOCATED ON THE TOP OF THE LEFT HANDLE.

FOR SCISSORS (U.S. CLS. 23, 28 AND 44).
FIRST USE 9-15-2006; IN COMMERCE 9-15-2006.

CLASS 8—(Continued).

3,482,651. ACME UNITED CORPORATION, FAIRFIELD, CT.
SN 77-278,162. FILED P.R. 9-12-2007; AM. S.R. 6-19-2008.



THE COLOR(S) GRAY, BEIGE, BROWN, YELLOW AND WHITE IS/ARE CLAIMED AS A FEATURE OF THE MARK. THE MARK CONSISTS OF THE CONFIGURATION OF A SCISSORS DESIGN WITH A MONKEY HEAD JUST ABOVE THE SCISSOR BLADES, MONKEY FEET ON TOP OF THE HANDLE AND BANANAS ON THE RIGHT SCISSOR BLADE. THE LEFT SCISSOR BLADE APPEARS IN GRAY AND THE RIGHT SCISSOR BLADE APPEARS IN BROWN WITH YELLOW BANANAS. THE SCISSOR HANDLES ARE BROWN WITH BEIGE FEET ON TOP, THE MONKEY HAS BROWN HAIR, A BEIGE FACE, BROWN MOUTH AND EYEBROWS, BROWN AND WHITE EYES AND A BROWN NOSE.

FOR SCISSORS (U.S. CLS. 23, 28 AND 44).
FIRST USE 9-15-2006; IN COMMERCE 9-15-2006.

CLASS 9—ELECTRICAL AND SCIENTIFIC APPARATUS

3,482,604. HEALTHRX CORPORATION, SPRINGFIELD, VA.
SN 77-093,131. FILED P.R. 1-29-2007; AM. S.R. 6-5-2008.

PI-DASHBOARD

THE MARK CONSISTS OF STANDARD CHARACTERS WITHOUT CLAIM TO ANY PARTICULAR FONT, STYLE, SIZE, OR COLOR.

FOR COMPUTER SOFTWARE FOR DATABASE MANAGEMENT IN THE FIELD OF BIOMEDICAL RESEARCH (U.S. CLS. 21, 23, 26, 36 AND 38).
FIRST USE 5-28-2008; IN COMMERCE 5-28-2008.

CLASS 9—(Continued).

3,482,608. CRF INC., WALTHAM, MA. SN 77-105,148. FILED P.R. 2-12-2007; AM. S.R. 11-28-2007.

TrialManager

THE MARK CONSISTS OF STANDARD CHARACTERS WITHOUT CLAIM TO ANY PARTICULAR FONT, STYLE, SIZE, OR COLOR.

FOR COMPUTER SOFTWARE FOR THE COLLECTION, EDITING, ORGANIZING, MODIFYING, BOOK MARKING, TRANSMISSION, STORAGE AND SHARING OF DATA AND INFORMATION (U.S. CLS. 21, 23, 26, 36 AND 38).

FIRST USE 9-25-2003; IN COMMERCE 9-25-2003.

3,482,624. HEALTH CARECHAIN, INC., DBA MD-IT, BOULDER, CO. SN 77-217,835. FILED P.R. 6-28-2007; AM. S.R. 5-30-2008.

INTELLIGENT TRANSCRIPTION

THE MARK CONSISTS OF STANDARD CHARACTERS WITHOUT CLAIM TO ANY PARTICULAR FONT, STYLE, SIZE, OR COLOR.

FOR DOWNLOADABLE COMPUTER SOFTWARE FOR MEDICAL TRANSCRIPTION (U.S. CLS. 21, 23, 26, 36 AND 38).

FIRST USE 4-1-2005; IN COMMERCE 9-1-2005.

3,482,628. GT ACQUISITION SUB, INC., SOUTH ST. PAUL, MN. SN 77-229,057. FILED P.R. 7-13-2007; AM. S.R. 6-28-2008.

MICRO.TAG

THE MARK CONSISTS OF STANDARD CHARACTERS WITHOUT CLAIM TO ANY PARTICULAR FONT, STYLE, SIZE, OR COLOR.

FOR RADIO FREQUENCY IDENTIFICATION TAGS FOR ANIMALS (U.S. CLS. 21, 23, 26, 36 AND 38).
FIRST USE 4-24-2008; IN COMMERCE 4-24-2008.

CLASS 9—(Continued).

3,482,666. GELLER DATA SOLUTIONS, INC., DBA GDSI, DAVIE, FL. SN 77-297,940. FILED P.R. 10-6-2007; AM. S.R. 6-9-2008.

ImportSite

THE MARK CONSISTS OF STANDARD CHARACTERS WITHOUT CLAIM TO ANY PARTICULAR FONT, STYLE, SIZE, OR COLOR.

FOR COMPUTER SOFTWARE FOR APPLICATION AND DATABASE INTEGRATION (U.S. CLS. 21, 23, 26, 36 AND 38).

FIRST USE 5-1-2007; IN COMMERCE 5-1-2007.

3,482,683. T. BERGMAN ENTERPRISES, INC., EDMOND, OK. SN 77-346,117. FILED P.R. 12-6-2007; AM. S.R. 6-25-2008.

Ear Plug Superstore

THE MARK CONSISTS OF STANDARD CHARACTERS WITHOUT CLAIM TO ANY PARTICULAR FONT, STYLE, SIZE, OR COLOR.

NO CLAIM IS MADE TO THE EXCLUSIVE RIGHT TO USE "EAR PLUG", APART FROM THE MARK AS SHOWN.

FOR EAR PLUGS NOT FOR MEDICAL PURPOSES; EAR PLUGS FOR SLEEPING; EAR PLUGS FOR SOUND-PROOFING; EAR PLUGS FOR SWIMMING; EAR PLUGS FOR SWIMMING PURPOSES (U.S. CLS. 21, 23, 26, 36 AND 38).

FIRST USE 5-15-1999; IN COMMERCE 5-15-1999.

3,482,693. JM FIBER OPTICS, INC., CHINO, CA. SN 77-383,717. FILED P.R. 1-29-2008; AM. S.R. 6-26-2008.

FIBRMAT

THE MARK CONSISTS OF STANDARD CHARACTERS WITHOUT CLAIM TO ANY PARTICULAR FONT, STYLE, SIZE, OR COLOR.

FOR FIBER OPTIC INTRUSION DETECTION SENSOR MAT (U.S. CLS. 21, 23, 26, 36 AND 38).

FIRST USE 5-28-1982; IN COMMERCE 5-28-1982.

CLASS 9—(Continued).

3,482,705. MUN, JOHNATHAN, PLEASANTON, CA. SN 77-412,137. FILED P.R. 3-4-2008; AM. S.R. 6-25-2008.

ROV MODELER

THE MARK CONSISTS OF STANDARD CHARACTERS WITHOUT CLAIM TO ANY PARTICULAR FONT, STYLE, SIZE, OR COLOR.

FOR COMPUTER SOFTWARE FOR COMPUTING AND VALUING PROJECT RISKS, OPTIMIZING PORTFOLIOS, SIMULATING AND FORECASTING THE FUTURE OF VARIOUS CORPORATE, FINANCIAL AND ECONOMIC VARIABLES, DECISION ANALYSIS, AND VALUING OF BASIC TO ADVANCED FINANCIAL, CREDIT AND MARKET RISKS (U.S. CLS. 21, 23, 26, 36 AND 38).

FIRST USE 6-2-2008; IN COMMERCE 6-2-2008.

3,482,706. MUN, JOHNATHAN, PLEASANTON, CA. SN 77-412,153. FILED P.R. 3-4-2008; AM. S.R. 6-25-2008.

ROV OPTIMIZER

THE MARK CONSISTS OF STANDARD CHARACTERS WITHOUT CLAIM TO ANY PARTICULAR FONT, STYLE, SIZE, OR COLOR.

FOR COMPUTER SOFTWARE FOR COMPUTING AND VALUING PROJECT RISKS, OPTIMIZING PORTFOLIOS, SIMULATING AND FORECASTING THE FUTURE OF VARIOUS CORPORATE, FINANCIAL AND ECONOMIC VARIABLES, DECISION ANALYSIS, AND VALUING OF BASIC TO ADVANCED FINANCIAL, CREDIT AND MARKET RISKS (U.S. CLS. 21, 23, 26, 36 AND 38).

FIRST USE 6-2-2008; IN COMMERCE 6-2-2008.

3,482,707. MUN, JOHNATHAN, PLEASANTON, CA. SN 77-412,157. FILED P.R. 3-4-2008; AM. S.R. 6-25-2008.

ROV VALUATOR

THE MARK CONSISTS OF STANDARD CHARACTERS WITHOUT CLAIM TO ANY PARTICULAR FONT, STYLE, SIZE, OR COLOR.

FOR COMPUTER SOFTWARE FOR COMPUTING AND VALUING PROJECT RISKS, OPTIMIZING PORTFOLIOS, SIMULATING AND FORECASTING THE FUTURE OF VARIOUS CORPORATE, FINANCIAL AND ECONOMIC VARIABLES, DECISION ANALYSIS, AND VALUING OF BASIC TO ADVANCED FINANCIAL, CREDIT AND MARKET RISKS (U.S. CLS. 21, 23, 26, 36 AND 38).

FIRST USE 6-2-2008; IN COMMERCE 6-2-2008.

CLASS 9—(Continued).

3,482,710. X-SPAN RESULTS, LLC, DURHAM, NC. SN 77-413,111. FILED P.R. 3-4-2008; AM. S.R. 6-18-2008.

Site Decision Systems

THE MARK CONSISTS OF STANDARD CHARACTERS WITHOUT CLAIM TO ANY PARTICULAR FONT, STYLE, SIZE, OR COLOR.

NO CLAIM IS MADE TO THE EXCLUSIVE RIGHT TO USE "DECISION SYSTEMS", APART FROM THE MARK AS SHOWN.

FOR COMPUTER SOFTWARE AND HARDWARE FOR HELPING ITS CLIENTS WORK THROUGH VARIOUS REAL ESTATE AND SITE MANAGEMENT EFFORTS (U.S. CLS. 21, 23, 26, 36 AND 38).

FIRST USE 2-4-2008; IN COMMERCE 2-4-2008.

3,482,719. FRIEDRICK SCHWEITZER, BOULDER, CO. SN 77-433,165. FILED 3-27-2008.

O.R. PEER

THE MARK CONSISTS OF STANDARD CHARACTERS WITHOUT CLAIM TO ANY PARTICULAR FONT, STYLE, SIZE, OR COLOR.

FOR EDUCATIONAL SOFTWARE FEATURING INSTRUCTION IN OPERATING ROOM PREPARATION (U.S. CLS. 21, 23, 26, 36 AND 38).

FIRST USE 6-30-2005; IN COMMERCE 6-30-2005.

3,482,730. QRS MUSIC TECHNOLOGIES, INC., NAPLES, FL. SN 78-866,609. FILED P.R. 4-21-2006; AM. S.R. 6-9-2008.

GLOKEYS

THE MARK CONSISTS OF STANDARD CHARACTERS WITHOUT CLAIM TO ANY PARTICULAR FONT, STYLE, SIZE, OR COLOR.

FOR ILLUMINATED PIANO KEYBOARDS HAVING AN ELECTRONIC CONTROLLER (U.S. CLS. 21, 23, 26, 36 AND 38).

FIRST USE 1-31-2006; IN COMMERCE 1-31-2006.

CLASS 9—(Continued).

3,482,734. TRAFFIC & PARKING CONTROL CO., INC., ELM GROVE, WI. SN 78-959,174. FILED P.R. 8-24-2006; AM. S.R. 5-13-2008.

BlinkerSign

THE MARK CONSISTS OF STANDARD CHARACTERS WITHOUT CLAIM TO ANY PARTICULAR FONT, STYLE, SIZE, OR COLOR.

FOR TRAFFIC SIGN INCLUDING LIGHT EMITTING DIODES; LIGHT EMITTING DIODE DISPLAYS; LUMINOUS OR MECHANICAL ROAD SIGNS; LUMINOUS SIGNS (U.S. CLS. 21, 23, 26, 36 AND 38).

FIRST USE 2-1-2001; IN COMMERCE 2-1-2001.

CLASS 10—MEDICAL APPARATUS

3,482,592. ELECTROMED, INC., NEW PRAGUE, MN. SN 76-683,215. FILED P.R. 10-22-2007; AM. S.R. 6-23-2008.

SMARTVEST WRAP

THE MARK CONSISTS OF STANDARD CHARACTERS WITHOUT CLAIM TO ANY PARTICULAR FONT, STYLE, SIZE, OR COLOR.

OWNER OF U.S. REG. NO. 3,016,390.

FOR MEDICAL THORACIC GARMENT, NAMELY, A BAND HAVING AIR CHAMBERS ADAPTED TO BE PLACED AROUND A PERSON'S THORAX USED TO APPLY PRESSURE AND PRESSURE PULSES TO THE PERSON'S THORAX (U.S. CLS. 26, 39 AND 44).

FIRST USE 11-14-2007; IN COMMERCE 11-14-2007.

CLASS 11—ENVIRONMENTAL CONTROL APPARATUS

3,482,685. TOTO, U.S.A., INC., MORROW, GA. SN 77-354,524. FILED P.R. 12-18-2007; AM. S.R. 6-24-2008.

WILLINGHAM

THE MARK CONSISTS OF STANDARD CHARACTERS WITHOUT CLAIM TO ANY PARTICULAR FONT, STYLE, SIZE, OR COLOR.

FOR PLUMBING FIXTURES, NAMELY, TOILETS, BIDETS, BATHTUBS, SHOWERS, SINKS, FAUCETS, AND LIGHTING FIXTURES (U.S. CLS. 13, 21, 23, 31 AND 34).

FIRST USE 2-1-2008; IN COMMERCE 2-1-2008.

CLASS 11—(Continued).

3,482,687. CTB IP, INC., WILMINGTON, DE. SN 77-371,213.
FILED 1-14-2008.

CLASS 14—JEWELRY

3,482,664. BOSWELL, LAUREN A., RED BLUFF, CA. SN 77-
293,542. FILED P.R. 10-2-2007; AM. S.R. 6-9-2008.

STEADI-FLOW

THE MARK CONSISTS OF STANDARD CHARACTERS
WITHOUT CLAIM TO ANY PARTICULAR FONT, STYLE,
SIZE, OR COLOR.

OWNER OF U.S. REG. NO. 3,024,203.
FOR MECHANIZED POULTRY LIVESTOCK WATER-
ERS (U.S. CLS. 13, 21, 23, 31 AND 34).
FIRST USE 12-17-2007; IN COMMERCE 12-17-2007.

CLASS 12—VEHICLES

3,482,631. SHORELINE MANUFACTURING, LLC, HUD-
SONVILLE, MI. SN 77-236,335. FILED P.R. 7-23-2007; AM.
S.R. 5-1-2008.

BEACH ROVER

THE MARK CONSISTS OF STANDARD CHARACTERS
WITHOUT CLAIM TO ANY PARTICULAR FONT, STYLE,
SIZE, OR COLOR.

NO CLAIM IS MADE TO THE EXCLUSIVE RIGHT TO
USE "ROVER", APART FROM THE MARK AS SHOWN.

FOR A SELF-POWERED MARINE TOTE DEVICE FOR
THE LAUNCHING, RECEIVING, AND TRANSPORTING
OF WATERCRAFT (U.S. CLS. 19, 21, 23, 31, 35 AND 44).
FIRST USE 7-1-2007; IN COMMERCE 7-1-2007.

3,482,638. THE ARMORED GROUP, PHOENIX, AZ. SN 77-
262,612. FILED P.R. 8-23-2007; AM. S.R. 6-6-2008.

**BALLISTIC ARMORED TACTICAL
TRANSPORT**

THE MARK CONSISTS OF STANDARD CHARACTERS
WITHOUT CLAIM TO ANY PARTICULAR FONT, STYLE,
SIZE, OR COLOR.

NO CLAIM IS MADE TO THE EXCLUSIVE RIGHT TO
USE "TACTICAL TRANSPORT", APART FROM THE MARK
AS SHOWN.

FOR ARMORED VEHICLES (U.S. CLS. 19, 21, 23, 31, 35
AND 44).
FIRST USE 4-3-2006; IN COMMERCE 4-3-2006.

PetStones

THE MARK CONSISTS OF STANDARD CHARACTERS
WITHOUT CLAIM TO ANY PARTICULAR FONT, STYLE,
SIZE, OR COLOR.

FOR PET JEWELRY (U.S. CLS. 2, 27, 28 AND 50).
FIRST USE 10-1-2007; IN COMMERCE 5-1-2008.

**CLASS 16—PAPER GOODS AND PRINTED
MATTER**

3,482,599. OPHTHONIX, INC., VISTA, CA. SN 77-028,576.
FILED P.R. 10-24-2006; AM. S.R. 6-28-2008.

Public!ze

THE MARK CONSISTS OF THE STYLIZED WORD
"PUBLICIZE" WITH THE SECOND "I" INVERTED.

FOR MARKETING KIT COMPROMISED PRIMARILY
OF PRINTED PROMOTIONAL MATERIALS, GRA-
PHICS, BROCHURES, POSTERS, COUNTER CARDS
AND PATIENT COMMUNICATIONS IN THE FIELD OF
EYE CARE AND EYEWEAR FOR USE BY OTHERS IN
THEIR PRACTICES AND BUSINESSES (U.S. CLS. 2, 5,
22, 23, 29, 37, 38 AND 50).

FIRST USE 11-30-2006; IN COMMERCE 11-30-2006.

CLASS 16—(Continued).

3,482,635. GEÄMI LTD., MORRISVILLE, NC. SN 77-254,201. FILED P.R. 8-13-2007; AM. S.R. 6-29-2008.

GREENWRAP

THE MARK CONSISTS OF STANDARD CHARACTERS WITHOUT CLAIM TO ANY PARTICULAR FONT, STYLE, SIZE, OR COLOR.

FOR PAPER PACKAGING MATERIAL AND PROTECTIVE PACKAGE WRAPPING MATERIAL FOR PACKING, NAMELY, HONEYCOMBED WRAPPING AND CUSHIONING PAPER AND TISSUE PAPER; PAPER PADDED ENVELOPES FOR PACKING; CUSHIONING PADS MADE OF PAPER FOR TRANSPORTING OR SHIPPING GOODS; CUSHIONING, STUFFING AND PUFFS MADE OF PAPER FOR PACKING; ROLLED PAPER PROTECTIVE PACKAGING MATERIAL FOR WRAPPING AND CUSHIONING; DISPENSERS FOR PACKAGING PAPER (U.S. CLS. 2, 5, 22, 23, 29, 37, 38 AND 50).

FIRST USE 9-25-2007; IN COMMERCE 9-25-2007.

3,482,665. TIME INC., NEW YORK, NY. SN 77-297,457. FILED P.R. 10-5-2007; AM. S.R. 6-24-2008.

I REALLY LOVE MY...

THE MARK CONSISTS OF STANDARD CHARACTERS WITHOUT CLAIM TO ANY PARTICULAR FONT, STYLE, SIZE, OR COLOR.

FOR MAGAZINE SECTIONS IN THE FIELD OF CELEBRITY NEWS AND CELEBRITY FASHION; MAGAZINES FEATURING CELEBRITY NEWS AND CELEBRITY FASHION (U.S. CLS. 2, 5, 22, 23, 29, 37, 38 AND 50).

FIRST USE 10-31-2002; IN COMMERCE 10-31-2002.

3,482,677. ZABORONEK, GINNY, BLAIRSTOWN, NJ. AND RICHARDS, MARGARET, WEST CHESTER, PA. SN 77-327,758. FILED 11-13-2007.

"Inspiring Butterflies"

THE MARK CONSISTS OF STANDARD CHARACTERS WITHOUT CLAIM TO ANY PARTICULAR FONT, STYLE, SIZE, OR COLOR.

FOR PRINTED INFORMATIONAL CARDS IN THE FIELD OF INSPIRING BUTTERFLIES (U.S. CLS. 2, 5, 22, 23, 29, 37, 38 AND 50).

FIRST USE 1-10-2008; IN COMMERCE 1-10-2008.

CLASS 16—(Continued).

3,482,682. CYGNUS BUSINESS MEDIA, INC., FORT ATKINSON, WI. SN 77-345,310. FILED P.R. 12-6-2007; AM. S.R. 4-10-2008.



OWNER OF U.S. REG. NO. 1,557,912.

THE COLOR(S) RED, BLACK, AND WHITE IS/ARE CLAIMED AS A FEATURE OF THE MARK.

THE MARK CONSISTS OF THE WORDS "SECURITY" AND "INTEGRATOR" IN RED, THE WORD "DEALER" IN BLACK, A BLACK AMPERSAND, AND A RED RECTANGLE WITH THE WORDING "NEW TECHNOLOGY AND INSTALLATION SOLUTIONS" IN WHITE.

FOR MAGAZINES FEATURING INTEGRATED SECURITY SYSTEMS INFORMATION (U.S. CLS. 2, 5, 22, 23, 29, 37, 38 AND 50).

FIRST USE 1-14-2008; IN COMMERCE 1-14-2008.

3,482,696. TATTOOS FOR TOTS, LLC, SAN MATEO, CA. SN 77-388,388. FILED P.R. 2-5-2008; AM. S.R. 6-24-2008.

Tattoos for Tots

OWNER OF U.S. REG. NO. 3,110,753.

NO CLAIM IS MADE TO THE EXCLUSIVE RIGHT TO USE "TATTOOS", APART FROM THE MARK AS SHOWN.

FOR TEMPORARY TATTOOS (U.S. CLS. 2, 5, 22, 23, 29, 37, 38 AND 50).

FIRST USE 5-13-2005; IN COMMERCE 5-18-2005.

3,482,697. TATTOOS FOR TOTS, LLC, SAN MATEO, CA. SN 77-388,390. FILED P.R. 2-5-2008; AM. S.R. 7-1-2008.



OWNER OF U.S. REG. NO. 3,110,753.

NO CLAIM IS MADE TO THE EXCLUSIVE RIGHT TO USE "TATTOOS", APART FROM THE MARK AS SHOWN.

FOR TEMPORARY TATTOOS (U.S. CLS. 2, 5, 22, 23, 29, 37, 38 AND 50).

FIRST USE 5-13-2005; IN COMMERCE 5-18-2005.

CLASS 16—(Continued).

3,482,708. BONNIER ACTIVE MEDIA, INC., DBA TIME4 MEDIA, INC., WINTER PARK, FL. SN 77-412,532. FILED P.R. 3-4-2008; AM. S.R. 6-23-2008.

Megapixels

THE MARK CONSISTS OF STANDARD CHARACTERS WITHOUT CLAIM TO ANY PARTICULAR FONT, STYLE, SIZE, OR COLOR.

OWNER OF U.S. REG. NOS. 636,827 AND 3,231,383. FOR PRINTED MATTER, NAMELY, A MONTHLY COLUMN IN A SCIENCE MAGAZINE FEATURING INSPIRING VISIONS FROM THE WORLD OF SCIENCE AND TECHNOLOGY, BILLED AS THE "MUST-SEE" PHOTOS OF THE MONTH (U.S. CLS. 2, 5, 22, 23, 29, 37, 38 AND 50).

FIRST USE 1-1-2006; IN COMMERCE 1-1-2006.

3,482,714. DUNKIN' CHERRIES PUBLISHING LLC, CUMMING, GA. SN 77-427,178. FILED P.R. 3-20-2008; AM. S.R. 6-26-2008.

ATLANTA PETZ

THE MARK CONSISTS OF STANDARD CHARACTERS WITHOUT CLAIM TO ANY PARTICULAR FONT, STYLE, SIZE, OR COLOR.

FOR MAGAZINES FEATURING PETS (U.S. CLS. 2, 5, 22, 23, 29, 37, 38 AND 50).

FIRST USE 7-18-2007; IN COMMERCE 9-15-2007.

3,482,716. SHORT, MELTON, CLANTON, AL. SN 77-427,884. FILED P.R. 3-20-2008; AM. S.R. 6-27-2008.

The Bible in 52 "Chunks"

THE MARK CONSISTS OF STANDARD CHARACTERS WITHOUT CLAIM TO ANY PARTICULAR FONT, STYLE, SIZE, OR COLOR.

NO CLAIM IS MADE TO THE EXCLUSIVE RIGHT TO USE "BIBLE", APART FROM THE MARK AS SHOWN.

FOR RELIGIOUS BOOKS AND PUBLICATIONS, NAMELY, TEXTBOOKS, WORKBOOKS, STUDY GUIDES AND TRAINING MATERIALS IN THE FIELD OF BIBLE INSTRUCTION, CHRISTIAN EDUCATION, AND DISCIPLESHIP (U.S. CLS. 2, 5, 22, 23, 29, 37, 38 AND 50).

FIRST USE 1-1-2008; IN COMMERCE 3-11-2008.

CLASS 20—FURNITURE AND ARTICLES NOT OTHERWISE CLASSIFIED

3,482,678. DECADE PRODUCTS, LLC, GRAND RAPIDS, MI. SN 77-328,070. FILED P.R. 11-13-2007; AM. S.R. 3-17-2008.

RACX

THE MARK CONSISTS OF STANDARD CHARACTERS WITHOUT CLAIM TO ANY PARTICULAR FONT, STYLE, SIZE, OR COLOR.

FOR NON-METAL PALLETS (U.S. CLS. 2, 13, 22, 25, 32 AND 50).

FIRST USE 2-26-2008; IN COMMERCE 3-11-2008.

3,482,727. WORLDWIDE CO., LTD., INCHEON, REPUBLIC OF KOREA. SN 78-831,458. FILED P.R. 3-7-2006; AM. S.R. 6-17-2008.

BAROQUE ENSEMBLE

THE MARK CONSISTS OF STANDARD CHARACTERS WITHOUT CLAIM TO ANY PARTICULAR FONT, STYLE, SIZE, OR COLOR.

FOR FURNITURE (U.S. CLS. 2, 13, 22, 25, 32 AND 50).

FIRST USE 6-20-2006; IN COMMERCE 6-20-2006.

CLASS 21—HOUSEWARES AND GLASS

3,482,589. SIMPLEHUMAN, LLC, TORRANCE, CA. SN 76-661,910. FILED P.R. 6-21-2006; AM. S.R. 6-24-2008.

FLIP TOP

THE MARK CONSISTS OF STANDARD CHARACTERS WITHOUT CLAIM TO ANY PARTICULAR FONT, STYLE, SIZE, OR COLOR.

FOR HOUSEWARES, NAMELY, PAPER TOWEL HOLDERS AND DISH STANDS (U.S. CLS. 2, 13, 23, 29, 30, 33, 40 AND 50).

FIRST USE 6-21-2006; IN COMMERCE 6-21-2006.

CLASS 21—(Continued).

3,482,660. THE LIBMAN COMPANY, ARCOLA, IL. SN 77-286,251. FILED P.R. 9-21-2007; AM. S.R. 6-26-2008.

FAMILY MADE IN THE USA
SINCE 1896

THE MARK CONSISTS OF STANDARD CHARACTERS WITHOUT CLAIM TO ANY PARTICULAR FONT, STYLE, SIZE, OR COLOR.

OWNER OF U.S. REG. NO. 3,216,980.

FOR BRUSHES, NAMELY, BRUSHES FOR PARQUET FLOORS, DISHWASHING BRUSHES, DUSTING BRUSHES, FLOOR BRUSHES, SCRUBBING BRUSHES, SCRAPING BRUSHES, GRILL BRUSHES, TOILET BRUSHES, WIRE BRUSHES NOT BEING MACHINE PARTS, BATH BRUSHES, DUSTING BRUSHES, ROOFING BRUSHES, POT CLEANING BRUSHES; BROOMS, NAMELY, HARD BROOMS, PLASTIC BROOMS, CORN BROOMS, WHISK BROOMS; MOPS, NAMELY, SPONGE MOPS, TWIST MOPS, WET MOPS, DUST MOPS, AND THEIR REFILLS; CLEANING PADS, SOAP HOLDERS AND DISPENSERS, DUST PANS, PLASTIC PAILS AND BUCKETS, TOILET BRUSH HOLDERS (U.S. CLS. 2, 13, 23, 29, 30, 33, 40 AND 50);

FIRST USE 10-31-2007; IN COMMERCE 10-31-2007.

3,482,701. AYSE SEN, LA MESA, CA. SN 77-397,639. FILED P.R. 2-14-2008; AM. S.R. 6-9-2008.

Baiden

THE MARK CONSISTS OF STANDARD CHARACTERS WITHOUT CLAIM TO ANY PARTICULAR FONT, STYLE, SIZE, OR COLOR.

FOR HYGIENIC AND BEAUTY CARE PRODUCTS, NAMELY, EXFOLIATING MITTS (U.S. CLS. 2, 13, 23, 29, 30, 33, 40 AND 50).

FIRST USE 12-11-2007; IN COMMERCE 12-16-2007.

CLASS 24—FABRICS**CLASS 24—(Continued).**

3,482,641. LION'S CREST LLC, PAOLI, PA. SN 77-268,716. FILED P.R. 8-30-2007; AM. S.R. 6-11-2008.

PURE PLUSH

THE MARK CONSISTS OF STANDARD CHARACTERS WITHOUT CLAIM TO ANY PARTICULAR FONT, STYLE, SIZE, OR COLOR.

FOR FABRIC FOR USE IN MANUFACTURING CLOTHING (U.S. CLS. 42 AND 50).

FIRST USE 8-30-2007; IN COMMERCE 6-11-2008.

3,482,674. KIRCHNER-LEIDA, VANESSA A., BEDFORD, MA. SN 77-319,808. FILED P.R. 11-2-2007; AM. S.R. 5-10-2008.

Hands, Face & Teeth

THE MARK CONSISTS OF STANDARD CHARACTERS WITHOUT CLAIM TO ANY PARTICULAR FONT, STYLE, SIZE, OR COLOR.

FOR BATH TOWELS; BEACH TOWELS; CHILDREN'S TOWELS; FACE TOWELS; GOLF TOWELS; HAND TOWELS; HAND TOWELS OF TEXTILE; HAND-TOWELS MADE OF TEXTILE FABRICS; HOODED TOWELS; JAPANESE COTTON TOWELS (TENUGUI); KITCHEN TOWELS; LARGE BATH TOWELS; TEA TOWELS; TERRY TOWELS; TOWEL SETS; TOWELLING COVERLETS; TOWELS; TOWELS (U.S. CLS. 42 AND 50).

FIRST USE 11-2-2007; IN COMMERCE 11-2-2007.

CLASS 25—CLOTHING

3,482,602. CMRG APPAREL, LLC, CANTON, MA. SN 77-079,688. FILED P.R. 1-10-2007; AM. S.R. 4-3-2008.

SHOESXL

THE MARK CONSISTS OF STANDARD CHARACTERS WITHOUT CLAIM TO ANY PARTICULAR FONT, STYLE, SIZE, OR COLOR.

FOR FOOTWEAR (U.S. CLS. 22 AND 39).

FIRST USE 1-1-2007; IN COMMERCE 1-1-2007.

CLASS 25—(Continued).

3,482,615. MILLTEX GROUP, INC., NEW YORK, NY. SN 77-130,618. FILED P.R. 3-14-2007; AM. S.R. 6-26-2008.

TIMPA

THE MARK CONSISTS OF STANDARD CHARACTERS WITHOUT CLAIM TO ANY PARTICULAR FONT, STYLE, SIZE, OR COLOR.

FOR BRAS, PANTIES, THONGS, BIKINIS, BRIEFS AND BOXER SHORTS (U.S. CLS. 22 AND 39).
FIRST USE 8-1-2006; IN COMMERCE 8-1-2007.

CLASS 28—TOYS AND SPORTING GOODS

3,482,663. SURFCO HAWAII, INC., PEARL CITY, HI. SN 77-292,750. FILED P.R. 10-1-2007; AM. S.R. 6-25-2008.

PADDLE GUARD

THE MARK CONSISTS OF STANDARD CHARACTERS WITHOUT CLAIM TO ANY PARTICULAR FONT, STYLE, SIZE, OR COLOR.

FOR AN EXTRUDED PLASTIC PROTECTIVE EDGING FOR RETROFITTING ONTO THE EDGE OF CARBON AND WOODEN PADDLES (U.S. CLS. 22, 23, 38 AND 50).
FIRST USE 10-0-2007; IN COMMERCE 10-0-2007.

CLASS 29—MEATS AND PROCESSED FOODS

3,482,601. MICHAEL FOODS OF DELAWARE, INC., MINNETONKA, MN. SN 77-059,210. FILED P.R. 12-7-2006; AM. S.R. 6-12-2008.

ALL EGGS

THE MARK CONSISTS OF STANDARD CHARACTERS WITHOUT CLAIM TO ANY PARTICULAR FONT, STYLE, SIZE, OR COLOR.

NO CLAIM IS MADE TO THE EXCLUSIVE RIGHT TO USE "EGGS", APART FROM THE MARK AS SHOWN.
FOR LIQUID WHOLE EGG PRODUCT (U.S. CL. 46).
FIRST USE 2-25-2008; IN COMMERCE 2-25-2008.

CLASS 29—(Continued).

3,482,654. SOY LABS, LLC, JEFFERSON CITY, MO. SN 77-281,471. FILED P.R. 9-17-2007; AM. S.R. 6-20-2008.

MICRONIZED SOY PROTEIN

THE MARK CONSISTS OF STANDARD CHARACTERS WITHOUT CLAIM TO ANY PARTICULAR FONT, STYLE, SIZE, OR COLOR.

NO CLAIM IS MADE TO THE EXCLUSIVE RIGHT TO USE "SOY PROTEIN", APART FROM THE MARK AS SHOWN.

FOR SOY PROTEIN FOR THE MANUFACTURE OF SOY-BASED FOODS AND SOY-BASED BEVERAGES, FUNCTIONAL FOODS, AND FUNCTIONAL BEVERAGES (U.S. CL. 46).
FIRST USE 2-0-2007; IN COMMERCE 2-0-2007.

3,482,656. SOY LABS, LLC, JEFFERSON CITY, MO. SN 77-281,482. FILED P.R. 9-17-2007; AM. S.R. 6-20-2008.

FUNCTIONAL SOY PROTEIN

THE MARK CONSISTS OF STANDARD CHARACTERS WITHOUT CLAIM TO ANY PARTICULAR FONT, STYLE, SIZE, OR COLOR.

NO CLAIM IS MADE TO THE EXCLUSIVE RIGHT TO USE "SOY PROTEIN", APART FROM THE MARK AS SHOWN.

FOR SOY PROTEIN FOR THE MANUFACTURE OF SOY-BASED FOODS AND SOY-BASED BEVERAGES, FUNCTIONAL FOODS, AND FUNCTIONAL BEVERAGES (U.S. CL. 46).
FIRST USE 2-0-2007; IN COMMERCE 2-0-2007.

3,482,689. HARBOR SEAFOOD, INC., NEW HYDE PARK, NY. SN 77-375,563. FILED P.R. 1-18-2008; AM. S.R. 6-27-2008.

SeaCakes

THE MARK CONSISTS OF THE STYLIZED WORD "SEACAKES".

FOR FROZEN SEAFOOD (U.S. CL. 46).
FIRST USE 2-22-2008; IN COMMERCE 2-22-2008.

CLASS 29—(Continued).

3,482,694. STOBER, JOHN, GOODRICH, ND. AND STOBER, STEPHANIE, GOODRICH, ND. SN 77-386,430. FILED 2-1-2008.

FLAX USA

THE MARK CONSISTS OF STANDARD CHARACTERS WITHOUT CLAIM TO ANY PARTICULAR FONT, STYLE, SIZE, OR COLOR.

FOR PROCESSED EDIBLE FLAX, NAMELY, EDIBLE MILLED FLAXSEED, EDIBLE COLD MILLED FLAXSEED, EDIBLE WHOLE SEED FLAXSEED, EDIBLE PREGROUND FLAXSEED, AND EDIBLE FLAX LIGNANS; EDIBLE FLAXSEED OIL (U.S. CL. 46).
FIRST USE 10-1-2001; IN COMMERCE 10-1-2001.

CLASS 30—STAPLE FOODS

3,482,643. RITA RESTAURANT CORP., MADISON, GA. SN 77-274,032. FILED P.R. 9-7-2007; AM. S.R. 6-27-2008.

DOUBLE STUFFED ENCHILADAS

THE MARK CONSISTS OF STANDARD CHARACTERS WITHOUT CLAIM TO ANY PARTICULAR FONT, STYLE, SIZE, OR COLOR.

NO CLAIM IS MADE TO THE EXCLUSIVE RIGHT TO USE "ENCHILADAS", APART FROM THE MARK AS SHOWN.

FOR ENCHILADAS (U.S. CL. 46).
FIRST USE 11-21-2007; IN COMMERCE 11-21-2007.

CLASS 30—(Continued).

3,482,653. SOY LABS, LLC, JEFFERSON CITY, MO. SN 77-281,465. FILED P.R. 9-17-2007; AM. S.R. 6-20-2008.

MICRONIZED SOY COMPLEX

THE MARK CONSISTS OF STANDARD CHARACTERS WITHOUT CLAIM TO ANY PARTICULAR FONT, STYLE, SIZE, OR COLOR.

NO CLAIM IS MADE TO THE EXCLUSIVE RIGHT TO USE "SOY COMPLEX", APART FROM THE MARK AS SHOWN.

FOR MICRO-MILLED SOY FLOUR FOR THE MANUFACTURE OF SOY-BASED FOODS AND SOY-BASED BEVERAGES, FUNCTIONAL FOODS, FUNCTIONAL BEVERAGES, AND TOPICAL COSMETIC PRODUCT APPLICATIONS, NAMELY, FACE POWDERS AND FACE CREAMS (U.S. CL. 46).

FIRST USE 2-0-2007; IN COMMERCE 2-0-2007.

3,482,655. SOY LABS, LLC, JEFFERSON CITY, MO. SN 77-281,478. FILED P.R. 9-17-2007; AM. S.R. 6-20-2008.

FUNCTIONAL SOY COMPLEX

THE MARK CONSISTS OF STANDARD CHARACTERS WITHOUT CLAIM TO ANY PARTICULAR FONT, STYLE, SIZE, OR COLOR.

NO CLAIM IS MADE TO THE EXCLUSIVE RIGHT TO USE "SOY COMPLEX", APART FROM THE MARK AS SHOWN.

FOR SOY FLOUR FOR THE MANUFACTURE OF SOY-BASED FOODS AND SOY-BASED BEVERAGES, FUNCTIONAL FOODS, FUNCTIONAL BEVERAGES, AND TOPICAL COSMETIC PRODUCT APPLICATIONS, NAMELY, FACE POWDERS AND FACE CREAMS (U.S. CL. 46).

FIRST USE 2-0-2007; IN COMMERCE 2-0-2007.

3,482,681. PIKE PLACE MARKET PRESERVATION AND DEVELOPMENT AUTHORITY, SEATTLE, WA. SN 77-341,488. FILED P.R. 11-30-2007; AM. S.R. 7-1-2008.

PIKE PLACE

THE MARK CONSISTS OF STANDARD CHARACTERS WITHOUT CLAIM TO ANY PARTICULAR FONT, STYLE, SIZE, OR COLOR.

OWNER OF U.S. REG. NOS. 2,233,478 AND 2,361,042. FOR COFFEE (U.S. CL. 46).
FIRST USE 4-8-2008; IN COMMERCE 4-8-2008.

CLASS 30—(Continued).

3,482,695. SIMMONS, KENT A, DBA FREEPORT COFFEE ROASTING, FREEPORT, ME. SN 77-387,541. FILED P.R. 2-4-2008; AM. S.R. 6-19-2008.

Freeport Coffee Roasting

THE MARK CONSISTS OF STANDARD CHARACTERS WITHOUT CLAIM TO ANY PARTICULAR FONT, STYLE, SIZE, OR COLOR.

NO CLAIM IS MADE TO THE EXCLUSIVE RIGHT TO USE "COFFEE", APART FROM THE MARK AS SHOWN, FOR COFFEE AND COFFEE SUBSTITUTES (U.S. CL. 46).

FIRST USE 4-28-2008; IN COMMERCE 4-28-2008.

CLASS 31—NATURAL AGRICULTURAL PRODUCTS

3,482,627. AGROPECUARIA PIEDADENSE S.A. DE C.V, SANTA ANA PACUECO, MEXICO. SN 77-226,867. FILED P.R. 7-11-2007; AM. S.R. 4-11-2008.



FOR FRESH FRUITS; FRESH VEGETABLES (U.S. CLS. 1 AND 46).

FIRST USE 6-5-2001; IN COMMERCE 2-20-2008.

3,482,667. W. ATLEE BURPEE COMPANY, WARMINSTER, PA. SN 77-298,239. FILED P.R. 10-8-2007; AM. S.R. 6-23-2008.

GREAT COMBINATIONS

THE MARK CONSISTS OF STANDARD CHARACTERS WITHOUT CLAIM TO ANY PARTICULAR FONT, STYLE, SIZE, OR COLOR.

FOR SEEDS AND BULBS; LIVING PLANTS (U.S. CLS. 1 AND 46).

FIRST USE 12-31-2007; IN COMMERCE 12-31-2007.

CLASS 31—(Continued).

3,482,669. W. ATLEE BURPEE COMPANY, WARMINSTER, PA. SN 77-298,275. FILED P.R. 10-8-2007; AM. S.R. 6-23-2008.

PRIZEWINNING COMBINATIONS

THE MARK CONSISTS OF STANDARD CHARACTERS WITHOUT CLAIM TO ANY PARTICULAR FONT, STYLE, SIZE, OR COLOR.

OWNER OF U.S. REG. NO. 1,962,263. FOR SEEDS AND BULBS; LIVING PLANTS (U.S. CLS. 1 AND 46).

FIRST USE 12-31-2007; IN COMMERCE 12-31-2007.

3,482,733. MARS, INCORPORATED, MCLEAN, VA. SN 78-956,483. FILED P.R. 8-21-2006; AM. S.R. 7-9-2007.

GOURMET FILETS

THE MARK CONSISTS OF STANDARD CHARACTERS WITHOUT CLAIM TO ANY PARTICULAR FONT, STYLE, SIZE, OR COLOR.

NO CLAIM IS MADE TO THE EXCLUSIVE RIGHT TO USE "FILETS", APART FROM THE MARK AS SHOWN, FOR PET FOOD (U.S. CLS. 1 AND 46).

FIRST USE 6-30-2007; IN COMMERCE 6-30-2007.

CLASS 33—WINES AND SPIRITS

3,482,704. LATITUDE BEVERAGE COMPANY, BOSTON, MA. SN 77-408,338. FILED P.R. 2-28-2008; AM. S.R. 6-19-2008.



FOR WINES (U.S. CLS. 47 AND 49).

FIRST USE 2-10-2008; IN COMMERCE 2-10-2008.

CLASS 33—(Continued).

3,482,723. SCHWARTZ, NORMAN, S, NEW YORK, NY. SN 78-771,809. FILED P.R. 12-13-2005; AM. S.R. 5-3-2008.

Lost grape of Bordeaux

THE MARK CONSISTS OF STANDARD CHARACTERS WITHOUT CLAIM TO ANY PARTICULAR FONT, STYLE, SIZE, OR COLOR.
FOR WINES (U.S. CLS. 47 AND 49).
FIRST USE 5-5-2008; IN COMMERCE 5-5-2008.

SERVICE MARKS

CLASS 35—ADVERTISING AND BUSINESS

3,482,596. SLAYDON, LES, BATON ROUGE, LA. SN 77-012,462. FILED P.R. 10-3-2006; AM. S.R. 6-16-2008.

Vacation2ndHome

THE MARK CONSISTS OF STANDARD CHARACTERS WITHOUT CLAIM TO ANY PARTICULAR FONT, STYLE, SIZE, OR COLOR.
FOR REAL ESTATE MARKETING SERVICES IN THE FIELD OF RESORT CONDOMINIUMS AND VACATION SECOND HOMES (U.S. CLS. 100, 101 AND 102).
FIRST USE 10-31-2005; IN COMMERCE 10-31-2005.

3,482,597. SLAYDON, LES, BATON ROUGE, LA. SN 77-012,536. FILED P.R. 10-3-2006; AM. S.R. 6-16-2008.

Vacation2ndHome.com

THE MARK CONSISTS OF STANDARD CHARACTERS WITHOUT CLAIM TO ANY PARTICULAR FONT, STYLE, SIZE, OR COLOR.
FOR REAL ESTATE MARKETING SERVICES IN THE FIELD OF RESORT CONDOMINIUMS AND VACATION SECOND HOMES (U.S. CLS. 100, 101 AND 102).
FIRST USE 10-31-2005; IN COMMERCE 10-31-2005.

CLASS 35—(Continued).

3,482,607. SABIOSO, INC., CLEARFIELD, UT. SN 77-104,147. FILED P.R. 2-9-2007; AM. S.R. 6-27-2008.

MONITOR, TRACK, MANAGE: ANYTHING, ANYWHERE

THE MARK CONSISTS OF STANDARD CHARACTERS WITHOUT CLAIM TO ANY PARTICULAR FONT, STYLE, SIZE, OR COLOR.

FOR PROVIDING A WEB-BASED PORTAL FOR MONITORING, TRACKING, AND MANAGEMENT OF ASSETS, NAMELY, FREIGHT, PACKAGES, VEHICLES, AND CONTAINERS; COMPUTERIZED TRACKING AND TRACING OF FREIGHT, PACKAGES, VEHICLES AND CONTAINERS; LOGISTICS MANAGEMENT IN THE FIELD OF REMOTE MONITORING, TRACKING AND MANAGEMENT OF ASSETS, NAMELY, FREIGHT, PACKAGES, VEHICLES, CONTAINERS AND INDIVIDUALS (U.S. CLS. 100, 101 AND 102).
FIRST USE 1-31-2004; IN COMMERCE 1-31-2004.

3,482,616. MICHAEL'S CLOSET, INC, RANDOLPH, NJ. SN 77-167,683. FILED P.R. 4-27-2007; AM. S.R. 6-28-2008.

MyRetailPoints

THE MARK CONSISTS OF STANDARD CHARACTERS WITHOUT CLAIM TO ANY PARTICULAR FONT, STYLE, SIZE, OR COLOR.

FOR ON-LINE RETAIL STORE SERVICES FEATURING APPAREL, HEADWEAR AND ACCESSORIES FEATURING A BONUS INCENTIVE PROGRAM FOR CUSTOMERS (U.S. CLS. 100, 101 AND 102).
FIRST USE 12-1-2006; IN COMMERCE 12-1-2006.

3,482,618. CHANNELADVISOR CORPORATION, MORRISVILLE, NC. SN 77-179,135. FILED P.R. 5-11-2007; AM. S.R. 6-30-2008.

SHOPPINGADVISOR

THE MARK CONSISTS OF STANDARD CHARACTERS WITHOUT CLAIM TO ANY PARTICULAR FONT, STYLE, SIZE, OR COLOR.

FOR COMPUTERIZED ONLINE ADVERTISING MANAGEMENT SERVICES REGARDING DATA SUBMITTED BY OTHERS IN THE FIELD OF RETAIL COMPARISON MARKETING (U.S. CLS. 100, 101 AND 102).
FIRST USE 5-7-2007; IN COMMERCE 5-7-2007.

CLASS 35—(Continued).

3,482,620. HARVEST INFO, INC., LOVELAND, OH. SN 77-193,031. FILED P.R. 5-30-2007; AM. S.R. 5-16-2008.

LOCAL INFO DIRECTORY

THE MARK CONSISTS OF STANDARD CHARACTERS WITHOUT CLAIM TO ANY PARTICULAR FONT, STYLE, SIZE, OR COLOR.

NO CLAIM IS MADE TO THE EXCLUSIVE RIGHT TO USE "INFO DIRECTORY", APART FROM THE MARK AS SHOWN.

FOR PROVIDING ON-LINE DIRECTORY INFORMATION SERVICES ALSO FEATURING ADVERTISING SERVICES AND HYPERLINKS TO OTHER WEBSITES (U.S. CLS. 100, 101 AND 102).

FIRST USE 2-0-2007; IN COMMERCE 2-0-2007.

3,482,625. HEALTH CARECHAIN, INC., DBA MD-IT, BOULDER, CO. SN 77-217,863. FILED P.R. 6-28-2007; AM. S.R. 5-31-2008.

INTELLIGENT TRANSCRIPTION

THE MARK CONSISTS OF STANDARD CHARACTERS WITHOUT CLAIM TO ANY PARTICULAR FONT, STYLE, SIZE, OR COLOR.

FOR MEDICAL TRANSCRIPTION SERVICES (U.S. CLS. 100, 101 AND 102).

FIRST USE 4-1-2005; IN COMMERCE 9-1-2005.

3,482,626. IOWA 80 GROUP, INC., WALCOTT, IA. SN 77-222,984. FILED P.R. 7-5-2007; AM. S.R. 6-19-2008.

SUPER TRUCK SHOWROOM

THE MARK CONSISTS OF STANDARD CHARACTERS WITHOUT CLAIM TO ANY PARTICULAR FONT, STYLE, SIZE, OR COLOR.

NO CLAIM IS MADE TO THE EXCLUSIVE RIGHT TO USE "SUPER TRUCK", APART FROM THE MARK AS SHOWN.

FOR RETAIL STORE SERVICES FEATURING TRUCK ACCESSORIES (U.S. CLS. 100, 101 AND 102).

FIRST USE 1-23-2006; IN COMMERCE 1-23-2006.

CLASS 35—(Continued).

3,482,630. DINING ALLIANCE, WEBSTER, NY. SN 77-232,421. FILED 7-18-2007.

Dining Alliance

THE MARK CONSISTS OF STANDARD CHARACTERS WITHOUT CLAIM TO ANY PARTICULAR FONT, STYLE, SIZE, OR COLOR.

FOR ADVERTISING, MARKETING AND PROMOTION SERVICES; BUSINESS CONSULTING, INQUIRIES OR INFORMATION; BUSINESS MARKETING CONSULTING SERVICES; PROCUREMENT, NAMELY, PURCHASING RESTAURANT SUPPLIES FOR OTHERS (U.S. CLS. 100, 101 AND 102).

FIRST USE 8-1-2006; IN COMMERCE 8-1-2006.

3,482,639. SMARKETING, LLC, SAN DIEGO, CA. SN 77-262,891. FILED P.R. 8-23-2007; AM. S.R. 7-2-2008.

INDIE EXCELLENCE

THE MARK CONSISTS OF STANDARD CHARACTERS WITHOUT CLAIM TO ANY PARTICULAR FONT, STYLE, SIZE, OR COLOR.

FOR CONDUCTING AUTHOR AWARD PROGRAM TO PROMOTE BOOKS, TO PROMOTE INTEREST AND EXCELLENCE IN AUTHORSHIP, AND TO PROMOTE BOOK PUBLISHING BY PRESENTING AWARDS AND PRIZES (U.S. CLS. 100, 101 AND 102).

FIRST USE 6-19-2006; IN COMMERCE 6-19-2006.

3,482,640. NATIONAL MARINE ELECTRONICS ASSOCIATION, INC., SEVERNA PARK, MD. SN 77-264,820. FILED P.R. 8-27-2007; AM. S.R. 6-9-2008.

INTERNATIONAL MARINE ELECTRONICS ASSOCIATION

THE MARK CONSISTS OF STANDARD CHARACTERS WITHOUT CLAIM TO ANY PARTICULAR FONT, STYLE, SIZE, OR COLOR.

NO CLAIM IS MADE TO THE EXCLUSIVE RIGHT TO USE "MARINE ELECTRONICS ASSOCIATION", APART FROM THE MARK AS SHOWN.

FOR ASSOCIATION SERVICES, NAMELY, PROMOTING THE INTERESTS OF THE MARINE ELECTRONICS (U.S. CLS. 100, 101 AND 102).

FIRST USE 6-6-2008; IN COMMERCE 6-6-2008.

CLASS 35—(Continued).

3,482,642. SCUBA.COM, IRVINE, CA. SN 77-271,452. FILED P.R. 9-4-2007; AM. S.R. 6-16-2008.



THE COLOR(S) BLUE, RED AND WHITE IS/ARE CLAIMED AS A FEATURE OF THE MARK.

THE COLOR BLUE APPEARS IN THE WORDING "SCUBA" AND "COM". THE COLORS RED AND WHITE APPEAR IN THE DESIGN COMPRISING THE PERIOD BETWEEN "SCUBA" AND "COM" SEPARATING THE WORDS "SCUBA" AND "COM". THE MARK APPEARS OVER A TRANSPARENT BACKGROUND.

FOR ON-LINE RETAIL STORE SERVICES FEATURING SCUBA GEAR (U.S. CLS. 100, 101 AND 102).

FIRST USE 4-1-2000; IN COMMERCE 4-1-2000.

3,482,644. SAN FRANCISCO PUBLIC GOLF ALLIANCE, SAN FRANCISCO, CA. SN 77-274,207. FILED P.R. 9-7-2007; AM. S.R. 6-12-2008.

San Francisco Public Golf Alliance

THE MARK CONSISTS OF STANDARD CHARACTERS WITHOUT CLAIM TO ANY PARTICULAR FONT, STYLE, SIZE, OR COLOR.

FOR PROMOTING PUBLIC AWARENESS OF THE NEED FOR PUBLIC GOLF COURSES (U.S. CLS. 100, 101 AND 102).

FIRST USE 8-3-2007; IN COMMERCE 8-3-2007.

CLASS 35—(Continued).

3,482,662. WORLD MARKET CENTER VENTURE, LLC, LAS VEGAS, NV. SN 77-288,182. FILED P.R. 9-25-2007; AM. S.R. 6-23-2008.

LAS VEGAS DESIGN CENTER

THE MARK CONSISTS OF STANDARD CHARACTERS WITHOUT CLAIM TO ANY PARTICULAR FONT, STYLE, SIZE, OR COLOR.

NO CLAIM IS MADE TO THE EXCLUSIVE RIGHT TO USE "DESIGN CENTER", APART FROM THE MARK AS SHOWN.

FOR ARRANGING, ORGANIZING, PROMOTING AND CONDUCTING TRADE EXHIBITIONS, TRADE CONVENTIONS, TRADE SHOWS AND TRADE FAIRS IN THE FIELDS OF HOME, OFFICE AND HOSPITALITY FURNISHINGS; ADVERTISING AND MARKETING OF TRADE SHOWROOMS AND RELATED SHOWROOM FACILITIES AND SERVICES TO MANUFACTURERS OF GOODS IN THE FIELDS OF HOME, OFFICE AND HOSPITALITY FURNISHINGS; ADVERTISING AND MARKETING OF TRADE SHOWROOMS FOR DISPLAY AND EXHIBITION OF GOODS OF MANUFACTURERS IN THE FIELDS OF HOME, OFFICE AND HOSPITALITY FURNISHINGS TO RETAILERS OF HOME, OFFICE AND HOSPITALITY FURNISHINGS (U.S. CLS. 100, 101 AND 102).

FIRST USE 5-1-2006; IN COMMERCE 5-1-2006.

3,482,671. NATIONAL AGING IN PLACE COUNCIL, WASHINGTON, DC. SN 77-300,429. FILED P.R. 10-10-2007; AM. S.R. 6-24-2008.

National Aging in Place Council

THE MARK CONSISTS OF STANDARD CHARACTERS WITHOUT CLAIM TO ANY PARTICULAR FONT, STYLE, SIZE, OR COLOR.

NO CLAIM IS MADE TO THE EXCLUSIVE RIGHT TO USE "COUNCIL", APART FROM THE MARK AS SHOWN.

FOR ASSOCIATION SERVICES, NAMELY, PROMOTING THE INTERESTS OF PROFESSIONALS IN THE FIELD OF SENIOR CITIZEN AFFAIRS (U.S. CLS. 100, 101 AND 102).

FIRST USE 11-18-2004; IN COMMERCE 11-18-2004.

CLASS 35—(Continued).

3,482,680. IPACTIONS, INC., MINDEN, NV. SN 77-338,649.
FILED P.R. 11-28-2007; AM. S.R. 6-19-2008.

IpAuctions

THE MARK CONSISTS OF STANDARD CHARACTERS WITHOUT CLAIM TO ANY PARTICULAR FONT, STYLE, SIZE, OR COLOR.

OWNER OF U.S. REG. NO. 2,756,143.

FOR ONLINE AUCTION SERVICES; ARRANGING AND CONDUCTING AUCTIONS IN THE FIELD OF INTELLECTUAL PROPERTY, TRADE SECRETS, PATENTS, TRADEMARKS, COPYRIGHTS, MAILING LISTS, CLIENT AND CUSTOMER DATABASES, DOMAIN NAMES, AND FINANCIAL INSTRUMENTS; ARRANGING AND CONDUCTION OF AUCTION SALES (U.S. CLS. 100, 101 AND 102).

FIRST USE 7-31-2001; IN COMMERCE 7-31-2001.

3,482,692. ELEGALSUPPLY.COM LLC, MULLICA HILL, NJ.
SN 77-382,353. FILED P.R. 1-28-2008; AM. S.R. 6-27-2008.

eLegalsupply.com

THE MARK CONSISTS OF STANDARD CHARACTERS WITHOUT CLAIM TO ANY PARTICULAR FONT, STYLE, SIZE, OR COLOR.

FOR ON-LINE RETAIL STORE SERVICES FEATURING LEGAL OFFICE SUPPLIES (U.S. CLS. 100, 101 AND 102).

FIRST USE 0-0-1999; IN COMMERCE 0-0-1999.

3,482,700. GREEN FLEET SYSTEMS, LLC, RANCHO DOMINQUEZ, CA. SN 77-395,385. FILED P.R. 2-12-2008; AM. S.R. 6-23-2008.

GREEN FLEET SYSTEMS

THE MARK CONSISTS OF STANDARD CHARACTERS WITHOUT CLAIM TO ANY PARTICULAR FONT, STYLE, SIZE, OR COLOR.

FOR TRANSPORTATION LOGISTICS SERVICES, NAMELY, ARRANGING THE TRANSPORTATION OF GOODS FOR OTHERS (U.S. CLS. 100, 101 AND 102).

FIRST USE 1-23-2008; IN COMMERCE 1-23-2008.

CLASS 35—(Continued).

3,482,711. BALAN BIOMEDICAL INC., WEST HENRIETTA, NY. SN 77-424,849. FILED 3-18-2008.

Balan

THE MARK CONSISTS OF STANDARD CHARACTERS WITHOUT CLAIM TO ANY PARTICULAR FONT, STYLE, SIZE, OR COLOR.

FOR MARKET RESEARCH SERVICES (U.S. CLS. 100, 101 AND 102).

FIRST USE 4-20-2006; IN COMMERCE 4-20-2006.

3,482,712. BALAN BIOMEDICAL INC., WEST HENRIETTA, NY. SN 77-424,875. FILED 3-18-2008.

Balan Biomedical

THE MARK CONSISTS OF STANDARD CHARACTERS WITHOUT CLAIM TO ANY PARTICULAR FONT, STYLE, SIZE, OR COLOR.

NO CLAIM IS MADE TO THE EXCLUSIVE RIGHT TO USE "BIOMEDICAL", APART FROM THE MARK AS SHOWN.

FOR MARKET RESEARCH SERVICES (U.S. CLS. 100, 101 AND 102).

FIRST USE 4-20-2006; IN COMMERCE 4-20-2006.

3,482,728. WORLDWIDE CO., LTD., INCHEON, REPUBLIC OF KOREA. SN 78-831,479. FILED P.R. 3-7-2006; AM. S.R. 6-17-2008.

BAROQUE ENSEMBLE

THE MARK CONSISTS OF STANDARD CHARACTERS WITHOUT CLAIM TO ANY PARTICULAR FONT, STYLE, SIZE, OR COLOR.

FOR RETAIL FURNITURE STORES; RETAIL STORE SERVICES FEATURING FURNITURE; AND RETAIL FURNITURE STORE SERVICES (U.S. CLS. 100, 101 AND 102).

FIRST USE 6-20-2006; IN COMMERCE 6-20-2006.

CLASS 36—INSURANCE AND FINANCIAL

CLASS 36—(Continued).

3,482,598. COMMERCE BANCORP, INC., CHERRY HILL, NJ. SN 77-026,760. FILED P.R. 10-23-2006; AM. S.R. 6-13-2008.

AMERICA'S BEST BANK

THE MARK CONSISTS OF STANDARD CHARACTERS WITHOUT CLAIM TO ANY PARTICULAR FONT, STYLE, SIZE, OR COLOR.

NO CLAIM IS MADE TO THE EXCLUSIVE RIGHT TO USE "BANK", APART FROM THE MARK AS SHOWN.

FOR BANKING SERVICES; BANKING SERVICES PROVIDED VIA THE INTERNET; INVESTMENT BROKERAGE SERVICES; INVESTMENT BROKERAGE SERVICES PROVIDED VIA THE INTERNET; INSURANCE BROKERAGE SERVICES; INSURANCE BROKERAGE SERVICES PROVIDED VIA THE INTERNET (U.S. CLS. 100, 101 AND 102).

FIRST USE 10-26-2006; IN COMMERCE 10-26-2006.

3,482,605. VANCO SERVICES, LLC, MINNETONKA, MN. SN 77-094,802. FILED P.R. 1-30-2007; AM. S.R. 11-23-2007.

DEPOSIT RC

THE MARK CONSISTS OF STANDARD CHARACTERS WITHOUT CLAIM TO ANY PARTICULAR FONT, STYLE, SIZE, OR COLOR.

NO CLAIM IS MADE TO THE EXCLUSIVE RIGHT TO USE "DEPOSIT", APART FROM THE MARK AS SHOWN.

FOR FINANCIAL SERVICES, NAMELY, ELECTRONIC FUNDS TRANSFER SERVICES (U.S. CLS. 100, 101 AND 102).

FIRST USE 1-30-2007; IN COMMERCE 1-30-2007.

3,482,606. GRIFFIN, PATRICK J., WOODSTOCK, NH. SN 77-099,587. FILED P.R. 2-5-2007; AM. S.R. 6-30-2008.

COPSRIDE

THE MARK CONSISTS OF STANDARD CHARACTERS WITHOUT CLAIM TO ANY PARTICULAR FONT, STYLE, SIZE, OR COLOR.

FOR CHARITABLE FUND RAISING BASED UPON MOTORCYCLE ACTIVITIES AND EVENTS TO RAISE MONEY FOR THE BENEFIT OF THE FAMILIES OF DECEASED LAW-ENFORCEMENT OFFICERS (U.S. CLS. 100, 101 AND 102).

FIRST USE 1-24-2007; IN COMMERCE 1-24-2007.

CLASS 36—(Continued).

3,482,617. DANAL, INC., SAN JOSE, CA. SN 77-178,247. FILED P.R. 5-10-2007; AM. S.R. 6-27-2008.

BilltoMobile

THE MARK CONSISTS OF STANDARD CHARACTERS WITHOUT CLAIM TO ANY PARTICULAR FONT, STYLE, SIZE, OR COLOR.

FOR ELECTRONIC PAYMENT PROCESSING AND TRANSMISSION SERVICES, NAMELY, SERVICE WHICH ENABLES PURCHASE OF GOODS OR SERVICES TO BILL THE CHARGES TO AN END-USER'S MOBILE PHONE BILLING STATEMENT (U.S. CLS. 100, 101 AND 102).

FIRST USE 2-28-2008; IN COMMERCE 2-28-2008.

3,482,622. GUILLIATT, MARK, FREMONT, NE. SN 77-213,419. FILED P.R. 6-22-2007; AM. S.R. 7-3-2008.

Business Owned Banking

THE MARK CONSISTS OF STANDARD CHARACTERS WITHOUT CLAIM TO ANY PARTICULAR FONT, STYLE, SIZE, OR COLOR.

FOR INSURANCE CONSULTATION (U.S. CLS. 100, 101 AND 102).

FIRST USE 6-13-2007; IN COMMERCE 6-13-2007.

3,482,652. LILLIE BEN, FRANKTOWN, CO. SN 77-278,681. FILED P.R. 9-13-2007; AM. S.R. 6-17-2008.

**FIDUCIARY SOLUTIONS TO
ENHANCE & PRESERVE WEALTH**

THE MARK CONSISTS OF STANDARD CHARACTERS WITHOUT CLAIM TO ANY PARTICULAR FONT, STYLE, SIZE, OR COLOR.

NO CLAIM IS MADE TO THE EXCLUSIVE RIGHT TO USE "FIDUCIARY", APART FROM THE MARK AS SHOWN.

FOR FINANCIAL CONSULTATION BY FIDUCIARY REPRESENTATIVES IN THE FIELD OF RETIREMENT AND EMPLOYEE BENEFIT PLANS (U.S. CLS. 100, 101 AND 102).

FIRST USE 8-16-2007; IN COMMERCE 8-16-2007.

CLASS 36—(Continued).

3,482,691. THE PENN MUTUAL LIFE INSURANCE COMPANY, HORSHAM, PA. SN 77-380,366. FILED P.R. 1-25-2008; AM. S.R. 6-19-2008.

FLEXIBLE CHOICE WHOLE LIFE

THE MARK CONSISTS OF STANDARD CHARACTERS WITHOUT CLAIM TO ANY PARTICULAR FONT, STYLE, SIZE, OR COLOR.

NO CLAIM IS MADE TO THE EXCLUSIVE RIGHT TO USE "WHOLE LIFE", APART FROM THE MARK AS SHOWN.

FOR LIFE INSURANCE UNDERWRITING (U.S. CLS. 100, 101 AND 102).

FIRST USE 4-4-2008; IN COMMERCE 4-8-2008.

CLASS 37—CONSTRUCTION AND REPAIR

3,482,611. BENJAMIN FRANKLIN FRANCHISING, LLC, SARASOTA, FL. SN 77-111,785. FILED P.R. 2-20-2007; AM. S.R. 6-27-2008.

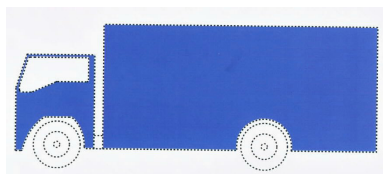

THE COLOR(S) BLUE (PMS 301) IS/ARE CLAIMED AS A FEATURE OF THE MARK.

THE MARK CONSISTS OF THE COLOR BLUE (PMS 301) USED OVER THE ENTIRE TRUCK. THE MATTER SHOWN IN THE DRAWING IN BROKEN LINES SERVES TO SHOW POSITIONING OF THE MARK AND IS NOT A FEATURE OF THE MARK.

FOR REPAIR, MAINTENANCE, AND INSTALLATION SERVICES IN THE FIELD OF PLUMBING (U.S. CLS. 100, 103 AND 106).

FIRST USE 8-0-2004; IN COMMERCE 8-0-2004.

3,482,703. WILLAWALL INVESTMENTS INC., SAN ANTONIO, TX. SN 77-407,218. FILED P.R. 2-27-2008; AM. S.R. 6-25-2008.

Salt Water Chlorinating
w/Co2 pH Control!

THE MARK CONSISTS OF STANDARD CHARACTERS WITHOUT CLAIM TO ANY PARTICULAR FONT, STYLE, SIZE, OR COLOR.

FOR SWIMMING POOL MAINTENANCE (U.S. CLS. 100, 103 AND 106).

FIRST USE 1-1-2007; IN COMMERCE 9-1-2007.

CLASS 38—COMMUNICATION

3,482,686. ROZANSKY & ASSOCIATES, LLC, DESPLAINES, IL. SN 77-365,228. FILED P.R. 1-7-2008; AM. S.R. 7-1-2008.

CONTINUITY TALK

THE MARK CONSISTS OF STANDARD CHARACTERS WITHOUT CLAIM TO ANY PARTICULAR FONT, STYLE, SIZE, OR COLOR.

FOR PODCASTING SERVICES (U.S. CLS. 100, 101 AND 104).

FIRST USE 8-7-2007; IN COMMERCE 8-7-2007.

3,482,724. THE MUSICIAN NETWORK, LLC, OVERLAND PARK, KS. SN 78-806,359. FILED P.R. 2-3-2006; AM. S.R. 4-16-2008.

MUSIC MAKER CHANNEL

THE MARK CONSISTS OF STANDARD CHARACTERS WITHOUT CLAIM TO ANY PARTICULAR FONT, STYLE, SIZE, OR COLOR.

NO CLAIM IS MADE TO THE EXCLUSIVE RIGHT TO USE "CHANNEL", APART FROM THE MARK AS SHOWN.

FOR BROADCASTING SERVICES, NAMELY, A CABLE TELEVISION CHANNEL FEATURING CONTENT SPECIFICALLY FOR MUSICIANS AND MUSIC MAKERS (U.S. CLS. 100, 101 AND 104).

FIRST USE 4-16-2008; IN COMMERCE 4-16-2008.

CLASS 39—TRANSPORTATION AND STORAGE

3,482,713. PISCIOTTA, PHIL, OAK GROVE, MO. SN 77-425,671. FILED P.R. 3-19-2008; AM. S.R. 7-1-2008.

FRESH FOOD EXPRESS

THE MARK CONSISTS OF STANDARD CHARACTERS WITHOUT CLAIM TO ANY PARTICULAR FONT, STYLE, SIZE, OR COLOR.

FOR PICK UP, DELIVERY AND STORAGE OF PERSONAL PROPERTY; STORAGE AND DELIVERY OF GOODS; TRANSPORT AND DELIVERY OF GOODS; EXPRESS DELIVERY OF GOODS BY TRUCK; DELIVERY OF GOODS; ALL THE FOREGOING PRIMARILY RELATED TO FOOD AND FOOD RELATED GOODS (U.S. CLS. 100 AND 105).

FIRST USE 3-1-2008; IN COMMERCE 3-1-2008.

CLASS 41—EDUCATION AND ENTERTAINMENT

3,482,590. KO, SOO RYONG, CERRITOS, CA. SN 76-678,576. FILED P.R. 6-22-2007; AM. S.R. 6-23-2008.

WORLD HAN KUM DO FEDERATION

THE MARK CONSISTS OF STANDARD CHARACTERS WITHOUT CLAIM TO ANY PARTICULAR FONT, STYLE, SIZE, OR COLOR.

NO CLAIM IS MADE TO THE EXCLUSIVE RIGHT TO USE "HAN KUM DO", APART FROM THE MARK AS SHOWN.

THE FOREIGN WORDING IN THE MARK TRANSLATES INTO ENGLISH AS "KOREAN ANCIENT SWORDSMANSHIP ARTS".

FOR MARTIAL ARTS INSTRUCTION AND TRAINING IN HAN KUM DO, A TRADITIONAL KOREAN MARTIAL ART WITH AN EMPHASIS ON SWORDSMANSHIP (U.S. CLS. 100, 101 AND 107).

FIRST USE 3-1-2005; IN COMMERCE 3-1-2005.

3,482,591. KO, SOO RYONG, CERRITOS, CA. SN 76-678,577. FILED P.R. 6-22-2007; AM. S.R. 6-23-2008.

WORLD HAN SUN DO FEDERATION

THE MARK CONSISTS OF STANDARD CHARACTERS WITHOUT CLAIM TO ANY PARTICULAR FONT, STYLE, SIZE, OR COLOR.

NO CLAIM IS MADE TO THE EXCLUSIVE RIGHT TO USE "HAN SUN DO", APART FROM THE MARK AS SHOWN.

THE FOREIGN WORDING IN THE MARK TRANSLATES INTO ENGLISH AS "KOREAN ANCIENT RELIGIOUS MEDITATION AND MARTIAL ARTS".

FOR MARTIAL ARTS INSTRUCTION AND TRAINING IN HAN SUN DO, A TRADITIONAL KOREAN MARTIAL ART WITH AN EMPHASIS ON SELF-DEFENSE (U.S. CLS. 100, 101 AND 107).

FIRST USE 3-1-2005; IN COMMERCE 3-1-2005.

CLASS 41—(Continued).

3,482,609. ENDORPHIN SPORTS MEDIA, MIDDLEBURG HEIGHTS, OH. SN 77-105,876. FILED P.R. 2-13-2007; AM. S.R. 6-20-2008.

The Original Race Report

THE MARK CONSISTS OF STANDARD CHARACTERS WITHOUT CLAIM TO ANY PARTICULAR FONT, STYLE, SIZE, OR COLOR.

FOR PUBLICATION AND ONLINE PUBLICATION OF REPORTS, BOOKS, AND POSTERS THAT OUTLINE ACCOMPLISHMENTS IN SPORTING EVENTS, NAMELY, RUNNING, CYCLING AND SWIMMING (U.S. CLS. 100, 101 AND 107).

FIRST USE 1-1-2007; IN COMMERCE 1-1-2007.

3,482,612. CRIME CHECK OF SPOKANE COUNTY, SPOKANE, WA. SN 77-119,647. FILED P.R. 3-1-2007; AM. S.R. 5-22-2008.

KEEP GUNS "OUTTA" SCHOO!

THE MARK CONSISTS OF STANDARD CHARACTERS WITHOUT CLAIM TO ANY PARTICULAR FONT, STYLE, SIZE, OR COLOR.

FOR EDUCATIONAL SERVICES, NAMELY, PROVIDING A PROGRAM TO KEEP GUNS OUT OF SCHOOLS (U.S. CLS. 100, 101 AND 107).

FIRST USE 3-17-2004; IN COMMERCE 3-17-2004.

3,482,613. LIFETIME ENTERTAINMENT SERVICES, NEW YORK, NY. SN 77-121,427. FILED P.R. 3-2-2007; AM. S.R. 6-4-2008.

AMERICA'S PSYCHIC CHALLENGE

THE MARK CONSISTS OF STANDARD CHARACTERS WITHOUT CLAIM TO ANY PARTICULAR FONT, STYLE, SIZE, OR COLOR.

FOR ENTERTAINMENT SERVICES IN THE NATURE OF AN ON-GOING REALITY BASED TELEVISION PROGRAM; AND PROVIDING A WEBSITE FEATURING INFORMATION ON A REALITY-BASED TELEVISION SERIES (U.S. CLS. 100, 101 AND 107).

FIRST USE 10-12-2007; IN COMMERCE 10-12-2007.

CLASS 41—(Continued).

3,482,614. DR. CYRIL I EVIAN, KING OF PRUSSIA, PA. SN 77-127,010. FILED P.R. 3-9-2007; AM. S.R. 6-24-2008.

THE PENNSYLVANIA INSTITUTE
FOR ADVANCED DENTAL
EDUCATION

THE MARK CONSISTS OF STANDARD CHARACTERS WITHOUT CLAIM TO ANY PARTICULAR FONT, STYLE, SIZE, OR COLOR.

NO CLAIM IS MADE TO THE EXCLUSIVE RIGHT TO USE "INSTITUTE FOR ADVANCED DENTAL EDUCATION", APART FROM THE MARK AS SHOWN, FOR EDUCATIONAL SERVICES, NAMELY, PROVIDING CLASSES, WORKSHOPS, AND SEMINARS IN THE FIELD OF DENTISTRY (U.S. CLS. 100, 101 AND 107).
FIRST USE 6-1-2008; IN COMMERCE 6-1-2008.

3,482,621. MATHISON, JULIET C.J., STONE MOUNTAIN, GA. SN 77-210,007. FILED P.R. 6-19-2007; AM. S.R. 5-29-2008.

Integrative Kinesiology

THE MARK CONSISTS OF STANDARD CHARACTERS WITHOUT CLAIM TO ANY PARTICULAR FONT, STYLE, SIZE, OR COLOR.

FOR EDUCATIONAL SERVICES, NAMELY, TRAINING IN THE FIELD OF INTEGRATIVE KINESIOLOGY (U.S. CLS. 100, 101 AND 107).
FIRST USE 5-14-2004; IN COMMERCE 5-14-2004.

3,482,634. KONSTANTIN POGOSOV, MATTHEWS, NC. SN 77-249,226. FILED P.R. 8-7-2007; AM. S.R. 7-1-2008.

X Stream Opera

THE MARK CONSISTS OF STANDARD CHARACTERS WITHOUT CLAIM TO ANY PARTICULAR FONT, STYLE, SIZE, OR COLOR.

NO CLAIM IS MADE TO THE EXCLUSIVE RIGHT TO USE "OPERA", APART FROM THE MARK AS SHOWN.

FOR PRESENTATION OF MUSICAL PERFORMANCE; MUSIC PRODUCTION SERVICES; ENTERTAINMENT, NAMELY, LIVE MUSIC CONCERTS (U.S. CLS. 100, 101 AND 107).
FIRST USE 9-24-2006; IN COMMERCE 9-24-2006.

CLASS 41—(Continued).

3,482,636. SHABOOM INC., SUQUAMISH, WA. SN 77-261,516. FILED P.R. 8-22-2007; AM. S.R. 6-4-2008.

Authentic Wealth

THE MARK CONSISTS OF STANDARD CHARACTERS WITHOUT CLAIM TO ANY PARTICULAR FONT, STYLE, SIZE, OR COLOR.

FOR CONDUCTING WORKSHOPS AND SEMINARS IN HAVING A HEALTHY RELATIONSHIP WITH MONEY AND WEALTH (U.S. CLS. 100, 101 AND 107).
FIRST USE 8-1-2006; IN COMMERCE 10-25-2006.

3,482,668. JACQUART FABRIC PRODUCTS, INC., IRONWOOD, MI. SN 77-298,251. FILED P.R. 10-8-2007; AM. S.R. 6-6-2008.

THE DEER HUNTERS ROUNDUP

THE MARK CONSISTS OF STANDARD CHARACTERS WITHOUT CLAIM TO ANY PARTICULAR FONT, STYLE, SIZE, OR COLOR.

FOR ENTERTAINMENT SERVICES, NAMELY, PROVIDING A WEB SITE FEATURING PRERECORDED AUDIO PROGRAMS RELATED TO HUNTING FOR STREAMING OVER THE INTERNET (U.S. CLS. 100, 101 AND 107).
FIRST USE 11-14-2007; IN COMMERCE 11-14-2007.

3,482,670. THE SCIENCE FESTIVAL FOUNDATION, NEW YORK, NY. SN 77-299,243. FILED P.R. 10-9-2007; AM. S.R. 6-24-2008.

WORLD SCIENCE FESTIVAL

THE MARK CONSISTS OF STANDARD CHARACTERS WITHOUT CLAIM TO ANY PARTICULAR FONT, STYLE, SIZE, OR COLOR.

NO CLAIM IS MADE TO THE EXCLUSIVE RIGHT TO USE "SCIENCE FESTIVAL", APART FROM THE MARK AS SHOWN.

FOR ORGANIZING FESTIVALS FEATURING A VARIETY OF ACTIVITIES, NAMELY, SCIENCE-THEMED LECTURES, DEBATES AND PANEL DISCUSSIONS, MUSIC AND DANCE PERFORMANCES, FILM SHOWINGS, LITERARY SYMPOSIA AND READINGS (U.S. CLS. 100, 101 AND 107).
FIRST USE 2-0-2006; IN COMMERCE 2-0-2006.

CLASS 41—(Continued).

3,482,679. BUYCOMPUTERNOW INC., DBA BUYONLINE-NOW, ROCHESTER, MN. SN 77-328,980. FILED P.R. 11-14-2007; AM. S.R. 6-26-2008.

OfficeSuppliesBlog

THE MARK CONSISTS OF STANDARD CHARACTERS WITHOUT CLAIM TO ANY PARTICULAR FONT, STYLE, SIZE, OR COLOR.

FOR ON-LINE JOURNALS, NAMELY, BLOGS FEATURING OFFICE PRODUCTS, OFFICE SUPPLIES, OFFICE FURNITURE, AND INFORMATION ABOUT ONLINE RETAIL WEBSITES (U.S. CLS. 100, 101 AND 107).

FIRST USE 5-24-2007; IN COMMERCE 5-24-2007.

3,482,688. ESPN, INC., BRISTOL, CT. SN 77-374,052. FILED P.R. 1-17-2008; AM. S.R. 6-16-2008.

RIVALRY WEEKEND

THE MARK CONSISTS OF STANDARD CHARACTERS WITHOUT CLAIM TO ANY PARTICULAR FONT, STYLE, SIZE, OR COLOR.

FOR ENTERTAINMENT SERVICES, NAMELY, TELEVISION PROGRAMS IN THE FIELD OF COLLEGIATE FOOTBALL AND BASKETBALL, PRODUCTION AND DISTRIBUTION OF RADIO AND TELEVISION BROADCASTS OF COLLEGIATE FOOTBALL AND BASKETBALL GAMES, EVENTS, AND PROGRAMS (U.S. CLS. 100, 101 AND 107).

FIRST USE 11-20-1994; IN COMMERCE 11-20-1994.

3,482,715. BLATCHFORD, BARBARA, CHICAGO, IL. SN 77-427,311. FILED P.R. 3-20-2008; AM. S.R. 6-30-2008.

THE KIDS CLUB FOR FLOWERS

THE MARK CONSISTS OF STANDARD CHARACTERS WITHOUT CLAIM TO ANY PARTICULAR FONT, STYLE, SIZE, OR COLOR.

FOR EDUCATION SERVICES, NAMELY, MENTORING IN THE FIELD OF TEACHING CHILDREN ABOUT HORTICULTURE VIA ACTIVITIES WITH LIVE PLANTS AND FLOWERS (U.S. CLS. 100, 101 AND 107).

FIRST USE 1-1-1979; IN COMMERCE 1-1-1979.

CLASS 41—(Continued).

3,482,722. THE INSTITUTE FOR EDUCATIONAL DEVELOPMENT, INC., CHANDLER, AZ. SN 78-702,869. FILED P.R. 8-29-2005; AM. S.R. 10-17-2007.

AN AMERICAN VIRTUAL ACADEMY

THE MARK CONSISTS OF STANDARD CHARACTERS WITHOUT CLAIM TO ANY PARTICULAR FONT, STYLE, SIZE, OR COLOR.

NO CLAIM IS MADE TO THE EXCLUSIVE RIGHT TO USE "ACADEMY", APART FROM THE MARK AS SHOWN.

FOR EDUCATIONAL SERVICES, NAMELY, DEVELOPING AND PROVIDING HIGH SCHOOL LEVEL CURRICULA IN A VARIETY OF SUBJECTS VIA AN ONLINE COMMUNICATION NETWORK (U.S. CLS. 100, 101 AND 107).

FIRST USE 5-11-2004; IN COMMERCE 5-11-2004.

CLASS 42—SCIENTIFIC AND COMPUTER SERVICES

3,482,684. INFOTRIEVE, INC., WILTON, CT. SN 77-354,422. FILED P.R. 12-18-2007; AM. S.R. 6-26-2008.

CONTENT SCM

THE MARK CONSISTS OF STANDARD CHARACTERS WITHOUT CLAIM TO ANY PARTICULAR FONT, STYLE, SIZE, OR COLOR.

NO CLAIM IS MADE TO THE EXCLUSIVE RIGHT TO USE "CONTENT", APART FROM THE MARK AS SHOWN.

FOR ONLINE, NON-DOWNLOADABLE SOFTWARE FOR USE IN MANAGEMENT, USAGE ANALYSIS, COPYRIGHT COMPLIANCE, RIGHTS ADMINISTRATION AND DELIVERY OF DOCUMENTS AND LITERATURE COLLECTIONS (U.S. CLS. 100 AND 101).

FIRST USE 10-11-2007; IN COMMERCE 10-11-2007.

CLASS 43—HOTEL AND RESTAURANT SERVICES

CLASS 43—(Continued).

3,482,632. BCN PROVISIONS, LLC, NEW YORK, NY. SN 77-244,338. FILED P.R. 8-1-2007; AM. S.R. 6-30-2008.

ZUCKER'S BAGELS & SMOKED FISH

THE MARK CONSISTS OF STANDARD CHARACTERS WITHOUT CLAIM TO ANY PARTICULAR FONT, STYLE, SIZE, OR COLOR.

NO CLAIM IS MADE TO THE EXCLUSIVE RIGHT TO USE "BAGELS & SMOKED FISH", APART FROM THE MARK AS SHOWN.

FOR RESTAURANT, BAKERY, CAFE AND CATERING SERVICES (U.S. CLS. 100 AND 101).

FIRST USE 5-19-2007; IN COMMERCE 5-19-2007.

3,482,675. KANG, SOPHIA, DBA STESO, TORRANCE, CA. AND KANG, STEFANO, DBA STESO, TORRANCE, CA. SN 77-322,040. FILED P.R. 11-5-2007; AM. S.R. 6-27-2008.

BY BRAZIL

THE MARK CONSISTS OF STANDARD CHARACTERS WITHOUT CLAIM TO ANY PARTICULAR FONT, STYLE, SIZE, OR COLOR.

FOR RESTAURANT SERVICES (U.S. CLS. 100 AND 101).

FIRST USE 0-0-2005; IN COMMERCE 0-0-2005.

3,482,699. BORDAY, ROBERT, HOLLYWOOD, FL. SN 77-394,829. FILED P.R. 2-12-2008; AM. S.R. 6-24-2008.

FALAFEL FUSION

THE MARK CONSISTS OF STANDARD CHARACTERS WITHOUT CLAIM TO ANY PARTICULAR FONT, STYLE, SIZE, OR COLOR.

FOR TAKE-OUT RESTAURANT SERVICES; RESTAURANT SERVICES; RESTAURANT SERVICES FEATURING SANDWICHES (U.S. CLS. 100 AND 101).

FIRST USE 11-7-2007; IN COMMERCE 11-7-2007.

CLASS 43—(Continued).

3,482,709. GUTIERREZ, JENNIFER, ENCINITAS, CA. SN 77-412,853. FILED P.R. 3-4-2008; AM. S.R. 6-16-2008.

CAMP 4 DOGS

THE MARK CONSISTS OF STANDARD CHARACTERS WITHOUT CLAIM TO ANY PARTICULAR FONT, STYLE, SIZE, OR COLOR.

FOR PET DAY CARE SERVICES (U.S. CLS. 100 AND 101).

FIRST USE 1-1-2008; IN COMMERCE 1-1-2008.

CLASS 44—MEDICAL, BEAUTY AND AGRICULTURAL SERVICES

3,482,637. FAMILY HOSPICE AND PALLIATIVE CARE, PITTSBURGH, PA. SN 77-261,638. FILED P.R. 8-22-2007; AM. S.R. 6-4-2008.

CENTER FOR COMPASSIONATE CARE

THE MARK CONSISTS OF STANDARD CHARACTERS WITHOUT CLAIM TO ANY PARTICULAR FONT, STYLE, SIZE, OR COLOR.

FOR HOSPICE IN-PATIENT SERVICES (U.S. CLS. 100 AND 101).

FIRST USE 7-0-2005; IN COMMERCE 7-0-2007.

3,482,659. KOWALS PEDIATRICS, BELLINGHAM, WA. SN 77-286,231. FILED P.R. 9-21-2007; AM. S.R. 6-27-2008.

KOWALS PEDIATRICS

THE MARK CONSISTS OF STANDARD CHARACTERS WITHOUT CLAIM TO ANY PARTICULAR FONT, STYLE, SIZE, OR COLOR.

NO CLAIM IS MADE TO THE EXCLUSIVE RIGHT TO USE "PEDIATRICS", APART FROM THE MARK AS SHOWN.

FOR MEDICAL SERVICES, NAMELY, PEDIATRIC CARE (U.S. CLS. 100 AND 101).

FIRST USE 11-15-2007; IN COMMERCE 11-15-2007.

CLASS 45—(Continued).

3,482,718. DOW, MICHAEL STEPHEN, TUCSON, AZ. SN 77-430,311. FILED P.R. 3-25-2008; AM. S.R. 6-27-2008.

An easy eating plan to
maintain your ideal weight
for the rest of your life.

THE MARK CONSISTS OF STANDARD CHARACTERS WITHOUT CLAIM TO ANY PARTICULAR FONT, STYLE, SIZE, OR COLOR.
FOR WEIGHT REDUCTION DIET PLANNING AND SUPERVISION (U.S. CLS. 100 AND 101).
FIRST USE 3-24-2008; IN COMMERCE 3-24-2008.

CLASS 45—PERSONAL AND LEGAL SERVICES

3,482,645. YAO-WEN HUANG, TAIPEI CITY, TAIWAN. SN 77-276,096. FILED 9-11-2007.

HackAlert

NO CLAIM IS MADE TO THE EXCLUSIVE RIGHT TO USE "HACKALERT", APART FROM THE MARK AS SHOWN.
THE COLOR(S) RED IS/ARE CLAIMED AS A FEATURE OF THE MARK.
THE MARK CONSISTS OF ALL THE ALPHABETS IN THE LOGO ARE IN RED COLOR.
FOR MONITORING OF COMPUTER SYSTEMS FOR SECURITY PURPOSES (U.S. CLS. 100 AND 101).
FIRST USE 10-13-2007; IN COMMERCE 12-12-2007.

CLASS 45—(Continued).

3,482,658. SHUMAKER, LOOP & KENDRICK, LLP, TOLEDO, OH. SN 77-285,385. FILED P.R. 9-21-2007; AM. S.R. 5-30-2008.

SHUMAKER

OWNER OF U.S. REG. NO. 2,713,228.
THE COLOR(S) BLACK AND BURNT ORANGE IS/ARE CLAIMED AS A FEATURE OF THE MARK.
THE MARK CONSISTS OF THE WORD "SHUMAKER" IN BLACK AND THE LINE BELOW IT IS IN BURNT ORANGE.
FOR LEGAL SERVICES (U.S. CLS. 100 AND 101).
FIRST USE 10-1-2007; IN COMMERCE 10-1-2007.

3,482,676. U.S. BUREAU OF THE CENSUS, WASHINGTON, DC. SN 77-322,622. FILED P.R. 11-6-2007; AM. S.R. 5-13-2008.

United States
Census
2010

OWNER OF U.S. REG. NOS. 2,296,084, 2,518,821, AND OTHERS.
NO CLAIM IS MADE TO THE EXCLUSIVE RIGHT TO USE "CENSUS 2010", APART FROM THE MARK AS SHOWN.
THE MARK CONSISTS OF THE WORDS "UNITED STATES CENSUS 2010", WITH THE WORDS "UNITED STATES" SITTING ATOP THE LARGER WORDS "CENSUS" AND "2010".
FOR RESEARCH SERVICES, NAMELY, CONDUCTING THE U.S. DECENNIAL CENSUS, INCLUDING THE PROVISION OF SUCH SERVICES BY MEANS OF THE INTERNET (U.S. CLS. 100 AND 101).
FIRST USE 12-31-2006; IN COMMERCE 12-31-2006.

* * * * *

PRIOR UNITED STATES CLASSIFICATION

APPLICATION IN ONE CLASS

COLLECTIVE MEMBERSHIP MARKS

CLASS 200—COLLECTIVE MEMBERSHIP

3,482,673. NATIONAL AGING IN PLACE COUNCIL, WASHINGTON, DC. SN 77-306,069. FILED P.R. 10-17-2007; AM. S.R. 6-24-2008.

NO CLAIM IS MADE TO THE EXCLUSIVE RIGHT TO USE "COUNCIL", APART FROM THE MARK AS SHOWN. FOR INDICATING MEMBERSHIP IN AN ORGANIZATION OF PROFESSIONALS IN THE FIELD OF SENIOR CITIZEN AFFAIRS (U.S. CL. 200). FIRST USE 11-18-2004; IN COMMERCE 11-18-2004.

National Aging in Place
Council

THE MARK CONSISTS OF STANDARD CHARACTERS WITHOUT CLAIM TO ANY PARTICULAR FONT, STYLE, SIZE, OR COLOR.

* * * * *

TRADEMARK REGISTRATIONS RENEWED

The designation "U.S. Cl." appearing in this section refers to the U.S. class in effect prior to Sep. 1, 1973 rather than the international class which applies to applications filed on or after that date. For adoption of international classification see notice in the OFFICIAL GAZETTE of Jun. 26, 1973 (911 O.G. TM 210).

122,493.	DEFENDER. U.S. CL. 13. (INT. CL. 6). REG. 8-20-1918.	851,216.	MISCELLANEOUS DESIGN. U.S. CL. 107. (INT. CL. 41). REG. 6-18-1968.
122,496.	"RUTHLESS" (STYLIZED). U.S. CL. 13. (INT. CL. 6). REG. 8-20-1918.	851,256.	JOHN MEYER OF NORWICH. U.S. CL. 39 ONLY. (INT. CLS. 10, 25 AND 26). REG. 6-25-1968.
199,556.	THE BOSTON GLOBE. U.S. CL. 38. (INT. CL. 16). REG. 6-9-1925.	852,144.	PENNAQUA PAC AND DESIGN. U.S. CL. 10. (INT. CL. 1). REG. 7-9-1968.
217,005.	LANDMATIC. U.S. CL. 23. (INT. CL. 8). REG. 8-24-1926.	852,213.	WELL-GUARD CONTROL AND DESIGN. U.S. CL. 21. (INT. CL. 9). REG. 7-9-1968.
220,367.	RED HOT DOLLARS. U.S. CL. 46. (INT. CL. 30). REG. 11-9-1926.	852,595.	W AND DESIGN. U.S. CL. 18. (INT. CL. 5). REG. 7-16-1968.
234,707.	CHRIS-CRAFT (STYLIZED). U.S. CL. 19. (INT. CL. 12). REG. 11-1-1927.	852,926.	D & B. U.S. CL. 101. (INT. CL. 35). REG. 7-16-1968.
337,112.	FEOSOL. U.S. CL. 18. (INT. CL. 5). REG. 7-28-1936.	856,135.	COOLMINT. U.S. CL. 46. (INT. CL. 30). REG. 9-3-1968.
357,933.	SPEED-WALL. U.S. CL. 16. (INT. CL. 2). REG. 6-21-1938.	856,239.	CARTAN. U.S. CL. 105. (INT. CL. 39). REG. 9-3-1968.
362,396.	MISCELLANEOUS DESIGN. U.S. CL. 46. (INT. CL. 30). REG. 11-15-1938.	857,829.	G & W (STYLIZED). U.S. CL. 21. (INT. CL. 9). REG. 10-1-1968.
434,594.	FUDGSICLE. U.S. CL. 46. (INT. CLS. 1, 5, 29, 30, 31 AND 32). REG. 11-25-1947.	858,931.	AGWAY. U.S. CL. 29. (INT. CL. 21). REG. 10-22-1968.
441,020.	OCEANSTAR. U.S. CL. 27. (INT. CL. 14). REG. 10-19-1948.	859,012.	CRY BABY. U.S. CL. 46. (INT. CL. 31). REG. 10-22-1968.
569,970.	DIEHL (STYLIZED). U.S. CL. 21 ONLY. (INT. CLS. 7 AND 9). REG. 2-3-1953.	859,528.	STEM-TEX. U.S. CL. 7. (INT. CL. 17). REG. 11-5-1968.
584,065.	STEEL BLUE. U.S. CL. 6. (INT. CL. 2). REG. 12-29-1953.	860,258.	AGRI-FLO. U.S. CL. 46. (INT. CL. 31). REG. 11-12-1968.
662,591.	FRANCE. U.S. CL. 35. (INT. CLS. 7 AND 17). REG. 6-3-1958.	860,654.	CULINOX. U.S. CL. 46. (INT. CL. 30). REG. 11-19-1968.
663,713.	ONE MAN AND DESIGN. U.S. CL. 19. (INT. CL. 10). REG. 7-1-1958.	860,891.	CALF KRUNCH. U.S. CL. 18. (INT. CL. 5). REG. 11-26-1968.
663,874.	STORCK (STYLIZED). U.S. CL. 46. (INT. CL. 30). REG. 7-1-1958.	862,751.	GRIN AND BEAR IT. U.S. CL. 38. (INT. CL. 16). REG. 12-31-1968.
663,954.	PADLOCK. U.S. CL. 5. (INT. CL. 17). REG. 7-8-1958.	867,913.	MISCELLANEOUS DESIGN. U.S. CL. 36. (INT. CL. 9). REG. 4-8-1969.
667,430.	CLIMATE CHANGER (STYLIZED). U.S. CL. 34. (INT. CL. 11). REG. 9-23-1958.	869,269.	PATRIARC. U.S. CL. 13. (INT. CL. 20). REG. 5-13-1969.
667,908.	HI-CONE. U.S. CL. 2. (INT. CL. 20). REG. 10-7-1958.	870,380.	ADEMCO AND DESIGN. U.S. CL. 21. (INT. CL. 9). REG. 6-3-1969.
668,901.	AVIEX. U.S. CL. 15. (INT. CLS. 1 AND 4). REG. 10-28-1958.	1,042,263.	ALPHAZ AND DESIGN. INT. CL. 16. (U.S. CL. 38). REG. 6-29-1976.
670,351.	KAMCHATKA. U.S. CL. 49. (INT. CL. 33). REG. 11-25-1958.	1,043,945.	MISCELLANEOUS DESIGN. INT. CLS. 6, 14, 16, 18, 20, 21, 24, 25, 26, 28 AND 34. (U.S. CLS. 1, 2, 3, 5, 8, 12, 13, 14, 22, 23, 25, 27, 28, 29, 30, 32, 33, 37, 38, 39, 40, 41, 42 AND 50). REG. 7-20-1976.
671,899.	KERR. U.S. CL. 44. (INT. CL. 10). REG. 12-30-1958.	1,051,944.	WELDLOK. INT. CL. 27. (U.S. CL. 42). REG. 11-2-1976.
675,115.	DISPENSER-PAK. U.S. CL. 46. (INT. CL. 32). REG. 3-3-1959.	1,052,095.	LA COUPE. INT. CL. 42. (U.S. CL. 100). REG. 11-2-1976.
676,224.	RACORD. U.S. CL. 18. (INT. CL. 5). REG. 3-31-1959.	1,053,706.	MASTERPIECES (STYLIZED). INT. CL. 30. (U.S. CL. 46). REG. 11-30-1976.
808,288.	AFTA. U.S. CL. 4. (INT. CL. 3). REG. 5-17-1966.	1,054,202.	PINE II. INT. CL. 5. (U.S. CL. 18). REG. 12-14-1976.
812,340.	ZIP-SLIP. INT. CL. 1. (U.S. CL. 1). REG. 8-9-1966.	1,055,804.	MISCELLANEOUS DESIGN. INT. CL. 42. (U.S. CL. 100). REG. 1-4-1977.
812,789.	TIZOX. U.S. CL. 6. (INT. CL. 1). REG. 8-16-1966.	1,058,385.	STRAT. INT. CL. 15. (U.S. CL. 36). REG. 2-8-1977.
815,543.	GOLDEN APPLE. U.S. CL. 46. (INT. CL. 32). REG. 9-20-1966.	1,060,117.	B (STYLIZED). INT. CL. 41. (U.S. CLS. 100, 101 AND 107). REG. 2-22-1977.
819,770.	MINI-SYNCLAMPS. U.S. CL. 13. (INT. CL. 6). REG. 12-6-1966.	1,061,116.	FLEXCOR. INT. CL. 6. (U.S. CL. 13). REG. 3-15-1977.
838,985.	CYCOLOY. INT. CL. 1. (U.S. CL. 1). REG. 11-21-1967.	1,061,508.	SIERRA. INT. CL. 5. (U.S. CL. 6). REG. 3-22-1977.
841,494.	SPRINGFIX. U.S. CL. 13. (INT. CL. 6). REG. 1-2-1968.	1,061,936.	MONTANE. INT. CL. 1. (U.S. CLS. 1, 5, 6, 10, 26 AND 46). REG. 3-29-1977.
842,241.	J H BAXTER (STYLIZED). U.S. CL. 106. (INT. CL. 40). REG. 1-9-1968.	1,063,091.	ADIPEX-P. INT. CL. 5. (U.S. CL. 18). REG. 4-12-1977.
847,160.	NICE N EASY (STYLIZED). U.S. CL. 52. (INT. CL. 3). REG. 4-2-1968.	1,063,622.	UV-CHEK. INT. CL. 1. (U.S. CL. 6). REG. 4-19-1977.
850,050.	THERMO-LUBE. U.S. CL. 6. (INT. CL. 1). REG. 6-4-1968.	1,066,763.	KARR AND DESIGN. INT. CL. 20. (U.S. CL. 32). REG. 5-31-1977.
850,181.	TROY-BILT. U.S. CL. 23. (INT. CL. 7). REG. 6-4-1968.	1,075,702.	"HE AIN'T HEAVY, FATHER . . . HE'S M' BROTHER" AND DESIGN. INT. CLS. 41 AND 42. (U.S. CLS. 100 AND 107). REG. 10-18-1977.
850,622.	D & B. U.S. CL. 38. (INT. CL. 16). REG. 6-11-1968.		
851,101.	MISCELLANEOUS DESIGN. U.S. CL. 39. (INT. CLS. 10, 25 AND 26). REG. 6-18-1968.		

- 1,078,425. SUN-GARD. INT. CL. 17. (U.S. CL. 1). REG. 11-29-1977.
- 1,079,312. PORTRAIT. INT. CL. 9. (U.S. CLS. 21, 23, 26, 36 AND 38). REG. 12-13-1977.
- 1,079,538. ALL AMERICAN SOAP BOX DERBY. INT. CL. 41. (U.S. CL. 107). REG. 12-13-1977.
- 1,084,143. MISTER DONUT (STYLIZED). INT. CL. 42 ONLY. (U.S. CL. 100). REG. 1-31-1978.
- 1,087,605. HOLERITE. INT. CL. 6. (U.S. CL. 14). REG. 3-21-1978.
- 1,090,565. POCKET-PACK. INT. CL. 20. (U.S. CL. 2). REG. 5-2-1978.
- 1,090,784. BIO-JECTOR. INT. CL. 10. (U.S. CL. 44). REG. 5-9-1978.
- 1,091,083. FLEX-O-SKIPS. INT. CL. 36. (U.S. CL. 102). REG. 5-9-1978.
- 1,093,207. RIGOUTAT. INT. CL. 15. (U.S. CL. 36). REG. 6-13-1978.
- 1,093,218. RUBBER & PLASTICS NEWS. INT. CL. 16. (U.S. CL. 38). REG. 6-13-1978.
- 1,093,258. EXPLORING. INT. CL. 16. (U.S. CL. 38). REG. 6-13-1978.
- 1,093,398. BLACK UNITED FUND. INT. CL. 36. (U.S. CL. 102). REG. 6-13-1978.
- 1,093,565. CURZATE. INT. CL. 5. (U.S. CL. 6). REG. 6-20-1978.
- 1,093,754. THE PODIUM. INT. CL. 16. (U.S. CL. 38). REG. 6-20-1978.
- 1,093,758. MORROW. INT. CL. 16. (U.S. CL. 38). REG. 6-20-1978.
- 1,094,048. CRL (STYLIZED). INT. CL. 42. (U.S. CL. 101). REG. 6-20-1978.
- 1,094,200. ATROBAN. INT. CL. 5. (U.S. CL. 6). REG. 6-27-1978.
- 1,094,752. MISCELLANEOUS DESIGN. INT. CL. 41. (U.S. CL. 107). REG. 6-27-1978.
- 1,095,631. CLAIRE. INT. CLS. 3, 4 AND 5. (U.S. CLS. 1, 4, 6, 15, 18, 44, 46, 50, 51 AND 52). REG. 7-11-1978.
- 1,095,989. VERDI (STYLIZED). INT. CL. 18. (U.S. CL. 3). REG. 7-11-1978.
- 1,096,385. SOF'N-SOIL. INT. CL. 1. (U.S. CL. 10). REG. 7-18-1978.
- 1,096,819. TAIL. INT. CL. 25. (U.S. CLS. 22 AND 39). REG. 7-18-1978.
- 1,096,966. MISCELLANEOUS DESIGN. INT. CL. 36. (U.S. CL. 101). REG. 7-18-1978.
- 1,097,934. FARMI. INT. CL. 7. (U.S. CL. 23). REG. 8-1-1978.
- 1,098,941. ACCENT AND DESIGN. INT. CL. 30. (U.S. CL. 46). REG. 8-8-1978.
- 1,099,158. SUPER STRIP. INT. CL. 3. (U.S. CL. 4). REG. 8-15-1978.
- 1,104,088. LAUROX. INT. CL. 1. (U.S. CL. 6). REG. 10-17-1978.
- 1,105,011. ESA AND DESIGN. INT. CLS. 1, 9, 10 AND 42. (U.S. CLS. 6, 21, 26, 44 AND 100). REG. 10-31-1978.
- 1,109,928. SUN-LITE. INT. CL. 9. (U.S. CL. 26). REG. 12-26-1978.
- 1,111,116. BBU AND DESIGN. U.S. CL. 200. REG. 1-9-1979.
- 1,112,314. THERM-A-REST. INT. CL. 20. (U.S. CL. 32). REG. 1-30-1979.
- 1,113,824. PIZZA STATION. INT. CL. 42. (U.S. CL. 100). REG. 2-20-1979.
- 1,117,574. MISCELLANEOUS DESIGN. INT. CL. 9 ONLY. (U.S. CL. 36). REG. 5-8-1979.
- 1,322,034. TURBOKING. INT. CL. 12. (U.S. CLS. 19 AND 23). REG. 2-26-1985.
- 1,323,830. FLOW SCIENCE AND DESIGN. INT. CL. 42. (U.S. CL. 100). REG. 3-5-1985.
- 1,324,169. ANACOMP. INT. CL. 9. (U.S. CLS. 26 AND 38). REG. 3-12-1985.
- 1,327,218. TACKLE GRIP. INT. CL. 28. (U.S. CL. 22). REG. 3-26-1985.
- 1,328,626. THE ROCK. INT. CL. 25. (U.S. CL. 39). REG. 4-2-1985.
- 1,329,886. ICM. INT. CL. 29. (U.S. CL. 46). REG. 4-9-1985.
- 1,329,987. ANACOMP. INT. CL. 35. (U.S. CL. 101). REG. 4-9-1985.
- 1,334,784. F.H.E. AND DESIGN. INT. CL. 41. (U.S. CL. 107). REG. 5-7-1985.
- 1,338,471. GYRO DATA AND DESIGN. INT. CL. 42. (U.S. CL. 100). REG. 5-28-1985.
- 1,339,048. TERM-ACON. INT. CL. 9. (U.S. CL. 21). REG. 6-4-1985.
- 1,339,049. POST/BOXE. INT. CL. 9. (U.S. CL. 21). REG. 6-4-1985.
- 1,343,722. MISCELLANEOUS DESIGN. INT. CL. 3. (U.S. CL. 52). REG. 6-25-1985.
- 1,344,300. CORT. INT. CL. 15. (U.S. CL. 36). REG. 6-25-1985.
- 1,345,556. HARVARD. INT. CL. 6. (U.S. CLS. 7 AND 13). REG. 7-2-1985.
- 1,348,160. KILBURN & FINCH AND DESIGN. INT. CL. 25. (U.S. CL. 39). REG. 7-9-1985.
- 1,351,344. AXIALVEYOR. INT. CL. 7. (U.S. CLS. 13, 19, 21, 23, 31, 34 AND 35). REG. 7-30-1985.
- 1,352,503. BOEING. INT. CL. 9. (U.S. CL. 26). REG. 8-6-1985.
- 1,352,761. AQUACULTURE MAGAZINE (STYLIZED). INT. CL. 16. (U.S. CL. 38). REG. 8-6-1985.
- 1,353,316. THE ROCK. INT. CL. 41. (U.S. CL. 107). REG. 8-6-1985.
- 1,353,702. GYROCLEAN. INT. CL. 7. (U.S. CLS. 23 AND 34). REG. 8-13-1985.
- 1,353,859. E-MON. INT. CL. 9. (U.S. CL. 21). REG. 8-13-1985.
- 1,405,896. KOLON. INT. CL. 25. (U.S. CL. 39). REG. 8-19-1986.
- 1,428,955. WHITE RAIN. INT. CL. 3. (U.S. CL. 51). REG. 2-17-1987.
- 1,451,466. FRESHFIELDS. INT. CL. 42. (U.S. CLS. 100 AND 101). REG. 8-4-1987.
- 1,467,134. MEDIDROPPERS. INT. CL. 9. (U.S. CL. 26). REG. 12-1-1987.
- 1,470,385. MAXEPA. INT. CL. 5. (U.S. CLS. 18 AND 46). REG. 12-29-1987.
- 1,470,893. HUMITUBE. INT. CL. 34. (U.S. CL. 17). REG. 12-29-1987.
- 1,471,053. ALLEY CATS. INT. CL. 42. (U.S. CL. 100). REG. 12-29-1987.
- 1,471,128. EC AND DESIGN. INT. CLS. 3, 18 AND 25. (U.S. CLS. 1, 3, 4, 6, 22, 39, 41, 50, 51 AND 52). REG. 1-5-1988.
- 1,474,216. BU (STYLIZED). INT. CL. 21. (U.S. CLS. 2, 30 AND 33). REG. 1-26-1988.
- 1,475,569. CHRISTMAS MEMORIES. INT. CL. 3. (U.S. CLS. 6 AND 51). REG. 2-9-1988.
- 1,480,662. RTURMX. INT. CL. 9. (U.S. CLS. 21 AND 26). REG. 3-15-1988.
- 1,481,357. POWER UP. INT. CL. 5. (U.S. CL. 18). REG. 3-22-1988.
- 1,481,724. KANIMI. INT. CL. 29. (U.S. CL. 46). REG. 3-22-1988.
- 1,486,113. 67. INT. CL. 16. (U.S. CLS. 21 AND 23). REG. 4-26-1988.
- 1,486,672. BLU-MOUSSE. INT. CL. 5. (U.S. CL. 44). REG. 5-3-1988.
- 1,486,704. DON'T QUIT. INT. CLS. 9, 16 AND 25 ONLY. (U.S. CLS. 21, 36, 38 AND 39). REG. 5-3-1988.
- 1,486,737. EB AND DESIGN. INT. CL. 9. (U.S. CLS. 21, 23, 26, 36 AND 38). REG. 5-3-1988.
- 1,486,930. WOBBLE WEDGE. INT. CL. 20. (U.S. CL. 50). REG. 5-3-1988.
- 1,487,166. CHILD'S PLAY THEATRE COMPANY. INT. CL. 41. (U.S. CL. 107). REG. 5-3-1988.
- 1,487,531. LA 411. INT. CL. 16. (U.S. CL. 38). REG. 5-10-1988.
- 1,487,532. THE STORY BOX. INT. CL. 16. (U.S. CL. 38). REG. 5-10-1988.
- 1,487,710. TOUMA. INT. CL. 33. (U.S. CL. 49). REG. 5-10-1988.
- 1,488,072. RMO. INT. CLS. 5, 10, 16, 41 AND 42. (U.S. CLS. 18, 38, 44, 100 AND 107). REG. 5-17-1988.
- 1,488,128. ELIMINATOR. INT. CL. 7. (U.S. CL. 23). REG. 5-17-1988.
- 1,488,169. MISCELLANEOUS DESIGN. INT. CL. 7. (U.S. CL. 24). REG. 5-17-1988.
- 1,488,197. CA-VTERM. INT. CL. 9. (U.S. CL. 38). REG. 5-17-1988.
- 1,488,212. BROOKFIELD AND DESIGN. INT. CL. 9. (U.S. CL. 26). REG. 5-17-1988.
- 1,489,068. BUNDL. INT. CL. 9. (U.S. CL. 38). REG. 5-24-1988.
- 1,489,139. ELEPHANT RECORDS. INT. CL. 9. (U.S. CLS. 21, 23, 26, 36 AND 38). REG. 5-24-1988.
- 1,489,851. MISCELLANEOUS DESIGN. INT. CLS. 6, 11, 12, 20, 21 AND 22. (U.S. CLS. 2, 13, 19, 21, 30, 32, 34, 44 AND 50). REG. 5-31-1988.
- 1,489,893. VCM 44. INT. CL. 7. (U.S. CL. 23). REG. 5-31-1988.
- 1,489,911. OKB (STYLIZED). INT. CL. 7. (U.S. CL. 23). REG. 5-31-1988.
- 1,490,083. J AND DESIGN. INT. CL. 12. (U.S. CL. 19). REG. 5-31-1988.

- 1,490,181. CAMBRIDGE DRY GOODS. INT. CLS. 18 AND 25. (U.S. CLS. 3 AND 39). REG. 5-31-1988.
- 1,490,523. SWITCHCARE. INT. CL. 37. (U.S. CLS. 100, 103 AND 106). REG. 5-31-1988.
- 1,490,735. PERRON RIGOT AND DESIGN. INT. CL. 3. (U.S. CLS. 1, 4, 6, 50, 51 AND 52). REG. 6-7-1988.
- 1,490,876. ELINCHROM. INT. CL. 9. (U.S. CLS. 21 AND 26). REG. 6-7-1988.
- 1,491,124. SPIRIT. INT. CL. 16. (U.S. CL. 38). REG. 6-7-1988.
- 1,491,141. PYRO-FLEX (STYLIZED). INT. CL. 17. (U.S. CL. 12). REG. 6-7-1988.
- 1,491,249. SOFT SYSTEM. INT. CL. 25. (U.S. CL. 39). REG. 6-7-1988.
- 1,491,251. DULON. INT. CL. 26. (U.S. CL. 40). REG. 6-7-1988.
- 1,491,416. MEL JACKSON TAX SERVICE. INT. CL. 35. (U.S. CL. 101). REG. 6-7-1988.
- 1,491,683. AMERICAN VOLKSSPORT ASSOCIATION. INT. CL. 42. (U.S. CLS. 100 AND 107). REG. 6-7-1988.
- 1,491,744. LIPOZYME. INT. CL. 1. (U.S. CL. 6). REG. 6-14-1988.
- 1,491,755. BERKEBILE 2+2 AND DESIGN. INT. CLS. 1 AND 3. (U.S. CLS. 6 AND 52). REG. 6-14-1988.
- 1,491,785. PIT STOP. INT. CL. 1. (U.S. CL. 6). REG. 6-14-1988.
- 1,491,792. SAFEGUARD. INT. CL. 5 ONLY. (U.S. CL. 6). REG. 6-14-1988.
- 1,491,818. NEOPOL. INT. CL. 3. (U.S. CLS. 51 AND 52). REG. 6-14-1988.
- 1,491,819. FOR YOU. INT. CLS. 3 AND 5. (U.S. CLS. 18, 46, 51 AND 52). REG. 6-14-1988.
- 1,491,826. SAF-T-CURE AND DESIGN. INT. CL. 3. (U.S. CLS. 51 AND 52). REG. 6-14-1988.
- 1,491,881. EI AND DESIGN. INT. CLS. 4, 9, 19, 35, 37, 39, 40 AND 42 ONLY. (U.S. CLS. 1, 6, 12, 15, 21, 23, 26, 36, 38, 100, 101, 103, 105 AND 106). REG. 6-14-1988.
- 1,491,932. BIRDALL (STYLIZED). INT. CL. 5. (U.S. CLS. 18 AND 46). REG. 6-14-1988.
- 1,491,995. EB. INT. CL. 9. (U.S. CLS. 21, 23, 26, 36 AND 38). REG. 6-14-1988.
- 1,492,082. TRAM. INT. CL. 10. (U.S. CL. 44). REG. 6-14-1988.
- 1,492,094. GREENIE. INT. CL. 10. (U.S. CL. 44). REG. 6-14-1988.
- 1,492,165. 11. INT. CL. 16. (U.S. CLS. 2 AND 32). REG. 6-14-1988.
- 1,492,256. SECUR-TEM + POLY AND DESIGN. INT. CL. 19. (U.S. CLS. 12 AND 33). REG. 6-14-1988.
- 1,492,279. LIGHT & MUSIC LUIGI BORMIOLI AND DESIGN. INT. CL. 21. (U.S. CLS. 2, 13, 23, 29, 30, 33, 40 AND 50). REG. 6-14-1988.
- 1,492,295. BASE (STYLIZED). INT. CL. 24. (U.S. CL. 42). REG. 6-14-1988.
- 1,492,300. PATHFINDER. INT. CL. 25. (U.S. CL. 39). REG. 6-14-1988.
- 1,492,365. MISCELLANEOUS DESIGN. INT. CL. 28. (U.S. CL. 22). REG. 6-14-1988.
- 1,492,380. FUN IN THE SUN. INT. CL. 28. (U.S. CL. 22). REG. 6-14-1988.
- 1,492,455. HOT 'N SLIM. INT. CL. 29. (U.S. CL. 46). REG. 6-14-1988.
- 1,492,486. HEARTH & SKILLET. INT. CL. 30. (U.S. CL. 46). REG. 6-14-1988.
- 1,492,655. TEACH-O-RAMA. INT. CL. 41. (U.S. CL. 107). REG. 6-14-1988.
- 1,492,764. NYCOA. INT. CL. 1. (U.S. CLS. 1 AND 6). REG. 6-21-1988.
- 1,492,822. SATURATION. INT. CL. 3. (U.S. CL. 51). REG. 6-21-1988.
- 1,492,844. LURON. INT. CL. 3. (U.S. CL. 51). REG. 6-21-1988.
- 1,493,078. BEAUTY HANDBOOK. INT. CL. 16. (U.S. CL. 38). REG. 6-21-1988.
- 1,493,212. CARRIE ALLEN. INT. CL. 25. (U.S. CL. 39). REG. 6-21-1988.
- 1,493,335. THE ORIGINAL CHILI BOWL. INT. CL. 29. (U.S. CL. 46). REG. 6-21-1988.
- 1,493,575. AJF. INT. CL. 39. (U.S. CLS. 100 AND 105). REG. 6-21-1988.
- 1,493,792. PEPPERMINT SCRUB. INT. CL. 3. (U.S. CL. 52). REG. 6-28-1988.
- 1,493,883. VIBRA-FLEX. INT. CL. 7. (U.S. CL. 23). REG. 6-28-1988.
- 1,493,954. MISCELLANEOUS DESIGN. INT. CL. 9. (U.S. CL. 21). REG. 6-28-1988.
- 1,494,181. DELTA AGRICULTURAL DIGEST. INT. CL. 16. (U.S. CL. 38). REG. 6-28-1988.
- 1,494,278. MBR. INT. CL. 19. (U.S. CL. 12). REG. 6-28-1988.
- 1,494,568. AJF A AND DESIGN. INT. CL. 39. (U.S. CLS. 100 AND 105). REG. 6-28-1988.
- 1,494,826. SELFER (STYLIZED). INT. CL. 7. (U.S. CL. 23). REG. 7-5-1988.
- 1,494,827. FREE SANDER (STYLIZED). INT. CL. 7. (U.S. CL. 23). REG. 7-5-1988.
- 1,494,839. COLD STEEL. INT. CL. 8. (U.S. CL. 23). REG. 7-5-1988.
- 1,495,164. PSYCHO. INT. CL. 25. (U.S. CL. 39). REG. 7-5-1988.
- 1,495,434. PONY BASEBALL. INT. CL. 41. (U.S. CL. 107). REG. 7-5-1988.
- 1,495,464. SHOWCASE. INT. CL. 42. (U.S. CL. 101). REG. 7-5-1988.
- 1,495,810. NOVOFLO. INT. CL. 19. (U.S. CL. 12). REG. 7-12-1988.
- 1,496,009. QUIK TATERS. INT. CL. 29. (U.S. CL. 46). REG. 7-12-1988.
- 1,496,177. SAFETY-KLEEN. INT. CL. 37. (U.S. CLS. 100, 103 AND 106). REG. 7-12-1988.
- 1,496,309. AZERTY. INT. CL. 42. (U.S. CL. 101). REG. 7-12-1988.
- 1,496,392. INSULCEL. INT. CL. 1. (U.S. CL. 6). REG. 7-19-1988.
- 1,496,910. CHAMPIGNON. INT. CL. 29. (U.S. CL. 46). REG. 7-19-1988.
- 1,497,340. VONSCHRADER AND DESIGN. INT. CLS. 3, 7 AND 35. (U.S. CLS. 6, 23, 52 AND 101). REG. 7-26-1988.
- 1,497,437. ATRA (STYLIZED). INT. CL. 7. (U.S. CL. 23). REG. 7-26-1988.
- 1,497,438. JETBROACH (STYLIZED). INT. CL. 7. (U.S. CL. 23). REG. 7-26-1988.
- 1,497,472. AUTO GAGE (STYLIZED). INT. CL. 9. (U.S. CL. 26). REG. 7-26-1988.
- 1,497,708. SCHOCKEN. INT. CL. 16. (U.S. CL. 38). REG. 7-26-1988.
- 1,497,744. PERFRIT (STYLIZED). INT. CL. 19. (U.S. CL. 12). REG. 7-26-1988.
- 1,497,766. PLASTEEL. INT. CL. 20. (U.S. CL. 32). REG. 7-26-1988.
- 1,498,194. GCO-10 LM WITH VISIGARD. INT. CL. 1. (U.S. CLS. 1, 5, 6, 10, 26 AND 46). REG. 8-2-1988.
- 1,499,793. GRANDMA BURGER'S. INT. CL. 29. (U.S. CL. 46). REG. 8-9-1988.
- 1,499,839. PAULA. INT. CL. 31. (U.S. CL. 46). REG. 8-9-1988.
- 1,500,427. CON-TECH AND DESIGN. INT. CL. 11. (U.S. CL. 21). REG. 8-16-1988.
- 1,500,484. CARRYPAC. INT. CL. 16. (U.S. CLS. 2, 5, 22, 23, 29, 37, 38 AND 50). REG. 8-16-1988.
- 1,500,485. ULTRAPAC. INT. CL. 16. (U.S. CL. 37). REG. 8-16-1988.
- 1,501,310. ONE YEAR. INT. CL. 16. (U.S. CLS. 37 AND 38). REG. 8-23-1988.
- 1,501,412. POLYSORB. INT. CL. 25. (U.S. CL. 39). REG. 8-23-1988.
- 1,501,503. GUY'S AND DESIGN. INT. CL. 29. (U.S. CL. 46). REG. 8-23-1988.
- 1,503,341. MISCELLANEOUS DESIGN. INT. CL. 41. (U.S. CL. 107). REG. 9-6-1988.
- 1,503,514. 1 SHOT. INT. CL. 2. (U.S. CL. 16). REG. 9-13-1988.
- 1,504,113. BANDIT. INT. CL. 28. (U.S. CL. 22). REG. 9-13-1988.
- 1,504,397. KATE MANTILINI. INT. CL. 42. (U.S. CL. 100). REG. 9-13-1988.
- 1,505,488. HELDFOND FORMULA. INT. CL. 3. (U.S. CL. 51). REG. 9-27-1988.
- 1,506,731. D*B*C. INT. CL. 1. (U.S. CL. 6). REG. 10-4-1988.
- 1,506,750. TAB-DET. INT. CL. 3. (U.S. CL. 52). REG. 10-4-1988.
- 1,508,087. COUNTRY SAMPLER. INT. CL. 16. (U.S. CL. 38). REG. 10-11-1988.
- 1,508,372. MISCELLANEOUS DESIGN. INT. CL. 28. (U.S. CL. 22). REG. 10-11-1988.
- 1,508,740. SUPER SAVE-LITE. INT. CL. 2. (U.S. CLS. 6, 11 AND 16). REG. 10-18-1988.
- 1,509,307. L7 AND DESIGN. INT. CL. 25. (U.S. CLS. 22 AND 39). REG. 10-18-1988.
- 1,509,352. TIARA. INT. CL. 27. (U.S. CL. 42). REG. 10-18-1988.
- 1,510,150. CHECKERS. INT. CL. 20. (U.S. CLS. 19 AND 50). REG. 10-25-1988.
- 1,514,217. SUNSHINE. INT. CL. 1. (U.S. CL. 6). REG. 11-29-1988.

- 1,514,402. MORTARA AND DESIGN. INT. CL. 9. (U.S. CL. 21). REG. 11-29-1988.
- 1,516,124. PENETRATE. INT. CL. 3. (U.S. CLS. 6 AND 52). REG. 12-13-1988.
- 1,516,938. SUPER "NO RINSE". INT. CL. 3. (U.S. CL. 52). REG. 12-20-1988.
- 1,516,981. KERNEL GUARD. INT. CL. 5. (U.S. CL. 6). REG. 12-20-1988.
- 1,517,389. KENDERMANNSSTANDARD CHARACTER MARK INT. CL. 33. (U.S. CL. 47). REG. 12-20-1988.
- 1,517,463. CENTIMARK CORPORATION. INT. CL. 37. (U.S. CL. 103). REG. 12-20-1988.
- 1,518,324. FAMILYNET. INT. CLS. 38 AND 41. (U.S. CLS. 104 AND 107). REG. 12-27-1988.
- 1,520,651. CELLSHIPPER. INT. CL. 9. (U.S. CLS. 2, 26 AND 38). REG. 1-17-1989.
- 1,525,447. MAST. INT. CL. 9. (U.S. CL. 38). REG. 2-21-1989.
- 1,526,617. RANWOOD AND DESIGN. INT. CL. 9. (U.S. CL. 36). REG. 2-28-1989.
- 1,526,634. ROI AND DESIGN. INT. CL. 9. (U.S. CL. 26). REG. 2-28-1989.
- 1,527,257. NURSERY. INT. CL. 32. (U.S. CL. 45). REG. 2-28-1989.
- 1,528,455. IN-N-OUT BURGER AND DESIGN. INT. CLS. 29, 30, 32 AND 42. (U.S. CLS. 45, 46 AND 100). REG. 3-7-1989.
- 1,528,456. IN-N-OUT BURGER AND DESIGN. INT. CLS. 29, 30, 32 AND 42. (U.S. CLS. 45, 46 AND 100). REG. 3-7-1989.
- 1,528,795. CYCLE SYSTEMS. INT. CL. 40. (U.S. CL. 106). REG. 3-7-1989.
- 1,529,454. MISCELLANEOUS DESIGN. INT. CL. 9. (U.S. CL. 36). REG. 3-14-1989.
- 1,529,455. VANGUARD (STYLIZED). INT. CL. 9. (U.S. CL. 36). REG. 3-14-1989.
- 1,530,077. THE WORLD FUND. INT. CL. 36. (U.S. CL. 102). REG. 3-14-1989.
- 1,531,598. Q QUANNAH (STYLIZED). INT. CL. 6. (U.S. CL. 13). REG. 3-28-1989.
- 1,532,234. SHENG KEE AND DESIGN. INT. CL. 30. (U.S. CL. 46). REG. 3-28-1989.
- 1,532,988. LETTER FROM EUROPE. INT. CL. 16. (U.S. CL. 38). REG. 4-4-1989.
- 1,532,989. LETTER FROM WASHINGTON. INT. CL. 16. (U.S. CL. 38). REG. 4-4-1989.
- 1,533,472. ROSSONE. INT. CLS. 29 AND 30. (U.S. CL. 46). REG. 4-4-1989.
- 1,533,516. BLUEJAY. INT. CL. 31. (U.S. CL. 46). REG. 4-4-1989.
- 1,536,308. MAGNOLIA S-O-F-T-Y AND DESIGN. INT. CL. 11. (U.S. CL. 13). REG. 4-25-1989.
- 1,537,178. FRAGRA MATICS AND DESIGN. INT. CL. 5. (U.S. CL. 6). REG. 5-2-1989.
- 1,539,047. THE LOW PRESSURE PEOPLE. INT. CL. 9. (U.S. CL. 26). REG. 5-16-1989.
- 1,539,451. IN-N-OUT BURGER AND DESIGN. INT. CLS. 29, 30, 32 AND 42. (U.S. CLS. 45, 46 AND 100). REG. 5-16-1989.
- 1,539,820. STI (STYLIZED). U.S. CL. 200. REG. 5-16-1989.
- 1,539,837. MICRORAM. INT. CL. 9. (U.S. CL. 21). REG. 5-16-1989.
- 1,542,373. H10-40. INT. CL. 9. (U.S. CL. 21). REG. 6-6-1989.
- 1,542,374. H10-30. INT. CL. 9. (U.S. CL. 21). REG. 6-6-1989.
- 1,542,860. FLORIDA LOTTERY AND DESIGN. INT. CL. 36. (U.S. CLS. 100, 101 AND 102). REG. 6-6-1989.
- 1,543,562. CERTI-SAWN. INT. CL. 19. (U.S. CL. 12). REG. 6-13-1989.
- 1,544,016. LEMSTONE. INT. CL. 42. (U.S. CL. 101). REG. 6-13-1989.
- 2,015,244. MEDIBOTTLE. INT. CL. 10. (U.S. CLS. 26, 39 AND 44). REG. 11-12-1996.
- 2,064,176. STROBEL. INT. CLS. 24 AND 25. (U.S. CLS. 22, 39, 42 AND 50). REG. 5-20-1997.
- 2,097,072. MAGNOLIA SPRINGS. INT. CL. 32. (U.S. CLS. 45, 46 AND 48). REG. 9-16-1997.
- 2,108,451. SERVERTRANSPARENCY. INT. CL. 9. (U.S. CLS. 21, 23, 26, 36 AND 38). REG. 10-28-1997.
- 2,114,381. ODOR-ARMOR. INT. CL. 5. (U.S. CLS. 6, 18, 44, 46, 51 AND 52). REG. 11-18-1997.
- 2,117,317. RESOLUTION SERIES. INT. CL. 9. (U.S. CLS. 21, 23, 26, 36 AND 38). REG. 12-2-1997.
- 2,119,254. FAITH (STYLIZED). INT. CL. 25. (U.S. CLS. 22 AND 39). REG. 12-9-1997.
- 2,119,799. LFIC. INT. CL. 10. (U.S. CLS. 26, 39 AND 44). REG. 12-9-1997.
- 2,120,122. Z-FLAKES. INT. CL. 29 ONLY. (U.S. CL. 46 ONLY). REG. 12-9-1997.
- 2,120,400. DELI DINNERS. INT. CL. 29. (U.S. CL. 46). REG. 12-9-1997.
- 2,120,531. PRIMUS. INT. CL. 33. (U.S. CLS. 47 AND 49). REG. 12-9-1997.
- 2,120,757. APT. INT. CL. 9. (U.S. CLS. 21, 23, 26, 36 AND 38). REG. 12-16-1997.
- 2,120,979. NATIONAL LIBRARY OF MEDICINE 1836 AND DESIGN. INT. CL. 42. (U.S. CLS. 100 AND 101). REG. 12-16-1997.
- 2,121,013. OLD NAVY. INT. CL. 9. (U.S. CLS. 21, 23, 26, 36 AND 38). REG. 12-16-1997.
- 2,121,224. COMMERCIAL SALES AND DESIGN. INT. CL. 35. (U.S. CLS. 100, 101 AND 102). REG. 12-16-1997.
- 2,121,666. RENAISSANCE. INT. CL. 12. (U.S. CLS. 19, 21, 23, 31, 35 AND 44). REG. 12-16-1997.
- 2,121,797. SUN BIRD (STYLIZED). INT. CL. 29 ONLY. (U.S. CL. 46). REG. 12-16-1997.
- 2,121,907. DRACOULL. INT. CL. 25. (U.S. CLS. 22 AND 39). REG. 12-16-1997.
- 2,121,912. UCF KNIGHTS AND DESIGN. INT. CLS. 25 AND 41. (U.S. CLS. 22, 39, 100, 101 AND 107). REG. 12-16-1997.
- 2,122,473. NATURSPAN. INT. CL. 1 ONLY. (U.S. CLS. 1, 5, 6, 10, 26 AND 46). REG. 12-16-1997.
- 2,123,483. LIGHTLY EXPRESSED LTD.. INT. CL. 11. (U.S. CLS. 13, 21, 23, 31 AND 34). REG. 12-23-1997.
- 2,123,625. SOMETHING YOU CAN COUNT ON ... AND MORE!. INT. CL. 36. (U.S. CLS. 100, 101 AND 102). REG. 12-23-1997.
- 2,123,645. ATHENA. INT. CLS. 6 AND 14. (U.S. CLS. 2, 12, 13, 14, 23, 25, 27, 28 AND 50). REG. 12-23-1997.
- 2,124,041. UNCLE WIGGILY. INT. CL. 25. (U.S. CLS. 22 AND 39). REG. 12-23-1997.
- 2,125,551. HATTERAS WORLD (STYLIZED). INT. CL. 16. (U.S. CLS. 2, 5, 22, 23, 29, 37, 38 AND 50). REG. 12-30-1997.
- 2,125,600. HISTOSTAIN. INT. CL. 1. (U.S. CLS. 1, 5, 6, 10, 26 AND 46). REG. 12-30-1997.
- 2,125,739. POETA MODA. INT. CL. 25. (U.S. CLS. 22 AND 39). REG. 12-30-1997.
- 2,126,049. FLASHGARD. INT. CL. 19. (U.S. CLS. 1, 12, 33 AND 50). REG. 12-30-1997.
- 2,127,286. WWW.INVENTION.COM. INT. CL. 42. (U.S. CLS. 100 AND 101). REG. 1-6-1998.
- 2,127,287. INVENTION. INT. CL. 42. (U.S. CLS. 100 AND 101). REG. 1-6-1998.
- 2,128,912. INVENTION.COM. INT. CL. 42. (U.S. CLS. 100 AND 101). REG. 1-13-1998.
- 2,130,523. ARE YOUR COWS GETTING THE MOST OUT OF THEIR CUD?. INT. CL. 5. (U.S. CLS. 6, 18, 44, 46, 51 AND 52). REG. 1-20-1998.
- 2,130,646. POST ROAD. INT. CL. 32. (U.S. CLS. 45, 46 AND 48). REG. 1-20-1998.
- 2,132,526. HONEST JOE COFFEE. INT. CLS. 30 AND 42. (U.S. CLS. 46, 100 AND 101). REG. 1-27-1998.
- 2,133,434. LIVE BY REQUEST. INT. CL. 41. (U.S. CLS. 100, 101 AND 107). REG. 1-27-1998.
- 2,133,921. MISCELLANEOUS DESIGN. INT. CL. 5. (U.S. CLS. 6, 18, 44, 46, 51 AND 52). REG. 2-3-1998.
- 2,137,312. LIL' ANGELS PHOTOGRAPHY. INT. CL. 42. (U.S. CLS. 100 AND 101). REG. 2-17-1998.
- 2,138,406. INDUSPARQUET. INT. CL. 19. (U.S. CLS. 1, 12, 33 AND 50). REG. 2-24-1998.
- 2,140,157. GRAMMAR SMART. INT. CL. 16. (U.S. CLS. 2, 5, 22, 23, 29, 37, 38 AND 50). REG. 3-3-1998.
- 2,140,854. BIG MOUTH. INT. CL. 11. (U.S. CLS. 13, 21, 23, 31 AND 34). REG. 3-3-1998.
- 2,141,114. BRANDFORCE. INT. CL. 35. (U.S. CLS. 100, 101 AND 102). REG. 3-3-1998.
- 2,141,708. CHERNE. INT. CL. 8. (U.S. CLS. 23, 28 AND 44). REG. 3-10-1998.
- 2,142,121. SPIRO. INT. CL. 11. (U.S. CLS. 13, 21, 23, 31 AND 34). REG. 3-10-1998.
- 2,145,170. TRIMEC. INT. CL. 9. (U.S. CLS. 21, 23, 26, 36 AND 38). REG. 3-17-1998.
- 2,149,266. GRAD WEEK. INT. CL. 39. (U.S. CLS. 100 AND 105). REG. 4-7-1998.
- 2,150,168. LOGIC TECHNOLOGIES. INT. CL. 9. (U.S. CLS. 21, 23, 26, 36 AND 38). REG. 4-14-1998.

- 2,150,865. THUNDER BLUNDERS. INT. CL. 28. (U.S. CLS. 22, 23, 38 AND 50). REG. 4-14-1998.
- 2,154,143. THE GIFT THEY USE THE WAY THEY CHOOSE. INT. CL. 39. (U.S. CLS. 100 AND 105). REG. 4-28-1998.
- 2,154,469. HEALTHY BITES. INT. CLS. 29 AND 30. (U.S. CL. 46). REG. 5-5-1998.
- 2,154,560. AT&T ONE RATE. INT. CL. 38. (U.S. CLS. 100, 101 AND 104). REG. 5-5-1998.
- 2,154,836. BRASS BEDS OF VIRGINIA MADE IN THE SULTRY SOUTH AND DESIGN. INT. CL. 20. (U.S. CLS. 2, 13, 22, 25, 32 AND 50). REG. 5-5-1998.
- 2,154,851. LUSCO'S. INT. CL. 30. (U.S. CL. 46). REG. 5-5-1998.
- 2,154,985. SERIDISC. INT. CL. 2. (U.S. CLS. 6, 11 AND 16). REG. 5-5-1998.
- 2,155,083. HEALTH EDUCATION ALLIANCE (STYLIZED). INT. CLS. 9, 16 AND 41. (U.S. CLS. 2, 5, 21, 22, 23, 26, 29, 36, 37, 38, 50, 100, 101 AND 107). REG. 5-5-1998.
- 2,155,286. RETAIN. INT. CL. 1. (U.S. CLS. 1, 5, 6, 10, 26 AND 46). REG. 5-5-1998.
- 2,155,418. DON'T FORGET THE GUY'S. INT. CLS. 29 AND 30. (U.S. CL. 46). REG. 5-5-1998.
- 2,155,445. SACHA. INT. CL. 25. (U.S. CLS. 22 AND 39). REG. 5-5-1998.
- 2,155,453. L'ONIE. INT. CL. 42. (U.S. CLS. 100 AND 101). REG. 5-5-1998.
- 2,155,505. WHERE THE HEART MEETS THE SOUL. INT. CL. 42. (U.S. CLS. 100 AND 101). REG. 5-5-1998.
- 2,155,531. LIGHTGIFT. INT. CL. 9. (U.S. CLS. 21, 23, 26, 36 AND 38). REG. 5-5-1998.
- 2,155,617. APPLAUSE AFFINITY. INT. CL. 24. (U.S. CLS. 42 AND 50). REG. 5-5-1998.
- 2,156,050. THE WIRE NEWS FROM THE ASSOCIATED PRESS AND DESIGN. INT. CL. 42. (U.S. CLS. 100 AND 101). REG. 5-12-1998.
- 2,156,066. MILLCREEK COFFEE ROASTERS. INT. CL. 30. (U.S. CL. 46). REG. 5-12-1998.
- 2,156,067. MILLCREEK COFFEE ROASTERS AND DESIGN. INT. CL. 30. (U.S. CL. 46). REG. 5-12-1998.
- 2,156,182. CARTE NOIRE. INT. CL. 30. (U.S. CL. 46). REG. 5-12-1998.
- 2,156,231. MCR. INT. CL. 41. (U.S. CLS. 100, 101 AND 107). REG. 5-12-1998.
- 2,157,144. SKYLINK. INT. CL. 9. (U.S. CLS. 21, 23, 26, 36 AND 38). REG. 5-12-1998.
- 2,157,298. FISHING FEVER. INT. CL. 9. (U.S. CLS. 21, 23, 26, 36 AND 38). REG. 5-12-1998.
- 2,157,583. SIMULFLUOR. INT. CLS. 1 AND 5. (U.S. CLS. 1, 5, 6, 10, 18, 26, 44, 46, 51 AND 52). REG. 5-12-1998.
- 2,158,131. TECSYS (STYLIZED). INT. CLS. 9 AND 42. (U.S. CLS. 21, 23, 26, 36, 38, 100 AND 101). REG. 5-19-1998.
- 2,158,258. TWISTALL. INT. CL. 16. (U.S. CLS. 2, 5, 22, 23, 29, 37, 38 AND 50). REG. 5-19-1998.
- 2,158,498. MISCELLANEOUS DESIGN. INT. CL. 21. (U.S. CLS. 2, 13, 23, 29, 30, 33, 40 AND 50). REG. 5-19-1998.
- 2,158,871. JOLLY PETS. INT. CL. 28. (U.S. CLS. 22, 23, 38 AND 50). REG. 5-19-1998.
- 2,158,944. TITAN. INT. CL. 9. (U.S. CLS. 21, 23, 26, 36 AND 38). REG. 5-19-1998.
- 2,159,005. MUNDY GAROTO AND DESIGN. INT. CL. 30. (U.S. CL. 46). REG. 5-19-1998.
- 2,159,150. NATURAL COOL MOISTURE. INT. CL. 11. (U.S. CLS. 13, 21, 23, 31 AND 34). REG. 5-19-1998.
- 2,159,153. CRYSTAL LIGHT. INT. CL. 32. (U.S. CLS. 45, 46 AND 48). REG. 5-19-1998.
- 2,159,228. RES-Q. INT. CL. 42. (U.S. CLS. 100 AND 101). REG. 5-19-1998.
- 2,159,391. SMART IDEAS. INT. CL. 9. (U.S. CLS. 21, 23, 26, 36 AND 38). REG. 5-19-1998.
- 2,159,750. THE BIG UNIT. INT. CL. 25. (U.S. CLS. 22 AND 39). REG. 5-19-1998.
- 2,160,063. ISDA & CO. INT. CLS. 25 AND 35. (U.S. CLS. 22, 39, 100, 101 AND 102). REG. 5-26-1998.
- 2,160,090. ULTRA-FLOW. INT. CL. 12. (U.S. CLS. 19, 21, 23, 31, 35 AND 44). REG. 5-26-1998.
- 2,160,189. AFA AND DESIGN. U.S. CL. 200. REG. 5-26-1998.
- 2,160,210. AMERICAN FASTPITCH ASSOCIATION. U.S. CL. 200. REG. 5-26-1998.
- 2,160,211. AMERICAN FASTPITCH ASSOCIATION. INT. CL. 25. (U.S. CLS. 22 AND 39). REG. 5-26-1998.
- 2,160,275. E-Z TRENCH. INT. CL. 7. (U.S. CLS. 13, 19, 21, 23, 31, 34 AND 35). REG. 5-26-1998.
- 2,160,313. VELVEL. INT. CL. 9. (U.S. CLS. 21, 23, 26, 36 AND 38). REG. 5-26-1998.
- 2,160,314. VELVEL AND DESIGN. INT. CL. 9. (U.S. CLS. 21, 23, 26, 36 AND 38). REG. 5-26-1998.
- 2,160,418. TSE. INT. CL. 25. (U.S. CLS. 22 AND 39). REG. 5-26-1998.
- 2,160,456. MISCELLANEOUS DESIGN. INT. CL. 39. (U.S. CLS. 100 AND 105). REG. 5-26-1998.
- 2,160,468. MONARCH DENTAL. INT. CLS. 35 AND 42. (U.S. CLS. 100, 101 AND 102). REG. 5-26-1998.
- 2,160,601. TRADER JOE'S. INT. CL. 29. (U.S. CL. 46). REG. 5-26-1998.
- 2,160,725. OUTDOOR LIFE. INT. CL. 38. (U.S. CLS. 100, 101 AND 104). REG. 5-26-1998.
- 2,161,044. JOURNEY. INT. CL. 16. (U.S. CLS. 2, 5, 22, 23, 29, 37, 38 AND 50). REG. 5-26-1998.
- 2,161,053. EDIFICE WRECKS AND DESIGN. INT. CLS. 25 AND 37. (U.S. CLS. 22, 39, 100, 103 AND 106). REG. 5-26-1998.
- 2,161,300. EASY KOTE. INT. CL. 2. (U.S. CLS. 6, 11 AND 16). REG. 6-2-1998.
- 2,161,355. THE RICHTER SCALE. INT. CL. 16. (U.S. CLS. 2, 5, 22, 23, 29, 37, 38 AND 50). REG. 6-2-1998.
- 2,161,395. MCCARDLE. INT. CL. 36. (U.S. CLS. 100, 101 AND 102). REG. 6-2-1998.
- 2,161,535. NICOLE COLLECTION. INT. CLS. 8, 16, 21 AND 24. (U.S. CLS. 2, 5, 13, 22, 23, 28, 29, 30, 33, 37, 38, 40, 42, 44 AND 50). REG. 6-2-1998.
- 2,161,665. SYSTEM 75. INT. CL. 8. (U.S. CLS. 23, 28 AND 44). REG. 6-2-1998.
- 2,161,782. EZ TEC. INT. CL. 28. (U.S. CLS. 22, 23, 38 AND 50). REG. 6-2-1998.
- 2,161,790. URGENT ACTION AMNESTY INTERNATIONAL AND DESIGN. INT. CL. 42. (U.S. CLS. 100 AND 101). REG. 6-2-1998.
- 2,161,930. MASTERS INN ECONOMY AND DESIGN. INT. CL. 42. (U.S. CLS. 100 AND 101). REG. 6-2-1998.
- 2,162,019. COOL-QUILT. INT. CL. 10. (U.S. CLS. 26, 39 AND 44). REG. 6-2-1998.
- 2,162,275. BBC AND DESIGN. INT. CL. 42. (U.S. CLS. 100 AND 101). REG. 6-2-1998.
- 2,162,373. LOBBYVISION. INT. CLS. 7 AND 9. (U.S. CLS. 13, 19, 21, 23, 26, 31, 34, 35, 36 AND 38). REG. 6-2-1998.
- 2,162,428. EAGLE PD AND DESIGN. INT. CL. 7 ONLY. (U.S. CLS. 13, 19, 21, 23, 31, 34 AND 35). REG. 6-2-1998.
- 2,162,467. BUCKLE-DOWN SKATEGOODS. INT. CL. 25. (U.S. CLS. 22 AND 39). REG. 6-2-1998.
- 2,162,502. TOTAL REACH. INT. CL. 9. (U.S. CLS. 21, 23, 26, 36 AND 38). REG. 6-2-1998.
- 2,162,539. LOXYS. INT. CL. 9. (U.S. CLS. 21, 23, 26, 36 AND 38). REG. 6-2-1998.
- 2,162,564. CSS HRIZON. INT. CL. 9. (U.S. CLS. 21, 23, 26, 36 AND 38). REG. 6-2-1998.
- 2,162,624. UNIGRAVE. INT. CL. 6. (U.S. CLS. 2, 12, 13, 14, 23, 25 AND 50). REG. 6-2-1998.
- 2,162,985. CREDITMASTER. INT. CL. 9. (U.S. CLS. 21, 23, 26, 36 AND 38). REG. 6-9-1998.
- 2,163,268. SHARE TECHNOLOGY CONNECTIONS RESULTS AND DESIGN. INT. CLS. 16, 41 AND 42. (U.S. CLS. 2, 5, 22, 23, 29, 37, 38, 50, 100, 101 AND 107). REG. 6-9-1998.
- 2,163,273. RENO A&E. INT. CLS. 9 AND 42. (U.S. CLS. 21, 23, 26, 36, 38, 100 AND 101). REG. 6-9-1998.
- 2,163,281. BIGTIME. INT. CL. 16. (U.S. CLS. 2, 5, 22, 23, 29, 37, 38 AND 50). REG. 6-9-1998.
- 2,163,282. JAM TV. INT. CL. 41. (U.S. CLS. 100, 101 AND 107). REG. 6-9-1998.
- 2,163,324. POWERPULSE. INT. CL. 7. (U.S. CLS. 13, 19, 21, 23, 31, 34 AND 35). REG. 6-9-1998.
- 2,163,356. RECOGNIZE HER STRENGTHS...ENCOURAGE HER DREAMS. INT. CL. 41. (U.S. CLS. 100, 101 AND 107). REG. 6-9-1998.
- 2,163,376. SMALL WORLD MINISTRIES, INC. WHERE LITTLE ONES TO HIM BELONG AND DESIGN. INT. CL. 36 ONLY. (U.S. CLS. 100, 101 AND 102). REG. 6-9-1998.
- 2,163,480. MISCELLANEOUS DESIGN. INT. CL. 5. (U.S. CLS. 6, 18, 44, 46, 51 AND 52). REG. 6-9-1998.
- 2,163,514. E AND DESIGN. INT. CL. 25. (U.S. CLS. 22 AND 39). REG. 6-9-1998.
- 2,163,561. TRACTOR BRAND JEANS AND DESIGN. INT. CL. 25. (U.S. CLS. 22 AND 39). REG. 6-9-1998.

- 2,163,581. ROAD ONE. INT. CLS. 37 AND 39. (U.S. CLS. 100, 103, 105 AND 106). REG. 6-9-1998.
- 2,163,723. MT WOODGEE (STYLIZED). INT. CLS. 25 AND 28. (U.S. CLS. 22, 23, 38, 39 AND 50). REG. 6-9-1998.
- 2,163,734. CRYSTAL CLEAR. INT. CL. 35. (U.S. CLS. 100, 101 AND 102). REG. 6-9-1998.
- 2,163,746. INTERNATIONAL LIFE SCIENCES INSTITUTE. INT. CLS. 16, 36 AND 41. (U.S. CLS. 2, 5, 22, 23, 29, 37, 38, 50, 100, 101, 102 AND 107). REG. 6-9-1998.
- 2,163,812. CHESAPEAKE WALLCOVERINGS CORPORATION. INT. CL. 27. (U.S. CLS. 19, 20, 37, 42 AND 50). REG. 6-9-1998.
- 2,163,959. MISCELLANEOUS DESIGN. INT. CL. 9. (U.S. CLS. 21, 23, 26, 36 AND 38). REG. 6-9-1998.
- 2,163,996. STAX. INT. CL. 9. (U.S. CLS. 21, 23, 26, 36 AND 38). REG. 6-9-1998.
- 2,164,043. FIRESTAR. INT. CL. 3. (U.S. CLS. 1, 4, 6, 50, 51 AND 52). REG. 6-9-1998.
- 2,164,120. HAB, INC. INT. CLS. 35 AND 36. (U.S. CLS. 100, 101 AND 102). REG. 6-9-1998.
- 2,164,138. WE SOLVE PROBLEMS. INT. CL. 35. (U.S. CLS. 100, 101 AND 102). REG. 6-9-1998.
- 2,164,201. TRES LECHES DE MEXICO. INT. CL. 30. (U.S. CL. 46). REG. 6-9-1998.
- 2,164,284. ULTIMATE ENERGY. INT. CL. 5. (U.S. CLS. 6, 18, 44, 46, 51 AND 52). REG. 6-9-1998.
- 2,164,286. EL PASADO AUTHENTIC MEXICAN CUISINE WITH A TOUCH OF THE PAST AND DESIGN. INT. CLS. 29 AND 30. (U.S. CL. 46). REG. 6-9-1998.
- 2,164,451. HEATLOK. INT. CL. 17. (U.S. CLS. 1, 5, 12, 13, 35 AND 50). REG. 6-9-1998.
- 2,164,539. PERRY ELLIS AMERICA. INT. CL. 25. (U.S. CLS. 22 AND 39). REG. 6-9-1998.
- 2,164,592. VEGA SINDOA. INT. CL. 33. (U.S. CLS. 47 AND 49). REG. 6-9-1998.
- 2,164,603. REVERSIBLE HUGS. INT. CL. 14. (U.S. CLS. 2, 27, 28 AND 50). REG. 6-9-1998.
- 2,164,611. RED ZENITH. INT. CL. 31. (U.S. CLS. 1 AND 46). REG. 6-9-1998.
- 2,164,654. VTA. INT. CL. 16. (U.S. CLS. 2, 5, 22, 23, 29, 37, 38 AND 50). REG. 6-9-1998.
- 2,164,671. ALL-FAN. INT. CL. 9. (U.S. CLS. 21, 23, 26, 36 AND 38). REG. 6-9-1998.
- 2,164,788. PGC. INT. CL. 14. (U.S. CLS. 2, 27, 28 AND 50). REG. 6-9-1998.
- 2,164,789. REGIONS HOSPITAL. INT. CL. 42. (U.S. CLS. 100 AND 101). REG. 6-9-1998.
- 2,164,835. SAFEAIR. INT. CL. 9. (U.S. CLS. 21, 23, 26, 36 AND 38). REG. 6-9-1998.
- 2,164,855. TOTAL GREASE MANAGEMENT. INT. CL. 37. (U.S. CLS. 100, 103 AND 106). REG. 6-9-1998.
- 2,164,912. CONSTANT CONTAMINATION CONTROL. INT. CL. 11. (U.S. CLS. 13, 21, 23, 31 AND 34). REG. 6-16-1998.
- 2,164,953. ICON. INT. CLS. 9, 28 AND 42. (U.S. CLS. 21, 22, 23, 26, 36, 38, 50, 100 AND 101). REG. 6-16-1998.
- 2,164,958. WATSON. INT. CL. 9. (U.S. CLS. 21, 23, 26, 36 AND 38). REG. 6-16-1998.
- 2,164,976. WRR. INT. CLS. 39, 40 AND 42 ONLY. (U.S. CLS. 100, 101, 103, 105 AND 106). REG. 6-16-1998.
- 2,164,980. DYNASYS. INT. CLS. 9 AND 42. (U.S. CLS. 21, 23, 26, 36, 38, 100 AND 101). REG. 6-16-1998.
- 2,164,999. PAINT 'N TEX. INT. CL. 2. (U.S. CLS. 6, 11 AND 16). REG. 6-16-1998.
- 2,165,021. BIG-IP. INT. CLS. 9 AND 42. (U.S. CLS. 21, 23, 26, 36, 38, 100 AND 101). REG. 6-16-1998.
- 2,165,042. JOSEF FRANK. INT. CLS. 6, 11, 14, 16, 20, 21, 24 AND 27 ONLY. (U.S. CLS. 2, 5, 12, 13, 14, 19, 20, 21, 22, 23, 25, 27, 28, 29, 30, 31, 32, 33, 34, 37, 38, 40, 42 AND 50). REG. 6-16-1998.
- 2,165,101. RWD AND DESIGN. INT. CL. 42. (U.S. CLS. 100 AND 101). REG. 6-16-1998.
- 2,165,102. OLD NORTH CHURCH. INT. CL. 16. (U.S. CLS. 2, 5, 22, 23, 29, 37, 38 AND 50). REG. 6-16-1998.
- 2,165,145. MISCELLANEOUS DESIGN. INT. CLS. 35 AND 42. (U.S. CLS. 100, 101 AND 102). REG. 6-16-1998.
- 2,165,150. RENO A & E AND DESIGN. INT. CLS. 9 AND 42. (U.S. CLS. 21, 23, 26, 36, 38, 100 AND 101). REG. 6-16-1998.
- 2,165,198. SRIM. INT. CL. 35. (U.S. CLS. 100, 101 AND 102). REG. 6-16-1998.
- 2,165,356. FDI AND DESIGN. INT. CLS. 35 AND 36. (U.S. CLS. 100, 101 AND 102). REG. 6-16-1998.
- 2,165,396. SARAH WOODE. INT. CL. 3. (U.S. CLS. 1, 4, 6, 50, 51 AND 52). REG. 6-16-1998.
- 2,165,443. REEL POWER. INT. CL. 9. (U.S. CLS. 21, 23, 26, 36 AND 38). REG. 6-16-1998.
- 2,165,521. ADVANTAGE. INT. CL. 9. (U.S. CLS. 21, 23, 26, 36 AND 38). REG. 6-16-1998.
- 2,165,535. IDSA. INT. CLS. 16, 35, 36 AND 42. (U.S. CLS. 2, 5, 22, 23, 29, 37, 38, 50, 100, 101 AND 102). REG. 6-16-1998.
- 2,165,585. LOOK SLIM WITHOUT THE GYM. INT. CL. 25. (U.S. CLS. 22 AND 39). REG. 6-16-1998.
- 2,165,612. HEALTHQUEST. INT. CL. 41. (U.S. CLS. 100, 101 AND 107). REG. 6-16-1998.
- 2,165,655. SAVE THE MUSIC. INT. CL. 42. (U.S. CLS. 100 AND 101). REG. 6-16-1998.
- 2,165,732. MODERN EDGE. INT. CLS. 18 AND 25. (U.S. CLS. 1, 2, 3, 22, 39 AND 41). REG. 6-16-1998.
- 2,165,778. VASOVIEW. INT. CL. 10. (U.S. CLS. 26, 39 AND 44). REG. 6-16-1998.
- 2,165,804. TRIENT. INT. CLS. 16 AND 42. (U.S. CLS. 2, 5, 22, 23, 29, 37, 38, 50, 100 AND 101). REG. 6-16-1998.
- 2,165,889. ORTEGA. INT. CL. 30. (U.S. CL. 46). REG. 6-16-1998.
- 2,165,902. ROYAL FIORD. INT. CL. 29. (U.S. CL. 46). REG. 6-16-1998.
- 2,166,023. CARNIVAL CRUISE AND DESIGN. INT. CL. 28. (U.S. CLS. 22, 23, 38 AND 50). REG. 6-16-1998.
- 2,166,042. SYNCHRON LX. INT. CLS. 5 AND 10. (U.S. CLS. 6, 18, 26, 39, 44, 46, 51 AND 52). REG. 6-16-1998.
- 2,166,044. THEORIA. INT. CL. 16 ONLY. (U.S. CLS. 2, 5, 22, 23, 29, 37, 38 AND 50). REG. 6-16-1998.
- 2,166,083. TURBO/MAXX. INT. CL. 12. (U.S. CLS. 19, 21, 23, 31, 35 AND 44). REG. 6-16-1998.
- 2,166,100. SCALP SCRIPTS. INT. CLS. 3, 26 AND 42. (U.S. CLS. 1, 4, 6, 37, 39, 40, 42, 50, 51, 52, 100 AND 101). REG. 6-16-1998.
- 2,166,136. MAX LAGER'S. INT. CL. 42. (U.S. CLS. 100 AND 101). REG. 6-16-1998.
- 2,166,138. THE BUYER'S GAMEPLAN. INT. CL. 35. (U.S. CLS. 100, 101 AND 102). REG. 6-16-1998.
- 2,166,144. BAX. INT. CL. 1. (U.S. CLS. 1, 5, 6, 10, 26 AND 46). REG. 6-16-1998.
- 2,166,149. HAL. INT. CL. 9. (U.S. CLS. 21, 23, 26, 36 AND 38). REG. 6-16-1998.
- 2,166,255. WELDWHEELS. INT. CL. 12. (U.S. CLS. 19, 21, 23, 31, 35 AND 44). REG. 6-16-1998.
- 2,166,303. RAINBOW. INT. CL. 9. (U.S. CLS. 21, 23, 26, 36 AND 38). REG. 6-16-1998.
- 2,166,321. GEM. INT. CL. 10. (U.S. CLS. 26, 39 AND 44). REG. 6-16-1998.
- 2,166,332. THE E-LOAN. INT. CL. 36. (U.S. CLS. 100, 101 AND 102). REG. 6-16-1998.
- 2,166,400. INTELLIMOTION. INT. CL. 10. (U.S. CLS. 26, 39 AND 44). REG. 6-16-1998.
- 2,166,432. EQUIVAC. INT. CL. 5. (U.S. CLS. 6, 18, 44, 46, 51 AND 52). REG. 6-16-1998.
- 2,166,438. GUNFIGHTER. INT. CL. 16. (U.S. CLS. 2, 5, 22, 23, 29, 37, 38 AND 50). REG. 6-16-1998.
- 2,166,439. SILBERCOTE. INT. CL. 2. (U.S. CLS. 6, 11 AND 16). REG. 6-16-1998.
- 2,166,479. SONTAC. INT. CL. 10. (U.S. CLS. 26, 39 AND 44). REG. 6-16-1998.
- 2,166,531. NICARAGUAN PRIDE. INT. CL. 34. (U.S. CLS. 2, 8, 9 AND 17). REG. 6-16-1998.
- 2,166,555. WINDLDR (STYLIZED). INT. CL. 9. (U.S. CLS. 21, 23, 26, 36 AND 38). REG. 6-16-1998.
- 2,166,759. MISCELLANEOUS DESIGN. INT. CLS. 39 AND 42. (U.S. CLS. 100, 101 AND 105). REG. 6-23-1998.
- 2,166,764. PRISM. INT. CL. 2. (U.S. CLS. 6, 11 AND 16). REG. 6-23-1998.
- 2,166,833. GRIZZLY. INT. CL. 7. (U.S. CLS. 13, 19, 21, 23, 31, 34 AND 35). REG. 6-23-1998.
- 2,166,978. EASTERN ALLOYS, INC.. INT. CL. 6. (U.S. CLS. 2, 12, 13, 14, 23, 25 AND 50). REG. 6-23-1998.
- 2,166,980. EA AND DESIGN. INT. CL. 6. (U.S. CLS. 2, 12, 13, 14, 23, 25 AND 50). REG. 6-23-1998.
- 2,167,035. PENTJAK SILAT BUKTI NEGARA AND DESIGN. INT. CL. 41. (U.S. CLS. 100, 101 AND 107). REG. 6-23-1998.
- 2,167,090. STANLEY ENVIRONMENTAL. INT. CLS. 35, 37 AND 42. (U.S. CLS. 100, 101, 102, 103 AND 106). REG. 6-23-1998.

- 2,167,107. SIGARMS. INT. CL. 13. (U.S. CLS. 2 AND 9). REG. 6-23-1998.
- 2,167,210. THIXCIN. INT. CL. 1. (U.S. CLS. 1, 5, 6, 10, 26 AND 46). REG. 6-23-1998.
- 2,167,232. HARCO AND DESIGN. INT. CL. 9. (U.S. CLS. 21, 23, 26, 36 AND 38). REG. 6-23-1998.
- 2,167,268. PERM A VITE. INT. CL. 5. (U.S. CLS. 6, 18, 44, 46, 51 AND 52). REG. 6-23-1998.
- 2,167,269. WOMANPRIME. INT. CL. 5. (U.S. CLS. 6, 18, 44, 46, 51 AND 52). REG. 6-23-1998.
- 2,167,345. AMAZON.COM. INT. CL. 35. (U.S. CLS. 100, 101 AND 102). REG. 6-23-1998.
- 2,167,369. SAVE THE MUSIC. INT. CL. 36. (U.S. CLS. 100, 101 AND 102). REG. 6-23-1998.
- 2,167,380. LEGENDS OF BASEBALL. INT. CL. 41. (U.S. CLS. 100, 101 AND 107). REG. 6-23-1998.
- 2,167,415. REDI-STORM. INT. CL. 6. (U.S. CLS. 2, 12, 13, 14, 23, 25 AND 50). REG. 6-23-1998.
- 2,167,491. WINDSTRIPS AND DESIGN. INT. CL. 19. (U.S. CLS. 1, 12, 33 AND 50). REG. 6-23-1998.
- 2,167,505. ACTIONEER. INT. CL. 9. (U.S. CLS. 21, 23, 26, 36 AND 38). REG. 6-23-1998.
- 2,167,570. Q Q-PANEL LAB PRODUCTS AND DESIGN. INT. CL. 9. (U.S. CLS. 21, 23, 26, 36 AND 38). REG. 6-23-1998.
- 2,167,658. K29 AND DESIGN. INT. CL. 5. (U.S. CLS. 6, 18, 44, 46, 51 AND 52). REG. 6-23-1998.
- 2,167,671. FUNFIT AND DESIGN. INT. CL. 41. (U.S. CLS. 100, 101 AND 107). REG. 6-23-1998.
- 2,167,672. FUNFIT. INT. CL. 41. (U.S. CLS. 100, 101 AND 107). REG. 6-23-1998.
- 2,167,745. FREQUENCY 256. INT. CL. 5. (U.S. CLS. 6, 18, 44, 46, 51 AND 52). REG. 6-23-1998.
- 2,167,753. FREQUENCY 64. INT. CL. 5. (U.S. CLS. 6, 18, 44, 46, 51 AND 52). REG. 6-23-1998.
- 2,167,957. U.S. LOGISTICS AND DESIGN. INT. CL. 39. (U.S. CLS. 100 AND 105). REG. 6-23-1998.
- 2,167,997. VERSINI. INT. CL. 25. (U.S. CLS. 22 AND 39). REG. 6-23-1998.
- 2,168,020. MISCELLANEOUS DESIGN. INT. CL. 30 ONLY. (U.S. CL. 46). REG. 6-23-1998.
- 2,168,040. BARRA OF MENDOCINO. INT. CL. 33. (U.S. CLS. 47 AND 49). REG. 6-23-1998.
- 2,168,053. BUSINESSBRIDGE. INT. CL. 9. (U.S. CLS. 21, 23, 26, 36 AND 38). REG. 6-23-1998.
- 2,168,079. STRIPENET. INT. CL. 7. (U.S. CLS. 13, 19, 21, 23, 31, 34 AND 35). REG. 6-23-1998.
- 2,168,093. STONE. INT. CL. 32. (U.S. CLS. 45, 46 AND 48). REG. 6-23-1998.
- 2,168,242. EXPRESS IT WITH LOBSTERS. INT. CL. 39. (U.S. CLS. 100 AND 105). REG. 6-23-1998.
- 2,168,272. PLAY ATTENTION. INT. CL. 9. (U.S. CLS. 21, 23, 26, 36 AND 38). REG. 6-23-1998.
- 2,168,401. PUPPY PACK. INT. CL. 16. (U.S. CLS. 2, 5, 22, 23, 29, 37, 38 AND 50). REG. 6-23-1998.
- 2,168,419. VTA AND DESIGN. INT. CL. 16. (U.S. CLS. 2, 5, 22, 23, 29, 37, 38 AND 50). REG. 6-23-1998.
- 2,168,420. VTA AND DESIGN. INT. CL. 39. (U.S. CLS. 100 AND 105). REG. 6-23-1998.
- 2,168,427. FLAVIA. INT. CL. 11. (U.S. CLS. 13, 21, 23, 31 AND 34). REG. 6-23-1998.
- 2,168,507. INTENSCENTS. INT. CLS. 1 AND 3. (U.S. CLS. 1, 4, 5, 6, 10, 26, 46, 50, 51 AND 52). REG. 6-23-1998.
- 2,168,558. PROTERRA. INT. CLS. 3, 25 AND 26. (U.S. CLS. 1, 4, 6, 22, 37, 39, 40, 42, 50, 51 AND 52). REG. 6-23-1998.
- 2,168,595. LABOR NETWORK. INT. CL. 35. (U.S. CLS. 100, 101 AND 102). REG. 6-23-1998.
- 2,168,644. LEXTRA. INT. CLS. 9 AND 21. (U.S. CLS. 2, 13, 21, 23, 26, 29, 30, 33, 36, 38, 40 AND 50). REG. 6-23-1998.
- 2,169,179. PROBUBUSINESS. INT. CL. 9. (U.S. CLS. 21, 23, 26, 36 AND 38). REG. 6-30-1998.
- 2,169,282. SMARTBUYS. INT. CL. 35. (U.S. CLS. 100, 101 AND 102). REG. 6-30-1998.
- 2,169,313. HORNER NOVELTY CO. AND DESIGN. INT. CL. 35. (U.S. CLS. 100, 101 AND 102). REG. 6-30-1998.
- 2,169,362. MAXFIELD'S. INT. CL. 30. (U.S. CL. 46). REG. 6-30-1998.
- 2,169,371. PRO-SHIELD. INT. CLS. 6, 11, 19 AND 22. (U.S. CLS. 1, 2, 7, 12, 13, 14, 19, 21, 22, 23, 25, 31, 33, 34, 42 AND 50). REG. 6-30-1998.
- 2,169,378. EXCEL AND DESIGN. INT. CL. 11. (U.S. CLS. 13, 21, 23, 31 AND 34). REG. 6-30-1998.
- 2,169,460. ONETIME. INT. CL. 19 ONLY. (U.S. CLS. 1, 12, 33 AND 50). REG. 6-30-1998.
- 2,169,476. CARFLECTOR. INT. CL. 12. (U.S. CLS. 19, 21, 23, 31, 35 AND 44). REG. 6-30-1998.
- 2,169,676. HOF'S HUT. INT. CL. 42. (U.S. CLS. 100 AND 101). REG. 6-30-1998.
- 2,169,715. CITRUS EXPRESS. INT. CL. 3. (U.S. CLS. 1, 4, 6, 50, 51 AND 52). REG. 6-30-1998.
- 2,169,739. WOLFERMAN'S. INT. CLS. 29 AND 30. (U.S. CL. 46). REG. 6-30-1998.
- 2,169,753. GET HOOKED. INT. CL. 42. (U.S. CLS. 100 AND 101). REG. 6-30-1998.
- 2,169,770. ASNA DATAGATE. INT. CL. 9. (U.S. CLS. 21, 23, 26, 36 AND 38). REG. 6-30-1998.
- 2,169,771. SCOOPS!. INT. CL. 30. (U.S. CL. 46). REG. 6-30-1998.
- 2,169,773. COORS FIELD. INT. CL. 18. (U.S. CLS. 1, 2, 3, 22 AND 41). REG. 6-30-1998.
- 2,169,808. COACH AND DESIGN. INT. CL. 25. (U.S. CLS. 22 AND 39). REG. 6-30-1998.
- 2,169,997. VEGGIE CAVIAR AND DESIGN. INT. CL. 29. (U.S. CL. 46). REG. 6-30-1998.
- 2,170,132. DUKE PEACOCK AND DESIGN. INT. CL. 9. (U.S. CLS. 21, 23, 26, 36 AND 38). REG. 6-30-1998.
- 2,170,275. MISCELLANEOUS DESIGN. INT. CL. 39. (U.S. CLS. 100 AND 105). REG. 6-30-1998.
- 2,170,413. LOGITECH AND DESIGN. INT. CL. 25. (U.S. CLS. 22 AND 39). REG. 6-30-1998.
- 2,170,444. OSMOTIC AQUATIC. INT. CL. 30. (U.S. CL. 46). REG. 6-30-1998.
- 2,170,451. STAFF SENSE. INT. CL. 35. (U.S. CLS. 100, 101 AND 102). REG. 6-30-1998.
- 2,170,484. SCREENMANAGER. INT. CL. 9. (U.S. CLS. 21, 23, 26, 36 AND 38). REG. 6-30-1998.
- 2,170,835. BARRIER BUBBLE. INT. CL. 16. (U.S. CLS. 2, 5, 22, 23, 29, 37, 38 AND 50). REG. 7-7-1998.
- 2,170,851. MISCELLANEOUS DESIGN. INT. CL. 39. (U.S. CLS. 100 AND 105). REG. 7-7-1998.
- 2,170,950. JANUS HIGH-YIELD FUND. INT. CL. 36. (U.S. CLS. 100, 101 AND 102). REG. 7-7-1998.
- 2,170,964. MEGA LIGHTER. INT. CL. 34. (U.S. CLS. 2, 8, 9 AND 17). REG. 7-7-1998.
- 2,171,269. IRIE TIME. INT. CL. 41. (U.S. CLS. 100, 101 AND 107). REG. 7-7-1998.
- 2,171,318. FIRST FOCUS. INT. CL. 16. (U.S. CLS. 2, 5, 22, 23, 29, 37, 38 AND 50). REG. 7-7-1998.
- 2,171,361. NEORATE. INT. CL. 1. (U.S. CLS. 1, 5, 6, 10, 26 AND 46). REG. 7-7-1998.
- 2,171,389. KIRIN. INT. CL. 30. (U.S. CL. 46). REG. 7-7-1998.
- 2,171,553. SALSALITO. INT. CL. 29. (U.S. CL. 46). REG. 7-7-1998.
- 2,171,612. GENESIS. INT. CL. 11. (U.S. CLS. 13, 21, 23, 31 AND 34). REG. 7-7-1998.
- 2,171,694. NATIONSUNIVERSITY. INT. CL. 41. (U.S. CLS. 100, 101 AND 107). REG. 7-7-1998.
- 2,171,777. THINKING TECHNOLOGIES. INT. CL. 9. (U.S. CLS. 21, 23, 26, 36 AND 38). REG. 7-7-1998.
- 2,172,119. BIKE-BUBBLE. INT. CL. 22. (U.S. CLS. 1, 2, 7, 19, 22, 42 AND 50). REG. 7-14-1998.
- 2,172,131. HOLLYWOOD BYTES (STYLIZED). INT. CL. 41. (U.S. CLS. 100, 101 AND 107). REG. 7-14-1998.
- 2,172,293. GENUINE BEAM. INT. CL. 33. (U.S. CLS. 47 AND 49). REG. 7-14-1998.
- 2,172,581. LANDS' END INLET. INT. CL. 35. (U.S. CLS. 100, 101 AND 102). REG. 7-14-1998.
- 2,172,953. NICKLAUS. INT. CL. 25. (U.S. CLS. 22 AND 39). REG. 7-14-1998.
- 2,172,969. FLOLIME. INT. CL. 1. (U.S. CLS. 1, 5, 6, 10, 26 AND 46). REG. 7-14-1998.
- 2,173,349. CLAREMONT INVESTMENT PARTNERS. INT. CL. 36. (U.S. CLS. 100, 101 AND 102). REG. 7-14-1998.
- 2,173,508. OUTDOOR LIFE. INT. CL. 42. (U.S. CLS. 100 AND 101). REG. 7-14-1998.
- 2,173,509. OUTDOOR LIFE. INT. CL. 9. (U.S. CLS. 21, 23, 26, 36 AND 38). REG. 7-14-1998.
- 2,173,613. GYMSHOE. INT. CL. 2. (U.S. CLS. 6, 11 AND 16). REG. 7-14-1998.
- 2,173,671. ZOC. INT. CL. 9. (U.S. CLS. 21, 23, 26, 36 AND 38). REG. 7-14-1998.
- 2,173,876. PHOENIX MERCURY AND DESIGN. INT. CL. 25. (U.S. CLS. 22 AND 39). REG. 7-14-1998.
- 2,174,223. NFL TAKE A PLAYER TO SCHOOL. INT. CL. 41. (U.S. CLS. 100, 101 AND 107). REG. 7-21-1998.

- 2,174,249. DESERT. INT. CL. 25. (U.S. CLS. 22 AND 39). REG. 7-21-1998.
- 2,174,372. MASONRYARTS. INT. CLS. 37 AND 40. (U.S. CLS. 100, 103 AND 106). REG. 7-21-1998.
- 2,174,452. ITW.COM. INT. CL. 42. (U.S. CLS. 100 AND 101). REG. 7-21-1998.
- 2,174,626. ACM MEDICAL LABORATORY AND DESIGN. INT. CL. 42. (U.S. CLS. 100 AND 101). REG. 7-21-1998.
- 2,174,713. A BETTER WORLD FUND. INT. CL. 36. (U.S. CLS. 100, 101 AND 102). REG. 7-21-1998.
- 2,174,722. MISCELLANEOUS DESIGN. INT. CL. 9. (U.S. CLS. 21, 23, 26, 36 AND 38). REG. 7-21-1998.
- 2,174,723. SCANDINAVIAN DIVING EQUIPMENT VIKING AND DESIGN. INT. CL. 9. (U.S. CLS. 21, 23, 26, 36 AND 38). REG. 7-21-1998.
- 2,174,724. V AND DESIGN. INT. CL. 9. (U.S. CLS. 21, 23, 26, 36 AND 38). REG. 7-21-1998.
- 2,174,725. VIKING AND DESIGN. INT. CL. 9. (U.S. CLS. 21, 23, 26, 36 AND 38). REG. 7-21-1998.
- 2,174,925. EBONITE AND DESIGN. INT. CL. 28. (U.S. CLS. 22, 23, 38 AND 50). REG. 7-21-1998.
- 2,175,335. CELLU M6. INT. CL. 10. (U.S. CLS. 26, 39 AND 44). REG. 7-21-1998.
- 2,175,381. LA COLLINE. INT. CL. 3. (U.S. CLS. 1, 4, 6, 50, 51 AND 52). REG. 7-21-1998.
- 2,175,556. MISCELLANEOUS DESIGN. INT. CL. 25. (U.S. CLS. 22 AND 39). REG. 7-21-1998.
- 2,175,559. XCL-S. INT. CL. 11. (U.S. CLS. 13, 21, 23, 31 AND 34). REG. 7-21-1998.
- 2,175,571. NEAXMAIL. INT. CL. 9. (U.S. CLS. 21, 23, 26, 36 AND 38). REG. 7-21-1998.
- 2,175,911. INDENA. INT. CL. 1. (U.S. CLS. 1, 5, 6, 10, 26 AND 46). REG. 7-28-1998.
- 2,176,234. STANLEY CONSULTANTS. INT. CLS. 35, 37 AND 42. (U.S. CLS. 100, 101, 102, 103 AND 106). REG. 7-28-1998.
- 2,176,600. DENTINEX. INT. CL. 36. (U.S. CLS. 100, 101 AND 102). REG. 7-28-1998.
- 2,176,663. LAMPPOST PIZZA. INT. CL. 42. (U.S. CLS. 100 AND 101). REG. 7-28-1998.
- 2,176,664. MISCELLANEOUS DESIGN. INT. CL. 42. (U.S. CLS. 100 AND 101). REG. 7-28-1998.
- 2,176,677. LAMPPOST PIZZA FOR THOSE WITH A TASTE FOR GREAT PIZZA. AND SPORTS. AND DESIGN. INT. CL. 42. (U.S. CLS. 100 AND 101). REG. 7-28-1998.
- 2,176,699. DURA-TUFF. INT. CL. 19. (U.S. CLS. 1, 12, 33 AND 50). REG. 7-28-1998.
- 2,176,781. O OLIVE OIL AND DESIGN. INT. CL. 29. (U.S. CL. 46). REG. 7-28-1998.
- 2,176,783. MAKING BUSINESS SIMPLE. INT. CL. 36. (U.S. CLS. 100, 101 AND 102). REG. 7-28-1998.
- 2,176,940. PACIFIC BAKERY. INT. CL. 30. (U.S. CL. 46). REG. 7-28-1998.
- 2,177,081. WEBSLINGER. INT. CL. 9. (U.S. CLS. 21, 23, 26, 36 AND 38). REG. 7-28-1998.
- 2,177,226. THE UNEXPLAINED. INT. CL. 9 ONLY. (U.S. CLS. 21, 23, 26, 36 AND 38). REG. 7-28-1998.
- 2,177,261. DOUBLE WEAR. INT. CL. 3. (U.S. CLS. 1, 4, 6, 50, 51 AND 52). REG. 7-28-1998.
- 2,178,264. SHALOM HOME INC. AND DESIGN. INT. CL. 35. (U.S. CLS. 100, 101 AND 102). REG. 8-4-1998.
- 2,178,369. FAIRWEATHER. INT. CL. 19. (U.S. CLS. 1, 12, 33 AND 50). REG. 8-4-1998.
- 2,178,417. SHEETROCK. INT. CLS. 2, 17 AND 19. (U.S. CLS. 1, 5, 6, 11, 12, 13, 16, 33, 35 AND 50). REG. 8-4-1998.
- 2,178,517. VISITOR. INT. CL. 25. (U.S. CLS. 22 AND 39). REG. 8-4-1998.
- 2,178,933. MISCELLANEOUS DESIGN. INT. CL. 9. (U.S. CLS. 21, 23, 26, 36 AND 38). REG. 8-4-1998.
- 2,179,099. MISCELLANEOUS DESIGN. INT. CL. 25. (U.S. CLS. 22 AND 39). REG. 8-4-1998.
- 2,179,554. GAMCO. INT. CL. 28. (U.S. CLS. 22, 23, 38 AND 50). REG. 8-4-1998.
- 2,179,915. IP INTER PRODUCT HOLLAND AND DESIGN. INT. CL. 6. (U.S. CLS. 2, 12, 13, 14, 23, 25 AND 50). REG. 8-11-1998.
- 2,179,930. JAMTV. INT. CL. 41. (U.S. CLS. 100, 101 AND 107). REG. 8-11-1998.
- 2,180,647. GNC. INT. CL. 5. (U.S. CLS. 6, 18, 44, 46, 51 AND 52). REG. 8-11-1998.
- 2,180,666. REGAL. INT. CL. 16. (U.S. CLS. 2, 5, 22, 23, 29, 37, 38 AND 50). REG. 8-11-1998.
- 2,181,142. BASELINE. INT. CL. 3. (U.S. CLS. 1, 4, 6, 50, 51 AND 52). REG. 8-11-1998.
- 2,181,368. SURESHOT. INT. CL. 8. (U.S. CLS. 23, 28 AND 44). REG. 8-11-1998.
- 2,181,480. INTERNATIONAL GAMCO. INT. CL. 28. (U.S. CLS. 22, 23, 38 AND 50). REG. 8-11-1998.
- 2,181,487. IRONCHEL. INT. CL. 5. (U.S. CLS. 6, 18, 44, 46, 51 AND 52). REG. 8-11-1998.
- 2,181,918. JANUS. INT. CL. 36. (U.S. CLS. 100, 101 AND 102). REG. 8-18-1998.
- 2,181,919. MISCELLANEOUS DESIGN. INT. CL. 36. (U.S. CLS. 100, 101 AND 102). REG. 8-18-1998.
- 2,182,077. SOCIETY FOR WOMEN'S HEALTH RESEARCH AND DESIGN. INT. CL. 42. (U.S. CLS. 100 AND 101). REG. 8-18-1998.
- 2,182,083. DAVANNI'S PIZZA & HOT HOAGIES AND DESIGN. INT. CL. 42. (U.S. CLS. 100 AND 101). REG. 8-18-1998.
- 2,182,191. VIEWTAINER. INT. CL. 20. (U.S. CLS. 2, 13, 22, 25, 32 AND 50). REG. 8-18-1998.
- 2,182,236. EPSON STYLUS. INT. CL. 2. (U.S. CLS. 6, 11 AND 16). REG. 8-18-1998.
- 2,182,922. TLC. INT. CL. 23. (U.S. CL. 43). REG. 8-18-1998.
- 2,182,952. SANTA MONICA AND DESIGN. INT. CL. 35. (U.S. CLS. 100, 101 AND 102). REG. 8-18-1998.
- 2,183,240. CHRISTIANS IN RECOVERY. INT. CL. 42. (U.S. CLS. 100 AND 101). REG. 8-25-1998.
- 2,183,357. HOUSE OF PRIME RIB AND DESIGN. INT. CL. 42. (U.S. CLS. 100 AND 101). REG. 8-25-1998.
- 2,183,394. E EDEN DAVID AND DESIGN. INT. CL. 9. (U.S. CLS. 21, 23, 26, 36 AND 38). REG. 8-25-1998.
- 2,183,512. BLUE MOUNTAIN ARTS POETS & ARTISTS HANDMADE THOUGHTS (STYLIZED). INT. CLS. 16 AND 21. (U.S. CLS. 2, 5, 13, 22, 23, 29, 30, 33, 37, 38, 40 AND 50). REG. 8-25-1998.
- 2,183,696. SOCIETY FOR WOMEN'S HEALTH RESEARCH. INT. CL. 42. (U.S. CLS. 100 AND 101). REG. 8-25-1998.
- 2,183,773. GET YOUR BURGER'S WORTH. INT. CL. 42. (U.S. CLS. 100 AND 101). REG. 8-25-1998.
- 2,183,794. DYNAMIC LIVING. INT. CL. 35. (U.S. CLS. 100, 101 AND 102). REG. 8-25-1998.
- 2,184,394. NATURE'S FINGERPRINT. INT. CL. 5. (U.S. CLS. 6, 18, 44, 46, 51 AND 52). REG. 8-25-1998.
- 2,184,602. BUFFERGEL. INT. CL. 5. (U.S. CLS. 6, 18, 44, 46, 51 AND 52). REG. 8-25-1998.
- 2,184,784. PART OF EVERY TRIP YOU TAKE. INT. CL. 39. (U.S. CLS. 100 AND 105). REG. 8-25-1998.
- 2,184,867. SLAPSHOT. INT. CL. 8. (U.S. CLS. 23, 28 AND 44). REG. 8-25-1998.
- 2,185,384. LET 'ER BUCK. INT. CLS. 14, 25 AND 26. (U.S. CLS. 2, 22, 27, 28, 37, 39, 40, 42 AND 50). REG. 9-1-1998.
- 2,185,429. SAS AUTOMATION GET A GRIP! AND DESIGN. INT. CL. 7. (U.S. CLS. 13, 19, 21, 23, 31, 34 AND 35). REG. 9-1-1998.
- 2,185,667. PEACHTREE. INT. CL. 9. (U.S. CLS. 21, 23, 26, 36 AND 38). REG. 9-1-1998.
- 2,185,743. QUIKWATER AND DESIGN. INT. CL. 11. (U.S. CLS. 13, 21, 23, 31 AND 34). REG. 9-1-1998.
- 2,185,744. MISCELLANEOUS DESIGN. INT. CLS. 6, 9 AND 11. (U.S. CLS. 2, 12, 13, 14, 21, 23, 25, 26, 31, 34, 36, 38 AND 50). REG. 9-1-1998.
- 2,185,933. TTL. INT. CL. 16. (U.S. CLS. 2, 5, 22, 23, 29, 37, 38 AND 50). REG. 9-1-1998.
- 2,185,981. LADY MOON FARMS AND DESIGN. INT. CL. 31. (U.S. CLS. 1 AND 46). REG. 9-1-1998.
- 2,186,217. RISHO AND DESIGN. INT. CL. 9. (U.S. CLS. 21, 23, 26, 36 AND 38). REG. 9-1-1998.
- 2,186,707. BIRCH TELECOM. INT. CL. 38. (U.S. CLS. 100, 101 AND 104). REG. 9-1-1998.
- 2,186,910. PHYSCOOL. INT. CL. 1. (U.S. CLS. 1, 5, 6, 10, 26 AND 46). REG. 9-1-1998.
- 2,187,073. GUILD CERTIFIED FELDENKRAIS TEACHER. U.S. CL. B. REG. 9-8-1998.
- 2,187,168. FAMOUS DAVE'S AND DESIGN. INT. CL. 9. (U.S. CLS. 21, 23, 26, 36 AND 38). REG. 9-8-1998.
- 2,187,449. RI RA. INT. CL. 42. (U.S. CLS. 100 AND 101). REG. 9-8-1998.
- 2,187,749. NMAN. INT. CL. 5. (U.S. CLS. 6, 18, 44, 46, 51 AND 52). REG. 9-8-1998.
- 2,187,776. ZIP-PAK. INT. CL. 20. (U.S. CLS. 2, 13, 22, 25, 32 AND 50). REG. 9-8-1998.
- 2,187,812. VIRTUAL SNOW AND DESIGN. INT. CL. 41. (U.S. CLS. 100, 101 AND 107). REG. 9-8-1998.

- 2,188,068. RISHO. INT. CL. 9. (U.S. CLS. 21, 23, 26, 36 AND 38). REG. 9-8-1998.
- 2,188,291. RIVERS WEST. INT. CL. 25. (U.S. CLS. 22 AND 39). REG. 9-8-1998.
- 2,188,524. SORTLOGIC. INT. CL. 9. (U.S. CLS. 21, 23, 26, 36 AND 38). REG. 9-8-1998.
- 2,188,865. MISCELLANEOUS DESIGN. INT. CL. 9. (U.S. CLS. 21, 23, 26, 36 AND 38). REG. 9-15-1998.
- 2,189,825. PART OF EVERY TRIP YOU TAKE. INT. CL. 16. (U.S. CLS. 2, 5, 22, 23, 29, 37, 38 AND 50). REG. 9-15-1998.
- 2,189,961. SNO BLOWER. INT. CL. 21. (U.S. CLS. 2, 13, 23, 29, 30, 33, 40 AND 50). REG. 9-15-1998.
- 2,190,330. SEAMCRAFT. INT. CLS. 9, 10 AND 18. (U.S. CLS. 1, 2, 3, 21, 22, 23, 26, 36, 38, 39, 41 AND 44). REG. 9-22-1998.
- 2,190,335. MILLER CHILDREN'S. INT. CLS. 41 AND 42. (U.S. CLS. 100, 101 AND 107). REG. 9-22-1998.
- 2,191,321. MISCELLANEOUS DESIGN. INT. CL. 25. (U.S. CLS. 22 AND 39). REG. 9-22-1998.
- 2,191,434. ASIAN DRAGON. INT. CL. 30. (U.S. CL. 46). REG. 9-22-1998.
- 2,191,552. PLASTIC PLUS. INT. CL. 20. (U.S. CLS. 2, 13, 22, 25, 32 AND 50). REG. 9-22-1998.
- 2,191,699. THE FULL LINE MANUFACTURER. INT. CL. 7. (U.S. CLS. 13, 19, 21, 23, 31, 34 AND 35). REG. 9-29-1998.
- 2,191,744. DJAUTO (STYLIZED). INT. CL. 11. (U.S. CLS. 13, 21, 23, 31 AND 34). REG. 9-29-1998.
- 2,192,339. ICE MOUNTAIN AND DESIGN. INT. CLS. 1 AND 32. (U.S. CLS. 1, 5, 6, 10, 26, 45, 46 AND 48). REG. 9-29-1998.
- 2,192,499. DITERA. INT. CL. 5. (U.S. CLS. 6, 18, 44, 46, 51 AND 52). REG. 9-29-1998.
- 2,192,510. TEX-CARE MEDICAL. INT. CLS. 10 AND 25. (U.S. CLS. 22, 26, 39 AND 44). REG. 9-29-1998.
- 2,192,806. FRABRITE. INT. CL. 16. (U.S. CLS. 2, 5, 22, 23, 29, 37, 38 AND 50). REG. 9-29-1998.
- 2,193,753. UNITED DOMINION REALTY TRUST. INT. CL. 36. (U.S. CLS. 100, 101 AND 102). REG. 10-6-1998.
- 2,193,782. SYNTHESOFT. INT. CL. 42. (U.S. CLS. 100 AND 101). REG. 10-6-1998.
- 2,194,568. LIBERTY HARDWARE AND DESIGN. INT. CL. 6 ONLY. (U.S. CLS. 2, 12, 13, 14, 23, 25 AND 50). REG. 10-13-1998.
- 2,195,181. PAR-PAK. INT. CL. 16. (U.S. CLS. 2, 5, 22, 23, 29, 37, 38 AND 50). REG. 10-13-1998.
- 2,196,250. DIDDE COLORTECH. INT. CL. 7. (U.S. CLS. 13, 19, 21, 23, 31, 34 AND 35). REG. 10-13-1998.
- 2,196,438. SUMATRAN. INT. CL. 11. (U.S. CLS. 13, 21, 23, 31 AND 34). REG. 10-13-1998.
- 2,196,454. S THE STANLEY GROUP AND DESIGN. INT. CLS. 35, 37 AND 42. (U.S. CLS. 100, 101, 102, 103 AND 106). REG. 10-13-1998.
- 2,196,540. FRAPRINT. INT. CL. 16. (U.S. CLS. 2, 5, 22, 23, 29, 37, 38 AND 50). REG. 10-13-1998.
- 2,196,612. BIRDSOURCE. INT. CL. 42. (U.S. CLS. 100 AND 101). REG. 10-13-1998.
- 2,197,034. PROVIDE. INT. CL. 9. (U.S. CLS. 21, 23, 26, 36 AND 38). REG. 10-20-1998.
- 2,197,210. MILLWORKS. INT. CL. 31. (U.S. CLS. 1 AND 46). REG. 10-20-1998.
- 2,197,290. COMMUNITY GROUP. INT. CL. 35. (U.S. CLS. 100, 101 AND 102). REG. 10-20-1998.
- 2,197,320. STIMULUS SYSTEM. INT. CL. 10. (U.S. CLS. 26, 39 AND 44). REG. 10-20-1998.
- 2,197,410. VOGT. INT. CL. 11. (U.S. CLS. 13, 21, 23, 31 AND 34). REG. 10-20-1998.
- 2,198,071. GLADIATOR. INT. CL. 11. (U.S. CLS. 13, 21, 23, 31 AND 34). REG. 10-20-1998.
- 2,198,156. MICROSOFT. INT. CL. 39. (U.S. CLS. 100 AND 105). REG. 10-20-1998.
- 2,198,178. SHREDIES. INT. CL. 30. (U.S. CL. 46). REG. 10-20-1998.
- 2,199,012. FRALIGHT. INT. CL. 16. (U.S. CLS. 2, 5, 22, 23, 29, 37, 38 AND 50). REG. 10-20-1998.
- 2,199,679. WISE GUYS. INT. CL. 41. (U.S. CLS. 100, 101 AND 107). REG. 10-27-1998.
- 2,200,381. STAGE. INT. CLS. 1 AND 5. (U.S. CLS. 1, 5, 6, 10, 18, 26, 44, 46, 51 AND 52). REG. 10-27-1998.
- 2,201,117. CALL AHEAD WE'LL BE READY. INT. CL. 42. (U.S. CLS. 100 AND 101). REG. 11-3-1998.
- 2,201,196. FORTIS FILMS. INT. CL. 41. (U.S. CLS. 100, 101 AND 107). REG. 11-3-1998.
- 2,201,438. CATALINA COLLECTION AND DESIGN. INT. CL. 10. (U.S. CLS. 26, 39 AND 44). REG. 11-3-1998.
- 2,201,713. AVANTGARDE ACOUSTIC. INT. CL. 9. (U.S. CLS. 21, 23, 26, 36 AND 38). REG. 11-3-1998.
- 2,202,151. CINEMALL. INT. CL. 41. (U.S. CLS. 100, 101 AND 107). REG. 11-3-1998.
- 2,202,197. THE MIRACLE WORKER. INT. CL. 3. (U.S. CLS. 1, 4, 6, 50, 51 AND 52). REG. 11-3-1998.
- 2,202,210. RWJF. INT. CL. 36. (U.S. CLS. 100, 101 AND 102). REG. 11-3-1998.
- 2,203,043. MISCELLANEOUS DESIGN. INT. CL. 1. (U.S. CLS. 1, 5, 6, 10, 26 AND 46). REG. 11-10-1998.
- 2,203,459. NEUROSURGICAL FOCUS. INT. CL. 42. (U.S. CLS. 100 AND 101). REG. 11-17-1998.
- 2,203,605. GROWERS CLUB AND DESIGN. INT. CL. 8. (U.S. CLS. 23, 28 AND 44). REG. 11-17-1998.
- 2,204,182. FIRST REPUBLIC PRESTIGE HOME INDEX. INT. CL. 16. (U.S. CLS. 2, 5, 22, 23, 29, 37, 38 AND 50). REG. 11-17-1998.
- 2,204,395. THE STANLEY GROUP. INT. CLS. 35, 37 AND 42. (U.S. CLS. 100, 101, 102, 103 AND 106). REG. 11-17-1998.
- 2,204,438. LA LOOP. INT. CL. 9. (U.S. CLS. 21, 23, 26, 36 AND 38). REG. 11-17-1998.
- 2,204,923. CHEF ITALIA. INT. CL. 29. (U.S. CL. 46). REG. 11-24-1998.
- 2,205,077. RADIO RAY. INT. CL. 11. (U.S. CLS. 13, 21, 23, 31 AND 34). REG. 11-24-1998.
- 2,205,163. OMNI-GUARD. INT. CL. 19. (U.S. CLS. 1, 12, 33 AND 50). REG. 11-24-1998.
- 2,205,390. COLLOQUY. INT. CL. 35. (U.S. CLS. 100, 101 AND 102). REG. 11-24-1998.
- 2,205,581. BING BANG AND DESIGN. INT. CL. 25. (U.S. CLS. 22 AND 39). REG. 11-24-1998.
- 2,205,721. BRIGHTSTART. INT. CL. 5. (U.S. CLS. 6, 18, 44, 46, 51 AND 52). REG. 11-24-1998.
- 2,206,985. SENSEA-CHARGE. INT. CL. 9. (U.S. CLS. 21, 23, 26, 36 AND 38). REG. 12-1-1998.
- 2,207,452. SUBTALAR MBA. INT. CL. 10. (U.S. CLS. 26, 39 AND 44). REG. 12-1-1998.
- 2,207,736. HEALTHY COLLECTION FAT FREE FROZEN YOGURT AND DESIGN. INT. CL. 30. (U.S. CL. 46). REG. 12-1-1998.
- 2,207,804. POLO TOWERS AND DESIGN. INT. CL. 36. (U.S. CLS. 100, 101 AND 102). REG. 12-8-1998.
- 2,208,331. CHICAGO BLUES CENTER. INT. CL. 25. (U.S. CLS. 22 AND 39). REG. 12-8-1998.
- 2,209,626. TRILITES (STYLIZED). INT. CL. 9. (U.S. CLS. 21, 23, 26, 36 AND 38). REG. 12-8-1998.
- 2,209,816. CENTEX FINANCIAL SERVICES. INT. CL. 36. (U.S. CLS. 100, 101 AND 102). REG. 12-8-1998.
- 2,210,276. MCPR. INT. CL. 1. (U.S. CLS. 1, 5, 6, 10, 26 AND 46). REG. 12-15-1998.
- 2,210,627. S B AND DESIGN. INT. CL. 36. (U.S. CLS. 100, 101 AND 102). REG. 12-15-1998.
- 2,212,223. DRIWOOD. INT. CL. 19. (U.S. CLS. 1, 12, 33 AND 50). REG. 12-22-1998.
- 2,212,417. SAFE KIDS BUCKLE UP AND DESIGN. INT. CLS. 16 AND 42. (U.S. CLS. 2, 5, 22, 23, 29, 37, 38, 50, 100 AND 101). REG. 12-22-1998.
- 2,212,700. STARLIGHT INTERNATIONAL. INT. CL. 26 ONLY. (U.S. CLS. 37, 39, 40, 42 AND 50). REG. 12-22-1998.
- 2,213,338. PACIFIC LIFECORP. INT. CL. 36. (U.S. CLS. 100, 101 AND 102). REG. 12-22-1998.
- 2,213,964. SAFE KIDS BUCKLE UP. INT. CLS. 16 AND 42. (U.S. CLS. 2, 5, 22, 23, 29, 37, 38, 50, 100 AND 101). REG. 12-29-1998.
- 2,214,104. BRIDGE OF HOPE AND DESIGN. INT. CLS. 36, 41 AND 42. (U.S. CLS. 100, 101, 102 AND 107). REG. 12-29-1998.
- 2,215,977. BRIDGE OF HOPE. INT. CLS. 36, 41 AND 42. (U.S. CLS. 100, 101, 102 AND 107). REG. 1-5-1999.
- 2,217,230. WX. INT. CL. 14. (U.S. CLS. 2, 27, 28 AND 50). REG. 1-12-1999.
- 2,218,347. FURNITURE/TODAY. INT. CL. 42. (U.S. CLS. 100 AND 101). REG. 1-19-1999.
- 2,218,447. UNISAT. INT. CL. 38. (U.S. CLS. 100, 101 AND 104). REG. 1-19-1999.
- 2,219,312. IRIMS. INT. CL. 9. (U.S. CLS. 21, 23, 26, 36 AND 38). REG. 1-19-1999.
- 2,220,770. ALLCONNECT. INT. CL. 42. (U.S. CLS. 100 AND 101). REG. 1-26-1999.

- 2,221,152. AMERICAN CAPITAL STRATEGIES. INT. CL. 36. (U.S. CLS. 100, 101 AND 102). REG. 2-2-1999.
- 2,221,853. DECAF BABUSHKA BLEND. INT. CL. 30. (U.S. CL. 46). REG. 2-2-1999.
- 2,222,847. TAYLOR & BYRNES AND DESIGN. INT. CL. 30. (U.S. CL. 46). REG. 2-9-1999.
- 2,222,962. SIBERIAN BLEND. INT. CL. 30. (U.S. CL. 46). REG. 2-9-1999.
- 2,222,963. RUSSIAN ROULETTE. INT. CL. 30. (U.S. CL. 46). REG. 2-9-1999.
- 2,223,936. MCCORMICK AND DESIGN. INT. CLS. 29 AND 30. (U.S. CL. 46). REG. 2-16-1999.
- 2,224,262. PARAGON HDS. INT. CL. 1. (U.S. CLS. 1, 5, 6, 10, 26 AND 46). REG. 2-16-1999.
- 2,224,601. MASTERCARD CORPORATE PAYMENT SOLUTIONS. INT. CL. 36. (U.S. CLS. 100, 101 AND 102). REG. 2-16-1999.
- 2,225,430. SPARKLETTTS. INT. CL. 11. (U.S. CLS. 13, 21, 23, 31 AND 34). REG. 2-23-1999.
- 2,226,071. J. JILL. INT. CL. 25. (U.S. CLS. 22 AND 39). REG. 2-23-1999.
- 2,228,321. PAO V "FM". INT. CL. 5. (U.S. CLS. 6, 18, 44, 46, 51 AND 52). REG. 3-2-1999.
- 2,228,680. QUIZNO'S SUBS OVEN BAKED CLASSICS AND DESIGN. INT. CL. 42. (U.S. CLS. 100 AND 101). REG. 3-2-1999.
- 2,228,878. WHITE NIGHTS ESPRESSO. INT. CL. 30. (U.S. CL. 46). REG. 3-2-1999.
- 2,231,951. THOMPSON AND DESIGN. INT. CL. 16. (U.S. CLS. 2, 5, 22, 23, 29, 37, 38 AND 50). REG. 3-16-1999.
- 2,233,309. LAKE SONOMA. INT. CL. 33. (U.S. CLS. 47 AND 49). REG. 3-23-1999.
- 2,234,499. SAVOY. INT. CL. 34. (U.S. CLS. 2, 8, 9 AND 17). REG. 3-23-1999.
- 2,236,542. MASTERCARD ONLINE (STYLIZED). INT. CLS. 9, 16, 36, 38, 39 AND 42. (U.S. CLS. 2, 5, 21, 22, 23, 26, 29, 36, 37, 38, 50, 100, 101, 102, 104 AND 105). REG. 4-6-1999.
- 2,236,808. DIABEST 2. INT. CL. 5. (U.S. CLS. 6, 18, 44, 46, 51 AND 52). REG. 4-6-1999.
- 2,237,093. BLOCK & BLOCK. INT. CL. 3. (U.S. CLS. 1, 4, 6, 50, 51 AND 52). REG. 4-6-1999.
- 2,237,340. L.A. 411. INT. CL. 41. (U.S. CLS. 100, 101 AND 107). REG. 4-6-1999.
- 2,237,485. BULLRIDER. INT. CL. 25. (U.S. CLS. 22 AND 39). REG. 4-6-1999.
- 2,238,399. ROCKWOOD PROGRAMS, INC. AND DESIGN. INT. CLS. 35 AND 36. (U.S. CLS. 100, 101 AND 102). REG. 4-13-1999.
- 2,238,585. KIMAX. INT. CL. 9. (U.S. CLS. 21, 23, 26, 36 AND 38). REG. 4-13-1999.
- 2,238,591. FERSCO SAWS AND DESIGN. INT. CL. 7. (U.S. CLS. 13, 19, 21, 23, 31, 34 AND 35). REG. 4-13-1999.
- 2,238,948. FISH FIRST. INT. CL. 37. (U.S. CLS. 100, 103 AND 106). REG. 4-13-1999.
- 2,239,241. 2 WAY QUIK-PIN. INT. CL. 28. (U.S. CLS. 22, 23, 38 AND 50). REG. 4-13-1999.
- 2,239,730. GO DEEPER. INT. CL. 3. (U.S. CLS. 1, 4, 6, 50, 51 AND 52). REG. 4-13-1999.
- 2,239,731. BORN YESTERDAY. INT. CL. 3. (U.S. CLS. 1, 4, 6, 50, 51 AND 52). REG. 4-13-1999.
- 2,239,749. EVITA 2 DURA. INT. CL. 10. (U.S. CLS. 26, 39 AND 44). REG. 4-13-1999.
- 2,240,731. MASTER WHOLESAL. INT. CL. 35. (U.S. CLS. 100, 101 AND 102). REG. 4-20-1999.
- 2,241,174. POWERTRACK. INT. CL. 36. (U.S. CLS. 100, 101 AND 102). REG. 4-20-1999.
- 2,242,122. WE KNOW WHAT COUNTS. INT. CL. 35. (U.S. CLS. 100, 101 AND 102). REG. 4-27-1999.
- 2,242,592. GPC AND DESIGN. INT. CL. 16. (U.S. CLS. 2, 5, 22, 23, 29, 37, 38 AND 50). REG. 5-4-1999.
- 2,242,743. NEIGHBORHOOD BIBLE CLUB. INT. CL. 16. (U.S. CLS. 2, 5, 22, 23, 29, 37, 38 AND 50). REG. 5-4-1999.
- 2,243,349. COSTCO WHOLESAL AND DESIGN. INT. CL. 36. (U.S. CLS. 100, 101 AND 102). REG. 5-4-1999.
- 2,243,831. FUN BUGS. INT. CL. 30. (U.S. CL. 46). REG. 5-4-1999.
- 2,245,418. EXPAND. INT. CL. 41. (U.S. CLS. 100, 101 AND 107). REG. 5-18-1999.
- 2,245,419. FACTS. INT. CL. 42. (U.S. CLS. 100 AND 101). REG. 5-18-1999.
- 2,246,533. DEVIS. INT. CLS. 9, 41 AND 42. (U.S. CLS. 21, 23, 26, 36, 38, 100, 101 AND 107). REG. 5-18-1999.
- 2,247,287. SINGH AND DESIGN. INT. CLS. 36 AND 37. (U.S. CLS. 100, 101, 102, 103 AND 106). REG. 5-25-1999.
- 2,247,351. MISCELLANEOUS DESIGN. INT. CL. 28. (U.S. CLS. 22, 23, 38 AND 50). REG. 5-25-1999.
- 2,247,453. VI AND DESIGN. INT. CL. 9. (U.S. CLS. 21, 23, 26, 36 AND 38). REG. 5-25-1999.
- 2,247,866. MISCELLANEOUS DESIGN. INT. CL. 33. (U.S. CLS. 47 AND 49). REG. 5-25-1999.
- 2,248,039. AFTERBURNER. INT. CL. 12. (U.S. CLS. 19, 21, 23, 31, 35 AND 44). REG. 5-25-1999.
- 2,248,138. QUIETSLEEP. INT. CL. 42. (U.S. CLS. 100 AND 101). REG. 5-25-1999.
- 2,248,324. MITOTONE. INT. CL. 5. (U.S. CLS. 6, 18, 44, 46, 51 AND 52). REG. 5-25-1999.
- 2,248,570. JUMPIN JAVA. INT. CL. 42. (U.S. CLS. 100 AND 101). REG. 6-1-1999.
- 2,249,559. PENNE RUSTICA. INT. CL. 30. (U.S. CL. 46). REG. 6-1-1999.
- 2,249,789. RABBIT RIDGE. INT. CL. 33. (U.S. CLS. 47 AND 49). REG. 6-1-1999.
- 2,250,259. SOUND STORM LABORATORIES. INT. CL. 9. (U.S. CLS. 21, 23, 26, 36 AND 38). REG. 6-1-1999.
- 2,250,540. ACA PLUS. INT. CL. 1. (U.S. CLS. 1, 5, 6, 10, 26 AND 46). REG. 6-1-1999.
- 2,250,938. TRADEWINDS. INT. CL. 42. (U.S. CLS. 100 AND 101). REG. 6-8-1999.
- 2,250,958. BEACON STREET. INT. CLS. 41 AND 42. (U.S. CLS. 100, 101 AND 107). REG. 6-8-1999.
- 2,251,825. REEL DEAL. INT. CL. 9. (U.S. CLS. 21, 23, 26, 36 AND 38). REG. 6-8-1999.
- 2,253,280. OCEAN REST. INT. CL. 20. (U.S. CLS. 2, 13, 22, 25, 32 AND 50). REG. 6-15-1999.

* * * * *

TRADEMARK REGISTRATIONS CANCELED

The designation "U.S. Cl." appearing in this section refers to the U.S. class in effect prior to Sep. 1, 1973 rather than the international class which applies to applications filed on or after that date. For adoption of international classification see notice in the OFFICIAL GAZETTE of Jun. 26, 1973 (911 O.G. TM 210).

SECTION 7(D)

- 2,448,733. COVENANT BIBLE COLLEGE. INT. CLS. 25 AND 41. REG. 5-8-2001.
2,502,978. STUMPTOWN BAR AND GRILL. INT. CL. 42. REG. 10-30-2001.
2,644,005. TAILPIPE TAP. INT. CL. 42. REG. 10-29-2002.
2,696,943. PURITY FOODS. INT. CL. 30. REG. 3-18-2003.
3,077,257. ALICE IN GENDERLAND: A CROSSDRESSER COMES OF AGE STANDARD CHARACTER MARK INT. CL. 16. REG. 4-4-2006.
3,187,061. HEALTHPLEX SOLUTIONS STANDARD CHARACTER MARK INT. CL. 35. REG. 12-19-2006.
3,343,891. ARRIBASTANDARD CHARACTER MARK INT. CL. 18 ONLY. REG. 11-27-2007.
- 1,457,908. IF YOU DON'T LOOK GOOD, WE DON'T LOOK GOOD. INT. CL. 3. REG. 9-22-1987.
1,457,917. QUALIS AND DESIGN. INT. CLS. 3, 5 AND 35. REG. 9-22-1987.
1,457,924. TEPOTA. INT. CL. 3. REG. 9-22-1987.
1,457,926. HW. INT. CL. 3. REG. 9-22-1987.
1,457,927. WINSTON. INT. CL. 3. REG. 9-22-1987.
1,457,930. PARFUM TEA ROSE AND DESIGN. INT. CL. 3. REG. 9-22-1987.
1,457,933. SHEER DELIGHT (STYLIZED). INT. CL. 3. REG. 9-22-1987.
1,457,934. PHFFT. INT. CL. 3. REG. 9-22-1987.
1,457,937. EUROBATH. INT. CL. 3. REG. 9-22-1987.
1,457,944. MARATHON 25. INT. CL. 3. REG. 9-22-1987.
1,457,947. FLARE FIGHTER. INT. CLS. 4 AND 11. REG. 9-22-1987.
1,457,949. OLEUM AND DESIGN. INT. CLS. 4 AND 42. REG. 9-22-1987.
1,457,961. LIFE SUPPORT. INT. CL. 5. REG. 9-22-1987.
1,457,962. VETRX AND DESIGN. INT. CL. 5. REG. 9-22-1987.
1,457,967. SUPER FELEROL. INT. CL. 5. REG. 9-22-1987.
1,457,970. COLDRIN. INT. CL. 5. REG. 9-22-1987.
1,457,971. TOLECTIN DS MCNEIL AND DESIGN. INT. CL. 5. REG. 9-22-1987.
1,457,973. MISCELLANEOUS DESIGN. INT. CL. 5. REG. 9-22-1987.
1,457,979. WATER FRESH. INT. CL. 5. REG. 9-22-1987.
1,457,985. RECOVER. INT. CL. 5. REG. 9-22-1987.
1,457,987. NORMALAID. INT. CL. 5. REG. 9-22-1987.
1,457,998. DECRA-LED. INT. CL. 6. REG. 9-22-1987.
1,458,010. SUPER 7000. INT. CL. 7. REG. 9-22-1987.
1,458,014. ALL-PRO AND DESIGN. INT. CL. 7. REG. 9-22-1987.
1,458,015. RODDING ROBOT. INT. CL. 7. REG. 9-22-1987.
1,458,016. GOOD. INT. CL. 7. REG. 9-22-1987.
1,458,017. MAGICARRY. INT. CL. 7. REG. 9-22-1987.
1,458,018. CRED A. INT. CL. 7. REG. 9-22-1987.
1,458,019. OPTIKLEER. INT. CL. 7. REG. 9-22-1987.
1,458,020. LAURIER AND DESIGN. INT. CL. 7. REG. 9-22-1987.
1,458,023. ROJ ELECTROTTEX AND DESIGN. INT. CLS. 7 AND 9. REG. 9-22-1987.
1,458,024. POWER PIC. INT. CL. 8. REG. 9-22-1987.
1,458,031. ELBA (STYLIZED). INT. CL. 9. REG. 9-22-1987.
1,458,042. MINORPC (STYLIZED). INT. CL. 9. REG. 9-22-1987.
1,458,049. AFP AND DESIGN. INT. CLS. 9, 16, 35 AND 42. REG. 9-22-1987.
1,458,052. HYBRIWASH. INT. CL. 9. REG. 9-22-1987.
1,458,053. CABISCO MATHEMATICS AND DESIGN. INT. CLS. 9 AND 16. REG. 9-22-1987.
1,458,062. ICONOMISER (STYLIZED). INT. CL. 9. REG. 9-22-1987.
1,458,064. TSS (STYLIZED). INT. CL. 9. REG. 9-22-1987.
1,458,065. INSTANT MUSIC. INT. CL. 9. REG. 9-22-1987.
1,458,067. TN TELENORMA AND DESIGN. INT. CLS. 9, 37, 38 AND 42. REG. 9-22-1987.
1,458,069. PHILLIPS ACID-FLAME-CHECK AND DESIGN. INT. CL. 9. REG. 9-22-1987.
1,458,070. PRESTIGE. INT. CL. 9. REG. 9-22-1987.
1,458,072. FOLIO. INT. CL. 9. REG. 9-22-1987.
1,458,073. DMC DATAMEDIA CORPORATION AND DESIGN. INT. CLS. 9 AND 16. REG. 9-22-1987.

SECTION 8

- 796,781. KAPERS BY KINNEY. U.S. CL. 39. REG. 9-28-1965.
829,921. WESTBURY. U.S. CL. 100. REG. 6-6-1967.
835,979. GUY DE BERAC (STYLIZED). U.S. CL. 39. REG. 9-26-1967.
1,028,019. KINNEY (STYLIZED). INT. CL. 25. REG. 12-23-1975.
1,117,574. MISCELLANEOUS DESIGN. INT. CL. 25 ONLY. REG. 5-8-1979.
1,303,001. ROYAL CROWN. INT. CL. 32. REG. 10-30-1984.
1,344,543. MS. CHAUS. INT. CL. 25. REG. 6-25-1985.
1,347,948. T-SEAT. INT. CL. 20. REG. 7-9-1985.
1,359,750. POWERCUTS. INT. CL. 41. REG. 9-10-1985.
1,366,144. CONTACTONE. INT. CL. 1. REG. 10-22-1985.
1,366,629. THE SANDLOT SPORTSWORD PUZZLE. INT. CL. 16. REG. 10-22-1985.
1,366,977. RENÉ BRIAND (STYLIZED). INT. CL. 33. REG. 10-22-1985.
1,367,413. CMTS. INT. CL. 9. REG. 10-29-1985.
1,451,699. AMERICA'S PHARMACY. INT. CL. 5. REG. 8-11-1987.
1,452,592. AMERICA'S PHARMACY. INT. CL. 42. REG. 8-11-1987.
1,457,847. MORTAR LIFE. INT. CL. 1. REG. 9-22-1987.
1,457,854. TUFREX. INT. CL. 1. REG. 9-22-1987.
1,457,856. GALXYL. INT. CLS. 1 AND 17. REG. 9-22-1987.
1,457,858. ASTRA-BRITE. INT. CL. 1. REG. 9-22-1987.
1,457,859. GLYCOSOME. INT. CL. 1. REG. 9-22-1987.
1,457,862. VITA HUME. INT. CLS. 1 AND 31. REG. 9-22-1987.
1,457,868. QUAKER STATE Q AND DESIGN. INT. CLS. 1 AND 4. REG. 9-22-1987.
1,457,872. INJECTOR CARE. INT. CL. 1. REG. 9-22-1987.
1,457,873. UCARLNK. INT. CL. 1. REG. 9-22-1987.
1,457,875. MONOSET. INT. CL. 1. REG. 9-22-1987.
1,457,882. HALTZ. INT. CL. 2. REG. 9-22-1987.
1,457,888. CIELO ALTO. INT. CL. 3. REG. 9-22-1987.
1,457,895. HAIR SPECIFICS. INT. CL. 3. REG. 9-22-1987.
1,457,899. ANDRON. INT. CL. 3. REG. 9-22-1987.

- 1,458,078. ACCESS+ (STYLIZED). INT. CL. 9. REG. 9-22-1987.
- 1,458,079. ULTRAPHONE. INT. CL. 9. REG. 9-22-1987.
- 1,458,082. HOMER. INT. CL. 9. REG. 9-22-1987.
- 1,458,084. VIBRALERT. INT. CL. 9. REG. 9-22-1987.
- 1,458,086. SCREENSCAN. INT. CL. 9. REG. 9-22-1987.
- 1,458,087. CAREER FINDER. INT. CL. 9. REG. 9-22-1987.
- 1,458,091. DENSEPAK. INT. CL. 9. REG. 9-22-1987.
- 1,458,092. SY-TOS. INT. CL. 9. REG. 9-22-1987.
- 1,458,093. C AND DESIGN. INT. CL. 9. REG. 9-22-1987.
- 1,458,097. COMMERCE (STYLIZED). INT. CL. 9. REG. 9-22-1987.
- 1,458,108. AD II. INT. CL. 9. REG. 9-22-1987.
- 1,458,109. BITSTREAM CARMINA. INT. CLS. 9 AND 16. REG. 9-22-1987.
- 1,458,110. BITSTREAM AMERIGO. INT. CLS. 9 AND 16. REG. 9-22-1987.
- 1,458,111. BITSTREAM CHARTER. INT. CLS. 9 AND 16. REG. 9-22-1987.
- 1,458,115. CRANECOM. INT. CL. 9. REG. 9-22-1987.
- 1,458,116. MISCELLANEOUS DESIGN. INT. CL. 9. REG. 9-22-1987.
- 1,458,117. UNITIP. INT. CL. 9. REG. 9-22-1987.
- 1,458,119. POWERMASTER. INT. CL. 9. REG. 9-22-1987.
- 1,458,121. APMS. INT. CL. 9. REG. 9-22-1987.
- 1,458,136. MASTERY. INT. CL. 9. REG. 9-22-1987.
- 1,458,137. AQUA EXPLORER. INT. CL. 9. REG. 9-22-1987.
- 1,458,138. QUICK DROP. INT. CL. 9. REG. 9-22-1987.
- 1,458,145. AXIOSCAN. INT. CL. 9. REG. 9-22-1987.
- 1,458,147. CULVERIN CORPORATION AND DESIGN. INT. CLS. 9 AND 42. REG. 9-22-1987.
- 1,458,154. GOODTIMES AND DESIGN. INT. CL. 9. REG. 9-22-1987.
- 1,458,157. SURFUSE. INT. CL. 9. REG. 9-22-1987.
- 1,458,158. CLIX. INT. CL. 9. REG. 9-22-1987.
- 1,458,170. MISCELLANEOUS DESIGN. INT. CL. 9. REG. 9-22-1987.
- 1,458,171. DANITA. INT. CL. 9. REG. 9-22-1987.
- 1,458,172. MISCELLANEOUS DESIGN. INT. CL. 9. REG. 9-22-1987.
- 1,458,173. AT&T. INT. CL. 9. REG. 9-22-1987.
- 1,458,179. DESKSTAR. INT. CL. 9. REG. 9-22-1987.
- 1,458,182. PIX. INT. CL. 9. REG. 9-22-1987.
- 1,458,183. SPE. INT. CL. 9. REG. 9-22-1987.
- 1,458,185. FDF. INT. CL. 9. REG. 9-22-1987.
- 1,458,195. FEATHERBRITE. INT. CL. 10. REG. 9-22-1987.
- 1,458,197. STRATOFUSE. INT. CL. 10. REG. 9-22-1987.
- 1,458,200. MAGNETRIEVER. INT. CL. 10. REG. 9-22-1987.
- 1,458,207. OMNI-SAT. INT. CL. 10. REG. 9-22-1987.
- 1,458,215. DUET. INT. CL. 11. REG. 9-22-1987.
- 1,458,220. MR. WINTER AND DESIGN. INT. CL. 11. REG. 9-22-1987.
- 1,458,241. FUEL SENTRY. INT. CL. 12. REG. 9-22-1987.
- 1,458,242. MISCELLANEOUS DESIGN. INT. CL. 13. REG. 9-22-1987.
- 1,458,244. EBEL THE ARCHITECTS OF TIME (STYLIZED). INT. CL. 14. REG. 9-22-1987.
- 1,458,250. OLE MATHIESEN (STYLIZED). INT. CL. 14. REG. 9-22-1987.
- 1,458,251. OTTO BACH. INT. CL. 15. REG. 9-22-1987.
- 1,458,254. STINGER. INT. CL. 15. REG. 9-22-1987.
- 1,458,265. TEAR 'N SHARE AND DESIGN. INT. CL. 16. REG. 9-22-1987.
- 1,458,267. TV MOVIE NEWS. INT. CL. 16. REG. 9-22-1987.
- 1,458,269. JS-FUJI. INT. CL. 16. REG. 9-22-1987.
- 1,458,277. ELEPHANT. INT. CLS. 16 AND 21. REG. 9-22-1987.
- 1,458,278. COMPUTER-GRAM. INT. CL. 16. REG. 9-22-1987.
- 1,458,279. WESTERN ROOFING INSULATION AND SIDING. INT. CL. 16. REG. 9-22-1987.
- 1,458,282. GIFTS OF THE HEART. INT. CLS. 16 AND 20. REG. 9-22-1987.
- 1,458,283. RED ROSE GALLERIE. INT. CLS. 16 AND 20. REG. 9-22-1987.
- 1,458,286. INSTITUTIONAL DISTRIBUTION. INT. CL. 16. REG. 9-22-1987.
- 1,458,287. STRIPES AND DESIGN. INT. CL. 16. REG. 9-22-1987.
- 1,458,289. K AND DESIGN. INT. CL. 16. REG. 9-22-1987.
- 1,458,293. MISCELLANEOUS DESIGN. INT. CL. 16. REG. 9-22-1987.
- 1,458,295. GROSSVILLE HIGH. INT. CL. 16. REG. 9-22-1987.
- 1,458,297. SALES EXPRESS. INT. CL. 16. REG. 9-22-1987.
- 1,458,299. THOROUGHbred RACING CALENDAR. INT. CL. 16. REG. 9-22-1987.
- 1,458,302. STEN-ETTE. INT. CL. 16. REG. 9-22-1987.
- 1,458,306. SATELLITE DIRECT AND DESIGN. INT. CL. 16. REG. 9-22-1987.
- 1,458,307. N NEWSPRINT SOUTH INC. AND DESIGN. INT. CL. 16. REG. 9-22-1987.
- 1,458,310. SILKEN MOODS. INT. CL. 16. REG. 9-22-1987.
- 1,458,311. SYNERGY. INT. CL. 16. REG. 9-22-1987.
- 1,458,313. SAMPLE SCRIPTS. INT. CL. 16. REG. 9-22-1987.
- 1,458,324. IOWA PORK TODAY. INT. CL. 16. REG. 9-22-1987.
- 1,458,326. WESTHEDGE. INT. CL. 16. REG. 9-22-1987.
- 1,458,327. MINSTREL BOOKS. INT. CL. 16. REG. 9-22-1987.
- 1,458,328. IRONHEDGE. INT. CL. 16. REG. 9-22-1987.
- 1,458,336. THE HAM SANDWICH. INT. CL. 16. REG. 9-22-1987.
- 1,458,337. THE B-O-M SPREAD. INT. CL. 16. REG. 9-22-1987.
- 1,458,340. SCHOOL MATE. INT. CL. 16. REG. 9-22-1987.
- 1,458,341. FORMSBRITE. INT. CL. 16. REG. 9-22-1987.
- 1,458,342. THE SWEET SEASONAL. INT. CL. 16. REG. 9-22-1987.
- 1,458,349. ULTRAGUARD. INT. CL. 17. REG. 9-22-1987.
- 1,458,350. MISCELLANEOUS DESIGN. INT. CLS. 18, 25 AND 28. REG. 9-22-1987.
- 1,458,358. THE SHUTTERY (STYLIZED). INT. CLS. 19 AND 20. REG. 9-22-1987.
- 1,458,363. CUSTOMFIT. INT. CL. 20. REG. 9-22-1987.
- 1,458,368. MISCELLANEOUS DESIGN. INT. CL. 20. REG. 9-22-1987.
- 1,458,372. RENNEN DAVIS. INT. CLS. 20 AND 21. REG. 9-22-1987.
- 1,458,374. BULLIT. INT. CL. 21. REG. 9-22-1987.
- 1,458,376. TERRAFIRMA. INT. CL. 21. REG. 9-22-1987.
- 1,458,377. CHRISTMASTIME. INT. CL. 21. REG. 9-22-1987.
- 1,458,382. SWEEP 'N' WIPE. INT. CL. 21. REG. 9-22-1987.
- 1,458,386. SULKY. INT. CL. 23. REG. 9-22-1987.
- 1,458,387. ANSO V WORRY-FREE. INT. CL. 23. REG. 9-22-1987.
- 1,458,390. MISCELLANEOUS DESIGN. INT. CL. 24. REG. 9-22-1987.
- 1,458,394. DOFIX-ROLLOFIX. INT. CL. 24. REG. 9-22-1987.
- 1,458,398. MAGGIEBETH. INT. CL. 24. REG. 9-22-1987.
- 1,458,403. BILLIGIO AND DESIGN. INT. CL. 25. REG. 9-22-1987.
- 1,458,407. LACROSSE REGISTERED AND DESIGN. INT. CL. 25. REG. 9-22-1987.
- 1,458,411. GLEN OUR FLANNEL (STYLIZED). INT. CL. 25. REG. 9-22-1987.
- 1,458,413. SUPPORTOPS. INT. CL. 25. REG. 9-22-1987.
- 1,458,416. ANOUSKA HEMPEL. INT. CL. 25. REG. 9-22-1987.
- 1,458,423. QUIK/CORD AND DESIGN. INT. CL. 25. REG. 9-22-1987.
- 1,458,425. JUNIOR PRO AND DESIGN. INT. CL. 25. REG. 9-22-1987.
- 1,458,429. LADY WALKER AND DESIGN. INT. CL. 25. REG. 9-22-1987.
- 1,458,430. KID TERRIFIC! AND DESIGN. INT. CL. 25. REG. 9-22-1987.
- 1,458,431. GRANBY CLUB COLLECTION AND DESIGN. INT. CL. 25. REG. 9-22-1987.
- 1,458,432. USA OLYMPICS AND DESIGN. INT. CL. 25. REG. 9-22-1987.
- 1,458,436. PHONE. INT. CL. 25. REG. 9-22-1987.
- 1,458,440. HOLLYWOOD EAST AND DESIGN. INT. CL. 25. REG. 9-22-1987.
- 1,458,442. FOOTDRYER (STYLIZED). INT. CL. 25. REG. 9-22-1987.
- 1,458,452. CITYSIDE. INT. CL. 25. REG. 9-22-1987.
- 1,458,457. ZERO STATS AND DESIGN. INT. CL. 25. REG. 9-22-1987.
- 1,458,460. RANDA PANDA. INT. CL. 25. REG. 9-22-1987.
- 1,458,465. RAVELLO. INT. CL. 25. REG. 9-22-1987.

- 1,458,476. LIFT-OFF. INT. CL. 28. REG. 9-22-1987.
 1,458,479. PRESTIGE PRINTS. INT. CLS. 28 AND 40. REG. 9-22-1987.
 1,458,480. NICHYU AND DESIGN. INT. CL. 28. REG. 9-22-1987.
 1,458,488. MISCELLANEOUS DESIGN. INT. CL. 28. REG. 9-22-1987.
 1,458,492. LAURAMITE. INT. CL. 28. REG. 9-22-1987.
 1,458,507. GIORGIO. INT. CL. 28. REG. 9-22-1987.
 1,458,509. THE MUSEUM COLLECTION (STYLIZED). INT. CL. 28. REG. 9-22-1987.
 1,458,513. ANGEL DREAMS. INT. CL. 28. REG. 9-22-1987.
 1,458,521. MISCELLANEOUS DESIGN. INT. CL. 28. REG. 9-22-1987.
 1,458,527. ZOMBOOKEE. INT. CL. 28. REG. 9-22-1987.
 1,458,530. PRO-FLEX. INT. CL. 28. REG. 9-22-1987.
 1,458,538. DELI-STIK. INT. CL. 29. REG. 9-22-1987.
 1,458,539. PORK LOVERS AND DESIGN. INT. CL. 29. REG. 9-22-1987.
 1,458,540. MISCELLANEOUS DESIGN. INT. CL. 29. REG. 9-22-1987.
 1,458,541. WILD CHEWS. INT. CL. 29. REG. 9-22-1987.
 1,458,544. MISS SCARLETT'S. INT. CL. 29. REG. 9-22-1987.
 1,458,554. MISCELLANEOUS DESIGN. INT. CLS. 29 AND 33. REG. 9-22-1987.
 1,458,555. VILLA NICOLA. INT. CLS. 29 AND 33. REG. 9-22-1987.
 1,458,559. STAGG CHAMPION CHILI AND DESIGN. INT. CL. 29. REG. 9-22-1987.
 1,458,562. BEEF BUDDIES. INT. CL. 29. REG. 9-22-1987.
 1,458,566. GRANDAD'S AND DESIGN. INT. CL. 29. REG. 9-22-1987.
 1,458,570. MI MAMA'S HOMEMADE STYLE TORTILLAS AND DESIGN. INT. CL. 30. REG. 9-22-1987.
 1,458,572. FERRERO ROCHER AND DESIGN. INT. CL. 30. REG. 9-22-1987.
 1,458,576. MINUTE MAID FRUIT JUICE. INT. CL. 30. REG. 9-22-1987.
 1,458,579. PACIFIC RICE PRODUCTS. INT. CL. 30. REG. 9-22-1987.
 1,458,581. MARVELOUS MUFFINS. INT. CL. 30. REG. 9-22-1987.
 1,458,583. KUKURE CURRY. INT. CL. 30. REG. 9-22-1987.
 1,458,592. G 1910 CANDY AND DESIGN. INT. CL. 30. REG. 9-22-1987.
 1,458,601. MARINADE-MAGIC AND DESIGN. INT. CL. 30. REG. 9-22-1987.
 1,458,602. HIDE A PAK. INT. CL. 30. REG. 9-22-1987.
 1,458,604. TORPEDO. INT. CL. 30. REG. 9-22-1987.
 1,458,606. CONTROL. INT. CL. 31. REG. 9-22-1987.
 1,458,607. PAUMA VALLEY SILVER. INT. CL. 31. REG. 9-22-1987.
 1,458,610. BOAR POWER AND DESIGN. INT. CL. 31. REG. 9-22-1987.
 1,458,611. QUEENCREST. INT. CL. 31. REG. 9-22-1987.
 1,458,614. COGEST. INT. CL. 31. REG. 9-22-1987.
 1,458,618. WINTERFEST BEER (STYLIZED). INT. CL. 32. REG. 9-22-1987.
 1,458,620. BLUE MOUNTAIN SPRING WATER. INT. CL. 32. REG. 9-22-1987.
 1,458,621. THOMAS KEMPER AND DESIGN. INT. CL. 32. REG. 9-22-1987.
 1,458,623. FEDERICO PATERNINA OLLAURI RIOJA, ESPANA BANDA AZUL (AND OTHER NOTATIONS) AND DESIGN. INT. CL. 33. REG. 9-22-1987.
 1,458,624. WONDERWINE. INT. CL. 33. REG. 9-22-1987.
 1,458,649. FLAGSHIP. INT. CL. 35. REG. 9-22-1987.
 1,458,654. PRIME SOURCE. INT. CL. 35. REG. 9-22-1987.
 1,458,655. MIDWEST GRAPHICS. INT. CL. 35. REG. 9-22-1987.
 1,458,669. CHARGEPLUS (STYLIZED). INT. CL. 36. REG. 9-22-1987.
 1,458,674. RATE SAVER PLUS PERSONAL CREDIT LINE. INT. CL. 36. REG. 9-22-1987.
 1,458,677. WE'RE BANKING ON THE TREASURE COAST. INT. CL. 36. REG. 9-22-1987.
 1,458,684. BH BANCORP HAWAII (STYLIZED). INT. CL. 36. REG. 9-22-1987.
 1,458,688. ALL STAR SALUTE TO SECRETARIES. INT. CL. 36. REG. 9-22-1987.
 1,458,689. CHECK SENSE (STYLIZED). INT. CL. 36. REG. 9-22-1987.
 1,458,693. CONCEPT 28. INT. CL. 36. REG. 9-22-1987.
 1,458,695. UCB. INT. CL. 36. REG. 9-22-1987.
 1,458,699. UNITEDVERSAL. INT. CL. 36. REG. 9-22-1987.
 1,458,703. MISCELLANEOUS DESIGN. INT. CLS. 37 AND 42. REG. 9-22-1987.
 1,458,723. SUPERSTAR CONNECTION. INT. CL. 38. REG. 9-22-1987.
 1,458,731. EMPIRE TOURS AND DESIGN. INT. CL. 39. REG. 9-22-1987.
 1,458,732. SAVEAWAY VACATIONS. INT. CL. 39. REG. 9-22-1987.
 1,458,733. MISCELLANEOUS DESIGN. INT. CL. 39. REG. 9-22-1987.
 1,458,735. CRUISEFEST. INT. CL. 39. REG. 9-22-1987.
 1,458,736. THE CRUISE CONNECTION. INT. CL. 39. REG. 9-22-1987.
 1,458,737. LESS FARE, MORE CARE.. INT. CL. 39. REG. 9-22-1987.
 1,458,741. SING-A-THON (STYLIZED). INT. CL. 41. REG. 9-22-1987.
 1,458,744. PART. INT. CL. 41. REG. 9-22-1987.
 1,458,745. COMMITTED FITNESS SYSTEMS. INT. CL. 41. REG. 9-22-1987.
 1,458,754. STRAY POP. INT. CL. 41. REG. 9-22-1987.
 1,458,770. PEOPLE SAMPLER. INT. CL. 41. REG. 9-22-1987.
 1,458,776. LORD'S & LADY'S HAIR SALONS AND DESIGN. INT. CL. 42. REG. 9-22-1987.
 1,458,780. PASQUA. INT. CL. 42. REG. 9-22-1987.
 1,458,786. AGE WAVE. INT. CL. 42. REG. 9-22-1987.
 1,458,788. SAY IT ON HOLD AND DESIGN. INT. CL. 42. REG. 9-22-1987.
 1,458,790. MAISON BLANCHE (STYLIZED). INT. CL. 42. REG. 9-22-1987.
 1,458,799. DU DOORS UNLIMITED AND DESIGN. INT. CL. 42. REG. 9-22-1987.
 1,458,807. THE DOUBLEDAY LARGE PRINT HOME LIBRARY. INT. CL. 42. REG. 9-22-1987.
 1,458,814. MICROTRADE. INT. CL. 42. REG. 9-22-1987.
 1,458,817. THE ECONOMY LEADER NATIONWIDE. INT. CL. 42. REG. 9-22-1987.
 1,458,818. SPECTRUM. INT. CL. 42. REG. 9-22-1987.
 1,458,820. TRILLIUM. INT. CL. 42. REG. 9-22-1987.
 1,458,821. SPECTRUM AND DESIGN. INT. CL. 42. REG. 9-22-1987.
 1,458,823. P.D. QUIX THE FASTER FOOD PLACE P.D. QUIX Q-CUTS AND DESIGN. INT. CL. 42. REG. 9-22-1987.
 1,458,829. CONCEPT ELITE. INT. CL. 42. REG. 9-22-1987.
 1,458,831. WE TAKE YOUR FUN SERIOUSLY. INT. CL. 42. REG. 9-22-1987.
 1,458,834. SUMPTUOUSLY VICTORIAN, SIMPLY CASUAL. INT. CL. 42. REG. 9-22-1987.
 1,458,838. MISCELLANEOUS DESIGN. INT. CL. 42. REG. 9-22-1987.
 1,458,839. BIOMAP. INT. CL. 42. REG. 9-22-1987.
 1,458,844. TECHTRON IMAGING NETWORK. INT. CL. 42. REG. 9-22-1987.
 1,458,848. GERTIE'S. INT. CL. 42. REG. 9-22-1987.
 1,458,852. BREAK TIME. INT. CL. 42. REG. 9-22-1987.
 1,458,862. HYSAN. INT. CL. 9. REG. 9-22-1987.
 1,458,863. MEMBRANE DIFFUSION. INT. CL. 11. REG. 9-22-1987.
 1,458,867. FAST TRACK. INT. CL. 16. REG. 9-22-1987.
 1,458,868. ALMOND CHIP CRISP. INT. CL. 30. REG. 9-22-1987.
 1,458,869. M.G. VALLEJO. INT. CL. 33. REG. 9-22-1987.
 1,458,873. WE DON'T JUST DO IT FAST, WE DO IT RIGHT. INT. CL. 37. REG. 9-22-1987.
 1,458,874. BEAUTIES OF AMERICA PAGEANT. INT. CL. 41. REG. 9-22-1987.
 1,458,876. THE GREAT GREY SHIRE HITCH. INT. CL. 41. REG. 9-22-1987.

- 1,491,792. SAFEGUARD. INT. CLS. 2, 21 AND 22 ONLY. REG. 6-14-1988.
- 1,491,881. EI AND DESIGN. INT. CL. 17 ONLY. REG. 6-14-1988.
- 1,752,957. HEALTH FIRST CONSULTING CORPORATION AND DESIGN. INT. CL. 41. REG. 2-16-1993.
- 1,833,075. SLOW DANCE. INT. CL. 3. REG. 4-26-1994.
- 1,946,364. WINDOW INTERIORS AND DESIGN. INT. CL. 42. REG. 1-9-1996.
- 1,952,138. INTOURIST AND DESIGN. INT. CL. 39. REG. 1-30-1996.
- 2,002,687. CENTROBAKE. INT. CL. 1. REG. 9-24-1996.
- 2,004,411. HAMPTONS HANDBOOK. INT. CL. 16. REG. 10-1-1996.
- 2,012,551. IR AND DESIGN. INT. CL. 9. REG. 10-29-1996.
- 2,015,270. ORION SYSTEMS GROUP, INC.. INT. CLS. 9 AND 42. REG. 11-12-1996.
- 2,085,397. Z LAND. INT. CL. 9. REG. 8-5-1997.
- 2,088,001. LIMIT. INT. CL. 1. REG. 8-12-1997.
- 2,094,742. THE TIPPERAIRY SOLUTION AND DESIGN. INT. CL. 18. REG. 9-9-1997.
- 2,098,507. SUPERIOR EMPLOYERS PLAN. INT. CL. 36. REG. 9-23-1997.
- 2,098,511. CONTORQ. INT. CL. 7. REG. 9-23-1997.
- 2,098,517. ULURU. INT. CLS. 9 AND 16. REG. 9-23-1997.
- 2,098,519. MEER (STYLIZED). INT. CLS. 3, 4, 5, 16, 21, 24, 29, 30, 31, 32, 33 AND 34. REG. 9-23-1997.
- 2,098,526. SAND COMB. INT. CL. 8. REG. 9-23-1997.
- 2,098,532. BIOGEL. INT. CLS. 12 AND 25. REG. 9-23-1997.
- 2,098,543. TAN WITHOUT THE SUN. INT. CL. 3. REG. 9-23-1997.
- 2,098,551. CARDKEY. INT. CL. 9. REG. 9-23-1997.
- 2,098,555. HD5. INT. CL. 9. REG. 9-23-1997.
- 2,098,560. NOBEL PRIZE SERIES. INT. CLS. 9 AND 16. REG. 9-23-1997.
- 2,098,574. CERAMCEL. INT. CL. 1. REG. 9-23-1997.
- 2,098,601. STORYBOOK ADVENTURES. INT. CL. 9. REG. 9-23-1997.
- 2,098,606. CLASSIC SUNDAE BY BROTHERS (STYLIZED). INT. CL. 30. REG. 9-23-1997.
- 2,098,607. COOKIE MAN AND DESIGN. INT. CL. 30. REG. 9-23-1997.
- 2,098,609. I! IMPACT UNLIMITED AND DESIGN. INT. CLS. 35 AND 42. REG. 9-23-1997.
- 2,098,614. HONEY AND DESIGN. INT. CL. 30. REG. 9-23-1997.
- 2,098,615. KEYBELT (STYLIZED). INT. CL. 7. REG. 9-23-1997.
- 2,098,621. IMS AND DESIGN. INT. CL. 9. REG. 9-23-1997.
- 2,098,637. REBEL SERIOUS ABOUT OUR PRODUCTS AND DESIGN. INT. CL. 29. REG. 9-23-1997.
- 2,098,640. DANDY. INT. CLS. 25, 39 AND 42. REG. 9-23-1997.
- 2,098,642. EIS INTERNATIONAL. INT. CL. 9. REG. 9-23-1997.
- 2,098,645. QCS. INT. CL. 42. REG. 9-23-1997.
- 2,098,646. VIKING COMPONENTS AND DESIGN. INT. CL. 9. REG. 9-23-1997.
- 2,098,649. GARDENERS' SECRET. INT. CL. 1. REG. 9-23-1997.
- 2,098,657. WAX ORCHARDS. INT. CL. 29. REG. 9-23-1997.
- 2,098,663. FARMAMEDICA. INT. CL. 42. REG. 9-23-1997.
- 2,098,673. LITEGLOW AND DESIGN. INT. CL. 11. REG. 9-23-1997.
- 2,098,677. FREEDOMS FOUNDATION. INT. CL. 41. REG. 9-23-1997.
- 2,098,682. BEASLEY'S DUNN'S RIVER FALLS BRAND GOURMET FOODS TASTE OF THE ISLANDS AND DESIGN. INT. CL. 30. REG. 9-23-1997.
- 2,098,685. MAXXESS. INT. CLS. 9 AND 36. REG. 9-23-1997.
- 2,098,686. DISCOVERY EXHIBITS. INT. CL. 41. REG. 9-23-1997.
- 2,098,692. POLITICAL WIZARD. INT. CL. 9. REG. 9-23-1997.
- 2,098,694. ST. THOMAS. INT. CLS. 30 AND 32. REG. 9-23-1997.
- 2,098,707. R-B AND DESIGN. INT. CL. 7. REG. 9-23-1997.
- 2,098,712. THE [] EMPLOYER. INT. CLS. 16 AND 41. REG. 9-23-1997.
- 2,098,719. SCARAB RED OASIS RED ALE AND DESIGN. INT. CL. 32. REG. 9-23-1997.
- 2,098,723. LOLA CION'S. INT. CLS. 29, 30 AND 42. REG. 9-23-1997.
- 2,098,728. DELTAN GROUP, INC. AND DESIGN. INT. CL. 42. REG. 9-23-1997.
- 2,098,735. W.& L.T.. INT. CL. 25. REG. 9-23-1997.
- 2,098,742. DOMUS SOFTWARE AND DESIGN. INT. CLS. 9 AND 42. REG. 9-23-1997.
- 2,098,754. DOLPHIN AND DESIGN. INT. CL. 1. REG. 9-23-1997.
- 2,098,763. EL SABOR DE CUBA. INT. CL. 30. REG. 9-23-1997.
- 2,098,767. HOMETRENDS. INT. CLS. 7, 9 AND 11. REG. 9-23-1997.
- 2,098,768. BRITON. INT. CLS. 6 AND 9. REG. 9-23-1997.
- 2,098,769. HUNTINGTON BEACH SURFING WALK OF FAME AND DESIGN. INT. CL. 42. REG. 9-23-1997.
- 2,098,776. REAL AND DESIGN. INT. CL. 9. REG. 9-23-1997.
- 2,098,779. P.M.P.X. 9950 IRON CARBON. INT. CL. 28. REG. 9-23-1997.
- 2,098,788. GOLDKENN ICE GOLD AND DESIGN. INT. CL. 30. REG. 9-23-1997.
- 2,098,791. SUTTER'S STATE FAIR SALT WATER TAFFY SUTTER CANDY COMPANY AND DESIGN. INT. CL. 30. REG. 9-23-1997.
- 2,098,794. READER. INT. CLS. 35 AND 42. REG. 9-23-1997.
- 2,098,807. FIRESIDE. INT. CL. 36. REG. 9-23-1997.
- 2,098,832. CYBER OCTAVE. INT. CL. 9. REG. 9-23-1997.
- 2,098,854. ELECTRIC VEHICLE INFRASTRUCTURE EVI AND DESIGN. INT. CL. 42. REG. 9-23-1997.
- 2,098,861. IHC HEALTH CENTER. INT. CL. 42. REG. 9-23-1997.
- 2,098,864. JC AND DESIGN. INT. CL. 36. REG. 9-23-1997.
- 2,098,865. JC AND DESIGN. INT. CL. 35. REG. 9-23-1997.
- 2,098,870. RITEPOINT. INT. CL. 16. REG. 9-23-1997.
- 2,098,871. THE NEW WAY TO BUY CARS. INT. CL. 39. REG. 9-23-1997.
- 2,098,875. GAGE MASTER. INT. CL. 9. REG. 9-23-1997.
- 2,098,878. SECURITY ZONE. INT. CL. 37. REG. 9-23-1997.
- 2,098,883. CALQUEST (STYLIZED). INT. CLS. 9 AND 38. REG. 9-23-1997.
- 2,098,884. GREAT CHOICES. INT. CL. 36. REG. 9-23-1997.
- 2,098,887. DEALER CONNECTION. INT. CL. 35. REG. 9-23-1997.
- 2,098,889. LASALLE PAPER. INT. CL. 16. REG. 9-23-1997.
- 2,098,894. 5 OCEANS AND DESIGN. INT. CL. 29. REG. 9-23-1997.
- 2,098,895. MEALS TO GO AND DESIGN. INT. CL. 16. REG. 9-23-1997.
- 2,098,898. ARTTODAY. INT. CL. 35. REG. 9-23-1997.
- 2,098,901. REALITY ZONE. INT. CL. 9. REG. 9-23-1997.
- 2,098,908. DAKOTA. INT. CL. 22. REG. 9-23-1997.
- 2,098,921. HEADBONE INTERACTIVE. INT. CL. 41. REG. 9-23-1997.
- 2,098,938. EYE OF THE NEEDLE APPAREL CAD SERVICES AND DESIGN. INT. CL. 42. REG. 9-23-1997.
- 2,098,973. PIPING ROCK NATURAL SPRING WATER. INT. CLS. 32 AND 39. REG. 9-23-1997.
- 2,098,974. IDXTEND (STYLIZED). INT. CLS. 9, 37 AND 42. REG. 9-23-1997.
- 2,098,985. LUMINA. INT. CL. 11. REG. 9-23-1997.
- 2,098,986. INFINITY. INT. CL. 11. REG. 9-23-1997.
- 2,098,993. MISCELLANEOUS DESIGN. INT. CL. 41. REG. 9-23-1997.
- 2,098,996. SLEEPTeam. INT. CLS. 35 AND 42. REG. 9-23-1997.
- 2,099,003. VITALINK. INT. CL. 35. REG. 9-23-1997.
- 2,099,006. WAY TO GO. INT. CL. 35. REG. 9-23-1997.
- 2,099,010. NILO. INT. CL. 28. REG. 9-23-1997.
- 2,099,013. 3-D I-D. INT. CLS. 9 AND 40. REG. 9-23-1997.
- 2,099,021. BIENFAIT. INT. CL. 3. REG. 9-23-1997.
- 2,099,024. BELLSOUTH CLASSIC. INT. CLS. 18, 20, 21, 24, 25, 28 AND 41. REG. 9-23-1997.
- 2,099,025. BOOTSIIE'S SOUTH LOUISIANA COOKING AND DESIGN. INT. CLS. 29 AND 30. REG. 9-23-1997.

- 2,099,032. MISCELLANEOUS DESIGN. INT. CL. 1. REG. 9-23-1997.
- 2,099,038. MISCELLANEOUS DESIGN. INT. CLS. 35, 40 AND 42. REG. 9-23-1997.
- 2,099,041. M-C INTERNATIONAL. INT. CL. 35. REG. 9-23-1997.
- 2,099,047. GFI AND DESIGN. INT. CL. 36. REG. 9-23-1997.
- 2,099,059. SPICE. INT. CL. 9. REG. 9-23-1997.
- 2,099,068. SECRETARIAT. INT. CL. 9. REG. 9-23-1997.
- 2,099,069. MR. HERO. INT. CL. 25. REG. 9-23-1997.
- 2,099,070. THE BODY INSTITUTE. INT. CL. 42. REG. 9-23-1997.
- 2,099,080. CALLAWAY (STYLIZED). INT. CLS. 36 AND 37. REG. 9-23-1997.
- 2,099,087. SANI-TUBE. INT. CL. 10. REG. 9-23-1997.
- 2,099,104. NEW ERA MEDICAL CLINIC AND DESIGN. INT. CL. 42. REG. 9-23-1997.
- 2,099,107. BIRD DOGS. INT. CL. 29. REG. 9-23-1997.
- 2,099,123. CATCH THE ONE THAT GOT AWAY. INT. CL. 28. REG. 9-23-1997.
- 2,099,130. LOV'NWOOD. INT. CL. 20. REG. 9-23-1997.
- 2,099,132. HAHN'S OLD FASHIONED CAKE COMPANY AND DESIGN. INT. CL. 30. REG. 9-23-1997.
- 2,099,135. GOLDEN FLOW. INT. CLS. 29 AND 32. REG. 9-23-1997.
- 2,099,143. PRIME USDA PRIME BEEF FARMLAND AND DESIGN. INT. CL. 29. REG. 9-23-1997.
- 2,099,147. FRAMEWORK. INT. CL. 42. REG. 9-23-1997.
- 2,099,154. SIMPLY LONDON. INT. CL. 42. REG. 9-23-1997.
- 2,099,158. LUCENT TECHNOLOGIES. INT. CL. 28. REG. 9-23-1997.
- 2,099,169. CRANBERRY CRAZE. INT. CL. 32. REG. 9-23-1997.
- 2,099,181. ENERZONE. INT. CL. 9. REG. 9-23-1997.
- 2,099,187. LUNA PIER COLLECTION LUNA PIER AND DESIGN. INT. CLS. 18 AND 25. REG. 9-23-1997.
- 2,099,189. CENTURY SOLUTION. INT. CL. 9. REG. 9-23-1997.
- 2,099,198. LEATHER WORLD. INT. CL. 35. REG. 9-23-1997.
- 2,099,203. OVM AND DESIGN. INT. CL. 39. REG. 9-23-1997.
- 2,099,206. PRODUCERS' REPORT AND DESIGN. INT. CL. 16. REG. 9-23-1997.
- 2,099,211. AIM (STYLIZED). INT. CL. 9. REG. 9-23-1997.
- 2,099,216. THE C.A.R.E. CHANNEL. INT. CLS. 9 AND 41. REG. 9-23-1997.
- 2,099,219. DATA CADDY. INT. CL. 20. REG. 9-23-1997.
- 2,099,229. HOMEGOLD. INT. CL. 36. REG. 9-23-1997.
- 2,099,236. HACKER TRAP. INT. CL. 9. REG. 9-23-1997.
- 2,099,241. BOASTIN' ROASTER. INT. CL. 29. REG. 9-23-1997.
- 2,099,242. LOUISIANA'S ENTERTAINMENT CAPITOL. INT. CL. 41. REG. 9-23-1997.
- 2,099,254. BIG TREE. INT. CL. 20. REG. 9-23-1997.
- 2,099,261. ROYAL WINGS TRAVEL. INT. CL. 39. REG. 9-23-1997.
- 2,099,268. RTPI. INT. CL. 36. REG. 9-23-1997.
- 2,099,270. HSR. INT. CLS. 20 AND 24. REG. 9-23-1997.
- 2,099,280. FRED. INT. CL. 9. REG. 9-23-1997.
- 2,099,283. HFX. INT. CL. 1. REG. 9-23-1997.
- 2,099,303. ALPHA HYDROXY ACID BIO TEXTURIZING CREAM. INT. CL. 3. REG. 9-23-1997.
- 2,099,309. SOUNDVIEW. INT. CL. 36. REG. 9-23-1997.
- 2,099,319. LAREDO BORDERPLEX AREA WIDE PHONE BOOK. INT. CL. 16. REG. 9-23-1997.
- 2,099,320. CIRCLE B BRAND AND DESIGN. INT. CL. 29. REG. 9-23-1997.
- 2,099,334. WEBSTICKER. INT. CL. 16. REG. 9-23-1997.
- 2,099,345. SUBMIT IT!. INT. CL. 42. REG. 9-23-1997.
- 2,099,358. UNIPROX. INT. CL. 9. REG. 9-23-1997.
- 2,099,368. WHOOP ASS. INT. CL. 30. REG. 9-23-1997.
- 2,099,369. CANDY ASS. INT. CL. 30. REG. 9-23-1997.
- 2,099,370. ASS KICKIN'. INT. CL. 32. REG. 9-23-1997.
- 2,099,372. DAILY SOUP. INT. CL. 42. REG. 9-23-1997.
- 2,099,376. PRO-GOLD. INT. CL. 31. REG. 9-23-1997.
- 2,099,385. DAKOTA LAKES PRODUCTS AND DESIGN. INT. CL. 35. REG. 9-23-1997.
- 2,099,414. MAXICARE. INT. CL. 20. REG. 9-23-1997.
- 2,099,427. CERAMPRESS. INT. CL. 11. REG. 9-23-1997.
- 2,099,430. NOSHVILLE. INT. CL. 42. REG. 9-23-1997.
- 2,099,438. EPISKIN. INT. CL. 3. REG. 9-23-1997.
- 2,099,442. MOONBREAKERS. INT. CL. 30. REG. 9-23-1997.
- 2,099,472. MISCELLANEOUS DESIGN. INT. CL. 28. REG. 9-23-1997.
- 2,099,476. DEFEN. INT. CL. 5. REG. 9-23-1997.
- 2,099,483. DUDLEY (STYLIZED). INT. CL. 18. REG. 9-23-1997.
- 2,099,491. MASSAGWORKS. INT. CL. 42. REG. 9-23-1997.
- 2,099,507. FIRST GEAR. INT. CL. 16. REG. 9-23-1997.
- 2,099,514. TOMMI GUNN. INT. CLS. 16 AND 25. REG. 9-23-1997.
- 2,099,534. SLAM!. INT. CL. 3. REG. 9-23-1997.
- 2,099,584. THE WILLIES. INT. CL. 41. REG. 9-23-1997.
- 2,099,595. BEVERLY HILLS BOULEVARD. INT. CL. 25. REG. 9-23-1997.
- 2,099,600. MSS MEMIC SAFETY SERVICES CHANGING A WORLD AT WORK AND DESIGN. INT. CLS. 35 AND 41. REG. 9-23-1997.
- 2,099,610. MISCELLANEOUS DESIGN. U.S. CL. A. REG. 9-23-1997.
- 2,099,611. L.G. JAMES DIRECT OUTFITTERS. INT. CL. 35. REG. 9-23-1997.
- 2,099,625. DURADRY. INT. CL. 24. REG. 9-23-1997.
- 2,099,628. MACH FIVE. INT. CL. 41. REG. 9-23-1997.
- 2,099,638. IDAHO GEM. INT. CL. 29. REG. 9-23-1997.
- 2,099,661. ACCOUNT LINK. INT. CL. 36. REG. 9-23-1997.
- 2,099,662. FEMEXAM. INT. CL. 5. REG. 9-23-1997.
- 2,099,667. SHAQUILLE O'NEAL. INT. CLS. 9, 16 AND 25. REG. 9-23-1997.
- 2,099,676. ENVIRO. INT. CL. 17. REG. 9-23-1997.
- 2,099,677. WOODEN MEMORIES. INT. CL. 20. REG. 9-23-1997.
- 2,099,692. ELIZABETH ANNE'S WITH LOVE AND CARE HYPOALLERGENIC AND DESIGN. INT. CL. 3. REG. 9-23-1997.
- 2,099,694. MULLIGAN BEER. INT. CL. 32. REG. 9-23-1997.
- 2,099,700. BREAK AWAY AND DESIGN. INT. CL. 6. REG. 9-23-1997.
- 2,099,710. T AND DESIGN. INT. CLS. 20 AND 24. REG. 9-23-1997.
- 2,099,718. LA PORCELLANA BIANCA P B AND DESIGN. INT. CLS. 8 AND 21. REG. 9-23-1997.
- 2,099,748. SECURITY 800. INT. CL. 38. REG. 9-23-1997.
- 2,099,750. MONOJECT AND DESIGN. INT. CL. 10. REG. 9-23-1997.
- 2,099,759. EVERTUFF. INT. CL. 1. REG. 9-23-1997.
- 2,099,762. MOVIE MAGIC. INT. CL. 30. REG. 9-23-1997.
- 2,099,777. SINGLEPOINT. INT. CLS. 36 AND 42. REG. 9-23-1997.
- 2,099,785. DUREX Q QUALITY AND DESIGN. INT. CLS. 5 AND 10. REG. 9-23-1997.
- 2,099,786. PINNACLE. INT. CL. 9. REG. 9-23-1997.
- 2,099,791. MISCELLANEOUS DESIGN. INT. CL. 7. REG. 9-23-1997.
- 2,099,802. SERVICEBUILDER. INT. CL. 9. REG. 9-23-1997.
- 2,099,818. PHILO-MUSIC THERAPY. INT. CL. 41. REG. 9-23-1997.
- 2,099,822. AT&T WIRELESS SERVICES. INT. CL. 38. REG. 9-23-1997.
- 2,099,826. GPSVISION. INT. CL. 9. REG. 9-23-1997.
- 2,099,846. SNAKEYES AND DESIGN. INT. CL. 28. REG. 9-23-1997.
- 2,099,847. SUN CITY GRAND. INT. CL. 36. REG. 9-23-1997.
- 2,099,848. FRUITITOP. INT. CL. 32. REG. 9-23-1997.
- 2,099,853. UNIARTE AND DESIGN. INT. CL. 19. REG. 9-23-1997.
- 2,099,861. CHANGING THE WAY THE WORLD LEARNS. INT. CL. 9. REG. 9-23-1997.
- 2,099,862. AVM. INT. CL. 9. REG. 9-23-1997.
- 2,099,863. LIAISON. INT. CL. 14. REG. 9-23-1997.
- 2,099,866. PROVIDENCE. INT. CL. 24. REG. 9-23-1997.
- 2,099,886. ANY BUS AND DESIGN. INT. CL. 9. REG. 9-23-1997.
- 2,099,906. GARRETT FREIGHTLINES, INC. AND DESIGN. INT. CL. 28. REG. 9-23-1997.
- 2,099,912. LIBERTY FALLS COLLECTION AND DESIGN. INT. CLS. 6 AND 20. REG. 9-23-1997.

- 2,099,916. MOISTUREPRO. INT. CL. 9. REG. 9-23-1997.
 2,099,917. 2 SPORTY SHORTY. INT. CL. 41. REG. 9-23-1997.
 2,099,929. BASEBALL CHEW. INT. CL. 29. REG. 9-23-1997.
 2,099,932. WONDER SEAT. INT. CL. 20. REG. 9-23-1997.
 2,099,945. HARVEST 2000 AND DESIGN. INT. CL. 30. REG. 9-23-1997.
 2,099,946. SIDECAR. INT. CL. 11. REG. 9-23-1997.
 2,099,950. REM GARSON. INT. CL. 42. REG. 9-23-1997.
 2,099,959. BIG COUNTRY. INT. CL. 5. REG. 9-23-1997.
 2,099,963. MISCELLANEOUS DESIGN. INT. CL. 9. REG. 9-23-1997.
 2,099,970. DEADTIME STORIES. INT. CL. 16. REG. 9-23-1997.
 2,099,976. CIRIO AND DESIGN. INT. CL. 30. REG. 9-23-1997.
 2,099,981. FINISHLINE. INT. CL. 7. REG. 9-23-1997.
 2,099,992. MASTER BLASTER. INT. CL. 12. REG. 9-23-1997.
 2,099,993. GK-60. INT. CL. 12. REG. 9-23-1997.
 2,099,994. GK-65. INT. CL. 12. REG. 9-23-1997.
 2,099,996. VAPOR RECORDS. INT. CL. 9. REG. 9-23-1997.
 2,100,004. CLETEMATE. INT. CL. 8. REG. 9-23-1997.
 2,100,005. MCBABY AND DESIGN. INT. CL. 25. REG. 9-23-1997.
 2,100,007. GREATER CINCINNATI BUSINESS CONNECTIONS. INT. CL. 35. REG. 9-23-1997.
 2,100,023. QUICK. INT. CL. 10. REG. 9-23-1997.
 2,100,036. CRESCENT BOOKS AND DESIGN. INT. CL. 16. REG. 9-23-1997.
 2,100,039. SMX ONLINE (STYLIZED). INT. CL. 9. REG. 9-23-1997.
 2,100,044. MAXFLI XS. INT. CL. 28. REG. 9-23-1997.
 2,100,062. PATHWAYS PRESCHOOL PLUS. INT. CLS. 41 AND 42. REG. 9-23-1997.
 2,100,064. PLATFORM-SLUSH. INT. CL. 10. REG. 9-23-1997.
 2,100,069. DOLCE. INT. CL. 31. REG. 9-23-1997.
 2,100,070. SVS STORED VALUE SYSTEMS (STYLIZED). INT. CL. 36. REG. 9-23-1997.
 2,100,073. MT AND DESIGN. INT. CL. 41. REG. 9-23-1997.
 2,100,076. THUNDER DOME. INT. CL. 28. REG. 9-23-1997.
 2,100,079. DOCKMATE (STYLIZED). INT. CL. 9. REG. 9-23-1997.
 2,100,089. FIRST IN THE MAILBOX. INT. CL. 35. REG. 9-23-1997.
 2,100,090. FUNFINDER. INT. CL. 28. REG. 9-23-1997.
 2,100,097. SYDNEY AND FRIENDS. INT. CL. 25. REG. 9-23-1997.
 2,100,107. KIT AND DESIGN. INT. CL. 25. REG. 9-23-1997.
 2,100,110. CHOICE ONE FOODS. INT. CLS. 29 AND 40. REG. 9-23-1997.
 2,100,111. RAPID REWARDS AND DESIGN. INT. CL. 39. REG. 9-23-1997.
 2,100,117. COINBANK. INT. CLS. 9 AND 36. REG. 9-23-1997.
 2,100,118. JIMMY HOUSTON'S BASS TOURNAMENT, USA. INT. CL. 28. REG. 9-23-1997.
 2,100,119. PREVIEW. INT. CL. 9. REG. 9-23-1997.
 2,100,121. MISCELLANEOUS DESIGN. INT. CLS. 16, 21, 25 AND 28. REG. 9-23-1997.
 2,100,122. SALISBURYLINK. INT. CL. 9. REG. 9-23-1997.
 2,100,129. THOMPSON TOTAL BRANDING. INT. CL. 35. REG. 9-23-1997.
 2,100,137. ASF-2001. INT. CL. 12. REG. 9-23-1997.
 2,100,146. MATADOR CAPITAL MANAGEMENT. INT. CL. 36. REG. 9-23-1997.
 2,100,147. BATTERYMARK. INT. CL. 9. REG. 9-23-1997.
 2,100,155. COMPOSITIONS OVERTURE. INT. CL. 9. REG. 9-23-1997.
 2,100,161. FASHION SEAL TRENDS. INT. CL. 42. REG. 9-23-1997.
 2,100,162. FASHION SEAL TRENDS. INT. CL. 16. REG. 9-23-1997.
 2,100,169. THE TRUXSTOR CUSTOM TRUCK ACCESSORIES AND DESIGN. INT. CL. 42. REG. 9-23-1997.
 2,100,191. MORTGAGE METER. INT. CL. 36. REG. 9-23-1997.
 2,100,193. FORTRESS. INT. CL. 19. REG. 9-23-1997.
 2,100,202. FIX. INT. CL. 5. REG. 9-23-1997.
 2,100,207. ACCUPIPETTE. INT. CL. 5. REG. 9-23-1997.
 2,100,210. BREADSONG. INT. CL. 30. REG. 9-23-1997.
 2,100,218. THE LUCKIEST UNLUCKY MAN ALIVE. INT. CL. 41. REG. 9-23-1997.
 2,100,231. TRUE JUICE. INT. CL. 32. REG. 9-23-1997.
 2,100,235. WISLINK. INT. CL. 42. REG. 9-23-1997.
 2,100,239. EVERYTHING BUT GAS. INT. CLS. 37 AND 42. REG. 9-23-1997.
 2,100,240. SIGNATURE LEADERSHIP. INT. CL. 41. REG. 9-23-1997.
 2,100,241. BREADSONG LE PAIN QUI CHANTE AND DESIGN. INT. CL. 30. REG. 9-23-1997.
 2,100,243. CASHAPPLY. INT. CL. 9. REG. 9-23-1997.
 2,100,245. ITSA HIT. INT. CL. 29. REG. 9-23-1997.
 2,100,247. ALTERNA. INT. CL. 19. REG. 9-23-1997.
 2,100,254. NBA FINALS AND DESIGN. INT. CL. 25. REG. 9-23-1997.
 2,100,264. WINLINK. INT. CL. 9. REG. 9-23-1997.
 2,100,265. 24 DOOR TO DOOR AND DESIGN. INT. CL. 14. REG. 9-23-1997.
 2,100,272. AQUA-FORCE. INT. CL. 1. REG. 9-23-1997.
 2,100,274. POC. INT. CL. 5. REG. 9-23-1997.
 2,100,279. TRUEVIEW. INT. CL. 35. REG. 9-23-1997.
 2,100,280. OFFICE ROVER. INT. CL. 9. REG. 9-23-1997.
 2,100,286. AUTHORITY (STYLIZED). INT. CL. 9. REG. 9-23-1997.
 2,100,298. CADD PRIZM AND DESIGN. INT. CL. 10. REG. 9-23-1997.
 2,100,308. ATTAIN. INT. CL. 9. REG. 9-23-1997.
 2,100,313. BLACK BOOK AUTOGRAPH XPRESS. INT. CL. 9. REG. 9-23-1997.
 2,100,318. GRASSGRABBER. INT. CL. 8. REG. 9-23-1997.
 2,100,325. GLOW AND DESIGN. INT. CL. 42. REG. 9-23-1997.
 2,100,333. PARSETTER TMM. INT. CL. 9. REG. 9-23-1997.
 2,100,359. COLLEAGUE. INT. CL. 9. REG. 9-23-1997.
 2,100,365. FLOW RIGHT. INT. CL. 10. REG. 9-23-1997.
 2,100,368. WAIST-EZE. INT. CL. 25. REG. 9-23-1997.
 2,100,376. THE LINEFINDER. INT. CL. 10. REG. 9-23-1997.
 2,100,387. KONNEKTING-PROFILES. INT. CL. 42. REG. 9-23-1997.
 2,100,395. DRUGLINK. INT. CL. 16. REG. 9-23-1997.
 2,100,408. CAPT.FLOSS. INT. CL. 10. REG. 9-23-1997.
 2,100,421. ORIGINAL ISLAND SPORT. INT. CL. 25. REG. 9-23-1997.
 2,100,426. COURSE ARCHITECT. INT. CL. 9. REG. 9-23-1997.
 2,100,430. WILDFIRE AND DESIGN. INT. CL. 41. REG. 9-23-1997.
 2,100,439. SKINNY DUDE AND DESIGN. INT. CL. 30. REG. 9-23-1997.
 2,100,440. DIRECT PARALLEL. INT. CL. 9. REG. 9-23-1997.
 2,100,455. HRNEWS. INT. CL. 16. REG. 9-23-1997.
 2,100,474. OFFSHORE SAILING SCHOOL. INT. CL. 41. REG. 9-23-1997.
 2,100,494. TAIL SHADES. INT. CL. 12. REG. 9-23-1997.
 2,100,501. OLDE BOARDS. INT. CL. 19. REG. 9-23-1997.
 2,100,504. AMERICA'S CHECK APPROVAL NETWORK. INT. CL. 36. REG. 9-23-1997.
 2,100,506. MISCELLANEOUS DESIGN. INT. CL. 30. REG. 9-23-1997.
 2,100,512. ULTIMATE FIT. INT. CL. 12. REG. 9-23-1997.
 2,100,516. SAFE-PULLER. INT. CL. 10. REG. 9-23-1997.
 2,100,523. #1 CHOICE IN WELDING. INT. CL. 9. REG. 9-23-1997.
 2,100,528. LOG HOME DESIGN IDEAS (STYLIZED). INT. CL. 16. REG. 9-23-1997.
 2,100,532. CANCER NEWS ON THE NET. INT. CL. 42. REG. 9-23-1997.
 2,100,537. THE PROGRAMMER'S SUPERSHOP. INT. CL. 35. REG. 9-23-1997.
 2,100,544. THERAPEUTIC MYOFACIAL LIFT MASSAGE. INT. CL. 42. REG. 9-23-1997.
 2,100,545. MELTS MORE COSTS LESS. INT. CL. 1. REG. 9-23-1997.
 2,100,546. SL FOREMAN. INT. CL. 5. REG. 9-23-1997.
 2,102,074. R ROMMANEL AND DESIGN. INT. CL. 14. REG. 9-30-1997.
 2,120,122. Z-FLAKES. INT. CLS. 1, 5, 30 AND 32 ONLY. REG. 12-9-1997.

- 2,121,797. SUN BIRD (STYLIZED). INT. CL. 30 ONLY. REG. 12-16-1997.
- 2,122,473. NATURSPAN. INT. CLS. 5 AND 30 ONLY. REG. 12-16-1997.
- 2,162,428. EAGLE PD AND DESIGN. INT. CL. 12 ONLY. REG. 6-2-1998.
- 2,164,976. WRR. INT. CL. 37 ONLY. REG. 6-16-1998.
- 2,165,042. JOSEF FRANK. INT. CL. 8 ONLY. REG. 6-16-1998.
- 2,168,020. MISCELLANEOUS DESIGN. INT. CL. 29 ONLY. REG. 6-23-1998.
- 2,194,568. LIBERTY HARDWARE AND DESIGN. INT. CL. 20 ONLY. REG. 10-13-1998.
- 2,212,700. STARLIGHT INTERNATIONAL. INT. CLS. 9, 14, 16, 18, 20, 21 AND 25 ONLY. REG. 12-22-1998.
- 2,269,399. AQUA RUSH. INT. CL. 32. REG. 8-10-1999.
- 2,357,218. WALTHAM THE WORLD'S LEADING AUTHORITY ON PET CARE AND NUTRITION. AUTORITE MONDIALE LEADER POUR LE BIEN ETRE ET LA NUTRITION DES ANIMAUX DE COMPAGNIE. AND DESIGN. INT. CL. 31. REG. 6-13-2000.
- 2,380,516. COACHWARE. INT. CL. 9. REG. 8-29-2000.
- 2,444,967. SOUP EXPRESS. INT. CL. 42. REG. 4-17-2001.
- 2,449,713. TIEL AND DESIGN. INT. CL. 41. REG. 5-8-2001.
- 2,465,762. DELCOMP. INT. CL. 9. REG. 7-3-2001.
- 2,470,088. COMPUTERCOP. INT. CL. 9. REG. 7-17-2001.
- 2,470,378. COOL TIPS. INT. CL. 9. REG. 7-17-2001.
- 2,481,457. WALNUT CREEK CHEESE AND DESIGN. INT. CL. 35. REG. 8-28-2001.
- 2,491,646. AEGIS. INT. CL. 36. REG. 9-25-2001.
- 2,491,647. GASTONE LUCIOLI. INT. CLS. 18 AND 25. REG. 9-25-2001.
- 2,491,649. LIQUIDITY LINQ. INT. CLS. 9, 36 AND 38. REG. 9-25-2001.
- 2,491,650. CINESCAPE PRESENTS. INT. CL. 16. REG. 9-25-2001.
- 2,491,653. WEBMEDIA MAGIC. INT. CL. 9. REG. 9-25-2001.
- 2,491,655. REDY-MAID. INT. CL. 29. REG. 9-25-2001.
- 2,491,656. INTERNET COMMUNICATIONS AND DESIGN. INT. CLS. 35, 38 AND 42. REG. 9-25-2001.
- 2,491,657. UTTERLY BUTTERLY. INT. CL. 29. REG. 9-25-2001.
- 2,491,661. HEIDI'S HOUSE THE ORIGINAL AND DESIGN. INT. CLS. 9, 18, 25, 39 AND 42. REG. 9-25-2001.
- 2,491,663. MISCELLANEOUS DESIGN. INT. CL. 9. REG. 9-25-2001.
- 2,491,664. MISCELLANEOUS DESIGN. INT. CL. 9. REG. 9-25-2001.
- 2,491,665. NETSPEC. INT. CL. 9. REG. 9-25-2001.
- 2,491,667. DESIGN.Y.C.. INT. CL. 35. REG. 9-25-2001.
- 2,491,668. SHARK. INT. CL. 7. REG. 9-25-2001.
- 2,491,670. NASCAR THUNDER THE OFFICIAL STORE OF NASCAR AND DESIGN. INT. CLS. 25, 28 AND 35. REG. 9-25-2001.
- 2,491,671. DREW'S FAMOUS PARTY MUSIC. INT. CL. 9. REG. 9-25-2001.
- 2,491,672. MI (STYLIZED). INT. CL. 6. REG. 9-25-2001.
- 2,491,673. MISCELLANEOUS DESIGN. INT. CL. 42. REG. 9-25-2001.
- 2,491,675. ORIGINAL LEATHER. INT. CLS. 25 AND 35. REG. 9-25-2001.
- 2,491,676. THE ORIGINAL LEATHER LINE EST. LONG AGO...NEW YORK AND DESIGN. INT. CL. 25. REG. 9-25-2001.
- 2,491,679. CANADA WHISTLER HIGHER GROUND AND DESIGN. INT. CL. 25. REG. 9-25-2001.
- 2,491,680. DRIVERMAX BY MIRENCO AND DESIGN. INT. CL. 9. REG. 9-25-2001.
- 2,491,681. POWER PUSHER. INT. CL. 12. REG. 9-25-2001.
- 2,491,682. LEWIS-CHESTER. INT. CL. 36. REG. 9-25-2001.
- 2,491,686. GAMEFACE VENTURES. INT. CL. 35. REG. 9-25-2001.
- 2,491,687. V VOR MOTORI AND DESIGN. INT. CL. 12. REG. 9-25-2001.
- 2,491,688. LITE-ROCK. INT. CL. 19. REG. 9-25-2001.
- 2,491,689. BOZANO. INT. CL. 36. REG. 9-25-2001.
- 2,491,691. JSALES. INT. CL. 9. REG. 9-25-2001.
- 2,491,693. MARAH. INT. CLS. 9 AND 41. REG. 9-25-2001.
- 2,491,695. INVENTIONAL COMPANY. INT. CL. 42. REG. 9-25-2001.
- 2,491,697. MISCELLANEOUS DESIGN. INT. CL. 8. REG. 9-25-2001.
- 2,491,699. HYPERION AUTOPILOT. INT. CL. 9. REG. 9-25-2001.
- 2,491,704. EFFICIENCEASE A MASTERPLANT SOLUTION BY FLOUR DANIEL AND DESIGN. INT. CL. 37. REG. 9-25-2001.
- 2,491,705. APARTMENT TEMPORARIES INCORPORATED. INT. CL. 35. REG. 9-25-2001.
- 2,491,706. CUMMINS EAGLE AND DESIGN. INT. CL. 7. REG. 9-25-2001.
- 2,491,707. U.N.O. SPORTS AND DESIGN. INT. CL. 28. REG. 9-25-2001.
- 2,491,708. MULTI-MILLIONAIRE. INT. CL. 24. REG. 9-25-2001.
- 2,491,709. VIRTUAL BROKER AND DESIGN. INT. CL. 35. REG. 9-25-2001.
- 2,491,711. BUTT'R TOPP (STYLIZED). INT. CL. 30. REG. 9-25-2001.
- 2,491,712. FIRE CRACKER GIANT. INT. CL. 29. REG. 9-25-2001.
- 2,491,716. MRS. ROSE AND DESIGN. INT. CL. 30. REG. 9-25-2001.
- 2,491,719. Y-ME RACE AGAINST BREAST CANCER. INT. CL. 36. REG. 9-25-2001.
- 2,491,720. MILESTONE TECHNOLOGIES. INT. CL. 42. REG. 9-25-2001.
- 2,491,721. MISCELLANEOUS DESIGN. INT. CLS. 9, 16, 35, 38, 40, 41 AND 42. REG. 9-25-2001.
- 2,491,725. MEXICRAFT AND DESIGN. INT. CLS. 6, 20 AND 21. REG. 9-25-2001.
- 2,491,726. EXCLAMATION POINTS! INC. AND DESIGN. INT. CLS. 39, 41 AND 42. REG. 9-25-2001.
- 2,491,727. PUZZLED ABOUT TECHNOLOGY INTEGRATION? DRAYTON, DRAYTON & LAMAR, INC. AND DESIGN. INT. CL. 42. REG. 9-25-2001.
- 2,491,731. HIP FLASK (STYLIZED). INT. CL. 16. REG. 9-25-2001.
- 2,491,734. MAXUM. INT. CL. 6. REG. 9-25-2001.
- 2,491,736. HYD-SPD. INT. CLS. 7 AND 8. REG. 9-25-2001.
- 2,491,738. STARR. INT. CL. 33. REG. 9-25-2001.
- 2,491,739. DESTROYER. INT. CL. 9. REG. 9-25-2001.
- 2,491,743. NO. 1 IN LEATHER SEATING!. INT. CLS. 20 AND 35. REG. 9-25-2001.
- 2,491,749. EXTENDING SUCCESS WORLDWIDE REALTY EXECUTIVES AND DESIGN. INT. CL. 35. REG. 9-25-2001.
- 2,491,750. CHICKY KFC AND DESIGN. INT. CL. 16. REG. 9-25-2001.
- 2,491,751. VISUAL FINANCIAL REPORTING. INT. CL. 9. REG. 9-25-2001.
- 2,491,752. CARELOGIC. INT. CL. 9. REG. 9-25-2001.
- 2,491,753. SERVICELOGIC. INT. CL. 9. REG. 9-25-2001.
- 2,491,754. CLOVERDALE RANCH. INT. CL. 33. REG. 9-25-2001.
- 2,491,755. ETERNAL PRESENCE. INT. CLS. 14 AND 21. REG. 9-25-2001.
- 2,491,756. POWERED BY INSWEB. INT. CL. 42. REG. 9-25-2001.
- 2,491,757. FOBOS. INT. CL. 9. REG. 9-25-2001.
- 2,491,761. IEN 2000. INT. CL. 9. REG. 9-25-2001.
- 2,491,762. DOG BITE DOG BITE AND DESIGN. INT. CL. 42. REG. 9-25-2001.
- 2,491,763. APADANA. INT. CL. 35. REG. 9-25-2001.
- 2,491,764. BOULDER CHIPS. INT. CL. 29. REG. 9-25-2001.
- 2,491,766. TRIAGO. INT. CL. 36. REG. 9-25-2001.
- 2,491,768. GN EXPRESS. INT. CL. 9. REG. 9-25-2001.
- 2,491,769. TRIZECHAHN OFFICE PROPERTIES. INT. CLS. 35 AND 36. REG. 9-25-2001.
- 2,491,770. CARDSITE. INT. CL. 9. REG. 9-25-2001.
- 2,491,772. TOP-10 AND DESIGN AND DESIGN. INT. CL. 42. REG. 9-25-2001.
- 2,491,773. METASUPPORT. INT. CL. 42. REG. 9-25-2001.
- 2,491,774. NUVIEW (STYLIZED). INT. CL. 9. REG. 9-25-2001.
- 2,491,776. NOAH AND DESIGN. INT. CL. 2. REG. 9-25-2001.

- 2,491,778. STARSTREAM. INT. CLS. 7 AND 9. REG. 9-25-2001.
- 2,491,779. POCKETCARD (STYLIZED). INT. CL. 36. REG. 9-25-2001.
- 2,491,780. GO FOR IT! "WHEN YOU'RE READY TO PLAY-BIG". INT. CL. 41. REG. 9-25-2001.
- 2,491,781. COOLNEIGHBORHOODS. INT. CL. 35. REG. 9-25-2001.
- 2,491,783. FAST LANE. INT. CLS. 9 AND 42. REG. 9-25-2001.
- 2,491,784. WICKED WOMEN. INT. CLS. 16, 25, 36 AND 42. REG. 9-25-2001.
- 2,491,785. VACATION RENTALS FROM SAND TO SNOW. INT. CL. 36. REG. 9-25-2001.
- 2,491,787. E ECL EUROATLANTIC CONTAINER LINE SA AND DESIGN. INT. CL. 39. REG. 9-25-2001.
- 2,491,793. THE POWER OF 7. INT. CL. 9. REG. 9-25-2001.
- 2,491,795. ECOTRICITY. INT. CL. 39. REG. 9-25-2001.
- 2,491,796. AUTUMN ORANGE. INT. CL. 28. REG. 9-25-2001.
- 2,491,799. FAITHWORKS. INT. CLS. 9 AND 16. REG. 9-25-2001.
- 2,491,800. EB ELECTRO BRAND AND DESIGN. INT. CL. 9. REG. 9-25-2001.
- 2,491,804. SOMEWHERE IN TIME,,, COLLECTIBLES AND DESIGN. INT. CL. 16. REG. 9-25-2001.
- 2,491,805. MITSUBISHI. INT. CLS. 8, 9, 15, 16, 18, 21, 22, 25, 27 AND 28. REG. 9-25-2001.
- 2,491,806. THEME (STYLIZED). INT. CL. 25. REG. 9-25-2001.
- 2,491,807. IT'S A BUCK. INT. CL. 35. REG. 9-25-2001.
- 2,491,809. ARGON ENGINEERING ASSOCIATES AND DESIGN. INT. CL. 42. REG. 9-25-2001.
- 2,491,812. D'BARRO. INT. CLS. 20 AND 21. REG. 9-25-2001.
- 2,491,813. ICOMSUITE. INT. CL. 39. REG. 9-25-2001.
- 2,491,814. ROGERS ELECTRIC ROGERS ELECTRIC SUPPLIES CO. AND DESIGN. INT. CL. 35. REG. 9-25-2001.
- 2,491,818. STUDIO IN THE ROUND. INT. CL. 42. REG. 9-25-2001.
- 2,491,819. WORLD SPA EXCHANGE AND DESIGN. INT. CL. 35. REG. 9-25-2001.
- 2,491,820. THE VIETNAM EXPERIENCE. INT. CL. 16. REG. 9-25-2001.
- 2,491,821. MAGIC EYE AND DESIGN. INT. CL. 9. REG. 9-25-2001.
- 2,491,823. BELLYBALLS. INT. CL. 14. REG. 9-25-2001.
- 2,491,828. HIPPOPP. INT. CL. 28. REG. 9-25-2001.
- 2,491,831. DOCTEUR PIERRE RICAUD. INT. CL. 3. REG. 9-25-2001.
- 2,491,834. KELBURON. INT. CL. 1. REG. 9-25-2001.
- 2,491,836. ACORN FOREIGN FORTY. INT. CL. 36. REG. 9-25-2001.
- 2,491,837. ACORN TWENTY. INT. CL. 36. REG. 9-25-2001.
- 2,491,838. INTERNATIONAL FRAUD SYMPOSIUM. INT. CL. 41. REG. 9-25-2001.
- 2,491,839. IXP. INT. CL. 9. REG. 9-25-2001.
- 2,491,841. VH1 ATWORK. INT. CL. 41. REG. 9-25-2001.
- 2,491,842. SUNSET BEACH BAR AND DESIGN. INT. CL. 42. REG. 9-25-2001.
- 2,491,843. LINKSTIME.COM AND DESIGN. INT. CL. 41. REG. 9-25-2001.
- 2,491,845. SMI. INT. CLS. 35, 36 AND 41. REG. 9-25-2001.
- 2,491,846. PTC RESEARCH FOUNDATION. INT. CLS. 16 AND 41. REG. 9-25-2001.
- 2,491,847. CHARITYVALUES.COM. INT. CLS. 35 AND 36. REG. 9-25-2001.
- 2,491,849. SCORPIAN SECURE CORPORATE INVESTIGATIONS AUTOMATION AND DESIGN. INT. CL. 9. REG. 9-25-2001.
- 2,491,851. FLUSTRRA. INT. CLS. 36, 38, 41 AND 42. REG. 9-25-2001.
- 2,491,852. FOR THE BEST GRIP ON THE WEB. INT. CL. 42. REG. 9-25-2001.
- 2,491,853. VOLCANIC AIR REFRESHER AND DESIGN. INT. CL. 5. REG. 9-25-2001.
- 2,491,856. SGN-30. INT. CLS. 1 AND 11. REG. 9-25-2001.
- 2,491,857. GKB AND DESIGN. INT. CL. 25. REG. 9-25-2001.
- 2,491,859. SWITCH CHIP (STYLIZED). INT. CL. 9. REG. 9-25-2001.
- 2,491,863. BISON TECHNOLOGY AND DESIGN. INT. CLS. 7, 37 AND 42. REG. 9-25-2001.
- 2,491,864. MISS MOLLY AND DESIGN. INT. CLS. 3, 5, 18, 21 AND 24. REG. 9-25-2001.
- 2,491,866. MONO-POST. INT. CL. 6. REG. 9-25-2001.
- 2,491,867. MISCELLANEOUS DESIGN. INT. CL. 42. REG. 9-25-2001.
- 2,491,870. 'THE ORIGINAL' BAD CO AND DESIGN. INT. CL. 41. REG. 9-25-2001.
- 2,491,871. BIG CRUISER. INT. CL. 30. REG. 9-25-2001.
- 2,491,873. THE WEB'S KNOWLEDGE MARKETPLACE. INT. CL. 35. REG. 9-25-2001.
- 2,491,876. THE BEST OF YESTERDAY. INT. CL. 35. REG. 9-25-2001.
- 2,491,877. JOHNSON MILLENNIUM. INT. CL. 9. REG. 9-25-2001.
- 2,491,878. STARFEEDER AND DESIGN. INT. CLS. 7 AND 9. REG. 9-25-2001.
- 2,491,879. TWISTED MYNDZ. INT. CL. 41. REG. 9-25-2001.
- 2,491,880. ISCA TECHNOLOGIES AND DESIGN. INT. CL. 21. REG. 9-25-2001.
- 2,491,881. SPECTROTILT. INT. CL. 9. REG. 9-25-2001.
- 2,491,882. 5TH SENSE. INT. CL. 9. REG. 9-25-2001.
- 2,491,883. ACOUSTIC CUP. INT. CL. 41. REG. 9-25-2001.
- 2,491,884. BATH STUFF. INT. CL. 3. REG. 9-25-2001.
- 2,491,885. HELPING FULFILL THE PROMISE OF E-COMMERCE. INT. CL. 35. REG. 9-25-2001.
- 2,491,886. AUTOMONEY AND DESIGN. INT. CL. 36. REG. 9-25-2001.
- 2,491,888. INFORAY. INT. CLS. 9, 35 AND 42. REG. 9-25-2001.
- 2,491,890. AQUILA CASCADIA EQUITY FUND AND DESIGN. INT. CL. 36. REG. 9-25-2001.
- 2,491,892. BILL-ME AND DESIGN. INT. CLS. 35 AND 42. REG. 9-25-2001.
- 2,491,893. GUARANTEED COMPREHENSIVE PRE-NEED PROGRAM HILLSIDE GUARANTEED AND DESIGN. INT. CLS. 36 AND 42. REG. 9-25-2001.
- 2,491,894. SPORTSVOICE. THE VOICE OF AUTHORITY FOR SPORTS PICKS & SCORES AND DESIGN. INT. CL. 41. REG. 9-25-2001.
- 2,491,897. ONTIME ANYWHERE ANYTIME AND DESIGN. INT. CL. 39. REG. 9-25-2001.
- 2,491,900. PRO-MEDIA. INT. CL. 9. REG. 9-25-2001.
- 2,491,901. SHR'EW (STYLIZED). INT. CL. 6. REG. 9-25-2001.
- 2,491,904. BLUE MOUNTAIN ARTS. INT. CL. 35. REG. 9-25-2001.
- 2,491,906. MELIA. INT. CL. 28. REG. 9-25-2001.
- 2,491,907. E-BIZCHAIN. INT. CLS. 9 AND 42. REG. 9-25-2001.
- 2,491,910. VALUFARES.COM AND DESIGN. INT. CL. 39. REG. 9-25-2001.
- 2,491,914. RIVERTECH CENTER. INT. CLS. 41 AND 42. REG. 9-25-2001.
- 2,491,915. MEDIA CHASE. INT. CL. 41. REG. 9-25-2001.
- 2,491,919. TRACS-LOC (STYLIZED). INT. CL. 9. REG. 9-25-2001.
- 2,491,920. OMG & DESIGN AND DESIGN. INT. CLS. 35 AND 41. REG. 9-25-2001.
- 2,491,921. ATLANTIC WESTERN CONSULTING. INT. CLS. 35 AND 37. REG. 9-25-2001.
- 2,491,925. MURCO. INT. CL. 29. REG. 9-25-2001.
- 2,491,926. WHERE PEOPLE AND TECHNOLOGY CONNECT. INT. CLS. 35 AND 42. REG. 9-25-2001.
- 2,491,929. NSERV AND DESIGN AND DESIGN. INT. CL. 35. REG. 9-25-2001.
- 2,491,932. GROW UPS. INT. CL. 6. REG. 9-25-2001.
- 2,491,935. THE TACKIE HORSE. INT. CL. 35. REG. 9-25-2001.
- 2,491,936. TELEGAMES AND DESIGN. INT. CL. 9. REG. 9-25-2001.
- 2,491,937. THEDIAL. INT. CLS. 35, 38 AND 41. REG. 9-25-2001.
- 2,491,939. INVESTORS CLICK HERE. INT. CLS. 36 AND 38. REG. 9-25-2001.
- 2,491,940. SUBASTA.COM AND DESIGN. INT. CL. 42. REG. 9-25-2001.

- 2,491,941. MISCELLANEOUS DESIGN. INT. CL. 3. REG. 9-25-2001.
- 2,491,942. DNA. INT. CL. 9. REG. 9-25-2001.
- 2,491,943. LOOP LOCK. INT. CL. 10. REG. 9-25-2001.
- 2,491,947. CHOLESTERLO. INT. CL. 5. REG. 9-25-2001.
- 2,491,949. MAMMOTHGOLF.COM. INT. CL. 35. REG. 9-25-2001.
- 2,491,951. SOLSTICE. INT. CL. 41. REG. 9-25-2001.
- 2,491,952. COLOURCELL. INT. CL. 11. REG. 9-25-2001.
- 2,491,953. ADEPT SYSTEMS INC AND DESIGN. INT. CLS. 9 AND 42. REG. 9-25-2001.
- 2,491,955. A NEW CHOICE IN PHONE, CABLE & INTERNET SERVICE. INT. CL. 38. REG. 9-25-2001.
- 2,491,957. THE BEER GARDEN AND DESIGN. INT. CL. 42. REG. 9-25-2001.
- 2,491,959. FARMGRO ORGANIC FOODS INC. AND DESIGN. INT. CL. 35. REG. 9-25-2001.
- 2,491,961. CV AND DESIGN. INT. CL. 42. REG. 9-25-2001.
- 2,491,962. NEST-WELL. INT. CL. 21. REG. 9-25-2001.
- 2,491,963. BIG AS A FACE COOKIES AND DESIGN. INT. CL. 30. REG. 9-25-2001.
- 2,491,967. IUNIVERSE.COM AND DESIGN. INT. CLS. 35 AND 41. REG. 9-25-2001.
- 2,491,968. MINILIBRARYXPRESS. INT. CL. 9. REG. 9-25-2001.
- 2,491,969. WOMEN'S POWER PSYCHOLOGY. INT. CLS. 41 AND 42. REG. 9-25-2001.
- 2,491,971. ENTERPRISEXPRESS. INT. CL. 9. REG. 9-25-2001.
- 2,491,972. Y AND DESIGN. INT. CL. 5. REG. 9-25-2001.
- 2,491,974. FIND MRO BY GRAINGER AND DESIGN. INT. CL. 35. REG. 9-25-2001.
- 2,491,975. SENIORS ONLY FINANCIAL. INT. CL. 36. REG. 9-25-2001.
- 2,491,977. H HUMUNITE AND DESIGN. INT. CL. 1. REG. 9-25-2001.
- 2,491,979. ELECTRONIC BACKPACK. INT. CL. 9. REG. 9-25-2001.
- 2,491,980. SKILNET (STYLIZED). INT. CL. 42. REG. 9-25-2001.
- 2,491,981. F*TEX (STYLIZED). INT. CLS. 1, 5, 7, 11, 22, 24, 40 AND 42. REG. 9-25-2001.
- 2,491,982. 403(B) EASY. INT. CL. 9. REG. 9-25-2001.
- 2,491,985. REINVENTING THE TECHNOLOGY OF SAFETY. INT. CL. 42. REG. 9-25-2001.
- 2,491,986. MINDSPAN. INT. CL. 35. REG. 9-25-2001.
- 2,491,987. DALLAS INTERNATIONAL TOY IMPORT SHOW AND DESIGN. INT. CL. 35. REG. 9-25-2001.
- 2,491,989. TWO5, INC. AN INTERNET VISIONARY COMPANY (STYLIZED). INT. CL. 35. REG. 9-25-2001.
- 2,491,990. DIGILERT. INT. CL. 35. REG. 9-25-2001.
- 2,491,991. CB RICHARD ELLIS AND DESIGN. INT. CLS. 36 AND 37. REG. 9-25-2001.
- 2,491,992. CADIAX. INT. CLS. 9, 10 AND 42. REG. 9-25-2001.
- 2,491,993. SOLAS AND DESIGN. INT. CL. 35. REG. 9-25-2001.
- 2,491,998. NEWCOLOR. INT. CLS. 9 AND 16. REG. 9-25-2001.
- 2,492,001. LYNK. INT. CL. 42. REG. 9-25-2001.
- 2,492,003. DEALS NOTHING OVER A DOLLAR AND DESIGN. INT. CL. 35. REG. 9-25-2001.
- 2,492,004. MEGATRACK. INT. CL. 9. REG. 9-25-2001.
- 2,492,005. TAPETTI. INT. CL. 30. REG. 9-25-2001.
- 2,492,010. MISCELLANEOUS DESIGN. INT. CL. 36. REG. 9-25-2001.
- 2,492,011. OUTDOORPLAY. INT. CLS. 35, 38, 39 AND 41. REG. 9-25-2001.
- 2,492,012. SIGNAGESOLUTIONS. INT. CL. 35. REG. 9-25-2001.
- 2,492,014. BANK'S VACUUM SUPERSTORES PICK UP MORE FOR LESS AND DESIGN. INT. CL. 35. REG. 9-25-2001.
- 2,492,015. MISCELLANEOUS DESIGN. INT. CL. 35. REG. 9-25-2001.
- 2,492,016. NETPERFORMANCE AND DESIGN. INT. CL. 42. REG. 9-25-2001.
- 2,492,018. THE MARK WINKLER COMPANY. INT. CLS. 36 AND 37. REG. 9-25-2001.
- 2,492,019. HOSPITALHUB.COM MORE HOSPITALS THAN YOU CAN FIT IN A SHOEBOX AND DESIGN. INT. CLS. 35, 38 AND 42. REG. 9-25-2001.
- 2,492,020. HOSPITALHUB.COM AND DESIGN. INT. CLS. 35, 38 AND 42. REG. 9-25-2001.
- 2,492,021. INOW INTERNET NOW AND DESIGN. INT. CLS. 9, 38 AND 42. REG. 9-25-2001.
- 2,492,024. TURBO PARTS INC AND DESIGN. INT. CL. 7. REG. 9-25-2001.
- 2,492,026. SPEECHFINDER (STYLIZED). INT. CL. 9. REG. 9-25-2001.
- 2,492,029. TRENDS. INT. CL. 36. REG. 9-25-2001.
- 2,492,031. PLANES, TRAINS, AUTOMOBILES . . . AND THE INTERNET. INT. CL. 35. REG. 9-25-2001.
- 2,492,033. HOP. INT. CLS. 6 AND 17. REG. 9-25-2001.
- 2,492,035. DOLLARSTATION. INT. CL. 36. REG. 9-25-2001.
- 2,492,038. DESYROUTE. INT. CLS. 9, 35 AND 42. REG. 9-25-2001.
- 2,492,039. M SOLUTIONS. INT. CL. 35. REG. 9-25-2001.
- 2,492,043. SEGA TOYS (STYLIZED). INT. CLS. 9 AND 28. REG. 9-25-2001.
- 2,492,044. BETAFLEX. INT. CL. 9. REG. 9-25-2001.
- 2,492,046. SSTI. INT. CLS. 37 AND 42. REG. 9-25-2001.
- 2,492,048. CREATIVE PRESENTATIONS VISUAL COMMUNICATIONS MADE SIMPLE AND DESIGN. INT. CL. 37. REG. 9-25-2001.
- 2,492,050. THE SHARPSHOOTERS. INT. CL. 9. REG. 9-25-2001.
- 2,492,053. BOARD BETTY AND DESIGN. INT. CL. 25. REG. 9-25-2001.
- 2,492,054. DRIVING THE NETWORK ECONOMY. INT. CL. 42. REG. 9-25-2001.
- 2,492,059. AUCTIVA. INT. CL. 35. REG. 9-25-2001.
- 2,492,060. NYTRO. INT. CL. 20. REG. 9-25-2001.
- 2,492,061. HOMEWORK HEROES. INT. CL. 36. REG. 9-25-2001.
- 2,492,062. CUPROFIT. INT. CL. 6. REG. 9-25-2001.
- 2,492,065. SHADES OF MANGO. INT. CL. 31. REG. 9-25-2001.
- 2,492,067. VALPOD AND DESIGN. INT. CL. 16. REG. 9-25-2001.
- 2,492,069. ECAMP WAVE (STYLIZED). INT. CL. 41. REG. 9-25-2001.
- 2,492,070. BDT AND DESIGN. INT. CL. 40. REG. 9-25-2001.
- 2,492,075. JULIA NATIONAL ASSOCIATION FOR WOMYN, INC. AND DESIGN. INT. CL. 42. REG. 9-25-2001.
- 2,492,076. EYEWITNESS BOOKS. INT. CL. 16. REG. 9-25-2001.
- 2,492,078. TWIN SHUTTLE TOWERS. INT. CL. 28. REG. 9-25-2001.
- 2,492,080. SHUTTLE GLIDER. INT. CL. 28. REG. 9-25-2001.
- 2,492,081. AEGIS SAFES AND DESIGN. INT. CL. 6. REG. 9-25-2001.
- 2,492,082. MISCELLANEOUS DESIGN. INT. CL. 42. REG. 9-25-2001.
- 2,492,083. GGA COMMUNICATIONS. INT. CL. 42. REG. 9-25-2001.
- 2,492,084. SHUTTLE TOWER. INT. CL. 28. REG. 9-25-2001.
- 2,492,085. MISCELLANEOUS DESIGN. INT. CL. 9. REG. 9-25-2001.
- 2,492,086. YOUR ONE STOP SHOP FOR FEELING GOOD. INT. CL. 35. REG. 9-25-2001.
- 2,492,088. MISCELLANEOUS DESIGN. INT. CL. 16. REG. 9-25-2001.
- 2,492,089. TRU. INT. CL. 41. REG. 9-25-2001.
- 2,492,091. ITT INDUSTRIES ENGINEERED FOR LIFE AND DESIGN. INT. CLS. 7 AND 9. REG. 9-25-2001.
- 2,492,094. THE INDIVIDUALS INVESTOR'S GUIDE TO COMPUTERIZED INVESTING. INT. CL. 16. REG. 9-25-2001.
- 2,492,095. EDUSYSTEMS AND DESIGN. INT. CLS. 35, 37, 41 AND 42. REG. 9-25-2001.
- 2,492,096. DBF AND DESIGN. INT. CL. 25. REG. 9-25-2001.
- 2,492,098. PIONEER STANDARD ELECTRON WORLD. INT. CLS. 35 AND 42. REG. 9-25-2001.

- 2,492,102. LEADING THE WAY WITH INNOVATIVE SOLUTIONS. INT. CL. 36. REG. 9-25-2001.
- 2,492,104. MULTIPRINTER. INT. CL. 7. REG. 9-25-2001.
- 2,492,105. MISCELLANEOUS DESIGN. INT. CL. 9. REG. 9-25-2001.
- 2,492,106. MONEYMANAGERSERVICES.COM RESOURCES FOR THE 21ST CENTURY ADVISER AND DESIGN. INT. CL. 36. REG. 9-25-2001.
- 2,492,108. WEIGHDOWN AT HOME AND DESIGN. INT. CLS. 9 AND 16. REG. 9-25-2001.
- 2,492,109. TIMESAVER. INT. CL. 14. REG. 9-25-2001.
- 2,492,113. TREASURE SOUNDS OF AMERICA. INT. CLS. 9 AND 35. REG. 9-25-2001.
- 2,492,116. SIVIT WALKBOARD. INT. CL. 9. REG. 9-25-2001.
- 2,492,117. CYBERSENSOR. INT. CL. 42. REG. 9-25-2001.
- 2,492,118. MEDSCHOOL.COM AND DESIGN. INT. CL. 41. REG. 9-25-2001.
- 2,492,121. VIBRANT PHOTO AND ELECTRONICS INC. (STYLIZED). INT. CLS. 16, 20 AND 35. REG. 9-25-2001.
- 2,492,122. CATSKILL MORNING FARM. INT. CLS. 29 AND 30. REG. 9-25-2001.
- 2,492,124. MISCELLANEOUS DESIGN. INT. CL. 35. REG. 9-25-2001.
- 2,492,127. LOANGENIE.COM. INT. CL. 36. REG. 9-25-2001.
- 2,492,128. INFRAMART (STYLIZED). INT. CL. 9. REG. 9-25-2001.
- 2,492,129. GREAT PLAINS SOFTWARE. INT. CL. 9. REG. 9-25-2001.
- 2,492,131. FLY BY THE SEAT. INT. CL. 40. REG. 9-25-2001.
- 2,492,132. LAME GAMES. INT. CL. 35. REG. 9-25-2001.
- 2,492,134. DAMP WIPES. INT. CL. 21. REG. 9-25-2001.
- 2,492,135. ST. JAMES. INT. CL. 42. REG. 9-25-2001.
- 2,492,136. LOGIC MICROSYSTEMS AND DESIGN. INT. CL. 42. REG. 9-25-2001.
- 2,492,137. HEALTHY CAMPUSES 2020. INT. CL. 41. REG. 9-25-2001.
- 2,492,142. TESSER. INT. CLS. 35 AND 42. REG. 9-25-2001.
- 2,492,143. HORIZON. INT. CL. 21. REG. 9-25-2001.
- 2,492,146. VERTEBRAE. INT. CL. 42. REG. 9-25-2001.
- 2,492,147. HYBRID. INT. CL. 42. REG. 9-25-2001.
- 2,492,148. CLARKE LOGISTICS. INT. CLS. 35 AND 39. REG. 9-25-2001.
- 2,492,149. MISCELLANEOUS DESIGN. INT. CL. 42. REG. 9-25-2001.
- 2,492,150. AROUND THE WORLD IN SECONDS. INT. CL. 38. REG. 9-25-2001.
- 2,492,151. DRAGGIN' WAGON. INT. CL. 28. REG. 9-25-2001.
- 2,492,152. INTREPID. INT. CL. 12. REG. 9-25-2001.
- 2,492,155. THE HUMAN BODY ON FILE. INT. CL. 16. REG. 9-25-2001.
- 2,492,156. HISPANIC BUSINESS FASTEST-GROWING 100. INT. CL. 16. REG. 9-25-2001.
- 2,492,158. MISCELLANEOUS DESIGN. INT. CLS. 35 AND 39. REG. 9-25-2001.
- 2,492,159. NETS HOT SHOTS FAN CLUB AND DESIGN. INT. CL. 16. REG. 9-25-2001.
- 2,492,164. PTP (STYLIZED). INT. CL. 42. REG. 9-25-2001.
- 2,492,166. RSP (STYLIZED). INT. CL. 1. REG. 9-25-2001.
- 2,492,167. DESIGN RESOURCE, LTD.. INT. CLS. 14 AND 42. REG. 9-25-2001.
- 2,492,170. PATHWAY TO EMPOWERMENT. INT. CL. 42. REG. 9-25-2001.
- 2,492,172. FORMULA PIGS. INT. CL. 31. REG. 9-25-2001.
- 2,492,175. FLYING NOODLE. INT. CL. 35. REG. 9-25-2001.
- 2,492,177. E-MAGINE THAT AND DESIGN. INT. CL. 35. REG. 9-25-2001.
- 2,492,179. SPEEDOTTER. INT. CLS. 12, 28 AND 37. REG. 9-25-2001.
- 2,492,180. COLIBRI FLOWERS AND DESIGN. INT. CL. 31. REG. 9-25-2001.
- 2,492,181. PSSI (STYLIZED). INT. CLS. 9 AND 42. REG. 9-25-2001.
- 2,492,190. EVECTOR. INT. CL. 38. REG. 9-25-2001.
- 2,492,191. EAROBICS BUILDS BETTER READERS. INT. CL. 9. REG. 9-25-2001.
- 2,492,194. GOLDEN MAC (STYLIZED). INT. CL. 36. REG. 9-25-2001.
- 2,492,198. GUAMCELL COMMUNICATIONS AND DESIGN. INT. CL. 38. REG. 9-25-2001.
- 2,492,199. ROBERT'S MARKETFARE. INT. CL. 35. REG. 9-25-2001.
- 2,492,202. TEALEAF TECHNOLOGY. INT. CLS. 9 AND 42. REG. 9-25-2001.
- 2,492,207. NEVER TRUST A SKINNY COOK. INT. CL. 16. REG. 9-25-2001.
- 2,492,211. THE COMPLEAT NATURALIST AND DESIGN. INT. CL. 35. REG. 9-25-2001.
- 2,492,214. WORLD CLASS TASTE. INT. CL. 42. REG. 9-25-2001.
- 2,492,216. CONTENDER'S CLUB. INT. CL. 41. REG. 9-25-2001.
- 2,492,217. VIVACITY (STYLIZED). INT. CL. 35. REG. 9-25-2001.
- 2,492,221. RATEEXCHANGE. INT. CL. 36. REG. 9-25-2001.
- 2,492,224. VICTOR VELONE. INT. CL. 14. REG. 9-25-2001.
- 2,492,225. ENSUREDMAIL. INT. CL. 38. REG. 9-25-2001.
- 2,492,228. TOOLFARM. INT. CLS. 35, 38 AND 41. REG. 9-25-2001.
- 2,492,229. 1-800-THE-VOICE. INT. CL. 41. REG. 9-25-2001.
- 2,492,230. MISCELLANEOUS DESIGN. INT. CL. 41. REG. 9-25-2001.
- 2,492,233. COMMERCIAL MAID AND DESIGN. INT. CL. 37. REG. 9-25-2001.
- 2,492,237. HIGH MOUNTAIN PROPERTIES AND DESIGN. INT. CLS. 36 AND 42. REG. 9-25-2001.
- 2,492,238. AMERICA'S FLYWAYS (STYLIZED). INT. CL. 16. REG. 9-25-2001.
- 2,492,243. CONSECO TERM. INT. CL. 36. REG. 9-25-2001.
- 2,492,244. BOTANICAL LIAISONS. INT. CL. 42. REG. 9-25-2001.
- 2,492,245. ROTEK. INT. CL. 9. REG. 9-25-2001.
- 2,492,246. WEBCRITERIA AND DESIGN. INT. CL. 42. REG. 9-25-2001.
- 2,492,252. SPINNAKER EQUIPMENT SERVICES, INC. AND DESIGN. INT. CL. 35. REG. 9-25-2001.
- 2,492,253. SURE WAY. INT. CL. 7. REG. 9-25-2001.
- 2,492,257. COX SAMPLING. INT. CL. 35. REG. 9-25-2001.
- 2,492,258. M&M'S (STYLIZED). INT. CL. 16. REG. 9-25-2001.
- 2,492,260. DYNAMIC RESPONSE MARKETING INCORPORATED AND DESIGN. INT. CL. 35. REG. 9-25-2001.
- 2,492,261. DIGIMETA. INT. CL. 9. REG. 9-25-2001.
- 2,492,262. ALLIED LIGHTING AND DESIGN. INT. CL. 11. REG. 9-25-2001.
- 2,492,264. TEZ. INT. CL. 29. REG. 9-25-2001.
- 2,492,265. PROLIANZ. INT. CL. 35. REG. 9-25-2001.
- 2,492,266. "GENERALLY SPEAKING". INT. CL. 41. REG. 9-25-2001.
- 2,492,270. TRANS 8. INT. CL. 36. REG. 9-25-2001.
- 2,492,271. KINDER MERENDERO. INT. CL. 30. REG. 9-25-2001.
- 2,492,272. M AND DESIGN. INT. CL. 41. REG. 9-25-2001.
- 2,492,274. THE INTEGRATED PROGRAMMING SOLUTION. INT. CL. 35. REG. 9-25-2001.
- 2,492,276. NEOCONTRACT. INT. CL. 35. REG. 9-25-2001.
- 2,492,277. MISCELLANEOUS DESIGN. INT. CL. 35. REG. 9-25-2001.
- 2,492,279. LOADED DRIVE AXLE. INT. CL. 12. REG. 9-25-2001.
- 2,492,281. RXCASH. INT. CL. 36. REG. 9-25-2001.
- 2,492,283. GET@YES. INT. CLS. 38 AND 42. REG. 9-25-2001.
- 2,492,288. CLEAR CHOICE. INT. CL. 42. REG. 9-25-2001.
- 2,492,289. BE NICE TO YOUR MONEY. INT. CL. 36. REG. 9-25-2001.
- 2,492,292. CRAFT RUG MILLS. INT. CL. 35. REG. 9-25-2001.
- 2,492,297. GORADIO. INT. CL. 35. REG. 9-25-2001.
- 2,492,298. CENTERWISE. INT. CL. 9. REG. 9-25-2001.
- 2,492,300. VINYL.COM AND DESIGN. INT. CL. 35. REG. 9-25-2001.
- 2,492,301. C-SENSE. INT. CL. 35. REG. 9-25-2001.
- 2,492,302. E AND DESIGN. INT. CLS. 9 AND 35. REG. 9-25-2001.
- 2,492,307. ARROZ DELMUNDO. INT. CL. 30. REG. 9-25-2001.

- 2,492,308. HARRY BUFFALO AND DESIGN. INT. CL. 42. REG. 9-25-2001.
- 2,492,313. THE DIGNITY YOU'VE EARNED, THE SERVICE YOU DESERVE. INT. CL. 42. REG. 9-25-2001.
- 2,492,314. ENFAMIL AND DESIGN. INT. CL. 30. REG. 9-25-2001.
- 2,492,316. FASHAWN HIGHFASHAWN HYPE FA SHAWN EST. SINCE CONCEPTION W. SHAWN OSBORN. INT. CL. 25. REG. 9-25-2001.
- 2,492,317. TMAR. INT. CL. 42. REG. 9-25-2001.
- 2,492,324. CHOCOLATE CITY ENTERTAINMENT. INT. CL. 41. REG. 9-25-2001.
- 2,492,332. IT'S YOUR MONEY. INT. CL. 35. REG. 9-25-2001.
- 2,492,335. IMAGINATION GONE WIRELESS. INT. CL. 42. REG. 9-25-2001.
- 2,492,336. OSCAR MAYER AND DESIGN. INT. CL. 29. REG. 9-25-2001.
- 2,492,340. SMALL BUSINESS LIFELINE AND DESIGN. INT. CL. 37. REG. 9-25-2001.
- 2,492,341. QUEEN OF THE CROP. INT. CL. 20. REG. 9-25-2001.
- 2,492,343. WEB-UNWIRED. INT. CL. 38. REG. 9-25-2001.
- 2,492,344. LUNA KIDS DANCE AND DESIGN. INT. CL. 41. REG. 9-25-2001.
- 2,492,345. TCW TECHNOLOGE. INT. CL. 36. REG. 9-25-2001.
- 2,492,349. LAUNCHFUEL AND DESIGN. INT. CL. 35. REG. 9-25-2001.
- 2,492,357. WELLDIET.COM. INT. CLS. 41 AND 42. REG. 9-25-2001.
- 2,492,358. TRIPLE SEAL. INT. CL. 2. REG. 9-25-2001.
- 2,492,359. BUN TRAINER. INT. CL. 28. REG. 9-25-2001.
- 2,492,361. NIAGARA. INT. CL. 31. REG. 9-25-2001.
- 2,492,363. VIRTUAL PROMOTIONS. REAL RESULTS. INT. CL. 35. REG. 9-25-2001.
- 2,492,364. 1ST RATE CLOTHES AT 2ND HAND PRICES. INT. CL. 35. REG. 9-25-2001.
- 2,492,365. CAFE COLORE (STYLIZED). INT. CL. 42. REG. 9-25-2001.
- 2,492,370. FIXTUREMATE. INT. CL. 9. REG. 9-25-2001.
- 2,492,371. CHICKEN BURRITO MADNESS!. INT. CL. 29. REG. 9-25-2001.
- 2,492,373. RAGING KNOWLEDGE. INT. CL. 35. REG. 9-25-2001.
- 2,492,374. GREATSPEED. INT. CL. 38. REG. 9-25-2001.
- 2,492,378. EXTINGT. INT. CL. 1. REG. 9-25-2001.
- 2,492,379. RASTAPOPOP AND DESIGN. INT. CL. 30. REG. 9-25-2001.
- 2,492,380. FANTASY FARE. INT. CL. 41. REG. 9-25-2001.
- 2,492,383. CYBERN@UTS. INT. CL. 16. REG. 9-25-2001.
- 2,492,384. THE EVOLUTION OF EBUSINESS. INT. CL. 42. REG. 9-25-2001.
- 2,492,385. DOT CONNECT. INT. CL. 35. REG. 9-25-2001.
- 2,492,389. GOLD MEDAL PERFORMANCE. INT. CL. 36. REG. 9-25-2001.
- 2,492,390. SUPER STACKERS. INT. CL. 29. REG. 9-25-2001.
- 2,492,391. ZEITOUN MIDDLE EASTERN FOOD AND DESIGN. INT. CL. 42. REG. 9-25-2001.
- 2,492,397. CONSERVATION AND DESIGN. INT. CL. 41. REG. 9-25-2001.
- 2,492,399. AURORA ICE FLOWER. INT. CL. 28. REG. 9-25-2001.
- 2,492,400. POMME POMME. INT. CL. 42. REG. 9-25-2001.
- 2,492,403. MCSI FINANCIAL SERVICES. INT. CL. 36. REG. 9-25-2001.
- 2,492,405. ATAPCO. INT. CLS. 36 AND 37. REG. 9-25-2001.
- 2,492,409. PRESCRIPTIVE MEDICINE FOR ELEARNING. INT. CL. 42. REG. 9-25-2001.
- 2,492,410. EXPRESSLEARNING (STYLIZED). INT. CL. 42. REG. 9-25-2001.
- 2,492,413. S N AND DESIGN. INT. CL. 29. REG. 9-25-2001.
- 2,492,414. TPEX. INT. CL. 40. REG. 9-25-2001.
- 2,492,415. PRESTIGE INFUNDTORY (STYLIZED). INT. CL. 36. REG. 9-25-2001.
- 2,492,416. INTERADNET AND DESIGN. INT. CL. 35. REG. 9-25-2001.
- 2,492,417. REED'S IGUANA FOOD. INT. CL. 31. REG. 9-25-2001.
- 2,492,420. CATCH FISH NOW!. INT. CL. 16. REG. 9-25-2001.
- 2,492,421. MS&A. INT. CL. 42. REG. 9-25-2001.
- 2,492,422. MISCELLANEOUS DESIGN. INT. CL. 35. REG. 9-25-2001.
- 2,492,424. CHALLENGE OPPORTUNITY REWARD & FUN. INT. CL. 35. REG. 9-25-2001.
- 2,492,425. CORF. INT. CL. 35. REG. 9-25-2001.
- 2,492,428. NETSPEAK. INT. CL. 9. REG. 9-25-2001.
- 2,492,429. GOOD VIBES GAZETTE. INT. CL. 16. REG. 9-25-2001.
- 2,492,433. EDIVU. INT. CL. 41. REG. 9-25-2001.
- 2,492,435. ASBOS. INT. CL. 36. REG. 9-25-2001.
- 2,492,439. BOS AND DESIGN. INT. CL. 40. REG. 9-25-2001.
- 2,492,443. SUNSET PASS. INT. CL. 35. REG. 9-25-2001.
- 2,492,449. ME & I. INT. CL. 25. REG. 9-25-2001.
- 2,492,450. SHADES OF GREY. INT. CL. 41. REG. 9-25-2001.
- 2,492,451. C & B BY CHRISTOPHER & BANKS. INT. CL. 25. REG. 9-25-2001.
- 2,492,452. WEDDING WRAPS BY KIM AND DESIGN. INT. CL. 25. REG. 9-25-2001.
- 2,492,455. YCI YORKVILLE COMMUNICATIONS, INC. AND DESIGN. INT. CL. 38. REG. 9-25-2001.
- 2,492,457. WOODEN IT BE LOVELY INC. AND DESIGN. INT. CL. 40. REG. 9-25-2001.
- 2,492,460. THE SILVER BUTLER. INT. CL. 21. REG. 9-25-2001.
- 2,492,462. GLOBAL INTELLIGENCE FOR THE INTERNET INVESTOR. INT. CL. 42. REG. 9-25-2001.
- 2,492,464. GEN3 PARTNERS. INT. CL. 35. REG. 9-25-2001.
- 2,492,465. GRUBBS CONSTRUCTION COMPANY GC AND DESIGN. INT. CL. 37. REG. 9-25-2001.
- 2,492,468. JET STREAM. INT. CL. 36. REG. 9-25-2001.
- 2,492,470. QOOL. INT. CL. 9. REG. 9-25-2001.
- 2,492,471. ZINGER. INT. CL. 28. REG. 9-25-2001.
- 2,492,473. SICK STYLE. INT. CL. 25. REG. 9-25-2001.
- 2,492,474. ZAPSTORE. INT. CL. 35. REG. 9-25-2001.
- 2,492,475. ZAPBOARD. INT. CL. 38. REG. 9-25-2001.
- 2,492,476. OMEGA AND DESIGN. INT. CL. 7. REG. 9-25-2001.
- 2,492,478. MILLION DOLLAR KIDS. INT. CL. 36. REG. 9-25-2001.
- 2,492,481. WWIII. INT. CL. 41. REG. 9-25-2001.
- 2,492,482. WEDDING WARRANTY III. INT. CL. 41. REG. 9-25-2001.
- 2,492,483. METRO MILLS. INT. CL. 27. REG. 9-25-2001.
- 2,492,484. BEL AIR ENTERTAINMENT AND DESIGN. INT. CL. 25. REG. 9-25-2001.
- 2,492,485. CONSERT (STYLIZED). INT. CL. 6. REG. 9-25-2001.
- 2,492,487. FLASHBACK. INT. CL. 9. REG. 9-25-2001.
- 2,492,491. IF ANYONE DESERVES IT, YOU DO. INT. CL. 20. REG. 9-25-2001.
- 2,492,492. EQUIFEST OF KANAS AND DESIGN. INT. CL. 41. REG. 9-25-2001.
- 2,492,493. GOLDEN PRIME. INT. CLS. 35 AND 36. REG. 9-25-2001.
- 2,492,494. LONGREEN. INT. CL. 41. REG. 9-25-2001.
- 2,492,495. FRESHNESS FACTOR. INT. CL. 35. REG. 9-25-2001.
- 2,492,497. PHO 95. INT. CL. 42. REG. 9-25-2001.
- 2,492,502. SONIC YOUTH THERAPY (STYLIZED). INT. CL. 42. REG. 9-25-2001.
- 2,492,506. LIGHTNING. INT. CL. 6. REG. 9-25-2001.
- 2,492,512. WHATZIT DAY. INT. CLS. 36 AND 41. REG. 9-25-2001.
- 2,492,513. ADVANTA HEALTH PLAN PLUS. INT. CL. 35. REG. 9-25-2001.
- 2,492,520. TECHNO CIRCLE.COM AND DESIGN. INT. CL. 35. REG. 9-25-2001.
- 2,492,522. EZPETRX.COM AND DESIGN. INT. CL. 35. REG. 9-25-2001.
- 2,492,524. JUST FOR MEN AND DESIGN. INT. CL. 3. REG. 9-25-2001.
- 2,492,528. AIRWEB. INT. CL. 7. REG. 9-25-2001.
- 2,492,529. GENTLE AS A LAMB KEEPS 'EM DRY AND DESIGN. INT. CL. 16. REG. 9-25-2001.
- 2,492,530. "THE BIGGLES" AND DESIGN. INT. CL. 16. REG. 9-25-2001.
- 2,492,531. THE BIGGLES. INT. CL. 16. REG. 9-25-2001.

- 2,492,538. TOW TALK AND DESIGN. INT. CL. 16. REG. 9-25-2001.
- 2,492,543. TWA TRANS WORLD CONNECTION AND DESIGN. INT. CL. 39. REG. 9-25-2001.
- 2,492,544. WE'RE GIVING THE BIG GUYS A LITTLE CUTTHROAT COMPETITION. INT. CL. 42. REG. 9-25-2001.
- 2,492,547. KWIK KUSHION. INT. CL. 17. REG. 9-25-2001.
- 2,492,550. DISLOCATED STYLES. INT. CL. 25. REG. 9-25-2001.
- 2,492,551. DETROIT PISTONS AND DESIGN. INT. CL. 38. REG. 9-25-2001.
- 2,492,557. ACCIDENT LAW CENTER, DI MARCO AND ARAUJO, A PROFESSIONAL LAW CORPORATION. INT. CL. 42. REG. 9-25-2001.
- 2,492,558. NEW GLORY AND DESIGN. INT. CL. 16. REG. 9-25-2001.
- 2,492,559. SPEEDBARS. INT. CL. 12. REG. 9-25-2001.
- 2,492,562. TRUEPROFILER. INT. CL. 36. REG. 9-25-2001.
- 2,492,563. TRUEPLANNER. INT. CL. 36. REG. 9-25-2001.
- 2,492,564. TRUELINK AND DESIGN. INT. CL. 36. REG. 9-25-2001.
- 2,492,565. REMOVA. INT. CL. 19. REG. 9-25-2001.
- 2,492,566. COUNTING CHOLESTEROL DOWN. INT. CLS. 16 AND 42. REG. 9-25-2001.
- 2,492,568. SPANAMERICA. INT. CL. 38. REG. 9-25-2001.
- 2,492,570. G & G AND DESIGN. INT. CL. 39. REG. 9-25-2001.
- 2,492,572. YOU CAN HAVE IT ALL SALE. INT. CL. 35. REG. 9-25-2001.
- 2,492,573. OUTTA THE BAG!. INT. CL. 28. REG. 9-25-2001.
- 2,492,577. ASTRUM AND DESIGN. INT. CL. 35. REG. 9-25-2001.
- 2,492,578. ONLINE LEARNING FOR A GLOBAL ECONOMY. INT. CL. 41. REG. 9-25-2001.
- 2,492,579. BE ANYWHERE LEARN EVERYWHERE. INT. CL. 41. REG. 9-25-2001.
- 2,492,580. WE'VE GOT POP. INT. CL. 38. REG. 9-25-2001.
- 2,492,584. MYREALESTATEBOOK.COM. INT. CL. 36. REG. 9-25-2001.
- 2,492,585. SKIN-GARD. INT. CL. 10. REG. 9-25-2001.
- 2,492,586. NEWS IN 30. INT. CL. 41. REG. 9-25-2001.
- 2,492,587. SOUL CAFE. INT. CL. 41. REG. 9-25-2001.
- 2,492,589. FLIERS DIRECT DIRECT DELIVERY OF YOUR MARKETING MESSAGE AND DESIGN. INT. CL. 35. REG. 9-25-2001.
- 2,492,591. MISCELLANEOUS DESIGN. INT. CL. 42. REG. 9-25-2001.
- 2,492,592. DE SU TIERRA A SU CASA. INT. CL. 35. REG. 9-25-2001.
- 2,492,593. NAPILI. INT. CL. 41. REG. 9-25-2001.
- 2,492,594. ROBODOC. INT. CL. 28. REG. 9-25-2001.
- 2,492,595. H&H BAGELS. INT. CL. 42. REG. 9-25-2001.
- 2,492,599. SI. INT. CL. 27. REG. 9-25-2001.
- 2,492,600. SI. INT. CL. 19. REG. 9-25-2001.
- 2,492,602. THE LEGEND LIVES ON. INT. CL. 19. REG. 9-25-2001.
- 2,492,606. COLIBRI. INT. CL. 13. REG. 9-25-2001.
- 2,492,611. SPRINT METAL. INT. CL. 6. REG. 9-25-2001.
- 2,492,614. COASTER WORKS. INT. CL. 9. REG. 9-25-2001.
- 2,492,617. S3. INT. CL. 6. REG. 9-25-2001.
- 2,492,621. DOUBLE EAGLE AND DESIGN. INT. CL. 9. REG. 9-25-2001.
- 2,492,623. P A M E L A L U E R H E R E O N E A R T H A N D DESIGN. INT. CL. 42. REG. 9-25-2001.
- 2,492,624. PANTRY PAL. INT. CL. 20. REG. 9-25-2001.
- 2,492,625. THE CHAMELEON CHANGING THE APPEARANCE OF YOUR NEXT EVENT. INT. CL. 19. REG. 9-25-2001.
- 2,492,632. THE GETTYS GROUP, INC.. INT. CLS. 37 AND 42. REG. 9-25-2001.
- 2,492,634. ADOPT-A-NEIGHBORHOOD. INT. CL. 37. REG. 9-25-2001.
- 2,492,637. COP-IN-A-BOX. INT. CL. 42. REG. 9-25-2001.
- 2,492,642. UTILITY. INT. CL. 9. REG. 9-25-2001.
- 2,492,644. SPOOKY CASTLE. INT. CL. 9. REG. 9-25-2001.
- 2,492,645. CRAZY DRAKE. INT. CL. 9. REG. 9-25-2001.
- 2,492,649. NEOMAG. INT. CL. 6. REG. 9-25-2001.
- 2,492,653. SNOOPY BY EVERHART. INT. CL. 9. REG. 9-25-2001.
- 2,492,655. WHERE SCIENCE MEETS SERVICE. INT. CLS. 35 AND 40. REG. 9-25-2001.
- 2,492,656. THE CHOICE IS INFINITELY CLEAR. INT. CL. 9. REG. 9-25-2001.
- 2,492,657. PRECISE POWER CORPORATION. INT. CLS. 7 AND 9. REG. 9-25-2001.
- 2,492,658. GO BOOK AND DESIGN. INT. CL. 9. REG. 9-25-2001.
- 2,492,659. QUESTAR AND DESIGN. INT. CL. 9. REG. 9-25-2001.
- 2,492,660. EDITOR'S DESK II. INT. CL. 20. REG. 9-25-2001.
- 2,492,661. GRAND PURSUITS BOX. INT. CL. 20. REG. 9-25-2001.
- 2,492,662. SOLIDDATA AND DESIGN. INT. CL. 9. REG. 9-25-2001.
- 2,492,663. OPT-INFLUENCE.COM. INT. CL. 35. REG. 9-25-2001.
- 2,492,664. OPT INFLUENCE AND DESIGN. INT. CL. 35. REG. 9-25-2001.
- 2,492,665. MYPAY-MYWAY.COM. INT. CL. 35. REG. 9-25-2001.
- 2,492,669. WALKING CO. AND DESIGN. INT. CL. 35. REG. 9-25-2001.
- 2,492,673. BALL RHEOFORM. INT. CL. 7. REG. 9-25-2001.
- 2,492,674. GCD H/R LAW AND DESIGN. INT. CL. 42. REG. 9-25-2001.
- 2,492,676. CHIARO TILE SYSTEM (STYLIZED). INT. CL. 19. REG. 9-25-2001.
- 2,492,677. IMYGE. INT. CL. 12. REG. 9-25-2001.
- 2,492,678. MISCELLANEOUS DESIGN. INT. CL. 12. REG. 9-25-2001.
- 2,492,680. WRANGLER RF-A. INT. CL. 12. REG. 9-25-2001.
- 2,492,682. HYPER-CAL. INT. CL. 11. REG. 9-25-2001.
- 2,492,683. LE GOURMET GIFT BASKET INC. AND DESIGN. INT. CL. 35. REG. 9-25-2001.
- 2,492,685. LEARNING TO GET AHEAD. INT. CL. 41. REG. 9-25-2001.
- 2,492,689. PRODUCTIVITY WITH THE SPEED OF LIGHT. INT. CL. 9. REG. 9-25-2001.
- 2,492,690. QUIXCEL. INT. CL. 9. REG. 9-25-2001.
- 2,492,696. WHERE LAUGHTER IS THE PRIZE. INT. CL. 41. REG. 9-25-2001.
- 2,492,697. OPTIMIZER. INT. CL. 9. REG. 9-25-2001.
- 2,492,700. LAWSTAR. INT. CL. 42. REG. 9-25-2001.
- 2,492,705. ANYPAY. INT. CL. 36. REG. 9-25-2001.
- 2,492,706. GATEWAY. INT. CL. 39. REG. 9-25-2001.
- 2,492,707. FUN IN THE SUN (STYLIZED). INT. CL. 9. REG. 9-25-2001.
- 2,492,708. LUCKY BUG. INT. CL. 9. REG. 9-25-2001.
- 2,492,714. KHEMPRO. INT. CL. 19. REG. 9-25-2001.
- 2,492,717. SEDIDAF. INT. CL. 11. REG. 9-25-2001.
- 2,492,721. QUICKFIX. INT. CL. 9. REG. 9-25-2001.
- 2,492,723. MISCELLANEOUS DESIGN. INT. CL. 35. REG. 9-25-2001.
- 2,492,725. BOONE INTERACTIVE SYSTEMS. INT. CL. 42. REG. 9-25-2001.
- 2,492,726. HOST COUNTRY USA AND DESIGN. INT. CL. 42. REG. 9-25-2001.
- 2,492,727. DFDS DAN TRANSPORT AND DESIGN. INT. CL. 39. REG. 9-25-2001.
- 2,492,728. BBQ LOVERS CHICKEN BASKET. INT. CL. 29. REG. 9-25-2001.
- 2,492,729. LOGICAL CHOICE. INT. CL. 36. REG. 9-25-2001.
- 2,492,732. HAPPY ART AND DESIGN. INT. CL. 42. REG. 9-25-2001.
- 2,492,733. TOMORROWS TECHNOLOGY TODAY. INT. CLS. 3, 5 AND 10. REG. 9-25-2001.
- 2,492,734. PREMIUM SEAFOOD NATURALLY AND DESIGN. INT. CL. 29. REG. 9-25-2001.
- 2,492,735. PADLOC. INT. CL. 9. REG. 9-25-2001.
- 2,492,736. DONGSIN. INT. CL. 40. REG. 9-25-2001.
- 2,492,737. VEIN ASSURE. INT. CL. 5. REG. 9-25-2001.
- 2,492,738. MACAFRICA. INT. CL. 41. REG. 9-25-2001.
- 2,492,741. MISCELLANEOUS DESIGN. INT. CLS. 38 AND 41. REG. 9-25-2001.
- 2,492,742. FLOSTOR. INT. CLS. 7 AND 39. REG. 9-25-2001.

- 2,492,745. CHECK PRINT. INT. CL. 9. REG. 9-25-2001.
2,492,747. MISCELLANEOUS DESIGN. INT. CL. 25. REG. 9-25-2001.
2,492,748. GOTTEETH.ORG. INT. CL. 42. REG. 9-25-2001.
2,492,749. EDUCATING FOR SUCCESS. INT. CL. 41. REG. 9-25-2001.
2,492,750. TOTAL PARKING SOLUTIONS. INT. CL. 35. REG. 9-25-2001.
2,492,751. ESPINE. INT. CL. 42. REG. 9-25-2001.
2,492,753. UNMATCHABLE VALUE FOR INVESTORS. INT. CL. 36. REG. 9-25-2001.
2,492,754. QUICK3D. INT. CL. 9. REG. 9-25-2001.
2,492,755. CORPORATE NOTES. INT. CL. 42. REG. 9-25-2001.
2,492,757. JUDAH SOUTHERN GOSPEL AND DESIGN. INT. CL. 41. REG. 9-25-2001.
2,492,758. PIRAPORA. INT. CL. 33. REG. 9-25-2001.
2,492,760. DISTRON. INT. CL. 9. REG. 9-25-2001.
2,492,761. BUSINESS CAFE. INT. CL. 41. REG. 9-25-2001.
2,492,764. BATTLE ASSAULT. INT. CL. 9. REG. 9-25-2001.
2,492,765. GAZEBO SOFTWARE SOLUTIONS. INT. CL. 42. REG. 9-25-2001.
2,492,766. NETROSECT. INT. CL. 9. REG. 9-25-2001.
2,492,768. EXISTOLOGY. INT. CL. 42. REG. 9-25-2001.
2,492,769. SLOW CHILDREN AT PLAY. INT. CL. 41. REG. 9-25-2001.
2,492,770. QUICKDOWN.COM. INT. CL. 36. REG. 9-25-2001.
2,492,772. NOPAL. INT. CL. 25. REG. 9-25-2001.
2,492,773. BUZZER. INT. CL. 42. REG. 9-25-2001.
2,492,776. WAPALL. INT. CL. 42. REG. 9-25-2001.
2,492,778. GEORGE BOY. II. INT. CL. 9. REG. 9-25-2001.
2,492,779. DT-VPI. INT. CL. 9. REG. 9-25-2001.
2,492,782. UP CLOSE. INT. CL. 41. REG. 9-25-2001.
2,492,784. BAYLIFE. INT. CL. 25. REG. 9-25-2001.
2,492,785. GETTING YOU BACK TO BUSINESS. INT. CL. 9. REG. 9-25-2001.
2,492,788. PIN PIZAZZ. INT. CL. 26. REG. 9-25-2001.
2,492,789. POFKYNOFKYSKY DOLL. INT. CL. 28. REG. 9-25-2001.
2,492,790. CHI HIGH ENERGY BEADS. INT. CL. 28. REG. 9-25-2001.
2,492,791. JIGGY. INT. CL. 16. REG. 9-25-2001.
2,492,792. DOMINIONS OF OUR ENDEAVOR (STYLIZED). INT. CL. 41. REG. 9-25-2001.
2,492,793. AVSOURCE. INT. CL. 9. REG. 9-25-2001.
2,492,795. LEGALCLICK. INT. CL. 35. REG. 9-25-2001.
2,492,796. 65TH SQUARE AND DESIGN. INT. CL. 28. REG. 9-25-2001.
2,492,797. HIPZONE. INT. CL. 25. REG. 9-25-2001.
2,492,798. SCRIVENERY PRESS. INT. CL. 16. REG. 9-25-2001.
2,492,799. MISCELLANEOUS DESIGN. INT. CL. 42. REG. 9-25-2001.
2,492,800. AVIDRAPIDTOOLS. INT. CL. 9. REG. 9-25-2001.
2,492,801. XSIM. INT. CL. 9. REG. 9-25-2001.
2,492,802. ECCOUNTABLE.COM. INT. CL. 42. REG. 9-25-2001.
2,492,804. COMPETITIVE CHARM. INT. CL. 41. REG. 9-25-2001.
2,492,805. SALES LIVE. INT. CL. 35. REG. 9-25-2001.
2,492,806. SERVICEWIZARD. INT. CL. 35. REG. 9-25-2001.
2,492,808. HEMPERS-LING. INT. CL. 18. REG. 9-25-2001.
2,492,809. PHLOCKSTOCK. INT. CL. 41. REG. 9-25-2001.
2,492,810. KING RESEARCH & LAW KNOWLEDGE IS OUR DOMAIN. (STYLIZED). INT. CL. 42. REG. 9-25-2001.
2,492,813. COLWYN BAY. INT. CL. 25. REG. 9-25-2001.
2,492,814. WHATYOUSEEK. INT. CL. 42. REG. 9-25-2001.
2,492,815. BIGBADTOYSTORE. INT. CL. 35. REG. 9-25-2001.
2,492,816. POISON APPLE. INT. CL. 41. REG. 9-25-2001.
2,492,818. BONHOMME. INT. CL. 42. REG. 9-25-2001.
2,492,819. CYBERCANINE.COM AND DESIGN. INT. CL. 31. REG. 9-25-2001.
2,492,820. HIGH & DRY. INT. CL. 19. REG. 9-25-2001.
2,492,826. FUSE. INT. CLS. 35 AND 41. REG. 9-25-2001.
2,492,827. MAJOR BEDHEAD. INT. CL. 28. REG. 9-25-2001.
2,492,829. TEBA. INT. CL. 11. REG. 9-25-2001.
2,492,834. VIEWPOINT VBX. INT. CL. 9. REG. 9-25-2001.
2,492,835. ADVENTURES FOR YOUR MIND. INT. CL. 25. REG. 9-25-2001.
2,492,841. FAMILY VALUES. INT. CLS. 16 AND 26. REG. 9-25-2001.
2,492,842. RSC DUE DILIGENCE. INT. CL. 35. REG. 9-25-2001.
2,492,844. FIRST JOB. INT. CL. 35. REG. 9-25-2001.
2,492,847. PRESCRIPTIVES POTION. INT. CL. 3. REG. 9-25-2001.
2,492,848. REALTY MASTERS. INT. CL. 16. REG. 9-25-2001.
2,492,849. MISCELLANEOUS DESIGN. INT. CL. 25. REG. 9-25-2001.
2,492,851. NOVO KAFE. INT. CL. 30. REG. 9-25-2001.
2,492,854. STAR WAY. INT. CL. 25. REG. 9-25-2001.
2,492,855. TRAVELPOINT. INT. CL. 9. REG. 9-25-2001.
2,492,857. SONICSCAN AND DESIGN. INT. CL. 9. REG. 9-25-2001.
2,492,859. NETSTORM. INT. CL. 9. REG. 9-25-2001.
2,492,860. INNOVATION. INT. CL. 20. REG. 9-25-2001.
2,492,861. REPURPOSE REALITY. INT. CL. 42. REG. 9-25-2001.
2,492,865. BLASTER PC. INT. CL. 9. REG. 9-25-2001.
2,492,867. FONE FRIEND. INT. CL. 9. REG. 9-25-2001.
2,492,869. PLATINUM. INT. CL. 16. REG. 9-25-2001.
2,492,870. MISCELLANEOUS DESIGN. INT. CL. 42. REG. 9-25-2001.
2,492,871. CABANA KIDS. INT. CL. 16. REG. 9-25-2001.
2,492,876. TORAMAG. INT. CL. 7. REG. 9-25-2001.
2,492,877. IMAGINET. INT. CL. 9. REG. 9-25-2001.
2,492,878. TUFFETS AND DESIGN. INT. CL. 20. REG. 9-25-2001.
2,492,879. TODAY'S CLASSIC HOMES WITH MITCHELL MCDANIEL. INT. CL. 41. REG. 9-25-2001.
2,492,884. SECURITY WITH A HUMAN FACE. INT. CL. 9. REG. 9-25-2001.
2,492,886. WARNER'S COTTON SUPREME. INT. CL. 25. REG. 9-25-2001.
2,492,887. KOLA. INT. CLS. 9, 38, 39 AND 42. REG. 9-25-2001.
2,492,888. DIGITRAK. INT. CL. 35. REG. 9-25-2001.
2,492,890. TRILOGY. INT. CLS. 35, 37 AND 42. REG. 9-25-2001.
2,492,892. MISCELLANEOUS DESIGN. INT. CL. 25. REG. 9-25-2001.
2,492,893. ACTION 21. INT. CL. 9. REG. 9-25-2001.
2,492,894. EVOLUTION, NOT REVOLUTION. INT. CL. 25. REG. 9-25-2001.
2,492,896. TAOS AND DESIGN. INT. CL. 9. REG. 9-25-2001.
2,492,897. VTEC. INT. CL. 12. REG. 9-25-2001.
2,492,900. PAPER, SCISSORS, ROCK. INT. CL. 16. REG. 9-25-2001.
2,492,902. TK. INT. CL. 16. REG. 9-25-2001.
2,492,903. ZING. INT. CLS. 9 AND 42. REG. 9-25-2001.
2,492,908. JUST DESIGN. INT. CL. 25. REG. 9-25-2001.
2,492,909. MISCELLANEOUS DESIGN. INT. CL. 35. REG. 9-25-2001.
2,492,910. HYDROSOLVE. INT. CL. 40. REG. 9-25-2001.
2,492,912. INSIGNIA CRAFTED FLOORING BY MOHAWK. INT. CL. 19. REG. 9-25-2001.
2,492,915. INCREDIBLE DOG FOOD. INCREDIBLE DOGS.. INT. CL. 31. REG. 9-25-2001.
2,492,916. DURA-MATIC. INT. CL. 13. REG. 9-25-2001.
2,492,917. KANISA. INT. CL. 9. REG. 9-25-2001.
2,492,922. NORTON MOBILE ESSENTIALS. INT. CL. 9. REG. 9-25-2001.
2,492,923. NAPA VALLEY PETITES AND DESIGN. INT. CL. 25. REG. 9-25-2001.
2,492,926. LITTLE SMART MOOSICAL BEADS. INT. CL. 28. REG. 9-25-2001.
2,492,927. P.A.L.. INT. CL. 18. REG. 9-25-2001.
2,492,929. TEAMCASUAL PACIFIC. INT. CL. 42. REG. 9-25-2001.
2,492,932. AUNTIE ITCH AND DESIGN. INT. CL. 5. REG. 9-25-2001.
2,492,933. OLD IRONSIDES. INT. CL. 33. REG. 9-25-2001.
2,492,935. EKCO COPPERELLE. INT. CL. 21. REG. 9-25-2001.
2,492,936. RIVERSTONE. INT. CL. 37. REG. 9-25-2001.
2,492,940. SANIMATE. INT. CL. 6. REG. 9-25-2001.
2,492,941. XTRA CREDIT. INT. CL. 9. REG. 9-25-2001.

- 2,492,944. BOMB SQUAD. INT. CL. 30. REG. 9-25-2001.
 2,492,945. DEFINITELY RAY-BAN. INT. CL. 9. REG. 9-25-2001.
 2,492,946. TITLESITE. INT. CL. 42. REG. 9-25-2001.
 2,492,947. SANWA JAPAN AND DESIGN. INT. CLS. 6, 9 AND 12. REG. 9-25-2001.
 2,492,948. DOCS ESQ.. INT. CL. 9. REG. 9-25-2001.
 2,492,949. TLC. INT. CL. 9. REG. 9-25-2001.
 2,492,950. TAQUA SYSTEMS. INT. CL. 9. REG. 9-25-2001.
 2,492,957. LIFEWAY MUSIC. INT. CLS. 9 AND 16. REG. 9-25-2001.
 2,492,958. STARWORKS. INT. CL. 9. REG. 9-25-2001.
 2,492,959. SOLID PARTNERS, FLEXIBLE SOLUTIONS. INT. CLS. 35 AND 36. REG. 9-25-2001.
 2,492,961. AVON SPA. INT. CL. 3. REG. 9-25-2001.
 2,492,971. HONEY VITA REAL 100% NATURAL AND DESIGN. INT. CL. 30. REG. 9-25-2001.
 2,492,975. CREDIT CARD SOLUTIONS. INT. CLS. 36, 41 AND 42. REG. 9-25-2001.
 2,492,976. NETPREDICTOR. INT. CL. 9. REG. 9-25-2001.
 2,492,977. QUINTESSENTIAL NATURAL. INT. CL. 5. REG. 9-25-2001.
 2,492,981. CASHPRO ATM. INT. CL. 36. REG. 9-25-2001.
 2,492,982. ONLY HUMAN. INT. CLS. 9, 25 AND 41. REG. 9-25-2001.
 2,492,983. RECORDSCOPE. INT. CL. 35. REG. 9-25-2001.
 2,492,986. C.R.S. CONCAVE REFLEX SYSTEM AND DESIGN. INT. CL. 11. REG. 9-25-2001.
 2,492,987. PRESENTATIONS PLAYOFFS. INT. CL. 41. REG. 9-25-2001.
 2,492,990. STILA AND DESIGN. INT. CL. 21. REG. 9-25-2001.
 2,492,993. CARRIAGE HOUSE. INT. CL. 11. REG. 9-25-2001.
 2,492,994. BABY BULLDOG. INT. CL. 13. REG. 9-25-2001.
 2,492,995. TEAM ART DIMENSIONAL DESIGN. INT. CL. 20. REG. 9-25-2001.
 2,492,997. WORLDSTREET. INT. CL. 42. REG. 9-25-2001.
 2,493,002. FEATHER LIGHT AND DESIGN. INT. CL. 18. REG. 9-25-2001.
 2,493,005. AMERICAN GENERATIONS. INT. CL. 25. REG. 9-25-2001.
 2,493,006. RPS HOST CONNECT. INT. CL. 35. REG. 9-25-2001.
 2,493,008. ROLLOVER PLUS. INT. CLS. 16 AND 36. REG. 9-25-2001.
 2,493,009. RANDOM PLAY. INT. CL. 41. REG. 9-25-2001.
 2,493,011. SOLITAIRE. INT. CL. 38. REG. 9-25-2001.
 2,493,012. GOOFBALLS. INT. CL. 29. REG. 9-25-2001.
 2,493,013. VROOM. INT. CL. 42. REG. 9-25-2001.
 2,493,015. BRAND ECOLOGY. INT. CL. 35. REG. 9-25-2001.
 2,493,016. MODA. INT. CL. 41. REG. 9-25-2001.
 2,493,017. OCEANIC ADVENTURES NEWPORT AQUARIUM. INT. CL. 41. REG. 9-25-2001.
 2,493,018. EPET (STYLIZED). INT. CL. 9. REG. 9-25-2001.
 2,493,021. BLACKBIRD. INT. CLS. 9 AND 36. REG. 9-25-2001.
 2,493,025. CAM SYSTEMS. INT. CL. 9. REG. 9-25-2001.
 2,493,027. NATREX. INT. CL. 10. REG. 9-25-2001.
 2,493,029. AUGER GEAR. INT. CL. 28. REG. 9-25-2001.
 2,493,030. INLITEN. INT. CLS. 9, 11 AND 20. REG. 9-25-2001.
 2,493,032. READY LAUNCH. INT. CL. 9. REG. 9-25-2001.
 2,493,033. GROUND ZERO. INT. CL. 28. REG. 9-25-2001.
 2,493,035. HORSETHIEF AVIATION AND DESIGN. INT. CL. 25. REG. 9-25-2001.
 2,493,036. HORSETHIEF (STYLIZED). INT. CL. 25. REG. 9-25-2001.
 2,493,038. CHANNEL LINE-UP. INT. CL. 9. REG. 9-25-2001.
 2,493,039. CRAMBO. INT. CL. 30. REG. 9-25-2001.
 2,493,040. EN-LAN (STYLIZED). INT. CL. 9. REG. 9-25-2001.
 2,493,041. DON'T GET CAUGHT IN THE WEB, MASTER IT!. INT. CL. 41. REG. 9-25-2001.
 2,493,043. LEGART. INT. CL. 21. REG. 9-25-2001.
 2,493,044. CYBELIUS. INT. CL. 9. REG. 9-25-2001.
 2,493,046. ROOKIENYC. INT. CL. 28. REG. 9-25-2001.
 2,493,047. SHYM. INT. CL. 9. REG. 9-25-2001.
 2,493,048. ARCADE AMERICA. INT. CLS. 25 AND 35. REG. 9-25-2001.
 2,493,050. SUCCESSEASE. INT. CL. 42. REG. 9-25-2001.
 2,493,051. MAMUT. INT. CL. 9. REG. 9-25-2001.
 2,493,053. QUIKBOND. INT. CL. 1. REG. 9-25-2001.
 2,493,055. SCRATCH AND SMOOCH. INT. CL. 28. REG. 9-25-2001.
 2,493,056. VOLCANO. INT. CL. 42. REG. 9-25-2001.
 2,493,057. SWEET TWEET. INT. CL. 28. REG. 9-25-2001.
 2,493,060. LIL JENNI LIL KENNI CLOTHING. INT. CL. 25. REG. 9-25-2001.
 2,493,061. MISCELLANEOUS DESIGN. INT. CL. 36. REG. 9-25-2001.
 2,493,063. MARINE SHUTTLE OPERATIONS AND DESIGN. INT. CL. 37. REG. 9-25-2001.
 2,493,064. GUARANTEED FRESH "OR I'LL DOUBLE YOUR MONEY BACK". AND DESIGN. INT. CL. 31. REG. 9-25-2001.
 2,493,065. SWITCH ENGINE. INT. CL. 9. REG. 9-25-2001.
 2,493,066. SWOOPS. INT. CL. 9. REG. 9-25-2001.
 2,493,067. BROBECK. INT. CL. 42. REG. 9-25-2001.
 2,493,068. LJR DIRECT. INT. CL. 36. REG. 9-25-2001.
 2,493,071. FRANKLIN PLANNER. INT. CL. 42. REG. 9-25-2001.
 2,493,073. FACEMAIL.COM. INT. CL. 16. REG. 9-25-2001.
 2,493,075. TMX. INT. CL. 14. REG. 9-25-2001.
 2,493,076. MISCELLANEOUS DESIGN. INT. CL. 41. REG. 9-25-2001.
 2,493,077. REASON. INT. CL. 35. REG. 9-25-2001.
 2,493,080. THT.COM. INT. CL. 42. REG. 9-25-2001.
 2,493,081. GLFORMS. INT. CL. 9. REG. 9-25-2001.
 2,493,082. CIGNA SOURCE 1. INT. CL. 35. REG. 9-25-2001.
 2,493,085. NRI NEGOTIATION RESOURCE INTERNATIONAL AND DESIGN. INT. CL. 42. REG. 9-25-2001.
 2,493,086. DINING OUT. INT. CL. 28. REG. 9-25-2001.
 2,493,088. GRECALE. INT. CL. 33. REG. 9-25-2001.
 2,493,090. MISCELLANEOUS DESIGN. INT. CL. 25. REG. 9-25-2001.
 2,493,091. FUEL YOUR FUTURE AIR NATIONAL GUARD AND DESIGN. INT. CL. 42. REG. 9-25-2001.
 2,493,092. SUMMER SHIMMER. INT. CL. 3. REG. 9-25-2001.
 2,493,095. SYNAPSE. INT. CL. 9. REG. 9-25-2001.
 2,493,096. HI-C. INT. CL. 30. REG. 9-25-2001.
 2,493,101. THE DARWIN TECHNOLOGY GROUP. INT. CL. 35. REG. 9-25-2001.
 2,493,104. DAB O PAINT. INT. CL. 2. REG. 9-25-2001.
 2,493,105. US FILTER (STYLIZED). INT. CL. 16. REG. 9-25-2001.
 2,493,109. SYNKO-MASTIC. INT. CL. 1. REG. 9-25-2001.
 2,493,110. CUSTOM MADE FURNITURE. ASSEMBLY LINE PRICES.. INT. CL. 35. REG. 9-25-2001.
 2,493,112. PANDA EGG. INT. CL. 9. REG. 9-25-2001.
 2,493,113. DURA-BOND. INT. CL. 24. REG. 9-25-2001.
 2,493,114. ABC FRUIT CHOMPS. INT. CL. 30. REG. 9-25-2001.
 2,493,116. BRAIN. INT. CL. 14. REG. 9-25-2001.
 2,493,117. COMCASH. INT. CL. 9. REG. 9-25-2001.
 2,493,118. WRIGHT PRIVATE INVESTMENT MANAGEMENT. INT. CL. 36. REG. 9-25-2001.
 2,493,120. DIRECWAY. INT. CLS. 9 AND 38. REG. 9-25-2001.
 2,493,124. HELIX. INT. CL. 25. REG. 9-25-2001.
 2,493,125. PLUTO DESIGN. INT. CL. 41. REG. 9-25-2001.
 2,493,127. DSDA- PRO. INT. CL. 9. REG. 9-25-2001.
 2,493,128. CYCLEWACKO.COM AND DESIGN. INT. CL. 35. REG. 9-25-2001.
 2,493,129. SPOOLCON. INT. CL. 37. REG. 9-25-2001.
 2,493,130. GIADI. INT. CL. 25. REG. 9-25-2001.
 2,493,131. PDX POLARDYNAMIX AND DESIGN. INT. CL. 9. REG. 9-25-2001.
 2,493,132. TEK.XAM. INT. CL. 41. REG. 9-25-2001.
 2,493,133. FABULOUS 40'S. INT. CL. 16. REG. 9-25-2001.
 2,493,135. DRUM PONCHO AND DESIGN. INT. CL. 18. REG. 9-25-2001.
 2,493,136. THE REFRESHING FLAVOR OF LIFE. INT. CL. 30. REG. 9-25-2001.
 2,493,137. LIFE SAVERS. THE REFRESHING FLAVOR OF LIFE.. INT. CL. 30. REG. 9-25-2001.
 2,493,139. HTTP:// (STYLIZED). INT. CLS. 11 AND 20. REG. 9-25-2001.
 2,493,140. ANTITESIS AND DESIGN. INT. CL. 41. REG. 9-25-2001.

- 2,493,142. PATIENTGUARD. INT. CL. 9. REG. 9-25-2001.
 2,493,144. LA CERVEZA LIGHT CON SABOR. INT. CL. 32. REG. 9-25-2001.
 2,493,145. THE POWER IS IN THE TEAM. INT. CL. 36. REG. 9-25-2001.
 2,493,147. GENERAL AMUSEMENTS. INT. CL. 9. REG. 9-25-2001.
 2,493,150. ECLIPSE. INT. CL. 11. REG. 9-25-2001.
 2,493,152. CARDINAL ONE SOURCE. INT. CLS. 35, 40 AND 42. REG. 9-25-2001.
 2,493,156. READING IS BIG. INT. CL. 24. REG. 9-25-2001.
 2,493,157. QD-STAT. INT. CL. 25. REG. 9-25-2001.
 2,493,158. DOUBLE ECRITURE. INT. CL. 3. REG. 9-25-2001.
 2,493,159. DAN THE DOZER. INT. CL. 28. REG. 9-25-2001.
 2,493,163. MEMORYLOCK. INT. CL. 6. REG. 9-25-2001.
 2,493,164. NIGHT COMBAT. INT. CL. 28. REG. 9-25-2001.
 2,493,165. PAGINGPRO. INT. CL. 37. REG. 9-25-2001.
 2,493,167. THE MORE YOU KNOW, THE FASTER YOU FLY. INT. CL. 42. REG. 9-25-2001.
 2,493,168. PURE SHIMANO GUTS AND DESIGN. INT. CL. 25. REG. 9-25-2001.
 2,493,169. NET THREADS. INT. CL. 25. REG. 9-25-2001.
 2,493,172. DRAIN GUARD. INT. CLS. 1 AND 7. REG. 9-25-2001.
 2,493,173. FLIP THE SWITCH. INT. CL. 25. REG. 9-25-2001.
 2,493,175. EYE TO I (STYLIZED). INT. CL. 41. REG. 9-25-2001.
 2,493,179. B-THERE.COM. INT. CL. 16. REG. 9-25-2001.
 2,493,183. ENRON FIELD. INT. CL. 41. REG. 9-25-2001.
 2,493,184. V 4 L AND DESIGN. INT. CL. 35. REG. 9-25-2001.
 2,493,185. NYBS. INT. CL. 25. REG. 9-25-2001.
 2,493,187. PLANETOUTDOORS.COM. INT. CL. 35. REG. 9-25-2001.
 2,493,189. THE SMART SOLUTION FOR SORE EYES!. INT. CL. 10. REG. 9-25-2001.
 2,493,191. LOCALMAX. INT. CLS. 35, 41 AND 42. REG. 9-25-2001.
 2,493,192. EQUIP. INT. CL. 9. REG. 9-25-2001.
 2,493,193. EMPIRE. INT. CL. 30. REG. 9-25-2001.
 2,493,194. LIGHT BULB HUGGER. INT. CL. 3. REG. 9-25-2001.
 2,493,195. SOURCELINK (STYLIZED). INT. CLS. 9 AND 42. REG. 9-25-2001.
 2,493,196. THE UNBRAKEABLE BOAT LOCK. INT. CL. 12. REG. 9-25-2001.
 2,493,197. PARFAIT. INT. CL. 20. REG. 9-25-2001.
 2,493,198. POWER BROWSER. INT. CL. 9. REG. 9-25-2001.
 2,493,201. VANTAS. INT. CLS. 35, 36, 38 AND 42. REG. 9-25-2001.
 2,493,204. SP 110. INT. CL. 7. REG. 9-25-2001.
 2,493,205. SP 250. INT. CL. 7. REG. 9-25-2001.
 2,493,207. KOA AND DESIGN. INT. CL. 42. REG. 9-25-2001.
 2,493,209. GOD PRINTS. INT. CL. 16. REG. 9-25-2001.
 2,493,211. BIORENAISSANCE TECHNOLOGIES AND DESIGN. INT. CL. 40. REG. 9-25-2001.
 2,493,212. REFLECT.COM. INT. CL. 35. REG. 9-25-2001.
 2,493,214. FIZZ BIZZ. INT. CL. 35. REG. 9-25-2001.
 2,493,216. ANYMOUSE. INT. CL. 9. REG. 9-25-2001.
 2,493,217. VITAL RX. INT. CL. 42. REG. 9-25-2001.
 2,493,218. ULTRAVIOLIGHT. INT. CL. 11. REG. 9-25-2001.
 2,493,220. EARTH WORM CASTINGS AND DESIGN. INT. CL. 1. REG. 9-25-2001.
 2,493,222. TOTALROOM. INT. CL. 9. REG. 9-25-2001.
 2,493,224. ULTRA-TOUGH. INT. CL. 25. REG. 9-25-2001.
 2,493,228. XSP-100 SHARK. INT. CL. 9. REG. 9-25-2001.
 2,493,231. HFI AND DESIGN. INT. CL. 20. REG. 9-25-2001.
 2,493,233. INFOFAST. INT. CL. 9. REG. 9-25-2001.
 2,493,234. THE BETTER WAY TO GIVE AND RECEIVE. INT. CLS. 35 AND 36. REG. 9-25-2001.
 2,493,235. EXOLVE. INT. CLS. 16, 35 AND 41. REG. 9-25-2001.
 2,493,240. BAGGY BRUSH. INT. CL. 21. REG. 9-25-2001.
 2,493,241. EXCURSION AND DESIGN. INT. CL. 9. REG. 9-25-2001.
 2,493,242. SPEEDLINK. INT. CL. 1. REG. 9-25-2001.
 2,493,243. TALL. INT. CL. 9. REG. 9-25-2001.
 2,493,246. DECISIONPOINT. INT. CL. 42. REG. 9-25-2001.
 2,493,247. SQUISH PAK!. INT. CLS. 21 AND 29. REG. 9-25-2001.
 2,493,249. GLACIER RUN. INT. CL. 25. REG. 9-25-2001.
 2,493,250. SUDA LA CAMISETA. INT. CL. 25. REG. 9-25-2001.
 2,493,251. FARM-IT-OUT.COM. INT. CL. 35. REG. 9-25-2001.
 2,493,255. GET MORE OUT OF LIFE- LOOK FOR THE YELLOW & GREEN. INT. CL. 5. REG. 9-25-2001.
 2,493,259. FAMILYCLICK.COM. INT. CL. 42. REG. 9-25-2001.
 2,493,261. GET IT FIXED RIGHT. NOW.. INT. CL. 42. REG. 9-25-2001.
 2,493,265. INDEPENDENCE. INT. CL. 19. REG. 9-25-2001.
 2,493,268. PEACE OF MIND PUBLISHING AND DESIGN. INT. CL. 41. REG. 9-25-2001.
 2,493,270. GIANT STEPS. INT. CL. 30. REG. 9-25-2001.
 2,493,271. 3SP. INT. CLS. 38 AND 42. REG. 9-25-2001.
 2,493,272. WILLIAMS CUSTOMER INFORMATION SOLUTION. INT. CL. 9. REG. 9-25-2001.
 2,493,275. O-BEX. INT. CL. 5. REG. 9-25-2001.
 2,493,277. RECODE. INT. CL. 25. REG. 9-25-2001.
 2,493,279. CHOW-NOW!. INT. CL. 42. REG. 9-25-2001.
 2,493,280. QSARIS. INT. CL. 9. REG. 9-25-2001.
 2,493,282. STAR OF INDIA. INT. CL. 30. REG. 9-25-2001.
 2,493,285. DECISION 2000. INT. CL. 25. REG. 9-25-2001.
 2,493,288. READY START. INT. CL. 9. REG. 9-25-2001.
 2,493,290. MARTY'S. INT. CL. 9. REG. 9-25-2001.
 2,493,294. PAYCARD PLUS. INT. CL. 36. REG. 9-25-2001.
 2,493,295. BINGO BLAST AND DESIGN. INT. CL. 9. REG. 9-25-2001.
 2,493,296. FOREVER, CAROLINE. INT. CL. 25. REG. 9-25-2001.
 2,493,297. APPROPRIATE BEHAVIOR. INT. CL. 25. REG. 9-25-2001.
 2,493,298. JOE COOL. INT. CL. 25. REG. 9-25-2001.
 2,493,302. BINGO BLAST. INT. CL. 9. REG. 9-25-2001.
 2,493,303. BENNY FITZ. INT. CLS. 9 AND 41. REG. 9-25-2001.
 2,493,306. BLUE DOT GUARDIAN. INT. CLS. 37 AND 42. REG. 9-25-2001.
 2,493,308. POWER PAC. INT. CL. 10. REG. 9-25-2001.
 2,493,310. TRUE HELP. INT. CL. 9. REG. 9-25-2001.
 2,493,311. HANWOOD AND DESIGN. INT. CLS. 9 AND 28. REG. 9-25-2001.
 2,493,312. MARIO RINALDI. INT. CL. 25. REG. 9-25-2001.
 2,493,316. MEDITERRANEAN SPRING BLEND. INT. CL. 30. REG. 9-25-2001.
 2,493,319. STYLEFIT CLUB. INT. CL. 35. REG. 9-25-2001.
 2,493,320. PHARMAVID. INT. CL. 42. REG. 9-25-2001.
 2,493,321. PK PULSAR. INT. CL. 11. REG. 9-25-2001.
 2,493,322. APPTRIEVE. INT. CL. 9. REG. 9-25-2001.
 2,493,323. SITEFORM +. INT. CLS. 20 AND 35. REG. 9-25-2001.
 2,493,324. ENVIRO-SPONGE. INT. CL. 21. REG. 9-25-2001.
 2,493,327. ILLUMINATION PROCESS. INT. CL. 41. REG. 9-25-2001.
 2,493,328. SEASONED TICKET. INT. CL. 42. REG. 9-25-2001.
 2,493,329. VISUALIZE...BUSINESS INSIGHTS THROUGH MAPPING. INT. CL. 35. REG. 9-25-2001.
 2,493,332. BOILERBASE. INT. CL. 9. REG. 9-25-2001.
 2,493,333. MIGRA STOP. INT. CL. 5. REG. 9-25-2001.
 2,493,335. WMX. INT. CL. 10. REG. 9-25-2001.
 2,493,336. N (STYLIZED). INT. CLS. 35, 36 AND 42. REG. 9-25-2001.
 2,493,337. TENZING. INT. CL. 38. REG. 9-25-2001.
 2,493,338. HAMMER-LOC. INT. CL. 25. REG. 9-25-2001.
 2,493,339. PIXELPIZZA. INT. CL. 9. REG. 9-25-2001.
 2,493,344. BANTA BUDDIES (STYLIZED). INT. CL. 10. REG. 9-25-2001.
 2,493,345. BANTA BUDDIES. INT. CL. 10. REG. 9-25-2001.
 2,493,346. CANDLE ILLUSIONS. INT. CLS. 4 AND 21. REG. 9-25-2001.
 2,493,350. EPROBE. INT. CL. 9. REG. 9-25-2001.
 2,493,351. MOON OVER MANAYUNK. INT. CL. 35. REG. 9-25-2001.
 2,493,353. OFOTO. INT. CL. 9. REG. 9-25-2001.
 2,493,357. MAKING SALES HAPPEN. INT. CL. 35. REG. 9-25-2001.

- 2,493,358. SCAMPA CLAUS. INT. CL. 11. REG. 9-25-2001.
 2,493,364. HSN MESA. INT. CL. 25. REG. 9-25-2001.
 2,493,367. THE STRESS KNOWLEDGE COMPANY. INT. CL. 42. REG. 9-25-2001.
 2,493,368. SPLASH POPS. INT. CL. 30. REG. 9-25-2001.
 2,493,369. VEGGIE CHA CHA. INT. CL. 32. REG. 9-25-2001.
 2,493,370. RAMROD. INT. CL. 13. REG. 9-25-2001.
 2,493,374. BAY SHORE SPRAY. INT. CL. 11. REG. 9-25-2001.
 2,493,376. DIGIMASTER. INT. CL. 9. REG. 9-25-2001.
 2,493,382. COMFORT AND JOY. INT. CL. 3. REG. 9-25-2001.
 2,493,384. BAM-JAC. INT. CL. 28. REG. 9-25-2001.
 2,493,391. BARRACUDA. INT. CL. 5. REG. 9-25-2001.
 2,493,394. THEUNDERGROUND CARPENTER. INT. CL. 20. REG. 9-25-2001.
 2,493,395. THE BEAUTY OF BRICK. INT. CL. 35. REG. 9-25-2001.
 2,493,396. COMBI-BIO. INT. CL. 42. REG. 9-25-2001.
 2,493,397. MS. BEHAVIN'. INT. CL. 3. REG. 9-25-2001.
 2,493,401. LOOK AT ME STUDIOS. INT. CL. 16. REG. 9-25-2001.
 2,493,403. CUSTOME.COM CUSTOM CREATIONS @ YOUR FINGERTIPS AND DESIGN. INT. CLS. 35 AND 42. REG. 9-25-2001.
 2,493,404. J CONSORTIUM AND DESIGN. INT. CL. 16. REG. 9-25-2001.
 2,493,405. BEHAVIORAL FINANCE APPROACH. INT. CL. 41. REG. 9-25-2001.
 2,493,408. VORTEX. INT. CL. 9. REG. 9-25-2001.
 2,493,410. KBO KNOWLEDGE-BASED ORGANIZATION. INT. CL. 41. REG. 9-25-2001.
 2,493,411. NUTRAPHEX. INT. CL. 35. REG. 9-25-2001.
 2,493,412. INTERNATIONAL CONTRACTING GROUP. INT. CL. 40. REG. 9-25-2001.
 2,493,418. MRS. WAGGYTAIL'S. INT. CL. 21. REG. 9-25-2001.
 2,493,423. COOLMONT. INT. CL. 30. REG. 9-25-2001.
 2,493,424. REVITALIFT SLIM. INT. CL. 3. REG. 9-25-2001.
 2,493,429. AMD EASYNOW!. INT. CL. 9. REG. 9-25-2001.
 2,493,430. EASYNOW!. INT. CL. 9. REG. 9-25-2001.
 2,493,431. AMD EASY NOW! PLATFORM DESIGN AND DESIGN. INT. CL. 9. REG. 9-25-2001.
 2,493,437. PEOPLECITE. INT. CL. 35. REG. 9-25-2001.
 2,493,439. ITS-ATTEST. INT. CL. 9. REG. 9-25-2001.
 2,493,440. WEBPUTTY. INT. CL. 42. REG. 9-25-2001.
 2,493,441. WEBPUTTY. INT. CL. 9. REG. 9-25-2001.
 2,493,443. INSOUND. INT. CL. 10. REG. 9-25-2001.
 2,493,448. IMGAMES. INT. CL. 9. REG. 9-25-2001.
 2,493,449. THE GIVING CONNECTION. INT. CL. 36. REG. 9-25-2001.
 2,493,453. REELEYES. INT. CL. 41. REG. 9-25-2001.
 2,493,455. GLOBAL CROSSING EZ PLAN. INT. CL. 38. REG. 9-25-2001.
 2,493,456. GLOBAL CROSSING ATM. INT. CL. 38. REG. 9-25-2001.
 2,493,457. GLOBAL CROSSING ESP. INT. CL. 35. REG. 9-25-2001.
 2,493,458. GLOBAL CROSSING EXPEDITER. INT. CL. 38. REG. 9-25-2001.
 2,493,460. REALJUKEBOX. INT. CLS. 35 AND 38. REG. 9-25-2001.
 2,493,462. GLOBAL CROSSING FRAME RELAY. INT. CL. 38. REG. 9-25-2001.
 2,493,464. COMAYAGUA. INT. CL. 30. REG. 9-25-2001.
 2,493,467. VISIONMAP. INT. CL. 9. REG. 9-25-2001.
 2,493,468. EYFLIGHT. INT. CL. 9. REG. 9-25-2001.
 2,493,469. FESTIVAL OF FINS. INT. CL. 35. REG. 9-25-2001.
 2,493,470. THE GLOBAL CONNECTION TO SMARTER SOLUTIONS. INT. CL. 38. REG. 9-25-2001.
 2,493,471. MIGHTYWORDS. INT. CLS. 35 AND 42. REG. 9-25-2001.
 2,493,472. JAMBANDS.COM. INT. CL. 38. REG. 9-25-2001.
 2,493,473. PHILOU. INT. CL. 3. REG. 9-25-2001.
 2,493,474. NETSCREEN GLOBAL MANAGER. INT. CL. 9. REG. 9-25-2001.
 2,493,476. SAMPLEMISER. INT. CL. 9. REG. 9-25-2001.
 2,493,477. MACROPLAY. INT. CL. 41. REG. 9-25-2001.
 2,493,478. LTC GROUP. INT. CLS. 35, 41 AND 42. REG. 9-25-2001.
 2,493,479. QUIK CAGE. INT. CL. 28. REG. 9-25-2001.
 2,493,480. UNICLIP. INT. CL. 6. REG. 9-25-2001.
 2,493,481. JIGGLES. INT. CL. 28. REG. 9-25-2001.
 2,493,485. DESIGNER ESSENTIALS. INT. CL. 27. REG. 9-25-2001.
 2,493,486. TAKE INCASE. INT. CL. 16. REG. 9-25-2001.
 2,493,488. PERSONALPATH.COM. INT. CLS. 9 AND 42. REG. 9-25-2001.
 2,493,491. MD SEPTIC. INT. CL. 5. REG. 9-25-2001.
 2,493,492. E-ADK. INT. CL. 9. REG. 9-25-2001.
 2,493,493. MISCELLANEOUS DESIGN. INT. CL. 35. REG. 9-25-2001.
 2,493,496. YI-DISH. INT. CL. 30. REG. 9-25-2001.
 2,493,497. SCAN IT SERVICE INNOVATIVE PROGRAMMING SYSTEMS AND DESIGN. INT. CL. 9. REG. 9-25-2001.
 2,493,498. SCAN IT PARTS INNOVATIVE PROGRAMMING SYSTEMS AND DESIGN. INT. CL. 9. REG. 9-25-2001.
 2,493,499. LUBBPMIA. INT. CL. 42. REG. 9-25-2001.
 2,493,501. ENDRO. INT. CL. 20. REG. 9-25-2001.
 2,493,502. DIGIPAPERS. INT. CL. 16. REG. 9-25-2001.
 2,493,504. ITCAPITAL. INT. CL. 42. REG. 9-25-2001.
 2,493,506. KOSHER CATCH AND DESIGN. INT. CL. 29. REG. 9-25-2001.
 2,493,511. DARK & LOVELY HAIRCARE DRY HAIR HEALER AND DESIGN. INT. CL. 3. REG. 9-25-2001.
 2,493,512. LOMBARD TECHNOLOGIES. INT. CLS. 6 AND 40. REG. 9-25-2001.
 2,493,513. GIGATAP. INT. CL. 9. REG. 9-25-2001.
 2,493,514. MAGICTV. INT. CL. 35. REG. 9-25-2001.
 2,493,515. VIRALBURST. INT. CL. 35. REG. 9-25-2001.
 2,493,516. VIRGEN DESATANUDOS. INT. CL. 3. REG. 9-25-2001.
 2,493,521. SWEET STAR. INT. CL. 28. REG. 9-25-2001.
 2,493,523. HATCHLETES. INT. CL. 28. REG. 9-25-2001.
 2,493,525. PAST LIVES ANTIQUES & COLLECTIBLES. INT. CL. 35. REG. 9-25-2001.
 2,493,526. A WALL STREET CENTURY. INT. CL. 41. REG. 9-25-2001.
 2,493,527. APPLE DAZZLE. INT. CL. 29. REG. 9-25-2001.
 2,493,528. WICKED WATERMELON. INT. CL. 1. REG. 9-25-2001.
 2,493,530. ELEGANT ACCENTS. INT. CL. 24. REG. 9-25-2001.
 2,493,533. THE AMERICAN DOG. INT. CL. 25. REG. 9-25-2001.
 2,493,534. VISTAONE METAFOLIO. INT. CL. 36. REG. 9-25-2001.
 2,493,538. SIR ALFRED'S. INT. CL. 29. REG. 9-25-2001.
 2,493,540. DR. DABADDA. INT. CLS. 9 AND 16. REG. 9-25-2001.
 2,493,541. PHARMING COUNTRY. INT. CL. 25. REG. 9-25-2001.
 2,493,543. SUB-ZERO. INT. CLS. 16 AND 28. REG. 9-25-2001.
 2,493,545. PNV. INT. CL. 35. REG. 9-25-2001.
 2,493,548. SMART STEP. INT. CL. 6. REG. 9-25-2001.
 2,493,549. VISOR. INT. CL. 9. REG. 9-25-2001.
 2,493,556. BEANIE E BABY. INT. CL. 28. REG. 9-25-2001.
 2,493,559. MISCELLANEOUS DESIGN. INT. CL. 24. REG. 9-25-2001.
 2,493,560. HEAVENLY SPIRAL. INT. CL. 20. REG. 9-25-2001.
 2,493,564. STRIKE UP A CONVERSATION. INT. CL. 28. REG. 9-25-2001.
 2,493,565. SILVER BULLET. INT. CL. 11. REG. 9-25-2001.
 2,493,569. LINK-ABLE AND DESIGN. INT. CL. 14. REG. 9-25-2001.
 2,493,571. HXP MODE AND DESIGN. INT. CL. 25. REG. 9-25-2001.
 2,493,575. FAITH HEALTHCARE PURCHASING ALLIANCE. INT. CLS. 35 AND 36. REG. 9-25-2001.
 2,493,576. PRIMER. INT. CL. 9. REG. 9-25-2001.
 2,493,577. SAFEFUEL. INT. CL. 36. REG. 9-25-2001.
 2,493,581. EASY SCORE. INT. CL. 36. REG. 9-25-2001.
 2,493,582. FASHION AVENUE. INT. CL. 14. REG. 9-25-2001.
 2,493,585. FORTUNE 100. INT. CL. 42. REG. 9-25-2001.
 2,493,586. PEVIDERM. INT. CL. 5. REG. 9-25-2001.

- 2,493,588. PRO-X NUTRACEUTICALS. INT. CL. 5. REG. 9-25-2001.
- 2,493,589. FUNCTION JUNCTION. INT. CL. 9. REG. 9-25-2001.
- 2,493,590. THE VALUE CUBE. INT. CL. 16. REG. 9-25-2001.
- 2,493,591. PAY-RITE. INT. CL. 36. REG. 9-25-2001.
- 2,493,592. BLUE NOTE. INT. CL. 20. REG. 9-25-2001.
- 2,493,593. EVERYTHING BUT THE BOWL. INT. CL. 30. REG. 9-25-2001.
- 2,493,594. EARTH'S ORIGINAL HEALTH SCIENCE. INT. CL. 5. REG. 9-25-2001.
- 2,493,599. MOUSEMATTRESS AND DESIGN. INT. CL. 9. REG. 9-25-2001.
- 2,493,600. SWIFTBOARD. INT. CL. 9. REG. 9-25-2001.
- 2,493,606. SWIFTFILL. INT. CL. 9. REG. 9-25-2001.
- 2,493,608. U. S. BELLOWS. INT. CL. 6. REG. 9-25-2001.
- 2,493,612. IW*SERVER. INT. CL. 9. REG. 9-25-2001.
- 2,493,613. THE MAJORS CUP. INT. CL. 41. REG. 9-25-2001.
- 2,493,614. CANNABIS CAFE. INT. CL. 42. REG. 9-25-2001.
- 2,493,616. METALINE. INT. CL. 9. REG. 9-25-2001.
- 2,493,617. MISCELLANEOUS DESIGN. INT. CL. 8. REG. 9-25-2001.
- 2,493,618. RADIOSONIC. INT. CL. 9. REG. 9-25-2001.
- 2,493,619. WEBEFT (STYLIZED). INT. CL. 36. REG. 9-25-2001.
- 2,493,622. SUPER STEEL AND DESIGN. INT. CL. 1. REG. 9-25-2001.
- 2,493,623. SUPERSTEEL. INT. CL. 1. REG. 9-25-2001.
- 2,493,624. CALIFORNIA FAMILY BUSINESS AWARD. INT. CL. 41. REG. 9-25-2001.
- 2,493,625. ENERGIZING MULTIVITAMIN. INT. CL. 5. REG. 9-25-2001.
- 2,493,626. 21ST CENTURY MEDICINE. INT. CL. 41. REG. 9-25-2001.
- 2,493,627. PRODUCTNETWORK. INT. CL. 35. REG. 9-25-2001.
- 2,493,629. HOT TOPICS (STYLIZED). INT. CL. 35. REG. 9-25-2001.
- 2,493,631. PRINCETON ECOM. INT. CL. 36. REG. 9-25-2001.
- 2,493,632. NEWS-JOURNAL ONLINE (STYLIZED). INT. CLS. 35, 38 AND 42. REG. 9-25-2001.
- 2,493,633. BOVINUS.COM. INT. CL. 35. REG. 9-25-2001.
- 2,493,634. SPLASH FREE. INT. CL. 20. REG. 9-25-2001.
- 2,493,635. ACADEMY OF LEGAL STUDIES IN BUSINESS. U.S. CL. 200. REG. 9-25-2001.
- 2,493,636. AMERICAN BUSINESS LAW ASSOCIATION. U.S. CL. 200. REG. 9-25-2001.
- 2,493,639. FOUNDATION BENEFIT PLAN. INT. CL. 36. REG. 9-25-2001.
- 2,493,640. ADVANCED WILDERNESS LIFE SUPPORT. INT. CL. 41. REG. 9-25-2001.
- 2,493,644. ITSPEAKS. INT. CL. 42. REG. 9-25-2001.
- 2,493,646. THE INTERNET AT YOUR FINGERTIPS. INT. CL. 9. REG. 9-25-2001.
- 2,493,647. INTERNET INVESTING. INT. CL. 42. REG. 9-25-2001.
- 2,493,648. STUKA DIVE BOMBER. INT. CL. 9. REG. 9-25-2001.
- 2,493,649. THE OUTPUT COMPANY. INT. CLS. 9, 35 AND 42. REG. 9-25-2001.
- 2,493,650. SERVICE SYSTEMS EXCELLENCE, INC.. INT. CL. 9. REG. 9-25-2001.
- 2,493,651. BROKER EXCELLENCE SALES TRACKER. INT. CL. 9. REG. 9-25-2001.
- 2,493,652. WEBSOURCE.COM. INT. CLS. 9 AND 35. REG. 9-25-2001.
- 2,493,654. JUST FOR GIRLS. INT. CL. 9. REG. 9-25-2001.
- 2,493,655. CLINICIAN SUPPORT TECHNOLOGY. INT. CL. 42. REG. 9-25-2001.
- 2,493,656. MISCELLANEOUS DESIGN. INT. CL. 16. REG. 9-25-2001.
- 2,493,657. HUMAN RESOURCES ON THE WEB. INT. CL. 35. REG. 9-25-2001.
- 2,493,661. ACCOUNTINGEXCHANGE. INT. CL. 35. REG. 9-25-2001.
- 2,493,662. WAFFLES CAFFE. INT. CL. 42. REG. 9-25-2001.
- 2,493,663. RECLOSE. INT. CLS. 16 AND 20. REG. 9-25-2001.
- 2,493,664. PURE RETINOL REPAIR SYSTEM. INT. CL. 3. REG. 9-25-2001.
- 2,493,667. 5-MINUTE RECONSTRUCTOR. INT. CL. 3. REG. 9-25-2001.
- 2,493,668. FULL IMMERSION TRAINING. INT. CL. 41. REG. 9-25-2001.
- 2,493,669. SUPER GLOVE. INT. CL. 28. REG. 9-25-2001.
- 2,493,672. MISCELLANEOUS DESIGN. INT. CL. 4. REG. 9-25-2001.
- 2,493,673. DIRECT MARKETING SOLUTIONS FOR E-BUSINESS. INT. CL. 35. REG. 9-25-2001.
- 2,493,674. SHIPPINGSOURCE.COM. INT. CL. 39. REG. 9-25-2001.
- 2,493,676. COLLEGE PUBLISHER. INT. CLS. 9 AND 41. REG. 9-25-2001.
- 2,493,677. CHAMBER ESITE. INT. CL. 42. REG. 9-25-2001.
- 2,493,678. BOATING INDUSTRY INTERNATIONAL. INT. CL. 16. REG. 9-25-2001.
- 2,493,679. ARCHITECTURE ON DEMAND. INT. CL. 9. REG. 9-25-2001.
- 2,493,681. ENGINEERED FOR SKIN. INT. CL. 3. REG. 9-25-2001.
- 2,493,682. IMAGEDMED.NET. INT. CLS. 9 AND 42. REG. 9-25-2001.
- 2,493,683. COIN-FREE. INT. CL. 9. REG. 9-25-2001.
- 2,493,685. WECOLLECTBILLS.COM. INT. CL. 36. REG. 9-25-2001.
- 2,493,687. FEMALESEXUALTHERAPY.COM. INT. CL. 42. REG. 9-25-2001.
- 2,493,689. MARKETING AS A BUSINESS STRATEGY. INT. CL. 35. REG. 9-25-2001.
- 2,493,690. THE ENTREPRENEURIAL PARENT. INT. CL. 42. REG. 9-25-2001.
- 2,493,692. WORLD CLASS BEARS. INT. CL. 28. REG. 9-25-2001.
- 2,493,695. ACCOUNTING TEAM. INT. CL. 42. REG. 9-25-2001.
- 2,493,699. EXCELLENCE IN PUBLIC PROCUREMENT. INT. CL. 41. REG. 9-25-2001.
- 2,493,700. GREAT CLASSIC MOVIES. INT. CL. 35. REG. 9-25-2001.
- 2,493,701. RETAIL OPERATIONS & CONSTRUCTION. INT. CL. 16. REG. 9-25-2001.
- 2,493,704. VENINI. INT. CL. 25. REG. 9-25-2001.
- 2,493,705. THE FEE BUSINESS EXPERTS. INT. CL. 36. REG. 9-25-2001.
- 2,493,706. JOINT NUTRIENT. INT. CL. 5. REG. 9-25-2001.
- 2,493,707. CILLI ORIGINAL DESIGNS. INT. CL. 25. REG. 9-25-2001.
- 2,493,708. MEMBERS EXPRESS. INT. CL. 36. REG. 9-25-2001.
- 2,511,439. AVON TECHNIQUES. INT. CL. 21. REG. 11-27-2001.
- 2,511,630. IMAXION. INT. CLS. 3 AND 5. REG. 11-27-2001.
- 2,516,321. PRINZ OPTICS. INT. CLS. 7 AND 9 ONLY. REG. 12-11-2001.
- 2,541,216. MISCELLANEOUS DESIGN. INT. CL. 9 ONLY. REG. 2-19-2002.
- 2,566,686. SPHERION AND DESIGN. INT. CL. 9 ONLY. REG. 5-7-2002.
- 2,573,791. GIGATERA. INT. CL. 42 ONLY. REG. 5-28-2002.
- 2,574,940. VITRULAN. INT. CLS. 21 AND 22 ONLY. REG. 6-4-2002.
- 2,577,267. BLUEARTH. INT. CL. 28 ONLY. REG. 6-11-2002.
- 2,577,808. CROSSMAX. INT. CL. 18 ONLY. REG. 6-11-2002.
- 2,581,197. LIVBAG. INT. CL. 12 ONLY. REG. 6-18-2002.
- 2,582,602. ISOLAC. INT. CL. 1 ONLY. REG. 6-18-2002.
- 2,582,738. COMPS.COM. INT. CLS. 9 AND 16 ONLY. REG. 6-18-2002.
- 2,583,019. MIRALLOY. INT. CL. 40 ONLY. REG. 6-18-2002.
- 2,583,151. EDU-LEADER. INT. CL. 16 ONLY. REG. 6-18-2002.
- 2,587,095. MISCELLANEOUS DESIGN. INT. CLS. 3, 9, 14, 20 AND 24 ONLY. REG. 7-2-2002.
- 2,587,822. MISCELLANEOUS DESIGN. INT. CL. 28 ONLY. REG. 7-2-2002.
- 2,593,890. INPUT. (STYLIZED). INT. CL. 28 ONLY. REG. 7-16-2002.

- | | |
|---|---|
| 2,596,641. URSULA'S ALCOVE. INT. CLS. 23 AND 24 ONLY. REG. 7-23-2002. | 1,515,826. UNITRAVEL. INT. CL. 39. REG. 12-6-1988. |
| 2,596,799. FAZIO GOLF COURSE DESIGNERS. INT. CL. 37 ONLY. REG. 7-23-2002. | 1,767,468. MARATHON. INT. CL. 19. REG. 4-27-1993. |
| 2,606,515. TOM FAZIO. INT. CL. 37 ONLY. REG. 8-13-2002. | 2,445,839. TEAM ALLIANCE. INT. CL. 39. REG. 4-24-2001. |
| 2,609,195. MISCELLANEOUS DESIGN. INT. CL. 37 ONLY. REG. 8-20-2002. | 2,576,760. WFX. INT. CL. 9. REG. 6-4-2002. |
| 2,611,299. PATIO COMPANION. INT. CL. 8 ONLY. REG. 8-27-2002. | 2,596,272. DOMAIN MULTIPLE LISTING SERVICE. INT. CL. 35. REG. 7-16-2002. |
| 2,627,737. POSSINI. INT. CL. 20 ONLY. REG. 10-1-2002. | 2,661,458. WAVE. INT. CL. 36. REG. 12-17-2002. |
| 2,657,746. FAZIO. INT. CL. 37 ONLY. REG. 12-10-2002. | 2,804,065. CATHY AND DESIGN. INT. CL. 3. REG. 1-13-2004. |
| 2,685,040. P POWER BEAT (STYLIZED). INT. CL. 9 ONLY. REG. 2-11-2003. | 2,815,913. RV AMERICA. INT. CL. 16. REG. 2-17-2004. |
| 2,694,829. V VANDERBILT (STYLIZED). INT. CLS. 14 AND 21 ONLY. REG. 3-11-2003. | 2,933,407. SYRENZSTANDARD CHARACTER MARK INT. CL. 41. REG. 3-15-2005. |
| | 3,170,931. DTM CLOTHING CO. AND DESIGN. INT. CL. 25. REG. 11-14-2006. |
| | 3,300,535. SIGGYS SIMPLY THE BESTSTANDARD CHARACTER MARK INT. CL. 43. REG. 10-2-2007. |
| | 3,316,145. EP (STYLIZED). INT. CL. 9. REG. 10-23-2007. |

SECTION 18

- 1,494,572. FTV AND DESIGN. INT. CL. 41. REG. 6-28-1988.

* * * * *

TRADEMARK REGISTRATIONS AMENDED, CORRECTED, ETC.

The designation "U.S. Cl." appearing in this section refers to the U.S. class in effect prior to Sep. 1, 1973 rather than the international class which applies to applications filed on or after that date. For adoption of international classification see notice in the OFFICIAL GAZETTE of Jun. 26, 1973 (911 O.G. TM 210).

Any change to the registration will be indicated at the bottom of each entry under ELEMENTS AMENDED, CORRECTED OR RESTRICTED. With the exception of changes to the goods and services, additions to the registration will appear in asterisks and deletions of the registration will appear in brackets. Elements which are only changed will be listed with no punctuation. As to the goods/services statement, amendments to the goods/services will appear in asterisks and deletions will appear in brackets. In addition if any change to the goods/services occurs, the element "Goods/Services" will be listed under ELEMENTS AMENDED, CORRECTED OR RESTRICTED.

234,988. REG. 11-8-1927. WHIRLPOOL PROPERTIES, INC. (MICHIGAN CORPORATION) 500 RENAISSANCE DRIVE, SUITE 101, SAINT JOSEPH, MI, 49085, SN 71-248,845. FILED 5-11-1927. PRINCIPAL REGISTER.

859,392. REG. 10-29-1968. VITA-PAKT CITRUS PRODUCTS CO. (CALIFORNIA CORPORATION) 707 N. BARRANCA, COVINA, CA, 91722, SN 72-264,699. FILED 2-14-1967. PRINCIPAL REGISTER.

KitchenAid

INT. CL. 8/U.S. CL. 23

FOR [OIL DROPPERS,] FOOD CHOPPERS, [COFFEE MILLS AND] CEREAL GRINDERS, FRUIT-JUICE EXTRACTORS, AND VEGETABLE SLICERS.

FIRST USE 11-25-1919; IN COMMERCE 11-25-1919.

ELEMENTS AMENDED
MARK

COLD COLD

THE WORD "COLD" IS DISCLAIMED APART FROM THE MARK AS SHOWN.

INT. CL. 32/U.S. CLS. 45, 46 AND 48

FOR CITRUS JUICE DRINKS CONTAINING WATER AND CITRUS JUICES; CITRUS JUICES.

FIRST USE 0-0-1953; IN COMMERCE 0-0-1953.

ELEMENTS AMENDED
GOODS/SERVICES
U.S. CLASS(ES)
DATE OF FIRST USE
DATE OF FIRST USE IN COMMERCE
[INTERNATIONAL CLASS(ES)]

1,248,876. REG. 8-23-1983. UNIVERSITY OF NOTRE DAME DU LAC, THE (INDIANA CORPORATION) NOTRE DAME, IN, 46556, SN 73-307,232. FILED 4-24-1981. PRINCIPAL REGISTER.

852,889. REG. 7-16-1968. MAJESTIC DISTILLING COMPANY, INC. (MARYLAND CORPORATION) 2200 MONUMENTAL ROAD, BALTIMORE, MD, 21227, SN 72-279,401. FILED 8-30-1967. PRINCIPAL REGISTER.

TRAVELERS CLUB

INT. CL. 33/U.S. CLS. 47 AND 49
FOR WHISKEY.

FIRST USE 6-10-1964; IN COMMERCE 6-10-1964.

ELEMENTS AMENDED
GOODS/SERVICES
OWNER ADDRESS
INTERNATIONAL CLASS(ES)
U.S. CLASS(ES)
DATE OF FIRST USE
DATE OF FIRST USE IN COMMERCE



INT. CL. 14/U.S. CL. 28
FOR JEWELRY—NAMELY, STICK PINS MADE OF PRECIOUS METALS AND CHARMS.
FIRST USE 0-0-1950; IN COMMERCE 0-0-1950.
INT. CL. 25/U.S. CL. 39

FOR CLOTHING—NAMELY, SWEATERS.
 FIRST USE 0-0-1950; IN COMMERCE 0-0-1950.
 INT. CL. 26/U.S. CL. 40
 FOR DECORATIVE SHAMROCK PATCHES MADE OF
 CHENILE ON FELT.
 FIRST USE 0-0-1950; IN COMMERCE 0-0-1950.

ELEMENTS AMENDED
 MARK

1,461,466. REG. 10-13-1987. SODEXO, INC. (DELAWARE
 CORPORATION) 9801 WASHINGTONIAN BOULEVARD,
 GAITHERSBURG, MD, 20878, SN 73-645,504. FILED 2-19-
 1987. PRINCIPAL REGISTER.

CREATIVE GOURMET

THE MARK CONSISTS OF STANDARD CHARACTERS
 WITHOUT CLAIM TO ANY PARTICULAR FONT, STYLE,
 SIZE, OR COLOR.
 OWNER OF U.S. REG. NO. 1,407,169.
 NO CLAIM IS MADE TO THE EXCLUSIVE RIGHT TO
 USE "GOURMETS", APART FROM THE MARK AS
 SHOWN.
 INT. CL. 42/U.S. CL. 100
 FOR CATERING, CAFETERIA AND RESTAURANT
 SERVICES.
 FIRST USE 12-0-1976; IN COMMERCE 12-0-1977.

ELEMENTS AMENDED
 MARK

1,475,514. REG. 2-2-1988. AIR LINE PILOTS ASSOCIATION,
 INT'L (VIRGINIA UNINC. ASSOCIATION) 535 HERN-
 DON PARKWAY, HERNDON, VA, 22070, SN 73-593,648.
 FILED 4-16-1986. PRINCIPAL REGISTER.



OWNER OF U.S. REG. NOS. 953,354 AND 1,189,636.
 NO CLAIM IS MADE TO THE EXCLUSIVE RIGHT TO
 USE "AIR LINE PILOTS ASSOCIATION, INT'L" AND
 "SCHEDULE WITH SAFETY", APART FROM THE MARK
 AS SHOWN.
 INT. CL. 200/U.S. CL. 200
 FOR INDICATING MEMBERSHIP IN AN ASSOCIA-
 TION OF COMMERCIAL AIRLINE PILOTS.
 FIRST USE 0-0-1972; IN COMMERCE 0-0-1972.

ELEMENTS AMENDED
 OWNER NAME
 MARK
 DISCLAIMER

1,489,619. REG. 5-24-1988. ROBERT MONDAVI WINERY
 (CALIFORNIA CORPORATION) 841 LATOUR COURT,
 SUITE M, NAPA, CA, 94558, SN 73-665,622. FILED 6-9-1987.
 PRINCIPAL REGISTER.

TO KALON

THE MARK CONSISTS OF STANDARD CHARACTERS
 WITHOUT CLAIM TO ANY PARTICULAR FONT, STYLE,
 SIZE, OR COLOR.
 INT. CL. 33/U.S. CL. 47
 FOR WINE.
 FIRST USE 5-7-1987; IN COMMERCE 5-7-1987.

ELEMENTS AMENDED
 DESCRIPTION OF MARK
 MARK
 [DESCRIPTION OF MARK]

1,490,876. REG. 6-7-1988. ELINCA (SWITZERLAND COR-
 PORATION) 11. AVENUE DE LONGEMALLE, RENENS,
 SWITZERLAND, 1020, SN 73-658,412. FILED 5-1-1987.
 PRINCIPAL REGISTER.

ELINCHROM

INT. CL. 9/U.S. CLS. 21 AND 26
 FOR ELECTRONIC POWER UNITS FOR ELECTRO-
 NIC FLASH PHOTOGRAPHY.
 FIRST USE 1-0-1962; IN COMMERCE 0-0-1971.

ELEMENTS CORRECTED
 OWNER NAME
 OWNER ADDRESS

1,492,469. REG. 6-14-1988. ITO EN, LTD. (JAPAN CORPORA-
 TION) 2-31-11 KABUKI-CHO, SHINJUKU-KU, TOKYO,
 JAPAN., SN 73-636,939. FILED 12-19-1986. PRINCIPAL
 REGISTER.

伊藤園

OWNER OF JAPAN REG. NO. 723360, DATED 10-20-1966,
 EXPIRES 10-20-1996.
 THE FOREIGN CHARACTERS IN THE MARK TRANSLI-
 TERATE TO "ITO-EN".
 INT. CL. 30/U.S. CL. 46
 FOR TEA, GREEN TEA, OOLONG TEA [, COFFEE,
 COCOA].
 FIRST USE ; IN COMMERCE .

ELEMENTS CORRECTED
 ASSIGNMENT/NAME CHANGE
 GOODS/SERVICES
 OWNER ADDRESS

1,691,558. REG. 6-9-1992. ALVIERO MARTINI S.P.A. (ITALY CORPORATION) VIA FILIPPO ARGELATI 1/A, MILANO, ITALY., SN 74-053,031. FILED 4-26-1990. PRINCIPAL REGISTER.

2,181,327. REG. 8-11-1998. COGNAC GAUTIER (FRANCE LIMITED COMPANY) 28 RUE DES PONTS, 16140 AIGRE, FRANCE., SN 75-195,900. FILED 10-28-1996. PRINCIPAL REGISTER.

ALVIERO MARTINI

1^A (LASSE

PRIORITY CLAIMED UNDER SEC. 44(D) ON ITALY APPLICATION NO. 42344C/89, FILED 11-7-1989, REG. NO. 526338, DATED 4-14-1990.

THE ENGLISH TRANSLATION OF THE WORD "1A CLASSE" IN THE MARK IS "ONE A CLASS".

INT. CL. 18/U.S. CLS. 1, 2, 3, 22 AND 41

FOR LEATHER GOODS, NAMELY, LUGGAGE, TRAVELLING BAGS, TRUNKS FOR TRAVELLING, ALL PURPOSE SPORTS BAGS, TOILETRY BAGS SOLD EMPTY, KEY CASES, HANDBAGS, PURSES AND UMBRELLAS.

ELEMENTS AMENDED
MARK

2,083,466. REG. 7-29-1997. SHAKLEE CORPORATION (DELAWARE CORPORATION) 4747 WILLOW ROAD, PLEASANTON, CA, 94588, SN 75-095,128. FILED 4-26-1996. PRINCIPAL REGISTER.

NATURE BRIGHT

INT. CL. 3/U.S. CLS. 1, 4, 6, 50, 51 AND 52

FOR LAUNDRY PRODUCT, NAMELY, AN ALL-FABRIC LAUNDRY BRIGHTENER.

FIRST USE 8-31-1982; IN COMMERCE 8-31-1982.

ELEMENTS AMENDED
MARK

2,178,350. REG. 8-4-1998. INSECT LORE PRODUCTS (CALIFORNIA CORPORATION) PO BOX 1535, SHAFTER, CA, 93263, SN 75-311,831. FILED 6-19-1997. PRINCIPAL REGISTER.

**THE BUTTERFLY
CELEBRATION**

OWNER OF U.S. REG. NOS. 943,370 AND 1,958,641. NO CLAIM IS MADE TO THE EXCLUSIVE RIGHT TO USE "BUTTERFLY", APART FROM THE MARK AS SHOWN.

INT. CL. 28/U.S. CLS. 22, 23, 38 AND 50

FOR BUTTERFLY HATCHING KITS FOR USE AS A HOBBY, AT PARTIES AND SPECIAL EVENTS, CONSISTING OF LIVE CATERPILLARS AND HATCHING CONTAINERS.

FIRST USE 4-4-1996; IN COMMERCE 4-4-1996.

ELEMENTS CORRECTED
OWNER NAME

PANATELA

THE MARK TRANSLATES INTO ENGLISH AS "CIGAR".
INT. CL. 33/U.S. CLS. 47 AND 49
FOR WINES, SPIRITS, BRANDY, COGNAC AND LIQUEURS.

FIRST USE 2-0-1998; IN COMMERCE 3-0-1998.

ELEMENTS CORRECTED
OWNER NAME

2,182,846. REG. 8-18-1998. HARKHAM INDUSTRIES, INC. (CALIFORNIA CORPORATION), DBA JONATHAN MARTIN, 857 SAN PEDRO STREET, LOS ANGELES, CA, 90014, SN 75-195,648. FILED 11-12-1996. PRINCIPAL REGISTER.

h y p e

INT. CL. 25/U.S. CLS. 22 AND 39

FOR [MEN'S,] WOMEN'S [AND CHILDREN'S] DRESS AND CASUAL AND ATHLETIC SHOES AND BOOTS AND * WOMEN'S AND CHILDREN'S * SLIPPERS, * MEN'S, WOMEN'S AND CHILDREN'S * BELTS [AND SUSPENDERS,] AND SLEEPWEAR, NAMELY, NIGHTGOWNS, [NEGLIGEES,] PAJAMAS AND BATHROBES, FOUNDATION GARMETS, IN THE NATURE OF PANTIES, [BRAS] AND SLIPS.

FIRST USE 10-9-1996; IN COMMERCE 10-9-1996.

ELEMENTS AMENDED
GOODS/SERVICES

2,183,394. REG. 8-25-1998. U.S. MUSIC CORPORATION (ILLINOIS CORPORATION) 444 EAST COURTLAND, MUNDELEIN, IL, 60060, SN 75-191,140. FILED 11-1-1996. PRINCIPAL REGISTER.



INT. CL. 9/U.S. CLS. 21, 23, 26, 36 AND 38

FOR MUSICAL INSTRUMENT AMPLIFIERS AND COMPONENTS THEREFOR, NAMELY, AUDIO SPEAKERS, SPEAKER CABINETS, SPEAKER ENCLOSURES, SOUND AMPLIFIERS, PRE-AMPLIFIERS, SOUND PROCESSING AND MODIFYING DEVICES, NAMELY, DELAY, REVERB AND DISTORTION EFFECT UNITS, FOR THE PURPOSE OF MODIFYING SOUND.

FIRST USE 8-0-1990; IN COMMERCE 8-0-1990.

ELEMENTS AMENDED
MARK

2,346,598. REG. 5-2-2000. SEMTEK INNOVATIVE SOLUTIONS CORPORATION (DELAWARE CORPORATION) 9340 HARARD WAY, STE D, SAN DIEGO, CA, 92123, SN 75-551,861. FILED 9-11-1998. PRINCIPAL REGISTER.

SEMTEK

INT. CL. 9/U.S. CLS. 21, 23, 26, 36 AND 38
FOR MAGNETIC STRIPE CARD TECHNOLOGY PRODUCTS, NAMELY, MAGNETIC STRIPE CARD READERS, DECODING CHIPS, WIRELESS CARD READERS, AND MAGNETIC READ/WRITE/MODIFY HEADS.
FIRST USE 9-1-1998; IN COMMERCE 9-1-1998.

ELEMENTS CORRECTED
OWNER NAME

2,410,939. REG. 12-5-2000. COGNAC GAUTIER (FRANCE LIMITED COMPANY) 28 RUE DES PONTS, 16140 AIGRE, FRANCE., SN 75-206,500. FILED 12-2-1996. PRINCIPAL REGISTER.

PINAR DEL RIO

INT. CL. 33/U.S. CLS. 47 AND 49
FOR COGNAC.
FIRST USE 11-5-1996; IN COMMERCE 11-5-1996.

ELEMENTS CORRECTED
OWNER NAME

2,459,469. REG. 6-12-2001. WITNESS FOR PEACE, INC. (MAINE NONPROFIT CORPORATION) 3628 12TH STREET, N.E., 1ST FLOOR, WASHINGTON, DC, 20017, SN 75-926,015. FILED 2-23-2000. PRINCIPAL REGISTER.

WITNESS FOR PEACE

INT. CL. 16/U.S. CLS. 2, 5, 22, 23, 29, 37, 38 AND 50
FOR PRINTED PUBLICATIONS, NAMELY, NEWSPAPERS, PAMPHLETS, [POSTERS] AND INFORMATIONAL LEAFLETS FEATURING INTERNATIONAL FINANCE, INTERNATIONAL LABOR RIGHTS, CORPORATE ACCOUNTABILITY, INTERNATIONAL DEBT RELIEF, AND INTERNATIONAL HUMAN RIGHTS ISSUES; * PRINTED PUBLICATIONS, NAMELY, POSTERS FEATURING INTERNATIONAL HUMAN RIGHTS ISSUES *.
FIRST USE 9-30-1983; IN COMMERCE 12-12-1983.
INT. CL. 41/U.S. CLS. 100, 101 AND 107

FOR EDUCATIONAL AND TRAINING SERVICES, NAMELY, ARRANGING AND CONDUCTING EDUCATIONAL STUDY TOURS, CONFERENCES, AND SEMINARS IN THE FIELDS OF * INTERNATIONAL * FINANCE, INTERNATIONAL LABOR RIGHTS, CORPORATE ACCOUNTABILITY, INTERNATIONAL DEBT RELIEF, AND INTERNATIONAL HUMAN RIGHTS.

FIRST USE 9-30-1983; IN COMMERCE 12-12-1983.

ELEMENTS AMENDED
GOODS/SERVICES
OWNER ADDRESS

2,477,390. REG. 8-14-2001. RAYPAK, INC. (CALIFORNIA CORPORATION) 2151 EASTMAN AVENUE, OXNARD, CA, 93030, SN 75-848,594. FILED 11-15-1999. PRINCIPAL REGISTER.



THE MARK CONSISTS OF STANDARD CHARACTERS WITHOUT CLAIM TO ANY PARTICULAR FONT, STYLE, SIZE, OR COLOR.

INT. CL. 11/U.S. CLS. 13, 21, 23, 31 AND 34
FOR SEALED COMBUSTION AIR INTAKE SYSTEM TO BOILER HEATERS CONSISTING OF A PRESSURIZED VENT PIPE, AIR-INTAKE ELBOW TERMINATION PIPE AND AN IN-LINE AIR FILTER TO PREVENT AIRBORNE PARTICLES FROM ENTERING THE BURNER FUEL-AIR MIXTURE.
FIRST USE 3-1-1999; IN COMMERCE 5-1-1999.

ELEMENTS AMENDED
MARK

2,571,140. REG. 5-21-2002. SEMTEK INNOVATION SOLUTIONS CORPORATION (DELAWARE CORPORATION) 4217-A PONDEROSA AVENUE, SAN DIEGO, CA, 92123, SN 76-174,935. FILED 12-4-2000. PRINCIPAL REGISTER.



INT. CL. 9/U.S. CLS. 21, 23, 26, 36 AND 38
FOR SECURE MAGNETIC STRIPE CARD TECHNOLOGY PRODUCTS, NAMELY, MAGNETIC STRIPE CARD READERS, DECODING CHIPS, WIRELESS CARD READERS, MAGNETIC READ, WRITE, AND MODIFY HEADS, ELECTRONIC MAGNETIC ENCODING AND DECODING MACHINES, AND MAGNETIC MEDIA, NAMELY, MAGNETIC STRIPE CARDS, SMART CARDS, AND CHIP CARDS.
FIRST USE 10-24-2000; IN COMMERCE 10-24-2000.

ELEMENTS CORRECTED
OWNER NAME

2,586,509. REG. 6-25-2002. PEPPERIDGE FARM, INCORPORATED (CONNECTICUT CORPORATION) 595 WESTPORT AVENUE, NORWALK, CT, 06851, SN 76-169,010. FILED 11-21-2000. PRINCIPAL REGISTER.

2,667,385. REG. 12-24-2002. CLEANTOOLS, INC. (ILLINOIS CORPORATION) 10 PLAZA DRIVE, WESTMONT, IL, 60559, SN 76-193,489. FILED P.R. 1-11-2001; AM. S.R. 9-20-2002. SUPPLEMENTAL REGISTER.

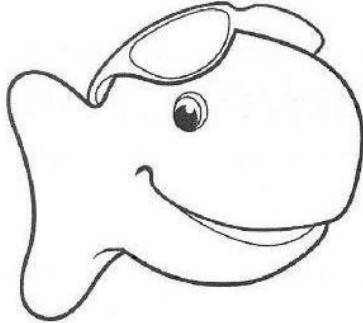

THE GLOSSER

INT. CL. 21/U.S. CLS. 2, 13, 23, 29, 30, 33, 40 AND 50
FOR CLEANING CLOTHS CONTAINING AUTOMOBILE WAXES AND CLEANERS.
FIRST USE 3-13-2001; IN COMMERCE 3-13-2001.

ELEMENTS CORRECTED
CITIZENSHIP

OWNER OF U.S. REG. NO. 2,176,927.
INT. CL. 29/U.S. CL. 46
FOR SOUPS.
FIRST USE 4-30-2001; IN COMMERCE 4-30-2001.

ELEMENTS AMENDED
MARK

2,697,731. REG. 3-18-2003. SEMTEK INNOVATIVE SOLUTIONS CORPORATION (DELAWARE CORPORATION) 4217-A PONDEROSA AVENUE, SAN DIEGO, CA, 92123, SN 76-416,332. FILED 6-3-2002. PRINCIPAL REGISTER.

2,586,747. REG. 6-25-2002. SEMTEK INNOVATION SOLUTIONS CORPORATION (DELAWARE CORPORATION) 4901 MORENA BLVD., SUITE 1108, SAN DIEGO, CA, 92117, SN 75-876,511. FILED P.R. 12-17-1999; AM. S.R. 3-18-2002. SUPPLEMENTAL REGISTER.

POCKETSWIPE



OWNER OF U.S. REG. NO. 2,547,305.
INT. CL. 9/U.S. CLS. 21, 23, 26, 36 AND 38
FOR SECURE MAGNETIC STRIPE CARD TECHNOLOGY PRODUCTS, NAMELY, MAGNETIC STRIPE CARD READERS THAT ARE ATTACHABLE TO HAND-HELD COMPUTERS AND PERSONAL DIGITAL ASSISTANTS (PDAS).
FIRST USE 1-16-2002; IN COMMERCE 3-6-2002.

INT. CL. 9/U.S. CLS. 21, 23, 26, 36 AND 38
FOR SECURE MAGNETIC STRIPE CARD TECHNOLOGY PRODUCTS, NAMELY, MAGNETIC STRIPE CARD READERS, DECODING CHIPS, WIRELESS CARD READERS, MAGNETIC READ/WRITE/MODIFY HEADS, MAGNETIC ENCODING AND DECODING MACHINES, AND MAGNETIC MEDIA, NAMELY, MAGNETIC STRIPE CARDS, SMART CARDS AND CHIP CARDS.
FIRST USE 5-1-2000; IN COMMERCE 5-1-2000.

ELEMENTS CORRECTED
OWNER NAME

ELEMENTS CORRECTED
OWNER NAME

2,768,747. REG. 9-30-2003. SEMTEK INNOVATIVE SOLUTIONS CORPORATION (DELAWARE CORPORATION) 4217-A PONDEROSA AVENUE, SAN DIEGO, CA, 92123, SN 76-342,155. FILED 11-27-2001. PRINCIPAL REGISTER.

2,657,070. REG. 12-3-2002. APPLIED GENETICS INCORPORATED DERMATICS (DELAWARE CORPORATION) 205 BUFFALO AVENUE, FREEPORT, NY, 11520, SN 76-198,189. FILED 1-17-2001. PRINCIPAL REGISTER.

ISWIPE

DIMERICINE

INT. CL. 9/U.S. CLS. 21, 23, 26, 36 AND 38
FOR SECURE MAGNETIC STRIPE CARD TECHNOLOGY PRODUCTS, NAMELY, MAGNETIC STRIPE CARD READERS THAT ARE ATTACHABLE TO HAND-HELD COMPUTERS AND PERSONAL DIGITAL ASSISTANTS (PDAS).
FIRST USE 10-21-2001; IN COMMERCE 10-21-2001.

INT. CL. 5/U.S. CLS. 6, 18, 44, 46, 51 AND 52
FOR PHARMACEUTICAL PREPARATIONS FOR THE PREVENTION OR TREATMENT OF SKIN DISEASES.
FIRST USE 9-10-2001; IN COMMERCE 9-10-2001.

ELEMENTS CORRECTED
GOODS/SERVICES

ELEMENTS CORRECTED
OWNER NAME

2,884,908. REG. 9-14-2004. SEMTEK INNOVATIVE SOLUTIONS CORPORATION (DELAWARE CORPORATION) 4217-A PONDEROSA AVENUE, SAN DIEGO, CA, 92123, SN 76-477,853. FILED 12-24-2002. PRINCIPAL REGISTER.

MOBILE SWIPE

OWNER OF U.S. REG. NOS. 2,346,598, 2,547,305 AND 2,571,140.

NO CLAIM IS MADE TO THE EXCLUSIVE RIGHT TO USE "MOBILE", APART FROM THE MARK AS SHOWN. INT. CL. 9/U.S. CLS. 21, 23, 26, 36 AND 38

FOR SECURE MAGNETIC STRIPE CARD TECHNOLOGY PRODUCTS, NAMELY, MAGNETIC STRIPE CARD READERS THAT ARE STAND-ALONE UNITS OR UNITS ATTACHABLE TO DESKTOP COMPUTERS, LAPTOP COMPUTERS, HAND-HELD COMPUTERS, TELEPHONES, PORTABLE TELEPHONES, WIRELESS TELEPHONES AND PERSONAL DIGITAL ASSISTANTS (PDAS).

FIRST USE 4-10-2002; IN COMMERCE 1-3-2003.

ELEMENTS CORRECTED
OWNER NAME

2,901,797. REG. 11-9-2004. CLOVERVALE FARMS, INC. (OHIO CORPORATION) 226 CONNECTICUT AVENUE, LORAIN, OH, 44052, SN 78-322,280. FILED 11-3-2003. PRINCIPAL REGISTER.

AUNTIE MAE'S

THE MARK CONSISTS OF STANDARD CHARACTERS WITHOUT CLAIM TO ANY PARTICULAR FONT, STYLE, SIZE, OR COLOR.

INT. CL. 30/U.S. CL. 46

FOR FOOD, NAMELY SANDWICHES.
FIRST USE 7-1-2003; IN COMMERCE 7-1-2003.

ELEMENTS CORRECTED
OWNER NAME

2,977,193. REG. 7-26-2005. LAURICE EL BADRY RAHME LTD. (NEW YORK CORPORATION), DBA LAURICE & CO., 9 BOND STREET, NEW YORK, NY, 10012, SN 76-488,130. FILED 2-7-2003. PRINCIPAL REGISTER.

MADISON SOIREE

INT. CL. 3/U.S. CLS. 1, 4, 6, 50, 51 AND 52
FOR FRAGRANCES, NAMELY PERFUMES AND COLOGNES.

FIRST USE 2-0-2003; IN COMMERCE 2-0-2003.
INT. CL. 4/U.S. CLS. 1, 6 AND 15

FOR CANDLES.
FIRST USE 2-0-2003; IN COMMERCE 2-0-2003.

ELEMENTS CORRECTED
GOODS/SERVICES

3,016,275. REG. 11-15-2005. ALLIANT TECHSYSTEMS INC. (DELAWARE CORPORATION) 5050 LINCOLN DRIVE, EDINA, MN, 554367097, SN 78-376,467. FILED 3-1-2004. PRINCIPAL REGISTER.



OWNER OF U.S. REG. NO. 1,054,411.
THE MARK CONSISTS OF A STYLIZATION OF THE WORD CHAMPION.

INT. CL. 28/U.S. CLS. 22, 23, 38 AND 50

FOR FULL LINE OF TARGETS, TARGET HOLDERS, AND TARGET LAUNCHERS.

FIRST USE 6-8-2004; IN COMMERCE 6-29-2004.

ELEMENTS CORRECTED
OWNER ADDRESS

3,065,034. REG. 3-7-2006. PERKINS, WOLF, MCDONNELL AND COMPANY (DELAWARE LTD LIAB CO) SUITE 2600, 310 S. MICHIGAN, CHICAGO, IL, 60604, SN 78-340,330. FILED 12-12-2003. PRINCIPAL REGISTER.



INT. CL. 36/U.S. CLS. 100, 101 AND 102
FOR INVESTMENT CONSULTATION AND ADVISORY SERVICES.

FIRST USE 9-28-1983; IN COMMERCE 9-28-1983.

ELEMENTS CORRECTED
ENTITY

3,105,710. REG. 6-20-2006. COMMUNITY COFFEE COMPANY OF TEXAS, INC. (TEXAS CORPORATION) 447 WEST 38TH STREET, HOUSTON, TX, 77018, SN 76-632,688. FILED 3-7-2005. PRINCIPAL REGISTER.

3,163,318. REG. 10-24-2006. GE SECURITY, INC. (DELAWARE CORPORATION) 8985 TOWN CENTER PARKWAY, BRADENTON, FL, 43202, SN 78-188,120. FILED 11-22-2002. PRINCIPAL REGISTER.

CAFE SPECIAL

THE MARK CONSISTS OF STANDARD CHARACTERS WITHOUT CLAIM TO ANY PARTICULAR FONT, STYLE, SIZE, OR COLOR.

OWNER OF U.S. REG. NO. 1,321,047. NO CLAIM IS MADE TO THE EXCLUSIVE RIGHT TO USE "CAFE", APART FROM THE MARK AS SHOWN. SEC. 2(F).

INT. CL. 30/U.S. CL. 46
FOR COFFEE .
FIRST USE 6-26-1981; IN COMMERCE 7-7-1981.



ELEMENTS CORRECTED
OWNER NAME

3,128,187. REG. 8-8-2006. LOTION, LLC (DELAWARE LTD LIAB CO) C/O GELFAND, RENNERT & FELDMAN LLP, 360 HAMILTON AVE., WHITE PLAINS, NY, 10601, SN 78-977,025. FILED 12-8-2003. PRINCIPAL REGISTER.

PRIORITY CLAIMED UNDER SEC. 44(D) ON SWITZERLAND APPLICATION NO. 09586/2002, FILED 11-8-2002, REG. NO. 508326, DATED 3-19-2003.
INT. CL. 9/U.S. CLS. 21, 23, 26, 36 AND 38

FOR [SCIENTIFIC, ELECTRICAL, CHECKING AND SUPERVISION APPARATUS AND INSTRUMENTS, NAMELY, INDUSTRIAL COMPUTERS FOR DIGITAL RECORDING, TRANSMISSION PROCESSING AND REPRODUCTION OF VIDEO IMAGES AND AUDIO; APPARATUS FOR VIDEO TRANSMISSION, SURVEILLANCE CHECKING AND SUPERVISION, NAMELY, COMPUTERS, COMPUTER PROGRAMS AND BLANK DISK STORAGE EQUIPMENT, NAMELY, BLANK COMPUTER DISCS AND BLANK DISCS FOR STORAGE OF COMPUTER DATA FOR DIGITAL VIDEO COMPRESSION AND TRANSMISSION; IMAGE PROCESSING SOFTWARE AND DIGITAL VIDEO NETWORKING SYSTEMS COMPRISED OF ELECTRONIC BOARDS AND COMPUTER SOFTWARE FOR SECURITY APPLICATIONS, NAMELY, TRAFFIC SURVEILLANCE, URBAN SURVEILLANCE, ACCESS CONTROL, PROCESS CONTROL, BUILDING AUTOMATION AND CLOSED CIRCUIT TELEVISION SYSTEMS, AND MEDIA APPLICATIONS, NAMELY, MULTIMEDIA INTRANETS, INTERACTIVE TELEVISION, CORPORATE TELEVISION, VIDEO LEARNING, VIDEO MEDICINE AND INTERACTIVE VIDEO FORUMS; DIGITAL SURVEILLANCE APPARATUS AND DEVICES, NAMELY, COMPUTERS AND COMPUTER PROGRAMS FOR COMPRESSING AND TRANSMITTING DIGITAL VIDEO AND AUDIO ON COMPUTER NETWORKS IN REAL TIME; BLANK MAGNETIC DATA CARRIER FOR DIGITAL VIDEO IMAGES AND SOUND; BLANK DISKS FOR COMPUTERS TO RECORD DIGITAL VIDEO IMAGES AND SOUND; COMPUTER PROGRAMS FOR DIGITAL VIDEO APPLICATIONS, NAMELY, COMPRESSING AND TRANSMITTING DIGITAL IMAGES AND SOUND VIA COMPUTER NETWORKS; DATA PROCESSORS AND COMPUTERS] *DIGITAL SURVEILLANCE APPARATUS AND DEVICES, NAMELY, COMPUTERS FOR COMPRESSING AND TRANSMITTING DIGITAL VIDEO IMAGES ON COMPUTER NETWORKS IN REAL TIME, NAMELY, DIGITAL VIDEO ENCODERS*.
FIRST USE 6-30-2003; IN COMMERCE 6-30-2003.

MARIAH CAREY

THE MARK CONSISTS OF STANDARD CHARACTERS WITHOUT CLAIM TO ANY PARTICULAR FONT, STYLE, SIZE, OR COLOR.

OWNER OF U.S. REG. NOS. 2,024,932, 2,590,372 AND OTHERS.

MARIAH CAREY IS THE NAME OF A LIVING INDIVIDUAL WHOSE CONSENT IS OF RECORD.
INT. CL. 9/U.S. CLS. 21, 23, 26, 36 AND 38

FOR A SERIES OF MUSICAL SOUND RECORDINGS; A SERIES OF MUSICAL VIDEO RECORDINGS; A SERIES OF AUDIO VISUAL RECORDINGS FEATURING MUSICAL AND MUSICAL BASED ENTERTAINMENT, A SERIES OF DOWNLOADABLE MUSICAL SOUND RECORDINGS, A SERIES OF DOWNLOADABLE MUSICAL VIDEO RECORDINGS, A SERIES OF DOWNLOADABLE AUDIO VISUAL RECORDINGS FEATURING MUSIC AND MUSICAL BASED ENTERTAINMENT, AND A SERIES OF DOWNLOADABLE RING TONES FOR MOBILE PHONES.

FIRST USE 6-0-1990; IN COMMERCE 6-0-1990.
INT. CL. 16/U.S. CLS. 2, 5, 22, 23, 29, 37, 38 AND 50
FOR CALENDARS.
FIRST USE 0-0-1991; IN COMMERCE 0-0-1991.

ELEMENTS CORRECTED
DATE OF FIRST USE
DATE OF FIRST USE IN COMMERCE

ELEMENTS AMENDED
GOODS/SERVICES

3,165,462. REG. 10-31-2006. PERSTORP SPECIALITY CHEMICALS AB (SWEDEN LTD LIAB CO) SE-284 80 PERSTORP, SWEDEN., SN 79-016,137. FILED 4-18-2005. PRINCIPAL REGISTER.

3,230,265. REG. 4-17-2007. OLD WORLD INDUSTRIES, INC. (ILLINOIS CORPORATION) 4065 COMMERCIAL AVENUE, NORTHBROOK, IL, 600621851, SN 76-616,621. FILED 10-20-2004. PRINCIPAL REGISTER.

OXYMER

FLUSH IT, FILL IT AND FORGET IT.

PRIORITY DATE OF 3-15-2005 IS CLAIMED.
OWNER OF INTERNATIONAL REGISTRATION 0864323
DATED 4-18-2005, EXPIRES 4-18-2015.
INT. CL. 1/U.S. CLS. 1

FOR [CHEMICALS USED IN INDUSTRY, SCIENCE AND PHOTOGRAPHY]; MONOALCOHOLS, DIALCOHOLS, TRIALCOHOLS AND POLYALCOHOLS AS WELL AS DERIVATES THEREOF NAMELY ETHERS AND ESTERS FOR USE IN INDUSTRY; [UNPROCESSED ARTIFICIAL RESINS FOR USE IN INDUSTRY;] UNPROCESSED PLASTICS; [ADHESIVES FOR INDUSTRIAL USE;] POLYMER COMPOSITIONS USED IN THE MANUFACTURE OF COMMERCIAL AND INDUSTRIAL GOODS; POLYURETHANE USED IN FOAMS, FIBRES, CASTINGS AND RESINS.

FIRST USE ; IN COMMERCE .

INT. CL. 17/U.S. CLS. 1, 5, 12, 13, 35 AND 50

FOR SYNTHETIC RUBBER AND SYNTHETIC ELASTOMERS FOR USE IN FURTHER MANUFACTURE; SEMI PROCESSED PLASTIC SUBSTANCES FOR USE IN FURTHER MANUFACTURE.

FIRST USE ; IN COMMERCE .

ELEMENTS CORRECTED
[GOODS/SERVICES]
[INTERNATIONAL CLASS(ES)]

THE MARK CONSISTS OF STANDARD CHARACTERS WITHOUT CLAIM TO ANY PARTICULAR FONT, STYLE, SIZE, OR COLOR.

INT. CL. 1/U.S. CLS. 1

FOR ANTIFREEZE AND COOLANTS.

FIRST USE 10-16-2006; IN COMMERCE 10-16-2006.

ELEMENTS AMENDED
MARK

3,254,330. REG. 6-19-2007. QUESTECH CORPORATION (VERMONT CORPORATION) 92 PARK STREET, RUTLAND, VT, 05701, SN 78-978,244. FILED 1-18-2006. PRINCIPAL REGISTER.

3,177,334. REG. 11-28-2006. IMAGE ONLINE DESIGN, INC. (CALIFORNIA CORPORATION) 1241 JOHNSON AVENUE, SUITE 201, SAN LUIS OBISPO, CA, 934013306, SN 76-188,422. FILED 1-2-2001. PRINCIPAL REGISTER.

Q-SEAL

.WEB

INT. CL. 9/U.S. CLS. 21, 23, 26, 36 AND 38

FOR COMPUTER ACCESSORIES, NAMELY, MOUSE PADS, CD HOLDERS.

FIRST USE 5-0-2006; IN COMMERCE 5-0-2006.

INT. CL. 18/U.S. CLS. 1, 2, 3, 22 AND 41

FOR FANNY PACKS AND BACKPACKS.

FIRST USE 5-0-2006; IN COMMERCE 5-0-2006.

INT. CL. 21/U.S. CLS. 2, 13, 23, 29, 30, 33, 40 AND 50

FOR THERMAL INSULATOR CONTAINERS FOR FOOD OR BEVERAGES; CUPS; MUGS; [BEVERAGES] * BEVERAGE * CAN INSULATING SLEEVES.

FIRST USE 5-0-2006; IN COMMERCE 5-0-2006.

INT. CL. 35/U.S. CLS. 100, 101 AND 102

FOR ONLINE RETAIL STORE SERVICES FEATURING COMPUTER ACCESSORIES.

FIRST USE 6-0-2006; IN COMMERCE 6-0-2006.

ELEMENTS CORRECTED
GOODS/SERVICES

THE MARK CONSISTS OF STANDARD CHARACTERS WITHOUT CLAIM TO ANY PARTICULAR FONT, STYLE, SIZE, OR COLOR.

OWNER OF U.S. REG. NO. 2,681,464.

NO CLAIM IS MADE TO THE EXCLUSIVE RIGHT TO USE SEAL, APART FROM THE MARK AS SHOWN.

INT. CL. 19/U.S. CLS. 1, 12, 33 AND 50

FOR SEALER COATINGS SOLD AS AN INTEGRAL COMPONENT OF NATURAL STONE AND OF WALL, FLOOR AND COUNTER TOP TILES OF CLAY, GLASS, GYPSUM, CERAMIC, AND EARTHENWARE; AND SEALER COATINGS SOLD AS AN INTEGRAL COMPONENT OF NON-METAL TILES.

FIRST USE 2-1-2006; IN COMMERCE 2-1-2006.

ELEMENTS AMENDED
MARK

3,276,336. REG. 8-7-2007. ROCHE DIAGNOSTICS OPERATIONS, INC. (INDIANA CORPORATION) 9115 HAGUE ROAD, INDIANAPOLIS, IN, 46250, SN 78-481,887. FILED 9-10-2004. PRINCIPAL REGISTER.



OWNER OF U.S. REG. NOS. 1,251,382, 2,001,778 AND OTHERS.

THE COLORS GREEN AND BLACK ARE CLAIMED AS A FEATURE OF THE MARK.

THE LETTER O IN THE MARK IS GREEN WHILE THE LETTERS C, B, A, S, ARE BLACK.

THE MARK CONSISTS OF THE WORD "COBAS" IN LOWER CASE LETTERS. THE LETTER "O" IS GREEN WITH BOLD PARENTHESES, IN GREEN, ON EACH SIDE OF THE LETTER.

INT. CL. 1/U.S. CLS. 1

FOR A FULL LINE OF IN VITRO DIAGNOSTIC AGENTS, NAMELY, REAGENTS, CONTROL SOLUTIONS FOR CALIBRATING AND MONITORING THE ACCURACY AND FUNCTION OF INSTRUMENTS AND TEST RESULTS, ADDITIVES, ENZYMES, ORGANISMS AND PROTEINS FOR USE IN SCIENCE, RESEARCH AND INDUSTRY.

FIRST USE 7-1-2006; IN COMMERCE 7-1-2006.

INT. CL. 5/U.S. CLS. 6, 18, 44, 46, 51 AND 52

FOR A FULL LINE OF AGENTS FOR MEDICAL [AND VETERINARY] PURPOSES, NAMELY, REAGENTS, SOLUTIONS AND TEST STRIPS FOR THE ANALYSIS OF BIOLOGICAL SAMPLES FOR DIAGNOSTIC PURPOSES.

FIRST USE 7-1-2006; IN COMMERCE 7-1-2006.

INT. CL. 9/U.S. CLS. 21, 23, 26, 36 AND 38

FOR DISPOSABLE ARTICLES AND ACCESSORIES FOR SCIENTIFIC INSTRUMENTS AND APPARATUS AND MEDICAL AND DIAGNOSTIC LABORATORY INSTRUMENTS AND APPARATUS, NAMELY, VESSELS, RECEPTACLES, CARTRIDGES, PIPETTES, PIPETTE TUBES, REAGENT RACKS AND CONTAINERS; DISPENSERS FOR TAKING UP, TREATMENT, DOSAGE AND DISTRIBUTION OF REAGENTS AND SOLUTIONS; COMPUTER HARDWARE AND SOFTWARE FOR USE WITH LABORATORY INSTRUMENTS, NAMELY, FOR USE IN DATA ANALYSIS AND DATABASE MANAGEMENT; DOWNLOADABLE ELECTRONIC PUBLICATIONS IN THE NATURE OF INSTRUCTION SHEETS AND INSTRUCTION MANUALS IN THE FIELD OF MEDICINE AND DIAGNOSTICS.

FIRST USE 7-1-2006; IN COMMERCE 7-1-2006.

INT. CL. 16/U.S. CLS. 2, 5, 22, 23, 29, 37, 38 AND 50

FOR PRINTED MATERIALS, NAMELY, INSTRUCTIONAL MATERIALS, PAMPHLETS AND BROCHURES IN THE FIELD OF IN VITRO DIAGNOSTIC AGENTS IN SCIENCE, RESEARCH AND INDUSTRY; PRINTED MATERIALS, NAMELY, INSTRUCTIONAL MATERIALS, PAMPHLETS AND BROCHURES IN THE FIELD OF IN VITRO DIAGNOSTIC AGENTS FOR MEDICAL AND VETERINARY DIAGNOSTIC PURPOSES; PRINTED MATERIALS, NAMELY, INSTRUCTIONAL MATERIALS, PAMPHLETS AND BROCHURES IN THE FIELD OF INSTRUMENTS AND APPARATUS FOR MEDICAL DIAGNOSTIC PURPOSES; PRINTED MATERIALS, NAMELY, INSTRUCTIONAL MATERIALS, PAMPHLETS AND BROCHURES IN THE FIELD OF SCIENTIFIC INSTRUMENTS AND APPARATUS FOR USE IN SCIENCE, RESEARCH AND INDUSTRY.

FIRST USE 7-1-2006; IN COMMERCE 7-1-2006.

INT. CL. 42/U.S. CLS. 100 AND 101

FOR TECHNICAL SCIENTIFIC CONSULTING SERVICES FOR OTHERS IN THE FIELD OF THE ESTABLISHMENT OF SCIENTIFIC, RESEARCH AND MEDICAL LABORATORIES; CONSULTING SERVICES FOR OTHERS IN THE FIELD OF DESIGN, DEVELOPMENT AND USE OF COMPUTER SOFTWARE FOR USE IN SCIENTIFIC, RESEARCH AND MEDICAL FIELDS; MEDICAL DIAGNOSTIC RESEARCH SERVICES.

FIRST USE 7-1-2006; IN COMMERCE 7-1-2006.

INT. CL. 44/U.S. CLS. 100 AND 101

FOR MEDICAL DIAGNOSTIC CONSULTANCY SERVICES FOR OTHERS; PROVIDING A DATABASE FEATURING INFORMATION IN THE FIELD OF MEDICAL DIAGNOSTICS; MEDICAL DIAGNOSTIC ANALYZER SERVICES FOR OTHERS.

FIRST USE 7-1-2006; IN COMMERCE 7-1-2006.

ELEMENTS CORRECTED
GOODS/SERVICES

3,329,618. REG. 11-6-2007. MICRONAS GMBH (FED REP GERMANY LTD LIAB CO) HANS-BUNTE-STR. 19, 79108 FREIBURG, FED REP GERMANY., SN 79-022,406. FILED 5-25-2005. PRINCIPAL REGISTER.



THE MARK CONSISTS OF STANDARD CHARACTERS WITHOUT CLAIM TO ANY PARTICULAR FONT, STYLE, SIZE, OR COLOR.

PRIORITY DATE OF 12-2-2004 IS CLAIMED.

OWNER OF INTERNATIONAL REGISTRATION 0881091 DATED 5-25-2005, EXPIRES 5-25-2015.

INT. CL. 9/U.S. CLS. 21, 23, 26, 36 AND 38

FOR [SEMI-CONDUCTOR COMPONENTS, NAMELY, TRANSISTORS, DIODES, MEMORIES, SENSORS,] INTEGRATED CIRCUITS, [WAFERS; COMPONENTS OF THE AFORESAID GOODS, NAMELY, THEIR CASINGS; AND HYBRID SYSTEMS COMPRISED OF SEMICONDUCTOR CHIPS, INTEGRATED CIRCUITS AND SENSORS; SOFTWARE AND SOFTWARE SYSTEMS, NAMELY, COMPUTER OPERATING SYSTEMS SOFTWARE]

FIRST USE ; IN COMMERCE .

ELEMENTS CORRECTED
GOODS/SERVICES
MARK TYPE
[INTERNATIONAL CLASS(ES)]

3,336,839. REG. 11-13-2007. RIDLEY BLOCK OPERATIONS, INC. (MINNESOTA CORPORATION) 424 NORTH RIVERFRONT DRIVE, MANKATO, MN, 56002, SN 78-816,173. FILED 2-16-2006. PRINCIPAL REGISTER.



THE MARK CONSISTS OF STANDARD CHARACTERS WITHOUT CLAIM TO ANY PARTICULAR FONT, STYLE, SIZE, OR COLOR.

INT. CL. 21/U.S. CLS. 2, 13, 23, 29, 30, 33, 40 AND 50

FOR NON-MECHANIZED ANIMAL FEEDERS AND BIODEGRADABLE CONTAINERS FOR ANIMAL FEED AND ANIMAL FEED SUPPLEMENTS.

FIRST USE 10-3-2006; IN COMMERCE 10-3-2006.

ELEMENTS AMENDED
DESCRIPTION OF MARK
MARK

3,343,891. REG. 11-27-2007. DAVIES, SCOTT M. (UNITED STATES INDIVIDUAL) 2418 LAS LONITAS DRIVE, HACIENDA HEIGHTS, CA, 91745, SN 78-779,313. FILED 12-22-2005. PRINCIPAL REGISTER.

3,352,544. REG. 12-11-2007. SCHNEIDER ELECTRIC INDUSTRIES SAS (FRANCE SOCIÉTÉ PAR ACTIONS SIMPLIFIÉE) 89, BOULEVARD FRANKLIN ROOSEVELT, F-92500 RUEIL-MALMAISON, FRANCE., SN 79-020,499. FILED 12-22-2005. PRINCIPAL REGISTER.

ARRIBA

THE MARK CONSISTS OF STANDARD CHARACTERS WITHOUT CLAIM TO ANY PARTICULAR FONT, STYLE, SIZE, OR COLOR.

THE FOREIGN WORDING IN THE MARK TRANSLATES INTO ENGLISH AS ABOVE OR OVERHEAD OR GET UP, COME ON.

INT. CL. 11/U.S. CLS. 13, 21, 23, 31 AND 34

FOR CARRYING CASES SPECIFICALLY ADAPTED FOR DJ LIGHTING [GEAR AND ELECTRIC LIGHTS] * EQUIPMENT *

FIRST USE 9-28-2005; IN COMMERCE 9-28-2005.

INT. CL. 18/U.S. CLS. 1, 2, 3, 22 AND 41

FOR CARRYING CASES NOT SPECIFICALLY ADAPTED FOR, BUT UTILIZED FOR CARRYING DJ LIGHTING GEAR AND ELECTRIC LIGHTS.

FIRST USE 9-28-2005; IN COMMERCE 9-28-2005.

ELEMENTS AMENDED
GOODS/SERVICES
MARK

3,349,866. REG. 12-4-2007. DE LUXE PACKAGING CORPORATION (NEW YORK CORPORATION) 63, NORTH STREET, SAUGERTIES, NY, 12477, SN 78-774,226. FILED 12-15-2005. PRINCIPAL REGISTER.

BAKER'S MATE

THE MARK CONSISTS OF STANDARD CHARACTERS WITHOUT CLAIM TO ANY PARTICULAR FONT, STYLE, SIZE, OR COLOR.

NO CLAIM IS MADE TO THE EXCLUSIVE RIGHT TO USE "BAKER'S", APART FROM THE MARK AS SHOWN.

INT. CL. 16/U.S. CLS. 2, 5, 22, 23, 29, 37, 38 AND 50

FOR PARCHMENT AND BAKING PAPER, PAPER FOR COOKING AND BAKING PURPOSES, PAPER FOR WRAPPING FOOD, FREEZER WRAPPING PAPER.

FIRST USE 9-23-2007; IN COMMERCE 9-23-2007.

ELEMENTS CORRECTED
OWNER NAME
OWNER ADDRESS
CITIZENSHIP
ENTITY

OSITRACK

THE MARK CONSISTS OF STANDARD CHARACTERS WITHOUT CLAIM TO ANY PARTICULAR FONT, STYLE, SIZE, OR COLOR.

PRIORITY DATE OF 7-5-2005 IS CLAIMED.

OWNER OF INTERNATIONAL REGISTRATION 0875836 DATED 12-22-2005, EXPIRES 12-22-2015.

INT. CL. 9/U.S. CLS. 21, 23, 26, 36 AND 38

FOR SCIENTIFIC AND ELECTRONIC APPARATUS AND INSTRUMENTS, AND ELECTRONIC DETECTION AND CONTROL APPARATUS, NAMELY, PORTABLE TERMINALS, NAMELY, PERSONAL RADIO TERMINALS, PORTABLE COMPUTER TERMINALS, PORTABLE CONTROLLING TERMINALS, PORTABLE MONITORING TERMINALS; ELECTRICAL CONNECTION BOXES; ELECTRONICALLY ENCODED BADGES; RADIO-FREQUENCY IDENTIFICATION TAG READERS, REMOTE RADIO TRANSMITTING AND RECEIVING STATIONS, SIGNAL RECEIVING STATIONS; RADIO-FREQUENCY IDENTIFICATION TAGS, RADIO-FREQUENCY IDENTIFICATION CREDENTIALS, NAMELY, CARDS AND TAGS, AND READERS FOR RADIO-FREQUENCY CREDENTIALS; RADIO-FREQUENCY IDENTIFICATION DEVICES AND SYSTEMS, NAMELY, RADIO-FREQUENCY IDENTIFICATION PERSONAL RADIO TERMINALS, RADIO-FREQUENCY IDENTIFICATION PORTABLE COMPUTER TERMINALS, RADIO-FREQUENCY IDENTIFICATION PORTABLE CONTROLLING TERMINALS, RADIO-FREQUENCY IDENTIFICATION PORTABLE MONITORING TERMINALS; RADIO-FREQUENCY IDENTIFICATION COMPUTER STATIONS, RADIO-FREQUENCY IDENTIFICATION CONTROLLING STATIONS, RADIO-FREQUENCY IDENTIFICATION MONITORING STATIONS; RADIO-FREQUENCY IDENTIFICATION CONFIGURATION BADGES, RADIO-FREQUENCY IDENTIFICATION BADGES, RADIO-FREQUENCY IDENTIFICATION TAGS, RADIO-FREQUENCY IDENTIFICATION STANDARD SYSTEM TAGS; * BUT NOT INCLUDING APPARATUS AND INSTRUMENTS FOR DETECTING, MEASURING AND/OR MONITORING LEVELS OF RADIATION, RADIOACTIVITY OR RADIOACTIVITY CONTAMINATION, AND OTHER RADIOLOGICAL INSTRUMENTS *.

FIRST USE ; IN COMMERCE .

ELEMENTS CORRECTED
GOODS/SERVICES

3,355,708. REG. 12-18-2007. 185 RED, INC. (PENNSYLVANIA CORPORATION), DBA FIRE ENGINE RED, P. O. BOX 1851, PHILADELPHIA, PA, 19105, SN 77-147,483. FILED 4-3-2007. PRINCIPAL REGISTER.

Fire Engine RED

THE MARK CONSISTS OF STANDARD CHARACTERS WITHOUT CLAIM TO ANY PARTICULAR FONT, STYLE, SIZE, OR COLOR.

INT. CL. 42/U.S. CLS. 100 AND 101

FOR APPLICATION SERVICE PROVIDER (ASP) FEATURING SOFTWARE IN THE FIELD OF EDUCATION FOR COLLECTING, STORING, MANAGING, TRANSMITTING AND SHARING OF DATA AND INFORMATION RELATING TO ADMISSIONS AND APPLICATIONS.

FIRST USE 12-6-2001; IN COMMERCE 12-6-2001.

ELEMENTS AMENDED
OWNER ADDRESS

3,356,765. REG. 12-18-2007. C.S. LEWIS (PTE.) LTD. (SINGAPORE CORPORATION) 15 BEACH ROAD #03-07, BEACH CENTRE, SINGAPORE, SINGAPORE, 189677, SN 76-574,298. FILED 2-6-2004. PRINCIPAL REGISTER.

FOR [GAMES, NAMELY, PARLOR GAMES, BOARD GAMES, ACTION SKILL GAMES, ACTION TARGET GAMES, ARCADE GAMES, CARD GAMES, COIN-OPERATED VIDEO GAMES, DART GAMES, EQUIPMENT SOLD AS A UNIT FOR PLAYING BOARD, CARD AND ACTION TARGET GAMES, MANIPULATIVE GAMES, PARTY GAMES, PINBALL GAMES, HAND HELD UNIT FOR PLAYING ELECTRONIC GAMES, STAND ALONE VIDEO OUTPUT GAME MACHINES, DOMINOS; PLAY-THINGS AND TOYS, NAMELY, INFANT TOYS, CRIB TOYS, BATH AND WATER TOYS, TEDDY BEARS, PLUSH TOYS, STUFFED TOY ANIMALS, TOY ANIMALS,] ACTION FIGURES, [TOY TRAIN SETS, TOY FURNITURE, TOY TELEPHONES, TOY CLOCKS, TOY BUILDING AND CONSTRUCTION BLOCKS, TOY ROBOTS, TOY MUSICAL INSTRUMENTS, TOY CARS, WIND-UP TOYS, RIDE-ON TOYS, PULL TOYS, BALLOONS, DOLLS, DOLL HOUSES, DOLL HOUSE FURNITURE, PUPPETS, SHAPE SORTERS, FLYING DISCS, JIGSAW AND MANIPULATIVE PUZZLES, PAPER FACE MASKS, YOYOS, KITES, TOY MODEL HOBBYCRAFT KITS, PINBALL MACHINES; GYMNASIAC AND SPORTING ARTICLES, NAMELY, BASEBALL GLOVES, BATTING GLOVES, BOXING GLOVES, GOALKEEPERS' GLOVES, GOLF GLOVES, HANDBALL GLOVES, HOCKEY GLOVES, KARATE GLOVES, RACQUETBALL GLOVES, SOFTBALL GLOVES, SWIMMING GLOVES, WATER SKI GLOVES, WEIGHT LIFTING GLOVES, BASEBALL MITTS, CATCHERS' MITTS, SOFTBALL MITTS, GOLF TEES, GOLF CLUBS, HEAD COVERS FOR GOLF CLUBS, TENNIS RACKETS, SCUBA FLIPPERS, SKATEBOARDS, ICE SKATES, ROLLER SKATES, SWIMMING FLOATS AND BOARDS FOR RECREATIONAL USE, SURF BOARDS, SWIMMING FLIPPERS, SNORKEL GEAR, NAMELY, SWIM FINNS, FLIPPERS FOR USE IN SNORKELING, SNORKEL STRAPS AND SNORKEL BAGS; BALLS, NAMELY, BASKETBALLS, BASEBALLS, FOOTBALLS, RUBBER BALLS, SOCCER BALLS, SUPER BALLS, GOLF BALLS, TENNIS BALLS; SPORT BALLS, KALEIDOSCOPIES, PLAYING CARDS, CHRISTMAS TREE DECORATIONS AND ORNAMENTS; TOY MUSICAL BOXES; PLASTIC BIKE TAGS].

FIRST USE 12-9-2005; IN COMMERCE 12-9-2005.

ELEMENTS CORRECTED
GOODS/SERVICES

LUCY PEVENSIE

3,365,822. REG. 1-8-2008. CLABER S.P.A. (ITALY JOINT STOCK COMPANY) VIA PONTEBBANA, 22, FIUME VENETO (PN), ITALY, 33080, SN 78-928,665. FILED 7-13-2006. PRINCIPAL REGISTER.

FUTURA

THE MARK CONSISTS OF STANDARD CHARACTERS WITHOUT CLAIM TO ANY PARTICULAR FONT, STYLE, SIZE, OR COLOR.

PRIORITY CLAIMED UNDER SEC. 44(D) ON ERPN CMNTY TM OFC APPLICATION NO. 003432275, FILED 10-30-2003, REG. NO. 003432275, DATED 1-5-2005, EXPIRES 10-30-2013.

THE NAME(S), PORTRAIT(S), AND/OR SIGNATURE(S) SHOWN IN THE MARK DOES NOT IDENTIFY A PARTICULAR LIVING INDIVIDUAL.

INT. CL. 25/U.S. CLS. 22 AND 39

FOR HALLOWEEN COSTUMES, MASQUERADE COSTUMES.

FIRST USE 12-9-2005; IN COMMERCE 12-9-2005.

INT. CL. 28/U.S. CLS. 22, 23, 38 AND 50

OWNER OF ERPN CMNTY TM OFC REG. NO. 5043526, DATED 3-20-2007, EXPIRES 4-27-2016.

THE FOREIGN WORDING IN THE MARK TRANSLATES INTO ENGLISH AS FUTURE

INT. CL. 9/U.S. CLS. 21, 23, 26, 36 AND 38

FOR PROGRAMMABLE ELECTRONIC CONTROL UNITS FOR IRRIGATION SPRINKLER SYSTEMS FOR HOUSEHOLD, HORTICULTURE, AND GARDEN USE.

FIRST USE ; IN COMMERCE .

ELEMENTS CORRECTED
FOREIGN REG. NO.

3,376,493. REG. 1-29-2008. GLOBAL INFOMERCIAL SERVICES, LLC (NEVADA CORPORATION) SUITE 430, 5190 NEIL ROAD, RENO, NV, 89502, SN 78-676,528. FILED 7-22-2005. PRINCIPAL REGISTER.

GI SERVICES

THE MARK CONSISTS OF STANDARD CHARACTERS WITHOUT CLAIM TO ANY PARTICULAR FONT, STYLE, SIZE, OR COLOR.

NO CLAIM IS MADE TO THE EXCLUSIVE RIGHT TO USE "SERVICES", APART FROM THE MARK AS SHOWN.

INT. CL. 35/U.S. CLS. 100, 101 AND 102
FOR PRODUCT MERCHANDISING.
FIRST USE 8-15-2005; IN COMMERCE 8-15-2005.

ELEMENTS CORRECTED
ENTITY

3,376,906. REG. 2-5-2008. ICYNENE INC. (CANADA CORPORATION) 6747 CAMPOBELLO ROAD, MISSISSAUGA, CANADA, L5N2L7, SN 77-013,145. FILED 10-4-2006. PRINCIPAL REGISTER.

El Sistema de Aislamiento Icynene

OWNER OF U.S. REG. NO. 1,566,643.
NO CLAIM IS MADE TO THE EXCLUSIVE RIGHT TO USE "EL SISTEMA DE AISLAMIENTO", APART FROM THE MARK AS SHOWN.

THE ENGLISH TRANSLATION OF "EL SISTEMA DE AISLAMIENTO ICYNENE" IS "THE INSULATION SYSTEM OF ICYNENE".

INT. CL. 16/U.S. CLS. 2, 5, 22, 23, 29, 37, 38 AND 50
FOR INSTRUCTION MANUAL FOR TROUBLESHOOTING REGARDING THE USAGE OF CHEMICAL PRODUCTS FOR PRODUCING INSULATION MATERIAL EXTENDING TO THE CHEMICALS, TRANSFER PUMPS AND PROPORTIONING PUMPS, DRUM PUMP, DIAPHRAGM PUMP, SPRAY GUN.

FIRST USE 10-1-2006; IN COMMERCE 10-1-2006.

ELEMENTS CORRECTED
MARK

3,378,538. REG. 2-5-2008. DE MARQUE INC. (CANADA CORPORATION) 400, BOUL. JEAN-LESAGE, BUREAU 540, QUEBEC, CANADA, G1K 8W1, SN 78-708,264. FILED 9-7-2005. PRINCIPAL REGISTER.

SCOOP!

THE MARK CONSISTS OF STANDARD CHARACTERS WITHOUT CLAIM TO ANY PARTICULAR FONT, STYLE, SIZE, OR COLOR.

PRIORITY CLAIMED UNDER SEC. 44(D) ON CANADA APPLICATION NO. 1259111, FILED 5-19-2005, REG. NO. TMA668252, DATED 7-19-2006, EXPIRES 7-19-2021.
INT. CL. 41/U.S. CLS. 100, 101 AND 107

FOR ONLINE EDUCATIONAL SERVICES, NAMELY, PROVIDING EDUCATIONAL SUPPORT IN THE FORM OF CLASSES, SEMINARS, WORKSHOPS, PROGRAMMED LEARNING COURSES, AND DIRECT ONLINE DIALOGS IN THE NATURE OF TUTORIALS TO TEACHERS, ALL IN THE FIELD OF USING NEW TECHNOLOGY IN THE TEACHING PROCESS FOR TEACHING CURRENT EVENTS.

FIRST USE ; IN COMMERCE .

ELEMENTS CORRECTED
FOREIGN RENEWAL REG. DATE

3,387,277. REG. 2-26-2008. AMERICAN HOSPITAL ASSOCIATION (ILLINOIS NOT- FOR PROFIT CORPORATION) ONE NORTH FRANKLIN, CHICAGO, IL, 60606, SN 76-675,179. FILED 4-5-2007. PRINCIPAL REGISTER.



OWNER OF U.S. REG. NOS. 1,348,716, 3,032,690 AND OTHERS.

NO CLAIM IS MADE TO THE EXCLUSIVE RIGHT TO USE "CERTIFIED" AND "HOSPITAL ASSOCIATION", APART FROM THE MARK AS SHOWN.

AS TO "AMERICAN HOSPITAL ASSOCIATION".
INT. CL. 42/U.S. CLS. 100 AND 101

FOR TESTING, ANALYSIS AND EVALUATION OF THE KNOWLEDGE AND SKILL OF OTHERS FOR THE PURPOSE OF CERTIFICATION IN THE FIELD OF HEALTHCARE ENVIRONMENTAL SERVICES MANAGEMENT.

FIRST USE 1-1-2002; IN COMMERCE 1-1-2002.

ELEMENTS AMENDED
ENTITY

3,399,695. REG. 3-18-2008. MAJOR LEAGUE BASEBALL PROPERTIES, INC. (NEW YORK CORPORATION) 245 PARK AVENUE, NEW YORK, NY, 10167, SN 78-760,130. FILED 11-23-2005. PRINCIPAL REGISTER.



OWNER OF U.S. REG. NOS. 2,573,096, 2,971,015 AND OTHERS.

INT. CL. 25/U.S. CLS. 22 AND 39

FOR CLOTHING, NAMELY, CAPS, HATS, VISORS, SHIRTS, T-SHIRTS, VESTS, PANTS, BASEBALL UNIFORMS, JERSEYS.

FIRST USE 6-0-2004; IN COMMERCE 6-0-2004.

ELEMENTS CORRECTED
[GOODS/SERVICES]

3,402,844. REG. 3-25-2008. THE ADMINISTRATORS OF THE TULANE EDUCATIONAL FUND (LOUISIANA NON-PROFIT CORPORATION) 300 GIBSON HALL 6823 ST. CHARLES AVENUE, NEW ORLEANS, LA, 70118, SN 78-154,822. FILED 8-15-2002. PRINCIPAL REGISTER.

GREEN WAVE

INT. CL. 9/U.S. CLS. 21, 23, 26, 36 AND 38

FOR ELECTRONIC PUBLICATIONS IN THE NATURE OF NEWSLETTERS AND TRANSCRIPTS OF INTERVIEWS IN THE FIELD OF EXTRACURRICULAR COLLEGE ACTIVITIES RECORDED ON COMPUTER MEDIA.

FIRST USE 12-1-1998; IN COMMERCE 12-1-1998.

ELEMENTS CORRECTED
[OWNER ADDRESS]

3,405,656. REG. 4-1-2008. MADAME MARTINE VAN DOORNE (BELGIUM INDIVIDUAL) 42, BOULEVARD DES MOULINS, MC-98000 MONACO, MONACO., SN 79-029,889. FILED 8-25-2006. PRINCIPAL REGISTER.

LABELISSIMO

THE MARK CONSISTS OF STANDARD CHARACTERS WITHOUT CLAIM TO ANY PARTICULAR FONT, STYLE, SIZE, OR COLOR.

PRIORITY DATE OF 2-27-2006 IS CLAIMED.

OWNER OF INTERNATIONAL REGISTRATION 0900527 DATED 8-25-2006, EXPIRES 8-25-2016.

INT. CL. 35/U.S. CLS. 100, 101 AND 102

FOR PROMOTING THE GOODS AND SERVICES OF OTHERS BY PROVIDING HYPERTEXT LINKS TO THE WEB SITES OF OTHERS; ADVERTISING; ADVERTISING SERVICES, NAMELY, PROMOTING AND MARKETING THE GOODS AND SERVICES OF OTHERS THROUGH ALL PUBLIC COMMUNICATION MEANS; ADVERTISING VIA ELECTRONIC MEDIA AND SPECIFICALLY THE INTERNET; BUSINESS MANAGEMENT. FIRST USE ; IN COMMERCE .

ELEMENTS CORRECTED
[GOODS/SERVICES]
[INTERNATIONAL CLASS(ES)]

3,405,721. REG. 4-1-2008. BIONORICA AG (FED REP GERMANY STOCK CORPORATION) KERSCHENSTEINER STRAÙE 11-15, 92318 NEUMARKT, FED REP GERMANY., SN 79-035,384. FILED 12-19-2006. PRINCIPAL REGISTER.

Phytoneering

THE MARK CONSISTS OF STANDARD CHARACTERS WITHOUT CLAIM TO ANY PARTICULAR FONT, STYLE, SIZE, OR COLOR.

PRIORITY DATE OF 6-30-2006 IS CLAIMED.

OWNER OF INTERNATIONAL REGISTRATION 0915918 DATED 12-19-2006, EXPIRES 12-19-2016.

OWNER OF U.S. REG. NO. 2,781,184.

INT. CL. 3/U.S. CLS. 1, 4, 6, 50, 51 AND 52

FOR ESSENTIAL OILS FOR USE IN THE MANUFACTURE OF COSMETICS, HAIR LOTIONS, PERFUMERY, ORAL HYGIENE, DENTAL HYGIENE AND DENTIFRICES; PLANT EXTRACTS, TINCTURES AND FLAVORINGS IN LIQUID, SOLID OR GASEOUS FORM FOR COSMETICS, FOR HAIR LOTIONS AND PERFUMERY, NAMELY, HORSE CHESTNUT, MARSHMALLOW, ARNICA, BITTER ORANGE, BIRCH, MARIGOLD, CHAMOMILE, CONEFLOWER, HERB OF FIELD HORSE, GENTIAN, FIVE FINGERS, COUCH GRASS, HAMAMELIS, HIBISCUS, HOPS, HERB OF ST. JOHNS, JUNIPER, KRAMERIA, LICORICE, MALLOW, MELILOT, BALM, MILFOIL, PASSION, BURNET, PINE, PLANTAIN, OAK, ROSEMARY, WILLOW BARK, SAGE, THYME, RED CLOVER, NETTLE, HEARTS EASE, MISTLETOE.

FIRST USE ; IN COMMERCE .

INT. CL. 5/U.S. CLS. 6, 18, 44, 46, 51 AND 52

FOR PHARMACEUTICAL PREPARATIONS, NAMELY, PLANT EXTRACTS FOR USE IN THE TREATMENT OF ANGINA, ATHEROSCLEROSIS, BRONCHIAL ASTHMA, CIRCULATORY DISORDERS, CONSTIPATION, DIARRHEA, HEART FAILURE, HEART RHYTHM DISORDERS, HIGH BLOOD PRESSURE, INDIGESTION, INSOMNIA, MIGRAINE, MOTION SICKNESS, NAUSEA, PEPTIC ULCERS, VOMITING AND ALLERGY; PHARMACEUTICAL PREPARATIONS, NAMELY, PLANT EXTRACTS FOR USE AS AN ANTI-DEPRESSANT, DIURETIC, HYPNOTIC, SEDATIVE, STIMULANT, AND TRANQUILIZER; PHARMACEUTICAL PREPARATIONS, NAMELY, FOR USE AS AN ANTI-DEPRESSANT, DIURETIC, HYPNOTIC, SEDATIVE, STIMULANT, AND TRANQUILIZER; HEMORRHOIDAL OINTMENT, LAXATIVE, NASAL DECONGESTANT CAPSULES, NASAL SPRAY PREPARATIONS, NON-NARCOTIC ANALGESICS, THROAT LOZENGES; MEDICAMENTS FOR THE TREATMENT OF GYNECOLOGICAL DISORDERS AFFECTING MENSTRUATION, STERILITY, MENSTRUAL SYNDROMES, DYSMENORRHOEA, INFERTILITY, GENITAL TRACT INFECTIONS, PELVIC INFLAMMATORY DISEASES, VAGINAL DISCOMFORT DUE TO MENOPAUSAL ATROPHIC CHANGES, ANATOMICAL ABNORMALITIES, NEOPLASIA, BREAST NEOPLASM, BREAST CANCER, MAMMA, MASTOPATHY AND MASTODYNIA; MENSTRUATION CIRCULATION REGULATING TABLETS, HORMONE PREPARATIONS, MEDICINES FOR TREATING PREMENSTRUAL SYNDROME AND DYSMENORRHOEA; MEDICINES FOR THE TREATMENT OF BREAST PAIN; PHARMACEUTICAL PREPARATIONS FOR USE IN THE TREATMENT OF DISORDERS OF THE CIRCULATORY ORGANS,

NAMELY, BLOOD CIRCULATION DISORDERS, HIGH BLOOD PRESSURE, HYPERTENSION, PULMONARY DISEASES, HEART RHYTHM DISORDERS AND HEART FAILURE; HORMONE REPLACEMENT MEDICATION; PHARMACEUTICAL AGENTS FOR THE TREATMENT OF DISORDERS OF THE URINARY, GENITAL AND ANAL ORGANS, NAMELY, FOR USE IN THE UROLOGY AND IN THE GENITOURINARY MEDICINE, FOR THE TREATMENT OF UROLOGICAL DISEASES, SEXUALLY TRANSMITTED DISEASES AND INFLAMMATORY PELVIC DISEASES; PHARMACEUTICAL PREPARATIONS FOR THE TREATMENT OF MENOPAUSAL COMPLAINTS DUE TO THERAPEUTICALLY INDUCED MENOPAUSE, TAMOXIFEN INDUCED HOT FLUSHES OF BREAST CANCER SURVIVORS, VAGINAL DISCOMFORT DUE TO MENOPAUSAL ATROPHIC CHANGES, CLIMACTIC SLEEP DISTURBANCES, DEPRESSIVE MOODS, OSTEOPROTECTION; PHARMACEUTICAL PREPARATIONS FOR THE PREVENTION OF OSTEOPOROSIS; DRUGS FOR CENTRAL NERVOUS SYSTEM, NAMELY, CENTRAL NERVOUS SYSTEM INFECTIONS, BRAIN DISEASES, CENTRAL NERVOUS SYSTEM MOVEMENT DISORDERS, OCULAR MOTILITY DISORDERS, SPINAL CORD DISEASES; ANTIDEPRESSANTS; PHARMACEUTICAL PREPARATIONS FOR THE TREATMENT OF PSYCHO VEGETATIVE DISORDERS, FOR DEPRESSIVE SYNDROME, FOR ANXIETY AND FOR NERVOUS UNREST; PHARMACEUTICAL PREPARATIONS FOR PERIPHERAL NERVOUS SYSTEM, NAMELY, PERIPHERAL NERVOUS SYSTEM INFECTIONS, PERIPHERAL NERVOUS SYSTEM MOVEMENT DISORDERS, NERVE COMPRESSION SYNDROMES, NEURITIS, NEURALGIA AND REGIONAL PAIN SYNDROMES; PHARMACEUTICAL PREPARATIONS FOR SENSORY ORGANS, NAMELY, FOR USE IN OPHTHALMOLOGY, OTOLARYNGOLOGY AND DERMATOLOGY; MEDICAMENTS FOR THE TREATMENT OF DISEASES AND DISORDERS OF THE KIDNEY; PHARMACEUTICAL PREPARATIONS AND PLANT EXTRACTS FOR THE TREATMENT OF THE KIDNEY AND UROLOGICAL DISORDERS, FOR CHRONIC INFECTIONS OF THE BLADDER, CYSTITIS, PYELONEPHRITIS, GLOMERULONEPHRITIS, INTERSTITIAL NEPHRITIS, NEPHROLITHIASIS, SUPPORTIVE CANCER TREATMENT AND FOR UROLITH PROPHYLAXIS; PHARMACEUTICAL PREPARATIONS FOR TREATMENT OF BLOOD CONDITIONS AND DISORDERS; PILLS FOR TREATING DIZZINESS, MEDICAMENTS FOR REGULATION OF THE IMMUNE SYSTEM; PHARMACEUTICAL PREPARATIONS FOR TREATING MIGRAINE AND DEPRESSION; MEDICINES WITH SECRETOLYTIC, EXPECTORANTIC AND ANTIPHLOGISTIC PROPERTIES FOR THE THERAPY OF INFLAMMATIONS OF THE UPPER AND LOWER RESPIRATORY ORGANS; PHARMACEUTICAL PREPARATIONS FOR TREATMENT OF SINUSES, BRONCHITIS AND RESPIRATORY TRACT; PHARMACEUTICAL PREPARATIONS, NAMELY, FOR THE TREATMENT OF TONSILLITIS, FOR STRENGTHENING THE IMMUNE SYSTEM, FOR THE TREATMENT OF RECIDIVATING DISEASES OF THE RESPIRATORY TRACT OR USED AS THERAPEUTIC PREPARATIONS FOR MOUTH AND THROAT; PHARMACEUTICAL PREPARATIONS MADE FROM WILLOW BARK, NAMELY, FOR USE IN THE TREATMENT OF MIGRAINE, ARTHRITIS, OSTEOARTHRITIS, FEVER, COUGH, COLD, DIARRHEA, PAIN, MENSTRUAL SYNDROMES AND PAIN, AND ALZHEIMER'S DISEASE; PHARMACEUTICAL PREPARATIONS FOR USE IN THE TREATMENT OF INFECTION OF RESPIRATORY TRACT, INFECTION OF URINARY TRACT, URINARY OBSTRUCTION, CHRONIC VENOUS INSUFFICIENCY, PROSTATE HYPERPLASIA, MUSCLE PAINS, SOFT TISSUE RHEUMATISM, MUSCULOSKELETAL DISEASE, LIVER DISEASE, HEPATITIS, CIRRHOSIS OF LIVER; PHARMACEUTICAL PREPARATIONS FOR USE IN THE TREATMENT, CURE, MITIGATION OR PREVENTION OF GINGIVITIS, HALITOSIS, STOMATITIS, PERIODONTICS, INFLAMMATION OF THE ORAL CAVITY AND PHARYNGEAL CAVITY, HYPERSENSITIVITY OF TEETH; PHARMACEUTICAL PREPARATIONS FOR TREATING TEMPORARY RELIEF OF OCCASIONAL MINOR IRRITATION AND PAIN OF THE MOUTH, THROAT, LIPS, GUMS, TEETH, PAIN, SORE MOUTH, SORE GUMS, SORE THROAT, PAIN ASSOCIATED WITH CANKER SORES, PAIN DUE TO MINOR IRRITATION OR INJURY OF THE MOUTH AND GUMS, PAIN DUE TO MINOR DENTAL PROCEDURES, PAIN DUE TO MINOR

IRRITATIONS CAUSED BY DENTURES OR ORTHODONTIC APPLIANCES, SORE GUMS DUE TO TEething IN INFANTS AND CHILDREN FOUR MONTHS OF AGE AND OLDER; PHARMACEUTICAL AND MEDICINAL PREPARATIONS AND SUBSTANCES, NAMELY, PREPARATIONS AND SUBSTANCES TO RELIEVE THE PAIN AND DISCOMFORT ASSOCIATED WITH SORE MOUTH, SORE GUMS, SORE THROAT, GINGIVITIS, STOMATITIS, PERIODONTITIS, HYPERSENSITIVITY OF TEETH AND OTHER DISEASES AND CONDITIONS OF THE MOUTH, GUMS, ORAL CAVITY AND PHARYNGEAL CAVITY; PHARMACEUTICAL PRODUCTS, NAMELY, MEDICATED DENTAL, GUMS AND MOUTH WASHES; MEDICATED DENTAL, GUMS AND MOUTH RINSE; PREPARATIONS FOR DENTAL PURPOSES, NAMELY, PLAQUE DISCLOSING REAGENTS, PERIODONTAL DIAGNOSTIC REAGENTS FOR MEDICAL PURPOSES FOR DETECTING DERIVATIVES FROM PERIODONTAL BACTERIA, CRIES DIAGNOSTIC REAGENTS FOR DETECTING DERIVATIVES FROM CRIES-CAUSAL BACTERIA AND MEDICINES FOR THE PREVENTION AND TREATMENT OF PERIODONTAL DISEASES, DENTAL CRIES, CANKER SORES, COLD SORES, MUCOSITIS AND ORAL AND TONGUE CANCERS; BIOLOGICAL PREPARATIONS FOR MEDICAL USE FOR THE TREATMENT AND PREVENTION OF PERIODONTAL DISEASES AND DENTAL CRIES; PHARMACEUTICAL PRODUCTS, NAMELY, MEDICATED TOOTHPASTES, MEDICATED ORAL-CARE GELS, MEDICATED DENTAL GELS, LOZENGES IN THE NATURE OF THROAT, MEDICATED LOZENGES, COUGH LOZENGES; MEDICATED CHEWING GUM; MEDICATED GELS AND FLUIDS IN THE NATURE OF DENTAL BLEACHING GELS, GUMS BALMS; PHARMACEUTICAL PRODUCTS, NAMELY, MEDICATED CHEWING GUMS AND LOZENGES WHICH PROVIDE A PROTECTIVE DENTAL OR GINGIVAL BARRIER, COATING OR SEALANT FOR PREVENTIVE, PROPHYLACTIC OR THERAPEUTIC HYGIENE USE; MEDICATED DENTAL FLOSS; MEDICATED DENTAL TAPES; MEDICATED DENTAL RIBBONS; MEDICATED TEETH WHITENER GELS; MEDICATED TOOTHPICKS, FLUORIDE CHEWING GUM AND CHEWABLE TABLETS FOR DISCLOSING DENTAL PLAQUE AND TARTAR; PHARMACEUTICAL PRODUCTS AND PREPARATIONS FOR ORAL, DENTAL AND GINGIVAL CARE; SANITARY PREPARATIONS FOR MEDICAL USE; SANITARY PREPARATIONS FOR HYGIENE, NAMELY, ANTI-SEPTICS, ORAL ANTI-SEPTICS, DISINFECTANTS FOR HEALTH PURPOSES; MEDICATED MOUTH SPRAYS AND DESENSITIZERS; DIETARY SUPPLEMENTS IN THE FORM OF TABLETS, DROPS, CAPSULES, EXTRACT PREPARATIONS, BALMS OR IN LIQUID FORM, CONTAINING PLANT EXTRACTS ; DIETETIC SUBSTANCES DERIVED FROM PLANTS, ADAPTED FOR MEDICAL USE IN THE FORM OF TABLETS, DROPS, CAPSULES, EXTRACT PREPARATIONS, BALMS OR IN LIQUID FORM, CONTAINING PLANT EXTRACTS; DIETETIC SUBSTANCES ADAPTED FOR MEDICAL USE IN THE FORM OF TABLETS, DROPS, CAPSULES, EXTRACT PREPARATIONS, BALMS OR IN LIQUID FORM; FOOD FOR MEDICALLY RESTRICTED DIETS, FOOD FOR DIABETICS, FOOD SUPPLEMENTS CONTAINING PLANT EXTRACTS, FOOD SUPPLEMENTS DERIVED FROM PLANTS OR PLANT EXTRACTS, ALL AFORESAID GOODS IN THE FORM OF TABLETS, DROPS, CAPSULES, EXTRACT PREPARATIONS, BALMS OR IN LIQUID FORM; DIETETIC SUBSTANCES DERIVED FROM PLANTS, ADAPTED FOR MEDICAL USE, NAMELY, FOOD FOR MEDICALLY RESTRICTED DIETS IN THE FORM OF TABLETS, DROPS, CAPSULES, EXTRACT PREPARATIONS, BALMS OR IN LIQUID FORM; FOOD SUPPLEMENTS AND DIETARY FOOD SUPPLEMENTS IN THE FORM OF TABLETS, DROPS, CAPSULES, EXTRACT PREPARATIONS, BALMS OR IN LIQUID FORM; VITAMIN AND MINERAL SUPPLEMENTS; FOOD AND FOOD SUPPLEMENTS, NAMELY, HERBAL TEAS FOR MEDICINAL PURPOSES AND MEDICINAL TEAS; DISINFECTANTS FOR MEDICAL INSTRUMENTS; MEDICAL PLASTERS; WOUND, BURN AND SURGICAL DRESSINGS; MATERIAL FOR STOPPING TEETH; DENTAL WAX.

FIRST USE ; IN COMMERCE .

FOR PRINTED MATTER, NAMELY, PUBLICATIONS IN THE FORM OF NEWSLETTERS AND BOOKLETS FOR USE BY PATIENTS REGARDING HEALTH AWARENESS, HEALTH INFORMATION, MEDICAL AND HEALTH CARE ISSUES AND DISEASE PREVENTION AND TREATMENT.

FIRST USE ; IN COMMERCE .
INT. CL. 30/U.S. CL. 46

FOR PLANT EXTRACTS, TINCTURES AND FLAVORINGS IN LIQUID, SOLID OR GASEOUS FORM FOR NON-NUTRITIONAL PURPOSES IN FOOD, NUTRITIONAL ADDITIVES, HERBAL TEAS.

FIRST USE ; IN COMMERCE .
INT. CL. 31/U.S. CLS. 1 AND 46

FOR PLANTS AND PARTS OF PLANTS, NAMELY, LIVING PLANTS, DRIED PLANTS, UNPROCESSED HERBS.

FIRST USE ; IN COMMERCE .
INT. CL. 35/U.S. CLS. 100, 101 AND 102

FOR RETAIL PHARMACY SERVICES.
FIRST USE ; IN COMMERCE .

INT. CL. 44/U.S. CLS. 100 AND 101

FOR MEDICAL SERVICES OF A PHARMACY, NAMELY, PROVIDING INFORMATION REGARDING HEALTH AWARENESS, HEALTHY LIVING, AND DISEASE PREVENTION AND TREATMENT.

FIRST USE ; IN COMMERCE .

ELEMENTS CORRECTED
GOODS/SERVICES

3,407,999. REG. 4-8-2008. INGENIX, INC. (DELAWARE CORPORATION) 12125 TECHNOLOGY DRIVE, EDEN PRAIRIE, MN, 55344, SN 77-084,508. FILED 1-17-2007. PRINCIPAL REGISTER.

WHERE THE EXPERIENCE MEETS
THE EXCEPTIONAL

THE MARK CONSISTS OF STANDARD CHARACTERS WITHOUT CLAIM TO ANY PARTICULAR FONT, STYLE, SIZE, OR COLOR.

INT. CL. 35/U.S. CLS. 100, 101 AND 102

FOR BUSINESS CONSULTATION SERVICES FOR THE HEALTHCARE INDUSTRY.

FIRST USE 9-15-2005; IN COMMERCE 9-15-2005.

INT. CL. 36/U.S. CLS. 100, 101 AND 102

FOR INSURANCE CONSULTATION SERVICES FOR THE HEALTHCARE INDUSTRY.

FIRST USE 9-15-2005; IN COMMERCE 9-15-2005.

INT. CL. 42/U.S. CLS. 100 AND 101

FOR COMPUTER AND INFORMATION TECHNOLOGY CONSULTATION SERVICES FOR THE HEALTHCARE INDUSTRY.

FIRST USE 9-15-2005; IN COMMERCE 9-15-2005.

ELEMENTS CORRECTED
OWNER NAME
OWNER ADDRESS
CITIZENSHIP

3,409,038. REG. 4-8-2008. MILANO FOOD CONCEPTS PRIVATE LIMITED (SINGAPORE PRIVATE LIMITED COMPANY) 50 RAFFLES PLACE, #31-01 SINGAPORE LAND TOWER, SINGAPORE, SINGAPORE, 048623, SN 78-729,620. FILED 10-10-2005. PRINCIPAL REGISTER.



PRIORITY CLAIMED UNDER SEC. 44(D) ON HONG KONG APPLICATION NO. 300484047, FILED 8-25-2005, REG. NO. 300484047, DATED 8-25-2005, EXPIRES 8-24-2015.

NO CLAIM IS MADE TO THE EXCLUSIVE RIGHT TO USE "COFFEE BAR AND BAKERY", APART FROM THE MARK AS SHOWN.

THE ENGLISH TRANSLATION OF "MILANO" IS MILAN.
INT. CL. 30/U.S. CL. 46

FOR COFFEE, NAMELY, COFFEE BEANS AND GROUND COFFEE BEANS; BREAD PRODUCTS NAMELY, FOCACCIA, CALZONES, DANISH PASTRIES, BISCUITS AND COOKIES; PIZZA.

FIRST USE ; IN COMMERCE .
INT. CL. 43/U.S. CLS. 100 AND 101

FOR RESTAURANT SERVICES; CATERING SERVICES.

FIRST USE ; IN COMMERCE .

ELEMENTS CORRECTED
FOREIGN REG. EXPIRATION DATE

3,411,019. REG. 4-8-2008. FREESCALE SEMICONDUCTOR, INC. (DELAWARE CORPORATION) 6501 WILLIAM CANNON DRIVE WEST, AUSTIN, TX, 78735, SN 78-978,469. FILED 3-1-2004. PRINCIPAL REGISTER.



INT. CL. 9/U.S. CLS. 21, 23, 26, 36 AND 38

FOR SEMICONDUCTORS, SEMICONDUCTOR PROCESSORS, SEMICONDUCTOR PROCESSOR CHIPS, INTEGRATED CIRCUITS, INTEGRATED CIRCUIT CHIPS, CIRCUIT BOARDS, MICROCOMPUTERS, MICROCONTROLLERS, MICROPROCESSORS MEMORIES AND SEMICONDUCTOR WAFERS; SEMICONDUCTORS FOR MACHINES AND MACHINE TOOLS; SEMICONDUCTORS FOR LIGHTING, HEATING, STEAM GENERATING, COOKING, REFRIGERATING, DRYING AND VENTILATING APPARATUS; SEMICONDUCTORS FOR CLOCKS AND TIME KEEPING APPARATUS AND INSTRUMENTS; SEMICONDUCTORS FOR MUSICAL INSTRUMENTS; SEMICONDUCTORS FOR GAMES AND PLAYTHINGS; DEVELOPMENT BOARDS; VIDEO SYSTEMS PRODUCTS; VIDEO GRAPHIC ACCELERATORS; MULTIMEDIA ACCELERATORS; COMPUTER PROGRAMS AND FIRMWARE FOR USE WITH ALL OF THE FOREGOING; INSTRUCTIONAL MATERIAL, NAMELY, DEVELOPMENT MANUALS, PRODUCT SPECIFICATIONS AND TRAINING MATERIALS; EQUIPMENT FOR THE TESTING AND PROGRAMMING OF INTEGRATED CIRCUITS AND SEMICONDUCTOR MEMORIES; COMPUTER SOFTWARE, NAMELY, APPLICATION INTEGRATION AND CONNECTIVITY SOFTWARE; COMPUTER OPERATING SYSTEM SOFTWARE; COMPUTER OPERATING PROGRAMS; AND COMPUTER SOFTWARE AND HARDWARE FOR THE FACILITATION OF THIRD PARTY SOFTWARE APPLICATIONS.

FIRST USE 4-4-2004; IN COMMERCE 4-4-2004.
INT. CL. 42/U.S. CLS. 100 AND 101

FOR LICENSING OF PATENTS, TRADEMARKS, COPYRIGHTS, AND INTELLECTUAL PROPERTY IN THE NATURE OF TRADE SECRETS AND/OR KNOW-HOW RELATED TO THE MANUFACTURE OF SEMICONDUCTORS AND THEIR USES, SEMICONDUCTORS, SOFTWARE RELATED TO THE MANUFACTURE OF SEMICONDUCTORS AND THEIR USES, TECHNOLOGY RELATED TO SEMICONDUCTORS AND THE MANUFACTURE OF SEMICONDUCTORS, TECHNOLOGY INCORPORATED IN AND RELATED TO SEMICONDUCTOR PRODUCTS, INTEGRATED CIRCUITS, CIRCUIT BOARDS, MICROCOMPUTERS, MICRO CONTROLLERS, MICROPROCESSORS AND COMPUTER PERIPHERALS, MEMORIES AND SEMICONDUCTOR WAFERS, DATA CONVERSION CIRCUITS, COMPUTER FIRMWARE, DEVELOPMENT BOARDS, COMPUTER PROGRAMS, INSTRUCTIONAL MATERIAL, NAMELY, DEVELOPMENT MANUALS, PRODUCT SPECIFICATIONS, AND TRAINING MATERIAL.

FIRST USE 5-25-2004; IN COMMERCE 5-25-2004.

ELEMENTS CORRECTED
DATE OF FIRST USE
DATE OF FIRST USE IN COMMERCE

3,411,352. REG. 4-15-2008. DPMS FIREARMS, LLC (DELAWARE LTD LIAB CO) 999 ROOSEVELT TRAIL, WINDHAM, ME, 04062, SN 77-067,319. FILED 12-19-2006. PRINCIPAL REGISTER.

RECEIVER RUG

THE MARK CONSISTS OF STANDARD CHARACTERS WITHOUT CLAIM TO ANY PARTICULAR FONT, STYLE, SIZE, OR COLOR.

NO CLAIM IS MADE TO THE EXCLUSIVE RIGHT TO USE "RECEIVER", APART FROM THE MARK AS SHOWN.
INT. CL. 13/U.S. CLS. 2 AND 9

FOR RIFLE RECEIVER TRIGGER GASKET.
FIRST USE 12-29-2005; IN COMMERCE 12-29-2005.

ELEMENTS CORRECTED
OWNER NAME
OWNER ADDRESS
CITIZENSHIP
ENTITY

3,411,686. REG. 4-15-2008. ENZYME SERVICES (N.Z.) LIMITED (NEW ZEALAND CORPORATION) 626 ROSEBANK ROAD, AVONDALE, AUCKLAND, NEW ZEALAND, 1007, SN 78-647,270. FILED 6-9-2005. PRINCIPAL REGISTER.



OWNER OF NEW ZEALAND REG. NO. 650550, DATED 6-27-2008, EXPIRES 12-21-2008.

OWNER OF NEW ZEALAND REG. NO. 650549, DATED 6-27-2002, EXPIRES 12-21-2008.

OWNER OF NEW ZEALAND REG. NO. 650548, DATED 6-27-2002, EXPIRES 12-21-2008.

OWNER OF NEW ZEALAND REG. NO. 650547, DATED 6-27-2002, EXPIRES 12-21-2008.

INT. CL. 1/U.S. CLS. 1

FOR CHEMICALS USED IN INDUSTRY, SCIENCE AND PHOTOGRAPHY AS WELL AS AGRICULTURE, HORTICULTURE AND FORESTRY; CHEMICAL SUBSTANCES FOR PRESERVING FOODSTUFFS AND ENZYMES USED FOR INDUSTRIAL PURPOSES.

FIRST USE ; IN COMMERCE .

INT. CL. 30/U.S. CL. 46

FOR FLAVORINGS, OTHER THAN ESSENTIAL OILS; ESSENCES FOR FOODSTUFFS OTHER THAN ETHERIC ESSENCES OR ESSENTIAL OILS.

FIRST USE ; IN COMMERCE .

INT. CL. 32/U.S. CLS. 45, 46 AND 48

FOR PREPARATIONS FOR MAKING BEVERAGES; ESSENCES FOR MAKING BEVERAGES.

FIRST USE ; IN COMMERCE .

INT. CL. 42/U.S. CLS. 100 AND 101

FOR SCIENTIFIC AND TECHNOLOGICAL SERVICES AND RESEARCH AND DESIGN RELATING THERETO IN THE FOOD AND BEVERAGE INDUSTRIES; INDUSTRIAL ANALYSIS AND RESEARCH SERVICES IN THE FOOD AND BEVERAGE INDUSTRIES; PROVIDING TECHNICAL INFORMATION AND RESEARCH IN THE FOOD AND BEVERAGE INDUSTRIES.

ELEMENTS CORRECTED
FOREIGN COUNTRY OF ORIGIN
FOREIGN REG. NO.
FOREIGN REG. DATE
FOREIGN REG. EXPIRATION DATE

3,412,965. REG. 4-15-2008. BROWNBUILDER FEDERAL CREDIT UNION (TEXAS FEDERALLY CHARTERED CREDIT UNION) 4101 CLINTON DRIVE, HOUSTON, TX. 77020, SN 78-739,882. FILED 10-25-2005. PRINCIPAL REGISTER.

FOR CLEANING CLOTHS.
FIRST USE 10-1-2007; IN COMMERCE 10-1-2007.
INT. CL. 24/U.S. CLS. 42 AND 50
FOR WASH CLOTHS .
FIRST USE 10-1-2007; IN COMMERCE 10-1-2007.

RIGHT CHOICE CREDIT UNION

ELEMENTS AMENDED
MARK

THE MARK CONSISTS OF STANDARD CHARACTERS WITHOUT CLAIM TO ANY PARTICULAR FONT, STYLE, SIZE, OR COLOR.

NO CLAIM IS MADE TO THE EXCLUSIVE RIGHT TO USE "CREDIT UNION", APART FROM THE MARK AS SHOWN.

INT. CL. 36/U.S. CLS. 100, 101 AND 102
FOR CREDIT UNION AND BANKING SERVICES, EXCLUDING CREDIT CARD AND DEBIT CARD SERVICES.

FIRST USE 2-0-2006; IN COMMERCE 2-0-2006.

ELEMENTS CORRECTED
DATE OF FIRST USE

3,416,417. REG. 4-22-2008. MCKINNON, KATHRYN (UNITED STATES INDIVIDUAL), DBA MCKINNON & CO., 21 ROBERTS ROAD, MARBLEHEAD, MA, 01945, SN 77-278,464. FILED P.R. 9-13-2007; AM. S.R. 2-3-2008. SUPPLEMENTAL REGISTER.

DAIKOMYO

Healing Services

THE MARK CONSISTS OF STANDARD CHARACTERS WITHOUT CLAIM TO ANY PARTICULAR FONT, STYLE, SIZE, OR COLOR.

NO CLAIM IS MADE TO THE EXCLUSIVE RIGHT TO USE "HEALING SERVICES", APART FROM THE MARK AS SHOWN.

THE FOREIGN WORDING IN THE MARK TRANSLATES INTO ENGLISH AS ENLIGHTENMENT.

INT. CL. 44/U.S. CLS. 100 AND 101
FOR PROVIDING IN-PERSON ENERGY HEALING SERVICES.

FIRST USE 8-15-2007; IN COMMERCE 8-15-2007.

ELEMENTS CORRECTED
OWNER ADDRESS

3,415,309. REG. 4-22-2008. GARY FONG, INC. (CALIFORNIA CORPORATION) SUITE 505, 4265 MARINA CITY DRIVE, MARINA DEL REY, CA, 902925809, SN 77-119,056. FILED 2-28-2007. PRINCIPAL REGISTER.

WHALE TAIL

THE MARK CONSISTS OF STANDARD CHARACTERS WITHOUT CLAIM TO ANY PARTICULAR FONT, STYLE, SIZE, OR COLOR.

INT. CL. 11/U.S. CLS. 13, 21, 23, 31 AND 34
FOR DIFFUSERS FOR PHOTOGRAPHIC FLASH UNITS.

FIRST USE 3-24-2007; IN COMMERCE 3-24-2007.

ELEMENTS AMENDED
OWNER ADDRESS
ENTITY

3,417,850. REG. 4-29-2008. SALON COMMODITIES, INC. (ILLINOIS CORPORATION) 1999 N. 15TH AVENUE, MELROSE PARK, IL, 60610, SN 77-253,882. FILED 8-13-2007. PRINCIPAL REGISTER.

A BEAUTIFUL BALANCE OF
NATURE AND SCIENCE

3,416,134. REG. 4-22-2008. MEI, LLC (MINNESOTA LIMITED LIABILITY COMPANY) 5940 NEWTON AVENUE SOUTH, MINNEAPOLIS, MN, 55419, SN 78-909,391. FILED 6-15-2006. PRINCIPAL REGISTER.

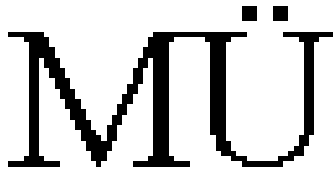

THE MARK CONSISTS OF STANDARD CHARACTERS WITHOUT CLAIM TO ANY PARTICULAR FONT, STYLE, SIZE, OR COLOR.

INT. CL. 21/U.S. CLS. 2, 13, 23, 29, 30, 33, 40 AND 50

THE MARK CONSISTS OF STANDARD CHARACTERS WITHOUT CLAIM TO ANY PARTICULAR FONT, STYLE, SIZE, OR COLOR.

INT. CL. 3/U.S. CLS. 1, 4, 6, 50, 51 AND 52
FOR HAIR CARE PREPARATIONS; NAMELY, SHAMPOOS, CONDITIONERS, PERMANENT WAVE PREPARATIONS, HAIR SPRAYS, STYLING GELS, HAIR STRAIGHTENING PREPARATIONS .

FIRST USE 6-10-2007; IN COMMERCE 6-10-2007.

ELEMENTS AMENDED
CITIZENSHIP

3,419,027. REG. 4-29-2008. PREMIER BEVERAGE COMPANY, LLC (DELAWARE LTD LIAB CO) 9801 PREMIER PKWY, MIRAMAR, FL, 33025, SN 77-017,816. FILED 10-10-2006. PRINCIPAL REGISTER.

RARE BIRD

THE MARK CONSISTS OF STANDARD CHARACTERS WITHOUT CLAIM TO ANY PARTICULAR FONT, STYLE, SIZE, OR COLOR.

INT. CL. 33/U.S. CLS. 47 AND 49

FOR WINES.

FIRST USE 12-18-2006; IN COMMERCE 12-18-2006.

ELEMENTS CORRECTED
OWNER NAME

3,422,673. REG. 5-6-2008. KATHRYN MCKINNON (UNITED STATES INDIVIDUAL), DBA MCKINNON & CO., 21 ROBERT ROAD, MARBLEHEAD, MA, 01945, SN 77-277,906. FILED 9-12-2007. PRINCIPAL REGISTER.

DAIKOMYO

Empowering Gems

THE MARK CONSISTS OF STANDARD CHARACTERS WITHOUT CLAIM TO ANY PARTICULAR FONT, STYLE, SIZE, OR COLOR.

NO CLAIM IS MADE TO THE EXCLUSIVE RIGHT TO USE "GEMS", APART FROM THE MARK AS SHOWN.

THE FOREIGN WORDING IN THE MARK TRANSLATES INTO ENGLISH AS "ENLIGHTENMENT."

INT. CL. 14/U.S. CLS. 2, 27, 28 AND 50

FOR GEMSTONE JEWELRY.

FIRST USE 12-6-2004; IN COMMERCE 12-6-2004.

INT. CL. 42/U.S. CLS. 100 AND 101

FOR DESIGNING JEWELRY FOR OTHERS.

FIRST USE 12-6-2004; IN COMMERCE 12-6-2004.

ELEMENTS CORRECTED
OWNER NAME

3,423,736. REG. 5-6-2008. DEBUONO, LAUREEN (UNITED STATES INDIVIDUAL) 229 BRANNAN STREET, #5J, SAN FRANCISCO, CA, 94107, AND DEBUONO, BARBARA (UNITED STATES INDIVIDUAL) 169 EAST 69TH STREET, #8A, NEW YORK, NY, 10021, SN 77-107,483. FILED 2-14-2007. PRINCIPAL REGISTER.

MAIA

THE MARK CONSISTS OF STANDARD CHARACTERS WITHOUT CLAIM TO ANY PARTICULAR FONT, STYLE, SIZE, OR COLOR.

INT. CL. 41/U.S. CLS. 100, 101 AND 107

FOR CHARITABLE SERVICES, NAMELY, PROVIDING EDUCATIONAL TRAINING IN THE HEALTHCARE AREA TO WOMEN IN SUB-SAHARAN AFRICA.

FIRST USE 5-1-2007; IN COMMERCE 5-1-2007.

INT. CL. 44/U.S. CLS. 100 AND 101

FOR CHARITABLE SERVICES, NAMELY, PROVIDING MEDICAL SERVICES AND FIRST AID SUPPLIES TO WOMEN IN SUB-SAHARAN AFRICA.

FIRST USE 5-1-2007; IN COMMERCE 5-1-2007.

ELEMENTS CORRECTED
GOODS/SERVICES

3,425,196. REG. 5-13-2008. SANDOW MEDIA, LLC (DELAWARE LTD LIAB CO) 3731 NW 8TH AVENUE, BOCA RATON, FL, 33431, SN 77-071,373. FILED 12-26-2006. PRINCIPAL REGISTER.

LUXE THE CHICAGO HOME REDEFINED

THE MARK CONSISTS OF STANDARD CHARACTERS WITHOUT CLAIM TO ANY PARTICULAR FONT, STYLE, SIZE, OR COLOR.

INT. CL. 16/U.S. CLS. 2, 5, 22, 23, 29, 37, 38 AND 50

FOR MAGAZINES FEATURING LUXURY HOME ARCHITECTURE, DESIGN, AND FURNISHINGS.

FIRST USE 2-21-2007; IN COMMERCE 2-21-2007.

ELEMENTS CORRECTED
CITIZENSHIP

3,425,859. REG. 5-13-2008. SANDOW MEDIA, LLC (DELAWARE LTD LIAB CO) 3731 NW 8TH AVENUE, BOCA RATON, FL, 33431, SN 77-243,405. FILED 7-31-2007. PRINCIPAL REGISTER.

LUXE SOURCE

THE MARK CONSISTS OF STANDARD CHARACTERS WITHOUT CLAIM TO ANY PARTICULAR FONT, STYLE, SIZE, OR COLOR.

INT. CL. 16/U.S. CLS. 2, 5, 22, 23, 29, 37, 38 AND 50

FOR MAGAZINES FEATURING REAL ESTATE, TRAVEL, FASHION, ENTERTAINMENT, THE ARTS AND HOME ARCHITECTURE, DESIGN AND FURNISHINGS.

FIRST USE 5-10-2004; IN COMMERCE 5-10-2004.

ELEMENTS CORRECTED
CITIZENSHIP

3,426,795. REG. 5-13-2008. SANDOW MEDIA, LLC (DELAWARE LTD LIAB CO) 3731 NW 8TH AVENUE, BOCA RATON, FL, 33431, SN 78-656,983. FILED 6-23-2005. PRINCIPAL REGISTER.

LUXE THE COLORADO HOME
REDEFINED

THE MARK CONSISTS OF STANDARD CHARACTERS WITHOUT CLAIM TO ANY PARTICULAR FONT, STYLE, SIZE, OR COLOR.

INT. CL. 16/U.S. CLS. 2, 5, 22, 23, 29, 37, 38 AND 50

FOR MAGAZINES FEATURING LUXURY HOME ARCHITECTURE, DESIGN, AND FURNISHINGS; AND INCLUDING ART, CULINARY AND LIFESTYLE ARTICLES .

FIRST USE 5-10-2004; IN COMMERCE 5-10-2004.

ELEMENTS CORRECTED
CITIZENSHIP

FOR SUITCASES; TRUNKS FOR TRAVELLING; TRAVELLING BAGS; BOSTON BAGS; HANDBAGS; ATTACHE CASES; BACKPACKS; RUCKSACKS; BAGS FOR CAMPERS, NAMELY, HUNTING BAGS AND ALL PURPOSE CARRYING BAGS FOR CAMPERS; BAGS FOR CLIMBERS, NAMELY, HIKING BAGS AND ALL PURPOSE CARRYING BAGS FOR CLIMBERS; BEACH BAGS; BRIEFCASES; WALLETS FOR BUSINESS CARDS; CARD CASES, NAMELY, CALLING CARD CASES AND NOTE CARD CASES; CARRY-ON BAGS; CHAIN MESH PURSES, NOT OF PRECIOUS METAL; CHARM BAGS (OMAMORI-IRE); WALLETS FOR USE AS COMMUTATION TICKET HOLDERS; FOLDING BRIEFCASES; GARMENT BAGS FOR TRAVEL; GLADSTONE BAGS; HAVERSACKS; JAPANESE UTILITY POUCHES (SHINGEN-BUKURO); KEY CASES; KORI WICKER TRUNKS; DOCUMENT CASES FOR HOLDING SHEET MUSIC; NET BAGS FOR SHOPPING, NAMELY, LEATHER NET BAGS FOR SHOPPING AND TEXTILE NET BAGS FOR SHOPPING; POCKET WALLETS; PURSES; PURSES, NOT OF PRECIOUS METAL; SCHOOL BAGS; SCHOOL SATCHELS; SCHOOL CHILDREN'S BACKPACKS; SHOPPING BAGS, NAMELY, LEATHER SHOPPING BAGS, TEXTILE SHOPPING BAGS, MESH SHOPPING BAGS, STRING SHOPPING BAGS AND CANVAS SHOPPING BAGS; SHOULDER BAGS; LEATHER SHOULDER STRAPS; SUITCASE HANDLES; LEATHER TRAVELLING SETS COMPRISING TRAVELLING BAG SETS, TRAVELLING CASES, TRAVELLING LUGGAGE SETS, TRAVELLING SUITCASE SETS AND TRAVELLING TRUNK SETS; VALISES; WALLETS, NOT OF PRECIOUS METAL; WHEELED SHOPPING BAGS; SUITCASE STRAPS AND STRAPS FOR LUGGAGE; DRAWSTRING ALL-PURPOSE CARRYING BAGS; POUCHES, NAMELY, DRAWSTRING POUCHES, LEATHER POUCHES, FELT POUCHES AND TOOL POUCHES, SOLD EMPTY.

FIRST USE ; IN COMMERCE .

ELEMENTS CORRECTED
GOODS/SERVICES

3,431,536. REG. 5-20-2008. ACE CO., LTD. (JAPAN CORPORATION) 5-2, 4-CHOME, BAKURO-MACHI, CHUOKU, OSAKA-SHI, OSAKA, JAPAN, 5410059, SN 79-039,057. FILED 1-22-2007. PRINCIPAL REGISTER.



PRIORITY DATE OF 7-24-2006 IS CLAIMED.
OWNER OF INTERNATIONAL REGISTRATION 0925611 DATED 1-22-2007, EXPIRES 1-22-2017.

NO CLAIM IS MADE TO THE EXCLUSIVE RIGHT TO USE "ATHLETE", APART FROM THE MARK AS SHOWN. THE MARK CONSISTS OF THE WORD "ATHLETE" WITH THE STYLIZED DEPICTION OF A HORNET WHERE THE HORNET'S WINGS ARE FLAMES.

INT. CL. 16/U.S. CLS. 2, 5, 22, 23, 29, 37, 38 AND 50

FOR BUSINESS CARD CASES, CASES FOR USE AS COMMUTATION TICKET HOLDERS.

FIRST USE ; IN COMMERCE .

INT. CL. 18/U.S. CLS. 1, 2, 3, 22 AND 41

3,432,112. REG. 5-20-2008. INTERACOUSTICS A/S (DENMARK CORPORATION) DREJERVAENGET 8, ASSENS, DENMARK, 5610, SN 77-074,199. FILED 1-2-2007. PRINCIPAL REGISTER.

OTOACCESS

THE MARK CONSISTS OF STANDARD CHARACTERS WITHOUT CLAIM TO ANY PARTICULAR FONT, STYLE, SIZE, OR COLOR.

INT. CL. 9/U.S. CLS. 21, 23, 26, 36 AND 38

FOR DATABASE PROGRAM, NAMELY, A DATABASE PROGRAM FOR RECORDING OF DATA REGARDING PERSONS TESTED FOR HEARING IMPAIRMENT.

FIRST USE 11-17-2006; IN COMMERCE 11-17-2006.

ELEMENTS CORRECTED
MARK

3,440,986. REG. 6-3-2008. EUROPEAN CHANNEL DEVELOPMENT LIMITED (UNITED KINGDOM LIMITED COMPANY) 5 ELSTREE GATE, BOREHAMWOOD, HERTFORDSHIRE, WD6 1JD, UNITED KINGDOM., SN 79-038,238. FILED 2-9-2007. PRINCIPAL REGISTER.

JARMIES

THE MARK CONSISTS OF STANDARD CHARACTERS WITHOUT CLAIM TO ANY PARTICULAR FONT, STYLE, SIZE, OR COLOR.

PRIORITY DATE OF 8-9-2006 IS CLAIMED.

OWNER OF INTERNATIONAL REGISTRATION 0923459 DATED 2-9-2007, EXPIRES 2-9-2017.

THE TERM "JARMIES" HAS NO MEANING IN A FOREIGN LANGUAGE.

INT. CL. 9/U.S. CLS. 21, 23, 26, 36 AND 38

FOR APPARATUS AND INSTRUMENTS FOR RECORDING AND REPRODUCING SOUND AND VIDEO; AMUSEMENT APPARATUS IN THE NATURE OF VIDEO GAME MACHINES FOR USE WITH TELEVISION RECEIVERS; CHILDREN'S EDUCATIONAL MUSIC DVDS AND LASER DISCS; ELECTRONIC CHILDREN'S BOOKS RECORDED ON COMPUTER MEDIA; AUDIO TAPES FEATURING RECORDED CHILDREN'S BOOKS; HAND-HELD UNITS FOR PLAYING ELECTRONIC GAMES FOR USE WITH EXTERNAL DISPLAY SCREENS OR MONITORS; COMPUTER GAME CARTRIDGES, PROGRAMS AND TAPES; PRE-RECORDED COMPACT DISKS FEATURING MUSIC; BLANK RECORDING DISKS; COMPACT DISCS (CD'S) FEATURING MUSIC; GRAMOPHONE RECORDS FEATURING MUSIC; AUDIO TAPES FEATURING MUSIC; AUDIO TAPE CASSETTES FEATURING MUSIC; VIDEO TAPES FEATURING MUSIC; AUDIO TAPES FEATURING MUSIC; AUDIO TAPE CASSETTES FEATURING MUSIC; VIDEO TAPES FEATURING ANIMATED CARTOONS; SUNGLASSES; CASES FOR SUNGLASSES; CALCULATORS; BICYCLE HELMETS; PROTECTION AND SAFETY FLOATS FOR BATHING AND SWIMMING; LIFE PRESERVING WATER WINGS FOR SAFETY AND PROTECTION; SWIMMING LIFE BELTS.

FIRST USE : IN COMMERCE .

INT. CL. 14/U.S. CLS. 2, 27, 28 AND 50

FOR TEACHING CLOCKS.

INT. CL. 16/U.S. CLS. 2, 5, 22, 23, 29, 37, 38 AND 50

FOR PAPER; CARDBOARD; CHILDREN'S BOOKS; PRINTED ANNUALS ABOUT FICTIONAL CHARACTERS; COMIC BOOKS, SONG BOOKS; MAGAZINES ABOUT FICTIONAL CHARACTERS AND STORIES; PHOTOGRAPH ALBUMS; POSTERS; STATIONERY; DRAWING AND PAINTING MATERIALS, APPARATUS AND INSTRUMENTS, NAMELY, PENCILS, PENS, PAINT BRUSHES, PALETTES, CANVASES AND TABLETS; PRINTED INSTRUCTIONAL AND TEACHING MATERIALS FEATURING FICTIONAL CHARACTERS AND STORIES; BOOK COVERS; BOOK MARKS; PRINTING BLOCKS, FONTS AND TYPES; PHOTOGRAPHS; PICTURES; CALENDARS; GIFT WRAP PAPER, GREETING CARDS, WRAPPING PAPER; STICKERS.

FIRST USE : IN COMMERCE .

INT. CL. 25/U.S. CLS. 22 AND 39

FOR [CLOTHING, NAMELY, SHIRTS, PANTS, SHORTS AND JACKETS; FOOTWEAR;] * DENIM JEANS, * HEADGEAR, NAMELY, HATS AND CAPS.

FIRST USE : IN COMMERCE .

INT. CL. 28/U.S. CLS. 22, 23, 38 AND 50

FOR TOYS, GAMES AND PLAYTHINGS, NAMELY, PLUSH TOYS AND BOARD GAMES; DECORATIONS FOR CHRISTMAS TREES; SPORTING BAGS AND CONTAINERS SPECIALLY ADAPTED FOR CARRYING SPORTS ARTICLES; PLAYING CARDS.

INT. CL. 41/U.S. CLS. 100, 101 AND 107

FOR ENTERTAINMENT SERVICES IN THE NATURE OF ONGOING TELEVISION PROGRAMS IN THE FIELD OF CHILDREN'S ENTERTAINMENT; PUBLISHING OF BOOKS AND MAGAZINES; PUBLICATION OF BOOKS AND MAGAZINES; ORGANIZATION OF SOCCER COMPETITIONS; PRODUCTION OF RADIO AND TELEVISION PROGRAMS, MOTION PICTURE FILMS AND TELEVISION SHOWS; ENTERTAINMENT SERVICES IN THE NATURE OF ONGOING TELEVISION AND RADIO PROGRAMS IN THE FIELD OF CHILDREN'S ENTERTAINMENT AND ENTERTAINMENT IN THE NATURE OF THEATRE PRODUCTIONS; THEATRE PRODUCTION SERVICES.

ELEMENTS CORRECTED
GOODS/SERVICES
OWNER ADDRESS

3,450,609. REG. 6-17-2008. COUNTRY PLACE LIVING, LLC (TEXAS LTD LIAB CO) SUITE 500, 1527 W/ STATE HIGHWAY 114 #354, GRAPEVINE, TX, 760518647, SN 77-209,245. FILED 6-19-2007. PRINCIPAL REGISTER.

DO WELL WHILE DOING GOOD

THE MARK CONSISTS OF STANDARD CHARACTERS WITHOUT CLAIM TO ANY PARTICULAR FONT, STYLE, SIZE, OR COLOR.

INT. CL. 43/U.S. CLS. 100 AND 101

FOR PROVIDING ASSISTED LIVING FACILITIES.

FIRST USE 11-30-2007; IN COMMERCE 11-30-2007.

ELEMENTS CORRECTED
OWNER NAME

3,451,655. REG. 6-17-2008. WGBH EDUCATIONAL FOUNDATION (MASSACHUSETTS CORPORATION) ONE GUEST STREET, BOSTON, MA, 02135, SN 78-826,389. FILED P.R. 3-1-2006; AM. S.R. 4-24-2008. SUPPLEMENTAL REGISTER.

KIDS AGAINST JUNK FOOD

THE MARK CONSISTS OF STANDARD CHARACTERS WITHOUT CLAIM TO ANY PARTICULAR FONT, STYLE, SIZE, OR COLOR.

INT. CL. 44/U.S. CLS. 100 AND 101

FOR PROVIDING A WEBSITE ON THE SUBJECT OF HEALTH, NUTRITION, AND CHILDHOOD OBESITY.

FIRST USE 6-1-2006; IN COMMERCE 6-1-2006.

ELEMENTS CORRECTED
OWNER NAME

AUGUST 5, 2008

U.S. PATENT AND TRADEMARK OFFICE

TM 1723

3,453,342. REG. 6-24-2008. SKEET-R-GONE, INC. (NORTH DAKOTA CORPORATION) 159 - 8TH AVENUE NW, WEST FARGO, ND, 58078. SN 77-314,582. FILED 10-26-2007. PRINCIPAL REGISTER.

FOR BIRD REPELLENTS.
FIRST USE 9-1-2007; IN COMMERCE 9-14-2007.

ELEMENTS CORRECTED
OWNER ADDRESS

Flock Buster

THE MARK CONSISTS OF STANDARD CHARACTERS WITHOUT CLAIM TO ANY PARTICULAR FONT, STYLE, SIZE, OR COLOR.

NO CLAIM IS MADE TO THE EXCLUSIVE RIGHT TO USE "FLOCK", APART FROM THE MARK AS SHOWN.
INT. CL. 5/U.S. CLS. 6, 18, 44, 46, 51 AND 52

* * * * *

TRADEMARK REGISTRATIONS—NEW CERTIFICATES

New Certificates issued under section 7(d) of the Trademark Act of 1946 for the unexpired term of the original registrations.

1,622,623. XCEL (STYLIZED). INT. CL. 25. D DBA XCEL WETSUITS HAWAII, HALEIWA, HI. REG. 11-13-1990. NEW CERT. SEC. 7(D) TO SEAL TRADEMARKS PTY LTD, BURLEIGH HEADS, QUEENSLAND, AUSTRALIA.

2,957,141. EXCEL LITE (STYLIZED). INT. CL. 32. DDB CORPORATION, MIAMI, FL. REG. 5-31-2005. NEW CERT. SEC. 7(D) TO REGISTRANT.

1,965,081. XCEL. INT. CL. 25. D DBA XCEL WETSUITS HAWAII, HALEIWA, HI. REG. 4-2-1996. NEW CERT. SEC. 7(D) TO SEAL TRADEMARKS PTY LTD, BURLEIGH HEADS, QUEENSLAND, AUSTRALIA.

2,975,385. XCEL PROSTANDARD CHARACTER MARK INT. CL. 41. EDMONT P. D, HALEIWA, HI. REG. 7-26-2005. NEW CERT. SEC. 7(D) TO REGISTRANT.

2,217,115. XCEL. INT. CL. 35. D, HALEIWA, HI. REG. 1-12-1999. NEW CERT. SEC. 7(D) TO REGISTRANT.

2,977,752. XCEL. INT. CL. 9. EDMONT P. D, HALEIWA, HI. REG. 7-26-2005. NEW CERT. SEC. 7(D) TO REGISTRANT.

2,345,952. EXCELWEAR. INT. CL. 25. GREAT OUTDOOR PROVISION COMPANY, RALEIGH, NC. REG. 4-25-2000. NEW CERT. SEC. 7(D) TO REGISTRANT.

3,381,937. SOCIALIZERSTANDARD CHARACTER MARK INT. CLS. 35, 38, 41, 42 AND 45. SOCIALIZER, LLC., RESTON, VA. REG. 2-12-2008. NEW CERT. SEC. 7(D) TO REGISTRANT.

2,825,694. XCEL. INT. CL. 12. THE TRUSTEE OF THE EDMONT P. D, HALEIWA, HI. REG. 3-23-2004. NEW CERT. SEC. 7(D) TO REGISTRANT.

3,405,193. POLYPOOLSTANDARD CHARACTER MARK INT. CLS. 19 AND 22. CINDEK HOLDINGS LIMITED, KOWLOON BAY, HONG KONG. REG. 4-1-2008. NEW CERT. SEC. 7(D) TO REGISTRANT.

2,836,886. MISCELLANEOUS DESIGN. INT. CL. 25. TRUSTEE OF THE EDMONT P. D, HALEIWA, HI. REG. 4-27-2004. NEW CERT. SEC. 7(D) TO REGISTRANT.

3,411,326. NOVASTAR (STYLIZED). INT. CL. 10. DRÄGER MEDICAL AG & CO. KG, LÜBECK, FED REP GERMANY. REG. 4-15-2008. NEW CERT. SEC. 7(D) TO REGISTRANT.

2,948,566. XCEL. INT. CL. 28. EDMONT P. D, HALEIWA, HI. REG. 5-10-2005. NEW CERT. SEC. 7(D) TO REGISTRANT.

3,447,260. MISCELLANEOUS DESIGN. INT. CL. 25. WILLIAMS, TALY, HALIBURTON, ONTARIO, CANADA. REG. 3-7-2006. NEW CERT. SEC. 7(D) TO REGISTRANT.

* * * * *

INDEX OF REGISTRANTS

AUGUST 5, 2008

(Registered; Renewed; Canceled; Amended, Corrected, etc.; New Certificates; 12c Publications.)

The designation "U.S. Cl." appearing in this section refers to the U.S. class in effect prior to Sep. 1, 1973 rather than the international class which applies to applications filed on or after that date. For adoption of international classification see notice in the OFFICIAL GAZETTE of Jun. 26, 1973 (911 O.G. TM 210).

& CO, SAN FRANCISCO, CA:
2,160,063. REN. 6-27-08. MULTIPLE CLASS, INT. CLS. 25 AND 35.

"DR. MAERTENS" MARKETING GMBH, SEESHAUPT, FED REP GERMANY AND "DR. MARTENS" INTERNATIONAL; TRADING GMBH, GRÄFELFING, FED REP GERMANY:
3,480,971, PUB. 5-20-2008. INT. CL. 25.

ÅBECO R & M AB, SE-504 60 BORÅS, SVERIGE, SWEDEN:
3,480,937, PUB. 5-20-2008. MULTIPLE CLASS, INT. CLS. 32 AND 34.

A & E STORES, INC., TETERBORO, NJ:
2,493,048, CANC. MULTIPLE CLASS, INT. CLS. 25 AND 35.

A & H SPORTSWEAR CO., INC., STOCKERTOWN, PA:
2,165,585. REN. 6-30-08. INT. CL. 25.

A & W RESTAURANTS, INC., FARMINGTON HILLS, MI:
2,491,871, CANC. INT. CL. 30.

A PHANTOM VOX CORPORATION, SANTURCE, PUERTO RICO:
3,482,112, INT. CL. 41.

A. O. SMITH CORPORATION, MILWAUKEE, WI:
3,481,357, INT. CL. 7.

A.L.S. ENTERPRISES, INC., MUSKEGON, MI:
3,479,843, PUB. 5-20-2008. MULTIPLE CLASS, INT. CLS. 9 AND 41.

A.S.V., INC., GRAND RAPIDS, MN:
3,480,136, PUB. 5-20-2008. INT. CL. 7.

A.T.S. ELECTRO-LUBE HOLDINGS LTD., DELTA, CANADA:
3,478,724, PUB. 5-20-2008. INT. CL. 7.

A&D COMPANY, LTD., JAPAN:
3,480,815, PUB. 5-20-2008. MULTIPLE CLASS, INT. CLS. 9 AND 42.

A&E TELEVISION NETWORKS, NEW YORK, NY:
2,177,226. REN. 7-3-08. INT. CL. 9.

A&M AQUATICS, INC., LANSING, MI:
3,482,556, MULTIPLE CLASS, INT. CLS. 21, 31, 37 AND 44.

A-DATA TECHNOLOGY CO., LTD., CHUNG HO CITY, TAIPEI, TAIWAN:
3,479,122, PUB. 5-20-2008. INT. CL. 9.

A-WAY HUNTING PRODUCTS, INC., BEAVERTON, MI:
3,479,493, PUB. 5-20-2008. INT. CL. 28.

A-1 ARCHERY, HUDSON, WI:
3,479,022, PUB. 5-20-2008. INT. CL. 9.

AARP, WASHINGTON, DC:
3,481,274, INT. CL. 41.

AB FOODS, LLC, ST. LOUIS, MO:
3,481,920, INT. CL. 29.

ABACA TECHNOLOGY CORPORATION, SAN JOSE, DE:
3,479,507, PUB. 5-20-2008. MULTIPLE CLASS, INT. CLS. 9 AND 42.

ABACUS FEDERAL SAVINGS BANK, NEW YORK, NY:
3,480,572, PUB. 5-20-2008. INT. CL. 36.

ABADIA RETUERTA S.A., SPAIN:
3,480,772, PUB. 5-20-2008. INT. CL. 33.
3,480,773, PUB. 5-20-2008. INT. CL. 33.

ABATEMENT TECHNOLOGIES, INC., SUWANEE, GA:
2,493,218, CANC. INT. CL. 11.

ABBOTT LABORATORIES, ABBOTT PARK, IL:
3,481,437, INT. CL. 10.
3,482,276, MULTIPLE CLASS, INT. CLS. 16 AND 41.

ABBOTT, VINNIE, NEW YORK, NY:
3,482,315, INT. CL. 41.

ABC INTERNATIONAL TRADERS, INC., NORTH HILLS, CA, DBA MGA ENTERTAINMENT:
2,493,669, CANC. INT. CL. 28.

ABEL UNLIMITED, INC., WEST PALM BEACH, FL:
2,493,634, CANC. INT. CL. 20.

ABERCROMBIE & FITCH TRADING CO., NEW ALBANY, OH:
3,481,426, INT. CL. 3.
3,481,427, INT. CL. 3.
3,481,991, INT. CL. 3.
3,481,992, INT. CL. 3.

ABG ACQUISITION CORPORATION, MIRA LOME, CA:
2,491,892, CANC. MULTIPLE CLASS, INT. CLS. 35 AND 42.

ABITA BREWING COMPANY, LLC, ABITA SPRINGS, LA:
3,481,795, INT. CL. 43.

ABL IP HOLDING LLC, CONYERS, GA:
3,478,981, PUB. 5-20-2008. INT. CL. 11.

ABLON, JOHN, WASHINGTON, DC:
2,114,381. REN. 6-30-08. INT. CL. 5.

ABNP PRODUCTIONS LLC, WILLOUGHBY, OH:
3,481,144, INT. CL. 9.

ABOUT LOW VISION, INC., ORANGE, CA:
3,479,921, PUB. 5-20-2008. INT. CL. 35.

ABRAHAMS, BRUCE, PLANTATION, FL:
2,492,696, CANC. INT. CL. 41.

ABRAHMS, DARRYL, REDMOND, WA:
3,482,362, INT. CL. 21.

ABREU, CARLOS, BEVERLY HILLS, CA:
3,479,926, PUB. 5-20-2008. INT. CL. 41.
3,480,507, PUB. 5-20-2008. INT. CL. 41.

ABBREVIETY, INC., CUPERTINO, CA:
3,479,161, PUB. 5-20-2008. INT. CL. 9.

ABSOLUTE ADVANTAGE MORTGAGE CORPORATION LLC, ADAMSTOWN, MD:
3,481,820, INT. CL. 36.

ABSOLUTE PLUS MANAGEMENT LLC, NEW YORK, NY:
3,482,561, INT. CL. 36.
3,482,562, INT. CL. 36.

ACADEMY OF APPLIED SCIENCE, INC., CONCORD, NH:
2,491,846, CANC. MULTIPLE CLASS, INT. CLS. 16 AND 41.

ACADIA OUTDOORS HOLDINGS C.V., AMSTELVEEN, NETHERLANDS:
3,481,996, INT. CL. 25.

ACC-AUTOMOTIVE CAREER CENTERS, INC., MESA, AZ:
2,098,887, CANC. INT. CL. 35.

ACCELERATED CHRISTIAN EDUCATION, INC., NASHVILLE, TN:
2,155,531. REN. 6-27-08. INT. CL. 9.

ACCESSORY NETWORK GROUP LLC, NEW YORK, NY:
2,165,732. REN. 6-28-08. MULTIPLE CLASS, INT. CLS. 18 AND 25.

ACCO BRANDS CORPORATION, LINCOLNSHIRE, IL, SWINGLINE INC., LONG ISLAND CITY, NY:
1,486,113. REN. 6-28-08. INT. CL. 16.

- ACCO BRANDS CORPORATION, LINCOLNSHIRE, IL:
2,491,739, CANC. INT. CL. 9.
2,493,163, CANC. INT. CL. 6.
- ACCOR, FRANCE:
3,480,905, PUB. 5-20-2008. MULTIPLE CLASS, INT. CLS. 16, 21, 34, 39 AND 43.
- ACCOUNT RECEIVABLE PROCESSING COMPANY, INC., OMAHA, NE:
2,100,243, CANC. INT. CL. 9.
- ACCOUNTING COMES ALIVE, INC., WASHINGTON, DC, DBA LEARNING COMES ALIVE:
3,479,469, PUB. 5-20-2008. INT. CL. 41.
- ACCU-SORT SYSTEMS, INC., HATFIELD, PA:
3,481,234, INT. CL. 9.
3,481,235, INT. CL. 9.
- ACCUTEK PACKAGING EQUIPMENT COMPANY, INC., VISTA, CA:
3,478,741, PUB. 5-20-2008. INT. CL. 7.
- ACE CO., LTD., OSAKA, JAPAN:
3,431,536, COR. MULTIPLE CLASS, INT. CLS. 16 AND 18.
- ACECOOK VIETNAM COMPANY LIMITED, HO CHI MINH CITY, VIETNAM:
3,480,608, PUB. 5-20-2008. INT. CL. 30.
- ACHILL RIVER CORPORATION, ASHEVILLE, NC:
1,352,761, REN. 7-3-08. INT. CL. 16.
- ACIST MEDICAL SYSTEMS, INC., EDEN PRAIRIE, MN:
3,481,673, INT. CL. 10.
- ACM MEDICAL LABORATORY, INC., ROCHESTER, NY:
2,174,626, REN. 7-3-08. INT. CL. 42.
- ACME UNITED CORPORATION, FAIRFIELD, CT:
3,482,647, INT. CL. 8.
3,482,648, INT. CL. 8.
3,482,649, INT. CL. 8.
3,482,650, INT. CL. 8.
3,482,651, INT. CL. 8.
- ACORN ENGINEERING COMPANY, CITY OF INDUSTRY, CA:
3,478,673, PUB. 5-20-2008. INT. CL. 11.
3,478,767, PUB. 5-20-2008. INT. CL. 21.
- ACR, INC., VISALIA, CA:
3,479,991, PUB. 5-20-2008. INT. CL. 41.
- ACRISON, INC., MOONACHIE, NJ:
1,458,108, CANC. INT. CL. 9.
- ACS WIRELESS, INC., SCOTTS VALLEY, CA TO GN NETCOM, INC., NASHUA, NH:
2,100,359, CANC. INT. CL. 9.
- ACTARIS S.A.S., BOULOGNE-BILLANCOURT, FRANCE:
3,480,952, PUB. 5-20-2008. MULTIPLE CLASS, INT. CLS. 9, 35, 38 AND 42.
- ACTIONEER, INC., BOSTON, MA:
2,167,505, REN. 7-3-08. INT. CL. 9.
- ACTIVE BODY CHIROPRACTIC, LTD, CHICAGO, IL:
3,479,846, PUB. 5-20-2008. INT. CL. 44.
- ACTIVE IMAGES, SANTA MONICA, CA:
2,491,731, CANC. INT. CL. 16.
- ACTIVECAMPAIGN, INC., CHICAGO, IL:
3,479,833, PUB. 5-20-2008. INT. CL. 42.
- ACTIVISION PUBLISHING, INC., SANTA MONICA, CA:
2,492,859, CANC. INT. CL. 9.
- AD COMMUNICATIONS PTY LTD, CHATSWOOD, AUSTRALIA:
3,480,803, PUB. 5-20-2008. INT. CL. 38.
- ADAMS, CAROLYN, NEW ORLEANS, LA, DBA TUFFETS:
2,492,878, CANC. INT. CL. 20.
- ADAMSON DESIGN GROUP, INC, SALEM, OR:
3,482,424, INT. CL. 25.
- ADAPTION TECHNOLOGIES VENTURES, LTD., THE WOODLANDS, TX:
3,479,940, PUB. 5-20-2008. INT. CL. 38.
3,480,522, PUB. 5-20-2008. INT. CL. 38.
- ADCOCK INGRAM LIMITED, BRYANSTON, SOUTH AFRICA:
2,099,692, CANC. INT. CL. 3.
- ADDAGARLA, SUMANTH, FREMONT, CA AND KIZHAKKARA, USHA, FREMONT, CA AND KIZHAKKARA, UDAY, FREMONT, CA AND RAJAGANGADHARAN, K. M., FREMONT, CA:
2,492,723, CANC. INT. CL. 35.
- ADEPT SYSTEMS INCORPORATED, BOCA RATON, FL:
2,491,953, CANC. MULTIPLE CLASS, INT. CLS. 9 AND 42.
- ADEYEMI, YATO, SCOTTSDALE, AZ AND GOSPEL MISSIONS INTERNATIONAL, PHOENIX, AZ:
3,479,890, PUB. 5-20-2008. INT. CL. 45.
- ADIRONDACK DIGITAL IMAGING SYSTEMS, INC., KEESVILLE, NY:
3,479,725, PUB. 5-20-2008. MULTIPLE CLASS, INT. CLS. 9 AND 13.
- ADL, DESIREE, LAGUNA NIGUEL, CA:
3,479,056, PUB. 5-20-2008. INT. CL. 30.
- ADLER FELS WINERY, LLC, SANTA ROSA, CA:
3,481,356, INT. CL. 33.
- ADMINISTRADORA DE MARCAS RD, S. DE R.L. DE C.V., C.P. 11320, MEXICO, D.F., MEXICO:
3,480,584, PUB. 5-20-2008. MULTIPLE CLASS, INT. CLS. 9, 16, 25, 35, 38 AND 41.
- ADMINISTRADORA DE MARCAS RD, S. DE R.L. DE C.V., ZUG, SWITZERLAND:
3,480,595, PUB. 5-20-2008. MULTIPLE CLASS, INT. CLS. 9, 16, 25, 35, 38 AND 41.
3,480,596, PUB. 5-20-2008. MULTIPLE CLASS, INT. CLS. 9, 16, 25, 35, 38 AND 41.
3,480,597, PUB. 5-20-2008. MULTIPLE CLASS, INT. CLS. 9, 16, 25, 35, 38 AND 41.
- ADMIRAL CRAFT EQUIPMENT CORP., HICKSVILLE, NY:
2,491,962, CANC. INT. CL. 21.
- ADOLFO, CARCAÑO RICALDE GUSTAVO, MERIDA, MEXICO:
3,481,755, INT. CL. 41.
- ADP OF NORTH AMERICA, INC., SAN RAMON, CA:
3,481,221, INT. CL. 36.
3,481,223, INT. CL. 35.
- ADP PLEASANTON NATIONAL SERVICE CENTER, INC., PLEASANTON, CA:
2,169,179, REN. 6-28-08. INT. CL. 9.
- ADP, INC., ROSELAND, NJ:
2,162,564, REN. 7-2-08. INT. CL. 9.
- ADRIENNE DENESE, M.D., P.C., NEW YORK, NY:
3,479,602, PUB. 5-20-2008. INT. CL. 3.
- ADTRAN, HUNTSVILLE, AL:
2,162,502, REN. 6-30-08. INT. CL. 9.
- ADVANCE EDUCATION, INC., DECATUR, GA:
3,479,832, PUB. 5-20-2008. MULTIPLE CLASS, INT. CLS. 41 AND 42.
- ADVANCE MAGAZINE PUBLISHERS INC., NEW YORK, NY, ADVANCE MAGAZINE PUBLISHERS INC., NEW YORK, NY:
1,532,988, REN. 7-2-08. INT. CL. 16.
1,532,989, REN. 7-2-08. INT. CL. 16.
- ADVANCE MAGAZINE PUBLISHERS INC., NEW YORK, NY:
3,480,492, PUB. 5-20-2008. INT. CL. 16.
- ADVANCE TECH INTERNATIONAL LIMITED, SHEUNG WAN, HONG KONG:
2,492,487, CANC. INT. CL. 9.
- ADVANCED BIOLOGICAL SERVICES, INC., ORANGE PARK, FL:
3,479,471, PUB. 5-20-2008. INT. CL. 11.
- ADVANCED LOGIC TECHNOLOGIES, LLC., AUSTIN, TX:
3,480,341, PUB. 5-20-2008. INT. CL. 37.
- ADVANCED MEDICAL NUTRITION, INC., PITTSBURGH, PA:
2,248,324, REN. 6-30-08. INT. CL. 5.
- ADVANCED METAL CORP., WILMINGTON, NC:
3,478,881, PUB. 5-20-2008. INT. CL. 37.
- ADVANCED MICRO DEVICES, INC., SUNNYVALE, CA:
2,493,429, CANC. INT. CL. 9.
2,493,430, CANC. INT. CL. 9.
2,493,431, CANC. INT. CL. 9.
- ADVANCED NUTRITIONAL RESEARCH, INC.:
1,457,961, CANC. INT. CL. 5.

ADVANCED TECHNOLOGY SERVICES, INC., PEORIA, IL:
2,491,695, CANC. INT. CL. 42.

ADVANCED WELLNESS SOLUTIONS LLC, POULSBORO, WA:
3,480,008, PUB. 5-20-2008. INT. CL. 44.

ADVANTA CORP., SPRING HOUSE, PA:
2,492,513, CANC. INT. CL. 35.

ADVANTAGE INTERNATIONAL FOODS CORP., WEST
CALDWELL, NJ:
3,479,139, PUB. 5-20-2008. INT. CL. 29.

ADVISER INVESTMENT MANAGEMENT, INC., NEWTON,
MA:
3,479,727, PUB. 5-20-2008. INT. CL. 36.

AEGIS ASSET MANAGEMENT, INC., ANAHEIM, CA:
2,491,646, CANC. INT. CL. 36.

AEGIS INDUSTRIES, LLC, RANCHO CUCAMONGA, CA:
2,492,081, CANC. INT. CL. 6.

AEHELPER, LLC, CHARLES CITY, VA:
3,480,010, PUB. 5-20-2008. INT. CL. 42.

AEROTONOMY, INCORPORATED, LITHIA SPRINGS, GA:
3,478,743, PUB. 5-20-2008. INT. CL. 42.

AGA, SUSIE, ALPHARETTA, GA:
3,481,102, INT. CL. 41.

AGAMATRIX, INC., SALEM, NH:
3,482,485, INT. CL. 9.

AGC, INC., CLEVELAND, OH:
2,492,841, CANC. MULTIPLE CLASS, INT. CLS. 16 AND
26.

AGC, LLC, CLEVELAND, OH:
2,493,530, CANC. INT. CL. 24.

AGE WAVE, INC., EMERYVILLE, CA:
1,458,786, CANC. INT. CL. 42.

AGENCE FRANCE PRESSE, PARIS, FRANCE:
1,458,049, CANC. MULTIPLE CLASS, INT. CLS. 9, 16, 35
AND 42.

AGEWELL, P.C., INDIANAPOLIS, IN:
3,481,050, MULTIPLE CLASS, INT. CLS. 3, 5, 10 AND 28.

AGFA-GEVAERT AKTIENGESSELLSCHAFT, LEVERKU-
SEN, FED REP GERMANY:
1,366,144, CANC. INT. CL. 1.

AGILENT TECHNOLOGIES, INC., SANTA CLARA, CA:
3,482,238, INT. CL. 9.

AGILYSYS, INC., MAYFIELD HEIGHTS, OH:
2,492,098, CANC. MULTIPLE CLASS, INT. CLS. 35 AND
42.

AGR STONE & TOOLS USA, INC., CONROE, TX:
3,480,474, PUB. 5-20-2008. INT. CL. 7.

AGRI LABORATORIES, LTD., ST. JOSEPH, MO:
3,482,299, INT. CL. 5.

AGROPECUARIA PIEDADENSE S.A. DE C.V, SANTA ANA
PACUECO, MEXICO:
3,482,627, INT. CL. 31.

AGRU KUNSTSTOFFTECHNIK GMBH, A-4540 BAD HALL,
AUSTRIA:
2,493,204, CANC. INT. CL. 7.
2,493,205, CANC. INT. CL. 7.

AGUA DULCE EXTENDED CARE, INC., TUCSON, AZ:
3,481,362, INT. CL. 44.

AHA! STUDIOS, INC., RACINE, WI:
3,482,008, INT. CL. 9.

AICHELE GROUP GMBH & CO. KG, FED REP GERMANY:
3,480,979, PUB. 5-20-2008. INT. CL. 35.

AIELLO, ANGELO M., HOPE, RI AND AIELLO, DAVID J.,
HOPE, RI:
3,481,836, INT. CL. 32.

AIR LINE PILOTS ASSOCIATION, INT'L, HERNDON, VA:
1,475,514, AM. U.S. CL. 200.

AIR METHODS CORPORATION, ENGLEWOOD, CO:
3,478,787, PUB. 5-20-2008. INT. CL. 35.

AIR NATIONAL GUARD, ARLINGTON, VA:
2,493,091, CANC. INT. CL. 42.

AIR SERV CORPORATION, ATLANTA, GA:
3,480,635, PUB. 5-20-2008. MULTIPLE CLASS, INT. CLS.
37, 39 AND 45.

AIRCELL LLC, LOUISVILLE, CO:
3,481,693, INT. CL. 9.

AIRLIFT IDEAS, INC., CHICAGO, IL:
3,480,704, PUB. 5-20-2008. INT. CL. 35.

AIRPORT RANCH ESTATES, LLC, PROSSER, WA, DBA
AIRFIELD ESTATES:
3,480,314, PUB. 5-20-2008. INT. CL. 33.
3,480,316, PUB. 5-20-2008. INT. CL. 33.

AISLINN COFFEE ENTERPRISES LLC, PORTLAND, OR:
3,478,573, PUB. 5-20-2008. INT. CL. 43.

AJ & R WORLDWIDE GROUP, INC., MIAMI, FL:
3,479,257, PUB. 5-20-2008. INT. CL. 29.

AKALMP, INC., INDIANAPOLIS, IN:
2,492,506, CANC. INT. CL. 6.

AKCIONERNO DRUJESTVO; "DATAMAX SISTEM HOLD-
ING", BULGARIA:
3,480,758, PUB. 5-20-2008. MULTIPLE CLASS, INT. CLS.
9, 35, 36, 38, 39 AND 42.

AKEENA SOLAR INC., LOS GATOS, CA:
3,481,373, MULTIPLE CLASS, INT. CLS. 9 AND 37.

AKIRO LLC, BROOKLYN, NY:
3,482,013, INT. CL. 3.

AKZO NOBEL CHEMICALS B.V., AMERSFOORT, NETHER-
LANDS, AKZO CHEMIE NEDERLAND B.V., AMERS-
FOORT, NETHERLANDS:
1,104,088, REN. 7-1-08. INT. CL. 1.

AKZO NOBEL COATINGS INTERNATIONAL B.V., NETH-
ERLANDS:
3,480,890, PUB. 5-20-2008. INT. CL. 2.

AL RUBA ADRBA SALES LLC, HACKENSACK, NJ:
3,478,580, PUB. 5-20-2008. INT. CL. 25.

ALABAMA FARMERS COOPERATIVE, INC., DECATUR,
AL:
3,479,204, PUB. 5-20-2008. INT. CL. 31.

ALARIS INCOME GROWTH FUND L.P., CALGARY, CA-
NADA:
3,480,733, PUB. 3-25-2008. INT. CL. 35.

ALASKA, INC., MEDLEY, FL:
3,480,464, PUB. 5-20-2008. INT. CL. 9.

ALBANY INTERNATIONAL CORP., ALBANY, NY:
3,482,367, INT. CL. 9.

ALBERT HANDTMANN ELTEKA GMBH & CO. KG,
BIBERACH, FED REP GERMANY:
1,458,492, CANC. INT. CL. 28.

ALBERTO INCANUTI S.R.L., ITALY:
3,480,849, PUB. 5-20-2008. INT. CL. 25.

ALBERTO-CULVER USA, INC., MELROSE PARK, IL:
3,482,350, INT. CL. 3.

ALBIREO STUDIOS, LLC, FREE UNION, VA:
3,482,151, INT. CL. 9.

ALBUM NETWORK, INC., HOLLYWOOD, CA:
1,359,750, CANC. INT. CL. 41.

ALC FLENCO GROUP S.R.L., ITALY:
3,480,954, PUB. 5-20-2008. MULTIPLE CLASS, INT. CLS.
1, 7 AND 17.

ALCOA INC., PITTSBURGH, PA:
2,493,486, CANC. INT. CL. 16.
3,479,769, PUB. 5-20-2008. INT. CL. 12.

ALCON, INC., CH-6331 HÜNENBERG, SWITZERLAND:
3,482,077, INT. CL. 5.

ALDES AERAULIQUE, FRANCE:
3,480,801, PUB. 5-20-2008. INT. CL. 11.

ALDINE INC., NEW YORK, NY:
3,481,482, INT. CL. 16.

ALESSANDRO MASINI, FLORENCE, ITALY:
3,480,592, PUB. 5-20-2008. INT. CL. 14.

ALEXANDRIA CONDOMINIUMS, L.L.C., DEERFIELD, IL:
3,478,706, PUB. 5-20-2008. INT. CL. 36.
3,478,707, PUB. 5-20-2008. INT. CL. 36.

ALFA CORPORATION, MONTGOMERY, AL:
3,478,496, PUB. 5-20-2008. MULTIPLE CLASS, INT. CLS.
36 AND 37.

ALFALFA NAIL SUPPLY, INC., BATON ROUGE, LA:
3,481,619, INT. CL. 3.

ALFRED KLETT KG, 42899 REMSCHEID, FED REP GER-
MANY:
2,098,615, CANC. INT. CL. 7.

ALFRED P. SLOAN FOUNDATION, NEW YORK, NY:
3,482,103, MULTIPLE CLASS, INT. CLS. 35 AND 41.

ALFRED STÖFFLER GMBH, FED REP GERMANY:
3,481,022, PUB. 5-20-2008. INT. CL. 16.

- ALGOTEC SYSTEMS LTD., RAANANA, ISRAEL:
2,492,877, CANC. INT. CL. 9.
- ALL RELO-SERVICES, INC., HOUSTON, TX:
3,479,297, PUB. 5-20-2008. INT. CL. 36.
- ALL SEASONS ARCHERY, INC., WATERVLIET, MI:
3,481,214, INT. CL. 28.
- ALL STATES ROOFING & CONSTRUCTION, INC, GUY,
TX:
3,478,856, PUB. 5-20-2008. INT. CL. 37.
- ALL WAYS ZEN, AUSTIN, TX:
3,479,165, PUB. 5-20-2008. INT. CL. 9.
- ALL-AMERICA ROSE SELECTIONS, INC., SAN FRANCIS-
CO, CA:
3,480,649, PUB. 5-20-2008. MULTIPLE CLASS, INT. CLS.
16, 31, 35 AND 41.
- ALL-TEST PRO, LLC, BRANFORD, CT:
3,480,455, PUB. 5-20-2008. INT. CL. 9.
- ALLCONNECT, INC., ATLANTA, GA, INTELLIGENT CON-
SUMER HOLDINGS, L.L.C., ATLANTA, GA:
2,220,770. REN. 7-2-08. INT. CL. 42.
- ALLEGIS GROUP, INC., HANOVER, MD:
3,480,444, PUB. 5-20-2008. INT. CL. 35.
- ALLEN SYSTEMS GROUP, INC., NAPLES, FL, MOBIUS
MANAGEMENT SYSTEMS, INC., NEW ROCHELLE, NY:
2,108,451. REN. 7-2-08. INT. CL. 9.
- ALLEN, ANN DE WEES, ST. PETERSBURG, FL:
3,481,468, INT. CL. 42.
- ALLERGAN, INC., IRVINE, CA:
3,481,684, INT. CL. 44.
- ALLIANCE DATA SYSTEMS CORPORATION, DALLAS,
TX:
2,205,390. REN. 7-3-08. INT. CL. 35.
- ALLIANCE SHIPPERS, INC., ORLAND PARK, IL:
2,445,839, CANC. INT. CL. 39.
- ALLIANT TECHSYSTEMS INC., HOPKINS, MN:
2,493,032, CANC. INT. CL. 9.
- ALLIANT TECHSYSTEMS INC., EDINA, MN:
3,016,275, COR. INT. CL. 28.
- ALLIED FABRICATING & WELDING CO., ROSE CITY, TX:
2,099,791, CANC. INT. CL. 7.
- ALLIED LIGHTING SYSTEMS INC, SAN DIEGO, CA:
2,492,262, CANC. INT. CL. 11.
- ALLIED PACKAGING CORPORATION, PHOENIX, AZ:
3,478,628, PUB. 5-20-2008. INT. CL. 8.
3,478,629, PUB. 5-20-2008. INT. CL. 7.
- ALLIED TELESIS, INC., BOTHELL, WA:
3,482,239, INT. CL. 9.
- ALLISON, JON P., TOWSON, MD:
3,479,164, PUB. 5-20-2008. INT. CL. 25.
- ALLTECH MANUFACTURING, LLC, ANNANDALE, MN:
3,480,102, PUB. 5-20-2008. INT. CL. 6.
- ALLTEL COMMUNICATIONS, INC., LITTLE ROCK, AR:
2,492,343, CANC. INT. CL. 38.
- ALLUX MEDICAL, INC., MENLO PARK, CA:
3,481,230, INT. CL. 10.
- ALM SURGICAL EQUIPMENT INC., ANAHEIM, CA:
2,493,335, CANC. INT. CL. 10.
- ALMA PUBLISHING INC., DALLAS, OR:
3,479,697, PUB. 5-20-2008. INT. CL. 41.
- ALOECORP, INC., LACEY, WA:
3,482,050, INT. CL. 5.
- ALONZO, LENI A., NORTHRIDGE, CA TO DM ENTER-
PRISES & DISTRIBUTORS, INC., MIAMI, FL:
2,098,763, CANC. INT. CL. 30.
- ALPHA TRADING, SERVICES, INC., BOXBOROUGH, MA:
3,478,976, PUB. 5-20-2008. INT. CL. 35.
3,478,977, PUB. 5-20-2008. INT. CL. 35.
3,478,980, PUB. 5-20-2008. INT. CL. 35.
- ALPHASOURCE INC., PHILADELPHIA, PA:
3,482,546, INT. CL. 22.
- ALPINE OVERHEAD DOORS, INC., BROOKLYN, NY:
2,167,415. REN. 6-27-08. INT. CL. 6.
- ALSIMAG TECHNICAL CERAMICS, INC., LAURENS, SC
TO CREDIT SUISSE FIRST BOSTON, ACTING THROUGH
ITS CAYMAN ISLANDS BRANCH, AS ADMINISTRA-
TIVE AGENT, NEW YORK, NY:
2,098,574, CANC. INT. CL. 1.
- ALSOP, KEVIN, POWAY, CA, DBA AMRYL ENTERTAIN-
MENT:
2,099,514, CANC. MULTIPLE CLASS, INT. CLS. 16 AND
25.
- ALSTOM POWER INC., WINDSOR, CT:
3,478,831, PUB. 5-20-2008. INT. CL. 11.
- ALTA COLLEGES, INC., DENVER, CO:
3,481,078, INT. CL. 41.
- ALTA HEIGHTS TECHNOLOGY CORPORATION, LOS
GATOS, CA:
3,482,339, INT. CL. 9.
- ALTAMIRANO, ANTONIO, MENLO PARK, CA:
3,480,475, PUB. 5-20-2008. INT. CL. 39.
- ALTO DE CASABLANCA, S.A., CASABLANCA, CHILE:
2,120,531. REN. 7-3-08. INT. CL. 33.
- ALTRES, INC., HONOLULU, HI:
2,176,783. REN. 6-28-08. INT. CL. 36.
- ALUMIN-NU CORPORATION, CLEVELAND, OH:
847,160. REN. 6-30-08. U.S. CL. 52 (INT. CL. 3).
- ALVA & ASSOCIATES, CHULA VISTA, CA:
3,479,097, PUB. 5-20-2008. INT. CL. 16.
- ALVIERO MARTINI S.P.A., MILANO, ITALY:
1,691,558, AM. INT. CL. 18.
- ALWAYS HOME REAL ESTATE, INC., BRENTWOOD, TN:
3,481,150, INT. CL. 36.
- ALZHEIMER'S FOUNDATION OF AMERICA, INC., NEW
YORK, NY:
3,478,568, PUB. 5-20-2008. INT. CL. 36.
- AMALGAMATED SOFTWARE OF NORTH AMERICA,
INC., SAN ANTONIO, TX:
2,169,770. REN. 6-28-08. INT. CL. 9.
- AMANDA'S RESTAURANTS, LLC, PALO ALTO, CA:
3,478,686, PUB. 5-20-2008. INT. CL. 41.
- AMARR COMPANY, WINSTON-SALEM, NC:
3,480,538, PUB. 5-20-2008. INT. CL. 6.
- AMATEUR SOFTBALL ASSOCIATION OF AMERICA, OK-
LAHOMA CITY, OK:
3,479,184, PUB. 5-20-2008. INT. CL. 35.
- AMAZONIA TECHNOLOGIES, INC., RENO, NV:
2,167,345. REN. 7-3-08. INT. CL. 35.
3,478,710, PUB. 5-20-2008. INT. CL. 35.
3,479,449, PUB. 5-20-2008. MULTIPLE CLASS, INT. CLS.
35 AND 39.
3,481,980, INT. CL. 25.
- AMAZONIA NUTRIENTS INC., MANHATTAN BEACH, CA:
3,479,813, PUB. 5-20-2008. INT. CL. 3.
- AMBRUS, SANDOR Z., TORONTO, ONTARIO, CANADA:
2,162,539. REN. 6-28-08. INT. CL. 9.
- AMC BURGERS, INC., SOUTHFIELD, MI:
3,481,681, INT. CL. 43.
- AMCOR FLEXIBLES TRANSPAC, B-1935 ZA VENTEM,
BELGIUM:
2,158,258. REN. 6-30-08. INT. CL. 16.
- AMCOR, INC., CARLSTADT, NJ:
3,479,620, PUB. 5-20-2008. MULTIPLE CLASS, INT. CLS. 9
AND 11.
- AMERICA WEST AIRLINES, INC., TEMPE, AZ:
1,458,737, CANC. INT. CL. 39.
- AMERICA'S CHOICE WARRANTY, LLC, BATON ROUGE,
LA:
3,479,614, PUB. 5-20-2008. INT. CL. 36.
- AMERICA'S PHARMACY, INC., NEWPORT BEACH, CA:
1,451,699, CANC. INT. CL. 5.
1,452,592, CANC. INT. CL. 42.
- AMERICAN AGRITECH, L.L.C, CHANDLER, AZ:
3,480,734, PUB. 5-20-2008. INT. CL. 1.
- AMERICAN AIRLINES, INC., FORT WORTH, TX:
2,160,456. REN. 6-30-08. INT. CL. 39.
2,492,543, CANC. INT. CL. 39.
- AMERICAN ASSOCIATION OF INDIVIDUAL INVESTORS,
CHICAGO, IL:
2,492,094, CANC. INT. CL. 16.
- AMERICAN ASSOCIATION OF NEUROLOGICAL SUR-
GEONS, THE, ROLLING MEADOWS, IL:
2,203,459. REN. 7-3-08. INT. CL. 42.
- AMERICAN BLINDS AND DRAPERIES, INC., HAYWARD,
CA:
3,479,051, PUB. 5-20-2008. INT. CL. 35.

- AMERICAN BUSINESS LAW ASSOCIATION, OXFORD, OH, DBA ACADEMY OF LEGAL STUDIES IN BUSINESS:
2,493,635, CANC. U.S. CL. 200.
- AMERICAN BUSINESS LAW ASSOCIATION, INC., OXFORD, OH, DBA ACADEMY OF LEGAL STUDIES IN BUSINESS:
2,493,636, CANC. U.S. CL. 200.
- AMERICAN CANCER SOCIETY, INC., ATLANTA, GA:
3,479,912, PUB. 5-20-2008. MULTIPLE CLASS, INT. CLS. 35 AND 36.
- AMERICAN CAPITAL STRATEGIES, LTD., BETHESDA, MD:
2,221,152, REN. 7-1-08. INT. CL. 36.
- AMERICAN CAR CARE CENTERS, INC., MEMPHIS, TN:
3,481,716, MULTIPLE CLASS, INT. CLS. 35, 37 AND 41.
- AMERICAN CASH FLOW CORPORATION, ORLANDO, FL:
3,479,548, PUB. 5-20-2008. INT. CL. 41.
- AMERICAN CHEMICAL SOCIETY, WASHINGTON, DC:
3,479,851, PUB. 5-20-2008. INT. CL. 9.
- AMERICAN COLLEGE OF CARDIOLOGY FOUNDATION, WASHINGTON, DC:
3,480,551, PUB. 5-20-2008. INT. CL. 35.
- AMERICAN CONCRETE INSTITUTE, FARMINGTON HILLS, MI:
3,478,906, PUB. 5-20-2008. MULTIPLE CLASS, INT. CLS. 36 AND 41.
- AMERICAN CONIFER SOCIETY, LEWISVILLE, NC:
3,479,315, PUB. 5-20-2008. INT. CL. 31.
- AMERICAN COUNCIL ON EDUCATION, WASHINGTON, DC:
3,479,559, PUB. 5-20-2008. INT. CL. 41.
- AMERICAN DENTAL TECHNOLOGIES, INC., SOUTH-FIELD, MI:
2,493,308, CANC. INT. CL. 10.
- AMERICAN DIABETES ASSOCIATION, INC., ALEXANDRIA, VA:
3,478,968, PUB. 5-20-2008. MULTIPLE CLASS, INT. CLS. 16 AND 41.
- AMERICAN DIGITAL CARTOGRAPHY INC., APPLETON, WI:
2,493,329, CANC. INT. CL. 35.
- AMERICAN FARM BUREAU FEDERATION, WASHINGTON, DC:
3,482,141, INT. CL. 36.
- AMERICAN FASTPITCH ASSOCIATION, ANAHEIM, CA:
2,160,189, REN. 6-28-08. U.S. CL. 200.
2,160,210, REN. 6-28-08. U.S. CL. 200.
2,160,211, REN. 6-28-08. INT. CL. 25.
- AMERICAN FEDERATION OF MOTORCYCLISTS, INCORPORATED, NEWARK, CA:
3,479,447, PUB. 5-20-2008. MULTIPLE CLASS, INT. CLS. 35 AND 41.
- AMERICAN GEOLOGICAL INSTITUTE, ALEXANDRIA, VA:
3,480,705, PUB. 5-20-2008. INT. CL. 42.
- AMERICAN GIRL, LLC, EL SEGUNDO, CA:
3,482,098, INT. CL. 28.
- AMERICAN GRANBY, INC., LIVERPOOL, NY, GROUND WATER INDUSTRIES, INC., LIVERPOOL, NY, DBA THE AMERICAN GRANBY CO.:
1,345,556, REN. 7-3-08. INT. CL. 6.
- AMERICAN GREASE STICK COMPANY, MUSKEGON, MI, DBA AGS:
3,481,973, INT. CL. 6.
- AMERICAN HOFMANN CORPORATION, LYNCHBURG, VA:
3,482,052, INT. CL. 9.
- AMERICAN HOSPITAL ASSOCIATION, CHICAGO, IL:
3,387,277, AM. INT. CL. 42.
- AMERICAN INSTANTS, INC., FLANDERS, NJ:
3,481,572, INT. CL. 32.
- AMERICAN INSTITUTE FOR PLASTIC SURGERY, PLANO, TX:
3,482,019, INT. CL. 10.
- AMERICAN INTERNATIONAL GROUP, INC., NEW YORK, NY:
2,492,221, CANC. INT. CL. 36.
2,493,577, CANC. INT. CL. 36.
3,480,250, PUB. 5-20-2008. INT. CL. 36.
3,480,312, PUB. 5-20-2008. INT. CL. 36.
3,480,495, PUB. 5-20-2008. INT. CL. 36.
3,480,508, PUB. 5-20-2008. INT. CL. 36.
3,480,509, PUB. 5-20-2008. INT. CL. 36.
- AMERICAN LIFELINE, INC, BARABOO, WI:
3,479,255, PUB. 5-20-2008. INT. CL. 5.
- AMERICAN LUNG ASSOCIATION OF THE SOUTHEAST, INCORPORATED, JACKSONVILLE, FL:
3,480,387, PUB. 5-20-2008. INT. CL. 35.
- AMERICAN MEDIA, INC., WESTLAKE VILLAGE, CA:
2,098,901, CANC. INT. CL. 9.
- AMERICAN NATIONAL BANK, DENVER, CO:
3,478,957, PUB. 5-20-2008. INT. CL. 36.
- AMERICAN NEWLAND COMMUNITIES, LP, SAN DIEGO, CA:
3,481,072, INT. CL. 36.
- AMERICAN PUBLIC POWER ASSOCIATION, WASHINGTON, DC:
3,482,182, INT. CL. 35.
- AMERICAN RACING EQUIPMENT, INC., RANCHO DOMINGUEZ, CA:
2,166,255, REN. 6-30-08. INT. CL. 12.
- AMERICAN RESEARCH COMPANY, INC., GREAT FALLS, VA:
3,480,447, PUB. 5-20-2008. INT. CL. 36.
- AMERICAN SAFETY RAZOR COMPANY, CEDAR KNOLLS, NJ:
2,166,321, REN. 6-30-08. INT. CL. 10.
- AMERICAN SECURITY INSURANCE GROUP, ATLANTA, GA:
1,458,669, CANC. INT. CL. 36.
- AMERICAN SOCIETY FOR MICROBIOLOGY, WASHINGTON, DC:
3,479,030, PUB. 5-20-2008. INT. CL. 16.
- AMERICAN SOCIETY FOR NUTRITION, BETHESDA, MD:
3,480,057, PUB. 5-20-2008. MULTIPLE CLASS, INT. CLS. 16, 35 AND 41.
- AMERICAN SOCIETY FOR SURGERY OF THE HAND, ROSEMONT, IL:
3,479,295, PUB. 5-20-2008. MULTIPLE CLASS, INT. CLS. 35 AND 41.
- AMERICAN SOCIETY FOR THERAPEUTIC RADIOLOGY AND ONCOLOGY, THE, FAIRFAX, VA:
3,480,598, PUB. 5-20-2008. MULTIPLE CLASS, INT. CLS. 16, 35, 41, 42 AND 44.
- AMERICAN SOCIETY OF CATARACT AND REFRACTIVE SURGERY, FAIRFAX, VA:
3,479,058, PUB. 5-20-2008. U.S. CL. B.
- AMERIPRISE FINANCIAL, INC., MINNEAPOLIS, MN:
3,479,815, PUB. 5-20-2008. INT. CL. 36.
- AMERISERVE FOOD DISTRIBUTION, INC., ADDISON, TX:
2,493,195, CANC. MULTIPLE CLASS, INT. CLS. 9 AND 42.
- AMES TRUE TEMPER PROPERTIES, INC., WILMINGTON, DE:
3,478,727, PUB. 5-20-2008. INT. CL. 12.
- AMETEK, INC., PAOLI, PA:
3,481,764, INT. CL. 9.
- AMMAS.COM LIMITED, TAKAPUNA, AUCKLAND, NEW ZEALAND:
3,480,585, PUB. 10-9-2007. MULTIPLE CLASS, INT. CLS. 35, 41, 42, 44 AND 45.
- AMNESTY INTERNATIONAL, U.S.A., NEW YORK, NY:
2,161,790, REN. 7-2-08. INT. CL. 42.
- AMODA, SANGO, BROOKLYN, NY:
3,170,931, CANC. INT. CL. 25.
- AMOREPACIFIC CORPORATION, SEOUL, REPUBLIC OF KOREA:
3,479,462, PUB. 5-20-2008. INT. CL. 3.
- AMPHENOL-TUCHEL ELECTRONICS GMBH, HEILBRONN, FED REP GERMANY:
3,482,160, INT. CL. 9.

- AMS RESEARCH CORPORATION, MINNETONKA, MN:
3,479,311, PUB. 5-20-2008. INT. CL. 10.
- AMSTED INDUSTRIES INCORPORATED, CHICAGO, IL:
2,100,137, CANC. INT. CL. 12.
- AMTECH CORPORATION, DALLAS, TX TO JOHNSON
CONTROLS, INC., MILWAUKEE, WI:
2,098,551, CANC. INT. CL. 9.
- AMY KATHERINE SMITH, SAN FRANCISCO, CA:
3,478,877, PUB. 5-20-2008. INT. CL. 41.
- AMY TENDERICH LLC, MILLBRAE, CA:
3,478,625, PUB. 5-20-2008. INT. CL. 44.
- ANA GLOBAL INC., SAN MATEO, CA:
3,480,130, PUB. 5-20-2008. MULTIPLE CLASS, INT. CLS.
20 AND 35.
- ANACOMP, INC., SAN DIEGO, CA:
1,324,169. REN. 7-3-08. INT. CL. 9.
1,329,987. REN. 7-3-08. INT. CL. 35.
- ANALYTIC SERVICES INC. DBA ANSER, ARLINGTON,
VA:
3,478,849, PUB. 5-20-2008. MULTIPLE CLASS, INT. CLS.
41 AND 42.
3,478,850, PUB. 5-20-2008. MULTIPLE CLASS, INT. CLS.
41 AND 42.
- ANCHORAGE FOUNDATION OF TEXAS, HOUSTON, TX:
3,478,897, PUB. 5-20-2008. INT. CL. 41.
- ANCIEN ET MYSTIQUE ORDRE DE LA ROSE CROIX, EN
ABRÉGÉ A.M.O.R.C., ÉGALEMENT CONNU SOUS LE
NOM DE ORDRE DE LA ROSE-CROIX, FRANCE:
3,480,753, PUB. 5-20-2008. MULTIPLE CLASS, INT. CLS.
3, 9, 16, 35, 38, 39 AND 41.
- ANDALE SOFTWARE, LLC, EAGAN, MN:
3,481,571, INT. CL. 9.
- ANDANTE S.P.A., 20063 - CERNUSCO SUL NAVIGLIO
(MILANO), ITALY:
2,491,878, CANC. MULTIPLE CLASS, INT. CLS. 7 AND 9.
- ANDERS ERICSSON, SWEDEN AND ANDREAS HURTIG,
SWEDEN AND MATHIAS RINGBLOM, SWEDEN:
3,480,935, PUB. 5-20-2008. INT. CL. 41.
- ANDERSON & MIDDLETON COMPANY, HOQUIAM, WA:
3,481,678, INT. CL. 33.
- ANDERSON ARMOR & SECURITY LLC, COLUMBIA, PA:
3,480,151, PUB. 5-20-2008. INT. CL. 9.
- ANDERSON PRESS INCORPORATED, FLORENCE, AL:
2,168,401. REN. 7-3-08. INT. CL. 16.
- ANDIN INTERNATIONAL INC., NEW YORK, NY:
3,479,331, PUB. 5-20-2008. MULTIPLE CLASS, INT. CLS.
14 AND 35.
- ANDIS COMPANY, STURTEVANT, WI:
2,206,985. REN. 7-3-08. INT. CL. 9.
- ANDRE ROMANELLI, INC., NEW YORK, NY:
2,493,312, CANC. INT. CL. 25.
- ANDREA ELECTRONICS CORPORATION, MELVILLE, NY:
2,493,127, CANC. INT. CL. 9.
- ANDREYO, KEVIN M., LEESPORT, PA:
2,492,796, CANC. INT. CL. 28.
- ANDROID INDUSTRIES, L.L.C., AUBURN HILLS, MI:
3,480,639, PUB. 5-20-2008. INT. CL. 40.
- ANGELANTONI INDUSTRIE S.P.A., MASSA MARTANA
(PERUGIA), ITALY:
3,482,153, INT. CL. 9.
- ANGELO CELLARS LLC, COLORADO SPRINGS, CO:
3,480,194, PUB. 5-20-2008. INT. CL. 33.
- ANGELOPOULOS, JIM, SAN JOSE, CA:
2,493,279, CANC. INT. CL. 42.
- ANGLO-AMERICAN CLAYS CORPORATION, ATLANTA,
GA:
1,457,858, CANC. INT. CL. 1.
- ANGULO GENERAL QUESERA, S.L., BURGOS, SPAIN:
3,479,862, PUB. 5-20-2008. INT. CL. 29.
- ANHEUSER-BUSCH, INCORPORATED, ST. LOUIS, MO:
2,493,144, CANC. INT. CL. 32.
2,493,250, CANC. INT. CL. 25.
3,479,093, PUB. 5-20-2008. INT. CL. 19.
- ANIMAL LOVERS PET CENTRE INC., SEQUIM, WA:
1,491,932. REN. 6-30-08. INT. CL. 5.
- ANIMAL PROTECTION INSTITUTE, SACRAMENTO, CA:
3,482,516, U.S. CL. B.
- ANNE C. SLENTZ, KANSAS CITY, MO:
3,479,388, PUB. 5-20-2008. INT. CL. 42.
- ANNIE INTERNATIONAL, INC., NORTH WALES, PA:
3,482,269, INT. CL. 8.
- ANNUNZIATA, VINCENZO, ITALY:
3,480,911, PUB. 5-20-2008. MULTIPLE CLASS, INT. CLS.
9, 18 AND 25.
- ANORGA, ALFONSO JOSE, JR., COMMERCE, CA:
3,481,370, INT. CL. 3.
3,481,371, INT. CL. 3.
- ANOUSKA HEMPEL LIMITED, LONDON, ENGLAND:
1,458,416, CANC. INT. CL. 25.
- ANSYR TECHNOLOGY CORPORATION, BELLEVUE, WA:
2,493,576, CANC. INT. CL. 9.
- ANTARUS BIOTECH, INC., HUNTSVILLE, AL:
3,481,262, INT. CL. 35.
- ANTEO GROUP, LLC, ATLANTA, GA:
3,478,632, PUB. 5-20-2008. MULTIPLE CLASS, INT. CLS.
35 AND 42.
3,478,633, PUB. 5-20-2008. MULTIPLE CLASS, INT. CLS.
35 AND 42.
- ANTHONY, FRANCES J., SUNBURY, OH:
2,242,743. REN. 7-2-08. INT. CL. 16.
- ANTHRO CORPORATION, TUALATIN, OR:
3,482,320, MULTIPLE CLASS, INT. CLS. 9 AND 20.
- ANTIX PARTNERSHIP, LLC, LEAWOOD, KS:
3,479,600, PUB. 5-20-2008. INT. CL. 35.
- ANTON PLATTNER, FED REP GERMANY:
3,481,007, PUB. 5-20-2008. INT. CL. 31.
- ANTONIO J. DEL RINCON PINEDA, DALLAS, TX:
2,492,813, CANC. INT. CL. 25.
- ANV CONSTRUCTION GROUP, INCORPORATED, MANA-
SSAS, VA:
3,480,304, PUB. 5-20-2008. INT. CL. 37.
- AOL LLC, DULLES, VA:
3,480,490, PUB. 5-20-2008. INT. CL. 38.
- APADANA, INC., NEW YORK, NY:
2,491,763, CANC. INT. CL. 35.
- APARICIO, JORGE, MIAMI, FL:
3,479,398, PUB. 5-20-2008. INT. CL. 5.
- APARTMENT TEMPORARIES INCORPORATED, IRVING,
TX:
2,491,705, CANC. INT. CL. 35.
- APDN (B.V.I) INC., ROADTOWN, BR.VIRGIN ISLANDS:
3,482,366, INT. CL. 16.
- APERTURE TECHNOLOGIES, INC., STAMFORD, CT:
3,480,242, PUB. 5-20-2008. INT. CL. 42.
3,480,518, PUB. 5-20-2008. INT. CL. 41.
3,480,519, PUB. 5-20-2008. INT. CL. 42.
- APOLLO PRODUCTS, INC., KANSAS CITY, MO:
2,166,100. REN. 6-30-08. MULTIPLE CLASS, INT. CLS. 3,
26 AND 42.
- APPAMAN INC., NEW YORK, NY:
3,479,724, PUB. 5-20-2008. INT. CL. 25.
3,479,762, PUB. 5-20-2008. INT. CL. 25.
- APPLIANCE SCIENTIFIC, DALLAS, TX:
3,479,857, PUB. 5-20-2008. INT. CL. 11.
3,479,858, PUB. 5-20-2008. INT. CL. 11.
- APPLIED GENETICS INCORPORATED DERMATICS,
FREEPORT, NY:
2,657,070, COR. INT. CL. 5.
- APPLIED MATERIALS, INC., SANTA CLARA, CA:
3,481,062, INT. CL. 37.
- APPLIED ROBOTICS, INC., HARWOOD, MD:
3,480,449, PUB. 5-20-2008. INT. CL. 7.
- APPLIED SEALS CO., LTD., CHANGHUA COUNTY, TAI-
WAN:
3,482,232, INT. CL. 17.
- APPLIED SEWING RESOURCES, INC., BENICIA, CA:
3,481,074, INT. CL. 18.
- APPOSITE TECHNOLOGIES, INC., BEVERLY HILLS, CA:
3,482,425, INT. CL. 9.
- APPRECIATING ASSETS, LLC, MARIETTA, GA:
3,480,079, PUB. 5-20-2008. INT. CL. 35.
- AQUA-LEISURE INDUSTRIES, INC., AVON, MA:
1,458,137, CANC. INT. CL. 9.
3,482,145, INT. CL. 28.

AQUA-VEE, LLC., MIAMI, FL:
3,481,329, INT. CL. 28.

AQUARIAN FOUNDATION, SEATTLE, WA:
3,481,187, INT. CL. 16.
3,481,188, INT. CL. 16.

AQUARIUM HOLDINGS OF NORTHERN KENTUCKY, LLC, NEWPORT, KY:
2,493,017, CANC. INT. CL. 41.

AQUASOL CORPORATION, PINEVILLE, NC:
3,478,996, PUB. 5-20-2008. INT. CL. 1.

AQUATICA, INC., MINNEAPOLIS, MN, DBA AQUATICA WATER GARDENS:
3,479,828, PUB. 5-20-2008. INT. CL. 19.

AQUILA DISTRIBUTORS, INC., NEW YORK, NY:
2,491,890, CANC. INT. CL. 36.

ARAMARK UNIFORM & CAREER APPAREL, INC., BURBANK, CA:
2,492,929, CANC. INT. CL. 42.

ARAUJO, JESS J., SANTA ANA, CA:
2,492,557, CANC. INT. CL. 42.

ARBONNE INTERNATIONAL, LLC, IRVINE, CA:
2,100,274, CANC. INT. CL. 5.

ARC LUXE LLC, CHARLOTTE, NC:
3,481,783, INT. CL. 20.

ARCADIA GROUP, ATLANTA, GA:
3,481,600, INT. CL. 9.

ARCELORMITTAL FLAT CARBON EUROPE SA, LUXEMBOURG:
3,480,843, PUB. 5-20-2008. MULTIPLE CLASS, INT. CLS. 6 AND 12.

ARCHON TECHNOLOGIES LTD., CALGARY, ALBERTA, T2P 4H4, CANADA:
3,478,503, PUB. 10-2-2007. MULTIPLE CLASS, INT. CLS. 37 AND 40.

ARCIERI, STANLEY, MILL VALLEY, CA, DBA BIOPHARMACA:
3,480,086, PUB. 5-20-2008. INT. CL. 5.

ARDENT OUTDOORS, INC., ST. LOUIS, MO:
3,478,747, PUB. 5-20-2008. INT. CL. 3.

ARGARD CO., LTD., WANGTHONGLANG, BANGKOK, THAILAND:
3,481,438, INT. CL. 9.
3,481,440, INT. CL. 9.

ARGON ENGINEERING ASSOCIATES, INC., FAIRFAX, VA:
2,491,809, CANC. INT. CL. 42.

ARGOSY GAMING COMPANY, ALTON, IL:
2,099,242, CANC. INT. CL. 41.

ARGYLE HOLDINGS, LLC, PORTLAND, ME:
3,482,444, MULTIPLE CLASS, INT. CLS. 19 AND 27.

ARIANNA FARMS 'ONO KONA COFFEE, LLC, CAMARILLO, CA:
3,480,098, PUB. 5-20-2008. INT. CL. 30.
3,480,109, PUB. 5-20-2008. INT. CL. 30.
3,480,110, PUB. 5-20-2008. INT. CL. 30.
3,480,111, PUB. 5-20-2008. INT. CL. 30.
3,480,112, PUB. 5-20-2008. INT. CL. 30.

ARISTOCRAT TECHNOLOGIES AUSTRALIA PTY LIMITED, NEW SOUTH WALES 2066, AUSTRALIA:
2,165,443, REN. 6-30-08. INT. CL. 9.

ARISTOCRAT TECHNOLOGIES AUSTRALIA PTY LTD., LANE COVE, NSW, AUSTRALIA:
3,478,740, PUB. 5-20-2008. INT. CL. 9.

ARISTOCRAT TECHNOLOGIES AUSTRALIA PTY LTD, LANE COVE, NSW, AUSTRALIA:
3,480,530, PUB. 5-20-2008. INT. CL. 28.

ARISTOCRAT TECHNOLOGIES AUSTRALIA PTY LTD, AUSTRALIA:
3,480,782, PUB. 5-20-2008. MULTIPLE CLASS, INT. CLS. 9 AND 41.

ARISTOCRAT TECHNOLOGIES AUSTRALIA PTY LTD, LANE COVE, NSW, AUSTRALIA:
3,481,391, INT. CL. 9.

ARISTOTLE INC., LITTLE ROCK, AR:
2,250,958, REN. 7-3-08. MULTIPLE CLASS, INT. CLS. 41 AND 42.

ARIZONA FAST SHIRTS, LLC, PHOENIX, AZ:
3,479,187, PUB. 5-20-2008. INT. CL. 40.

ARIZONA LIGHT CREATIONS, INC., SCOTTSDALE, AZ:
2,493,358, CANC. INT. CL. 11.

ARIZONA MAIL ORDER COMPANY, INC., TUCSON, AZ:
3,482,356, INT. CL. 25.

ARIZONA NUTRITIONAL SCIENCES, LLC, CAVE CREEK, AZ:
3,479,356, PUB. 2-12-2008. INT. CL. 5.

ARJO LIMITED, GLOUCESTER, UNITED KINGDOM:
2,491,943, CANC. INT. CL. 10.

ARK ASSOCIATES, INC., QUINCY, MA:
2,493,695, CANC. INT. CL. 42.

ARMOR HOLDINGS PRODUCTS, LLC, JACKSONVILLE, FL:
3,479,106, PUB. 5-20-2008. INT. CL. 9.

ARNELL, PETER, NEW YORK CITY, NY:
2,492,789, CANC. INT. CL. 28.

ARNOLD & RICHTER CINE TECHNIK GMBH & CO. BETRIEBS KG, FED REP GERMANY:
3,480,891, PUB. 5-20-2008. MULTIPLE CLASS, INT. CLS. 9 AND 11.

3,480,892, PUB. 5-20-2008. MULTIPLE CLASS, INT. CLS. 9 AND 11.

AROBELLA MEDICAL, LLC, MINNETONKA, MN:
3,481,561, INT. CL. 10.
3,481,672, INT. CL. 10.
3,481,679, INT. CL. 10.

ARQ ENTERPRISES, INC, POWAY, CA:
2,182,191, REN. 7-3-08. INT. CL. 20.

ART IN A BOX, INC., NEW YORK, NY:
3,479,684, PUB. 5-20-2008. INT. CL. 16.

ARTER NEON SIGN, INC., S. EL MONTE, CA:
3,478,793, PUB. 5-20-2008. INT. CL. 9.

ARTHRITIS FOUNDATION, INC., THE, ATLANTA, GA:
1,458,688, CANC. INT. CL. 36.

ARTHUR MURRAY INTERNATIONAL, INC., CORAL GABLES, FL:
1,492,655, REN. 6-28-08. INT. CL. 41.

ARTISAN CONFECTIONS COMPANY, HERSHEY, PA:
3,479,425, PUB. 5-20-2008. INT. CL. 30.
3,479,426, PUB. 5-20-2008. INT. CL. 30.
3,479,495, PUB. 5-20-2008. INT. CL. 30.

ARTISAN ENTERTAINMENT INC., SANTA MONICA, CA, INTERNATIONAL VIDEO ENTERTAINMENT, INC., CANOGA PARK, CA:
1,334,784, REN. 7-3-08. INT. CL. 41.

ARTIX ENTERTAINMENT, LLC, LAND O' LAKES, CA:
3,480,368, PUB. 5-20-2008. INT. CL. 41.

ARTIX ENTERTAINMENT, LLC, LAND O' LAKES, FL:
3,480,375, PUB. 5-20-2008. INT. CL. 41.

ARTIX ENTERTAINMENT, LLC, SAN FRANCISCO, CA:
3,480,377, PUB. 5-20-2008. INT. CL. 41.

ARTIX ENTERTAINMENT, LLC, LAND O' LAKES, CA:
3,480,562, PUB. 5-20-2008. INT. CL. 28.

ARTSY DOTS, LLC, PEMBROKE PINES, FL:
3,481,268, INT. CL. 14.

ARUZE CORPORATION, TOKYO, JAPAN:
3,478,814, PUB. 3-18-2008. INT. CL. 9.

ARZANA' SPA, ITALY:
3,480,824, PUB. 5-20-2008. INT. CL. 12.

ASBERRY, DEBRA, EDGEWATER, MD:
3,479,882, PUB. 5-20-2008. INT. CL. 39.

ASBILL, KAYE E, RICHMOND, VA:
2,492,782, CANC. INT. CL. 41.

ASHLAND LICENSING AND INTELLECTUAL PROPERTY LLC, DUBLIN, OH, ARCHER-DANIELS-MIDLAND COMPANY, MINNEAPOLIS, MN:
812,340, REN. 7-3-08. U.S. CL. 1 (INT. CL. 1).

ASIAN PACIFIC BANCORP INC, CLAYTON, MO:
3,481,104, INT. CL. 36.

ASILLEM LLC, SHERBORN, MA:
3,479,003, PUB. 5-20-2008. INT. CL. 43.

ASSET ACCEPTANCE LLC, WARREN, MI:
3,480,066, PUB. 5-20-2008. INT. CL. 36.

ASSET MARKETING SYSTEMS INSURANCE SERVICES, LLC, SAN DIEGO, CA:
2,491,975, CANC. INT. CL. 36.

ASSOCIATED BAPTIST PRESS, JACKSONVILLE, FL:
2,491,799, CANC. MULTIPLE CLASS, INT. CLS. 9 AND

16.
ASSOCIATED PRESS, THE, NEW YORK, NY:
2,156,050. REN. 6-30-08. INT. CL. 42.
- ASSOCIATED PRODUCTION MUSIC LLC, HOLLYWOOD, CA:
3,479,734. PUB. 5-20-2008. MULTIPLE CLASS, INT. CLS. 35 AND 41.
- ASSOCIATED PUBLISHING COMPANY, INC., ABILENE, TX:
2,099,319. CANC. INT. CL. 16.
- ASSOCIATED SPACE DESIGN, INC., ATLANTA, GA:
3,481,539. MULTIPLE CLASS, INT. CLS. 37 AND 42.
- ASSOCIATED WHOLESALE GROCERS, INC., KANSAS CITY, KS:
2,493,423. CANC. INT. CL. 30.
3,479,850. PUB. 5-20-2008. MULTIPLE CLASS, INT. CLS. 29 AND 30.
3,479,853. PUB. 5-20-2008. INT. CL. 30.
- ASSOCIATES IN MEDICAL MARKETING CO., INC., NEW-TOWN, PA:
3,478,605. PUB. 5-20-2008. INT. CL. 16.
3,478,606. PUB. 5-20-2008. INT. CL. 16.
- ASSOCIATION RESERVES, INC., CALABASAS, CA:
3,481,117. INT. CL. 42.
- ASSURANCEAMERICA CORPORATION, ATLANTA, GA:
3,482,316. INT. CL. 36.
- ASTRAZENECA UK LIMITED, LONDON, ENGLAND:
3,482,189. INT. CL. 44.
- ASTRUM DIGITAL INFORMATION, INC., ALEXANDRIA, VA:
2,492,577. CANC. INT. CL. 35.
- ASV WINES, INC., DELANO, CA:
3,482,428. INT. CL. 33.
- AT&T CORP., NEW YORK, NY:
2,099,822. CANC. INT. CL. 38.
- AT&T INTELLECTUAL PROPERTY II, L.P., RENO, NV:
1,458,170. CANC. INT. CL. 9.
1,458,172. CANC. INT. CL. 9.
1,458,173. CANC. INT. CL. 9.
2,154,560. REN. 7-2-08. INT. CL. 38.
3,478,702. PUB. 5-20-2008. MULTIPLE CLASS, INT. CLS. 37 AND 38.
- ATALLAH, SAMIRA, MIAMI, FL:
2,492,391. CANC. INT. CL. 42.
- ATAPCO PROPERTIES, INC., BALTIMORE, MD:
2,492,405. CANC. MULTIPLE CLASS, INT. CLS. 36 AND 37.
- ATAPIC REAL ESTATE INVESTMENT, LLC, JACKSONVILLE, FL:
3,482,379. INT. CL. 36.
- ATCOM SERVICES, INC., CLARK, NJ:
3,480,488. PUB. 5-20-2008. MULTIPLE CLASS, INT. CLS. 20 AND 35.
3,480,489. PUB. 5-20-2008. MULTIPLE CLASS, INT. CLS. 20 AND 35.
- ATD-AMERICAN CO., WYNCOTE, PA:
2,099,219. CANC. INT. CL. 20.
- ATEK, INC., SANTA ANA, CA:
3,479,713. PUB. 5-20-2008. INT. CL. 9.
- ATF, INC., LINCOLNWOOD, IL:
3,482,462. INT. CL. 12.
- ATHENA INTERNATIONAL, CHICAGO, IL:
2,123,645. REN. 7-2-08. MULTIPLE CLASS, INT. CLS. 6 AND 14.
- ATLANTIC REPRESENTATIONS, INC., SANTA FE SPRINGS, CA. DBA ATLANTIC INC.:
3,481,079. INT. CL. 9.
- ATLANTIC WESTERN CONSULTING, INC., WOBURN, MA:
2,491,921. CANC. MULTIPLE CLASS, INT. CLS. 35 AND 37.
- ATLANTIS ENERGY, INC., COLFAX, CA:
3,478,826. PUB. 5-20-2008. INT. CL. 9.
- ATLAS COPCO AIRPOWER,; NAAMLOZE VEN-NOOTSCHAP, BELGIUM:
3,480,899. PUB. 5-20-2008. MULTIPLE CLASS, INT. CLS. 7, 35 AND 37.
- ATLAS SOUNDOLIER, LP DBA ATLAS SOUND, LP, ENNIS, TX:
1,493,954. REN. 7-3-08. INT. CL. 9.
- ATOMIC ENERGY OF CANADA LIMITED, ONTARIO, CANADA:
3,480,740. PUB. 5-20-2008. INT. CL. 1.
- ATRONIC INTERNATIONAL GMBH, LÜBBECKE, FED REP GERMANY:
3,478,659. PUB. 5-20-2008. MULTIPLE CLASS, INT. CLS. 9 AND 41.
3,478,723. PUB. 5-20-2008. MULTIPLE CLASS, INT. CLS. 9 AND 41.
- ATWOOD, AARON D., PALMYRA, IL:
3,482,148. INT. CL. 31.
- AU'SOME, INC., MONMOUTH, NJ:
3,481,297. INT. CL. 29.
- AUCTIVA CORPORATION, GRANITE BAY, CA:
2,492,059. CANC. INT. CL. 35.
- AUDIO HOUSE, INC., THE, NEW YORK, NY:
2,491,883. CANC. INT. CL. 41.
- AUDIOLINK, INC., WATERTOWN, MA:
2,493,644. CANC. INT. CL. 42.
- AUDLEY SHOES GMBH, FED REP GERMANY:
3,480,763. PUB. 5-20-2008. MULTIPLE CLASS, INT. CLS. 18 AND 25.
- AUGAT INC., MANSFIELD, MA:
1,458,091. CANC. INT. CL. 9.
- AUGUST KIRCHNER, WALDFEUCHT-HAAREN, FED REP GERMANY AND GOTTHARD KIRCHNER, WALDFEUCHT-HAAREN, FED REP GERMANY:
3,478,705. PUB. 1-8-2008. INT. CL. 30.
- AUGUST STORCK KG, 13403 BERLIN, FED REP GERMANY, AUGUST STORCK G. M. B. H., HALLE, WESTPHALIA, FED REP GERMANY:
663,874. REN. 7-3-08. U.S. CL. 46 (INT. CL. 30).
- AUGUSTINE, DAVID, LAGUNA NIGUEL, CA:
3,481,951. INT. CL. 21.
- AUNT BETSY'S LLC, WEST HAVEN, CT:
3,481,080. INT. CL. 30.
- AURELIO, JULIO FRANCISCO ANTONIO, BUENOS AIRES, ARGENTINA:
3,480,658. PUB. 10-9-2007. MULTIPLE CLASS, INT. CLS. 35 AND 42.
- AUSTRALIA VISION SERVICES PTY. LTD., WYONG NORTH, NEW SOUTH WALES, AUSTRALIA:
2,493,131. CANC. INT. CL. 9.
- AUTISM SOCIETY OF AMERICA, INC., BETHESDA, MD:
3,480,632. PUB. 5-20-2008. MULTIPLE CLASS, INT. CLS. 16, 36, 41, 44 AND 45.
- AUTO ADDITIONS, INC., SALEM, OR:
3,482,100. INT. CL. 9.
- AUTO ADVISORY SERVICES, INC., TUSTIN, CA:
3,479,286. PUB. 5-20-2008. INT. CL. 16.
3,479,287. PUB. 5-20-2008. INT. CL. 45.
- AUTO METER PRODUCTS, INC., SYCAMORE, IL:
1,497,472. REN. 6-28-08. INT. CL. 9.
- AUTO VENTSHADE COMPANY, LAWRENCEVILLE, GA TO LUND, INC., SUWANEE, GA:
2,100,494. CANC. INT. CL. 12.
- AUTODEALING SOFTWARE LIMITED, DUBLIN 2, IRELAND:
2,491,649. CANC. MULTIPLE CLASS, INT. CLS. 9, 36 AND 38.
- AUTODESK, INC., SAN RAFAEL, CA:
3,479,250. PUB. 5-20-2008. INT. CL. 9.
- AUTOMATED INSTALLMENT SYSTEMS, INC., ST. LOUIS, MO:
3,482,433. INT. CL. 36.
- AUTOMATIC DEVICES COMPANY, ALLENTOWN, PA, AUTOMATIC DEVICES COMPANY, ALLENTOWN, PA:
869,269. REN. 7-1-08. U.S. CL. 13 (INT. CL. 20).
- AUTOMATIC PRINCESS HOLDINGS, LLC, WHITE PLAINS, NY:
3,128,187. COR. MULTIPLE CLASS, INT. CLS. 9 AND 16.
- AUTOMATIC SYSTEMS, INC., KANSAS CITY, MO:
1,351,344. REN. 7-3-08. INT. CL. 7.

AUTOMOBILE CLUB OF SOUTHERN CALIFORNIA, COSTA MESA, CA:
2,161,044. REN. 6-30-08. INT. CL. 16.

AUTOMOBILE PROTECTION CORPORATION, NORCROSS, GA:
2,123,625. REN. 7-3-08. INT. CL. 36.

AUTOMONEY, INC., LA MESA, CA:
2,491,886. CANC. INT. CL. 36.

AUTOMOTIVE CASTING TECHNOLOGY, INC., FRUITPORT, MI:
3,482,570. INT. CL. 42.

AVA, INC., UNIVERSAL CITY, TX, DBA AMERICAN VOLKSSPORT ASSOCIATION:
1,491,683. REN. 6-30-08. INT. CL. 42.

AVANTGARDE ACOUSTIC LAUTSPRECHERSYSTEME GMBH, 65520 BAD CAMBERG, FED REP GERMANY:
2,178,933. REN. 6-30-08. INT. CL. 9.
2,201,713. REN. 6-30-08. INT. CL. 9.

AVB, INC., MILWAUKIE, OR:
3,481,739. INT. CL. 30.

AVEDA CORPORATION, MINNEAPOLIS, MN:
3,481,360. INT. CL. 42.
3,481,864. INT. CL. 3.
3,481,865. INT. CL. 3.
3,481,866. INT. CL. 3.
3,481,867. INT. CL. 3.
3,481,868. INT. CL. 3.
3,481,869. INT. CL. 3.
3,481,870. INT. CL. 3.

AVENIR ASSOCIATES INC, PISCATAWAY, NJ:
3,478,964. PUB. 5-20-2008. MULTIPLE CLASS, INT. CLS. 35 AND 42.

AVF GROUP LIMITED, TF1 7YE, UNITED KINGDOM:
3,482,120. INT. CL. 6.

AVI FOODSYSTEMS INC., WARREN, OH:
2,222,847. REN. 7-1-08. INT. CL. 30.

AVIAT AIRCRAFT, INC., AFTON, WY:
3,478,855. PUB. 5-20-2008. MULTIPLE CLASS, INT. CLS. 16, 35, 37 AND 40.

AVID TECHNOLOGY, INC., TEWKSBURY, MA:
3,482,480. INT. CL. 9.

AVNET, INC., PHOENIX, AZ:
3,479,935. PUB. 5-20-2008. INT. CL. 41.

AVOCENT HUNTSVILLE CORP., HUNTSVILLE, AL:
2,491,839. CANC. INT. CL. 9.

AVON PRODUCTS, INC., NEW YORK, NY:
2,492,961. CANC. INT. CL. 3.
2,511,439. CANC. INT. CL. 21.
3,481,656. INT. CL. 3.
3,481,706. INT. CL. 3.

AVTV NETWORKS, INC., HACKENSACK, NJ:
3,478,672. PUB. 5-20-2008. INT. CL. 38.

AW DIRECT, INC., JANESVILLE, WI:
2,492,538. CANC. INT. CL. 16.

AXIS SYSTEMS, INC., SUNNYVALE, CA:
2,492,801. CANC. INT. CL. 9.

AXYGEN SCIENTIFIC, INC., UNION CITY, CA:
3,481,863. INT. CL. 9.

AYSE SEN, LA MESA, CA:
3,482,701. INT. CL. 21.

AZIENDA GOMBA SOCIETA' SEMPLICE AGRICOLA, ITALY:
3,480,866. PUB. 5-20-2008. INT. CL. 33.

AZIENDA SPECIALE; "REAL PRECIOUS QUALITY", ITALY:
3,481,040. PUB. 5-20-2008. MULTIPLE CLASS, INT. CLS. 41 AND 42.
3,481,041. PUB. 5-20-2008. MULTIPLE CLASS, INT. CLS. 41 AND 42.

AZIENDA VINICOLA SAN GIOVANNI DI PERINI DORIGO BERNADETTE & C. - S.N.C., I-31015 CONEGLIANO (TREVISO), ITALY:
3,480,920. PUB. 5-20-2008. INT. CL. 33.

AZIMA, INC., WOBURN, MA:
3,480,100. PUB. 5-20-2008. INT. CL. 42.
3,480,101. PUB. 5-20-2008. INT. CL. 42.

AZUMA LEASING CT, LP, AUSTIN, TX:
3,479,885. PUB. 5-20-2008. INT. CL. 43.

B.B. KIRKBRIDE BIBLE CO., INC., INDIANAPOLIS, IN:
2,231,951. REN. 7-3-08. INT. CL. 16.

B.B. WALKER COMPANY, OSHEBORO, NC:
1,458,429. CANC. INT. CL. 25.

B.I.G. CORPORATION, DENVER, CO:
3,482,010. INT. CL. 25.

B.N. TECHNOLOGY, INC., LOS ANGELES, CA:
2,491,656. CANC. MULTIPLE CLASS, INT. CLS. 35, 38 AND 42.

B&C SRL, BOLOGNA, ITALY:
3,478,899. PUB. 1-29-2008. MULTIPLE CLASS, INT. CLS. 7 AND 21.

B-THERE.COM CORP., WESTPORT, CT:
2,493,179. CANC. INT. CL. 16.

BABBIDGE, MICHAEL J., DESTIN, FL:
2,492,420. CANC. INT. CL. 16.

BABCOCK & WILCOX COMPANY, THE, NEW ORLEANS, LA:
1,458,015. CANC. INT. CL. 7.

BABCOCK & WILCOX COMPANY, THE, BARBERTON, OH:
2,175,559. REN. 6-27-08. INT. CL. 11.

BABYLEGS, LLC, SEATTLE, WA:
3,481,971. INT. CL. 25.

BACANI, SHARON L., ANTIOCH, CA:
3,481,975. MULTIPLE CLASS, INT. CLS. 16 AND 25.

BACARDI & COMPANY LIMITED, VADUZ, LIECHTENSTEIN:
3,482,323. INT. CL. 33.
3,482,325. INT. CL. 33.

BACKBONE ENTERTAINMENT, IRVINE, CA:
3,480,068. PUB. 5-20-2008. MULTIPLE CLASS, INT. CLS. 9, 28 AND 42.
3,480,069. PUB. 5-20-2008. MULTIPLE CLASS, INT. CLS. 9, 28 AND 42.

BACKSAVER ACQUISITION CORPORATION, HOLLISTON, MA:
2,099,932. CANC. INT. CL. 20.

BACON PRODUCTS CORPORATION, CHATTANOOGA, TN:
3,480,407. PUB. 5-20-2008. INT. CL. 21.
3,480,408. PUB. 5-20-2008. INT. CL. 21.

BAD DAWGS, INC., PLYMOUTH, NH:
3,481,310. INT. CL. 43.

BAER, DONALD F., RANCHO PALOS VERDES, CA:
1,458,839. CANC. INT. CL. 42.

BAGBLOCKER, INC., GREENWOOD, IN:
3,482,108. INT. CL. 3.

BAGEL WORKS, INC., KEENE, NH:
2,132,526. REN. 7-2-08. MULTIPLE CLASS, INT. CLS. 30 AND 42.

BAHASH, TIMOTHY J., PHILADELPHIA, PA:
3,482,056. MULTIPLE CLASS, INT. CLS. 3 AND 21.

BAIK, SOOK, OCEANSIDE, CA:
1,458,581. CANC. INT. CL. 30.

BAILEY NURSERIES, INC., SAINT PAUL, MN:
3,481,283. INT. CL. 31.

BAILEY, HELEN, CHICAGO, IL:
3,482,202. INT. CL. 41.

BAKER COMMODITIES, INC., LOS ANGELES, CA:
2,164,855. REN. 7-3-08. INT. CL. 37.

BAKER HUGHES INCORPORATED, HOUSTON, TX:
3,481,860. INT. CL. 1.

BALABAN, DAVID, BELLEVILLE, NJ:
3,478,613. PUB. 5-20-2008. INT. CL. 16.

BALAKIAN, LEO, REEDLEY, CA AND BALAKIAN, ROSALIE, REEDLEY, CA:
1,458,611. CANC. INT. CL. 31.

BALAN BIOMEDICAL INC., WEST HENRIETTA, NY:
3,482,711. INT. CL. 35.
3,482,712. INT. CL. 35.

BALARES, ANALISA, NEW YORK, NY:
3,481,636. INT. CL. 41.

BALDWIN RICHARDS FOODS CO., FRANKFORT, IL:
3,479,415. PUB. 5-20-2008. MULTIPLE CLASS, INT. CLS. 35, 40 AND 42.

BALL CORPORATION, BROOMFIELD, CO:
2,492,673. CANC. INT. CL. 7.

- BALLANTYNE OF OMAHA, INC., OMAHA, NE:
2,198,071. REN. 7-3-08. INT. CL. 11.
- BALLET MAKERS, INC., TOTOWA, NJ:
3,482,081. INT. CL. 25.
- BALTIMORE COUNTY EMPLOYEES FEDERAL CREDIT UNION, TOWSON, MD:
3,478,966. PUB. 5-20-2008. MULTIPLE CLASS, INT. CLS. 35 AND 36.
- BALTZ, BRUCE, MIAMI, FL:
3,481,948. INT. CL. 3.
- BAMBOO-ABBOTT INC., EDISON, NJ:
2,493,197. CANC. INT. CL. 20.
- BANCO BOZANO, SIMONSEN S.A., RIO DE JANEIRO, BRAZIL:
2,491,689. CANC. INT. CL. 36.
- BANCORP HAWAII, INC., HONOLULU, HI:
1,458,684. CANC. INT. CL. 36.
- BANK OF AMERICA CORPORATION, CHARLOTTE, NC:
3,481,776. INT. CL. 35.
- BANK OF NEW YORK, THE, NEW YORK, NY:
2,492,894. CANC. INT. CL. 25.
- BANK'S VACUUM CORP., NOVI, MI:
2,492,014. CANC. INT. CL. 35.
- BANKAMERICA CORPORATION, SAN FRANCISCO, CA:
1,458,814. CANC. INT. CL. 42.
- BANKLER, STEVEN, SAN ANTONIO, TX:
2,164,138. REN. 6-30-08. INT. CL. 35.
- BANTA CORPORATION, MENASHA, WI:
2,493,344. CANC. INT. CL. 10.
2,493,345. CANC. INT. CL. 10.
- BANTAM DOUBLEDAY DELL PUBLISHING GROUP, INC., NEW YORK, NY:
1,458,807. CANC. INT. CL. 42.
- BARB, INC. DBA STAGED HOMES, CONCORD, CA:
3,479,024. PUB. 5-20-2008. INT. CL. 41.
- BARBIER, JOHAN, FORT LAUDERDALE, FL AND BEL-HOSTE, MARC, FORT LAUDERDALE, FL:
3,482,318. INT. CL. 11.
- BARDEEN AGENCY, INC., LOS ANGELES, CA:
3,481,197. INT. CL. 44.
- BARMAR, LLC, NEW YORK, NY, DBA LA PALAPA:
3,482,002. INT. CL. 30.
- BARNETT OUTDOORS, INC., ODESSA, FL:
1,504,113. REN. 6-30-08. INT. CL. 28.
- BARNHARDT MANUFACTURING COMPANY, CHARLOTTE, NC:
3,482,633. INT. CL. 3.
- BARONE, MICHAEL A., LAS VEGAS, NV:
3,481,309. INT. CL. 37.
- BARRA, CHARLES, REDWOOD VALLEY, CA AND BARRA, MARTHA, REDWOOD VALLEY, CA:
2,168,040. REN. 6-30-08. INT. CL. 33.
- BARRERA, CHRISTINE, A., ATLANTA, GA:
2,492,816. CANC. INT. CL. 41.
- BARRY CALLEBAUT AG, ZURICH, SWITZERLAND:
1,458,602. CANC. INT. CL. 30.
- BARSH, LAURENCE I., NEW YORK, NY, BARSH, LAURENCE I., NEW YORK, NY:
2,248,138. REN. 6-28-08. INT. CL. 42.
- BARTOLO, JERRY, LOCUST HILL, ONTARIO, CANADA:
1,458,374. CANC. INT. CL. 21.
- BARTON & GRAY LLC, BOSTON, MA:
3,478,687. PUB. 5-20-2008. INT. CL. 36.
- BASF SE, FED REP GERMANY:
3,480,924. PUB. 5-20-2008. MULTIPLE CLASS, INT. CLS. 1 AND 2.
- BASIC SPIRIT INCORPORATED, PUGWASH, NOVA SCOTIA, CANADA:
3,481,064. MULTIPLE CLASS, INT. CLS. 6, 14 AND 21.
- BASKIN ASSOCIATES INC., GLENCOE, IL:
3,481,278. INT. CL. 35.
- BASS PRO TRADEMARKS, L.L.C., SPRINGFIELD, MO:
3,479,071. PUB. 5-20-2008. INT. CL. 25.
3,479,073. PUB. 5-20-2008. INT. CL. 25.
3,479,077. PUB. 5-20-2008. INT. CL. 28.
3,479,370. PUB. 5-20-2008. INT. CL. 18.
- BATASIOLO SPA, ITALY:
3,480,847. PUB. 5-20-2008. INT. CL. 33.
- BATEMAN, JAMES R., JR., BOGALUSA, LA:
2,098,776. CANC. INT. CL. 9.
- BATH & BODY WORKS BRAND MANAGEMENT, INC., REYNOLDSBURG, OH:
3,482,074. MULTIPLE CLASS, INT. CLS. 3 AND 4.
- BATTENFELD TECHNOLOGIES, INC., COLUMBIA, MO:
3,482,508. INT. CL. 8.
- BATTLE, SHANE, ANTIOCH, CA:
3,481,801. INT. CL. 3.
- BAUR, DAVIDA ANN, SATELLITE BEACH, FL AND YOUNG, JOANNE, MERRITT ISLAND, FL:
3,481,376. INT. CL. 20.
- BAXA, THOMAS, MICHAEL, LOS ANGELES, CA:
3,482,262. MULTIPLE CLASS, INT. CLS. 16 AND 25.
- BAYER AKTIENGESELLSCHAFT, LEVERKUSEN-BAYERWERK, FED REP GERMANY:
3,480,168. PUB. 5-20-2008. INT. CL. 5.
3,480,547. PUB. 5-20-2008. MULTIPLE CLASS, INT. CLS. 1 AND 17.
3,482,033. INT. CL. 5.
- BAYER CROPSCIENCE LP, RESEARCH TRIANGLE PARK, NC:
2,493,391. CANC. INT. CL. 5.
- BAYERISCHE MOTOREN WERKE AKTIENGESELLSCHAFT, FED REP GERMANY:
3,481,031. PUB. 5-20-2008. MULTIPLE CLASS, INT. CLS. 12 AND 28.
- BAYLOR UNIVERSITY, WACO, TX:
1,474,216. REN. 7-3-08. INT. CL. 21.
- BAYVI LLC, HONOLULU, HI:
3,480,438. PUB. 5-20-2008. INT. CL. 25.
- BBI, INC., COLORADO SPRINGS, CO, DBA BARNETT BICYCLE INSTITUTE:
3,479,612. PUB. 5-20-2008. INT. CL. 41.
- BC INTERNATIONAL COSMETIC & IMAGE SERVICES, INC., ORLANDO, FL:
3,480,487. PUB. 5-20-2008. INT. CL. 3.
- BCN PROVISIONS, LLC, NEW YORK, NY:
3,482,632. INT. CL. 43.
- BE BORDERLESS, INC., CHICAGO, IL:
3,478,880. PUB. 5-20-2008. INT. CL. 42.
- BE THERE NOW, INC., SEATTLE, WA:
2,492,861. CANC. INT. CL. 42.
- BEACH BRANDS, MARINA DEL REY, CA:
3,481,847. INT. CL. 21.
- BEATTIE, CHRISTOPHER C., LOS ANGELES, CA:
3,482,069. INT. CL. 25.
- BEAUTOPIA LLC, MINNEAPOLIS, MN, SB & JM ENTERPRISES, INC., HOUSTON, TX:
1,493,792. REN. 7-3-08. INT. CL. 3.
- BEAUTOPIA, LLC, MINNEAPOLIS, MN, SB & JM ENTERPRISES, INC., HOUSTON, TX:
1,492,822. REN. 7-3-08. INT. CL. 3.
- BEAUTY HANDBOOK CORPORATION, NEW YORK, NY:
1,493,078. REN. 6-28-08. INT. CL. 16.
- BEAUTY VENTURE, INC., TORONTO, ONTARIO, CANADA AND BEAUTYVENTURE, INC., FORT LAUDERDALE, FL:
3,478,579. PUB. 5-20-2008. INT. CL. 3.
- BECKMAN COULTER, INC., FULLERTON, CA:
2,166,042. REN. 7-3-08. MULTIPLE CLASS, INT. CLS. 5 AND 10.
- BECKY LEBEAU, BEVERLY HILLS, CA, DBA FANTASYONE:
3,478,657. PUB. 5-20-2008. INT. CL. 41.
- BECTION DICKINSON AND COMPANY, FRANKLIN LAKES, NJ:
2,165,521. REN. 7-3-08. INT. CL. 9.
- BEEFMASTER BREEDERS UNITED, SAN ANTONIO, TX, BEEFMASTER BREEDERS UNIVERSAL, SAN ANTONIO, TX:
1,111,116. REN. 6-30-08. U.S. CL. 200.
- BEGHELLI NORTH AMERICA, MIRAMAR, FL:
3,481,765. INT. CL. 11.
- BEGIN SMART LLC, NEW YORK, NY:
3,481,351. MULTIPLE CLASS, INT. CLS. 16 AND 41.
3,482,352. INT. CL. 16.

BEIERSDORF AG, FED REP GERMANY:
3,481,032, PUB. 5-20-2008. MULTIPLE CLASS, INT. CLS. 3 AND 5.

BEIJING AIMER LINGERIE CO., LTD., CHAOYANG DISTRICT, CHINA:
3,481,547, INT. CL. 25.

BEIJING GOME APPLIANCE CO., LTD, CHINA:
3,480,864, PUB. 5-20-2008. INT. CL. 35.

BEIJING HUAYU WANJU YOUXIANGONGSI, CHINA:
3,480,964, PUB. 5-20-2008. INT. CL. 28.

BEIJING NEOMOD ACCESSORIES CO., LTD., BEIJING, CHINA:
3,481,004, PUB. 5-20-2008. INT. CL. 25.

BEL FUSE INC., JERSEY CITY, NJ:
1,458,157, CANC. INT. CL. 9.

BELFOR USA GROUP INC., BIRMINGHAM, MI:
3,479,340, PUB. 5-20-2008. INT. CL. 37.
3,479,341, PUB. 5-20-2008. INT. CL. 40.

BELKER, WHITNEY, MIAMI BEACH, FL:
3,479,800, PUB. 5-20-2008. INT. CL. 9.

BELL INDUSTRIES, INC., INDIANAPOLIS, IN:
2,157,144, REN. 7-2-08. INT. CL. 9.

BELL LITHO, INC., ELK GROVE VILLAGE, IL:
3,478,516, PUB. 5-20-2008. MULTIPLE CLASS, INT. CLS. 9, 35, 39, 40 AND 42.

BELLA FIGURA, INC., DENVER, CO:
3,482,011, INT. CL. 35.

BELLA PORTA LLC, HEMPSTEAD, NY:
3,482,498, MULTIPLE CLASS, INT. CLS. 35 AND 37.

BELLE VIE PHOTOGRAPHY, LANSDALE, PA:
3,478,608, PUB. 5-20-2008. INT. CL. 41.

BELLSOUTH CORPORATION, ATLANTA, GA TO AT&T DELAWARE INTELLECTUAL PROPERTY, INC., WILMINGTON, DE:
2,099,024, CANC. MULTIPLE CLASS, INT. CLS. 18, 20, 21, 24, 25, 28 AND 41.

BELTER FINANCIAL SERVICES, INC., NAPERVILLE, IL:
3,481,570, INT. CL. 35.

BENCHMARK PERFORMANCE GROUP, INC., HOUSTON, TX:
3,482,452, INT. CL. 39.
3,482,454, INT. CL. 39.

BENEDETTO ARTS GMBH, SOLINGEN, FED REP GERMANY:
3,480,654, PUB. 5-20-2008. INT. CL. 25.

BENJAMIN FRANKLIN FRANCHISING, LLC, SARASOTA, FL:
3,482,611, INT. CL. 37.

BENSON, GEORGE L., ELCHO, WI:
3,481,989, MULTIPLE CLASS, INT. CLS. 16 AND 28.

BENTLEY LINGERIE, INC., JERSEY CITY, NJ:
1,458,436, CANC. INT. CL. 25.

BENTLEY SYSTEMS, INCORPORATED, EXTON, PA:
3,478,872, PUB. 5-20-2008. MULTIPLE CLASS, INT. CLS. 9, 41 AND 42.

BENTON, JAMES K., BLOOMFIELD, MI:
3,479,665, PUB. 5-20-2008. MULTIPLE CLASS, INT. CLS. 16 AND 25.

BENZIGER FAMILY RANCH, GLEN ELLEN, CA, DBA M.G. VALLEJO WINERY:
1,458,869, CANC. INT. CL. 33.

BERGE, HONG XU, SCAPPOOSE, OR, DBA DIMENSION TRADE COMPANY, LLC:
3,479,686, PUB. 5-20-2008. INT. CL. 17.

BERKEBILE OIL COMPANY, INC., THE, SOMERSET, PA:
1,491,755, REN. 6-28-08. MULTIPLE CLASS, INT. CLS. 1 AND 3.

BERKLEY ACCIDENT AND HEALTH, LLC, HAMILTON SQUARE, NJ:
3,478,778, PUB. 5-20-2008. MULTIPLE CLASS, INT. CLS. 35, 41 AND 44.

BERKLINE CORPORATION, THE, MORRISTOWN, TN:
2,492,491, CANC. INT. CL. 20.

BERKSHIRE FASHIONS, INC., EDISON, NJ:
2,493,002, CANC. INT. CL. 18.

BERNARD CHAUS INCORPORATED, NEW YORK, NY:
1,344,543, CANC. INT. CL. 25.

BERNDT, MICHAEL E, NEW YORK, NY:
3,479,603, PUB. 5-20-2008. INT. CL. 41.

BERNHARD KRETEN, SACRAMENTO, CA:
2,251,825, REN. 6-30-08. INT. CL. 9.

BERNHARD STEINER PIANOS U.S.A., INC., DALLAS, TX:
1,458,251, CANC. INT. CL. 15.

BERRY BUTTER, LLC, BALTIMORE, MD:
3,480,383, PUB. 5-20-2008. INT. CL. 3.

BERRY, ALI, DORCHESTER CENTER, MA:
3,479,231, PUB. 5-20-2008. INT. CL. 30.

BES BEAUTY EXPRESS SERVICE; THOMAS BERNECKER, FED REP GERMANY:
3,480,755, PUB. 5-20-2008. INT. CL. 3.

BESAM US INC., CROFTON, MD:
3,479,348, PUB. 5-20-2008. MULTIPLE CLASS, INT. CLS. 35 AND 37.

BETA GROWTH NETWORK LLC, WESTLAKE, OH:
2,492,364, CANC. INT. CL. 35.

BETCO CORPORATION, LTD., TOLEDO, OH:
2,173,613, REN. 7-3-08. INT. CL. 2.

BETHESDA-CHEVY CHASE ORTHOPAEDIC ASSOCIATES, LLP, BETHESDA, MD:
3,480,423, PUB. 5-20-2008. INT. CL. 44.

BETTER HOMES REALTY & AUCTION, LLC, HUNTINGBURG, IN:
3,479,460, PUB. 5-20-2008. INT. CL. 35.

BETZ AND SONS, INC., SAN FRANCISCO, CA, DBA HOUSE OF PRIME RIB:
2,183,357, REN. 6-30-08. INT. CL. 42.

BEVERAGES PRIVATE LABEL HOLDING INC, MIAMI BEACH, FL:
3,479,384, PUB. 5-20-2008. INT. CL. 32.

BEVERAGES UNLIMITED LLC, CHARLESTOWN, ST. CHRIST-NEVIS:
3,479,439, PUB. 2-12-2008. INT. CL. 32.

BEYOND PORTALS, INC., ASHBURN, VA:
3,479,499, PUB. 5-20-2008. INT. CL. 42.

BEYOND6, LLC, SANTA FE, NM:
3,479,078, PUB. 5-20-2008. INT. CL. 42.

BFS DIVERSIFIED PRODUCTS, LLC, INDIANAPOLIS, IN:
2,126,049, REN. 6-28-08. INT. CL. 19.

BFW, INC., LEXINGTON, KY:
1,458,195, CANC. INT. CL. 10.

BGB MOTORSPORTS, LLC, ORMOND BEACH, FL:
3,480,000, PUB. 5-20-2008. INT. CL. 25.

BHL S.A., L-1114 LUXEMBOURG, LUXEMBOURG:
3,480,871, PUB. 5-20-2008. INT. CL. 3.

BHUNGRY INC., WOODLAND HILLS, CA:
3,479,380, PUB. 5-20-2008. INT. CL. 35.

BI NUTRACEUTICALS, INC., LONG BEACH, CA:
2,122,473, REN. 6-30-08. INT. CL. 1.
2,122,473, CANC. MULTIPLE CLASS, INT. CLS. 5 AND 30.

BI-LO, LLC, GREENVILLE, SC:
2,493,064, CANC. INT. CL. 31.

BICYCLE CITY, LLC, CINCINNATI, OH:
3,481,116, INT. CL. 35.
3,481,158, INT. CL. 25.
3,481,161, INT. CL. 18.

BIG APPLE PERFORMING ARTS, INC., NEW YORK, NY:
3,479,506, PUB. 5-20-2008. INT. CL. 41.

BIG COMFY CORP., TORONTO, ONTARIO M6P 3M9, CANADA:
2,492,827, CANC. INT. CL. 28.

BIG ISLAND OUTDOOR GROUP, LLC, EXCELSIOR, MN:
3,481,385, INT. CL. 25.

BIG TREE FARM, LLC, SALLEY, SC:
3,479,642, PUB. 5-20-2008. INT. CL. 44.

BIG TREE FURNITURE & INDUSTRIES, INC., CITY OF COMMERCE, CA:
2,099,254, CANC. INT. CL. 20.

BIGBADTOYSTORE, INC., SOMERSET, WI:
2,492,815, CANC. INT. CL. 35.

BIGFOOT ENTERTAINMENT LTD., SINGAPORE, SINGAPORE:
3,482,166, INT. CL. 41.

- BILL A. DUFFY, INC., WALNUT CREEK, CA, DBA BDA SPORTS MANAGEMENT:
3,480,535, PUB. 5-20-2008. INT. CL. 35.
- BILL COMMUNICATIONS, INC., NEW YORK, NY:
2,493,701, CANC. INT. CL. 16.
- BILL SHERER CORPORATION, THE, OCALA, FL:
2,493,150, CANC. INT. CL. 11.
- BILL VARIE PHOTOGRAPHY, INC., VAN NUYS, CA:
2,493,175, CANC. INT. CL. 41.
- BILLEDEAUX HEARING CENTER, L.L.C., LAFAYETTE, LA:
3,482,306, INT. CL. 44.
- BILLION SOULS, INC., ORLANDO, FL:
3,479,141, PUB. 5-20-2008. MULTIPLE CLASS, INT. CLS. 16, 41 AND 45.
- BILLY B BEAUTY, L.L.C., WEST HOLLYWOOD, CA:
3,481,832, MULTIPLE CLASS, INT. CLS. 3 AND 21.
- BINGWA SOFTWARE COMPANY, INC, NORCROSS, GA:
2,491,979, CANC. INT. CL. 9.
- BIO-ENGINEERED SUPPLEMENTS & NUTRITION, INC., BOCA RATON, FL:
3,478,948, PUB. 5-20-2008. INT. CL. 5.
3,479,325, PUB. 5-20-2008. INT. CL. 41.
- BIO-MEDICAL RESEARCH LIMITED, GALWAY, IRELAND:
3,480,715, PUB. 5-20-2008. MULTIPLE CLASS, INT. CLS. 10 AND 28.
- BIOACTIVE SKINCARE, LLC, MIAMI, FL:
3,478,875, PUB. 5-20-2008. INT. CL. 3.
- BIODIGESTOR TECHNOLOGIES, INC., GRAND FORKS, ND:
2,492,070, CANC. INT. CL. 40.
- BIOFORCE SOUTH AFRICA (PROPRIETARY) LIMITED, MIDRAND, GAUTENG, SOUTH AFRICA:
3,481,510, INT. CL. 5.
- BIONORICA AG, FED REP GERMANY:
3,405,721, COR. MULTIPLE CLASS, INT. CLS. 3, 5, 16, 30, 31, 35 AND 44.
- BIONOVA PRODUCE, INC., NOGALES, AZ:
3,481,442, INT. CL. 31.
- BIOTECHNOLOGY INDUSTRY ORGANIZATION, WASHINGTON, DC:
3,481,384, INT. CL. 35.
- BIOTEST LABORATORIES, LLC, COLORADO SPRINGS, CO:
3,478,674, PUB. 5-20-2008. INT. CL. 5.
- BIOVERSE, INC., BLOOMINGTON, MN:
2,100,272, CANC. INT. CL. 1.
- BIRCH TELECOM, INC., KANSAS CITY, MO:
2,186,707, REN. 6-28-08. INT. CL. 38.
- BIRGE, BARBARA, CHARLOTTE, NC:
3,479,976, PUB. 5-20-2008. INT. CL. 41.
- BISHOP ROCK SOFTWARE LLC, LAKE FOREST, CA:
3,481,474, INT. CL. 45.
3,481,509, INT. CL. 45.
- BITSTREAM INC., CAMBRIDGE, MA:
1,458,109, CANC. MULTIPLE CLASS, INT. CLS. 9 AND 16.
1,458,110, CANC. MULTIPLE CLASS, INT. CLS. 9 AND 16.
1,458,111, CANC. MULTIPLE CLASS, INT. CLS. 9 AND 16.
- BIT9, INC., CAMBRIDGE, MA:
3,482,326, INT. CL. 9.
- BIUNNO, MICHAEL, J, STATEN ISLAND, NY:
2,492,766, CANC. INT. CL. 9.
- BLACK & DECKER CORPORATION, THE, TOWSON, MD:
2,492,399, CANC. INT. CL. 28.
- BLACK ENTERTAINMENT TELEVISION LLC, WASHINGTON, DC:
3,482,310, INT. CL. 41.
- BLACK PATCH CIGAR CO., LLC, LEXINGTON, KY:
3,481,429, INT. CL. 34.
- BLACKBIRD HOLDING, INC., CHARLOTTE, NC:
2,493,021, CANC. MULTIPLE CLASS, INT. CLS. 9 AND 36.
- BLACKBIRD HOLDINGS, INC., CHARLOTTE, NC:
2,493,065, CANC. INT. CL. 9.
- BLACKCOMB SKIING ENTERPRISES LIMITED PARTNERSHIP, WHISTLER, BRITISH COLUMBIA V0N 1B4, CANADA:
2,491,679, CANC. INT. CL. 25.
- BLACKMUSTARD, INC., COLUMBIA, SC:
3,482,300, INT. CL. 30.
- BLACKSTONE INVESTMENT GROUP, INC., AURORA, MO:
3,479,414, PUB. 5-20-2008. INT. CL. 35.
- BLACKWOOD TRADING, LLC., NEW YORK, NY:
2,661,458, CANC. INT. CL. 36.
- BLACK20, INC., LONG ISLAND CITY, NY:
3,479,755, PUB. 5-20-2008. INT. CL. 41.
- BLAISE ANDRESKI, CRYSTAL FALLS, MI AND JOAN ANDRESKI, CRYSTAL FALLS, MI:
3,481,610, INT. CL. 45.
- BLANCHARD TRAINING AND DEVELOPMENT, INC., ESCONDIDO, CA:
3,482,487, INT. CL. 35.
- BLATCHFORD, BARBARA, CHICAGO, IL:
3,482,715, INT. CL. 41.
- BLAYLOCK, WILLIAM, EDMONDS, WA:
3,480,294, PUB. 5-20-2008. INT. CL. 37.
- BLIND DOG PRODUCTIONS, LTD., TEMPLE, TX:
3,478,799, PUB. 5-20-2008. INT. CL. 6.
3,478,800, PUB. 5-20-2008. INT. CL. 6.
- BLOM, SALISHA, EDGERTON, MN:
3,480,135, PUB. 5-20-2008. INT. CL. 41.
- BLOOMBERG L.P., NEW YORK, NY:
3,482,588, MULTIPLE CLASS, INT. CLS. 9, 16, 35, 38, 41 AND 42.
- BLOOMSBURY PUBLISHING PLC, LONDON, UNITED KINGDOM:
3,481,686, INT. CL. 16.
- BLUE DOT SERVICES, INC., SUNRISE, FL:
2,493,306, CANC. MULTIPLE CLASS, INT. CLS. 37 AND 42.
- BLUE LINE EQUIPMENT, LLC, PRESCOTT, AZ:
3,481,520, INT. CL. 7.
- BLUE MOUNTAIN SPRING WATER, INC., HARRISBURG, PA:
1,458,620, CANC. INT. CL. 32.
- BLUE STAR COFFEE ROASTERS, TWISP, WA:
3,478,783, PUB. 5-20-2008. INT. CL. 30.
- BLUE 2, LLC, ST. LOUIS, MO:
3,481,531, INT. CL. 35.
- BLUEARTH INSTITUTE, MELBOURNE, VICTORIA, AUSTRALIA:
2,577,267, CANC. INT. CL. 28.
- BMA HOLDINGS, LLC, CLEVELAND, OH:
2,183,512, REN. 7-1-08. MULTIPLE CLASS, INT. CLS. 16 AND 21.
- BMA HOLDINGS, LLC, REDWOOD CITY, CA:
2,491,904, CANC. INT. CL. 35.
- BMB-INSTITUTE GMBH & CO. KG, FED REP GERMANY:
3,480,913, PUB. 5-20-2008. MULTIPLE CLASS, INT. CLS. 16, 28, 35, 41 AND 42.
- BMJ INTERNATIONAL CO. INC., NEW YORK, NY:
3,479,354, PUB. 5-20-2008. INT. CL. 25.
- BNG ENTERPRISES, INC., PHOENIX, AZ:
3,481,307, INT. CL. 3.
- BNP PARIBAS, PARIS, FRANCE:
3,480,603, PUB. 5-20-2008. INT. CL. 36.
- BOARD OF TRUSTEES OF THE UNIVERSITY OF MASSACHUSETTS, THE, BOSTON, MA:
2,493,541, CANC. INT. CL. 25.
- BOARDOM, INC., HUNTINGTON BEACH, CA:
3,481,486, INT. CL. 41.
- BOBBER PRODUCTS, INC., FULLERTON, CA:
1,327,218, REN. 7-3-08. INT. CL. 28.
- BOBBILEE GRANT, CHATTEROY, WA:
3,481,412, INT. CL. 21.
- BOBBLE BABES, LLC, ELK RIVER, MN:
3,478,788, PUB. 5-20-2008. MULTIPLE CLASS, INT. CLS. 21, 25 AND 28.
- BOC ASSET MANAGEMENT GMBH, A-1010 WIEN, AUSTRIA:
3,480,788, PUB. 2-12-2008. INT. CL. 42.

BOCA FOODS, INC., HARRISON, NJ TO SILVER LAKE COOKIE COMPANY, ISLIP, NY:
2,100,506, CANC. INT. CL. 30.

BODEGAS NEKEAS, S. COOP, 31154 ANORBE (NAVARRA), SPAIN:
2,164,592, REN. 6-30-08, INT. CL. 33.

BODY BY JAKE, INC., LOS ANGELES, CA:
1,486,704, REN. 6-27-08, MULTIPLE CLASS, INT. CLS. 9, 16 AND 25.

BODY PRESERVES, LOS ANGELES, CA:
2,491,884, CANC. INT. CL. 3.

BOEING MANAGEMENT COMPANY, SEAL BEACH, CA:
1,352,503, REN. 7-3-08, INT. CL. 9.
3,481,239, INT. CL. 28.

BOGAN, TRACI, RACINE, WI:
3,478,637, PUB. 5-20-2008, MULTIPLE CLASS, INT. CLS. 25, 35 AND 45.

BOHINC, GARY, CHARDON, OH:
3,479,687, PUB. 5-20-2008, INT. CL. 44.

BOILER BAY INC., SANTA CRUZ, CA:
2,493,332, CANC. INT. CL. 9.

BOJANGLES' INTERNATIONAL, LLC, CHARLOTTE, NC:
3,481,168, INT. CL. 43.

BOLDUC, ANNE, MONTREAL, QUEBEC, CANADA:
2,491,819, CANC. INT. CL. 35.

BOLLORE, FRANCE:
3,480,960, PUB. 5-20-2008, MULTIPLE CLASS, INT. CLS. 9 AND 37.

BONAMONDO, INC., EVERETT, WA, FORMERLY AD REWARD NETWORK, INC., FORMERLY ADYOURMONEY.COM, INC.:
3,480,302, PUB. 5-20-2008, INT. CL. 35.

BONE'S STEAKHOUSE, INC., HUDSON, FL:
3,480,638, PUB. 5-20-2008, INT. CL. 43.

BONITA PACKAGING PRODUCTS, INC., PORTLAND, OR:
3,478,766, PUB. 5-20-2008, INT. CL. 16.

BONNIER ACTIVE MEDIA, INC., WINTER PARK, FL:
2,160,725, REN. 7-3-08, INT. CL. 38.
2,173,508, REN. 6-28-08, INT. CL. 42.
2,173,509, REN. 6-28-08, INT. CL. 9.

BONNIER ACTIVE MEDIA, INC., WINTER PARK, FL, DBA TIME4 MEDIA, INC.:
3,482,708, INT. CL. 16.

BONUS.COM, INC., PALO ALTO, CA:
2,098,921, CANC. INT. CL. 41.
3,482,369, INT. CL. 41.

BONZOLIO, INCORPORATED, OCEANSIDE, CA:
3,480,132, PUB. 5-20-2008, INT. CL. 35.

BOO FOO WOO CO., LTD., JAPAN:
3,480,857, PUB. 5-20-2008, MULTIPLE CLASS, INT. CLS. 18 AND 25.

BOOKSMART STUDIO, INC., ROCHESTER, NY:
3,479,778, PUB. 5-20-2008, INT. CL. 16.

BOOM INTERNATIONAL MARKETPLACE INC., LONDON, ONTARIO, CANADA:
3,482,247, INT. CL. 18.

BOONE, THOMAS A., BOWIE, MD:
2,492,725, CANC. INT. CL. 42.

BORAL INDUSTRIES, INC., ROSWELL, GA:
2,165,145, REN. 6-28-08, MULTIPLE CLASS, INT. CLS. 35 AND 42.

BORDAY, ROBERT, HOLLYWOOD, FL:
3,482,699, INT. CL. 43.

BORMIOLI LUIGI S.P.A., PARMA, 43100, ITALY, VETRERIA ING. LUIGI BORMIOLI & C., S.P.A., PARMA, ITALY:
1,492,279, REN. 7-3-08, INT. CL. 21.

BORSA ITALIANA S.P.A., MILANO, ITALY:
3,480,614, PUB. 5-20-2008, MULTIPLE CLASS, INT. CLS. 16, 35, 36 AND 38.

BOSCH REXROTH CANADA CORP., WELLAND, ONTARIO, CANADA TO BOSCH REXROTH CANADA CORP., WELLAND, ONTARIO, CANADA:
2,609,195, CANC. INT. CL. 37.

BOSHART INDUSTRIES, INC., MILVERTON, CANADA:
3,478,822, PUB. 5-20-2008, INT. CL. 11.

BOSKOVICH, MICHAEL G., ROSEVILLE, CA:
2,492,177, CANC. INT. CL. 35.

BOSTON ACOUSTICS, INC., PEABODY, MA:
3,482,517, INT. CL. 9.

BOSTON RED SOX BASEBALL CLUB LIMITED PARTNERSHIP, BOSTON, MA:
1,043,945, REN. 6-27-08, MULTIPLE CLASS, INT. CLS. 6, 14, 16, 18, 20, 21, 24, 25, 26, 28 AND 34.
1,060,117, REN. 6-30-08, INT. CL. 41.

BOSTON SCIENTIFIC SCIMED, INC., MAPLE GROVE, MN:
3,481,986, INT. CL. 10.

BOSWELL, LAUREN A., RED BLUFF, CA:
3,482,664, INT. CL. 14.

BOTANICAL LIAISONS, BOULDER, CO:
2,492,244, CANC. INT. CL. 42.

BOULDER POTATO COMPANY, BOULDER, CO:
2,491,764, CANC. INT. CL. 29.

BOUNCING BRAIN PRODUCTIONS, LLC, CHARLOTTE, NC:
3,481,499, INT. CL. 41.

BOUND SOUTH, INC., FT. LAUDERDALE, FL:
3,478,936, PUB. 5-20-2008, INT. CL. 41.

BOUNTIFUL BERRY, INC., BROWNFIELD, ME:
3,480,208, PUB. 5-20-2008, INT. CL. 30.

BOUYGUES OFFSHORE, 78180 SAINT QUENTIN EN YVELINES, FRANCE:
2,491,901, CANC. INT. CL. 6.

BOVA DIAMONDS, INC., DALLAS, TX:
3,478,785, PUB. 5-20-2008, INT. CL. 35.

BOVIS-NELSEN, NATALIE, MARINA DEL REY, CA:
3,480,326, PUB. 5-20-2008, INT. CL. 32.

BOWERMAN, COURTNEY, NEW YORK, NY:
3,478,586, PUB. 5-20-2008, INT. CL. 14.

BOWMAN DESIGN, INC., ARLINGTON, MA:
3,479,633, PUB. 5-20-2008, MULTIPLE CLASS, INT. CLS. 35 AND 42.

BOXERCRAFT INCORPORATED, ATLANTA, GA:
3,479,785, PUB. 5-20-2008, MULTIPLE CLASS, INT. CLS. 25 AND 35.
3,479,788, PUB. 5-20-2008, MULTIPLE CLASS, INT. CLS. 25 AND 35.

BOYD GAMING CORPORATION, LAS VEGAS, NV:
3,479,421, PUB. 2-12-2008, INT. CL. 41.
3,479,422, PUB. 2-12-2008, INT. CL. 43.

BP PRODUCTS NORTH AMERICA INC., WARRENVILLE, IL:
3,481,968, INT. CL. 30.

BR 111 IMPORTS & EXPORTS, INC., MEDLEY, FL:
2,138,406, REN. 6-27-08, INT. CL. 19.

BRAD GREEN, SAN DIEGO, CA:
3,479,561, PUB. 5-20-2008, INT. CL. 25.

BRAD JANNENGA, PHOENIX, AZ:
3,480,342, PUB. 5-20-2008, INT. CL. 35.

BRADKIN, TANIA, ALEXANDRIA, VA:
2,493,418, CANC. INT. CL. 21.

BRADLEY PHARMACEUTICALS, INC., FAIRFIELD, NJ:
3,482,470, INT. CL. 5.

BRADLEY-MORRIS, INC., KENNESAW, GA:
3,479,265, PUB. 5-20-2008, INT. CL. 35.

BRADY WORLDWIDE, INC., MILWAUKEE, WI:
3,482,409, MULTIPLE CLASS, INT. CLS. 9 AND 16.

BRAINCRUMBS DESIGN, INC., DENVER, CO, DBA THE BOKKA GROUP:
3,482,421, INT. CL. 35.

BRAINFOOD, INC., DALLAS, TX:
2,177,081, REN. 6-30-08, INT. CL. 9.

BRAINSTORM TUTORING, LLC, RAMSEY, NJ:
3,479,344, PUB. 5-20-2008, INT. CL. 41.

BRAMAG HANDELS AG, 7000 CHUR, SWITZERLAND:
2,491,661, CANC. MULTIPLE CLASS, INT. CLS. 9, 18, 25, 39 AND 42.

BRAND NEW PRODUCTS, LLC, CHICAGO, IL:
3,479,962, PUB. 5-20-2008, INT. CL. 30.
3,480,050, PUB. 5-20-2008, INT. CL. 30.

BRAND X, L.L.C., NEW YORK, NY:
3,480,568, PUB. 3-6-2007, INT. CL. 25.

BRANDJUICE CONSULTING INC, DENVER, CO:
3,481,811, INT. CL. 42.

BRANDT'S FRUIT TREES, INC., WAPATO, WA:
2,164,611, REN. 6-28-08, INT. CL. 31.

- BRANNEN BANKS OF FLORIDA, INC., INVERNESS, FL:
3,480,483, PUB. 5-20-2008. INT. CL. 36.
- BRAO CAFFE' VERONA S.R.L. CON MARCHIO CENTRO
CAFFE' VERONA (C.C.V. S.R.L.), NEGRAR FRAZ. AR-
BIZZANO (VERONA), ITALY:
2,491,716, CANC. INT. CL. 30.
- BRASS BEDS OF VIRGINIA, INC., RICHMOND, VA:
2,154,836. REN. 7-2-08. INT. CL. 20.
- BRAVE BUNNY, INC., CRESTWOOD, KY:
2,492,747, CANC. INT. CL. 25.
- BRAVO SPORTS, SANTA FE SPRINGS, CA:
3,481,491, INT. CL. 12.
- BREADSONG BAKING COMPANY, L.L.C., LAKE OSWE-
GO, OR TO BREADSONG BAKING COMPANY, L.L.C.,
LAKE OSWEGO, OR:
2,100,210, CANC. INT. CL. 30.
- BREADSONG BAKING COMPANY, L.L.C., LK OSWEGO,
OR TO BREADSONG BAKING COMPANY, L.L.C., LK
OSWEGO, OR:
2,100,241, CANC. INT. CL. 30.
- BREAKAWAY PARTNERS, SANTA MONICA, CA:
3,479,692, PUB. 5-20-2008. INT. CL. 36.
- BREAKTHROUGH PROMOTIONS LIMITED, LONDON,
WC2B 6QX, UNITED KINGDOM:
2,491,784, CANC. MULTIPLE CLASS, INT. CLS. 16, 25, 36
AND 42.
- BREENE GRAPHICS, INC., CHATSWORTH, CA:
3,480,093, PUB. 5-20-2008. INT. CL. 40.
- BRENNAN, SUSAN O., TEQUESTA, FL:
2,183,240. REN. 7-1-08. INT. CL. 42.
- BRENTWOOD INDUSTRIES, INC., READING, PA:
3,479,516, PUB. 5-20-2008. INT. CL. 12.
- BRETT STERN, PORTLAND, OR:
3,479,930, PUB. 5-20-2008. INT. CL. 29.
3,479,931, PUB. 5-20-2008. INT. CL. 29.
- BREWED TO SERVE RESTAURANT GROUP, INC., ATLAN-
TA, GA:
2,166,136. REN. 6-30-08. INT. CL. 42.
- BRIAN THORNBURG, DO. PA, NAPLES, FL:
3,479,759, PUB. 5-20-2008. INT. CL. 44.
- BRIDGE BANK, N.A., SAN JOSE, CA:
3,478,753, PUB. 2-12-2008. INT. CL. 36.
- BRIDGE OF HOPE, INC., EXTON, PA:
2,214,104. REN. 6-28-08. MULTIPLE CLASS, INT. CLS. 36,
41 AND 42.
2,215,977. REN. 6-28-08. MULTIPLE CLASS, INT. CLS. 36,
41 AND 42.
- BRIDGESTONE CORPORATION, TOKYO, JAPAN:
3,481,267, INT. CL. 12.
- BRIDGESTONE CORPORATION, CHUO-KU, TOKYO, JA-
PAN:
3,481,374, INT. CL. 12.
- BRIDGEWAY SOFTWARE, INC., BELLAIRE, TX:
2,099,068, CANC. INT. CL. 9.
- BRIGHT HOUSE NETWORKS LLC, EAST SYRACUSE, NY:
3,481,137, INT. CL. 38.
- BRIGHT OF AMERICA, LLC, SUMMERSVILLE, WV:
3,481,906, INT. CL. 4.
- BRIGHTON MANOR COMPANY, CLEVELAND, OH:
3,482,146, INT. CL. 41.
- BRINKER INTERNATIONAL HOLDINGS, L.P., DALLAS,
TX:
3,481,648, INT. CL. 43.
- BRINKER INTERNATIONAL PAYROLL COMPANY, L.P.,
DALLAS, TX:
2,249,559. REN. 6-28-08. INT. CL. 30.
- BRISK SOURCES INC., INDUSTRY, CA:
3,480,183, PUB. 5-20-2008. INT. CL. 3.
- BRISSON, PAUL, SCHENECTADY, NY:
3,478,821, PUB. 5-20-2008. MULTIPLE CLASS, INT. CLS.
35 AND 41.
- BRITISH BROADCASTING CORPORATION, THE, LON-
DON W1A 1AA, ENGLAND:
2,162,275. REN. 7-3-08. INT. CL. 42.
- BROADCAST ONE, INC., CHASKA, MN:
3,478,717, PUB. 5-20-2008. INT. CL. 41.
- BROBECK, PHLEGER & HARRISON LLP, SAN FRANCIS-
CO, CA:
2,493,067, CANC. INT. CL. 42.
- BRODER BROS., CO., PLYMOUTH, MI:
2,099,187, CANC. MULTIPLE CLASS, INT. CLS. 18 AND
25.
- BRODEUR & PARTNERS, LLC, BOSTON, MA:
3,482,507, MULTIPLE CLASS, INT. CLS. 35 AND 45.
- BRODY, NEVILLE, LONDON, UNITED KINGDOM:
2,492,826, CANC. MULTIPLE CLASS, INT. CLS. 35 AND
41.
- BROGAARD, RIKKE, LAGUNA HILLS, CA:
3,481,798, INT. CL. 9.
3,481,799, INT. CL. 9.
- BRONCO WINE COMPANY, CERES, CA:
3,481,659, INT. CL. 33.
- BRONZE AGE SOFTWARE CORPORATION, OTTAWA,
CANADA:
3,481,361, INT. CL. 9.
- BRONZE BAY TANNING, LLC, EAST LANSING, MI:
3,479,798, PUB. 5-20-2008. INT. CL. 44.
- BRONZE WORLD TRAVEL LLC, SILVER SPRING, MD:
3,478,813, PUB. 10-2-2007. INT. CL. 39.
- BROOKDALE SENIOR LIVING INC., CHICAGO, IL:
3,478,973, PUB. 5-20-2008. MULTIPLE CLASS, INT. CLS.
35, 36 AND 44.
- BROOKE, JOHN ARTHUR, MARNE, MI:
1,458,326, CANC. INT. CL. 16.
1,458,328, CANC. INT. CL. 16.
- BROOKFIELD ENGINEERING LABORATORIES, INC.,
MIDDLEBORO, MA:
1,488,212. REN. 6-30-08. INT. CL. 9.
- BROOKS, SCOTT A., READING, PA:
2,493,128, CANC. INT. CL. 35.
- BROOKSHIRE GROCERY COMPANY, TYLER, TX:
3,478,776, PUB. 5-20-2008. MULTIPLE CLASS, INT. CLS.
16 AND 43.
- BROTHER RECORDS, INC., DEL MAR, CA:
1,117,574. REN. 6-30-08. INT. CL. 9.
1,117,574, CANC. INT. CL. 25.
- BROTHERS INTERNATIONAL DESSERTS INC., IRVINE,
CA:
2,098,606, CANC. INT. CL. 30.
- BROUWERIJ BOSTEELS, BUGGENHOUT, BELGIUM:
3,479,299, PUB. 1-15-2008. INT. CL. 32.
- BROWN BROTHERS HARRIMAN & CO., NEW YORK, NY:
3,481,475, INT. CL. 36.
3,481,476, INT. CL. 35.
- BROWN SHOE COMPANY, INC., ST. LOUIS, MO:
1,491,249. REN. 7-3-08. INT. CL. 25.
- BROWN, DANIEL EDWARD, DULUTH, MN:
3,480,027, PUB. 5-20-2008. INT. CL. 12.
- BROWN, SUSAN M., CAROL STREAM, IL:
3,479,113, PUB. 5-20-2008. INT. CL. 44.
- BROWNBUILDER FEDERAL CREDIT UNION, HOUSTON,
TX:
3,412,965, COR. INT. CL. 36.
- BRUNK, KEVIN, MONTROSE, IA:
3,480,434, PUB. 5-20-2008. INT. CL. 35.
- BRUNSWICK CORPORATION, LAKE FOREST, IL:
2,125,551. REN. 7-2-08. INT. CL. 16.
- BRUNSWICK ICE AND COAL COMPANY, INC., LAW-
RENCEVILLE, VA:
2,170,444. REN. 6-30-08. INT. CL. 30.
- BRYAN, FREDERICK D., CHATSWORTH, CA:
3,481,184, MULTIPLE CLASS, INT. CLS. 9 AND 41.
- BRYANT, SHAWN J., NEW YORK, NY:
2,491,686, CANC. INT. CL. 35.

- BSH BOSCH UND SIEMENS HAUSGERAETE GMBH, MUNICH, FED REP GERMANY:
 3,479,870, PUB. 5-20-2008. INT. CL. 7.
 3,479,871, PUB. 5-20-2008. INT. CL. 7.
 3,479,873, PUB. 5-20-2008. INT. CL. 7.
 3,479,874, PUB. 5-20-2008. INT. CL. 7.
 3,479,875, PUB. 5-20-2008. INT. CL. 7.
 3,479,876, PUB. 5-20-2008. INT. CL. 7.
 3,479,877, PUB. 5-20-2008. INT. CL. 7.
 3,479,878, PUB. 5-20-2008. INT. CL. 7.
 3,479,879, PUB. 5-20-2008. INT. CL. 7.
 3,479,889, PUB. 5-20-2008. INT. CL. 7.
 3,479,893, PUB. 5-20-2008. INT. CL. 7.
 3,479,894, PUB. 5-20-2008. INT. CL. 7.
 3,479,895, PUB. 5-20-2008. INT. CL. 7.
 3,480,042, PUB. 5-20-2008. INT. CL. 7.
- BTA DIGITAL WORKS AG, CH-8630, RUTI/ZH, SWITZERLAND:
 2,493,649, CANC. MULTIPLE CLASS, INT. CLS. 9, 35 AND 42.
- BUCCANEERS LIMITED PARTNERSHIP, TAMPA, FL:
 3,480,352, PUB. 5-20-2008. INT. CL. 25.
- BUCKEYE BARBECUE CO., WAYNESVILLE, OH:
 3,480,157, PUB. 5-20-2008. INT. CL. 30.
- BUCKNER, KRISTOPHER T., LAWNSDALE, CA:
 3,478,959, PUB. 5-20-2008. INT. CL. 45.
- BUD'S BIKER PARTS, INC., HELENA, MT:
 3,482,478, INT. CL. 7.
- BUFFALO RUN, LLC, FORT LAUDERDALE, FL:
 3,479,500, PUB. 5-20-2008. INT. CL. 29.
- BUGATCHI UOMO APPAREL, INC., BOCA RATON, FL:
 3,479,346, PUB. 5-20-2008. INT. CL. 25.
- BUHLER, ADAM M, BOSTON, MA AND SMITH, KEITH D, BRIGHTON, MA:
 3,480,204, PUB. 5-20-2008. INT. CL. 41.
- BUILDING CODE CONSULTING SERVICES, L.L.P., DALLAS, TX:
 3,479,974, PUB. 5-20-2008. INT. CL. 42.
- BUILDING MATERIAL IMPORTS, INC., PETALUMA, CA:
 3,480,476, PUB. 5-20-2008. INT. CL. 19.
- BUILT BY REFERRAL REALTY GROUP, LTD., CHANDLER, AZ:
 3,479,537, PUB. 5-20-2008. INT. CL. 36.
- BULGARI SPA, I-00186 ROMA, ITALY:
 3,480,743, PUB. 5-20-2008. INT. CL. 14.
- BULOVA CORPORATION, WOODSIDE, NY:
 3,481,240, INT. CL. 14.
- BURGER KING BRANDS, INC., MIAMI, FL:
 2,183,773, REN. 6-30-08. INT. CL. 42.
- BURKE INDUSTRIAL COATINGS, RIDGFIELD, WA:
 3,481,403, INT. CL. 2.
- BURLINGTON BIO-MEDICAL & SCIENTIFIC CORP., FARMINGDALE, NY, AKA BURLINGTON SCIENTIFIC CORP.:
 2,098,649, CANC. INT. CL. 1.
- BURLINGTON MEDICAL SUPPLIES, INC., HAVERHILL, MA:
 1,458,138, CANC. INT. CL. 9.
- BURNES HOME ACCENTS, LLC, ROUND ROCK, TX:
 3,481,732, MULTIPLE CLASS, INT. CLS. 16 AND 20.
 3,481,733, MULTIPLE CLASS, INT. CLS. 16 AND 20.
- BURNHAM & MORRILL COMPANY, PARSIPPANY, NJ:
 2,165,889, REN. 6-27-08. INT. CL. 30.
- BURRELL, TRAVIS, LOS ANGELES, CA AND ZUCKERMAN, ROBERT, LOS ANGELES, CA:
 3,478,858, PUB. 5-20-2008. INT. CL. 28.
- BURTON, M. BENJAMIN, BERGENFIELD, NJ:
 3,479,869, PUB. 5-20-2008. INT. CL. 10.
- BUSCH ENTERTAINMENT CORPORATION, ST. LOUIS, MO:
 2,492,397, CANC. INT. CL. 41.
- BUSINESS SERVICE CORPORATION, SAN DIEGO, CA:
 3,478,967, PUB. 5-20-2008. INT. CL. 16.
- BUSQUETS, CARMEN, KEY BISCAYNE, FL:
 3,481,051, MULTIPLE CLASS, INT. CLS. 18, 25 AND 42.
- BUTCHER COMPANY, THE, STURTEVANT, WI, BUTCHER COMPANY, INC., THE, MARLBORO, MA, DBA THE RAMSEY COMPANY:
 2,167,745, REN. 6-28-08. INT. CL. 5.
 2,167,753, REN. 6-28-08. INT. CL. 5.
 2,169,715, REN. 6-28-08. INT. CL. 3.
- BUTLER, RHETT A, MENLO PARK, CA:
 3,479,626, PUB. 5-20-2008. INT. CL. 9.
- BUTLERS FARMHOUSE CHEESE LIMITED, UNITED KINGDOM:
 3,481,005, PUB. 5-20-2008. INT. CL. 29.
- BUTTERFLY WORLDWIDE, LLC, ANN ARBOR, MI:
 3,482,119, INT. CL. 20.
- BUXTON, DONNA PATRICK, PANAMA CITY BEACH, FL AND BUXTON, DAVID LLOYD, PANAMA CITY BEACH, FL:
 3,481,972, INT. CL. 5.
- BUYANDHOLD.COM, INC., NEW YORK, NY:
 2,493,526, CANC. INT. CL. 41.
- BUYCOMPUTERNOW INC., ROCHESTER, MN, DBA BUYONLINENOW:
 3,482,679, INT. CL. 41.
- BUZZER INC., NEW YORK, NY:
 2,492,773, CANC. INT. CL. 42.
- BVS ENTERTAINMENT, INC., BURBANK, CA:
 3,481,669, INT. CL. 28.
- BVS, INC., CEDAR RAPIDS, IA:
 3,479,269, PUB. 5-20-2008. MULTIPLE CLASS, INT. CLS. 9 AND 42.
- BWT AKTIENGESELLSCHAFT, AUSTRIA:
 3,480,846, PUB. 5-20-2008. MULTIPLE CLASS, INT. CLS. 11 AND 21.
- C AND C WINE SERVICES, INC., SANTA ROSA, CA:
 3,480,321, PUB. 5-20-2008. INT. CL. 33.
- C S P INTERNATIONAL INDUSTRIA CALZE S.P.A., CERESARA (MANTOVA), ITALY:
 2,492,854, CANC. INT. CL. 25.
- C. & J. CLARK INTERNATIONAL LIMITED, SOMERSET, BA 16 OYA, UNITED KINGDOM:
 2,174,249, REN. 7-3-08. INT. CL. 25.
- C. H. GUENTHER & SON, INC., SAN ANTONIO, TX:
 1,492,486, REN. 6-30-08. INT. CL. 30.
- C. R. BARD, INC., MURRAY HILL, NJ:
 3,481,049, INT. CL. 10.
- C. R. LAURENCE CO., INC., LOS ANGELES, CA:
 1,094,048, REN. 6-28-08. INT. CL. 42.
- C.B. FLEET INVESTMENT CORPORATION, WILMINGTON, DE:
 3,481,067, INT. CL. 25.
- C.D.B. APPAREL, INC., NEW YORK, NY:
 3,481,156, INT. CL. 25.
- C.F. MARTIN & CO., NAZARETH, PA:
 1,458,254, CANC. INT. CL. 15.
- C.G.M. SERVICES, INC., LOUISVILLE, KY:
 3,478,839, PUB. 5-20-2008. MULTIPLE CLASS, INT. CLS. 35, 41 AND 43.
- C.K.F. FOODS, INC., MOUNT PROSPECT, IL:
 3,482,135, INT. CL. 29.
- C.S. LEWIS (PTE.) LTD., SINGAPORE, SINGAPORE:
 3,356,765, COR. MULTIPLE CLASS, INT. CLS. 25 AND 28.
- C.S.B. COMMODITIES, INC., WESTBURY, NY:
 3,480,089, PUB. 5-20-2008. INT. CL. 21.
 3,480,124, PUB. 5-20-2008. INT. CL. 21.
- C-LINE, LLC, CHESTERFIELD, MO:
 3,479,644, PUB. 5-20-2008. INT. CL. 26.
- C-MAX AUTO SUPERSTORES, INC., WALNUT, CA TO CARMAX BUSINESS SERVICES, LLC, GLEN ALLEN, VA:
 2,098,871, CANC. INT. CL. 39.
- CASH ENTERTAINMENT, INC., NYC, NY:
 3,481,148, INT. CL. 35.
- CABLE & WIRELESS (WEST INDIES) LTD., BRACKNELL, BERKSHIRE, UNITED KINGDOM:
 2,492,428, CANC. INT. CL. 9.
- CABOT TECHNOLOGY CORPORATION, PHILADELPHIA, PA:
 1,458,200, CANC. INT. CL. 10.

- CADBURY ADAMS USA LLC, PARSIPPANY, NJ, WARNER-LAMBERT PHARMACEUTICAL COMPANY, MORRIS PLAINS, NJ:
856,135. REN. 6-30-08. U.S. CL. 46 (INT. CL. 30).
- CAFRAMO LIMITED, WIARTON, ONTARIO, CANADA:
3,478,951. PUB. 5-20-2008. INT. CL. 11.
- CAIN, MARC A. CHICAGO, IL:
3,479,338. PUB. 2-12-2008. MULTIPLE CLASS, INT. CLS. 14 AND 25.
- CAL AGRI PRODUCTS, LLC, LOS ANGELES, CA:
3,480,256. PUB. 5-20-2008. INT. CL. 1.
- CALDWELL WATSON REAL ESTATE GROUP, INC., HOUSTON, TX:
3,480,513. PUB. 5-20-2008. MULTIPLE CLASS, INT. CLS. 36 AND 37.
- CALGON CARBON CORPORATION, PITTSBURGH, PA:
3,480,234. PUB. 5-20-2008. INT. CL. 9.
- CALICO BRANDS, INC., HOME GARDENS, CA:
2,170,964. REN. 7-3-08. INT. CL. 34.
- CALIFORNIA ASSOCIATION OF FOOD BANKS, OAKLAND, CA:
3,480,433. PUB. 5-20-2008. INT. CL. 35.
- CALIFORNIA EARTH MINERALS, INC., CULVER CITY, CA:
3,480,582. PUB. 2-12-2008. INT. CL. 5.
- CALIFORNIA EXOTIC NOVELTIES LLC, CHINO, CA:
3,481,982. INT. CL. 10.
- CALIFORNIA EXOTIC NOVELTIES, INC., CHINO, CA:
2,201,438. REN. 7-2-08. INT. CL. 10.
- CALIFORNIA RAISIN MARKETING BOARD, AN INSTRUMENTALITY OF THE STATE OF CALIFORNIA, DEPARTMENT OF FOOD AND AGRICULTURE, SACRAMENTO, CA:
3,478,773. PUB. 5-20-2008. INT. CL. 35.
- CALIFORNIA STATE UNIVERSITY, FRESNO FOUNDATION, FRESNO, CA:
2,493,624. CANC. INT. CL. 41.
- CALL SCIENCES, INC., GLENCOE, IL:
3,479,654. PUB. 5-20-2008. INT. CL. 38.
- CALLAHAN MARKETING GROUP, INC., CHICAGO, IL, DBA THE CHOICE FOR STAFFING:
2,493,101. CANC. INT. CL. 35.
- CALLAWAY & KIRK COMPANY LLC, NEW YORK, NY:
3,480,700. PUB. 5-20-2008. INT. CL. 16.
- CALLAWAY GOLF COMPANY, CARLSBAD, CA:
2,099,080. CANC. MULTIPLE CLASS, INT. CLS. 36 AND 37.
- CALLE SOCCER LLC, PROVO, UT:
3,481,615. MULTIPLE CLASS, INT. CLS. 25 AND 28.
3,481,616. MULTIPLE CLASS, INT. CLS. 25 AND 28.
- CALLPOD, INC., CHICAGO, IL:
3,481,277. INT. CL. 9.
- CALSOTA SUPPLY, LLC, ST. PAUL, MN:
3,482,319. INT. CL. 35.
- CAMARATA, ROBYN A., SELAH, WA AND CAMARATA, JAMES F., SELAH, WA:
2,493,662. CANC. INT. CL. 42.
- CAMBREX PROFARMACO MILANO S.R.L., MILANO, ITALY:
3,479,172. PUB. 5-20-2008. INT. CL. 5.
- CAMBRIDGE INVESTMENT RESEARCH, INC., FAIRFIELD, IA:
2,493,705. CANC. INT. CL. 36.
- CAMERON, WILLIAM, L., MATTHEWS, NC:
3,482,178. INT. CL. 25.
- CAMP SHANE LLC, CROTON ON HUDSON, NY:
3,479,443. PUB. 5-20-2008. INT. CL. 41.
- CAMPANELLA, DIANA, SCOTTSDALE, AZ:
3,481,402. INT. CL. 35.
- CAMPBELL-EWALD COMPANY, WARREN, MI:
3,478,542. PUB. 5-20-2008. INT. CL. 35.
- CANAAN TECHNOLOGY, LLC, NORWALK, CT AND FELTON, DAVID R, NORWALK, CT:
3,478,691. PUB. 5-20-2008. INT. CL. 37.
- CANADA WEST SHOE MANUFACTURING INC., WINNIPEG, MANITOBA R2X 2N6, CANADA:
2,237,485. REN. 7-3-08. INT. CL. 25.
- CANADIAN ATLAS FURNITURE CORPORATION, ONTARIO L4T 3T1, CANADA:
2,492,060. CANC. INT. CL. 20.
- CANADIAN IMPERIAL BANK OF COMMERCE, NEW YORK, NY:
2,493,678. CANC. INT. CL. 16.
- CANALPLAST S.P.A., 20051 - LIMBIATE (MI), ITALY:
3,481,076. INT. CL. 17.
- CANEW IDEAS, CLARKS SUMMIT, PA:
1,458,295. CANC. INT. CL. 16.
- CANFIELD SCIENTIFIC, INC., FAIRFIELD, NJ:
3,479,934. PUB. 5-20-2008. INT. CL. 9.
- CANIGLIA, RONALD J., SCOTTSDALE, AZ:
3,479,115. PUB. 5-20-2008. MULTIPLE CLASS, INT. CLS. 3 AND 44.
- CANON COMMUNICATIONS LLC, LOS ANGELES, CA:
2,493,411. CANC. INT. CL. 35.
- CANTOLINO, CHRISTOPHER R., BRADENTON, FL:
3,480,358. PUB. 5-20-2008. INT. CL. 1.
- CANYON TECHNICAL SERVICES LTD., CALGARY, CANADA:
3,478,811. PUB. 5-20-2008. MULTIPLE CLASS, INT. CLS. 1, 37, 40 AND 42.
- CAPCOM CO. LTD., CHOU-KU, OSAKA, JAPAN:
3,481,667. INT. CL. 9.
- CAPITAL FINANCIAL HOME EQUITY LLC, CHESAPEAKE, VA:
3,479,924. PUB. 5-20-2008. INT. CL. 36.
- CAPITAL PAYMENTS PROCESSING, LLC, MIAMI, FL:
3,479,478. PUB. 5-20-2008. INT. CL. 36.
- CAPITOL RECORDS, INC., NEW YORK, NY, DBA BLUE NOTE RECORDS:
2,493,592. CANC. INT. CL. 20.
- CAPT. SUB CANADA LTD., TRURO, NOVA SCOTIA, CANADA:
3,478,784. PUB. 12-4-2007. MULTIPLE CLASS, INT. CLS. 30 AND 43.
- CAPTAIN, LAURA G., DEERFIELD BEACH, FL:
3,479,721. PUB. 5-20-2008. INT. CL. 44.
- CARAMOOMEL PRODUCTS INC., KELOWNA, BRITISH COLUMBIA V1X 4W4, CANADA:
2,169,997. REN. 6-30-08. INT. CL. 29.
- CARBERY MILK PRODUCTS LIMITED, BALLINEEN, COUNTY CORK, IRELAND:
2,582,602. CANC. INT. CL. 1.
- CARBO LUXEMBOURG HOLDING S.A., L-1371 LUXEMBOURG, LUXEMBOURG:
3,479,014. PUB. 5-20-2008. INT. CL. 35.
- CARDIFF SEASIDE MARKET, INC., CARDIFF BY THE SEA, CA:
3,479,994. PUB. 5-20-2008. MULTIPLE CLASS, INT. CLS. 35 AND 43.
- CARDINAL HEALTH 2, INC., LAS VEGAS, NV:
2,493,152. CANC. MULTIPLE CLASS, INT. CLS. 35, 40 AND 42.
- CARGILL MEAT SOLUTIONS CORPORATION, WICHITA, KS:
3,480,505. PUB. 5-20-2008. INT. CL. 29.
3,480,506. PUB. 5-20-2008. INT. CL. 29.
- CARGILL, INCORPORATED, WAYZATA, MN:
2,492,172. CANC. INT. CL. 31.
3,480,357. PUB. 5-20-2008. INT. CL. 31.
3,480,498. PUB. 5-20-2008. INT. CL. 36.
3,481,435. INT. CL. 31.
- CARGO BED LICENSING INC., EDMONTON, CANADA:
3,482,343. INT. CL. 12.
- CARL ZEISS AG, 73447 OBERKOCHEN, FED REP GERMANY:
1,458,145. CANC. INT. CL. 9.
- CARLEN ENTERPRISES, INC., LONG BEACH, CA:
3,481,717. INT. CL. 25.
- CARLOW UNIVERSITY, PITTSBURGH, PA:
3,479,261. PUB. 5-20-2008. INT. CL. 41.
3,479,262. PUB. 5-20-2008. INT. CL. 41.
- CARLSBAD GOURMET, CARLSBAD, CA:
3,478,972. PUB. 5-20-2008. MULTIPLE CLASS, INT. CLS. 29 AND 30.

CARMELCO, LLC, BENTONVILLE, AR, DBA BACK NINE GOLF ACADEMY:
3,479,956, PUB. 5-20-2008. INT. CL. 41.

CARMICHAEL TRAINING SYSTEMS, INC., COLORADO SPRINGS, CO:
3,478,611, PUB. 5-20-2008. MULTIPLE CLASS, INT. CLS. 9, 16, 25, 41 AND 44.

CARNIVAL CORPORATION, MIAMI, FL:
2,166,023. REN. 6-28-08. INT. CL. 28.
3,481,695, MULTIPLE CLASS, INT. CLS. 39, 41 AND 43.
3,481,696, MULTIPLE CLASS, INT. CLS. 39, 41 AND 43.
3,481,697, MULTIPLE CLASS, INT. CLS. 39, 41 AND 43.
3,481,698, MULTIPLE CLASS, INT. CLS. 39, 41 AND 43.
3,481,699, MULTIPLE CLASS, INT. CLS. 39, 41 AND 43.
3,481,700, MULTIPLE CLASS, INT. CLS. 39, 41 AND 43.
3,481,701, MULTIPLE CLASS, INT. CLS. 39, 41 AND 43.

CAROLINA BIOLOGICAL SUPPLY COMPANY, BURLINGTON, NC:
1,458,053, CANC. MULTIPLE CLASS, INT. CLS. 9 AND 16.

CAROLINAS CONSULTING GROUP, INC., THE GREENSBORO, NC TO RICHARD M FURR, GREENSBORO, NC:
2,100,240, CANC. INT. CL. 41.

CARPENTER ADVANCED CERAMICS, INC., AUBURN, CA:
3,479,497, PUB. 5-20-2008. INT. CL. 9.

CARRIED AWAY, LLC, DENVER, CO:
3,479,743, PUB. 5-20-2008. INT. CL. 43.

CARRIER CORPORATION, FARMINGTON, CT:
3,480,462, PUB. 5-20-2008. INT. CL. 11.

CARROLL COMPANY, GARLAND, TX:
1,054,202. REN. 6-27-08. INT. CL. 5.

CARTAN TOURS, INC., MINNEAPOLIS, MN, CARTAN TRAVEL BUREAU, INC., CHICAGO, IL:
856,239. REN. 6-30-08. U.S. CL. 105 (INT. CL. 39).

CARTER, JAMES E., MISSION VIEJO, CA:
2,492,977, CANC. INT. CL. 5.

CARTER, JOHN R, PELHAM, AL, DBA TELLURIDE:
3,480,036, PUB. 5-20-2008. INT. CL. 41.

CARUTH C. BYRD ENTERTAINMENT, INC., CARROLLTON, TX:
2,157,298. REN. 6-27-08. INT. CL. 9.

CASCADE DESIGNS, INC., SEATTLE, WA:
1,112,314. REN. 6-28-08. INT. CL. 20.

CASCONE, ANNETTE, RAHWAY, NJ AND CASCONE, GINA, NEW YORK, NY:
2,099,970, CANC. INT. CL. 16.

CASE VINICOLE DI SICILIA S.P.A., MARASALA (TRAPANI), ITALY:
2,493,088, CANC. INT. CL. 33.

CASH SYSTEMS, INC., LAS VEGAS, NV:
3,478,721, PUB. 5-20-2008. INT. CL. 36.
3,478,726, PUB. 5-20-2008. INT. CL. 36.

CASH TECHNOLOGIES, INC., LOS ANGELES, CA:
2,100,117, CANC. MULTIPLE CLASS, INT. CLS. 9 AND 36.

CASHMERE HOUSE, INC., SANTA ANA, CA:
2,160,418. REN. 6-28-08. INT. CL. 25.

CASIO KEISANKI KABUSHIKI KAISHA, SHIBUYA-KU, JAPAN, DBA CASIO COMPUTER CO., LTD.:
3,482,085, INT. CL. 9.

CASS INFORMATION SYSTEMS, INC., BRIDGETON, MO:
3,480,108, PUB. 5-20-2008. MULTIPLE CLASS, INT. CLS. 35, 36 AND 42.

CASTILLO, LORENZO, A., NEW YORK, NY:
2,933,407, CANC. INT. CL. 41.

CATALYST CONCEPTS, INC., NEW CASTLE, WA:
2,493,033, CANC. INT. CL. 28.

CATHARSIS MEDICAL TECHNOLOGY, INC., MOULTONBORO, NH:
2,493,142, CANC. INT. CL. 9.

CATHOLIC SOCIAL WORKERS NATIONAL ASSOCIATION, INC., INDIANAPOLIS, IN:
3,479,312, PUB. 5-20-2008. INT. CL. 35.

CATHOLIC YOUTH WORLD NETWORK, INC., THORNWOOD, NY:
3,478,626, PUB. 5-20-2008. INT. CL. 41.

CATSKILL MORNING FARM INC, LIVINGSTON MANOR, NY:
2,492,122, CANC. MULTIPLE CLASS, INT. CLS. 29 AND 30.

CAUCHO TECHNOLOGY, INC., LA JOLLA, CA:
3,479,936, PUB. 5-20-2008. INT. CL. 9.

CAVALERA, MASSIMILIANO, PHOENIX, AZ AND CAVALERA, IGOR, PHOENIX, AZ:
3,479,662, PUB. 5-20-2008. INT. CL. 41.

CAVALRY TRANSPORTATION, LLC, NASHVILLE, TN:
3,479,786, PUB. 5-20-2008. INT. CL. 35.

CAVALUZZI, FRANK A., LORDS VALLEY, PA:
3,478,584, PUB. 5-20-2008. INT. CL. 41.

CAVUTO, MARIE T., CINNAMINSON, NJ:
2,100,544, CANC. INT. CL. 42.

CB RICHARD ELLIS, INC., LOS ANGELES, CA:
2,491,991, CANC. MULTIPLE CLASS, INT. CLS. 36 AND 37.

CC MARINE BRAND ACQUISITION, LLC, SARASOTA, FL, CHRIS SMITH & SONS BOAT CO., ALGONAC, MI:
234,707. REN. 6-27-08. U.S. CL. 19 (INT. CL. 12).

CCC SOFTWARE PROFESSIONALS OY, 90460 OULUNSAALO, FINLAND:
2,493,044, CANC. INT. CL. 9.

CCS INTERNATIONAL LTD., NEW YORK, NY:
2,099,236, CANC. INT. CL. 9.

CDOC, INC., CARMEL, IN:
2,492,243, CANC. INT. CL. 36.

CE PRIME, INC., CARLSBAD, CA:
3,481,573, INT. CL. 42.
3,481,575, INT. CL. 42.

CECIL I. WALKER MACHINERY CO., BELLE, WV:
1,091,083. REN. 7-2-08. INT. CL. 36.

CEDAR GROVE COMPOSTING, INC., SEATTLE, WA:
3,480,122, PUB. 5-20-2008. INT. CL. 1.

CEDAR SHAKE & SHINGLE BUREAU, SUMAS, WA, RED CEDAR SHINGLE & HANDSPLIT SHAKE BUREAU, BELLEVUE, WA:
1,543,562. REN. 6-30-08. INT. CL. 19.

CELLFISH MEDIA LLC, NEW YORK, NY:
3,481,406, INT. CL. 35.
3,481,407, INT. CL. 35.

CELLYNNNE CORPORATION, HAINES CITY, FL:
3,482,203, INT. CL. 16.

CENGAGE LEARNING, INC., STAMFORD, CT:
2,099,861, CANC. INT. CL. 9.

CENTAUR TECHNOLOGY, AUSTIN, TX:
3,478,842, PUB. 5-20-2008. INT. CL. 9.

CENTENE CORPORATION, CLAYTON, MO:
3,481,231, INT. CL. 44.

CENTER FOR APPLIED RESEARCH & TECHNOLOGY, INC., BLUEFIELD, WV:
3,478,779, PUB. 5-20-2008. INT. CL. 35.

CENTER FOR CHILDREN'S ADVOCACY, INC., HARTFORD, CT:
3,480,005, PUB. 5-20-2008. MULTIPLE CLASS, INT. CLS. 9 AND 16.
3,480,006, PUB. 5-20-2008. MULTIPLE CLASS, INT. CLS. 9 AND 16.

CENTER FOR LEADERSHIP IN SCHOOL REFORM INC., LOUISVILLE, KY, DBA D/B/A THE SCHLECHTY CENTER:
3,479,252, PUB. 5-20-2008. MULTIPLE CLASS, INT. CLS. 9, 16 AND 41.

CENTEX CORPORATION, DALLAS, TX:
2,209,816. REN. 7-3-08. INT. CL. 36.

CENTIMARK CORPORATION, CANONSBURG, PA:
2,205,163. REN. 6-30-08. INT. CL. 19.

CENTIMARK INTERNATIONAL CORPORATION, WILMINGTON, DE, CENTIMARK CORPORATION, BETHEL PARK, PA:
1,517,463. REN. 6-30-08. INT. CL. 37.

CENTRAL CORPORATE CREDIT UNION, SOUTHFIELD, MI:
2,493,708, CANC. INT. CL. 36.

CENTRAL GARDEN & PET COMPANY, LAFAYETTE, CA:
2,492,143, CANC. INT. CL. 21.

- CENTRAL SAFETY EQUIPMENT CO., BURLINGTON, NJ:
2,493,480, CANC. INT. CL. 6.
- CENTRAL STATES NUMISMATIC SOCIETY, BELLEVILLE,
IL:
3,479,208, PUB. 5-20-2008. INT. CL. 35.
- CENTRICITY, INC., LAKE OSWEGO, OR:
2,492,298, CANC. INT. CL. 9.
- CEPSTRAL, LLC, PITTSBURGH, PA:
3,480,411, PUB. 5-20-2008. INT. CL. 42.
- CEREAL INGREDIENTS, INC., LEAVENWORTH, KS:
3,481,170, INT. CL. 30.
3,481,171, INT. CL. 30.
- CEREBRAL CHOICE SOFTWARE SOLUTIONS, INC., SYR-
ACUSE, NY:
3,481,803, INT. CL. 9.
- CERTIFICATION BOARD OF CARDIOVASCULAR COM-
PUTED TOMOGRAPHY, MONTGOMERY VILLAGE, MD:
3,479,406, PUB. 5-20-2008. INT. CL. 41.
- CERWIN VEGA, INC., HOLLYWOOD, FL:
3,480,189, PUB. 5-20-2008. INT. CL. 9.
- CFC TECHNOLOGY CORPORATION, PLYMOUTH, MN:
3,478,791, PUB. 5-20-2008. INT. CL. 42.
- CFMT LLC, BOULDER, CO:
3,478,797, PUB. 12-11-2007. INT. CL. 19.
- CGEAR AUSTRALIA PTY LTD, PORT MELBOURNE VIC
3207, AUSTRALIA:
3,480,820, PUB. 5-20-2008. MULTIPLE CLASS, INT. CLS.
22, 24 AND 27.
- CGG, LLC, ARLINGTON, VA:
3,478,999, PUB. 5-20-2008. MULTIPLE CLASS, INT. CLS.
35 AND 44.
- CHADD, INC. (CHILDREN & ADULTS WITH ATTENTION-
DEFICIT/HYPERACTIVITY DISORDER), LANDOVER,
MD:
2,492,061, CANC. INT. CL. 36.
- CHAIN DRUG MARKETING ASSOCIATION, INC., NOVI,
MI:
3,479,494, PUB. 5-20-2008. MULTIPLE CLASS, INT. CLS.
8, 9 AND 21.
- CHAIR COVERS & LINENS, INC., MADISON HEIGHTS, MI:
3,479,560, PUB. 5-20-2008. INT. CL. 43.
- CHAKRANICITY LLC, SANDY HOOK, CT:
3,479,088, PUB. 5-20-2008. INT. CL. 45.
- CHAMBAX LLC, DUBLIN, OH:
3,480,364, PUB. 5-20-2008. INT. CL. 35.
- CHAMBAX LLC, COLUMBUS, OH:
3,480,365, PUB. 5-20-2008. INT. CL. 35.
- CHANEL, INC., NEW YORK, NY:
2,493,158, CANC. INT. CL. 3.
- CHANG, CALVIN, ANAHEIM, CA:
3,481,282, INT. CL. 10.
- CHANG, TAE YOUNG, IRVINE, CA, DBA HIGHTEL, INC.:
3,479,775, PUB. 5-20-2008. MULTIPLE CLASS, INT. CLS.
7, 8 AND 21.
- CHANGZHOU HAWK DISPLAY APPLIANCE MANUFAC-
TURE CO., LTD., CHANGZHOU CITY, JIANGSU PRO-
VINCE, CHINA:
3,481,101, INT. CL. 6.
- CHANNELADVISOR CORPORATION, MORRISVILLE, NC:
3,482,618, INT. CL. 35.
- CHANNELL COMMERCIAL CORPORATION, TEMECULA,
CA:
3,481,152, INT. CL. 20.
- CHANTECLER S.P.A., ITALY:
3,480,998, PUB. 5-20-2008. INT. CL. 35.
- CHAOYANG BAOLANSI METICULOUS & CHEMICAL CO.,
LTD., CHAOYANG CITY, GUANGDONG PROVINCE,
CHINA:
2,804,065, CANC. INT. CL. 3.
- CHAPMAN MANUFACTURING COMPANY, INC., AVON,
MA:
2,492,993, CANC. INT. CL. 11.
- CHAPMAN, DALE A., PLEASANT VALLEY, NY AND
BEGLEY, ROBERT, VERO BEACH, FL:
3,482,210, INT. CL. 41.
- CHARCO 2000, INC., SHELTON, CT:
2,492,994, CANC. INT. CL. 13.
- CHARCOAL COMPANION INCORPORATED, EMERY-
VILLE, CA:
2,611,299, CANC. INT. CL. 8.
- CHARDON LABORATORIES INC., REYNOLDSBURG, OH:
3,478,861, PUB. 5-20-2008. MULTIPLE CLASS, INT. CLS.
11 AND 40.
- CHARISMA SALES, INC., SAINT CLOUD, FL:
3,481,513, INT. CL. 28.
- CHARLES LAUZIER, FRANCE:
3,480,822, PUB. 5-20-2008. MULTIPLE CLASS, INT. CLS.
6, 19 AND 24.
- CHARLES, PATRICK, WOODLAND HILLS, CA:
3,481,249, INT. CL. 41.
- CHASE PRODUCTS COMPANY, BROADVIEW, IL:
2,189,961, REN. 6-30-08. INT. CL. 21.
- CHAUTAUQUA, INC., DURHAM, NC:
3,480,453, PUB. 5-20-2008. INT. CL. 41.
- CHECKERS INDUSTRIAL PRODUCTS, INC., LOUISVILLE,
CO:
1,510,150, REN. 6-30-08. INT. CL. 20.
- CHECKPOINT SYSTEMS, INC., THOROFARE, NJ:
3,481,629, INT. CL. 9.
- CHELTON USA, INC., BUFFALO GROVE, IL:
3,480,125, PUB. 5-20-2008. INT. CL. 30.
- CHEMICO INTERNATIONAL, INC., CORPUS CHRISTI, TX:
3,482,447, INT. CL. 11.
- CHEMTURA CORPORATION, MIDDLEBURY, CT:
1,516,981, REN. 7-2-08. INT. CL. 5.
- CHENG SHIN RUBBER USA, INC., SUWANEE, GA:
3,480,539, PUB. 5-20-2008. INT. CL. 12.
- CHERNE INDUSTRIES INCORPORATED, MINNEAPOLIS,
MN:
2,140,854, REN. 6-28-08. INT. CL. 11.
2,141,708, REN. 6-28-08. INT. CL. 8.
- CHESAPEAKE WALLCOVERINGS CORPORATION, BO-
WIE, MD:
2,163,812, REN. 7-3-08. INT. CL. 27.
- CHESEBROUGH PONDS, INC., WILMINGTON, DE:
2,492,936, CANC. INT. CL. 37.
- CHEWY TOYS LLC, DENVER, CO:
3,479,482, PUB. 5-20-2008. INT. CL. 28.
- CHF INDUSTRIES, INC., NEW YORK, NY:
2,099,866, CANC. INT. CL. 24.
- CHHARU TSHONGDEL, BONDEY, PARO, BHUTAN:
3,479,251, PUB. 5-20-2008. INT. CL. 30.
- CHICAGO READER, INCORPORATED, CHICAGO, IL:
2,098,794, CANC. MULTIPLE CLASS, INT. CLS. 35 AND
42.
- CHILDREN OF DAVAONN'E, CHESAPEAKE, VA:
3,481,143, INT. CL. 36.
- CHILDREN'S APPAREL NETWORK, LTD., ELIZABETH,
NJ:
3,479,923, PUB. 5-20-2008. INT. CL. 25.
- CHILDREN'S PEDIATRICS CENTERS, LLC, CANTON, GA:
3,480,480, PUB. 5-20-2008. INT. CL. 25.
- CHILDREN'S WORLD LEARNING CENTERS, INC., GOLD-
EN, CO TO ARAMARK EDUCATIONAL RESOURCES,
INC., GOLDEN, CO:
2,100,062, CANC. MULTIPLE CLASS, INT. CLS. 41 AND
42.
- CHILDSPLAY, INC., TEMPE, AZ:
1,487,166, REN. 7-2-08. INT. CL. 41.
- CHILTON, TOM, SANTA FE, NM:
2,098,686, CANC. INT. CL. 41.
- CHINA DAILY NEWS, INC., MONTEREY PARK, CA:
3,479,091, PUB. 5-20-2008. INT. CL. 16.
- CHINA MIST TEA COMPANY, SCOTTSDALE, AZ:
3,478,918, PUB. 5-20-2008. INT. CL. 35.
- CHIPNUTS TECHNOLOGY (SHANGHAI) INC., PUDONG,
SHANGHAI, CHINA:
3,481,394, INT. CL. 9.
- CHIPPENDALES USA, LLC, PLAINVIEW, NY:
3,478,786, PUB. 5-20-2008. INT. CL. 41.
- CHIPPER SNAX, INC., SALT LAKE CITY, UT:
3,482,076, INT. CL. 29.
- CHIRON DIAGNOSTICS CORPORATION, MEDFIELD, MA
TO BAYER CORPORATION, PITTSBURGH, PA:
2,100,023, CANC. INT. CL. 10.

CHIZARI, ABOLGHASEM, CAMBRIDGE, UNITED KINGDOM:
3,479,160, PUB. 5-20-2008. INT. CL. 10.

CHOCOLAFABRIKEN LINDT & SPRÜNGLI AG, SWITZERLAND:
3,480,901, PUB. 5-20-2008. INT. CL. 30.

CHOCOLATE CITY ENTERTAINMENT, INC., CLINTON, MD:
2,492,324, CANC. INT. CL. 41.

CHOCOLATES GAROTO S.A., ESPIRITO SANTO, BRAZIL:
2,159,005, REN. 6-30-08. INT. CL. 30.

CHOI, HAK LAK, REPUBLIC OF KOREA:
3,480,764, PUB. 5-20-2008. INT. CL. 43.

CHOICE FIRST DISTRIBUTION, LLC, PHOENIX, AZ:
3,481,258, INT. CL. 25.

CHRIST CHURCH IN THE CITY OF BOSTON, INC., BOSTON, MA:
2,165,102, REN. 6-30-08. INT. CL. 16.

CHRISTIANITY TODAY INTERNATIONAL, CAROL STREAM, IL:
3,480,225, PUB. 5-20-2008. INT. CL. 9.

CHRISTINE'S LLC, EASLEY, SC:
3,481,750, INT. CL. 21.

CHRISTMAS SPIRIT FOUNDATION, CHESTERFIELD, MO:
3,480,732, PUB. 5-20-2008. INT. CL. 35.

CHRISTOPHER & BANKS, INC., PLYMOUTH, MN:
2,492,451, CANC. INT. CL. 25.

CHRISTOPHER DEAN MAJER, SPOKANE, WA:
3,480,175, PUB. 5-20-2008. INT. CL. 35.

CHRISTOPHER M. KUEHNEL, CLEVELAND, WI:
3,479,983, PUB. 5-20-2008. INT. CL. 9.

CHRYSLER, DOUGLAS, SPANGLE, WA:
3,479,496, PUB. 5-20-2008. INT. CL. 36.

CHUBB COMPUTER SERVICES, INC., WARREN, NJ:
2,493,668, CANC. INT. CL. 41.

CHURCH & DWIGHT CO., INC., PRINCETON, NJ:
3,482,062, INT. CL. 21.

CH2O, INC., OLYMPIA, WA:
3,479,479, PUB. 5-20-2008. INT. CL. 1.

CICALESE, TONI, BUSHKILL, PA, DBA ALL4PRINTING GROUP:
3,479,280, PUB. 5-20-2008. INT. CL. 35.

CIGNA INTELLECTUAL PROPERTY, INC., WILMINGTON, DE:
2,493,082, CANC. INT. CL. 35.

CILLI ORIGINAL DESIGNS, RICHMOND, VA:
2,493,707, CANC. INT. CL. 25.

CIMMETRY SYSTEMS CORP., MONTREAL, QUEBEC, CANADA:
3,478,989, PUB. 5-20-2008. INT. CL. 9.
3,478,990, PUB. 5-20-2008. INT. CL. 9.

CINDEX HOLDINGS LIMITED, HONG KONG, HONG KONG:
3,405,193 NEW CERT. 8-5-2008. MULTIPLE CLASS, INT. CLS. 19 AND 22.

CINNAFILM, INC., ALBUQUERQUE, NM:
3,481,299, MULTIPLE CLASS, INT. CLS. 41 AND 42.

CINSA, S.A. DE C.V., SALTILLO, MEXICO:
3,479,797, PUB. 5-20-2008. INT. CL. 21.

CIRIO DEL MONTE ITALIA S.P.A., ROMA, ITALY:
2,099,976, CANC. INT. CL. 30.

CIS BIO INTERNATIONAL, SOCIÉTÉ ANONYME, FRANCE:
3,480,887, PUB. 5-20-2008. MULTIPLE CLASS, INT. CLS. 1, 5, 10 AND 42.

CITIZEN HOLDINGS KABUSHIKI KAISHA, NISHI-TOKYO-SHI, TOKYO, JAPAN, TA CITIZEN HOLDINGS CO., LTD.:
3,479,238, PUB. 5-20-2008. MULTIPLE CLASS, INT. CLS. 7, 9, 37 AND 42.

CITIZEN HOLDINGS KABUSHIKI KAISHA, NISHI-TOKYO-SHI, TOKYO, JAPAN, TA CITIZEN HOLDINGS CO., LTD.:
3,479,239, PUB. 5-20-2008. MULTIPLE CLASS, INT. CLS. 7 AND 9.

CITIZEN'S SCHOLARSHIP FOUNDATION OF AMERICA, INC., ST. PETER, MN:
2,100,121, CANC. MULTIPLE CLASS, INT. CLS. 16, 21, 25 AND 28.

CITRA ANTICOAGULANTS, INC., BRAINTREE, MA:
3,480,274, PUB. 5-20-2008. INT. CL. 5.

CITY OF BOULDER, COLORADO, BOULDER, CO:
3,479,149, PUB. 5-20-2008. INT. CL. 41.

CITY OF DEARBORN, MICHIGAN, DEARBORN, MI:
3,479,467, PUB. 5-20-2008. INT. CL. 41.

CITY OF PIGEON FORGE, TENNESSEE, PIGEON FORGE, TN:
3,479,137, PUB. 5-20-2008. INT. CL. 41.

CITY PUBLIC SERVICE, SAN ANTONIO, TX:
3,480,503, PUB. 5-20-2008. INT. CL. 42.

CJ MEDIA, INC., SEOUL, REPUBLIC OF KOREA:
3,480,703, PUB. 5-13-2008. INT. CL. 41.

CLABER S.P.A., FIUME VENETO (PN), ITALY:
3,365,822, COR. INT. CL. 9.

CLAIRE-SPRAYWAY, INC., ADDISON, IL, CLAIRE MANUFACTURING COMPANY, ADDISON, IL:
1,095,631, REN. 6-30-08. MULTIPLE CLASS, INT. CLS. 3, 4 AND 5.

CLANCY, DENNIS M. AND MUDD, RICHARD J., OVERLAND, MO:
1,366,629, CANC. INT. CL. 16.

CLAREMONT INVESTMENT PARTNERS, SUMMIT, NJ:
2,173,349, REN. 7-3-08. INT. CL. 36.

CLARENCE J. VENNE, L.L.C., LEVITTOWN, PA:
3,480,295, PUB. 5-20-2008. INT. CL. 28.
3,480,296, PUB. 5-20-2008. INT. CL. 28.

CLARITAS INC., SAN DIEGO, CA:
3,479,015, PUB. 5-20-2008. MULTIPLE CLASS, INT. CLS. 9, 16 AND 35.
3,479,114, PUB. 5-20-2008. INT. CL. 35.

CLARK, KERRIE, ENCINO, CA:
2,491,823, CANC. INT. CL. 14.

CLARKE INC., ETOBICOKE, ONTARIO, CANADA:
2,492,148, CANC. MULTIPLE CLASS, INT. CLS. 35 AND 39.

CLAUDE AND MONIQUE, WAUSEON, OH:
3,480,477, PUB. 5-20-2008. INT. CL. 18.

CLAUDIA G., INC., CORAL SPRINGS, FL:
2,493,516, CANC. INT. CL. 3.

CLAVERACK RURAL ELECTRIC COOPERATIVE, INC., WYSOX, PA AND NORTHWESTERN RURAL ELECTRIC COOPERATIVE ASSOCIATION, INC., CAMBRIDGE SPRINGS, PA:
3,479,668, PUB. 5-20-2008. INT. CL. 35.

CLAYTON ON THE PARK, L.L.C., ST. LOUIS, MO:
2,492,818, CANC. INT. CL. 42.

CLEANWISE, INC., MARLBOROUGH, MA:
3,478,752, PUB. 5-20-2008. INT. CL. 42.

CLEAR BLUE SKY PRODUCTIONS, INC., BELLEVUE, WA:
2,493,061, CANC. INT. CL. 36.

CLEAR SKY BURNERS LLC, TEMPE, AZ:
3,479,005, PUB. 5-20-2008. INT. CL. 35.

CLEMENT COMMUNICATIONS, INC., CONCORDVILLE, PA:
1,491,124, REN. 6-28-08. INT. CL. 16.

CLIENTS FIRST FINANCIAL, HINGHAM, MA:
3,482,497, INT. CL. 36.

CLINICAL TOPICALS LLC, NEW YORK, NY:
3,482,619, MULTIPLE CLASS, INT. CLS. 3 AND 5.

CLINICIAN SUPPORT TECHNOLOGY, INC., FRAMINGHAM, MA:
2,493,655, CANC. INT. CL. 42.

CLIX SYSTEMS, INC., CAMBRIDGE, MA:
3,481,189, INT. CL. 12.

CLOROX COMPANY, THE, OAKLAND, CA:
1,458,606, CANC. INT. CL. 31.
3,482,329, INT. CL. 3.

CLOVERVALE FARMS, INC., LORAIN, OH:
2,901,797, COR. INT. CL. 30.

CLOYES GEAR AND PRODUCTS, INC., FT. SMITH, AR:
2,191,699, REN. 7-2-08. INT. CL. 7.

CLUTCH AUTO LIMITED, NEW DELHI - 110 055, INDIA:
3,479,228, PUB. 5-20-2008. INT. CL. 12.

CLYDE COMPANIES, INC., OREM, UT:
3,479,638, PUB. 5-20-2008. INT. CL. 36.

- CMRG APPAREL, LLC, CANTON, MA:
3,482,602, INT. CL. 25.
- CMT ASSET MANAGEMENT LIMITED, CHICAGO, IL:
3,481,219, INT. CL. 36.
- COACH SERVICES, INC., NEW YORK, NY:
2,169,808, REN. 7-3-08. INT. CL. 25.
- COASTAL ENVIRONMENTS, INCORPORATED, BATON ROUGE, LA:
3,478,719, PUB. 5-20-2008. INT. CL. 42.
- COBB TUNING PRODUCTS, LLC, SALT LAKE CITY, UT:
3,478,641, PUB. 5-20-2008. MULTIPLE CLASS, INT. CLS. 7, 9, 12, 25, 35, 37, 40 AND 42.
- COBB, BOBBY J., GREENVILLE, SC:
3,480,346, PUB. 5-20-2008. INT. CL. 43.
3,480,347, PUB. 5-20-2008. INT. CL. 30.
- COCA-COLA COMPANY, THE, ATLANTA, GA:
1,458,576, CANC. INT. CL. 30.
2,493,096, CANC. INT. CL. 30.
- CODDINGTON ENVIRONMENTAL, INC., NEW YORK, NY:
3,480,088, PUB. 5-20-2008. INT. CL. 3.
- COED SPORTSWEAR, INC., NEWFIELDS, NH:
3,482,535, INT. CL. 25.
- COFAIR PRODUCTS, INC., SKOKIE, IL:
3,478,742, PUB. 5-20-2008. INT. CL. 17.
- COGENT TECHNOLOGIES, INC, BROOKLYN PARK, MN, DBA RESEARCH, INC:
3,480,237, PUB. 5-20-2008. INT. CL. 11.
- COGENT, INC., SO. PASADENA, CA:
3,480,379, PUB. 5-20-2008. INT. CL. 9.
- COGNAC GAUTIER, 16140 AIGRE, FRANCE:
2,181,327, COR. INT. CL. 33.
2,410,939, COR. INT. CL. 33.
- COHEN, ALAN, FAIR LAWN, NJ, DBA ACM RECORDS, INC. AND EVELYNE COHEN, FAIR LAWN, NJ, DBA ACM RECORDS, INC.:
3,480,182, PUB. 5-20-2008. MULTIPLE CLASS, INT. CLS. 9 AND 41.
- COJAB, JACOBO S., LONG BRANCH, NJ:
3,478,549, PUB. 5-20-2008. INT. CL. 24.
- COL-HAN, INC., BOULDER, CO, DBA THE OASIS BREWERY:
2,098,719, CANC. INT. CL. 32.
- COLBY MANUFACTURING CORP., TULLYTOWN, PA:
3,479,072, PUB. 5-20-2008. INT. CL. 10.
- COLD STEEL, INC., VENTURA, CA:
1,494,839, REN. 6-27-08. INT. CL. 8.
- COLE CHEVROLET-CADILLAC, INC., BLUEFIELD, WV, DBA COLE CHEVROLET-CADILLAC-GMC:
3,479,728, PUB. 5-20-2008. INT. CL. 35.
- COLE, CAROL, ENCINITAS, CA:
3,479,514, PUB. 5-20-2008. INT. CL. 3.
- COLEBROOK BOSSON SAUNDERS PRODUCTS LTD., UNITED KINGDOM:
3,480,858, PUB. 5-20-2008. MULTIPLE CLASS, INT. CLS. 16 AND 20.
- COLEMAN COMPANY, INC., THE, WICHITA, KS:
2,098,908, CANC. INT. CL. 22.
- COLEMAN, ANDREA, STEVENSONRANCH, CA:
3,482,322, INT. CL. 18.
- COLEMAN, EMILY H., NEWPORT BEACH, CA:
1,458,770, CANC. INT. CL. 41.
- COLIBRI FLOWERS SA, BOGOTA, COLOMBIA:
2,492,180, CANC. INT. CL. 31.
- COLLEGE OF AMERICAN PATHOLOGISTS, NORTHFIELD, IL:
3,479,635, PUB. 5-20-2008. MULTIPLE CLASS, INT. CLS. 41 AND 44.
- COLLEGE PUBLISHER, INC., BOSTON, MA:
2,493,676, CANC. MULTIPLE CLASS, INT. CLS. 9 AND 41.
- COLLINGS GUITARS, INC., AUSTIN, TX:
3,478,885, PUB. 5-20-2008. INT. CL. 15.
- COLLINS INTERNATIONAL CO., LTD., FAIR LAWN, NJ:
3,482,331, INT. CL. 11.
- COLLINS, CRAIG L., LA JOLLA, CA:
2,493,599, CANC. INT. CL. 9.
- COLONEY, MIKE, PEACHTREE CITY, GA AND JOLLY, CHRISTIAN, PEACHTREE CITY, GA AND HENSON, ERIC, PEACHTREE CITY, GA AND HAUGH, CHRIS, PEACHTREE CITY, GA AND BROWN, JONATHAN, PEACHTREE CITY, GA AND LAMBING, DON JR., PEACHTREE CITY, GA AND HAYLOCK, RYAN, PEACHTREE CITY, GA:
2,492,769, CANC. INT. CL. 41.
- COLONIAL DAMES COMPANY, LTD., COMMERCE, CA:
3,479,318, PUB. 5-20-2008. INT. CL. 3.
- COLORADO NANOTECHNOLOGY ALLIANCE, DENVER, CO:
3,479,158, PUB. 5-20-2008. INT. CL. 35.
- COLORADO STATE PATROL, DENVER, CO:
3,479,424, PUB. 2-12-2008. INT. CL. 25.
- COLT INTERNATIONAL, INC., WEBSTER, TX:
3,480,567, PUB. 5-20-2008. INT. CL. 42.
- COLTEC INDUSTRIAL PRODUCTS LLC, CHARLOTTE, NC, FRANCE PACKING COMPANY, PHILADELPHIA 15, PA:
662,591, REN. 7-1-08. U.S. CL. 35 (INT. CLS. 7 AND 17).
- COLUMBIA ACORN TRUST, CHICAGO, IL:
2,491,836, CANC. INT. CL. 36.
2,491,837, CANC. INT. CL. 36.
- COLUMBIA BIBLE COLLEGE BROADCASTING CO., COLUMBIA, SC:
3,481,305, INT. CL. 41.
- COLUMBIA INSURANCE COMPANY, OMAHA, NE:
3,480,579, PUB. 5-20-2008. INT. CL. 27.
- COLUMBUS PRECISION TOOL, INC., WESTERVILLE, OH:
3,481,946, INT. CL. 28.
- COMBE INCORPORATED, WHITE PLAINS, NY:
2,492,524, CANC. INT. CL. 3.
- COMEFLY OUTDOOR CO., LTD., CHINA:
3,480,879, PUB. 5-20-2008. MULTIPLE CLASS, INT. CLS. 9, 18, 20, 22 AND 25.
- COMERCIAL CARDEPORT LTDA., SANTIAGO, CHILE:
3,479,773, PUB. 5-20-2008. INT. CL. 12.
- COMITÉ INTERNATIONAL OLYMPIQUE, 1007 LAUSANNE, SWITZERLAND, DBA INTERNATIONAL OLYMPIC COMMITTEE:
3,479,681, PUB. 5-20-2008. MULTIPLE CLASS, INT. CLS. 35 AND 41.
3,479,682, PUB. 5-20-2008. MULTIPLE CLASS, INT. CLS. 35 AND 41.
3,479,683, PUB. 5-20-2008. MULTIPLE CLASS, INT. CLS. 35 AND 41.
- COMMAND NUTRITIONALS, LLC, FAIRFIELD, NJ:
3,480,631, PUB. 5-20-2008. MULTIPLE CLASS, INT. CLS. 40 AND 42.
- COMMAND PACKAGING, LOS ANGELES, CA:
3,479,883, PUB. 5-20-2008. INT. CL. 16.
- COMMERCE BANCORP, INC., CHERRY HILL, NJ:
3,482,598, INT. CL. 36.
- COMMERCIAL CASH REGISTER CORPORATION, IRVINE, CA, DBA COMCASH:
2,493,117, CANC. INT. CL. 9.
- COMMITTED FITNESS SYSTEMS, INC.:
1,458,745, CANC. INT. CL. 41.
- COMMUNEXUS SAN DIEGO, SAN DIEGO, CA, DBA SAN DIEGO TELECOM COUNCIL:
3,479,968, PUB. 5-20-2008. INT. CL. 35.
- COMMONWEALTH CASE MANAGEMENT, LLC, LEXINGTON, KY:
2,492,313, CANC. INT. CL. 42.
- COMMTEK COMMUNICATIONS CORPORATION, BOISE, ID:
1,458,306, CANC. INT. CL. 16.
- COMMUNIQUE TELECOMMUNICATIONS, INC., ONTARIO, CA:
1,458,116, CANC. INT. CL. 9.
- COMMUNITY CAREER AND TECHNOLOGY CENTER, INC., PEORIA, IL:
2,491,914, CANC. MULTIPLE CLASS, INT. CLS. 41 AND 42.
- COMMUNITY COFFEE COMPANY OF TEXAS, INC., HOUSTON, TX:
3,105,710, COR. INT. CL. 30.

COMMUNITY GROUP, INC., GLEN ALLEN, VA:
2,197,290, REN. 7-3-08. INT. CL. 35.

COMMUNITY REDEVELOPMENT AGENCY LLC, LOS ANGELES, CA:
3,479,118, PUB. 5-20-2008. INT. CL. 35.

COMPAGNIE FINANCIÈRE ET DE PARTICIPATIONS ROULLIER, 35400 SAINT MALO, FRANCE:
3,479,371, PUB. 5-20-2008. INT. CL. 1.

COMPAGNIE INDUSTRIELLE ET; FINANCIERE D'INGENIERIE - INGENICO, F-92200 NEUILLY S/SEINE, FRANCE:
3,480,766, PUB. 12-18-2007. INT. CL. 36.

COMPANION HABITATS, COLORADO SPRINGS, CO:
2,158,498, REN. 6-30-08. INT. CL. 21.

COMPBENEFITS CORPORATION, LOUISVILLE, KY:
3,482,235, MULTIPLE CLASS, INT. CLS. 36 AND 44.

COMPLEAT NATURALIST, LTD., THE, ASHEVILLE, NC:
2,492,211, CANC. INT. CL. 35.

COMPLETE PROPS, SIMI VALLEY, CA:
3,480,593, PUB. 5-20-2008. INT. CL. 16.

COMPO GMBH & CO. KG, MUENSTER, FED REP GERMANY:
3,481,053, INT. CL. 1.

COMPONENTONE, LLC, PITTSBURGH, PA:
2,493,310, CANC. INT. CL. 9.

COMPREHENSIVE AGE MANAGEMENT SYSTEMS & AESTHETIC PLASTIC SURGERY, PLLC, NEW YORK, NY:
3,481,164, INT. CL. 44.

COMPS, INC., BETHESDA, MD TO COSTAR REALTY INFORMATION, INC., BETHESDA, MD:
2,582,738, CANC. MULTIPLE CLASS, INT. CLS. 9 AND 16.

COMPUTATIONAL SYSTEMS, INC., KNOXVILLE, TN:
2,492,857, CANC. INT. CL. 9.

COMPUTER ASSOCIATES THINK, INC., ISLANDIA, NY:
1,488,197, REN. 6-28-08. INT. CL. 9.

COMPUTER ASSOCIATES THINK, INC., ISLANDIA, NY, UNISOFT INC., SEATTLE, WA:
1,489,068, REN. 6-28-08. INT. CL. 9.

COMPUTER SERVICES, INC., PADUCAH, KY:
3,481,846, INT. CL. 9.

COMPUTER TASK GROUP, INC., BUFFALO, NY:
2,493,504, CANC. INT. CL. 42.

COMPUTERCOP CORP., BOHEMIA, NY:
2,470,088, CANC. INT. CL. 9.

COMVEST CAPITAL, LLC, CLARKSBURG, WV:
3,479,222, PUB. 5-20-2008. INT. CL. 7.

CONAIR CORPORATION, STAMFORD, CT:
3,481,469, INT. CL. 10.
3,481,478, INT. CL. 21.
3,481,479, INT. CL. 21.
3,481,480, INT. CL. 21.
3,481,490, INT. CL. 7.
3,481,626, INT. CL. 9.
3,481,647, INT. CL. 20.
3,482,283, INT. CL. 11.

CONAIR CORPORATION, STAMFORD, DE:
3,482,372, INT. CL. 11.

CONANT, ARLENE M., MARINETTE, WI AND CONANT, DONALD J., MARINETTE, WI:
2,492,207, CANC. INT. CL. 16.

CONCEP GROUP LIMITED, LONDON, UNITED KINGDOM:
3,479,847, PUB. 5-20-2008. INT. CL. 42.

CONCEPT AVENUE U LTD., BROOKLYN, NY:
1,458,829, CANC. INT. CL. 42.

CONCEPT VENUES LTD, LONDON W1F 9BZ, UNITED KINGDOM:
3,479,301, PUB. 5-20-2008. MULTIPLE CLASS, INT. CLS. 41 AND 43.

CONCESSIONS INTERNATIONAL, LLC, ATLANTA, GA:
2,502,978, CANC. INT. CL. 42.
2,644,005, CANC. INT. CL. 42.

CONCRETE EQUIPMENT CO., INC., BLAIR, NE:
1,458,014, CANC. INT. CL. 7.

CONFERENCE OF SOUTHWEST FOUNDATIONS, INC., DALLAS, TX:
3,479,488, PUB. 5-20-2008. MULTIPLE CLASS, INT. CLS. 35 AND 41.
3,479,489, PUB. 5-20-2008. MULTIPLE CLASS, INT. CLS. 35 AND 41.

CONNECTICUT RESOURCES RECOVERY AUTHORITY, HARTFORD, CT:
3,481,264, INT. CL. 41.

CONNOR, ROBERT A., MINNEAPOLIS, MN:
3,482,353, INT. CL. 35.

CONCOPHILLIPS COMPANY, HOUSTON, TX:
3,478,975, PUB. 5-20-2008. INT. CL. 4.
3,478,979, PUB. 5-20-2008. INT. CL. 4.

CONQUET, RUDOLPH A., NEW YORK, NY:
3,479,639, PUB. 5-20-2008. INT. CL. 16.

CONSERVATION TECHNOLOGY, LTD., NORTHBROOK, IL:
1,500,427, REN. 7-3-08. INT. CL. 11.

CONSERVERA GALLEGA, S.A., SPAIN:
3,480,942, PUB. 5-20-2008. INT. CL. 29.

CONSONA CRM INC., INDIANAPOLIS, IN:
2,492,917, CANC. INT. CL. 9.

CONSORTIUM ON READING EXCELLENCE, BERKELEY, CA:
3,479,570, PUB. 5-20-2008. MULTIPLE CLASS, INT. CLS. 16 AND 41.

CONSTANS, GEORGE, NEVIS, MN:
3,480,171, PUB. 5-20-2008. INT. CL. 5.

CONSTELLATION ENERGY GROUP, INC., BALTIMORE, MD:
3,481,207, MULTIPLE CLASS, INT. CLS. 35 AND 37.

CONSTELLATION SPIRITS INC., CHICAGO, IL:
3,481,823, INT. CL. 33.

CONSUMER STUDIO LLC, PLEASANTVILLE, NY:
3,479,355, PUB. 5-20-2008. INT. CL. 35.

CONTACT LENS ASSOCIATION OF OPHTHALMOLOGISTS, INC., WOODBURY, MN:
3,479,436, PUB. 5-20-2008. INT. CL. 35.

CONTEX A/S, ALLEROED, DENMARK:
3,480,727, PUB. 5-20-2008. INT. CL. 9.

CONTINENTAL AKTIENGESELLSCHAFT, 30165 HANNOVER, FED REP GERMANY:
3,481,033, PUB. 5-20-2008. INT. CL. 12.

CONTRACTPOWER, LLC, WEST PALM BEACH, FL:
3,479,321, PUB. 5-20-2008. INT. CL. 35.

CONTROL FLOW, INC., HOUSTON, TX:
3,479,543, PUB. 5-20-2008. INT. CL. 7.

CONTROLLI S.R.L., ITALY:
3,480,919, PUB. 5-20-2008. INT. CL. 9.

CONVERSE INC., NORTH ANDOVER, MA:
3,481,708, INT. CL. 25.

CONVERTIBLE CASTLES, INC., NORTON, MA:
3,479,698, PUB. 5-20-2008. INT. CL. 35.

CONVOY OF HOPE, SPRINGFIELD, MO:
3,481,057, INT. CL. 44.
3,481,058, INT. CL. 43.
3,481,059, INT. CL. 45.

CONWAY, ANDREW D., LAKE VILLA, IL:
2,493,384, CANC. INT. CL. 28.

CONXION CORPORATION, SANTA CLARA, CA:
2,493,271, CANC. MULTIPLE CLASS, INT. CLS. 38 AND 42.

COOK COMMUNICATION MINISTRIES, COLORADO SPRINGS, CO:
2,493,209, CANC. INT. CL. 16.

COOK COMMUNICATIONS MINISTRIES, COLORADO SPRINGS, CO:
3,479,887, PUB. 5-20-2008. INT. CL. 16.

COOK, MICHAEL G., BREA, CA:
2,492,217, CANC. INT. CL. 35.

COOK, STEVE C., AUSTIN, TX:
3,479,723, PUB. 5-20-2008. INT. CL. 42.

COOKSON ELECTRONICS, INC., JERSEY CITY, NJ:
3,481,321, MULTIPLE CLASS, INT. CLS. 1, 2 AND 6.

COOMBS, STANLENE F, SNELLVILLE, GA, DBA PICKNEY ENTERPRISES:
3,479,182, PUB. 5-20-2008. INT. CL. 25.

- COORS BREWING COMPANY, DENVER, CO:
1,458,618, CANC. INT. CL. 32.
2,169,773, REN. 6-30-08, INT. CL. 18.
3,481,382, INT. CL. 32.
- COPAN INDUSTRIES, BRADENTON, FL:
2,493,464, CANC. INT. CL. 30.
- COPS AND ROBBERS, INC., TOLUCA LAKE, CA:
2,492,214, CANC. INT. CL. 42.
- CORA & PETER KUO INCORPORATION, WEST DISTRICT,
TAICHUNG, TAIWAN:
2,685,040, CANC. INT. CL. 9.
- CORECON, INC., SANDWICH, IL:
3,481,401, INT. CL. 12.
- CORENET GLOBAL, INC., ATLANTA, GA:
2,156,231, REN. 7-2-08, INT. CL. 41.
- CORNELIA ZICU INTERNATIONAL, LLC, NEW YORK,
NY:
3,481,160, MULTIPLE CLASS, INT. CLS. 18, 24, 30, 35
AND 43.
- CORPORATION OF KATE MANTILINI, BEVERLY HILLS,
CA:
1,504,397, REN. 6-27-08, INT. CL. 42.
- CORPORATION SERVICE COMPANY, WILMINGTON, DE:
3,479,169, PUB. 5-20-2008, INT. CL. 35.
- CORPSTAR LIMOUSINE SERVICES, LLC, GLENDALE, CA:
3,479,332, PUB. 5-20-2008, INT. CL. 39.
- CORT MUSICAL INSTRUMENT CO., LTD., INCHEON,
REPUBLIC OF KOREA:
1,344,300, REN. 7-3-08, INT. CL. 15.
- CORTEC CORPORATION, ST. PAUL, MN:
3,481,579, INT. CL. 17.
- CORWIN, THOMAS N, TRAVERSE CITY, MI:
3,479,763, PUB. 5-20-2008, INT. CL. 37.
- COSMETIC DERMATOLOGY, INC., MIAMI, FL:
3,482,122, INT. CL. 3.
- COSMICSTEP SOFTWARE, INC, KENMORE, WA:
3,478,654, PUB. 5-20-2008, INT. CL. 9.
- COSMODOG, LTD., CHICAGO, IL:
3,478,703, PUB. 5-20-2008, INT. CL. 28.
- COSTCO WHOLESALE MEMBERSHIP, INC., ISSAQUAH,
WA:
2,243,349, REN. 7-3-08, INT. CL. 36.
- COTSEN, THOMAS ADAM, SANTA MONICA, CA:
3,077,257, CANC. INT. CL. 16.
- COTY B.V., HAARLEM, BENELUX:
3,480,569, PUB. 5-20-2008, INT. CL. 3.
- COTY DEUTSCHLAND GMBH, FED REP GERMANY:
3,480,767, PUB. 5-20-2008, INT. CL. 3.
- COUNCIL FOR RESPONSIBLE NUTRITION, WASHING-
TON, DC:
3,481,415, INT. CL. 35.
- COUNCIL ON EDUCATION IN MANAGEMENT, INC.,
CHARLOTTE, NC:
3,479,263, PUB. 5-20-2008, INT. CL. 41.
- COUNT YOUR STEPS, BLOOMFIELD HILLS, MI:
3,480,445, PUB. 5-20-2008, INT. CL. 41.
- COURREGES PARFUMS, PARIS, FRANCE:
3,480,643, PUB. 5-20-2008, INT. CL. 3.
- COUSIN CORPORATION OF AMERICA, LARGO, FL:
2,492,788, CANC. INT. CL. 26.
2,492,790, CANC. INT. CL. 28.
- COUTTS & CO., LONDON WC2R 0QS, ENGLAND:
2,098,864, CANC. INT. CL. 36.
2,098,865, CANC. INT. CL. 35.
- COVALENCE SPECIALTY MATERIALS CORP., MINNEA-
POLIS, MN:
1,458,349, CANC. INT. CL. 17.
- COVENANT BIBLE COLLEGE, STRATHMORE, ALBERTA,
CANADA:
2,448,733, CANC. MULTIPLE CLASS, INT. CLS. 25 AND
41.
- COVENANT REVIEW, LLC, NEW YORK, NY:
3,479,477, PUB. 5-20-2008, INT. CL. 16.
- COX TARGET MEDIA, INC., LARGO, FL:
2,492,257, CANC. INT. CL. 35.
- COYLE, CECELIA, MINEOLA, NY:
3,479,513, PUB. 5-20-2008, INT. CL. 35.
- CPACKET NETWORKS INC., MOUNTAIN VIEW, CA:
3,482,273, INT. CL. 40.
- CRABBY BILL'S U.S.A., LLC, INDIAN ROCKS BEACH, FL:
3,478,984, PUB. 5-20-2008, INT. CL. 43.
- CRACKPOT ENTERTAINMENT LLC, SHELBURNE FALLS,
MA:
3,481,349, INT. CL. 9.
- CRAFT RUG MILLS, INC., EASTON, PA:
2,492,292, CANC. INT. CL. 35.
- CRAFTMADE INTERNATIONAL INC., COPPELL, TX:
3,481,797, INT. CL. 11.
- CRAIN MANAGEMENT SERVICES, INC., DETROIT, MI,
CRAIN AUTOMOTIVE GROUP, INC., AKRON, OH:
1,093,218, REN. 7-1-08, INT. CL. 16.
- CRAIN, C. WESLEY, MADISON, CT:
2,493,614, CANC. INT. CL. 42.
- CRAMER, INC., KANSAS CITY, KS:
2,493,548, CANC. INT. CL. 6.
- CRANECOM, INC., TUSTIN, CA:
1,458,115, CANC. INT. CL. 9.
- CRAYOLA PROPERTIES, INC., EASTON, PA, BINNEY &
SMITH INC., EASTON, PA:
1,492,365, REN. 7-3-08, INT. CL. 28.
- CRAYOLA PROPERTIES, INC., EASTON, PA:
3,481,770, INT. CL. 16.
- CRB HORSETHIEF AVIATION, INC., AUSTIN, TX:
2,493,035, CANC. INT. CL. 25.
2,493,036, CANC. INT. CL. 25.
- CRC INDUSTRIES, INC, WARMINSTER, PA, UNITED
STATES AVIEX COMPANY, NILES, MI:
668,901, REN. 7-2-08, U.S. CL. 15 (INT. CLS. 1 AND 4).
- CREASPINE SAS, PESSAC, FRANCE:
3,479,490, PUB. 5-20-2008, INT. CL. 10.
- CREATIVE LABORATORIES, INC., EAGAN, MN:
2,493,397, CANC. INT. CL. 3.
- CREATIVE MANAGER, INC., OAKHURST, NJ:
3,478,576, PUB. 5-20-2008, MULTIPLE CLASS, INT. CLS. 9
AND 42.
- CREATIVE MARKETING ASSOCIATES, INC., KANSAS
CITY, MO:
2,154,143, REN. 6-30-08, INT. CL. 39.
- CREATIVE PRESENTATIONS, INC., METAIRIE, LA:
2,492,048, CANC. INT. CL. 37.
- CREATIVE SEASONINGS, INC., COVINA, CA:
1,458,601, CANC. INT. CL. 30.
- CREATIVE TECHNOLOGY LTD., SINGAPORE:
2,492,865, CANC. INT. CL. 9.
- CREATIVE TECHNOLOGY LTD., SINGAPORE, SINGA-
PORE:
3,481,233, INT. CL. 9.
- CREDENCE SYSTEMS CORPORATION, FREMONT, CA:
2,098,621, CANC. INT. CL. 9.
- CREDENCE SYSTEMS CORPORATION, MILPITAS, CA:
2,099,862, CANC. INT. CL. 9.
- CREO PRODUCTS INC., BURNABY, B.C. V5G 4M1, CANA-
DA:
2,493,095, CANC. INT. CL. 9.
- CRF INC., WALTHAM, MA:
3,482,608, INT. CL. 9.
- CRIME CHECK OF SPOKANE COUNTY, SPOKANE, WA:
3,482,612, INT. CL. 41.
- CRIO INVERSIONES, S.A. DE C.V., ANTIGUO CUSCA-
TLAN, EL SALVADOR:
3,481,060, MULTIPLE CLASS, INT. CLS. 29 AND 30.
- CRONE, GEORGE RANDALL, MISSOULA, MT:
3,479,910, PUB. 5-20-2008, INT. CL. 18.
- CROSSFIRE, INC., KALAMAZOO, MI:
2,493,370, CANC. INT. CL. 13.
- CROSSROADS SYSTEMS, INC., AUSTIN, TX:
3,481,643, INT. CL. 9.
- CROSSTEX INTERNATIONAL, INC., HAUPPAUGE, NY:
2,099,087, CANC. INT. CL. 10.
- CROSSWORLDS SOFTWARE, INC., BURLINGAME, CA:
2,492,105, CANC. INT. CL. 9.
- CROUSE COMMUNICATIONS, INC., LAKE FOREST, IL:
2,492,274, CANC. INT. CL. 35.
- CRS RETAIL SYSTEMS, INC., NEWBURGH, NY:
3,481,063, INT. CL. 9.

CRUSHTOWN, LLC, MINNEAPOLIS, MN:
3,480,334, PUB. 5-20-2008. INT. CL. 42.

CRYSTAL CLEAR INDUSTRIES, INC., ROSLYN, NY:
2,163,734. REN. 7-1-08. INT. CL. 35.

CRYTEK GMBH, FRANKFURT AM MAIN, FED REP GERMANY:
3,478,802, PUB. 5-20-2008. MULTIPLE CLASS, INT. CLS. 9 AND 28.

CS OILSEEDS, INC., GENEVA, IL TO CENTRAL SOYA COMPANY, INC., FORT WAYNE, IN:
2,002,687, CANC. INT. CL. 1.

CSL BEHRING AG, BERN 22, SWITZERLAND:
3,482,549, INT. CL. 5.

CSSR HOLDINGS, LLC, AMERICAN FORK, UT:
3,481,484, INT. CL. 43.

CTB IP, INC., WILMINGTON, DE:
3,482,465, INT. CL. 7.
3,482,687, INT. CL. 11.

CTVGLOBEMEDIA PUBLISHING INC., SCARBOROUGH, CANADA:
3,479,491, PUB. 5-20-2008. MULTIPLE CLASS, INT. CLS. 16 AND 41.

CUESTIX, INC., DBA CUESTIX, INTERNATIONAL, LA-FAYETTE, CO:
3,478,711, PUB. 5-20-2008. INT. CL. 28.

CULINARY BUDDY CORP., MIAMI BEACH, FL:
3,479,859, PUB. 5-20-2008. INT. CL. 21.

CULINARY INNOVATIONS LLC, LACKHAWAXEN, PA:
3,482,007, INT. CL. 30.

CUMMINS EAGLE, INC., ASHLAND, VA:
2,491,706, CANC. INT. CL. 7.

CUOMO, ANTHONY J., M.D., SAN DIEGO, CA:
1,458,744, CANC. INT. CL. 41.

CURA HOME CARE SERVICES, LLC, PHOENIX, AZ:
3,481,222, INT. CL. 44.

CUREVAC GMBH, TUBINGEN, FED REP GERMANY:
3,478,720, PUB. 5-20-2008. MULTIPLE CLASS, INT. CLS. 1, 5 AND 44.

CURTIS, RICHARD, ROUND ROCK, TX:
3,480,239, PUB. 5-20-2008. INT. CL. 41.

CURTIS, VICTOR, LOS ANGELES, CA:
3,479,502, PUB. 5-20-2008. INT. CL. 16.

CUSTOME.COM, INC., DALLAS, TX:
2,493,403, CANC. MULTIPLE CLASS, INT. CLS. 35 AND 42.

CUSTOMER EFFECTIVE, INC., GREENVILLE, SC:
3,479,716, PUB. 5-20-2008. INT. CL. 42.

CV THERAPEUTICS, INC., PALO ALTO, CA:
2,491,961, CANC. INT. CL. 42.

CVON GROUP LIMITED, LONDON, UNITED KINGDOM:
3,479,444, PUB. 5-20-2008. MULTIPLE CLASS, INT. CLS. 35, 38 AND 42.

CYBERDREAMING NETWORK, INC., THE, LOS ANGELES, CA:
2,493,600, CANC. INT. CL. 9.
2,493,606, CANC. INT. CL. 9.

CYCLE SYSTEMS INC., ROANOKE, VA:
1,528,795. REN. 7-3-08. INT. CL. 40.

CYDEX PHARMACEUTICALS, INC., LENEXA, KS:
3,479,381, PUB. 5-20-2008. MULTIPLE CLASS, INT. CLS. 5 AND 45.

CYGNUS BUSINESS MEDIA, INC., FORT ATKINSON, WI:
3,479,648, PUB. 5-20-2008. INT. CL. 35.
3,482,682, INT. CL. 16.

CYNTHIA KING, NEW YORK, NY:
3,478,832, PUB. 5-20-2008. INT. CL. 5.

CYTOSPORT, INC., BENICIA, CA:
3,482,186, INT. CL. 5.

D. P. BOSTWICK AND ASSOCIATES, INC., BIRMINGHAM, MI:
3,480,721, PUB. 5-20-2008. INT. CL. 35.

D.C. TAYLOR CO., CEDAR RAPIDS, IA:
1,458,119, CANC. INT. CL. 9.

D.G YUENGLING & SON, INC., POTTSVILLE, PA:
3,481,134, MULTIPLE CLASS, INT. CLS. 16, 21, 25 AND 28.

D.S. LANAH INC., DEWITT, NY:
1,458,527, CANC. INT. CL. 28.

D&B KING, INC., WINTER GARDEN, FL:
3,480,359, PUB. 5-20-2008. INT. CL. 37.

D-LINK SYSTEMS, INC., FOUNTAIN VALLEY, CA:
3,479,611, PUB. 5-20-2008. INT. CL. 41.
3,479,613, PUB. 5-20-2008. INT. CL. 41.

D'ASCOLI, EDMONT P., HALEIWA, HI, DBA XCEL WET-SUITS HAWAII TO SEAL TRADEMARKS PTY LTD, BURLEIGH HEADS, QUEENSLAND, AUSTRALIA:
1,622,623 NEW CERT. 8-5-2008. INT. CL. 25.
1,965,081 NEW CERT. 8-5-2008. INT. CL. 25.

D'BARRO COMMERCE CORPORATION, HOUSTON, TX:
2,491,812, CANC. MULTIPLE CLASS, INT. CLS. 20 AND 21.

DACS, INC., PORTSMOUTH, VA:
3,481,419, INT. CL. 20.

DAEWOO CORPORATION, CHUNG-GU, SEOUL, REPUBLIC OF KOREA:
1,458,540, CANC. INT. CL. 29.

DAEWOO ELECTRONICS CO., LTD., SEOUL, REPUBLIC OF KOREA:
2,492,986, CANC. INT. CL. 11.

DAIGRE, COLIN SCOTT, LOS ANGELES, CA:
3,479,217, PUB. 5-20-2008. INT. CL. 35.

DAILY SOUP FRANCHISE MANAGEMENT GROUP, LLC, UPPER MONTCLAIR, NJ:
2,099,372, CANC. INT. CL. 42.

DAIMLER AG, D-70327 STUTTGART, FED REP GERMANY:
3,479,919, PUB. 5-20-2008. INT. CL. 28.

DAIRY CREST LIMITED, ESHER SURREY, ENGLAND:
2,491,657, CANC. INT. CL. 29.

DAIRY FARMERS OF AMERICA, INC., KANSAS CITY, MO:
3,480,668, PUB. 3-6-2007. INT. CL. 29.

DAIRY QUEEN OF GREATER ST. LOUIS, INC., ST. LOUIS, MO:
2,492,728, CANC. INT. CL. 29.

DAIRYCHEQ INC., WATERLOO, ONTARIO, CANADA:
3,482,293, INT. CL. 9.

DAISY D'S PAPER COMPANY, SALT LAKE CITY, UT:
3,480,037, PUB. 5-20-2008. INT. CL. 16.

DAKOTA LAKES PRODUCTS, INC., KENSAL, ND:
2,099,385, CANC. INT. CL. 35.

DALEYWARE.COM, LAS VEGAS, NV:
3,480,046, PUB. 5-20-2008. INT. CL. 9.

DANAL, INC., SAN JOSE, CA:
3,482,617, INT. CL. 36.

DANCIN' FEELIN' LTD., THE, WARWICK, RI:
2,492,230, CANC. INT. CL. 41.

DANEL ELECTRONIC SA, 92100 BOULOGNE BILLAN-COURT, FRANCE:
2,492,004, CANC. INT. CL. 9.

DANIEL J. MASSEY AND SAMUEL L. MASSEY, DAMASCUS, AR:
3,480,381, PUB. 5-20-2008. INT. CL. 41.

DANIEL ROTH ET GÉRARD GENTA HAUTE HORLOGERIE SA, 1217 MEYRIN, SWITZERLAND:
3,481,775, INT. CL. 14.

DANIEL, SIMON RICHARD, SURREY, UNITED KINGDOM:
3,482,215, INT. CL. 9.

DANIELS, KATHARINE, MONTEREY, CA:
3,481,119, INT. CL. 41.

DANISCO A/S, DK-1001 COPENHAGEN K, DENMARK:
2,493,663, CANC. MULTIPLE CLASS, INT. CLS. 16 AND 20.

DANITAS RADIO A/S, COPENHAGEN, DENMARK:
1,458,171, CANC. INT. CL. 9.

DANNY NEWTON FINANCIAL SERVICES INC, RALEIGH, NC:
3,478,962, PUB. 5-20-2008. INT. CL. 36.

DANTHERM FILTRATION HOLDING A/S, MARIAGER, DENMARK:
3,480,622, PUB. 5-20-2008. MULTIPLE CLASS, INT. CLS. 9, 11 AND 37.

DARBY O'BRIEN ADVERTISING, INC., SOUTH HADLEY, MA:
2,492,132, CANC. INT. CL. 35.

- DARIEN, JEFF, NEW YORK, NY:
2,099,628, CANC. INT. CL. 41.
- DATA BECKER CORPORATION, NEEDHAM, MA:
2,493,648, CANC. INT. CL. 9.
- DATA RESEARCH ASSOCIATES, INC., ST. LOUIS, MO:
2,492,896, CANC. INT. CL. 9.
- DATA SAFE-MEDIA LTD., NEWBRIDGE, EDINBURGH,
LOTHIANS, UNITED KINGDOM:
3,482,102, INT. CL. 16.
- DATA TRANSLATION, INC., MARLBORO, MA:
2,492,779, CANC. INT. CL. 9.
- DATADOE, FT. LAUDERDALE, FL:
3,478,591, PUB. 5-20-2008. INT. CL. 36.
- DATAKEY ELECTRONICS, INC., SAVAGE, MN:
3,479,949, PUB. 5-20-2008. INT. CL. 9.
- DATAMEDIA CORPORATION, PENNSAUKEN, NJ:
1,458,073, CANC. MULTIPLE CLASS, INT. CLS. 9 AND
16.
- DATATRAC CORPORATION, SANDY SPRINGS, GA:
3,479,230, PUB. 5-20-2008. INT. CL. 9.
- DAUGERDAS, PAUL MICHAEL, HENDERSON, NV:
3,481,281, INT. CL. 16.
- DAVANNI'S, INC., PLYMOUTH, MN:
2,182,083, REN. 6-28-08. INT. CL. 42.
2,201,117, REN. 7-3-08. INT. CL. 42.
- DAVE BOWMAN ENTERPRISES, INC., LUTZ, FL:
3,479,028, PUB. 5-20-2008. INT. CL. 41.
- DAVIA BAILEY, SEATTLE, WA:
3,480,581, PUB. 5-20-2008. INT. CL. 35.
- DAVID CLARK COMPANY INCORPORATED, WORCE-
STER, MA:
1,542,373, REN. 7-3-08. INT. CL. 9.
1,542,374, REN. 7-3-08. INT. CL. 9.
- DAVID E. EASTERDAY & CO., INC., MT. EATON, OH:
3,478,896, PUB. 5-20-2008. INT. CL. 2.
- DAVID JACK EVERETT, BRACKNELL, BERKSHIRE RG42
4UR, UNITED KINGDOM:
3,480,856, PUB. 5-20-2008. MULTIPLE CLASS, INT. CLS.
3, 9, 16, 18, 25, 28, 30, 32 AND 41.
- DAVID MARGOLIS, INC., DENVER, CO:
2,493,405, CANC. INT. CL. 41.
- DAVID MILLER, FORT HUACHUCA, AZ:
3,481,683, INT. CL. 35.
- DAVID ROBERT ZABALZA, STOCKTON, CA:
3,479,745, PUB. 5-20-2008. MULTIPLE CLASS, INT. CLS. 9
AND 41.
- DAVID STUART SANDLER, MINNEAPOLIS, MN:
3,479,542, PUB. 5-20-2008. MULTIPLE CLASS, INT. CLS. 9
AND 41.
- DAVIES, SCOTT M., HACIENDA HEIGHTS, CA:
3,343,891, CANC. INT. CL. 18.
3,343,891, AM. INT. CL. 11.
- DAVIS, ART, NEW YORK, NY:
2,099,818, CANC. INT. CL. 41.
- DAVIS, JENNIFER P., RIVERDALE, GA:
3,478,902, PUB. 5-20-2008. MULTIPLE CLASS, INT. CLS.
3, 35 AND 44.
- DAVIS, WAYNE N., HUDDLESTON, VA:
3,481,236, INT. CL. 12.
- DAY, PHILLIP, CHANDLER, AZ:
3,479,856, PUB. 5-20-2008. INT. CL. 36.
- DAYMEN PHOTO MARKETING LP, MARKHAM, ONTAR-
IO, CANADA:
3,481,818, INT. CL. 9.
- DAZBOG COFFEE CO., DENVER, CO:
2,221,853, REN. 6-30-08. INT. CL. 30.
2,222,962, REN. 7-1-08. INT. CL. 30.
2,222,963, REN. 6-30-08. INT. CL. 30.
2,228,878, REN. 7-1-08. INT. CL. 30.
- DBD, INC., CONSHOHOCKEN, PA:
3,479,342, PUB. 5-20-2008. INT. CL. 25.
- DBF INTERNATIONAL INC., TORONTO, ONTARIO, M8Z
4Y4, CANADA:
2,492,096, CANC. INT. CL. 25.
- DCEDUCATION.COM, INC., BELLE HAVEN, VA:
2,492,751, CANC. INT. CL. 42.
- DCWV ACQUISITION CORPORATION, SAN FRANCISCO,
CA:
3,480,712, PUB. 5-20-2008. MULTIPLE CLASS, INT. CLS.
16, 35 AND 41.
- DD IP HOLDER LLC, CANTON, MA:
1,084,143, REN. 7-1-08. INT. CL. 42.
- DE CARACOL CORPORATION, GAITHERSBURG, MD:
3,481,788, INT. CL. 3.
- DE DIETRICH (USA), INC., UNION, NJ:
1,458,117, CANC. INT. CL. 9.
- DE HERRERA, JOHN ALLEN, MONTECITO, CA:
3,482,378, INT. CL. 25.
- DE LA FUENTE CASTRO, ALEJANDRO, MONCLOVA,
MEXICO:
3,480,378, PUB. 5-20-2008. INT. CL. 11.
- DE MARQUE INC., QUEBEC, CANADA:
3,378,538, COR. INT. CL. 41.
- DE YOUNG COMMUNITIES, INC., FRESNO, CA:
3,482,094, INT. CL. 37.
- DEAN INTELLECTUAL PROPERTY SERVICES II, L.P.,
DALLAS, TX:
3,481,809, INT. CL. 32.
- DEBORAH CHADDOCK BROWN, HUDSON, OH, DBA
ALLWRITE INK:
3,480,117, PUB. 5-20-2008. INT. CL. 36.
- DEBUONO, LAUREEN, SAN FRANCISCO, CA AND DE-
BUONO, BARBARA, NEW YORK, NY:
3,423,736, COR. MULTIPLE CLASS, INT. CLS. 41 AND
44.
- DECADE PRODUCTS, LLC, GRAND RAPIDS, MI:
3,482,678, INT. CL. 20.
- DEFECTED RECORDS LTD, LONDON, UNITED KING-
DOM:
3,480,910, PUB. 5-20-2008. MULTIPLE CLASS, INT. CLS.
9, 18, 25, 35, 38 AND 41.
- DEFENSE PROCUREMENT MANUFACTURING SER-
VICES, INC., ST. CLOUD, MN:
3,411,352, COR. INT. CL. 13.
- DEFENSTECH INTERNATIONAL, INC., IRVINE, CA:
3,482,344, INT. CL. 9.
- DEGUDENT GMBH, D-63457 HANAU/MAIN, FED REP
GERMANY:
3,478,518, PUB. 5-20-2008. MULTIPLE CLASS, INT. CLS.
5, 9 AND 10.
- DEGUSSA GALVANOTECHNIK GMBH, SCHWAEBISCH
GMUEND, FED REP GERMANY:
2,583,019, CANC. INT. CL. 40.
- DEI HEADQUARTERS, INC., VISTA, CA, AKA DIRECTED
ELECTRONICS, INC.:
2,493,288, CANC. INT. CL. 9.
- DEINDE TUNDE DAWODU, WASHINGTON, DC AND
SEGUNDO NAZATI, WASHINGTON, DC:
3,481,241, INT. CL. 25.
- DELAWARE CAPITAL FORMATION, INC., WILMINGTON,
DE:
2,247,453, REN. 6-28-08. INT. CL. 9.
- DELAWARE CAPITAL FORMATION, INC., WILMING-
TON, DE:
2,492,689, CANC. INT. CL. 9.
- DELAWARE MANAGEMENT HOLDINGS, INC., WIL-
MINGTON, DE:
3,478,942, PUB. 5-20-2008. INT. CL. 36.
3,478,944, PUB. 5-20-2008. INT. CL. 36.
3,478,945, PUB. 5-20-2008. INT. CL. 36.
- DELICATO VINEYARDS, INC., MANTECA, CA:
3,479,089, PUB. 5-20-2008. INT. CL. 33.
- DELILA A. HARVEY, EVANSVILLE, IN:
3,479,952, PUB. 5-20-2008. INT. CL. 18.
- DELL INC., ROUND ROCK, TX:
2,465,762, CANC. INT. CL. 9.
3,478,780, PUB. 2-12-2008. INT. CL. 42.
- DELSTAR TECHNOLOGIES INC., MIDDLETOWN, DE:
3,482,536, INT. CL. 17.
- DELTA EDGE MANAGEMENT GROUP, LP, MONSEY, NY:
3,481,122, INT. CL. 36.
- DELTA GALIL INDUSTRIES LTD., TEL AVIV, ISRAEL:
3,478,866, PUB. 5-20-2008. INT. CL. 25.
3,478,867, PUB. 5-20-2008. INT. CL. 25.

DELTA GROUP, INC., DALLAS, TX:
2,098,728, CANC. INT. CL. 42.

DELUCA, TOM, ORLANDO, FL:
3,480,578, PUB. 5-20-2008. INT. CL. 41.

DELZOTTO, JOSEPH A., AURORA, CO:
3,478,616, PUB. 5-20-2008. INT. CL. 37.

DEMET'S CANDY COMPANY, GREENWICH, CT:
3,481,567, INT. CL. 30.

DEMETER ASSOCIATION, INC., AURORA, NY:
2,099,610, CANC. U.S. CL. A.

DEMILEC INC., QUEBEC, CANADA:
2,164,451. REN. 6-30-08. INT. CL. 17.

DEMPTOS GLASS COMPANY LLC, LOUISVILLE, KY:
2,492,933, CANC. INT. CL. 33.

DENATALE JR, JOHN, MORICHES, NY:
3,481,725, INT. CL. 9.

DENTAL KALEIDOSCOPE, CANTON, MA:
3,479,675, PUB. 5-20-2008. INT. CL. 35.

DENTSPLY INTERNATIONAL INC., YORK, PA:
3,479,772, PUB. 5-20-2008. INT. CL. 1.

DERMARITE INDUSTRIES, LLC, HAWTHORNE, NJ:
3,481,409, INT. CL. 5.

DESERT ECO SYSTEMS PTY LTD, EVANDALE SA, AUSTRALIA:
3,480,818, PUB. 5-20-2008. MULTIPLE CLASS, INT. CLS. 5 AND 11.

DESERT SKY HOLDINGS, LLC, TARZANA, CA:
3,480,127, PUB. 5-20-2008. INT. CL. 25.

DESERT U.S.A. CORPORATION, SAN FRANCISCO, CA:
3,478,878, PUB. 4-15-2008. INT. CL. 11.

DESICCARE, INC., POMONA, CA:
3,482,657, INT. CL. 1.

DESIGN RESOURCE, LTD., NEW YORK, NY:
2,492,167, CANC. MULTIPLE CLASS, INT. CLS. 14 AND 42.

DESIGNER SKIN, LLC, TEMPE, AZ:
3,481,845, INT. CL. 3.

DESIGNER SKIN, LLC, INDIANAPOLIS, IN:
3,481,851, INT. CL. 3.
3,481,852, INT. CL. 3.
3,481,853, INT. CL. 3.

DESIGNER SKIN, LLC, TEMPE, AZ:
3,481,854, INT. CL. 3.

DESIGNER SKIN, LLC, INDIANAPOLIS, IN:
3,481,855, INT. CL. 3.
3,481,856, INT. CL. 3.

DESTILADORA SANTA VIRGINIA S.A. DE C.V., TEPATILTLÁN DE MORELOS, JALISCO, MEXICO:
3,481,461, INT. CL. 33.

DETROIT PISTONS BASKETBALL COMPANY, AUBURN HILLS, MI:
2,492,551, CANC. INT. CL. 38.

DETROIT TIGERS, INC., DETROIT, MI 48201, MI:
3,480,285, PUB. 5-20-2008. INT. CL. 41.

DETROIT TIGERS, INC., DETROIT, MI:
3,480,300, PUB. 5-20-2008. INT. CL. 16.

DEUTECH BANK, AG, NEW YORK BRANCH, NEW YORK, NY:
1,457,934, CANC. INT. CL. 3.

DEUTSCHE TELEKOM AG, BONN 53113, FED REP GERMANY:
3,479,446, PUB. 2-26-2008. INT. CL. 28.

DEVELOPMENT INFOSTRUCTURE, INC., ARLINGTON, VA, DBA DEVIS, INC.:
2,246,533. REN. 6-28-08. MULTIPLE CLASS, INT. CLS. 9, 41 AND 42.

DEXTER APACHE HOLDING, INC., FAIRFIELD, IA:
1,488,169. REN. 7-3-08. INT. CL. 7.

DF WORLD OF SPICES GMBH, FED REP GERMANY:
3,480,804, PUB. 5-20-2008. MULTIPLE CLASS, INT. CLS. 1, 5, 21, 29 AND 30.

DFDS DAN TRANSPORT CORPORATION, ELIZABETH, NJ:
2,492,727, CANC. INT. CL. 39.

DIABETES WIRELESS, LLC, HOUSTON, TX:
3,481,195, INT. CL. 44.

DIABLOSPORT, LLC, BOCA RATON, FL:
3,481,085, INT. CL. 9.

DIAMOND AUDIO TECHNOLOGY, INC., SANTA MONICA, CA:
2,491,900, CANC. INT. CL. 9.

DIAMOND RESORTS HOLDINGS, LLC, LAS VEGAS, NV:
2,207,804. REN. 7-3-08. INT. CL. 36.

DIATEX S.P.A., ITALY:
3,480,860, PUB. 5-20-2008. INT. CL. 7.

DIAZ, ROGER, SAN ANTONIO, TX:
3,478,514, PUB. 5-20-2008. INT. CL. 43.

DICK'S SPORTING GOODS, INC., PITTSBURGH, PA:
3,481,298, INT. CL. 28.

DICKSON, JASON, SIMI VALLEY, CA:
3,478,712, PUB. 5-20-2008. INT. CL. 28.

DIEHL SHIFTING & CO., NURNBERG, FED REP GERMANY, DIEHL MANUFACTURING COMPANY, BRIDGEWATER TOWNSHIP, NJ:
569,970. REN. 7-1-08. U.S. CL. 21 (INT. CLS. 7 AND 9).

DIERBERGS MARKETS, INC., CHESTERFIELD, MO:
3,481,812, INT. CL. 30.

DIGILOG INTERACTIVE HOLDING S.A., CH 1260 NYON, SWITZERLAND:
2,491,990, CANC. INT. CL. 35.

DIGITAL CHAINSAW, INC., ST. PETERSBURG, FL:
2,492,016, CANC. INT. CL. 42.

DIGITAL DEMOGRAPHICS, INC., NEW BRUNSWICK, NJ:
2,493,515, CANC. INT. CL. 35.

DIGITAL IMS, INC, LINCOLN, NE:
3,481,937, INT. CL. 35.

DINING ALLIANCE, WEBSTER, NY:
3,482,630, INT. CL. 35.

DINOCO INTERNATIONAL CORPORATION, ATHENS, GA:
3,480,283, PUB. 5-20-2008. INT. CL. 5.

DIOCESE OF CENTRAL FLORIDA, INCORPORATED, ORLANDO, FL:
3,478,750, PUB. 5-20-2008. INT. CL. 45.
3,478,751, PUB. 5-20-2008. INT. CL. 45.

DIPIETRO, JOSEPH, NORTH ANDOVER, MA:
3,480,664, PUB. 2-13-2007. INT. CL. 16.

DIRECT BUSINESS TECHNOLOGIES, INC., CENTERVILLE, OH:
2,493,198, CANC. INT. CL. 9.

DIRECT FUTURES, LLC, CHICAGO, IL:
3,480,439, PUB. 5-20-2008. INT. CL. 36.

DIRECT MARKETING ASSOCIATION, INC., NEW YORK, NY:
3,480,002, PUB. 5-20-2008. INT. CL. 41.

DIRECT METALS CO., LLC, KENNESAW, GA:
3,478,986, PUB. 5-20-2008. INT. CL. 35.

DIRTBOY DESIGNS, LLC, ELTOPIA, WA:
3,478,823, PUB. 5-20-2008. INT. CL. 14.

DIRTY CHAMBER MUSIC GROUP LLC, PALM COAST, FL:
3,479,389, PUB. 5-20-2008. INT. CL. 9.

DISCOVERY COMMUNICATIONS, INC., BETHESDA, MD, DBA THE DISCOVERY CHANNEL:
2,492,835, CANC. INT. CL. 25.

DISCOVERY COMMUNICATIONS, INC., BETHESDA, MD:
2,493,626, CANC. INT. CL. 41.

DISCZILLA, LLC, PEYTON, CO:
3,478,792, PUB. 5-20-2008. INT. CL. 35.

DISLOCATED STYLES, LLC, SOUTHFIELD, MI:
2,492,550, CANC. INT. CL. 25.

DISNEY ENTERPRISES, INC., BURBANK, CA:
3,481,177, INT. CL. 9.
3,482,128, INT. CL. 18.
3,482,129, INT. CL. 24.

DISORDERLY KIDS, LLC, HUNTINGTON PARK, CA:
2,493,296, CANC. INT. CL. 25.
2,493,297, CANC. INT. CL. 25.

DISPENSER BEVERAGES, INC., SAN LEANDRO, CA:
3,480,033, PUB. 5-20-2008. INT. CL. 30.

DISTINCTIVE COSMETIC INGREDIENTS, SOUTH CLINTON AVE., NM:
3,482,270, INT. CL. 1.

DISTRIBUTION MARKETING SERVICES, L.P., HOUSTON, TX:
3,482,472, INT. CL. 30.
3,482,473, INT. CL. 30.

- DITTMAN III, WILLIAM, WATERFORD, CT:
3,480,078, PUB. 5-20-2008. INT. CL. 41.
- DITTMAR GMBH & CO. KG, 38112 BRAUNSCHWEIG, FED REP GERMANY:
3,480,895, PUB. 5-20-2008. MULTIPLE CLASS, INT. CLS. 18, 24 AND 25.
- DIVA MEDICAL SYSTEMS BV, MAASTRICHT, NETHERLANDS:
1,458,082, CANC. INT. CL. 9.
- DIVERSEY CORPORATION, MISSISSAUGA, ONTARIO, CANADA:
1,498,194, REN. 7-3-08. INT. CL. 1.
- DJ AUTO COMPONENTS CORPORATION, GUEISHAN, TAOYUAN 333, TAIWAN:
2,191,744, REN. 6-30-08. INT. CL. 11.
- DLJ LONG TERM INVESTMENT CORPORATION, CHICAGO, IL:
2,492,029, CANC. INT. CL. 36.
- DM PERSONAL PRODUCTS COMPANY, INC., SALT LAKE CITY, UT:
1,428,955, REN. 7-3-08. INT. CL. 3.
- DMB FINANCIAL, LLC, BEVERLY, MA:
3,480,463, PUB. 5-20-2008. INT. CL. 36.
- DOCSI CORPORATION, LOS ANGELES, CA:
3,482,416, INT. CL. 35.
- DODSON PUBLICATIONS, INC., RENO, NV:
1,458,279, CANC. INT. CL. 16.
- DOFIX-DOHLEMANN GMBH, WEILHEIM/TECK, FED REP GERMANY:
1,458,394, CANC. INT. CL. 24.
- DOG GONE CLEAN INC., SAINT CLAIR SHORES, MI:
3,479,981, PUB. 5-20-2008. INT. CL. 44.
- DOHENY ENTERPRISES, INC., KENOSHA, WI:
3,478,803, PUB. 5-20-2008. INT. CL. 35.
- DOIG, DANIEL, BARRIE, CANADA:
3,478,718, PUB. 5-20-2008. INT. CL. 19.
- DOLAN, ROBERT, MUNDELEIN, IL:
2,493,303, CANC. MULTIPLE CLASS, INT. CLS. 9 AND 41.
- DOLCAS BIOTECH, LLC, CHESTER, NJ:
3,478,585, PUB. 5-20-2008. INT. CL. 5.
- DOLLAR EMPIRE LLC, VERNON, CA:
3,479,121, PUB. 5-20-2008. INT. CL. 16.
- DOLLAR TREE STORES, INC., CHESAPEAKE, VA:
2,492,003, CANC. INT. CL. 35.
- DOMESTIC SECURITIES, INC., MONTVALE, NJ:
2,100,308, CANC. INT. CL. 9.
- DOMETIC CORPORATION, ELKHART, IN:
2,100,039, CANC. INT. CL. 9.
- DOMUS SOFTWARE LIMITED, OTTAWA, ONTARIO, K2P 0G5, CANADA TO IBM CANADA LIMITED, MARKHAM, ONTARIO, CANADA:
2,098,742, CANC. MULTIPLE CLASS, INT. CLS. 9 AND 42.
- DON MART CLOTHES, INC., PHILLIPSBURG, PA:
3,482,414, INT. CL. 25.
- DON'T HARSH MY MELLOW, LLC, DELRAY BEACH, FL:
3,479,505, PUB. 5-20-2008. MULTIPLE CLASS, INT. CLS. 14, 16, 18, 20, 21, 25, 28 AND 35.
- DONAHOE, JAMES JOSEPH, WHITE PLAINS, NY:
3,482,368, INT. CL. 25.
- DONG IN, CHO, YOOSUNG-GU, DAEJUN, REPUBLIC OF KOREA:
3,481,358, MULTIPLE CLASS, INT. CLS. 16, 38 AND 41.
3,481,359, MULTIPLE CLASS, INT. CLS. 16, 38 AND 41.
- DONGSIN DIAFLX CO., LTD., SUNGNAM, REPUBLIC OF KOREA:
2,492,736, CANC. INT. CL. 40.
- DONMAR ENTERPRISES, INC., ROCHELLE PARK, NJ:
3,481,883, INT. CL. 35.
- DONOVAN, SANDRA, INDIANAPOLIS, IN:
2,098,692, CANC. INT. CL. 9.
- DOOLY COUNTY CHAMBER OF COMMERCE, INC., VIENNA, CA, VIENNA-DOOLY COUNTY CHAMBER OF COMMERCE, INC., VIENNA, GA:
1,503,341, REN. 7-1-08. INT. CL. 41.
- DOPPELT, JOYCE, EVANSTON, IL AND WOLVERTON, WHITNIE CROWN, EVANSTON, IL:
3,479,120, PUB. 5-20-2008. INT. CL. 3.
- DORFMAN, LOUIS B., COSTA MESA, CA:
1,495,164, REN. 6-28-08. INT. CL. 25.
- DORLING KINDERSLEY LIMITED, LONDON, UNITED KINGDOM:
2,492,076, CANC. INT. CL. 16.
- DORSEY, THOMAS R., BONITA, CA:
2,100,376, CANC. INT. CL. 10.
- DOTPOTS, INC., ARCADIA, FL:
3,479,920, PUB. 5-20-2008. INT. CL. 21.
- DOUBLE L GROUP, LTD., DYERSVILLE, IA:
2,492,820, CANC. INT. CL. 19.
- DOUGLAS HOLLAENDER ENTERPRISES, INC., LOVELAND, OH:
3,478,553, PUB. 5-20-2008. INT. CL. 6.
- DOUGLASS, WILLIAM A., CAMBRIDGE, MA:
2,492,300, CANC. INT. CL. 35.
- DOW AGROSCIENCES LLC, INDIANAPOLIS, IN:
3,481,676, INT. CL. 5.
- DOW, MICHAEL STEPHEN, TUCSON, AZ:
3,482,718, INT. CL. 44.
- DOWNNEY CREATIONS, LLC, INDIANAPOLIS, IN:
3,478,622, PUB. 5-20-2008. MULTIPLE CLASS, INT. CLS. 37 AND 42.
- DOWNSTREAM LLC, PORTLAND, OR:
2,493,125, CANC. INT. CL. 41.
- DR PEPPER/SEVEN UP, INC., PLANO, TX:
3,481,907, INT. CL. 32.
- DR. CYRIL I EVIAN, KING OF PRUSSIA, PA:
3,482,614, INT. CL. 41.
- DR. DAVE'S OMEGA-3 FOODS, SEATTLE, WA:
3,481,772, INT. CL. 30.
- DR. ING. H.C. F. PORSCHE AG, STUTTGART-ZUFFENHAUSEN, FED REP GERMANY:
3,479,045, PUB. 5-20-2008. INT. CL. 41.
- DRÄGER MEDICAL AG & CO. KG, LÜBECK, FED REP GERMANY:
3,411,326 NEW CERT. 8-5-2008. INT. CL. 10.
- DRAGER MEDICAL AG & CO. KG, 23558 LUBECK, FED REP GERMANY:
2,239,749, REN. 6-28-08. INT. CL. 10.
- DRAYTON, DRAYTON & LAMAR, INC., AUGUSTA, GA:
2,491,727, CANC. INT. CL. 42.
- DREAMGEAR, LLC, TORRANCE, CA:
3,481,742, INT. CL. 28.
- DREAMSCO CO., LTD., REPUBLIC OF KOREA:
3,480,868, PUB. 5-20-2008. INT. CL. 35.
3,480,869, PUB. 5-20-2008. INT. CL. 3.
- DREAMWORKS ANIMATION L.L.C., GLENDALE, CA:
3,482,486, INT. CL. 41.
- DRESSER, INC., ADDISON, TX:
3,482,037, INT. CL. 9.
- DREW TECHNOLOGIES, INC, ANN ARBOR, MI:
3,482,542, INT. CL. 9.
- DRIVE PLUS, INC., LOCK HAVEN, PA:
2,492,279, CANC. INT. CL. 12.
- DRIVER, JOHN A, WATERFORD, CA:
3,482,054, MULTIPLE CLASS, INT. CLS. 29 AND 31.
- DRIVE4U.COM, INC., VERDI, NV:
2,491,897, CANC. INT. CL. 39.
- DRIWOOD MOULDING COMPANY., FLORENCE, SC:
2,212,223, REN. 7-3-08. INT. CL. 19.
- DROGA KOLINSKA, ZIVILSKA INDUSTRIJA, D.D., SLOVENIA:
3,480,925, PUB. 5-20-2008. INT. CL. 29.
3,480,926, PUB. 5-20-2008. INT. CL. 29.
3,480,927, PUB. 5-20-2008. INT. CL. 29.
- DRY CORP LLC, WILMINGTON, NC:
3,479,181, PUB. 5-20-2008. INT. CL. 10.
- DRY CORP, LLC, WILMINGTON, NC:
3,479,155, PUB. 5-20-2008. INT. CL. 10.
- DS WATERS OF AMERICA, INC., ATLANTA, GA:
2,225,430, REN. 6-30-08. INT. CL. 11.
3,481,217, INT. CL. 43.
- DS WATERS OF AMERICA, LP, ATLANTA, GA:
1,527,257, REN. 6-28-08. INT. CL. 32.

DSCI, FREEHOLD, NJ:
3,481,675, INT. CL. 42.

DSM N.V., 6411 TE HEERLEN, NETHERLANDS:
2,491,834, CANC. INT. CL. 1.

DSP COMMUNICATIONS, INC., CHEVY CHASE, MD:
2,492,867, CANC. INT. CL. 9.

DST INNOVIS, INC., RANCHO CORDOVA, CA:
2,491,942, CANC. INT. CL. 9.

DUCKWORTH, ROBERT, ONA, WV:
2,493,214, CANC. INT. CL. 35.

DUN & BRADSTREET CORPORATION, THE, SHORT HILLS, NJ, DUN & BRADSTREET, INC., NEW YORK, NY:
850,622, REN. 6-28-08, U.S. CL. 38 (INT. CL. 16).

DUN & BRADSTREET CORPORATION, THE, SHORT HILLS, NJ, DUN AND BRADSTREET, INC., NEW YORK, NY:
852,926, REN. 7-2-08, U.S. CL. 101 (INT. CL. 35).

DUNDON, ELAINE GM, SANTA FE, NM:
3,479,756, PUB. 5-20-2008, INT. CL. 41.

DUNKIN' CHERRIES PUBLISHING LLC, CUMMING, GA:
3,482,714, INT. CL. 16.

DUNLOP MAXFLI SPORTS CORPORATION, GREENVILLE, SC TO DICK'S SPORTING GOODS, INC., PITTSBURGH, PA:
2,100,044, CANC. INT. CL. 28.

DUOS TECHNOLOGIES, INC., JACKSONVILLE, FL:
3,482,418, INT. CL. 9.

DURGIN & CROWELL LUMBER COMPANY, INC., NEW LONDON, NH:
3,481,353, INT. CL. 40.

DURHAM CONVENTION & VISITORS BUREAU, DURHAM, NC:
3,481,259, MULTIPLE CLASS, INT. CLS. 14, 16 AND 35.

DWYER INSTRUMENTS, INC., MICHIGAN CITY, IN:
1,539,047, REN. 7-3-08, INT. CL. 9.

DX TRADING CO., LTD., OSAKA-FU, JAPAN:
2,493,513, CANC. INT. CL. 9.

DYNAMIC HARDWARE CONCEPTS LLC, PLAINFIELD, NJ:
3,481,813, INT. CL. 7.

DYNAMIC LIVING, INC., BLOOMFIELD, CT:
2,183,794, REN. 6-28-08, INT. CL. 35.

DYNAMIC RESPONSE MARKETING INCORPORATED, SANTA ROSA, CA:
2,492,260, CANC. INT. CL. 35.

DYNAMO HOUSE PROPRIETARY LIMITED, MITCHAM, AUSTRALIA:
3,481,877, INT. CL. 3.
3,481,878, INT. CL. 3.

DYNAMOTIVE ENERGY SYSTEMS CORPORATION, VANCOUVER, B.C., CANADA:
3,482,437, MULTIPLE CLASS, INT. CLS. 37, 39 AND 40.

DYNASTY CONSOLIDATED INDUSTRIES, INC., DALLAS, TX:
2,253,280, REN. 6-28-08, INT. CL. 20.

DYNASYS, 67300 SCHILTIGHEIM, FRANCE:
2,164,980, REN. 7-3-08, MULTIPLE CLASS, INT. CLS. 9 AND 42.

DYNOJET RESEARCH, INC., NORTH LAS VEGAS, NV:
3,479,597, PUB. 5-20-2008, INT. CL. 7.
3,479,598, PUB. 5-20-2008, INT. CL. 7.

DZMITRY KHAUSTOVICH, RICHMOND HILL, NY:
3,482,354, INT. CL. 42.

E & H DISTRIBUTING CO., LAS VEGAS, NV:
2,164,286, REN. 7-3-08, MULTIPLE CLASS, INT. CLS. 29 AND 30.

E & H DISTRIBUTING CO., NORTH LAS VEGAS, NV:
3,481,981, INT. CL. 35.

E. & J. GALLO WINERY, MODESTO, CA:
3,481,312, INT. CL. 33.

E. G. HARMON LTD., GAYLORD, MI:
2,493,585, CANC. INT. CL. 42.

E. I. DU PONT DE NEMOURS AND COMPANY, WILMINGTON, DE:
2,166,144, REN. 7-3-08, INT. CL. 1.

E. S. ORIGINALS INC., NEW YORK, NY:
1,458,440, CANC. INT. CL. 25.

E.I. DU PONT DE NEMOURS AND COMPANY, WILMINGTON, DE:
1,093,565, REN. 7-2-08, INT. CL. 5.

E&B EXERCISE LLC, YONKERS, NY:
2,492,471, CANC. INT. CL. 28.

E-COLOR, INC., SAN FRANCISCO, CA:
2,492,085, CANC. INT. CL. 9.

E-DENTIST.COM, INC., PHOENIX, AZ:
2,492,593, CANC. INT. CL. 41.

E-DESTINACCESS, INC., COTO DE CAZA, CA:
3,479,758, PUB. 5-20-2008, INT. CL. 9.

E-MILES, LLC, DALLAS, TX:
3,482,519, INT. CL. 35.

E-QUEST, INC., MEDFORD, NJ, DBA CUSTOM SADDLERY:
3,480,469, PUB. 5-20-2008, INT. CL. 18.

E-Z CATCH & COMPANY, CARMEL, CA:
2,099,123, CANC. INT. CL. 28.

EARLY BIRD BABY, LLC, BROOKLINE, NH:
3,478,888, PUB. 5-20-2008, INT. CL. 16.
3,478,889, PUB. 5-20-2008, INT. CL. 16.

EARTH COMMERCE, INC., POMPANO, FL:
2,491,940, CANC. INT. CL. 42.

EARTH FRIENDS WILDLIFE FOUNDATION, JACKSON, WY:
3,482,603, MULTIPLE CLASS, INT. CLS. 35, 36 AND 42.

EARTHCOMM, INC., HEWLETT, NY:
2,492,795, CANC. INT. CL. 35.

EARTHWORK SOLUTIONS, INC., HOUSTON, TX:
3,480,264, PUB. 5-20-2008, INT. CL. 42.
3,480,265, PUB. 5-20-2008, INT. CL. 42.
3,480,266, PUB. 5-20-2008, INT. CL. 42.

EAST RIVER REALTY COMPANY, LLC, NEW YORK, NY:
3,481,998, INT. CL. 36.

EASTERN ALLOYS, INC., MAYBROOK, NY:
2,166,978, REN. 6-30-08, INT. CL. 6.
2,166,980, REN. 6-30-08, INT. CL. 6.

EASTERN COLOR & CHEMICAL COMPANY, PROVIDENCE, RI:
3,478,884, PUB. 9-18-2007, INT. CL. 1.

EASTERN PCM, LLC, HARRISBURG, PA:
3,478,798, PUB. 5-20-2008, INT. CL. 37.

EASTERN TEXAS PATHOLOGY LABORATORIES, ATHENS, TX:
3,479,703, PUB. 5-20-2008, INT. CL. 42.

EASTERN WHOLESALE FENCE CO., INC., MEDFORD, NY:
3,479,399, PUB. 5-20-2008, INT. CL. 19.

EASTLAND MEDIA, INC., SOMERVILLE, MA:
3,480,200, PUB. 5-20-2008, MULTIPLE CLASS, INT. CLS. 38 AND 41.

EASTMAN KODAK COMPANY, ROCHESTER, NY:
1,457,875, CANC. INT. CL. 1.
2,493,376, CANC. INT. CL. 9.

EASTWAY FAIR COMPANY LIMITED, TORTOLA, BR. VIRGIN ISLANDS:
3,482,042, MULTIPLE CLASS, INT. CLS. 7 AND 9.

EATON CORPORATION, CLEVELAND, OH:
1,458,521, CANC. INT. CL. 28.
3,479,226, PUB. 5-20-2008, INT. CL. 9.

EATWARE INTELLECTUAL PROPERTIES LIMITED, KWUN TONG, HONG KONG:
3,481,399, MULTIPLE CLASS, INT. CLS. 16 AND 21.

EBIT AET S.P.A., I-16153 GENOVA, ITALY:
3,478,512, PUB. 10-23-2007, INT. CL. 9.

EBONITE HOLDINGS, INC., HOPKINSVILLE, KY:
2,174,925, REN. 6-28-08, INT. CL. 28.

EBOX COMPANY, SAN FRANCISCO, CA:
2,493,493, CANC. INT. CL. 35.

EBSCO INDUSTRIES, INC., BIRMINGHAM, AL:
1,508,372, REN. 7-2-08, INT. CL. 28.

EB5 CORPORATION, PORTLAND, OR, EB5 CORPORATION, PORTLAND, OR:
1,505,488, REN. 6-28-08, INT. CL. 3.

ECAPITAL SOLUTIONS, INC, CENTERVILLE, VA:
2,492,190, CANC. INT. CL. 38.

ECHOSTAR ACQUISITION L.L.C., ENGLEWOOD, CO:
1,458,723, CANC. INT. CL. 38.

- ECI SOFTWARE, INC., CAMARILLO, CA:
3,481,562, INT. CL. 9.
- ECIL NORTH AMERICA LLC, AKRON, OH:
3,481,094, INT. CL. 9.
3,481,095, INT. CL. 9.
- ECO DISTRIBUTORS, LLC, PLANTATION, FL:
3,480,034, PUB. 5-20-2008. INT. CL. 1.
- ECO-SAFE USA, INC., TARZANA, CA:
3,480,728, PUB. 5-20-2008. INT. CL. 5.
- ECOLOGICAL AND TOXICOLOGICAL ASSOCIATION OF THE DYESTUFFS MANUFACTURING INDUSTRY, CH-4005 BASLE, SWITZERLAND:
1,055,804, REN. 6-27-08. INT. CL. 42.
- ECOVAL CORPORATION, WILLIAMSVILLE, NY:
3,482,234, INT. CL. 5.
- EDDY, IAN, ST. PETERS, MO:
3,480,271, PUB. 5-20-2008. INT. CL. 9.
3,480,272, PUB. 5-20-2008. INT. CL. 41.
- EDELBROCK CORPORATION, TORRANCE, CA:
3,478,569, PUB. 5-20-2008. INT. CL. 6.
- EDGE COMMUNICATIONS, INC., NASHVILLE, TN:
2,099,189, CANC. INT. CL. 9.
- EDGEWATER MARINE INDUSTRIES, LLC, NEW BEDFORD, MA:
3,482,468, INT. CL. 16.
- EDGEWOOD CONSULTING GROUP, SEAL BEACH, CA:
2,492,302, CANC. MULTIPLE CLASS, INT. CLS. 9 AND 35.
- EDIFICE WRECKING CO., INC., WATERTOWN, MA:
2,161,053, REN. 6-30-08. MULTIPLE CLASS, INT. CLS. 25 AND 37.
- EDISON INTERNATIONAL, ROSEMEAD, CA:
3,481,995, MULTIPLE CLASS, INT. CLS. 35, 39, 40 AND 42.
- EDL TECHNOLOGY, LLC, FREDERICK, MD:
3,481,940, INT. CL. 35.
- EDU-SCIENCE (H.K.) LIMITED, KOWLOON, HONG KONG:
3,482,301, INT. CL. 28.
- EDUCATION AND TRAINING PROGRAMS, INC., EAST HARTFORD, CT:
2,492,137, CANC. INT. CL. 41.
- EDUCATION MANAGEMENT LLC, PITTSBURGH, PA:
3,480,621, PUB. 9-26-2006. INT. CL. 41.
- EDWARDS LIFESCIENCES CORPORATION, IRVINE, CA:
3,482,168, INT. CL. 10.
- EDX ELECTRONICS, INC., WINTER SPRINGS, FL:
3,482,348, INT. CL. 35.
- EDYMA RESTAURADORES, S.L.; SOCIEDAD UNIPERSONAL, SPAIN:
3,480,875, PUB. 5-20-2008. INT. CL. 41.
- EEYE, INC., IRVINE, CA:
3,481,816, MULTIPLE CLASS, INT. CLS. 9 AND 42.
- EFCI DESIGNS, LLC, SACRAMENTO, CA:
3,479,625, PUB. 5-20-2008. INT. CL. 25.
- EFFIE HORNING, OCEANSIDSE, CA:
3,479,549, PUB. 5-20-2008. INT. CL. 41.
- EFFIGI INC., LAVAL, QUEBEC, CANADA:
3,478,501, PUB. 5-20-2008. MULTIPLE CLASS, INT. CLS. 18 AND 25.
3,480,574, PUB. 5-20-2008. MULTIPLE CLASS, INT. CLS. 20, 24 AND 25.
- EFINANCE PORTAL, INC., MANASQUAN, NJ:
3,481,142, MULTIPLE CLASS, INT. CLS. 35 AND 38.
- EFUNDS CORPORATION, TUSTIN, CA:
2,493,619, CANC. INT. CL. 36.
- EGAMES, INC., LANGHORNE, PA:
2,492,644, CANC. INT. CL. 9.
- EGAMES, INC., LANGHOM, PA:
2,492,645, CANC. INT. CL. 9.
- EIDER, SOCIÉTÉ PAR ACTIONS SIMPLIFIÉE, FRANCE:
3,480,898, PUB. 5-20-2008. INT. CL. 25.
- EIZO NANA CORPORATION, HAKUSAN-SHI, ISHIKAWA, JAPAN:
2,170,484, REN. 7-1-08. INT. CL. 9.
- EKCO HOUSEWARES, INC., RESTON, VA:
2,492,935, CANC. INT. CL. 21.
- EL POLLO LOCO, INC., IRVINE, CA:
2,492,371, CANC. INT. CL. 29.
- ELBA CORPORATION, MAPO-KU, SEOUL, REPUBLIC OF KOREA:
1,458,031, CANC. INT. CL. 9.
- ELCOTEL, INC., SARASOTA, FL:
2,493,470, CANC. INT. CL. 38.
- ELDORA SPEEDWAY, INC., NEW WESTON, OH:
3,479,746, PUB. 5-20-2008. INT. CL. 25.
3,479,748, PUB. 5-20-2008. INT. CL. 41.
3,479,749, PUB. 5-20-2008. INT. CL. 41.
3,479,750, PUB. 5-20-2008. MULTIPLE CLASS, INT. CLS. 25 AND 41.
- ELECTRIC VEHICLE INFRASTRUCTURE, INC., AUBURN, CA:
2,098,854, CANC. INT. CL. 42.
- ELECTRO BRAND, INC., CHICAGO, IL:
2,491,800, CANC. INT. CL. 9.
- ELECTROMED, INC., NEW PRAGUE, MN:
3,482,592, INT. CL. 10.
- ELECTRONIC ARTS INC., SAN MATEO, CA:
1,458,065, CANC. INT. CL. 9.
- ELECTRONIC ARTS INC., REDWOOD CITY, CA:
2,100,426, CANC. INT. CL. 9.
- ELECTRONIC DATA SYSTEMS CORPORATION, PLANO, TX:
1,458,649, CANC. INT. CL. 35.
- ELECTRONIC MERCHANT SYSTEMS, INDEPENDENCE, OH:
3,479,688, PUB. 5-20-2008. INT. CL. 36.
- ELEGALSUPPLY.COM LLC, MULLICA HILL, NJ:
3,482,692, INT. CL. 35.
- ELEGANT USA, LLC, TOTOWA, NJ:
2,100,512, CANC. INT. CL. 12.
- ELEMENTALS SKIN CARE, LLC, SCOTTSDALE, AZ:
2,100,202, CANC. INT. CL. 5.
- ELEMENTIS SPECIALTIES, INC., HIGHSTOWN, NJ:
2,167,210, REN. 6-30-08. INT. CL. 1.
- ELEMENTSHIELD, MARINA DEL REY, CA:
3,479,199, PUB. 5-20-2008. INT. CL. 40.
- ELEPHANT RECORDS INC., CONCORD, ONTARIO, CANADA:
1,489,139, REN. 7-1-08. INT. CL. 9.
- ELEPHANT SANCTUARY IN TENNESSEE, THE, HOHENWALD, TN:
3,479,988, PUB. 5-20-2008. INT. CL. 35.
- ELINCA, RENENS, SWITZERLAND:
1,490,876, REN. 6-27-08. INT. CL. 9.
- ELINCA S.A., RENENS, SWITZERLAND:
1,490,876, COR. INT. CL. 9.
- ELKAY MANUFACTURING COMPANY, OAK BROOK, IL:
3,480,246, PUB. 5-20-2008. INT. CL. 3.
- ELLENCHANNELL INC., RICHMOND HILL, ONTARIO, CANADA:
3,480,615, PUB. 5-20-2008. MULTIPLE CLASS, INT. CLS. 29 AND 30.
- ELLIANOS, LLC, LAKE CITY, FL:
3,481,830, INT. CL. 35.
- ELLIE ROSE LINK-ABLE DESIGNS, L.L.C., ST. LOUIS, MO:
2,493,569, CANC. INT. CL. 14.
- ELLIE SHOES, INC, ORANGE, CA:
3,481,543, INT. CL. 25.
- ELLIOTT, RICK, FORT MYERS, FL:
3,479,960, PUB. 5-20-2008. INT. CL. 37.
- ELLIOTT, SHARON NORRIS, SOUTH GATE, CA:
3,481,220, INT. CL. 41.
- ELLIPTIC SEMICONDUCTOR INC., OTTAWA, CANADA:
3,482,171, MULTIPLE CLASS, INT. CLS. 9, 16 AND 42.
- ELLMAN INNOVATIONS, LLC, OCEANSIDE, NY:
3,481,147, INT. CL. 10.
- ELMER'S INVESTMENTS, INC., WILMINGTON, DE:
2,493,104, CANC. INT. CL. 2.
- ELMER'S PRODUCTS, INC., COLUMBUS, OH:
3,481,238, INT. CL. 28.
- ELMHULTS KONSTRUKTION AB, SE-343 00 ÄLMHULT, SWEDEN:
3,480,918, PUB. 5-20-2008. MULTIPLE CLASS, INT. CLS. 7, 12 AND 37.
- ELRAE ENTERPRISES, INC., MORTON, IL:
3,481,674, INT. CL. 12.

ELSEVIER BV, AMSTERDAM, NETHERLANDS:
3,479,316, PUB. 5-20-2008. INT. CL. 9.
3,479,317, PUB. 5-20-2008. INT. CL. 41.

ELUMA, INC., TEWKSBURY, MA:
3,481,525, INT. CL. 42.

ELUMX LLC, FAYETTEVILLE, GA:
3,481,898, INT. CL. 11.

ELVIS PRESLEY ENTERPRISES, INC., MEMPHIS, TN:
3,479,347, PUB. 5-20-2008. INT. CL. 39.

ELWOOD PACKAGING, INC., CHICAGO, IL:
3,478,554, PUB. 5-20-2008. INT. CL. 16.

ELYNX, LTD., CINCINNATI, OH:
3,482,385, INT. CL. 38.
3,482,386, INT. CL. 38.

EMBARE INDUSTRIAS ALIMENTICIAS S/A, LAGOA DA PRATA, MINAS GERAIS, BRAZIL:
3,482,068, INT. CL. 30.

EMBARE INDUSTRIAS ALIMENTICIAS S/A, LAGOA DA PRATA, BRAZIL:
3,482,574, INT. CL. 30.

EMERGENCY COMMITTEE FOR AMERICAN TRADE, WASHINGTON, DC:
3,479,197, PUB. 5-20-2008. MULTIPLE CLASS, INT. CLS. 16 AND 35.

EMERSON ELECTRIC CO., ST. LOUIS, MO:
2,493,172, CANC. MULTIPLE CLASS, INT. CLS. 1 AND 7.
3,480,665, PUB. 5-20-2008. U.S. CL. B.

EMGEE/CLEANTOOLS, INC., WESTMONT, IL:
2,667,385, COR. INT. CL. 21.

EMI (IP) LIMITED, LONDON, W8 5SW, ENGLAND:
3,480,573, PUB. 9-26-2006. INT. CL. 9.

EMMA HITT MEDICAL WRITING, LLC, MARIETTA, GA:
3,480,138, PUB. 5-20-2008. INT. CL. 35.

EMMAS PUBLISHING, L.P., INDIANAPOLIS, IN:
1,508,087, REN. 6-30-08. INT. CL. 16.

EMOTIONAL INTELLIGENCE AND DIVERSITY INSTITUTE, THE, LOS ANGELES, CA:
3,479,944, PUB. 5-20-2008. INT. CL. 41.
3,479,945, PUB. 5-20-2008. INT. CL. 16.
3,479,946, PUB. 5-20-2008. INT. CL. 16.
3,479,947, PUB. 5-20-2008. INT. CL. 41.

EMPACHER VERWALTUNGS GMBH & CO. KG, FED REP GERMANY:
3,480,873, PUB. 5-20-2008. INT. CL. 12.

EMPIRE TRAVEL SERVICE, INC., SAN FRANCISCO, CA:
1,458,731, CANC. INT. CL. 39.

EMPLOY CHECK, INC., EVANSVILLE, IN:
3,479,970, PUB. 5-20-2008. INT. CL. 45.

EMPORDALIA S.C.C.L., PAU, GIRONA, SPAIN:
3,481,178, MULTIPLE CLASS, INT. CLS. 29 AND 33.

EMPOWERMENT ENTERPRISE, LLC, TULSA, OK:
3,479,328, PUB. 5-20-2008. INT. CL. 41.

EMPROBE, INC., PORT GAMBLE, WA:
3,480,197, PUB. 5-20-2008. INT. CL. 10.

EMS TECHNOLOGIES CANADA, LTD., OTTAWA, ONTARIO, CANADA:
2,098,883, CANC. MULTIPLE CLASS, INT. CLS. 9 AND 38.

EMTRACE TECHNOLOGIES, INC., SEOUL, REPUBLIC OF KOREA:
3,479,018, PUB. 5-20-2008. INT. CL. 42.

EMUSE MEDIA LIMITED, DUBLIN, IRELAND:
3,479,335, PUB. 5-20-2008. INT. CL. 41.
3,479,336, PUB. 5-20-2008. INT. CL. 42.

ENCOMPASS GROUP, L.L.C., MCDONOUGH, GA:
2,493,560, CANC. INT. CL. 20.

ENCOMPASS GROUP, LLC, MCDONOUGH, GA:
2,099,414, CANC. INT. CL. 20.

ENCORE ASSOCIATES, INC, SAN RAMON, CA:
3,482,295, MULTIPLE CLASS, INT. CLS. 9 AND 42.

ENCYCLOPAEDIA BRITANNICA, INC., CHICAGO, IL:
1,486,737, REN. 7-2-08. INT. CL. 9.
1,491,995, REN. 6-28-08. INT. CL. 9.

ENDORPHIN SPORTS MEDIA, MIDDLEBURG HEIGHTS, OH:
3,482,609, INT. CL. 41.

ENERGISTICS CONSORTIUM, INC., HOUSTON, TX:
3,478,762, PUB. 5-20-2008. INT. CL. 41.
3,478,763, PUB. 5-20-2008. INT. CL. 42.

ENERGY ADDITIVES, INC., BATTLE CREEK, MI:
2,099,283, CANC. INT. CL. 1.

ENERGY ADVANTAGE INC., BURLINGTON, ONTARIO, CANADA:
3,478,668, PUB. 5-20-2008. MULTIPLE CLASS, INT. CLS. 35, 36 AND 42.

ENERGY FOCUS, INC., SOLON, OH:
2,123,483, REN. 7-3-08. INT. CL. 11.

ENERZONE SYSTEMS CORPORATION, PARKER, TX TO RESEARCH PRODUCTS CORPORATION, MADISON, WI:
2,099,181, CANC. INT. CL. 9.

ENER1 HOLDINGS, INC., FORT LAUDERDALE, FL:
3,482,251, INT. CL. 9.

ENESCO, LLC, ITASCA, IL:
2,493,481, CANC. INT. CL. 28.

ENGEL, STEPHEN, GOLDEN VALLEY, MN:
2,493,169, CANC. INT. CL. 25.

ENGENDERHEALTH, INC., NEW YORK, NY:
3,481,908, INT. CL. 41.

ENGINEERING DESIGN TECHNOLOGIES, INC., MARIETTA, GA:
3,479,397, PUB. 5-20-2008. INT. CL. 37.

ENGLAND/CORSAIR, INC., NEW TAZEWELL, TN:
2,493,110, CANC. INT. CL. 35.

ENPAPER MFG. CO., LTD., GYEONGGI-DO, REPUBLIC OF KOREA:
3,481,244, INT. CL. 16.

ENRICO COVERI S.R.L., MILAN, ITALY, COVERI, ENRICO, FLORENCE, ITALY:
1,471,128, REN. 7-2-08. MULTIPLE CLASS, INT. CLS. 3, 18 AND 25.

ENRON CORP., HOUSTON, TX:
2,493,183, CANC. INT. CL. 41.

ENSURETEK, L.L.C., CLEVELAND, OH:
2,491,849, CANC. INT. CL. 9.

ENT FEDERAL CREDIT UNION, COLORADO SPRINGS, CO:
3,482,287, INT. CL. 36.

ENTEGRION, INC., RESEARCH TRIANGLE PARK, NC:
3,480,404, PUB. 5-20-2008. INT. CL. 42.

ENTERPRISE RENT-A-CAR COMPANY, ST. LOUIS, MO:
3,479,308, PUB. 5-20-2008. INT. CL. 39.

ENTRACITY, CARLSBAD, CA:
3,481,335, INT. CL. 41.

ENTREPRENEURIAL MEDICAL CONSULTING, LLC, LOS ANGELES, CA:
3,479,304, PUB. 5-20-2008. INT. CL. 44.

ENTROPY SOLUTIONS, INC., EDEN PRAIRIE, MN:
3,479,401, PUB. 5-20-2008. INT. CL. 11.

ENVIRO-DYNAMICS, INC., DALLAS, TX:
2,491,853, CANC. INT. CL. 5.
2,493,324, CANC. INT. CL. 21.

ENVIRONMENTAL HEALTH TESTING, LLC, ORLANDO, FL:
3,478,571, PUB. 5-20-2008. INT. CL. 41.

ENVIROSMART LLC, CHICAGO, IL:
3,482,217, INT. CL. 3.

ENZON, INC., SOUTH PLAINFIELD, NJ:
1,458,838, CANC. INT. CL. 42.

ENZYMES SERVICES (N.Z.) LIMITED, AVONDALE, AUCKLAND, NEW ZEALAND:
3,411,686, COR. MULTIPLE CLASS, INT. CLS. 1, 30, 32 AND 42.

EPACIFIC.COM INCORPORATED, GOLETA, CA:
2,493,294, CANC. INT. CL. 36.

EPAX AS, NORWAY:
3,480,845, PUB. 5-20-2008. MULTIPLE CLASS, INT. CLS. 1, 5 AND 29.

EPET, LTD., INDIANAPOLIS, IN:
2,493,018, CANC. INT. CL. 9.

EPI ENVIRONMENTAL PRODUCTS INC., CONROE, TX TO EPI ENVIRONMENTAL TECHNOLOGIES INC., LAS VEGAS, NV:
2,099,676, CANC. INT. CL. 17.

- EPI 04, INC., TALLAHASSEE, FL:
3,479,972, PUB. 5-20-2008. INT. CL. 19.
- EPIPHANY TELLURIDE, LLC, GREENWOOD VILLAGE, CO:
3,479,852, PUB. 5-20-2008. INT. CL. 43.
- EPISKIN, INC., HACKENSACK, NJ:
2,099,438, CANC. INT. CL. 3.
- EPSILON ELECTRONICS, INC., MONTEBELLO, CA:
3,480,071, PUB. 5-20-2008. INT. CL. 9.
3,480,072, PUB. 5-20-2008. INT. CL. 9.
- EQUICAP INVESTMENTS, LLC, DALLAS, TX:
3,482,363, INT. CL. 11.
- EQUIFIRST CORPORATION, CHARLOTTE, NC:
2,493,581, CANC. INT. CL. 36.
- ERGON, INC., JACKSON, MS:
1,491,881, REN. 6-30-08. MULTIPLE CLASS, INT. CLS. 4, 9, 19, 35, 37, 39, 40 AND 42.
1,491,881, CANC. INT. CL. 17.
- ERNST & YOUNG U.S. LLP, NEW YORK, NY:
2,493,468, CANC. INT. CL. 9.
- ERWIN PEARL, INC., NEW YORK, NY:
2,164,603, REN. 6-28-08. INT. CL. 14.
- ESA BIOSCIENCES, INC., CHELMSFORD, MA:
1,105,011, REN. 7-2-08. MULTIPLE CLASS, INT. CLS. 1, 9, 10 AND 42.
- ESCO CORPORATION, PORTLAND, OR:
1,087,605, REN. 6-28-08. INT. CL. 6.
- ESCO GLOBAL REALTY CORP., MILL BAY, BC, CANADA:
3,482,024, INT. CL. 36.
- ESI INTERNATIONAL, ARLINGTON, VA:
2,492,578, CANC. INT. CL. 41.
2,492,579, CANC. INT. CL. 41.
- ESNIPE, INC., BELLEVUE, WA:
3,480,722, PUB. 5-20-2008. INT. CL. 35.
- ESPN, INC., BRISTOL, CT:
3,482,688, INT. CL. 41.
- ESPO ENGINEERING CORPORATION, WILLOWBROOK, IL:
2,099,038, CANC. MULTIPLE CLASS, INT. CLS. 35, 40 AND 42.
- ESPRO INFORMATION TECHNOLOGIES LTD., KFAR SABA, ISRAEL:
3,480,586, PUB. 8-7-2007. MULTIPLE CLASS, INT. CLS. 9, 16, 37 AND 42.
- ESSENBURG, JAN, SEATTLE, WA:
2,492,982, CANC. MULTIPLE CLASS, INT. CLS. 9, 25 AND 41.
- ESSEX SPECIALTY PRODUCTS, INC., AUBURN HILLS, MI:
2,493,242, CANC. INT. CL. 1.
- ESSEX TOPCROP SALES LIMITED, ESSEX, ONTARIO N8M 2Y1, CANADA:
2,197,210, REN. 7-3-08. INT. CL. 31.
- ESTEE LAUDER INC., NEW YORK, NY:
2,177,261, REN. 7-3-08. INT. CL. 3.
2,492,847, CANC. INT. CL. 3.
- ETABLISSEMENTS CAILLAU, 92130 ISSY LES MOULINEAUX, FRANCE:
2,492,033, CANC. MULTIPLE CLASS, INT. CLS. 6 AND 17.
- ETHNICGROCER.COM, INC., CHICAGO, IL:
2,492,592, CANC. INT. CL. 35.
- ETRO S.P.A., MILANO, ITALY:
2,163,514, REN. 7-3-08. INT. CL. 25.
- EURASIA CONCEPTS, INC., SUITE 300, CA:
3,481,342, INT. CL. 9.
- EURO-STAR REITMODEN GMBH & CO. KG, MONCHEN-GLABACH, FED REP GERMANY:
2,064,176, REN. 7-1-08. MULTIPLE CLASS, INT. CLS. 24 AND 25.
- EUROATLANTIC CONTAINER LINE S.A, VALPARAISO, CHILE:
2,491,787, CANC. INT. CL. 39.
- EUROPEAN CHANNEL DEVELOPMENT LIMITED, UNITED KINGDOM:
3,440,986, COR. MULTIPLE CLASS, INT. CLS. 9, 14, 16, 25, 28 AND 41.
- EUROVENT ENVIRONMENTAL CONTROL LTD, WEST MIDLANDS, UNITED KINGDOM:
2,491,952, CANC. INT. CL. 11.
- EURX SP.Z.00, GDANSK, POLAND:
3,478,931, PUB. 5-20-2008. MULTIPLE CLASS, INT. CLS. 1, 5 AND 42.
- EUTECTIC CORPORATION, MENOMONEE FALLS, WI:
2,099,759, CANC. INT. CL. 1.
- EVANS, CARL S., LINCOLNSHIRE, IL:
2,492,307, CANC. INT. CL. 30.
- EVANS, TAMIKO, PLAINFIELD, NJ:
3,479,554, PUB. 5-20-2008. MULTIPLE CLASS, INT. CLS. 25 AND 41.
- EVERYDAY BIOGRAPHIES LTD, EDGWARE, UNITED KINGDOM:
3,479,844, PUB. 5-20-2008. INT. CL. 35.
- EVO PARTNERS, LP, SAN ANTONIO, TX, DBA ENTRUST TECHNOLOGY CONSULTING SERVICES:
3,478,572, PUB. 5-20-2008. INT. CL. 42.
- EVONIK STOCKHAUSEN GMBH, KREFELD 47805, FED REP GERMANY:
1,491,818, REN. 7-1-08. INT. CL. 3.
- EWALD DÖRKEN AG, 58313 HERDECKE, FED REP GERMANY:
3,478,506, PUB. 5-20-2008. INT. CL. 19.
- EWESTERN INC., COLVILLE, WA:
3,482,022, INT. CL. 34.
- EXACTECH, INC., GAINESVILLE, FL:
3,479,123, PUB. 5-20-2008. INT. CL. 10.
- EXANE, FRANCE:
3,480,903, PUB. 5-20-2008. MULTIPLE CLASS, INT. CLS. 35 AND 36.
- EXCEL DRYER, INC., EAST LONGMEADOW, MA:
2,169,378, REN. 7-2-08. INT. CL. 11.
- EXERCISE DESIGN INC. TECHNOLOGIES, LAKEWOOD, CO:
2,492,902, CANC. INT. CL. 16.
- EXHIBIT APS; C/O SØREN DANDANELL NIELSEN, DENMARK:
3,481,017, PUB. 5-20-2008. MULTIPLE CLASS, INT. CLS. 35, 38 AND 41.
- EXHIBITECH, INC., SOUTH BEND, IN, DBA LOV'N WOOD MANUFACTURING:
2,099,130, CANC. INT. CL. 20.
- EXIDE CORPORATION, ALPHARETTA, GA:
2,493,408, CANC. INT. CL. 9.
- EXOLVE, INC., WASHINGTON, DC:
2,493,235, CANC. MULTIPLE CLASS, INT. CLS. 16, 35 AND 41.
- EXOUSA NUTRITION PRODUCTS, INC., NATIONAL CITY, CA:
2,493,706, CANC. INT. CL. 5.
- EXPERT KNOWLEDGE SYSTEMS, LLC, WHITE PLAINS, NY:
3,480,723, PUB. 5-20-2008. INT. CL. 16.
- EXPONENT TRADING COMPANY L.L.C., SPOKANE, WA:
3,479,175, PUB. 5-20-2008. INT. CL. 35.
3,479,176, PUB. 5-20-2008. INT. CL. 35.
- EXPRESS CAPITAL MORTGAGE INC., CHANDLER, AZ:
3,480,216, PUB. 5-20-2008. INT. CL. 36.
- EXPRESS LEARNING, INC., BURNSVILLE, MN:
2,492,409, CANC. INT. CL. 42.
2,492,410, CANC. INT. CL. 42.
- EXPRESS LIMOUSIN RANCHES, LTD., YUKON, OK:
2,493,633, CANC. INT. CL. 35.
- EXPRESS SCRIPTS, INC., ST. LOUIS, MO:
3,481,205, INT. CL. 35.
3,481,206, INT. CL. 35.
- EXPRESSLY YOURS, INC., CENTENNIAL, CO:
3,482,442, INT. CL. 21.
3,482,443, INT. CL. 21.
- EXTREME PAINTBALL DESIGN LLC, BROOKLYN PARK, MN:
3,479,958, PUB. 5-20-2008. INT. CL. 28.
- EXTRUMED, LLC, PLACENTIA, CA:
3,478,777, PUB. 5-20-2008. MULTIPLE CLASS, INT. CLS. 10, 40 AND 42.

EYE JEWELS, INC., LAS VEGAS, NV:
3,478,953, PUB. 5-20-2008. INT. CL. 38.

EYE KRAFT OPTICAL, INC., ST. CLOUD, MN:
1,109,928. REN. 6-28-08. INT. CL. 9.

EYE-HUGS, LLC, COLUMBUS, OH:
3,481,685, INT. CL. 9.

EZ PETSHOP.COM, INC., VALLEY STREAM, NY:
2,492,522, CANC. INT. CL. 35.

F. BARKOW, INC., MILWAUKEE, WI:
3,479,954, PUB. 5-20-2008. INT. CL. 6.

F. DOHMEN CO., THE, GERMANTOWN, WI:
2,492,385, CANC. INT. CL. 35.

F. KORBEL & BROS., GUERNEVILLE, CA:
2,233,309. REN. 6-30-08. INT. CL. 33.

F.A. MACCLUER, INC., NEW YORK, NY:
1,458,411, CANC. INT. CL. 25.

F.M.E. CORPORATION, HAYWARD, CA TO NEOPOST,
INC., HAYWARD, CA:
2,100,264, CANC. INT. CL. 9.

F+W PUBLICATIONS, INC., CINCINNATI, OH:
3,481,583, MULTIPLE CLASS, INT. CLS. 16 AND 40.

FAB FOREVER LLC, HENDERSON, NV:
3,478,649, PUB. 5-20-2008. INT. CL. 41.

FABRIC EDITIONS, LLC., GREENVILLE, SC:
3,482,521, INT. CL. 24.

FABRICTECH 2000, LLC, CEDAR GROVE, NJ:
3,479,990, PUB. 5-20-2008. INT. CL. 36.

FACES IN THE CROWD, INC., WESTON, CT:
3,481,884, INT. CL. 42.

FACTS ON FILE, INC., NEW YORK, NY:
2,492,155, CANC. INT. CL. 16.

FAGES, CATHERINE, DENVER, CO:
3,481,366, INT. CL. 18.

FAIRCHILD HOLDING CORP., DULLES, VA:
2,491,672, CANC. INT. CL. 6.

FAIRKEEP PRODUCTS, LLC, BENTONVILLE, AR:
3,479,047, PUB. 5-20-2008. MULTIPLE CLASS, INT. CLS.
20 AND 22.

FAITH HEALTHCARE PURCHASING ALLIANCE, INC.,
LONDON, KY:
2,493,575, CANC. MULTIPLE CLASS, INT. CLS. 35 AND
36.

FALTSKOG, MARGARET C, BURNT HILLS, NY:
3,480,696, PUB. 5-20-2008. INT. CL. 42.

FAMIGLIA CHIARI S.R.L., ITALY:
3,480,823, PUB. 5-20-2008. MULTIPLE CLASS, INT. CLS.
29, 30, 31, 32, 33, 35 AND 43.

FAMILY FINANCIAL NETWORK, L.L.C., GREENWICH,
CT:
3,481,308, INT. CL. 41.

FAMILY HOSPICE AND PALLIATIVE CARE, PITTS-
BURGH, PA:
3,482,637, INT. CL. 44.

FAMILY LIFE COUNCIL OF GREATER GREENSBORO,
INC., GREENSBORO, NC:
2,199,679. REN. 6-30-08. INT. CL. 41.

FAMILYCLICK.COM LLC, VIRGINIA BEACH, VA:
2,493,259, CANC. INT. CL. 42.

FAMILYNET, LLC, ATLANTA, GA:
1,518,324. REN. 6-30-08. MULTIPLE CLASS, INT. CLS. 38
AND 41.

FAMOUS DAVE'S OF AMERICA, INC., MINNETONKA,
MN:
2,187,168. REN. 6-28-08. INT. CL. 9.

FANTASY FARE, INC., ATLANTA, GA:
2,492,380, CANC. INT. CL. 41.

FANTASY SHOES S.R.L., ITALY:
3,481,001, PUB. 5-20-2008. INT. CL. 25.

FARAR, JORDAN MARK, SAN DIEGO, CA:
3,481,145, INT. CL. 9.

FARLEY'S AND SATHERS CANDY COMPANY, INC.,
ROUND LAKE, MN:
220,367. REN. 6-30-08. U.S. CL. 46 (INT. CL. 30).

FARM & HOME FOODS, INC., ENGLEWOOD, CO:
2,492,734, CANC. INT. CL. 29.

FARMAMEDICA, S.A., GUATEMALA CITY, GUATEMALA:
2,098,663, CANC. INT. CL. 42.

FARMERS GROUP, INC., LOS ANGELES, CA:
3,478,630, PUB. 5-20-2008. INT. CL. 36.

FARMERS HYBRID COMPANIES, INC., WEST DES
MOINES, IA:
1,458,610, CANC. INT. CL. 31.

FARMERS' RICE COOPERATIVE, SACRAMENTO, CA:
2,191,434. REN. 7-3-08. INT. CL. 30.

FARMGRO ORGANIC FOODS INC., REGINA, SASKATCH-
EWAN, CANADA:
2,491,959, CANC. INT. CL. 35.

FARMLAND FOODS, INC., KANSAS CITY, MO:
2,099,143, CANC. INT. CL. 29.

FARMS FOR CITY KIDS FOUNDATION, INC., PORT
WASHINGTON, NY:
3,478,825, PUB. 5-20-2008. INT. CL. 41.

FARRIS ENTERPRISES, LLC, WHITEFISH, MT:
3,481,919, INT. CL. 36.

FAST OFFICE, INC., NEW YORK, NY:
3,479,382, PUB. 5-20-2008. INT. CL. 35.

3,479,383, PUB. 5-20-2008. INT. CL. 35.

FAST SEARCH & TRANSFER ASA, OSLO, NORWAY:
1,458,072, CANC. INT. CL. 9.

FASTEST, INC., ST. PAUL, MN:
2,492,940, CANC. INT. CL. 6.

FASTLANE TECHNOLOGIES INCORPORATED, HALIFAX,
NOVA SCOTIA, B3J 1M5, CANADA:
2,491,783, CANC. MULTIPLE CLASS, INT. CLS. 9 AND
42.

FATBRAIN.COM, INC., SANTA CLARA, CA:
2,493,471, CANC. MULTIPLE CLASS, INT. CLS. 35 AND
42.

FATHER FLANAGAN'S BOYS' HOME, BOYS TOWN, NE:
1,075,702. REN. 6-30-08. MULTIPLE CLASS, INT. CLS. 41
AND 42.

FAULTLINE CORP., SOLANA BEACH, CA, DBA FAULT-
LINE CLOTHING:
3,479,339, PUB. 5-20-2008. INT. CL. 25.

FBC FINANCE CO., TORRANCE, CA:
3,479,735, PUB. 5-20-2008. MULTIPLE CLASS, INT. CLS.
29 AND 30.

FBTS, INC., CORAL GABLES, FL:
2,492,131, CANC. INT. CL. 40.

FCW IMPORTS & EXPORTS, LLC, SOUTH SAN FRANCIS-
CO, CA:
3,482,155, INT. CL. 30.

FDI CORP., SALINAS, PUERTO RICO TO JUGOS DEL
VALLE, S.A. DEC.V., MEXICO CITY, MEXICO:
2,099,848, CANC. INT. CL. 32.

FEDCO LLC, DORAL, FL:
3,479,591, PUB. 5-20-2008. INT. CL. 35.

FEDERAL RESERVE BANK OF KANSAS CITY, KANSAS
CITY, MO:
3,479,508, PUB. 5-20-2008. INT. CL. 9.

FEDERICO PATERNINA, S.A., HARO, LOGRANO, SPAIN:
1,458,623, CANC. INT. CL. 33.

FEDEX GROUND PACKAGE SYSTEM, INC., MOON
TOWNSHIP, PA:
2,493,006, CANC. INT. CL. 35.

FELDENKRAIS GUILD OF NORTH AMERICA, PORT-
LAND, OR:
2,187,073. REN. 6-30-08. U.S. CL. B.

FELIZ, RUBEN D., SANFORD, FL:
3,478,578, PUB. 5-20-2008. INT. CL. 37.

FELLOWES, INC., ITASCA, IL:
1,492,165. REN. 6-30-08. INT. CL. 16.

FELTON, MARK, SHERMAN OAKS, CA:
3,480,170, PUB. 5-20-2008. INT. CL. 28.

FENDER MUSICAL INSTRUMENTS CORPORATION,
SCOTTSDALE, AZ, CBS INC., NEW YORK, NY:
1,058,385. REN. 6-27-08. INT. CL. 15.

FENGHUA NANFANG MACHINUFACTURE CO., LTD.,
CHINA:
3,480,750, PUB. 5-20-2008. INT. CL. 8.

FENTON ENVIRONMENTAL TECHNOLOGIES, INC., NEW
ORLEANS, LA:
3,481,511, INT. CL. 11.

FERALON GROUP L.L.C., HOUSTON, TX:
3,480,362, PUB. 5-20-2008. INT. CL. 43.

- FERNO-WASHINGTON, INC., WILMINGTON, OH, FERNO MANUFACTURING COMPANY, CIRCLEVILLE, OH: 663,713. REN. 7-3-08. U.S. CL. 19 (INT. CL. 10).
- FERRARA PAN CANDY CO., INC., FOREST PARK, IL: 2,243,831. REN. 6-27-08. INT. CL. 30.
- FERRERO S.P.A., ALBA (CUNEO PROVINCE), ITALY: 1,458,572. CANC. INT. CL. 30.
- FERRERO S.P.A., ITALY:
3,480,798, PUB. 5-20-2008. MULTIPLE CLASS, INT. CLS. 29, 30 AND 32.
3,480,872, PUB. 5-20-2008. INT. CL. 30.
- FERRO CORPORATION, CLEVELAND, OH, TIZON CHEMICAL CORPORATION, FLEMINGTON, NJ: 812,789. REN. 7-3-08. U.S. CL. 6 (INT. CL. 1).
- FERRO CORPORATION, CLEVELAND, OH: 1,063,622. REN. 6-30-08. INT. CL. 1.
- FETTO, JOSEPH F., NEW YORK, NY: 2,119,799. REN. 7-3-08. INT. CL. 10.
- FI-SOFT, LLC, SPRING, TX: 3,481,815, INT. CL. 42.
- FIAT AUTO S.P.A., ITALY:
3,480,800, PUB. 5-20-2008. MULTIPLE CLASS, INT. CLS. 3, 11, 12, 14, 16, 18, 20, 24, 25, 28, 30, 32 AND 33.
- FIBER-LINE, INC., HATFIELD, PA: 3,481,454, INT. CL. 1.
- FIBERWEB ITALIA S.P.A., TREZZANO ROSA, ITALY, NEUBERGER S.P.A., TREZZANO ROSA, ITALY: 1,492,295. REN. 7-3-08. INT. CL. 24.
- FIDUCIAIRE DE DISTRIBUTION INTERNATIONALE, 73290 LA MOTTE SERVOLEX, FRANCE: 2,165,356. REN. 6-28-08. MULTIPLE CLASS, INT. CLS. 35 AND 36.
- FIEL, PAUL, SIERRA VISTA, AZ:
3,480,402, PUB. 5-20-2008. INT. CL. 37.
3,480,431, PUB. 5-20-2008. INT. CL. 36.
- FIERRES INC., SAN JUAN, PUERTO RICO: 2,492,772. CANC. INT. CL. 25.
- FIFTH THIRD BANCORP, CINCINNATI, OH: 3,481,501, MULTIPLE CLASS, INT. CLS. 35 AND 36.
- FINANCIAL MANAGEMENT GROUP, INC., CINCINNATI, OH: 3,482,471, INT. CL. 36.
- FINNAREN & HALEY, INCORPORATED, CONSHOHOCKEN, PA, DBA FINNAREN & HALEY, INC.: 1,457,882. CANC. INT. CL. 2.
- FIREHOUSE NATURAL SPRING WATER II, FLORHAM PARK, NJ: 3,481,977, INT. CL. 32.
- FIREHOUSE RESTAURANT GROUP, INC., JACKSONVILLE, FL: 3,482,187, INT. CL. 43.
3,482,188, INT. CL. 35.
- FIREMAN'S FUND INSURANCE COMPANY, NOVATO, CA: 2,492,415. CANC. INT. CL. 36.
- FIREMATIC MANUFACTURING INC., EAST YAPHANK, NY: 3,480,625. PUB. 5-20-2008. INT. CL. 9.
- FIRESIDE THRIFT CO., NEWARK, CA: 2,098,807. CANC. INT. CL. 36.
- FIRST ADVANTAGE CORPORATION, ST. PETERSBURG, FL: 2,162,985. REN. 7-2-08. INT. CL. 9.
- FIRST NATIONAL BANK & TRUST CO., SHAWNEE, OK: 3,478,955. PUB. 5-20-2008. INT. CL. 36.
- FIRST NATIONAL BANK OF OMAHA, OMAHA, NE: 2,171,318. REN. 7-3-08. INT. CL. 16.
- FIRST NATIONAL BUSINESS CORPORATION, SPRINGFIELD, MO: 3,482,229, INT. CL. 36.
- FIRST NATIONAL OF NEBRASKA, INC., OMAHA, NE: 3,479,676, PUB. 5-20-2008. INT. CL. 36.
3,480,485, PUB. 5-20-2008. INT. CL. 36.
- FIRST QUALITY RETAIL SERVICES, LLC, GREAT NECK, NY: 3,482,274, INT. CL. 16.
- FIRST QUALITY TISSUE, LLC, GREAT NECK, NY: 3,482,584, INT. CL. 16.
- FISH FIRST - LEWIS RIVER, WOODLAND, WA: 2,238,948. REN. 6-28-08. INT. CL. 37.
- FISH, MEREDITH, NEW YORK, NY: 3,478,854, PUB. 5-20-2008. MULTIPLE CLASS, INT. CLS. 3 AND 44.
- FISHEL TOYS LIMITED, TSIMSHATSUI, KOWLOON, HONG KONG: 1,458,509. CANC. INT. CL. 28.
- FISHER HOUSE FOUNDATION, ROCKVILLE, MD: 3,480,096, PUB. 5-20-2008. INT. CL. 39.
- FISHER, DAWN, PORTLAND, OR: 3,481,917, INT. CL. 3.
- FISKARS BRANDS, INC., MADISON, WI: 3,480,588, PUB. 5-20-2008. INT. CL. 8.
- FIST FIRST FIGHTING, LLC, KENTWOOD, MI: 3,478,557, PUB. 5-20-2008. INT. CL. 25.
- FIT & HEALTHY SCHOOLS, INC., WOODBRIDGE, VA: 3,482,548, INT. CL. 41.
- FITMOM, INC., TORONTO, ONTARIO: 3,482,572, INT. CL. 9.
- FITNESS TRAINERS TO GO, INC., DALLAS, TX: 3,479,366, PUB. 5-20-2008. INT. CL. 41.
3,479,367, PUB. 5-20-2008. INT. CL. 41.
- FIVE RIVERS, INC., BOISE, ID: 3,482,550, INT. CL. 40.
- FJH MUSIC COMPANY INC., THE, FORT LAUDERDALE, FL: 2,163,281. REN. 6-30-08. INT. CL. 16.
- FLAEM NUOVA S.P.A., ITALY: 3,480,945. PUB. 5-20-2008. MULTIPLE CLASS, INT. CLS. 7 AND 10.
- FLANNERY, NEIL M., MANTOLOKING, PA: 3,481,530, INT. CL. 21.
- FLATBURGER, INC., TROY, NY: 3,481,886, INT. CL. 35.
- FLEETWOOD ENTERPRISES, INC., RIVERSIDE, CA: 3,481,620, INT. CL. 12.
- FLEXA GROUP A/S, 8783 HORNSYLD, DENMARK: 3,479,256, PUB. 5-20-2008. MULTIPLE CLASS, INT. CLS. 20, 24 AND 35.
- FLEXILE, INC., CHICO, CA: 2,596,272. CANC. INT. CL. 35.
- FLEXTANK INC., ATHENS, GA: 3,480,126, PUB. 5-20-2008. INT. CL. 20.
- FLIGHTSAFETY DEVELOPMENT CORP., LAS VEGAS, NV: 3,478,863, PUB. 5-20-2008. MULTIPLE CLASS, INT. CLS. 9 AND 41.
- FLIPSIDE, INC., EL SEGUNDO, CA: 2,493,448. CANC. INT. CL. 9.
- FLOORING 101, INC., OXNARD, CA: 3,481,462, INT. CL. 35.
- FLOOZ.COM, INC., NEW YORK, NY: 2,493,234. CANC. MULTIPLE CLASS, INT. CLS. 35 AND 36.
- FLOPHOUSE RECORDS, BANGOR, ME: 3,480,149, PUB. 5-20-2008. INT. CL. 9.
- FLOR A. MAYORAL, M.D., P.A., MIAMI, FL: 3,481,202, INT. CL. 5.
- FLORAGEM, LLC, VISTA, CA: 3,482,087, INT. CL. 31.
- FLORIDA PEST CONTROL & CHEMICAL CO., GAINESVILLE, FL: 3,480,221, PUB. 5-20-2008. INT. CL. 37.
- FLORIKAN-E.S.A. CORP., SARASOTA, FL: 3,481,414, INT. CL. 1.
- FLORISTS' TRANSWORLD DELIVERY, INC., DOWNERS GROVE, IL: 2,493,692. CANC. INT. CL. 28.
- FLOSTOR ENGINEERING, HAYWARD, CA: 2,492,742. CANC. MULTIPLE CLASS, INT. CLS. 7 AND 39.
- FLOW SCIENCE INCORPORATED, PASADENA, CA: 1,323,830. REN. 7-3-08. INT. CL. 42.
- FLOWERS, INC., BOGART, GA: 3,482,223, MULTIPLE CLASS, INT. CLS. 11, 16, 20, 21, 24, 28 AND 35.
3,482,224, MULTIPLE CLASS, INT. CLS. 16, 20, 21, 28

- AND 35.
3,482,226, MULTIPLE CLASS, INT. CLS. 16, 20, 21, 28 AND 35.
3,482,227, MULTIPLE CLASS, INT. CLS. 11, 16, 20, 21, 24, 28 AND 35.
- FLOYD READY ASSOCIATES, INC., JACKSON, MS:
2,238,591. REN. 6-30-08. INT. CL. 7.
- FLOYD, JACK L., FOUNTAIN HILLS, AZ:
3,479,206, PUB. 5-20-2008. INT. CL. 43.
- FLUKE CORPORATION, EVERETT, WA:
1,480,662. REN. 7-2-08. INT. CL. 9.
- FLUOR ENTERPRISES, INC., ALISO VIEJO, CA:
2,491,704, CANC. INT. CL. 37.
- FLUXTROL MANUFACTURING, INC., AUBURN HILLS, MI:
2,491,663, CANC. INT. CL. 9.
2,491,664, CANC. INT. CL. 9.
- FLYBY CAPITAL, INC., MISSION, KS, BORDEN, INC., COLUMBUS, OH:
1,501,503. REN. 7-2-08. INT. CL. 29.
- FLYBY CAPITAL, INC., MISSION, KS:
2,155,418. REN. 7-2-08. MULTIPLE CLASS, INT. CLS. 29 AND 30.
- FLYING LAB SOFTWARE, LLC, SEATTLE, WA:
3,482,009, MULTIPLE CLASS, INT. CLS. 9 AND 41.
- FLYING STINGRAYS, LTD., WEST BAY RD.; GRAND CAYMAN, CAYMAN ISLANDS:
2,127,286. REN. 7-3-08. INT. CL. 42.
- FLYING STINGRAYS, LTD., WEST BAY RD. GRAND CAYMAN, CAYMAN ISLANDS:
2,127,287. REN. 7-3-08. INT. CL. 42.
- FLYING STINGRAYS, LTD., WEST BAY RD.; GRAND CAYMAN, CAYMAN ISLANDS:
2,128,912. REN. 7-3-08. INT. CL. 42.
- FLYNT/AMTEX, INC., BURLINGTON, NC:
2,192,510. REN. 6-30-08. MULTIPLE CLASS, INT. CLS. 10 AND 25.
- FM ACOUSTICS LTD., CH-8132 EGG, SWITZERLAND:
2,117,317. REN. 7-1-08. INT. CL. 9.
- FMC CORPORATION, PHILADELPHIA, PA:
2,088,001, CANC. INT. CL. 1.
- FMP DIRECT, INC., LIBERTYVILLE, IL:
2,100,089, CANC. INT. CL. 35.
- FMR CORP., BOSTON, MA:
2,098,685, CANC. MULTIPLE CLASS, INT. CLS. 9 AND 36.
- FMR LLC, BOSTON, MA:
3,482,132, INT. CL. 36.
- FNC KOLON CORPORATION, SEOUL, REPUBLIC OF KOREA:
1,405,896. REN. 6-30-08. INT. CL. 25.
- FNC MEDICAL CORPORATION, VENTURA, CA:
3,482,513, INT. CL. 5.
- FOAMEX ASIA CO., LTD., VISTA, CA:
3,478,662, PUB. 5-20-2008. INT. CL. 8.
- FOCUS 12, INC., BOULDER, CO:
1,486,930. REN. 7-2-08. INT. CL. 20.
- FOLDFAST GOALS, LLC, WILMINGTON, DE:
3,480,206, PUB. 5-20-2008. INT. CL. 28.
- FOLSOM, CHRISTY, NEW YORK, NY:
2,449,713, CANC. INT. CL. 41.
- FONCIA, FRANCE:
3,480,992, PUB. 5-20-2008. MULTIPLE CLASS, INT. CLS. 35, 36, 42 AND 45.
- FONE-IN LTD., THE VALLEY, ANGUILLA:
3,479,345, PUB. 2-12-2008. INT. CL. 41.
- FOOD CHAIN RECORDS, L.L.C., HOLLYWOOD, CA:
2,188,865. REN. 7-2-08. INT. CL. 9.
- FOOD SOLUTIONS, INC., GREENSBORO, NC:
3,481,365, MULTIPLE CLASS, INT. CLS. 30 AND 32.
- FOR THE BEST IN YOU...MISTER BLACKWELL COSMETICS INC., DECATUR, GA, DBA ARTIE FITZGERALD:
3,481,911, INT. CL. 3.
- FOR YOU, INC., LORIS, SC:
1,491,819. REN. 7-2-08. MULTIPLE CLASS, INT. CLS. 3 AND 5.
- FORCELLI, ROBERT, HOPEWELL, NY:
2,492,216, CANC. INT. CL. 41.
- FORCEMANAGEMENT, LLC, CHARLOTTE, NC:
3,479,136, PUB. 5-20-2008. INT. CL. 35.
- FORD MOTOR COMPANY, DEARBORN, MI:
3,480,494, PUB. 5-20-2008. INT. CL. 12.
3,480,497, PUB. 5-20-2008. INT. CL. 27.
- FORECLOSURESDAILY.COM, LARGO, FL:
3,479,765, PUB. 5-20-2008. INT. CL. 36.
- FORESTRY RESOURCES, INC., FORT MYERS, FL:
3,481,109, INT. CL. 1.
- FORMLINC INFORMATION SYSTEMS, L.C., CENTERVILLE, UT:
2,493,081, CANC. INT. CL. 9.
- FORMS AND SURFACES COMPANY, LLC, CARPINTERIA, CA:
2,493,323, CANC. MULTIPLE CLASS, INT. CLS. 20 AND 35.
- FORT JAMES OPERATING COMPANY, ATLANTA, GA:
1,458,341, CANC. INT. CL. 16.
- FORT KNOCKS ENTERTAINMENT, INC., MIAMI, FL:
3,482,358, INT. CL. 41.
- FORTIS FILMS, LOS ANGELES, CA:
2,201,196. REN. 6-28-08. INT. CL. 41.
- FORTIS N.V., ARCHIMEDES LAAN 6, HOLLAND, NETHERLANDS:
2,492,959, CANC. MULTIPLE CLASS, INT. CLS. 35 AND 36.
- FOSHAN RIFENG ENTERPRISES CO., LTD, GUANGDONG, CHINA:
3,479,812, PUB. 5-20-2008. MULTIPLE CLASS, INT. CLS. 6, 11, 17, 19 AND 20.
3,479,814, PUB. 5-20-2008. MULTIPLE CLASS, INT. CLS. 6, 11, 17, 19 AND 20.
- FOSSIL, INC., RICHARDSON, TX:
2,493,116, CANC. INT. CL. 14.
3,480,484, PUB. 5-20-2008. INT. CL. 14.
3,480,511, PUB. 5-20-2008. INT. CL. 25.
3,482,018, INT. CL. 35.
- FOUNDATION BENEFIT PLANNING LLC, MEQUON, WI:
2,493,639, CANC. INT. CL. 36.
- FOUNDATION FOR NORTH AMERICAN WILD SHEEP, CODY, WY:
3,479,290, PUB. 5-20-2008. INT. CL. 41.
- FOUNTAIN PAJOT, FRANCE:
3,480,888, PUB. 5-20-2008. MULTIPLE CLASS, INT. CLS. 12, 22 AND 25.
- FOUR PAWS PRODUCTS, LTD., HAUPPAUGE, NY:
3,480,566, PUB. 5-20-2008. INT. CL. 21.
- FOURHEADS, LLC, SAN FRANCISCO, CA:
3,480,253, PUB. 5-20-2008. INT. CL. 18.
- FOURTH TORO FAMILY LIMITED PARTNERSHIP, THE, NEW YORK, NY:
2,492,595, CANC. INT. CL. 42.
- FOWLERS OF BRISTOL LTD, UNITED KINGDOM:
3,480,808, PUB. 5-20-2008. MULTIPLE CLASS, INT. CLS. 9, 18 AND 25.
- FOX CHASE CANCER CENTER, PHILADELPHIA, PA:
3,480,023, PUB. 5-20-2008. MULTIPLE CLASS, INT. CLS. 41, 42, 44 AND 45.
3,480,044, PUB. 5-20-2008. MULTIPLE CLASS, INT. CLS. 41, 42 AND 44.
- FOXY'S LAIR, INC., CAPE CANAVERAL, FL:
3,481,377, INT. CL. 16.
- FP STORES, INC., GARDENA, CA:
3,480,164, PUB. 5-20-2008. INT. CL. 35.
- FRAGRA-MATICS MANUFACTURING COMPANY, INC., PINE BLUFF, AR, CAR FRESH MANUFACTURING COMPANY, INC., PINE BLUFF, AR:
1,537,178. REN. 6-30-08. INT. CL. 5.
- FRAMEWORK INC., TARRYTOWN, NY:
2,099,147, CANC. INT. CL. 42.
- FRANCISCO JAVIER LOPEZ PEREZ, E-08027 BARCELONA, SPAIN:
3,480,894, PUB. 5-20-2008. MULTIPLE CLASS, INT. CLS. 35, 36 AND 45.
- FRANK AND STEIN ASSOCIATES, LLC, PITTSBURGH, PA:
3,479,596, PUB. 5-20-2008. INT. CL. 38.

- FRANK BRUNCKHORST CO., L.L.C., BROOKLYN, NY:
FRANK BRUNCKHORST CO., L.P., BROOKLYN, NY:
2,120,400. REN. 6-30-08. INT. CL. 29.
- FRANK BRUNCKHORST CO., L.L.C., BROOKLYN, NY:
2,171,553. REN. 7-3-08. INT. CL. 29.
- FRANK CAPURRO & SON, LLC, MOSS LANDING, CA:
3,480,467. PUB. 5-20-2008. INT. CL. 31.
- FRANK DE FINA, PLAINSBORO, NJ:
3,479,143. PUB. 5-20-2008. MULTIPLE CLASS, INT. CLS.
16 AND 41.
- FRANK MILLER & SONS, INC., CHICAGO, IL:
1,514,217. REN. 7-3-08. INT. CL. 1.
- FRANK N. MAGID ASSOCIATES, INC., MARION, IA:
3,479,313. PUB. 5-20-2008. INT. CL. 41.
- FRANK PUBLIC RELATIONS, LTD, LONDON, UNITED
KINGDOM:
3,480,671. PUB. 10-2-2007. INT. CL. 35.
- FRANK RUSSELL COMPANY, TACOMA, WA:
3,482,432. MULTIPLE CLASS, INT. CLS. 9, 16 AND 36.
- FRANK 151 MEDIA GROUP LLC, NEW YORK, NY:
3,479,669. PUB. 5-20-2008. INT. CL. 25.
- FRANKLIN COVEY CO., SALT LAKE CITY, UT:
2,493,071. CANC. INT. CL. 42.
3,480,281. PUB. 5-20-2008. INT. CL. 35.
- FRANKLIN INTERNATIONAL, INC., COLUMBUS, OH:
3,481,565. MULTIPLE CLASS, INT. CLS. 1 AND 17.
- FRANKLIN SPORTS, INC., STOUGHTON, MA:
3,481,955. INT. CL. 28.
- FRANKLIN TOOL SYSTEMS, INC., SACRAMENTO, CA:
3,479,232. PUB. 5-20-2008. INT. CL. 8.
- FRANZ KALDEWEI GMBH & CO. KG, AHLEN, FED REP
GERMANY:
3,479,524. PUB. 5-20-2008. INT. CL. 11.
3,479,526. PUB. 5-20-2008. INT. CL. 11.
3,479,527. PUB. 5-20-2008. INT. CL. 11.
3,479,529. PUB. 5-20-2008. INT. CL. 11.
3,479,530. PUB. 5-20-2008. INT. CL. 11.
3,479,532. PUB. 5-20-2008. INT. CL. 11.
3,479,533. PUB. 5-20-2008. INT. CL. 11.
3,479,534. PUB. 5-20-2008. INT. CL. 11.
3,479,535. PUB. 5-20-2008. INT. CL. 11.
- FRASER PAPERS LIMITED, MADAWASKA, ME:
2,192,806. REN. 6-30-08. INT. CL. 16.
2,196,540. REN. 6-30-08. INT. CL. 16.
2,199,012. REN. 6-30-08. INT. CL. 16.
- FRAZER ENTERPRISES, INC., RALEIGH, NC:
2,099,003. CANC. INT. CL. 35.
- FRAZIER, LARRY, NEWBURGH, NY:
3,482,484. INT. CL. 25.
- FREDERICK GOLDMAN, INC., NEW YORK, NY:
2,100,265. CANC. INT. CL. 14.
- FREEDOM CONCRETE PUMPING, LLC, CANTON, MI:
3,481,780. INT. CL. 37.
- FREEDOMS FOUNDATION AT VALLEY FORGE, VALLEY
FORGE, PA:
2,098,677. CANC. INT. CL. 41.
- FREEIQ, LLC, NORCROSS, GA:
3,479,092. PUB. 5-20-2008. MULTIPLE CLASS, INT. CLS.
35, 38 AND 41.
- FREELY CREATIVE, INC., STOWE, VT:
2,099,334. CANC. INT. CL. 16.
- FREEMAN, JOEL A., SEVERN, MD:
3,480,446. PUB. 5-20-2008. INT. CL. 41.
- FREEMAN, MICHAEL E., EGG HARBOR, WI:
2,492,530. CANC. INT. CL. 16.
2,492,531. CANC. INT. CL. 16.
- FREEMAN, VIVIAN V., NEWSOMS, VA:
3,481,325. INT. CL. 16.
- FREESCALE SEMICONDUCTOR, INC., AUSTIN, TX:
3,411,019. COR. MULTIPLE CLASS, INT. CLS. 9 AND 42.
- FREESIA USA, INC., VERNON, CA:
3,478,619. PUB. 5-20-2008. INT. CL. 3.
- FREEZE 24/7 INTERNATIONAL LLC, NEW YORK, NY:
3,480,012. PUB. 5-20-2008. INT. CL. 3.
- FREGATE, FRANCE:
3,480,842. PUB. 5-20-2008. MULTIPLE CLASS, INT. CLS.
16 AND 41.
- FRESH DIRECT, LLC, LONG ISLAND CITY, NY:
3,479,032. PUB. 5-20-2008. MULTIPLE CLASS, INT. CLS.
35 AND 43.
- FRESH EXPRESS INCORPORATED, SALINAS, CA:
3,482,337. MULTIPLE CLASS, INT. CLS. 29 AND 30.
3,482,338. MULTIPLE CLASS, INT. CLS. 29 AND 30.
- FRESHFIELDS INTERNATIONAL LIMITED, LONDON
ECRY IHS, UNITED KINGDOM:
1,451,466. REN. 6-30-08. INT. CL. 42.
- FRESHWAY FOOD SYSTEMS, INC., SIOUX FALLS, SD:
3,479,083. PUB. 5-20-2008. INT. CL. 43.
- FRIEDRICK SCHWEITZER, BOULDER, CO:
3,482,719. INT. CL. 9.
- FRIENDS & FRIENDS, INC., MIAMI, FL:
3,478,864. PUB. 5-20-2008. MULTIPLE CLASS, INT. CLS.
25, 28, 35, 37, 41, 42 AND 45.
- FRISDOO, LLC, ATLANTA, GA:
3,481,355. MULTIPLE CLASS, INT. CLS. 25 AND 28.
- FRITO-LAY NORTH AMERICA, INC., PLANO, TX:
2,169,771. REN. 6-30-08. INT. CL. 30.
- FRUTA DEL PACIFICO S.A., SPAIN:
3,480,832. PUB. 5-20-2008. INT. CL. 31.
- FRUTAROM INCORPORATED, NORTH BERGEN, NJ:
2,098,519. CANC. MULTIPLE CLASS, INT. CLS. 3, 4, 5, 16,
21, 24, 29, 30, 31, 32, 33 AND 34.
- FRX SOFTWARE CORPORATION, DENVER, CO:
2,491,751. CANC. INT. CL. 9.
- FSB ACQUISITION COMPANY, LLC, NORTH LAS VEGAS,
NV:
2,493,133. CANC. INT. CL. 16.
- FTS APPAREL, INC., COLORADO SPRINGS, CO:
2,493,173. CANC. INT. CL. 25.
- FUJIAN XIAMEN TUNGSTEN PRODUCTS PLANT, XIA-
MEN, CHINA:
2,099,032. CANC. INT. CL. 1.
- FUJISANKEI COMMUNICATIONS INTERNATIONAL,
INC., NEW YORK, NY:
3,480,555. PUB. 5-20-2008. INT. CL. 41.
- FUJITSU CONSULTING INC., EDISON, NJ:
2,492,424. CANC. INT. CL. 35.
- FULL SAIL, INC., WINTER PARK, FL:
3,480,558. PUB. 5-20-2008. INT. CL. 41.
- FULLER BRUSH COMPANY INC., THE, GREAT BEND, KS:
1,343,722. REN. 7-3-08. INT. CL. 3.
- FUNDEX GAMES, LTD., INDIANAPOLIS, IN:
3,479,545. PUB. 5-20-2008. INT. CL. 28.
- FUNFIT, INC., ROCKVILLE, MD:
2,167,671. REN. 7-3-08. INT. CL. 41.
2,167,672. REN. 7-3-08. INT. CL. 41.
- FURNITURE ROW, LLC, DENVER, CO:
3,481,424. INT. CL. 35.
- FUTURE ELECTRONICS, INC., POINTE CLAIRE, QUEBEC,
CANADA:
2,492,909. CANC. INT. CL. 35.
- FUTURE MERCHANTS, INC., NEW YORK, NY:
3,481,199. INT. CL. 42.
- FUTURELOGIC INCORPORATED, GLENDALE, CA:
3,481,885. INT. CL. 9.
- FUZION FOOD GROUP, INC., SIOUX FALLS, SD:
3,481,315. INT. CL. 43.
- FXEXPRESS PUBLICATIONS, INC., YARDLEY, PA:
3,480,395. PUB. 5-20-2008. INT. CL. 16.
- F5 NETWORKS, INC., SEATTLE, WA, F5 LABS, INC.,
SEATTLE, WA:
2,165,021. REN. 6-30-08. MULTIPLE CLASS, INT. CLS. 9
AND 42.
- G & W ELECTRIC COMPANY, BLUE ISLAND, IL, G & W
ELECTRIC SPECIALTY COMPANY, BLUE ISLAND, IL:
857,829. REN. 7-1-08. U.S. CL. 21 (INT. CL. 9).
- G.A.A.G., L.L.C., SELMA, AL:
1,492,256. REN. 6-28-08. INT. CL. 19.
- G&H WIRE HOLDINGS, INC., CHICAGO, IL:
3,481,287. INT. CL. 10.
3,481,288. INT. CL. 10.
- GABOR SHOES AG, ROSENHEIM, FED REP GERMANY:
3,480,838. PUB. 4-15-2008. INT. CL. 25.
- GABRIDGE, MICHAEL G., ESTES PARK, CO:
1,520,651. REN. 6-28-08. INT. CL. 9.

GALES, MELANIE M., HARVEY, IL:
3,482,347, INT. CL. 25.

GALILEO INTERNATIONAL, L.L.C., PARSIPPANY, NJ:
2,492,855, CANC. INT. CL. 9.

GALPIN AUTO SPORTS LLC, VAN NUYS, CA:
3,482,279, INT. CL. 37.

GALT VENTURES, INC., METAIRIE, LA:
2,493,290, CANC. INT. CL. 9.

GALVA FOAM MARINE INDUSTRIES, INC., CAMDEN-
TON, MO:
2,100,193, CANC. INT. CL. 19.

GAM ASSOCIATES, INC., GOSHEN, NY:
2,161,535, REN. 6-28-08. MULTIPLE CLASS, INT. CLS. 8,
16, 21 AND 24.

GAME JUICE, INC., MIAMI, FL:
3,479,043, PUB. 5-20-2008. INT. CL. 32.

GAMELOGIC INC., WALTHAM, MA:
3,482,048, INT. CL. 41.
3,482,240, INT. CL. 41.

GAMING LABORATORIES INTERNATIONAL, INC., LA-
KEWOOD, NJ:
3,481,574, INT. CL. 41.

GAMING, KARAWAY, TUCSON, AZ:
3,481,602, INT. CL. 9.

GAMMA MEDIZINISCH-WISSENSCHAFTLICHE FOR-
TBILDUNGSGESELLSCHAFT M.B.H., A-3400 KLOSTER-
NEUBURG, AUSTRIA:
2,491,992, CANC. MULTIPLE CLASS, INT. CLS. 9, 10
AND 42.

GANNETT SATELLITE INFORMATION NETWORK, INC.,
MCLEAN, VA:
3,481,301, MULTIPLE CLASS, INT. CLS. 16 AND 41.

GARAGA INC., QUEBEC, CANADA:
3,482,595, INT. CL. 6.

GARCIA Y DE LOS RIOS, JUAN GUILLERMO, C.P. 03100,
DF, MEXICO:
2,492,971, CANC. INT. CL. 30.

GARCIA-HUIDOBRO, RODRIGO, FOREST HILLS, NY:
3,479,386, PUB. 5-20-2008. INT. CL. 29.

GARCIA, JUAN GRANADOS, 08029 BARCELONA, SPAIN:
2,491,957, CANC. INT. CL. 42.

GARCIA, LAZARO, MIAMI, FL AND GARCIA, JOSE,
MIAMI, FL:
3,481,796, INT. CL. 43.
3,481,892, INT. CL. 43.

GARCIA, ROBERT T., CAMP PENDLETON, CA:
3,482,383, INT. CL. 9.

GARDEN STATE BASEBALL, TRENTON, NJ:
2,099,710, CANC. MULTIPLE CLASS, INT. CLS. 20 AND
24.

GARDNER, CARTON & DOUGLAS, CHICAGO, IL:
2,492,674, CANC. INT. CL. 42.

GARDNER, COLIN J, TEMPE, AZ:
3,481,421, INT. CL. 36.

GARLINGHOUSE, LLC, EL SEGUNDO, CA:
2,100,528, CANC. INT. CL. 16.

GARMIN LTD., CAMANA BAY, CAYMAN ISLANDS:
3,481,702, INT. CL. 9.

GARRISON NATURAL SPRING WATER, INC., PLAIN-
VIEW, NY, DBA PIPING ROCK NATURAL SPRING
WATER:
2,098,973, CANC. MULTIPLE CLASS, INT. CLS. 32 AND
39.

GARRISON, BRANDY, OCEANSIDE, CA AND GARRISON,
PATRICK, OCEANSIDE, CA:
3,482,246, INT. CL. 18.

GARSON INTERNATIONAL INC., NEW YORK, NY:
2,099,950, CANC. INT. CL. 42.

GARY FONG, INC., MARINA DEL REY, CA:
3,415,309, AM. INT. CL. 11.

GARZA TRANSPORT COMPANY, INC., MCALLEN, TX:
2,492,570, CANC. INT. CL. 39.

GARZA, RAYNALDO, MONARCH BEACH, CA:
3,482,445, INT. CL. 16.

GASEOSAS POSADA TOBON S.A., MEDELLIN, COLOM-
BIA:
3,480,544, PUB. 5-20-2008. INT. CL. 32.

GATES FORMED-FIBRE PRODUCTS, INC., AUBURN, ME:
2,493,113, CANC. INT. CL. 24.

GATHER INC., BOSTON, MA:
3,482,110, MULTIPLE CLASS, INT. CLS. 35, 38, 41, 42
AND 45.

GAVEY, JAMES E, FAIRFIELD, CT:
3,481,446, INT. CL. 5.

GAZEBO SOFTWARE SOLUTIONS, INC., LITTLETON, CO:
2,492,765, CANC. INT. CL. 42.

GE MEDICAL SYSTEMS INFORMATION TECHNOLOGIES,
INC., MILWAUKEE, WI:
1,492,082, REN. 6-30-08. INT. CL. 10.

GE MEDICAL SYSTEMS INFORMATION TECHNOLOGIES,
INC., MILWAUKEE, WI, MARQUETTE MEDICAL SYS-
TEMS, INC., MILWAUKEE, WI:
2,166,400, REN. 7-3-08. INT. CL. 10.

GE SECURITY, INC., BRADENTON, FL:
3,163,318, AM. INT. CL. 9.

GEAMI LTD., MORRISVILLE, NC:
3,482,635, INT. CL. 16.

GEBAL CO., INC., JENSEN BEACH, FL, DBA FANCY
FLAVORS:
3,482,690, MULTIPLE CLASS, INT. CLS. 29, 30 AND 32.

GEBR. KEMPER GMBH + CO. KG METALLWERKE, FED
REP GERMANY:
3,480,786, PUB. 5-20-2008. MULTIPLE CLASS, INT. CLS. 6
AND 40.

GEDDES, DAVID HAMLEN, MARIETTA, GA, DBA DYNE-
MIA.COM:
3,480,040, PUB. 5-20-2008. INT. CL. 44.

GELLER DATA SOLUTIONS, INC., DAVIE, FL, DBA GDSI:
3,482,666, INT. CL. 9.

GEM PLUMBING & HEATING CO., INC., LINCOLN, RI:
3,479,939, PUB. 5-20-2008. INT. CL. 37.

GEMINI IMPORT & DISTRIBUTORS, INC., SUNRISE, FL:
2,493,130, CANC. INT. CL. 25.

GEMMA, ANTHONY, LINCOLN, RI:
3,481,934, INT. CL. 35.

GEN 3 PARTNERS, INC, BOSTON, MA:
2,492,464, CANC. INT. CL. 35.

GENERAL BINDING CORPORATION, NORTHBROOK, IL:
2,491,668, CANC. INT. CL. 7.

GENERAL CABLE TECHNOLOGIES CORPORATION,
HIGHLAND HEIGHTS, KY:
3,482,342, INT. CL. 9.

GENERAL CIGAR CO., INC., RICHMOND, VA:
1,470,893, REN. 6-30-08. INT. CL. 34.

GENERAL CONTAINER COMPANY, LLC, HILLSDALE,
MI:
3,481,447, INT. CL. 30.

GENERAL CONVERTERS & ASSEMBLERS, INC., RACINE,
WI:
3,479,412, PUB. 5-20-2008. INT. CL. 5.

GENERAL DYNAMICS ITRONIX CORPORATION, SPO-
KANE VALLEY, WA:
2,492,658, CANC. INT. CL. 9.

GENERAL ELECTRIC COMPANY, SCHENECTADY, NY:
3,481,496, INT. CL. 7.
3,481,654, INT. CL. 40.

GENERAL MILLS, INC., MINNEAPOLIS, MN:
2,493,593, CANC. INT. CL. 30.

GENERAL NUTRITION INVESTMENT COMPANY, PITTS-
BURGH, PA:
2,180,647, REN. 6-28-08. INT. CL. 5.
2,181,487, REN. 6-28-08. INT. CL. 5.
2,184,394, REN. 6-28-08. INT. CL. 5.

GENERAL WIG MANUFACTURERS, INC., MIAMI LAKES,
FL:
3,482,351, INT. CL. 26.

GENERATION YES CORPORATION, OLYMPIA, WA:
3,480,432, PUB. 5-20-2008. INT. CL. 41.
3,480,510, PUB. 5-20-2008. INT. CL. 41.

GENESIS HEALTHCARE HOLDING COMPANY II, INC.,
KENNETT SQUARE, PA:
3,481,279, INT. CL. 44.

GENLYTE THOMAS GROUP LLC, LOUISVILLE, KY:
3,480,557, PUB. 5-20-2008. INT. CL. 11.

- GENMAR IP LLC, MINNEAPOLIS, MN:
3,481,821, INT. CL. 9.
- GENNARI, LESLIE, READING, MA:
3,480,278, PUB. 5-20-2008. INT. CL. 4.
- GENPAK LLC, GLEN FALLS, NY:
2,098,895, CANC. INT. CL. 16.
- GENTEX BUILDING PRODUCTS, INC., AKRON, OH:
2,178,369, REN. 6-30-08. INT. CL. 19.
- GENZYME CORPORATION, CAMBRIDGE, MA:
2,100,207, CANC. INT. CL. 5.
- GEOCENTRIC LLC, SILVER SPRING, MD:
3,479,747, PUB. 5-20-2008. INT. CL. 42.
- GEOLOGICA AS, 4003 STAVANGER, NORWAY:
2,491,757, CANC. INT. CL. 9.
- GEORGIA FOAM, INC., FREDERICKSBURG, VA:
3,481,333, INT. CL. 19.
- GERE, TRAVIS M, WRJ, VT:
3,481,557, INT. CL. 35.
- GERRESHEIMER GLASS ASSET MANAGEMENT INC., VINELAND, NJ:
2,238,585, REN. 6-30-08. INT. CL. 9.
- GERVAIS, GAGNON, COVINGTON & ASSOCIATES INC., PUBLIC AND GOVERNMENT RELATIONS, MONTREAL, PROVINCE OF QUEBEC, CANADA:
2,492,082, CANC. INT. CL. 42.
2,492,083, CANC. INT. CL. 42.
- GETRONICS INTELLECTUAL PROPERTY BV, AMSTERDAM, NETHERLANDS:
3,479,511, PUB. 5-20-2008. MULTIPLE CLASS, INT. CLS. 16 AND 41.
- GETTY IMAGES, INC., SEATTLE, WA:
3,482,365, INT. CL. 42.
- GETTYS GROUP, INC., THE, CHICAGO, WI:
2,492,632, CANC. MULTIPLE CLASS, INT. CLS. 37 AND 42.
- GFI GROUP, INC., NEW YORK, NY:
2,099,047, CANC. INT. CL. 36.
- GFI HOLDINGS, INC., OMAHA, NE:
2,491,712, CANC. INT. CL. 29.
- GHUMAN, NEIL, MARYSVILLE, WA:
3,479,448, PUB. 5-20-2008. INT. CL. 35.
- GIANNI VERSACE S.P.A., ITALY:
3,481,008, PUB. 5-20-2008. INT. CL. 20.
- GIANNULLI, THOMAS C., SIMI VALLEY, CA:
3,480,061, PUB. 5-20-2008. INT. CL. 3.
- GIANT CAMPUS, INC., SEATTLE, WA:
3,479,615, PUB. 5-20-2008. INT. CL. 41.
- GIELOW PICKLES INC., LEXINGTON, MI:
2,198,178, REN. 6-30-08. INT. CL. 30.
- GIERSCH, DANIEL, MONACO 98000, MONACO:
3,478,670, PUB. 5-20-2008. MULTIPLE CLASS, INT. CLS. 9, 38 AND 41.
- GIGATERA AG, ZURICH, SWITZERLAND:
2,573,791, CANC. INT. CL. 42.
- GILERO, LLC, RALEIGH, NC:
3,478,934, PUB. 5-20-2008. MULTIPLE CLASS, INT. CLS. 40 AND 42.
3,478,935, PUB. 5-20-2008. MULTIPLE CLASS, INT. CLS. 40 AND 42.
- GINGER PEACHY DESIGNS, LLC, PACIFIC PALISADES, CA:
3,479,455, PUB. 5-20-2008. INT. CL. 35.
- GIORGIO BEVERLY HILLS, INC.:
1,458,507, CANC. INT. CL. 28.
- GITTEL ON THE GO, INC., SHERMAN OAKS, CA:
3,479,565, PUB. 5-20-2008. MULTIPLE CLASS, INT. CLS. 35 AND 45.
- GITTER'S CARD GALLERY, INC., NEW YORK, NY, DBA GITTER, ANAPOL & GLAZER COMMUNICATIONS:
2,004,411, CANC. INT. CL. 16.
- GIVING CONNECTION LLC, THE, NORTHBROOK, IL:
2,493,449, CANC. INT. CL. 36.
- GKB, INC., BILLINGS, MT:
2,491,857, CANC. INT. CL. 25.
- GLASS, JASON S., ALEXANDRIA, KY, DBA RENT IT TODAY:
3,480,097, PUB. 5-20-2008. INT. CL. 36.
- GLATT GMBH, 79589 BINZEN, FED REP GERMANY:
3,480,982, PUB. 5-20-2008. MULTIPLE CLASS, INT. CLS. 40 AND 42.
- GLC ENTERPRISES, LLC, CITY OF INDUSTRY, CA:
3,478,663, PUB. 5-20-2008. INT. CL. 37.
- GLIDDEN COMPANY, THE, STRONGSVILLE, OH:
357,933, REN. 6-30-08. U.S. CL. 16 (INT. CL. 2).
- GLO SKIN CARE, L.L.C., DENVER, CO:
2,492,502, CANC. INT. CL. 42.
- GLOBAL AVIAN SPECIALISTS LTD., ABBOTSFORD, BRITISH COLUMBIA:
2,187,749, REN. 6-30-08. INT. CL. 5.
- GLOBAL CLOTHING NETWORK, INC., WAYNE, NJ:
3,481,826, INT. CL. 25.
3,481,828, INT. CL. 25.
- GLOBAL COLLECTIVE DESIGN INCORPORATED, RICHMOND, CANADA:
3,480,613, PUB. 5-20-2008. INT. CL. 25.
- GLOBAL CROSSING HOLDINGS LIMITED, HAMILTON HM12, BERMUDA:
2,493,462, CANC. INT. CL. 38.
- GLOBAL CROSSING LTD., HAMILTON, HM12, BERMUDA:
2,493,455, CANC. INT. CL. 38.
2,493,456, CANC. INT. CL. 38.
2,493,457, CANC. INT. CL. 35.
2,493,458, CANC. INT. CL. 38.
- GLOBAL EDUCATION ONLINE CORPORATION, SAN RAMON, CA, DBA GLOBAL BUSINESS SERVICE CORPORATION:
3,480,095, PUB. 5-20-2008. INT. CL. 9.
- GLOBAL GAMING GROUP, LAS VEGAS, NV:
3,482,527, INT. CL. 9.
3,482,529, INT. CL. 9.
- GLOBAL INFOMERCIAL SERVICES, LLC, RENO, NV:
3,376,493, COR. INT. CL. 35.
- GLOBAL NURSING SOLUTIONS, INC., PITTSBURGH, PA:
3,480,460, PUB. 5-20-2008. INT. CL. 35.
- GLOBAL PARTS SUPPORT, INC., PEMBROKE PINES, FL:
3,479,006, PUB. 5-20-2008. INT. CL. 12.
- GLOBAL PAYMENT HOLDING COMPANY, ATLANTA, GA:
2,100,504, CANC. INT. CL. 36.
- GLOBAL SOURCING & INNOVATIONS, INC., LEE, MA:
3,481,532, INT. CL. 15.
- GLOBAL TECH RESOURCES LLC, LAS VEGAS, NV:
3,480,039, PUB. 5-20-2008. INT. CL. 9.
- GLOBALTEC SOLUTIONS, L.L.P., ADDISON, TX:
3,479,617, PUB. 5-20-2008. INT. CL. 41.
- GLOBE MOTORS, INC., DAYTON, OH:
3,479,718, PUB. 5-20-2008. INT. CL. 12.
- GLOBYTE, INC., CORAL GABLES, FL:
2,492,705, CANC. INT. CL. 36.
- GLOVEBRUSH CORP., SIMI VALLEY, CA:
3,481,640, INT. CL. 14.
- GLR NETWORKS LLC, MIAMI, FL:
3,481,410, INT. CL. 41.
- GMAC LLC, DETROIT, MI:
3,481,503, INT. CL. 36.
- GN NETCOM/UNEX INC., NASHULA, NH:
2,491,768, CANC. INT. CL. 9.
- GN RESOUND A/S, DENMARK:
3,481,014, PUB. 5-20-2008. INT. CL. 10.
- GO MODULAR INC., NORTH DARTMOUTH, MA:
3,482,419, MULTIPLE CLASS, INT. CLS. 35, 37 AND 42.
- GOALKEEPER INCENTIVE SYSTEMS, DEL MAR, CA:
3,482,469, INT. CL. 28.
- GODART, F. THOMAS, FORT LAUDERDALE, FL:
3,482,277, INT. CL. 37.
- GOFISH CORPORATION, SAN FRANCISCO, CA:
3,478,894, PUB. 10-16-2007. INT. CL. 41.
3,479,267, PUB. 10-16-2007. INT. CL. 41.
- GOFISH.COM, INC., PORTLAND, ME:
2,492,297, CANC. INT. CL. 35.
- GOLD CROSS AMBULANCE SERVICE, INC., MENASHA, WI:
3,482,702, MULTIPLE CLASS, INT. CLS. 9 AND 16.
- GOLDEN PRIME SERVICES L.L.C., OREM, UT:
2,492,493, CANC. MULTIPLE CLASS, INT. CLS. 35 AND

36.
GOLDEN STATE BULB GROWERS, WATSONVILLE, CA:
2,492,361, CANC. INT. CL. 31.
GOLDEN STATE SOFTWARE SYSTEMS, INC., ENCINITAS,
CA:
2,493,589, CANC. INT. CL. 9.
GOLDENWOOD INTERNATIONAL, INC., LOS ANGELES,
CA:
1,458,425, CANC. INT. CL. 25.
GOLDILOCKS BAKE SHOP, INC., METRO, MANILA,
PHILIPPINES:
3,478,815, PUB. 5-20-2008. INT. CL. 30.
GOLDKENN S.A., GENEVE 1234, SWITZERLAND:
2,098,788, CANC. INT. CL. 30.
GOLDSBORO/WAYNE TRANSPORTATION AUTHORITY,
GOLDSBORO, NC:
2,492,706, CANC. INT. CL. 39.
GOLDSTEIN, IRA, RALEIGH, NC AND GOLDSTEIN,
DAVID, RALEIGH, NC:
3,479,046, PUB. 5-20-2008. INT. CL. 16.
GOLDSTEIN, SAMANTHA, WOODLAND HILLS, CA:
3,478,679, PUB. 5-20-2008. INT. CL. 41.
GOLIGHT, INC., CULBERTSON, NE:
2,205,077, REN. 7-3-08. INT. CL. 11.
GOMEZ, ERNESTO BARBA, CHIHUAHUA, CHIHUAHUA,
MEXICO:
2,164,201, REN. 6-28-08. INT. CL. 30.
GOMEZ, FIDENCIO, RANCHO CUCAMONGA, CA:
3,478,599, PUB. 5-20-2008. MULTIPLE CLASS, INT. CLS. 9
AND 41.
GONZÁLEZ-TORRES, ABRAHAM MARCELO, TIZAYUCA,
HIDALGO, MEXICO:
3,482,407, INT. CL. 30.
GONZALES, JONATHAN M, VENTURA, CA:
3,481,902, INT. CL. 41.
GONZALEZ, FEDERICO, CATHEDRAL CITY, CA:
3,481,191, INT. CL. 25.
GONZALEZ, JUAN R. TENORIO, SAN GERMAN, PUERTO
RICO, DBA ANTITESIS:
2,493,140, CANC. INT. CL. 41.
GOOD AUTOMATIC WINDLASS & MARINE SALES, INC.,
BARNEGAT, NJ:
1,458,016, CANC. INT. CL. 7.
GOODELL, ALEXANDRA, OAKLAND, CA, DBA OUTTA
THE BAG!:
2,492,573, CANC. INT. CL. 28.
GOODMAN COMPANY, L.P., HOUSTON, TX:
3,482,029, INT. CL. 9.
GOODWILL INDUSTRIES-MANASOTA, INC., SARASOTA,
FL:
2,492,844, CANC. INT. CL. 35.
GOODWINOL PRODUCTS CORPORATION, PIERCE, CO:
1,457,962, CANC. INT. CL. 5.
GOODYEAR TIRE & RUBBER COMPANY, THE, AKRON,
OH:
2,162,428, REN. 7-2-08. INT. CL. 7.
2,162,428, CANC. INT. CL. 12.
2,492,621, CANC. INT. CL. 9.
2,492,680, CANC. INT. CL. 12.
GOPET, LLC, MARTINDALE, PA:
3,481,536, INT. CL. 28.
GORDINI U.S.A. INC., ESSEX JUNCTION, VT:
3,481,190, INT. CL. 24.
GORDON RAMSAY RESTAURANT HOLDING US LP, NEW
YORK, NY:
3,480,629, PUB. 5-20-2008. MULTIPLE CLASS, INT. CLS.
29, 30 AND 43.
GOSS, WILLIAM A, ORANGE PARK, FL:
2,100,218, CANC. INT. CL. 41.
GOSSAMER GEAR, INC., AUSTIN, TX:
3,478,911, PUB. 5-20-2008. INT. CL. 18.
GOTTLIEB, THEODORE B., ZEPHYR COVE, NV AND
BUTLER, PAMELA L., ZEPHYR COVE, NV:
3,482,544, INT. CL. 41.
GOTTROX LLC, CHICAGO, IL:
3,479,174, PUB. 5-20-2008. INT. CL. 9.
GOTUIT MEDIA CORP., WOBURN, MA:
3,478,527, PUB. 5-20-2008. INT. CL. 38.
3,478,532, PUB. 5-20-2008. INT. CL. 38.
GOTVMAIL COMMUNICATIONS, LLC, WESTON, MA:
3,481,130, INT. CL. 38.
3,481,131, INT. CL. 38.
3,481,132, INT. CL. 38.
3,481,133, INT. CL. 38.
3,481,135, INT. CL. 38.
3,481,136, INT. CL. 38.
GRA-TAC, INC., BOWLING GREEN, KY:
3,479,791, PUB. 5-20-2008. INT. CL. 37.
GRABLE, ANNA L., SANTEE, CA:
3,479,909, PUB. 5-20-2008. INT. CL. 25.
GRACE, NEW YORK, NY:
3,479,044, PUB. 5-20-2008. INT. CL. 35.
3,479,049, PUB. 5-20-2008. INT. CL. 35.
GRAFFITI ANSWERS, INC., NEW YORK, NY:
2,492,634, CANC. INT. CL. 37.
GRANBERRY SUPPLY CORP., PHOENIX, AZ:
3,479,971, PUB. 5-20-2008. INT. CL. 17.
GRAND CIRCUIT, INC., COLUMBUS, OH:
3,480,716, PUB. 5-20-2008. INT. CL. 41.
GRAND HAVEN HOMES, AUSTIN, TX:
3,480,139, PUB. 5-20-2008. INT. CL. 37.
GRAND TRAVERSE DEVELOPMENT COMPANY, ACME,
MI, DBA GRAND TRAVERSE RESORT VILLAGE:
1,458,820, CANC. INT. CL. 42.
GRANDE CHEESE COMPANY, BROWNSVILLE, WI:
3,479,831, PUB. 5-20-2008. INT. CL. 29.
GRANDE COMMUNICATIONS NETWORKS, INC., SAN
MARCOS, TX:
3,481,649, INT. CL. 38.
GRANDIN, MARK S., JACKSONVILLE, FL:
2,491,726, CANC. MULTIPLE CLASS, INT. CLS. 39, 41
AND 42.
GRANITE INDUSTRIES, INC., ARCHBOLD, OH:
2,492,617, CANC. INT. CL. 6.
GRANITE TECHNOLOGIES, INC., GOLDEN, CO:
3,478,862, PUB. 5-20-2008. INT. CL. 42.
GRANT, MOLLIE HUNTER, MT. PLEASANT, SC:
3,479,102, PUB. 5-20-2008. INT. CL. 25.
GRAPHIC ARTS SHOW COMPANY, INC., MCLEAN, VA:
1,458,655, CANC. INT. CL. 35.
GREAT AMERICAN INSURANCE COMPANY, CINCINNA-
TI, OH:
2,098,884, CANC. INT. CL. 36.
GREAT CIRCLE VENTURES HOLDINGS, LLC, SAVAN-
NAH, GA:
1,096,819, REN. 6-30-08. INT. CL. 25.
GREAT NORTHERN CORP., APPLETON, WI:
3,478,938, PUB. 5-20-2008. INT. CL. 16.
GREAT PLAINS FLAX SEEDS, INC., LITTLETON, CO:
3,482,349, INT. CL. 31.
GREAT PLAINS SOFTWARE, INC., FARGO, ND:
2,492,129, CANC. INT. CL. 9.
GREATER CINCINNATI CHAMBER OF COMMERCE, CIN-
CINNATI, OH:
2,100,007, CANC. INT. CL. 35.
GREATER D.C. CARES, INC., WASHINGTON, DC:
3,478,756, PUB. 5-20-2008. INT. CL. 35.
3,478,757, PUB. 5-20-2008. INT. CL. 35.
3,478,760, PUB. 5-20-2008. INT. CL. 35.
GREATER MEDIA, INC., BRAintree, MA:
3,480,398, PUB. 5-20-2008. INT. CL. 38.
3,480,400, PUB. 5-20-2008. INT. CL. 38.
GREATER PHILADELPHIA CHAMBER OF COMMERCE,
PHILADELPHIA, PA:
2,493,677, CANC. INT. CL. 42.
GREAVES TOURS LLC, CHICAGO, IL:
3,479,463, PUB. 5-20-2008. MULTIPLE CLASS, INT. CLS.
39 AND 43.
GREAVES TOURS, LLC, CHICAGO, IL:
3,479,730, PUB. 5-20-2008. MULTIPLE CLASS, INT. CLS.
39 AND 43.
GREEN BLUE INSTITUTE, CHARLOTTESVILLE, VA, DBA
GREENBLUE:
3,479,309, PUB. 5-20-2008. MULTIPLE CLASS, INT. CLS.

- 35 AND 41.
GREEN FLEET SYSTEMS, LLC, RANCHO DOMINQUEZ, CA:
3,482,700, INT. CL. 35.
GREEN FOR GOOD, INC., EDMONDS, WA:
3,482,282, INT. CL. 35.
GREEN, JR. WALTER H. NORFOLK, VA:
3,480,669, PUB. 5-20-2008. INT. CL. 25.
GREENE PLASTICS CORPORATION, HOPE VALLEY, RI:
1,458,368, CANC. INT. CL. 20.
GREENFIELD ONLINE, INC., WILTON, CT:
3,480,287, PUB. 5-20-2008. INT. CL. 35.
GREENFIELD WORLD TRADE, INC., FT. LAUDERDALE, FL:
3,478,943, PUB. 5-20-2008. MULTIPLE CLASS, INT. CLS. 35 AND 39.
GREENMAN, REBECCA, MANALAPAN, NJ:
2,491,780, CANC. INT. CL. 41.
GREENSPAN, AVIVA, TORONTO, CANADA:
3,481,464, INT. CL. 25.
3,481,465, INT. CL. 25.
GRETCHEN'S OF SCHWARTZ, BELLEVUE, WA:
3,478,790, PUB. 5-20-2008. INT. CL. 30.
GRIFFIN INTERNATIONAL COMPANIES, INC., MINNEAPOLIS, MN:
3,482,381, MULTIPLE CLASS, INT. CLS. 9 AND 16.
GRIFFIN LLC, VALDOSTA, GA:
2,491,776, CANC. INT. CL. 2.
GRIFFIN TECHNOLOGY, INC., NASHVILLE, TN:
3,478,515, PUB. 5-20-2008. INT. CL. 9.
GRIFFIN, PATRICK J., WOODSTOCK, NH:
3,482,606, INT. CL. 36.
GRIFFITH, STEPHEN, TROY, OH AND BENFIELD, SCOTT, NAPERVILLE, IL:
3,480,473, PUB. 5-20-2008. INT. CL. 35.
GRILL MEDIC, INC., MOORESVILLE, NC:
3,482,404, MULTIPLE CLASS, INT. CLS. 35 AND 37.
GRINGO FOODS, INC., SPARKS, NV:
2,100,439, CANC. INT. CL. 30.
GRIZZLY GAS HOLDING GMBH, A-1010 WIEN, AUSTRIA:
3,480,936, PUB. 5-20-2008. MULTIPLE CLASS, INT. CLS. 4, 6 AND 32.
GRIZZLY INDUSTRIAL, INC., BELLINGHAM, WA:
2,166,833, REN. 7-3-08. INT. CL. 7.
GRM INFORMATION MANAGEMENT SERVICES, INC., JERSEY CITY, NJ:
3,482,732, MULTIPLE CLASS, INT. CLS. 38, 39 AND 40.
GROCERY MANUFACTURERS ASSOCIATION, WASHINGTON, DC:
3,478,903, PUB. 5-20-2008. MULTIPLE CLASS, INT. CLS. 16, 35 AND 41.
GROOVY GIRL PUBLISHING, INC. LA JOLLA, CA:
3,480,332, PUB. 5-20-2008. MULTIPLE CLASS, INT. CLS. 35 AND 41.
GROUPWARE TECHNOLOGIES, INC., WAUWATOSA, WI:
2,197,034, REN. 7-3-08. INT. CL. 9.
GROVER, JILL W., BRIGHAM CITY, UT, DBA JILLIE WILLIE:
3,480,084, PUB. 5-20-2008. INT. CL. 25.
GRUBBS CONSTRUCTION COMPANY, BROOKSVILLE, FL:
2,492,465, CANC. INT. CL. 37.
GRUPO BIMBO, S.A. B. DE C.V., MEXICO CITY, MEXICO:
3,478,734, PUB. 10-23-2007. INT. CL. 31.
GRUPO OMNILIFE S.A. DE C.V., ZAPOPAN, JALISCO 45129, MEXICO:
2,133,921, REN. 6-27-08. INT. CL. 5.
GRYPHON PROMOTIONS, INC. (ROBERT J. FARINA), HOLLYWOOD, CA:
2,493,629, CANC. INT. CL. 35.
GSE LINING TECHNOLOGY, INC., HOUSTON, TX:
3,481,155, INT. CL. 19.
GT ACQUISITION SUB, INC., SOUTH ST. PAUL, MN:
3,482,628, INT. CL. 9.
GT MEDIA, INC., BROOMFIELD, CO:
1,458,154, CANC. INT. CL. 9.
2,098,601, CANC. INT. CL. 9.
GUAM CELLULAR & PAGING, TAMUNING, GUAM, DBA GUAMCELL COMMUNICATIONS:
2,492,198, CANC. INT. CL. 38.
GUAN POH DIM SUM PTE LTD, SINGAPORE, SINGAPORE:
3,482,086, INT. CL. 30.
GUARDIAN MORTGAGE DOCUMENTS, INC., LAKEWOOD, CO:
3,480,707, PUB. 5-20-2008. MULTIPLE CLASS, INT. CLS. 35 AND 45.
GUCCI AMERICA, INC., NEW YORK, NY:
3,481,990, MULTIPLE CLASS, INT. CLS. 14 AND 18.
GUERLAIN S.A, PARIS, FRANCE:
3,480,680, PUB. 5-20-2008. INT. CL. 3.
GUILLIATT, MARK, FREMONT, NE:
3,482,622, INT. CL. 36.
GUITAR CENTER, INC., WEST LAKE VILLAGE, CA:
3,481,408, MULTIPLE CLASS, INT. CLS. 9 AND 15.
GULF PUBLISHING COMPANY, HOUSTON, TX:
2,242,592, REN. 7-2-08. INT. CL. 16.
GULF STREAM COACH, INC., NAPPANEE, IN:
3,482,218, INT. CL. 12.
GUNFLINT DEVELOPMENT GROUP, LLC, CHANHASSEN, MN:
3,481,411, INT. CL. 43.
GUNITE CORPORATION, ROCKFORD, IL:
3,482,012, INT. CL. 12.
GUNKOL GUNES ENERJISI VE KLIMA SANAYI AS, IZMIR, TURKEY:
2,492,829, CANC. INT. CL. 11.
GUNLER, INC., THE WOODLANDS, TX:
3,479,685, PUB. 5-20-2008. INT. CL. 5.
GUNOLD + STICKMA GMBH, STOCKSTADT, FED REP GERMANY:
1,458,386, CANC. INT. CL. 23.
GURU DENIM INC., VERNON, CA:
3,482,001, INT. CL. 25.
GUSDORF, KAREN, NEW YORK, NY, DBA K. KOMPANY:
1,458,289, CANC. INT. CL. 16.
GUTIERREZ, JENNIFER, ENCINITAS, CA:
3,482,709, INT. CL. 43.
GUTTERSUCKERS, INC., SEATTLE, WA:
3,479,457, PUB. 5-20-2008. INT. CL. 37.
3,479,558, PUB. 5-20-2008. INT. CL. 37.
GWR MEDICAL, INC., CHADDS FORD, PA:
3,482,495, INT. CL. 35.
GYRODATA, INCORPORATED, HOUSTON, TX:
1,338,471, REN. 7-3-08. INT. CL. 42.
G1 BUSINESS APPLICATIONS CORP., CAMBRIDGE, MA:
2,493,051, CANC. INT. CL. 9.
H & S BAKERY, INC., BALTIMORE, MD:
3,479,008, PUB. 5-20-2008. INT. CL. 30.
H. B. L'ONIE INTERNATIONAL, INC., SAN DIEGO, CA:
2,155,453, REN. 6-27-08. INT. CL. 42.
H. PACIFICA, INC., LOS ANGELES, CA:
2,205,581, REN. 7-3-08. INT. CL. 25.
H. ROCKER ELECTRIC CO., INC., HAMMOND, LA:
3,480,083, PUB. 5-20-2008. INT. CL. 37.
H.H. BROWN RETAIL, INC., GREENWICH, CT:
2,493,224, CANC. INT. CL. 25.
HAAS OUTDOORS, INC., WEST POINT, MS:
3,481,111, INT. CL. 37.
HAB, INC., LA CROSSE, WI:
2,164,120, REN. 6-30-08. MULTIPLE CLASS, INT. CLS. 35 AND 36.
HABEAS MIRTH CORP., LOS ANGELES, CA:
3,482,717, MULTIPLE CLASS, INT. CLS. 35 AND 43.
HACIENDA QUEILES, S.L., TUDELA (NAVARRA), SPAIN:
3,479,212, PUB. 5-20-2008. INT. CL. 29.
HAGGAR CLOTHING CO., DALLAS, TX:
2,493,005, CANC. INT. CL. 25.
HAHN'S OLD FASHIONED CAKE CO., FARMINGDALE, NY:
2,099,132, CANC. INT. CL. 30.
HAIR TECH, INC., ATLANTA, GA:
3,482,292, INT. CL. 5.
HAKAKIAN, CYRUS, NEW YORK, NY:
2,493,704, CANC. INT. CL. 25.

HALE, STEVE C., CENTRAL POINT, OR:
3,480,104, PUB. 5-20-2008. INT. CL. 9.
3,480,105, PUB. 5-20-2008. INT. CL. 9.

HALEY & ALDRICH, INC., CAMBRIDGE, MA:
2,492,890, CANC. MULTIPLE CLASS, INT. CLS. 35, 37
AND 42.

HALF MOON YOGA, INC., LOUISVILLE, KY:
3,479,601, PUB. 5-20-2008. INT. CL. 41.

HALL, GARY L., KNOXVILLE, TN:
3,480,238, PUB. 5-20-2008. INT. CL. 38.

HALL, SHELLIE L., CHICAGO, IL:
3,481,953, INT. CL. 9.

HALLMARK HOMES, INC., WOODBRIDGE, NJ:
3,479,693, PUB. 5-20-2008. INT. CL. 37.
3,479,695, PUB. 5-20-2008. INT. CL. 37.
3,479,696, PUB. 5-20-2008. INT. CL. 37.
3,479,699, PUB. 5-20-2008. INT. CL. 37.

HALLMARK LICENSING, INC., KANSAS CITY, MO:
3,482,046, INT. CL. 16.
3,482,047, INT. CL. 16.

HAMAKOR JUDAICA, INC., NILES, IL:
3,479,361, PUB. 5-20-2008. INT. CL. 35.

HAMILTON BEACH BRANDS, INC., GLEN ALLEN, VA:
3,481,397, INT. CL. 7.

HAMILTON SUNDSTRAND CORPORATION, WINDSOR
LOCKS, CT:
1,458,183, CANC. INT. CL. 9.

HAMMOND, CATHY, SAN DIEGO, CA:
3,482,092, MULTIPLE CLASS, INT. CLS. 16, 41 AND 44.

HAMPTON ROADS PARTNERSHIP, NORFOLK, VA:
3,481,270, INT. CL. 35.

HAMZY, HASSAN A., SR., KISSIMMEE, FL:
3,480,043, PUB. 5-20-2008. INT. CL. 41.

HANDI-FOIL CORPORATION, WHEELING, IL:
3,481,584, INT. CL. 16.

HANDS OFF IT'S MINE, CLAREMONT, CA:
3,479,995, PUB. 5-20-2008. INT. CL. 25.

HANDY & HARMAN, RYE, NY:
2,492,485, CANC. INT. CL. 6.

HANGZHOU SILAN MICROELECTRONICS CO., LTD.,
CHINA:
3,480,831, PUB. 5-20-2008. INT. CL. 9.

HANLEY-WOOD, LLC, WASHINGTON, DC:
3,479,536, PUB. 5-20-2008. INT. CL. 41.

HANNA-BARBERA PRODUCTIONS, INC., BURBANK, CA:
3,478,828, PUB. 5-20-2008. INT. CL. 28.

HANSEN BEVERAGE COMPANY, CORONA, CA:
3,482,096, MULTIPLE CLASS, INT. CLS. 5 AND 32.

HANSEN, DALE, PORTLAND, OR:
2,164,043, REN. 7-3-08. INT. CL. 3.

HANSGROHE AG, SCHILTACH, FED REP GERMANY:
3,482,357, INT. CL. 11.

HAPPY GUESTS INTERNATIONAL, INC., SEATTLE, WA:
2,169,753, REN. 7-3-08. INT. CL. 42.

HAPPY HANDS (HK) LIMITED, WANCHAI, HONG KONG:
3,479,277, PUB. 5-20-2008. INT. CL. 16.

HAPPY HEART, INC., LOVELAND, CO:
3,480,195, PUB. 5-20-2008. MULTIPLE CLASS, INT. CLS.
14 AND 16.

HARBOR SEAFOOD, INC., NEW HYDE PARK, NY:
3,479,868, PUB. 5-20-2008. INT. CL. 29.
3,479,922, PUB. 5-20-2008. INT. CL. 29.
3,482,689, INT. CL. 29.

HARCO LABORATORIES, INCORPORATED, BRANFORD,
CT:
2,167,232, REN. 7-3-08. INT. CL. 9.

HARCOURT, INC., ORLANDO, FL:
2,493,280, CANC. INT. CL. 9.

HARDWARE SECRETS, LLC, MINDEN, NV:
3,479,808, PUB. 5-20-2008. INT. CL. 35.

HARDWICK BANK & TRUST COMPANY, DALTON, GA:
1,458,689, CANC. INT. CL. 36.

HARDY, PHILLIP, OAKLAND PARK, FL:
3,480,275, PUB. 5-20-2008. INT. CL. 16.

HAREBRAIN, INC., MINNEAPOLIS, MN:
3,482,254, INT. CL. 20.

HARGRAY COMMUNICATIONS GROUP, INC., HILTON
HEAD ISLAND, SC:
3,479,653, PUB. 5-20-2008. INT. CL. 38.

HARKHAM INDUSTRIES, INC., LOS ANGELES, CA, DBA
JONATHAN MARTIN:
2,182,846, AM. INT. CL. 25.

HARLAND CLARKE CORP., SAN ANTONIO, TX:
2,180,666, REN. 6-28-08. INT. CL. 16.

HARLAND FINANCIAL SOLUTIONS, INC., PORTLAND,
OR:
1,458,147, CANC. MULTIPLE CLASS, INT. CLS. 9 AND
42.

HARLEMLIVE, INC., NEW YORK, NY:
3,480,228, PUB. 5-20-2008. INT. CL. 41.

HARMAN INTERNATIONAL INDUSTRIES, INCORPO-
RATED, NORTHBRIDGE, CA:
2,491,877, CANC. INT. CL. 9.

HARPER, CLETE D., BAKERSFIELD, CA:
3,482,053, INT. CL. 35.

HARPERCOLLINS PUBLISHERS L.L.C., NEW YORK, NY:
1,093,758, REN. 6-28-08. INT. CL. 16.

HARRAH'S LICENSE COMPANY, LLC, LAS VEGAS, NV:
3,479,369, PUB. 5-20-2008. INT. CL. 41.

HARRIS CORPORATION, MELBOURNE, FL:
3,481,388, INT. CL. 9.

HARRIS, CHERYL, ACTON, CA:
3,481,284, MULTIPLE CLASS, INT. CLS. 16, 21 AND 25.

HARRIS, STEPHEN M., HENERSON, NV:
2,099,846, CANC. INT. CL. 28.

HARRY AND DAVID, MEDFORD, OR:
2,169,739, REN. 7-2-08. MULTIPLE CLASS, INT. CLS. 29
AND 30.
3,480,479, PUB. 5-20-2008. INT. CL. 35.

HARRY W. PRICHETT AND EDWIN BRIT WYCKOFF
PARTNERSHIP, THE, NEW YORK, NY:
3,479,135, PUB. 5-20-2008. INT. CL. 41.

HARRY WINSTON, INC., NEW YORK, NY:
1,457,926, CANC. INT. CL. 3.
1,457,927, CANC. INT. CL. 3.

HARSCO TECHNOLOGIES CORPORATION, FAIRMONT,
MN:
2,493,321, CANC. INT. CL. 11.

HART BREWING, INC.:
1,458,621, CANC. INT. CL. 32.

HART SCHAFFNER & MARX, CHICAGO, IL:
2,099,963, CANC. INT. CL. 9.

HARTFORD LIFE INSURANCE COMPANY, HARTFORD,
CT:
3,479,677, PUB. 5-20-2008. INT. CL. 36.

HARTZ HOTEL SERVICES, INC., SECAUCUS, NJ, DBA
GRAND HOSPITALITY:
3,481,069, INT. CL. 43.

HARTZ MOUNTAIN CORPORATION, THE, SECAUCUS,
NJ:
3,482,360, INT. CL. 18.
3,482,361, INT. CL. 18.

HARVARD CORPORATION, EVANSVILLE, WI:
2,164,912, REN. 6-28-08. INT. CL. 11.

HARVEST INFO, INC., LOVELAND, OH:
3,482,620, INT. CL. 35.

HARVEST 2000 INTERNATIONAL, INC., AZUSA, CA:
2,099,945, CANC. INT. CL. 30.

HASBRO, INC., PAWTUCKET, RI:
2,493,159, CANC. INT. CL. 28.

HAT FLAGS, INC., RALEIGH, NC:
2,493,231, CANC. INT. CL. 20.

HATCHETT, JERRY, TUPELO, MS:
2,492,035, CANC. INT. CL. 36.

HATCO CORPORATION, MILWAUKEE, WI:
3,480,159, PUB. 5-20-2008. INT. CL. 11.

HATHAWAY PROCESS INSTRUMENTATION, INC., CAR-
ROLLTON, TX:
2,492,044, CANC. INT. CL. 9.

HAUSER, MARION A., OAK PARK, IL AND HAUSER,
ROSS A., OAK PARK, IL:
3,480,650, PUB. 5-20-2008. INT. CL. 44.

HAWAII FOREST & TRAIL, LTD., KAILUA-KONA, HI:
3,482,268, INT. CL. 39.

- HAWAIIAN AIRLINES, INC., HONOLULU, HI:
1,458,293, CANC. INT. CL. 16.
1,458,733, CANC. INT. CL. 39.
- HAWAIIAN HOST, INC., HONOLULU, HI:
3,480,227, PUB. 5-20-2008. MULTIPLE CLASS, INT. CLS. 29 AND 30.
- HAWKINS, CHARLES JOSEPH, AUSTIN, TX:
3,479,029, PUB. 5-20-2008. INT. CL. 43.
- HAWKINS, KEVIN LAWRENCE, LOS ANGELES, CA:
3,481,691, INT. CL. 41.
- HAWKINS, KEVIN W., SILVER SPRING, MD, DBA JUICE TO LIVE:
3,478,614, PUB. 5-20-2008. INT. CL. 35.
- HAWKS NEST, LLC., LANCASTER, CA:
3,480,371, PUB. 5-20-2008. INT. CL. 25.
3,480,374, PUB. 5-20-2008. INT. CL. 16.
3,480,556, PUB. 5-20-2008. INT. CL. 25.
- HAYNES CORPORATION, NAPLES, FL:
3,479,708, PUB. 5-20-2008. INT. CL. 7.
- HAYWARD, COLIN B., SANTA BARBARA, CA:
3,482,005, INT. CL. 25.
- HAZELDEN FOUNDATION, CENTER CITY, MN:
3,481,824, INT. CL. 41.
- HAZERA GENETICS LTD., M.P. SHIKMIM 79837, ISRAEL:
3,482,006, INT. CL. 31.
- HBBS, COPPEROPOLIS, CA:
3,482,105, INT. CL. 41.
- HBI BRANDED APPAREL ENTERPRISES, LLC, WINSTON-SALEM, NC:
3,482,134, INT. CL. 25.
- HDT HOLDINGS CORP., NEW YORK, NY:
2,163,561, REN. 6-30-08. INT. CL. 25.
- HEALING HEALTHCARE SYSTEMS, RENO, NV:
2,099,216, CANC. MULTIPLE CLASS, INT. CLS. 9 AND 41.
- HEALING POWER, INC., WOODLAND HLS, CA:
3,480,292, PUB. 5-20-2008. INT. CL. 5.
3,480,338, PUB. 5-20-2008. INT. CL. 5.
3,480,339, PUB. 5-20-2008. INT. CL. 5.
- HEALTH CARE EXCEL, INCORPORATED, INDIANAPOLIS, IN:
3,479,253, PUB. 5-20-2008. INT. CL. 35.
- HEALTH CARE TRAINING SYSTEMS, INC., MEDFORD, OR:
3,480,045, PUB. 5-20-2008. INT. CL. 41.
- HEALTH CARECHAIN, INC., BOULDER, CO, DBA MD-IT:
3,482,624, INT. CL. 9.
3,482,625, INT. CL. 35.
- HEALTH EDUCATION ALLIANCE, INC., WHITE PLAINS, NY:
2,155,083, REN. 7-2-08. MULTIPLE CLASS, INT. CLS. 9, 16 AND 41.
- HEALTH FIRST CONSULTING CORPORATION, INDIANAPOLIS, IN TO GREENVILLE HOSPITAL SYSTEM, GREENVILLE, SC:
1,752,957, CANC. INT. CL. 41.
- HEALTH INDUSTRY DISTRIBUTORS ASSOCIATION, ALEXANDRIA, VA:
3,479,884, PUB. 5-20-2008. INT. CL. 35.
- HEALTHCARE NEWS NETWORK, LLC, CAPE CORAL, FL:
3,479,278, PUB. 5-20-2008. MULTIPLE CLASS, INT. CLS. 35, 38 AND 41.
- HEALTHCARE SYSTEMS SOLUTION INC., JACKSONVILLE BEACH, FL:
2,493,439, CANC. INT. CL. 9.
- HEALTHIA CONSULTING, INC., MINNEAPOLIS, MN:
3,407,999, COR. MULTIPLE CLASS, INT. CLS. 35, 36 AND 42.
- HEALTHPLEX, INC., LEWIS CENTER, OH:
3,187,061, CANC. INT. CL. 35.
- HEALTHRX CORPORATION, SPRINGFIELD, VA:
3,482,604, INT. CL. 9.
- HEALTHSTAT, LLC, WILLOW GROVE, PA:
3,482,317, MULTIPLE CLASS, INT. CLS. 16 AND 35.
- HEALTHSTRING, LLC, CHICAGO, IL:
3,482,410, MULTIPLE CLASS, INT. CLS. 42 AND 44.
3,482,411, MULTIPLE CLASS, INT. CLS. 42 AND 44.
- HEALTHY DIRECTIONS, LLC, POTOMAC, MD:
3,480,655, PUB. 5-20-2008. INT. CL. 5.
- HEALTHY HANDFULS, LLC, SAN FRANCISCO, CA:
3,481,774, INT. CL. 30.
- HEALTHY INNOVATIONS INC., CARLSBAD, CA:
3,481,569, MULTIPLE CLASS, INT. CLS. 30 AND 32.
- HEANEY, PATRICK D, RICHMOND, VA:
3,480,702, PUB. 5-20-2008. INT. CL. 44.
- HEARST BUSINESS MEDIA CORPORATION, NEW YORK, NY:
2,100,313, CANC. INT. CL. 9.
- HEATCRAFT REFRIGERATION PRODUCTS LLC, STONE MOUNTAIN, GA:
3,478,617, PUB. 5-20-2008. MULTIPLE CLASS, INT. CLS. 7, 9 AND 11.
- HEAVEN TO HOME, LLC, GILBERT, AZ:
3,481,690, INT. CL. 4.
3,481,757, INT. CL. 4.
- HEAVENLY TOYS, INC., SAN DIEGO, CA:
1,458,513, CANC. INT. CL. 28.
- HEAVYOCITY MEDIA, INC., NEW YORK, NY:
3,482,209, MULTIPLE CLASS, INT. CLS. 35, 41 AND 42.
- HEB GROCERY COMPANY, L.P., SAN ANTONIO, TX:
3,482,415, INT. CL. 29.
- HEBEGRACE, INC., POTRERO, COSTA RICA:
3,480,158, PUB. 5-20-2008. INT. CL. 18.
- HEBEI HUABEI OILFIELD RONGSHENG; MACHINERY MANUFACTURE CO., LTD., CHINA:
3,480,765, PUB. 5-20-2008. INT. CL. 7.
- HECKLER & KOCH GMBH, OBERNDORF/NECKAR, FED REP GERMANY:
3,480,575, PUB. 5-20-2008. MULTIPLE CLASS, INT. CLS. 8, 13 AND 25.
- HEIDELBERG WEB SYSTEMS, INC., DOVER, NH:
2,491,778, CANC. MULTIPLE CLASS, INT. CLS. 7 AND 9.
- HEIDELBERGER DRUCKMASCHINER AG, D-69115 HEIDELBERG, FED REP GERMANY:
2,491,998, CANC. MULTIPLE CLASS, INT. CLS. 9 AND 16.
- HEINZ KETTLER GMBH & CO., 59469 ENSE-PARSIT, FED REP GERMANY:
2,491,828, CANC. INT. CL. 28.
- HELEN OF TROY LIMITED, ST. MICHAEL, BARBADOS:
2,493,565, CANC. INT. CL. 11.
- HELENE CURTIS, INC., CHICAGO, IL:
1,457,895, CANC. INT. CL. 3.
- HELIUM, INC., ANDOVER, MA:
3,482,305, MULTIPLE CLASS, INT. CLS. 35, 36, 39, 41, 42, 44 AND 45.
- HELIX SCHUHFABRIK GMBH & CO., 95152 SELBITZ, FED REP GERMANY:
2,493,124, CANC. INT. CL. 25.
- HELLO DIRECT, INC., SAN JOSE, CA:
2,100,280, CANC. INT. CL. 9.
- HELSETH, ALICE M., DENVER, CO:
2,100,387, CANC. INT. CL. 42.
- HEMPEL A/S, DENMARK:
3,480,754, PUB. 5-20-2008. INT. CL. 2.
3,480,850, PUB. 5-20-2008. INT. CL. 2.
- HENKEL KGAA, DUESSELDORF, FED REP GERMANY:
3,480,663, PUB. 5-20-2008. INT. CL. 16.
- HENLEY-PUTNAM UNIVERSITY, SAN JOSE, CA:
3,481,758, INT. CL. 41.
- HENRY COMPANY, HUNTINGTON PARK, CA:
2,493,109, CANC. INT. CL. 1.
- HENRY HEIDE, INC., NEW BRUNSWICK, NJ TO HERSHEY CHOCOLATE & CONFECTIONERY CORPORATION, WHEAT RIDGE, CO:
2,099,762, CANC. INT. CL. 30.
- HENSCHEL-STEINAU, INC., ENGLEWOOD, NJ:
3,481,646, INT. CL. 20.
- HENSON FURNITURE SUPPLY, INC., TUPELO, MS:
2,099,270, CANC. MULTIPLE CLASS, INT. CLS. 20 AND 24.
- HERBAL GROUPS INC., CHATSWORTH, CA:
3,481,460, INT. CL. 5.
- HERGENREDER, JAMES E., LONGMONT, CO:
3,481,748, INT. CL. 31.

- HERITAGE SOLAR, INC., ALISO VIEJO, CA:
3,479,557, PUB. 5-20-2008. INT. CL. 37.
- HERMES INTERNATIONAL, FRANCE:
3,480,825, PUB. 5-20-2008. INT. CL. 18.
- HERZOGENRATH, KEITH, HITCHCOCK, TX, DBA TEXAS
REDHEAD PRODUCTS:
3,479,670, PUB. 5-20-2008. INT. CL. 12.
- HESTRA-HANDSKEN AB, S-330 HESTRA, SWEDEN:
3,480,396, PUB. 5-20-2008. INT. CL. 25.
- HEYER, IVOR, SANTA TERESA DEL TUY, EDO. MIRAN-
DA, VENEZUELA:
3,478,528, PUB. 5-20-2008. INT. CL. 12.
3,478,530, PUB. 5-20-2008. INT. CL. 12.
- HEYWARD, MARK, WINDERMERE, FL:
3,479,214, PUB. 5-20-2008. INT. CL. 31.
- HI-LEX CORPORATION, HYOGO-KEN, JAPAN:
3,480,698, PUB. 1-8-2008. INT. CL. 12.
3,480,699, PUB. 12-18-2007. INT. CL. 6.
- HI-TECH ELECTRONIC PRODUCTS & MFG., INC., OGLE-
BY, IL:
3,480,311, PUB. 5-20-2008. INT. CL. 9.
- HI-VAC CORPORATION, MARIETTA, OH:
3,480,184, PUB. 5-20-2008. INT. CL. 7.
- HICKOK, RICHARD, FIFIELD, BUCHANAN, MI:
3,481,328, INT. CL. 11.
- HIDDEN WATER POOLS, INC., DEL MAR, CA:
3,481,232, INT. CL. 19.
- HIERRO JOAN CARLES, AVILES, SPAIN AND PEREZ
MARIA ESTHER, AVILES, SPAIN:
3,479,584, PUB. 5-20-2008. INT. CL. 5.
- HIGH FALLS BREWING COMPANY, LLC, ROCHESTER,
NY:
3,479,189, PUB. 5-20-2008. INT. CL. 32.
3,479,191, PUB. 5-20-2008. INT. CL. 32.
3,479,192, PUB. 5-20-2008. INT. CL. 32.
3,479,240, PUB. 5-20-2008. INT. CL. 32.
3,479,241, PUB. 5-20-2008. INT. CL. 32.
3,479,245, PUB. 5-20-2008. INT. CL. 32.
3,479,246, PUB. 5-20-2008. INT. CL. 32.
- HIGH MOUNTAIN PROPERTIES, PARK CITY, UT:
2,492,237, CANC. MULTIPLE CLASS, INT. CLS. 36 AND
42.
- HIGH SIERRA SPORT COMPANY, VERNON HILLS, IL:
3,480,350, PUB. 5-20-2008. INT. CL. 18.
- HIGH VOLTAGE GRAPHICS, INC., FT. COLLINS, CO:
2,168,644. REN. 7-3-08. MULTIPLE CLASS, INT. CLS. 9
AND 21.
- HIGH WEST DISTILLERY, LLC, PARK CITY, UT:
3,480,448, PUB. 5-20-2008. INT. CL. 33.
- HIGHER OCTAVE MUSIC, INC., MALIBU, CA TO ESOTER-
OTICA, LLC, MALIBU, CA:
2,098,832, CANC. INT. CL. 9.
- HIGHLAND FORWARDING, INC., MANCHESTER, NH:
3,481,535, INT. CL. 39.
- HIGHLANDS PUBLICATIONS, INC., BIRMINGHAM, AL:
3,481,858, INT. CL. 16.
- HIGHWAYHARBOR MANAGEMENT CO., NORTH MAN-
KATO, MN:
3,481,749, INT. CL. 35.
- HILL, JOHN, RIVERBANK, CA:
3,480,030, PUB. 5-20-2008. INT. CL. 35.
- HILTRAC B.V., NETHERLANDS:
3,480,862, PUB. 5-20-2008. INT. CL. 12.
- HINDSIGHT NUTRITIONALS, LLC, INDIANAPOLIS, IN:
3,480,162, PUB. 5-20-2008. INT. CL. 5.
- HIPLINE, LLC, NEW YORK, NY:
2,492,797, CANC. INT. CL. 25.
- HIRAIWA, TAKANORI, WAKAYAMA, JAPAN:
3,482,552, MULTIPLE CLASS, INT. CLS. 25 AND 28.
- HIROMORI INC., TOKYO, JAPAN:
2,493,139, CANC. MULTIPLE CLASS, INT. CLS. 11 AND
20.
- HISPANIC BUSINESS INC., SANTA BARBARA, CA:
2,492,156, CANC. INT. CL. 16.
- HISPEC WHEEL & TIRE, INC., MISHAWAKA, IN:
3,478,916, PUB. 5-20-2008. INT. CL. 12.
3,478,917, PUB. 5-20-2008. INT. CL. 12.
- HISTORICAL & GENEALOGICAL SOCIETY OF SOMERSET
COUNTY, SOMERSET, PA:
3,479,086, PUB. 5-20-2008. INT. CL. 41.
- HIT DOCTOR INC., ERIAL, NJ:
3,480,355, PUB. 5-20-2008. INT. CL. 41.
- HITACHI AMERICA, LTD., TARRYTOWN, NY:
1,458,097, CANC. INT. CL. 9.
- HITACHI MEDICAL CORPORATION, CHIYODA-KU, TO-
KYO, JAPAN:
3,481,263, INT. CL. 10.
- HJK ENTERPRISES, LLC, KNOXVILLE, TN:
2,493,135, CANC. INT. CL. 18.
- HMS FIELDBUS SYSTEMS AB, S-302 50 HALMSTAD,
SWEDEN TO HMS INDUSTRIAL NETWORKS AB, S-302
50 HALMSTAD, SWEDEN:
2,099,886, CANC. INT. CL. 9.
- HNI TECHNOLOGIES INC., MUSCATINE, IA:
3,482,084, INT. CL. 20.
- HOAG MEMORIAL HOSPITAL PRESBYTERIAN, NEW-
PORT BEACH, CA:
3,482,185, INT. CL. 36.
- HOBBINS, MARK, TRABUCO CANYON, CA:
3,482,400, INT. CL. 45.
- HOBBY LOBBY STORES, INC., OKLAHOMA CITY, OK:
3,481,910, INT. CL. 26.
- HOCHSTEDLER, MARK, LITTLETON, CO:
3,480,257, PUB. 5-20-2008. INT. CL. 37.
- HOF'S HUT RESTAURANTS, INC., SIGNAL HILL, CA:
2,169,676, REN. 6-30-08. INT. CL. 42.
- HOFFMAN, ANDREA R., SAN ANTONIO, TX:
2,100,408, CANC. INT. CL. 10.
- HOFFMAN, IRWIN, SANTE FE, NM TO HOFFMAN,
IRWIN, SANTE FE, NM:
2,099,694, CANC. INT. CL. 32.
- HOFFMANN GMBH QUALITÄTWERKZEUGE, FED REP
GERMANY:
3,480,759, PUB. 5-20-2008. MULTIPLE CLASS, INT. CLS.
7, 8, 9 AND 20.
- HOLIDAY BRIGHT LIGHTS, INC., OMAHA, NE:
3,479,632, PUB. 5-20-2008. INT. CL. 11.
- HOLIDAY HANG-UPS INC., SCITUATE, MA, DBA HOLI-
DAY HANG-UPS INC.:
3,479,334, PUB. 5-20-2008. INT. CL. 9.
- HOLISTA HEALTH (CANADA) INC., BURNABY, BRITISH
COLUMBIA:
3,480,630, PUB. 1-1-2008. INT. CL. 5.
- HOLLAND USA, INC., NORTH MANKATO, MN:
3,481,250, INT. CL. 35.
- HOLLANDIA FLOWERS, INC., SANTA BARBARA, CA:
3,479,211, PUB. 5-20-2008. INT. CL. 31.
- HOLLEY PERFORMANCE PRODUCTS, INC., BOWLING
GREEN, KY:
2,248,039, REN. 7-1-08. INT. CL. 12.
- HOLLINGSWORTH & VOSE COMPANY, EAST WALPOLE,
MA:
3,480,372, PUB. 5-20-2008. INT. CL. 40.
3,481,819, INT. CL. 11.
- HOLLISTER INCORPORATED, LIBERTYVILLE, IL:
3,479,124, PUB. 5-20-2008. INT. CL. 10.
3,481,922, MULTIPLE CLASS, INT. CLS. 38 AND 44.
3,481,923, MULTIPLE CLASS, INT. CLS. 38 AND 44.
- HOLLYWOOD SOUND INTERNATIONAL CORP., TEMPLE
CITY, CA, DBA HOLLYWOOD SOUND LABS:
2,493,241, CANC. INT. CL. 9.
- HOLMES, SCOTT W., LOS ANGELES, CA:
3,482,058, INT. CL. 25.
- HOLT'S COMPANY, PHILADELPHIA, PA, HOLT'S COM-
PANY, PHILADELPHIA, PA:
2,234,499, REN. 7-2-08. INT. CL. 34.
- HOLT'S COMPANY, PHILADELPHIA, PA:
3,482,216, INT. CL. 34.
- HOLTZMAN'S LITTLE FOLK SHOP, INC., CITY OF IN-
DUSTRY, CA:
1,458,430, CANC. INT. CL. 25.
- HOMAX PRODUCTS, INC., BELLINGHAM, WA, HMX
ACQUISITION CORPORATION, ST. LOUIS, MO:
2,164,999, REN. 7-2-08. INT. CL. 2.

- HOME HEALTH PRODUCTS, INC., VIRGINIA BEACH, VA:
1,457,987, CANC. INT. CL. 5.
- HOME LOAN INVESTMENT BANK, FSB, WARWICK, RI:
3,480,550, PUB. 5-20-2008. INT. CL. 36.
- HOME MULTIENERGY, S.L., SPAIN:
3,480,965, PUB. 5-20-2008. MULTIPLE CLASS, INT. CLS.
9, 12 AND 28.
- HOME SLICE, LLC, WASHINGTON, DC:
3,478,593, PUB. 5-20-2008. INT. CL. 12.
- HOMEGOLD, INC., COLUMBIA, SC:
2,099,229, CANC. INT. CL. 36.
- HOMEMADE WINE CRAFTS LIMITED, BURLINGTON,
ONTARIO, CANADA:
1,458,624, CANC. INT. CL. 33.
- HOMETOWN DISCOUNT, EAST EARL, PA:
2,492,529, CANC. INT. CL. 16.
- HON HAI PRECISION INDUSTRY CO., LTD., TAIPEI
HSIEN, TAIWAN:
3,479,025, PUB. 5-20-2008. INT. CL. 9.
- HONDA GIKEN KOGYO KABUSHIKI KAISHA, MINATO-
KU, TOKYO, JAPAN, TA HONDA MOTOR CO., LTD.:
2,492,897, CANC. INT. CL. 12.
- HONDA LOCK MFG. CO., LTD., MIYAZAKI-CITY, MIYA-
ZAKI, JAPAN:
3,480,661, PUB. 4-15-2008. INT. CL. 12.
- HONEY'S PLACE, INC., BURBANK, CA:
3,480,308, PUB. 5-20-2008. INT. CL. 35.
3,480,529, PUB. 5-20-2008. INT. CL. 35.
- HONEYWELL INC., MINNEAPOLIS, MN TO HONEYWELL
INTERNATIONAL INC., MORRISTOWN, NJ:
2,099,916, CANC. INT. CL. 9.
- HONEYWELL INTERNATIONAL INC., MORRISTOWN, NJ,
PITTSWAY CORPORATION, NORTHBROOK, IL:
870,380. REN. 7-2-08. U.S. CL. 21 (INT. CL. 9).
- HOOKAH HOOKAH TOBACCO CO., STATESBORO, GA:
3,480,427, PUB. 5-20-2008. INT. CL. 34.
- HOOPS L. P., MEMPHIS, TN:
3,482,340, INT. CL. 9.
- HOOT AEROBIC SYSTEMS, INC., LAKE CHARLES, LA:
3,479,068, PUB. 5-20-2008. INT. CL. 11.
- HORIZON HOBBY, INC., CHAMPAIGN, IL:
3,481,677, INT. CL. 28.
- HORIZONTAL FUSION, LLC, FAYETTEVILLE, NC:
3,479,140, PUB. 5-20-2008. INT. CL. 41.
3,479,142, PUB. 5-20-2008. INT. CL. 41.
- HORMEL FOODS, LLC, AUSTIN, MN:
3,480,277, PUB. 5-20-2008. INT. CL. 30.
- HORNER NOVELTY CO., INC., JEFFERSONVILLE, IN:
2,169,313. REN. 7-3-08. INT. CL. 35.
- HORSELAND LLC, VERNON HILL, IL:
3,482,586, INT. CL. 38.
- HORSEMEN'S PRIDE, INC., STREETSBORO, OH:
2,158,871. REN. 6-27-08. INT. CL. 28.
- HORSTMAN, CHADLER M, SCOTTSDALE, AZ:
3,479,064, PUB. 5-20-2008. INT. CL. 25.
- HOSPITALHUB, INC., BOCA RATON, FL:
2,492,019, CANC. MULTIPLE CLASS, INT. CLS. 35, 38
AND 42.
2,492,020, CANC. MULTIPLE CLASS, INT. CLS. 35, 38
AND 42.
- HOST COUNTRY USA INTERNET SERVICES, LLC, SOUTH
ORANGE, NJ:
2,492,726, CANC. INT. CL. 42.
- HOSUNG NEW YORK TRADING, INC., BROOKLYN, NY:
3,479,938, PUB. 5-20-2008. INT. CL. 28.
- HOT BOX PIZZA, LLC, INDIANAPOLIS, IN:
3,480,380, PUB. 5-20-2008. INT. CL. 43.
3,480,382, PUB. 5-20-2008. INT. CL. 43.
3,480,385, PUB. 5-20-2008. INT. CL. 43.
- HOT TAR, INC., CAIRO, GA:
3,478,535, PUB. 5-20-2008. INT. CL. 30.
- HOTFINDZ INC., MACON, GA:
3,479,619, PUB. 4-15-2008. INT. CL. 35.
- HOTTAPE ACQUISITION, LLC, THOMASVILLE, NC:
3,480,642, PUB. 5-20-2008. INT. CL. 17.
- HOUGHTON MIFFLIN COMPANY, BOSTON, MA:
2,492,191, CANC. INT. CL. 9.
- HOUSE FOOD INDUSTRIAL CO., LTD., HIGASHI-OSAKA,
OSAKA, JAPAN:
1,458,583, CANC. INT. CL. 30.
- HOUSE OF BLUES BRANDS CORP., WEST HOLLYWOOD,
CA:
2,155,505. REN. 6-30-08. INT. CL. 42.
- HOVALWERK AKTIENGESELLSCHAFT, LIECHTEN-
STEIN:
3,480,769, PUB. 5-20-2008. MULTIPLE CLASS, INT. CLS. 9
AND 11.
- HQ GLOBAL WORKPLACES, INC., DALLAS, TX:
2,493,201, CANC. MULTIPLE CLASS, INT. CLS. 35, 36, 38
AND 42.
- HR REMEDY, LLC, THE WOODLANDS, TX:
3,479,055, PUB. 5-20-2008. INT. CL. 35.
- HRADICAL DESIGNS, LTD., TSMISHATSUI EAST, KOW-
LOON, HONG KONG:
2,493,654, CANC. INT. CL. 9.
- HSN LP, ST. PETERSBURG, FL:
2,493,364, CANC. INT. CL. 25.
- HU-MAN ELEMENT PRODUCTIONS, INC., LOS ANGELES,
CA:
3,481,261, INT. CL. 41.
- HUAIAN CITY KANGDA FEED CO., LTD., JIANGSU,
CHINA:
3,480,814, PUB. 5-20-2008. INT. CL. 31.
- HUANG, WEN-TSE, KAOHSIUNG CITY, TAIWAN:
2,492,778, CANC. INT. CL. 9.
- HUB RESEARCH & DEVELOPMENT CO, INC., SALT LAKE
CITY, UT:
3,479,435, PUB. 5-20-2008. MULTIPLE CLASS, INT. CLS. 5
AND 32.
- HUBBARD FEEDS INC., MANKATO, MN:
860,891. REN. 6-28-08. U.S. CL. 18 (INT. CL. 5).
2,099,376, CANC. INT. CL. 31.
2,205,721. REN. 6-28-08. INT. CL. 5.
- HUBBARD MEDIA GROUP, LLC, ST. PAUL, MN:
3,481,603, MULTIPLE CLASS, INT. CLS. 38 AND 41.
- HUCUL, LESLIE, LAS VEGAS, NV:
3,478,912, PUB. 5-20-2008. INT. CL. 11.
- HUFF INDUSTRIES, INC., CORINTH, MS:
2,493,194, CANC. INT. CL. 3.
- HUGHES ELECTRONICS CORPORATION, EL SEGUNDO,
CA:
2,493,120, CANC. MULTIPLE CLASS, INT. CLS. 9 AND
38.
- HUGHES, CARRIE, BRICK, NJ:
3,480,051, PUB. 5-20-2008. INT. CL. 35.
- HUGHES, MICHAEL T., DULUTH, GA:
2,492,677, CANC. INT. CL. 12.
2,492,678, CANC. INT. CL. 12.
- HUGHES, WILLIAM R., WESTLAKE, OH:
3,482,060, INT. CL. 9.
- HUHTAMAKI FINANCE B.V., 2132 HE HOOFDDORP,
NETHERLANDS:
3,480,388, PUB. 5-20-2008. INT. CL. 3.
3,480,390, PUB. 5-20-2008. INT. CL. 3.
3,480,391, PUB. 5-20-2008. INT. CL. 3.
3,480,440, PUB. 5-20-2008. INT. CL. 3.
- HULME, NAOMI, ADDISON, TX:
3,482,174, MULTIPLE CLASS, INT. CLS. 16 AND 41.
- HUMAN FACTORS INTERNATIONAL, INC., FAIRFIELD,
IA:
3,478,927, PUB. 5-20-2008. INT. CL. 35.
- HUMAN POTENTIAL, LLC, SALT LAKE CITY, UT:
2,493,618, CANC. INT. CL. 9.
- HUME FINANCIAL SERVICES, INC., MARIETTA, GA TO
HUME GROUP, INC., THE, MARIETTA, GA:
1,458,336, CANC. INT. CL. 16.
1,458,337, CANC. INT. CL. 16.
1,458,342, CANC. INT. CL. 16.
- HUMMINGBIRD USA INC., BURLINGTON, MA:
2,492,948, CANC. INT. CL. 9.
- HUMPHREYS PHARMACAL, INCORPORATED, EAST
HAMPTON, CT:
3,479,709, PUB. 5-20-2008. MULTIPLE CLASS, INT. CLS. 3
AND 5.

HUMUNITE HOLDING LTD, DUBLIN 2, IRELAND:
2,491,977, CANC. INT. CL. 1.

HUNGRY MINDS, INC., INDIANAPOLIS, IN:
2,491,653, CANC. INT. CL. 9.

HUNT POWER, L.P., DALLAS, TX:
1,353,859, REN. 7-3-08. INT. CL. 9.

HUNTER DOUGLAS, INC., UPPER SADDLE RIVER, NJ:
2,155,617, REN. 7-2-08. INT. CL. 24.

HUNTER FAN COMPANY, MEMPHIS, TN:
2,164,671, REN. 6-30-08. INT. CL. 9.
3,480,576, PUB. 5-31-2005. INT. CL. 11.
3,481,887, INT. CL. 11.
3,481,926, INT. CL. 11.
3,481,927, INT. CL. 11.
3,481,928, INT. CL. 11.
3,481,943, INT. CL. 11.
3,481,944, INT. CL. 11.
3,481,978, INT. CL. 11.

HUNTINGTON BEACH SURFING WALK OF FAME, INC.,
HUNTINGTON BEACH, CA:
2,098,769, CANC. INT. CL. 42.

HUNTINGTON HILL VENTURES, LLC., TUALATIN, OR:
3,481,769, INT. CL. 43.

HUNTLEIGH TECHNOLOGY PLC, LUTON., UNITED
KINGDOM:
3,478,749, PUB. 3-4-2008. MULTIPLE CLASS, INT. CLS. 10
AND 20.

HUNTSMAN INTERNATIONAL LLC, THE WOODLANDS,
TX:
3,479,666, PUB. 5-20-2008. INT. CL. 35.

HUONG MY TRADING CO., INC., FOUNTAIN VALLEY,
CA:
3,482,117, INT. CL. 28.

HUPA INTERNATIONAL, INC., WALNUT, CA:
3,479,272, PUB. 12-18-2007. INT. CL. 28.
3,479,288, PUB. 12-18-2007. INT. CL. 28.

HURWITZ, S. ROBERT, NEWPORT BEACH, CA:
2,493,491, CANC. INT. CL. 5.

HUSBAND FOR A DAY, INC., FENTON, MI:
3,479,581, PUB. 5-20-2008. INT. CL. 37.

HUSSEIN, DAVID A., OAKLAND, CA:
3,482,091, MULTIPLE CLASS, INT. CLS. 3, 14 AND 25.

HUTCHINGS & HUTCHINGS CPAS, P.A., DURHAM, NC:
2,242,122, REN. 7-2-08. INT. CL. 35.

HY CITE CORPORATION, MADISON, WI:
2,098,985, CANC. INT. CL. 11.
2,098,986, CANC. INT. CL. 11.

HYBRIDIGITAL, INC., DALLAS, TX:
2,492,147, CANC. INT. CL. 42.
2,492,384, CANC. INT. CL. 42.

HYBRITECH INCORPORATED, SAN DIEGO, CA:
1,458,052, CANC. INT. CL. 9.

HYDE MANUFACTURING COMPANY, SOUTHBRIDGE,
MA:
2,491,736, CANC. MULTIPLE CLASS, INT. CLS. 7 AND 8.

HYDRANT, SAN FRANCISCO, CA:
3,479,111, PUB. 5-20-2008. INT. CL. 35.

HYDRASOFT CORPORATION, MORTON, IL:
1,458,862, CANC. INT. CL. 9.

HYPERCOM CORPORATION, PHOENIX, AZ:
2,491,761, CANC. INT. CL. 9.

HYPERION SOLUTIONS CORPORATION, SUNNYVALE,
CA:
2,491,699, CANC. INT. CL. 9.

HYPONEX CORPORATION, COPLEY, OH:
1,457,862, CANC. MULTIPLE CLASS, INT. CLS. 1 AND
31.

H2O TO GO, LLC, MERCHANTVILLE, NJ:
3,482,327, INT. CL. 32.

I SPORT, LLC, ORANGE, CA:
3,479,861, PUB. 5-20-2008. INT. CL. 44.

I.T. WORKS, INC., FAIRFAX, VA:
2,492,802, CANC. INT. CL. 42.

I-FULFILLMENT, INC., CHICAGO, IL:
2,491,885, CANC. INT. CL. 35.

IBASIS, INC., BURLINGTON, MA:
3,481,225, INT. CL. 16.
3,481,444, INT. CL. 16.
3,481,548, INT. CL. 16.
3,481,552, INT. CL. 16.
3,481,553, INT. CL. 16.

IBEX CAPITAL MARKETS, INC., BOSTON, MA:
2,493,534, CANC. INT. CL. 36.

IBIQUITY DIGITAL CORPORATION, COLUMBIA, MD:
3,481,084, INT. CL. 35.

IBL HOLDING B.V., 1058 FA AMSTERDAM, NETHER-
LANDS:
1,458,817, CANC. INT. CL. 42.

ICAD, INC., NASHUA, NH:
3,481,767, INT. CL. 10.

ICE TUBES, INC., TALLMADGE, OH:
3,479,396, PUB. 5-20-2008. INT. CL. 21.

ICG LICENSING, LLC, LONG ISLAND CITY, NY:
3,478,540, PUB. 5-20-2008. MULTIPLE CLASS, INT. CLS.
6, 11, 20 AND 21.
3,478,541, PUB. 5-20-2008. MULTIPLE CLASS, INT. CLS.
11, 20 AND 21.

ICON CORPORATION, CAMBRIDGE, MA:
1,458,062, CANC. INT. CL. 9.

ICON INTERVENTIONAL SYSTEMS, INC., ATLANTA, GA:
3,482,032, INT. CL. 10.

ICON IP, INC, LOGAN, UT:
2,164,953, REN. 6-30-08. MULTIPLE CLASS, INT. CLS. 9,
28 AND 42.

ICYNENE INC., MISSISSAUGA, CANADA:
3,376,906, COR. INT. CL. 16.

ID BUSINESS SOLUTION LIMITED, GUILFORD, UNITED
KINGDOM:
3,480,735, PUB. 5-20-2008. MULTIPLE CLASS, INT. CLS.
9, 16 AND 42.

IDEAL MEDIA, LLC, CHICAGO, IL:
1,458,286, CANC. INT. CL. 16.

IDEASONE, INC., KAMUELA, HI:
3,480,525, PUB. 5-20-2008. INT. CL. 3.
3,481,389, INT. CL. 5.

IDEC CORPORATION, OSAKA, JAPAN:
2,166,555, REN. 6-30-08. INT. CL. 9.

IDENTCO IDENTIFICATION CORPORATION, INGLESIDE,
IL:
2,185,933, REN. 7-1-08. INT. CL. 16.

IDENTITY THEFT RESOURCE CENTER, SAN DIEGO, CA:
3,482,417, INT. CL. 45.

IDENTIX INCORPORATED, MINNETONKA, MN:
2,492,884, CANC. INT. CL. 9.

IDISPENSE, LLC, TOLEDO, OH:
2,181,142, REN. 7-3-08. INT. CL. 3.

IDOC, LLC, FLORHAM PARK, NJ:
3,479,126, PUB. 5-20-2008. MULTIPLE CLASS, INT. CLS.
35 AND 41.

IDX SYSTEMS CORPORATION, SOUTH BURLINGTON,
VT:
2,098,974, CANC. MULTIPLE CLASS, INT. CLS. 9, 37
AND 42.

IF&P FOODS, INC., INDIANAPOLIS, IN:
3,479,776, PUB. 5-20-2008. INT. CL. 39.

IFIND GROUP LLC, NEW YORK, NY:
3,481,354, INT. CL. 35.

IGT, RENO, NV:
2,492,941, CANC. INT. CL. 9.
3,482,296, INT. CL. 9.
3,482,298, INT. CL. 9.

IGUASU TRADING, USA, INC., LOS ANGELES, CA:
3,480,719, PUB. 5-20-2008. INT. CL. 25.
3,480,720, PUB. 5-20-2008. INT. CL. 25.

IHOST NETWORKS, INC., BELLEVUE, WA:
3,478,550, PUB. 5-20-2008. INT. CL. 42.

IKOR INCORPORATED, KENNETT SQUARE, PA:
3,479,270, PUB. 5-20-2008. MULTIPLE CLASS, INT. CLS.
35, 36, 42, 44 AND 45.

ILIMA CONSIDINE, PORTLAND, OR AND JACOB ROSE,
PORTLAND, OR:
3,478,676, PUB. 5-20-2008. INT. CL. 9.

- ILLINOIS TOOL WORKS INC., GLENVIEW, IL:
2,174,452. REN. 6-30-08. INT. CL. 42.
2,181,368. REN. 7-1-08. INT. CL. 8.
2,184,867. REN. 7-1-08. INT. CL. 8.
2,187,776. REN. 7-3-08. INT. CL. 20.
3,479,588. PUB. 5-20-2008. INT. CL. 17.
- ILLINOIS TOOL WORKS, INC., GLENVIEW, IL, DYE-STUFFS AND CHEMICALS, INC., ST. LOUIS, MO, DBA THE DYKEM COMPANY:
584,065. REN. 6-30-08. U.S. CL. 6 (INT. CL. 2).
- ILLINOIS TOOL WORKS, INC., GLENVIEW, IL:
667,908. REN. 7-3-08. U.S. CL. 2 (INT. CL. 20).
- ILLUMITEX, INC., AUSTIN, TX, DBA ILLUMITEX, INC.:
3,479,411, PUB. 5-20-2008. INT. CL. 9.
- IMAGE III, INC., NASHVILLE, TN:
2,493,689, CANC. INT. CL. 35.
- IMAGE MEDICAL CORPORATION, PALO ALTO, CA:
2,493,682, CANC. MULTIPLE CLASS, INT. CLS. 9 AND 42.
- IMAGE ONLINE DESIGN, INC., SAN LUIS OBISPO, CA:
3,177,334, COR. MULTIPLE CLASS, INT. CLS. 9, 18, 21 AND 35.
- IMAGINON, INC., SAN CARLOS, CA:
2,492,021, CANC. MULTIPLE CLASS, INT. CLS. 9, 38 AND 42.
- IMAJEN, LLC, BALTIMORE, MD:
3,482,355, INT. CL. 25.
- IMAZ VILLAR, JULIAN, PARCELA 3; E-08350 ARENYS DE MAR (BARCEL, SPAIN):
3,480,933, PUB. 5-20-2008. MULTIPLE CLASS, INT. CLS. 3, 18 AND 24.
- IMLCORP LLC, MARIETTA, GA:
3,479,754, PUB. 5-20-2008. INT. CL. 13.
- IMMEDIA, LLC, SCOTTSDALE, AZ:
3,480,697, PUB. 5-20-2008. INT. CL. 38.
3,480,701, PUB. 5-20-2008. INT. CL. 38.
- IMPACT BASEBALL, INC., SEDALIA, NC:
3,480,058, PUB. 5-20-2008. INT. CL. 41.
- IMPACT UNLIMITED, INC., DAYTON, NJ:
2,098,609, CANC. MULTIPLE CLASS, INT. CLS. 35 AND 42.
- IMPERIAL TOY LLC, NORTH HILLS, CA:
1,492,380. REN. 6-28-08. INT. CL. 28.
- IMPRESSLINE, INC., DALLAS, TX:
3,482,139, MULTIPLE CLASS, INT. CLS. 35 AND 40.
- IMTMEDICAL AG, BUCHS SG, SWITZERLAND:
3,480,813, PUB. 5-20-2008. INT. CL. 10.
- IN-N-OUT BURGERS, IRVINE, CA:
1,528,455. REN. 7-3-08. MULTIPLE CLASS, INT. CLS. 29, 30, 32 AND 42.
- IN-N-OUT BURGERS, BALDWIN PARK, CA:
1,528,456. REN. 7-3-08. MULTIPLE CLASS, INT. CLS. 29, 30, 32 AND 42.
- IN-N-OUT BURGERS, IRVINE, CA:
1,539,451. REN. 7-3-08. MULTIPLE CLASS, INT. CLS. 29, 30, 32 AND 42.
- IN-STRIDE, INC., SAN ANTONIO, TX:
2,493,157, CANC. INT. CL. 25.
- INCREASE GLOBAL NETWORK INC, NASHVILLE, TN:
3,480,080, PUB. 5-20-2008. INT. CL. 41.
- INCREASE GLOBAL NETWORK INC., NASHVILLE, TN:
3,480,217, PUB. 5-20-2008. INT. CL. 41.
- INCURRENT SOLUTIONS, INC., PARSIPPANY, NJ:
2,491,770, CANC. INT. CL. 9.
- INDENA S.P.A., MILAN, ITALY:
2,175,911. REN. 6-28-08. INT. CL. 1.
- INDEPENDENT BANKERS' BANK, SPRINGFIELD, IL:
3,479,103, PUB. 5-20-2008. INT. CL. 36.
- INDEPENDENT FUNDING, LLC, WAYNE, PA:
3,481,172, INT. CL. 36.
- INDEPENDENT SCHOOL DISTRICT #192, FARMINGTON, MN, DBA FARMINGTON AREA PUBLIC SCHOOLS:
3,479,363, PUB. 5-20-2008. INT. CL. 41.
- INDEPENDENT SCHOOL DISTRICT #192, FARMINGTON, MN, DBA FARMINGTON SCHOOL DISTRICT:
3,479,364, PUB. 5-20-2008. INT. CL. 41.
- INDIA BROADCAST LIVE, INC., LOS ANGELES, CA:
3,479,566, PUB. 5-20-2008. INT. CL. 38.
- INDIAN S.R.L., CAVRIAGO, REGGIO EMILIA, ITALY:
3,479,048, PUB. 5-20-2008. INT. CL. 30.
- INDIANA HEMOPHILIA & THROMBOSIS CENTER, INC., INDIANAPOLIS, IN:
3,481,425, INT. CL. 41.
- INDIGO INVESTMENT SYSTEMS, INC., SARASOTA, FL:
2,576,760, CANC. INT. CL. 9.
- INDOMITUS ASSET MANAGEMENT LLC, NORTH HUNTINGDON, PA:
3,479,618, PUB. 5-20-2008. INT. CL. 5.
- INDOMITUS ASSET MANAGEMENT, L.L.C., NORTH HUNTINGDON, PA:
3,479,254, PUB. 5-20-2008. INT. CL. 5.
- INDUSTERR ANSTALT, SCHAAN, LIECHTENSTEIN:
2,085,397, CANC. INT. CL. 9.
- INDUSTRIAL DESIGNERS SOCIETY OF AMERICA, DULLES, VA:
2,165,535. REN. 7-3-08. MULTIPLE CLASS, INT. CLS. 16, 35, 36 AND 42.
- INDUSTRIAL GASKET & SHIM COMPANY, INC., MEADOW LANDS, PA:
3,479,918, PUB. 5-20-2008. INT. CL. 17.
- INDUSTRIAS ALEN, S.A. DE C.V., SANTA CATARINA, N.L., MEXICO:
3,482,089, INT. CL. 21.
- INDUSTRIAS TECNOS, S.A. DE C.V., CUERNAVACA, MORELOS, MEXICO:
2,492,606, CANC. INT. CL. 13.
- INDUSTRYCLOSEOUTS.COM, INC., TORRANCE, CA:
2,492,760, CANC. INT. CL. 9.
- INETGIANT, INC., STATEN ISLAND, NY:
3,480,236, PUB. 5-20-2008. INT. CL. 35.
- INEXMARKET LLC, PALO ALTO, CA:
3,481,313, MULTIPLE CLASS, INT. CLS. 35 AND 44.
- INFINITY SYSTEMS, INC., CHATSWORTH, CA TO HARMAN INTERNATIONAL INDUSTRIES, INCORPORATED, NORTH RIDGE, CA:
2,100,155, CANC. INT. CL. 9.
- INFLEXXION, INC., NEWTON, MA:
3,482,255, INT. CL. 16.
- INFOBLOX, INC., SUNNYVALE, CA:
2,492,785, CANC. INT. CL. 9.
- INFOHIGHWAY COMMUNICATIONS CORPORATION, LTD., BEIJING, CHINA:
2,492,870, CANC. INT. CL. 42.
- INFORAY HOLDING, N.V., 3833 LB LEUSDEN, NETHERLANDS:
2,491,888, CANC. MULTIPLE CLASS, INT. CLS. 9, 35 AND 42.
- INFOTRIEVE, INC., WILTON, CT:
3,482,684, INT. CL. 42.
- INFOVISION, INC., FORT COLLINS, CO:
2,491,894, CANC. INT. CL. 41.
- INFRARED DATA ASSOCIATION, WALNUT CREEK, CA:
2,012,551, CANC. INT. CL. 9.
- INFRATEC GMBH INFRAROTSSENSORIK; UND MESSTECHNIK, FED REP GERMANY:
3,481,026, PUB. 5-20-2008. INT. CL. 9.
- INFUSION TECHNOLOGY, INC., DENVER, CO:
1,458,197, CANC. INT. CL. 10.
- INGENIOUS SYSTEMS RESEARCH, LLC, WILMINGTON, DE:
3,481,670, INT. CL. 42.
- INGLEY, CAROL, WASHINGTON, DC:
3,481,092, INT. CL. 42.
- INKJETWAREHOUSE.COM INC., CANTON, CT:
3,479,194, PUB. 5-20-2008. MULTIPLE CLASS, INT. CLS. 2 AND 9.
- INLITEN, L.L.C., NORTHFIELD, IL:
2,493,030, CANC. MULTIPLE CLASS, INT. CLS. 9, 11 AND 20.
- INMAN, RONALD CALVIN, ELIZABETHTOWN, NC AND INMAN, SUSAN, ELIZABETHTOWN, NC AND INMAN, ALBERT LEROY, ELIZABETHTOWN, NC AND INMAN, BRENDA SEYER, ELIZABETHTOWN, NC AND FAIRCLOTH, SUSANNE INMAN, ELIZABETHTOWN, NC AND FAIRCLOTH, DAVID JAMES, ELIZABETHTOWN, NC:
3,481,081, MULTIPLE CLASS, INT. CLS. 18 AND 28.

INNER SIGHT, LLC, KEALAKEKUA, HI:
3,479,145, PUB. 12-18-2007. INT. CL. 9.

INNOFRESH PRODUCTS, INC., PHOENIX, AZ:
3,479,739, PUB. 5-20-2008. INT. CL. 5.

INNOSPENSE CAPITAL BV, NETHERLANDS:
3,480,797, PUB. 5-20-2008. INT. CL. 21.

INNOVATION ASSET GROUP, INC., WILSONVILLE, OR:
3,478,848, PUB. 5-20-2008. MULTIPLE CLASS, INT. CLS. 9 AND 42.

INNOVATIONS & DEVELOPMENT INC, EDGEWATER, NJ:
3,479,012, PUB. 5-20-2008. MULTIPLE CLASS, INT. CLS. 35 AND 42.

INNOVATIVE LEARNING STRATEGIES LLC, APPLETON, WI:
3,480,349, PUB. 5-20-2008. INT. CL. 41.

INNOVATIVE PROCESSING SOLUTIONS, LLC (F/K/A TRANSCOM ACQUISITION COMPANY, LLC), CHATTANOOGA, TN:
2,493,545, CANC. INT. CL. 35.

INNOVATIVE PROGRAMMING SYSTEMS, INC., GRAND BLANC, MI:
2,493,497, CANC. INT. CL. 9.
2,493,498, CANC. INT. CL. 9.

INNOVATIVE WIRELESS TECHNOLOGIES, INC., FOREST, VA:
3,481,754, INT. CL. 9.

INNUIITY, INC., REDMOND, WA:
3,482,243, MULTIPLE CLASS, INT. CLS. 35 AND 36.

INPUT PROJEKTENTWICKLUNGS-GMBH, A-6922 WOLFURT, AUSTRIA:
2,593,890, CANC. INT. CL. 28.

INRANGE DEVELOPMENT CORPORATION, MUSKEGON, MI:
2,491,793, CANC. INT. CL. 9.

INRAY FITNESS PRODUCTS CORP., TAOYUAN, TAIWAN:
3,481,999, INT. CL. 28.

INRESCO PORTFOLIOS LTD., ETNA, NH:
2,492,435, CANC. INT. CL. 36.

INSECT LORE PRODUCTS, SHAFTER, CA:
2,178,350, COR. INT. CL. 28.

INSIDE CONTACTLESS, FRANCE:
3,480,802, PUB. 5-20-2008. MULTIPLE CLASS, INT. CLS. 9 AND 42.

INSIGHT EQUITY A.P. X, LP, SOUTHLAKE, TX:
2,492,655, CANC. MULTIPLE CLASS, INT. CLS. 35 AND 40.
2,492,656, CANC. INT. CL. 9.

INSITE ARCHITECTURE, INC., HOUSTON, TX:
3,480,022, PUB. 5-20-2008. INT. CL. 42.

INSONUS MEDICAL, INC., NEWARK, CA:
2,493,443, CANC. INT. CL. 10.

INSPIRE ME TODAY, LLC, BOULDER, CO:
3,481,979, INT. CL. 45.

INSPIRED DESIGN, LLC, CLARKSVILLE, MI:
3,482,143, INT. CL. 42.

INSPIRED STUDIOS, INC., ROSELAND, NJ:
2,492,697, CANC. INT. CL. 9.
2,492,721, CANC. INT. CL. 9.

INSTITUTE FOR THE STUDY OF HUMAN KNOWLEDGE, THE, LOS ALTOS, CA:
1,094,752. REN. 7-3-08. INT. CL. 41.

INSTITUTE OF CONSTRUCTION MANAGEMENT & TECHNOLOGY, PHOENIX, AZ:
3,480,004, PUB. 5-20-2008. INT. CL. 41.

INSULATING COATINGS CORPORATION, INVERNESS, FL:
2,492,358, CANC. INT. CL. 2.

INSWEB CORPORATION, GOLD RIVER, CA:
2,491,756, CANC. INT. CL. 42.

INTEGRA LIFESCIENCES CORPORATION, PLAINSBORO, NJ:
2,207,452. REN. 7-3-08. INT. CL. 10.

INTEGRAL MANAGEMENT, LLC, MIAMI BEACH, FL:
3,480,119, PUB. 5-20-2008. INT. CL. 35.

INTEGRASCREEN SINGAPORE PTE LTD, SINGAPORE, SINGAPORE:
3,478,634, PUB. 5-20-2008. INT. CL. 42.
3,478,635, PUB. 5-20-2008. INT. CL. 42.
3,480,737, PUB. 5-20-2008. MULTIPLE CLASS, INT. CLS. 35 AND 42.
3,480,738, PUB. 5-20-2008. MULTIPLE CLASS, INT. CLS. 35 AND 42.

INTEGRATED PROCESS TECHNOLOGIES, LLC, HARTFORD, CT:
2,492,340, CANC. INT. CL. 37.

INTEGRATED REIMBURSEMENT STRATEGIES, LLC, PLYMOUTH, MA:
3,479,672, PUB. 5-20-2008. INT. CL. 35.

INTELSTAF HEALTHCARE, INC., OAKBROOK TERRACE, IL:
3,479,298, PUB. 5-20-2008. INT. CL. 35.

INTELLISPHERE, LLC, PLAINSBORO, NJ:
3,482,252, INT. CL. 41.

INTELVAC CORPORATION, GEORGETOWN, ONTARIO, CANADA:
3,482,159, INT. CL. 9.

INTER PRODUCT B.V., 6716 BZ EDE, NETHERLANDS:
2,179,915. REN. 7-3-08. INT. CL. 6.

INTERACOUSTICS A/S, ASSENS, DENMARK:
3,432,112, COR. INT. CL. 9.

INTERADNET, INC., RALEIGH, NC:
2,492,416, CANC. INT. CL. 35.

INTERCO INCORPORATED, ST. LOUIS, MO:
1,458,465, CANC. INT. CL. 25.

INTERCONTINENTALEXCHANGE, INC., ATLANTA, GA:
3,481,890, INT. CL. 36.

INTEREP NATIONAL RADIO SALES, INC., NEW YORK, NY:
3,480,003, PUB. 5-20-2008. INT. CL. 35.

INTERGRAPH CORPORATION, HUNTSVILLE, AL:
1,458,158, CANC. INT. CL. 9.

INTERLINE BRANDS, INC., JACKSONVILLE, FL:
3,479,540, PUB. 5-20-2008. INT. CL. 35.
3,480,660, PUB. 5-20-2008. INT. CL. 35.

INTERMOUNTAIN HEALTH CARE, INC., SALT LAKE CITY, UT:
2,098,861, CANC. INT. CL. 42.

INTERNATIONAL ASSOCIATION OF LIGHTING DESIGNERS, LTD., CHICAGO, IL AND PORTMAN LIGHTFAIR ASSOCIATES, L.P., ATLANTA, GA AND ILLUMINATING ENGINEERING SOCIETY OF NORTH AMERICA, NEW YORK, NY:
3,478,546, PUB. 5-20-2008. MULTIPLE CLASS, INT. CLS. 35 AND 41.

INTERNATIONAL ASSOCIATION OF PLUMBING AND MECHANICAL OFFICIALS, ONTARIO, CA:
3,481,605, INT. CL. 42.

INTERNATIONAL BILLIARDS ASSOCIATION, INVERGROVE HEIGHTS, MN:
3,478,819, PUB. 5-20-2008. MULTIPLE CLASS, INT. CLS. 35 AND 41.

INTERNATIONAL BULLION & METAL BROKERS (USA) INC., SUNRISE, FL:
3,480,424, PUB. 5-20-2008. INT. CL. 14.

INTERNATIONAL BUSINESS MACHINES CORPORATION, AMONK, NY:
2,491,986, CANC. INT. CL. 35.

INTERNATIONAL BUSINESS MACHINES CORPORATION, ARMONK, NY:
2,493,050, CANC. INT. CL. 42.
2,493,612, CANC. INT. CL. 9.
3,482,114, MULTIPLE CLASS, INT. CLS. 9, 16 AND 42.

INTERNATIONAL COMMUNICATIONS INDUSTRIES ASSOCIATION, INC., FAIRFAX, VA:
2,492,987, CANC. INT. CL. 41.

INTERNATIONAL ENGINE INTELLECTUAL PROPERTY COMPANY, LLC, WARRENVILLE, IL:
3,482,403, MULTIPLE CLASS, INT. CLS. 7 AND 12.

INTERNATIONAL FACILITY MANAGEMENT ASSOCIATION, HOUSTON, TX:
3,478,693, PUB. 5-20-2008. INT. CL. 41.

- INTERNATIONAL FILING COMPANY, HATTIESBURG, MS, KRUYSMAN, INC., NEW YORK, NY:
1,500,484. REN. 6-30-08. INT. CL. 16.
- INTERNATIONAL FILING COMPANY, LLC, HATTIESBURG, MS, KRUYSMAN, INC., NEW YORK, NY:
1,500,485. REN. 6-30-08. INT. CL. 16.
- INTERNATIONAL GAMCO, INC., OMAHA, NE:
2,179,554. REN. 7-3-08. INT. CL. 28.
2,181,480. REN. 7-3-08. INT. CL. 28.
- INTERNATIONAL INTIMATES, INC., NEW YORK, NY, DBA BON BEBE:
3,482,093. MULTIPLE CLASS, INT. CLS. 24 AND 25.
- INTERNATIONAL LIFE SCIENCES INSTITUTE, WASHINGTON, DC:
2,163,746. REN. 6-30-08. MULTIPLE CLASS, INT. CLS. 16, 36 AND 41.
- INTERNATIONAL MARKET BRANDS, INC., KIRKLAND, WA:
2,099,959. CANC. INT. CL. 5.
- INTERNATIONAL MERCHANDISING CORPORATION, CLEVELAND, OH:
3,480,548. PUB. 5-20-2008. INT. CL. 41.
- INTERNATIONAL MOBILE MACHINES CORPORATION, KING OF PRUSSIA, PA:
1,458,079. CANC. INT. CL. 9.
- INTERNATIONAL OUTLAW MOTORCYCLE GANG INVESTIGATORS ASSOCIATION, CONCORD, NH:
3,479,220. PUB. 5-20-2008. U.S. CL. 200.
- INTERNATIONAL PIPELINING TECHNOLOGIES, INC., SAN DIEGO, CA:
3,481,294. INT. CL. 37.
3,481,295. INT. CL. 37.
3,481,296. INT. CL. 37.
- INTERNATIONAL PRESS OF BOSTON, INC., SOMERVILLE, MA:
3,478,736. PUB. 5-20-2008. INT. CL. 16.
- INTERNATIONAL RESOURCING SERVICES, INC., NORTHBROOK, IL TO INTERNATIONAL RESOURCES, LLC, NORTHBROOK, IL:
2,099,912. CANC. MULTIPLE CLASS, INT. CLS. 6 AND 20.
- INTERNATIONAL SOAP BOX DERBY, INC., AKRON, OH:
1,079,538. REN. 6-30-08. INT. CL. 41.
- INTERNATIONAL TACTICAL OFFICERS TRAINING ASSOCIATION, LLC, TERRE HAUTE, IN:
3,480,178. PUB. 5-20-2008. INT. CL. 35.
- INTERNET.COM CORPORATION, DARIEN, CT:
2,492,462. CANC. INT. CL. 42.
2,493,647. CANC. INT. CL. 42.
- INTEROCEAN, INC., NEW YORK, NY:
1,329,886. REN. 7-3-08. INT. CL. 29.
- INTERPARK CORPORATION, SEOUL, REPUBLIC OF KOREA:
3,478,879. PUB. 5-20-2008. MULTIPLE CLASS, INT. CLS. 35, 41 AND 42.
- INTERPLAN CORPORATION, STOCKTON, CA:
2,176,600. REN. 7-3-08. INT. CL. 36.
- INTERPRETIVE SOFTWARE, INC., CHARLOTTESVILLE, VA:
2,492,761. CANC. INT. CL. 41.
- INTERSECTIONS INC., CHANTILLY, VA:
3,481,612. INT. CL. 45.
3,481,671. INT. CL. 45.
- INTERSOCIETAL ACCREDITATION COMMISSION, COLOMBIA, MD:
3,478,520. PUB. 5-20-2008. U.S. CL. B.
- INTERSPORT TELEVISION, CHICAGO, IL:
2,493,613. CANC. INT. CL. 41.
- INTERSTAR SYSTEMS, INC., HOUSTON, TX:
2,492,637. CANC. INT. CL. 42.
- INTERTAPE POLYMER CORP., BRADENTON, FL, ATLANTIC GUMMED PAPER CORPORATION, BROOKLYN 1, NY:
663,954. REN. 6-30-08. U.S. CL. 5 (INT. CL. 17).
- INTERTEK GROUP PLC., LONDON, UNITED KINGDOM:
3,480,636. PUB. 5-20-2008. INT. CL. 42.
- INTERVOICE, INC., RICHARDSON, TX:
1,458,086. CANC. INT. CL. 9.
- INTIMA MODA S.P.A., ITALY:
3,480,922. PUB. 5-20-2008. INT. CL. 25.
- INTIMA MODA S.P.A., MODENA, FRAZIONE COGNENTO, ITALY:
3,480,940. PUB. 5-20-2008. INT. CL. 25.
- INTOWN SUITES MANAGEMENT, INC., ATLANTA, GA:
3,479,394. PUB. 5-20-2008. INT. CL. 43.
- INTRA CORPORATION, WESTLAND, MI:
2,492,370. CANC. INT. CL. 9.
- INTRAGLOBE, INC., PLEASANTON, CA:
2,491,907. CANC. MULTIPLE CLASS, INT. CLS. 9 AND 42.
- INTREPID POWERBOATS, INC., LARGO, FL:
2,492,152. CANC. INT. CL. 12.
- INVENSYS SYSTEMS, INC., FOXBORO, MA AND INVENSYS SYSTEMS, INC., FOXBORO, MA:
3,480,016. PUB. 5-20-2008. INT. CL. 9.
- INVENTEC BESTA CO., LTD., TAIPEI, TAIWAN:
3,482,249. INT. CL. 9.
- INVENTEC MULTIMEDIA & TELECOM CORPORATION, TAIPEI CITY, TAIWAN:
3,480,682. PUB. 5-20-2008. INT. CL. 35.
3,480,683. PUB. 5-20-2008. INT. CL. 9.
3,480,684. PUB. 5-20-2008. INT. CL. 36.
3,480,685. PUB. 5-20-2008. INT. CL. 37.
3,480,686. PUB. 5-20-2008. INT. CL. 38.
3,480,687. PUB. 5-20-2008. INT. CL. 41.
3,480,688. PUB. 5-20-2008. INT. CL. 42.
3,480,689. PUB. 5-20-2008. INT. CL. 35.
3,480,690. PUB. 5-20-2008. INT. CL. 42.
3,480,691. PUB. 5-20-2008. INT. CL. 41.
3,480,692. PUB. 5-20-2008. INT. CL. 38.
3,480,693. PUB. 5-20-2008. INT. CL. 36.
3,480,694. PUB. 5-20-2008. INT. CL. 37.
- INVENTIO AG, HERGISWIL, SWITZERLAND, INVENTIO AG, HERGISWIL, SWITZERLAND:
2,162,373. REN. 6-30-08. MULTIPLE CLASS, INT. CLS. 7 AND 9.
- INVESTMENT MANAGEMENT CONSULTANTS ASSN. INC., GREENWOOD VILLAGE, CO:
3,479,419. PUB. 5-20-2008. MULTIPLE CLASS, INT. CLS. 35, 41 AND 42.
- INVICTA CAPITAL LIMITED, LONDON, UNITED KINGDOM:
3,478,768. PUB. 5-20-2008. MULTIPLE CLASS, INT. CLS. 36 AND 41.
- INVITROGEN CORPORATION, CARLSBAD, CA:
2,125,600. REN. 7-3-08. INT. CL. 1.
3,478,886. PUB. 5-20-2008. INT. CL. 1.
- IOIP HOLDINGS, LLC, FORT WAYNE, IN:
3,478,796. PUB. 5-20-2008. INT. CL. 3.
- IORIO, MATTHEW T., GREENWICH, CT:
3,481,551. INT. CL. 36.
- IOVATION INC., PORTLAND, OR:
3,480,055. PUB. 5-20-2008. MULTIPLE CLASS, INT. CLS. 42 AND 45.
- IOWA 80 GROUP, INC., WALCOTT, IA:
3,482,626. INT. CL. 35.
- IP MINING CORPORATION, NEWPORT BEACH, CA:
3,478,971. PUB. 5-20-2008. INT. CL. 9.
- IPACTIONS, INC., MINDEN, NV:
3,482,680. INT. CL. 35.
- IPEX INC., DON MILLS., CANADA:
3,478,648. PUB. 5-20-2008. INT. CL. 19.
- IPIPE, INC., RICHMOND, VA:
2,492,433. CANC. INT. CL. 41.
- IPSWICH SHELLFISH COMPANY, INC., IPSWICH, MA:
2,168,242. REN. 6-30-08. INT. CL. 39.
- IRDETO B.V., 2132 HD HOOFFDORP, NETHERLANDS:
2,491,721. CANC. MULTIPLE CLASS, INT. CLS. 9, 16, 35, 38, 40, 41 AND 42.
- IRETURN INC., SHERWOOD PARK AB, CANADA:
3,480,353. PUB. 5-20-2008. INT. CL. 45.
- IRIS TECHNOLOGIES, INC., GREENSBURG, PA:
2,493,038. CANC. INT. CL. 9.
- IRIS USA, INC., PLEASANT PRARIE, WI:
3,481,314. INT. CL. 20.

IRON HAUS, DEVINE, TX:
3,480,142, PUB. 5-20-2008. INT. CL. 41.

IRON PONY MOTORCYCLE RENTAL, LLC, MENTOR, OH:
3,481,483, INT. CL. 39.

IRVIN, GAYLE, ST. CHARLES, MO:
3,479,417, PUB. 5-20-2008. INT. CL. 44.

IRWIN FASHION IMPORTS, INC., NEW YORK, NY TO R & R MENSWEAR, LTD., SCARSDALE, NY:
2,100,368, CANC. INT. CL. 25.

ISA-THE INSTRUMENTATION, SYSTEMS, AND AUTOMATION SOCIETY, RESEARCH TRIANGLE PARK, NC:
3,481,334, MULTIPLE CLASS, INT. CLS. 35 AND 41.

ISAGENIX WORLDWIDE, LLC, CHANDLER, AZ:
3,480,472, PUB. 5-20-2008. INT. CL. 5.

ISCA TECHNOLOGIES, INC., RIVERSIDE, CA:
2,491,880, CANC. INT. CL. 21.

ISCO INDUSTRIES, LLC, LOUISVILLE, KY:
3,479,242, PUB. 5-20-2008. INT. CL. 35.
3,479,243, PUB. 5-20-2008. INT. CL. 35.

ISHIMARU SEIMEN KABUSHIKI KAISHA, JAPAN:
3,481,009, PUB. 5-20-2008. INT. CL. 30.

ISI BRANDS INC., GRAND RAPIDS, MI:
1,457,970, CANC. INT. CL. 5.

ISLE OF CAPRI CASINOS, INC., ST. LOUIS, MO:
2,250,938. REN. 7-3-08. INT. CL. 42.
3,481,433, INT. CL. 43.

ISRAEL DISCOUNT BANK OF NEW YORK, NEW YORK, NY:
3,478,647, PUB. 2-12-2008. INT. CL. 36.

ISRAIR AIRLINES AND TOURISM LTD., TEL AVIV, ISRAEL:
3,478,949, PUB. 5-20-2008. INT. CL. 39.

ISRAM WHOLESALE TOURS AND TRAVEL LTD., NEW YORK, NY:
1,458,732, CANC. INT. CL. 39.

IT'S JUST LUNCH INTERNATIONAL, LLC, PALM DESERT, CA:
3,479,996, PUB. 5-20-2008. INT. CL. 45.

ITALSEMPIONE -; SPEDIZIONI INTERNAZIONALI S.P.A., ITALY:
3,480,855, PUB. 5-20-2008. MULTIPLE CLASS, INT. CLS. 35, 36 AND 39.

ITI SCOTLAND LIMITED, GLASGOW G2 2LB, UNITED KINGDOM:
3,478,524, PUB. 3-4-2008. MULTIPLE CLASS, INT. CLS. 7 AND 42.

ITO-EN LTD., NERIMA-KU, TOKYO, JAPAN TO ITO-EN LTD., SHINJUKU-KU, TOKYO, JAPAN:
1,492,469, COR. INT. CL. 30.

ITT CORPORATION, WHITE PLAINS, NY:
3,479,333, PUB. 5-20-2008. INT. CL. 6.

ITT MANUFACTURING ENTERPRISES, INC., WILMINGTON, DE:
2,492,091, CANC. MULTIPLE CLASS, INT. CLS. 7 AND 9.

IU COSMETICS S.A. DE C.V., LEON GTO, MEXICO:
3,478,758, PUB. 5-20-2008. MULTIPLE CLASS, INT. CLS. 3 AND 16.
3,478,761, PUB. 5-20-2008. MULTIPLE CLASS, INT. CLS. 3 AND 16.

IUNIVERSE.COM, INC., LINCOLN, NE:
2,491,967, CANC. MULTIPLE CLASS, INT. CLS. 35 AND 41.

IVEY, MITCHELL, GOLDSBORO, NC:
2,491,807, CANC. INT. CL. 35.

IVI CHECKMATE CORP., ROSWELL ROAD, GA:
2,493,040, CANC. INT. CL. 9.

IWIN, INC., SAN FRANCISCO, CA:
3,481,888, INT. CL. 9.

J & B INC., BILLINGS, MT:
3,480,589, PUB. 5-20-2008. MULTIPLE CLASS, INT. CLS. 30, 35 AND 43.

J CONSORTIUM, INC., CUPERTINO, CA:
2,493,404, CANC. INT. CL. 16.

J. & P. COATS, LIMITED, GLASGOW, SCOTLAND, UNITED KINGDOM:
2,182,922. REN. 6-30-08. INT. CL. 23.

J. F. KNAUER INDUSTRIE-ELEKTRONIK GMBH, FED REP GERMANY:
3,481,035, PUB. 5-20-2008. INT. CL. 7.

J. GARCIA CARRION, S.A., JUMILLA (MURCIA), SPAIN:
3,482,479, INT. CL. 33.

J. H. BAXTER & CO., SAN MATEO, CA:
842,241. REN. 7-3-08. U.S. CL. 106 (INT. CL. 40).

J. WALTER THOMPSON COMPANY, INC., NEW YORK, NY:
2,100,129, CANC. INT. CL. 35.

J. WESTON WALCH, PUBLISHER, PORTLAND, ME:
3,479,913, PUB. 5-20-2008. INT. CL. 40.

J.C. PENNEY COMPANY, INC., PLANO, TX:
2,492,572, CANC. INT. CL. 35.

J.J. HAINES & COMPANY, INC., GLEN BURNIE, MD:
3,480,626, PUB. 5-20-2008. INT. CL. 19.

J.P. CORR III, APEX, NC:
3,480,288, PUB. 5-20-2008. INT. CL. 41.
3,480,291, PUB. 5-20-2008. INT. CL. 41.

J.P. KING AUCTION COMPANY, INC., GADSDEN, AL:
3,478,547, PUB. 5-20-2008. INT. CL. 35.

J.R. CARLSON LABORATORIES, INC., ARLINGTON HEIGHTS, IL:
3,479,473, PUB. 5-20-2008. INT. CL. 5.

J.R. SIMPLOT COMPANY, BOISE, ID:
2,099,638, CANC. INT. CL. 29.
3,482,133, INT. CL. 1.

J.T. DAVENPORT & SONS, INC., SANFORD, NC:
2,099,006, CANC. INT. CL. 35.

J.T. RONNEFELDT KG, FED REP GERMANY:
3,480,948, PUB. 5-20-2008. INT. CL. 30.

J&M SALES, INC., GARDENA, CA:
3,481,779, INT. CL. 25.

JA WORLDWIDE, COLORADO SPRINGS, CO:
3,478,908, PUB. 5-20-2008. MULTIPLE CLASS, INT. CLS. 16 AND 41.

JAB DISTRIBUTORS, LLC, GLENVIEW, IL, DBA PROTECT-A-BED:
3,482,288, INT. CL. 24.

JACK BLACK, L.L.C., CARROLLTON, TX:
3,482,500, INT. CL. 3.

JACK DANIEL'S PROPERTIES, INC., SAN RAFAEL, CA:
3,482,440, INT. CL. 33.

JACK HOLT LTD, LONDON, UNITED KINGDOM:
3,481,837, INT. CL. 6.

JACK RABBIT CREATIONS, INC., ATLANTA, GA, LANCASTER, ERICA, ATLANTA, GA, DBA JACK RABBIT CREATIONS, INC.:
2,175,556. REN. 6-28-08. INT. CL. 25.

JACK'S COUNTRY STORE, INC., OCEAN PARK, WA:
3,480,324, PUB. 5-20-2008. INT. CL. 35.

JACKSON/CHARVEL MANUFACTURING, INC., SCOTTSDALE, AZ:
3,480,571, PUB. 5-20-2008. INT. CL. 15.

JACKSON, GLORIA M, RIO VISTA, CA:
3,479,244, PUB. 5-20-2008. INT. CL. 44.

JACOBS VEHICLES SYSTEMS, INC., BLOOMFIELD, CT, JACOBS MANUFACTURING COMPANY, THE, BLOOMFIELD, CT:
1,490,083. REN. 7-2-08. INT. CL. 12.

JACOBS, JEFFREY, GOODYEAR, AZ, DBA SOUTHWEST SPECIALTY FOOD CO.:
2,099,370, CANC. INT. CL. 32.

JACOFIN S.R.L., CIVITELLA IN VAL DI CHIANA (AREZZO), ITALY:
2,491,647, CANC. MULTIPLE CLASS, INT. CLS. 18 AND 25.

JACQUART FABRIC PRODUCTS, INC., IRONWOOD, MI:
3,482,668, INT. CL. 41.

JACRI SA, SWITZERLAND:
3,480,867, PUB. 5-20-2008. INT. CL. 14.

JAM PRODUCTIONS, LTD., CHICAGO, IL:
2,163,282. REN. 7-3-08. INT. CL. 41.
2,179,930. REN. 7-3-08. INT. CL. 41.

JAM SESSION S.R.L., ITALY:
3,480,745, PUB. 5-20-2008. MULTIPLE CLASS, INT. CLS. 9, 18 AND 25.

- JANUS INTERNATIONAL HOLDING LLC, DENVER, CO:
2,170,950, REN. 7-3-08. INT. CL. 36.
2,181,918, REN. 7-3-08. INT. CL. 36.
2,181,919, REN. 7-3-08. INT. CL. 36.
3,481,964, INT. CL. 36.
- JAPNA INC., EDISON, NJ:
3,481,604, INT. CL. 25.
- JAS D. EASTON, INC., VAN NUYS, CA:
2,491,796, CANC. INT. CL. 28.
- JASIC, INC., AUSTIN, TX:
3,482,038, INT. CL. 25.
- JAVIER R. RIOS MD A PROFESSIONAL CORPORATION,
RIVERSIDE, CA, DBA MAGNOLIA CLINICA MEDICA
FAMILIAR, CHICAGO CLINICA MEDICA FAMILIAR:
3,479,350, PUB. 2-12-2008. INT. CL. 44.
- JAZZ PHARMACEUTICALS, INC., PALO ALTO, CA:
3,478,852, PUB. 5-20-2008. INT. CL. 35.
- JAZZMAN SPORTSWEAR CORP., NEW YORK, NY:
3,480,143, PUB. 5-20-2008. INT. CL. 25.
- JB I, INC., CANTON, MA:
2,493,249, CANC. INT. CL. 25.
- JBSERVERS.NET, STANWOOD, WA:
3,480,147, PUB. 5-20-2008. INT. CL. 42.
- JBT, LLC, BETHESDA, MD:
3,480,258, PUB. 5-20-2008. INT. CL. 43.
3,480,260, PUB. 5-20-2008. INT. CL. 43.
- JC CELLARS, OAKLAND, CA:
3,478,698, PUB. 5-20-2008. INT. CL. 33.
- JEANNE LOUISE GROUP (FE) LTD., KOWLOON BAY,
HONG KONG:
2,175,381, REN. 6-27-08. INT. CL. 3.
- JED C. KAMINETSKY, M.D., P.C., NEW YORK, NY:
2,493,687, CANC. INT. CL. 42.
- JEFF KOVARSKY, PLANO, TX:
3,479,420, PUB. 5-20-2008. INT. CL. 41.
- JEFFERSON NATIONAL FINANCIAL CORP., LOUISVILLE,
KY:
3,479,359, PUB. 5-20-2008. INT. CL. 36.
- JEFFERSON SCHOLARS FOUNDATION, CHARLOTTES-
VILLE, VA:
3,479,980, PUB. 5-20-2008. INT. CL. 36.
- JEFFERSON, B. RUSSELL, JR., HOT SPRINGS, AR:
3,479,225, PUB. 5-20-2008. MULTIPLE CLASS, INT. CLS.
29 AND 30.
- JELD-WEN, INC., KLAMATH FALLS, OR:
2,100,247, CANC. INT. CL. 19.
2,492,095, CANC. MULTIPLE CLASS, INT. CLS. 35, 37, 41
AND 42.
- JENNIFER A WARDELL, WARWICK, NY, DBA WARWICK
GARDENS:
3,479,247, PUB. 5-20-2008. MULTIPLE CLASS, INT. CLS.
35 AND 44.
- JENNIFER L. WHITE, LEBANON, OH:
1,458,874, CANC. INT. CL. 41.
- JENNIFER M. FREILICH, RIVERSIDE, CA:
3,478,774, PUB. 5-20-2008. INT. CL. 41.
- JERICHI, TERESA, GARDEN GROVE, CA:
3,482,464, INT. CL. 21.
- JERKINS JR., FRED, GALLOWAY, NJ:
3,479,568, PUB. 5-20-2008. INT. CL. 41.
- JESUS YOUTH, DAYTON, NJ:
3,479,512, PUB. 5-20-2008. INT. CL. 45.
- JILL EWING, UNITED KINGDOM:
3,480,882, PUB. 5-20-2008. MULTIPLE CLASS, INT. CLS.
9, 16 AND 41.
- JIM BEAM BRANDS CO., DEERFIELD, IL:
670,351, REN. 7-3-08. U.S. CL. 49 (INT. CL. 33).
2,172,293, REN. 7-3-08. INT. CL. 33.
- JIMMY J. LEONARD, CORAL GABLES, FL:
3,480,115, PUB. 5-20-2008. INT. CL. 41.
- JJMD INVESTMENTS, INC., CHARLOTTESVILLE, VA:
3,479,842, PUB. 5-20-2008. MULTIPLE CLASS, INT. CLS.
35 AND 43.
- JM FIBER OPTICS, INC., CHINO, CA:
3,482,693, INT. CL. 9.
- JMJ ENTERPRISE, INC., LANCASTER, PA, DBA MIMI'S
CURVY CORNER:
3,480,155, PUB. 5-20-2008. INT. CL. 35.
- JML INDUSTRIES, INC., JONESBORO, AR:
3,482,142, INT. CL. 41.
- JMTM LLC, WILMINGTON, DE:
3,480,056, PUB. 5-20-2008. INT. CL. 34.
- JMTM, INC., WILMINGTON, DE:
3,480,351, PUB. 5-20-2008. INT. CL. 34.
- JMTM, LLC, WILMINGTON, DE:
3,480,165, PUB. 5-20-2008. INT. CL. 34.
3,480,310, PUB. 5-20-2008. INT. CL. 34.
- JMV SERVICES, INC., DALLAS, TX:
3,481,529, MULTIPLE CLASS, INT. CLS. 35, 41 AND 42.
- JOELEC CORPORATION, KANGNAM-GU, SEOUL, REPUB-
LIC OF KOREA:
1,491,251, REN. 7-3-08. INT. CL. 26.
- JOH. WILH. VON EICKEN GMBH, FED REP GERMANY:
3,481,037, PUB. 5-20-2008. INT. CL. 34.
- JOHANSON DIELECTRICS, INC, SYLMAR, CA:
3,478,493, PUB. 5-20-2008. INT. CL. 9.
- JOHN B KEENE, LAKE CITY, FL:
3,481,075, INT. CL. 26.
- JOHN BONITO, HENDERSON, NV:
3,479,900, PUB. 5-20-2008. INT. CL. 28.
- JOHN BOOS & CO., EFFINGHAM, IL:
3,482,039, MULTIPLE CLASS, INT. CLS. 20 AND 21.
3,482,040, MULTIPLE CLASS, INT. CLS. 20 AND 21.
- JOHN DAUGHERTY REAL ESTATE, INC., HOUSTON, TX,
DBA JOHN DAUGHERTY, REALTORS:
3,479,099, PUB. 5-20-2008. INT. CL. 36.
- JOHN H. DANIEL COMPANY, KNOXVILLE, TN:
3,481,473, INT. CL. 25.
- JOHN MACINTYRE & SON (MACMADE) LIMITED, GLAS-
GOW, UNITED KINGDOM:
2,492,109, CANC. INT. CL. 14.
- JOHN MEYER, INC., NEW YORK, NY, JOHN MEYER OF
NORWICH, INC., NORWICH, CT:
851,256, REN. 6-30-08. U.S. CL. 39 (INT. CLS. 10, 25 AND
26).
- JOHN VOLPI & COMPANY, INC., ST. LOUIS, MO:
3,480,196, PUB. 5-20-2008. INT. CL. 29.
- JOHNS MANVILLE, DENVER, CO:
1,494,278, REN. 6-30-08. INT. CL. 19.
- 3,482,157, MULTIPLE CLASS, INT. CLS. 1 AND 19.
- JOHNSON & JOHNSON, NEW BRUNSWICK, NJ:
1,457,971, CANC. INT. CL. 5.
- JOHNSON TECHNOLOGIES CORPORATION, NASHVILLE,
TN:
3,481,514, INT. CL. 25.
3,481,682, INT. CL. 25.
- JOHNSON-MILLER & ASSOCIATES, LTD., CHICAGO, IL,
DBA I & B IMPORTS:
3,480,673, PUB. 1-2-2007. INT. CL. 33.
- JOHNSON, JEAN, CHESTERFIELD, MO:
3,482,330, INT. CL. 35.
3,482,371, INT. CL. 35.
3,482,373, INT. CL. 35.
- JOHNSON, KURT ALAN, LAKE FOREST, CA:
2,491,867, CANC. INT. CL. 42.
- JOHNSON, RANDALL DAVID, CHICAGO, IL:
2,159,750, REN. 7-2-08. INT. CL. 25.
- JOHNSON, SHEILA C., THE PLAINS, VA:
3,482,568, INT. CL. 43.
- JOHNSON, STACY L., TROY, MI:
3,480,212, PUB. 5-20-2008. INT. CL. 31.
- JOHNSTON FARMS, EDISON, CA:
1,533,516, REN. 6-28-08. INT. CL. 31.
- JON MORGAN, M.D. SKIN PRODUCTS, INC., COLUMBIA,
SC:
2,099,303, CANC. INT. CL. 3.
- JONATHAN DREW, INC., MIAMI, FL, DBA DREW ESTATE:
3,482,281, INT. CL. 34.
- JONES GROUP, INC., THE, RALEIGH, NC:
2,492,589, CANC. INT. CL. 35.
- JONES, WARREN H., CAZENOVIA, NY:
2,099,946, CANC. INT. CL. 11.
- JONMOR INVESTMENTS, INC., WILMINGTON, DE:
3,481,352, INT. CL. 29.
- JONQUIL, INC., SANTA MONICA, CA:
3,481,668, INT. CL. 25.

- JORDAN OUTDOOR ENTERPRISES, LTD., COLUMBUS, GA:
3,482,585, INT. CL. 25.
- JOSEPH A. MENNA DMD, INC., HOPKINTON, MA:
3,482,388, INT. CL. 44.
- JOSHUA D. KESSELMAN, PHOENIX, AZ:
3,480,177, PUB. 5-20-2008. INT. CL. 9.
- JOSIE G., INC., CLEVELAND, OH:
2,492,308, CANC. INT. CL. 42.
- JOURNAL SENTINEL INC., MILWAUKEE, WI:
3,481,861, INT. CL. 41.
3,481,862, INT. CL. 41.
- JOURNEY EDUCATION MARKETING, INC., DALLAS, TX:
3,482,121, INT. CL. 35.
- JP STUDIOS INC., LOS ANGELES, CA:
3,478,824, PUB. 5-20-2008. INT. CL. 41.
- JPJ INVESTMENT HOLDING CO., CARSON CITY, NV:
3,481,661, MULTIPLE CLASS, INT. CLS. 7, 8 AND 9.
- JPMORGAN CHASE & CO., NEW YORK, NY:
3,478,847, PUB. 5-20-2008. INT. CL. 36.
- JS CABLE CO., LTD., REPUBLIC OF KOREA:
3,480,947, PUB. 5-20-2008. INT. CL. 9.
- JSA INTERNATIONAL, POMPANO BEACH, FL:
3,481,175, INT. CL. 25.
- JT SPORTS LLC, BENTONVILLE, AR:
3,482,184, INT. CL. 28.
- JTH TAX, INC., VIRGINIA BEACH, VA:
3,480,370, PUB. 5-20-2008. INT. CL. 35.
- JUDSON JAY PATTERSON, APEX, NC:
3,481,487, INT. CL. 30.
- JUICE CLUB, INC., EMERYVILLE, CA:
2,099,169, CANC. INT. CL. 32.
- JUICE IT UP FRANCHISE CORP., IRVINE, CA:
2,248,570, REN. 6-28-08. INT. CL. 42.
- JUICE MARKETING, INC., CHARLOTTE, NC:
3,479,173, PUB. 5-20-2008. INT. CL. 35.
- JUICY COUTURE, INC., PACOIMA, CA:
3,481,417, INT. CL. 32.
- JULIA NATIONAL ASSOCIATION FOR WOMYN, INC., OVIEDO, FL:
2,492,075, CANC. INT. CL. 42.
- JULIE INTERNATIONAL, INC., LOS ANGELES, CA:
3,479,646, PUB. 5-20-2008. INT. CL. 25.
- JUNIPER NETWORKS, INC., SUNNYVALE, CA:
2,493,474, CANC. INT. CL. 9.
- JUPITER ONE MUSIC, INC., LAKE SUCCESS, NY:
3,478,735, PUB. 2-12-2008. INT. CL. 41.
- JUPITERIMAGES CORPORATION, TUCSON, AZ:
2,098,898, CANC. INT. CL. 35.
- JURISTAFF, INC., PHILADELPHIA, PA:
3,480,451, PUB. 5-20-2008. INT. CL. 35.
- JUST BASIC SPORTS, INC., WOOSTER, OH:
3,480,210, PUB. 5-20-2008. INT. CL. 18.
- JUST ERNIE INC., NEW YORK, NY:
2,492,908, CANC. INT. CL. 25.
- JUSTICE CO., LTD., OSAKA, JAPAN:
3,481,777, MULTIPLE CLASS, INT. CLS. 3 AND 5.
- JYGA CONCEPT INC., SAINT-NICOLAS (QUÉBEC) G7A 2N2, CANADA:
3,478,498, PUB. 5-10-2005. INT. CL. 9.
- K&K HOME FASHIONS, LTD., SCARSDALE, NY:
3,482,311, INT. CL. 24.
- K&M ENVIRONMENTAL INC., VIRGINIA BEACH, VA:
2,164,835, REN. 6-28-08. INT. CL. 9.
- K&N MANAGEMENT, AUSTIN, TX:
3,481,705, INT. CL. 43.
- K-CLAW, INC., HOUSTON, TX:
3,480,063, PUB. 5-20-2008. INT. CL. 25.
- KABA AG, SWITZERLAND:
3,480,897, PUB. 5-20-2008. MULTIPLE CLASS, INT. CLS. 6 AND 9.
- KABUSHIKI KAISHA NKB, CHIYODA-KU, TOKYO, JAPAN:
2,493,112, CANC. INT. CL. 9.
- KABUSHIKI KAISHA ONWARD HOLDINGS, TOKYO, JAPAN, TA ONWARD HOLDINGS CO., LTD.:
3,478,859, PUB. 5-20-2008. MULTIPLE CLASS, INT. CLS. 25, 35, 41 AND 43.
- KABUSHIKI KAISHA SEGA ENTERPRISES, TOKYO, JAPAN, DBA SEGA ENTERPRISES, LTD.:
2,492,043, CANC. MULTIPLE CLASS, INT. CLS. 9 AND 28.
- KABUSHIKI KAISHA SONY COMPUTER ENTERTAINMENT, TOKYO 107-0062, JAPAN, TA SONY COMPUTER ENTERTAINMENT INC.:
3,478,513, PUB. 5-20-2008. INT. CL. 9.
- KABUSHIKI KAISHA SQUARE ENIX, TOKYO, JAPAN, TA SQUARE ENIX CO., LTD.:
3,481,703, MULTIPLE CLASS, INT. CLS. 9 AND 41.
- KACZANOWSKI, CONNIE, NEW YORK, NY:
3,482,097, INT. CL. 41.
- KADANT LAMORT, VITRY LE FRANCOIS, FRANCE:
1,353,702, REN. 7-3-08. INT. CL. 7.
- KAHLER, GARY, OCEANSIDE, CA:
3,482,412, INT. CL. 15.
- KAI U.S.A., LTD., WILSONVILLE, OR, DBA KERSHAW KNIVES:
2,491,697, CANC. INT. CL. 8.
- KAJEET, INC., BETHESDA, MD:
3,482,334, MULTIPLE CLASS, INT. CLS. 9, 38 AND 41.
- KALLAUGHER, KEVIN, GLYNDON, MD:
3,478,523, PUB. 5-20-2008. INT. CL. 16.
- KALLENBACH, THOMAS J., BOZEMAN, MT:
3,481,731, MULTIPLE CLASS, INT. CLS. 9 AND 42.
- KAMPGROUNDS OF AMERICA, INC., BILLINGS, MT:
2,493,207, CANC. INT. CL. 42.
- KANADY, BETH, PLAINFIELD, IL:
3,480,251, PUB. 5-20-2008. INT. CL. 41.
- KANG, SOPHIA, TORRANCE, CA, DBA STESO AND KANG, STEFANO, TORRANCE, CA, DBA STESO:
3,482,675, INT. CL. 43.
- KANGAROO RIDGE WINE COMPANY PTY LIMITED, AUSTRALIA:
3,480,744, PUB. 5-20-2008. INT. CL. 33.
- KANNAX INC., TOKYO, JAPAN:
3,479,580, PUB. 5-20-2008. INT. CL. 35.
- KANSAS HORSE COUNCIL, INC., THE, SABETHA, KS:
2,492,492, CANC. INT. CL. 41.
- KAPPA KAPPA PSI, NATIONAL HONORARY FRATERNITY FOR COLLEGE AND UNIVERSITY BANDSMEN, STILLWATER, OK AND TAU BETA SIGMA NATIONAL HONORARY SORORITY FOR COLLEGE AND UNIVERSITY BANDSWOMEN, STILLWATER, OK:
1,093,754, REN. 7-3-08. INT. CL. 16.
- KAPRO INDUSTRIES LTD, BIKAT BEIT HAKEREM, ISRAEL:
3,480,392, PUB. 5-20-2008. INT. CL. 9.
- KARAM PRASAD, LLC, WHITE PLAINS, NY:
3,482,219, INT. CL. 25.
- KARATZAS, EVAN, PORTSMOUTH, NH:
3,479,964, PUB. 5-20-2008. MULTIPLE CLASS, INT. CLS. 9 AND 42.
- KARDIA HEALTH SYSTEMS, INC., MINNEAPOLIS, MN:
3,479,761, PUB. 5-20-2008. INT. CL. 42.
- KAREN COLLIGAN, SAN FRANCISCO, CA, DBA PEOPLE-THINK:
3,479,353, PUB. 5-20-2008. INT. CL. 41.
- KARNOVA CORP., BURBANK, NJ:
3,481,874, MULTIPLE CLASS, INT. CLS. 16 AND 20.
- KARSTEN MANUFACTURING CORPORATION, PHOENIX, AZ:
3,481,957, INT. CL. 28.
3,482,003, INT. CL. 28.
3,482,427, INT. CL. 25.
- KASEMSANT, PIYASAK, BOULDER, CO:
3,480,187, PUB. 5-20-2008. INT. CL. 43.
3,480,201, PUB. 5-20-2008. INT. CL. 43.
- KASEREI CHAMPIGNON HOFMEISTER KG, HEISING, FED REP GERMANY:
1,496,910, REN. 6-30-08. INT. CL. 29.
- KASEYAMA CORPORATION, OKAYAMA, JAPAN:
2,492,892, CANC. INT. CL. 25.
- KATHERINE MCKINNON, MARBLEHEAD, MA, DBA MCKINNON & CO.:
3,422,673, COR. MULTIPLE CLASS, INT. CLS. 14 AND 42.

- KATZ, HAROLD, LOS ANGELES, CA:
3,479,969, PUB. 5-20-2008. INT. CL. 3.
- KAWAI, TAKEO, YOKOHAMA-SHI, JAPAN:
2,491,673, CANC. INT. CL. 42.
- KAYABA INDUSTRY CO., LTD., TOKYO, JAPAN:
3,478,940, PUB. 2-19-2008. INT. CL. 12.
- KAYTEE PRODUCTS INCORPORATED, CHILTON, WI:
3,481,497, INT. CL. 28.
- KAZ INCORPORATED, NEW YORK, NY:
2,159,150, REN. 7-2-08. INT. CL. 11.
- KDB COMMUNICATIONS, INC., WHITTIER, CA:
2,492,793, CANC. INT. CL. 9.
- KELLEY, JEANNINE WHITE, SAUSALITO, CA:
2,150,865, REN. 6-28-08. INT. CL. 28.
- KELLEY, NICHOLAS T, SAN FRANCISCO, CA:
3,481,901, INT. CL. 30.
- KELLOGG NORTH AMERICA COMPANY, BATTLE CREEK, MI:
3,481,200, INT. CL. 29.
3,481,896, INT. CL. 30.
3,482,578, INT. CL. 30.
- KELLWOOD COMPANY, CHESTERFIELD, MO:
2,492,923, CANC. INT. CL. 25.
- KENNE BELL, INC., RANCHO CUCAMONGA, CA:
2,491,859, CANC. INT. CL. 9.
- KENNY FLOYD, COLUMBIA, SC:
2,492,450, CANC. INT. CL. 41.
- KENWOOD DEVELOPMENT, L.P., HOUSTON, TX, DBA TUSCAN LAKES DEVELOPMENT, L.P.:
3,479,273, PUB. 5-20-2008. INT. CL. 37.
3,479,274, PUB. 5-20-2008. INT. CL. 37.
- KERABEN, S.A., 12520 NULES (CASTELLON), SPAIN:
1,767,468, CANC. INT. CL. 19.
- KERR CORPORATION, ORANGE, CA:
671,899, REN. 7-2-08. U.S. CL. 44 (INT. CL. 10).
- KEYMETRIC, INC., SEATTLE, WA:
3,479,811, PUB. 5-20-2008. INT. CL. 42.
- KEYPLATFORM, PARIS, FRANCE:
3,480,988, PUB. 5-20-2008. INT. CL. 35.
- KEYSTONE CONSOLIDATED INDUSTRIES, INC., DALLAS, TX, KEYSTONE STEEL & WIRE COMPANY, SOUTH BARTONVILLE (PEORIA), IL:
122,493, REN. 6-30-08. U.S. CL. 13 (INT. CL. 6).
- KEYSTONE CONSOLIDATED INDUSTRIES, INC., DALLAS, TX, KEYSTONE STEEL & WIRE COMPANY, SOUTH BARTVILLE (PEORIA), IL:
122,496, REN. 6-30-08. U.S. CL. 13 (INT. CL. 6).
- KEYSTONE SCENT COMPANY, INC., BALTIMORE, MD:
2,167,658, REN. 6-30-08. INT. CL. 5.
- KFC CORPORATION, LOUISVILLE, KY:
2,491,750, CANC. INT. CL. 16.
- KICKS & STICKS, LLC, BUFORD, GA:
3,479,817, PUB. 5-20-2008. INT. CL. 35.
- KIDS ON-LINE AMERICA, INC., SAN FRANCISCO, CA:
2,492,887, CANC. MULTIPLE CLASS, INT. CLS. 9, 38, 39 AND 42.
- KIDSCOUNT, LLC, NEW HOPE, PA:
3,482,398, INT. CL. 41.
- KIELB, FRANK, BROOMALL, PA:
3,480,461, PUB. 5-20-2008. INT. CL. 41.
- KILLER LOOP EYEWEAR S.R.L., AGORDO (BL), ITALY:
2,492,945, CANC. INT. CL. 9.
- KIM, JEONG HO, NEW YORK, NY:
3,481,524, INT. CL. 25.
3,481,576, INT. CL. 25.
3,481,577, INT. CL. 25.
- KIM, SUN TAE, SEOUL, REPUBLIC OF KOREA:
2,491,665, CANC. INT. CL. 9.
- KIND MEDIA LLC, NEW YORK, NY:
2,493,472, CANC. INT. CL. 38.
- KINETIC COMPUTER CORP., BILLERICA, MA:
2,492,054, CANC. INT. CL. 42.
- KINETICS TECHNOLOGY INTERNATIONAL CORPORATION, SAN DIMA, CA:
1,458,121, CANC. INT. CL. 9.
- KING ARTHUR'S COURT, L.L.C., CULLMAN, AL:
3,479,487, PUB. 5-20-2008. INT. CL. 3.
- KING BROADCASTING COMPANY, SEATTLE, WA:
3,480,077, PUB. 5-20-2008. MULTIPLE CLASS, INT. CLS. 35 AND 41.
- KING PRODUCTS AND SOLUTIONS INC., MISSISSAUGA, ONTARIO, CANADA:
3,478,805, PUB. 5-20-2008. MULTIPLE CLASS, INT. CLS. 9, 38 AND 42.
- KING, PATRICIA SMITH, MADISON, WI:
2,492,810, CANC. INT. CL. 42.
- KINGS & PRIESTS UNLIMITED, INC., DOUGLASVILLE, GA:
3,479,809, PUB. 5-20-2008. INT. CL. 41.
- KINGSTON-MIAMI TRADING CO., MIAMI, FL:
3,478,592, PUB. 5-20-2008. INT. CL. 29.
- KINNDER INDUSTRIES, LLC, PORTLAND, OR, OR:
3,480,565, PUB. 5-20-2008. INT. CL. 25.
- KINNEY SHOE CORPORATION, NEW YORK, NY:
796,781, CANC. U.S. CL. 39.
1,028,019, CANC. INT. CL. 25.
- KIRBY ASH ENTERPRISES, INC., KANSAS CITY, MO:
3,479,959, PUB. 5-20-2008. INT. CL. 41.
- KIRCHNER-LEIDA, VANESSA A., BEDFORD, MA:
3,482,674, INT. CL. 24.
- KIRIN CO., LTD, PUSAN, 612-060, REPUBLIC OF KOREA:
2,171,389, REN. 7-3-08. INT. CL. 30.
- KIRKEY, BRYAN, ATLANTA, GA:
3,480,389, PUB. 5-20-2008. INT. CL. 19.
- KISER, JOSEPH KENT, TROY, OH AND KISER, JOSEPH KENT, TROY, OH:
3,481,174, INT. CL. 35.
- KISSNER MILLING COMPANY LIMITED, CAMBRIDGE, CANADA:
3,480,284, PUB. 5-20-2008. INT. CL. 1.
- KITCHEN CABINET CONSULTING, LLC, RENSSELAERVILLE, NY:
3,482,583, MULTIPLE CLASS, INT. CLS. 35 AND 36.
- KITCHEN CABINET MANUFACTURERS ASSOCIATION, RESTON, VA:
3,479,200, PUB. 5-20-2008. U.S. CL. A.
- KITCHENS, ANTHONY DANIEL, SANTA MONICA, CA:
3,482,566, INT. CL. 28.
- KLEFEKER, JOHN M., WEYMOUTH, MA, DBA FAMILY HEARING CARE CENTER:
3,482,377, INT. CL. 16.
- KLEIMAN, PAUL L., CULVER CITY, CA:
3,482,554, INT. CL. 10.
- KLIO-ETERNA SCHREIBGERATE GMBH & CO., 77709 WOLFACH, FED REP GERMANY:
2,493,656, CANC. INT. CL. 16.
- KLUSSENDORF PRODUKT AND VERTRIEBS GMBH, 13599 BERLIN, FED REP GERMANY:
2,491,821, CANC. INT. CL. 9.
- KMGI CORP., SUNNY ISLES BEACH, FL:
3,481,939, INT. CL. 39.
- KN LTD., SAN RAFAEL, CA:
3,479,575, PUB. 5-20-2008. MULTIPLE CLASS, INT. CLS. 20 AND 24.
- KNIGHTRIDERS MOTORCYCLE CLUB, CHICAGO, IL:
3,478,789, PUB. 2-12-2008. U.S. CL. 200.
- KNOTT, MICHAEL JAMES, SANTA ROSA, CA:
2,492,229, CANC. INT. CL. 41.
- KNOWLEDGE BASED SYSTEMS, INC., COLLEGE STATION, TX:
3,478,905, PUB. 5-20-2008. INT. CL. 9.
- KNOWLEDGE LEARNING CORPORATION, PORTLAND, OR:
3,482,302, MULTIPLE CLASS, INT. CLS. 41 AND 43.
- KNOWLEDGE TECHNOLOGIES INTERNATIONAL LIMITED, WARWICKSHIRE CV 326 JX, ENGLAND:
2,493,410, CANC. INT. CL. 41.
- KNÜRR AG, FED REP GERMANY:
3,480,854, PUB. 5-20-2008. MULTIPLE CLASS, INT. CLS. 9, 11, 20 AND 40.
- KO, SOO RYONG, CERRITOS, CA:
3,482,590, INT. CL. 41.
3,482,591, INT. CL. 41.
- KOBE BEEF AMERICA, INC., REDMOND, OR:
3,478,870, PUB. 5-20-2008. INT. CL. 29.

KOCH ENTERTAINMENT, LP, PORT WASHINGTON, NY:
2,160,313. REN. 7-3-08. INT. CL. 9.
2,160,314. REN. 7-3-08. INT. CL. 9.

KOEHN, RICHARD K., SALT LAKE CITY, UT:
3,481,331, INT. CL. 5.
3,481,332, INT. CL. 5.

KOENIG & BAUER AG, FED REP GERMANY:
3,480,995, PUB. 5-20-2008. MULTIPLE CLASS, INT. CLS.
7, 9 AND 37.

KOHGENDO CO., LTD., TOKYO, JAPAN:
3,482,016, INT. CL. 3.

KOHLER CO., KOHLER, WI:
3,482,191, MULTIPLE CLASS, INT. CLS. 6 AND 11.

KOHN, ROBERT H., NEW YORK, NY:
2,166,044. REN. 6-30-08. INT. CL. 16.

KOMAL HERBALS, INC., SEWICKLEY, PA:
3,478,531, PUB. 5-20-2008. INT. CL. 5.

KOMKIN, ANDREY V, BARNAUL, RUSSIAN FED.:
3,479,577, PUB. 5-20-2008. INT. CL. 10.

KONAMI DIGITAL ENTERTAINMENT CO., LTD., TOKYO,
JAPAN:
3,481,083, INT. CL. 28.
3,482,558, MULTIPLE CLASS, INT. CLS. 9 AND 41.

KONGPOWER TECHNOLOGY CO., LTD., FONGYUAN
CITY, TAIWAN:
3,479,742, PUB. 5-20-2008. INT. CL. 9.

KONGSBERG OFFSHORE AS, 3601 KONGSBERG, NOR-
WAY:
2,493,129, CANC. INT. CL. 37.

KONINKLIJKE PHILIPS ELECTRONICS N.V., EINDHO-
VEN, NETHERLANDS:
2,492,026, CANC. INT. CL. 9.

KONINKLIJKE PHILIPS ELECTRONICS N.V., NETHER-
LANDS:
3,480,885, PUB. 5-20-2008. INT. CL. 9.

KONSTANTIN POGOSOV, MATTHEWS, NC:
3,482,634, INT. CL. 41.

KOOKA WINES, INC., SEATTLE, WA:
3,479,095, PUB. 5-20-2008. INT. CL. 33.

KOOLSPAN, INC., NORTH BETHESDA, MD:
3,482,095, INT. CL. 9.

KOP-COAT, INC., PITTSBURGH, PA:
3,481,838, INT. CL. 2.

KORN, JONATHAN, ROCKY HILL, CT AND LO, GRACE,
ROCKY HILL, CT:
3,479,674, PUB. 5-20-2008. INT. CL. 21.

KORRECT KRITTERS, LLC, NEW PORT RICHEY, FL:
3,479,752, PUB. 5-20-2008. MULTIPLE CLASS, INT. CLS.
41 AND 44.

KOSHER CATCH, INC., BROOKLYN, NY:
2,493,506, CANC. INT. CL. 29.

KOSTENKO, CONSTANTIN, ARLINGTON, VA:
3,479,574, PUB. 5-20-2008. INT. CL. 42.

KOWALS PEDIATRICS, BELLINGHAM, WA:
3,482,659, INT. CL. 44.

KOZAK, ANDRZEJ W, EL CAJON, CA:
3,479,162, PUB. 5-20-2008. INT. CL. 10.

KOZIO, INC., LONGMONT, CO:
3,479,037, PUB. 5-20-2008. INT. CL. 9.
3,479,039, PUB. 5-20-2008. INT. CL. 9.

KRAFT FOODS HOLDINGS, INC., NORTHFIELD, IL,
KRAFT FOODS, INC., NORTHFIELD, IL:
2,159,153. REN. 7-2-08. INT. CL. 32.

KRAFT FOODS HOLDINGS, INC., NORTHFIELD, IL:
2,492,336, CANC. INT. CL. 29.
2,493,527, CANC. INT. CL. 29.
3,481,609, INT. CL. 32.

KRAFT FOODS SCHWEIZ HOLDING AG, CH-8008 ZUR-
ICH, SWITZERLAND:
2,156,182. REN. 7-2-08. INT. CL. 30.

KRAMER INDUSTRIES, INC., IDAHO FALLS, ID:
2,492,067, CANC. INT. CL. 16.

KRAUSE PUBLICATIONS, INC., IOLA, WI:
2,492,512, CANC. MULTIPLE CLASS, INT. CLS. 36 AND
41.

KRELITZ INDUSTRIES, INC., MINNEAPOLIS, MN:
1,458,654, CANC. INT. CL. 35.

KREX, INC., NORTHBROOK, IL:
3,479,379, PUB. 5-20-2008. INT. CL. 36.

KRISTEN JANE EDWARDS, HERMOSA BEACH, CA:
3,481,594, INT. CL. 35.

KRISTIANSSEN, KATE, BEAVERTON, OR:
3,481,201, MULTIPLE CLASS, INT. CLS. 2, 3 AND 21.

KROEGER MEDIA INC., LA SALLE, CANADA:
3,482,241, INT. CL. 38.

KROLL INC., NEW YORK, NY:
3,478,675, PUB. 5-20-2008. MULTIPLE CLASS, INT. CLS.
36 AND 45.

KROMBERG & SCHUBERT GMBH & CO. KG, FED REP
GERMANY:
3,480,958, PUB. 5-20-2008. INT. CL. 9.

KROTHER, JASON N, BLOOMINGTON, IN:
3,481,632, INT. CL. 25.

KRUETLE, SYLVIA C., FT. COLLINS, CO:
2,165,612. REN. 7-3-08. INT. CL. 41.

KS KOLBENSCHMIDT GMBH, NECKARSULM, FED REP
GERMANY:
3,478,817, PUB. 5-20-2008. INT. CL. 7.

KTK ASSOCIATES, INC., GOLIAD, TX:
3,479,720, PUB. 5-20-2008. INT. CL. 40.

KUDER, INC., ADEL, IA:
3,478,589, PUB. 5-20-2008. INT. CL. 38.
3,478,595, PUB. 5-20-2008. INT. CL. 38.

KULWUTHIVILAS, VICHAI, BANGKOK, THAILAND:
3,482,055, INT. CL. 3.

KUNSTDÜNGER S.N.C.; DI C. WALZL & CO., I-39028
SILANDRO, BOLZANO, ITALY:
3,480,921, PUB. 5-20-2008. MULTIPLE CLASS, INT. CLS.
6, 16 AND 20.

KURARAY CO., LTD., KURASHIKI CITY, OKAYAMA
PREFECTURE, JAPAN:
3,478,529, PUB. 11-6-2007. MULTIPLE CLASS, INT. CLS. 1
AND 17.

KVH INDUSTRIES, INC., MIDDLETOWN, RI:
3,479,520, PUB. 5-20-2008. MULTIPLE CLASS, INT. CLS. 9
AND 38.

KWAK, TAE Y., IRVINE, CA:
3,482,179, INT. CL. 11.

KWI, INC., PITTSFIELD, MA:
2,492,717, CANC. INT. CL. 11.

KWIK TRIP, INC., LA CROSSE, WI:
3,479,781, PUB. 5-20-2008. INT. CL. 30.

KYPREOS, TONY V., BAY SHORE, NY:
2,470,378, CANC. INT. CL. 9.

L'OREAL, 75008 PARIS, FRANCE:
2,493,424, CANC. INT. CL. 3.

L & L PACKING COMPANY, CHICAGO, IL:
1,499,793. REN. 7-3-08. INT. CL. 29.

L.L. BEAN, INC., FREEPORT, ME:
1,492,300. REN. 7-3-08. INT. CL. 25.

L.R.A., L.L.C., OKLAHOMA CITY, OK:
3,482,518, INT. CL. 32.

L&P PROPERTY MANAGEMENT COMPANY, SOUTH-
GATE, CA:
1,497,766. REN. 7-3-08. INT. CL. 20.
2,191,552. REN. 7-3-08. INT. CL. 20.

L'OREAL, PARIS, FRANCE:
3,479,096, PUB. 5-20-2008. INT. CL. 3.

LA BROSSE ET DUPONT, PARIS, FRANCE:
1,458,277, CANC. MULTIPLE CLASS, INT. CLS. 16 AND
21.

LA COLLINE INTERNATIONAL, FRANCE:
3,480,863, PUB. 5-20-2008. INT. CL. 3.

LA COMMUNAUTÉ EUROPÉENNE; REPRESENTÉE PAR
LA COMMISSION DES; COMMUNAUTÉS EUR-
OPÉENNES, BELGIUM:
3,480,811, PUB. 2-12-2008. MULTIPLE CLASS, INT. CLS.
9, 38 AND 41.

LA COUPE PRODUCTS INC., MISSISSAUGA, ONTARIO,
CANADA:
3,480,724, PUB. 5-20-2008. INT. CL. 3.

LA COUPE PRODUCTS INC., MISSISSAUGA, ONTARIO,
CANADA, LA COUPE NEW YORK, INC., NEW YORK,
NY:
1,052,095. REN. 6-27-08. INT. CL. 42.

- LA COZZA, INC., NEW YORK, NY:
2,493,013, CANC. INT. CL. 42.
- LA CROSSE FOOTWEAR, INC., PORTLAND, OR:
1,458,407, CANC. INT. CL. 25.
- LA DUNI CONCEPTS LLC, DALLAS, TX:
3,481,618, INT. CL. 43.
- LA FORTUNA S.A., LONTUE, CHILE:
3,479,631, PUB. 5-20-2008. INT. CL. 33.
- LA FROMAGERIE, INC., LOS ANGELES, CA:
3,481,542, INT. CL. 35.
- LA LOOP LLC, NEW YORK, NY:
2,204,438. REN. 7-3-08. INT. CL. 9.
- LA LUCKY TRADING, INC., LOS ANGELES, CA:
2,493,559, CANC. INT. CL. 24.
- LA PORCELLANA BIANCA S.P.A., 52100 AREZZO, ITALY:
2,099,718, CANC. MULTIPLE CLASS, INT. CLS. 8 AND 21.
- LA UNIDAD LATINA, LAMBDA UPSILON LAMBDA FRATERNITY, INC., NEW YORK, NY:
3,478,653, PUB. 5-20-2008. INT. CL. 35.
- LA-Z-BOY INCORPORATED, MONROE, MI:
3,478,671, PUB. 5-20-2008. MULTIPLE CLASS, INT. CLS. 9, 16, 18, 20, 21, 25 AND 28.
- LABELSON, ROSS, GARDENIA, CA, DBA BUCKLE DOWN SKATEGOODS:
2,162,467. REN. 6-30-08. INT. CL. 25.
- LABOR NETWORK, INC., ELGIN, IL:
2,168,595. REN. 7-2-08. INT. CL. 35.
- LABORATOIRE CENTRAL DES PONTS ET CHAUSSEES (LCPC), 75015 PARIS, FRANCE:
2,492,038, CANC. MULTIPLE CLASS, INT. CLS. 9, 35 AND 42.
- LABORATOIRE DE: CONTACTOLOGIE APPLIQUÉE - LCA, F-28000 CHARTRES, FRANCE:
3,480,902, PUB. 5-20-2008. MULTIPLE CLASS, INT. CLS. 3, 5 AND 10.
- LABORATOIRES GOEMAR, FRANCE:
3,481,016, PUB. 5-20-2008. MULTIPLE CLASS, INT. CLS. 1 AND 5.
- LABORATORI FITOCOSMESI; & FARMACEUTICI S.R.L., ITALY:
3,480,827, PUB. 5-20-2008. INT. CL. 3.
- LABORATORIOS PHARMAVID, LTDA, SANTAFE DE BOGOTA, COLOMBIA:
2,493,320, CANC. INT. CL. 42.
- LABROSSE, LUC R, LINCOLN, RI, DBA PLANNED LEGAL ADVOCACY CARE FOR EVERYONE:
3,480,156, PUB. 5-20-2008. INT. CL. 45.
- LACKEY, JOHN F., RICHMOND, KY:
2,098,938, CANC. INT. CL. 42.
- LACROSSE FOOTWEAR, INC., PORTLAND, OR:
2,493,338, CANC. INT. CL. 25.
- LADYMOON FARMS, INCORPORATED, CHAMBERSBURG, PA, BEDDARD, TOM, CHAMBERSBURG, PA:
2,185,981. REN. 6-30-08. INT. CL. 31.
- LAGARDE, INCORPORATED, OLATHE, KS:
3,480,401, PUB. 5-20-2008. MULTIPLE CLASS, INT. CLS. 9 AND 42.
- LAGARDERE SERVICES, F-75008 PARIS, FRANCE:
3,481,013, PUB. 5-20-2008. MULTIPLE CLASS, INT. CLS. 35 AND 43.
- LAI LAI TRAVEL AGENCY, INC., MONTEREY PARK, CA:
2,166,759. REN. 7-3-08. MULTIPLE CLASS, INT. CLS. 39 AND 42.
- LAKE FOREST ASSET MANAGEMENT CORP., LAKE FOREST, IL:
2,492,031, CANC. INT. CL. 35.
- LAKELAND FINANCE LLC, CHARLOTTESVILLE, VA:
3,479,690, PUB. 5-20-2008. INT. CL. 39.
- LAKESHORE TECHNICAL COLLEGE, CLEVELAND, WI:
2,492,685, CANC. INT. CL. 41.
- LAMADRID, ED, NEW YORK, NY:
2,099,491, CANC. INT. CL. 42.
- LAMP POST PIZZA, TUSTIN, CA:
2,176,663. REN. 6-30-08. INT. CL. 42.
2,176,664. REN. 6-28-08. INT. CL. 42.
2,176,677. REN. 6-30-08. INT. CL. 42.
- LAMPS PLUS, INC., CHATSWORTH, CA:
2,627,737, CANC. INT. CL. 20.
- LANCEL INTERNATIONAL SA, SWITZERLAND:
3,480,904, PUB. 5-20-2008. MULTIPLE CLASS, INT. CLS. 18 AND 25.
- LANCÔME PARFUMS ET BEAUTE & CIE, PARIS, FRANCE:
2,099,021, CANC. INT. CL. 3.
3,478,682, PUB. 5-20-2008. INT. CL. 3.
3,478,695, PUB. 5-20-2008. INT. CL. 3.
- LAND ARCHITECTURE, INC., ROSEVILLE, CA:
3,480,478, PUB. 5-20-2008. INT. CL. 42.
- LAND O'LAKES PURINA FEED LLC, SHOREVIEW, MN:
1,458,614, CANC. INT. CL. 31.
- LANDIS & STAefa, INC., BUFFALO GROVE, IL TO SIEMENS BUILDING TECHNOLOGIES, INC., BUFFALO GROVE, IL:
2,099,786, CANC. INT. CL. 9.
- LANDIS, GARY, PLANO, TX AND LANDIS, CHERYL, PLANO, TX:
3,479,629, PUB. 5-20-2008. INT. CL. 20.
- LANDMARK NATIONAL BANK, MANHATTAN, KS:
3,478,494, PUB. 11-16-2004. INT. CL. 36.
- LANDS' END DIRECT MERCHANTS, INC., RICHFIELD, MN:
2,172,581. REN. 6-30-08. INT. CL. 35.
- LANDSCAPE STRUCTURES, INC., DELANO, MN:
3,481,286, INT. CL. 28.
- LANE AUTOMOTIVE, WATERVLIET, MI:
3,478,963, PUB. 5-20-2008. MULTIPLE CLASS, INT. CLS. 16 AND 35.
- LANGENDORFER, HEATHER L, SAN CARLOS, CA, DBA ATALANTA ATHLETICWEAR:
3,480,133, PUB. 5-20-2008. INT. CL. 25.
- LANXESS DEUTSCHLAND GMBH, LEVERKUSEN, FED REP GERMANY:
3,482,380, MULTIPLE CLASS, INT. CLS. 1 AND 17.
- LANZO, CHARLES PATRICK, ACWORTH, GA:
3,482,170, INT. CL. 29.
- LARCAN INC., ONTARIO, CANADA:
3,479,376, PUB. 5-20-2008. INT. CL. 9.
- LARKSPUR HOTELS, LLC, LARKSPUR, CA:
3,482,457, INT. CL. 25.
- LAROH, INC., CINCINNATI, OH:
3,479,737, PUB. 5-20-2008. INT. CL. 35.
- LAS VEGAS SANDS CORP., LAS VEGAS, NV:
3,479,372, PUB. 5-20-2008. INT. CL. 26.
- LAS VEGAS WHOLESALE JEWELERS, INC., LAS VEGAS, NV:
3,478,806, PUB. 5-20-2008. INT. CL. 35.
- LASALLE BANK CORPORATION, CHICAGO, IL:
2,492,981, CANC. INT. CL. 36.
- LASALLE NATIONAL BANK, CHICAGO, IL:
1,458,530, CANC. INT. CL. 28.
- LAST POST LIMITED, UNITED KINGDOM:
3,480,877, PUB. 5-20-2008. MULTIPLE CLASS, INT. CLS. 38, 41, 42 AND 45.
- LATINO TAX, LLC, ATLANTIC CITY, NJ:
3,480,252, PUB. 5-20-2008. INT. CL. 35.
- LATITUDE BEVERAGE COMPANY, BOSTON, MA:
3,482,704, INT. CL. 33.
- LAUNCH MEDIA, INC., SANTA MONICA, CA:
2,491,920, CANC. MULTIPLE CLASS, INT. CLS. 35 AND 41.
- LAUNCHFUEL, INC., RESTON, VA:
2,492,349, CANC. INT. CL. 35.
- LAURENT D PRODUCT, INC. D/B/A PRIVE PRODUCTS, LOS ANGELES, CA:
3,481,505, INT. CL. 3.
- LAURICE EL BADRY RAHME LTD., NEW YORK, NY, DBA LAURICE & CO.:
2,977,193, COR. MULTIPLE CLASS, INT. CLS. 3 AND 4.
- LAURIER INCORPORATED, MANCHESTER, NY:
1,458,020, CANC. INT. CL. 7.
- LAVELLE, GERALYN A., PALATINE, IL:
3,482,165, INT. CL. 28.
3,482,225, INT. CL. 28.
- LAWRY FREIGHT SYSTEM, INC., WESTFIELD, MA:
3,479,702, PUB. 5-20-2008. INT. CL. 39.

LAWSON PRODUCTS, INC., DES PLAINES, IL:
3,481,395, INT. CL. 41.

LAWSTAR, INC., BEVERLY HILLS, CA:
2,492,700, CANC. INT. CL. 42.

LAZ PRODUCTS, INC., TARPON SPRINGS, FL:
2,100,318, CANC. INT. CL. 8.

LAZERNET GRAPHICS, INC., NEW YORK, NY:
1,458,818, CANC. INT. CL. 42.
1,458,821, CANC. INT. CL. 42.

LC TRADEMARKS, INC., DETROIT, MI:
1,113,824, REN. 6-30-08, INT. CL. 42.

LDI CORPORATION, GONIC, NH:
2,492,809, CANC. INT. CL. 41.

LE GOURMET GIFT BASKET, INC., DENVER, CO:
2,492,683, CANC. INT. CL. 35.

LE REVE DESTINATION SERVICES, INC., LAGUNA NI-
GUEL, CA:
3,481,151, MULTIPLE CLASS, INT. CLS. 39, 43 AND 45.

LEADERSHIFT AUTHENTIC INSIGHTS, INC., CORDOVA,
TN:
3,479,757, PUB. 5-20-2008, INT. CL. 35.

LEAMAN CONTAINER, INC., FORT WORTH, TX:
2,492,547, CANC. INT. CL. 17.

LEARNING CURVE BRANDS, INC., DYERSVILLE, IA:
2,100,365, CANC. INT. CL. 10.

LEARNING FOR LIFE, INC., IRVING, TX:
1,093,258, REN. 7-3-08, INT. CL. 16.

LEASE-TECH GROUP, INC, LAS VEGAS, NV:
3,480,074, PUB. 5-20-2008, INT. CL. 41.
3,480,114, PUB. 5-20-2008, INT. CL. 41.

LEASE2SAVE.COM, INC., SAN DIEGO, CA:
2,492,149, CANC. INT. CL. 42.

LEATHER BOULEVARD, BARRINGTON, NH, DBA ROCK-
HEM & CHICSTONE:
3,480,268, PUB. 5-20-2008, INT. CL. 35.

LEATHER CENTER, INC., CARROLLTON, TX:
2,491,743, CANC. MULTIPLE CLASS, INT. CLS. 20 AND
35.

LEAVING EARTH, LLC, ROCHESTER, NY:
3,478,574, PUB. 5-20-2008, INT. CL. 9.
3,478,575, PUB. 5-20-2008, INT. CL. 9.

LEE PROCUREMENT SOLUTIONS CO., DAVENPORT, IA:
1,458,324, CANC. INT. CL. 16.

LEE, HARRY, CRESTWOOD, KY:
3,479,694, PUB. 5-20-2008, INT. CL. 41.

LEE, YOUNG MIN, BUENA PARK, CA:
3,482,434, INT. CL. 5.

LEECO INDUSTRIES, INC., OLIVE BRANCH, MS:
2,492,341, CANC. INT. CL. 20.

LEFT BRAIN ENTERPRISES, LLC, WILMINGTON, DE:
3,479,932, PUB. 5-20-2008, INT. CL. 21.

LEGACY OF TRUTH MINISTRIES, INC., DULUTH, GA:
3,481,434, INT. CL. 9.
3,481,456, INT. CL. 9.
3,481,457, INT. CL. 41.

LEGACY PADDLESPOITS LLC, GREENSBORO, NC:
3,481,251, INT. CL. 12.

LEGEND GROUP HOLDINGS, LLC, PALM BEACH GAR-
DENS, FL:
3,480,600, PUB. 5-20-2008, INT. CL. 36.

LEGENDS OF BASEBALL, INC., COLUMBUS, OH:
2,167,380, REN. 6-30-08, INT. CL. 41.

LEISURE BAY INDUSTRIES, INC., LAKE MARY, FL:
2,169,371, REN. 6-28-08, MULTIPLE CLASS, INT. CLS. 6,
11, 19 AND 22.

LEMIRE, RAYMOND, HANOVER, MA:
2,492,175, CANC. INT. CL. 35.

LEMON, EVE, ATLANTA, GA:
2,492,379, CANC. INT. CL. 30.

LENGA INVESTMENT MANAGEMENT HOLDCO, LLC,
CHICAGO, IL:
3,482,164, INT. CL. 36.

LENNON, ANNE P., RESTON, VA AND LENNON, DENNIS
R., RESTON, VA, DBA WINDOW INTERIORS:
1,946,364, CANC. INT. CL. 42.

LEPCO INCORPORATED, HOUSTON, TX:
1,458,863, CANC. INT. CL. 11.

LERCHL, WOLFGANG, 01109 DRESDEN, FED REP GER-
MANY:
3,482,017, INT. CL. 42.

LES GRANDS CHAIS DE FRANCE, 67290 PETERSBACH,
FRANCE:
3,419,027, COR. INT. CL. 33.

LESLIE, JAMES, HOWARD BEACH, NY:
2,100,245, CANC. INT. CL. 29.

LESOWSKE, CHARLES J, SISTERS, OR:
3,481,709, INT. CL. 16.

LESSER, KENNETH, DENVER, CO:
3,480,323, PUB. 5-20-2008, INT. CL. 14.

LESSMANN GMBH, 86732 OETTINGEN, FED REP GER-
MANY:
3,479,827, PUB. 5-20-2008, MULTIPLE CLASS, INT. CLS. 7
AND 21.

LETTUCE ENTERTAIN YOU ENTERPRISES, INC, CHICA-
GO, IL:
3,480,213, PUB. 5-20-2008, INT. CL. 43.

LEUPOLD & STEVENS, INC., BEAVERTON, OR:
3,481,245, INT. CL. 9.
3,481,247, INT. CL. 9.

LEVCHENKO, CYNTHIA, COLD SPRING HARBOR, NY:
2,491,969, CANC. MULTIPLE CLASS, INT. CLS. 41 AND
42.

LEVEL 8 SYSTEMS, INC., PRINCETON, NJ:
2,492,225, CANC. INT. CL. 38.

LEVINGER COMPANY, DELRAY BEACH, FL:
2,492,660, CANC. INT. CL. 20.
2,492,661, CANC. INT. CL. 20.

LEVI STRAUSS & CO., SAN FRANCISCO, CA:
2,493,277, CANC. INT. CL. 25.

LEVITT, DAVID, RALEIGH, NC:
3,479,979, PUB. 5-20-2008, INT. CL. 37.

LEVY FOOD SERVICE LIMITED PARTNERSHIP, CHICA-
GO, IL:
3,478,995, PUB. 5-20-2008, INT. CL. 41.

LEWIS BANKS LTD., THERFIELD, UNITED KINGDOM:
3,478,810, PUB. 5-20-2008, INT. CL. 25.
3,478,812, PUB. 5-20-2008, INT. CL. 12.

LEWIS BROTHERS BAKERIES, INCORPORATED, EVANS-
VILLE, IN, DBA LEWIS BAKERIES, INC.:
3,482,245, INT. CL. 30.

LEWIS JOSEPH TURCHI, D.D.S., INCORPORATED, ROLL-
ING HILLS ESTATES, CA:
2,492,748, CANC. INT. CL. 42.

LEWIS-CHESTER ASSOCIATES, INC., SUMMIT, NJ:
2,491,682, CANC. INT. CL. 36.

LEWIS, DONNA DOLEMAN, YPSILANTI TOWNSHIP, MI:
3,479,589, PUB. 5-20-2008, INT. CL. 35.
3,479,590, PUB. 5-20-2008, INT. CL. 35.

LEXIEGIRL CLOTHING, INC., NORTHBRIDGE, CA:
3,480,386, PUB. 5-20-2008, INT. CL. 25.

LEXISNEXIS PUBLIC RECORDS SERVICES INC., MINNEA-
POLIS, MN:
2,491,838, CANC. INT. CL. 41.

LEYBOLD SYSTEMS GMBH, D-63450 HANAU, FED REP
GERMANY:
2,492,876, CANC. INT. CL. 7.

LG HOUSEHOLD & HEALTH CARE LTD., SEOUL, REPUB-
LIC OF KOREA:
3,481,586, INT. CL. 3.

LG VERWALTUNGS, GMBH, DORTMUND, FED REP
GERMANY:
3,478,987, PUB. 5-20-2008, INT. CL. 16.
3,478,988, PUB. 5-20-2008, INT. CL. 19.

LI GUANJUN, CHINA:
3,480,841, PUB. 5-20-2008, INT. CL. 8.

LIANG, SAM, EL MONTE, CA:
3,481,068, INT. CL. 30.

LIBERATION ENTERTAINMENT INC., LOS ANGELES, CA:
3,481,453, INT. CL. 41.

LIBERTY DIVERSIFIED INDUSTRIES, INC., MINNEAPO-
LIS, MN:
3,480,248, PUB. 5-20-2008, INT. CL. 20.

- LIBERTY HARDWARE MFG. CORP., WINSTON-SALEM, NC:
2,194,568. REN. 6-30-08. INT. CL. 6.
2,194,568. CANC. INT. CL. 20.
- LIBERTY LAKE INTERNET EXCHANGE, LLC, LIBERTY LAKE, WA:
3,479,343. PUB. 5-20-2008. INT. CL. 42.
- LIBRARY VIDEO COMPANY, WYNNEWOOD, PA:
3,479,188. PUB. 5-20-2008. INT. CL. 9.
- LIFELONG FITNESS ALLIANCE, REDWOOD CITY, CA:
3,480,245. PUB. 5-20-2008. INT. CL. 44.
- LIFESIZE COMMUNICATIONS, INC., AUSTIN, TX:
3,482,023. INT. CL. 38.
- LIFESTYLE EVOLUTION, INC., SHARPSBURG, PA:
3,480,399. PUB. 5-20-2008. INT. CL. 29.
- LIFETIME ENTERTAINMENT SERVICES, NEW YORK, NY:
3,482,613. INT. CL. 41.
- LIFETOUGH, INC., EDEN PRAIRIE, MN:
2,491,818. CANC. INT. CL. 42.
- LIFEWAY CHRISTIAN RESOURCES OF THE SOUTHERN BAPTIST CONVENTION, NASHVILLE, TN:
2,492,957. CANC. MULTIPLE CLASS, INT. CLS. 9 AND 16.
- LIFTEX CORPORATION, WARMINSTER, PA:
3,478,907. PUB. 5-20-2008. MULTIPLE CLASS, INT. CLS. 6 AND 22.
- LIGHTEL TECHNOLOGIES, INC., KENT, WA:
3,482,458. INT. CL. 9.
- LIGHTSPAN, INC., SAN DIEGO, CA:
2,493,540. CANC. MULTIPLE CLASS, INT. CLS. 9 AND 16.
- LIL' ANGELS, LLC, MEMPHIS, TN:
2,137,312. REN. 6-28-08. INT. CL. 42.
- LILLIE BEN, FRANKTOWN, CO:
3,482,652. INT. CL. 36.
- LILSTONE, INC., ALHAMBRA, CA:
3,479,294. PUB. 5-20-2008. INT. CL. 9.
- LIMALAND TEENS FOR CHRIST, INC., LIMA, OH, DBA TEENS FOR CHRIST:
3,479,259. PUB. 5-20-2008. INT. CL. 45.
- LIMMER, ROBERT, CLOSTER, NJ:
3,481,343. INT. CL. 8.
- LIMONEIRA COMPANY, SANTA PAULA, CA:
1,499,839. REN. 7-3-08. INT. CL. 31.
- LIN, CHUN-CHIH, TAIPEI, TAIWAN:
3,480,099. PUB. 5-20-2008. INT. CL. 7.
- LINCOLN ELECTRIC COMPANY, THE, CLEVELAND, OH TO LINCOLN GLOBAL, INC., MONTEREY PARK, CA:
2,100,523. CANC. INT. CL. 9.
- LINDA P. COPELAND, BELMONT, NC:
3,479,986. PUB. 5-20-2008. INT. CL. 17.
- LINDY-GERTIE ENTERPRISES, INC., BURR RIDGE, IL:
1,458,848. CANC. INT. CL. 42.
- LINE 7 LIMITED, AUCKLAND, NEW ZEALAND, LINE SEVEN LIMITED, HERNE BAY, AUCKLAND, NEW ZEALAND:
1,509,307. REN. 7-2-08. INT. CL. 25.
- LINEN HOUSE PTY LTD, AUSTRALIA:
3,480,984. PUB. 5-20-2008. INT. CL. 24.
- LINET SPOL. S R.O., CZECH REPUBLIC:
3,480,796. PUB. 5-20-2008. MULTIPLE CLASS, INT. CLS. 10, 20 AND 37.
- LING, WONG SIU, HONG KONG, HONG KONG:
3,482,230. INT. CL. 43.
- LINGUIS-TECHS, NEWTOWN, PA:
2,166,138. REN. 6-30-08. INT. CL. 35.
- LINH T. LUU-MURPHY, CALISTOGA, CA:
3,480,134. PUB. 5-20-2008. INT. CL. 44.
- LINKSTIME.COM, INC., BELLEVUE, WA:
2,491,843. CANC. INT. CL. 41.
- LINNAEA FARM, DURANGO, CO:
3,479,440. PUB. 5-20-2008. INT. CL. 29.
- LION RIBBON COMPANY, INC., WILMINGTON, DE:
859,528. REN. 7-3-08. U.S. CL. 7 (INT. CL. 17).
- LION'S CREST LLC, PAOLI, PA:
3,482,641. INT. CL. 24.
- LIOW, TIAN KONG, CARSON, CA:
3,479,402. PUB. 5-20-2008. INT. CL. 25.
- LIPYANEK, SUSAN E, BRICK, NJ:
3,481,275. INT. CL. 9.
- LIQUID PUBLISHING, LLC, NORTH MIAMI BEACH, FL:
3,482,233. MULTIPLE CLASS, INT. CLS. 9, 16 AND 25.
- LIQUIDATION CONNECT INC., SAN DIEGO, CA:
3,480,325. PUB. 5-20-2008. INT. CL. 35.
- LIQUIDPIXELS, INCORPORATED, FAIRPORT, NY:
3,479,075. PUB. 5-20-2008. INT. CL. 42.
- LISA FRANK, INC., TUCSON, AZ:
2,493,057. CANC. INT. CL. 28.
- LISNOV, ROBIN K., CHICAGO, IL, DBA RAVENOUS RITA ENTERPRISES, INCORPORATED:
2,491,963. CANC. INT. CL. 30.
- LIST-UNIVERSE.COM CORPORATION, GREEN BAY, WI:
2,492,663. CANC. INT. CL. 35.
2,492,664. CANC. INT. CL. 35.
- LISTING, LINDA, CANONSBURG, PA, DBA URSULA'S ALCOVE:
2,596,641. CANC. MULTIPLE CLASS, INT. CLS. 23 AND 24.
- LITEGLOW INDUSTRIES, INC., POMPANO, FL:
2,098,673. CANC. INT. CL. 11.
- LITHOTEL SOFTWARE DESIGN LTD., WHITBY, CANADA:
3,481,726. INT. CL. 9.
- LITTLE GIANT PUMP COMPANY, OKLAHOMA CITY, OK:
1,488,128. REN. 7-3-08. INT. CL. 7.
- LITTLE, SUSAN A. S., FREDERICKTOWN, OH:
2,492,808. CANC. INT. CL. 18.
- LITTLER, MENDELSON, FASTIFF, TICHY & MATHIASON, P.C., SAN FRANCISCO, CA TO LITTLER MENDELSON, P.C., SAN FRANCISCO, CA:
2,098,712. CANC. MULTIPLE CLASS, INT. CLS. 16 AND 41.
- LIVBAG., 755017 PARIS, FRANCE:
2,581,197. CANC. INT. CL. 12.
- LIVE NATION MOTOR SPORTS, INC., AURORA, IL:
2,493,090. CANC. INT. CL. 25.
- LIVETV, LLC, MELBOURNE, CA:
2,541,216. CANC. INT. CL. 9.
- LIZ CLAIBORNE, INC., NEW YORK, NY:
3,482,553. INT. CL. 3.
- LLOYDCO, LLC, MENLO PARK, CA:
3,482,422. INT. CL. 8.
- LNT MERCHANDISING COMPANY, LLC, CLIFTON, NJ:
3,482,045. MULTIPLE CLASS, INT. CLS. 11, 20 AND 24.
- LOANGENIE.COM, INC., IRVINE, CA:
2,492,127. CANC. INT. CL. 36.
- LOCKE, NELSON, PEMBROKE PINES, FL:
3,479,310. PUB. 5-20-2008. INT. CL. 41.
3,479,403. PUB. 5-20-2008. INT. CL. 36.
- LOEFFLER'S SAFETY SHOES, INC., ST. PAUL, MN:
1,458,457. CANC. INT. CL. 25.
- LOGIC MICROSYSTEMS, L.L.C., SHAWNEE MISSION, KS:
2,492,136. CANC. INT. CL. 42.
- LOGIC PRODUCTIONS, INC., MIDLAND, TX:
2,150,168. REN. 6-30-08. INT. CL. 9.
- LOGITECH INTERNATIONAL S.A., APPLES, SWITZERLAND:
2,170,413. REN. 7-3-08. INT. CL. 25.
- LOGITECH INTERNATIONAL S.A., CH 1143 APPLES, SWITZERLAND:
2,493,646. CANC. INT. CL. 9.
- LOHMAN MANUFACTURING COMPANY, INC., NEOSHO, MO TO FLAMBEAU, INC., BARABOO, WI:
2,100,076. CANC. INT. CL. 28.
- LOLA CION'S, INC., WAUKEGAN, IL:
2,098,723. CANC. MULTIPLE CLASS, INT. CLS. 29, 30 AND 42.
- LOMBARD TECHNOLOGIES, INC., BETHESDA, MD:
2,493,512. CANC. MULTIPLE CLASS, INT. CLS. 6 AND 40.
- LONDON GROUP, LLC, OLD WESTBURY, NY:
3,478,841. PUB. 5-20-2008. INT. CL. 33.
- LONG & FOSTER COMPANIES, INC., FAIRFAX, VA:
3,479,441. PUB. 5-20-2008. INT. CL. 38.
- LONG HAUL CLINCS LLC, FORT MYERS, FL:
3,482,698. MULTIPLE CLASS, INT. CLS. 35 AND 44.

LONG SHOE CORPORATION, TAIPEI HSIEN, TAIWAN:
2,100,107, CANC. INT. CL. 25.

LONG, JOANNE M., ORANGEVILLE, PA:
2,099,107, CANC. INT. CL. 29.

LONGWOOD SOFTWARE, INC., MAYNARD, MA:
3,480,015, PUB. 5-20-2008. INT. CL. 9.

LORD AND MASON ENTERPRISES, INC., GERMAN-
TOWN, MD:
3,482,034, INT. CL. 27.

LORD'S & LADY'S HAIR SALON, INC., WEST ROXBURY,
MA:
1,458,776, CANC. INT. CL. 42.

LOTUFO, ROBERT J, HIXSON, TN:
3,479,744, PUB. 5-20-2008. INT. CL. 19.

LOTUS GARDEN MEDITATION CENTER, CARMICHAEL,
CA:
3,481,257, INT. CL. 41.

LOUIS GARNEAU SPORTS INC., QUEBEC, CANADA:
2,098,532, CANC. MULTIPLE CLASS, INT. CLS. 12 AND
25.

LOURENS FISHER; DESIGN & INVESTMENTS N.V., NETH-
ERLD ANTILLES:
3,480,834, PUB. 5-20-2008. MULTIPLE CLASS, INT. CLS.
9, 25, 28 AND 41.

LOVE HEALS, LLC, OJAI, CA:
3,479,221, PUB. 5-20-2008. INT. CL. 25.

LOVE, TIMOTHY, EDWARDS, MS:
3,481,848, INT. CL. 37.

LOVELAND PRODUCTS, INC., GREELEY, CO, UNITED
AGRI PRODUCTS, INC., GREELEY, CO:
1,491,785, REN. 6-30-08. INT. CL. 1.

LOVELAND PRODUCTS, INC., GREELEY, CO:
2,250,540, REN. 6-30-08. INT. CL. 1.

LOVER'S LANE I.P., LTD., PLYMOUTH, MI:
3,481,790, INT. CL. 35.

LOWE, MARK A, BRENTWOOD, NY AND OLIVER,
DWIGHT A, FT LAUDERDALE, FL:
3,478,816, PUB. 5-20-2008. INT. CL. 9.

LOYALTY AWARD SERVICES, DALLAS, TX:
3,479,509, PUB. 5-20-2008. INT. CL. 35.

LPG SYSTEMS, 26000 VALENCE, FRANCE:
2,175,335, REN. 7-3-08. INT. CL. 10.

LPG SYSTEMS (SOCIÉTÉ ANONYME), F-26000 VALENCE,
FRANCE:
3,480,949, PUB. 5-20-2008. INT. CL. 10.

LR PHARMACEUTICALS, LP, YARDLEY, PA:
2,491,947, CANC. INT. CL. 5.

LRC PRODUCTS LIMITED, CHINGFORD, LONDON E4
8QA, ENGLAND:
2,099,785, CANC. MULTIPLE CLASS, INT. CLS. 5 AND
10.

LS INDUSTRIAL SYSTEMS CO., LTD., SEOUL, REPUBLIC
OF KOREA:
3,482,237, INT. CL. 9.

LTC FINANCIAL PARTNERS, LLC, KIRKLAND, WA:
3,482,735, MULTIPLE CLASS, INT. CLS. 16 AND 41.

LTI ACQUISITION, LLC, FORT WAYNE, IN, DBA LAMBDA
TECH:
2,099,826, CANC. INT. CL. 9.

LUCAS INDUSTRIE PLC, SOLIHULL MIDLANDS, ENG-
LAND:
1,458,070, CANC. INT. CL. 9.

LUCASEY MANUFACTURING CORPORATION, OAK-
LAND, CA:
2,491,734, CANC. INT. CL. 6.

LUCENT TECHNOLOGIES INC., MURRAY HILL, NJ:
2,099,158, CANC. INT. CL. 28.

LUCIANO, ROBERT A., RENO, NV:
2,492,893, CANC. INT. CL. 9.

LUCKY DOG EQUIPMENT, INC., WOODINVILLE, WA:
2,099,472, CANC. INT. CL. 28.

LUCKY 13, INC., BOISE, ID:
3,480,679, PUB. 5-20-2008. INT. CL. 43.

LUCY ACTIVEWEAR, INC., PORTLAND, OR:
3,482,503, INT. CL. 25.

LUDWIG CREATIVE, INC., PORTLAND, OR:
3,478,612, PUB. 5-20-2008. INT. CL. 16.

LUER, PAMELA, MINNEAPOLIS, MN:
2,492,623, CANC. INT. CL. 42.

LUMINEX CORPORATION, AUSTIN, TX:
3,481,211, MULTIPLE CLASS, INT. CLS. 1 AND 5.
3,481,212, MULTIPLE CLASS, INT. CLS. 1 AND 5.

LUNA KIDS DANCE, ALBANY, CA:
2,492,344, CANC. INT. CL. 41.

LUNCHBAGZ, LLC, HEWLETT, NY:
3,481,814, INT. CL. 35.

LUND, INC., SUWANEE, GA:
2,169,476, REN. 7-3-08. INT. CL. 12.

LUNGARO, JIM, SOUTH HOLLAND, IL:
3,479,886, PUB. 5-20-2008. INT. CL. 29.

LUONGO, JOSEPH S., LAS VEGAS, NV:
2,491,688, CANC. INT. CL. 19.

LUPIN PHARMACEUTICALS, INC., BALTIMORE, MD:
3,482,025, INT. CL. 5.

LUSCO'S INC., GREENWOOD, MS:
2,154,851, REN. 6-30-08. INT. CL. 30.

LUTEX COMPANY LIMITED, WANCHAI, HONG KONG:
3,479,201, PUB. 5-20-2008. INT. CL. 3.

LYNCH, JONES & RYAN LLC, NEW YORK, NY:
2,493,068, CANC. INT. CL. 36.

LYNN DAVIS LASHER, HOUSTON, TX:
3,481,344, INT. CL. 30.

LYNN KLEINER'S MUSIC RHAPSODY, REDONDO
BEACH, CA:
3,480,646, PUB. 5-20-2008. INT. CL. 41.

LYNN, MAC, BRENTWOOD, TN:
2,171,694, REN. 7-3-08. INT. CL. 41.

L8-P INC, MISSISSAUGA, ONTARIO:
3,481,327, MULTIPLE CLASS, INT. CLS. 14 AND 25.

M & M CONSTRUCTION CONCEPTS & GUTTERS, LLC,
OREGON, OH:
3,480,223, PUB. 5-20-2008. INT. CL. 37.

M GROUP LLC, AKRON, OH:
3,482,256, INT. CL. 9.

M. L. ROBERT, II, L.L.C., NEW ORLEANS, LA:
2,492,199, CANC. INT. CL. 35.

M.S. DAFFNER DIAMONDS INTERNATIONAL, INC, RA-
MAT GAN, 52522, ISRAEL:
3,480,224, PUB. 5-20-2008. INT. CL. 14.

MÓVEIS CASA VERDE LTDA., MIRASSOL, STATE OF SAO
PAULO, BRAZIL:
3,478,495, PUB. 5-20-2008. INT. CL. 20.

MA 2, INC., SAN FRANCISCO, CA:
3,481,149, INT. CL. 42.

MAC KAF, INC., LOS ANGELES, CA:
3,478,548, PUB. 5-20-2008. INT. CL. 20.

MACDONALD, FRANK, ORINDA, CA AND MACDONALD,
SUSANNA, ORINDA, CA:
3,480,020, PUB. 5-20-2008. INT. CL. 19.

MACGREGOR GOLF NORTH AMERICA, INC., ALBANY,
GA:
3,482,439, INT. CL. 28.

MACHINERYLINK, INC., KANSAS CITY, MO:
3,481,958, INT. CL. 44.

MACNRO ENTERPRISES, ABERDEEN, NJ:
2,492,625, CANC. INT. CL. 19.

MACROPLAY.COM, INC., SAN FRANCISCO, CA:
2,493,477, CANC. INT. CL. 41.

MADAME MARTINE VAN DOORNE, MC-98000 MONACO,
MONACO:
3,405,656, COR. INT. CL. 35.

MADAN GROUP, JACKSONVILLE, FL:
2,493,357, CANC. INT. CL. 35.

MADISON, MARK E., SCHAUMBURG, IL:
2,492,039, CANC. INT. CL. 35.

MAGIC EYE, INC., PROVINCETOWN, MA:
3,479,427, PUB. 5-20-2008. INT. CL. 16.

MAGIC PICTURES COMPANY, CORPUS CHRISTI, TX:
2,493,514, CANC. INT. CL. 35.

MAGNEQUENCH GMBH, ESSEN, FED REP GERMANY:
2,492,649, CANC. INT. CL. 6.

MAGNETAR CAPITAL L.L.C., EVANSTON, IL:
3,478,664, PUB. 5-20-2008. INT. CL. 36.
3,478,665, PUB. 5-20-2008. INT. CL. 36.

- MAGNETI MARELLI POWERTRAIN S.P.A., CORBETTA, MILAN, ITALY:
2,492,425, CANC. INT. CL. 35.
- MAGNETNOTES, LTD., TOLEDO, OH:
3,478,636, PUB. 5-20-2008. INT. CL. 16.
- MAGNOLIA SPRINGS WATER CO., L.L.C., KENTWOOD, LA:
2,097,072, REN. 7-2-08. INT. CL. 32.
- MAHAFFEY, ANITA C, SAN DIEGO, CA:
3,481,760, INT. CL. 25.
- MAHARISHI AYUR-VED PRODUCTS INTERNATIONAL, INC., COLORADO SPRINGS, CO:
2,493,594, CANC. INT. CL. 5.
- MAINE WILD BLUEBERRY COMPANY, THE, MACHIAS, ME:
1,458,541, CANC. INT. CL. 29.
- MAINTENANCENET, INC., CARLSBAD, CA:
3,481,831, MULTIPLE CLASS, INT. CLS. 9 AND 42.
- MAIQUEZ INVESTMENTS, INC, MIAMI, FL:
3,479,838, PUB. 5-20-2008. INT. CL. 5.
- MAISON BLANCHE, INC., BATON ROUGE, LA:
1,458,790, CANC. INT. CL. 42.
- MAJESTIC DISTILLING COMPANY, INC., BALTIMORE, MD:
852,889, AM. U.S. CL. 33.
- MAJOR FARMS, INC., SALINAS, CA:
3,478,642, PUB. 5-20-2008. INT. CL. 31.
3,478,645, PUB. 5-20-2008. INT. CL. 31.
- MAJOR LEAGUE BASEBALL PROPERTIES, INC., NEW YORK, NY:
3,399,695, COR. INT. CL. 25.
- MAJOR LEAGUE LACROSSE LLC, BRIGHTON, MA:
3,481,237, INT. CL. 25.
3,482,212, INT. CL. 25.
3,482,291, INT. CL. 25.
- MAJOR LEAGUE SOCCER, LLC, NEW YORK, NY:
3,479,593, PUB. 5-20-2008. MULTIPLE CLASS, INT. CLS. 9, 16, 25, 28 AND 41.
3,479,595, PUB. 5-20-2008. MULTIPLE CLASS, INT. CLS. 9, 16, 25, 28 AND 41.
- MAJOR MOTION SPORTSWEAR, SAN FERNANDO, CA:
2,099,595, CANC. INT. CL. 25.
- MAKHSUDOVA, NORA, LA JOLLA, CA:
3,478,843, PUB. 5-20-2008. INT. CL. 32.
- MALEK PARTNERS LLC, MIAMI, FL:
3,480,166, PUB. 5-20-2008. INT. CL. 35.
- MALIBU DREAM GIRL, BELL, CA:
3,481,872, INT. CL. 25.
- MALO CREATIONS INC., CHOMEDEY, QUEBEC, CANADA:
2,217,230, REN. 7-1-08. INT. CL. 14.
- MALVERN FEDERAL SAVINGS BANK, PAOLI, PA:
1,458,674, CANC. INT. CL. 36.
- MAMA'S SPECIAL FAMILY, INC., HYDE PARK, VT:
3,480,343, PUB. 5-20-2008. INT. CL. 30.
3,480,344, PUB. 5-20-2008. INT. CL. 30.
- MAMMOTH SPORTS GROUP, INC., JESSUP, MD:
2,491,949, CANC. INT. CL. 35.
- MANAGEMENT OF DEVELOPMENT ASSISTANCE - MODA, CHEVY CHASE, MD:
2,493,016, CANC. INT. CL. 41.
- MANAGEMENT SCIENCE ASSOCIATES, INC., PITTSBURGH, PA:
2,492,301, CANC. INT. CL. 35.
- MANAGING EDITOR INC., JENKINTOWN, PA, DBA MEI:
3,479,539, PUB. 5-20-2008. INT. CL. 9.
- MANGIA SPECIALTIES INC., KING OF PRUSSIA, PA:
3,479,203, PUB. 5-20-2008. INT. CL. 35.
3,479,209, PUB. 5-20-2008. INT. CL. 19.
- MANHATTAN GROUP, LLC, MINNEAPOLIS, MN:
3,482,236, INT. CL. 28.
- MANJAR S.A., SAN MARTIN, BUENOS AIRES, ARGENTINA:
2,492,005, CANC. INT. CL. 30.
- MANN PACKING CO., INC., SALINAS, CA:
3,481,564, INT. CL. 29.
- MANN, WANDA, NEW YORK, NY:
3,479,704, PUB. 5-20-2008. INT. CL. 41.
- MANNA MARKETING & DEVELOPMENT GROUP, INC., DALLAS, TX:
3,480,393, PUB. 5-20-2008. INT. CL. 20.
- MANNINGTON MILLS, INC., SALEM, NJ:
2,493,485, CANC. INT. CL. 27.
3,481,179, INT. CL. 27.
3,481,889, INT. CL. 27.
- MANSION PRODUCTIONS, LLC, CARSON CITY, NV, DBA MANSION PRODUCTIONS, INC.:
3,480,481, PUB. 5-20-2008. INT. CL. 9.
- MANSON, DORIAN, YONKERS, NY:
3,482,289, MULTIPLE CLASS, INT. CLS. 9 AND 41.
- MANTEL, MIKE, REDONDO BEACH, CA, DBA MANHATTAN CHEMICAL:
2,493,528, CANC. INT. CL. 1.
- MANTIUS INTERNATIONAL, INC., ST. PAUL, MN:
2,493,502, CANC. INT. CL. 16.
- MAPA SPONTEX, INC., COLUMBIA, TN:
2,209,626, REN. 7-3-08. INT. CL. 9.
- MAPLE LEAF FOODS INC, TORONTO ONTARIO, CANADA:
2,098,894, CANC. INT. CL. 29.
- MAR-LEES SEAFOOD, LLC, NEW BEDFORD, MA:
3,479,461, PUB. 5-20-2008. INT. CL. 29.
- MARC DANZINELLI, SWITZERLAND:
3,480,941, PUB. 5-20-2008. INT. CL. 14.
- MARCANTONIO, LYNN H., SAN ANTONIO, TX:
2,493,564, CANC. INT. CL. 28.
- MARENO, EDMUND D. JR., STERLING HEIGHTS, MI:
2,491,879, CANC. INT. CL. 41.
- MARGOLIS, ANDREW B, ATLANTA, GA AND SHEPHERD, ROGER, WOODSTOCK, GA AND HOLLAND, JONATHAN, ACWORTH, GA:
3,479,984, PUB. 5-20-2008. INT. CL. 41.
- MARI MEZON DO MYU CO., LTD; (MARIE MAISON DE MIEUX CO., LTD), JAPAN:
3,480,978, PUB. 5-20-2008. INT. CL. 28.
- MARI'S NEW YORK, INC, NEW YORK, NY:
3,480,269, PUB. 5-20-2008. INT. CL. 30.
- MARIE-LISE BERCOVICI BISCHOFF, CH-1950 SION, SWITZERLAND:
3,480,994, PUB. 5-20-2008. INT. CL. 3.
- MARIETTA CORPORATION, CORTLAND, NY:
2,168,558, REN. 6-28-08. MULTIPLE CLASS, INT. CLS. 3, 25 AND 26.
- MARIN FERNANDEZ, CRISTOBAL, SPAIN:
3,480,934, PUB. 5-20-2008. MULTIPLE CLASS, INT. CLS. 28, 35 AND 38.
- MARIN, JAIME S., ORLANDO, FL:
3,480,681, PUB. 5-20-2008. INT. CL. 9.
- MARINE HARVEST USA, LLC, MIAMI, FL, BEAGLE PRODUCTS; INC., COCONUT GROVE, FL, DBA WINDWARD SEAFOODS:
2,165,902, REN. 6-30-08. INT. CL. 29.
- MARINE SHUTTLE OPERATIONS, INC., HOUSTON, TX:
2,493,063, CANC. INT. CL. 37.
- MARIO ENRICO MAYA, CALI, COLOMBIA:
3,479,144, PUB. 5-20-2008. INT. CL. 43.
- MARION, JOSEPH, SANTA BARBARA, CA:
3,478,534, PUB. 5-20-2008. INT. CL. 16.
- MARITIME-ONTARIO FREIGHT LINES LIMITED, BRAMPTON, ONTARIO:
3,480,647, PUB. 3-11-2008. MULTIPLE CLASS, INT. CLS. 35 AND 39.
- MARK DAVID-TOOZE, AUSTRALIA AND BELINDA DAVID-TOOZE, AUSTRALIA:
3,480,821, PUB. 5-20-2008. MULTIPLE CLASS, INT. CLS. 18 AND 25.
- MARK DUNOW, RENO, NV:
3,478,946, PUB. 5-20-2008. INT. CL. 28.
- MARK NET WORLD, INC., MEQUON, WI TO TRISEPT TECHNOLOGY, LLC, MILWAUKEE, WI:
2,099,203, CANC. INT. CL. 39.
- MARK WINKLER COMPANY, THE, ALEXANDRIA, VA:
2,492,018, CANC. MULTIPLE CLASS, INT. CLS. 36 AND 37.
- MARKET PLANNING SOLUTIONS INC., TULSA, OK:
3,481,657, INT. CL. 42.

MARKETING ARCHITECTS, INC., MINNEAPOLIS, MN:
3,481,913, INT. CL. 35.

MARKETING TECHNOLOGY SOLUTIONS INC., EDISON, NJ:
3,479,836, PUB. 5-20-2008. INT. CL. 35.
3,479,837, PUB. 5-20-2008. INT. CL. 35.

MARKLAND LABS, LTD., MARIANNA, AR:
1,458,278, CANC. INT. CL. 16.

MARRIOTT INTERNATIONAL, INC., BETHESDA, MD:
3,481,502, INT. CL. 43.
3,482,125, INT. CL. 36.

MARS FISHCARE NORTH AMERICA, INC., CHALFONT, PA:
3,481,949, INT. CL. 1.

MARS, INCORPORATED, MCLEAN, VA:
2,168,427, REN. 7-3-08. INT. CL. 11.

MARS, INCORPORATED, MC LEAN, VA:
2,357,218, CANC. INT. CL. 31.

MARS, INCORPORATED, MCLEAN, VA:
2,492,258, CANC. INT. CL. 16.
3,479,456, PUB. 5-20-2008. INT. CL. 31.
3,481,272, INT. CL. 30.
3,482,512, INT. CL. 30.
3,482,733, INT. CL. 31.

MARSHALL BANKFIRST CORP., MINNEAPOLIS, MN:
3,482,088, INT. CL. 36.

MARSHALL, BRIAN, SALEM, VA:
2,492,559, CANC. INT. CL. 12.

MARSHFIELD DOORSYSTEMS, INC., MARSHFIELD, WI:
3,481,915, MULTIPLE CLASS, INT. CLS. 19 AND 40.

MARSIN MEDICAL INTERNATIONAL, INC., PHILADELPHIA, PA:
2,492,585, CANC. INT. CL. 10.

MARTIAL ARTS MARKETING, INCORPORATED, LAKEWOOD, CO:
2,587,822, CANC. INT. CL. 28.

MARTIN, SAMUEL B., WALKERTON, VA:
3,481,124, INT. CL. 36.

MARTINEZ JR., MISAEL, BROWNSVILLE, TX:
2,492,792, CANC. INT. CL. 41.

MARVEL CHARACTERS, INC., BEVERLY HILLS, CA:
3,481,507, INT. CL. 16.

MARVIN, DORIS MOORE, RICHARDSON, TX:
3,479,193, PUB. 5-20-2008. INT. CL. 16.

MARY QUANT COSMETICS JAPAN LTD., TOKYO, JAPAN:
2,237,093, REN. 6-28-08. INT. CL. 3.

MARY QUANT COSMETICS JAPAN LTD., SHIBUYA-KU, TOKYO, JAPAN:
2,239,730, REN. 6-28-08. INT. CL. 3.
2,239,731, REN. 6-28-08. INT. CL. 3.

MARYED INTERNATIONAL, INC, STUART, FL:
3,479,796, PUB. 5-20-2008. INT. CL. 25.

MASCHINENFABRIK GUSTAV EIRICH GMBH & CO. KG, 74736 HARDHEIM, FED REP GERMANY:
3,480,810, PUB. 5-20-2008. MULTIPLE CLASS, INT. CLS. 7 AND 9.

MASCHOTT LLC, FAIRFAX, VA:
3,481,751, INT. CL. 28.

MASONITE HOLDINGS, INC., TAMPA, FL:
3,481,042, INT. CL. 19.

MASONRY ARTS, INC., BESSEMER, AL:
2,174,372, REN. 6-30-08. MULTIPLE CLASS, INT. CLS. 37 AND 40.

MASRI, RODNEY, STATESBORO, GA:
3,479,606, PUB. 5-20-2008. INT. CL. 34.

MASSACHUSETTS OFFICE OF THE INSPECTOR GENERAL, BOSTON, MA:
2,493,699, CANC. INT. CL. 41.

MASSIMO GUERRIERI, GREAT NECK, NY, DBA VIVINLI-NEA:
3,479,929, PUB. 5-20-2008. INT. CL. 10.

MASTER CRAFT PRODUCTS CORP., DANA POINT, CA:
2,203,605, REN. 7-3-08. INT. CL. 8.

MASTER LOCK COMPANY LLC, OAK CREEK, WI:
3,481,439, INT. CL. 9.
3,481,441, INT. CL. 9.

MASTER WHOLESALE, INC., SEATTLE, WA:
2,240,731, REN. 6-27-08. INT. CL. 35.

MASTERCARD INTERNATIONAL INCORPORATED, PURCHASE, NY:
2,224,601, REN. 7-3-08. INT. CL. 36.
2,236,542, REN. 7-3-08. MULTIPLE CLASS, INT. CLS. 9, 16, 36, 38, 39 AND 42.

MASTERCHEM INDUSTRIES LLC, IMPERIAL, MO:
3,481,756, INT. CL. 2.
3,481,759, INT. CL. 2.

MASTERCORE TECHNOLOGIES, INC., BOLINGBROOK, IL:
3,479,504, PUB. 5-20-2008. INT. CL. 21.

MASTRAN MUSIC GROUP, LLC, NASHVILLE, TN:
3,479,908, PUB. 5-20-2008. INT. CL. 9.

MAT-PAC, INC., HOWELL, NJ:
3,478,974, PUB. 5-20-2008. MULTIPLE CLASS, INT. CLS. 8, 16 AND 21.

MATADOR CAPITAL MANAGEMENT CORPORATION, ST. PETERSBURG, FL:
2,100,146, CANC. INT. CL. 36.

MATAS LLC, RENO, NV, DBA THE PEACOCK COLLECTION:
3,480,026, PUB. 5-20-2008. INT. CL. 24.

MATHISON, JULIET C.J., STONE MOUNTAIN, GA:
3,482,621, INT. CL. 41.

MATRICAL, INC., SPOKANE, WA:
3,480,232, PUB. 5-20-2008. INT. CL. 9.

MATSUI INTERNATIONAL CO., INC., GARDENA, CA:
3,482,382, INT. CL. 2.

MATTEL, INC., EL SEGUNDO, CA:
2,492,151, CANC. INT. CL. 28.
2,493,086, CANC. INT. CL. 28.
2,493,164, CANC. INT. CL. 28.
3,478,731, PUB. 5-20-2008. INT. CL. 41.
3,479,167, PUB. 5-20-2008. INT. CL. 28.
3,480,594, PUB. 5-20-2008. INT. CL. 28.
3,480,610, PUB. 5-20-2008. INT. CL. 28.
3,480,634, PUB. 1-9-2007. INT. CL. 28.
3,480,678, PUB. 5-20-2008. INT. CL. 28.
3,481,254, INT. CL. 28.
3,482,073, INT. CL. 28.
3,482,537, INT. CL. 28.

MATTHEW BENDER & COMPANY, INCORPORATED, NEWARK, NJ:
2,100,286, CANC. INT. CL. 9.

MATUR, S.L., 07800 IBIZA, SPAIN:
3,482,534, MULTIPLE CLASS, INT. CLS. 35 AND 43.

MAUI EXCELLENT, LLC, MAKAWAO, HI:
3,479,283, PUB. 5-20-2008. INT. CL. 5.

MAURICE RASGON, INC., VENICE, CA:
3,481,481, INT. CL. 3.

MAURICE SPORTING GOODS, INC., NORTHBROOK, IL:
2,493,029, CANC. INT. CL. 28.

MAVERICK MULTIMEDIA, EDMONDS, WA, DBA MAVERICK LABEL:
3,479,177, PUB. 5-20-2008. INT. CL. 16.

MAVERICK OVERSEAS TRADING, INC., ELIZABETH, NJ:
2,493,622, CANC. INT. CL. 1.

MAVERICK OVERSEAS TRADING, INC, ELIZABETH, NJ:
2,493,623, CANC. INT. CL. 1.

MAX ROHR, INC., WILMINGTON, DE:
2,166,531, REN. 6-30-08. INT. CL. 34.

MAXFIELD CANDY COMPANY, INC., SALT LAKE CITY, UT:
2,169,362, REN. 6-30-08. INT. CL. 30.

MAXFLIGHT CORPORATION, TOMS RIVER, NJ:
3,479,052, PUB. 5-20-2008. MULTIPLE CLASS, INT. CLS. 9 AND 41.

MAXI-LIFT, INC., DALLAS, TX:
2,176,699, REN. 6-28-08. INT. CL. 19.

MAXWELL TECHNOLOGIES, INC., SAN DIEGO, CA:
3,480,059, PUB. 5-20-2008. INT. CL. 9.

MAXXAIR VENT CORPORATION, TAMPA, FL:
2,166,083, REN. 6-30-08. INT. CL. 12.

MAY, SANDRA J, SOUTH AMBOY, NJ:
3,481,844, INT. CL. 3.

MAYBRUN, INC., SANTA ANA, CA:
3,480,616, PUB. 5-20-2008. INT. CL. 21.

- MAYERS, MERRI, CIRENCESTER, UNITED KINGDOM:
2,493,382, CANC. INT. CL. 3.
- MAYJUH LLC, BELLINGHAM, WA, DBA JOGO:
3,479,679, PUB. 5-20-2008. INT. CL. 41.
- MAZDA MOTOR CORPORATION, HIROSHIMA, JAPAN:
3,482,560, INT. CL. 12.
- MBRP INC., ONTARIO, CANADA:
3,482,028, INT. CL. 7.
- MBV LAW LLP, SAN FRANCISCO, CA:
3,478,853, PUB. 5-20-2008. INT. CL. 45.
- MC CORPORATION LIMITED, LONDON, ENGLAND:
3,479,033, PUB. 5-20-2008. INT. CL. 25.
- MCA INC., UNIVERSAL CITY, CA:
1,494,572, CANC. INT. CL. 41.
- MCCABE FUNERAL HOME, FARMINGTON HILLS, MI:
3,478,882, PUB. 5-20-2008. INT. CL. 41.
- MCCARDLE REALTY, INC., WILLIAMSBURG, VA:
2,161,395, REN. 7-1-08. INT. CL. 36.
- MCCARROLL, DON, ORANGE, CA:
3,480,019, PUB. 5-20-2008. INT. CL. 6.
- MCCLATCHY U.S.A., INC., SACRAMENTO, CA:
3,479,026, PUB. 5-20-2008. INT. CL. 16.
3,479,027, PUB. 5-20-2008. INT. CL. 16.
3,480,191, PUB. 5-20-2008. INT. CL. 41.
3,480,502, PUB. 5-20-2008. INT. CL. 41.
3,480,532, PUB. 5-20-2008. INT. CL. 16.
- MCCORMICK & COMPANY, INCORPORATED, SPARKS, MD:
2,223,936, REN. 7-3-08. MULTIPLE CLASS, INT. CLS. 29 AND 30.
- MCDANIEL, MITCHELL L., JACKSONVILLE, FL:
2,492,879, CANC. INT. CL. 41.
- MCDONALD'S CORPORATION, OAK BROOK, IL:
2,100,005, CANC. INT. CL. 25.
- MCDONNELL, SUSAN, NEWTOWN SQUARE, PA:
2,493,351, CANC. INT. CL. 35.
- MCGINNIS, MARTHA, E, EVANSTON, IL:
2,492,732, CANC. INT. CL. 42.
- MCILHENNY COMPANY, AVERY ISLAND, LA:
3,482,294, INT. CL. 30.
- MCKEE FOODS KINGMAN, INC., KINGMAN, AZ:
3,479,867, PUB. 5-20-2008. INT. CL. 30.
- MCKINLEY, INC., ANN ARBOR, MI:
3,478,969, PUB. 5-20-2008. INT. CL. 36.
- MCKINNON, KATHRYN, MARBLEHEAD, MA, DBA MCKINNON & CO.:
3,416,417, COR. INT. CL. 44.
- MCLANE GROUP INTERNATIONAL, L. P., SAN FRANCISCO, CA, DBA M-C INTERNATIONAL:
2,099,041, CANC. INT. CL. 35.
- MCNAIR, HOWARD, CLOVIS, CA:
2,493,479, CANC. INT. CL. 28.
- MCNEIL NUTRITIONALS, LLC, FORT WASHINGTON, PA:
3,481,105, INT. CL. 5.
3,481,106, INT. CL. 5.
- MCS (U.S.A.), INC., HIGHLAND PARK, IL:
2,492,558, CANC. INT. CL. 16.
- MCS CARGO SYSTEMS, INC., BENSENVILLE, IL:
3,479,823, PUB. 5-20-2008. INT. CL. 39.
- MCSI, INC., DAYTON, OH:
2,492,403, CANC. INT. CL. 36.
- MCSPADDEN, KEMPER J., THIBODAUX, LA:
2,493,211, CANC. INT. CL. 40.
- MDC SERVICES, INC., DALLAS, TX:
2,160,468, REN. 6-28-08. MULTIPLE CLASS, INT. CLS. 35 AND 42.
- ME BATH EXPERIENCE INC., LOS ANGELES, CA:
3,479,678, PUB. 5-20-2008. INT. CL. 3.
- MEAD CORPORATION, THE, DAYTON, OH:
2,099,507, CANC. INT. CL. 16.
- MEAD JOHNSON & COMPANY, EVANSVILLE, IN:
2,492,314, CANC. INT. CL. 30.
- MECCA WAREHOUSE LIMITED, HAMILTON, NEW ZEALAND:
3,480,644, PUB. 5-20-2008. INT. CL. 9.
- MECENA FINANCE LTD., ZUG, SWITZERLAND:
3,480,580, PUB. 5-20-2008. INT. CL. 35.
- MED-STAFF, LLC, ST. LOUIS, MO:
3,479,365, PUB. 5-20-2008. INT. CL. 44.
- MEDA PHARMACEUTICALS INC., SOMERSET, NJ, CARTER-WALLACE, INC., NEW YORK, NY:
852,595, REN. 7-2-08. U.S. CL. 18 (INT. CL. 5).
- MEDEX MERCHANDISING, INC., MELROSE PARK, IL:
3,481,140, INT. CL. 35.
- MEDI-LAW SOLUTIONS, SHORT HILLS, NJ:
3,479,563, PUB. 5-20-2008. INT. CL. 45.
- MEDI-PROMOTIONS, INC., LINDHURST, NJ:
1,458,313, CANC. INT. CL. 16.
- MEDIA-SCREEN LLC, SAN FRANCISCO, CA:
3,482,661, MULTIPLE CLASS, INT. CLS. 16 AND 42.
- MEDIACHASE, LTD., WEST HOLLYWOOD, CA:
2,491,915, CANC. INT. CL. 41.
- MEDICAL DEVELOPMENT INTERNATIONAL LTD., INC., PONTE VEDRA BEACH, FL:
3,481,784, INT. CL. 42.
- MEDICAL DIRECTIONS, INC., TUCSON, AZ:
3,479,841, PUB. 5-20-2008. INT. CL. 41.
- MEDICAL KNOWLEDGE GROUP LLC, NEW YORK, NY:
3,478,820, PUB. 5-20-2008. INT. CL. 35.
- MEDICAL MUTUAL OF OHIO, CLEVELAND, OH:
3,479,610, PUB. 5-20-2008. INT. CL. 36.
- MEDICAL SOLUTIONS, INC., CHANTILLY, VA:
3,482,271, INT. CL. 11.
- MEDICAL UNIFORM MANUFACTURING INC, BELLAIRE, TX:
3,480,366, PUB. 5-20-2008. INT. CL. 10.
- MEDIMEDIA USA, INC., YARDLEY, PA:
3,482,376, INT. CL. 16.
- MEDINA, WILLIAM DAVID, DREXEL HILL, PA:
2,492,272, CANC. INT. CL. 41.
- MEDISYNC HEALTHCARE SOLUTIONS, LLC, CINCINNATI, OH:
3,481,897, INT. CL. 41.
- MEDPORT LLC, PROVIDENCE, RI:
1,090,565, REN. 7-2-08. INT. CL. 20.
- MEDSCHOOL.COM, INC., SANTA MONICA, CA:
2,492,118, CANC. INT. CL. 41.
- MEDTRONIC XOMED, INC., JACKSONVILLE, FL:
3,481,613, INT. CL. 10.
- MEGA INDUSTRIES, INC., NEW YORK, NY:
2,492,224, CANC. INT. CL. 14.
- MEGESTER, INC., CLEARWATER, FL:
3,479,826, PUB. 5-20-2008. INT. CL. 5.
3,480,541, PUB. 5-20-2008. INT. CL. 32.
- MEI, LLC, MINNEAPOLIS, MN:
3,416,134, AM. MULTIPLE CLASS, INT. CLS. 21 AND 24.
- MEI, YUE QIN WILLIAM, CHICAGO, IL:
3,481,833, INT. CL. 30.
- MEISEL PHOTOGRAPHIC CORPORATION:
1,458,340, CANC. INT. CL. 16.
- MEL JACKSON TAX SERVICE, INC., CHARLOTTE, NC:
1,491,416, REN. 6-27-08. INT. CL. 35.
- MELIA ENTERPRISES, INC., DECATUR, GA:
2,491,906, CANC. INT. CL. 28.
- MEMIC SERVICES, INC., PORTLAND, ME, DBA MEMIC SAFETY SERVICES:
2,099,600, CANC. MULTIPLE CLASS, INT. CLS. 35 AND 41.
- MEMORIAL HEALTH SERVICES, INC., LONG BEACH, CA:
2,190,335, REN. 7-3-08. MULTIPLE CLASS, INT. CLS. 41 AND 42.
- MENARD, INC., EAU CLAIRE, WI:
3,481,721, INT. CL. 12.
3,481,722, INT. CL. 12.
3,481,734, INT. CL. 8.
3,481,735, INT. CL. 12.
3,481,736, INT. CL. 20.
3,481,737, INT. CL. 20.
3,481,738, INT. CL. 8.
- MENDWELL LLC, IDAHO FALLS, ID:
3,480,336, PUB. 5-20-2008. INT. CL. 36.
- MERBETH, LAURA J., SUSSEX, WI:
3,482,488, INT. CL. 20.
- MERCIAN CORPORATION, CHUO-KU, TOKYO, JAPAN:
2,493,396, CANC. INT. CL. 42.

- MERCK KGAA, 64293 DARMSTADT, FED REP GERMANY:
2,492,910, CANC. INT. CL. 40.
- MEREDITH COLLEGE, RALEIGH, NC:
3,480,179, PUB. 5-20-2008. INT. CL. 41.
3,480,180, PUB. 5-20-2008. INT. CL. 16.
- MEREDITH CORPORATION, DES MOINES, IA:
3,482,725, MULTIPLE CLASS, INT. CLS. 16 AND 43.
- MERIT DIAMOND CORPORATION, HOLLYWOOD, FL:
3,481,740, INT. CL. 14.
- MERLYN ASSOCIATES, INC., TUSTIN, CA, DBA MERLYN MEDICAL:
3,479,442, PUB. 5-20-2008. INT. CL. 10.
- MERRILL LYNCH BANK & TRUST CO., FSB, NEW YORK, NY, FIRST REPUBLIC BANK, SAN FRANCISCO, CA:
2,204,182, REN. 6-30-08. INT. CL. 16.
- MESSAGE MANAGEMENT AS, NORWAY:
3,480,916, PUB. 5-20-2008. MULTIPLE CLASS, INT. CLS. 9, 38 AND 42.
- MESSAGEMEDIA, INC., BOULDER, CO:
2,492,805, CANC. INT. CL. 35.
2,492,806, CANC. INT. CL. 35.
- MESSIER-BUGATTI, 78140 VELIZY VILLACOUBLAY, FRANCE:
2,491,981, CANC. MULTIPLE CLASS, INT. CLS. 1, 5, 7, 11, 22, 24, 40 AND 42.
- METACREATIONS CORPORATION, PRINCETON JUNCTION, NJ:
2,491,773, CANC. INT. CL. 42.
- METAFOUNDATION DBA POST CARBON INSTITUTE, SEBASTOPOL, CA:
3,478,978, PUB. 5-20-2008. INT. CL. 42.
- METALS USA BUILDING PRODUCTS, L.P., DALLAS, TX:
3,481,528, INT. CL. 6.
- METAXA B.V., NETHERLANDS:
3,481,018, PUB. 5-20-2008. MULTIPLE CLASS, INT. CLS. 21, 25 AND 33.
- METHODE ELECTRONICS, INC., CHICAGO, IL:
1,339,048, REN. 7-3-08. INT. CL. 9.
1,339,049, REN. 7-3-08. INT. CL. 9.
- METRIX INSTRUMENT CO., L.P., HOUSTON, TX:
1,458,084, CANC. INT. CL. 9.
2,099,358, CANC. INT. CL. 9.
- METRO INDUSTRIES INC., WILKES BARRE, PA, INTERMETRO INDUSTRIES CORPORATION, WILKES BARRE, PA:
1,489,851, REN. 7-2-08. MULTIPLE CLASS, INT. CLS. 6, 11, 12, 20, 21 AND 22.
- METROPOLITAN BANK & TRUST, MAYFIELD HEIGHTS, OH:
2,492,289, CANC. INT. CL. 36.
- METROPOLITAN EDUCATION DISTRICT, SAN JOSE, CA:
2,492,749, CANC. INT. CL. 41.
- METROPOLITAN LIFE INSURANCE COMPANY, LONG ISLAND CITY, NY:
3,479,630, PUB. 5-20-2008. INT. CL. 36.
- METZ BAKING COMPANY, SIOUX CITY, IA:
2,491,711, CANC. INT. CL. 30.
- MEXICRAFT, INC., MIAMI, FL:
2,491,725, CANC. MULTIPLE CLASS, INT. CLS. 6, 20 AND 21.
- MEYER ACQUISITION CORPORATION, INC., SAN ANTONIO, CA:
1,493,883, REN. 6-30-08. INT. CL. 7.
- MEYER, KARL R., SCOTTSDALE, AZ:
3,480,466, PUB. 5-20-2008. MULTIPLE CLASS, INT. CLS. 39 AND 40.
- MEYERS PRINTING COMPANY, MINNEAPOLIS, MN:
3,479,731, PUB. 5-20-2008. INT. CL. 16.
- MFA INCORPORATED, COLUMBIA, MO:
3,481,984, INT. CL. 1.
- MFA OIL CO., COLUMBIA, MO:
1,458,852, CANC. INT. CL. 42.
- MGI LUXURY GROUP SA, 2502 BIEL, SWITZERLAND:
1,458,244, CANC. INT. CL. 14.
- MI MAMA'S TORTILLA, INC., OMAHA, NE:
1,458,570, CANC. INT. CL. 30.
- MIA BRAZILIA LLC, SAN DIEGO, CA:
3,479,352, PUB. 5-20-2008. INT. CL. 25.
- MIAMI UNIVERSITY COMMUNITY FEDERAL CREDIT UNION, OXFORD, OH:
3,480,286, PUB. 5-20-2008. INT. CL. 35.
- MICHAEL FOODS OF DELAWARE, INC., MINNETONKA, MN:
3,482,601, INT. CL. 29.
- MICHAEL'S CLOSET, INC, RANDOLPH, NJ:
3,482,616, INT. CL. 35.
- MICHAUD, JULIE, BOSTON, MA:
3,481,467, INT. CL. 3.
- MICHEL RICHARD, LLC, WASHINGTON, DC:
3,478,609, PUB. 5-20-2008. INT. CL. 43.
- MICHELLE HUESGEN, SAINT PETERS, MO, DBA MICHELLE VOLKERDING:
3,479,849, PUB. 5-20-2008. INT. CL. 41.
- MICHIGAN FIRST CREDIT UNION, LATHRUP VILLAGE, MI:
3,478,765, PUB. 5-20-2008. INT. CL. 36.
- MICHIGAN PHYSICIANS MUTUAL LIABILITY COMPANY, EAST LANSING, MI:
2,098,507, CANC. INT. CL. 36.
- MICRONAS GMBH, FREIBURG, FED REP GERMANY:
2,166,149, REN. 6-30-08. INT. CL. 9.
- MICRONAS GMBH, 79108 FREIBURG, FED REP GERMANY:
3,329,618, COR. INT. CL. 9.
- MICROSOFT CORPORATION, REDMOND, WA:
2,198,156, REN. 6-30-08. INT. CL. 39.
- MICROVENTION, INC., ALISO VIEJO, CA:
3,482,460, INT. CL. 10.
3,482,551, INT. CL. 10.
- MID RIVER MINERALS, INC., MORRIS, IL:
2,172,969, REN. 7-3-08. INT. CL. 1.
- MIDAS INTERNATIONAL CORPORATION, ITASCA, IL:
1,322,034, REN. 7-3-08. INT. CL. 12.
- MIDDLETON, CYNDI M., PEPPERELL, MA, DBA FOUR PAWS DESIGN:
3,479,472, PUB. 5-20-2008. INT. CL. 35.
- MIDO AG (MIDO SA) (MIDO LTD), LE LOCLE, SWITZERLAND, MIDO SOCIETE ANONYME, BIENNE, SWITZERLAND:
441,020, REN. 6-30-08. U.S. CL. 27 (INT. CL. 14).
- MIDWAY AMUSEMENT GAMES, LLC, CHICAGO, IL:
2,493,543, CANC. MULTIPLE CLASS, INT. CLS. 16 AND 28.
- MIDWEST INTERNATIONAL STANDARD PRODUCTS, INC., CHARLEVOIX, MI:
3,479,552, PUB. 5-20-2008. INT. CL. 7.
- MIDWEST PRINTING, INCORPORATED, WHEATON, IL:
3,481,687, INT. CL. 20.
- MIELE, INC., PRINCETON, NJ:
3,482,156, INT. CL. 7.
- MIGUEL TORRES S.A., SPAIN:
3,480,852, PUB. 5-20-2008. INT. CL. 33.
- MIHAYLOV, STEFAN V., SAN FRANCISCO, CA:
3,480,009, PUB. 5-20-2008. INT. CL. 9.
- MIKKESEN, JOHN, PHOENIX, AZ:
2,492,927, CANC. INT. CL. 18.
- MILANO FOOD CONCEPTS PRIVATE LIMITED, SINGAPORE, SINGAPORE:
3,409,038, COR. MULTIPLE CLASS, INT. CLS. 30 AND 43.
- MILESTONE TECHNOLOGIES, INC., FREMONT, CA:
2,491,720, CANC. INT. CL. 42.
- MILLCREEK COFFEE ROASTERS, SALT LAKE CITY, UT:
2,156,066, REN. 6-27-08. INT. CL. 30.
2,156,067, REN. 6-27-08. INT. CL. 30.
- MILLER FREEMAN, INC., SAN FRANCISCO, CA:
2,491,667, CANC. INT. CL. 35.
- MILLER INDUSTRIES, INC., OOLTEWAH, TN:
2,163,581, REN. 6-30-08. MULTIPLE CLASS, INT. CLS. 37 AND 39.
- MILLER, JAMES, P, SAUSALITO, CA:
3,480,181, PUB. 5-20-2008. INT. CL. 3.
- MILLER, SCOTT A., TRENTON, NJ:
3,482,126, INT. CL. 9.
- MILLIPORE CORPORATION, BILLERICA, MA:
2,157,583, REN. 7-3-08. MULTIPLE CLASS, INT. CLS. 1

- AND 5.
MILLTEX GROUP, INC., NEW YORK, NY:
3,482,615, INT. CL. 25.
MILUS INTERNATIONAL S.A., SWITZERLAND:
3,480,889, PUB. 5-20-2008. INT. CL. 14.
MIMAAPPAREL, INC., DOVER, DE:
3,479,892, PUB. 5-20-2008. INT. CL. 35.
MIND STRONG MEDIA, INC., DES PLAINES, IL:
3,481,556, INT. CL. 16.
MINDFULL CORPORATION, CHESTERFIELD, MO:
3,481,782, INT. CL. 28.
MINE O' MINE, INC., LOS ANGELES, CA:
2,099,667, CANC. MULTIPLE CLASS, INT. CLS. 9, 16
AND 25.
MINER, MARGUERITE, OCEANSIDE, CA, DBA MAGGIE-
BETH:
1,458,398, CANC. INT. CL. 24.
MINISTERIO INTERNACIONAL EL REY JESUS, INC.,
MIAMI, FL:
3,481,448, INT. CL. 41.
MINIT CHEF SPECIALITY FOODS, INC., DUNMORE, PA:
2,204,923, REN. 7-1-08. INT. CL. 29.
MINNESOTA MINING AND MANUFACTURING COM-
PANY, SAINT PAUL, MN, AKA 3M:
1,458,136, CANC. INT. CL. 9.
MINNESOTA TIMBERWOLVES BASKETBALL, NORTH
MANKATO, MN:
2,100,073, CANC. INT. CL. 41.
MINNESOTA VIKINGS FOOTBALL, LLC, EDEN PRAIRIE,
MN:
3,481,662, INT. CL. 41.
3,481,663, INT. CL. 41.
MIR MAQBOOL ALAM KHAN, NEW YORK, NY:
3,482,672, MULTIPLE CLASS, INT. CLS. 9 AND 41.
MIRACLE WORLD CORPORATION, SANTA CLARA, CA:
3,482,392, INT. CL. 3.
MIRENCO, INC, RADCLIFFE, IA:
2,491,680, CANC. INT. CL. 9.
MIRRA, DAVID, GREENVILLE, NC:
3,480,641, PUB. 5-20-2008. INT. CL. 12.
MISS MOLLY COSMETICS FOR KIDS PTY LTD., NEW
SOUTH WALES 2039, AUSTRALIA:
2,491,864, CANC. MULTIPLE CLASS, INT. CLS. 3, 5, 18,
21 AND 24.
MISSION ITECH HOCKEY, INC., IRVINE, CA:
3,482,161, INT. CL. 28.
MISSISSIPPI AUTHORITY FOR EDUCATIONAL TELEVI-
SION, JACKSON, MS:
2,492,741, CANC. MULTIPLE CLASS, INT. CLS. 38 AND
41.
MISSISSIPPI RIVER FESTIVAL, LLC, THE, EDWARDS-
VILLE, IL:
2,493,076, CANC. INT. CL. 41.
MISSOURI HIGHER EDUCATION LOAN AUTHORITY,
CHESTERFIELD, MO:
2,492,281, CANC. INT. CL. 36.
MISSOURI INSULATION & SUPPLY, INC., OZARK, MO:
3,480,207, PUB. 5-20-2008. MULTIPLE CLASS, INT. CLS.
35 AND 37.
MIST AND COOL LLC, SIMI VALLEY, CA:
3,480,188, PUB. 5-20-2008. INT. CL. 11.
MISTER TWISTER IP, LLC, IRVINE, CA:
3,482,436, INT. CL. 44.
MISTERS UNLIMITED, LLC, FORT LAUDERDALE, FL:
3,481,061, INT. CL. 11.
MITEK CORPORATION, PHOENIX, AZ:
2,160,090, REN. 7-3-08. INT. CL. 12.
3,481,224, INT. CL. 9.
MITSUBISHI ELECTRIC CORPORATION, CHIYODA-KU,
TOKYO, JAPAN:
3,478,692, PUB. 5-20-2008. INT. CL. 7.
MITSUBISHI MOTORS NORTH AMERICA, INC., CYPRESS,
CA:
3,481,771, INT. CL. 9.
MITSUBISHI SHOJI KAISHA, LTD., CHIYODA-KU, TO-
KYO, JAPAN:
2,491,805, CANC. MULTIPLE CLASS, INT. CLS. 8, 9, 15,
16, 18, 21, 22, 25, 27 AND 28.
MITTON, MICHELLE R., ANCHORAGE, AK:
3,480,331, PUB. 5-20-2008. INT. CL. 41.
MM SYSTEMS CORPORATION, PENDERGRASS, GA:
1,491,141, REN. 6-27-08. INT. CL. 17.
MMI BUSINESS BROKERS, INC., INDEPENDENCE, OH:
2,491,709, CANC. INT. CL. 35.
MMRC, LTD CO, SAN ANTONIO, TX:
3,480,233, PUB. 5-20-2008. INT. CL. 5.
MO INDUSTRIES, LLC, LOS ANGELES, CA:
3,480,524, PUB. 5-20-2008. INT. CL. 25.
MOBBSIX, LLC, LAKE OSWEGO, OR:
3,481,322, INT. CL. 14.
MODERN LUXURY MEDIA, LLC, CHICAGO, IL:
3,482,720, MULTIPLE CLASS, INT. CLS. 9 AND 16.
MOELLER GMBH, BONN, FED REP GERMANY:
3,479,021, PUB. 5-20-2008. INT. CL. 9.
MOFFLY PUBLICATIONS, INC., GREENWICH, CT:
3,478,769, PUB. 5-20-2008. MULTIPLE CLASS, INT. CLS.
16, 35 AND 41.
MOHAWK BRANDS, INC., WILMINGTON, DE, BIGELOW-
SANFORD, INC., GREENVILLE, NC:
1,051,944, REN. 6-27-08. INT. CL. 27.
MOHAWK CARPET CORPORATION, CALHOUN, GA:
2,492,912, CANC. INT. CL. 19.
MOIST, SHARON, BOSEMAN, MT:
3,482,111, INT. CL. 41.
MOLINA, NESTOR A., MIAMI, FL:
3,480,082, PUB. 5-20-2008. INT. CL. 41.
MOLINOS DE EL SALVADOR, SOCIEDAD ANONIMA DE
CAPITAL VARIABLE, SAN SALVADOR, EL SALVADOR:
3,481,163, INT. CL. 30.
MOLOGOUSIS, WILLIAM A., CICERO, IL:
3,479,432, PUB. 5-20-2008. INT. CL. 37.
MOMENTA, INC., NORTHWOOD, NH:
3,479,219, PUB. 5-20-2008. INT. CL. 16.
3,481,428, INT. CL. 16.
MONA LISA GALLERY & FRAMING, INC., MAPLEWOOD,
NJ:
3,479,066, PUB. 5-20-2008. MULTIPLE CLASS, INT. CLS.
35 AND 40.
MONARCH DESIGNS, INC., SCOTTSDALE, AZ, M&M
LUGGAGE CO., INC., JERSEY CITY, NJ, DBA VERDI:
1,095,989, REN. 7-1-08. INT. CL. 18.
MONDRIAN HOLDINGS, LLC, NEW YORK, NY:
3,479,119, PUB. 5-20-2008. MULTIPLE CLASS, INT. CLS.
36 AND 37.
MONEYMANAGERSERVICES.COM LLC, BETHESDA, MD:
2,492,106, CANC. INT. CL. 36.
MONOGRAM BRANDS, LLC, MEMPHIS, TN:
2,099,320, CANC. INT. CL. 29.
MONSANTO KASEI COMPANY, TOKYO, JAPAN:
1,457,854, CANC. INT. CL. 1.
MONSTER (CALIFORNIA), INC., LOS ANGELES, CA:
3,482,265, INT. CL. 35.
MONSTER, LLC, LAS VEGAS, NV:
3,480,583, PUB. 5-20-2008. INT. CL. 9.
MONTEFIORE MEDICAL CENTER, BRONX, NY:
3,482,275, MULTIPLE CLASS, INT. CLS. 9 AND 42.
3,482,341, MULTIPLE CLASS, INT. CLS. 9 AND 42.
MONTEGO BAY TRADING COMPANY, MERRITT IS-
LAND, FL:
2,098,682, CANC. INT. CL. 30.
MONTEREY JAZZ FESTIVAL, INC., MONTEREY, CA:
851,216, REN. 6-28-08. U.S. CL. 107 (INT. CL. 41).
MONTGOMERY, MRS. ANNIE WILHELMINA ALSTON,
WASHINGTON, DC, DBA MRS. ANNIE A. MONTGOM-
ERY:
1,458,741, CANC. INT. CL. 41.
MOON DEVIL, TEMPE, AZ:
3,479,074, PUB. 5-20-2008. INT. CL. 35.
MOONMAID BOTANICALS, COSBY, TN:
3,480,160, PUB. 5-20-2008. INT. CL. 3.
MOORBROOK TEXTILES LIMITED, AYR KA8 8HJ, SCOT-
LAND:
2,491,708, CANC. INT. CL. 24.
MOORE NORTH AMERICA, INC., GRAND ISLAND, NY:
2,492,104, CANC. INT. CL. 7.

- MOORE, AARON, EVERETT, WA:
3,480,154, PUB. 5-20-2008. INT. CL. 25.
- MOORE, ANDREW, OTTAWA, KS AND MAXWELL, ANDREW, OTTAWA, KS:
3,481,271, INT. CL. 25.
- MOORE, WILDEY J., WARREN, CT:
2,492,916, CANC. INT. CL. 13.
- MORALES, ROBERT M., SAN ANTONIO, TX:
3,481,804, INT. CL. 11.
- MORETON BAY CORPORATION PTY LTD, CLEVELAND, AUSTRALIA:
3,479,023, PUB. 5-20-2008. INT. CL. 9.
- MORHACK, GEORGE C., ORLANDO, FL, DBA CARRINGTON CREATIONS:
2,492,995, CANC. INT. CL. 20.
- MORKES, INC., PALATINE, IL:
3,479,127, PUB. 5-20-2008. MULTIPLE CLASS, INT. CLS. 30 AND 35.
3,479,131, PUB. 5-20-2008. MULTIPLE CLASS, INT. CLS. 30 AND 35.
- MORPHOGENIX, LLC, NEW YORK, NY:
3,482,242, INT. CL. 41.
- MORRIS ANIMAL FOUNDATION, DENVER, CO:
3,480,430, PUB. 5-20-2008. MULTIPLE CLASS, INT. CLS. 36 AND 41.
- MORRIS/SWITZER & ASSOCIATES, INC., WILLISTON, VT:
2,492,421, CANC. INT. CL. 42.
- MORRISON MOLDED FIBER GLASS COMPANY, BRISTOL, VA:
1,458,703, CANC. MULTIPLE CLASS, INT. CLS. 37 AND 42.
- MORSE, JONATHAN E., SAN ANTONIO, TX AND SAWYER-MORSE, MARY KAYE, SAN ANTONIO, TX:
2,492,357, CANC. MULTIPLE CLASS, INT. CLS. 41 AND 42.
- MORTARA INSTRUMENT, INC., MILWAUKEE, WI:
1,514,402, REN. 6-30-08. INT. CL. 9.
- MORTGAGE MARKET GUIDE, LLC, HOLMDEL, NJ:
3,480,373, PUB. 5-20-2008. INT. CL. 41.
- MORTON INTERNATIONAL, INC., CHICAGO, IL, WORCESTER SALT COMPANY, NEW YORK, NY:
362,396, REN. 6-28-08. U.S. CL. 46 (INT. CL. 30).
- MORTON INTERNATIONAL, INC., CHICAGO, IL, MORTON INTERNATIONAL, INC., CHICAGO, IL:
860,258, REN. 6-28-08. U.S. CL. 46 (INT. CL. 31).
860,654, REN. 6-28-08. U.S. CL. 46 (INT. CL. 30).
- MORTON INTERNATIONAL, INC., CHICAGO, IL:
2,203,043, REN. 7-1-08. INT. CL. 1.
- MOSS, KATE, LONDON, UNITED KINGDOM:
3,479,067, PUB. 5-20-2008. INT. CL. 18.
- MOTHERWOMAN, INC., AMHERST, MA:
3,479,153, PUB. 5-20-2008. INT. CL. 45.
- MOTOR COACH INDUSTRIES, INC., SCHAUMBURG, IL:
2,121,666, REN. 6-28-08. INT. CL. 12.
- MOTOROLA, INC., SCHAUMBURG, IL:
2,493,467, CANC. INT. CL. 9.
- MOULIN D'OR COMPANY SARL, KISIRWAN, LEBANON:
3,479,305, PUB. 5-20-2008. INT. CL. 43.
- MOUNTAIN WEST REAL ESTATE, INC., CHULA VISTA, CA:
3,479,147, PUB. 5-20-2008. INT. CL. 36.
- MPS GROUP, INC., JACKSONVILLE, FL:
2,492,265, CANC. INT. CL. 35.
- MR LUCK, INC., GREENTOWN, PA:
3,481,622, INT. CL. 37.
- MR. AQUA CO., LTD., SHULIN CITY, TAIPEI COUNTY, TAIWAN:
3,481,103, INT. CL. 11.
- MR. H2O, LLC, SANTA MONICA, CA:
3,481,472, INT. CL. 21.
- MR. JOHN M. WILLIAMS, PUNTA GORDA, FL:
2,492,565, CANC. INT. CL. 19.
- MR. RICHIES FOODS INC., FLEMINGTON, NJ:
2,493,538, CANC. INT. CL. 29.
- MRP ACQUISITION LLC, ST. JOHNSBURY, VT, DBA MOOSE RIVER PUBLISHING INC.:
3,478,733, PUB. 2-12-2008. MULTIPLE CLASS, INT. CLS. 35, 38 AND 44.
- MRS. GREEN'S NATURAL MARKET, INC., EDMONTON, CANADA:
3,478,919, PUB. 5-20-2008. INT. CL. 35.
- MT. DEFIANCE WINE COMPANY, HOOD RIVER, OR:
3,481,451, INT. CL. 33.
- MT. WOODGEE SURFBOARDS PTY. LTD., BURLEIGH HEADS, QUEENSLAND, 4220, AUSTRALIA:
2,163,723, REN. 7-3-08. MULTIPLE CLASS, INT. CLS. 25 AND 28.
- MTD PRODUCTS INC, CLEVELAND, OH, WATCO MACHINE PRODUCTS, INC., TROY, NY:
850,181, REN. 7-1-08. U.S. CL. 23 (INT. CL. 7).
- MTI ENTERPRISES, INC., NEW YORK, NY, DBA MUSIC THEATRE INTERNATIONAL:
3,480,736, PUB. 5-20-2008. MULTIPLE CLASS, INT. CLS. 9 AND 16.
- MUELLER, BARTRAM P, COLLIERVILLE, TN:
2,492,494, CANC. INT. CL. 41.
- MUHAMMAD, GENGHIS KHALID (GKM), NEW YORK, NY:
3,478,507, PUB. 5-20-2008. INT. CL. 41.
- MULLER, ALBERT J., GLEN RIDGE, NJ:
2,493,165, CANC. INT. CL. 37.
- MULTICARE HEALTH SYSTEM, TACOMA, WA:
3,478,890, PUB. 5-20-2008. INT. CL. 44.
- MULVANEY, KATHLEEN, WEST BABYLON, NY:
3,482,509, INT. CL. 20.
- MUN, JOHNATHAN, PLEASANTON, CA:
3,482,705, INT. CL. 9.
3,482,706, INT. CL. 9.
3,482,707, INT. CL. 9.
- MUNDO L.L.C, WEST NEW YORK, NJ:
2,492,819, CANC. INT. CL. 31.
- MUNGO, PAUL, VIRGINIA BEACH, VA:
3,482,090, INT. CL. 21.
- MUNOZ, MICHAEL, GLENDORA, CA:
3,482,175, INT. CL. 41.
- MUNRO & ASSOCIATES, INC., TROY, MI:
3,479,430, PUB. 5-20-2008. MULTIPLE CLASS, INT. CLS. 35, 40 AND 42.
- MUNSOK SO, TOWN AND COUNTRY, MO:
3,480,384, PUB. 5-20-2008. INT. CL. 43.
3,480,501, PUB. 5-20-2008. INT. CL. 43.
- MURIDAL INC., LE GARDEUR, QUEBEC, J5Z 4W8, CANADA:
3,478,509, PUB. 5-20-2008. MULTIPLE CLASS, INT. CLS. 19 AND 40.
- MURIDAL INC., LE GARDEUR, QUEBEC, CANADA:
3,478,510, PUB. 5-20-2008. MULTIPLE CLASS, INT. CLS. 19 AND 40.
- MURPHY, JOHN S., GLENDALE, CA, DBA MURPHY & ASSOCIATES, INC.:
3,479,323, PUB. 5-20-2008. INT. CL. 9.
- MURPHY, LINDA M, NAPLES, FL:
3,478,898, PUB. 5-20-2008. INT. CL. 9.
- MUSICBABY LLC, CHEYENNE, WY:
3,479,807, PUB. 5-20-2008. INT. CL. 35.
- MUSICIP CORPORATION, MONROVIA, CA:
3,482,520, INT. CL. 9.
- MVP ENTERTAINMENT, INC., OAK BROOK, IL:
2,491,650, CANC. INT. CL. 16.
- MVP.COM SPORTS, INC., FT. LAUDERDALE, FL:
2,493,187, CANC. INT. CL. 35.
- MW SECURITY AB, SWEDEN:
3,480,807, PUB. 5-20-2008. MULTIPLE CLASS, INT. CLS. 9, 42 AND 45.
- MY GIZMOS, INC., MINDEN, NV:
3,481,204, MULTIPLE CLASS, INT. CLS. 37 AND 42.
- MY TALENT LINK, LLC, MAYFIELD HEIGHTS, OH:
3,479,897, PUB. 5-20-2008. INT. CL. 42.
3,479,898, PUB. 5-20-2008. INT. CL. 42.
- MYCELIUM HOLDINGS LLC, PRINCETON, NJ:
3,479,608, PUB. 5-20-2008. INT. CL. 42.
- MYCHELLE DERMACEUTICALS LLC, FRISCO, CO:
3,480,587, PUB. 5-20-2008. INT. CL. 3.
- MYERS, HAROLD KEITH, MONTREAL, QUEBEC, CANADA:
3,482,312, INT. CL. 9.

- MYKKO, NAAMLOZE VENNOOTSCHAP, BELGIUM:
3,481,015, PUB. 5-20-2008. INT. CL. 20.
- MYMENU CANADA INC., KITCHENER, ONTARIO, CANADA:
3,481,345, INT. CL. 35.
3,481,346, INT. CL. 35.
- MYWORLDIS INCORPORATED, CHARLOTTE, NC:
3,480,145, PUB. 5-20-2008. INT. CL. 45.
- M2 INNOVATIVE CONCEPTS, INC., TACOMA, WA:
2,492,676, CANC. INT. CL. 19.
- M25 INVESTMENTS, LLC, WAXAHACHIE, TX:
3,479,374, PUB. 5-20-2008. INT. CL. 9.
- MÜLHENS GMBH & CO. KG, 50823 KÖLN, FED REP GERMANY:
3,480,776, PUB. 5-20-2008. INT. CL. 3.
- N GOLDRING CORPORATION, NEW ORLEANS, LA:
3,479,062, PUB. 5-20-2008. INT. CL. 39.
- NAACH COMPANY, SAN JOSE, CA:
3,482,131, MULTIPLE CLASS, INT. CLS. 25 AND 41.
- NABISCO BRANDS COMPANY, WILMINGTON, DE:
2,493,136, CANC. INT. CL. 30.
2,493,137, CANC. INT. CL. 30.
- NACA LOGISTICS (USA), INC., CARSON, CA:
3,478,759, PUB. 5-20-2008. MULTIPLE CLASS, INT. CLS. 35 AND 39.
- NAF NAF DISTRIBUTION B.V., NETHERLANDS:
3,480,923, PUB. 5-20-2008. MULTIPLE CLASS, INT. CLS. 18 AND 25.
- NAKED LONGBOARDS, LLC, VENTURA, CA:
3,479,266, PUB. 5-20-2008. MULTIPLE CLASS, INT. CLS. 20 AND 25.
- NAKHEEL CO LLC, DUBAI, UNITED ARAB EMIR.:
3,480,742, PUB. 5-20-2008. MULTIPLE CLASS, INT. CLS. 35 AND 42.
- NAMCO BANDAI GAMES AMERICA INC., SANTA CLARA, CA:
2,492,764, CANC. INT. CL. 9.
- NAMCO BANDAI GAMES INC., TOKYO, JAPAN:
3,481,840, MULTIPLE CLASS, INT. CLS. 9 AND 41.
3,481,841, INT. CL. 28.
- NAME BADGE PRODUCTIONS, LLC, MIDDLETON, WI:
3,481,932, INT. CL. 20.
- NAN'S TROPISCAPES, INC., NAPLES, FL:
3,482,044, INT. CL. 27.
- NANTKER, JUDITH, CARPINTERIA, CA:
2,492,053, CANC. INT. CL. 25.
- NAPOLITANO, LEONARD SEVERIN, TEMPLETON, CA:
3,479,961, PUB. 5-20-2008. INT. CL. 43.
- NATIONAL AGING IN PLACE COUNCIL, WASHINGTON, DC:
3,482,671, INT. CL. 35.
3,482,673, U.S. CL. 200.
- NATIONAL AMUSEMENTS, INC., DEDHAM, MA:
3,481,962, INT. CL. 41.
- NATIONAL ASSOCIATION FOR STOCK CAR AUTO RACING, INC., DAYTONA BEACH, FL:
2,491,670, CANC. MULTIPLE CLASS, INT. CLS. 25, 28 AND 35.
- NATIONAL ASSOCIATION OF PEDIATRIC NURSE PRACTITIONERS, CHERRY HILL, NJ:
3,480,017, PUB. 5-20-2008. INT. CL. 35.
- NATIONAL AUDUBON SOCIETY, INC., NEW YORK, NY AND CORNELL UNIVERSITY, ITHACA, NY:
2,196,612, REN. 6-30-08. INT. CL. 42.
- NATIONAL AUTOMOTIVE PARTS ASSOCIATION, ATLANTA, GA:
1,457,872, CANC. INT. CL. 1.
- NATIONAL BLACK UNITED FUND, INC., NEWARK, NJ:
1,093,398, REN. 6-30-08. INT. CL. 36.
- NATIONAL BROADCAST MEDIA CORPORATION, AUSTIN, TX:
3,479,741, PUB. 5-20-2008. INT. CL. 35.
- NATIONAL CASA ASSOCIATION, SEATTLE, WA:
3,482,067, INT. CL. 16.
- NATIONAL CHEMICALS, INC., WINONA, MN:
1,506,731, REN. 7-3-08. INT. CL. 1.
1,506,750, REN. 7-3-08. INT. CL. 3.
1,516,124, REN. 7-3-08. INT. CL. 3.
1,516,938, REN. 7-3-08. INT. CL. 3.
- NATIONAL CONSUMER LAW CENTER, INC., BOSTON, MA:
3,479,521, PUB. 5-20-2008. MULTIPLE CLASS, INT. CLS. 16, 35, 41 AND 45.
3,479,522, PUB. 5-20-2008. MULTIPLE CLASS, INT. CLS. 16, 35, 41 AND 45.
- NATIONAL EDUCATION KNOWLEDGE INDUSTRY ASSOCIATION, INC., WASHINGTON, DC:
3,478,947, PUB. 5-20-2008. INT. CL. 35.
- NATIONAL EXPRESS CREDIT CORP., WILMINGTON, DE:
3,478,525, PUB. 5-20-2008. INT. CL. 35.
- NATIONAL FAMILY PARTNERSHIP, MIAMI, FL:
3,478,895, PUB. 5-20-2008. INT. CL. 35.
- NATIONAL FINANCIAL COMPUTER SYSTEMS, INC., SNELLVILLE, GA:
1,458,179, CANC. INT. CL. 9.
- NATIONAL FIRE PROTECTION ASSOCIATION, INC., QUINCY, MA:
3,480,270, PUB. 5-20-2008. MULTIPLE CLASS, INT. CLS. 9 AND 16.
- NATIONAL FOOTBALL LEAGUE, NEW YORK, NY:
2,174,223, REN. 7-2-08. INT. CL. 41.
- NATIONAL INDUSTRIES FOR THE BLIND, ALEXANDRIA, VA:
3,482,646, MULTIPLE CLASS, INT. CLS. 35, 39, 40, 41 AND 42.
- NATIONAL LIBRARY OF MEDICINE OF THE U.S. DEPARTMENT OF HEALTH AND HUMAN SERVICES, THE, BETHESDA, MD:
2,120,979, REN. 6-28-08. INT. CL. 42.
- NATIONAL LIFE INSURANCE COMPANY, MONTPELIER, VT:
3,481,578, INT. CL. 36.
- NATIONAL MANGO BOARD INC., ORLANDO, FL:
3,479,659, PUB. 5-20-2008. MULTIPLE CLASS, INT. CLS. 31 AND 35.
- NATIONAL MARINE ELECTRONICS ASSOCIATION, INC., SEVERNA PARK, MD:
3,482,640, INT. CL. 35.
- NATIONAL MEDICAL HEALTH CARD SYSTEMS, INC., PORT WASHINGTON, NY:
2,493,217, CANC. INT. CL. 42.
- NATIONAL MORTGAGE COMPLIANCE, LLC, WASHOUGAL, WA:
3,480,263, PUB. 5-20-2008. INT. CL. 36.
- NATIONAL MULTIPLE SCLEROSIS SOCIETY, NEW YORK, NY:
3,481,293, MULTIPLE CLASS, INT. CLS. 36 AND 41.
- NATIONAL REGISTRY OF REHABILITATION TECHNOLOGY SUPPLIERS, LAGO VISTA, TX:
3,481,100, MULTIPLE CLASS, INT. CLS. 40, 41 AND 42.
- NATIONAL SAFETY COMPLIANCE, INC., LAKEWOOD, NJ:
3,478,563, PUB. 5-20-2008. MULTIPLE CLASS, INT. CLS. 41, 42 AND 44.
- NATIONAL SINGLES ASSOCIATION, INC., ATLANTA, GA:
3,479,007, PUB. 5-20-2008. INT. CL. 35.
- NATIONAL SOCIETY OF COMPLIANCE PROFESSIONALS, CORNWALL BRIDGE, CT:
3,479,300, PUB. 5-20-2008. INT. CL. 35.
- NATIONAL TECHNICAL INFORMATION SERVICE U.S. DEPARTMENT OF COMMERCE, SPRINGFIELD, VA:
2,165,198, REN. 7-1-08. INT. CL. 35.
- NATIONAL-LOUIS UNIVERSITY, CHICAGO, IL:
3,480,329, PUB. 5-20-2008. INT. CL. 41.
- NATIVE FOODS, INCORPORATED, PALM SPRINGS, CA:
3,479,319, PUB. 5-20-2008. INT. CL. 43.
- NATUFIT NEDERLAND B.V., NETHERLANDS:
3,480,896, PUB. 5-20-2008. MULTIPLE CLASS, INT. CLS. 29, 30 AND 44.
- NATUR RESEARCH, INC., LOS ANGELES, CA:
3,482,731, INT. CL. 5.

NATURAL ORGANICS INC., MELVILLE, NY:
2,493,255, CANC. INT. CL. 5.

NATURAL ORGANICS, INC., MELVILLE, NY:
3,481,694, INT. CL. 5.

NATURAL PLANT PROTECTION S.A., 64150 NOGUERES, FRANCE:
3,482,043, INT. CL. 5.

NATURAL SELECTION FOODS, LLC, SAN JUAN BAUTISTA, CA:
3,481,392, INT. CL. 31.

NATURAL SOURCE INTERNATIONAL, LTD., NEW YORK, NY:
2,228,321. REN. 7-2-08. INT. CL. 5.

NATURALCHECK, LLC, WILMINGTON, DE:
3,482,154, INT. CL. 1.

NATURE'S PATH FOODS INC., DELTA, BRITISH COLUMBIA, V4G 1E8, CANADA:
2,098,614, CANC. INT. CL. 30.

NATURE'S WAY PRODUCTS, INC., SPRINGVILLE, UT:
1,481,357. REN. 6-28-08. INT. CL. 5.

NATURESMART, LLC, RONKONKOMA, NY:
2,236,808. REN. 7-3-08. INT. CL. 5.

NAUTILUS, INC., VANCOUVER, WA:
3,479,260, PUB. 5-20-2008. INT. CL. 28.

NAVHOUSE CORPORATION, BOLTON, CANADA:
3,478,669, PUB. 5-20-2008. INT. CL. 37.

NAVICORE OY, ESPOO, FINLAND:
3,478,639, PUB. 5-20-2008. INT. CL. 42.

NAVIGANT CONSULTING, INC., CHICAGO, IL:
2,493,336, CANC. MULTIPLE CLASS, INT. CLS. 35, 36 AND 42.

NAZARIAN, KAMRAN, NEW YORK, NY:
2,491,806, CANC. INT. CL. 25.

NBA PROPERTIES, INC., NEW YORK, NY:
2,100,254, CANC. INT. CL. 25.
3,482,035, INT. CL. 25.

NCM ASSOCIATES, INC., OVERLAND PARK, KS:
3,482,116, INT. CL. 41.

ND INDUSTRIES, INC., CLAWSON, MI:
3,478,770, PUB. 5-20-2008. MULTIPLE CLASS, INT. CLS. 1, 4, 17 AND 40.

NEALANDERS INTERNATIONAL INC., MISSISSAUGA, CANADA:
3,479,834, PUB. 5-20-2008. INT. CL. 29.

NEATWALL, STRATHAM, NH:
3,479,216, PUB. 5-20-2008. INT. CL. 37.

NEC INFRONTIA CORPORATION, KANAGAWA, JAPAN:
2,175,571. REN. 7-3-08. INT. CL. 9.

NEDERLANDER ORGANIZATION, INC., NEW YORK, NY:
3,478,709, PUB. 5-20-2008. MULTIPLE CLASS, INT. CLS. 35 AND 41.

NEIGHBORHOOD SENIOR LIVING, INC., DALLAS, TX:
3,450,609, COR. INT. CL. 43.

NEIL PRYDE LIMITED, TUEN MUN, HONG KONG:
3,482,522, INT. CL. 25.

NELLIE MAE CORPORATION, BRAINTREE, MA:
3,479,156, PUB. 5-20-2008. INT. CL. 36.
3,479,157, PUB. 5-20-2008. INT. CL. 36.

NELSON, JACK, DECATUR, AL:
2,169,282. REN. 7-3-08. INT. CL. 35.

NEOCUTIS SA, PULLY, SWITZERLAND:
3,481,339, INT. CL. 3.

NEOMED, INC., WOODSTOCK, GA:
3,481,891, INT. CL. 10.

NEOMODAL.COM, LLC, CHARLOTTE, NC:
2,492,276, CANC. INT. CL. 35.

NEON ENTERPRISE SOFTWARE, INC., SUGAR LAND, TX:
3,478,560, PUB. 5-20-2008. INT. CL. 9.

NEOPAX, NORTHRIDGE, CA:
3,481,611, INT. CL. 18.

NEPHRO CUISINE, INC., COLTON, CA:
3,481,303, INT. CL. 29.

NERDHEALTH, LLC, POMPANO, FL:
3,481,167, INT. CL. 44.

NERDHEALTH, LLC, POMPANO BEACH, FL:
3,481,255, INT. CL. 44.

NESTLE WATERS NORTH AMERICA INC., GREENWICH, CT:
2,192,339. REN. 7-2-08. MULTIPLE CLASS, INT. CLS. 1 AND 32.

NET VENTURES, INC., WEST BLOOMFIELD, MI:
2,100,532, CANC. INT. CL. 42.

NETCENTIVES, INC., SAN FRANCISCO, CA:
2,493,167, CANC. INT. CL. 42.

NETPREDICT, INC., MENLO PARK, CA:
2,492,976, CANC. INT. CL. 9.

NETPROSPECT, NEW YORK, NY:
2,492,470, CANC. INT. CL. 9.

NETSPROUT, INC., SAN FRANCISCO, CA:
3,480,457, PUB. 5-20-2008. INT. CL. 42.

NETSTAIRS.COM, INC., FT. LAUDERDALE, FL:
3,482,066, MULTIPLE CLASS, INT. CLS. 9 AND 38.

NETSWITCH, INC., SOUTH SAN FRANCISCO, CA, DBA NETSWITCH TECHNOLOGY MANAGEMENT:
3,480,230, PUB. 5-20-2008. INT. CL. 42.

NETWORK COMMUNICATIONS, INC., LAWRENCEVILLE, GA:
2,492,584, CANC. INT. CL. 36.

NETWORK DIGICALITY, INC., CORONADO, CA:
3,478,681, PUB. 5-20-2008. MULTIPLE CLASS, INT. CLS. 9 AND 42.

NETWORK ENTERPRISES, INC., NASHVILLE, TN:
2,492,580, CANC. INT. CL. 38.

NETWORK FOR GOOD, INC., BETHESDA, MD:
3,479,891, PUB. 5-20-2008. INT. CL. 36.

NETWORK STRATEGIES, INC., ROSWELL, GA:
3,478,577, PUB. 5-20-2008. INT. CL. 42.

NEUMARKTER LAMMSBRÄU GEBR. EHRNSPERGER E.K., NEUMARKT IN DER OBERPFALZ, FED REP GERMANY:
3,482,109, INT. CL. 32.

NEUSOFT GROUP LTD., SHENYANG LIAONING PROVINCE, CHINA:
3,482,587, MULTIPLE CLASS, INT. CLS. 9 AND 42.

NEUSTAT, PAULA, NEW CITY, NY:
3,481,554, INT. CL. 20.
3,481,713, INT. CL. 20.

NEUTAR L.L.C., LEWISTON, ME:
2,493,027, CANC. INT. CL. 10.

NEVELS, MARGARET, ANTIOCH, CA AND NEVELS, JOEL, ANTIOCH, CA:
2,493,073, CANC. INT. CL. 16.

NEW BALANCE ATHLETIC SHOE, INC., BOSTON, MA:
3,481,243, INT. CL. 25.

NEW ENGLAND CONFECTIONERY COMPANY, CAMBRIDGE, MA, DBA CANDY CUP CUPBOARD:
1,053,706. REN. 6-27-08. INT. CL. 30.

NEW ENTERTAINMENT, LTD., HUNG HOM, KOWLOON, HONG KONG:
2,492,594, CANC. INT. CL. 28.

NEW ERA OF NETWORKS, INC., ENGLEWOOD, CO:
2,493,492, CANC. INT. CL. 9.

NEW HEIGHTS MEDIA, INC., FORT LEE, NJ:
3,481,635, INT. CL. 16.

NEW JERSEY BASKETBALL, LLC, EAST RUTHERFORD, NJ:
2,492,159, CANC. INT. CL. 16.

NEW JERSEY TRANSIT CORPORATION, NEWARK, NJ:
3,481,086, INT. CL. 39.
3,481,087, MULTIPLE CLASS, INT. CLS. 35 AND 39.
3,481,088, MULTIPLE CLASS, INT. CLS. 35 AND 39.
3,481,089, MULTIPLE CLASS, INT. CLS. 35 AND 39.

NEW LIFE INTERNATIONAL, BRENTWOOD, TN:
3,478,834, PUB. 5-20-2008. INT. CL. 36.

NEW LIFE LANDSCAPE AND TREE CARE, INC., BRYN MAWR, PA:
2,492,591, CANC. INT. CL. 42.

NEW MAJORITY CALIFORNIA, COSTA MESA, CA:
3,479,710, PUB. 5-20-2008. MULTIPLE CLASS, INT. CLS. 35 AND 41.
3,479,711, PUB. 5-20-2008. MULTIPLE CLASS, INT. CLS. 35 AND 41.

3,480,617, PUB. 5-20-2008. MULTIPLE CLASS, INT. CLS. 35 AND 41.

- NEW MARBAS S.P.A., I-24020 PARRE (BERGAMO), ITALY:
3,480,970, PUB. 5-20-2008. INT. CL. 25.
- NEW MOTION, INC., IRVINE, CA:
3,480,470, PUB. 5-20-2008. INT. CL. 41.
- NEW ORLEANS JAZZ & HERITAGE FESTIVAL AND FOUNDATION, INC., NEW ORLEANS, LA:
3,482,623, MULTIPLE CLASS, INT. CLS. 25 AND 41.
- NEW RESOURCE GROUP CONSULTING, INC., PASADENA, CA:
3,479,792, PUB. 5-20-2008. INT. CL. 9.
- NEW URBAN ENTERTAINMENT TELEVISION, CHEVY CHASE, MD:
2,492,586, CANC. INT. CL. 41.
2,492,587, CANC. INT. CL. 41.
- NEW WORLD PASTA COMPANY, HARRISBURG, PA:
3,481,785, INT. CL. 30.
- NEW YORK MAGAZINE HOLDINGS LLC, NEW YORK, NY:
1,458,867, CANC. INT. CL. 16.
- NEW YORK MERCANTILE EXCHANGE, INC., NEW YORK, NY:
3,481,652, INT. CL. 36.
- NEW YORK STATE UNITED TEACHERS, LATHAM, NY:
3,479,213, PUB. 5-20-2008. INT. CL. 35.
- NEWAGE MARKETING CORPORATION, EAST PROVIDENCE, RI:
3,481,383, INT. CL. 35.
- NEWAY VALVE, INC., STAFFORD, TX:
3,479,314, PUB. 5-20-2008. INT. CL. 6.
- NEWELL OPERATING COMPANY, ATLANTA, GA:
3,482,149, INT. CL. 20.
- NEWELL, CO., FREEPORT, IL:
1,458,363, CANC. INT. CL. 20.
- NEWFREY LLC, NEWARK, DE, EMHART INC., NEWARK, DE:
2,171,612, REN. 7-2-08. INT. CL. 11.
- NEWPORT CORPORATION, IRVINE, CA:
3,481,639, INT. CL. 9.
- NEWS-JOURNAL CORPORATION, DAYTONA BEACH, FL:
2,493,632, CANC. MULTIPLE CLASS, INT. CLS. 35, 38 AND 42.
- NEWSPRINT SOUTH, INC., GRENADA, MS:
1,458,307, CANC. INT. CL. 16.
- NEWSWEEK BUDGET TRAVEL, INC., NEW YORK, NY:
3,478,772, PUB. 5-20-2008. INT. CL. 16.
- NEXGEN SOFTWARE SERVICES, INC., THE WOODLANDS, TX:
3,479,660, PUB. 5-20-2008. INT. CL. 42.
- NEXIS FIBERS AG, SWITZERLAND:
3,480,836, PUB. 5-20-2008. INT. CL. 23.
- NEXSTAR, INC., LITTLE CANADA, MN:
3,481,495, MULTIPLE CLASS, INT. CLS. 9 AND 16.
- NEXT DAY MOULDING PORTLAND, PORTLAND, OR:
3,479,085, PUB. 5-20-2008. MULTIPLE CLASS, INT. CLS. 35 AND 37.
- NEY DENTAL INTERNATIONAL, INC., BLOOMFIELD, CT TO DENTSPLY IONINTERNATIONAL INC., BURLINGTON, NJ:
2,099,427, CANC. INT. CL. 11.
- NFA CORP., CHELSEA, MA:
1,458,423, CANC. INT. CL. 25.
- NGUYEN, TAN, SAN DIEGO, CA:
3,481,825, INT. CL. 18.
- NICCA U.S.A., INC., FOUNTAIN INN, SC:
2,171,361, REN. 6-28-08. INT. CL. 1.
- NICHOLS, MARKYIA, OWINGS MILLS, MD:
3,481,368, INT. CL. 3.
- NICKEL & NICKEL VINEYARDS, LLC, OAKVILLE, CA:
3,481,194, INT. CL. 33.
- NICKLAUS COMPANIES LLC, NORTH PALM BEACH, FL:
2,172,953, REN. 7-3-08. INT. CL. 25.
- NIELSEN BUSINESS MEDIA, INC., NEW YORK, NY:
3,481,938, INT. CL. 35.
- NIKKO CERAMICS, INC., LYNDHURST, NJ:
1,458,377, CANC. INT. CL. 21.
- NILES, HASSAN M., RALEIGH, NC:
3,480,599, PUB. 6-27-2006. INT. CL. 25.
- NILO ENTERPRISES, INC., CARLSBAD, CA:
2,099,010, CANC. INT. CL. 28.
- NINGBO SUNSHINE TRAFFIC EQUIPMENT CO., LTD., ZHENHAI, 315000 NINGBO, CHINA:
3,481,027, PUB. 5-20-2008. INT. CL. 12.
- NINIO, JULIEN, D, LOS ANGELES, AR:
2,492,768, CANC. INT. CL. 42.
- NINTENDO CO., LTD., KYOTO-SHI, KYOTO, JAPAN:
3,478,869, PUB. 5-20-2008. INT. CL. 28.
- NINTENDO OF AMERICA INC., REDMOND, WA:
3,482,582, INT. CL. 16.
- NIPPON SHEET GLASS CO., LTD., CHUO-KU, OSAKA, JAPAN:
2,493,043, CANC. INT. CL. 21.
- NIPPON YUGI-GANGU CO., LTD., ASAKUSA, TOKYO, 111, JAPAN:
1,458,480, CANC. INT. CL. 28.
- NISSAN CHEMICAL INDUSTRIES, LTD., CHIYODA-KU, TOKYO, JAPAN:
3,478,922, PUB. 5-20-2008. INT. CL. 1.
3,480,465, PUB. 5-20-2008. INT. CL. 1.
- NITTANY CORPORATION, WILMINGTON, DE:
2,491,655, CANC. INT. CL. 29.
- NITTO DENKO CORPORATION, OSAKA, JAPAN:
3,482,169, INT. CL. 5.
- NITTO KOHKI CO., LTD., TOKYO, JAPAN:
1,494,826, REN. 7-3-08. INT. CL. 7.
1,494,827, REN. 7-3-08. INT. CL. 7.
1,497,437, REN. 7-3-08. INT. CL. 7.
1,497,438, REN. 7-3-08. INT. CL. 7.
- NO LIMIT, LLC, WESTPORT, CT:
3,481,276, INT. CL. 30.
- NO WATER NO LIFE LLC, NEW YORK, NY:
3,480,185, PUB. 5-20-2008. INT. CL. 35.
- NOAH'S NATURALS, LLC, LOS ANGELES, CA:
3,481,099, INT. CL. 3.
- NOBEL FOUNDATION, THE, STOCKHOLM, SWEDEN SE-10245:
2,098,560, CANC. MULTIPLE CLASS, INT. CLS. 9 AND 16.
- NOIR LASER COMPANY, L.L.C., SOUTH LYON, MI:
3,481,660, INT. CL. 9.
- NOKIA CORPORATION, FINLAND:
3,480,819, PUB. 5-20-2008. INT. CL. 9.
- NOLOGY ENGINEERING, INC., SAN SAN MARCOS, CA:
2,163,324, REN. 6-28-08. INT. CL. 7.
- NOMIR MEDICAL TECHNOLOGIES, INC., WALTHAM, MA:
3,482,307, INT. CL. 10.
- NOODLE & BOO, LLC, SAN JOSE, CA:
3,481,607, MULTIPLE CLASS, INT. CLS. 3 AND 4.
- NOODLES & COMPANY, BROOMFIELD, CO:
3,480,259, PUB. 5-20-2008. INT. CL. 43.
- NORDIC NATURALS, INC., WATSONVILLE, CA:
3,480,198, PUB. 5-20-2008. INT. CL. 5.
- NORDIC PAPER SEFFLE AKTIEBOLAG, SÄFFLE, SWEDEN:
3,349,866, COR. INT. CL. 16.
- NORDMARK ARZNEIMITTEL GMBH & CO. KG, UETERSEN, FED REP GERMANY:
3,478,958, PUB. 2-12-2008. INT. CL. 5.
- NORINCO, FRANCE:
3,480,835, PUB. 5-20-2008. INT. CL. 6.
- NORMENT SECURITY GROUP, INC., MONTGOMERY, AL:
3,479,207, PUB. 5-20-2008. INT. CL. 19.
- NORMET CORPORATION, PELTOSALMI, FINLAND, ORION-YHTYMA OY, SF-74510 PELTOSALMI, FINLAND:
1,097,934, REN. 6-30-08. INT. CL. 7.
- NORPAC FOODS, INC., LAKE OSWEGO, OR:
2,444,967, CANC. INT. CL. 42.
- NORTEL NETWORKS LIMITED, QUEBEC, CANADA:
2,099,802, CANC. INT. CL. 9.
- NORTH AMERICA SYNDICATE, INC., NEW YORK, NY:
862,751, REN. 6-27-08. U.S. CL. 38 (INT. CL. 16).
- NORTH AMERICAN COMPANY FOR LIFE AND HEALTH INSURANCE, CHICAGO, IL:
3,478,961, PUB. 5-20-2008. INT. CL. 36.

NORTH AMERICAN MORTAR SUPPLY, INC., EDMONTON, ALBERTA, CANADA:
1,457,847, CANC. INT. CL. 1.

NORTH AMERICAN POLO LEAGUE, LLC, HOUSTON, TX:
3,481,196, INT. CL. 25.
3,481,504, INT. CL. 25.
3,481,526, INT. CL. 41.

NORTH AMERICAN SPINE SOCIETY, BURR RIDGE, IL:
3,479,816, PUB. 5-20-2008. INT. CL. 35.

NORTH AMERICAN WATCH CORPORATION, LYNDHURST, NJ TO MOVADO LLC, WILMINGTON, DE:
2,099,863, CANC. INT. CL. 14.

NORTH STAR ENTERPRISES, INC., OVERLAND PARK, KS:
1,458,788, CANC. INT. CL. 42.

NORTH WESTERN LEAD COMPANY (HYDE) LIMITED, HYDE, CHESHIRE, ENGLAND:
1,457,998, CANC. INT. CL. 6.

NORTHEAST ENTREPRENEUR FUND, INC., VIRGINIA, MN:
3,481,956, MULTIPLE CLASS, INT. CLS. 35 AND 41.

NORTHERN TECHNOLOGIES INTERNATIONAL CORPORATION, BEACHWOOD, OH:
3,482,207, INT. CL. 1.
3,482,208, INT. CL. 16.

NORTHSIDE DEVELOPMENT, INC., NEW YORK, NY:
3,482,387, INT. CL. 3.

NORTHWESTERN COLLEGE, ST. PAUL, MN:
3,480,542, PUB. 5-20-2008. INT. CL. 41.

NORTON, KATHLEEN, HINGHAM, MA, DBA CHEFS AT PLAY:
3,480,214, PUB. 5-20-2008. INT. CL. 41.

NORWOOD OPERATING COMPANY, INDIANAPOLIS, IN:
2,098,870, CANC. INT. CL. 16.

NOSHVILLE LLC, NASHVILLE, TN:
2,099,430, CANC. INT. CL. 42.

NOSSE, ROBERT T, ANN ARBOR, MI:
3,481,835, INT. CL. 28.

NOSTER FINANCE, S.L., SPAIN:
3,481,021, PUB. 5-20-2008. MULTIPLE CLASS, INT. CLS. 35, 36, 38 AND 42.

NOTESHUFFLE.COM, LLC, SHERMAN OAKE, CA:
3,481,930, INT. CL. 35.

NOTION MUSIC, INC., GREENSBORO, NC:
3,481,727, INT. CL. 9.

NOTSOLDSEPARATELY.COM, LLC, MAPLE SHADE, NJ:
3,480,209, PUB. 5-20-2008. INT. CL. 42.

NOURICHE NUTRITION LTD, LAKE ST. LOUIS, MO:
3,480,047, PUB. 5-20-2008. INT. CL. 5.

NOVACARD INFORMATIONSSYSTEME GMBH, FED REP GERMANY:
3,480,787, PUB. 5-20-2008. MULTIPLE CLASS, INT. CLS. 9 AND 16.

NOVANITEK, INC., DALLAS, TX:
3,481,300, INT. CL. 7.

NOVARTIS AG, SWITZERLAND:
3,480,985, PUB. 5-20-2008. INT. CL. 5.

NOVARTIS AG, BASEL, SWITZERLAND:
3,482,610, INT. CL. 3.

NOVELLUS CAPITAL MANAGEMENT, LLC, BELLEVUE, WA:
3,481,666, INT. CL. 36.

NOVO NORDISK A/S, DK-2880, BAGSVAERD, DENMARK:
3,478,952, PUB. 5-20-2008. INT. CL. 10.

NOVOCOL, INC., NEW CASTLE, DE:
3,482,451, INT. CL. 3.

NOVOZYMES A/S, DK-2880, DENMARK, NOVO INDUSTRI A/S, BAGSVAERD, DENMARK:
1,491,744, REN. 6-30-08. INT. CL. 1.

NOWCASTING INTERNATIONAL LIMITED, ENNIS, COUNTY CLARE, IRELAND:
3,479,017, PUB. 5-20-2008. MULTIPLE CLASS, INT. CLS. 35 AND 42.

NPI, INC., KANSAS CITY, MO:
3,480,322, PUB. 5-20-2008. INT. CL. 35.

NPP GOLF ASSOCIATES L.L.C., PHOENIX, AZ TO MARRIOTT INTERNATIONAL, INC., BETHESDA, MD:
2,100,430, CANC. INT. CL. 41.

NSERV CORP., ROLLING MEADOWS, IL:
2,491,929, CANC. INT. CL. 35.

NSPIRED NATURAL FOODS, INC., SAN LEANDRO, CA:
2,492,413, CANC. INT. CL. 29.

NSS MUSIC, NEW YORK, NY:
3,482,082, INT. CL. 41.

NT DOOR CONTROLS LIMITED, WALSALL, WSI 4NF, ENGLAND TO INGERSOLL-RAND ARCHITECTURAL HARDWARE GROUP LIMITED., BIRMINGHAM, ENGLAND, GREAT BRITAIN:
2,098,768, CANC. MULTIPLE CLASS, INT. CLS. 6 AND 9.

NTI HOLDINGS CORP., CHANTILLY, VA:
2,120,122, REN. 6-28-08. INT. CL. 29.
2,120,122, CANC. MULTIPLE CLASS, INT. CLS. 1, 5, 30 AND 32.

NU VISION GROUP LLC, NEW YORK, NY:
3,481,443, INT. CL. 3.

NU-WAY PRODUCTS, INC., MISSOULA, MT:
2,100,516, CANC. INT. CL. 10.

NUAW DESIGNS, LLC, WILMINGTON, DE:
3,481,549, INT. CL. 14.

NUC ELECTRONICS CO., LTD., DAEGU, REPUBLIC OF KOREA:
3,482,501, INT. CL. 11.

NUCARA MANAGEMENT GROUP, CONRAD, IA:
3,478,782, PUB. 5-20-2008. INT. CL. 35.

NUHEAT INDUSTRIES LIMITED, DELTA, B.C., CANADA:
3,480,226, PUB. 5-20-2008. MULTIPLE CLASS, INT. CLS. 9 AND 11.
3,480,235, PUB. 5-20-2008. MULTIPLE CLASS, INT. CLS. 9 AND 11.
3,480,361, PUB. 5-20-2008. INT. CL. 11.

NUNHEMS B.V., NETHERLANDS:
3,480,878, PUB. 5-20-2008. MULTIPLE CLASS, INT. CLS. 29, 31 AND 44.

NUSSDORF, JEFFREY MARK, HENDERSON, NV:
3,482,173, INT. CL. 20.

NUSTAR, INC., SHAKOPEE, MN:
2,491,681, CANC. INT. CL. 12.

NUSTART ENERGY DEVELOPMENT, LLC, KENNETT SQUARE, PA:
3,479,805, PUB. 5-20-2008. INT. CL. 42.

NUTANDBOLTGUY INC., PINE BUSH, NY:
3,481,413, INT. CL. 35.

NUTRA-VET RESEARCH CORPORATION, POUGHKEEPSIE, NY:
1,457,967, CANC. INT. CL. 5.

NUTRACEUTICAL SCIENCES INSTITUTE, INC., DEERFIELD BEACH, FL:
3,479,271, PUB. 5-20-2008. INT. CL. 5.

NUTRAMAX LABORATORIES, INC., EDGEWOOD, MD:
3,481,550, INT. CL. 5.

NUTRASENTIAL HEALTH PRODUCTS, INC., MIAMI, FL:
3,482,231, INT. CL. 5.

NUTRI-STAHLL, INC., ONTARIO, CA:
3,479,680, PUB. 5-20-2008. INT. CL. 11.

NUTRICOLOGY, INC., HAYWARD, CA:
2,167,268, REN. 6-27-08. INT. CL. 5.

NUTRICOLOGY, INC., ALAMEDA, CA:
2,167,269, REN. 6-28-08. INT. CL. 5.

NUVICO, LLC, ENGLEWOOD, NJ:
3,479,031, PUB. 5-20-2008. INT. CL. 9.

NUVIEW, INC., HOUSTON, TX:
2,491,774, CANC. INT. CL. 9.

NUVO NETWORK MANAGEMENT INC., OTTAWA, CANADA:
3,480,591, PUB. 2-12-2008. INT. CL. 35.

NVS CORPORATION, LYNN, MA, DBA NU-VIEW SERVICES CORPORATION:
1,458,019, CANC. INT. CL. 7.

NYFIX, INC., STAMFORD, CT:
3,482,515, INT. CL. 42.

NYLON CORPORATION OF AMERICA, INC., MANCHESTER, NH, NYCOA, INC., MANCHESTER, NH:
1,492,764, REN. 6-30-08. INT. CL. 1.

- NYSE GROUP, INC., NEW YORK, NY:
 3,482,193, MULTIPLE CLASS, INT. CLS. 36 AND 38.
 3,482,194, INT. CL. 36.
 3,482,195, INT. CL. 36.
 3,482,196, INT. CL. 36.
 3,482,197, MULTIPLE CLASS, INT. CLS. 36 AND 38.
 3,482,198, MULTIPLE CLASS, INT. CLS. 36 AND 38.
- NYT MANAGEMENT SERVICES, INC., TAMPA, FL:
 199,556, REN. 6-30-08. U.S. CL. 38 (INT. CL. 16).
- NZN INTERNATIONAL LICENSING PTY LIMITED, SYDNEY, AUSTRALIA:
 3,482,136, MULTIPLE CLASS, INT. CLS. 29, 30 AND 35.
- O OLIVE OIL, LLC, SAN RAFAEL, CA:
 2,176,781, REN. 7-3-08. INT. CL. 29.
- O. M. I. CREATIONS, LLC, WINSTON-SALEM, NC:
 3,481,935, INT. CL. 42.
- O.C. TANNER COMPANY, SALT LAKE CITY, UT:
 3,481,208, INT. CL. 18.
- O.C. TANNER COMPANY, SALT LAKE CITY, UT:
 3,481,209, INT. CL. 20.
- O.R. SOLUTIONS, INC., CHANTILLY, VA:
 2,100,064, CANC. INT. CL. 10.
- O'BRIEN'S IRISH SANDWICH BARS LIMITED, DUBLIN 2, IRELAND:
 2,493,039, CANC. INT. CL. 30.
- O'CONNELL, MAUREEN, GRAPEVINE, TX:
 3,479,475, PUB. 5-20-2008. INT. CL. 14.
- O'NEILL, ROSALINDA, CALABASAS, CA:
 3,481,987, MULTIPLE CLASS, INT. CLS. 35 AND 41.
- OÜ INBIO, ESTONIA:
 3,480,778, PUB. 5-20-2008. INT. CL. 5.
- OBESITY RESEARCH INSTITUTE, LLC, CARLSBAD, CA:
 3,482,124, INT. CL. 5.
- OBSHCHESTVO S OGRANICHENNOY OTVETSTVENNOSTYU KOMPANIA "TUNAYCHA", SAKHALIN, RUSSIAN FED.:
 3,480,612, PUB. 10-3-2006. MULTIPLE CLASS, INT. CLS. 29, 31 AND 40.
- OBSHCHESTVO S OGRANICHENNOY OTVETSTVENNOSTYU "INTERRA", RUSSIAN FED.:
 3,480,962, PUB. 5-20-2008. MULTIPLE CLASS, INT. CLS. 9, 10 AND 16.
 3,480,963, PUB. 5-20-2008. MULTIPLE CLASS, INT. CLS. 9, 10 AND 16.
- OCEAN DISTRIBUTORS INTERNATIONAL INC., PALM BEACH GARDENS, FL:
 3,480,146, PUB. 5-20-2008. INT. CL. 29.
- OCO, INC., WALTHAM, MA:
 3,479,057, PUB. 5-20-2008. INT. CL. 42.
- OCTEAU, GUY, MONTREAL, QUEBEC, CANADA:
 3,482,511, INT. CL. 25.
- OCWEN FINANCIAL CORPORATION, WEST PALM BEACH, FL:
 3,481,637, INT. CL. 9.
- ODESSE, INC., CHATSWORTH, CA:
 3,479,872, PUB. 5-20-2008. MULTIPLE CLASS, INT. CLS. 35 AND 41.
- ODDZON, INC., PAWTUCKET, RI:
 2,493,521, CANC. INT. CL. 28.
- ODWALLA, INC., HALF MOON, CA:
 2,493,369, CANC. INT. CL. 32.
- ODWALLA, INC., HALF MOON BAY, CA:
 3,480,148, PUB. 5-20-2008. INT. CL. 32.
 3,480,254, PUB. 5-20-2008. INT. CL. 32.
- ODYSSEY MEDIA, INC., NORTH HALEDON, NJ:
 3,480,450, PUB. 5-20-2008. INT. CL. 9.
- ODYSSEY PETS LLC, DALLAS, TX, DBA ODYSSEY PETS:
 3,479,942, PUB. 5-20-2008. INT. CL. 31.
- OERLIKON CONTRAVES AG, SWITZERLAND:
 3,480,790, PUB. 5-20-2008. MULTIPLE CLASS, INT. CLS. 9 AND 13.
 3,480,791, PUB. 5-20-2008. MULTIPLE CLASS, INT. CLS. 9 AND 13.
 3,480,792, PUB. 5-20-2008. MULTIPLE CLASS, INT. CLS. 9 AND 13.
 3,480,795, PUB. 5-20-2008. MULTIPLE CLASS, INT. CLS. 9 AND 13.
- OFFICE CLUB, INC., THE, DELRAY BEACH, FL:
 3,480,011, PUB. 5-20-2008. INT. CL. 9.
- OFFICIAL PILLOWTEX LLC, WILMINGTON, DE:
 3,482,571, MULTIPLE CLASS, INT. CLS. 21 AND 24.
- OFFSHORE SAILING SCHOOL LTD., FORT MYERS, FL:
 2,100,474, CANC. INT. CL. 41.
- OFOTO, INC., EMERYVILLE, CA:
 2,493,353, CANC. INT. CL. 9.
- OHANA CAPITAL, LLC, POTOMAC, MD:
 3,478,601, PUB. 5-20-2008. INT. CL. 35.
- OK COOL, INC., WANTAGH, NY:
 3,478,620, PUB. 5-20-2008. INT. CL. 43.
- OKADA AIYON CORP., MINATO-KU, OSAKA, JAPAN:
 1,489,911, REN. 6-30-08. INT. CL. 7.
- OKAMURA CORPORATION, JAPAN:
 3,480,848, PUB. 5-20-2008. INT. CL. 20.
- OKAYAMA COMPANY, SOUTH ORANGE, NJ:
 2,493,240, CANC. INT. CL. 21.
- OKI ELECTRIC INDUSTRY CO., LTD., MINATO-KU, TOKYO, JAPAN:
 3,478,857, PUB. 5-20-2008. INT. CL. 9.
- OL' BALLPARK CO., THE, ORLAND PARK, IL:
 2,491,876, CANC. INT. CL. 35.
- OLD II WARSAW BAKERY, INC., BENSENVILLE, IL:
 3,482,496, INT. CL. 30.
- OLD NAVY (APPAREL), LLC, SAN FRANCISCO, CA, GPS (DELAWARE), INC., SAN FRANCISCO, CA:
 2,121,013, REN. 6-30-08. INT. CL. 9.
- OLD WORLD INDUSTRIES, INC., NORTHBROOK, IL:
 3,230,265, AM. INT. CL. 1.
- OLDE MILL COMPANY, INC., LORTON, VA:
 3,479,616, PUB. 5-20-2008. MULTIPLE CLASS, INT. CLS. 6, 8, 18, 21 AND 30.
- OLE MATHIESEN A/S, COPENHAGEN K, DENMARK:
 1,458,250, CANC. INT. CL. 14.
- OLEUM CORPORATION, NAPLES, FL:
 1,457,949, CANC. MULTIPLE CLASS, INT. CLS. 4 AND 42.
- OLGA'S KITCHEN, INC., TROY, MI:
 3,479,783, PUB. 5-20-2008. INT. CL. 43.
- OLIN CORPORATION, ST. LOUIS, MO:
 1,458,242, CANC. INT. CL. 13.
- OLIVA OCHOA, JOSEP, GRANOLLERS, SPAIN AND OLIVA OCHOA, XAVIER, GRANOLLERS, SPAIN:
 3,482,248, INT. CL. 10.
- OLIVE BRANDS, LLC, MARIETTA, GA:
 3,478,781, PUB. 5-20-2008. INT. CL. 35.
- OLIVE FARM, LLC, THE, PORTLAND, OR:
 2,493,316, CANC. INT. CL. 30.
- OLSON, STEVEN P., MONROE, GA:
 3,479,989, PUB. 5-20-2008. INT. CL. 20.
- OLYMPIC PACKAGING CORPORATION, WINSTON-SALEM, NC:
 2,492,389, CANC. INT. CL. 36.
- OLYMPUS MEDICAL SYSTEMS CORP., TOKYO, JAPAN:
 3,481,311, INT. CL. 10.
- OMEGA DESIGN CORPORATION, EXTON, PA:
 2,492,476, CANC. INT. CL. 7.
- OMNEX CONTROL SYSTEMS ULC, PORTLAND, OR:
 3,478,517, PUB. 5-20-2008. INT. CL. 9.
- OMNI-SOFT, INC., PLANO, TX:
 2,188,524, REN. 6-28-08. INT. CL. 9.
- OMNIRIM SOLUTIONS, INC., VANCOUVER, CANADA:
 3,479,582, PUB. 5-20-2008. INT. CL. 42.
 3,479,583, PUB. 5-20-2008. INT. CL. 42.
- OMP, INC., LONG BEACH, CA:
 3,479,854, PUB. 5-20-2008. INT. CL. 35.
 3,479,855, PUB. 5-20-2008. INT. CL. 35.
- OMYA AG, SWITZERLAND:
 3,480,861, PUB. 5-20-2008. INT. CL. 1.
- ONCE UPON A TART, INC., NEW YORK, NY:
 3,479,034, PUB. 5-20-2008. INT. CL. 43.
- ONCOGENE SCIENCE DIAGNOSTICS, INC., CAMBRIDGE, MA:
 2,491,972, CANC. INT. CL. 5.

ONCOR ELECTRIC DELIVERY COMPANY, DALLAS, TX:
3,479,621, PUB. 5-20-2008. INT. CL. 35.
3,479,622, PUB. 5-20-2008. INT. CL. 35.
3,479,623, PUB. 5-20-2008. INT. CL. 35.

ONCUE MARKETING, LLC, STILLWATER, OK:
3,482,313, INT. CL. 35.

ONE MOORE CATCH INC., PUNTA GORDA, FL:
3,480,229, PUB. 5-20-2008. INT. CL. 41.
3,480,241, PUB. 5-20-2008. INT. CL. 25.

ONE OF THE SEVENTY, INC., SAN DIEGO, CA:
3,482,600, MULTIPLE CLASS, INT. CLS. 36 AND 41.

ONECLIP.COM, INC., NEW YORK, NY:
2,492,363, CANC. INT. CL. 35.

ONLINE GAMING SYSTEMS, BOCA RATON, FL:
2,493,295, CANC. INT. CL. 9.
2,493,302, CANC. INT. CL. 9.

OPEN ENTERPRISES, INC., SAN FRANCISCO, CA:
2,492,429, CANC. INT. CL. 16.

OPEN SOURCE MATTERS, INC., NEW YORK, NY:
3,479,210, PUB. 5-20-2008. INT. CL. 9.
3,479,224, PUB. 5-20-2008. INT. CL. 9.

OPENTV ADVERTISING HOLDINGS, INC., SAN FRANCISCO, CA:
2,493,025, CANC. INT. CL. 9.

OPHTHONIX, INC., VISTA, CA:
3,482,599, INT. CL. 16.

OPPKNOX, LLC, MARLTON, NJ:
3,480,739, PUB. 5-20-2008. INT. CL. 43.

OPTESSA INC., EDMONTON ALBERTA, CANADA:
3,482,539, INT. CL. 9.

OPTIMAL NUTRITION INC, SAN DIEGO, CA:
3,479,438, PUB. 5-20-2008. INT. CL. 39.

OPTIMEDICA CORPORATION, SANTA CLARA, CA:
3,482,266, INT. CL. 10.

OPTIMO, INC., ATLANTA, GA:
3,481,350, INT. CL. 41.

OPTIMUM CARE INTERNATIONAL TECH. INC., TAIPEI CITY, TAIWAN:
3,478,729, PUB. 5-20-2008. INT. CL. 9.
3,478,730, PUB. 5-20-2008. INT. CL. 9.

OPTIMUS ENTERPRISE, INC., ANAHEIM, CA:
3,478,603, PUB. 5-20-2008. INT. CL. 8.

OPTIONS A TO Z, DELRAY BEACH, FL:
3,482,502, INT. CL. 41.

ORACLE INTERNATIONAL CORPORATION, REDWOOD CITY, CA:
3,482,581, INT. CL. 9.

ORANGE INTERNATIONAL TRADING; (TIANJIN) INC., CHINA:
3,480,906, PUB. 5-20-2008. INT. CL. 28.

ORBIMAGE SI OPCO INC., DULLES, VA, DBA/AKA/TA: DBA GEOEYE:
3,482,049, INT. CL. 9.

ORBITECH CENTRAL AG, HORW 6048, SWITZERLAND:
2,098,517, CANC. MULTIPLE CLASS, INT. CLS. 9 AND 16.

OREGON SCIENTIFIC INTERNATIONAL LIMITED, HAMILTON HM11, BERMUDA:
3,480,590, PUB. 4-8-2008. MULTIPLE CLASS, INT. CLS. 16 AND 35.

ORFEVERIE CHRISTOFLE, F-75008 PARIS, FRANCE:
3,480,771, PUB. 11-13-2007. MULTIPLE CLASS, INT. CLS. 8 AND 14.

ORGANIC ANSWERS, HUNTINGTON, NY:
2,493,220, CANC. INT. CL. 1.

ORGANIC MOTION, INC., NEW YORK, NY:
3,480,255, PUB. 5-20-2008. MULTIPLE CLASS, INT. CLS. 9 AND 42.

ORGANIC SALES & MARKETING, INC., RAYNHAM, MA:
3,478,901, PUB. 5-20-2008. INT. CL. 1.

ORIGENE TECHNOLOGIES, INC., ROCKVILLE, MD:
3,481,517, MULTIPLE CLASS, INT. CLS. 1 AND 5.

ORIGIN MEDSYSTEMS, INC., SANTA CLARA, CA:
2,165,778. REN. 6-30-08. INT. CL. 10.

ORIGINAL BAD COMPANY TOURING CORPORATION, MILL NECK, NY:
2,491,870, CANC. INT. CL. 41.

ORIGINAL CHILI BOWL, INC., THE, ONTARIO, CA:
1,493,335. REN. 7-3-08. INT. CL. 29.

ORIGINAL LEATHER STORE, INC., THE, NEW YORK, NY:
2,491,675, CANC. MULTIPLE CLASS, INT. CLS. 25 AND 35.
2,491,676, CANC. INT. CL. 25.

ORION CORPORATION, YONGSAN-KU SEOUL, REPUBLIC OF KOREA:
3,482,374, INT. CL. 30.

ORION SYSTEMS GROUP, INC., RONKONKOMA, NY:
2,015,270, CANC. MULTIPLE CLASS, INT. CLS. 9 AND 42.

ORIS HOLDING AG, SWITZERLAND:
3,480,969, PUB. 5-20-2008. INT. CL. 14.

ORTHO-TAIN, INC., WINNETKA, IL:
3,481,073, INT. CL. 10.

OSBORNE ORTHOPEDIC GROUP, INC., NASSAWADOX, VA:
3,482,250, INT. CL. 10.

OSBORNE, W. SHAWN, BROOKLYN, NY:
2,492,316, CANC. INT. CL. 25.

OSI/FLEMING'S, LLC, TAMPA, FL:
3,479,474, PUB. 5-20-2008. INT. CL. 43.

OSNAT GAD, INC., NEW YORK, NY:
3,481,843, INT. CL. 14.

OSONMAKINDE, OLA-A-A, GLENWOOD, IL, FORMERLY AYOMORE AYIGBE:
2,492,134, CANC. INT. CL. 21.

OSSIAN, INC., DAVENPORT, IA:
2,100,545, CANC. INT. CL. 1.

OTANI, HIDEKI, SOUTH SAN FRANCISCO, CA, DBA ORIENTAL TRADING COMPANY:
1,458,868, CANC. INT. CL. 30.

OTKRYTOE AKTSIONERNOE OBSHCHESTVO; "KONDI-TERSKAYA FABRIKA "UDARNITSA", RU-119049 MOSKVA, RUSSIAN FED.:
3,480,746, PUB. 5-20-2008. INT. CL. 30.
3,480,747, PUB. 5-20-2008. INT. CL. 30.
3,480,748, PUB. 5-20-2008. MULTIPLE CLASS, INT. CLS. 29 AND 30.
3,480,749, PUB. 5-20-2008. INT. CL. 30.

OTOE-MISSOURIA TRIBE OF OKLAHOMA, RED ROCK, OK:
3,480,560, PUB. 5-20-2008. INT. CL. 41.

OTUWHERE ESTATE WINES LIMITED, CHRISTCHURCH, NEW ZEALAND:
3,481,893, INT. CL. 33.

OTV SA, FRANCE:
3,480,783, PUB. 5-20-2008. INT. CL. 11.

OUG PRESS, PITTSBURGH, PA:
3,481,291, INT. CL. 16.

OUTDOORPLAY, INC., HOOD RIVER, OR:
2,492,011, CANC. MULTIPLE CLASS, INT. CLS. 35, 38, 39 AND 41.

OUTOTEC OYJ, 02200 ESPOO, FINLAND:
3,478,666, PUB. 5-6-2008. MULTIPLE CLASS, INT. CLS. 6, 37, 40 AND 42.

OVERLAND DATA, INC., SAN DIEGO, CA:
2,491,968, CANC. INT. CL. 9.
2,491,971, CANC. INT. CL. 9.

OVERTON BOAT & RV STORAGE, LLC, LAS VEGAS, NV:
3,479,901, PUB. 5-20-2008. INT. CL. 39.

OVERTON'S, INC., GREENVILLE, NC:
3,481,747, INT. CL. 28.

OWENS CORNING INTELLECTUAL CAPITAL, LLC, TOLEDO, OH:
3,481,470, INT. CL. 17.
3,481,471, INT. CL. 17.

OWSIANY, DAVID, MATTHEW, ORLANDO, FL, DBA DAVEAWESOME:
3,480,205, PUB. 5-20-2008. INT. CL. 41.

OXBOX DESIGN, NEW YORK, NY:
3,480,120, PUB. 5-20-2008. INT. CL. 42.

OZIO LIFESTYLES, LLC, CULVER CITY, CA:
3,481,879, INT. CL. 25.

O2MICRO, INC., SANTA CLARA, CA:
3,482,272, INT. CL. 9.

- P&D ENTERPRISES, INC., PARKER, CO, DBA WALLABY'S LIQUOR WAREHOUSE:
3,481,871, INT. CL. 35.
- PA TREND INC., REPUBLIC OF KOREA:
3,480,752, PUB. 5-20-2008. INT. CL. 18.
- PACE ANALYTICAL SERVICES, INC., MINNEAPOLIS, MN:
3,479,264, PUB. 5-20-2008. INT. CL. 42.
- PACIFIC BAKERY, OCEANSIDE, CA:
2,176,940, REN. 6-28-08. INT. CL. 30.
- PACIFIC COAST FEATHER COMPANY, SEATTLE, WA:
3,478,623, PUB. 5-20-2008. INT. CL. 24.
- PACIFIC COAST WIRE ROPE & FITTINGS, INC., OAKLAND, CA, DBA FEENEY WIRE ROPE & FITTINGS, INC.:
3,479,349, PUB. 5-20-2008. INT. CL. 6.
3,479,351, PUB. 5-20-2008. INT. CL. 6.
- PACIFIC LIFE INSURANCE COMPANY, NEWPORT BEACH, CA:
2,213,338, REN. 6-30-08. INT. CL. 36.
- PACIFIC PARKING SYSTEMS, INC., IRVINE, CA:
2,492,750, CANC. INT. CL. 35.
- PACIFIC RICE PRODUCTS, INC., BERKELEY, CA:
1,458,579, CANC. INT. CL. 30.
- PACIFIC VISION PROPRIETARY LTD., SURRY HILLS NSW 2010, AUSTRALIA:
3,481,459, INT. CL. 33.
- PADCOM, INC., BETHLEHEM, PA:
2,493,222, CANC. INT. CL. 9.
- PADDLE SURF HAWAII, LLC, AIEA, HI:
3,481,719, INT. CL. 28.
- PAGE, GEORGE, SALFORD, MANCHESTER M6 8FL, ENGLAND:
2,172,119, REN. 6-30-08. INT. CL. 22.
- PALMONE, INC., SUNNYVALE, CA:
2,493,549, CANC. INT. CL. 9.
- PANCHO BARNES ENTERPRISES, INC., SANTA MONICA, CA:
3,479,999, PUB. 5-20-2008. INT. CL. 32.
- PANGAEA ENTERTAINMENT GROUP, BEVERLY HILLS, CA:
3,478,840, PUB. 5-20-2008. INT. CL. 41.
- PAPER MAGIC GROUP, INC., THE WILMINGTON, DE:
2,493,346, CANC. MULTIPLE CLASS, INT. CLS. 4 AND 21.
- PAPERLESS ENVIRONMENTS, LLC, BATON ROUGE, LA:
3,478,835, PUB. 5-20-2008. INT. CL. 42.
- PAR-PAK LTD., BRAMPTON, ONTARIO L6T 1E5, CANADA:
2,195,181, REN. 6-30-08. INT. CL. 16.
- PARABLE FRANCHISING, LLC, SAN LOUIS OBISPO, CA:
1,544,016, REN. 7-3-08. INT. CL. 42.
- PARADIGM GEOPHYSICAL CORP., HOUSTON, TX:
3,482,158, INT. CL. 9.
- PARADIGM HEALTH SYSTEMS, INC, CONCORD, CA:
2,493,488, CANC. MULTIPLE CLASS, INT. CLS. 9 AND 42.
- PARADIGM4, INC., HARTFORD, CT:
2,492,335, CANC. INT. CL. 42.
- PARAGON VISION SCIENCES, INC., MESA, AZ:
2,224,262, REN. 6-28-08. INT. CL. 1.
- PARALLEL TECHNOLOGIES, INC., REDMOND, WA:
2,100,440, CANC. INT. CL. 9.
- PARAMOUNT WINDOW MFG. INC., BURTON, MI:
2,493,265, CANC. INT. CL. 19.
- PARAMOUNT WINDOWS, TEMPE, AZ:
3,478,746, PUB. 5-20-2008. INT. CL. 6.
- PARCELPORTR, LLC, NORTH HAVEN, CT:
3,479,914, PUB. 5-20-2008. MULTIPLE CLASS, INT. CLS. 35 AND 39.
3,479,915, PUB. 5-20-2008. MULTIPLE CLASS, INT. CLS. 35 AND 39.
3,479,917, PUB. 5-20-2008. MULTIPLE CLASS, INT. CLS. 35 AND 39.
- PARCO FOODS, L.L.C., BLUE ISLAND, IL TO PARCO FOODS, L.L.C., BLUE ISLAND, IL:
2,098,607, CANC. INT. CL. 30.
- PARFUMS DE COEUR, LTD., DARIEN, CT:
1,833,075, CANC. INT. CL. 3.
- PARFUMS GIVENCHY, 92300 LEVALLOIS PERRET, FRANCE:
2,491,941, CANC. INT. CL. 3.
- PARK, JEE WOO, LOS ANGELES, CA:
3,478,559, PUB. 5-20-2008. INT. CL. 32.
- PARKELL, INC., EDGEWOOD, NY:
1,486,672, REN. 6-30-08. INT. CL. 5.
- PARKER PRODUCTS, INC., FORT WORTH, TX:
3,481,689, INT. CL. 30.
- PARKER, II, WILLIAM M., CHICAGO, IL:
3,479,562, PUB. 5-20-2008. INT. CL. 35.
- PARLEC, INC., FAIRPORT, NY:
2,100,333, CANC. INT. CL. 9.
- PARLIAMENT IMPORT COMPANY, ATLANTIC CITY, NJ:
1,366,977, CANC. INT. CL. 33.
- PARMALAT S.P.A., ITALY:
3,481,002, PUB. 5-20-2008. INT. CL. 29.
- PARMALAT SPA, ITALY:
3,480,996, PUB. 5-20-2008. MULTIPLE CLASS, INT. CLS. 5, 29, 30 AND 32.
- PAROMI TEA, LLC, BETHESDA, MD:
3,482,304, INT. CL. 30.
- PAROTEX S.R.L., BUSTO ARSIZIO, VARESE, ITALY:
3,478,804, PUB. 5-20-2008. MULTIPLE CLASS, INT. CLS. 24 AND 25.
- PARTITION SYSTEMS INCORPORATED OF SOUTH CAROLINA, COLUMBIA, SC:
3,481,720, MULTIPLE CLASS, INT. CLS. 11 AND 20.
- PASCAL COMPANY, INC., BELLVIEW, WA:
676,224, REN. 6-30-08. U.S. CL. 18 (INT. CL. 5).
- PASQUA INC., NEW YORK, NY:
1,458,780, CANC. INT. CL. 42.
- PASS & SEYMOUR, INC., SYRACUSE, NY, SLATER ELECTRIC INC., GLEN COVE, NY:
1,061,116, REN. 6-30-08. INT. CL. 6.
- PASTARIA, LLC, MONTEREY PARK, CA:
3,480,607, PUB. 5-20-2008. INT. CL. 43.
- PASTARITO S.R.L., ITALY:
3,480,977, PUB. 5-20-2008. MULTIPLE CLASS, INT. CLS. 35 AND 43.
- PATERNO IMPORTS, LTD., LAKE BLUFF, IL, DBA TERLATO WINES INTERNATIONAL:
3,479,764, PUB. 5-20-2008. INT. CL. 35.
- PATIENT CHOICE HEALTHCARE, INC., ST. LOUIS PARK, MN:
3,478,497, PUB. 5-20-2008. INT. CL. 36.
- PATIENT OPTION, INC., CHICAGO, IL:
3,479,437, PUB. 5-20-2008. INT. CL. 36.
- PATRICK MCCLEAR, AUSTIN, TX:
2,491,873, CANC. INT. CL. 35.
- PAUL BOS, EL CAJON, CA, DBA PAUL BOS HEAT TREATING:
2,492,439, CANC. INT. CL. 40.
- PAULB, LLC, LITITZ, PA:
3,479,546, PUB. 5-20-2008. MULTIPLE CLASS, INT. CLS. 1, 6, 7 AND 8.
3,479,547, PUB. 5-20-2008. INT. CL. 35.
- PAULITH USA, INC., COMMERCE, CA:
3,482,140, INT. CL. 25.
- PAWLING CORPORATION, PAWLING, NY:
3,481,512, INT. CL. 17.
- PAYLESS SHOESOURCE WORLDWIDE, INC., TOPEKA, KS:
3,482,321, INT. CL. 25.
3,482,324, INT. CL. 35.
- PB BRANDS, LLC, MASPETH, NY:
3,482,459, INT. CL. 30.
- PCS EDVENTURES!.COM, INC., BOISE, ID:
3,478,928, PUB. 5-20-2008. INT. CL. 41.
- PEACE OF MIND PUBLISHING LLC, TARZANA, CA:
2,493,268, CANC. INT. CL. 41.
- PEACHTREE CITY MARKETING GROUP, L.L.C., PEACHTREE CITY, GA, DBA THE HOME SOURCE REALTORS:
3,478,956, PUB. 5-20-2008. MULTIPLE CLASS, INT. CLS. 35 AND 37.
- PEARCE, CAMERON, SAN JUAN, CA:
2,121,907, REN. 7-1-08. INT. CL. 25.

PEBBLE TECHNOLOGY, INC., SCOTTSDALE, AZ:
3,481,960, INT. CL. 19.
3,481,961, INT. CL. 19.

PEDIATRIC DENTAL HEALTHCARE, INC., PLAINVILLE, MA:
3,479,951, PUB. 5-20-2008. INT. CL. 44.

PEDRO HENRIQUE VIEIRA XAVIER; CARRADINHA, P-1050-064 LISBOA, PORTUGAL:
3,480,812, PUB. 5-20-2008. INT. CL. 28.

PEDRO J. LASALDE, SAN GERMAN, PUERTO RICO:
3,481,492, INT. CL. 28.

PEELLE COMPANY, THE, BAY SHORE, NY:
1,458,017, CANC. INT. CL. 7.

PEEP, INC., LOS ANGELES, CA:
3,481,302, INT. CL. 25.

PEGG, CAROL A., MURRIETA, CA:
2,491,804, CANC. INT. CL. 16.

PEI LICENSING, INC., MIAMI, FL:
2,164,539, REN. 7-3-08. INT. CL. 25.

PEIKKO FINLAND OY, FINLAND:
3,480,939, PUB. 5-20-2008. INT. CL. 6.

PELLA CORPORATION, PELLA, IA:
3,481,598, INT. CL. 19.

PELLEGRINI BROTHERS WINES, INC., SOUTH SAN FRANCISCO, CA, DBA PELLEGRINI FAMILY VINEYARDS:
2,491,754, CANC. INT. CL. 33.

PEN-TAB INDUSTRIES, INC., FRONT ROYAL, VA:
2,492,869, CANC. INT. CL. 16.

PENA, JOSE, LAS VEGAS, NV:
3,480,363, PUB. 5-20-2008. INT. CL. 45.

PENKY LLC, WILMINGTON, DE:
3,482,565, MULTIPLE CLASS, INT. CLS. 35 AND 45.

PENN CORPORATION, KALAMAZOO, MI:
1,458,372, CANC. MULTIPLE CLASS, INT. CLS. 20 AND 21.

PENNINGTON SEED, INC. OF NEBRASKA, MADISON, GA, PENNINGTON GRAIN & SEED, INC., MADISON, GA:
852,144, REN. 6-28-08. U.S. CL. 10 (INT. CL. 1).

PENSION MAXIMA INVESTMENT ADVISORY, ARCADIA, CA:
3,478,615, PUB. 5-20-2008. INT. CL. 36.

PENTAIR WATER POOL AND SPA, INC., SANFORD, NC:
3,482,309, INT. CL. 7.

PENTAPHARM A.G. (PENTAPHARM S.A.) (PENTAPHARM LTD.), BASLE, SWITZERLAND:
1,457,859, CANC. INT. CL. 1.

PENTECH INTERNATIONAL, INC., EDISON, NJ:
1,458,287, CANC. INT. CL. 16.

PENTON BUSINESS MEDIA, INC., NEW YORK, NY, FARM PRESS PUBLICATIONS, INC., CLARKSDALE, MS:
1,494,181, REN. 6-27-08. INT. CL. 16.

PEOPLE SEARCH MEDIA, LLC, PALO ALTO, CA:
3,480,094, PUB. 5-20-2008. INT. CL. 42.

PEP BOYS MANNY, MOE & JACK OF CALIFORNIA, THE, PHILADELPHIA, PA:
2,100,239, CANC. MULTIPLE CLASS, INT. CLS. 37 AND 42.

PEPPERIDGE FARM, INCORPORATED, NORWALK, CT:
2,586,509, AM. INT. CL. 29.
3,481,651, INT. CL. 30.

PEPSICO, INC., PURCHASE, NY:
2,493,590, CANC. INT. CL. 16.

PERDUE HOLDINGS, INC., WILMINGTON, DE:
2,099,241, CANC. INT. CL. 29.

PEREZ SOFTWARE SERVICES, INC., COLUMBIA, SC, AKA PSSSI:
2,492,181, CANC. MULTIPLE CLASS, INT. CLS. 9 AND 42.

PERFECT IMAGE MEDICAL CORP., LOS ANGELES, CA:
3,481,128, INT. CL. 41.

PERFORMANCE BRANDS, INC., SUNRISE, FL:
3,481,449, INT. CL. 3.
3,481,450, INT. CL. 3.
3,482,031, INT. CL. 3.

PERFORMANCE LABS, INC., CALABASAS, CA:
2,493,625, CANC. INT. CL. 5.

PERFORMANCE MOTION DEVICES, INC., LINCOLN, MA:
3,482,482, INT. CL. 9.

PERFORMANCE POLYMER SOLUTIONS, INC., CENTERVILLE, OH:
3,481,203, INT. CL. 1.

PERFORMANCE PRODUCTS INCORPORATED., SAN ANTONIO, TX:
2,130,523, REN. 6-30-08. INT. CL. 5.

PERFUMER'S WORKSHOP, LTD., THE, NEW YORK, NY:
1,457,930, CANC. INT. CL. 3.

PERIGEE INVESTMENT ADVISORS, LLC, HERSHEY, PA:
3,481,193, INT. CL. 36.

PERIOD FINANCIAL CORPORATION, FREDERICK, MD:
3,481,248, INT. CL. 16.

PERKINELMER, INC., WALTHAM, MA:
3,481,198, INT. CL. 11.

PERKINS, WOLF, MCDONNELL AND COMPANY, CHICAGO, IL:
3,065,034, COR. INT. CL. 36.

PERLMAN ERIC, GRANADA HILLS, CA:
3,481,967, INT. CL. 35.

PERRIGO COMPANY OF TENNESSEE, SMYRNA, TN TO VI-JON, INC., ST. LOUIS, MO:
2,098,543, CANC. INT. CL. 3.

PERRY, ROBERT C., LAKE OSWEGO, OR, DBA SECURTECH CO.:
2,493,216, CANC. INT. CL. 9.

PERSHING INVESTMENTS LLC, NEWARK, DE:
3,478,993, PUB. 5-20-2008. INT. CL. 36.
3,478,994, PUB. 5-20-2008. INT. CL. 36.

PERSONAL CARE PRODUCTS, INC., BINGHAM FARMS, MI:
3,479,656, PUB. 5-20-2008. INT. CL. 3.

PERSONALITY.COM, INC., NEW KENSINGTON, PA:
2,492,799, CANC. INT. CL. 42.

PERSTORP SPECIALITY CHEMICALS AB, SWEDEN:
3,165,462, COR. MULTIPLE CLASS, INT. CLS. 1 AND 17.

PET VALU CANADA INC., MARKHAM, CANADA:
3,481,778, INT. CL. 31.

PETERKA, KAIA ELISABETH, NEW YORK, NY:
3,478,656, PUB. 5-20-2008. INT. CL. 18.

PETERSEN MACHINERY GROUP A/S, ULDM, DENMARK:
3,479,036, PUB. 5-20-2008. INT. CL. 7.

PETERSON, ANDREW, L, WEST JORDAN, UT:
3,480,458, PUB. 5-20-2008. INT. CL. 21.

PETLAS LASTIK; SANAYI VE TICARET ANONIM SIRKETI, TURKEY:
3,480,981, PUB. 5-20-2008. INT. CL. 12.

PETROCOM, L.L.C., HARAHAN, LA:
3,479,864, PUB. 5-20-2008. INT. CL. 38.

PETROLEUM ASSET MANAGEMENT COMPANY, NASHVILLE, TN:
2,492,117, CANC. INT. CL. 42.

PETRONOMICS PARTNERS OF TEXAS, G.P., L.L.C., HOUSTON, TX:
3,479,599, PUB. 5-20-2008. INT. CL. 35.

PFIZER INC, NEW YORK, NY:
3,481,405, MULTIPLE CLASS, INT. CLS. 35 AND 44.

PFIZER INC., NEW YORK, NY:
2,492,566, CANC. MULTIPLE CLASS, INT. CLS. 16 AND 42.

PGA TOUR, INC., PONTE VEDRA BEACH, FL:
2,179,099, REN. 6-30-08. INT. CL. 25.

PHANTOM GOURMET, INC., BOSTON, MA:
3,480,554, PUB. 5-20-2008. INT. CL. 41.

PHARM EAST, INC., KEAAU, HI:
3,480,249, PUB. 5-20-2008. INT. CL. 5.

PHARMA VENTURES LTD, OXFORD, OXFORDSHIRE, UNITED KINGDOM:
3,480,405, PUB. 5-20-2008. INT. CL. 41.

PHARMA-NATURAL INC., HIALEAH, FL:
3,481,941, INT. CL. 5.

PHARMACEUTICAL SERVICES CORPORATION, POMONA, CA AND BRANDRETH, EDWARD J., ENCINITAS, CA:
3,479,470, PUB. 5-20-2008. INT. CL. 35.

- PHARMACEUTICAL SERVICES CORPORATION, POMONA, CA:
3,481,320, INT. CL. 9.
- PHARMACIA AB, UPPSALA, SWEDEN TO PHARMARCIA LKB BIOTECHNOLOGY AB, S-751 82 UPPSALA, SWEDEN:
1,458,042, CANC. INT. CL. 9.
- PHILHOBAR DESIGN CANADA LTD., MONTREAL, QUEBEC H2N 2J1, CANADA:
3,478,505, PUB. 3-4-2008. MULTIPLE CLASS, INT. CLS. 24 AND 25.
- PHILIP B. PARKER AND WAYNE M. WILLIAMS, SHERMAN OAKS, CA. DBA MUZLINK, LLC:
3,482,538, MULTIPLE CLASS, INT. CLS. 9, 35, 38 AND 42.
- PHILIPS ELECTRONICS NORTH AMERICA CORPORATION, NEW YORK, NY:
3,480,648, PUB. 5-20-2008. INT. CL. 9.
- PHILLIPS CABLES LIMITED, SCARBOROUGH, ONTARIO, CANADA:
1,458,069, CANC. INT. CL. 9.
- PHILLIPS PRODUCTS COMPANY, LLC, PRINCETON, MN:
3,480,161, PUB. 5-20-2008. INT. CL. 33.
- PHILOSOPHY, INC., PHOENIX, AZ:
2,202,197, REN. 7-2-08. INT. CL. 3.
3,482,026, INT. CL. 3.
- PHILOU, SAN FRANCISCO, CA:
2,493,473, CANC. INT. CL. 3.
- PHNOM PENH EXPRESS, INC., LONG BEACH, CA:
3,481,850, MULTIPLE CLASS, INT. CLS. 36 AND 39.
- PHO 95, INC., HUNTINGTON BEACH, CA:
2,492,497, CANC. INT. CL. 42.
- PHOENIX INTANGIBLES HOLDING COMPANY, WILMINGTON, DE:
2,493,270, CANC. INT. CL. 30.
- PHOENIX PERFORMANCE PRODUCTS INC., MISSISSAUGA, ONTARIO L5T 1K1, CANADA:
2,094,742, CANC. INT. CL. 18.
- PHOENIX WORLDWIDE INDUSTRIES, INC., MIAMI, FL:
3,479,080, PUB. 5-20-2008. INT. CL. 9.
- PHOINIX GLOBAL LLC, ALICE, TX:
3,482,563, INT. CL. 40.
- PHOTOGRAVE CORP., STATEN ISLAND, NY:
2,164,788, REN. 7-3-08. INT. CL. 14.
- PHULI COHAN MD, LLC, NEWTON, MA:
3,480,190, PUB. 5-20-2008. INT. CL. 5.
3,480,192, PUB. 5-20-2008. INT. CL. 5.
- PHYSICIAN'S SCIENCE & NATURE, INC., NEWPORT COAST, CA:
3,479,551, PUB. 5-20-2008. INT. CL. 5.
- PHYSICIANS FORMULA COSMETICS, INC., AZUSA, CA:
2,493,092, CANC. INT. CL. 3.
- PHYSIOTHERAPY CORPORATION, EXTON, PA:
3,480,454, PUB. 5-20-2008. INT. CL. 44.
3,480,514, PUB. 5-20-2008. INT. CL. 44.
- PH4 CORPORATION, BLOOMFIELD HILLS, MI:
2,099,847, CANC. INT. CL. 36.
- PI FINANCIAL CORP, VANCOUVER, CANADA:
3,478,874, PUB. 5-20-2008. INT. CL. 36.
- PIAZZA TOMASSO INTERNATIONAL INC., MONTREAL (QUEBEC), CANADA:
3,480,656, PUB. 5-20-2008. INT. CL. 30.
3,480,657, PUB. 5-20-2008. INT. CL. 30.
- PICOTTE, BRETT, WILLARD, MO:
3,481,585, INT. CL. 28.
- PIERCE BIOTECHNOLOGY, INC., ROCKFORD, IL:
3,479,645, PUB. 5-20-2008. INT. CL. 1.
- PIERCE, CATHERINE, AUSTIN, TX:
3,480,152, PUB. 5-20-2008. INT. CL. 41.
- PIERO GUIDI DI PIERINO GIUSEPPE GUIDI & C. S.N.C., 61020 SCHIETI DI URBINO, ITALY:
2,587,095, CANC. MULTIPLE CLASS, INT. CLS. 3, 9, 14, 20 AND 24.
- PIERRE FABRE MEDICAMENT, 92100 BOULOGNE, FRANCE:
2,511,630, CANC. MULTIPLE CLASS, INT. CLS. 3 AND 5.
- PIEZOCRYST ADVANCED SENSORIES GMBH, AUSTRIA:
3,481,039, PUB. 5-20-2008. INT. CL. 9.
- PIKA TECHNOLOGIES INC., OTTAWA, ONTARIO, CANADA:
3,478,818, PUB. 3-11-2008. MULTIPLE CLASS, INT. CLS. 9 AND 42.
- PIKE PLACE MARKET PRESERVATION AND DEVELOPMENT AUTHORITY, SEATTLE, WA:
3,482,681, INT. CL. 30.
- PINCEIS ATLAS S/A, ESTEIO/RS, BRAZIL:
3,479,955, PUB. 5-20-2008. INT. CL. 16.
- PININFARINA EXTRA S.R.L., ITALY:
3,480,900, PUB. 5-20-2008. INT. CL. 21.
- PINK DOT, INC., CAMARILLO, CA:
1,458,823, CANC. INT. CL. 42.
- PINNACLE FOODS GROUP, INC., WILMINGTON, DE:
2,492,390, CANC. INT. CL. 29.
- PIONEER HI-BRED INTERNATIONAL, INC., JOHNSTON, IA:
3,481,763, MULTIPLE CLASS, INT. CLS. 35 AND 42.
- PIONEER/ECLIPSE CORPORATION:
1,458,064, CANC. INT. CL. 9.
- PIPER-HEIDSIECK, ANCIENNE MAISON HEIDSIECK FONDEE EN 1785, COMPAGNIE CHAMPENOISE, REIMS, FRANCE:
3,478,704, PUB. 5-20-2008. INT. CL. 33.
- PIPER-HEIDSIECK, ANCIENNE MAISON; HEIDSIECK FONDEE EN 1785; COMPAGNIE CHAMPENOISE; (SOCIÉTÉ PAR ACTIONS SIMPLIFIÉE; UNIPERSONNELLE), FRANCE:
3,480,980, PUB. 5-20-2008. MULTIPLE CLASS, INT. CLS. 32 AND 33.
- PIPING TECHNOLOGY & PRODUCTS INC., HOUSTON, TX:
2,493,608, CANC. INT. CL. 6.
- PIPITONE, DAMON, SOUTH PASADENA, CA:
2,099,584, CANC. INT. CL. 41.
- PIRATE NATION, INC., LAS VEGAS, NV:
2,172,131, REN. 7-2-08. INT. CL. 41.
- PISCIOTTA, PHIL, OAK GROVE, MO:
3,482,713, INT. CL. 39.
- PIT STOP RESTORATION LLC, BROOKLYN PARK, MN:
3,480,397, PUB. 5-20-2008. INT. CL. 37.
- PITNEY BOWES INC., STAMFORD, CT:
3,482,264, INT. CL. 35.
- PIXEL STREAMS, LLC, PORTLAND, OR:
3,478,876, PUB. 5-20-2008. INT. CL. 42.
- PLANET DANCE LLC, CINCINNATI, OH:
3,478,631, PUB. 5-20-2008. INT. CL. 41.
- PLANET EARTH FOUNDATION, SEATTLE, WA:
3,481,043, INT. CL. 42.
3,481,044, INT. CL. 42.
3,481,045, INT. CL. 42.
3,481,046, INT. CL. 42.
3,481,047, INT. CL. 42.
3,481,048, INT. CL. 42.
- PLANET HOLLYWOOD (REGION IV), INC., ORLANDO, FL:
3,481,071, INT. CL. 41.
- PLANET TOYS, INC., NEW YORK, NY:
3,481,252, INT. CL. 28.
- PLANETWIDE GAMES, INC., ALISO VIEJO, CA:
3,481,929, INT. CL. 42.
- PLANNED ADMINISTRATORS, INC., COLUMBIA, SC:
3,481,518, INT. CL. 36.
- PLANTCARE AG, SWITZERLAND:
3,480,968, PUB. 5-20-2008. MULTIPLE CLASS, INT. CLS. 9, 11 AND 21.
- PLATEMATE.BIZ, WEST PALM BEACH, FL, DBA PLATEMATE STUDIOS, INC.:
3,480,081, PUB. 5-20-2008. INT. CL. 41.
- PLAYCORE WISCONSIN, INC., JANESVILLE, WI:
2,492,078, CANC. INT. CL. 28.
2,492,080, CANC. INT. CL. 28.
2,492,084, CANC. INT. CL. 28.
- PLAYROOM FOR KIDS, INC., THE, CHESTERFIELD, VA:
3,479,609, PUB. 5-20-2008. INT. CL. 41.
- PLAYSAM I KALMAR AKTIEBOLAG, KALMAR, SWEDEN:
3,479,825, PUB. 5-20-2008. INT. CL. 16.
- PLEASURE PATROL, LLC, BURBANK, CA:
2,492,086, CANC. INT. CL. 35.

PLEXUS BIOMEDICAL, INC., OAKLAND, TN:
3,481,560, INT. CL. 10.

PLEXUS RESEARCH, INC., FRAMINGHAM, MA:
3,480,412, PUB. 5-20-2008. INT. CL. 35.

PLUMADORE, PAUL, RIVERDALE, NY:
3,478,624, PUB. 5-20-2008. INT. CL. 35.

PLZENSKY PRAZDROJ, A.S., CZECH REPUBLIC:
3,480,806, PUB. 5-20-2008. INT. CL. 41.

PMMS CONSULTING GROUP (NORTH AMERICA), INC., TORONTO, ONTARIO, CANADA:
2,493,085, CANC. INT. CL. 42.

PO-JACK L.L.C., BRIARCLIFF MANOR, NY:
3,480,725, PUB. 5-20-2008. INT. CL. 41.

POCKETCARD INC., LINDENHURST, IL:
2,491,779, CANC. INT. CL. 36.

POINT LAKE MARKETING, INC., VANCOUVER, CANADA:
3,479,107, PUB. 5-20-2008. MULTIPLE CLASS, INT. CLS. 14, 35, 40 AND 42.

POINTSERVE, INC., AUSTIN, TX:
2,491,752, CANC. INT. CL. 9.
2,491,753, CANC. INT. CL. 9.

POINTSOURCE, LLC, BRADENTON, FL:
3,478,970, PUB. 5-20-2008. MULTIPLE CLASS, INT. CLS. 35 AND 42.

POLARIS INDUSTRIES INC., MEDINA, MN:
3,481,704, INT. CL. 12.
3,481,931, INT. CL. 12.

POLITO'S PIZZA, LLC., STEVENS POINT, WI:
3,480,240, PUB. 5-20-2008. INT. CL. 30.

POLLARD, ALBERT C., WHITE STONE, VA:
3,482,364, INT. CL. 7.

POLO RELATIONS LTD, UNITED KINGDOM:
3,480,774, PUB. 5-20-2008. INT. CL. 25.

POLSKY, JOHN W., FLUSHING, NY:
2,493,661, CANC. INT. CL. 35.

POMME POMME FRIES CORP., MASPETH, NY:
2,492,400, CANC. INT. CL. 42.

PONT EMBALLAGE, FRANCE:
3,480,884, PUB. 5-20-2008. MULTIPLE CLASS, INT. CLS. 6, 20 AND 21.

PONY BASEBALL, INC., WASHINGTON, PA:
1,495,434, REN. 7-1-08. INT. CL. 41.

POP INTERNATIONAL GALLERIES, INC., NEW YORK, NY:
3,480,054, PUB. 5-20-2008. INT. CL. 35.

PORTER, ROGER, LORIS, SC:
2,160,275, REN. 6-30-08. INT. CL. 7.

PORTER, STARR, MILL VALLEY, CA:
3,482,190, INT. CL. 43.

POT EN MAND B.V., NETHERLANDS:
3,480,809, PUB. 5-20-2008. MULTIPLE CLASS, INT. CLS. 4, 20, 21 AND 28.

POTOMAC PARTY CRUISES, INC., ALEXANDRIA, VA:
2,098,640, CANC. MULTIPLE CLASS, INT. CLS. 25, 39 AND 42.

POTOMAC PUBLISHING, INC., POTOMAC, MD:
3,479,819, PUB. 5-20-2008. MULTIPLE CLASS, INT. CLS. 16 AND 35.

POTOMACWAVE CONSULTING, INC, KIRKLAND, WA:
3,479,998, PUB. 5-20-2008. INT. CL. 35.

POTOMACWAVE CONSULTING, INC., KIRKLAND, WA:
3,479,997, PUB. 5-20-2008. INT. CL. 35.

POWER PLATE NORTH AMERICA, INC., NORTHBROOK, IL:
3,481,423, MULTIPLE CLASS, INT. CLS. 10 AND 28.

POWER TOOLS INC., WOBURN, MA:
3,481,601, INT. CL. 9.

POWER-SELLES IMPORTS, INC., WOODINVILLE, WA:
3,481,718, INT. CL. 35.

POWERED AIRE INC., GREENVILLE, PA:
3,480,282, PUB. 5-20-2008. INT. CL. 11.

POZZA, DEBORAH C., DEFUNIACK SPRINGS, FL:
3,479,793, PUB. 5-20-2008. INT. CL. 28.

PPM 2000 INC., EDMONTON, ALBERTA, CANADA:
2,219,312, REN. 6-28-08. INT. CL. 9.

PRAIRIE BERRY, L.L.C., HILL CITY, SD:
3,478,937, PUB. 5-20-2008. INT. CL. 33.

PRAXEIS, LLC, JACKSONVILLE, FL:
3,479,637, PUB. 5-20-2008. INT. CL. 43.

PRECISE POWER CORPORATION, BRADENTON, FL:
2,492,657, CANC. MULTIPLE CLASS, INT. CLS. 7 AND 9.

PREFERRED NUTRITION INC., ACTON, CANADA:
3,478,865, PUB. 5-20-2008. INT. CL. 41.

PREFERRED PROFESSIONAL INSURANCE COMPANY, OMAHA, NE:
3,479,002, PUB. 5-20-2008. INT. CL. 36.

PREMIER TECHNOLOGIES INTERNATIONAL, LTD, DENVER, CO:
2,099,280, CANC. INT. CL. 9.

PRESCIENT WORLDWIDE, LLC, WALLINGFORD, CT:
3,478,887, PUB. 5-20-2008. INT. CL. 35.

PRESCRIPTIVE MUSIC, LLC, WOODLAND HILLS, CA:
3,481,827, INT. CL. 16.

PRESTIGE REWARDS PROGRAM, INC., NEW PORT RICHEY, FL:
3,481,588, INT. CL. 35.

PRICE, DONALD H., PORT TOWNSEND, WA:
3,482,506, INT. CL. 13.

PRICEWATERHOUSECOOPERS LLP, NEW YORK, NY:
2,493,145, CANC. INT. CL. 36.

PRIDE PLASTICS, INC., FLINT, MI:
1,347,948, CANC. INT. CL. 20.

PRIMA INDUSTRIE SPA, ITALY:
3,480,870, PUB. 5-20-2008. INT. CL. 7.

PRIMARY INVESTMENTS GROUP LIMITED, TORTOLA, BR. VIRGIN ISLANDS:
2,164,284, REN. 7-3-08. INT. CL. 5.

PRIME FINANCIAL GROUP, INC., MARIETTA, GA:
2,493,657, CANC. INT. CL. 35.

PRIME FITNESS, LLC, BONNEY LAKE, WA:
3,481,621, INT. CL. 41.

PRIMLAND LTD., MEADOWS OF DAN, VA:
3,481,390, MULTIPLE CLASS, INT. CLS. 41 AND 43.

PRIMORIGEN BIOSCIENCES LLC, MADISON, WI:
3,482,532, MULTIPLE CLASS, INT. CLS. 1, 40 AND 42.

PRIMWELL INVESTMENT PTE. LTD., SINGAPORE 0104, SINGAPORE TO GITI TIRE PTE. LTD INCORPORATED, SINGAPORE, SINGAPORE:
2,099,993, CANC. INT. CL. 12.
2,099,994, CANC. INT. CL. 12.

PRINCESS CARE, LLC, SURPRISE, AZ:
3,479,624, PUB. 5-20-2008. INT. CL. 8.

PRINCETON ECOM CORPORATION, PRINCETON, NJ:
2,493,631, CANC. INT. CL. 36.

PRINTCAFE IP MANAGEMENT, INC., PITTSBURGH, PA:
2,100,119, CANC. INT. CL. 9.

PRINTING RESEARCH, INC., DALLAS, TX:
2,168,079, REN. 7-3-08. INT. CL. 7.

PRINZ OPTICS GMBH, D-55442 STROMBERG, FED REP GERMANY:
2,516,321, CANC. MULTIPLE CLASS, INT. CLS. 7 AND 9.

PRISM, INCORPORATED, OVIEDO, FL:
3,481,215, MULTIPLE CLASS, INT. CLS. 35 AND 41.
3,481,216, MULTIPLE CLASS, INT. CLS. 35 AND 41.

PRO STEP MARKETING, INC., HUNTERSVILLE, NC:
3,480,025, PUB. 5-20-2008. INT. CL. 41.

PRO-BIOTIKS LABS, INC., OGDEN, UT:
3,479,041, PUB. 5-20-2008. INT. CL. 5.

PRO-FEET, INC., BURLINGTON, NC:
1,458,442, CANC. INT. CL. 25.

PROACTIVE REMEDIES, LLC, LEESBURG, VA:
3,480,564, PUB. 5-20-2008. INT. CL. 5.

PROBASCO, TIMOTHY C., FORT LAUDERDALE, FL:
3,481,066, INT. CL. 16.

PRODUCT EXCELLENCE INC., CONCORD, CANADA:
3,480,672, PUB. 2-12-2008. INT. CL. 3.

PRODUCT QUEST MANUFACTURING, INC., HOLLY HILL, FL:
3,481,954, INT. CL. 3.

PRODUCTION CAR CARE PRODUCTS, INC., STOCKTON, CA:
2,099,534, CANC. INT. CL. 3.

PRODUCTNETWORK, INC., WAITE PARK, MN:
2,493,627, CANC. INT. CL. 35.

- PRODUCTORES DEL MAR DE MEXICO, S.A. DE C.V., MAZATLÁN, MEXICO:
3,479,362, PUB. 5-20-2008. MULTIPLE CLASS, INT. CLS. 29 AND 35.
- PROF. DR. MED. CHRISTIAN KRENKEL, A-5020 SALZBURG, AUSTRIA:
3,480,865, PUB. 5-20-2008. INT. CL. 10.
- PROFESSIONAL CONVENTION MANAGEMENT ASSOCIATION, CHICAGO, IL:
3,481,319, INT. CL. 35.
- PROFESSIONAL RETAIL STORE MAINTENANCE ASSOCIATION, ADDISON, TX:
3,479,004, PUB. 5-20-2008. U.S. CL. B.
- PROFESSIONAL UNIFORMS, INC., GRAND RAPIDS, MI:
2,099,611, CANC. INT. CL. 35.
- PROFESSIONAL WOMEN IN CONSTRUCTION CORP., NEW YORK, NY:
3,478,891, PUB. 5-20-2008. INT. CL. 35.
3,478,892, PUB. 5-20-2008. INT. CL. 35.
- PROFI-TECH GMBH, GINGEN, FED REP GERMANY:
3,482,259, INT. CL. 4.
- PROFITABLE SPEECH, LLC, CLIFTON PARK, NY AND KLEIN, DALE G., CLIFTON PARK, NY:
3,478,646, PUB. 5-20-2008. INT. CL. 44.
- PROFLOWERS, INC., SAN DIEGO, CA:
2,492,495, CANC. INT. CL. 35.
- PROGRAMMER'S PARADISE, INC., SHREWSBURY, NJ:
2,100,537, CANC. INT. CL. 35.
- PROGRAMMING CONCEPTS, LTD., SAN ANTONIO, TX:
2,247,351, REN. 7-2-08. INT. CL. 28.
- PROGRESS SOFTWARE CORPORATION, BEDFORD, MA:
3,479,128, PUB. 5-20-2008. INT. CL. 41.
3,479,129, PUB. 5-20-2008. INT. CL. 42.
3,479,130, PUB. 5-20-2008. INT. CL. 9.
3,479,132, PUB. 5-20-2008. INT. CL. 41.
3,479,133, PUB. 5-20-2008. INT. CL. 42.
3,479,134, PUB. 5-20-2008. INT. CL. 9.
- PROGRESSIVE GAMING INTERNATIONAL CORP., LAS VEGAS, NV:
3,480,261, PUB. 5-20-2008. INT. CL. 9.
3,482,594, MULTIPLE CLASS, INT. CLS. 9 AND 41.
- PROJECT CUDDLE, INC., COSTA MESA, CA:
3,479,185, PUB. 5-20-2008. MULTIPLE CLASS, INT. CLS. 35 AND 45.
3,479,186, PUB. 5-20-2008. MULTIPLE CLASS, INT. CLS. 35 AND 45.
- PROMAN, MATTHEW, GARDEN CITY, NY:
3,478,508, PUB. 5-20-2008. INT. CL. 41.
- PROMAX NUTRITION, INC., CONCORD, CA:
3,481,768, INT. CL. 5.
- PROPEX CONCRETE SYSTEMS CORPORATION, AUSTELL, GA:
2,492,600, CANC. INT. CL. 19.
- PROPEX GEOSOLUTIONS CORPORATION, AUSTELL, GA:
2,492,599, CANC. INT. CL. 27.
- PROSPECT MANAGEMENT, LLC, ROCHESTER, NY:
3,480,128, PUB. 5-20-2008. INT. CL. 36.
3,480,129, PUB. 5-20-2008. INT. CL. 36.
- PROSTALUND OPERATIONS AB, UPSALA, SWEDEN:
3,481,028, PUB. 5-20-2008. MULTIPLE CLASS, INT. CLS. 10, 42 AND 44.
- PROTECT THE PLANET, INC., HONOLULU, HI:
3,482,144, INT. CL. 41.
- PROTEUS INDUSTRIES, INC., GLOUCESTER, MA:
3,478,587, PUB. 5-20-2008. INT. CL. 29.
- PROVIDE COMMERCE, INC., SAN DIEGO, CA:
3,482,211, INT. CL. 35.
- PROXY REAL ESTATE, LLC, BELLEVUE, WA:
3,479,863, PUB. 5-20-2008. INT. CL. 36.
- PRUKOP, SHANE, VENTURA, CA:
3,479,445, PUB. 5-20-2008. INT. CL. 35.
- PTP SOLUTIONS, LLC, BETHESDA, MD:
2,492,164, CANC. INT. CL. 42.
- PUBLISHING DATA MANAGEMENT INC., NEW YORK, NY:
3,482,204, MULTIPLE CLASS, INT. CLS. 35, 40 AND 41.
- PULLMANTUR, S.A., SPAIN:
3,480,751, PUB. 5-20-2008. INT. CL. 39.
- PULLTEX, S.L., SANT BOI DE LLOBREGAT, SPAIN:
3,479,835, PUB. 5-20-2008. INT. CL. 21.
- PURCHASING POWER, LLC, ATLANTA, GA:
3,478,873, PUB. 5-20-2008. MULTIPLE CLASS, INT. CLS. 35 AND 36.
- PURE & NATURAL COMPANY, SCOTTSDALE, AZ, UNITED STATES BORAX & CHEMICAL CORPORATION, LOS ANGELES, CA:
1,492,844, REN. 7-3-08. INT. CL. 3.
- PURE AND SIMPLE SOLUTIONS, LLC, HUNTINGTON WOODS, MI:
3,479,296, PUB. 5-20-2008. INT. CL. 14.
- PURE FISHING, INC., SPIRIT LAKE, IA:
3,481,519, INT. CL. 28.
- PURITY FOODS, INC., CLAYTON, OH:
2,696,943, CANC. INT. CL. 30.
- PUSH INC., NEW YORK, NY, DBA KAREN KARCH:
3,482,476, INT. CL. 14.
3,482,477, MULTIPLE CLASS, INT. CLS. 14 AND 35.
- PYLON ELECTRONICS, INC., OTTAWA, CANADA:
3,479,592, PUB. 5-20-2008. MULTIPLE CLASS, INT. CLS. 37 AND 42.
- PYN, S.A. DE C.V., MEXICO D.F., MEXICO:
3,479,458, PUB. 5-20-2008. INT. CL. 27.
3,479,459, PUB. 5-20-2008. INT. CL. 24.
- Q-LAB CORPORATION, CLEVELAND, OH:
2,167,570, REN. 6-30-08. INT. CL. 9.
- Q, INTERACTIVE, INC., CHICAGO, IL:
2,491,781, CANC. INT. CL. 35.
- QC AMERICAN, ANN ARBOR, MI:
3,479,957, PUB. 5-20-2008. MULTIPLE CLASS, INT. CLS. 7 AND 42.
- QINGDAO YEBIO BIOENGINEERING; CO., LTD., QINGDAO BONDED ZONE, CHINA:
3,480,789, PUB. 5-20-2008. INT. CL. 5.
- QPAY, INC., NORTH MIAMI BEACH, FL:
3,479,454, PUB. 5-20-2008. MULTIPLE CLASS, INT. CLS. 9 AND 36.
- QRS MUSIC TECHNOLOGIES, INC., NAPLES, FL:
3,482,730, INT. CL. 9.
- QUADRA PRO ALOFT LLC, SCOTTSDALE, AZ:
3,481,950, INT. CL. 10.
- QUAKER STATE CORPORATION, OIL CITY, PA:
1,457,868, CANC. MULTIPLE CLASS, INT. CLS. 1 AND 4.
- QUALCOMM INCORPORATED, SAN DIEGO, CA:
3,482,130, MULTIPLE CLASS, INT. CLS. 38 AND 42.
- QUALIS GROUP, L.L.C., DES MOINES, IA:
1,457,917, CANC. MULTIPLE CLASS, INT. CLS. 3, 5 AND 35.
- QUALITAU, INC., SUNNYVALE, CA:
2,159,228, REN. 7-2-08. INT. CL. 42.
- QUALITY CALL SOLUTIONS, INC., SANTA CLARA, CA:
2,098,645, CANC. INT. CL. 42.
- QUALITY CHRISTMAS TREE, LTD., HOUSTON, TX:
3,478,600, PUB. 5-20-2008. INT. CL. 31.
- QUALITY MEASUREMENT LIMITED, WEST SUSSEX RH15 9LB, ENGLAND:
2,098,875, CANC. INT. CL. 9.
- QUANNAH CORPORATION, SAN ANTONIO, TX:
1,531,598, REN. 7-3-08. INT. CL. 6.
- QUANTUM FOODS, LLC, BOLINGBROOK, IL:
2,100,110, CANC. MULTIPLE CLASS, INT. CLS. 29 AND 40.
- QUESTAR CORPORATION, NEW HOPE, PA:
2,492,659, CANC. INT. CL. 9.
- QUESTAR CORPORATION, SALT LAKE CITY, UT:
3,480,708, PUB. 7-31-2007. MULTIPLE CLASS, INT. CLS. 39 AND 40.
- QUESTECH CORPORATION, RUTLAND, VT:
3,254,330, AM. INT. CL. 19.
- QUIAMBAO, ROMEO BUGAY, CHINO HILLS, CA, DBA PHONE CARD CONNECTION:
3,479,736, PUB. 5-20-2008. INT. CL. 38.
- QUICKDOWN.COM, L.C., PLEASANT GROVE, UT:
2,492,770, CANC. INT. CL. 36.
- QUICKIE MANUFACTURING CORPORATION, CINNAMINSON, NJ:
1,458,382, CANC. INT. CL. 21.

QUIDEL CORPORATION, SAN DIEGO, CA:
 2,099,662, CANC. INT. CL. 5.
 QUIKRETE INTERNATIONAL, INC., ATLANTA, GA,
 QUIKRETE COMPANY, COLUMBUS, OH:
 850,050. REN. 7-2-08. U.S. CL. 6 (INT. CL. 1).
 QUIKSILVER, INC., HUNTINGTON BEACH, CA:
 3,480,741, PUB. 5-20-2008. INT. CL. 41.
 QUIKWATER, INC., SAND SPRINGS, OK:
 2,185,743. REN. 6-30-08. INT. CL. 11.
 QUINTESSENCE INCORPORATED, CHICAGO, IL:
 1,457,899, CANC. INT. CL. 3.
 QUIZNO'S MASTERLLC, THE, DENVER, CO:
 2,228,680. REN. 6-30-08. INT. CL. 42.
 QWEST COMMUNICATIONS INTERNATIONAL INC, DEN-
 VER, CO:
 2,099,748, CANC. INT. CL. 38.
 QWEST COMMUNICATIONS INTERNATIONAL INC.,
 DENVER, CO:
 3,479,327, PUB. 5-20-2008. INT. CL. 20.
 3,480,468, PUB. 5-20-2008. INT. CL. 38.
 QWIZDOM, INC., PUYALLUP, WA:
 3,480,620, PUB. 5-20-2008. INT. CL. 9.
 R & B REALTY GROUP DBA OAKWOOD WORLDWIDE,
 LOS ANGELES, CA:
 3,480,731, PUB. 5-20-2008. INT. CL. 43.
 R. J. THOMPSON SECURITIES, INC., OMAHA, NE:
 2,492,468, CANC. INT. CL. 36.
 R. WOLFE ASSOCIATES LLC, CINCINNATI, OH:
 2,492,755, CANC. INT. CL. 42.
 RACAL TRACS LIMITED, BRACKNELL, BERKSHIRE,
 ENGLAND:
 2,491,919, CANC. INT. CL. 9.
 RACHID T. TOUMA & FRERES, KAB-ELIAS, LEBANON:
 1,487,710. REN. 7-2-08. INT. CL. 33.
 RACINGTHEPLANET LIMITED, THE PEAK, HONG KONG:
 3,481,338, MULTIPLE CLASS, INT. CLS. 25 AND 41.
 RADAR NETWORKS, INC., SAN FRANCISCO, CA:
 3,481,988, INT. CL. 42.
 RADCAL CORPORATION, MONROVIA, CA:
 3,481,631, INT. CL. 9.
 RADIIENT TECHNOLOGIES, INC., SANTA CLARA, CA:
 3,481,400, INT. CL. 9.
 RADIO NETWORKS, LLC, NEW YORK, NY:
 2,493,191, CANC. MULTIPLE CLASS, INT. CLS. 35, 41
 AND 42.
 RADISSON HOTELS INTERNATIONAL, INC., MINNEAPO-
 LIS, MN:
 2,099,154, CANC. INT. CL. 42.
 RADY CHILDREN'S HOSPITAL AND HEALTH CENTER,
 SAN DIEGO, CA:
 3,479,163, PUB. 5-20-2008. MULTIPLE CLASS, INT. CLS.
 35, 42 AND 44.
 RAGING KNOWLEDGE, INC., NORWALK, CT:
 2,492,373, CANC. INT. CL. 35.
 RAHMANI, MAURICE, BEVERLY HILLS, CA:
 3,482,405, INT. CL. 25.
 RAI, GABRIEL, VISTA, CA:
 3,479,822, PUB. 5-20-2008. INT. CL. 9.
 RAINER KAUPER, FED REP GERMANY:
 3,480,946, PUB. 5-20-2008. MULTIPLE CLASS, INT. CLS.
 18, 25 AND 28.
 RAISE YOUR HAND FOR PUBLIC SCHOOLS, SAN ANTO-
 NIO, TX:
 3,481,624, INT. CL. 35.
 3,481,625, INT. CL. 35.
 3,481,627, INT. CL. 35.
 3,481,628, INT. CL. 35.
 RAL & ASSOCIATES, INC., BEN WHEELER, TX:
 3,480,150, PUB. 5-20-2008. INT. CL. 20.
 RALSTON PURINA COMPANY, ST. LOUIS, MO:
 2,492,915, CANC. INT. CL. 31.
 RAM OPTICAL INSTRUMENTATION, INC., ROCHESTER,
 NY:
 1,526,634. REN. 7-3-08. INT. CL. 9.
 RAND MCNALLY & COMPANY, SKOKIE, IL:
 2,100,090, CANC. INT. CL. 28.
 3,479,009, PUB. 5-20-2008. INT. CL. 9.
 RAN-
 DA NECKWEAR, INC., HACKENSACK, NJ TO RAN-
 DA CORP., NEW YORK, NY:
 1,458,460, CANC. INT. CL. 25.
 RANDALL COMMUNICATIONS PTY LTD, ALEXANDRIA
 NSW 2015, AUSTRALIA:
 3,481,036, PUB. 5-20-2008. MULTIPLE CLASS, INT. CLS.
 9, 16 AND 25.
 RANDALL INTERNATIONAL, L.P., CARLSBAD, CA:
 3,479,116, PUB. 5-20-2008. MULTIPLE CLASS, INT. CLS. 3
 AND 5.
 RANDALL S. CORPORATION, KIRKLAND, WA:
 3,478,551, PUB. 5-20-2008. INT. CL. 41.
 RANDOM HOUSE VALUE PUBLISHING, INC., NEW
 YORK, NY TO RANDOM HOUSE INC., NEW YORK, NY:
 2,100,036, CANC. INT. CL. 16.
 RANDOM HOUSE, INC., NEW YORK, NY:
 1,497,708. REN. 6-30-08. INT. CL. 16.
 RATHSKELLER PRESS LLC, ATLANTA, GA:
 3,479,661, PUB. 5-20-2008. INT. CL. 41.
 RAYMOND CREATIVE, LLC, ST. LOUIS, MO:
 3,481,455, MULTIPLE CLASS, INT. CLS. 35 AND 41.
 RAYPAK, INC., OXNARD, CA:
 2,477,390, AM. INT. CL. 11.
 RAYTHEON COMPANY, WALTHAM, MA:
 3,481,182, INT. CL. 9.
 RAZAVI GLOBAL MEDIA, INC., SANTA MONICA, CA:
 3,479,726, PUB. 5-20-2008. INT. CL. 35.
 RBLOCK, INC., SUNNYVALE, CA:
 3,481,463, MULTIPLE CLASS, INT. CLS. 35, 38, 42 AND
 45.
 RBS LYNK INCORPORATED, ATLANTA, GA:
 2,492,001, CANC. INT. CL. 42.
 RCN TELECOM SERVICES, INC., PRINCETON, NJ:
 2,491,955, CANC. INT. CL. 38.
 REACHUSA SALES GROUP, LLC, CINCINNATI, OH:
 2,493,673, CANC. INT. CL. 35.
 READYMADE PRODUCTIONS PTY LTD, AUSTRALIA:
 3,480,959, PUB. 5-20-2008. MULTIPLE CLASS, INT. CLS.
 16 AND 41.
 REAL-T-MASTERS INC., MISSISSAUGA, ONTARIO, L5N
 4J9, CANADA:
 2,492,848, CANC. INT. CL. 16.
 REALNETWORKS, INC., SEATTLE, WA:
 2,493,460, CANC. MULTIPLE CLASS, INT. CLS. 35 AND
 38.
 REALTY EXECUTIVES INTERNATIONAL, INC., PHOE-
 NIX, AZ:
 2,491,749, CANC. INT. CL. 35.
 REALTY WORLD, INC., COSTA MESA, CA, REALTY
 WORLD CORPORATION, WASHINGTON, DC:
 1,096,966. REN. 6-27-08. INT. CL. 36.
 REASON, INC., AURORA, CO:
 2,493,077, CANC. INT. CL. 35.
 REBEL CO., THE, ATLANTA, GA:
 2,098,637, CANC. INT. CL. 29.
 RECESS FITNESS, HEALTH AND PLAY LLC, PORTLAND,
 OR:
 3,480,653, PUB. 5-20-2008. MULTIPLE CLASS, INT. CLS.
 35, 41 AND 44.
 RECKITT BENCKISER INC., PARSIPPANY, NJ:
 3,481,269, MULTIPLE CLASS, INT. CLS. 3 AND 5.
 3,481,829, INT. CL. 30.
 RECOGNITION INSIGHT, LLC, FORT MYERS, FL:
 3,482,446, INT. CL. 9.
 RECON OIL INDUSTRIES LIMITED, MUMBAI 400 059,
 INDIA:
 2,492,264, CANC. INT. CL. 29.
 RECORDSCOPE, INC., PLANTATION, FL:
 2,492,983, CANC. INT. CL. 35.
 RECOVERCARE, LLC, RADNOR, PA:
 2,197,320. REN. 7-3-08. INT. CL. 10.
 RED BRICK PIZZA, INC., PALMDALE, CA:
 3,480,243, PUB. 5-20-2008. INT. CL. 30.
 RED BULL GMBH, FUSCHL AM SEE, AUSTRIA:
 3,479,607, PUB. 5-27-2008. INT. CL. 32.
 RED DEVIL, INC., TULSA, OK:
 2,169,460. REN. 7-3-08. INT. CL. 19.

- RED HOUSE PICTURES, LLC, WOODSTOCK, NY:
3,480,561, PUB. 5-20-2008. INT. CL. 41.
- RED LEVEL NETWORKS LLC, NOVI, MI:
3,478,950, PUB. 5-20-2008. INT. CL. 42.
- RED ROSE COLLECTION, INC.:
1,458,282, CANC. MULTIPLE CLASS, INT. CLS. 16 AND 20.
- RED ROSE COLLECTION, INC., BURLMGAME, CA:
1,458,283, CANC. MULTIPLE CLASS, INT. CLS. 16 AND 20.
- RED SKY INTERACTIVE, SAN FRANCISCO, CA:
2,493,147, CANC. INT. CL. 9.
- RED SLATE BRANDS, INC., ROAD TOWN, BR.VIRGIN ISLANDS:
3,481,566, MULTIPLE CLASS, INT. CLS. 26 AND 28.
- RED STEER GLOVE COMPANY, SALEM, OR:
3,478,661, PUB. 5-20-2008. INT. CL. 9.
- REDDY - BUFFALOES PUMP INC., BAXLEY, GA:
2,098,707, CANC. INT. CL. 7.
- REDFORDS PUB, INC., CHICAGO, IL:
2,208,331, REN. 7-3-08. INT. CL. 25.
- REDNP LLC, DENVER, CO:
3,479,183, PUB. 5-20-2008. INT. CL. 37.
- REDOBLE, VICTORIA, SAN DIEGO, CA:
3,480,662, PUB. 5-20-2008. INT. CL. 5.
- REED ASSOCIATES, CHARLESTON, SC:
2,493,012, CANC. INT. CL. 29.
- REED DENTAL CERAMIC LABORATORY, INC., WILMINGTON, NC:
2,492,417, CANC. INT. CL. 31.
- REED ELSEVIER INC., NETWON, MA:
1,487,531, REN. 6-30-08. INT. CL. 16.
- REED ELSEVIER INC., NEWTON, MA:
2,237,340, REN. 6-30-08. INT. CL. 41.
- REED ELSEVIER PROPERTIES INC., WILMINGTON, DE:
2,218,347, REN. 6-30-08. INT. CL. 42.
- REED MANUFACTURING, ERIE, PA:
3,480,220, PUB. 5-20-2008. INT. CL. 7.
- REEDER, SARAH LUCE, JOPLIN, MO, DBA THE TACKIE HORSE:
2,491,935, CANC. INT. CL. 35.
- REELEYES, INC., VENICE, CA:
2,493,453, CANC. INT. CL. 41.
- REFLECT.COM LLC, CINCINNATI, OH:
2,493,212, CANC. INT. CL. 35.
- REFRACTORY INTELLECTUAL PROPERTY GMBH & CO., VIENNA, AUSTRIA, OSTERREICHISCH-AMERIKANISCHE MAGNESIT AKTIENGESELLSCHAFT, RA-DENTHEIN, AUSTRIA:
1,497,744, REN. 6-30-08. INT. CL. 19.
- REFRIGIWEAR, INC., DAHLONEGA, GA:
3,480,623, PUB. 5-20-2008. INT. CL. 35.
3,480,624, PUB. 5-20-2008. INT. CL. 35.
- REGELIN, DAVID A., BROOKLYN, NY:
3,479,982, PUB. 5-20-2008. INT. CL. 41.
- REGENESIS, INC., MISSION, KS:
3,480,048, PUB. 5-20-2008. INT. CL. 41.
- REGIONS HOSPITAL, ST. PAUL, MN, HEALTHPARTNERS, INC., MINNEAPOLIS, MN:
2,164,789, REN. 7-1-08. INT. CL. 42.
- REGIUS VESTIO, LLC, NEW YORK, NY:
3,479,865, PUB. 5-20-2008. INT. CL. 25.
- REH KENDERMANN GMBH WEINKELLEREI, BINGEN, FED REP GERMANY:
1,517,389, REN. 6-28-08. INT. CL. 33.
- REID, DUSTIN, AUSTIN, TX:
3,479,090, PUB. 5-20-2008. INT. CL. 3.
- RELANGHE S.R.L., ITALY:
3,480,880, PUB. 5-20-2008. INT. CL. 30.
3,480,881, PUB. 5-20-2008. INT. CL. 30.
- RELAY PRODUCTIONS LLC, MIDDLETON, WI:
3,480,186, PUB. 5-20-2008. INT. CL. 41.
- RELIABLE ELEVATOR, INC., SAN DIEGO, CA:
3,480,053, PUB. 5-20-2008. INT. CL. 37.
- REMARKABLE CONCEPTS LIMITED, CHRISTCHURCH, NEW ZEALAND:
3,482,483, INT. CL. 16.
- REMINGTON HOTEL CORPORATION, DALLAS, TX:
3,481,326, MULTIPLE CLASS, INT. CLS. 43 AND 44.
- REMNANT FELLOWSHIP, BRENTWOOD, TN:
2,492,108, CANC. MULTIPLE CLASS, INT. CLS. 9 AND 16.
- REMOTE EQUIPMENT SYSTEMS, INC., ALPHARETTA, GA:
2,493,192, CANC. INT. CL. 9.
- RENEW LIFE FORMULAS, INC., CLEARWATER, FL:
3,478,713, PUB. 5-20-2008. INT. CL. 5.
3,478,714, PUB. 5-20-2008. INT. CL. 16.
3,478,715, PUB. 5-20-2008. INT. CL. 29.
3,478,716, PUB. 5-20-2008. INT. CL. 44.
- RENEWABLE ENERGY POLICY PROJECT, WASHINGTON, DC:
2,491,951, CANC. INT. CL. 41.
- RENKOO, INC., REDWOOD CITY, CA:
3,479,205, PUB. 5-20-2008. INT. CL. 38.
- RENO A&E, RENO, NV:
2,163,273, REN. 7-3-08. MULTIPLE CLASS, INT. CLS. 9 AND 42.
2,165,150, REN. 6-28-08. MULTIPLE CLASS, INT. CLS. 9 AND 42.
- RENOWN HEALTH, RENO, NV:
3,482,505, MULTIPLE CLASS, INT. CLS. 42, 44 AND 45.
- RENT ME FLORIDA, LLC, ENGLEWOOD, FL:
3,480,193, PUB. 5-20-2008. INT. CL. 35.
- RENTECH, INC., LOS ANGELES, CA:
3,478,893, PUB. 5-20-2008. MULTIPLE CLASS, INT. CLS. 35, 37 AND 42.
- RENTMAKER, INC., WATERTOWN, MA:
2,492,422, CANC. INT. CL. 35.
- RENTOKIL INITIAL 1927 PLC, LONDON SW1W 9RF, UNITED KINGDOM:
3,478,775, PUB. 5-20-2008. MULTIPLE CLASS, INT. CLS. 26, 28, 31 AND 44.
- RENTRAK CORPORATION, PORTLAND, OR:
2,492,888, CANC. INT. CL. 35.
- REP AMERICA, ALBUQUERQUE, NM:
3,479,963, PUB. 5-20-2008. INT. CL. 35.
- REPAIRNOW.COM, INC., STERLING, VA:
2,493,261, CANC. INT. CL. 42.
- REPLYNET LLC, ARLINGTON, VA:
2,492,150, CANC. INT. CL. 38.
- REPROTECT, INC., BALTIMORE, MD:
2,184,602, REN. 7-3-08. INT. CL. 5.
- RESEARCH CREDIT GROUP, INC., HUDSON, OH:
3,481,318, INT. CL. 9.
3,481,324, INT. CL. 9.
- RESEARCH SYSTEMS CORPORATION, EVANSVILLE, IN:
2,492,842, CANC. INT. CL. 35.
- RESORTQUEST INTERNATIONAL, INC., MEMPHIS, TN:
2,491,785, CANC. INT. CL. 36.
- RESOURCE COMMERCIAL FLOORING NETWORK, LLC, AURORA, CO:
3,481,880, INT. CL. 37.
- RESOURCE HOLDINGS, LLC, COLUMBUS, OH:
2,492,124, CANC. INT. CL. 35.
- RESTAURANT DEVELOPERS CORP., INDEPENDENCE, OH:
2,099,069, CANC. INT. CL. 25.
- RESTAURANT DEVELOPERS CORPORATION, MIDDLEBURG HEIGHTS, OH:
3,478,598, PUB. 5-20-2008. INT. CL. 43.
- RETAIL LICENSING COMPANY, LAS VEGAS, NV:
3,482,577, MULTIPLE CLASS, INT. CLS. 18, 25, 35 AND 36.
- RETAIL ROYALTY COMPANY, LAS VEGAS, NV:
3,481,218, INT. CL. 30.
- RETIRED PROFESSIONAL FOOTBALL PLAYERS OF CHICAGO/DOLLARS FOR SCHOLARS, A DIVISION OF SCHOLARSHIP AMERICA, INC., BUFFALO GROVE, IL:
3,479,567, PUB. 5-20-2008. INT. CL. 36.
- REVLON CONSUMER PRODUCTS CORPORATION, NEW YORK, NY:
3,481,753, INT. CL. 3.

RFID MEXICO, S.A. DE C.V., SAN PEDRO GARZA GARCIA, NUEVO LEON C.P., MEXICO:
3,482,280, INT. CL. 9.

REP SRL RICOSTRUZIONE; FASCIA PRESTAMPATA, ITALY:
3,480,833, PUB. 5-20-2008. MULTIPLE CLASS, INT. CLS. 12 AND 37.

RHEAD, RAY M., TRACY, CA, DBA THE AMERICAN DOG:
2,493,533, CANC. INT. CL. 25.

RHETT, INC., BURLINGAME, CA:
1,458,544, CANC. INT. CL. 29.

RHINO LININGS USA, INC., SAN DIEGO, CA:
3,478,926, PUB. 5-20-2008. INT. CL. 7.

RHINO-HIDE, L.L.C., LAKELAND, FL:
3,481,107, MULTIPLE CLASS, INT. CLS. 1, 16 AND 19.

RHODE ISLAND RESOURCE RECOVERY CORPORATION, JOHNSTON, RI:
3,478,604, PUB. 5-20-2008. INT. CL. 40.

RI RA HOLDINGS LLC, NEW CANNAN, CT, RI RA HOLDINGS LLC, NEW CANNAN, CT:
2,187,449, REN. 7-2-08. INT. CL. 42.

RIANI BUCKI MODE GMBH, FED REP GERMANY:
3,480,777, PUB. 5-20-2008. MULTIPLE CLASS, INT. CLS. 14, 18, 24 AND 25.

RIAS CORPORATION, FREMONT, CA:
2,492,374, CANC. INT. CL. 38.

RIAZI, SHIRIN, WEST HILLS, CA:
3,482,106, INT. CL. 9.

RIBBIES, INC., EDMOND, OK:
3,479,787, PUB. 5-20-2008. INT. CL. 26.
3,479,789, PUB. 5-20-2008. INT. CL. 26.

RICH BRANDS, LLC, PHOENIX, AZ, MINNETONKA, INC., MINNETONKA, MN:
1,475,569, REN. 7-3-08. INT. CL. 3.

RICHARD E. SWAN, EAST BRIDGEWATER, MA:
3,478,910, PUB. 5-20-2008. INT. CL. 13.

RICHARD HART, ALEXANDRIA, VA:
3,481,728, INT. CL. 33.

RICHARD WM. FESLER, GUALALA, CA:
3,479,927, PUB. 5-20-2008. INT. CL. 31.

RICHARD-MARSHALL FINE FLOORING, INC., HAWTHORNE, CA:
2,100,501, CANC. INT. CL. 19.

RICHARD, CAROL A., CLAY COMO, MO:
3,479,465, PUB. 5-20-2008. INT. CL. 39.

RICHARDS, STEPHEN J., ALPHARETTA, GA:
2,098,526, CANC. INT. CL. 8.

RICHARDSON-VICKS INC., WILTON, CT:
1,457,908, CANC. INT. CL. 3.

RICHEMONT INTERNATIONAL SA, SWITZERLAND:
3,480,928, PUB. 5-20-2008. INT. CL. 14.
3,480,972, PUB. 5-20-2008. INT. CL. 14.

RICHEMONT ITALIA S.P.A., ITALY:
3,480,944, PUB. 5-20-2008. INT. CL. 16.

RICHMAN, MARK, NEWPORT BEACH, CA AND PACINO, ROBERTA, NEWPORT BEACH, CA:
3,481,645, INT. CL. 43.

RICHMAN, MARK, LOS ANGELES, CA AND PACINO, ROBERTA, LOS ANGELES, CA:
3,481,817, INT. CL. 43.

RICHMOND FOODS GROUP, INC., FAIRPORT, NY:
3,479,258, PUB. 5-20-2008. INT. CL. 30.

RICHMOND, RAQUEL (KELI), FORT WAYNE, IN AND JOUSTRA, DIANNE, NEW HAVEN, IN:
3,481,712, INT. CL. 41.

RICHTER, JAKE, CHICHESTER, NH:
2,161,355, REN. 7-2-08. INT. CL. 16.

RIDLEY BLOCK OPERATIONS, INC., MANKATO, MN:
3,336,839, AM. INT. CL. 21.

RIGHTIME ECONOMETRICS, INC., RYDAL, PA:
2,099,268, CANC. INT. CL. 36.

RIGHTPOINT GROUP, LLC., NORTHBROOK, IL:
3,481,745, INT. CL. 42.

RIGOUTAT & FILS SA, 94340 JOINVILLE DE PONT, FRANCE, ROLAND RIGOUTAT, JOINVILLE-LE-PONT, FRANCE:
1,093,207, REN. 7-3-08. INT. CL. 15.

RIPLEY ENTERTAINMENT INC., ORLANDO, FL:
2,191,321, REN. 7-3-08. INT. CL. 25.

RISHO KOGYO CO., LTD., KITA-KU, OSAKA, JAPAN:
2,186,217, REN. 7-1-08. INT. CL. 9.
2,188,068, REN. 7-1-08. INT. CL. 9.

RISING STAR LEARNING CENTER, INC., MABLETON, GA:
3,478,504, PUB. 5-20-2008. INT. CL. 43.

RITA RESTAURANT CORP., MADISON, GA:
3,482,643, INT. CL. 30.

RITE TRACK EQUIPMENT SERVICES, INC., WEST CHESTER, OH:
3,482,402, INT. CL. 9.

RITTAL GMBH & CO. KG, FED REP GERMANY:
3,480,931, PUB. 5-20-2008. INT. CL. 9.

RIVER LIGHT V, L.P., NEW YORK, NY:
3,479,178, PUB. 5-20-2008. INT. CL. 25.

RIVER METALS RECYCLING LLC, FORT MITCHELL, KY:
3,479,248, PUB. 5-20-2008. INT. CL. 40.

RIVERA, ALEXANDRIA NICOLE, LAS VEGAS, NV:
3,481,581, INT. CL. 43.

RIVERS WEST APPAREL, INC., SEATTLE, WA:
2,188,291, REN. 7-3-08. INT. CL. 25.

RIVERSIDE DISTRIBUTING, LTD., HIDALGO, TX:
2,100,069, CANC. INT. CL. 31.

RJR POLYMERS, INC., OAKLAND, CA:
2,493,053, CANC. INT. CL. 1.

RKL CORPORATION, MAPLE GROVE, MN:
2,493,412, CANC. INT. CL. 40.

RLI INSURANCE COMPANY, PEORIA, IL:
3,480,419, PUB. 5-20-2008. INT. CL. 36.

RMO, INC., DENVER, CO:
1,488,072, REN. 7-2-08. MULTIPLE CLASS, INT. CLS. 5, 10, 16, 41 AND 42.

RO-MAC LUMBER AND SUPPLY, INC, LEESBURG, FL:
3,482,286, INT. CL. 19.

ROANOKE TECHNOLOGY CORPORATION, ROANOKE RAPIDS, NC:
2,491,772, CANC. INT. CL. 42.

ROBERN, INC., BRISTOL, PA:
3,482,267, INT. CL. 11.

ROBERT F. BULLOCK, INC., ELLENWOOD, GA, DBA GRANDAD'S:
1,458,566, CANC. INT. CL. 29.

ROBERT J. WALKER, VALLEY STREAM, NY:
3,479,663, PUB. 5-20-2008. INT. CL. 35.

ROBERT KWOK, MD, INC, SAN JOSE, CA:
2,099,104, CANC. INT. CL. 42.

ROBERT MONDAVI WINERY, NAPA, CA:
1,489,619, AM. INT. CL. 33.
3,482,504, INT. CL. 33.

ROBERT WOOD JOHNSON FOUNDATION, THE, PRINCETON, NJ:
2,202,210, REN. 6-28-08. INT. CL. 36.

ROBERTO'S WINDS, INC., NEW YORK, NY:
3,478,555, PUB. 5-20-2008. MULTIPLE CLASS, INT. CLS. 15 AND 35.

ROBERTS SYSTEMS, INC., CHARLOTTE, NC:
2,099,981, CANC. INT. CL. 7.

ROBERTS, DENNIS, IRVINE, CA:
3,316,145, CANC. INT. CL. 9.

ROBERTS, JAMES MILNOR JR., ARLINGTON, VA AND THOMPSON-ROBERTS, PRISCILLA B., ARLINGTON, VA:
2,492,266, CANC. INT. CL. 41.

ROBERTS, LISA M., FAIRFIELD, CT:
2,493,690, CANC. INT. CL. 42.

ROBINSON LERER & MONTGOMERY, LLC, NEW YORK, NY:
3,479,010, PUB. 5-20-2008. INT. CL. 35.
3,479,011, PUB. 5-20-2008. INT. CL. 35.

ROBYN LESSER D.M.D., P.A., TAMPA, FL:
3,480,218, PUB. 5-20-2008. INT. CL. 44.

ROCHE DIAGNOSTICS GMBH, 68305 MANNHEIM, FED REP GERMANY:
3,481,185, INT. CL. 44.

- ROCHE DIAGNOSTICS OPERATIONS, INC., INDIANAPOLIS, IN:
2,158,944. REN. 6-30-08. INT. CL. 9.
3,276,336. COR. MULTIPLE CLASS, INT. CLS. 1, 5, 9, 16, 42 AND 44.
- ROCHER PARTICIPATIONS, CARNAC, FRANCE:
2,491,831. CANC. INT. CL. 3.
- ROCHESTER MIDLAND CORPORATION, ROCHESTER, NY:
1,457,944. CANC. INT. CL. 3.
- ROCK SPRINGS RANCH, INC., PAICINES, CA:
2,098,993. CANC. INT. CL. 41.
- ROCKET BALL, LTD., HOUSTON, TX:
3,481,375. INT. CL. 28.
- ROCKFORD FURNITURE MART, INC., ROCKFORD, IL:
2,099,198. CANC. INT. CL. 35.
- ROCKWOOD PROGRAMS, INC., WILMINGTON, DE, E. W. BLANCH HOLDINGS, INC., MINNEAPOLIS, MN:
2,238,399. REN. 6-30-08. MULTIPLE CLASS, INT. CLS. 35 AND 36.
- ROCKY MOUNTAIN BIOSYSTEMS, INC., WHEAT RIDGE, CO:
3,481,436. INT. CL. 10.
- RODALE INC., EMMAUS, PA:
3,480,456. PUB. 5-20-2008. INT. CL. 44.
- RODMAN POLYSHIPS, S.A., SPAIN:
3,480,932. PUB. 5-20-2008. INT. CL. 12.
- RODRIGUEZ VILLARREAL, RUBÉN, MONTERREY, MEXICO:
3,479,306. PUB. 5-20-2008. INT. CL. 6.
- ROEHL TRANSPORT, INC., MARSHFIELD, WI:
3,480,280. PUB. 5-20-2008. INT. CL. 39.
- ROEMMER, CAROL, DANA POINT, CA:
3,480,459. PUB. 5-20-2008. INT. CL. 42.
- ROEX, INC., IRVINE, CA:
2,493,588. CANC. INT. CL. 5.
3,481,985. INT. CL. 5.
- ROGAN, BRANDON T, DEERFIELD, IL, DBA GINKIS:
3,480,203. PUB. 5-20-2008. INT. CL. 42.
- ROGER & GALLET; SOCIÉTÉ PAR ACTIONS SIMPLIFIÉE, F-92200 NEUILLY-SUR-SEINE, FRANCE:
3,480,938. PUB. 5-20-2008. INT. CL. 3.
- ROGERS ELECTRIC SUPPLIES CO., SIOUX CITY, IA:
2,491,814. CANC. INT. CL. 35.
- ROHM AND HAAS ELECTRONIC MATERIALS LLC, MARLBOROUGH, MA:
2,210,276. REN. 6-30-08. INT. CL. 1.
- ROJ ELECTROTEX S.P.A., BIELLA (VERCELLI), ITALY:
1,458,023. CANC. MULTIPLE CLASS, INT. CLS. 7 AND 9.
- ROLEX WATCH USA, INC., NEW YORK, NY:
3,481,226. MULTIPLE CLASS, INT. CLS. 36 AND 41.
- ROMAIN, NICOLAS G, MARGATE, FL, DBA NORTH AMERICAN TUNING:
3,480,070. PUB. 5-20-2008. INT. CL. 35.
- ROMMANEL INDUSTRIA E COMERCIO LTDA., SAO PAULO, SP, BRAZIL:
2,102,074. CANC. INT. CL. 14.
- RON MATUSALEM & MATUSA OF FLORIDA, INC., MIAMI, FL:
3,482,020. INT. CL. 43.
- RON TAI IRON FACTORY, TAICHUNG CITY, TAIWAN:
3,481,110. INT. CL. 7.
- RONALD BUSSINK AMUSEMENT DESIGN GMBH, FED REP GERMANY:
3,480,986. PUB. 5-20-2008. INT. CL. 28.
3,480,987. PUB. 5-20-2008. INT. CL. 28.
- RONK, THOMAS C., CORONA DEL MAR, CA:
3,481,786. INT. CL. 36.
- ROOF ADVISORY GROUP, INC., HARRISBURG, PA:
3,479,848. PUB. 5-20-2008. INT. CL. 36.
- ROOKIE SKATEBOARDS, LLC, NEW YORK, NY:
2,493,046. CANC. INT. CL. 28.
- ROOMSPINNERS REDESIGN, MAPLE VALLEY, WA, DBA ROOMSPINNERS AND ROOMSPINNERS REDESIGN, COVINGTON, WA, DBA ROOMSPINNERS:
3,479,358. PUB. 5-20-2008. INT. CL. 42.
- ROOZEE, WILLIAM P., FLOWER MOUND, TX:
3,480,267. PUB. 5-20-2008. INT. CL. 42.
- ROSANDER, CHRISTINE, LOS ANGELES, CA:
3,481,794. INT. CL. 9.
- ROSANNE BELLER, INC., COMMACK, NY:
3,480,328. PUB. 5-20-2008. INT. CL. 25.
- ROSE, SETH WARREN, BROOKLYN HEIGHTS, NY:
2,493,617. CANC. INT. CL. 8.
- ROSENBERG FOREST PRODUCTS SOUTH, DILLARD, OR, U.S. PLYWOOD CORPORATION, WILTON, CT:
1,495,810. REN. 7-3-08. INT. CL. 19.
- ROSENGARD, ANDREA, NEW YORK, NY, DBA ANDREA ROSE:
2,493,319. CANC. INT. CL. 35.
- ROSENN, JENKINS & GREENWALD, L.L.P., WILKES-BARRE, PA:
3,481,800. INT. CL. 45.
- ROSNER, CARY, BELLEROSE, NY:
3,481,895. INT. CL. 9.
- ROSS-SIMONS OF WARWICK, INC., CRANSTON, RI:
3,482,314. INT. CL. 35.
- ROSTOMYAN, EDGAR, SAN DIEGO, CA:
3,480,330. PUB. 5-20-2008. INT. CL. 41.
- ROSTROPOVICH, OLGA, NEW YORK, NY:
3,479,196. PUB. 5-20-2008. INT. CL. 9.
- ROTAM LTD., CHAI WAN, HONG KONG:
3,481,228. INT. CL. 5.
3,481,229. INT. CL. 5.
3,482,579. INT. CL. 5.
- ROTEK SYSTEMS INC., BURNSVILLE, MN:
2,492,245. CANC. INT. CL. 9.
- ROUND-UP ASSOCIATION, THE, PENDLETON, OR:
2,185,384. REN. 7-3-08. MULTIPLE CLASS, INT. CLS. 14, 25 AND 26.
- ROUNDABOUT THEATRE COMPANY, INC., NEW YORK, NY:
3,480,035. PUB. 5-20-2008. INT. CL. 35.
- ROUSSEL UCLAF, PARIS, FRANCE:
1,457,973. CANC. INT. CL. 5.
- ROUTZEN, CHRISTIAN, SAN FRANCISCO, CA:
3,478,904. PUB. 5-20-2008. INT. CL. 41.
- ROUX ASSOCIATES, INC., ISLANDIA, NY:
3,482,401. INT. CL. 42.
- ROUX LABORATORIES, INC., JACKSONVILLE, FL:
1,457,933. CANC. INT. CL. 3.
- ROXFOX CO., CHULA VISTA, CA:
3,480,244. PUB. 5-20-2008. INT. CL. 35.
- ROYAL APPLIANCE MFG. CO., GLENWILLOW, OH:
3,482,726. INT. CL. 7.
- ROYAL CHEMICAL CORPORATION, BELLE CHASSE, LA:
2,161,300. REN. 7-2-08. INT. CL. 2.
- ROYAL CROWN COLA CO., RYE BROOK, NY:
1,303,001. CANC. INT. CL. 32.
- ROYAL WINGS, INC., AURORA, CO:
2,099,261. CANC. INT. CL. 39.
- ROZANSKY & ASSOCIATES, LLC, DESPLAINES, IL:
3,482,686. INT. CL. 38.
- RPATH, INC., RALEIGH, NC:
3,479,324. PUB. 5-20-2008. INT. CL. 9.
- RPS TECHNOLOGIES, INC., MIAMISBURG, OH:
3,482,336. INT. CL. 12.
- RTM ENTERPRISES, LLC, NEW YORK, NY:
3,481,741. INT. CL. 5.
- RUBBERMAID OFFICE PRODUCTS INC., MARYVILLE, TN:
1,458,302. CANC. INT. CL. 16.
- RUBINSTEIN, HELENA, 75008 PARIS, FRANCE:
2,493,664. CANC. INT. CL. 3.
- RUFFNUTS PTY LTD; (ACN 092856105), FORBES, AUSTRALIA:
3,481,029. PUB. 5-20-2008. INT. CL. 12.
- RUGGEDCOM INC., WOODBRIDGE, CANADA:
3,478,688. PUB. 5-20-2008. INT. CL. 9.
- RULE 66, LLC, ESCONDIDO, CA:
3,481,166. INT. CL. 25.
- RUM CAKE FAIRY DESSERT COMPANY LLC, HILLSBOROUGH, NJ:
3,480,651. PUB. 5-20-2008. INT. CL. 30.
- RUMETAGRO LLC, FLORENCE, MA:
3,480,144. PUB. 5-20-2008. INT. CL. 45.

RUMM COLOR STUDIO, LLC, WOODSTOCK, GA:
3,478,618, PUB. 5-20-2008. INT. CL. 44.

RUSH DIRECT, INC., WOOD DALE, IL:
3,480,403, PUB. 5-20-2008. INT. CL. 18.

RUSSELL CORPORATION, ATLANTA, GA:
2,099,483, CANC. INT. CL. 18.

RUSSELL, ERICH, PASO ROBLES, CA, DBA RABBIT RIDGE VINEYARDS:
2,247,866, REN. 7-3-08. INT. CL. 33.
2,249,789, REN. 7-3-08. INT. CL. 33.

RUSSULA S.A., LA CORUÑA, SPAIN:
3,482,150, MULTIPLE CLASS, INT. CLS. 37 AND 42.

RUSTIC RIVER LTD., MONTEBELLO, CA:
2,493,185, CANC. INT. CL. 25.

RUUD, ROBERT, D., GRANITE BAY, CA:
3,479,110, PUB. 5-20-2008. INT. CL. 25.

RW ENVIRONMENTS, LLC, NOVATO, CA:
3,479,407, PUB. 5-20-2008. INT. CL. 1.

RWD TECHNOLOGIES, LLC, BALTIMORE, MD:
2,165,101, REN. 6-30-08. INT. CL. 42.

RWI RESOURCES, LLC, MARIETTA, GA:
3,481,165, INT. CL. 32.

RX/IBR, HOUSTON, TX:
2,493,275, CANC. INT. CL. 5.

RYDER CLIPS UNLIMITED, INC., LIGHTHOUSE POINT, FL:
3,478,941, PUB. 5-20-2008. INT. CL. 26.

RYERSON PROCUREMENT CORPORATION, CHICAGO, IL:
3,482,244, MULTIPLE CLASS, INT. CLS. 6, 35 AND 40.

RZN NUTRACEUTICALS, INC., MIAMI, FL:
3,478,851, PUB. 5-20-2008. INT. CL. 5.

S & K FAMOUS BRANDS INC., GLEN ALLEN, VA:
1,348,160, REN. 6-30-08. INT. CL. 25.

S & S CAR CARE, INCORPORATED, NORTH CANTON, OH:
1,099,158, REN. 7-3-08. INT. CL. 3.

S. MARTINELLI & COMPANY, WATSONVILLE, CA:
815,543, REN. 7-3-08. U.S. CL. 46 (INT. CL. 32).

S&C ELECTRIC CO., CHICAGO, IL:
3,479,168, PUB. 5-20-2008. INT. CL. 9.

S&D CARWASH MANAGEMENT, LLC, CARMICHAEL, CA:
3,481,213, INT. CL. 37.

S&D WINDOW CLEANING LLC, IRWIN, PA:
3,480,001, PUB. 5-20-2008. INT. CL. 37.

S&K FAMOUS BRANDS, INC., RICHMOND, VA:
1,458,431, CANC. INT. CL. 25.

SA HANSEN TRANSMISSIONS - INTERNATIONAL NV.; NAAMLOZE VENNOOTSCHAP, BELGIUM:
3,480,768, PUB. 12-18-2007. INT. CL. 7.

SAAL, ELAINE, DEER PARK, NY:
3,481,555, INT. CL. 35.

SABEUS, INC., CALABASAS, CA:
3,481,489, INT. CL. 9.

SABIC INNOVATIVE PLASTICS IP B.V., BERGEN OP ZOOM, NETHERLANDS, BORG-WARNER CORPORATION, CHICAGO, IL:
838,985, REN. 7-2-08. U.S. CL. 1 (INT. CL. 1).

SABINSA CORPORATION, PISCATAWAY, NJ:
2,163,480, REN. 7-3-08. INT. CL. 5.

SABIOSO, INC., CLEARFIELD, UT:
3,482,607, INT. CL. 35.

SACHA LONDON, S.L., ELDA (ALICANTE), SPAIN, MB MARKETING S.A., FRIBORG, SWITZERLAND:
2,155,445, REN. 7-2-08. INT. CL. 25.

SAFE KIDS WORLDWIDE, WASHINGTON, DC:
2,213,964, REN. 7-3-08. MULTIPLE CLASS, INT. CLS. 16 AND 42.

SAFE KIDS WORLDWIDE, WASHINGTON, DC:
2,212,417, REN. 7-3-08. MULTIPLE CLASS, INT. CLS. 16 AND 42.

SAFEGUARD CHEMICAL CORPORATION, BRONX, NY:
1,491,792, REN. 6-30-08. INT. CL. 5.
1,491,792, CANC. MULTIPLE CLASS, INT. CLS. 2, 21 AND 22.

SAFEHOIST TECHNOLOGIES, INC., SPOKANE, WA, DBA SAFEHOIST, INC.:
3,481,952, INT. CL. 9.

SAFETGARD SPORT OPTICS, LLC, LAKEWOOD, CO:
3,481,515, MULTIPLE CLASS, INT. CLS. 2 AND 9.
3,481,516, MULTIPLE CLASS, INT. CLS. 2 AND 9.

SAFETY HELMETS CANADA, INC., MEMPHIS, TN:
3,482,070, INT. CL. 27.

SAFETY-KLEEN SYSTEMS, INC., PLANO, TX:
1,496,177, REN. 7-2-08. INT. CL. 37.

SAFEWAY INC., PLEASANTON, CA:
3,481,141, INT. CL. 35.

SAFILO - SOCIETA' AZIONARIA FABBRICA ITALIANA LAVORAZIONE OCCHIALI S.P.A., PIEVE DI CADORE (BELLUNO), ITALY:
1,458,093, CANC. INT. CL. 9.

SAGE HOSPITALITY RESOURCES LLC, DENVER, CO:
3,481,120, INT. CL. 43.

SAGE SOFTWARE, INC., IRVINE, CA:
2,185,667, REN. 7-3-08. INT. CL. 9.

SAINT JOE, INC., LOVELAND, CO:
3,480,060, PUB. 5-20-2008. INT. CL. 42.

SALISBURY ASSOCIATES MEDICAL PRACTICE MANAGEMENT CORPORATION, WORCESTER, MA:
2,100,122, CANC. INT. CL. 9.

SALOMON S.A., 74370 METZ-TESSY, FRANCE:
2,577,808, CANC. INT. CL. 18.

SALON COMMODITIES, INC., MELROSE PARK, IL:
3,417,850, AM. INT. CL. 3.

SAM RABY ENTERPRISES LLC, BLUFFDALE, UT:
3,479,664, PUB. 5-20-2008. INT. CL. 20.

SAMBRAILO PACKAGING, WATSONVILLE, CA:
3,481,077, INT. CL. 16.

SAMMELT, MARTIN, FED REP GERMANY AND MÄRZ, JOACHIM, FED REP GERMANY:
3,480,955, PUB. 5-20-2008. MULTIPLE CLASS, INT. CLS. 12, 25 AND 28.

SAMMY USA CORP., ELK GROVE VILLAGE, IL:
2,100,118, CANC. INT. CL. 28.

SAMPLE, GINA M., DEL MAR, CA, DBA SAMPLE DESIGN:
3,480,327, PUB. 5-20-2008. INT. CL. 22.

SAN FRANCISCO FORTY NINERS, LIMITED, SANTA CLARA, CA, DBA SAN FRANCISCO FORTY NINERS:
3,480,219, PUB. 5-20-2008. INT. CL. 41.

SAN FRANCISCO PUBLIC GOLF ALLIANCE, SAN FRANCISCO, CA:
3,482,644, INT. CL. 35.

SANACOR, L.L.C., AMERICAN FORK, UT:
3,481,173, INT. CL. 10.

SAND CAPITAL LLC, SCOTTSDALE, AZ:
3,479,705, PUB. 5-20-2008. INT. CL. 36.
3,479,706, PUB. 5-20-2008. INT. CL. 36.

SANDERSON PLUMBING PRODUCTS INC., COLUMBUS, MS:
1,536,308, REN. 6-30-08. INT. CL. 11.

SANDOW MEDIA, LLC, BOCA RATON, FL:
3,425,196, COR. INT. CL. 16.
3,425,859, COR. INT. CL. 16.
3,426,795, COR. INT. CL. 16.

SANDY LIVINGSTON, HOLIDAY, FL:
2,493,401, CANC. INT. CL. 16.

SANITA A/S, DENMARK:
3,480,859, PUB. 5-20-2008. INT. CL. 25.

SANITATION STRATEGIES, LLC, OKEMOS, MI:
3,478,868, PUB. 5-20-2008. INT. CL. 35.

SANKEI SHIMBUN CO., LTD., TOKYO, JAPAN:
3,481,488, INT. CL. 16.

SANOFI-AVENTIS, 75013 PARIS, FRANCE:
3,479,159, PUB. 5-20-2008. INT. CL. 16.

SANSUM-SANTA BARBARA MEDICAL FOUNDATION CLINIC, SANTA BARBARA, CA:
3,480,710, PUB. 5-20-2008. MULTIPLE CLASS, INT. CLS. 41, 42 AND 44.
3,480,711, PUB. 5-20-2008. MULTIPLE CLASS, INT. CLS. 41, 42 AND 44.

- SANTA CLARA VALLEY TRANSPORTATION AUTHORITY, SAN JOSE, CA:
2,164,654. REN. 6-28-08. INT. CL. 16.
2,168,419. REN. 7-3-08. INT. CL. 16.
2,168,420. REN. 7-3-08. INT. CL. 39.
2,170,275. REN. 7-3-08. INT. CL. 39.
2,184,784. REN. 7-3-08. INT. CL. 39.
2,189,825. REN. 7-3-08. INT. CL. 16.
- SANTA FE GREENHOUSES, INC., SANTA FE, NM:
2,492,065. CANC. INT. CL. 31.
- SANTA FE TRUST INC., SANTA FE, NM:
3,480,319. PUB. 5-20-2008. INT. CL. 36.
- SANTA MONICA CONVENTION AND VISITORS BUREAU, SANTA MONICA, CA:
2,182,952. REN. 6-30-08. INT. CL. 35.
- SANTORO, LUCIO AND SANTORO, MEERA, LONDON, UNITED KINGDOM:
3,481,546. INT. CL. 16.
- SANWA SHUTTER CORPORATION, SHINJUKU-KU, TOKYO, JAPAN:
2,492,947. CANC. MULTIPLE CLASS, INT. CLS. 6, 9 AND 12.
- SARAMAR, L.L.C., CHICAGO, IL:
3,482,308. INT. CL. 21.
- SARLA SOFTWARE, L.L.C., BARRINGTON, RI:
3,480,309. PUB. 5-20-2008. INT. CL. 16.
- SAROYAN LUMBER COMPANY, INC., HUNTINGTON PARK, CA:
3,479,691. PUB. 5-20-2008. INT. CL. 19.
- SARTORIUS AG, D-37075 GOETTINGEN, FED REP GERMANY:
3,481,157. INT. CL. 9.
- SARTORIUS STEDIM BIOTECH GMBH, GOTTINGEN, FED REP GERMANY:
2,245,418. REN. 6-30-08. INT. CL. 41.
2,245,419. REN. 6-30-08. INT. CL. 42.
- SAS AUTOMATION, LTD., XENIA, OH:
2,185,429. REN. 6-27-08. INT. CL. 7.
- SATA GMBH & CO. KG, FED REP GERMANY:
3,481,003. PUB. 5-20-2008. INT. CL. 7.
- SAVANNAH TRIMS, INC., LAKE PARK, FL:
3,480,167. PUB. 5-20-2008. INT. CL. 6.
- SAVEN CORPORATION, CHARLESTON, WV:
3,478,722. PUB. 5-20-2008. INT. CL. 31.
- SAVORY CHEF, LLC, TULSA, OK:
3,479,768. PUB. 5-20-2008. INT. CL. 35.
- SAVOY LINEN SERVICES, INC., STRATFORD, CT:
3,478,558. PUB. 5-20-2008. MULTIPLE CLASS, INT. CLS. 43 AND 45.
- SAY, STEVEN R, PEORIA, AZ:
3,481,614. INT. CL. 8.
- SAYEN, MICHAEL E, MCKINNEY, TX, DBA THE TRADEWINDS GROUP:
3,479,941. PUB. 5-20-2008. INT. CL. 42.
- SAYERS GROUP, LLC, MT. PROSPECT, IL, DBA SAYERS COMPUTER SOURCE:
2,491,926. CANC. MULTIPLE CLASS, INT. CLS. 35 AND 42.
- SAYS JR, CLIFTON A., STARKS, LA:
3,479,538. PUB. 5-20-2008. INT. CL. 38.
- SB PHILLIPS LLC, BALTIMORE, MD:
3,480,504. PUB. 5-20-2008. INT. CL. 29.
- SC COMPANIES, INC., MUSCATINE, IA, DBA THE STANLEY GROUP AND DBA THE STANLEY CONSULTANTS GROUP:
2,167,090. REN. 7-3-08. MULTIPLE CLASS, INT. CLS. 35, 37 AND 42.
2,176,234. REN. 7-3-08. MULTIPLE CLASS, INT. CLS. 35, 37 AND 42.
2,196,454. REN. 7-3-08. MULTIPLE CLASS, INT. CLS. 35, 37 AND 42.
2,204,395. REN. 7-3-08. MULTIPLE CLASS, INT. CLS. 35, 37 AND 42.
- SCAG POWER EQUIPMENT, MAYVILLE, WI:
3,481,680. INT. CL. 7.
- SCENTUAL CANDLE INC., WASHINGTON COURT HOUSE, OH:
2,493,672. CANC. INT. CL. 4.
- SCHERING-PLOUGH ANIMAL HEALTH CORPORATION, SUMMIT, NJ, AGRI-BIO CORP., ITHACA, NY:
1,090,784. REN. 7-1-08. INT. CL. 10.
- SCHERING-PLOUGH ANIMAL HEALTH CORPORATION, SUMMIT, NJ, BURROUGHS WELLCOME CO., RESEARCH TRIANGLE PARK, NC:
1,094,200. REN. 7-3-08. INT. CL. 5.
- SCHIFF PARTNERS, INC, WILTON, CT:
3,480,029. PUB. 5-20-2008. INT. CL. 42.
- SCHILL + SEILACHER AKTIENGESELLSCHAFT, FED REP GERMANY:
3,480,816. PUB. 5-20-2008. MULTIPLE CLASS, INT. CLS. 5, 16, 24 AND 25.
- SCHLAGE LOCK COMPANY, CARMEL, IN:
3,481,336. INT. CL. 7.
3,481,337. INT. CL. 7.
- SCHMIDT, MARKUS W., 90762 FUERTH, FED REP GERMANY:
2,173,671. REN. 6-30-08. INT. CL. 9.
- SCHNEIDER ELECTRIC INDUSTRIES SAS, FRANCE:
3,352,544. COR. INT. CL. 9.
- SCHNURSTEIN, KENNETH W., CHICAGO, IL:
2,493,060. CANC. INT. CL. 25.
- SCHOLASTIC INC., NEW YORK, NY:
2,492,900. CANC. INT. CL. 16.
2,493,156. CANC. INT. CL. 24.
3,479,195. PUB. 5-20-2008. INT. CL. 41.
3,480,306. PUB. 5-20-2008. INT. CL. 16.
3,480,537. PUB. 5-20-2008. INT. CL. 16.
- SCHOOLSYSTEMS, LLC, CEDAR RAPIDS, IA:
3,480,065. PUB. 5-20-2008. INT. CL. 42.
- SCHOTT BROS. INC., ELIZABETH, NJ:
3,482,389. INT. CL. 25.
- SCHROEDER & TREMAYNE, INC., ST. LOUIS, MO:
3,478,502. PUB. 5-20-2008. INT. CL. 25.
- SCHROEDER, DONALD WAYNE, HOUSTON, TX:
2,171,269. REN. 6-28-08. INT. CL. 41.
- SCHULTZ, WILLIAM L., MERIDIAN, ID:
2,493,501. CANC. INT. CL. 20.
- SCHWAN'S IP, LLC, MARSHALL, MN:
1,496,009. REN. 6-30-08. INT. CL. 29.
- SCHWARTZ, NORMAN, S, NEW YORK, NY:
3,482,723. INT. CL. 33.
- SCHWING GMBH, 44653 HERNE, FED REP GERMANY:
3,480,805. PUB. 5-20-2008. MULTIPLE CLASS, INT. CLS. 7, 9, 12 AND 42.
- SCIELE PHARMA, INC., ATLANTA, GA:
2,099,476. CANC. INT. CL. 5.
- SCIENTIFIC SOLUTIONS INC., MENTOR, OH:
1,539,837. REN. 7-1-08. INT. CL. 9.
- SCIENTIFIC TOYS, LTD., KOWLOON, HONG KONG:
2,161,782. REN. 7-3-08. INT. CL. 28.
- SCIGENE CORPORATION, SUNNYVALE, CA:
3,480,276. PUB. 5-20-2008. INT. CL. 9.
- SCONZA CANDY COMPANY, OAKLAND, CA:
2,099,442. CANC. INT. CL. 30.
- SCOOP MANAGEMENT LLC, NEW YORK, NY:
3,480,163. PUB. 5-20-2008. INT. CL. 35.
- SCOPE E-KNOWLEDGE CENTER PRIVATE LIMITED, NANDANAM, CHENNAI, INDIA:
3,479,293. PUB. 5-20-2008. MULTIPLE CLASS, INT. CLS. 35, 42 AND 45.
- SCOR, FRANCE:
3,480,886. PUB. 5-20-2008. MULTIPLE CLASS, INT. CLS. 35 AND 36.
- SCORPION PROTECTIVE COATINGS, INC., CLOVERDALE, IN:
3,479,987. PUB. 5-20-2008. INT. CL. 35.
- SCOTT & YORK, UNITED KINGDOM:
3,480,943. PUB. 5-20-2008. MULTIPLE CLASS, INT. CLS. 9, 16, 35, 36, 38, 40, 41, 42 AND 45.
- SCOTT ADAMS, OKLAHOMA CITY, OK:
3,479,579. PUB. 5-20-2008. INT. CL. 35.
- SCOTT PAPER COMPANY, DELAWARE COUNTY, PA:
1,457,937. CANC. INT. CL. 3.
- SCREAMING GIRAFFE, INC., DENVER, CO:
3,481,445. INT. CL. 43.

SCREENPRINT/DOW, INC., WILMINGTON, MA:
1,490,523. REN. 7-1-08. INT. CL. 37.

SCUBA.COM, IRVINE, CA:
3,482,642. INT. CL. 35.

SDS GLOBAL LOGISTICS, INC., LONG ISLAND CITY, NY:
3,482,220. INT. CL. 39.

SEA FOR YOURSELF, INC., MENLO PARK, CA:
3,482,071. INT. CL. 41.

SEABROOK WALLCOVERINGS, INC., MEMPHIS, TN:
1,458,310. CANC. INT. CL. 16.
1,458,311. CANC. INT. CL. 16.

SEACOAST BANKING CORPORATION OF FLORIDA,
STUART, FL:
1,458,677. CANC. INT. CL. 36.

SEAL NORTH AMERICA, YORBA LINDA, CA:
2,492,791. CANC. INT. CL. 16.

SEAL TRADEMARKS PTY LTD, BURLEIGH HEADS,
QUEENSLAND, AUSTRALIA:
2,217,115 NEW CERT. 8-5-2008. INT. CL. 35.
2,345,952 NEW CERT. 8-5-2008. INT. CL. 25.
2,825,694 NEW CERT. 8-5-2008. INT. CL. 12.
2,836,886 NEW CERT. 8-5-2008. INT. CL. 25.
2,948,566 NEW CERT. 8-5-2008. INT. CL. 28.
2,957,141 NEW CERT. 8-5-2008. INT. CL. 32.
2,975,385 NEW CERT. 8-5-2008. INT. CL. 41.
2,977,752 NEW CERT. 8-5-2008. INT. CL. 9.

SEALED AIR CORPORATION (US), ELMWOOD PARK, NJ:
2,170,835. REN. 7-3-08. INT. CL. 16.
3,479,229. PUB. 5-20-2008. INT. CL. 7.

SEAMCRAFT, INC., CHICAGO, IL:
2,190,330. REN. 7-2-08. MULTIPLE CLASS, INT. CLS. 9,
10 AND 18.

SEAN HOWARD PRODUCTIONS, INC., FAIRHOPE, AL:
3,478,900. PUB. 5-20-2008. INT. CL. 27.

SEAN MCKIRDY, NEWINGTON, CT AND ROBERT NUTI-
NI, SUFFIELD, CT:
3,479,790. PUB. 5-20-2008. INT. CL. 41.

SEARCHLES, INC., WASHINGTON D.C., DC:
3,479,391. PUB. 5-20-2008. INT. CL. 38.
3,479,392. PUB. 5-20-2008. MULTIPLE CLASS, INT. CLS.
38, 42 AND 45.
3,479,393. PUB. 5-20-2008. INT. CL. 42.
3,479,395. PUB. 5-20-2008. INT. CL. 9.

SEARLES, LINDA, ANNADALE, NJ:
3,480,577. PUB. 8-22-2006. MULTIPLE CLASS, INT. CLS. 9
AND 41.

SEARS BRANDS, LLC, HOFFMAN ESTATES, IL:
3,481,593. INT. CL. 37.

SEARS PETROLEUM & TRANSPORT CORP, ROME, NY:
2,492,166. CANC. INT. CL. 1.

SEASONED TICKET, LLC., DURHAM, NC:
2,493,328. CANC. INT. CL. 42.

SEATTLE SPORTS LEAGUES, INC., SEATTLE, WA:
3,479,481. PUB. 5-20-2008. INT. CL. 35.
3,479,483. PUB. 5-20-2008. INT. CL. 35.
3,479,484. PUB. 5-20-2008. INT. CL. 35.
3,479,485. PUB. 5-20-2008. INT. CL. 35.

SECURE SOURCE HOME LOAND, LTD, INDEPENDENCE,
OH:
2,100,191. CANC. INT. CL. 36.

SECURITY AMERICA, INC., CHARLESTON, WV:
3,478,764. PUB. 5-20-2008. INT. CL. 45.

SECURITY WITH ADVANCED TECHNOLOGY, INC.,
WESTMINSTER, CO:
3,479,967. PUB. 5-20-2008. INT. CL. 42.

SECURITY ZONE, INC., TRENTON, NJ:
2,098,878. CANC. INT. CL. 37.

SEDLAR, JERI, NEW YORK, NY, DBA JS ENTERPRISES:
3,478,992. PUB. 5-20-2008. INT. CL. 41.

SEELECT, INC., ORANGE, CA:
3,481,125. INT. CL. 30.

SEPEX GMBH & CO. KG, BOTTRUP, FED REP GER-
MANY:
3,478,699. PUB. 5-20-2008. MULTIPLE CLASS, INT. CLS.
6, 7, 9 AND 37.

SEGMA LLC, SILVER SPRING, MD:
3,479,722. PUB. 5-20-2008. INT. CL. 42.

SEIKO EPSON KABUSHIKI KAISHA, SHINJUKU-KU, TO-
KYO, JAPAN, TA SEIKO EPSON CORPORATION:
2,182,236. REN. 6-28-08. INT. CL. 2.

SELECT EQUITY GROUP, INC., NEW YORK, NY:
3,479,020. PUB. 5-20-2008. INT. CL. 36.

SELECT MEDICAL PRODUCTS, INC., SANFORD, FL:
2,162,019. REN. 6-30-08. INT. CL. 10.

SELECTIVE STAFFING SERVICES, DALLAS, TX:
2,170,451. REN. 6-28-08. INT. CL. 35.

SELLARS ABSORBENT MATERIALS, INC., MILWAUKEE,
WI:
3,481,781. INT. CL. 16.

SELVAAG BLUETHINK AS, 0512 OSLO, NORWAY:
3,479,569. PUB. 5-20-2008. MULTIPLE CLASS, INT. CLS.
9, 37 AND 42.

SEMINOLE TRIBE OF FLORIDA, HOLLYWOOD, FL:
3,479,902. PUB. 5-20-2008. INT. CL. 43.

SEMTEK INNOVATION SOLUTIONS CORPORATION, SAN
DIEGO, CA:
2,571,140. COR. INT. CL. 9.
2,586,747. COR. INT. CL. 9.

SEMTEK INNOVATIVE SOLUTIONS CORPORATION, SAN
DIEGO, CA:
2,346,598. COR. INT. CL. 9.
2,697,731. COR. INT. CL. 9.
2,768,747. COR. INT. CL. 9.
2,884,908. COR. INT. CL. 9.

SENIOR STAFF LLC, ASHBURN, VA:
3,478,921. PUB. 5-20-2008. INT. CL. 35.

SENSE TECHNOLOGIES, INC., FORT LAUDERDALE, FL:
2,492,745. CANC. INT. CL. 9.

SENSORMEDICS CORPORATION, ANAHEIM, CA:
1,458,207. CANC. INT. CL. 10.

SENER, RANDALL HALL, LOS ANGELES, CA:
3,480,493. PUB. 5-20-2008. INT. CL. 36.

SEPARATION TECHNOLOGY, INC., ALTAMONTE
SPRINGS, FL:
3,479,000. PUB. 5-20-2008. INT. CL. 9.

SEPRACOR INC., MARLBOROUGH, MA:
3,482,065. INT. CL. 5.

SEQUOIA RECORDS, INC., ENCINITAS, CA:
3,478,744. PUB. 2-12-2008. INT. CL. 9.

SER SOLUTIONS, INC., DULLES, VA:
2,098,642. CANC. INT. CL. 9.

SERICOL LIMITED, KENT CT10 2LE, UNITED KINGDOM:
2,154,985. REN. 6-27-08. INT. CL. 2.

SERVICE KING PAINT & BODY, LLC, RICHARDSON, TX:
3,480,013. PUB. 5-20-2008. INT. CL. 37.
3,480,014. PUB. 5-20-2008. INT. CL. 37.
3,480,024. PUB. 5-20-2008. INT. CL. 37.

SERVICE PAYMENT PLAN, INC., CHICAGO, IL:
3,480,376. PUB. 5-20-2008. INT. CL. 35.

SERVICE SYSTEMS EXCELLENCE, INC., MOKENA, IL:
2,493,650. CANC. INT. CL. 9.
2,493,651. CANC. INT. CL. 9.

SERVIDYNE, INC., ATLANTA, GA:
3,480,709. PUB. 5-20-2008. MULTIPLE CLASS, INT. CLS.
9, 36, 37 AND 42.

SESAME WORKSHOP, NEW YORK, NY:
3,479,148. PUB. 5-20-2008. MULTIPLE CLASS, INT. CLS.
3, 5, 8, 10, 11, 12, 14, 18, 20, 21, 24, 27, 29, 30 AND 32.

SESDERMA, S.L., VALENCIA, SPAIN:
3,480,420. PUB. 5-20-2008. INT. CL. 3.
3,480,421. PUB. 5-20-2008. INT. CL. 3.

SESTRAP, ROBERT, VASHON, WA:
2,098,657. CANC. INT. CL. 29.

SEVEN LIGHTS, LLC, CHICAGO, IL:
3,482,575. INT. CL. 16.
3,482,576. INT. CL. 16.

SEVEN SEAS HEALTH CARE LIMITED, NORTH HUMBER-
SIDE, ENGLAND:
1,470,385. REN. 7-3-08. INT. CL. 5.

SEXY HAIR CONCEPTS, LLC, CHATSWORTH, CA:
3,478,939. PUB. 5-20-2008. INT. CL. 3.

SF (IP) LIMITED, NEW TERRITORIES, HONG KONG:
3,479,154. PUB. 4-8-2008. MULTIPLE CLASS, INT. CLS. 16
AND 39.

- SFC FLUIDICS, LLC, FAYETTEVILLE, AR:
3,482,530, INT. CL. 9.
3,482,531, INT. CL. 9.
- SFC, LTD., TOLEDO, OH:
3,480,394, PUB. 5-20-2008. MULTIPLE CLASS, INT. CLS. 35, 40 AND 42.
- SHA SHA LADIES INTERNATIONAL LLC, PETERSBURG, WV:
3,480,007, PUB. 5-20-2008. INT. CL. 41.
- SHABAZZ-EL, WISE, SCRANTON, PA:
3,482,420, INT. CL. 25.
- SHABOOM INC., SUQUAMISH, WA:
3,482,636, INT. CL. 41.
- SHABOT, EDWARD J, ELBERON, NJ:
3,480,369, PUB. 5-20-2008. INT. CL. 42.
- SHACKELFORD'S FLORIST, INC., MEMPHIS, TN:
3,480,293, PUB. 5-20-2008. INT. CL. 35.
- SHAFFER BOWERS CORPORATION, VERNON, CA:
3,481,522, INT. CL. 25.
3,481,523, INT. CL. 25.
- SHAFFER, MARIE KENNEDY, LOS ANGELES, CA AND SHAFFER, JAMES, LOS ANGELES, CA:
3,481,227, INT. CL. 25.
- SHAFFNER PHOTOGRAPHY, INC., CHARLOTTE, NC:
2,493,339, CANC. INT. CL. 9.
- SHAKLEE CORPORATION, PLEASANTON, CA:
2,083,466, AM. INT. CL. 3.
- SHAKOPEE MDEWAKANTON SIOUX COMMUNITY, PRIOR LAKE, MN:
3,480,552, PUB. 5-20-2008. INT. CL. 43.
3,480,553, PUB. 5-20-2008. INT. CL. 43.
- SHALOM HOME, INC., COLORADO SPRINGS, CO:
2,178,264, REN. 7-1-08. INT. CL. 35.
- SHANE SHEIBANI, M.D., INC., LOS ANGELES, CA, DBA NEW ME INSTITUTE:
3,478,500, PUB. 5-20-2008. INT. CL. 5.
- SHANGHAI ROBUSTWORKS HARDWARE TOOLS CO., LTD, SHANGHAI, CHINA:
3,479,466, PUB. 5-20-2008. INT. CL. 8.
- SHANGHAI STOCK EXCHANGE, CHINA:
3,480,830, PUB. 5-20-2008. INT. CL. 36.
- SHANGHAI TOBACCO (GROUP) CORPORATION, SHANGHAI, CHINA:
3,478,511, PUB. 5-20-2008. INT. CL. 33.
- SHANTOU JINXINXING; TRADING DEVELOPMENT CO., LTD., CHINA:
3,480,837, PUB. 5-20-2008. INT. CL. 25.
- SHANTOU SAYONA FOOTWEAR CO., LTD., SHANTOU, CHINA:
3,481,506, INT. CL. 25.
- SHAR PRODUCTS COMPANY, ANN ARBOR, MI:
3,479,235, PUB. 5-20-2008. INT. CL. 15.
- SHARE INC., CHICAGO, IL:
2,163,268, REN. 6-30-08. MULTIPLE CLASS, INT. CLS. 16, 41 AND 42.
- SHARON LOEFF DESIGNS, LLC, SCOTTSDALE, AZ:
3,481,070, INT. CL. 14.
- SHARP KABUSHIKI KAISHA, OSAKA, JAPAN, TA SHARP CORPORATION:
3,482,580, INT. CL. 9.
- SHAW INDUSTRIES GROUP, INC., DALTON, GA:
1,458,387, CANC. INT. CL. 23.
- SHAW INDUSTRIES GROUP, INC., DALTON, GA AND COLUMBIA INSURANCE COMPANY, OMAHA, NE:
2,492,483, CANC. INT. CL. 27.
- SHAW'S SUPERMARKETS, INC., EAST BRIDGEWATER, MA:
2,100,231, CANC. INT. CL. 32.
- SHEARER, DAVID M, NORTH HALEDON, NJ:
3,479,302, PUB. 5-20-2008. INT. CL. 35.
- SHEERINO'KHO, FRANCE:
3,480,930, PUB. 5-20-2008. MULTIPLE CLASS, INT. CLS. 3 AND 4.
3,480,950, PUB. 5-20-2008. MULTIPLE CLASS, INT. CLS. 3 AND 4.
3,480,953, PUB. 5-20-2008. MULTIPLE CLASS, INT. CLS. 3 AND 4.
- SHELL TRADEMARK MANAGEMENT B.V., THE HAGUE, NETHERLANDS:
3,480,618, PUB. 5-20-2008. MULTIPLE CLASS, INT. CLS. 4 AND 37.
- SHELTER ONE, INC., GRANTS PASS, OR:
3,480,032, PUB. 5-20-2008. INT. CL. 6.
- SHENG KEE OF CALIFORNIA, INC., BRISBANE, CA:
1,532,234, REN. 6-30-08. INT. CL. 30.
- SHENZHEN SION TRADE CO., LTD., CHINA:
3,481,023, PUB. 5-20-2008. INT. CL. 28.
- SHERIDAN BROADCASTING CORPORATION, PITTSBURGH, PA:
3,480,515, PUB. 5-20-2008. MULTIPLE CLASS, INT. CLS. 38 AND 41.
3,480,516, PUB. 5-20-2008. MULTIPLE CLASS, INT. CLS. 38 AND 41.
- SHERMAN, WILLIAM M., DAMARISCOTTA, ME:
2,492,754, CANC. INT. CL. 9.
- SHERWOOD MEDICAL COMPANY, ST. LOUIS, MO TO SHERWOOD SERVICES AG, SCHAFFHAUSEN, SWITZERLAND:
2,099,750, CANC. INT. CL. 10.
- SHERWOOD-DROLET CORPORATION LTD., SHERBROOKE, QUEBEC, CANADA:
2,098,779, CANC. INT. CL. 28.
- SHIELDS, LORETTA, PUNTA GORDA, FL:
3,480,337, PUB. 5-20-2008. INT. CL. 4.
- SHIKOKU KAKOKI CO., LTD., ITANO-GUN, TOKUSHIMA-KEN, JAPAN:
1,458,269, CANC. INT. CL. 16.
- SHILLING, LYNNNDON, ALTOONA, IA:
3,482,261, INT. CL. 30.
- SHIMANO INC., SAKAI, OSAKA, JAPAN:
2,493,168, CANC. INT. CL. 25.
- SHINDAIWA, INC., TUALATIN, OR:
3,478,924, PUB. 5-20-2008. INT. CL. 7.
- SHINING OCEAN, INC., SUMNER, WA:
1,481,724, REN. 6-27-08. INT. CL. 29.
- SHIPPINGSOURCE COM, INC., BREDA, IA:
2,493,674, CANC. INT. CL. 39.
- SHOFU, INC., KYOTO 605, JAPAN:
1,492,094, REN. 7-3-08. INT. CL. 10.
- SHOOTERS BILLIARDS & SPORTS BAR, LP, CEDAR PARK, TX:
3,479,285, PUB. 5-20-2008. MULTIPLE CLASS, INT. CLS. 41 AND 43.
- SHORELINE MANUFACTURING, LLC, HUDSONVILLE, MI:
3,482,631, INT. CL. 12.
- SHORT, MELTON, CLANTON, AL:
3,482,716, INT. CL. 16.
- SHOWCASE, INC., ATLANTA, GA:
1,495,464, REN. 7-1-08. INT. CL. 42.
- SHOWTIME NETWORKS INC., NEW YORK, NY:
3,480,486, PUB. 5-20-2008. INT. CL. 28.
- SHUBIN, STEVE, DRIPPING SPRINGS, TX:
3,479,109, PUB. 5-20-2008. INT. CL. 10.
3,479,433, PUB. 5-20-2008. INT. CL. 10.
- SHULHAFFER, ALEXANDRIA M., LOUISVILLE, KY:
3,480,619, PUB. 5-20-2008. INT. CL. 25.
- SHUMAKER, LOOP & KENDRICK, LLP, TOLEDO, OH:
3,482,658, INT. CL. 45.
- SHUMAN PRODUCE, INC., COBBTOWN, GA:
3,481,485, INT. CL. 31.
- SHYM TECHNOLOGY, INC., NEEDHAM, MA:
2,493,047, CANC. INT. CL. 9.
- SIDE TRACKED RECORDS, CARMEL, IN:
3,481,186, INT. CL. 9.
- SIDELINE, INC., SCOTTSDALE, AZ:
2,493,285, CANC. INT. CL. 25.
- SIEGEL, DANIEL J., LOS ANGELES, CA:
3,482,079, MULTIPLE CLASS, INT. CLS. 9 AND 41.
3,482,080, MULTIPLE CLASS, INT. CLS. 9 AND 41.
- SIEMENS AKTIENGESELLSCHAFT, MUNICH, FED REP GERMANY:
2,492,116, CANC. INT. CL. 9.

SIEMENS INDUSTRIAL AUTOMATION, INC., ALPHARETTA, GA:
2,120,757. REN. 6-30-08. INT. CL. 9.

SIEMENS WATER TECHNOLOGIES HOLDING CORP., WARRENDALE, PA:
2,493,105. CANC. INT. CL. 16.

SIEMON COMPANY, THE, WATERTOWN, CT:
2,098,555. CANC. INT. CL. 9.

SIERRA DEL ORO LAND COMPANY, GLENDALE, CA:
1,458,607. CANC. INT. CL. 31.

SIERRA DESIGN GROUP, RENO, NV:
2,492,707. CANC. INT. CL. 9.
2,492,708. CANC. INT. CL. 9.

SIERRA ENTERTAINMENT, INC., LOS ANGELES, CA:
3,481,372. INT. CL. 9.

SIG SAUER INC., EXETER, NH:
2,167,107. REN. 7-3-08. INT. CL. 13.

SIGALOS, DEBRA, SAN CLEMENTE, CA:
3,300,535. CANC. INT. CL. 43.

SIGLIN, CHRISTOPHER, SAN CLEMENTE, CA:
3,479,978. PUB. 5-20-2008. INT. CL. 41.

SIGMA ASSESSMENT SYSTEMS, INC., PORT HURON, MI:
3,478,700. PUB. 5-20-2008. MULTIPLE CLASS, INT. CLS. 35 AND 44.

SIGNAGESOLUTIONS, LLC, POWELL, TN:
2,492,012. CANC. INT. CL. 35.

SIGNATURE FENCING & FLOORING, LLC, NEW YORK, NY:
3,479,501. PUB. 5-20-2008. INT. CL. 19.

SILBERLINE MANUFACTURING CO., INC., TAMAQUA, PA:
2,166,439. REN. 6-28-08. INT. CL. 2.

SILER, TODD, GREENWOOD VILLAGE, CO:
3,479,925. PUB. 5-20-2008. INT. CL. 41.

SILICON GENESIS CORPORATION, SAN JOSE, CA:
3,482,541. MULTIPLE CLASS, INT. CLS. 7, 42 AND 45.

SILK, JEFFREY E., OREM, UT:
3,482,061. INT. CL. 10.

SILVA, DAVE, BOISE, ID:
3,482,557. INT. CL. 45.
3,482,559. INT. CL. 45.

SILVER BUTLER COMPANY, THE, BRISTOL, VA:
2,492,460. CANC. INT. CL. 21.

SILVERBACK, LLC, FORT WORTH, TX:
3,479,973. PUB. 5-20-2008. INT. CL. 35.

SIMA K, LLC, NEW YORK, NY:
3,481,688. INT. CL. 14.

SIMA PRODUCTS CORPORATION, OAKMONT, PA:
3,481,418. INT. CL. 11.

SIMMONS, KENT A, FREEPORT, ME, DBA FREEPORT COFFEE ROASTING:
3,482,695. INT. CL. 30.

SIMMONS, LEAH D, BAKERSFIELD, CA:
3,480,429. PUB. 5-20-2008. INT. CL. 42.

SIMMONS, VERNON, GULFPORT, MS:
2,815,913. CANC. INT. CL. 16.

SIMON & SCHUSTER, INC., NEW YORK, NY:
1,458,327. CANC. INT. CL. 16.

SIMON AND SIMON, P.C., CHICAGO, IL:
3,480,413. PUB. 5-20-2008. INT. CL. 44.

SIMONIDES, VERONICA M., SANTEE, CA:
3,479,452. PUB. 5-20-2008. INT. CL. 44.

SIMPLEHUMAN, LLC, TORRANCE, CA:
3,482,589. INT. CL. 21.

SIMS DELTEC, INC., ST. PAUL, MN TO SMITHS MEDICAL MD, INC., ST. PAUL, MN:
2,100,298. CANC. INT. CL. 10.

SIMULA, INC., PHOENIX, AZ:
2,491,985. CANC. INT. CL. 42.

SINELLI, JEFFREY, DALLAS, TX:
3,479,198. PUB. 5-20-2008. INT. CL. 30.

SINGELPOINT LLC, SACRAMENTO, CA:
2,099,777. CANC. MULTIPLE CLASS, INT. CLS. 36 AND 42.

SINGH MANAGEMENT CO., INC., WEST BLOOMFIELD, MI:
2,247,287. REN. 7-3-08. MULTIPLE CLASS, INT. CLS. 36 AND 37.

SINSEI SHOJI CO., LTD., TOKYO, JAPAN:
2,166,303. REN. 7-1-08. INT. CL. 9.

SIP XTREME, L.L.C., ANTHEM, AZ:
3,481,180. MULTIPLE CLASS, INT. CLS. 9 AND 38.

SIPLAST, INC., ARKADDELPHIA, AZ, W. R. GRACE & CO., CAMBRIDGE, MA:
1,496,392. REN. 6-30-08. INT. CL. 1.

SIRONA DENTAL SYSTEMS GMBH, FED REP GERMANY:
3,480,883. PUB. 5-20-2008. INT. CL. 10.

SISKIN ENTERPRISES, INC., SALT LAKE CITY, UT:
3,480,313. PUB. 5-20-2008. INT. CL. 2.
3,480,317. PUB. 5-20-2008. INT. CL. 2.

SISTERS, INC., BUCKNER, KY:
3,480,222. PUB. 5-20-2008. INT. CL. 43.

SITELIFE, INC., OAK LAWN, IL:
3,479,992. PUB. 5-20-2008. INT. CL. 38.

SITESPECT, INC., BOSTON, MA:
3,481,810. INT. CL. 9.

SIVACO WIRE GROUP 2004 L.P., MONTREAL, QUEBEC, CANADA:
3,481,822. INT. CL. 6.

SJR FOODS, LTD., HOUSTON, TX:
3,479,013. PUB. 5-20-2008. INT. CL. 30.

SKC INC., EIGHTY FOUR, PA:
3,481,090. INT. CL. 7.

SKEET-R-GONE, INC., WEST FARGO, ND:
3,453,342. COR. INT. CL. 5.

SKILLSOFT CORPORATION, NASHUA, NH:
2,492,069. CANC. INT. CL. 41.

SKILNET CORPORATION, ATLANTA, GA:
2,491,980. CANC. INT. CL. 42.

SKIPPACK CREEK CORPORATION, WILMINGTON, DE:
2,491,925. CANC. INT. CL. 29.

SKORKA, RICHARD, FLOWER MOUND, TX:
3,481,363. INT. CL. 6.

SKOY ENTERPRISES, ENCINITAS, CA:
3,480,335. PUB. 5-20-2008. INT. CL. 21.

SKY WATCH, LLC., WARRENTON, VA:
3,478,588. PUB. 5-20-2008. INT. CL. 45.

SKYLINE DISPLAYS, INC., EAGAN, MN:
3,479,953. PUB. 5-20-2008. INT. CL. 20.
3,480,523. PUB. 5-20-2008. INT. CL. 20.

SKYLON INNOVATIONS, INC., GREENSBORO, NC:
3,479,647. PUB. 5-20-2008. INT. CL. 42.
3,479,650. PUB. 5-20-2008. INT. CL. 42.
3,479,652. PUB. 5-20-2008. INT. CL. 42.

SKYQUEST INC., S. EL MONTE, CA, DBA CXRACING:
3,480,137. PUB. 5-20-2008. INT. CL. 7.

SL MARKETING SA, LOCARNO, SWITZERLAND:
3,478,660. PUB. 10-23-2007. INT. CL. 25.

SLAMAN, PAUL, MISSION VIEJO, CA:
3,481,341. INT. CL. 7.

SLAYDON, LES, BATON ROUGE, LA:
3,482,596. INT. CL. 35.
3,482,597. INT. CL. 35.

SLEEPTech LLC, KINNELON, NJ:
2,098,996. CANC. MULTIPLE CLASS, INT. CLS. 35 AND 42.

SLIPPERY ROCK UNIVERSITY OF PENNSYLVANIA OF THE STATE SYSTEM OF HIGHER EDUCATION, SLIPPERY ROCK, PA, SLIPPERY ROCK UNIVERSITY OF PENNSYLVANIA OF THE STATE SYSTEM OF HIGHER EDUCATION, SLIPPERY ROCK, PA:
1,328,626. REN. 7-3-08. INT. CL. 25.

SLIPPERY ROCK UNIVERSITY OF PENNSYLVANIA OF THE STATE SYSTEM OF HIGHER EDUCATION, SLIPPERY ROCK, PA:
1,353,316. REN. 7-3-08. INT. CL. 41.

SMALL BUSINESS INSURANCE AGENCY, INC., WORCESTER, MA:
2,210,627. REN. 6-28-08. INT. CL. 36.

SMALL WORLD, INC., MOUNT JULIET, TN:
2,163,376. REN. 7-3-08. INT. CL. 36.

SMALLEY, DAVID C., FREDERICKSBURG, VA, DBA THE SHARPSHOOTERS:
2,492,050. CANC. INT. CL. 9.

SMALLWOOD JR., JAMES, DENVER, CO:
3,480,318. PUB. 5-20-2008. INT. CL. 28.

- SMANIA SPA, ITALY:
3,480,761, PUB. 5-20-2008. MULTIPLE CLASS, INT. CLS. 16, 19, 20 AND 21.
- SMARKETING, LLC, SAN DIEGO, CA:
3,482,639, INT. CL. 35.
- SMART BRANDS INC., RICHMOND, CANADA:
3,480,087, PUB. 5-20-2008. INT. CL. 3.
- SMART TECHNOLOGIES ULC, CALGARY, CANADA:
2,159,391, REN. 6-30-08. INT. CL. 9.
- SMARTTALENT LLC, SEATTLE, WA:
3,481,290, INT. CL. 35.
3,481,292, INT. CL. 35.
3,481,347, INT. CL. 35.
3,481,348, INT. CL. 35.
- SMEAD MANUFACTURING COMPANY, THE, HASTINGS, MN:
1,042,263, REN. 6-27-08. INT. CL. 16.
- SMILEHOUSE OY, FINLAND:
3,480,784, PUB. 5-20-2008. MULTIPLE CLASS, INT. CLS. 9 AND 35.
- SMITH, BRENN, TUCKER, GA:
3,479,035, PUB. 5-20-2008. INT. CL. 41.
- SMITH, KATHARINE, CRANSTON, RI:
3,478,667, PUB. 5-20-2008. INT. CL. 35.
- SMITH, SIDNEY HOFFMAN, NEW ORLEANS, LA:
3,478,845, PUB. 5-20-2008. INT. CL. 41.
- SMITHKLINE BEECHAM CORPORATION, PHILADELPHIA, PA, SMITH, KLINE & FRENCH LABORATORIES, PHILADELPHIA, PA:
337,112, REN. 6-30-08. U.S. CL. 18 (INT. CL. 5).
- SMITHSONIAN INSTITUTION, WASHINGTON, DC:
3,478,610, PUB. 5-20-2008. INT. CL. 41.
- SMOKEY'S PEANUTS, INC., ATHENS, GA:
3,480,452, PUB. 5-20-2008. INT. CL. 43.
- SMOOTH-ON, INC., EASTON, PA:
3,479,281, PUB. 5-20-2008. INT. CL. 1.
- SMRT, THOMAS J., MARENGO, IL, DBA FOX VALLEY DRAFT HORSE FARMS:
1,458,876, CANC. INT. CL. 41.
- SNAK KING CORPORATION, CITY OF INDUSTRY, CA:
2,154,469, REN. 7-2-08. MULTIPLE CLASS, INT. CLS. 29 AND 30.
- SNAP DRAPE INTERNATIONAL, INC., CARROLLTON, TX:
3,478,583, PUB. 5-20-2008. MULTIPLE CLASS, INT. CLS. 24 AND 26.
- SNEAKER HEADZ, LLC, ROYAL OAK, MI, DBA BURN RUBBER:
3,479,896, PUB. 5-20-2008. INT. CL. 35.
3,480,437, PUB. 5-20-2008. INT. CL. 35.
- SNOWANGEL FITNESS, LLC, LOUISVILLE, KY:
3,480,085, PUB. 5-20-2008. INT. CL. 41.
- SNOWPULSE SA, SWITZERLAND:
3,480,893, PUB. 5-20-2008. INT. CL. 9.
- SNUGGIE TOY INC., PLAINVIEW, NY:
3,478,536, PUB. 5-20-2008. INT. CL. 28.
3,478,537, PUB. 5-20-2008. INT. CL. 28.
- SNUGHOUSE ENERGY AUDITS LLC, EAST TROY, WI:
3,482,555, INT. CL. 35.
- SNYDER, CHRISTOPHER J, PORTAGE, MI:
3,481,959, INT. CL. 41.
- SOCIALE, INC., EAGAN, MN:
3,479,081, PUB. 5-20-2008. INT. CL. 43.
- SOCIALIZER, LLC., RESTON, VA:
3,381,937 NEW CERT. 8-5-2008. MULTIPLE CLASS, INT. CLS. 35, 38, 41, 42 AND 45.
- SOCIETA COSMETICI S.P.A., 10122 TORINO, ITALY:
1,457,888, CANC. INT. CL. 3.
- SOCIETE ANONYME DE LA MANUFACTURE; D'HORLOGERIE AUDEMARS PIGUET & CIE, SWITZERLAND:
3,480,826, PUB. 5-20-2008. INT. CL. 14.
- SOCIETE ANONYME; GRANDS TERROIRS ET SIGNATURES, FRANCE:
3,480,817, PUB. 5-20-2008. INT. CL. 33.
- SOCIETE BIC, CLICHY, FRANCE:
3,480,527, PUB. 5-20-2008. INT. CL. 16.
- SOCIETE DES PRODUITS NESTLE S.A., 1800 VEVEY, SWITZERLAND:
1,458,265, CANC. INT. CL. 16.
2,493,368, CANC. INT. CL. 30.
- SOCIETE DES PRODUITS NESTLE S.A., VEVEY, SWITZERLAND:
3,481,916, INT. CL. 31.
- SOCIETE DES PRODUITS NESTLE, S.A., 1800 VEVEY, SWITZERLAND:
1,492,455, REN. 6-30-08. INT. CL. 29.
- SOCIETE GENERALE, FRANCE:
3,480,840, PUB. 5-20-2008. INT. CL. 36.
- SOCIETE PARISIENNE DE PARFUMS ET COSMETIQUES, PARIS, FRANCE:
3,481,766, INT. CL. 3.
- SOCIETY FOR HUMAN RESOURCE MANAGEMENT, ALEXANDRIA, VA:
2,100,455, CANC. INT. CL. 16.
- SOCIETY FOR SCIENCE & THE PUBLIC, WASHINGTON, DC:
3,482,629, MULTIPLE CLASS, INT. CLS. 35 AND 41.
- SOCIETY OF COMPETITIVE INTELLIGENCE PROFESSIONALS, ALEXANDRIA, VA:
3,479,655, PUB. 5-20-2008. MULTIPLE CLASS, INT. CLS. 35 AND 41.
- SOCIETY OF STRANDERS, INC., COLUMBIA, SC:
3,478,492, PUB. 5-20-2008. INT. CL. 25.
- SOCIÉTÉ DES VINS ET SPIRITUEUX; LA MARTINIQUAISE (SOCIÉTÉ ANONYME), FRANCE:
3,480,853, PUB. 5-20-2008. INT. CL. 33.
- SODEXHO ALLIANCE, 78180 MONTIGNY-LE-BRETONNEUX, FRANCE:
3,482,455, INT. CL. 43.
- SODEXHO ALLIANCE, MONTIGNY-LE-BRETONNEUX, FRANCE:
3,482,456, INT. CL. 43.
- SODEXO, INC., GAITHERSBURG, MD:
1,461,466, AM. INT. CL. 42.
- SOFT SHEEN/CARSON, INC., CHICAGO, IL:
2,493,511, CANC. INT. CL. 3.
2,493,667, CANC. INT. CL. 3.
- SOFTCARE INNOVATIONS, INC., WATERLOO, CANADA:
3,478,652, PUB. 11-20-2007. INT. CL. 20.
- SOFTWARE PROJECTS, INC., BALL GROUND, GA:
2,493,525, CANC. INT. CL. 35.
- SOFTWARESHIELD TECHNOLOGIES, INC., VANCOUVER, CANADA:
3,480,531, PUB. 5-20-2008. INT. CL. 9.
- SOL NÉ COLLECTIONS, INC., CENTENNIAL, CO:
3,479,948, PUB. 5-20-2008. INT. CL. 35.
- SOLAMATRIX, INC., TAMPA, FL, METALLIZED PRODUCTS, INC., ST. PETERSBURG, FL:
1,078,425, REN. 6-30-08. INT. CL. 17.
- SOLAS, INC, TOTOWA, NJ:
2,491,993, CANC. INT. CL. 35.
- SOLE ASSETS HOLDINGS, INC., AGOURA HILLS, CA:
3,482,205, INT. CL. 25.
- SOLE COMFORT, INC., NEWPORT BEACH, CA:
3,482,083, INT. CL. 25.
- SOLID DATA SYSTEMS, INC., SANTA CLARA, CA:
2,492,662, CANC. INT. CL. 9.
- SOLIUM CAPITAL INC., CALGARY, ALBERTA, CANADA:
3,480,604, PUB. 10-30-2007. INT. CL. 9.
3,480,605, PUB. 10-30-2007. INT. CL. 9.
- SOLOLA.; SOCIÉTÉ PAR ACTIONS SIMPLIFIÉE, FRANCE:
3,480,874, PUB. 2-12-2008. INT. CL. 25.
- SOLUTIONS A NON-PROFIT CORPORATION, SEATTLE, WA:
2,492,975, CANC. MULTIPLE CLASS, INT. CLS. 36, 41 AND 42.
- SOMBRERO MAN ENTERPRISES, INC., MARIETTA, GA:
3,482,030, INT. CL. 42.
- SOMMARS, ROBERT SCOTT, HUNTINGTON BEACH, CA AND O'REILLY, HEATHER, HUNTINGTON BEACH, CA:
2,492,473, CANC. INT. CL. 25.
- SONDERGAARD, ANNE M., FRESNO, CA:
859,012, REN. 7-3-08. U.S. CL. 46 (INT. CL. 31).

- SONETICS CORPORATION, HOUSTON, TX:
1,458,078, CANC. INT. CL. 9.
- SONHO DE CRIANÇA PRODUTOS INFANTIS LTDA.,
CIDADE DE BIRIGUI, ESTADO DE SÃO PAULO, BRA-
ZIL:
3,482,041, INT. CL. 25.
- SONIC CASH, INC., BOISE, ID:
3,480,116, PUB. 5-20-2008. INT. CL. 36.
- SONNINA SÜBWAREN GMBH, FED REP GERMANY:
3,480,914, PUB. 5-20-2008. INT. CL. 30.
- SONORA MILLS FOODS, INC., RANCHO DOMINGUEZ,
CA:
3,482,390, MULTIPLE CLASS, INT. CLS. 29 AND 30.
- SONY BMG MUSIC ENTERTAINMENT, NEW YORK, NY,
CBS INC., NEW YORK, NY:
1,079,312, REN. 7-3-08. INT. CL. 9.
- SONY BMG MUSIC ENTERTAINMENT, NEW YORK, NY:
2,133,434, REN. 6-30-08. INT. CL. 41.
- SONY ERICSSON MOBILE COMMUNICATIONS AB,
LUND, SWEDEN:
3,481,538, MULTIPLE CLASS, INT. CLS. 9 AND 38.
3,481,540, MULTIPLE CLASS, INT. CLS. 9 AND 38.
- SONY KABUSHIKI KAISHA, TOKYO, JAPAN, TA SONY
CORPORATION:
3,481,304, INT. CL. 9.
- SONY KABUSHIKI KAISHA (ALSO TRADING AS SONY
CORPORATION), TOKYO, JAPAN:
2,493,066, CANC. INT. CL. 9.
3,481,364, INT. CL. 9.
- SOOTHSOFT INNOVATIONS WORLDWIDE, INC., GRAND
ISLAND, NE:
3,479,578, PUB. 5-20-2008. MULTIPLE CLASS, INT. CLS.
10, 11 AND 20.
- SOPHIE MATSSON MED FIRMA; SOPHIE GALLERY,
SWEDEN:
3,480,983, PUB. 5-20-2008. INT. CL. 14.
- SOREMARTEC S.A., 6700 SCHOPPACH-ARLON, BELGIUM:
2,492,271, CANC. INT. CL. 30.
- SORICE, DEMUS JOSEPH, SHERMAN OAKS, CA:
3,479,171, PUB. 5-20-2008. INT. CL. 41.
- SORKIN, HERBERT M., CLIFTON, NJ:
2,493,496, CANC. INT. CL. 30.
- SOS-BOLTING, INC., NEWARK, DE:
3,481,280, MULTIPLE CLASS, INT. CLS. 7, 37 AND 42.
- SOUND STORM LABORATORIES CORPORATION, OX-
NARD, CA:
2,250,259, REN. 7-3-08. INT. CL. 9.
- SOUNDVIEW TECHNOLOGY GROUP, INC., OLD GREEN-
WICH, CT:
2,099,309, CANC. INT. CL. 36.
- SOURCE MEDICAL SOLUTIONS, INC., BIRMINGHAM, AL:
3,478,677, PUB. 5-20-2008. MULTIPLE CLASS, INT. CLS.
39 AND 42.
- SOUTH STREET CAPITAL MANAGEMENT L.P., NEW
YORK, NY:
3,480,320, PUB. 5-20-2008. INT. CL. 36.
- SOUTHDOWN MEAT COMPANY, INC., WEST CHESTER,
PA TO VISIONARY DESIGN, INC., ATGLEN, PA:
1,458,539, CANC. INT. CL. 29.
- SOUTHEASTERN METALS MANUFACTURING COM-
PANY, INC., BUFFALO, NY:
3,480,169, PUB. 5-20-2008. INT. CL. 6.
- SOUTHEASTERN NEWSPAPERS COMPANY, LLC, AUGUS-
TA, GA:
3,481,711, INT. CL. 16.
3,481,714, INT. CL. 16.
- SOUTHERN BRICK INSTITUTE, INC., CONYERS, GA:
2,493,395, CANC. INT. CL. 35.
- SOUTHERN COMFORT PROPERTIES, INC., SAN RAFAEL,
CA:
3,481,658, INT. CL. 41.
- SOUTHERN RESTAURANT GROUP, INC., DESTIN, FL:
3,482,284, INT. CL. 43.
- SOUTHERN SEASONINGS, INC., BROUSSARD, LA:
2,099,025, CANC. MULTIPLE CLASS, INT. CLS. 29 AND
30.
- SOUTHERN STATES COOPERATIVE, INCORPORATED,
RICHMOND, VA:
858,931, REN. 7-2-08. U.S. CL. 29 (INT. CL. 21).
2,200,381, REN. 7-2-08. MULTIPLE CLASS, INT. CLS. 1
AND 5.
3,481,839, INT. CL. 31.
- SOUTHERN UNION COMPANY, AUSTIN, TX TO ENERGY
WORLDNET, INC., AUSTIN, TX:
2,099,059, CANC. INT. CL. 9.
- SOUTHWEST AIRLINES CO., DALLAS, TX:
2,100,111, CANC. INT. CL. 39.
- SOUTHWEST SPECIALTY FOOD, INC., GOODYEAR, AZ:
2,099,368, CANC. INT. CL. 30.
2,099,369, CANC. INT. CL. 30.
- SOY LABS, LLC, JEFFERSON CITY, MO:
3,482,653, INT. CL. 30.
3,482,654, INT. CL. 29.
3,482,655, INT. CL. 30.
3,482,656, INT. CL. 29.
- SOYANG TECHNOLOGIES CO., LTD., CHINA:
3,480,775, PUB. 5-20-2008. INT. CL. 22.
- SOYKA, STEVE, NORTHRIDGE, CA:
3,480,360, PUB. 5-20-2008. INT. CL. 39.
- SOYO FOODS GMBH, SWITZERLAND:
3,481,000, PUB. 5-20-2008. INT. CL. 33.
- SP INDUSTRIES INC., BUENA, NJ:
2,492,682, CANC. INT. CL. 11.
- SPAMEDICA INTERNATIONAL SRL, WARRENS, ST. MI-
CHAEL, BARBADOS:
3,478,732, PUB. 5-20-2008. MULTIPLE CLASS, INT. CLS.
41 AND 44.
3,481,386, INT. CL. 9.
- SPARKS ENTERTAINMENT, INC., NAPLES, FL:
2,493,055, CANC. INT. CL. 28.
- SPC DIGITAL, INC., BIRMINGHAM, AL:
3,481,641, INT. CL. 38.
3,481,642, INT. CL. 38.
- SPECIAL OPERATIONS WARRIOR FOUNDATION, INC.,
TAMPA, FL:
3,478,544, PUB. 5-20-2008. MULTIPLE CLASS, INT. CLS.
14, 25, 36, 41 AND 45.
- SPECIALIZE FITNESS, INC., BROOKLYN, NY:
3,479,651, PUB. 5-20-2008. INT. CL. 41.
- SPECIALTY PROMOTIONS & ADVERTISING, INC.,
BROOMFIELD, CO:
3,478,933, PUB. 5-20-2008. INT. CL. 35.
- SPECTRA-LASE, INC., OMAHA, NE:
3,478,590, PUB. 5-20-2008. INT. CL. 9.
- SPECTRON SYSTEMS TECHNOLOGIES, INC., HAUP-
PAUGE, NY:
2,491,881, CANC. INT. CL. 9.
- SPECTRUM LABORATORIES, INC., RANCHO DOMIN-
GUEZ, CA:
1,467,134, REN. 7-2-08. INT. CL. 9.
- SPEIDEL, LLC., EAST PROVIDENCE, RI:
3,481,723, INT. CL. 14.
- SPEIRS, GREGORY, BRONXVILLE, NY:
2,492,849, CANC. INT. CL. 25.
- SPEISER, AARON, LOS ANGELES, CA:
3,479,777, PUB. 5-20-2008. INT. CL. 41.
- SPENCER GIFTS LLC, EGG HARBOR TOWNSHIP, NJ:
2,100,325, CANC. INT. CL. 42.
- SPENCO MEDICAL CORPORATION, WACO, TX:
1,501,412, REN. 7-2-08. INT. CL. 25.
- SPERIAN RESPIRATORY PROTECTION USA, LLC, SANTA
ANA, CA:
3,481,521, INT. CL. 9.
- SPHERION ATLANTIC ENTERPRISES LLC, FORT LAU-
DERDALE, FL:
2,566,686, CANC. INT. CL. 9.
- SPICERS PAPER, INC., SANTA FE SPRINGS, CA:
2,098,889, CANC. INT. CL. 16.
- SPINELLI S.R.L., ITALY:
3,480,780, PUB. 10-16-2007. MULTIPLE CLASS, INT. CLS.
29 AND 33.
- SPINNAKER EQUIPMENT SERVICES, INC., SAN FRAN-
CISCO, CA:
2,492,252, CANC. INT. CL. 35.

- SPIRIT RIVER, INC., ROSEBURG, OR:
3,481,787, INT. CL. 28.
3,481,791, INT. CL. 28.
- SPIRO INTERNATIONAL S.A., CH-3178 BOESINGEN, SWITZERLAND:
2,142,121. REN. 7-3-08. INT. CL. 11.
- SPIROPULOS, MARCELA B., CHARLOTTESVILLE, VA:
2,492,784, CANC. INT. CL. 25.
- SPLAIN, JACQUELINE, HERNANDO, FL, DBA SPLAIN DEVELOPMENT, LLC:
3,479,330, PUB. 5-20-2008. INT. CL. 9.
- SPLIT ENDZ HAIRCUTTERS, INC, BROOMALL, PA AND DIGIACOMO, ARTHUR J, WEST CHESTER, PA:
3,478,925, PUB. 5-20-2008. INT. CL. 44.
- SPOKANE TELEVISION, INC., SPOKANE, WA:
3,479,564, PUB. 5-20-2008. INT. CL. 38.
- SPORIAN MICROSYSTEMS, INC., LAFAYETTE, CO:
3,481,969, INT. CL. 9.
- SPORTS MASTERS INTERNATIONAL, NAPLES, FL:
2,491,845, CANC. MULTIPLE CLASS, INT. CLS. 35, 36 AND 41.
- SPORTS PERSPECTIVES INTERNATIONAL, INC., WASHINGTON, DC:
3,480,717, PUB. 5-20-2008. INT. CL. 41.
- SPORTSMED CENTER FOR FITNESS, LTD., CAROL STREAM, IL:
1,458,831, CANC. INT. CL. 42.
- SPORTWALL INTERNATIONAL INC., CARPINTERIA, CA:
3,481,873, INT. CL. 28.
3,481,947, INT. CL. 10.
- SPOTZER MEDIA GROUP B.V., 1075 HM AMSTERDAM, NETHERLANDS:
3,479,227, PUB. 5-20-2008. INT. CL. 35.
- SPRAY NINE CORPORATION, JOHNSTOWN, NY:
3,482,593, INT. CL. 3.
- SPRAYLAT CORPORATION, PELHAM, NY, PORTER PAINT CO., LOUISVILLE, KY:
1,503,514. REN. 7-1-08. INT. CL. 2.
- SPRINGFIELD TRAVEL SERVICE, INC., SPRINGFIELD, VA:
1,458,735, CANC. INT. CL. 39.
1,458,736, CANC. INT. CL. 39.
- SPRINGFIELD WIRE, INC., SPRINGFIELD, MA:
3,479,450, PUB. 5-20-2008. INT. CL. 11.
- SPRINGFIX LINKAGES, LLC, CLINTON TOWNSHIP, MI:
841,494. REN. 7-3-08. U.S. CL. 13 (INT. CL. 6).
- SPROUTLOUD MEDIA NETWORKS, LLC, SUNRISE, FL:
3,479,061, PUB. 5-20-2008. INT. CL. 35.
- SPS PARTNERS LLC, MAYFIELD VILLAGE, OH:
3,478,561, PUB. 5-20-2008. INT. CL. 36.
- SPURR, THURLOW, ORLANDO, FL:
3,478,728, PUB. 5-20-2008. INT. CL. 41.
- SQUARE D COMPANY, PARK RIDGE, IL:
852,213. REN. 6-28-08. U.S. CL. 21 (INT. CL. 9).
- SRG, INC., PLEASANTON, CA:
3,481,707, INT. CL. 43.
- SSG LTD., DALLAS, TX:
2,492,128, CANC. INT. CL. 9.
- ST TELECOM INC., MIRAMAR, FL:
3,478,795, PUB. 5-20-2008. INT. CL. 35.
- ST. JUDE MEDICAL, ATRIAL FIBRILLATION DIVISION, INC., MINNETONKA, MN:
3,482,375, INT. CL. 9.
- ST. PIERRE, TRACY M., WAKEFIELD, MA:
3,482,027, INT. CL. 28.
- ST. THOMAS BEVERAGE, INC., SANTA FE SPRINGS, CA:
2,098,694, CANC. MULTIPLE CLASS, INT. CLS. 30 AND 32.
- STADLBAUER MARKETING + VERTRIEB; GESELLSCHAFT M.B.H., A-5027 SALZBURG, AUSTRIA:
3,481,020, PUB. 5-20-2008. INT. CL. 28.
- STAFFME.NET, LLC, KNOXVILLE, TN:
3,479,373, PUB. 5-20-2008. INT. CL. 36.
- STAGG FOODS, INC., COMMERCE, CA:
1,458,559, CANC. INT. CL. 29.
- STANADYNE AUTOMOTIVE CORP., WINDSOR, CT:
1,458,241, CANC. INT. CL. 12.
- STANDARD CANDY COMPANY, NASHVILLE, TN:
2,493,114, CANC. INT. CL. 30.
- STANDARD ETHANOL, LLC, NORTH PLATTE, NE:
3,482,564, INT. CL. 4.
- STANDARD TEXTILE CO., INC., CINCINNATI, OH:
3,481,582, INT. CL. 24.
- STANISLAUS PARTNERS, STOCKTON, CA, STANISLAUS PARTNERS, STOCKTON, CA:
1,533,472. REN. 6-27-08. MULTIPLE CLASS, INT. CLS. 29 AND 30.
- STAR BRIDGE SYSTEMS, INC., DRAPER, UT:
2,493,679, CANC. INT. CL. 9.
- STAR TELEVISION PRODUCTIONS LIMITED, TORTOLA, BR. VIRGIN ISLANDS:
3,478,836, PUB. 5-20-2008. INT. CL. 38.
3,478,837, PUB. 5-20-2008. INT. CL. 41.
3,478,838, PUB. 5-20-2008. INT. CL. 45.
- STARFACTORY INTERNATIONAL FOOTBALL MANAGEMENT AKTIENGESELLSCHAFT, FL-9494 SCHAAN, LIECHTENSTEIN:
3,480,770, PUB. 5-20-2008. INT. CL. 35.
- STARK CARPET CORP., NEW YORK, NY:
3,479,040, PUB. 5-20-2008. INT. CL. 24.
- STARLIGHT INTERNATIONAL, LTD. LP, MONTEREY, CA:
2,492,010, CANC. INT. CL. 36.
2,492,015, CANC. INT. CL. 35.
2,492,088, CANC. INT. CL. 16.
- STARLIGHT INTERNATIONAL, LTD, L.P., MONTEREY, CA:
2,212,700. REN. 7-3-08. INT. CL. 26.
2,212,700, CANC. MULTIPLE CLASS, INT. CLS. 9, 14, 16, 18, 20, 21 AND 25.
- STARLING, ELAINE, SHINGLE SPRINGS, CA:
3,482,474, MULTIPLE CLASS, INT. CLS. 14 AND 35.
- STARMAX RESOURCE LLC, CLEVELAND, OH:
3,482,449, INT. CL. 21.
- STARR & BROWN, INC., PORTLAND, OR, DBA STARR WINERY:
2,491,738, CANC. INT. CL. 33.
- STATE OF FLORIDA DEPARTMENT OF THE LOTTERY, TALLAHASSEE, FL:
1,542,860. REN. 6-30-08. INT. CL. 36.
- STAUFF CORPORATION, WALDWICK, NJ:
3,479,888, PUB. 5-20-2008. MULTIPLE CLASS, INT. CLS. 6, 7, 9, 19 AND 20.
3,479,916, PUB. 5-20-2008. MULTIPLE CLASS, INT. CLS. 6, 7, 9, 19 AND 20.
- STE D'EXPLOITATION DE PRODUITS POUR LES INDUSTRIES CHIMIQUES-S.E.P.P.I.C., 75321 PARIS CEDEX 07, FRANCE, PRODUITS CHIMIQUES DE LA MONTAGNE NOIRE, 81 CASTRES, FRANCE:
1,061,936. REN. 6-30-08. INT. CL. 1.
- STEAM WHISTLE BREWING INC., TORONTO, CANADA:
3,479,357, PUB. 5-20-2008. INT. CL. 32.
- STEAMLAB.SYSTEMS AG, FED REP GERMANY:
3,480,907, PUB. 5-20-2008. MULTIPLE CLASS, INT. CLS. 7, 37, 40 AND 42.
- STEELCASE INC., GRAND RAPIDS, MI:
3,480,627, PUB. 5-20-2008. INT. CL. 20.
- STEFKOM SOCIETA' PER AZIONI, AKA STEFKOM SPA:
1,458,403, CANC. INT. CL. 25.
- STEINBERG, WILLIAM F., SOUTHFIELD, MI, DBA CONCEPT 28 ASSOCIATES:
1,458,693, CANC. INT. CL. 36.
- STEINBOCK MACHINERY CORP., CARNEGIE, PA:
3,478,596, PUB. 5-20-2008. INT. CL. 6.
- STEMICK OPTICAL INC., SOUTH PASADENA, CA:
3,480,067, PUB. 5-20-2008. INT. CL. 9.
- STEMLIFELINE INC., SAN CARLOS, CA:
3,479,523, PUB. 5-20-2008. MULTIPLE CLASS, INT. CLS. 39 AND 44.
3,479,525, PUB. 5-20-2008. MULTIPLE CLASS, INT. CLS. 39 AND 44.
- 3,479,528, PUB. 5-20-2008. MULTIPLE CLASS, INT. CLS. 39 AND 44.
- STEP III ENTERTAINMENT, INC., ODESSA, TX:
1,471,053. REN. 6-30-08. INT. CL. 42.

STEPHAN MACHINERY GMBH, HAMELN, FED REP GERMANY:
1,489,893. REN. 6-28-08. INT. CL. 7.

STEPHENS INVESTMENT MANAGEMENT GROUP, LLC, LITTLE ROCK, AR:
3,481,965, INT. CL. 36.

STERIS INC., TEMECULA, CA:
3,481,606, INT. CL. 1.
3,481,762, MULTIPLE CLASS, INT. CLS. 10 AND 11.

STERLING CUT GLASS COMPANY, INC., ERLANGER, KY:
3,478,519, PUB. 5-20-2008. MULTIPLE CLASS, INT. CLS. 21 AND 35.

STERLING LIFE INSURANCE COMPANY, GLENVIEW, IL:
3,479,903, PUB. 5-20-2008. INT. CL. 36.
3,479,904, PUB. 5-20-2008. INT. CL. 36.
3,479,905, PUB. 5-20-2008. INT. CL. 36.
3,479,906, PUB. 5-20-2008. INT. CL. 36.
3,479,907, PUB. 5-20-2008. INT. CL. 36.

STERLING RESOURCES, INC., PARAMUS, NJ:
2,380,516, CANC. INT. CL. 9.

STEVEN T. GRUBART, DOWNERS GROVE, IL:
3,480,202, PUB. 5-20-2008. INT. CL. 25.

STEVENS-HENAGER COLLEGE, INC., OGDEN, UT:
3,479,928, PUB. 5-20-2008. INT. CL. 41.

STI/SPFA, LAKE ZURICH, IL:
1,539,820. REN. 7-2-08. U.S. CL. 200.

STI, LTD., PHOENIX, AZ:
2,492,238, CANC. INT. CL. 16.

STICKI RICE, LLC, CHARLOTTE, NC AND JENKINS, AMY, CHARLOTTE, NC:
3,478,725, PUB. 5-20-2008. MULTIPLE CLASS, INT. CLS. 14, 20 AND 35.

STILA COSMETICS, INC., LOS ANGELES, CA:
2,492,990, CANC. INT. CL. 21.

STILETTO MAGAZINE, LOS ANGELES, CA:
3,479,016, PUB. 5-20-2008. MULTIPLE CLASS, INT. CLS. 16 AND 41.

STILLWATER DESIGNS AND AUDIO, INC., STILLWATER, OK:
3,479,125, PUB. 5-20-2008. INT. CL. 9.

STINGER WELLHEAD PROTECTION, INC., OKLAHOMA CITY, OK:
3,479,150, PUB. 5-20-2008. MULTIPLE CLASS, INT. CLS. 37 AND 40.

STIRRINGS, LLC, FALLS RIVER, MA:
3,481,306, INT. CL. 33.

STOBER, JOHN, GOODRICH, ND AND STOBER, STEPHANIE, GOODRICH, ND:
3,482,694, INT. CL. 29.

STOCKGROUP INFORMATION SYSTEMS INC., VANCOUVER, BRITISH COLUMBIA, CANADA:
2,491,939, CANC. MULTIPLE CLASS, INT. CLS. 36 AND 38.

STOKES, ELBERT HARVEY, JR., GLENWOOD, AR:
3,482,391, INT. CL. 11.

STOLAREK, ANDY, LOS ANGELES, CA, DBA ANDREW STOLAREK:
3,479,326, PUB. 5-20-2008. INT. CL. 41.

STOLLE MACHINERY COMPANY, LLC, CENTENNIAL, CO:
2,196,250. REN. 7-1-08. INT. CL. 7.

STONE BREWING CO., ESCONDIDO, CA:
2,168,093. REN. 6-28-08. INT. CL. 32.

STONER, INCORPORATED, QUARRYVILLE, PA:
3,480,307, PUB. 5-20-2008. INT. CL. 1.

STORED VALUE SYSTEMS, INC., LOUISVILLE, KY:
2,100,070, CANC. INT. CL. 36.

STRANGE, VALERIE, MIDDLEBURG, FL AND WOODESHICK, ROCHELLE, NESCOPECK, PA AND KROLIKOWSKI, JUNE, NESCOPECK, PA:
3,481,123, INT. CL. 25.

STRATA MARKETING, INC., CHICAGO, IL:
3,480,706, PUB. 5-20-2008. MULTIPLE CLASS, INT. CLS. 9, 41 AND 42.

STRATEGIC PARTNERS, INC., CHATSWORTH, CA:
3,480,563, PUB. 5-20-2008. INT. CL. 40.

STRATICOM INC, T/A THE STRATIS GROUP, CALDWELL, NJ:
3,479,104, PUB. 5-20-2008. INT. CL. 5.

STRATUS PHARMACEUTICALS INC, MIAMI, FL:
2,493,586, CANC. INT. CL. 5.

STREAMLIGHT, INC., EAGLEVILLE, PA:
3,480,021, PUB. 5-20-2008. INT. CL. 11.

STRESS DIRECTIONS, INC., LINCOLN, MA:
2,493,367, CANC. INT. CL. 42.

STRICKLAND-FULLER PARTNERSHIP, WICHITA, KS:
3,481,793, INT. CL. 14.

STROHL SYSTEMS GROUP, INC., KING OF PRUSSIA, PA:
3,480,279, PUB. 5-20-2008. MULTIPLE CLASS, INT. CLS. 9 AND 35.

STRONGMAIL SYSTEMS, INC., REDWOOD SHORES, CA:
3,478,982, PUB. 5-20-2008. INT. CL. 9.
3,478,983, PUB. 5-20-2008. MULTIPLE CLASS, INT. CLS. 37 AND 42.

STRUCTURAL GROUP, INC., HANOVER, MD:
3,478,621, PUB. 5-20-2008. INT. CL. 6.

STRUCTUS BUILDING TECHNOLOGIES, INC., BEND, OR:
3,482,278, INT. CL. 7.

STRUDEX FIBRES LIMITED, WATERLOO, CANADA:
3,482,051, INT. CL. 27.

STUART LEVINE & ASSOCIATES LLC, JERICHO, NY:
2,583,151, CANC. INT. CL. 16.

STUART M. SCHMIDT, PHILADELPHIA, PA:
3,479,933, PUB. 5-20-2008. INT. CL. 16.

STUDENTS IN FREE ENTERPRISE, INC., SPRINGFIELD, MO:
3,482,573, MULTIPLE CLASS, INT. CLS. 25 AND 41.

STUDEX CORPORATION, GARDENA, CA:
2,161,665. REN. 7-1-08. INT. CL. 8.

STUDIO IP HOLDINGS LLC, WILMINGTON, DE:
3,480,031, PUB. 5-20-2008. INT. CL. 25.

STUDIO LABELS PTY LTD; ACN 125 870 304, AUSTRALIA:
3,481,034, PUB. 5-20-2008. INT. CL. 40.

STUDIO 4 ENTERPRISES INC., SAINT PAUL, MN:
3,478,960, PUB. 5-20-2008. MULTIPLE CLASS, INT. CLS. 9 AND 41.

STYLEHIVE, INC., SAN FRANCISCO, CA:
3,480,670, PUB. 5-20-2008. INT. CL. 42.

SUASION RESOURCES INC., NORTH CALDWELL, NJ:
2,141,114. REN. 6-30-08. INT. CL. 35.

SUBMIT IT!, INC., BEDFORD, MA TO MICROSOFT CORPORATION, REDMOND, WA:
2,099,345, CANC. INT. CL. 42.

SUCCESS NRG INC., PUNTA GORDA, FL:
3,480,064, PUB. 5-20-2008. INT. CL. 41.

SUGAR PUBLISHING INCORPORATED, SAN FRANCISCO, CA:
3,482,394, MULTIPLE CLASS, INT. CLS. 38, 41 AND 44.
3,482,395, MULTIPLE CLASS, INT. CLS. 38 AND 41.
3,482,396, MULTIPLE CLASS, INT. CLS. 38, 41 AND 43.
3,482,397, MULTIPLE CLASS, INT. CLS. 38, 41 AND 44.

SUIZA DAIRY CORPORATION, SAN JUAN, PUERTO RICO:
3,482,137, MULTIPLE CLASS, INT. CLS. 29, 30, 32 AND 35.

SUMMER SCIENCE DAY CAMPS, INC., CANTON, GA:
3,479,050, PUB. 5-20-2008. INT. CL. 41.

SUMMIT BUSINESS ASSOCIATION, LLC, SPANISH FORK, UT:
3,479,400, PUB. 5-20-2008. INT. CL. 6.

SUMMIT FLEXIBLE PRODUCTS, LTD., DAYTON, OH:
3,479,571, PUB. 5-20-2008. INT. CL. 27.

SUN CHEMICAL CORPORATION, PARSIPPANY, NJ:
3,478,965, PUB. 5-20-2008. INT. CL. 2.

SUN RUN GENERATION LLC, SAN FRANCISCO, CA:
3,479,236, PUB. 5-20-2008. MULTIPLE CLASS, INT. CLS. 35, 39 AND 40.
3,479,375, PUB. 5-20-2008. MULTIPLE CLASS, INT. CLS. 35, 39 AND 40.

SUN SEED COMPANY, INC., BOWLING GREEN, OH:
3,482,525, INT. CL. 31.
3,482,526, INT. CL. 31.
3,482,528, INT. CL. 31.

SUNBEAM PRODUCTS, INC., BOCA RATON, FL:
3,482,118, INT. CL. 9.

- SUNDEBY, BJORN, CH-6314 UNTERAGERI, SWITZERLAND:
2,491,851, CANC. MULTIPLE CLASS, INT. CLS. 36, 38, 41 AND 42.
- SUNDEEN, NANCY, MAPLE GROVE, MN:
3,481,730, INT. CL. 39.
- SUNEX INTERNATIONAL INC., TRAVELERS REST, SC:
3,481,242, INT. CL. 8.
- SUNFX IP PTY LTD, WESTON, AUSTRALIA:
3,479,486, PUB. 5-20-2008. INT. CL. 3.
- SUNROCK VENTURES MANAGEMENT, LLC, TAMPA, FL:
3,480,038, PUB. 5-20-2008. INT. CL. 36.
- SUNSET BEACH BAR/WEST INDIES DIVE BAR N.V., SINT MAARTEN, NETHERLD ANTILLES:
2,491,842, CANC. INT. CL. 42.
- SUNSET PASS CO., KERMIT, TX:
2,492,443, CANC. INT. CL. 35.
- SUNSHINE MAKERS, INC., HUNTINGTON HARBOUR, CA:
3,479,416, PUB. 5-20-2008. INT. CL. 3.
- SUNSHINE MARKETING OF N.E. FL., INC., JACKSONVILLE, FL:
3,478,801, PUB. 5-20-2008. INT. CL. 26.
- SUNSHINE SYSTEMS, LLC., WHEELING, IL:
3,480,172, PUB. 5-20-2008. INT. CL. 11.
3,480,521, PUB. 5-20-2008. INT. CL. 9.
- SUNTEX INTERNATIONAL INC., EASTON, PA:
3,479,453, PUB. 5-20-2008. INT. CL. 41.
- SUPERIOR SURGICAL MFG. CO., INC., SEMINOLE, FL:
2,100,161, CANC. INT. CL. 42.
- SUPERIOR SURGICAL MFG. CO., INC., SEMINOLE, FL TO FASHION SEAL CORP., LAS VEGAS, NV:
2,100,162, CANC. INT. CL. 16.
- SUPERTEL HOSPITALITY, INC., NORFOLK, NE:
2,161,930, REN. 7-2-08. INT. CL. 42.
- SUPRACOR, INC., SAN JOSE, CA:
3,479,065, PUB. 5-20-2008. INT. CL. 25.
- SURFCO HAWAII, INC., PEARL CITY, HI:
3,482,663, INT. CL. 28.
- SURFMARK L.L.C., OVERLAND PARK, KS:
2,492,378, CANC. INT. CL. 1.
- SURFTECH, INC., SPRINGFIELD, MO:
2,239,241, REN. 6-28-08. INT. CL. 28.
- SURFWAX, INC., MENLO PARK, CA:
2,491,852, CANC. INT. CL. 42.
- SURYA, INC., CARLSBAD, CA:
2,119,254, REN. 7-3-08. INT. CL. 25.
- SUSTAINABLE TRAVEL INTERNATIONAL, BOULDER, CO:
3,480,247, PUB. 5-20-2008. U.S. CL. B.
- SUSTAINABLECIRCLES CORP., SAN FRANCISCO, CA:
3,481,183, INT. CL. 41.
- SUTHERLAND PRODUCTS, INC., MAYODAN, NC:
3,480,303, PUB. 5-20-2008. INT. CL. 3.
- SUTTER CANDY COMPANY, INC, HAYESVILLE, OH:
2,098,791, CANC. INT. CL. 30.
- SUZUKI, DAVID S., SEATTLE, WA:
3,480,528, PUB. 5-20-2008. INT. CL. 10.
- SVENSKT TENN AB, 114 84 STOCKHOLM, SWEDEN:
2,165,042, REN. 6-30-08. MULTIPLE CLASS, INT. CLS. 6, 11, 14, 16, 20, 21, 24 AND 27.
2,165,042, CANC. INT. CL. 8.
- SVOBODNY, RAY D., EDINA, MN:
3,479,544, PUB. 5-20-2008. INT. CL. 31.
- SWAN, RICHARD E., EAST BRIDGEWATER, MA:
3,478,909, PUB. 5-20-2008. INT. CL. 13.
- SWANCOR IND. CO., LTD., NANTOU CITY, TAIWAN:
3,479,320, PUB. 5-20-2008. INT. CL. 1.
- SWEET ROMEO LLC, NEW YORK, NY:
3,481,592, INT. CL. 25.
- SWIIS-LINK, INC., PARADISE, CA:
3,478,594, PUB. 5-20-2008. INT. CL. 19.
- SWIMC, INC., WILMINGTON, DE, SHERWIN-WILLIAMS COMPANY, THE, CLEVELAND, OH:
1,508,740, REN. 7-3-08. INT. CL. 2.
- SWIMC, INC., WILMINGTON, DE, SWIMC, INC., WILMINGTON, DE:
2,166,764, REN. 7-3-08. INT. CL. 2.
- SWIMC, INC., WILMINGTON, FED REP GERMANY:
3,479,069, PUB. 5-20-2008. INT. CL. 2.
3,479,117, PUB. 5-20-2008. INT. CL. 2.
- SWIMC, NIC., WILMINGTON, DE:
2,166,438, REN. 7-3-08. INT. CL. 16.
- SWISHER INTERNATIONAL, INC., JACKSONVILLE, FL:
3,479,405, PUB. 5-20-2008. INT. CL. 34.
- SWISS ARMY BRAND LTD., MONROE, CT:
2,163,959, REN. 6-30-08. INT. CL. 9.
- SWITCHBACK SHELVING, LLC, MURRAY, UT:
2,492,624, CANC. INT. CL. 20.
- SWORD, CHUCK, BEREAS, OH:
3,479,829, PUB. 5-20-2008. INT. CL. 28.
- SYMANTEC CORPORATION, CUPERTINO, CA:
2,492,922, CANC. INT. CL. 9.
- SYMBILITY SOLUTIONS, INC., KITCHENER, CANADA:
3,478,696, PUB. 5-20-2008. INT. CL. 36.
3,478,697, PUB. 5-20-2008. INT. CL. 9.
- SYMONS & CO. PTY. LIMITED, NORTH ROCKS NSW 2151, AUSTRALIA:
3,479,108, PUB. 5-20-2008. INT. CL. 9.
- SYNEL INDUSTRIES LTD., YOKNEAM, ISRAEL:
2,492,958, CANC. INT. CL. 9.
- SYNERFIED CAPITAL INC., MIAMI, FL:
3,481,976, INT. CL. 5.
- SYNOPSIS, INC., MOUNTAIN VIEW, CA:
1,525,447, REN. 6-30-08. INT. CL. 9.
- SYNQ SOLUTIONS, INC., ATLANTA, GA:
3,482,335, MULTIPLE CLASS, INT. CLS. 35 AND 40.
- SYNTECH FIBRES (PVT) LTD, KARACHI - 74900, PAKISTAN:
2,099,625, CANC. INT. CL. 24.
- SYNTHESOFT CORPORATION, BELLEVUE, WA:
2,193,782, REN. 7-3-08. INT. CL. 42.
- SYREMONT S.P.A., MILAN, ITALY:
1,457,856, CANC. MULTIPLE CLASS, INT. CLS. 1 AND 17.
- SYSTAR SA, 92213, SAINT-CLOUD, CEDEX, FRANCE:
2,168,053, REN. 6-28-08. INT. CL. 9.
- SYSTEM CAPITAL CORPORATION, HOUSTON, TX:
2,492,194, CANC. INT. CL. 36.
- SYTRON CORPORATION, MARLBORO, MA:
1,458,092, CANC. INT. CL. 9.
- T AND N, INC., FORISTELL, MO:
3,479,732, PUB. 5-20-2008. INT. CL. 1.
- T. BERGMAN ENTERPRISES, INC., EDMOND, OK:
3,482,683, INT. CL. 9.
- T. ELIOT, INC., SEATTLE, WA:
3,479,604, PUB. 5-20-2008. INT. CL. 11.
- T.J.F. GOLF, INC., JUPITER, FL:
2,596,799, CANC. INT. CL. 37.
2,606,515, CANC. INT. CL. 37.
2,657,746, CANC. INT. CL. 37.
- T&A MARKETING PRODUCTS, EDMOND, OK:
3,480,153, PUB. 5-20-2008. INT. CL. 35.
- TA CHEN INTERNATIONAL, INC., LONG BEACH, CA:
3,481,097, INT. CL. 19.
3,481,098, INT. CL. 19.
- TAAVE SOFTWARE COMPANY, MORRISVILLE, NC:
2,493,350, CANC. INT. CL. 9.
- TABOOLA.COM LTD., BET DAGAN, ISRAEL:
3,481,994, INT. CL. 42.
3,481,997, INT. CL. 42.
- TAG SPORTS, LLC, SAINT LOUIS, MO, AKA THE AUBUCHON GROUP, LLC:
3,480,103, PUB. 5-20-2008. INT. CL. 35.
- TAHOE UNITED MANAGEMENT, INC., LAS VEGAS, NV:
3,479,249, PUB. 5-20-2008. INT. CL. 36.
3,479,275, PUB. 5-20-2008. INT. CL. 36.
- TAI-PAN TRADING INTERNATIONAL, INC., SANDY, UT:
3,481,498, INT. CL. 21.
- TAIT TOWERS, INC., LITITZ, PA:
3,478,883, PUB. 5-20-2008. MULTIPLE CLASS, INT. CLS. 19, 37 AND 42.
- TAKARA U.S.A. CORPORATION, NEW YORK, NY:
2,493,523, CANC. INT. CL. 28.

TAKASAGO KORYO KOGYO KABUSHIKI KAISHA, TOKYO, JAPAN, TA TAKASAGO INTERNATIONAL CORPORATION:
2,168,507. REN. 7-3-08. MULTIPLE CLASS, INT. CLS. 1 AND 3.

TAL, OFER, MONTREAL, CANADA:
3,478,807. PUB. 5-20-2008. INT. CL. 3.

TALENTSPRING, INC., REDMOND, WA:
3,481,452. INT. CL. 35.

TALL SHIP EDUCATION ACADEMY INCORPORATED, SAN FRANCISCO, CA, SPORTSBRIDGE: THE CENTER FOR GIRLS AND WOMEN IN SPORTS, SAN FRANCISCO, CA:
2,163,356. REN. 7-3-08. INT. CL. 41.

TAMER PRODUCTS, INC., CORAL SPRINGS, FL:
3,482,258. INT. CL. 11.

TAMKO BUILDING PRODUCTS, INC., JOPLIN, MO:
3,480,211. PUB. 5-20-2008. INT. CL. 19.

TANGO ADVANCED NUTRITION, INC., SAN FRANCISCO, CA:
3,480,091. PUB. 5-20-2008. INT. CL. 5.

TAP PHARMACEUTICAL PRODUCTS, INC., LAKE FOREST, IL:
3,480,367. PUB. 5-20-2008. INT. CL. 42.
3,480,499. PUB. 5-20-2008. MULTIPLE CLASS, INT. CLS. 9, 35 AND 42.
3,480,500. PUB. 5-20-2008. MULTIPLE CLASS, INT. CLS. 9, 35 AND 42.

TAQUA, LLC, RICHARDSON, TX:
2,492,950. CANC. INT. CL. 9.

TARGET BRANDS, INC., MINNEAPOLIS, MN:
2,492,642. CANC. INT. CL. 9.

TARGETOR OY, 90440 KEMPELE, FINLAND:
3,478,533. PUB. 5-20-2008. MULTIPLE CLASS, INT. CLS. 9 AND 42.

TARGETSMART COMMUNICATIONS, INC., WASHINGTON, DC:
3,482,345. INT. CL. 35.

TARMA DESIGNS, PETALUMA, CA:
3,482,297. INT. CL. 14.

TATE, MICHAEL ALAN, BIRMINGHAM, AL:
3,482,213. INT. CL. 16.

TATTOOS FOR TOTS, LLC, SAN MATEO, CA:
3,482,696. INT. CL. 16.
3,482,697. INT. CL. 16.

TAYLOR BRANDS LLC, KINGSPORT, TN:
3,482,524. INT. CL. 8.

TAYLOR MADE GOLF COMPANY, INC., CARLSBAD, CA:
1,458,350. CANC. MULTIPLE CLASS, INT. CLS. 18, 25 AND 28.

TAYLOR MADE SALES AGENCY, INC., NICHOLASVILLE, KY:
3,479,223. PUB. 5-20-2008. MULTIPLE CLASS, INT. CLS. 35, 43 AND 44.

TAYLOR VOSE ASSOCIATES, SOUTH ORANGE, NJ, DBA GRUNNINGS:
1,458,592. CANC. INT. CL. 30.

TAYLOR, MARCY LEIGH, LUBBOCK, TX:
2,493,499. CANC. INT. CL. 42.

TBC WORLDWIDE, INC., SAN MATEO, CA:
3,481,544. INT. CL. 5.

TBEA CO., LTD., CHINA:
3,480,997. PUB. 5-20-2008. INT. CL. 9.

TBP ADVISORS, LTD., PURCHASE, NY:
3,478,915. PUB. 5-20-2008. INT. CL. 36.

TCI SUPPLY, INC., THOMASVILLE, NC:
3,479,799. PUB. 5-20-2008. INT. CL. 20.

TCS ENTERTAINMENT, INC., LA VERNE, CA:
3,478,871. PUB. 5-20-2008. INT. CL. 41.

TCS FINANCIAL SERVICES, INC., WESTTOWN, PA:
3,481,789. INT. CL. 36.

TCW GROUP, INC., THE, LOS ANGELES, CA:
2,492,345. CANC. INT. CL. 36.

TDY INDUSTRIES, INC., PITTSBURGH, PA, LANDIS MACHINE COMPANY, WAYNESBORO, PA:
217,005. REN. 6-30-08. U.S. CL. 23 (INT. CL. 8).

TEALEAF TECHNOLOGY, INC., SAN FRANCISCO, CA:
2,492,202. CANC. MULTIPLE CLASS, INT. CLS. 9 AND 42.

TEAM BACKWOODS, LLC, MORROW, OH:
3,480,262. PUB. 5-20-2008. INT. CL. 9.

TEAM EDGE, LLC, EATONTOWN, NJ:
3,481,114. INT. CL. 41.

TEAPORTS, PORTLAND, OR:
2,493,193. CANC. INT. CL. 30.
2,493,282. CANC. INT. CL. 30.

TECH SERVICE 2U, CARMICHAEL, CA:
3,479,166. PUB. 5-20-2008. MULTIPLE CLASS, INT. CLS. 37 AND 42.

TECHGUARD SECURITY, LLC, CHESTERFIELD, MO:
3,480,512. PUB. 5-20-2008. INT. CL. 9.

TECHNICAL CHEMICAL COMPANY, DALLAS, TX:
3,480,173. PUB. 5-20-2008. INT. CL. 1.

TECHNOCIRCLE.COM, INC., BERGENFIELD, NJ:
2,492,520. CANC. INT. CL. 35.

TECHNOLOGIE BIOLACTIS INC., LA BAIE, CANADA:
3,482,426. INT. CL. 5.

TECHNOLOGY ADVANCEMENT GROUP, INC., DULLES, VA:
3,479,042. PUB. 5-20-2008. INT. CL. 38.

TECHNOLOGY PATHWAYS, LLC, CORONADO, CA:
3,481,744. INT. CL. 9.

TECHTRON GRAPHIC ARTS, INC., CHICAGO, IL:
1,458,844. CANC. INT. CL. 42.

TECSYS INC., DORVAL, QUEBEC, CANADA:
2,158,131. REN. 6-30-08. MULTIPLE CLASS, INT. CLS. 9 AND 42.

TEEN CITY PRODUCTIONS, INC., DECATUR, GA:
3,479,282. PUB. 5-20-2008. INT. CL. 41.

TEKELEC, MORRISVILLE, NC:
2,493,243. CANC. INT. CL. 9.

TEKHNE SRL, ITALY:
3,480,762. PUB. 5-20-2008. INT. CL. 20.

TEKTRO TECHNOLOGY CORPORATION, CHANGHUA, TAIWAN:
3,480,297. PUB. 5-20-2008. INT. CL. 12.
3,480,299. PUB. 5-20-2008. INT. CL. 12.

TELADVOCATE COMMUNICATIONS, LLC, WESLEY CHAPEL, FL:
3,479,740. PUB. 5-20-2008. INT. CL. 36.

TELASIS TEKSTIL URUNLERI; SANAYI VE TICARET ANONIM SIRKETI, TURKEY:
3,480,876. PUB. 5-20-2008. INT. CL. 24.

TELE ATLAS NORTH AMERICA, INC., LEBANON, NH:
3,478,638. PUB. 5-20-2008. MULTIPLE CLASS, INT. CLS. 35, 39 AND 42.

TELEDYNE INDUSTRIES, INC., FORT COLLINS, CO:
1,457,985. CANC. INT. CL. 5.

TELEDYNE TECHNOLOGIES INCORPORATED, LOS ANGELES, CA:
2,493,616. CANC. INT. CL. 9.

TELEGAMES, INC., DESOTO, TX:
2,491,936. CANC. INT. CL. 9.

TELENORMA TELEFONBAU UND NORMALZEIT LEHNER & CO., FRANKFURT AM MAIN, FED REP GERMANY TO TELENORMA GMBH, FRANKFURT AM MAIN, FED REP GERMANY:
1,458,067. CANC. MULTIPLE CLASS, INT. CLS. 9, 37, 38 AND 42.

TELEPO AB, SWEDEN:
3,480,757. PUB. 5-20-2008. MULTIPLE CLASS, INT. CLS. 9, 38 AND 42.

TELIGENCE (CANADA), INC., VANCOUVER, CANADA:
3,481,054. INT. CL. 45.

TELIGENCE (US), INC., VANCOUVER, CANADA:
3,480,674. PUB. 5-20-2008. INT. CL. 41.

TELLURIDE CLOTHING CO., INC., NATICK, MA:
1,490,181. REN. 6-30-08. MULTIPLE CLASS, INT. CLS. 18 AND 25.

TELTREND INC., ST. CHARLES, IL:
2,492,949. CANC. INT. CL. 9.

TEMLADOR, JOHN, SALINAS, CA:
3,481,905. INT. CL. 25.

TEMPLE ISRAEL OF HOLLYWOOD, INC., LOS ANGELES, CA:
2,491,893. CANC. MULTIPLE CLASS, INT. CLS. 36 AND 42.

42.
TEND SKIN INTERNATIONAL, INC., DAVIE, FL:
2,493,681, CANC. INT. CL. 3.
- TENDTOBUSINESS, INC., WAYNE, NJ:
2,493,591, CANC. INT. CL. 36.
- TENZING COMMUNICATIONS, INC., SEATTLE, WA:
2,493,337, CANC. INT. CL. 38.
- TEO, SIE P., BROOKLYN, NY:
3,481,146, INT. CL. 35.
- TEORA VINCENZO, ITALY:
3,480,839, PUB. 5-20-2008. MULTIPLE CLASS, INT. CLS.
3, 9, 14, 18 AND 25.
- TERADATA US, INC., MIAMISBURG, OH:
2,493,246, CANC. INT. CL. 42.
- TERAL INC., PONCE, PUERTO RICO:
3,479,179, PUB. 5-20-2008. INT. CL. 5.
- TERASEM MOVEMENT FOUNDATION, INC., BRISTOL, VT:
3,480,305, PUB. 5-20-2008. INT. CL. 42.
- TERESA'S II, INC., PRINCETON, NJ, DBA T2 VENTURES:
2,492,365, CANC. INT. CL. 42.
- TERO LTD, THESSALONIKI, GREECE:
3,480,785, PUB. 5-20-2008. MULTIPLE CLASS, INT. CLS.
35 AND 42.
- TERRAFIRMA CERAMICS, INC., NEW YORK, NY:
1,458,376, CANC. INT. CL. 21.
- TERRA VALE LIMITED, BR. VIRGIN ISLANDS:
3,480,951, PUB. 5-20-2008. MULTIPLE CLASS, INT. CLS.
35, 36, 37 AND 42.
- TERUMO MEDICAL CORPORATION, SOMERSET, NJ:
3,482,214, INT. CL. 9.
- TESSER, INC., BOULDER, CO:
2,492,142, CANC. MULTIPLE CLASS, INT. CLS. 35 AND
42.
- TESTA, HURWITZ & THIBEAULT, LLP, BOSTON, MA:
2,493,080, CANC. INT. CL. 42.
- TESTA, MICHAEL T, SAN ANSLEMO, CA:
3,479,279, PUB. 5-20-2008. INT. CL. 36.
- TETRA TECHNOLOGIES, INC., THE WOODLANDS, TX:
3,481,558, INT. CL. 42.
3,481,559, INT. CL. 42.
- TEVCO, INC., WILMINGTON, DE, LEMMON PHARMACAL
COMPANY, SELLERSVILLE, PA:
1,063,091, REN. 7-3-08. INT. CL. 5.
- TEXAS HAND THERAPY CENTER, INC., HOUSTON, TX:
3,479,322, PUB. 5-20-2008. INT. CL. 44.
- TEXAS INSTRUMENTS INCORPORATED, DALLAS, TX TO
ACER INCORPORATED, TAIPEI, TAIWAN:
2,100,079, CANC. INT. CL. 9.
- TEXAS TACO CABANA, L.P., SAN ANTONIO, TX:
2,492,871, CANC. INT. CL. 16.
- TGN 409, F-69300 CALUIRE ET CUIRE, FRANCE:
3,480,999, PUB. 5-20-2008. INT. CL. 14.
- THABIT, BRUCE A., ENCINO, CA:
2,491,762, CANC. INT. CL. 42.
- THALER, LISA J., NEW YORK, NY:
3,481,792, INT. CL. 44.
- THALGO - TCH, ROQUEBRUNE SUR ARGENS, FRANCE:
1,490,735, REN. 7-3-08. INT. CL. 3.
- THE ADMINISTRATORS OF THE TULANE EDUCA-
TIONAL FUND, NEW ORLEANS, LA:
3,402,844, COR. INT. CL. 9.
- THE AMERICAN ACADEMY OF ORAL MEDICINE, INC.,
EDMONDS, WA:
3,478,640, PUB. 5-20-2008. INT. CL. 35.
- THE ANTIQUE BOAT MUSEUM, CLAYTON, NY:
3,479,518, PUB. 5-20-2008. MULTIPLE CLASS, INT. CLS.
35 AND 41.
3,479,519, PUB. 5-20-2008. MULTIPLE CLASS, INT. CLS.
35 AND 41.
- THE ARMOR ALL/STP PRODUCTS COMPANY, OAK-
LAND, CA:
3,482,450, INT. CL. 21.
- THE ARMORED GROUP, PHOENIX, AZ:
3,481,903, INT. CL. 12.
3,482,638, INT. CL. 12.
- THE AURI GROUP, LLC, INDIANAPOLIS, IN:
3,479,866, PUB. 5-20-2008. INT. CL. 9.
- THE BAKER COMPANY, SANFORD, ME:
3,480,545, PUB. 5-20-2008. INT. CL. 9.
- THE BINDING SITE, LTD, BIRMINGHAM, ENGLAND:
3,479,719, PUB. 5-20-2008. MULTIPLE CLASS, INT. CLS.
1, 5, 9 AND 10.
- THE BLEVINS GROUP, LLC, NEW YORK, NY:
3,481,477, INT. CL. 30.
- THE BOARD OF REGENTS OF THE UNIVERSITY OF
TEXAS SYSTEM, AUSTIN, TX:
3,479,418, PUB. 5-20-2008. INT. CL. 41.
- THE BONEYARD INC, CHURCH HILL, TN:
3,479,689, PUB. 5-20-2008. INT. CL. 39.
- THE BOOK DEPOSITORY LTD., HEMPSTED, UNITED
KINGDOM:
3,478,809, PUB. 5-20-2008. INT. CL. 40.
- THE BRAINY BABY COMPANY, LLC, ALPHARETTA, GA:
3,482,000, INT. CL. 9.
- THE BUHL COMPANY INC., CORTE MADERA, CA:
3,478,794, PUB. 5-20-2008. INT. CL. 25.
- THE BUTCHER COMPANY, STURTEVANT, WI:
3,481,644, INT. CL. 3.
- THE CALDWELL GROUP, INC., ROCKFORD, IL:
3,478,829, PUB. 5-20-2008. INT. CL. 6.
- THE CALIFORNIA SPEEDWAY CORPORATION, DAYTO-
NA BEACH, FL:
3,482,206, INT. CL. 16.
- THE CARTOON NETWORK, INC., ATLANTA, GA:
3,481,246, INT. CL. 25.
3,482,147, INT. CL. 14.
- THE CENTER FOR CASE MANAGEMENT, INC., SOUTH
NATICK, MA:
3,482,107, INT. CL. 44.
- THE CITY OF MESQUITE, MESQUITE, TX:
3,479,780, PUB. 5-20-2008. MULTIPLE CLASS, INT. CLS.
35, 36, 37, 39, 41, 42 AND 45.
- THE COCA-COLA COMPANY, ATLANTA, GA:
3,481,655, INT. CL. 41.
- THE COMPHY CO., LOS ANGELES, CA:
3,479,190, PUB. 5-20-2008. MULTIPLE CLASS, INT. CLS.
24 AND 25.
- THE COUNCIL OF INDEPENDENT RESTAURANTS OF
AMERICA, D/B/A DINE ORIGINALS, TUCSON, AZ:
3,479,202, PUB. 5-20-2008. INT. CL. 35.
- THE CREATIVE WORKPLACE, LLC, LOUISVILLE, KY:
3,481,974, INT. CL. 41.
- THE CROSSTRaining CLUB FRANCHISE COMPANY,
LAGUNA NIGUEL, CA:
3,478,597, PUB. 5-20-2008. INT. CL. 41.
- THE DAAVLIN DISTRIBUTING COMPANY, BRYAN, OH:
3,480,041, PUB. 5-20-2008. INT. CL. 10.
- THE DARIEN GROUP, INC., DARIEN CENTER, NY:
3,481,633, INT. CL. 7.
- THE DIAL CORPORATION, SCOTTSDALE, AZ:
3,481,715, INT. CL. 3.
- THE DILLER CORPORATION, CINCINNATI, OH:
2,492,860, CANC. INT. CL. 20.
- THE DWYER GROUP, INC., WACO, TX:
3,479,881, PUB. 5-20-2008. INT. CL. 35.
- THE ENKEBOLL CO., CARSON, CA, DBA ENKEBOLL
DESIGNS:
3,482,260, INT. CL. 19.
- THE EQUIPMENT SUPERSTORE, LLC, WILMINGTON, OH:
3,480,273, PUB. 5-20-2008. INT. CL. 35.
- THE EQUUS GROUP, INC., SEATTLE, WA:
3,478,521, PUB. 5-20-2008. INT. CL. 35.
3,478,522, PUB. 5-20-2008. INT. CL. 35.
- THE EVANGELICAL FREE CHURCH OF AMERICA, MIN-
NEAPOLIS, MN:
3,481,378, INT. CL. 45.
3,481,379, INT. CL. 45.
3,481,380, INT. CL. 36.
3,481,381, INT. CL. 45.
- THE FANFARE GROUP, INC., MOUNTAIN VIEW, CA:
3,481,508, INT. CL. 9.
- THE FRUIT TREE PLANTING FOUNDATION, LAKESIDE,
CA, DBA FTPF:
3,479,818, PUB. 5-20-2008. INT. CL. 44.

- THE GAMES PORTAL LIMITED, ALDERNEY, UNITED KINGDOM:
3,478,627, PUB. 12-18-2007. MULTIPLE CLASS, INT. CLS. 36 AND 41.
- THE GENTLE ART, INC., NEW ALBANY, OH:
3,479,985, PUB. 5-20-2008. INT. CL. 23.
- THE GLEASON WORKS, ROCHESTER, NY:
3,481,904, INT. CL. 7.
- THE GOVERNOR AND COMPANY OF THE BANK OF IRELAND, DUBLIN, IRELAND, DBA BANK OF IRELAND GROUP:
3,480,601, PUB. 2-5-2008. INT. CL. 36.
3,480,602, PUB. 2-12-2008. INT. CL. 36.
- THE HARTZ MOUNTAIN CORPORATION, SECAUCUS, NJ:
3,481,210, MULTIPLE CLASS, INT. CLS. 1 AND 3.
- THE HEART OF AMERICA FOUNDATION, WASHINGTON, DC:
3,479,555, PUB. 5-20-2008. MULTIPLE CLASS, INT. CLS. 35, 36, 37, 41, 42 AND 43.
- THE HERCULES TIRE & RUBBER COMPANY, FINDLAY, OH:
3,482,180, INT. CL. 12.
- THE HERFF JONES COMPANY OF INDIANA, INC., INDIANAPOLIS, IN:
3,482,176, INT. CL. 16.
- THE HERITAGE INSTITUTE, PORTLAND, OR:
3,479,451, PUB. 5-20-2008. INT. CL. 41.
- THE INSTITUTE FOR EDUCATIONAL DEVELOPMENT, INC., CHANDLER, AZ:
3,482,722, INT. CL. 41.
- THE INTERNATIONAL RHINO FOUNDATION, YULEE, FL:
3,479,628, PUB. 5-20-2008. MULTIPLE CLASS, INT. CLS. 35, 36, 39, 41 AND 42.
- THE INTERTECH GROUP, INC., NORTH CHARLESTON, SC:
3,478,643, PUB. 5-20-2008. MULTIPLE CLASS, INT. CLS. 35, 36 AND 42.
3,478,644, PUB. 5-20-2008. MULTIPLE CLASS, INT. CLS. 35, 36 AND 42.
- THE ITALIAN TRADE COMMISSION, CHICAGO, IL:
3,482,152, INT. CL. 35.
- THE JOHNS HOPKINS HEALTH SYSTEM CORPORATION, BALTIMORE, MD:
3,482,569, INT. CL. 35.
- THE KILPATRICK COMPANY, INC., BOYNTON BEACH, FL:
3,480,496, PUB. 5-20-2008. INT. CL. 35.
- THE KROGER CO. OF MICHIGAN, LIVONIA, MI:
3,481,653, INT. CL. 30.
- THE LIBMAN COMPANY, ARCOLA, IL:
3,482,660, INT. CL. 21.
- THE MARSTON GROUP, P.C., MEMPHIS, TN:
3,481,387, INT. CL. 35.
- THE MCCLATCHY COMPANY, SACRAMENTO, CA:
3,479,082, PUB. 5-20-2008. INT. CL. 41.
- THE MEDICINE BOTTLE COMPANY, INC., WESTERN SPRINGS, IL:
2,015,244, REN. 7-1-08. INT. CL. 10.
- THE MELTING POT RESTAURANTS, INC., TAMPA, FL:
3,482,448, MULTIPLE CLASS, INT. CLS. 29 AND 30.
- THE MEYER RESOURCE GROUP, INC., WACO, TX:
3,481,422, INT. CL. 16.
- THE MINDFUL DOG, INC., NEW YORK, NY:
3,480,121, PUB. 5-20-2008. INT. CL. 44.
- THE MORLET SELECTION, INCORPORATED, ST. HELENA, CA:
3,479,770, PUB. 5-20-2008. INT. CL. 33.
- THE MUD MASTER GROUP, LLC, SUMMIT, MS:
3,480,543, PUB. 5-20-2008. MULTIPLE CLASS, INT. CLS. 1 AND 35.
- THE MUSICIAN NETWORK, LLC, OVERLAND PARK, KS:
3,482,724, INT. CL. 38.
- THE NAKED ORCHID, LLC, SOUTHERN PINES, NC:
3,481,265, INT. CL. 35.
3,481,266, INT. CL. 35.
- THE NORTH FACE APPAREL CORP., WILMINGTON, DE:
3,479,423, PUB. 5-20-2008. INT. CL. 25.
- THE OPTIONS INSIDER INCORPORATED, CHICAGO, IL:
3,478,745, PUB. 5-20-2008. INT. CL. 36.
- THE OUTSOURCING PARTNERSHIP, LLC D/B/A ACCUME PARTNERS LLC, MOORESTOWN, NJ:
3,481,500, INT. CL. 35.
- THE OXFORD ASSET; MANAGEMENT COMPANY LIMITED, UNITED KINGDOM:
3,480,956, PUB. 5-20-2008. INT. CL. 36.
- THE PEDIATRIC BRAIN TUMOR FOUNDATION OF THE UNITED STATES, INC., ASHEVILLE, NC:
3,479,084, PUB. 5-20-2008. INT. CL. 36.
- THE PENINSULAR AND ORIENTAL STEAM NAVIGATION COMPANY, LONDON, UNITED KINGDOM:
3,480,659, PUB. 5-20-2008. MULTIPLE CLASS, INT. CLS. 39, 41 AND 43.
- THE PENN MUTUAL LIFE INSURANCE COMPANY, HORSHAM, PA:
3,482,691, INT. CL. 36.
- THE PEW CHARITABLE TRUSTS, PHILADELPHIA, PA:
3,479,001, PUB. 5-20-2008. INT. CL. 35.
- THE PNC FINANCIAL SERVICES GROUP, INC., PITTSBURGH, PA:
2,099,661, CANC. INT. CL. 36.
- THE PRINCETON REVIEW, INC., NEW YORK, NY:
2,140,157, REN. 6-30-08. INT. CL. 16.
- THE PROCTER & GAMBLE COMPANY, CINCINNATI, OH:
3,481,942, INT. CL. 3.
3,481,945, INT. CL. 3.
3,482,406, MULTIPLE CLASS, INT. CLS. 29 AND 30.
3,482,533, INT. CL. 3.
- THE REAL ESTATE TOMATO, PARADISE, CA:
3,479,100, PUB. 5-20-2008. INT. CL. 42.
- THE RELATED COMPANIES, L.P., NEW YORK, NY:
3,479,431, PUB. 5-20-2008. MULTIPLE CLASS, INT. CLS. 36, 37 AND 45.
- THE RENDON GROUP INCORPORATED, WASHINGTON, DC:
3,478,526, PUB. 5-20-2008. MULTIPLE CLASS, INT. CLS. 35, 38, 41, 42 AND 45.
- THE SANDBAGGER CORPORATION, VOLO, IL:
3,480,333, PUB. 5-20-2008. INT. CL. 7.
- THE SCIENCE FESTIVAL FOUNDATION, NEW YORK, NY:
3,482,670, INT. CL. 41.
- THE SELLING SOURCE, INC., LAS VEGAS, NV:
3,481,537, MULTIPLE CLASS, INT. CLS. 35 AND 42.
- THE SERGIO CORPORATION, SOUTH BEND, IN:
3,482,463, INT. CL. 45.
- THE SHERWIN-WILLIAMS COMPANY, CLEVELAND, OH:
3,482,547, INT. CL. 2.
- THE SKYLINE STUDIOS, INC., LOS ANGELES, CA, DBA THE SKYLINE STUDIOS:
3,480,073, PUB. 5-20-2008. INT. CL. 35.
- THE SNIP-ITS CORPORATION, NATICK, MA:
3,479,784, PUB. 5-20-2008. INT. CL. 44.
- THE SOCIETY FOR WOMEN'S HEALTH RESEARCH, WASHINGTON, DC:
2,182,077, REN. 7-2-08. INT. CL. 42.
2,183,696, REN. 7-2-08. INT. CL. 42.
- THE SOLOMON R. GUGGENHEIM FOUNDATION, NEW YORK, NY:
3,482,228, MULTIPLE CLASS, INT. CLS. 9, 11, 16, 18, 20, 21, 25 AND 28.
- THE SOLOMON WINE COMPANY, MODESTO, CA:
3,481,082, INT. CL. 33.
- THE SOUTHERN CO., INC., MEMPHIS, TN:
3,479,105, PUB. 5-20-2008. MULTIPLE CLASS, INT. CLS. 35 AND 37.
- THE SPRING AIR COMPANY, ELK GROVE VILLAGE, IL, KARR SPRING COMPANY, HOLLAND, MI:
1,066,763, REN. 6-30-08. INT. CL. 20.
- THE STATE OF OREGON ACTING BY AND THROUGH THE STATE BOARD OF HIGHER EDUCATION ON BEHALF OF THE UNIVERSITY OF OREGON, EUGENE, OR:
3,482,004, MULTIPLE CLASS, INT. CLS. 9, 16 AND 41.
- THE STUDENT LOAN PROCESSORS, INC., MESA, AZ:
3,479,820, PUB. 5-20-2008. MULTIPLE CLASS, INT. CLS. 35 AND 36.

- THE SUHANOSKY FAMILY, NANTUCKET, MA:
3,479,385, PUB. 5-20-2008. INT. CL. 43.
- THE TALBOTS GROUP, LIMITED PARTNERSHIP, HINGHAM, MA:
2,226,071. REN. 6-30-08. INT. CL. 25.
- THE TAUNTON PRESS, INC., NEWTOWN, CT:
3,481,330, INT. CL. 16.
- THE TEMPLAR COMPANY PLC, UNITED KINGDOM:
3,481,012, PUB. 5-20-2008. MULTIPLE CLASS, INT. CLS. 9, 16 AND 28.
- THE TIMKEN COMPANY, CANTON, OH:
3,478,565, PUB. 5-20-2008. MULTIPLE CLASS, INT. CLS. 4, 7 AND 42.
- THE TRAVELERS INDEMNITY COMPANY, HARTFORD, CT:
3,479,368, PUB. 5-20-2008. INT. CL. 36.
- THE TRUSTEE OF JK INVESTMENT TRUST, HALEIWA, HI:
3,481,416, MULTIPLE CLASS, INT. CLS. 3 AND 44.
- THE TRUSTEES OF THE RODNEY A. HAMILTON LIVING TRUST A CALIFORNIA TRUST, COMPRISING RODNEY A. HAMILTON, A UNITED STATES C, LOS ANGELES, CA:
3,481,112, INT. CL. 35.
- THE TRUSTEES OF THE UNIVERSITY OF PENNSYLVANIA, PHILADELPHIA, PA:
3,479,845, PUB. 5-20-2008. INT. CL. 44.
- THE UNITED METHODIST PUBLISHING HOUSE, NASHVILLE, TN:
3,478,562, PUB. 5-20-2008. MULTIPLE CLASS, INT. CLS. 9 AND 16.
- THE UNITED STATES SHOE CORPORATION, PORT WASHINGTON, NY:
3,481,367, INT. CL. 35.
- THE UPPER ROOM, NASHVILLE, TN:
3,478,929, PUB. 5-20-2008. INT. CL. 14.
3,478,930, PUB. 5-20-2008. INT. CL. 21.
3,478,932, PUB. 5-20-2008. INT. CL. 16.
- THE WALKING COMPANY HOLDINGS, INC., SANTA BARBARA, CA:
2,492,669, CANC. INT. CL. 35.
- THE WELLCARE MANAGEMENT GROUP, INC., TAMPA, FL:
3,479,138, PUB. 5-20-2008. MULTIPLE CLASS, INT. CLS. 35, 36 AND 44.
- THE WHEEL WAREHOUSE INC., KETTERING, OH:
3,480,471, PUB. 5-20-2008. INT. CL. 37.
- THE WILL-BURT COMPANY, ORRVILLE, OH:
3,479,821, PUB. 5-20-2008. INT. CL. 9.
- THE WINE ADVOCATE, INC., MONKTON, MD:
3,479,733, PUB. 5-20-2008. INT. CL. 41.
- THE WOODSIDE INSTITUTE, INC., WOODSIDE, CA:
3,482,429, INT. CL. 35.
3,482,430, INT. CL. 35.
- THE ZONDERVAN CORPORATION L.L.C., GRAND RAPIDS, MI:
3,481,805, INT. CL. 41.
- THEATREWORKS/USA CORP., NEW YORK, NY:
3,479,738, PUB. 5-20-2008. INT. CL. 41.
- THEDIAL.COM, INC., SEATTLE, WA:
2,491,937, CANC. MULTIPLE CLASS, INT. CLS. 35, 38 AND 41.
- THERMAFIBER, INC., WABASH, IN:
3,479,151, PUB. 5-20-2008. MULTIPLE CLASS, INT. CLS. 17 AND 19.
3,482,222, INT. CL. 17.
- THERMAMAX; HOCHTEMPERATURDÄMMUNGEN GMBH, FED REP GERMANY:
3,480,781, PUB. 5-20-2008. MULTIPLE CLASS, INT. CLS. 4, 7, 17, 37 AND 42.
- THERMO COOL SALES, INC., HIALEAH, FL:
1,458,220, CANC. INT. CL. 11.
- THERMOFLOW INC., SUDBURY, MA:
3,479,839, PUB. 5-20-2008. INT. CL. 9.
3,479,840, PUB. 5-20-2008. INT. CL. 9.
- THIBEAU, 59200 TOURCOING, FRANCE:
2,492,528, CANC. INT. CL. 7.
- THIBEAULT, ANTONIO MARK, CAMBRIDGE, MA AND BARNES, LINDA LOUISE, CAMBRIDGE, MA:
2,493,394, CANC. INT. CL. 20.
- THIELE TECHNOLOGIES, INC., MINNEAPOLIS, MN:
2,492,253, CANC. INT. CL. 7.
- THINK COMPUTER CORPORATION, PALO ALTO, CA:
3,479,515, PUB. 5-20-2008. INT. CL. 9.
- THINK NOCTURNAL, LLC, EXETER, NH:
3,479,641, PUB. 5-20-2008. MULTIPLE CLASS, INT. CLS. 35 AND 42.
- THINKING TECHNOLOGIES, INC., SCHAUMBURG, IL:
2,171,777. REN. 7-3-08. INT. CL. 9.
- THINKLOGICAL, MILFORD, CT:
3,481,914, INT. CL. 9.
- THOMAS & BETTS INTERNATIONAL, INC., WILMINGTON, DE:
3,480,666, PUB. 5-20-2008. INT. CL. 6.
- THOMAS C. WRIGHT, INC., SAN DIEGO, CA:
1,487,532. REN. 7-3-08. INT. CL. 16.
- THOMPSON & CO. OF TAMPA, INC., TAMPA, FL:
3,481,773, MULTIPLE CLASS, INT. CLS. 16 AND 35.
- THOMPSON BEVERAGE ACQUISITION CORPORATION, DALLAS, TX:
2,493,247, CANC. MULTIPLE CLASS, INT. CLS. 21 AND 29.
- THOMPSON, KIMBERLY, HOUSTON, TX:
3,480,028, PUB. 5-20-2008. INT. CL. 35.
- THOR TECH, INC., SAGINAW, MI:
3,482,123, INT. CL. 12.
- THOR, INC., MANHATTAN BEACH, CA:
3,481,404, MULTIPLE CLASS, INT. CLS. 35 AND 42.
- THORNTON-TERMOHLEN GROUP CORPORATION, HENDERSON, NV:
3,481,634, MULTIPLE CLASS, INT. CLS. 37 AND 42.
3,481,664, MULTIPLE CLASS, INT. CLS. 37 AND 42.
- THOUARS, PAUL DE, MONROVIA, CA:
2,167,035. REN. 7-3-08. INT. CL. 41.
- THREE J PRODUCTIONS, LLC, WEST HAVEN, CT:
3,479,658, PUB. 5-20-2008. INT. CL. 16.
- THREE LUCK CO., LTD., HIGASHIOSAKASHI, JAPAN:
3,482,192, INT. CL. 28.
- THRIFTY, INC., TULSA, OK:
3,479,510, PUB. 5-20-2008. INT. CL. 39.
- TI CREDIA MANUFACTURING LIMITED, STAFFORDSHIRE, ENGLAND:
1,458,018, CANC. INT. CL. 7.
- TIANJIN CARBON BLACK PLANT, BEICHEN DISTRICT, TIANJIN, CHINA:
2,098,754, CANC. INT. CL. 1.
- TICKTOCKSTOCK.COM, BAKERSFIELD, CA:
3,479,771, PUB. 5-20-2008. INT. CL. 36.
- TIFFANY CENTRE SQUARE, INC., CENTRE SQUARE, PA:
1,458,834, CANC. INT. CL. 42.
- TIGERNETORDER, INC., PALM COAST, FL:
2,493,700, CANC. INT. CL. 35.
- TILCO INTERNATIONAL INC., ST-JEAN-SUR-RICHLEIU, QUEBEC, CANADA:
1,458,479, CANC. MULTIPLE CLASS, INT. CLS. 28 AND 40.
- TIMBER-TOP, INC., WATERTOWN, CT:
819,770. REN. 7-3-08. U.S. CL. 13 (INT. CL. 6).
- TIME FACTORY S.R.L., 47891 DOGANA, SAN MARINO:
3,479,404, PUB. 5-13-2008. INT. CL. 14.
- TIME INC., NEW YORK, NY:
3,479,070, PUB. 5-20-2008. INT. CL. 16.
3,479,498, PUB. 5-20-2008. INT. CL. 44.
3,482,461, INT. CL. 16.
3,482,665, INT. CL. 16.
- TIME LIFE INC., ALEXANDRIA, VA:
2,491,820, CANC. INT. CL. 16.
- TIME WARNER ENTERTAINMENT COMPANY, L.P., NEW YORK, NY:
2,492,484, CANC. INT. CL. 25.
- TIMELY INVENTIONS LLC, BEVERLY HILLS, CA:
3,481,118, INT. CL. 16.
- TIMEX CORPORATION, MIDDLEBURY, CT:
2,493,075, CANC. INT. CL. 14.

- TIPPS, EILEEN, ST. PETERSBURG, FL:
2,492,481, CANC. INT. CL. 41.
2,492,482, CANC. INT. CL. 41.
- TISCA TISCHHAUSER & CO., AG., BUEHLER AR, SWITZERLAND:
1,509,352, REN. 6-28-08, INT. CL. 27.
- TKO ENTERPRISES, INC., PLAINFIELD, IN:
3,479,390, PUB. 5-20-2008, INT. CL. 40.
- TMA RESOURCES, INC., MCLEAN, VA:
2,492,317, CANC. INT. CL. 42.
- TMT MARINER, 59160 LOMME, FRANCE:
835,979, CANC. U.S. CL. 39.
- TMW MARKETING COMPANY, INC., FREMONT, CA:
2,167,997, REN. 7-2-08, INT. CL. 25.
- TNA ENTERTAINMENT, LLC, DALLAS, TX:
3,479,063, PUB. 5-20-2008, INT. CL. 41.
- TNE BROOKLYN BREWERY CORPORATION, BROOKLYN, NY:
2,130,646, REN. 7-3-08, INT. CL. 32.
- TNS NORTH AMERICA, INC., NEW YORK, NY:
2,493,233, CANC. INT. CL. 9.
- TODDCO, LLC, SEVERNA PARK, MD:
3,481,882, INT. CL. 30.
- TODSON, INC., DEER PARK, NY:
2,099,992, CANC. INT. CL. 12.
- TOM TOM PRODUCTS, INC., MINNEAPOLIS, MN:
1,458,562, CANC. INT. CL. 29.
- TOM WHITMAN PRESENTS, INC., WEST HOLLYWOOD, CA:
3,479,576, PUB. 5-20-2008, INT. CL. 41.
3,479,585, PUB. 5-20-2008, INT. CL. 41.
- TOMLINSON, CHARLES, MESA, AZ:
3,481,834, INT. CL. 7.
- TOMMY BAHAMA GROUP, INC., NEW YORK, NY:
2,100,421, CANC. INT. CL. 25.
- TOMOYE CORPORATION, GATINEAU, CANADA:
3,480,606, PUB. 11-6-2007, INT. CL. 42.
- TOOLE, RODNEY MAURICE, NEW YORK, NY:
3,482,441, INT. CL. 9.
- TOOLFARM, INC., SAN FRANCISCO, CA:
2,492,228, CANC. MULTIPLE CLASS, INT. CLS. 35, 38 AND 41.
- TOP 10 SEARCH, LLC, ALPHARETTA, GA:
2,493,041, CANC. INT. CL. 41.
- TOPCO ASSOCIATES, LLC, SKOKIE, IL:
3,482,257, INT. CL. 30.
- TOPLINE SOLUTIONS, INC., OAKLAND, CA:
3,481,710, INT. CL. 42.
- TOR MINERALS INTERNATIONAL, INC., CORPUS CHRISTI, TX:
3,481,340, INT. CL. 2.
- TORAY INDUSTRIES, INC., CHUO-KU, TOKYO, JAPAN:
1,458,390, CANC. INT. CL. 24.
- TORAY KABUSHIKI KAISHA, CHUO-KU, TOKYO, JAPAN, TA TORAY INDUSTRIES, INC.:
3,479,098, PUB. 5-20-2008, INT. CL. 17.
- TORUNSKIE ZAKŁADY MATERIALÓW; OPATRUNKOWYCH SPÓŁKA AKCYJNA, PL-87-100 TORUN, POLAND:
3,480,989, PUB. 5-20-2008, INT. CL. 5.
3,480,990, PUB. 5-20-2008, INT. CL. 5.
- TORUNSKIE ZAKŁADY MATERIALÓW; OPATRUNKOWYCH, SPÓŁKA AKCYJNA, PL-87-100 TORUN, POLAND:
3,480,991, PUB. 5-20-2008, INT. CL. 5.
- TOSOH CORPORATION, SHUNAN-SHI, YAMAGUCHI, JAPAN:
3,478,830, PUB. 5-20-2008, MULTIPLE CLASS, INT. CLS. 1 AND 5.
- TOTO, U.S.A., INC., MORROW, GA:
3,482,685, INT. CL. 11.
- TOUCH TONE TECHNOLOGIES, INC., BOCA RATON, FL:
2,492,046, CANC. MULTIPLE CLASS, INT. CLS. 37 AND 42.
- TOURNEAU, LLC, NEW YORK, NY:
2,493,582, CANC. INT. CL. 14.
- TOWERS, PERRIN, FORSTER & CROSBY, INC., PHILADELPHIA, PA:
2,492,665, CANC. INT. CL. 35.
- TOWN OF MIAMI LAKES, MIAMI LAKES, FL:
3,480,633, PUB. 5-20-2008, INT. CL. 35.
- TOWNSEND, CLIFFORD V, MIAMI, FL:
2,099,917, CANC. INT. CL. 41.
- TOY BOX, LLC., BELLINGHAM, WA:
3,482,183, INT. CL. 39.
- TOY TRUCK LINES, INC., FT. PIERCE, FL:
2,099,906, CANC. INT. CL. 28.
- TOYO BOSEKI KABUSHIKI KAISHA, JAPAN:
3,480,966, PUB. 5-20-2008, INT. CL. 17.
3,480,967, PUB. 5-20-2008, INT. CL. 17.
- TRADEMARKS HOLDING, LLC, ANNAPOLIS, MD:
3,479,760, PUB. 5-20-2008, MULTIPLE CLASS, INT. CLS. 35 AND 43.
- TRADER JOE'S COMPANY, MONROVIA, CA:
2,160,601, REN. 6-28-08, INT. CL. 29.
- TRADITIONAL MEDICINALS, INC., SEBASTOPOL, CA:
3,482,431, INT. CL. 5.
- TRAFFIC & PARKING CONTROL CO., INC., ELM GROVE, WI:
3,482,734, INT. CL. 9.
- TRANE INTERNATIONAL INC., PISCATAWAY, NJ, TRANE COMPANY, THE, LA CROSSE, WI:
667,430, REN. 7-3-08, U.S. CL. 34 (INT. CL. 11).
- TRANQUIL SPACE FOUNDATION, WASHINGTON, DC:
3,478,564, PUB. 5-20-2008, MULTIPLE CLASS, INT. CLS. 35 AND 36.
- TRANS FASHION INDUSTRIES, INC., NEW YORK, NY:
1,458,413, CANC. INT. CL. 25.
- TRANSAMERICA CORPORATION, SAN FRANCISCO, CA:
2,492,270, CANC. INT. CL. 36.
- TRANSPARENT CORPORATION, COLUMBUS, OH, DBA TRANSPARENT CORPORATION:
3,480,415, PUB. 5-20-2008, INT. CL. 9.
3,480,418, PUB. 5-20-2008, INT. CL. 9.
- TRANSTEL COMMUNICATIONS, INC., SALT LAKE CITY, UT:
2,493,011, CANC. INT. CL. 38.
- TRANSUNION INTERACTIVE, INC., SAN LUIS OBISPO, CA:
2,492,562, CANC. INT. CL. 36.
2,492,563, CANC. INT. CL. 36.
2,492,564, CANC. INT. CL. 36.
- TRAVEL DYNAMICS, INC., SCOTTSDALE, AZ:
2,492,089, CANC. INT. CL. 41.
- TRAVELERS DIGEST, CENTRAL, HONG KONG:
3,480,075, PUB. 5-20-2008, INT. CL. 39.
- TRAXXAS LP, PLANO, TX:
3,481,729, INT. CL. 28.
- TREASURE SOUNDS OF AMERICA, INC., NEW YORK, NY:
2,492,113, CANC. MULTIPLE CLASS, INT. CLS. 9 AND 35.
- TREFFILETTI, LUCI M., ALBANY, NY, DBA BOOTIEBELT BY LOOLOO:
3,479,636, PUB. 5-20-2008, INT. CL. 25.
- TRELLEBORG INDUSTRI AB, S-231 81 TRELLEBORG, SWEDEN:
2,174,722, REN. 6-30-08, INT. CL. 9.
- TRELLEBORG INDUSTRI AB, TRELLEBORG, SWEDEN:
2,174,723, REN. 6-30-08, INT. CL. 9.
2,174,724, REN. 6-30-08, INT. CL. 9.
2,174,725, REN. 6-30-08, INT. CL. 9.
- TRENDIUM, INC., SUNRISE, FL:
3,482,127, INT. CL. 9.
- TRI-COASTAL DESIGN GROUP, INC., GARDEN CITY, NY:
3,481,139, INT. CL. 18.
- TRI-STATE DOOR AND HARDWARE INC., PHILADELPHIA, PA, DBA DOORS UNLIMITED:
1,458,799, CANC. INT. CL. 42.
- TRIADVOCATES LLC, PHOENIX, AZ:
3,478,991, PUB. 5-20-2008, INT. CL. 35.
- TRIAGO S.A., 75001 PARIS, FRANCE:
2,491,766, CANC. INT. CL. 36.
- TRIALIA FOODS AUSTRALIA PTY LTD, NOBLE PARK NORTH, AUSTRALIA:
3,480,645, PUB. 5-20-2008, MULTIPLE CLASS, INT. CLS. 5, 29 AND 30.

- TRIANGLE MARTIAL ARTS ASSOCIATION, SAN FRANCISCO, CA:
3,479,950, PUB. 5-20-2008. INT. CL. 41.
- TRIENT TECHNOLOGIES, INC., WOODVILLE, WI:
2,165,804, REN. 6-28-08. MULTIPLE CLASS, INT. CLS. 16 AND 42.
- TRIGUYS, ARLINGTON HEIGHTS, IL:
3,481,638, INT. CL. 35.
- TRILEGIANT CORPORATION, NORWALK, CT:
3,479,060, PUB. 5-20-2008. MULTIPLE CLASS, INT. CLS. 35, 36 AND 45.
- TRIMEC TECHNOLOGY PTY. LIMITED, CARINGBAH, NEW SOUTH WALES 2229, AUSTRALIA:
2,145,170, REN. 6-30-08. INT. CL. 9.
- TRINITY TRAILER MFG., INC., BOISE, ID:
3,479,094, PUB. 5-20-2008. INT. CL. 12.
- TRINTECH TECHNOLOGIES LIMITED, LEOPARDSTOWN DUBLIN, IRELAND:
3,481,396, INT. CL. 9.
- TRISH ROY, PA, CUDJOE KEY, FL:
3,480,113, PUB. 5-20-2008. INT. CL. 36.
- TRIUMPH PHARMACEUTICALS INC., ST. LOUIS, MO:
3,479,233, PUB. 5-20-2008. INT. CL. 3.
- TRIVITA, INC., SCOTTSDALE, AZ:
3,482,370, INT. CL. 5.
- TRIXXI CLOTHING COMPANY, INC., VERNON, CA:
3,478,708, PUB. 5-20-2008. INT. CL. 25.
- TRIZEC HOLDINGS OPERATING LLC, CHICAGO, IL:
2,491,769, CANC. MULTIPLE CLASS, INT. CLS. 35 AND 36.
- TROPICAL CHEESE INDUSTRIES, INC., PERTH AMBOY, NJ:
3,481,153, INT. CL. 29.
- TROPICANA PRODUCTS, INC., BRADENTON, FL:
2,100,279, CANC. INT. CL. 35.
- TROUW INTERNATIONAL B.V., NETHERLANDS:
3,480,993, PUB. 5-20-2008. INT. CL. 31.
- TROXEL PRODUCTS, LLC, WEST POINT, MS:
3,480,406, PUB. 5-20-2008. INT. CL. 28.
- TRU-BALANCE, LLC, WINDSOR, CO:
3,479,640, PUB. 5-20-2008. INT. CL. 12.
- TRUCKMAR IND. E COM. DE PRODUTOS EM METAIS LTDA., CENTRO-NITEROI 24030-050, BRAZIL:
3,479,307, PUB. 5-20-2008. INT. CL. 12.
- TRUE MEDIA, LLC., MESA, AZ:
3,480,174, PUB. 5-20-2008. INT. CL. 35.
- TRUE VALUE COMPANY, CHICAGO, IL, SERVISTAR COAST TO COAST CORPORATION, BUTLER, PA:
2,121,224, REN. 6-28-08. INT. CL. 35.
- TRUSTCITE LIMITED, NORTH SHORE CITY, AU, NEW ZEALAND:
3,482,499, INT. CL. 35.
- TRUSTEES OF THE JOHN F. KENNEDY CENTER FOR THE PERFORMING ARTS, WASHINGTON, DC:
3,478,754, PUB. 5-20-2008. INT. CL. 41.
- TRUSTEES OF THE UNIVERSITY OF PENNSYLVANIA, THE, PHILADELPHIA, PA:
3,479,860, PUB. 5-20-2008. INT. CL. 44.
- TRUSTHOUSE FORTE CALIFORNIA, INC., EL CAJON, CA:
829,921, CANC. U.S. CL. 100.
- TRUSTMARK INSURANCE COMPANY, LAKE FOREST, IL:
3,480,298, PUB. 5-20-2008. INT. CL. 36.
3,480,301, PUB. 5-20-2008. INT. CL. 36.
- TRUSTUS INTERNATIONAL TRADING INC., VANCOUVER, BRITISH COLUMBIA, CANADA:
3,482,435, INT. CL. 25.
- TRUXSTOR INC., LONG LAKE, MN:
2,100,169, CANC. INT. CL. 42.
- TRW INC., CLEVELAND, OH:
1,458,185, CANC. INT. CL. 9.
- TRX LABS INC., PHOENIX, AZ:
3,481,761, INT. CL. 5.
- TUCKER, RICHARD T., LAKE WYLIE, SC:
1,493,212, REN. 7-3-08. INT. CL. 25.
- TUFF BETTY BAGS, SARASOTA, FL AND CRANKY TIKI, INC., SARASOTA, FL:
3,479,180, PUB. 5-20-2008. INT. CL. 35.
- TULLE HAT COMPANY, CASTLE ROCK, CO:
3,481,138, INT. CL. 25.
- TULLGREN, TERRANCE NEAL, MIAMI BEACH, FL:
2,492,170, CANC. INT. CL. 42.
- TUPMAN, EILEEN N., OCEANSIDE, CA:
3,481,289, INT. CL. 28.
- TURBO PARTS, LLC, LATHAM, NY:
2,492,024, CANC. INT. CL. 7.
- TURBOTEC PRODUCTS, INC., WINDSOR, CT:
3,480,340, PUB. 5-20-2008. INT. CL. 11.
- TURNERWORLD LLC, CUMMING, GA:
3,482,036, MULTIPLE CLASS, INT. CLS. 16 AND 25.
- TURTLE BAY INSTITUTE, INC., PRINCETON, NJ:
3,482,359, INT. CL. 35.
- TUTM ENTERTAINMENT, INC., EDISON, NJ:
2,491,671, CANC. INT. CL. 9.
- TV FANFARE PUBLICATIONS, INC., VALENCIA, CA, DBA TV MOVIE NEWS:
1,458,267, CANC. INT. CL. 16.
- TWENTIETH CENTURY FOX FILM CORPORATION, LOS ANGELES, CA:
3,481,983, INT. CL. 41.
3,482,113, INT. CL. 18.
- TWO5, INC., LOVETTSVILLE, VA:
2,491,989, CANC. INT. CL. 35.
- TY INC., WESTMONT, IL:
2,493,556, CANC. INT. CL. 28.
- TY-LAN ENTERPRISES INC., LONDON, CANADA:
3,481,127, INT. CL. 6.
- TYCO ELECTRONICS LOGISTICS AG, CH 9323 STENACH/SG, SWITZERLAND:
2,163,996, REN. 7-3-08. INT. CL. 9.
- TYNDALE HOUSE PUBLISHERS, INC., CAROL STREAM, IL, TYNDALE HOUSE PUBLISHERS, INC., WHEATON, IL:
1,501,310, REN. 7-3-08. INT. CL. 16.
- U L CANADA INC., TORONTO, ONTARIO, CANADA:
1,458,538, CANC. INT. CL. 29.
- U.S. BANCORP LICENSING, INC., MINNEAPOLIS, MN, U.S. BANCORP, MINNEAPOLIS, MN:
2,241,174, REN. 7-3-08. INT. CL. 36.
- U.S. BUREAU OF THE CENSUS, WASHINGTON, DC:
3,482,676, INT. CL. 45.
- U.S. CONSUMER PROTECTION, L.L.C., RIDGEWOOD, NJ:
3,479,492, PUB. 5-20-2008. MULTIPLE CLASS, INT. CLS. 35 AND 45.
- U.S. LOGISTICS INC., HICKSVILLE, NY:
2,167,957, REN. 7-3-08. INT. CL. 39.
- U.S. MUSIC CORPORATION, MUNDELEIN, IL:
2,183,394, REN. 6-30-08. INT. CL. 9.
2,183,394, AM. INT. CL. 9.
- U.S. POLYMERS, INC., MONTEBELLO, CA:
3,482,303, INT. CL. 19.
- U-HAUL INTERNATIONAL, INC, PHOENIX, AZ:
3,479,303, PUB. 5-20-2008. INT. CL. 35.
- UBIQ TECHNOLOGIES PTY. LTD., ADELAIDE, AUSTRALIA:
3,478,954, PUB. 5-20-2008. INT. CL. 9.
- UCB SERVICES, INC., CHICAGO, IL:
1,458,695, CANC. INT. CL. 36.
- UDDEHOLM TOOLING AKTIEBOLAG, SE-683 85 HAGFORS, SWEDEN:
3,481,025, PUB. 5-20-2008. INT. CL. 6.
- UDDEHOLM TOOLING AKTIEBOLAG, SWEDEN:
3,481,038, PUB. 5-20-2008. INT. CL. 6.
- UDR, INC., HIGHLANDS RANCH, CO:
2,193,753, REN. 6-28-08. INT. CL. 36.
- UGITECH, UGINE, FRANCE:
2,492,611, CANC. INT. CL. 6.
- ULTIMATE NUTRITION, INC., FARMINGTON, CT:
3,479,152, PUB. 5-20-2008. INT. CL. 5.
- ULTIMATE NUTRITIONS, INC., FARMINGTON, CT:
3,479,289, PUB. 5-20-2008. INT. CL. 5.
- UMG RECORDINGS, INC., SANTA MONICA, CA:
2,170,132, REN. 6-30-08. INT. CL. 9.
- UNBREAKABLE LOCK COMPANY, BERWYN, PA:
2,493,196, CANC. INT. CL. 12.

- UNCAS MANUFACTURING COMPANY, PROVIDENCE, RI:
3,479,880, PUB. 5-20-2008. INT. CL. 14.
- UNCLE ED'S OIL SHOPPES, INC., BATTLE CREEK, MI:
1,458,873, CANC. INT. CL. 37.
- UNCLE WIGGILY CLASSICS, INC., WILTON, CT:
2,124,041, REN. 7-3-08. INT. CL. 25.
- UNCOMMON KNOWLEDGE LIMITED, HOVE, UNITED KINGDOM:
3,482,057, INT. CL. 44.
- UNDEFEATED, INC., LOS ANGELES, CA:
3,447,260 NEW CERT. 8-5-2008. INT. CL. 25.
- UNGER ENTERPRISES INCORPORATED, BRIDGEPORT, CT:
1,458,024, CANC. INT. CL. 8.
- UNGER MARKETING INTERNATIONAL, LLC, BRIDGEPORT, CT:
3,481,925, INT. CL. 8.
- UNI-MED VERLAG AKTIENGESELLSCHAFT, FED REP GERMANY:
3,481,011, PUB. 5-20-2008. INT. CL. 16.
- UNIARTE, S.A., TOLEDO, SPAIN:
2,099,853, CANC. INT. CL. 19.
- UNIBOARD CANADA INC., LAVAL, CANADA:
3,479,053, PUB. 5-20-2008. INT. CL. 19.
3,479,054, PUB. 5-20-2008. INT. CL. 19.
- UNICORN PRODUCTS LIMITED, FOREST HILL, LONDON, GREAT BRITAIN:
1,458,476, CANC. INT. CL. 28.
- UNIFIEDMARKET, INC., ENCINITAS, CA:
3,482,021, INT. CL. 36.
- UNILEVER SUPPLY CHAIN, INC., CLINTON, CT:
434,594, REN. 6-30-08. U.S. CL. 46 (INT. CLS. 1, 5, 29, 30, 31 AND 32).
1,458,604, CANC. INT. CL. 30.
2,493,251, CANC. INT. CL. 35.
3,478,570, PUB. 5-20-2008. MULTIPLE CLASS, INT. CLS. 16, 43 AND 44.
- UNILOCK DI UMBERTO CROSTI & C. S.A.S., I-20090 TREZZANO SUL NAVIGLIO (MILANO), ITALY:
3,481,019, PUB. 5-20-2008. INT. CL. 7.
- UNION CARBIDE CORPORATION, DANBURY, CT:
1,457,873, CANC. INT. CL. 1.
- UNION OF ORTHODOX JEWISH CONGREGATIONS OF AMERICA, NEW YORK, NY:
3,478,552, PUB. 5-20-2008. U.S. CL. A.
- UNION TELECOM, INC., CHICAGO, IL:
3,480,546, PUB. 5-20-2008. INT. CL. 16.
- UNION TOSTADORA, S.A., 26006 LOGRONO (LA RIOJA), SPAIN:
2,492,851, CANC. INT. CL. 30.
- UNIQUE LOGIC & TECHNOLOGY, INC., ASHEVILLE, NC:
2,168,272, REN. 6-30-08. INT. CL. 9.
- UNIQUE PAVING MATERIALS CORPORATION, CLEVELAND, OH:
3,480,076, PUB. 5-20-2008. INT. CL. 19.
- UNIROM INC., BURLINGTON, ONTARIO L7N 3N4, CANADA:
2,099,211, CANC. INT. CL. 9.
- UNISOURCE WORLDWIDE, INC., NORCROSS, GA:
3,481,899, INT. CL. 16.
3,481,909, INT. CL. 16.
3,481,966, INT. CL. 16.
- UNITE EURO THERAPY, INC., SAN DIEGO, CA:
3,479,541, PUB. 5-20-2008. INT. CL. 3.
- UNITED BISCUITS (UK) LIMITED, HAYES, MIDDLESEX, UNITED KINGDOM:
3,479,087, PUB. 5-20-2008. INT. CL. 30.
- UNITED DOMINION INDUSTRIES, CHARLOTTE, NC, DBA CECO DOOR PRODUCTS:
2,492,714, CANC. INT. CL. 19.
- UNITED FEATHER & DOWN, INC., DES PLAINES, IL:
3,482,523, MULTIPLE CLASS, INT. CLS. 20, 22 AND 24.
- UNITED FEATURE SYNDICATE, INC., NEW YORK, NY:
2,492,653, CANC. INT. CL. 9.
2,493,298, CANC. INT. CL. 25.
- UNITED INSURANCE COMPANY OF AMERICA, CHICAGO, IL:
1,458,699, CANC. INT. CL. 36.
- UNITED SPACE ALLIANCE, LLC, CAPE CANAVERAL, FL:
3,479,975, PUB. 5-20-2008. INT. CL. 37.
- UNITED STATES ARTISTS, INC., LOS ANGELES, CA:
3,482,221, INT. CL. 36.
- UNITED STATES BRASS CORPORATION, PLANO, TX:
1,458,215, CANC. INT. CL. 11.
- UNITED STATES CELLULAR CORPORATION, CHICAGO, IL:
2,492,568, CANC. INT. CL. 38.
- UNITED STATES GYPSUM COMPANY, CHICAGO, IL:
1,096,385, REN. 7-1-08. INT. CL. 1.
2,178,417, REN. 7-2-08. MULTIPLE CLASS, INT. CLS. 2, 17 AND 19.
- UNITED STATES OLYMPIC COMMITTEE, COLORADO SPRINGS, CO:
1,458,432, CANC. INT. CL. 25.
- UNITED STATIONERS SUPPLY CO., DEERFIELD, IL, INTER CITY PAPERS LIMITED, VILLE LASALLE, QUEBEC, CANADA:
1,496,309, REN. 6-30-08. INT. CL. 42.
- UNITED VAN LINES, LLC, FENTON, MO:
2,170,851, REN. 6-30-08. INT. CL. 39.
- UNITRAVEL CORPORATION, ST. LOUIS, MO:
1,515,826, CANC. INT. CL. 39.
- UNIVERSAL COMMUNICATIONS NETWORK, INC., NEW YORK, NY, DBA NEW TANG DYNASTY TELEVISION:
3,479,794, PUB. 5-20-2008. INT. CL. 38.
3,479,795, PUB. 5-20-2008. INT. CL. 38.
- UNIVERSAL ENGRAVING, INC., OVERLAND PARK, KS:
2,162,624, REN. 6-28-08. INT. CL. 6.
- UNIVERSAL SANITARY EQUIPMENT MANUFACTURING COMPANY, INC., TOMAH, WI:
2,185,744, REN. 6-28-08. MULTIPLE CLASS, INT. CLS. 6, 9 AND 11.
- UNIVERSAL SATELLITE COMMUNICATIONS, INC., PERRIS, CA:
2,218,447, REN. 7-3-08. INT. CL. 38.
- UNIVERSITY GAMES CORPORATION, SAN FRANCISCO, CA:
3,480,428, PUB. 5-20-2008. INT. CL. 16.
- UNIVERSITY LANDING LLC, RALEIGH, NC:
3,479,218, PUB. 5-20-2008. INT. CL. 36.
- UNIVERSITY OF CENTRAL FLORIDA, ORLANDO, FL:
2,121,912, REN. 7-3-08. MULTIPLE CLASS, INT. CLS. 25 AND 41.
3,481,587, INT. CL. 41.
3,481,589, INT. CL. 41.
3,481,590, INT. CL. 25.
3,481,591, INT. CL. 25.
- UNIVERSITY OF MARYLAND, BALTIMORE COUNTY, BALTIMORE, MD:
3,479,965, PUB. 5-20-2008. INT. CL. 16.
3,479,966, PUB. 5-20-2008. INT. CL. 41.
- UNIVERSITY OF NOTRE DAME DU LAC, THE, NOTRE DAME, IN:
1,248,876, AM. MULTIPLE CLASS, INT. CLS. 14, 25 AND 26.
- UNIVISION COMMUNICATIONS INC., LOS ANGELES, CA:
3,478,545, PUB. 5-20-2008. INT. CL. 35.
- UPPER COLUMBIA MILL, LLC, PORTLAND, OR:
3,479,276, PUB. 5-20-2008. MULTIPLE CLASS, INT. CLS. 19 AND 20.
- UPSCO, INC., MORAVIA, NY:
3,480,422, PUB. 5-20-2008. INT. CL. 12.
- UPSIDE LIVING, INC., MICCO, FL:
3,479,627, PUB. 5-20-2008. MULTIPLE CLASS, INT. CLS. 20, 21 AND 27.
- UPSITE TECHNOLOGIES, INC., SANTA FE, NM:
3,479,586, PUB. 5-20-2008. MULTIPLE CLASS, INT. CLS. 35 AND 41.
3,479,587, PUB. 5-20-2008. INT. CL. 35.
- UPSTATE DAIRY FARMS, INC., BROOKLYN, NY:
2,099,135, CANC. MULTIPLE CLASS, INT. CLS. 29 AND 32.

- URBAN OUTFITTERS (DELAWARE), INC., PHILADELPHIA, PA:
3,480,442, PUB. 5-20-2008. INT. CL. 25.
3,480,443, PUB. 5-20-2008. INT. CL. 25.
3,481,752, INT. CL. 25.
- URBAN PEAK DENVER, DENVER, CO:
3,478,913, PUB. 5-20-2008. INT. CL. 43.
3,478,914, PUB. 5-20-2008. INT. CL. 43.
- URBIN, MATTHEW C., TARZANA, CA:
2,492,932, CANC. INT. CL. 5.
- US AIR GUITAR LLC, NEW YORK, NY:
3,482,567, MULTIPLE CLASS, INT. CLS. 25 AND 41.
- US LEC CORP., CHARLOTTE, NC:
2,492,283, CANC. MULTIPLE CLASS, INT. CLS. 38 AND 42.
- USA FINANCIAL MARKETING CORPORATION, ADA, MI:
3,479,468, PUB. 5-20-2008. INT. CL. 9.
- USHINO, ANTHONY T., LOS ANGELES, CA AND DAO, PATRICIA, WEST LOS ANGELES, CA:
3,481,323, INT. CL. 42.
- USI, INC., MADISON, CT:
3,479,360, PUB. 5-20-2008. MULTIPLE CLASS, INT. CLS. 7 AND 16.
- UTICA COLLEGE, UTICA, NY:
3,479,715, PUB. 5-20-2008. INT. CL. 42.
- UTILITY COMPOSITES INTERNATIONAL, L.P., ROUND ROCK, TX:
3,480,714, PUB. 5-20-2008. INT. CL. 20.
- UTILITY COMPOSITES INTL LTD, ROUND ROCK, TX:
3,480,677, PUB. 5-20-2008. INT. CL. 20.
- UV PROCESS SUPPLY, INC., CHICAGO, IL:
1,491,826, REN. 6-28-08. INT. CL. 3.
- UWT GMBH, BETZIGAU, FED REP GERMANY:
3,478,860, PUB. 5-20-2008. MULTIPLE CLASS, INT. CLS. 9 AND 37.
- V. ALEXANDER & CO., INC., MEMPHIS, TN:
3,480,215, PUB. 5-20-2008. MULTIPLE CLASS, INT. CLS. 35, 36 AND 39.
- V. MANE FILS S.A., LE BAR SUR LOUP, FRANCE:
2,186,910, REN. 7-3-08. INT. CL. 1.
- V.E.W., LTD., NEW YORK, NY:
3,479,801, PUB. 5-20-2008. INT. CL. 31.
3,479,802, PUB. 5-20-2008. INT. CL. 43.
- V.O.R. MOTORI S.R.L., 20025 RONCO BRIANTINO, MILAN, ITALY:
2,491,687, CANC. INT. CL. 12.
- VAHOVIUS, CHET J., ENTERPRISE, AL:
3,480,441, PUB. 5-20-2008. INT. CL. 35.
- VAIL TRADEMARKS, INC., VAIL, CO:
3,481,936, INT. CL. 43.
- VAKKO HOLDING A.S., TURKEY:
3,480,844, PUB. 2-12-2008. MULTIPLE CLASS, INT. CLS. 3, 18, 24 AND 25.
- VALASSIS COMMUNICATIONS, INC., LIVONIA, MI:
3,481,743, INT. CL. 35.
3,481,900, INT. CL. 35.
- VALENT BIOSCIENCES CORPORATION, LIBERTYVILLE, IL:
2,155,286, REN. 7-2-08. INT. CL. 1.
2,192,499, REN. 6-30-08. INT. CL. 5.
- VALIDAS, INC., MISSOURI CITY, TX:
3,481,842, INT. CL. 38.
- VALLEY CUSTOM TIRE, INC., VERNON, CA:
3,481,192, INT. CL. 12.
- VALLEY FORGE FINANCIAL, FAIRFAX, VA:
3,480,141, PUB. 5-20-2008. INT. CL. 36.
- VALLIA INVESTMENTS LTD, GLACIS ROAD, GIBRALTAR:
2,491,856, CANC. MULTIPLE CLASS, INT. CLS. 1 AND 11.
- VALLOUREC & MANNESMANN TUBES, FRANCE:
3,480,908, PUB. 5-20-2008. MULTIPLE CLASS, INT. CLS. 6, 16 AND 42.
- VALMET PANELBOARD GMBH, HANNOVER, FED REP GERMANY:
2,491,863, CANC. MULTIPLE CLASS, INT. CLS. 7, 37 AND 42.
- VALSPAR SOURCING, INC., MINNEAPOLIS, MN:
808,288, REN. 7-3-08. U.S. CL. 4 (INT. CL. 3).
- VALUE CITY OF MICHIGAN, INC., WESTLAND, MI:
1,458,452, CANC. INT. CL. 25.
2,492,332, CANC. INT. CL. 35.
- VALUES.COM INC, HAUPPAUGE, NY:
2,491,847, CANC. MULTIPLE CLASS, INT. CLS. 35 AND 36.
- VALUTRAVEL, INC., ANCHORAGE, AK:
2,491,910, CANC. INT. CL. 39.
- VAN DE VELDE N.V., BELGIUM:
3,480,828, PUB. 5-20-2008. INT. CL. 25.
- VAN DER HOEVEN, MARTIN, SAN DIEGO, CA:
2,492,359, CANC. INT. CL. 28.
- VAN HOUTEN, LYNN ROSS, EDGEWOOD, WA:
3,481,563, INT. CL. 36.
- VAN KAMPEN INVESTMENTS INC., NEW YORK, NY:
1,458,297, CANC. INT. CL. 16.
- VANCE, RONALD, PHILADELPHIA, PA:
2,491,693, CANC. MULTIPLE CLASS, INT. CLS. 9 AND 41.
- VANCO SERVICES, INC., MINNEAPOLIS, MN:
2,492,102, CANC. INT. CL. 36.
- VANCO SERVICES, LLC, MINNETONKA, MN:
3,482,605, INT. CL. 36.
- VANDERBILT UNIVERSITY, NASHVILLE, TN:
2,694,829, CANC. MULTIPLE CLASS, INT. CLS. 14 AND 21.
- VANGUARD GROUP, INC., THE, MALVERN, PA:
2,492,729, CANC. INT. CL. 36.
2,492,753, CANC. INT. CL. 36.
2,493,008, CANC. MULTIPLE CLASS, INT. CLS. 16 AND 36.
- VANITY FAIR, INC., BOWLING GREEN, KY:
3,481,432, INT. CL. 25.
3,482,075, INT. CL. 25.
- VAO INTOURIST, MOSCOW, 103009, RUSSIAN FED.:
1,952,138, CANC. INT. CL. 39.
- VAPOR RECORDS, INC., BEVERLY HILLS, CA:
2,099,996, CANC. INT. CL. 9.
- VARIETY FOODS, INC., WARREN, MI:
2,099,929, CANC. INT. CL. 29.
- VARSIITY GOLD, INC., GILBERT, AZ:
3,479,572, PUB. 5-20-2008. INT. CL. 35.
3,479,573, PUB. 5-20-2008. INT. CL. 35.
- VASA TECHNOLOGY SOLUTIONS, INC., WEST JORDAN, UT:
3,478,737, PUB. 5-20-2008. INT. CL. 37.
3,478,738, PUB. 5-20-2008. INT. CL. 37.
3,478,739, PUB. 5-20-2008. INT. CL. 37.
- VASILIOS MANIATIS, INDIANAPOLIS, IN:
3,479,714, PUB. 5-20-2008. INT. CL. 36.
- VASQUEZ, JOSE LUCIO, LOS ANGELES, CA AND CRUZ CRUZ, JOSE LUIS, LOS ANGELES, CA:
3,480,062, PUB. 5-20-2008. INT. CL. 41.
- VAST RESOURCES, INC., SAN FERNANDO, CA:
2,492,733, CANC. MULTIPLE CLASS, INT. CLS. 3, 5 AND 10.
- VAUNIX TECHNOLOGY CORPORATION, HAVERHILL, MA:
3,481,623, INT. CL. 9.
- VAZQUEZ, RONALDO, CHULA VISTA, CA AND VAZQUEZ, RITA, CHULA VISTA, CA:
3,481,458, INT. CL. 36.
- VECTORBEAM TECHNOLOGIES PTY LTD, CHELTENHAM, VICTORIA, AUSTRALIA:
3,480,675, PUB. 3-25-2008. INT. CL. 11.
3,480,676, PUB. 3-25-2008. INT. CL. 11.
- VEE-ARC CORPORATION, WESTBORO, MA TO FURNAS ELECTRIC COMPANY, BATAVIA, IL:
1,458,010, CANC. INT. CL. 7.
- VEGASEL SERVICES U.S.A., MARINA DEL REY, CA:
3,479,215, PUB. 5-20-2008. INT. CL. 35.
- VELCON FILTERS, INC., COLORADO SPRINGS, CO:
3,479,146, PUB. 5-20-2008. INT. CL. 7.
- VENTEX TECHNOLOGIES, INC., RIVIERA BEACH, FL:
3,481,091, INT. CL. 9.

- VERA VICTOR JR., FRESNO, CA:
3,479,337, PUB. 5-20-2008. INT. CL. 41.
- VERACI PIZZA, SEATTLE, WA:
3,480,726, PUB. 5-20-2008. MULTIPLE CLASS, INT. CLS.
30 AND 43.
- VERATHON INC., BOTHELL, WA:
2,166,479. REN. 6-28-08. INT. CL. 10.
- VERBATIM AMERICAS LLC, CHARLOTTE, NC:
3,482,072, INT. CL. 2.
- VERGENZA INC., NEW YORK, NY:
3,479,899, PUB. 5-20-2008. INT. CL. 10.
- VERIDICOM, INC., SANTA CLARA, CA:
2,491,882, CANC. INT. CL. 9.
- VERIFONE ISRAEL LTD., ROSH HA'AIN, ISRAEL:
3,480,611, PUB. 5-20-2008. MULTIPLE CLASS, INT. CLS.
38 AND 42.
- VERITAS V, LLC, SALINAS, CA:
3,480,106, PUB. 5-20-2008. INT. CL. 31.
3,480,107, PUB. 5-20-2008. INT. CL. 31.
3,480,435, PUB. 5-20-2008. INT. CL. 29.
3,480,436, PUB. 5-20-2008. INT. CL. 31.
- VERSA-GARD, LLC, BUFORD, GA:
3,479,409, PUB. 5-20-2008. INT. CL. 20.
- VERSO VERILINK, LLC F/K/A WINSLOW ASSET HOLDINGS, LLC, MADISON, AL:
2,493,228, CANC. INT. CL. 9.
- VERSUS, L.P., PHILADELPHIA, PA:
3,480,417, PUB. 5-20-2008. INT. CL. 41.
3,481,398, INT. CL. 41.
- VERTEBRAE, INC., SEATTLE, WA:
2,492,146, CANC. INT. CL. 42.
- VERTIS, INC., BALTIMORE, MD:
2,493,478, CANC. MULTIPLE CLASS, INT. CLS. 35, 41
AND 42.
- VETESSA PHARMACEUTICAL, INC., DORAL, FL:
3,482,494, INT. CL. 35.
- VI-JON, INC., ST. LOUIS, MO, CERTIFIED CHEMICALS, INC., CAMDEN, NJ:
1,061,508. REN. 6-30-08. INT. CL. 5.
- VIA CHRISTI REGIONAL MEDICAL CENTER, INC., WICHITA, KS:
2,492,288, CANC. INT. CL. 42.
- VIACOM INTERNATIONAL INC., NEW YORK, NY:
2,165,655. REN. 7-3-08. INT. CL. 42.
2,167,369. REN. 7-3-08. INT. CL. 36.
2,491,841, CANC. INT. CL. 41.
2,493,009, CANC. INT. CL. 41.
3,482,263, INT. CL. 41.
- VIBRAM S.P.A., ITALY:
3,480,793, PUB. 5-20-2008. MULTIPLE CLASS, INT. CLS.
12, 26 AND 28.
3,480,794, PUB. 5-20-2008. MULTIPLE CLASS, INT. CLS.
12, 26 AND 28.
- VIBRANT PHOTO AND ELECTRONICS INC., MISSISSAUGA, ONTARIO:
2,492,121, CANC. MULTIPLE CLASS, INT. CLS. 16, 20
AND 35.
- VIBRATION MOUNTINGS & CONTROLS, INC., BLOOMINGDALE, NJ:
3,478,499, PUB. 5-20-2008. INT. CL. 11.
- VIBROSYSTEM INC., LONGUEUIL, CANADA:
3,478,684, PUB. 5-20-2008. INT. CL. 9.
3,478,685, PUB. 5-20-2008. INT. CL. 9.
- VIC-VINCENT, VICTOR N, GULF BREEZE, FL AND SMITH, STEVEN J., GULF BREEZE, FL:
3,479,292, PUB. 5-20-2008. INT. CL. 25.
- VICTAULIC COMPANY, EASTON, PA:
3,482,481, INT. CL. 9.
- VICTORIA'S SECRET STORES BRAND MANAGEMENT, INC., REYNOLDSBURG, OH:
3,480,517, PUB. 5-20-2008. INT. CL. 25.
3,480,520, PUB. 5-20-2008. INT. CL. 25.
3,480,533, PUB. 5-20-2008. INT. CL. 18.
3,480,549, PUB. 5-20-2008. INT. CL. 3.
3,482,540, INT. CL. 3.
- VICTORY DAYS CORPORATION, INDIANAPOLIS, IN:
3,480,315, PUB. 5-20-2008. INT. CL. 41.
- VIDAONE, INC., SAN DIEGO, CA, DBA EXPOSE SOFTWARE CORP.:
3,479,993, PUB. 5-20-2008. INT. CL. 9.
- VIDEO FRANCHISE HOLDING CORPORATION, AUSTIN, TX:
2,492,414, CANC. INT. CL. 40.
- VIDEOMINING CORPORATION, STATE COLLEGE, PA:
3,479,937, PUB. 5-20-2008. INT. CL. 35.
- VIENA AGROPECUARIA LTDA., PIRAPORA, BRAZIL:
2,492,758, CANC. INT. CL. 33.
- VISSMANN WERKE GMBH & CO KG, ALLENDORF, FED REP GERMANY:
3,480,718, PUB. 3-4-2008. MULTIPLE CLASS, INT. CLS. 9,
11, 37 AND 41.
- VIEWCAST.COM, INC., DALLAS, TX:
2,492,834, CANC. INT. CL. 9.
- VIJAYA FOODS INC., CHICAGO, IL:
3,480,695, PUB. 5-20-2008. INT. CL. 30.
- VIKING INTERWORKS, INC., RANCHO SANTA MARGARITA, CA:
2,098,646, CANC. INT. CL. 9.
- VIKING LODGE MUSIC, LLC, CANTON, GA:
3,480,290, PUB. 5-20-2008. INT. CL. 9.
- VILLA NICOLA, LTD., BIRMINGHAM, MI:
1,458,554, CANC. MULTIPLE CLASS, INT. CLS. 29 AND
33.
1,458,555, CANC. MULTIPLE CLASS, INT. CLS. 29 AND
33.
- VILLAFRANCA, ENRIQUE, DALLAS, TX:
3,480,131, PUB. 5-20-2008. INT. CL. 43.
- VILLAGE FARMS, L.P., EATONTOWN, NJ:
3,481,665, INT. CL. 31.
- VILLAGE VOICE MEDIA HOLDINGS, LLC, PHOENIX, AZ:
3,479,806, PUB. 5-20-2008. MULTIPLE CLASS, INT. CLS.
16 AND 41.
- VILLANUEVA, CELIA, HOUSTON, TX:
3,482,104, INT. CL. 33.
- VILLEROY & BOCH A.G., METTLACH, FED REP GERMANY:
3,481,596, INT. CL. 11.
3,481,597, INT. CL. 11.
- VILLEROY & BOCH AG, FED REP GERMANY:
3,481,010, PUB. 5-20-2008. INT. CL. 11.
- VILLOLDO, ALBERTO, MIAMI, FL:
2,493,327, CANC. INT. CL. 41.
- VINAIGRETTE, INC., SANTA FE, NM:
3,479,649, PUB. 5-20-2008. INT. CL. 43.
- VINCE, DALE, STROUD, GLOUCESTERSHIRE, GL5 3AP, UNITED KINGDOM:
2,491,795, CANC. INT. CL. 39.
- VINH-SANH TRADING CORPORATION, CITY OF COMMERCE, CA:
2,168,020. REN. 7-2-08. INT. CL. 30.
2,168,020, CANC. INT. CL. 29.
- VIP EXPERIENCE LIMITED, UNITED KINGDOM:
3,480,756, PUB. 5-20-2008. INT. CL. 9.
- VIPDESK.COM, INC., ALEXANDRIA, VA:
3,479,387, PUB. 5-20-2008. INT. CL. 35.
- VIPER ROOM DEVELOPMENT, LLC, LOS ANGELES, CA:
3,479,667, PUB. 5-20-2008. MULTIPLE CLASS, INT. CLS.
34 AND 35.
- VIPRMEDIA LLC, ORLANDO, FL:
3,479,830, PUB. 5-20-2008. INT. CL. 41.
- VIRGIN COMICS, LLC, NEW YORK, NY:
3,481,993, INT. CL. 16.
- VIRGINIA FOUNDATION FOR INDEPENDENT COLLEGES, RICHMOND, VA:
2,493,132, CANC. INT. CL. 41.
- VIRGO PUBLISHING, LLC, PHOENIX, AZ:
3,479,717, PUB. 5-20-2008. INT. CL. 16.
- VIRTUAL INFORMATION EXECUTIVES, LLC, PORTLAND, OR:
3,479,038, PUB. 5-20-2008. INT. CL. 35.
- VIRTUAL SNOW TRAINING SYSTEM, LA CRESCENTA, CA:
2,187,812. REN. 7-3-08. INT. CL. 41.
- VISION FUELS, LLC, URBANDALE, IA:
3,481,317, MULTIPLE CLASS, INT. CLS. 35 AND 40.

- VISION SELECT, LLC, LAKE WORTH, FL:
3,478,556, PUB. 5-20-2008. INT. CL. 35.
- VISIONMOS INTERNATIONAL, INC., TEMPE, AZ:
3,482,078, INT. CL. 9.
- VISTA INNOVATIONS, INCORPORATED, RIVERSIDE, CA:
2,493,189, CANC. INT. CL. 10.
- VISUAL SOUND LLC, SPRING HILL, TN:
3,480,176, PUB. 5-20-2008. INT. CL. 15.
- VISUALSONICS, INC., TORONTO, CANADA:
3,478,651, PUB. 5-20-2008. INT. CL. 10.
- VITA-PAKT CITRUS PRODUCTS CO., COVINA, CA:
859,392, AM. U.S. CL. 32.
- VITAL PHARMACEUTICALS, INC., DAVIE, FL:
3,481,580, INT. CL. 1.
- VITALICIOUS, INC., NEW YORK, NY:
3,482,453, INT. CL. 30.
- VITALITA NUTRITIONAL PRODUCTS, LLC, CHICAGO, IL:
3,482,438, INT. CL. 32.
- VITALITY FOODSERVICE, INC., TAMPA, FL, PASCO
PACKING CO., DADE CITY, FL:
675,115. REN. 7-1-08. U.S. CL. 46 (INT. CL. 32).
- VITAMINS 4 LESS, INC., INDIANA, PA:
2,493,184, CANC. INT. CL. 35.
- VITASOY INTERNATIONAL HOLDINGS LIMITED, NEW
TERRITORIES, HONG KONG:
3,478,694, PUB. 12-4-2007. MULTIPLE CLASS, INT. CLS.
29 AND 30.
- VITRA PATENTE AG, SWITZERLAND:
3,481,024, PUB. 5-20-2008. INT. CL. 20.
- VITRULAN TEXTILGLAS GMBH, 95509 MARKTSCHOR-
GAST, FED REP GERMANY:
2,574,940, CANC. MULTIPLE CLASS, INT. CLS. 21 AND
22.
- VIVE LE SPORT DI MONTI FEDERICO, ITALY:
3,480,915, PUB. 5-20-2008. INT. CL. 25.
- VIVENDI GAMES EUROPE S.A., MEUDON-LA-FORET
CEDEX, FRANCE, DBA VIVENDI GAMES MOBILE:
3,481,963, INT. CL. 9.
- VLC, INC., BOZEMAN, MT:
2,493,683, CANC. INT. CL. 9.
- VOCE, STELLA MARIS, GARDENA, CA:
1,458,754, CANC. INT. CL. 41.
- VOGT POWER INTERNATIONAL INC., LOUISVILLE, KY:
2,197,410. REN. 6-30-08. INT. CL. 11.
- VOGUE TYRE & RUBBER COMPANY, MOUNT PROSPECT,
IL:
3,481,093, INT. CL. 12.
- VOICEDATAWARE INC., IRVING, TX:
2,492,800, CANC. INT. CL. 9.
- VOID STAR CREATIONS LLC, SOUTH CAROLINA, SC:
3,481,630, INT. CL. 9.
- VOITUS CORPORATION, SEATTLE, WA:
2,492,776, CANC. INT. CL. 42.
- VOLCANO COMMUNICATIONS COMPANY, PINE GROVE,
CA, DBA VOLCANO COMMUNICATIONS GROUP:
2,493,056, CANC. INT. CL. 42.
- VOLKSWAGEN AKTIENGESELLSCHAFT, D-38436,
WOLFSBURG, FED REP GERMANY:
2,492,179, CANC. MULTIPLE CLASS, INT. CLS. 12, 28
AND 37.
- VOLKSWAGEN AKTIENGESELLSCHAFT, 38436 WOLFS-
BURG, FED REP GERMANY:
3,480,957, PUB. 5-20-2008. MULTIPLE CLASS, INT. CLS.
12, 35 AND 37.
- VON DUPRIN LLC, INDIANAPOLIS, IN:
2,099,700, CANC. INT. CL. 6.
- VON LUTZOW, JAMES ANTHONY, GILBERT, AZ:
3,481,894, INT. CL. 5.
- VON SCHRADER COMPANY, RACINE, WI:
1,497,340. REN. 6-27-08. MULTIPLE CLASS, INT. CLS. 3,
7 AND 35.
- VOODOO RIDE, LLC, CHICAGO, IL:
3,481,113, INT. CL. 3.
- VOX ENTERTAINMENT, EL SEGUNDO, CA:
3,479,701, PUB. 5-20-2008. MULTIPLE CLASS, INT. CLS.
35 AND 41.
- VOX ENTERTAINMENT, INC., EL SEGUNDO, CA:
3,479,707, PUB. 5-20-2008. MULTIPLE CLASS, INT. CLS.
35 AND 41.
- 3,479,810, PUB. 5-20-2008. INT. CL. 35.
- VS ENERGY, INC., WASHINGTON, PA:
3,479,480, PUB. 5-20-2008. MULTIPLE CLASS, INT. CLS.
35, 41 AND 42.
- VSM GROUP AB, SWEDEN:
3,480,976, PUB. 5-20-2008. INT. CL. 7.
- VSM GROUP AKTIEBOLAG, HUSKVARNA, SWEDEN:
3,480,289, PUB. 5-20-2008. INT. CL. 7.
- VTECH INDUSTRIES, L.L.C., WHEELING, IL:
2,492,926, CANC. INT. CL. 28.
- VUE TECHNOLOGY LLC, SLIDELL, LA:
3,479,550, PUB. 5-20-2008. INT. CL. 11.
3,479,553, PUB. 5-20-2008. INT. CL. 11.
3,479,556, PUB. 5-20-2008. INT. CL. 11.
- VUZIX CORPORATION, ROCHESTER, NY:
3,478,846, PUB. 5-20-2008. INT. CL. 9.
- VYCOR MEDICAL LLC, CORAM, NY:
3,482,285, INT. CL. 10.
- VYSARN PTY LTD., BENTLY, AUSTRALIA:
2,098,511, CANC. INT. CL. 7.
- V4 HOLDINGS, LLC, ANN ARBOR, MI:
3,482,162, INT. CL. 9.
3,482,163, INT. CL. 9.
- W & L T SEFRANEK + CO., CH-6300 ZUG, SWITZERLAND:
2,098,735, CANC. INT. CL. 25.
- W. ATLEE BURPEE COMPANY, WARMINSTER, PA:
3,482,667, INT. CL. 31.
3,482,669, INT. CL. 31.
- W. C. BRADLEY COMPANY, COLUMBUS, GA:
1,457,947, CANC. MULTIPLE CLASS, INT. CLS. 4 AND
11.
- W. HAKING ENTERPRISES LIMITED, NORTH POINT,
HONG KONG:
1,458,182, CANC. INT. CL. 9.
- W.F. YOUNG, INCORPORATED, EAST LONGMEADOW,
MA:
3,479,766, PUB. 5-20-2008. INT. CL. 5.
3,479,767, PUB. 5-20-2008. INT. CL. 5.
3,479,803, PUB. 5-20-2008. INT. CL. 5.
3,480,018, PUB. 5-20-2008. INT. CL. 5.
- W.R. HAMBRECHT + CO., INC., SAN FRANCISCO, CA:
3,481,493, INT. CL. 36.
- W.W. GRAINGER, INC., LAKE FOREST, IL:
2,491,974, CANC. INT. CL. 35.
- WACKER CHEMIE AG, FED REP GERMANY:
3,480,973, PUB. 5-20-2008. MULTIPLE CLASS, INT. CLS.
1, 16 AND 17.
- WAGGENER EDSTROM WORLDWIDE, INC., LAKE OSWE-
GO, OR:
3,482,466, INT. CL. 35.
3,482,467, INT. CL. 35.
- WAGNON, JOSEPH, OAKLAND, CA:
3,480,140, PUB. 5-20-2008. INT. CL. 42.
- WAI LAN YOGA TRUST, MALIBU, CA:
3,481,052, INT. CL. 9.
- WAIT, MARVIN, SAN MARCOS, CA AND WAIT, SUSAN,
SAN MARCOS, CA:
2,492,602, CANC. INT. CL. 19.
- WAL-MART STORES, INC., BENTONVILLE, AR, WHITE
STAG MANUFACTURING CO., PORTLAND, OR:
851,101. REN. 6-30-08. U.S. CL. 39 (INT. CLS. 10, 25 AND
26).
- WAL-MART STORES, INC., BENTONVILLE, AR:
2,098,767, CANC. MULTIPLE CLASS, INT. CLS. 7, 9 AND
11.
3,481,159, MULTIPLE CLASS, INT. CLS. 9, 14, 18 AND 24.
- WALD LLC, MAYSVILLE, KY:
3,481,121, INT. CL. 12.
- WALDON, PATRICIA L., ST. PETERSBURG, FL:
2,492,233, CANC. INT. CL. 37.
- WALGREEN CO., DEERFIELD, IL:
3,481,162, MULTIPLE CLASS, INT. CLS. 30 AND 32.
- WALKER, APRIL, BROOKLYN, NY:
3,479,413, PUB. 5-20-2008. INT. CL. 25.
- WALKER, C.S., OLYMPIA FIELDS, IL:
3,481,181, INT. CL. 25.

WALKER, RICHARD F., INDIAN ROCKS BEACH, FL:
3,481,859, INT. CL. 5.

WALL STREET SYSTEMS DELAWARE, INC., UNITED STATES:
3,480,760, PUB. 5-20-2008. MULTIPLE CLASS, INT. CLS. 9 AND 42.

WALLACE, HEATHER, MINNEAPOLIS, MN:
3,478,567, PUB. 5-20-2008. INT. CL. 44.

WALLINS, KIMBERLY, SAN FRANCISCO, CA:
3,478,923, PUB. 5-20-2008. INT. CL. 35.

WALNUT CREEK FOODS INC., WALNUT CREEK, OH:
2,481,457, CANC. INT. CL. 35.

WALONG MARKETING , INC., BUENA PARK, CA:
3,479,594, PUB. 5-20-2008. INT. CL. 30.

WALSH, JOHN P., NORTH ANDOVER, MA:
3,481,129, INT. CL. 3.

WALT GARTRELL MINISTRIES INC., VAN BUREN, AR:
2,492,757, CANC. INT. CL. 41.

WALTON COUNTY CHAMBER OF COMMERCE, SANTA ROSA BEACH, FL:
3,479,700, PUB. 5-20-2008. INT. CL. 41.

WANGLER, THOMAS M., BATAVIA, IL:
3,479,911, PUB. 5-20-2008. INT. CL. 37.

WANKER, WILLIAM P., SANTA FE, NM AND KELLY, PAMELA W., SANTA FE, NM:
3,481,273, MULTIPLE CLASS, INT. CLS. 10 AND 25.

WARD MEDIA, INC., NEW YORK, NY:
3,479,605, PUB. 5-20-2008. INT. CL. 9.

WARD, KIMBERLY, CARROLLTON, TX:
2,492,452, CANC. INT. CL. 25.

WARNACO U.S., INC., BRIDGEPORT, CT:
2,492,886, CANC. INT. CL. 25.

WARNER PRESS, INC., ANDERSON, IN:
3,482,328, INT. CL. 16.

WASHINGTON HOSPITAL CENTER CORPORATION, WASHINGTON, DC:
3,480,482, PUB. 5-20-2008. INT. CL. 44.

WASHINGTON MUTUAL, INC., SEATTLE, WA:
2,492,478, CANC. INT. CL. 36.
3,482,346, MULTIPLE CLASS, INT. CLS. 36 AND 45.

WASHINGTON, ROBIN, SANTEE, CA:
2,493,571, CANC. INT. CL. 25.

WASSERMANN, THOMAS, ALEXANDRIA, VA:
3,481,420, INT. CL. 5.

WATER ENVIRONMENT FEDERATION, ALEXANDRIA, VA:
3,482,014, MULTIPLE CLASS, INT. CLS. 35 AND 41.

WATER PIK, INC., FORT COLLINS, CO:
2,493,374, CANC. INT. CL. 11.

WATERSMOLITOR, INC., MINNEAPOLIS, MN:
3,482,333, MULTIPLE CLASS, INT. CLS. 9, 16, 35 AND 41.

WATKINS MANUFACTURING CORPORATION, VISTA, CA:
2,196,438, REN. 7-3-08. INT. CL. 11.

WATSON, TRACI R., COMPTON, CA:
3,482,721, INT. CL. 5.

WATV, LLC, LOS ANGELES, CA:
3,481,176, INT. CL. 41.

WAUSAU METALS CORPORATION, WAUSAU, WI:
1,458,358, CANC. MULTIPLE CLASS, INT. CLS. 19 AND 20.

WAYNE SEGER, CHARLEVOIX, MI:
3,479,434, PUB. 5-20-2008. INT. CL. 16.

WEALTH ARCHITECTS, LLC, PALO ALTO, CA:
3,481,802, INT. CL. 36.

WEAR INCORPORATED, LAGUNA BEACH, CA:
3,479,237, PUB. 2-12-2008. INT. CL. 25.

WEBCOUNTRY, INC., LOS ANGELES, CA:
2,492,544, CANC. INT. CL. 42.

WEBCRITERIA, INC., PORTLAND, OR:
2,492,246, CANC. INT. CL. 42.

WEBER, JUDITH, 90425 NUERNBERG, FED REP GERMANY:
2,491,707, CANC. INT. CL. 28.

WEBER, STEVEN, HIDDEN HILLS, CA:
3,481,568, INT. CL. 12.

WEBPUTTY, INC., SAN JOSE, CA:
2,493,440, CANC. INT. CL. 42.
2,493,441, CANC. INT. CL. 9.

WEBSHARES, INC., COSTA MESA, CA:
2,492,383, CANC. INT. CL. 16.

WEBSOURCE, INC., DIX HILLS, NY:
2,493,652, CANC. MULTIPLE CLASS, INT. CLS. 9 AND 35.

WEBVISION, INC., TORRANCE, CA:
2,491,813, CANC. INT. CL. 39.

WECOLLECTBILLS.COM, INC., ELLICOTT CITY, MD:
2,493,685, CANC. INT. CL. 36.

WEDSAFE, INC., CHICAGO, IL:
3,480,356, PUB. 5-20-2008. INT. CL. 36.

WEEDPRO, INC., ALPHARETTA, GA:
3,480,640, PUB. 5-20-2008. INT. CL. 44.

WEEKS, JASON, PALM BEACH GARDENS, FL:
3,479,112, PUB. 5-20-2008. INT. CL. 35.

WEINER, LORI, BOCA RATON, FL AND STONER, JODI, BOCA RATON, FL:
3,481,849, INT. CL. 16.

WELCH, RITA, A, BOCA RATON, FL AND WELCH, CRAIG, A., BOCA RATON, FL:
3,479,059, PUB. 5-20-2008. INT. CL. 41.

WELDON OWEN, INC., SAN FRANCISCO, CA:
3,481,545, INT. CL. 16.

WELDON, WILLIAMS & LICK, INC., FORT SMITH, AR:
3,478,689, PUB. 5-20-2008. INT. CL. 40.
3,478,690, PUB. 5-20-2008. INT. CL. 35.

WELK MUSIC GROUP, INC., SANTA MONICA, CA, VANGUARD RECORDING SOCIETY, INC., NEW YORK, NY:
867,913, REN. 6-28-08. U.S. CL. 36 (INT. CL. 9).

WELK MUSIC GROUP, INC., SANTA MONICA, CA:
1,526,617, REN. 6-28-08. INT. CL. 9.
1,529,454, REN. 6-28-08. INT. CL. 9.

WELK MUSIC GROUP, INC., SANTA MONICA, CA, WELK RECORD GROUP, SANTA MONICA, CA:
1,529,455, REN. 6-28-08. INT. CL. 9.

WELLFORD, MICHAEL R., WARSAW, VA, DBA THOROUGHNBRED RACING CALENDAR:
1,458,299, CANC. INT. CL. 16.

WELLMED, LLC, TARZANA, CA:
2,492,737, CANC. INT. CL. 5.

WELLNESS CARE, INC., WHEATON, IL:
2,493,333, CANC. INT. CL. 5.

WELLPOINT, INC., INDIANAPOLIS, IN:
3,479,464, PUB. 5-20-2008. INT. CL. 41.

WELLS FARGO & COMPANY, MINNEAPOLIS, MN, EDUCAP INC., WASHINGTON, DC:
2,166,332, REN. 7-1-08. INT. CL. 36.

WELLS FARGO & COMPANY, MINNEAPOLIS, MN:
3,481,746, MULTIPLE CLASS, INT. CLS. 36 AND 45.

WELLS' DAIRY, INC., LEMARS, IA:
2,492,944, CANC. INT. CL. 30.

WENCO L.L.C., NEW YORK CITY, NY, DBA SILVERMARK:
3,481,096, MULTIPLE CLASS, INT. CLS. 8, 9 AND 21.

WESCO, INC., MUSKEGON, MI:
3,480,348, PUB. 5-20-2008. INT. CL. 35.

WEST LICENSING CORPORATION, CLAYMONT, DE:
2,493,437, CANC. INT. CL. 35.

WEST PAK AVOCADO, INC., TEMECULA, CA:
3,482,413, INT. CL. 31.

WEST, TERESA, GRANITE BAY, CA:
2,099,070, CANC. INT. CL. 42.

WESTBRIDGE AGRICULTURAL PRODUCTS, VISTA, CA:
3,479,782, PUB. 5-20-2008. INT. CL. 1.

WESTERN AMERICA EQUITIES LLC, BELLEVUE, WA:
3,478,844, PUB. 5-20-2008. INT. CL. 35.

WESTIN HOTEL MANAGEMENT, L.P., WHITE PLAINS, NY:
3,482,177, INT. CL. 43.

WESTPORT CAPITAL PARTNERS LLC, WESTPORT, CT:
3,478,827, PUB. 5-20-2008. INT. CL. 36.

WESTWAYNE, INC., ATLANTA, GA:
2,493,015, CANC. INT. CL. 35.

WETSPOT PRODUCTIONS, CANTON, MI:
3,481,918, INT. CL. 16.

- WEYERHAEUSER COMPANY, FEDERAL WAY, WA:
3,480,730, PUB. 5-20-2008. INT. CL. 17.
- WGBH EDUCATIONAL FOUNDATION, BOSTON, MA:
3,451,655, COR. INT. CL. 44.
- WHALEN, MICHAEL L, MOLINE, IL:
3,479,410, PUB. 5-20-2008. INT. CL. 43.
- WHAT-U-SEEK, CORP., NORTHVILLE, MI:
2,492,814, CANC. INT. CL. 42.
- WHEAT, JARED R., NORCROSS, GA:
3,480,540, PUB. 5-20-2008. INT. CL. 5.
- WHEATLEY PLAZA ASSOCIATES, MANHASSET, NY:
3,478,748, PUB. 5-20-2008. MULTIPLE CLASS, INT. CLS.
35, 36, 37 AND 41.
3,478,920, PUB. 5-20-2008. MULTIPLE CLASS, INT. CLS.
35, 36 AND 41.
- WHEELER, ANNEMARIE R., VISALIA, CA:
3,479,329, PUB. 5-20-2008. INT. CL. 45.
- WHG TM CORP., LAS VEGAS, NV:
3,481,970, INT. CL. 43.
- WHINK PRODUCTS COMPANY, ELDORA, IA:
1,457,979, CANC. INT. CL. 5.
- WHIRLPOOL PROPERTIES, INC., SAINT JOSEPH, MI:
234,988, AM. U.S. CL. 23.
- WHITE HORSES TRADING COMPANY LIMITED, ST.
MARTIN, GUERNSEY, UNITED KINGDOM:
3,482,181, INT. CL. 25.
- WHITE, CYNTHIA, NEW YORK, NY:
3,478,808, PUB. 5-20-2008. INT. CL. 41.
- WHITE, DENNIS R., YORBA LINDA, CA:
3,482,423, INT. CL. 21.
- WHITE, JENNIFER E., WOODINVILLE, WA, DBA LAUGH-
ING DOG ENTERPRISES:
3,482,290, INT. CL. 41.
- WHITE, MELISSA A., SAVAGE, MN, DBA WHITE PAWS
PET SITTING:
3,480,052, PUB. 5-20-2008. INT. CL. 45.
- WHITE'S BOOTS, INC., SPOKANE, WA:
3,480,409, PUB. 5-20-2008. INT. CL. 25.
3,480,410, PUB. 5-20-2008. INT. CL. 25.
3,480,414, PUB. 5-20-2008. INT. CL. 25.
3,480,416, PUB. 5-20-2008. INT. CL. 25.
- WHITE'S PLUMBING SUPPLIES, INC., WEST HAVEN, CT:
3,478,755, PUB. 5-20-2008. INT. CL. 11.
- WHITNELL, AUDREY L., NEWARK, MO, DBA JOSIE'S
ORIGINAL SOAP CO.:
3,480,354, PUB. 5-20-2008. INT. CL. 3.
- WHITNEY DESIGN, INC., BRIDGETON, MO:
3,482,172, INT. CL. 21.
- WHIZBANG! LABS, INC., LOS ANGELES, CA:
2,492,277, CANC. INT. CL. 35.
- WHOLE CHILD FRANCHISING, LLC, BLACKSBURG, VA:
3,479,101, PUB. 5-20-2008. INT. CL. 41.
- WHOLE ENERGY FUELS CORPORATION, BELLINGHAM,
WA:
3,478,771, PUB. 5-20-2008. MULTIPLE CLASS, INT. CLS. 4
AND 35.
- WHOLE FOODS MARKET IP, L.P., AUSTIN, TX:
3,481,541, MULTIPLE CLASS, INT. CLS. 35 AND 36.
- WHOLISTIC DIALOGUE, LLC, NEW YORK, NY:
3,479,377, PUB. 5-20-2008. INT. CL. 38.
3,479,378, PUB. 5-20-2008. INT. CL. 44.
- WICKED FASHIONS, INC., FORT LEE, NJ:
3,480,570, PUB. 5-20-2008. INT. CL. 25.
- WICKED SEASONING, LLC, GREAT FALLS, MT:
3,479,428, PUB. 5-20-2008. INT. CL. 30.
- WIDMER BROTHERS BREWING COMPANY, PORTLAND,
OR:
3,478,701, PUB. 2-12-2008. INT. CL. 32.
- WIELAND-WERKE AG, D-89079 ULM, FED REP GER-
MANY:
2,492,062, CANC. INT. CL. 6.
- WIENER, WEISS & MADISON, A PROFESSIONAL COR-
PORATION, SHREVEPORT, LA:
2,492,946, CANC. INT. CL. 42.
- WIGWAM MILLS, INC., SHEBOYGAN, WI:
3,482,543, MULTIPLE CLASS, INT. CLS. 3 AND 25.
3,482,545, MULTIPLE CLASS, INT. CLS. 3 AND 25.
- WILBUR-ELLIS COMPANY, SAN FRANCISCO, CA:
3,481,393, INT. CL. 1.
- WILCOX, JEFFREY ALAN, PEORIA, AZ:
2,491,755, CANC. MULTIPLE CLASS, INT. CLS. 14 AND
21.
- WILD ADVENTURES VALDOSTA, LLC, VALDOSTA, GA:
3,480,637, PUB. 5-20-2008. INT. CL. 41.
- WILD ROOT, LLC, DALLAS, TX:
3,481,108, INT. CL. 22.
- WILDERNESS MEDICINE OF UTAH, L.L.C., SALT LAKE
CITY, UT:
2,493,640, CANC. INT. CL. 41.
- WILDMAN, FRANK, PH.D., BERKELEY, CA:
3,479,170, PUB. 5-20-2008. INT. CL. 9.
- WILEY SUBSCRIPTION SERVICES, INC., HOBOKEN, NJ:
3,482,253, INT. CL. 44.
- WILFLO, CINCINNATI, OH:
3,481,285, INT. CL. 25.
- WILIAN HOLDING COMPANY, DES MOINES, IA:
2,491,866, CANC. INT. CL. 6.
- WILKHAHN WILKENING + HAHNE GMBH + CO., 31848
BAD MÜNDE, FED REP GERMANY:
3,480,929, PUB. 5-20-2008. INT. CL. 20.
- WILLAWALL INVESTMENTS INC., SAN ANTONIO, TX:
3,482,703, INT. CL. 37.
- WILLEY, BRANDON, TEMPE, AZ:
3,479,643, PUB. 5-20-2008. INT. CL. 42.
- WILLIAM FRICK AND COMPANY, LIBERTYVILLE, IL:
3,481,260, INT. CL. 35.
- WILLIAM FRICK CORPORATION, LIBERTYVILLE, IL:
3,479,079, PUB. 5-20-2008. INT. CL. 22.
- WILLIAM HATCHER WINES, LLC, DUNDEE, OR:
3,481,169, INT. CL. 33.
- WILLIAM UNDERWOOD COMPANY, PARSIPPANY, NJ:
1,098,941, REN. 6-27-08. INT. CL. 30.
- WILLIAMS ENERGY SERVICES, TULSA, OK:
2,493,272, CANC. INT. CL. 9.
- WILLIAMS FOODS, INC., SAN ANTONIO, TX:
2,121,797, REN. 7-1-08. INT. CL. 29.
2,121,797, CANC. INT. CL. 30.
- WILLIAMS II, HUGHES EDGAR, HOUSTON, TX:
2,492,798, CANC. INT. CL. 16.
- WILLIAMS/GERARD PRODUCTIONS, INC., CHICAGO, IL:
2,099,206, CANC. INT. CL. 16.
- WILLIAMS, DOUGLAS, LOS ANGELES, CA:
3,482,399, INT. CL. 25.
- WILLIAMS, JOHN D., FAIRBANKS, AK AND WILLIAMS,
NANCY D., FAIRBANKS, AK:
3,479,284, PUB. 5-20-2008. INT. CL. 30.
- WILLIAMS, LYNN, FRISCO, TX:
3,479,729, PUB. 5-20-2008. INT. CL. 21.
- WILLIAMS, ROLAND, PETALUMA, CA:
3,479,824, PUB. 5-20-2008. INT. CL. 44.
- WILLIS, LARRELL I., LAKE LAND, FL:
3,481,924, INT. CL. 1.
- WILSON SPORTING GOODS CO., CHICAGO, IL:
3,481,466, INT. CL. 28.
- WILSON, CHAD, CORSICANA, TX:
2,100,004, CANC. INT. CL. 8.
- WILSON, JESSICA, SAUSALITO, CA:
3,480,231, PUB. 5-20-2008. INT. CL. 41.
- WILSON'S GUN SHOP, INC., BERRYVILLE, AR:
3,478,566, PUB. 5-20-2008. INT. CL. 13.
- WILTON INDUSTRIES, INC., WOODRIDGE, IL:
3,482,475, INT. CL. 21.
- WILTRON COMPANY, MOUNTAIN VIEW, CA:
1,367,413, CANC. INT. CL. 9.
- WILZIG, IVAN, NEW YORK, NY:
3,478,538, PUB. 5-20-2008. INT. CL. 9.
3,478,539, PUB. 5-20-2008. MULTIPLE CLASS, INT. CLS.
9, 21 AND 25.
- WIND RELATED, INC., HAMILTON, MT:
1,458,488, CANC. INT. CL. 28.
- WINDSTRIPS, L.L.C., BOULDER, CO:
2,167,491, REN. 6-28-08. INT. CL. 19.
- WINNING KIDS, INCORPORATED, PALM BEACH GAR-
DENS, FL:
3,480,090, PUB. 5-20-2008. MULTIPLE CLASS, INT. CLS. 9

- AND 16.
WINTERGREEN SOFTWARE, INC.:
1,458,087, CANC. INT. CL. 9.
WINTHROP CORPORATION, THE, MILFORD, CT:
2,493,118, CANC. INT. CL. 36.
WINTROUB, BARBARA L., SANTA MONICA, CA:
3,482,138, INT. CL. 9.
WINTRUST FINANCIAL CORPORATION, LAKE FOREST,
IL:
3,480,536, PUB. 5-20-2008. INT. CL. 36.
WIRSOL GMBH, WAGHAUSEL-KIRRLACH, FED REP
GERMANY:
3,479,291, PUB. 5-20-2008. MULTIPLE CLASS, INT. CLS.
9, 11, 37, 40 AND 42.
WIS SARL, PARIS, FRANCE:
3,479,531, PUB. 5-20-2008. INT. CL. 35.
WISCONSIN MILK MARKETING BOARD, INC., MADISON,
WI:
2,100,235, CANC. INT. CL. 42.
WISE EARTH SCHOOL OF AYURVEDA, LTD., CANDLER,
NC:
3,480,526, PUB. 5-20-2008. INT. CL. 35.
WISEPAC ACTIVE PACKAGING; COMPONENTS COR-
PORATION, CHINA:
3,480,851, PUB. 5-20-2008. INT. CL. 1.
WITNESS FOR PEACE, INC., WASHINGTON, DC:
2,459,469, AM. MULTIPLE CLASS, INT. CLS. 16 AND 41.
WL HOMES LLC, NEWPORT BEACH, CA:
3,481,256, MULTIPLE CLASS, INT. CLS. 36 AND 37.
WLG, INC., SCHAUMBURG, IL:
3,480,345, PUB. 5-20-2008. INT. CL. 39.
WM. H. LEAHY ASSOCIATES, INC., GLENVIEW, IL:
3,482,393, INT. CL. 30.
WM. WRIGLEY JR. COMPANY, CHICAGO, IL:
3,481,316, INT. CL. 30.
WMG PRODUCTIONS LLC, LOS ANGELES, CA:
3,479,943, PUB. 5-20-2008. INT. CL. 41.
WN PHARMACEUTICALS LTD., COQUITLAM, CANADA:
3,480,652, PUB. 10-31-2006. INT. CL. 5.
WN PHARMACEUTICALS LTD., COQUITLAM, BC, CANA-
DA:
3,481,921, INT. CL. 5.
WNBA ENTERPRISES, LLC, SECAUCUS, NJ:
2,173,876, REN. 7-3-08. INT. CL. 25.
WOLFGANG BLINDOW, FED REP GERMANY:
3,480,961, PUB. 5-20-2008. MULTIPLE CLASS, INT. CLS. 6
AND 20.
WOLFINGTON, RYAN, LAS VEGAS, NV:
3,482,199, INT. CL. 41.
3,482,200, INT. CL. 41.
3,482,201, INT. CL. 41.
WOLFNET TECHNOLOGIES, LLC, MINNEAPOLIS, MN:
3,479,076, PUB. 5-20-2008. INT. CL. 36.
WOLTERS KLUWER HEALTH INC, CONSHOCKEN, PA:
2,100,395, CANC. INT. CL. 16.
WOOD COMPOSITE TECHNOLOGIES INC., NISKU, CANA-
DA:
3,480,667, PUB. 3-25-2008. MULTIPLE CLASS, INT. CLS.
19 AND 42.
WOODE ENTERPRISES INC., BROOKLYN, NY:
2,165,396, REN. 7-2-08. INT. CL. 3.
WOODEN IT BE LOVELY INC., ATLANTA, GA:
2,492,457, CANC. INT. CL. 40.
WOODEN MEMORIES, INC., MAPLE SHADE, NJ:
2,099,677, CANC. INT. CL. 20.
WOODLAND SALES, INC., SCOTTSDALE, AZ TO INNO-
FRESH PRODUCTS, INC., PHOENIX, AZ:
2,100,546, CANC. INT. CL. 5.
WOODMASTER DESIGNS INC., HAYWARD, CA:
3,481,807, INT. CL. 19.
WORDS'WORTH COMMUNICATION, INC., ATLANTA,
GA:
2,492,804, CANC. INT. CL. 41.
WORKMAN PUBLISHING CO., INC., NEW YORK, NY AND
SCHILLER, DAVID, NEW YORK, NY:
3,481,055, INT. CL. 16.
WORLD FUND, INC., THE, NEW YORK, NY, WORLD
FUND USA, INC., THE, NEW YORK, NY:
1,530,077, REN. 7-3-08. INT. CL. 36.
WORLD FUND, INC., THE, NEW YORK, NY:
2,174,713, REN. 7-2-08. INT. CL. 36.
WORLD LINK FOR LAW., 8001 ZURICH, SWITZERLAND:
3,478,607, PUB. 5-20-2008. INT. CL. 35.
WORLD MARKET CENTER VENTURE, LLC, LAS VEGAS,
NV:
3,482,662, INT. CL. 35.
WORLD MARKETING INC., NEW YORK, NY:
2,125,739, REN. 6-30-08. INT. CL. 25.
2,178,517, REN. 6-27-08. INT. CL. 25.
WORLD PUBLICATIONS, LLC, WINTER PARK, FL:
3,479,774, PUB. 5-20-2008. INT. CL. 41.
WORLD RADIO MISSIONARY FELLOWSHIP, INC., COL-
ORADO SPRINGS, CO:
3,482,489, INT. CL. 44.
3,482,490, INT. CL. 16.
3,482,491, INT. CL. 38.
3,482,492, INT. CL. 41.
3,482,493, INT. CL. 16.
WORLD WRESTLING ENTERTAINMENT, INC., STAM-
FORD, CT:
3,481,534, INT. CL. 41.
3,481,617, INT. CL. 16.
WORLDPASS TRAVEL GROUP, LLC, EL DORADO HILLS,
CA:
2,149,266, REN. 7-1-08. INT. CL. 39.
WORLDSTREET CORPORATION, CAMBRIDGE, MA:
2,492,997, CANC. INT. CL. 42.
WORLDVIEW TECHNOLOGIES, INC., CHICAGO, IL:
3,478,833, PUB. 5-20-2008. INT. CL. 9.
WORLDWIDE CO., LTD., INCHEON, REPUBLIC OF KOR-
EA:
3,482,727, INT. CL. 20.
3,482,728, INT. CL. 35.
WORLDWIDE PCE LLC, CLEARWATER, FL:
3,479,634, PUB. 5-20-2008. INT. CL. 35.
WORTH IT INC., NEW YORK, NY:
2,492,449, CANC. INT. CL. 25.
WORTHLEY, BRAD, BELLEVUE, WA:
3,480,049, PUB. 5-20-2008. INT. CL. 41.
WOTTON, THOMAS H., BEALETON, VA, DBA HOME
SWEET HOME IMPROVEMENTS:
3,479,779, PUB. 5-20-2008. INT. CL. 37.
WOWZATV LLC, SAN JOSE, CA, DBA WOWZA MEDIA
SYSTEMS:
3,479,234, PUB. 5-20-2008. INT. CL. 9.
WOYOME FOUNDATION FOR AFRICA, ACCRA, GHANA:
3,479,503, PUB. 5-20-2008. INT. CL. 36.
3,479,657, PUB. 5-20-2008. INT. CL. 36.
WREATHS ACROSS AMERICA, HARRINGTON, ME:
3,479,751, PUB. 5-20-2008. INT. CL. 35.
WREN GARDEN PRODUCTS, INC., SOUTH NORWALK,
CT:
2,491,932, CANC. INT. CL. 6.
WRIGHT & FILIPPIS, INC., ROCHESTER HILLS, MI:
3,478,543, PUB. 5-20-2008. MULTIPLE CLASS, INT. CLS.
40 AND 44.
WRQ, INC., SEATTLE, WA:
2,493,322, CANC. INT. CL. 9.
WRR ENVIRONMENTAL SERVICES CO., INC., EAU
CLAIRE, WI:
2,164,976, REN. 6-30-08. MULTIPLE CLASS, INT. CLS. 39,
40 AND 42.
2,164,976, CANC. INT. CL. 37.
WTC-TRADE MART, L.P., DALLAS, TX:
2,491,987, CANC. INT. CL. 35.
WTW WHOLESALE TIRES & WHEELS, INC., SANTA FE
SPRINGS, CA:
3,481,599, INT. CL. 12.
WUNDERMAN, HUGH, MERRICK, NY:
3,478,655, PUB. 5-20-2008. MULTIPLE CLASS, INT. CLS.
35 AND 41.
3,480,729, PUB. 5-20-2008. MULTIPLE CLASS, INT. CLS.
35 AND 41.

- WUXI GUANG MING (GROUP) CO., LTD., CHINA:
3,481,006, PUB. 5-20-2008. INT. CL. 25.
- WYETH, MADISON, NJ:
3,480,534, PUB. 5-20-2008. INT. CL. 16.
3,480,559, PUB. 5-20-2008. INT. CL. 5.
- WYETH HOLDINGS CORPORATION, MADISON, NJ, SOLVAY (SOCIETE ANONYME), B-1050 BRUSSELS, BELGIUM:
2,166,432, REN. 6-30-08. INT. CL. 5.
- WYNNE SYSTEMS, INC., IRVINE, CA:
3,480,491, PUB. 5-20-2008. INT. CL. 42.
- W2BI, INC., UNION, NJ:
3,481,494, INT. CL. 9.
- X-SPAN RESULTS, LLC, DURHAM, NC:
3,482,710, INT. CL. 9.
- X, INC., CANOGA PARK, CA, DBA ONE STOP SHOP:
3,482,332, INT. CL. 35.
- XANALYS CORPORATION, WALTHAM, MA:
2,164,958, REN. 6-30-08. INT. CL. 9.
- XEROX CORPORATION, NORWALK, CT:
3,482,063, INT. CL. 42.
3,482,064, INT. CL. 42.
- XICAT INTERACTIVE LTD., LONDON WC1R 4BB, UNITED KINGDOM:
2,492,614, CANC. INT. CL. 9.
- XIE, HANG, HONOLULU, HI:
3,480,199, PUB. 5-20-2008. INT. CL. 41.
- XM SATELLITE RADIO INC., WASHINGTON, DC:
3,481,912, INT. CL. 41.
3,482,167, INT. CL. 41.
- XO WINE GLASS INC., MANHATTAN BEACH, CA:
3,479,408, PUB. 5-20-2008. INT. CL. 35.
- XORA, INC., MOUNTAIN VIEW, CA:
3,478,650, PUB. 5-20-2008. INT. CL. 35.
3,478,658, PUB. 5-20-2008. INT. CL. 35.
- XOSKELETON, INC., COLUMBIA, MD:
3,481,650, INT. CL. 14.
- XSE GROUP, INC., MIDDLETOWN, CT:
3,478,581, PUB. 5-20-2008. INT. CL. 2.
3,478,582, PUB. 5-20-2008. INT. CL. 2.
- XTRA CORPORATION, ST. LOUIS, MO:
1,493,575, REN. 7-3-08. INT. CL. 39.
1,494,568, REN. 7-3-08. INT. CL. 39.
- XTREME TECHNOLOGIES, L.L.C., COEUR D'ALENE, ID:
2,269,399, CANC. INT. CL. 32.
- Y-ME NATIONAL BREAST CANCER ORGANIZATION, CHICAGO, IL:
2,491,719, CANC. INT. CL. 36.
3,481,806, INT. CL. 36.
- YALE UNIVERSITY, NEW HAVEN, CT:
2,493,476, CANC. INT. CL. 9.
- YAMAHA CORPORATION, SHIZUOKA, JAPAN:
3,481,126, INT. CL. 9.
- YANG BEY INDUSTRIAL CO., LTD., TAICHUNG HSIEN 427, TAIWAN:
3,481,115, INT. CL. 7.
- YANGZHOU GARHOPE INSTRUMENT CO., LTD, JIANGDU, JIANGSU, CHINA:
3,480,974, PUB. 5-20-2008. INT. CL. 9.
- YAO-WEN HUANG, TAIPEI CITY, TAIWAN:
3,482,645, INT. CL. 45.
- YBANEZ-GONZALES, INC., OXNARD, CA:
3,479,712, PUB. 5-20-2008. INT. CL. 43.
- YEATES, STEPHEN, TORONTO, ONTARIO:
2,492,735, CANC. INT. CL. 9.
- YEKALON INDUSTRY, INC., CHINA:
3,480,909, PUB. 5-20-2008. INT. CL. 19.
- YEN, ALAIN, MORENO VALLEY, CA:
3,481,857, INT. CL. 25.
3,481,875, INT. CL. 25.
3,481,876, INT. CL. 25.
- YESICAN.CC, LLC, AUSTIN, TX:
3,478,997, PUB. 5-20-2008. INT. CL. 25.
3,478,998, PUB. 5-20-2008. INT. CL. 25.
- YG ENTERTAINMENT, INC., SEOUL, REPUBLIC OF KOREA:
3,479,517, PUB. 5-20-2008. MULTIPLE CLASS, INT. CLS. 9 AND 41.
- YG LABORATORIES, INC., HUNTINGTON BEACH, CA:
3,482,384, INT. CL. 3.
- YIELDING LIMITED, KOWLOON BAY, KOWLOON, HONG KONG:
2,493,311, CANC. MULTIPLE CLASS, INT. CLS. 9 AND 28.
- YJ LICENSING COMPANY, INC., EAST POINT, GA:
3,481,431, INT. CL. 41.
- YMCA OF METROPOLITAN WASHINGTON, WASHINGTON, DC:
3,479,268, PUB. 5-20-2008. MULTIPLE CLASS, INT. CLS. 41 AND 45.
- YODLE, INC., NEW YORK, NY:
3,479,429, PUB. 2-12-2008. INT. CL. 42.
- YOGURT VENTURES U.S.A., INC., ATLANTA, GA:
2,207,736, REN. 7-3-08. INT. CL. 30.
- YONGFANG, GUO, WEIHAI CITY, CHINA:
3,481,595, INT. CL. 12.
- YOO, BYUNG HAK, LOS ANGELES, CA:
3,478,602, PUB. 5-20-2008. INT. CL. 25.
- YORKVILLE COMMUNICATIONS, INC., YORKVILLE, TN:
2,492,455, CANC. INT. CL. 38.
- YOSHIKI MIYAJIMA, RANCHO SANTA MARGARITA, CA:
2,492,261, CANC. INT. CL. 9.
- YOUCENTRIC, INC., CHARLOTTE, NC:
2,491,691, CANC. INT. CL. 9.
- YOUNG LEADERSHIP COUNCIL, NEW ORLEANS, LA:
2,493,469, CANC. INT. CL. 35.
- YOUNG, NANCY, TRACY, CA AND YOUNG, MARCEL-LUS, TRACY, CA:
3,481,808, INT. CL. 22.
- YUEN, SE KIT, KWUN TONG, KOWLOON, HONG KONG:
3,480,628, PUB. 4-10-2007. MULTIPLE CLASS, INT. CLS. 9, 11 AND 38.
- YUNNAN BAIYAO GROUP CO., LTD., KUNMING, CHINA:
3,478,678, PUB. 5-20-2008. MULTIPLE CLASS, INT. CLS. 5 AND 30.
3,478,680, PUB. 5-20-2008. MULTIPLE CLASS, INT. CLS. 5 AND 30.
- YYOL, LLC, VANCOUVER, WA:
3,479,977, PUB. 5-20-2008. MULTIPLE CLASS, INT. CLS. 16 AND 28.
- YZ ENTERPRISES, INC., MAUMEE, OH:
3,478,985, PUB. 5-20-2008. INT. CL. 30.
- Z-MAN FISHING PRODUCTS, INC., LADSON, SC:
3,479,753, PUB. 5-20-2008. INT. CL. 28.
- ZABORONEK, GINNY, BLAIRSTOWN, NJ AND RICHARDS, MARGARET, WEST CHESTER, PA:
3,482,677, INT. CL. 16.
- ZACKIN PUBLICATIONS, INC., OXFORD, CT:
3,481,933, INT. CL. 36.
- ZAGO S.R.L., ITALY:
3,480,799, PUB. 5-20-2008. INT. CL. 32.
- ZANER-BLOSER, INC., COLUMBUS, OH:
3,481,533, INT. CL. 16.
- ZANOTTI S.P.A., PEGOGNAGA (MANTOVA), ITALY:
3,482,059, INT. CL. 11.
- ZAPHEALTH.COM, INC., NEW YORK, NY:
2,492,474, CANC. INT. CL. 35.
2,492,475, CANC. INT. CL. 38.
- ZEBRA SKIMMERS CORP., CHAGRIN FALLS, OH:
3,480,426, PUB. 5-20-2008. INT. CL. 7.
- ZETT KABUSHIKI KAISHA, JAPAN:
3,480,779, PUB. 5-20-2008. MULTIPLE CLASS, INT. CLS. 3, 4, 9, 18, 20, 25 AND 28.
- ZHEJIANG CEREALS, OILS & FOODSTUFFS IMPORT & EXPORT CO., LTD., HANGZHOU, CHINA:
3,481,253, INT. CL. 33.
- ZHEJIANG HAORYUN MUYE YOUXIAN GONGSI, CHINA:
3,481,030, PUB. 5-20-2008. INT. CL. 19.
- ZHEJIANG HENGLIN JIAJU; YOUXIAN GONGSI, 313300 ZHEJIANG, CHINA:
3,480,917, PUB. 5-20-2008. INT. CL. 20.
- ZHEJIANG PUJIANG ZHONGXING CO., LTD., CHINA:
3,480,829, PUB. 5-20-2008. INT. CL. 6.

ZHEJIANG ZHONGHUI; FUR & LEATHER CO., LTD,
TONGXIANG CITY; 314511 ZHEJIANG PROVINCE, CHINA:
3,480,975, PUB. 5-20-2008. INT. CL. 25.

ZHOU ELIN, CHINA:
3,480,912, PUB. 5-20-2008. INT. CL. 8.

ZICAM, LLC, PHOENIX, AZ:
3,482,729, INT. CL. 5.

ZIDZIK, JOHN, HENDERSON, NV AND ZIDZIK, KRISTEN,
HENDERSON, NV:
3,481,430, INT. CL. 25.

ZIFF-DAVIS PUBLISHING COMPANY, NEW YORK, NY TO
ZIFF DAVIS PUBLISHING HOLDINGS INC., NEW YORK,
NY:
2,100,147, CANC. INT. CL. 9.

ZILA PHARMACEUTICALS, INC., PHOENIX, AZ:
3,482,115, MULTIPLE CLASS, INT. CLS. 5 AND 10.

ZING NETWORK, INC., SAN FRANCISCO, CA:
2,492,903, CANC. MULTIPLE CLASS, INT. CLS. 9 AND
42.

ZING TOYS, INC, BANKS, OR:
3,480,092, PUB. 5-20-2008. INT. CL. 28.

ZLOTNICK, MARILYN RUTH, TARZANA, CA:
2,492,738, CANC. INT. CL. 41.

ZODIAC INTERNATIONAL, ISSY LES MOULINEAUX CE-
DEX, FRANCE:
3,482,101, INT. CL. 12.

ZOOLOGICAL SOCIETY OF SAN DIEGO, INC., SAN
DIEGO, CA:
2,100,097, CANC. INT. CL. 25.

ZORKAFOR'S SANDVEG INC, ALEXANDRIA, VA:
3,481,369, INT. CL. 43.

ZOULLA, INC., GREENVILLE, MI:
1,457,924, CANC. INT. CL. 3.

ZUCCA VOLANTE LLP, MURRAY, UT:
3,479,671, PUB. 5-20-2008. INT. CL. 9.
3,479,673, PUB. 5-20-2008. INT. CL. 9.

ZUITSPTS, INC., VISTA, CA:
3,482,408, INT. CL. 25.

ZWICKER SERVICES, INC., GLENSIDE, PA:
3,481,056, INT. CL. 16.

1 SKY FOUNDATION, SANTE FE, NM:
3,479,476, PUB. 5-20-2008. MULTIPLE CLASS, INT. CLS.
35, 41 AND 42.

1031 ADVISERS, INC., JACKSONVILLE, FL:
3,481,724, INT. CL. 36.

1058822 ONTARIO LTD., LONDON, ONTARIO, CANADA:
3,482,015, MULTIPLE CLASS, INT. CLS. 9 AND 41.

1099 PRO, INC., CALABASAS, CA:
3,481,065, INT. CL. 9.

1673911 ONTARIO LTD., MISSISSAUGA, ONTARIO:
3,482,514, MULTIPLE CLASS, INT. CLS. 10 AND 11.

185 RED, INC., PHILADELPHIA, PA, DBA FIRE ENGINE
RED:
3,355,708, AM. INT. CL. 42.

2 CHIX, LOS ANGELES, CA:
3,480,609, PUB. 5-20-2008. INT. CL. 25.

2 UNDER ENTERTAINMENT, COLUMBUS, OH:
3,479,804, PUB. 5-20-2008. INT. CL. 41.

2FEETSOUTH LLC, GARDNER, MA:
3,481,608, INT. CL. 25.

21ST CENTURY CINEMA, INC., ABINGDON, VA:
2,202,151, REN. 7-2-08. INT. CL. 41.

24TH & K STREET ASSOCIATIONS, LIMITED PARTNER-
SHIP, WASHINGTON, DC:
2,492,135, CANC. INT. CL. 42.

26 BRIX, LLC, SAN JUAN CAPISTRANO, CA, DBA B
CELLARS:
3,482,099, INT. CL. 41.

291 FROM VENICE, INC., VENICE, CA:
3,481,154, INT. CL. 25.

3DCD, LLC, RUCKERSVILLE, VA:
2,099,013, CANC. MULTIPLE CLASS, INT. CLS. 9 AND
40.

3PF.COM, INC., PORTLAND, OR:
2,492,158, CANC. MULTIPLE CLASS, INT. CLS. 35 AND
39.

3RD MIRAGE, INC., HOBOKEN, NJ:
2,492,690, CANC. INT. CL. 9.

3WISHES.COM, INC., CREEDMOOR, NC:
3,480,713, PUB. 5-20-2008. INT. CL. 35.

4R, INC., LAMBERTVILLE, MI:
3,480,425, PUB. 5-20-2008. INT. CL. 16.

4W INTERNACIONAL, S.A., PANAMA, PANAMA:
3,481,692, INT. CL. 16.

4004 INCORPORATED, PORT WASHINGTON, NY:
3,481,527, INT. CL. 25.

401(K) PRO, INC., SHERMAN OAKS, CA:
2,491,982, CANC. INT. CL. 9.

55 CONSULTANTS, INC., SAN JOSE, CA:
3,480,118, PUB. 5-20-2008. INT. CL. 6.
3,480,123, PUB. 5-20-2008. INT. CL. 16.

800 RESPONSE MARKETING LLC, BURLINGTON, VT:
3,482,510, INT. CL. 38.

818 VENTURE PARTNERS, LLC, LONGMONT, CO:
3,481,881, INT. CL. 43.

9061-4371 QUEBEC INC., SHERBROOKE, CANADA:
3,479,019, PUB. 5-20-2008. INT. CL. 28.

99 RESTAURANTS, LLC, NASHVILLE, TN:
3,478,683, PUB. 5-20-2008. INT. CL. 43.

* * * * *