

This table is not intended to be exhaustive, but rather provides a guide for readers regarding entities likely to be affected by this action. Other types of entities not listed in the table could also be affected. To determine whether your facility would be affected by this action, you should carefully examine the applicability criteria in part 372 subpart B of Title 40 of the Code of Federal Regulations. If you have questions regarding the applicability of this action to a particular entity, consult the person listed in the preceding **FOR FURTHER INFORMATION CONTACT** section.

B. How Should I Submit CBI to the Agency?

Do not submit information that you consider to be CBI electronically through EPA's electronic public docket or by e-mail. Commenters wishing to submit proprietary information for consideration must clearly distinguish such information from other comments and clearly label it as CBI. Send submissions containing such proprietary information directly to the following address only, and not to the public docket, to ensure that proprietary information is not inadvertently placed in the docket: Attention: OEI Document Control Officer, Mail Code: 2822T, U.S. EPA, 1200 Pennsylvania Ave. NW., Washington, DC 20460. You may claim information that you submit to EPA as CBI by marking any part or all of that information as CBI (if you submit CBI on disk or CD-ROM, mark the outside of the disk or CD-ROM as CBI and then identify electronically within the disk or CD-ROM the specific information that is CBI). The EPA will disclose information claimed as CBI only to the extent allowed by the procedures set forth in 40 CFR part 2.

In addition to one complete version of the comment that includes any information claimed as CBI, a copy of the comment that does not contain the information claimed as CBI must be submitted for inclusion in the public docket and EPA's electronic public docket. If you submit the copy that does not contain CBI on disk or CD-ROM, mark the outside of the disk or CD-ROM clearly that it does not contain CBI. Information not marked as CBI will be included in the public docket and EPA's electronic public docket without prior notice. If you have any questions about CBI or the procedures for claiming CBI, please consult the person identified in the **FOR FURTHER INFORMATION CONTACT** section.

II. Background Information

A. What Does This Notice Do and What Action Does This Notice Affect?

This notice extends the comment period for EPA's June 14, 2005 notice of data availability concerning the proposed rule to add a DINP category to the EPCRA section 313 list of toxic chemicals (70 FR 34437).

B. Why and for How Long Is EPA Extending the Comment Period?

EPA received a request from the public for a 30-day extension of the comment period for the June 14, 2005 DINP notice of data availability. The request was for additional time to review relevant information and prepare comments on the revised DINP hazard assessment that was made available for public comment in the notice of data availability. EPA considered the request and determined that extending the comment period is an appropriate action. Therefore, EPA is extending the comment period on the June 14, 2005 notice of data availability by 30 days until October 12, 2005. All comments should be submitted following the detailed instructions as provided in Unit I. of the **SUPPLEMENTARY INFORMATION** section of this document. All comments must be received by October 12, 2005.

List of Subjects in 40 CFR Part 372

Environmental protection, Chemicals, Community right-to-know, Hazardous substances, Intergovernmental relations, Reporting and recordkeeping requirements, Superfund.

Dated: September 6, 2005.

Kimberly T. Nelson,

Assistant Administrator for Office of Environmental Information.

[FR Doc. 05-18090 Filed 9-9-05; 8:45 am]

BILLING CODE 6560-50-P

DEPARTMENT OF TRANSPORTATION

National Highway Traffic Safety Administration

49 CFR Part 571

[Docket No. NHTSA 2004-19239]

RIN 2127-AG41

Federal Motor Vehicle Safety Standards; Rearview Mirrors

AGENCY: National Highway Traffic Safety Administration, DOT.

ACTION: Notice of proposed rulemaking (NPRM).

SUMMARY: In response to a petition for rulemaking, this document proposes to require straight trucks with a gross vehicle weight rating (GVWR) of between 4,536 kilograms (10,000 pounds) and 11,793 kilograms (26,000 pounds) to be equipped with a rear object detection system. The purpose of the proposed requirement is to alert drivers to persons and objects directly behind the vehicle, thereby reducing backing-related deaths and injuries. This notice proposes two compliance options. Vehicle manufacturers could satisfy the proposed requirement either by installing a mirror system or rear video system that would make the area to the rear of the vehicle visible to the driver. The notice also asks a series of questions to help the agency determine whether the proposed requirements should be extended to vehicles in other weight classes and whether existing straight trucks engaged in interstate commerce should be retrofitted to meet the proposed requirements, as part of a future rulemaking.

DATES: Comments must be received on or before November 14, 2005.

ADDRESSES: You may submit comments identified by DOT DMS Docket Number above by any of the following methods:

- Web site: <http://dms.dot.gov>.

Follow the instructions for submitting comments on the DOT electronic docket site.

- Fax: 1-202-493-2251.

- Mail: Docket Management Facility; U.S. Department of Transportation, 400 Seventh Street, SW., Nassif Building, Room PL-401, Washington, DC 20590-001.

- Hand Delivery: Room PL-401 on the plaza level of the Nassif Building, 400 Seventh Street, SW., Washington, DC., between 9 a.m. and 5 p.m., Monday through Friday, except Federal Holidays.

- Federal eRulemaking Portal: Go to <http://www.regulations.gov>. Follow the online instructions for submitting comments.

Instructions: All submissions must include the agency name and docket number or Regulatory Identification Number (RIN) for this rulemaking. For detailed instructions on submitting comments and additional information on the rulemaking process, see the Public Participation heading of the Supplementary Information section of this document. Note that all comments received will be posted without change to <http://dms.dot.gov>, including any personal information provided. Please see the Privacy Act heading under Regulatory Notices.

Docket: For access to the docket to read background documents or

comments received, go to <http://dms.dot.gov> at any time or to Room PL-401 on the plaza level of the Nassif Building, 400 Seventh Street, SW., Washington, DC, between 9 a.m. and 5 p.m., Monday through Friday, except Federal Holidays.

FOR FURTHER INFORMATION CONTACT: For non-legal issues, you may contact Dr. Keith Brewer, Office of Crash Avoidance Standards (NVS-121), NHTSA, 400 Seventh Street, SW., Washington, DC 20590 (Telephone: 202-366-5280) (FAX: 202-366-4329).

For legal issues, you may contact Mr. Eric Stas, Office of the Chief Counsel, NHTSA, 400 Seventh Street, SW., Washington, DC 20590 (Telephone: 202-366-2992) (FAX: 202-366-3820).

SUPPLEMENTARY INFORMATION:

Table of Contents

- I. Executive Summary
- II. Background
 - A. Petition for Rulemaking
 - B. Request for Comments
 - C. Advanced Notice of Proposed Rulemaking (ANPRM)
 - D. Comments on the ANPRM
- III. Size of the Safety Problem
 - A. Number of Injuries and Fatalities
 - B. Vehicle Type Involvement in Backing Crashes
 - C. Other Data and Summary
- IV. Agency Proposal
 - A. Summary of Proposal
 - B. Compliance Options
 - 1. Cross-View Mirrors
 - 2. Rear Video Systems
 - C. Applicability
 - D. Non-Visual Systems
 - E. Retrofitting of Existing Commercial Vehicles
 - F. FMCSA Issues Related to Retrofit and Preemption
 - G. Effective Date
- V. Benefits
- VI. Costs
- VII. Public Participation
- VIII. Rulemaking Analyses and Notice

I. Executive Summary

In response to a petition for rulemaking, the National Highway Traffic Safety Administration (NHTSA) is proposing to amend Federal Motor Vehicle Safety Standard (FMVSS) No. 111, *Rearview Mirrors*, to require a rear object detection system on straight trucks¹ with a GVWR of between 4,536 kilograms (kg) (10,000 pounds) and 11,793 kg (26,000 pounds). Most of these vehicles have a significant blind spot in the rear. The purpose of the proposed requirement is to provide a uniform standard that would alert

¹ A "straight truck" is a single-unit truck composed of an undetachable cab and body. Body types routinely incorporated as part of straight trucks include an enclosed box, flat bed, dump bed, bulk container, or special purpose equipment.

drivers of persons and objects directly behind the vehicle and to thereby reduce backing-related deaths and injuries. Children, the elderly, and persons with impaired senses are target populations of particular concern in backing-related incidents.

NHTSA is proposing a regulation at this time for a number of reasons. First, agency research has demonstrated that straight trucks have a disproportionately higher back-up fatality rate than other vehicle types. Research indicates that backing straight trucks annually cause at least 79 fatalities (both on-road and off-road) and 148 injuries. The incidence rate for straight truck backing fatalities is 21.89 per 100 billion vehicle miles traveled and 29.68 per million registered vehicles, figures 8 to 17 times greater than for passenger vehicles.

Second, technologies currently exist that could make a substantial area directly behind such trucks visible to the driver. Elimination of this blind spot could significantly mitigate the backing problem associated with these vehicles. Further, because individual States have begun to regulate in this area, NHTSA believes it is appropriate to develop a uniform set of requirements for rear object detection.

In developing a proposed performance standard for rear object detection, NHTSA carefully considered a range of technologies. NHTSA examined both visual systems (e.g., cross-view mirrors and video cameras) and non-visual systems (e.g., sonar/infrared devices and audible back-up alarms) in order to evaluate their efficacy in preventing backing-related injuries and fatalities.

We believe primary responsibility for object detection should be placed upon the driver, such that the driver has visible confirmation that the pathway is clear before backing; non-visual systems, by their nature, cannot provide such confirmation. Consequently, we are proposing two compliance options that would provide a visual image to the driver of a 3 meter (m) by 3 m area immediately behind the vehicle. We propose that the following requirements would become effective for covered vehicles that are manufactured one year after publication of a final rule.

Option 1: Cross-View Mirrors

Under the first proposed compliance option, a cross-view mirror system would be required. A cross-view mirror is typically a convex mirror mounted on the driver's side, upper rear corner of a vehicle that is used in conjunction with the driver's side exterior rearview mirror to view the area directly behind a vehicle.

The cross-view mirror would be required to: (1) Have no discontinuities in the slope of its surface; (2) be adjustable both in the horizontal and vertical directions; (3) be installed on stable supports on the upper rear corner of the driver's side of the vehicle; (4) have an average radius of curvature of no less than 203 millimeters (mm), and (5) be placed such that the geometric centers of the two mirrors would be separated by no more than 5 m.

We also are proposing test requirements to ensure that the mirror system provides a detection zone that would permit the driver to survey the area behind the vehicle for obstacles before backing. The proposed test requirements would be similar in nature to the school bus mirror test requirements of FMVSS No. 111, which utilize a number of cylinders to simulate objects that would be difficult or impossible to see without the aid of mirrors.

Option 2: Rear Video Systems

Under the second proposed compliance option, a rear video system would be required that provides the same 3 m by 3 m field of view as in Option 1. To maximize its effectiveness, the system's monitor would be required to be mounted as close to the centerline of the vehicle as practicable near the top of the windshield and have an image size of between 90 cm² and 160 cm². The video camera would be required to be adjustable so that it may tilt in both the horizontal and vertical directions, for aiming purposes, and the video monitor similarly would be required to be adjustable so as to accommodate drivers of different statures.

The proposed test procedures, designed to ensure compliance with the rear video system's detection zone requirement, would be essentially the same as those for the cross-view mirrors compliance option.

Although we do not believe that non-visual systems alone would achieve our safety objectives related to rear object detection, we intend neither to require nor to prohibit the voluntary installation of such systems by manufacturers.

Finally, although we are not proposing to do so at this time, NHTSA is requesting comments as to whether, in the interests of safety, the proposed requirements should be extended to vehicles in other weight classes and whether existing commercial vehicles in the designated weight class should be required to be retrofitted with rear object detection systems that would comply with the new standard.

The agency estimates that requiring a visual rear detection system would

result annually in a net reduction of 23 fatalities, 43 injuries, and an estimated \$32 million in property damage savings (present discounted value). The associated cost burden is estimated to be approximately \$77 million annually (in 2004 economics).

II. Background

A. Petition for Rulemaking

In March 1995, Mr. Dee Norton submitted a petition for rulemaking to the agency seeking to amend FMVSS No. 111 to require convex, cross-view mirrors on the rear of the cargo box of stepvans and walk-in style delivery and service trucks. The petition was intended to prevent future tragedies similar to one that befell Mr. Norton's grandson, who was killed when he was struck and backed over by a delivery truck in an apartment complex parking lot because the driver was unable to see the area directly behind the vehicle in its side-mounted rearview mirrors.

In determining whether to grant the petition and deciding how to substantively respond, NHTSA decided to solicit comment from the public. To this end, NHTSA issued a request for comments, which was later followed by an Advanced Notice of Proposed Rulemaking (ANPRM).

B. Request for Comments

NHTSA published a notice in the **Federal Register** on June 17, 1996, seeking information on cross-view mirrors and other alternative rear object detection systems (61 FR 30586).² We received six comments in response to that notice.

Commenters described a variety of available rear object detection devices, including both visual and non-visual systems. Visual systems include not only cross-view mirrors, but also video cameras mounted on the rear of the vehicle that are connected to a monitor in the occupant compartment. Existing non-visual systems include ultrasound, radar, microwave, and infrared sensor mechanisms, which detect an object and provide an auditory signal to the driver that an obstruction is behind the vehicle, as well as audible alarms that sound whenever a vehicle is backing. These comments provided initial insights that helped NHTSA to direct the course of the rulemaking process.

² This Request for Comments and the comments subsequently received are available in hard copy in Docket No. NHTSA-96-53. However, for ease of reference, the Request for Comments also has been included in the electronic docket for the present rulemaking (Docket No. NHTSA-2000-7967-25).

C. Advanced Notice of Proposed Rulemaking

NHTSA issued an ANPRM on November 27, 2000, to gather further data on key issues related to rear object detection (65 FR 70681).³ In addition to a request for general comments, the ANPRM posed twenty specific questions for public input, which were broken down into four main categories: (1) Questions concerning rear cross-view mirrors; (2) questions concerning rear video systems; (3) questions concerning other rear object detection systems, and (4) other questions. Generally, the cross-view mirror questions concerned the size, design, and placement of mirrors, the size of the detection area behind the vehicle, the use and capabilities of exterior, audible back-up alarms (as an alternative to mirrors), and test procedures. The rear video systems questions sought input regarding image size, display color, screen size and location, need for a system failure alert, possible conflicts with State laws against video screens/monitors in view of the driver, and test procedures.

The questions pertaining to other rear object detection systems asked about the capabilities and limitations of these non-visual systems, including efforts to increase the range of sensors so that they are effective at higher backing speeds. These questions also raised the issue of how to craft test procedures that would ensure the accuracy and reliability of non-visual systems under a variety of environmental conditions. The "other" category of questions asked whether manufacturers who have installed rear visibility systems have experienced significant property damage prevention benefits, whether this area should be regulated by the Federal government or the States, whether and how subcategories of vehicles should be defined, and whether existing commercial trucks in the applicable weight range should be required to be retrofitted with rear object detection systems.

D. Comments on the ANPRM

NHTSA received fourteen comments in response to the ANPRM, including submissions from trade associations, automobile and rear object detection system manufacturers, fleet operators, organized labor, a State agency, and individuals.⁴ In addition to responding

³ Docket No. NHTSA-2000-7967-1.

⁴ Comments were received from: (1) The National Private Truck Council (NPTC); (2) the American Trucking Associations (ATA); (3) the Towing and Recovery Association of America (TRAA); (4) the National Truck Equipment Association (NTEA); (5)

to the questions posed in the ANPRM, commenters also raised a variety of issues, including scope of the regulatory requirement, potential exclusions, alternatives to regulation, maintenance and training requirements, and preemption. The following discussion summarizes the comments received on the ANPRM.

Scope and Exclusions

NHTSA received a range of views regarding the scope of a regulation for rear object detection systems. Several commenters advocated narrowing coverage due to purported unsuitability of or lack of necessity for such systems on certain vehicles. For example, ATA stated that a "one-size-fits-all" approach would not be successful, because there is too much diversity in equipment and operations. NTEA stated that the rear object detection standard should only apply to "standard type vehicles."

Commenters also offered numerous suggestions for vehicles which they believe should be excluded from the requirements of an amended standard, including tow trucks, car carriers, flat beds, stake trucks, dump trucks, tradesmen's and mechanic's bodies, platform bodies, tank trucks, any vehicle equipped with a crane or aerial device operating in a rotational manner, and other special units.

Other commenters, such as NYDOT, urged NHTSA to expand coverage of the standard to include lighter vehicles commonly used in residential deliveries (e.g., trucks with a GVWR of 6,500 lbs. to 16,000 lbs.). NATC suggested that other vehicles with large blind spots (e.g., windowless vans and light trucks with campers or canopy shells) may also be suitable for coverage under a revised FMVSS No. 111. These recommended changes could bring some passenger vehicles within the ambit of the rule. NYDOT suggested consideration of a phase-in period to permit earlier implementation of requirements for trucks that can readily be equipped with existing technology.

In response to the questions about retrofitting, commenters expressed divergent views. NYDOT urged NHTSA to take the lead on retrofitting of existing vehicles so that there would not be a patchwork of remedial activities by the 50 States. Others, such as ABC,

Ford Motor Company (Ford); (6) Sheffield Partners LLC (Sheffield); (7) Rostra Precision Controls, Inc. (Rostra); (8) Reliant Energy (Reliant); (9) ABC Supply Co., Inc. (ABC); (10) Federal Express Corporation (FedEx); (11) the International Brotherhood of Teamsters (Teamsters); (12) the New York Department of Transportation (NYDOT); (13) the Nevada Automotive Test Center (NATC); and (14) Ronald G. Silc. These comments can be found in Docket No. NHTSA-2000-7967.

opposed retrofitting, stating that retrofitting its entire fleet would be a "very lengthy and costly operation."

Rearview Mirrors

Regarding rearview mirrors, the commenters generally agreed with NHTSA's tentative determination that cross-view mirrors should be placed no more than 5 meters (approximately 16 feet) from the driver's side rear view mirror, as the image size arguably becomes too small beyond this distance to be useful to the driver. However, ATA urged greater clarity in how NHTSA would measure the distance between the two mirrors.

Commenters also discussed the issue of trucks that are particularly long or high, thereby posing greater challenges in terms of rear object detection. For example, FedEx expressed concerns about situations where the height of a truck is so great that a top-mounted cross-view mirror is not visible in the side mirror. NYDOT stated that some trucks approaching 11,793 kg (26,000 pounds) may exceed the length where it would be feasible to use a cross-view mirror system, but it urged the agency to maintain some alternative rear object detection requirement for such vehicles.

In the ANPRM, we requested comments on whether a 3 m by 3 m detection area behind a vehicle would be adequate. Some commenters suggested alternative detection zones that would be either larger or asymmetrical, but they did not provide a strong rationale or data to support their position. However, ATA and Ford suggested that NHTSA's estimation of the backing speed used to calculate the detection zone (*i.e.*, 3 mph) underestimates actual backing speeds. These organizations stated that a reasonable estimate of backing speeds could be in the 5 mph to 8 mph range.

Rear Video Systems

Commenters likewise expressed a range of views on rear video systems. Some commenters, such as ABC, expressed concern about the expense of this technology. Other commenters, such as the Teamsters, specifically requested that NHTSA adopt a performance standard that would permit use of video systems.

Reliant argued that the presence of a video camera may encourage theft (presumably of the camera), but NATC made the argument that video cameras and rear mirrors may deter theft of items from the back of the vehicle when stopped.

In terms of the image presented by a rear video system, commenters suggested that an acceptable size for a

screen may be as small as 3.8 cm (1.5 inches) on the diagonal and as large as 25.4 cm (10 inches) on the diagonal. NATC stated that the size of the screen needed will depend upon the placement of the monitor relative to the driver's seating position. Reliant expressed concern about placing a video monitor in a truck's "already full" cab.

Varying views were expressed regarding screen color for rear video monitors. Mr. Silc stated that military-green monitors are more efficient than black-and-white monitors and that they provide three-times better contrast to the human eye and greater visibility. However, NATC reasoned that a black-and-white screen would be sufficient, because color would be lost in strong daylight and a black-and-white screen's contrast would be helpful in distinguishing objects and movement.

Regarding placement for the video screen, one suggestion was to have the monitor in a location similar to a car's rearview mirror, where the driver's eyes can constantly be glancing at it. NATC urged NHTSA to conduct human factors analysis to determine the optimal placement of the monitor in the truck cab.⁵

NHTSA received conflicting viewpoints regarding the need for a system failure alert for the rear video system. Mr. Silc stated that it is unnecessary, arguing that if the screen is black, the system is either turned off or malfunctioning, and that either situation would be easily detectable by the driver. In contrast, the Teamsters supported use of a failure alert, expressing concern that the image of the monitor must reflect in real time the area behind the truck.

In response to the ANPRM's questions about State laws regulating the existence and use of video monitors/screens in the occupant compartment which are in view of the driver, ATA stated that such restrictions are similar to those contained in Federal Motor Carrier Safety Regulation (FMCSR) 393.88. That provision specifically prohibits monitors that are in view of the driver that can receive a television signal or can be used to view video tapes. However, such prohibitions would not be applicable here, where the image presented only displays the area to the rear of the vehicle for backing purposes

⁵ We note that NHTSA has defined and is conducting an innovative, detailed human factors analysis to understand driver requirements for indirect viewing surfaces in the cabs of heavy trucks. Related static and dynamic testing was initiated in 2004 and is expected to be completed in 2005. The results from this testing will assist the agency in defining a performance specification to be used to evaluate various indirect viewing technologies in future cab designs.

and where auxiliary video input connections are missing.

Audible Backup Alarms

The ANPRM asked a number of questions regarding the efficacy of audible backup alarms and whether trucks equipped with OSHA-specified alarms should be excluded from the standard's new performance requirements. Some commenters such as NATC and ATA favored exclusion of such vehicles, arguing that audible backup alarms provide an effective warning for most pedestrians. As an added benefit, commenters stated that those systems are relatively easy to maintain.

However, other commenters pointed out significant limitations associated with backup alarm systems. NYDOT stated that young children, who account for a disproportionate number of the fatalities and injuries related to backing crashes, may not understand or be able to properly respond to such alarms. Rostra stated that auditory backup alarms do not work adequately with the hearing impaired, and the Teamsters added that the elderly may also experience problems with such systems (*e.g.*, due to decreased mobility, hearing impairment). Reliant added that these alarms can be turned off and that drivers may forget to turn them on again, and it also stated that residential customers frequently complain about loud backing alarms on trucks used at night.

Other Non-Visual Rear Object Detection Systems

Commenters expressed a range of views about the efficacy of a variety of non-visual rear object detection systems, such as those utilizing sonar and infrared technology. The Teamsters stated that manufacturers should be permitted to use non-visual systems as well as visual systems for rear object detection. NPTC argued that additional data are required on the effectiveness of devices other than mirrors, before such non-visual systems would be suitable as compliance options. Offering yet another possible approach, Federal Express confirmed that its vehicles are equipped with sonar backing systems used in concert with cross-view mirrors.

Comments also were received regarding the timing of the alert and detection capabilities provided by non-visual systems. Rostra stated that detection time should be derived from the distance of a calibrated test object; the speed of the alert would depend upon the distance from the sensor and the vehicle's closing speed vis-à-vis the object. Ford stated that typical latency times for radar and ultrasonic systems

are approximately 250–400 milliseconds (ms), but it added that a system's alert time could be increased by relying on multiple sensors to validate that the system is detecting a "true" target. In this context, commenters again raised concerns that NHTSA's assumption of a 3 mph backing speed may be an underestimation.

Ford also stated that surface characteristics are very complex in the real world and that the reflective characteristics of irregular surfaces are infinite. Because of this inability of non-visual systems to detect all objects, Ford argued that NHTSA must specify a limited number of objectively defined obstacles for any certification test.

Equipment Damage

The ANPRM also asked questions about potential damage to various rear object detection systems. Some commenters, such as Reliant, argued that mirrors are high maintenance items due to breakage and theft. Others suggested that damage inflicted by dirt, mud, rocks, brush, and limbs could limit the mirrors' effectiveness. ATA stated that while rear detection systems could be damaged by vibration and shock, it believes that these systems could be designed to withstand most of these conditions.

Testing

In response to questions about test procedures for the potential new rear object detection provisions, commenters generally urged NHTSA to conduct testing under as many different conditions as possible under which objects would be difficult to detect. Regarding mirrors, NATC stated that test procedures should utilize objects of various sizes, colors, heights, and positions, and the organization urged NHTSA to conduct testing under rugged conditions (e.g., vibration, humidity, and extreme high and low temperatures).

For non-visual rear object detection systems, commenters stated that a well-defined and objective standard and test methodology are even more important, including specification of the size and shape of objects to be detected in such tests. Ford suggested use of the standard pole target developed by the International Organization for Standardization (ISO), which the company has used since 1996 for testing both its ultrasonic and radar systems. Furthermore, both Rostra and NATC stated their belief that environmental conditions should be specified as part of any performance test for non-visual systems under the standard. Factors such as temperature, rain, snow,

humidity, dirt, driving surfaces, submersion, and mounting surfaces were specifically mentioned as potentially affecting such systems' detection capabilities.

Costs and Benefits

Commenters provided varying estimates regarding the cost of cross-view mirrors, ranging from \$80–\$160 per truck (depending upon whether one or two mirrors are required). ATA stated that NHTSA should factor in the potentially frequent damage to cross-view mirrors from a variety of sources over the life of the vehicle when determining the cost of the regulation. Figures were not provided regarding the cost of rear video systems, although NATC expressed doubt regarding the availability of such systems for as little as \$200, a figure mentioned in the ANPRM.

Rostra provided some figures to put the economic costs of backing crashes in perspective, stating that back-up accidents cost U.S. drivers over \$1.3 billion per year. Sheffield qualitatively described the benefits of a rear object detection system as including reduction in equipment damage, repair costs, insurance rates, and downtime.

According to Rostra, the Insurance Institute for Highway Safety (IIHS) tested six mid-size SUVs in crashes at 5 mph and found that only two of them suffered less than \$5,000 in damages during four crash tests. Rostra stated that the cost of an object detection system is often less than the cost of the insurance deductible incurred when there is a collision. NATC suggested that the insurance industry could participate in encouraging the use of these systems through monetary incentives (presumably a reduction in premiums).

Federal vs. State Regulation

The ANPRM asked whether it would be better to allow States to address the safety problem associated with backing trucks, because the States routinely regulate vehicles in use and regulate by type of use. ABC argued that due to frequent and regular interstate movement of truck traffic, requirements for rear detection systems should be addressed at the Federal level, asserting that a patchwork of differing individual State standards would render compliance extremely difficult.

Need for a Requirement

There were differences of opinion among the commenters as to the need to amend FMVSS No. 111 to set a requirement for rear object detection. Some commenters, such as Reliant, NATC, and the Teamsters, expressed

support for a performance standard for backing vehicles, although there was not any consensus regarding the best approach for such standard (e.g., suggestions provided for various technologies or driver-based backing programs). Other commenters, such as NPTC, ATA, and FedEx opposed a federal requirement for rear object detection, recommending instead that NHTSA support voluntary programs that leave improvements to the discretion of the fleet operators.

Training and Recordkeeping

Several commenters raised the issue of driver back-up training, either as a supplement to or substitute for rear object detection systems under the standard. The Teamsters recommended a requirement for employers to develop and implement procedures for drivers to follow in the event that rear object detection technology fails or is damaged, and they also supported required maintenance and recordkeeping for the system. ATA favored voluntary training (and possible operations restrictions) for drivers as the remedy for backing problems, stating that without appropriate training, drivers simply ignore rear object detection systems and their images.

FMCSA Regulations/Funding

NYDOT expressed concern that if NHTSA amends FMVSS No. 111, FMCSA would deem State requirements for cross-view mirrors or other rear object detection devices to be a burden on interstate commerce that would create a breach of the conditions for States to receive Motor Carrier Safety Assistance Program (MCSAP) funding. For example, New York State's earlier proposed legislation related to rear object detection was vetoed by the Governor because it was determined to be incompatible with a FMCSA regulation, thereby jeopardizing millions of dollars of FMCSA grants.

NYDOT stated that if NHTSA cannot persuade FMCSA to change its regulations, NHTSA should specify parameters for State action so that States may avoid loss of MCSAP funding. Several commenters stated that NHTSA should clearly articulate whether and to what extent a revised FMVSS No. 111 preempts State requirements related to rear object detection.

NTEA commented that if NHTSA does proceed with a rulemaking for rear object detection, it should convince the FMCSA to issue a regulation requiring vehicle owners to properly maintain the system when the vehicle is in use. Otherwise, NTEA argues, the standard alone would have little effect,

particularly in light of the potential for damage and misalignment.

III. Size of the Safety Problem

A. Number of Injuries and Fatalities

In order to determine an appropriate regulatory response, NHTSA undertook an analysis designed to ascertain the size of the backing problem by gathering data on the annual number of incidents of people being backed over by a motor vehicle of any size or type, both on-road and off-road (*e.g.*, in parking lots, driveways). The data were then analyzed further to determine, to the extent possible, the number of incidents attributable to straight trucks.

Since the time of the ANPRM, our analysis has been refined to incorporate additional data. NHTSA analyzed 1999 Fatality Analysis Reporting System (FARS) data, 2000–2001 National Electronic Injury Surveillance System (NEISS) data, and 1995–1999 General Estimates System (GES) data. Generally, we found that backing injuries and fatalities remain a matter of ongoing concern, despite changes in the vehicle population and technology.

The following are the highlights of our findings regarding injuries and fatalities associated with backing of straight trucks. Data suggest that straight trucks involved in backing incidents result annually in an estimated 79 fatalities. This figure represents 13 on-road fatalities and an estimated 66 off-road fatalities. In addition, data suggest that there are annually about 148 injuries attributable to backing straight trucks. We believe that these figures provide a conservative estimate of the problem, because many workplace incidents, a potentially significant source of backing injuries and fatalities, may go unreported.

A more detailed summary of our findings is provided below, including the details and methodology related to the above statistics. However, for a more complete discussion of the fatality and injury data related to this proposal, please consult the Preliminary Regulatory Evaluation (PRE) that has been placed in the docket for this rulemaking.

1. Fatality Data

To obtain a general understanding of fatalities associated with backing vehicles at the time of the ANPRM, the agency gathered data on the annual number of incidents of people being backed over by a motor vehicle of any type or size. (Fatality and injuries specifically attributable to straight trucks are discussed subsequently.) To this end, we initially reviewed FARS

data for 1991 to 1997. The FARS data system contains information on all fatal traffic crashes within the 50 States, the District of Columbia, and Puerto Rico. This search found a total of 381 backing fatalities for all vehicle types over this time period, or approximately 54 fatalities per year. To verify the accuracy of the 1991 to 1997 data, the agency later analyzed 1999 FARS data, which revealed 58 backing fatalities.

However, by design, a fatality is included in the FARS database only if a motor vehicle is involved in a crash while traveling on a roadway customarily open to the public. Thus, FARS excludes other likely scenarios for backing fatalities, such as events where someone is backed over in a driveway, parking lot, or in a workplace such as a warehouse or construction site.

We believe it is also important to consider off-road fatalities because on-road fatalities only represent a part of the problem in terms of backing-related incidents. Moreover, we believe that off-road backing fatalities represent a significant portion of the total fatalities that the agency is seeking to address under this rulemaking and should not be excluded.

To ascertain the number of off-road backing fatalities, the agency worked with the National Center for Health Statistics (NCHS) to gather data on these incidents. NCHS and NHTSA initiated a study utilizing 1998 death certificates in order to confirm the agency's information regarding the frequency of backing-related fatalities. The report is based on 4,046 death certificates out of an estimated 5,500 cases from 1998, sampled from 35 states and the District of Columbia. As of May of 2004, the death certificate study is complete and available in the agency's public docket (Docket Number NHTSA–2000–7967–22). This study reported 91 fatalities occurring in 1998 due to backing vehicles (15 on-road and 76 off-road fatalities). Although the fatality data from the joint NCHS–NHTSA study do not represent a national value nor can they be extrapolated to one, we have assumed that the percent distribution between on- and off-road backing fatalities is representative of what is currently occurring nationally (*i.e.*, 16.48% on-road fatalities and 83.52% off-road fatalities). Based upon that assumption, we applied the on-road/off-road percentage distribution from the death certificate study to the national sample represented by the FARS data, from which we estimate that annually, there are 276 off-road backing fatalities.

2. Injury Data

In addition to fatality data, NHTSA conducted an inquiry into the number of non-fatal injuries associated with backing crashes. This analysis relied upon information drawn from the National Electronic Injury Surveillance System (NEISS) and GES databases. However, because these two databases overlap, it is not possible to sum the results to directly determine an annual total of such injuries. Nevertheless, the available information demonstrates that there are a significant number of non-motorist injuries that are attributable to backing vehicles.

The NEISS database, the first source of injury data considered, is a statistically valid injury surveillance and follow-back system that has been operated by the Consumer Product Safety Commission (CPSC) for nearly thirty years. The system's primary purpose has been to provide timely data on consumer product-related injuries occurring in the U.S. NEISS injury data are gathered from the emergency departments of 100 hospitals selected as a probability sample of the more than 5,300 U.S. hospitals with emergency departments. Surveillance data enable CPSC analysts to generate national estimates of the number of injuries.

During the course of this rulemaking, NHTSA funded a study of the July–December 2000 NEISS file, which showed 64 cases in which a pedestrian or a pedalcyclist was injured by a backing vehicle. These are the first relevant data available since the NEISS was expanded to include injuries sustained in motor vehicle crashes. This data sample translates into a six-month national estimate of 3,556 injuries. To determine whether this number may be summed for an annual estimate, we also examined the January–June 2001 NEISS file. The 2001 file showed 75 cases where a non-motorist was injured by a backing vehicle, which translates into an estimated 3,863 national injuries over that six-month period. Because there is only a small difference between the estimates, we believe that the rate of non-motorist backing injuries is fairly constant over the course of the year. Therefore, summing the two injury figures for the six-month periods, we estimate 7,419 annual injuries to non-motorists are attributable to backing injuries. The GES injury data will be discussed subsequently, in the context of the data related specifically to straight trucks.

3. Workplace Data

We are also concerned about backing-related injuries and fatalities that may

occur at the workplace, which may not be captured in other databases for various reasons. Consequently, we examined the Occupational Safety and Health Administration's (OSHA) Web site, which documents at least 15 fatalities with the cause listed as being crushed between a backing vehicle and a loading dock. The OSHA Web site also includes over 50 reports of workers being killed by backing vehicles.⁶ OSHA has not performed a study to catalog all backing-related fatalities in the workplace, so it is not possible to definitively characterize the extent of the problem in the workplace environment. However, the anecdotal data assembled by OSHA document the existence and nature of a safety concern.

Another area of concern is construction sites. Under 29 CFR Part 1926, *Health and Safety Regulations for Construction*, OSHA has issued requirements for back-up alarms on vehicles and equipment used in construction in order to address the issue of backing injuries/fatalities, unless someone is standing to the rear to direct the backing vehicle. However, OSHA was unable to provide any statistical data regarding the effectiveness of the required systems.

Many backing crashes that occur in the workplace may go unreported to police, because they are handled privately by the businesses involved. In those cases, important incidence data may fail to be included in the FARS or NCHS databases, so the statistics generated from those sources may underestimate the actual backing problem. NHTSA would be interested in additional information on the backing crashes encountered in the workplace.

As further indication of a backing problem, we are aware that several major employers with extensive truck fleets have begun equipping their vehicles with rear object detection systems, although we do not have firm figures regarding implementation on a national scale. For example, United Parcel Service (UPS) installed video monitoring systems on its entire fleet of 65,000 delivery trucks by October 2001. Similarly, the United States Postal Service (USPS) and Potomac Electric Power Company (PEPCO) have equipped their vehicles with cross-view mirrors, and FedEx has installed both cross-view mirrors and sonar-based rear object detection systems on its vehicles. Further, NHTSA has learned that some trucks equipped with rear video systems

also come with an audio feed, which place a microphone near the rear of a vehicle that is connected to a speaker near the driver. Such audio feed would allow an unnoticed person in the path of a backing vehicle to yell to alert the driver as to that person's presence. While these companies were undoubtedly concerned with backing crashes that occur on public and private roads, we understand that prevention of injuries and fatalities in loading and docking areas of worksites was also a factor in adopting such equipment.

B. Vehicle Type Involvement in Backing Crashes

NHTSA has conducted research to determine the rate of involvement of specific types of vehicles in pedestrian and pedalcyclist backing fatalities, both on-road and off-road. As discussed below, NHTSA found that straight trucks are involved in a disproportionately high number of backing crashes resulting in pedestrian and pedalcyclist fatalities.

For on-road incidents, the FARS data showed the following vehicle-type involvement for 1991–1997 pedestrian and pedalcyclist backing fatalities:

TABLE 1.—CUMULATIVE NUMBER OF PEDESTRIAN AND PEDALCYCLIST FATALITIES IN ON-ROAD BACKING CRASHES (FARS DATA FROM 1991–1997)

Vehicle type	Number of fatalities
Passenger car	129
Light truck/van	139
Bus	1
Straight truck over 4,536 kg GVWR	81
Unknown truck over 4,536 kg GVWR	12
Combination truck	15
Other	2
Unknown	2
Total	381

Based on the above FARS data, after distributing unknowns, we estimate straight trucks were involved in 92 on-road backing fatalities over the 7 year period, resulting in 13 fatalities per year. Thus, straight trucks were accountable for approximately 24% of the on-road backing fatalities during that period.

Again, attributing the same percentage of backing incidents for straight trucks that occur on-road as occur off-road (as reflected in Table 1) yields 66 annual off-road fatalities (0.24×276). Summation of the on-road and off-road

fatalities yields 79 annual fatalities attributable to backing straight trucks.

Turning to the injury data specific to straight trucks, we examined the data from the GES, which include only injuries incurred in police-reported incidents. GES data overlap the previously discussed NEISS data, which record both police-reported incidents as well as unreported incidents. Therefore, the GES data on backing-related injury crashes are probably not representative of all backing-related injury crashes, because the data do not include information about injuries from backing

maneuvers in private areas such as driveways, parking lots, and work sites.

Nevertheless, the GES data are useful for other reasons. First, the GES data break down accidents by both vehicle type and maneuver, so it is possible to determine the percentage of non-fatal backing injuries attributable to straight trucks (approximately two percent). We expect that the percentage of backing injuries for straight trucks would not change significantly from year to year. Further, we believe that the proportion of backing injuries attributable to straight trucks in the GES data and the NEISS data are comparable, so

⁶ These cases were identified by searching OSHA's Accident Investigation Search database and

by entering appropriate key words. See <http://www.osha.gov/cgi-bin/inv/invl>.

extrapolating to the larger NEISS database, the number of backing injuries attributable to straight trucks would translate into approximately 148 injuries per year (*i.e.*, two percent of the 7,419 total injuries).

The Preliminary Regulatory Evaluation accompanying this notice estimates the severity of these injuries attributable to backing straight trucks, based upon the Abbreviated Injury Scale (AIS). AIS is an anatomically-based system that classifies individual injuries by body region on a six-point ordinal scale of risk to life, with the MAIS score

being the maximum injury level(s) an individual receives.⁷ According to the PRE, of the anticipated annual backing injuries, there are expected to be 120 MAIS–1 injuries, 19 MAIS–2 injuries, 7 MAIS–3 injuries, and 1 MAIS–4 injury (difference of 1 injury due to rounding). Please consult the PRE for a more complete discussion of backing injury severity levels (*see* Chapter III).

However, we believe that the figures for cumulative number of backing crashes and the absolute number of fatalities do not provide a complete picture of the problem. Instead, one

must consider the relative risk posed by different types of vehicles. We have used the number of vehicles in the fleet and the miles driven to calculate the rate of backing deaths for different vehicle types. This calculation was based upon estimates of registered vehicles and vehicle miles traveled information. As demonstrated in Table 2 below, straight trucks are significantly overrepresented in backing crashes resulting in pedestrian and pedalcyclist fatalities.⁸

TABLE 2.—RATE OF ON-ROAD FATAL BACKING CRASHES (CUMULATIVE FARS DATA FROM 1991–1997)

Vehicle type	Pedestrians and pedalcyclists killed by a backing vehicle per million registered vehicles	Pedestrians and pedalcyclists killed by a backing vehicle per 100 billion vehicle miles traveled
Passenger cars	1.05	1.26
Light trucks/vans	2.32	2.80
Combination trucks	9.94	2.21
Straight trucks over 4,356 kg GVWR	29.68	21.89

Table 2 provides the rate of pedestrians and pedalcyclists killed by straight trucks while backing is 21.89 per 100 billion vehicle miles traveled, and 29.68 per million registered vehicles. This risk is significantly higher than that for passenger vehicles (*i.e.*, combining categories of passenger cars and light trucks/vans). Based upon this analysis, straight trucks stand out as a significant risk in terms of backing incidents.

In its comments on the ANPRM, ATA expressed disagreement with the agency’s assessment of the size of the backing problem, arguing that NHTSA did not quantify accurately the relative hazard associated with each vehicle type in its risk conversion. ATA argued that considering the number of pedestrians and pedalcyclists killed by a backing vehicle per million registered vehicles “will certainly overstate the rate for straight and combination trucks relative to passenger cars and light trucks because of the fewer number of commercial vehicles” and that it does not take into account the number of backings that these vehicles perform. For the same reasons, ATA objected to NHTSA’s analysis of the number of backing-related deaths by different vehicle types per 100 billion vehicle miles traveled.

Instead, ATA argued that it is more likely that straight trucks used for deliveries to businesses back up more as a percentage of miles driven than do passenger cars and light trucks. According to ATA, because straight trucks are typically utilized in local delivery operations and can make several deliveries per day, drivers are required to perform several backing operations per day. For this reason, ATA stated that straight trucks are likely to have a higher number of backings as a percentage of miles driven than private vehicles. Conversely, ATA argued that straight trucks used in home delivery settings, by practice, avoid backing up. This practice led ATA to believe that vehicles used in this manner are likely to have fewer backings related to miles traveled. Based upon these theories, ATA concluded that straight and combination trucks are likely to be safer relative to other types of vehicles.

We do not agree with ATA’s rationale regarding quantification of relative hazard. If it is true, as ATA argues, that straight trucks are likely to back up more often than other types of vehicles, we believe that straight trucks, based upon their vehicle type, would be expected to present a greater risk in terms of backing incidents. As a result,

we would expect that installation of a rear object detection system on straight trucks, more than on any other vehicle type, would reduce backing-related risks.

Furthermore, it is important to note that the number of pedestrians and pedalcyclists killed by straight trucks while backing, per 100 billion vehicle miles traveled, is eight to seventeen times greater than for passenger vehicles. If straight trucks used in deliveries to homes avoid backing, it is logical to assume that an inordinate amount of fatalities involve straight trucks making business deliveries. When one considers that large fleet carriers such as UPS, the U.S. Postal Service, and FedEx, have all equipped their vehicles with rear object detection systems, we are even more convinced that the remaining straight trucks are overrepresented in the data.

In addition, there is a fundamental difference between straight trucks and passenger vehicles, namely the fact that most straight trucks have a large blind spot directly behind the vehicle. Passenger vehicles, which usually have interior rearview mirrors and rear windows, generally have a more direct view of this area. Thus, passenger vehicle backing incidents are most likely to result from driver error,

⁷ The AIS system scores injuries based upon the following levels: AIS–1 (minor injury); AIS–2 (moderate injury); AIS–3 (serious injury); AIS–4 (severe injury); AIS–5 (critical injury), and AIS–6 (maximum injury). *National Accident Sampling*

System, 1993 Crashworthiness Data System, Injury Coding Manual, (January 1993) (DOT HS 807 969).

⁸ Since the time of the ANPRM, NHTSA discovered a number of minor errors in its

statistical data related to vehicle type involvement in backing crashes. These errors were corrected prior to incorporating the relevant information in this notice.

pedestrian/pedalcyclist error, or some combination thereof, problems without a clear remedy. However, in the case of straight trucks, visibility behind the vehicle is an objective problem amenable to amelioration through a regulatory requirement for a rear object detection system.

C. Other Data and Summary

NHTSA has considered comments in response to its APRM related to the number of victims of backing crashes. NYDOT commented that New York State has recorded 14,349 backing crashes involving trucks with an enclosed or walk-in delivery bay that resulted in 35 deaths and 5,393 injuries between 1990 and 1999; these crashes also were said to have resulted in 8,921 instances of property damage.

Based upon the totality of the above information, we believe that there is a demonstrated backing problem associated with straight trucks resulting in a significant number of injuries and fatalities. These backing incidents occur on public roads, in private locations, and in workplace settings. While our existing data are most complete for on-road backing fatalities and injuries, preliminary data suggest that the problem is even greater in off-road locations, including private locations and in workplace settings.

IV. Agency Proposal

A. Summary of Proposal

To address the identified problem of backing-related deaths and injuries associated with straight trucks, NHTSA is proposing to amend FMVSS No. 111, *Rearview Mirrors*, to require straight trucks with a GVWR of between 4,536 kg (10,000 pounds) and 11,793 kg (26,000 pounds) to be equipped with either a cross-view mirror or rear video system in order to provide the driver with a visual image of a 3 m by 3 m area immediately behind the vehicle. However, this requirement would not apply to those trucks for which the detection area is already visible through existing mirrors already required under the standard.

The NPRM sets out proposed requirements for each of these two compliance options, as well as test procedures suitable for each option. However, in light of concerns regarding the feasibility of attaching rear object detection systems on certain types of trucks, we are requesting comments on categories of vehicles that the agency should consider excluding from the requirements of a final rule.

We propose that the requirements would be effective for new vehicles

covered under the standard that are manufactured one year or later after publication of a final rule. However, we are also seeking public comment to help determine whether requirements for a rear object detection system should be extended to vehicles in other weight classes and whether existing commercial straight trucks should be required to be retrofitted, as part of a future rulemaking.

B. Compliance Options

In developing our proposed performance standard for rear object detection, NHTSA carefully considered a range of technologies. NHTSA examined both visual systems (e.g., cross-view mirrors and video cameras) and non-visual systems (e.g., sonar/infrared devices and audible back-up alarms) in order to evaluate their efficacy in preventing backing-related injuries and fatalities.

We believe that primary responsibility for object detection should be placed upon the driver, such that the driver has visible confirmation that the pathway is clear before backing; non-visual systems, by their nature, cannot provide such confirmation. Consequently, we are proposing two visual systems as compliance options, one for cross-view mirrors and another for rear video systems.

1. Cross-View Mirrors

Under proposed Option 1, vehicle manufacturers would be required to install rear cross-view mirrors on covered vehicles so as to provide a 3 m by 3 m field of view of the area directly behind the vehicle. NHTSA's research has determined that a 3 m by 3 m area is the maximum detection zone that could be provided by a cross-view mirror system, but one which we believe would be adequate in light of the standard's safety objective.⁹

Selection of the proposed detection zone was based upon study results that found typical backing speeds to be 3.3 mph.¹⁰ However, as discussed earlier, commenters suggested that the agency's assumptions regarding backing speed have underestimated real world experience, although data were not provided to demonstrate this point. If new data show that backing speeds have been significantly underestimated, this may necessitate extension of the proposed rearward field of view requirement. Because cross-view mirrors are not effective in providing a

field of view beyond the 3 m by 3 m zone currently proposed, a change in calculation of backing speeds may preclude adoption of this technology as a compliance option and instead result in adoption of a requirement for a video camera, a device that does not possess the same field of view limitations.

As proposed, the cross-view mirror would work in conjunction with the outside rearview mirror on the driver's side of the vehicle, and the placement of the cross-view mirror would be such that the geometric centers of the two mirrors are separated by no more than 5 m. We have tentatively decided that 5 m is the furthest distance at which the mirror system could provide a meaningful image to the driver of any object behind the vehicle, a position with which commenters generally agreed.¹¹ Longer trucks that cannot meet this requirement for maximum distance between mirrors would be required to install a video system that complies with Option 2.

Our proposal also sets out other proposed requirements which the cross-view mirror would be required to meet, including that it would be required to: (1) Have no discontinuities in the slope of its surface; (2) be adjustable both in the horizontal and vertical directions; (3) be installed on stable supports on the upper rear corner of the vehicle on the driver's side, and (4) have an average radius of curvature of no less than 203 mm as determined under paragraph S12 of existing FMVSS No. 111.

In addition, we are proposing test requirements to ensure that the detection zone specified under the proposed standard would be met. The procedures to verify compliance with these requirements are modeled in part after the existing school bus mirror test required under paragraph S13 of FMVSS No. 111, which utilizes a number of cylinders to simulate objects in front of the vehicle that would be difficult or impossible to see without the aid of mirrors. The proposed testing procedure would utilize the driver eye location specified in the current school bus mirror test that is based on the 25th-percentile adult female template. The proposed rule would require that the entire top surface of all the cylinders located at the rear of the vehicle described in the test procedure be visible to the driver when those procedures are followed. In our

⁹ "Read Cross-view Mirror Performance: Perception and Optical Measurements," WESTAT (November 1998) (Docket No. NHSTA-2000-7967-18).

¹⁰ *Id.* at 48.

¹¹ This determination is based upon the findings of the WESTAT study, which reported diminished performance at the longest mirror separation distance tested (195 inches). "Read Cross-view Mirror Performance: Perception and Optical Measurements," WESTAT (November 1998) (Docket No. NHSTA-2000-7967-18).

proposal, we have simplified the carryover school bus procedural dimensions being used, and we have provided tolerances when possible.

2. Rear Video Systems

Under the second compliance option, a rear video system would be required. The minimum field of view would be the same as that specified for the cross-view mirror option (*i.e.*, 3 m by 3 m).

We are proposing several requirements for rear video systems. First, the system would be required to include a monitor that depicts a reversed image similar to what would be observed in a rearview mirror and which is mounted in full view of the driver. The monitor would be required to be mounted as close to the centerline of the vehicle as practicable near the top of the windshield, but located such that the distance from the center point of the eye location of a 25th-percentile adult female seated in the driver's seat to the center of the monitor is no more than 100 cm. We believe that it would be beneficial to place the monitor in a location that is similar to that of a rearview mirror in a passenger vehicle. Presumably, truck drivers have extensive personal experience in driving passenger vehicles, so they would be accustomed to checking for objects behind the vehicle in that location. Would there be any difficulty having the monitor too close, such that for drivers who need reading glasses, the image in the monitor would be unfocused?

If the monitor's placement causes it to fall within the vehicle's head impact area, the mounting would be required to deflect, collapse, or break away when subjected to a force of 400 Newtons (N) in any forward direction that is not more than 45° from the forward longitudinal direction, as is required for passenger car interior mirrors pursuant to S5.1.2 of FMVSS No. 111. We are concerned, however, that a monitor that fully breaks away from its mounting could create an additional hazard and cause potential injury in a crash. How likely is this situation to occur, and what preventative steps could be taken? Would it be feasible to equip the vehicle with a non-adjustable monitor that is fully integrated into the dashboard?

This proposed compliance option also would require that the video system's monitor have an image size between 90 cm² and 160 cm². We are proposing a size range for the monitor that maintains approximately the same size-to-distance ratio as that between the sideview mirror and the driver. We believe that the monitor size recommended by Mr. Silc (1.5 inches) would not be adequate. Accordingly, we believe that the range

that we have proposed would provide the driver with an image that is of a meaningful size and that would catch the driver's attention. The video camera would be required to be adjustable so that it may tilt in both the horizontal and vertical directions, for aiming purposes, and the video monitor similarly would be required to be adjustable so as to accommodate drivers of different statures. Would any implementation problems be expected related to the aimability requirement for the video camera and monitor?

The proposed test procedures are intended to ensure that the detection zone specified under the video system option is essentially the same as that for the cross-view mirrors compliance option.

C. Applicability

NHTSA is proposing to make the new requirements for a rear object detection system applicable to new straight trucks with a GVWR of between 4,536 kg (10,000 pounds) and 11,793 kg (26,000 pounds).

The lower bound of this weight range is based on FARS data, which show that the rate of fatal backing crashes for these vehicles is substantially greater than that of vehicles with lower GVWRs. The upper bound of 11,793 kg is based on the agency's belief that it represents the maximum weight of a typical straight truck. We note, however, that paragraph S7 of FMVSS No. 111 currently defines requirements for a narrower weight class between 4,536 kg and 11,340 kg. Accordingly, the agency is requesting comments on the proposed upper bound, specifically whether straight trucks greater than 11,340 kg also should be required to be equipped with a rear object detection system.

We note that for certain vehicles, the proposed detection zone may be visible using the vehicle's existing mirrors already required under FMVSS No. 111, in which case the rear object detection system that is the subject of this proposal would not be required. Accordingly, we are proposing that testing under the standard first be conducted to see whether the targets are visible with the mirrors already being supplied on that particular vehicle. If the targets are visible, the rear object detection system would not be required.

Furthermore, we are aware that this weight classification encompasses a wide range of vehicles of many shapes and sizes, some of which may pose mounting and/or maintenance challenges for the rear object detection systems that would be required under the proposal. As a result, we might consider excluding certain types of

trucks from the standard's new requirements when we issue a final rule, particularly where it can be demonstrated that a rear object detection system would not be practicable. As discussed below, we are requesting additional public input on defining appropriate categories of straight trucks for possible exclusion.

In the ANPRM, NHTSA asked for comment on the appropriateness of applying a requirement for rear object detection to straight trucks in the designated weight range. A number of comments were received, the majority of which sought exclusion for certain types of trucks (*e.g.*, flat beds, stake bodies, dump trucks, common light duty pickup truck beds, and other high-cube or full-size van applications such as tradesmen's or mechanic's bodies). Generally, commenters argued that many of these vehicles have body styles which do not permit installation of cross-view mirrors in an effective position or that the vehicles are used in a rugged environment that would cause damage to the mirrors or other systems, thereby requiring frequent replacement or repair.

For example, commenters argued that under the circumstances in which most dump trucks are used, any system that is installed is likely to be damaged rather quickly. Commenters stated that dump trucks, as well as other work vehicles used off-road, may experience more vibration than vehicles used solely on-road; according to the commenters, such usage could either damage the system or render it ineffective due to misalignment. Commenters also argued that vibration could cause frequent deviation of cross-view mirrors and video cameras from their aimed position. In addition, commenters stated that other vehicles, such as stake bodies, tow trucks, and flat beds, may have no viable location to mount a rear object detection system.

While we acknowledge that some vehicles may not be suitable for installation of one or more of the proposed systems, NHTSA would need to be confident that there was no suitable system available for a given type of vehicle before we exclude it from the safety requirement. To help to better define the applicability of the standard once a final rule is issued, we offer the following preliminary views on coverage, which may be modified based upon public input.

We anticipate that it would be reasonable and practicable for the standard to apply to trucks in the designated weight range that have cargo boxes mounted on their chasses. Such vehicles have a configuration suitable

for mounting a rear object detection device, and these vehicles are regularly used in deliveries to both businesses and private residences. The States of New Jersey, New York, and Washington already have applied regulations to these types of vehicles, and we believe that it is important for any final rule to cover them, because of their constant presence in residential areas.

Dump trucks and tank trucks are two types of trucks that we also believe have the potential to be covered under the standard. Vehicles with dump bodies make regular residential deliveries of products such as topsoil, gravel, and mulch. Commenters on the ANPRM claimed that the rugged environment in which dump trucks sometimes operate likely would damage any system installed on the back of the vehicle. Also, the commenters argued that if a damaged rear vision system had to be replaced on a regular basis, it would make the cost of the regulation too high. However, we are concerned about the potential for injury and fatality related to backing dump trucks. (The website of the Occupational Safety and Health Administration documents over two dozen fatalities caused by backing dump trucks.) We believe that a more robust system could be used which would withstand possible abuse and still provide the vehicle operators with the necessary rear vision.

Regarding dump trucks, we seek input on the following issues. How frequently would one expect the work environment and vehicle use patterns to cause failure of a rear visibility system (e.g., due to vibration, camera breakage, lens degradation)? Could a durable video system be mounted on the backs of these types of trucks in such a way that the camera would be protected but at the same time remain effective (i.e., remain properly aimed at the detection zone specified in the standard)?

Tank trucks, such as those used for delivery of home heating fuel, water for pools, and other liquids, and for septic tank cleaning, pose a different set of problems. Although they are not used in a rugged environment, the design of these vehicles and the curvature of the tank may make it impossible to use a cross-view mirror system, due to the inability to mount a mirror in an effective location. However, we believe that a video system with a camera mounted near the license plate may be a viable option for providing the requisite rearward view.

More problematic are vehicles such as flat beds and stake bodies that have no place to mount a mirror and have only a limited number of places where a camera could be mounted. However,

even unloaded, these vehicles still may have a blind spot immediately behind the vehicle of sufficient size that could cause a child to be hidden from view, and once loaded with cargo, visibility would be expected to decline further.

We invite input on these and other categories of vehicles that are potential candidates for exclusion from the proposed standard's requirements. We request that any such comments provide information to demonstrate why none of the proposed compliance options would be practicable for that class of vehicles.

In response to NYDOT's comment that NHTSA should consider extending the standard to trucks that weigh less than 4,536 kg (10,000 pounds), we are not proposing such a requirement at this time because current data do not support such an action. Although smaller trucks often enter residential neighborhoods for the purposes of deliveries or other commercial transactions, many of these vehicles are configured as passenger-carrying vehicles, which do not have the same rear visibility limitations as larger vehicles. Nevertheless, we are continuing our research into injuries and fatalities associated with backing vehicles with a GVWR of less than 4,536 kg (10,000 pounds), and we may revisit this issue if data demonstrate that these vehicles pose a significant backing problem.

We invite comment as to whether there are vehicles within the class proposed for coverage that could meet the field of view requirements without being equipped with a rear object detection system. What would be examples of such vehicles? Could such vehicles continue to meet the proposed requirements in a fully loaded condition? Should such vehicles be excluded from the proposed requirements of the standard?

We also invite comment as to whether the proposal should be applied to buses. Smaller buses frequently are used in areas of high pedestrian traffic, such as around airports. In addition, school buses and city buses are used in areas of high pedestrian density.

Comments on the following specific questions would assist the agency in possible future rulemakings:

1. For vehicles under 4,536 kg (10,000 pounds) GVWR, should further criteria be used to identify those vehicles most likely to be used as commercial vehicles in delivery service or which may have rear vision constraints?

2. What would be the optimal minimum weight for delivery trucks that should be subject to the standard's requirements for a rear object detection system? Would it be appropriate, when

the applicable vehicle characteristics are defined, to lower the applicable weight to 2,722 kg (6,000 pounds) GVWR, or some other weight? Would some light trucks, such as a pick-up truck with a cargo box, benefit from a rear visibility system?

3. Should the standard apply to vehicles over 203 cm (80 in.) in width (or some other figure) and with no windows to the side and rear regardless of their weight? Should wider vehicles with limited or no visibility via windows of the proposed 3 m by 3 m area to the rear of the vehicle be required to have a rear object detection system?

4. Should the standard apply to buses, and if so, should any types of buses be excluded?

5. As noted above, the proposed test procedures for rear object detection systems are modeled after the standard's test procedures for school buses, although with simplified dimensional requirements and tolerances for most of those dimensions. Should these modified dimensional requirements be used for the school bus provisions as well?

D. Non-Visual Systems

After carefully considering the merits of a range of rear object detection devices, we have tentatively concluded that current non-visual systems (e.g., sonar/infrared systems and back-up alarms that emit an audible warning) do not provide by themselves an adequate and effective means of rear object detection for the following reasons.

Foremost, we are concerned that non-visual systems, particularly back-up alarms, implicitly shift the detection burden from the driver to persons who might unwittingly end up in the path of the backing vehicle. We remain particularly concerned that children, the primary focus of the protections contemplated by this rulemaking, often would be unable to comprehend and/or appropriately respond to an audible signal. We also note that a 2003 study reported that preschool children did not respond to audible back-up alarms with avoidance behavior, although about half of them did look toward the vehicle or halt their gait.¹² While we understand that some non-visual systems (e.g., infrared systems) have the ability to detect children in some circumstances, we are not convinced that they will be able to do so consistently in all cases.

¹² R E Sapien, J. Widman Roux, and L. Fullerton-Gleason, "Children's Response to a Commercial Back-up Warning Device," 9 *Injury Prevention* 87-88 (2003). See Docket No. NHTSA-2000-7967-21 for information related to this study.

Research on the capabilities of these non-visual systems is extremely limited, and we are concerned about the lack of human factor testing, which involves an assessment of how people interact with a given piece of equipment. For example, in some instances, a non-visual system may tend to give false warnings or fail to provide any warning, such as when a truck is backing on an incline or a decline. When backing a truck up a hill, the hill itself may enter into the sensors' detection area and cause the system to alert the driver that an obstacle is present. Backing the truck down a hill can also be problematic for non-visual systems, because obstacles may be below the system's detection zone, and consequently, the driver would not receive any warning. Although the driver may get out to investigate the first few times, warnings in similar situations may be ignored once the driver is familiar with a certain area or simply becomes aware that hills of a certain grade trigger the warning device.

In addition, we believe that the virtually infinite number of characteristics of object surface reflectivities and other factors would render a test procedure for non-visual systems either ineffective (due to the omission of some possible object characteristics) or overly burdensome (if an attempt is made to include a large range of test objects).

In sum, we believe that if a rear object detection system allows a driver to actually see a child or other person, the driver would be more likely to take appropriate action and to prevent a collision. Although we are not proposing a compliance option utilizing non-visual systems, we are not prohibiting vehicle manufacturers from installing them voluntarily. Although such systems do not add significantly to the safety benefits to be gained through the visual requirements proposed, they do not appear to cause substantial harm. There is no reason for the agency to preclude vehicle makers from providing non-visual systems as an additional customer feature.

We also considered the role of driver training, but we do not believe that it is an adequate substitute for the visual image provided by a rear object detection system. The nature of such training would vary according to the form and function of the myriad straight trucks on U.S. roadways. However, such training could be a useful supplement to each of the proposed rear object detection systems, both in terms of understanding and successfully using that system, and otherwise promoting safe backing practices.

E. Retrofitting of Existing Commercial Vehicles

Recently, NHTSA was delegated authority to promulgate safety standards for commercial motor vehicles and equipment subsequent to initial manufacture where the standards are based upon and similar to a Federal motor vehicle safety standard promulgated, either simultaneously or previously, under chapter 301 of Title 49 U.S.C. (see delegation of authority at 49 CFR 1.50(n)). This authority to promulgate safety standards for commercial motor vehicles reflects the fact that certain safety features may have sufficiently significant value to warrant their incorporation in existing commercial vehicles that transport property or passengers in interstate commerce.¹³ When utilizing this "retrofit" authority, NHTSA plans to coordinate with the Federal Motor Carrier Safety Administration regarding any such provision.

At this time, we are not proposing to require any existing commercial straight trucks to be retrofitted to meet the standard's newly proposed requirements for rear object detection systems. However, we are soliciting additional comments on several questions related to retrofitting, in the event that NHTSA later determines that such a requirement would be appropriate. The following discussion reflects our preliminary thinking regarding the feasibility and value of retrofitting existing commercial vehicles to meet the proposed requirements for an amended FMVSS No. 111.

Experience suggests that equipping existing commercial straight trucks with rear object detection systems would provide safety and economic benefits. As with new trucks, owners of existing commercial trucks would benefit from the elimination of the sizable blind spot directly behind their vehicles; with such systems, drivers would be able to see children and other pedestrians (safety benefit), as well as poles and other obstructions before any collision-related damage occurs (economic benefit). However, there also would be costs. We are exploring the possibility of retrofitting these commercial vehicles as a means of maximizing the benefit of the proposed requirement. Would any special problems be anticipated with retrofitting specific vehicle types? Should certain commercial vehicles be excluded from any future retrofitting requirement?

¹³ The terms "commercial motor vehicle" and "interstate commerce" are defined under FMCSA regulations at 49 CFR 390.5.

The States of New Jersey, New York, and Washington presumably considered such benefits and costs when passing legislation requiring the retrofitting of trucks in those States with rear object detection systems. As a further example, UPS, one of the largest delivery companies, has chosen to retrofit its vehicles with video systems. Thus, experience suggests that retrofitting in this context has been deemed by some to be reasonable, economically feasible, and practicable. In addition, requiring retrofitting of existing commercial vehicles would permit the public to realize the full benefit of these safety devices approximately ten years sooner than would otherwise occur, if only new vehicles were required to be so equipped.

Public input on the following questions would assist the agency regarding retrofitting. What are expected to be the potential costs and benefits of retrofitting existing commercial vehicles with a rear object detection system consistent with the proposed requirements for FMVSS No. 111? Should any types of such vehicles be excluded? How much lead time would be required to retrofit existing commercial vehicles to meet the proposed requirements for rear object detection?

F. FMCSA Issues Related To Retrofit and Preemption

In light of the comments of the New York State Department of Transportation (NYDOT) and the National Truck Equipment Association (NTEA) pertaining to FMCSA preemption of State law, we believe that it is necessary to clarify the scope and nature of FMCSA's policies and programs. NHTSA consulted with FMCSA in drafting the current proposal, and FMCSA provided the following input, particularly regarding how its regulations and programs would impact a State's efforts to adopt rear object detection requirements for vehicles operating within the State.

According to FMCSA, that agency does not consider a State's adoption of safety requirements that are identical to the FMVSSs (applicable only to vehicles manufactured on or after the effective date of the safety standard) to be a matter of concern under the Motor Carrier Safety Assistance Program (MCSAP).¹⁴ The example referenced by the NYDOT in its comments concerned the State's efforts to adopt a rear object detection system requirement applicable to vehicles operated in interstate commerce, prior to NHTSA's

¹⁴ See 49 CFR Part 350.

publication of a rulemaking proposal on the subject. FMCSA concluded that the State should either limit the applicability of its requirement to commercial motor vehicles operating exclusively in intrastate commerce or adopt requirements compatible with the FMVSSs, in the event NHTSA adopts requirements for a rear object detection system. Therefore, if NHTSA amends FMVSS No. 111 to require a rear object detection system, FMCSA stated that it would not consider a State's adoption of those requirements for vehicles manufactured on or after the effective date to be inconsistent with the MCSAP regulations.

Additionally, with regard to NTEA's remarks, FMCSA stated that it is committed to ensuring that its requirements for vehicle parts and accessories necessary for safe operations¹⁵ are consistent with the requirements under NHTSA's FMVSSs. Part 393 of the FMCSA's safety regulations already includes many cross-references to specific requirements under the FMVSSs, such as lamps and reflectors, anti-lock braking systems (ABS), automatic brake adjusters, rear impact guards and protection, seat belts, and emergency exits on school buses. If NHTSA amends FMVSS No. 111 to require a rear object detection system, FMCSA stated that it would consider amending 49 CFR Part 393 to require motor carriers operating in interstate commerce to ensure that such systems are maintained. According to FMCSA, amending Part 393 also would result in the States being required under the MCSAP to adopt compatible motor carrier safety regulations within three years of the effective date of the FMCSA rulemaking.

G. Effective Date

We are proposing to require covered new vehicles to comply with the rear object detection requirements to prevent backing deaths and injuries one year after publication of a final rule. We have tentatively concluded that a relatively rapid implementation schedule would be appropriate. Installation of cross-view mirrors would not involve substantial engineering efforts or changes in manufacturing processes. Manufacturers might need additional time to implement more technically demanding video systems, although we believe that one year would provide sufficient time for manufacturers to incorporate these systems as well.

¹⁵ See 49 CFR Part 393.

V. Benefits

The agency estimates that this proposal would result in a net reduction of 23 fatalities and 43 injuries annually once all single-unit trucks are equipped with a rear object detection system, assuming a 33% effectiveness rate for these crash avoidance devices.¹⁶ The present discounted value of anticipated property damage savings is estimated to be \$32 million annually (at a 3-percent discount rate). In most of these cases, the benefits would result from the ability of the rear object detection system to allow the driver to prevent the collision entirely.

The PRE provides additional detail regarding benefits, including values at a 7-percent discount rate and a discussion of the methodology used in calculating those benefits (see Chapter IV of the PRE).

In addition, because our estimate of the effectiveness of rear object detection systems (33 percent) is based primarily upon the findings of a single study conducted by Federal Express in 1984, the agency decided to include a sensitivity analysis in the PRE to examine how different effectiveness rates would impact the results of our cost and benefit analyses. Accordingly, in the sensitivity analysis, we have examined the net costs, benefits, and cost per equivalent life saved if rear object detection systems were 20 percent, 40 percent, and 60 percent effective (see Chapter VII of the PRE).

VI. Costs

Although discussed more fully in the PRE (see Chapters V and VII), the following summarizes our estimation of the costs associated with this proposal to require rear object detection systems in new straight trucks. The agency estimates that about 18 percent of the 365,000 new single-unit trucks sold annually have cross-view mirrors or video cameras, leaving the remaining 299,300 new trucks affected by this rulemaking. In addition, based on the agency-sponsored study discussed previously, we have tentatively

¹⁶ As discussed in Chapter IV of the PRE, NHTSA's estimation of the effectiveness of rear object detection systems is based upon two public comments referencing a 1984 pilot study conducted by FedEx in four cities that found that backing incidents were reduced by 33 percent when cross-view mirrors were installed. Although the study itself was not made directly available, the Nevada Automotive Test Center provided the 33 percent figure (Docket No. NHTSA-2000-7967-7), and the Teamsters qualitatively discussed that a reduction in incidents occurred (Docket No. NHTSA-2000-7967-8). We have decided to use the same value for the effectiveness of video camera systems, although we believe that such systems may be somewhat more effective.

determined that 5 meters is the maximum distance between a cross-view mirror (mounted at the rear of a truck) and an outside rearview mirror (mounted next to the driver) that would provide a meaningful image. Under the proposal, trucks with a mirror separation of more than 5 meters would be required to use a camera system.

Therefore, of the 299,300 trucks, we estimate a counter-measure distribution of about 25 percent with mirrors and 75 percent with a camera system. The estimated consumer cost per vehicle, including installation, for an 8-inch diameter mirror and hardware is \$51.64, for a 10-inch diameter mirror and hardware is \$56.85, and for a camera system, monitor, and mounting hardware is \$325.10. It is possible that there may be some maintenance and repair costs associated with rear object detection systems, although we do not have information as to the frequency or extent of such activities. We invite comments regarding maintenance and repair costs associated with the rear object detection systems discussed in this proposal.

Based upon this information, the total consumer cost of this proposal is estimated to be \$77 million annually (in 2004 economics). The cost per equivalent life saved is estimated to be \$2.3 million (at a 3-percent discount rate).

VII. Public Participation

How Can I Influence NHTSA's Thinking on This Notice?

In developing this notice, NHTSA tried to address the concerns of all stakeholders. Your comments will help us determine what standard should be set for rear object detection as part of FMVSS No. 111. We invite you to provide different views on the questions we ask, new approaches and technologies about which we did not ask, new data, how this notice may affect you, or other relevant information. We welcome your views on all aspects of this notice, but we especially request comments on the specific questions articulated throughout this document. Your comments will be most effective if you follow the suggestions below:

- Explain your views and reasoning as clearly as possible.
- Provide empirical evidence, wherever possible, to support your views.
- If you estimate potential costs, explain how you arrived at the estimate.
- Provide specific examples to illustrate your concerns.
- Offer specific alternatives.
- Reference specific sections of the notice in your comments, such as the

units or page numbers of the preamble, or the regulatory sections.

- Be sure to include the name, date, and docket number of the proceeding as part of your comments.

How Do I Prepare and Submit Comments?

Your comments must be written in English. To ensure that your comments are correctly filed in the Docket, please include the docket number of this document in your comments.

Please submit two copies of your comments, including any attachments, to Docket Management at the address given above under **ADDRESSES**.

Comments may also be submitted to the docket electronically by logging onto the Dockets Management System Web site at <http://dms.dot.gov>. Click on "Help & Information" or "Help/Info" to obtain instructions for filing your document electronically.

How Can I Be Sure That My Comments Were Received?

If you wish Docket Management to notify you upon its receipt of your comments, enclose a self-addressed, stamped postcard in the envelope containing your comments. Upon receiving your comments, Docket Management will return the postcard by mail. Each electronic filer will receive electronic confirmation that his or her submission has been received.

How Do I Submit Confidential Business Information?

If you wish to submit any information under a claim of confidentiality, you should submit three copies of your complete submission, including the information you claim to be confidential business information, to the Chief Counsel, NHTSA, at the address given above under **FOR FURTHER INFORMATION CONTACT**. In addition, you should submit two copies, from which you have deleted the claimed confidential business information, to Docket Management at the address given above under **ADDRESSES**. When you send a comment containing information claimed to be confidential business information, you should include a cover letter delineating that information, as specified in our confidential business information regulation. (See 49 CFR part 512).

Will the Agency Consider Late Comments?

We will consider all comments that Docket Management receives before the close of business on the comment closing date indicated above under **DATES**. To the extent possible, we will

also consider comments that Docket Management receives after that date. If Docket Management receives a comment too late for us to consider it in developing a rule (assuming that one is issued), we will consider that comment as an informal suggestion for future rulemaking action.

How Can I Read Comments Submitted By Other People?

You may read the comments received by Docket Management at the address given above under **ADDRESSES**. The hours of the Docket are indicated above in the same location.

You may also review filed public comments on the Internet. To read the comments on the Internet, take the following steps:

- (1) Go to the Docket Management System (DMS) Web page of the Department of Transportation (<http://dms.dot.gov/>).
- (2) On that page, click on "search."
- (3) On the next page (<http://dms.dot.gov/search/>), type in the four-digit docket number shown at the beginning of this document. (Example: If the docket number were "NHTSA-2002-1234," you would type "1234.") After typing the docket number, click on "search."

- (4) On the next page, which contains docket summary information for the docket you selected, click on the desired comments. You may download the comments. However, since the comments are imaged documents, instead of word processing documents, the downloaded comments are not word searchable.

Please note that even after the comment closing date, we will continue to file relevant information in the Docket as it becomes available. Furthermore, some people may submit late comments. Accordingly, we recommend that you periodically check the Docket for new material.

Data Quality Act Statement

Pursuant to the Data Quality Act, in order for substantive data submitted by third parties to be relied upon and used by the agency, it must also meet the information quality standards set forth in the DOT Data Quality Act guidelines. Accordingly, members of the public should consult the guidelines in preparing information submissions to the agency. DOT's guidelines may be accessed at <http://dmses.dot.gov/submit/DataQualityGuidelines.pdf>.

VIII. Rulemaking Analyses and Notice

A. Vehicle Safety Act

Under 49 U.S.C. Chapter 301, *Motor Vehicle Safety* (49 U.S.C. 30101 *et seq.*),

the Secretary of Transportation is responsible for prescribing motor vehicle safety standards that are practicable, meet the need for motor vehicle safety, and are stated in objective terms.¹⁷ These motor vehicle safety standards set a minimum standard for motor vehicle or motor vehicle equipment performance.¹⁸ When prescribing such standards, the Secretary must consider all relevant, available motor vehicle safety information.¹⁹ The Secretary also must consider whether a proposed standard is reasonable, practicable, and appropriate for the type of motor vehicle or motor vehicle equipment for which it is prescribed and the extent to which the standard will further the statutory purpose of reducing traffic accidents and associated deaths.²⁰ The responsibility for promulgation of Federal motor vehicle safety standards has been delegated to NHTSA.²¹

In proposing to require a rear object detection system for straight trucks, the agency carefully considered these statutory requirements.

First, this proposal is preceded by both a Request for Comments and an Advance Notice of Proposed Rulemaking, which facilitated the efforts of the agency to obtain and consider relevant motor vehicle safety information, as well as public comments. Further, in preparing this document, the agency carefully evaluated previous agency research and vehicle testing relevant to this proposal. We also conducted a new death certificate study to ascertain the number of backing-related fatalities and injuries, and we updated our analyses to determine the relevant target population and potential costs and benefits of our proposal. In sum, this document reflects our consideration of all relevant, available motor vehicle safety information.

Second, to ensure that the proposed rear object detection requirements are practicable, the agency considered the cost, availability, and suitability of various rear object detection systems for mounting on straight trucks, consistent with our safety objectives. We note that the visual systems contemplated under the proposal (*i.e.*, cross-view mirrors and video cameras) are already installed on many vehicles proposed for coverage under these amendments. However, we have requested comments as to types of

¹⁷ 49 U.S.C. 30111(a).

¹⁸ 49 U.S.C. 30102(a)(9).

¹⁹ 49 U.S.C. 30111(b).

²⁰ *Id.*

²¹ 49 U.S.C. 105 and 322; delegation of authority at 49 CFR 1.50.

vehicles for which such systems would be impracticable due to rugged work environments or the lack of an appropriate mounting location; if such practicability concerns cannot be resolved, the agency may find it appropriate to exclude such vehicles from the requirements of the final rule. Although the costs for some rear object detection systems (*i.e.*, video cameras) may be relatively high, we believe that manufacturers would be able to pass these costs on to vehicle customers without experiencing appreciable changes in sales. In sum, we believe that this proposal to prevent deaths and injuries associated with backing straight trucks is practicable.

Third, the proposed regulatory text following this preamble is stated in objective terms in order to specify precisely what performance is required and how performance will be tested to ensure compliance with the standard. Specifically, the proposal sets forth performance requirements for both cross-view mirrors and video systems. Mirrors and video cameras are familiar technologies, and we do not believe that the specifications for these devices themselves or their placement are likely to be misinterpreted.

The proposal also includes test requirements for visual detection of a 3 m by 3 m area behind the vehicle, as marked by a set of test cylinders. This test is modeled after a similar test for object detection in front of school buses, which has been part of the standard for a number of years. Thus, the agency believes that this test procedure is sufficiently objective and would not result in any uncertainty as to whether a given vehicle satisfies the proposed rear object detection requirements.

Fourth, we believe that this proposal will meet the need for motor vehicle safety because the proposed rear object detection requirement would eliminate the blind spot directly behind most straight trucks and allow visual confirmation by the driver that the way is clear, thereby preventing backing-related deaths and injuries.

Finally, we believe that this proposal is reasonable and appropriate for motor vehicles subject to the proposed requirements. As discussed elsewhere in this notice, the agency is concerned with the amount of fatalities and serious injuries related from backing straight trucks. Our statistical data indicates that vehicles subject to the proposed requirements have a high rate of backing incidents resulting in death and injury. Available evidence also suggests that rear object detection systems are an effective countermeasure in these situations. Accordingly, we believe that

this proposal is appropriate for covered vehicles that are or would become subject to these provisions of FMVSS No. 111 because it furthers the agency's objective of preventing deaths and serious injuries associated with backing incidents.

B. Executive Order 12866 and DOT Regulatory Policies and Procedures

Executive Order 12866, "Regulatory Planning and Review" (58 FR 51735, October 4, 1993), provides for making determinations whether a regulatory action is "significant" and therefore subject to review by the Office of Management and Budget (OMB) and to the requirements of the Executive Order. The Order defines a "significant regulatory action" as one that is likely to result in a rule that may:

- (1) Have an annual effect on the economy of \$100 million or more or adversely affect in a material way the economy, a sector of the economy, productivity, competition, jobs, the environment, public health or safety, or State, local, or Tribal governments or communities;
- (2) Create a serious inconsistency or otherwise interfere with an action taken or planned by another agency;
- (3) Materially alter the budgetary impact of entitlements, grants, user fees, or loan programs or the rights and obligations of recipients thereof; or
- (4) Raise novel legal or policy issues arising out of legal mandates, the President's priorities, or the principles set forth in the Executive Order.

This rulemaking document was reviewed by OMB under E.O. 12866. Further, this action has been determined to be "significant" under the Department of Transportation's Regulatory Policies and Procedures (44 FR 11034, February 26, 1979). As discussed in the Preliminary Regulatory Evaluation (PRE), this rulemaking amending FMVSS No. 111 to require installation of rear object detection systems on certain new vehicles is expected have a total consumer cost estimated at \$77 million annually (in 2004 economics).

The agency has prepared a separate document (*i.e.*, the PRE) addressing in detail the benefits and costs of the proposed rule, as well as alternatives considered. A copy of the PRE is being placed in the docket.

As discussed in that document and in the preceding sections of this notice, requiring a rear object detection system on straight trucks has the potential to prevent a number of backing-related deaths and injuries, thereby furthering the agency's safety mission. Straight trucks have an incidence rate for

backing fatalities that is 8 to 17 times greater than for passenger vehicles. However, by requiring installation of either a cross-view mirror or rear video camera, we believe that it would be possible to eliminate the blind spot behind these vehicles, to permit vehicle operators to have visual confirmation that the area immediately behind the vehicle is clear, and to thereby reduce the number of backing-related injuries and fatalities.

We estimate that this proposal would result in a net reduction of 23 fatalities and 43 injuries annually once all straight trucks are equipped with a rear object detection system, assuming a 33 percent effectiveness rate for these crash avoidance devices. The present discounted value of anticipated property damage savings is estimated to be \$32 million annually. In most cases, these benefits would result from the ability of the system to prevent the collision entirely.

Our estimation of the cost of the proposed rule is based upon the following. We estimate that about 18 percent of the 365,000 new straight trucks sold annually already come equipped with a rear object detection system that would meet the proposed requirements of the rule. That leaves the remaining 299,300 new straight trucks affected by this rulemaking. Because agency-sponsored research has shown 5 meters to be the maximum distance between a cross-view mirror and an outside rearview mirror that could provide a meaningful image, under this proposal, trucks with a mirror separation of more than 5 meters would be required to use a camera system. Accordingly, NHTSA estimates a counter-measure distribution of about 25 percent for mirrors and 75 percent for cameras. The estimated consumer cost per vehicle, including installation, for an 8-inch diameter mirror and hardware is \$51.64, for a 10-inch diameter mirror and hardware is \$56.85, and for a camera system, monitoring, and mounting hardware is \$325.10. The cost per equivalent life saved is estimated to be \$2.3 million.

Although the costs for some rear object detection systems may be fairly substantial, we believe that single-unit truck manufacturers would be able to pass these costs on to vehicle customers without experiencing appreciable changes in sales. It is expected that the proposed requirements and associated costs would apply evenly across the industry and not adversely impact any one segment of that industry.

As part of this rulemaking, the agency considered a number of regulatory alternatives. We considered a variety of

systems for rear object, but we decided that a visual system was needed in the interest of safety, in order to provide the driver with a view of the backing vehicle's pathway and to maintain driver responsibility for safe operation of the vehicle while backing. We also considered the use of detection zones of different sizes and the possibility of excluding certain types of vehicles from the proposed requirements. Once again, a complete discussion of these issues related to benefits, costs, and alternatives may be found in the PRE.

C. Regulatory Flexibility Act

Pursuant to the Regulatory Flexibility Act (5 U.S.C. 601 *et seq.*, as amended by the Small Business Regulatory Enforcement Fairness Act (SBREFA) of 1996), whenever an agency is required to publish a notice of rulemaking for any proposed or final rule, it must prepare and make available for public comment a regulatory flexibility analysis that describes the effect of the rule on small entities (*i.e.*, small businesses, small organizations, and small governmental jurisdictions). However, no regulatory or flexibility analysis is required if the head of an agency certifies that the rule will not have a significant economic impact on a substantial number of small entities. SBREFA amended the Regulatory Flexibility Act to require Federal agencies to provide a statement of the factual basis for certifying that a rule will not have a significant economic impact on a substantial number of small entities.

NHTSA has considered the effects of this rulemaking action under the Regulatory Flexibility Act and has included a regulatory flexibility analysis in the PRE. This analysis discusses potential regulatory alternatives that the agency considered that would still meet the identified safety need of eliminating the blind spot behind straight trucks. Alternatives considered included the use of detection zones of different sizes and exclusion of certain types of vehicles from the proposed requirements.

To summarize the conclusions of that analysis, the agency believes that the proposal would have a significant economic impact on a substantial number of small businesses. There are a substantial number of single-unit truck manufacturers (about 750 in the U.S.), and the cost of video cameras is relatively high. We estimate that there are approximately 12 mirror manufacturers, of which 3 are small businesses. We do not expect manufacturers of video cameras to be classified as small businesses.

As with any other Federal motor vehicle safety standard, single-unit truck manufacturers would be required to certify the vehicle's compliance with all applicable FMVSSs. However, we anticipate that single-unit truck manufacturers would pass the cost of the rear object detection system on to consumers. Further, we believe that the increase in price would have a small impact, at most, on the sales of single-unit trucks, because such vehicles are usually a necessary expense for businesses conducting routine operations. We also expect that the proposed requirements and associated costs would apply evenly across the industry and not adversely impact any one segment of that industry.

We expect that the proposed requirements could have a small positive economic impact on mirror manufacturers, due to increased sales volumes.

D. Executive Order 13132 (Federalism)

Executive Order 13132, "Federalism" (64 FR 43255, August 10, 1999), requires NHTSA to develop an accountable process to ensure "meaningful and timely input by State and local officials in the development of regulatory policies that have federalism implications." "Policies that have federalism implications" are defined in the Executive Order to include regulations that have "substantial direct effects on the States, on the relationship between the national government and the States, or on the distribution of power and responsibilities among the various levels of government." Under Executive Order 13132, the agency may not issue a regulation with Federalism implications, that imposes substantial direct compliance costs, and that is not required by statute, unless the Federal government provides the funds necessary to pay the direct compliance costs incurred by State and local governments, the agency consults with State and local governments, or the agency consults with State and local officials early in the process of developing the proposed regulation. NHTSA also may not issue a regulation with Federalism implications and that preempts a State law unless the agency consults with State and local officials early in the process of developing the regulation.

The proposed rule to amend this Federal motor vehicle safety standard is being issued pursuant to NHTSA's statutory authority under section 30111 of the Motor Vehicle Safety Act (49 U.S.C. Chapter 301), and was analyzed in accordance with the principles and criteria set forth in Executive Order

13132. The agency determined that the rule would not have sufficient Federalism implications to warrant consultations with State and local officials or the preparation of a Federalism summary impact statement. This proposed rule would not have any substantial effects on the States, or on the current distribution of power and responsibilities among the various local officials. The reason is that this proposed rule, if made final, would apply to motor vehicle manufacturers, and not to the States or local governments. Thus, the requirements of Section 6 of the Executive Order do not apply to this proposed rule. We would note that States may comment on this proposal and that one State (New York) did comment on the ANPRM.

Section 30103(b) of 49 U.S.C. provides, "When a motor vehicle safety standard is in effect under this chapter, a State or a political subdivision of a State may prescribe or continue in effect a standard applicable to the same aspect of performance of a motor vehicle or motor vehicle equipment only if the standard is identical to the standard prescribed under this chapter."

If adopted, our proposed amendments would preempt all state statutes, regulations and common law requirements that differ with it. More specifically, the amended FMVSS No. 111 would preempt State requirements for a rear object detection system on new motor vehicles that is not the same as the one that would be required under the standard. Thus, for example, it would preempt aspects of at least three State laws currently in force (*i.e.*, provisions in New Jersey,²² New York,²³ and Washington²⁴).

Our proposal reflects careful balancing of a variety of considerations and objectives in this field. As a primary matter, we believe that the proposal should reflect the fact that drivers have the responsibility to ensure that the pathway is clear before backing the vehicle. To this end, the NPRM is proposing several technological options that would ensure that drivers can visually confirm that the pathway is clear, including cross-view mirrors, a rear video camera, or even the driver's vision (if the configuration of the vehicle is such that the driver can see all relevant test points). We have concerns that non-visual systems, such as infrared and sonar systems, may not be sufficiently reliable or provide the same level of certainty as visual

²² N.J. Stat. Ann. § 39:3-71.1 (West 2004).

²³ N.Y. Vehicle and Traffic Law § 375(9)(e) (McKinney 2003).

²⁴ Wash. Rev. Code Ann. § 46.37.400 (West 2004).

systems. We are also concerned that other systems, such as audible back-up alarms, could shift the burden to the person behind the backing vehicle to get out of the way; some pedestrians (e.g., children, the elderly) may be ill-equipped to take the necessary evasive action in those situations. Thus, we believe that requiring a visual rear object detection system, as proposed, would adequately address the identified backing problem with straight trucks.

We also intend to specify a uniform set of requirements for rear object detection systems installed on straight trucks consistent with the Federal system established by Congress. Congress provided NHTSA with the responsibility to establish performance standards to ensure that motor vehicles—including straight trucks—are manufactured in such a way as to meet the need for motor vehicle safety. Congress gave FMCSA the responsibility to ensure that straight trucks are operationally safe in accordance with a uniform Federal, rather than a myriad of State, operational standards. As noted above, FMCSA has concluded that States should adopt requirements consistent with the FMVSS or should limit State requirements to vehicles that will operate solely in intrastate commerce. Although we do not propose to prohibit the voluntary installation of supplemental systems by manufacturers, we believe our proposal addresses the safety need and that supplemental State or local requirements would subvert the Federal safety program Congress has established between NHTSA and FMCSA.

E. Executive Order 12988 (Civil Justice Reform)

Pursuant to Executive Order 12988, “Civil Justice Reform” (61 FR 4729, February 7, 1996), the agency has considered whether this proposed rule would have any retroactive effect. We conclude that it would not have such an effect. Under 49 U.S.C. 30103, whenever a Federal motor vehicle safety standard is in effect, a State may not adopt or maintain a safety standard applicable to the same aspect of performance which is not identical to the Federal standard, except to the extent that the State requirement imposes a higher level of performance and applies only to vehicles procured for the State’s use. 49 U.S.C. 30161 sets forth a procedure for judicial review of final rules establishing, amending, or revoking Federal motor vehicle safety standards. That section does not require submission of a petition for reconsideration or other administrative

proceedings before parties may file a suit in court.

F. Executive Order 13045 (Protection of Children From Environmental Health and Safety Risks)

Executive Order 13045, “Protection of Children from Environmental Health and Safety Risks” (62 FR 19855, April 23, 1997), applies to any rule that: (1) is determined to be “economically significant” as defined under Executive Order 12866, and (2) concerns an environmental, health, or safety risk that the agency has reason to believe may have a disproportionate effect on children. If the regulatory action meets both criteria, the agency must evaluate the environmental health or safety effects of the planned rule on children, and explain why the planned regulation is preferable to other potentially effective and reasonably feasible alternatives considered by the agency.

This proposed rule is not subject to Executive Order 13045 because it is not “economically significant,” as defined in Executive Order 12866.

G. Paperwork Reduction Act

Under the Paperwork Reduction Act of 1995 (PRA), a person is not required to respond to a collection of information by a federal agency unless the collection displays a valid OMB control number. NHTSA has determined that, if made final, this proposed rule would not impose any “collection of information” burdens on the public, within the meaning of the PRA. This rulemaking would not impose any filing or recordkeeping requirements on any manufacturer or any other party. For this reason, we discuss neither electronic filing and recordkeeping nor do we discuss a fully electronic reporting option.

H. National Technology Transfer and Advancement Act

Section 12(d) of the National Technology Transfer and Advancement Act of 1995 (NTTAA), Public Law 104–113, (15 U.S.C. 272) directs the agency to evaluate and use voluntary consensus standards in its regulatory activities unless doing so would be inconsistent with applicable law or is otherwise impractical. Voluntary consensus standards are technical standards (e.g., materials specifications, test methods, sampling procedures, and business practices) that are developed or adopted by voluntary consensus standards bodies, such as the Society of Automotive Engineers (SAE). The NTTAA directs us to provide Congress (through OMB) with explanations when the agency decides not to use available

and applicable voluntary consensus standards. The NTTAA does not apply to symbols.

NHTSA is not aware of any voluntary consensus standards related to the proposed rear object detection systems that are available at this time. However, NHTSA will consider any such standards as they become available.

I. Unfunded Mandates Reform Act

Section 202 of the Unfunded Mandates Reform Act of 1995 (UMRA) requires federal agencies to prepare a written assessment of the costs, benefits, and other effects of proposed or final rules that include a Federal mandate likely to result in the expenditure by State, local, or tribal governments, in the aggregate, or by the private sector, of more than \$100 million annually (adjusted for inflation with base year of 1995). Before promulgating a NHTSA rule for which a written statement is needed, section 205 of the UMRA generally requires the agency to identify and consider a reasonable number of regulatory alternatives and adopt the least costly, most cost-effective, or least burdensome alternative that achieves the objectives of the rule. The provisions of section 205 do not apply when they are inconsistent with applicable law. Moreover, section 205 allows the agency to adopt an alternative other than the least costly, most cost-effective, or least burdensome alternative if the agency publishes with the final rule an explanation of why that alternative was not adopted.

This proposal will not result in the expenditure of \$100 million or more by State, local, or tribal governments, in the aggregate, or to the private sector. Thus, this proposal is not subject to the requirements of sections 202 and 205 of the UMRA.

J. National Environmental Policy Act

NHTSA has analyzed this proposed rulemaking action for the purposes of the National Environmental Policy Act. The agency has determined that implementation of this action will not have any significant impact on the quality of the human environment.

K. Regulatory Identifier Number (RIN)

The Department of Transportation assigns a regulation identifier number (RIN) to each regulatory action listed in the Unified Agenda of Federal Regulations. The Regulatory Information Service Center publishes the Unified Agenda in April and October of each year. You may use the RIN contained in the heading at the beginning of this document to find this action in the Unified Agenda.

L. Privacy Act

Please note that anyone is able to search the electronic form of all comments received into any of our dockets by the name of the individual submitting the comment (or signing the comment, if submitted on behalf of an association, business, labor union, etc.). You may review DOT's complete Privacy Act Statement in the Federal Register published on April 11, 2000 (Volume 65, Number 70; Pages 19477-78), or you may visit http://dms.dot.gov.

List of Subjects in 49 CFR Parts 571

Motor vehicle safety, Reporting and recordkeeping requirements, Tires.

In consideration of the foregoing, NHTSA is proposing to amend 49 CFR part 571 as follows:

PART 571—FEDERAL MOTOR VEHICLE SAFETY STANDARDS

1. The authority citation for part 571 of Title 49 would continue to read as follows:

Authority: 49 U.S.C. 322, 30111, 30115, 30117, and 30166; delegation of authority at 49 CFR 1.50.

2. Section 571.111 would be amended by revising S4, S7, S7.1, S8, S8.1, and S13 Figure 3, and by adding new S7.2, S7.2.1, S7.2.2, S14, S14.1, S14.2, S14.3, S14.4, S14.5, S14.6, and Figure 5 to read as follows:

§ 571.111 Standard No. 111; Rearview mirrors.

* * * * *

S4. Definitions

Convex mirror means a mirror having a curved reflective surface whose shape is the same as that of the exterior surface of a section of a sphere.

Effective mirror surface means the portions of a mirror that reflect images, excluding the mirror rim or mounting brackets.

Straight truck means a single-unit truck composed of an undetachable cab and body.

Unit magnification mirror means a plane or flat mirror with a reflective surface through which the angular height and width of the image of an object is equal to the angular height and width of the object when viewed directly at the same distance except for flaws that do not exceed normal manufacturing tolerances. For the

purposes of this regulation, a prismatic day-night adjustment rearview mirror, one of whose positions provides unit magnification, is considered a unit magnification mirror.

* * * * *

S7. Requirements for multipurpose passenger vehicles and trucks with a GVWR of more than 4,536 kg and less than 11,793 kg and buses, other than school buses, with a GVWR of more than 4,536 kg.

S7.1 Each multipurpose passenger vehicle and truck with a GVWR of more than 4,536 kg and less than 11,793 kg and each bus, other than a school bus, with a GVWR of more than 4,536 kg must have outside mirrors of unit magnification, each with not less than 323 cm² of reflective surface, installed with stable supports on both sides of the vehicle. The mirrors must be located so as to provide the driver a view to the rear along both sides of the vehicle and shall be adjustable both in the horizontal and vertical directions to view the rearward scene.

S7.2 When tested in accordance with the procedures of S14, each straight truck with a GVWR of more than 4,536 kg and less than 11,793 kg must have either a convex cross-view mirror that meets the requirements of S7.2.1 or a video monitoring system that meets the requirements of S7.2.2. However, this requirement does not apply if the straight truck equipped with the mirrors specified in S7.1 or the mirrors specified in S7.1 and S5.1 can comply with S7.2.1(a), when tested in accordance with S14.

S7.2.1 Cross-view Mirror. A convex mirror must be located with stable supports on the upper rear corner of the vehicle on the driver's side, such that:

- (a) The entire top surface of all the test cylinders (right circular in shape) must be visible;
(b) Its geometric center must be no more than 5,000 mm from the geometric center of the outside rearview mirror on the driver's side;
(c) It must not have any discontinuities or flaws that exceed normal manufacturing tolerances in the slope of its surface;

(d) It must provide for adjustment by tilting in both the horizontal and vertical directions; and

(e) It must have an average radius of curvature of no less than 203 mm, as determined under S12.

S7.2.2 Video Monitoring System. A video monitoring system must be located on the vehicle and have properties such that:

- (a) The entire top surface of all the test cylinders (right circular in shape) must be visible;
(b) It must include a video monitor mounted in full view of the driver;
(c) The monitor must be mounted as close to the centerline of the vehicle as practicable near the top of the windshield, but located such that the distance from the center point of the eye location of a 25th-percentile adult female seated in the driver's seat to the center of the monitor is no more than 1,000 mm;
(d) The system must provide an image size of not less than 90 cm² and not more than 160 cm², and the image must be reversed to show the scene as if it were viewed through a rearview mirror;
(e) The video camera and monitor each must be adjustable by tilting in both the horizontal and vertical directions;

(f) The system must provide an image only when the vehicle's transmission is in reverse; and

(g) If the monitor is in the head impact area, as defined in 49 CFR § 571.3, the mounting must deflect, collapse, or break away when subjected to a force of 400 ± 1 Newtons (N) in any forward direction that is not more than 45° from the forward longitudinal direction.

S8. Requirements for multipurpose passenger vehicles and trucks with a GVWR of 11,793 kg or more.

S8.1 Each multipurpose passenger vehicle and truck with a GVWR of 11,793 kg or more must have outside mirrors of unit magnification, each with not less than 323 cm² reflective surface, installed with stable supports on both sides of the vehicle. The mirrors must be located so as to provide the driver a view to the rear along both sides of the vehicle and must be adjustable both in the horizontal and vertical directions to view the rearward scene.

* * * * *

S13. School bus mirror test procedures. * * *

* * * * *

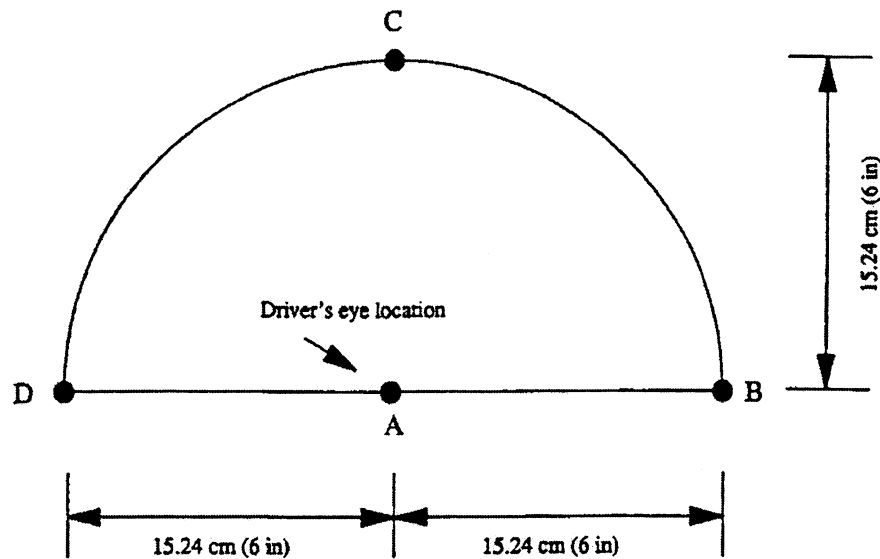

Figure 3 - Camera Locations for School Bus Field-of-View Test and for Cross-View Mirror and Video System Test

* * * * *

S14. *Cross-view mirror and video system test procedures.* When determining compliance with the requirements of S7.2, the vehicle is tested in accordance with the following conditions and procedures.

S14.1 Utilize cylinders of a color which provides a high contrast with the surface on which the vehicle is parked.

S14.2 The cylinders are 305 ± 1 mm high and 305 ± 1 mm in diameter.

S14.3 Place the cylinders at locations as specified in S14.3(a) through S14.3(d) below and as illustrated in Figure 5.

(a) Place cylinders G, H, and I so that they are tangent to a transverse vertical plane tangent to the rearward-most surface of the vehicle's rear bumper. Place cylinders D, E, and F so that their centers are located in a transverse vertical plane that is $1,500 \pm 10$ mm rearward of a transverse vertical plane passing through the centers of cylinders G, H, and I. Place cylinders A, B, and C so that their centers are located in a transverse vertical plane that is $3,000 \pm 10$ mm rearward of the transverse vertical plane passing through the centers of cylinders G, H, and I.

(b) Place cylinders B, E, and H so that their centers are within 10 mm of the longitudinal vertical plane that passes through the vehicle's longitudinal centerline.

(c) Place cylinders A, D, and G so that their centers are in a longitudinal vertical plane that is $1,500 \pm 10$ mm, toward the passenger side, from the longitudinal vertical plane passing through the center of cylinders B, E, and H.

(d) Place cylinders C, F, and I so that their centers are in a longitudinal vertical plane that is $1,500 \pm 10$ mm, toward the driver side, from the longitudinal vertical plane passing through the centers of cylinders B, E, and H.

S14.4 The driver's eye location is the eye location of a 25th-percentile adult female, when seated in the driver's seat as follows:

(a) The center point of the driver's eye location is the point located 685 ± 5 mm vertically above the intersection of the seat cushion and the seat back at the longitudinal centerline of the seat.

(b) Adjust the driver's seat to the midway point between the forward-most and rearward-most positions. If there is not an adjustment position at the midway point, use the closest adjustment position to the rear of the midpoint. If the seat is separately adjustable in the vertical direction, adjust it to the lowest position. If the seat back is adjustable, adjust the seat back angle to the manufacturer's nominal design riding position in accordance with the manufacturer's recommendations.

S14.5 *Adjustment of Viewing Devices.*

(a) If a cross-view mirror is used, adjust the driver's side exterior mirror and the cross-view mirror in accordance with the manufacturer's recommendations before the test. If there are no manufacturer's recommendations, adjust the mirrors to meet the field-of-view requirements herein. The mirrors must not be moved or readjusted thereafter.

(b) If a video system is used, adjust the monitor and video camera in accordance with the manufacturer's recommendations. If there are no manufacturer's recommendations, adjust the monitor and video camera to meet the field-of-view requirements herein. The monitor and video camera must not be moved or readjusted thereafter.

(c) If an inside rearview mirror is used, adjust the mirror to achieve the field of view specified in S5.1.1.

S14.6 *Determination of Compliance.*

(a) If mirrors are used for compliance purposes, place a 35 mm or larger format camera, or video camera, so that the center of its image plane is located at the center point of the driver's eye location or at any single point within a semicircular area established by a 152 ± 1 mm radius parallel to and forward of the center point (determined in accordance with Figure 3 of S13). With the camera or video camera at any location on or within the semicircle, look through the camera or video camera at the driver's side mirror (or the inside rearview mirror if so equipped) and determine if the entire top surface of each cylinder is directly visible, and photograph the results. If a video camera is used, the monitor's output may be recorded for the test results.

(b) If a video system is used for compliance purposes, place a 35 mm or larger format camera, or video camera, so that the center of its image plane is located at the center point of the driver's eye location or at any single point within a semicircular area established by a 152 ± 1 mm radius parallel to and

forward of the center point (determined in accordance with Figure 3 of S13). With the camera or video camera at any location on or within the semicircle,

look through the camera or video camera at the video system monitor and determine if the entire top surface of each cylinder is directly visible, and

photograph the results. If a video camera is used, the monitor's output may be recorded for the test results.

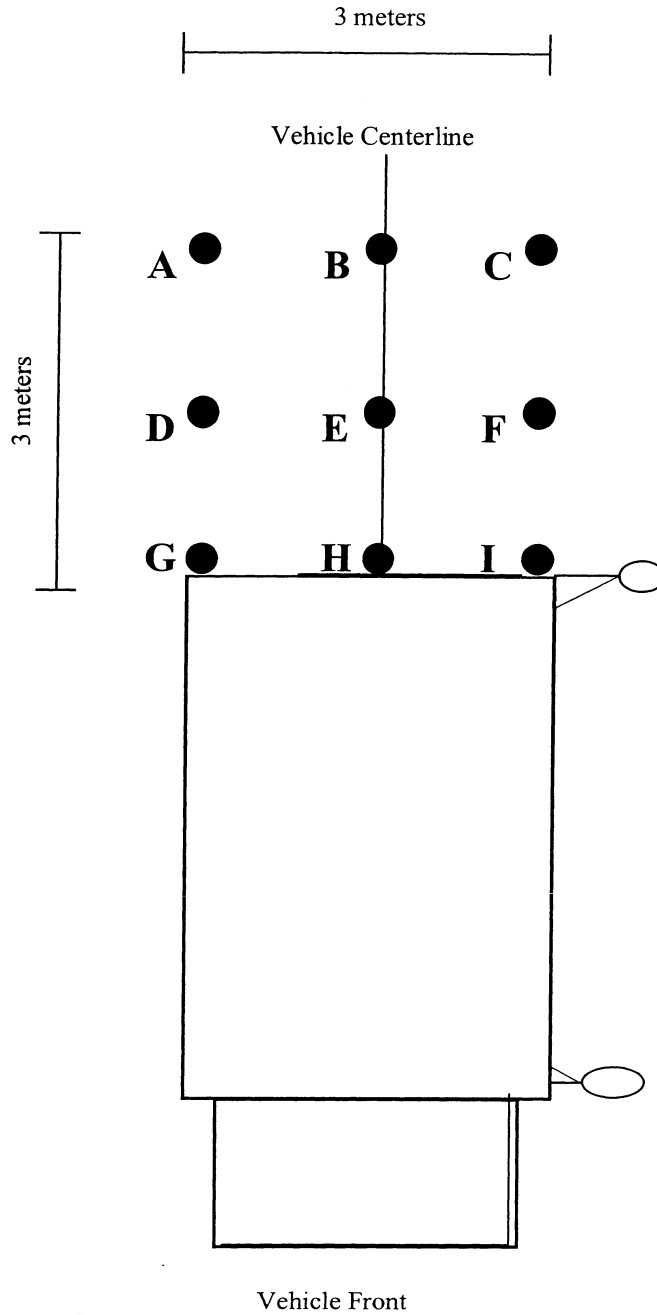

Figure 5.
Location of Test Cylinders for Rear Object Detection Test
All Dimensions in Meters (m)

Issued: September 2, 2005.

Stephen R. Kratzke,

Associate Administrator for Rulemaking.

[FR Doc. 05-17987 Filed 9-9-05; 8:45 am]

BILLING CODE 4910-59-P