

Tips for safer mining equipment

Simple design principles can improve equipment safety in mines

Equipment is the primary cause of injury in 11% of all mining accidents and a secondary cause in another 10%. Purchasers should select new equipment carefully to ensure that the machine incorporates good ergonomic design criteria that maximize the safety of their mine workers.

One potential problem area is the workstation—the control center of the machine. Safety problems often occur when the workstation provides insufficient clearance or visibility to the operator or has controls that are difficult to reach. This is especially true for underground mines, where confined space is an issue. In reclined or stooped postures, operators will have less strength and agility and often experience reduced visibility.

We have conducted and published much research in Human Factors design of mining machine workstations. This information is currently being compiled into a series of Human Factors design recommendation reports.

The reports will cover many topics, including workstation layout, control design, seating, and visibility. Each topic has a list of basic or first principles of design. Understanding these principles is the key to designing or purchasing a workstation that is both safe and efficient. Following is a sampling of these main topics and first principles.

Workstation Layout

- The workstation should fit operators from the 5th- to 95th-percentile range. In other words, it should fit all but the

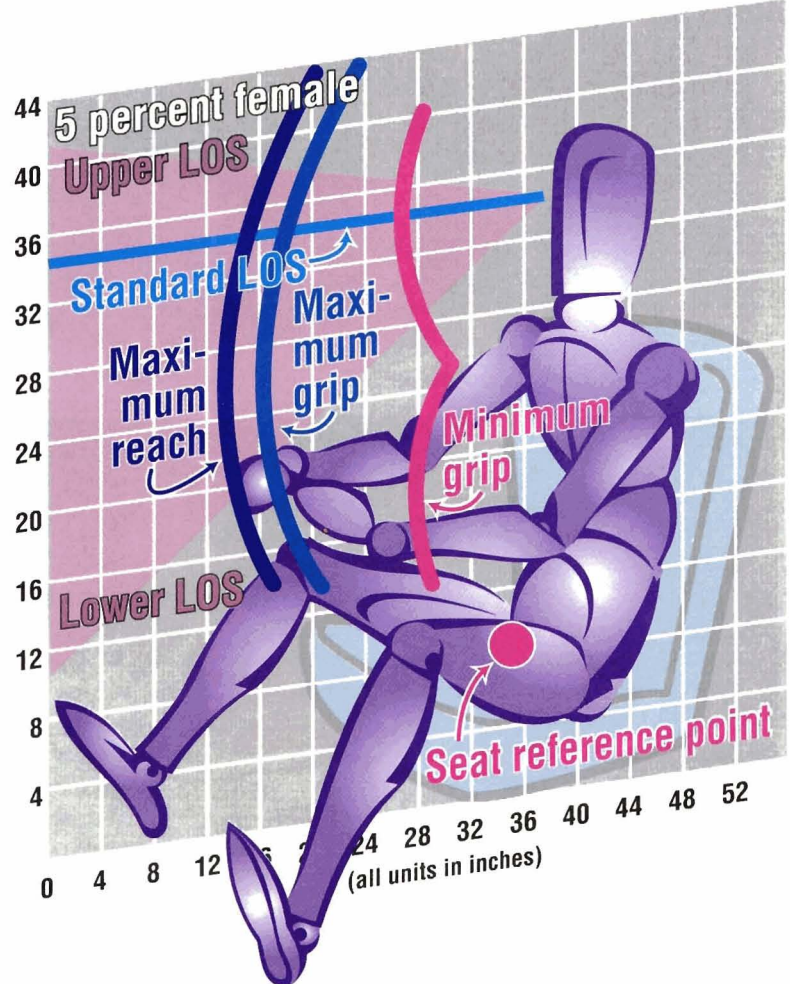

Reach envelopes and lines of sight (LOS) for fifth-percentile female operators in 42-inch workstation heights

smallest 5% and largest 5% of the mining population. Consider the limitations of operators with shorter arms when identifying the arm reach envelope for the location of controls (see schematic on page 1). For clearance requirements for the head, knees, etc., use data from the largest members of the user population.

- Where practical, distribute the workload as evenly as possible between hands and feet. Position emergency controls and primary controls that require precision operation for easy access by either hand.
- Anticipate all potential safety hazards and required emergency actions before starting to design.
- Maintain the relative placement of controls and displays for similar types of equipment. This takes advantage of

established habits and helps to eliminate confusion when moving from one machine to another.

Control design

- Design controls to comply with anthropometric data on human operators. For example, push buttons should be large enough to activate easily with a gloved hand. The force required to engage a panic bar should not exceed the capabilities of the operator in his or her normal operating position.
- Ensure that the operator can identify the proper controls quickly and accurately. For example, critical controls should be larger than noncritical controls.
- Where feasible, the speed of a vehicle or component should be

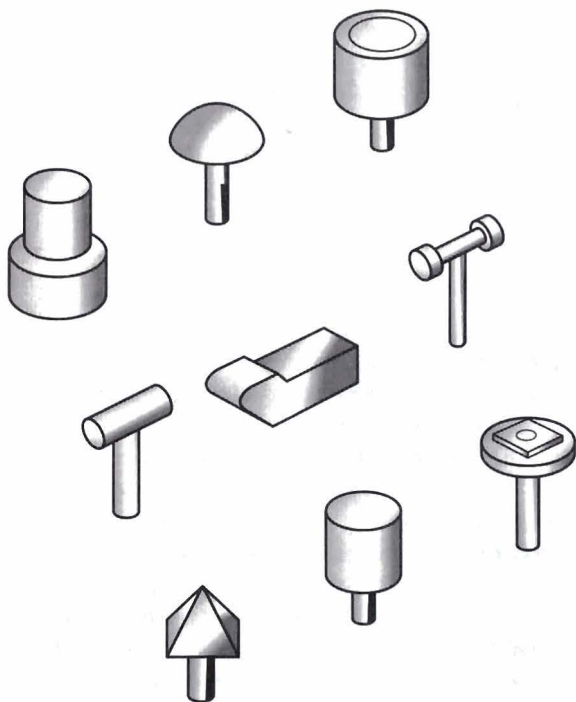

Several recommended knob shapes for roof bolters wearing gloves.

proportional to the displacement of the control from its rest position and in the same direction.

- Controls should have sufficient resistance to reduce the possibility of inadvertent activation by the weight of a hand or foot.
- Design controls to withstand or guard against abuse, such as from falling roof and ribs or from the forces imposed during a panic response in an emergency stop. Also, design control surfaces to prevent slipping.

Seating

- The seat should fit and adjust to body dimensions, distribute weight to relieve pressure points, and support posture. In other words, the seat should be comfortable.
- The seat should provide design features to guard against shocks caused by rough roadways and minor collisions that tend to unseat a person.
- The seat should not hinder the operator's ability to control the machine. For example, the seat back should not interfere with shoulder

objects that should be visible to perform a job safely and efficiently.

- Provide enough contrast between the luminance of the object or location of interest and the surrounding background to ensure that the task can be performed safely and efficiently.

Our design recommendations will be useful to everyone in the industry, not just machine designers. For instance, the first report will include a Maintainability Design Checklist

movement.

- The seat should not hinder the operator's ability to enter or exit the workstation. For example, it should be possible to move arm rests out of the way.
- Design the seat so that mine personnel can easily maintain or replace it. Use modular components when possible.

Visibility

- The workstation should provide an unobstructed line of site to locations or

for coal mining equipment. The checklist provides a summary of design review points so that equipment buyers can evaluate the maintainability of new or existing underground equipment. It specifically focuses on identifying design features that impact downtime, repair costs, labor hours, and maintenance expertise required.

Our first recommendation report will be published in late 1996 and will cover underground mobile mining equipment. A subsequent report will address surface mining equipment. The report will also be published as a World Wide Web page on the Internet (accessible via <http://www.usbm.gov>). Users contacting the web page will be able to pose questions directly to experts in Human Factors design.

Richard L. Unger, Civil Engineer, (412) 892-4372 (ungerrl@ptmba.usbm.gov).

Reprinted from the August 1996 edition of the U.S. Department of Energy's Mining Health and Safety UPDATE, Vol. 1, No. 2—the latest developments in Federal mine health and safety research.

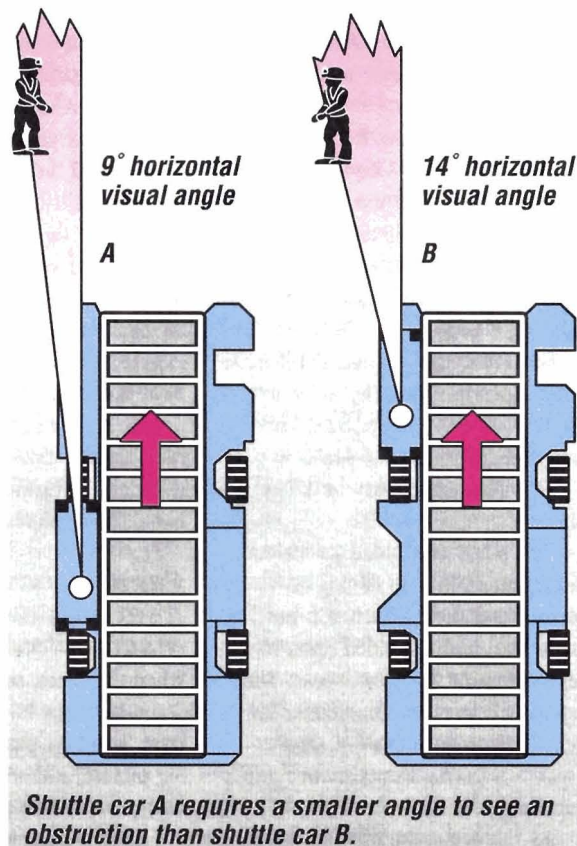

Shuttle car A requires a smaller angle to see an obstruction than shuttle car B.