

RI 9143

Bureau of Mines Report of Investigations/1987

Protective Structures for Low-Coal Shuttle Car Operator

**By John R. Bartels, August J. Kwitowski,
and William D. Mayercheck**



UNITED STATES DEPARTMENT OF THE INTERIOR



Report of Investigations 9143

Protective Structures for Low-Coal Shuttle Car Operator

**By John R. Bartels, August J. Kwitowski,
and William D. Mayercheck**

**UNITED STATES DEPARTMENT OF THE INTERIOR
Donald Paul Hodel, Secretary**

**BUREAU OF MINES
David S. Brown, Acting Director**

Library of Congress Cataloging in Publication Data:

Bartels, John R.

Protective structures for low-coal shuttle car operator.

(Report of investigations; 9143)

Bibliography: p. 21

Supt. of Docs. no.: I 28.23: 9143

1. Mine haulage—Safety measures. 2. Coal mines and mining—Safety measures. I. Kwitowski, August J. II. Mayercheck, William D. III. Title. IV. Series: Report of investigations (United States. Bureau of Mines); 9143

TN23.U43

[TN331]

622 s

[622'.8]

87-600183

CONTENTS

	<u>Page</u>
Abstract.....	1
Introduction.....	2
Technical approach.....	2
Design concepts.....	6
Limited coverage concepts.....	7
Roll-bar canopy.....	7
Sliding canopy.....	10
Flip-top-canopy operator compartment.....	10
Testing.....	15
Summary of test results.....	18
Conclusions.....	21
References.....	21
Appendix.--Symbols used in this report.....	22

ILLUSTRATIONS

1. Canopy-to-machine height relationships.....	4
2. Operator-head-room-to-compartment-length relationships.....	4
3. Coal miner anthropometrics.....	5
4. Shuttle car seat.....	8
5. Roll-bar protection.....	9
6. Sliding canopy.....	11
7. Flip-top operator compartment.....	11
8. Flip-top compartment in raised position.....	12
9. Sling seat.....	13
10. Schematic of modified hydraulic system.....	15
11. Human eye reference measurement instrument (HERMI).....	16
12. Visual attention locations for shuttle car.....	16
13. Roll-bar loadings.....	18
14. Structural analysis of roll-bar member 1.....	18
15. Structural analysis of roll-bar member 2.....	18
16. Finite-element grid.....	19

TABLES

1. High-speed low-coal shuttle car accidents, 1982-84.....	3
2. Specifications for shuttle car, roll-bar canopy, and sliding compartment..	10
3. Specifications for shuttle car and the flip-top canopy operator compartment.....	14
4. Visual attention locations priority scores for shuttle car.....	17
5. Visual attention location score.....	20

UNIT OF MEASURE ABBREVIATIONS USED IN THIS REPORT

ft ³	cubic foot	kip/in ²	kip per square inch
ft	foot	lb	pound
hp	horsepower	min	minute
in	inch	pct	percent
in ²	square inch	psi	pound (force) per square inch
in ³	cubic inch	s	second
kip·in	kip inch		
kip/in	kip per inch		

PROTECTIVE STRUCTURES FOR LOW-COAL SHUTTLE CAR OPERATOR

By John R. Bartels,¹ August J. Kwitowski,¹ and William D. Mayercheck²

ABSTRACT

This report discusses the Bureau of Mines' efforts to develop partial protective structures for operators of low-coal shuttle cars. In coal seams 48 in high or less, full-coverage canopies are generally difficult or may be impossible to implement on high-speed face equipment due to the restrictions they impose on the operator's vision and comfort. Limited coverage is one alternative that provides an acceptable level of operator protection in thin-seam applications where conventional full-coverage canopies cannot be used. Three possible limited-coverage design scenarios (roll bars, sliding canopies, and flip-top canopies) were designed, fabricated, and evaluated for low-coal shuttle cars. All three designs were determined to be feasible and desirable for low-coal shuttle car application.

¹Civil engineer.

²Supervisory physical scientist.

Pittsburgh Research Center, Bureau of Mines, Pittsburgh, PA.

INTRODUCTION

Since January 1, 1974, cabs and canopies have been required on underground face equipment by Federal law (30 CFR 75.1710) and have been successful in reducing the total number of face equipment operator injuries. The Mine Safety and Health Administration (MSHA), U.S. Department of Labor, has estimated that 233 lives have been saved from January 1971 through December 1985 (6-7).³ MSHA has also estimated that approximately 70 pct of all equipment operator accidents that occurred in coal seams 48 in or less could have been prevented had protective structures been employed on all face equipment (6-7).

Through past Bureau programs, adequate canopy equipment has been developed for application to mining equipment used where seam heights are 48 in or less. Canopies are used in 48- to 60-in seams, but not without problems. In seam heights less than 48 in, previous attempts to apply canopy technologies have resulted in adverse comments from operators and mine management. Typical problems are reduced visibility and fatigue caused by unusual and cramped operator positions.

Although advancements have been made to improve operator safety, preventable injuries continue to occur. A 1983 study showed that there were 616 preventable accidents between 1975 and 1978 for equipment operated in coal seam heights less than 48 in (3). Of the preventable accidents, the most frequent types of equipment involved were high-speed face

equipment such as shuttle cars, scoops, and tractors, which accounted for 226 injuries, or 36 pct of such accidents.

Successful designs for all equipment types have not yet been developed. Face equipment such as continuous miners, roof bolters, and face drills, are usually much easier to equip with protective operator cabs and canopies than shuttle cars. These types of face equipment perform their functions primarily at one location; i.e., a continuous miner extracts coal at the face, whereas shuttle cars frequently travel through the working section. Also the tram rate of shuttle cars is significantly higher than that of other types of face equipment. These factors require that a shuttle car be maneuverable and have as much clearance as possible in order to tram through the tight spots in the section. The requirement for tramping clearance is opposed by the fact that a primary goal in shuttle car design is to maximize the amount of cut coal that can be transported from the face. The overall effect of these factors is that space that could otherwise be utilized for the operator is used for increased coal capacity and tram clearance.

The limited-coverage technique was developed as a means of providing operator protection in seams 48 in or less. This technique provides protection from the most frequent injuries while maintaining adequate operator visibility and comfort.

TECHNICAL APPROACH

The limited success of current design methods in producing acceptable operator compartments for thin-seam, high-speed face equipment required that new design approaches be taken. The initial problem was to determine the most frequent types

and causes of high-speed, low-coal face equipment accidents. Afterwards, the goal was to determine the most effective means of either preventing the accidents or protecting the operator without creating additional hazards.

Accident analysis (table 1) indicated that, for high-speed face equipment, the majority of accidents (87 pct) were pinching and/or squeezing. These are

³Underlined numbers in parentheses refer to items in the list of references preceding the appendix.

TABLE 1. - High-speed low-coal shuttle car accidents, 1982-84

Year	Total	Pinching and/or squeezing		Roof fall		Other	
		No.	Pct	No.	Pct	No.	Pct
1982.....	334	289	87	34	10	11	3
1983.....	261	229	89	19	7	13	4
1984.....	275	235	85	35	13	5	2
Total..	870	753	87	88	10	29	2

accidents where the operator becomes crushed between the machine frame and overhead obstructions or the rib. The major causes of this type of accident were lack of operator visibility and lack of adequate protection.

Based on this data, it was concluded that a significant number of low-coal, high-speed face equipment accidents could be prevented with alternatives to full-coverage canopies. (However full-coverage canopies are the most preferable means of protection where they are practical.) In low coal, full coverage can restrict physical movement and visibility to such an extent that safe machine operation becomes difficult. Therefore, limited coverage was determined to be a viable option in cases where no operator protection was available.

This report is aimed at preventing injury due to the most common type of low-coal, high-speed face equipment accident, pinching and/or squeezing. In order to achieve this, operator coverage must be kept to a minimum to provide adequate visibility and be strategically placed to provide maximum protection. This requires the operator protection to be placed above and in front of the operator's head to prevent trapping the operator between the machine frame and overhead obstructions. Also side restraints should be provided to prevent the operator from leaning out of the protective envelope and becoming squeezed between the moving machine and rib.

The Bureau of Mines has sponsored several programs to advance the design and application of canopies and to demonstrate the new technologies in underground coal mines. These programs have made advances in human factors engineering and standardized operator controls and seat design. Additionally, a number

of design factors which must be considered in low coal canopy designs have been defined. These design considerations, which are listed below, have been incorporated into this program:

Overall Safety

Safety must remain the keystone criteria of good compartment design. This involves operator protection from as many conceivable injuries as possible, from life-threatening injuries due to roof falls to bruises and contusions caused by sharp corners within the cab. Safety also involves providing a comfortable physical and psychological environment to promote safe work habits.

Adequacy of Operator Vision and Vision Windows

Restricted visibility is the operator's major objection to canopies. Owing to either their width or location in the compartment, canopy posts often obstruct vital areas from the operator's view. The view of the roof is often obstructed by the thickness and shape of the canopy top. It is imperative that the machine operator be able to see over the top of the machine frame to safely operate the equipment. The proper canopy-to-machine height relationships (3-4) for safe operation are shown in figure 1.

Other common causes of vision obstruction include sideboards, tire covers, and machine frames that are too high for the seam height. Poor visibility is a serious safety hazard. Machine operators are less likely to hit overhead obstructions or lean out of the protective canopy if they can comfortably view the area beyond the machine from within the canopy while tramming.

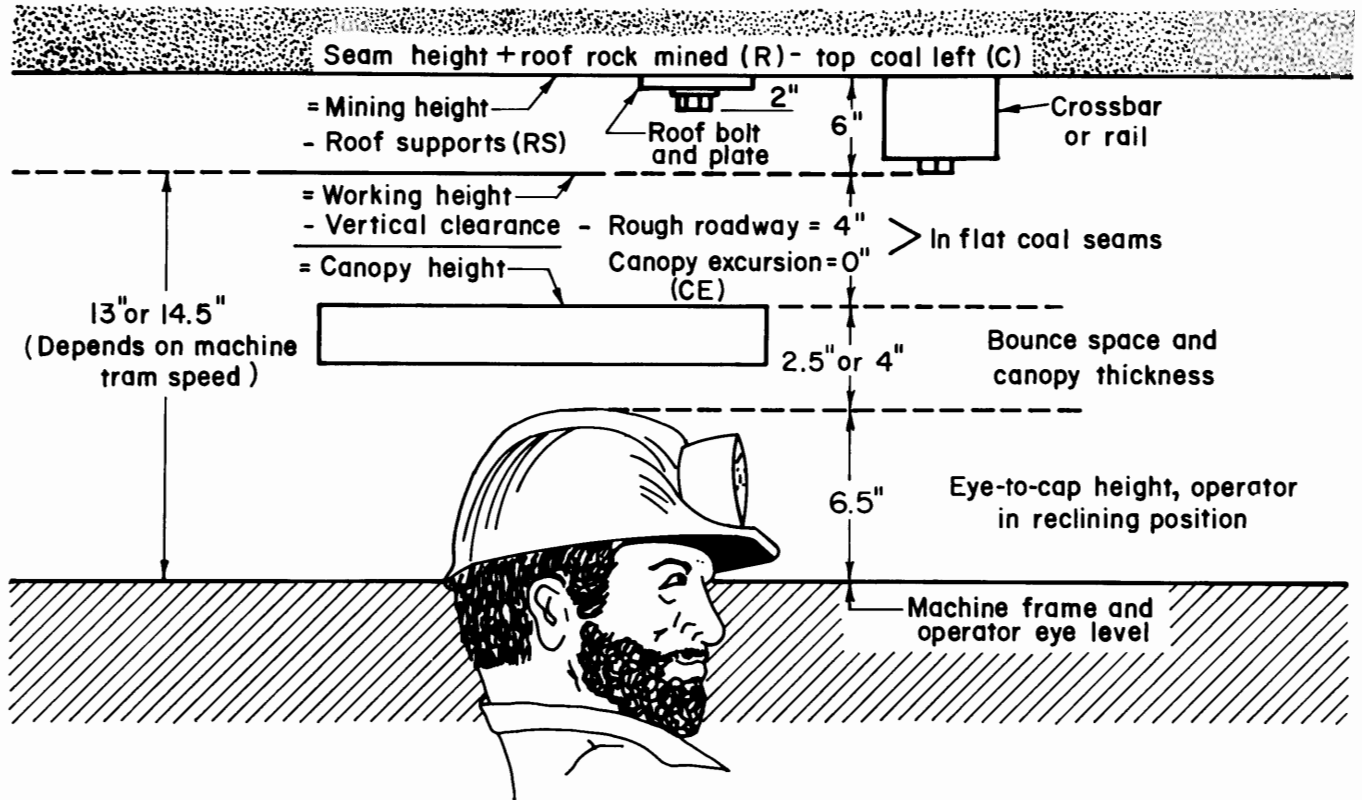

FIGURE 1.—Canopy-to-machine height relationships.

Operator Comfort

Machine operators become fatigued quickly if adequate working space is not provided within thin-seam compartments. As canopy heights are lowered for thin-seam operation, the operator is placed in an increasingly reclined position. This requires an increased working length if comfort is to be maintained. The relationship of operator headroom to proper working length (3-4) is shown in figure 2. Additionally, the compartment width must be adequate for comfortable operation and visibility alongside the machine.

Seating

Most original equipment manufacturer (OEM) low-coal shuttle car seating is inadequate. Proper seating should be padded and equipped with an adjustable back (with lumbar support) and an adjustable headrest. Specific requirements are that the eye level of a 5th-percentile female and 95th-percentile male operator be high

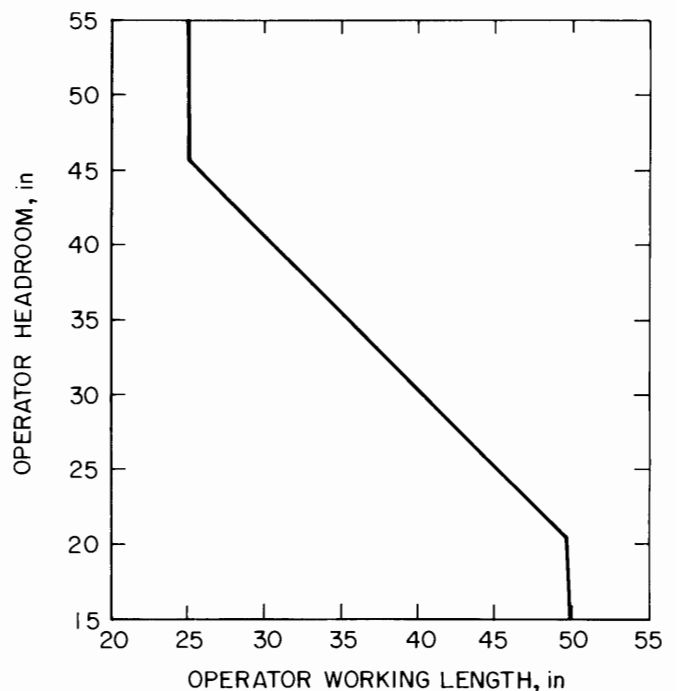
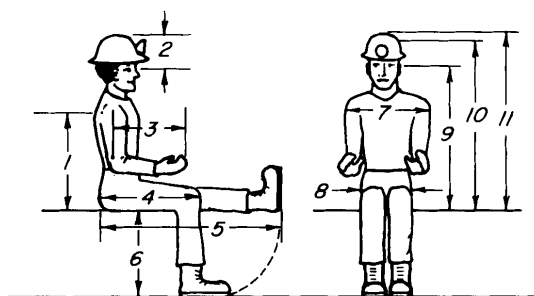

FIGURE 2.—Operator-head-room-to-compartment-length relationships. Lowest possible headroom.



		Dimensions, in	
		5th percentile female	95th percentile male
1	Shoulder height	19.7	25.7
2	Eye-to-helmet top	6.0	6.5
3	Forearm-hand length	15.3	20.2
4	Buttock-knee length	20.5	25.9
5	Buttock-leg length	38.0	46.1
6	Back-of-knee height	14.8	18.2
7	Shoulder breadth	14.1	20.1
8	Hip breadth	12.9	15.4
9	Eye height	26.9	33.9
10	Sitting height	30.9	38.4
11	Sitting height with helmet	32.9	40.4

FIGURE 3.—Coal miner anthropometrics.

enough to see over the top of the machine frame and the seat width be adequate for a 95th-percentile male. (See figure 3.)

Ingress and Egress

Another major complaint of operators is the difficulty of ingress and egress caused by canopy design. Openings must be free of obstacles that tend to snag the operator's belt, cap-lamp battery, or self-rescuer. Two important design features can be employed to aid the operator. The first is to use as many handrails and handholds as are feasible to facilitate quick and smooth ingress and egress. The second feature for design consideration involves alternate exits. There are situations when the operator must exit in a hurry (for example, fire, inundation, etc.). If for any reason the main egress route from the machine is blocked, there should be an alternative way out. This alternative escape opening should measure at least 18 by 30 in.

Complexity of Design

Based on the results of previous canopy projects, it has become apparent that overly complex canopy designs have not all been successful. Canopies with numerous and complex moving parts and/or extensive hydraulic adjustments are difficult to install and maintain, and their novel features are often not used or become damaged to the point where they cannot be used. Designs should be kept as simple as possible to minimize operational problems.

Frequency of Maintenance and Ease of Field Retrofit

Complicated canopy designs that incorporate too many hydraulic adjustment features, too many moving parts, and "gadget type" features often fall into disrepair because the frequent maintenance they require is simply not done. Past experience has shown that a simple, structurally sound and human-engineered canopy design is the most accepted type of canopy. Canopies should be constructed of readily available materials and should require minimal machining work.

Structural Integrity

Each canopy should be designed to withstand a vertical load of 18,000 lb or 15 psi distributed over the plan view area of the canopy roof structure in compliance with 30 CFR 75.1710. A design feature which is not an MSHA requirement, but should be incorporated, is the ability of the canopy to withstand significant horizontal impacts without deforming the canopy top, posts, or the compartment support structure.

With these considerations in mind, a list of features that should be included in a limited-coverage operator structure was compiled. These features are as follows:

1. Floating deck for maximum operator room.
2. Wider and longer compartment for comfort and visibility.
3. Padded adjustable seat and headrest.
4. Optimum location of controls for easier operation.
5. Handholds for ingress and egress.
6. Optional emergency exit for ingress or egress.
7. Reduced canopy size for better visibility.

8. Side protection to prevent operator from leaning out.
9. Lower sideboards for better visibility.
10. Wheel covers removed for better visibility.
11. Optimum location of canopy support posts for better visibility.
12. Simplicity of design for ease of fabrication.
13. Structural integrity for operator protection.

DESIGN CONCEPTS

The initial step in this project was to select a typical low-coal shuttle car to retrofit with improved operator protective structure concepts. There are two general shuttle car designs of the straight-through chain conveyor type commonly used in low-coal mining operations. Both designs possess unique advantages and disadvantages. The first is a center-driven configuration that provides the operator with a marginal, but acceptable, field of vision in both tram directions. This configuration poses some vision difficulties when tramping outby with a full load of coal, particularly when the operator tries to align the shuttle car with the dumpsite. The second general configuration is the end-driven shuttle car. This configuration provides excellent vision when tramping outby by eliminating the need to look over the coal pile. However, it does restrict vision when tramping inby due to its position on the far end of the car. Since both of these design configurations are relatively common, it was decided that design concepts should be developed for both vehicle types. Two shuttle cars were available on-site, a National Mine Service (NMS) Torkar 28B-S12-40 center-driven shuttle car and a FMC 6L-52 end-driven shuttle car.⁴ Although neither of these cars are typically used in low coal, they were determined to be adequate

for demonstrating the overall design concepts.

Three design concepts were chosen to be developed into prototype operator protective structures. All three were based on the limited-coverage philosophy. These concepts eliminated the major drawback of current canopy designs by providing adequate visibility. Although these designs do not provide the ideal objective of providing full-coverage operator protection, they do protect the operator from the most frequent cause of shuttle car operator injuries (pinching and/or squeezing accidents). Thus, the implementation of these designs constitutes a vast improvement over the current practice of providing no protection.

A philosophy of human factors design was adapted to the necessary functions of the shuttle cars. The restricted environment of low-coal requires special considerations. Absolute comfort for the operator is not possible given the limited space compartment. Compromises must be made with respect to what is theoretically desirable versus what is possible from a practical viewpoint. Thus, the human factors challenge was how to best meet both the functional requirements and at the same time avoid undue physiological or psychological stress on the operator.

The first concept to be developed was a roll-bar configuration. This concept had the advantage of providing a protective envelope which could be quickly and

⁴Reference to specific products does not imply endorsement by the Bureau of Mines.

easily retrofitted underground between working shifts.

The second concept was a sliding canopy which would provide protection over one end of the operator compartment at a time; it must be slid from one end of the cab to the other, depending upon the operator's position for the current tram direction. While slightly more complex to install than the roll-bar design, this concept had the advantage of providing some roof fall protection in addition to protection from pinching and/or squeezing type accidents.

The third concept was a "flip-top" design which featured an arc-shaped canopy that could be flipped from one end of the operator compartment to the other depending on the tram direction. It was

decided that this design should be developed into a total operator compartment design concept utilizing the latest in anthropometric design criteria.

Prior to construction, each of the concepts was built in mockup form utilizing plywood and plastic pipe. This technique had proven extremely useful in previous Bureau programs. The plywood mockups allowed design deficiencies to be readily identified and corrected prior to actual hardware construction. Once the mockups were evaluated for operator comfort, visibility, and general overall suitability for the selected shuttle cars, the designs were finalized and actual fabrication commenced. A detailed description of each canopy design is listed below.

LIMITED COVERAGE CONCEPTS

ROLL-BAR CANOPY

The simplest and most obvious solution for providing limited-coverage protection is a roll-bar type protective structure. This type of protection is recommended only for the most restrictive environment (seam heights less than 42 in), where more comprehensive protection cannot be provided. This concept can provide protection and maintain reasonable operator visibility in all but the lowest coal seam applications (less than 32 in) where batch-type haulage is commonly applied.

The base vehicle chosen for design work was the National Mine Service Torkar 28B-S12-52. This shuttle car was originally designed for moderately low-coal operation (40- to 52-in seam heights), but still provided a suitable base for concept construction and evaluation. Also, the OEM operator compartment came with a full-floating tram deck, which precluded the need for construction of a new floating mechanism or radical rearrangement of the operator controls.

The initial task was to prepare the shuttle car for low-coal operation. First, the high wheel covers were removed and replaced with belt material to improve operator visibility over the top of the car.

The original tram deck was too narrow for adequate operator comfort or visibility along the side of the shuttle car without leaning out of the compartment (a major cause of operator injuries (3-4)). Ideally, the seating width should be at least 20 in, and compartments should be at least 30 in wide, not including space taken up by controls (3-4). The tram deck of the Torkar was widened by 8 in to give the operator a full view along the side of the machine and provide 30 in side-to-side room for the operator.

OEM seating consisted of an 8-in-wide steel plate that folded up to provide the operator with very minimal back support; this seating arrangement was removed. A new seating system was devised to overcome the limitations imposed by bidirectional equipment compartment design, which requires opposing seats at either end of the cab that are small enough not to interfere with the tram and brake controls. The new design consists of a single seat with track-mounted rollers so it can be moved from one end to the other with minimal effort. This seat (fig. 4) contains numerous features for operator comfort. They are as follows:

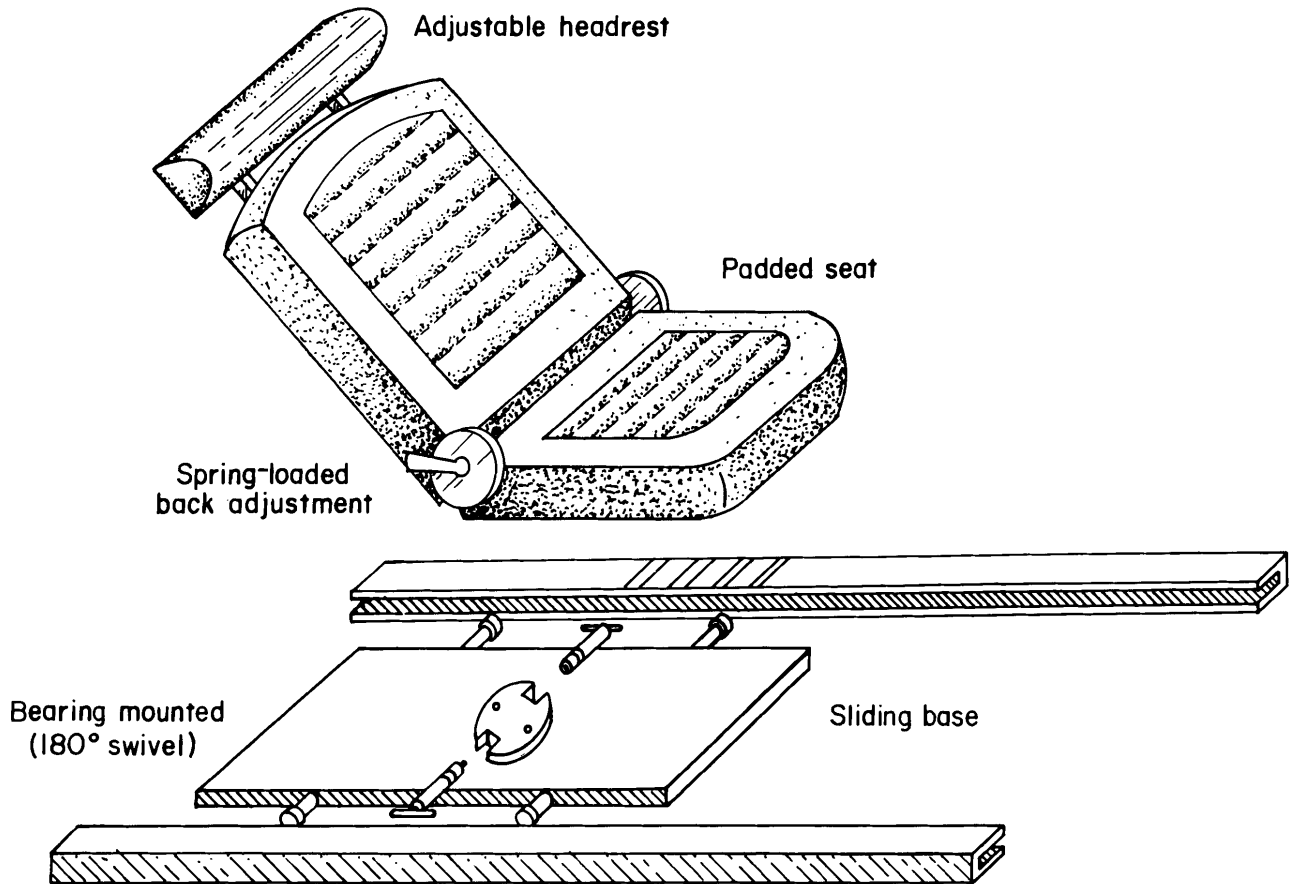

FIGURE 4.—Shuttle car seat.

1. Padded seat, 20 in wide.
2. Padded backrest with lumbar support.
3. Padded headrest.
4. Horizontal seat adjustments for comfortable control reach.
5. Vertically adjustable backrest for proper seating height.
6. Adjustable headrest for comfort.
7. Rugged construction to withstand the mining environment.

This totally adjustable seating system provided comfort and proper seating height for visibility through the entire range from 5th percentile female to 95th percentile male.

The next problem was designing and installing the roll bars. The main concern is proper placement to provide the maximum operator protection. The main thrust of this protection is to prevent pinching and/or squeezing accidents. The roll bar should therefore be placed in front of,

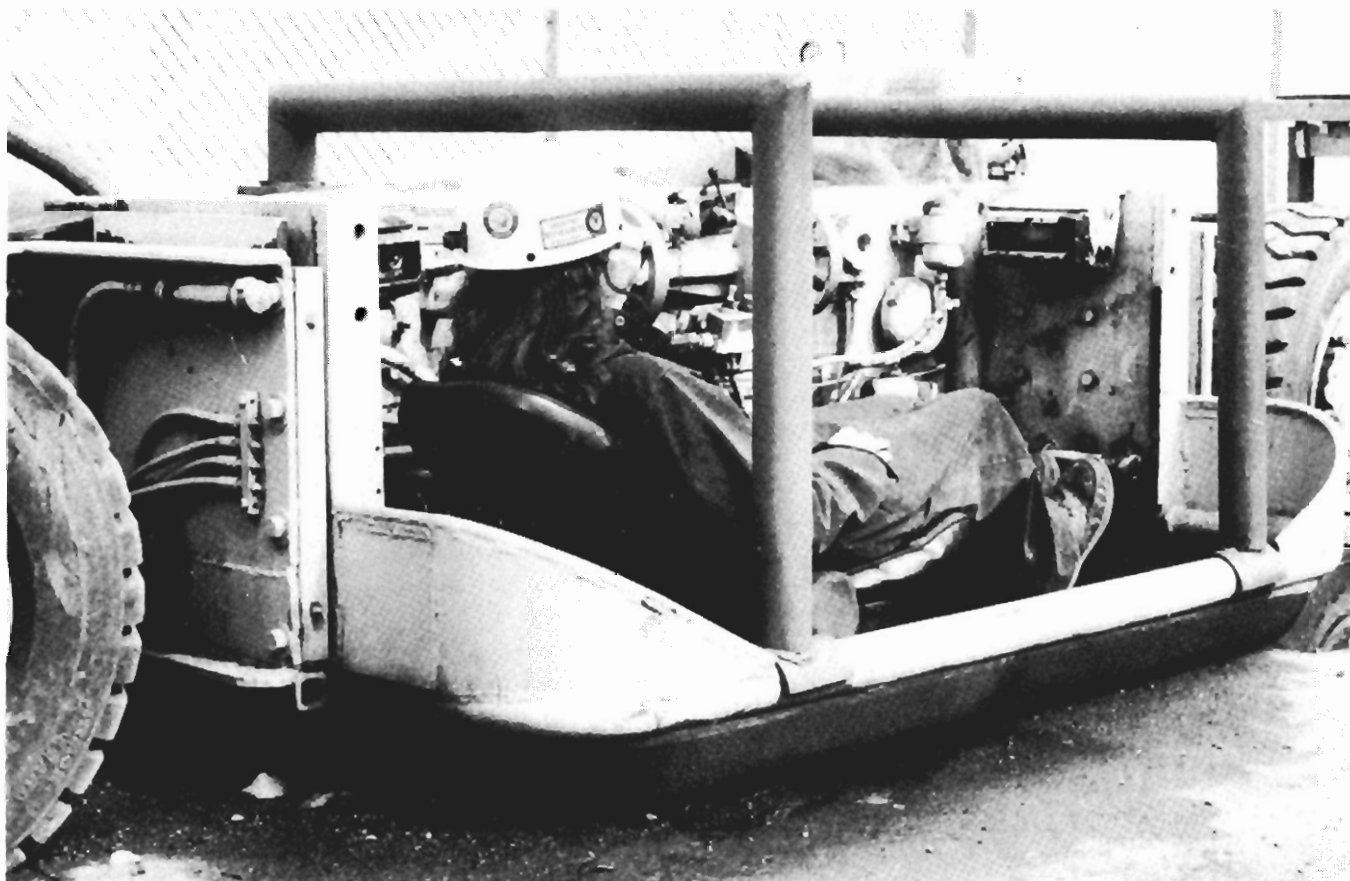

FIGURE 5.—Roll bar protection.

instead of directly over, the operator's head. The next consideration is to place the roll bar so that the temptation to lean out of the cab is inhibited.

The roll-bar concept was applied to the modified National Mine Service Torkar compartment (fig. 5). Two roll bars constructed of 3 in structural steel tubing were placed at the quarter points in from each end of the 76-in-long compartment. The resulting structure was capable of supporting vertical loads of at least

18,000 lb and lateral loading of 4,000 lb.

The complete package of roll bars, wider compartment, full floating deck, and improved seating meets most of the ideal design criteria. This type of operator protection can be easily implemented on face equipment, providing some protection in mining environments where no other protective measures exist and where conditions preclude the implementation of more complete protection.

Complete specifications for the shuttle car with roll-bar protection are given in table 2.

TABLE 2. -Specifications for shuttle car, roll-bar canopy, and sliding compartment

Shuttle car:	
Unit weight.....lb..	26,000
Overall length.....ft..	26
Frame height.....in..	32
Working height.....in..	40
Width.....in..	109
Conveyor width.....in..	55
Conveyor speed...ft/min..	60
Capacity (water level)....cu ft..	130
Tram speed.....mph..	4.0
Tire size.....	12 by 20
Ground clearance.....in..	6.5
Wheel base.....ft..	9
Boom extension.....in..	40
Turning radius:	
Inside.....ft..	7-5/6
Outside.....ft..	22
Motor: Hydraulic....hp..	45
Roll-bar canopy, in:	
Height (with cab).....	36
Width.....	32
Length.....	76
Post thickness.....	3
Seat width.....	20
Sliding canopy, in:	
Height (with cab).....	38
Width.....	32
Length.....	76
Canopy coverage.....	37.5 by 37.5
Post thickness.....	3
Seat width.....	20

SLIDING CANOPY

The second concept constructed was a sliding canopy design (fig. 6). This system provides the operator with significant roof fall protection in addition to protection from pinching and/or squeezing accidents. For the shuttle car used, this design is acceptable for coal seams heights as low as 40 in. Depending on the shuttle car's frame height, suitable operator protection is obtainable in even lower coal seams, minimizing the most frequent high speed face equipment

operator injuries (the pinching and/or squeezing accident) and providing ample ingress and egress points.

The sliding canopy provides protection over the half of the cab where the operator is sitting and an unrestricted field of vision in the opposite direction. The canopy position is repositioned manually, with minimal operator effort, and is automatically locked in position.

This concept was also constructed on the improved Torkar base vehicle. The canopy was constructed of a 37.5-in-square, 3/4-in plate with rounded corners to minimize hang-ups in the event of roofing. The canopy is supported on 3-in o-posts mounted on 3-in cam followers which slide in two 3/4-in-thick C-channels and are locked in place by spring-loaded latches.

Again, support posts were located to provide the maximum protection and visibility. The outside post was located at the quarter point to prevent the operator from leaning out; the inside posts were located at mid point to provide a clear line-of-sight to the conveyor. Handholds were provided for easy ingress and egress and to assist in sliding the canopy from one half of the compartment to the other. The canopy vertical load capacity far exceeded MSHA's minimum requirement of 18,000 lb distributed over the plan view area. The horizontal load capacity was calculated to be 4,000 lb. The design also provides alternative egress routes. The sliding canopy provides protection from pinching and/or squeezing accidents and partial protection from roof falls. Specifications for the sliding canopy are given in table 2.

FLIP-TOP-CANOPY OPERATOR COMPARTMENT

The most recent design was the flip-top canopy integrated into a totally anthropometrically designed operator compartment (fig. 7). This concept is somewhat more complex than the preceding concepts, requiring that the retrofit be made either in a rebuild shop or during initial construction at the manufacturer's plant. Although it is more complex, this design is considered to be beneficial in terms of increased protection and overall

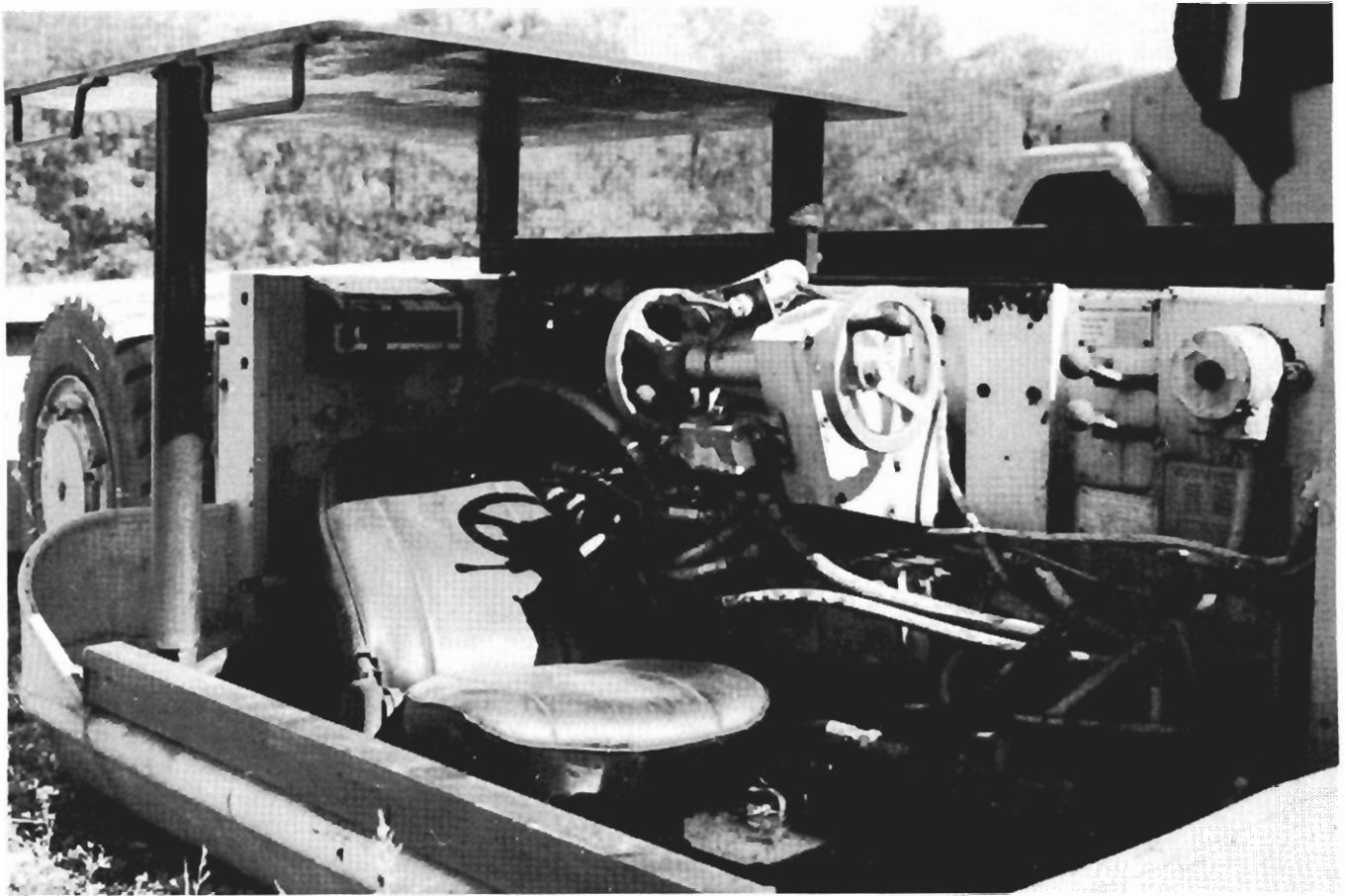

FIGURE 6.—Sliding canopy.

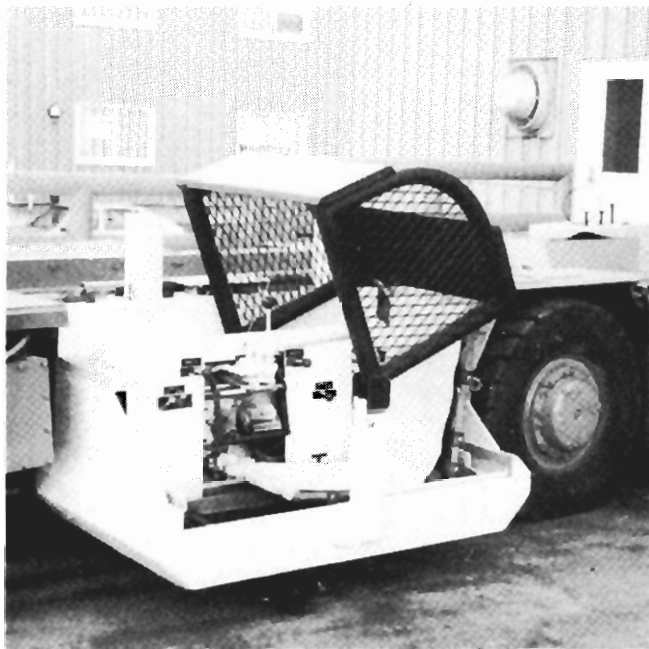

FIGURE 7.—Flip-top operator compartment.

improvement in the operator's work environment.

The total design concept is applicable to even lower case designs. It was designed for and mounted to an available FMC 6L-52 end-driven shuttle car. An end-driven shuttle car was selected because the flip-top concept provides the maximum possible visibility when tramping inby. End-driven shuttle cars have inherently poor visibility inby due to the position of the operator's compartment at the far end of the shuttle car and thus very little interference with the operator's vision can be tolerated.

The final design resulted in an operator compartment that was 59 in long, 39 in wide, and 44 in high. The canopy top and side frames form a quarter circle with 25-in radial support arms pinned at the center. The top is rotated (flipped) from end to end (depending on the

direction of tram) via a 10,000 in lb 1,600-psi rotary actuator (fig. 7).

Numerous design features combining the best in available low-coal canopy technology were included in the construction of this operator compartment. These features are described below.

1. The operator compartment was designed to make optimum use of the available space. The compartment was made as wide as possible without interfering with vehicle operation. The pedal area was recessed under the conveyor motor and fender guards to increase the operator's leg room, utilizing previously unused space. Finally, the canopy configuration provides the maximum possible head room for the seam heights under consideration (fig. 7).

2. The tram deck was constructed to be semifloating with a hydraulically adjustable bottom point to take full advantage of prevailing entry heights, provide maximum compartment height, and give the operator a comfortable ride (fig. 8).

3. The operator's protection envelope is strategically placed and screened-in with expanded metal to provide visibility, prevent the intrusion of material into the operator compartment, and prevent the operator from leaning out of the protective envelope.

4. A human factors approach was taken in the design and layout of the operator controls to provide for easy operation of the shuttle car. Design guidelines were based on the following recent SAE (Society of Automotive Engineers) standards:

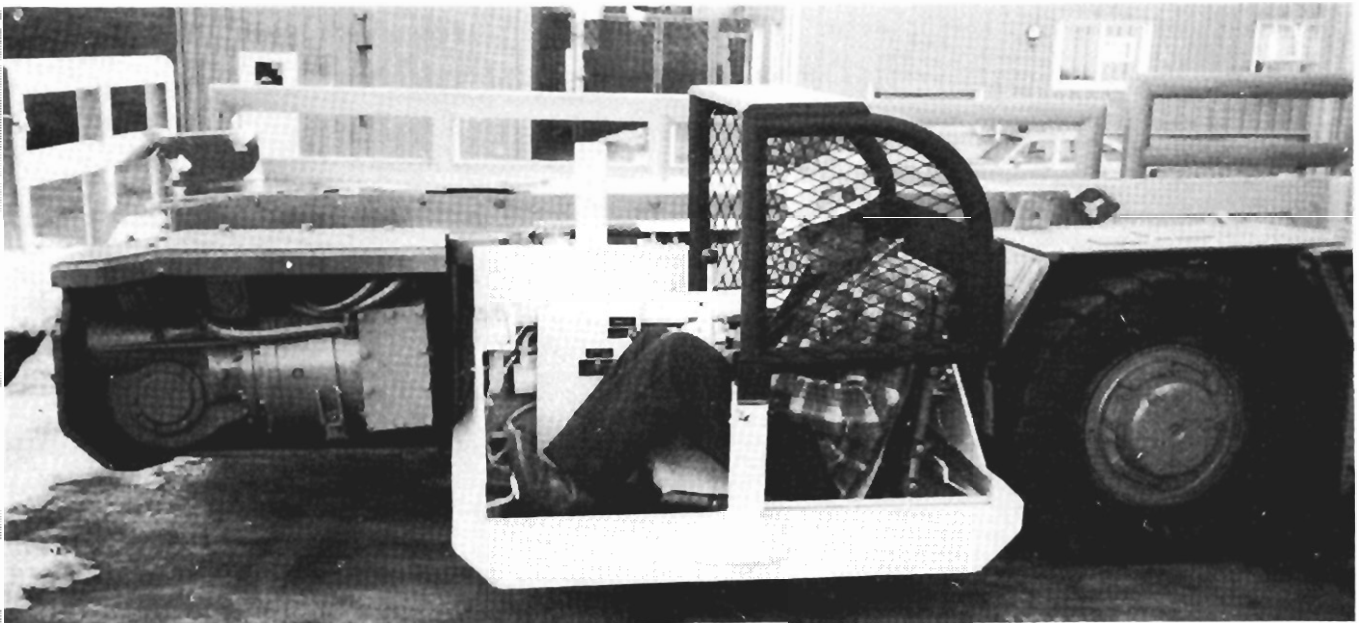

FIGURE 8.—Flip-top compartment in raised position.

- a SAE J1314 - Human Factors Design Guidelines for Mobile Underground Mining Equipment
- b SAE J833a - U.S.A. Male and Female Physical Dimensions for Construction and Industrial Equipment
- c SAE J898a - Control Locations for Construction and Industrial Equipment

The most notable of the control improvements was the implementation of positive-direction joystick steering. Steering is accomplished through the use of a standard four-way valve fitted with a half-metering spool to provide more precise steering control. Positive-direction steering avoids operator confusion when changing from one tramping direction to the other. The selected hardware also requires less space than conventional orbital steering valves and provides additional operator room, which is at a premium in low coal vehicles.

Another improvement in the shuttle car control system was the use of a new, sequence-valve-controlled automatic parking brake system. This parking brake provides improved brake control through the use of a pulse-sequence valve that automatically re-energizes the parking brake whenever the pressure bleeds off below a predetermined threshold value.

All of the shuttle car controls are strategically placed within the operator's reach envelope. Activation of the foot controls is consistent so that confusion is avoided when changing tram direction (right foot always operates tram pedal and left foot always operates brake). Additional features of the flip-top-canopy design are as follows:

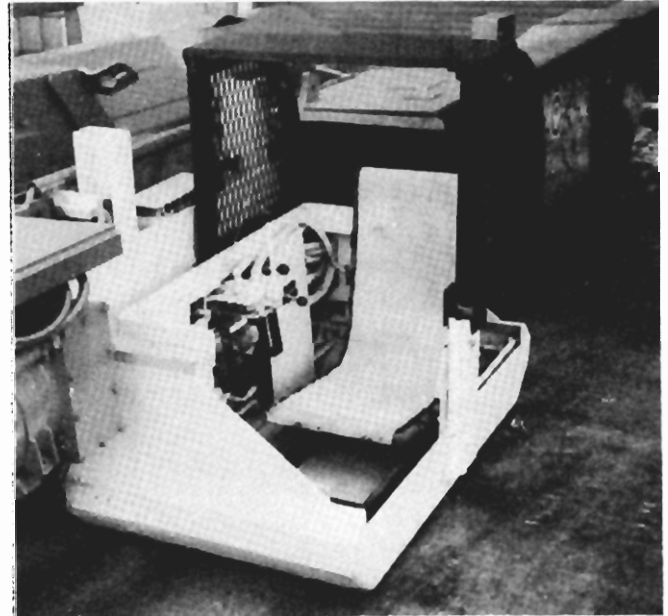

FIGURE 9.—Sling seat.

5. The operator compartment utilizes a fully adjustable, sling-type seat (fig. 9) that is flipped and moved from one side of the compartment to the other when changing tram direction. This provides increased operator comfort and improved access to the control pedals. The seat may be moved forward or backward by releasing the locking pin; it may be raised or lowered by tightening or loosening the sling.

6. The canopy is a unique flip-top design that provides protection from pinching and/or squeezing accidents and some roof fall protection while leaving the operator's field of vision completely unobstructed; it is flipped 90° to the other side of the compartment by a rotary actuator to provide protection when tramping in the opposite direction. The

flip-top actuator control is placed in a protective box outside of the operator compartment to prevent accidental activation, of the canopy with the operator inside the cab, and yet, is conveniently located for easy access. The flip-top canopy is a quarter-circular design with a 25-in radius, constructed of 2.5-in-OD, high-strength structural steel tubing and covered with 0.75-in steel plate. The

canopy unit is supported and rotated by a 1.5-in 90-kip/in² tool-steel shaft.

7. All control improvements are easily integrated into the stock hydraulic system with some system modifications (fig. 10). All added controls are of flow-through center construction and placed in series with the existing controls. Specifications for the flip-top canopy and shuttle car are given in table 3.

TABLE 3. - Specifications for shuttle car and the flip-top canopy operator compartment

Shuttle car:	
Unit weight.....lb..	22,000
Overall length.....ft..	24
Frame height.....in..	35
Working height.....in..	48
Width.....in..	107
Conveyor width.....in..	55
Conveyor speed.....ft/min..	64
Capacity (water level).....cu ft..	160
Tram speed.....mph..	4.2
Tire size.....	10 by 15
Ground clearance.....in..	7.5
Wheel base.....ft..	8-1/6
Boom extension.....in..	41
Turning radius:	
Inside.....ft..	9-1/12
Outside.....ft..	21-5/12
Motors, 250-V dc:	
Traction (2).....hp..	15
Conveyor.....hp..	15
Flip-top canopy operator compartment:	
Height.....in..	44
Width.....in..	39
Length.....in..	59
Canopy coverage.....in..	25 by 34
Flip-top flip speed.....sec..	3.5
Seat width.....in..	20
Floating bottom point.....in..	0-10

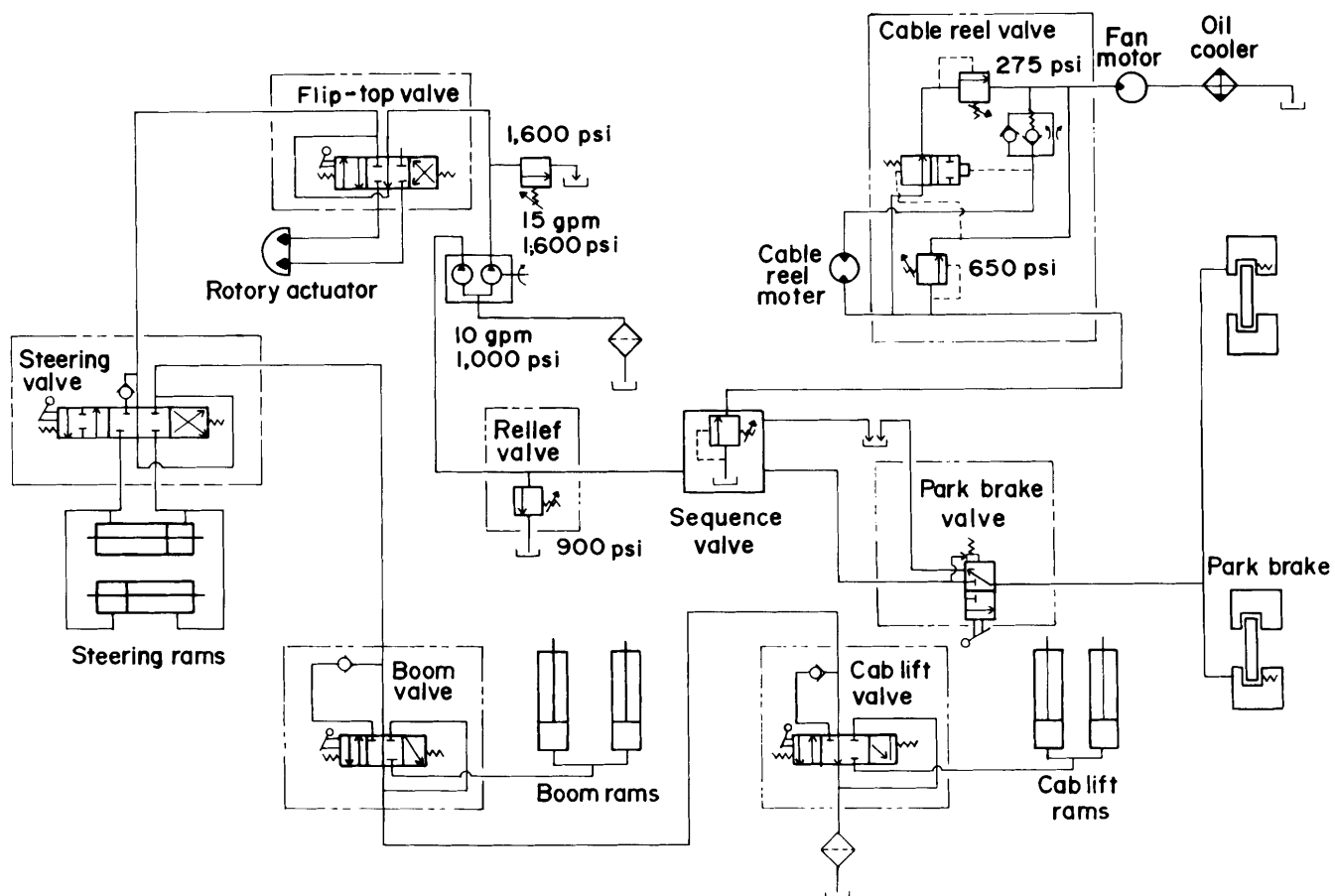

FIGURE 10.—Schematic of modified hydraulic system.

TESTING

All of the canopy concepts were verified to insure that they were in compliance with the MSHA requirements set forth in 30 CFR 75.1710, which requires canopies to withstand a vertical load of 18,000 lb, or 15 psi distributed over the plan view area of the canopy. The roll bar and the sliding canopy were verified mathematically utilizing computer software packages. The roll bar was analyzed using Structural Software System's FATPAK. The sliding canopy was analyzed using the University of

California-Berkley's SAP IV program. Due to its structural complexity, the flip-top canopy was physically tested using established MSHA guidelines (7).

The three new canopy concepts, as well as the OEM canopies and tram deck with no canopy, were also tested using the Bureau-developed Human Eye Reference Measurement Instrument (HERMI) (6). This testing established a quantitative measurement of operator visibility for each of the canopy types.

The HERMI (fig. 11) is an instrument that identifies the eye positions of the 5th percentile female and 95th percentile male performing reasonable neck and trunk flexion. The HERMI is placed in the operator cab, simulating the position of the operator's eyes in a straight-ahead position, at maximum comfortable neck flexion, and at maximum comfortable trunk flexion.

Visibility measurements were taken using previously established visual attention locations (6) (fig. 12), which indicate points the operator must see in order to safely operate the equipment. These visual attention locations were determined by interviews with operators and equipment manufacturers and then ranked by priority. Vision to each attention point was established by taking a photograph of the HERMI in the operator's cab with the camera placed at each of the visual attention locations. Examination of the photographs allowed direct determination of whether the 5th or 9th percentile operator could see that location, and whether the operator would have to flex his or her neck and/or trunk.

Using this method, it is possible to develop a scoring system by which a visibility score for a particular machine can be computed. First, a weighting system is developed to indicate the priority of each of the visual attention locations (table 4), where 3 = most significant, 2 = significant, and 1 = least significant. Next, a weighting system is applied to the HERMI (fig. 11), where 3 = location can be seen without flexion, 2 = location can be seen with neck flexion, 1 = location can be seen with neck and trunk flexion, and 0 = location cannot be seen.

The visibility score can be computed as follows:

$$V = P \times (U + L),$$

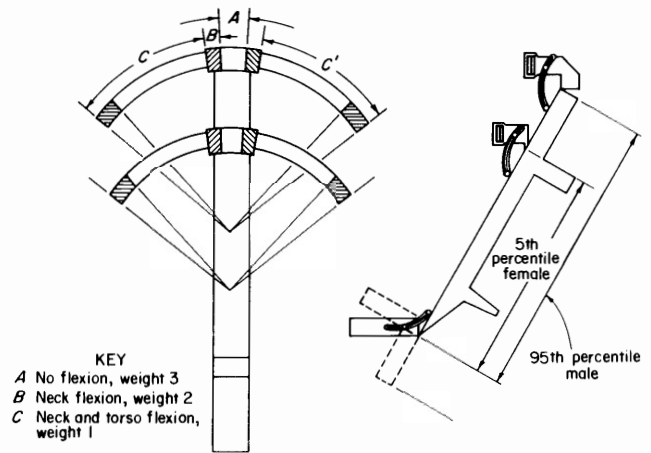

FIGURE 11.—Human eye reference measurement instrument (HERMI).

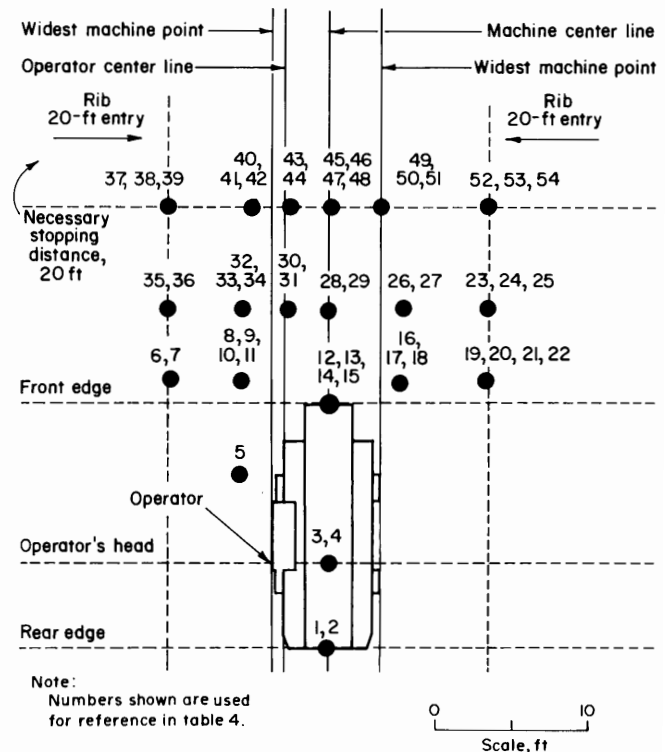

FIGURE 12.—Visual attention locations for shuttle car.

TABLE 4. - Visual attention locations priority scores for shuttle car

Point No. ¹	Up-down location	Priority ²	Point No. ¹	Up-down location	Priority ²
1....	Operator eye height....	2	28...	Median machine height..	1
2....	Highest machine point..	2	29...	Seam height.....	3
3....	Operator eye height....	2	30...	Floor.....	2
4....	Highest machine point..	2	31...	Seam height.....	3
5....	Operator eye height....	3	32...	Floor.....	3
6....	Floor.....	3	33...	Median machine height..	1
7....	Highest machine point..	3	34...	Highest machine point..	3
8....	Floor.....	3	35...	Floor.....	3
9....	Median machine height..	3	36...	Highest machine point..	3
10...	Operator eye height....	3	37...	Floor.....	3
11...	Highest machine point..	3	38...	Operator eye height....	3
12...	Median machine point...	1	39...	Highest machine point..	3
13...	Operator eye height....	2	40...	Floor.....	3
14...	Highest machine point..	2	41...	Operator eye height....	3
15...	Seam height.....	1	42...	Highest machine point..	3
16...	Floor.....	3	43...	Median machine height..	1
17...	Median machine height..	3	44...	Highest machine point..	3
18...	Highest machine point..	3	45...	Floor.....	1
19...	Floor.....	3	46...	Median machine height..	3
20...	Median machine height..	2	47...	Operator eye height....	3
21...	Operator eye height....	2	48...	Highest machine point..	3
22...	Highest machine point..	3	48...	Floor.....	3
23...	Floor.....	3	59...	Operator eye height....	3
24...	Operator eye height....	3	51...	Highest machine point..	3
25...	Highest machine point..	3	52...	Floor.....	3
26...	Floor.....	3	53...	Highest machine point..	3
27...	Highest machine point..	3	54...	..Do.....	3

¹See figure 12.

²3 - most significant, 2 - significant, 1 - least significant.

where V = Visibility score,

P = Priority weight for visual attention locations,

U = 95th percentile (upper arc) points,

and L = 5th percentile (lower arc) points.

qualitatively evaluated at the Bureau's mining equipment test facility (METF) in order to obtain operators' reactions to the new concepts. A part of the METF features simulated mine workings, complete with an adjustable roof height. Several shuttle car operators were asked to maneuver the shuttle cars equipped with the limited-coverage canopies through the entries and to give their reactions to each of the three concepts.

Once the initial testing was completed, the limited-coverage compartments were

SUMMARY OF TEST RESULTS

All three of the compartment designs easily met MSHA load-capacity requirements. The roll-bar canopy was evaluated using a moment distribution technique with applied loads of 18,000 lb vertical and 4,000 lb horizontal (fig. 13). Analysis indicated that the canopy was well below yield at these loadings (figs. 14-15). The sliding canopy analysis was a somewhat more complex plate and shell canopy that required a finite-element analysis (fig. 16). This canopy was subjected to the same 18,000 lb vertical and 4,000 lb horizontal loadings, and it also never exceeded its elastic limit at these loadings.

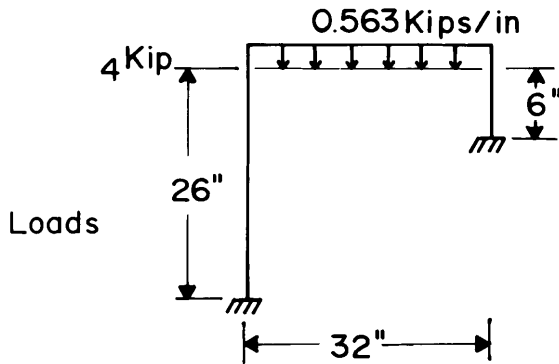

Material: 3-in ϕ schedule 80 pipe;
 $A = 3.02 \text{ in}^2$
 $I = 3.89 \text{ in}^4$
 $S = 2.23 \text{ in}^3$

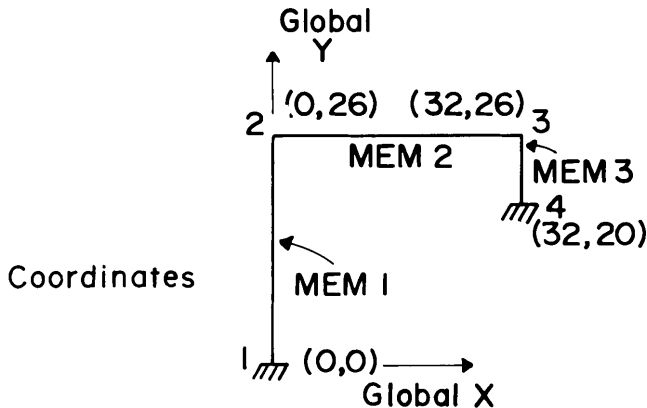

FIGURE 13.—Roll-bar loadings.

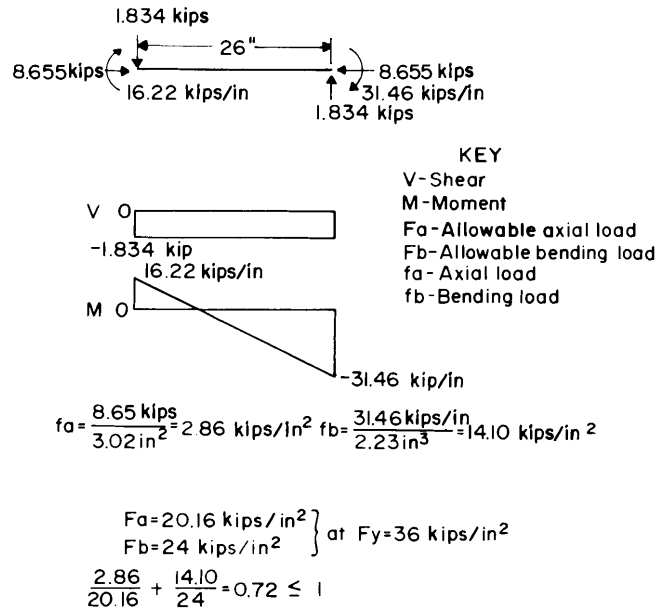

FIGURE 14.—Structural analysis of roll-bar member 1.

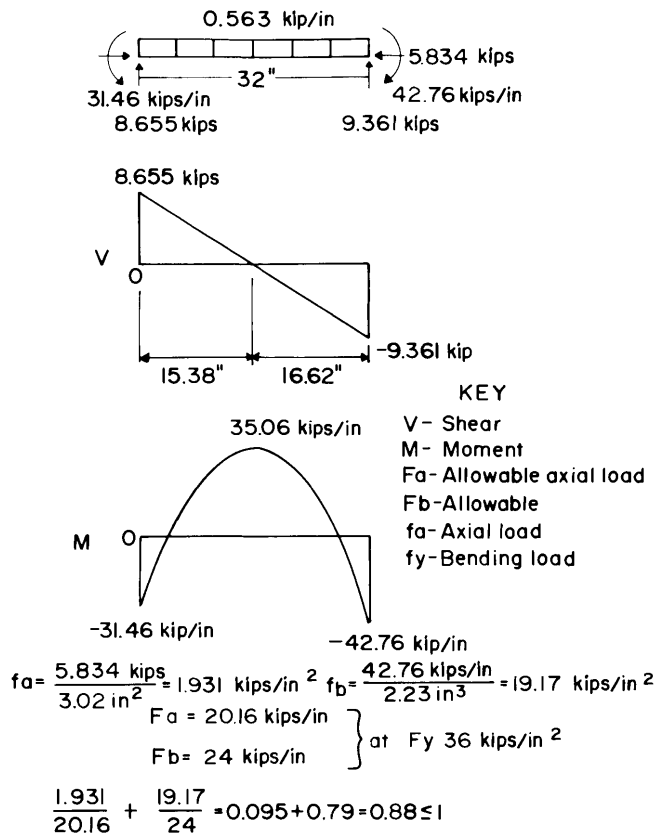

FIGURE 15.—Structural analysis of roll-bar member 2.

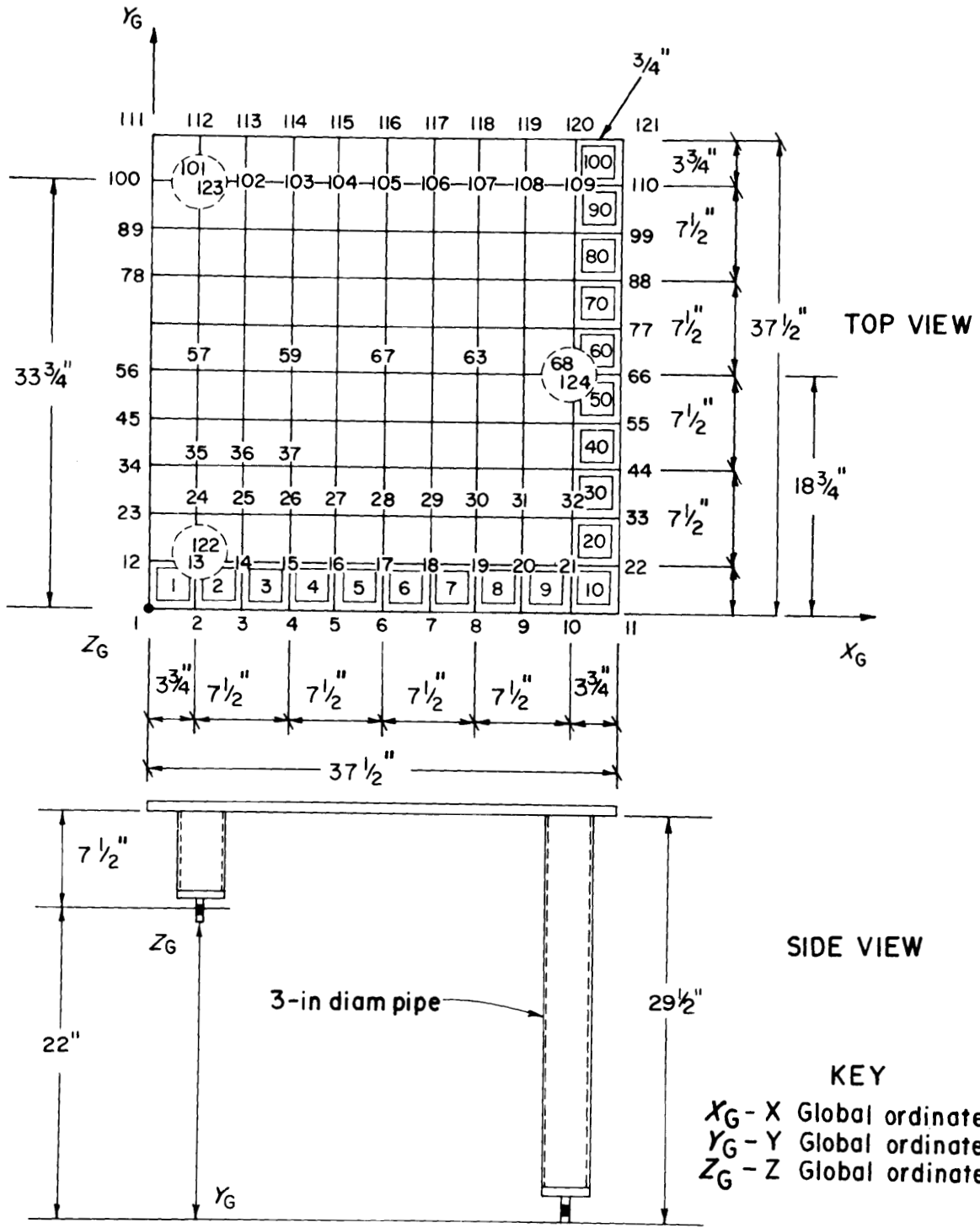

FIGURE 16.—Finite-element grid used for analysis of sliding canopy.

Due to the complexity of the flip-top canopy, it was decided to perform physical testing rather than mathematical analysis. The standard MSHA procedure (5) was used; the canopy was loaded to 11,745 lb distributed over the middle third of the canopy (15 psi distributed over the plan view area), and deflections were recorded using a dial gauge indicator. A total of 10 pct residual deflection in the canopy is permitted after the load is removed. The flip-top canopy showed 0.163 in deflection at full load with 0 in residual deflection, indicating it is well within the structural integrity limits set by MSHA.

Limited-coverage designs improved visibility and operator comfort through compartment modification, improved seating, and implementation of an alternative means of operator protection in low coal where conventional full-coverage canopies are usually removed or not implemented. Operator visibility was quantitatively measured using the Bureau-developed (HERMI.)

Visibility measurements were taken at 54 previously established points where operators must have adequate visibility for safe operation of their equipment. These readings were added together to produce visual attention location scores (tables 5).

The designs were evaluated on the basis of 898 possible points, which represents the ideal visibility score. As expected, the compartment with no canopy ranked highest, with 700 points, or 78 pct of the ideal score. This configuration is probably the most commonly used in low-coal mines, but could hardly be recommended since it provides the operator with no protection.

TABLE 5. - Visual attention location score

	Points (898 = ideal)	Score pct of ideal
No canopy.....	700	78
Flip-top canopy	665	74
Sliding canopy.	665	74
Roll bar.....	615	68
FMC OEM canopy.	543	60
NMS OEM canopy.	531	59

The flip-top-canopy operator compartment tied for second, with 665 points, or 74 pct of the ideal score. This configuration is the most comprehensive operator-oriented compartment, providing good visibility, good pinching and/or squeezing protection, and some roof fall protection. Since it is a cab-and-canopy compartment concept, its complexity precludes in-mine installation, and it would best be installed by the manufacturer or in a rebuild shop. Of all the concepts considered, the flip-top-canopy design should afford the greatest improvement in safety because of the overall improvement in the operator's environment.

The sliding canopy tied for second with 665 points, or 74 pct of the ideal score. This configuration provides reasonably good visibility, good pinching and/or squeezing protection, and some roof fall protection. Overall, it is a good limited-coverage design for in-mine installations and provides an immediate solution to the problem of operator protection. The sliding canopy is limited by the machine frame height and OEM compartment design; some compartment modification is required. Additionally, it is slightly more complex than the roll-bar design, thus requiring more maintenance.

The roll-bar configuration ranked third, with 615 points, or 68 pct of the ideal score. This was still a respectable rating. The lower rating is due to the necessity of placing one roll bar in front of the operator's field of vision. The main advantage of this system is that it is quite simple. It provides good protection from pinching and/or squeezing accidents and can be adapted to almost any machine underground between shifts.

The lowest ranking configurations were the OEM full-coverage canopies, with 531 points or 59 pct of ideal, and, 543 points or 60 pct of ideal. These configurations do provide good overhead roof fall protection, but their limited visibility may encourage operators to lean out of the canopy, making the operators vulnerable to pinching and/or squeezing accidents. This is the reason why variances are generally granted by MSHA to permit the removal of canopies.

In the qualitative evaluation at the Bureau's test facilities, at least three operators were asked to maneuver shuttle cars equipped with each of the limited-coverage canopies through the mine entries. The shuttle car operators were quite satisfied with the improvements in

visibility afforded by the new designs and especially liked the comfort of the padded seats as opposed to the standard steel plate commonly used for shuttle car seating. The Bureau plans to conduct an extensive in-mine evaluation of the flip-top-canopy design with a mine operator.

CONCLUSIONS

Limited-coverage canopies can provide partial operator protection for miners working in situations where conventional full-coverage canopies cannot be employed. The basic advantages of these systems are as follows:

1. Protection from the most frequent type of shuttle car operator injuries (those caused by pinching and/or squeezing accidents), which account for 87 pct if all low-coal shuttle car accidents.

2. Greater visibility, roof and working areas, compared to full-coverage canopies, resulting in safer operation.

3. Canopies are designed to withstand lateral loads and provide a safer "shell" for the operator.

4. For the roll-bar and sliding canopies, installation can be performed underground.

5. The designs are simple and adaptable to a variety of equipment.

6. Operator exits have minimal obstructions, affording quick exit if necessary.

7. Operator comfort is increased, thereby reducing fatigue.

8. The overall improvement in operator space and human factors-engineered on a human-factors basis engineered control layouts provides an improved psychological environment for operators and therefore promotes safer working conditions.

It is recommended that the designs developed during the course of this project be used on shuttle cars such as those described and on shuttle cars with lower frames. These designs could also be adapted to other types of high-speed mobile face equipment, such as scoops and tractors, to provide canopy technology that would improve the safety and efficiency of mine equipment operators.

REFERENCES

1. Aljoe, W. W., and K. L. Whitehead. Advancement of Cab and Canopy Design and Use in Coal Mines (contract J0199005, BCR). BuMines OFR 109-85, 1981, 306 pp.; NTIS PB 86-153574.

2. Billmeyer, H. Extension of Low Coal Canopy Technology To Include Drilling and Cutting Machines (contract H0318007, Wyle Labs). BuMines OFR 132-84, 1983, 56 pp.; NTIS PB 84-215052.

3. Lineberry, G. T., and L. Adler. Velocity Clearance and Curves for Mobile Mining Equipment. Min. Eng. (Littleton, Co.), v. 36, No. 8, 1984, pp. 1196-1200.

4. Sanders, M. S. Visual Attention Locations for Operating Continuous Miners, Shuttle Cars, and Scoops: A

Summary (contract J0387213, Canyon Res. Group, Inc.). BuMines OFR 29(2)-82, 1981, 67 pp.; NTIS PB 82-187949.

5. Sawyer, S. G., and D. K. Brogran. A Testing Procedure for Certification of Underground Protective Cabs and Canopies. MSHA (U.S. Dep. Labor) IR 1002, 1974, 15 pp.

6. Sawyer, S. G., and J. A. McCormick. Cabs and Canopies Underground to Protect Miners. Coal Min. & Process., v. 10, No. 2, Feb. 1975, pp. 40-44.

7. Zona, A. ((MSHA) U.S. Dep. Labor). Private communications, Jan. 1986; available upon request from J. R. Bartels, BuMines, Pittsburgh, PA.

APPENDIX.--SYMBOLS USED IN THIS REPORT

A	area
d	depth
f_a	axial stress
f_b	bending stress
F_a	allowable axial stress
F_b	allowable bending stress
I	moment of inertia
o	outside dimension
r	radius
S_x	section modulus
t	thickness

U.S. Department of the Interior
Bureau of Mines—Prod. and Distr.
Cochrans Mill Road
P.O. Box 18070
Pittsburgh, Pa. 15236

AN EQUAL OPPORTUNITY EMPLOYER

OFFICIAL BUSINESS
PENALTY FOR PRIVATE USE, \$300

- Do not wish to receive this material, please remove from your mailing list.
- Address change. Please correct as indicated.