

HYDRAULIC PRESTRESSING UNITS: AN INNOVATION IN ROOF SUPPORT TECHNOLOGY

Thomas M. Barczak, *Research Geophysicist*
Stephen C. Tadolini, *Section Chief, Geotechnical Engineering*
National Institute for Occupational Safety and Health
Pittsburgh Research Laboratory
Pittsburgh, Pennsylvania USA

Paul McKelvey, *Director--AMSS*
New Concept Mining
Johannesburg, South Africa

ABSTRACT

A new generation of hydraulic mine support prestressing devices has been developed. These thin-walled steel shells are machine-welded and can be inflated with water or any liquid to provide prestressing for a wide variety of roof support products ranging from Can supports to props and cable bolts. With an expansion capability of several inches, depending on the geometry and size of the unit, they can also establish roof contact eliminating the need for wooden wedges or crib blocks that are commonly employed with several standing roof support products. Capable of withstanding pressures from 1,000 to 6,000 psi, these cells are able to transfer roof loading into the support structure without rupturing. A recent development has been the addition of an inexpensive yield valve that provides control of the maximum pressure and load development on the support. This paper examines the performance capabilities of these inflatable prestressing units and the impact they have on the performance of various support systems, including an evaluation of the overall stiffness of the support system and the load control during yielding of the prestressing unit. Recommendations are made regarding the design requirements of the prestressing unit to optimize the support performance. A summary of mine applications using this technology is provided with general comments regarding their impact on ground control.

INTRODUCTION

A primary goal of any roof support system is to support the mine roof as soon as possible. This goal has led to prestressing roof support systems so that an immediate active support load is applied to the mine roof. Although the benefit of prestressing remains a debatable issue, most mining engineers will agree that prestressing generally has inherent advantages over a strictly passive roof support system. The active roof loading provided by prestressing closes separations in the roof and increases frictional restraint along bedding, joints, and other fracture planes, thereby enhancing beam building.

While pretensioning of intrinsic supports has been practiced since the earliest days of roof bolting, prestressing of standing supports has not been done nearly as much. And since most standing supports are passive, closure of the opening must occur for a resistive load to be developed. In the case of timber cribs, some 5-10% closure is required before the crib provides significant roof support capacity and as much as 40% closure before attaining its

full load capacity (1). This soft response can cause damage to the roof beam, dislodgment of key blocks of roof rock, and subsequent unraveling of the roof structure with implications for the safety of the miners.

The development of low-cost, inflatable bladders that can function as easy-to-install prestressing units (PSU's) has provided active loading to a wide variety of support systems that previously were utilized only as passive supports in many different mining operations. Developed in the late 1990's, this new generation of water-filled PSU's has evolved rapidly for use in the hard rock mining industry, especially in South Africa, where blasting is still the predominant extraction method, with thousands being used on a daily basis. Preloading helps to keep the supports, such as timber props and cribs, in place during the dynamic loading associated with the blasting. Recently, this technology has been introduced to coal mining operations in the United States and Australia.

The purpose of this paper is to examine this new generation of PSU's in more detail including: the range of support applications using this technology, the performance characteristics of the units relative to their expansion capabilities, load capacities, yielding characteristics, and their impact on the overall support stiffness. Proper installation procedures to ensure the full benefit of this technology are also discussed. In-service observations from early trials of these units in U.S. coal mines are presented.

HISTORICAL OVERVIEW OF PRESTRESSING SYSTEMS

Preloading of standing roof supports is carried out in compression and since most supports are completely passive, the preload is generally achieved by incorporating some sort of expansive unit within or on top of the support structure. Systems for preloading standing supports can be categorized as follows: wedging, mechanical devices, air-filled rubber bladders, grout-filled bags, and water-filled metal diaphragms.

Wedging - Wooden wedges have been used since the earliest times to secure a crib or prop support against the mine roof. Although generally not known for their prestressing capability, driving wooden wedges in place with a 5-10 lb hammer can generate 2-4 tons of preload on timber posts or cribs depending on the size of wedge used (2). Preloading in this manner is a laborious task and because of the low mechanical efficiency of wedges (~20%), a lot of effort is required for minimal benefit.

Mechanical Devices - Mechanical devices for prestressing standing roof supports are relatively rare. The Loadmaster or Power Wedge¹ (figure 1) is one example. Using a torque wrench, pre-loads of up to 11 tons can be achieved with 300 ft-lbs of applied torque (3). Any mechanical device, and wedges in particular, suffer from poor efficiency. A screw thread is at best 25% efficient, and when combined with a wedge the overall efficiency may be as low as 5%. This is a disadvantage when the pre-stress unit is required to be manually set such as with the Loadmaster or Power Wedge prop.

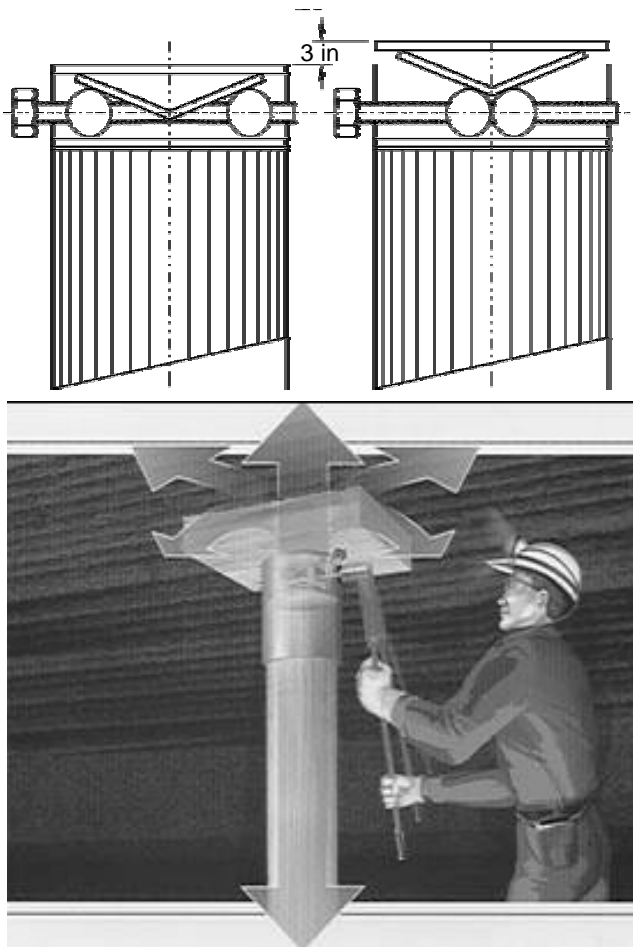

Figure 1. Mechanical device used to preload (various) timber post support systems.

Air-Filled Rubber Bladders - Prestressing of roof support using air-inflated Vetter Bags¹ was carried out in the early 1980's in South African mines. The air bags were placed on top of the crib and inflated to preload the support prior to driving in wooden wedges. The air pressure was then released and the bag was removed and reused on the next support, leaving the wedges to sustain the preload.

Grout-Filled Bags - In 1990, a South African company called HLH introduced the Packsetter – a woven polypropylene bag with a thermoplastic liner into which a special grout was pumped at pressures of up to 60 psi. Depending on the size of the grout bag, loads of up to 80 tons have been achieved using a single bag. This system was effective, economical and very successful in South

African mines. It eliminates the use of wedges and blocking material used to fill in gaps between the top of the crib and the roof. The main disadvantages were the inconvenience of transporting, mixing, and pumping the grout. HLH then developed the Propsetter. Strata Products USA has marketed the Propsetter system as shown in figure 2 in the U.S. for the past 10 years. This system provided up to 10 tons of active loading, but material creep typically reduced it to around 5 tons of sustainable preload on timber props (4). Until now, the Propsetter has been the most commonly used prestressing system on standing roof supports in U.S. coal mines.



Figure 2. Propsetter grout bag has been the most commonly used prestressing system in the United States thus far.

Water-Inflated Steel Diaphragms - The use of water as a prestressing medium provides advantages over the grout-based systems used in the past. First, water is generally available underground, eliminating the need to bring in additional materials. In addition, prestressing can be repeated if necessary to offset creep that may occur in the support structure, particularly timber support systems. While initially a controversial idea, the development of leak-tight inlet valves and improved fabrication techniques has led to greater acceptance of this technology. The use of inflatable steel diaphragms to pre-load mine props was first tried at Winkelhaak Gold Mine in South Africa in 1978. While the preloads achieved were adequate and technically the trial was successful, the idea was abandoned because of the high cost of the units at that time. Then in 1997, New Concept Mining carried out further development resulting in the introduction of the Jackpot which has become the most popular design for prestressing of posts and props. Subsequent to the development of the Jackpot for prestressing props, flat circular and rectangular units (Jackpacks) were developed for prestressing crib type supports. The Jackpot and Jackpack products are marketed by the Heintzmann Corporation. Similar products are also manufactured by other companies in South Africa and are being distributed through other vendors in the United States.

PERFORMANCE CHARACTERISTICS OF HYDRAULIC PRESTRESSING UNITS

Hydraulic prestressing units (PSU's) work on the principle whereby a sealed deformable steel diaphragm is inflated with pressurized water resulting in the conversion of hydraulic energy into active loading onto the mine roof and floor upon installation of the roof support. Hydraulic PSU's have been developed for the

¹Mention of company name or product does not constitute endorsement by the National Institute of Occupational Safety and Health.

prestressing of post or prop type supports, crib or pack type supports, as well as for cable bolt or intrinsic roof anchors. The development continues to expand as new support applications are introduced.



Figure 3. Jackpot prestressing cap on a timber post.

Post or Prop Type Supports

The Jackpot (figure 3) is a cap-shaped unit designed for prop-type supports. It is fabricated in various sizes ranging from 5.5 to 10.4 inches in diameter to accommodate different size props, particularly timber posts. It is designed to fit over the top of the post with the lip helping to keep the unit in place. The shape of the unit is critical to its performance capabilities. The perimeter section that forms the lip of the cap is about 2 inches high and $\frac{3}{4}$ of an inch wide. This shape not only contributes to its strength, but also allows for considerable expansion of the unit if necessary during inflation. As the unit is pressurized with a gap between the top of the support and the mine roof, the bottom interior section of the cap expands downward unrolling the interior face of the lip. Although the Jackpot can be expanded to a spherical shape, the useful expansion capability of the Jackpot is 3-4 inches, and it is generally recommended that this expansion be limited to less than 3 inches to ensure the full loading capability of the unit. At expansions of less than 2.5 inches, the unit has an installation pressure rating of 2,000 psi with a burst pressure of 6,000 psi. Figure 4 shows calibration curves for standard Jackpot production units correlating pressure to support load. It is seen from the figure that the loading is linearly related to the internal pressure of the cell. Since some work is required to deform the metal structure, the effective area of the unit is somewhat less than the top surface area

calculated from the diameter of the unit. For example, the effective diameter of the 10-inch diameter unit is 9.5 inches. The cell initially requires about 100 psi water pressure to cause it to inflate.

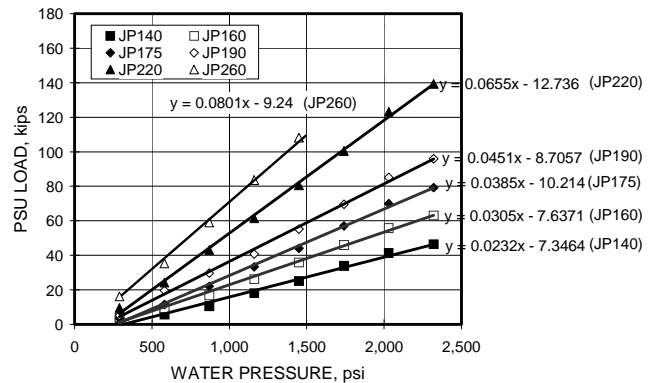

Figure 4. Calibration curves showing load as a function of internal water pressure for Jackpot PSU.

Crib or Pack Type Supports

Since the surface area of these supports is so much bigger than those for prop-type supports, a different design is employed. These units can be described as “flatjack” constructions where two thin (1-2 mm) sheets of cold-rolled steel are machine welded along the perimeter to form an encapsulated cell that can be pressurized. The units can be fabricated in various shapes (circular, square, rectangular) and sizes to accommodate different support geometries. Typical Jackpacks PSU's are shown in figure 5.



Figure 5. The Jackpack PSU's can be fabricated in a variety of shapes and sizes to accommodate specific support applications.

The expansion capability of the Jackpack units can vary depending on the size and shape of the unit. Square geometries tend to perform better (expand more evenly with less folding of the metal) than circular geometries at high levels of expansion. A 36 x 36-inch unit has been tested at expansions up to 12 inches at 300 psi of loading. However, the cell is more likely to rupture at lower pressures when folding of the metal container is excessive at these large expansions. It is recommended that the cell expansion be limited to 6 inches or less to ensure the full operating pressure of the cell is maintained with a high level of confidence.

The burst pressure on the Jackpacks is considerably lower than that of the Jackpots. The burst pressure can vary depending of the shape and deformation of the cell. Maximum pressures of 1,000 psi are attainable under full contact loading conditions. Loads of 400 tons with an internal pressure of 800 psi have been

achieved under these ideal loading conditions. Because of the larger area, Jackpacks are typically fitted with a pressure relief valve to control loading and avoid over pressurization. Yield settings are typically in the range of 250-350 psi.

Cable Bolt or Roof Anchor Supports

Pretensioning of roof bolts and some cable bolts is achieved by tightening the end nut to a predetermined torque. Although this has been an effective means of pretensioning conventional roof bolts, this approach is more problematic with cable bolts since the wire strands twist when the torque is applied and can untwist when the torque is removed resulting in a decay of the achieved tension. Nut tightening to achieve pretension is also subject to significant frictional losses that further reduce the efficiency of this approach. These factors lead to a high variability (up to 45%) in the achieved pretension load (5). Another approach for pre-tensioning cable bolts is to use a hydraulic jack. Tensioning jacks are heavy and manually applied and the procedure can be time consuming. In addition, barrel and wedge type anchors, often used with these cables, are subject to distortion or slippage, resulting in some reduction of pretension load following release of the jack (6).

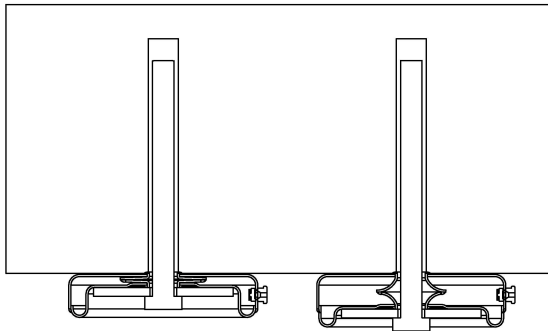

Figure 6. Donut-shaped PSU used to pretension cable bolts.

Conversely, donut-shaped PSU's create axial loads in the cables without twisting the cables' strands and have around 5% variation in preload. The donut-shaped PSU (figure 6) is fitted underneath the roof bolt or cable bolt end plate and applies tension by hydraulic inflation. This avoids the common causes of load loss associated with both frictional and anchorage effects. Typical load capacities for these units are 25 tons and 50 tons for the 6-inch-diameter units and 8-inch-diameter units respectively. The load-pressure relationship for the 8-inch-diameter design is shown in figure 7. Tests in the UK using a resin-anchored rock bolt and an

8-inch-diameter PSU demonstrated "lock in" of the pretension using a two-speed resin system. This is feasible because the tensioning procedure using donuts is quick and simple. Application of the tension after the fast resin has cured, but the slow resin is still liquid, results in retention of this load over most of the bolt length, even if the donut is subsequently depressurized and removed.

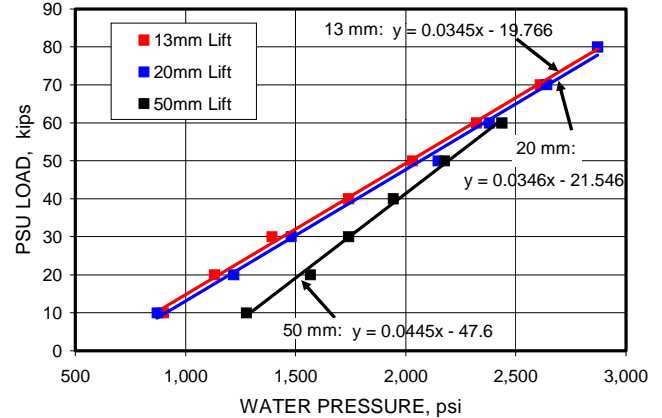

Figure 7. Calibration curves for cable bolt PSU.

Pressure Relief Valve

The use of water also allows the incorporation of a pressure relief valve (PRV) to limit the load development in the PSU. By expelling water through the PRV at a designated pressure, the PSU will provide a degree of controlled yielding to the support until the PSU is fully compressed and no fluid remains. The valve, as shown in figure 8, is a simple plastic unit with a spring loaded plunger that seats against the body to act as a check valve. The yield pressure is controlled by the stiffness of the spring. The Jackpack pressure relief is typically set at 250-350 psi, sufficient to develop loads comparable to the capacities of larger scale supports such as the Can. The smaller Jackpot PSU's, which are designed for posts or prop-type supports, require considerably higher yield pressures to develop comparable load to the capacities of those support systems. The pressure relief on these PSU's is typically set between 1,500 and 2,000 psi.

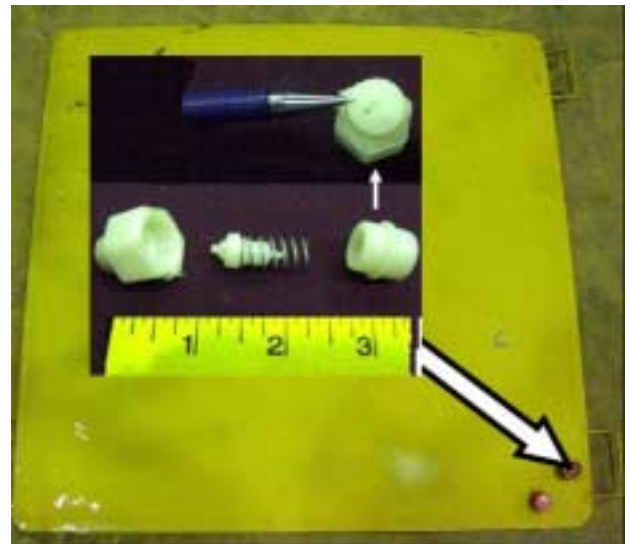

Figure 8. Pressure relief valve installed to provide load control or prevent over pressurization of PSU.

Studies were conducted using a 36 x 36-inch Jackpack to evaluate the performance characteristics of the pressure relief valve. The tests showed that the load required to produce yielding of the support was 317 kips (158.5 tons), which was higher than anticipated based on the manufacturer's specifications. Comparing this to the capacity of a Can support, a 30-inch-diameter Can will yield at approximately 150 tons, therefore the Can will yield before the PSU yields in this particular case. If the goal is to have the PSU yield prior to the Can, then a lower rated yield valve or a smaller sized PSU would need to be used. This design issue illustrates the need to install the proper yield valve for a particular support. In the studies conducted on the 36 x 36-inch Jackpack, the load dropped to about 150 kips (75 tons) when the load frame displacement was held, providing an indication of the resetting behavior of the PRV. The yield valve was also cycled several times during the tests to confirm the repeatability of the unit over several loading cycles.

GROUND CONTROL PERFORMANCE RELATED ISSUES

Jackpack Preload Can Vary with Inflation Height

The Jackpack will change shape as it is inflated and this will cause a variation in preload for the same fluid pressure. The cell is originally flat. When inflated, it forms a pillow shape and the curvature from the perimeter of the cell results in less contact area on the mine roof as the inflation thickness increases. Figure 9a shows the correlation of inflation thickness to achieve preload for a 36 x 36-inch PSU over a thickness range from 1 to 6 inches with inflation pressures ranging from 0 to 300 psi. Figure 9b shows the preload for 24-inch-diameter circular PSU for a relatively constant inflation pressure of 115 psi. The following conclusions are derived from this laboratory study.

- For a given inflation thickness, equivalent to the gap between the support and the mine roof, the preload will increase proportionally with an increase in the inflation pressure.
- The achieved preload for a given inflation pressure will decrease proportionally as the inflation thickness increases. Using the 24-inch-diameter circular cell as an example, the preload at 115 psi inflation pressure under full contact conditions decreases by 5.8 kips (2.9 tons) for each inch of increased bladder thickness as shown in figure 9b. Likewise, the preload decreases by about 25 kips (12.5 tons) for each additional inch of bladder thickness for the 36x36-inch PSU (figure 9a).

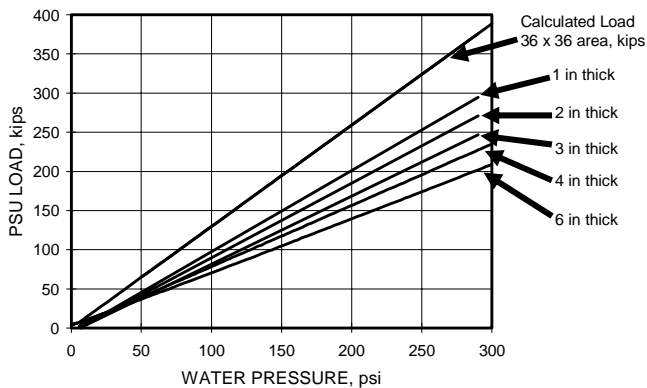

Figure 9a. Variation in load development in 36 x 36-inch PSU for inflation thickness ranging from 1 to 6 inches.

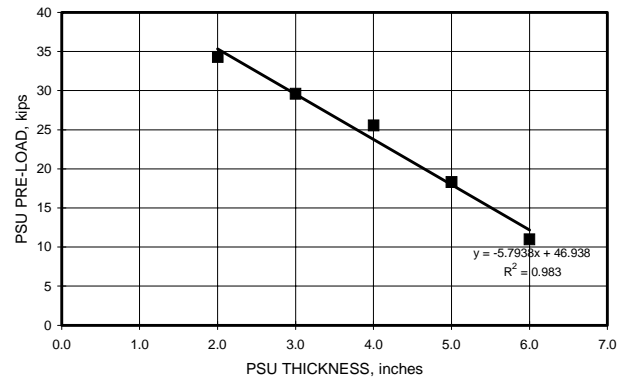

Figure 9b. Load as a function of inflation thickness for a 24-inch diameter circular PSU.

Preload and Load-Pressure Response Will Vary with Contact Conditions

A question that has been asked by mines using the PSU's to preload supports is: How much preload is developed when an oversized PSU is placed on top of a support such as the Can shown in figure 10? Is the preload determined by the pressure acting on the larger roof contact area or is it dictated by the smaller area of the support, i.e., the Can in figure 10? Since there must be load transfer between the PSU and the support, whatever load is acting on the roof by pressurization of the cell is also acting on the support. Therefore, the water pressure acting on the larger mine roof contact surface for the most part controls the preload developed on the support. The part of the cell that is not in direct contact with the support is transferring the force acting in this portion of the cell to the support. In this sense, it is no different that having timber blocks on top that are larger than the Can. Whatever roof load that is being carried by the timber blocks is also being carried by the Can. The stress acting on the timber blocks against the mine roof is lower than the stress acting on the Can, but the load is the same. So, the preload can be estimated by taking the roof contact area times the water pressure. Remember, when making this estimate, that the contact area will be a smaller percentage of the full un-inflated area of the cell with this percentage dependent on the inflation thickness.

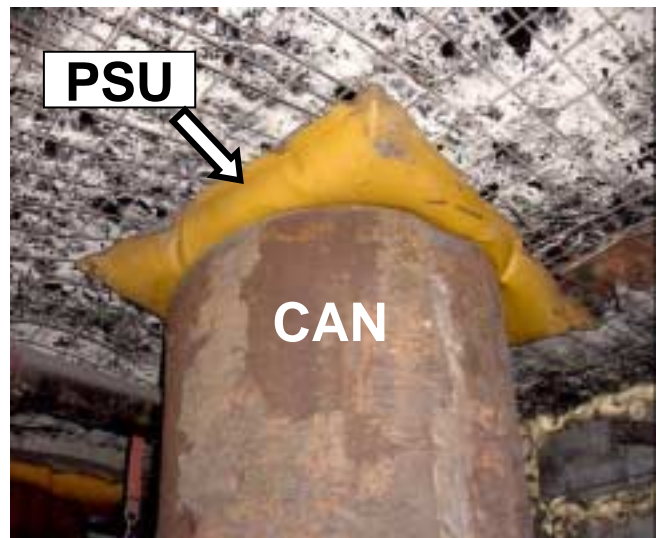

Figure 10. Oversized PSU inflated on top of Can support.

As noted, this conclusion is qualified with the comment “for the most part”. This is necessary because the PSU is not a rigid structure. The PSU will deform when the contact area of the support is smaller than the PSU. The resulting shape of the PSU will reduce the preload from the full contact condition or rigid assumption made in the preceding paragraph. This can be explained by analyzing the forces involved. Because fluids cannot contain shearing stress, the water pressures act normally (at right angles) to the interior surface of the cell. Since the roof contact is relatively flat, the water pressure is “directly” used in developing active roof loading and preloading of the support. On the bottom side where the PSU contacts the support, the PSU will expand or swell outward due to the internal pressures in the zones adjacent to the smaller support contact area (see figure 10). If the shape remained perfectly symmetrical, then shear forces will still not exist and the preload would be the same since the resultant vertical forces would be the same. However, this ideal condition does not exist and the resulting stress in the metal container decreases the effective hydraulic pressure of the water. Another way of envisioning this is to think that some of the work of the water pressure is lost to deform the cell instead of being used to preload the support. Another contributing factor is that the empty shell itself (no water inside) can carry some load. This component will be maximized for full contact conditions as a uniform ring around the perimeter will provide a significant load capacity (10 kips or more.) The total capacity of the PSU is the hydraulic load plus the structural capacity of the cell.

Figure 11 is an example for a three-inch inflation thickness on a 24-inch diameter PSU showing three support contact conditions: (1) full top and bottom contact equivalent to having the PSU fully sandwiched between the mine roof and the support, (2) a simulated 17.75-inch-diameter support, and (3) a simulated 14-inch-diameter support. The full contact condition is equivalent to having a support as large as or bigger than the PSU. Conversely, the other two conditions simulate a smaller support than the PSU or an oversized PSU. At this inflation thickness, the contact diameter on the mine roof is approximately 19.5 inches. As seen in the figure, full top and bottom contact condition provides a slightly larger load than what the contact area suggests it should be. The reason for this is that the empty cell has some load carrying capability (about 10 kips in this particular PSU), much like a soft drink (soda) can has load carrying capability without the liquid in it or a Can support has capacity without the fill material in it. As the support contact area decreases, the support load decreases for a given water pressure in the PSU. This is expected since the unsupported section of the PSU forms a larger rounded shape as the unsupported section grows in size. However, the achieved preload will always be closer to that determined by the full roof contact area than the support contact area.

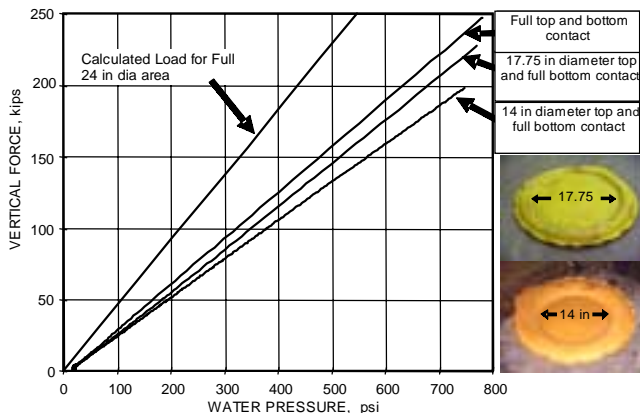

Figure 11. Impact of contact area on pressure-load response of PSU.

Variation in PSU Stiffness Due to Contact Conditions

This section deals with the stiffness of the hydraulic cell, not the system stiffness which includes the combination of the PSU and the support element. That topic is discussed in the next section. Because as an elastic (bulk) modulus of about 300,000 psi, the hydraulic bladder can be a very stiff system. For this to happen, the PSU shell must not be severely stressed beyond its elastic limits where permanent deformations cause the shell to change shape during loading after the cell is inflated upon installation. This condition only exists for full top and bottom contact conditions where the cell is fully sandwiched between the mine roof and the support product. Once the compliance is achieved between the contact surfaces of the mine roof and the support, the fluid being confined by the cell is compressed by the applied loading providing a stiff response. For a 24-inch-diameter circular PSU with an inflation thickness of 1 inch, stiffness up to 5,000 tons/in can be achieved in this full contact condition. This is an order of magnitude higher than any standing roof support structure.

If the bladder is not fully confined on the top and bottom during inflation, then the unconfined portions of the cell will expand or balloon as shown in figure 10. This can temporarily cause a reduction in stiffness while the ballooning is occurring. Once the cell is fully reformed by sufficient pressure development within the cell, it will attain a stiffness comparable to the full contact stiffness, providing the metal container maintains a consistent shape and does not wrinkle or develop folds in the unconfined ballooned areas. This concept is illustrated in figure 12, which compares the stiffness of a 3-inch-thick, 24-inch-diameter, circular PSU under full top and bottom contact and when the PSU was sandwiched between two 17.75-inch-diameter concrete disks. In this particular test, about 0.5 inches of displacement occurred transforming the cell from a flat section to the donut-shaped structure. As shown, the stiffness of cell during this transformation was less than 50 tons/inch. The range of displacement required to transform the cell into a final shape depends on the volume of fluid that must be displaced. As shown, the stiffness transitions to a final stiffness of 1,150 tons/in. It is also seen from this figure that if the cell is unloaded and then reloaded, the cell resumes its final stiffness from the previous loading and quickly approaches a stiffness comparable to full contact conditions.

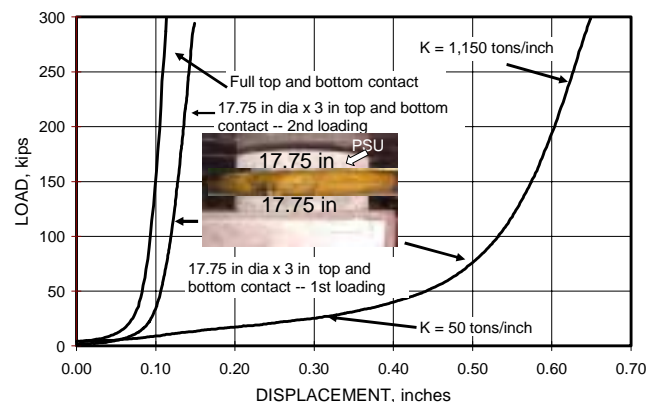

Figure 12. Transforming of PSU to a ballooned shape increases the stiffness of the cell. Note difference between first and second loading of the PSU sandwiched between two concrete disks.

Any folds that develop while the cell is ballooning to a new shape can significantly degrade the rigidity of the cell, preventing it from maintaining its shape such that the full stiffness capability of the cell may not be achieved. Geometric changes that occur when

over-sized PSU's are loaded can produce shear stresses that exceed the capability of the thin walled vessel. This causes folds to develop, which dramatically reduce the stiffness of the cell. The behavior is similar to that of a soft drink (soda) can under axial load. As long as the can is free from any wrinkles, then the axial loading capacity of the can is quite high (you can stand on it and it will support your weight). However, as soon as a wrinkle occurs, the can buckles and quickly loses its load capacity. Figure 13 shows an example of the reduction in stiffness caused by folding for a partial contact cell, in this case a 14-inch-diameter simulated support contact on a 24-inch-diameter cell.

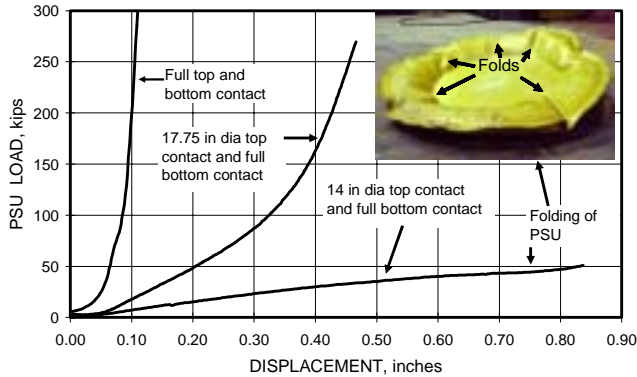

Figure 13. Stiffness of PSU can be significantly reduced if partial contact causes the cell to fold in areas outside of the support contact area.

Impact of PSU Stiffness on Support System Stiffness

Since the prestressing unit is used in series with the support structure, the overall support stiffness will never be as high as when the PSU is not used (see equation 1). However, for full contact conditions, the stiffness of the cell is an order of magnitude higher than the support, hence, the stiffness of the support system (PSU and the support element) will be controlled by the support element regardless of what support is used. For partial contact conditions where the hydraulic cell is larger than the support, the prestressing unit will control the initial stiffness of the support system until the cell is reshaped and stressed by the loading application. Beyond this point, the support will again control the stiffness of the support system since the cell stiffness increases dramatically once it is fully ballooned. If sufficient pressure is applied to reform the cell during inflation, then the support stiffness and not the cell will again govern the support response during roof to floor convergence. The caveat to this conclusion is that if the folding occurs, the cell again controls the stiffness of the support system. Figure 14 compares the load-displacement response for a 24-inch-diameter Can support that is preloaded to about 50 kips with water pressure of less than 100 psi in a 30 x 30 inch PSU compared to a passive support response without the PSU. As shown in the figure, the initial response of the Can with the PSU is softer prior to yielding than the Can without the PSU. The 6-inch thick, over-sized PSU, was deformed by the Can as the load developed, causing a reduced stiffness. In this case, the PSU was not inflated with enough pressure to produce the ballooning of the cell that eventually occurred as the loading developed.

$$K_{\text{System}} = \frac{K_{\text{Support}} \times K_{\text{PSU}}}{K_{\text{Support}} + K_{\text{PSU}}} \quad (1)$$

where K = stiffness.

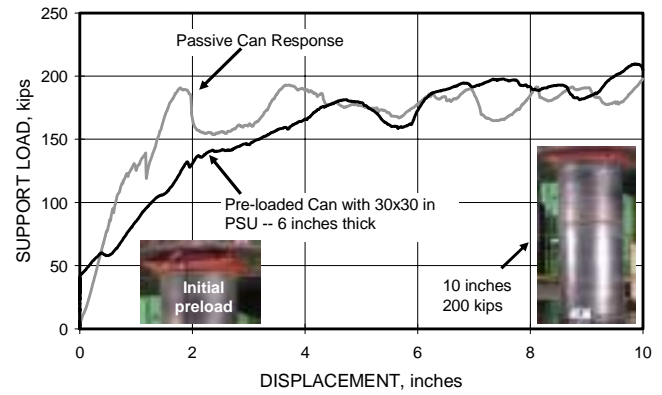

Figure 14. Comparison of pre-load Can support and a passive Can support.

Use of PSU to Control Load on the Support

The Jackpack PSU's are fitted with a yield valve to limit the pressure from the roof loading. The valve as shown in figure 8, is a simple plastic unit with a spring loaded plunger that seats against the body of valve to act as a check valve. There are two holes in the base of the housing about 1.0 mm in size (about the size of a mechanical pencil lead) through which the fluid must flow to relieve the pressure in the diaphragm. Obviously this small of an opening has a relatively small flow rate that limits the capability of the PSU to control pressure increases in the cell or support load development from active roof loading. Figure 15 compares a 36x36-inch PSU response to load frame displacement rates of 0.01, 0.08, 0.16, and 0.32 inches per minute. At rates equal or below 0.08 inches per minute the PSU can limit the load development on the support, in this case at approximately 300 kips. However, at rates between 0.16 and 0.32 inches per minute, the load continues to increase beyond the yield valve rating to the point where the valve fully opens and begins to exert control on the load development, although at a higher load. As seen in figure 15, at slow loading rates the yield valve opens at a load of about 320 kips and is able to maintain this load by opening and closing as needed. However, at a rate of 0.16 inches per minute, the load reaches a level of about 400 kips before the valve fully opens. Here the valve remains fully open and the load continues to build slowly, reaching a load of nearly 500 kips after 1 inch of convergence. At 0.32 inches per minute, the load builds to about 950 kips after 1 inch of convergence. At a loading rate of 0.5 inches per minute, the load continues to build at a rate of 3,200 kips per inch of convergence even while the yield valve is fully open.

Therefore, the capability of the PSU to limit load development on the support (assuming the support is not yielding and providing this function) will depend on the loading rate and to some extent on the size of the unit. Loading rates can vary significantly in different mining conditions. However, the threshold rate of 0.08 inches per minute, when the valve can no longer limit the load development, is a significantly faster loading rate than is likely to occur in nearly all mining conditions. The exception being bump or bounce prone situations that produce dynamic loading. Recent studies in a longwall tailgate at a western PA mine operating in the Pittsburgh seam found outby convergence rates in the abutment zone to be on the order of 0.0005 inches per minute and 0.005 inches per minute just inby the face (7). Even the convergence rate inby the face is an order of magnitude slower than what the PSU is capable of handling, so it is concluded that the PSU can be an effective support load control device in longwall tailgate applications. The support performance characteristics are

also relevant to this discussion. If the support has a yielding load below that of the PSU, and assuming this yielding behavior is not rate dependent, then in theory, the PSU will never reach the pressure relieving state since the support yielding capacity will limit the load. In this case, the yield valve is not really necessary.

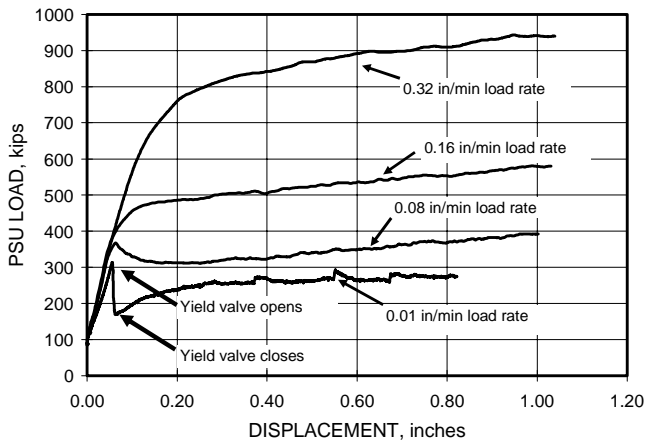

Figure 15. Yield valve performance for different loading rates.

Operation in Bump or Bounce Prone Areas

No dynamic testing was conducted on the PSU's at NIOSH. Although the threshold-loading rate of 0.08 inches per minute is adequate for most mining conditions, dynamic or impact loading will cause pressure intensification beyond the yield valve rating. Whether this causes the PSU to rupture will depend on the level of loading and the condition of the cell prior to the dynamic loading. Under ideal conditions, the Jackpack PSU has a pressure rating of 1,000 psi. If the static pressure is limited to 250 psi by a pressure relieve valve, it is likely that the PSU would survive the dynamic loading. On the other hand, if the PSU is highly deformed or loaded unevenly, then it is much more likely that the PSU could rupture from the dynamic loading. Therefore, the capability of the PSU to function in this environment may be dependent upon the yielding characteristics of the support, which can vary widely for the various standing supports that are now available. It should be noted that the yield load of the support is also likely to increase for dynamic loading.

PROPER INSTALLATION PROCEDURES

Basic installation requirements for both crib and prop PSU's are similar. The support should be set perpendicular to the roof on a clean floor. Although the units have considerable expansion capability to establish roof contact, the optimum performance will be realized when the contact distance between the support and the uninflated PSU is minimized. This will maximize the contact area and the resulting preload will be maximized.

The contact area at the mine roof or floor should be free of obstructions such as roof bolts, channels, or steel straps. Beyond these, the PSU will conform reasonably well to roof or floor rock surfaces. Meshing will not cause a problem. If the unit is to be installed directly on Can supports, the PSU should be placed on the closed end of the Can. Tests have shown the weld sections on the open end of the Can can puncture the PSU on occasion when the Can deforms. The PSU needs to be big enough to have access to the inlet port for inflating the PSU. As the PSU inflates the inlet port orientation may rotate if the inflation thickness is large, and

this needs to be taken into account in the sizing of the PSU as well. The inlet port and yield port should not be in direct contact with the support or mine roof or floor.

Selecting the size of the PSU brings up several interesting points. There are several standard Jackpot and Jackpack sizes currently available. Custom sizes can be made if the need is justified. Selecting an oversized PSU (i.e. larger than the support) will provide a higher preload for a given inflation pressure and will provide a higher yield load for the same yield pressure. These can be considered advantages of using an oversized bladder. The disadvantage of using an oversized bladder is that it can reduce the initial stiffness of the support if it is not fully inflated under pressure to a permanent deformed (ballooned) shape. Another disadvantage of an oversized PSU is that the irregular shape caused by ballooning will most likely significantly increase the probability of premature rupture. A similar argument can be made in reference to the contact surface between the support and the PSU. If the support surface is irregular such as that of a wood crib product including Link-N-Lock, Hercules crib, Tri-Log crib, etc, then providing a full contact surface with the PSU by adding a full layer of timber, would provide for more efficient load transfer through the PSU. In addition to these performance issues, the cost of the PSU increases with increase in size, providing another incentive not to use over-sized units.

The amount of preload that is needed can also raise some interesting questions, particularly since the preload that can be developed by these units can exceed the yield load rating of many supports. This discussion should begin with why the preload is used in the first place. The primary justification for preloading standing supports is to: (1) increase the overall stiffness of the roof support, for example, by "closing gaps" in multi-piece units such as timber cribbing, (2) closing gaps in the immediate roof structure to enhance beam building, much the same way as pre-tensioning roof bolts, and (3) securing the support to offset timber shrinkage, creep, or any other issue that may cause the support to loose contact with the mine roof prior to any roof loading. Since these are all load-dependent functions, then the amount of preload needed can be examined based on completing these tasks. Preloading beyond these requirements depends on whether the mining induced stresses can be controlled by the additional preloading. This is a complex question upon which research continues, but there is most likely a diminishing benefit for preloading beyond this level.

RANGE OF SUPPORT APPLICATIONS

As noted in the introductory comments, water-filled PSU's have been extensively used in South African hard rock mines on various timber packs and timber posts support systems. Coal mining applications in the U.S. and Australia have begun during the past year. The majority of these applications have been on the Can support and the Pencil Prop. Some preliminary trials have been made with the following supports (1) MX props, (2) Spider Props, (3) Wedge Props, (4) conventional timber posts, (5) Link-N-Lock, (6) Hercules cribs, (7) Sand Props and (8) Bolt Props.

OBSERVATIONS FROM APPLICATIONS IN U.S. COAL MINES

The applications in U.S. and Australian coal mines have been primarily longwall tailgate installations and shield recovery operations. At this point, these have been primarily trial evaluations, but results to date have been positive. The tailgate

applications generally report improved ground conditions when prestressing is applied. The shield recovery operations provide another interesting perspective. In one case, the mine was using Can supports as part of the shield recovery operation. Cans were normally installed once a shield was removed to provide ground control and safety to the mine workers in this critical area. In addition to the benefits of providing an active roof load to minimize ground movements, the mine felt that the fast installation of the PSU's compared to the more laborious process of topping off the Can's with crib timbers was a significant safety advantage to the mine workers.

The problems and concerns expressed by the mines are summarized as follows. The inlet check valve was damaged on several occasions when high flow was used to fill the PSU's in a matter of a few seconds and the check valve was on occasion destroyed by the high flow rate. A different check valve design is currently being pursued to help alleviate this problem or a flow control device can be used to limit the flow from the source. The problem can also be avoided by using the hydraulic pump supplied by the manufacturer. The air pump also has the advantage of being able to control the preloading pressure. The problem generally occurred on the longwall recovery operations where a very high flow rate is available. The other primary concern expressed by several western mines was what would happen in bounce prone conditions where an impact or dynamic load would be applied to the support system.

CONCLUSIONS

Standing supports have traditionally been totally passive support systems, meaning entry convergence must occur before the support develops any load carrying capacity. This is no longer the case. The PSU can economically turn almost any passive standing support into an active support that can apply considerable immediate load to the mine roof and floor. This represents a major change in standing support design. In addition to functioning as a preloading device, the development of an inexpensive yield valve also allows the unit to function as a yielding or load control device. By correctly designing the yield pressure in relation to the load capacity of a support, the PSU can then turn a non-yielding support into a yielding support at least through a few inches, depending on the PSU installed. This can significantly improve the capability of very stiff, but brittle supports, such as conventional concrete cribbing, cuttable cribs used in longwall recovery operations, and pumpable cribs used in longwall tailgate applications; just to name a few.

Another advantage of the PSU is that it can fill the gap between the top of the support and the mine roof. Most standing support systems, like the Can, must be topped off with a secondary support material to fill the gap between the top of the support and the roof. The Backpack PSU can perform this function and preload the support as well. When inflated, the PSU will conform to the roof surface and provide more uniform loading on the support than timber blocks or wooden wedges where full support coverage is not typically achieved. Since the PSUs are transported into the mine in a collapsed form, they also reduce the volume of material that must be brought into the mine to construct the support systems.

It is important to understand that the preload is primarily determined by the overall size of the PSU, not the size of the support. This might be important if the goal is to avoid putting the support into yield with the preload. The use of over-sized PSU's relative to the support size can provide for larger preloading capability, but the oversized PSU can also decrease the initial stiffness of the support if it is not fully pressurized to a permanent shape. Over-sized PSU's are also more likely to fail prematurely than ones that are fully sandwiched between the mine roof or floor and the roof support structure.

The application of this technology in underground coal mining is currently limited, but several trials are underway in the United States in longwall applications, both in tailgates and shield recovery operations, and the technology has a proven history in mining applications in countries around the world. A few concerns have been identified from the trials thus far, but overall the response had been very positive. Modifications to improve the inlet check valve to avoid damage to high flow rates are already underway. As experience is gained with their use, additional designs that are specifically suited to a particular support are likely to follow.

REFERENCES

1. Barczak, T.M. and Gearhart, D.F. Engineering Methods for Design and Employment of Wood Cribs. U.S. Bureau of Mines Information Circular 9361, 1993, 34 pp.
2. Tests in NIOSH's Mine Roof Simulator, June 1995.
3. Tests in NIOSH's Mine Roof Simulator, August 1997.
4. Barczak, T.M. and Gearhart, D.F. Renewed Interest In Prop Supports As A Replacement For Wood Cribs. Proceedings, 14th International Conference on Ground Control in Mining, Morgantown, WV, Aug. 1-3, 1995, pp. 149-158.
5. Rataj, M. and Thomas, R. New Methods and Technologies of Roof Bolting in Australian Coal Mines. Proceedings, 16th International Conference on Ground Control in Mining, Morgantown, WV, Aug. 5-7, 1997, pp. 149-157.
6. Rataj, M. Improvement in Pre-Tensioning of Strand Bolts in Australian Coal Mines. Proceedings, 21st International Conference on Ground Control in Mining, Morgantown, WV, Aug. 6-8, 2002, pp. 145-149.
7. Barczak, T.M., Chen, J. and Bower, J. Pumpable Roof Supports: Developing Design Criteria by Measurement of the Ground Reaction Curve. Proceedings, 22nd International Conference on Ground Control in Mining, Morgantown, WV, Aug. 5-7, 2003, pp. 283-293.